

LIEBHERR

Crawler crane with lattice mast

LR 11000

LR 11000-001

Operating instructions

BAL No.: 23501-04-02

Serial No.	
Date	

ORIGINAL OPERATING MANUAL

The operating manual is part of the crane!

It must always be available within reach!

The regulations for crane operation must be observed!

Liebherr-Werk Ebingen GmbH

Postfach 1361

D-89582 Ebingen / Donau

+49 (0) 7391 502-0

+49 (0) 7391 502-3399

info.lwe@liebherr.com

www.liebherr.com

Preface

Manufacturer

Liebherr - Werk Ehingen GmbH
Postfach 1361
D-89582 Ehingen / Donau
+49 (0) 7391 502-0
+49 (0) 7391 502-3399
info.lwe@liebherr.com
www.liebherr.com

General

This crane was built according to the state of technology and recognized safety technical regulations. Despite that, dangers to body and life for the user and / or third persons or damage to the crane and / or other material assets can occur.

This crane may only be used:

- In impeccable technical condition.
- For destined use.
- By trained personnel, which acts in a safety and danger conscious way.
- When no safety relevant problems are present.
- When no modifications were made on the crane.

Any problems, which could affect safety must be fixed immediately.

Modifications on the crane may only be made with written approval by Liebherr-Werk Ehingen GmbH.

Data logger

This crane is equipped with a data recording device. Among others, the following data is recorded:



- Date and time of day.
- Entered set up configuration of the crane.
- Actual load.
- Percentage of utilization of the crane.
- Boom radius (working radius).
- Main boom angle, luffing jib angle.
- Total telescopic boom length, length of each telescopic section.
- Every actuation of bypass devices.

The recorded data can be read with a respective software.

Safety and warning display

The safety and warning display is directed to all persons who work with the crane.

The terms **DANGER**, **WARNING**, **CAUTION** and **NOTICE** used in the crane documentation are intended to point out certain rules of conduct to all persons working with the crane.

Warning signs	Signal word	Explanation
	DANGER	Designates a dangerous situation which will lead to death or serious injury if it is not prevented. ¹⁾
	WARNING	Designates a dangerous situation, which can lead to death or serious injury if it is not prevented. ¹⁾
	CAUTION	Designates a dangerous situation, which can lead to slight or medium-grade injuries if it is not prevented. ¹⁾
	NOTICE	Designates a dangerous situation, which can lead to property damage if it is not prevented.

¹⁾ This could also result in property damage.

Additional notes

The term **Note** is used in the crane documentation to make all persons working with the crane aware of useful information and tips.

Sign	Signal word	Explanation
	Note	Designates useful information and tips.

Crane documentation

The crane documentation is comprised of:

- All supplied documents on paper and in digital form.
- All supplied programs and applications.
- All subsequently supplied information, updates and addenda for the crane documentation.

The crane documentation:

- Makes it possible for you to operate the crane safely.
- Supports you to utilize the permissible application possibilities of the crane.
- Provides you with information about the functionality of important components and systems.



Note

Terminology in the crane documentation.

Certain expressions are used in the crane documentation.

- ▶ In order to avoid misunderstandings, the same expressions should always be used.

Translations from the German version of the crane documentation: The crane documentation has been translated to be best of one's knowledge. Liebherr-Werk Ehingen GmbH assumes no liability for translation errors. The German version of the crane documentation is solely applicable for factual accuracy. If you find any errors or if any misunderstandings arise when reading the crane documentation, please contact Liebherr-Werk Ehingen GmbH immediately.

**WARNING**

Danger of accident due to incorrect operation of the crane!

Incorrect operation of the crane can lead to accidents!

Personnel can be killed or seriously injured!

This could result in property damage!

- ▶ Only authorized and trained expert personnel are permitted to work on the crane.
- ▶ The crane documentation is part of the crane and must be accessible on the crane.
- ▶ The crane documentation and on-site regulations and specifications (such as accident prevention regulations) must be observed.

Using the crane documentation:

- **Makes it easier** to become familiar with the crane.
- **Avoids** problems due to improper operation.

Observing the crane documentation:

- **Increases** reliability in use.
- **Extends** the service life of the crane.
- **Minimizes** repair costs and downtime.

Place the crane documentation accessible in the driver's cab or in the crane cab.

**WARNING**

Outdated version of crane documentation!

If subsequently supplied information, updates and addenda to the crane documentation are not observed and added, there is a danger of accidents!

Personnel can be killed or seriously injured!

This could result in property damage!

- ▶ Observe and add all subsequently supplied information, updates and addenda for the crane documentation.
- ▶ Make sure that all affected persons always know and understand the latest version of the crane documentation.

**WARNING**

Crane documentation is not understood!

If parts of the crane documentation are not understood and the tasks are carried out on or with the crane, then there is a danger of accidents!

Personnel can be killed or seriously injured!

This could result in property damage!

- ▶ Clear up open questions regarding the crane documentation with Liebherr Service before carrying out the respective task.

This documentation may not be reproduced or duplicated, distributed or used for purposes of competition, neither in part nor in excerpts. All rights are expressly reserved in accordance with copyright laws.

All accident prevention guidelines, operating instructions, load charts etc. are based on destined use of the crane.

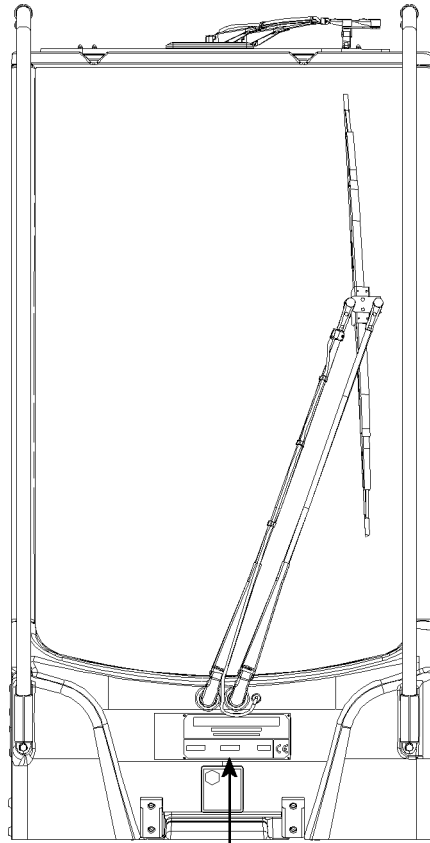

1

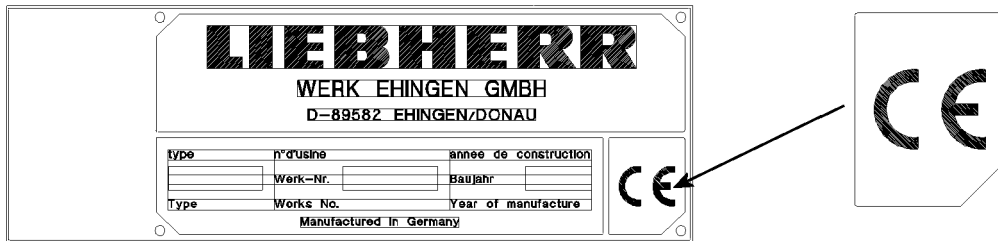

2



Fig.110001

LWE/LR 11000-001/23501-04-02/en

CE marking

The CE marking is a mark according to EU laws:

- Cranes with CE-marking according to the European machinery directive 2006/42/EC and the EN 13000! Data tag Crane with CE-marking, see illustration 1.
- Cranes that are operated outside the respective area of application of the European machinery directive do not require a CE marking. Data tag Crane without CE marking, see illustration 2.
- It is prohibited to market and operate cranes without CE marking, which do not meet the product-specific regulations valid in Europe, when a CE marking is specified for the country.
- It is prohibited to operate cranes with a tipping load utilization of 85 % within the European Union or in countries that only permit a lower tipping load utilization! The national regulations apply. These cranes may not have a CE marking!

Destined use

The destined use of the crane consists solely in vertical lifting and lowering of free and non-adhered loads, whose weight and center of gravity are known.

To do so, a hook or hook block approved by Liebherr must be reeved on the hoist rope and it may only be operated within the permissible crane configurations.

Driving with the crane, with or without an attached load is only permissible if a corresponding driving or load chart is available. The set up configurations intended for it and the safety conditions must be observed according to the corresponding crane documentation.

Any other use or any other exceeding utilization is **not** destined use.

Destined use also includes the adherence of the required safety guidelines, conditions, prerequisites, set up conditions and working steps in the crane documentation (for example: Operating instructions, load charts, erection and take down charts, job planner).

The manufacturer is **not** liable for damages, which are caused by non-destined use or improper use of the crane. Any associated risk it is carried solely by the owner, the operator and the user of the crane.

Non-destined use

Non-destined use is:

- Working outside the permissible set up configurations according to the load chart.
- Working outside the permissible boom radii and slewing ranges according to the load chart.
- Selecting load charts, which do not correspond to the actual set up configuration.
- Selection of a set up configuration via code or via manual entry, which does not correspond to the actual set up configuration.
- Working with bypassed / deactivated safety equipment, for example bypassed load torque limiter or with bypassed hoist limit switch.
- Increasing the boom radius of the lifted load after a LMB shut off, for example by diagonally pulling the load.
- Using the support pressure display as information in order to utilize the crane up to the tipping limit!
- Use of equipment parts which are not approved for the crane.
- Operation of the crane in an area exposed to explosion hazards.
- Using the crane at sports and recreational events, especially for "Bungee" jumps and / or "Dinner in the sky".
- On-road driving in non-permissible travel condition (axle load, dimension).
- Driving with the equipment in place in a non-permissible travel condition.
- Pushing, pulling or lifting loads with the level control, the sliding beams or the support cylinders.
- Pushing, pulling or lifting loads by actuating the slewing gear, the luffing gear or the telescoping gear.
- Ripping stuck objects loose with the crane.
- Utilizing the crane for a longer period of time for material handling tasks.
- Releasing the crane suddenly (grapple or dumping operation).
- Utilizing the crane when the weight of the load, which is suspended on the crane is changed, for example by filling a container suspended on the load hook, except:

- The load torque limiter was checked before for function with a known load.
- The crane cab is occupied.
- The crane is operational.
- The container size is selected in such a way that an overload of the crane with full load is eliminated within the valid used load chart.

The crane may **not** be used for:

- Attaching a stuck load for which the weight and center of gravity are not known and which is released only by flame cutting, for example.
- Letting persons drive along outside the driver's cab.
- Transporting personnel in the crane cab while driving.
- Transporting personnel with the load handling equipment and on the load.
- Transporting of persons with work baskets (cherry pickers), if the national regulations of the responsible work safety organization are not observed.
- Transporting loads and objects on the crane chassis.
- Transporting loads and objects on the crane superstructure.
- Transporting loads and objects on the boom lattice sections and / or the crane boom.
- Two hook operation without auxiliary equipment.
- Extended material handling operation.
- Crane operation on a barge if the conditions are not determined and the written release by **Liebherr Werk Ehingen GmbH** is not present.

The crane documentation must be read and used by all persons who are involved in use, operation, assembly and maintenance of the crane.

Ambient temperature

The crane is designed for an ambient temperature of -20 °C to +50 °C.

If the ambient temperature is lower than -20 °C the crane must be modified with „auxiliary equipment for working at low temperatures“.



WARNING

Working at low temperatures without the corresponding auxiliary equipment!
The crane components can be damaged and fail. The load can rip off.
Death or severe bodily injuries.

If the crane is operated at an ambient temperature lower than -20 °C:

- ▶ Make sure that the crane is equipped with the corresponding „auxiliary equipment for working at low temperatures“. Observe and adhere to the Crane operating instructions, chapter 2.08.
- ▶ Use the operating fluids for the corresponding ambient temperature in time. Observe and adhere to the Crane operating instructions, chapter 7.07.

Safety equipment

Special attention must be paid to the safety equipment built into the crane. The safety equipment must constantly be checked for functionality. The crane may not be operated if the safety equipment are not working or not working correctly.



Note

Your motto must always be:

- ▶ **Safety first!**

The crane has been built in accordance with the applicable travel operation and driving regulations and has been approved by the relevant authorities.

Equipment and spare parts



WARNING

Danger to life if original equipment parts are **not** used!

If the crane is operated with equipment parts, which are **not** original, then the crane can fail and cause fatal accidents!

Crane components can be damaged!

- ▶ Operate the crane only with original equipment parts!
- ▶ Crane operation with equipment parts, which do **not** belong to the crane is prohibited!
- ▶ If there is any doubt about the origin of equipment parts, contact Liebherr Service!



WARNING

The crane permit and the manufacturer's warranty will become void!

If any original installed parts are modified, manipulated or replaced (e.g. removal of parts, installation of non-original Liebherr parts), both the crane permit and the manufacturer's warranty will become void.

- ▶ Leave installed original parts unchanged!
- ▶ Do not remove installed original parts!
- ▶ Use only Original Liebherr spare parts!
- ▶ If there is any doubt about the origin of spare parts, contact Liebherr Service!

For ordering equipment and spare parts, always keep the crane number handy and provide it.

Definition of directional data for mobile cranes

Driving forwards: Driving with the driver's cab on the front.

Driving in reverse: Driving with the taillights of the crane chassis on the front.

Front, rear, right, left in the **driver's cab** refer to the crane chassis. The driver's cab is always in the front.

Front, rear, right, left in the **crane cab** refer to the crane superstructure. Front is always in direction of the placed down boom.

0° turning angle of the crane superstructure: The boom points in the longitudinal direction to the rear past the rear of the vehicle.

180° turning angle of the crane superstructure: The boom points in the longitudinal direction to the front past the driver's cab.

Definition of directional data for crawler cranes

Driving forward driving forward from the view of the crane operator seated in the crane cab. Turntable in 0° or 180° position.

Driving reverse driving backward from the view of the crane operator seated in the crane cab. Turntable in 0° or 180° position.

Front, rear, right, left always orient themselves on the **crawler track** from the position of the chain tension devices. The chain tension devices on the crawler track are always on the front.

Front, rear, right, left refer to the direction of view of the crane operator seated in the **crane cab**. Front is always in direction of the placed down boom.

Optional equipment and functions

The equipment marked with * and the functions are optionally available and are **not** part of the standard crane (optional equipment).

Conversion chart

	Initial unit	Multiplication factor	Target unit
Length	mm	0.03937	in
	in	25.4000	mm
	mm	0.00328	ft
	ft	304.8	mm
	cm	0.39370	in
	in	2.5400	cm
	cm	0.0328	ft
	ft	30.48	cm
	m	39.37	in
	in	0.0254	m
	m	3.281	ft
	ft	0.3048	m
	km	0.62137	mile
	mile	1.6093	km
Surface	cm ²	0.155	in ²
	in ²	6.4516	cm ²
	m²	10.764	ft²
	ft²	0.0929	m²
Volume	cm ³	0.06102	in ³
	in ³	16.387	cm ³
	m ³	35.3147	ft ³
	ft ³	0.0283	m ³
	l	0.001	m ³
	m ³	1000	l
	l	61.024	in ³
	in ³	0.016387	l
	l	0.0353	ft ³
	ft ³	28.32	l
	l	0.264178	US. liq. gal
	US. liq. gal	3.7853265	l

	Initial unit	Multiplication factor	Target unit
Mass (weight)	kg	2.20462	lb
	lb	0.45359	kg
	t	2204.62	lb
	lb	0.0004536	t
	t	1.1023	short ton US (tn. sh.)
	short ton US (tn. sh.)	0.90718	t
	t	0.45359	kip
	kip	2.20462	t
Mass / length	kg/m	0.055998	lb/in
	lb/in	17.857781	kg/m
	kg/m	0.67197	lb/ft
	lb/ft	1.48816	kg/m
Force	N	0.2248	lbf
	lbf	4.4483986	N
	kN	224.809	lbf
	lbf	0.0044483986	kN
Turning moment	Nm	8.85075	lbf·in
	lbf·in	0.112984	Nm
	Nm	0.73756	lbf·ft
	lbf·ft	1.3559	Nm
Performance	HP (DIN HP)	0.7355	kW
	kW	1.3596	HP (DIN HP)
Speed	m/s	39.37	in/s
	in/s	0.0254	m/s
	m/s	3.28084	ft/s
	ft/s	0.3048	m/s
	km/h	0.62137	mph (mi/h)
	mph (mi/h)	1.60935	km/h
	m/s	2.2369	mph (mi/h)
	mph (mi/h)	0.44704	m/s

	Initial unit	Multiplication factor	Target unit
Pressure	kPa (kN/m ²)	0.01	bar
	bar	100	kPa (kN/m ²)
	bar	14.5038	psi
	psi	0.06895	bar
	kPa (kN/m²)	0.145038	psi
	psi	6.894759	kPa (kN/m²)
	N/cm ²	1.450377	psi
	psi	0.6894759	N/cm ²
	N/m ²	0.000145038	psi
	psi	6894.759	N/m ²
	t/m ²	204.81	lbs/ft ²
	lbs/ft ²	0.0048828	t/m ²
Load-related surface	m ² /t	0.004882	ft ² /lbs
	ft ² /lb	204.81	m ² /t
Temperature	°C	([°C] · 1.8) + 32	°F
	°F	([°F] - 32) / 1.8	°C

Conversion chart

Contents

1 Description of crane

1.01 Terminology	1
1 Component overview crawler travel gear	3
2 Component overview turntable	3
3 Component overview winches	5
4 Component overview derrick ballast	5
5 S2 // SL // SLF // SL3F-boom	6
6 SW1 boom combination	8
7 SDB/B2/BW // S2DB/B2/BW // SL2DB/B2/BW boom combination	10
8 SL2DFB/BC/B2/BW // SL4DFB/BC/B2 boom combination	12
9 SDWB/B2/BW boom combination	14
10 PDB/B2/BW boom combination	16
11 PDW3B/B2/BW boom combination	18
1.02 Product description	1
1 Crawler travel gear	3
2 Crane superstructure	3
3 Boom systems / boom combinations	5
4 Auxiliary equipment	5
1.03 Technical data	1
1 Dimensions and weights Crane components	5
2 Dimensions of the crane basic unit	5
3 Noise emission	6
4 Vibrations	7
5 Crane speeds	7
6 Crane surface pressure	8
7 Load handling equipment	8
8 Hoist ropes	8
9 Control ropes	8
10 Guy rope	8
11 Assembly rope	9
12 Crawler center section with turntable frame lower section	9
13 Turntable with crawler center section with SA-frame	9
14 Crawler center section with Quick-Connection (QC)	10
15 Turntable frame lower section with Quick-Connection (QC)	10
16 Central ballast platform	10
17 Catwalk crawler	11
18 Mechanical auxiliary support	11
19 Turntable without SA-frame	11
20 SA-frame with winch 4	12
21 Turntable with SA-frame	12
22 Winch 1	12
23 Winch 2	13
24 Winch 5	13
25 Winch 6	13
26 Counterweight platform	14

27	Ballast plate for central ballast / counterweight / derrick ballast	14
28	S-pivot section	14
29	S-intermediate section 6 m	15
30	S-intermediate section 12 m	15
31	S-adapter	16
32	S-end section	16
33	SL-reducer	17
34	P-adapter bottom left / P-adapter bottom right	17
35	Cross carrier 3 m , P-adapter bottom	17
36	P-adapter top, 3 m	18
37	Bridges	18
38	L-intermediate section 6 m	18
39	L-intermediate section 12 m	19
40	L-end section	19
41	F-connector head	20
42	Roller set	20
43	W- and WA-frame 1 - pivot section	20
44	WA-frame 2 - pivot section	21
45	WA-frame - intermediate section 1 and 2	21
46	WA-frame - end section 1 and 2	21
47	D-pivot section with winch 3	22
48	D-intermediate section 12 m	22
49	D-intermediate section 6 m	22
50	D-end section	23
51	F-assembly unit with F-end section	23
52	F-assembly unit	23
53	F-intermediate section 6 m	24
54	F-intermediate section 12 m	24
55	F-end section	24
56	Suspended ballast guide B2	25
57	Ballast pallet	25
58	Ballast pallet special design (LTR as ballast)	25
59	Ramp	26
60	Cross beam	26
61	Ballast trailer	26
62	Ballast trailer guide with adapter for ballast trailer	27
63	Ballast trailer guide extension	27
64	Boom nose 32 t	27
65	Roller cart	28
66	Overview rods	28

2 Safety

2.03	Job planning	1
1	Planning Crane operation	3
2.04	General safety technical guidelines	1
1	Danger zone of crane	3
2	Traffic endangerment and environmental damage	3
3	Endangering air traffic	3
4	Movement on the crane	4

5	Emergency exit	5
6	Personal protective equipment	7
7	Securing persons to prevent them from falling	12
8	Rescuing the assembly personnel	14
9	Crane operator's cab with retractable / extendable step	15
10	Crane cab with incline adjustment	16
11	Securing bracket	17
12	Closing the side window pane	18
13	Transport	18
14	Stops	19
15	Heated crane components	19
16	Crane operator responsibilities	20
17	Selecting the crane operating location	22
18	Slopes and excavations	26
19	Load burdens on the ground due to crane operation	29
20	Support	33
21	Aligning the crane	35
22	Checking the safety measures	36
23	Safety guidelines in case of external power supply	37
24	Grounding	37
25	Working in the vicinity of transmitters	39
26	Crane operation in case of thunderstorms	40
27	Wind influences	41
28	Lifting a load with two cranes	47
29	Working ranges of several cranes overlap	49
30	Hand signals for guidance	50
31	Travel operation	58
32	Crane operation	60
33	Lifting of personnel	66
34	Securing personnel on shut off crane	67
35	Welding work on the load	69

2.04.10	Ladders	1
1	Safety guidelines	3
2	Safety signs	3
3	Ladder inspection	8
4	User guidelines	8
5	Ladder access	9

2.05	Signs on the crane	1
1	Signs	3

2.05.10	Labeling of load lifting equipment	1
1	Identifications on the hook block or load hooks	3
2	Identifications on single hook or double hook	4
3	Identifications on auxiliary weights	5

2.06	Antifall guards on the crane	1
1	Personal protective equipment	3
2	Safety ropes as fall protection equipment	5
3	Platforms on the crawler carriers	15
4	Assembly of railing on crawler center section	19

5	Catwalk / stairs crawler travel gear	29
6	Disassembly Catwalk / stairs crawler travel gear	39
7	Ladder Turntable frame lower section	49
8	Catwalks and railing on the turntable frame main section	53
9	Main boom assembly platform on turntable	73
10	Cab platform rear	77
11	Ladder turntable frame main section	81
12	Stairs turntable frame main section	83
13	Railings on the S-pivot section	85
14	Fall protection equipment on the counterweight bracket	87
15	Fall protection equipment on counterweights	91
16	Railing on ballast trailer guide	93
17	Ladders on ballast trailer guide	95
18	Extension ladder on ballast trailer	97
19	Railing on ballast trailer	105

2.08	Working in low temperatures	1
1	Auxiliary equipment	3
2	Ambient temperatures below -20 °C	3
3	Maintenance	7

2.15	General safety technical notes for operation with ballast trailer	1
1	Safety guidelines	3
2	Inspection of tires and disk wheels	4

2.25	Crane on floating device	1
1	Non-destined use	3
2	Destined use	3
3	Floating device	3
4	Operating conditions	3
5	Crane transport on floating devices	4
6	Increased corrosion	5

3 Crane assembly

3.01	Crawler carrier assembly	1
1	Component overview	3
2	Fastening points	3
3	Assembling turntable frame lower section with Quick Connection (QC) on crawler center section with QC	6
4	Assembling the crawler center section	11
5	Assembly of crawler carrier with the auxiliary crane	22
6	Disassembly of crawler carrier with the auxiliary crane	31
7	Assembly of the crawler carrier with SA-frame	46
8	Disassembly of the crawler carrier with SA-frame	59
9	Disassembling the crawler center section	73
3.02	Turntable assembly	1
1	Component overview	3
2	Fastening points	3
3	Turntable assembly	9
4	Disassembly of turntable	15

LWE/LR 11000-001/23501-04-02/en

3.03 Central ballast	1
1 Components	3
2 Fastening points and weights	3
3 Central ballast combinations	6
4 Permissible counterweight assemblies	7
5 Installing the central ballast	8
6 Disassembling the central ballast	21
3.04 Mechanical auxiliary support	1
1 Fastening points	3
2 Assembling the mechanical auxiliary support	3
3 Disassembling the mechanical auxiliary support	9
3.05 Assembly of SA bracket	1
1 Component overview	3
2 Attachment points SA-frame	3
3 Assembling SA-frame	5
4 Disassembling the SA-frame	29
3.06 Assembly conditions	1
1 Assembly conditions for operation on crawlers	3
3.07.10 Assembly winch 1	1
1 Component overview	3
2 Fastening points winch 1	3
3 Assembly winch 1	5
4 Disassembly winch 1	15
3.07.20 Assembly winch 2	1
1 Component overview	3
2 Fastening points winch 2	3
3 Assembly winch 2	5
4 Disassembly winch 2	15
3.07.30 Assembly winch 3	1
1 Component overview	3
3.07.50 Assembly winch 5	1
1 Component overview	3
2 Fastening points winch 5	3
3 Installation winch 5 from transport into operating position	5
4 Assembly winch 5	11
5 Disassembly winch 5	21
3.07.60 Assembly winch 6	1
1 Component overview	3
2 Fastening points winch 6	3
3 Installation winch 6 from transport into operating position	5
4 Assembly winch 6	11
5 Disassembly winch 6	23
3.80 Transport of crane and crane components	1
1 Safety	3

4 Operation of crane superstructure

4.01 Operating and control instruments on the crane superstructure	1
1 Operating and monitoring instruments	3
2 Overview Control units crane cab	10
3 Control platform	11
4 Instrument panel	12
5 Operating unit HATZ Diesel aggregate*	16
6 Operating and control unit (BKE)	16
7 LICCON computer system monitors	22
8 Camera monitoring	23
9 Pedal carrier	24
10 Touch displays	27
11 Master switch assignment MS1	31
12 Master switch assignment MS2	39
13 Master switch assignment MS3	53
4.02 LICCON computer system	1
1 General	3
2 System start of the LICCON computer system	5
3 Overview of general operating elements on the LICCON monitors	7
4 <i>Set up</i> program	12
5 The <i>Crane operation</i> program on LICCON monitor 0	71
6 The <i>Crane operation</i> program on LICCON monitor 1	157
7 The <i>Crane operation</i> program on LICCON monitor 2	179
8 Speed reduction master switch / pedal sensor	193
9 Power-Save mode and Stand-by mode in the LICCON computer system	201
10 The <i>Working range limitation</i> program	209
11 <i>Chart view</i> program: Curve illustration of load charts	216
4.03 Crane start up and taking the crane out of service	1
1 Crane commissioning	3
2 Bringing the crane operator's cab into operating position	3
3 Checks before start up	11
4 Work station - Crane operator's cab	23
5 Supply via external feed / power aggregate	35
6 Preheating the hydraulic oil with the Hydraulic oil preheating*	37
7 Starting the LICCON computer system (before engine start)	38
8 Starting and stopping the engine	41
9 Starting the LICCON computer system parallel to the engine	47
10 Load weighing and load display	49
11 Bringing the crane operator's cab into transport position	55
4.04 Safety equipment	1
1 General	3
2 Quick test Crane geometry	3
3 Quick test Overload protection	3
4 LICCON computer system	3
5 Safety systems on the crane	9

4.05 Crane operation	1
1 LICCON computer system	3
2 Master switch functions	5
3 Lifting and lowering	17
4 Luffing	39
5 Turning	47
4.06 Rope reeving	1
1 Wire ropes and rope end connections	3
2 Reeving in the hoist rope	5
3 Reeving the hook block in and out	8
4 Reeving in / reeving out the hook block, L-shaped rope end connection (LR 11000 only)	11
5 Attaching and removing the load hook*	16
6 Attaching / removing the hoist limit switch weight	19
7 Assembling / disassembling the wedge lock	21
8 Rope reeving	22
4.07 Counterweight	1
1 Component overview	3
2 Fastening points	3
3 Permissible counterweight assemblies	5
4 Installing the counterweight	6
5 Removing the counterweight	15
4.08 Working with a load	1
1 Safety guidelines	3
2 Checks before starting to work with the crane	4
3 Crane movement - Telescoping	5
4 Taking on a load	7
5 Crane operation	13
6 Crane rope pretension	15
4.10 Driving from the crane operator's cab	1
1 Prerequisites for driving the crane (crawler operation)	3
2 Displays in LICCON monitor	7
3 Preparing for driving the crane	13
4 Driving the crane: Load chart available	16
5 Driving the crane: No load chart is available	17
6 Driving the crane: Ballast trailer installed	21
7 Driving the crawler crane	22
4.20 Procedure for shut off of crane movements	1
1 General	3
2 Instructions for resuming crane movement	17

5 Equipment

5.01 Safety technical notes for assembly and disassembly	1
1 Rope pulleys	3
2 Ropes	3
3 Control measures	4
4 Relapse cylinder	6
5 Pneumatic springs	7

6	Manual rope winches	7
7	Weights	7
8	Guy rods	8
9	Auxiliary guying	8
10	Bypassing the overload protection	9
11	Bypassing the hoist top shut off	11
12	Pin connections	11
13	Retaining elements	14
14	Assembly / disassembly	22
15	Erection / take down	67
5.02 SA-frame		1
1	SA-frame	3
5.03 Boom systems		1
1	Boom components	3
2	Arrangement of intermediate sections on the boom	3
3	Auxiliary guying	7
5.05 D-boom		1
1	Component overview	3
2	Fastening points for derrick components	3
3	D-boom assembly on the crane	7
4	Erecting the D-boom	35
5	D-boom assembly on the ground	42
6	Flying D-boom assembly	44
7	Disassembling	49
8	D-boom disassembly on the ground	75
9	Flying D-boom disassembly	77
5.07 SW/SDW boom combination		1
1	Component overview	3
2	Fastening points	6
3	Assembling	13
4	Erecting the boom	59
5	Crane operation	65
6	Disassembling	67
5.10 Boom nose lattice boom		1
1	Component overview	3
2	Fastening points for boom nose 32 t	4
3	Installing the boom nose 32 t	7
4	Crane operation	21
5	Disassembling the 32 t boom nose	23
5.13 SLF-boom combination		1
1	Component overview	3
2	Fastening points for the F-jib	5
3	Assembling the F-jib	8
4	Assembly variation V1 — Assembling the F-jib in parts	11
5	Assembly variant V2 — Assembling the complete F-jib (maximum length of 12 m) on the ground	23

6	Assembly variant V3 — Assembling the complete F-jib (maximum length of 12 m) in flying mode	33
7	Assembly variant V4 — Assembling the complete F-jib (maximum length of 12 m) in flying mode	43
8	Establishing the electrical connections	45
9	Checking the function of the safety equipment	45
10	Erecting the boom	46
11	Operating the crane	48
12	Disassembling the F-jib	49
5.14 Roller set		1
1	Roller sets overview	3
2	Component overview	3
3	Fastening points for roller set	4
4	Assembly rack for roller set	4
5	Boom configurations	5
6	Combinations End section - Roller set	7
7	Assembling the roller set / roller sets	8
8	Removing the roller set / roller sets	15
5.19 Hook blocks		1
1	Hook blocks	3
2	Radio sending unit for the incline display hook block	3
3	Procedure in case of slack rope	3
5.19.10 Hook block incline sensors		1
1	Assembling the receiver-incline sensor*	3
2	Assembling the sending unit-incline sensor* on the hook block	6
5.30 Pin pulling device		1
1	Pinning and unpinning with pin pulling device	3
5.31 Bluetooth Terminal (BTT)		1
1	Display / operating element BTT	3
2	Start menu of the BTT	12
3	Settings and status displays on the BTT	15
4	<i>Engine operation</i> menu	17
5	<i>Menu Crane cab / stepladder</i>	29
6	<i>Test system</i> menu	35
7	Operation BTT	37
8	Measures in case of problems	39
5.35.10 Derrick ballast - ballast trailer		1
1	Product description	3
2	Component overview	4
3	Fastening points	5
4	Ballast trailer radii	7
5	Stability and tipping safety	9
6	Operating elements on the control panels	13
7	Assembling / disassembling the ballast trailer with the BTT-E	15
8	Pre-assembling the ballast trailer	15
9	Assembling the ballast trailer on the turntable	35
10	Working with the ballast trailer	51

11	Disassembling the ballast trailer	99
12	Removing the ballast trailer	114
13	Emergency operation in case of a defective control module of the ballast trailer control	134
14	Maintenance intervals / maintenance instructions for the ballast trailer	137
5.36.10 Derrick ballast - suspended ballast		1
1	Product description	3
2	Component overview	4
3	Fastening points	8
4	Pull cylinder extension conditions	12
5	Derrick ballast radii	15
6	Assembling the suspended ballast	21
7	Assembling the suspended ballast with suspended ballast guide	28
8	Ballasting the ballast pallet	57
9	Crane operation with the derrick ballast	62
10	Crawler operation with derrick ballast	96
11	Disassembling the suspended ballast	97
12	Disassembling the suspended ballast with the suspended ballast guide	111
13	Removing the ballast pallet	137
5.36.20 Derrick ballast - suspended ballast - special design LTR		1
1	Product description	3
2	Usage	5
3	Component overview	6
4	Fastening points for suspended ballast components	10
5	Pull cylinder extension conditions	16
6	Derrick ballast radii	17
7	Assembling without suspended ballast guide	20
8	Assembly with suspended ballast guide*	26
9	Ballasting the ballast pallet	47
10	Crane operation with the derrick ballast	54
11	Crawler operation with derrick ballast	88
12	Disassembling, ballasted ballast pallet	89
13	Disassembling, complete	93
5.36.30 Derrick ballast - suspended ballast - special design Ballast Constant (BC)		1
1	Product description	3
2	Component overview	5
3	Fastening points for suspended ballast components	6
4	Derrick ballast radii	7
5	Pull cylinder extension conditions	8
6	Assembly	9
7	Crane operation with the derrick ballast	15
8	Crawler operation with derrick ballast	48
9	Disassembling	49
5.36.40 Derrick ballast - suspended ballast - special design VarioTray		1
1	Product description	3
2	Component overview	4
3	Fastening points	8
4	Pull cylinder extension conditions	11
5	Derrick ballast radii	13

6	Assembly	20
7	Installing the divisible ballast pallet „VarioTray“	20
8	Assembling the suspended ballast	23
9	Assembling the suspended ballast with suspended ballast guide	25
10	Ballasting the divisible ballast pallet „VarioTray“	45
11	Crane operation with small ballast pallet	48
12	Crane operation with the derrick ballast	54
13	Crawler operation with derrick ballast	88
14	Disassembling	89
15	Removing the ballast on the divisible ballast pallet „VarioTray“	90
16	Disassembling the suspended ballast	93
17	Disassembling the suspended ballast with the suspended ballast guide	95
18	Removing the divisible ballast pallet „VarioTray“	112

5.38 S/SL-boom		1
1	Component overview S-pivot section	3
2	Fastening points	3
3	Assembly S2/SL/SL3-boom	11
4	Assembling the boom system in flying mode	27
5	Assembling the boom combinations with substructure	37
6	Assembling the S-guy rods	38
7	Assembling the roller sets on the boom head	40
8	Performing the function checks	41
9	Erecting the boom	42
10	Operating the crane	45
11	Disassembly S2/SL/SL3-boom	49

5.39.10 LD/SLD/SD boom combination		1
1	Component overview LD/SLD/SD boom	3
2	Fastening points	3
3	Assembly SD/S2D/SL2D-boom	11
4	Installing the derrick ballast	30
5	Assembling the boom system in flying mode (guying on the flying assembly intermediate section)	30
6	Assembling the boom system in flying mode (guying on S-pivot section)	41
7	Assembling the boom combinations with substructure	50
8	Assembling the S-guy rods	52
9	Assembling the roller sets on the boom head	53
10	Performing the function checks	54
11	Erecting the boom	56
12	Operating the crane	59
13	Disassembly SD/S2D/SL2D-boom	63

5.44 PD - boom combination		1
1	Component overview P-boom	3
2	Fastening points	3
3	Installing the central ballast	11
4	Assembly PD-boom	13
5	Assembling the boom combinations with substructure	42
6	Assembling the guy rods	44
7	Assembling the roller sets on the boom head	47
8	Performing the function checks	49

9	Erecting the boom	50
10	Operating the crane	53
11	Disassembly PD-boom	56

5.61	Pulley cart	1
1	Component overview	3
2	Fastening points for pulley cart	3
3	Assembly	5
4	Disassembly	7

5.62	Assembly shoes	1
1	Assembly shoes	3

6 Additional equipment

6.02	Heater / engine preheating / Air conditioning system Crane operator's cab	1
1	Climate control systems	3
2	Safety guidelines	3
3	Climate control	4
4	Adjusting the air supply	9
5	Air distribution	10
6	Defrosting the window	12
7	Climate control system*	13
8	Auxiliary heater	14
9	Maintenance Heater	26
10	Maintenance Auxiliary heater	27

6.05	Emergency take-down	1
1	Emergency control	2
2	Emergency control with assembly plate Variation 1 (V1)	9
3	Emergency control of slewing gear(s) with assembly plate Variation 1 (V1)	15
4	Emergency control with assembly plate(s) Variation 2 (V2)	19
5	Emergency control slewing gear(s) with assembly plate(s) Variation 2 (V2)	31
6	Completing emergency control	31

7 Service and maintenance

7.01	Maintenance and service - General	1
1	Technical safety instructions	3
2	Warranty and coverage	7
3	Liebherr Service	8
4	Taking an oil sample	8
5	Cleaning	9
6	Disposal	10

7.02	Maintenance intervals Crawler chassis	1
1	Maintenance and inspection schedule	3

7.02.50	Maintenance intervals ballast trailer	1
1	Maintenance and inspection schedule	3

7.03	Maintenance intervals - Crane superstructure	1
1	Maintenance and inspection schedule	3

7.03.50	Maintenance intervals - Crane boom	1
1	Maintenance and inspection schedule	3
7.04	Maintenance guidelines - Crane chassis	1
1	Travel gear	3
2	Central lubrication system	7
3	Servicing the track chain	16
4	Ladders	27
7.04.50	Ballast trailer maintenance instructions	1
1	Maintenance	3
2	Ballast trailer tires	3
3	Hydraulic hose lines	3
4	Slewing gear	4
5	Wheel set drive	7
6	Central lubrication system	9
7.05	Maintenance guidelines - Crane superstructure	1
1	Safety guidelines	3
2	Engine	3
3	Cooling system	5
4	Air filter system	7
5	Fuel system	8
6	Urea system*	14
7	Exhaust system	15
8	Pump distributor gear	15
9	Central lubrication system	17
10	Slewing ring connection	23
11	Slewing gear	24
12	Hoist gears	26
13	Assembly winch	28
14	Auxiliary heater*	29
15	Hydraulic system	31
16	Hydraulic hose lines	34
17	Air dryer	35
18	Electrical system	36
19	Ballast trailer*	39
20	Ladders	43
21	Window cleaning system	45
7.05.50	Maintenance guidelines - Crane boom	1
1	Lattice mast boom	3
2	Rope pulleys and guide pulleys	4
3	Crane ropes	4
7.06	Fill quantities, lubrication schedule	1
1	Fill quantities	3
2	Lubrication schedule	4
7.07	Service fluids and lubricants	1
1	Specified service fluids and lubricants for Liebherr cranes	3

8 Inspections of cranes

8.01	Periodic crane inspections	1
1	General information	3
2	Inspection of carrying crane structures, especially steel structures	4
3	Inspection of locking system of telescopic boom	79
4	Inspection of safety ropes and anchor points	81
5	Inspection of load handling equipment and assembly aids	83
6	Inspection of fastening equipment	84
7	Inspection of diaphragm reservoir	84
8	Inspection of relapse cylinders	84
9	Inspection of rope pulleys	85
10	Inspection of carrier rollers	85
11	Inspection of extension conditions of sliding beams	87
12	Inspection of the function of the overload protection	87
13	Inspecting the pin connections	87
14	Inspection of slewing ring connection	87
15	Inspection of the mounting of the load bearing equipment	88
16	Inspection of the tele extension with eccentric, illustration 1	89
17	Inspection of change over pulleys, illustration 2	90
18	Inspection of the oil and fuel tanks	90
8.03	Inspection of winches	1
1	Inspecting the hoist and retracting winches	3
2	Inspection of the auxiliary reeving winch, recovery winch and spare wheel winch	4
3	Monitoring the winches	5
8.04	Inspection of crane wire ropes	1
1	Crane ropes	3
2	Importance of inspection	3
3	Personal protective equipment	3
4	Qualification Inspection personnel	3
5	Unscheduled inspection	3
6	Intervals	4
7	Areas	4
8	Documenting inspection results	5
9	Wire ropes and rope end connections	5
10	Degree of severity	7
11	Abbreviations Rope diameter	7
12	Distortions and mechanical damage	8
13	Removal criteria Overview	8
14	Checking for broken strands	9
15	Determining the number of broken wires	9
16	Checking the rope end connection	14
17	Checking of rope diameter	14
18	Corrosion	17
19	Corkscrew-like distortion	19
20	Basket formation	20
21	Protruding, distorted insert or strand	21
22	Loop formation	22
23	Kinking or rope loops pulled closed	23
24	Buckles	24
25	Effects of heat, arcs	25

26	Combined degree of severity	25
27	Flattenings	25
28	Current checklist	28
8.05 Inspection of load hooks		1
1	Safety guidelines	3
2	Inspection intervals	3
3	Inspecting and monitoring the load hook	3
8.06 Inspection of hydraulic hose lines		1
1	Safety guidelines	3
2	Inspection intervals	3
3	Checking the end of the service life	3
4	Inspecting the hydraulic hose lines for damage	4
5	Inspecting the hydraulic hose lines for leaks	5
6	Documenting the inspection	5
7	Replacing hydraulic hose lines	5
8.12 Inspection of safety switching on the relapse supports		1
1	S-boom relapse retainer	3
2	D-boom relapse retainer	5
3	W-lattice jib relapse retainer	7
4	F-lattice jib relapse retainer	17
8.14 Inspection of accumulator pressure in anti-tilt cylinder		1
1	Checking the accumulator pressure in the W-relapse cylinder	3
8.15 Inspection of guy rods		1
1	Safety guidelines	3
2	Inspection intervals	3
3	Checking the guy rods	3
8.16 Inspection of fiber guy ropes		1
1	Safety guidelines	3
2	Inspection intervals	4
3	Inspecting the fiber guy ropes	4
8.17 Inspection of ladders		1
1	Safety guidelines	3
2	Inspection intervals	3
3	Inspecting ladders	3
4	Inspection sheet and check list	3
8.90 Inspection chart for cranes		1
1	Inspection chart for recurring inspections of Liebherr cranes	3

90 Attachment

90.01 Foreword to attachment		1
1	Foreword	3
90.05 Update confirmation		1
1	Change confirmation form	3
2	Update confirmation	3

1 Description of crane

LWE/LR 11000-001/23501-04-02/en

LWE/LR 11000-001/23501-04-02/en

1.01 Terminology

1	Component overview crawler travel gear	3
2	Component overview turntable	3
3	Component overview winches	5
4	Component overview derrick ballast	5
5	S2 // SL // SLF // SL3F-boom	6
6	SW1 boom combination	8
7	SDB/B2/BW // S2DB/B2/BW // SL2DB/B2/BW boom combination	10
8	SL2DFB/BC/B2/BW // SL4DFB/BC/B2 boom combination	12
9	SDWB/B2/BW boom combination	14
10	PDB/B2/BW boom combination	16
11	PDW3B/B2/BW boom combination	18

Fig.195219

LWE/LR 11000-001/23501-04-02/en

1 Component overview crawler travel gear

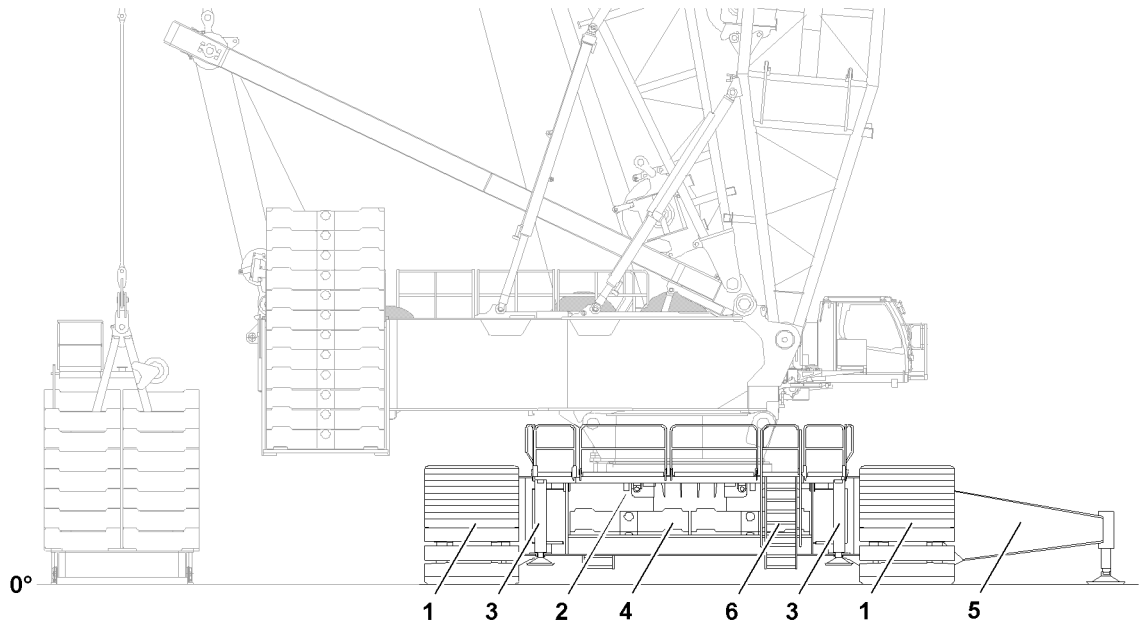

Fig.146670: Component overview crawler travel gear

- | | |
|-------------------------------------|---------------------------------------|
| 1 Crawler carrier | 4 Central ballast |
| 2 Crawler center section | 5 Mechanical auxiliary support |
| 3 Hydraulic assembly support | 6 Access / railing / catwalk |

2 Component overview turntable

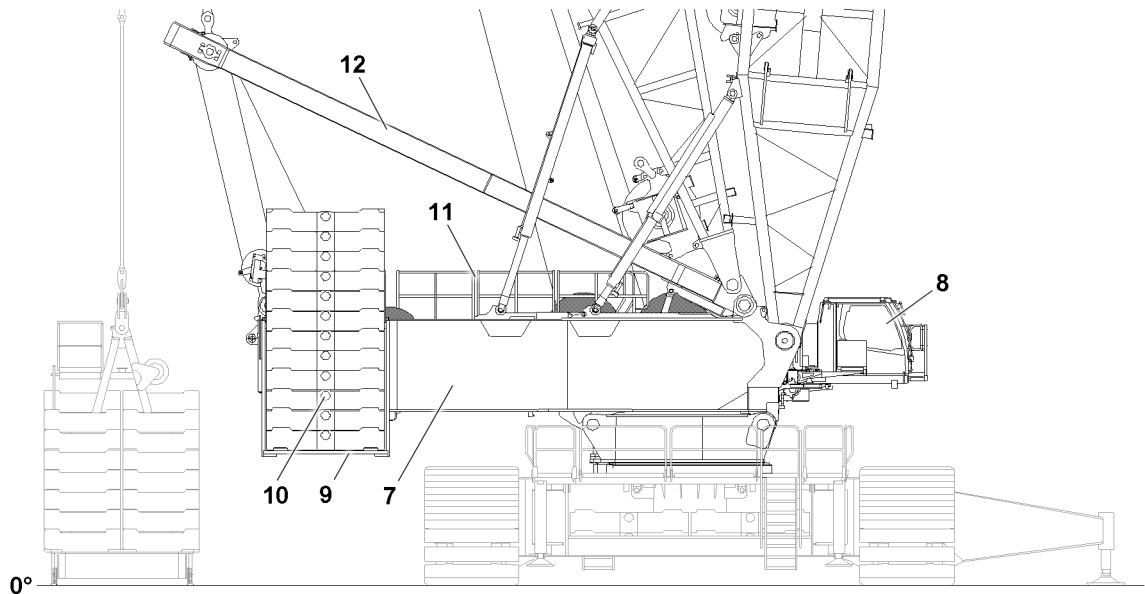

Fig.146671: Component overview turntable

- | | |
|--------------------------------|-----------------------------|
| 7 Turntable | 10 Counterweight |
| 8 Crane cab | 11 Turntable railing |
| 9 Counterweight bracket | 12 SA-frame |

LWE/LR 11000-001/23501-04-02/en

Fig.195219

LWE/LR 11000-001/23501-04-02/en

3 Component overview winches

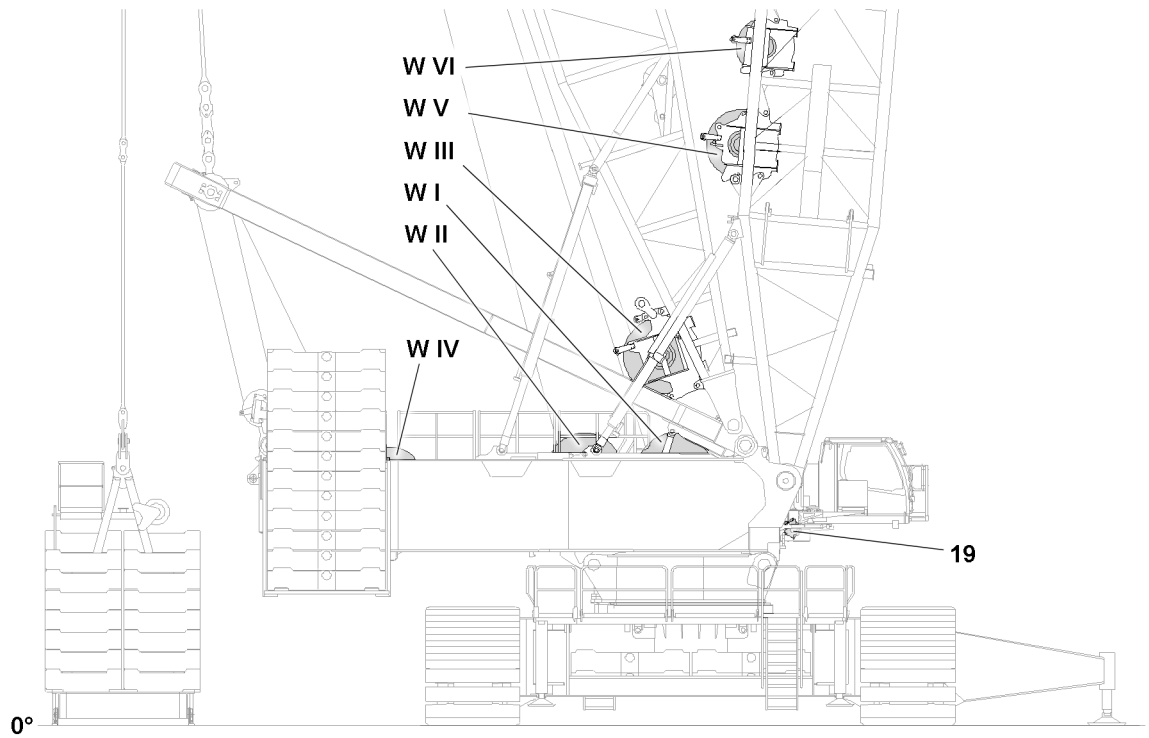

Fig.146736: Component overview winches

- | | |
|----------------------|--------------------------|
| W I Winch 1 | W V Winch 5 |
| W II Winch 2 | W VI Winch 6 |
| W III Winch 3 | 19 Assembly winch |
| W IV Winch 4 | |

4 Component overview derrick ballast

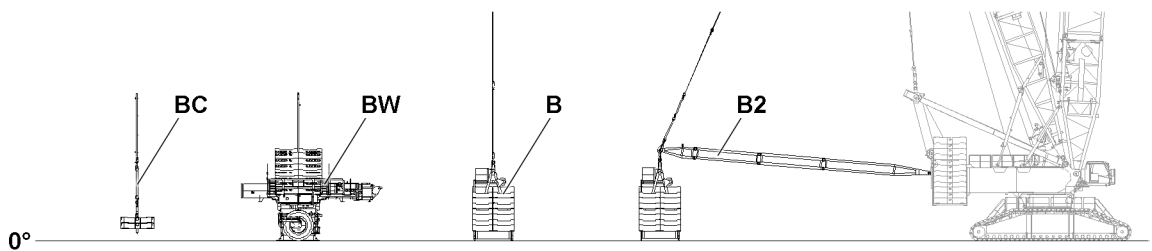

Fig.146737: Component overview derrick ballast

- | | |
|--|--|
| BC Derrick ballast - suspended ballast - special design Ballast Constant (BC) | B Derrick ballast - suspended ballast |
| BW Derrick ballast - ballast trailer | B2 Derrick ballast - suspended ballast with guide |

LWE/LR 11000-001/23501-04-02/en

5 S2 // SL // SLF // SL3F-boom

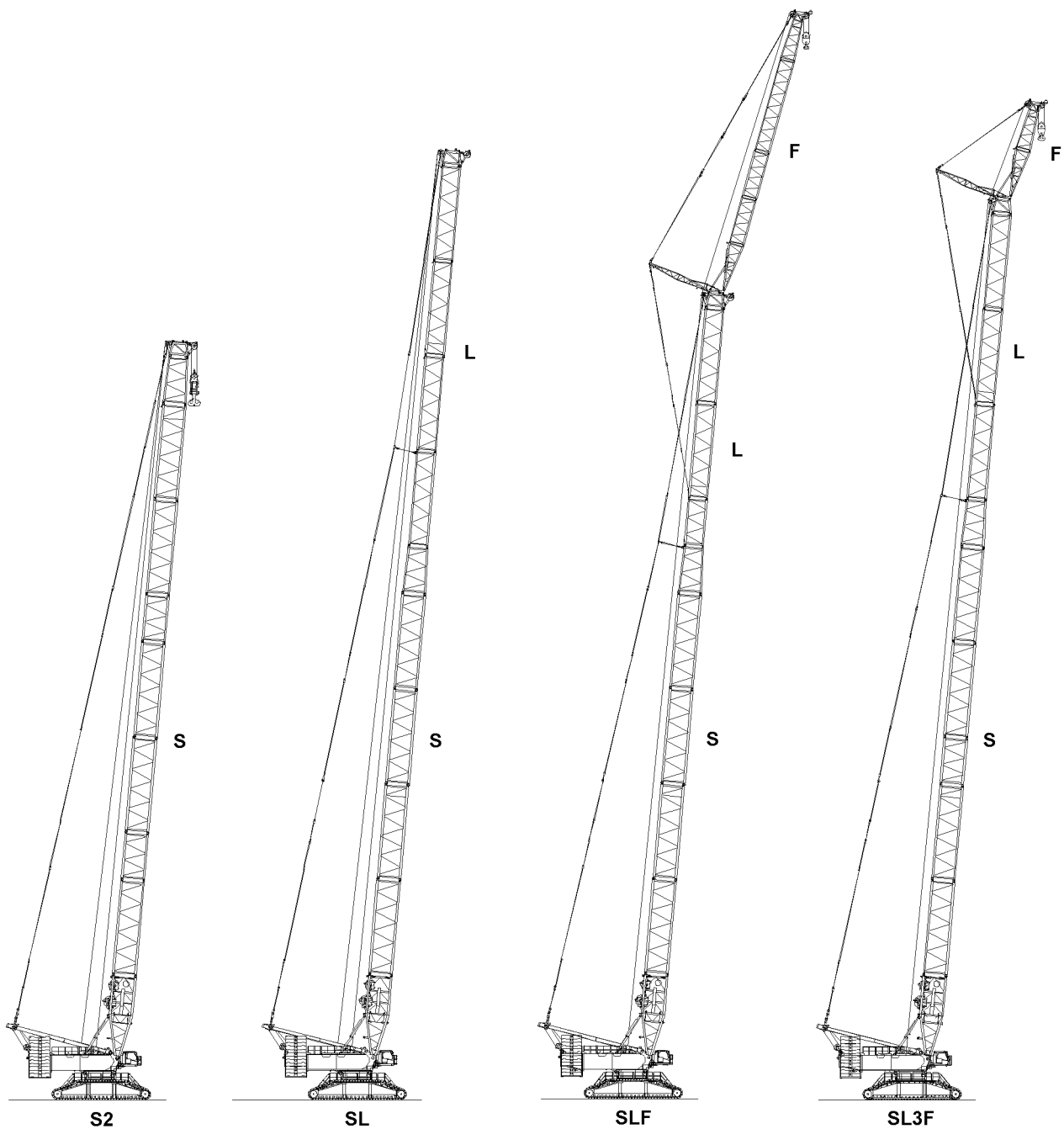

Fig.120894: S2 // SL // SLF / SL3F

LWE/LR 11000-001/23501-04-02/en

**WARNING**

The crane can topple over!

- ▶ Make sure that all boom systems are installed only according to the respective assembly chapter and the associated rod plans.
- ▶ Make sure that danger notes for assembly and for crane operation are observed and adhered to.
- ▶ Do not use the following boom illustrations for assembly purposes.

5.1 S2 boom combination

S2 Main boom

- Heavy version, supplemented on the bottom with reinforced lattice sections
- Variation **S2**

5.2 SL boom combination

SL Main boom

- Heavy-duty version, supplemented on top with light lattice sections **L**
- With roller set / roller sets on L-end section

5.3 SLF boom combination

SL Main boom

- Heavy-duty version, supplemented on top with light lattice sections **L**
- With roller set / roller sets on L-end section

F Auxiliary boom

- With F-lattice sections and FA-frame

5.4 SL3F boom combination

SL3 Main boom

- Heavy-duty version, supplemented on top with light lattice sections **L**
- With F-connector head
- Variant **SL3**

F Auxiliary boom

- With F-lattice sections and FA-frame

6 SW1 boom combination

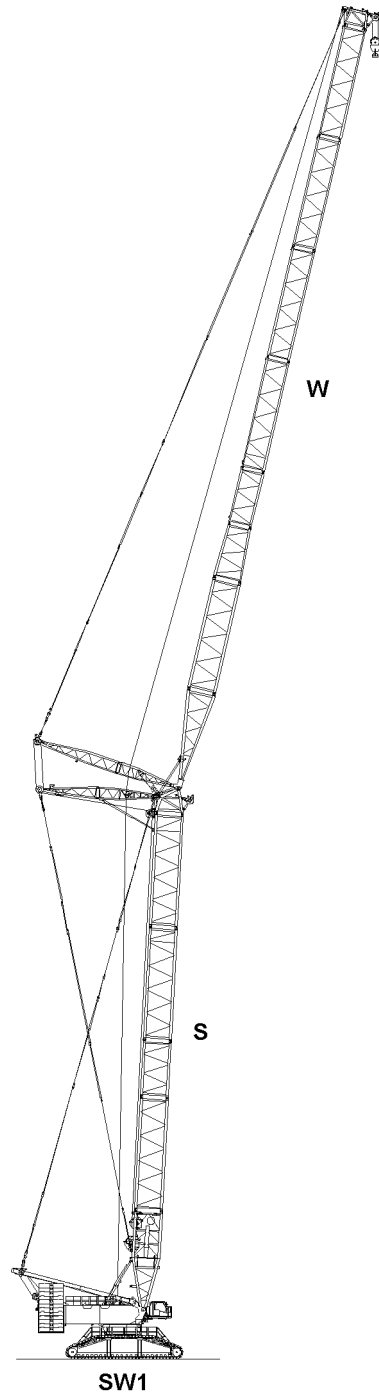

Fig.119469: SW1

LWE/LR 11000-001/23501-04-02/en

**WARNING**

The crane can topple over!

- ▶ Make sure that all boom systems are installed only according to the respective assembly chapter and the associated rod plans.
- ▶ Make sure that danger notes for assembly and for crane operation are observed and adhered to.
- ▶ Do not use the following boom illustrations for assembly purposes.

6.1 SW1 boom combination

- S** Main boom
 - Heavy version
- W1** Luffing lattice jib
 - Heavy lattice section **S**, supplemented on top with light **L** lattice sections
 - Short WA-frames
 - Variant **W1**

7 SDB/B2/BW // S2DB/B2/BW // SL2DB/B2/BW boom combination

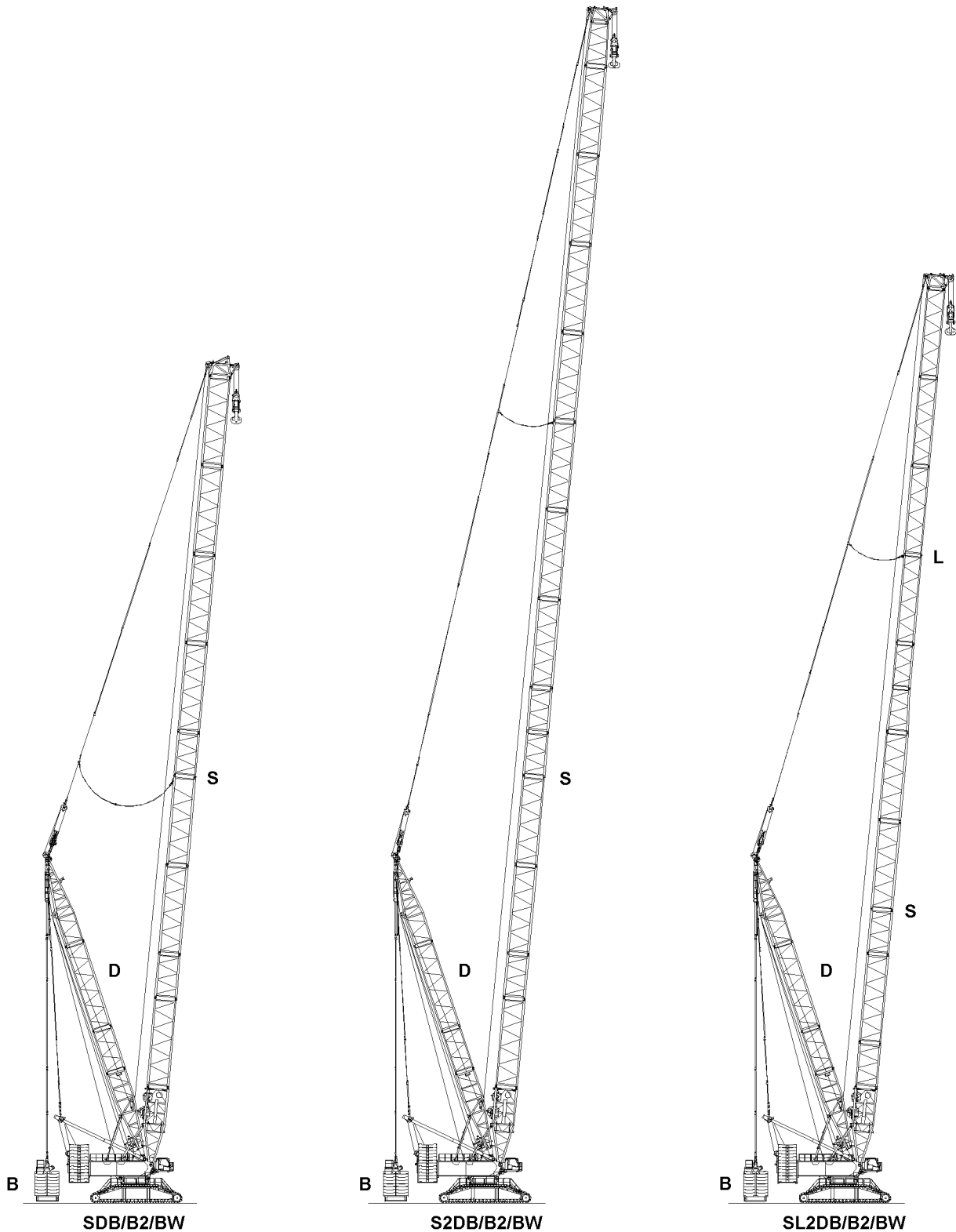

Fig.120895: SDB/B2/BW // S2DB/B2/BW // SL2DB/B2/BW

LWE/LR 11000-001/23501-04-02/en

**WARNING**

The crane can topple over!

- ▶ Make sure that all boom systems are installed only according to the respective assembly chapter and the associated rod plans.
- ▶ Make sure that danger notes for assembly and for crane operation are observed and adhered to.
- ▶ Do not use the following boom illustrations for assembly purposes.

7.1 SDB/B2/BW-boom combination

- S** Main boom
 - Heavy version
- D** Derrick boom
 - Alone as assembly device or in connection with SD or SL2D
- B** Derrick ballast
 - Suspended ballast
- B2** Derrick ballast
 - Suspended ballast with guide
- BW** Derrick ballast
 - Ballast trailer

7.2 S2DB/B2/BW boom combination

- S2** Main boom
 - Heavy version, supplemented on the bottom with reinforced lattice sections
 - Variation **S2**
- D** Derrick boom
 - Alone as assembly device or in connection with SD or SL2D
- B** Derrick ballast
 - Suspended ballast
- B2** Derrick ballast
 - Suspended ballast with guide
- BW** Derrick ballast
 - Ballast trailer

7.3 SL2DB/B2/BW boom combination

- SL2** Main boom
 - Heavy-duty version, supplemented on top with light lattice sections **L**
 - With roller set / roller sets on L-end section
 - Variant **SL2**
- D** Derrick boom
 - Alone as assembly device or in connection with SD or SL2D
- B** Derrick ballast
 - Suspended ballast
- B2** Derrick ballast
 - Suspended ballast with guide
- BW** Derrick ballast
 - Ballast trailer

8 SL2DFB/BC/B2/BW // SL4DFB/BC/B2 boom combination

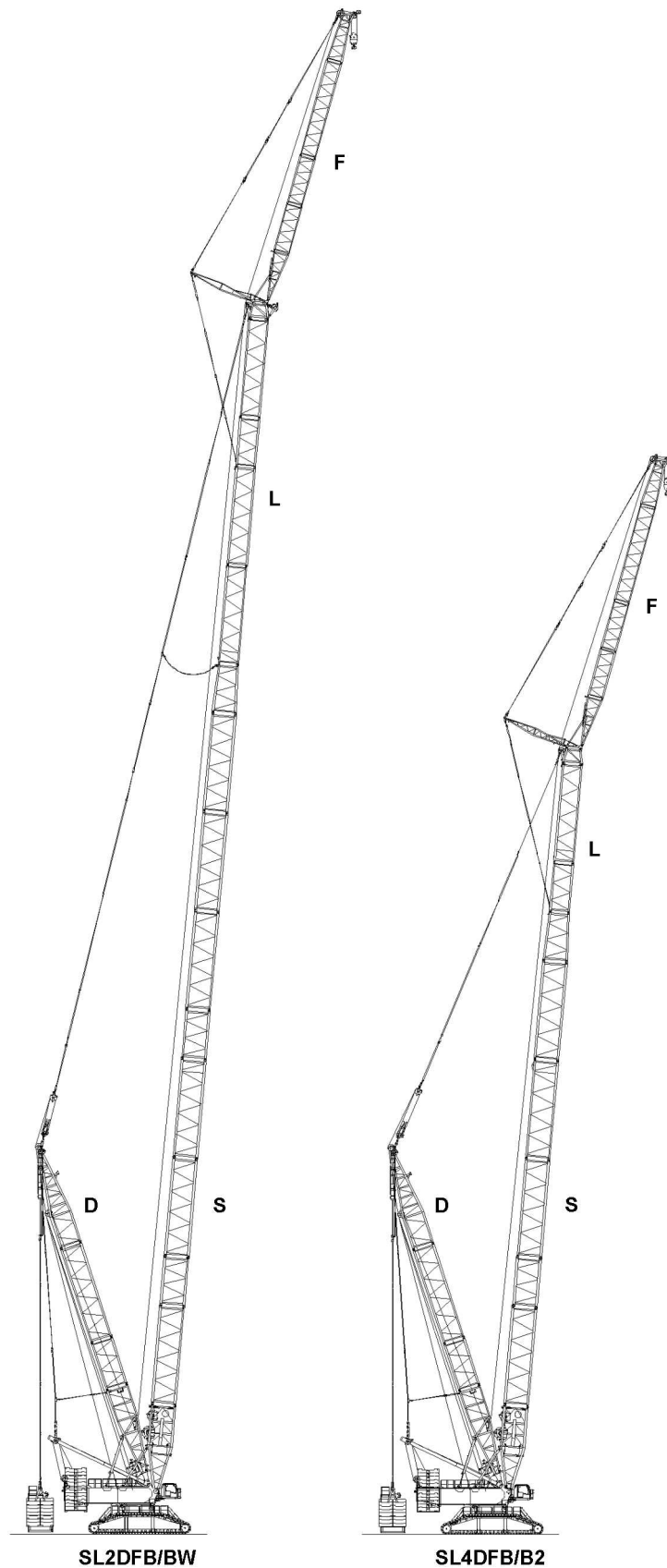

Fig.120896: SL2DFB/BC/B2/BW // SL4DFB/BC/B2

LWE/LR 11000-001/23501-04-02/en

**WARNING**

The crane can topple over!

- ▶ Make sure that all boom systems are installed only according to the respective assembly chapter and the associated rod plans.
- ▶ Make sure that danger notes for assembly and for crane operation are observed and adhered to.
- ▶ Do not use the following boom illustrations for assembly purposes.

8.1 SL2DFB/BC/B2/BW boom combination

- SL2** Main boom
 - Heavy-duty version, supplemented on top with light lattice sections **L**
 - With roller set / roller sets on L-end section
 - Variant **SL2**
- D** Derrick boom
 - Alone as assembly device or in connection with SD or SLD
- F** Auxiliary boom
 - With F-lattice sections and FA-frame
- B** Derrick ballast
 - Suspended ballast
- BC** Derrick ballast
 - Suspended ballast - special design Ballast Constant
 - Derrick ballast plates without suspended ballast pallet
 - With or without cross beam
- B2** Derrick ballast
 - Suspended ballast with guide
- BW** Derrick ballast
 - Ballast trailer

8.2 SL4DFB/BC/B2 boom combination

- SL4** Main boom
 - Heavy-duty version, supplemented on top with light lattice sections **L**
 - With F-connector head
 - Variant **SL4**
- D** Derrick boom
 - Alone as assembly device or in connection with SD or SLD
- F** Auxiliary boom
 - With F-lattice sections and FA-frame
- B** Derrick ballast
 - Suspended ballast
- BC** Derrick ballast
 - Suspended ballast - special design Ballast Constant
 - Derrick ballast plates without suspended ballast pallet
 - With or without cross beam
- B2** Derrick ballast
 - Suspended ballast with guide

9 SDWB/B2/BW boom combination

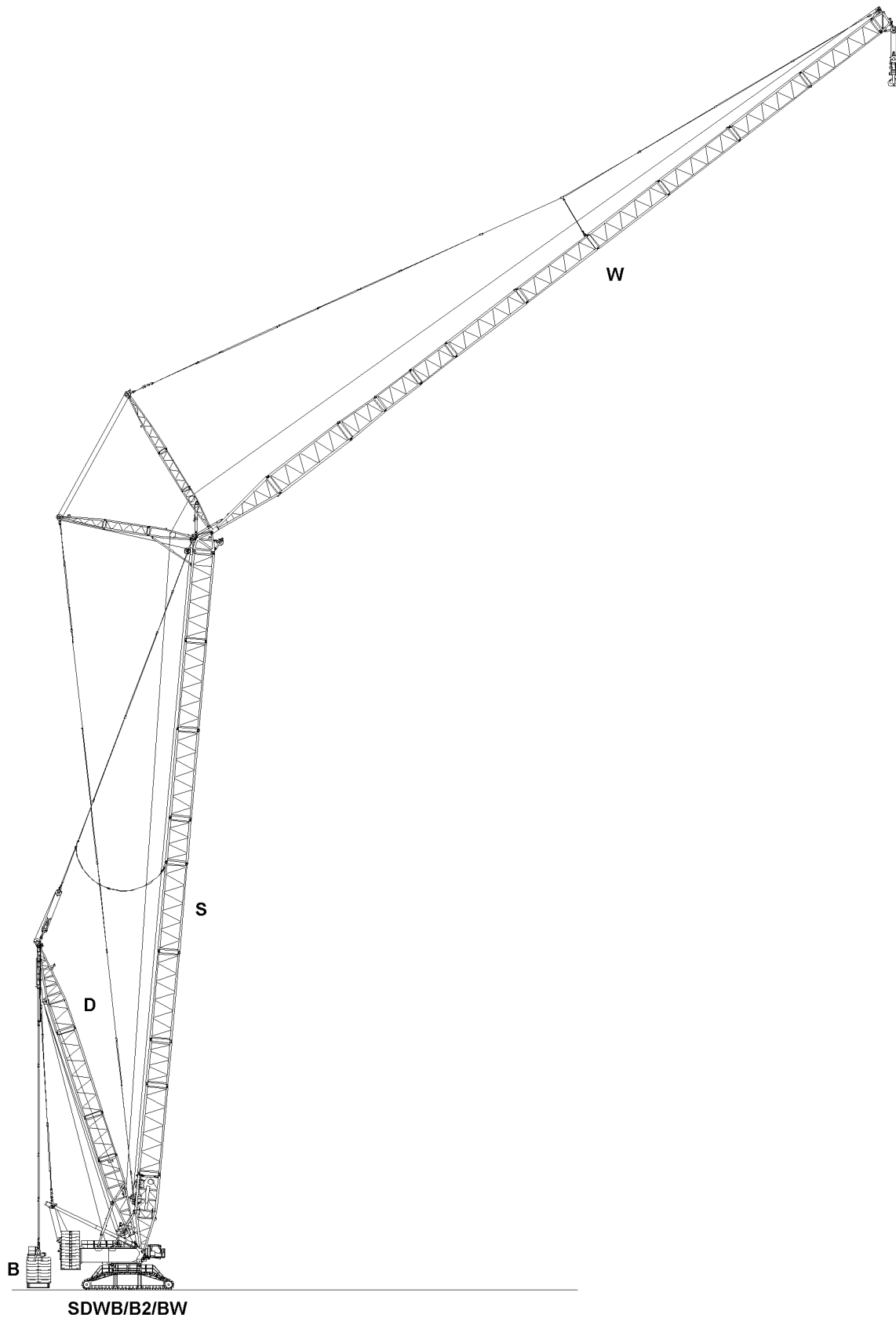

Fig.120941: SDWB/B2/BW

LWE/LR 11000-001/23501-04-02/en

**WARNING**

The crane can topple over!

- ▶ Make sure that all boom systems are installed only according to the respective assembly chapter and the associated rod plans.
- ▶ Make sure that danger notes for assembly and for crane operation are observed and adhered to.
- ▶ Do not use the following boom illustrations for assembly purposes.

9.1 SDWB/B2/BW boom combination

- S** Main boom
 - Heavy version
- D** Derrick boom
 - Alone as assembly device or in connection with SD or SLD
- W** Luffing lattice jib
 - Heavy lattice section **S**, supplemented on top with light **L** lattice sections
 - Long WA-frames
- B** Derrick ballast
 - Suspended ballast
- B2** Derrick ballast
 - Suspended ballast with guide
- BW** Derrick ballast
 - Ballast trailer

10 PDB/B2/BW boom combination

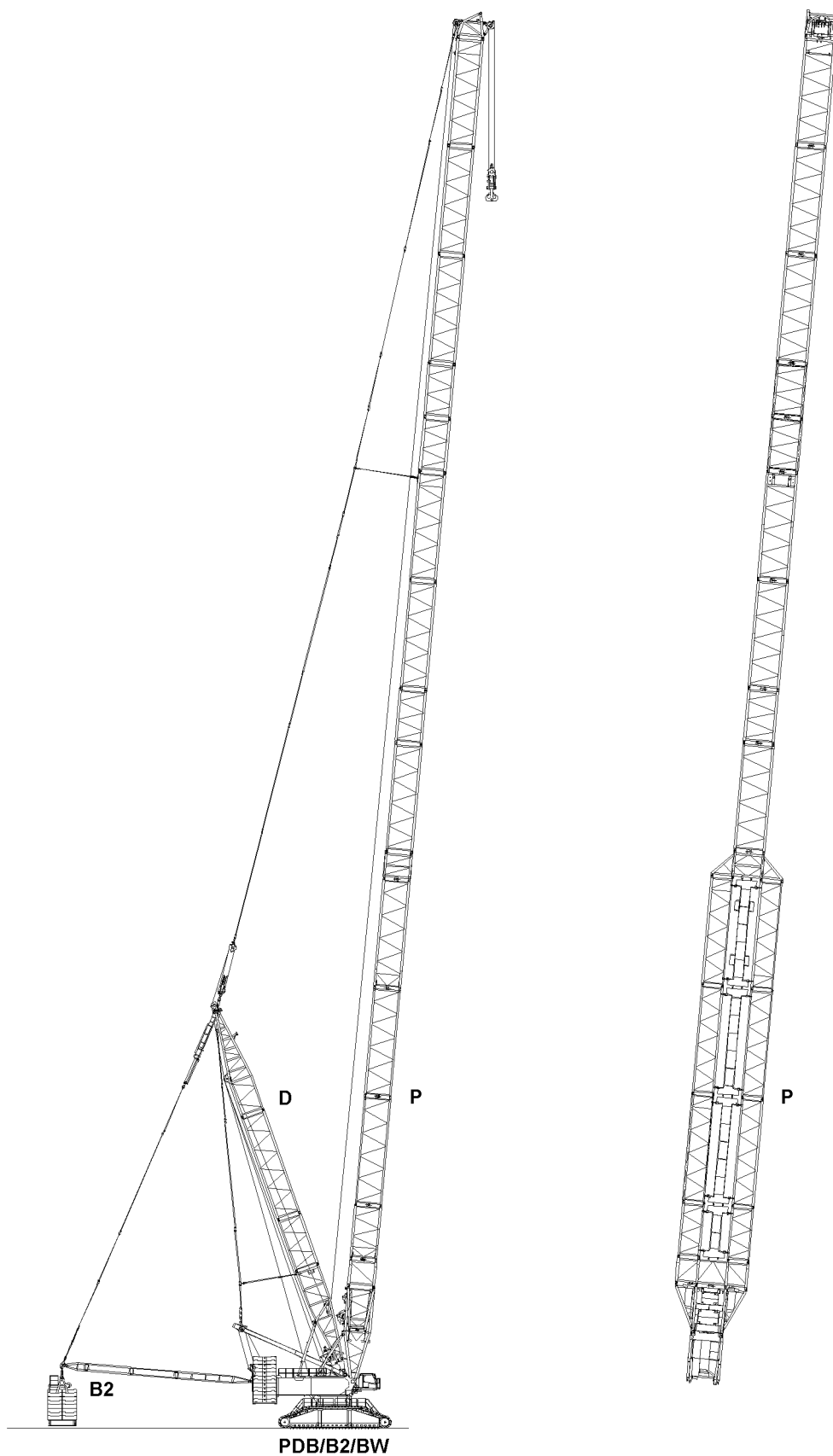

Fig.120897: PDB/B2/BW

LWE/LR 11000-001/23501-04-02/en

**WARNING**

The crane can topple over!

- ▶ Make sure that all boom systems are installed only according to the respective assembly chapter and the associated rod plans.
- ▶ Make sure that danger notes for assembly and for crane operation are observed and adhered to.
- ▶ Do not use the following boom illustrations for assembly purposes.

10.1 PDB/B2/BW boom combination

- P** Main boom
 - PowerBoom
- D** Derrick boom
 - Alone as assembly device or in connection with PD or PDW
- B** Derrick ballast
 - Suspended ballast
- B2** Derrick ballast
 - Suspended ballast with guide
- BW** Derrick ballast
 - Ballast trailer

11 PDW3B/B2/BW boom combination

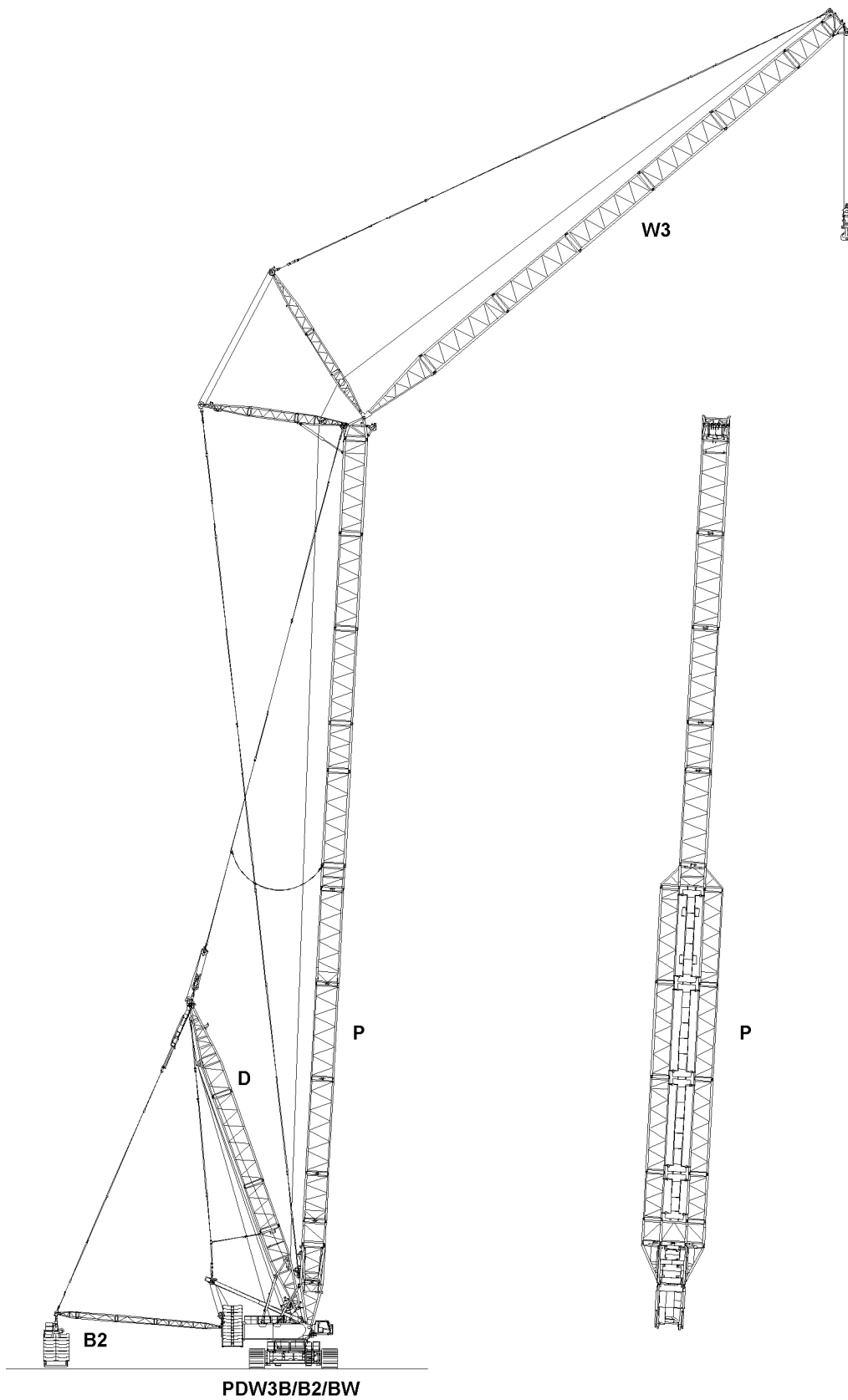

Fig.120898: PDW3B/B2/BW

LWE/LR 11000-001/23501-04-02/en

**WARNING**

The crane can topple over!

- ▶ Make sure that all boom systems are installed only according to the respective assembly chapter and the associated rod plans.
- ▶ Make sure that danger notes for assembly and for crane operation are observed and adhered to.
- ▶ Do not use the following boom illustrations for assembly purposes.

11.1 PDW3B/B2/BW boom combination

- P** Main boom
 - PowerBoom
- D** Derrick boom
 - Alone as assembly device or in connection with PD or PDW
- W3** Luffing lattice jib
 - Heavy lattice sections **S**
 - Long WA-frames
- B** Derrick ballast
 - Suspended ballast
- B2** Derrick ballast
 - Suspended ballast with guide
- BW** Derrick ballast
 - Ballast trailer

Empty page!

LWE/LR 11000-001/23501-04-02/en

1.02 Product description

1	Crawler travel gear	3
2	Crane superstructure	3
3	Boom systems / boom combinations	5
4	Auxiliary equipment	5

Fig.195219

LWE/LR 11000-001/23501-04-02/en

1 Crawler travel gear

1.1 Frame

- In-house manufactured, distortion-resistant welded structure made from high-strength, close-grained structural steel
- The crawler carriers can be removed and can be installed / removed by the crane itself

1.2 Crawler travel gear

- Dirt protected crawler track with flat bottom pads
- Pad width: 2.0 m / 2.4 m *
- Track width: 9.2 m

1.3 Drive

- Hydraulic travel drives with planetary gears
- The crawler chains can be controlled independently and in the opposite direction

1.4 Travel power

- Travel direction *forwards*: Stepless speed from 0 km/h to 1.36 km/h
- Travel direction *reverse*: Stepless speed from 0 km/h to 0.9 km/h
- **Note**: The *forward* driving direction refers to the crawler travel gear, independently of the position of the crane superstructure. The chain tension devices are always located on the front of the crawler travel gear.

1.5 Central ballast

- 2 platforms each 5.0 t
- 8 central ballast plates each 10.0 t
- Total central ballast 90.0 t
- Expansion: 4 central ballast plates each 10.0 t
- Total central ballast^{expanded} 130,0 t

2 Crane superstructure

2.1 Turntable frame

- In-house manufactured, distortion-resistant welded structure made from high-strength, close-grained structural steel
- Connection to the crawler travel gear via the slewing ring connection
- Turntable frame swingable by 360°

2.2 Diesel engine

- Number of cylinders: 8
- Make: LIEBHERR
- Water cooled

**Note**

- ▶ Engine type, see also separate operating instructions for the diesel engine.

2.2.1 Engine type D 9508 A7-04 with exhaust aftertreatment system SCR

- Performance: 500 KW at 1600 rpm
- Maximum torque: 3165 Nm at 1500 rpm

2.2.2 Engine type D 9508 A7-03 without exhaust aftertreatment system

- Performance: 500 KW at 1600 rpm
- Maximum torque: 3165 Nm at 1500 rpm

2.3 Crane cab

- Air conditioned crane cab can be tilted backwards
- Wrap-around heat-insulating safety glass
- Roof window with composite-safety glass
- Standardized control units ergonomically located
- Thermostatically regulated warm water auxiliary heater

2.4 Crane control

- All crane movements are controlled by three 4-way master switches as well as two 2-way hand / foot levers
- All working movements can be actuated independently from each other

2.5 Winch 1

- Standard hoist winch, hydraulically driven via axial piston displacement pumps and integrated planetary gear
- Disk brakes spring loaded and hydraulically vented

2.6 Winch 4

- Intake gear
 - For adjusting the main boom in operating modes without a derrick boom
 - For adjusting the derrick boom in operating modes with a derrick boom

2.7 Assembly winch

- To reeve the ropes in

2.8 Slewing gear

- Slewing gear hydraulic driven via axial piston displacement pumps and integrated planetary gear
- Disk brakes spring loaded and hydraulically vented
- Slewing speed steplessly regulated from 0 rpm to 0.95 rpm

2.9 Counterweight

- 2 platforms with each 5.0 t
- 24 counterweight plates* each 10,0 t

- Total counterweight 250.0 t

2.10 Safety equipment

- Hoist limit switch for hoist limitation
- Rope drum limit switch with 3 safety coils
- Safety valves against hose and pipe bursts
- Wind warning system
- Electronic incline display
- Airplane warning light

2.11 Electrical system

- Modern data bus technology
- 24 Volt Direct current
- 2x 3 12V batteries, each with 70 Ah

3 Boom systems / boom combinations

3.1 Boom systems



Note

- ▶ See the Crane operating instructions, chapter 1.01.
-

3.2 Optional winches*

- Winch 2* as the second hoist winch
- Winch 3* for adjusting the main boom in operating modes with derrick boom
- Winch 5* for adjusting the luffing lattice jib
- Winch 6* as an auxiliary hoist gear

4 Auxiliary equipment

4.1 Mechanical auxiliary support

- To erect long boom combinations without derrick ballast

4.2 Hydraulic assembly support

- Lifting of basic machine for assembly / removal
- Consisting of 4 support cylinders, including support plates, installed on center section

4.3 Hydraulic assembly cylinder

- For self-assembly / disassembly of crawler travel gear

4.4 Pin pulling device

- Including mobile hydraulic aggregate
- For assembly / disassembly of pins on crawler travel gear and center section as well as boom intermediate sections

1.03 Technical data

1	Dimensions and weights Crane components	5
2	Dimensions of the crane basic unit	5
3	Noise emission	6
4	Vibrations	7
5	Crane speeds	7
6	Crane surface pressure	8
7	Load handling equipment	8
8	Hoist ropes	8
9	Control ropes	8
10	Guy rope	8
11	Assembly rope	9
12	Crawler center section with turntable frame lower section	9
13	Turntable with crawler center section with SA-frame	9
14	Crawler center section with Quick-Connection (QC)	10
15	Turntable frame lower section with Quick-Connection (QC)	10
16	Central ballast platform	10
17	Catwalk crawler	11
18	Mechanical auxiliary support	11
19	Turntable without SA-frame	11
20	SA-frame with winch 4	12
21	Turntable with SA-frame	12
22	Winch 1	12
23	Winch 2	13
24	Winch 5	13
25	Winch 6	13
26	Counterweight platform	14
27	Ballast plate for central ballast / counterweight / derrick ballast	14
28	S-pivot section	14
29	S-intermediate section 6 m	15
30	S-intermediate section 12 m	15
31	S-adapter	16
32	S-end section	16
33	SL-reducer	17
34	P-adapter bottom left / P-adapter bottom right	17
35	Cross carrier 3 m , P-adapter bottom	17
36	P-adapter top, 3 m	18
37	Bridges	18
38	L-intermediate section 6 m	18
39	L-intermediate section 12 m	19
40	L-end section	19
41	F-connector head	20
42	Roller set	20
43	W- and WA-frame 1 - pivot section	20
44	WA-frame 2 - pivot section	21
45	WA-frame - intermediate section 1 and 2	21
46	WA-frame - end section 1 and 2	21

47	D-pivot section with winch 3	22
48	D-intermediate section 12 m	22
49	D-intermediate section 6 m	22
50	D-end section	23
51	F-assembly unit with F-end section	23
52	F-assembly unit	23
53	F-intermediate section 6 m	24
54	F-intermediate section 12 m	24
55	F-end section	24
56	Suspended ballast guide B2	25
57	Ballast pallet	25
58	Ballast pallet special design (LTR as ballast)	25
59	Ramp	26
60	Cross beam	26
61	Ballast trailer	26
62	Ballast trailer guide with adapter for ballast trailer	27
63	Ballast trailer guide extension	27
64	Boom nose 32 t	27
65	Roller cart	28
66	Overview rods	28

Empty page!

LWE/LR 11000-001/23501-04-02/en

Fig.195219

LWE/LR 11000-001/23501-04-02/en

1 Dimensions and weights Crane components



Note

- ▶ The following listed weights are reference values and may not match your crane exactly.
- ▶ The illustrations of crane components / crane parts are examples and may not apply exactly to your crane.



WARNING

Danger of accidents when handling crane components / crane parts!

- ▶ Make sure that the actual weight is known before fastening crane components / crane parts.
- ▶ Check the weight label on the crane components / crane parts.
- ▶ Fasten crane components / crane parts solely with approved and sufficiently load bearing fastening equipment.
- ▶ Make sure that crane components / crane parts are fastened only on the intended fastening points.

2 Dimensions of the crane basic unit

All dimension data in meters (m)

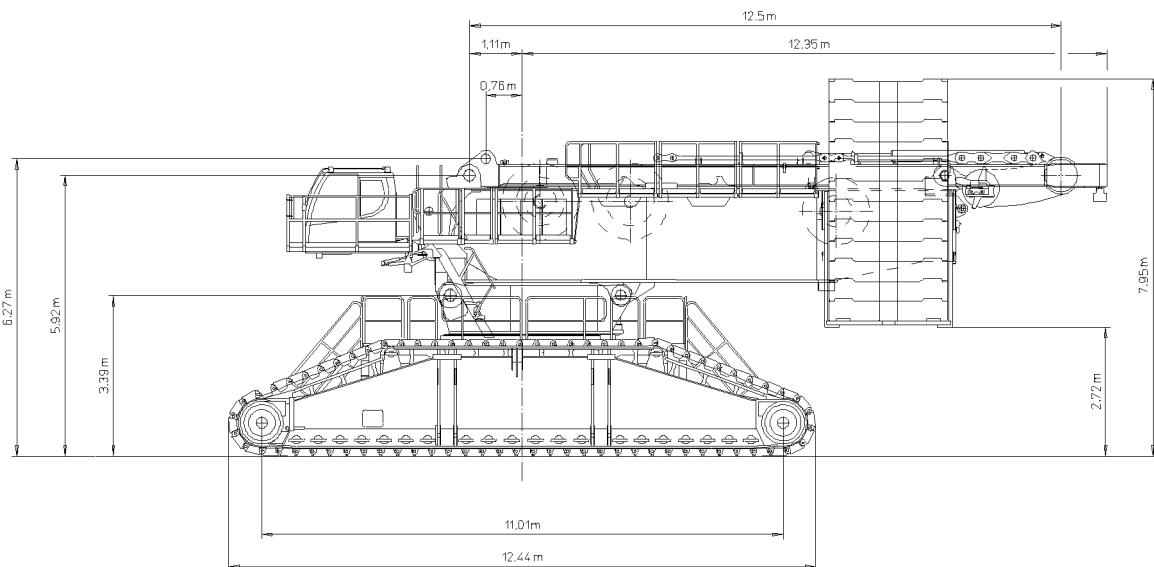

Fig.145943: Side view

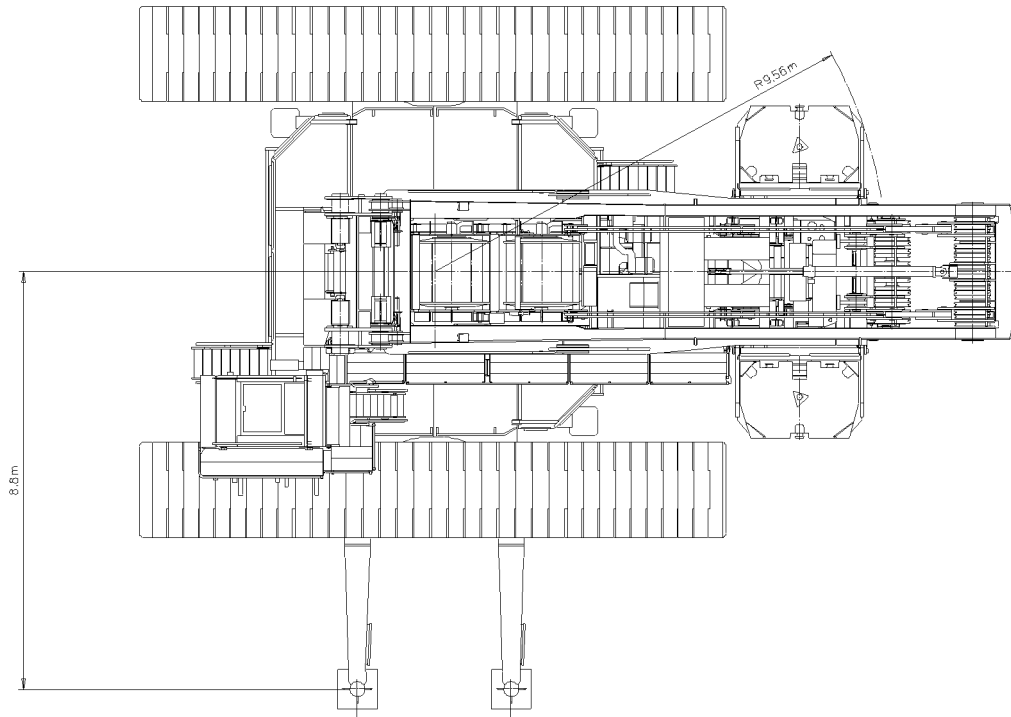

Fig.145944: Overhead view

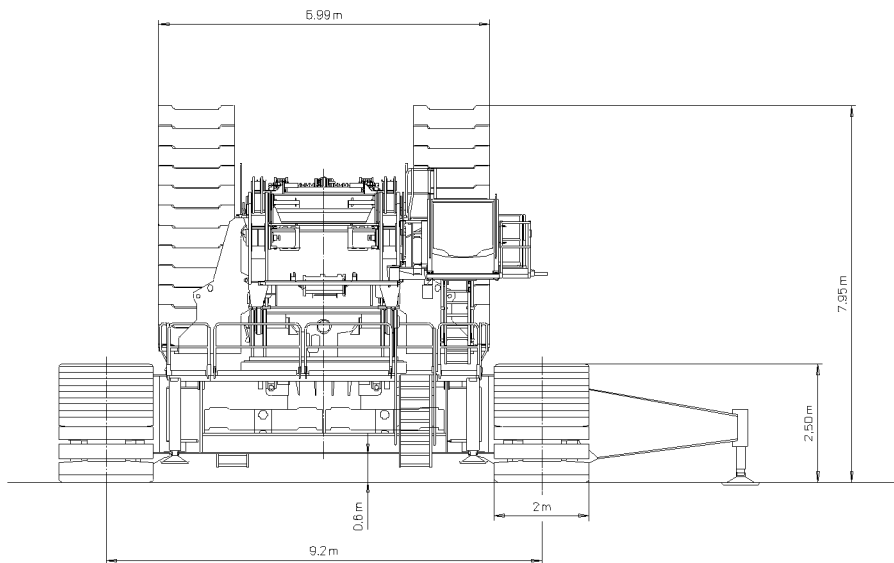

Fig.145945: Front view

3 Noise emission

Control platform Crane cab	
Sound pressure level [L_{pA}], according to EN13000	70 db(A)

LWE/LR 11000-001/23501-04-02/en

4 Vibrations

Vibrations transferred to the operator	Value
Total vibration value to which the upper body limbs are exposed	Not more than 2.5 m/s ²
Effective value of weighted acceleration to which the entire body is exposed	Not more than 0.5 m/s ²

5 Crane speeds



Note

► The crane speeds refer to a nominal engine rpm of 1600 rpm !

Drives	Speed
Winch 1	0 m/min to 120 m/min for single strand
Winch 2	0 m/min to 120 m/min for single strand
Winch 3	0 m/min to 115 m/min for single strand
Winch 5	0 m/min to 105 m/min for single strand
Winch 6	0 m/min to 118 m/min for single strand
Winch 4	0 m/min to 60 m/min for single strand

Drives	RPM
Slewing gear	0 rpm to 0.89 rpm

Drives	Rapid gear travel speed (normal gear)
2 drives per crawler carrier	Forward: 0 km/h to 1.41 km/h (0.29 km/h)
	Reverse: 0 km/h to 1.17 km/h (0.24 km/h)

6 Crane surface pressure



Note

- Determining the surface pressure in relation to the various set up configurations and load cases, see the LICCON job planner.

	Track pad width 2.0 m
Maximum surface pressure of the crane at nominal load	1900 kN/m ²

7 Load handling equipment



Note

- For load handling equipment, see load chart manual.

8 Hoist ropes

	Rope diameter	Rope category number RCN
Winch 1	32 mm	See Rope certificate
Winch 2	32 mm	See Rope certificate
Winch 6	28 mm	See Rope certificate

9 Control ropes

	Rope diameter	Rope category number RCN
Winch 3	32 mm	See Rope certificate
Winch 4	32 mm	See Rope certificate
Winch 5	32 mm	See Rope certificate

10 Guy rope

	Rope diameter	Rope category number RCN
Auxiliary guying	40 mm	See Rope certificate

11 Assembly rope

	Rope diameter	Rope category number RCN
Assembly winch	8 mm	See Rope certificate

12 Crawler center section with turntable frame lower section

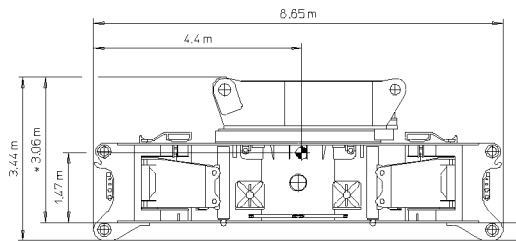

Fig.117655: Crawler center section with turntable frame lower section

Component	Weight	Width
Crawler center section with turntable frame lower section	60.0 t	3.5 m

13 Turntable with crawler center section with SA-frame

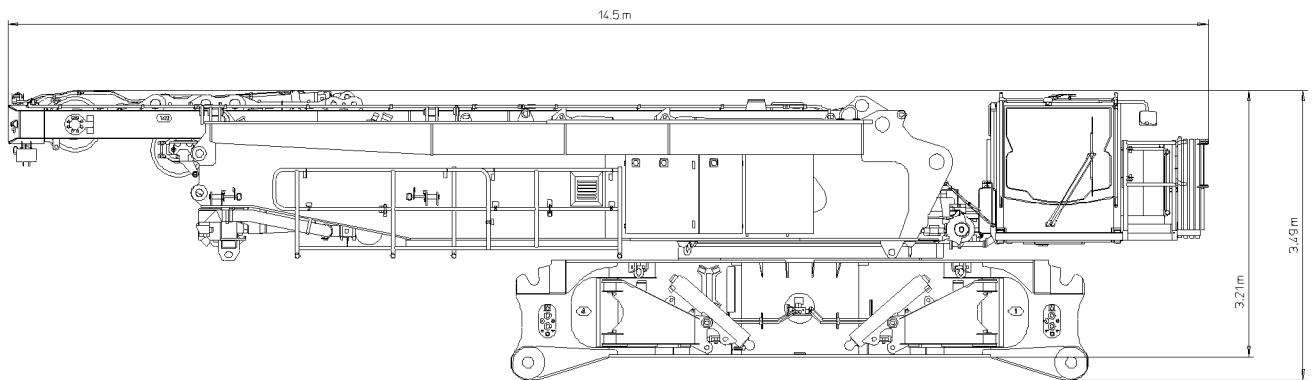

Fig.145523: Turntable with SA-frame

Component	Weight
Turntable / crawler center section with SA-frame	59.0 t

LWE/LR 11000-001/23501-04-02/en

14 Crawler center section with Quick-Connection (QC)

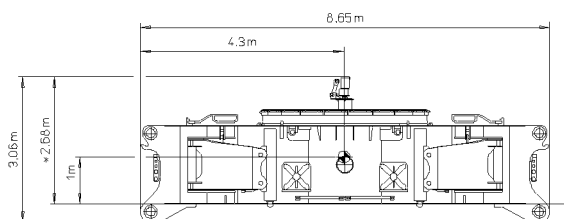

Fig.126151: Crawler center section with Quick-Connection (QC)

Component	Weight	Width
Crawler center section with turntable frame lower section	40.0 t	3.5 m

15 Turntable frame lower section with Quick-Connection (QC)

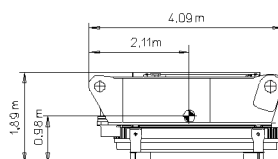

Fig.126152: Turntable frame lower section with Quick-Connection (QC)

Component	Weight	Width
Crawler center section with turntable frame lower section	27.1 t	3.5 m

16 Central ballast platform

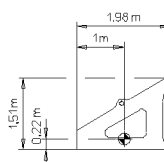

Fig.117656: Central ballast platform

Component	Weight	Width
Central ballast platform	5.0 t	5.3 m

17 Catwalk crawler

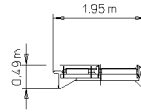

Fig.117657: Catwalk crawler

Component	Weight	Width
Catwalk crawler	1.0 t	6.7 m

18 Mechanical auxiliary support

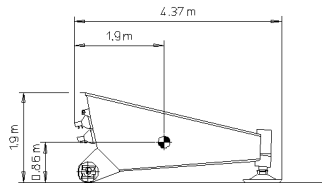

Fig.117658: Mechanical auxiliary support

Component	Weight	Width
Mechanical auxiliary support	3.1 t	0.8 m

19 Turntable without SA-frame

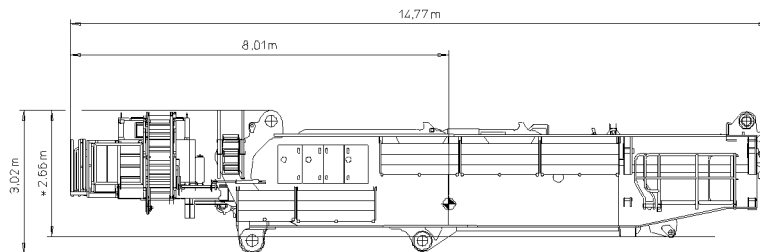

Fig.117659: Turntable without SA-frame

Component	Weight	Width
Turntable without SA-frame	45.0 t	3.5 m

LWE/LR 11000-001/23501-04-02/en

20 SA-frame with winch 4

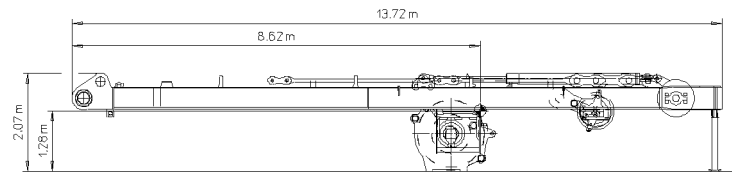

Fig.117660: SA-frame with winch 4

Component	Weight	Width
SA-frame with winch 4	34.0 t	3.1 m

21 Turntable with SA-frame

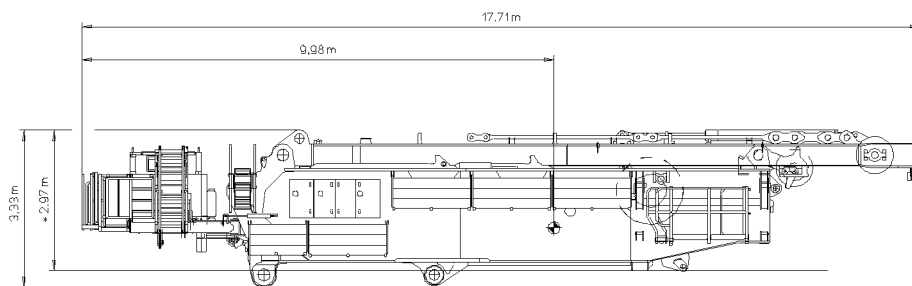

Fig.117661: Turntable with SA-frame

Component	Weight	Width
Turntable with SA-frame	77.0 t	3.5 m

22 Winch 1

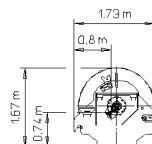

Fig.117662: Winch 1

Component	Weight	Width
Winch 1	14.0 t	2.1 m

23 Winch 2

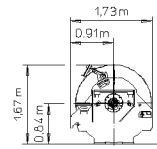

Fig.117663: Winch 2

Component	Weight	Width
Winch 2	14.0 t	2.2 m

24 Winch 5

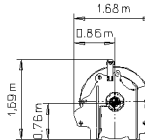

Fig.126153: Winch 5

Component	Weight	Width
Winch 5	11.0 t	2.2 m

25 Winch 6

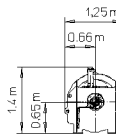

Fig.126154: Winch 6

Component	Weight	Width
Winch 6	5.2 t	1.9 m

LWE/LR 11000-001/23501-04-02/en

26 Counterweight platform

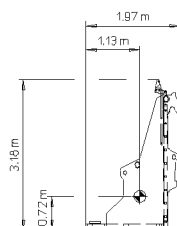

Fig.117664: Counterweight platform

Component	Weight	Width
Counterweight platform	6.0 t	2.8 m

27 Ballast plate for central ballast / counterweight / derrick ballast

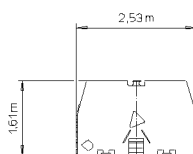

Fig.117665: Ballast plate for central ballast / counterweight / derrick ballast

Component	Weight	Width
Ballast plate	10.0 t	0.5 m
Ballast plate	5.0 t	0.3 m

28 S-pivot section

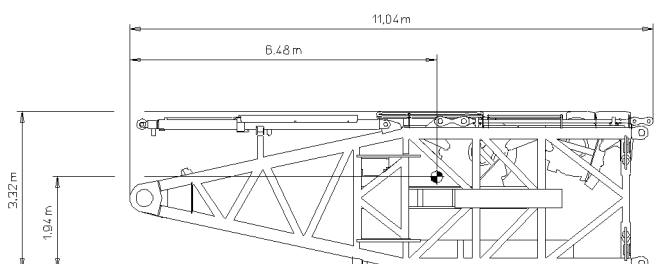

Fig.117666: S-pivot section

LWE/LR 11000-001/23501-04-02/en

Component	Weight	Width
S-pivot section without winch 5 without winch 6	26.8 t	3.7 m
S-pivot section with winch 5 without winch 6	37.8 t	
S-pivot section without winch 5 with winch 6	32.0 t	
S-pivot section with winch 5 and winch 6	43.1 t	

29 S-intermediate section 6 m

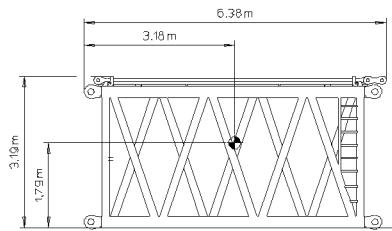

Fig.117667: S-intermediate section 6 m

Component	Weight	Width
S-intermediate section 6 m 3228.25	8.0 t	3.5 m
S-intermediate section 6 m 3228.20	7.5 t	

30 S-intermediate section 12 m

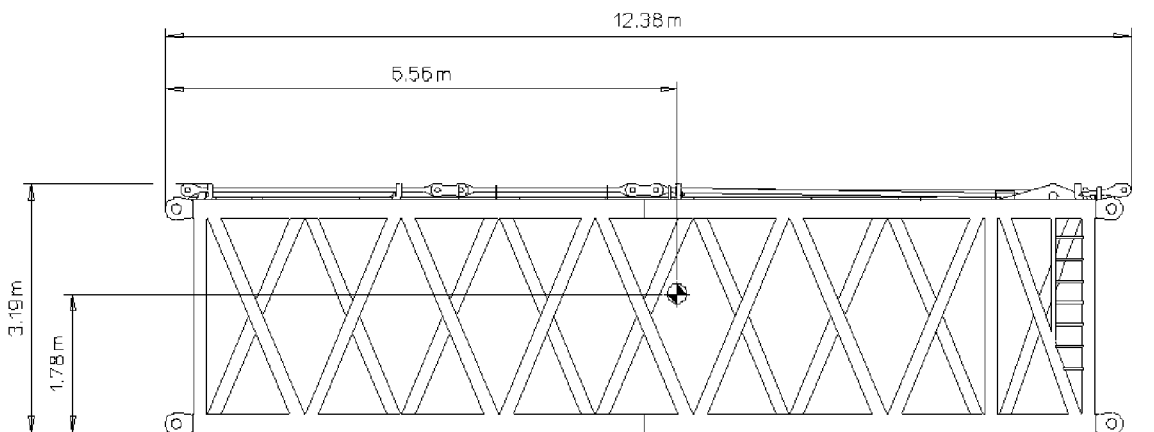

Fig.117671: S-intermediate section 12 m

LWE/LR 11000-001/23501-04-02/en

Component	Weight	Width
S-intermediate section 12 m 3228.40	17.0 t	3.5 m
S-intermediate section 12 m 3228.25	13.8 t	
S-intermediate section 12 m 3228.25 FLM	15.6 t	
S-intermediate section 12 m 3228.20	12.7 t	
S-intermediate section 12 m 3228.16	10.6 t	

31 S-adapter

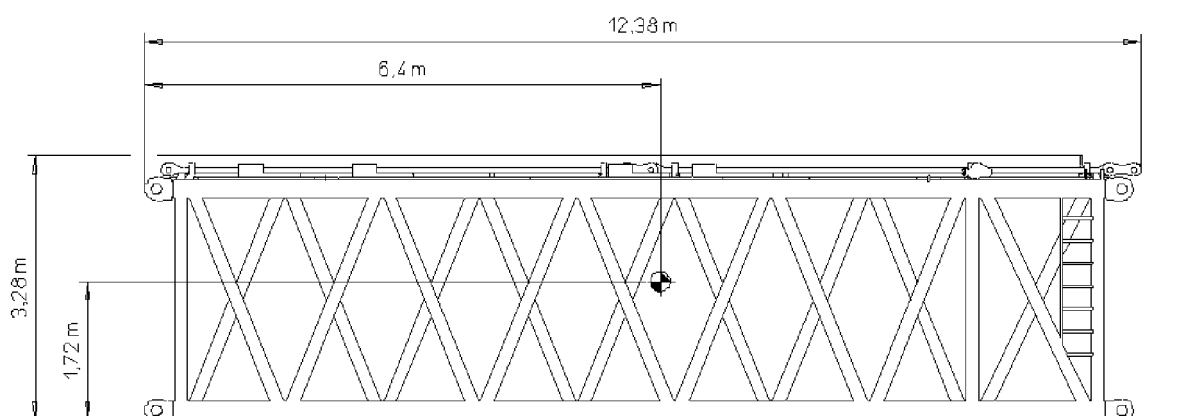

Fig.117674: S-adapter

Component	Weight	Width
S-adapter 12 m 3228.25/20A	13.6 t	3.5 m

32 S-end section

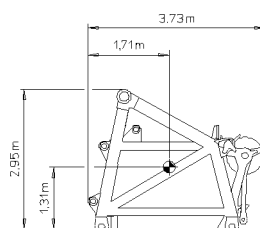

Fig.117682: S-end section

Component	Weight	Width
S-end section	9.8 t	3.5 m

33 SL-reducer

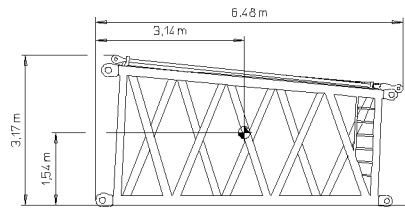

Fig.117675: SL-reducer

Component	Weight	Width
SL-reducer	5.7 t	3.5 m

34 P-adapter bottom left / P-adapter bottom right

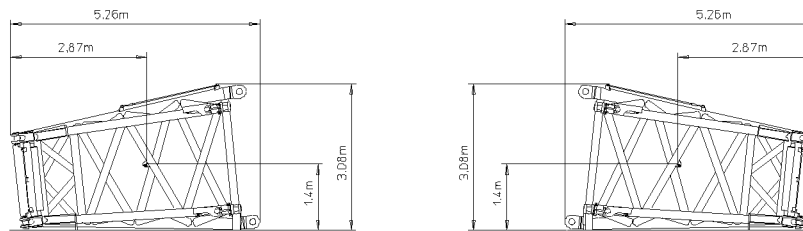

Fig.119454: P-adapter bottom left / P-adapter bottom right

Component	Weight	Width
P-adapter	4.3 t	2.5 m

35 Cross carrier 3 m , P-adapter bottom

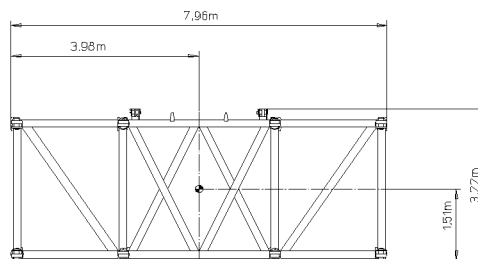

Fig.119455: Cross carrier 3 m , P-adapter bottom

Component	Weight	Width
Cross carrier 3 m , P-adapter bottom	9.0 t	3.4 m

LWE/LR 11000-001/23501-04-02/en

36 P-adapter top, 3 m

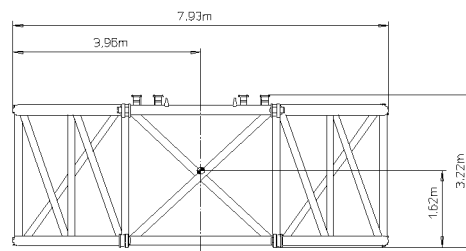

Fig.119456: P-adapter top 3 m

Component	Weight	Width
P-adapter top 3 m	9.8 t	3.3 m

37 Bridges

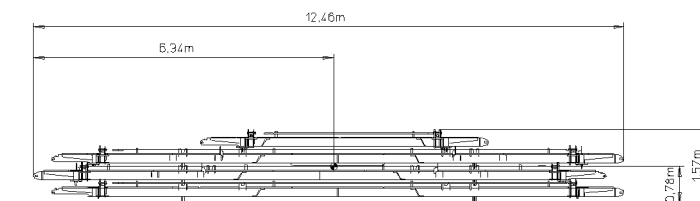

Fig.119457: Bridges

Component	Weight	Width
Bridges	5.0 t	2.4 m

38 L-intermediate section 6 m

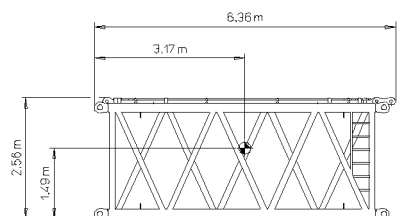

Fig.117681: L-intermediate section 6 m

Component	Weight	Width
L-intermediate section 6 m 2722.20	4.6 t	3.0 m
L-intermediate section 6 m 2722.20 F	4.7 t	

39 L-intermediate section 12 m

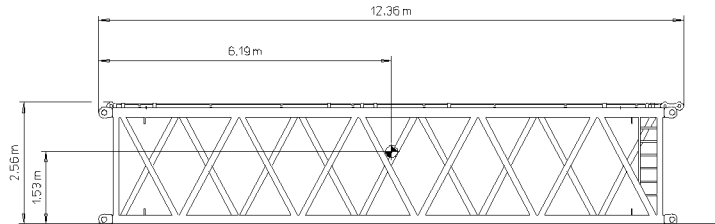

Fig.117678: L-intermediate section 12 m

Component	Weight	Width
L-intermediate section 12 m 2722.20	8.1 t	3.0 m
L-intermediate section 12 m 2722.20 F	8.4 t	
L-intermediate section 12 m 2722.16	7.3 t	
L-intermediate section 12 m 2722.16 F	7.7 t	

40 L-end section

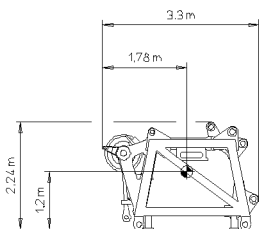

Fig.117683: L-end section

Component	Weight	Width
L-end section	7.6 t	3.0 m

LWE/LR 11000-001/23501-04-02/en

41 F-connector head

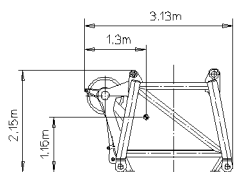

Fig.126155: F-connector head

Component	Weight	Width
F-connector head	3.4 t	3.0 m

42 Roller set

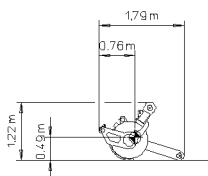

Fig.117684: Roller set

Component	Weight	Width
Roller set 1 (400 t)	2.5 t	1.5 m
Roller set 2 (350 t)	2.2 t	1.1 m

43 W- and WA-frame 1 - pivot section

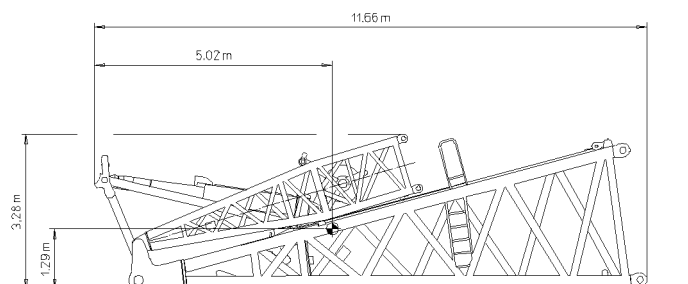

Fig.117686: W- and WA-frame 1 - pivot section

Component	Weight	Width
W- and WA-frame 1 - pivot section	18.5 t	3.7 m

44 WA-frame 2 - pivot section

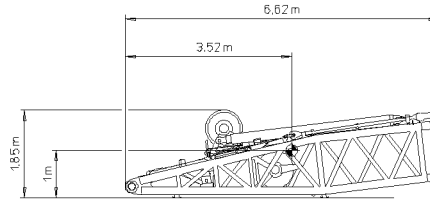

Fig.117687: WA-frame 2 - pivot section

Component	Weight	Width
WA-frame 2 - pivot section	5.8 t	3.0 m

45 WA-frame - intermediate section 1 and 2

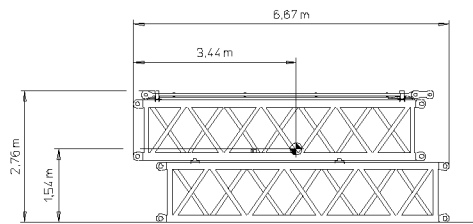

Fig.117688: WA-frame - intermediate section 1 and 2

Component	Weight	Width
WA-frame - intermediate section 1 and 2	4.7 t	2.9 m

46 WA-frame - end section 1 and 2

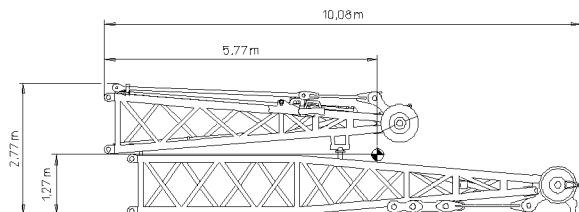

Fig.117689: WA-frame - end section 1 and 2

Component	Weight	Width
WA-frame - end section 1 and 2	11.6 t	2.9 m

LWE/LR 11000-001/23501-04-02/en

47 D-pivot section with winch 3

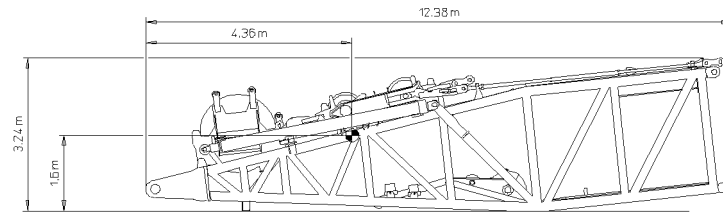

Fig.117690: D-pivot section with winch 3

Component	Weight	Width
D-pivot section with winch 3	37.6 t ¹⁾	3.5 m

1) Also taken into account in the weight: 2x D-relapse support and luffing pulley block

48 D-intermediate section 12 m

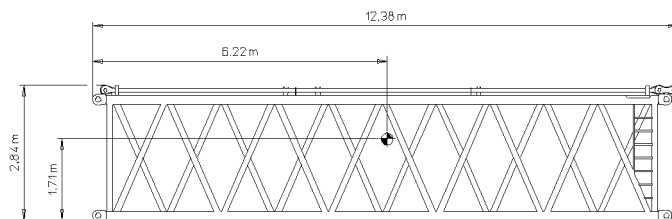

Fig.117691: D-intermediate section 12 m

Component	Weight	Width
D-intermediate section 12 m	10.1 t	3.1 m

49 D-intermediate section 6 m

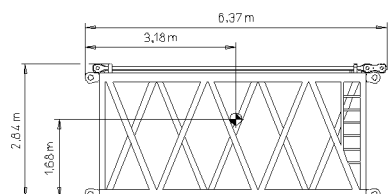

Fig.117692: D-intermediate section 6 m

Component	Weight	Width
D-intermediate section 6 m	6.0 t	3.1 m

50 D-end section

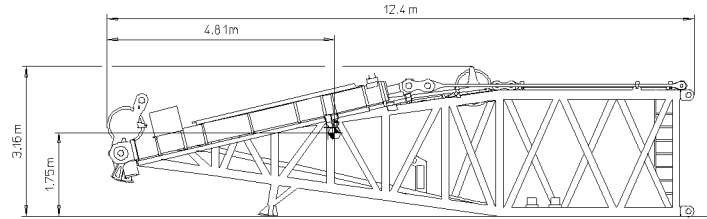

Fig.117693: D-end section

Component	Weight	Width
D-end section	22.5 t	3.1 m

51 F-assembly unit with F-end section

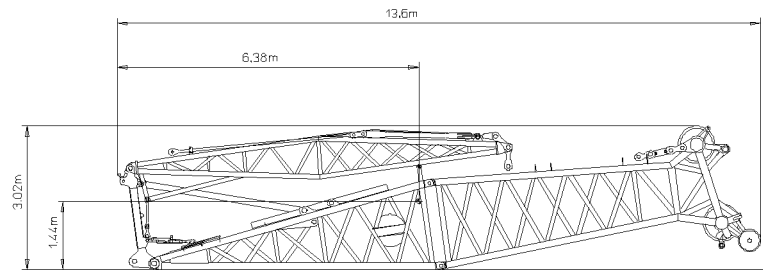

Fig.119458: F-assembly unit with F-end section

Component	Weight	Width
F-assembly unit with F-end section	7.8 t	3.0 m

52 F-assembly unit

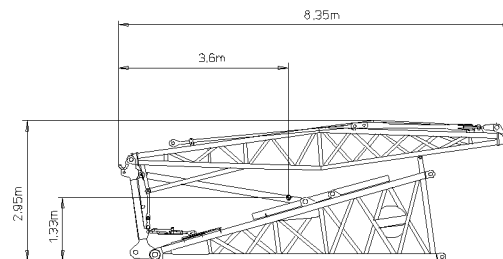

Fig.119459: F-assembly unit

Component	Weight	Width
F-assembly unit	5.0 t	3.0 m

LWE/LR 11000-001/23501-04-02/en

53 F-intermediate section 6 m

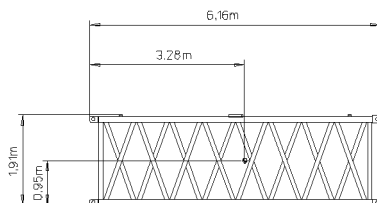

Fig.119460: F-intermediate section 6 m

Component	Weight	Width
F-intermediate section 6 m	1.7 t	2.5 m

54 F-intermediate section 12 m

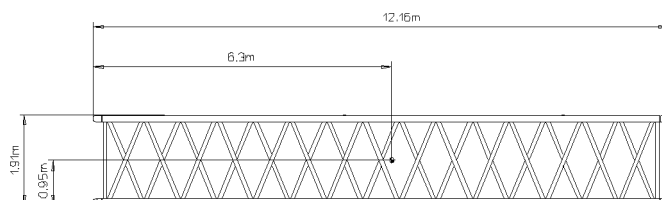

Fig.119461: F-intermediate section 12 m

Component	Weight	Width
F-intermediate section 12 m	3.0 t	2.5 m

55 F-end section

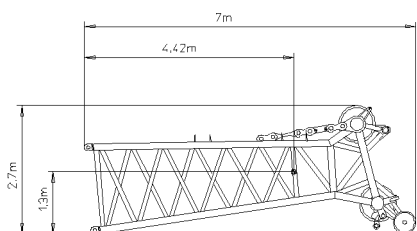

Fig.119462: F-end section

Component	Weight	Width
F-end section	2.8 t	2.5 m

56 Suspended ballast guide B2

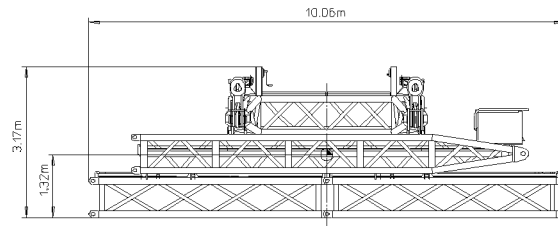

Fig.119463: Suspended ballast guide B2

Component	Weight	Width
Suspended ballast guide B2	9.2 t	3.0 m

57 Ballast pallet

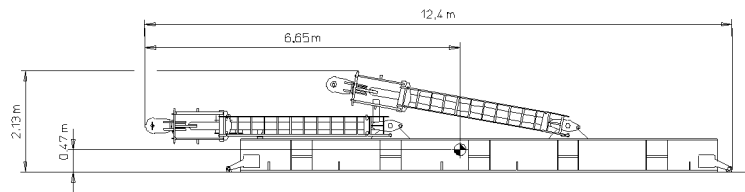

Fig.117694: Ballast pallet

Component	Weight	Width
Ballast pallet	15.1 t	3.0 m

58 Ballast pallet special design (LTR as ballast)

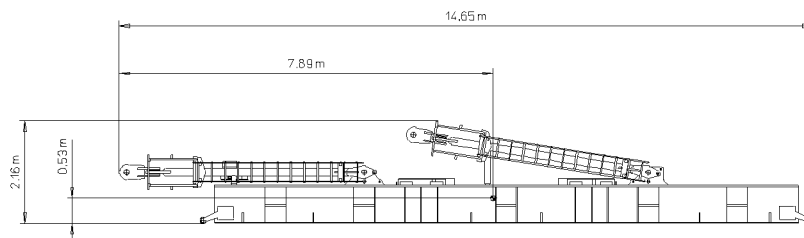

Fig.145938: Ballast pallet special design

Component	Weight	Width
Ballast pallet special design	20.3 t	3.0 m

LWE/LR 11000-001/23501-04-02/en

59 Ramp

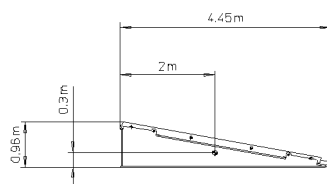

Fig.145940: Ramp for ballast pallet special design

Component	Weight	Width
Ramp for ballast pallet special design	3.3 t	1.1 m

60 Cross beam

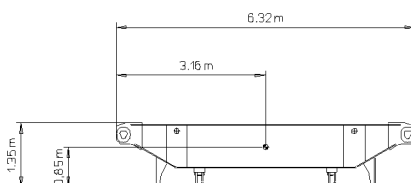

Fig.145939: Cross beam

Component	Weight	Width
Cross beam	2.0 t	1.08 m

61 Ballast trailer

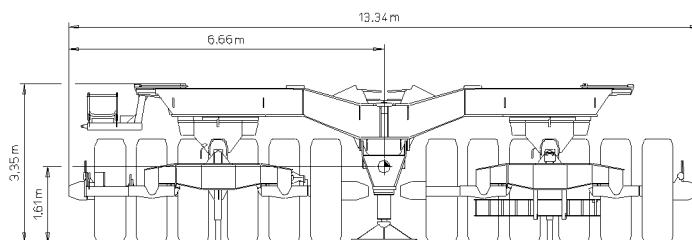

Fig.126156: Ballast trailer

Component	Weight	Width
Ballast trailer	76.0 t	3.0 m

62 Ballast trailer guide with adapter for ballast trailer

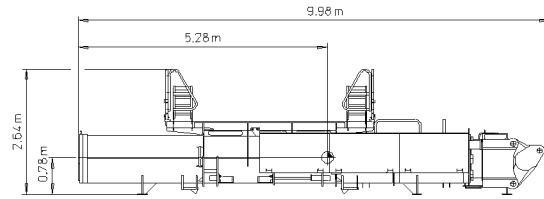

Fig.126157: Ballast trailer guide with adapter for ballast trailer

Component	Weight	Width
Ballast trailer guide with adapter for ballast trailer	25.3 t	3.0 m
Ballast trailer guide without adapter for ballast trailer	24.0 t	3.0 m

63 Ballast trailer guide extension

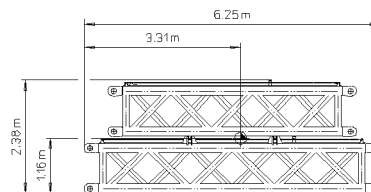

Fig.126158: Ballast trailer guide extension

Component	Weight	Width
Ballast trailer guide extension	7.2 t	3.0 m

64 Boom nose 32 t

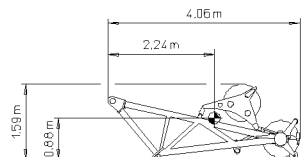

Fig.117695: Boom nose 32 t

Component	Weight	Width
Boom nose 32 t	0.8 t	0.9 m

LWE/LR 11000-001/23501-04-02/en

65 Roller cart

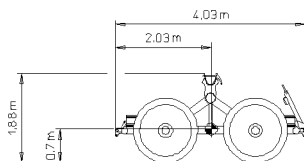

Fig.117696: Roller cart

Component	Weight	Width
Roller cart	7.0 t	2.5 m

66 Overview rods



Note

► Use of rods, see Rod plan!

Article	Designation	Nominal length	Width	Height	Weight
967746908	Rod complete	6184 mm	223 mm	164 mm	0.4 t
967743808	Rod complete	12184 mm	223 mm	164 mm	0.6 t
967913408	Rod complete	1615 mm	160 mm	300 mm	0.2 t
967846208	Pull rod complete	3620 mm	263 mm	263 mm	0.4 t
967846608	Pull bracket	755 mm	40 mm	260 mm	0.1 t
967845508	Pull bracket complete	1352 mm	60 mm	400 mm	0.1 t
967897608	Pull rod complete	3684 mm	223 mm	164 mm	0.3 t
967898308	Pull rod complete	8706 mm	223 mm	164 mm	0.5 t
968026108	Pull rod preassembled	6250 mm	150 mm	250 mm	0.4 t
968026208	Pull rod complete	4120 mm	200 mm	190 mm	0.3 t
967704008	Rod complete	12220 mm	223 mm	190 mm	0.7 t
967733608	Rod complete	6220 mm	223 mm	190 mm	0.4 t
968026008	Pull rod complete	6160 mm	263 mm	260 mm	0.5 t
968242208	Pull rod complete	6317 mm	320 mm	164 mm	0.5 t
968190208	Pull rod complete	6211 mm	226 mm	270 mm	0.4 t
968246608	Pull rod complete	1680 mm	102 mm	202 mm	0.1 t

2 Safety

LWE/LR 11000-001/23501-04-02/en

LWE/LR 11000-001/23501-04-02/en

2.03 Job planning

1 Planning Crane operation

3

LWE/LR 11000-001/23501-04-02/en

Fig.195219

LWE/LR 11000-001/23501-04-02/en

1 Planning Crane operation

In addition to a perfectly working crane and a well-trained crew, the **planning for crane operation** is an important principle for safe crane operation.



WARNING

Missing information!

Death, severe bodily injuries, property damage.

► Obtain the required information and adhere to it.

Obtain the following information before crane operation and adhere to it:

- Type of crane operation
- National laws and regulations
- Height and width clearance measurements
- When mobile crane: Job site, distance and travel route
- Space prerequisites at the job site
- Electrical transmission lines with voltage data
- Movement restrictions caused by buildings
- Weight and dimensions of the load(s) to be lifted
- Geometric form and air resistance coefficient of the load(s) to be lifted
- Required lifting height and boom projection
- Ground bearing capacity at the job site
- Required space for the assembly and disassembly of the crane
- Weather data and weather forecasts

Assemble the equipment for crane operation:

- Hook block / load hook
- Auxiliary boom
- Fastening equipment
- Counterweight
- Base materials for support plates

Empty page!

LWE/LR 11000-001/23501-04-02/en

2.04 General safety technical guidelines

1	Danger zone of crane	3
2	Traffic endangerment and environmental damage	3
3	Endangering air traffic	3
4	Movement on the crane	4
5	Emergency exit	5
6	Personal protective equipment	7
7	Securing persons to prevent them from falling	12
8	Rescuing the assembly personnel	14
9	Crane operator's cab with retractable / extendable step	15
10	Crane cab with incline adjustment	16
11	Securing bracket	17
12	Closing the side window pane	18
13	Transport	18
14	Stops	19
15	Heated crane components	19
16	Crane operator responsibilities	20
17	Selecting the crane operating location	22
18	Slopes and excavations	26
19	Load burdens on the ground due to crane operation	29
20	Support	33
21	Aligning the crane	35
22	Checking the safety measures	36
23	Safety guidelines in case of external power supply	37
24	Grounding	37
25	Working in the vicinity of transmitters	39
26	Crane operation in case of thunderstorms	40
27	Wind influences	41
28	Lifting a load with two cranes	47
29	Working ranges of several cranes overlap	49
30	Hand signals for guidance	50
31	Travel operation	58
32	Crane operation	60
33	Lifting of personnel	66
34	Securing personnel on shut off crane	67
35	Welding work on the load	69

Fig.195219

LWE/LR 11000-001/23501-04-02/en

**Note**

- ▶ The illustrations in this chapter are only examples. The illustrations may differ depending on the crane model.

1 Danger zone of crane

1.1 Crane in operation

The danger zone of the crane is made up of the areas which are accessed during crane operation by the load or by movements of the crane or the crane components.

**WARNING**

Do not stay in danger zone!

Personnel within the danger zone can be hit by falling loads or components.

Personnel in the danger zone can be caught by moving crane components or loads.

Fatal or severe injuries can be the result.

- ▶ Warn any personnel within the danger zone with the warning device of the crane.
- ▶ After the warning is issued, wait and ensure that no personnel remains within the danger zone.
- ▶ If required, block off the danger zone with a safety distance.

1.2 Crane out of service

Place the crane out of service, failure to comply with the regulations represents considerable danger for the entire area around the crane.

**WARNING**

Actual wind speed higher than the wind speed permitted for the crane set up configuration!

Personnel within the danger zone can be hit by a toppling crane or crane components.

- ▶ Make sure that the condition of the crane complies with the regulations and the wind speed charts.
- ▶ If required, block off the danger zone with a safety distance.

**WARNING**

Icing on the boom!

Personnel within the danger zone can be hit by a falling ice.

- ▶ Make sure that there are no persons within the danger zone.
- ▶ If required, block off the danger zone with a safety distance.

2 Traffic endangerment and environmental damage

**WARNING**

Danger of slipping and skidding!

If the road becomes contaminated due to technical defects, open tank covers or leaking hydraulic oil, then this would pose a severe traffic endangerment.

Fatal accidents can result.

- ▶ Remove oil immediately and thoroughly.

3 Endangering air traffic

When working with crane, heights are reached which could endanger air traffic. This applies especially to areas near airports.

**WARNING**

Endangering air traffic!

If no protective measures are taken, this can result in endangerment to air traffic.

- ▶ Get the approval from agency responsible for air traffic.
- ▶ Install the airplane warning light on the boom head and turn it on.
- ▶ If the airplane warning lights is operated for a longer period of time, with the engine turned off, then the battery can be discharged and as the result the airplane warning light turns off. To prevent the battery from discharging, an external electrical power supply must be established.

4 Movement on the crane

**WARNING**

Danger of slipping and falling!

The traction of steps, walkways and hand rails changes due to effects of the weather, such as wetness, ice, snow, frost and dirt.

Personnel can be severely injured or killed.

The crane can be damaged.

- ▶ Step on the walkways and steps only by taking the present conditions into account, such as icing in winter or dirt.
- ▶ Step or place a load only on the approved walkways and steps.
- ▶ Observe the signage.
- ▶ Replace damaged safety signs (warning signs) immediately.

5 Emergency exit

5.1 Emergency exit - driver's cab

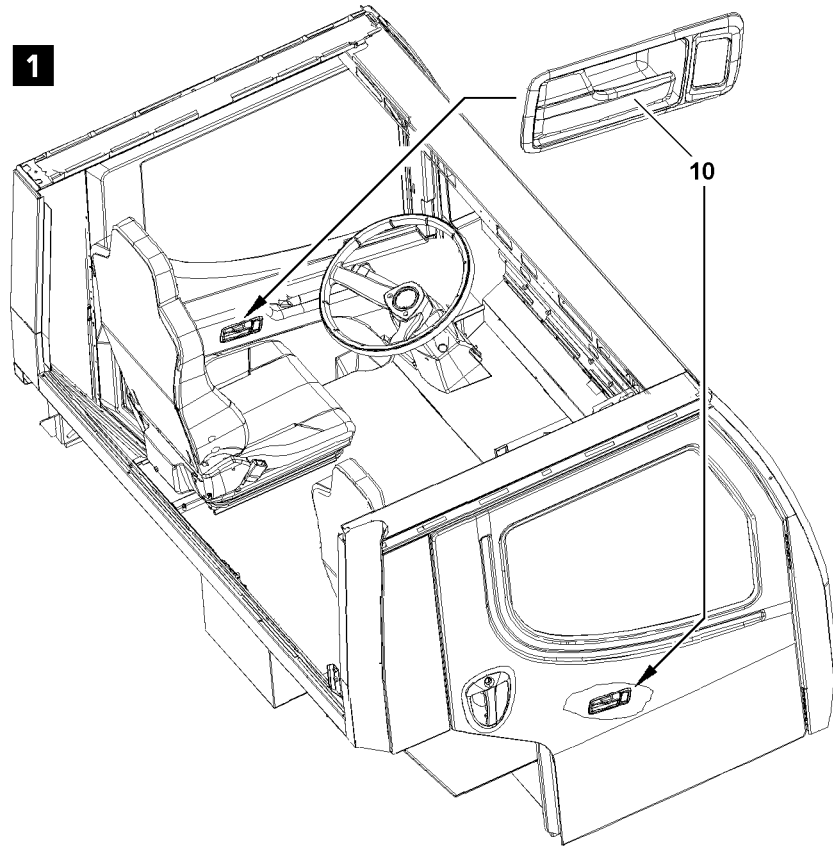

Fig.120932: Example for emergency exit - driver's cab

The driver's cab can be exited through the „left driver's door“ or the „right passenger door“, see illustration 1.



Note

- ▶ Exit the driver's cab through the „left driver's door“ or the „right passenger door“, see illustration 1: Pull and open the door handle 10 on the „left driver's door“ or the „right passenger door“.

5.2 Emergency exist crane cab



WARNING

Danger of falling!

If the crane driver cannot leave the crane cab through the door or if the crane cab is tilted, then there is a danger of falling during the emergency exit.

Death or severe injuries.

- ▶ Exit carefully in an emergency.

During the emergency exit there is an increase danger of accidents:

- ▶ Accept third-party assistance.

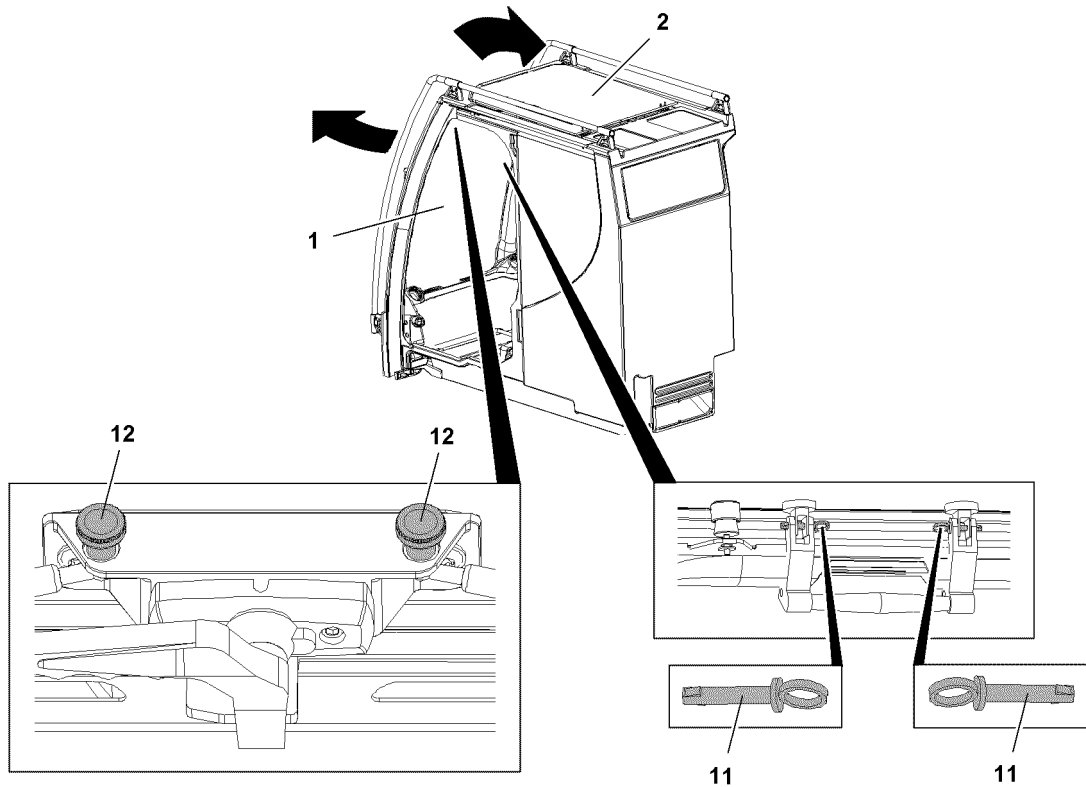

Fig.121111: Examples for emergency exit from the crane cab

If the emergency exit through the door is not possible, then the crane cab can be exited through additional openings.

The following openings are possible:

- 1 Front window
- 2 Roof window

5.2.1 Emergency exit through front window

- Unlock all turn handles.
- Open the front window 1.
- Leave the crane cab through the front window 1.

5.2.2 Emergency exit through the roof window

There are two ways to unlock the roof window 2 for the emergency exit:

- Unpin both pins 11.
- Release both thumbscrews 12.
- Unlock all turn handles.
- Unlock the roof window 2 for the emergency exit.
- Open the roof window 2.
- Leave the crane cab through the roof window 2.

5.2.3 Emergency exit with EMERGENCY hammer*

Certain crane types carry an EMERGENCY hammer* in the crane cab.

- Knock the front window out with the EMERGENCY hammer* or a suitable object.
- Leave the crane cab.

6 Personal protective equipment

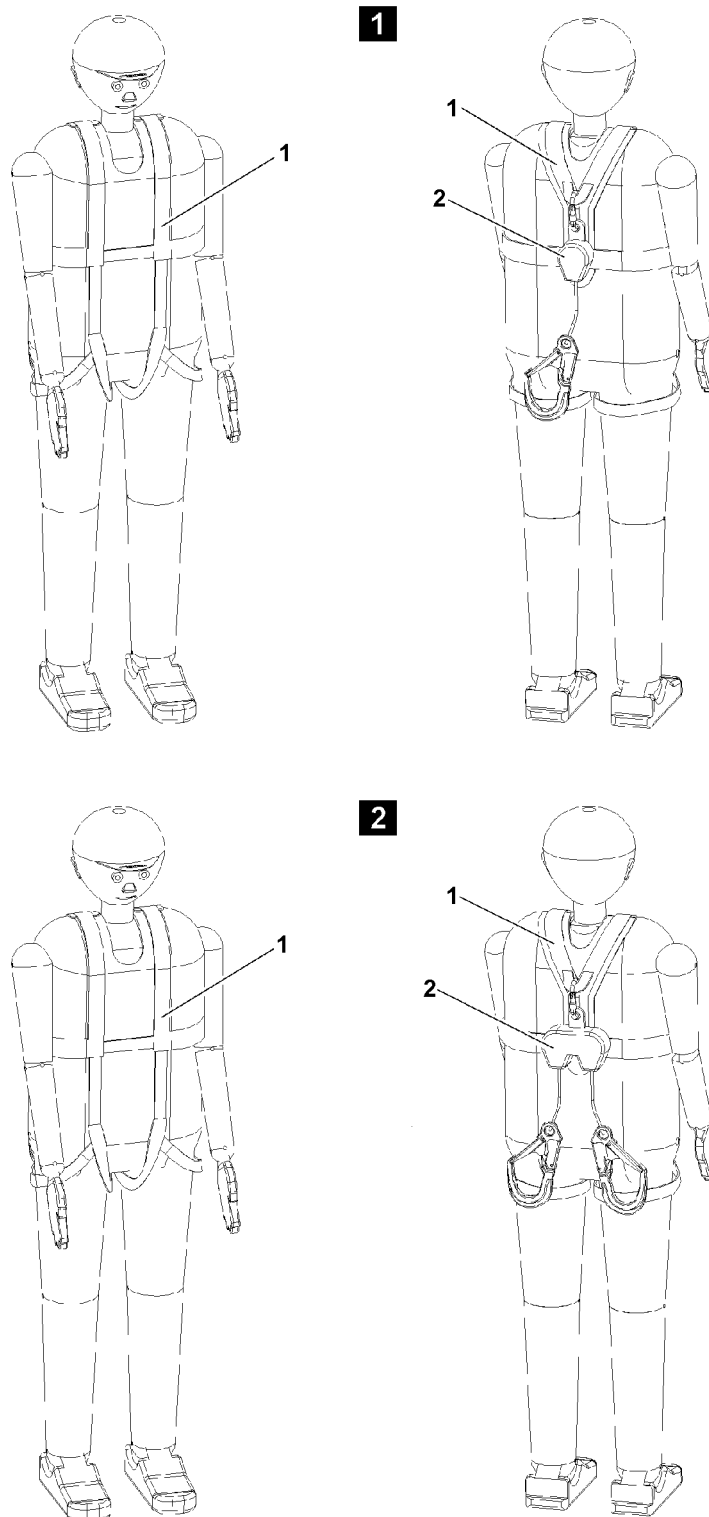

Fig.121161: Examples for safety harness and height safety equipment

**WARNING**

Danger of falling!

If personal protective equipment is not worn during assembly or maintenance work, then the assembly personnel can be killed or severely injured.

- ▶ Observe and adhere the operating instructions and maintenance instructions of the manufacturer for the personal protective equipment.
- ▶ Ensure through regular inspections that the product identification is not damaged.
- ▶ The crane operator must make personal protective equipment available for the assembly personnel.
- ▶ The crane operator must ensure that the personal protective equipment is worn by the assembly personnel.
- ▶ The assembly personnel is obligated to carry the personal protective equipment and to wear it.
- ▶ Check personal protective equipment before use for damage and completeness.
- ▶ Replace defective or damaged personal protective equipment with functioning protective equipment.

**WARNING**

Impermissible fall arrest system!

If a fall arrest system is used, which was not obtained via Liebherr-Werk Ehingen GmbH, there is a danger of falling. Another fall arrest system is **NOT** designed for the crane structure.

Personnel can be severely injured or killed.

- ▶ Utilize exclusively fall arrest systems from Liebherr-Werk Ehingen GmbH.

The personal protective equipment includes the following equipment:

- Supplied fall arrest systems (safety harness **1** and height rescue equipment **2**).
- Head protection with chin strap: Protection from falling parts at assembly and disassembly. Hitting the head during assembly and disassembly work
- Non-skid and slip resistance safety gloves
As a rule, when working with ropes, penetration safe safety gloves must be used.
- Safety shoes: Protection from falling parts at assembly and disassembly.
- Warning apparel

**WARNING**

Danger of fatal injury!

Even personal protective equipment does not provide 100 % protection.

A helmet can protect against small falling objects, but not against falling loads.

Personnel can be killed or seriously injured.

- ▶ Always remain alert.
- ▶ Always be safety conscious.
- ▶ Standing under suspended loads is prohibited.

**WARNING**

Danger of accident!

If the following measures are not carried out, personnel can be killed or severely injured.

- ▶ A plan for rescue actions, taking all possible emergencies into account, must be on hand.
- ▶ The following points can endanger the safe function of the personal protective equipment: for example extreme temperatures, routing of connecting devices, routing over or around sharp edges, chemical influences, electrical effects, cuts, abrasion, climatic influences or swing movements during falls.
- ▶ For that reason, safety preparations must be made.

**WARNING**

Important for the safety of the user!

- ▶ If the personal protective equipment is sold to another country, then the purchaser must make the manufacturer's operating instructions as well as the inspection and maintenance documents available in the language of the user country.

6.1 Identification of protective equipment

Every personal protective equipment or other equipment must be marked clearly and permanently in the language of the user country.

If the identification is no longer legible, then the personal protective equipment must be handed to an expert for inspection.

6.2 Supplied fall arrest system (safety harness and height safety equipment)

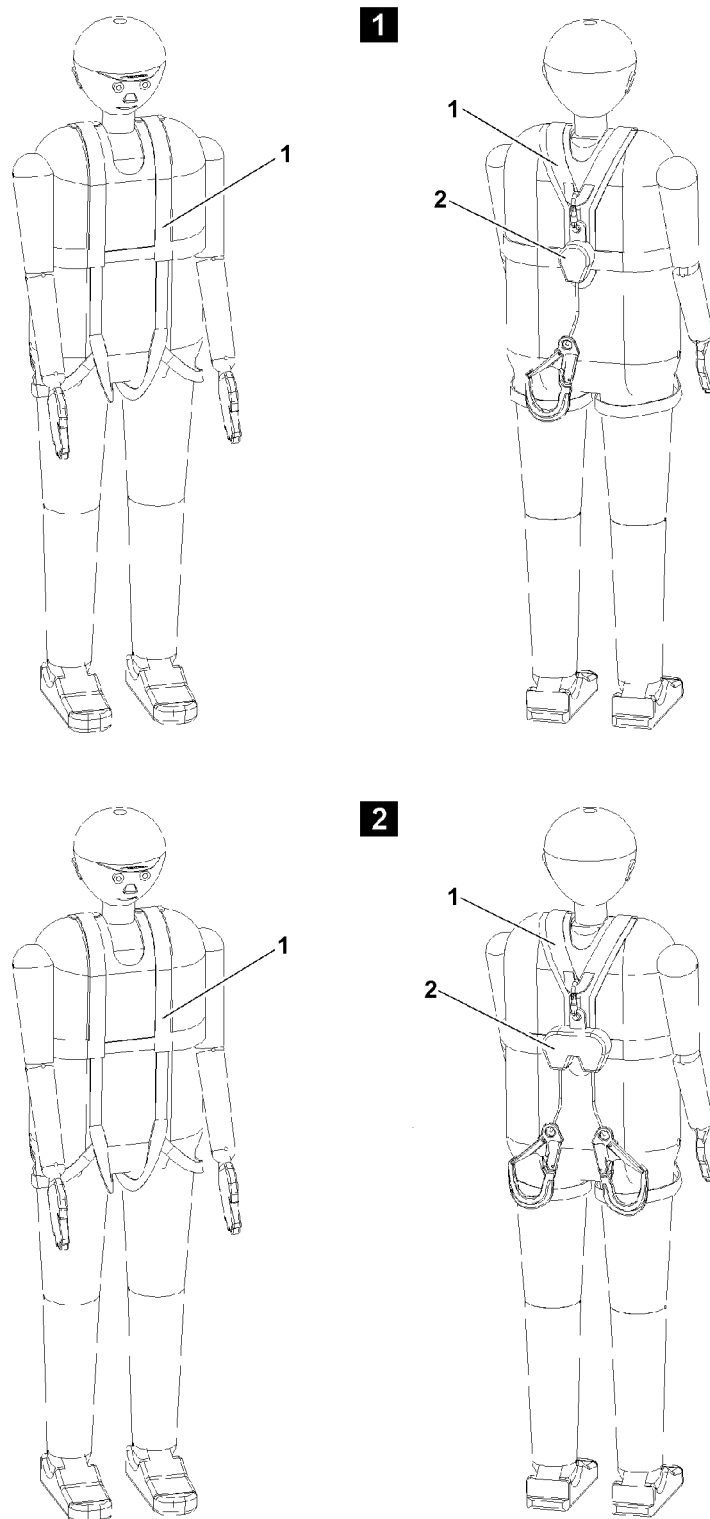

Fig.121161: Examples for safety harness and height safety equipment

The supplied fall arrest system, consisting of safety harness **1** and height safety device **2** must be worn where no other fall protection equipment, such as railings, can be installed for technical reasons.

In these cases, marked fastening and hook points for the fall arrest systems are provided on the components.

Height rescue system, see section "Saving the assembly personnel".



Note

- ▶ For cranes, which do not include the fall arrest system and the height rescue system as part of the scope of delivery can purchase the fall arrest system, consisting of safety harness **1** and height rescue equipment **2** as well as the height rescue system at the Liebherr-Werk Ehingen GmbH.

Part of the category „Aids for working at a height“ are, for example:

- Lifting platforms
- Scaffolding
- Auxiliary cranes
- Ladders



WARNING

Danger of falling!

If the fall arrest system is not worn during assembly or maintenance work, then the assembly personnel can fall down and be killed or severely injured.

- ▶ All work at a height, where there is a danger of falling must be carried out with suitable aids.
- ▶ If fall protection equipment is available, then the fall protection equipment must be used, see Crane operating instructions, chapter 2.06.
- ▶ If aids are not available and work cannot be carried out from the ground, then the assembly personnel must secure themselves with the supplied fall arrest system to prevent falling.
- ▶ The supplied fall arrest system must be fastened on the fastening and hook points as well as on the safety ropes. For safety points, see Crane operating instructions, chapter 2.06.
- ▶ The assembly personnel must be instructed in practice on how to wear the supplied fall arrest system (safety harness **1** and height safety equipment **2**). Annual practice instructions and drills must be carried out.
- ▶ The supplied fall arrest system must be used.
- ▶ The fall arrest system consists of a safety harness **1**, approved according to **EN 361** and a height safety equipment **2**, approved according to **EN 360** (for horizontal application and sharp edges).
- ▶ The supplied fall arrest system may not be changed in its configuration. Extending or shortening the fall arrest rope is prohibited.
- ▶ The fall absorber is integrated in the height safety device **2**. The utilization of an additional fall absorber is prohibited.
- ▶ The supplied fall arrest system is effective from a height of 2.5 m.
- ▶ The fall space must be free of obstacles.
- ▶ Solely the intended safety points designed for this purpose on the crane may be used.
- ▶ The operating instructions of the manufacturer for the supplied fall arrest systems (safety harnesses **1** and height safety equipment **2**) must be observed and adhered to.
- ▶ Only step on the aids, ladders and catwalks with clean shoes.
- ▶ Keep aids, ladders and catwalks free of heavy dirt.
- ▶ Keep aids, ladders and catwalks free of snow and ice.
- ▶ The safety harness **1** and the height safety equipment **2** must be inspected annually by authorized and trained expert personnel and the results must be documented in the inspection log book for the fall arrest system.
- ▶ After every fall, the safety harness **1** and the height safety equipment **2** must be removed and inspected by an authorized and trained expert.
- ▶ The results must be documented in the inspection log book.
- ▶ Only after written release by expert personnel may the fall arrest system be reused.

6.3 Use of single strand height safety equipment

Height safety equipment with a belt strap, see illustration **1**, is intended for all cranes which have no catwalks with safety ropes. Use the supplied height safety equipment with extendable belt strap and snap hook (**EN 362 Class A**) with swivel.

6.4 Use of double strand height safety equipment

Height safety equipment with two belt straps, see illustration 2, is intended for cranes with catwalks, which are equipped with two ropes as fastening device on the left and right hand side of the catwalk. For example lattice sections, lattice booms, possibly telescopic booms or assembly units. Use the supplied height safety equipment with two extendable belt straps and snap hooks (**EN 362 Class A**) with swivels.



WARNING

Danger of falling!

- ▶ If two safety ropes are installed on the booms, lattice sections and other components, then the height safety equipment with two belt straps must always be used and one belt strap per safety rope must be hooked.

6.5 Documentation Fall arrest systems and Height rescue system



Note

- ▶ The documentation of the fall arrest systems (safety harnesses and height safety equipment) and the height rescue system must be carried out according to the operating instructions of the respective manufacturer.
- ▶ The crane operator, who employs the user, is responsible for the creation of documentation and entry of the required data.

7 Securing persons to prevent them from falling



WARNING

Danger of falling!

- ▶ Wear the supplied fall arrest systems (safety harnesses and height safety equipment) correctly.
- ▶ When accessing a ladder, do not hold any objects in your hands.
- ▶ When accessing a ladder, adhere to the 3-point support. See the Crane operating instructions, chapter 2.04.10.

7.1 Working on the telescopic boom head and / or auxiliary boom

Reeve the hoist rope in or out on the pulley head:

- For ladder work, use the supplied ladder. For fastening and hook points, see Crane operating instructions, chapter 2.06.
- For cranes, which carry a ladder along **with** hook device:
Use the hook device to secure the ladder.
- For cranes, which carry a ladder along **without** hook device:
Use the rigging belt to secure the ladder.
- When ascending, the assembly personnel must ensure a 3-point support.
- If there is a danger of falling, the assembly personnel must hook themselves with the snap hooks of the fall arrest system on the fastening points and secure themselves against falling.

7.2 Walking on the telescopic boom



WARNING

Danger of falling!

The assembly personnel can fall down by slipping on the telescopic boom and be killed or severely injured!

- ▶ The telescopic boom may only be accessed if assembly personnel is protected with suitable safety measures to prevent them from falling.
- ▶ If safety ropes are present on the telescopic boom, then the assembly personnel must hook themselves with the supplied fall arrest system on the safety ropes of the telescopic boom on the left and right with both snap hooks and secure themselves against falling.
- ▶ Without safety measures, it is **strictly** prohibited to step on the telescopic boom.

Assembly of the hoist rope or the TY-guying:

- During assembly, the assembly personnel must hook themselves on the fastening devices on the left and right with both snap hooks of the fall arrest system and secure themselves against falling.

7.3 Access to lattice sections or booms

Climbing the ladder:

- When ascending, the assembly personnel must ensure a 3-point support.

Changing from ladder to catwalk **without** transition aid:

- From a transition height above 1.8 m: **Before** transitioning, the assembly personnel must hook at least one snap hook of the fall arrest system on a safety rope and secure themselves against falling.

Changing from ladder to catwalk **with** transition aid:

- **After** transitioning, the assembly personnel must hook at least one snap hook of the fall arrest system on a safety rope and secure themselves against falling.

7.4 Walking on lattice sections or booms

Walking on catwalks:

- When walking on catwalks, the assembly personnel must hook themselves on the safety ropes on the left and right with both snap hooks of the fall arrest system and secure themselves against falling.
- When changing the fall arrest system over to a new lattice section, the assembly personnel must be hooked with at least one snap hook of the fall arrest system one safety device.

7.5 Working on lattice sections or booms

Pinning, unpinning the lattice sections of pull rods:

- During pinning, unpinning of lattice sections or pull rods, the assembly personnel must hook themselves on the safety ropes on the left and right with both snap hooks of the fall arrest system and secure themselves against falling.

Attaching the lattice sections:

- When attaching the lattice sections, the assembly personnel must hook themselves on the safety ropes on the left and right with both snap hooks of the fall arrest system and secure themselves against falling.

7.6 Descending from lattice sections or booms

Accessing the ladder **without** transition aid:

- From a transition height above 1.8 m: **Before** stepping on the ladder, the assembly personnel must hook at least one snap hook of the fall arrest system on a safety rope and secure themselves against falling.
- When stepping on the ladder, the assembly personnel must ensure a 3-point support.

- The snap hook of the fall arrest system may only be unhooked after standing safely on the ladder (3-point support).

Accessing the ladder **with** transition aid:

- When stepping on the ladder, the assembly personnel must ensure a 3-point support.

Climbing down the ladder:

- When descending, the assembly personnel must ensure a 3-point support.

8 Rescuing the assembly personnel

The height rescue system is only supplied on certain crane types.

The height rescue system, consisting of the rappelling rescue device, is an evacuation and rescue device. It is used to lift the fallen person to be able to unhook him from the height safety equipment and to lower him by rope.



WARNING

Danger of falling!

- ▶ The assembly personnel must be instructed and trained properly in the correct handling of the height rescue system. Annual practice instructions and drills must be carried out.
- ▶ The supplied height rescue system must be kept available.
- ▶ The operating instructions of the manufacturer for the height rescue system must be observed and adhered to.
- ▶ The height rescue system must be inspected annually by authorized and trained expert personnel and documented in the inspection log book.

8.1 First aid measures after rescue



WARNING

Danger of fatal injury!

- ▶ After the rescue, the patient must be positioned with the upper body raised (in seated or squatting position).
- ▶ Immediate flat position or even shock position can be fatal.

9 Crane operator's cab with retractable / extendable step

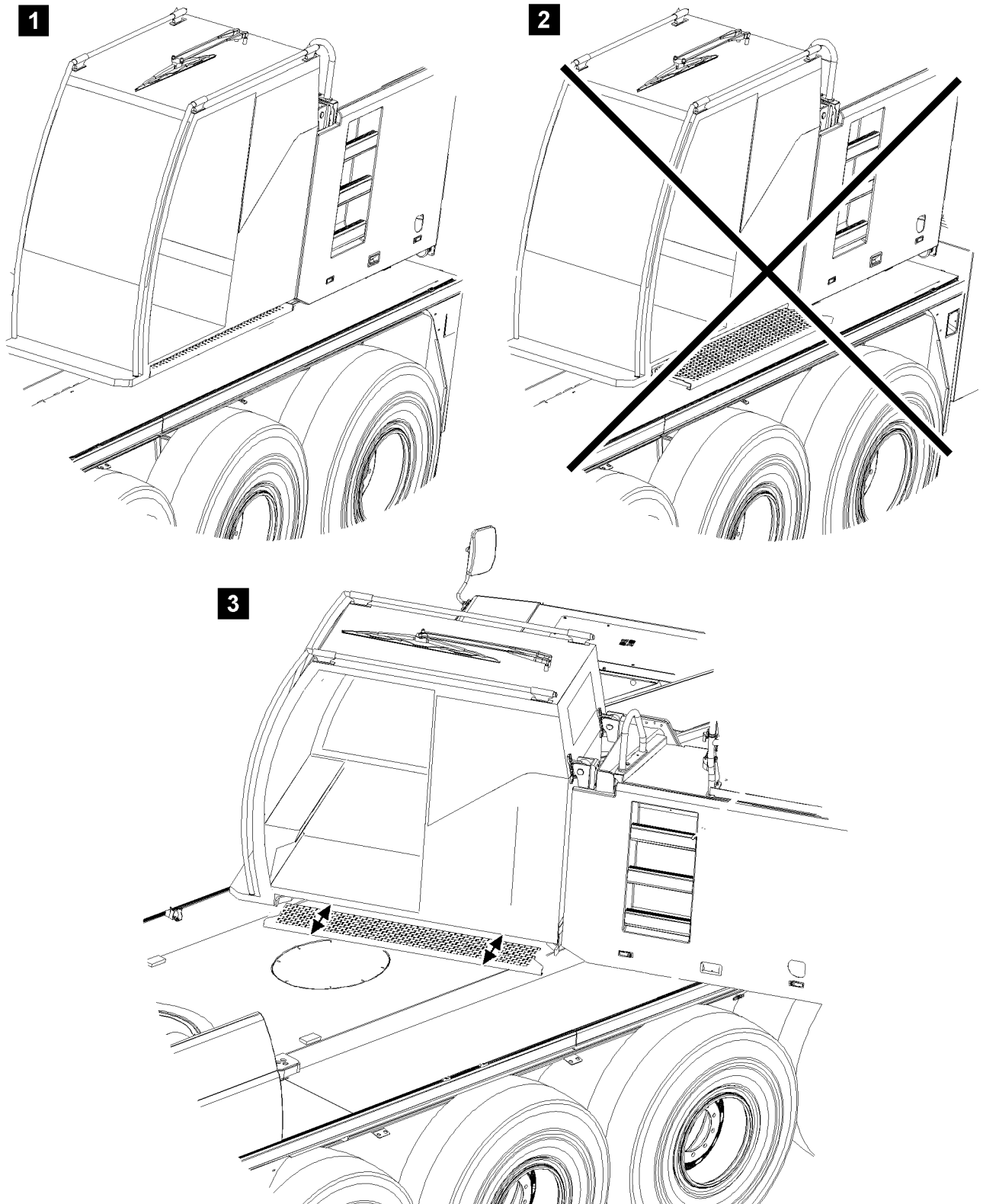

LWE/LR 11000-001/23501-04-02/en

Fig.121159: Example for crane operator's cab with retractable / extendable step

9.1 Entering / exiting of crane superstructure alignment length axis crane chassis

See illustration 1

Before entering the crane cab or existing from the crane cab, the following prerequisites must be met:

- The crane superstructure is aligned in length axis of the crane chassis.
- The step under the crane cab is retracted.
- The crane cab with incline adjustment is in 0° position.
- Folding ladders are folded into the ascent and descent position.



Note

- ▶ When all folding ladders are folded into the ascent and descent position, then a safe descent is possible from every position. See also the Crane operating instructions, chapter 2.07.



WARNING

Danger of falling!

If the crane superstructure is aligned in length axis of the crane chassis and the step can **not** be moved in, then there is a danger of falling when entering / exiting. See illustration 2.

Personnel can be severely injured or killed.

- ▶ Set up a suitable access, such as a ladder or platform, to ensure safe entry into the crane cab.
- ▶ When exiting the crane cab in position crane superstructure in length axis crane chassis, always move the step in completely.

9.2 Entering / exiting a swung crane superstructure

See illustration 3

Before entering the crane cab or existing from the crane cab, the following prerequisites must be met:

- The crane superstructure is swung to the point where a safe access to walkable surfaces of the crane chassis is ensured.
- For the crane cab with incline adjustment, the crane cab is in 0° position.
- All folding ladders are folded into the ascent and descent position.



Note

- ▶ Use extendable step!
- ▶ The extended step allows comfortable entry into the crane cab as well as safe exit from the crane to the crane chassis.
- ▶ When all folding ladders are folded into the ascent and descent position, then a safe descent is possible from every position. See also the Crane operating instructions, chapter 2.07.

10 Crane cab with incline adjustment



WARNING

Danger of falling!

If the crane cab cannot be swung from an inclined position (for example 20° position) to the 0° position, for example due to a problem, then utmost caution must be used when entering / exiting the crane cab.

There is a danger of falling. Personnel can be severely injured or killed.

- ▶ For safety reasons, we recommend to take advantage of outside help.
- ▶ If necessary, have platforms or other suitable entry aids set up to ensure safe exit from the crane cab.

**WARNING**

Danger of accident!

If the door of the crane cab is opened in inclined position, then the door can move back suddenly. Hands can be crushed or injured.

- ▶ When the crane cab is in inclined position, open the door carefully.

11 Securing bracket

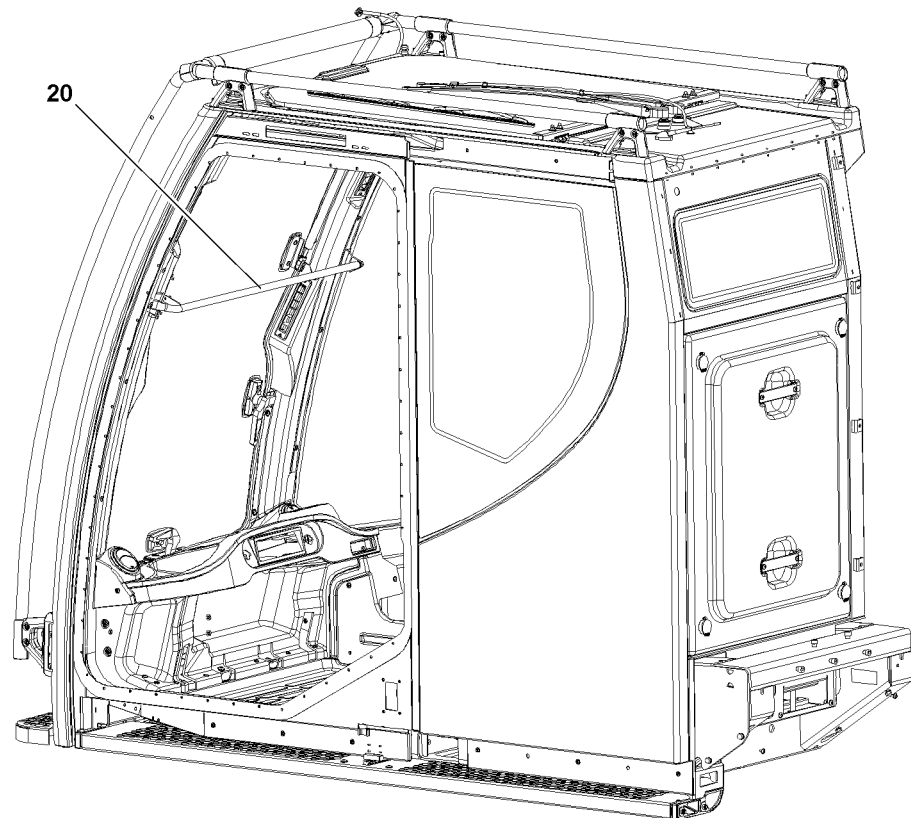

Fig.121158: Example for crane cab with securing bracket

**Note**

- ▶ The securing bracket **20** is installed to protect the crane operator from a danger of falling when the front window is open.
- ▶ Do not use the securing bracket **20** as a handle.

12 Closing the side window pane



WARNING

Danger of crushing!

Never close the side window pane carelessly or uncontrolled. Significant crushing injuries can occur.

- ▶ During closing, watch the side window pane as it moves up.
- ▶ Make sure that no personnel or objects are crushed.

13 Transport



WARNING

Error during transport!

Death, severe bodily injuries, property damage.

- ▶ To avoid accidents, observe and follow the notes provided in the following sections.

13.1 Crane and crane components

Follow the notes provided below to safely transport the crane and crane components:

- Close the crane operator's cab and all cover doors.
- Use suitable transport vehicles.
- Use rigging devices with sufficient load capacity.
- Regularly inspect the rigging and fastening points. See the Crane operating instructions, chapter 8.01.
- Properly support and secure the components on the transport vehicle.
- Use special transport devices. See the Crane operating instructions, chapter 3.80.

13.2 Lattice sections

Follow the notes provided below to safely transport the telescoped lattice sections:

- Securely rig the lattice sections on the transport vehicle and secure them together in at least two independent points.

13.3 Mobile cranes

Follow the notes provided below for the safe transport of mobile cranes.

- To ensure the largest possible frictional coefficient to the transport surface, clean the wheels before transport.
- When driving on the transport vehicle, check the easy movement of the vehicle with the aid of a guide to avoid hitting too hard.
- Engage the parking brake. See the Crane operating instructions, chapter 3.04.
- Lower the crane with the level control to obtain a center of gravity as low as possible. Level control, see Crane operating instructions, chapter 3.03
- Stopping the mobile crane: Place wedges under the wheels. See the Crane operating instructions, chapter 2.04.
- Close the driver's cab.

13.4 Accelerating, changing the load

NOTICE

Permissible acceleration exceeded!
Damage to crane.

- ▶ Observe the maximum permissible longitudinal acceleration of 1.0 g.
- ▶ Observe the maximum permissible lateral acceleration of 0.8 g.
- ▶ Offloading and running is prohibited during rail transport.

If higher accelerations are expected (rail transport, maneuvering operation):

- ▶ Carry out the special measures to secure the crane and crane components.

NOTICE

Frequent dynamic load change!
Premature fatigue of load bearing crane components.

- ▶ Demount and properly secure components with large masses.

Components with large masses are, for example:

- Folding jibs
- Counterweights

14 Stops



WARNING

Defective fastening equipment or fastening points!
The load can fall down.

- ▶ Make sure that the fastening points and fastening equipment are in a perfect condition.
- ▶ Regularly inspect the rigging and fastening points. See the Crane operating instructions, chapter 8.01.
- ▶ Check the fastening equipment regularly. See the Crane operating instructions, chapter 8.01.



WARNING

Load bearing capacity of the fastening equipment is **not** sufficient!
The load can fall down.

- ▶ Determine the weight of the crane component to be fastened.
- ▶ Fasten the components solely with approved and sufficiently load bearing fastening equipment.



WARNING

Component incorrectly fastened!
The load can fall down.

- ▶ Attach the components only on the intended fastening points.

15 Heated crane components



WARNING

Danger of burns!

You can get severely burnt on the surfaces of hot components.

This applies especially to exhaust systems, the engines and the respective gears in the crane chassis and in the crane superstructure.

- ▶ Let the components cool off before touching them.
- ▶ Proceed with special caution near heated crane components.

16 Crane operator responsibilities

16.1 General

The crane operator's primary responsibility is to use and operate the crane in a manner that is safe for both himself and others.

The following important safety guidelines will help you achieve this.

Many crane accidents are caused by incorrect crane control.



WARNING

Danger due to operating error!

- ▶ In your interest and in the interest of others, make sure that you know your crane. Also learn to recognize all dangers connected with the work to be carried out.

Operating errors, which are made again and again while operating or driving a crane are especially careless while working, in particular:

- Slewing too quickly
- Stopping the load too quickly
- Pulling the load at an angle
- Allowing slack rope formation
- Overloading the crane
- Driving too fast with a load and / or equipment on an uneven roadway
- Attaching the load incorrectly
- Unsuitable operation; especially angular pulling, breaking away stuck loads
- Wind action on suspended loads
- Mistakes when driving on a road, for example:
 - Overspeeding the engine when driving downhill
 - Driving with turned on differential lock
- Crashing into bridges, roofs or high voltage wires due to insufficient headroom
- Inadequate support; support base, substructure under the support plates
- Mistakes during assembly or disassembly of booms
- Incorrect positioning of the crane when it is taken out of service
- Exceeding the permissible wind speeds in operation and when out of service

In many cases, crane damage is caused by improper maintenance:

- Insufficient oil, grease or antifreeze
- Contamination
- Broken cable wires, defective tires, worn components
- Emergency limit switch or load torque limiter (LMB) not operating properly
- Brake and clutch failure
- Hydraulic defects; for example cracked hoses
- Loose bolts

16.2 Working on the crane superstructure or boom



WARNING

Danger of falling!

When working on the crane superstructure or boom, personnel must be secured with appropriate safety measures to prevent them from falling. If this is not observed, working personnel can fall and be killed or severely injured.

- ▶ For all work on the crane where there is a danger of falling, suitable safety measures must be taken.
- ▶ The crane superstructure or the boom may not be accessed without suitable aids.
- ▶ Suitable aids are, for example: Lifting platforms, scaffoldings, ladders, assembly platforms, auxiliary crane.
- ▶ If railing are present on the crane superstructure, then they must be swung into operating position and secured for all work, see Crane operating instructions, chapter 2.06.
- ▶ Step on aids and stepping surfaces on the crane only with clean shoes.
- ▶ Keep aids and stepping surfaces on the crane clean and free from snow and ice.
- ▶ If the work cannot be carried out with such aids nor from the ground, then the assembly personnel must secure themselves with supplied fall arrest systems to avoid falling, see section „Personal protective equipment“.
- ▶ It is prohibited to step on the driver's cab or crane cab roof and specially marked surfaces, see Crane operating instructions, chapter 2.05.

16.3 Obligations of the crane operator

1. Before starting to work, the crane operator must check the brake function and the emergency shut off devices. He must monitor the condition of the crane for obvious defects. On wireless controlled cranes, he must check the assignment of control unit and crane.
2. The crane operator must cease crane operation in case of problems endangering the safety.
3. The crane operator must report all defects on the crane to the appropriate supervisor, also to his replacement in case of crane change.
4. The crane operator must make sure that:
 - All control systems are set to neutral or idle position before release of the energy supply to the drive components.
 - The control systems are set to neutral or idle position and the energy supply is shut off before leaving the control platform.
 - When taking down the control unit for wireless control, the control unit is secured to prevent unauthorized operation.
5. The crane operator must ensure that cranes subjected to wind are not operated past the limits which were set by the crane manufacturer, and that the boom is taken down at least when the critical wind speeds for the crane are reached and at the end of the work.
6. The crane operator must monitor the load during all crane movements or the load handling equipment when moving the crane without a load, if they could cause a dangerous situation. If observation is not possible, then the crane operator may move the crane only with the aid of a guide.
7. The crane operator must give warning signs when necessary.
8. The crane operator may not move loads over personnel.
9. Any loads attached by hand may only be moved by the crane operator after he received a clear sign from the person who attached the load, the guide or any other responsible party which was assigned to that task by the contractor. If signals must be used to communicate with the crane operator, then these signals must be agreed upon before use between the responsible party and the crane operator. If the crane operator determines that the loads are not properly attached, then he may not move these loads.
10. As long as a load is suspended on the crane, the crane operator must keep the control systems within reach. This does not apply for towing of vehicles with towing cranes.
11. The crane operator may not run up to end positions operationally, if they are limited by the emergency limit switches.
12. After a load torque limiter was triggered, the crane operator may not take on an overload by pulling in / raising the boom.

13. The crane operator may **not** bypass the overload protection to increase the hoisting power of the crane.

17 Selecting the crane operating location

In the following illustrations 1 to 3 the possible situations are shown as an example.

It is very important to choose an appropriate placement location in order to minimize safety risks.

It must always be possible to take down the crane in order to take down the crane in a timely manner in the case of unexpected weather conditions.

It must always be possible to position the crane in a safe out of service position.

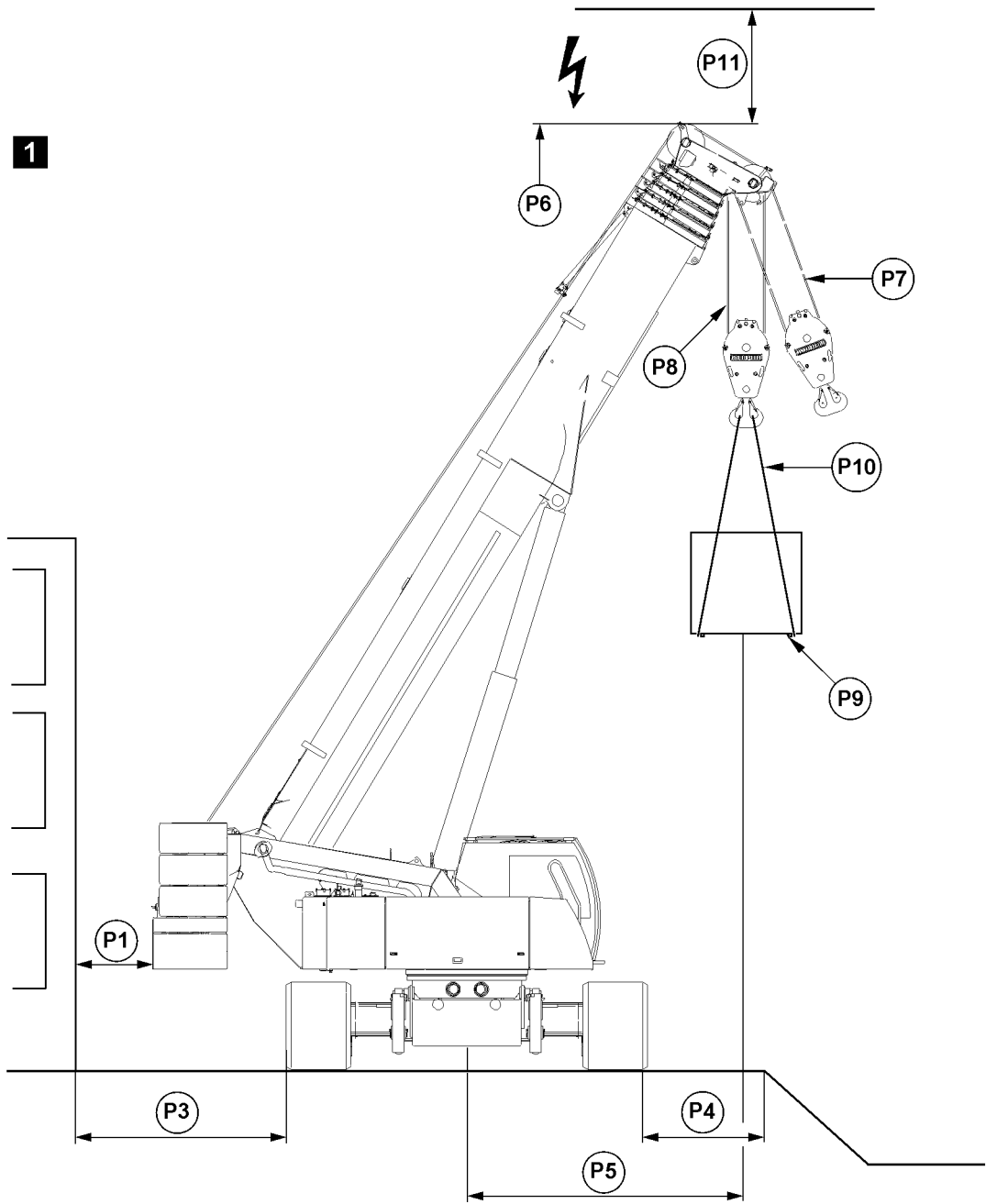

Fig.121166: Example for crawler crane with telescopic boom

LWE/LR 11000-001/23501-04-02/en

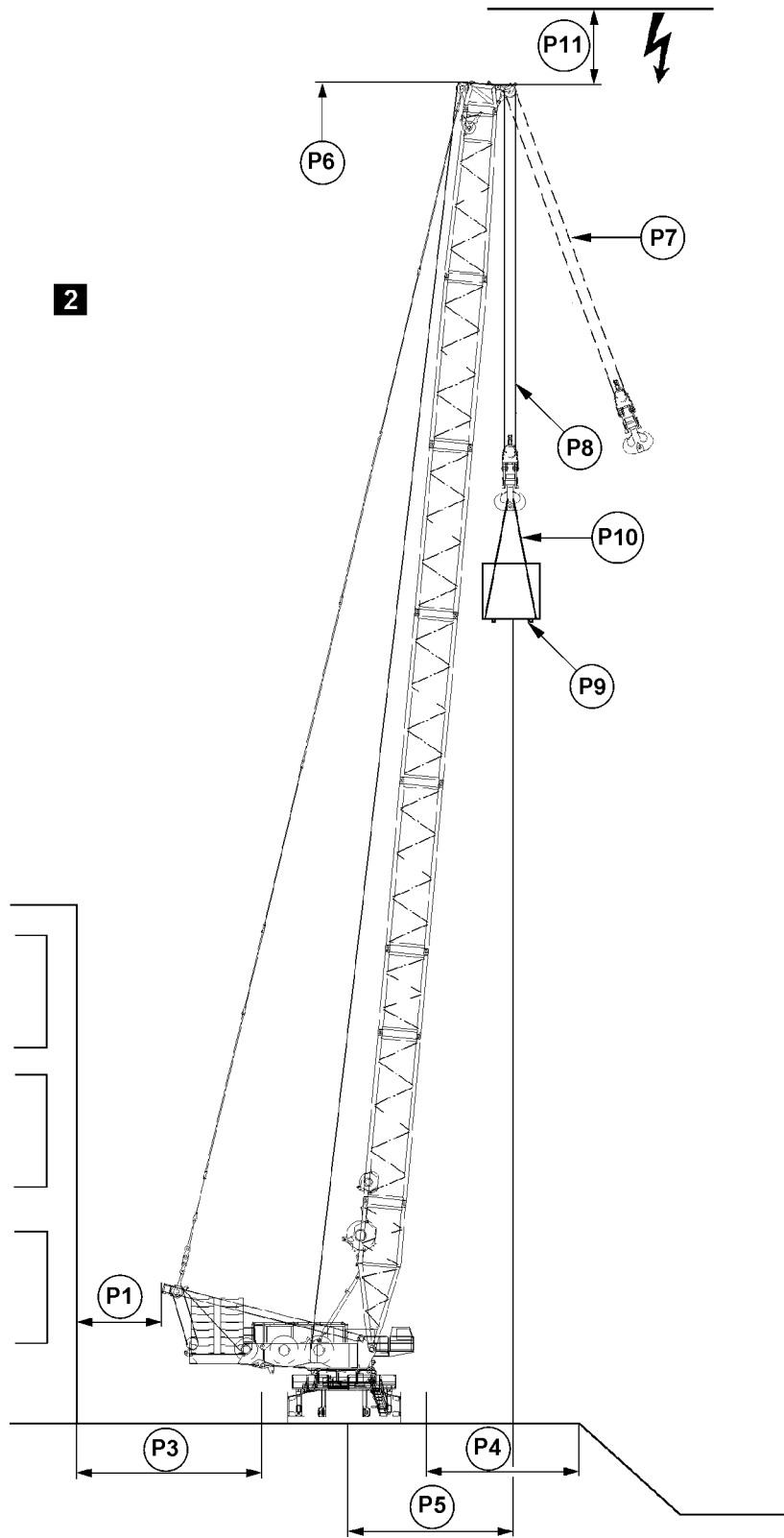

Fig.121167: Example for crawler crane with lattice mast boom

LWE/LR 11000-001/23501-04-02/en

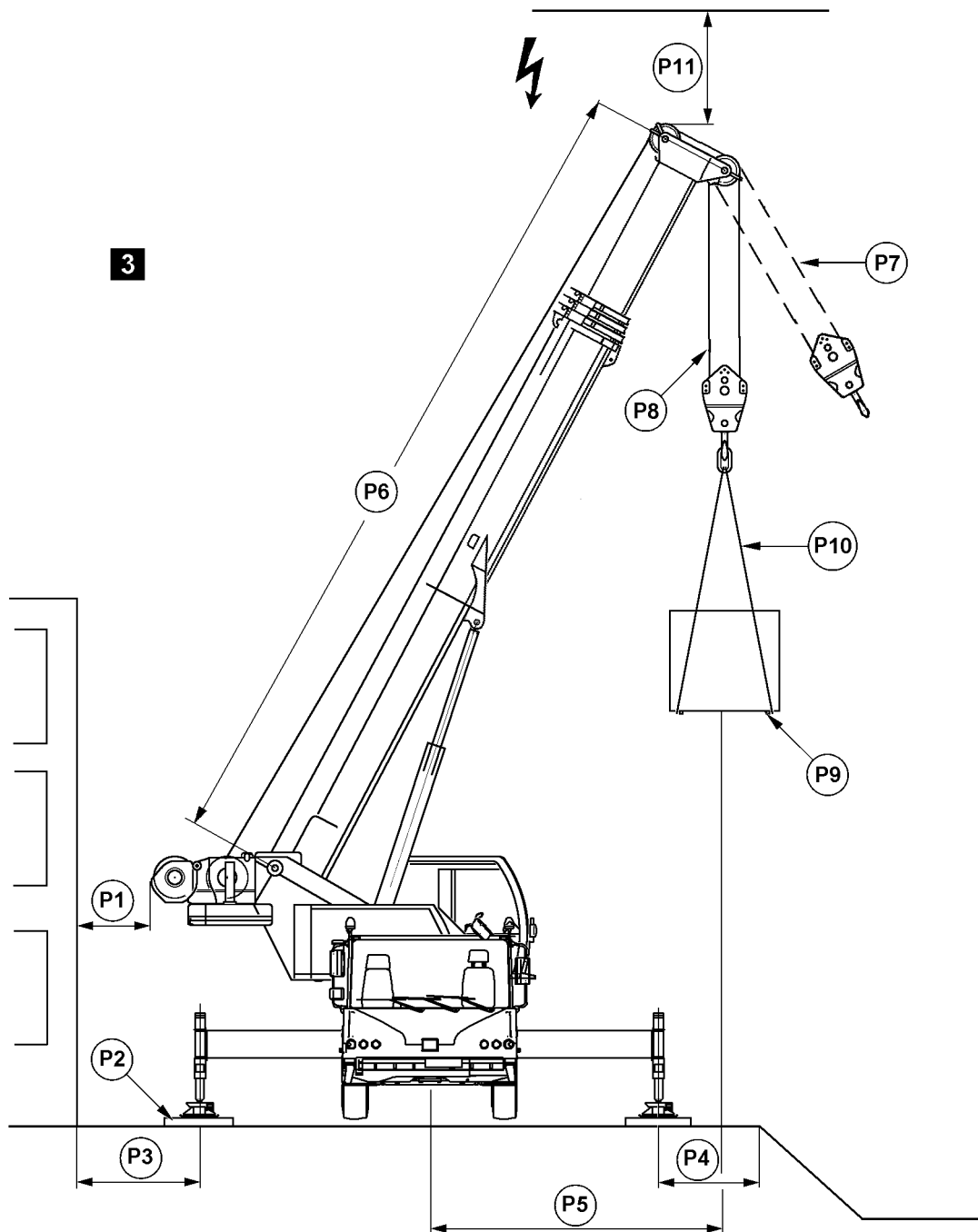

Fig.121168: Example for mobile cranes



DANGER

Danger of accidents due to ground with **insufficient** load bearing capacity!

If the crane is supported or driven on ground with **insufficient** load bearing capacity, then the crane can topple over and kill personnel.

- ▶ Only support or drive the crane on ground with sufficient load bearing capacity.
- ▶ Act responsibly when planning and selecting the crane location and route.
- ▶ Observe the following points.

Sign	When selecting the placement location for the crane, observe and adhere to the following:
P1	Select the placement location in such a way that crane movements can be carried out without collision and that the supports can be extended to the support base specified in the load charts. Make sure that no personnel is injured or killed. Always keep a safety distance of 0.5 m. If this is not possible, block the danger zone off.
P2	When crane support is required: Support the crane correctly and support the support plates large enough according to the load bearing capacity of the ground and the placement location.
P3	Keep a safety distance to basements or similar.
P4	Keep a safety distance to slopes or similar.
P5	Keep the boom radius to as low as possible.
P6	Select the correct boom length to the load case.
P7	Angular pull is prohibited.
P8	Select the correct reeving of the hoist rope to the load case.
P9	Bear in mind the weight and the wind exposure surface of the load.
P10	Select fastening equipment according to the weight of the load, the type of attachment and the incline angle.
P11	Keep sufficient distance to electrical overhead wiring.

18 Slopes and excavations

In the following illustrations 4 and 5 the possible situations are shown as an example.

The crane may not be set up too close to slopes or excavations. Maintain adequate safety distance **A** and safety distance **B** in accordance with the type of soil.

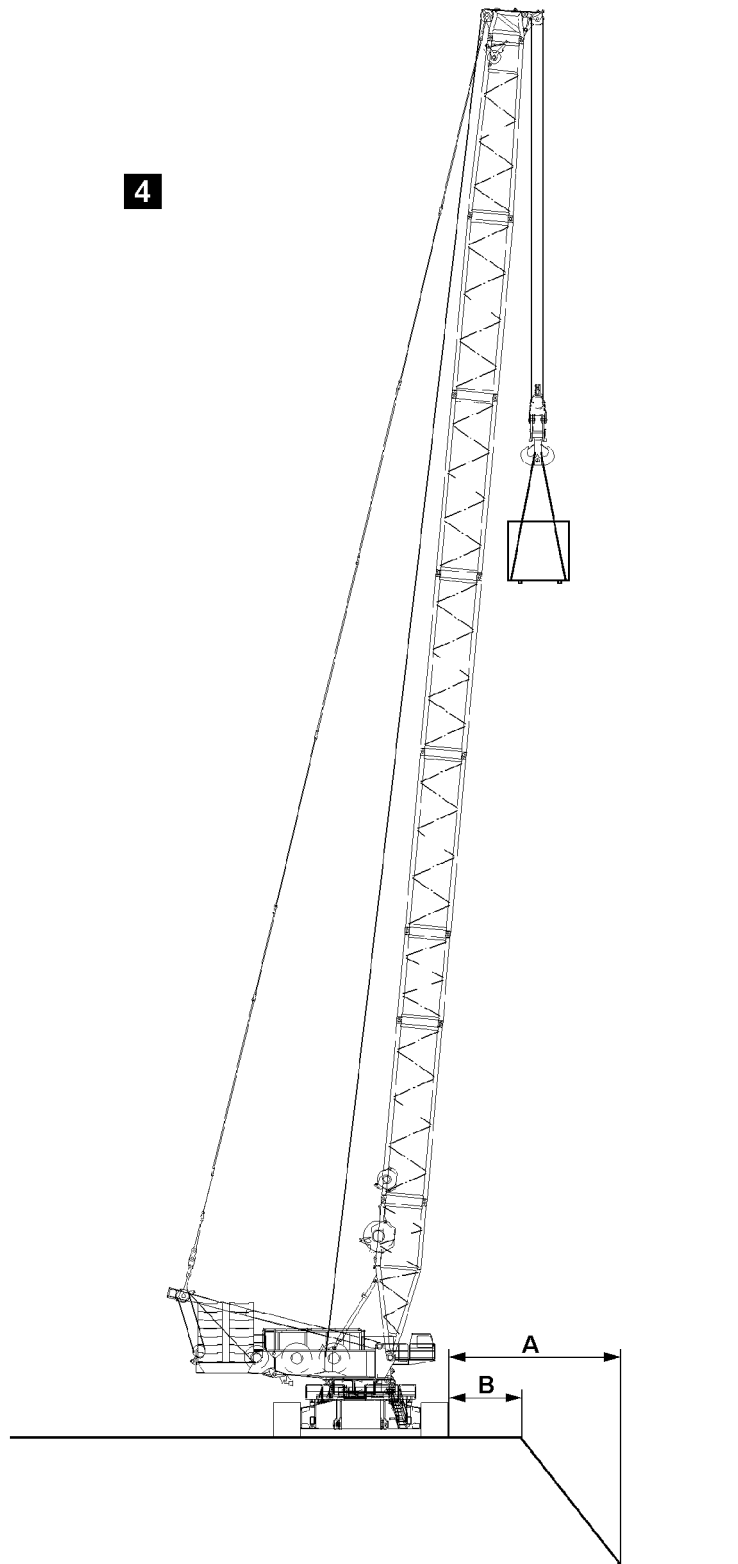

Fig.121162: Example for crawler cranes

- A** Distance to bottom of excavation **B** Distance to excavation

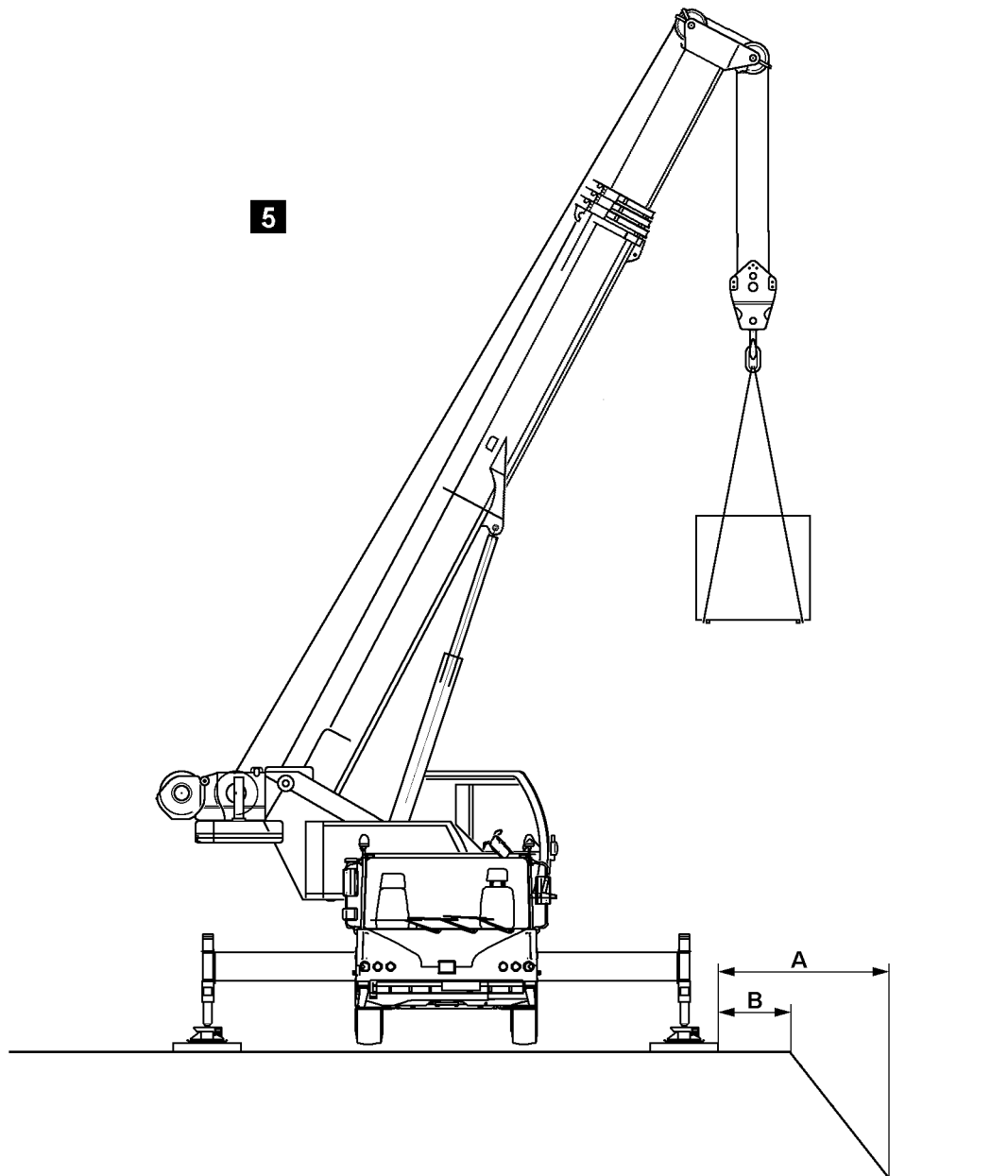

Fig.121163: Example for mobile cranes

- A** Distance to bottom of excavation **B** Distance to excavation



WARNING

The crane can topple over!

The edge of the slope or excavation can break in if safety distance **A** or safety distance **B** is too small. If the edge of the slope or excavation break in, the crane can topple over and kill personnel.

► Always maintain the required safety distance **A** and safety distance **B**.

19 Load burdens on the ground due to crane operation



Note

- ▶ Take into account that on a crane with high counterweight the crawler pressures or support forces at low load can be higher than at high load.

19.1 Load burdens on the ground on cranes on crawlers

For cranes on crawlers significant forces are transferred via the track pads of the crawlers into the ground (crawler pressures).

- The ground must be able to safely withstand the resulting pressure.
- If the area of the track pads is inadequate, then the crawlers must be supported from below according to the load bearing capacity of the ground.
- The required substructure can be calculated from the load bearing capacity of the ground and the crawler pressures of the crane.



WARNING

Load bearing capacity of the ground insufficient!
The ground can give, the crane can topple over.
Death or severe bodily injuries.

- ▶ Support large enough, according to the load bearing capacity of the ground with suitable materials, such as wooden beams or steel plates.

To obtain an even pressure distribution over the substructure surface:

- ▶ Set the crawlers centered on the substructure.



Note

- ▶ The respective ideal crawler pressure can be determined with the job planner program.

19.2 Load burdens on the ground on cranes on supports

When the crane is supported, significant forces (support forces) are transferred by the support cylinders via the support plates into the ground.

The ground must be able to safely withstand the resulting pressure.

If the support plate surface area is inadequate, then the support plates must be supported from below according to the load bearing capacity of the ground.

The required support surface areas can be calculated from the load bearing capacity of the ground and the support forces of the crane.



WARNING

Load bearing capacity of the ground insufficient!
The ground can give, the crane can topple over.
Death or severe bodily injuries.

- ▶ Support large enough, according to the load bearing capacity of the ground with suitable materials, such as wooden beams or steel plates.

To obtain an even pressure distribution over the substructure surface:

- ▶ Set the support plates centered on the substructure.

19.3 Examples for the load bearing capacity of the ground

Soil type		Permissible ground pressure [kN/m ²]
1.	Organic ground: Peat, sludge, muck	0
2.	Uncompacted fill: Construction debris	0 to 100
3.	Non-cohesive ground: Sand, gravel, rocks and mix	200
4.	Cohesive soil:	
	a) Clayed silt, mixed with topsoil	120
	b) Silt, consisting of poor clay and coarse clay	130
	c) Plastic clay, consisting of potter's clay and fill	
	Stiff	90
	Semi-solid	140
	Solid	200
	d) Mixed granular ground, clay to sand, gravel and rocky areas	
	Stiff	150
	Semi-solid	220
	Solid	330
5.	Rock in evenly solid condition:	
	a) Brittle, with traces of decomposition	1500
	b) Not brittle	4000

Examples: Permissible ground pressure of the ground

If there is any doubt about the load bearing capacity of the ground at the placement location, soil tests must be carried out by an authorized inspector, for example with a ram penetrometer.

19.4 Calculation examples

The following are general calculation examples. The values are used only to explain the calculation steps. The crane specific values are in chapter 1.03 of the crane operating instructions.

Example: Calculation of ground pressure of support plates for cranes on supports		□
Support force according to Crane operating instructions, chapter 1.03 for example: 720 kN	720 kN	
Surface of square support plate with 550 mm side length according to chapter 1.03, for example: 0.55 m x 0.55 m = 0.3 m ²	0.3 m ²	
80 % as carrying surface of support plate: 0.3 m ² x 0.8 = 0.24 m ²	0.24 m ²	
Ground pressure = Support force / load bearing surface support plate	720 kN / 0.24 m ² = 3000 kN/m ²	
Ground pressure per support:	3000 kN/m²	

Example: Calculation of ground pressure

- The value of the ground pressure is far higher than the permissible ground pressure for all types of granular soil.
- If this crane is utilized on bedrock, gravel type of ground, permissible ground pressure 200 kN/cm², then the support surface must be increased.

Example: Calculation of required support surface for cranes on supports		□
Support force according to Crane operating instructions, chapter 1.03 for example: 720 kN	720 kN	
Ground pressure from chart <i>Permissible ground pressures</i> for example: 200 kN/m ²	200 kN/m ²	
Required support surface = Support force / permissible ground pressure	720 kN / 200 kN/m ² = 3.6 m ²	
Required support surface per support:	3.6 m²	

Example: Calculation of support surface

- The surface of the substructure for each support plate must be at least **3.6 m²**.
- The height of the substructure must be selected depending on the load distribution angle.



Note

- ▶ The corresponding ideal support forces can be determined with the Job planner.

19.5 LICCON job planner

The calculation of support forces and crawler pressures with the LICCON job planner are based on idealized assumptions: level and homogenous ground, rigid crane structure, no consideration in regard to wind.

Side deformations of the boom system due to wind, incline position and elastic compliance of the steel structure can lead to increase of support forces or to increase of crawler pressures.

The determination of the values, taking wind load on the crane and the load into account, as well as the elastic deformation of the crane can only be carried out by the crane manufacturer or a qualified authorized inspector.

19.5.1 Example for crane on crawler with derrick boom, suspended ballast and short (main) boom system

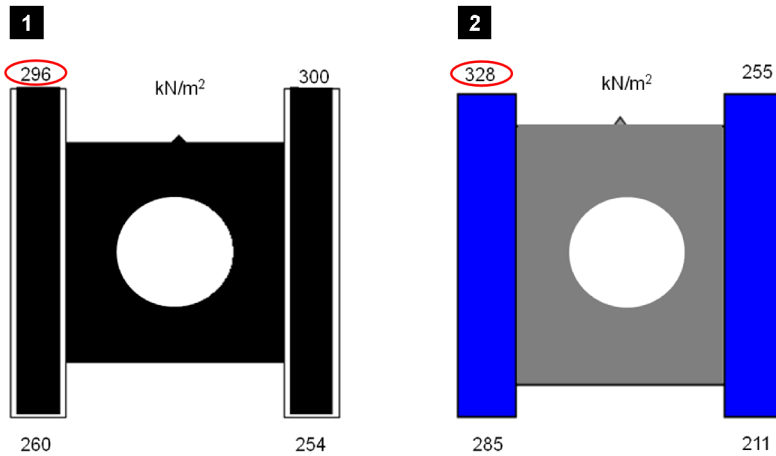

Fig.125052: Example for crane on crawler with derrick boom, suspended ballast and short (main) boom system

Illustration 1: Idealized crawler pressures from Job planner calculated with the aid of a rigid body system and no consideration regarding wind

Illustration 2: Idealized crawler pressures with consideration of elastic deformation and wind on crane and load

19.5.2 Example for crane on crawler with derrick boom, suspended ballast and long (main) boom system

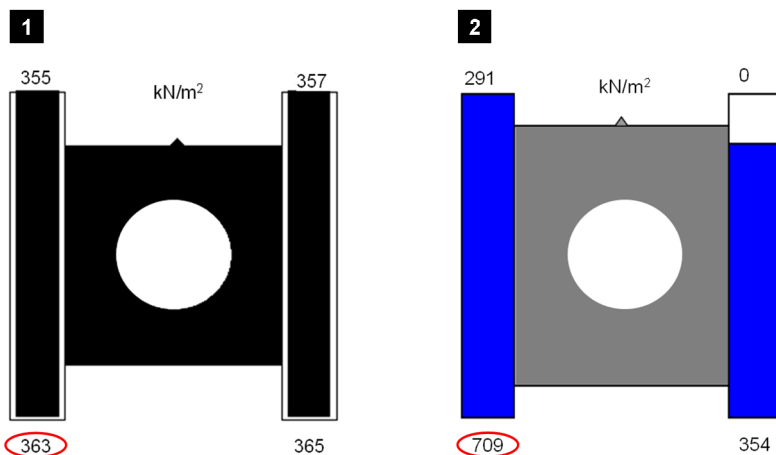

Fig.125053: Example for crane on crawler with derrick boom, suspended ballast and long (main) boom system

Illustration 1: Idealized crawler pressures from Job planner calculated with the aid of a rigid body system and no consideration regarding wind

Illustration 2: Idealized crawler pressures with consideration of elastic deformation and wind on crane and load

19.5.3 Example for crane on supports

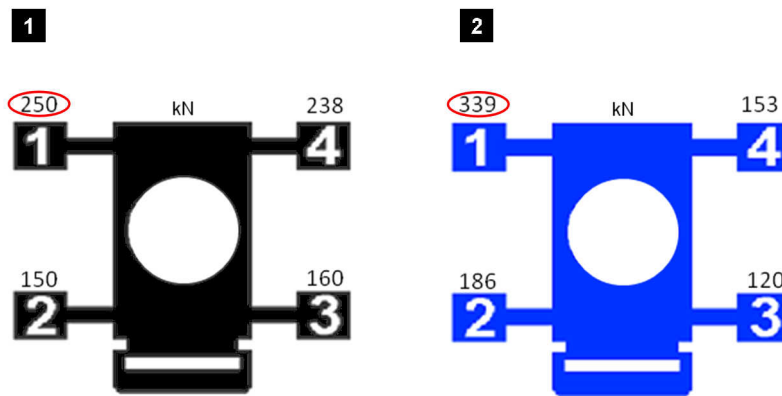

Fig.125054: Example for crane on supports

Illustration 1: Support forces from Job planner calculated with the aid of a rigid body system and no consideration regarding wind

Illustration 2: Support forces with consideration of elastic deformation and wind on crane and load

20 Support

20.1 Support plates

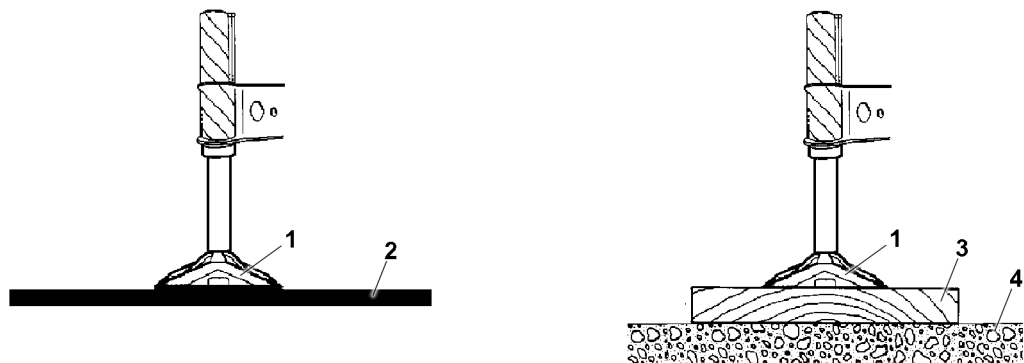

Fig.144244: Support plates

- | | | | |
|---|--|---|---------------------------------|
| 1 | Support plate | 3 | Substructure |
| 2 | Ground (no substructure necessary) | 4 | Ground (substructure necessary) |

When supporting the crane, the support plates must lay horizontally on the ground or on the substructure.



WARNING

The support plate are **not** laying horizontally!
The crane can topple over, death, property damage.

- ▶ Before supporting the crane, align the support plates horizontally.

20.2 Supporting the crane

The maximum permitted deviation from the horizontal position is $\pm 0.5\%$ ($\pm 0.3^\circ$)



WARNING

The crane is **not** horizontally aligned!
The crane can topple over, death, property damage.

- ▶ Align the crane horizontally.



DANGER

The crane can topple over!
When actuating the supports with attached load and / or at loaded derrick ballast guying, the incline and the force conditions of the entire boom system change.

There is **no** shut off by the LICCON overload protection.

The crane can topple over.

Personnel can be severely injured or killed.

- ▶ When a load is suspended it is prohibited to actuate the support.
- ▶ When the derrick ballast guying is loaded it is prohibited to actuate the support.

It is absolutely essential that the crane be supported with the support base exactly in accordance with the load chart to ensure safe crane operation.

The match of the sliding beams placement surfaces must be observed to ensure proper force transfer between the sliding beams.

The crane may only be supported in these extension conditions.



WARNING

The crane can topple over!

If only the sliding beams on the load side are extended, then the crane can topple over and kill personnel.

- ▶ Move all 4 sliding beams and support cylinders out according to the data in the load chart and pin.
- ▶ In intermediate positions between the support bases, do **not** support.
- ▶ Pin the sliding beams to support base according to the load chart.
- ▶ Fully insert and secure the pins.



WARNING

Risk of toppling the crane due to incorrect extension of the sliding beams!

The load suspended on the hook causes tension and deformation of the hoist rope and telescopic boom. The same applies for operation with lattice jib and guy ropes. If the load is dropped from the fastening ropes or if the fastening or hoist rope breaks in this situation, a sudden relief occurs. The boom snaps back quickly. This can cause the crane to topple over.

Despite previous assumption, it might become necessary to swing the load to the opposite side. This can cause the crane to topple over.

The boom and / or counterweight momentum may cause the crane to topple when slewing from the longitudinal vehicle direction.

- ▶ Move all 4 sliding beams and support cylinders out according to the data in the load chart.

20.3 Supporting the crane with *variable support*

When supporting the crane with *variable support* special measures are required. These measures are described in detail in the Crane operating instructions, chapter 6.26.

21 Aligning the crane

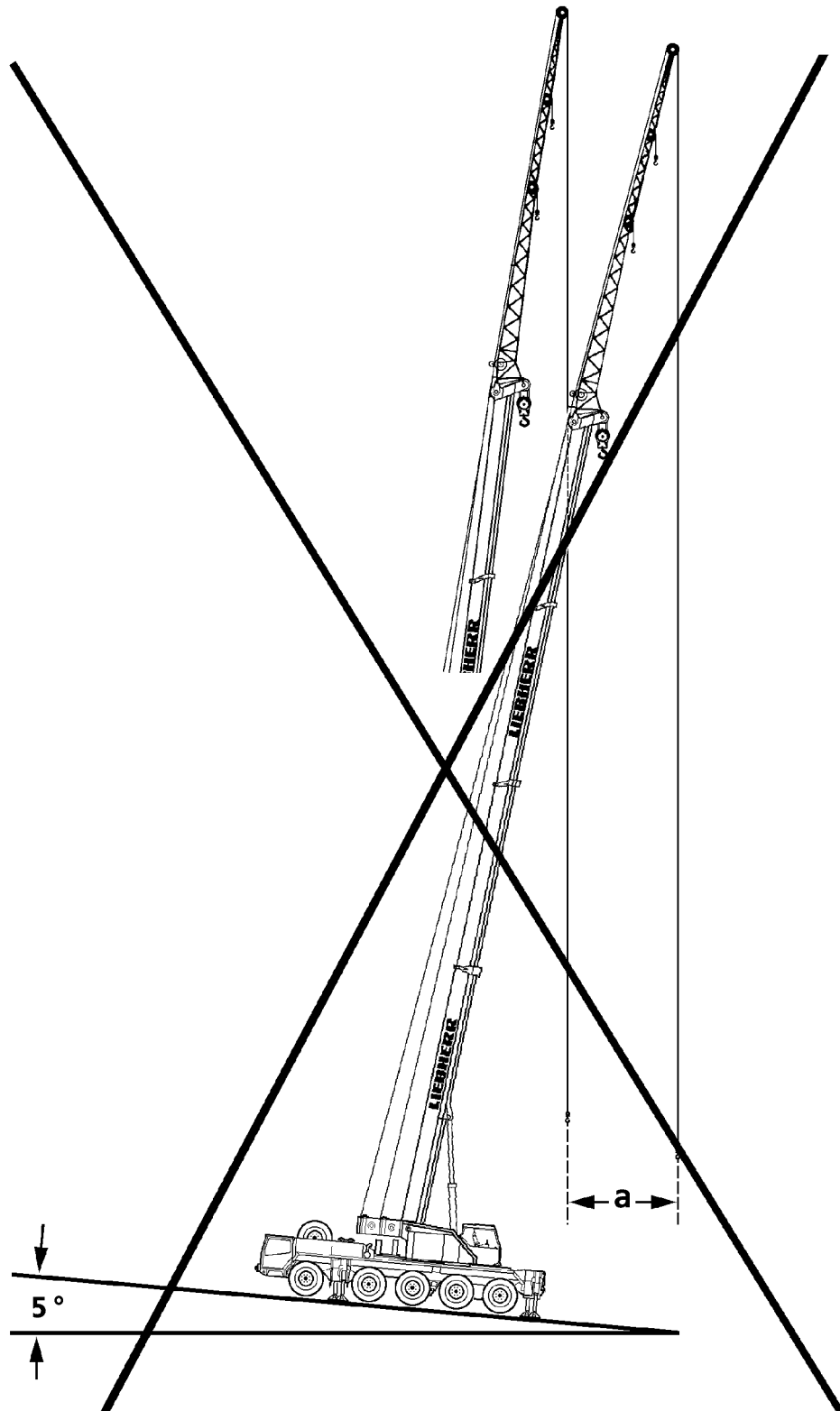

Fig. 121164: Example for **non-permissible** incline position

In addition to the proper substructure for the supports, the horizontal alignment of the crane is of utmost importance for safe crane operation.

**DANGER**

The crane can topple over due to the incline position!

If the crane is positioned at an incline, and if the boom is turned towards the slope, then the boom radius is increased as a result.

It is possible that the slewing gear can no longer hold the crane superstructure and, in extreme cases, the crane can topple over.

Personnel can be severely injured or killed.

▶ Align the crane horizontally before starting crane operation.

If the horizontal alignment of the crane has to be readjusted:

▶ Set the load down on the ground before readjusting the crane.

For cranes on crawlers, readjustment is **not** possible:

▶ If possible, use load charts for limited terrain incline.

Example: At a boom length of 50 m, an incline position of the crane by only 5° at a boom radius of 10 m causes an increase of the radius of $a = 4$ m.

22 Checking the safety measures

- The placement location has been selected so that all planned lifts included in the load chart for the erected set up configuration can be lifted.
- The load bearing capacity of the ground is adequate.
- There is safe clearance to excavations and slopes.
- There are no live transmission wires within the working range of the crane.
- There are no obstacles that will hinder required crane movements.
- The crane is horizontally aligned.
- When crane support is required:
 - All four sliding beams and support cylinders have been extended according to the support base given in the load chart.
 - The sliding beams have been secured with pins to prevent them from moving.
 - The support plates are pinned and secured in operating position.
- On mobile cranes:
 - The axle suspension is blocked.
 - The axles are relieved, which means the tires do not touch the ground.

23 Safety guidelines in case of external power supply

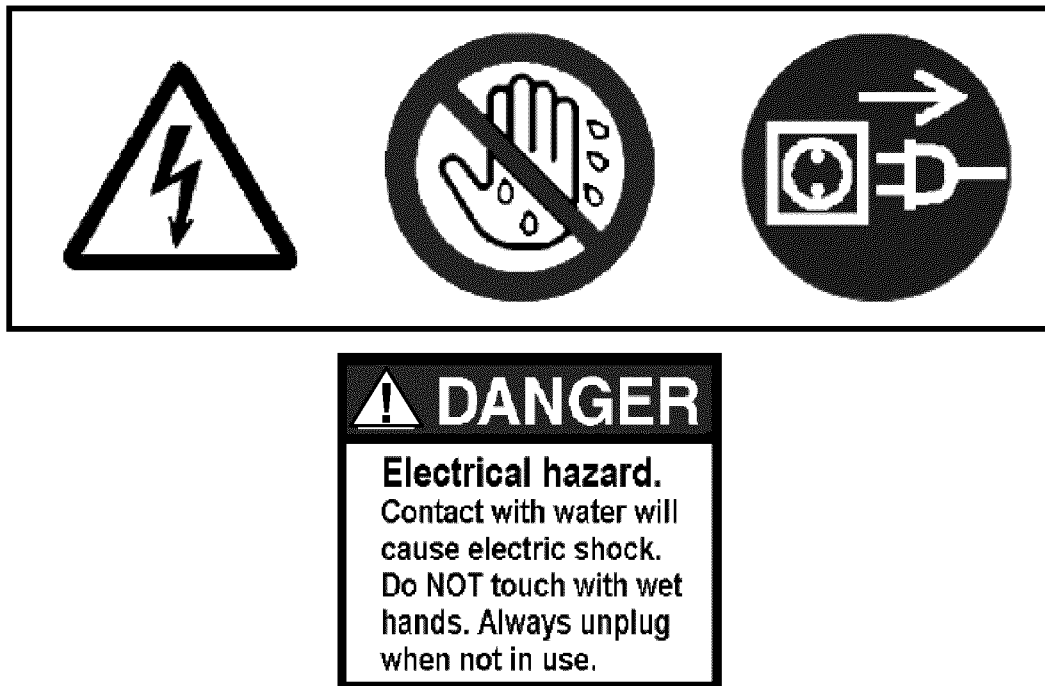

Fig.197720

A potential hazard exists when supplying a crane with an external power supply from a low voltage distribution system (100 V AC to 400 V AC).

A special electrical hazard is present when a protective conductor is interrupted (caused by the mechanical stress on flexible supply lines or the service connection), loose terminal connections, high wire or contact resistance, mixed up conductors, defective or missing protective equipment (FI / fault interrupters) in combination with a body contact on the crane.



WARNING

Danger of fatal injury if the body conducts current!

Water and / or defective devices can cause hazardous stray voltages when touched. The person touching the crane is subject to lethal currents.

- ▶ The external supply cable must be in good working order.

Make sure that the external flexible supply cable is in good working order.

Where applicable, we recommend the use of a power isolating transformer.

24 Grounding

24.1 Grounding the crane



WARNING

Danger of fatal injury due to electric shock!

There is a danger of electrical shock, if the crane is not properly grounded.

- ▶ Properly ground the crane.
- ▶ Make sure that there is a potential equalization between the crane and the ground.

The crane must be grounded before start up:

- Near transmitters (radio and TV transmitters, radio stations, etc.)

- Near high frequency switching stations
- In case of severe possibility of thunderstorms or potential thunderstorms

The crane can become electrostatically charged, especially if the crane is equipped with synthetic support mats or if the support mats are placed on insulating materials (such as wooden planks).

24.2 Grounding the load



WARNING

Danger of fatal injury due to electric shock!

There is a risk of electrical shock, if the load is not properly grounded.

- ▶ Properly ground the load.
 - ▶ Make sure that there is a potential equalization between the load and the ground.
-

The load must be grounded before operation:

- Near transmitters (radio and TV transmitters, radio stations, etc.)
- Near high frequency switching stations
- In case of severe possibility of thunderstorms or potential thunderstorms

The load can become electrostatically charged, even if the crane is grounded. This applies in particular if a hook block with pulleys made of synthetic material and non-conductive fastening equipment (for example plastic or manila ropes) are used.

25 Working in the vicinity of transmitters

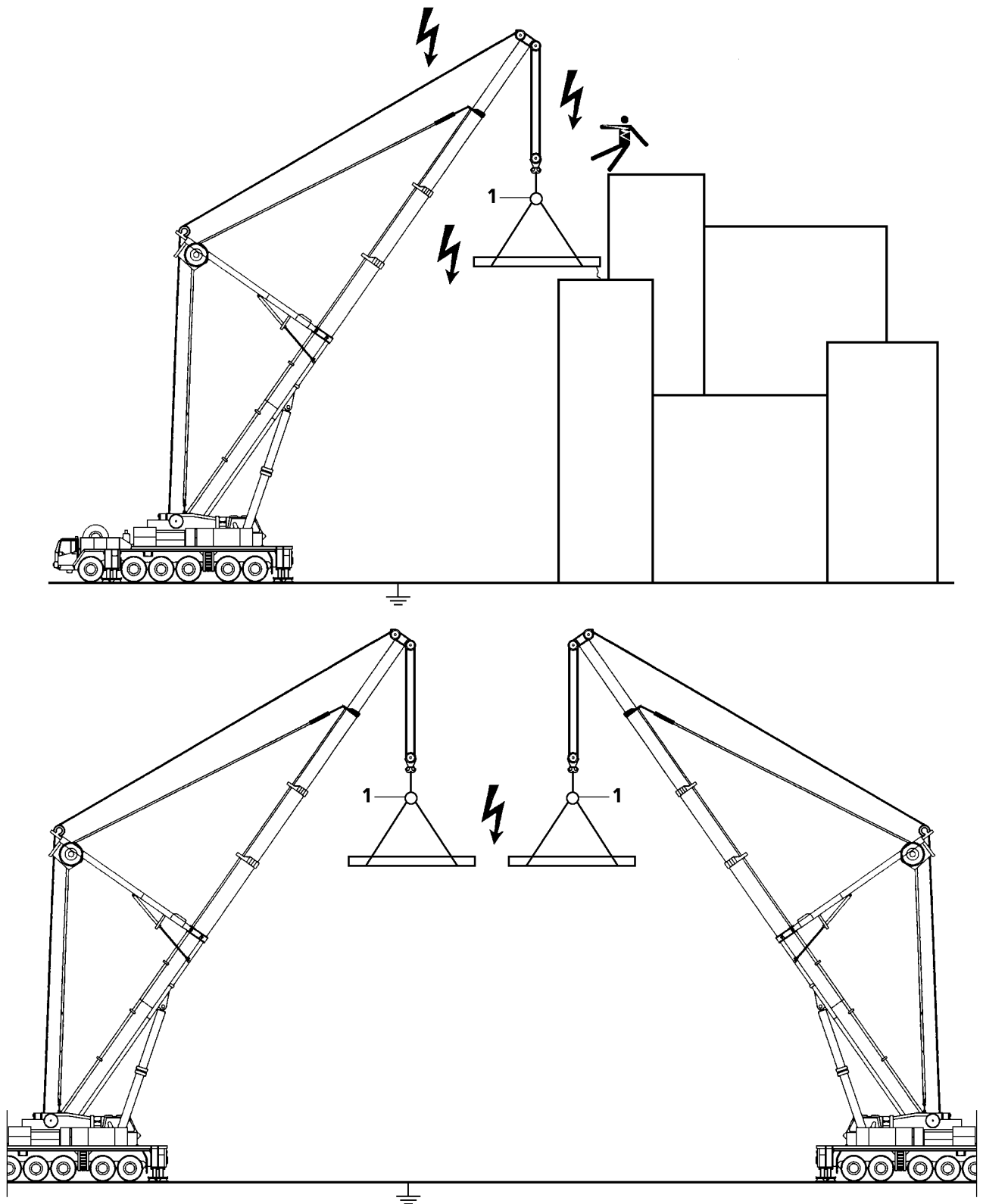

Fig.121165: Example for electrostatic charge

Strong electromagnetic fields are likely to be present if the construction site is close to a transmitter.

These electromagnetic fields can pose direct or indirect danger to persons or objects, for example:

- Effect on human organs due to temperature increase.

- Danger of burns or inflammation due to temperature increase
- Spark or electric arc formation



DANGER

Danger due to electromagnetic fields!

- ▶ Before operating a crane in the vicinity of transmitters, be sure to consult with Liebherr-Werk Ehingen GmbH.
- ▶ Also consult a high frequency specialist.

High frequency (HF) radiation from a transmitter requires supplementary work safety protection and special environmental specifications for crane operators and personnel:

1. Each crane must be „fully“ grounded. Check visually or with a simple continuity tester to ensure that ladder, crane cab and rope pulleys are grounded.
2. All personnel working on the crane or with large metal objects must protect themselves from burns by wearing non-conductive synthetic gloves and suitable clothing while working.
3. There is no need to panic if you feel your hand warm up. Always work under the assumption that the respective workpiece, structural steel member or support is „hot“.
4. The temperature of objects affected by high frequency radiation depends on their „size“. Cranes, carriers and coverings, for example, are „hotter“.
5. Contact with other crane loads is not permitted when operating the crane (arcing). Since defects caused by burns considerably reduce rope's load bearing capacity, any such occurrences must be reported immediately to the customer service of Liebherr-Werk Ehingen GmbH so that the ropes can be inspected.
6. An insulator **1** is required at all times between the crane load hook and fastening equipment. It is strictly prohibited to remove this insulator **1**.
7. Do not touch the ropes above the insulator **1**.
8. Loads that are attached to the crane may not be touched by any unprotected parts of the body after the load has been lifted or set down.
9. Do not work with a bare upper torso or in short pants, this is prohibited.
10. To minimize absorption of high-frequency radiation, larger loads should be transported horizontally if possible.
11. Loads must be grounded, or additional insulation used (rubber material between the object and gloves) when manual work is required.
12. Use a suitable measuring instrument to check the „temperature“ of the workpiece.
For example, if 500 V can be measured on a workpiece at a distance of 1 cm to 2 cm, then the workpiece may not be touched with bare hands.
The greater the distance, the higher is the voltage on the object:
At 10 cm distance, approx. 600 V are present, at 30 cm distance approx. 2000 V are present.
13. When refueling the crane, it must be ensured that no sparks are created within a radius of 6 m, neither by handling larger metallic parts nor by other work.
14. To avoid secondary accidents, use personal protective equipment when working on components that are high off the ground.
15. Any accidents and unexpected events must immediately be reported to the local construction supervisor and the safety engineer.

26 Crane operation in case of thunderstorms

In weather conditions, which can include lightning:

- Stop work on the crane.
- If possible, place the load down.
- If possible, telescope the boom in and / or put it down in the boom receptacle and bring it into a safe condition.

If this is not possible, the crane cab must remain occupied by the crane operator to keep the crane and the load always under control.

**WARNING**

Danger of accidents due to lightning strikes!

- ▶ Make sure that there are no persons near the immediate area of the crane.

27 Wind influences

**Note**

- ▶ The wind speeds are valid for a 360° wind direction for a 3-second wind gust at the highest point of the crane.

**WARNING**

Disregard of permissible wind speeds!

If the permissible wind speeds are disregarded, the crane can topple over. Personnel can be severely injured or killed.

- ▶ It is prohibited to erect the crane to measure the wind speed.
- ▶ Observe the permissible wind speeds depending on the assembly / crane conditions and act accordingly, see following chart.

Assembly / crane conditions	Reference for permissible wind speed
Erection and take down of various boom configurations	Wind speed charts and / or erection and take-down charts.
Crane operation	Load chart manual
When the permissible wind speed according to the load charts is exceeded in crane operation, then crane operation is prohibited .	Wind speed charts
Interruption of crane operation when crane remains equipped	Wind speed charts
Crane out of operation, when crane remains equipped	Wind speed charts

**Note**

No wind speed charts available!

For a set up configuration for which no wind speed charts are available:

- ▶ Observe and adhere the maximum wind speeds of the load charts.

The wind load on the crane boom has **not** been taken into account for the planning of crane operation with the LICCON job planner.

- As a result, the actual values of the support force and / or the crawler pressure can be significantly higher than the values determined with the LICCON Job planner.
- The wind affecting the crane and the load, the elastic distortion of the crane structure, incline position as well as wind exposure surface (A_w) per ton of hoist load larger than 1.2 m²/t can significantly increase the support force and / or the crawler pressure.

**WARNING**

Increase of support force and / or the crawler pressure!

The resulting pressure on the ground becomes larger.

The permissible ground pressure can be exceeded.

- ▶ Do not exceed the permissible ground pressure.

**Note**

- ▶ The determining factor for all crane work in the actual wind speed at the job site of the crane.
- ▶ The current wind speed can be checked at the nearest weather bureau.
- ▶ Be aware that the wind speed on the boom jib is higher than near the ground.
- ▶ Always observe the national valid regulations.

27.1 Wind speed charts for *variable support*

For *variable support*: Observe and adhere to the wind speed charts according to the support base for the smallest extension length of the sliding beams.

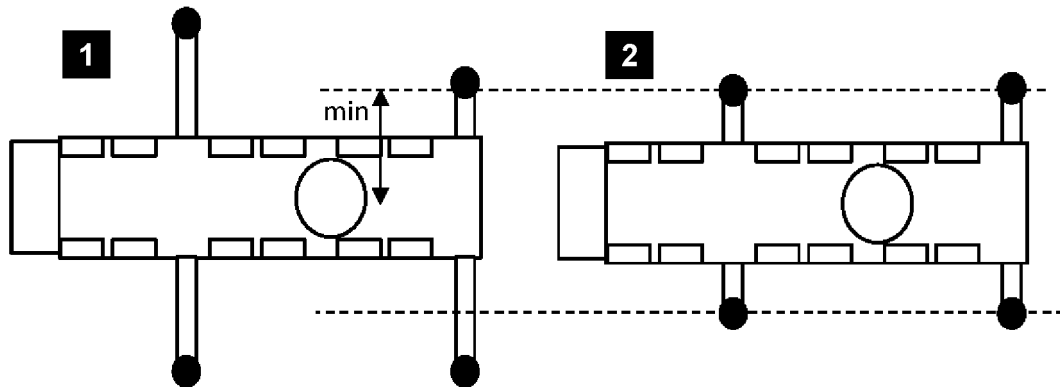

Fig.121577: Example for the selection of wind speed charts for *variable support*

Example for the selection of wind speed charts for *variable support*:

- The crane is supported with *variable support* according to illustration 1.
- Select wind speed charts according to the support base in illustration 2.

**Note**

No wind speed charts available!

If the smallest extension length of a sliding beam is less than those of the wind speed charts on hand:

- ▶ Observe and adhere the maximum wind speeds of the load charts.

27.2 Wind speed, wind gust speed and wind direction

The depiction of the wind is made by statement of wind speed (wind force), wind gust speed and wind direction.

High above the ground, the wind is less influenced by the surface condition of the ground. In the lower layers of the atmosphere, the wind speed is reduced by the ground friction. One differentiates between roughness of terrain, influence of obstacles and influence of terrain contours. Vegetation, buildings etc have great influence on the wind speed, wind gust speed and wind direction.

The site selection is thus especially important for wind measurement.

The wind speed, wind gust speed and wind direction are subject to significant time and local fluctuations. For that reason it is important to have reliable information regarding the expected wind speed, wind gust speed and wind direction during a load lift and to carry out exact wind measurements.

For mobile cranes, always assume a wind load of 360°. The determining factor is the „3 second gust speed“ on the highest point of the boom.

27.3 Measurement of wind speed

The anemometer installed on the crane boom measures the wind speed on the tip of the boom and shows the current wind speed in the crane cab.

The function of the anemometer must be checked every time before erection of the boom by manually actuating the shell start for easy movement and proper function.

Before lifting a load, especially with large wind exposure surface, the wind speed and the wind direction expected during the lift must be known. Information can be obtained for example at the local weather bureau. The determining factor is the „3 second gust speed“ on the highest point of the boom.



WARNING

Overload of crane!

The acoustic wind warning is only issued if the standard wind exposure surface in the load chart is exceeded (wind surface per ton load: 1 m², drag: 1.2) given wind speed.

If the permissible wind speed must be reduced for loads due to large wind exposure surfaces, no acoustic wind warning is issued.

There is no shut off of crane movement.

- ▶ The wind exposure surface and the wind resistance coefficient for the load to be lifted must be known.
- ▶ The maximum permissible wind speed specified in the load chart must be reduced for large wind exposure surfaces as described in the load chart manual chapter "Wind influences during crane operation".

For safe determination of wind speed, the crane must be turned before application by 360°. The highest measured value while doing so must be compared with the „maximum permissible wind speed“ for the load according to the load chart. Thus the possibility that the result of the measurement is distorted due to nearby buildings, cranes or components is eliminated.

In gusty wind conditions, the probability of sudden high wind speed increases. In gusty wind conditions no large surface loads may be lifted.



Note

- ▶ If in doubt and in case of questions for further information and / or training in the area of „Wind influences in crane operation“ contact the Customer Service at Liebherr-Werk Ebingen GmbH.

27.4 Conversion chart for wind force



Note

- ▶ The influence of the wind on the surrounding is described clearly in the Beaufort scale to provide an orientation for the crane driver.
- ▶ The wind force of the Beaufort scale refers to the wind speed determined over 10 minutes at a height of 10 m.

Wind force		Wind speed		Effect of the wind Inland
Beaufort number	Designation	[m/s]	[km/h]	
0	Calm	0 to 0.2	1	Calm, smoke rises vertically
1	Slight air movement (draft)	0.3 to 1.5	1 to 5	Wind direction is shown only by observing the trail of smoke, not by the wind sock
2	Light breeze	1.6 to 3.3	6 to 11	Wind can be felt on the face, the leaves rustle, wind sock moves slightly
3	Gentle breeze	3.4 to 5.4	12 to 19	Leaves and small twigs in constant motion Wind extends a flag
4	Moderate breeze	5.5 to 7.9	20 to 28	Swirls up dust and loose paper, moves twigs and thin branches

Wind force		Wind speed		Effect of the wind Inland
Beaufort number	Designation	[m/s]	[km/h]	
5	Fresh breeze	8.0 to 10.7	29 to 38	Small deciduous trees begin to sway, whitecaps form at sea
6	Strong breeze	10.8 to 13.8	39 to 49	Thicker branches move; telephone lines begin to whistle, umbrellas are difficult to use
7	Near gale	13.9 to 17.1	50 to 61	Entire trees swaying; difficult to walk into wind
8	Gale force wind	17.2 to 20.7	62 to 74	Breaks branches off trees, impedes walking in open areas considerably
9	Gale	20.8 to 24.4	75 to 88	Minor damage to property (chimney caps and roofing tile are blown off)
10	Severe storm	24.5 to 28.4	89 to 102	Trees are uprooted, significant damage to property
11	Violent storm	28.5 to 32.6	103 to 117	Extensive, widespread storm damage
12	Hurricane	32.7 and more	118 and more	Major destruction

Beaufort scale

27.5 Height dependant wind speed



Note

- ▶ The maximum permissible wind speed (v_{max}) and the maximum permissible wind speed according to the load chart (v_{max_TAB}) always refers to the 3 second wind gust speed, which is present in the maximum height of the crane.
- ▶ Instead of the 3 second wind gust speed, weather information services often report a wind speed (v_m), which is averaged within a time period of 10 minutes (so-called 10 minute average). It refers to the wind force on the Beaufort scale, normally to the medium value of the wind speed, which is determined within a time from of 10 minutes at a height of 10 m above ground or above sea level.
- ▶ The determining factor for the calculation of the 3 second wind gust speed in maximum height of the crane is significantly higher than the medium value of the wind speed, which is determined over a time of 10 minutes at a height of 10 m above ground.



Note

- ▶ The following chart shows the 3-second wind gust speed depending on the height and the Beaufort number and l or the wind speed determined over a time of 10 minutes at a height of 10 m.
- ▶ With the aid of this chart the 3-second wind gust speed for a certain height can be determined.

Beaufort number	3	4	5 ^a	5	6	7 ^a	7	8	9	10
v_m [m/s ^b]	5.4	7.9	10.1	10.7	13.8	14.3	17.1	20.7	24.4	28.4
z [m]	$v(z)$ [m/s]									
10	7.6	11.1	14.1	15.0	19.3	20.0	23.9	29.0	34.2	39.8
20	8.1	11.9	15.2	16.1	20.7	21.5	25.7	31.1	36.6	42.7
30	8.5	12.4	15.8	16.8	21.6	22.4	26.8	32.4	38.2	44.5
40	8.7	12.8	16.3	17.3	22.3	23.1	27.6	33.4	39.4	45.8
50	8.9	13.1	16.7	17.7	22.8	23.6	28.3	34.2	40.3	46.9

Beaufort number	3	4	5 ^a	5	6	7 ^a	7	8	9	10
60	9.1	13.3	17.0	18.0	23.3	24.1	28.8	34.9	41.1	47.9
70	9.3	13.5	17.3	18.3	23.6	24.5	29.3	35.5	41.8	48.7
80	9.4	13.7	17.6	18.6	24.0	24.8	29.7	36.0	42.4	49.4
90	9.5	13.9	17.8	18.8	24.3	25.1	30.1	36.4	42.9	50.0
100	9.6	14.1	18.0	19.1	24.6	25.4	30.4	36.9	43.4	50.6
110	9.7	14.2	18.2	19.2	24.8	25.7	30.8	37.2	43.9	51.1
120	9.8	14.3	18.3	19.4	25.1	25.9	31.1	37.6	44.3	51.6
130	9.9	14.5	18.5	19.6	25.3	26.2	31.3	37.9	44.7	52.0
140	10.0	14.6	18.7	19.8	25.5	26.4	31.6	38.2	45.1	52.5
150	10.0	14.7	18.8	19.9	25.7	26.6	31.8	38.5	45.4	52.9
160	10.1	14.8	18.9	20.1	25.9	26.8	32.1	38.8	45.7	53.2
170	10.2	14.9	19.1	20.2	26.0	27.0	32.3	39.1	46.0	53.6
180	10.3	15.0	19.2	20.3	26.2	27.1	32.5	39.3	46.3	53.9
190	10.3	15.1	19.3	20.4	26.4	27.3	32.7	39.5	46.6	54.2
200	10.4	15.2	19.4	20.6	26.5	27.4	32.8	39.8	46.9	54.6
^a Wind stages for the crane in operation: 1 light $v_m = 10.1$ m/s at $z = 10$ m $v(z) = 14.1$ m/s $q(z) = 125$ N/m ² 2 normal $v_m = 14.3$ m/s at $z = 10$ m $v(z) = 20.0$ m/s $q(z) = 250$ N/m ²										
^b Upper limit of Beaufort scale										

3-second wind gust speed depending on the height and the Beaufort number and / or the wind speed determined over a time of 10 minutes at a height of 10 m

Sign	Unit	Definition
v_m	[m/s]	Wind speed determined over a time of 10 minutes at a height of 10 m
z	[m]	Height above level ground
$v(z)$	[m/s]	Speed effective at height z , decisive for the calculation of a 3 second gust
$q(z)$	[N/m ²]	At a height z effective quasi-static back pressure, determined from $v(z)$

Symbol

27.6 Wind influences during erection and take down



WARNING

The crane can topple over!

If a boom or a boom system is erected or taken down and the expected wind speeds are larger than the maximum permissible wind speeds according to the wind speed chart, then the crane can topple over and fatally injure personnel.

- ▶ If wind speeds are expected which are larger than the maximum permissible wind speeds for erection, then erection of the boom or erection of the boom system is prohibited.
- ▶ If wind speeds are expected, which are larger than the maximum permissible wind speeds for take down, then the boom or the boom system must be taken down immediately.

**WARNING**

Wind speed higher than permissible!

When the permissible wind speed for „Crane out of operation“ is higher than the permissible wind speed for take down: Take down of the boom is not permissible in case of unexpected increase of wind speed.

Toppling crane. Death, severe injury, property damage.

- ▶ If wind speeds are expected which are higher than the maximum permissible wind speeds for "Crane out of operation", then take the equipment and the boom down.
- ▶ Always take the boom down for safety reasons if weather conditions are unclear, see Erection and take down charts.
- ▶ Observe the permissible wind speeds for take down.

27.7 Wind influences in crane operation

**WARNING**

The crane can topple over!

Unforeseeable factors, such as sudden wind gusts on the crane and the load cannot be exactly predicted in advance.

- ▶ The size and shape of the load has a significant influence on the permissible wind speed during crane operation.
- ▶ Carry out a professional job planning with authorized and trained expert personnel. All environmental conditions, such as weather forecast and wind speeds must be taken into account.
- ▶ The authorized and trained expert personnel must have sufficient knowledge in the area of „Wind influences in crane operation“.

**Note**

- ▶ Calculation examples are included in the load charts. If you need further information, contact Liebherr-Werk Ehingen GmbH.

Depending on crane application, for example:

1. Lifting of large surfaced loads.
2. Working with long boom combinations.
3. Erection and take down of boom combinations.

The crane operator must check with appropriate information sources about the expected wind speeds, at:

1. The start of crane operation.
2. Interruption of crane operation.
3. Resumption of crane operation

**WARNING**

The crane can topple over!

If the crane is operated at wind speeds which are larger than the maximum permissible wind speeds according to the load chart, then the crane can topple over and kill personnel.

- ▶ If wind speeds are expected which are larger than the maximum permissible wind speeds for the equipped crane, then the equipment and the boom must be taken down.
- ▶ If wind speeds are expected which are larger than the maximum permissible winds speeds for crane operation, then it is prohibited to lift a load.

27.8 Wind influences for „Crane out of operation“



WARNING

Toppling crane. Death, severe injury, property damage!

If the crane is taken out of operation in set up condition and the expected wind speeds are higher than the maximum permissible wind speeds according to the wind chart, then the crane can topple over and fatally injure personnel.

- ▶ If wind speeds are expected which are higher than the maximum permissible wind speeds for „Crane out of operation“, then take the equipment and the boom down.
- ▶ Always take the boom down for safety reasons if weather conditions are unclear, see Erection and take down charts.
- ▶ Observe the permissible wind speeds for take down.

28 Lifting a load with two cranes

Before lifting a load with two cranes, the crane operator or a representative of the operator must determine the work sequence and assign a responsible supervisory person for the operation. The responsible supervisor must monitor the operation and remain in constant contact with the crane operators.



WARNING

Overload and toppling of the cranes!

If the load is not lifted or lowered exactly evenly by both cranes, then the center of gravity changes. The cranes can be overloaded and topple over.

Personnel can be killed or seriously injured.

- ▶ Make sure that the cranes are horizontally aligned.
- ▶ Observe the national valid standards, regulations and accident prevention guidelines.
- ▶ Determine the utilization degree of the cranes in operation, depending on the complexity of the load lift.
- ▶ Plan for sufficient safety reserves.
- ▶ Avoid side load on the boom.
- ▶ Carry out crane movements synchronously and slowly.



Note

- ▶ The total weight and the center of gravity of the load must be known exactly.
- ▶ Carry out the job planning in detail and with care.
- ▶ Avoid fastening points below the center of gravity of the load.

When the operational conditions or the work to be carried out require:

- ▶ Set up an assembly plan and operating instructions for the operation.

In the drawing is shown how the center of gravity for the load changes if the load is lifted or lowered unevenly. Already a slight incline of the load can cause the crane to be overloaded.

If the load on crane 2 (F_2) is lowered, the load on crane 1 (F_1) increases. Crane 1 can thereby be overloaded.

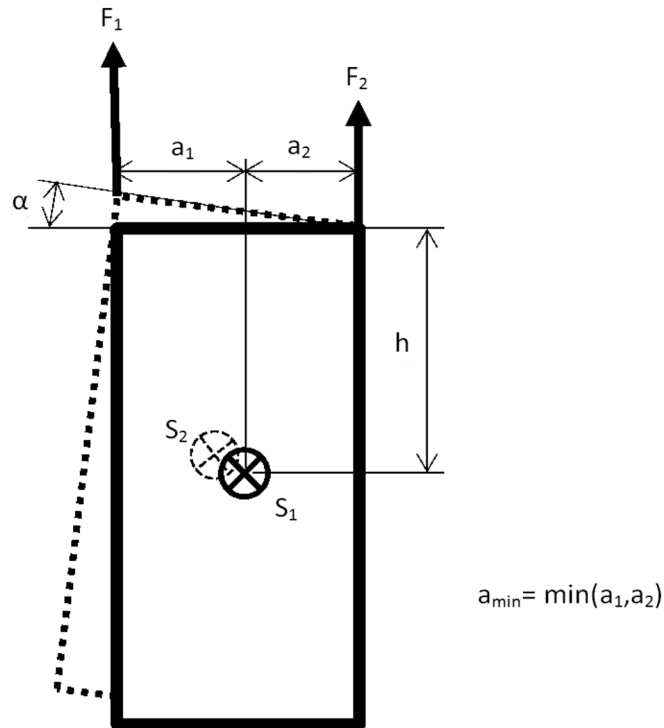

Fig.124126: Geometric conditions

F_1	Load on crane 1	F_2	Load on crane 2
S_1	Center of gravity of load	S_2	Center of gravity of load at incline position
h	Vertical distance between center of gravity of load and fastening points	α	Angle of load at incline position
a_1	Horizontal distance between center of gravity of load and fastening point crane 1	a_2	Horizontal distance between center of gravity of load and fastening point crane 2
a_{\min}	Smallest horizontal distance between center of gravity of load and fastening point (minimum from a_1 and a_2)		

The following diagram shows the dependence of the ratio of h/a_{\min} at a maximum permissible incline position of the load of 3° in reference to the permissible load utilization of cranes in percentages.

30 Hand signals for guidance

For all crane movements, the crane operator must always keep the load as well as the crane hook or load handling equipment when the crane is not loaded, in his field of vision.



WARNING

Danger of accident if standing under suspended loads!

- ▶ Always keep loads in sight.
- ▶ Standing under suspended loads is prohibited.

If this is not possible, the crane operator may only operate the crane if he is signed by an assigned guide.

The operator may be guided by hand signals or a two-way radio. It must be ensured that there are no misunderstandings.



WARNING

Danger of accident caused by misunderstood hand signals!

- ▶ Hand signals must be mutually agreed upon and clearly executed.
- ▶ In any case, **national regulations** must be observed.

30.1 Hand signals

30.1.1 Start operation, follow my instructions

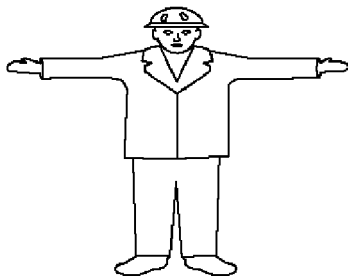

Fig.111700: Start operation, follow my instructions

Both arms stretched out horizontally with hands open and palms directed to the front.

30.1.2 Stop (normal stop)



Fig.144245: Stop (normal stop)

Arm stretched out, palm of hand facing down, move the arm horizontally backward and forward.

30.1.3 Emergency stop (quick stop)

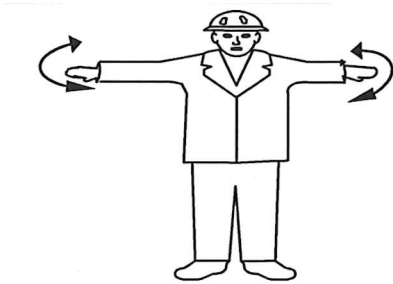

Fig.144246: Emergency stop (quick stop)

Both arms stretched out, both hand palms facing down, move arms horizontally backward and forward.

30.1.4 End operation, no longer follow my instructions

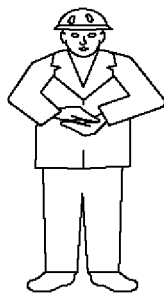

Fig.111703: End operation, no longer follow my instructions

Fold hands together at chest height in front of body.

30.1.5 Creeper gear or very slow movement

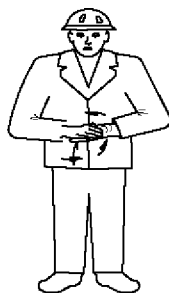

Fig.111704: Creeper gear or very slow movement

Rub palms together in circular motion. After this sign, all other applicable hand signals apply.

30.2 Vertical movements

30.2.1 Showing the vertical distance

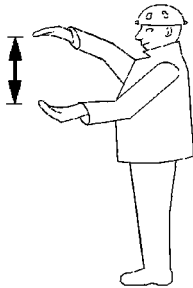

Fig.121364: Showing the vertical distance

Both arms stretched out in front of the body one on top of the other, with opposing palms.

30.2.2 Lifting / lowering a load with even speed



Fig.111706: Lifting / lowering a load with even speed

Lift one arm overhead with closed hand and index finger pointing upward, with small horizontal circular movements with forearm.

30.2.3 Lifting slowly



Fig.121365: Lifting slowly

Give lift signal with one hand, the other palm is not moving and positioned over the hand, which gives the signal.

30.2.4 Lowering the load while stationary

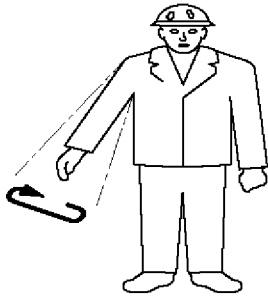

Fig.111708: Lowering the load while stationary

Point one arm away from the body, downward, with hand closed and index finger pointing down. Make small circular movements with forearm.

30.2.5 Lowering slowly



Fig.121366: Lowering slowly

Give lowering signal with one hand, do not move the other palm and hold it under the hand, pointing to the hand which gives the signal.

30.3 Horizontal movements

30.3.1 Moving / swinging in specified direction

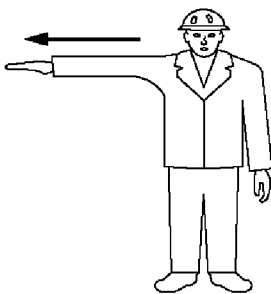

Fig.111710: Moving / swinging in specified direction

Hold stretched out arm horizontally into the desired direction, with the hand open and the palm pointing down.

30.3.2 Moving away from me



Fig.111711: Moving away from me

Stretch out both arms simultaneously with forearms in front, with both hands open and the palms pointing down. Move the forearms repeatedly between the horizontal and vertical position up and down.

30.3.3 Moving toward me

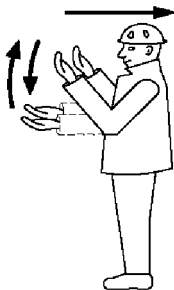

Fig.111712: Moving toward me

Stretch out both arms simultaneously with forearms vertically, with both hands open and the palms pointing to the rear. Move the forearms repeatedly up and down.

30.3.4 Moving both track chains

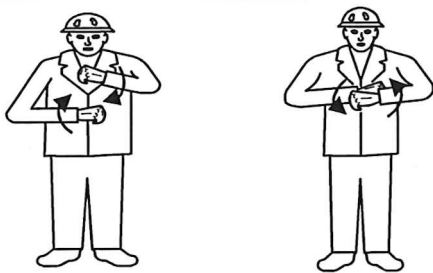

Fig.144247: Moving both track chains

Turn both fists around each other in front of the body in direction of the movement (forward or reverse).

30.3.5 Moving one track chain



Fig.144248: Moving one track chain

Lift one fist to show blockage of chain on one side. Turn the other fist vertically in front of the body to signal movement of the opposite chain.

30.3.6 Showing the horizontal distance

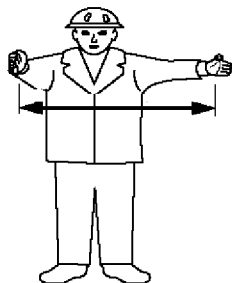

Fig.121380: Showing the horizontal distance

Keep both arms stretched out horizontally in front of the body with the palms opposite each other.

30.3.7 Transfer (between two cranes or two hooks)

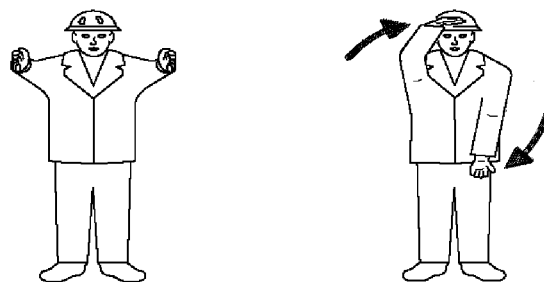

Fig.121368: Transfer (between two cranes or two hooks)

Hold both arms stretched out to the front, parallel and horizontally and turn by 90° in direction of the transfer.



WARNING

Load bearing capacity is **not** sufficient!

The crane can topple over, death, property damage.

- ▶ Make sure that the load bearing capacity of the individual crane and hook is sufficient even if the transfer of the load is suddenly asymmetric.

30.4 Machine related movements

30.4.1 Lifting with main winch

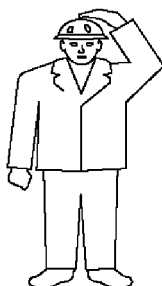

Fig.111719: Lifting with main winch

Place one hand on your head and hold the other arm on the side of the body.

After this signal all other hand signals apply only for the main winch.



Note

- ▶ If two or more main winches are present, then the signaller can show the number of the crane by pointing to it or signal with one finger.

30.4.2 Lifting with auxiliary winch

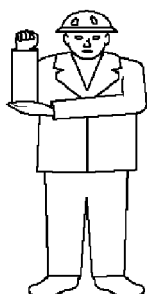

Fig.111720: Lifting with auxiliary winch

Hold one forearm vertically with closed hand and touch the elbow of this arm with the other hand.

After this signal all other hand signals apply only for the auxiliary winch.

30.4.3 Lifting the boom

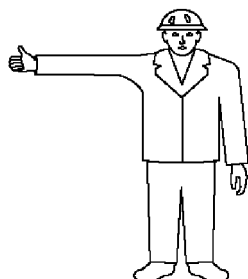

Fig.111721: Lifting the boom

Hold one arm horizontally with thumb directed upward.

30.4.4 Lowering the boom

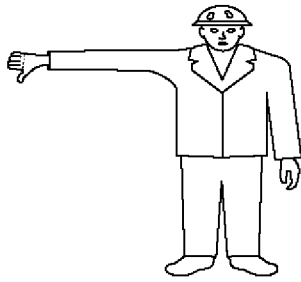

Fig.111722: Lowering the boom

Hold one arm horizontally with thumb directed downward.

30.4.5 Extending the boom



Fig.144249: Extending the boom

Hold both hands (with closed fists) stretched out to the front, with both thumbs directed away from each other.

30.4.6 Retracting the boom



Fig.144250: Retracting the boom

Hold both hands (with closed fists) stretched out to the front, with both thumbs directed toward each other.

30.4.7 Lifting the boom and lower the load at the same time

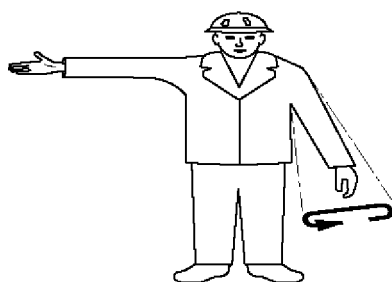

Fig.111725: Lifting the boom and lower the load at the same time

Hold one arm stretched out horizontally with thumb directed upward and stretch the other arm downward and away from the body, make small flat circles with the forearm.

30.4.8 Lowering the boom and lift the load at the same time

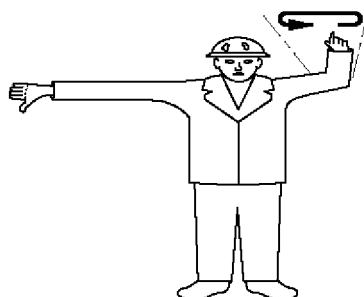

Fig.111726: Lowering the boom and lift the load at the same time

Hold one arm stretched out with thumb pointing down, stretch the other forearm upward and make small flat circles.

31 Travel operation

31.1 Starting to drive

Before starting to drive the crane

- Close all doors.
- Keep the doors closed during the travel operation.

31.2 Turning / driving in reverse



WARNING

Danger of accidents when turning or driving in reverse!

When turning or driving in reverse, personnel can be overlooked and killed.

Objects can be severely damaged.

- ▶ When turning or driving in reverse, the driver must act in such a way that he does not endanger other traffic participants.
- ▶ The driver may only drive in reverse or reset when persons or devices are **not** endangered. If this can **not** be ensured, then he must use a guide.
- ▶ An acoustical back up warning device will never replace the guide.
- ▶ Make sure that there are no persons or objects behind the vehicle when driving in reverse.
- ▶ Make sure that no personnel is injured or killed.
- ▶ Make sure that no objects are damaged.
- ▶ Driving in reverse is only permissible at slow driving speed (maneuvering speed).
- ▶ Adhere to the national regulations.

31.3 Stopping the mobile crane

Make sure that the following prerequisites are met:

- The mobile crane is standing on load bearing, level and tractive ground.
- The parking brake is applied.



WARNING

Parking brake is **not** applied!

The mobile crane can roll off, death, property damage.

- ▶ Park the mobile crane exclusively with applied parking brake.

- Turn off the ignition and pull out the ignition key.

When a battery master switch is present:

- Turn off the battery master switch and remove the switch cam.



WARNING

Downhill or uphill slope is too large!

The mobile crane can roll off, death, property damage.

- ▶ Park the mobile crane at an downhill or uphill slope of no more than maximum 18 %.

Under the following conditions the mobile crane must be additionally secured with wheel chocks to prevent it from rolling off:

- The mobile crane is parked on a slope or an incline.
- The mobile crane is defective, particularly when the brake system is defective.



WARNING

Wheel chocks incorrectly placed!

The mobile crane can roll off, death, property damage.

- ▶ So that the wheel chocks have an immediate braking action and hold the mobile crane in park position: Place all wheel chocks tightly directly under the wheel.
- ▶ Place all specified wheel chocks.
- ▶ All wheel chocks must counteract the downhill slope force.

If necessary:

- Place wheel chocks.

32 Crane operation

32.1 Before starting to work

Before starting to work with the crane:

- Close all doors.
- Keep the doors closed during crane operation.

32.2 While working with the crane



WARNING

Defective crane!

Death, severe bodily injuries, property damage.

If an erroneous function of a crane movement is recognized during crane operation:

- ▶ Telescope the boom in completely and place it down, find the source of the problem and remedy it.

32.3 Crane operation with a load



WARNING

The crane can topple over!

If the crane is in condition which is **not** operationally safe, the crane can topple over or crane components can fall down.

Personnel can be severely injured or killed.

- ▶ Before starting to work, the crane operator must ensure that the crane is in operationally safe condition.
- ▶ If safe crane operation cannot be ensured by the crane operator, then crane operation is prohibited until an operationally safe condition for the crane is established.
- ▶ Safety equipment, for example: Load torque limiter, hoist limit switch, brakes must be fully functioning, otherwise crane operation is prohibited.

Make sure that the following prerequisites are met:

- The load torque limiter must be adjusted according to the current set up configuration of the crane.
- The loads given in the load chart may not be exceeded.
- The crane may never be subjected with a load which exceeds those specified in the load charts.
- The weight, center of gravity and dimensions of the load to be lifted must be known.
- Load carriers, load handling and fastening equipment must be in accordance with specified requirements.



Note

- ▶ Make sure that the weight of the hook block and the weight of the fastening equipment is subtracted from the load given in the load chart, see the following chart.

Example:		
Maximum permissible load according to chart		30.000 t
Weight of the hook block	350 kg	- 0.350 t
Weight of the fastening rope	50 kg	- 0.050 t
Actual load capacity of the crane		= 29.600 t

The weight of the load to be lifted, in this example, may not exceed **29.6 t**.

**DANGER**

There is a high danger of accidents should the following points not be observed!

- ▶ Observe the following points.

Great danger of accidents exists if:

- The load torque limiter is not set in accordance with the current crane set up configuration and is therefore not able to provide proper protection.
- The load torque limiter is defective or taken out of operation.
- The hoist limit switches are defective or not functioning.
- For crawler cranes and mobile cranes with luffing lattice jib:
The angle sensor and the force test brackets are not functioning.
- For mobile cranes and crawler cranes with support:
The sliding beams of the hydraulic supports are not extended to the dimensions specified in the load chart.
- On crawler cranes:
The crawlers are not supported with stable base material sufficiently large for the ground conditions.
- For mobile cranes and crawler cranes with support:
The support plates are not supported with stable materials large enough for the ground conditions.
- Angular pulling is performed.
Angular pulling to the side is particularly dangerous, because the boom has only minimal lateral resistance momentum.

Angular pull is prohibited.

- Load attached during disassembly is too heavy and is freely suspended on the crane after release.
- The load hook is used to break away stuck loads.
Even if the weight of a stuck load does not exceed the permissible load capacity, the crane can topple over backwards if the load is suddenly released due to the tension of the boom, which can cause it to tip backwards.
- Working when the wind is excessively strong.
Comply with the load chart specifications.
- The crane is not levelled and the load is slewed in the direction of the slope.
- If improper crane movements cause the suspended load to swing like a pendulum.
- The loads and boom radii specified in the load charts are exceeded.
- When working in the vicinity of electricity transmission lines:
 - The electricity transmission lines were not turned off by expert electricians.
 - The danger zone was not covered or blocked off.

**WARNING**

Danger of current transfer!

If electricity transmission lines are not shut off nor covered nor blocked off, then there is an increased danger of accident due to current transfer.

- ▶ Adhere to the safety distance according to the following chart.

If the crane becomes electrified despite having taken all necessary precautions, proceed as follows:

- ▶ Remain calm!
- ▶ Do not leave the crane cab.
- ▶ Warn people outside: Stay in place and do not touch the crane.
- ▶ Move the crane away from the danger zone.

Nominal voltage	Safety clearance	
Up to 50 kV	4 m	10 ft
More than 50 kV to 200 kV	5 m	15 ft
More than 200 kV to 350 kV	7 m	20 ft
More than 350 kV to 500 kV	8 m	25 ft

Nominal voltage	Safety clearance	
More than 500 kV to 750 kV	11 m	35 ft
More than 750 kV to 1000 kV	14 m	45 ft
More than 1000 kV	Determination by power supplier or authorized electrician	Determination by power supplier or authorized electrician

Safety distance to electrical power lines depending on the nominal voltage

32.3.1 Counterweight and / or ballast

The type of counterweight and / or ballast required depends on the weight of the load to be lifted and the boom radius required for crane operation. The deciding factor for the selection of the counterweight and / or ballast is the data in the corresponding load chart.



WARNING

The crane can topple over!

If the counterweight and / or ballast is not installed according to the load chart, then the crane can topple over and fatally injure personnel.

- ▶ Install the counterweight and / or ballast according to the load chart.

32.3.2 Hoist gear, hoist rope

The lifting capability of the crane depends on the pull force of the hoist gear and the number of possible hoist rope reevings. When using a single strand, the crane can only lift a load that is pulled by the hoist gear.

If the load to be lifted is heavier than the pull force of the hoist gear, then the hoist rope must be reeved as needed according to the principle of a pulley between the pulley head on the boom and the hook block.

When reeving, carefully observe the load chart specifications and the operating instructions.



WARNING

Hoist rope failure!

If the maximum pull force of the hoist gear is exceeded, the hoist rope can break or the hoist gear can be damaged.

The load can fall and kill personnel.

- ▶ Observe the maximum tensile force of the hoist gear.

32.4 Interrupting crane operation



WARNING

Impermissible weather conditions!

If the crane is exposed to impermissible weather conditions during interruption of crane operation, situations can occur which could bring the crane into an unsafe condition.

Toppling crane, death, severe bodily injuries, property damage.

- ▶ Get the weather forecast for the entire period during which the crane is set up.

If the predicted wind speeds are above the permissible values according to the load chart and / or the wind speed chart:

- ▶ Place the boom and equipment down in time before impermissible wind speeds occur. See Crane operating instructions, wind speed charts and Erection and take down charts.

When wind conditions are present, which are above the permissible values of the wind speed chart and the boom can no longer be taken down:

- ▶ Make sure that there is no danger for persons, crane and surrounding area. Secure the crane and surrounding area of the crane far enough against access. Warn persons in the surrounding area and bring them in safety.

A weather forecast includes information about:

- Changing weather conditions
- Wind
- Ice
- Precipitation
- Flooding
- Lightning



WARNING

Defective crane!

Death, severe bodily injuries, property damage.

If a crane movement occurs during the interruption of crane operation:

- ▶ Make sure, when an unintentional crane movement occurs, for example as a result of leak, no danger for persons, crane and surrounding is created.

Leaks can occur all on pressurized hydraulic cylinders, for example on the following cylinders:

- Support cylinder
- Luffing cylinder
- Telescoping cylinder
- Control cylinder



Note

- ▶ Movements can occur on hydraulic cylinders also as a result of changing oil temperature.

**WARNING**

Set up crane is not supervised!

Situations during interruption of crane operation may occur which could cause the crane to become unsafe if left unsupervised.

Toppling crane, death, severe bodily injuries, property damage.

- ▶ Always watch the crane and keep it under control.

If the crane is in set up condition:

- ▶ Do **not** leave the crane.

If the crane can **not** be constantly kept under control:

- ▶ Place the equipment down and telescope the boom in and place it down.
- ▶ The boom on the crane may only be placed down if the predicted wind speeds according to the wind speed charts are less than the maximum permissible wind speeds during assembly and disassembly.
- ▶ Before the crane is unsupervised: Establish an emergency plan.
- ▶ Carry out the measures listed below.

**Note**

- ▶ An emergency plan includes information how the crane is brought into a safe condition if an unforeseen event occurs.

If possible:

- Take down and secure the equipment, see the erection and take-down charts.
- Telescope the boom in and secure it. The crane boom may only be telescoped when the prevalent wind speed is lower than the wind speed indicated in the load chart for the boom.
- Place the boom down and secure it. The crane boom may only be placed down if the wind speeds are lower than the maximum permitted wind speeds according to the wind speed charts or does not exceed them according to the assembly / disassembly instructions.

On mobile cranes:

- Lift the axles to the maximum position and block the hydraulic suspension.

On lattice mast cranes:

- Set the Derrick ballast, if present, down on the ground.
- Place the load completely on the ground and unhook from the crane hook.
- Remove the fastening ropes from the hook.
- Place the load completely on the ground and unhook from the crane hook.
- Remove the fastening ropes from the hook.

When the hook block remains installed:

- Lift the hook block into the highest position.
- Make sure that the hook block does not touch other crane parts or obstacles.
- Make sure that all measures were taken to keep the crane in a safe condition if something happens.
- If possible, turn the engines off.
- Set all control levers into neutral position or into a locked position.
- Turn all secondary systems off, except systems, which are required for restart.
- Establish the energy supply and functionality of safety equipment.
- Close off all control devices, which are not in use.
- Disconnect all control devices, which are connected with cables, if possible, and secure them to prevent unauthorized use.
- Secure control devices without cables to prevent unauthorized use.
- Make sure that the batteries in control devices without cables are charged.
- Make sure that access to the crane and operation for unauthorized personnel is excluded: Lock the driver's cab and the crane operator's cab.
- Secure all keys to prevent unauthorized access.

If the construction site has limited space:

- The decision not to take the boom down while the crane is unsupervised can only be made by an authorized and qualified crane operator, who is familiar with the construction site.

- Make sure that no danger can occur for persons, crane and its surroundings should something unforeseen happen.
- Make sure for the duration of the interruption of crane operation, that the predicted wind speeds do not exceed the permissible values for the respective set up configuration, see wind speed chart.
- If the wind speed charts do not provide values for the set up condition, the permissible wind speed in the load chart shall be observed.

If crane operation with a set up crane is interrupted:

- Make sure measures are initiated in time by trained, qualified personnel to bring the crane into a safe condition if anything happens.
- Make sure that no danger can occur for persons, crane and its surroundings should something unforeseen happen.

If the predicted wind speeds are above the permissible values:

- Bring the boom and equipment in time into a permissible condition before impermissible wind speeds occur, depending on the predicted wind speed, or place it completely on the ground. See Crane operating instructions, wind speed charts and Erection and take down charts.
- Telescope the telescopic boom in and luff down to 0°. Position the boom and auxiliary boom, see the Crane operating instructions, wind speed charts and erection and take-down charts.

Incidents are for example:

- Vandalism
- The ground giving way due to severe rain
- Melting ice under the supports
- Storm and thunderstorm
- Storm and wind
- Lightning
- Flooding
- Landslides
- Washouts
- For mobile cranes and crawler cranes with support:
Slippage of support cylinders (leak, temperature changes)
- For cranes with a telescopic boom:
Slippage of luffing cylinders (leak, temperature changes)

32.5 Resuming crane operation

Before resuming crane operation, the crane operator is obligated, among others, but not exclusively, to inspect the crane condition, the safety equipment, as well as the environmental conditions.



WARNING

Danger of accident!

When the crane operator leaves the crane cab:

- ▶ Before resuming work, check the operating mode setting and reset, if necessary.

32.6 Ending crane operation

Before the crane operator may leave the crane, the following prerequisites must be met:

- Place the load fully on the ground and unhook from the crane hook.
- On crane with telescopic boom: Telescope the telescopic boom all the way in and take down the boom in the boom receptacle.
- On crane with lattice mast boom: Set down the lattice mast boom and disassemble if necessary.
- Bring the control lever (master switch) to 0-position.
- Apply the parking brake on the crane chassis.
- Turn the engine off and pull out the ignition key.
- When a battery master switch is present: Turn off the battery master switch and remove the switch cam.
- Lock the crane cab.
- Secure the crane to prevent unauthorized use.

- For mobile crane: Make sure that the driver's cab is **not** occupied. Lock the driver's cab. Secure the crane to prevent it from rolling off unintentionally, see section „Parking the vehicle“.
- Make sure that no danger can occur for persons, crane and its surroundings should something unforeseen happen.

33 Lifting of personnel

33.1 Destined use

- The destined use of the crane is **lifting of loads**.
- **Lifting of personnel** is **not** considered to be destined use of the crane.



Note

- ▶ These instructions do **not** apply for work platforms, which are attached on the crane boom and are used to lift personnel. This subject is governed by international standards for mobile aerial work platforms.



WARNING

Non-designated use of the crane!

Personnel can be severely injured or killed.

- ▶ The crane is **not** intended to lift personnel.
- ▶ The crane may **not** be used for recreational purposes and exhibitions, such as lifting personnel for shows, bungee jumping or Dinner in the sky.
- ▶ The crane may **not** be used for lifting of devices with personnel on them or under the device, such as lifting of tents.
- ▶ Exception: If lifting of personnel for special work situations is the least dangerous possibility to carry out the work, then personnel may be lifted or brought into a suspended position when using lifting cages (cherry pickers).

33.2 Prerequisites for lifting of personnel

Make sure that the following prerequisites are met:

- Lifting personnel with cranes is permissible by national and local laws in the country where this crane application is carried out.



DANGER

Lifting of personnel!

Accidents which occur when lifting personnel often result in severe injuries or even death.

- ▶ This exceptional application is within the scope of responsibility of the user and is only permitted if the requirements and instructions in the next sections are observed and adhered to.
- ▶ The company, the supervisor, the crane operator and auxiliary personnel must proceed especially carefully and safety conscious.
- ▶ Before the lifting procedure, a meeting must be held with all associated personnel.
- ▶ The following warning notes and safety regulations must be strictly observed.

33.2.1 Legal prerequisites

Make sure that the following prerequisites are met:

- Special arrangements were made for the use of the lifting cage (cherry picker) according to the requirements of national laws.
- If required by national laws: The use of the crane to lift personnel was reported to the state agency for occupational health and safety. The lifting procedure may possibly require a special permit.
- Before the implementation of the lifting procedure with the aid of a work-specific risk analysis for the possibility of rescuing personnel in emergencies was defined.

- To rescue personnel in emergencies, precautionary measures must be present on the crane, if they are required by national laws.
- The measures for safe operation near power lines, depending on the conditions on the job site and the national laws / national regulations were observed and adhered to.

33.2.2 Prerequisites for crane equipment and accessories

Make sure that the following prerequisites are met:

- The hoist gear to lift personnel must also be able to be moved in emergency operation.
- Before lifting personnel, the crane was inspected. No damage was found.
- The lifting cage (cherry picker) is utilized according to national laws and / or standards and according to intended purpose.
- Before lifting personnel, the lifting cage (cherry picker) was carefully inspected. No damage was found.
- Every emergency rescue device was inspected and its operational readiness was determined, if required by national laws.
- Any hooks in use must be equipped with a latch, which prevents the hook mouth to open. According to national laws, the latch must be manually closable or lockable or must automatically close via a spring.

33.2.3 Inspection before operation

Make sure that the following inspections are made before use of the lifting cage (cherry picker):

- On every new construction site and after every modification or repair: To ensure the operating safety of the lifting cage (cherry picker) and the lifting equipment, a test with 125 % of the nominal load carrying capacity of the lifting cage (cherry picker) without personnel must be carried out. During the test, the lifting cage (cherry picker) may only be lifted just above the ground.
- A test lift with loaded lifting cage (cherry picker) without personnel must be carried out. The weight in the lifting cage (cherry picker) for the test lift must be at least as large as the weight of the personnel and the weight with the work equipment carried along. For this test lift, the course of all planned movements of the lifting procedure must be simulated.
- This test lift must be carried out for every location on a construction site, where personnel must be carried.

33.2.4 Prerequisites for operation with lifting cage (cherry picker)

Make sure that the following prerequisites are met for operation with lifting cage (cherry picker):

- The personnel and technical prerequisites for safe use and operation of the emergency control of the crane are present.
- The emergency control for emergency rescue of the person in the lifting cage is functioning.
- The rope pull is limited to 50 % of the maximum rope pull.
- The crane is utilized only to 50 % of its maximum load bearing capacity of the valid load chart.

34 Securing personnel on shut off crane

34.1 Terms and abbreviations

- PSAgA: Personal protective equipment to prevent falling
- HSG: Height safety device

34.2 Destined use

Cranes are **not** designed to protect personnel against falling.

When the following prerequisites are met, the personnel protection may be permissible:

- A justified individual case is present.
- A project-specific written risk assessment and work procedure for the precise case by the employer is on hand.

- The specific safety measures are strictly adhered to.
- The crane is intended by the manufacturer for personnel protection.

Limitations for movement and operation:

- Moving the secured person on the crane **from** job site and **to** job site is impermissible.
- Moving the secured person on the crane **from** job site and **to** job site is permissible only in case of a rescue operation.
- Operation of the crane by the secured person is impermissible.

34.3 Prerequisites



WARNING

Prerequisites for personnel protection are **not** met!

Danger of accident. Death, severe bodily injuries.

- ▶ Carry out the personnel protection on the shut off crane only when **all** prerequisites in this section have been met.

Make sure that the following prerequisites are met:

- The country-specific, legal regulations are being observed.
- The written risk assessment shows:
 - Technical protective measures with at least the same protective effect are **not** available.
 - The normal fastening devices can **not** be used.
 - Personnel protection on the shut off crane is the safest and most useful method to carry out this work.
- Last transport and personnel protection occur independent of each other:
 - Do **not** carry out personnel protection at the same time as load transport. Simultaneous personnel movement is impermissible.
 - Riding along on the load is impermissible.
- Determination of fastening points and rescue plan for the precise case is on hand from the employer.

34.3.1 Personnel and qualification

Make sure that the following prerequisites for personnel and qualification are met:

- The crane operator is suited and competent to operate the crane.
- Person, which is secured, must be trained in handling the PSAG.
- The following persons are present on the job site and separately instructed:
 - A supervisor
 - The crane operator
 - The required number of rescue staff according to the rescue plan
- Access protection, fall protection on the shut off crane is made in accordance with the project-specific risk assessment on hand and the measures to be taken.
- The supervisor monitors the safe execution of work. He may **not** take part in the work.
- An effective communication must be ensured between crane operator and the secured person.

34.3.2 PSAG, rescue equipment and tools

Make sure that the following prerequisites and measures are met:

- Use only HSG (height safety device) according to EN 360 in connection with a safety harness according to EN 361 to secure the person.
- Connecting device is suited for the occurring stress on the edges, see Manufacturer's documentation or device identification.
- Recurring inspections have been made. There are **no** visible defects present.
- At least 1 m connecting device of the maximum possible extension length of the HSG (height safety device) must remain in the housing.
- Fasten the HSG (height safety device) with two separate connecting devices (for example Securing on crane hook and on crane pulley block).

- Position the crane in such a way that the HSG (height safety device) is at least 5 m and plumb **over** the person, which is being secured.
- Do **not** exceed the maximum permissible deflection of the HSG (height safety device)
- Keep the required space **underneath** the person, which is being secured.
- All required objects (tools, building material) for the work are secured to prevent them from falling.

34.3.3 Crane

Make sure that the following prerequisites are met:

- The maintenance intervals and periodic crane inspections have been adhered to. There are **no** visible defects present.
- The load on the crane hook in any possible position is at least 600 kg , see Load chart (take the crane pulley block into account).
- Ensure sufficient load bearing capacity: For the load cases catching, pendular fall and possible angular pull adhere to the manufacturer's instructions.
- The crane is secured against movements and inadvertent movement (remote control is deactivated, crane control is activated).
- Only for aligning loads in the end position: Carry out a minimum of crane movements with the least possible speed.
- The overload protection is active.
- Auxiliary booms are **not** used.

34.4 Fastening device

Make sure that the following prerequisites are met:

- The crane hook is equipped with the hook safety.
- On the carrying device two connecting devices separated from each other can be fastened.
- HSG (height safety device) is redundantly fastened.
- Suitable fastening devices according to EN 795 Type B are on hand:
 - Round sling or fastening rope with steel core
 - Belt loop
- Textile components must be protected against greases, oils and other aggressive substances.
- Use only steel carabiners according to EN 362 with Tri-Lock function.

34.5 Rescue

A person in an accident must be lifted or lowered with the aid of the crane.

Carry out the following measures to ensure a safe rescue operation:

- Determine the rescue plan and rescue chain at the preparation of the mission.
- Ensure the rescue of a person involved in an accident immediately with locally available means and trained personnel.
- Have the rescue mission coordinated by another person, with visual and voice contact to the crane operator, ground personnel as well as to the person, which is rescued.

34.6 Additional risks

Make sure that the following risks are taken into account:

- Wind effect and environmental influences
- Crushing and shearing points
- Endangerment by additional cranes, for example material transport

35 Welding work on the load



Note

- ▶ The load must also be grounded.

In case of welding work on the load, the screw clamp of the welding unit must be attached on the work piece to avoid current flow via hoist rope, crane superstructure or crane chassis.

2.04.10 Ladders

1	Safety guidelines	3
2	Safety signs	3
3	Ladder inspection	8
4	User guidelines	8
5	Ladder access	9

Fig.195219

LWE/LR 11000-001/23501-04-02/en

1 Safety guidelines

The ladders have been built according to the present level of technology and recognized safety technical regulations. Despite that, during their use dangers to life and physical condition of the user and / or third parties can occur.

The ladders may exclusively be used in a flawless technical condition and according to their missions as well as with constant awareness of safety and dangers.

Changes on the structure may exclusively be made with written approval of the manufacturer.

The ladders are exclusively designated for the ascent and descent of personnel.

Any other use is not as intended and therefore prohibited.

The manufacturer is **not** liable for damages, which are caused by unintended use or improper usage.



WARNING

Danger of falling!

If the following safety guidelines are not observed, personnel can fall down and be killed or severely injured.

- ▶ Observe and adhere to the assembly and safety guidelines for ladders.
- ▶ Observe and adhere to the safety signs on the ladders.
- ▶ Install and secure the ladders properly.
- ▶ Use ladders exclusively if you are healthy enough to do this.
- ▶ Climb up / down the ladder with the 3-point support.
- ▶ Use the rungs as handles.
- ▶ Step into the rungs deep enough.
- ▶ Never bring the ladder to a new position during use.
- ▶ Do not use damaged ladders and replace them immediately.
- ▶ Repair the ladder exclusively through authorized service facilities.





2 Safety signs





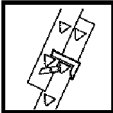
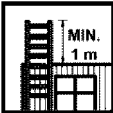

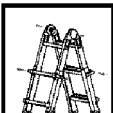
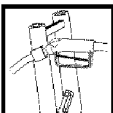
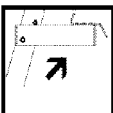
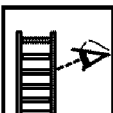







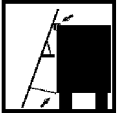

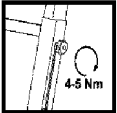





Note





- ▶ All safety signs on the ladders must be complete and always legible.
- ▶ Observe and adhere to the manufacturer's operating instructions.

Sign	Explanation
	Read the operating instructions.
	Maximum number of users on one ladder.
	Correct set up angle 65° to 75°.





Sign	Explanation
	Before use: Engage the lift out safety.
	Ladder overhang above the exit level.
	Secure the upper / lower end of the ladder.
	Before use: Tension the safety struts on stepladders.
	Before use: Engage the locking pin joints and pull pin locks.
	To open / close the tank cover and to ascent / descent: Insert the fuel nozzle into the retainer.
	Fold the platform out before setting up the ladder.
	Before use: Check the ladder for damage.
	Check the legs of the ladder.
	Maximum load.

Sign	Explanation
	Do not use the three uppermost rungs of an extension ladders as rungs to stand on.
	Do not use the four uppermost rungs / steps of a stepladder without a platform to stand on.
	Do not use the two uppermost rungs of a stepladder with integrated extension ladder as rungs to stand on.
	If hinged ladders are used as stepladders: Spread the ladder legs to the stop.
	Place the upper placement angle flat. Hold the belt on tension.
	Hook the hook on the platform of the refueling ladder on the vehicle.
	Tighten the star knob on the beam extension tightly.
	Do not use a damaged ladder.
	Preclude any contaminants on the ground.
	Make sure the upper end of the ladder is placed correctly. Place the ladder only on safe surfaces.

Sign	Explanation
	Only one person may climb up / down on any accessible leg of the ladder.
	Avoid leaning out to the side. The body's center of gravity should be between the ladder beams.
	Face the ladder when climbing up / down the ladder.
	Use the ladder only with suitable shoes.
	Do not use a stepladder as a leaning (extension) ladder.
	Do not use the inner section of multi-part hinged ladders without outer sections as a stepladder.
	Crushing danger.
	Set the ladder up on horizontal and solid ground.
	Set the ladder up on solid ground.
	Use the ladder in the correct set up direction.

Sign	Explanation
	Do not carry along bulky objects or objects over 10 kg on the ladder.
	It is not permitted to step off the ladder to the side.
	During transport, pay attention to danger due to power lines.
	Do not use the ladder as a walkway.
	Do not transport snow and ice shovels over the ladder. Use hooks!
	Danger due to shearing point.
	Do not use a ladder to climb up to another lever.
	Make sure that both ladder sections are opened completely and secured. Avoid an incorrect ladder position.
	Only use the platform ladder with a locked spreader lock.
	Only permissible ladder rungs / platforms may be used as standing and stepping surfaces. Other surfaces such as placement surfaces for cable clips or attachment hooks may not be used as standing and stepping surfaces.

LWE/LR 11000-001/23501-04-02/en

Sign	Explanation
	If a crossbar is part of the scope of delivery of the mobile platform ladder: Only use the platform ladder with the crossbar assembled.
	If auxiliary weights are part of the scope of delivery of the mobile platform ladder: Only use the platform ladder with the auxiliary weights assembled.
	If a foot brake is installed on the mobile platform ladder: Use the foot brake.
	Make sure that the joint is locked.
	In unfavorable weather conditions, do not use the ladder in the open.

3 Ladder inspection

Make sure that the following conditions are met:

- All ladders are inspected at least every 12 months. See chapter 8.17.
- The inspection may be made exclusively by authorized and trained expert personnel.

4 User guidelines

Make sure that the following prerequisites are met before using the ladder:

- A risk evaluation had been made.
 - The national legal regulations have been taken into account.
- Use are able to use a ladder as far as your health is concerned.
- The ladder is suited for the respective application.
- The ladder is complete and not damaged (visual inspection).
- The ladder is free of contaminants, such as:
 - Ice
 - Snow
 - Frost
 - Wet paint
 - Lubricants
- The legs of the ladders are not worn.
- Screws and connections have been checked for tight seating.
- The base is:
 - Level
 - Horizontal
 - Slip-resistant

- Unmoveable

Before setting the ladder up:

- Secure the locking devices of the ladder.
- Tension the spreaders of the stepladder.
- Do **not** set up the ladder from above.
- Do **not** set the ladder on braces or steps.

When using the ladder:

- Make sure that no children are playing on the ladders.
- Set the ladder up in the correct set up angle.
- Subject the ladder with no more than maximum 150 kg.
- Use the ladder exclusively as described in section „Ladder access“.
- Do **not** use the ladder outside in strong wind.
- Do **not** subject the ladder excessively to loads in side assembly work.
- Face the ladder when climbing up or down the ladder.
- Step on the ladder with suitable shoes.
- Do not use the ladder as a walkway.
- Secure the ladder to prevent it from being knocked over inadvertently.
- For leaning ladders, do not step on the uppermost three steps / rungs, in reference to the ladder placement point.
- For stepladders, do not step on the uppermost two steps / rungs.
- When working on a ladder, hold on tightly with one hand.
If this is not possible: Take additional safety measures, such as: Use the WORK POSITIONING SYSTEM (WPS).

For repair, maintenance and storage of a ladder:

- Have repairs and maintenance made by expert personnel according to the manufacturer's instructions.
- Store the ladders according to the manufacturer's instructions.

Before transporting the ladders:

- Lock and secure the ladders in their provided transport retainers.

5 Ladder access

Wearing the personal protection equipment to prevent falling and the ladder safeguard depend on the type of work, among others.

5.1 Ladder safeguards

The ladder can be secured to prevent it from sliding away to the side by:

- Restraint device, for example: Tether or side stops on component
- Friction lock, for example: Rubber caps or plastic caps on the end of the ladder beam at direct placement on a surface

The ladder can be secured to prevent it from tipping to the rear by:

- the correct placement angle

5.2 3-point support

A 3-point support is ensured when:

- Two hands have a safe hold and one leg is standing safely.
- Two legs are standing safely and one hand has a safe hold.
- Two legs are standing safely in straddle position on a stepladder which can be accessed from both sides, on the third respective rungs / steps from the top. The user locks the ladder with the knees.
- Two legs are standing safely and at the same time, the body is leaned on higher rungs / steps of the leaning (extension) ladder. The center of gravity of the body must always be between the two ladder beams.

- A WORK POSITIONING SYSTEM (WPS) is used.

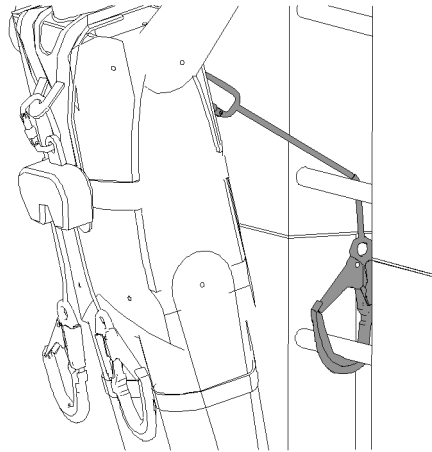

Fig.126746: Example of how to use the WPS

5.3 Light and / or heavy work

The following lists various light and heavy work

Examples for light work:

- Installing / removing retaining pins or spring retainers
- Fastening components, disengaging fastening equipment
- Pushing the transition aid out / in
- Establishing / disconnecting electrical or hydraulic connection between components
- Actuating the hand pump for the folding jib
- Reeving the auxiliary winch in / out
- Setting up / taking down foldable railings
- Carrying out maintenance and inspection work
- Refueling the crane chassis and / or crane superstructure

Examples for heavy work:

- Knocking the connector pins in / out
- Installing / removing the wind warning
- Reeving the hoist rope in / out
- Installing / removing the connector pin with assembly aid (hydraulic cylinder or mechanical assembly tool)
- Installing / removing the rope lock

5.4 Remove the end section on the leaning ladder

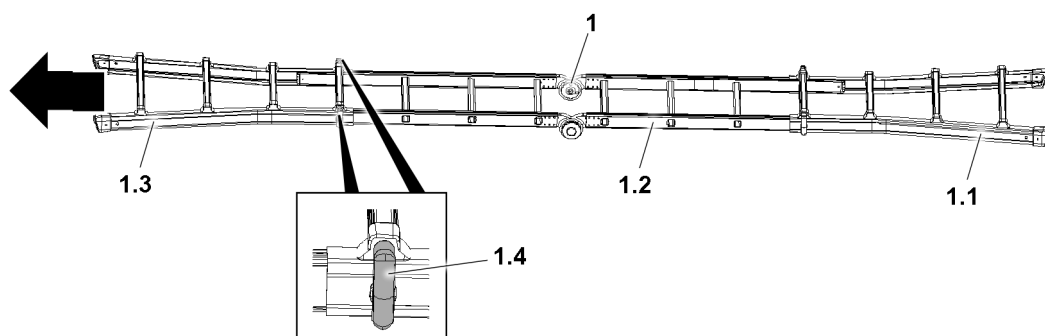

Fig.126873: Leaning (extension) ladder 1

The leaning ladder **1** consists of the following components:

- **1.1** Base
- **1.2** Center section
- **1.3** End section
- **1.4** Locks

When the end section **1.3** is wider than the leaning tube **2** or the intended placement surface, the leaning ladder **1** cannot be placed fully expanded. In order to position the leaning ladder **1** fully expanded, the end section **1.3** must be disassembled and removed.



CAUTION

Fingers in the spring range of the lock **1.4**!

Finger crushing when locking and unlocking.

▶ Grip the lock **1.4** outside of the spring range.

▶ Release the locks **1.4** on the left and right.

▶ Slide the end section **1.3** out of the center section **1.2** and remove it.

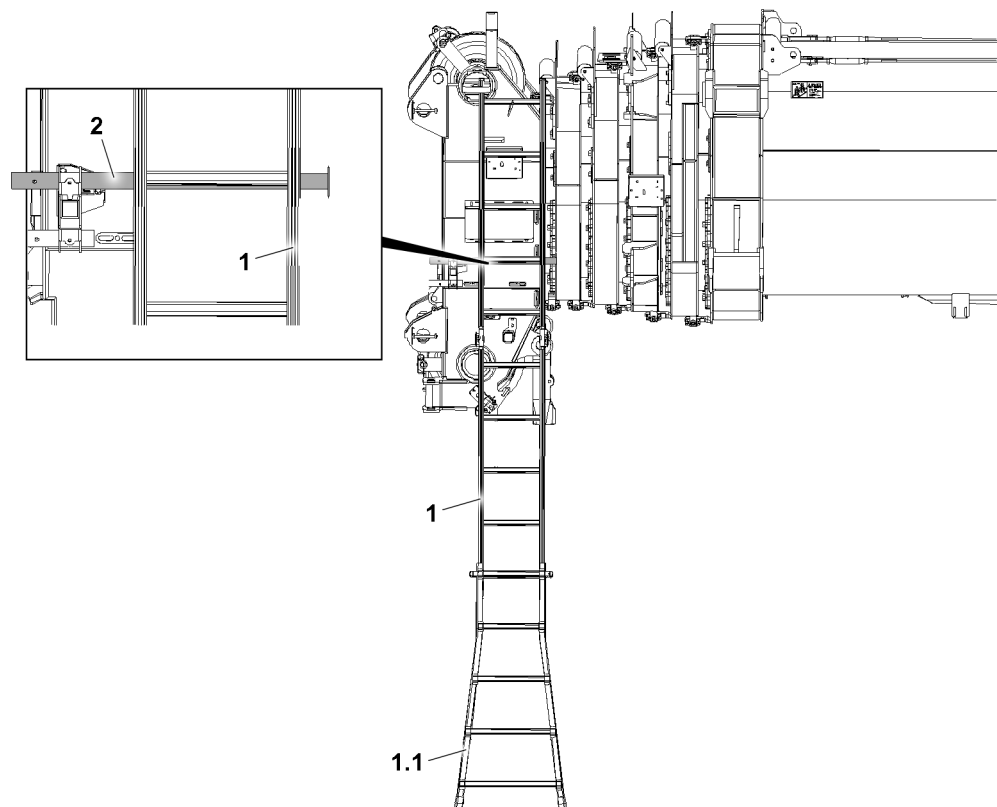

Fig.126874: Leaning ladder **1** placed on the leaning tube **2**

When placing the leaning ladder **1**, the base **1.1** must be placed on the ground.

▶ Place the leaning ladder **1** on the leaning tube **2** or the intended placement surface.



WARNING

The leaning ladder **1** is wider than the leaning tube **2** or the intended placement surface!

Assembly personnel can fall when stepping on the leaning ladder **1** and be severely injured.

▶ When stepping on the leaning ladder **1** make sure that the leaning ladder **1** **is not** wider than the leaning tube **2** or the intended placement surface.

▶ Climb on the leaning ladder **1**. Carry out the assembly work.

Before leaving the jobsite, the end section **1.3** must be reinstalled.

▶ Before leaving the jobsite: Install the end section **1.3**.

- ▶ Secure the leaning ladder **1** in transport position.

5.5 Types of ladders

5.5.1 Stepladder

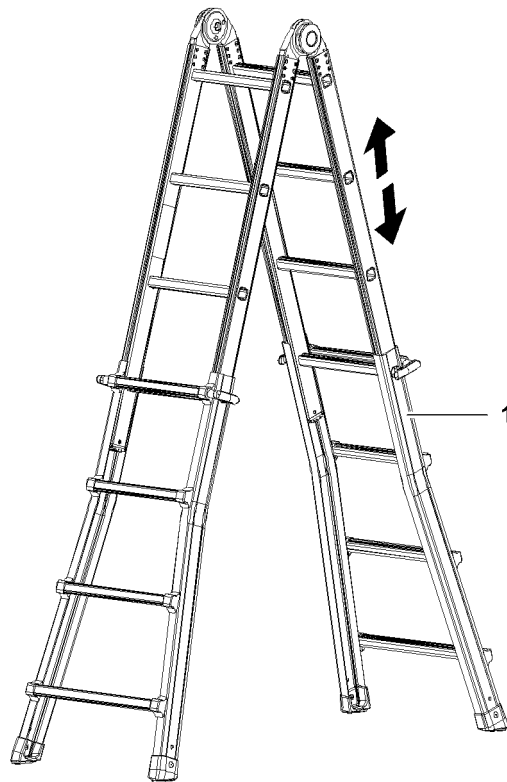

Fig.121175: Examples for stepladders



WARNING

Danger of falling when transitioning from a stepladder **1** to other components!
Personnel can fall down and be killed or severely injured.

- ▶ Do **not** transition from a stepladder **1** to other components.



WARNING

Danger of falling!
Personnel can fall down and be killed or severely injured.

- ▶ When using stepladders **1**, adhere to the 3-point support.
- ▶ Adhere to the prerequisites and conditions for the use of stepladders **1**.

Prerequisites for the use of stepladders **1**:

- Make sure that the weight of the tool carried along is not more than 10 kg.

Access	Work
Maximum rise to the third rung / step from the top	Maximum rise to the third rung / step from the top
3-point support required	3-point support required
	Rise to 1 m: Personal protective equipment to prevent falling not required

Access	Work
	Rise above 1 m to 7 m Light work: Personal protective equipment to prevent falling not required
	Rise above 1 m to 7 m Heavy work: Personal protective equipment to prevent falling required

Conditions for access and work on stepladders 1

5.5.2 Leaning (extension) ladder

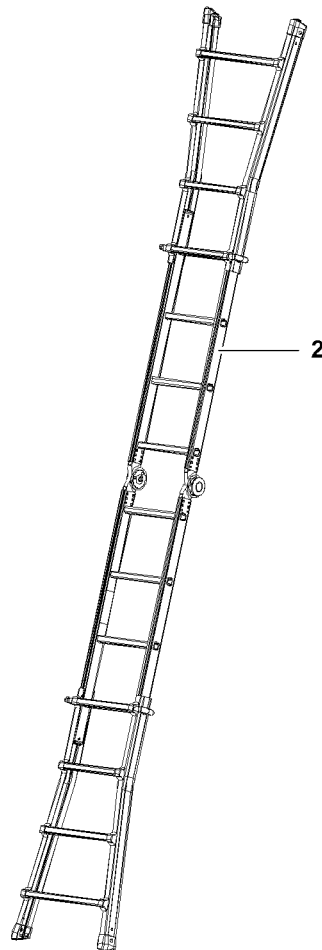

Fig.121176: Example for leaning (extension) ladders



WARNING

Danger of falling!

Personnel can fall down and be killed or severely injured.

- ▶ When using leaning (extension) ladders **2**, adhere to the 3-point support.
- ▶ Adhere to the prerequisites and conditions for the use of leaning (extension) ladders **2**.

Prerequisites for the use of leaning (extension) ladders **2**:

- Make sure that the leaning (extension) ladder **2** is positioned onto a level placement surface.

- Make sure that the leaning ladder **2** is placed in an incline angle of 65° to 75° (approx. 1:4) to the horizontal.
- Make sure that the ladder overhang when leaning it on components is selected in such a way that the leaning (extension) ladder **2** is safely placed when subjected to a load / flex due to ascending persons.
- Make sure that the weight of the tool carried along is not more than 10 kg.

Access	Work
Maximum rise to the fourth rung / step from the top, in reference to the placement point	Maximum rise to the fourth rung / step from the top, in reference to the placement point
3-point support required	3-point support required
	Rise to 1 m: Ladder safeguard not required Personal protective equipment to prevent falling not required
	Rise above 1 m to 7 m Light work: Ladder safeguard required Personal protective equipment to prevent falling not required
	Rise above 1 m to 7 m Heavy work: Ladder safeguard and protection to prevent it from tipping to the rear required Personal protective equipment to prevent falling required

Conditions for access and work on leaning (extension) ladders 2

5.5.3 Leaning (extension) ladder with transition

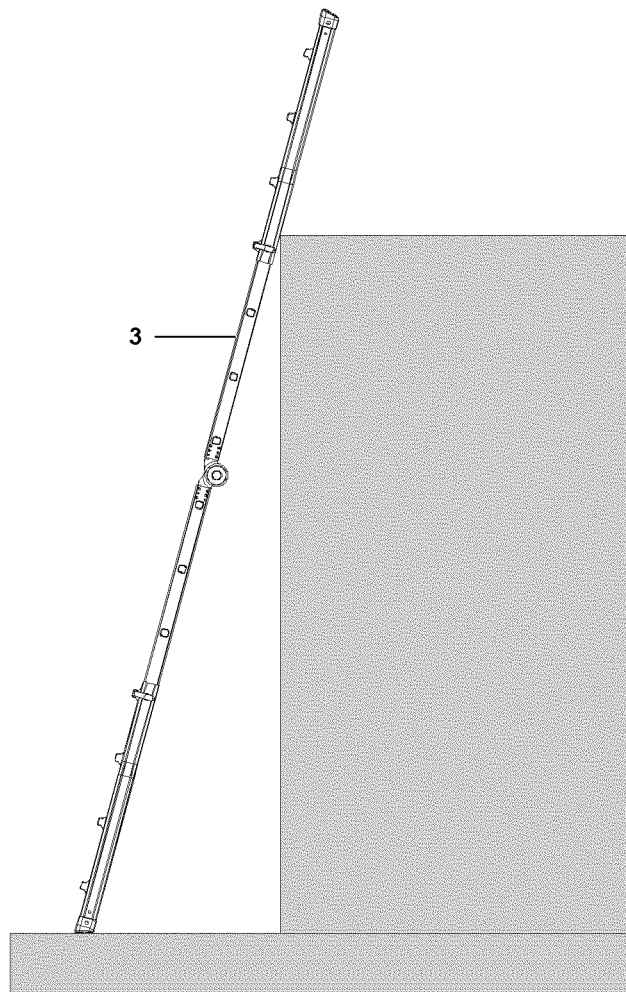

Fig.121177: Examples for leaning (extension) ladders with transition



WARNING

Danger of falling!

Personnel can fall down and be killed or severely injured.

- ▶ When transitioning, adhere to the 3-point support.
- ▶ Adhere to the prerequisites and conditions for the use of leaning (extension) ladders with transition **3**.

Prerequisites for the use of leaning (extension) ladders with transition **3**:

- Make sure that the leaning (extension) ladder with transition **3** is positioned onto a level placement surface.
- Make sure that the leaning ladder with transition **3** is placed in an incline angle of 65° to 75° (approx. 1:4) to the horizontal.
- Make sure, for transitioning to higher work locations, when no other safehold possibilities are available, that the ladders beams of the leaning (extension) ladder go past the placement location by at least 1 m.
- Make sure that the transition area is slip-resistant.
- Make sure that the ladder position can be recognized from above.
- Make sure that the ladder overhang when leaning it on components is selected in such a way that the leaning (extension) ladder is safely placed when subjected to a load / flex due to ascending persons.
- Make sure that the weight of the tool carried along is not more than 10 kg.

Access	Transition
Maximum rise to a rung / step below the placement edge	Maximum rise to a rung / step below the placement edge
3-point support required	3-point support required
Personal protective equipment to prevent falling not required	Personal protective equipment to prevent falling not required
	Rise to 1 m: Ladder safeguard not required
	Rise above 1 m to 7 m: Ladder safeguard required

Conditions for access and transition to leaning (extension) ladders with transition 3

5.5.4 Vertical ladder with transition aid

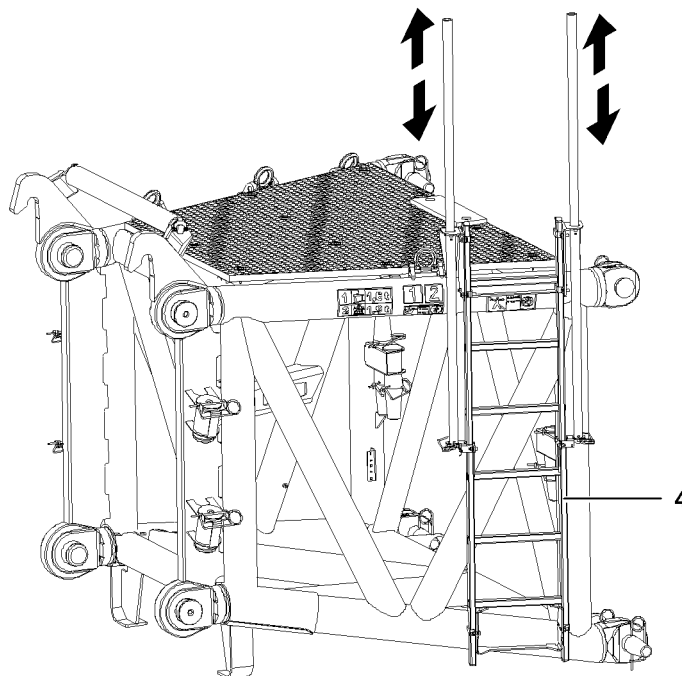

Fig.121178: Example for vertical ladder with transition aid



WARNING

Danger of falling!
Personnel can fall down and be killed or severely injured.

When using vertical ladders with transition aid 4:

- ▶ Adhere to the 3-point support.

Before transitioning:

- ▶ Hook the personal protective equipment to prevent falling on a suitable location (for example: uppermost rung, safety rope or separate hook point).
- ▶ Adhere to the prerequisites and conditions for the use of vertical ladders with transition aid 4.

Prerequisites for the use of vertical ladders with transition aid 4:

- Make sure, a centered grip reachable from the transition edge and a possibility to support oneself with the second hand is present for transitioning.
- Make sure that the transition area is slip-resistant.
- Make sure that the ladder position can be recognized from above.
- Make sure that the weight of the tool carried along is not more than 10 kg.

Access	Work
3-point support required	3-point support required
If necessary: use a WORK POSITIONING SYSTEM (WPS) at a suitable hook point.	If necessary: use a WORK POSITIONING SYSTEM (WPS) at a suitable hook point.

Conditions for access and work on vertical ladders with transition aid 4

Ascent	Transition
3-point support required	3-point support required
Rise to 5 m: Personal protective equipment to prevent falling not required	Rise to 1.8 m: Without transition aid: Personal protective equipment to prevent falling not required
Rise above 5 m: Fall arrest system with moving along fall arrest device or back protection required	Rise above 1.8 m: Without transition aid: Personal protective equipment to prevent falling required

Conditions for ascent and transition to vertical ladders with / without transition aid 4

5.5.5 Platform ladder

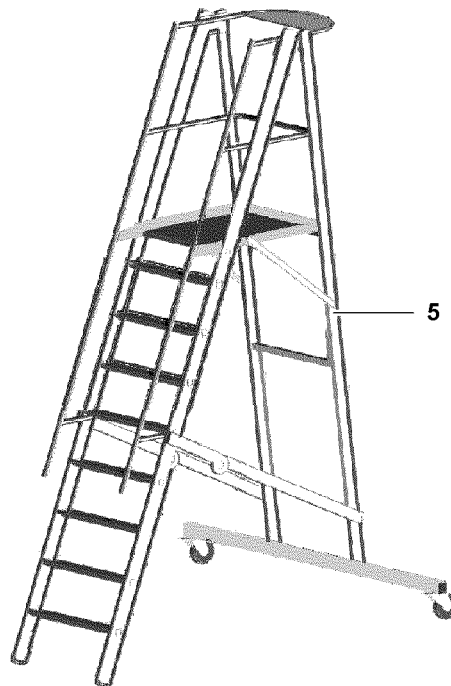

Fig.121179: Example for platform ladder

**WARNING**

Danger of falling when transitioning from a platform ladder **5** to other components!
Personnel can fall down and be killed or severely injured.

- ▶ Do **not** transition from a platform ladder **5** to other components.

**WARNING**

Danger of falling!
Personnel can fall down and be killed or severely injured.

For use of platform ladders **5**:

- ▶ Adhere to the 3-point support.
- ▶ Adhere to the prerequisite and conditions for the use of platform ladders **5**.

Prerequisite for the use of platform ladders **5**:

- Make sure that the weight of the tool carried along is not more than 10 kg.

Access	Working on the ladder	Working on the platform
Maximum rise to platform height	Maximum rise to platform height	Maximum height: Platform height
3-point support required	3-point support required	3-point support required
	Rise to 1 m: Personal protective equipment to prevent falling not required	
	Rise above 1 m to 7 m Light work: Personal protective equipment to prevent falling not required	Platform height Light work: Personal protective equipment to prevent falling not required
	Rise above 1 m to 7 m Heavy work: Personal protective equipment to prevent falling required	Platform height Heavy work: Personal protective equipment to prevent falling required

Conditions for access and work on platform ladders 5

2.05 Signs on the crane

1 Signs

3

LWE/LR 11000-001/23501-04-02/en

Fig.195219

LWE/LR 11000-001/23501-04-02/en

1 Signs

1.1 7725039 – Warning of high voltage



Fig.116269: Warning of high voltage



Note

► Only for certain countries.

1.2 772564008 – Slewing range



Fig.116270: Slewing range



Note

► Only for certain countries.

1.3 772580408 – Limitation of maximum travel speed



Fig.106035: Limitation of maximum travel speed

1.4 Vehicle height

	Vehicle height
970610408	
970629508	
970596108	
970608708	
979459108	

Vehicle height



Note

- ▶ Vehicle height x.x m (x.x ft)

1.5 Note for assembly aid

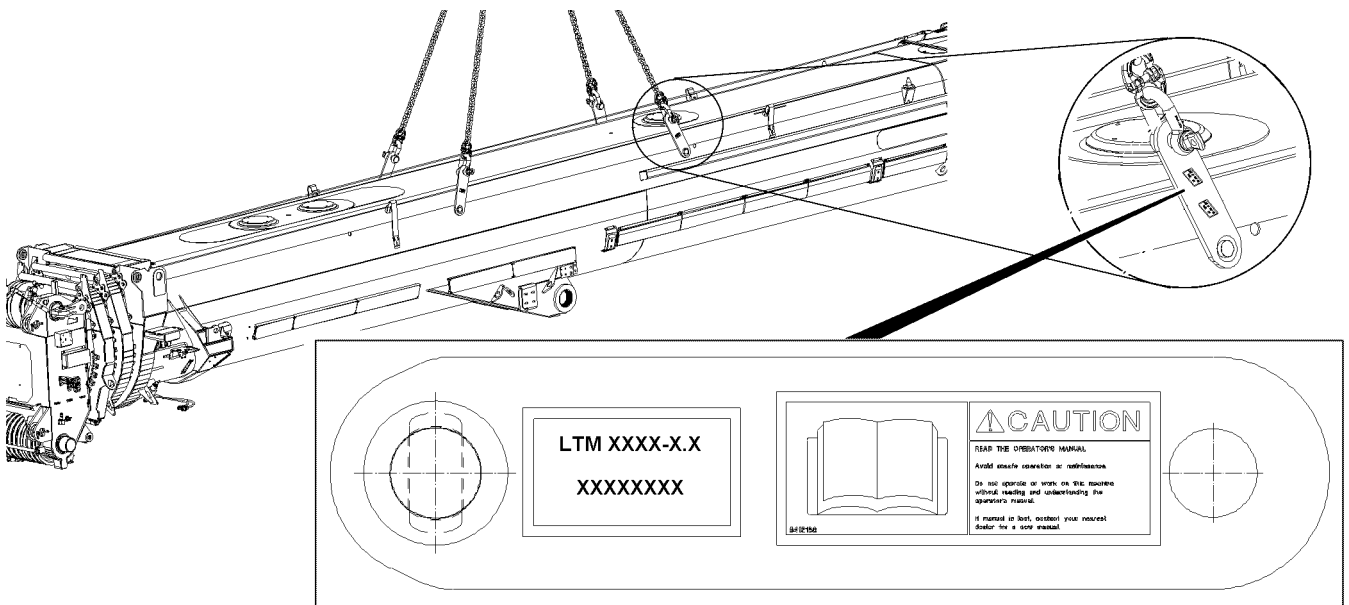

Fig.122741

Id. No.	Mobile crane
966713608	LTM 1750–9.1 LTM 1450-8.1
968483508	LTM 1500-8.1
962961708	LTM 11200-9.1, LTM 1400-7.1, LTM 1350-6.1, LTM 1300-6.2,
	LTM 1250-6.1, LTM 1250-5.1, LTM 1220-5.2, LTM 1200-5.1,
	LTM 1160-5.2, LTM 1160-5.1, LTM 1130-5.1, LTM 1100-4.2,
	LTM 1095-5.1, LTM 1090-4.1,
	LTR 11200, LTR 1220, LTR 1100

Note for assembly aid



WARNING

Incorrect assembly aids!
Falling telescopic boom, death, property damage.

To assemble and disassemble the telescopic boom:
▶ Use solely the assembly aids that belong to the crane.

1.6 9412158 – Reading the operating instructions

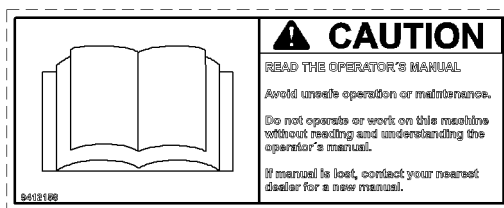

Fig.106048: Reading the operating instructions

LWE/LR 11000-001/23501-04-02/en

**WARNING**

Danger of accident due to non-observance of operating instructions!

If the operating instructions are not read or understood, then this can lead to unsafe operation and improper maintenance.

Accidents with bodily injuries and property damage can result.

- ▶ The crane may only be operated if the contents of the operating instructions have been read and understood.
- ▶ Replace lost or incomplete operating instructions immediately.

1.7 97004046 – Safety harness, maximum two persons



Fig.115119: Safety harness, maximum two persons

**DANGER**

Danger of accidents due to overloaded safety ropes!

If safety ropes are used by more than two persons, then the safety ropes can be overloaded and fail in case of an accident.

Personnel can be severely injured or killed.

- ▶ Safety ropes are designed to secure a maximum of two persons against falling, one on the right and one on the left.

1.8 97017585 – Falling telescopic boom during disassembly / assembly

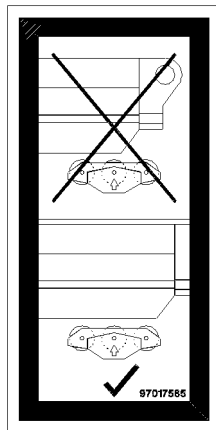

Fig.118467: Falling telescopic boom during disassembly / assembly

**WARNING**

Fatal accidents due to falling telescopic boom!

- ▶ Make sure that all pulleys are touching and carrying during the assembly and disassembly of the telescopic boom.

1.9 97018351 – Falling telescopic boom during transport!

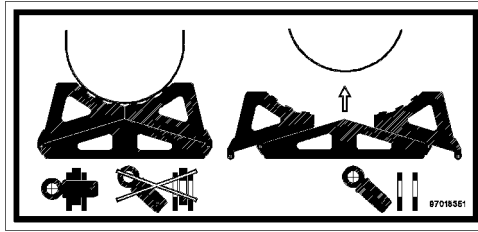

Fig.118466: Falling telescopic boom during transport



WARNING

Fatal accidents due to falling telescopic boom during transport!

- ▶ Pin and secure the transport bracket on the left and right.

1.10 97018564 – Falling telescopic boom during transport!

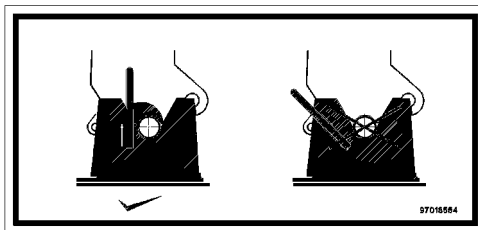

Fig.118533: Falling telescopic boom during transport



WARNING

Fatal accidents due to falling telescopic boom during transport!

- ▶ Lock the telescopic boom in the head receptacle.

1.11 97027147 – Overloading of combi box is prohibited

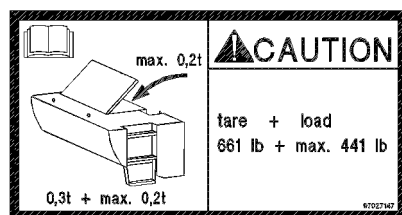

Fig.113829: Overloading of combi box is prohibited



WARNING

Danger of overload!

If the combi box is subjected to a load of more than 0.2 t, the combi box can be damaged!

- ▶ The own weight of the combi box is 0.3 t and may be loaded with a maximum payload of 0.2 t.
- ▶ Do not subject the combi box to a weight of more than 0.2 t.

1.12 97036733 – Fastening point

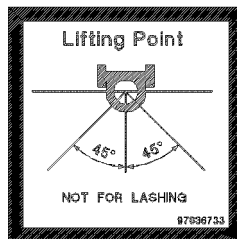

Fig.121184: Fastening point



WARNING

Damage of fastening points!

- ▶ Use the fastening point solely to lift the load.
- ▶ Observe the maximum permissible fastening angle.



Note

- ▶ Fastening points and fastening angle.

1.13 Suspended load fastening point

	Suspended load fastening point
97038434	<p style="text-align: center;"><i>Fastening point</i></p>
97037482	
97039068	



WARNING

Mortal danger if the load falls down!

If the maximum suspended load or the maximum fastening angle is exceeded, the load can fall down and kill personnel.

- ▶ Observe the maximum permissible suspended load and fastening angle.

1.14 Suspended load fastening point

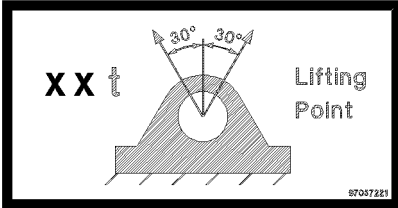
Suspended load fastening point	
97037221	
97037223	



WARNING

Mortal danger if the load falls down!

If the maximum suspended load or the maximum fastening angle is exceeded, the load can fall down and kill personnel.

- ▶ Observe the maximum permissible suspended load and fastening angle.

1.15 Suspended load fastening point

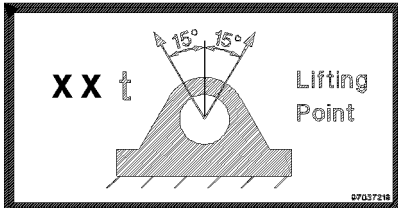
Suspended load fastening point	
97037219	



WARNING

Mortal danger if the load falls down!

If the maximum suspended load or the maximum fastening angle is exceeded, the load can fall down and kill personnel.

- ▶ Observe the maximum permissible suspended load and fastening angle.

LWE/LR 11000-001/23501-04-02/en

1.16 97037625 – Suspended load Fastening points / rigging points

LIFTING AND LASHING			
Type [t]	Lashing Capacity		
	LC-N [daN]	LC-Q [daN]	
4	4 000	2 000	
6,7	6 700	4 690	
10	10 000	7 000	
16	16 000	11 200	
31,5	31 500	22 050	

Fig.119988: Fastening points / rigging points



Note

- Fastening points and rigging points.

1.17 9402377 – Fastening point / lifting point



Fig.127586: Fastening point / lifting point



Note

- Fastening point / lifting point.

1.18 97096132 – Fastening points N-assembly unit

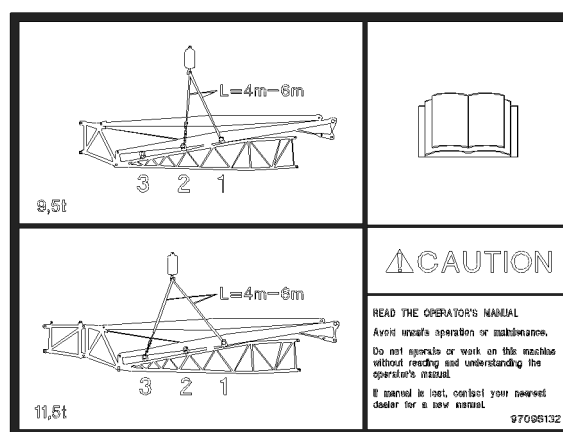

Fig.144774: Fastening points N-assembly unit

**WARNING**

Incorrectly selected fastening points!

The N-assembly unit can tip over and kill personnel.

- ▶ Fasten the N-assembly unit only on the intended fastening points.
- ▶ Use fastening equipment with the correct strand length.
- ▶ Observe and adhere to the operating instructions.
- ▶ Replace lost or incomplete operating instructions immediately.

1.19 97036735 – Fastening point for lattice section

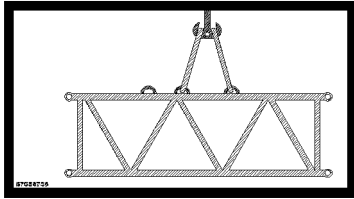

Fig.116266: Fastening point for lattice section

**Note**

- ▶ Fastening points for lattice section.

1.20 97036736 – Fastening point for lattice sections

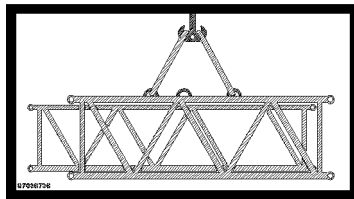

Fig.116267: Fastening point for lattice sections

**Note**

- ▶ Fastening points for lattice sections.

1.21 97038442 – Fastening point for lattice section

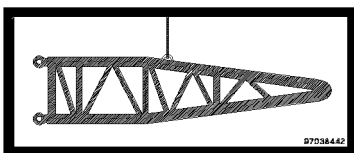

Fig.116288: Fastening point for lattice sections

**Note**

- ▶ Fastening point for lattice section.

1.22 97038452 – Fastening point for lattice sections

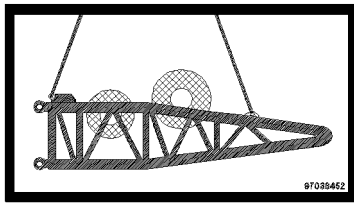

Fig.116289: Fastening point for lattice sections



Note

► Fastening points for lattice sections.

1.23 97038454 – Fastening point for lattice sections

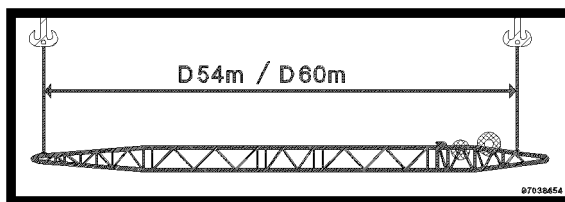

Fig.116290: Fastening point for lattice sections



Note

► Fastening points for lattice sections.

1.24 97037871 – Fastening points for lattice sections

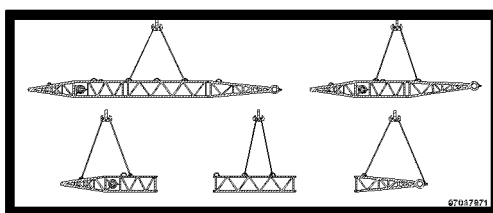

Fig.116292: Fastening points for lattice sections



Note

► Fastening points for lattice sections.

1.25 97057767 – Fastening points for lattice sections

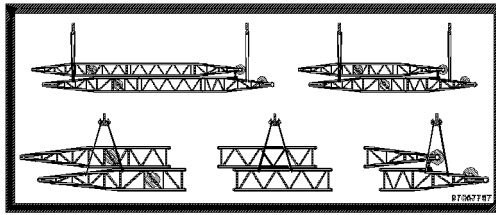

Fig.121181: Fastening points for lattice sections



Note

► Fastening points for lattice sections.

1.26 97057524 – Fastening point for assembly of lattice sections

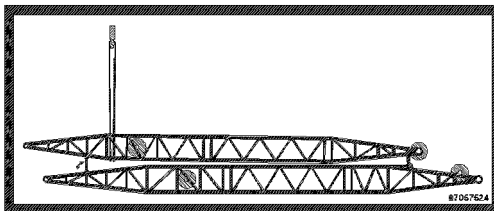

Fig.121182: Fastening point for assembly of lattice sections



Note

► Fastening point for assembly of lattice sections.

1.27 97057097 – Fastening point to turn the component

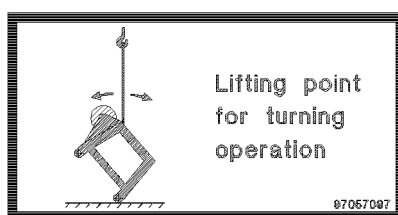

Fig.119987: Fastening point to turn the component



Note

► Fastening point to turn the component.

1.28 97039035 – Suspended load Assembly unit

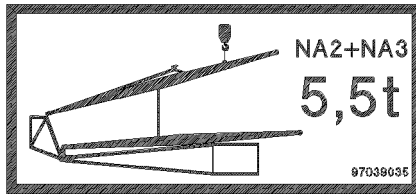

Fig.117348: Suspended load Assembly unit



Note

- ▶ Notice the suspended load.

1.29 97059339 – Suspended load Derrick pivot section

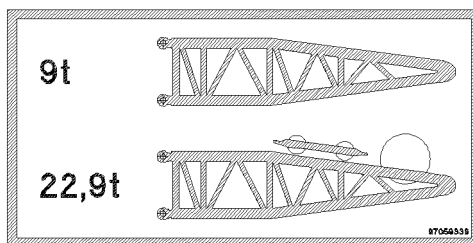

Fig.127469: Suspended load Derrick pivot section



Note

- ▶ Suspended load Derrick pivot section.
- ▶ Suspended load Derrick pivot section with rope winch and luffing pulley block.

1.30 97003109 – Accessing of step ladder



Fig.109032: Accessing of step ladder



WARNING

Danger of falling!

If the step ladder is accessed before it is completely folded out, the assembly personnel can fall and be fatally injured.

- ▶ Before stepping on the step ladder, fold the lowest step out.

1.31 97003110 – Folding the step ladder in and out

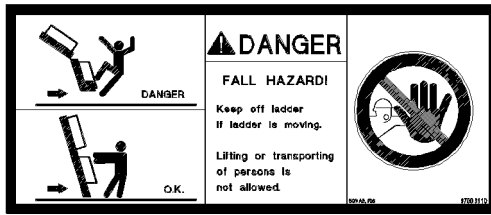

Fig.109033: Folding the step ladder in and out



WARNING

Danger of falling!

When folding the step ladder in or out or when driving the crane, no persons may remain on the step ladder or within the entire danger zone! Persons can fall from the step ladder or be killed as the step ladder folds in or out.

- ▶ Fold the step ladder in and out only if there are no persons within the danger zone.

1.32 97006167 – Identification of the support base

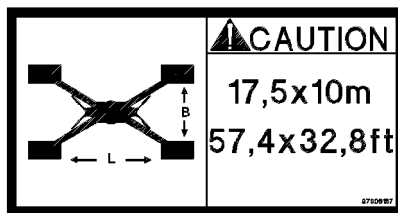

Fig.116285: Identification of the support base



Note

- ▶ The support beams are swung out / extended to a support base of 17.50 m x 10.0 m ; (57.4 ft x 32.8 ft).

1.33 97006167 – Identification of the support base

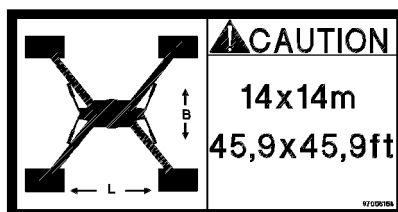

Fig.116286: Identification of the support base



Note

- ▶ The support beams are swung out / extended to a support base of 14.0 m x 14.0 m ; (45.9 ft x 45.9 ft).

1.34 97008514 – Warning of head injuries

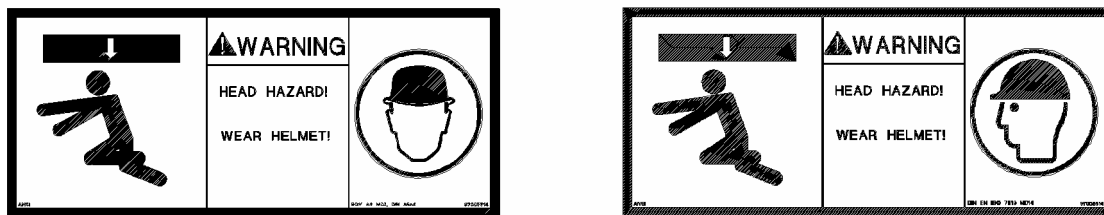

Fig.110550: Warning of head injuries



WARNING

Head injuries!

Due to falling parts, personnel can be killed or severely injured.

Hitting the head can cause injuries.

- ▶ Protect your head with a hard hat.
- ▶ Always remain aware of your surroundings and behave in a safe manner.

1.35 97009799 – Data logger

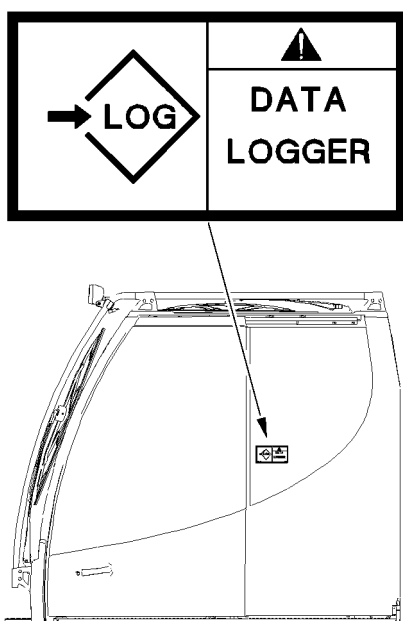

Fig.116261: Data logger



Note

- ▶ Data logger.

1.36 97012949 – Maximum load

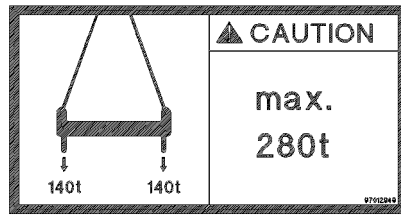

Fig.116263: Maximum load



CAUTION

Property damage due to overload!

If the cross beam is subjected to a higher load than permissible, damage can occur.

▶ Do not overload the cross beam.

1.37 97012095 – Maximum load

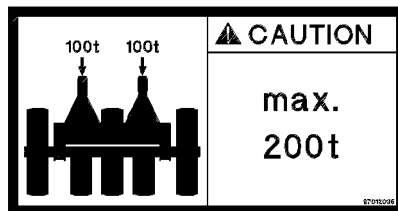

Fig.116265: Maximum load



CAUTION

Property damage due to overload!

If the roller cart is subjected to a higher load than permissible, damage can occur.

▶ Do not overload the roller cart.

1.38 97069053 – Storage boxes open

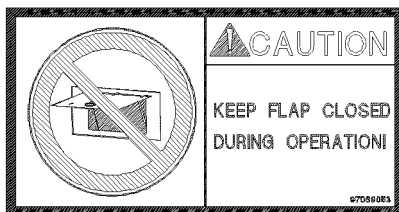

Fig.144736: Storage boxes open

NOTICE

Storage boxes open!

Damage of storage boxes.

▶ Before crane operation and before driving the crane, close the storage boxes.

1.39 97068370 – Closing the cab door



Fig.144737: Closing the cab door



WARNING

Cab door during crane operation **not** closed!
The crane operator can fall down.
Death, severe bodily injuries.
► Close the cab door during crane operation.

1.40 97053409 – Entanglement hazard during winch operation

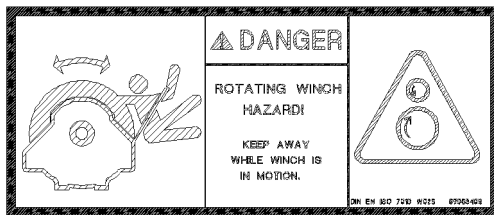

Fig.144738: Entanglement hazard during winch operation



DANGER

Entanglement hazard during winch operation!
Body parts can be caught and entangled.
Death, severe bodily injuries, property damage.
► Do **not** stand in the hazard area of the winch.

1.41 97011689 – Danger of crushing

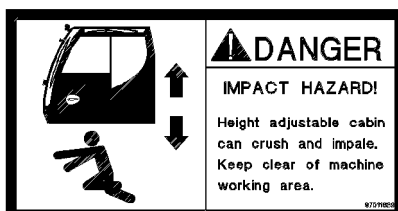

Fig.111047: Danger of crushing



DANGER

Danger of fatal injury!
► It is prohibited to remain within the danger zone of the cab.
► Keep away from the movement range of the cab.

1.42 97011690 – Overload of cab is prohibited

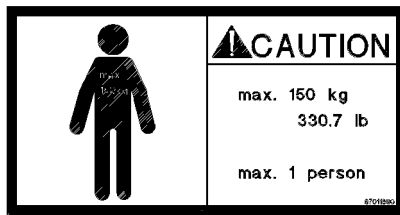

Fig.111048: Overload of cab is prohibited



WARNING

Danger of overload!

If the cab is subjected to a load of more than 150 kg then the cab or the telescoping arm can be damaged!

- ▶ Only one person at a time may remain in the cab!
- ▶ Do not subject the cab to a weight of more than 150 kg.

1.43 97016304 – Refueling

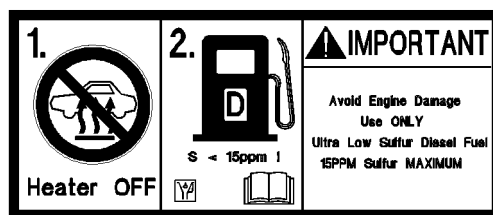

Fig.113766: Refueling



WARNING

Danger of fire and explosion!

- ▶ Turn the auxiliary heater* off approx. 3 min before refueling the fuel tank.
- ▶ Before refueling the fuel tank, turn the engine off.

NOTICE

Property damage to the engine!

If incorrect fuel is added, the engine can be severely damaged.

- ▶ Refuel with fuel according to the Engine manufacturer's operating instructions.

1.44 97046488 – Corrosion inhibitor - antifreeze fluids

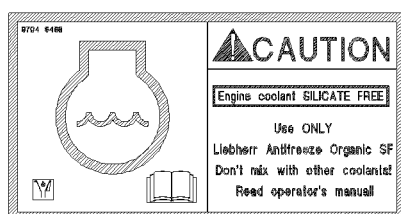

Fig.127585: Corrosion inhibitor - antifreeze fluids

NOTICE

Mixing of different corrosion inhibitor-antifreeze agents!

Damage to the cooling system!

- ▶ Fill the cooling system with corrosion inhibitor-antifreeze, see Service fill list.

1.45 97016392 – Crushing danger for feet



Fig.112474: Crushing danger for feet

**WARNING**

Crushing danger for feet!

Feet can be trapped or crushed.

- ▶ Keep feet away.

1.46 97012737 – Danger of accident



Fig.111748: Danger of accident

**WARNING**

Danger of accident!

- ▶ Close the windshield when driving.

1.47 97023034 – Disassembling

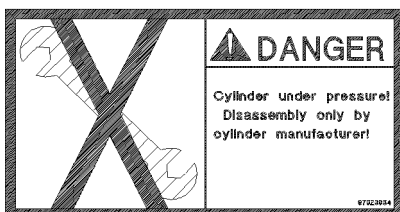

Fig.116264: Disassembling

**DANGER**

Danger of fatal injury due to repair!

Cylinder is pressurized.

Disassembly of the cylinder can result in death or serious injuries.

- ▶ The cylinder may only be removed by the manufacturer.

1.48 97036732 – Access via 3-point support

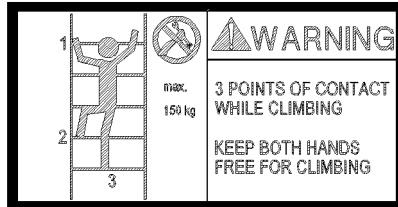

Fig.115172: Access via 3-point support

**DANGER**

Access via 3-point support!

While climbing up and down via a ladder, the assembly personnel can fall down and be injured severely.

- ▶ When climbing up and down, a 3-point support must be ensured.
- ▶ Use ladders only up to a weight of 150 kg.
- ▶ When climbing up and down, hands must be free.

A 3-point support is ensured when:

- two legs are standing safely and one hand has a safe hold.
- two hands have a safe hold and one leg is standing safely.

1.49 97003112 – Maximum suspended load

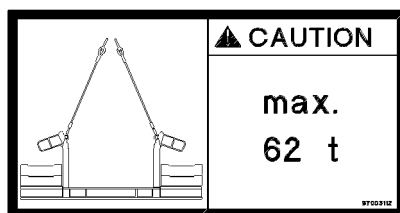

Fig.116282: Maximum suspended load

**WARNING**

Maximum suspended load!

If the maximum suspended load of 62 t is exceeded, the load can fall down and kill personnel.

- ▶ Observe the maximum permissible suspended load.

1.50 97036917 – Maximum suspended load

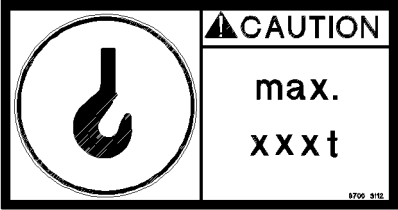
	Suspended load fastening point
97047630	
97036917	
97047630	



WARNING

Mortal danger if the load falls down!

If the maximum suspended load is exceeded, the load can fall down and kill personnel.

- ▶ Observe the maximum permissible suspended load.

1.51 97037383 – Urea

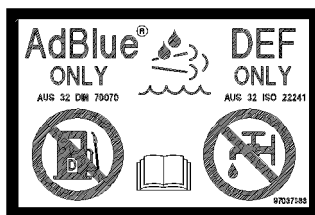

Fig.115173: Urea



CAUTION

Property damage due to incorrect operating fluids!

When refilling urea and the urea which is specified by the engine manufacturer is not used, then damage can occur.

- ▶ Refill **exclusively** urea.
- ▶ See engine manufacturer's operating instructions.

1.52 97037952 – Warning of fatal electric shock

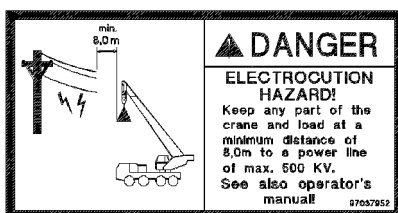

Fig.116280: Warning of fatal electric shock

**DANGER**

Danger of fatal injury due to electric shock!

If the boom or the hoist rope is under electric current, then death or severe injuries can occur if anyone touches the crane, the vehicle or the load.

- Keep a minimum distance of 8.0 m to current carrying parts.

1.53 97042730 – Falling luffing cylinder

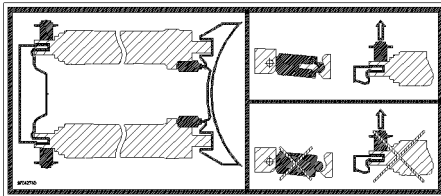

Fig.118465: Falling luffing cylinder

**WARNING**

Mortal danger if the luffing cylinders fall down!

- Make sure, before unpinning the luffing cylinder, that the erection cylinders are place don both luffing cylinders.

1.54 97047810 – Pin brackets

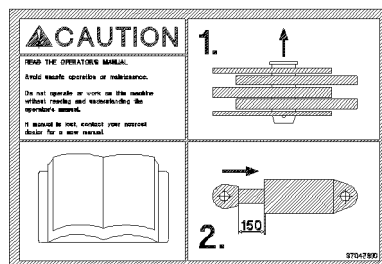

Fig.121709: Pin brackets

NOTICE

Damage of brackets due to collision!

- Make sure, before pinning and unpinning, that the hydraulic cylinder is set to a distance of 150 mm.

1.55 97042797 – Overload of components

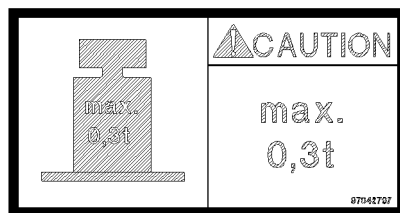

Fig.117347: Overload of components

**DANGER**

Danger of falling due to overload!

If a component, such as a sliding beam platform, is subjected to a weight of more than 0.3 t , then the sliding beam platform can break.

Personnel can fall down and be severely injured or killed.

- ▶ Subject the component (sliding beam platform) to no more than maximum 0.3 t.

1.56 97041305 – Overload of components

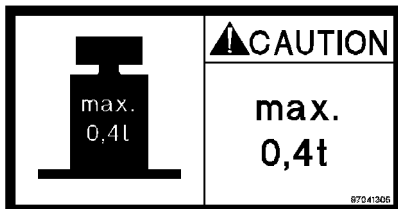

Fig.116792: Warning of overload of components

**DANGER**

Danger of falling due to overload!

If a component, such as a sliding beam platform, is subjected to a weight of more than 0.4 t , then the sliding beam platform can break.

Personnel can fall down and be severely injured or killed.

- ▶ Subject the component (sliding beam platform) to no more than maximum 0.4 t.

1.57 97070905 – Removing the auxiliary jib (boom nose)

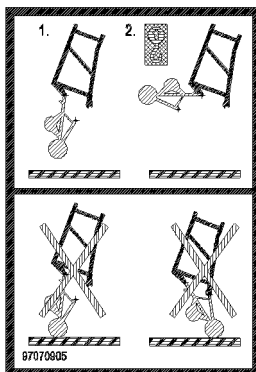

Fig.122645: Removing the auxiliary jib (boom nose)

NOTICE

Property damage

Before placing the N-head down:

- ▶ Remove the auxiliary jib (boom nose).

1.58 97033982 – Mounting / demounting the Derrick pivot section

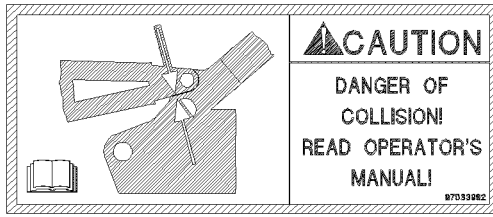

Fig.127470: Mounting / demounting the Derrick pivot section

NOTICE

Derrick pivot section assembly procedure carried out incorrectly!

Damage to the Derrick pivot section receptacle.

- ▶ Perform the assembly procedure according to the operating instructions.

1.59 Maximum sound power level

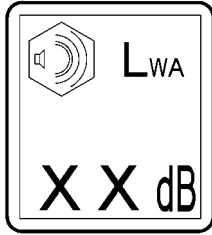
	Maximum sound power level
975809508	 <p>Maximum sound power level</p>
971693308	
971693408	
971693508	
971693608	

1.60 977055908 – Fastening point for swingable sliding beam

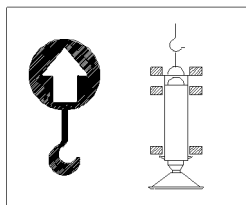

Fig.106894: Fastening point for swingable sliding beam

LWE/LR 11000-001/23501-04-02/en

1.61 971494208 – Limitation of maximum travel speed

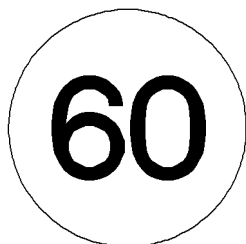

Fig.106034: Limitation of maximum travel speed

1.62 971539808 – Warning notice for unpinning the auxiliary boom on the pulley head

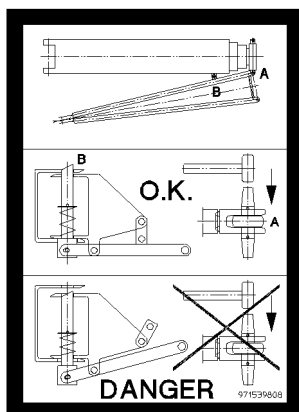

Fig.106040: Warning notice for unpinning the auxiliary boom on the pulley head



DANGER

Danger of fatal injury!

If the auxiliary boom is not locked correctly to the pivot section, it can fall down. Personnel can be severely injured or killed.

- ▶ Unpinning the auxiliary boom on the pulley head is prohibited.

1.63 971539908 – Warning notice for unlocking the auxiliary boom

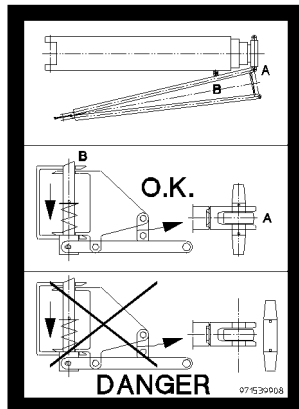

Fig.106041: Warning notice for unlocking the auxiliary boom



DANGER

Danger of fatal injury!

If the auxiliary boom is not locked correctly to the pulley head, it can fall down. Personnel can be severely injured or killed.

- ▶ Unpinning the auxiliary boom on the pivot section is prohibited.

1.64 978673908 – Warning of suspended load

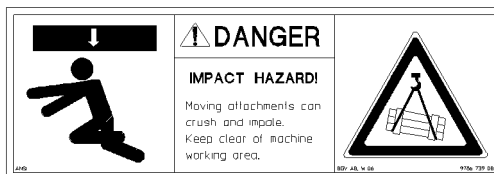

Fig.106026: Warning of suspended load



DANGER

Danger of fatal injury under suspended load!

- ▶ Standing under a suspended load is prohibited.
- ▶ Keep away from the working range of the machine.

1.65 978674008 – Access for unauthorized personnel prohibited



Fig.106037: Access for unauthorized personnel prohibited

**DANGER**

Danger of fatal injury!

If the crane or the working area is accessed by unauthorized personnel, life threatening injuries can occur as a result.

- ▶ It is prohibited for unauthorized personnel to enter the crane or the working area.

1.66 97039753 – Danger of stumbling

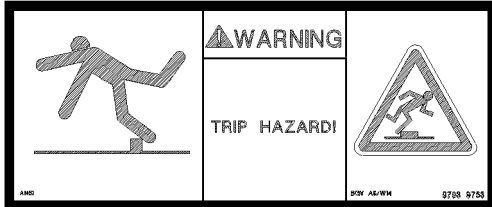

Fig.117346: Danger of stumbling

**WARNING**

Danger of stumbling!

- ▶ Move carefully.

1.67 978674108 – Warning of crushing danger

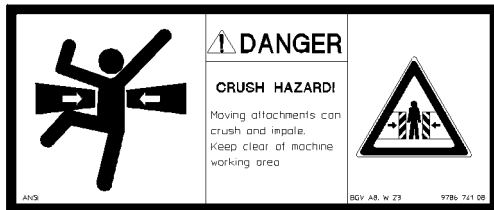

Fig.106027: Danger of crushing

**DANGER**

Danger of fatal injury when remaining in areas with crushing danger!

- ▶ It is prohibited for anyone to remain in areas where there is a crushing danger.
- ▶ Keep away from the working range of the machine.

1.68 97016911 – Danger of collision

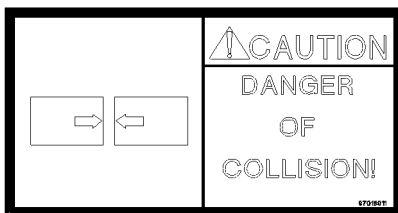

Fig.117344: Danger of collision

NOTICE

Danger of collision!
 ► Avoid a collision.

1.69 978674308 – Radio remote control

Fig.106047: Radio remote control

**WARNING**

Danger of injury due to crane operation with radio remote control!

- The crane can be operated with radio remote control!
- During crane operation, it is prohibited for anyone to remain in the danger zone!

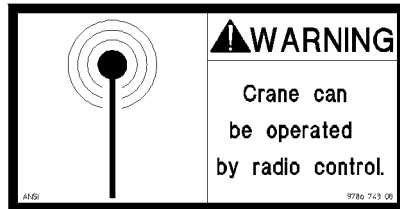
1.70 978674408 – Danger of burning hands

Fig.106028: Danger of burning hands

**WARNING**

Danger of burns when touching hot surfaces!

- Do not touch hot surfaces.

1.71 978674508 – Warning of rotating parts

Fig.106029: Warning of rotating parts

**WARNING**

Rotating parts!

The rotating fan blade can cause finger and hand injuries.

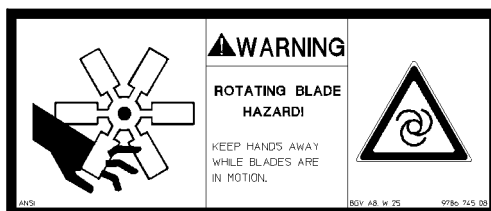
- Keep your hands away from the rotating fan blade.

1.72 978674608 - Crushing danger for hands



Fig.106030: Crushing danger for hands



WARNING

Danger of injuries for hands!

Hands can be caught, trapped or crushed within the danger zone.

► Keep hands away from the danger zone!

1.73 978674808 – Personal protective equipment



Fig.123900: Personal protective equipment



DANGER

Danger of falling!

► Use the personal protective equipment.

1.74 978674908 – Walking on the area is prohibited



Fig.106038: Walking on the area is prohibited



WARNING

Danger of accident!

If the prohibited area is accessed, accidents can occur.

Personnel can be severely injured or killed.

► Do not access the prohibited area.

1.75 978675008 – Access prohibited



Fig.106039: Access prohibited



WARNING

Danger of falling!

If the crane is accessed by unauthorized personnel, life threatening injuries can occur.

- ▶ Do not get on the crane.

1.76 978687408 – Rigging point



Fig.112475: Rigging point



WARNING

Rigging point!

- ▶ Use the rigging point **solely** for rigging.
- ▶ Lifting on the rigging point is prohibited.

1.77 97036734 – Rigging point

NOT FOR LIFTING!			
Type (t)	Lashing Capacity		
	LC-N [daN]	LC-Q [daN]	
4	4 000	2 800	
9,7	8 700	4 800	
10	10 000	7 000	
16	16 000	11 200	
31,5	31 500	22 050	

Diagram showing a rigging point with angles of 45° and 60° and a vertical line 'N'. Small text at the bottom left reads '97036734'.

Fig.116287: Rigging point



WARNING

Rigging point!

- ▶ Use the rigging point **solely** for rigging.
- ▶ Lifting on the rigging point is **prohibited**.

1.78 978867108 – Warning of fatal electric shock

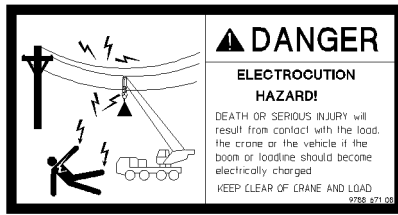

Fig.106814: Warning of fatal electric shock



DANGER

Danger of fatal injury due to electric shock!

If the boom or the hoist rope is under electric current, then death or severe injuries can occur if anyone touches the crane, the vehicle or the load.

► Keep away from the crane and the load.

1.79 97094940 – Spark catcher

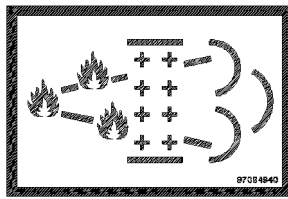

Fig.144735: Spark catcher



Note

► The exhaust system is equipped with an integrated spark catcher.

1.80 979383308 – Oil change

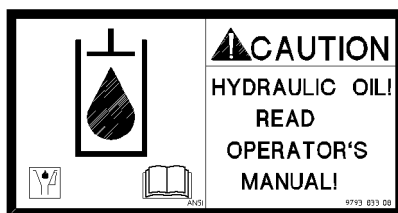

Fig.113827: Oil change



CAUTION

Property damage due to oil change!

If the oil specified in the operating instructions is not used during the oil change, it can lead to damage.

► See Crane operating instructions, chapter 7.07

1.81 979561108 – Counterweight

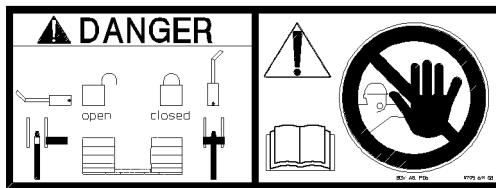

Fig.109026: Counterweight



WARNING

The counterweight can fall down!

If the auxiliary crane is removed on the counterweight before the counterweight is locked on both sides with the turntable, then the counterweight will fall down and can fatally injure assembly personnel.

- ▶ Do not remove the auxiliary crane until the counterweight is locked and secured on both sides with the turntable. See Crane operating instructions, chapter 4.07.

1.82 97001802 – Falling platform

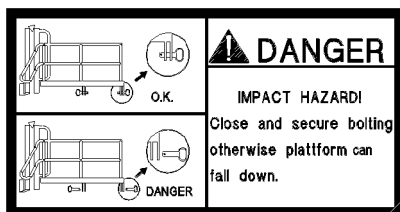

Fig.117345: Falling platform



WARNING

The platform can fall down!

- ▶ Pin and secure the platform in assembly / disassembly position.

1.83 973974408 - Transport weights of the components

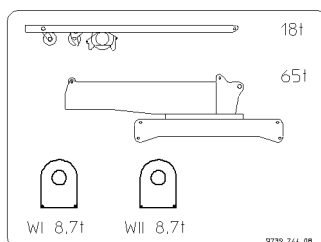

Fig.112440: Transport weights of the components

1.84 973974608 - Transport weights of the components

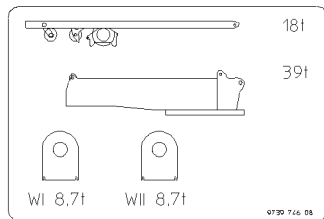

Fig.112441: Transport weights of the components

1.85 97011336 - Transport weights of the components

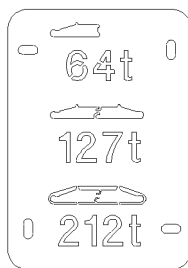

Fig.116271: Transport weights of the components

1.86 97068839 - Transport weights of the components / fastening length of the fastening equipment

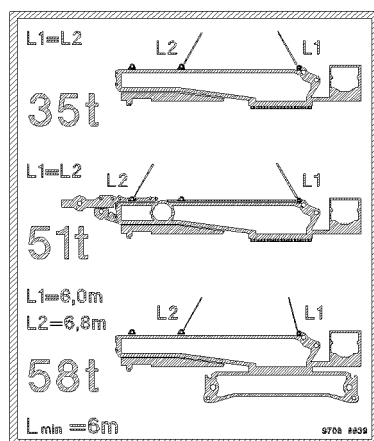
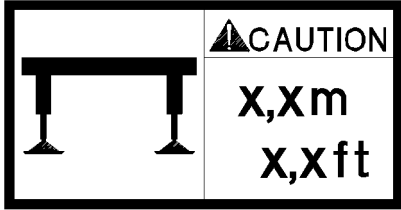

Fig.127587: Transport weights of the components / fastening length of the fastening equipment

1.87 Identification of sliding beam

	Identification of sliding beam
978675108	 <p style="text-align: center;"><i>Identification of sliding beam</i></p>
978675208	
978772808	
978772908	
978809308	
978809408	
978809508	
978818408	
978818508	
978875908	
978902608	
978903108	
97029203	
978903208	
979126008	
979126108	
979210508	
979210608	
979210608	
979210708	
979309108	
979309208	
97019140	
97003224	
979410808	

Identification of sliding beam



Note

- ▶ Extend the sliding beams to a support width of X.X m (X.X ft).

LWE/LR 11000-001/23501-04-02/en

1.88 Identification Track width retracted

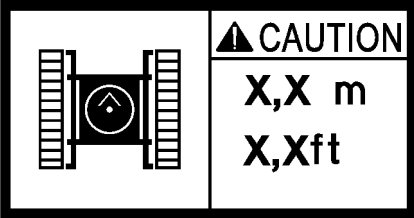
Identification Track width retracted	
97009840	 <p style="text-align: center;"><i>Identification of track width</i></p>
97009841	
97017044	
97017045	
97017046	

Identification of track width



Note

► Track width retracted to x.xx m (x.x ft)

1.89 976624808 – Fastening the load

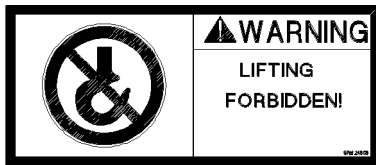

Fig.116283: Fastening the load



WARNING

Fastening the load is prohibited!

If the load is lifted on this point, the load can fall down and kill personnel.

► Lifting the load on unmarked locations is prohibited.

1.90 Note Weight sliding beams

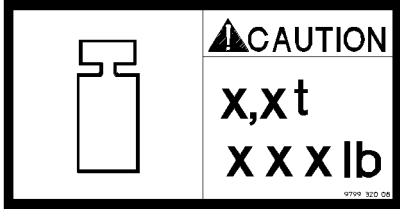
Weight of sliding beams	
979932008	 <p style="text-align: center;"><i>Weight of sliding beams</i></p>
979932108	
979932708	
979932808	



Note

► Pay attention to the weight of the sliding beams.

1.91 97047566 – Center of gravity Counterweight

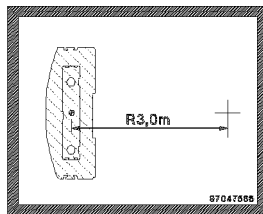

Fig.118491: Notice sign: Distance between center of gravity of counterweight and center of rotation



Note

► Noted on this notice sign is the distance between the center of rotation and the center of gravity of the counterweight.

1.92 97047566 – Center of gravity Counterweight

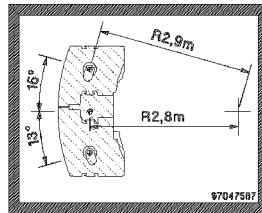

Fig.118492: Notice sign: Distance between center of gravity of counterweight and center of rotation



Note

- Noted on this notice sign is the distance between the center of rotation and the center of gravity of the counterweight.

1.93 97047566 – Center of gravity Counterweight

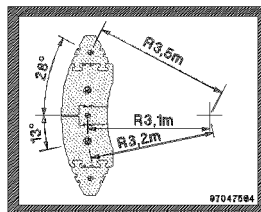

Fig.118493: Notice sign: Distance between center of gravity of counterweight and center of rotation



Note

- Noted on this notice sign is the distance between the center of rotation and the center of gravity of the counterweight.

1.94 97047566 – Center of gravity Counterweight

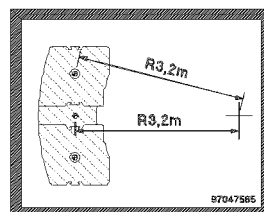

Fig.118494: Notice sign: Distance between center of gravity of counterweight and center of rotation

**Note**

- ▶ Noted on this notice sign is the distance between the center of rotation and the center of gravity of the counterweight.

1.95 97047566 – Center of gravity Counterweight

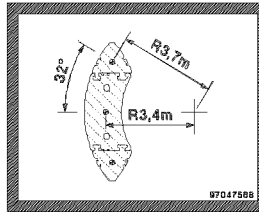

Fig.118495: Notice sign: Distance between center of gravity of counterweight and center of rotation

**Note**

- ▶ Noted on this notice sign is the distance between the center of rotation and the center of gravity of the counterweight.

1.96 97047566 – Center of gravity Counterweight

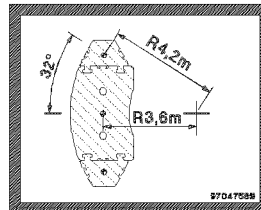

Fig.118496: Notice sign: Distance between center of gravity of counterweight and center of rotation

**Note**

- ▶ Noted on this notice sign is the distance between the center of rotation and the center of gravity of the counterweight.

1.97 Minimum rope reeving / minimum hook block weight



⚠ CAUTION					
LTM 1400-7.1			LTM 1450-8.1		
	 WT _{min} =?	 n _{min} =?		 WT _{min} =?	 n _{min} =?
TN			TN		
N-14,0m	3,1 t	n = 5	N-14,0m	3,1 t	n = 5
N-21,0m	2,6 t	n = 4	N-17,5m	2,6 t	n = 5
N-28,0m	1,4 t	n = 2	N-21,0m	2,6 t	n = 4
TN + 			N-24,5m	2,6 t	n = 4
N-14,0m	2,3 t	n = 3	N-28,0m	1,4 t	n = 2
N-21,0m	2,3 t	n = 2	TNH		
			N-14,0m	2,3 t	n = 3
			N-17,5m	1,8 t	n = 3
			N-21,0m	2,3 t	n = 2
			N-24,5m	1,8 t	n = 2

Fig.127972: Minimum rope reeving / minimum hook block weight with luffing lattice jib / boom nose

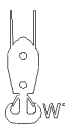
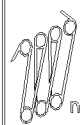
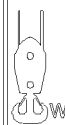

WARNING

Minimum rope reeving / minimum hook block weight not adhered to!
 Too low hook block weight leads to the formation of slack rope.
 Rope reeving too low, hoist rope is overloaded.
 ► Adhere to the hook block weight and hoist rope reeving.

Example: LTM 1400-7.1

With a luffing lattice jib -TN **N-21 m** a hook block with a weight of **2.6 t** **must** be installed and minimum rope reeving of **4** must be used.

With a luffing lattice jib **N-21 m** and boom nose a hook block with a weight of **2.3 t** **must** be installed and minimum rope reeving of **2** must be used.

2.05.10 Labeling of load lifting equipment

1	Identifications on the hook block or load hooks	3
2	Identifications on single hook or double hook	4
3	Identifications on auxiliary weights	5

Fig.195219

LWE/LR 11000-001/23501-04-02/en

1 Identifications on the hook block or load hooks

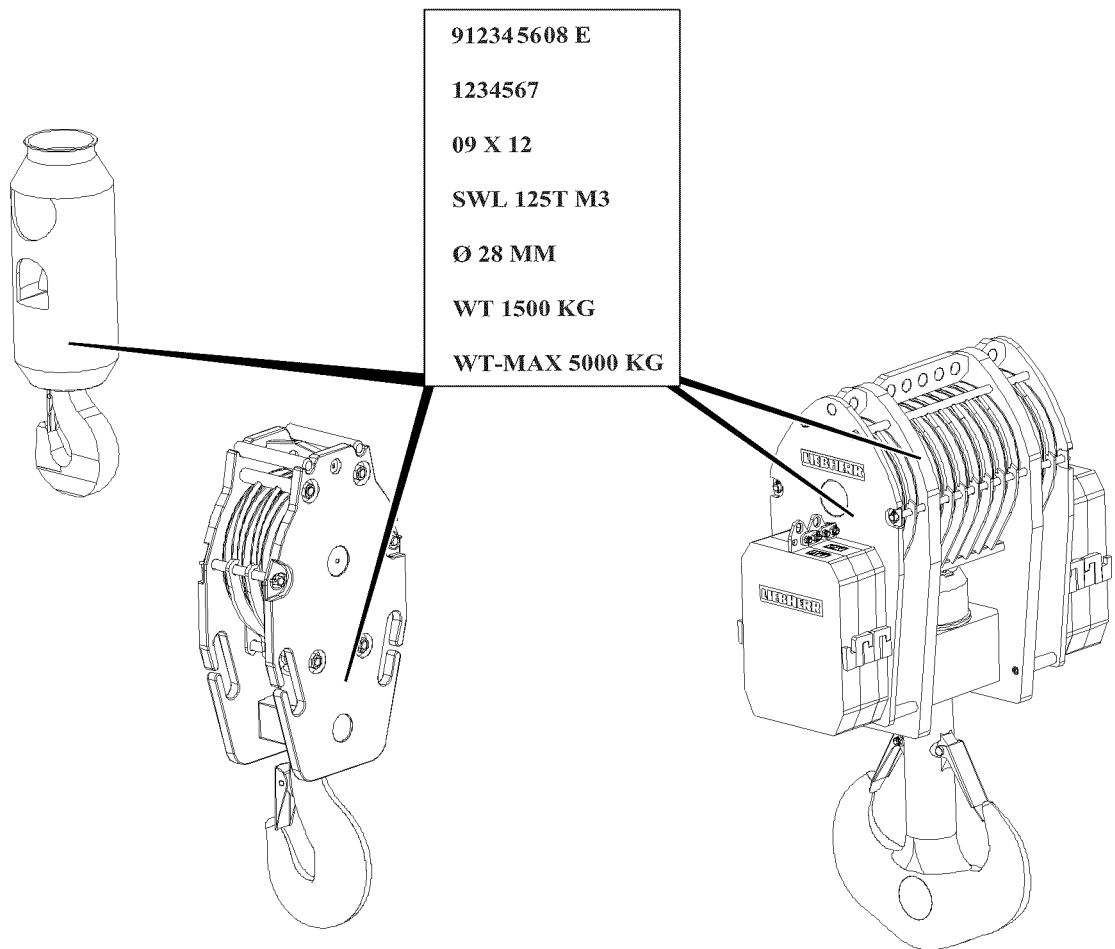

Fig.118509



Note

- ▶ For the load hooks and hook blocks approved for this crane type refer to the load chart.
- ▶ The hook blocks shown are examples only and can deviate from the existing hook block.

Punch mark area	Explanation
912345608 E	Liebherr Id. No. „E = entschärft (deburred)“
123456	Series or factory test number
09 X 12	Month of construction / supplier marks / year of construction
SWL 125T M3	SWL (Safe Working Load) = Load carrying capacity for power train group M3
Ø 28 mm	Hoist rope diameter
WT 1500 Kg	WT (Weight Tara) = Own weight (without auxiliary weights)

Punch mark area	Explanation
WT-MAX 5000 Kg	WT-Max = Maximum permissible own weight of lower pulley block and total number of progressively installed auxiliary weights
	Limits the number of installed auxiliary weights
	Determination via addition of assembled own weights (number of auxiliary weights + hook block)

Identifications on the hook block or load hooks

2 Identifications on single hook or double hook

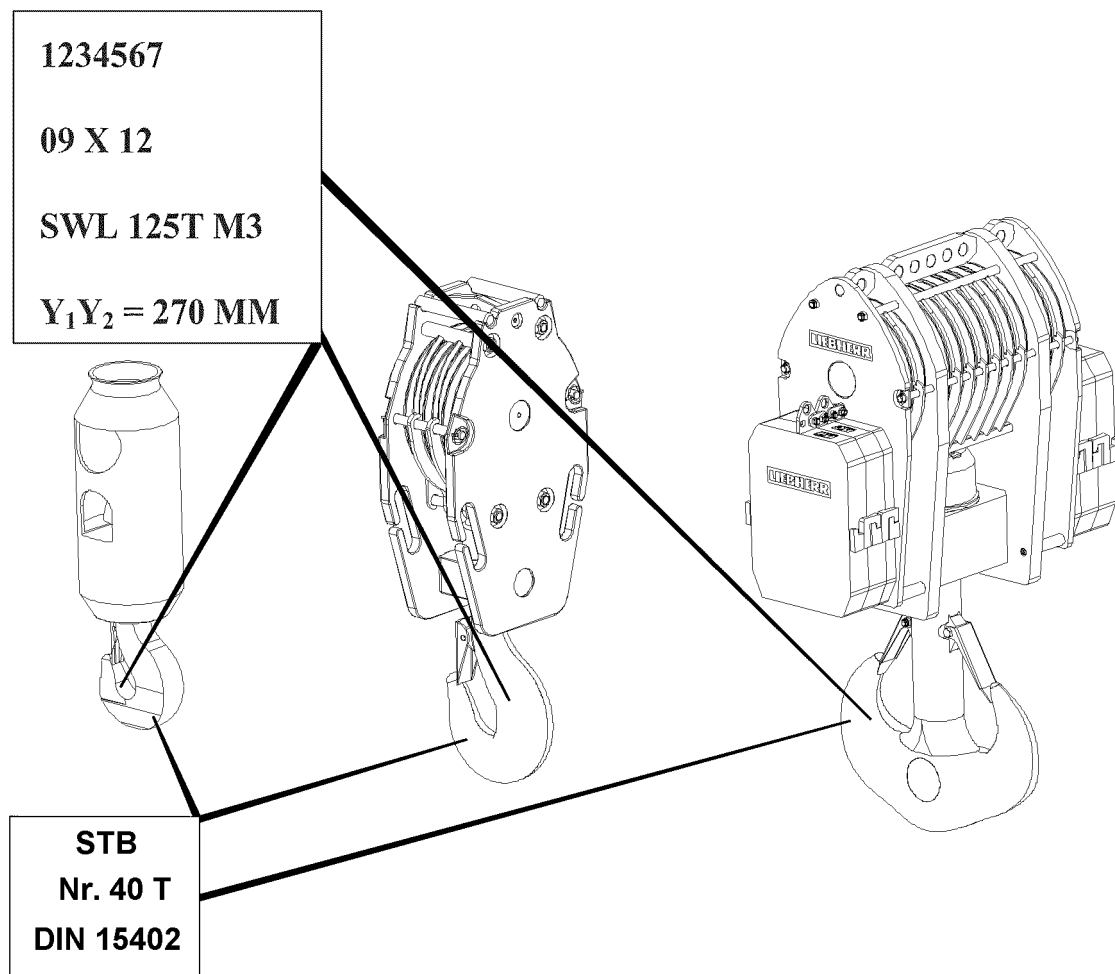

Fig.118510

Punch mark area	Explanation
STB	Hook manufacturer
40-T	Hook number + strength class according to DIN 15 400
DIN	Hook shape according to DIN 15 401 / DIN 15 402
123456	Series or factory test number
09 X 12	Month of construction / supplier marks / year of construction

Punch mark area	Explanation
SWL 125T M3	SWL (Safe Working Load) = Load carrying capacity for power train group M3
Y1Y2 = 270 mm	Dimension Y or dimension Y1 and dimension Y2 according to DIN (= Test dimensions for recurrent tests)

Identifications on single hook or double hook

3 Identifications on auxiliary weights

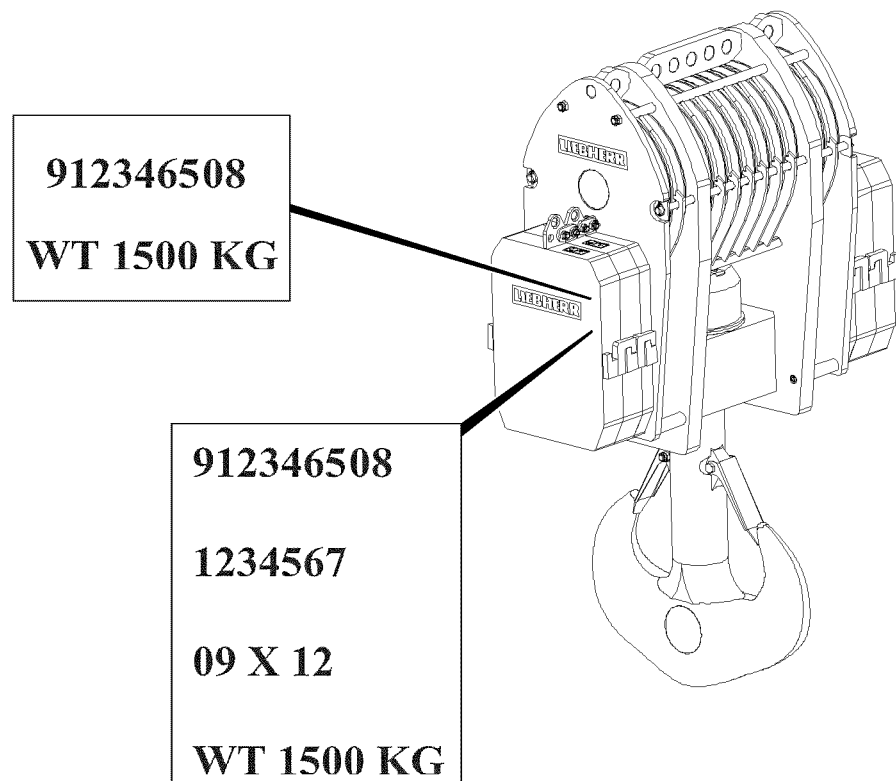

Fig.118511



Note

- The own weight of the individual auxiliary weight is noted on the side on the respective auxiliary weight.

3.1 Identifications on auxiliary weights at delivery

Punch mark area	Explanation
912346508	Liebherr Id. No.
WT 1500 Kg	WT (Weight Tara) = Own weight of individual auxiliary weight

Identifications of auxiliary weights at delivery

3.2 Identifications on auxiliary weights for reorder

Punch mark area	Explanation
912346508	Liebherr Id. No.
123456	Series or factory test number
09 X 12	Month of construction / supplier marks / year of construction
WT 1500 Kg	WT (Weight Tara) = Own weight of individual auxiliary weight

Identifications of auxiliary weights at reorder

2.06 Antifall guards on the crane

1	Personal protective equipment	3
2	Safety ropes as fall protection equipment	5
3	Platforms on the crawler carriers	15
4	Assembly of railing on crawler center section	19
5	Catwalk / stairs crawler travel gear	29
6	Disassembly Catwalk / stairs crawler travel gear	39
7	Ladder Turntable frame lower section	49
8	Catwalks and railing on the turntable frame main section	53
9	Main boom assembly platform on turntable	73
10	Cab platform rear	77
11	Ladder turntable frame main section	81
12	Stairs turntable frame main section	83
13	Railings on the S-pivot section	85
14	Fall protection equipment on the counterweight bracket	87
15	Fall protection equipment on counterweights	91
16	Railing on ballast trailer guide	93
17	Ladders on ballast trailer guide	95
18	Extension ladder on ballast trailer	97
19	Railing on ballast trailer	105

Fig.195219

LWE/LR 11000-001/23501-04-02/en

1 Personal protective equipment



Fig.123919



WARNING

Danger of falling!

During assembly / disassembly, inspection and maintenance work, personnel must be secured with appropriate aids to prevent them from falling.

Death, severe injury, property damage.

- ▶ All work aloft, where there is a danger of falling must be carried out with suitable aids.
- ▶ If aids are not available and work cannot be carried out from the ground, then the assembly personnel must secure themselves with the supplied fall arrest system to prevent falling, see Crane operating instructions, chapter 2.04.
- ▶ If fall protection equipment is available, then it must be used, see Crane operating instructions, chapter 2.06.
- ▶ When lifting, lowering, swinging crane parts in and out, no persons may remain in the danger zone.
- ▶ If railings are present for the crane, then they must be brought into the corresponding position and secured for assembly / disassembly work.
- ▶ It is prohibited to lean the auxiliary ladder against the component being disassembled.
- ▶ Only step on the aids, ladders and catwalks with clean shoes.
- ▶ Keep aids, ladders and catwalks free of heavy dirt, snow and ice.
- ▶ During all assembly and disassembly work, maintenance work and inspections, travel or crane operation is prohibited.
- ▶ Remaining on a suspended load is prohibited.
- ▶ Stepping or walking on crane components and lattice sections, which have an incline of more than 20° is prohibited.
- ▶ For all assembly work, the crane operator of the main crane must be in voice contact with the crane operator / crane operators of the auxiliary crane / auxiliary cranes.
- ▶ For assembly / disassembly tasks, the crane operator may only initiate crane movements when the responsible guide has explicitly released the movement.



WARNING

Danger of accident due to fall arrest system exposed to a fall!

If a fall arrest system is not replaced after a fall, then the fall arrest system can fail in case of a new fall.

Death, severe injury, property damage.

- ▶ After every fall, the fall arrest system must be removed and inspected by authorized and trained experts.
- ▶ The results must be documented in the inspection log book.
- ▶ Only after written release by expert personnel may the fall arrest system be reused.



Note

- ▶ The sign 3 marks the fastening points, where assembly personnel must hook in with a fall arrest system to secure themselves against falling.

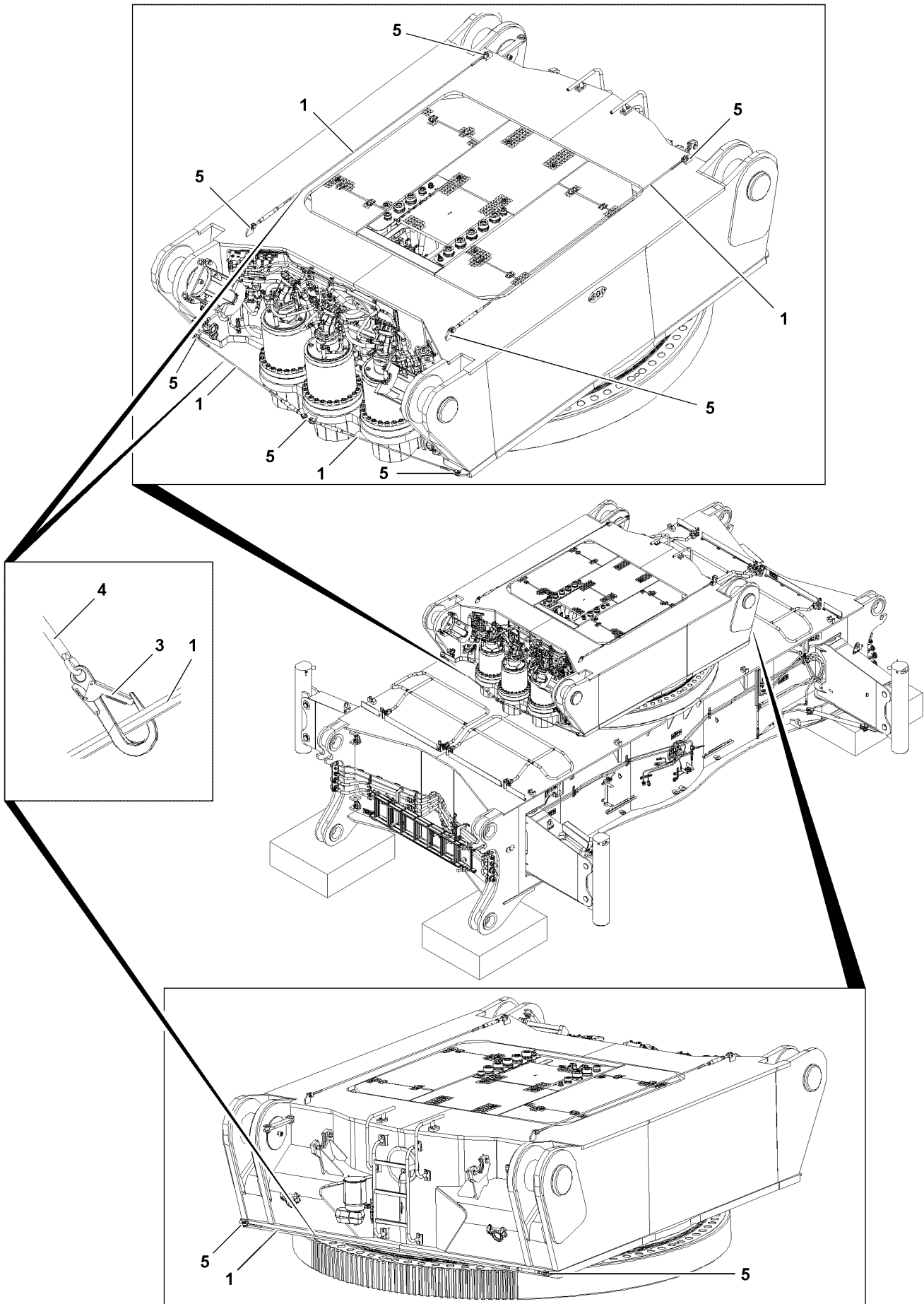

Fig.117738

LWE/LR 11000-001/23501-04-02/en

2 Safety ropes as fall protection equipment



WARNING

Danger of falling!

During assembly and disassembly, assembly personnel must be secured with appropriate aids to prevent them from falling.

Death, severe injury, property damage.

- ▶ Any work, where there is a danger of falling, must be carried out with suitable aids (for example: lifting platforms, scaffoldings, ladders, auxiliary crane).
- ▶ If the work cannot be carried out with such aids nor from the ground, then the assembly personnel must secure themselves with approved fall arrest systems **4** to avoid falling, see Crane operating instructions, chapter 2.04.
- ▶ The assembly personnel must hook themselves for all assembly / disassembly work, maintenance work and inspections with an approved fall arrest system **4** on the safety ropes **1** with both snap hooks **3** and secure themselves to prevent them from falling.
- ▶ Fall absorbers may not be used, because they stretch too much in case of a fall.
- ▶ On the safety ropes **1** on the left and right no more than maximum two persons may hook themselves with snap hooks **3** and to prevent them from falling.
- ▶ Transferring the snap hooks **3** is only permissible on the connection points.
- ▶ When transferring the snap hooks **3**, one snap hook **3** must always remain hooked on one safety rope **1**.
- ▶ Never release both snap hooks **3** simultaneously from the safety rope **1**.
- ▶ Before any assembly / disassembly work, maintenance and inspection work it must be ensured that all obstacles below the work place have been removed and that there is sufficient clearance in case of a fall.
- ▶ During all assembly / disassembly work, maintenance work and inspections, travel or crane operation is prohibited.

2.1 Safety ropes turntable frame lower section

NOTICE

Danger of damage!

- ▶ Never hang loads or objects on the safety ropes **1**.

2.2 Safety ropes on lattice sections

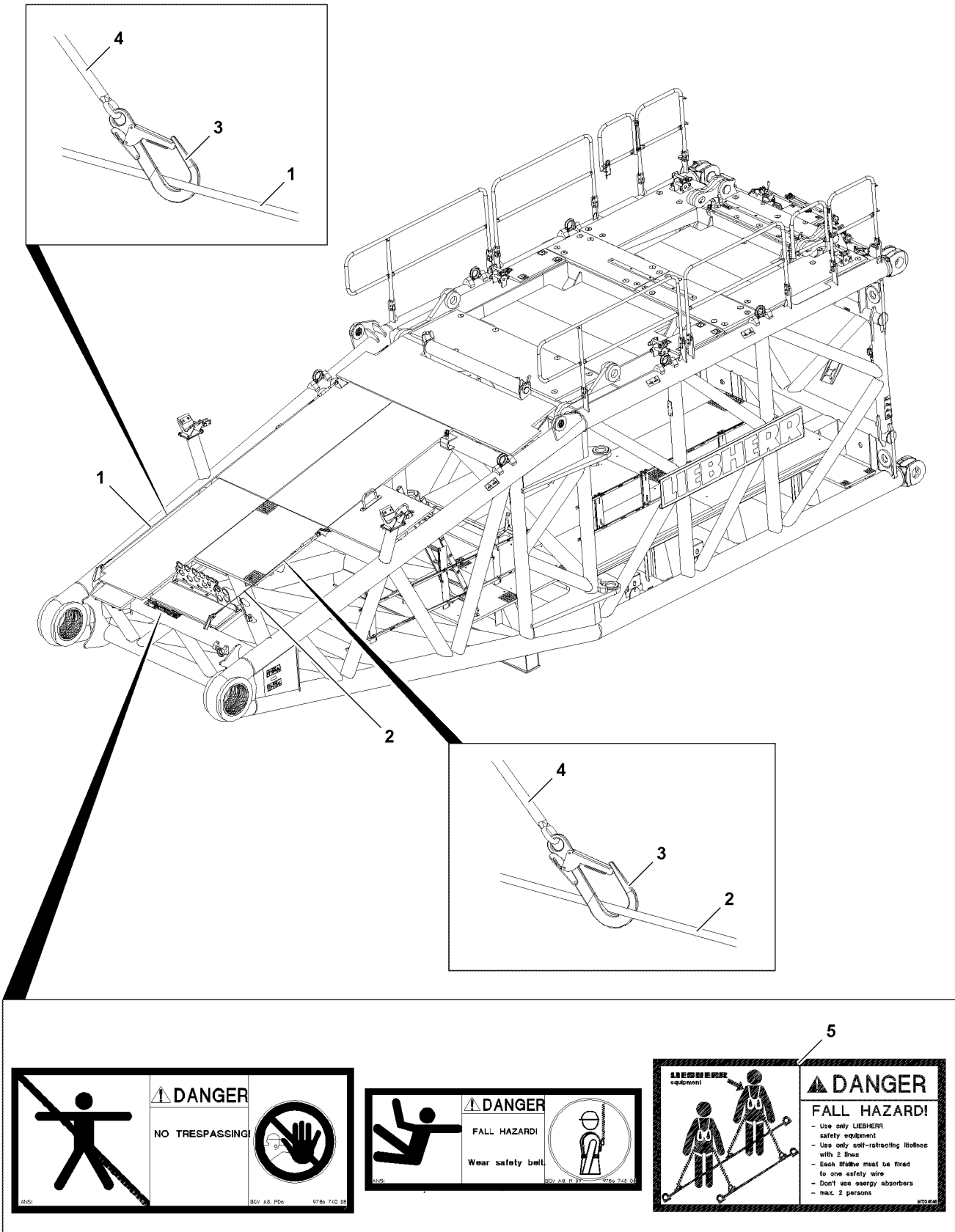
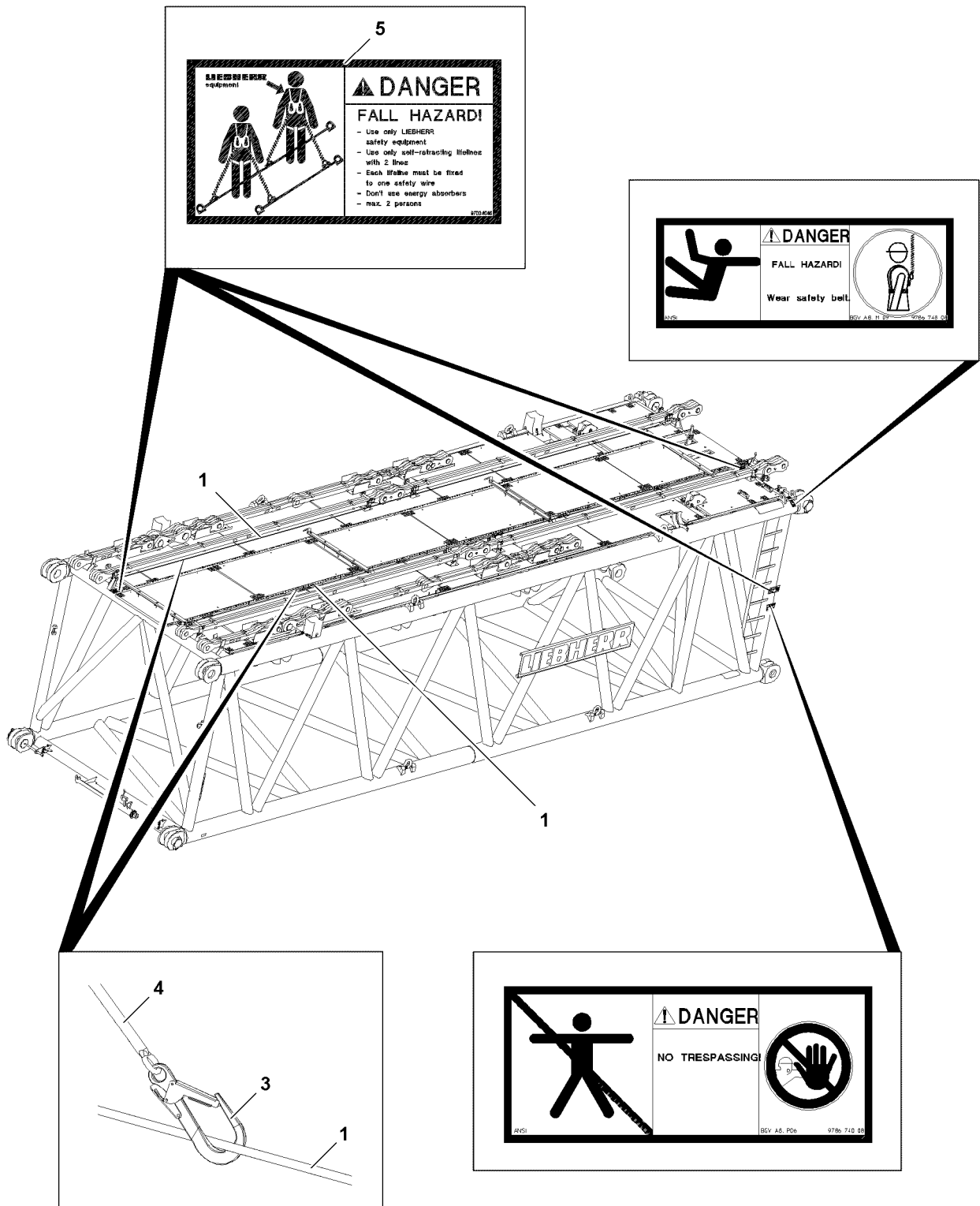

Fig.117740: S-pivot section

LWE/LR 11000-001/23501-04-02/en



LWE/LR 11000-001/23501-04-02/en

Fig.117741: S-intermediate section (6.0 m and 12.0 m) // S-adapter

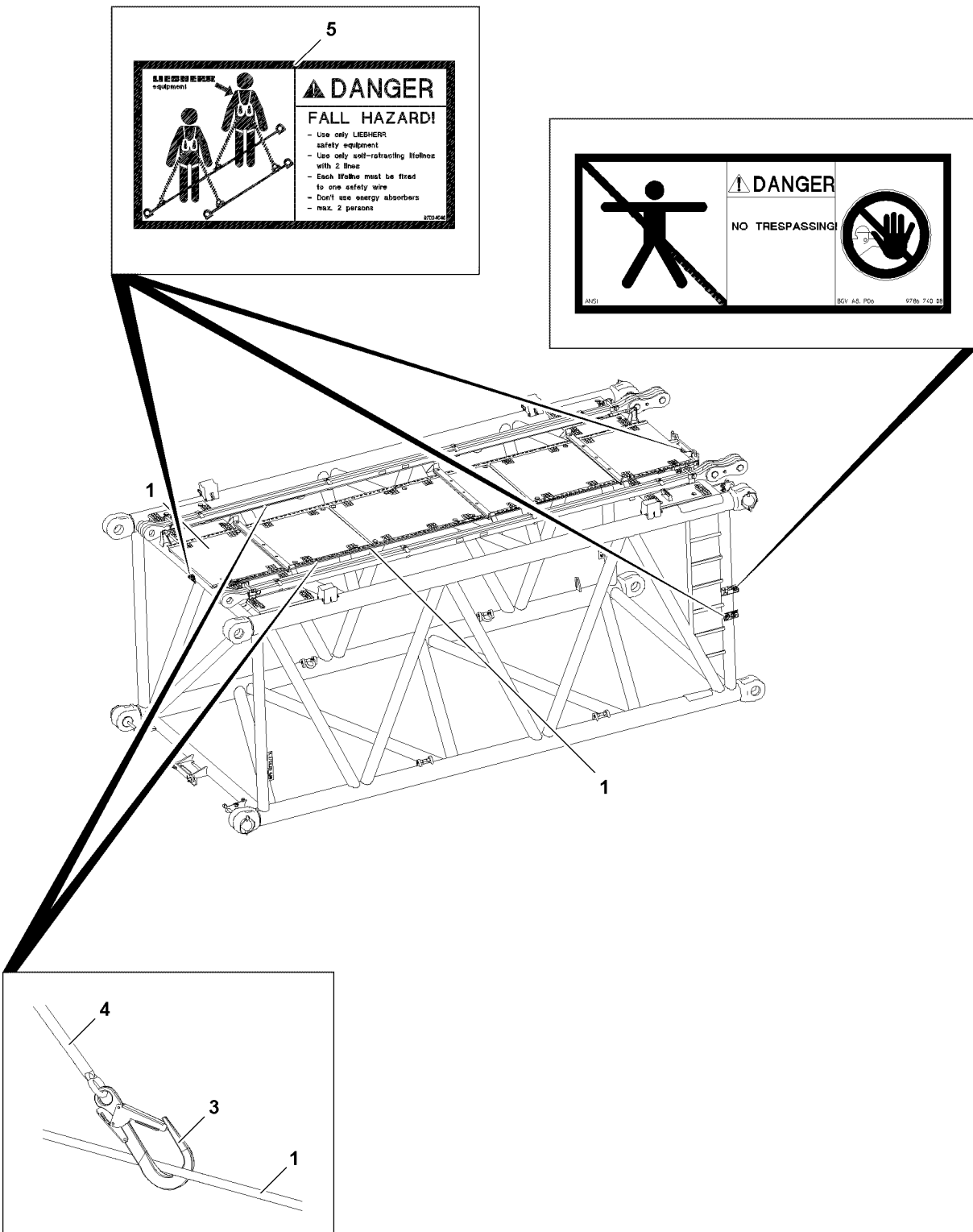

Fig.117742: L-intermediate section (6.0 m and 12.0 m) // SL-reducer section

LWE/LR 11000-001/23501-04-02/en

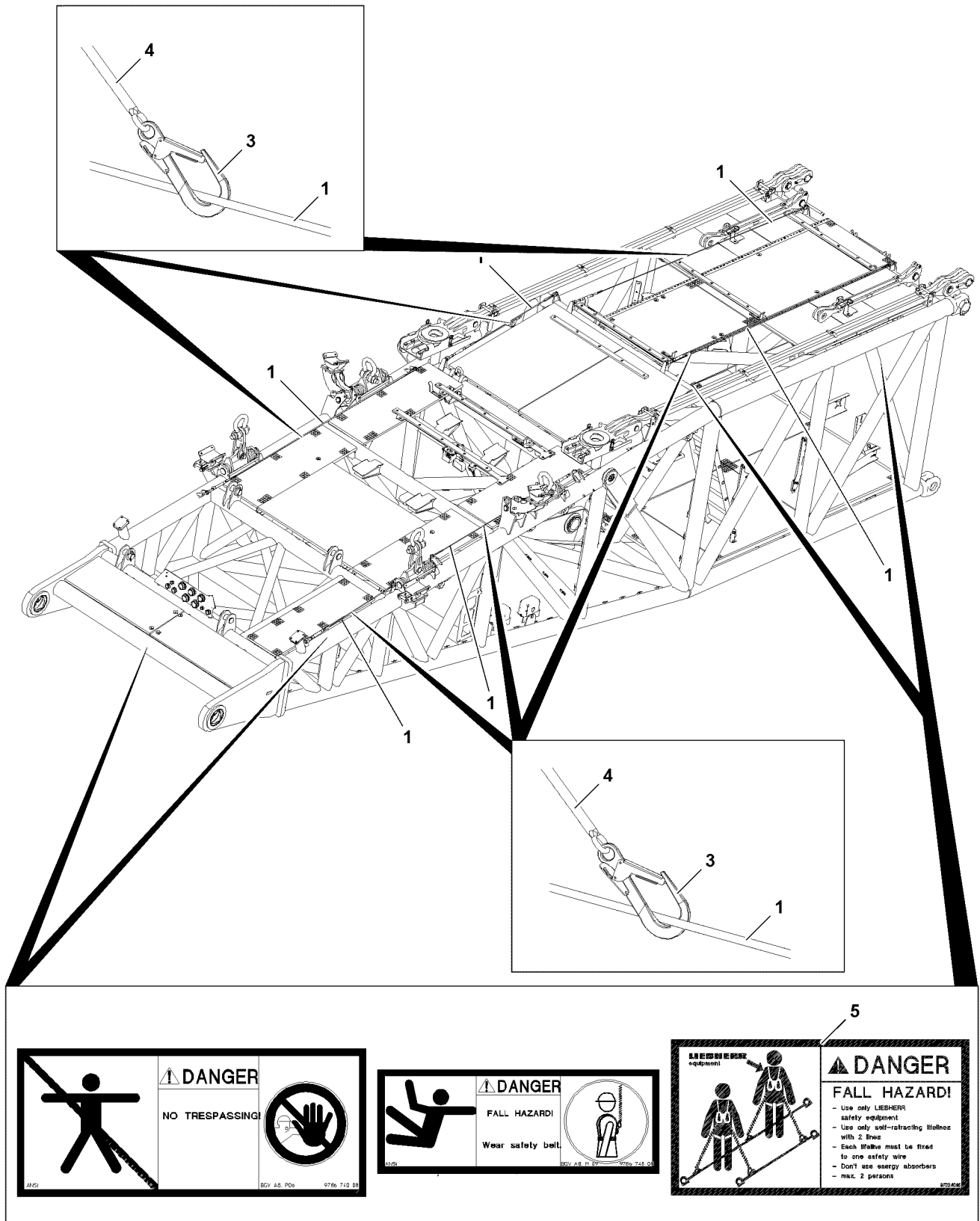

Fig.117743: D-pivot section

LWE/LR 11000-001/23501-04-02/en

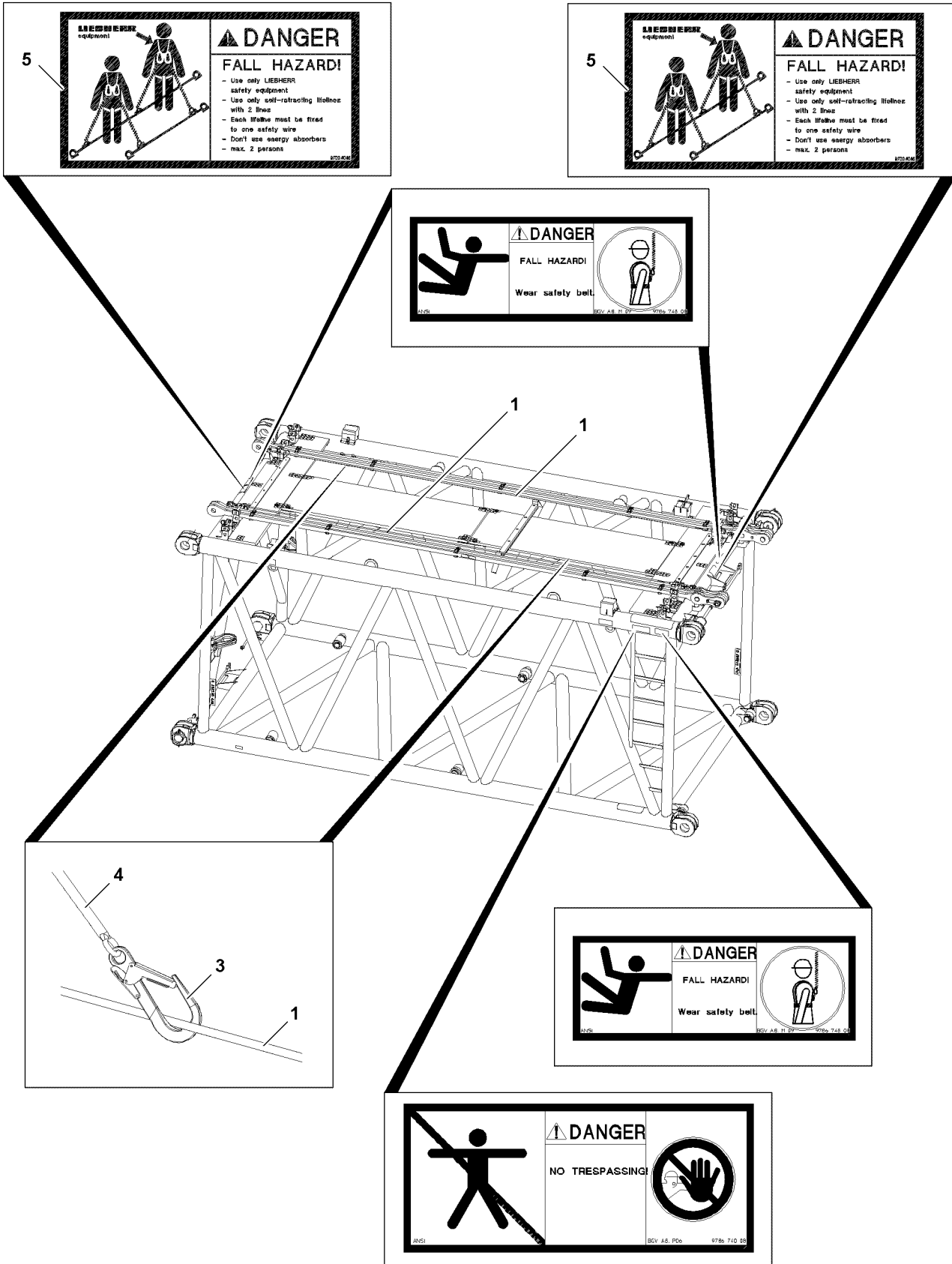

Fig.117746: D-intermediate section (6.0 m and 12.0 m)

LWE/LR 11000-001/23501-04-02/en

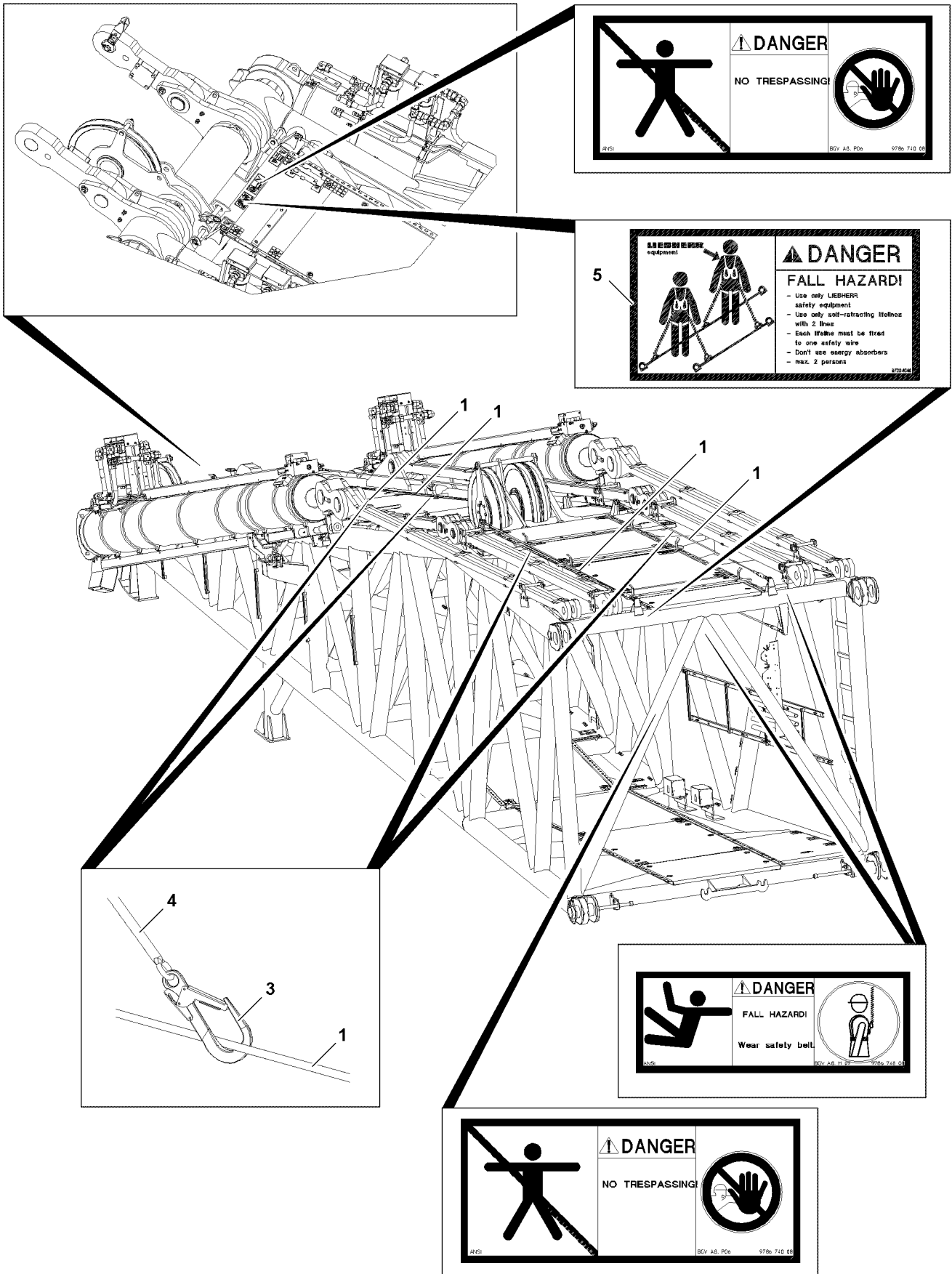

Fig.117744: D-end section

LWE/LR 11000-001/23501-04-02/en

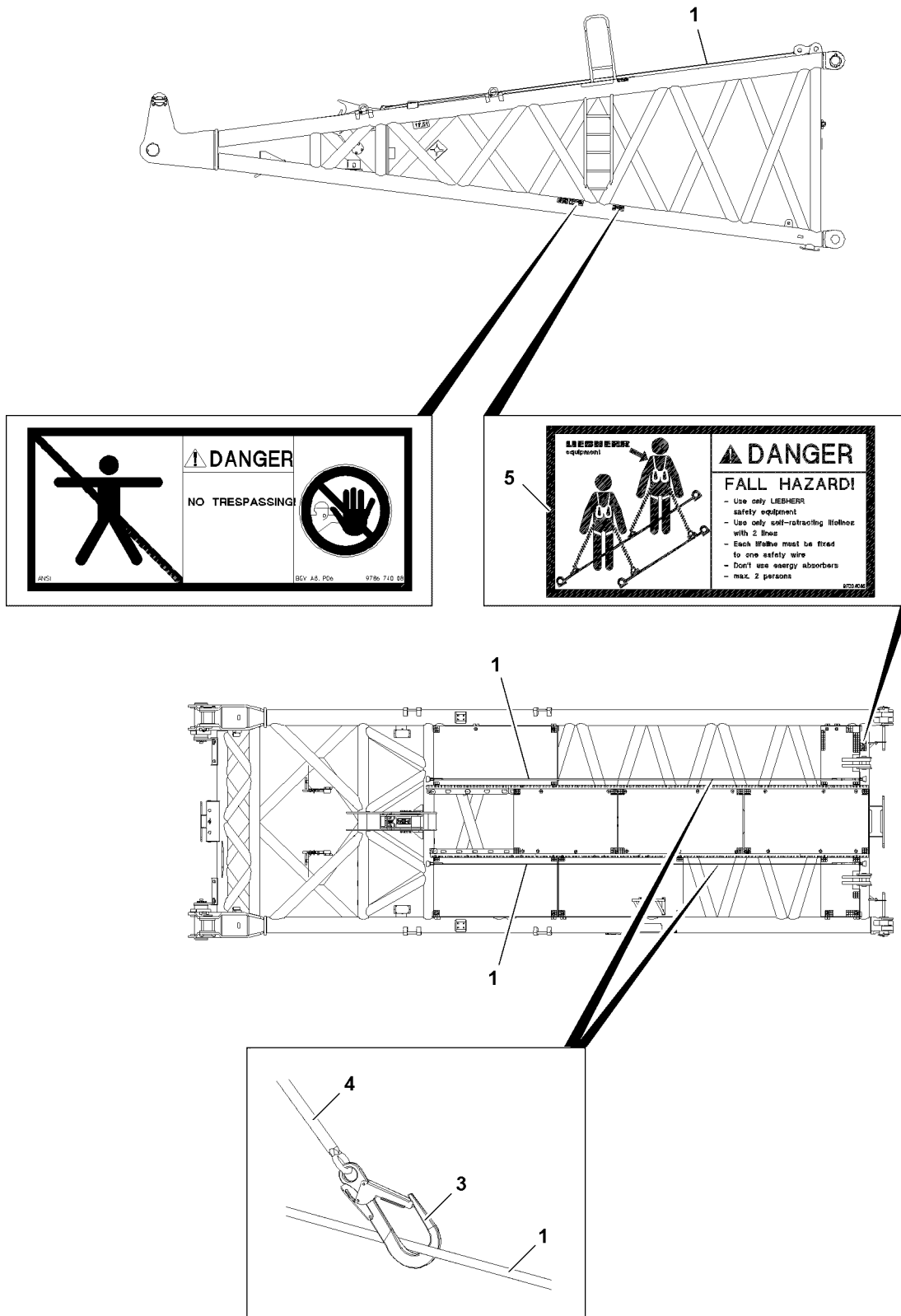

Fig.117745: W-pivot section

LWE/LR 11000-001/23501-04-02/en

2.3 Replacing safety ropes subjected by a fall



WARNING

Danger of accidents due to fall subjected safety ropes!

If fall subjected safety ropes **1** are not replaced after a fall, then the safety ropes can fail in case of another fall.

Death, severe injury, property damage.

- ▶ **Expert personnel** must immediately replace any safety ropes **1** which were subjected in a fall and inspect the respective anchor points **3** for damage.
 - ▶ If the anchor points **3** are damaged, then they must be replaced immediately by **expert personnel**.
 - ▶ Only after a written release by **expert personnel** may the safety ropes **1** and the respective anchor points **3** be put into operation.
-

2.4 Inspection of safety ropes and anchor points

For detailed description of „Inspection of safety ropes and anchor points“ refer to the Crane operating instructions, chapter 8.01.

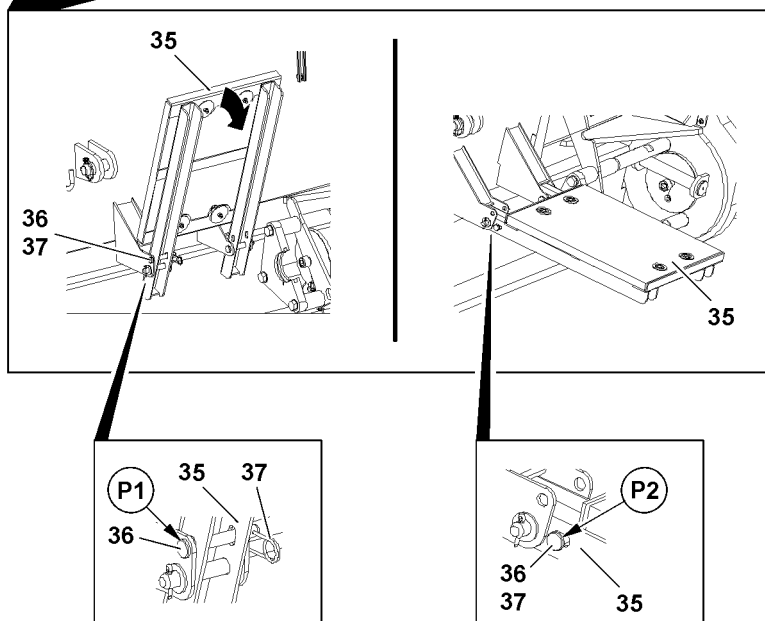
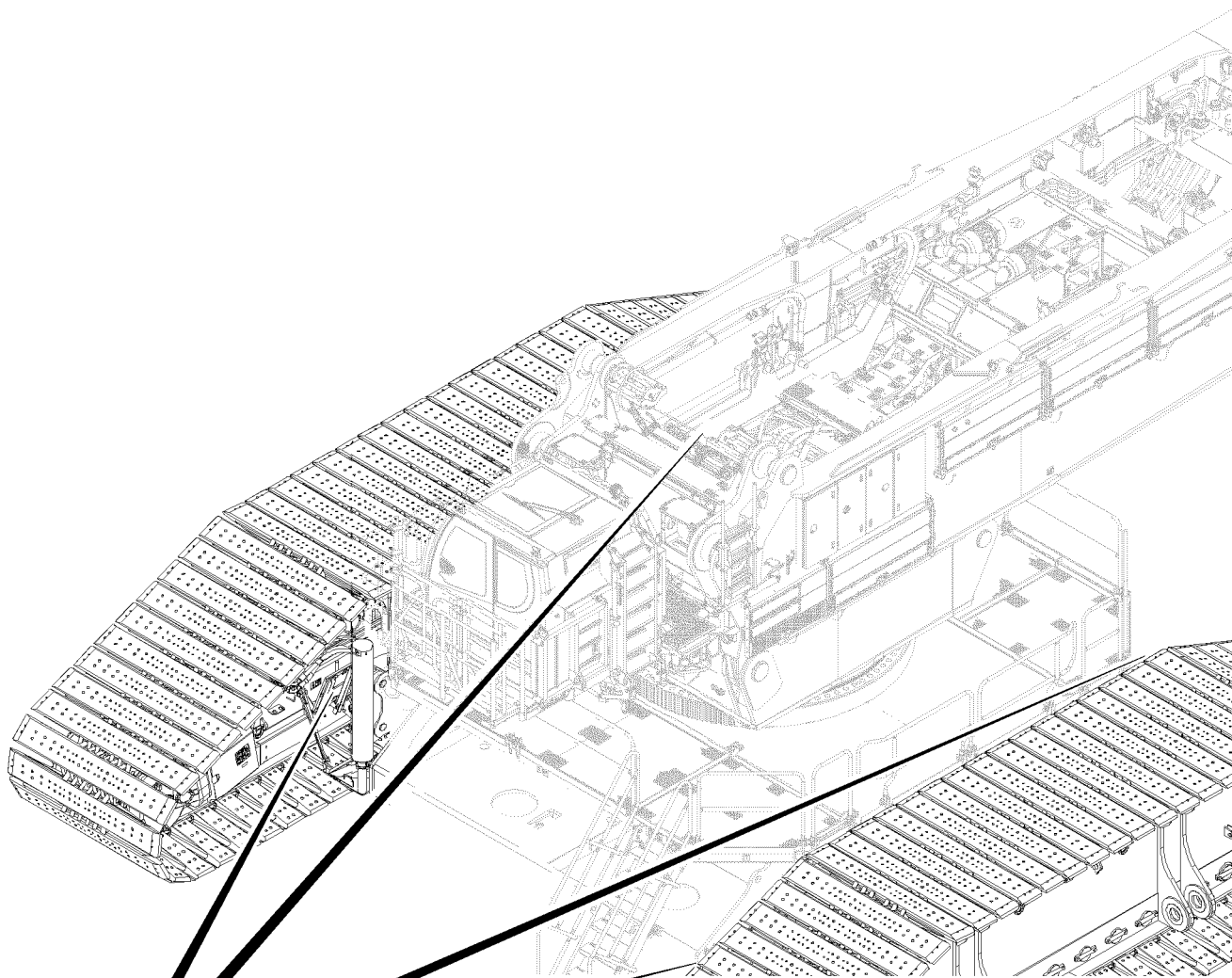

Fig.118183

LWE/LR 11000-001/23501-04-02/en

3 Platforms on the crawler carriers



Note

- ▶ The platforms **35** on the crawler carriers are used for better accessibility of the upper pin points at assembly of the crawler carriers on the crawler center section.
- ▶ Two platforms each are on each crawler carrier.

NOTICE

Damage of platforms!

If the platforms **35** are in operating position during crane operation, then the platforms **35** can be damaged.

- ▶ Make sure that the platforms **35** are in operating position during crane operation.



WARNING

Danger of crushing!

When folding down the platforms **35**, fingers or limbs can be crushed and personnel can be severely damaged.

- ▶ Do not reach into the danger zone.
- ▶ Hold the platform **35** before unpinning of pin **36**.

3.1 Folding the platform down from transport position into operating position

- ▶ Hold the platform **35** in transport position.
- ▶ Remove the spring retainer **37** and unpin the pin **36** at point **P1**.
- ▶ Fold the platform down into operating position.

When the platform is in operating position:

- ▶ Insert the pin **36** on point **P2** and secure with spring retainer **37**.

Result:

- The platform is in operating position.

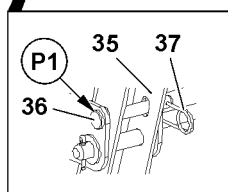
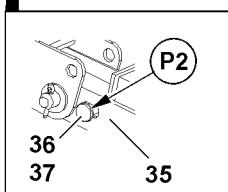
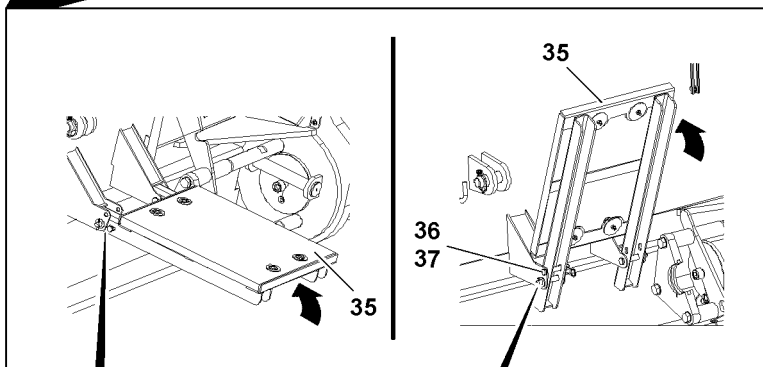
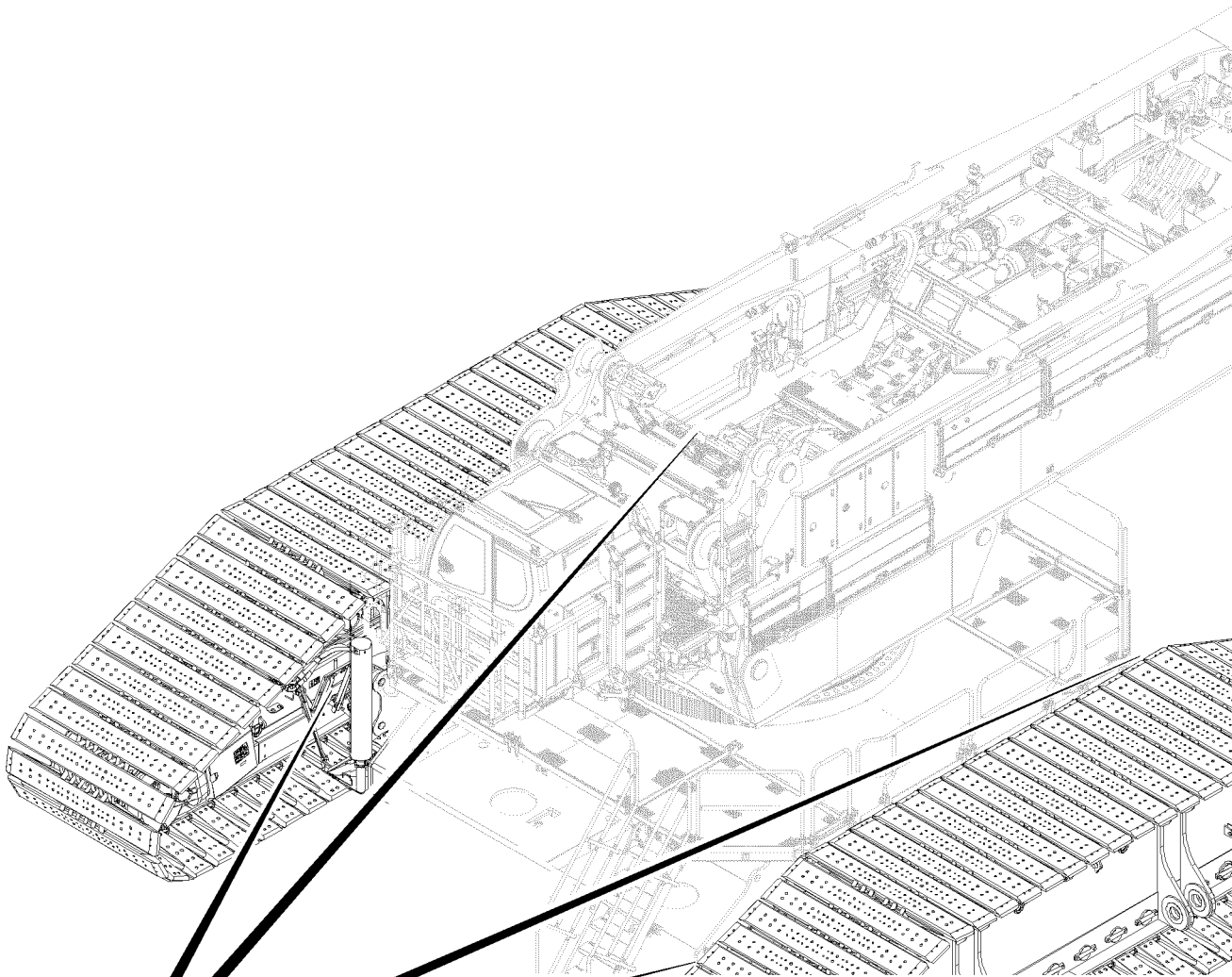

Fig.118185

LWE/LR 11000-001/23501-04-02/en

3.2 Folding the platform from operating position into transport position

- ▶ Remove the spring retainer **37** and unpin the pin **36** at point **P2**.
- ▶ Fold the platform **35** up into transport position.

When the platform is in transport position:

- ▶ Insert the pin **36** on point **P1** and secure with spring retainer **37**.

Result:

- The platform is in transport position.

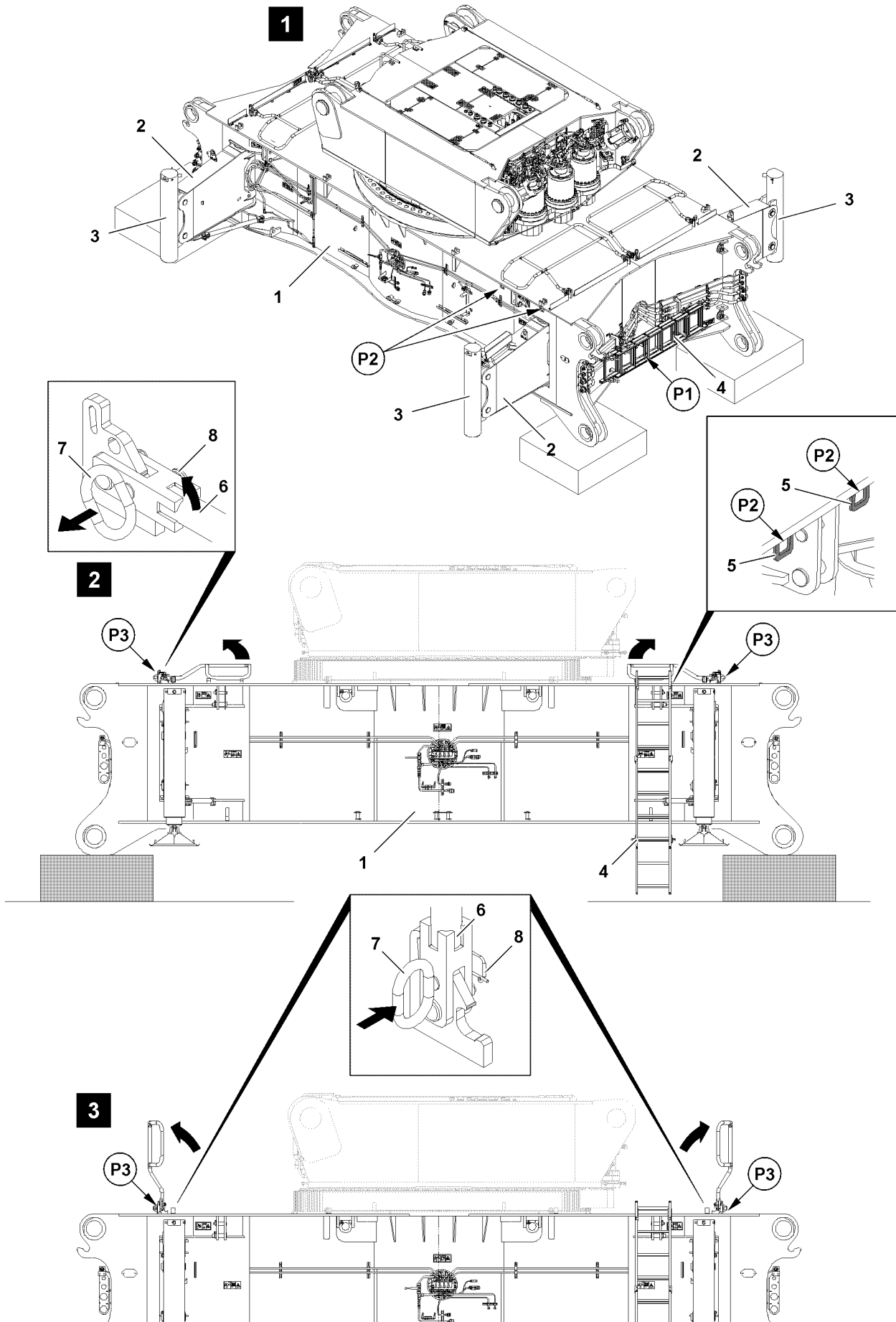

Fig.119726

LWE/LR 11000-001/23501-04-02/en

4 Assembly of railing on crawler center section



WARNING

Danger of falling!

During assembly and disassembly of the railing, personnel must be secured with appropriate aids to prevent them from falling.

Even at the assembly of protective equipment there is a danger of falling.

Death, severe injury, property damage.

- ▶ Hang the personal protective equipment on the provided safety ropes.
 - ▶ Keep a safety distance to edges.
-

4.1 Bringing the extension ladder into operating position

Make sure that the following prerequisites are met:

- The crawler center section **1** is laying properly on the support.
- The hydraulic assembly supports **2** are swung out and properly pinned.
- The crawler center section **1** is horizontally aligned.
- ▶ Remove the extension ladder **4** from the transport position at point **P1**.
- ▶ Extend the extension ladder **4** to the maximum length and lock.
- ▶ Hang the extension ladder **4** with hooks **4.1** on the bars **5** (points **P2**).

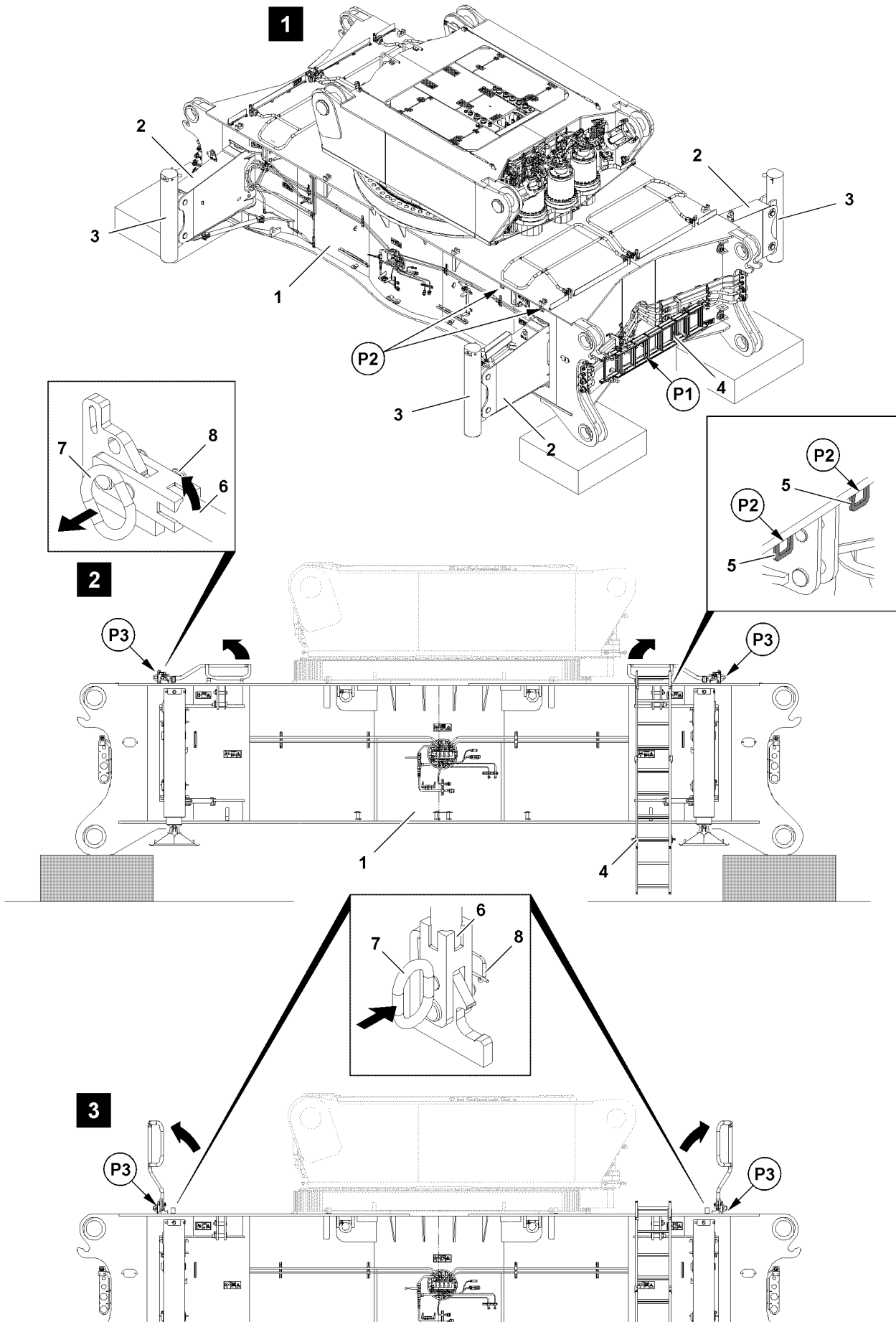

Fig.119726

LWE/LR 11000-001/23501-04-02/en

4.2 Swinging the railing on the crawler center section into operating position

Make sure that the following prerequisites are met:

- Both extension ladders **4** are properly installed on the crawler center section **1**.



WARNING

Danger of falling!

During assembly and disassembly of the railing, personnel must be secured with appropriate aids to prevent them from falling.

Even at the assembly of protective equipment there is a danger of falling.

Death, severe injury, property damage.

- ▶ Hang the personal protective equipment on the provided safety ropes.
- ▶ Keep a safety distance to edges.

- ▶ Release the railing **6** from the transport position: Remove the spring retainer **8** and unpin the pin **7**, see illustration **2**.



WARNING

Danger of crushing!

When swinging the railings **6**, fingers and hands can be crushed.

- ▶ Do not reach with your hands into the danger zone.

When the railings **6** are released:

- ▶ Swing the railing **6** into operating position.
- ▶ Secure the railing **6** in operating position: Insert the pin **7** and secure with spring retainer **8**, see illustration **3**.



Note

- ▶ The procedure to install the railing on the opposite side is identical with the above procedure.

- ▶ Bring the railing **6** on the opposite side in operating position.

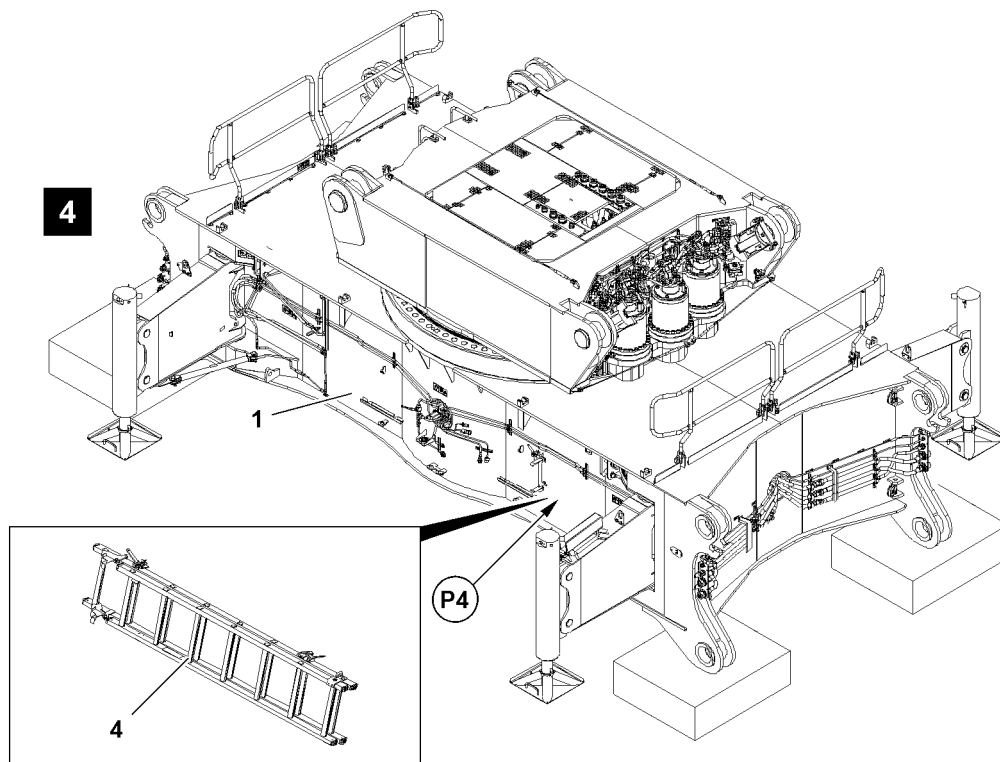

Fig.119727

4.3 Placing the extension ladder down in park position for assembly

**Note**

- ▶ Remove the extension ladder from the operating position and place it in park position before installation of the central ballast.
- ▶ Place the extension ladder alternatively outside the crane operating range.
- ▶ If the extension ladder is in park position when the central ballast is installed, then the extension ladder is no longer accessible.

Make sure that the following prerequisites are met:

- The turntable frame main section is properly assembled and secured on the crawler center section.
- The SA-frame is properly assembled and secured on the turntable frame main section.
- The crawler carriers are properly assembled and secured on the crawler center section.
- ▶ Unhook the extension ladder **4** from operating position.
- ▶ Slide the extension ladder **4** together to short length and lock.
- ▶ Hang the extension ladder **4** in park position on the side on the crawler center section, point **P4**.
- ▶ Secure the extension ladder **4** properly in park position.

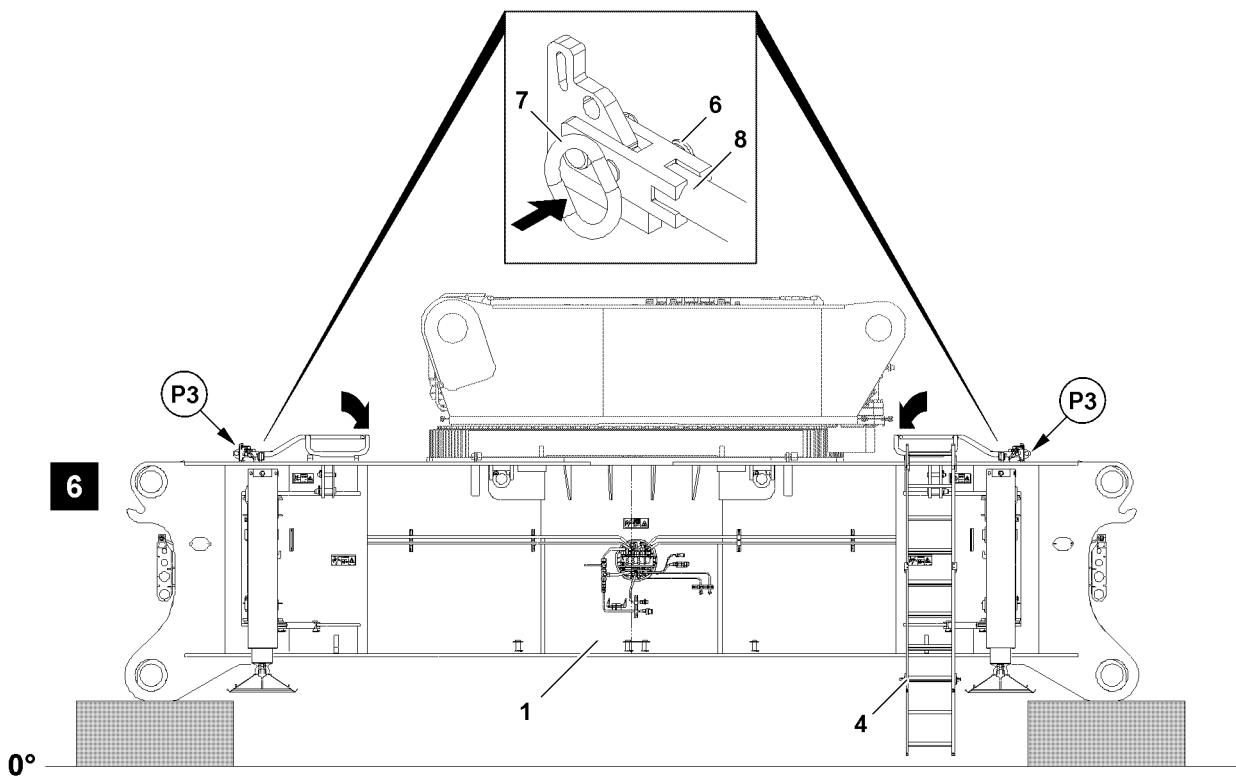
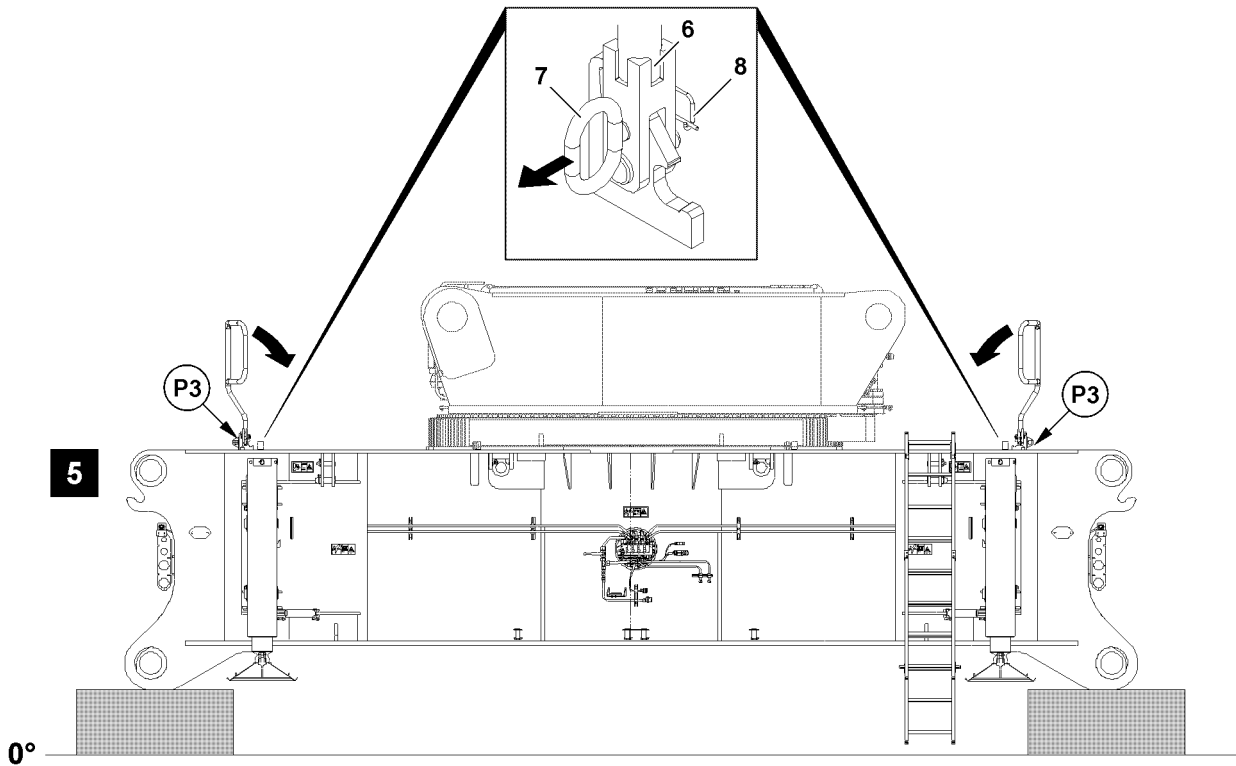

Fig.119728

LWE/LR 11000-001/23501-04-02/en

4.4 Swinging the railing on the crawler center section into transport position

Make sure that the following prerequisites are met:

- Both extension ladders **4** are properly installed on the crawler center section **1**.



WARNING

Danger of falling!

During assembly and disassembly of the railing, personnel must be secured with appropriate aids to prevent them from falling.

Even for assembly and disassembly of protective devices there is a danger of falling.

Death, severe injury, property damage.

- ▶ Hang the personal protective equipment on the provided safety ropes, see section „Safety ropes as fall protection“.
- ▶ Keep a safety distance to edges.

- ▶ Release the railing **6** in operating position: Remove the spring retainer **8** and unpin the pin **7**.



WARNING

Danger of crushing!

When swinging the railings **6**, fingers and hands can be crushed.

- ▶ Do not reach with your hands into the danger zone.

When the railings **6** are released:

- ▶ Swing the railing **6** into transport position.
- ▶ Secure the railings **6** in transport position: Insert the pin **7** and secure with spring retainer **8**, see illustration **2**.



Note

- ▶ The procedure to remove the railing on the opposite side is identical with the above procedure.
- ▶ Bring the railing **6** on the opposite side on the crawler center section **1** into transport position as described above.

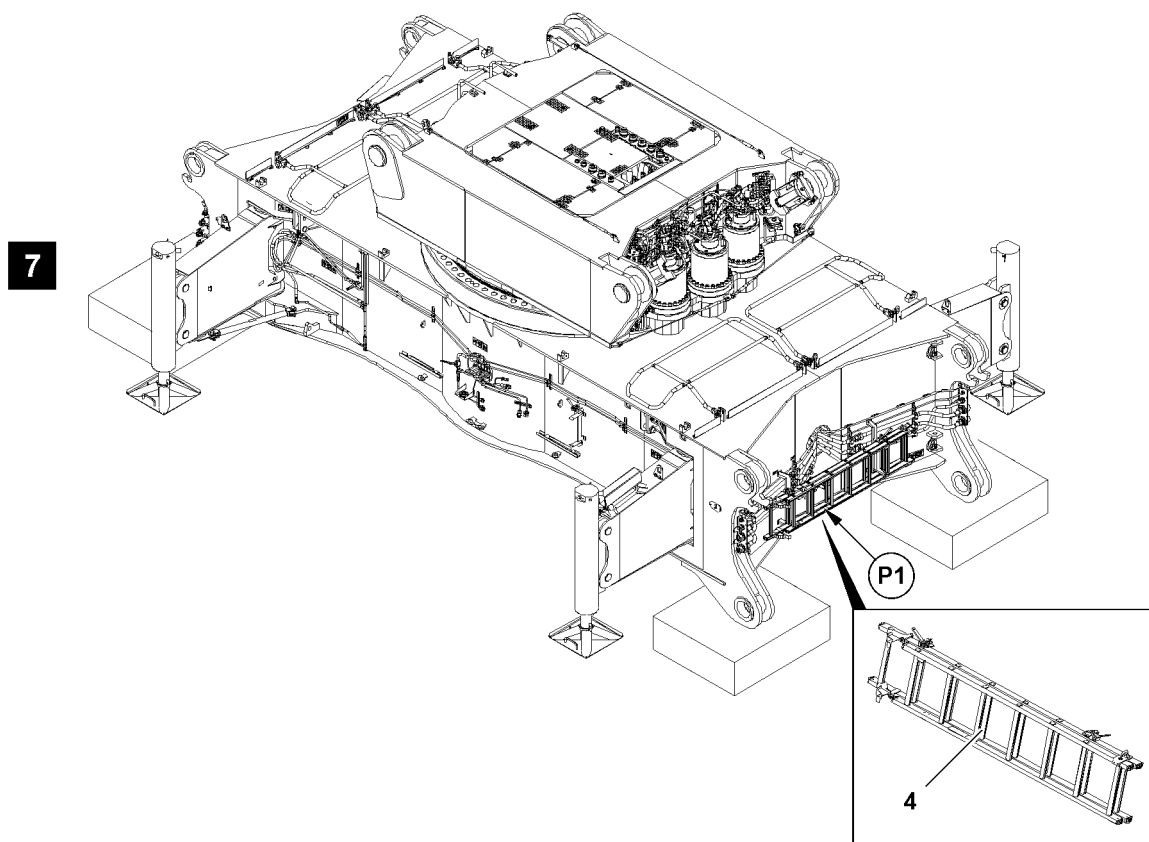

Fig.119729

4.5 Bringing the extension ladder into transport position

Make sure that the following prerequisites are met:

- The central ballast is removed.
 - The crawler carriers are removed.
 - The crawler center section **1** is laying properly on the support.
 - The hydraulic assembly supports **2** are swung out and properly pinned.
 - The crawler center section **1** is horizontally aligned.
- ▶ Unhook the extension ladder **4** from operating position.
 - ▶ Slide the extension ladder **4** together to short length and lock.
 - ▶ Hang the extension ladder **4** in transport position on the crawler center section, point **P1**.
 - ▶ Secure the extension ladder **4** properly in transport position.

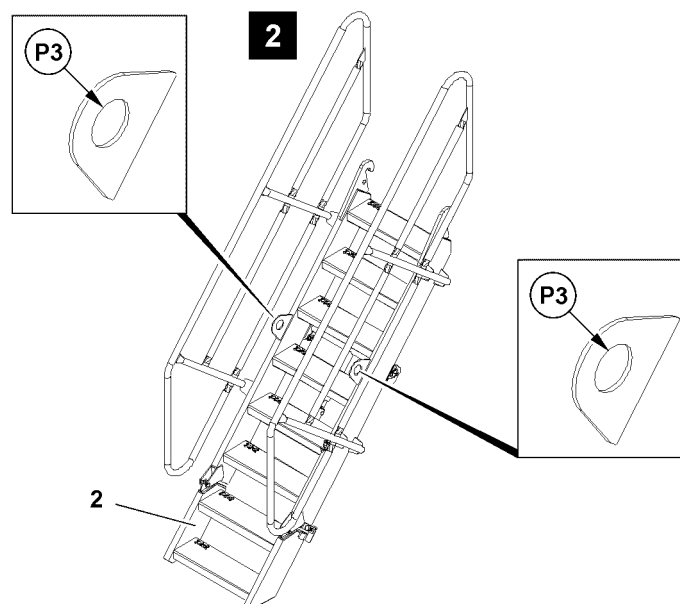
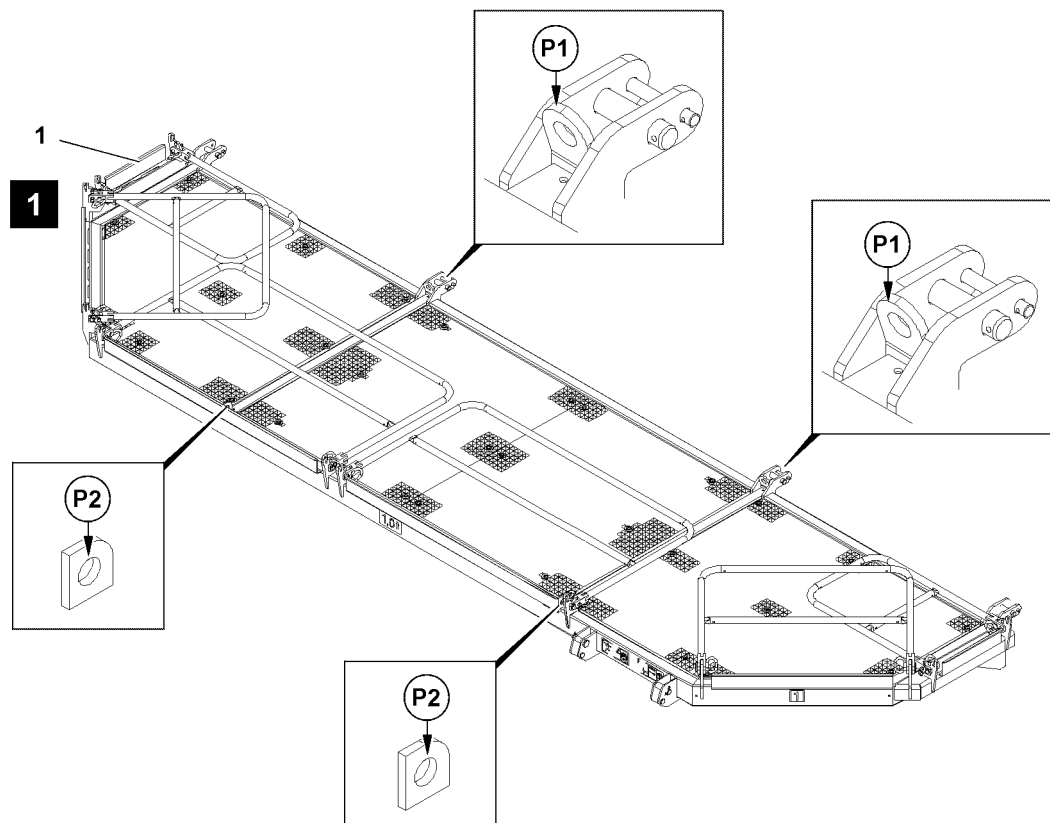

Fig.117739

5 Catwalk / stairs crawler travel gear

5.1 Fastening points catwalk / stairs

Fastening points	
P1 + P2	Catwalk 1 with railing

Fastening points	
P3	Stairs 2 with railing



WARNING

Component incorrectly fastened!

Life-threatening situations can arise if components are incorrectly or improperly fastened.

Components can fall down.

Death, severe injury, property damage.

- ▶ Attach the components only on the intended fastening points.
- ▶ Make sure that there are no persons within the danger zone.
- ▶ Make sure that there are no obstacles within the assembly area.

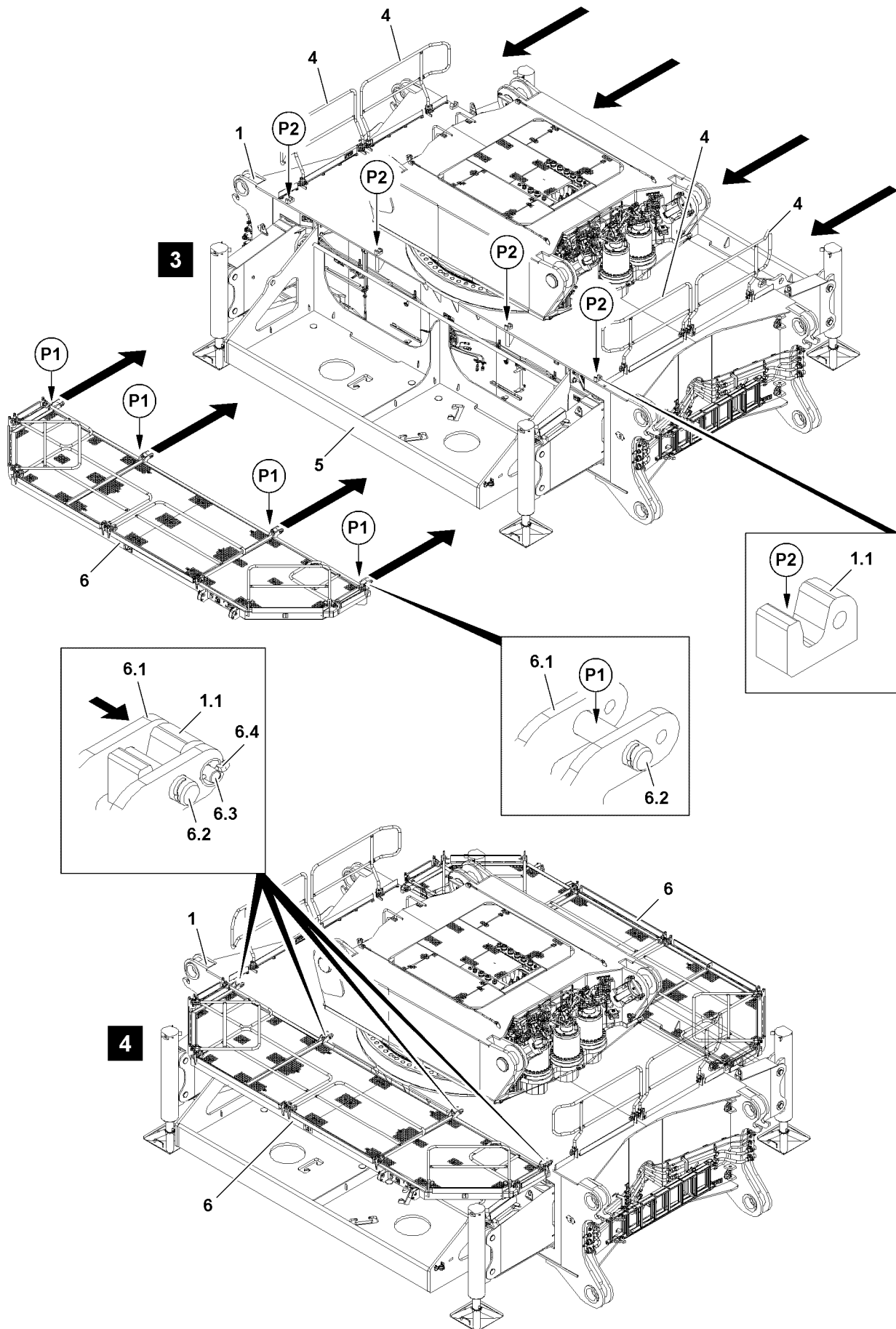

Fig.117731

LWE/LR 11000-001/23501-04-02/en

5.2 Assembling catwalks on crawler center section



WARNING

Danger of falling!

During assembly and disassembly of the catwalks, assembly personnel must be secured with appropriate aids to prevent them from falling.

Even at the assembly of protective equipment there is a danger of falling.

Death, severe injury, property damage.

- ▶ Hang the personal protective equipment on the provided safety ropes.
- ▶ Keep a safety distance to edges.



WARNING

Danger of crushing!

Death, severe injury, property damage.

- ▶ Make sure that there are no persons or obstacles within the danger zone when swinging the catwalks **6** in.

5.2.1 Assembling the first catwalk



Note

- ▶ For simpler illustration, the crane is shown in the following illustrations without turntable and crawler travel gear.

Make sure that the following prerequisites are met:

- The turntable frame main section is properly installed on the crawler center section.
- The SA-frame is properly installed on the turntable frame main section.
- Winches (winch 1, winch 2, winch 4) are properly installed on the turntable frame main section.
- The crawler carriers are properly assembled on the crawler center section.
- The crawler travel gear is completely lowered to the ground.
- The central ballast brackets are properly assembled on the crawler center section.
- The central ballast is placed according to the erection and take down chart.
- The catwalk is properly fastened on the auxiliary crane, see section „Fastening points catwalk / stairs“

- ▶ Lift the catwalk **6** with the auxiliary crane.
- ▶ Swing the catwalk **6** in with the auxiliary crane to the crawler center section **1**.
- ▶ Hang the catwalk **6** with the hook pins **6.2** (point **P1**) on the hooks **1.1** (point **P2**), see illustration **3**.

When the catwalk **6** is properly hooked with the hook pins **6.2** on the hooks **1.1**:

- ▶ Insert the retaining pins **6.3** on all pin points and secure with locking pin **6.4**, see illustration **4**.

Result:

- The catwalk **6** is properly assembled and secured.
- ▶ Remove the fastening equipment on the first catwalk **6**.

5.2.2 Assembling the second catwalk



Note

- ▶ The assembly of the second catwalk is identical with the assembly procedure of the first catwalk.
- ▶ Assemble the second catwalk according to the description of the first catwalk.

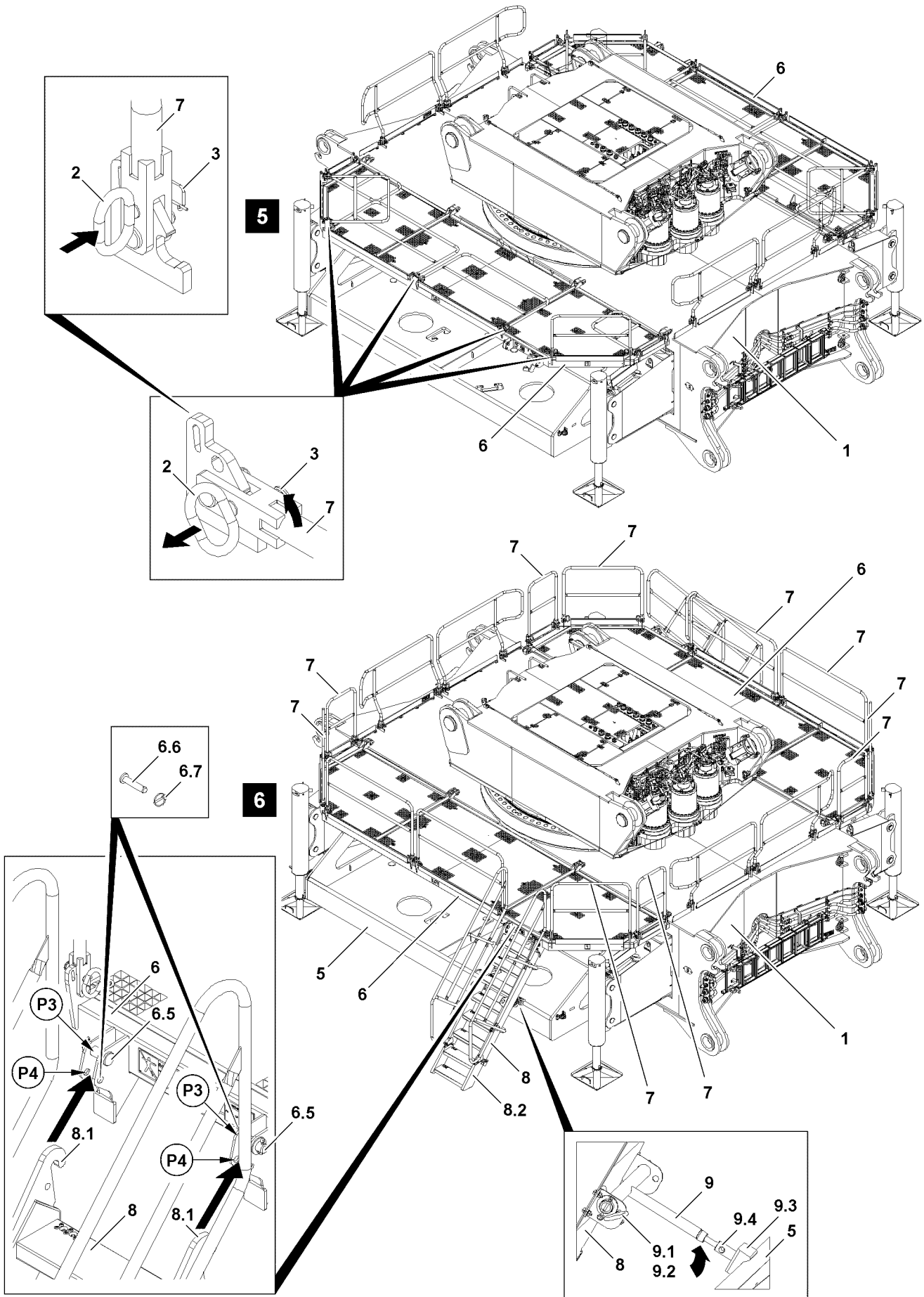

Fig.117732

LWE/LR 11000-001/23501-04-02/en

5.3 Swinging the railing on the catwalk into operating position

**WARNING**

Danger of crushed limbs!

When swinging the railings, fingers and hands can be crushed.

▶ Do not reach with your hands into the danger zone.

▶ Release the railing **7** from the transport position: Remove the spring retainer **3** and unpin the pin **2**, see illustration **5**.

When the railings **7** are released:

▶ Swing the railing **7** into operating position.

▶ Secure the railing **7** in operating position: Insert the pin **2** and secure with spring retainer **3**.

**Note**

▶ The assembly procedure of the railing on the second catwalk is identical with the procedure on the first catwalk.

▶ Swing and secure railing **7** on the second catwalk into operating position.

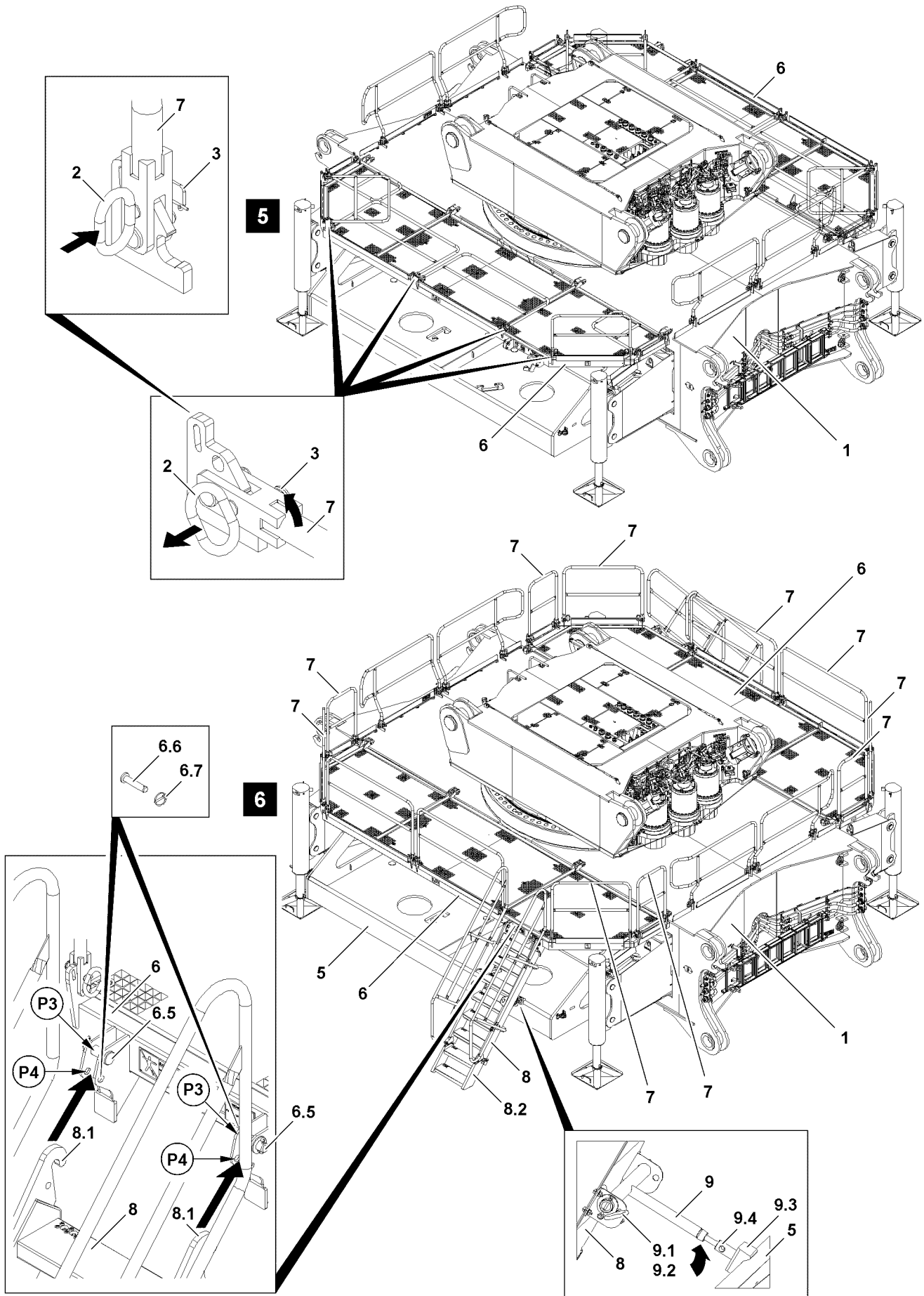

Fig.117732

LWE/LR 11000-001/23501-04-02/en

5.4 Assembling the stairs on the catwalk



WARNING

Danger of crushing!

Death, severe injury, property damage.

- ▶ Make sure that there are no persons or obstacles within the danger zone when swinging the stairs **8** in to the catwalk **6**.

5.4.1 Assembling the stairs

NOTICE

Property damage of stairs!

If the support **9** is not installed or improperly installed, then the stairs **8** can be damaged.

- ▶ Make sure that the support **9** is properly installed before the stairs **8** are accessed.

Make sure that the following prerequisites are met:

- The catwalks **6** are assembled on both sides on the crawler center section.
- The railings **7** are in operating position.

- ▶ Fasten the stairs **8** on the auxiliary crane, see section „Fastening points catwalk / stairs“.
- ▶ Lift the stairs **8** with the auxiliary crane.
- ▶ Swing the stairs **8** in with the auxiliary crane to the installation position on the catwalk **6**.
- ▶ Hang the stairs **8** with the hook **8.1** at point **P3** on the catwalk **6**.

When the stairs **8** are properly hooked on the catwalk **6**:

- ▶ Secure the stairs **8** at point **P4** with pin **6.6** and locking pin **6.7**.



Note

- ▶ The assembly procedure of the stairs on the second catwalk is identical with the procedure on the first catwalk.

5.4.2 Assembling the support

Make sure that the following prerequisite is met:

- The stairs **8** are properly assembled and secured on the catwalk **6**.

- ▶ Release the support **9** in transport position: Release and unpin the pin **9.1**.
- ▶ Swing the support **9** upward into operating position.
- ▶ Pin the support **9** in operating position with pin **9.1** and secure with spring retainer **9.2**, see illustration **6**.
- ▶ Support the stairs **8**: Support the pressure section **9.3** by turning the pressure rod **9.4**.

Result:

- The stairs **8** are supported against the central ballast bracket **5**, see illustration **6**.

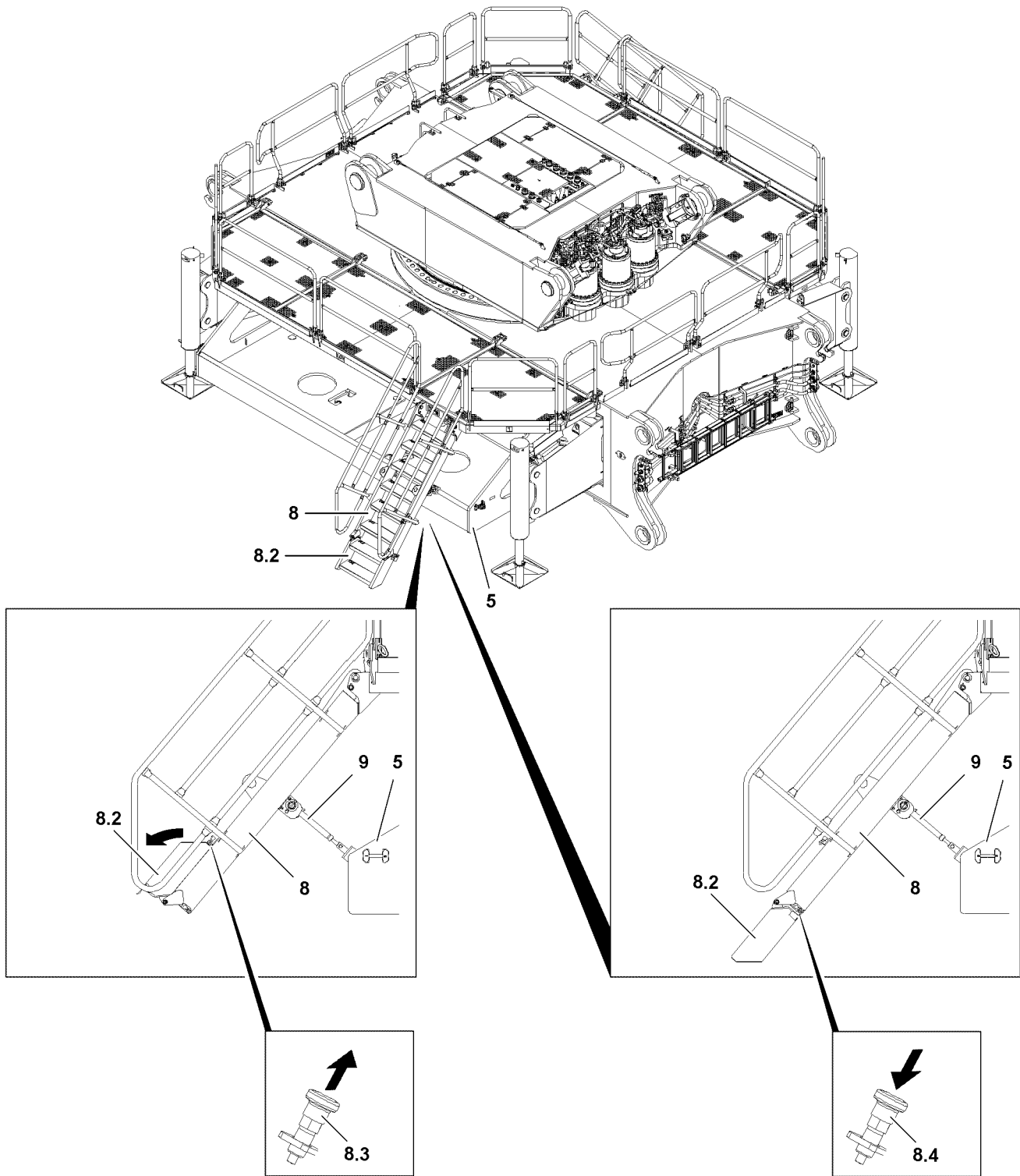

Fig.117736

5.4.3 Swinging the stair folding section into operating position

Make sure that the following prerequisites are met:

- The stairs **8** are properly assembled and secured.
- The support **9** is properly installed and secured.
- The stairs **8** are properly supported by the support **9** on the central ballast bracket **5**.



WARNING

Danger of crushed limbs!

When swinging the stair folding section **8.2**, fingers and hands can be crushed.

- ▶ Do not reach with your hands into the danger zone.
-

- ▶ Pull the detent pin **8.3** up and hold.

Result:

- The stair folding section **8.2** is released.

- ▶ Fold the stair folding section **8.2** completely down until the detent pin **8.4** engages.

Result:

- The stair folding section **8.2** is in operating position.

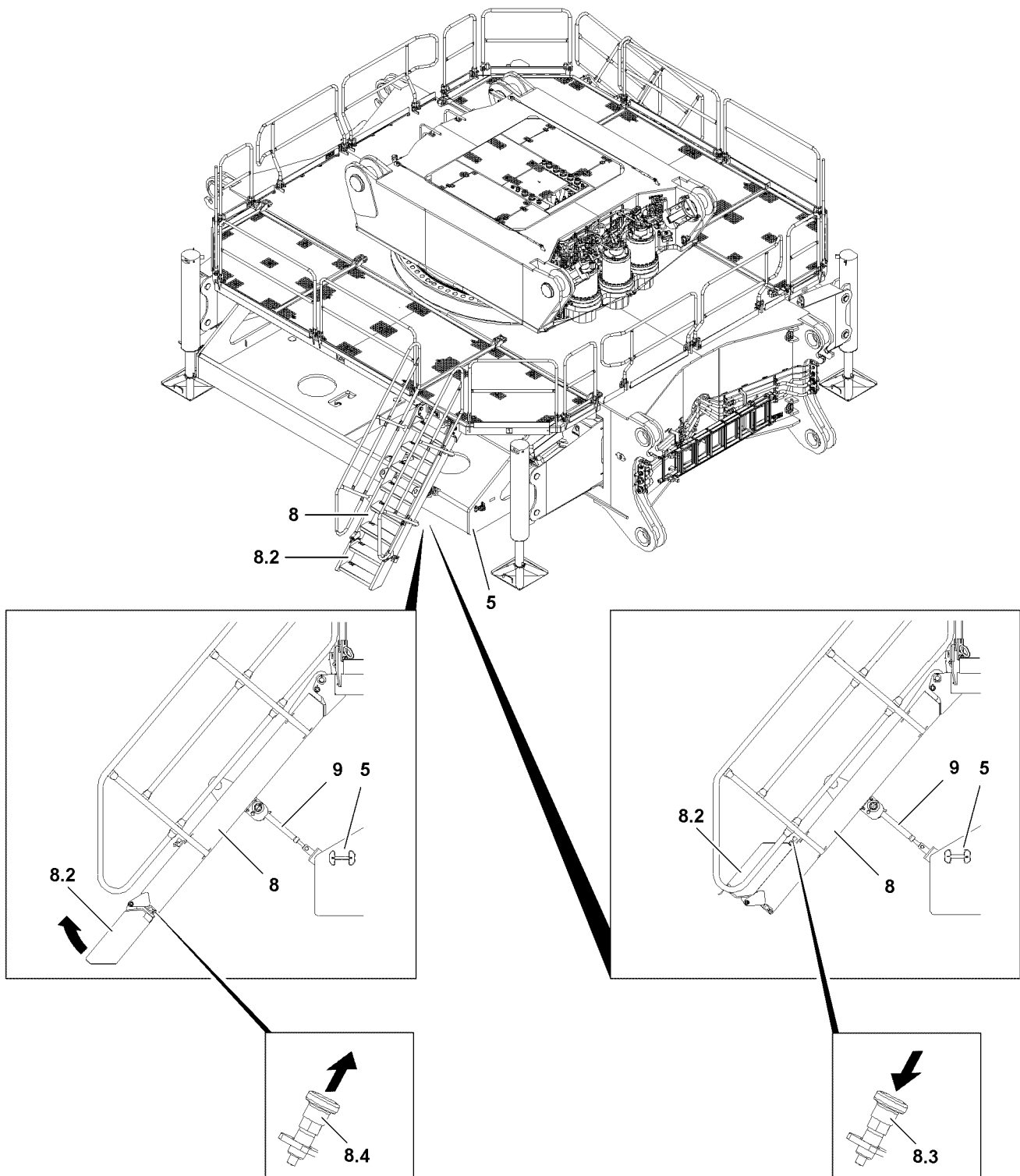

Fig.117748

6 Disassembly Catwalk / stairs crawler travel gear

6.1 Disassembling the stairs on the catwalk

**WARNING**

Danger of crushing!

Death, severe injury, property damage.

- ▶ Make sure that there are no persons or obstacles within the danger zone when removing the stairs **8**.

6.1.1 Swinging the stair folding section into transport position

**WARNING**

Danger of crushed limbs!

When swinging the stair folding section **8.2**, fingers and hands can be crushed.

- ▶ Do not reach with your hands into the danger zone.

- ▶ Pull the detent pin **8.4** up and hold.

Result:

- The stair folding section **8.2** is released.

- ▶ Fold the stair folding section **8.2** completely up until the detent pin **8.3** engages.

Result:

- The stair folding section **8.2** is in operating position.

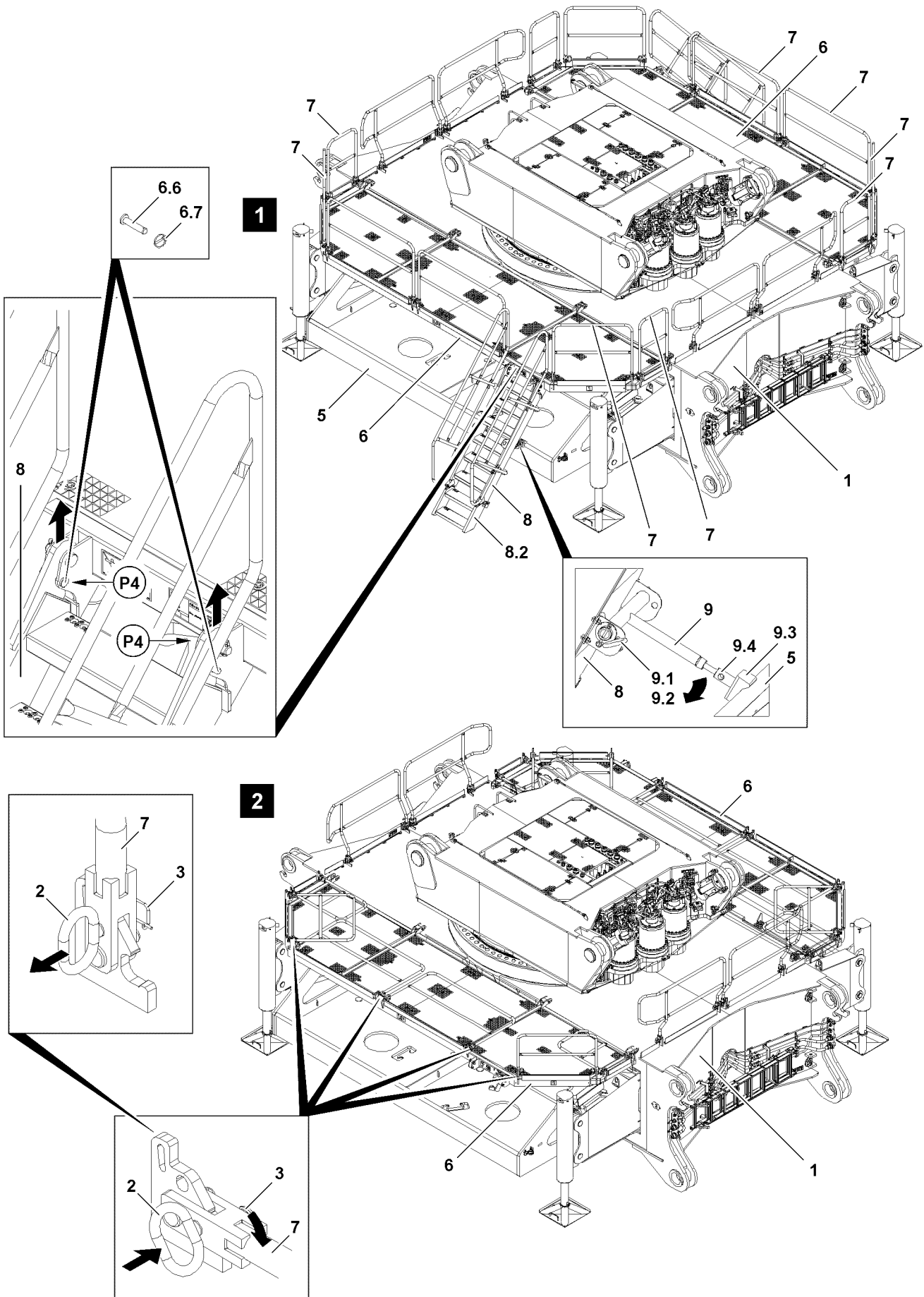

Fig.117749

LWE/LR 11000-001/23501-04-02/en

6.1.2 Removing the support

Make sure that the following prerequisite is met:

- The stair folding section **8.2** is properly folded in transport position and secured.

- ▶ Relieve the pressure section **9.3** by turning the pressure rod **9.4**.

Result:

- The pressure section **9.3** is „cleared“.
- The stairs **8** are **no longer** supported.

- ▶ Release the support **9** in operating position: Release and unpin the pin **9.1**.
- ▶ Swing the support **9** downward into transport position.
- ▶ Pin the support **9** in transport position with pin **9.1** and secure with spring retainer **9.2**.

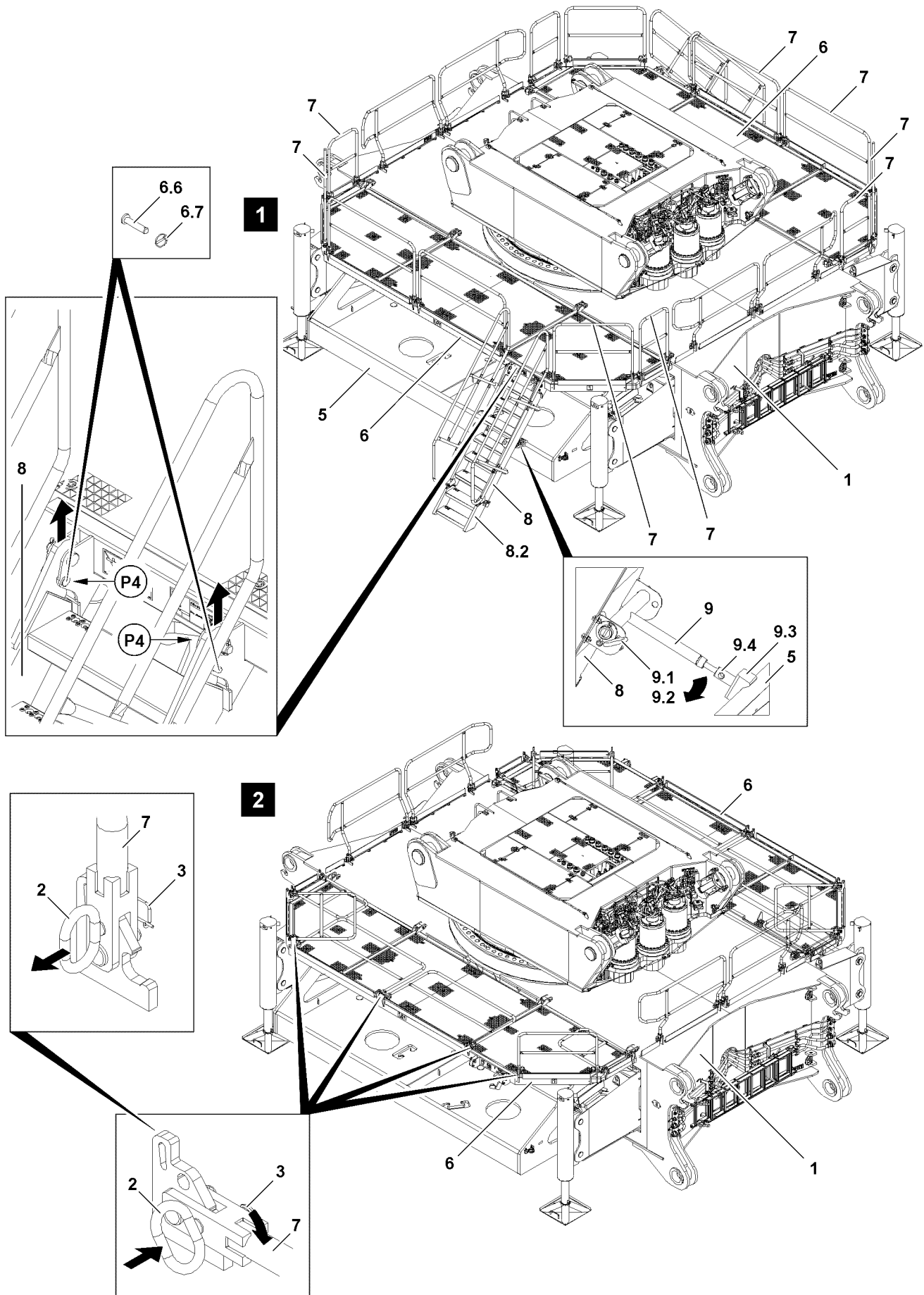

Fig.117749

LWE/LR 11000-001/23501-04-02/en

6.1.3 Disassembling the stairs



WARNING

Oscillating stairs!

When disassembling the stairs, they can start to swing back and forth.

Death, severe injury, property damage.

- ▶ Make sure that there are no obstacles or persons within the danger zone.
- ▶ Secure the stairs **8** with an auxiliary rope to prevent them from swinging back and forth.

Make sure that the following prerequisites are met:

- The stair folding section **8.2** is in transport position.
- The retaining pin **6.6** is released and unpinned on both sides at point **P4**.
- ▶ Fasten the stairs **8** on the auxiliary crane, see section „Fastening points catwalk / stairs“.
- ▶ Lift the stairs **8** with the auxiliary crane.

When the stairs **8** are lifted out on the catwalk **6**:

- ▶ Swing the stairs **8** out with auxiliary crane.
- ▶ Place the stairs **8** with the auxiliary crane on a proper support.



Note

- ▶ The disassembly procedure of the stairs on the second catwalk is identical with the procedure on the first catwalk.

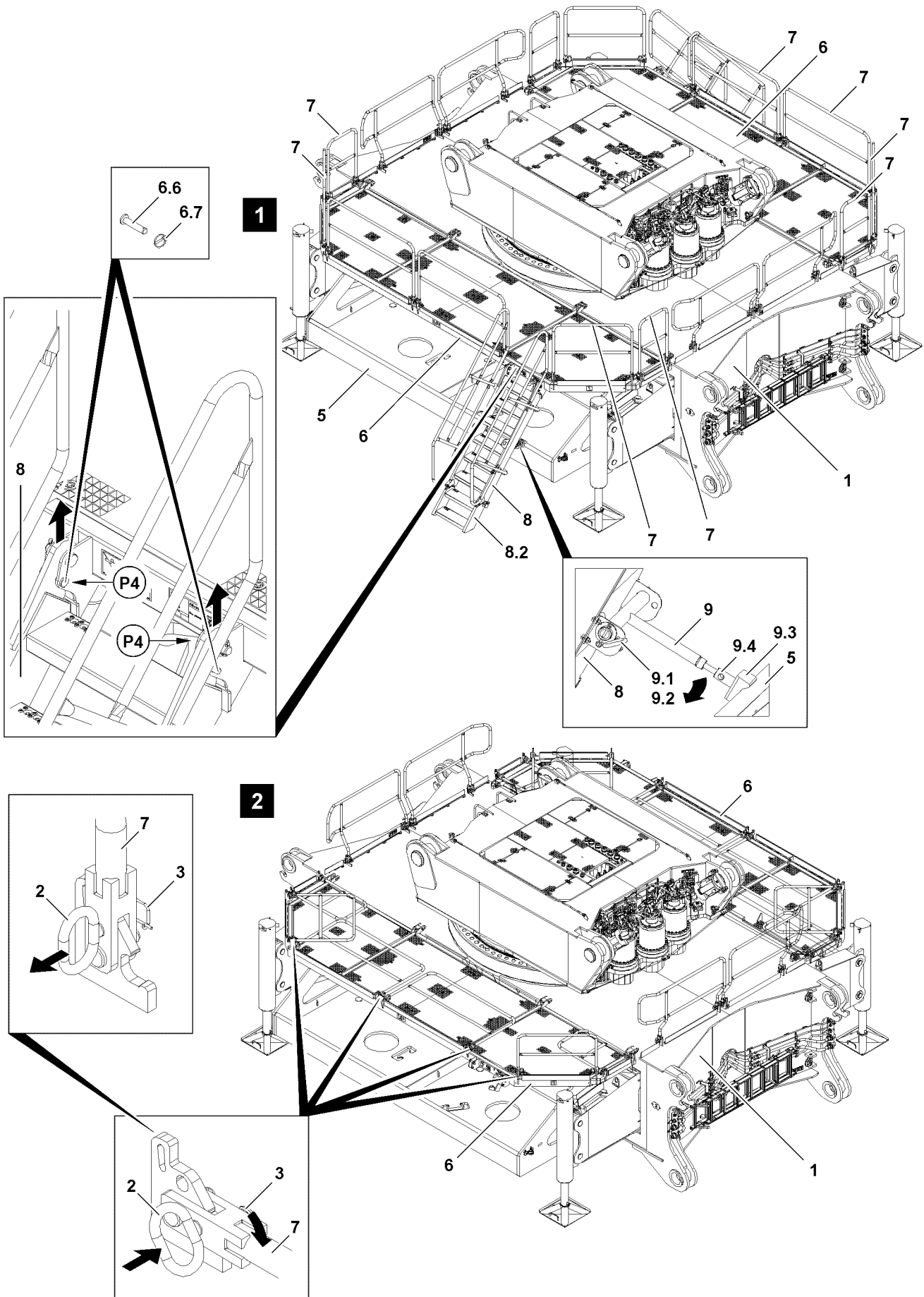

Fig.117749

LWE/LR 11000-001/23501-04-02/en

6.2 Swinging the railing on the catwalk into transport position



WARNING

Danger of crushed limbs!

When swinging the railings, fingers and hands can be crushed.

▶ Do not reach with your hands into the danger zone.

▶ Release the railing **7** in operating position: Remove the spring retainer **3** and unpin the pin **2**, see illustration **2**.

When the railings **7** are released:

▶ Swing the railing **7** into transport position.

▶ Secure the railings **7** in transport position: Insert the pin **2** and secure with spring retainer **3**.



Note

▶ The disassembly procedure of the railings on the second catwalk is identical with the procedure on the first catwalk.

▶ Swing and secure railing **7** on the second catwalk into transport position.

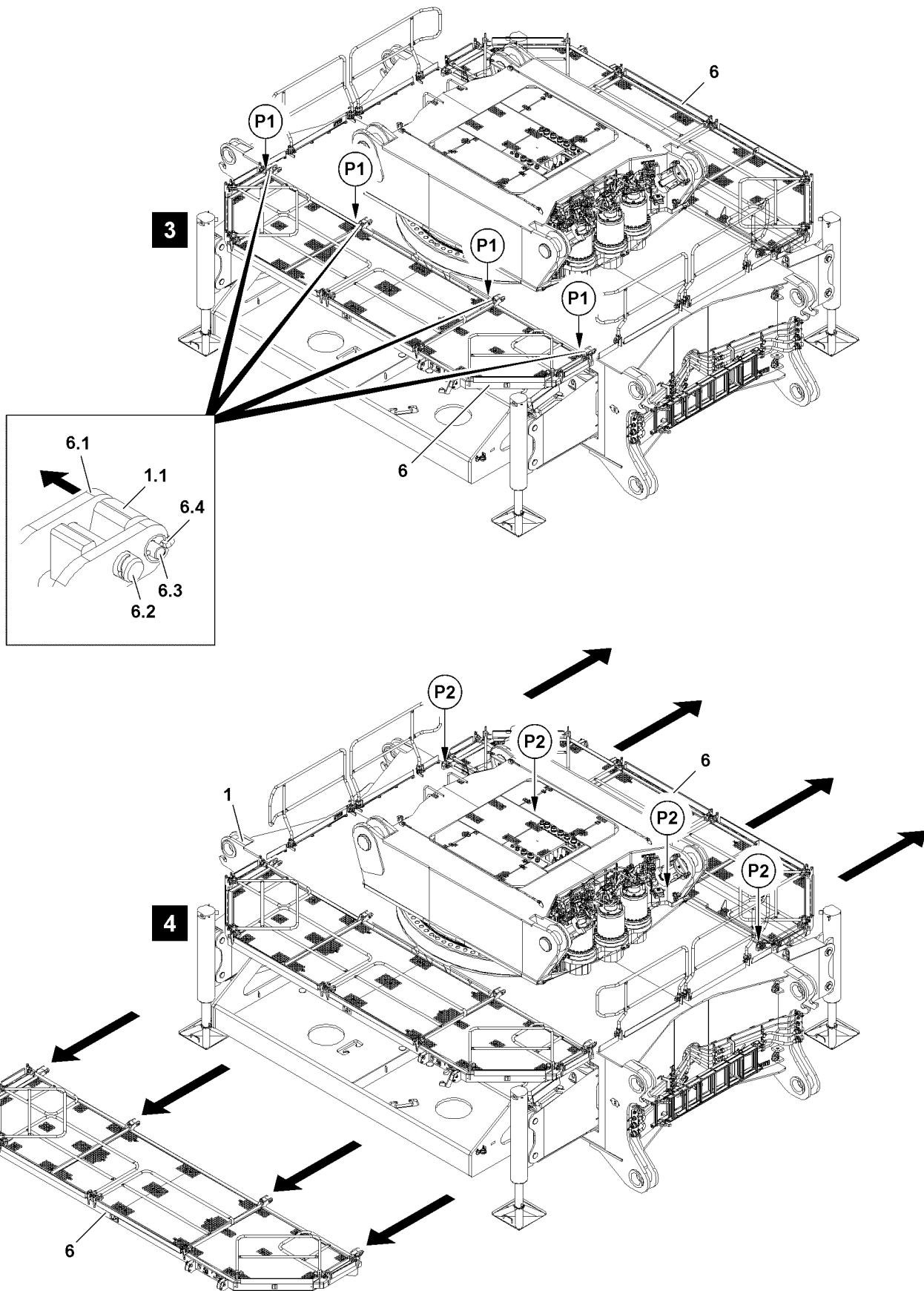

Fig.117750

LWE/LR 11000-001/23501-04-02/en

6.3 Disassembling catwalks on crawler center section

Make sure that the following prerequisites are met:

- The stairs are disassembled on the catwalks.
- All railings on the catwalks are in transport position.



WARNING

Danger of falling!

During assembly and disassembly of the catwalks, assembly personnel must be secured with appropriate aids to prevent them from falling.

Even at the assembly of protective equipment there is a danger of falling.

Death, severe injury, property damage.

- ▶ Hang the personal protective equipment on the provided safety ropes.
- ▶ Keep a safety distance to edges.



WARNING

Danger of crushing!

Death, severe injury, property damage.

- ▶ Make sure that there are no persons or obstacles within the danger zone when removing the catwalks **6** on the crawler center section.

6.3.1 Disassembling the first catwalk

Make sure that the following prerequisite is met:

- The catwalk is properly fastened on the auxiliary crane, see section „Fastening points catwalk / stairs“

When the catwalk **6** is properly fastened on the auxiliary crane:

- ▶ Bring the fastening equipment with the auxiliary crane carefully to tension.

When the fastening equipment is tensioned:

- ▶ Release and unpin the retaining pins **6.3** on all pin points.
- ▶ Lift the catwalk **6** with the auxiliary crane and swing out.
- ▶ Place the catwalk **6** on the load bearing support.
- ▶ Remove the fastening equipment on the first catwalk **6**.

6.3.2 Disassembling the second catwalk



Note

- ▶ The disassembly of the second catwalk is identical with the disassembly procedure of the first catwalk.
- ▶ Disassemble the second catwalk according to the description of the first catwalk.

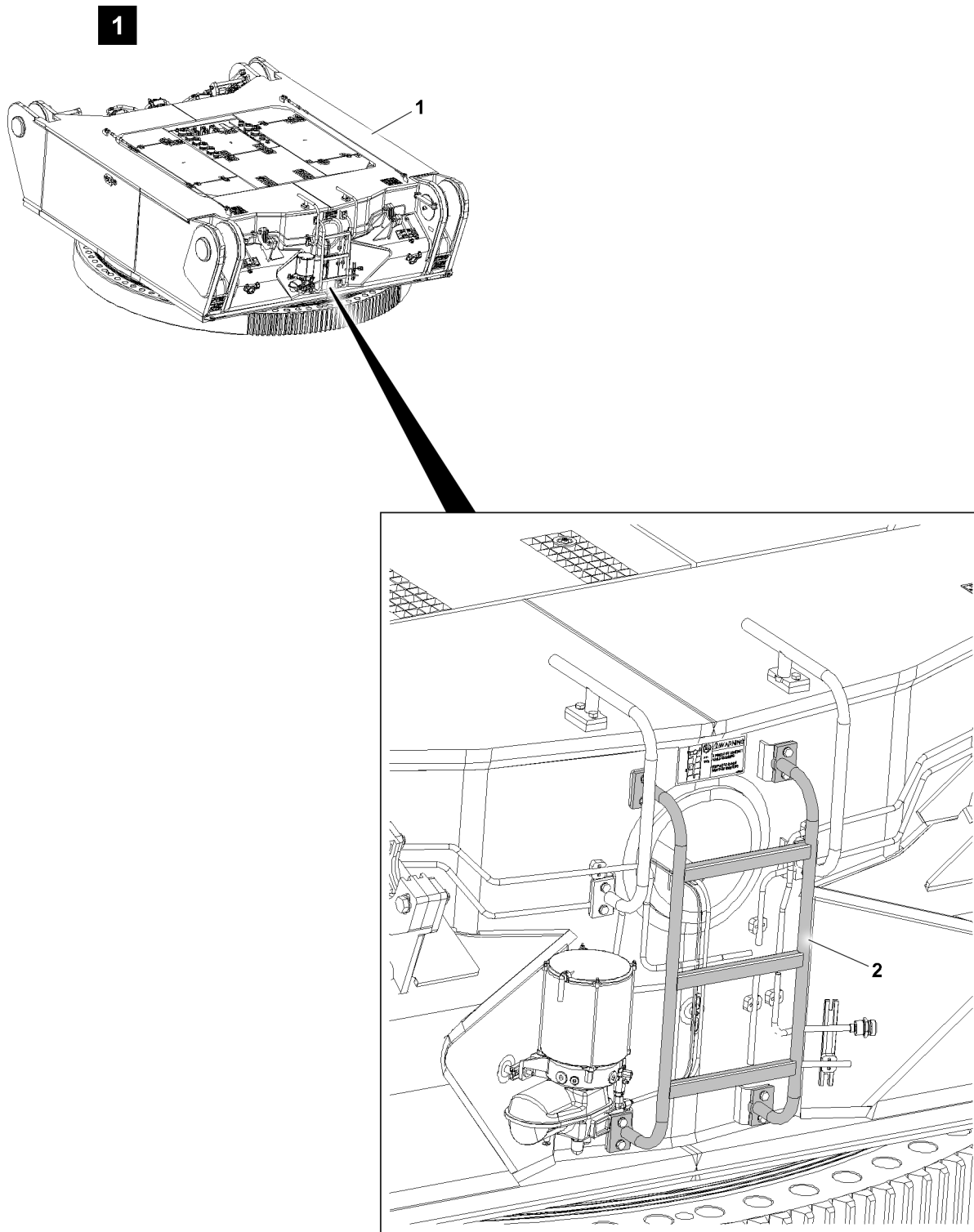

Fig.126312

LWE/LR 11000-001/23501-04-02/en

7 Ladder Turntable frame lower section

Depending on the crane type, there are three different versions of ladders turntable frame lower section available:

- Fixed ladder
- Removable ladder
- Removable ladder QC¹⁾

1) QC: Quick Connection



WARNING

Danger of falling!

During assembly and disassembly of the ladder, assembly personnel must be secured with appropriate aids to prevent them from falling.

Even at the assembly of protective equipment there is a danger of falling.

Death, severe injury, property damage.

- ▶ Hang the personal protective equipment on the provided safety ropes.
- ▶ Keep a safety distance to edges.



WARNING

Danger of falling!

Death, severe injury, property damage.

- ▶ When ascending and descending, the assembly personnel must ensure a 3-point support.
- ▶ When ascending and descending, use rungs and ladder beams as handles.
- ▶ The assembly personnel must step into the rungs sufficiently deep.

7.1 Fixed ladder



Note

- ▶ Fixed ladder 2, see illustration 1.

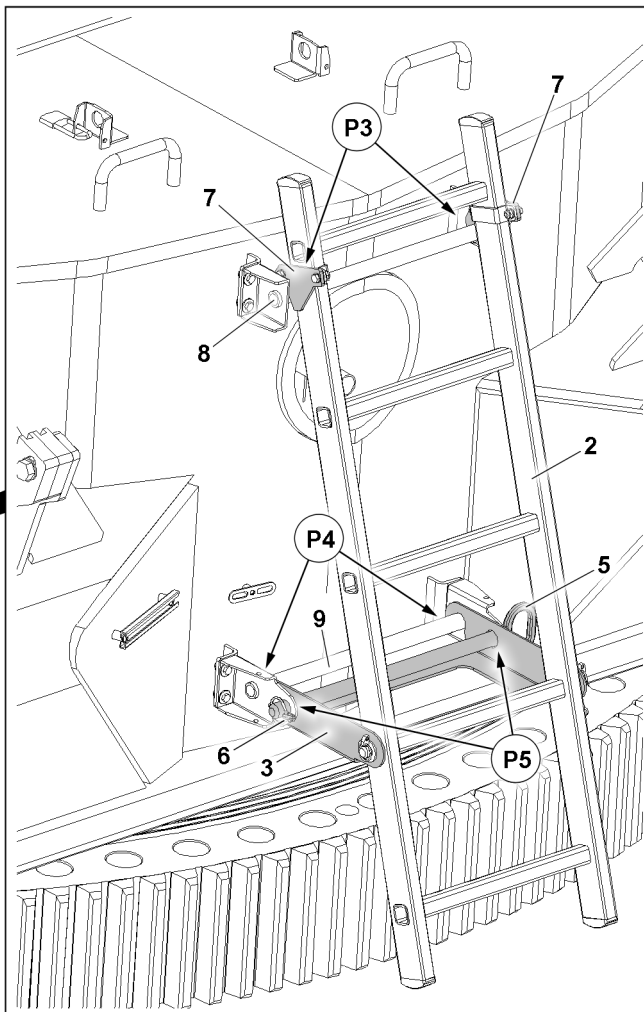
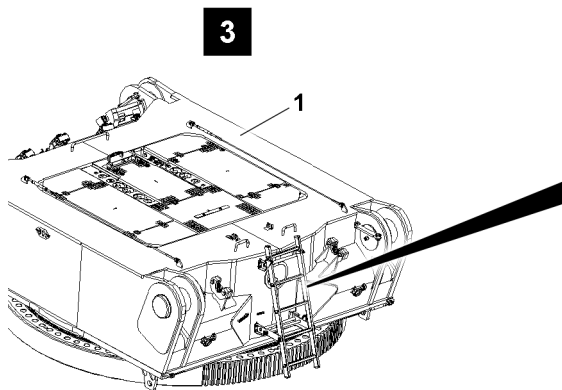
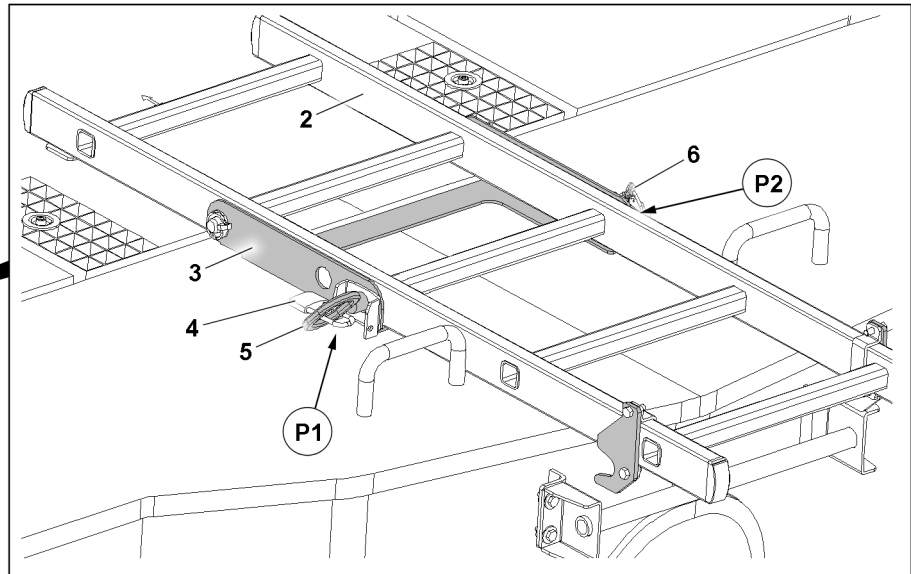
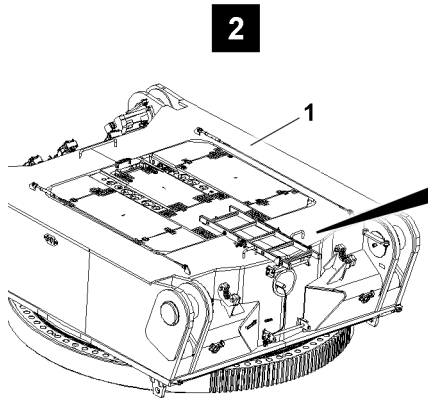

Fig.126311

LWE/LR 11000-001/23501-04-02/en

7.2 Removable ladder

7.2.1 Bringing the removable ladder into assembly position

- ▶ Open and remove the lock **4** at point **P1**, see illustration **2**.
- ▶ Remove the safety locking pin **6** at point **P2**.
- ▶ Unpin the grip pin **5**.



WARNING

Danger of crushed limbs!

When removing the ladder **2** the folding mechanism **3** can swing downward uncontrolled! Fingers and hands can be crushed.

- ▶ When removing the ladder, hold the folding mechanism.

- ▶ Take the removable ladder **2** from park position.
- ▶ Hang the removable ladder with the hook **7** on points **P3** on rod **8**, see illustration **3**.
- ▶ Hang the removable ladder **2** with the folding mechanism **3** on points **P4** on rod **9**.
- ▶ Insert the grip pin **5** at points **P5** and secure with safety locking pin **6**.

Result:

- Removable ladder **2** secured in assembly position.

7.2.2 Bringing the removable ladder into park position

- ▶ Remove the safety locking pin **6** at point **P5** and unpin the grip pin **5**, see illustration **3**.



WARNING

Danger of crushed limbs!

When removing the ladder **2** the folding mechanism **3** can swing downward uncontrolled! Fingers and hands can be crushed.

- ▶ When removing the ladder, hold the folding mechanism.

- ▶ Take the removable ladder **2** from assembly position.
- ▶ Fold the folding mechanism **3** in.
- ▶ Place the removable ladder **2** down in park position, see illustration **2**.
- ▶ Insert the grip pin **5** at point **P1** through the retainer on the turntable and through the rungs of the removable ladder **2**.
- ▶ Secure the grip pin **5** at point **2** with safety locking pin **6**.
- ▶ Attach the lock **4** at point **P1**.

Result:

- Removable ladder **2** secured in park position.

7.3 Removable ladder QC



Note

- ▶ Removable ladder QC differs from the removable ladder only by the number of rungs.
- ▶ Assembly and disassembly of the removable ladder QC are identical with the assembly and disassembly of the removable ladder.

Ladder	Removable ladder	Removable ladder QC ¹⁾
Number of rungs	5	6

1) QC: Quick Connection

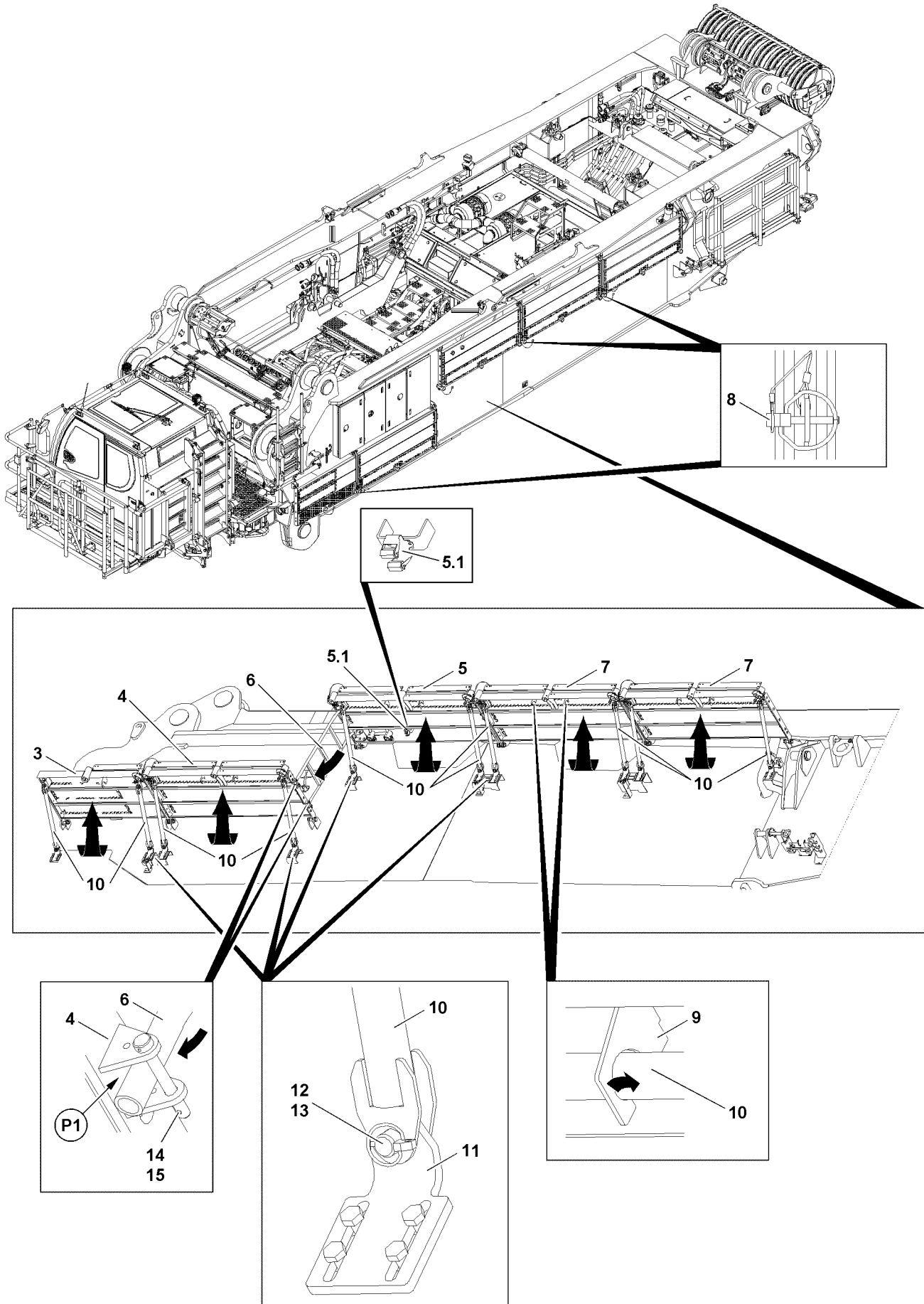

Fig.118173

LWE/LR 11000-001/23501-04-02/en

8 Catwalks and railing on the turntable frame main section



WARNING

Danger of falling!

For assembly and disassembly of the protective equipment and / or the fall protection equipment there is also a danger of falling for the assembly personnel.

Death, severe injury, property damage.

- ▶ Use suitable and approved aids, such as working platforms.
- ▶ The assembly personnel must secure themselves during assembly and disassembly work with suitable aids to prevent them from falling.
- ▶ Use personal protective equipment.

8.1 Assembling the catwalks on the left turntable frame main section in operating position



WARNING

Danger of accident due to catwalks!

Due to improper assembly of the catwalks, the catwalks can suddenly fold down.

Death, severe injury, property damage.

- ▶ Make sure that the catwalks are pinned and secured properly in operating position.



Note

- ▶ Carry out the assembly of the catwalks starting with catwalk **3** from the „front“ to the „rear“.

Make sure that the following prerequisites are met:

- The turntable frame main section is on the flatbed trailer.
- Appropriate aids, such as a scaffolding or working platform are available.

8.1.1 Assembling catwalk 3 in operating position

- ▶ Release the transport retainers for all catwalks: Remove locking pins **8** on the catwalks.
- ▶ Swing the catwalks **3** upward into operating position.
- ▶ Take the supports **10** from the transport retainers **9** on the underside of the catwalk **3**.
- ▶ Pin the supports **10** on both sides on the retaining plates **11** with pins **12** and secure with locking pins **13**.

Result:

- The catwalk **3** is in operating position.

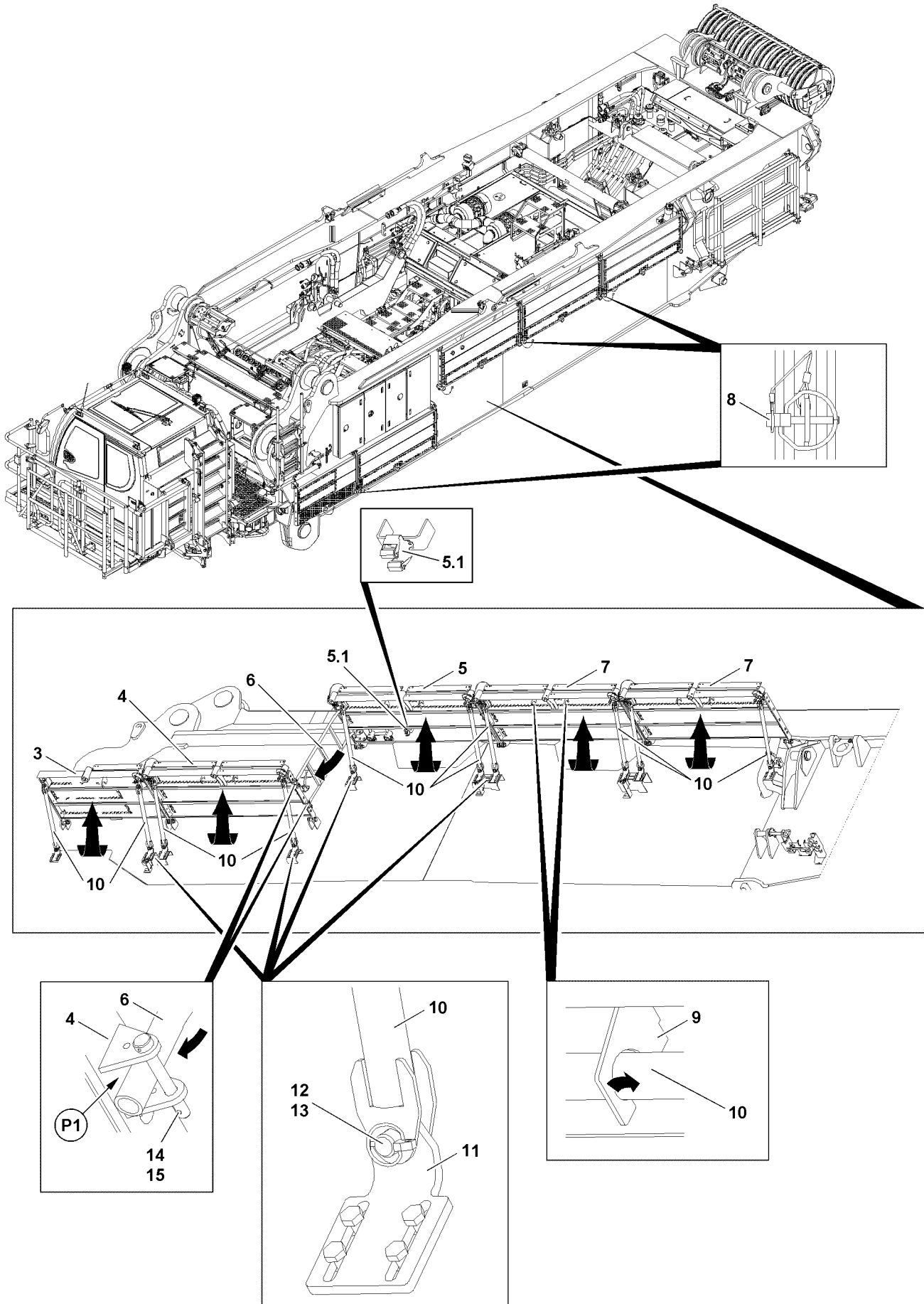

Fig.118173

LWE/LR 11000-001/23501-04-02/en

8.1.2 Assembling catwalk 4 in operating position



Note

▶ The assembly of the catwalk 4 is identical to the installation of the catwalk 3.

▶ Assemble the catwalk 4 properly, pin and secure.

Result:

– The catwalk 4 is in operating position.

8.1.3 Assembling catwalk 5 in operating position

Make sure that the following prerequisites are met:

- The catwalk 3 is properly assembled and secured.
- The catwalk 4 is properly assembled and secured.

▶ Swing the catwalks 5 upward into operating position.



WARNING

Swinging ladder!

If the ladder 6 is released from the clamp 5.1 then the ladder 6 can swing down by itself. Death, severe injury, property damage.

- ▶ Make sure that the ladder 6 is held safely in position when releasing it from the clamp 5.1.
- ▶ After releasing it, move the ladder 6 downward vertically.

▶ Pull the ladder 6 from the clamp 5.1 on the catwalk 5 and guide it carefully downward.

▶ Let the ladder 6 hang first in this position.

▶ Take the supports 10 from the transport retainers 9 on the underside of the catwalk 5.

▶ Pin the supports 10 on both sides on the retaining plates 11 with pins 12 and secure with locking pins 13.

Result:

– The catwalk 5 is in operating position.

▶ Fasten the ladder 6 on the catwalk 4 at point P1: Insert the pins 14 on both sides and secure with spring retainers 15.

Result:

– The ladder 6 is in operating position.

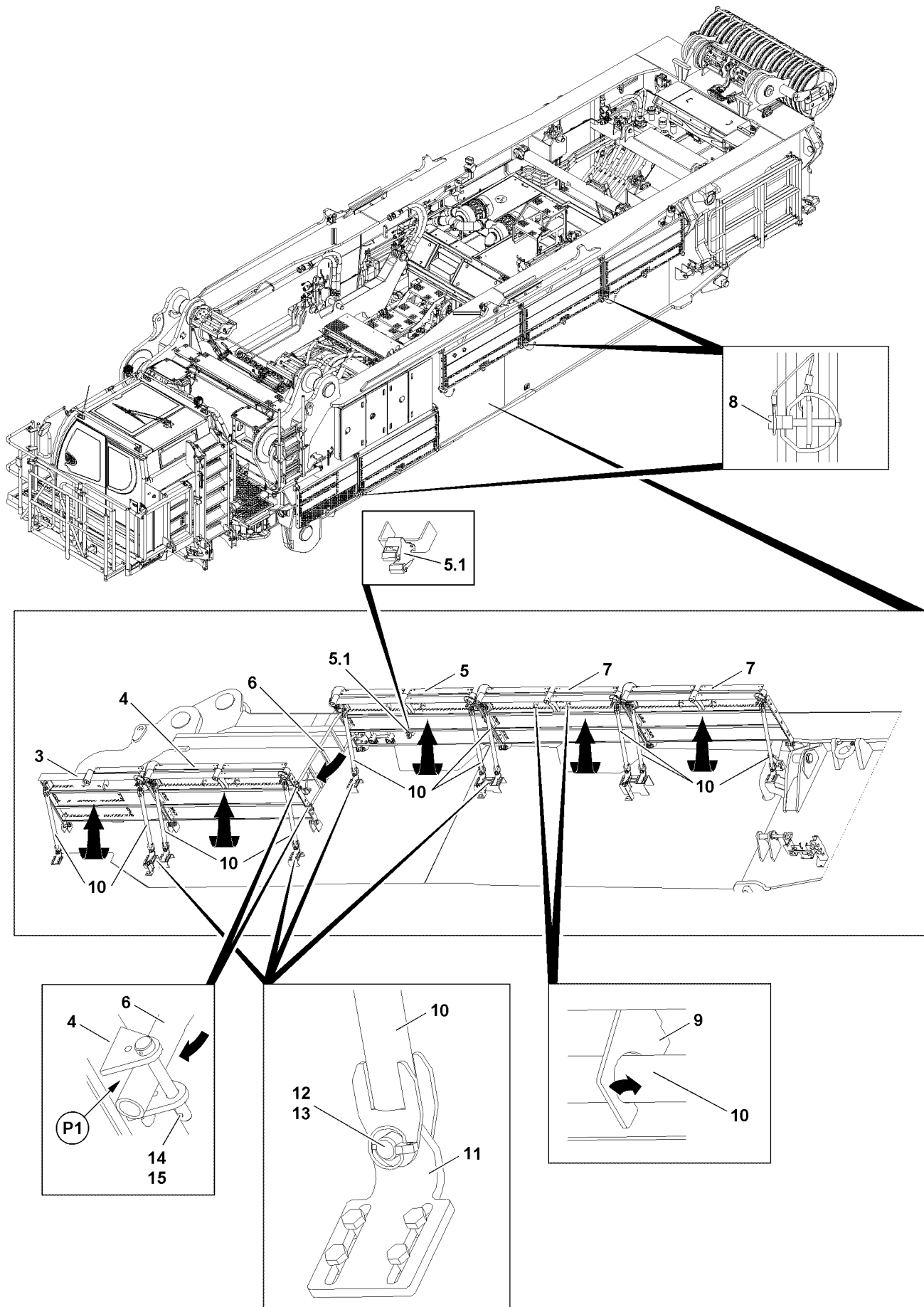

Fig.118173

LWE/LR 11000-001/23501-04-02/en

8.1.4 Assembling catwalk 7 in operating position

Make sure that the following prerequisites are met:

- The catwalk **5** is properly assembled and secured.
 - The ladder **6** is properly installed and secured.
 - The catwalks **7** are released in transport position.
- ▶ Swing the catwalks **7** upward into operating position.
 - ▶ Take the supports **10** from the transport retainers **9** on the underside of the catwalk **7**.
 - ▶ Pin the supports **10** on both sides on the retaining plates **11** with pins **12** and secure with locking pins **13**.

Result:

- The catwalk **7** is in operating position.



Note

- ▶ The assembly of the second catwalk **7** is identical with the assembly of the first catwalk **7**.
-
- ▶ Assemble the second catwalk **7** properly, pin and secure.

Result:

- All catwalks on the outside of the turntable frame main section are in operating position.

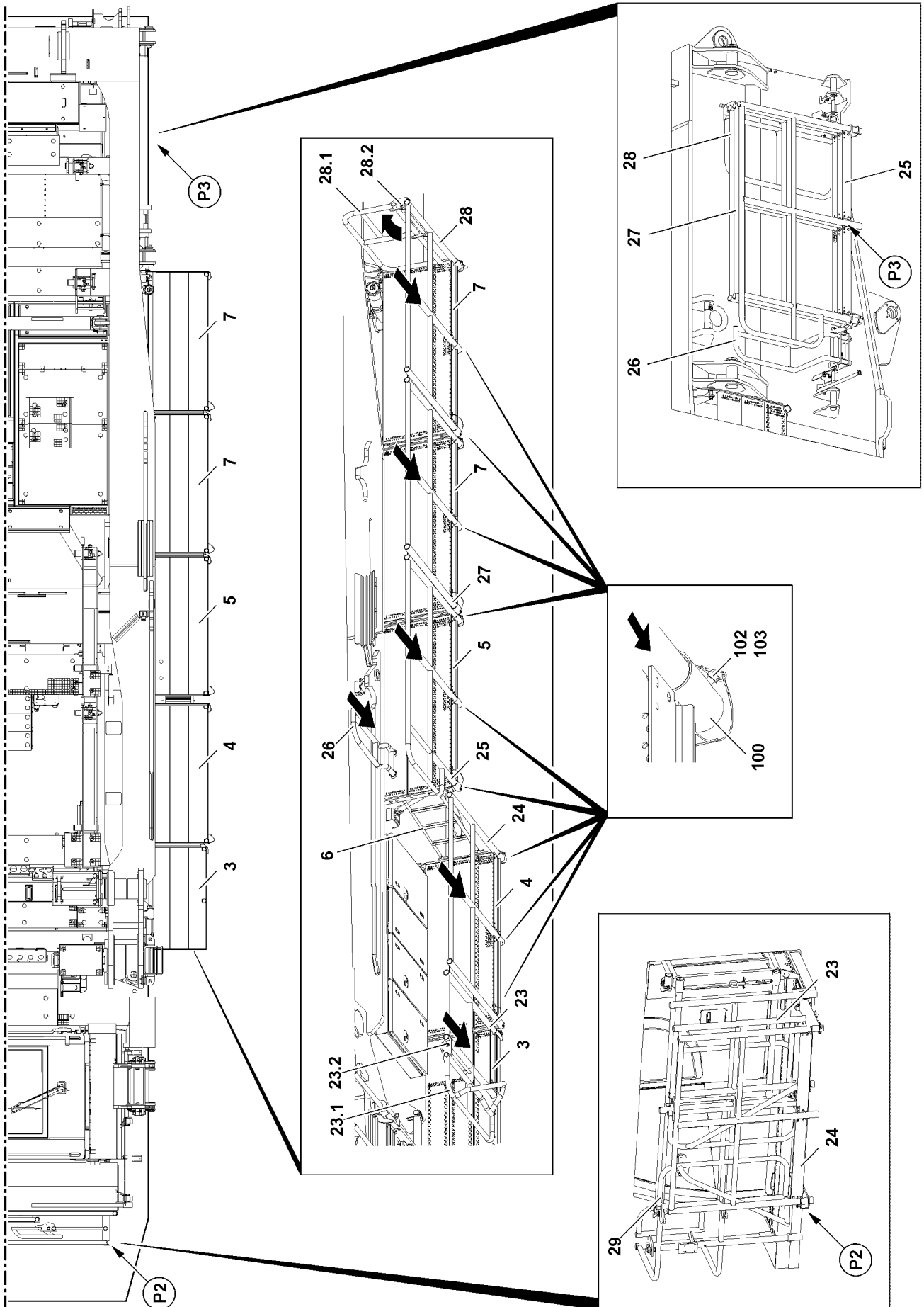

Fig.118174

8.2 Assembling the railings on the left turntable frame main section in operating position

Make sure that the following prerequisites are met:

- The crane operator's cab is in transport position.
- The catwalks on the turntable frame main section are assembled in operating position and secured.
- The ladder **6** is installed and secured in operating position.
- The railings are released in the transport retainers at point **P2** and point **P3**.

8.2.1 Assemble railing 24 on catwalk 4

- ▶ Remove the railing **24** from the transport retainer at point **P2**.
- ▶ Insert the railing **24** in the receptacle sleeves **100** on catwalk **4**.

When the railing **24** is properly inserted in the receptacle sleeves **100** on catwalk **4**:

- ▶ Pin the railing **24** in the receptacle sleeves **100** with pin **102** and secure with spring retainer **103**.

8.2.2 Assemble railing 23 on catwalk 3

- ▶ Remove the railing **23** from the transport retainer at point **P2**.
- ▶ Insert the railing **23** in the receptacle sleeves **100** on catwalk **3**.

When the railing **23** is properly inserted in the receptacle sleeves **100** on catwalk **3**:

- ▶ Pin the railing **23** in the receptacle sleeves **100** with pin **102** and secure with spring retainer **103**.
- ▶ Lock the swing bar **23.1** in operating position in stretched direction to railing **23**.

8.2.3 Assemble railing 25 and railing 26 on catwalk 5

- ▶ Remove the railing **25** from the transport retainer at point **P3**.
- ▶ Insert the railing **25** in the receptacle sleeves **100** on catwalk **5**.

When the railing **25** is properly inserted in the receptacle sleeves **100** on catwalk **5**:

- ▶ Pin the railing **25** in the receptacle sleeves **100** with pin **102** and secure with spring retainer **103**.

When the railing **25** is properly installed and secured:

- ▶ Remove the railing **26** from the transport retainer at point **P3**.
- ▶ Insert the railing **26** in the receptacle sleeves **100** on catwalk **5**.

When the railing **26** is properly inserted in the receptacle sleeves **100** on catwalk **5**:

- ▶ Pin the railing **26** in the receptacle sleeves **100** with pin **102** and secure with spring retainer **103**.

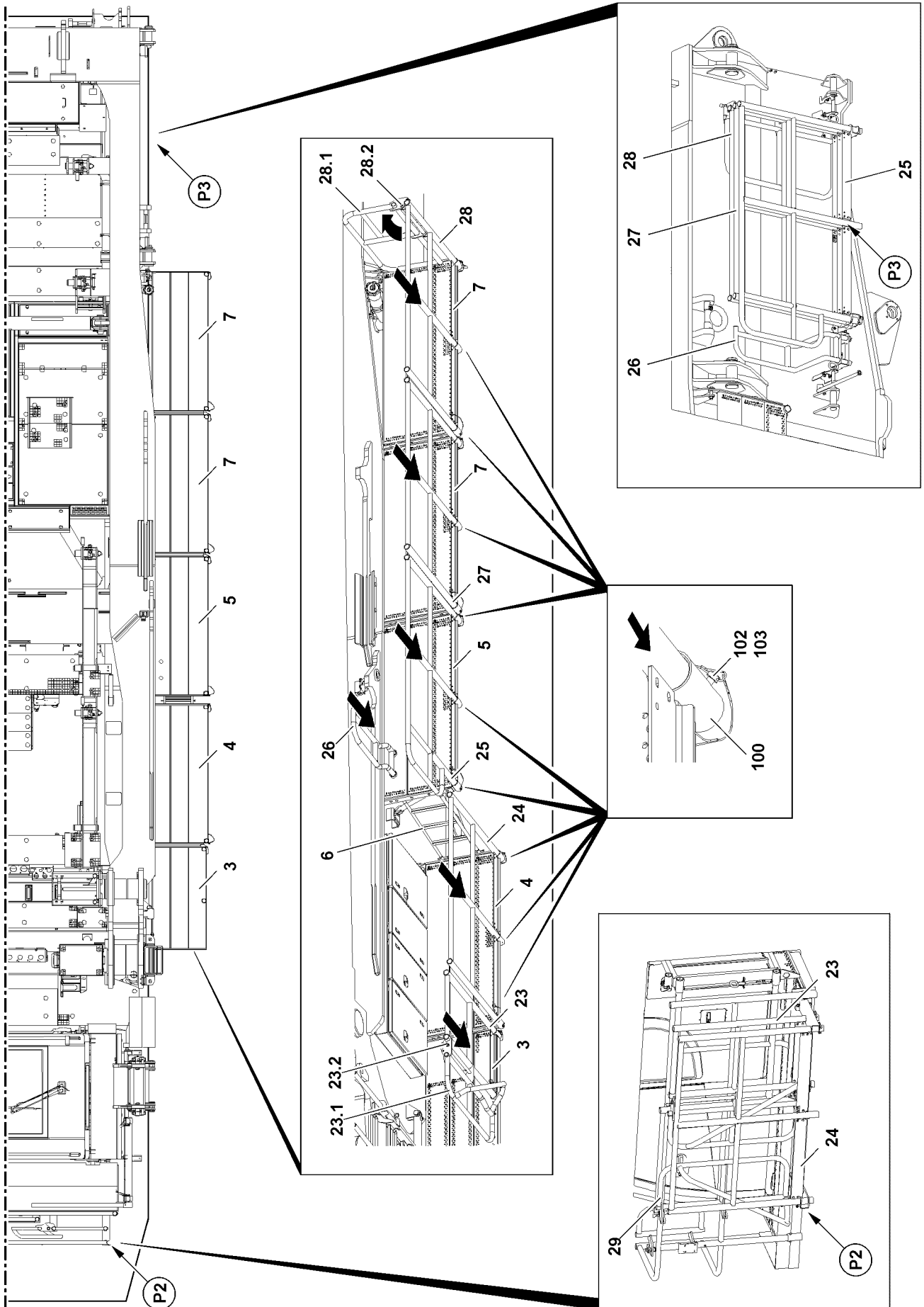

Fig.118174

LWE/LR 11000-001/23501-04-02/en

8.2.4 Assemble railing 27 on catwalk 7

- ▶ Remove the railing 27 from the transport retainer at point P3.
- ▶ Insert the railing 27 in the receptacle sleeves 100 on catwalk 7.

When the railing 27 is properly inserted in the receptacle sleeves 100 on catwalk 7:

- ▶ Pin the railing 27 in the receptacle sleeves 100 with pin 102 and secure with spring retainer 103.

8.2.5 Assemble railing 28 on catwalk 7

- ▶ Remove the railing 28 from the transport retainer at point P3.
- ▶ Insert the railing 28 in the receptacle sleeves 100 on catwalk 7.

When the railing 28 is properly inserted in the receptacle sleeves 100 on catwalk 7:

- ▶ Pin the railing 28 in the receptacle sleeves 100 with pin 102 and secure with spring retainer 103.
- ▶ Bring the swing bar 28.1 from railing 28 in operating position: Pull the detent pin 28.2 up and swing the swing bar 28.1 outward into operating position.

Result:

- The swing bar 28.1 is locked at a 90° angle to railing 28 (operating position).

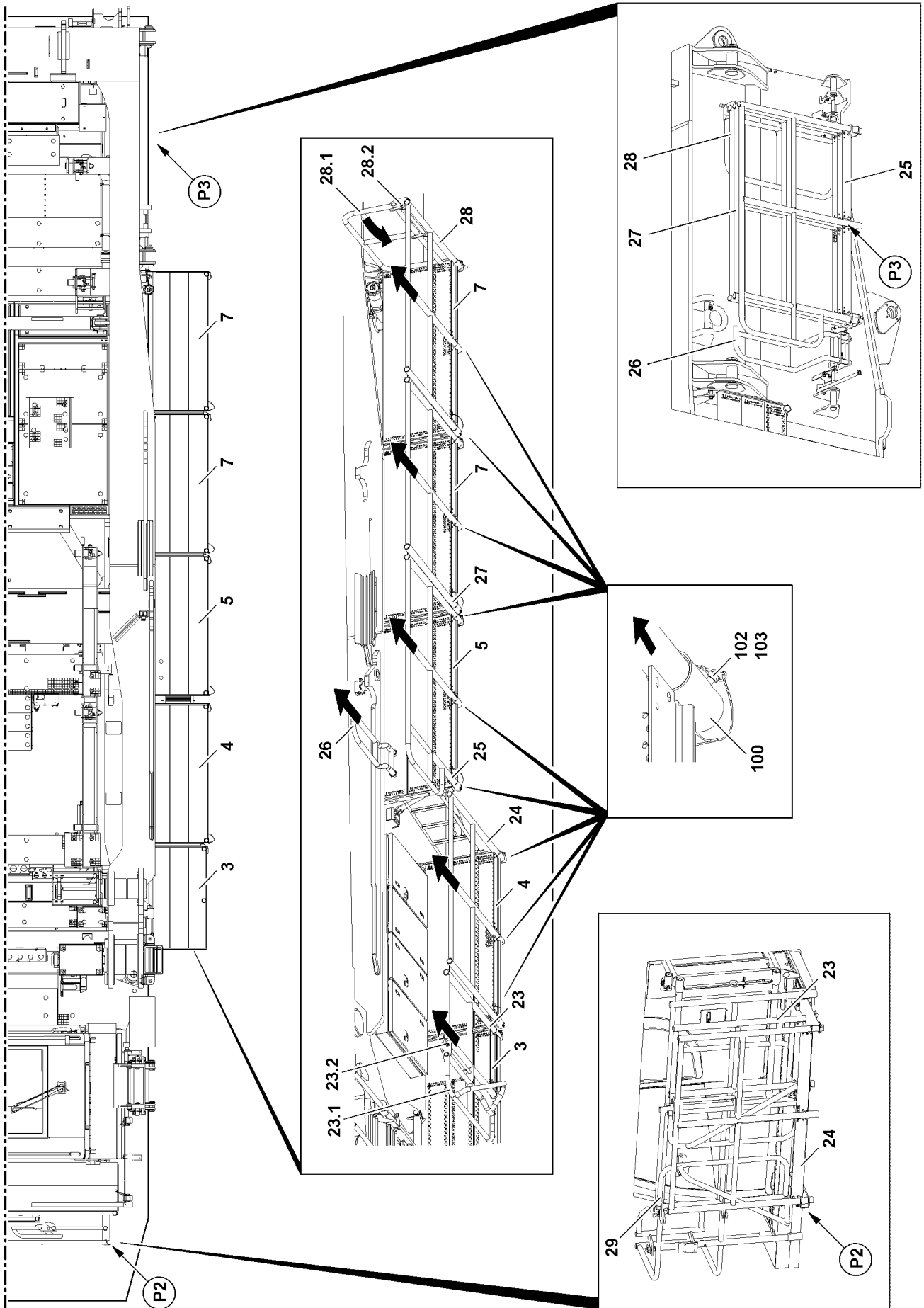

Fig.118177

8.3 Assembling the railings on the left turntable frame main section in transport position

Make sure that the following prerequisites are met:

- The turntable frame main section is on the flatbed trailer.
- The crane operator's cab is in transport position.

8.3.1 Disassemble railing 28 on catwalk 7

- ▶ Bring the swing bar **28.1** from railing **28** in transport position: Pull the detent pin **28.2** up and swing the swing bar **28.1** inward into transport position.
- ▶ Lock the swing bar **28.1** in transport position.
- ▶ Release the railing **28** in the receptacle sleeves **100** on catwalk **7**.
- ▶ Lift the railing **28** from the receptacle sleeves **100** on catwalk **7**.
- ▶ Insert the railing **28** in the transport retainer on the turntable frame main section at point **P3**, insert pins and secure with spring retainers.

8.3.2 Disassemble railing 27 on catwalk 7

- ▶ Release the railing **27** in the receptacle sleeves **100** on catwalk **7**.
- ▶ Lift the railing **27** from the receptacle sleeves **100** on catwalk **7**.
- ▶ Insert the railing **27** in the transport retainer on the turntable frame main section at point **P3**, insert pins and secure with spring retainers.

8.3.3 Disassemble railing 25 and railing 26 on catwalk 5

- ▶ Release the railing **25** in the receptacle sleeves **100** on catwalk **5**.
- ▶ Lift the railing **25** from the receptacle sleeves **100** on catwalk **5**.
- ▶ Insert the railing **25** in the transport retainer on the turntable frame main section at point **P3**, insert pins and secure with spring retainers.
- ▶ Release the railing **26** in the receptacle sleeves **100** on catwalk **5**.
- ▶ Lift the railing **26** from the receptacle sleeves **100** on catwalk **5**.
- ▶ Insert the railing **26** in the transport retainer on the turntable frame main section at point **P3**, insert pins and secure with spring retainers.

8.3.4 Disassemble railing 23 on catwalk 3

- ▶ Release the railing **23** in the receptacle sleeves **100** on catwalk **3**.
- ▶ Lift the railing **23** from the receptacle sleeves **100** on catwalk **3**.
- ▶ Insert the railing **23** in the transport retainer on the crane operator's cab at point **P2**, insert pin and secure with spring retainer.

8.3.5 Disassemble railing 24 on catwalk 4

- ▶ Release the railing **24** in the receptacle sleeves **100** on catwalk **4**.
- ▶ Lift the railing **24** from the receptacle sleeves **100** on catwalk **4**.
- ▶ Insert the railing **24** in the transport retainer on the crane operator's cab at point **P2**, insert pin and secure with spring retainer.

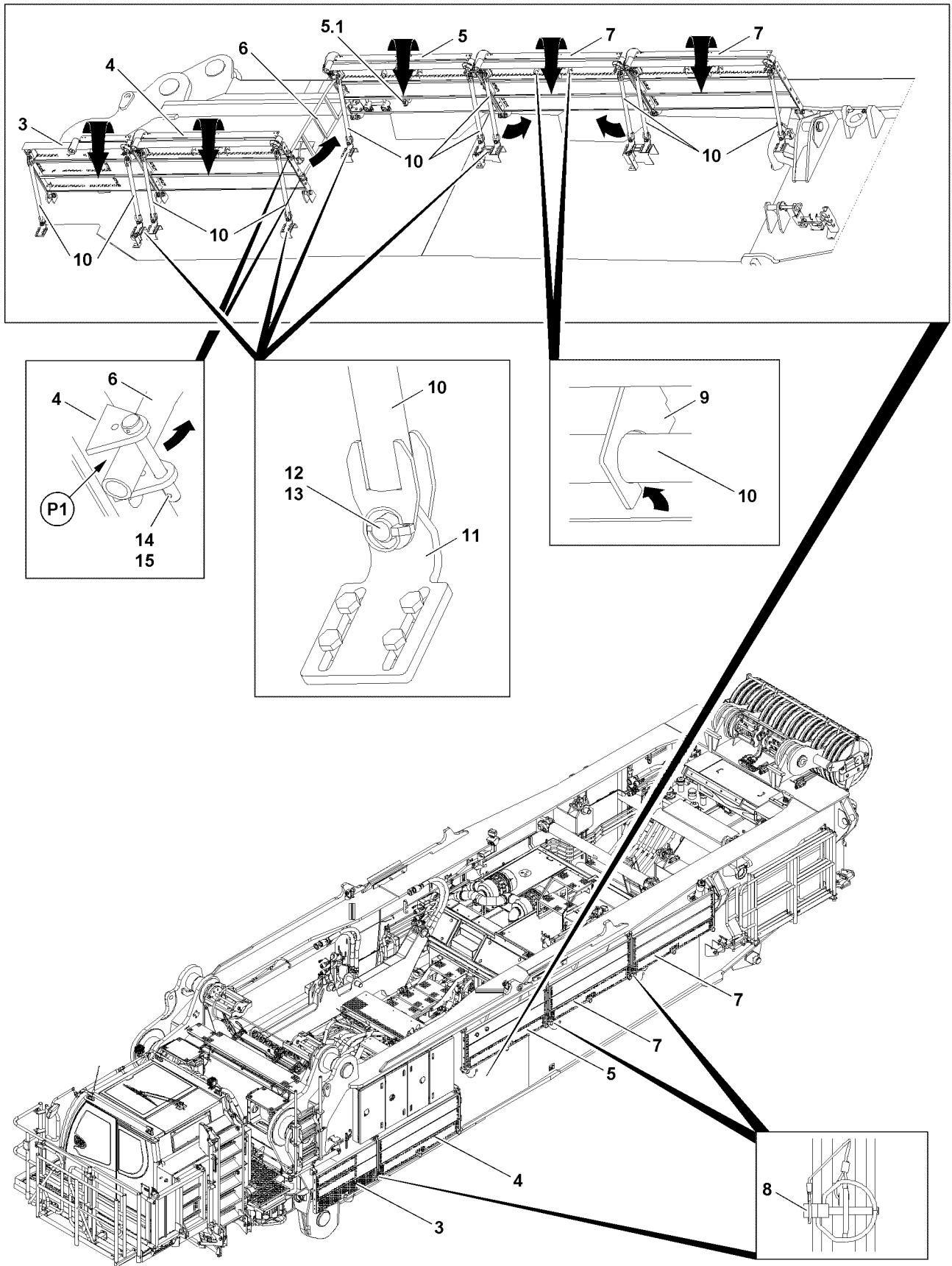

Fig.118178

LWE/LR 11000-001/23501-04-02/en

8.4 Bringing the catwalks on the left turntable frame main section in transport position



WARNING

Danger of accident due to catwalks!

Catwalks can fold down suddenly during disassembly.

Death, severe injury, property damage.

- ▶ Make sure that the catwalks are held safely in position by a second person during unpinning.
- ▶ Lower the catwalks slowly and controlled into the transport position after unpinning.



Note

- ▶ Carry out the disassembly of the catwalks starting with catwalk **7** from the „rear“ to the „front“.

Make sure that the following prerequisites are met:

- All railings on the catwalks are disassembled.

8.4.1 Bringing catwalks 7 into transport position

- ▶ Release the supports **10** on both sides on retaining plates **11** and unpin.
- ▶ Place the supports **10** in the transport retainers **9** on the underside of the catwalk **7**.
- ▶ Swing the catwalk **7** downward into transport position.
- ▶ Let the catwalk **7** hang first in this position.



Note

- ▶ The disassembly of the second catwalk **7** is identical with the disassembly of the first catwalk **7**.
- ▶ Disassemble the second catwalk **7** properly.

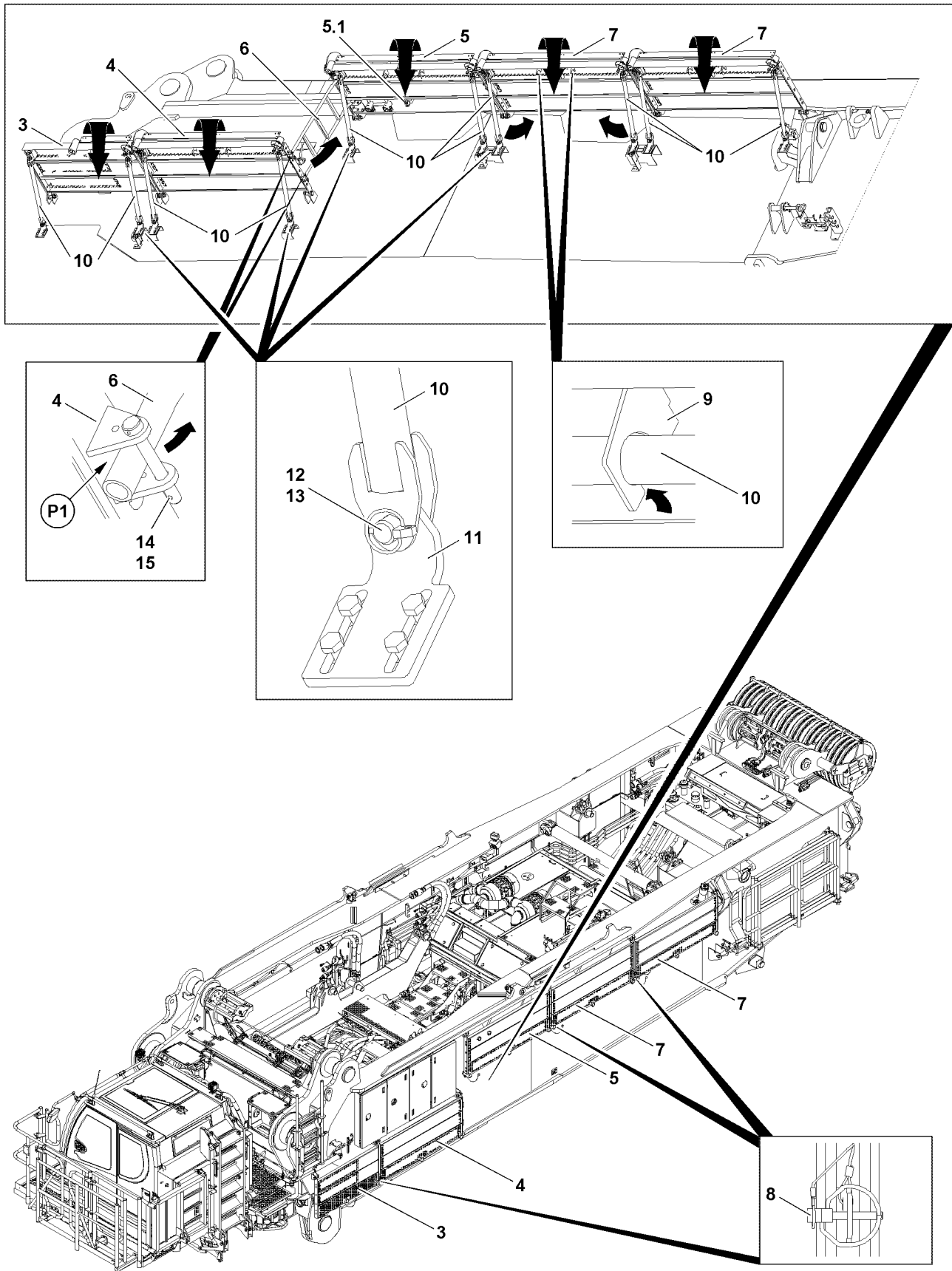

Fig.118178

LWE/LR 11000-001/23501-04-02/en

8.4.2 Bringing catwalk 5 into transport position

- ▶ Release the ladder 6 on catwalk 4 at point P1 and unpin.
- ▶ Let the ladder 6 hang first in this position.
- ▶ Release the supports 10 on both sides on retaining plates 11 and unpin.
- ▶ Place the supports 10 in the transport retainers 9 on the underside of the catwalk 5.
- ▶ Swing the ladder 6 up and lock on clamp 5.1.
- ▶ Swing the catwalk 5 downward into transport position.

When the catwalk 5 is in transport position:

- ▶ Let the catwalk 5 hang first in this position.

8.4.3 Securing catwalks 7 and catwalks 5 in transport position

In transport position, retaining brackets are between the catwalks, on which the catwalks are secured for transport.

- ▶ Secure the catwalks in transport position: Insert the locking pins 8 in the retaining brackets between the catwalks.

Result:

- The catwalks are secured.

8.4.4 Bringing catwalk 4 into transport position

- ▶ Release the supports 10 on both sides on retaining plates 11 and unpin.
- ▶ Place the supports 10 in the transport retainers 9 on the underside of the catwalk 4.
- ▶ Swing the catwalk 4 downward into transport position.

When the catwalk 4 is in transport position:

- ▶ Let the catwalk 4 hang first in this position.

8.4.5 Bringing catwalk 3 into transport position

- ▶ Release the supports 10 on both sides on retaining plates 11 and unpin.
- ▶ Place the supports 10 in the transport retainers 9 on the underside of the catwalk 3.
- ▶ Swing the catwalk 3 downward into transport position.

When the catwalk 3 is in transport position:

- ▶ Let the catwalk 3 hang first in this position.

8.4.6 Securing catwalk 3 and catwalk 4 in transport position

In transport position, retaining brackets are between the catwalks, on which the catwalks are secured for transport.

- ▶ Secure the catwalks in transport position: Insert the locking pins 8 in the retaining brackets between the catwalks.

Result:

- The catwalks are secured.

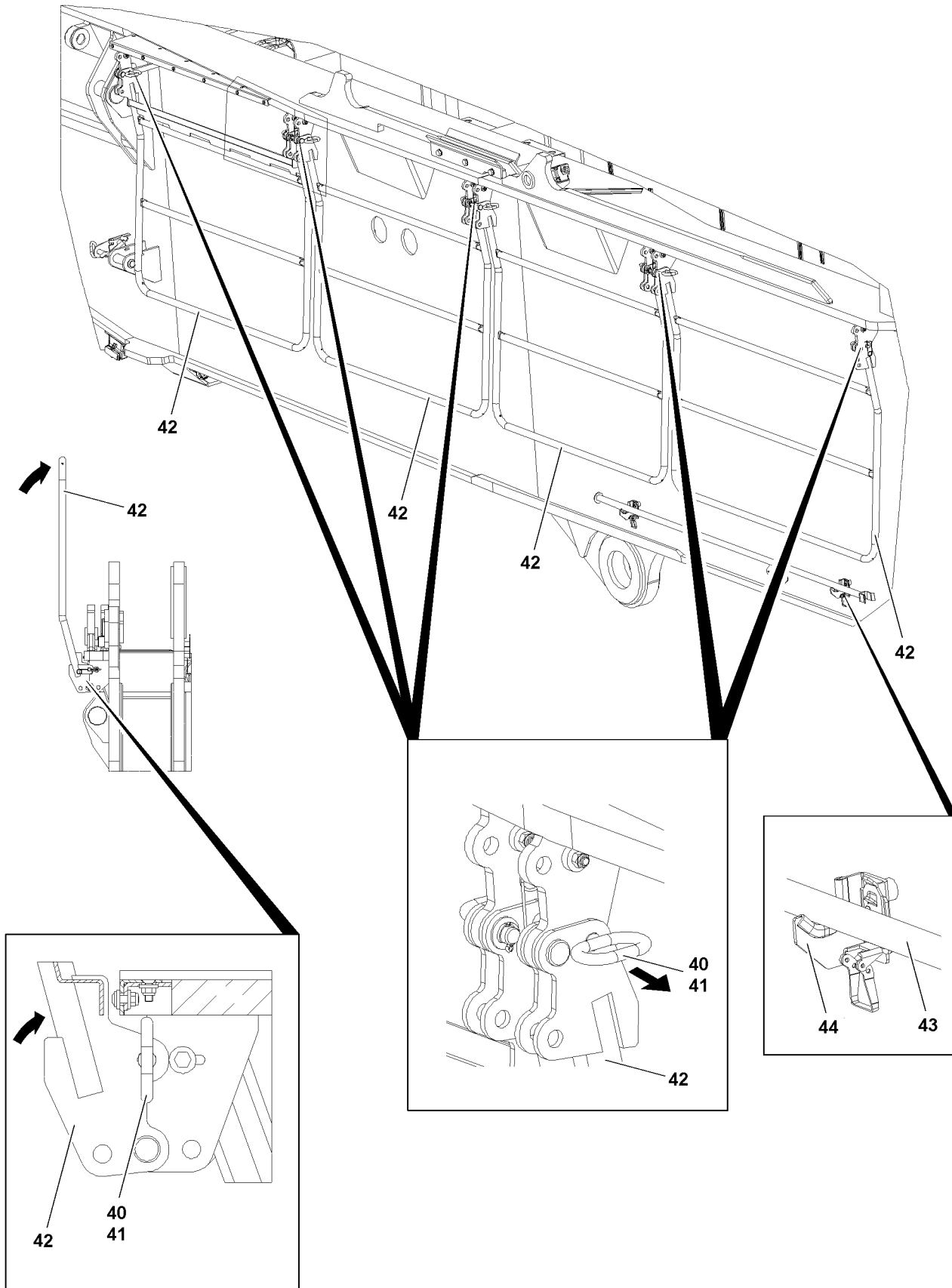

Fig.119732

8.5 Assembling the railings on the right turntable frame main section in operating position



WARNING

Danger of accident due to railing **42**!

Due to improper assembly of the railings **42**, the railings can suddenly fold down.

Death, severe injury, property damage.

- ▶ Make sure that the railings **42** are pinned and secured properly in operating position.

Make sure that the following prerequisites are met:

- The turntable frame main section is on the flatbed trailer.
- The railings on the left turntable frame main section are in operating position.
- Appropriate aids, such as a scaffolding or working platform are available.

- ▶ Release the railings **42** in transport position: Remove the spring retainer **41** and unpin the pin **40**.



WARNING

Danger of crushing!

In the swing range of the railings **42** hands can be crushed.

- ▶ Do not reach into the swing range of the railings.

- ▶ Swing the railings **42** upward into operating position: Use assembly rod **43**.

- ▶ Pin and secure railings **42** in operating position: Insert the pin **40** and secure with spring retainer **41**.

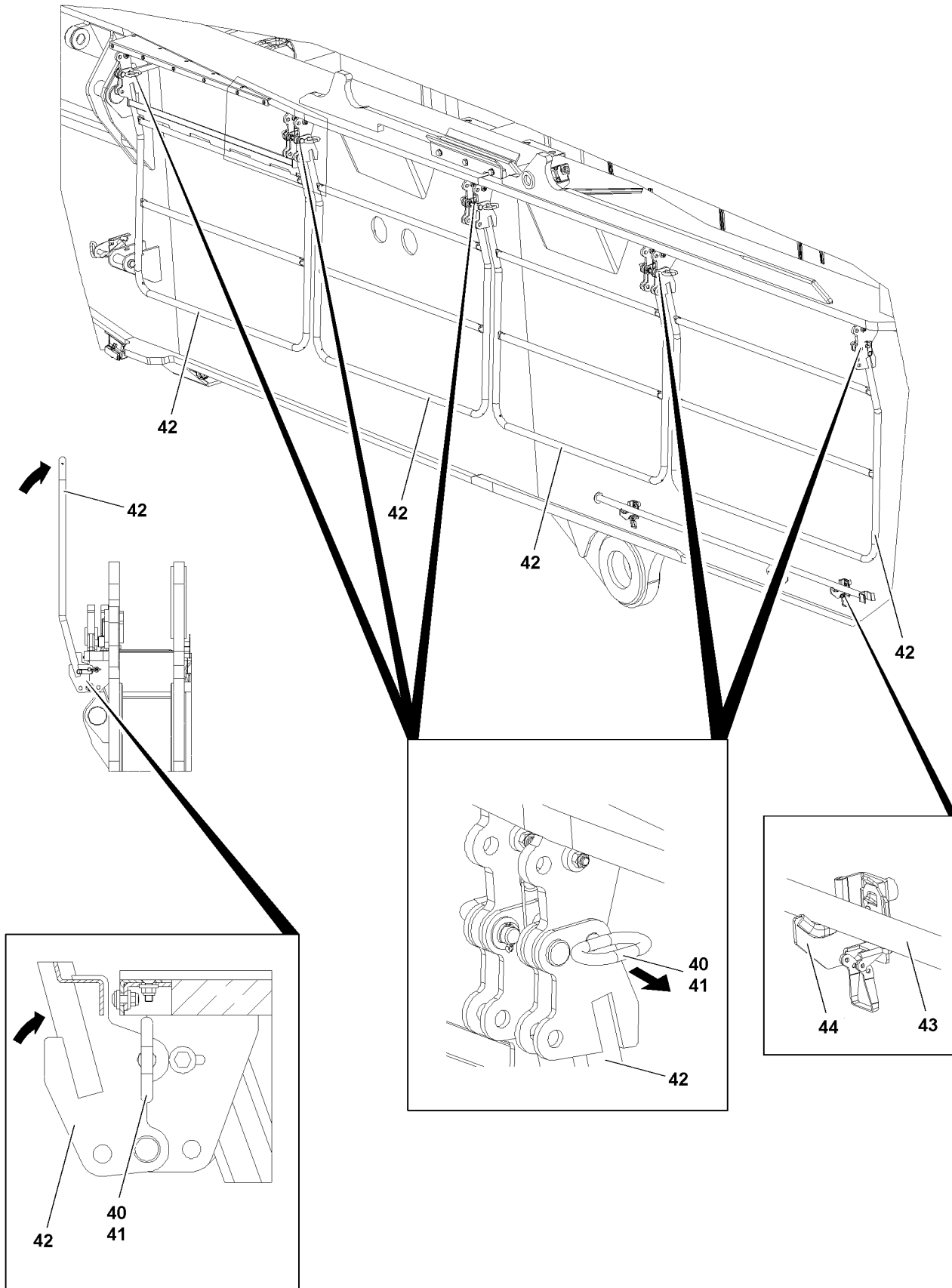

Fig.119732

LWE/LR 11000-001/23501-04-02/en

8.6 Bringing the railings on the right turntable frame main section in transport position



WARNING

Danger of accident due to railing **42**!

Due to improper assembly of the railings **42**, the railings can suddenly fold down.

Death, severe injury, property damage.

- ▶ Make sure that the railings **42** are pinned and secured properly in operating position.

Make sure that the following prerequisites are met:

- The turntable frame main section is on the flatbed trailer.
- The railings on the left turntable frame main section are in operating position.
- Appropriate aids, such as a scaffolding or working platform are available.



WARNING

Danger of accidents due to railings **42** swinging downward!

- ▶ Make sure that the railings are held by a person or are secured in operating position before unpinning.

- ▶ Release the railing **42** in operating position: Remove the spring retainer **41** and unpin the pin **40**.



WARNING

Danger of crushing!

In the swing range of the railings **42** hands can be crushed.

- ▶ Do not reach into the swing range of the railings **42**.

- ▶ Swing the railings **42** downward into transport position: Use assembly rod **43**.
- ▶ Pin and secure railings **42** in transport position: Insert the pin **40** and secure with spring retainer **41**.
- ▶ Insert the assembly rod **43** in the transport retainer **44** and secure.

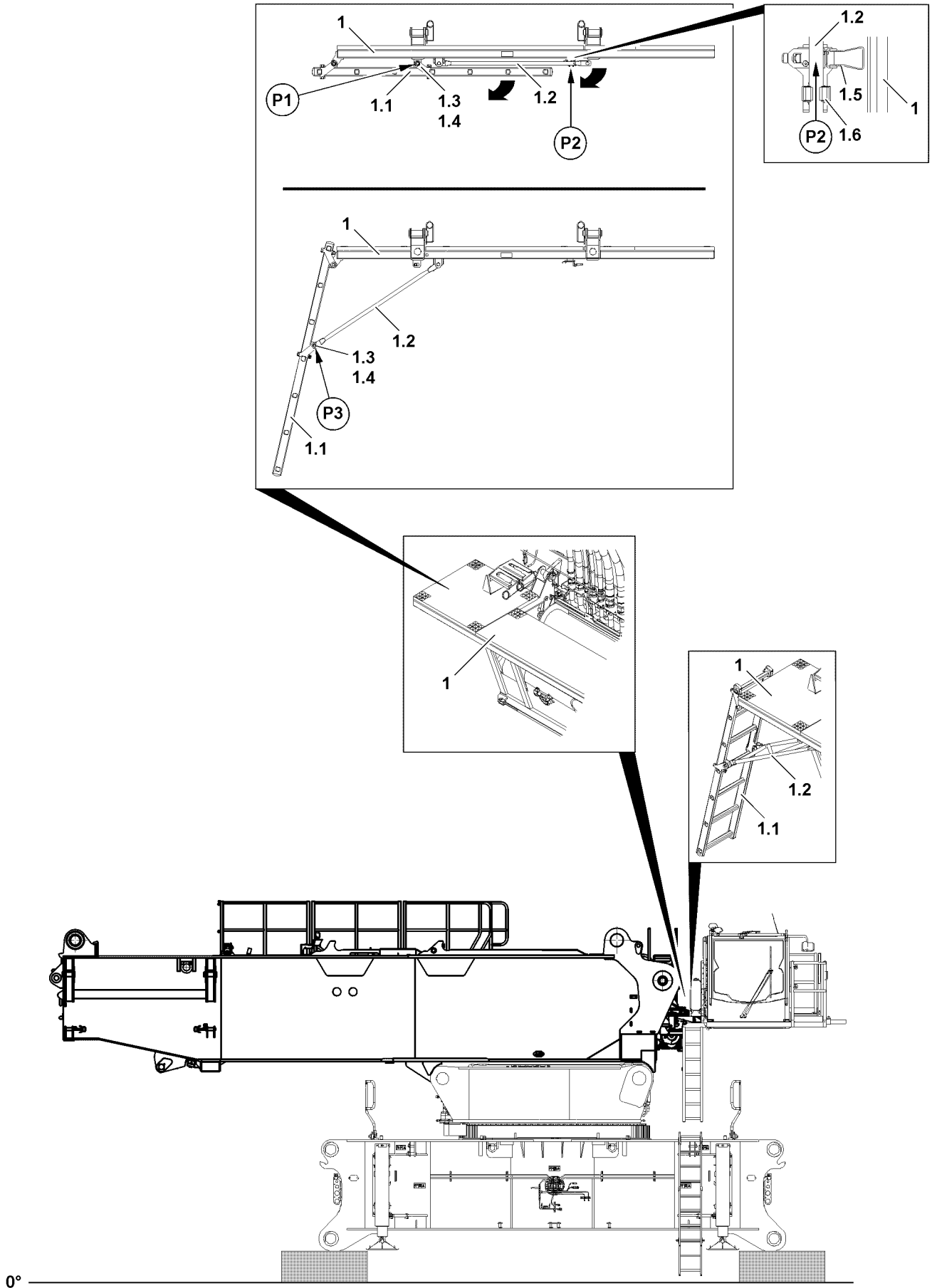

LWE/LR 11000-001/23501-04-02/en

Fig.119730

9 Main boom assembly platform on turntable

9.1 Bringing the ladder on the main boom assembly platform into operating position

Access to the crane operator's cab **3** is provided via the ladder **1.1** on the main boom assembly platform **1** at assembly of the turntable frame main section **3** on the turntable frame lower section **2**.



Note

- ▶ The ladder **1.1** on the main boom assembly platform **1** remains during crane operation in operating position.

Make sure that the following prerequisites are met:

- The catwalks on the crawler travel gear are in operating position.
- The railings on the crawler travel gear are in operating position.
- The turntable frame main section **3** is properly pinned and secured on the turntable frame lower section **2**.



WARNING

Swinging ladder!

If the transport retainer on the ladder **1.1** is released, then the ladder **1.1** can swing down by itself. Death, severe injury, property damage.

- ▶ Make sure that the ladder **1.1** is held safely in position when releasing the transport retainer.
- ▶ After releasing it, move the ladder **1.1** controlled downward into operating position.
- ▶ Release the transport retainer for the ladder at point **P1**: Remove the locking pin **1.4** and unpin the pin **1.3**.

When the transport retainer is released:

- ▶ Lower the ladder **1.1** slowly.



WARNING

Swinging strut!

If the transport retainer on the strut **1.2** is released, then the strut **1.2** can swing down by itself. Death, severe injury, property damage.

- ▶ Make sure that the strut **1.2** is held safely in position when releasing the transport retainer.
- ▶ After releasing it, move the strut **1.2** downward vertically.
- ▶ Release the transport retainer for the strut at point **P2**: Open the retaining bar **1.5**.
- ▶ Pull the strut **1.2** from the clamp **1.6** and guide downward.
- ▶ Pin the ladder **1.1** in operating position: Insert the pin **1.3** at point **P3** and secure with locking pin **1.4**.

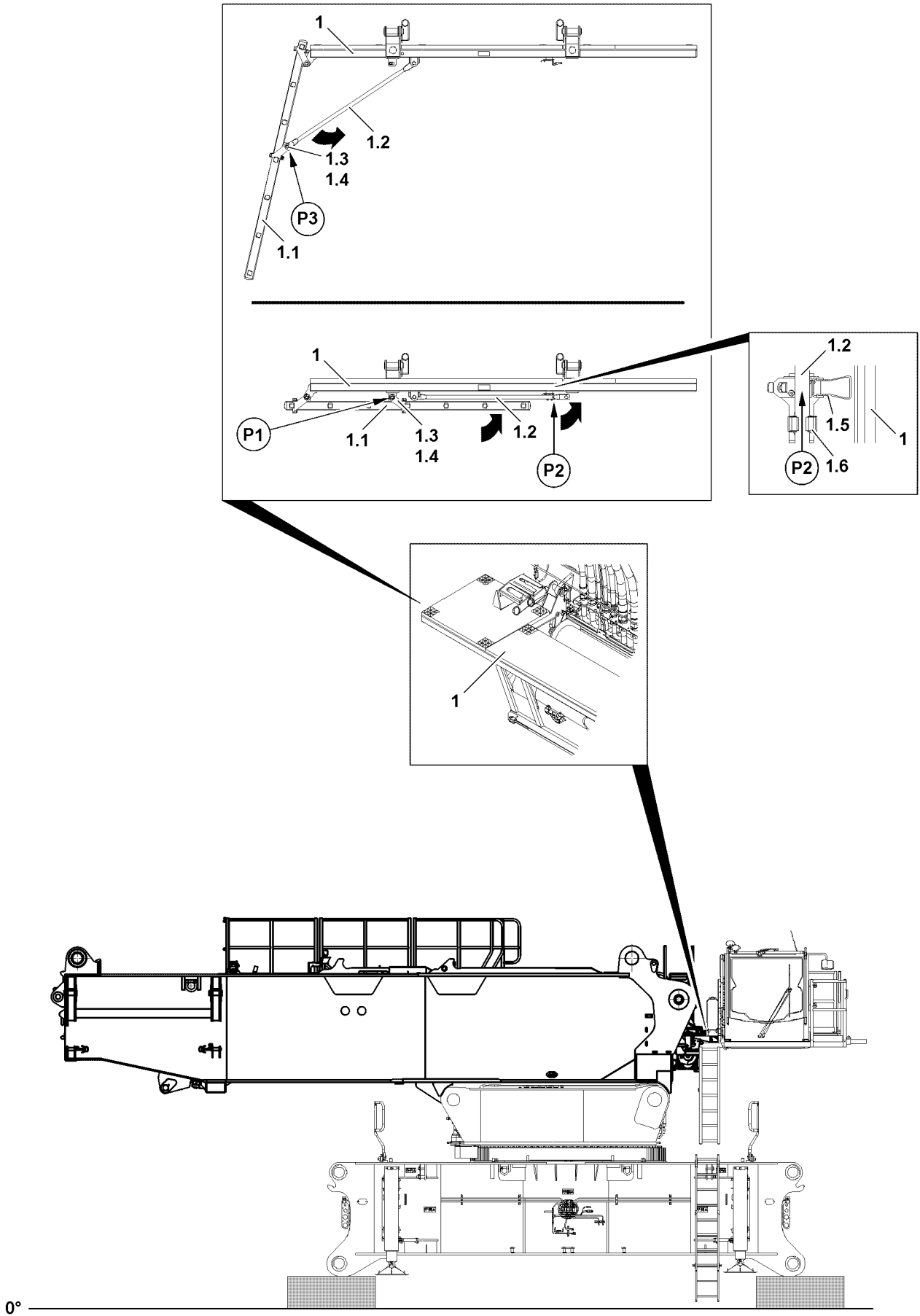

Fig.119731

LWE/LR 11000-001/23501-04-02/en

9.2 Bringing the ladder on the main boom assembly platform into transport position

- ▶ Unpin the support **1.2** at point **P3**: Remove the locking pin **1.4** and unpin the pin **1.3**.

When the support **1.2** is unpinned on ladder **1.1**:

- ▶ Guide the support **1.2** upward and engage it at point **P2** in clamp **1.6**.
- ▶ Close the retaining bar **1.5** at point **P2**.

Result:

- The support **1.2** is properly secured in transport position.
- ▶ Swing the ladder **1.1** up into transport position. Insert the pin **1.3** at point **P1** and secure with locking pin **1.4**.
- ▶ Pin the ladder **1.1** with the pin **1.3** at point **P1** and secure with locking pin **1.4**.

Result:

- The ladder **1.1** is pinned and secured in transport position.

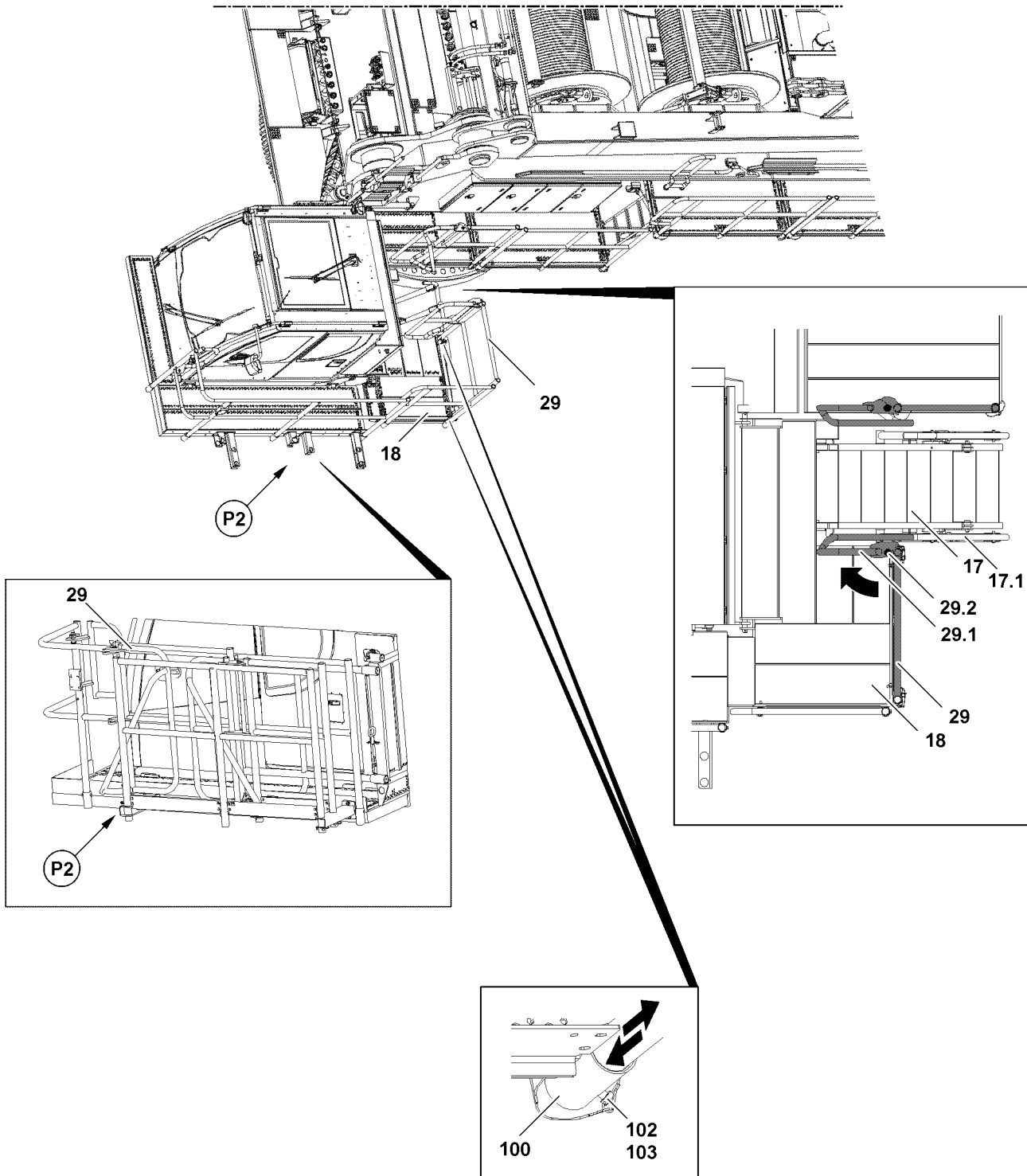

Fig.118191

LWE/LR 11000-001/23501-04-02/en

10 Cab platform rear



WARNING

Danger of falling!

If the crawler carriers and the catwalks are not correctly assembled on the crawler center section, then the operating or assembly personnel can fall off from the crane operator's cab.

Death, severe injury, property damage.

- ▶ Swing the access stairs only into operating position when the crawler carriers and the catwalks are properly assembled on the crawler travel gear, see Crane Operating instructions, chapter 3.01.
- ▶ Make sure that the crawler carriers and the catwalks on the crawler center section are properly assembled.



WARNING

Danger of accident!

Death, severe injury, property damage.

- ▶ Make sure that no personnel is within the danger zone when lowering the access stairs **17**.
- ▶ Lowering the access stairs **17**, see Crane operating instructions, chapter 4.03.

NOTICE

Damage to the crane operator's cab!

If the access stairs **17** are swung into transport position - with assembled railing **29** on the cab platform **18**, then property damage can occur.

- ▶ Make sure that the access stairs **17** remain in operating position during crane operation.

10.1 Bringing the railing on the cab platform into operating position

Make sure that the following prerequisites are met:

- The crawler carriers are properly assembled on the crawler center section.
- The catwalks and stairs on the crawler travel gear are properly assembled.
- The crane operator's cab is in operating position.
- The access stairs **17** are in operating position.
- The cab platform **18** are in operating position.

- ▶ Remove the railing **29** from the transport retainer at point **P2**.
- ▶ Insert the railing **29** in the receptacle sleeves **100** on cab platform **18**.

When the railing **29** is properly inserted in the receptacle sleeves **100** on cab platform **18**:

- ▶ Pin the railing **29** in the receptacle sleeves **100** with pin **102** and secure with spring retainer **103**.
- ▶ Bring the swing bar **29.1** from railing **29** in operating position: Pull the detent pin **29.2** up and swing the swing bar **29.1** outward into operating position.

Result:

- The swing bar **29.1** is locked at a 90° angle to railing **29** (operating position).

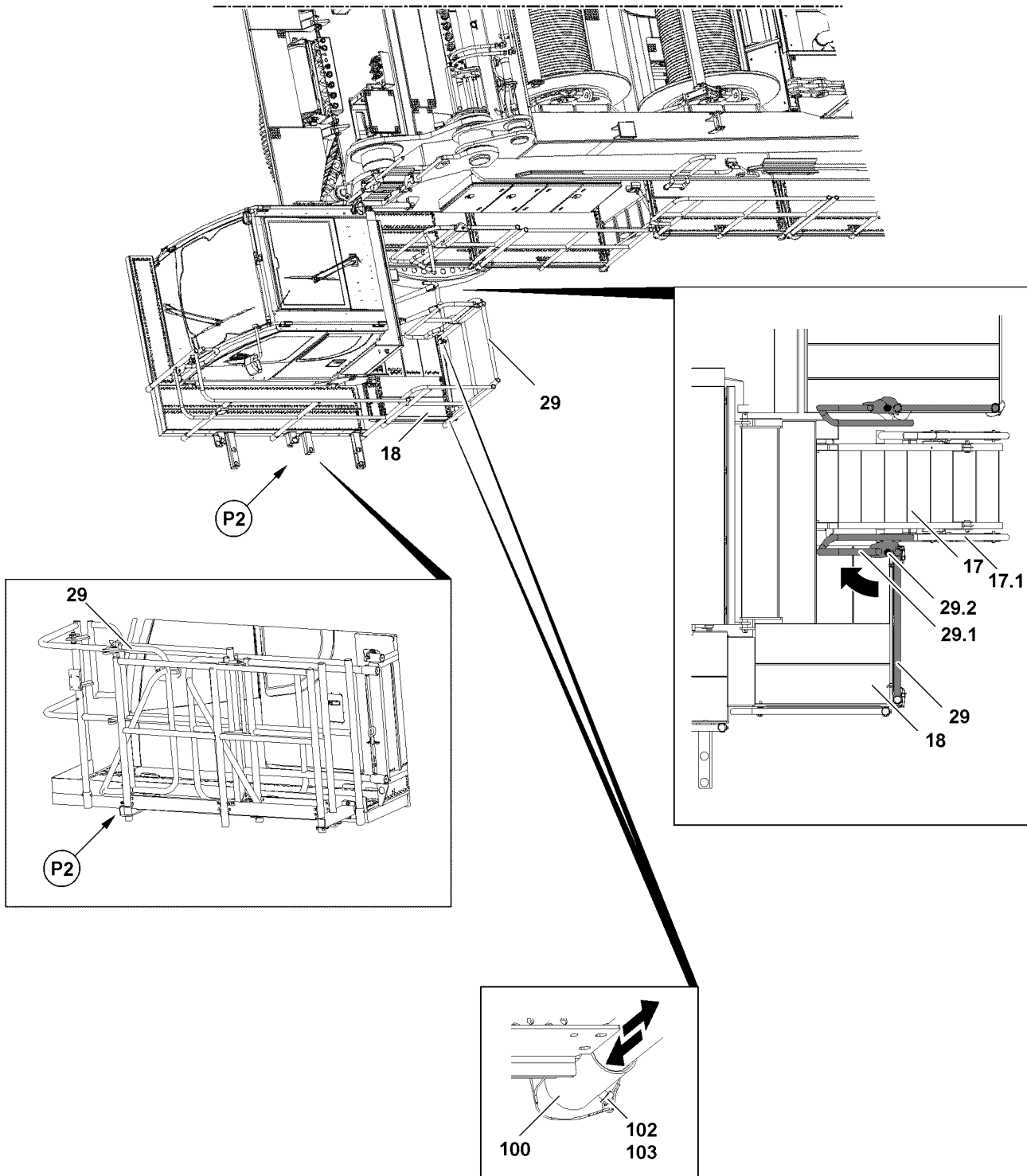

Fig.118191

LWE/LR 11000-001/23501-04-02/en

10.2 Bringing the railing on the cab platform into transport position

- ▶ Bring the swing bar **29.1** from railing **29** in transport position: Pull the detent pin **29.2** up and swing the swing bar **29.1** inward into transport position.
- ▶ Lock the swing bar **29.1** in transport position.
- ▶ Release the railing **29** in the receptacle sleeves **100** on cab platform **18**.
- ▶ Lift the railing **29** from the receptacle sleeves **100** on cab platform **18**.
- ▶ Insert the railing **29** in the transport retainer on the crane operator's cab at point **P2**, insert pins and secure with spring retainers.



Note

- ▶ Swing the access stairs **17** into transport position, see Crane operating instructions, chapter 4.03.
-

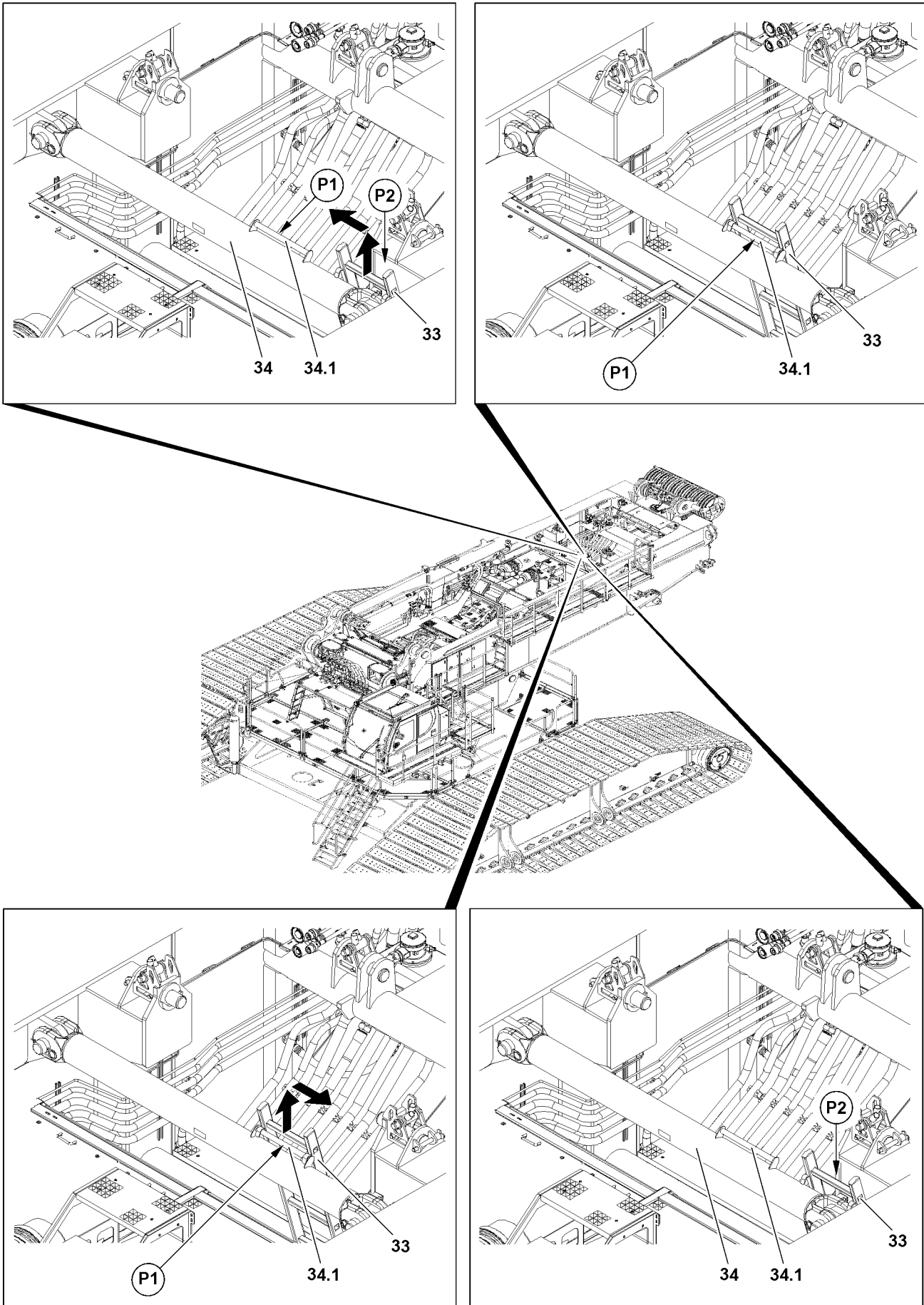

Fig.118180

LWE/LR 11000-001/23501-04-02/en

11 Ladder turntable frame main section



Note

- ▶ Ladder **33** is used for assembly personnel to get down to the pin devices of winch 4 or the installation position of winch 4.

NOTICE

Damage of ladder!

If the ladder **33** is in assembly position before installation of winch 4, then the ladder **33** can be damaged.

- ▶ Make sure that the ladder **33** is in park position at assembly of winch 4.



WARNING

Danger of falling!

Death, severe injury, property damage.

- ▶ When ascending and descending, the assembly personnel must ensure a 3-point support.
- ▶ When ascending and descending, use rungs and ladder beams as handles.
- ▶ The assembly personnel must step into the rungs sufficiently deep.

11.1 Bringing the ladder into assembly position

- ▶ Release the ladder **33** in park position at point **P2**.
- ▶ Remove the ladder **33** from park position at point **P2**.
- ▶ Hang the ladder **33** on point **P1** on rod **34.1** of strut **34**.

11.2 Bringing the ladder into park position

- ▶ Remove the ladder **33** from assembly position at point **P1**.
- ▶ Bring the ladder **33** on point **P2** into park position.
- ▶ Secure the ladder **33** in park position at point **P2**.

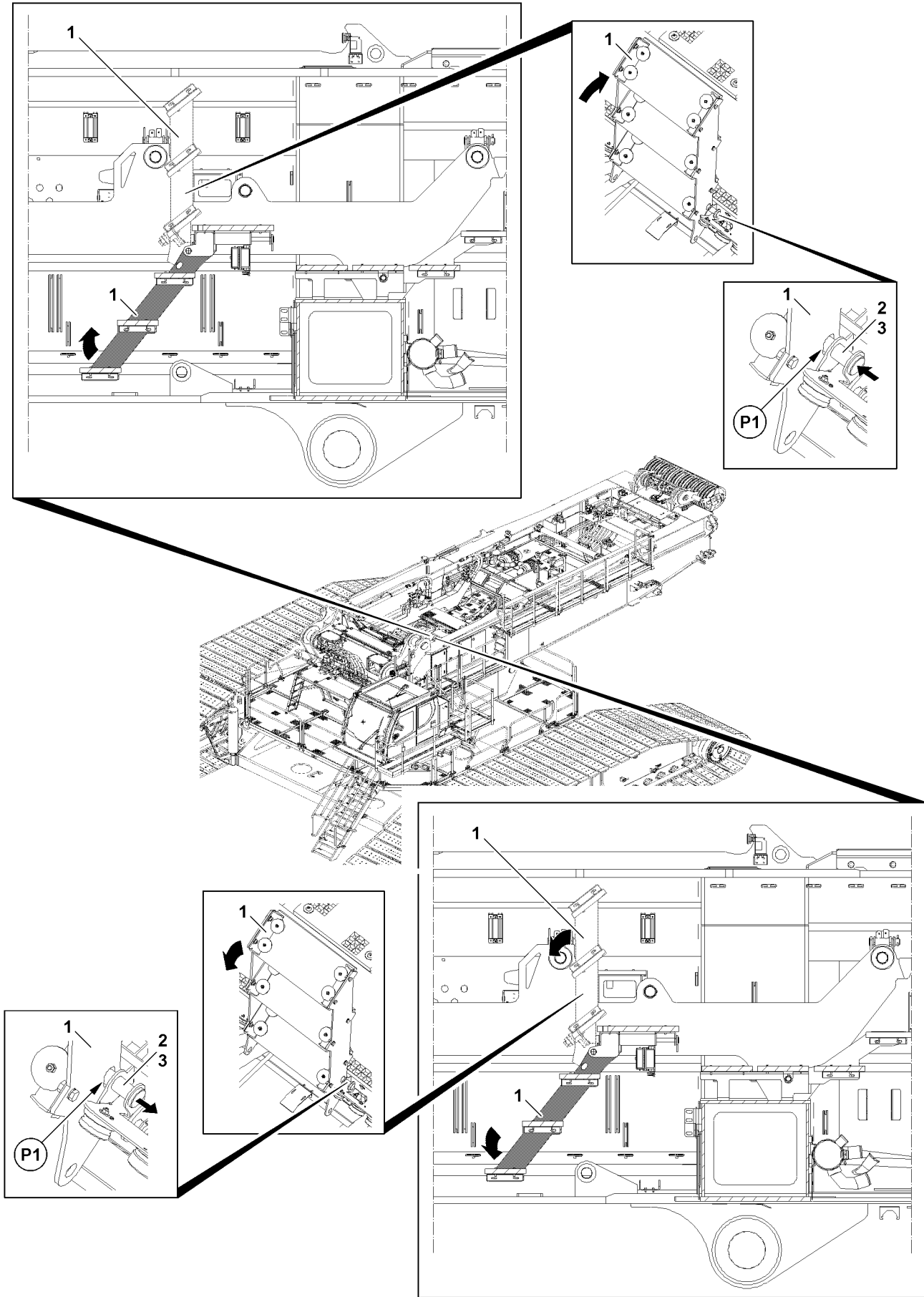

Fig.118202

LWE/LR 11000-001/23501-04-02/en

12 Stairs turntable frame main section



Note

- ▶ The stairs **1** are used in operating position for assembly personnel to get down to the rotary connection or the turntable frame lower section.
- ▶ To improve accessibility during assembly work in the area of the hydraulic and electrical connections on the rotary connection, fold the stairs up in assembly position and secure.

12.1 Bringing the stairs into assembly position



WARNING

Danger of accident due to stairs!

The stairs can fold down by themselves from the assembly position.
Death, severe injury, property damage.

- ▶ Make sure that the stairs are pinned and secured properly in assembly position.
- ▶ Release the stairs **1** in operating position.
- ▶ Fold the stairs **1** up in assembly position.
- ▶ Pin the stairs **1** at point **P1** in assembly position with pin **2** and secure with retaining element **3**.

12.2 Bringing the stairs into operating position



WARNING

Danger of accident due to stairs!

The stairs can fold down by themselves from the assembly position.
Death, severe injury, property damage.

- ▶ Make sure that the stairs are held in position before unpinning.
- ▶ After releasing them, fold the stairs down into operating position.
- ▶ Hold the stairs **1** in assembly position.
- ▶ Release the stairs **1** at point **P1**: Remove retaining element **3** and unpin pin **2**.
- ▶ Swing the stairs **1** downward into operating position.

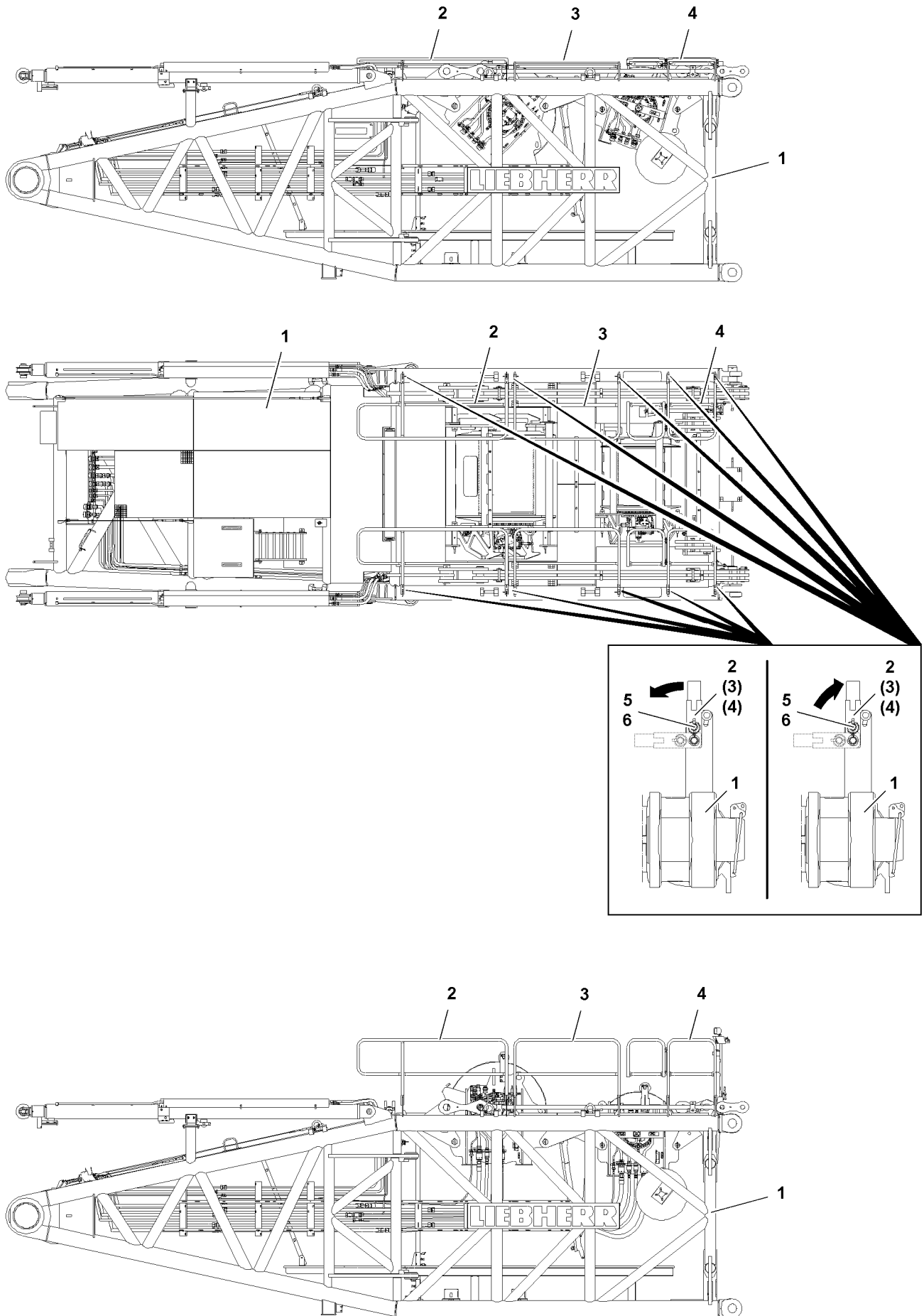

Fig.118192

LWE/LR 11000-001/23501-04-02/en

13 Railings on the S-pivot section



WARNING

Danger of crushing!

When swinging the railings, fingers and hands can be crushed.

- ▶ Do not reach with your hands into the danger zone.

13.1 Positioning the railings into operating position

- ▶ Unpin railing (railing 2, railing 3, railing 4) in transport position: Remove the locking pin 5 and unpin the grip pin 5.
- ▶ Swing the railings individually into operation position up and hold.
- ▶ Secure the railing in operating position: Insert the grip pin 5 and secure with locking pin 5.
- ▶ Bring the railing on the opposite side properly into operating position.

13.2 Bringing the railings into transport position

- ▶ Unpin the railings individually in operating position: Remove the locking pin 5 and unpin the grip pin 5.
- ▶ Swing the railings downward into transport position.
- ▶ Secure the railings in transport position: Insert the grip pin 5 and secure with locking pin 5.
- ▶ Bring the railing on the opposite side properly into transport position.

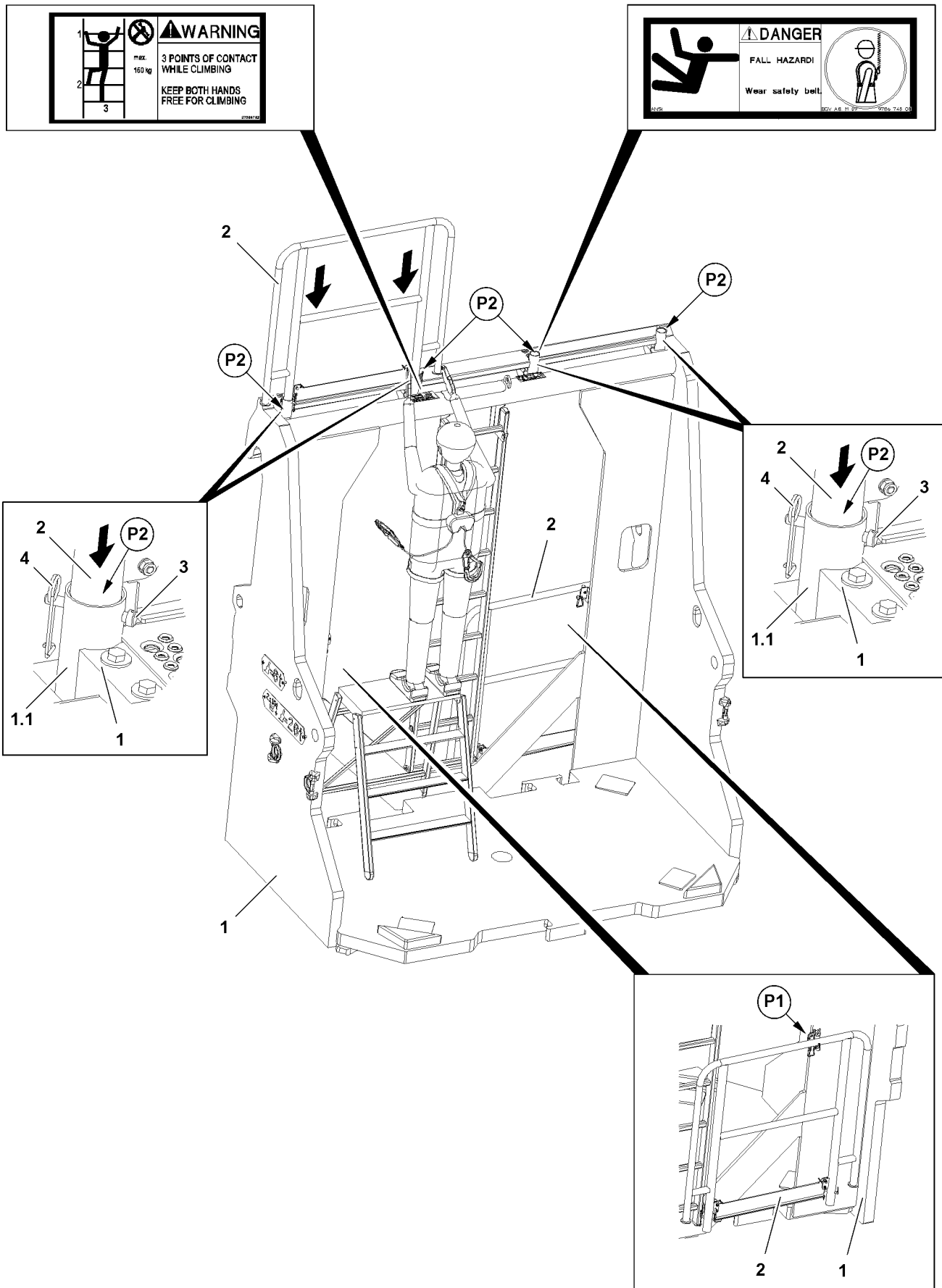

Fig.118184

LWE/LR 11000-001/23501-04-02/en

14 Fall protection equipment on the counterweight bracket



Note

- ▶ Liebherr-Werk Ehingen GmbH recommends for the safe assembly / disassembly of the railings 2 to use an assembly platform or a stepladder with sufficiently sized placement surface.



WARNING

- Falling assembly personnel!
During the assembly / disassembly of the railings 2 the assembly personnel can fall down.
Death, severe injury, property damage.
- ▶ Carry out the assembly of the railings with utmost caution.

14.1 Bringing the railings on the counterweight bracket into operating position

Make sure that the following prerequisites are met:

- The counterweight bracket 1 is on the flatbed trailer or on the ground.
- An assembly platform or a stepladder is available.
- ▶ Release the railing 2 in transport position at point P1.
- ▶ Remove the railing 2 from the transport receptacle.
- ▶ Set the railing 2 on points P2 in the sleeve 1.1.
- ▶ Secure the railing 2 with pin: Insert the pin 3 on sleeve 1.1 and secure with spring retainer 4.

Result:

- The railing 2 is properly pinned and secured in operating position.



Note

- ▶ The assembly of the second railing is identical with the assembly of the first railing.
- ▶ Assemble the second railing according to the description above in operating position.

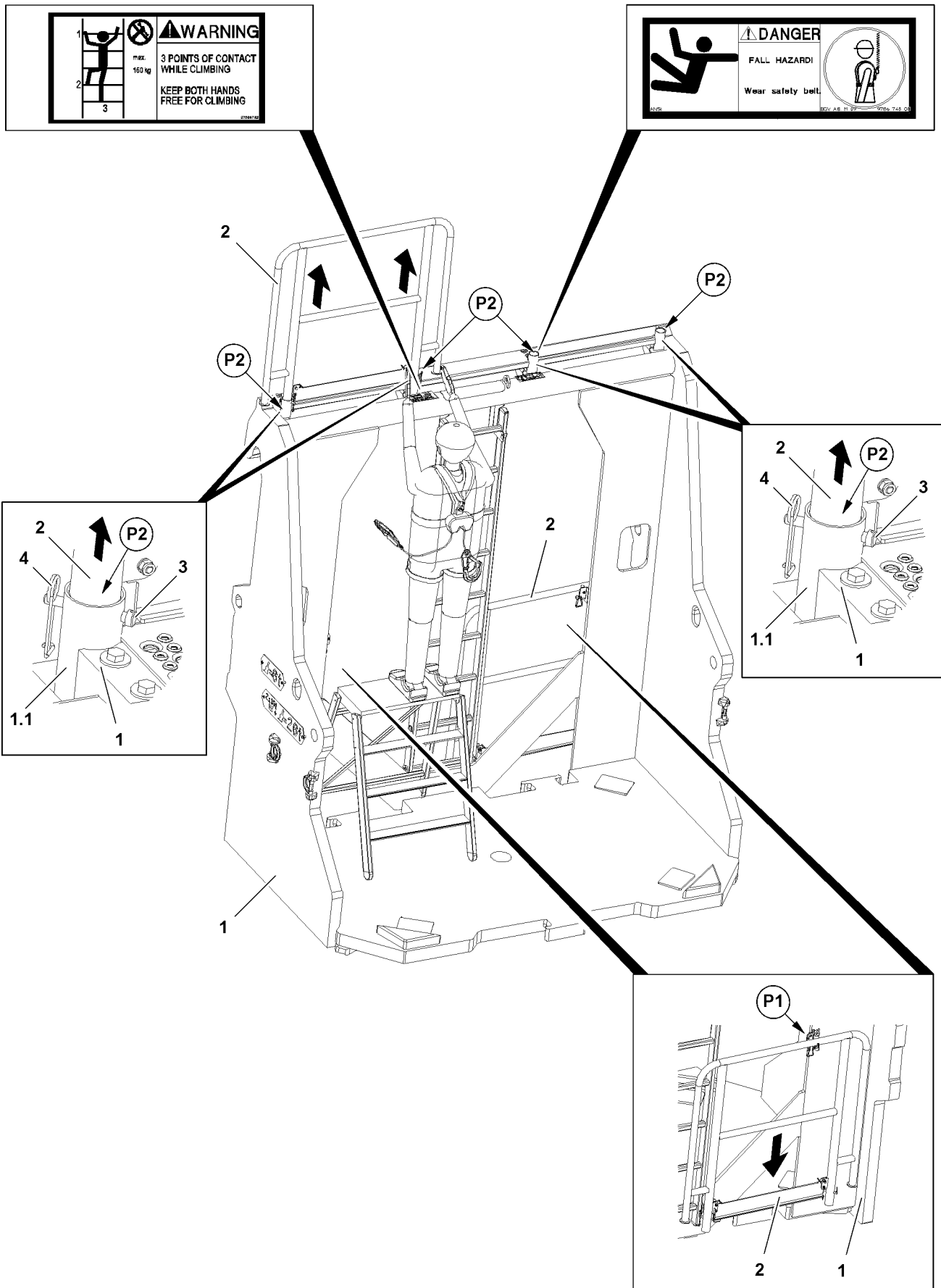

Fig.118186

LWE/LR 11000-001/23501-04-02/en

14.2 Bringing the railings on the counterweight bracket into transport position

Make sure that the following prerequisites are met:

- The counterweight bracket **1** is on the flatbed trailer or on the ground.
- An assembly platform is on hand.
- ▶ Release the railing **2** in operating position: Remove the spring retainer **4** and unpin the pin **3** on the sleeve **1.1**.
- ▶ Lift the railing **2** from the sleeves **1.1**.
- ▶ Set the railing **2** on point **P1** in transport position.



Note

- ▶ The disassembly of the second railing is identical with the disassembly of the first railing.
-
- ▶ Bring the second railing in transport position and secure.

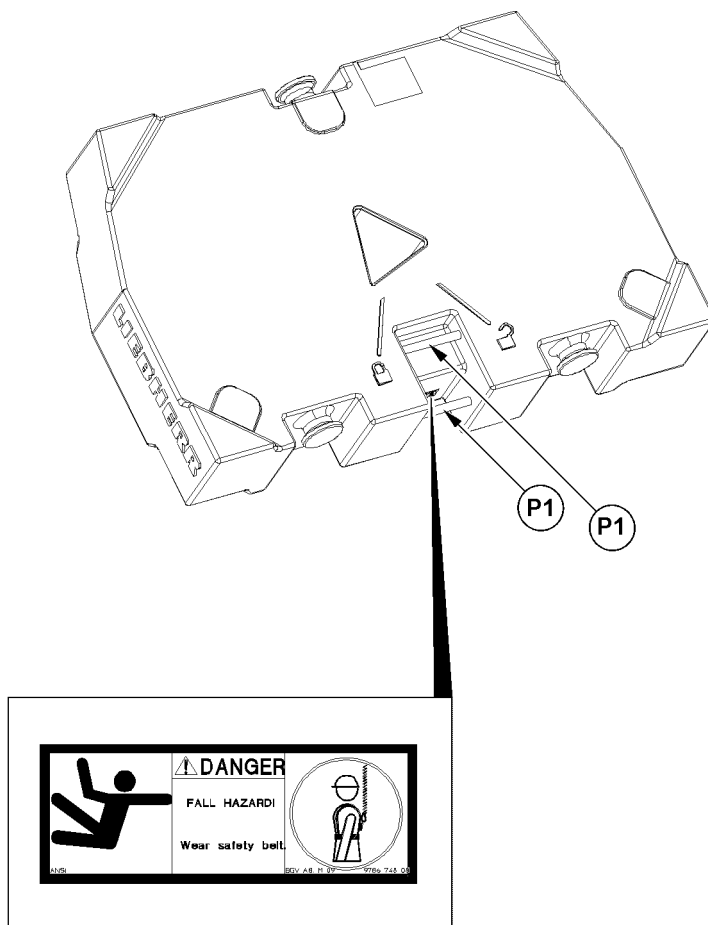

Fig.118182

LWE/LR 11000-001/23501-04-02/en

15 Fall protection equipment on counterweights

15.1 Fastening and hook points on the counterweights

The hook points **P1** are integrated in the counterweights.



WARNING

When working aloft, there is a danger of falling!
Death, severe injury, property damage.

- ▶ Assembly personnel must wear an approved fall arrest system and protective equipment before performing any assembly / disassembly and maintenance work on the counterweights.
 - ▶ The assembly personnel must hook themselves on the hook points **P1** with an approved fall arrest system to prevent them from falling.
-

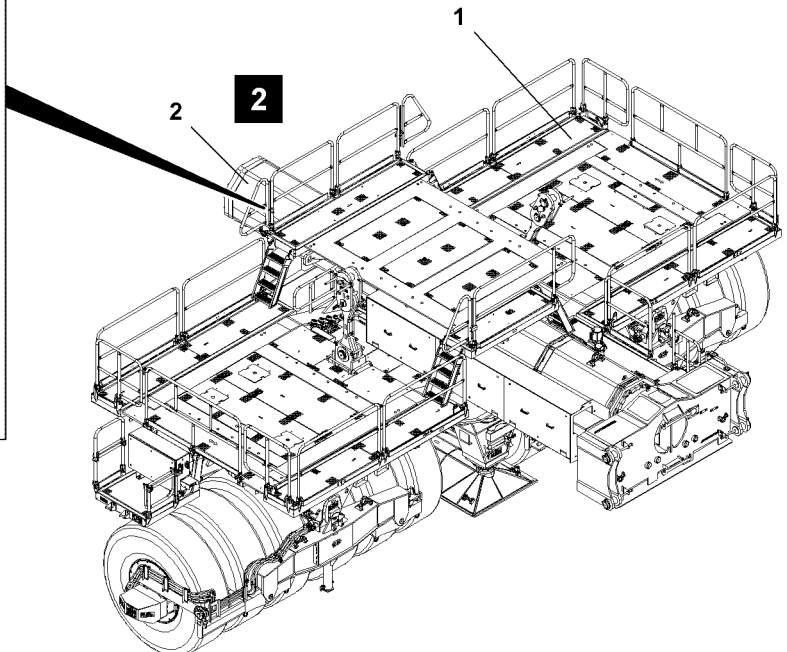
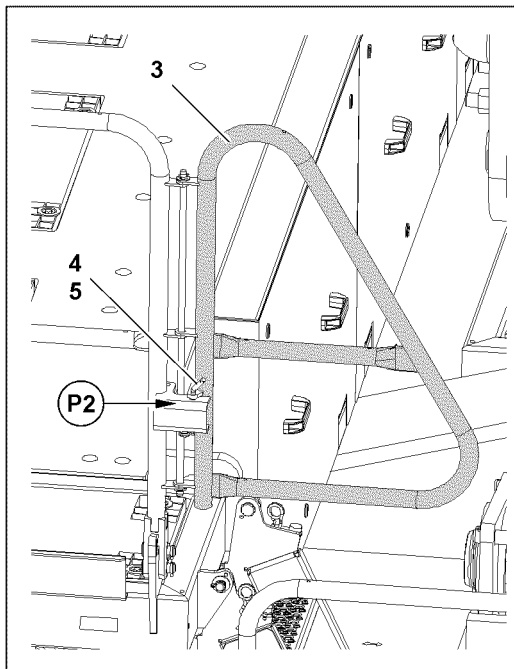
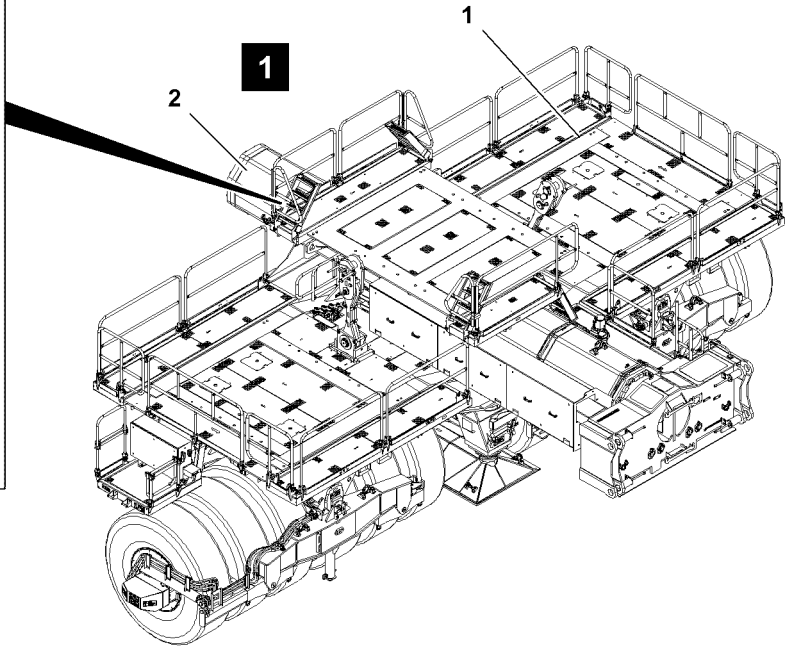
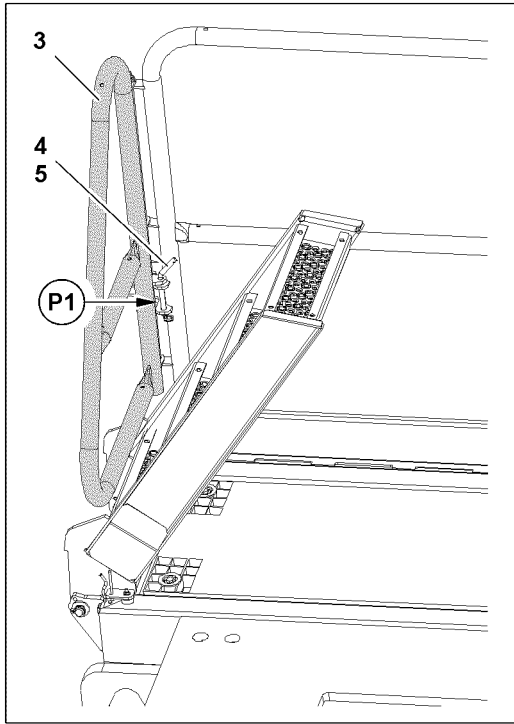

LWE/LR 11000-001/23501-04-02/en

Fig. 121032

16 Railing on ballast trailer guide



Note

- ▶ The assembly and disassembly of the railings is identical and is described on the example for one railing.



WARNING

Danger of falling!

During assembly and disassembly of the railing, personnel must be secured with appropriate aids to prevent them from falling.

Even at the assembly of protective equipment there is a danger of falling.

Death, severe injury, property damage.

- ▶ Use personal protective equipment.

16.1 Swinging the railing into operating position

The ballast trailer guide **2** is equipped with three foldable railings **3**, see illustration **1**.

- ▶ Release the railing **3** from the transport position: Remove the cotter pin **5** at point **P1** and unpin the pin **4**, see illustration **1**.



WARNING

Danger of crushed limbs!

When swinging the railing, fingers and hands can be crushed.

- ▶ Do not reach with your hands into the danger zone.

- ▶ Swing the railing **3** into operating position.

- ▶ Secure the railing **3** in operating position: Insert the pin **4** at point **P2** and secure with cotter pin **5**, see illustration **2**.

16.2 Swinging the railings into transport position

- ▶ Release the railing **3** from the operating position: Remove the cotter pin **5** at point **P2** and unpin the pin **4**, see illustration **2**.



WARNING

Danger of crushed limbs!

When swinging the railing, fingers and hands can be crushed.

- ▶ Do not reach with your hands into the danger zone.

- ▶ Swing the railing **3** into transport position.

- ▶ Secure the railings **3** in transport position: Insert the pin **4** at point **P1** and secure with cotter pin **5**, see illustration **1**.

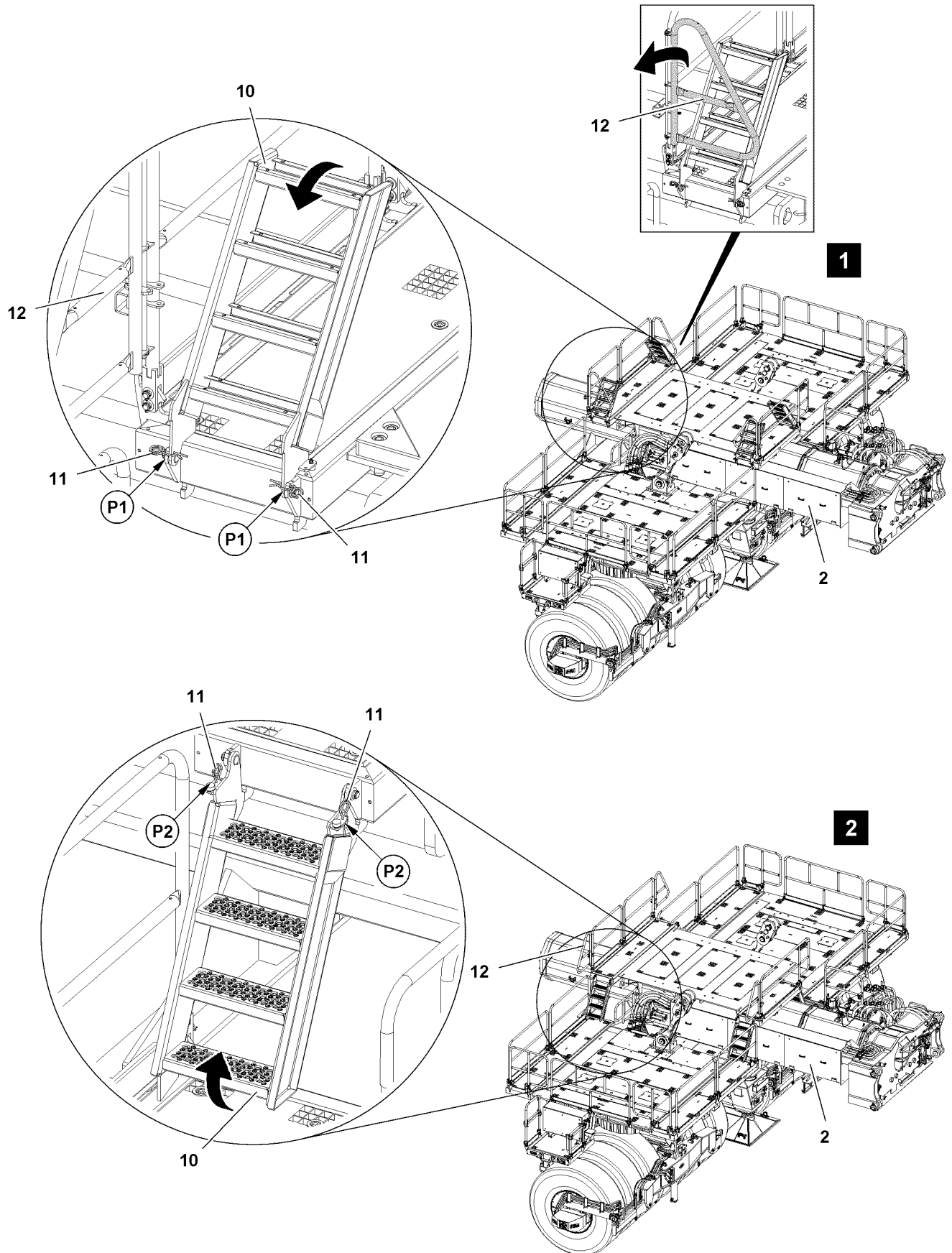

LWE/LR 11000-001/23501-04-02/en

Fig.121024

17 Ladders on ballast trailer guide

The ballast trailer guide **2** is equipped with four ladders **10**.

The ladders **10** are used for assembly personnel to ascent and descent on the guide.

The assembly and disassembly of the ladders **10** is described on the example of one ladder.

NOTICE

Damage of ladder!

If the ladders **10** are in operating position before installation of the ballast trailer guide **2**, ladders **10** can be damaged.

- ▶ Make sure that ladders **10** are in transport position at installation of the ballast trailer guide **2**.
-

17.1 Swinging the ladder into operating position

Make sure that the following prerequisites are met:

- The ballast trailer guide **2** is installed.
- The railing **12** is open, see illustration **1**.

- ▶ Release the ladder **10** from transport position: Remove the safety spring **11** at point **P1**, see illustration **1**.



WARNING

Danger of crushing!

When swinging the ladder, it can fall down by itself due to its own weight.

Crushing injuries of limbs can occur.

- ▶ Hold the ladder **10** and swing it slowly into operating position.

- ▶ Swing the ladder **10** from transport position into operating position to the stop, see illustration **2**.
 - ▶ Fasten the safety spring **11** at point **P2** in park position, see illustration **2**.
-

17.2 Swinging the ladder into transport position

Make sure that the following prerequisite is met:

- The railing **12** is open, see illustration **2**.

- ▶ Remove the safety spring **11** at point **P2** from park position, see illustration **2**.



WARNING

Danger of crushing!

When swinging the ladder, it can fall down by itself due to its own weight.

Crushing injuries of limbs can occur.

- ▶ Hold the ladder **10** and swing it slowly into transport position.

- ▶ Swing the ladder **10** from operating position into transport position, see illustration **1**.
 - ▶ Secure the ladder **10** in transport position with safety spring **11** at point **P1**, see illustration **1**.
-

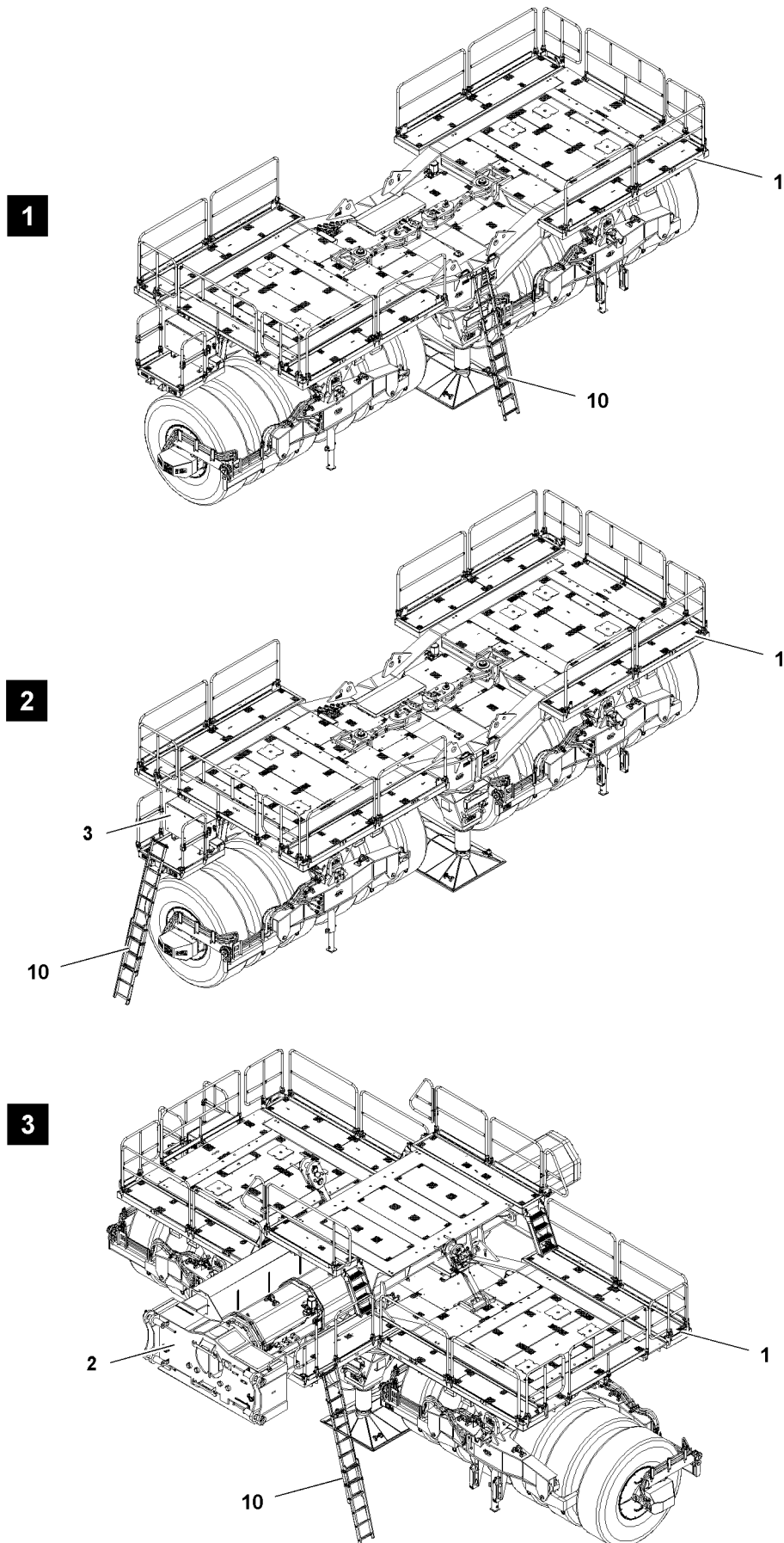

Fig. 121025

18 Extension ladder on ballast trailer

The extension ladder **10** is used for assembly personnel to ascent and descent on the ballast trailer.

Area of operation of the extension ladder:

- Extension ladder on ballast trailer **1**, see illustration **1**
- Extension ladder on control cabinet **3**, see illustration **2**
- Extension ladder on ballast trailer guide **2**, see illustration **3**



Note

- ▶ The weight of the extension ladder is 12.5 kg.
-



WARNING

Danger of falling!

Death, severe injury, property damage.

- ▶ When ascending and descending, the assembly personnel must ensure a 3-point support.
 - ▶ When ascending and descending, use rungs and ladder beams as handles.
 - ▶ The assembly personnel must step into the rungs sufficiently deep.
-

NOTICE

Danger of crushing!

During assembly and disassembly of the extension ladder fingers and hands can be crushed.

- ▶ Do not reach with your hands into the danger zone.
 - ▶ Install the ladder solely from the ground.
 - ▶ Step on the extension ladder only when the extension ladder is secured in ascent and descent position.
 - ▶ Observe the national regulations and standards regarding the use of rung ladders.
-

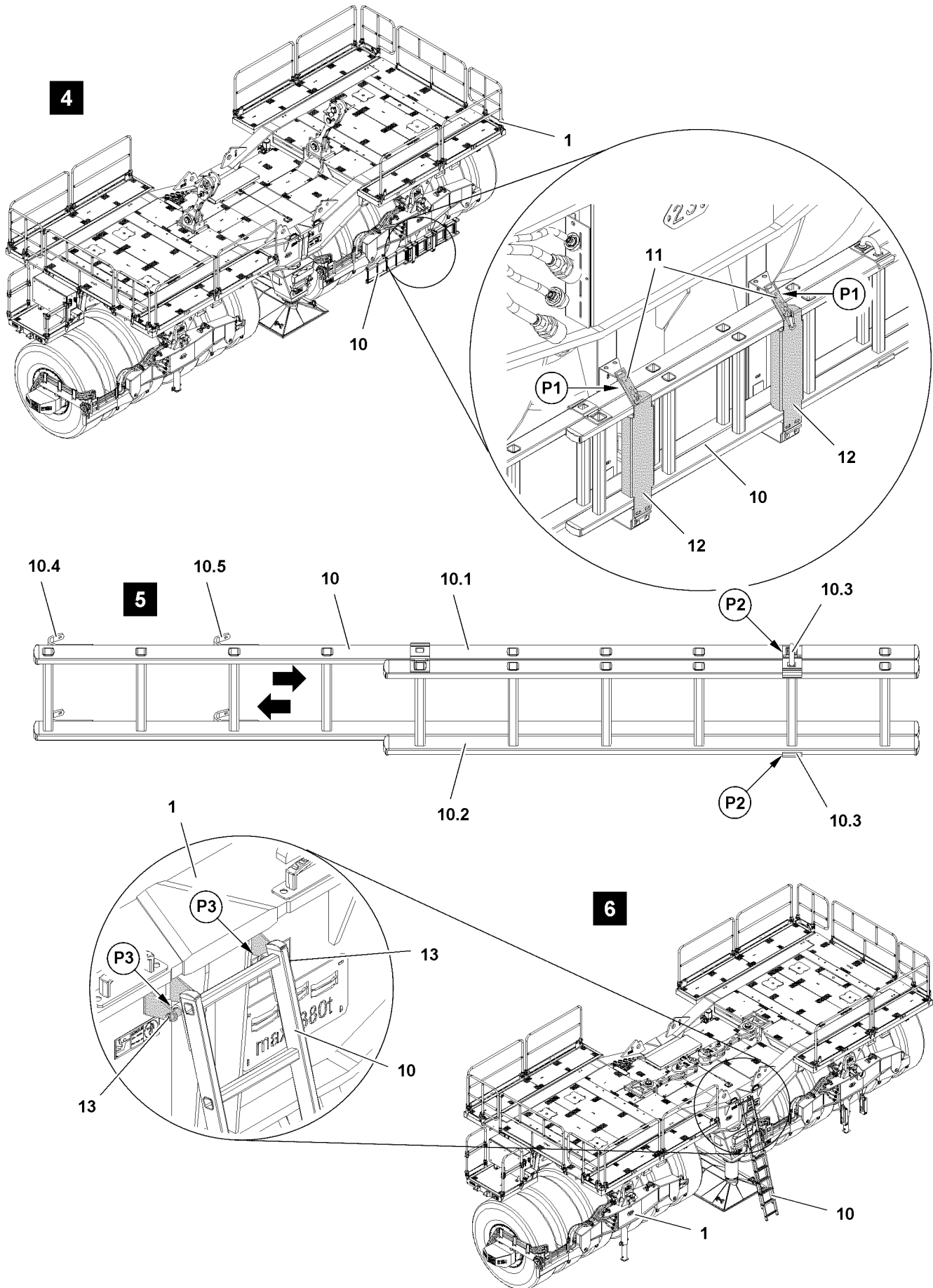

LWE/LR 11000-001/23501-04-02/en

Fig. 121026

18.1 Extension ladder on ballast trailer

Make sure that the following prerequisite is met:

- The ballast trailer **1** is supported.

18.1.1 Hanging the extension ladder in operating position

- ▶ Release the extension ladder **10** from the transport position: Open both turnbuckles **11** at points **P1**, swing the retainer **12** and remove the extension ladder **10**, see illustration **4**.

NOTICE

Danger of crushed limbs!

When sliding the upper extension ladder section **10.1**, fingers and hands can be crushed.

- ▶ Do not reach with your hands into the danger zone.

-
- ▶ Pull the extension ladder **10** out: Pull the two sided lock **10.3** out on points **P2** and turn to the side, see illustration **5**.
 - ▶ Move the upper extension ladder section **10.1** by **one** rung.
 - ▶ Turn and engage the two sided lock **10.3** again on points **P2**.
 - ▶ Hang the extension ladder **10** with the hooks **10.4** at points **P3** on the receptacles **13** on the ballast trailer **1**, see illustration **6**.

18.1.2 Setting the extension ladder in transport position

- ▶ Disengage the extension ladder **10** with the hooks **10.4**, see illustration **6**.
- ▶ Pull the extension ladder **10** in: Pull the two sided lock **10.3** out on points **P2** and turn to the side, see illustration **5**.

NOTICE

Danger of crushed limbs!

When sliding the upper extension ladder section **10.1**, fingers and hands can be crushed.

- ▶ Do not reach with your hands into the danger zone.

-
- ▶ Move the upper extension ladder section **10.1** until it is flush with the lower extension ladder section **10.2**.
 - ▶ Turn and engage the two sided lock **10.3** again on points **P2**, see illustration **5**.
 - ▶ Fasten the extension ladder **10** in transport position on the ballast trailer **1**: Open both turnbuckles **11**, swing the retainer **12** and set the extension ladder **10** in, see illustration **6**.
 - ▶ Close both turnbuckles **11** again.

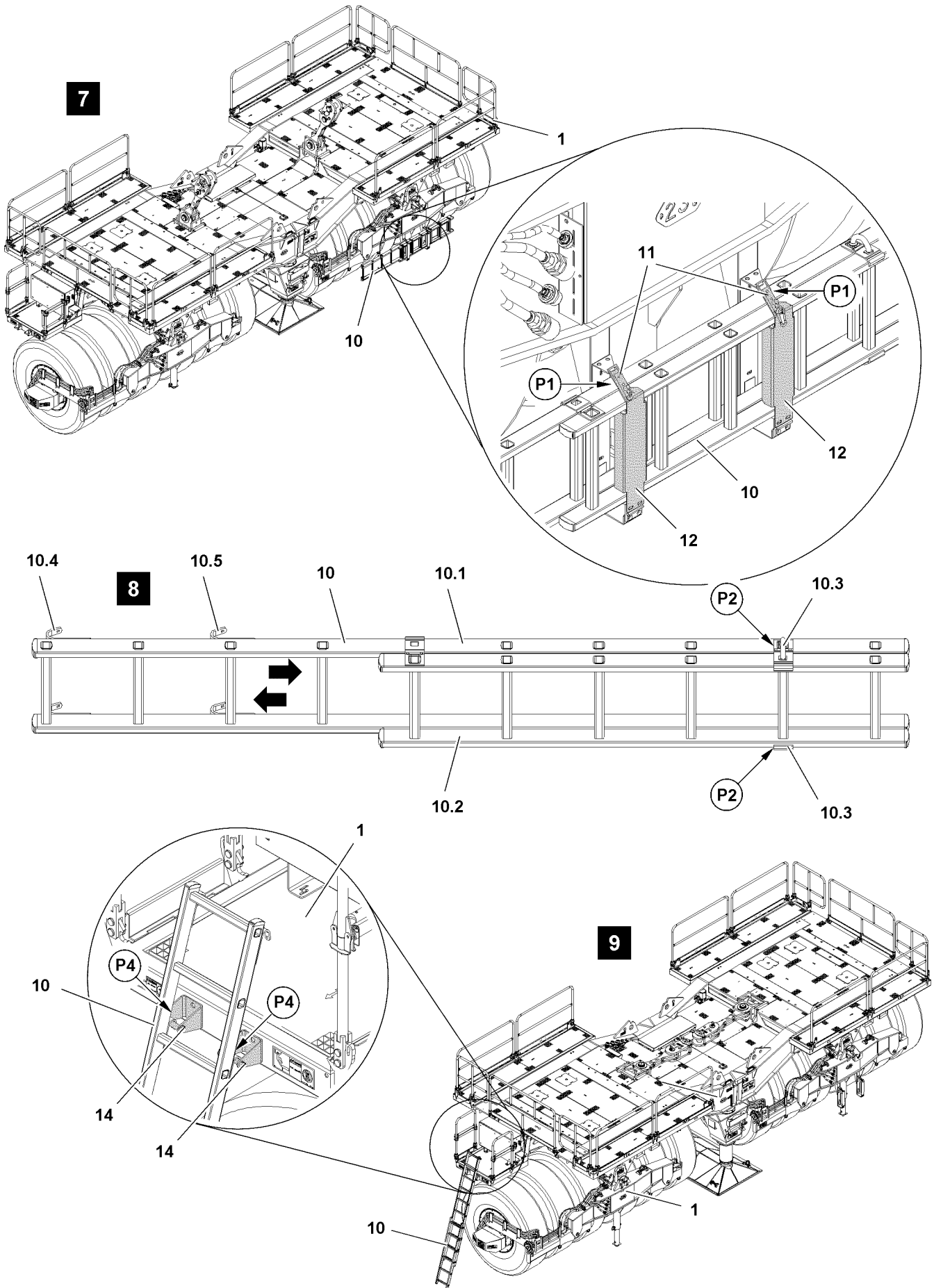

LWE/LR 11000-001/23501-04-02/en

Fig.121027

18.2 Extension ladder on control cabinet pedestal

Make sure that the following prerequisite is met:

- The ballast trailer **1** is supported.

18.2.1 Hanging the extension ladder in operating position

- ▶ Release the extension ladder **10** from the transport position: Open both turnbuckles **11** at points **P1**, swing the retainer **12** and remove the extension ladder **10**, see illustration **7**.

NOTICE

Danger of crushed limbs!

When sliding the upper extension ladder section **10.1**, fingers and hands can be crushed.

- ▶ Do not reach with your hands into the danger zone.

-
- ▶ Pull the extension ladder **10** out: Pull the two sided lock **10.3** out on points **P2** and turn to the side, see illustration **8**.
 - ▶ Move the upper extension ladder section **10.1** by **two** rungs.
 - ▶ Turn and engage the two sided lock **10.3** again on points **P2**.
 - ▶ Hang the extension ladder **10** with the hooks **10.5** at points **P4** on the receptacles **14** on the control cabinet platform **3**, see illustration **9**.

18.2.2 Setting the extension ladder in transport position

- ▶ Disengage the extension ladder **10** with the hooks **10.5**, see illustration **9**.



Note

- ▶ Pull the extension ladder **10** in and fasten in transport position, see section „Extension ladder on ballast trailer“ - „Set the extension ladder in transport position.“
-
- ▶ Set the extension ladder in transport position.

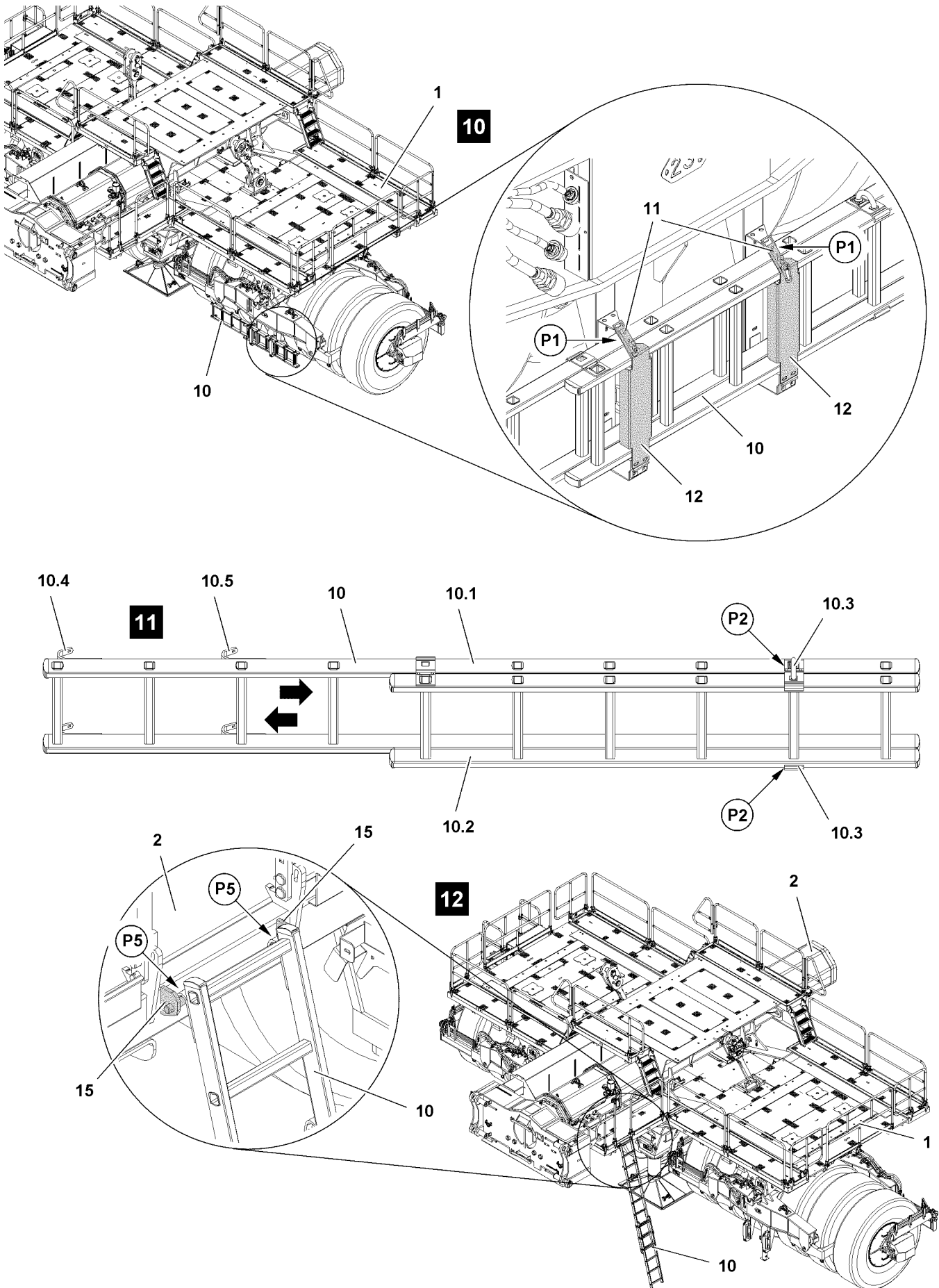

Fig.121028

18.3 Extension ladder on ballast trailer guide

Make sure that the following prerequisite is met:

- The ballast trailer guide **2** is installed.

18.3.1 Hanging the extension ladder in operating position

- ▶ Release the extension ladder **10** from the transport position: Open both turnbuckles **11** at points **P1**, swing the retainer **12** and remove the extension ladder **10**, see illustration **10**.

NOTICE

Danger of crushed limbs!

When sliding the upper extension ladder section **10.1**, fingers and hands can be crushed.

- ▶ Do not reach with your hands into the danger zone.

-
- ▶ Pull the extension ladder **10** out: Pull the two sided lock **10.3** out on points **P2** and turn to the side, see illustration **11**.
 - ▶ Move the upper extension ladder section **10.1** by **three** rungs.
 - ▶ Turn and engage the two sided lock **10.3** again on points **P2**, see illustration **11**.
 - ▶ Hang the extension ladder **10** with the hooks **10.4** at points **P5** on the receptacles **15** on the ballast trailer guide **2**, see illustration **12**.

18.3.2 Setting the extension ladder in transport position

- ▶ Disengage the extension ladder **10** with the hooks **10.4**, see illustration **12**.



Note

- ▶ Pull the extension ladder **10** in and fasten in transport position, see section „Extension ladder on ballast trailer“ - „Set the extension ladder in transport position.“
-
- ▶ Set the extension ladder in transport position.

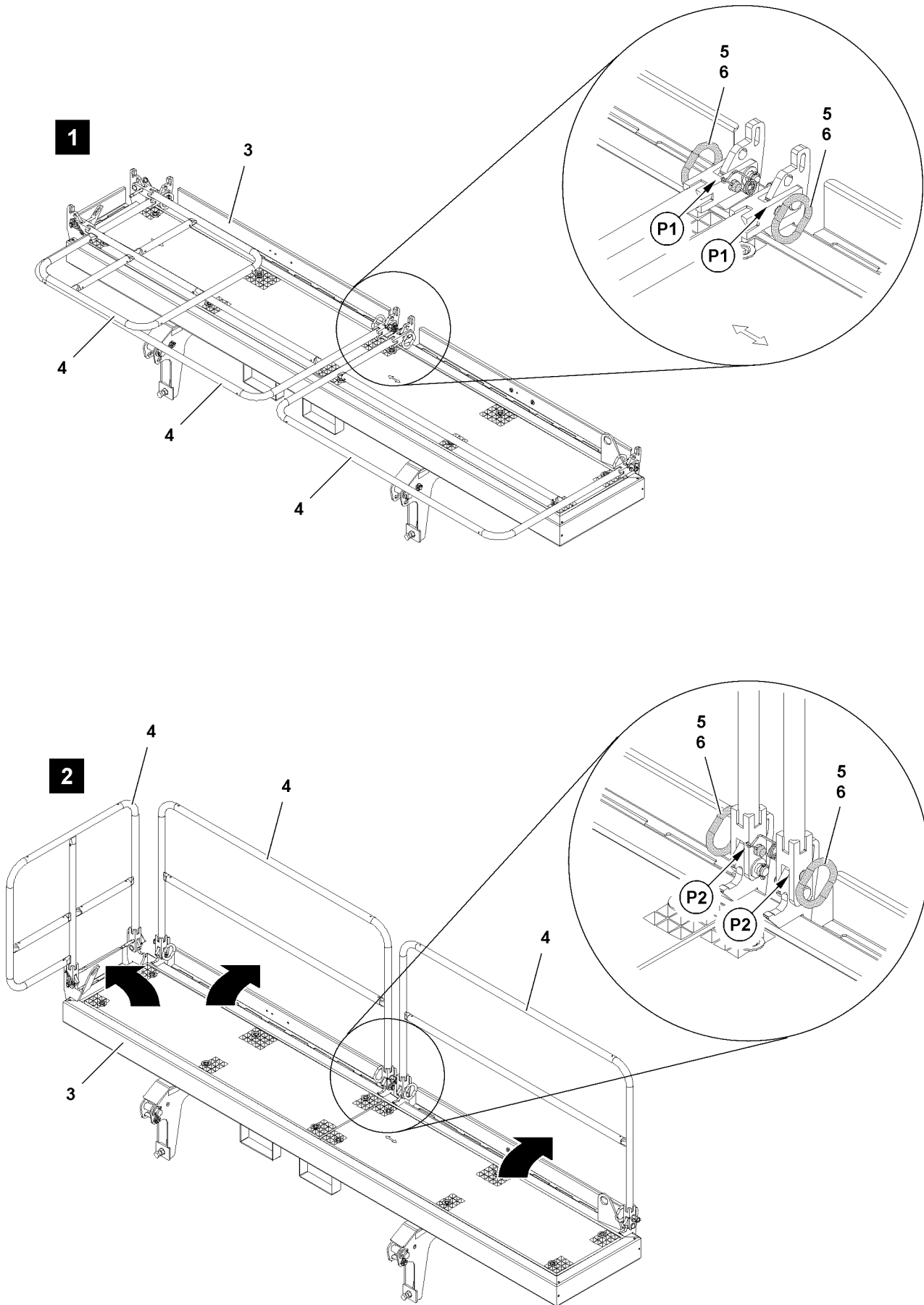

Fig.121029

19 Railing on ballast trailer



Note

- ▶ The assembly and disassembly of the railings is identical and is described on the example for one railing, see illustration.



WARNING

Danger of falling!

During assembly and disassembly of the railing, personnel must be secured with appropriate aids to prevent them from falling.

Even at the assembly of protective equipment there is a danger of falling.

Death, severe injury, property damage.

- ▶ Use personal protective equipment.



WARNING

Danger of crushed limbs!

When swinging the railings, fingers and hands can be crushed.

- ▶ Do not reach with your hands into the danger zone.

19.1 Railing on platforms

The platform 3 is equipped with three railings 4, see illustration 1.

19.1.1 Swinging the railings on the platforms in operating position

- ▶ Release the railing 4 from the transport position: Remove the spring retainer 6 at point P1 and unpin the pin 5, see illustration 1.
- ▶ Swing the railing 4 into operating position.
- ▶ Secure the railing 4 in operating position: Insert the pin 5 at point P2 and secure with spring retainer 6, see illustration 2.

19.1.2 Swinging the railings on the platforms in transport position



WARNING

Danger of crushed limbs!

The railing 4 can swing down by itself due to its own weight when it is unpinned.

Fingers and hands can be crushed.

- ▶ Before unpinning, hold the railing and swing it down slowly.

- ▶ Release the railing 4 from the operating position: Remove the spring retainer 6 at point P2 and unpin the pin 5, see illustration 2.
- ▶ Swing the railing 4 into transport position.
- ▶ Secure the railings 4 in transport position: Insert the pin 5 at point P1 and secure with spring retainer 6, see illustration 1.

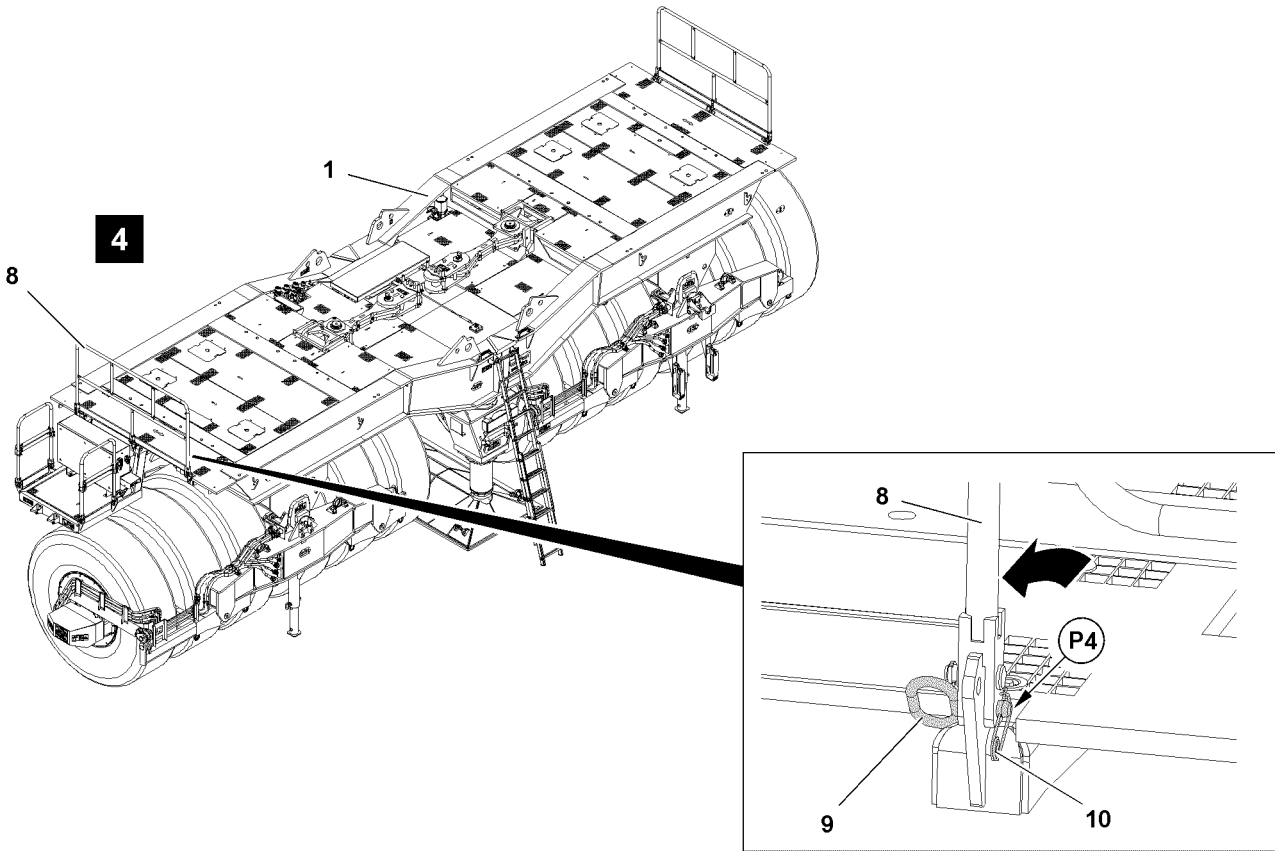
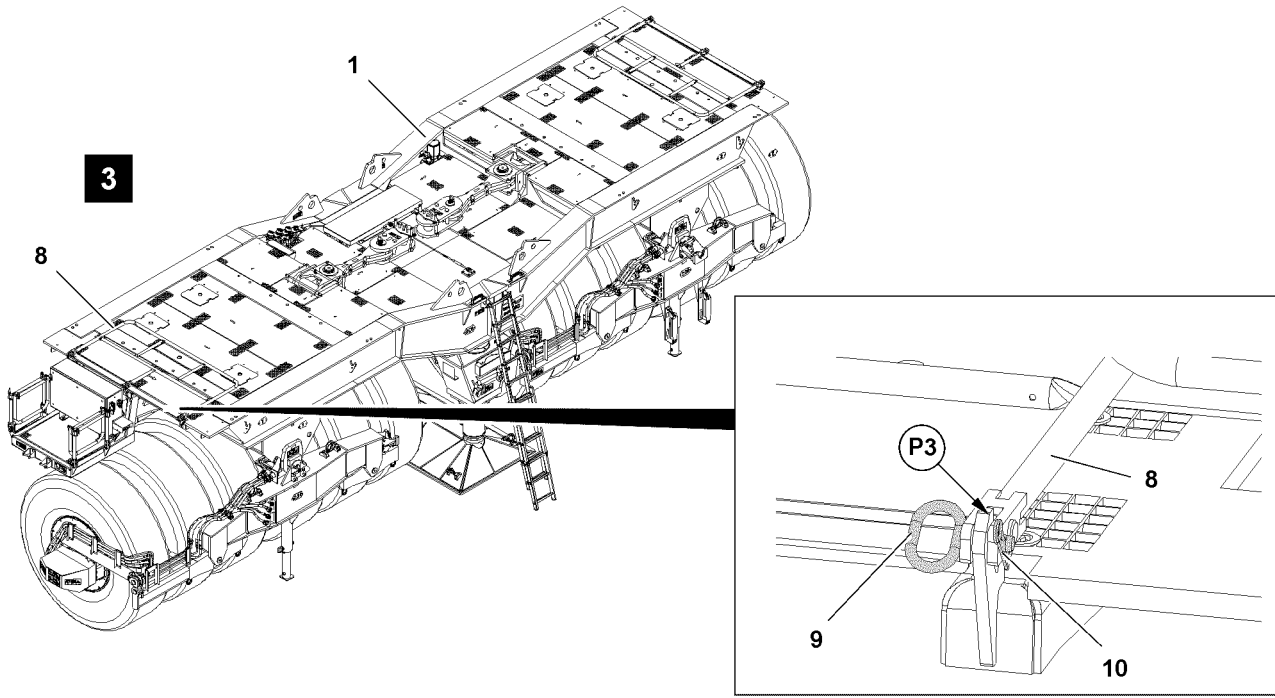

Fig.121030

19.2 Railing on ballast trailer

19.2.1 Swinging the railing on the ballast trailer into operating position

The ballast trailer **1** is equipped with two railings **8**, see illustration **3**.

- ▶ Release the railing **8** from the transport position: Remove the spring retainer **10** at point **P3** and unpin the pin **9**, see illustration **3**.
- ▶ Swing the railing **8** into operating position.
- ▶ Secure the railing **8** in operating position: Insert the pin **9** at point **P4** and secure with spring retainer **10**, see illustration **4**.

19.2.2 Swinging the railing on the ballast trailer into transport position



WARNING

Danger of crushed limbs!

The railing **8** can swing down by itself due to its own weight when it is unpinned. Fingers and hands can be crushed.

- ▶ Before unpinning, hold the railing and swing it down slowly.
-
- ▶ Release the railing **8** from the operating position: Remove the spring retainer **10** at point **P4** and unpin the pin **9**, see illustration **4**.
 - ▶ Swing the railing **8** into transport position.
 - ▶ Secure the railings **8** in transport position: Insert the pin **9** at point **P3** and secure with spring retainer **10**, see illustration **3**.

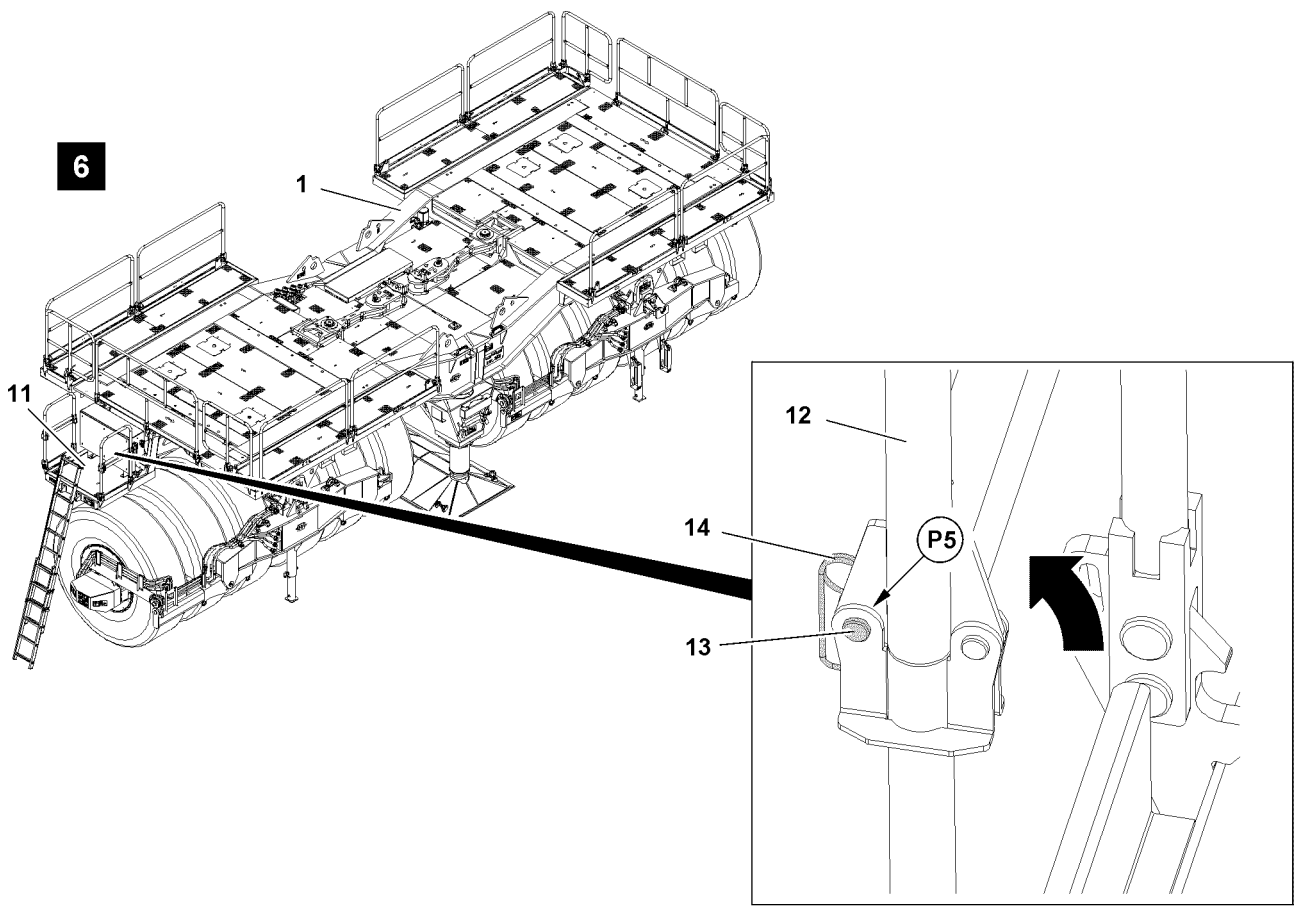
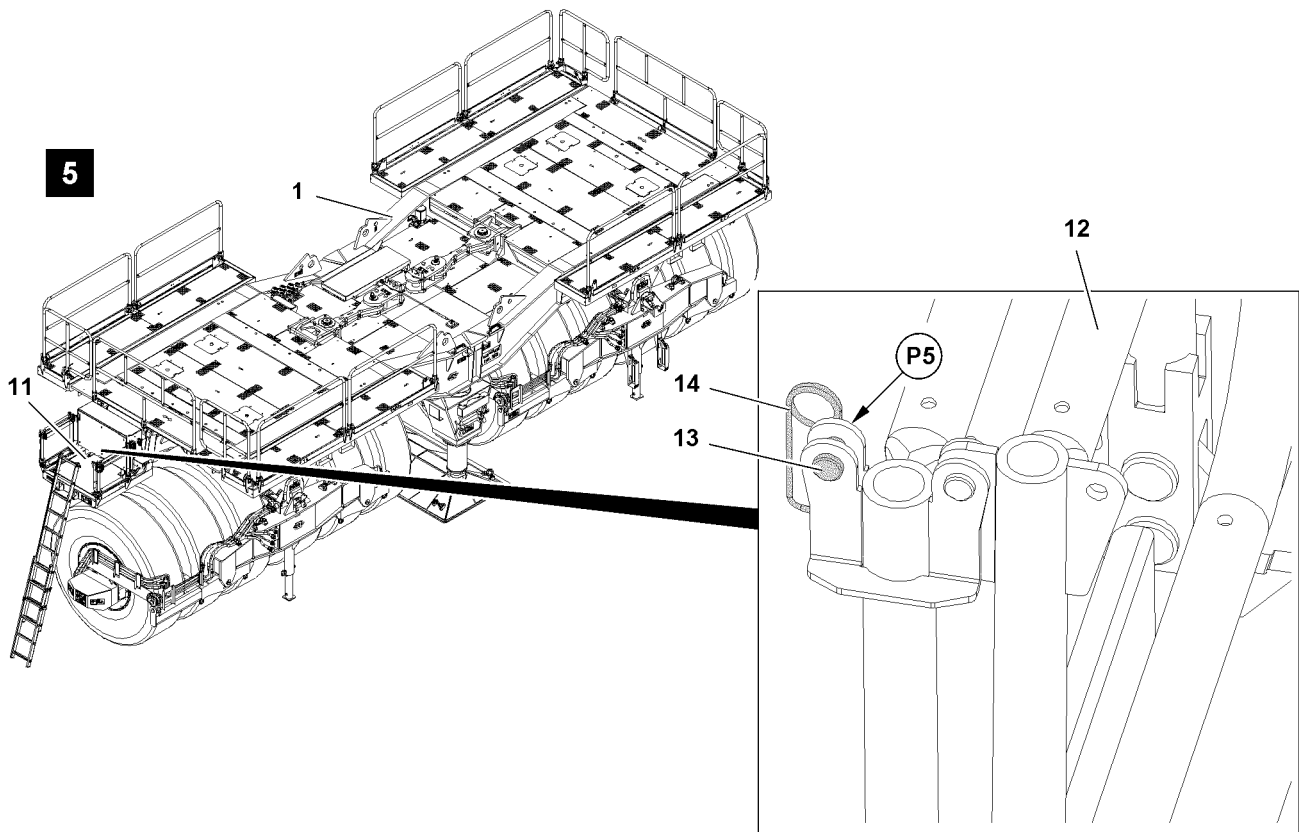

Fig.121031

LWE/LR 11000-001/23501-04-02/en

19.3 Railing on the control cabinet platform

19.3.1 Swinging the railing on the control cabinet platform into operating position

The control cabinet platform **11** is equipped with two railings **12**, see illustration **5**.

- ▶ Remove the spring retainer **14** at point **P5** and unpin the pin **13**, see illustration **5**.
- ▶ Swing the railing **12** into operating position.
- ▶ Secure the railing **12** in operating position: Insert the pin **13** at point **P5** and secure with spring retainer **14**, see illustration **6**.

19.3.2 Swinging the railing on the control cabinet platform into transport position



WARNING

Danger of crushed limbs!

The railing **12** can swing down by itself due to its own weight when it is unpinned.

Fingers and hands can be crushed.

- ▶ Before unpinning, hold the railing and swing it down slowly.
-
- ▶ Release the railing **12** from the operating position: Remove the spring retainer **14** at point **P5** and unpin the pin **13**, see illustration **6**.
 - ▶ Swing the railing **12** into transport position.
 - ▶ Secure the railings **12** in transport position: Insert the pin **13** at point **P5** and secure with spring retainer **14**, see illustration **5**.

Empty page!

LWE/LR 11000-001/23501-04-02/en

2.08 Working in low temperatures

1	Auxiliary equipment	3
2	Ambient temperatures below -20 °C	3
3	Maintenance	7

Fig.195219

LWE/LR 11000-001/23501-04-02/en

1 Auxiliary equipment

Without „auxiliary equipment for working at low temperatures“, the crane can be operated and stored at ambient temperatures between -20 °C and +50 °C.

At ambient temperatures below -20 °C , the crane must be modified with „auxiliary equipment for working at low temperatures“.



WARNING

Working at low temperatures without the corresponding auxiliary equipment!
The crane components can be damaged and fail. The load can rip off.
Death or severe bodily injuries.

If the crane is operated at an ambient temperature lower than -20 °C:

- ▶ Make sure that the crane is equipped with the corresponding „auxiliary equipment for working at low temperatures“.
- ▶ Match the operating fluids in time to the ambient temperature.

2 Ambient temperatures below -20 °C

2.1 Winter operation

Low temperatures, such as snow, frost and ice can impair crane operation and cause problems on the crane. Freezing takes place often at low temperatures.



WARNING

Snow and ice on the crane components!
The crane components can be damaged and fail.
Personnel can fall from the accesses!

- ▶ Remove the snow and ice from all accesses, steps and catwalks.
- ▶ Remove the snow and ice from all rope pulleys and winches.
- ▶ Remove the snow and ice from the hose drum and limit switch.
- ▶ Remove the snow and ice from the crane.



WARNING

Snow and ice below the support plates or the crawler carriers!
The crane can slip and fatally injure personnel.

- ▶ Remove the snow and ice on top and below the support plates.
- ▶ Remove the snow and ice on top and below the crawler carrier.
- ▶ Remove the snow and ice from the travel gear.

Prerequisites for start up with the ambient temperature below -20 °C

- The hose drum and cable are easily movable.
- All rope pulleys are easily movable.
- The view from the crane cab is free. The mirrors are free of snow and ice.
- Fastening equipment is approved for the ambient temperatures present.
- The load fastening points are approved for the ambient temperatures present.

2.2 Preheating time

Crane components	Preheating time
Engine preheating up to start at -40 °C ambient temperature	45 minutes
Preheat the hydraulic system in the crane superstructure and the crane chassis	30 minutes
Preheat the crane cab / driver's cab for start up at the same time up to 5 °C	10 minutes
Total preheating time	75 minutes

2.3 Engine preheating

If the ambient temperature is lower than -20 °C the chassis engine and / or superstructure engine must be preheated before starting.

Depending on the crane type, a chassis engine and / or a superstructure engine is installed.

The preheating of the chassis engine is described in the Crane operating instructions, chapter 6.01.

The preheating of the superstructure engine is described in the Crane operating instructions, chapter 6.02.

- ▶ Preheat the chassis engine and / or the superstructure engine.
- ▶ Start the chassis engine and / or the superstructure engine.

When the chassis engine and / or the superstructure engine has reached its operating temperature:

- ▶ Turn off engine preheating.

2.4 Preheating the hydraulic oil

If the ambient temperature is lower than -20 °C the hydraulic oil must be preheated prior to crane operation.

NOTICE

Hydraulic oil **not** preheated!

The hydraulic system can be damaged during crane operation.

- ▶ Preheat the hydraulic oil to at least 20 °C before crane operation.
- ▶ Retract and extend all the hydraulic cylinders in an unloaded state over the entire stroke multiple times.



WARNING

Persons in the area of the hoist movement!

Personnel can be injured.

- ▶ Observe the area of the hoist movement.
- ▶ Make sure that there are **no** persons in the area of the hoist movement.

2.4.1 Turning the hydraulic oil preheating on

Make sure that the following prerequisites are met:

- The engine is running.
- Hydraulic oil preheating is available.

The hydraulic oil preheating is described in the Crane operating instructions, chapter 4.03.

- ▶ Turn the hydraulic oil preheating on.

When the hydraulic oil is preheated:

- ▶ Turn the hydraulic oil preheating off.

2.4.2 Supporting the crane

The supporting of the mobile crane is described in the Crane operating instructions, chapter 3.05.

All support plates must be supported with suitable and stable materials.

If moveable support plates are not available, the support plates must be supported **on one side of the crane** with greased polyamide plates.



WARNING

No movable support plates or crane **not** supported with greased polyamide plates! The sliding beams can bend. The support plates can suddenly move to the side. The load can swing and fatally injure personnel.

► Use moveable support plates.

If there are no movable support plates available:

► Support the support plates **on one side of the crane** with greased polyamide plates.

When supporting the crane, extend the support cylinder a maximum of 50 %.

The wheels must not come in to contact with the ground after the crane is supported.

- Support the support plates when necessary.
- Support the crane.

2.4.3 Cranes with lattice mast boom

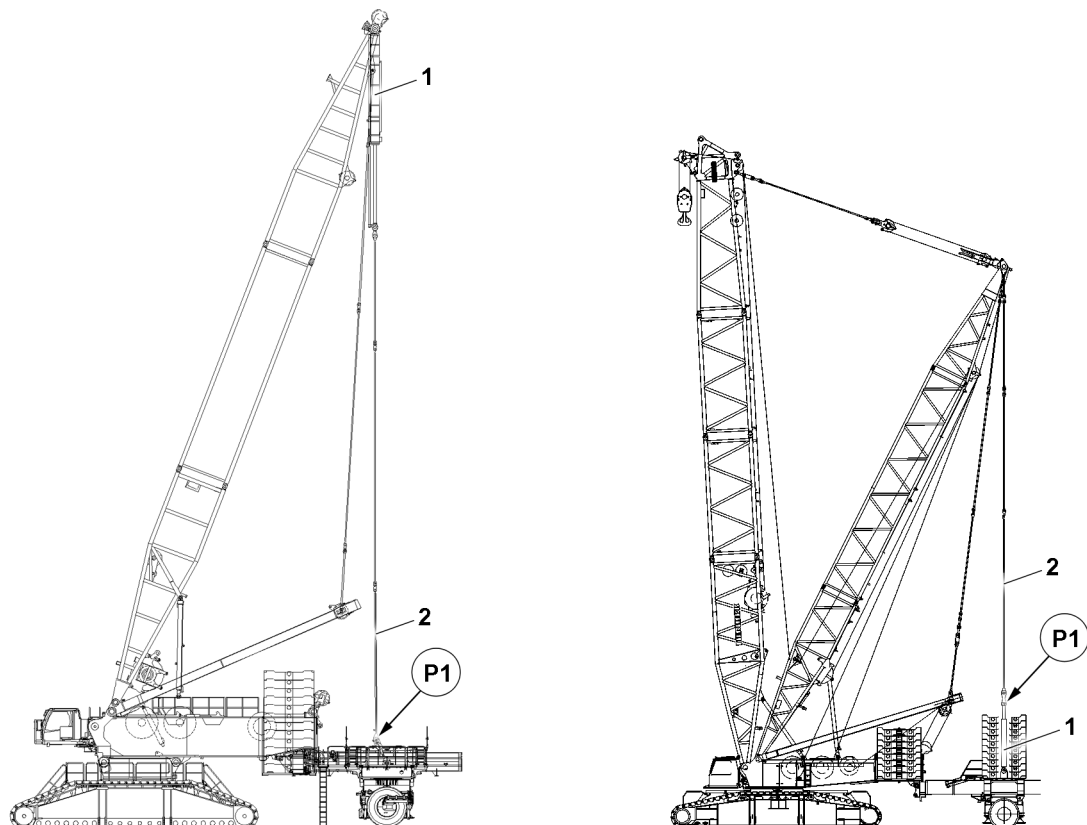

Fig.126875: Removing the guy rods on the derrick ballast

At ambient temperatures of less than $-20\text{ }^{\circ}\text{C}$, the pull cylinders must be preheated by means of retraction and extension. Before the pull cylinders can be preheated, the guy rods **2** must be removed at position **P1** on the derrick ballast.

Disassembly and assembly of the guy rods **2** on the derrick ballast is described in the Crane operating instructions, chapter 5.35 and chapter 5.36.

- ▶ Remove the guy rods **2** at position **P1** on the derrick ballast.

NOTICE

Danger of collision!

Damage of the guy rods, derrick ballast or other components.

- ▶ When retracting and extending the guy rods, avoid contact with other components.

- ▶ Retract and extend the pull cylinders **1** in an unloaded state over the entire stroke multiple times.

When additional hydraulic cylinders are installed on the crane with lattice mast:

- ▶ Retract and extend the hydraulic cylinders in an unloaded state over the entire stroke multiple times.

2.4.4 Cranes with telescopic boom

Make sure that the following prerequisites are met:

- The crane is supported and horizontally aligned.
- No load is hanging on the hook
- ▶ Retract and extend the luffing cylinder in an unloaded state over the entire stroke multiple times.
- ▶ Retract and extend the telescoping cylinder in an unloaded state over the entire stroke multiple times.

2.5 Assembling / disassembling the crane component

Below an ambient temperature of -20 °C the danger of damage is greater if the crane component is struck during assembly or disassembly. Especially the counterweight is subject to greater danger of damage if struck.

NOTICE

Striking of the crane component during assembly or disassembly!

Crane components can be damaged.

- ▶ Do **not** strike the crane component during assembly and disassembly
 - ▶ Carry out all work slowly and with utmost caution.
-

2.6 Reduce rope pull

When working at an ambient temperature below -20 °C Liebherr-Werk Ehingen recommends reducing the rope pull.

The rope pull on the hoist rope can be reduced by increasing the rope reeving.



Note

Increase of rope reeving!

Due to the increased rope reeving, the hoist rope length may not be sufficient for lowering the hook block to the ground.

- ▶ Pay attention to rope length.
-

NOTICE

Rope reeving higher than specified in the load chart!

Danger of slack rope formation due to a too low hook block weight. Damage of hoist rope.

- ▶ Increase the hook block weight accordingly.
 - ▶ Increase the rope reeving specified in the load chart.
-

2.7 Increase the hook block weight

The calculation of the minimum required hook block weight is described in the load chart.

Ambient temperature	Increase the hook block weight
-21 °C to -30 °C	Increase the minimum required hook block weight by 10 %.
-31 °C to -40 °C	Increase the minimum required hook block weight by 15 %.

- ▶ Increase the minimum required hook block weight depending on the ambient temperature. Observe and adhere to the „hook block weight“ charts.

**Note**

- ▶ Observe and comply with the permissible hook block weights for erection and take down of the boom systems in the erection and take down charts.

2.8 Crane operation

In case of an ambient temperature below -20 °C , crane operation requires an anticipatory working procedure adapted to the weather conditions.

**WARNING**

Sudden acceleration and deceleration of crane movements!

Crane components can break.

Death or severe bodily injuries.

- ▶ Accelerate and decelerate crane movements sensitively and with utmost caution.

2.8.1 Decrease crane utilization

Cranes with lattice mast boom

In the case of cranes with pull cylinders in the derrick ballast guying, if the ambient temperature is between -30 °C and -40 °C the maximum derrick ballast must be reduced. The maximum load is also reduced due to the reduction of the maximum derrick ballast.

**Note**

- ▶ Take load reduction into account during job planning.
- ▶ Reduce the maximum derrick ballast between an ambient temperature of -30 °C and -40 °C by 15 %.

Cranes with telescopic boom

In the case of cranes with a telescopic boom, if the ambient temperature is between -30 °C and -40 °C crane utilization must be reduced.

- ▶ Reduce the crane utilization at an ambient temperature between -30 °C and -40 °C by 15 %.

3 Maintenance

3.1 Load bearing crane structures

Checking the load bearing crane structure is described in the Crane operating instructions, chapter 8.01.

- ▶ The load bearing crane structure must be subjected more frequently to a visual inspection.

3.2 Rope pulleys and hydraulic cylinders

Checking the rope pulleys and the hydraulic cylinders is described in the Crane operating instructions, chapter 8.01.

- ▶ The rope pulleys and hydraulic cylinders must be subjected more frequently to a visual inspection.

2.15 General safety technical notes for operation with ballast trailer

1	Safety guidelines	3
2	Inspection of tires and disk wheels	4

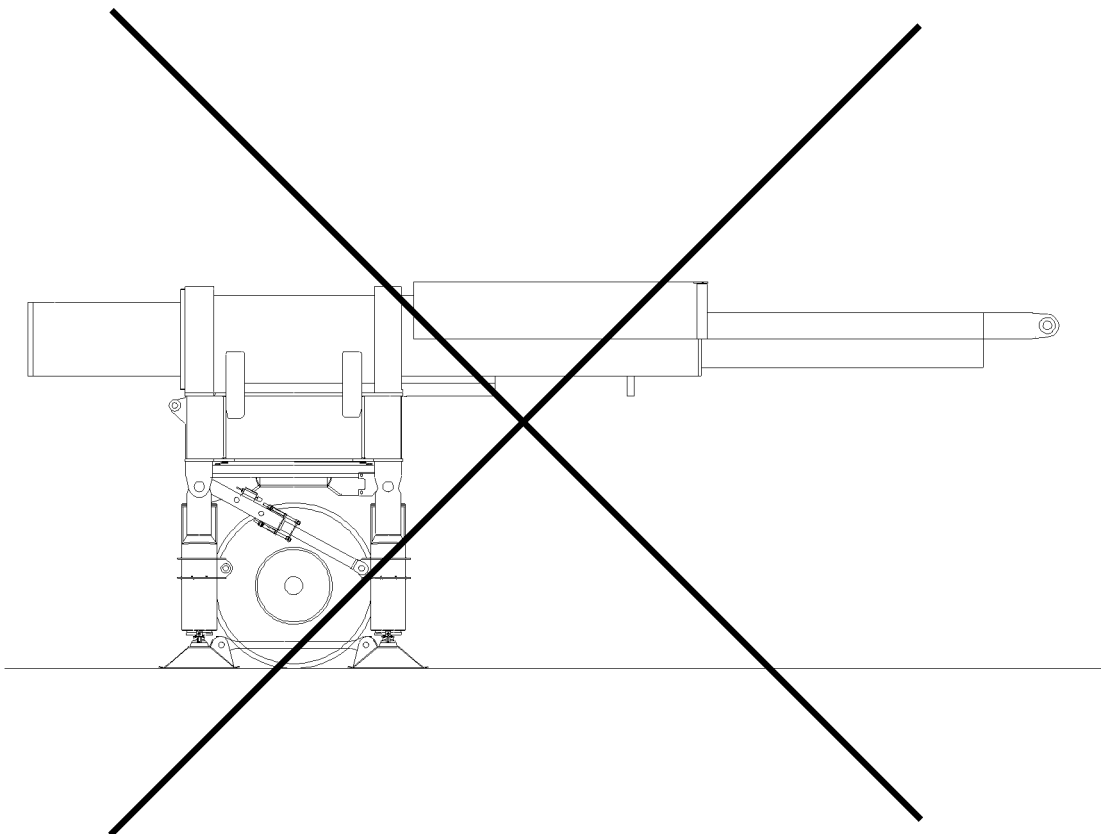
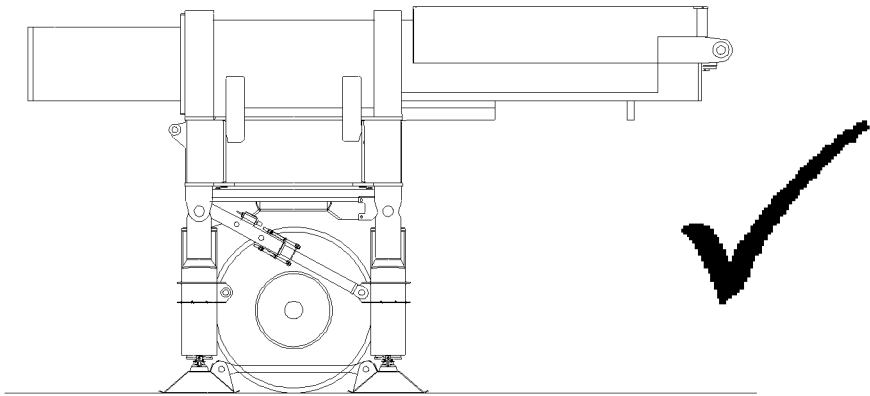

Fig.107353

LWE/LR 11000-001/23501-04-02/en

1 Safety guidelines



WARNING

Risk of falling!

- ▶ During assembly or disassembly work on the ballast trailer, assembly personnel must be secured with appropriate aids! If this is not observed, assembly personnel can fall and suffer life-threatening or fatal injuries!



WARNING

Danger of tipping the ballast trailer!

If the following notes are not observed, the freestanding ballast trailer or the ballast trailer which needs to be disassembled can tip over!

Personnel can be severely injured or killed!

- ▶ The ballast trailer may only be parked on level ground of sufficient load bearing capacity!
- ▶ The ballast trailer may only be unpinned from the crane and parked if the ballast trailer guide is fully retracted!
- ▶ The ballast trailer may only be unpinned from the crane and parked if the support cylinders are extended and the tires are relieved!
- ▶ The ballast trailer may only be unpinned from the crane and parked if the strut on the support cylinders is pinned and secured!



WARNING

Mortal danger if the permissible travel speed is exceeded!

If the permissible travel speed is exceeded, the tires can be damaged!

Personnel can be severely injured or killed!

As a result, significant property damage can occur on the crane and on the ballast trailer!

- ▶ The travel speed of the ballast trailer when turning or driving with maximum ballast on the tires may be not more than maximum 1 km/h (0.28 m/s)!



WARNING

The crane can topple over if the level of the travel path differs!

Due to impermissible level differences between the ballast trailer route and the crane placement level, the entire crane system can be pulled back suddenly!

The relapse cylinders can run to block position. The relapse cylinders and the boom system can be damaged!

Personnel can be severely injured or killed!

- ▶ Do not exceed or fall below the permissible level difference between the ballast trailer travel path and the crane placement level!
- ▶ The travel path of the crane or the circular path of the ballast trailer must be level and of sufficient load bearing capacity!
- ▶ The permissible level difference of the ballast trailer travel path and crane travel path for „towing“ and „parallel driving“ may be no more than maximum 250 mm !
- ▶ The permissible level difference of the ballast trailer path and the crane travel path in relation to the crane travel path for circular driving may be no more than maximum 250 mm - based on a constant uphill incline or constant downhill incline on a 90° turning range!



WARNING

The crane can topple over!

If the following notes are not observed, the crane can topple over!

Personnel can be severely injured or killed!

- ▶ When lifting or lowering the ballast trailer, pay attention to the horizontal alignment of the ballast trailer!
- ▶ The assembly or disassembly work must be carried out according to the Crane operating instructions, chapter 5.35 or chapter 5.11!

NOTICE

Danger of damage to the crane and the ballast trailer!

Due to steering movements on the crawler tracks while driving parallel, the crane and the ballast trailer can be significantly damaged!

- ▶ When driving parallel, steering the crawler tracks is prohibited!
- ▶ For parallel driving, the side tire distortion on the wheel sets must be observed by an instructed person over the entire travel route of the crane. If the tires distort by more than 100 mm, then the position of the wheel sets must be corrected!

**Note**

General safety technical guidelines!

- ▶ The ballast trailer guy rods must be assembled and secured according to the Rod plan. The numbering on the rod plan must be identical to the numbering on the guy rods!

2 Inspection of tires and disk wheels

**Note**

- ▶ See Crane operating instructions, chapter 8.01!

**WARNING**

Mortal danger when using non-approved tires!

Due to the use of tires, which are not explicitly approved by **LIEBHERR-Werk Ehingen GmbH**, uncontrollable operation conditions on the ballast trailer can occur due to the heavy load!

The tires can be destroyed and the ballast trailer as well as the crane can be significantly damaged! Personnel can be severely injured or killed!

- ▶ Use only spare tires which have been approved in writing by **LIEBHERR-Werk Ehingen GmbH**!
- ▶ Using spare tires which have been not explicitly approved in writing by **LIEBHERR-Werk Ehingen GmbH** is prohibited!

NOTICE

Damage to tires!

Due to external environmental influences (for example: rain, wind, snow, frost, sun exposure) and the great weight load on the tires by the ballast trailer, the tires can become porous and the body can lose its original strength!

- ▶ The tires must be replaced according to the data of the tire manufacturer at least after 5 years, or if an expert representative of the tire manufacturer states in writing, after extensive inspection of the tires, that the tires can be utilized for an additional operation period stated by the expert representative!

**Note**

Tightening torque of ballast trailer tires!

- ▶ The tightening torque for the wheel lugs is 600 Nm !
- ▶ Check the wheel lugs according to the specified maintenance intervals for tight seating, see Crane operating instructions, chapter 7.02!

2.1 Tires with air inflation

It is imperative to comply with the following instructions:

- After extended downtime, the inflation pressure must be checked before using the ballast trailer.
- The tires must be protected against UV rays during extended downtimes with tarps or wooden boards.

**Note**

Inflation pressure of ballast trailer tires!

- ▶ The inflation pressure in all tires, which were approved in writing by **LIEBHERR-Werk Ebingen GmbH** is **10 bar** !
- ▶ Check the inflation pressure according to the specified maintenance intervals for tight seating, see Crane operating instructions, chapter 7.02!

**WARNING**

Risk of accident due to damaged ballast trailer tires!

Due to extended downtime of the crane, when the ballast trailer tires are not relieved with supports, the tires can get out of round!

As a result, the tires can be destroyed and the ballast trailer as well as the crane can be significantly damaged!

Personnel can be severely injured or killed!

- ▶ During extended downtimes, the ballast trailer tires must always be relieved by the outrigger supports!

**WARNING**

Risk of accident due to damaged ballast trailer tires!

When driving the crane on insufficiently prepared ground, the tires can become damaged or punctured by large rocks or other foreign matter!

As a result, the ballast trailer as well as the crane can be significantly damaged!

Personnel can be severely injured or killed!

- ▶ The travel route of the crane or the ballast trailer must be level, of sufficient load bearing capacity and free of rocks or other foreign matter!
- ▶ The travel route of the crane must be walked off personally in advance by the crane operator!
- ▶ Rocks and other foreign matter on the travel route must be removed before starting to travel!
- ▶ If the crane operator cannot ensure that the ballast trailer tires may not be damaged when moving the crane, then the ballast trailer tires must be foamed with a special foam approved by **LIEBHERR-Werk Ebingen GmbH**. Contact **LIEBHERR-Werk Ebingen GmbH** in this regard!
- ▶ If you decide to foam the ballast trailer tires, then ballast trailer operation is only permissible if all tires of the ballast trailer have been foamed according to the specifications of **LIEBHERR-Werk Ebingen GmbH**!

2.2 Tires foamed with special foam

The tires of the ballast trailer are foamed with a special, high quality foam.

Due to extended downtime of the crane, when the ballast trailer tires are not relieved with supports, the tires can get out of round.

It is imperative to comply with the following instructions:

- Relieve the tires on the ballast trailer if it is at a standstill for more than 2 h via the support cylinders.
- The tires must be protected against UV rays during extended downtimes with tarps or wooden boards.

**WARNING**

Mortal danger when using non-approved tire foams!

Due to the use of tire foams, which are not explicitly approved by **LIEBHERR-Werk Ebingen GmbH**, uncontrollable operation conditions on the ballast trailer can occur due to the heavy load!

The tires can be destroyed and the ballast trailer as well as the crane can be significantly damaged!

Personnel can be severely injured or killed!

- ▶ Use of spare tires filled with water, air or special foam of lower quality is prohibited!
- ▶ Using spare tires which have been not explicitly approved in writing by **LIEBHERR-Werk Ebingen GmbH** is prohibited!

**WARNING**

Danger of accidents due to retreaded tires!

If tires foamed with the special foam are retreaded, the usage properties can be significantly changed negatively!

The tires can be destroyed and the ballast trailer as well as the crane can be significantly damaged!

Personnel can be severely injured or killed!

- ▶ Tires which are filled with special foam may not be retreaded, except if a written approval has been issued by the tire manufacturer!
-

2.25 Crane on floating device

1	Non-destined use	3
2	Destined use	3
3	Floating device	3
4	Operating conditions	3
5	Crane transport on floating devices	4
6	Increased corrosion	5

Fig.195219

LWE/LR 11000-001/23501-04-02/en

1 Non-destined use



WARNING

Non-destined use!

The boom can break off. The crane can topple over.
Death, severe injuries, property damage.

- ▶ Only use the crane as designated.
- ▶ Comply with the operating conditions and notes provided in this chapter.

Liebherr mobile cranes and crawler cranes are **not** designed for special requirements according to „EN 13852-2, Cranes - Offshore Cranes“ or other offshore specifications and regulations.

For a precise definition of **non**-destined use, see the preface to the crane operating instructions.

2 Destined use

Liebherr mobile cranes and crawler cranes are solely designed for assembly work and erection work and can only withstand a limited number of load cycles.

Liebherr mobile cranes and crawler cranes are designed for special characteristics and movements: evenly distributed drive forces, only occasional operation and load conditions according to „EN 13000, Cranes - Mobile Cranes“ and comparable international standards.

For a precise definition of destined use, see the preface to the crane operating instructions.

3 Floating device

The term floating device includes all floating devices such as barges, ships and freight barges.

The floating device must fulfil the requirements for crane operation.

4 Operating conditions

Observe the areas of responsibility:

- The crane contractor and crane operator are responsible for ensuring that the conditions for crane operation at the job site are fulfilled. Consultation of a naval engineer is strongly recommended.
- The correct functional, technical and static interaction between the crane and the floating device is the sole responsibility of the crane contractor and the crane operator. This must be clarified and checked before operating the crane on a floating device.

Observe the following to ensure the safe operation of the crane on floating devices:

- Comply with all country-specific, legal regulations and conditions.
- Perform a risk assessment to ensure safe working conditions.
- Outtrigger forces or crawler pressures resulting from crane operation must be safely supported by the steel structure of the floating device.
- Assemble and operate the crane according to manufacturer specifications.
- Comply with the maximum permissible lateral deflection angle between the hoist rope and the rope pulley. The deflection angle consists of the lateral elastic deformation of the boom system, the inclination of the crane supporting surface and a possible diagonal pull on the hoist rope.

Maximum permissible deflection angle:

- 2.5° with a hoist rope diameter of less than 23 mm
- 5° with a hoist rope diameter of 23 mm or more
- The conditions when working on a floating device must correspond with the conditions on land.

- Lifting and lowering loads in very calm waters and on very calmly moving floating devices corresponds to lifting and lowering loads on land.

4.1 Floating device, supported/jacked up

Observe the following to ensure the safe operation of the crane on supported/jacked up floating devices:

- For crawler cranes, observe the maximum permissible ground inclination of $\pm 0.3^\circ$ for the crane, see the load charts.
- Supported/jacked up cranes must be horizontally levelled (0°).

4.2 Floating device, non-supported/non-jacked up

Observe the following to ensure the safe operation of the crane on **non-supported/non-jacked up** floating devices:

- Crane operation on a floating device is only permissible in very calm waters.
- Crane operation on a floating device is only permissible with a main boom (no derrick operation, no operation with a luffing jib permitted).
- Before the crane is operated on the floating device: The inclination of the floating device in the lateral and longitudinal direction must be calculated in advance. This inclination results from the interaction of the crane with the floating device.
- The inclination of the floating device shall **not** exceed the maximum permissible ground inclination of the crane according to the load chart.
- Comply with the maximum permissible ground inclination according to the load charts:
 - $\pm 0.3^\circ$ for cranes operating on crawler.
 - 0° for cranes operating on outriggers.
- Load values must be reduced when the above defined inclination values are exceeded.
- Load charts for higher permissible ground inclinations (for example 1° , 2°) can be provided upon request of LWE customers solely for operation with a „main boom“ and with a „main boom + auxiliary jib“.
- LTR 1060, LTR 1100 and LTR 1220 are programmed with load charts that permit operation up to a maximum ground inclination of 4° . The crane's respective maximum permissible ground inclination depends on the crane's operating mode.

5 Crane transport on floating devices

Observe the areas of responsibility:

- The crane contractor is solely responsible for transporting the crane on a floating device.
- The crane contractor and crane operator are responsible for the assembly and disassembly of the crane on the floating device.

Observe the following to ensure the safe transport of the crane on floating devices:

- When being „transported on a floating device“, the crane must be secured to prevent the following:
 - Damage to and loosening of crane components
 - Slipping of the crane
 - Inadvertent turning of the superstructure
 - Capsizing of the floating device
- Transport at sea can have a negative impact on the structural strength/stability and the fatigue strength of the crane.

Ensure that before „transport on a floating device“ the following measures are carried out:

- Lower the boom and support it by adequate means.
- For telescopic cranes: disassemble counterweight plates and secure them on the floating device.
- For crawler cranes: support slewing platform and counterweight with adequate means and secure to prevent slipping.
- Observe the instructions for transporting the crane and crane components, see chapter 3.80 of the crane operating instructions.

6 Increased corrosion

Extremely salty air in a maritime environment can cause increased corrosion to the crane.

Increased corrosion can cause premature damage of components (for example the hydraulic cylinder, wire ropes, electrical and electronic components, driver's cab).

Submerging the hook block in water causes damage to the hook block and the rope.

Crane contractor and crane operator are solely responsible for avoiding increased corrosion.

Measures to avoid corrosion:

- Avoid direct contact of the crane and its components with salt water.
- Do **not** submerge the hook block in water.

Measures to recognize premature damage:

- Have the crane checked regularly and extensively by a qualified person.

Empty page!

LWE/LR 11000-001/23501-04-02/en

3 Crane assembly

LWE/LR 11000-001/23501-04-02/en

LWE/LR 11000-001/23501-04-02/en

3.01 Crawler carrier assembly

1	Component overview	3
2	Fastening points	3
3	Assembling turntable frame lower section with Quick Connection (QC) on crawler center section with QC	6
4	Assembling the crawler center section	11
5	Assembly of crawler carrier with the auxiliary crane	22
6	Disassembly of crawler carrier with the auxiliary crane	31
7	Assembly of the crawler carrier with SA-frame	46
8	Disassembly of the crawler carrier with SA-frame	59
9	Disassembling the crawler center section	73

Fig.195219

LWE/LR 11000-001/23501-04-02/en

1 Component overview



Note

► Dimensions and weights, see Crane operating instructions, chapter 1.03.

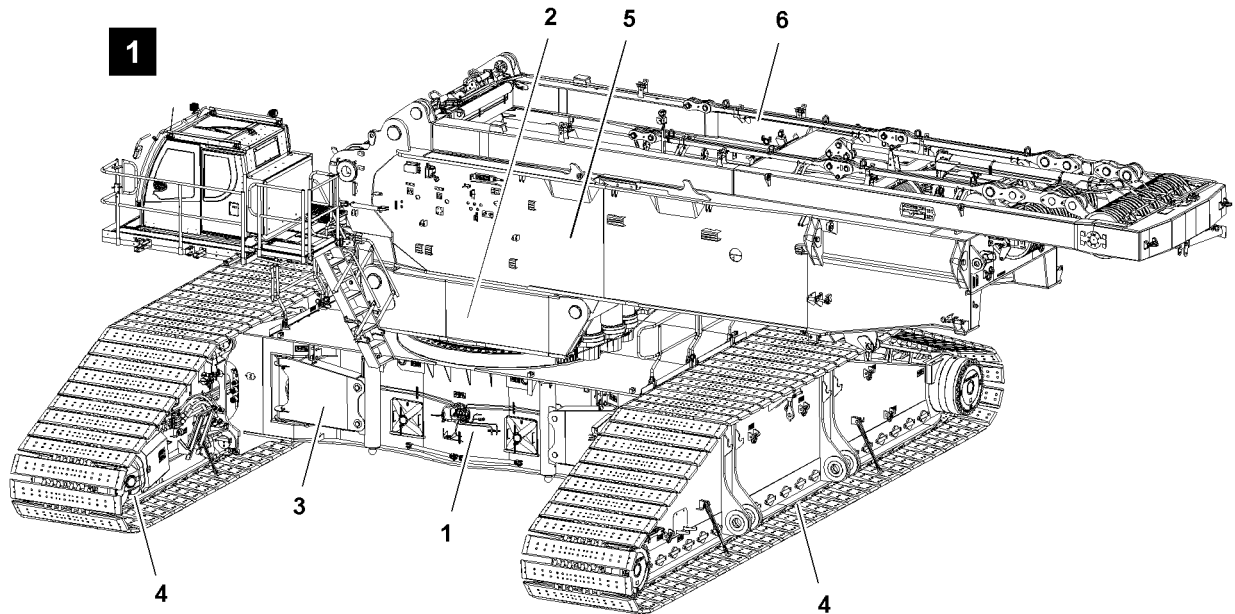

Fig.123920: Components overview

Position	Component
1	Crawler center section
2	Turntable frame lower section
3	Support
4	Crawler carrier
5	Turntable frame main section
6	SA-frame

2 Fastening points



WARNING

Components incorrectly fastened!
Death, severe bodily injuries, property damage.

► Fasten the components only on the intended fastening points on both sides.

2.1 Fastening points crawler center section (turntable frame lower section fixed assembled)



WARNING

Danger of accident due to grating covers!
Death, severe bodily injuries, property damage.

- ▶ Make sure that the grating covers at point **P1** are closed off properly immediately after removing the fastening equipment.

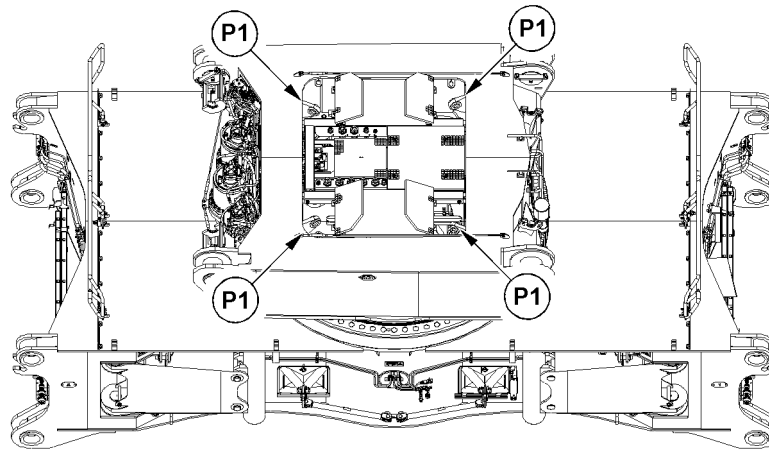

Fig.126163: Fastening points on crawler center section

Fastening points	Component
P1	Crawler center section

2.2 Fastening points crawler center section with QC (turntable frame lower section not assembled)

2.2.1 Fastening points on crawler center section with QC

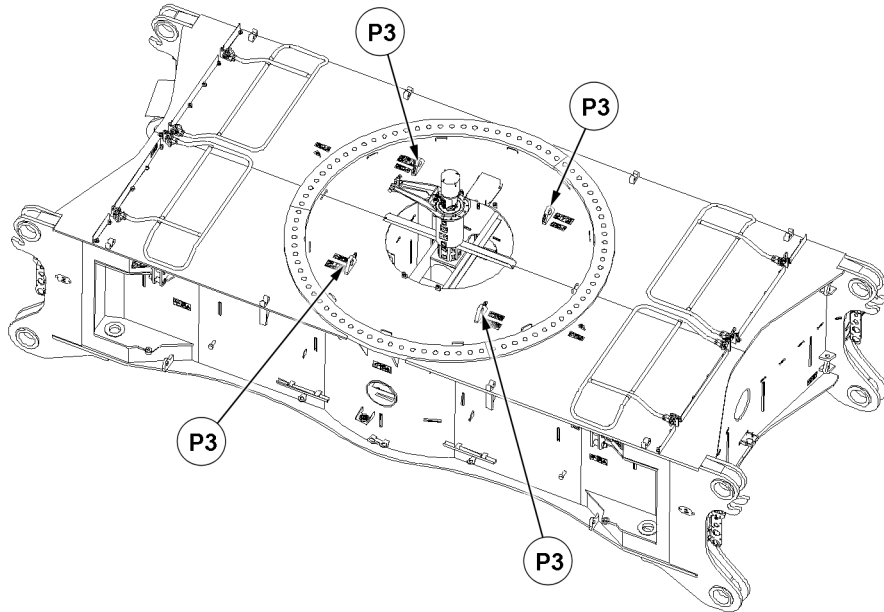

Fig.126161: Fastening points on crawler center section with Quick Connection (QC)

Fastening points	Component
P3	Fastening points on crawler center section with Quick Connection (QC)

2.2.2 Fastening points on turntable frame lower section with QC



WARNING

Danger of accident due to grating covers!

Death, severe bodily injuries, property damage.

- Make sure that the grating covers at point **P1** are closed off properly immediately after removing the fastening equipment.

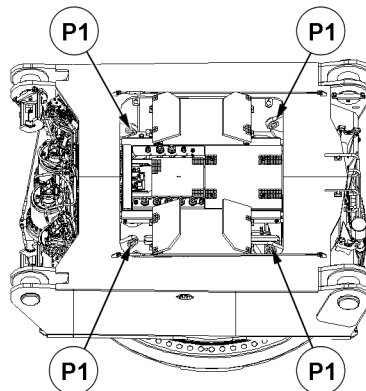

Fig.126160: Fastening points on turntable frame lower section with QC

LWE/LR 11000-001/23501-04-02/en

Fastening points	Component
P1	Turntable frame lower section with QC

2.3 Fastening points on the crawler carrier

NOTICE

Danger of property damage!

If the lashing lugs at point **P2** are not folded down into transport position after assembly with the auxiliary crane, then the crawler carrier and the hook points can be damaged later when driving the crane.

- ▶ Make sure that the lashing lugs at point **P2** are folded in transport position after completion of the crawler carrier assembly.

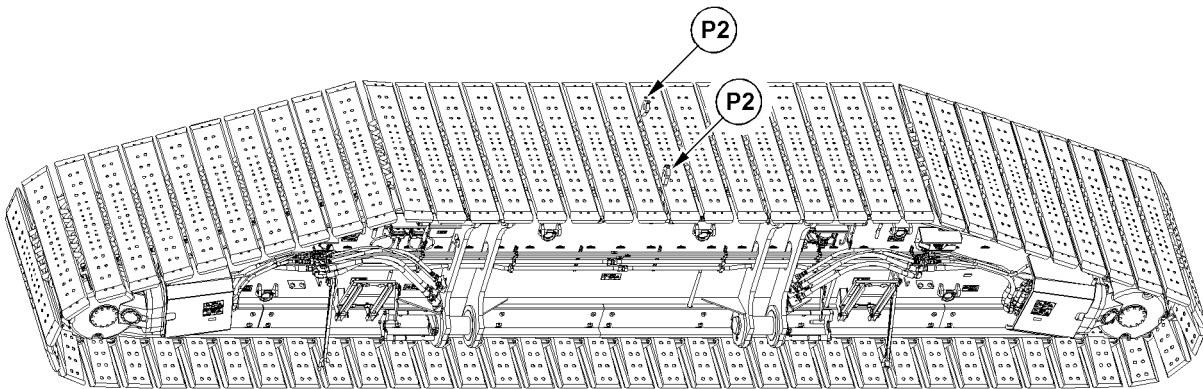

Fig.126162: Fastening points on the crawler carrier

Fastening points	Component
P2	Crawler carrier

3 Assembling turntable frame lower section with Quick Connection (QC) on crawler center section with QC



Note

- ▶ The Quick Connection (QC) is a quick assembly device for the assembly of the turntable frame lower section on the crawler center section. The Quick Connection (QC) is described further in the assembly description as QC.



WARNING

The crawler center section can topple over!

If the turntable frame lower section is not assembled on the crawler center section at the assembly of the first crawler carrier, then the crawler center section can tilt and topple over.

Death, severe bodily injuries, property damage.

- ▶ Make sure that the assembly area of the crawler center section is level and load bearing to take on the weight of the crawler center section with the turntable frame lower section.
- ▶ The crawler center section is properly supported.

Make sure that the following prerequisites are met:

- An auxiliary crane with sufficient load carrying capacity is available.
- The crawler center section is properly supported and horizontally aligned, see section „Supporting the crawler center section without turntable frame lower section“
- The extension ladder is in operating position, see Crane operating instructions, chapter 2.06.
- The railings on the crawler center section are in operating position, see Crane operating instructions, chapter 2.06.

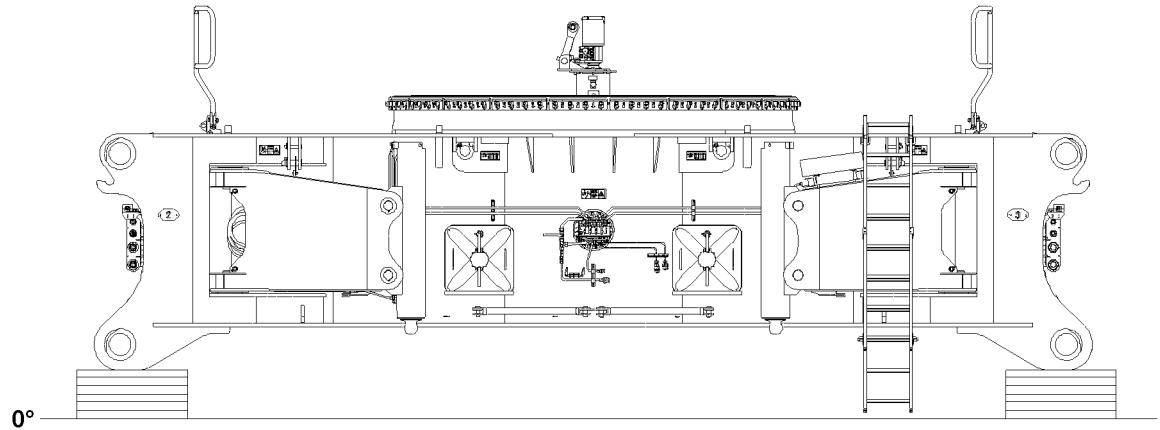

Fig.126164: Crawler center section with QC on supporting base

3.1 Placing the turntable frame lower section on the crawler center section

Make sure that the following prerequisites are met:

- The centering pins **8** are properly installed and secured on the lower section of the QC **1.1**.
- The centering pins **8** are greased with water repellent grease.

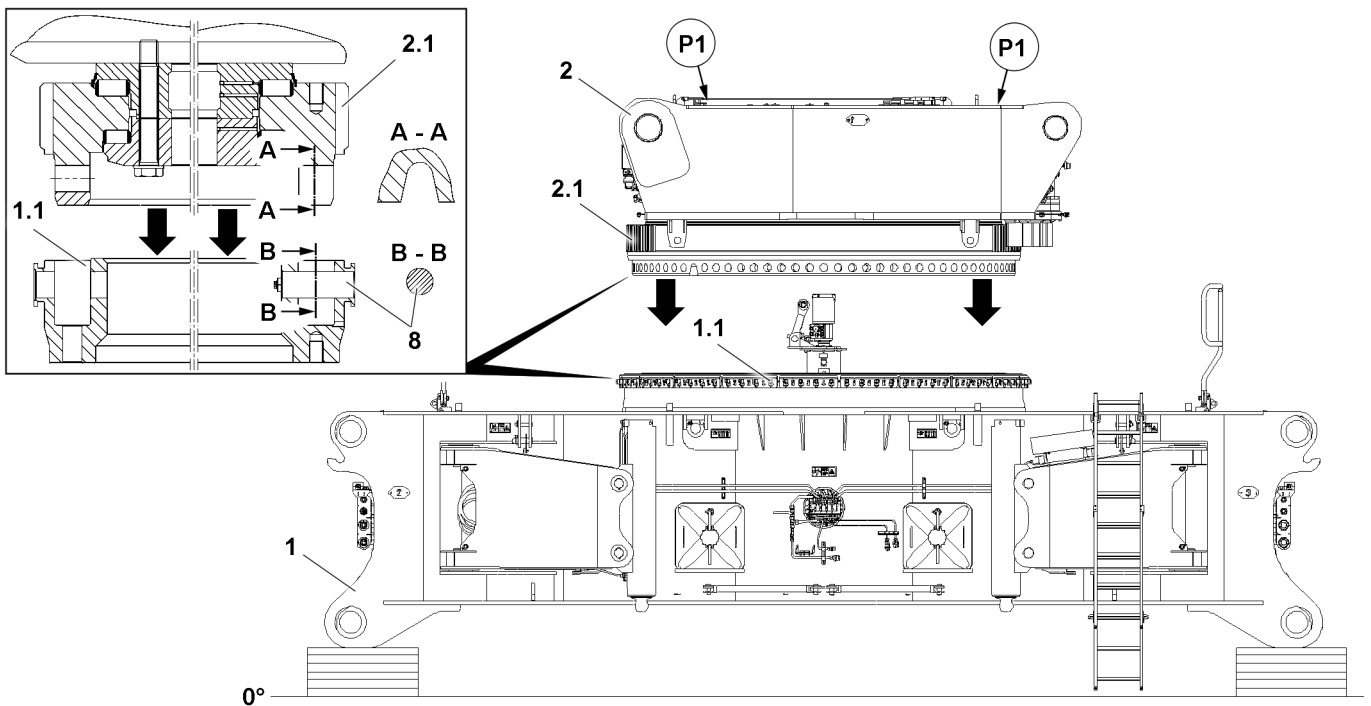

Fig.126165: Placing the turntable frame lower section on the crawler center section

- ▶ Properly fasten the turntable frame lower section **2** on the fastening points **P1** on the auxiliary crane, see also section „Fastening points“.

LWE/LR 11000-001/23501-04-02/en

**DANGER**

Danger of accident!

It is prohibited for anyone to remain within the swing range of the auxiliary crane and under the turntable frame lower section **2** when swinging the turntable frame lower section **2** in and lowering it.

- ▶ Swing the turntable frame lower section **2** with the auxiliary crane slowly over the aligned crawler center section.

**Note**

- ▶ Pay attention to the exact alignment of the turntable frame lower section **2** or the pocket receptacles **A-A** to the centering pins **8**.
- ▶ Before lowering the turntable frame lower section **2**, bring it into position in such a way that the pocket receptacles **A-A** are positioned over the centering pins **8** on the crawler center section **1**.
- ▶ Carefully lower the turntable frame lower section **2** slowly.

**WARNING**

Sheering off of limbs!

During the assembly of the QC on the roller ring connection, fingers and hands can be crushed or limbs can be severed.

Death, severe bodily injuries, property damage.

- ▶ Do not reach with your hands into the danger zone.

**WARNING**

Tipping turntable frame lower section!

If the turntable frame lower section **2** is set on the crawler center section, then it can tip over and fall down when removing the fastening equipment.

Death, severe bodily injuries, property damage.

- ▶ Make sure that the fastening equipment remains „on tension“ between the turntable frame lower section **2** and the auxiliary crane until the pins of the QC are properly pinned and secured.
- ▶ Set the turntable frame lower section **2** carefully on the crawler center section **1**.

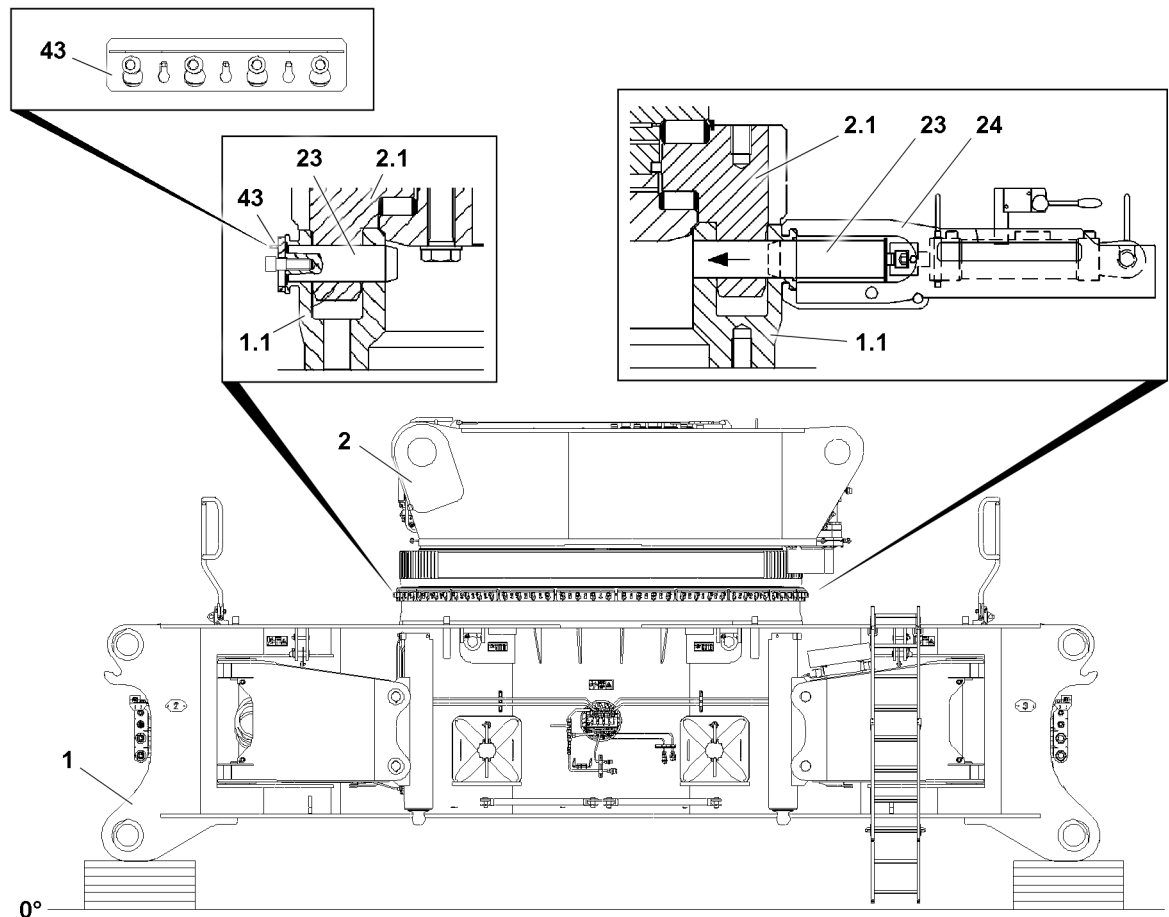

Fig.126166: Pin and secure the QC

When the turntable frame lower section 2 is properly set on the crawler center section 1:

- ▶ Pin the QC properly, see section „Pinning the Quick Connection“.

3.2 Pinning the Quick Connection

Make sure that the following prerequisites are met:

- The turntable frame lower section 2 is properly set on the crawler center section 1.
- The pin bores are clear on the circumference of the QC.
- The fastening equipment on the turntable frame lower section 2 is tensioned.
- The connector pins 23 are greased with water repellent grease.

3.2.1 Pinning



Note

- ▶ Align the pin bores by lifting or lowering the turntable frame lower section 2.



WARNING

Danger of accidents if connector pins loosen up by themselves!
Death, severe bodily injuries, property damage.

- ▶ After pinning, secure the connector pins 23 immediately with the retaining bars 43.
 - ▶ Secure the connector pins 23 with retaining bars 43
-
- ▶ Insert all connector pins 23 around the circumference of the QC by hand.

Problem remedy

The connector pins cannot be pinned or only with difficulty?

- ▶ Make sure that the pin bores align over the entire circumference of the QC.
- ▶ Make sure that all pin bores are greased.
- ▶ If still difficult, use the hydraulic pin pulling device.

When all retaining pins are properly pinned:

- ▶ Attach the retaining bars **43** and secure all connector pins **23** around the circumference of the QC.

When all connector pins **23** are properly secured:

- ▶ Carefully relieve the fastening equipment on the turntable frame lower section **2**.
- ▶ Remove the fastening equipment.

Result:

- The turntable frame lower section **2** is properly assembled.

3.3 Assembling the drawbars on the rotary connection on the turntable frame lower section

Make sure that the following prerequisites are met:

- All connector pins **23** of the QC are properly pinned.
- All connector pins **23** are properly secured with the retaining bars **43**.
- The fastening equipment on the turntable frame lower section **2** has been removed.

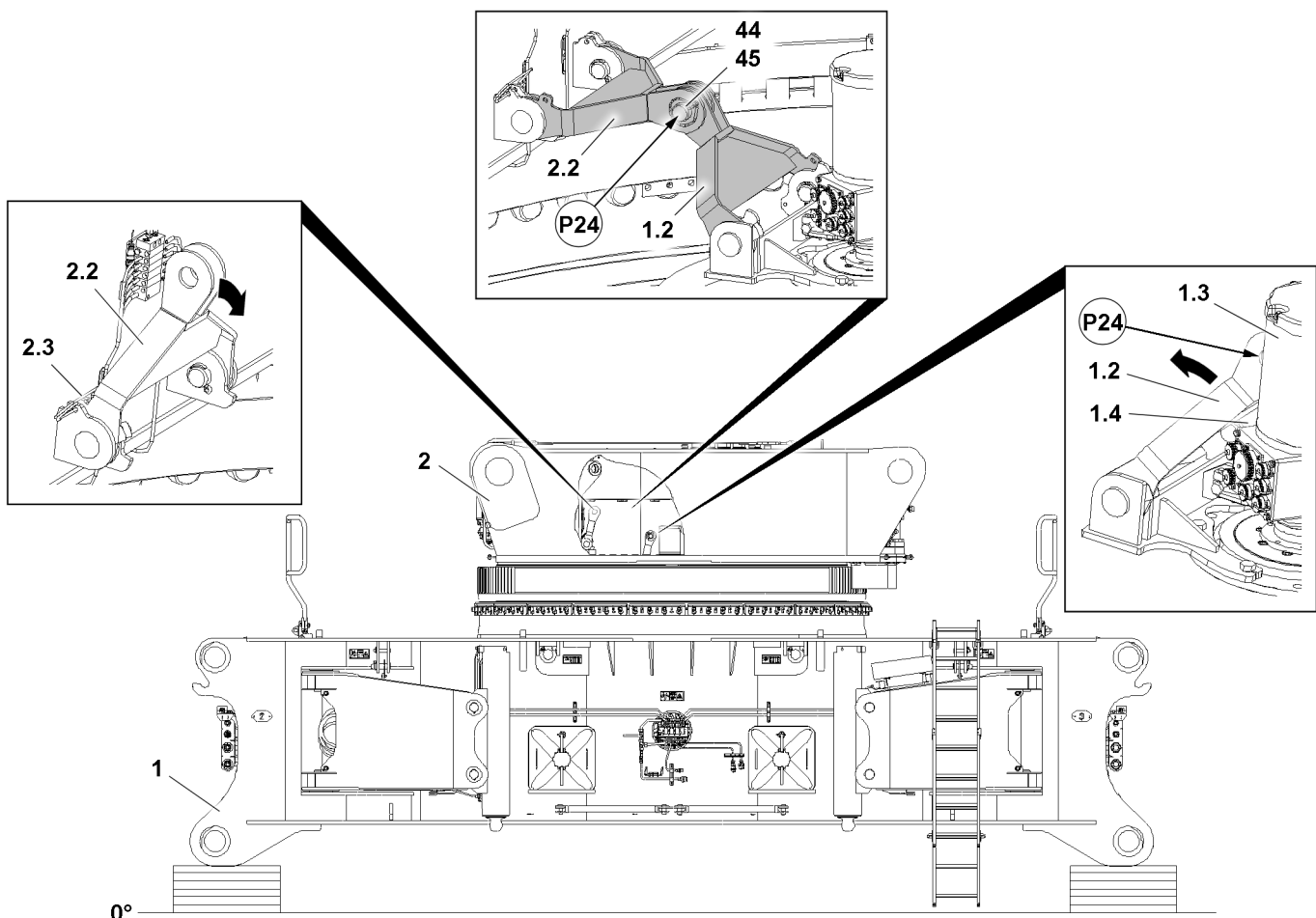

Fig.126167: Assembling the drawbars on the rotary connection on the turntable frame lower section

**WARNING**

Drawbars can fold down!

When unpinning the drawbars from the transport positions, they can fold down by themselves. Death, severe bodily injuries, property damage.

- ▶ Make sure that the drawbars are safely held in position before unpinning.
-
- ▶ Unpin the drawbar **2.2** on the turntable frame lower section **2** from transport position: Remove the spring retainer **2.3**.
 - ▶ Fold the drawbar **2.2** slowly downward.
 - ▶ Unpin the drawbar **1.2** on the rotary connection **1.3** from transport position: Remove the spring retainer **1.4**.
 - ▶ Fold the drawbar **1.2** slowly forward.
 - ▶ Pin the drawbar **1.2** of the rotary connection **1.3** with the drawbar **2.2** on the turntable frame lower section **2**.
 - ▶ Insert the pin **44** at point **P24** and secure properly with locking pin **45**.

**Note**

Install the assembly supports!

- ▶ Continue the assembly of the crawler carriers with section „Installing the assembly supports“

4 Assembling the crawler center section

**WARNING**

Danger of falling!

During assembly / disassembly, inspection and maintenance work, personnel must be secured with appropriate aids to prevent them from falling.

Death, severe bodily injuries, property damage.

- ▶ All work aloft, where there is a danger of falling must be carried out with suitable aids.
- ▶ If aids are not available and work cannot be carried out from the ground, then the assembly personnel must secure themselves with the supplied fall arrest system to prevent falling, see Crane operating instructions, chapter 2.04.
- ▶ If fall protection equipment is available, then it must be used, see Crane operating instructions, chapter 2.06.
- ▶ When lifting, lowering, swinging crane parts in and out, no persons may remain in the danger zone.
- ▶ If railings are present for the crane, then they must be brought into the corresponding position and secured for assembly / disassembly work.
- ▶ It is prohibited to lean the auxiliary ladder against the component being disassembled.
- ▶ Only step on the aids, ladders and catwalks with clean shoes.
- ▶ Keep aids, ladders and catwalks free of heavy dirt, snow, frost and ice.
- ▶ During all assembly and disassembly work, maintenance work and inspections, travel or crane operation is prohibited.
- ▶ Remaining on a suspended load is prohibited.
- ▶ Stepping or walking on crane components and lattice sections, which have an incline of more than 20° is prohibited.
- ▶ For all assembly work, the crane operator of the main crane must be in voice contact with the crane operator / crane operators of the auxiliary crane / auxiliary cranes.
- ▶ For assembly / disassembly tasks, the crane operator may only initiate crane movements when the responsible guide has explicitly released the movement.

**WARNING**

Danger of impact / crushing!

When installing / removing crane components with the auxiliary crane, crane components can start to swing back and forth.

When lifting / lowering and positioning crane components, there is an increased danger of impacts / crushing.

Death, severe bodily injuries, property damage.

- ▶ Make sure that personnel cannot be caught by components.
- ▶ When working in danger zones: Use aids to protect limbs.
- ▶ Guide components with suitable aids to minimize oscillation.

**DANGER**

The components can fall down!

If the corresponding component is disengaged from the auxiliary crane before the corresponding component is pinned, then the corresponding component can fall down.

Death, severe bodily injuries, property damage.

- ▶ Do not disengage the auxiliary crane until the respective component is pinned and secured.

4.1 Supporting the crawler center section

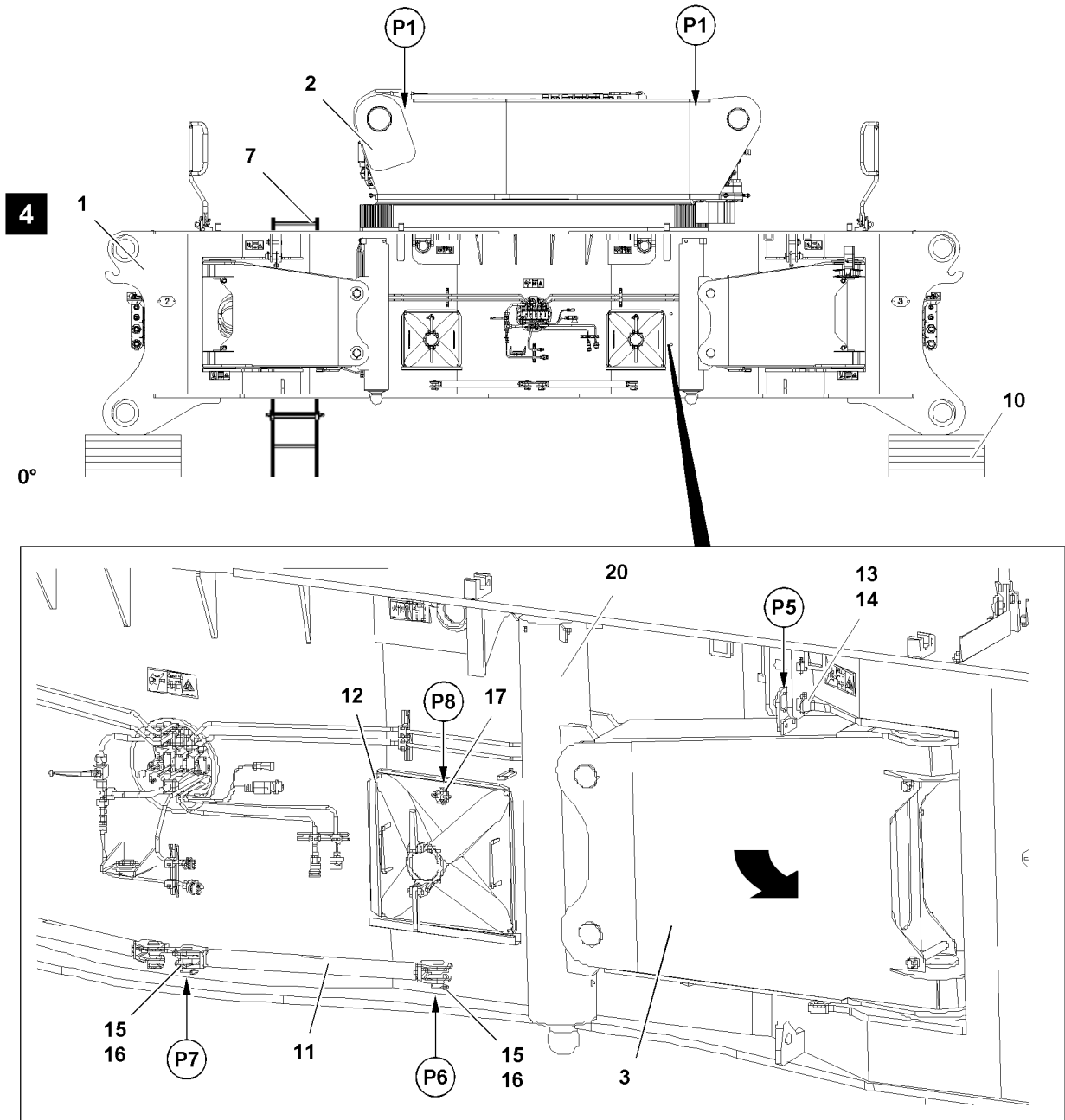

Fig.126241

4.1.1 Support the crawler center section with turntable frame lower section

Make sure that the following prerequisites are met:

- An auxiliary crane with sufficient load carrying capacity is available.
- The placement location must be level and have adequate load-bearing capacity.

LWE/LR 11000-001/23501-04-02/en

**WARNING**

Danger of accidents due to improper supporting base!

If the crawler center section is not properly supported, then it can sink into the ground.

Death, severe bodily injuries, property damage.

- ▶ The supporting base must safely take on the weight of the crawler center section.
- ▶ The supporting base must be made large enough for the ground conditions, with solid materials, such as wood, steel or concrete slabs, see Crane operating instructions, chapter 2.04.

Make sure that the following prerequisite is met:

- Suitable material must be available for the supporting base of the crawler center section.
- ▶ Support the crawler center section **1** with hardwood timbers or other suitable materials from below.

**WARNING**

Danger of falling!

During assembly and disassembly of crane components, personnel must be secured with appropriate aids to prevent them from falling.

Death, severe bodily injuries, property damage.

- ▶ Use personal protective equipment.
- ▶ Fold the grating covers open on the turntable frame lower section **2** at points **P1**.
- ▶ Attach the fastening equipment on the four fastening brackets at points **P1**, see section „Fastening points“.
- ▶ Lift the crawler center section **1** with the auxiliary crane and set it on the supporting base **10**, see illustration **4**.
- ▶ Set the extension ladder **7** up, see Crane operating instructions, chapter 2.06.
- ▶ Remove the fastening equipment.

4.1.2 Support the crawler center section without turntable frame lower section

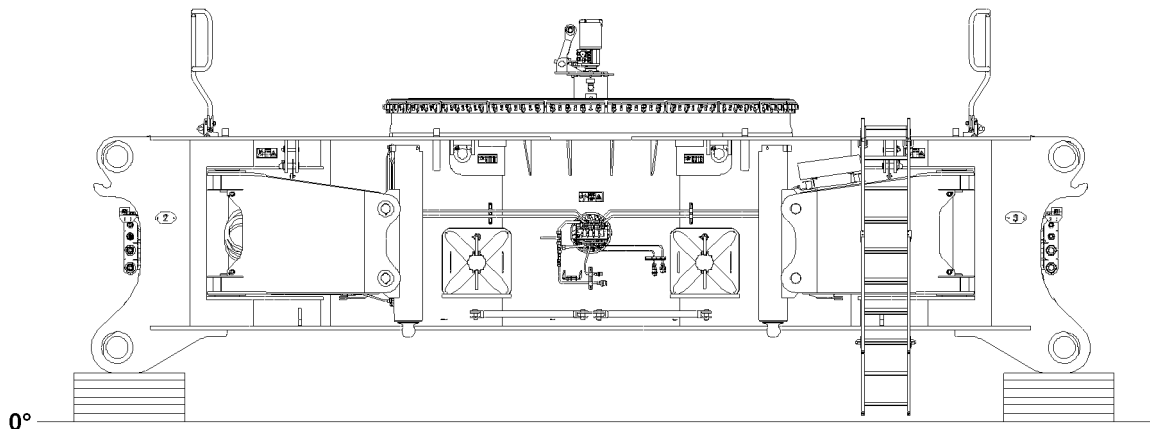

Fig.126164: Support the crawler center section without turntable frame lower section

Make sure that the following prerequisites are met:

- An auxiliary crane with sufficient load carrying capacity is available.
- The placement location must be level and have adequate load-bearing capacity.

**WARNING**

Danger of accidents due to improper supporting base!

If the crawler center section is not properly supported, then it can sink into the ground.

Death, severe bodily injuries, property damage.

- ▶ The supporting base must safely take on the weight of the crawler center section.
- ▶ The supporting base must be made large enough for the ground conditions, with solid materials, such as wood, steel or concrete slabs, see Crane operating instructions, chapter 2.04.

Make sure that the following prerequisite is met:

- Suitable material must be available for the supporting base of the crawler center section.
- ▶ Support the crawler center section with hardwood timbers or other suitable materials from below.



WARNING

Danger of falling!

During assembly and disassembly of crane components, personnel must be secured with appropriate aids to prevent them from falling.

Death, severe bodily injuries, property damage.

- ▶ Use personal protective equipment.

- ▶ Attach the fastening equipment on the four fastening brackets at points **P3**, see section „Fastening points“.
- ▶ Lift the crawler center section with the auxiliary crane and set it on the supporting base **10**.
- ▶ Remove the fastening equipment.

4.2 Installing the assembly supports



Note

- ▶ The swinging out and locking procedure of the support is the same for all four assembly supports and is therefore described only once.

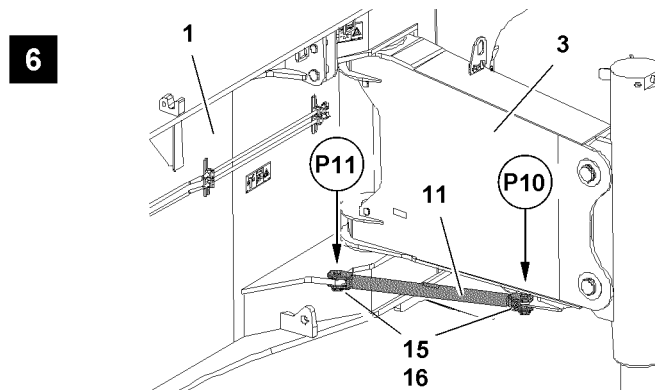

Fig.116937: Installing the assembly supports

- ▶ Release the support **3** from the transport position: Remove the safety locking pin **14** at point **P5** and unpin the pin **13**, see illustration 4.
- ▶ Swing the support **3** out so that it can be pinned at point **P10** and at point **P11**, see illustration 6.



WARNING

Falling bar!

The bar **11** can fall down due to its own weight when unpinning it.

Death, severe bodily injuries, property damage.

- ▶ For safety reasons, **two** persons must always be used to unpin the bar.
- ▶ Make sure that there are no persons within the danger zone during the entire unpinning procedure.



Note

- ▶ The weight of the bar is 10 kg.

- ▶ Release the rod **11** in the transport receptacle: Remove the safety locking pin **16** at point **P6** and at point **P7** and unpin the pin **15**, see illustration 4.

When rod **11** is unpinned in the transport receptacle:

- ▶ Place the rod **11** in operating position, see illustration 6.

**WARNING**

Rod not secured!

If the rod **11** is not properly secured in operating position, then it can loosen up by itself in crane operation.

This can cause the crane to topple over.

Death, severe bodily injuries, property damage.

- ▶ Make sure that the rod **11** is properly secured with pin **15** and safety locking pin **16**.
 - ▶ Make sure that all four assembly supports are properly secured.
-
- ▶ Secure the support **3** in operating position: Pin the rod **11** with pin **15** at point **P10** and at point **P11** and secure with safety locking pin **16**, see illustration **6**.

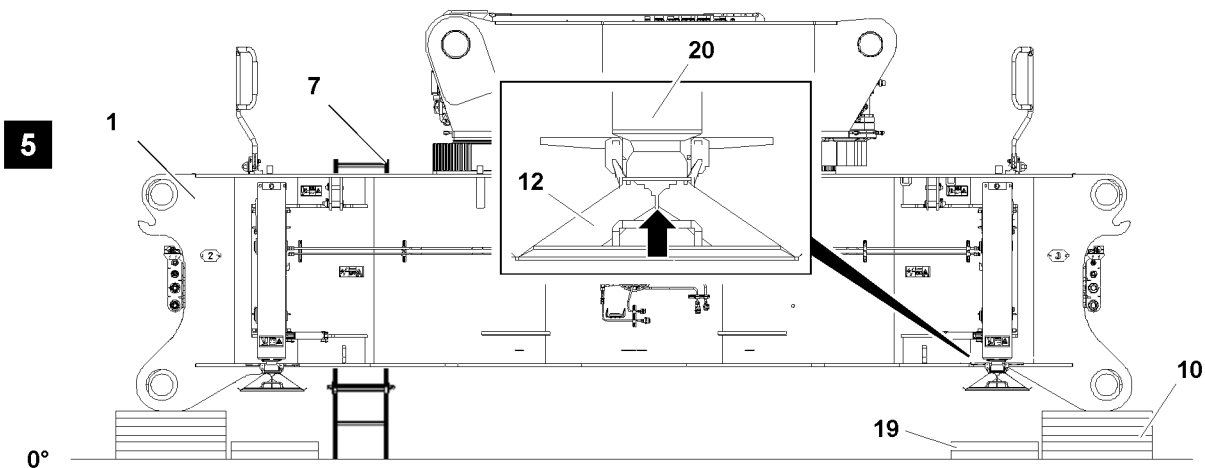

Fig.126242

**WARNING**

Falling support plate!

The support plate **12** can fall down due to its own weight when releasing it.

Death, severe bodily injuries, property damage.

- ▶ For safety reasons, assemble the support plate always with **two** persons.
- ▶ Make sure that there are no persons within the danger zone during the entire unpinning procedure.

**Note**

- ▶ The weight of the support plate is 33 kg.
-
- ▶ Release the support plate **12** from the transport position: Remove the safety locking pin **17** at point **P8**, see illustration **4**.
 - ▶ Take the support plates **12** from the transport retainer and install on the ball head of the support cylinder **20**, see illustration **5**.

4.3 Connecting the hydraulic aggregate

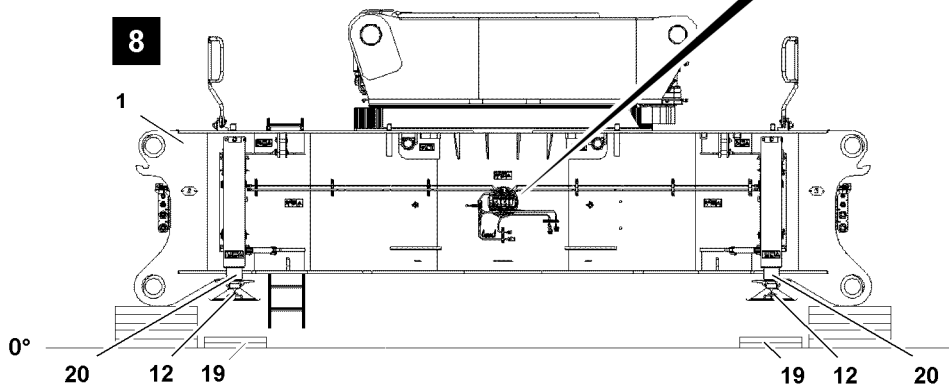
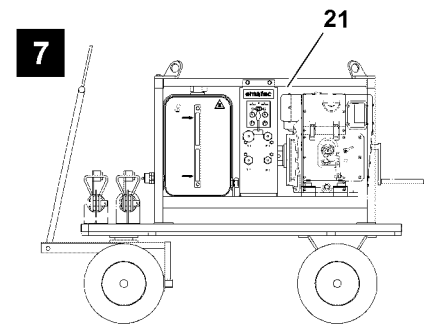
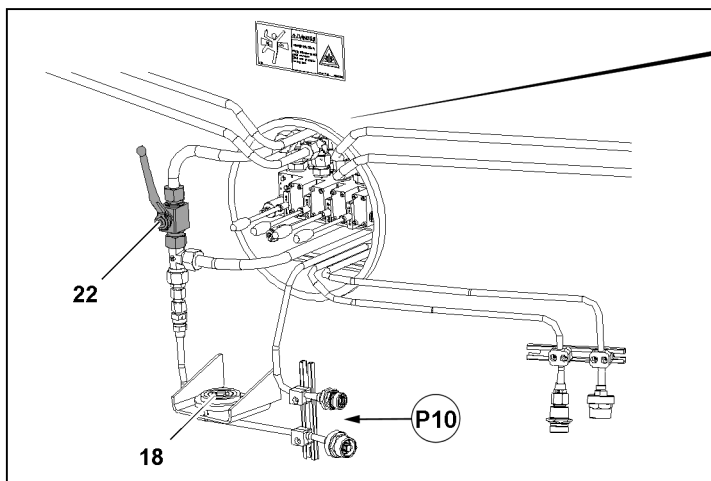
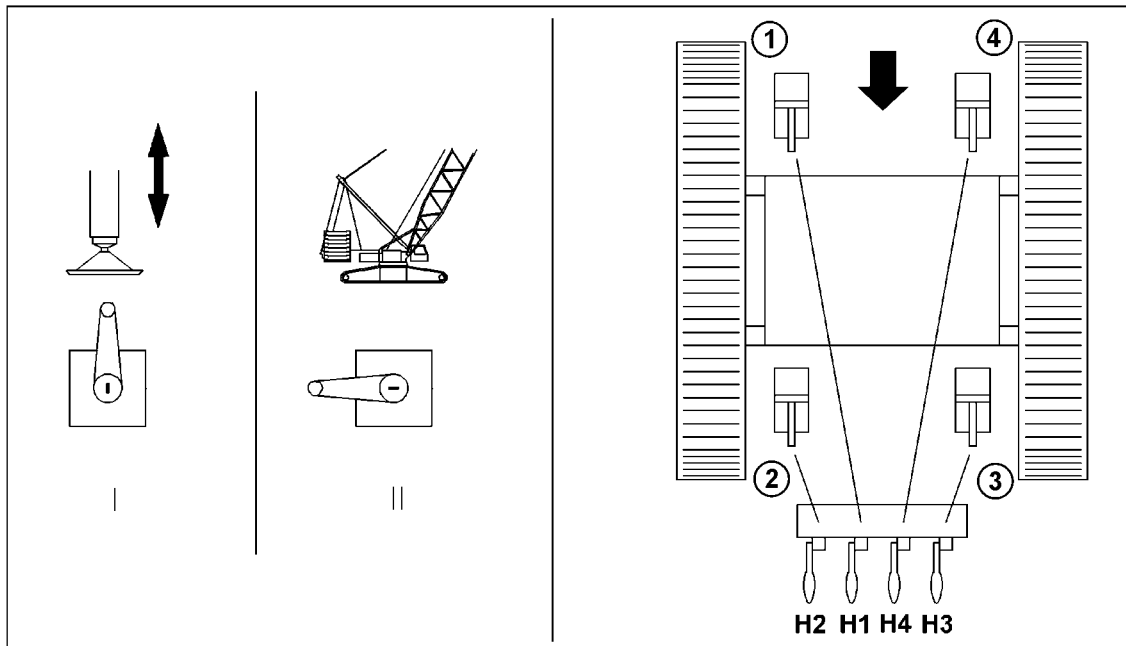

Fig.122406

LWE/LR 11000-001/23501-04-02/en

Make sure that the following prerequisites are met:

- The assembly supports are locked with the rods.
- The support plates are properly locked with the support cylinders.



Note

- ▶ The support cylinders are marked with numbers.



Note

- ▶ Observe the information in the Operating and Maintenance manual of the hydraulic aggregate.
- ▶ Hydraulic connections from hydraulic aggregate **21** to the crawler center section **1**, see Hydraulic diagram.



WARNING

Pressure in the hydraulic lines!

If the pressure supply is not interrupted before connecting / releasing the hydraulic lines, the hydraulic oil can escape with high pressure.

Death, severe bodily injuries, property damage.

- ▶ Release the pressure in the hydraulic system before connecting / disconnecting: Interrupt the pressure supply and wait for a short time.
- ▶ Connect the coupling components (sleeve and connector) and screw together with the hand-tightened nut.
- ▶ Tighten the hydraulic coupling by hand. Rotate the hand-tightened nut until it reaches a tangible, fixed stop position.
- ▶ Establish the hydraulic connections from the hydraulic aggregate **21** to the crawler center section **1** at point **P10**, see illustration **8**.

4.4 Lifting the crawler center section over the assembly support



WARNING

The crawler center section can topple over!

Depending on the assembly condition of the crawler center section and the extension condition of the support cylinders, the support forces on the support cylinders can occur up to **114 t**.

Death, severe bodily injuries, property damage.

- ▶ Make sure that the ground under the support cylinders is able to safely take on the occurring support forces.
- ▶ Make sure that the support cylinders are supported from below over a large surface with load bearing materials.
- ▶ Make sure that the support cylinders are moved in and / or out evenly.
- ▶ When supporting or lowering the crawler center section pay attention to horizontal orientation.

Make sure that the following prerequisites are met:

- The supporting base **19** had been properly established.
- The hydraulic connections from the hydraulic aggregate **21** to the crawler center section **1** have been properly established.
- The support cylinders **20** of the assembly support have been properly supported.
- The ball valve **22** is in position I „assembly support“.



WARNING

Danger of accidents due to improper supporting base!

If the support plates **12** are not properly supported, then they can sink into the ground.

Death, severe bodily injuries, property damage.

- ▶ The supporting base must be able to safely take on the weight of the crawler center section, the turntable frame lower section and the crawler carrier.
- ▶ The supporting base must be made large enough for the ground conditions, with solid materials, such as wood, steel or concrete slabs, see Crane operating instructions, chapter 2.04.

4.4.1 Lifting the crawler center section with the hydraulic hand levers

Make sure that the following prerequisite is met:

- The hydraulic aggregate **21** is turned on.



Note

- ▶ The support cylinders are marked with numbers.
- ▶ Pay attention to the identification on the hand lever and on the support cylinder, see illustration 8.

Ball valve positions	
Position I	Assembly support
Position II	Crane operation / crawler carrier installation with SA-frame

Function assignment of hand levers for the support cylinders	
H1	Hand lever for the support cylinder 1 , right rear
H2	Hand lever for support cylinder 2 , right front
H3	Hand lever for support cylinder 3 , left front
H4	Hand lever for support cylinder 4 , left rear

- ▶ Move the ball valve **22** in position I „assembly support“, see illustration 8.



WARNING

Danger of tipping the crawler center section!

If the support cylinders **20** are moved out unevenly, the crawler center section can tip over.

Death, severe bodily injuries, property damage.

- ▶ When lifting the crawler center section, pay attention to the horizontal alignment, check visually.
- ▶ Extend the support cylinders **20** completely: Actuate the hand lever **H1**, hand lever **H2**, hand lever **H3** and hand lever **H4**.

Result:

- The support cylinders **20** extend.

4.4.2 Lifting the crawler center section with the control panel



Note

- ▶ Alternatively to the operation of the assembly support with the hand levers, the assembly support can also be operated with the control panel **200**, see Electrical wiring diagram.

Make sure that the following prerequisites are met:

- The electric external feed (maximum 24 V) to the crawler center section is properly established, see Electrical wiring diagram.
- The dummy plug on the socket at point **P25** or on the socket at point **P26** on the crawler center section has been removed.
- The control panel **200** is connected on the socket at point **P25** or on the socket at point **P26** on the crawler center section, see Electrical wiring diagram.
- The hydraulic aggregate **21** is turned on.



WARNING

Danger of tipping the crawler center section!

If the support cylinders **20** are moved out unevenly, the crawler center section can tip over.

Death, severe bodily injuries, property damage.

- ▶ When lifting the crawler center section, pay attention to the horizontal alignment, check visually.

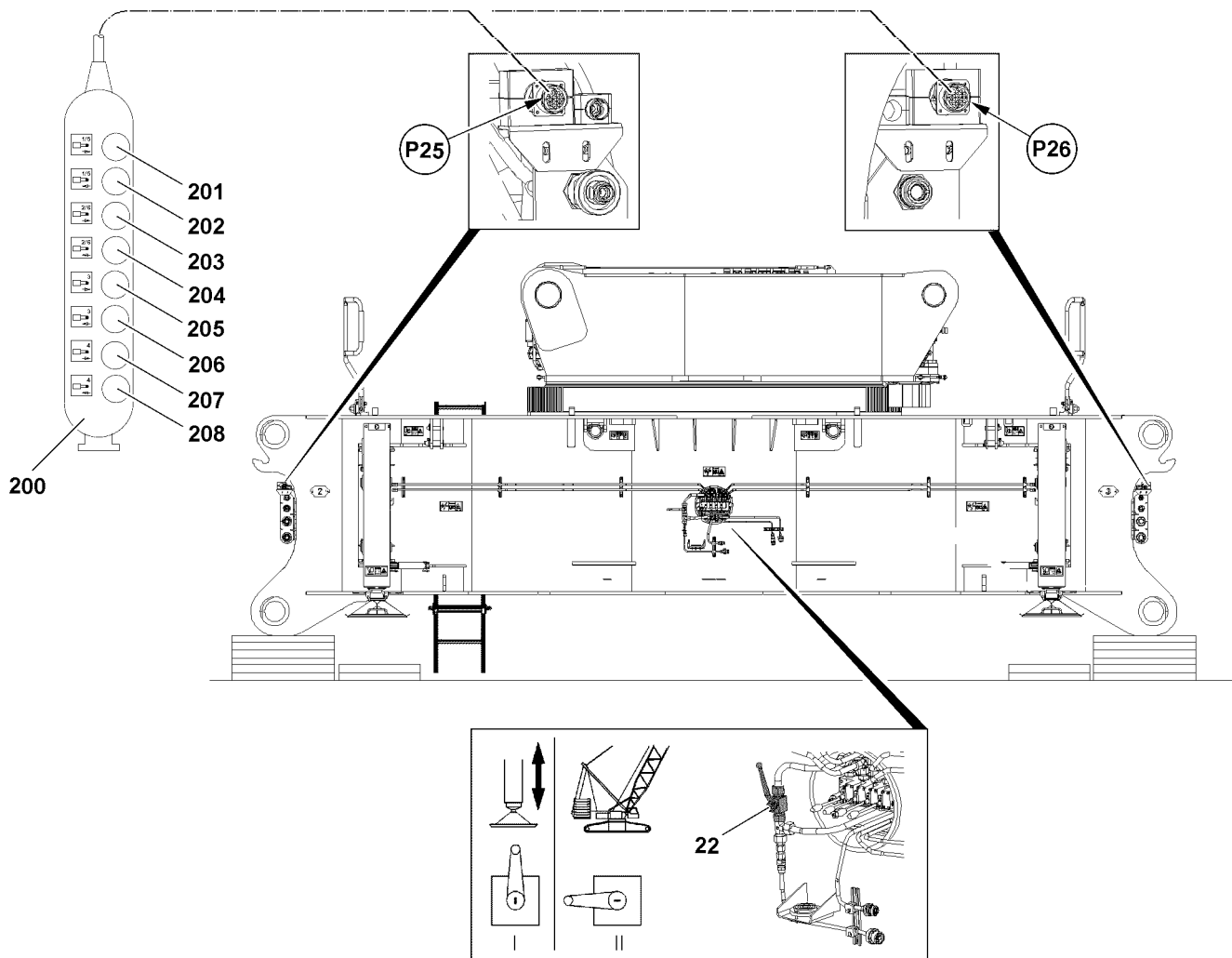

Fig.122403: Lifting the crawler center section with the control panel 200

Support right rear

- ▶ Press button 201.

Result:

- The right rear support cylinder extends.

- ▶ Press button 202.

Result:

- The right rear support cylinder retracts.

Support right front

- ▶ Press button 203.

Result:

- Support cylinder moves out on the right front.

- ▶ Press button 204.

Result:

- Support cylinder moves in on the right front.

Support left front

- ▶ Press button **205**.

Result:

- The left front support cylinder extends.

- ▶ Press button **206**.

Result:

- The left front support cylinder retracts.

Support left rear

- ▶ Press button **207**.

Result:

- The left rear support cylinder extends.

- ▶ Press button **208**.

Result:

- The left rear support cylinder retracts.

4.5 Aligning the crawler center section horizontally**Note**

- ▶ The horizontal alignment of the crawler center section is checked and aligned with the aid of the sight gauge **18**.
- ▶ The center of the sight gauge **18** shows the precise incline value.

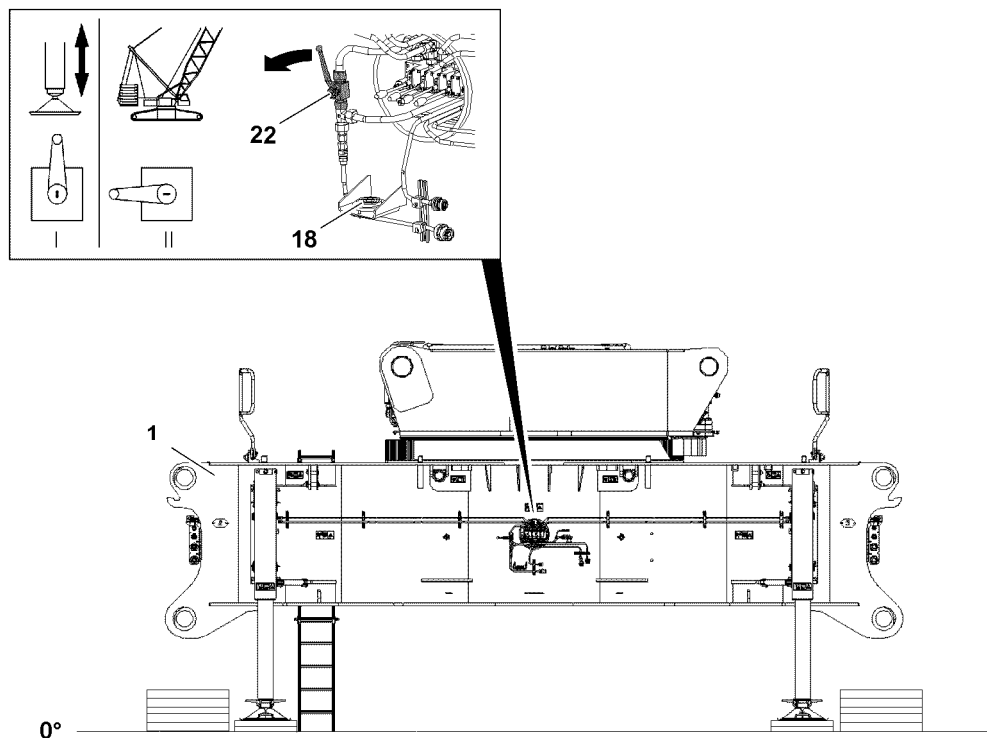

Fig.122404: Aligning the crawler center section horizontally

- ▶ Align the crawler center section horizontally with the aid of the sight gauge **18**.

When the crawler center section is properly supported and horizontally aligned:

- ▶ Actuate the ball valve **22** in position II „Crane operation / crawler carrier installation“.
- ▶ Turn the hydraulic aggregate **21** off.

When supported with the control panel:

- ▶ Store the control panel **200** safely.
- ▶ Remove the supporting base **10**.
- ▶ Align the extension ladder **7** again, see Crane operating instructions, chapter 2.06.

5 Assembly of crawler carrier with the auxiliary crane



WARNING

Danger of falling!

During assembly / disassembly, inspection and maintenance work, personnel must be secured with appropriate aids to prevent them from falling.

Death, severe bodily injuries, property damage.

- ▶ All work aloft, where there is a danger of falling must be carried out with suitable aids.
- ▶ If aids are not available and work cannot be carried out from the ground, then the assembly personnel must secure themselves with the supplied fall arrest system to prevent falling, see Crane operating instructions, chapter 2.04.
- ▶ If fall protection equipment is available, then it must be used, see Crane operating instructions, chapter 2.06.
- ▶ When lifting, lowering, swinging crane parts in and out, no persons may remain in the danger zone.
- ▶ If railings are present for the crane, then they must be brought into the corresponding position and secured for assembly / disassembly work.
- ▶ It is prohibited to lean the auxiliary ladder against the component being disassembled.
- ▶ Only step on the aids, ladders and catwalks with clean shoes.
- ▶ Keep aids, ladders and catwalks free of heavy dirt, snow, frost and ice.
- ▶ During all assembly and disassembly work, maintenance work and inspections, travel or crane operation is prohibited.
- ▶ Remaining on a suspended load is prohibited.
- ▶ Stepping or walking on crane components and lattice sections, which have an incline of more than 20° is prohibited.
- ▶ For all assembly work, the crane operator of the main crane must be in voice contact with the crane operator / crane operators of the auxiliary crane / auxiliary cranes.
- ▶ For assembly / disassembly tasks, the crane operator may only initiate crane movements when the responsible guide has explicitly released the movement.



WARNING

Danger of impact / crushing!

When installing / removing crane components with the auxiliary crane, crane components can start to swing back and forth.

When lifting / lowering and positioning crane components, there is an increased danger of impacts / crushing.

Death, severe bodily injuries, property damage.

- ▶ Make sure that personnel cannot be caught by components.
- ▶ When working in danger zones: Use aids to protect limbs.
- ▶ Guide components with suitable aids to minimize oscillation.



DANGER

The components can fall down!

If the corresponding component is disengaged from the auxiliary crane before the corresponding component is pinned, then the corresponding component can fall down.

Death, severe bodily injuries, property damage.

- ▶ Do not disengage the auxiliary crane until the respective component is pinned and secured.

5.1 Preparing the crawler carrier for assembly

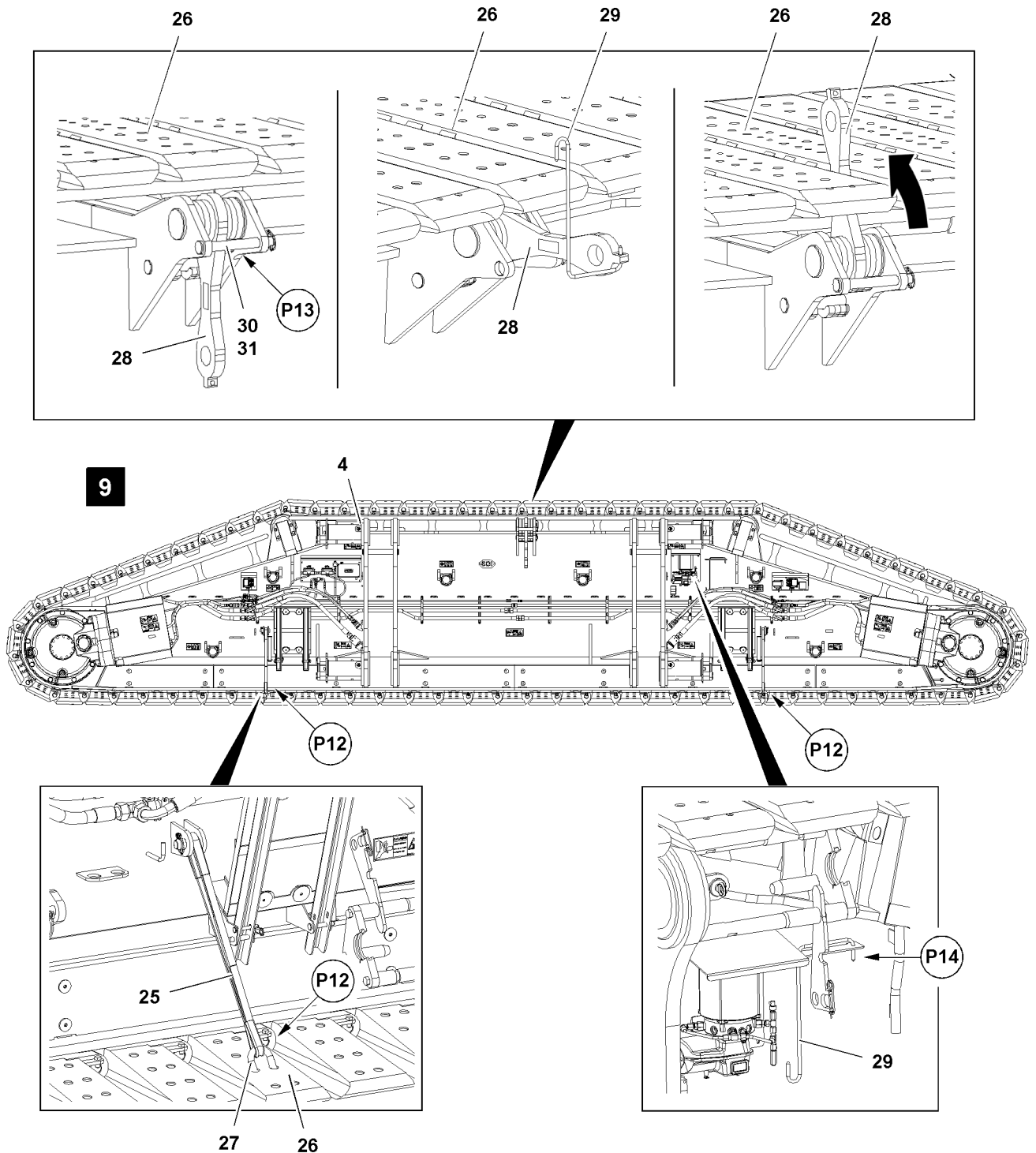

Fig.126240

Make sure that the following prerequisites are met:

- An auxiliary crane with sufficient load carrying capacity is available.
- The turntable frame lower section is properly assembled on the crawler center section (only for crane with QC)
- The assembly supports are in operating position.
- The crawler center section is supported: The support cylinders are moved out completely.
- The crawler center section is horizontally aligned.

LWE/LR 11000-001/23501-04-02/en

**WARNING**

Danger of falling!

During assembly and disassembly of crane components, personnel must be secured with appropriate aids to prevent them from falling.

Death, severe bodily injuries, property damage.

- ▶ Use personal protective equipment.

**Note**

- ▶ Hang in two belts **25** per crawler carrier side.

The track pads **26** must be secured before assembly of the crawler carriers with the belts **25** to prevent sag.

- ▶ Hang the belts **25** with the bars **27** on points **P12** on the track pads, see illustration **9**.

**Note**

- ▶ The brackets **28** must be swung in operating position between the track pads **26**, „upward“.

- ▶ Remove the safety locking pin **31** at point **P13** and unpin the pin **30**, see illustration **9**.

**Note**

- ▶ The handle **29** is fastened in transport position at point **P14**.

- ▶ Swing the brackets **28** with the handle **29** up, see illustration **9**.
- ▶ Attach the fastening equipment on the brackets **28** of the crawler carrier.

5.2 Installing the first crawler carrier with the auxiliary crane

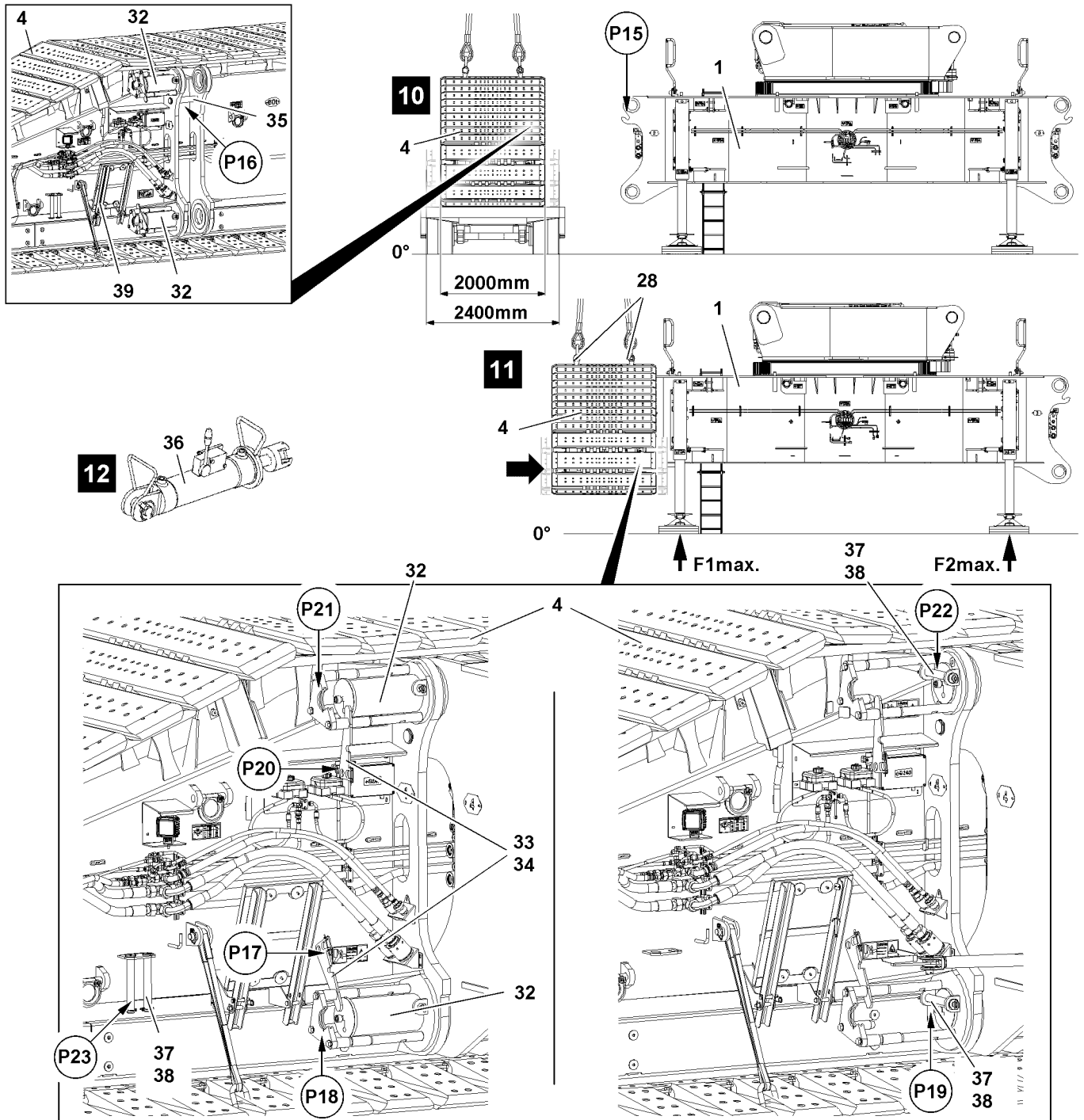

Fig.126243: Installing the first crawler carrier with the auxiliary crane

LWE/LR 11000-001/23501-04-02/en

**WARNING**

The crawler center section can topple over!

Depending on the assembly condition of the crawler center section and the extension condition of the support cylinders, the support forces on the support cylinders can occur up to **114 t**.

Death, severe bodily injuries, property damage.

- ▶ Make sure that the ground under the support cylinders is able to safely take on the occurring support forces.
- ▶ Make sure that the support cylinders are supported from below over a large surface with load bearing materials.
- ▶ Make sure that the support cylinders are moved in and / or out evenly.
- ▶ When supporting or lowering the crawler center section pay attention to horizontal orientation.

**Note**

- ▶ Note the identification on the crawler carrier and the crawler center section.
- ▶ The crawler carrier and the crawler center section are marked with numbers.

**Note**

- ▶ For assembly of the crawler carriers on the crawler center section, the assembly procedure and the process are identical for both crawler carrier sides.
- ▶ For that reason, the assembly of the crawler carrier is only described for one side as an example.

**WARNING**

Danger of falling!

During assembly and disassembly of crane components, personnel must be secured with appropriate aids to prevent them from falling.

Death, severe bodily injuries, property damage.

- ▶ Use personal protective equipment.

Make sure that the following prerequisites are met:

- The turntable frame lower section is properly assembled on the crawler center section (only for QC)
- The track pads are secured to prevent them from sagging.
- The pins **32** are secured in transport position, see illustration **10**.
- ▶ Carefully swing crawler carrier **4** with the auxiliary crane up to the pin points on the crawler center section **1**.

NOTICE

Ground pressure!

- ▶ The forces $F1_{max}$ and $F2_{max}$ are calculated for the crawler center section with the turntable frame lower section and track pads with a width of 2400 mm, see illustration **10** and illustration **11**.

Crawler center section with one crawler carrier	
Force	Support force per support
$F1_{max}$	61 t
$F2_{max}$	9 t

- ▶ Hang the crawler carrier **4** with centering pins **35** at points **P16** on the centerings at points **P15** on the crawler center section **1**, see illustration **10** and illustration **11**.
- ▶ Release the pin **32** from transport position: Remove the spring retainer **34** at point **P17** and swing the retaining bar **33** upward, see illustration **11**.
- ▶ Insert the spring retainer **34** again on point **P17**.
- ▶ Connect the pin pulling cylinder **36** in the hydraulic supply line or on the hydraulic aggregate, see illustration **12**.
- ▶ Set the pin pulling cylinder **36** in the pin pulling device at point **P18**, see illustration **11**.

- ▶ Insert the pin **32** with the pin pulling cylinder **36** to the stop.
- ▶ Remove the pin pulling cylinder **36**, see illustration **12**.

**Note**

- ▶ The retaining pins **37** are at point **P23** in park position, see illustration **11**.
- ▶ Remove the safety locking pin **38** and unpin the retaining pin **37** from the park position at point **P23**.

**WARNING**

The pin is not secured!

If the retaining pins **37** are not secured, the retaining pins can loosen up by themselves during crane operation.

This can cause the crane to topple over.

Death, severe bodily injuries, property damage.

- ▶ Make sure that the retaining pins **37** are secured with safety locking pins **38**.
- ▶ Secure the pins **32**: Insert the retaining pin **37** at point **P19** and secure with safety locking pin **38**.
- ▶ Fold the assembly platform **39** down, see Crane operating instructions, chapter 2.06.
- ▶ Release the pin **32** from transport position: Remove the spring retainer **34** at point **P20** and swing the retaining bar **33** downward, see illustration **11**.
- ▶ Reinstall the spring retainer **33** again at point **P20**, see illustration **11**.
- ▶ Set the pin pulling cylinder **36** in the pin pulling device at point **P21**.
- ▶ Insert the pin **32** with the pin pulling cylinder **36** to the stop.
- ▶ Remove the pin pulling cylinder **36**, see illustration **12**.

**Note**

- ▶ The retaining pins are at point **P23** in park position, see illustration **11**.
- ▶ Remove the safety locking pin **38** and unpin the retaining pin **37** from the park position at point **P23**.

**WARNING**

The pin is not secured!

If the retaining pins **37** are not secured, the retaining pins can loosen up by themselves during crane operation.

This can cause the crane to topple over.

Death, severe bodily injuries, property damage.

- ▶ Make sure that the retaining pins **37** are secured with safety locking pins **38**.
- ▶ Secure the pins **32**: Insert the retaining pin **37** at point **P22** and secure with safety locking pin **38**.
- ▶ Pin the crawler carrier **4** on the other crawler carrier side with the crawler center section.
- ▶ Remove the fastening equipment.

5.3 Installing the second crawler carrier with the auxiliary crane

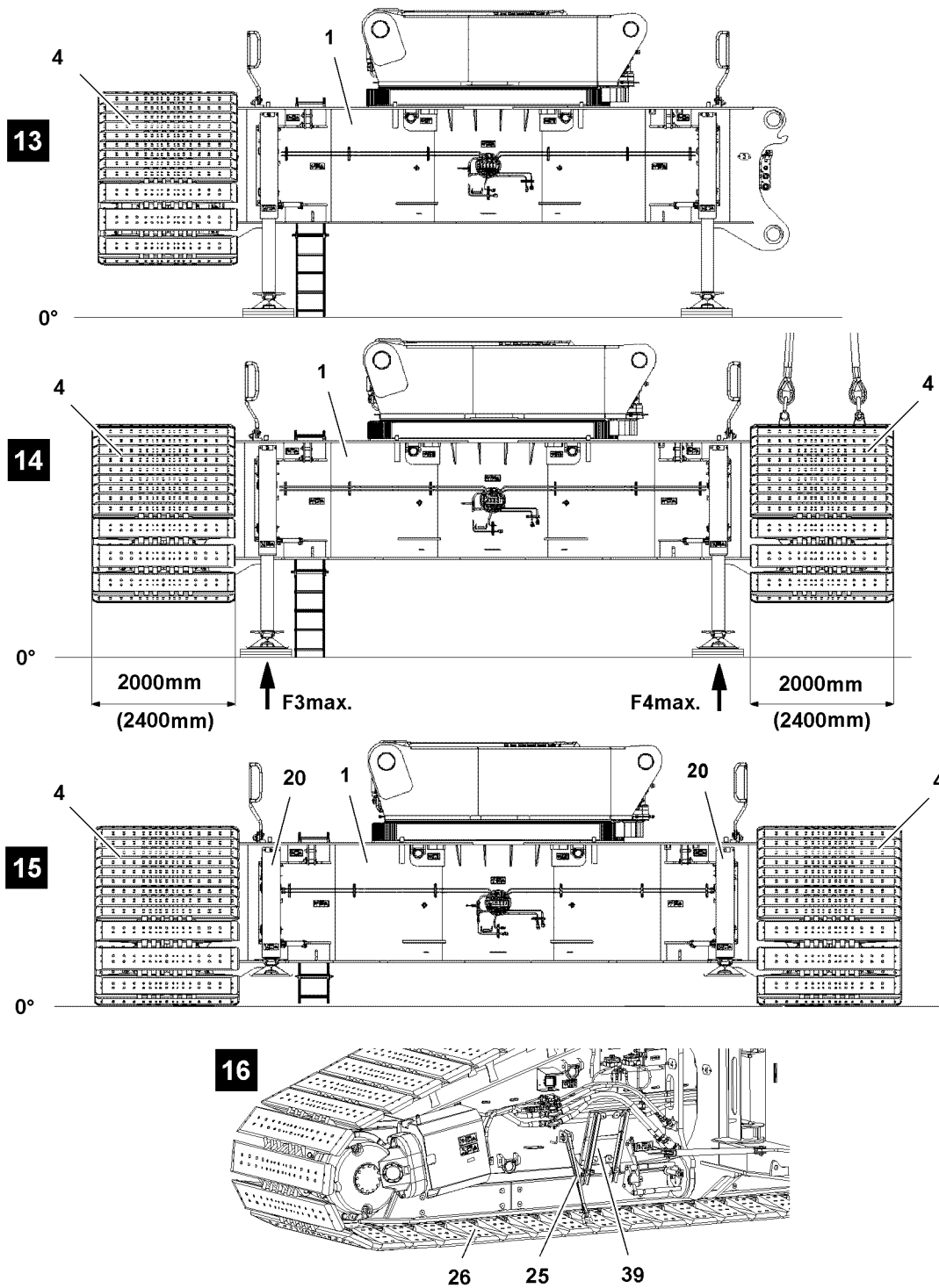

Fig.126244

LWE/LR 11000-001/23501-04-02/en



WARNING

Toppling crawler travel gear!

Depending on the assembly condition of the crawler travel gear and the extension condition of the support cylinders, the support forces on the support cylinders can occur up to **114 t**.

Death, severe bodily injuries, property damage.

- ▶ Make sure that the ground under the support cylinders is able to safely take on the occurring support forces.
- ▶ Make sure that the support cylinders are supported from below over a large surface with load bearing materials.
- ▶ Make sure that the support cylinders are moved in and / or out evenly.
- ▶ When supporting or lowering the crawler center section pay attention to horizontal orientation.

Make sure that the following prerequisite is met:

- The first crawler carrier **4** is pinned and secured on the crawler center section **1**.



Note

- ▶ For assembly of the crawler carriers on the crawler center section, the assembly procedure and the process are identical for both crawler carriers.
- ▶ For that reason, the assembly of the crawler carrier is only described for crawler carrier as an example.

NOTICE

Ground pressure!

- ▶ The forces $F_{3_{max}}$ and $F_{4_{max}}$ are calculated for the crawler center section with the turntable frame lower section and track pads with a width of 2400 mm , see illustration **14**.

Crawler center section with two crawler carriers	
Forces	Support force per support
$F_{3_{max}}$	53 t
$F_{4_{max}}$	53 t

- ▶ Install the second crawler carrier, see section „Installing the first crawler carrier with the auxiliary crane“.

5.4 Lowering the crawler track



WARNING

Danger of accidents due to improper supporting base!

Death, severe bodily injuries, property damage.

- ▶ The support must be able to safely take on the weight of the crawler travel gear, the turntable frame lower section and the crawler center section.
- ▶ The supporting base must be made large enough for the ground conditions, with solid materials, such as wood, steel or concrete slabs, see Crane operating instructions, chapter 2.04.

LWE/LR 11000-001/23501-04-02/en

NOTICE

Environmental pollution due to hydraulic oil!

When retracting the assembly support, if a hydraulic aggregate with full hydraulic oil tank is used, then the hydraulic oil tank on the hydraulic aggregate can be flooded when retracting the assembly support. Hydraulic oil can escape causing severe environmental pollution.

- ▶ Make sure that the hydraulic oil tank on the hydraulic aggregate has sufficient capacity to be able to safely take on the hydraulic oil of the assembly support.
- ▶ Make sure that the extension and retraction of the assembly support is carried out solely with the same hydraulic aggregate.
- ▶ Make sure that suitable measures are made to prevent an oil spill in the environment.

Make sure that the following prerequisites are met:

- The second crawler carrier **4** is properly pinned and secured on the crawler center section **1**.
- The hydraulic aggregate is turned on.
- The ball valve **22** is in position I.
- ▶ Move the support cylinders **20** in all the way.

Result:

- Both crawler carriers **4** are standing on the ground.
- ▶ Remove the fastening equipment.

NOTICE

Damage to the brackets!

- ▶ After removing the fastening equipment, the brackets **28** must be swung down.
- ▶ Swing the brackets **28** down, see section „Preparing the crawler carrier for assembly“.
- ▶ Disengage the belts **25** on the track pads **26**, see illustration **16**.
- ▶ Fold the assembly platforms **39** up again into transport position, see Crane operating instructions, chapter 2.06 and illustration **16**.

5.5 Establishing the connections to the crawler carriers

Make sure that the following prerequisite is met:

- Both crawler carriers are properly installed, pinned and secured.

5.5.1 Establishing the hydraulic connections

The hydraulic connections are made with quick couplings.

When connecting hydraulic lines with quick couplings, make sure that the coupling procedure is carried out correctly.

**WARNING**

Pressure in the hydraulic lines!

If the pressure supply is not interrupted before connecting / releasing the hydraulic lines, the hydraulic oil can escape with high pressure.

Death, severe bodily injuries, property damage.

- ▶ Release the pressure in the hydraulic system before connecting / disconnecting: Interrupt the pressure supply and wait for a short time.

**WARNING**

Loss of pressure or leakage!

Incorrectly coupled or self-loosening quick couplings (particularly return lines) can result in serious accidents due to component failure.

- ▶ Check that the quick couplings have been properly connected before using the crane.
- ▶ Connect the coupling components (sleeve and connector) and screw together with the hand-tightened nut.

- ▶ Tighten the hydraulic coupling by hand. Rotate the hand-tightened nut until it reaches a tangible, fixed stop position.
- ▶ Establish the hydraulic connections, see Hydraulic diagram.

5.5.2 Establishing the electrical connections

- ▶ Establish the electrical connections, see Electric wiring diagram.

5.5.3 Establishing the connections to the central lubrication system

- ▶ Establish the connections to the central lubrication system.

6 Disassembly of crawler carrier with the auxiliary crane



WARNING

Danger of falling!

During assembly / disassembly, inspection and maintenance work, personnel must be secured with appropriate aids to prevent them from falling.

Death, severe bodily injuries, property damage.

- ▶ All work aloft, where there is a danger of falling must be carried out with suitable aids.
- ▶ If aids are not available and work cannot be carried out from the ground, then the assembly personnel must secure themselves with the supplied fall arrest system to prevent falling, see Crane operating instructions, chapter 2.04.
- ▶ If fall protection equipment is available, then it must be used, see Crane operating instructions, chapter 2.06.
- ▶ When lifting, lowering, swinging crane parts in and out, no persons may remain in the danger zone.
- ▶ If railings are present for the crane, then they must be brought into the corresponding position and secured for assembly / disassembly work.
- ▶ It is prohibited to lean the auxiliary ladder against the component being disassembled.
- ▶ Only step on the aids, ladders and catwalks with clean shoes.
- ▶ Keep aids, ladders and catwalks free of heavy dirt, snow, frost and ice.
- ▶ During all assembly and disassembly work, maintenance work and inspections, travel or crane operation is prohibited.
- ▶ Remaining on a suspended load is prohibited.
- ▶ Stepping or walking on crane components and lattice sections, which have an incline of more than 20° is prohibited.
- ▶ For all assembly work, the crane operator of the main crane must be in voice contact with the crane operator / crane operators of the auxiliary crane / auxiliary cranes.
- ▶ For assembly / disassembly tasks, the crane operator may only initiate crane movements when the responsible guide has explicitly released the movement.



WARNING

Danger of impact / crushing!

When installing / removing crane components with the auxiliary crane, crane components can start to swing back and forth.

When lifting / lowering and positioning crane components, there is an increased danger of impacts / crushing.

Death, severe bodily injuries, property damage.

- ▶ Make sure that personnel cannot be caught by components.
- ▶ When working in danger zones: Use aids to protect limbs.
- ▶ Guide components with suitable aids to minimize oscillation.

**DANGER**

The components can fall down!

If the corresponding component is disengaged from the auxiliary crane before the corresponding component is pinned, then the corresponding component can fall down.

Death, severe bodily injuries, property damage.

- ▶ Do not disengage the auxiliary crane until the respective component is pinned and secured.

6.1 Disconnecting the connections to the crawler carriers

Make sure that the following prerequisites are met:

- The turntable is removed.
- The central ballast has been removed.
- An auxiliary crane is available.
- The disassembly location must be level and have adequate load-bearing capacity.
- Suitable material must be available for the supporting base of the assembly supports.
- The support plates are installed.

6.1.1 Disconnecting the hydraulic connections

The hydraulic connections are made with quick couplings.

When disconnecting hydraulic lines with quick couplings, make sure that the coupling procedure is carried out correctly.

**WARNING**

Pressure in the hydraulic lines!

If the pressure supply is not interrupted before connecting / releasing the hydraulic lines, the hydraulic oil can escape with high pressure.

Death, severe bodily injuries, property damage.

- ▶ Release the pressure in the hydraulic system before connecting / disconnecting: Interrupt the pressure supply and wait for a short time.
- ▶ Release the hydraulic coupling by hand.
- ▶ Disconnect the hydraulic connections, see Hydraulic diagram.
- ▶ Protect the hydraulic connections from contamination with caps.

6.1.2 Disconnecting the electrical connections

- ▶ Disconnect the electrical connections to the crawler carrier, see Electrical wiring diagram.

6.1.3 Disconnecting the connection to the central lubrication system

- ▶ Disconnect the connection to the central lubrication system.
- ▶ Protect the connections of the central lubrication system with caps from contamination.

6.2 Preparing the crawler carrier for disassembly

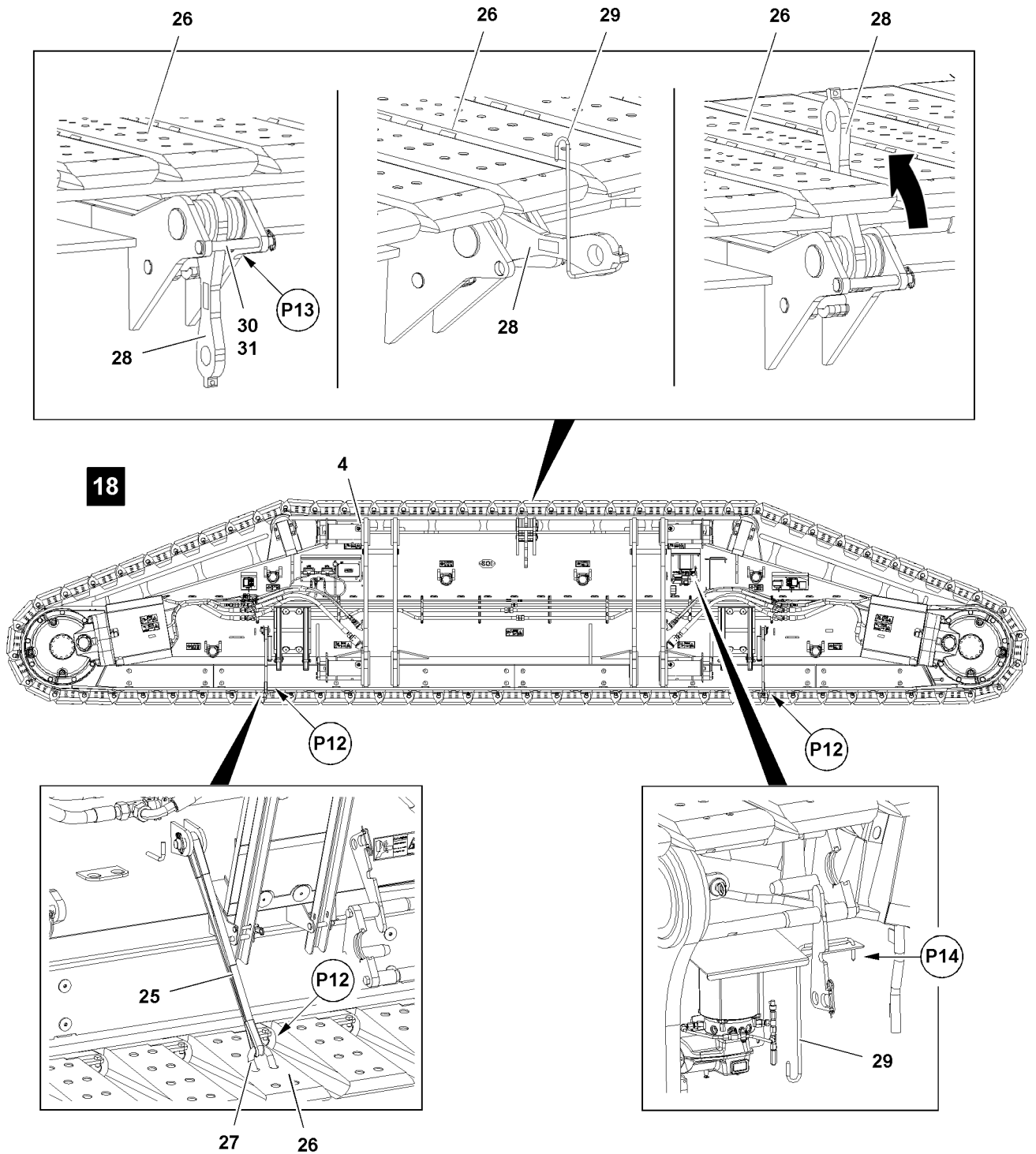

Fig. 126239



WARNING

Danger of falling!

During assembly and disassembly of crane components, personnel must be secured with appropriate aids to prevent them from falling.

Death, severe bodily injuries, property damage.

► Use personal protective equipment.

**Note**

- ▶ Hang in two belts **25** per crawler carrier side.

The track pads **26** must be secured before removal of the crawler carriers with the belts **25** to prevent them from sagging.

- ▶ Hang the belts **25** with the bars **27** on points **P12** on the track pads, see illustration **18**.

**Note**

- ▶ The brackets **28** must be swung in operating position between the track pads **26**, „upward“.

- ▶ Remove the safety locking pin **31** at point **P13** and unpin the pin **30**, see illustration **18**.

**Note**

- ▶ The handle **29** is fastened in transport position at point **P14**.

- ▶ Swing the brackets **28** with the handle **29** up, see illustration **18**.

- ▶ Attach the fastening equipment on the brackets **28** of the crawler carrier.

6.3 Connecting the hydraulic aggregate

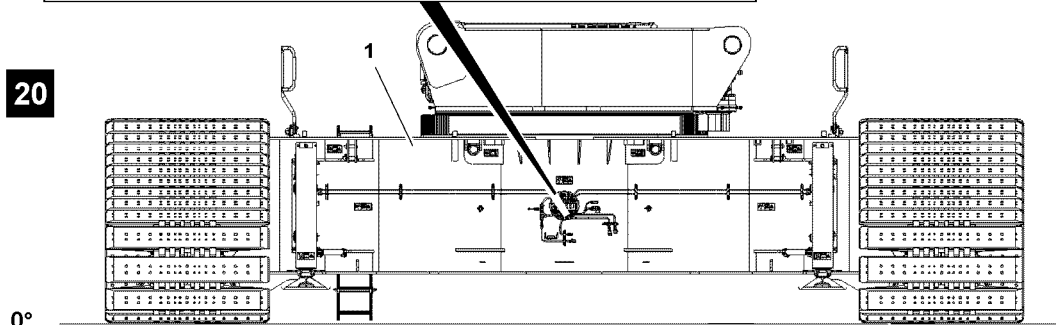
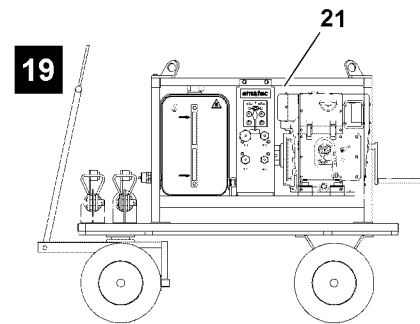
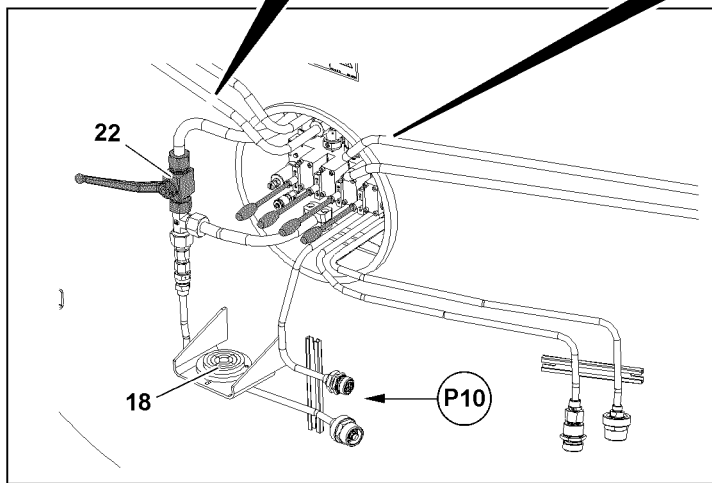
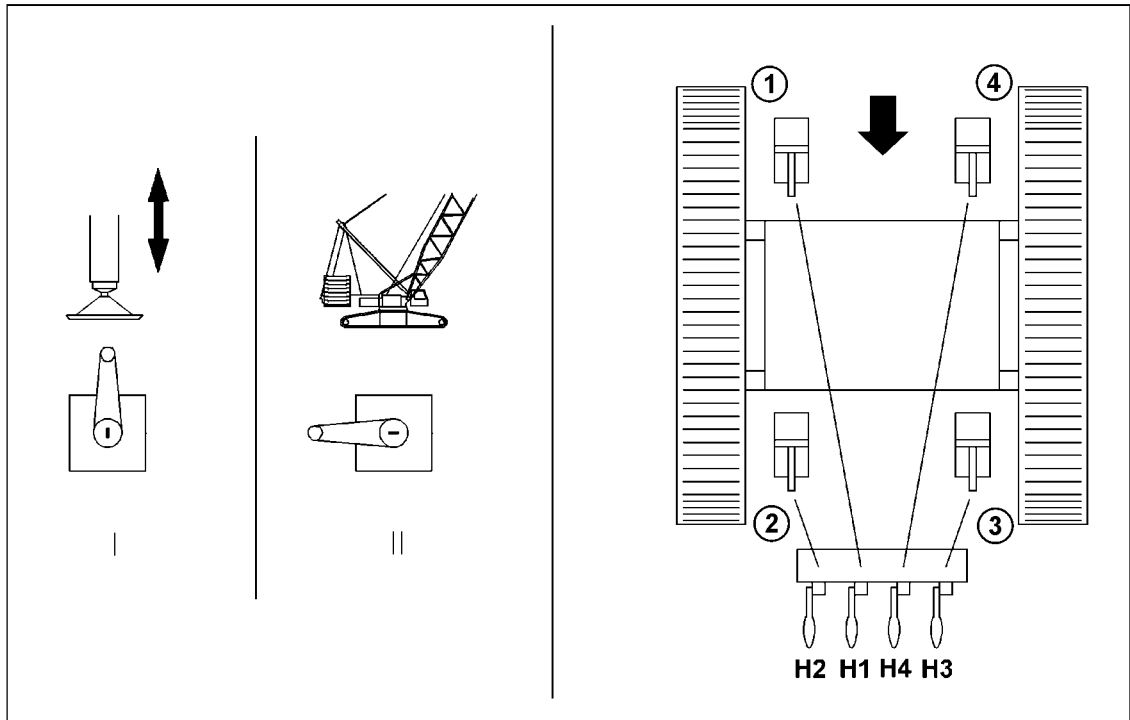

Fig.122264

LWE/LR 11000-001/23501-04-02/en

Make sure that the following prerequisites are met:

- The assembly supports are locked in operating position.
- The support plates are properly locked with the support cylinders.
- The central ballast has been removed.



Note

- ▶ The support cylinders are marked with numbers.
- ▶ Pay attention to the identification on the hand lever and on the support cylinder, see illustration **20**.

Ball valve positions

Position I	Assembly support
Position II	Crane operation / crawler carrier installation with SA-frame

Function assignment of hand levers for the support cylinders

H1	Hand lever for the support cylinder 1 , right rear
H2	Hand lever for support cylinder 2 , right front
H3	Hand lever for support cylinder 3 , left front
H4	Hand lever for support cylinder 4 , left rear



Note

- ▶ Observe the information in the Operating and Maintenance manual of the hydraulic aggregate.
 - ▶ Hydraulic connections from hydraulic aggregate **21** to the crawler center section **1**, see Hydraulic diagram.
-
- ▶ Establish the hydraulic connections from the hydraulic aggregate **21** to the crawler center section **1** at point **P10**, see illustration **20**.

6.4 Lifting the crawler center section with the crawler carriers

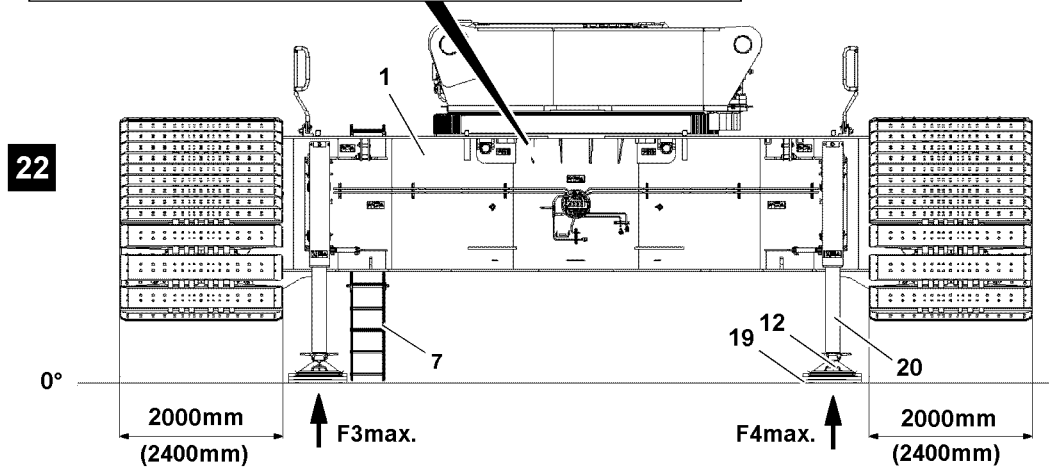
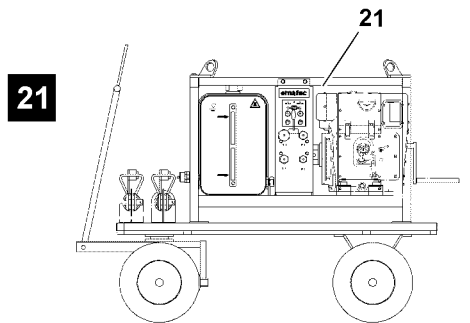
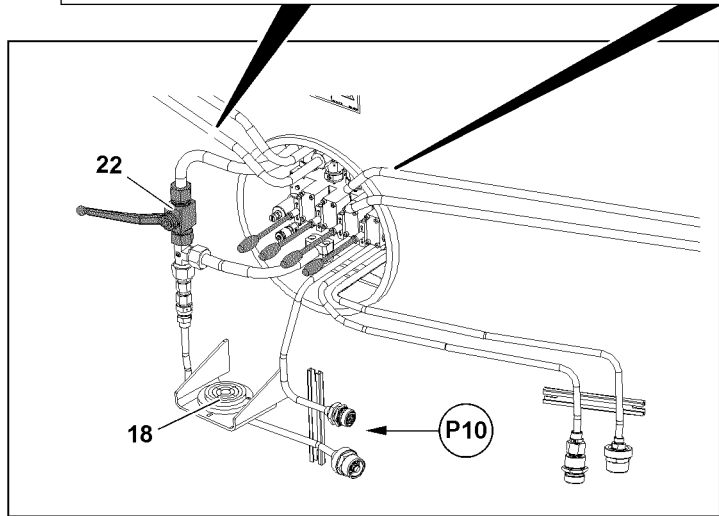
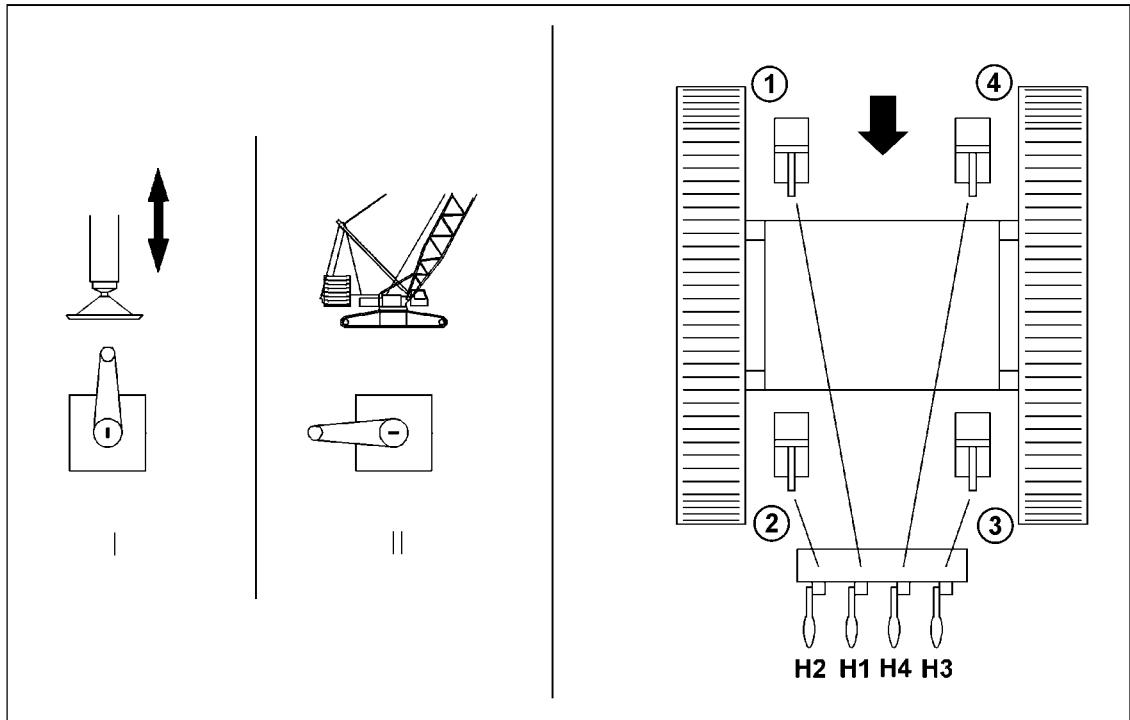

Fig.122271

LWE/LR 11000-001/23501-04-02/en

**WARNING**

The crawler center section can topple over!

Depending on the assembly condition of the crawler center section and the extension condition of the support cylinders, the support forces on the support cylinders can occur up to **114 t**.

Death, severe bodily injuries, property damage.

- ▶ Make sure that the ground under the support cylinders is able to safely take on the occurring support forces.
- ▶ Make sure that the support cylinders are supported from below over a large surface with load bearing materials.
- ▶ Make sure that the support cylinders are moved in and / or out evenly.
- ▶ When supporting or lowering the crawler center section pay attention to horizontal orientation.

- ▶ Turn the hydraulic aggregate **21** on, see illustration **21**.
- ▶ Move the ball valve **22** in position I „assembly support“, see illustration **22**.

NOTICE

Ground pressure!

- ▶ The forces $F3_{max}$ and $F4_{max}$ are calculated for the crawler center section with the turntable frame lower section and track pads with a width of 2400 mm, see illustration **22**.

Crawler center section with two crawler carriers	
Forces	Support force per support
$F3_{max}$	53 t
$F4_{max}$	53 t

**WARNING**

Danger of accidents due to improper supporting base!

If the support plates **12** are not properly supported, then they can sink into the ground.

Death, severe bodily injuries, property damage.

- ▶ The supporting base must be able to safely take on the weight of the crawler center section, the turntable frame lower section and the crawler carrier.
- ▶ The supporting base must be made large enough for the ground conditions, with solid materials, such as wood, steel or concrete slabs, see Crane operating instructions, chapter 2.04.

- ▶ Construct the supporting base **19**, see illustration **22**.
- ▶ Extend the support cylinders completely: Actuate the hand lever **H1**, hand lever **H2**, hand lever **H3** and hand lever **H4**.

Result:

- The support cylinders **20** extend.

**WARNING**

Danger of tipping the crawler center section!

If the support cylinders **20** are moved out unevenly, the crawler center section can tip over.

Death, severe bodily injuries, property damage.

- ▶ When lifting the crawler center section, pay attention to the horizontal alignment, check visually.

**Note**

- ▶ The horizontal alignment of the crawler center section is checked and aligned with the aid of the sight gauge **18**, see illustration **22**.
- ▶ The center of the sight gauge **18** shows the precise incline value.

- ▶ Align the crawler center section horizontally with the aid of the sight gauge **18**, see illustration **22**.
- ▶ Align the extension ladder **7** again, see Crane operating instructions, chapter 2.06.

6.5 Removing the first crawler carrier with the auxiliary crane

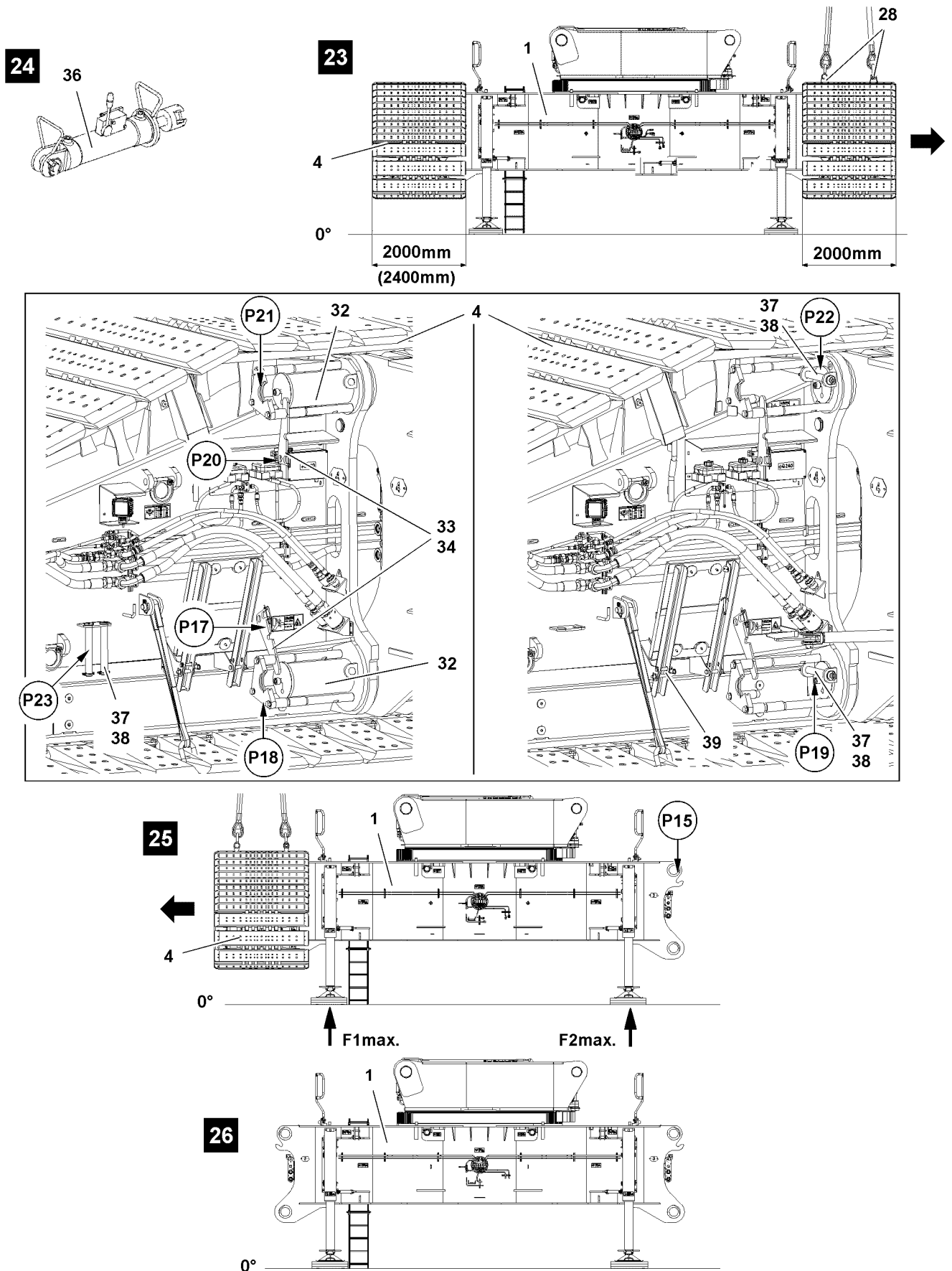

Fig.122272

LWE/LR 11000-001/23501-04-02/en

**Note**

- ▶ For disassembly of the crawler carriers on the crawler center section, the disassembly procedure and the process are identical for both crawler carrier sides.
- ▶ For that reason, the disassembly of the crawler carriers is only described for one side as an example.

**WARNING**

Danger of falling!

During assembly and disassembly of crane components, personnel must be secured with appropriate aids to prevent them from falling.

Death, severe bodily injuries, property damage.

- ▶ Use personal protective equipment.

**WARNING**

Toppling crawler center section!

If the turntable frame lower section is disassembled before disassembly of the crawler carriers on the crawler center section, then the crawler center section can topple over.

Death, severe bodily injuries, property damage.

- ▶ Make sure that the assembly area of the crawler center section is level and of sufficient load bearing capacity.
- ▶ Make sure that the turntable frame lower section remains properly assembled on the crawler center section until both crawler carriers are properly disassembled.

Make sure that the following prerequisites are met:

- The turntable frame lower section is assembled on the crawler center section.
- An auxiliary crane with sufficient load carrying capacity is available.
- The track pads are secured to prevent them from sagging.

- ▶ Attach the fastening equipment on the brackets **28** of the crawler carrier.
- ▶ Tension the fastening equipment, see illustration **23**.
- ▶ Fold the assembly platform **39** down, see Crane operating instructions, chapter 2.06.
- ▶ Release the pin **32**: Remove the safety locking pin **38** and unpin the retaining pin **37** at point **P22**.

**Note**

- ▶ The retaining pins **37** are at point **P23** in park position, see illustration **23**.

- ▶ Insert the retaining pin **37** in park position at point **P23** and secure with safety locking pin **38**.
- ▶ Set the pin pulling cylinder **36**, see illustration **24**, in the pin pulling device at point **P21**.
- ▶ Unpin the pin **32** with the pin pulling cylinder **36** to the stop.
- ▶ Remove the pin pulling cylinder **36**, see illustration **23**.
- ▶ Secure pin **32** in transport position: Remove the spring retainer **34** at point **P20** and swing the retaining bar **33** upward, see illustration **23**.
- ▶ Secure the retaining bar **33** again on point **P20** with spring retainer **34**, see illustration **23**.

Result:

- The pin **32** is secure in transport position.

- ▶ Fold the assembly platform **39** up, see Crane operating instructions, chapter 2.06.
- ▶ Release the pin **32**: Remove the safety locking pin **38** and unpin the retaining pin **37** at point **P19**.
- ▶ Insert the retaining pin **37** in park position at point **P23** and secure with safety locking pin **38**.
- ▶ Set the pin pulling cylinder **36** in the pin pulling device at point **P18**.
- ▶ Unpin the pin **32** with the pin pulling cylinder **36** to the stop.
- ▶ Remove the pin pulling cylinder **36**, see illustration **23**.
- ▶ Secure pin **32** in transport position: Remove the spring retainer **34** at point **P17** and swing the retaining bar **33** downward, see illustration **23**.
- ▶ Secure the retaining bar **33** again on point **P17** with spring retainer **34**, see illustration **23**.

Result:

- The pin **32** is secure in transport position.

- ▶ Unpin the crawler carrier **4** on the other crawler carrier side.

NOTICE

Ground pressure!

- ▶ The forces $F1_{max}$ and $F2_{max}$ are calculated for the crawler center section with the turntable frame lower section and track pads with a width of 2400 mm, see illustration **23** and illustration **25**.

Crawler center section with one crawler carrier	
Forces	Support force per support
$F1_{max}$	61 t
$F2_{max}$	9 t

- ▶ Lift the crawler carrier **4** with the auxiliary crane.

When the crawler carrier is raised above the hook points at point **P15**:

- ▶ Swing the crawler carrier **4** out.
- ▶ Set the crawler carrier **4** down.
- ▶ Remove the fastening equipment.
- ▶ Swing the brackets **28** down, see section „Preparing the crawler carrier for assembly“.

6.6 Removing the second crawler carrier with the auxiliary crane

**Note**

- ▶ For disassembly of the crawler carriers on the crawler center section, the disassembly procedure and the process are identical for both crawler carriers.
- ▶ For that reason, the disassembly of the crawler carrier is only described for crawler carrier as an example.

**WARNING**

Danger of falling!

During assembly and disassembly of crane components, personnel must be secured with appropriate aids to prevent them from falling.

Death, severe bodily injuries, property damage.

- ▶ Use personal protective equipment.

Make sure that the following prerequisite is met:

- The first crawler carrier has been removed.
- ▶ Remove the second crawler carrier, see section „Removing the first crawler carrier with the auxiliary crane“.

6.7 Supporting the crawler center section

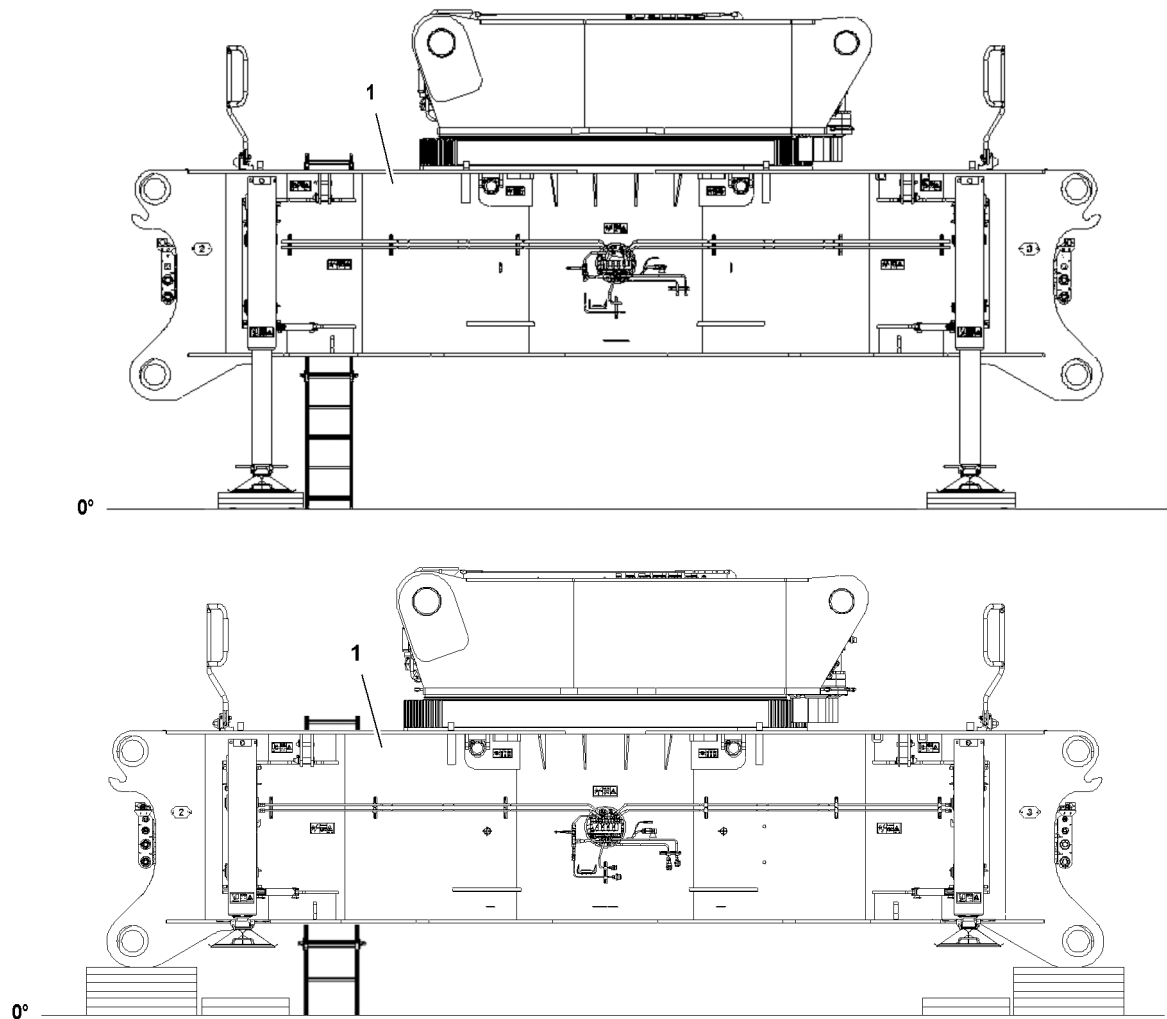

Fig.126238

Make sure that the following prerequisites are met:

- The crawler carriers are completely disassembled.
 - The disassembly location is level and sufficiently load bearing.
- Support the crawler center section, see section „Disassembling the crawler center section“.

6.8 Lowering the crawler center section on the supporting base



WARNING

Danger of accidents due to improper supporting base!

If the crawler center section is not properly supported, then it can sink into the ground. Death, severe bodily injuries, property damage.

- The supporting base must safely take on the weight of the crawler center section.
- The supporting base must be made large enough for the ground conditions, with solid materials, such as wood, steel or concrete slabs, see Crane operating instructions, chapter 2.04.



WARNING

Danger of tipping over!

If the support cylinders are moved out unevenly, the crawler center section can tip over. Death, severe bodily injuries, property damage.

- When lifting the crane, pay attention to the horizontal alignment, check visually.

Make sure that the following prerequisite is met:

- The crawler center section 1 is supported from below.
- ▶ Lower the crawler center section on the supporting base, see section „Disassembling the crawler center section“.

6.9 Disassembling the turntable frame lower section with the QC on the crawler center section with QC

Make sure that the following prerequisites are met:

- The crawler carriers are properly disassembled on the crawler center section.
- The crawler center section is properly supported from below.
- The support cylinders have been fully retracted.

6.9.1 Disassembling the drawbars of the rotary connection on the turntable frame lower section

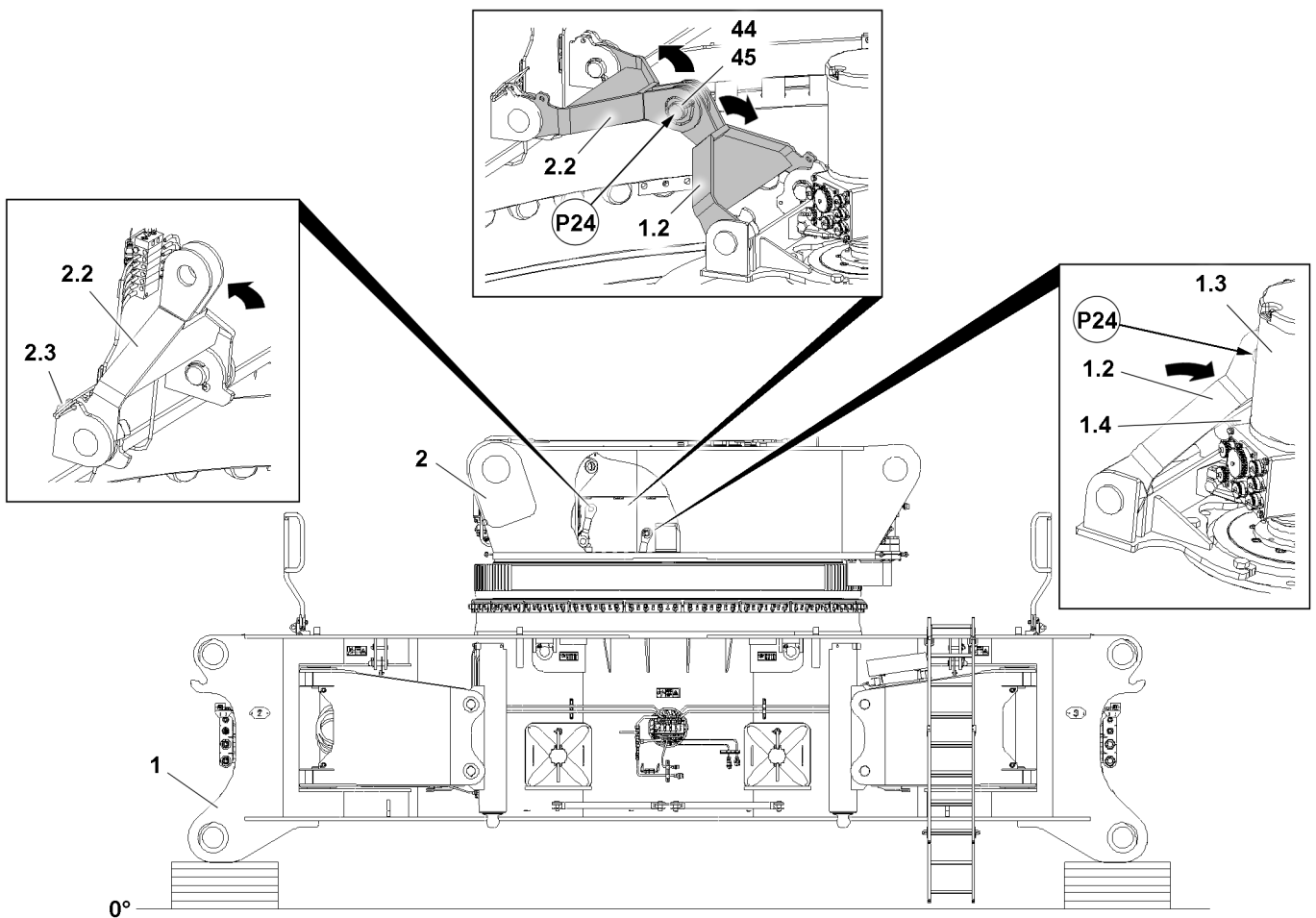

Fig.126168: Disassembling the drawbars of the rotary connection on the turntable frame lower section



WARNING

Danger of crushing!

When unpinning the drawbars, they can fold down and crush fingers and hands.

- ▶ Make sure that the drawbars are safely held in position before unpinning.
- ▶ Unpin the drawbars: Remove the locking pin 45 at point P24 and unpin the pin 44.

When the drawbars are unpinned:

- ▶ Fold the drawbar 1.2 up in transport position (see arrow).

- ▶ Secure the drawbar **1.2** in transport position with spring retainer **1.4**.

When the drawbars are unpinned:

- ▶ Fold the drawbar **2.2** up in transport position (see arrow).
- ▶ Secure the drawbar **2.2** in transport position with spring retainer **2.3**.
- ▶ Insert the pins **44** in the drawbar at point **P24** and secure with locking pin **45**.

Result:

- The drawbars between the turntable frame lower section **2** and rotary connection **1.3** are in transport position.

6.9.2 Unpinning the Quick Connection

Make sure that the following prerequisite is met:

- The drawbars between the turntable frame lower section **2** and rotary connection **1.3** are in transport position.

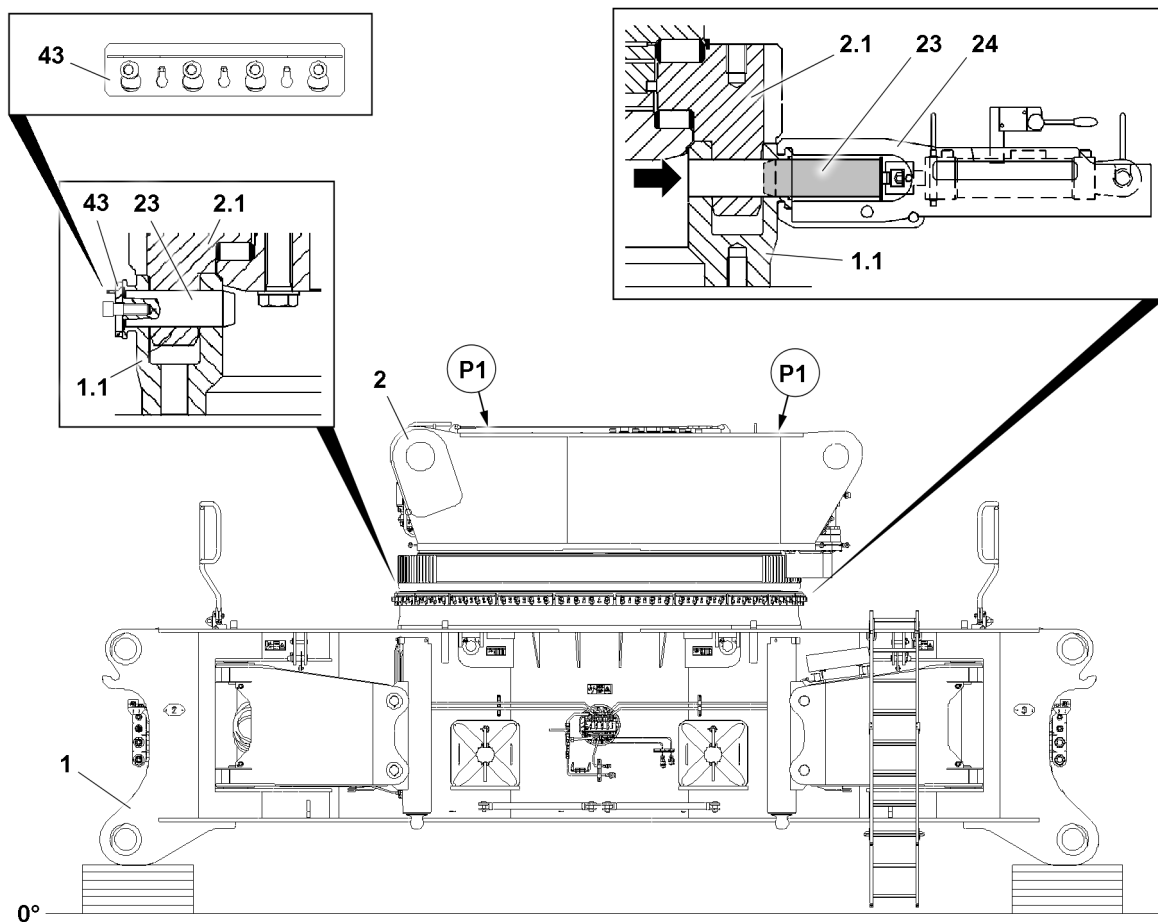

Fig.126169: Unpinning the Quick Connection

- ▶ Properly fasten the turntable frame lower section **2** on the fastening points **P1** on the auxiliary crane, see also section „Fastening points“.



WARNING

Tipping turntable frame lower section!

During the disassembly of the turntable frame lower section **2** the turntable frame lower section **2** can tip over and fall down.

Death, severe bodily injuries, property damage.

- ▶ Make sure that the fastening equipment between the turntable frame lower section **2** and auxiliary crane is tensioned before the pins of the QC are unpinned.

**DANGER**

Danger of accident!

Death, severe bodily injuries, property damage.

- ▶ It is prohibited for anyone to remain within the danger range of the auxiliary crane and under the turntable frame lower section **2** when lifting and swinging the turntable frame lower section **2** out.
- ▶ Swing the turntable frame lower section **2** out slowly with the auxiliary crane after unpinning the QC.

When the turntable frame lower section **2** is properly fastened on the auxiliary crane:

- ▶ Carefully bring the fastening equipment to „tension“.

When the fastening equipment is tensioned:

- ▶ Remove the retaining bar **43** on the circumference of the QC.
- ▶ Unpin the pin **23** of the QC with the pin pulling device **24**.

When all pins **23** of the QC are properly unpinned:

- ▶ Lift the turntable frame lower section **2** with the auxiliary crane from the crawler center section.
- ▶ Swing the turntable frame lower section **2** out with the auxiliary crane and set it properly on a load bearing support base or on a flatbed trailer.
- ▶ Remove the auxiliary crane.

6.10 Removing the hydraulic aggregate

Make sure that the following prerequisite is met:

- The crawler center section **1** is set down on the supporting base.
- ▶ Remove the hydraulic aggregate, see section „Disassembling the crawler center section“.

6.11 Disassembling the assembly support

- ▶ Remove the assembly support, see section „Disassembling the crawler center section“.

7 Assembly of the crawler carrier with SA-frame



WARNING

Danger of falling!

During assembly / disassembly, inspection and maintenance work, personnel must be secured with appropriate aids to prevent them from falling.

Death, severe bodily injuries, property damage.

- ▶ All work aloft, where there is a danger of falling must be carried out with suitable aids.
- ▶ If aids are not available and work cannot be carried out from the ground, then the assembly personnel must secure themselves with the supplied fall arrest system to prevent falling, see Crane operating instructions, chapter 2.04.
- ▶ If fall protection equipment is available, then it must be used, see Crane operating instructions, chapter 2.06.
- ▶ When lifting, lowering, swinging crane parts in and out, no persons may remain in the danger zone.
- ▶ If railings are present for the crane, then they must be brought into the corresponding position and secured for assembly / disassembly work.
- ▶ It is prohibited to lean the auxiliary ladder against the component being disassembled.
- ▶ Only step on the aids, ladders and catwalks with clean shoes.
- ▶ Keep aids, ladders and catwalks free of heavy dirt, snow, frost and ice.
- ▶ During all assembly and disassembly work, maintenance work and inspections, travel or crane operation is prohibited.
- ▶ Remaining on a suspended load is prohibited.
- ▶ Stepping or walking on crane components and lattice sections, which have an incline of more than 20° is prohibited.
- ▶ For all assembly work, the crane operator of the main crane must be in voice contact with the crane operator / crane operators of the auxiliary crane / auxiliary cranes.
- ▶ For assembly / disassembly tasks, the crane operator may only initiate crane movements when the responsible guide has explicitly released the movement.



WARNING

Danger of impact / crushing!

When installing / removing crane components with the auxiliary crane, crane components can start to swing back and forth.

When lifting / lowering and positioning crane components, there is an increased danger of impacts / crushing.

Death, severe bodily injuries, property damage.

- ▶ Make sure that personnel cannot be caught by components.
- ▶ When working in danger zones: Use aids to protect limbs.
- ▶ Guide components with suitable aids to minimize oscillation.



DANGER

The components can fall down!

If the corresponding component is disengaged from the auxiliary crane before the corresponding component is pinned, then the corresponding component can fall down.

Death, severe bodily injuries, property damage.

- ▶ Do not disengage the auxiliary crane until the respective component is pinned and secured.

7.1 Assembly of the crawler carrier with SA-frame

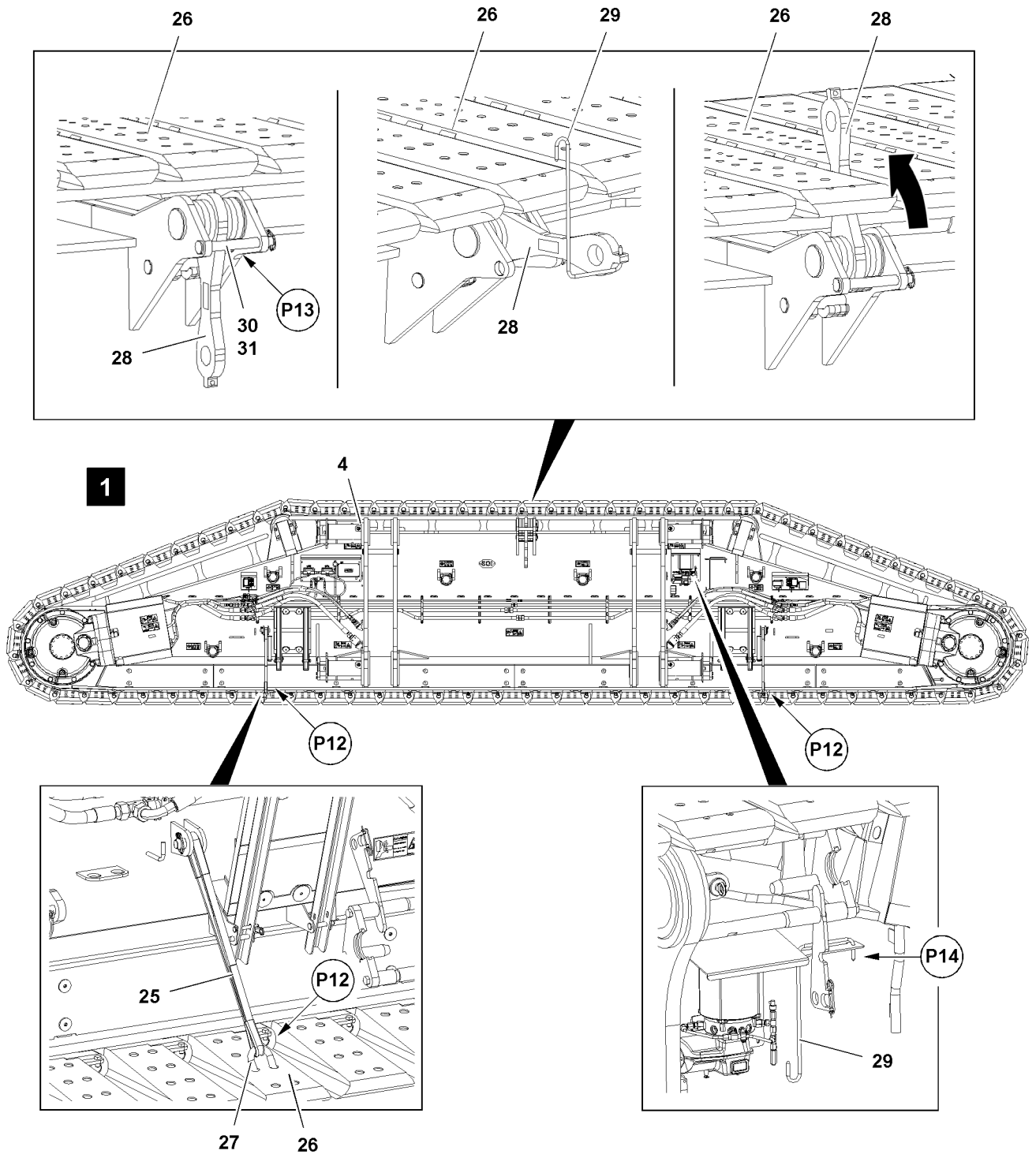

Fig.126237

7.1.1 Preparing the crawler carrier for assembly

Make sure that the following prerequisite is met:

- The placement location must be level and have adequate load-bearing capacity.

LWE/LR 11000-001/23501-04-02/en

**WARNING**

Danger of accidents due to improper supporting base!
If the crane is not properly supported, then it can sink into the ground.
Death, severe bodily injuries, property damage.

- ▶ The supporting base must be able to safely take on the weight of the crawler carrier, the turntable and the crawler center section.
- ▶ The supporting base must be made large enough for the ground conditions, with solid materials, such as wood, steel or concrete slabs, see Crane operating instructions, chapter 2.04.

**WARNING**

Danger of falling!
During assembly and disassembly of crane components, personnel must be secured with appropriate aids to prevent them from falling.
Death, severe bodily injuries, property damage.

- ▶ Use personal protective equipment.

**Note**

- ▶ Hang in two belts **25** per crawler carrier side.

The track pads **26** must be secured before assembly of the crawler carriers with the belts **25** to prevent sag.

- ▶ Hang the belts **25** with the bars **27** on points **P12** on the track pads, see illustration 1.

**Note**

- ▶ The brackets **28** must be swung in operating position between the track pads **26**, „upward“.
- ▶ Remove the safety locking pin **31** at point **P13** and unpin the pin **30**, see illustration 1.

**Note**

- ▶ The handle **29** is fastened in transport position at point **P14**.
- ▶ Swing the brackets **28** with the handle **29** up, see illustration 1.

7.1.2 Installing the first crawler carrier with SA-frame

**WARNING**

The crane can topple over!
Depending on the assembly condition of the crane and the extension condition of the support cylinders, the support forces on the support cylinders can occur up to **114 t**.
Death, severe bodily injuries, property damage.

- ▶ Make sure that the ground under the support cylinders is able to safely take on the occurring support forces.
- ▶ Make sure that the support cylinders are supported from below over a large surface with load bearing materials.
- ▶ Make sure that the support cylinders are moved in and / or out evenly.
- ▶ When supporting or lowering the crawler center section pay attention to horizontal orientation.

**Note**

- ▶ Note the identification on the crawler carrier and the crawler center section.
- ▶ The crawler carrier and the crawler center section are marked with numbers.

**Note**

- ▶ For assembly of the crawler carriers on the crawler center section, the assembly procedure and the process are identical for both crawler carrier sides.
- ▶ For that reason, the assembly of the crawler carrier is only described for one side as an example.

**WARNING**

Danger of falling!

During assembly and disassembly of crane components, personnel must be secured with appropriate aids to prevent them from falling.

Death, severe bodily injuries, property damage.

- ▶ Use personal protective equipment.

NOTICE

Damage to crane!

If the following instructions are not observed, the crane can be severely damaged when unloading the crawler carrier.

- ▶ The specifications in the load charts SA-operation must be adhered to.

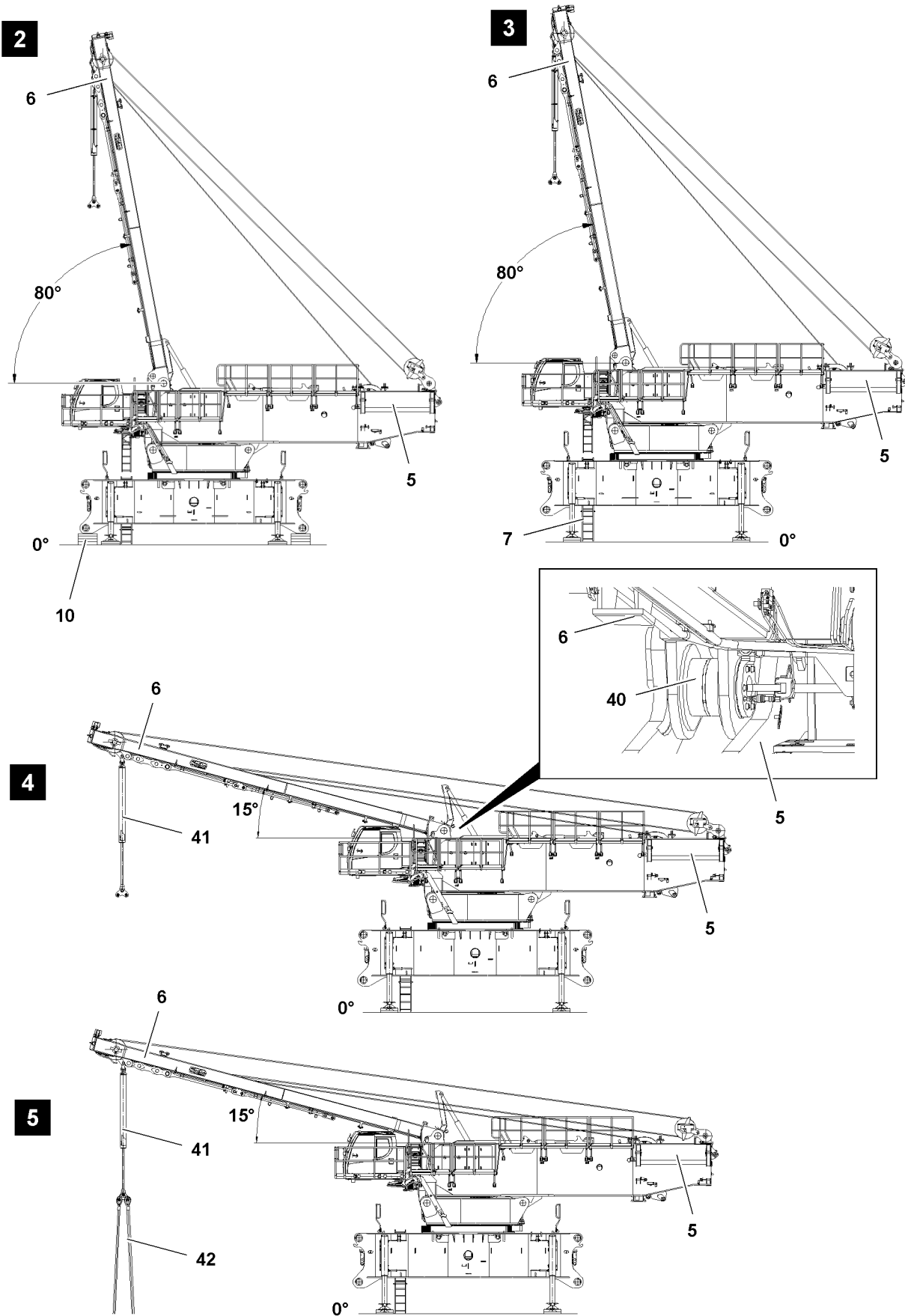

Fig.126221: Installing the first crawler carrier with SA-frame

Make sure that the following prerequisites are met:

- The track pads of the crawler carrier are secured to prevent them from sagging.

- The turntable is properly installed and secured on the crawler center section, see Crane operating instructions, chapter 3.02.
- The maximum height of the transport vehicle of the crawler carriers may not exceed 1000 mm.
- The operating mode „SA-frame“ has been set and confirmed on the LICCON computer system.
- The SA-frame is erected to approx. 80°, see Crane operating instructions, chapter 5.02.
- Observe the SA-frame angle display on the LICCON monitor, see Crane operating instructions, chapter 4.02

**Note**

- ▶ External hydraulic aggregate: Function assignment for the hand lever on the crawler center section for extending / retracting the support cylinders, see section „Lifting the crawler center section“.

**WARNING**

Danger of tipping the crane!

If the support cylinders are moved out unevenly, the crane can tip over.

Death, severe bodily injuries, property damage.

- ▶ When lifting the crane, pay attention to the horizontal alignment, check visually.

- ▶ Lift the crane.
- ▶ Align crane horizontally.
- ▶ Remove the supporting base **10**, see illustration **3**.
- ▶ Align the extension ladder **7** again, see illustration **3**, see Crane operating instructions, chapter 2.06.

NOTICE

Damage to crane!

When luffing the SA-frame **6** down to 15°, there is the danger that the connector pins **40** of the derrick boom will collide with the turntable frame main section **5**.

The SA-frame **6** can be damaged by a collision resulting in high repair costs.

- ▶ Make sure, when luffing the SA-frame down to 15° that the connector pins **40** of the derrick boom are pinned.

When the connector pins **40** are pinned:

- ▶ Luff the SA-frame **6** forward to 15°, see illustration **4**.

**Note**

- ▶ The pull cylinder **41** may not be moved out all the way.
- ▶ If the pull cylinder **41** is completely extended and the limit switch position is reached, an error display occurs on the LICCON monitor and the LMB stop.

- ▶ Move the pull cylinder **41** out.
- ▶ Pin and secure the fastening equipment **42** on the pull cylinder **41**, see illustration **5**.

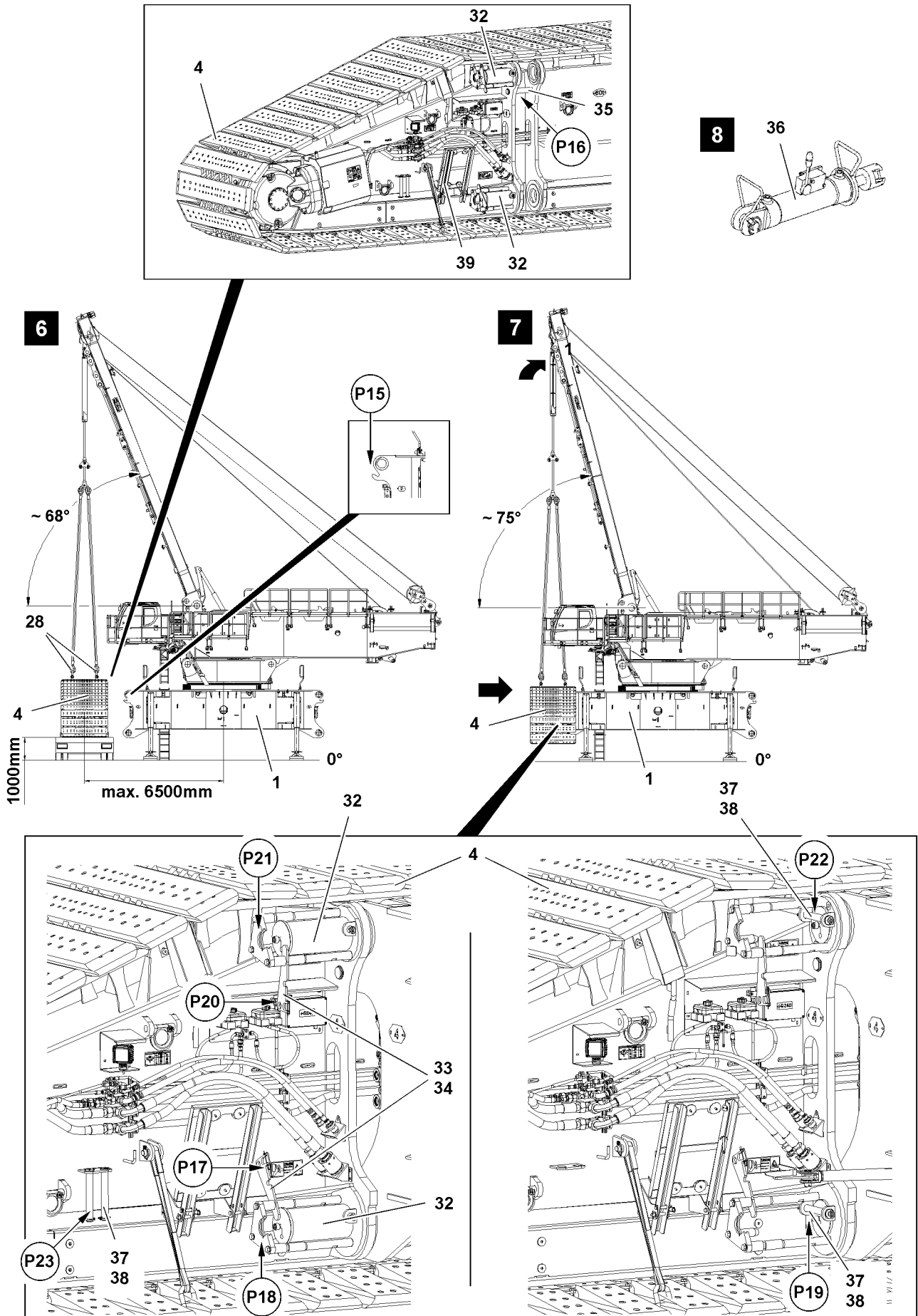

Fig.126222

LWE/LR 11000-001/23501-04-02/en

**WARNING**

Danger of tipping over!

If the following instructions are not observed, the crane can tip over at assembly.

Death, severe bodily injuries, property damage.

- ▶ The maximum permissible distance of 6500 mm between the crawler carrier and the center of the turntable may not be exceeded.

- ▶ Attach the fastening equipment on the brackets **28** of the crawler carrier, see illustration **6**.
- ▶ Carefully swing crawler carrier **4** with the auxiliary crane up to the pin points on the crawler center section **1**.
- ▶ Hang the crawler carrier **4** with centering pins **35** at points **P16** on the centerings at points **P15** on the crawler center section **1**, see illustration **6** and illustration **7**.
- ▶ Release the pin **32** from transport position: Remove the spring retainer **34** at point **P17** and swing the retaining bar **33** upward, see illustration **7**.
- ▶ Insert the spring retainer **34** again on point **P17**.
- ▶ Connect the pin pulling cylinder **36** in the hydraulic supply line or on the hydraulic aggregate, see illustration **8**.
- ▶ Set the pin pulling cylinder **36** in the pin pulling device at point **P18**.
- ▶ Insert the pin **32** with the pin pulling cylinder **36** to the stop.
- ▶ Remove the pin pulling cylinder **36**, see illustration **7**.

**Note**

- ▶ The retaining pins **37** are at point **P23** in park position, see illustration **7**.

- ▶ Remove the safety locking pin **38** and unpin the retaining pin **37** from the park position at point **P23**.

**WARNING**

The pin is not secured!

If the retaining pins **37** are not secured, the retaining pins can loosen up by themselves during crane operation.

This can cause the crane to topple over.

Death, severe bodily injuries, property damage.

- ▶ Make sure that the retaining pins **37** are secured with safety locking pin **38**.

- ▶ Secure the pins **32**: Insert the retaining pin **37** at point **P19** and secure with safety locking pin **38**.
- ▶ Fold the assembly platform **39** down, see Crane operating instructions, chapter 2.06.
- ▶ Release the pin **32** from transport position: Remove the spring retainer **34** at point **P20** and swing the retaining bar **33** downward, see illustration **7**.
- ▶ Reinstall the spring retainer **33** again at point **P20**, see illustration **7**.
- ▶ Set the pin pulling cylinder **36** in the pin pulling device at point **P21**.
- ▶ Insert the pin **32** with the pin pulling cylinder **36** to the stop.
- ▶ Remove the pin pulling cylinder **36**, see illustration **7**.

**Note**

- ▶ The retaining pins are at point **P23** in park position, see illustration **7**.

- ▶ Remove the safety locking pin **38** and unpin the retaining pin **37** from the park position at point **P23**.

**WARNING**

The pin is not secured!

If the retaining pins **37** are not secured, the retaining pins can loosen up by themselves during crane operation.

This can cause the crane to topple over.

Death, severe bodily injuries, property damage.

- ▶ Make sure that the retaining pins **37** are secured with safety locking pin **38**.

- ▶ Secure the pins **32**: Insert the retaining pin **37** at point **P22** and secure with safety locking pin **38**, see illustration **7**.
- ▶ Pin the crawler carrier **4** on the other crawler carrier side with the crawler center section.
- ▶ Remove the fastening equipment.

NOTICE

Damage to the brackets!

- ▶ After removing the fastening equipment, the brackets **28** must be swung down.
-
- ▶ Swing the brackets **28** down, see section „Preparing the crawler carrier for assembly“.

7.1.3 Installing the second crawler carrier with SA-frame

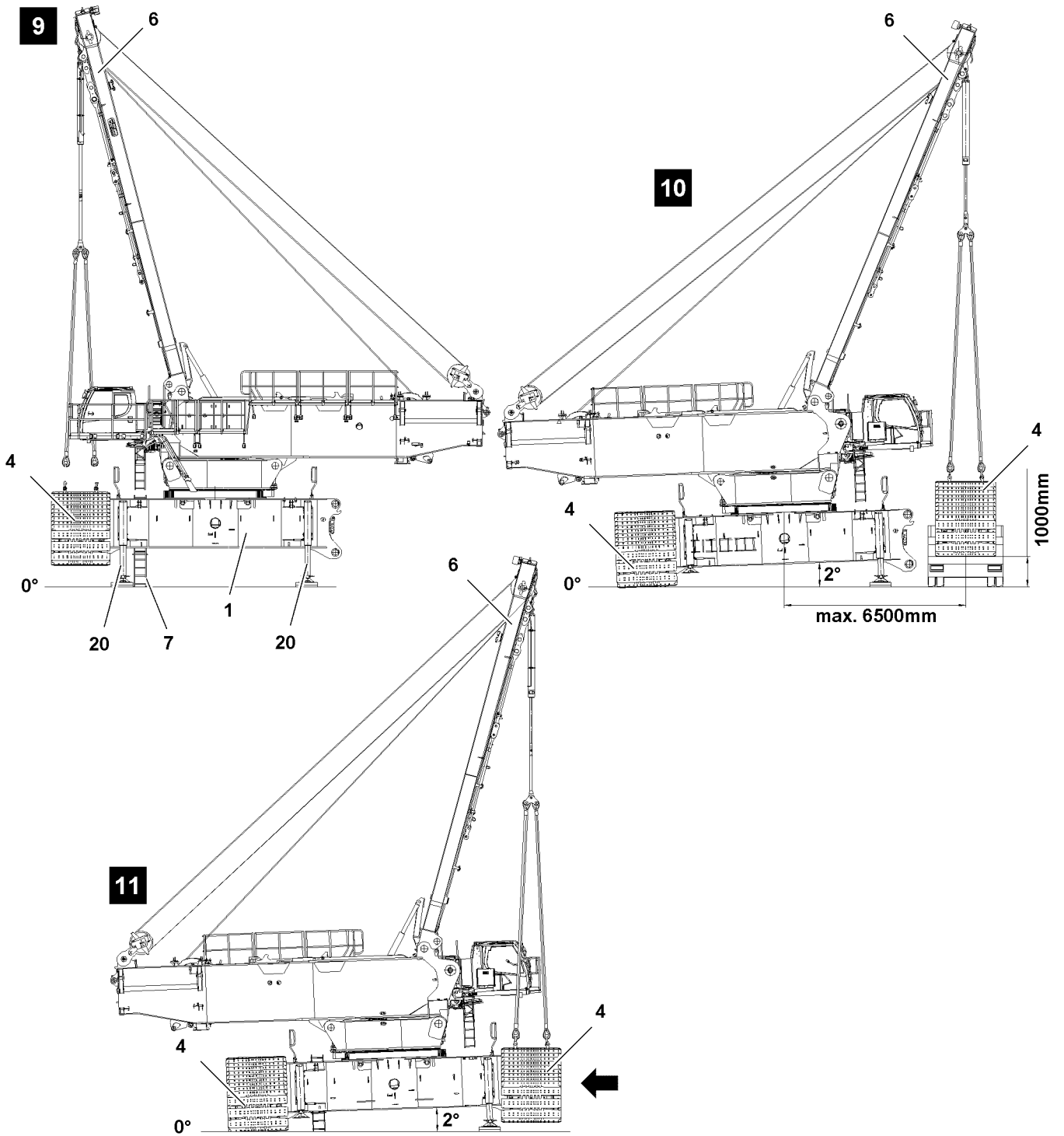

Fig.126223: Installing the second crawler carrier with SA-frame

LWE/LR 11000-001/23501-04-02/en

**WARNING**

The crane can topple over!

Depending on the assembly condition of the crane and the extension condition of the support cylinders, the support forces on the support cylinders can occur up to **114 t**.

Death, severe bodily injuries, property damage.

- ▶ Make sure that the ground under the support cylinders is able to safely take on the occurring support forces.
- ▶ Make sure that the support cylinders are supported from below over a large surface with load bearing materials.
- ▶ Make sure that the support cylinders are moved in and / or out evenly.
- ▶ When supporting or lowering the crawler center section pay attention to horizontal orientation.

Make sure that the following prerequisite is met:

- The first crawler carrier **4** is pinned and secured on the crawler center section **1**, see illustration **9**.

**Note**

- ▶ For assembly of the crawler carriers on the crawler center section, the assembly procedure and the process are identical for both crawler carriers.
- ▶ For that reason, the assembly of the crawler carrier is only described for crawler carrier as an example.

**WARNING**

The crane can tip over!

If the support cylinders are moved out / in unevenly, the crane can tip over.

Death, severe bodily injuries, property damage.

- ▶ When moving the support cylinders **20** in / out, pay attention to the horizontal alignment, check visually.
- ▶ Move the support cylinders **20** in evenly until the first crawler carrier is standing on the ground.

When the first crawler carrier is standing on the ground:

- ▶ Move the support cylinder **20** on the side of the already installed crawler carrier all the way in.
- ▶ Move the opposite support cylinders out again until the angle between the ground and the crawler center section is approx. 2°.

**WARNING**

Danger of tipping over!

Before turning the turntable, if the first assembled crawler carrier is not positioned on the ground, there is a danger of tipping over.

Death, severe bodily injuries, property damage.

- ▶ The support cylinders on the side of the already installed crawler carrier have to be moved in all the way.
- ▶ Turn the turntable by 180°, see illustration **10**.
- ▶ Align the extension ladder **7** again, see Crane operating instructions, chapter 2.06.

**WARNING**

Danger of tipping over!

If the following instructions are not observed, the crane can tip over at assembly.

Death, severe bodily injuries, property damage.

- ▶ The maximum permissible distance of 6500 mm between the crawler carrier and the center of the turntable may not be exceeded.
- ▶ Install the second crawler carrier, see illustration **10** and illustration **11**, see section „Installing the first crawler carrier with SA-frame“.

7.1.4 Lowering the crane

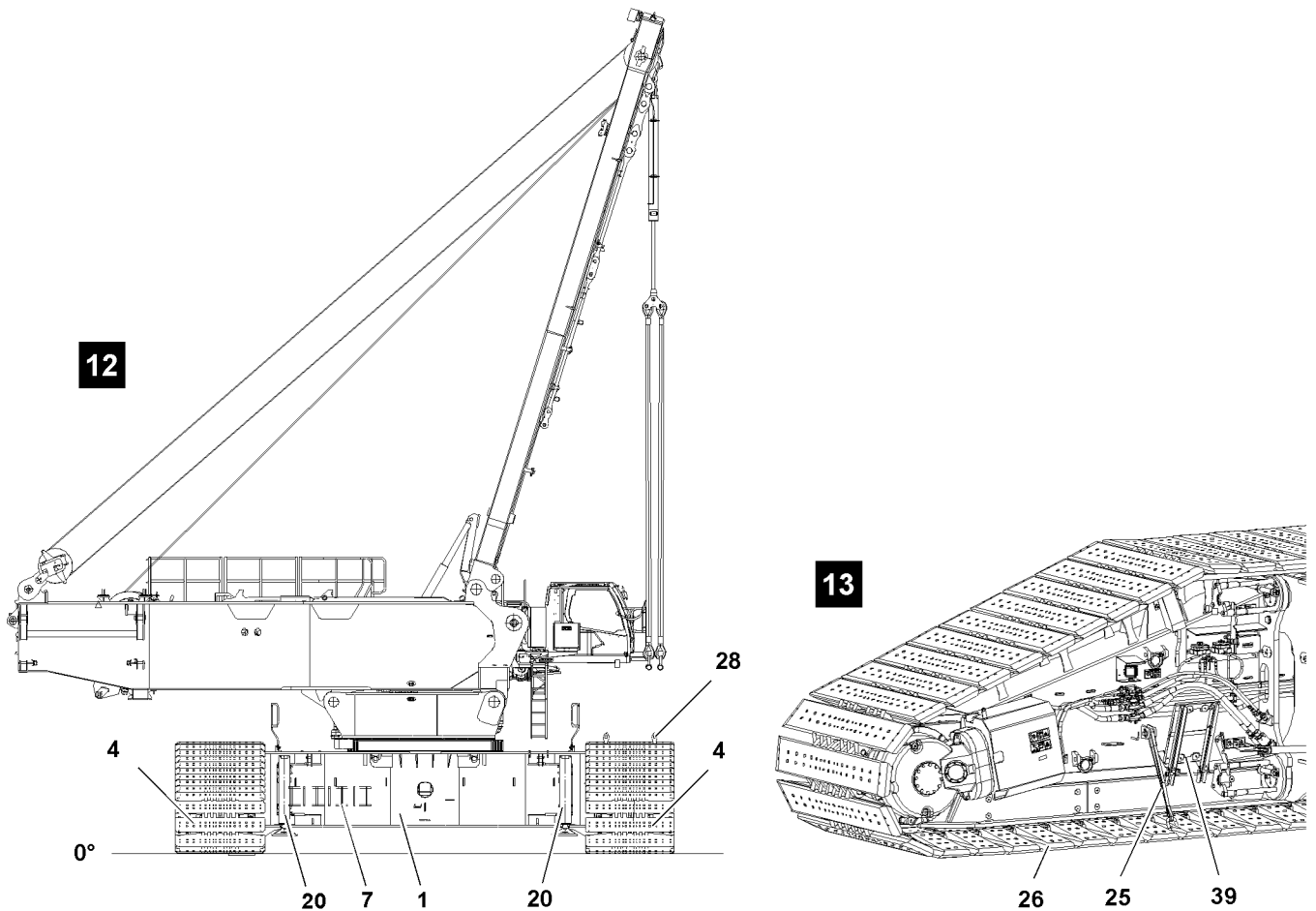

Fig.126224



WARNING

Danger of accidents due to improper supporting base!
Death, severe bodily injuries, property damage.

- ▶ The supporting base must take on the weight of the crane safely.
- ▶ The supporting base must be made large enough for the ground conditions, with solid materials, such as wood, steel or concrete slabs, see Crane operating instructions, chapter 2.04.



Note

- ▶ External hydraulic aggregate: Function assignment for the hand lever on the crawler center section for extending / retracting the support cylinders, see section „Lifting the crawler center section“.

NOTICE

Environmental pollution due to hydraulic oil!

When retracting the assembly support, if a hydraulic aggregate with full hydraulic oil tank is used, then the hydraulic oil tank on the hydraulic aggregate can be flooded when retracting the assembly support. Hydraulic oil can escape causing severe environmental pollution.

- ▶ Make sure that the hydraulic oil tank on the hydraulic aggregate has sufficient capacity to be able to safely take on the hydraulic oil of the assembly support.
- ▶ Make sure that the extension and retraction of the assembly support is carried out solely with the same hydraulic aggregate.
- ▶ Make sure that suitable measures are made to prevent an oil spill in the environment.

Make sure that the following prerequisite is met:

- The second crawler carrier **4** is pinned and secured on the crawler center section **1**.
- ▶ Move the support cylinders **20** in all the way.

Result:

- Both crawler carriers **4** are standing on the ground, see illustration **12**.
- ▶ Remove the fastening equipment.

NOTICE

Damage to the brackets!

- ▶ After removing the fastening equipment, the brackets **28** must be swung down.
- ▶ Swing the brackets **28** down, see section „Preparing the crawler carrier for assembly“.
- ▶ Fasten the extension ladder **7** in park position, see illustration **12**, see Crane operating instructions, chapter 2.06.
- ▶ Disengage the belts **25** on the track pads **26**, see illustration **13**.
- ▶ Fold the assembly platforms **39** up again into transport position, see Crane operating instructions, chapter 2.06 and illustration **13**.

7.1.5 Establishing the connections to the crawler carriers

Make sure that the following prerequisite is met:

- Both crawler carriers are properly installed, pinned and secured.

Establishing the hydraulic connections

The hydraulic connections are made with quick couplings.

When connecting hydraulic lines with quick couplings, make sure that the coupling procedure is carried out correctly.



WARNING

Pressure in the hydraulic lines!

If the pressure supply is not interrupted before connecting / releasing the hydraulic lines, the hydraulic oil can escape with high pressure.

Death, severe bodily injuries, property damage.

- ▶ Release the pressure in the hydraulic system before connecting / disconnecting: Interrupt the pressure supply and wait for a short time.



WARNING

Loss of pressure or leakage!

Incorrectly coupled or self-loosening quick couplings (particularly return lines) can result in serious accidents due to component failure.

- ▶ Check that the quick couplings have been properly connected before using the crane.
- ▶ Connect the coupling components (sleeve and connector) and screw together with the hand-tightened nut.
- ▶ Tighten the hydraulic coupling by hand. Rotate the hand-tightened nut until it reaches a tangible, fixed stop position.
- ▶ Establish the hydraulic connections, see Hydraulic diagram.

Establishing the electrical connections

- ▶ Establish the electrical connections, see Electric wiring diagram.

Establishing the connections to the central lubrication system

- ▶ Establish the connections to the central lubrication system.

8 Disassembly of the crawler carrier with SA-frame



WARNING

Danger of falling!

During assembly / disassembly, inspection and maintenance work, personnel must be secured with appropriate aids to prevent them from falling.

Death, severe bodily injuries, property damage.

- ▶ All work aloft, where there is a danger of falling must be carried out with suitable aids.
- ▶ If aids are not available and work cannot be carried out from the ground, then the assembly personnel must secure themselves with the supplied fall arrest system to prevent falling, see Crane operating instructions, chapter 2.04.
- ▶ If fall protection equipment is available, then it must be used, see Crane operating instructions, chapter 2.06.
- ▶ When lifting, lowering, swinging crane parts in and out, no persons may remain in the danger zone.
- ▶ If railings are present for the crane, then they must be brought into the corresponding position and secured for assembly / disassembly work.
- ▶ It is prohibited to lean the auxiliary ladder against the component being disassembled.
- ▶ Only step on the aids, ladders and catwalks with clean shoes.
- ▶ Keep aids, ladders and catwalks free of heavy dirt, snow, frost and ice.
- ▶ During all assembly and disassembly work, maintenance work and inspections, travel or crane operation is prohibited.
- ▶ Remaining on a suspended load is prohibited.
- ▶ Stepping or walking on crane components and lattice sections, which have an incline of more than 20° is prohibited.
- ▶ For all assembly work, the crane operator of the main crane must be in voice contact with the crane operator / crane operators of the auxiliary crane / auxiliary cranes.
- ▶ For assembly / disassembly tasks, the crane operator may only initiate crane movements when the responsible guide has explicitly released the movement.



WARNING

Danger of impact / crushing!

When installing / removing crane components with the auxiliary crane, crane components can start to swing back and forth.

When lifting / lowering and positioning crane components, there is an increased danger of impacts / crushing.

Death, severe bodily injuries, property damage.

- ▶ Make sure that personnel cannot be caught by components.
- ▶ When working in danger zones: Use aids to protect limbs.
- ▶ Guide components with suitable aids to minimize oscillation.



DANGER

The components can fall down!

If the corresponding component is disengaged from the auxiliary crane before the corresponding component is pinned, then the corresponding component can fall down.

Death, severe bodily injuries, property damage.

- ▶ Do not disengage the auxiliary crane until the respective component is pinned and secured.

8.1 Disconnecting the connections to the crawler carriers

8.1.1 Disconnecting the hydraulic connections

The hydraulic connections are made with quick couplings.

When disconnecting hydraulic lines with quick couplings, make sure that the coupling procedure is carried out correctly.

**WARNING**

Pressure in the hydraulic lines!

If the pressure supply is not interrupted before connecting / releasing the hydraulic lines, the hydraulic oil can escape with high pressure.

Death, severe bodily injuries, property damage.

- ▶ Release the pressure in the hydraulic system before connecting / disconnecting: Interrupt the pressure supply and wait for a short time.
-
- ▶ Release the hydraulic coupling by hand.
 - ▶ Disconnect the hydraulic connections, see Hydraulic diagram.
 - ▶ Protect the hydraulic connections from contamination with caps.

8.1.2 Disconnecting the electrical connections

- ▶ Disconnect the electrical connections to the crawler carrier, see Electrical wiring diagram.

8.1.3 Disconnecting the connection to the central lubrication system

- ▶ Disconnect the connection to the central lubrication system.
- ▶ Protect the connections of the central lubrication system with caps from contamination.

8.2 Preparing the crawler carrier for disassembly

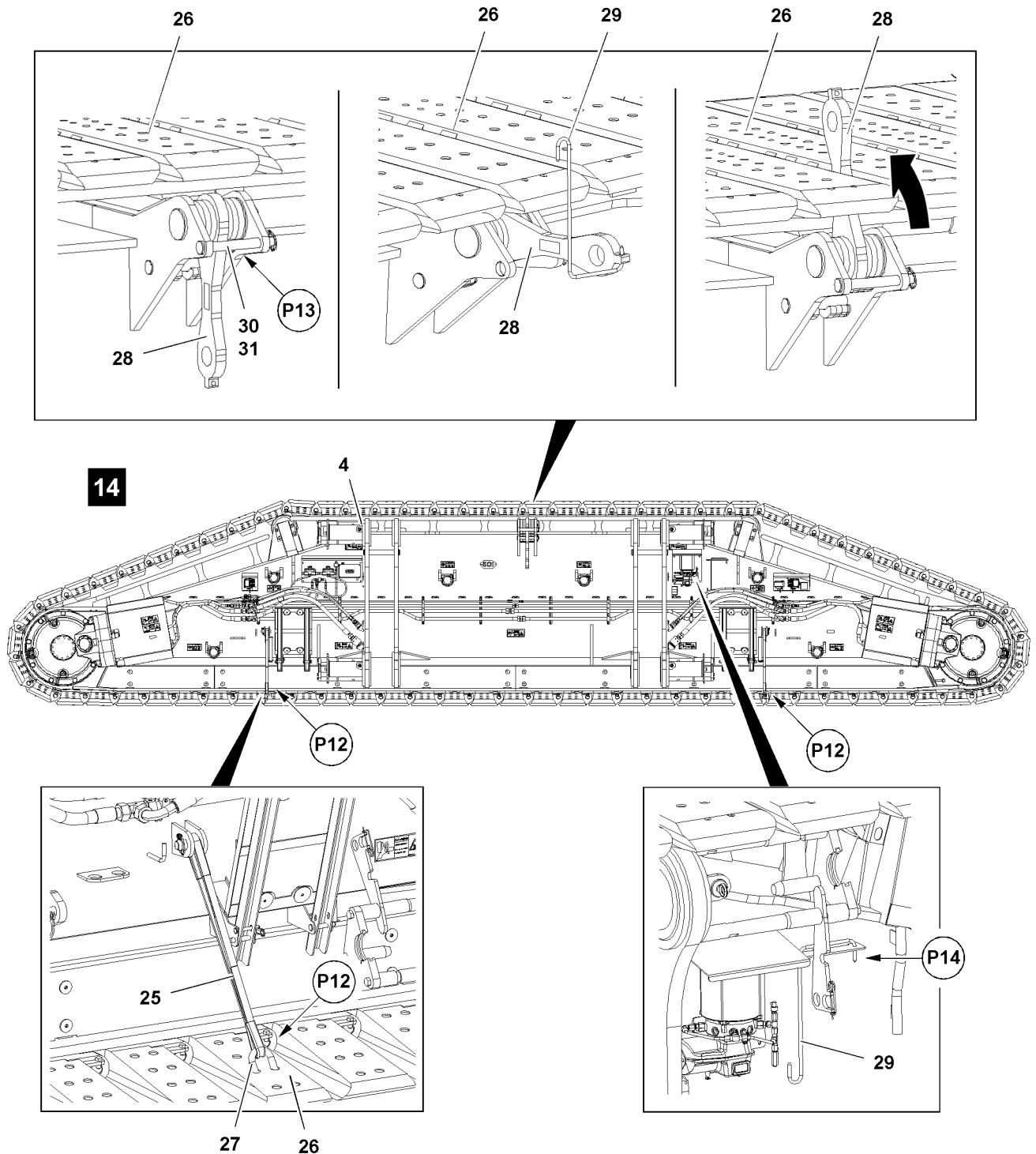

Fig.126225: Preparing the crawler carrier for disassembly



WARNING

Danger of falling!

During assembly and disassembly of crane components, personnel must be secured with appropriate aids to prevent them from falling.

Death, severe bodily injuries, property damage.

► Use personal protective equipment.

**Note**

- ▶ Hang in two belts **25** per crawler carrier side.

The track pads **26** must be secured before removal of the crawler carriers with the belts **25** to prevent them from sagging.

- ▶ Hang the belts **25** with the bars **27** on points **P12** on the track pads, see illustration **14**.

**Note**

- ▶ The brackets **28** must be swung in operating position between the track pads **26**, „upward“.

- ▶ Remove the safety locking pin **31** at point **P13** and unpin the pin **30**, see illustration **14**.

**Note**

- ▶ The handle **29** is fastened in transport position at point **P14**.

- ▶ Swing the brackets **28** with the handle **29** up, see illustration **14**.

8.3 Supporting support plates

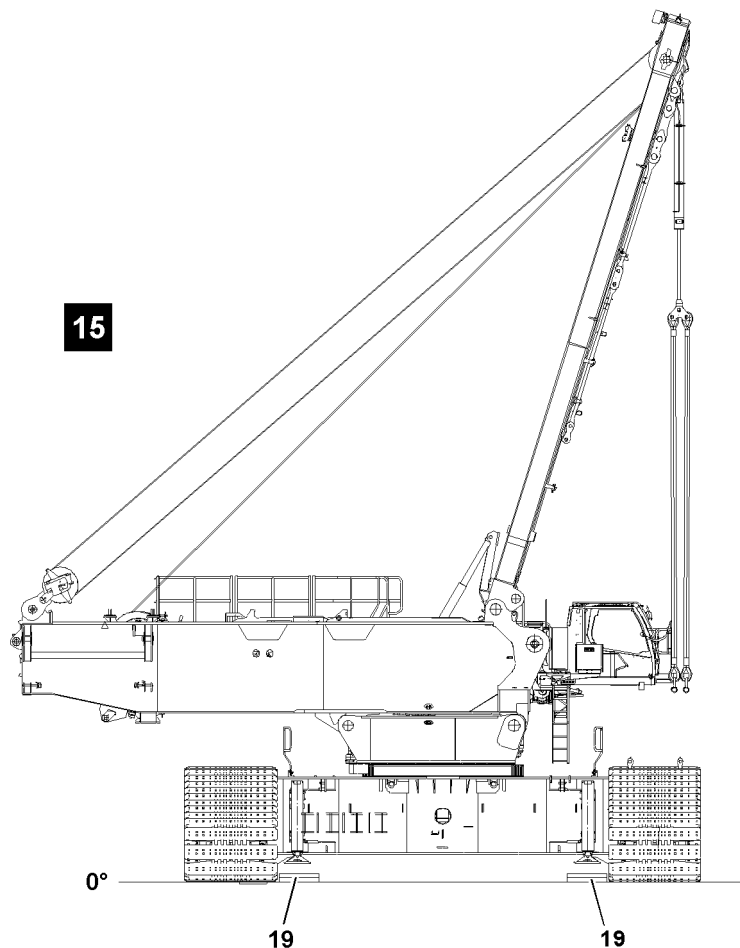

Fig.126226: Supporting support plates

**WARNING**

The crane can topple over!

Depending on the assembly condition of the crane and the extension condition of the support cylinders, the support forces on the support cylinders can occur up to **114 t**.

Death, severe bodily injuries, property damage.

- ▶ Make sure that the ground under the support cylinders is able to safely take on the occurring support forces.
- ▶ Make sure that the support cylinders are supported from below over a large surface with load bearing materials.
- ▶ Make sure that the support cylinders are moved in and / or out evenly.
- ▶ When supporting or lowering the crawler center section pay attention to horizontal orientation.

**WARNING**

Danger of falling!

During assembly and disassembly of crane components, personnel must be secured with appropriate aids to prevent them from falling.

Death, severe bodily injuries, property damage.

- ▶ Use personal protective equipment.

**WARNING**

Danger of accidents due to improper supporting base!

If the support plates are not properly supported, then they can sink into the ground.

Death, severe bodily injuries, property damage.

- ▶ The supporting base must be able to safely take on the weight of the crawler center section, the turntable frame lower section and the crawler carrier.
- ▶ The supporting base must be made large enough for the ground conditions, with solid materials, such as wood, steel or concrete slabs, see Crane operating instructions, chapter 2.04.

Make sure that the following prerequisites are met:

- The central ballast has been removed.
- The disassembly location must be level and have adequate load-bearing capacity.
- Suitable material must be available for the supporting base **19** of the assembly supports.
- The assembly supports are locked in operating position.
- The support plates are properly locked with the support cylinders.
- The track pads are secured to prevent them from sagging.
- ▶ Support the crane with hardwood timbers or other suitable materials from below, see illustration **15**.

8.4 Disassembling the first crawler carrier with SA-frame

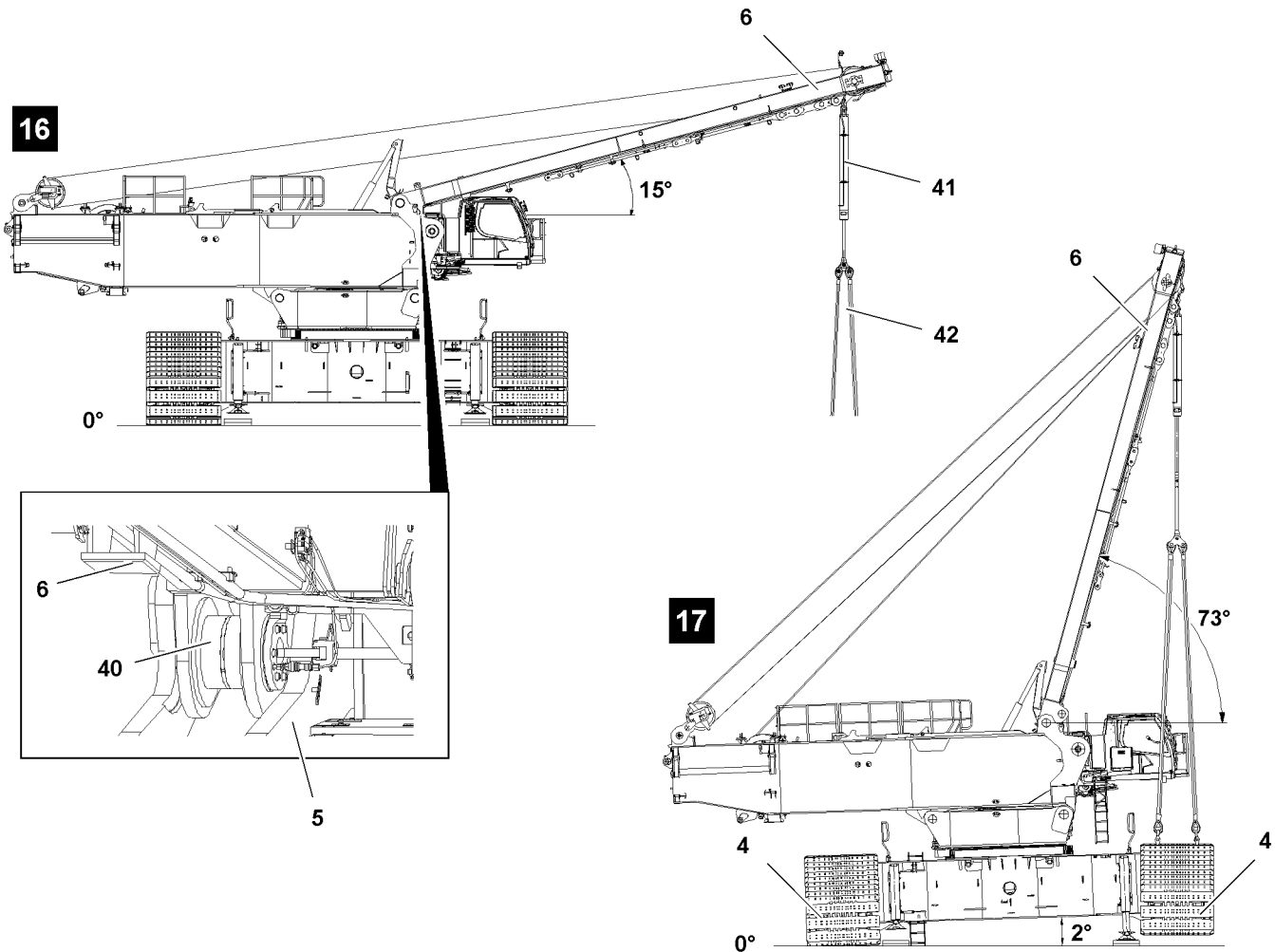

Fig.126227: Disassembling the first crawler carrier with SA-frame



Note

- ▶ For disassembly of the crawler carriers on the crawler center section, the disassembly procedure and the process are identical for both crawler carrier sides.
- ▶ For that reason, the disassembly of the crawler carriers is only described for one side as an example.



Note

- ▶ External hydraulic aggregate: Function assignment for the hand lever on the crawler center section for extending / retracting the support cylinders, see section „Lifting the crawler center section“.



WARNING

Danger of falling!

During assembly and disassembly of crane components, personnel must be secured with appropriate aids to prevent them from falling.

Death, severe bodily injuries, property damage.

- ▶ Use personal protective equipment.

NOTICE

Damage to crane!

When luffing the SA-frame **6** down to 15°, there is the danger that the connector pins **40** of the derrick boom will collide with the turntable frame main section **5**.

The SA-frame **6** can be damaged by a collision resulting in high repair costs.

- ▶ Make sure, when luffing the SA-frame down to 15° that the connector pins **40** of the derrick boom are pinned.

When the connector pins **40** are pinned:

- ▶ Luff the SA-frame **6** forward to 15°, see illustration **16**.

**Note**

- ▶ The pull cylinder **41** may not be moved out all the way.
- ▶ If the pull cylinder **41** is completely extended and the limit switch position is reached, an error display occurs on the LICCON monitor and the LMB stop.

- ▶ Move the pull cylinder **41** out.

- ▶ Pin and secure the fastening equipment **42** on the pull cylinder **41**, see illustration **16**.

**WARNING**

The crane can tip over!

If the support cylinders are moved out / in unevenly, the crane can tip over.

Death, severe bodily injuries, property damage.

- ▶ When moving the support cylinders **20** in / out, pay attention to the horizontal alignment, check visually.
- ▶ Lift the first crawler carrier: The support cylinder on the side of the crawler carrier which is being disassembled is moved out until the angle between the ground and the crawler center section is approximately 2°, see illustration **17**.

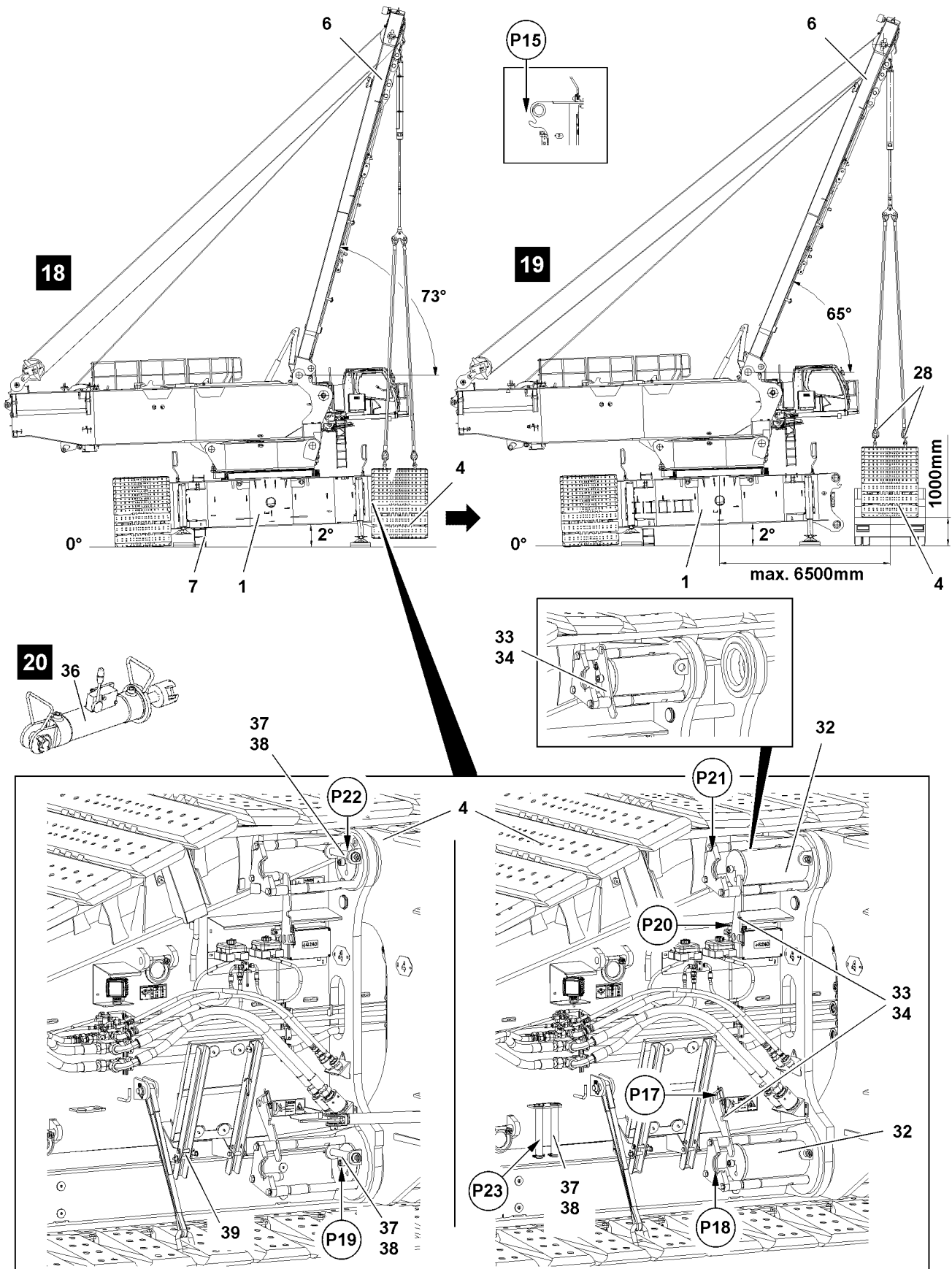

Fig.126228: Lift the crawler carrier out on the crawler center section and swing out

- ▶ Set the extension ladder 7 up, see Crane operating instructions, chapter 2.06.
- ▶ Tension the fastening equipment.

LWE/LR 11000-001/23501-04-02/en

- ▶ Fold the assembly platform **39** down, see Crane operating instructions, chapter 2.06.
- ▶ Release the pin **32**: Remove the safety locking pin **38** and unpin the retaining pin **37** at point **P22**, see illustration **18**.

**Note**

- ▶ The retaining pins **37** are at point **P23** in park position, see illustration **18**.
- ▶ Insert the retaining pin **37** in park position at point **P23** and secure with safety locking pin **38**.
- ▶ Set the pin pulling cylinder **36**, see illustration **20**, in the pin pulling device at point **P21**.
- ▶ Unpin the pin **32** with the pin pulling cylinder **36** to the stop.
- ▶ Remove the pin pulling cylinder **36**, see illustration **18**.
- ▶ Secure pin **32** in transport position: Remove the spring retainer **34** at point **P20** and swing the retaining bar **33** upward, see illustration **18**.
- ▶ Secure the retaining bar **33** again on point **P20** with spring retainer **34**, see illustration **18**.

Result:

- The pin **32** is secure in transport position.

- ▶ Fold the assembly platform **39** up, see Crane operating instructions, chapter 2.06.
- ▶ Release the pin **32**: Remove the safety locking pin **38** at point **P19** and unpin the retaining pin **37**.
- ▶ Insert the retaining pin **37** in park position at point **P23** and secure with safety locking pin **38**.
- ▶ Set the pin pulling cylinder **36** in the pin pulling device at point **P18**.
- ▶ Unpin the pin **32** with the pin pulling cylinder **36** to the stop.
- ▶ Remove the pin pulling cylinder **36**, see illustration **18**.
- ▶ Secure pin **32** in transport position: Remove the spring retainer **34** at point **P17** and swing the retaining bar **33** downward, see illustration **18**.
- ▶ Secure the retaining bar **33** again on point **P17** with spring retainer **34**.

Result:

- The pin **32** is secure in transport position.

- ▶ Unpin the crawler carrier **4** on the other crawler carrier side.
- ▶ Lift the crawler carrier **4** with the auxiliary crane.

When the crawler carrier is raised above the hook points at point **P15**:

- ▶ Swing the crawler carrier **4** out, see illustration **18**.

**WARNING**

Danger of tipping over!

If the following instructions are not observed, the crane can tip over at disassembly.

Death, severe bodily injuries, property damage.

- ▶ The maximum permissible distance of 6500 mm between the crawler carrier and the center of the turntable may not be exceeded.

- ▶ Set the crawler carrier **4** on the transport vehicle, see illustration **19**.
- ▶ Remove the fastening equipment.
- ▶ Swing the brackets **28** down, see section „Preparing the crawler carrier for assembly“.

8.5 Disassembling the second crawler carrier with SA-frame

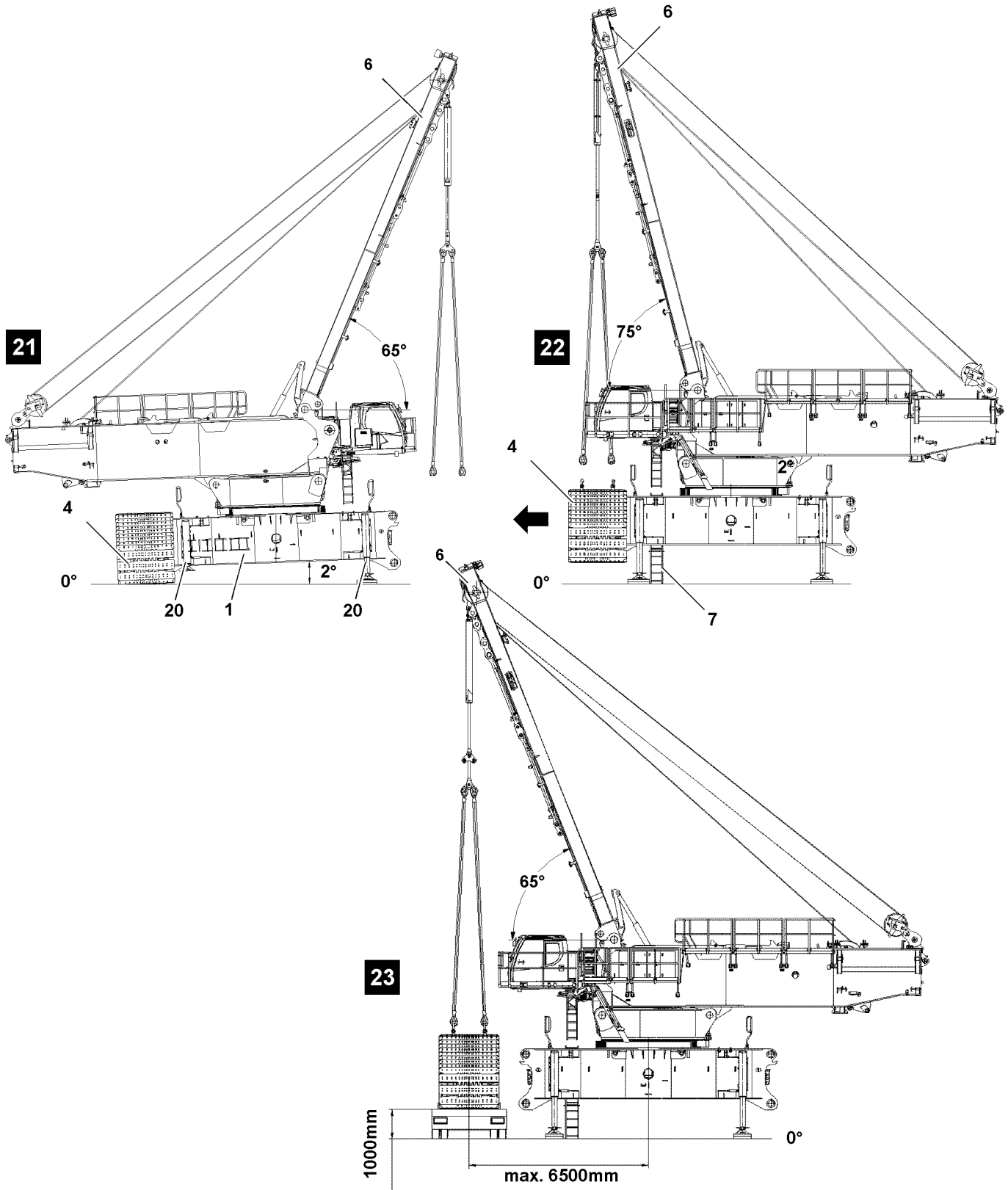

Fig.126229

LWE/LR 11000-001/23501-04-02/en

**Note**

- ▶ For disassembly of the crawler carriers on the crawler center section, the disassembly procedure and the process are identical for both crawler carriers.
- ▶ For that reason, the disassembly of the crawler carrier is only described for crawler carrier as an example.

**WARNING**

Danger of falling!

During assembly and disassembly of crane components, personnel must be secured with appropriate aids to prevent them from falling.

Death, severe bodily injuries, property damage.

- ▶ Use personal protective equipment.

Make sure that the following prerequisite is met:

- The first crawler carrier has been removed.

**WARNING**

Danger of tipping over!

Before turning the turntable, if the second crawler carrier is not positioned on the ground, there is a danger of tipping over.

Death, severe bodily injuries, property damage.

- ▶ The support cylinders **20** on the side of the crawler carrier, which still must be removed, must be moved in all the way, see illustration **21**.
- ▶ Make sure that the crawler carrier is standing on the ground.

- ▶ Turn the turntable by 180°.

- ▶ Move the opposite support cylinders out until the crane is in horizontal position.

When the crane is aligned in horizontal direction:

- ▶ Extend all support cylinders completely, see illustration **22**.
- ▶ Align crane horizontally.
- ▶ Align the extension ladder **7** again, see Crane operating instructions, chapter 2.06.

**WARNING**

Danger of tipping over!

If the following instructions are not observed, the crane can tip over at disassembly.

Death, severe bodily injuries, property damage.

- ▶ The maximum permissible distance of 6500 mm between the crawler carrier and the center of the turntable may not be exceeded.

- ▶ Remove the second crawler carrier, see section „Removing the first crawler carrier with SA-frame“, see illustration **23**.

8.6 Removing the fastening equipment

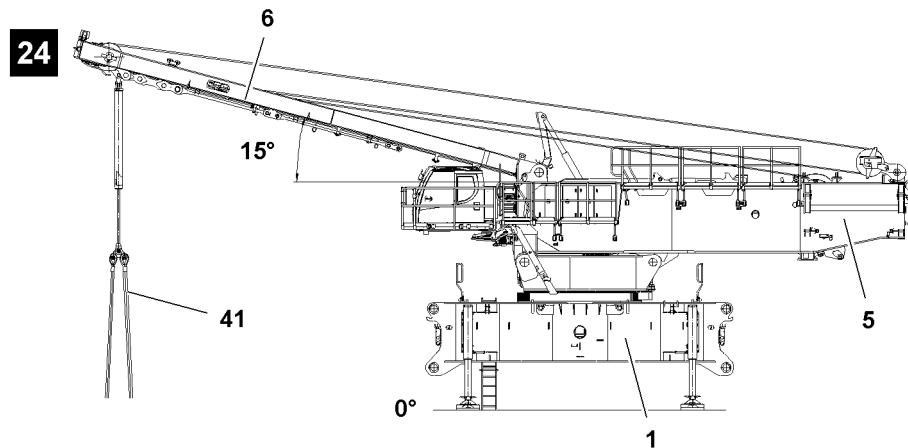

Fig.126233

- ▶ Luff the SA-frame forward to 15°.
- ▶ Remove the fastening equipment 41, see illustration 24.

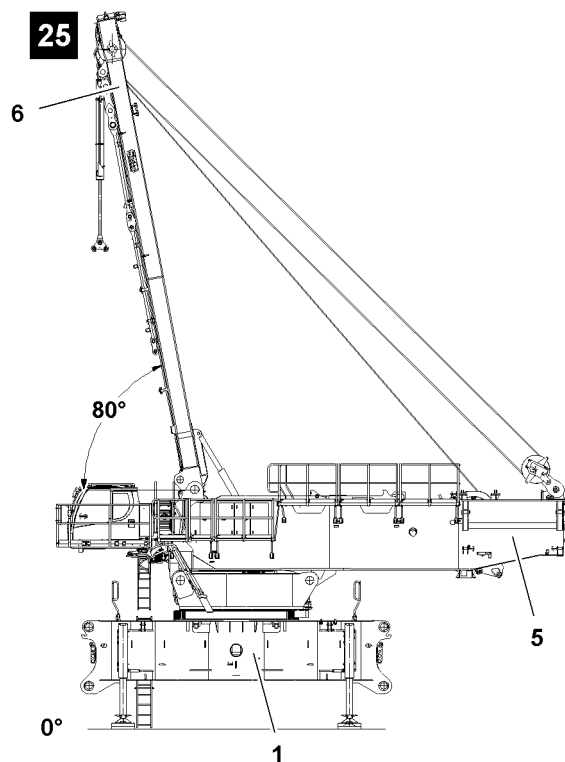

Fig.126234

- ▶ Luff the SA-frame up again to approximately 80°, see illustration 25.

8.7 Supporting the crawler center section

Make sure that the following prerequisites are met:

- The crawler carriers are completely disassembled.
- The disassembly location is level and sufficiently load bearing.
- The SA-frame is erected to at least 80°.

- ▶ Support the crawler center section, see section „Disassembling the crawler center section“.

8.8 Lowering the crane on the supporting base

Make sure that the following prerequisites are met:

- The crane is supported.
- The operating mode „SA-frame“ has been set and confirmed on the LICCON computer system.
- The SA-frame is erected to at least 80°, see Crane operating instructions, chapter 5.02.



Note

- ▶ External hydraulic aggregate: Function assignment for the hand lever on the crawler center section for extending / retracting the support cylinders, see section „Lifting the crawler center section“.



WARNING

Danger of tipping the crane!

If the support cylinders are moved out unevenly, the crane can tip over.

Death, severe bodily injuries, property damage.

- ▶ When lifting the crane, pay attention to the horizontal alignment, check visually.

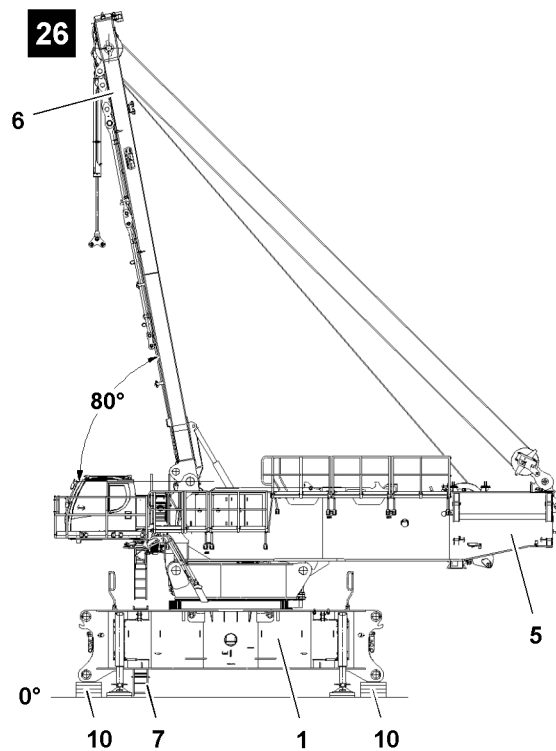

Fig.126235: Lowering the crawler center section on the supporting base

- ▶ Lower the crane on the supporting base, see section „Disassembling the crawler center section“, see illustration 26.

8.9 Placing the SA-frame down

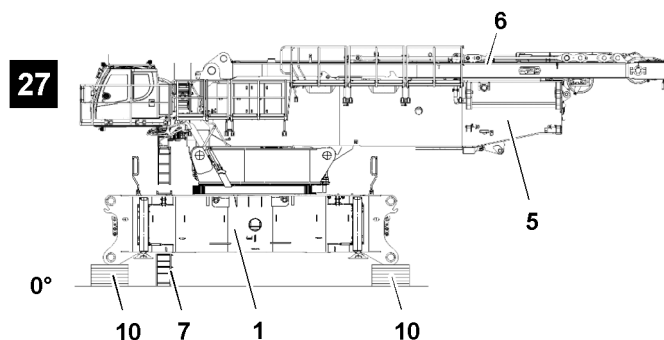

Fig.126230: Placing the SA-frame onto the turntable

When the crane is laying on the supporting base:

- ▶ Place the SA-frame down, see Crane operating instructions, chapter 5.02, see illustration 27.

8.10 Removing the hydraulic aggregate

Make sure that the following prerequisite is met:

- The crawler center section 1 is set down on the supporting base.
- ▶ Remove the hydraulic aggregate, see section „Disassembling the crawler center section“.

8.11 Disassembling the assembly support

- ▶ Remove the assembly support, see section „Disassembling the crawler center section“.

9 Disassembling the crawler center section



WARNING

Danger of falling!

During assembly / disassembly, inspection and maintenance work, personnel must be secured with appropriate aids to prevent them from falling.

Death, severe bodily injuries, property damage.

- ▶ All work aloft, where there is a danger of falling must be carried out with suitable aids.
- ▶ If aids are not available and work cannot be carried out from the ground, then the assembly personnel must secure themselves with the supplied fall arrest system to prevent falling, see Crane operating instructions, chapter 2.04.
- ▶ If fall protection equipment is available, then it must be used, see Crane operating instructions, chapter 2.06.
- ▶ When lifting, lowering, swinging crane parts in and out, no persons may remain in the danger zone.
- ▶ If railings are present for the crane, then they must be brought into the corresponding position and secured for assembly / disassembly work.
- ▶ It is prohibited to lean the auxiliary ladder against the component being disassembled.
- ▶ Only step on the aids, ladders and catwalks with clean shoes.
- ▶ Keep aids, ladders and catwalks free of heavy dirt, snow, frost and ice.
- ▶ During all assembly and disassembly work, maintenance work and inspections, travel or crane operation is prohibited.
- ▶ Remaining on a suspended load is prohibited.
- ▶ Stepping or walking on crane components and lattice sections, which have an incline of more than 20° is prohibited.
- ▶ For all assembly work, the crane operator of the main crane must be in voice contact with the crane operator / crane operators of the auxiliary crane / auxiliary cranes.
- ▶ For assembly / disassembly tasks, the crane operator may only initiate crane movements when the responsible guide has explicitly released the movement.



WARNING

Danger of impact / crushing!

When installing / removing crane components with the auxiliary crane, crane components can start to swing back and forth.

When lifting / lowering and positioning crane components, there is an increased danger of impacts / crushing.

Death, severe bodily injuries, property damage.

- ▶ Make sure that personnel cannot be caught by components.
- ▶ When working in danger zones: Use aids to protect limbs.
- ▶ Guide components with suitable aids to minimize oscillation.



DANGER

The components can fall down!

If the corresponding component is disengaged from the auxiliary crane before the corresponding component is pinned, then the corresponding component can fall down.

Death, severe bodily injuries, property damage.

- ▶ Do not disengage the auxiliary crane until the respective component is pinned and secured.

9.1 Supporting the crawler center section

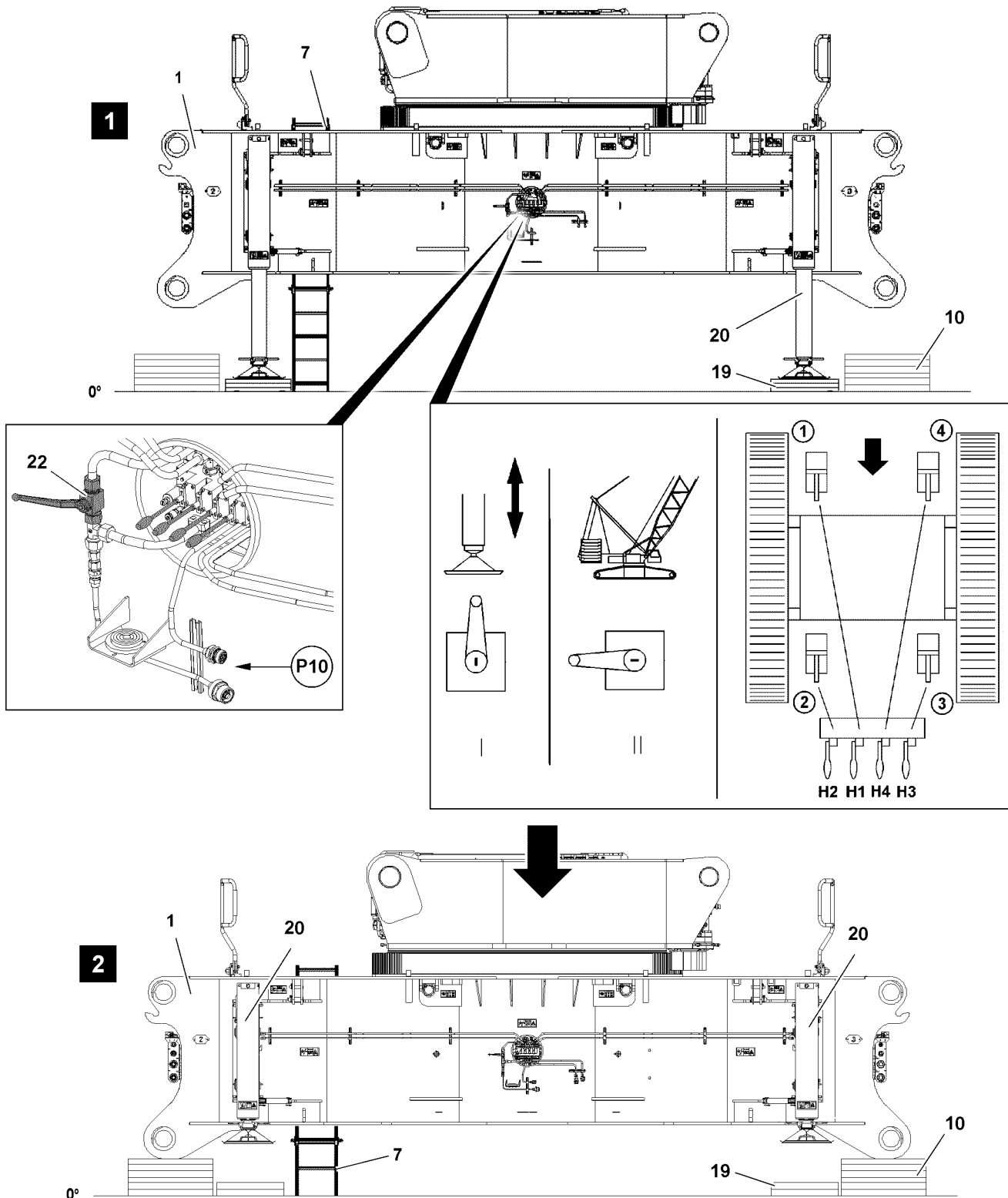

Fig.126231: Support the crawler center section / set the crawler center section of the supporting base

LWE/LR 11000-001/23501-04-02/en

**WARNING**

Danger of falling!

During assembly and disassembly of crane components, personnel must be secured with appropriate aids to prevent them from falling.

Death, severe bodily injuries, property damage.

- ▶ Use personal protective equipment.

Make sure that the following prerequisites are met:

- The crawler carriers are completely disassembled.
- The disassembly location is level and sufficiently load bearing.

**Note**

- ▶ The supporting base **10** must be high enough so that the support cylinders **20** can be completely moved in and folded down in transport position.
- ▶ The supporting base **10** must take on the weight of the crawler center section **1** safely.
- ▶ Support the crawler center section **1** with hardwood timbers or other suitable materials from below, see illustration 1.

9.2 Lowering the crawler center section on the supporting base

Make sure that the following prerequisites are met:

- The crawler center section is supported properly with materials of sufficient load-bearing capacity.
- The hydraulic connections from the hydraulic aggregate to the crawler center section **1** have been properly established.

**WARNING**

Danger of accidents due to improper supporting base!

If the crawler center section **1** is not properly supported, then it can sink into the ground.

Death, severe bodily injuries, property damage.

- ▶ The supporting base must be able to safely take on the weight of the crawler center section **1** and the turntable frame lower section.
- ▶ The supporting base must be made large enough for the ground conditions, with solid materials, such as wood, steel or concrete slabs, see Crane operating instructions, chapter 2.04.

9.2.1 Lowering the crawler center section with the hydraulic hand levers

**WARNING**

Danger of tipping the crawler center section!

If the support cylinders **20** are moved in unevenly, the crawler center section can tip over.

Death, severe bodily injuries, property damage.

- ▶ When lowering the crawler center section, pay attention to the horizontal alignment, check visually.

**Note**

- ▶ The support cylinders are marked with numbers.
- ▶ Pay attention to the identification on the hand lever and on the support cylinder, see illustration 1.

Ball valve positions	
Position I	Assembly support
Position II	Crane operation / crawler carrier installation with SA-frame

Function assignment of hand levers for the support cylinders	
H1	Hand lever for the support cylinder 1 , right rear
H2	Hand lever for support cylinder 2 , right front
H3	Hand lever for support cylinder 3 , left front
H4	Hand lever for support cylinder 4 , left rear

- ▶ Actuate the hand lever **H1**, hand lever **H2**, hand lever **H3** and hand lever **H4**.

Result:

- The support cylinders **20** move in.
- ▶ Move the support cylinders **20** in and set the crawler center section **1** on the supporting base **10**, see illustration **2**.
- ▶ Align the extension ladder **7** again, see Crane operating instructions, chapter 2.06, see illustration **2**.
- ▶ Remove the supporting base **19**.

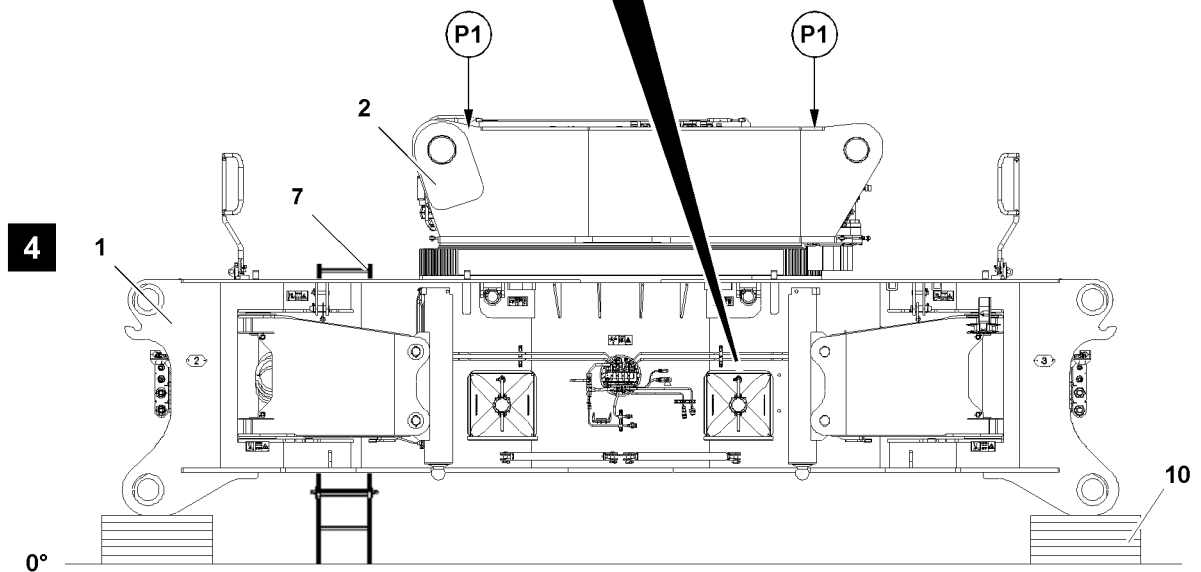
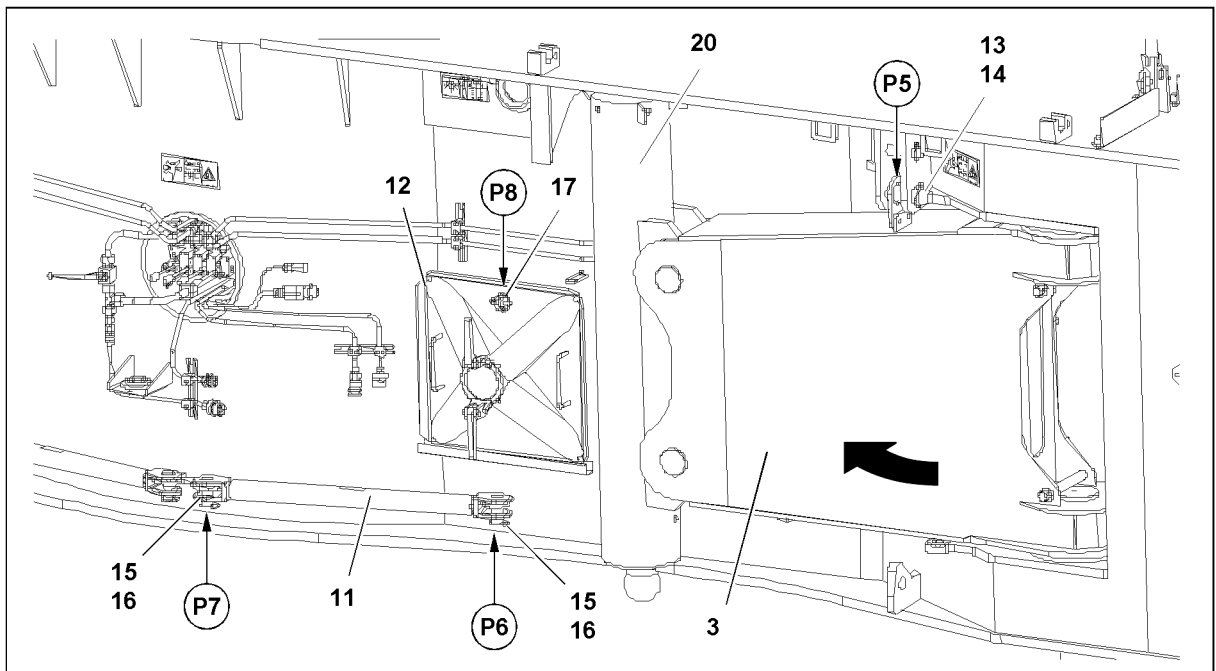
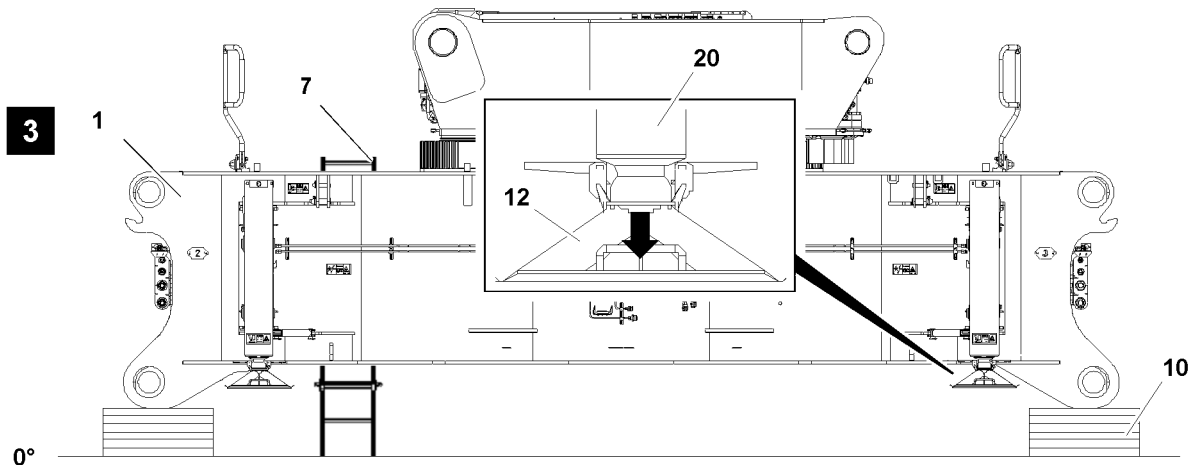

Fig.126232

LWE/LR 11000-001/23501-04-02/en

**WARNING**

Falling support plate!

The support plate **12** can fall down due to its own weight when releasing it.

Death, severe bodily injuries, property damage.

- ▶ For safety reasons, assemble the support plate always with **two** persons.
- ▶ Make sure that there are no persons within the danger zone during the entire disassembly procedure.

**Note**

- ▶ The weight of the support plate is 33 kg.

- ▶ Release the support plates **12** on the ball head of the support cylinder **20**, see illustration **3**.

**WARNING**

Support plates not secured!

If the support plates **12** are not properly secured in transport position, then the support plates can loosen up by themselves during transport.

This can cause accidents.

Death, severe bodily injuries, property damage.

- ▶ Make sure that the support plates **12** are in the transport position and secured with safety locking pins **17**.
- ▶ Position and secure the support plates **12** in transport position and secure: Attach the safety locking pin **17** at point **P8**, see illustration **4**.
- ▶ Remove all support plates.

9.2.2 Lower the crawler center section with the control panel

**Note**

- ▶ Alternatively to the operation of the assembly support with the hand levers, the assembly support can also be operated with the control panel **200**, see Electrical wiring diagram.

Make sure that the following prerequisites are met:

- The electric external feed (maximum 24 V) to the crawler center section is properly established, see Electrical wiring diagram.
- The control panel **200** is connected on the socket at point **P25** or on the socket at point **P26** on the crawler center section, see Electrical wiring diagram.
- The hydraulic aggregate **21** is turned on.



WARNING

Danger of tipping the crawler center section!

If the support cylinders **20** are moved in unevenly, the crawler center section can tip over. Death, severe bodily injuries, property damage.

- ▶ When lowering the crawler center section, pay attention to the horizontal alignment, check visually.

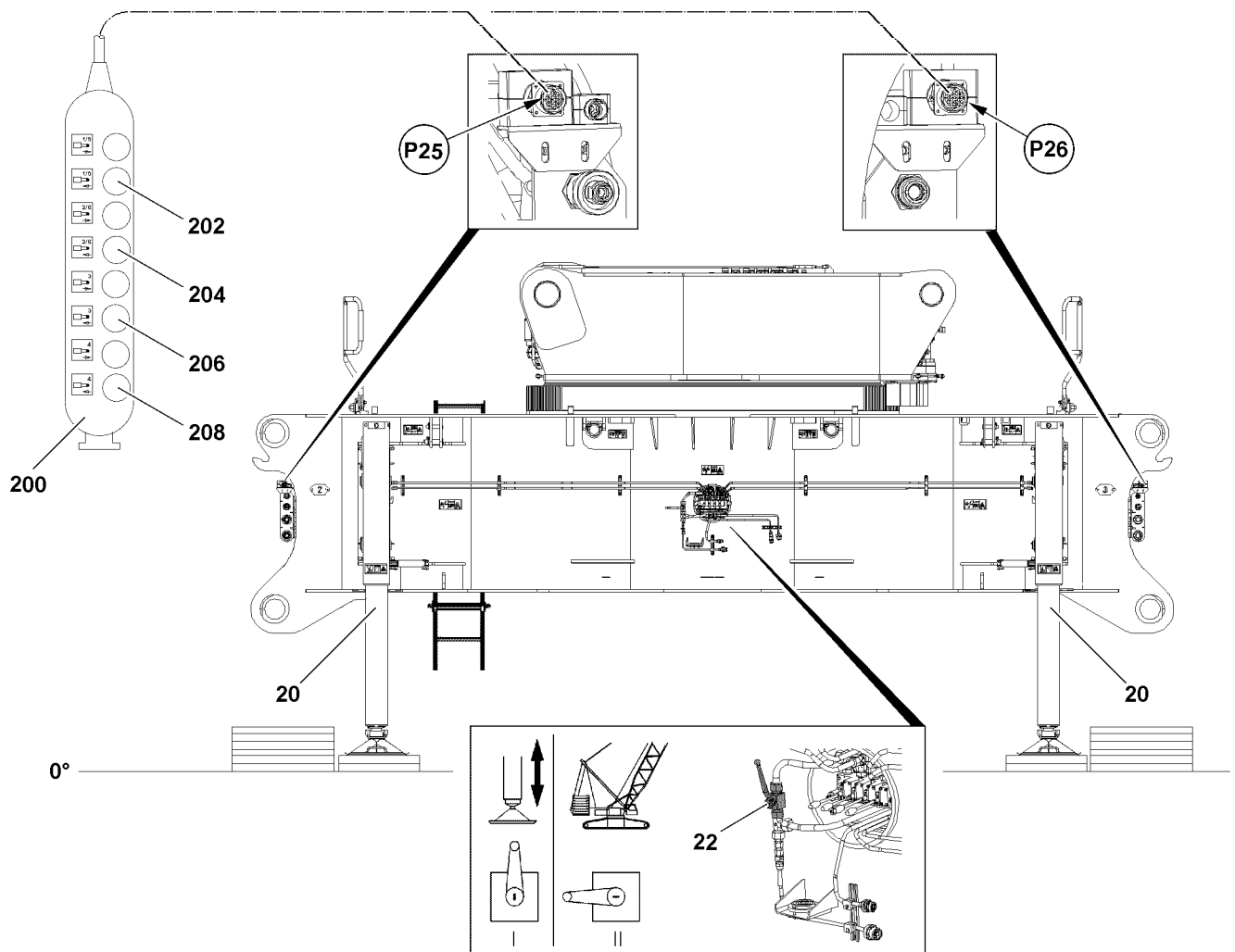

Fig.122407: Lower the crawler center section with the control panel **200**

Support right rear

- ▶ Press button **202**.

Result:

- The right rear support cylinder retracts.

Support right front

- ▶ Press button **204**.

Result:

- Support cylinder moves in on the right front.

Support left front

- ▶ Press button **206**.

Result:

- The left front support cylinder retracts.

Support left rear

- ▶ Press button **208**.

Result:

- The left rear support cylinder retracts.
- ▶ Lower the crawler center section completely until the crawler center section is laying on the supporting base.
- ▶ Remove the control panel **200** and store it properly.
- ▶ Close the socket on the crawler center section - after removing the control panel- with dummy plug.

9.3 Disconnecting the hydraulic aggregate

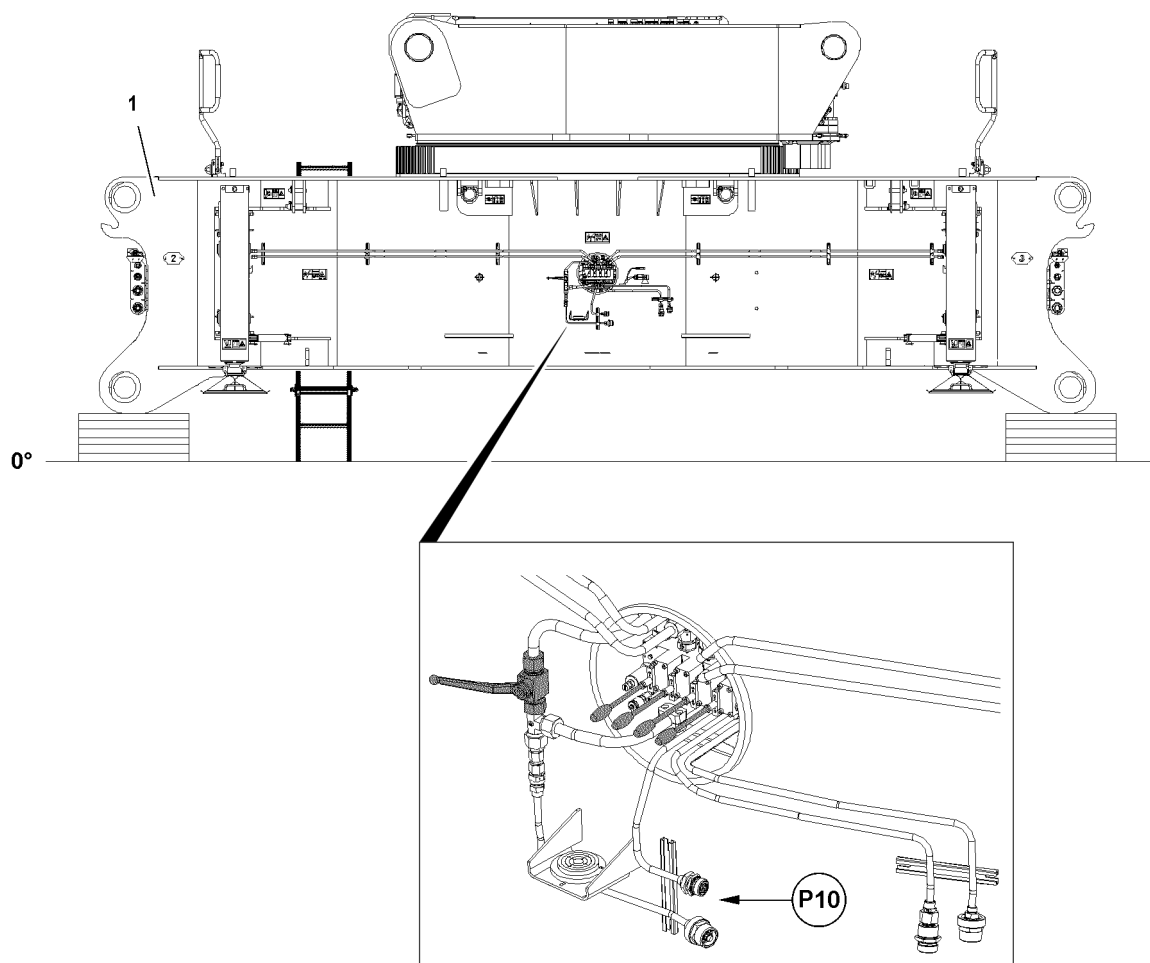

Fig.126236: Disconnecting the hydraulic aggregate

Make sure that the following prerequisites are met:

- All support cylinders are fully retracted.
- The crawler center section is laying completely on the supporting base.

When disconnecting hydraulic lines with quick couplings, make sure that the coupling procedure is carried out correctly.



WARNING

Pressure in the hydraulic lines!

If the pressure supply is not interrupted before connecting / releasing the hydraulic lines, the hydraulic oil can escape with high pressure.

Death, severe bodily injuries, property damage.

- ▶ Release the pressure in the hydraulic system before connecting / disconnecting: Interrupt the pressure supply and wait for a short time.

-
- ▶ Release the hydraulic coupling by hand.



Note

- ▶ Observe the information in the Operating and Maintenance manual of the hydraulic aggregate.
- ▶ Hydraulic connections from the hydraulic aggregate to the crawler center section **1**, see Hydraulic diagram.

-
- ▶ Disconnect the hydraulic connections from the hydraulic aggregate to the crawler center section **1** at point **P10**, see illustration **1**.
 - ▶ Protect the hydraulic connections from contamination with caps.

9.4 Disassembling the assembly supports

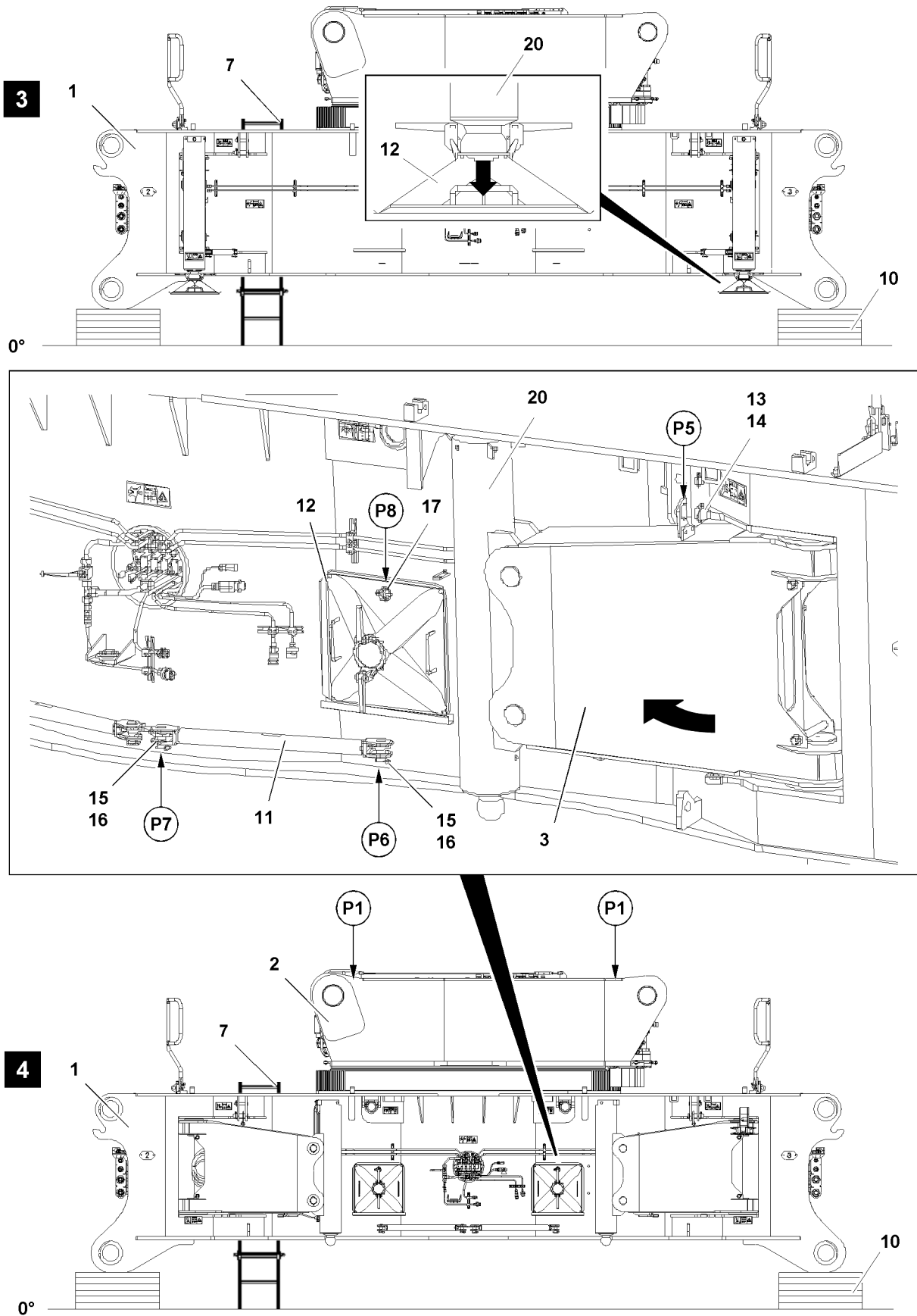

Fig.126232

LWE/LR 11000-001/23501-04-02/en

**Note**

- ▶ The swinging in and locking procedure of the support is the same for all four assembly supports and is therefore described only once.

**WARNING**

Falling bar!

The bar **11** can fall down due to its own weight when unpinning it.

Death, severe bodily injuries, property damage.

- ▶ For safety reasons, **two** persons must always be used to unpin the bar.
- ▶ Make sure that there are no persons within the danger zone during the entire unpinning procedure.

**Note**

- ▶ The weight of the bar is 10 kg.

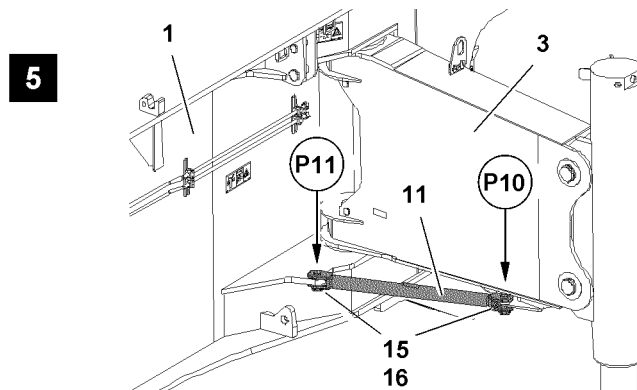

Fig.116956: Disassembling the assembly supports

- ▶ Release the bar **11** from the operating position: Remove the safety locking pin **16** at point **P10** and at point **P11** and unpin the pin **15**, see illustration 5.
- ▶ Remove the bar **11** and position in transport position, see illustration 4.

**WARNING**

The pin is not secured!

If the pins **16** are not secured, the connector pins can loosen up by themselves during transport operation.

This can cause accidents.

Death, severe bodily injuries, property damage.

- ▶ Make sure that the pins **15** are secured with safety locking pins **16**.
- ▶ Secure the bar **11** in transport position: Insert the pin **15** at point **P6** and at point **P7** and secure with safety locking pin **16**, see illustration 4.
- ▶ Remove the safety locking pin **14** at point **P5** and unpin the pin **13**, see illustration 4.

Result:

- The support **3** can be swung into transport position.
- ▶ Swing the support **3** in so that it can be pinned at point **P5**, see illustration 4.

**WARNING**

The pin is not secured!

If the pins **13** are not secured, the connector pins can loosen up by themselves during transport operation.

This can cause accidents.

Death, severe bodily injuries, property damage.

- ▶ Make sure that the pins **13** are secured with safety locking pins **14**.

- ▶ Secure the support **3** in transport position: Insert the pin **13** on point **P5** and secure with safety locking pin **14**, see illustration **4**.
- ▶ Fold the grating covers open on the turntable frame lower section **2** at points **P1**.
- ▶ Attach the fastening equipment on the four fastening brackets at points **P1**, see section „Fastening points“.
- ▶ Lift the crawler center section **1** with the auxiliary crane and place it on the transport vehicle.
- ▶ Remove the supporting base **10**.

3.02 Turntable assembly

1	Component overview	3
2	Fastening points	3
3	Turntable assembly	9
4	Disassembly of turntable	15

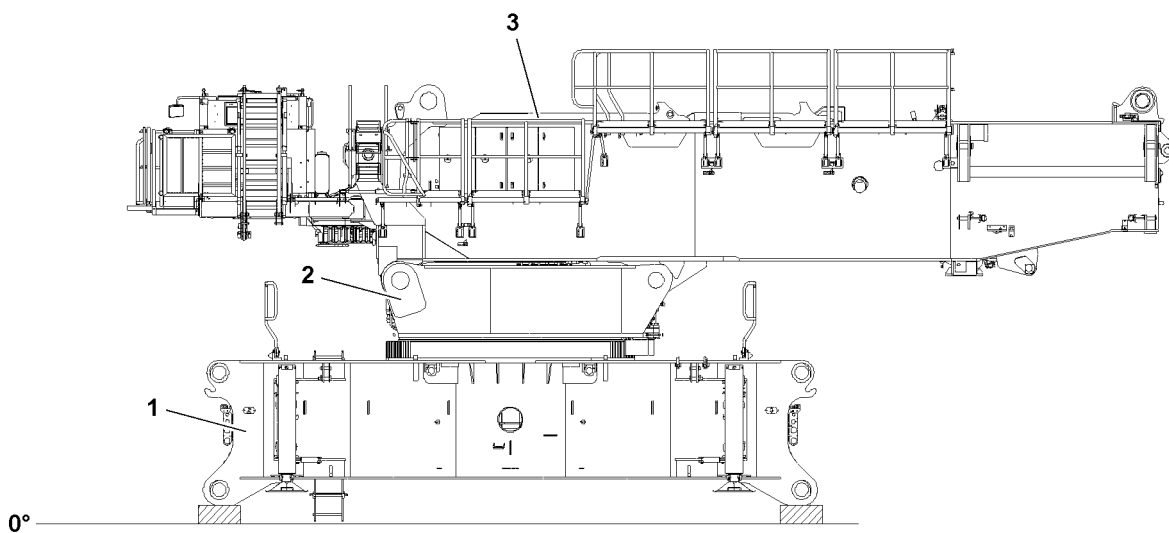

Fig.118557

1 Component overview

Position	Component description
1	Crawler center section ¹⁾
2	Turntable frame lower section ¹⁾
3	Turntable frame main section

1) Crawler center section and turntable frame lower section are preassembled at the factory as an assembly unit.

2 Fastening points



Note

- ▶ Pay attention to the labels of the fastening points on the components.

2.1 Fastening points Crawler center section with turntable frame lower section



WARNING

Fastening equipment can be ripped off!

- ▶ Make sure to use fastening equipment on the fastening points **P1** always only in connection with shackles.
- ▶ Make sure that the fastening equipment has a sufficient load carrying capacity.
- ▶ Make sure that the auxiliary crane / the auxiliary cranes have a sufficient load carrying capacity to be able to safely take on the crawler center section in connection with the turntable frame lower section.
- ▶ For dimensions and weights of the crawler center section with turntable lower section, see Crane operating instructions, chapter 1.03.
- ▶ Make sure that there are no persons within the danger zone of the crawler center section.

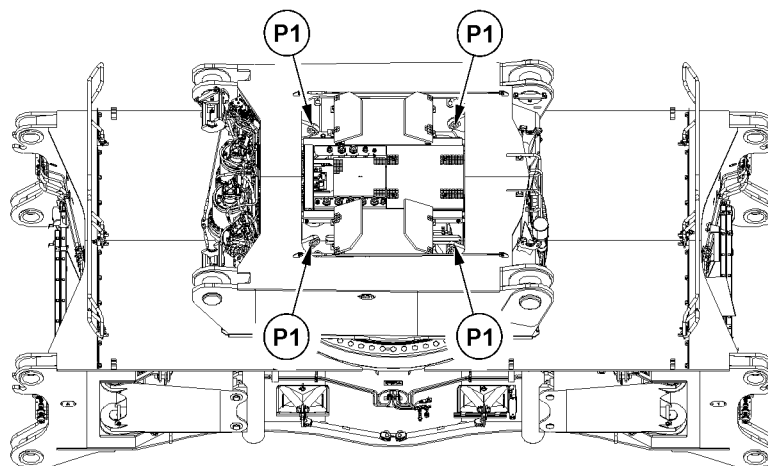

Fig.118554: Fastening points Crawler center section with turntable frame lower section

Fastening points	
P1	Crawler center section with turntable frame lower section

2.2 Fastening points on turntable frame main section



WARNING

Fastening equipment can be ripped off!

- ▶ Make sure to use fastening equipment on the fastening points always only in connection with shackles.
- ▶ Make sure that the fastening equipment has a sufficient load carrying capacity and the required minimum length.
- ▶ Make sure that the auxiliary crane / the auxiliary cranes have a sufficient load carrying capacity to be able to safely take on the turntable frame main section.
- ▶ For dimensions and weights of turntable frame main section, see Crane operating instructions, chapter 1.03.
- ▶ Make sure that there are no persons within the danger zone of the turntable frame main section.



Note

- ▶ The turntable frame main section can be fastened and installed either with one or with two auxiliary cranes, depending on the transport condition.
- ▶ For dimension Y as well as other dimensions for the turntable, refer to the Crane operating instructions, chapter 1.03.

2.2.1 Fastening the transport unit „Turntable“ with an auxiliary crane

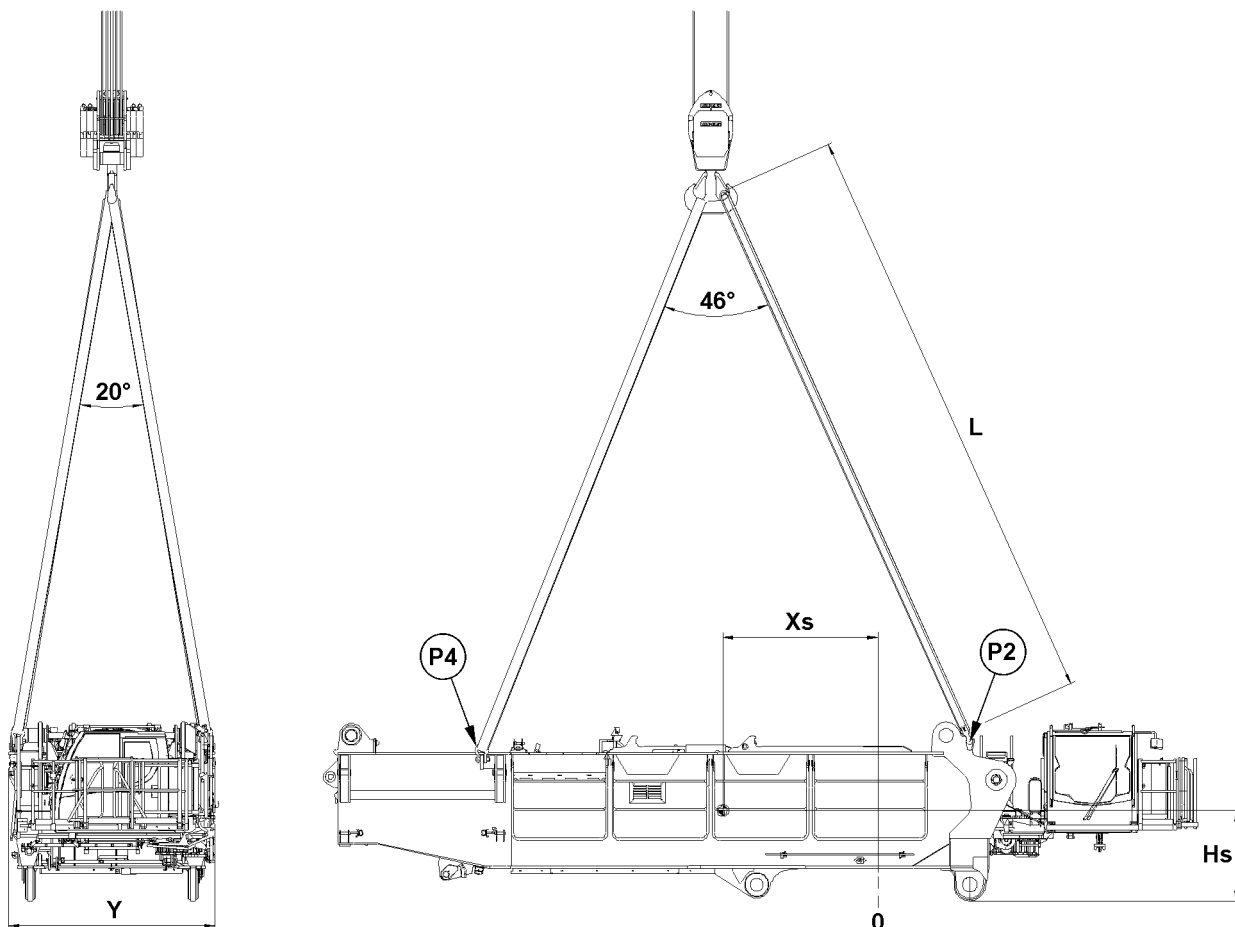

Fig.119451: Take on the load of the turntable frame main section with one auxiliary crane

	Weight	Suspended load at		Center of gravity		Length ³⁾
		P4	P2	Xs ²⁾	Hs	L
Transport unit Turntable ¹⁾	45.0 t	22.8 t	22.3 t	2.62 m	1.56 m	10.00 m

¹⁾ Without winches and without SA-frame

²⁾ Starting from the center point 0 (rotation point) of the roller ring connection

³⁾ Minimum length of fastening equipment

2.2.2 Fastening the transport unit „Turntable with winches“ with two auxiliary cranes

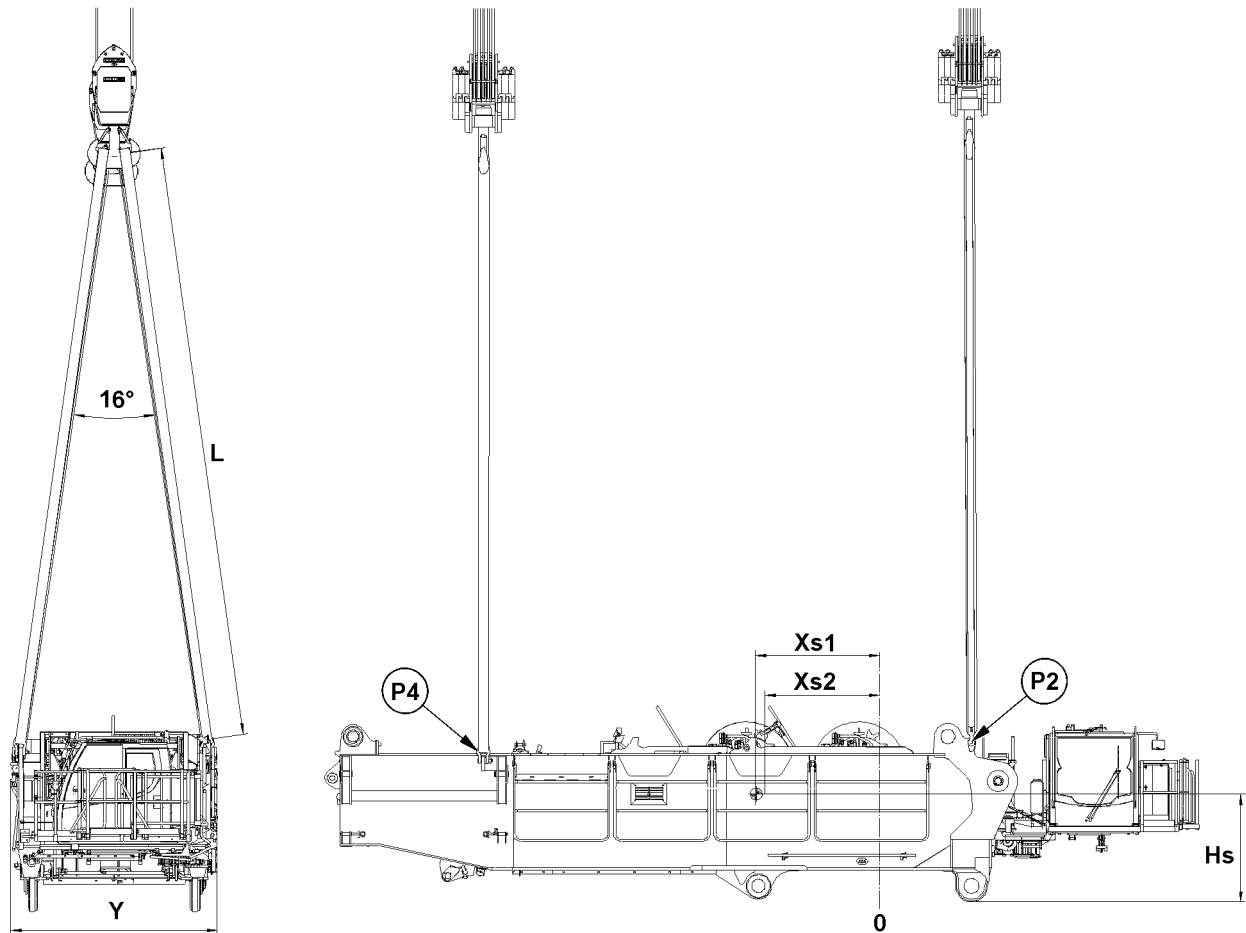

Fig.119452: Take on the load of the turntable frame main section with two auxiliary cranes

	Weight	Suspended load at		Center of gravity			Length ⁴⁾
		P4	P2	Xs1 ³⁾	Xs2 ³⁾	Hs	L
Transport unit Turntable ¹⁾	72.1 t	32.2 t	40.0 t	2.12 m		1.81 m	10.00 m
Transport unit Turntable ²⁾	58.5 t	32.7 t	25.9 t		2.09 m	1.81 m	10.00 m

¹⁾ With winch 1 and winch 2

²⁾ With winch 1 without winch 2

³⁾ Starting from the center point 0 (rotation point) of the roller ring connection

⁴⁾ Minimum length of fastening equipment

LWE/LR 11000-001/23501-04-02/en

2.2.3 Fastening the transport unit „Turntable with SA-frame and winch 4“ with two auxiliary cranes

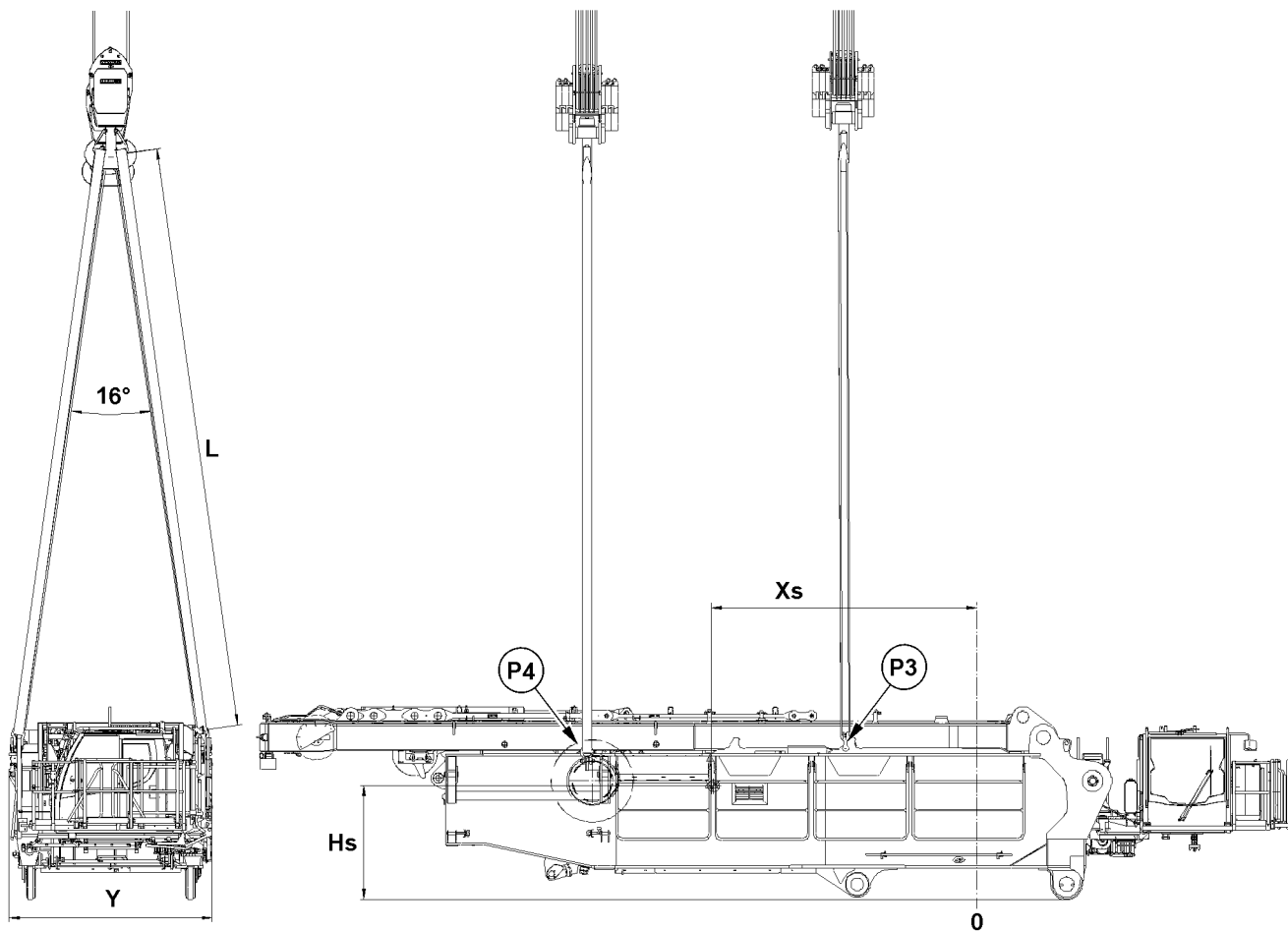

Fig.119453: Take on the load of the turntable frame main section with two auxiliary cranes

	Weight	Suspended load at		Center of gravity		Length ³⁾
		P4	P3	Xs ²⁾	Hs	L
Transport unit Turntable ¹⁾	76.8 t	39.8 t	37.1 t	4.55 m	1.96 m	10.00 m

¹⁾ With SA-frame, roller frame and winch 4

²⁾ Starting from the center point 0 (rotation point) of the roller ring connection

³⁾ Minimum length of fastening equipment

Empty page!

LWE/LR 11000-001/23501-04-02/en

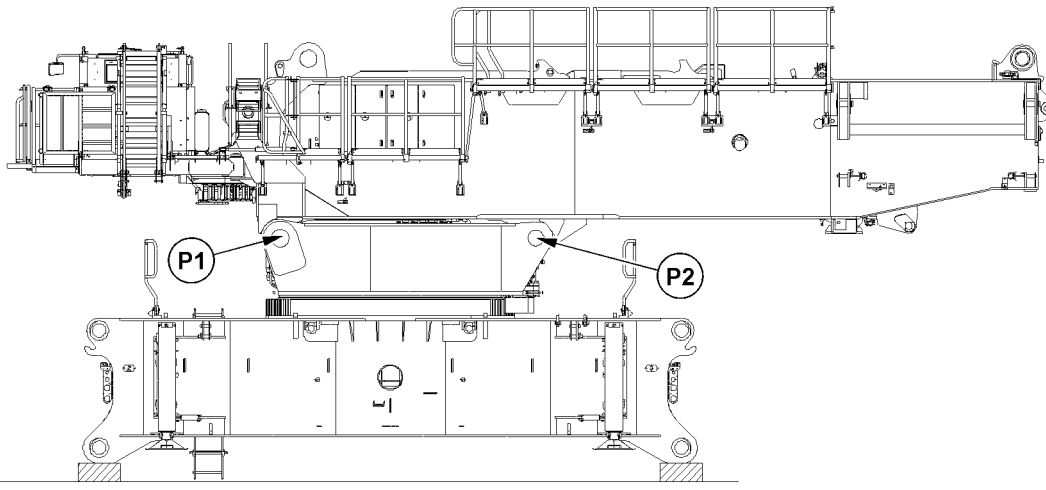
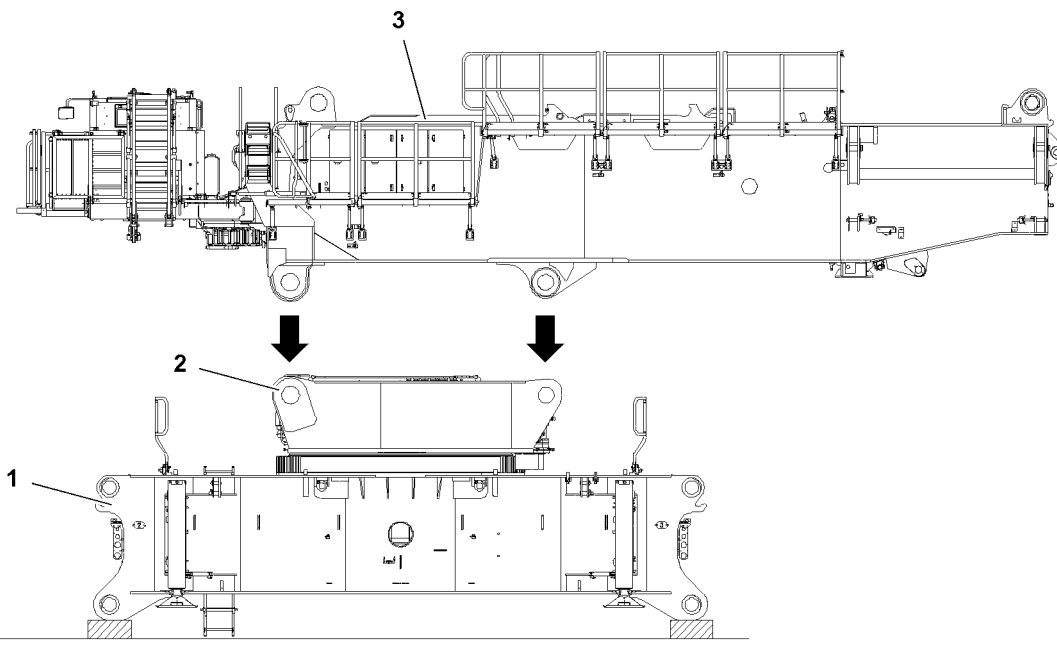
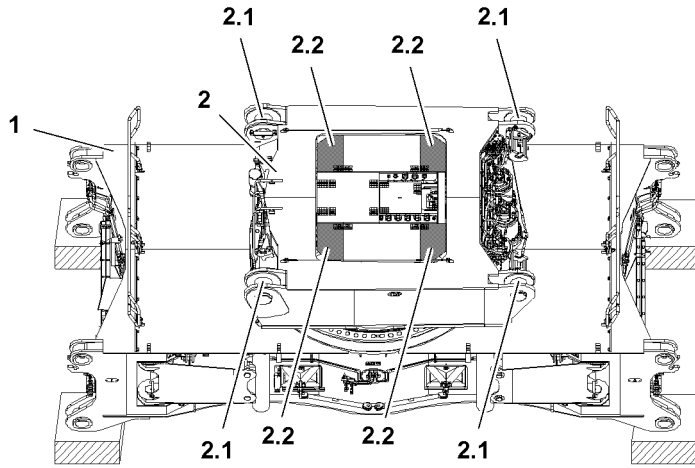

Fig.118552

LWE/LR 11000-001/23501-04-02/en

3 Turntable assembly



WARNING

Danger of falling!

During assembly / disassembly, inspection and maintenance work, assembly personnel must be secured with appropriate aids to prevent them from falling.

If this is not observed, assembly personnel could fall and suffer life-threatening or fatal injuries.

- ▶ The assembly personnel must always move carefully and anticipatory on the crane, the crane components or lattice sections.
- ▶ All work aloft, where there is a danger of falling must be carried out with suitable aids.
- ▶ If fall protection equipment is available, then it must be used.
- ▶ If aids are not available and work cannot be carried out from the ground, then the assembly personnel must secure themselves with the approved fall arrest system to prevent falling, see Crane operating instructions, chapter 2.04.
- ▶ The fall arrest system must be attached on the fastening and hook points as well as on the safety ropes.
- ▶ Always secure ladders on structural parts and / or components to prevent them from falling over.
- ▶ Only step on the aids, ladders and catwalks with clean shoes.
- ▶ Keep aids, ladders and catwalks free of heavy dirt, snow, frost and ice.
- ▶ Stepping or walking on crane components and lattice sections, which have an incline of more than 20° is prohibited.



Note

- ▶ For the assembly of the turntable frame main section **3** on the turntable frame lower section **2** use a pin pulling device, see Crane operating instructions, chapter 5.30.

Make sure that the following prerequisites are met:

- The ground is level and of sufficient load bearing capacity.
- The crawler center section **1** is laying on the support.
- The crawler center section is horizontally aligned.
- The pins **2.1** on the turntable frame lower section **2** are completely unpinned.
- The fastening equipment on the turntable frame lower section **2** has been removed.
- The grating flaps **2.2** on the turntable frame lower section **2** are closed.
- At least one auxiliary crane is available.

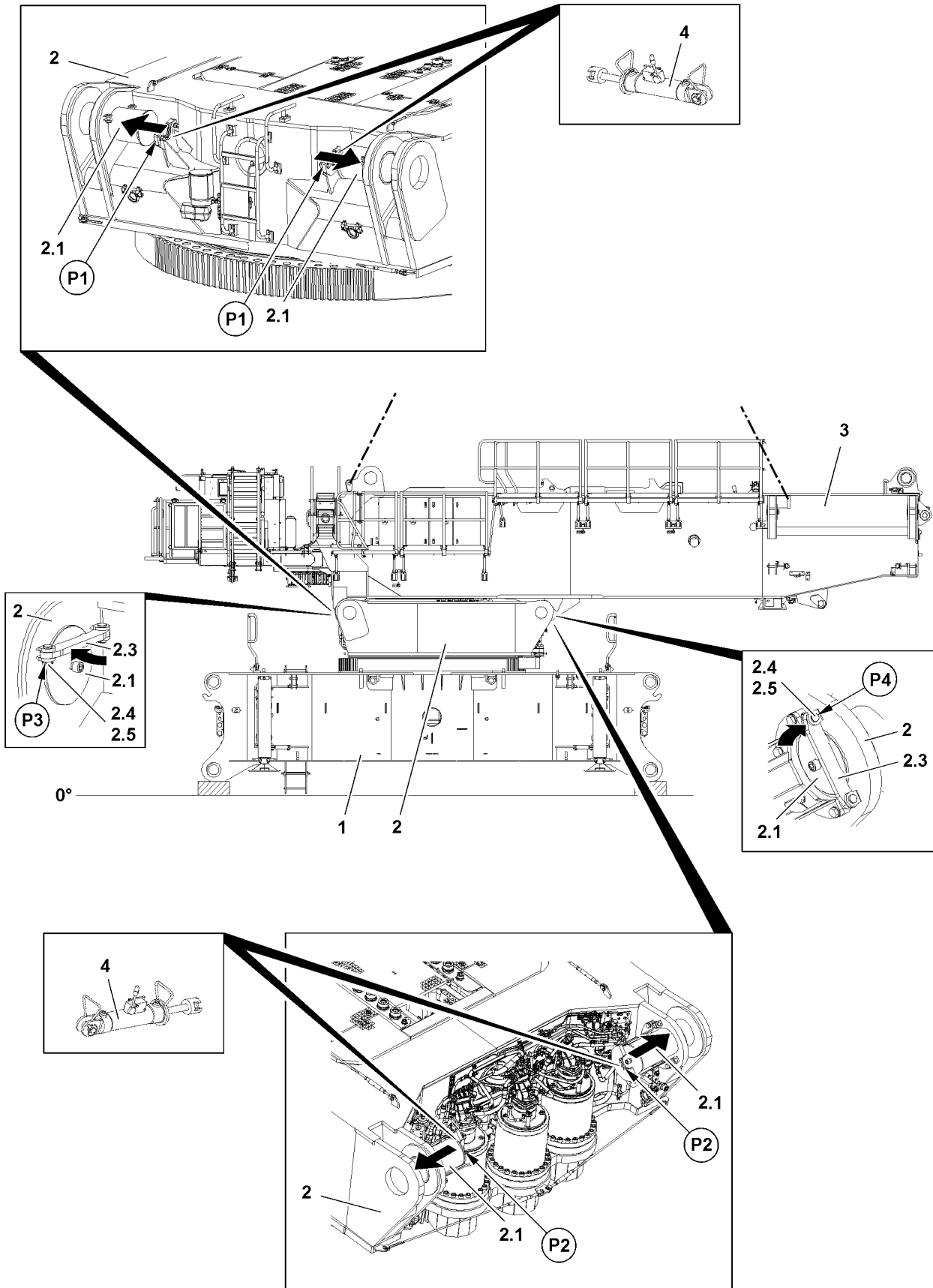

Fig.118555

LWE/LR 11000-001/23501-04-02/en

3.1 Assembly Turntable frame main section

Make sure that the following prerequisites are met:

- The crane operator's cab is in transport position.
- The railings and fall protection equipment on the left of the turntable frame main section **3** is in operating position.
- The SA-frame is not installed.

3.1.1 Pinning the turntable frame main section on the front

- ▶ Attach the turntable frame main section **3** properly on the auxiliary crane / auxiliary cranes, see section „Fastening points“.

When the turntable frame main section **3** is properly fastened on the auxiliary crane / auxiliary cranes:

- ▶ Lift the turntable frame main section **3** with the auxiliary crane.
- ▶ Swing the turntable frame main section **3** in to the crawler center section **1**.
- ▶ Position the turntable frame main section **3** over the pin points on the turntable frame lower section **2**.
- ▶ Set the turntable frame main section **3** on the turntable frame lower section **2**.

When the turntable frame main section **3** is properly set on the turntable frame lower section:

- ▶ Place the pin pulling cylinder **4** properly in the front pin pulling devices at point **P1**.
- ▶ Insert the pins **2.1** with the pin pulling cylinder **4** completely on both sides, see Crane operating instructions, chapter 5.30.

Result:

- The turntable frame main section **3** is pinned in the front area with the turntable frame lower section **2**.
- ▶ Secure the pins **2.1** with retaining bars **2.3**: Close the retaining bars **2.3** on both sides and secure with pin **2.4** and locking pin **2.5** at point **P3**.

Result:

- The pins **2.1** are secured on both sides in the front turntable area.

3.1.2 Pinning the turntable frame main section on the rear

- ▶ Remove the pin pulling cylinder **4** from the front pin pulling devices at point **P1**.
- ▶ Place the pin pulling cylinder **4** properly in the rear pin pulling devices at point **P2**.
- ▶ Insert the pins **2.1** with the pin pulling cylinder **4** completely on both sides, see Crane operating instructions, chapter 5.30.

Result:

- The turntable frame main section **3** is pinned in the rear area with the turntable frame lower section **2**.
- ▶ Secure the pins **2.1** with retaining bars **2.3**: Close the retaining bars **2.3** on both sides and secure with pin **2.4** and locking pin **2.5** at point **P4**.

Result:

- The pins **2.1** are secured on both sides in the rear turntable area.
- The turntable frame main section **3** is properly pinned and secured with the turntable frame lower section **2**.

When the turntable frame main section **3** is properly pinned and secured:

- ▶ Remove the fastening equipment on the turntable frame main section **3** and swing the auxiliary crane out.

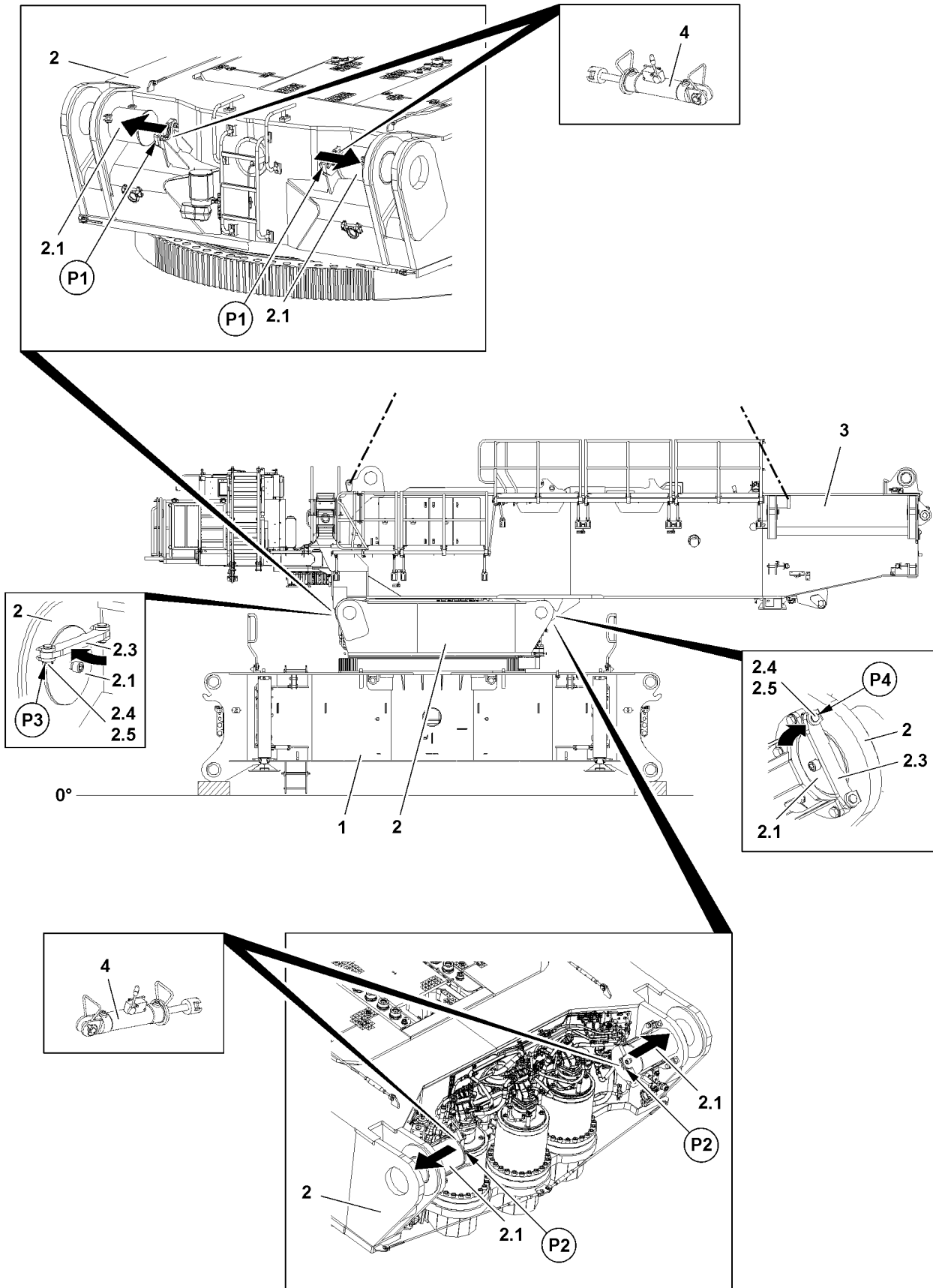

Fig.118555

LWE/LR 11000-001/23501-04-02/en

3.2 Establishing the electrical connections

**Note**

- ▶ To establish the electrical connections between the turntable frame main section and the turntable frame lower section use the Electric wiring diagram.

Make sure that the following prerequisite is met:

- The turntable frame main section is completely and properly installed on the turntable frame lower section.
- ▶ Establish the electrical connections.
- ▶ Make sure that all electrical connections are established.

3.3 Establishing the hydraulic connections

When connecting and releasing hydraulic lines with quick couplings, make sure that the coupling procedure is carried out correctly.

**DANGER**

Danger of accident due to loss of pressure or leakage!

Incorrectly coupled or self-loosening quick couplings (particularly return lines) can result in serious accidents due to component failure.

- ▶ Check that the quick couplings have been properly connected before using the crane.

**Note**

- ▶ To connect or release the hydraulic lines with quick couplings, see Crane operating instructions, chapter 5.01.
- ▶ Release the pressure in the hydraulic system before connecting and disconnecting: Turn the engine off and wait for short time.
- ▶ Assembling coupling components (sleeve and connector) by using hand-tightened nut.
- ▶ Connect coupling components.

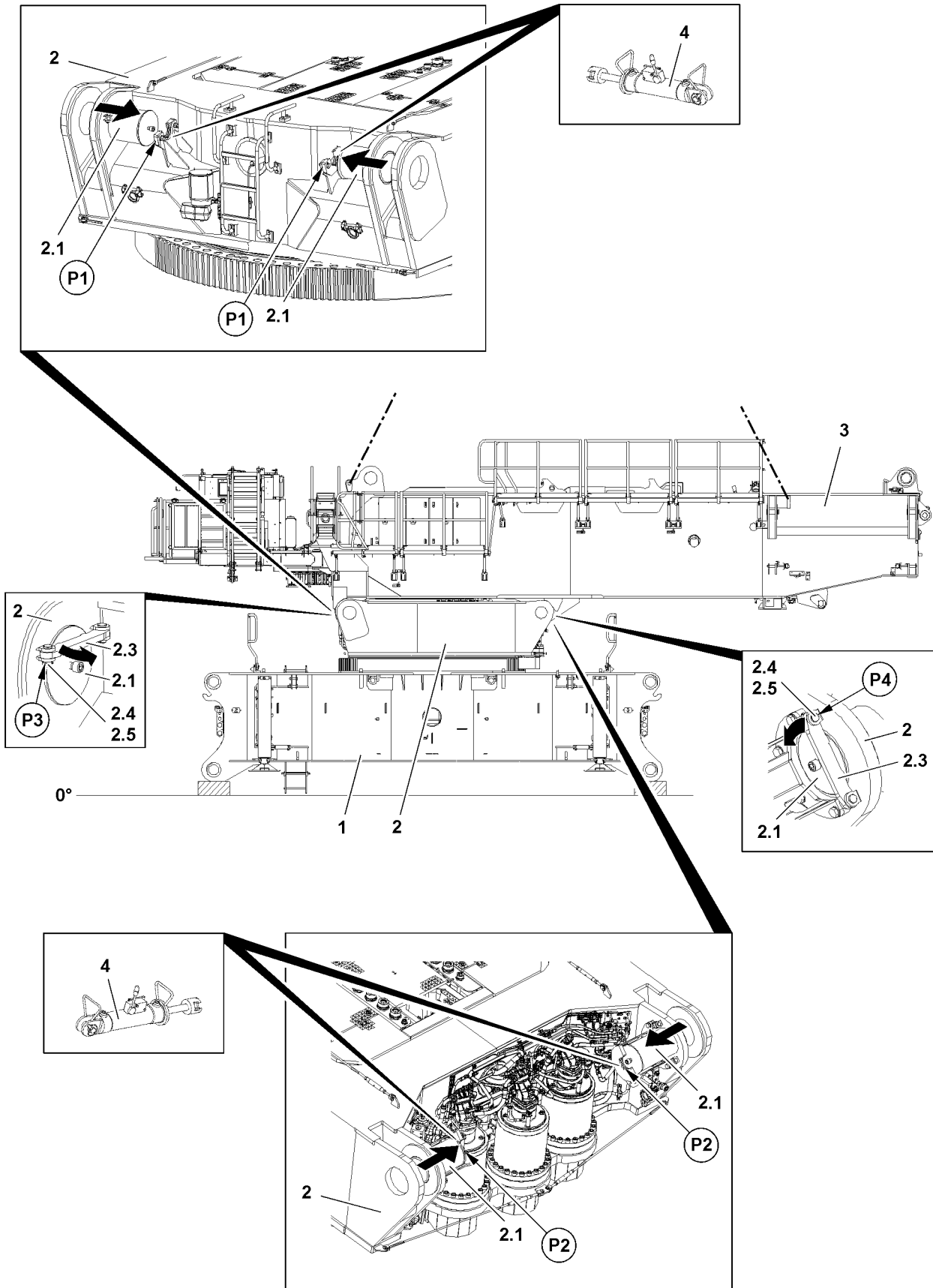

Fig.118556

LWE/LR 11000-001/23501-04-02/en

4 Disassembly of turntable



WARNING

Danger of falling!

During assembly / disassembly, inspection and maintenance work, assembly personnel must be secured with appropriate aids to prevent them from falling.

If this is not observed, assembly personnel could fall and suffer life-threatening or fatal injuries.

- ▶ The assembly personnel must always move carefully and anticipatory on the crane, the crane components or lattice sections.
- ▶ All work aloft, where there is a danger of falling must be carried out with suitable aids.
- ▶ If fall protection equipment is available, then it must be used.
- ▶ If aids are not available and work cannot be carried out from the ground, then the assembly personnel must secure themselves with the approved fall arrest system to prevent falling, see Crane operating instructions, chapter 2.04.
- ▶ The fall arrest system must be attached on the fastening and hook points as well as on the safety ropes.
- ▶ Always secure ladders on structural parts and / or components to prevent them from falling over.
- ▶ Only step on the aids, ladders and catwalks with clean shoes.
- ▶ Keep aids, ladders and catwalks free of heavy dirt, snow, frost and ice.
- ▶ Stepping or walking on crane components and lattice sections, which have an incline of more than 20° is prohibited.



Note

- ▶ For the disassembly of the turntable frame main section **3** on the turntable frame lower section **2** use a pin pulling device, see Crane operating instructions, chapter 5.30.

Make sure that the following prerequisites are met:

- At least one auxiliary crane is available.
- The derrick ballast has been removed.
- The main boom has been removed.
- The derrick boom has been removed.
- The counterweight has been removed.
- The SA-frame has been removed.
- Winch 1 and winch 2 have been removed on the turntable frame main section.

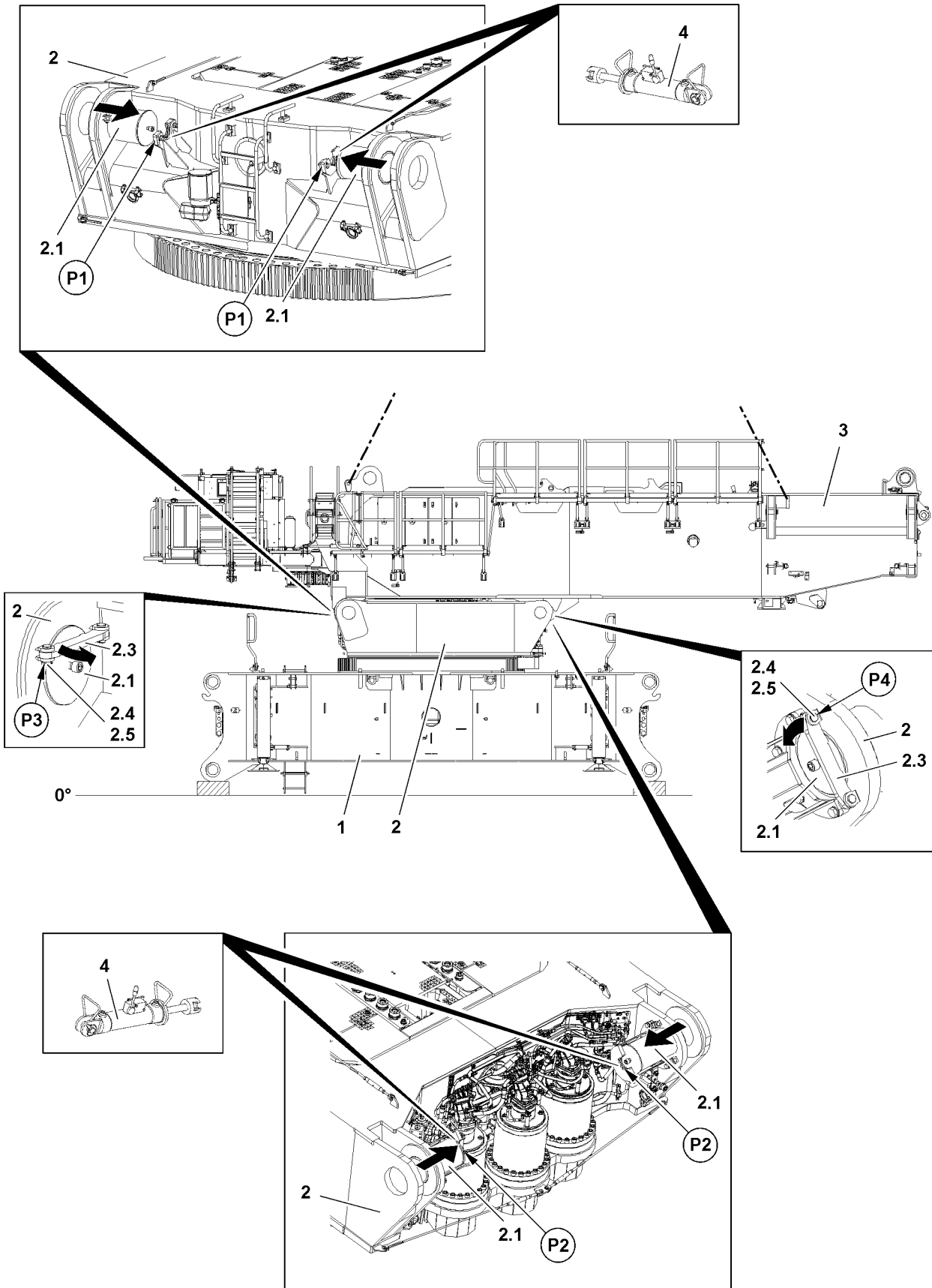

Fig.118556

LWE/LR 11000-001/23501-04-02/en

4.1 Disconnecting the electrical connections

NOTICE

Damage to cables!

If the cables are not properly stored after unplugging, then the cables can be significantly damaged.

▶ Store the cables properly after unplugging.

▶ Disconnect the electrical connections and store the plugs and cables properly.

4.2 Disconnecting the hydraulic connections

When connecting and releasing hydraulic lines with quick couplings, make sure that the coupling procedure is carried out correctly.



DANGER

Danger of accident due to loss of pressure or leakage!

Incorrectly coupled or self-loosening quick couplings (particularly return lines) can result in serious accidents due to component failure.

▶ Check that the quick couplings have been properly connected before using the crane.



Note

▶ To connect or release the hydraulic lines with quick couplings, see Crane operating instructions, chapter 5.01.

▶ Release the pressure in the hydraulic system before connecting and disconnecting: Turn the engine off and wait for short time.

▶ Assembling coupling components (sleeve and connector) by using hand-tightened nut.

▶ Connect coupling components.

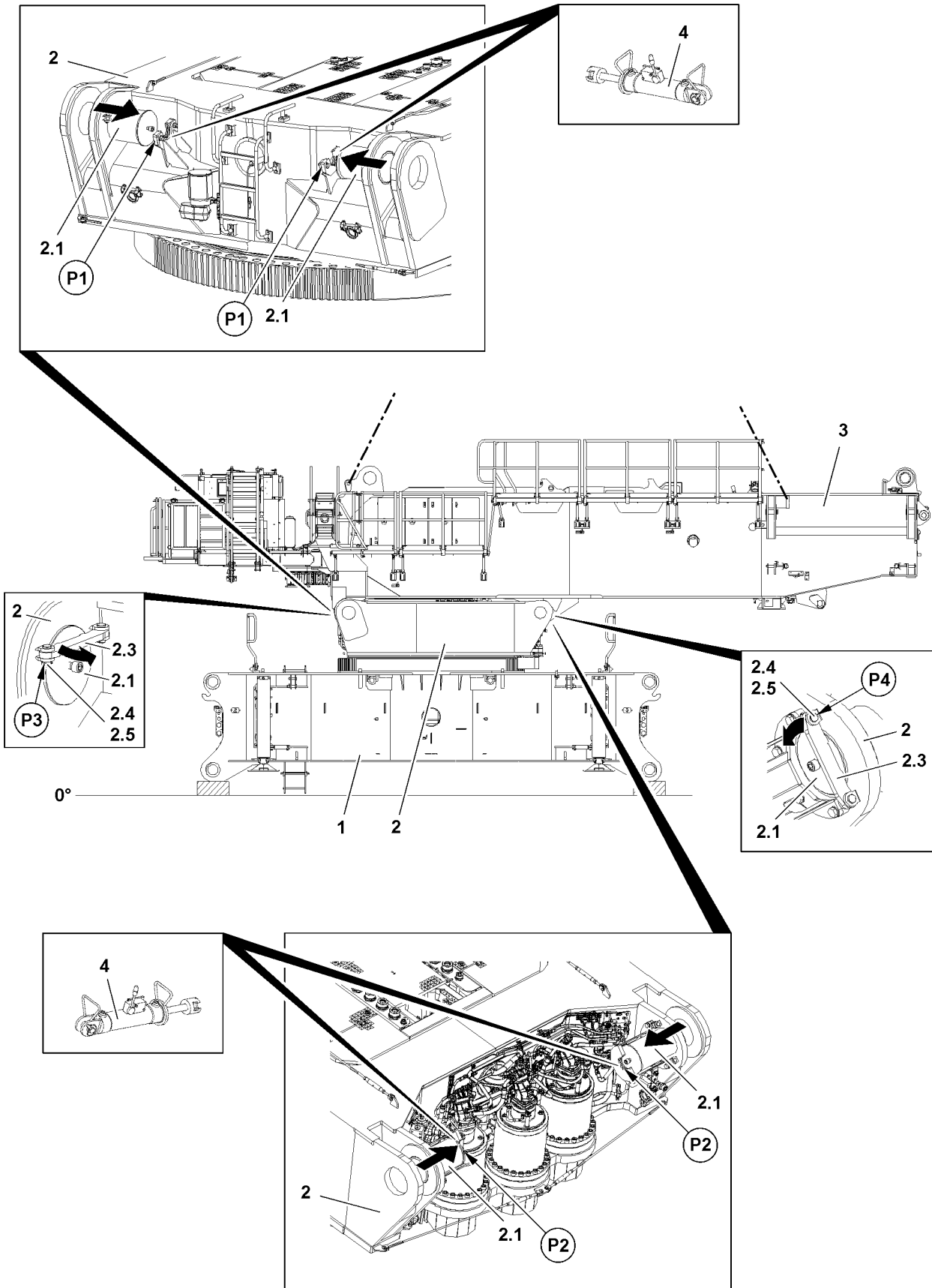

Fig.118556

LWE/LR 11000-001/23501-04-02/en

4.3 Disassembly Turntable frame main section

Make sure that the following prerequisites are met:

- The ground is level and of sufficient load bearing capacity.
- The crawler center section **1** is laying on the support.
- The crawler center section is horizontally aligned.
- The crane operator's cab is in transport position.
- The fastening equipment has been properly pinned and secured on the fastening points of the turntable frame main section **3**, see section „Fastening points“.
- The electrical connections between the turntable frame main section **3** and the turntable frame lower section **2** are disconnected.
- The hydraulic connections between the turntable frame main section **3** and the turntable frame lower section **2** are disconnected.

4.3.1 Unpinning the turntable frame main section on the rear

- ▶ Bring the fastening equipment between the turntable frame main section **3** and the auxiliary crane carefully to „tension“.

When the turntable frame main section **3** is properly secured by the auxiliary crane:

- ▶ Release pins **2.1** on both sides: Remove the locking pin **2.5** and pin **2.4** on both sides at point **P4**.

Result:

- The retaining bar **2.3** is released.
- ▶ Swing the retaining bar **2.3** out on both sides.

Result:

- The pins **2.1** are released.

When the pins **2.1** are released on both sides:

- ▶ Place the pin pulling cylinder **4** on the rear area of the turntable frame main section **3** on both sides in the pin pulling device at point **P2**.
- ▶ Unpin the pins **2.1** with the pin pulling cylinder **4** completely on both sides, see Crane operating instructions, chapter 5.30.

Result:

- The turntable frame main section **3** is unpinned in the rear area on the turntable frame lower section **2**.

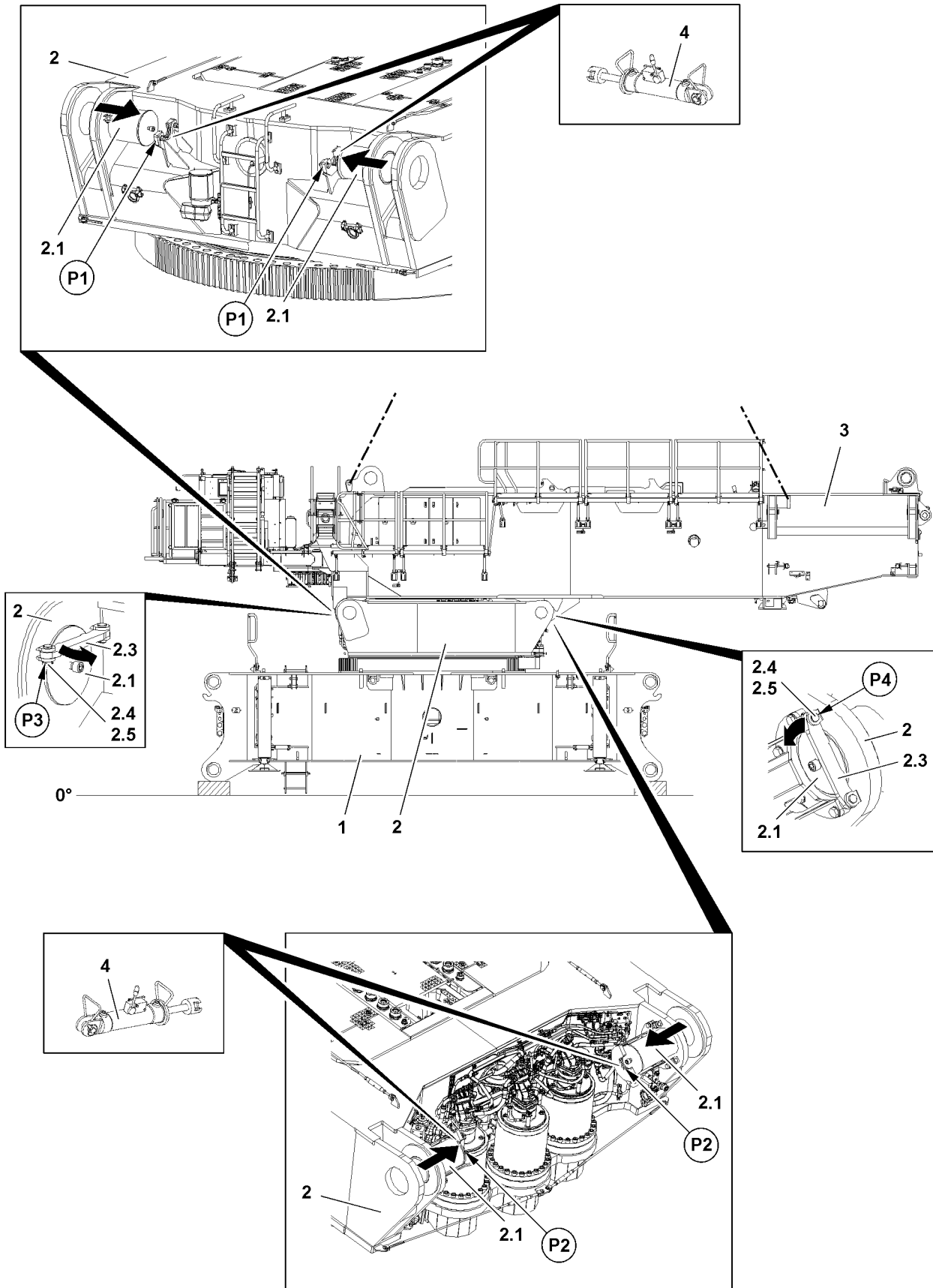

Fig.118556

LWE/LR 11000-001/23501-04-02/en

4.3.2 Unpinning the turntable frame main section on the front

- ▶ Release pins **2.1** on both sides: Remove the locking pin **2.5** and pin **2.4** on both sides at point **P3**.

Result:

- The retaining bar **2.3** is released.

- ▶ Swing the retaining bar **2.3** out on both sides.

Result:

- The pins **2.1** are released.

When the pins **2.1** are released on both sides:

- ▶ Place the pin pulling cylinder **4** on the front area of the turntable frame main section **3** on both sides in the pin pulling device at point **P1**.
- ▶ Unpin the pins **2.1** with the pin pulling cylinder **4** completely on both sides, see Crane operating instructions, chapter 5.30.

Result:

- The turntable frame main section **3** is completely unpinned.

NOTICE

Damage to crane!

- ▶ Make sure that all pins **2.1** are completely unpinned before lifting the turntable frame main section **3** off.

When all four pins **2.1** between the turntable frame main section **3** and the turntable frame lower section **2** are unpinned:

- ▶ Lift the turntable frame main section **3** with the auxiliary crane from the turntable frame lower section **2**.
- ▶ Swing the turntable frame main section **3** out with the auxiliary crane.
- ▶ Set the turntable frame main section **3** on a load bearing support or on a flatbed trailer.

When the turntable frame main section **3** is properly set on the support or on the flatbed trailer:

- ▶ Remove the fastening equipment and the auxiliary crane.

Empty page!

LWE/LR 11000-001/23501-04-02/en

3.03 Central ballast

1	Components	3
2	Fastening points and weights	3
3	Central ballast combinations	6
4	Permissible counterweight assemblies	7
5	Installing the central ballast	8
6	Disassembling the central ballast	21

Fig.195219

LWE/LR 11000-001/23501-04-02/en

1 Components

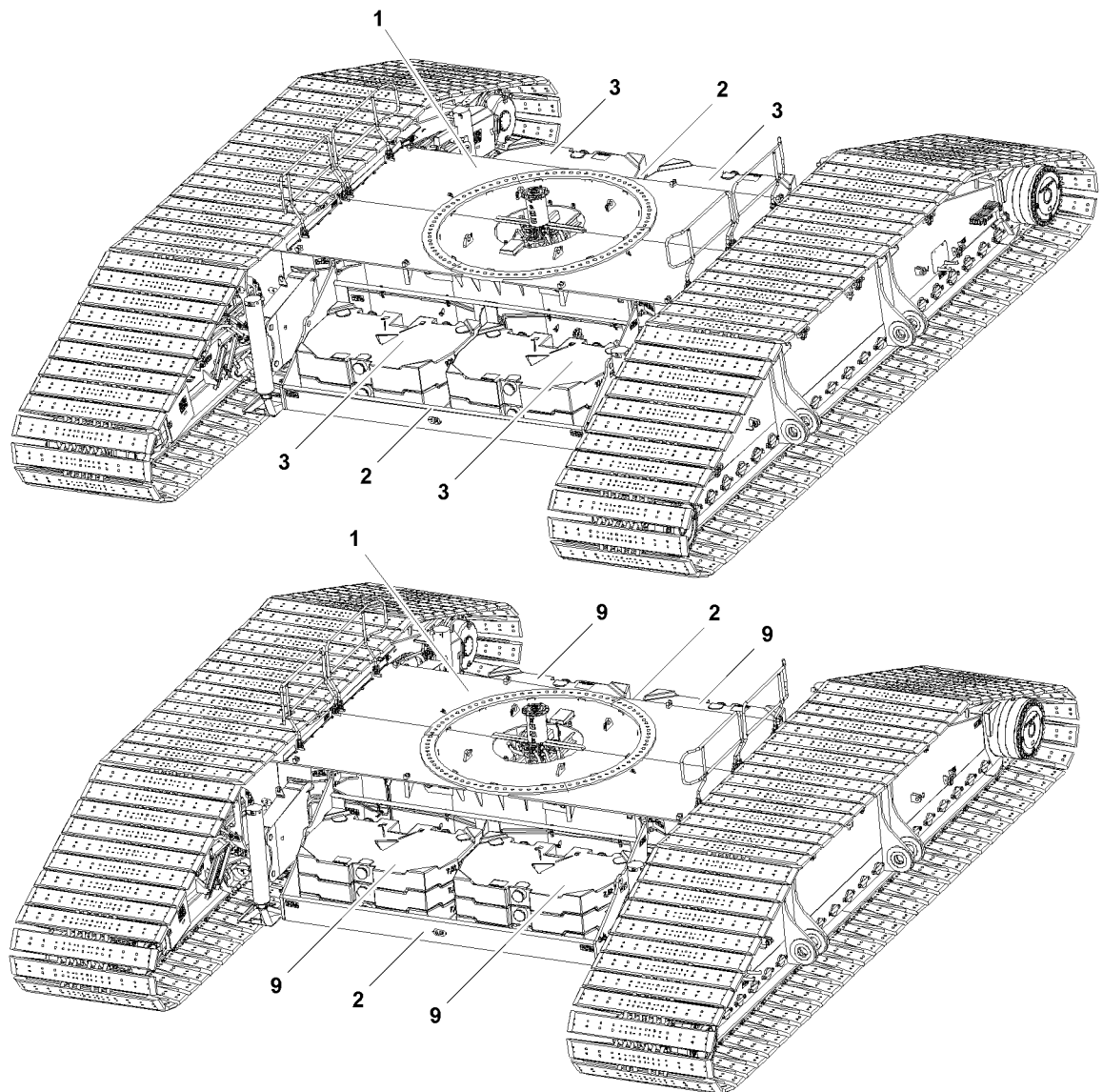

Fig. 126080

- | | | | |
|---|--------------------------|---|---|
| 1 | Crawler center section | 3 | Ballast plate 10.0 t |
| 2 | Central ballast brackets | 9 | Alternative to 10 t ballast plates: Ballast plate 7.5 t |

2 Fastening points and weights



Note

- ▶ The ballast plates **3**, the ballast plates **9** and the central ballast consoles **2** are marked with their own weight.

2.1 Fastening points central ballast bracket



WARNING

Falling central ballast bracket!

- ▶ Fasten the central ballast bracket properly on the fastening points **P1**.
- ▶ Make sure that the central ballast bracket **2** is always fastened horizontally on the auxiliary crane.

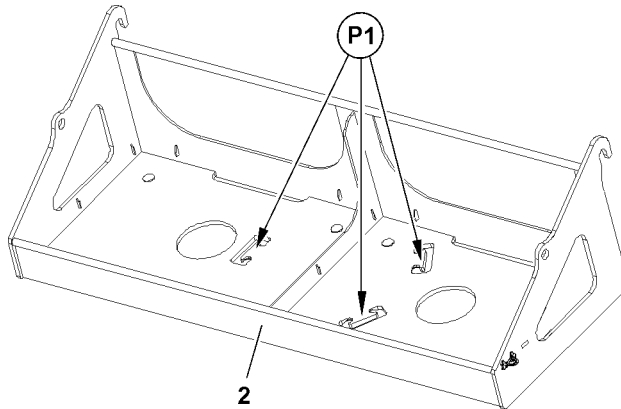

Fig.118217: Central ballast bracket

Fastening points	
P1	Central ballast bracket

2.2 Fastening points central ballast bracket with ballast plates



WARNING

Tipping central ballast bracket!

If the central ballast bracket **2** is fastened on the auxiliary crane with more than the maximum permissible two ballast plates (ballast plates **3** or ballast plates **9**), then the central ballast bracket can tip over.

The ballast plates can fall down.

Death, severe bodily injuries, property damage.

- ▶ Make sure that the assembly of the central ballast bracket is carried out with maximum two inside ballast plates.
- ▶ Make sure that the central ballast bracket **2** is always fastened horizontally on the auxiliary crane.

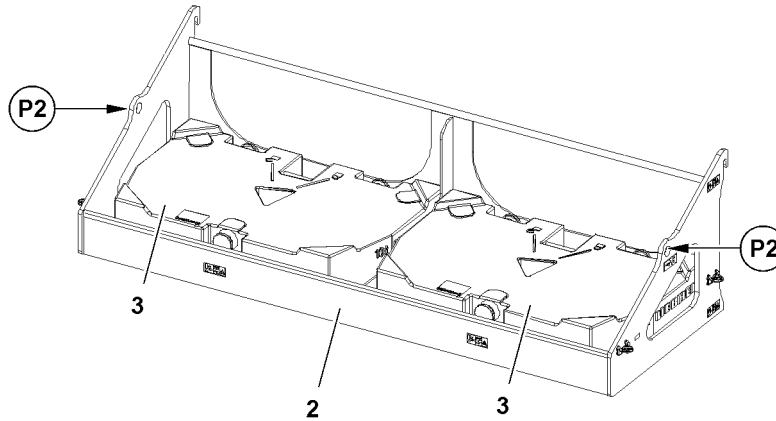

Fig.118225: Central ballast bracket **with** ballast plates



WARNING

Falling central ballast bracket!

If no shackles are used when fastening the central ballast bracket **2**, in connection with the inside ballast plates, then the fastening ropes can be damaged and rip off.

Death, severe bodily injuries, property damage.

- ▶ Make sure that per fastening point fastening equipment with a minimum 5.0 m length is used.
- ▶ Fasten the central ballast bracket **2** only on the fastening points **P2** in connection with shackles.

Fastening points	
P2	Central ballast bracket with ballast plates ¹⁾

1) Maximum permissible: 2 x 10.0 t or 2 x 7.5 t „inside positioned“

2.3 Weight central ballast bracket

Weight	Component
5.0 t	Central ballast bracket 2

2.4 Weight ballast plate

Individual weight	Component
10.0 t	Ballast plate 3
7.5 t	Ballast plate 9

2.5 Weight central ballast bracket with ballast plates



WARNING

Falling central ballast bracket!

- ▶ Make sure that the central ballast bracket, including the inside positioned ballast plates, do not exceed the maximum permissible total weight of 25.0 t at assembly.

LWE/LR 11000-001/23501-04-02/en

Weight	Component
25.0 t	Central ballast bracket with 2 x 10.0 t ballast plate ¹⁾
20.0 t	Central ballast bracket with 2 x 7.5 t ballast plate

1) Maximum permissible: 2 x 10.0 t „inside“

3 Central ballast combinations

Various central ballast combinations can be placed in the central ballast stacks.



WARNING

The crane can topple over!

- ▶ Make sure that the ballast plates are always placed symmetrically on the central ballast brackets.
- ▶ Make sure that both central ballast brackets always have the identical number of the same ballast plates and an identical weight.

For erection / take down of boom systems the following applies:

- ▶ Always place the central ballast according to the Erection / take down chart.

For crane operation the following applies:

- ▶ Always place the central ballast according to the load chart.

4 Permissible counterweight assemblies

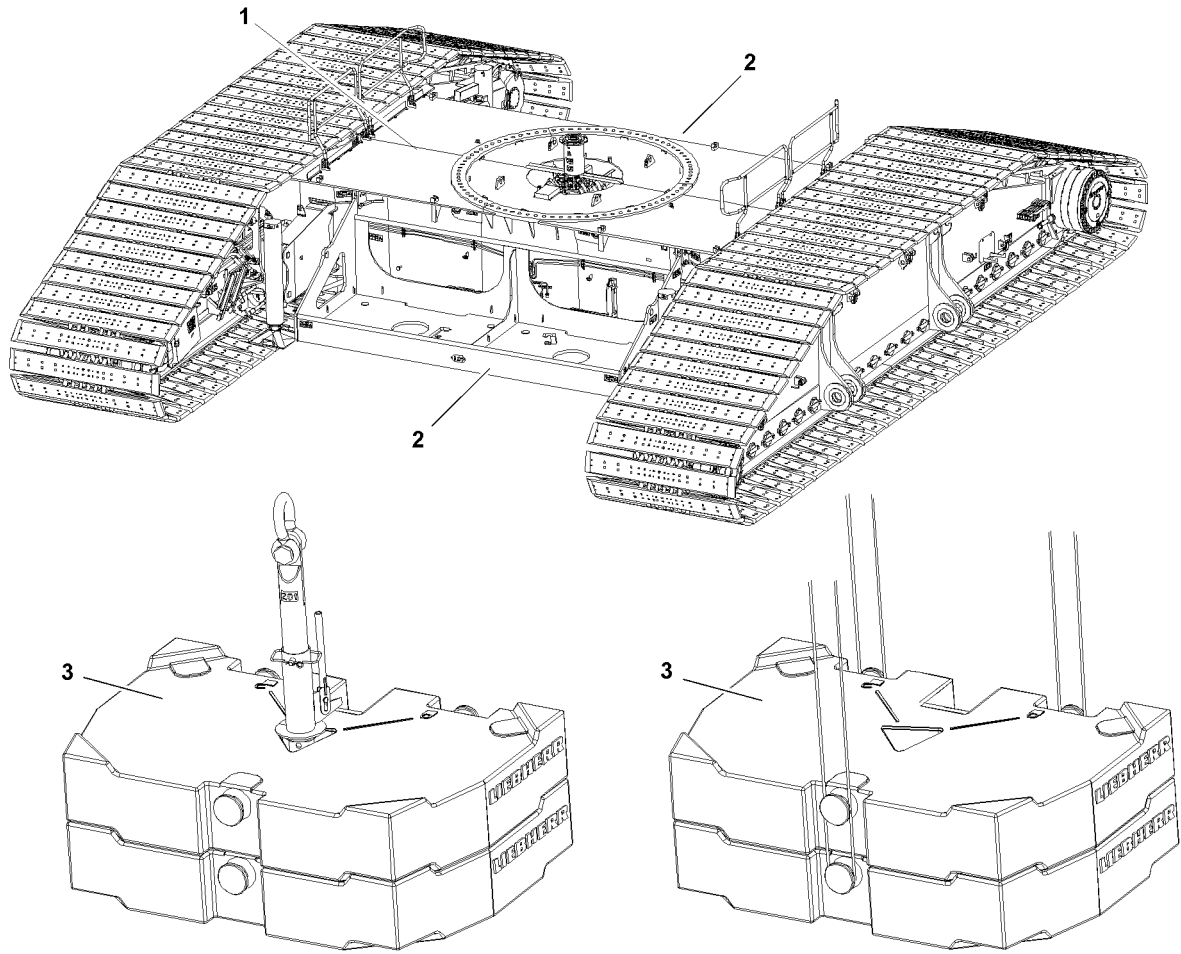

Fig.122412: Permissible counterweight assemblies



WARNING

Overload fastening points counterweight assemblies!

If more than the permissible number of counterweights are lifted together, then the fastening points can be overloaded.

The counterweights and components can fall down.

Death, severe bodily injuries, property damage.

► Attach only the maximum permissible number of counterweights per lift.

Individual weight Counterweight plate	Maximum number of same counterweight plates per lift over	
	Twistlock	Bitt
10.0 t	2	2
7.5 t	2	2

LWE/LR 11000-001/23501-04-02/en

5 Installing the central ballast



WARNING

Danger of falling!

During assembly / disassembly, inspection and maintenance work, personnel must be secured with appropriate aids to prevent them from falling.

Death, severe bodily injuries, property damage.

- ▶ All work aloft, where there is a danger of falling must be carried out with suitable aids.
- ▶ If aids are not available and work cannot be carried out from the ground, then the assembly personnel must secure themselves with the supplied fall arrest system to prevent falling, see Crane operating instructions, chapter 2.04.
- ▶ If fall protection equipment is available, then it must be used, see Crane operating instructions, chapter 2.06.
- ▶ When lifting, lowering, swinging crane parts in and out, no persons may remain in the danger zone.
- ▶ If railings are present for the crane, then they must be brought into the corresponding position and secured for assembly / disassembly work.
- ▶ It is prohibited to lean the auxiliary ladder against the component being disassembled.
- ▶ Only step on the aids, ladders and catwalks with clean shoes.
- ▶ Keep aids, ladders and catwalks free of heavy dirt, snow, frost and ice.
- ▶ During all assembly and disassembly work, maintenance work and inspections, travel or crane operation is prohibited.
- ▶ Remaining on a suspended load is prohibited.
- ▶ Stepping or walking on crane components and lattice sections, which have an incline of more than 20° is prohibited.
- ▶ For all assembly work, the crane operator of the main crane must be in voice contact with the crane operator / crane operators of the auxiliary crane / auxiliary cranes.
- ▶ For assembly / disassembly tasks, the crane operator may only initiate crane movements when the responsible guide has explicitly released the movement.



WARNING

Danger of impact / crushing!

When installing / removing crane components with the auxiliary crane, crane components can start to swing back and forth.

When lifting / lowering and positioning crane components, there is an increased danger of impacts / crushing.

Death, severe bodily injuries, property damage.

- ▶ Make sure that personnel cannot be caught by components.
- ▶ When working in danger zones: Use aids to protect limbs.
- ▶ Guide components with suitable aids to minimize oscillation.



DANGER

The components can fall down!

If the corresponding component is disengaged from the auxiliary crane before the corresponding component is pinned, then the corresponding component can fall down.

Death, severe bodily injuries, property damage.

- ▶ Do not disengage the auxiliary crane until the respective component is pinned and secured.



WARNING

Danger of impact / crushing!

If anyone remains within the assembly / disassembly area of the ballast, they would be exposed to a danger of impact / crushing.

Death, severe bodily injuries, property damage.

- ▶ Make sure that there are no persons between the components which are to be assembled / disassembled and the crawler travel gear.

Make sure that the following prerequisites are met:

- The installation of the crawler carriers is completed.
- Both crawler carriers are standing on the ground.
- The assembly supports are in operating position.
- The support cylinders on the assembly supports are moved in.
- The crane is horizontally aligned.
- The railings on the crawler center section are in operating position, see Crane operating instructions, chapter 2.06.
- The extension ladder on the crawler center section is removed on both sides.
- There are no persons or objects in the assembly area of the central ballast brackets.

5.1 Assembling the central ballast brackets

Make sure that the following prerequisites are met:

- The assembly supports are pinned in operating position and secured.
- The retaining pins **6** are unpinned on both sides at point **P3**.
- The fastening equipment for the assembly of the central ballast brackets must have a minimum length of 5000 mm.



Note

- ▶ It is permissible to install the central ballast bracket **2** under certain prerequisites with placed ballast plates.
 - ▶ Observe section „Installing the central ballast brackets with placed ballast plates“ in this chapter.
-

5.1.1 Assembling the first central ballast bracket (turntable is assembled on the crawler center section)

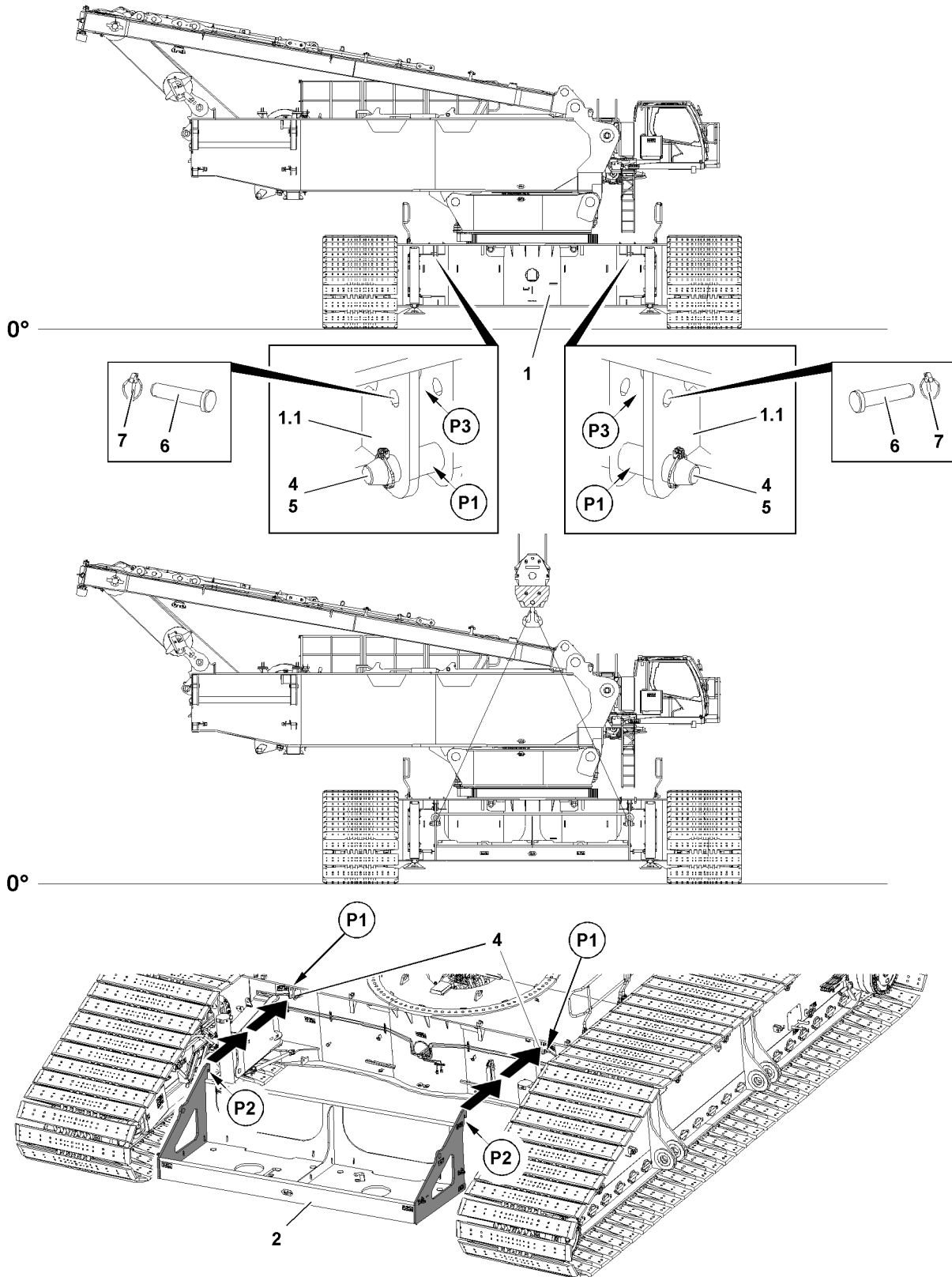

Fig.122413: Assemble the central ballast bracket on the crawler center section

LWE/LR 11000-001/23501-04-02/en

**Note**

- ▶ Due to better accessibility for assembly / disassembly of the central ballast brackets **2** we recommend to carry out the assembly / disassembly of the central ballast brackets **2** on the side facing away from the crane operator's cab.
- ▶ After assembly of the first central ballast bracket **2** and the respective ballast plates, turn the turntable by 180°.

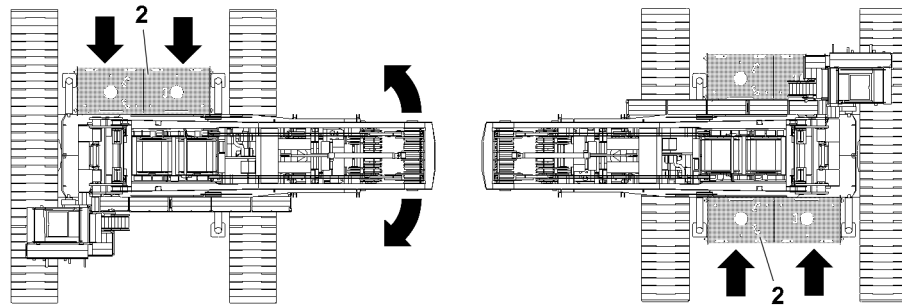

Fig.126087: Turn the turntable for assembly of the central ballast by 180°

Make sure that the following prerequisite is met:

- The turntable is in 90° position to the crawler travel gear.

- ▶ Fasten the central ballast bracket **2** onto the auxiliary crane.

**WARNING**

Danger of crushing!

Death, severe bodily injuries, property damage.

- ▶ Make sure, when swinging the central ballast brackets in to the hook points **P1** on the crawler center section **1**, that there are no persons or objects within the danger zone.

- ▶ Swing the central ballast bracket **2** in with the auxiliary crane to the hook points **P1**.
- ▶ Hang the central ballast bracket **2** on the hook pins **4** on both sides.

When the central ballast bracket is properly hooked on the hook pins **4**:

- ▶ Insert the retaining pins **6** on both sides at point **P3** and secure with locking pin **7**.

When the first central ballast bracket is properly assembled and secured:

- ▶ Place the ballast plates properly on the central ballast bracket, see section „Placing the ballast plates“.

When the ballasting of the first central ballast bracket is completed:

- ▶ Assemble the catwalk / staircase on the crawler carrier, see Crane operating instructions, chapter 2.06.

When the catwalk is properly assembled and secured:

- ▶ Assemble the staircase, see Crane operating instructions, chapter 2.06.

**WARNING**

Danger of accidents when turning the turntable!

Death, severe bodily injuries, property damage.

- ▶ Make sure that no persons or objects are within the danger zone when turning the turntable.

When the staircase is properly assembled and secured:

- ▶ Turn the turntable by 180°.

5.1.2 Assembling the second central ballast bracket (turntable is assembled on the crawler center section)



Note

- ▶ The procedure for assembly of the second central ballast bracket is identical with the assembly of the first central ballast bracket.
-

Make sure that the following prerequisites are met:

- The first central ballast bracket is properly assembled and secured.
 - The first catwalk is properly assembled and secured.
 - The staircase is properly assembled and secured on the catwalk.
 - The turntable is turned by 180°.
- ▶ Assemble the second central ballast bracket, see section „Assembling the first central ballast bracket“ (turntable is assembled on the crawler center section).
 - ▶ Assemble the second catwalk, see Crane operating instructions, chapter 2.06.
 - ▶ Assemble the second staircase, see Crane operating instructions, chapter 2.06.

5.1.3 Assembling the first central ballast bracket (turntable is not assembled on the crawler center section)

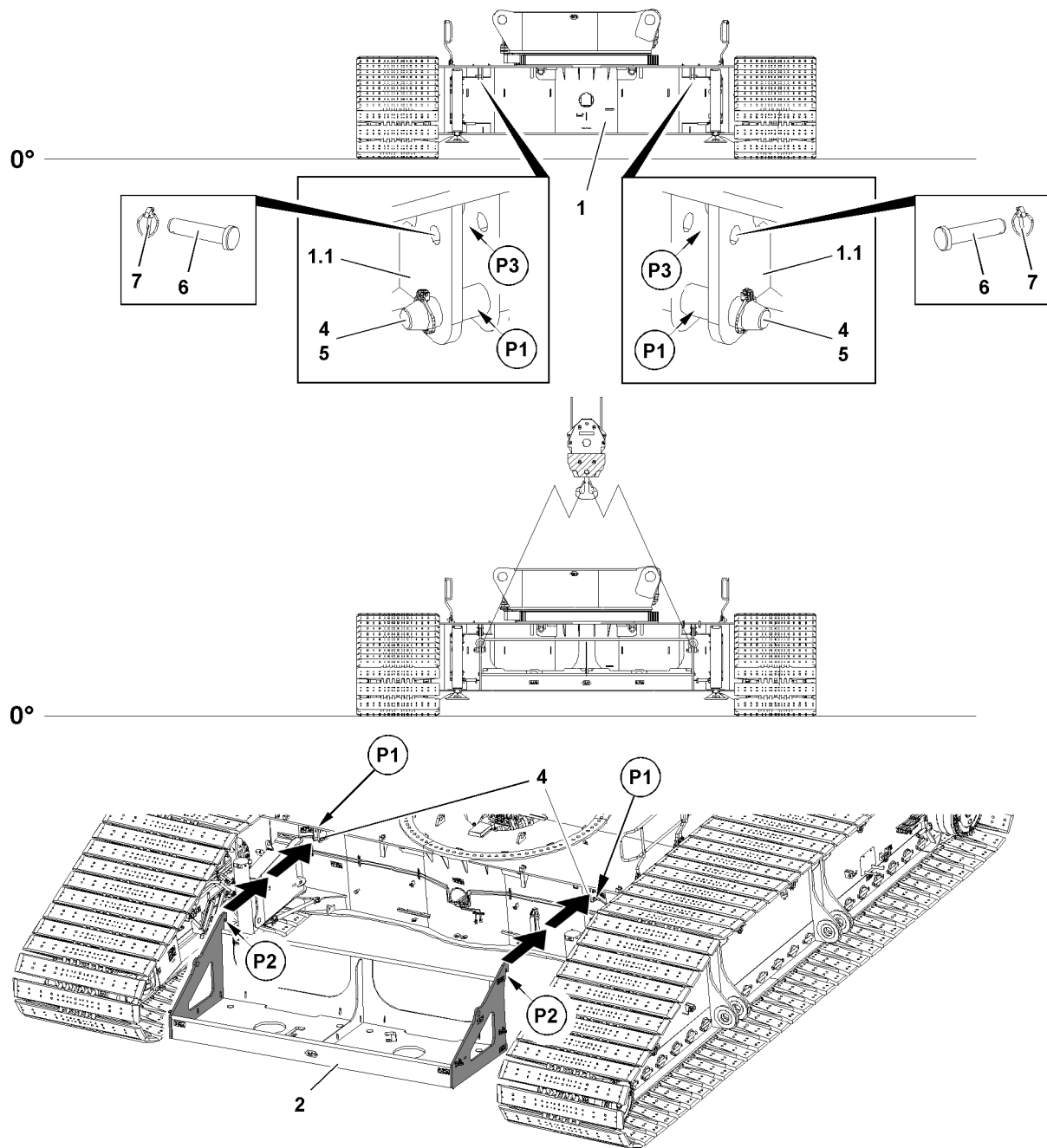

Fig.126081: Assemble the central ballast bracket on the crawler center section

- ▶ Fasten the central ballast bracket 2 onto the auxiliary crane.



WARNING

Danger of crushing!
Death, severe bodily injuries, property damage.

- ▶ Make sure, when swinging the central ballast brackets in to the hook points **P1** on the crawler center section 1, that there are no persons or objects within the danger zone.
- ▶ Swing the central ballast bracket 2 in with the auxiliary crane to the hook points **P1**.
- ▶ Hang the central ballast bracket 2 on the hook pins 4 on both sides.

When the central ballast bracket is properly hooked on the hook pins **4**:

- ▶ Insert the retaining pins **6** on both sides at point **P3** and secure with locking pin **7**.

When the first central ballast bracket is properly assembled and secured:

- ▶ Place the ballast plates properly on the central ballast bracket, see section „Placing the ballast plates“.

When the ballasting of the first central ballast bracket is completed:

- ▶ Assemble the catwalk / staircase on the crawler carrier, see Crane operating instructions, chapter 2.06.

When the catwalk is properly assembled and secured:

- ▶ Assemble the staircase, see Crane operating instructions, chapter 2.06.

5.1.4 Assembling the second central ballast bracket (turntable is not assembled on the crawler center section)



Note

- ▶ The procedure for assembly of the second central ballast bracket is identical with the assembly of the first central ballast bracket.

Make sure that the following prerequisites are met:

- The first central ballast bracket is properly assembled and secured.
- The first catwalk is properly assembled and secured.
- The staircase is properly assembled and secured on the catwalk.
- ▶ Assemble the second central ballast bracket, see section „Assembling the first central ballast bracket“ (turntable is not assembled on the crawler center section).
- ▶ Assemble the second catwalk, see Crane operating instructions, chapter 2.06.
- ▶ Assemble the second staircase, see Crane operating instructions, chapter 2.06.

5.2 Installing the central ballast brackets with placed ballast plates

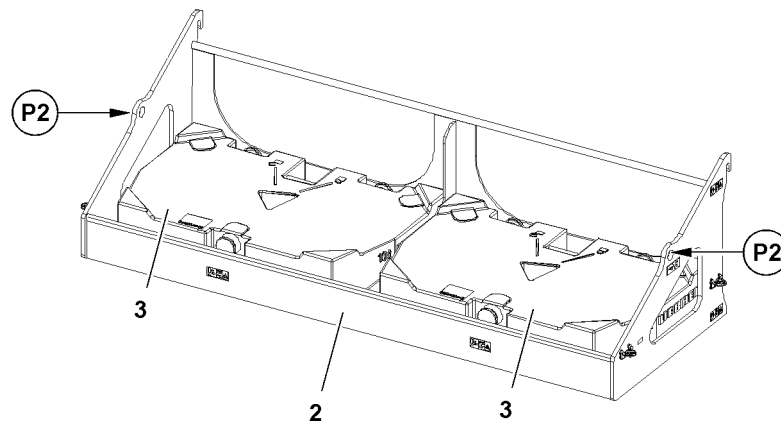

Fig.118225: Central ballast bracket with two inside ballast plates



WARNING

Overload of fastening points bracket!

If the central ballast bracket **2** is lifted with more than two ballast plates, then the fastening points will be overloaded.

The central ballast bracket **2** and the ballast plates can fall down.

Death, severe bodily injuries, property damage.

- ▶ Make sure that maximum two ballast plates are placed on the central ballast bracket **2** to be lifted.

**Note**

- ▶ When placing the ballast plates on the central ballast bracket **2** observe Section „Placing the ballast plates“ in this chapter.

Make sure that the following prerequisites are met:

- The assembly supports are pinned in operating position and secured.
- The retaining pins **6** are unpinned on both sides at point **P3**.
- The fastening equipment for the assembly of the central ballast brackets must have a minimum length of 5000 mm.

5.2.1 Assembling the central ballast brackets with placed ballast plates (turntable is assembled on the crawler center section)

**Note**

- ▶ The procedure for the assembly of the central ballast brackets with placed ballast plates is identical with the assembly of the central ballast brackets without ballast plates, see section „Assembling the central ballast brackets“.

Make sure that the following prerequisite is met:

- The turntable is in 90° position to the crawler travel gear.

5.2.2 Assembling the central ballast brackets with placed ballast plates (turntable is not assembled on the crawler center section)

**Note**

- ▶ The procedure for the assembly of the central ballast brackets with placed ballast plates is identical with the assembly of the central ballast brackets without ballast plates, see section „Assembling the central ballast brackets“.

5.3 Place the ballast plates

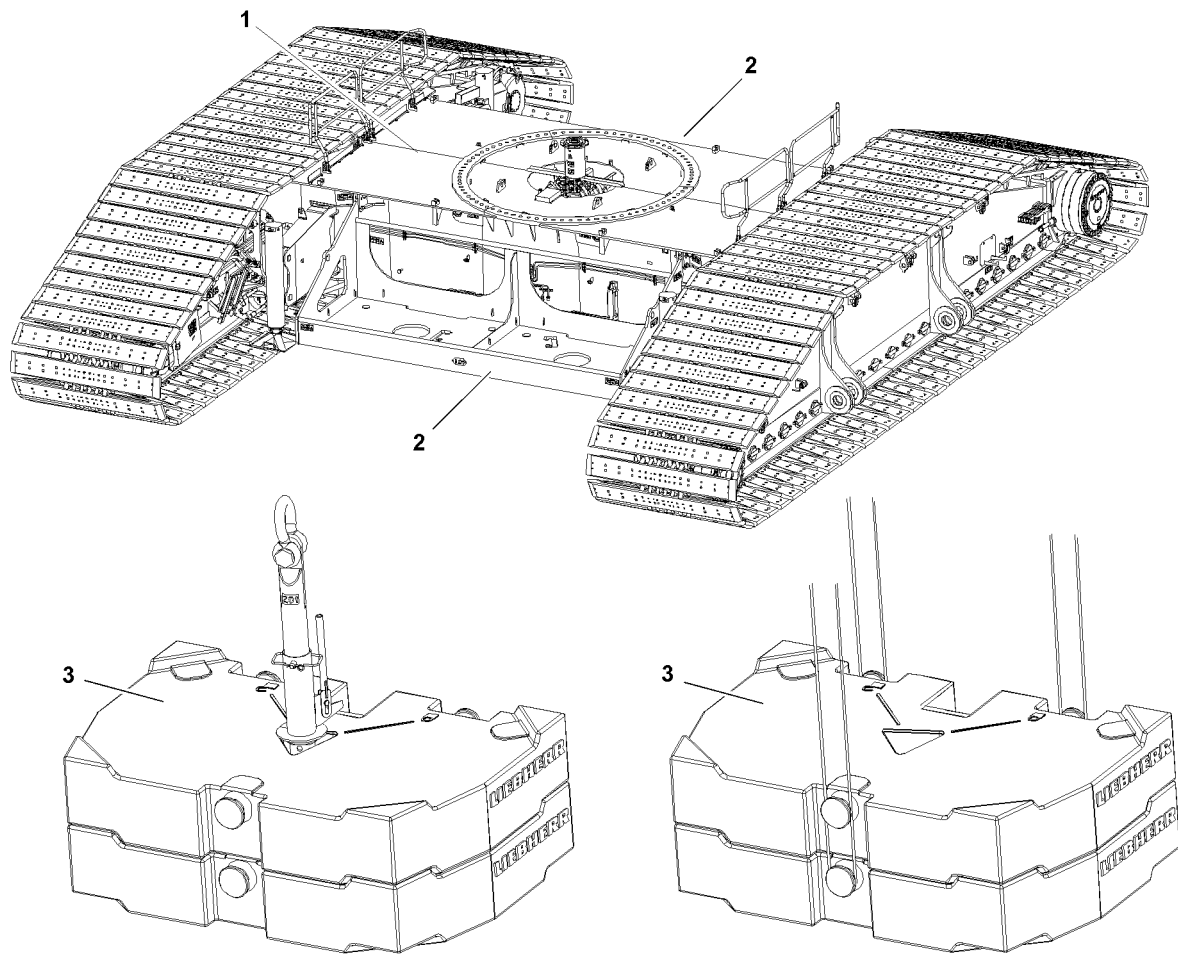

Fig.122412: Place the ballast plates



WARNING

Central ballast too low / too high!

If the placed central ballast deviates from the specified data in the load charts or the assembly conditions, then the crane can be damaged or topple over.

Death, severe bodily injuries, property damage.

► Make sure that the central ballast is placed according to the load chart.



WARNING

Damaged ballast plates!

Damage on the ballast plates **3** can cause the fastening equipment to release.

The ballast plates **3** and components can fall down.

Death, severe bodily injuries, property damage.

► Do not use damaged ballast plates **3** and replace them immediately.



WARNING

Asymmetric central ballast distribution!

If the central ballast is not distributed evenly on both central ballast brackets **2**, then this can lead to overloads on the crane.

The crane can be damaged and components can fall down.

Death, severe bodily injuries, property damage.

► Make sure that the central ballast is distributed evenly on the central ballast brackets **2**.

**WARNING**

Toppling central ballast stack!

Lopsided stacked ballast plates **3** create instability in the central ballast stack **4**.

The ballast plates **3** can tip from the central ballast brackets **2** and cause the crane to topple over.

Death, severe bodily injuries, property damage.

► Make sure that the ballast plates **3** are placed correctly in the centerings.

Make sure that the following prerequisite is met:

- The central ballast brackets **2** are properly installed and secured on the crawler center section **1**.

5.3.1 Placing the ballast plates, fastening system: „Twistlock“

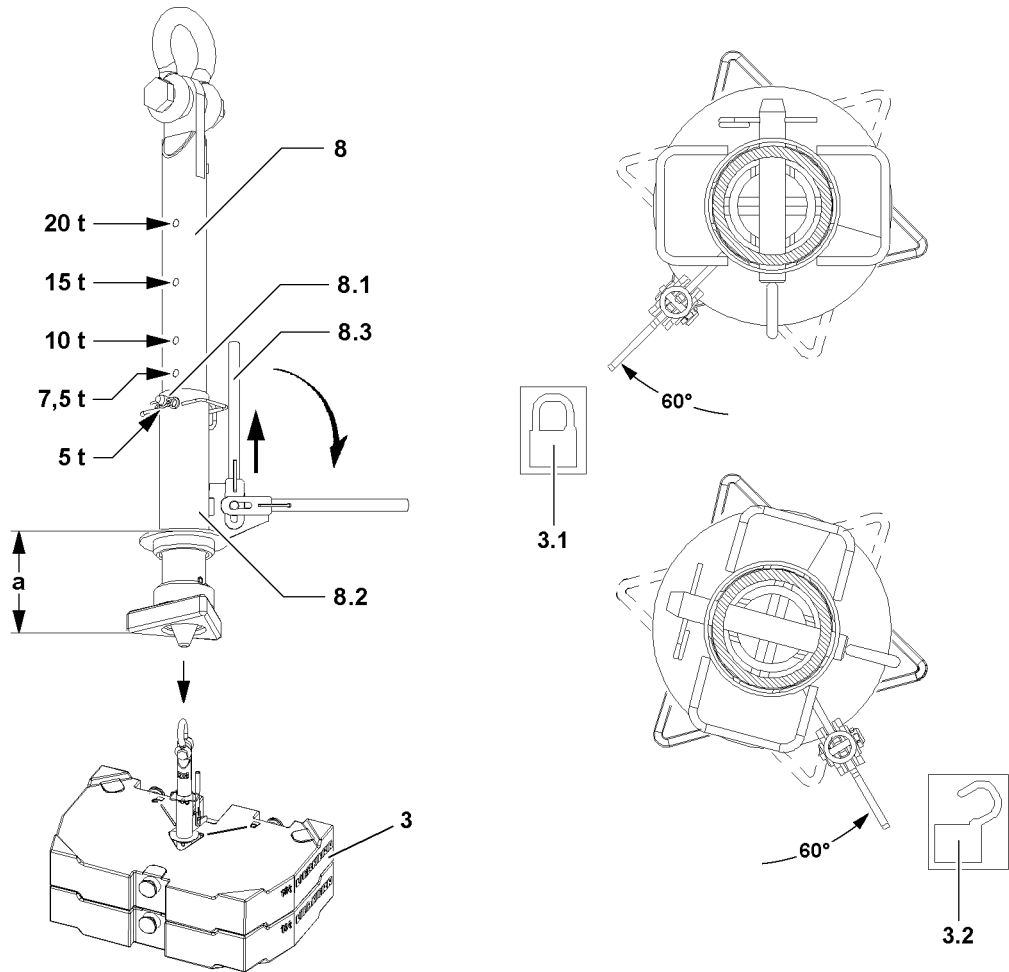

Fig.126084: Fastening system „Twistlock“:

**WARNING**

Overload of receptacle stud and ballast plates!

If more than the permissible number of ballast plates **3** are lifted with the receptacle stud **8**, the receptacle stud **8** and the ballast plates **3** can be overloaded and damaged.

The ballast plates **3** can fall down.

Death, severe bodily injuries, property damage.

► Observe the chart „Permissible central ballast assemblies“ in this chapter.

**WARNING**

Damage of receptacle stud and ballast plates!

If two ballast plates **3** are lifted which do not lay correctly in their centerings, the receptacle stud **8** and the ballast plates **3** can be damaged.

Damage can cause the ballast plates **3** to fall down.

Death, severe bodily injuries, property damage.

- ▶ Make sure that the ballast plates **3** to be lifted are placed correctly in the centerings.

**WARNING**

The Twistlock system opens by itself!

If the receptacle stud **8** is not correctly locked, the Twistlock system can open by itself.

The ballast plates **3** can fall down.

Death, severe bodily injuries, property damage.

- ▶ Make sure, when initiating a lift, that the lever **8.3** points directly on the „Locked“ icon **3.1** of the ballast plates **3**.

**Note**

- ▶ During a lift, the locked Twistlock system cannot release by itself due to its gravitational retention.
- ▶ During a lift, the locked Twistlock system cannot be released by hand due to its gravitational retention.

Before the receptacle stud **8** is guided in the ballast plates **3**, make sure that the insertion length **a** of the receptacle stud **8** is set correctly.

The insertion length **a** of the receptacle stud **8** for the ballast plates **3** can be adjusted by hand.

If the insertion length **a** of the receptacle stud **8** is to be adjusted:

- ▶ Release and unpin the pin **8.1**.
- ▶ Adjust the insertion length **a** by moving the guide sleeve **8.2** to the desired value, observe the stages.
- ▶ Insert and secure pin **8.1**.

Result:

- The receptacle stud **8** is adjusted.

**Note**

- ▶ The receptacle stud **8** in the illustration is set to 5 t.
- ▶ Fasten the receptacle stud **8** on the auxiliary crane and guide it into the ballast plate(s) **3**.
- ▶ Pull the lever **8.3** up and fold it down.
- ▶ Turn the receptacle stud **8** with the lever **8.3** by 60° until it points to the „Locked“ icon **3.1** of the ballast plate **3**.

**Note**

- ▶ The receptacle stud **8** is locked by lifting the ballast plate(s) **3**.
- ▶ Lift the ballast plate(s) **3** or the central ballast assembly with the receptacle stud **8** and place it carefully on the centerings on the central ballast bracket **2** or on another ballast plate **3**.

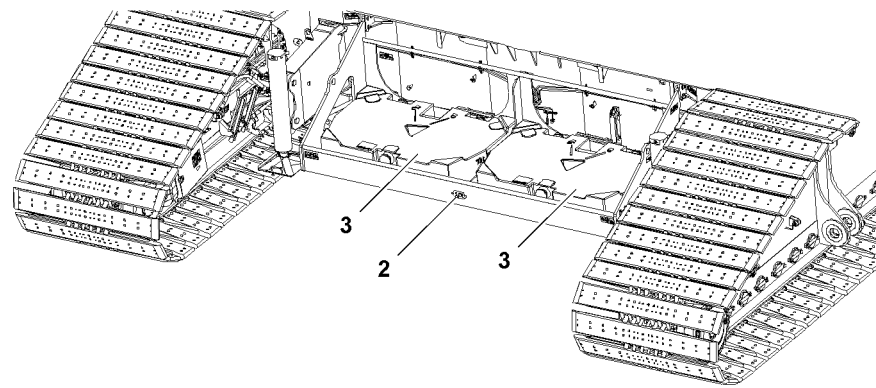

Fig. 126086: Ballast plates placed in the central ballast bracket

When the ballast plates **3** are placed down:

- ▶ Turn the receptacle stud **8** with the lever **8.3** by 60° to the stop in direction of the „Unlocked“ icon **3.2** of the ballast plate **3**.

Result:

- The receptacle stud **8** is unlocked.
- ▶ Carefully pull out the receptacle stud **8**.
- ▶ Place the ballast plates **3** according to the load chart.

When the ballast plates are properly placed on the first central ballast bracket:

- ▶ Turn the turntable by 180°.

When the turntable is turned by 180°:

- ▶ Carry out the assembly of the second central ballast bracket and the ballast plates according to the assembly of the first central ballast bracket.

5.3.2 Placing the ballast plates, fastening points: Bitt

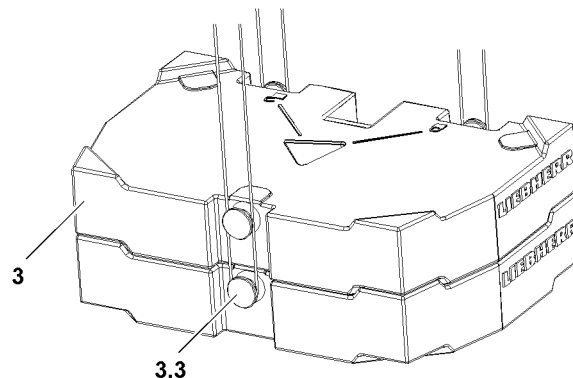

Fig. 126085: Fastening points „Bitt“



WARNING

Overloaded ballast plates!

If more than the permissible loads are lifted, the bits **3.3** are overloaded.

The ballast plates **3** can be damaged and fall down.

Death, severe bodily injuries, property damage.

- ▶ Observe the chart „Permissible central ballast assemblies“ in this chapter.

**WARNING**

Incorrect handling of the fastening equipment!

If the fastening equipment is not attached correctly and / or if it is not secured sufficiently to prevent it from loosening up, the ballast plates **3** can fall down.

Death, severe bodily injuries, property damage.

- ▶ Make sure that the fastening equipment is correctly attached on the bits **3.3** and that it is secured sufficiently to prevent it from loosening up.

- ▶ Fasten the ballast plates **3** or central ballast assembly on the auxiliary crane.

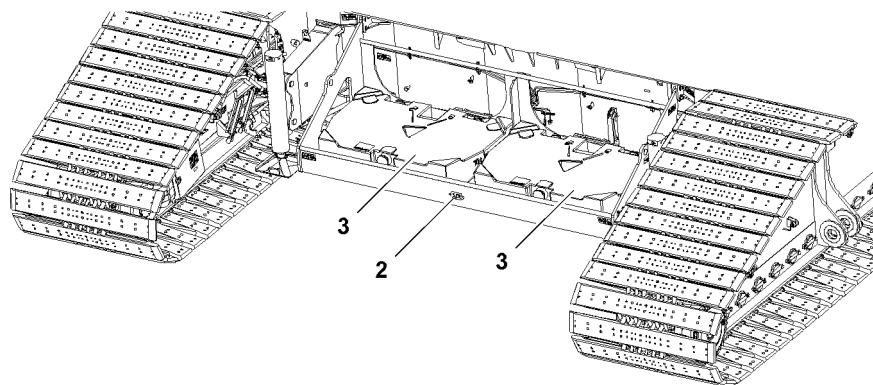

Fig. 126086

- ▶ Place the ballast plates **3** or the central ballast assembly on the centerings of the central ballast bracket **2** or on another ballast plate **3**.

When the ballast plates are properly placed on the first central ballast bracket:

- ▶ Turn the turntable by 180°.

When the turntable is turned by 180°:

- ▶ Carry out the assembly of the second central ballast bracket and the ballast plates according to the assembly of the first central ballast bracket.

6 Disassembling the central ballast



WARNING

Danger of falling!

During assembly / disassembly, inspection and maintenance work, personnel must be secured with appropriate aids to prevent them from falling.

Death, severe bodily injuries, property damage.

- ▶ All work aloft, where there is a danger of falling must be carried out with suitable aids.
- ▶ If aids are not available and work cannot be carried out from the ground, then the assembly personnel must secure themselves with the supplied fall arrest system to prevent falling, see Crane operating instructions, chapter 2.04.
- ▶ If fall protection equipment is available, then it must be used, see Crane operating instructions, chapter 2.06.
- ▶ When lifting, lowering, swinging crane parts in and out, no persons may remain in the danger zone.
- ▶ If railings are present for the crane, then they must be brought into the corresponding position and secured for assembly / disassembly work.
- ▶ It is prohibited to lean the auxiliary ladder against the component being disassembled.
- ▶ Only step on the aids, ladders and catwalks with clean shoes.
- ▶ Keep aids, ladders and catwalks free of heavy dirt, snow, frost and ice.
- ▶ During all assembly and disassembly work, maintenance work and inspections, travel or crane operation is prohibited.
- ▶ Remaining on a suspended load is prohibited.
- ▶ Stepping or walking on crane components and lattice sections, which have an incline of more than 20° is prohibited.
- ▶ For all assembly work, the crane operator of the main crane must be in voice contact with the crane operator / crane operators of the auxiliary crane / auxiliary cranes.
- ▶ For assembly / disassembly tasks, the crane operator may only initiate crane movements when the responsible guide has explicitly released the movement.



WARNING

Danger of impact / crushing!

When installing / removing crane components with the auxiliary crane, crane components can start to swing back and forth.

When lifting / lowering and positioning crane components, there is an increased danger of impacts / crushing.

Death, severe bodily injuries, property damage.

- ▶ Make sure that personnel cannot be caught by components.
- ▶ When working in danger zones: Use aids to protect limbs.
- ▶ Guide components with suitable aids to minimize oscillation.



DANGER

The components can fall down!

If the corresponding component is disengaged from the auxiliary crane before the corresponding component is pinned, then the corresponding component can fall down.

Death, severe bodily injuries, property damage.

- ▶ Do not disengage the auxiliary crane until the respective component is pinned and secured.



WARNING

Danger of impact / crushing!

If anyone remains within the assembly / disassembly area of the ballast, they would be exposed to a danger of impact / crushing.

Death, severe bodily injuries, property damage.

- ▶ Make sure that there are no persons between the components which are to be assembled / disassembled and the crawler travel gear.

Make sure that the following prerequisites are met:

- Both crawler carriers are standing on the ground.
- The crane is aligned in horizontal direction.
- The turntable is in 90° position to the crawler travel gear

or:

- The turntable is disassembled on the crawler travel gear.
- The staircases to the catwalks are disassembled, see Crane operating instructions, chapter 2.06.
- The catwalks are disassembled, see Crane operating instructions, chapter 2.06.
- There are no persons or objects in the assembly area of the central ballast brackets.

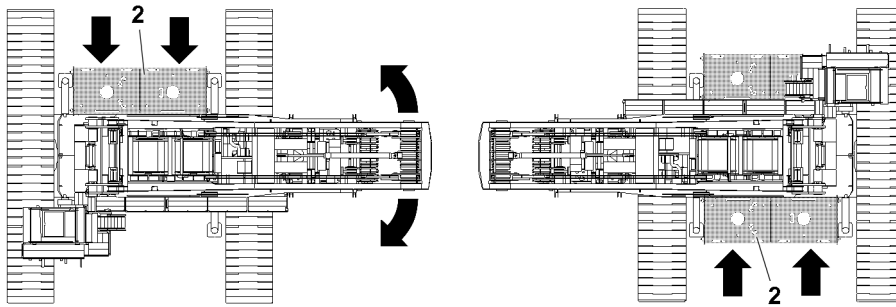

Fig.126087: Turn the turntable for assembly of the central ballast by 180°



Note

- ▶ Due to better accessibility for assembly / disassembly of the central ballast brackets we recommend to carry out the assembly / disassembly of the central ballast brackets on the side facing away from the crane operator's cab.
- ▶ After lifting the ballast plates off and after disassembly of the first central ballast bracket, turn the turntable by 180°.

6.1 Removing the ballast plates



Note

- ▶ It is permissible to remove the central ballast bracket **2** under certain prerequisites with placed ballast plates **3**.
- ▶ Observe section „Removing the central ballast brackets with placed ballast plates“ in this chapter.



WARNING

Damaged ballast plates!

Damage on the ballast plates **3** can cause the fastening equipment to release.

The ballast plates **3** and components can fall down.

Death, severe bodily injuries, property damage.

- ▶ Do not use damaged ballast plates **3** and replace them immediately.

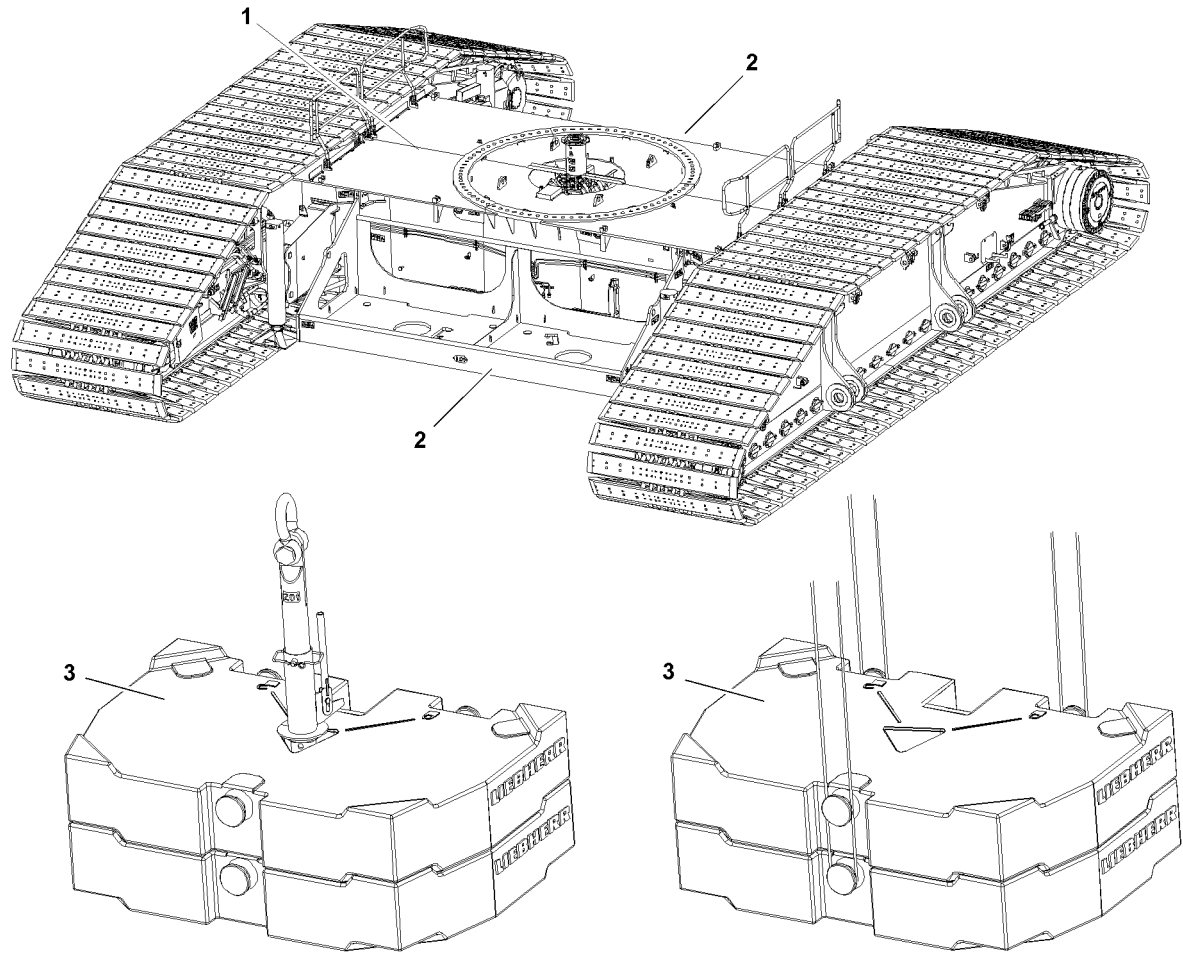

Fig.122412

LWE/LR 11000-001/23501-04-02/en

6.1.1 Removing the ballast plates, fastening system: „Twistlock“

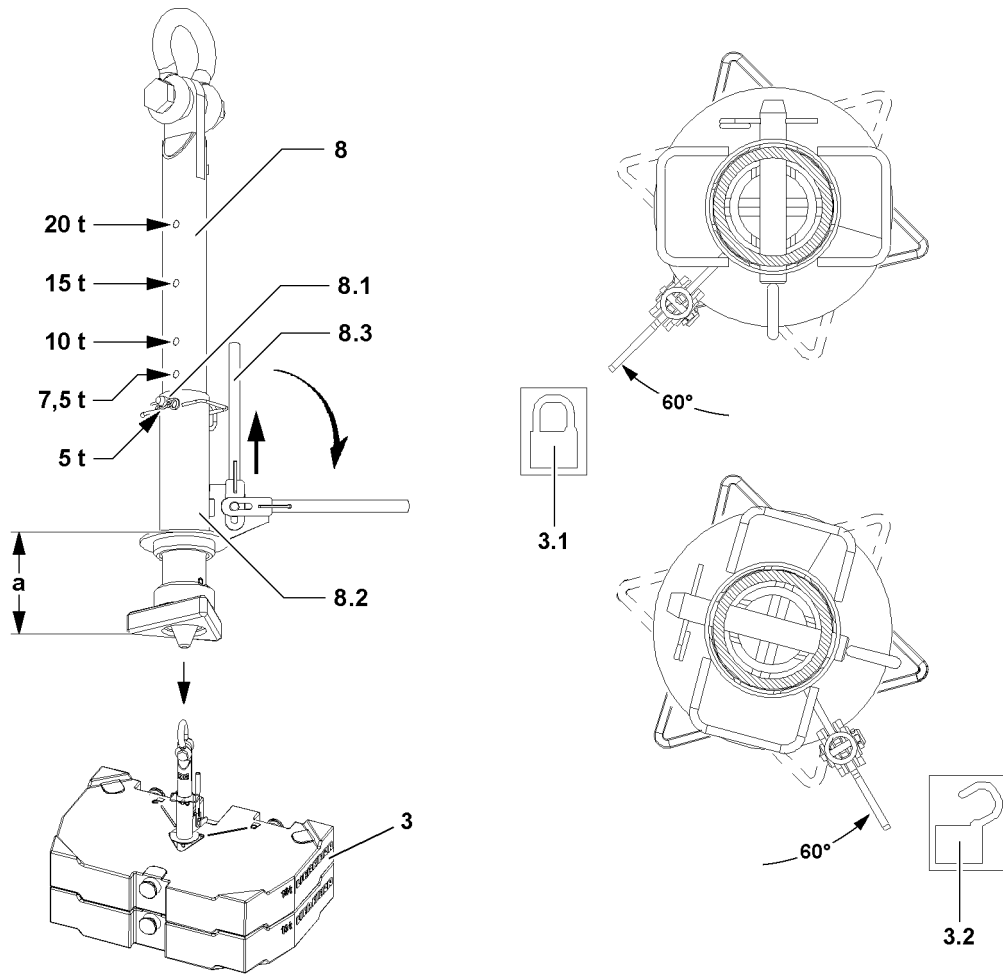

Fig.126084: Fastening points „Twistlock“:



WARNING

Overload of receptacle stud and central ballast plates!

If more than the permissible number of ballast plates **3** are lifted with the receptacle stud **8**, the receptacle stud **8** and the ballast plates **3** can be overloaded and damaged.

The ballast plates **3** can fall down.

Death, severe bodily injuries, property damage.

► Observe the chart „Permissible central ballast assemblies“ in this chapter.



WARNING

Damage of receptacle stud and central ballast plates!

If two ballast plates **3** are lifted which do not lay correctly in their centerings, the receptacle stud **8** and the ballast plates **3** can be damaged.

Damage can cause the ballast plates **3** to fall down.

Death, severe bodily injuries, property damage.

► Make sure that the ballast plates **3** to be lifted are placed correctly in the centerings.

**WARNING**

The Twistlock system opens by itself!

If the receptacle stud **8** is not correctly locked, the Twistlock system can open by itself.

The ballast plates **3** can fall down.

Death, severe bodily injuries, property damage.

- ▶ Make sure, when initiating a lift, that the lever **8.3** points directly on the „Locked“ icon **3.1** of the ballast plates **3**.

**Note**

- ▶ During a lift, the locked Twistlock system cannot release by itself due to its gravitational retention.
- ▶ During a lift, the locked Twistlock system cannot be released by hand due to its gravitational retention.

Before the receptacle stud **8** is guided in the ballast plates **3**, make sure that the insertion length **a** of the receptacle stud **8** is set correctly.

The insertion length **a** of the receptacle stud **8** for the ballast plates **3** can be adjusted by hand.

If the insertion length **a** of the receptacle stud **8** is to be adjusted:

- ▶ Release and unpin the pin **8.1**.
- ▶ Adjust the insertion length **a** by moving the guide sleeve **8.2** to the desired value, observe the stages.
- ▶ Insert and secure pin **8.1**.

Result:

- The receptacle stud **8** is adjusted.

**Note**

- ▶ The receptacle stud **8** in the illustration is set to 5 t.

- ▶ Fasten the receptacle stud **8** on the auxiliary crane and guide it into the ballast plate(s) **3**.
- ▶ Pull the lever **8.3** up and fold it down.
- ▶ Turn the receptacle stud **8** with the lever **8.3** by 60° until it points to the „Locked“ icon **3.1** of the ballast plate **3**.

**Note**

- ▶ The receptacle stud **8** is locked by lifting the ballast plate(s) **3**.

- ▶ Lift the ballast plate(s) **3** or the central ballast assembly with the receptacle stud **8** and place them carefully on a suitable storage location.

When the ballast plates **3** are placed down:

- ▶ Turn the receptacle stud **8** with the lever **8.3** by 60° to the stop in direction of the „Unlocked“ icon **3.2** of the ballast plate **3**.

Result:

- The receptacle stud **8** is unlocked.
- ▶ Carefully pull out the receptacle stud **8**.

6.1.2 Removing the ballast plates, fastening points: Bitt

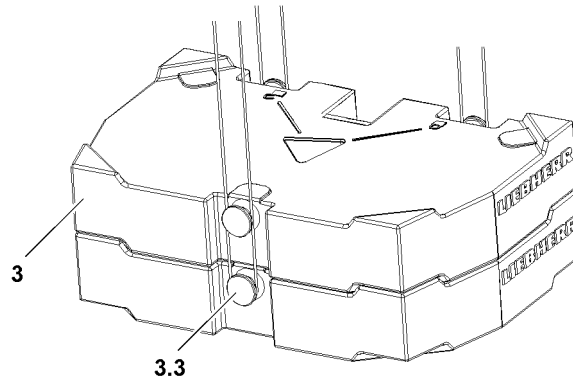

Fig.126085: Fastening points „Bitt“



WARNING

Overloaded ballast plates!

If more than the permissible loads are lifted, the bits **3.3** are overloaded.

The ballast plates **3** can be damaged and fall down.

Death, severe bodily injuries, property damage.

► Observe the chart „Permissible central ballast assemblies“ in this chapter.



WARNING

Incorrect handling of the fastening equipment!

If the fastening equipment is not attached correctly and / or if it is not secured sufficiently to prevent it from loosening up, the ballast plates **3** can fall down.

Death, severe bodily injuries, property damage.

► Make sure that the fastening equipment is correctly attached on the bits **3.3** and that it is secured sufficiently to prevent it from loosening up.

► Fasten the ballast plates **3** or central ballast assembly on the auxiliary crane.

► Remove the ballast plates **3** or the central ballast assembly from the central ballast bracket **3** and place it on a suitable storage location.

6.2 Removing the central ballast brackets

Make sure that the following prerequisites are met:

- The retaining pins **6** are unpinned on both sides at point **3**.
- The fastening equipment for the assembly of the central ballast brackets must have a minimum length of 5000 mm.



Note

► It is permissible to install the central ballast bracket **2** under certain prerequisites with placed ballast plates.

► Observe section „Removing the central ballast brackets with placed ballast plates“ in this chapter.

6.2.1 Disassembling the first central ballast bracket (turntable is assembled on the crawler center section)

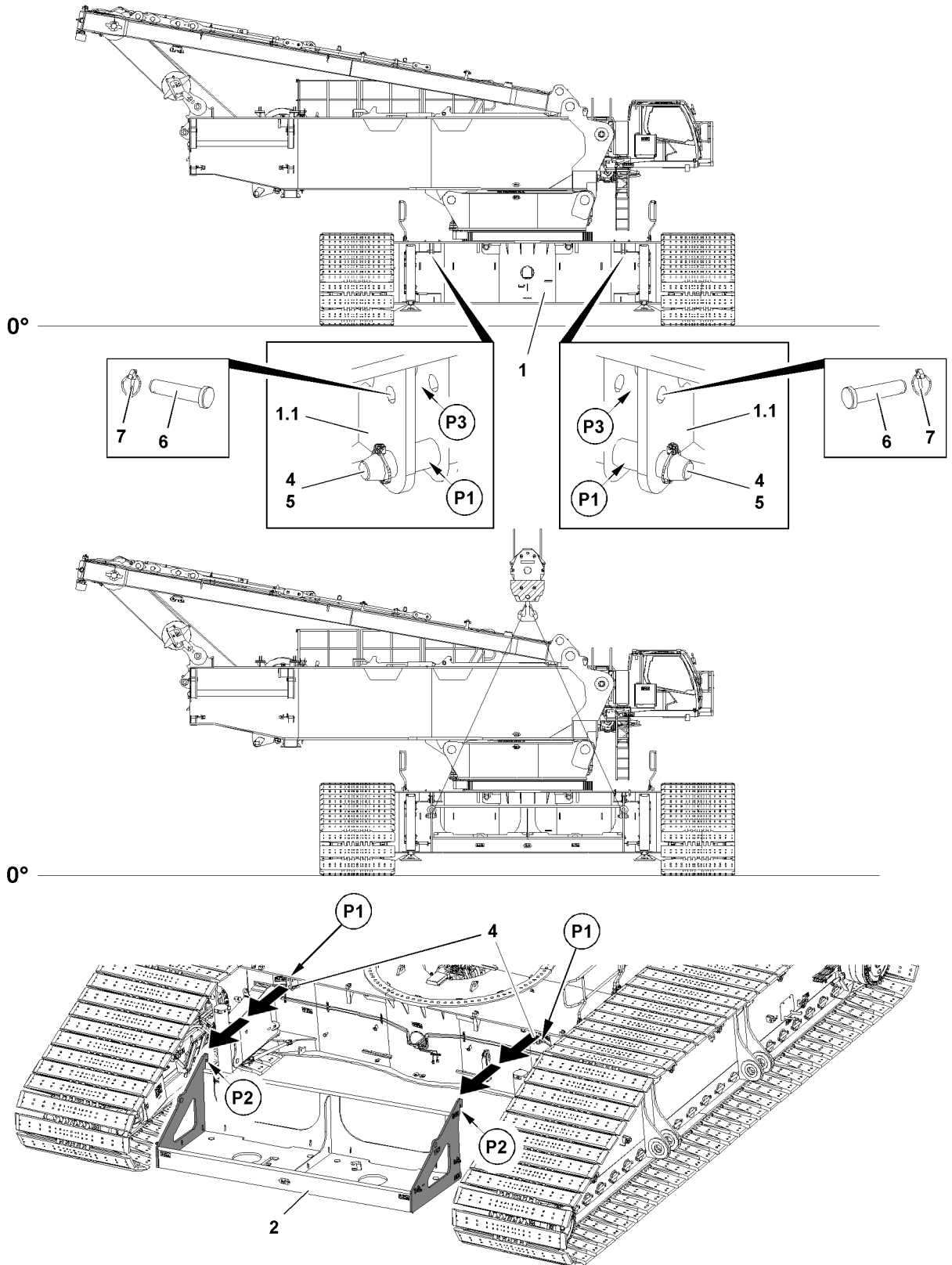

Fig.126088: Disassemble the central ballast bracket on the crawler center section

LWE/LR 11000-001/23501-04-02/en

**Note**

- ▶ Due to better accessibility for assembly / disassembly of the central ballast brackets **2** we recommend to carry out the assembly / disassembly of the central ballast brackets **2** on the side facing away from the crane operator's cab.
- ▶ After assembly of the first central ballast bracket **2** and the respective ballast plates, turn the turntable by 180°.

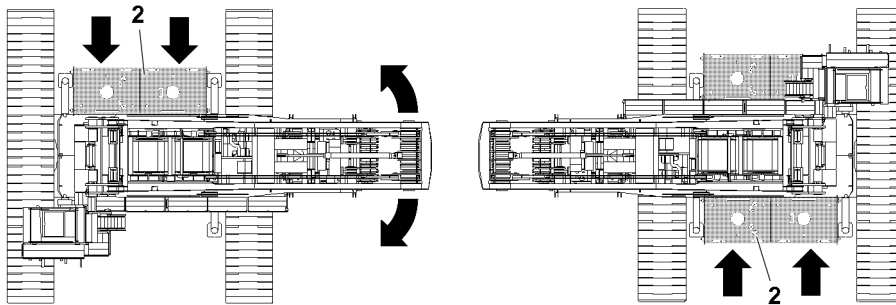

Fig.126087

Make sure that the following prerequisite is met:

- The turntable is in 90° position to the crawler travel gear.

- ▶ Remove the retaining pin **6** at point **P3** and unpin.
- ▶ Position the fastening equipment with the auxiliary crane in the center above fastening points.
- ▶ Fasten the central ballast bracket **2** onto the auxiliary crane.
- ▶ Tighten the fastening equipment with the auxiliary crane.
- ▶ Lift the central ballast bracket **2** with the auxiliary crane and swing out.

When the first central ballast bracket is properly removed:

- ▶ Turn the turntable by 180°.

When the turntable is turned by 180°:

- ▶ Carry out the disassembly of the second central ballast bracket according to the disassembly of the first central ballast bracket.

6.3 Disassembling the central ballast brackets with placed ballast plates (turntable is not assembled on the crawler center section)

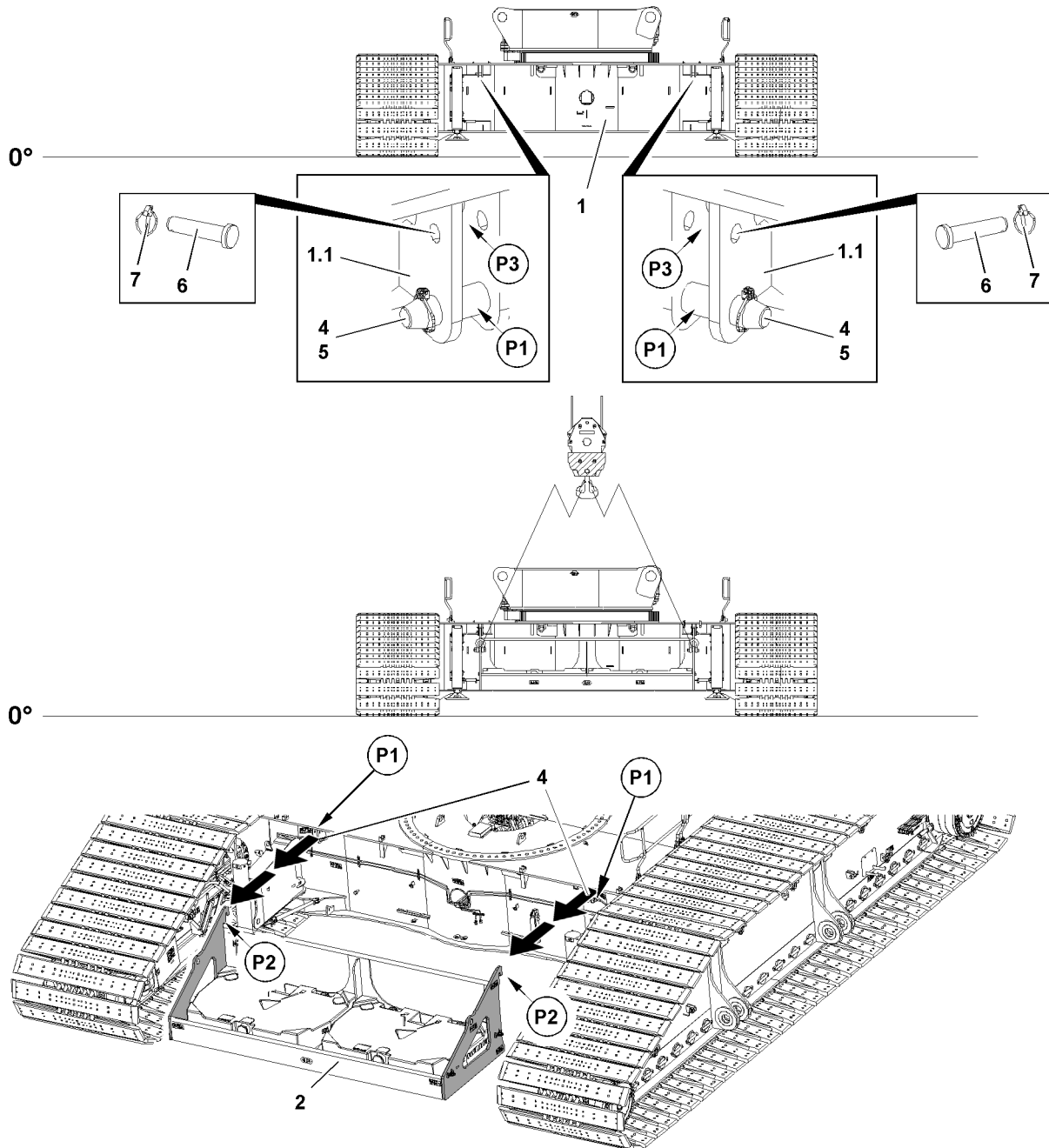

Fig.126091: Removing the central ballast brackets with placed ballast plates



WARNING

Danger of accidents due to angular pull!

If pulled angularly, a suspended central ballast bracket **2** can start to swing back and forth after releasing it from the crawler center section **1**.

Death, severe bodily injuries, property damage.

- ▶ Always position the fastening equipment in the center above the fastening points.
- ▶ Take special caution when unhooking the central ballast bracket **2**.

**WARNING**

Overload of fastening points central ballast bracket!

If the central ballast bracket **2** is lifted with more than two placed ballast plates **3**, then the fastening points will be overloaded.

The central ballast bracket **2** and the ballast plates **3** can fall down.

Death, severe bodily injuries, property damage.

- ▶ Make sure that maximum two ballast plates **3** are placed on the central ballast bracket **2** to be lifted.

**Note**

- ▶ When removing the ballast plates **3** from the central ballast bracket **2** observe section „Removing the ballast plates“ in this chapter.

- ▶ Remove the retaining pin **6** at point **P3** and unpin.
- ▶ Position the fastening equipment with the auxiliary crane in the center above central ballast bracket **2**.
- ▶ Fasten the central ballast bracket **2** onto the auxiliary crane.
- ▶ Tighten the fastening equipment with the auxiliary crane.
- ▶ Lift the central ballast bracket **2** with the auxiliary crane and swing out.

When the first central ballast bracket is properly removed:

- ▶ Carry out the disassembly of the second central ballast bracket according to the disassembly of the first central ballast bracket.

3.04 Mechanical auxiliary support

1	Fastening points	3
2	Assembling the mechanical auxiliary support	3
3	Disassembling the mechanical auxiliary support	9

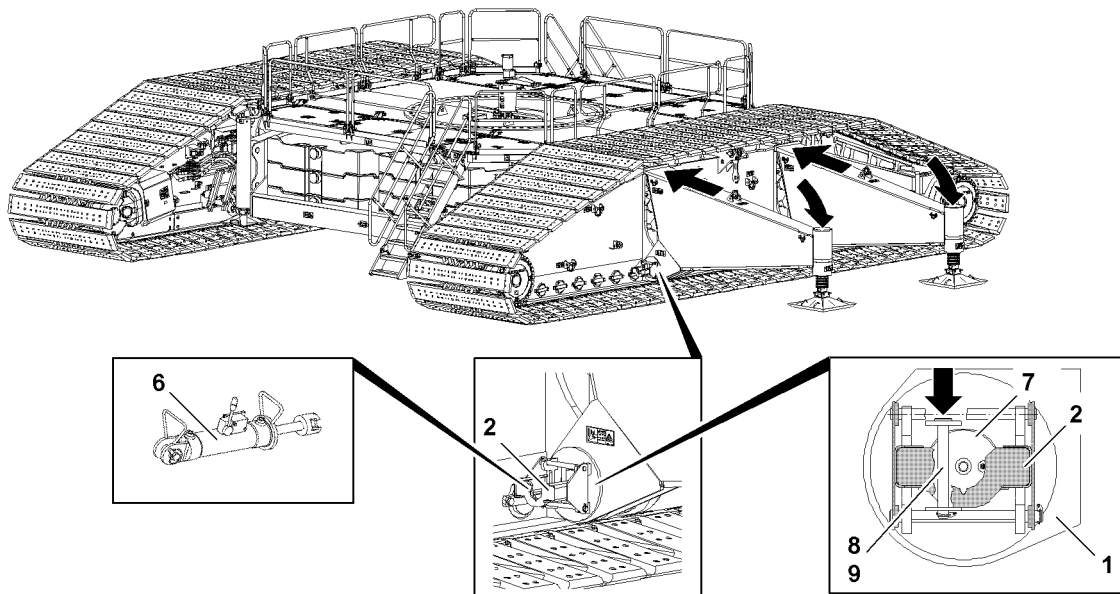
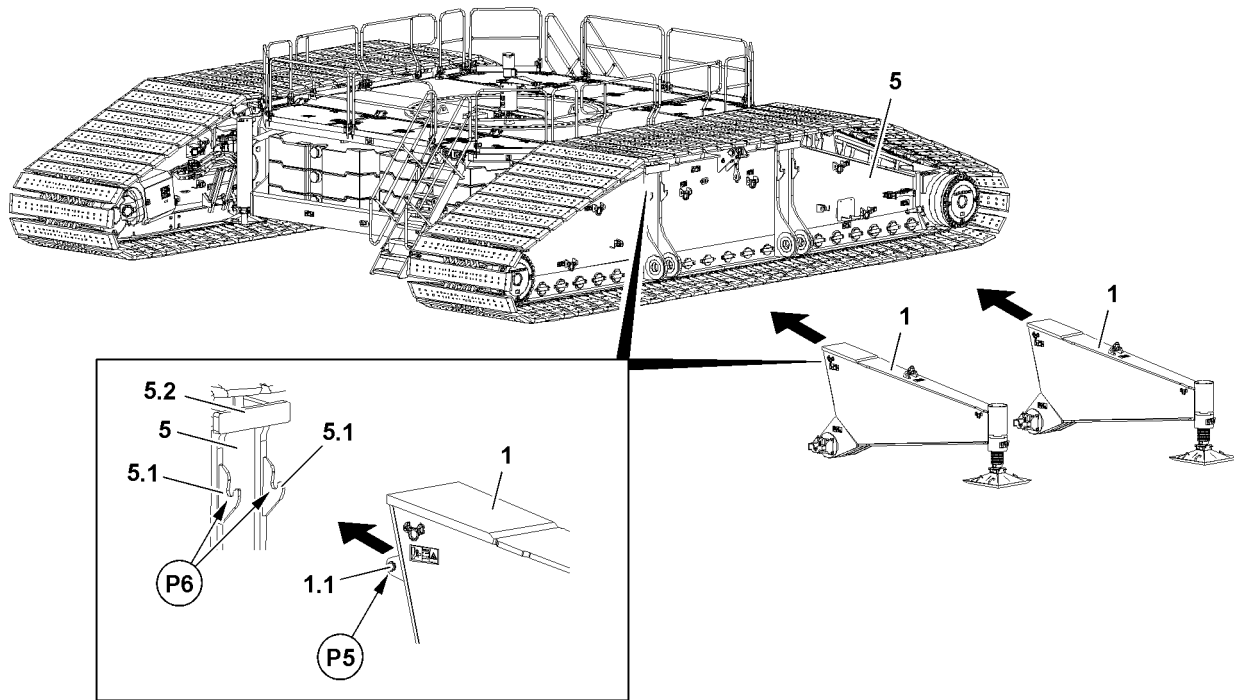
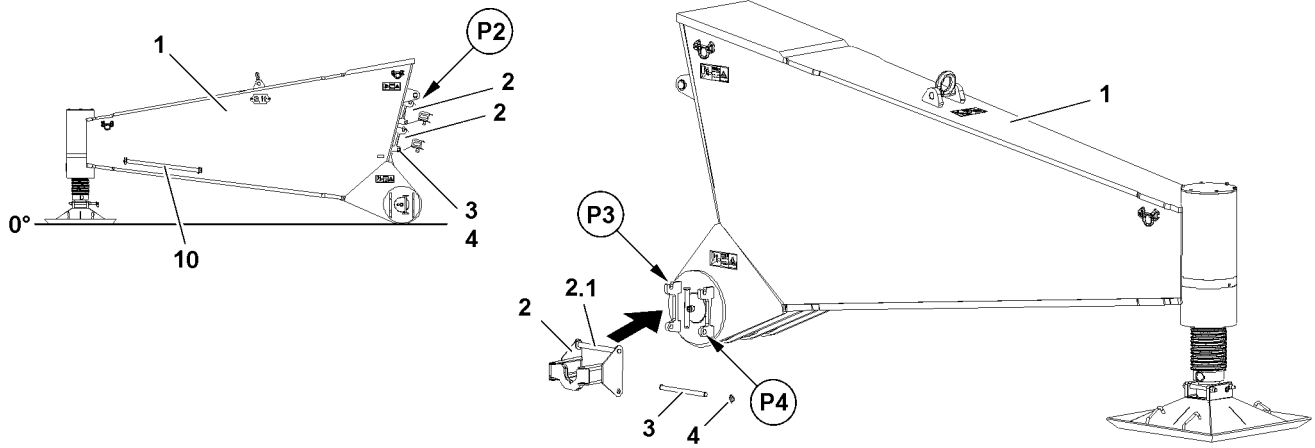

Fig.118230

LWE/LR 11000-001/23501-04-02/en

1 Fastening points

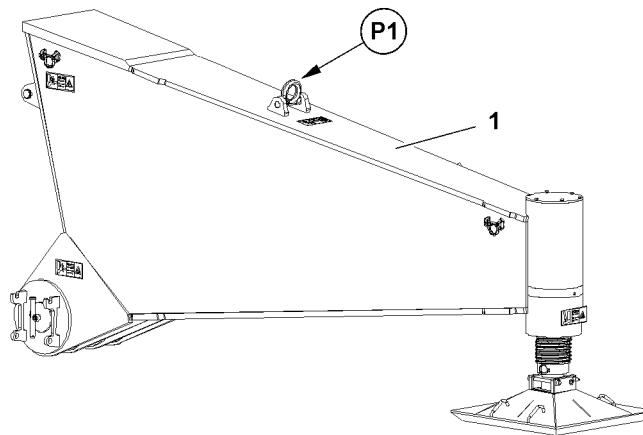

Fig.118550: Mechanical auxiliary support

Fastening point for mechanical auxiliary support	
P1	For Assembly / disassembly

2 Assembling the mechanical auxiliary support

Make sure that the following prerequisites are met:

- The crawler carriers are properly assembled on the crane.
- The crane is horizontally aligned.
- The ground has sufficient load bearing capacity in the area of the support plates.
- An auxiliary crane is available.



Note

- ▶ The mechanical auxiliary support is required to erect and / or take down long boom combinations.
- ▶ The mechanical auxiliary support can be installed on the left crawler carrier or on the right crawler carrier.
- ▶ Install the mechanical auxiliary support always on the crawler carrier side, which is used to place or take down the boom system.



WARNING

The crane can topple over!

If long boom combinations are erected or taken down without mechanical auxiliary support 1, then the crane can topple over.

Personnel can be severely injured or killed.

- ▶ Observe and adhere to the data in the erection and take down charts.
- ▶ Install the mechanical auxiliary support only in pairs on the crawler carrier.
- ▶ Erection and / or take down of long boom systems with only one installed support beam is prohibited.

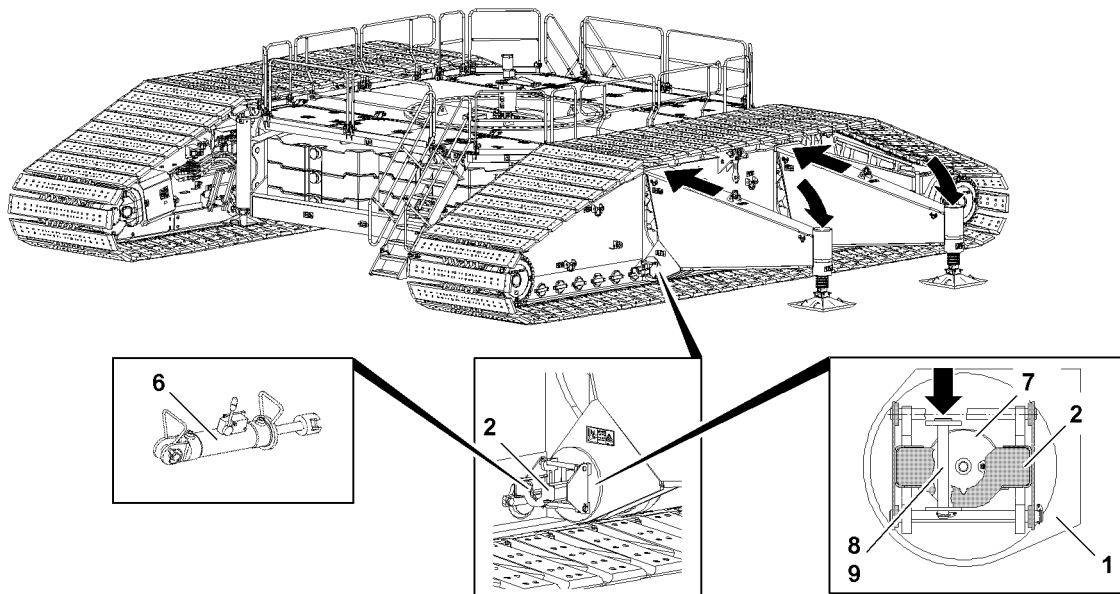
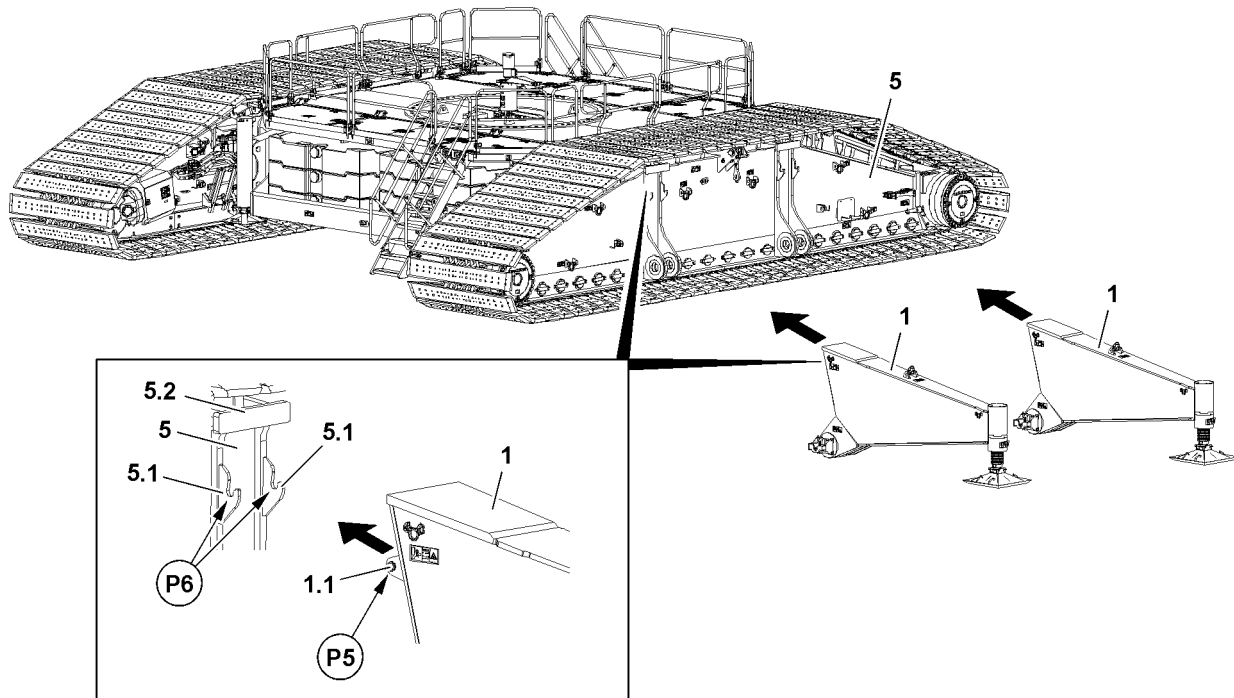
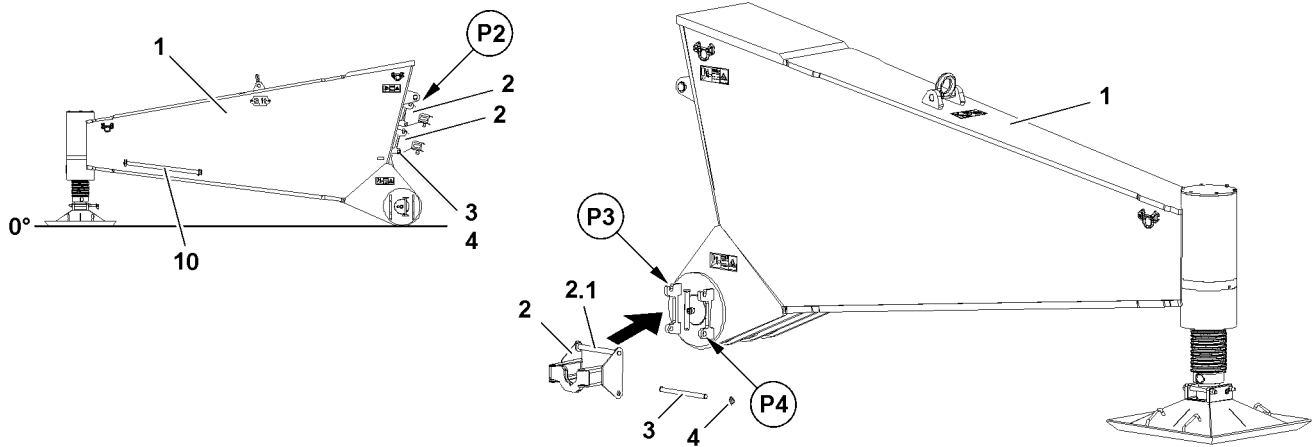

Fig.118230

LWE/LR 11000-001/23501-04-02/en

2.1 Installing the pin pulling device on the support beam

NOTICE

Damage to pin pulling device!

If the pin pulling devices **2** are not taken from the park position before installation of the mechanical auxiliary support **1** on the crawler carrier **5**, then they can be damaged.

- ▶ Take the pin pulling devices **2** from the park position before installation of the mechanical auxiliary support **1**.



Note

- ▶ The installation of the pin pulling device **2** is identical for both sides of the support beam.

- ▶ Release the first pin pulling device **2** in park position: Release the pin **3** at point **P2** and unpin.
- ▶ Take the pin pulling device **2** from the park position.
- ▶ Hang the pin pulling device **2** on the support beam **1** at point **P3** in operating position.

When the pin pulling device **2** are properly hooked on point **P3** in operating position:

- ▶ Secure the pin pulling device **2** in operating position: Insert the pin **3** at point **P4** and secure with locking pin **4**.

2.2 Installing the mechanical auxiliary support on the crawler travel gear



Note

- ▶ The installation of the mechanical auxiliary support **1** is the same for both support beams on the left and right hand side!

Make sure that the following prerequisites are met:

- The pin pulling devices **2** are installed on both sides on the respective support beam **1**.
- There are no objects or obstacles within the assembly area of the mechanical auxiliary support **1**.

- ▶ Fasten the mechanical auxiliary support **1** on point **P1** on the auxiliary crane.
- ▶ Swing the mechanical auxiliary support **1** in with the auxiliary crane to the hook points **5.1** (points **P6**) on the crawler carrier **5**.
- ▶ Hang the mechanical auxiliary support **1** with the hook pins **1.1** (point **P5**) in the hook points (point **P4**) on the crawler carrier **5**.

When the mechanical auxiliary support is properly hooked on the crawler carrier **5**:

- ▶ Lower the mechanical auxiliary support **1** with the auxiliary crane into operating position.
- ▶ Place the pin pulling cylinder **6** in the pin pulling device **2**.
- ▶ Insert the connector pins **7** with the pin pulling cylinder **6** in on both sides, see Crane operating instructions, chapter 5.30.

When the connector pins **7** are pinned on both sides on the support beam **1**:

- ▶ Secure the connector pins **7** with retaining pin **8** and locking pin **9**.

Result:

- The first support beam is pinned and secured on the crawler carrier.
- ▶ Release the fastening equipment from the first support beam **1**.
- ▶ Remove the auxiliary crane.
- ▶ Install the second support beam properly on the crawler carrier.

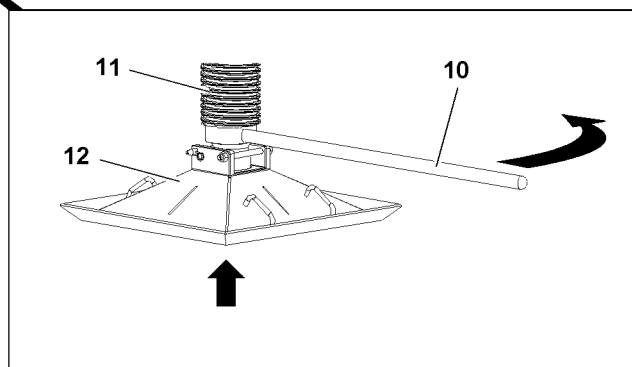
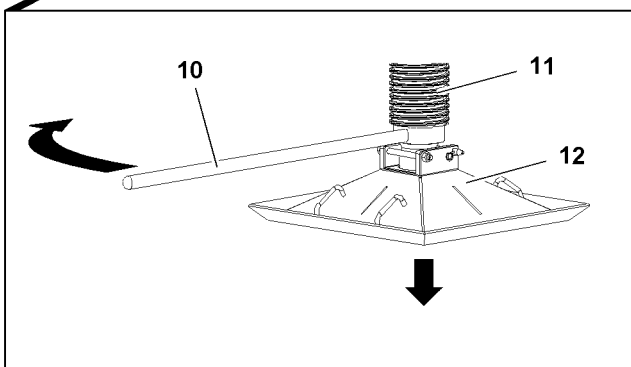
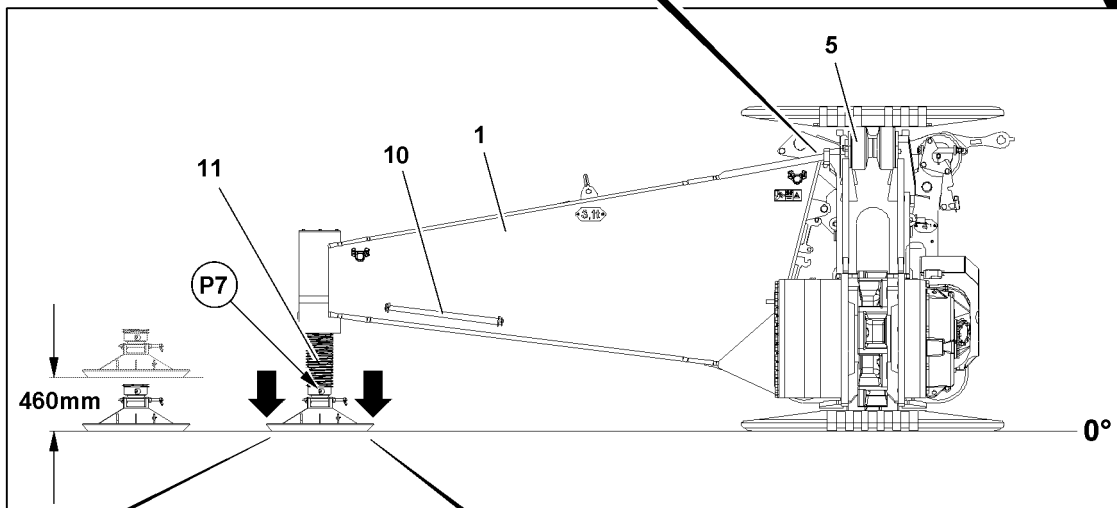
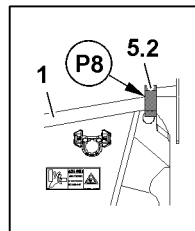
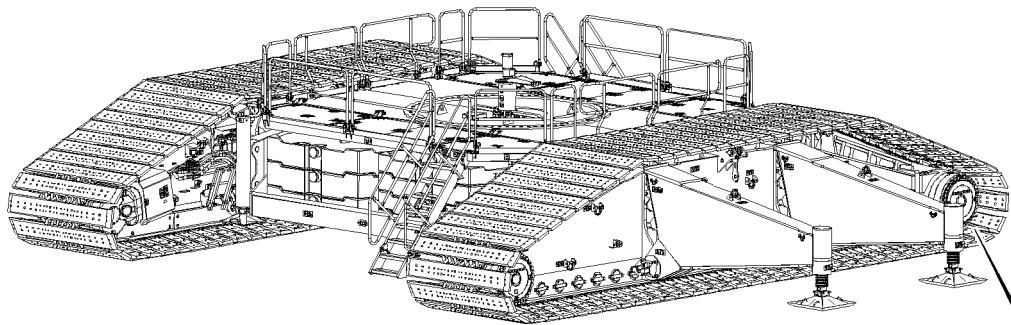

Fig.118551

LWE/LR 11000-001/23501-04-02/en

2.3 Adjusting the mechanical auxiliary support



Note

- ▶ The mechanical auxiliary support **1** is only an erection and take down device.
- ▶ Due to the mechanical auxiliary support **1**, the stability momentum of the crane increases toward the side, on which the auxiliary support is installed.



DANGER

The crane can topple over!

If the load momentum is increased in crane operation due to the use of the mechanical auxiliary support **1**, the crane will tip over.

Personnel can be severely injured or killed.

- ▶ The increase of stability momentum through the mechanical auxiliary support **1** may not be used to increase the load momentum.
- ▶ The use of the mechanical auxiliary support **1** in crane operation is prohibited.
- ▶ Make sure that the mechanical auxiliary support **1** is only used for erection and take down of long boom systems.
- ▶ Support the support plates large enough for the ground conditions with solid materials, such as wood, steel or concrete slabs, see Crane operating instructions, chapter 2.04.



WARNING

Jerky movements during erection / take down of the boom system!

If the mechanical auxiliary support **1** is not placed on the pressure plate **5.2** on the crawler carrier **5** (point **P8**, then the boom system can move jerkily during erection and / or take down.

Personnel can be severely injured or killed.

The crane can be damaged.

- ▶ Turn the support plates **12** with the spindle **11** until the mechanical auxiliary support **1** touches on the pressure plates at point **P8**.



Note

- ▶ Adjustment range of support plate **12** via the spindle: 460 mm.

- ▶ Remove the pipe **10** from the transport retainer on the mechanical auxiliary support **1**.
- ▶ Insert the pipe **10** at point **P7** into the bore on the spindle **11**.
- ▶ Support the support plates **12** on both sides properly with load bearing materials.
- ▶ Turn the spindle **11** downward until the support plate **12** makes surface contact with the support.

When the support plate **12** is laying on the support:

- ▶ Continue to turn the spindle **11** until the mechanical auxiliary support **1** is touching on the pressure plate **5.2**.

When the mechanical auxiliary support **1** is touching on the pressure plate **5.2**:

- ▶ Remove the pipe **10** on the spindle **11** and install it properly in park position on the support beam **12**.



Note

- ▶ The adjustment of the second support plate **12** is identical with the adjustment of the first support plate **12**.

- ▶ Adjust the second support plate.

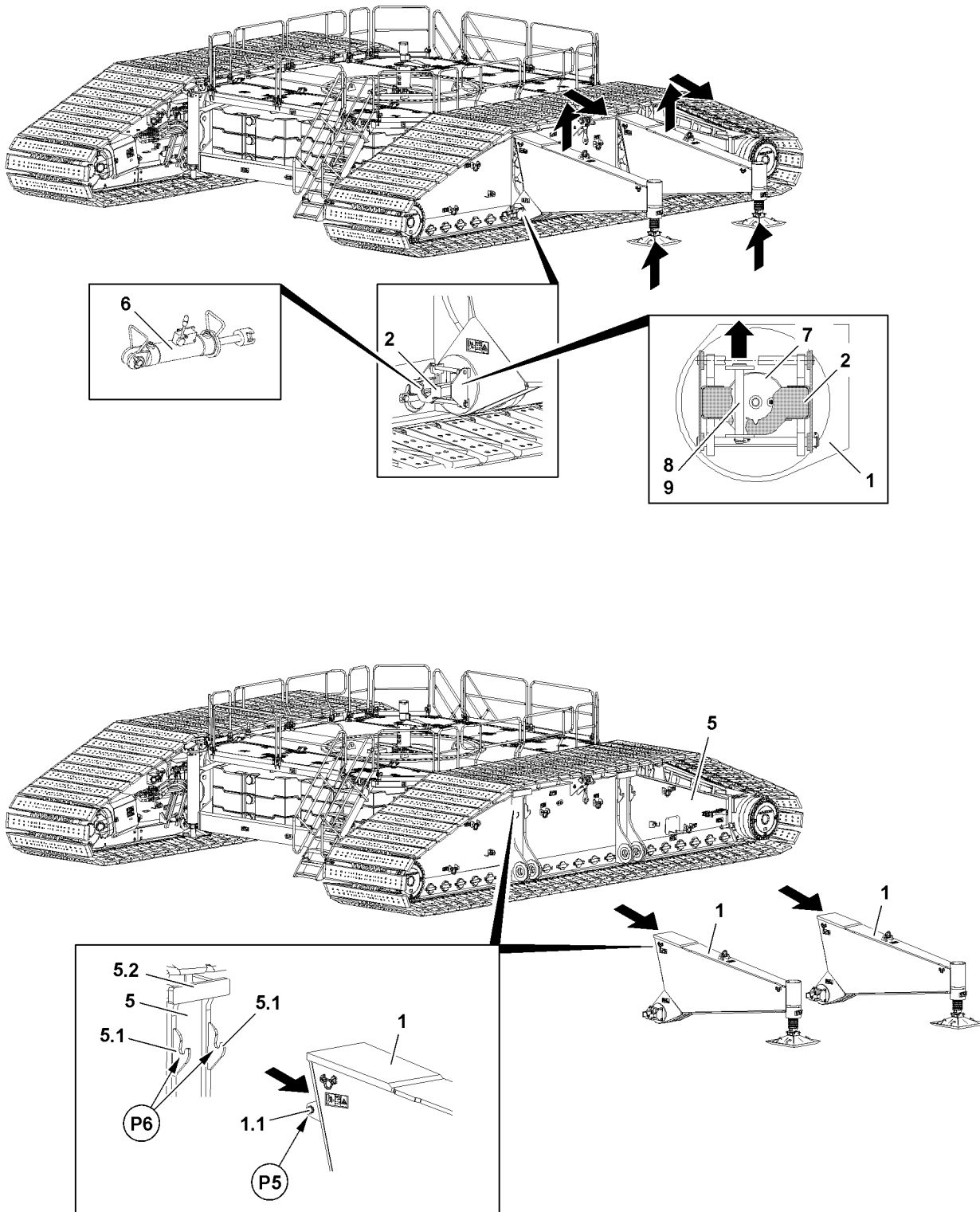

Fig.118558

LWE/LR 11000-001/23501-04-02/en

3 Disassembling the mechanical auxiliary support

Make sure that the following prerequisites are met:

- The main boom has been removed on the crane.
- The crane is horizontally aligned.
- The support plates are not in contact with the ground.
- The pin pulling device is installed.
- An auxiliary crane is available.

3.1 Removing the mechanical auxiliary support on the crawler travel gear



Note

- ▶ The removal of the mechanical auxiliary support **1** is the same for both support beams on the left and right hand side!

Make sure that the following prerequisites are met:

- The pin pulling devices **2** are installed on both sides on the respective support beam **1**.
- There are no objects or obstacles within the assembly area of the mechanical auxiliary support **1**.
- ▶ Fasten the mechanical auxiliary support **1** on point **P1** on the auxiliary crane, see section „Fastening points“.
- ▶ Carefully bring fastening equipment on the support beam **1** to tension.

When the fastening equipment is tensioned:

- ▶ Release and remove the retaining pin **8**.

Result:

- The connector pin **7** is released.
- ▶ Place the pin pulling cylinder **6** in the pin pulling device **2**.
- ▶ Unpin the connector pins **7** with the pin pulling cylinder **6** completely on both sides, see Crane operating instructions, chapter 5.30.

When the connector pins **7** are unpinned on both sides on the support beam **1**:

- ▶ Carefully lift the support beam **1** with the auxiliary crane and swing out.



WARNING

Toppling support beam!

The support beams can fall over after removal.

Personnel can be severely injured or killed.

- ▶ Secure the support beam **1** immediately after setting it on the support or the flatbed trailer to prevent it from falling over.

- ▶ Place the support beam **1** on the load bearing support.

or

Set the support beam **1** on the flatbed trailer.

- ▶ Secure the support beam **1** immediately after setting it down to prevent it from falling over.

When the support beam **1** is properly secured to prevent it from falling over:

- ▶ Remove the auxiliary crane.
- ▶ Remove the pin pulling devices **2** on the support beam **1** and install in park position on the support beam.
- ▶ Secure the pin pulling devices **2** properly in parking position.
- ▶ Remove the second support beam **1** properly on the crawler carrier and secure.

Empty page!

LWE/LR 11000-001/23501-04-02/en

3.05 Assembly of SA bracket

1	Component overview	3
2	Attachment points SA-frame	3
3	Assembling SA-frame	5
4	Disassembling the SA-frame	29

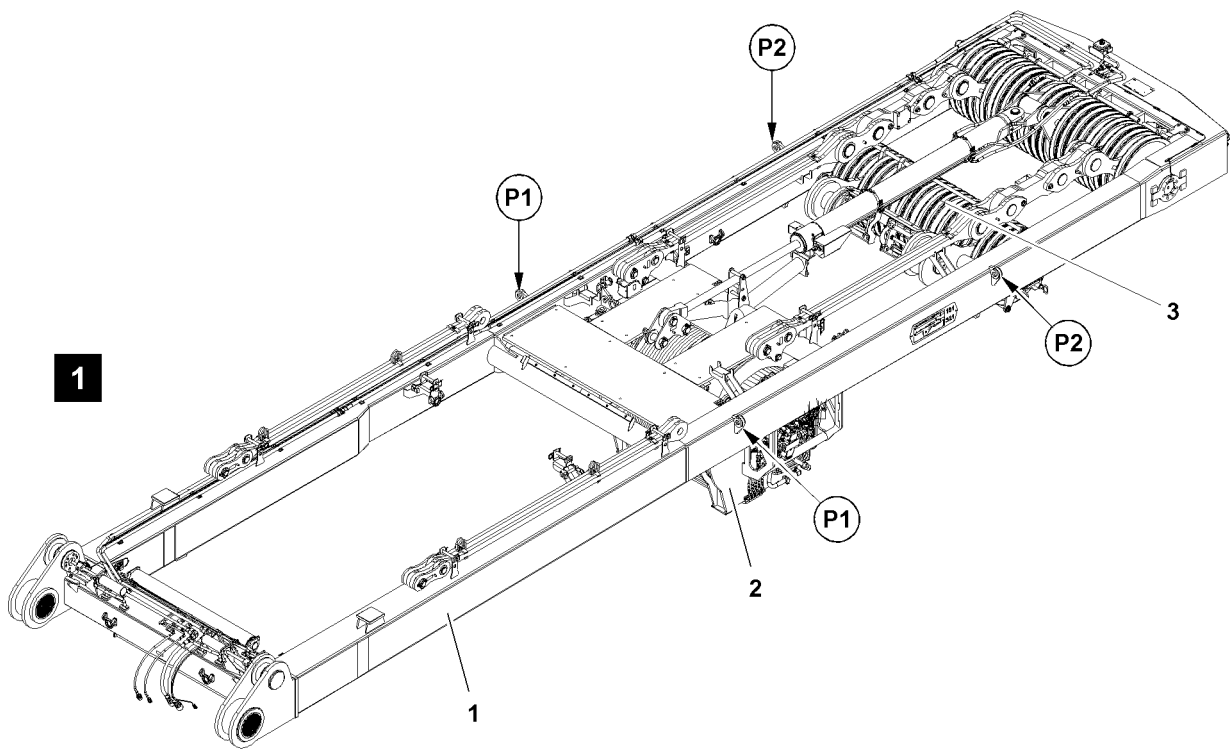

Fig.116915

1 Component overview



Note

► Dimensions and weights, see Crane operating instructions, chapter 1.03.

Position	Component
1	SA-frame
2	Winch 4
3	Pulley support

2 Attachment points SA-frame



WARNING

Component incorrectly fastened!

Life-threatening situations can arise due to improper or incorrect attachment of the corresponding components.

Death, severe injury, property damage.

► Fasten the components only on the intended fastening points on both sides.

Fastening points	
P1 and P2	SA-frame with winch 4

Fig.195219

LWE/LR 11000-001/23501-04-02/en

3 Assembling SA-frame



WARNING

Danger of falling!

During assembly / disassembly, inspection and maintenance work, personnel must be secured with appropriate aids to prevent them from falling.

Death, severe injury, property damage.

- ▶ All work aloft, where there is a danger of falling must be carried out with suitable aids.
- ▶ If aids are not available and work cannot be carried out from the ground, then the assembly personnel must secure themselves with the supplied fall arrest system to prevent falling, see Crane operating instructions, chapter 2.04.
- ▶ If fall protection equipment is available, then it must be used, see Crane operating instructions, chapter 2.06.
- ▶ When lifting, lowering, swinging crane parts in and out, no persons may remain in the danger zone.
- ▶ If railings are present for the crane, then they must be brought into the corresponding position and secured for assembly / disassembly work.
- ▶ Only step on the aids, ladders and catwalks with clean shoes.
- ▶ Keep aids, ladders and catwalks free of heavy dirt, snow and ice.
- ▶ During all assembly and disassembly work, maintenance work and inspections, travel or crane operation is prohibited.
- ▶ Remaining on a suspended load is prohibited.
- ▶ Stepping or walking on crane components and lattice sections, which have an incline of more than 20° is prohibited.
- ▶ For all assembly work, the crane operator of the main crane must be in voice contact with the crane operator / crane operators of the auxiliary crane / auxiliary cranes.
- ▶ For assembly / disassembly tasks, the crane operator may only initiate crane movements when the responsible guide has explicitly released the movement.



WARNING

Danger of impact / crushing!

When installing / removing crane components with the auxiliary crane, crane components can start to swing back and forth.

When lifting / lowering and positioning crane components, there is an increased danger of impacts / crushing.

Death, severe injury, property damage.

- ▶ Make sure that personnel cannot be caught by components.
- ▶ When working in danger zones: Use aids to protect limbs.
- ▶ Guide components with suitable aids to minimize oscillation.



DANGER

The components can fall down!

If the corresponding component is disengaged from the auxiliary crane before the corresponding component is pinned, then the corresponding component can fall down.

Death, severe injury, property damage.

- ▶ Do not disengage the auxiliary crane until the corresponding component is pinned and secured.

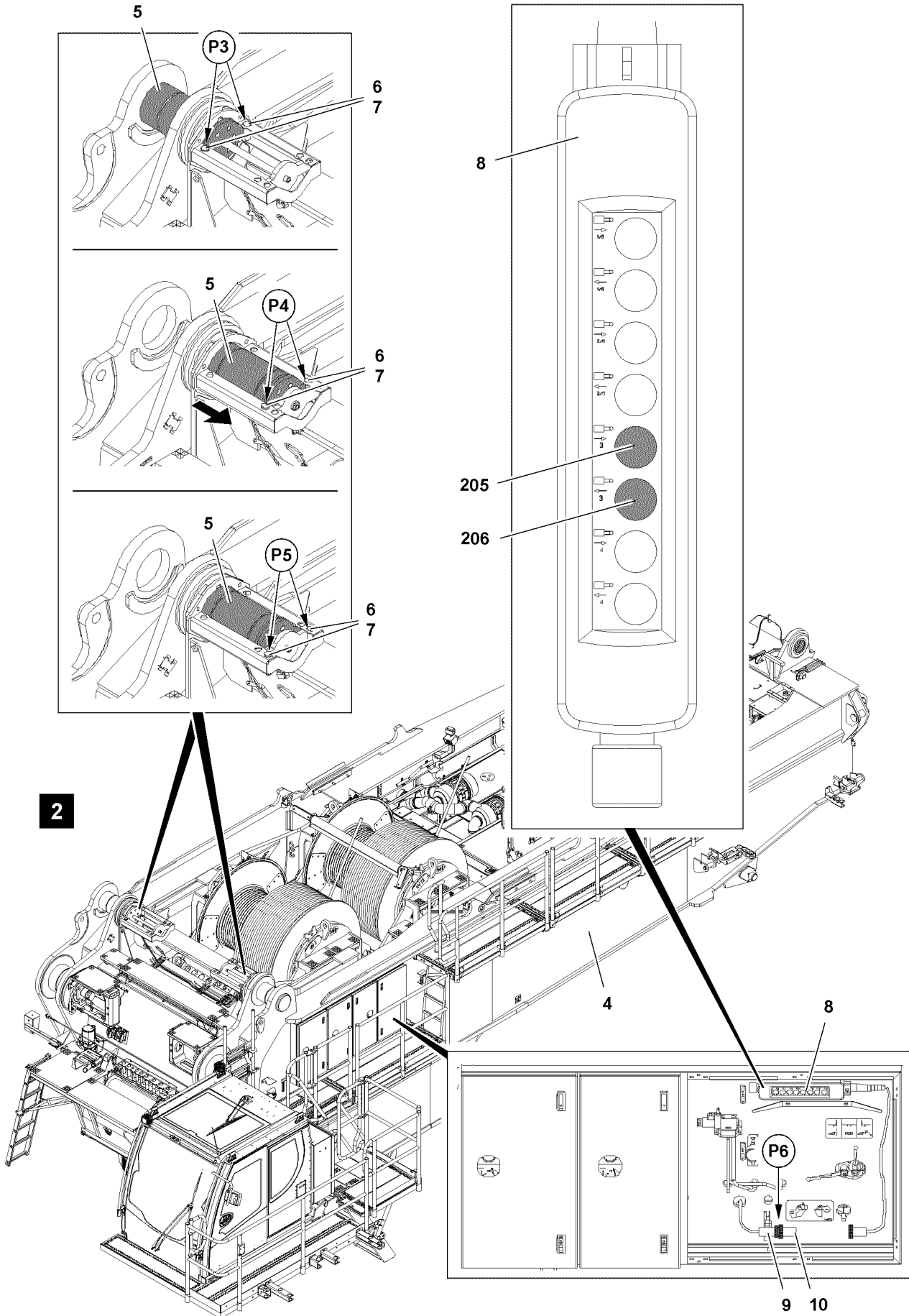

Fig.116916

LWE/LR 11000-001/23501-04-02/en

3.1 Preparing the pin locations on the turntable

Make sure that the following prerequisites are met:

- The installation of the turntable **4** on the crawler center section is completed.
- The crawler center section is laying on the supporting bases or is standing in tracks.
- The crane is aligned in horizontal direction.
- The crane engine is running.



WARNING

Danger of falling!

During assembly and disassembly of crane components, personnel must be secured with appropriate aids to prevent them from falling.

Death, severe injury, property damage.

▶ Use personal protective equipment.

- ▶ Release the pin **5**: Remove the safety locking pin **7** on both sides at points **P3** and unpin the retaining pin **6**, see illustration **2**.
- ▶ Insert the retaining pin **6** at points **P4** on both sides and secure with safety locking pin **7**, see illustration **2**.
- ▶ Open the control cabinet on the turntable **4**, see illustration **2**.
- ▶ Remove the dummy plug **10** on the connection **9** at point **P6**, see illustration **2**.



Note

▶ Electrical connections, see Electric wiring diagram.

- ▶ Connect the control panel **8** on the connection **9** at point **P6**, see illustration **2**.
- ▶ Unpin the pin **5**: Press button **205** on the control panel **8**, see illustration **2**.

When the pins **5** are unpinned:

- ▶ Remove the safety locking pin **7** on both sides at points **P4** and unpin the retaining pin **6**, see illustration **2**.
- ▶ Insert the retaining pin **6** at points **P5** on both sides and secure with safety locking pin **7**, see illustration **2**.

Result:

- The pin is prepared for unpinning.

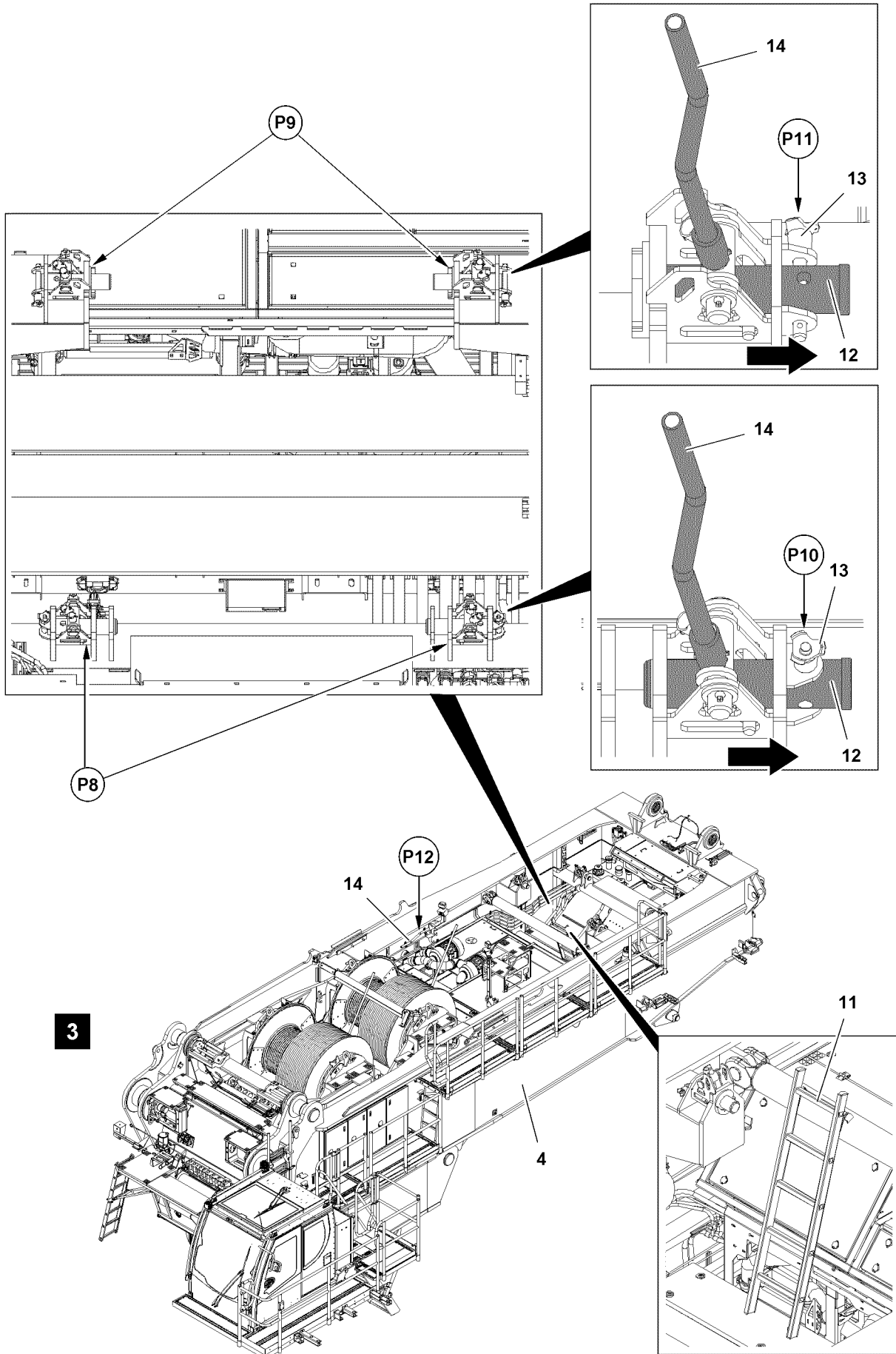

Fig.116917

LWE/LR 11000-001/23501-04-02/en

**WARNING**

Danger of falling!

During assembly and disassembly of crane components, personnel must be secured with appropriate aids to prevent them from falling.

Death, severe injury, property damage.

- ▶ Use personal protective equipment.

**Note**

- ▶ Bring the ladder **11** into assembly / park position, see Crane operating instructions, chapter 2.06.

- ▶ Bring the ladder **11** in assembly position, see illustration **3**.

- ▶ Release the pins **12** at points **P8** and on points **P9**: Unpin the ball locking pins **13** at points **P10** and points **P11**, see illustration **3**.

**Note**

- ▶ The lever **14** is positioned at point **P12** in the transport position, see illustration **3**.

- ▶ Unpin pins **12** at points **P8** and points **P9** with the lever **14**, see illustration **3**.

- ▶ Secure the pins **12** at points **P8** and points **P9**: Insert the ball locking pins **13** at points **P10** and points **P11**, see illustration **3**.

NOTICE

Danger of property damage!

If the ladder **11** is not in park position at installation of the SA-frame in the turntable, then a collision will occur at installation of the SA-frame between winch 4 and the ladder **11**.

This could result in high property damage.

- ▶ Make sure that the ladder **11** is in park position at installation of the SA-frame in the turntable.

When all pins **12** are unpinned and secured at points **P8** and points **P9**:

- ▶ Bring the ladder **11** in park position.

4

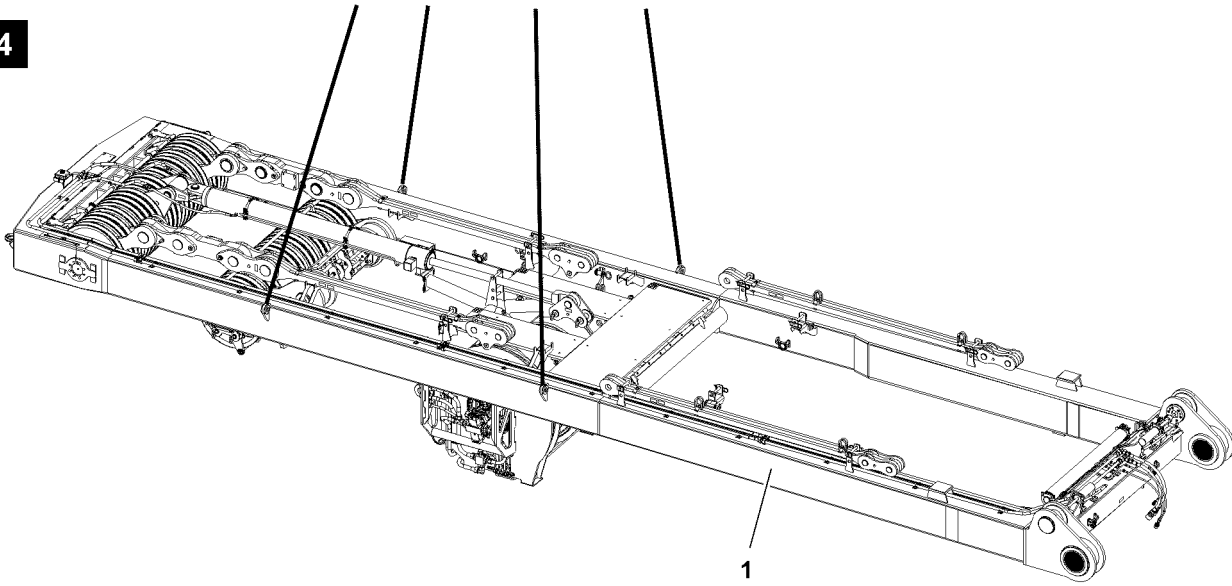

5

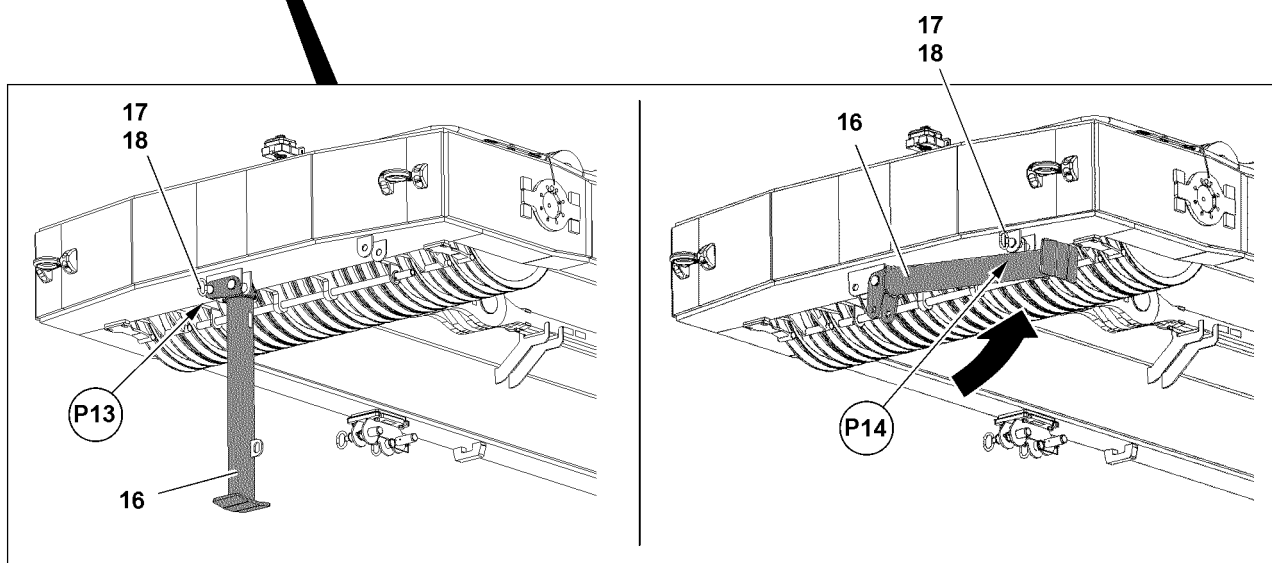
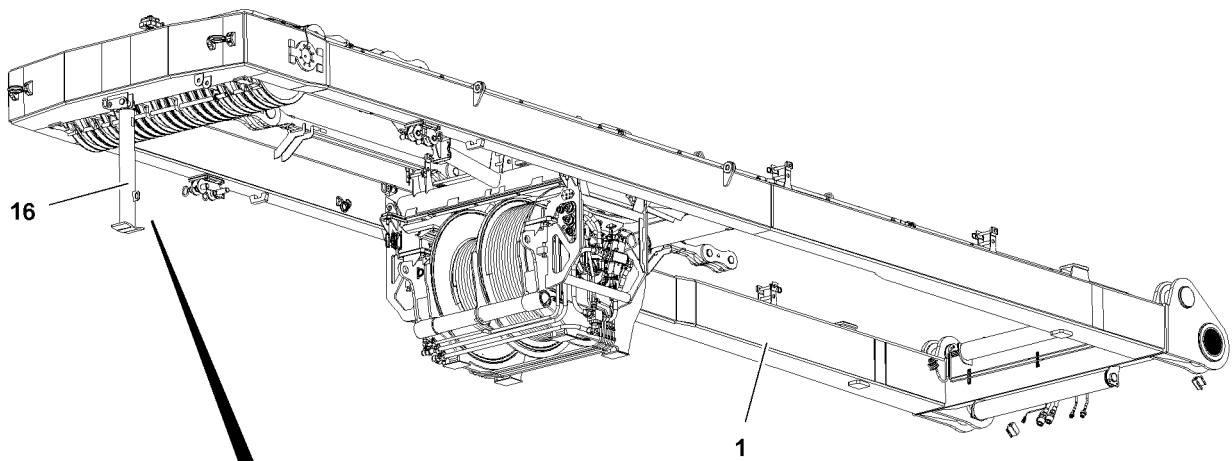

Fig.116918

LWE/LR 11000-001/23501-04-02/en

3.2 Pinning the SA-frame on the turntable

3.2.1 Fastening the SA-frame on the auxiliary crane

Make sure that the following prerequisites are met:

- The ladder **11** is in park position.
- An auxiliary crane with an adequate load-bearing capacity is available.



WARNING

Danger of falling!

During assembly and disassembly of crane components, personnel must be secured with appropriate aids to prevent them from falling.

Death, severe injury, property damage.

▶ Use personal protective equipment.

- ▶ Attach the fastening equipment on the SA-frame **1**, see section „Fastening points SA-frame“.
- ▶ Tension the fastening equipment.

When the fastening equipment is tensioned:

- ▶ Release the rigging between the SA-frame **1** and the transport vehicle.
- ▶ Lift the SA-frame **1** with the auxiliary crane, see illustration **4**.

3.2.2 Swinging the support into operating position

- ▶ Release the support **16** at point **P13** from the transport position: Remove the safety locking pin **18** and unpin the pin **17**, see illustration **5**.



WARNING

Support swinging down!

The support **16** can swing down during pinning.

Death, severe injury, property damage.

- ▶ For safety reasons, carry out the pinning of the support always with **two** persons.
- ▶ Make sure that there are no persons within the danger zone during the entire pin procedure.



Note

- ▶ The weight of the support is 35 kg.

- ▶ Swing the support **16** into operating position, see illustration **5**.
- ▶ Secure the support **16** at point **P14** in operating position: Insert the pin **17** and secure with safety locking pin **18**, see illustration **5**.

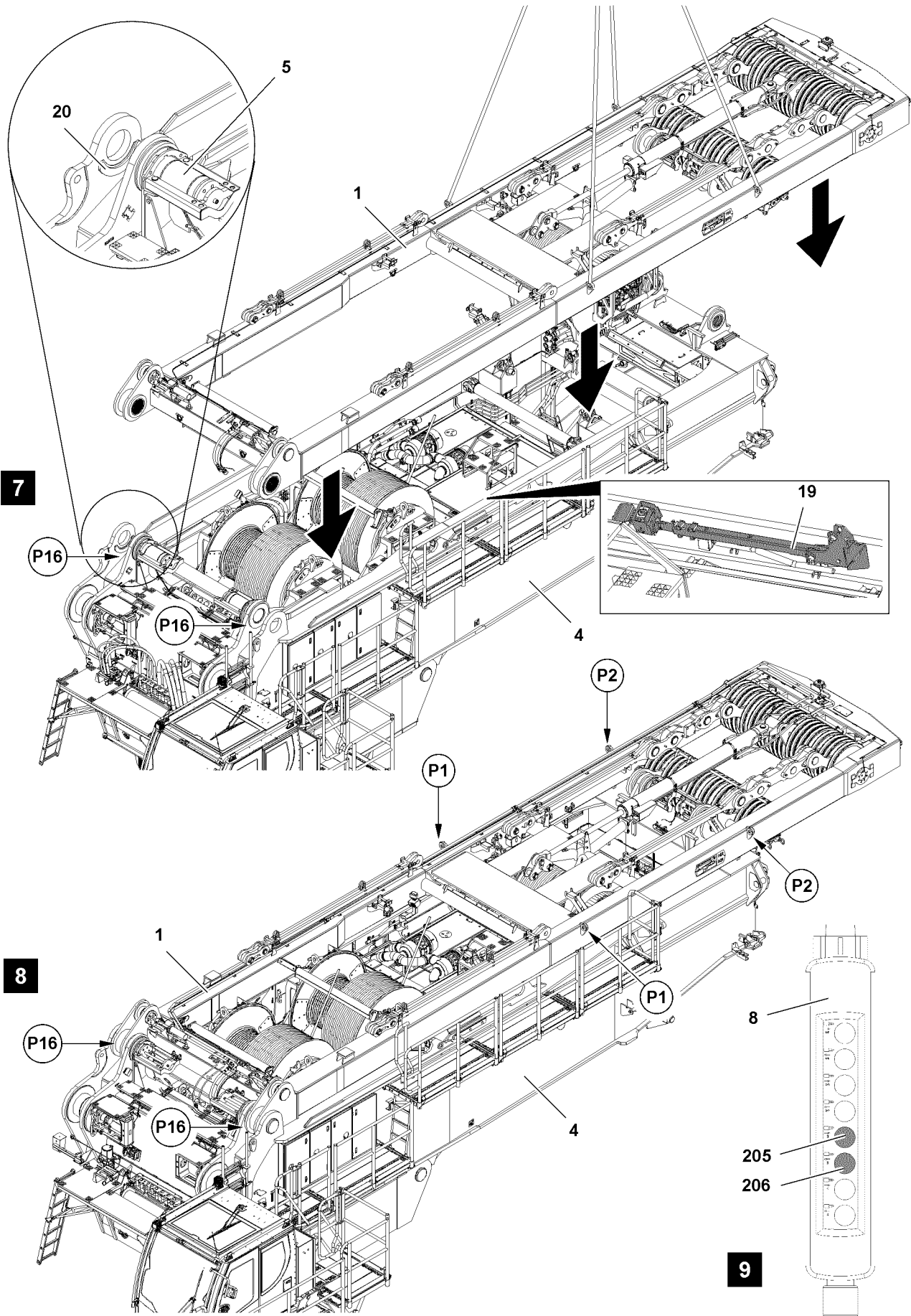

Fig.116919

3.2.3 Pinning the SA-frame

Make sure that the following prerequisites are met:

- The pins on the turntable for the installation of the SA-frame are unpinned.
- The pins on the turntable for the installation of winch 4 are unpinned.
- The pins on the pulley support for the installation on the turntable are unpinned.
- The camera for winch 1 has been placed down.
- The crane engine is running.



WARNING

Danger of falling!

During assembly and disassembly of crane components, personnel must be secured with appropriate aids to prevent them from falling.

Death, severe injury, property damage.

- ▶ Use personal protective equipment.

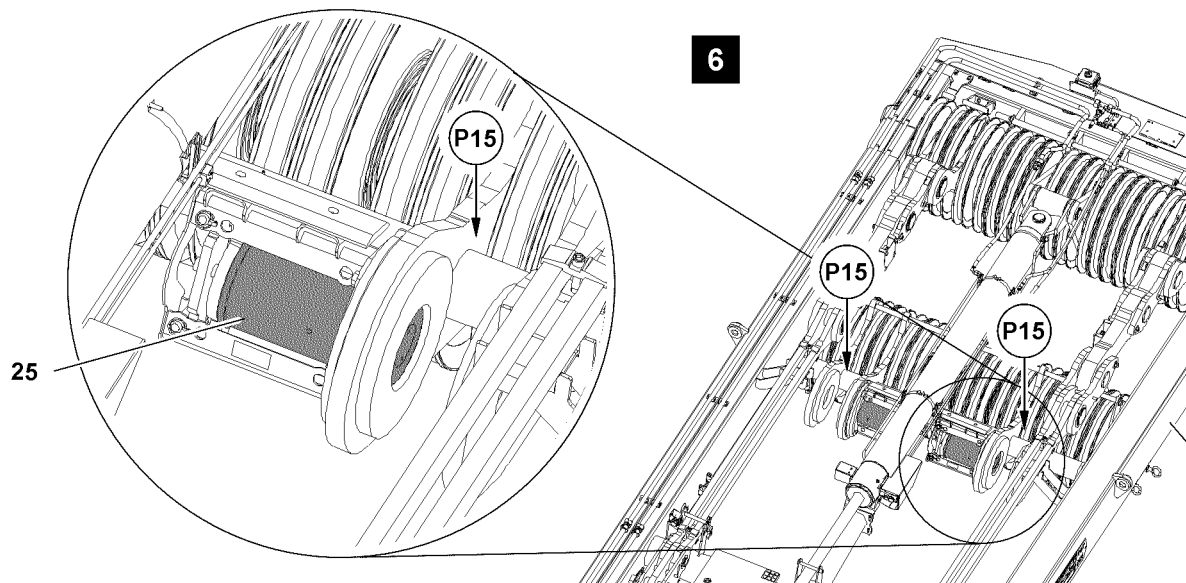

Fig.116923: The pins 25 are unpinned.

NOTICE

Danger of property damage!

If the pins 25 at points P15 are in **pinned** position when moving the SA-frame in the turntable, components can be severely damaged.

- ▶ Make sure that the pins 25 of the SA-frame at points P15 are in **unpinned** position when moving in, see illustration 6.

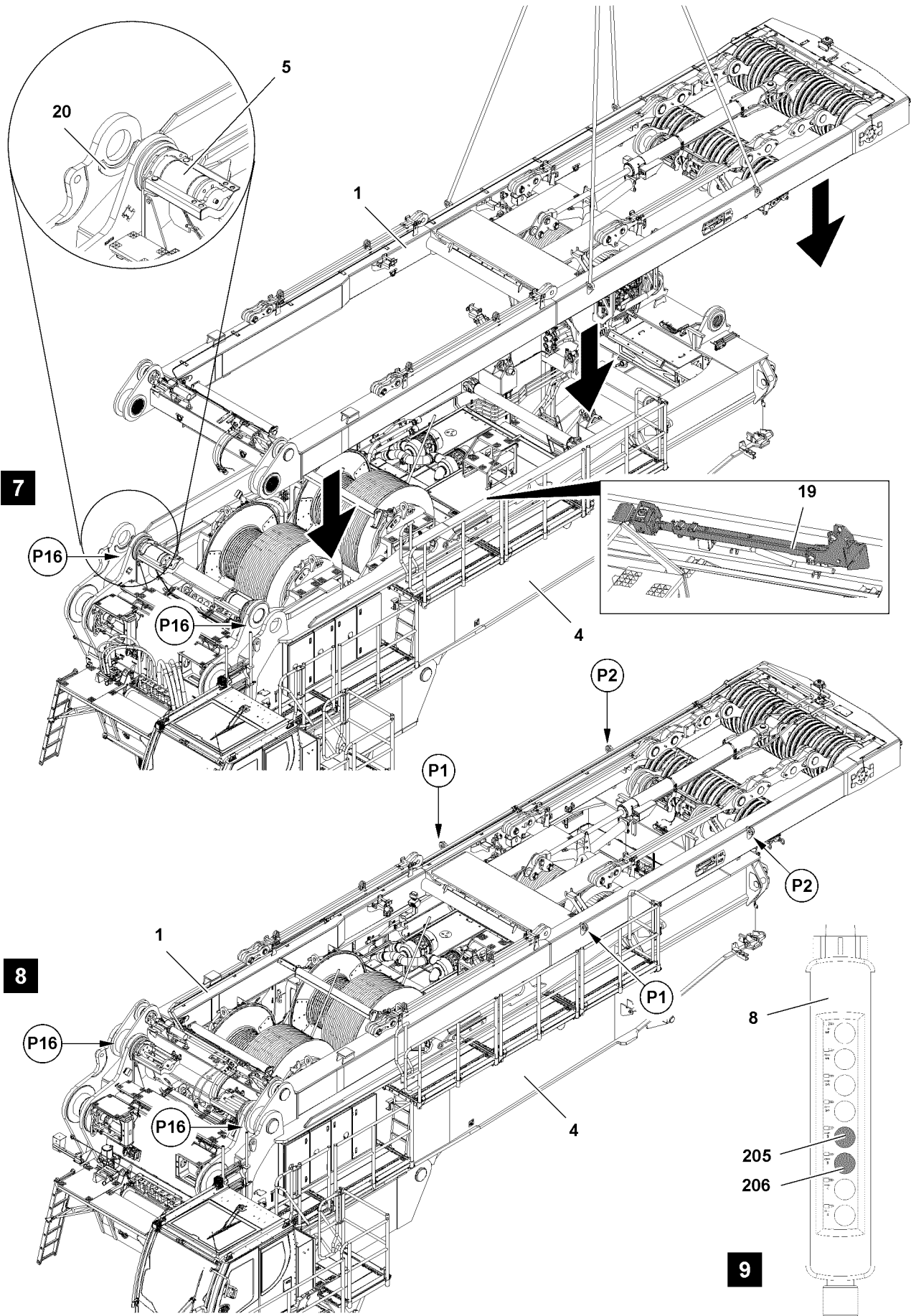

Fig.116919

LWE/LR 11000-001/23501-04-02/en

NOTICE

Danger of property damage!

If the pins **5** at points **P16** are in **pinned** position when moving the SA-frame in the turntable, components can be severely damaged.

- ▶ Make sure that the pins **5** are in **unpinned** position when moving the SA-frame into the turntable, see points **P16** / in illustration 7.

NOTICE

Danger of property damage!

If the camera for winch **1 19** is in operating position - when swinging the SA-frame to the turntable - it will be damaged when moving the SA-frame in.

- ▶ Make sure that the camera for winch **1 19** is in transport position when moving the SA-frame in, see illustration 7.

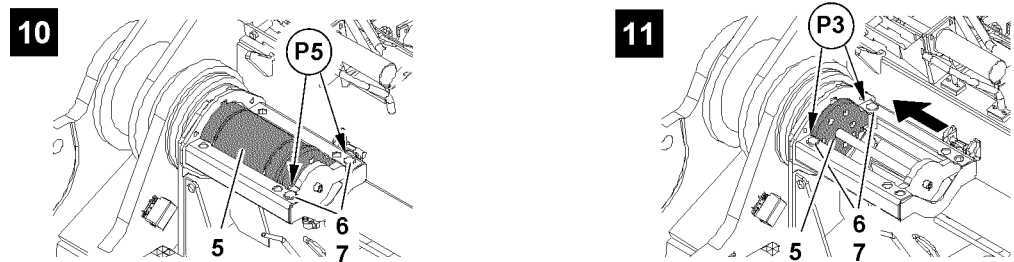

Fig.116920: Insert the pin 5.

- ▶ Lift the SA-frame **1** with the auxiliary crane and position it on the turntable **4**.
- ▶ Place the SA-frame **1** in the centerings **20** at point **P16** on the turntable **4**, see illustration 7.

Result:

- Align the pin bores.
- ▶ Insert the pin **5**: Press button **206** on the control panel **8**, see illustration 9 and illustration 10.

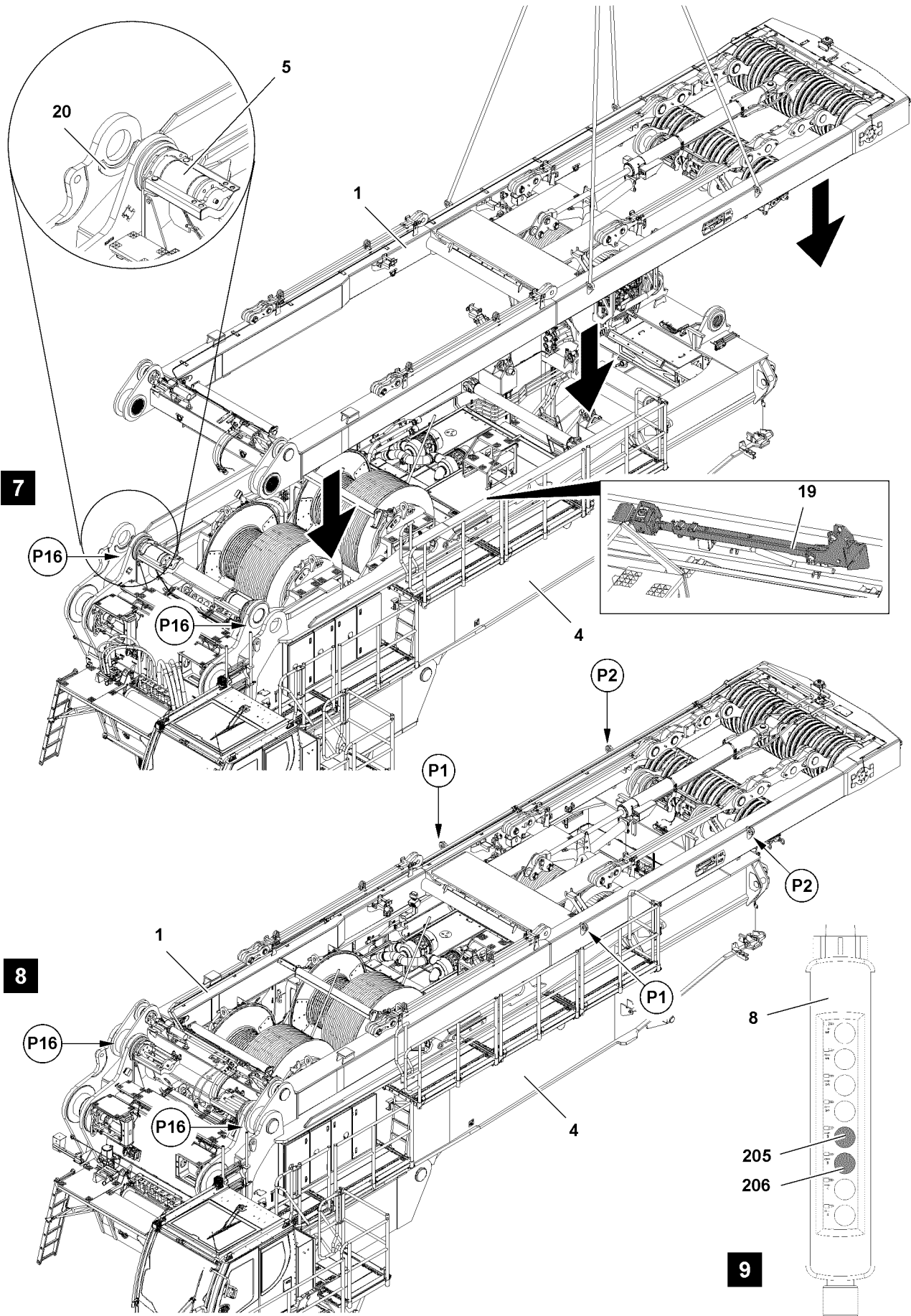

Fig.116919

LWE/LR 11000-001/23501-04-02/en

**WARNING**

The pin is not secured!

If the pins **5** are not secured, the pins can loosen up by themselves during crane operation. This can cause the crane to topple over.

Death, severe injury, property damage.

- ▶ Make sure that the pins **5** with pins **6** are secured.

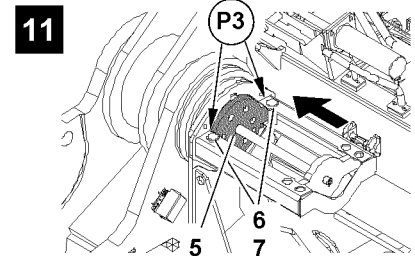
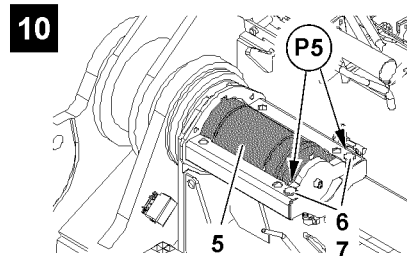

Fig.116920: Insert the pin 5.

When the pins **5** are pinned:

- ▶ Remove the safety locking pin **7** on both sides at points **P5** and unpin the retaining pin **6**, see illustration **10**.
- ▶ Insert the retaining pin **6** at points **P3** on both sides and secure with safety locking pin **7**, see illustration **11**.

When the SA-frame is pinned:

- ▶ Remove the fastening equipment on points **P1**, see illustration **8**.

**WARNING**

Danger of falling!

Death, severe injury, property damage.

- ▶ The fastening equipment may only be removed on points **P2** with the aid of a work platform.

- ▶ Remove the fastening equipment on points **P2**, see illustration **8**.

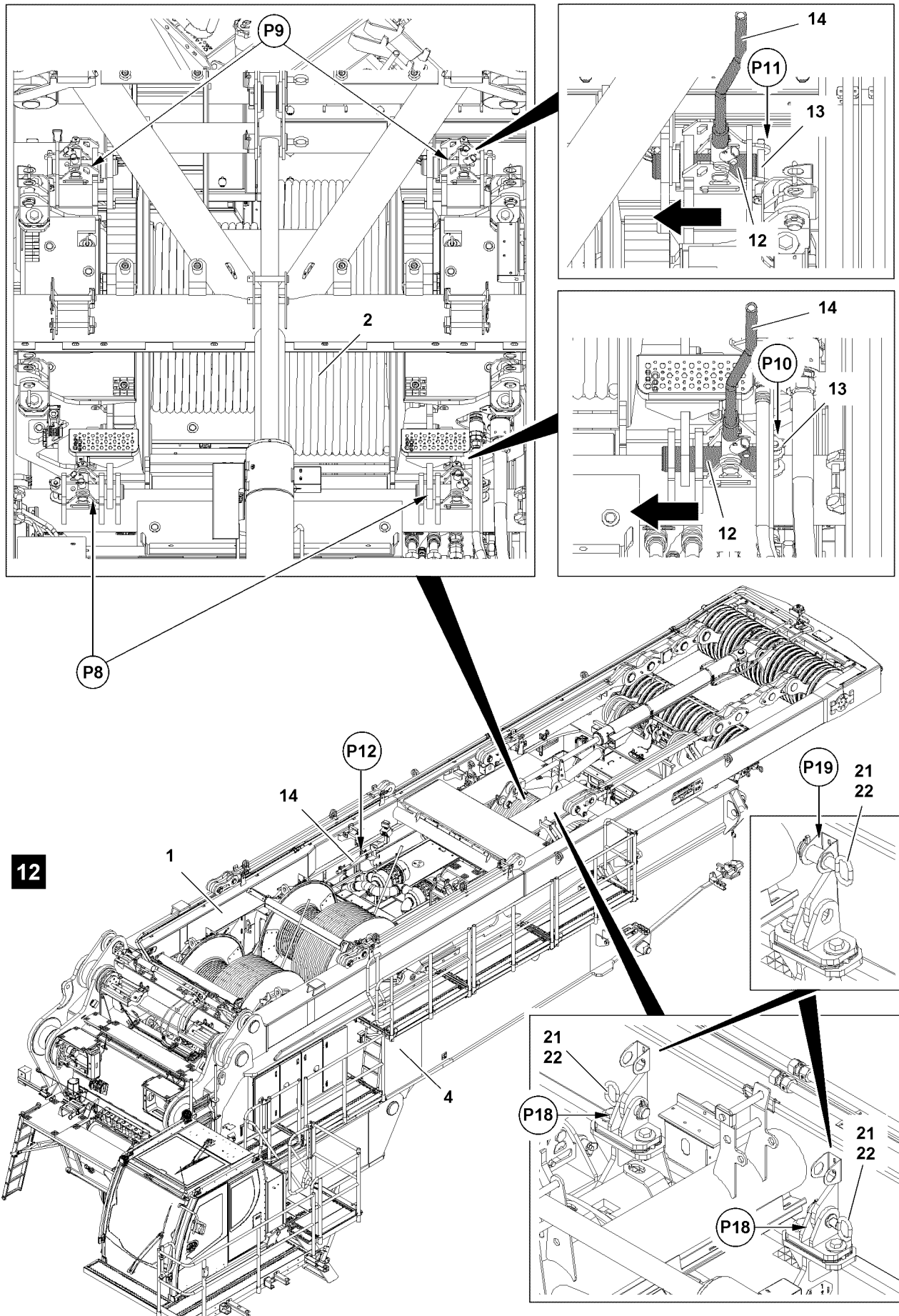

Fig.116921

LWE/LR 11000-001/23501-04-02/en

3.3 Pinning winch 4 on the turntable

Make sure that the following prerequisites are met:

- The SA-frame is pinned on the turntable.
- The fastening equipment has been removed.



WARNING

Danger of falling!

During assembly and disassembly of crane components, personnel must be secured with appropriate aids to prevent them from falling.

Death, severe injury, property damage.

▶ Use personal protective equipment.

- ▶ Release the pins **12** at points **P8** and on points **P9**: Unpin the ball locking pins **13** at points **P10** and points **P11**, see illustration **12**.



Note

- ▶ The lever **14** is positioned at point **P12** in the transport position, see illustration **12**.

- ▶ Insert pins **12** at points **P8** and points **P9** on both sides with the lever **14**, see illustration **12**.



WARNING

The pin is not secured!

If the pins **12** are not secured, the pins can loosen up by themselves during crane operation.

This can cause the crane to topple over.

Death, severe injury, property damage.

▶ Make sure that the pins **12** are secured with ball locking pins **13**.

- ▶ Secure the pins **12** at points **P8** and points **P9**: Insert the ball locking pins **13** at points **P10** and points **P11**, see illustration **12**.

When winch 4 is pinned on the turntable and secured:

- ▶ Remove the safety locking pins **22** at points **P18** and unpin the connector pins **21**, see illustration **12**.

Result:

- Winch 4 is released from the SA-frame.
- ▶ Insert the connector pins **21** at points **P19** in park position and secure with safety locking pin **22**.

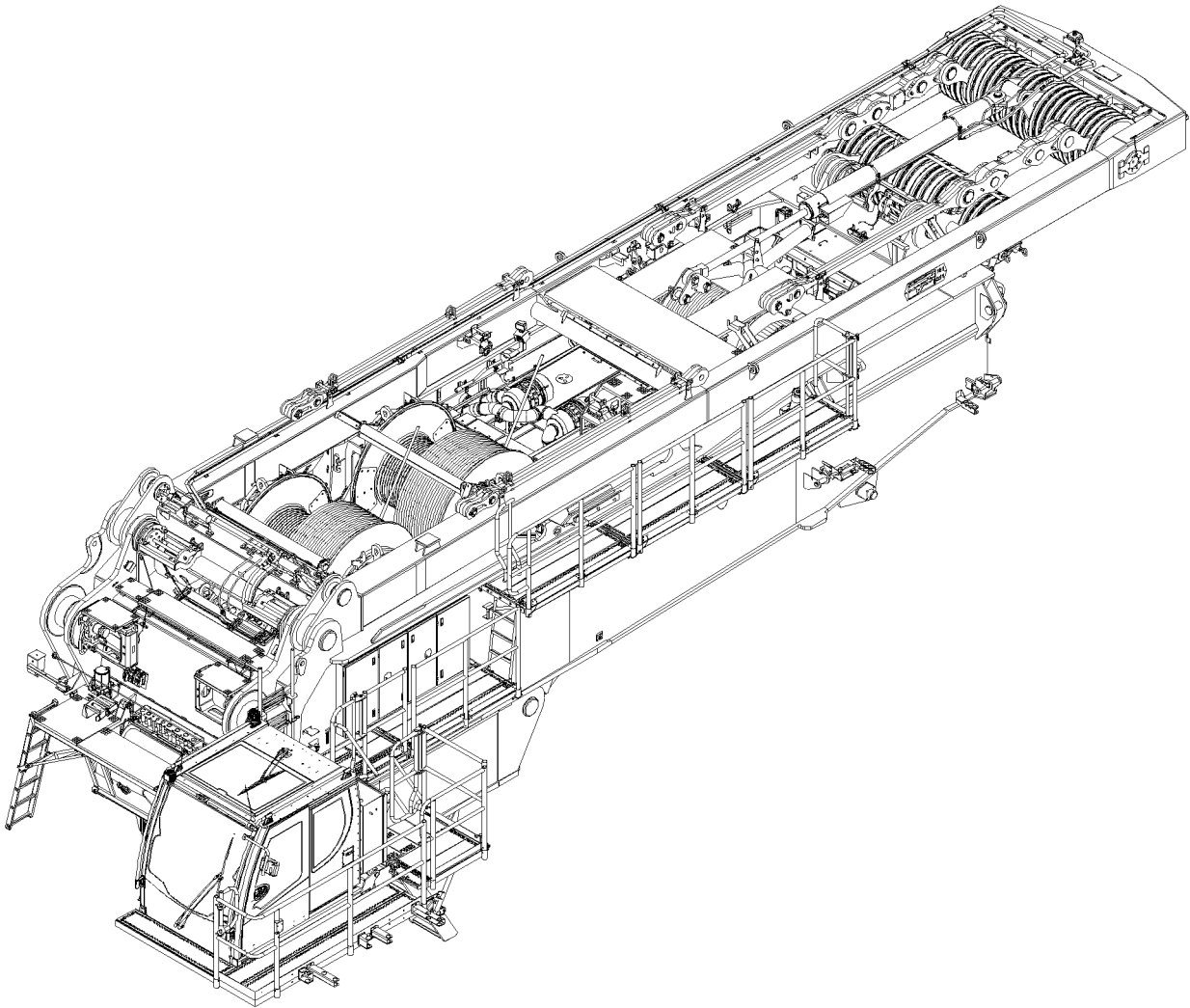

Fig.116922

LWE/LR 11000-001/23501-04-02/en

3.4 Establishing the connections to the SA-frame

Make sure that the following prerequisites are met:

- The SA-frame is installed, pinned and secured.
- The winch 4 is installed, pinned and secured.

3.4.1 Establishing the hydraulic connections

The hydraulic connections are made with quick couplings.

When connecting hydraulic lines with quick couplings, make sure that the coupling procedure is carried out correctly.



WARNING

Pressure in the hydraulic lines!

If the pressure supply is not interrupted before connecting / releasing the hydraulic lines, the hydraulic oil can escape with high pressure.

Death, severe injury, property damage.

- ▶ Release the pressure in the hydraulic system before connecting / disconnecting: Interrupt the pressure supply and wait for a short time.



WARNING

Loss of pressure or leakage!

Incorrectly coupled or self-loosening quick couplings (particularly return lines) can result in serious accidents due to component failure.

Death, severe injury, property damage.

- ▶ Check that the quick couplings have been properly connected before using the crane.
- ▶ Connect the coupling components (sleeve and connector) and screw together with the hand-tightened nut.
- ▶ Tighten the hydraulic coupling by hand. Rotate the hand-tightened nut until it reaches a tangible, fixed stop position.
- ▶ Establish the hydraulic connections, see Hydraulic diagram.

3.4.2 Establishing the electrical connections

- ▶ Establish the electrical connections, see Electric wiring diagram.

3.4.3 Establishing the connections to the central lubrication system

- ▶ Establish the connections to the central lubrication system.

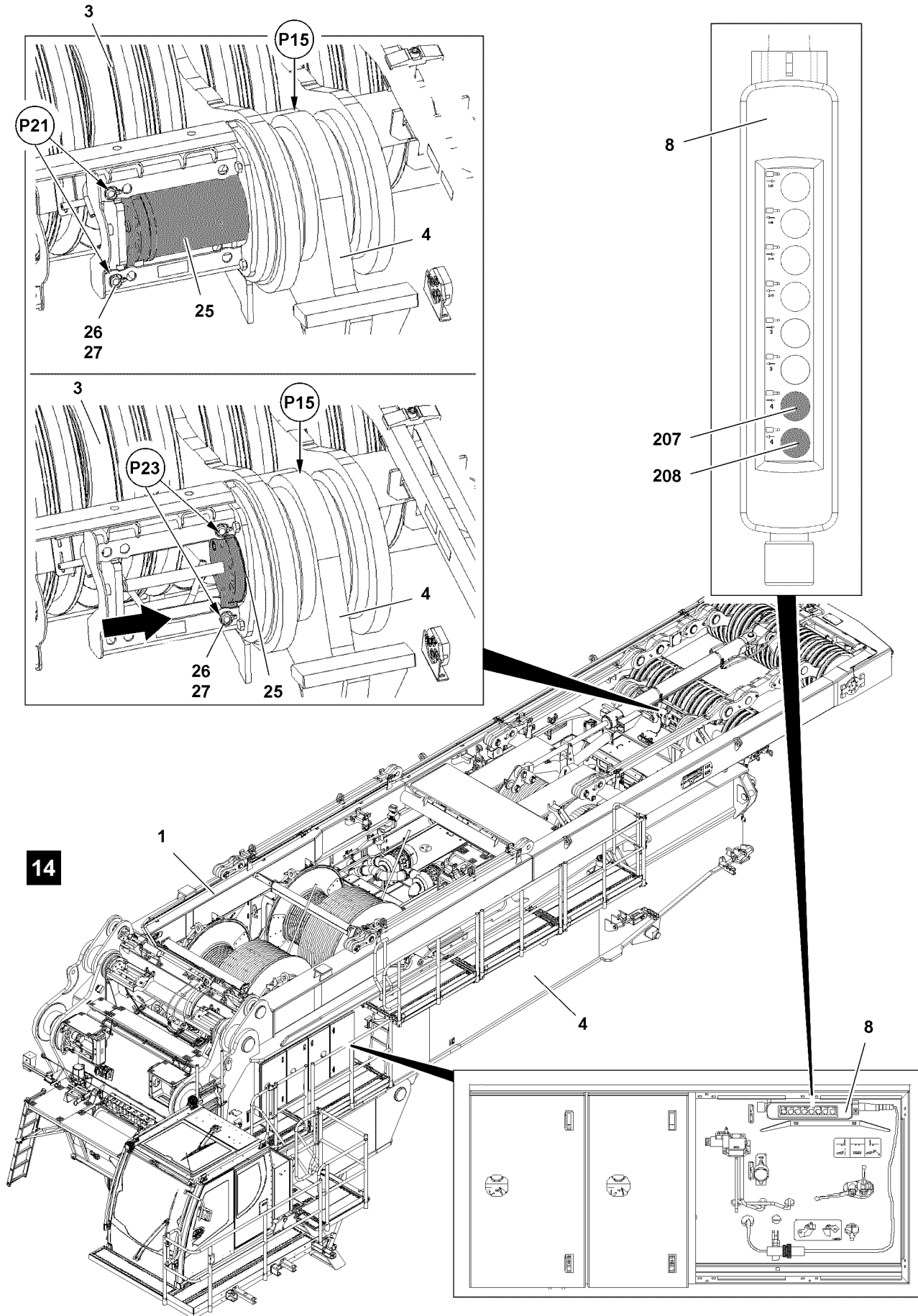

Fig.116924

LWE/LR 11000-001/23501-04-02/en

3.5 Pinning the pulley support with the turntable

Make sure that the following prerequisites are met:

- All hydraulic connections have been made.
- All electrical connections have been made.
- The connections of the central lubrication system are established.
- The pins **26** are on points **P21**.
- The crane engine is running.



WARNING

Danger of falling!

During assembly and disassembly of crane components, personnel must be secured with appropriate aids to prevent them from falling.

Death, severe injury, property damage.

- ▶ Use personal protective equipment.

- ▶ Pin the pulley support **3** with the turntable **4** at points **P15** on both sides: Press button **208** on the control panel **8**, see illustration **14**.

Result:

- The pins **25** extend.

When the pins **25** are pinned:

- ▶ Remove the safety locking pin **27** on both sides at points **P21** and unpin the retaining pin **26**, see illustration **14**.



WARNING

The pin is not secured!

If the pins **25** are not secured, the pins can loosen up by themselves during crane operation.

This can cause the crane to topple over.

Death, severe injury, property damage.

- ▶ Make sure that the pins **25** with pins **26** are secured.

- ▶ Insert the retaining pin **26** at points **P23** on both sides and secure with safety locking pin **27**, see illustration **14**.

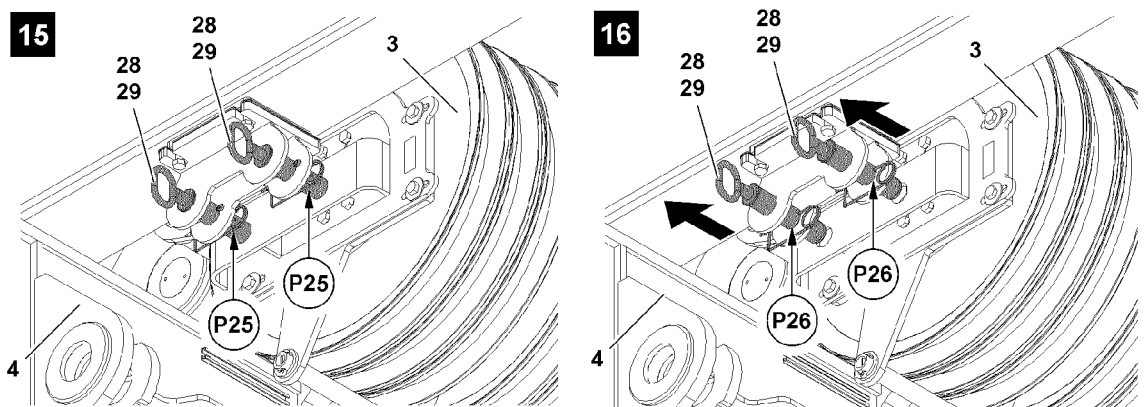

Fig.116925: Release the pulley support from the SA-frame

When pulley support **3** is pinned and secured on the turntable **4**:

- ▶ Release the pulley support **3** from the SA-frame: Remove the spring retainer **29** on points **P25** on both sides and unpin the grip pin **28** to the stop, see illustration **15**.
- ▶ Secure the grip pin **28** in park position with spring retainer **29** at points **P26**, see illustration **16**.

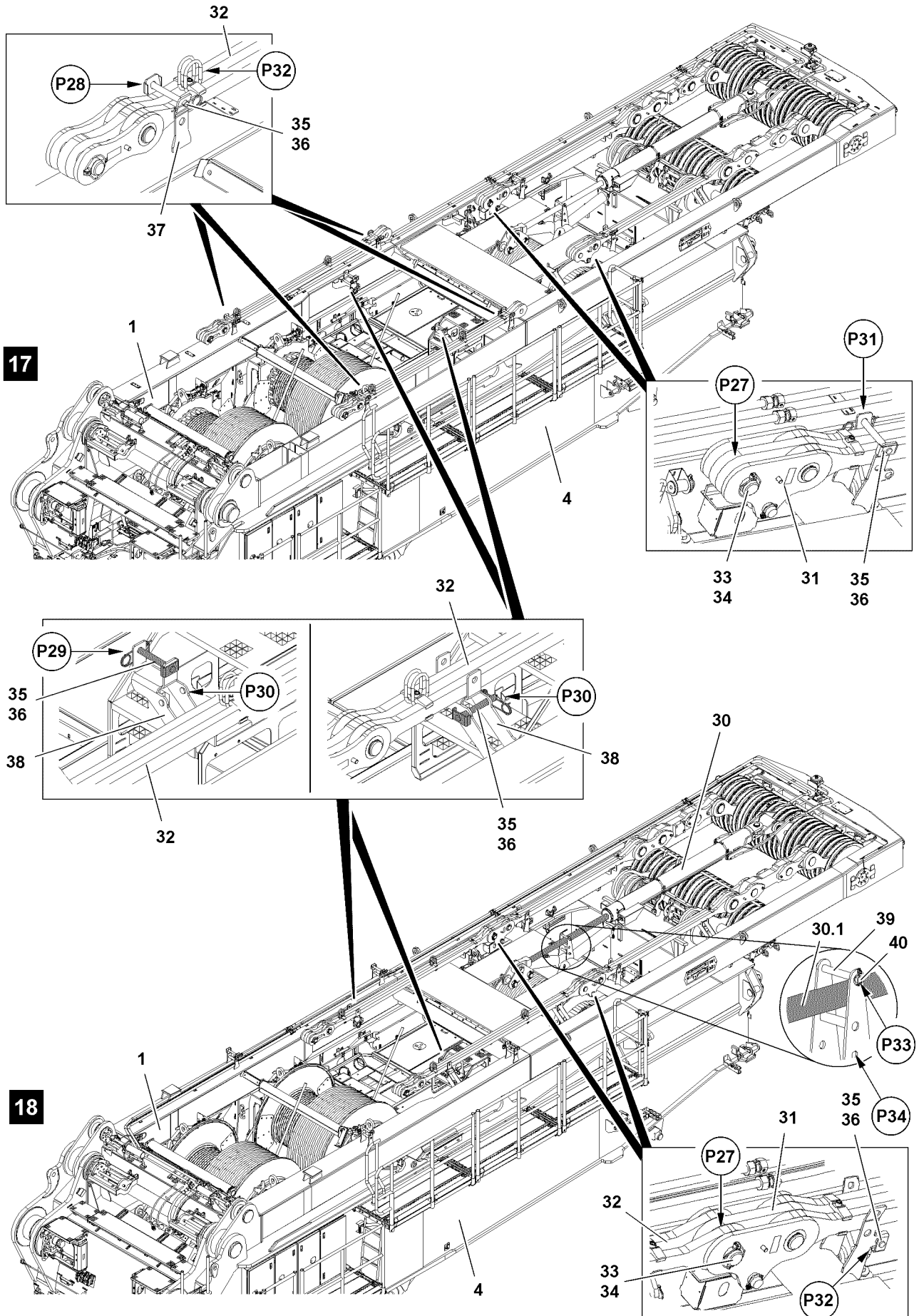

Fig.122241

3.6 Pinning the pull rods

Make sure that the following prerequisites are met:

- The winch 4 is installed, pinned and secured.
- The pulley support is pinned and secured on the turntable.



WARNING

The crane can topple over!
Death, severe injury, property damage.

- ▶ The guying must be installed according to the rod plans, see Rod plan.

- ▶ Prepare the connection point on the pull rods **31**: Remove the safety locking pin **34** at points **P27** and unpin the connector pin **33**.
- ▶ Remove the spring retainer **36** at points **P28** on the retainers **37** and unpin pin **35**.

Result:

- The pull rods **32** are released and can be removed from the retainers **37**.
- ▶ Prepare the placement location for the pull rods **32**: Remove the spring retainer **36** at points **P29** and unpin pin **35** on the retainers **38**.
- ▶ Insert pin **35** on points **P30** in park position and secure with spring retainer **36**.
- ▶ Attach the pull rods **32** on the points **P32** on the auxiliary crane.
- ▶ Lift the pull rods **32** and swing to the connection point on the pull rods **31**.
- ▶ Insert the pin **35** again at points **P28** and secure with spring retainer **36**.
- ▶ Place the pull rods **32** in operating position on retainers **38** so that the bores align at the connection point.



WARNING

The pin is not secured!

If the connector pins are not secured, the connector pins can loosen up by themselves during crane operation.

This can cause the crane to topple over.

Death, severe injury, property damage.

- ▶ Make sure that the connector pins **33** are secured with safety locking pins **34**.

- ▶ Insert the connector pins **33** at points **P27** and secure with safety locking pin **34**.

Result:

- The pull rods **31** are pinned and secured with pull rods **32** for crane operation.
- ▶ Release the pull rods **31**: Remove the spring retainer **36** at points **P31** and unpin pin **35**.
- ▶ Insert pin **35** on points **P32** in park position and secure with spring retainer **36**.

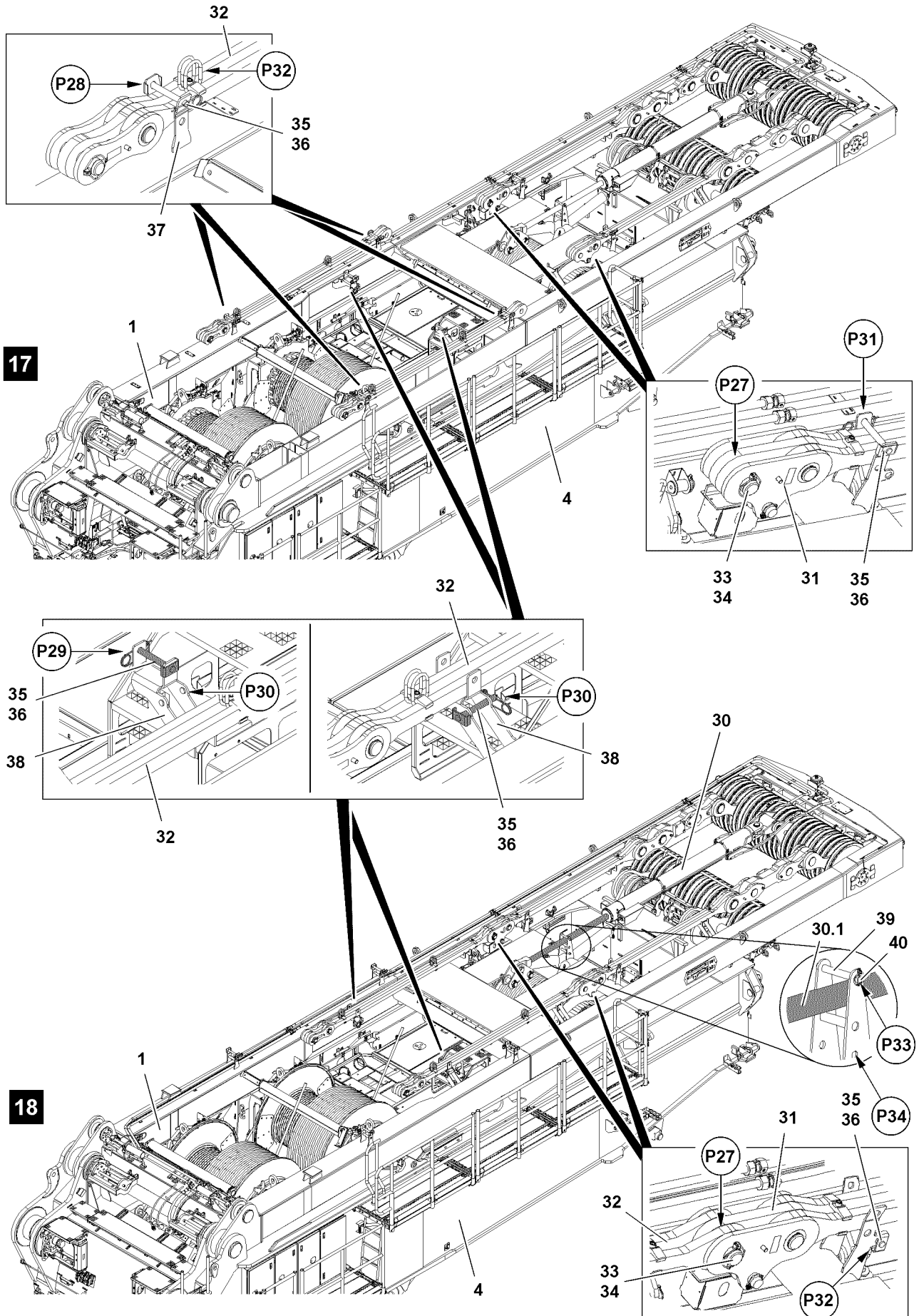

Fig.122241

LWE/LR 11000-001/23501-04-02/en

**WARNING**

Danger due to oscillating guying!

During assembly work with the SA-frame, the pull rods can start to move back and forth.

Death, severe injury, property damage.

- ▶ During assembly work with the SA-frame make sure that the pull rods are secured in their retainers.

When additional assembly work must be carried out with the SA-frame:

- ▶ Pin and secure the pull rods **31** and pull rods **32** on the retainers.

3.7 Removing the transport retainer on the assembly cylinder

If the assembly cylinder **30** on the SA-frame is required for crawler assembly, then the transport retainer of the assembly cylinder must be removed.

**Note**

- ▶ Before erecting the SA-frame in operation position, remove the transport retainer of the assembly cylinder.

**WARNING**

Danger of accident due to assembly cylinder!

If the SA-frame is erected to more than 90° after removing the transport retainer, then the assembly cylinder **30** swings forward by itself.

Death, severe injury, property damage.

- ▶ Make sure that no personnel is within the danger zone when erecting the SA-frame.
- ▶ Make sure that no objects or obstacles are within the danger zone.

- ▶ Release retaining pin **39** on point **P33** and unpin.

When the retaining pin **39** is unpinned at point **P33**:

- ▶ Insert the retaining pin **39** at point **P34** in transport position and secure with spring retainer **40**.

Result:

- The assembly cylinder is prepared for crawler carrier assembly.

Fig.195219

LWE/LR 11000-001/23501-04-02/en

4 Disassembling the SA-frame



WARNING

Danger of falling!

During assembly / disassembly, inspection and maintenance work, personnel must be secured with appropriate aids to prevent them from falling.

Death, severe injury, property damage.

- ▶ All work aloft, where there is a danger of falling must be carried out with suitable aids.
- ▶ If aids are not available and work cannot be carried out from the ground, then the assembly personnel must secure themselves with the supplied fall arrest system to prevent falling, see Crane operating instructions, chapter 2.04.
- ▶ If fall protection equipment is available, then it must be used, see Crane operating instructions, chapter 2.06.
- ▶ When lifting, lowering, swinging crane parts in and out, no persons may remain in the danger zone.
- ▶ If railings are present for the crane, then they must be brought into the corresponding position and secured for assembly / disassembly work.
- ▶ Only step on the aids, ladders and catwalks with clean shoes.
- ▶ Keep aids, ladders and catwalks free of heavy dirt, snow and ice.
- ▶ During all assembly and disassembly work, maintenance work and inspections, travel or crane operation is prohibited.
- ▶ Remaining on a suspended load is prohibited.
- ▶ Stepping or walking on crane components and lattice sections, which have an incline of more than 20° is prohibited.
- ▶ For all assembly work, the crane operator of the main crane must be in voice contact with the crane operator / crane operators of the auxiliary crane / auxiliary cranes.
- ▶ For assembly / disassembly tasks, the crane operator may only initiate crane movements when the responsible guide has explicitly released the movement.



WARNING

Danger of impact / crushing!

When installing / removing crane components with the auxiliary crane, crane components can start to swing back and forth.

When lifting / lowering and positioning crane components, there is an increased danger of impacts / crushing.

Death, severe injury, property damage.

- ▶ Make sure that personnel cannot be caught by components.
- ▶ When working in danger zones: Use aids to protect limbs.
- ▶ Guide components with suitable aids to minimize oscillation.



DANGER

The components can fall down!

If the corresponding component is disengaged from the auxiliary crane before the corresponding component is pinned, then the corresponding component can fall down.

Death, severe injury, property damage.

- ▶ Do not disengage the auxiliary crane until the corresponding component is pinned and secured.

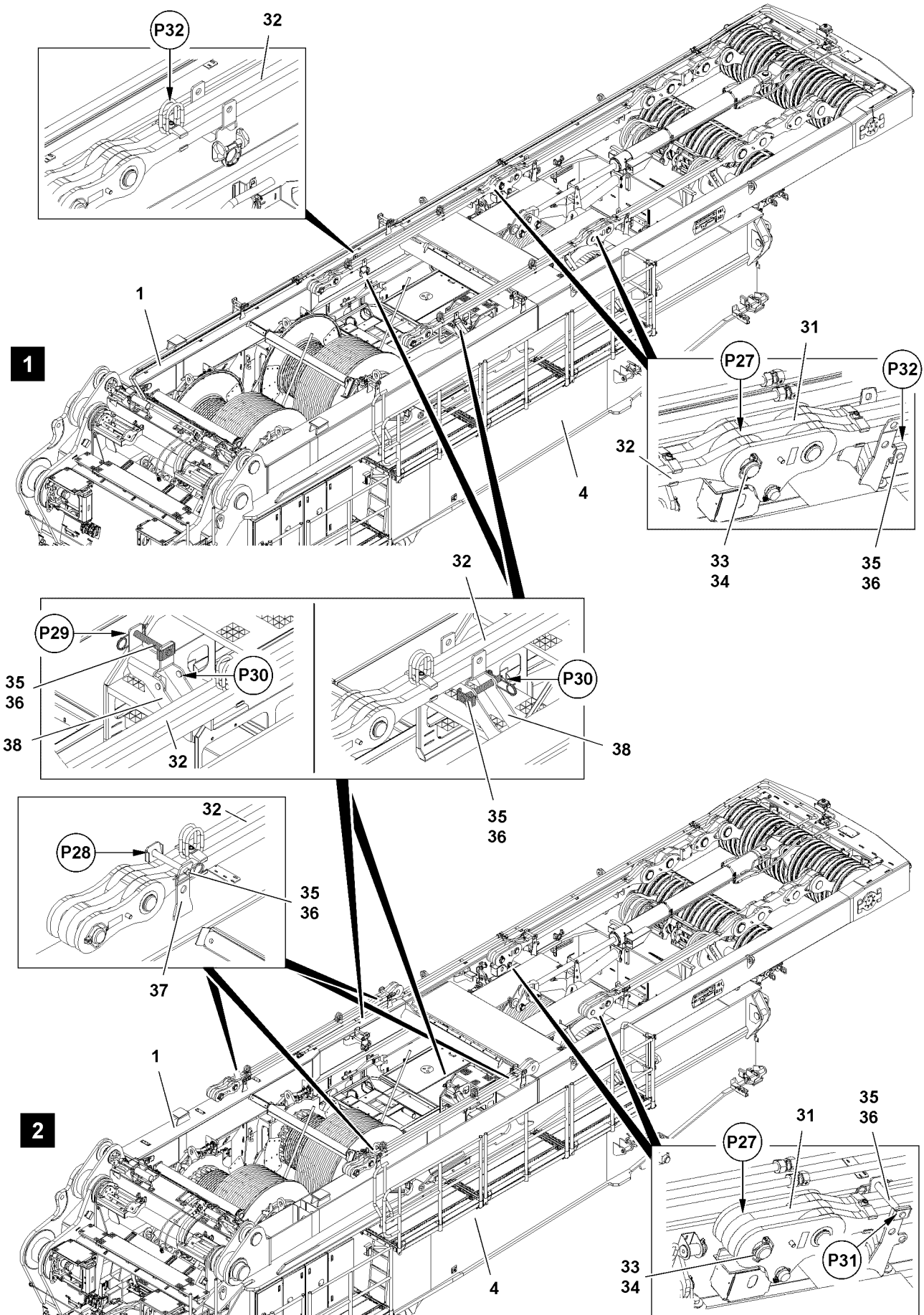

Fig.116927

LWE/LR 11000-001/23501-04-02/en

4.1 Unpinning the pull rods

Make sure that the following prerequisite is met:

- The SA-frame is laying all the way on the turntable.

- ▶ Remove the spring retainer **36** at points **P32** from the park position and unpin the pin **35**, see illustration **11**.



WARNING

The pin is not secured!

If the pins **35** are not secured, the connector pins can loosen up by themselves during transport operation.

Death, severe injury, property damage.

- ▶ Make sure that the pins **35** are secured with spring retainers **36**.

- ▶ Secure the pull rods **31**: Insert the pin **35** at points **P31** and secure with spring retainer **36**, see illustration **2**.

- ▶ Remove the safety locking pins **34** at points **P27** and unpin the connector pins **33**, see illustration **1**.

Result:

- The pull rods **31** are separated from pull rods **32**.

- ▶ Remove the spring retainers **36** at points **P28** on the retainers **37** and unpin the pin **35**, see illustration **1**.

Result:

- The pull rods **32** can be placed in the retainers **37**.

- ▶ Fasten the pull rods **32** at points **P32** on the auxiliary crane, see illustration **1**.

- ▶ Lift the pull rods **32** and swing to park position on the SA-frame **1**.

- ▶ Place the pull rods **32** in park position on the retainers **37**, see illustration **2**.



WARNING

The pin is not secured!

If the pins **35** are not secured, the connector pins can loosen up by themselves during transport operation.

Death, severe injury, property damage.

- ▶ Make sure that the pins **35** are secured with spring retainers **36**.

- ▶ Insert the pins **35** at points **P28** again and secure with spring retainer **36**, see illustration **2**.

Result:

- The pull rods **31** are pinned and secured for transport.

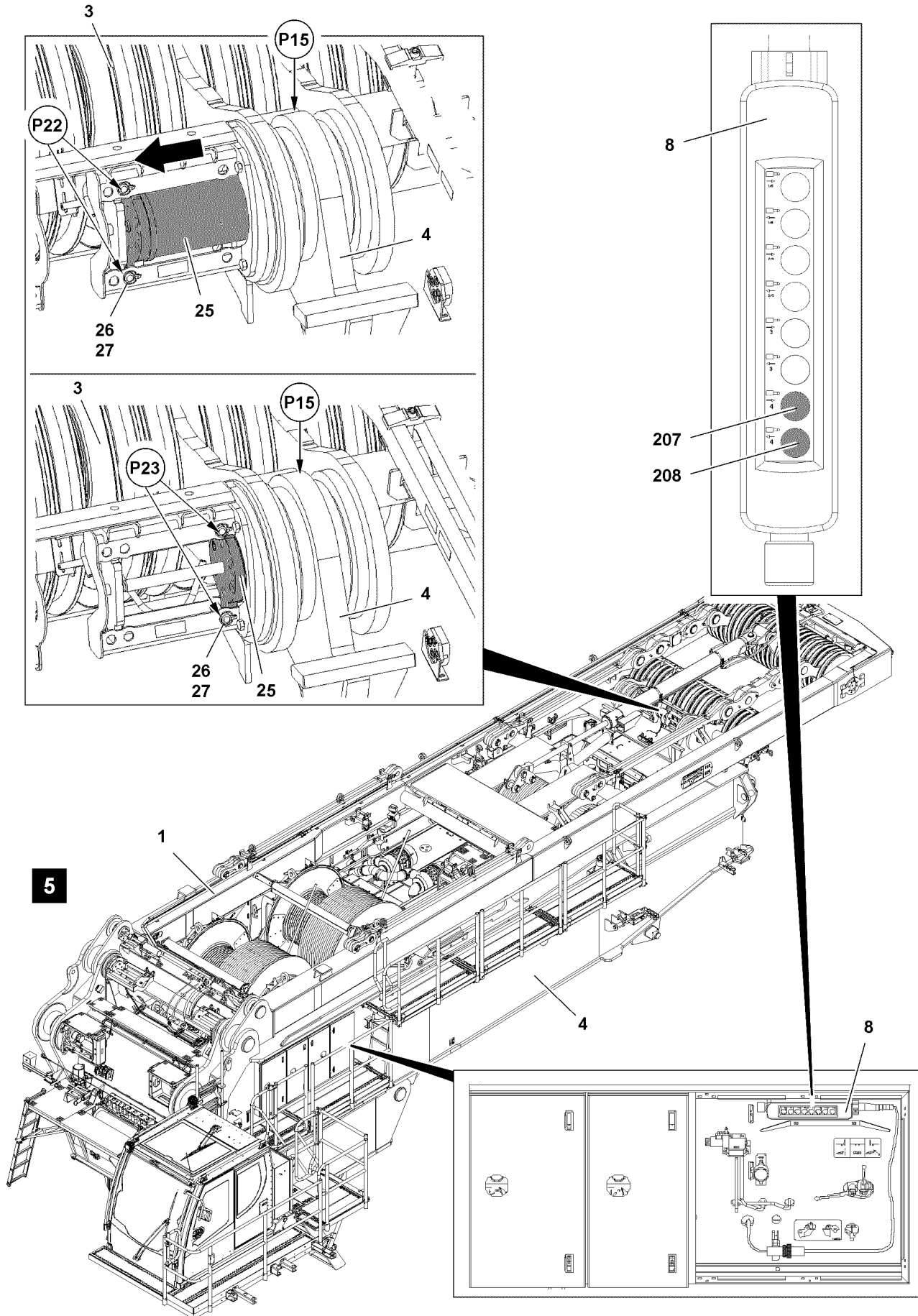

Fig.116929

LWE/LR 11000-001/23501-04-02/en

4.2 Unpinning the pulley support on the turntable

Make sure that the following prerequisite is met:

- All hydraulic connections have been made.
- The crane engine is running.



WARNING

Danger of falling!

During assembly and disassembly of crane components, personnel must be secured with appropriate aids to prevent them from falling.

Death, severe injury, property damage.

- ▶ Use personal protective equipment.

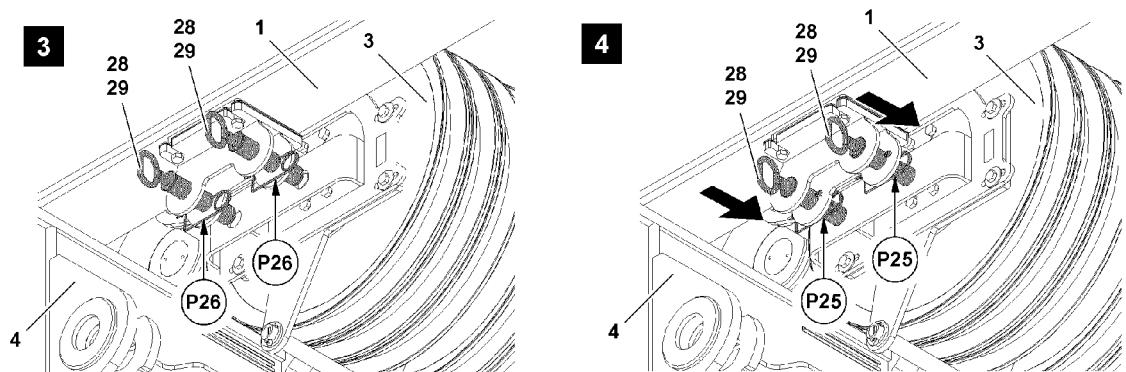

Fig.116928: Connect the pulley support with the SA-frame

- ▶ Connect the pulley support 3 with the SA-frame 1: Remove the spring retainer 29 at points P26 on both sides and insert the grip pin 28 to the stop, see illustration 3.



WARNING

The pin is not secured!

If the grip pins 28 are not secured, the pins can loosen up by themselves during transport operation. Death, severe injury, property damage.

- ▶ Make sure that the pins 28 are secured with spring retainers 29.

- ▶ Secure the grip pin 28 with spring retainer 29 at points P25, see illustration 4.

Result:

- The pulley support 3 is pinned and secured on the SA-frame 1 for transport.
- ▶ Remove the safety locking pin 27 on both sides at points P23 and unpin the retaining pin 26, see illustration 5.
- ▶ Insert the retaining pin 26 at points P22 on both sides and secure with safety locking pin 27, see illustration 5.

When the pulley support 3 is connected with the SA-frame 1:

- ▶ Unpin the pulley support 3 on the turntable 4 at points P15 on both sides: Press button 207 on the control panel 8, see illustration 5.

Result:

- The pins 25 move in.

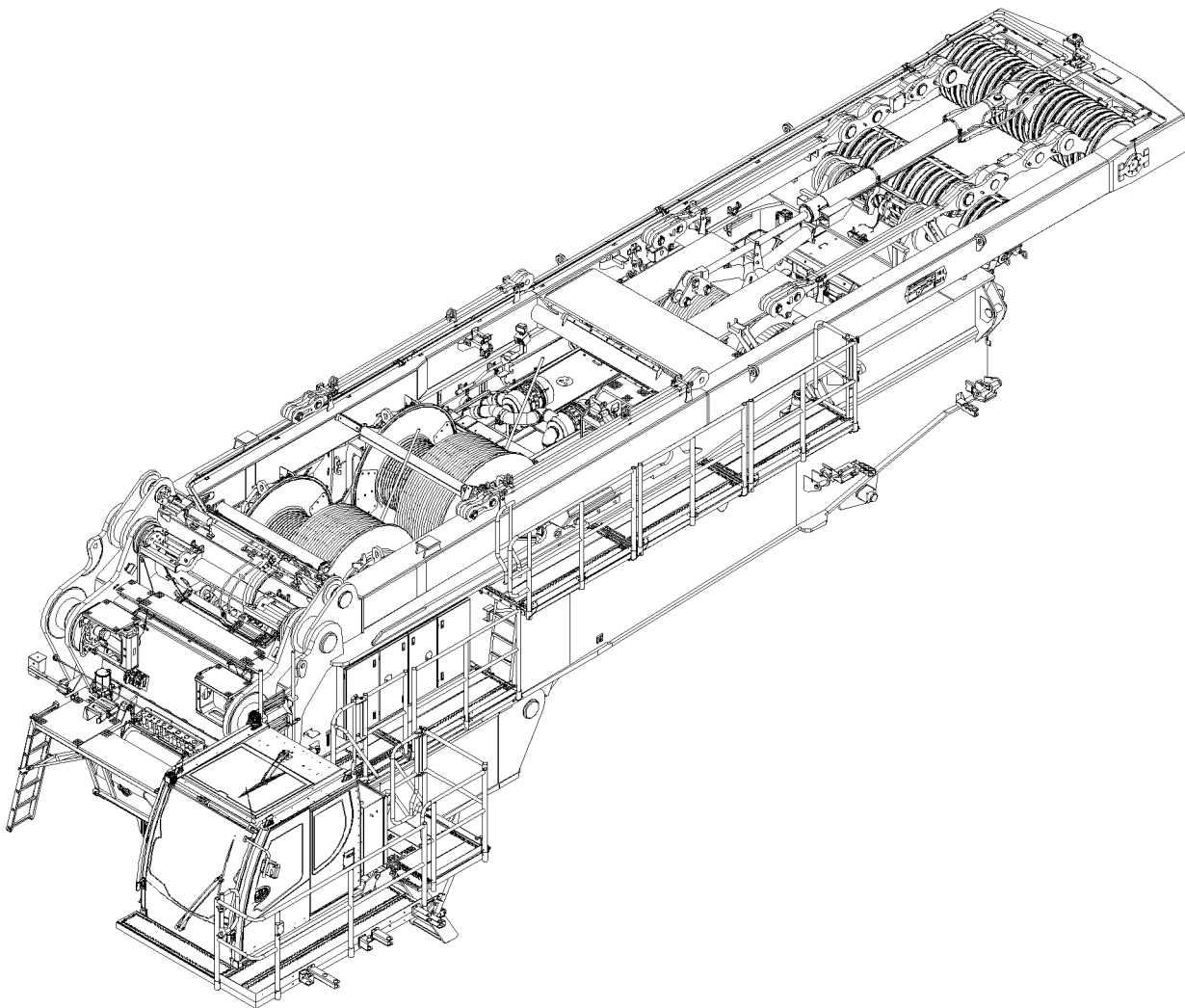

Fig.116922

LWE/LR 11000-001/23501-04-02/en

4.3 Disconnecting the connections to the SA-frame

4.3.1 Disconnecting the hydraulic connections

The hydraulic connections are made with quick couplings.

When disconnecting hydraulic lines with quick couplings, make sure that the coupling procedure is carried out correctly.



WARNING

Pressure in the hydraulic lines!

If the pressure supply is not interrupted before connecting / releasing the hydraulic lines, the hydraulic oil can escape with high pressure.

Death, severe injury, property damage.

▶ Release the pressure in the hydraulic system before connecting / disconnecting: Interrupt the pressure supply and wait for a short time.

-
- ▶ Release the hydraulic coupling by hand.
 - ▶ Disconnect the hydraulic connections, see Hydraulic diagram.
 - ▶ Protect the hydraulic connections from contamination with caps.

4.3.2 Disconnecting the electrical connections

- ▶ Disconnect the electrical connections, see Electric wiring diagram.

4.3.3 Disconnecting the connection to the central lubrication system

- ▶ Disconnect the connection to the central lubrication system.
- ▶ Protect the connections of the central lubrication system with caps from contamination.

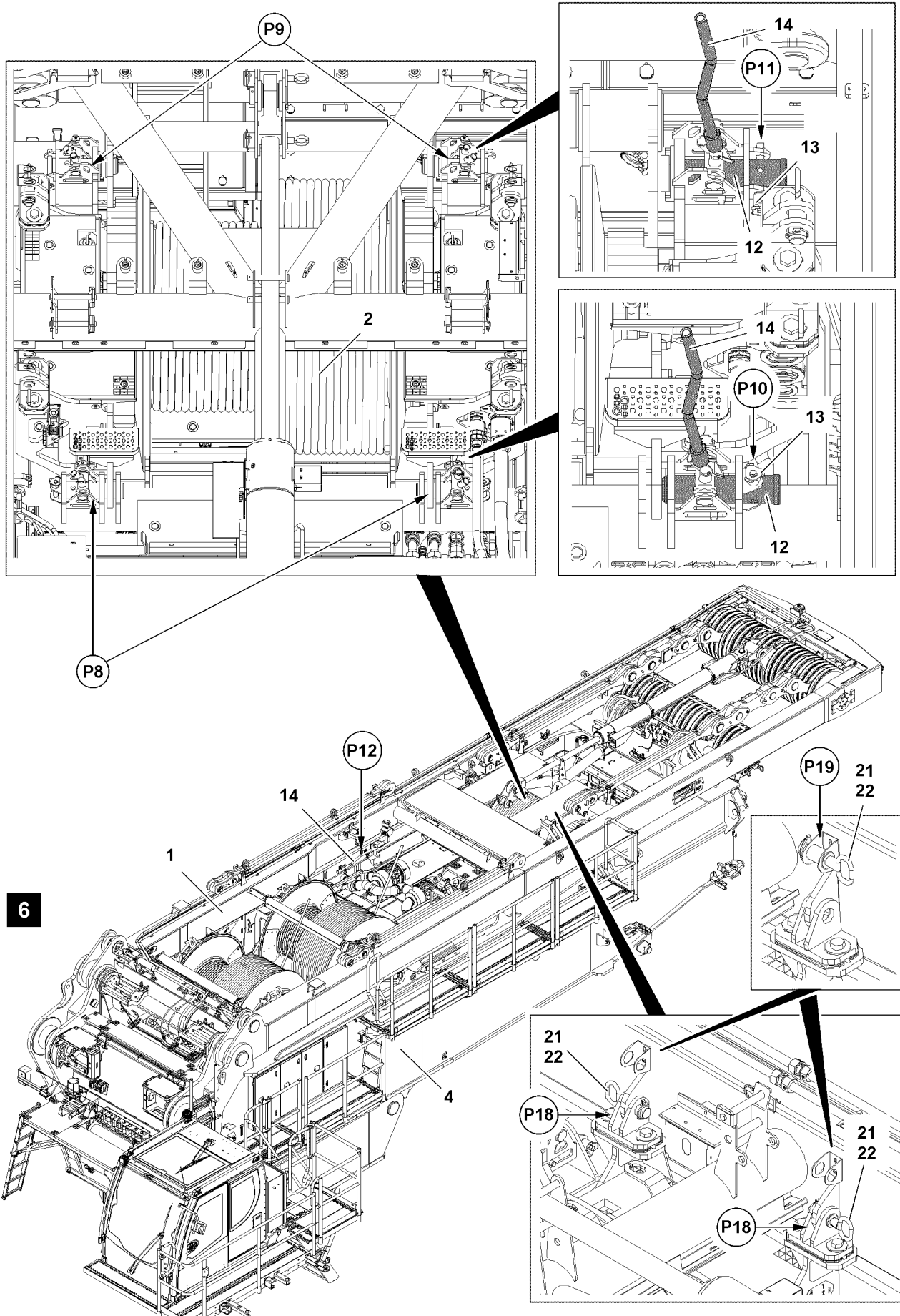

Fig.116930

LWE/LR 11000-001/23501-04-02/en

4.4 Unpinning winch 4 on the turntable

Make sure that the following prerequisite is met:

- The pull rods are placed down in transport position and are secured.



WARNING

Danger of falling!

During assembly and disassembly of crane components, personnel must be secured with appropriate aids to prevent them from falling.

Death, severe injury, property damage.

- ▶ Use personal protective equipment.

- ▶ Remove the safety locking pin **22** at points **P19** and unpin the connector pin **21** from park position.



WARNING

The pin is not secured!

If the connector pins **21** are not secured, the pins can loosen up by themselves during transport.

Death, severe injury, property damage.

- ▶ Make sure that the connector pins **21** are secured with safety locking pins **22**.

- ▶ Connect winch 4 with SA-frame: Insert the connector pins **21** at points **P18** and secure with safety locking pin **22**.

- ▶ Release the pins **12** at points **P8** and on points **P9**: Unpin the ball locking pins **13** at points **P10** and points **P11**, see illustration **6**.



Note

- ▶ The lever **14** is positioned at point **P12** in the transport position, see illustration **6**.

When winch 4 is pinned and secured with the SA-frame:

- ▶ Unpin pins **12** at points **P8** and points **P9** on both sides with the lever **14**, see illustration **6**.

Result:

- Winch 4 is separated from the turntable.

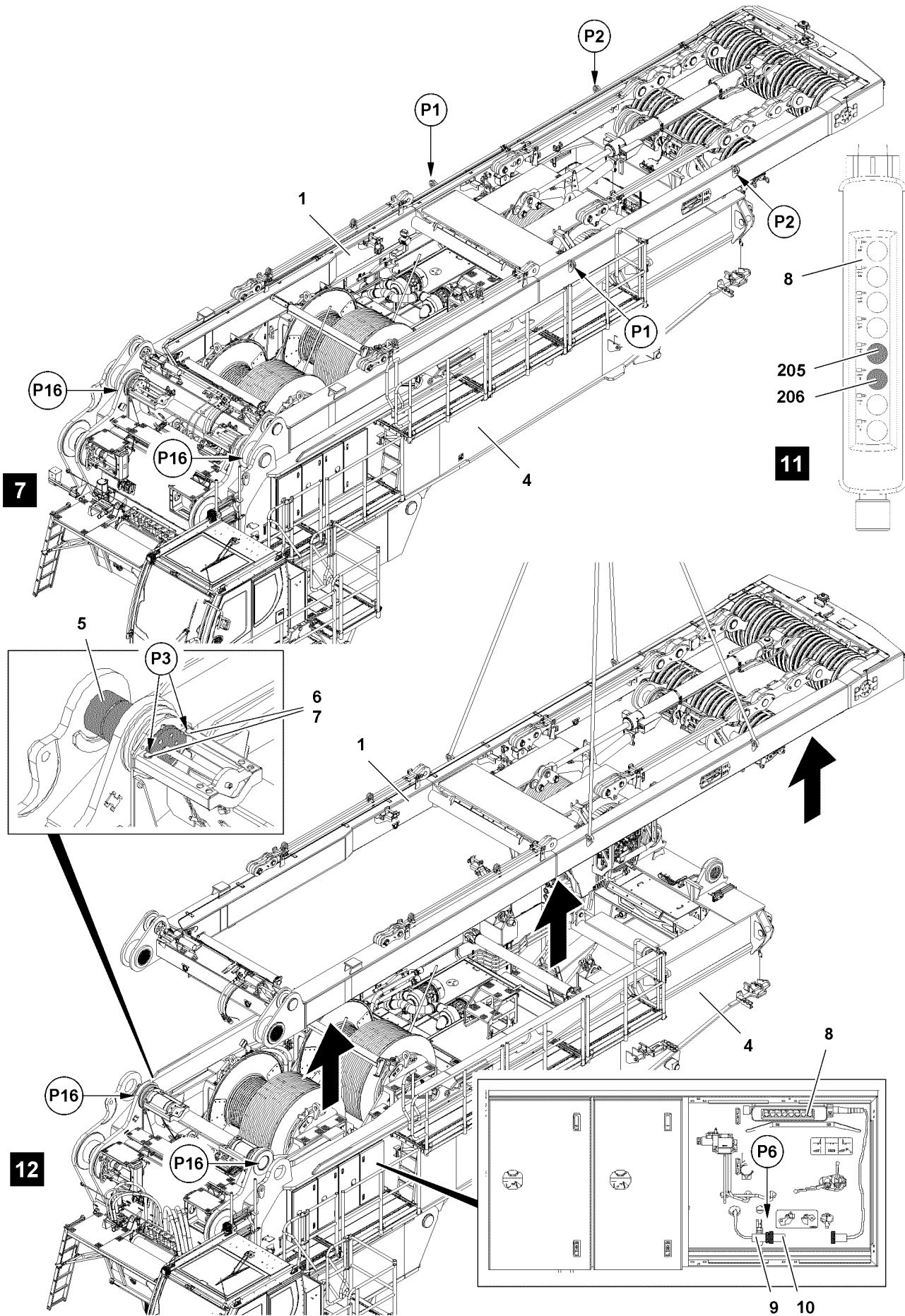

Fig. 116931

LWE/LR 11000-001/23501-04-02/en

4.5 Unpinning the SA-frame on the turntable



WARNING

Danger of falling!

During assembly and disassembly of crane components, personnel must be secured with appropriate aids to prevent them from falling.

Death, severe injury, property damage.

- ▶ Use personal protective equipment.

4.5.1 Fastening the SA-frame on the auxiliary crane

Make sure that the following prerequisite is met:

- An auxiliary crane with an adequate load-bearing capacity is available.

- ▶ Attach the fastening equipment at points **P1** on the SA-frame **1**, see illustration 7.



WARNING

Danger of falling!

Death, severe injury, property damage.

- ▶ The fastening equipment may only be attached on points **P2** with the aid of a work platform.

- ▶ Attach the fastening equipment at points **P2** on the SA-frame **1**, see illustration 7.

- ▶ Tension the fastening equipment.

4.5.2 Unpinning the SA-frame

Make sure that the following prerequisites are met:

- The pull rods are placed down in transport position and are secured.
- The hydraulic connections are disconnected.
- The electrical connections are disconnected.
- The connections of the central lubrication system are disconnected.
- The assembly cylinder is properly secured in transport position.
- The winch 4 is pinned and secured with the SA-frame.
- The pulley support is pinned and secured with the SA-frame.
- The fastening equipment is tensioned.
- The crane engine is running.

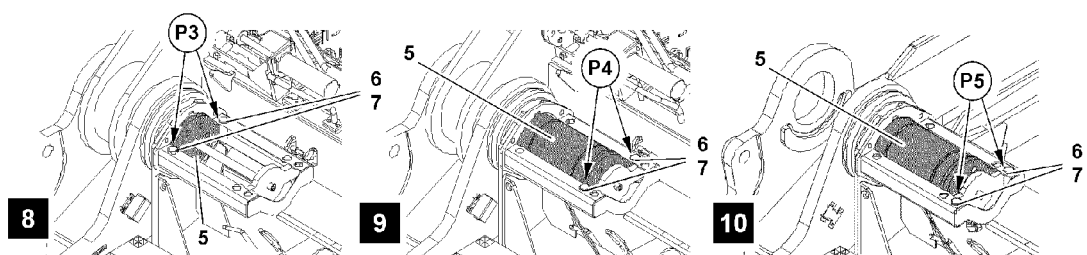

Fig.116932: Unpin the pins 5.

- ▶ Release the pin **5**: Remove the safety locking pin **7** on both sides at points **P3** and unpin the retaining pin **6**, see illustration 8.
- ▶ Insert the retaining pin **6** at points **P4** on both sides and secure with safety locking pin **7**, see illustration 9.

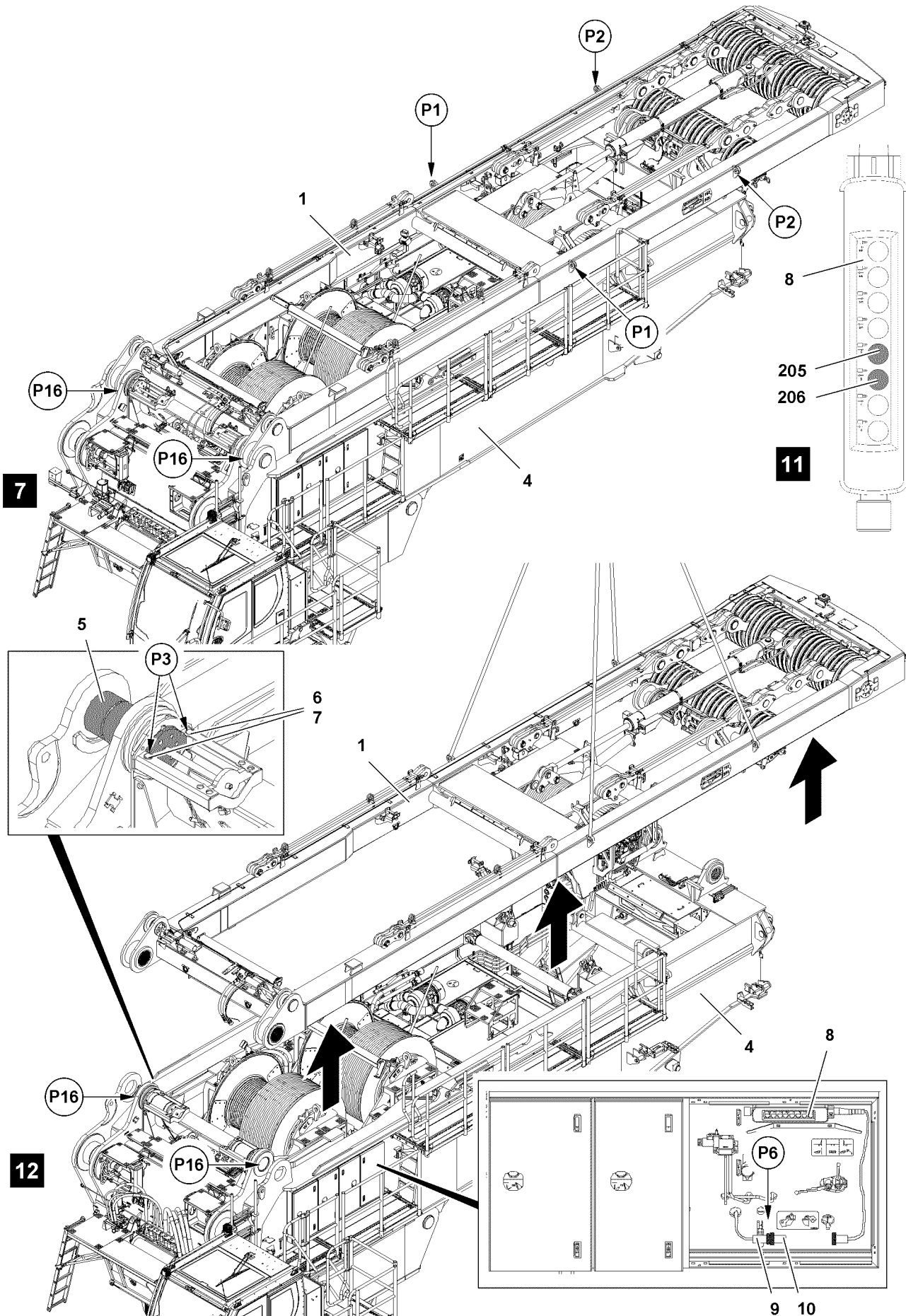

Fig.116931

LWE/LR 11000-001/23501-04-02/en

- ▶ Open the control cabinet on the turntable **4** and remove the control panel, see illustration **12**.
- ▶ Unpin the pin **5**: Press button **205** on the control panel **8**, see illustration **11**.

When the pins **5** are unpinned:

- ▶ Remove the safety locking pin **7** on both sides at points **P4** and unpin the retaining pin **6**, see illustration **9**.

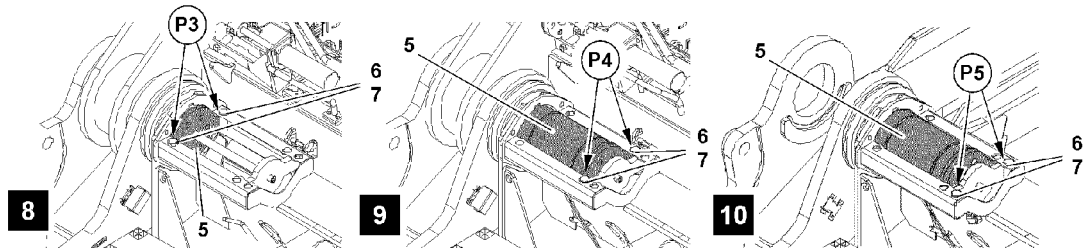

Fig.116932: Unpin the pins **5**.

- ▶ Insert the retaining pin **6** at points **P5** on both sides and secure with safety locking pin **7**, see illustration **10**.

Result:

– The SA-frame **1** can be removed.

- ▶ Lift the SA-frame **1** with the auxiliary crane, swing it and lower it until the support can be brought into transport position.
- ▶ Insert the pins **5** again: Press button **206** on the control panel **8**, see illustration **11**.

When the pins **5** are pinned:

- ▶ Remove the safety locking pin **7** on both sides at points **P5** and unpin the retaining pin **6**, see illustration **10**.
- ▶ Insert the retaining pin **6** at points **P3** on both sides and secure with safety locking pin **7**, see illustration **12**.
- ▶ Disconnect the control panel **8** on connection **9** at point **P6**.
- ▶ Connect the dummy plug **10** on connection **9**, see illustration **12**.
- ▶ Close the control cabinet.

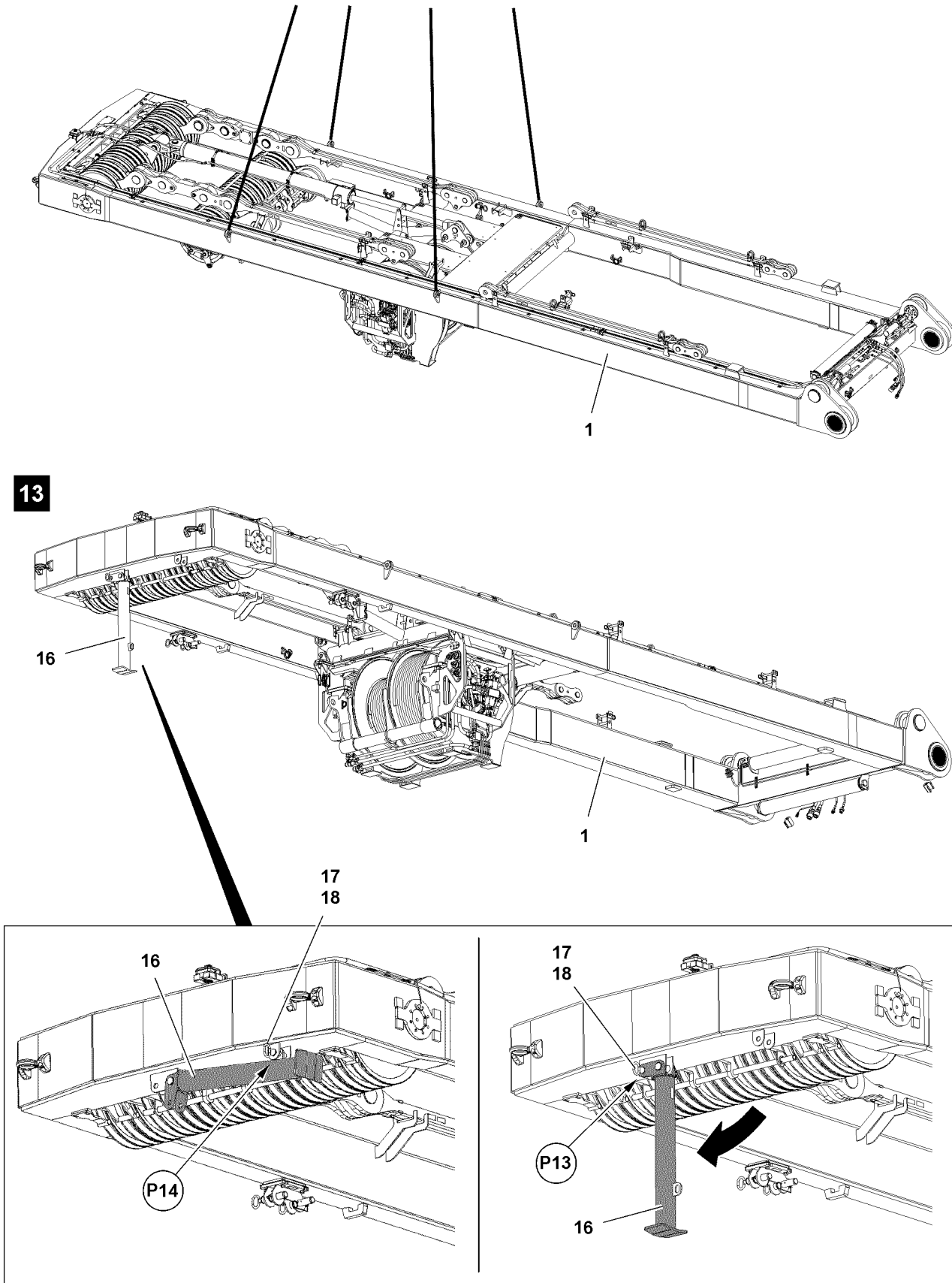

LWE/LR 11000-001/23501-04-02/en

Fig.116933

4.5.3 Swinging the support into the transport position



Note

- ▶ The weight of the support is 35 kg.



WARNING

Support swinging down!

The support **16** can swing downward due to its own weight when unpinning it.

Death, severe injury, property damage.

- ▶ For safety reasons, **two** persons must always be used to unpin the support.
- ▶ Make sure that there are no persons within the danger zone during the entire unpinning procedure.

- ▶ Release the support **16** at point **P14** from the transport position: Remove the safety locking pin **18** and unpin the pin **17**, see illustration **13**.
- ▶ Swing support **16** into transport position, see illustration **13**.



WARNING

The pin is not secured!

If the pin **17** is not secured, the pin can loosen up by itself during transport.

Death, severe injury, property damage.

- ▶ Make sure that the pin **17** is secured with safety locking pin **18**.

- ▶ Secure the support **16** at point **P13** in transport position: Insert the pin **17** and secure with safety locking pin **18**, see illustration **13**.

When the support **16** is swung into the transport position:

- ▶ Place the SA-frame **1** on the ground or on the transport vehicle.

Empty page!

LWE/LR 11000-001/23501-04-02/en

3.06 Assembly conditions

1 Assembly conditions for operation on crawlers

3

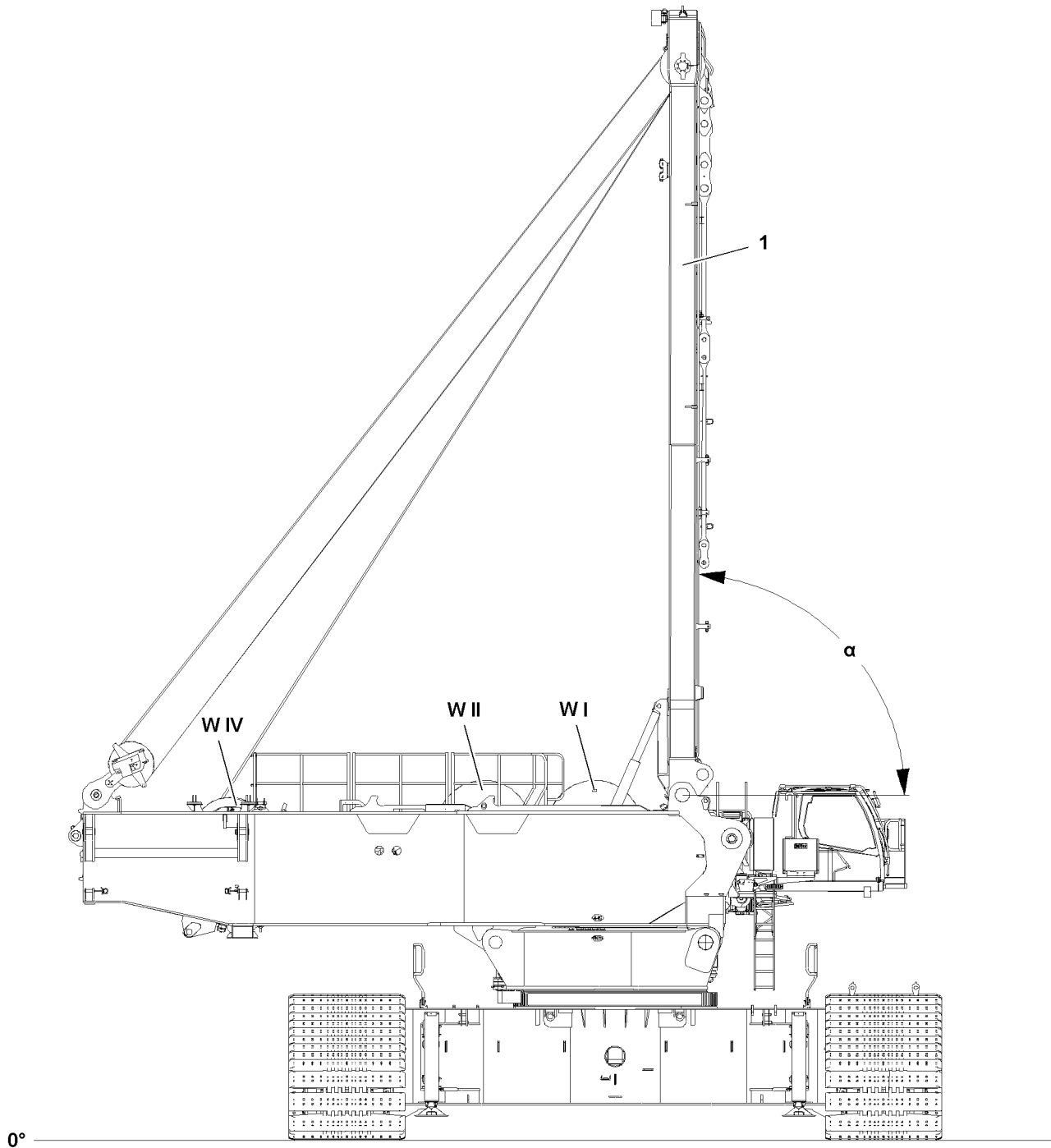

Fig.118229

LWE/LR 11000-001/23501-04-02/en

1 Assembly conditions for operation on crawlers



Note

► Always check the following charts in context.

The assembly conditions take the following components into account:

- 1 SA-frame
- **W I** Winch 1
- **W II** Winch 2
- **W IV** Winch 4

1.1 Definition of assembly conditions

Assembly condition	SA-bracket, angle α	Winch I	Winch II	Winch IV	S/D-pivot section
1	Placed down	–	–	with rope	–
2	90°	–	–	with rope	–
3	Placed down	with rope	–	with rope	–
4	90°	with rope	–	with rope	–
5	Placed down	with rope	with rope	with rope	–
6	90°	with rope	with rope	with rope	–
7	90°	–	–	with rope	installed (laying on the ground)

Description of assembly conditions

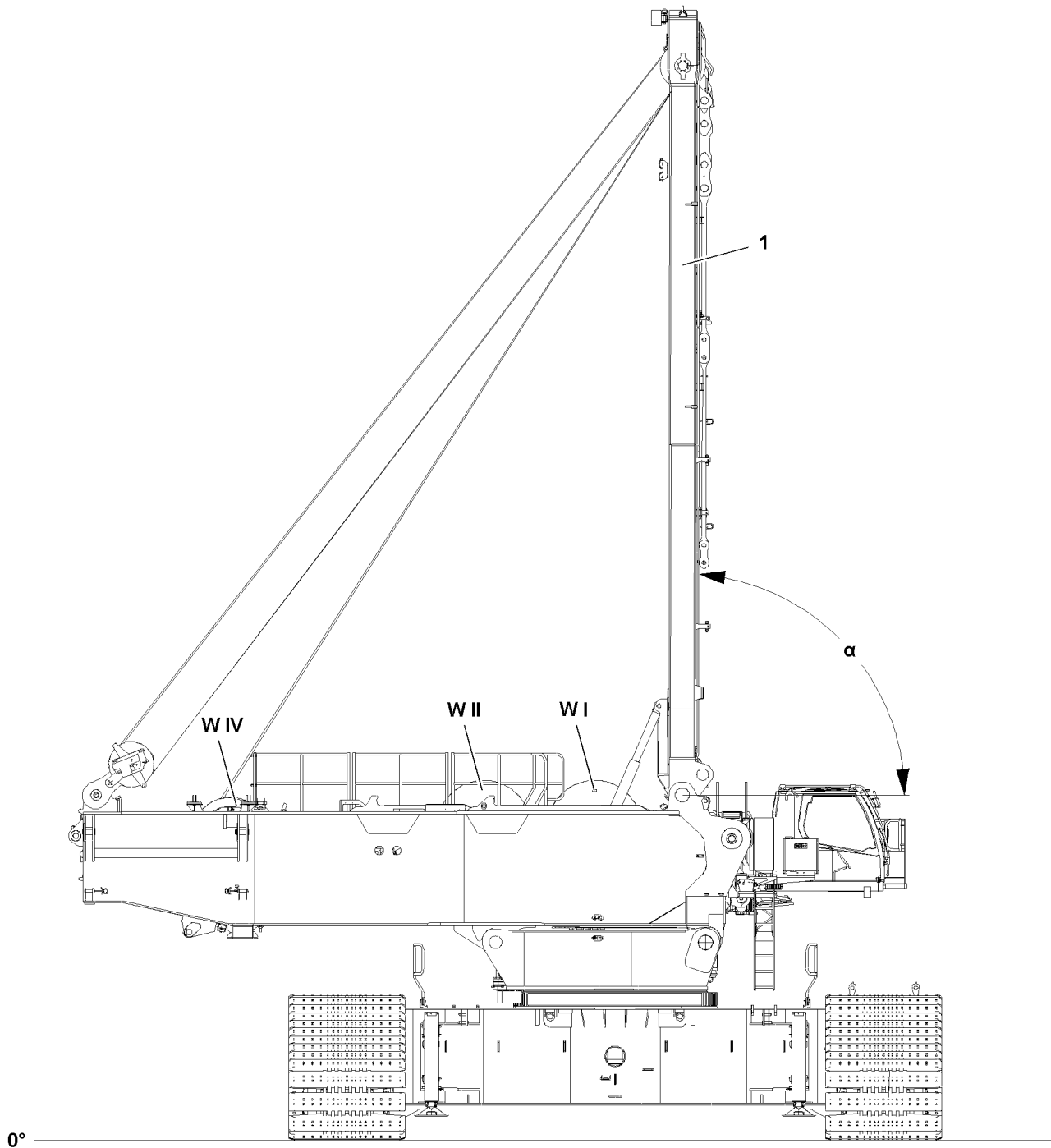

Fig.118229

LWE/LR 11000-001/23501-04-02/en

1.2 Permissible turntable ballast / ballast combinations



Note

► Definition of assembly conditions, see section „Definition of assembly conditions“.

Assembly condition	360° on crawler 9.6 m x 9.2 m				
	Central ballast				
	130 t	90 t	50 t	10 t	0 t
1	230 t	190 t	150 t	110 t	90 t
2	250 t	230 t	190 t	150 t	130 t
3	250 t	210 t	170 t	130 t	110 t
4	250 t	230 t	190 t	150 t	150 t
5	250 t	210 t	170 t	130 t	130 t
6	250 t	250 t	210 t	170 t	150 t
7	250 t	230 t	190 t	150 t	150 t

Maximum permissible turntable ballast for assembly conditions on crawlers

Empty page!

LWE/LR 11000-001/23501-04-02/en

3.07.10 Assembly winch 1

1	Component overview	3
2	Fastening points winch 1	3
3	Assembly winch 1	5
4	Disassembly winch 1	15

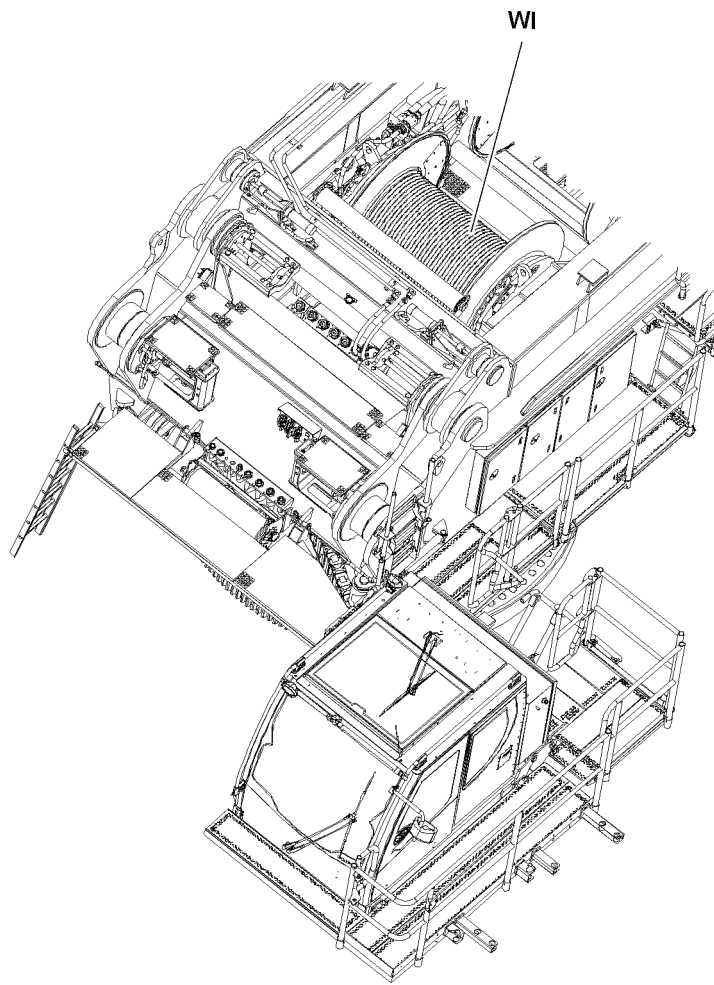

Fig.118559

LWE/LR 11000-001/23501-04-02/en

1 Component overview



Note

- ▶ Dimensions and weights of winch 1, see Crane operating instructions, chapter 1.03.



Note

- ▶ The winch 1 is marked with its own weight.

2 Fastening points winch 1



WARNING

Winch incorrectly fastened!

Life-threatening situations can arise if the winch is incorrectly or improperly attached.
Death, severe bodily injuries, property damage.

- ▶ Attach the winch only on the intended fastening points.
- ▶ Attach the fastening equipment on winch solely in connection with shackles.
- ▶ Make sure that the shackles and fastening equipment have sufficient load capacity.
- ▶ Observe the technical safety instructions during assembly and disassembly, see Crane operating instructions, chapter 5.01.

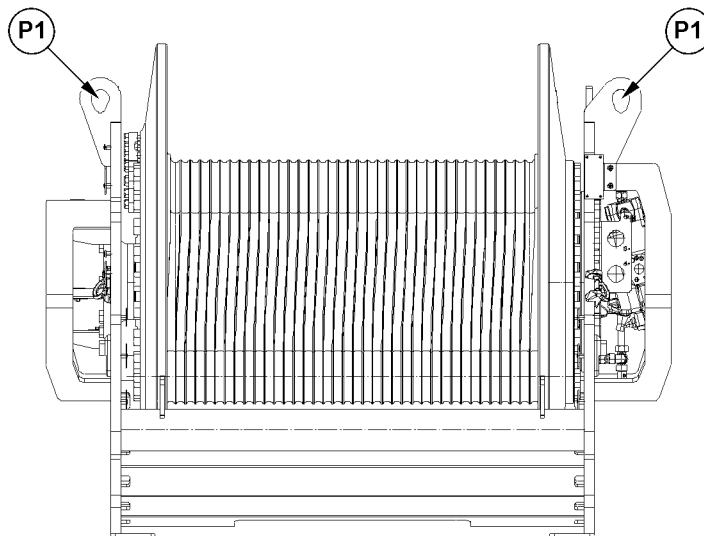

Fig.118560: Fastening points winch 1

Fastening points	
P1	Winch 1

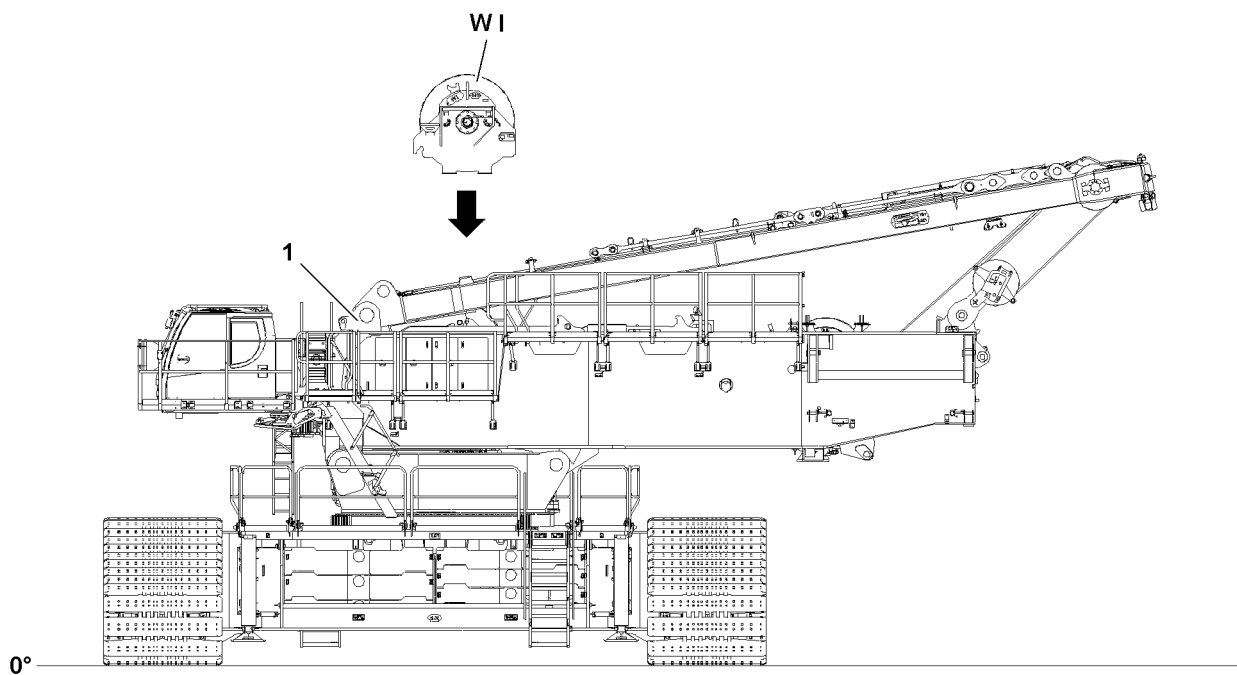

Fig.118563

3 Assembly winch 1



WARNING

Danger of falling!

During assembly / disassembly, inspection and maintenance work, assembly personnel must be secured with appropriate aids to prevent them from falling.

If this is not observed, assembly personnel could fall and suffer life-threatening or fatal injuries.

- ▶ The assembly personnel must always move carefully and anticipatory on the crane, the crane components or lattice sections.
- ▶ All work aloft, where there is a danger of falling must be carried out with suitable aids.
- ▶ If fall protection equipment is available, then it must be used.
- ▶ If aids are not available and work cannot be carried out from the ground, then the assembly personnel must secure themselves with the approved fall arrest system to prevent falling, see Crane operating instructions, chapter 2.04.
- ▶ The fall arrest system must be attached on the fastening and hook points as well as on the safety ropes.
- ▶ Always secure ladders on structural parts and / or components to prevent them from falling over.
- ▶ Only step on the aids, ladders and catwalks with clean shoes.
- ▶ Keep aids, ladders and catwalks free of heavy dirt, snow, frost and ice.
- ▶ Stepping or walking on crane components and lattice sections, which have an incline of more than 20° is prohibited.



WARNING

Components not pinned and secured!

If a component is released from the auxiliary crane before having been pinned and secured, the component can slip and fall down.

Death, severe bodily injuries, property damage.

- ▶ Do not disengage the auxiliary crane until the corresponding component is pinned and secured.



WARNING

Danger of impact / crushing!

When installing / removing crane components with the auxiliary crane, crane components can start to swing back and forth.

When lifting / lowering and positioning crane components, there is an increased danger of impacts / crushing.

Death, severe bodily injuries, property damage.

- ▶ Make sure that personnel cannot be caught by components.
- ▶ When working in danger zones: Use aids to protect limbs.
- ▶ Guide components with suitable aids to minimize oscillation.

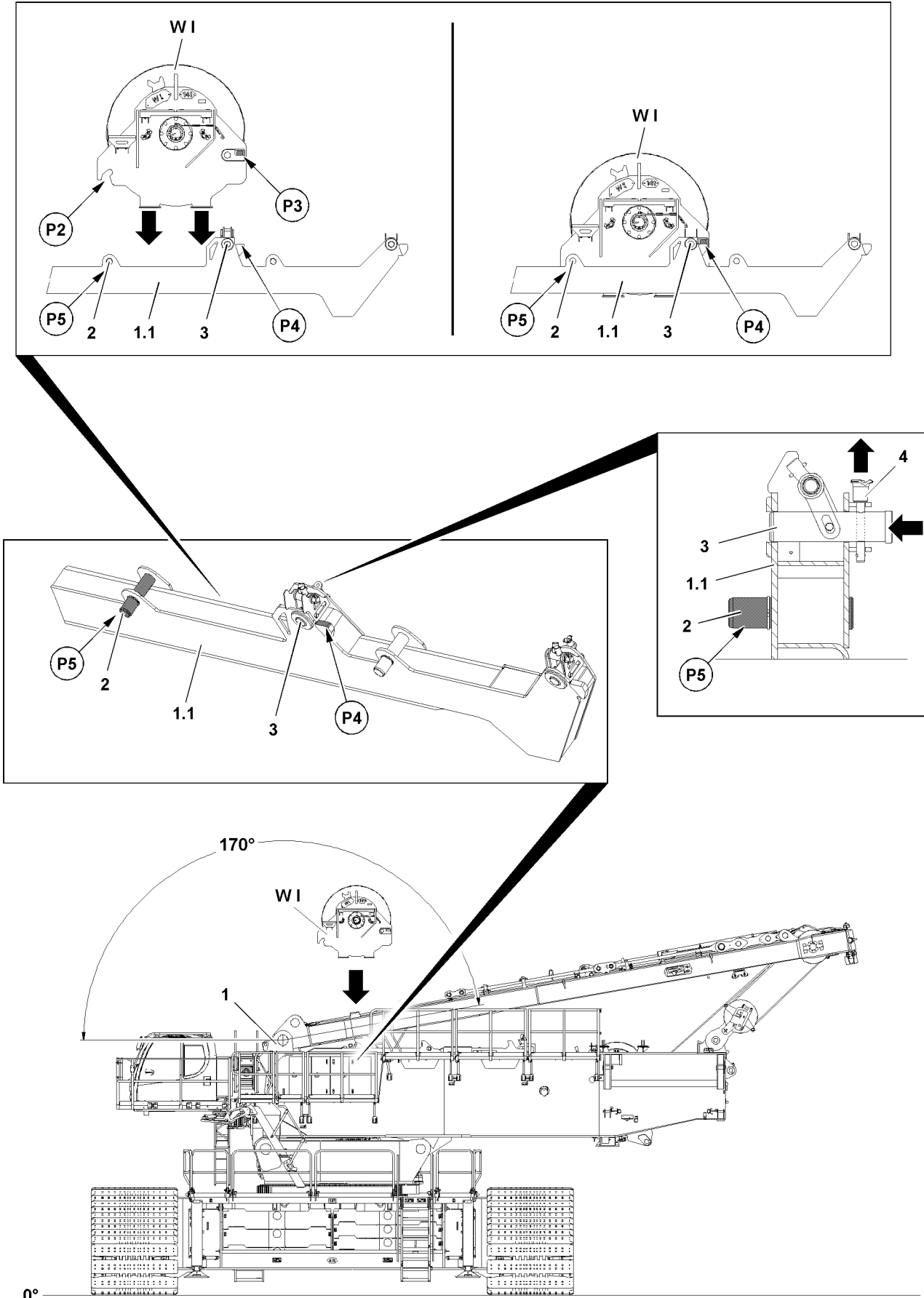

Fig.126245

LWE/LR 11000-001/23501-04-02/en

3.1 Installing winch 1



WARNING

Danger of accident during installation of winch 1!
Death, severe bodily injuries, property damage.

- ▶ Make sure that the following prerequisites are met for the installation of winch 1.

Make sure that the following prerequisites are met:

- The turntable 1 is properly installed.
- SA-frame and winch 4 are properly installed.
- The SA-frame is at approx. 170°; pay attention to SA-frame angle display on the LICCON monitor, see Crane operating instructions, chapter 4.02
- The crawler carriers are properly installed.
- The central ballast is properly installed.
- Gratings, catwalks and fall protection equipment are properly installed.
- Access stairs to the catwalks are properly installed.
- The access stairs to the cab platform are in operating position.
- An auxiliary crane with sufficient load carrying capacity is available.

3.1.1 Lifting winch 1 from the flatbed trailer



WARNING

Danger of accident due to incorrect attachment!
Life-threatening situations can arise if the winch 1 is incorrectly or improperly attached.
Death, severe bodily injuries, property damage.

- ▶ Fasten winch 1 only on the fastening points (points **P1**).
- ▶ Make sure that the fastening equipment is correctly attached on the fastening points (points **P1**) and that it is secured sufficiently to prevent it from loosening up.
- ▶ Attach the fastening equipment (points **P1**) on the fastening points, see section „Fastening points Winch 1“.
- ▶ Bring the fastening equipment to „tension“ with the auxiliary crane.
- ▶ Release and remove the transport retainers on the flatbed trailer.



WARNING

Falling components!

When lifting winch 1 from the flatbed trailer, components or winch 1 can fall down.
Death, severe bodily injuries, property damage.

- ▶ Make sure that there are no persons within the danger zone.
- ▶ Lift winch 1 with the auxiliary crane from the flatbed trailer.

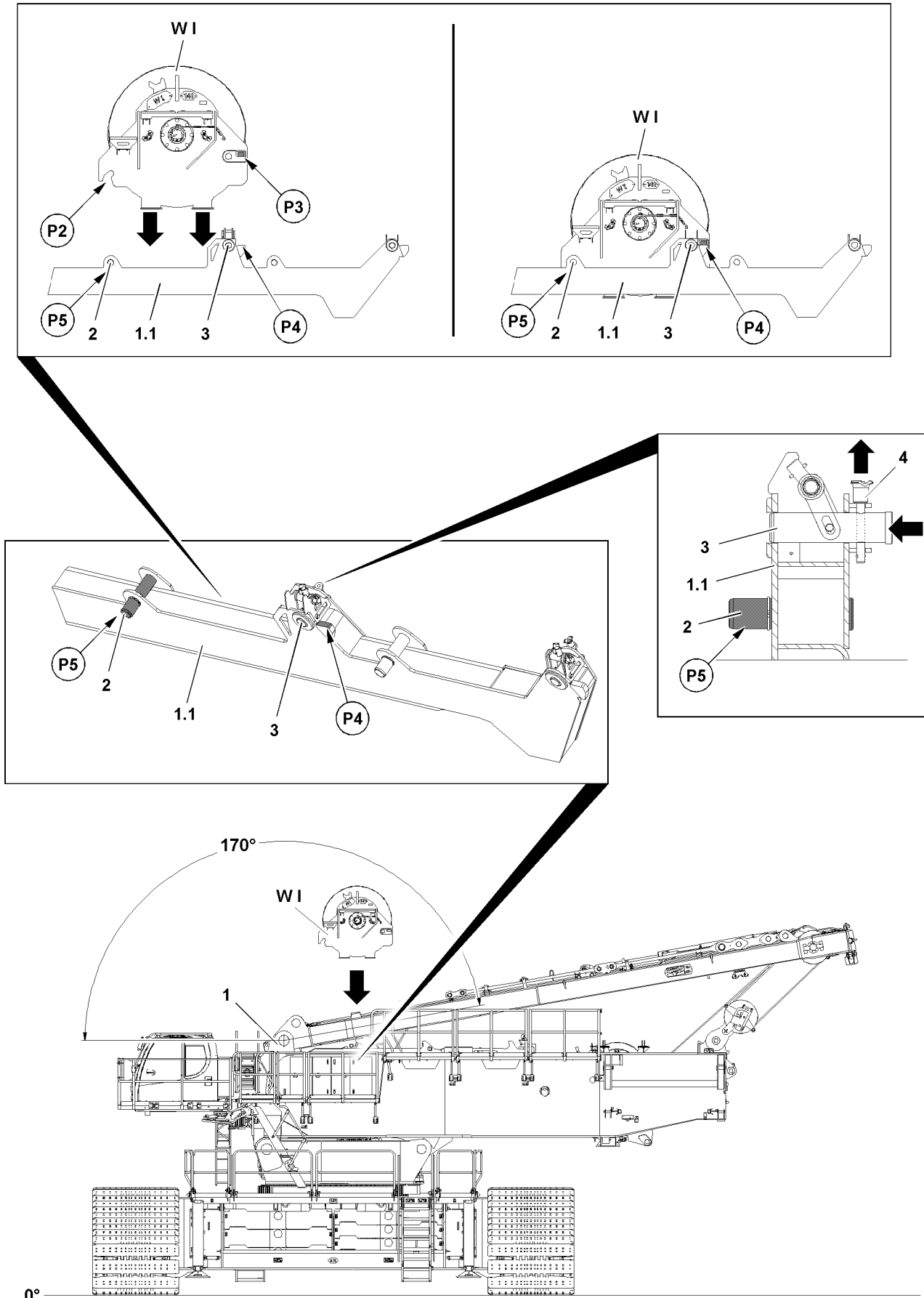

Fig.126245

LWE/LR 11000-001/23501-04-02/en

3.1.2 Positioning winch 1

Make sure that the following prerequisites are met:

- The pins **3** are unpinned completely on both sides.
- The pins **3** are secured in the „unpinned“ position with ball locking pins **4**.



WARNING

Danger of accident when swinging in and lowering winch 1!

When swinging in and lowering winch 1 on the turntable **1**, limbs can be crushed or even severed. Death, severe bodily injuries, property damage.

- ▶ Make sure that there are no persons within the danger zone.
- ▶ Do not reach with your hands into the danger zone.

NOTICE

Property damage!

If the following notes are not observed, damage can result to the crane or winch 1.

- ▶ When retracting winch 1, it must be ensured that winch 1 does not hit against the turntable **1**!



Note

- ▶ The guide must be in constant visual and acoustic contact with the crane operator.



Note

- ▶ Pay attention to exact alignment of winch 1 to the installation position or the pocket receptacles, point **P2**, to the centering pins **2**.
- ▶ Before lowering, bring winch 1 into position that the pocket receptacles, point **P2** are above the centering pins **2** at point **P5** on the turntable **1**!

- ▶ Carefully swing winch 1 in with the auxiliary crane to the turntable **1**.
- ▶ Position and align winch 1.

When winch 1 is aligned:

- ▶ Set winch 1 on both sides at point **P5** on the centering pins **2** and at point **P4** on the receptacle plates on the turntable **1**.

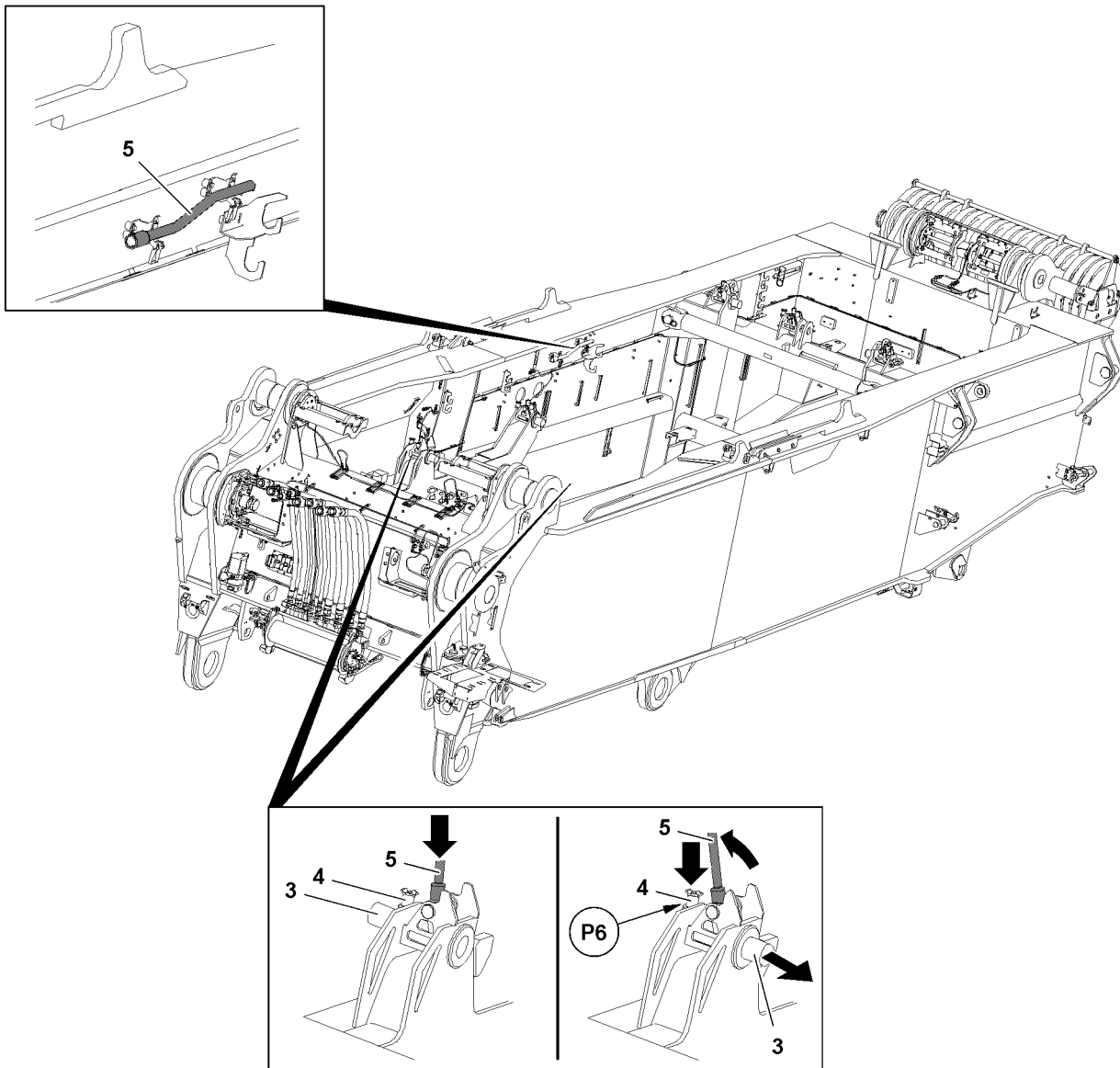

Fig.118561

3.1.3 Pinning winch 1

Make sure that the following prerequisites are met:

- Winch 1 is laying on both sides on the centering pins **2**, point **P5**.
- Winch 1 is laying on both sides on the receptacle plates, point **P4**.
- ▶ Release the pins **3**: Remove the ball locking pins **4**.
- ▶ Release the control lever **5** in park position.
- ▶ Remove the control lever **5** from the park position and set it on the stud of the pin pulling device.
- ▶ Insert pins **3** on both sides with the control lever **5** on winch 1.



WARNING

The pins can loosen up by themselves!

- ▶ Secure pins **3** immediately after pinning with ball locking pins **4**!
-

When the pins **3** on winch 1 are completely pinned on both sides:

- ▶ Secure the pins **3** in „Pinned“ position: Pin the ball locking pin **4** again at point **P6**.
- ▶ Release the fastening equipment on winch 1.
- ▶ Remove the auxiliary crane.
- ▶ Place the control lever **5** in park position and secure it properly.

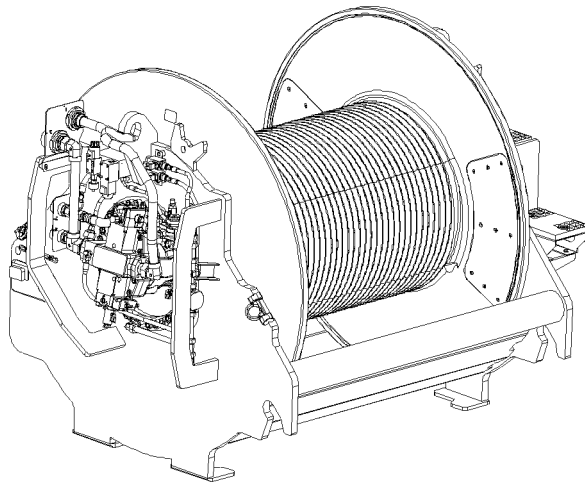

Fig.118567

LWE/LR 11000-001/23501-04-02/en

3.2 Establishing the hydraulic connections to winch 1



Note

- ▶ Establish the connections to winch 1 only when winch 1 is properly installed and secured on the turntable.

Make sure that the following prerequisites are met:

- The winch 1 is properly installed, pinned and secured.

3.2.1 Establishing the hydraulic connections to the winch



Note

- ▶ After the hydraulic connections to the winch are established, the expansion tank must be checked and emptied.

The hydraulic connections for the winch are made with quick couplings.

When connecting hydraulic lines with quick couplings, make sure that the coupling procedure is carried out correctly.



WARNING

Pressure in the hydraulic lines!

If the pressure supply is not interrupted before connecting / releasing the hydraulic lines, the hydraulic oil can escape with high pressure.

Death, severe bodily injuries, property damage.

- ▶ Release the pressure in the hydraulic system before connecting / disconnecting: Interrupt the pressure supply and wait for a short time.



WARNING

Loss of pressure or leakage!

Incorrectly coupled or self-loosening quick couplings (particularly return lines) can result in serious accidents due to component failure.

- ▶ Check that the quick couplings have been properly connected before using the crane.
- ▶ Connect the coupling components (sleeve and connector) and screw together with the hand-tightened nut.
- ▶ Tighten the hydraulic coupling by hand. Rotate the hand-tightened nut until it reaches a tangible, fixed stop position.
- ▶ Establish the hydraulic connections to the winch.

3.2.2 Establishing the electrical connections to the winch

- ▶ Establish the electrical connections to the winch, see Electric wiring diagram.

3.2.3 Establishing the connections of the central lubrication system to the winch

- ▶ Establishing the connections of the central lubrication system to the winch.

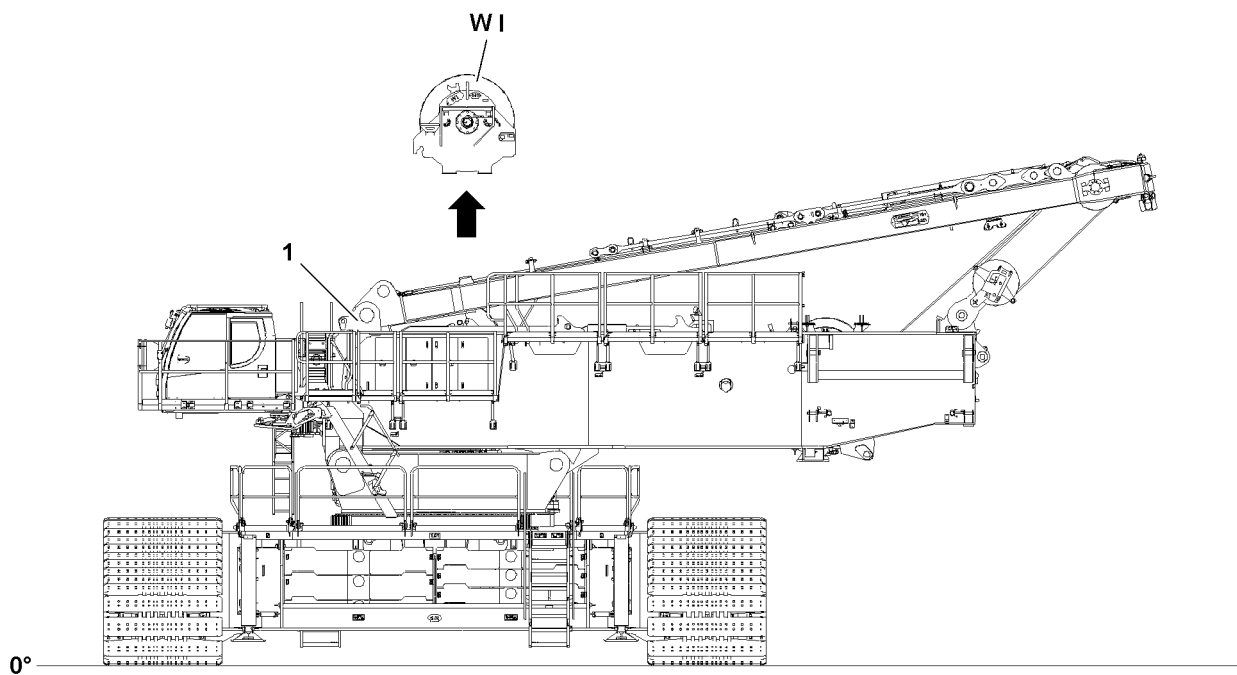

Fig.118564

LWE/LR 11000-001/23501-04-02/en

4 Disassembly winch 1



WARNING

Danger of falling!

During assembly / disassembly, inspection and maintenance work, assembly personnel must be secured with appropriate aids to prevent them from falling.

If this is not observed, assembly personnel could fall and suffer life-threatening or fatal injuries.

- ▶ The assembly personnel must always move carefully and anticipatory on the crane, the crane components or lattice sections.
- ▶ All work aloft, where there is a danger of falling must be carried out with suitable aids.
- ▶ If fall protection equipment is available, then it must be used.
- ▶ If aids are not available and work cannot be carried out from the ground, then the assembly personnel must secure themselves with the approved fall arrest system to prevent falling, see Crane operating instructions, chapter 2.04.
- ▶ The fall arrest system must be attached on the fastening and hook points as well as on the safety ropes.
- ▶ Always secure ladders on structural parts and / or components to prevent them from falling over.
- ▶ Only step on the aids, ladders and catwalks with clean shoes.
- ▶ Keep aids, ladders and catwalks free of heavy dirt, snow, frost and ice.
- ▶ Stepping or walking on crane components and lattice sections, which have an incline of more than 20° is prohibited.



WARNING

Components not pinned and secured!

If a component is released from the auxiliary crane before having been pinned and secured, the component can fall down.

Death, severe bodily injuries, property damage.

- ▶ Remove the auxiliary crane only after the respective component has been properly pinned and secured.



WARNING

Danger of impact / crushing!

When installing / removing crane components with the auxiliary crane, crane components can start to swing back and forth.

When lifting / lowering and positioning crane components, there is an increased danger of impacts / crushing.

Death, severe bodily injuries.

- ▶ Make sure that personnel cannot be caught by components.
- ▶ When working in danger zones: Use aids to protect limbs.
- ▶ Guide components with suitable aids to minimize oscillation.

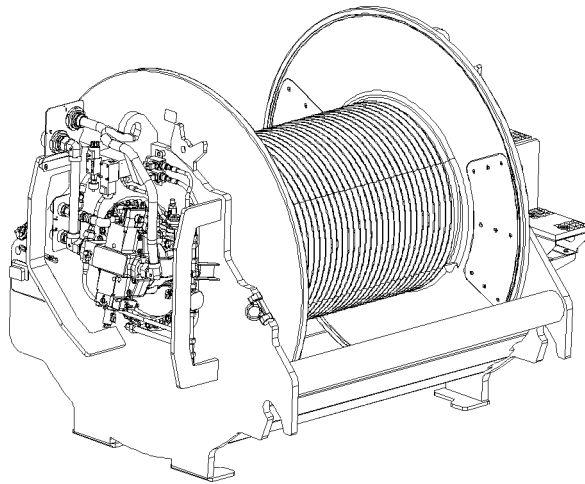

Fig.118567

4.1 Disconnecting the connections to winch 1

Make sure that the following prerequisites are met:

- The hoist rope is completely spooled up to the winch.
- The hoist rope is secured on the winch to prevent it from spooling out by itself.

4.1.1 Disconnecting the hydraulic connections to the winch

When releasing hydraulic lines with quick couplings, make sure that the uncoupling procedure is carried out correctly.



WARNING

Pressure in the hydraulic lines!

If the pressure supply is not interrupted before connecting / releasing the hydraulic lines, the hydraulic oil can escape with high pressure.

Death, severe bodily injuries, property damage.

- ▶ Release the pressure in the hydraulic system before connecting / disconnecting: Interrupt the pressure supply and wait for a short time.

-
- ▶ Release the hydraulic coupling by hand.
 - ▶ Disconnect the hydraulic connections to the winch.
 - ▶ Close the hydraulic hoses and hydraulic lines off properly with the intended caps.
 - ▶ Bring the hydraulic hoses in park position for transport and secure them properly.

4.1.2 Disconnecting the electrical connections to the winch

- ▶ Disconnect the electrical connections to the winch.
- ▶ Close the electrical connections properly off with the intended caps.

4.1.3 Disconnecting the connections of the central lubrication system to the winch

- ▶ Disconnect the connections to the winch.
- ▶ Close the lube line connections properly off with the intended caps.

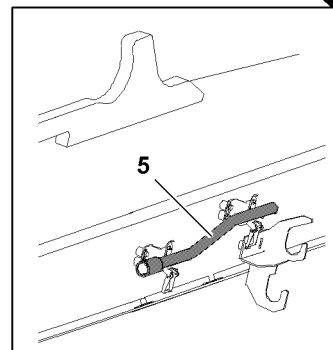
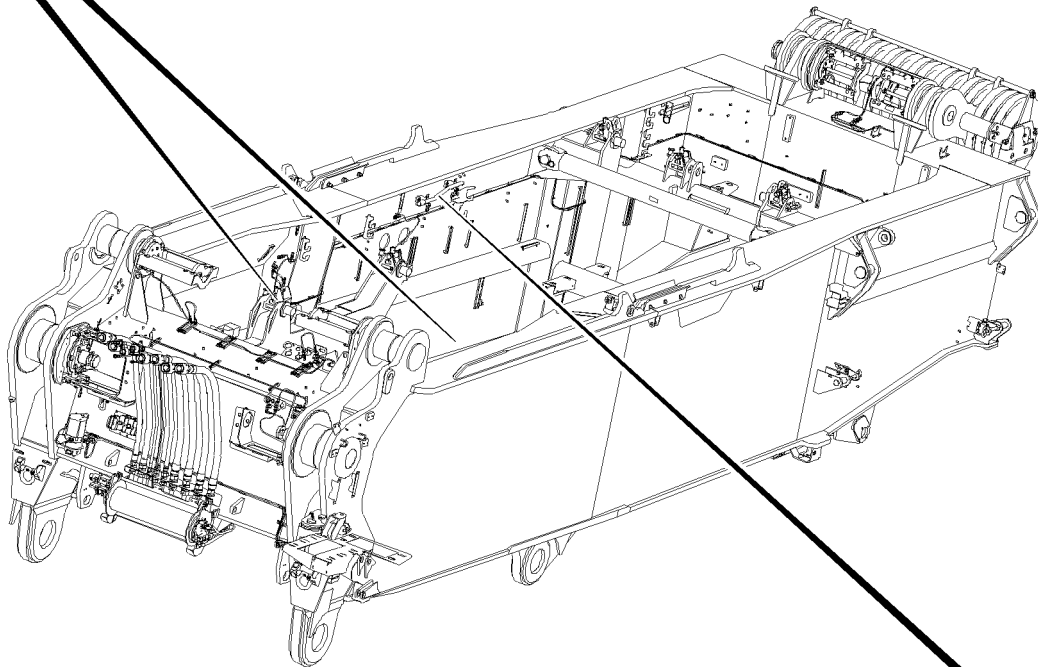
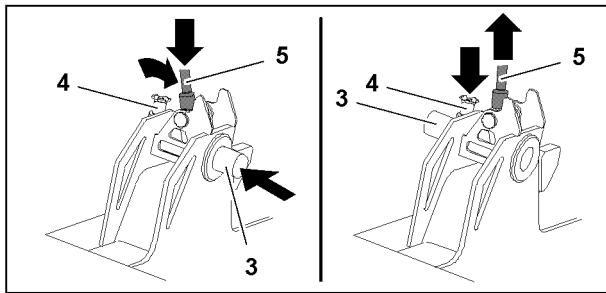

Fig.118566

LWE/LR 11000-001/23501-04-02/en

4.2 Removing winch 1

4.2.1 Unpinning winch 1

Make sure that the following prerequisites are met:

- The hydraulic connections are properly disconnected and closed off.
- The electrical connections are properly disconnected and closed off.
- The connections of the central lubrication system are properly disconnected and closed off.
- An auxiliary crane with sufficient load carrying capacity is available.



WARNING

Danger of accident due to incorrect attachment!

Life-threatening situations can arise if the winch 1 is incorrectly or improperly attached.

Death, severe bodily injuries, property damage.

- ▶ The fastening equipment may be attached on the winch 1 only on the intended fastening points.
- ▶ Make sure that the fastening equipment is properly attached on winch 1 and that it is secured sufficiently to prevent it from loosening up.

- ▶ Attach the fastening equipment on both sides on winch 1, see section „Fastening points Winch 1“.

When the fastening equipment is properly fastened on winch 1:

- ▶ Bring the fastening equipment with the auxiliary crane carefully to „tension“.

When the fastening equipment is tensioned:

- ▶ Release pins **3** on both sides: Remove the ball locking pins **4**.
- ▶ Unpin the pins **3** with the control lever on both sides completely.
- ▶ Secure the pins **3** in the „unpinned“ position with ball locking pins **4**.
- ▶ Place the control lever **5** in park position and secure it properly.

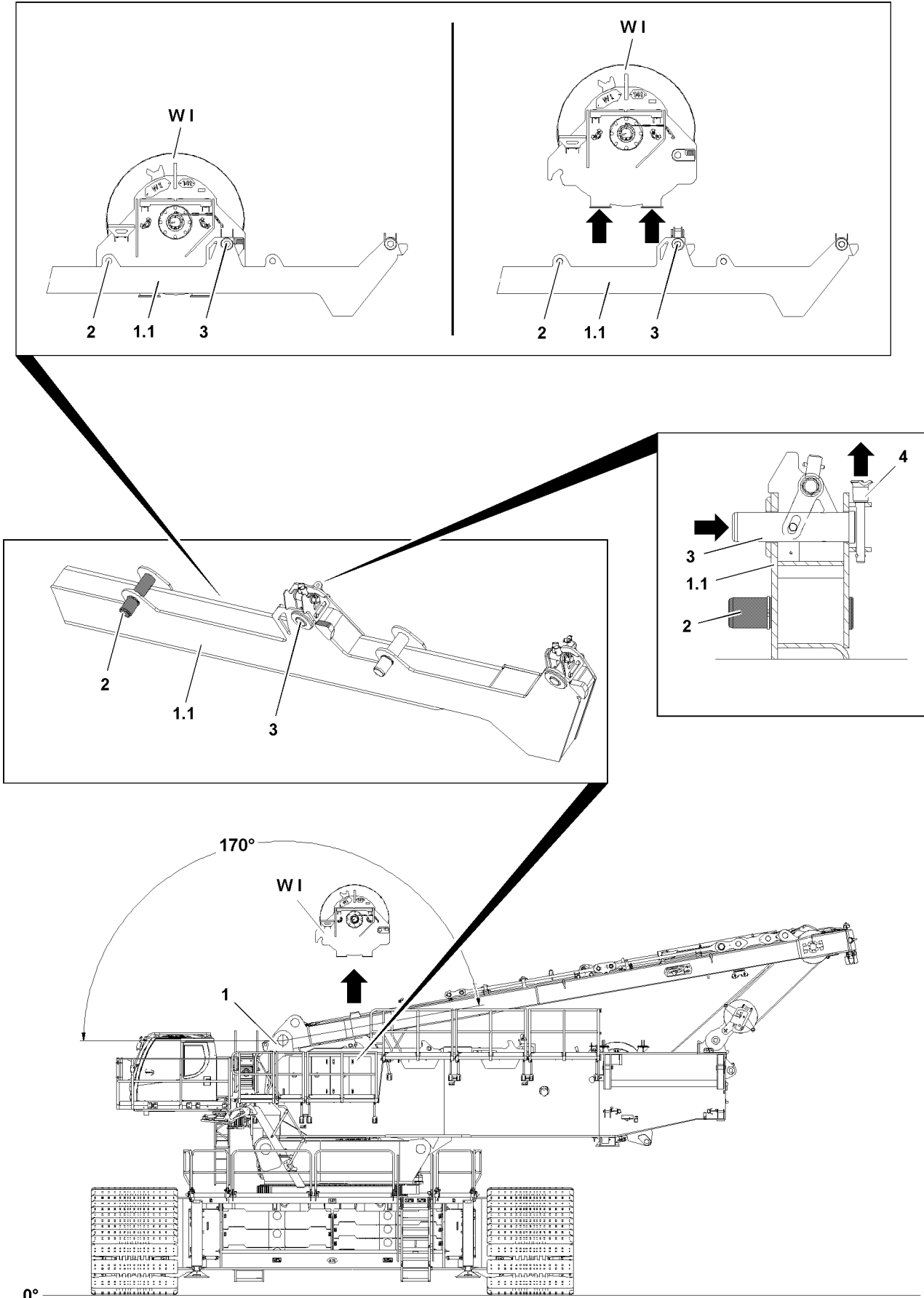

Fig.126246

LWE/LR 11000-001/23501-04-02/en

4.2.2 Lifting winch 1 from the turntable

Make sure that the following prerequisites are met:

- Winch 1 is properly unpinned on the turntable 1.
- The SA-frame is at approx. 170°; pay attention to SA-frame angle display on the LICCON monitor, see Crane operating instructions, chapter 4.02



WARNING

Falling components!

When lifting the winch 1 on the turntable 1, components or winch 1 can fall down.

Personnel can be severely injured or killed.

▶ Make sure that there are no persons within the danger zone.

▶ Carefully lift winch 1 with the auxiliary crane from the turntable 1.



WARNING

Toppling winch!

When setting winch 1 on the ground, the winch can sink into the ground and fall over.

Death, severe bodily injuries, property damage.

▶ Make sure that the ground has sufficient load bearing capacity to safely take on the weight of the winch.

▶ Swing winch 1 out with the auxiliary crane and set it on the ground on a suitable support.

or

Swing winch 1 out with the auxiliary crane and set it on the flatbed trailer.

When winch 1 has been set down properly:

▶ Remove the auxiliary crane.

Empty page!

LWE/LR 11000-001/23501-04-02/en

3.07.20 Assembly winch 2

1	Component overview	3
2	Fastening points winch 2	3
3	Assembly winch 2	5
4	Disassembly winch 2	15

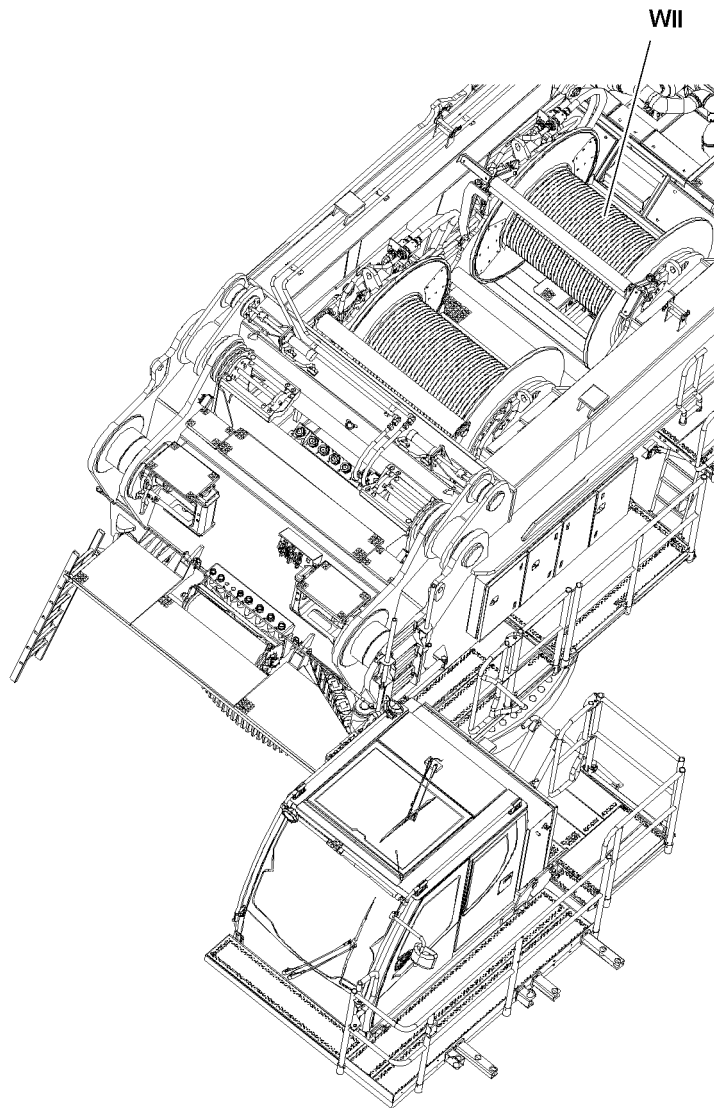

Fig.118568

LWE/LR 11000-001/23501-04-02/en

1 Component overview



Note

- ▶ Dimensions and weights of winch 2, see Crane operating instructions, chapter 1.03.



Note

- ▶ The winch 2 is marked with its own weight.

2 Fastening points winch 2



WARNING

Winch incorrectly fastened!

Life-threatening situations can arise if the winch is incorrectly or improperly attached.
Death, severe bodily injuries, property damage.

- ▶ Attach the winch only on the intended fastening points.
- ▶ Attach the fastening equipment on winch 2 solely in connection with shackles.
- ▶ Make sure that the shackles and fastening equipment have sufficient load bearing capacity.
- ▶ Observe the technical safety instructions during assembly and disassembly, see Crane operating instructions, chapter 5.01.

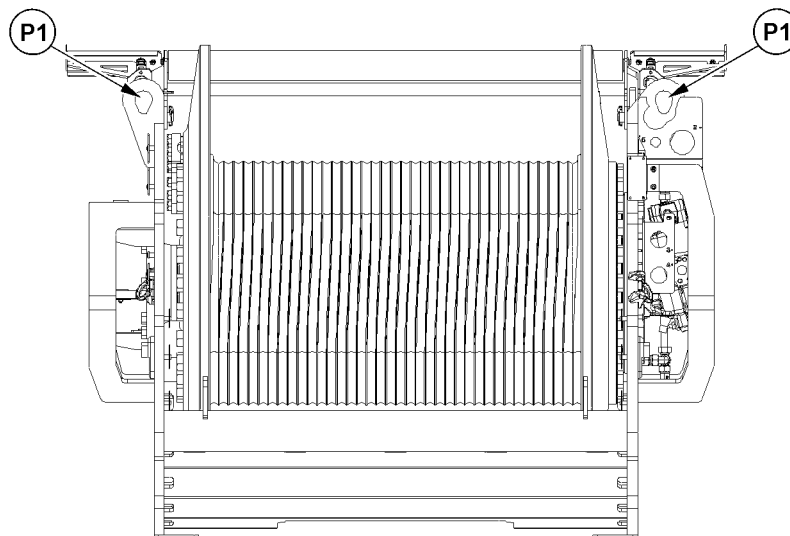

Fig.118587: Fastening points winch 2

Fastening points	
P1	Winch 2

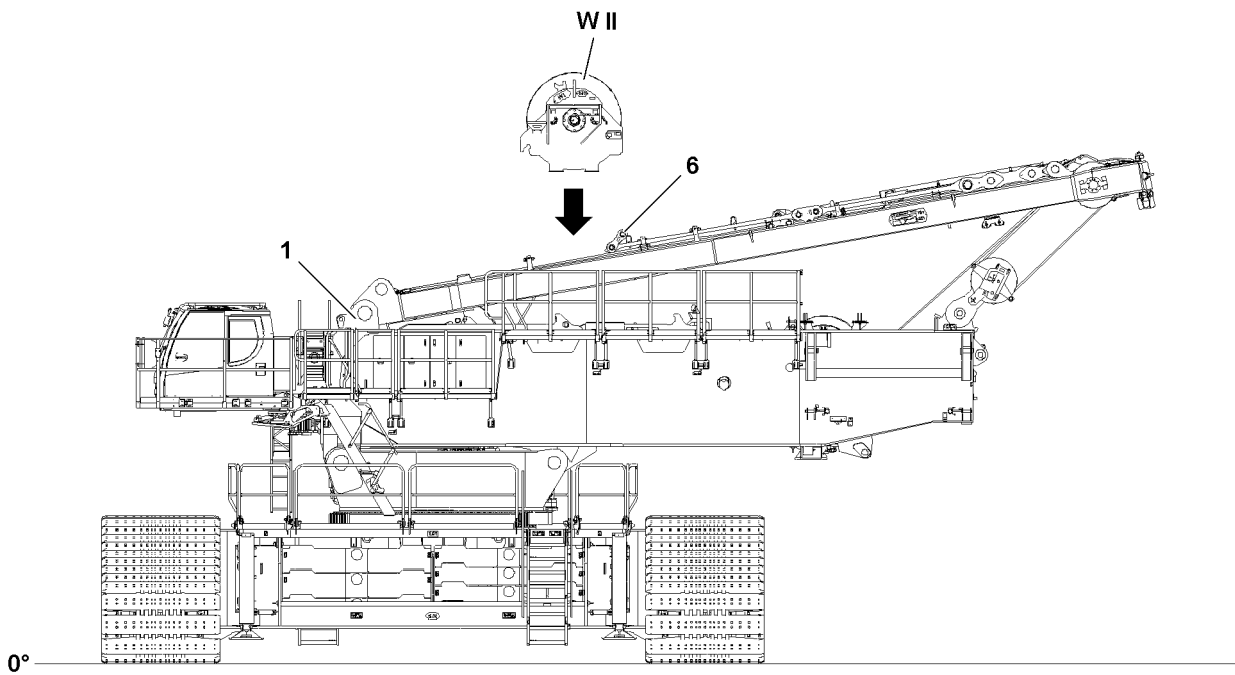

Fig.118569

3 Assembly winch 2



WARNING

Danger of falling!

During assembly / disassembly, inspection and maintenance work, assembly personnel must be secured with appropriate aids to prevent them from falling.

If this is not observed, assembly personnel could fall and be killed or seriously injured!

- ▶ The assembly personnel must always move carefully and anticipatory on the crane, the crane components or lattice sections.
- ▶ All work aloft, where there is a danger of falling must be carried out with suitable aids.
- ▶ If fall protection equipment is available, then it must be used.
- ▶ If aids are not available and work cannot be carried out from the ground, then the assembly personnel must secure themselves with the approved fall arrest system to prevent falling, see Crane operating instructions, chapter 2.04.
- ▶ The fall arrest system must be attached on the fastening and hook points as well as on the safety ropes.
- ▶ Always secure ladders on structural parts and / or components to prevent them from falling over.
- ▶ Only step on the aids, ladders and catwalks with clean shoes.
- ▶ Keep aids, ladders and catwalks free of heavy dirt, snow, frost and ice.
- ▶ Stepping or walking on crane components and lattice sections, which have an incline of more than 20° is prohibited.



WARNING

Components not pinned and secured!

If a component is released from the auxiliary crane before having been pinned and secured, the component can slip and fall down.

Death, severe bodily injuries, property damage.

- ▶ Do not disengage the auxiliary crane until the respective component is pinned and secured.



WARNING

Danger of impact / crushing!

When installing / removing crane components with the auxiliary crane, crane components can start to swing back and forth.

When lifting / lowering and positioning crane components, there is an increased danger of impacts / crushing.

Death, severe bodily injuries.

- ▶ Make sure that personnel cannot be caught by components.
- ▶ When working in danger zones: Use aids to protect limbs.
- ▶ Guide components with suitable aids to minimize oscillation.

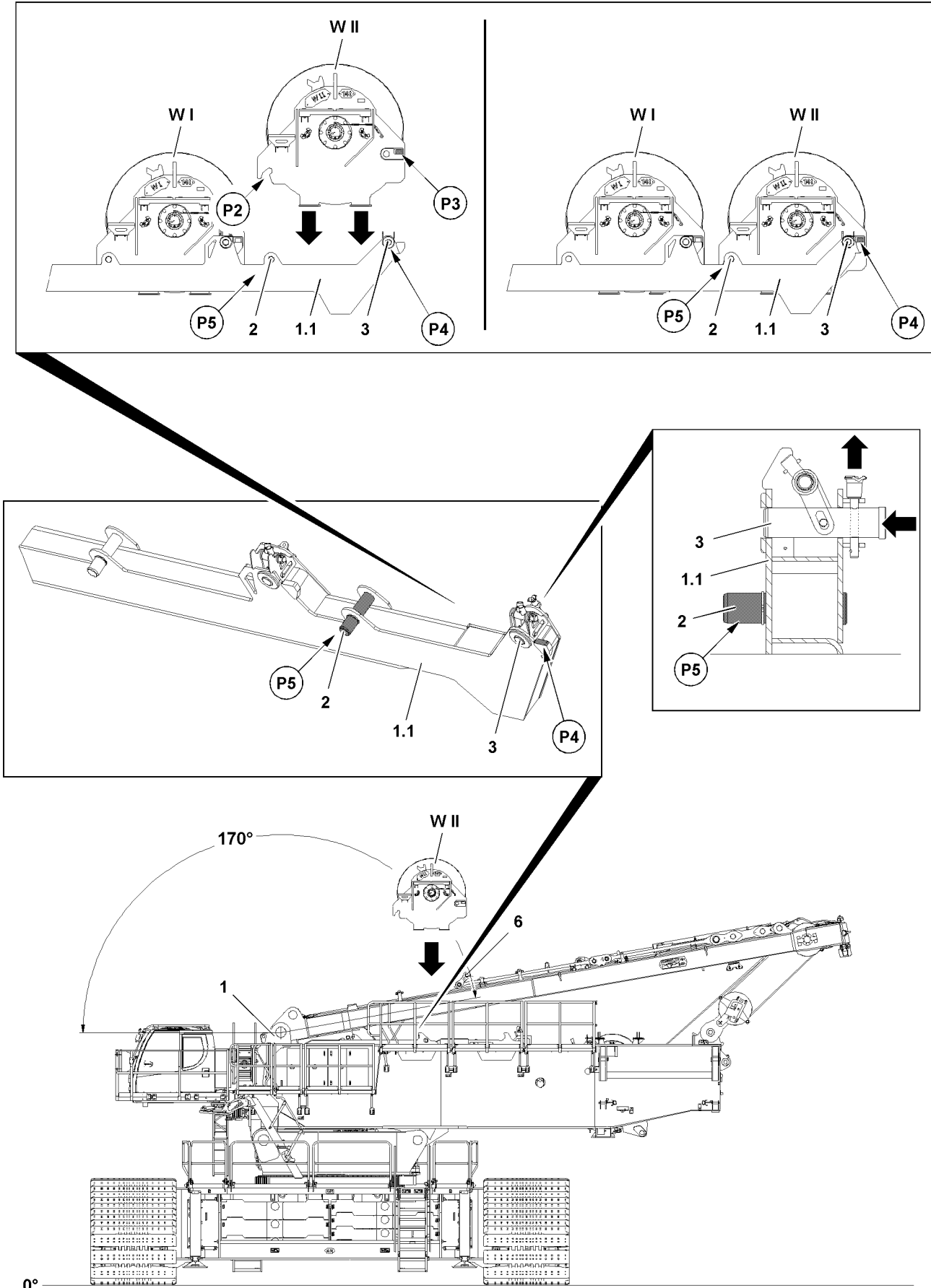

Fig.126247

LWE/LR 11000-001/23501-04-02/en

3.1 Installing winch 2



WARNING

Danger of accident during installation of winch 2!
Death, severe bodily injuries, property damage.

- ▶ Make sure that the following prerequisites are met for the installation of winch 2.

Make sure that the following prerequisites are met:

- The turntable **1** is properly installed.
- SA-frame and winch 4 are properly installed.
- The SA-frame is at approx. 170°; pay attention to SA-frame angle display on the LICCON monitor, see Crane operating instructions, chapter 4.02.
- The brackets **6** on the SA-frame have been changed over to the rear.
- The crawler carriers are properly installed.
- The central ballast is properly installed.
- Gratings, catwalks and fall protection equipment are properly installed.
- Access stairs to the catwalks are properly installed.
- The access stairs to the cab platform are in operating position.
- An auxiliary crane with appropriate load carrying capacity is available.

3.1.1 Lifting winch 2 from the flatbed trailer



WARNING

Danger of accident due to incorrect attachment!
Life-threatening situations can arise if the winch 2 is incorrectly or improperly attached.
Death, severe bodily injuries, property damage.

- ▶ Fasten winch 2 only on the fastening points (points **P1**).
- ▶ Make sure that the fastening equipment is correctly attached on the fastening points (points **P1**) and that it is secured sufficiently to prevent it from loosening up.

- ▶ Attach the fastening equipment (points **P1**) on the fastening points, see section „Fastening points Winch 2“.
- ▶ Bring the fastening equipment to „tension“ with the auxiliary crane.
- ▶ Release and remove the transport retainers on the flatbed trailer.



WARNING

Falling components!

When lifting winch 2 from the flatbed trailer, components or winch 2 can fall down.
Death, severe bodily injuries, property damage.

- ▶ Make sure that there are no persons within the danger zone.
- ▶ Lift winch 2 with the auxiliary crane from the flatbed trailer.

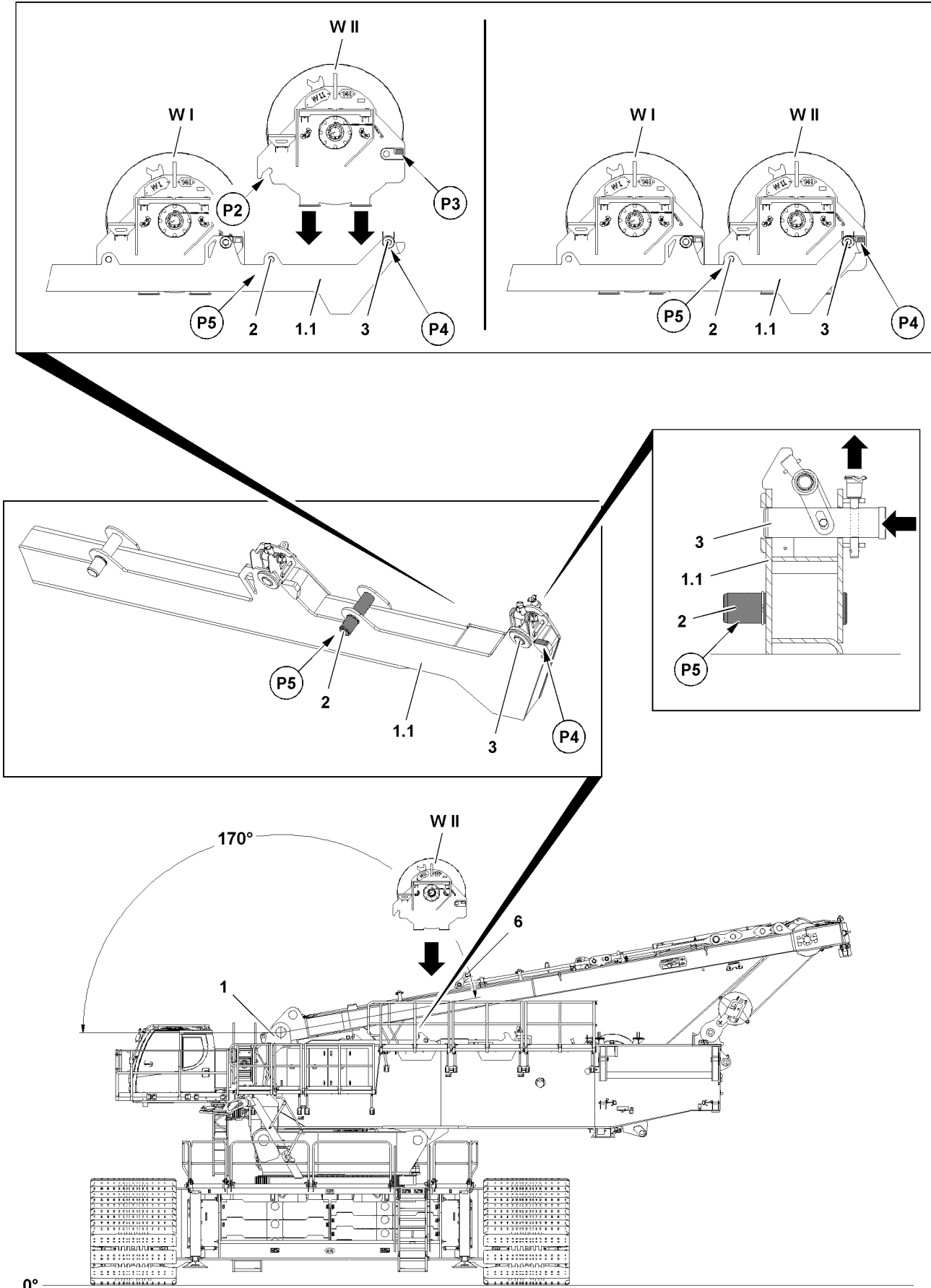

Fig.126247

LWE/LR 11000-001/23501-04-02/en

3.1.2 Positioning winch 2

Make sure that the following prerequisites are met:

- The pins **3** are unpinned completely on both sides.
- The pins **3** are secured in the „unpinned“ position with ball locking pins **4**.



WARNING

Danger of accident when swinging in and lowering winch 2!

When swinging in and lowering winch 2 on the turntable **1** limbs can be crushed or even severed. Death, severe bodily injuries, property damage.

- ▶ Make sure that there are no persons within the danger zone.
- ▶ Do not reach with your hands into the danger zone.

NOTICE

Property damage!

If the following notes are not observed, damage can result to the crane or winch 2.

- ▶ When retracting winch 2, it must be ensured that winch 2 does not hit against the turntable **1**!



Note

- ▶ The guide must be in constant visual and acoustic contact with the crane operator.



Note

- ▶ Pay attention to exact alignment of winch 2 to the installation position or the pocket receptacles, point **P2**, to the centering pins **2**.
- ▶ Before lowering, bring winch 2 into position that the pocket receptacles, point **P2** are above the centering pins **2** at point **P5** on the turntable **1**!

- ▶ Carefully swing winch 2 in with the auxiliary crane to the turntable **1**.
- ▶ Position and align winch 2.

When winch 2 is aligned:

- ▶ Set winch 2 on both sides at point **P5** on the centering pins **2** and at point **P4** on the receptacle plates on the turntable **1**.

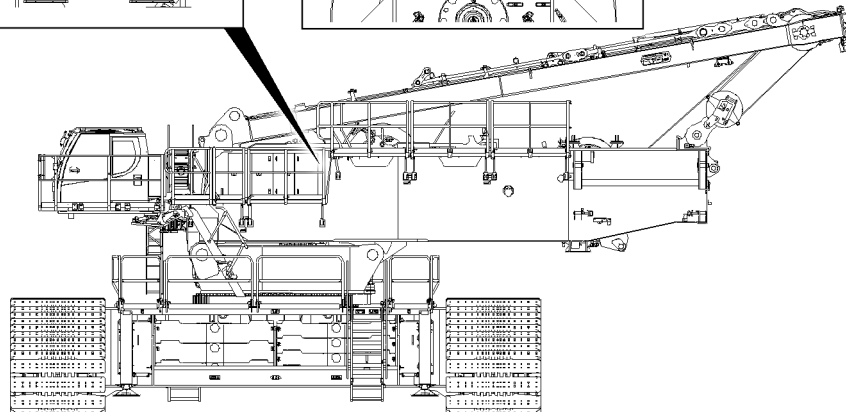
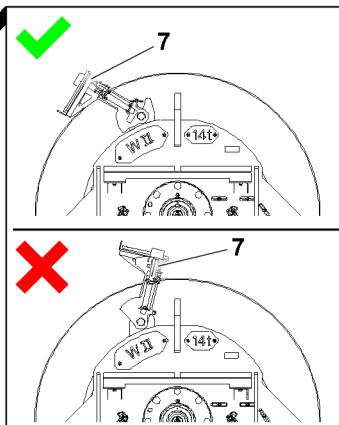
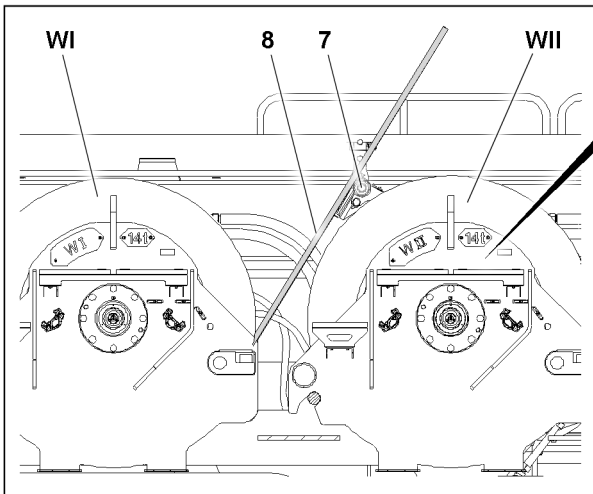
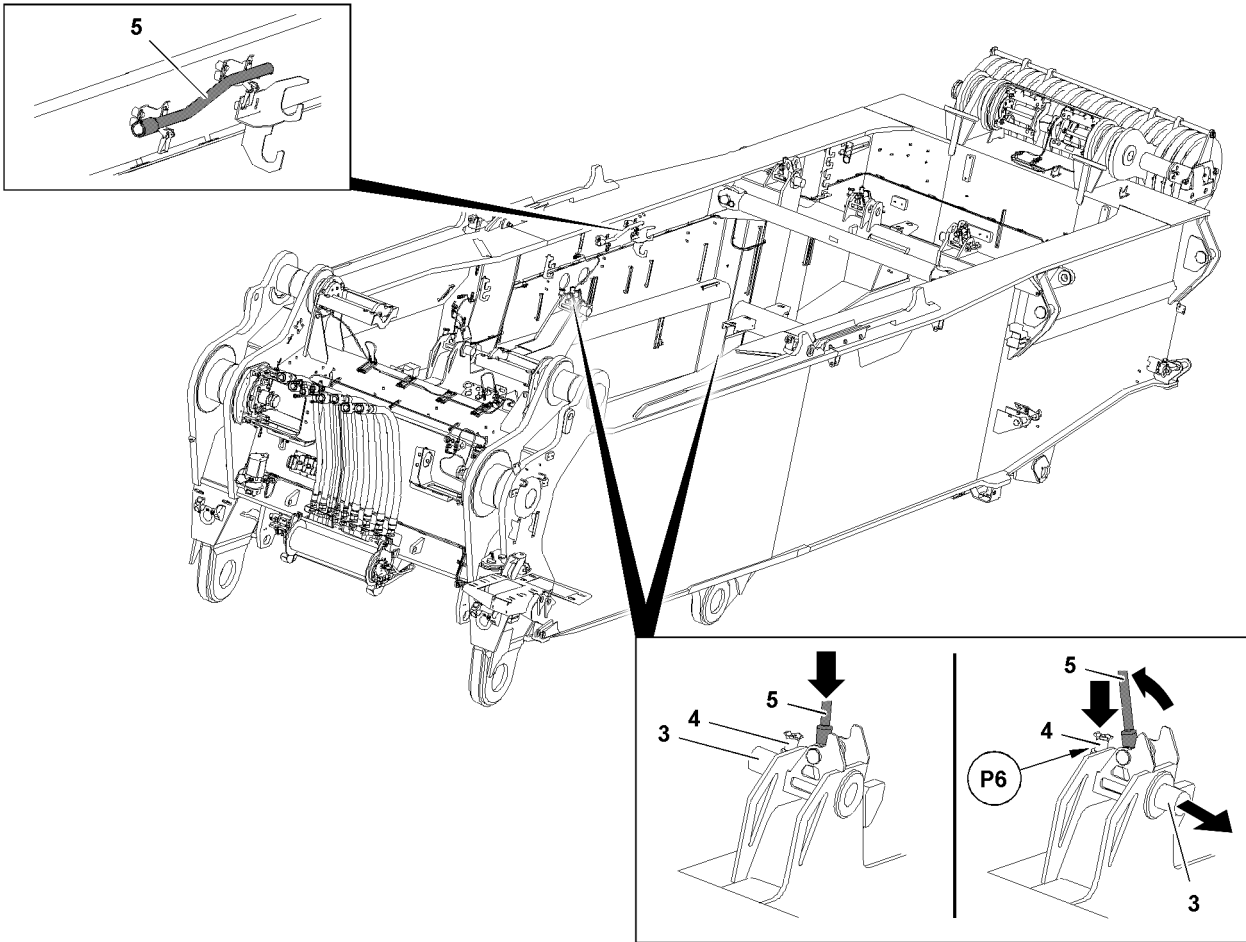

0°

Fig.128219

LWE/LR 11000-001/23501-04-02/en

3.1.3 Pinning winch 2

Make sure that the following prerequisites are met:

- Winch 2 is positioned on both sides on the centering pins **2**, point **P5**.
- Winch 2 is positioned on both sides on the mounting plates, point **P4**.
- ▶ Release the pin **3**: Remove the ball locking pins **4**.
- ▶ Release the control lever **5** in park position.
- ▶ Remove the control lever **5** from the park position and set it on the stud of the pin pulling device.
- ▶ Insert pins **3** on both sides with the control lever **5** on winch 2.



WARNING

The pins can loosen up by themselves!

- ▶ Secure pins **3** immediately after pinning with ball locking pins **4**!

When the pins **3** on winch 2 are completely pinned on both sides:

- ▶ Secure the pins **3** in the „pinned“ position: Pin the ball locking pin **4** again at point **P6**.
- ▶ Release the fastening equipment on winch 2.
- ▶ Remove the auxiliary crane.
- ▶ Place the control lever **5** in park position and secure it properly.

3.1.4 Protective roller on winch 2

The purpose of the protective roller **7** of winch 2 **WII** is to deflect the hoist rope **8** of winch 1 **WI** during derrick operation if necessary to prevent hoist rope contact with winch 2 **WII** and the resulting property damage.



Note

- ▶ The hoist rope **8** of winch 1 **WI** is represented in the indicated installation situation for clarification purposes only.



WARNING

Load can be ripped off!

If during crane operation the hoist rope **8** comes into contact with winch 2 **WII**, the hoist rope **8** can be significantly damaged and rip off. Crane components can be damaged significantly.

The load can rip off.

Death, severe bodily injuries, property damage.

- ▶ Make sure that the protective roller **7** is in the position shown before starting to work with the crane.
- ▶ Make sure that the hoist rope **8** of winch 1 **WI** never comes into contact with winch 2 **WII**.

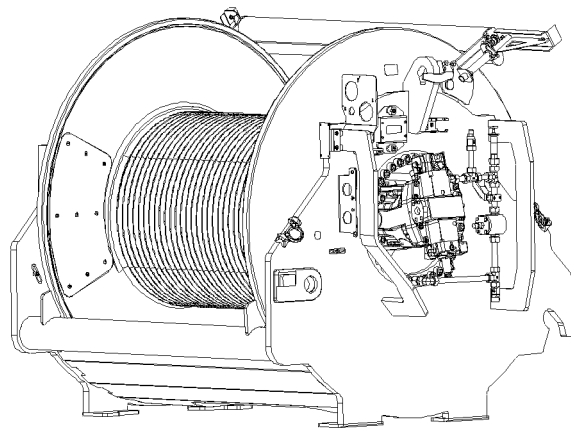

Fig.118588

LWE/LR 11000-001/23501-04-02/en

3.2 Establishing the hydraulic connections to winch 2



Note

- ▶ Establish the connections to winch 2 only when winch 2 is properly installed and secured on the turntable.

Make sure that the following prerequisites are met:

- The winch 2 is properly installed, pinned and secured.

3.2.1 Establishing the hydraulic connections to the winch



Note

- ▶ After the hydraulic connections to the winch are established, the expansion tank must be checked and emptied.

The hydraulic connections for the winch are made with quick couplings.

When connecting hydraulic lines with quick couplings, make sure that the coupling procedure is carried out correctly.



WARNING

Pressure in the hydraulic lines!

If the pressure supply is not interrupted before connecting / releasing the hydraulic lines, the hydraulic oil can escape with high pressure.

Death, severe bodily injuries, property damage.

- ▶ Release the pressure in the hydraulic system before connecting / disconnecting: Interrupt the pressure supply and wait for a short time.



WARNING

Loss of pressure or leakage!

Incorrectly coupled or self-loosening quick couplings (particularly return lines) can result in serious accidents due to component failure.

- ▶ Check that the quick couplings have been properly connected before using the crane.
- ▶ Connect the coupling components (sleeve and connector) and screw together with the knurled nut.
- ▶ Tighten the hydraulic coupling by hand. Rotate the knurled nut until it reaches a tangible, fixed stop position.
- ▶ Establish the hydraulic connections to the winch.

3.2.2 Establishing the electrical connections to the winch

- ▶ Establish the electrical connections to the winch, see Electric wiring diagram.

3.2.3 Establishing the connections of the central lubrication system to the winch

- ▶ Establishing the connections of the central lubrication system to the winch.

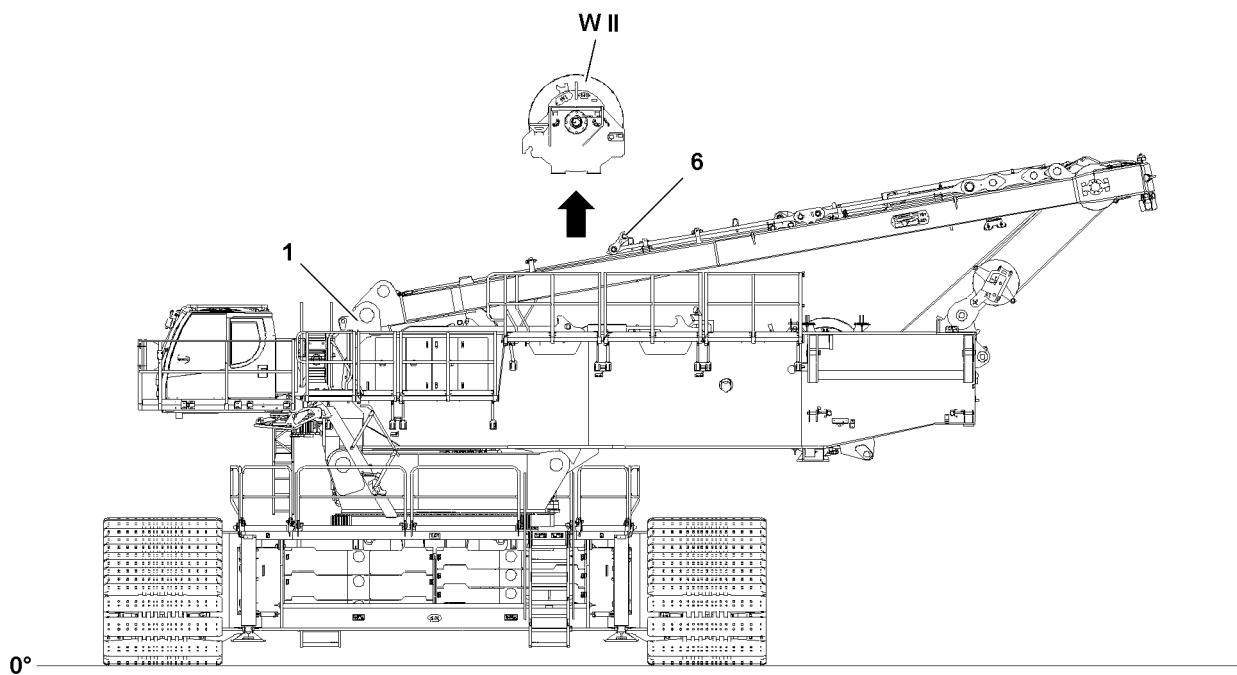

Fig.118572

4 Disassembly winch 2



WARNING

Danger of falling!

During assembly / disassembly, inspection and maintenance work, assembly personnel must be secured with appropriate aids to prevent them from falling.

If this is not observed, assembly personnel could fall and be killed or seriously injured!

- ▶ The assembly personnel must always move carefully and anticipatory on the crane, the crane components or lattice sections.
- ▶ All work aloft, where there is a danger of falling must be carried out with suitable aids.
- ▶ If fall protection equipment is available, then it must be used.
- ▶ If aids are not available and work cannot be carried out from the ground, then the assembly personnel must secure themselves with the approved fall arrest system to prevent falling, see Crane operating instructions, chapter 2.04.
- ▶ The fall arrest system must be attached on the fastening and hook points as well as on the safety ropes.
- ▶ Always secure ladders on structural parts and / or components to prevent them from falling over.
- ▶ Only step on the aids, ladders and catwalks with clean shoes.
- ▶ Keep aids, ladders and catwalks free of heavy dirt, snow, frost and ice.
- ▶ Stepping or walking on crane components and lattice sections, which have an incline of more than 20° is prohibited.



WARNING

Components not pinned and secured!

If a component is released from the auxiliary crane before having been pinned and secured, the component can fall down.

Death, severe bodily injuries, property damage.

- ▶ Remove the auxiliary crane only after the respective component has been properly pinned and secured.



WARNING

Danger of impact / crushing!

When installing / removing crane components with the auxiliary crane, crane components can start to swing back and forth.

When lifting / lowering and positioning crane components, there is an increased danger of impacts / crushing.

Death, severe bodily injuries.

- ▶ Make sure that personnel cannot be caught by components.
- ▶ When working in danger zones: Use aids to protect limbs.
- ▶ Guide components with suitable aids to minimize oscillation.

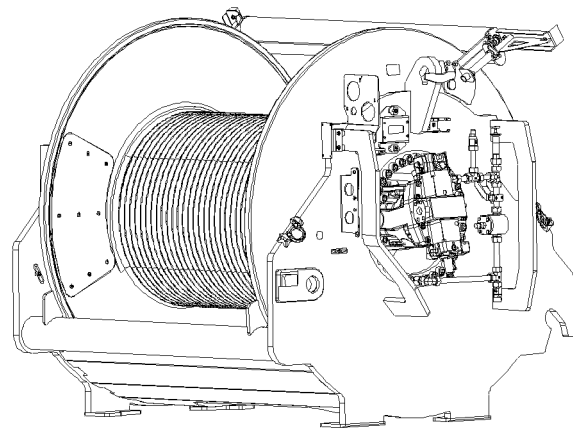

Fig.118588

4.1 Disconnecting the connections to winch 2

Make sure that the following prerequisites are met:

- The hoist rope is completely spooled up to the winch.
- The hoist rope is secured on the winch to prevent it from spooling out by itself.

4.1.1 Disconnecting the hydraulic connections to the winch

When releasing hydraulic lines with quick couplings, make sure that the uncoupling procedure is carried out correctly.



WARNING

Pressure in the hydraulic lines!

If the pressure supply is not interrupted before connecting / releasing the hydraulic lines, the hydraulic oil can escape with high pressure.

Death, severe bodily injuries, property damage.

- ▶ Release the pressure in the hydraulic system before connecting / disconnecting: Interrupt the pressure supply and wait for a short time.

-
- ▶ Release the hydraulic coupling by hand.
 - ▶ Disconnect the hydraulic connections to the winch.
 - ▶ Close the hydraulic hoses and hydraulic lines off properly with the intended caps.
 - ▶ Bring the hydraulic hoses in park position for transport and secure them properly.

4.1.2 Disconnecting the electrical connections to the winch

- ▶ Disconnect the electrical connections to the winch.
- ▶ Close the electrical connections properly off with the intended caps.

4.1.3 Disconnecting the connections of the central lubrication system to the winch

- ▶ Disconnect the connections to the winch.
- ▶ Close the lube line connections properly off with the intended caps.

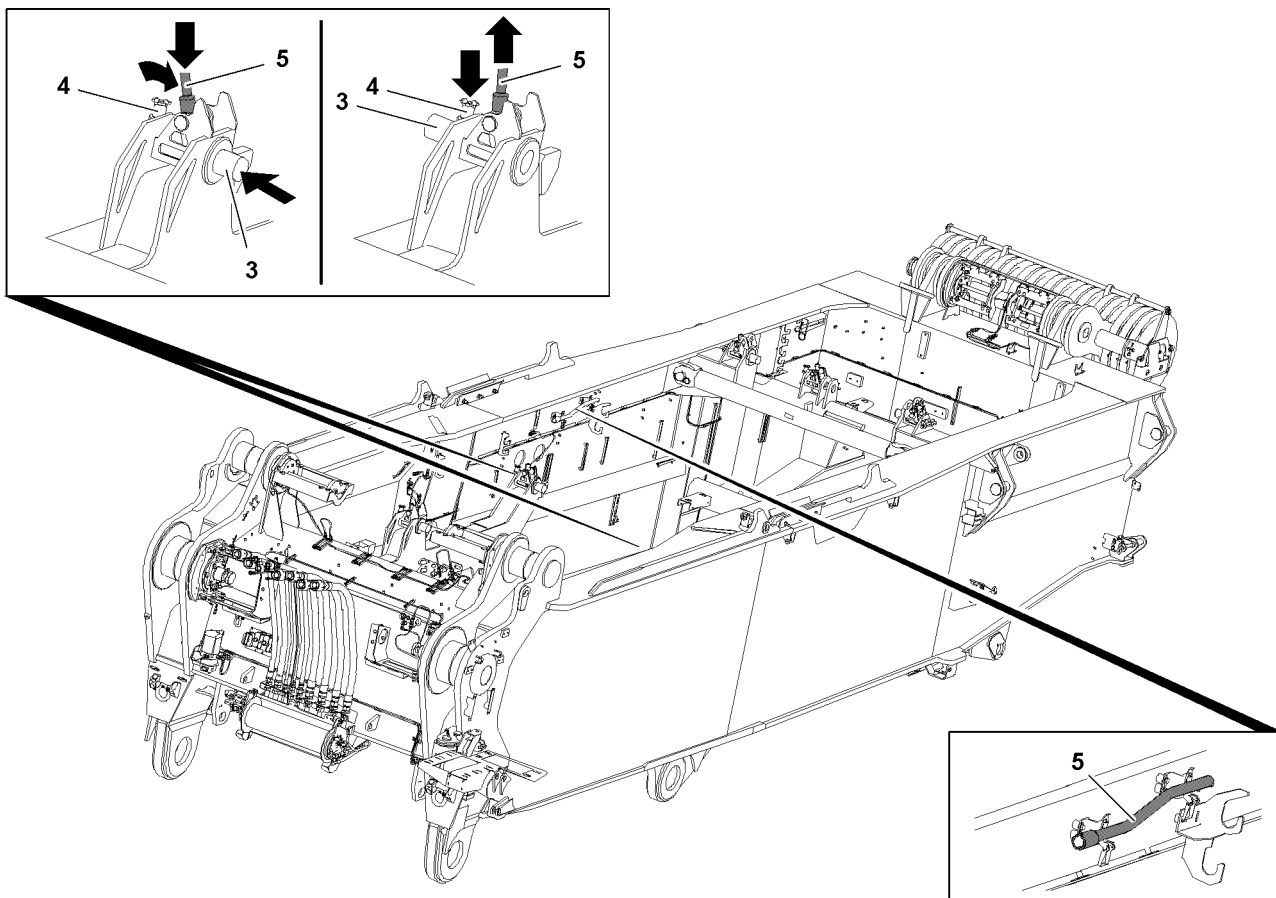

Fig.118573

4.2 Removing winch 2

4.2.1 Unpinning winch 2

Make sure that the following prerequisites are met:

- The hydraulic connections are properly disconnected and closed off.
- The electrical connections are properly disconnected and closed off.
- The connections of the central lubrication system are properly disconnected and closed off.
- An auxiliary crane with appropriate load carrying capacity is available.



WARNING

Danger of accident due to incorrect attachment!

Life-threatening situations can arise if the winch 2 is incorrectly or improperly attached.

Death, severe bodily injuries, property damage.

- ▶ The fastening equipment may be attached on the winch only on the intended fastening points.
- ▶ Make sure that the fastening equipment is properly attached on winch 2 and that it is secured sufficiently to prevent it from loosening up.

- ▶ Attach the fastening equipment on both sides on winch 2, see section „Fastening points Winch 2“.

When the fastening equipment is properly fastened on winch 2:

- ▶ Bring the fastening equipment with the auxiliary crane carefully to „tension“.

When the fastening equipment is tensioned:

- ▶ Release pins **3** on both sides: Remove the ball locking pins **4**.
- ▶ Unpin the pins **3** with the control lever on both sides completely.
- ▶ Secure the pins **3** in the „unpinned“ position with ball locking pins **4**.
- ▶ Place the control lever **5** in park position and secure it properly.

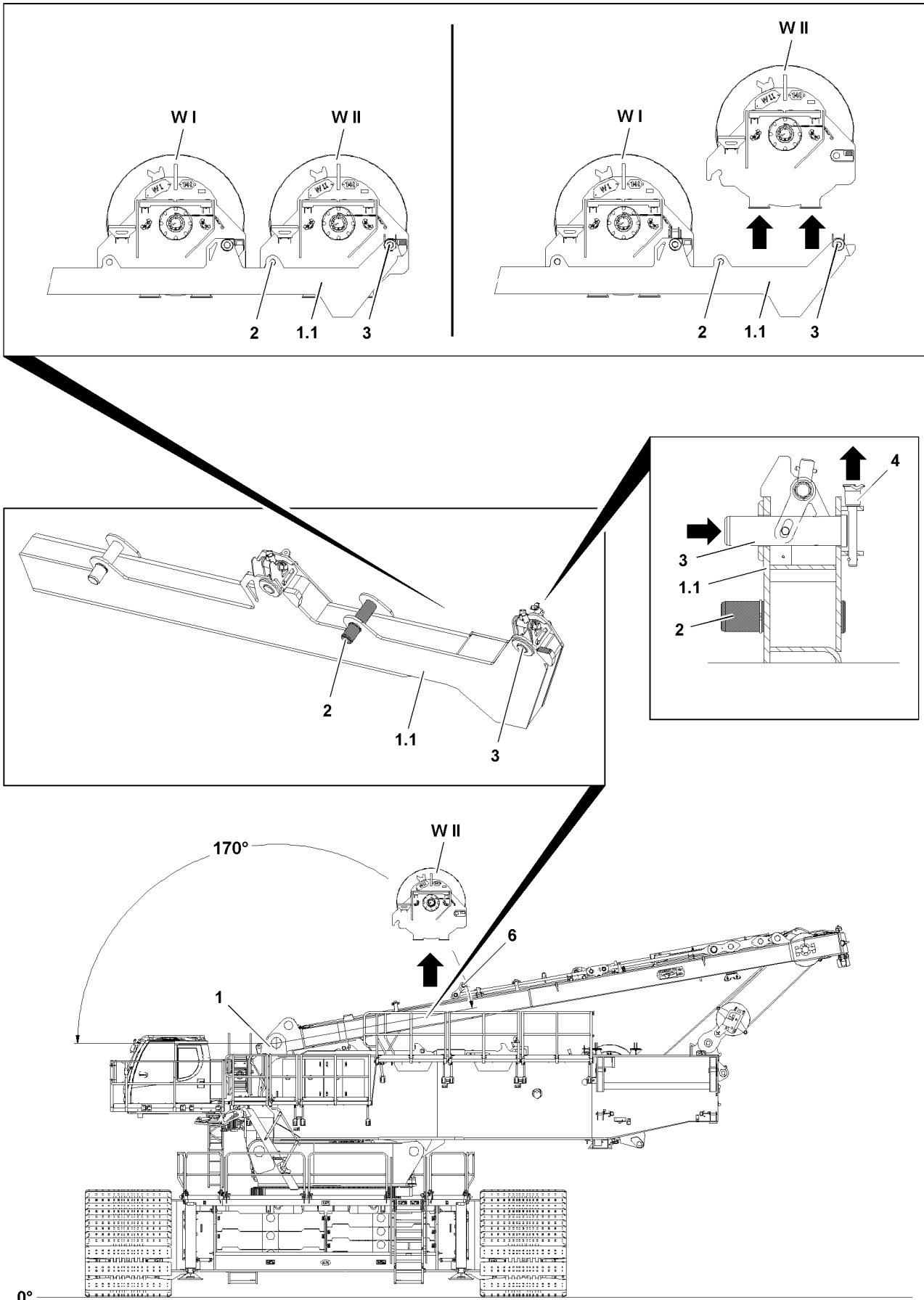

Fig.126248

LWE/LR 11000-001/23501-04-02/en

4.2.2 Lifting winch 2 from the turntable

Make sure that the following prerequisites are met:

- Winch 2 is properly unpinned on the turntable **1**.
- The SA-frame is at approx. 170°; pay attention to SA-frame angle display on the LICCON monitor, see Crane operating instructions, chapter 4.02
- The brackets **6** on the SA-frame have been changed over to the rear.



WARNING

Falling components!

When lifting the winch 2 on the turntable **1**, components or winch 2 can fall down.

Death, severe bodily injuries, property damage.

▶ Make sure that there are no persons within the danger zone.

▶ Carefully lift winch 2 with the auxiliary crane from the turntable **1**.



WARNING

Toppling winch!

When setting the winch on the ground, the winch can sink into the ground and fall over.

Death, severe bodily injuries, property damage.

▶ Make sure that the ground has sufficient load bearing capacity to safely take on the weight of the winch.

▶ Swing winch 2 out with the auxiliary crane and set it on the ground on a suitable substructure.

or

Swing winch 2 out with the auxiliary crane and set it on the flatbed trailer.

When winch 2 has been set down properly:

▶ Remove the auxiliary crane.

Empty page!

LWE/LR 11000-001/23501-04-02/en

3.07.30 Assembly winch 3

1 Component overview

3

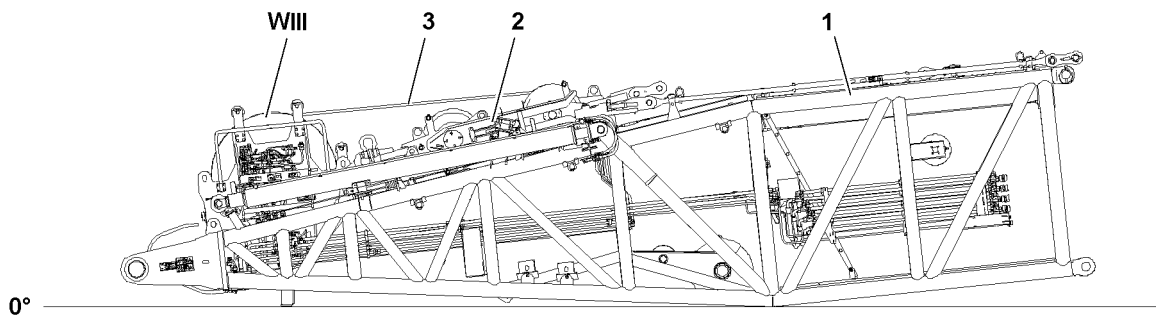
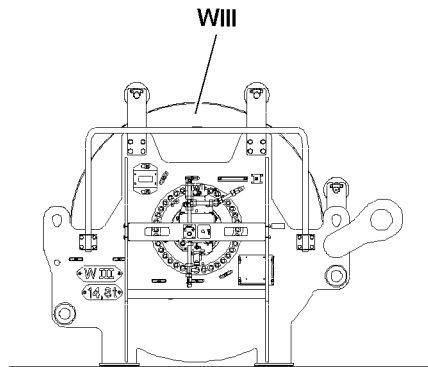

Fig.118575

LWE/LR 11000-001/23501-04-02/en

1 Component overview

**Note**

- ▶ Winch 3 is installed at the factory on the derrick pivot section **1** (D-pivot section).

**Note**

- ▶ In the transport unit „D-pivot section with winch 3“ the pulley block **2** in transport position is also taken into account. In this case the hoist rope **3** of winch 3 has already been reeved at the factory on pulley block **2**.
- ▶ For dimensions and weights of the transport unit „D-pivot section with winch 3“, see Crane operating instructions, chapter 1.03.

Empty page!

LWE/LR 11000-001/23501-04-02/en

3.07.50 Assembly winch 5

1	Component overview	3
2	Fastening points winch 5	3
3	Installation winch 5 from transport into operating position	5
4	Assembly winch 5	11
5	Disassembly winch 5	21

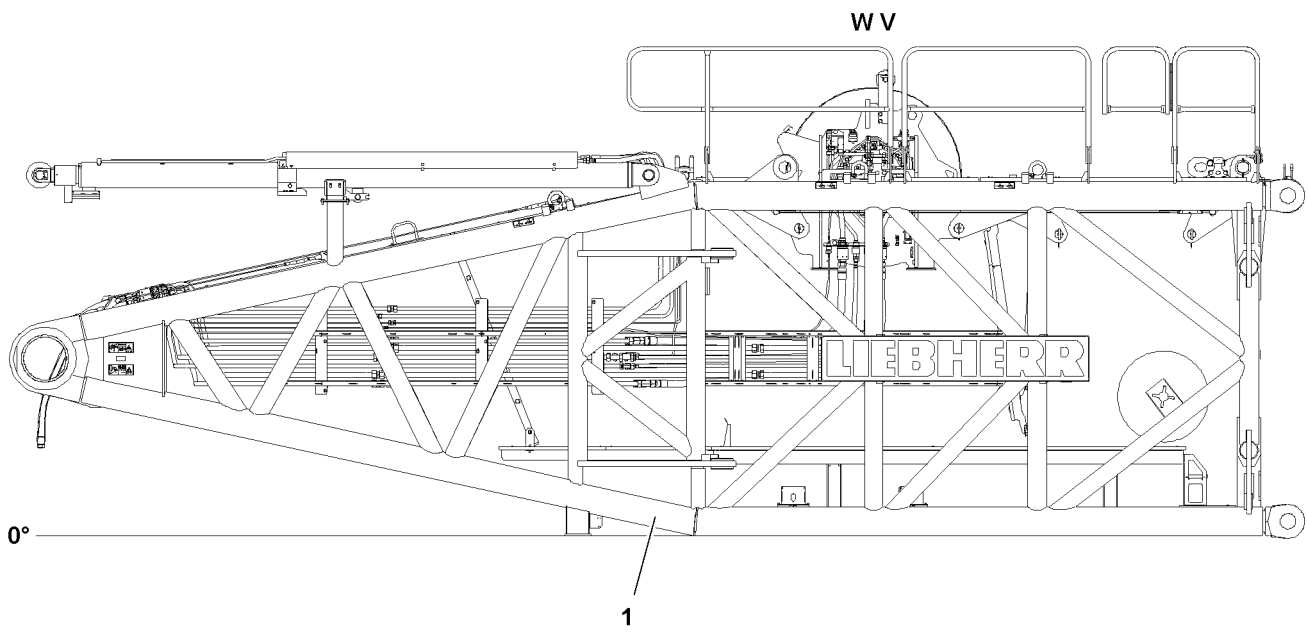

Fig.118582

1 Component overview



Note

- ▶ The weight of winch 5 together with the S-pivot section 1, see Crane operating instructions, chapter 1.03.



Note

- ▶ The winch 5 is marked with its own weight.

2 Fastening points winch 5



WARNING

Winch incorrectly fastened!

Life-threatening situations can arise if the winch is incorrectly or improperly attached.

Death, severe bodily injuries, property damage.

- ▶ Attach the winch only on the intended fastening points.
- ▶ Attach the fastening equipment on winch solely in connection with shackles.
- ▶ Make sure that the shackles and fastening equipment have sufficient load capacity.
- ▶ Observe the technical safety instructions during assembly and disassembly, see Crane operating instructions, chapter 5.01.

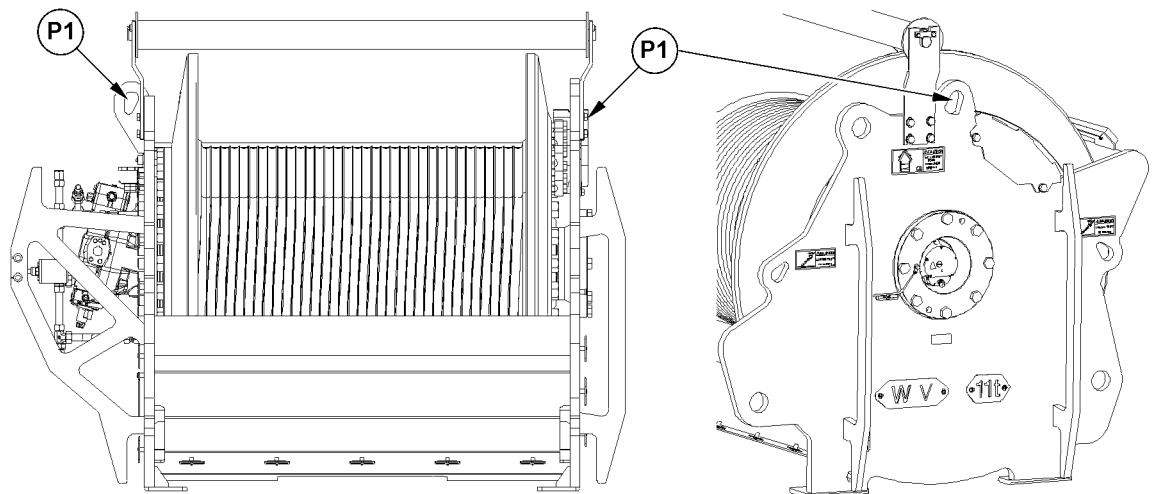

Fig.118583: Fastening points winch 5

Fastening points	
P1	Winch 5

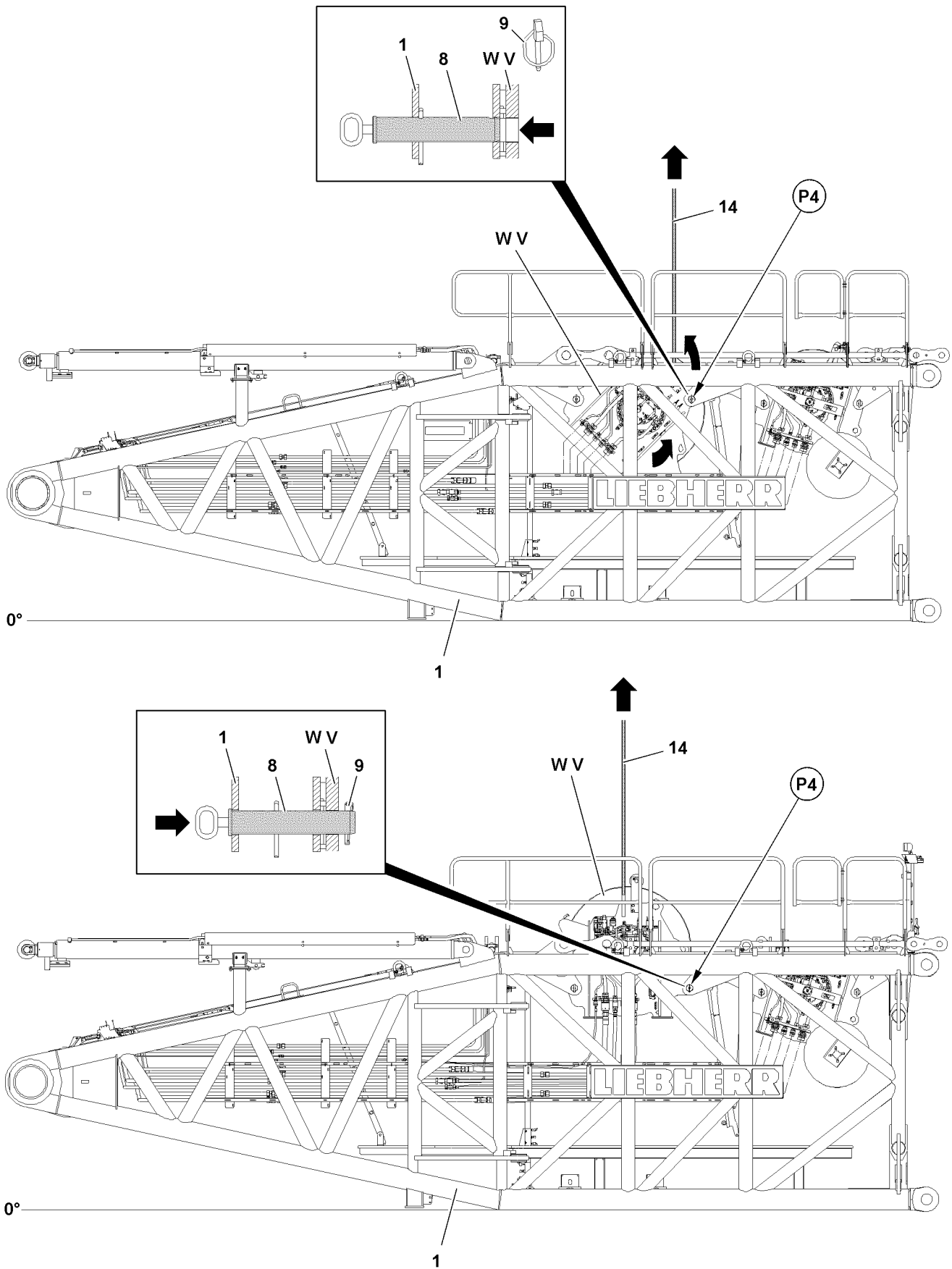

Fig.118585

3 Installation winch 5 from transport into operating position



WARNING

Danger of falling!

During assembly / disassembly, inspection and maintenance work, assembly personnel must be secured with appropriate aids to prevent them from falling.

If this is not observed, assembly personnel could fall and suffer life-threatening or fatal injuries.

- ▶ The assembly personnel must always move carefully and anticipatory on the crane, the crane components or lattice sections.
- ▶ All work aloft, where there is a danger of falling must be carried out with suitable aids.
- ▶ If fall protection equipment is available, then it must be used.
- ▶ If aids are not available and work cannot be carried out from the ground, then the assembly personnel must secure themselves with the approved fall arrest system to prevent falling, see Crane operating instructions, chapter 2.04.
- ▶ The fall arrest system must be attached on the fastening and hook points as well as on the safety ropes.
- ▶ Always secure ladders on structural parts and / or components to prevent them from falling over.
- ▶ Only step on the aids, ladders and catwalks with clean shoes.
- ▶ Keep aids, ladders and catwalks free of heavy dirt, snow, frost and ice.
- ▶ Stepping or walking on crane components and lattice sections, which have an incline of more than 20° is prohibited.



WARNING

Components not pinned and secured!

If a component is released from the auxiliary crane before having been pinned and secured, the component can slip and fall down.

Death, severe bodily injuries, property damage.

- ▶ Do not disengage the auxiliary crane until the corresponding component is pinned and secured.



WARNING

Danger of impact / crushing!

When installing / removing crane components with the auxiliary crane, crane components can start to swing back and forth.

When lifting / lowering and positioning crane components, there is an increased danger of impacts / crushing.

Death, severe bodily injuries.

- ▶ Make sure that personnel cannot be caught by components.
- ▶ When working in danger zones: Use aids to protect limbs.
- ▶ Guide components with suitable aids to minimize oscillation.

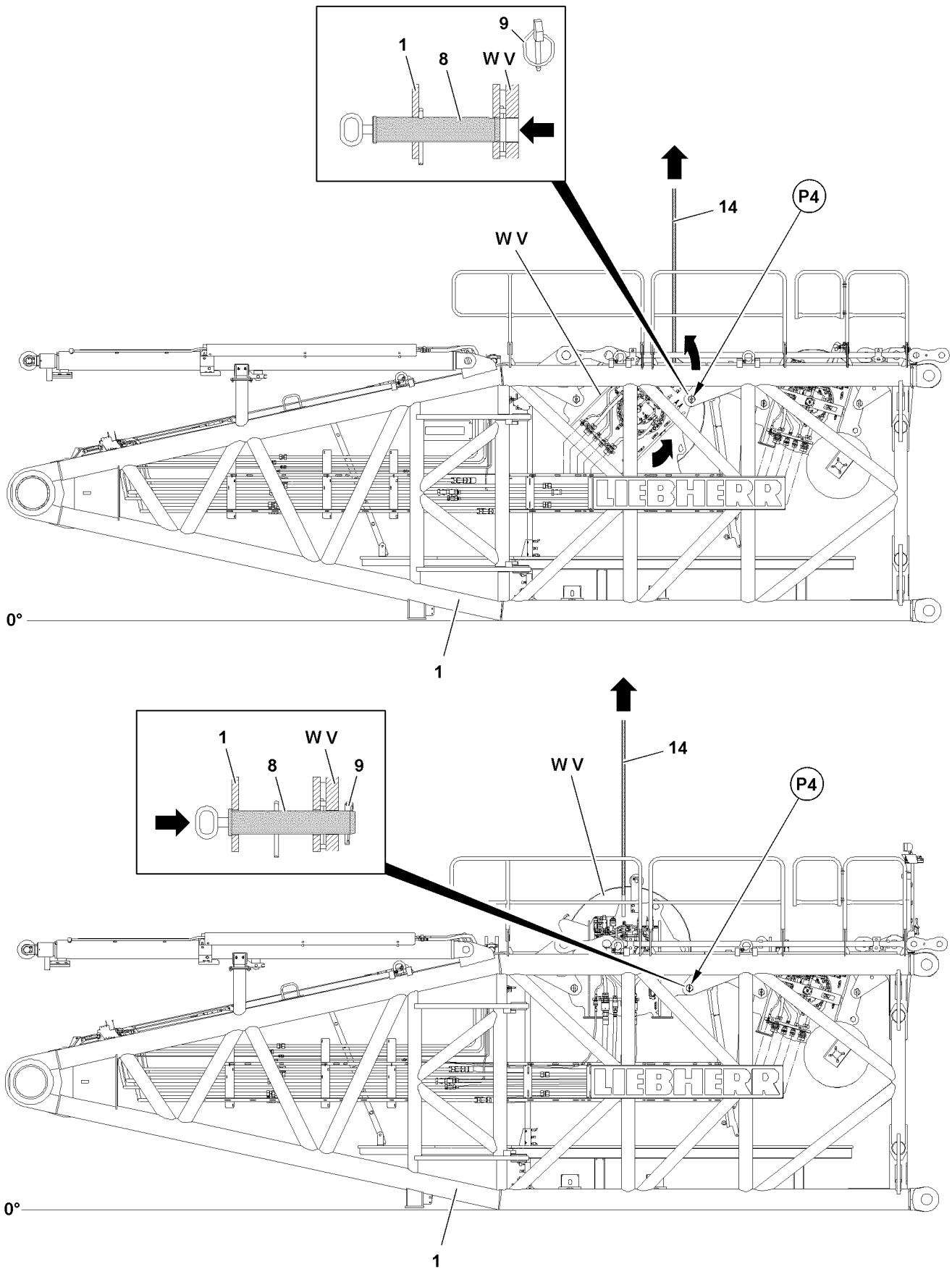

Fig.118585

3.1 Bringing winch 5 from transport position into operating position

Make sure that the following prerequisites are met:

- The fall protection equipment is in operating position.
- An auxiliary crane with sufficient load carrying capacity is available.



Note

▶ During the installation procedure of winch 5 from transport into operating position, all hydraulic and electrical connections as well as the central lubrication connection remain connected with winch 5.

▶ Attach winch 5 with fastening equipment **14** on the auxiliary crane.



WARNING

Danger of accident due to winch 5!

If the pins **8** at point **P4** are unpinned on both sides and the fastening equipment **14** is not tensioned, then winch 5 can suddenly swing downward.

Death, severe bodily injuries, property damage.

- ▶ Make sure that the fastening equipment **14** is tensioned before the pins **8** are unpinned on both sides on point **P4**.
- ▶ Make sure that no personnel is within the danger zone when unpinning winch 5.

When winch 5 is properly fastened on the auxiliary crane:

- ▶ Carefully bring the fastening equipment **14** to tension.

When the fastening equipment is tensioned:

- ▶ Release pins **8** on both sides at point **P4** and unpin.
- ▶ Lift winch 5 with the auxiliary crane into operating position upward until the pin bores align at point **P4**.

When the pin bores align at point **P4**:

- ▶ Insert the pins **8** completely on both sides.
- ▶ Secure the pins **8** on both sides with locking pins **9**.

When winch 5 is properly pinned and secured in operating position:

- ▶ Remove the auxiliary crane and the fastening equipment **14** on winch 5.

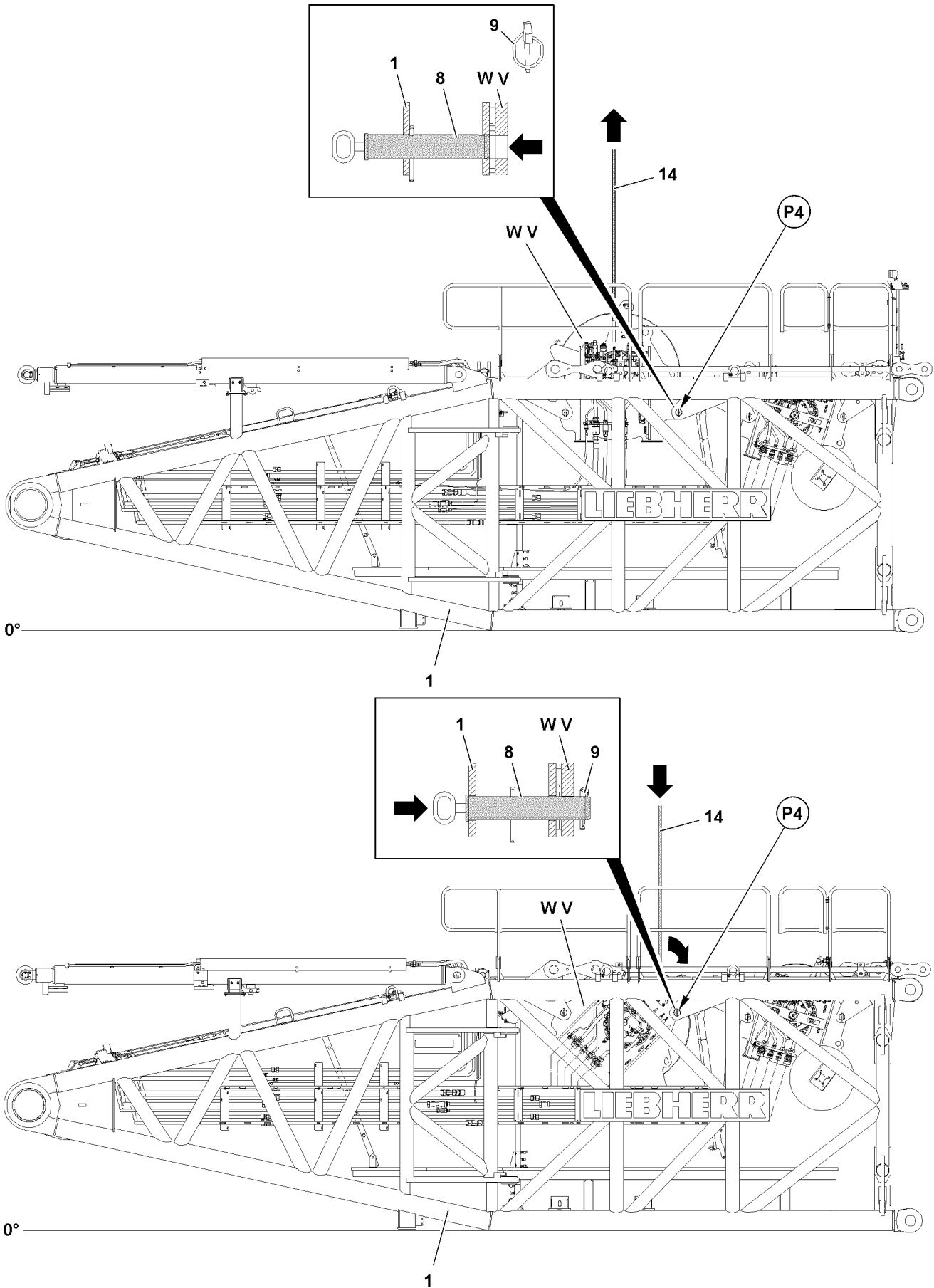

Fig.118586

3.2 Bringing winch 5 from operating position into transport position

Make sure that the following prerequisites are met:

- The fall protection equipment is in operating position.
- An auxiliary crane with sufficient load carrying capacity is available.



Note

- ▶ During the removal procedure of winch 5 from operating to transport position, all hydraulic and electrical connections as well as the central lubrication connection remain connected with winch 5.
- ▶ Attach winch 5 with fastening equipment **14** on the auxiliary crane.



WARNING

Danger of accident due to winch 5!

If the pins **8** at point **P4** are unpinned on both sides and the fastening equipment **14** is not tensioned, then winch 5 can suddenly swing downward.

Death, severe bodily injuries, property damage.

- ▶ Make sure that the fastening equipment **14** is tensioned before the pins **8** are unpinned on both sides on point **P4**.
- ▶ Make sure that no personnel is within the danger zone when unpinning winch 5.

When winch 5 is properly fastened on the auxiliary crane:

- ▶ Carefully bring the fastening equipment **14** to tension.

When the fastening equipment is tensioned:

- ▶ Release pins **8** on both sides at point **P4** and unpin.
- ▶ Lower winch 5 into transport position until the upper pin bores of winch 5 align with the pin bores at point **P4**.

When the pin bores align at point **P4**:

- ▶ Insert the pins **8** completely on both sides.
- ▶ Secure the pins **8** on both sides with locking pins **9**.

When winch 5 is properly pinned and secured in transport position:

- ▶ Remove the auxiliary crane and the fastening equipment **14** on winch 5.

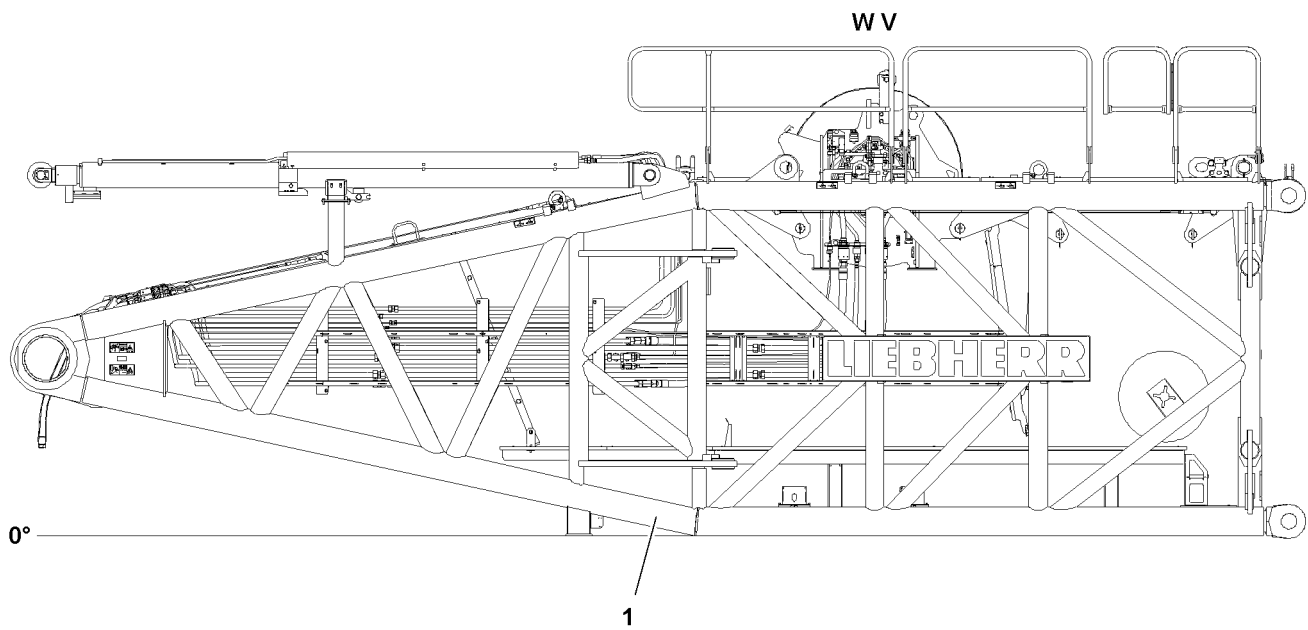

Fig.118582

LWE/LR 11000-001/23501-04-02/en

4 Assembly winch 5



Note

- ▶ The description in this section may only be used when winch 5 is delivered separately from the S-pivot section 1 to the installation and / or job location of the crane.



WARNING

Danger of falling!

During assembly / disassembly, inspection and maintenance work, assembly personnel must be secured with appropriate aids to prevent them from falling.

If this is not observed, assembly personnel could fall and suffer life-threatening or fatal injuries.

- ▶ The assembly personnel must always move carefully and anticipatory on the crane, the crane components or lattice sections.
- ▶ All work aloft, where there is a danger of falling must be carried out with suitable aids.
- ▶ If fall protection equipment is available, then it must be used.
- ▶ If aids are not available and work cannot be carried out from the ground, then the assembly personnel must secure themselves with the approved fall arrest system to prevent falling, see Crane operating instructions, chapter 2.04.
- ▶ The fall arrest system must be attached on the fastening and hook points as well as on the safety ropes.
- ▶ Always secure ladders on structural parts and / or components to prevent them from falling over.
- ▶ Only step on the aids, ladders and catwalks with clean shoes.
- ▶ Keep aids, ladders and catwalks free of heavy dirt, snow, frost and ice.
- ▶ Stepping or walking on crane components and lattice sections, which have an incline of more than 20° is prohibited.



WARNING

Components not pinned and secured!

If a component is released from the auxiliary crane before having been pinned and secured, the component can slip and fall down.

Death, severe bodily injuries, property damage.

- ▶ Do not disengage the auxiliary crane until the corresponding component is pinned and secured.



WARNING

Danger of impact / crushing!

When installing / removing crane components with the auxiliary crane, crane components can start to swing back and forth.

When lifting / lowering and positioning crane components, there is an increased danger of impacts / crushing.

Death, severe bodily injuries.

- ▶ Make sure that personnel cannot be caught by components.
- ▶ When working in danger zones: Use aids to protect limbs.
- ▶ Guide components with suitable aids to minimize oscillation.

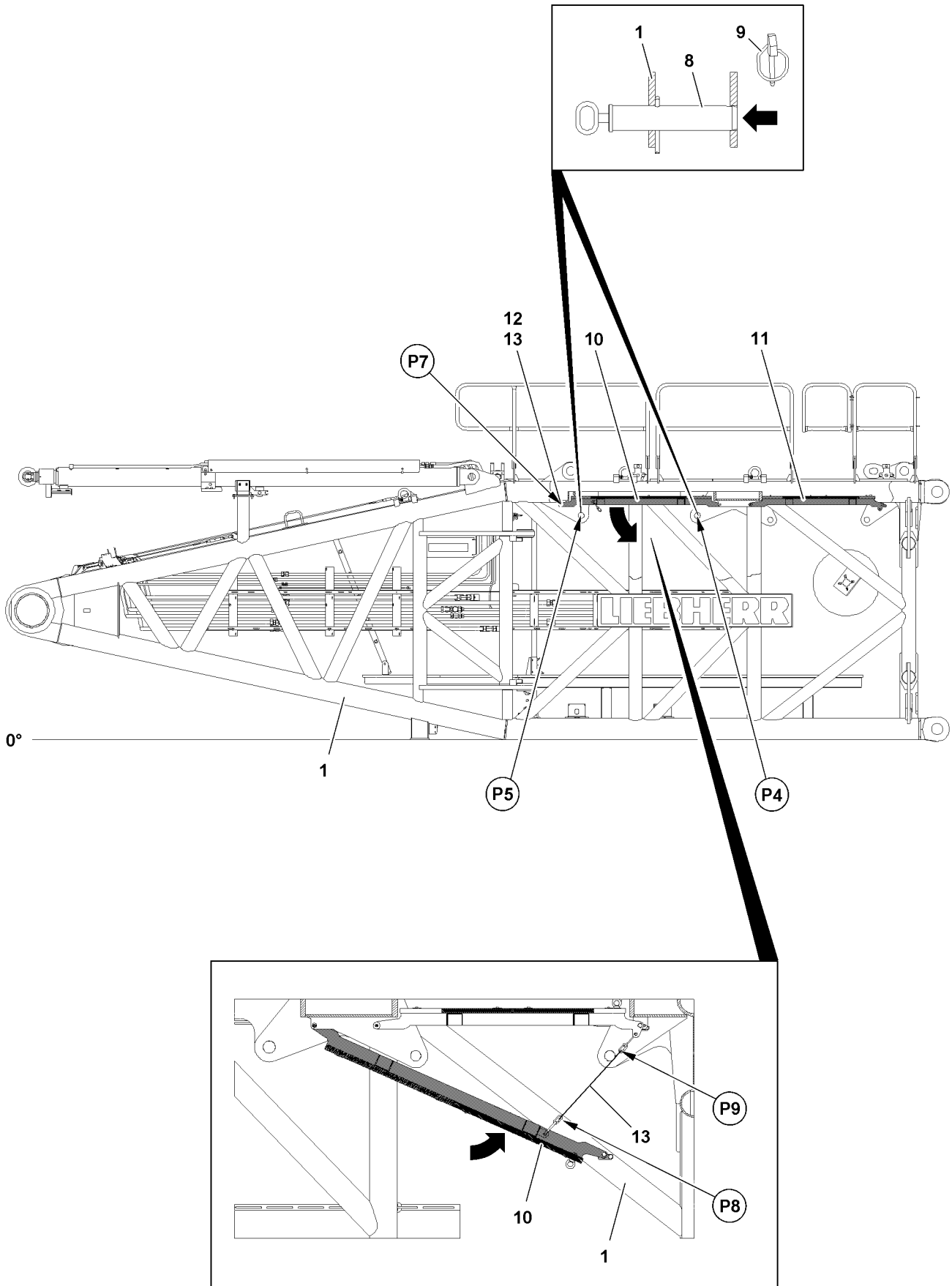

Fig.118584

4.1 Preparing installation of winch 5



Note

- ▶ If winch 5 is not installed in transport condition of the S-pivot section **1**, then the installation / assembly opening of winch 5 on the S-pivot section is closed off with a catwalk **10**.
- ▶ The catwalk **10** must be unpinned for the installation of winch 5 on the S-pivot section **1** on one side, swung down and secured in this position.

Make sure that the following prerequisites are met:

- The fall protection equipment is properly installed.
 - The railings are in operating position.
 - The assembly openings of winch 5 and winch 6 are closed off by the catwalks **10** and catwalks **11**.
 - An auxiliary crane with sufficient load carrying capacity is available.
- ▶ Fasten the catwalk **10** on the auxiliary crane.

When the catwalk **10** is properly fastened on the auxiliary crane:

- ▶ Carefully bring the fastening equipment to tension.
- ▶ Unpin the pin **12**: Remove the spring retainer **13** at point **P7** on both sides and unpin the pin **12** on both sides.



WARNING

Danger of accident due to catwalk!

If there is any personnel within the swing range when lowering the catwalk **10**, then personnel can be severely injured or killed.

- ▶ Make sure that there are no persons within the swing range of the catwalk **10**.

When the pins **12** are unpinned on both sides:

- ▶ Lower the catwalk **10** slowly downward with the auxiliary crane.

When the catwalk **10** is lowered down completely:

- ▶ Pin and secure the catwalk **10** in assembly position between point **P8** and point **P9** on both sides and secure.

When the catwalk **10** is properly secured in assembly position:

- ▶ Remove the auxiliary crane.
- ▶ Release the connector pin **8** for winch 5 at point **P4** and point **P5** on both sides: Remove the locking pin **9**.
- ▶ Unpin the connector pin **8** at point **P4** and point **P5** on both sides to the stop.

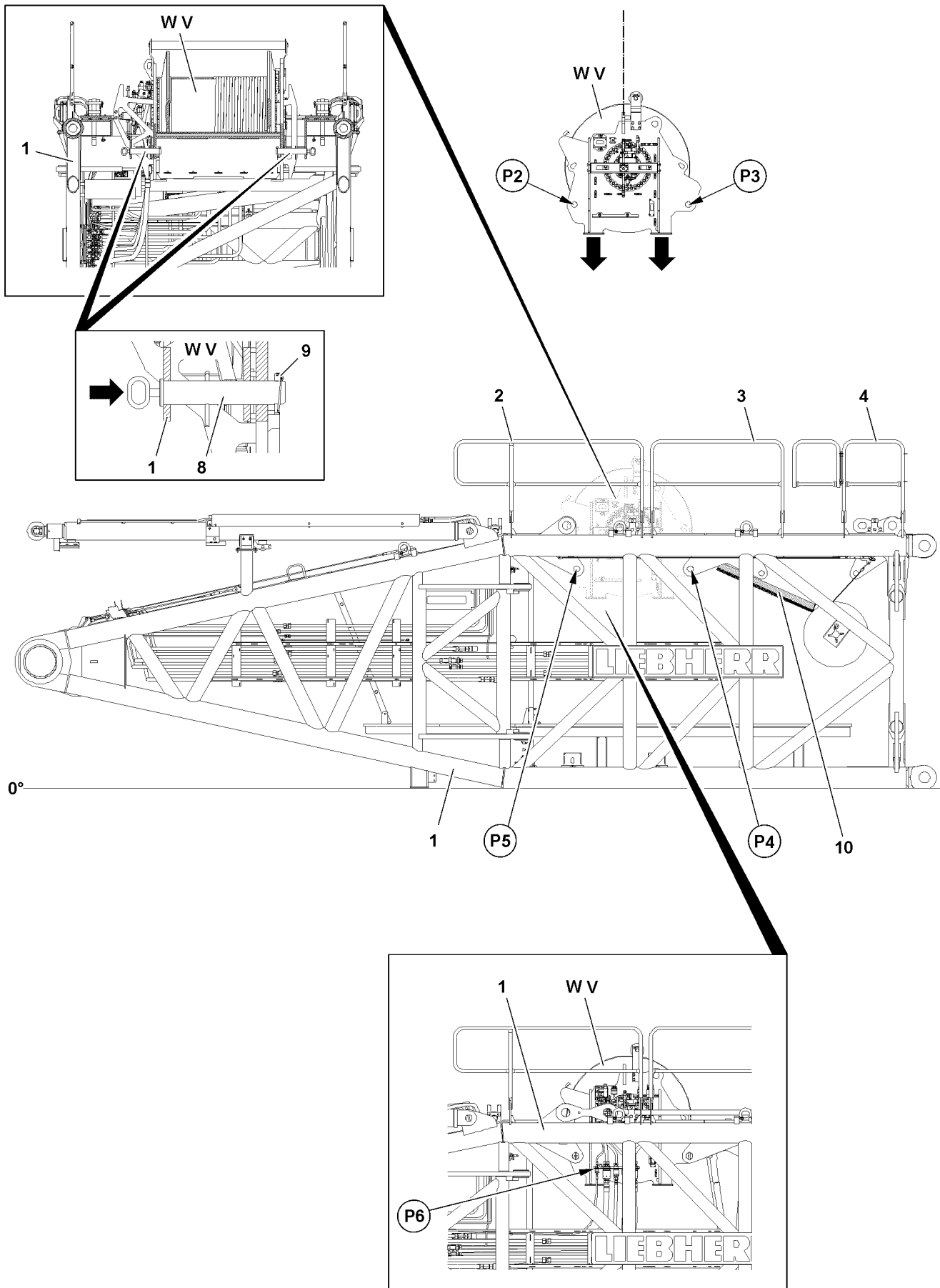

Fig.118578

LWE/LR 11000-001/23501-04-02/en

4.2 Installing winch 5



WARNING

Danger of accident during installation of winch 5!
Death, severe bodily injuries, property damage.

- ▶ Make sure that the following prerequisites are met for the installation of winch 5.

Make sure that the following prerequisites are met:

- The assembly opening winch 6 is properly closed and secured with the catwalk **11**.
- The catwalks **10** are in assembly position.
- An auxiliary crane with sufficient load carrying capacity is available.

4.2.1 Lifting winch 5 from the flatbed trailer



WARNING

Danger of accident due to incorrect attachment!

Life-threatening situations can arise if the winch 5 is incorrectly or improperly attached.
Death, severe bodily injuries, property damage.

- ▶ Fasten winch 5 only on the fastening points (points **P1**).
- ▶ Make sure that the fastening equipment is correctly attached on the fastening points (points **P1**) and that it is secured sufficiently to prevent it from loosening up.

- ▶ Attach the fastening equipment (points **P1**) on the fastening points, see section „Fastening points Winch 5“.
- ▶ Bring the fastening equipment to „tension“ with the auxiliary crane.
- ▶ Release and remove the transport retainers on the flatbed trailer.



WARNING

Falling components!

When lifting winch 5 from the flatbed trailer, components or winch 5 can fall down.
Death, severe bodily injuries, property damage.

- ▶ Make sure that there are no persons within the danger zone.
- ▶ Lift winch 5 with the auxiliary crane from the flatbed trailer.

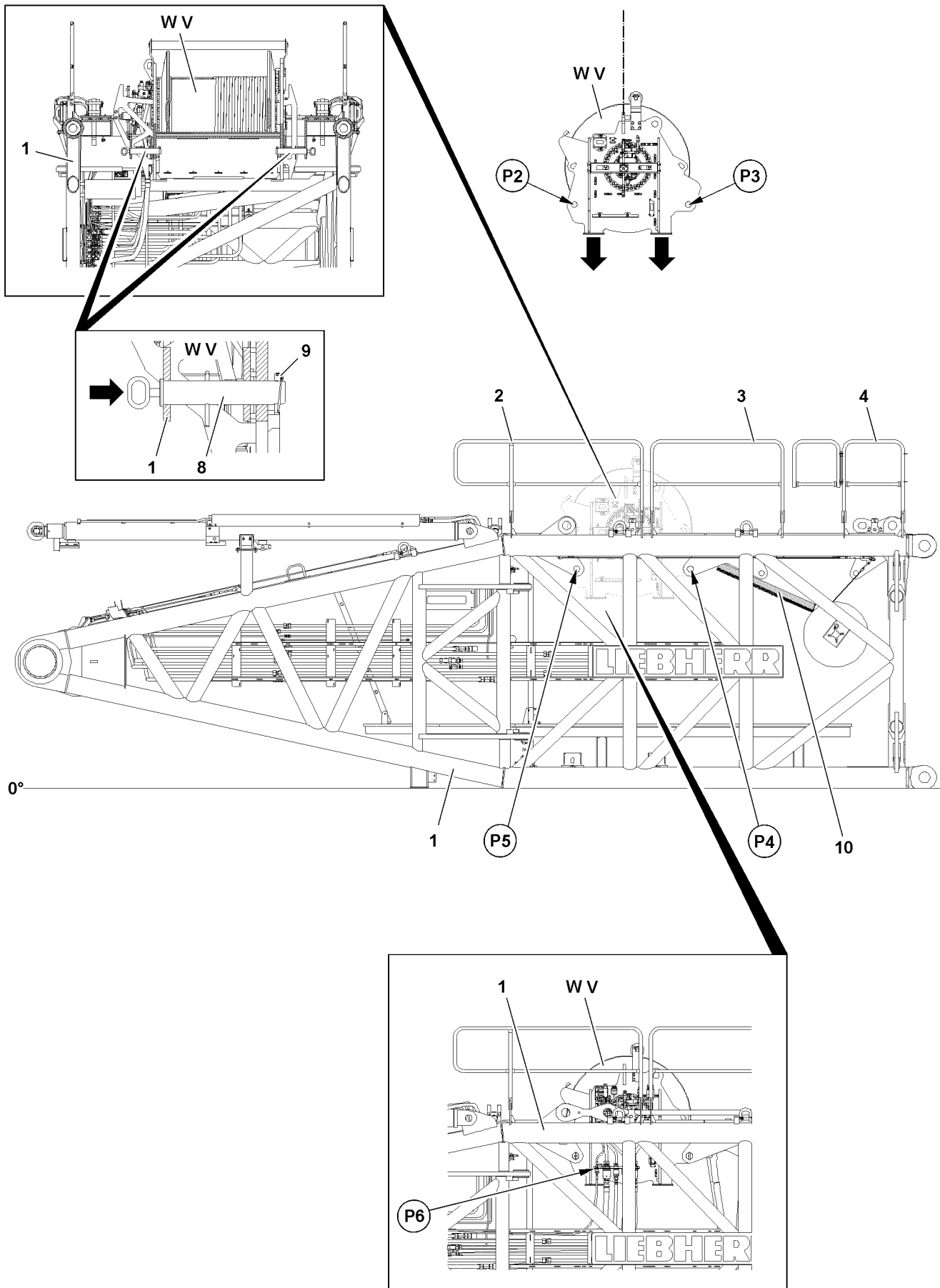

Fig.118578

LWE/LR 11000-001/23501-04-02/en

4.2.2 Positioning winch 5

Make sure that the following prerequisites are met:

- Pins **8** are completely unpinned on both sides at point **P4** and point **P5**.



WARNING

Danger of accident when swinging in and lowering winch 5!

When swinging in and lowering winch 5 in the assembly opening of the S-pivot section **1**, limbs can be crushed or even severed.

Death, severe bodily injuries, property damage.

- ▶ Make sure that there are no persons within the danger zone.
- ▶ Do not reach with your hands into the danger zone.

NOTICE

Property damage!

If the following notes are not observed, damage can result to the crane or winch 5.

- ▶ When retracting winch 5, it must be ensured that winch 5 does not hit against the S-pivot section **1**.



Note

- ▶ The guide must be in constant visual and acoustic contact with the crane operator.



Note

- ▶ Pay attention to the exact alignment of winch 5 to the installation position.

- ▶ Swing winch 5 in with the auxiliary crane to the S-pivot section **1**.
- ▶ Position and align winch 5.

When winch 5 is aligned:

- ▶ Lower winch 5 with the auxiliary crane in the assembly opening until the pin bores of winch 5 (point **P2** and point **P3**) align with the pin bores on the S-pivot section (point **P4** and point **P5**) on both sides.

4.2.3 Pinning winch 5

Make sure that the following prerequisites are met:

- The pin bores between winch 5 and the S-pivot section **1** align.



WARNING

The connector pins can loosen up!

- ▶ Make sure that the pins **8** are immediately secured with the locking pin **9** after pinning winch 5 in the S-pivot section **1**.

- ▶ Insert the pins **8** at point **P4** and point **P5** on both sides and secure with locking pin **9**.

When winch 5 is properly pinned and secured on all four pin points:

- ▶ Remove the auxiliary crane.

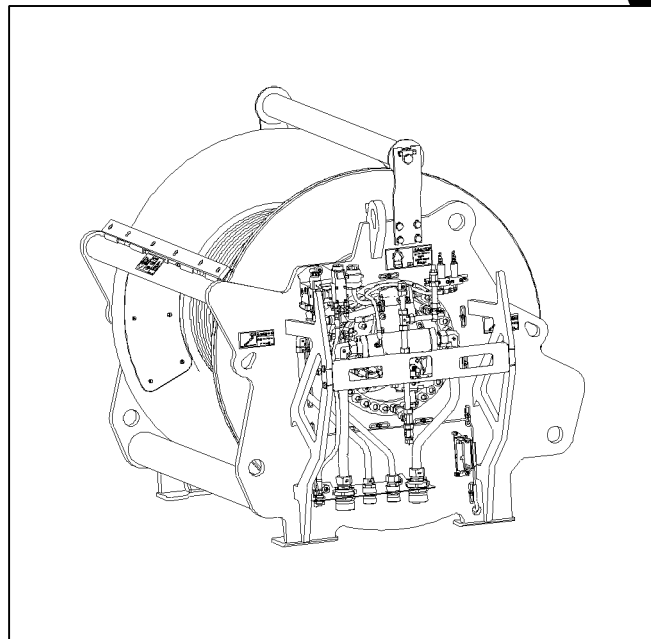
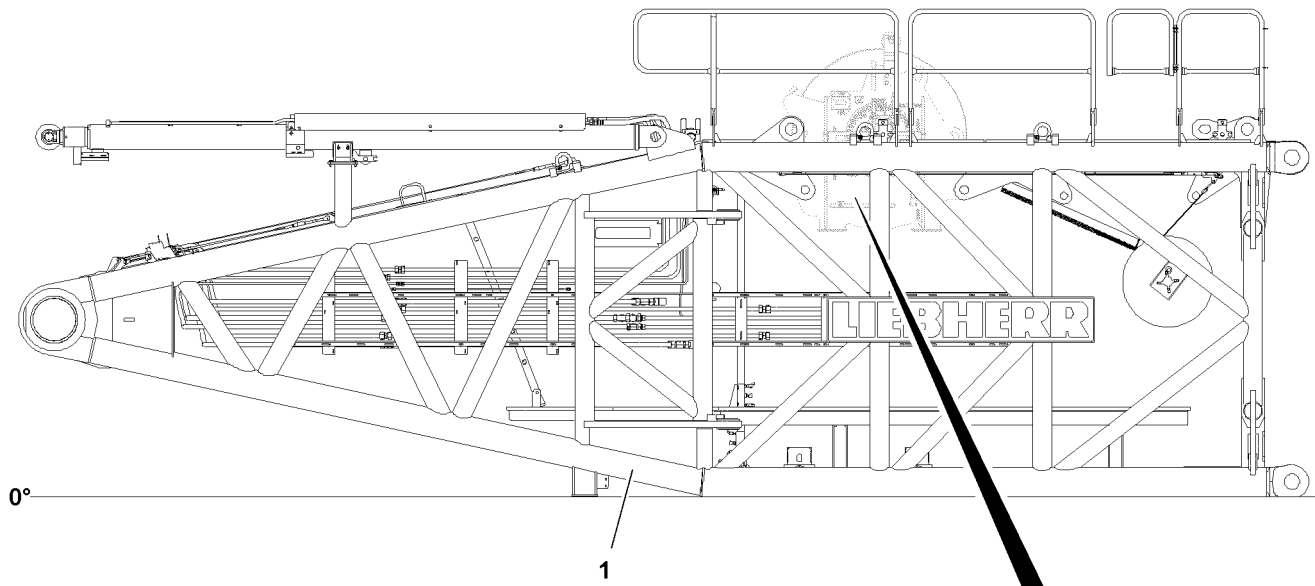

Fig.118579

4.3 Establishing the hydraulic connections to winch 5



Note

- ▶ Establish the connections to winch 5 only when winch 5 is properly installed and secured on the S-pivot section.

Make sure that the following prerequisites are met:

- The winch 5 is properly installed, pinned and secured.

4.3.1 Establishing the hydraulic connections to the winch



Note

- ▶ After the hydraulic connections to the winch are established, the expansion tank must be checked and emptied.

The hydraulic connections for the winch are made with quick couplings.

When connecting hydraulic lines with quick couplings, make sure that the coupling procedure is carried out correctly.



WARNING

Pressure in the hydraulic lines!

If the pressure supply is not interrupted before connecting / releasing the hydraulic lines, the hydraulic oil can escape with high pressure.

Death, severe bodily injuries, property damage.

- ▶ Release the pressure in the hydraulic system before connecting / disconnecting: Interrupt the pressure supply and wait for a short time.



WARNING

Loss of pressure or leakage!

Incorrectly coupled or self-loosening quick couplings (particularly return lines) can result in serious accidents due to component failure.

- ▶ Check that the quick couplings have been properly connected before using the crane.
- ▶ Connect the coupling components (sleeve and connector) and screw together with the hand-tightened nut.
- ▶ Tighten the hydraulic coupling by hand. Rotate the hand-tightened nut until it reaches a tangible, fixed stop position.
- ▶ Establish the hydraulic connections to the winch.

4.3.2 Establishing the electrical connections to the winch

- ▶ Establish the electrical connections to the winch, see Electric wiring diagram.

4.3.3 Establishing the connections of the central lubrication system to the winch

- ▶ Establishing the connections of the central lubrication system to the winch.

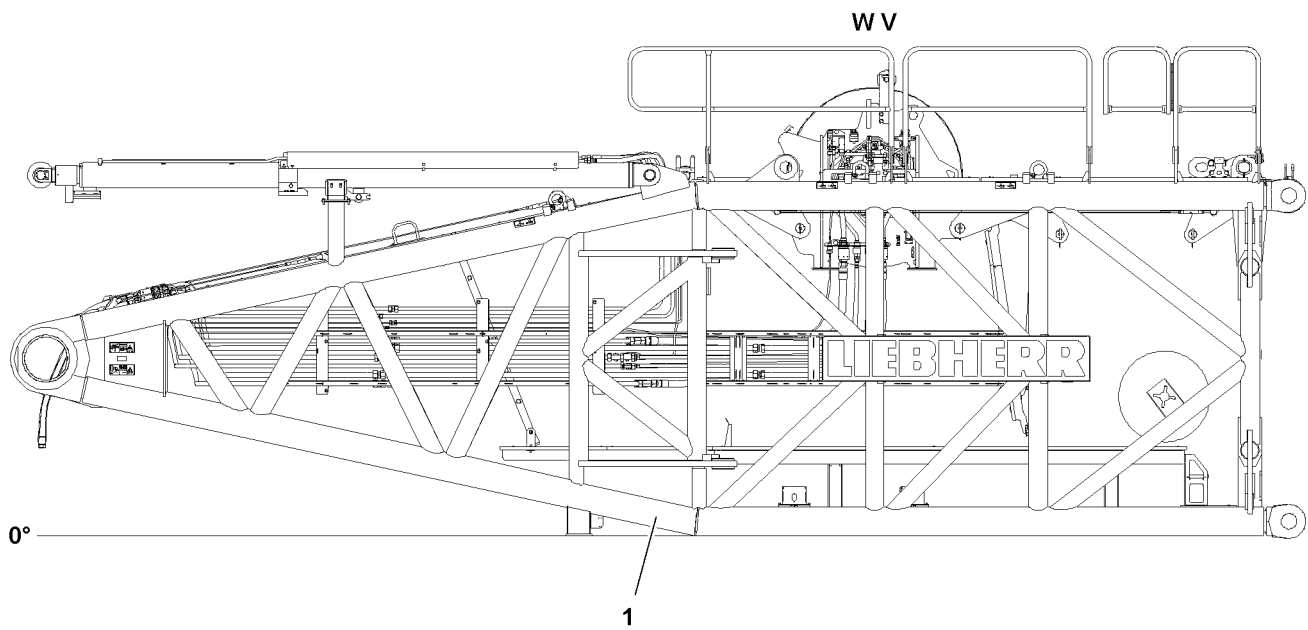

Fig.118582

LWE/LR 11000-001/23501-04-02/en

5 Disassembly winch 5



Note

- ▶ The description in this section only has to be used when winch 5 is to be transported separately from the S-pivot section 1.



WARNING

Danger of falling!

During assembly / disassembly, inspection and maintenance work, assembly personnel must be secured with appropriate aids to prevent them from falling.

If this is not observed, assembly personnel could fall and suffer life-threatening or fatal injuries.

- ▶ The assembly personnel must always move carefully and anticipatory on the crane, the crane components or lattice sections.
- ▶ All work aloft, where there is a danger of falling must be carried out with suitable aids.
- ▶ If fall protection equipment is available, then it must be used.
- ▶ If aids are not available and work cannot be carried out from the ground, then the assembly personnel must secure themselves with the approved fall arrest system to prevent falling, see Crane operating instructions, chapter 2.04.
- ▶ The fall arrest system must be attached on the fastening and hook points as well as on the safety ropes.
- ▶ Always secure ladders on structural parts and / or components to prevent them from falling over.
- ▶ Only step on the aids, ladders and catwalks with clean shoes.
- ▶ Keep aids, ladders and catwalks free of heavy dirt, snow, frost and ice.
- ▶ Stepping or walking on crane components and lattice sections, which have an incline of more than 20° is prohibited.



WARNING

Components not pinned and secured!

If a component is released from the auxiliary crane before having been pinned and secured, the component can slip and fall down.

Death, severe bodily injuries, property damage.

- ▶ Do not disengage the auxiliary crane until the corresponding component is pinned and secured.



WARNING

Danger of impact / crushing!

When installing / removing crane components with the auxiliary crane, crane components can start to swing back and forth.

When lifting / lowering and positioning crane components, there is an increased danger of impacts / crushing.

Death, severe bodily injuries.

- ▶ Make sure that personnel cannot be caught by components.
- ▶ When working in danger zones: Use aids to protect limbs.
- ▶ Guide components with suitable aids to minimize oscillation.

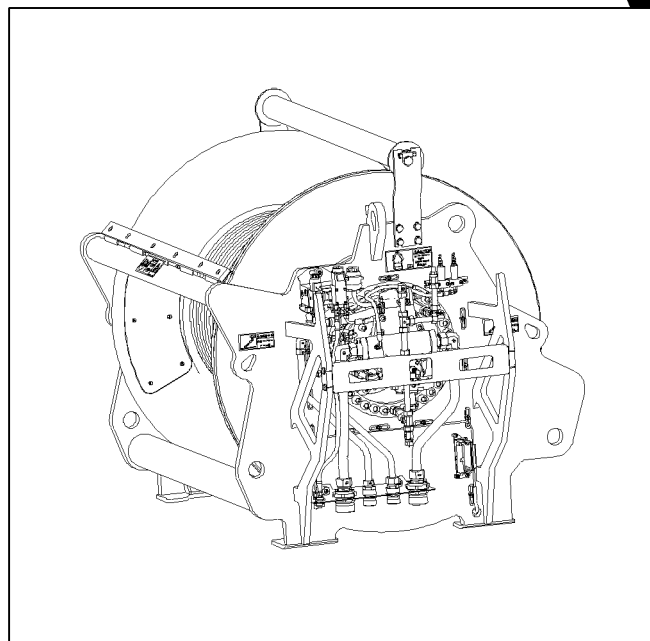
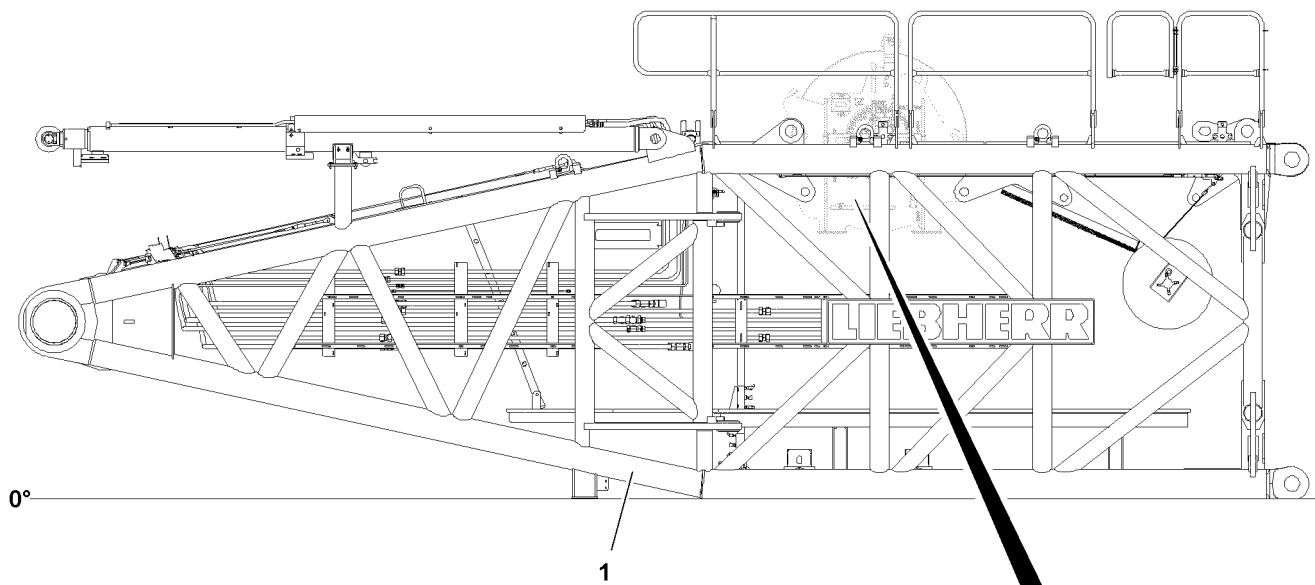

Fig.118579

5.1 Disconnecting the connections to winch 5

Make sure that the following prerequisites are met:

- The hoist rope is completely spooled up to the winch.
- The hoist rope is secured on the winch to prevent it from spooling out by itself.

5.1.1 Disconnecting the hydraulic connections to the winch

When releasing hydraulic lines with quick couplings, make sure that the uncoupling procedure is carried out correctly.



WARNING

Pressure in the hydraulic lines!

If the pressure supply is not interrupted before connecting / releasing the hydraulic lines, the hydraulic oil can escape with high pressure.

Death, severe bodily injuries, property damage.

- ▶ Release the pressure in the hydraulic system before connecting / disconnecting: Interrupt the pressure supply and wait for a short time.

-
- ▶ Release the hydraulic coupling by hand.
 - ▶ Disconnect the hydraulic connections to the winch.
 - ▶ Close the hydraulic hoses and hydraulic lines off properly with the intended caps.
 - ▶ Bring the hydraulic hoses in park position for transport and secure them properly.

5.1.2 Disconnecting the electrical connections to the winch

- ▶ Disconnect the electrical connections to the winch.
- ▶ Close the electrical connections properly off with the intended caps.

5.1.3 Disconnecting the connections of the central lubrication system to the winch

- ▶ Disconnect the connections to the winch.
- ▶ Close the lube line connections properly off with the intended caps.

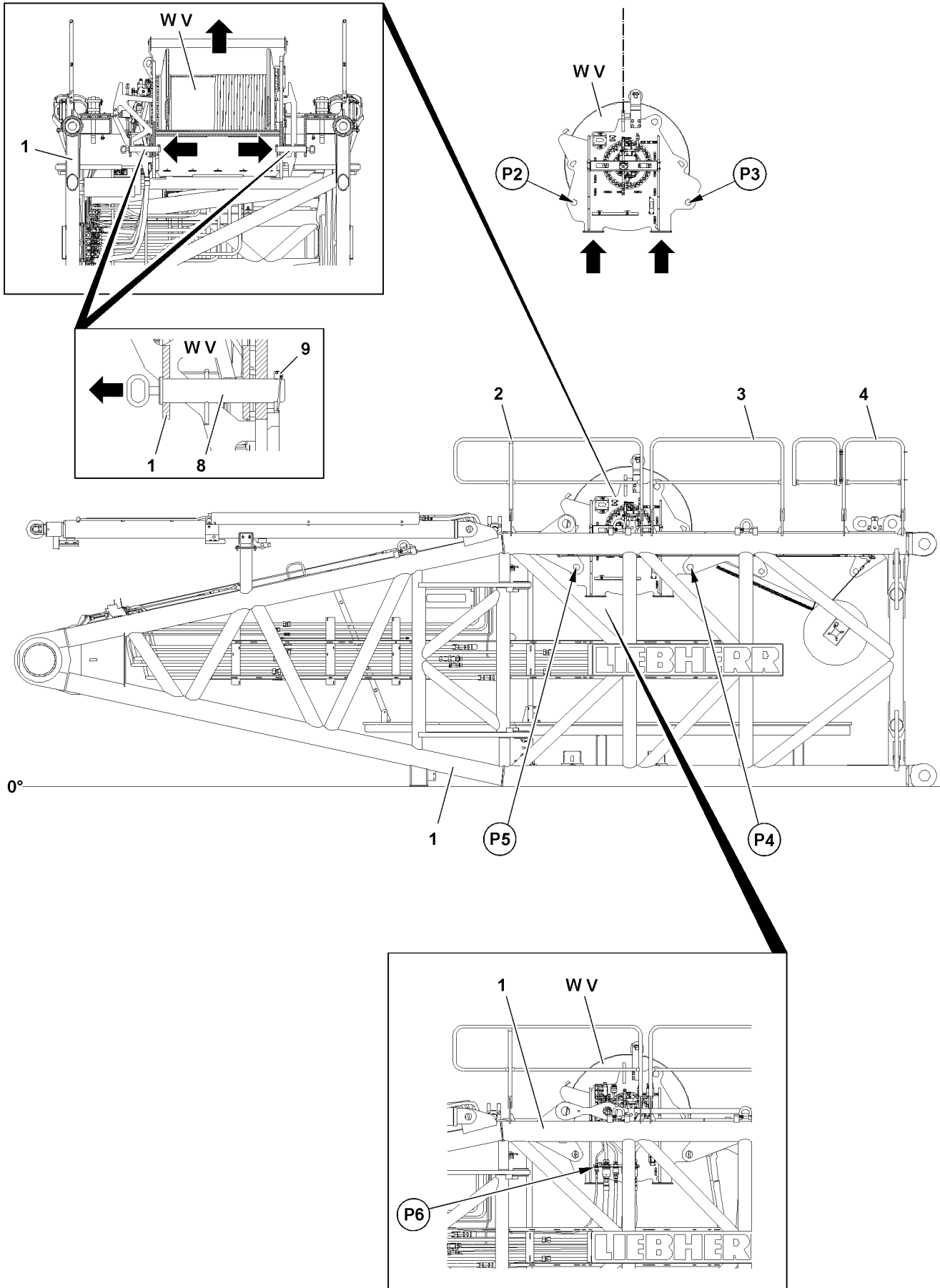

Fig.118580

LWE/LR 11000-001/23501-04-02/en

5.2 Removing winch 5

5.2.1 Unpinning winch 5

Make sure that the following prerequisites are met:

- The hydraulic connections are properly disconnected and closed off.
- The electrical connections are properly disconnected and closed off.
- The connections of the central lubrication system are properly disconnected and closed off.
- An auxiliary crane with sufficient load carrying capacity is available.



WARNING

Danger of accident due to incorrect attachment!

Life-threatening situations can arise if the winch 5 is incorrectly or improperly attached.

Death, severe bodily injuries, property damage.

- ▶ The fastening equipment may be attached on the winch only on the intended fastening points.
- ▶ Make sure that the fastening equipment is properly attached on winch 5 and that it is secured sufficiently to prevent it from loosening up.

- ▶ Attach the fastening equipment on both sides on winch 5, see section „Fastening points Winch 5“.

When the fastening equipment is properly fastened on winch 5:

- ▶ Bring the fastening equipment with the auxiliary crane carefully to „tension“.

When the fastening equipment is tensioned:

- ▶ Release pins **8** on both sides: Remove the locking pin **9** at point **P4** and point **P5**.
- ▶ Unpin pins **8** completely on both sides at point **P4** and point **P5**.

5.2.2 Lifting winch 5 from the S-pivot section

Make sure that the following prerequisites are met:

- Winch 5 is properly unpinned on the S-pivot section **1**.
- All connections to winch 5 are disconnected.



WARNING

Falling components!

When lifting the winch 5 on the S-pivot section **1**, components or winch 5 can fall down.

Death, severe bodily injuries, property damage.

- ▶ Make sure that there are no persons within the danger zone.

- ▶ Lift winch 5 carefully out with the auxiliary crane on the S-pivot section **1**.



WARNING

Toppling winch!

When setting winch 5 on the ground, the winch can sink into the ground and fall over.

Death, severe bodily injuries, property damage.

- ▶ Make sure that the ground has sufficient load bearing capacity to safely take on the weight of winch 5.

- ▶ Swing winch 5 out with the auxiliary crane and set it on the ground on a suitable support.

or

- ▶ Swing winch 5 out with the auxiliary crane and set it on the flatbed trailer.

When winch 5 has been set down properly:

- ▶ Remove the auxiliary crane.

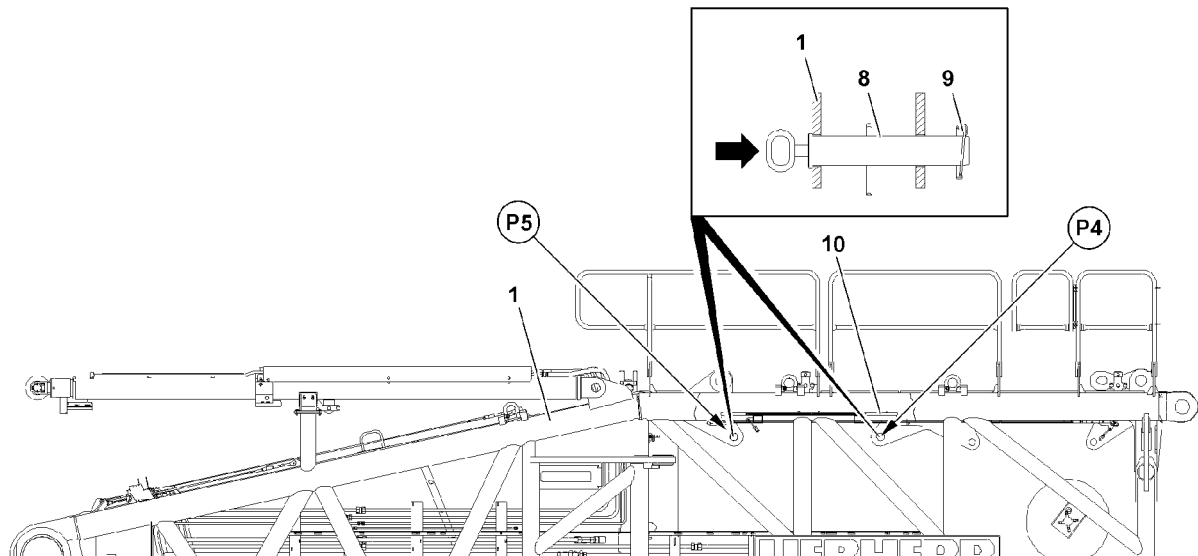

Fig.118581

5.2.3 Inserting the pins for transport

- ▶ Insert the pins **8** at point **P4** and point **P5** completely on both sides.
- ▶ Secure the pins **8** at point **P4** and point **P5** on both sides with locking pins **9**.

5.2.4 Closing the assembly opening winch 5



WARNING

Falling assembly personnel!

If the assembly opening of winch 5 is not properly closed off and secured after disassembly of the winch, then assembly personnel can fall down.

Death, severe bodily injuries, property damage.

- ▶ Make sure, after disassembly of winch 5, that the assembly opening is properly closed off and secured with the catwalk **10**.
- ▶ Release the catwalk **10** in transport position and swing it upward.
- ▶ Close the assembly opening winch 5: Properly pin and secure the catwalk **10** in up position.

Result:

- The assembly opening of winch 5 is closed off by the catwalk **10**.

3.07.60 Assembly winch 6

1	Component overview	3
2	Fastening points winch 6	3
3	Installation winch 6 from transport into operating position	5
4	Assembly winch 6	11
5	Disassembly winch 6	23

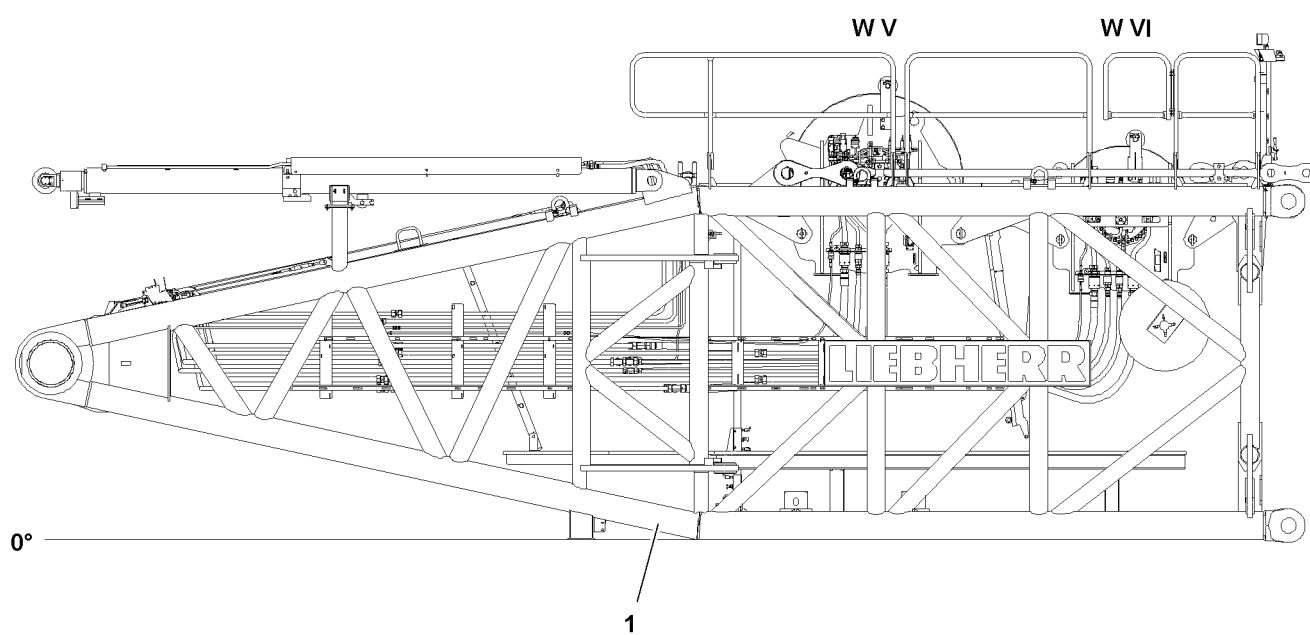

Fig.118591

1 Component overview



Note

- ▶ The weight of winch 6 together with the S-pivot section 1, see Crane operating instructions, chapter 1.03.



Note

- ▶ The winch 6 is marked with its own weight.

2 Fastening points winch 6



WARNING

Winch incorrectly fastened!

Life-threatening situations can arise if the winch is incorrectly or improperly attached.

Death, severe bodily injuries, property damage.

- ▶ Attach the winch only on the intended fastening points.
- ▶ Attach the fastening equipment on winch solely in connection with shackles.
- ▶ Make sure that the shackles and fastening equipment have sufficient load capacity.
- ▶ Observe the technical safety instructions during assembly and disassembly, see Crane operating instructions, chapter 5.01.

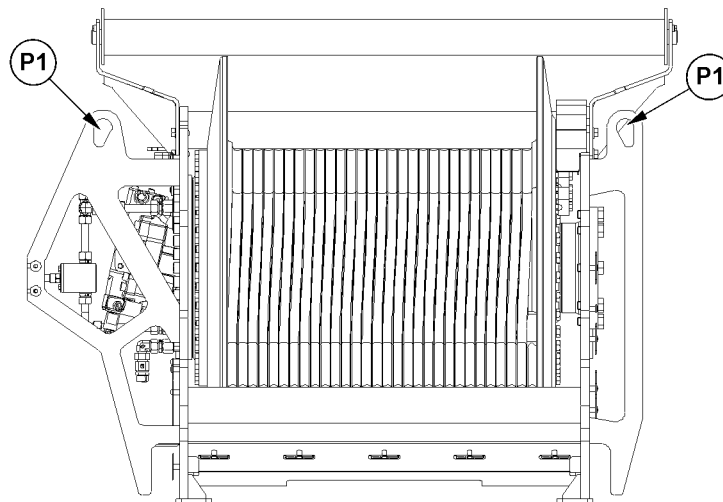

Fig.118592: Fastening points winch 6

Fastening points	
P1	Winch 6

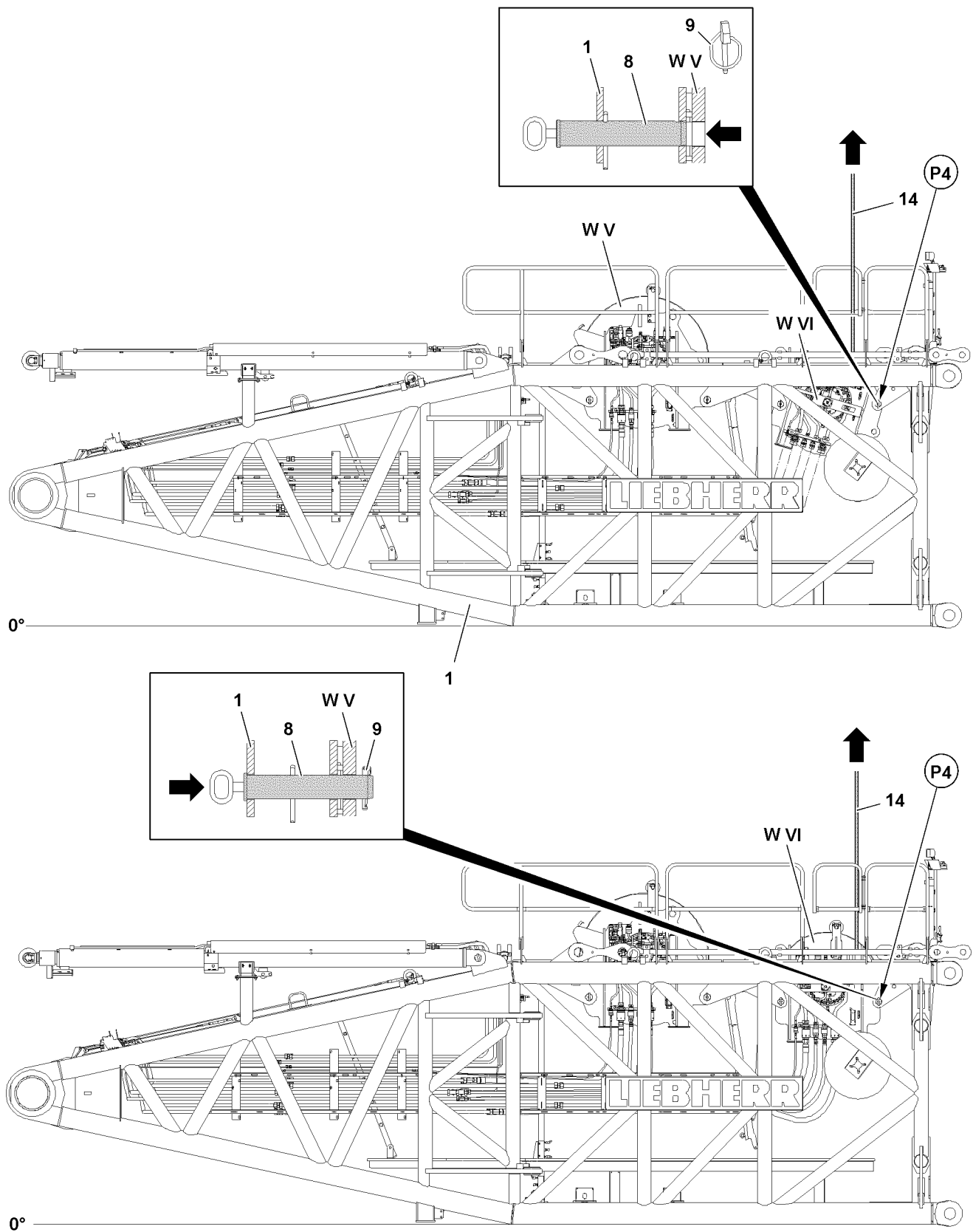

Fig.118593

3 Installation winch 6 from transport into operating position



WARNING

Danger of falling!

During assembly / disassembly, inspection and maintenance work, assembly personnel must be secured with appropriate aids to prevent them from falling.

If this is not observed, assembly personnel could fall and suffer life-threatening or fatal injuries.

- ▶ The assembly personnel must always move carefully and anticipatory on the crane, the crane components or lattice sections.
- ▶ All work aloft, where there is a danger of falling must be carried out with suitable aids.
- ▶ If fall protection equipment is available, then it must be used.
- ▶ If aids are not available and work cannot be carried out from the ground, then the assembly personnel must secure themselves with the approved fall arrest system to prevent falling, see Crane operating instructions, chapter 2.04.
- ▶ The fall arrest system must be attached on the fastening and hook points as well as on the safety ropes.
- ▶ Always secure ladders on structural parts and / or components to prevent them from falling over.
- ▶ Only step on the aids, ladders and catwalks with clean shoes.
- ▶ Keep aids, ladders and catwalks free of heavy dirt, snow, frost and ice.
- ▶ Stepping or walking on crane components and lattice sections, which have an incline of more than 20° is prohibited.



WARNING

Components not pinned and secured!

If a component is released from the auxiliary crane before having been pinned and secured, the component can slip and fall down.

Death, severe bodily injuries, property damage.

- ▶ Do not disengage the auxiliary crane until the corresponding component is pinned and secured.



WARNING

Danger of impact / crushing!

When installing / removing crane components with the auxiliary crane, crane components can start to swing back and forth.

When lifting / lowering and positioning crane components, there is an increased danger of impacts / crushing.

Death, severe bodily injuries.

- ▶ Make sure that personnel cannot be caught by components.
- ▶ When working in danger zones: Use aids to protect limbs.
- ▶ Guide components with suitable aids to minimize oscillation.

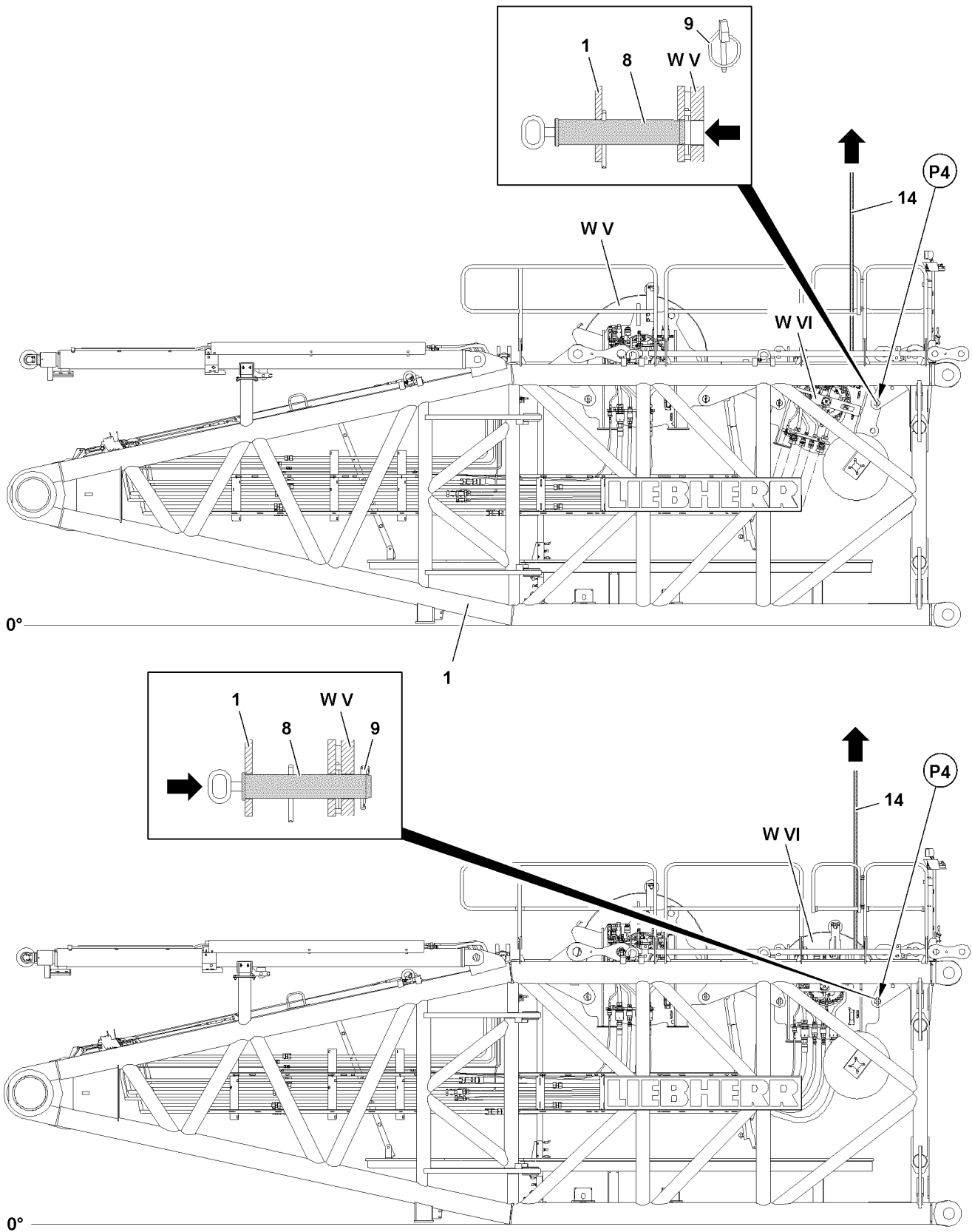

Fig.118593

3.1 Bringing winch 6 from transport position into operating position.

Make sure that the following prerequisites are met:

- The fall protection equipment is in operating position.
- An auxiliary crane with sufficient load carrying capacity is available.



Note

▶ During the installation procedure of winch 6 from transport into operating position, all hydraulic and electrical connections as well as the central lubrication connection remain connected with winch 6.

▶ Attach winch 6 with fastening equipment **14** on the auxiliary crane.



WARNING

Danger of accident due to winch 6!

If the pins **8** at point **P4** are unpinned on both sides and the fastening equipment **14** is not tensioned, then winch 6 can suddenly swing downward.

Death, severe bodily injuries, property damage.

▶ Make sure that the fastening equipment **14** is tensioned before the pins **8** are unpinned on both sides on point **P4**.

▶ Make sure that no personnel is within the danger zone when unpinning winch 6.

When winch 6 is properly fastened on the auxiliary crane:

▶ Carefully bring the fastening equipment **14** to tension.

When the fastening equipment is tensioned:

▶ Release pins **8** on both sides at point **P4** and unpin.

▶ Lift winch 6 with the auxiliary crane into operating position upward until the pin bores align at point **P4**.

When the pin bores align at point **P4**:

▶ Insert the pins **8** completely on both sides.

▶ Secure the pins **8** on both sides with locking pins **9**.

When winch 6 **W VI** is properly pinned and secured in operating position:

▶ Remove the auxiliary crane and the fastening equipment **14** on winch 6.

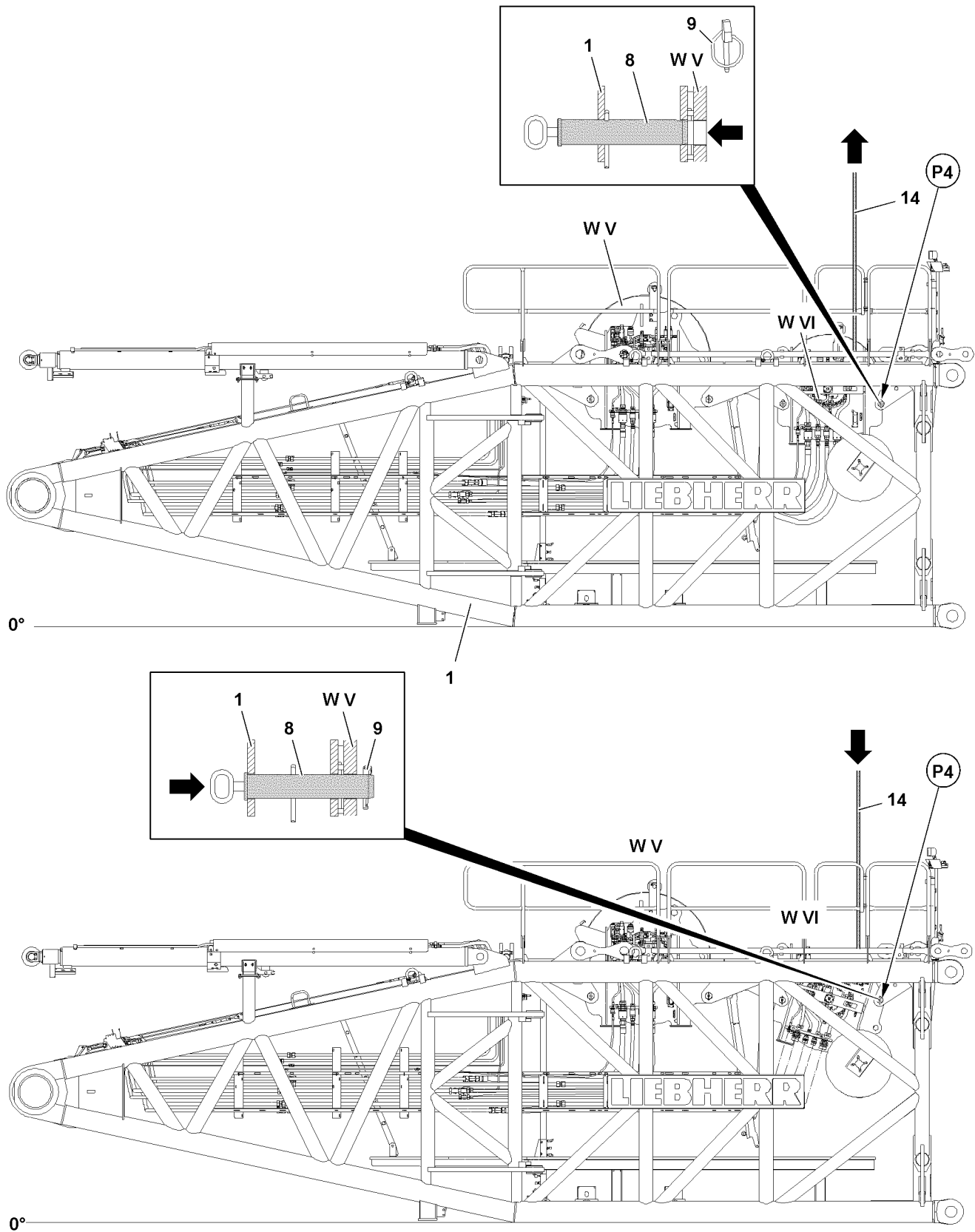

Fig.118594

LWE/LR 11000-001/23501-04-02/en

3.2 Bringing winch 6 from operating position into transport position

Make sure that the following prerequisites are met:

- The fall protection equipment is in operating position.
- An auxiliary crane with sufficient load carrying capacity is available.



Note

- ▶ During the removal procedure of winch 6 from operating to transport position, all hydraulic and electrical connections as well as the central lubrication connection remain connected with winch 6.
- ▶ Attach winch 6 with fastening equipment **14** on the auxiliary crane.



WARNING

Danger of accident due to winch 6!

If the pins **8** at point **P4** are unpinned on both sides and the fastening equipment **14** is not tensioned, then winch 6 can suddenly swing downward.

Death, severe bodily injuries, property damage.

- ▶ Make sure that the fastening equipment **14** is tensioned before the pins **8** are unpinned on both sides on point **P4**.
- ▶ Make sure that no personnel is within the danger zone when unpinning winch 6.

When winch 6 is properly fastened on the auxiliary crane:

- ▶ Carefully bring the fastening equipment **14** to tension.

When the fastening equipment is tensioned:

- ▶ Release pins **8** on both sides at point **P4** and unpin.
- ▶ Lower winch 6 into transport position until the upper pin bores of winch 6 align with the pin bores at point **P4**.

When the pin bores align at point **P4**:

- ▶ Insert the pins **8** completely on both sides.
- ▶ Secure the pins **8** on both sides with locking pins **9**.

When winch 6 is properly pinned and secured in transport position:

- ▶ Remove the auxiliary crane and the fastening equipment **14** on winch 6.

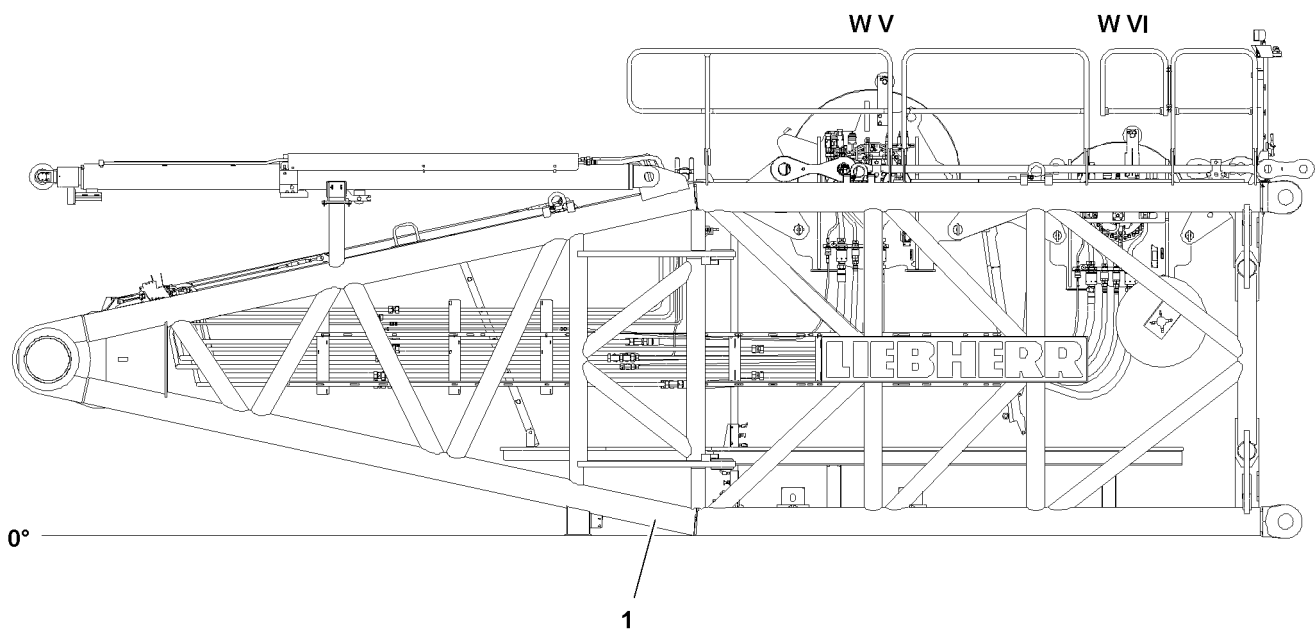

Fig.118591

4 Assembly winch 6



Note

- ▶ The description in this section may only be used when winch 6 is delivered separately from the S-pivot section 1 to the installation and / or job location of the crane.



WARNING

Danger of falling!

During assembly / disassembly, inspection and maintenance work, assembly personnel must be secured with appropriate aids to prevent them from falling.

If this is not observed, assembly personnel could fall and suffer life-threatening or fatal injuries.

- ▶ The assembly personnel must always move carefully and anticipatory on the crane, the crane components or lattice sections.
- ▶ All work aloft, where there is a danger of falling must be carried out with suitable aids.
- ▶ If fall protection equipment is available, then it must be used.
- ▶ If aids are not available and work cannot be carried out from the ground, then the assembly personnel must secure themselves with the approved fall arrest system to prevent falling, see Crane operating instructions, chapter 2.04.
- ▶ The fall arrest system must be attached on the fastening and hook points as well as on the safety ropes.
- ▶ Always secure ladders on structural parts and / or components to prevent them from falling over.
- ▶ Only step on the aids, ladders and catwalks with clean shoes.
- ▶ Keep aids, ladders and catwalks free of heavy dirt, snow, frost and ice.
- ▶ Stepping or walking on crane components and lattice sections, which have an incline of more than 20° is prohibited.



WARNING

Components not pinned and secured!

If a component is released from the auxiliary crane before having been pinned and secured, the component can slip and fall down.

Death, severe bodily injuries, property damage.

- ▶ Do not disengage the auxiliary crane until the corresponding component is pinned and secured.



WARNING

Danger of impact / crushing!

When installing / removing crane components with the auxiliary crane, crane components can start to swing back and forth.

When lifting / lowering and positioning crane components, there is an increased danger of impacts / crushing.

Death, severe bodily injuries.

- ▶ Make sure that personnel cannot be caught by components.
- ▶ When working in danger zones: Use aids to protect limbs.
- ▶ Guide components with suitable aids to minimize oscillation.

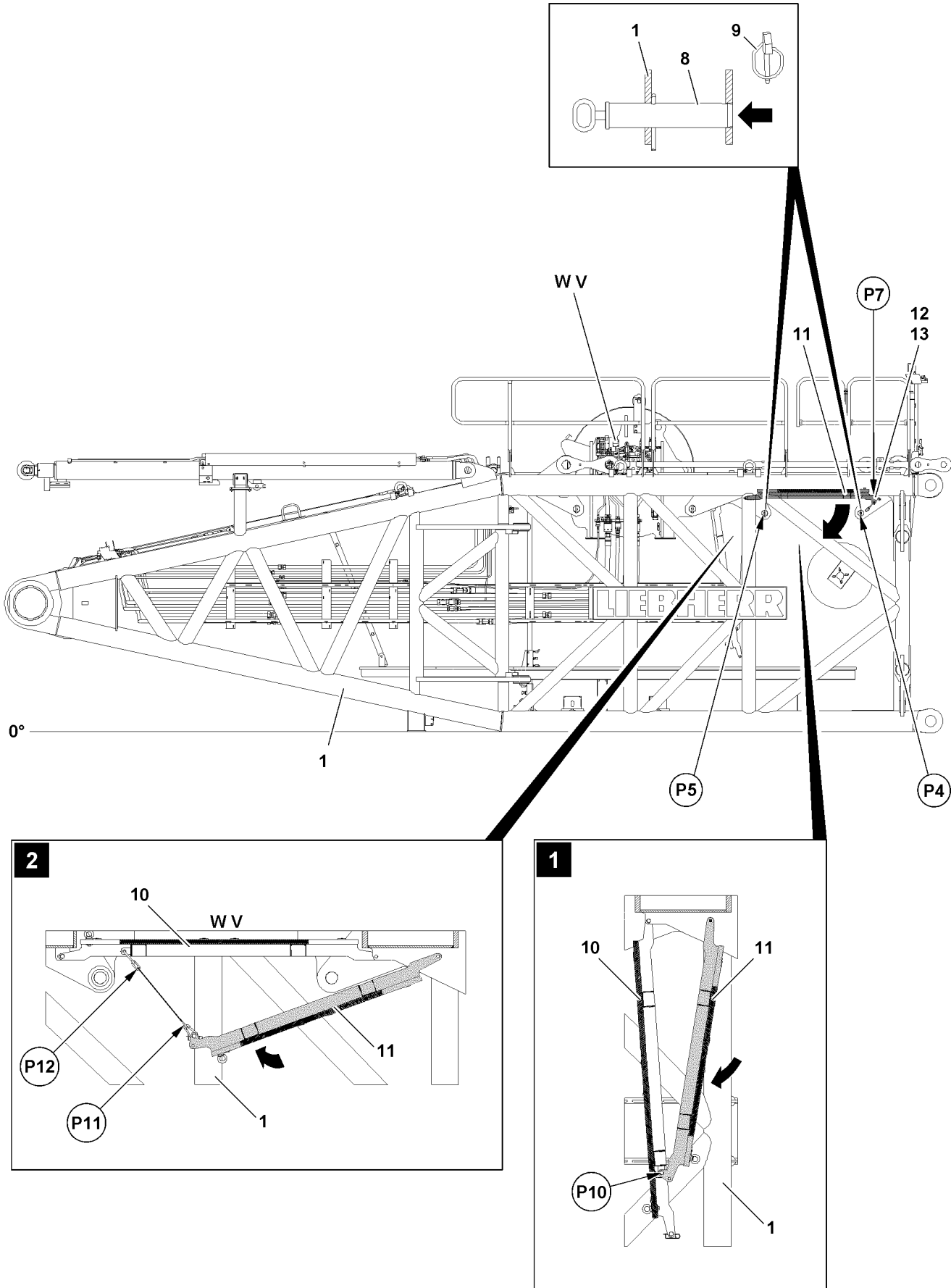

Fig.118596

LWE/LR 11000-001/23501-04-02/en

4.1 Preparing installation of winch 6



Note

- ▶ If winch 6 is not installed in transport condition of the S-pivot section 1, then the installation / assembly opening of winch 6 on the S-pivot section is closed off with a catwalk 11.
- ▶ The catwalk 11 must be unpinned for the installation of winch 6 on the S-pivot section 1 on one side, swung down and secured in this position.

Make sure that the following prerequisites are met:

- The fall protection equipment is properly installed.
- The railings are in operating position.
- The assembly opening of winch 6 is closed off by the catwalk 11.
- An auxiliary crane with sufficient load carrying capacity is available.



WARNING

Danger of accident due to catwalk!

If there is any personnel within the swing range when lowering the catwalk 11, then personnel can be severely injured or killed.

- ▶ Make sure that there are no persons within the swing range of the catwalk 11.

4.1.1 If winch 5 is installed

- ▶ Fasten the catwalk 11 on the auxiliary crane.

When the catwalk 11 is properly fastened on the auxiliary crane:

- ▶ Carefully bring the fastening equipment to tension.
- ▶ Unpin the pin 12: Remove the spring retainer 13 at point P7 on both sides and unpin the pin 12 on both sides.

When the pins 12 are unpinned on both sides:

- ▶ Lower the catwalk 11 slowly downward with the auxiliary crane.

When the catwalk 11 is lowered down completely:

- ▶ Pin and secure the catwalk 11 in assembly position at point P10 with catwalk 10 on both sides, illustration 1.

When the catwalk 10 is properly secured in assembly position:

- ▶ Remove the auxiliary crane.
- ▶ Release the connector pin 8 for winch 6 at point P4 and point P5 on both sides: Remove the locking pin 9.
- ▶ Unpin the connector pin 8 at point P4 and point P5 on both sides to the stop.

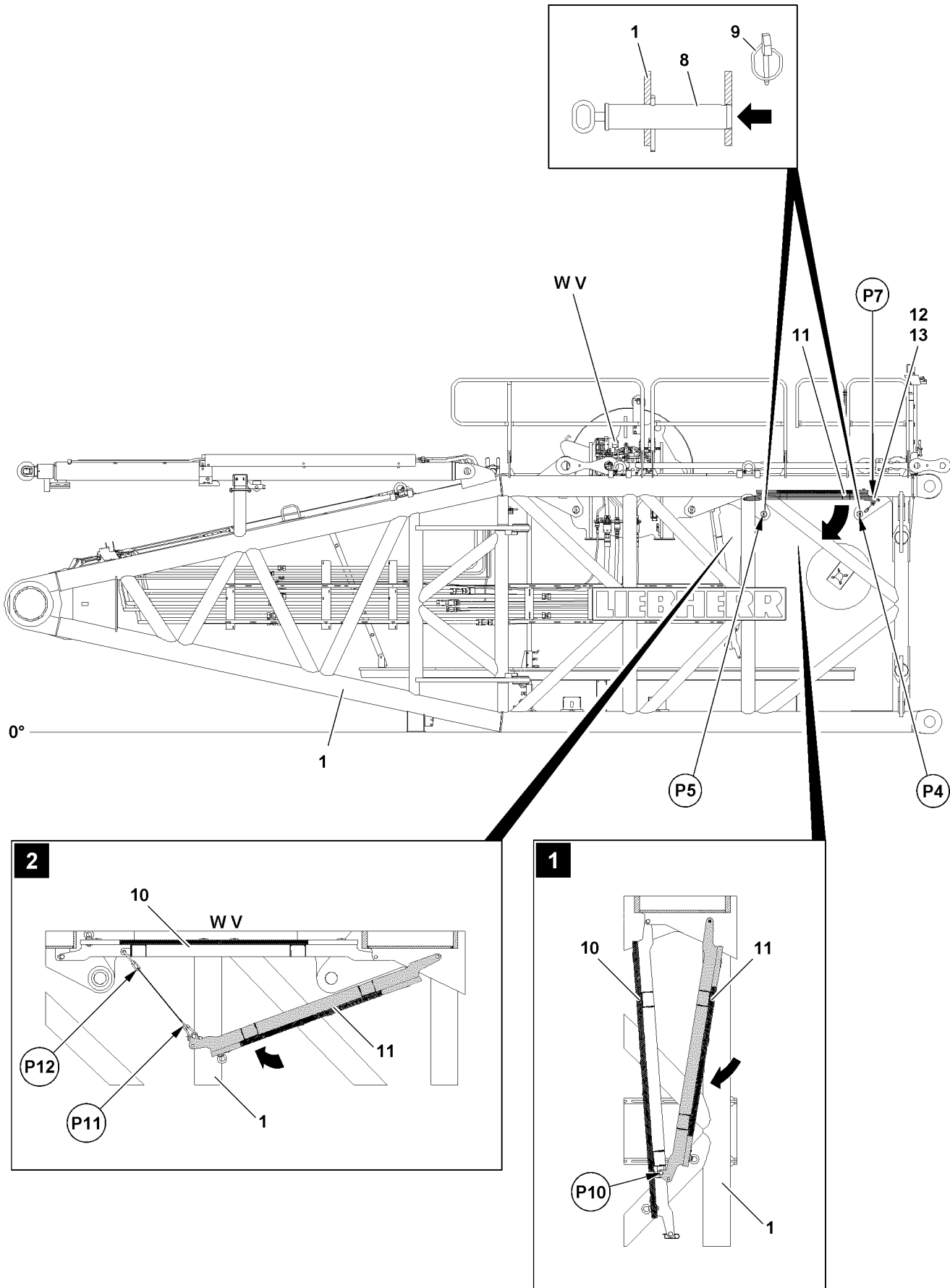

Fig.118596

4.1.2 If winch 5 is not installed

- ▶ Fasten the catwalk **11** on the auxiliary crane.

When the catwalk **11** is properly fastened on the auxiliary crane:

- ▶ Carefully bring the fastening equipment to tension.
- ▶ Unpin the pin **12**: Remove the spring retainer **13** at point **P7** on both sides and unpin the pin **12** on both sides.

When the pins **12** are unpinned on both sides:

- ▶ Lower the catwalk **11** slowly downward with the auxiliary crane.

When the catwalk **11** is lowered down completely:

- ▶ Pin and secure the catwalk **11** in assembly position between point **P11** and point **P12** on both sides and secure, illustration **2**.

When the catwalk **11** is properly secured in assembly position:

- ▶ Remove the auxiliary crane.
- ▶ Release the connector pin **8** for winch 6 at point **P4** and point **P5** on both sides: Remove the locking pin **9**.
- ▶ Unpin the connector pin **8** at point **P4** and point **P5** on both sides to the stop.

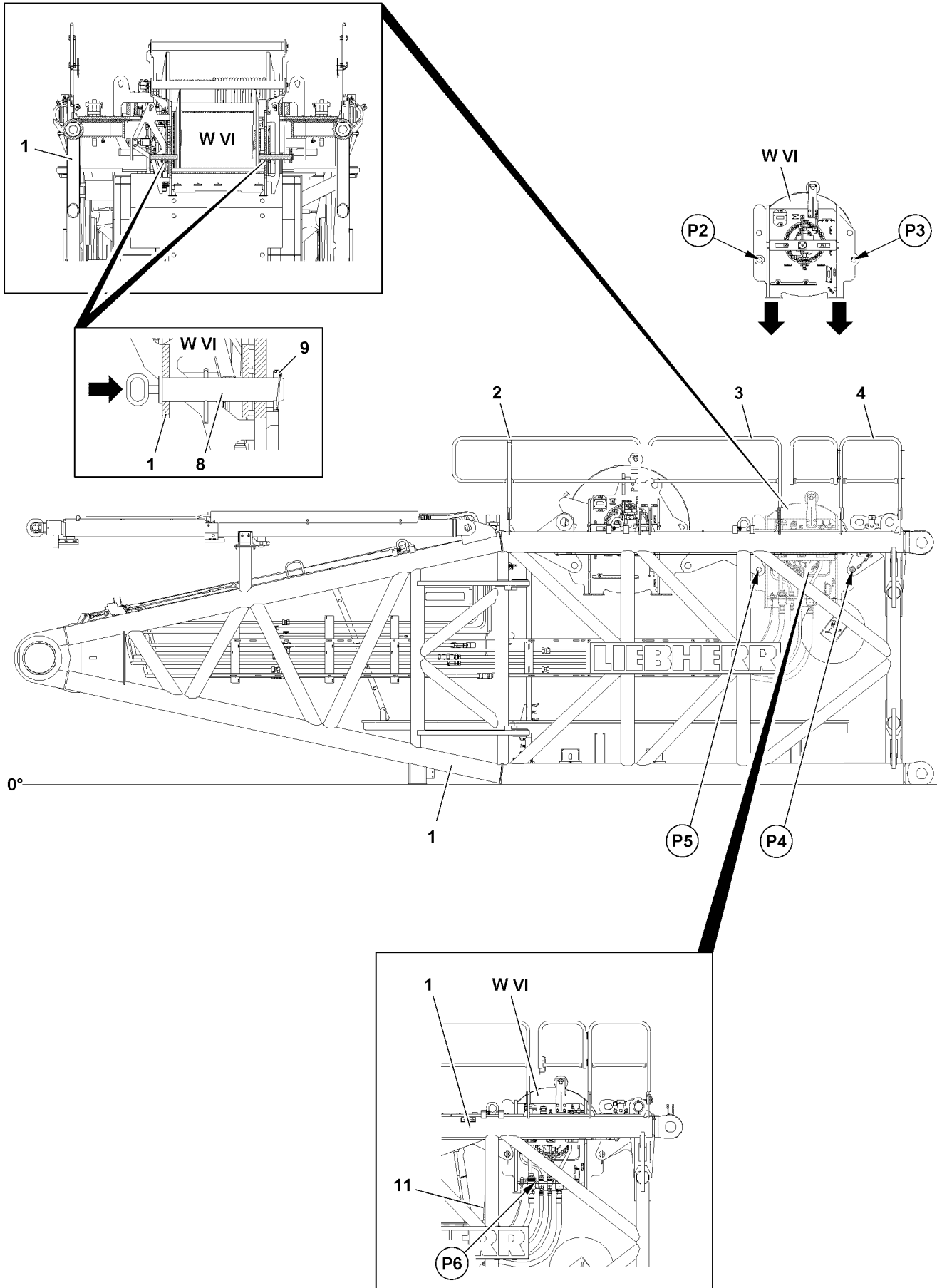

Fig.118597

LWE/LR 11000-001/23501-04-02/en

4.2 Installing winch 6



WARNING

Danger of accident during installation of winch 6!
Death, severe bodily injuries, property damage.

- ▶ Make sure that the following prerequisites are met for the installation of winch 6.

Make sure that the following prerequisites are met:

- Winch 5 is properly installed.
- The catwalk **11** is in assembly position.
- An auxiliary crane with sufficient load carrying capacity is available.

4.2.1 Lifting winch 6 from the flatbed trailer



WARNING

Danger of accident due to incorrect attachment!
Life-threatening situations can arise if the winch 6 is incorrectly or improperly attached.
Death, severe bodily injuries, property damage.

- ▶ Fasten winch 6 only on the fastening points (points **P1**).
- ▶ Make sure that the fastening equipment is correctly attached on the fastening points (points **P1**) and that it is secured sufficiently to prevent it from loosening up.

- ▶ Attach the fastening equipment (points **P1**) on the fastening points, see section „Fastening points Winch 6“.
- ▶ Bring the fastening equipment to „tension“ with the auxiliary crane.
- ▶ Release and remove the transport retainers on the flatbed trailer.



WARNING

Falling components!

When lifting winch 6 from the flatbed trailer, components or winch 6 can fall down.
Death, severe bodily injuries, property damage.

- ▶ Make sure that there are no persons within the danger zone.
- ▶ Lift winch 6 with the auxiliary crane from the flatbed trailer.

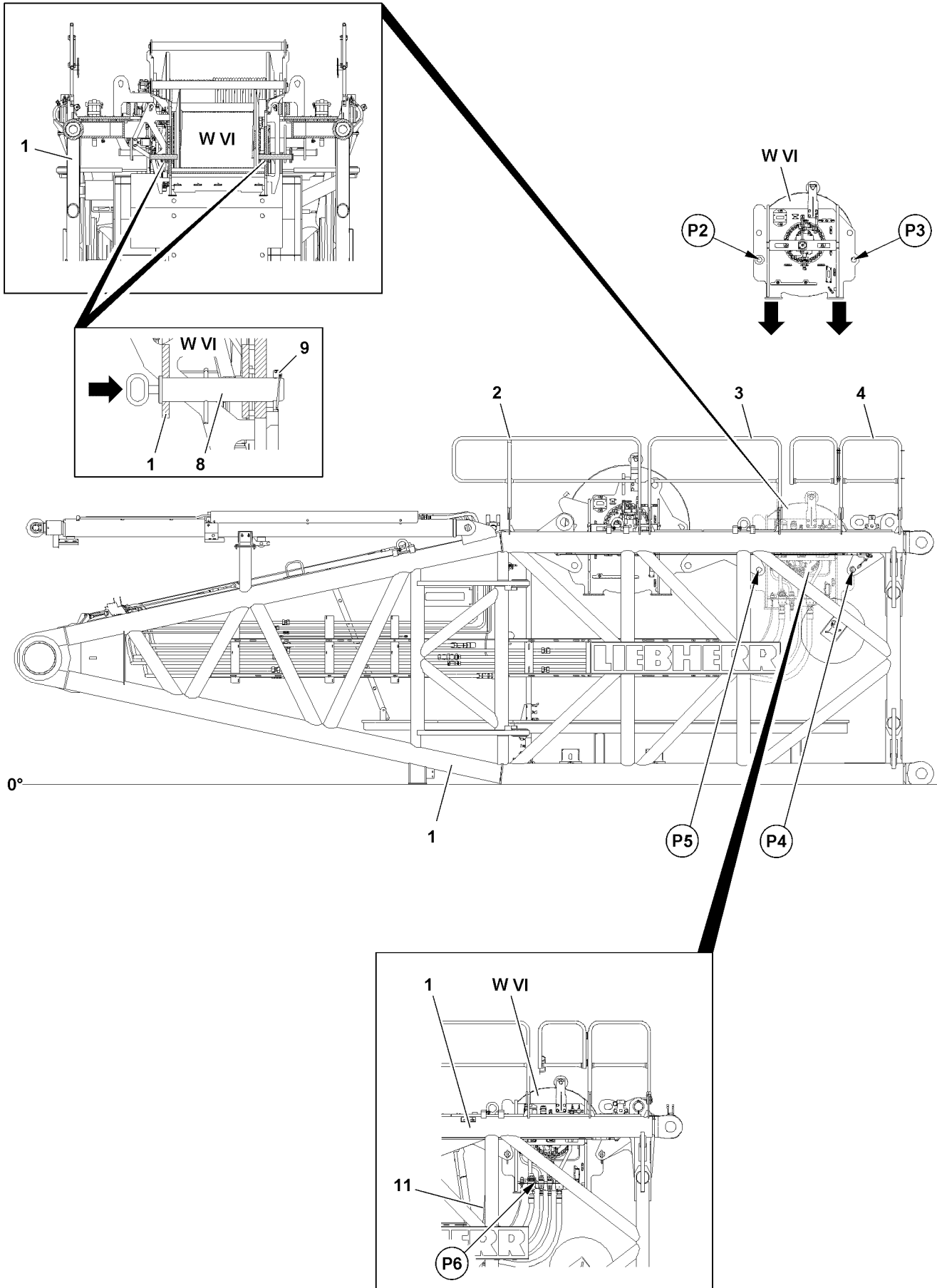

Fig.118597

LWE/LR 11000-001/23501-04-02/en

4.2.2 Positioning winch 6

Make sure that the following prerequisites are met:

- Pins **8** are completely unpinned on both sides at point **P4** and point **P5**.



WARNING

Danger of accident when swinging in and lowering winch 6!

When swinging in and lowering winch 6 in the assembly opening of the S-pivot section **1**, limbs can be crushed or even severed.

Death, severe bodily injuries, property damage.

- ▶ Make sure that there are no persons within the danger zone.
- ▶ Do not reach with your hands into the danger zone.

NOTICE

Property damage!

If the following notes are not observed, damage can result to the crane or winch 6.

- ▶ When retracting winch 6, it must be ensured that winch 6 does not hit against the S-pivot section **1**.



Note

- ▶ The guide must be in constant visual and acoustic contact with the crane operator.



Note

- ▶ Pay attention to the exact alignment of winch 6 to the installation position.

- ▶ Swing winch 6 in with the auxiliary crane to the S-pivot section **1**.
- ▶ Position and align winch 6.

When winch 6 is aligned:

- ▶ Lower winch 6 with the auxiliary crane in the assembly opening until the pin bores of winch 6 (point **P2** and point **P3**) align with the pin bores on the S-pivot section (point **P4** and point **P5**) on both sides.

4.2.3 Pinning winch 6

Make sure that the following prerequisites are met:

- The pin bores between winch 6 and the S-pivot section **1** align.



WARNING

The connector pins can loosen up!

- ▶ Make sure that the pins **8** are immediately secured with the locking pin **9** after pinning winch 6 in the S-pivot section **1**.

- ▶ Insert the pins **8** at point **P4** and point **P5** on both sides and secure with locking pin **9**.

When winch 6 is properly pinned and secured on all four pin points:

- ▶ Remove the auxiliary crane.

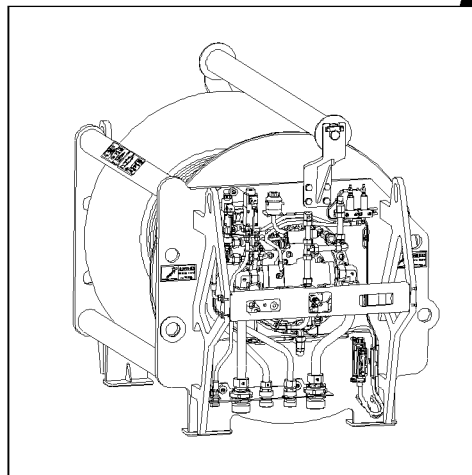
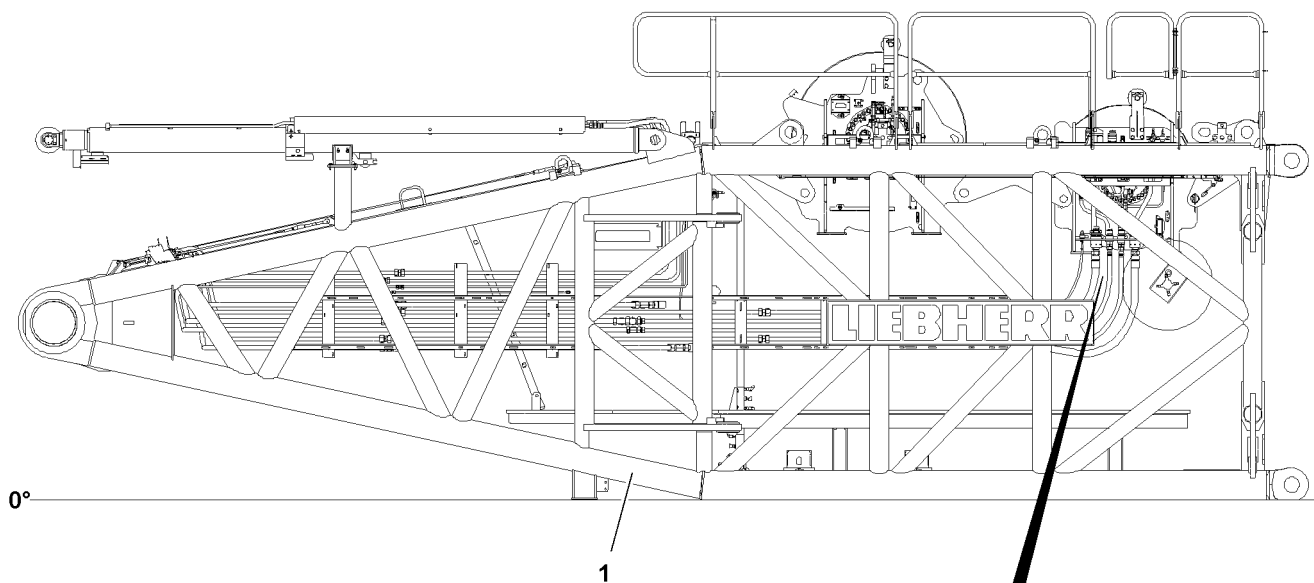

Fig.118598

4.3 Establishing the hydraulic connections to winch 6



Note

- ▶ Establish the connections to winch 6 only when winch 6 is properly installed and secured on the S-pivot section.

Make sure that the following prerequisites are met:

- The winch 6 is properly installed, pinned and secured.

4.3.1 Establishing the hydraulic connections to the winch



Note

- ▶ After the hydraulic connections to the winch are established, the expansion tank must be checked and emptied.

The hydraulic connections for the winch are made with quick couplings.

When connecting hydraulic lines with quick couplings, make sure that the coupling procedure is carried out correctly.



WARNING

Pressure in the hydraulic lines!

If the pressure supply is not interrupted before connecting / releasing the hydraulic lines, the hydraulic oil can escape with high pressure.

Death, severe bodily injuries, property damage.

- ▶ Release the pressure in the hydraulic system before connecting / disconnecting: Interrupt the pressure supply and wait for a short time.



WARNING

Loss of pressure or leakage!

Incorrectly coupled or self-loosening quick couplings (particularly return lines) can result in serious accidents due to component failure.

- ▶ Check that the quick couplings have been properly connected before using the crane.
- ▶ Connect the coupling components (sleeve and connector) and screw together with the hand-tightened nut.
- ▶ Tighten the hydraulic coupling by hand. Rotate the hand-tightened nut until it reaches a tangible, fixed stop position.
- ▶ Establish the hydraulic connections to the winch.

4.3.2 Establishing the electrical connections to the winch

- ▶ Establish the electrical connections to the winch, see Electric wiring diagram.

4.3.3 Establishing the connections of the central lubrication system to the winch

- ▶ Establishing the connections of the central lubrication system to the winch.

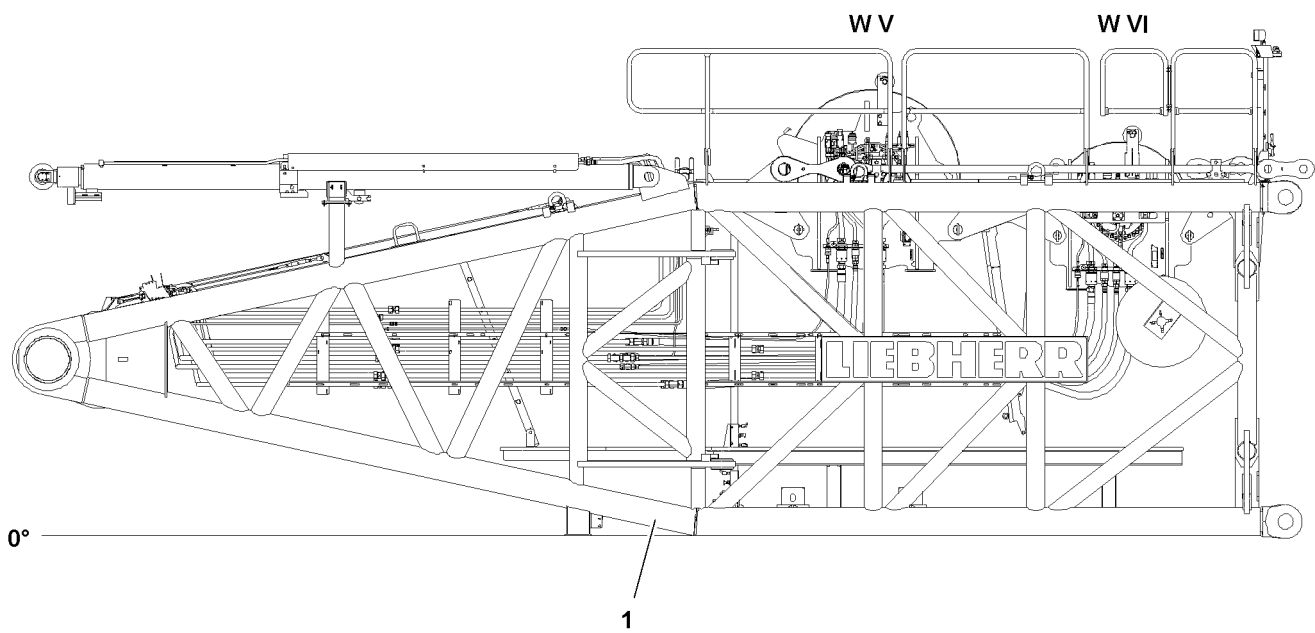

Fig.118591

5 Disassembly winch 6



Note

- ▶ The description in this section only has to be used when winch 6 is to be transported separately from the S-pivot section 1.



WARNING

Danger of falling!

During assembly / disassembly, inspection and maintenance work, assembly personnel must be secured with appropriate aids to prevent them from falling.

If this is not observed, assembly personnel could fall and suffer life-threatening or fatal injuries.

- ▶ The assembly personnel must always move carefully and anticipatory on the crane, the crane components or lattice sections.
- ▶ All work aloft, where there is a danger of falling must be carried out with suitable aids.
- ▶ If fall protection equipment is available, then it must be used.
- ▶ If aids are not available and work cannot be carried out from the ground, then the assembly personnel must secure themselves with the approved fall arrest system to prevent falling, see Crane operating instructions, chapter 2.04.
- ▶ The fall arrest system must be attached on the fastening and hook points as well as on the safety ropes.
- ▶ Always secure ladders on structural parts and / or components to prevent them from falling over.
- ▶ Only step on the aids, ladders and catwalks with clean shoes.
- ▶ Keep aids, ladders and catwalks free of heavy dirt, snow, frost and ice.
- ▶ Stepping or walking on crane components and lattice sections, which have an incline of more than 20° is prohibited.



WARNING

Components not pinned and secured!

If a component is released from the auxiliary crane before having been pinned and secured, the component can slip and fall down.

Death, severe bodily injuries, property damage.

- ▶ Do not disengage the auxiliary crane until the corresponding component is pinned and secured.



WARNING

Danger of impact / crushing!

When installing / removing crane components with the auxiliary crane, crane components can start to swing back and forth.

When lifting / lowering and positioning crane components, there is an increased danger of impacts / crushing.

Death, severe bodily injuries.

- ▶ Make sure that personnel cannot be caught by components.
- ▶ When working in danger zones: Use aids to protect limbs.
- ▶ Guide components with suitable aids to minimize oscillation.

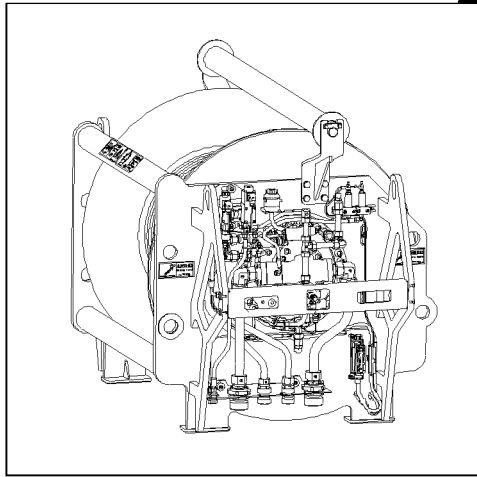
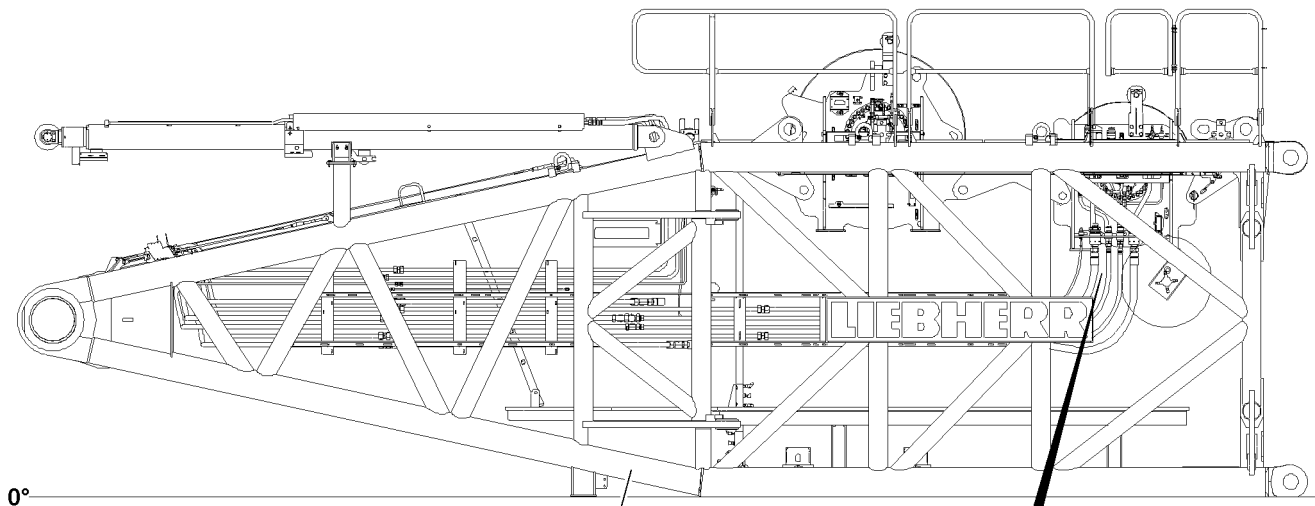

Fig.118598

LWE/LR 11000-001/23501-04-02/en

5.1 Disconnecting the connections to winch 6

Make sure that the following prerequisites are met:

- The hoist rope is completely spooled up to the winch.
- The hoist rope is secured on the winch to prevent it from spooling out by itself.

5.1.1 Disconnecting the hydraulic connections to the winch

When releasing hydraulic lines with quick couplings, make sure that the uncoupling procedure is carried out correctly.



WARNING

Pressure in the hydraulic lines!

If the pressure supply is not interrupted before connecting / releasing the hydraulic lines, the hydraulic oil can escape with high pressure.

Death, severe bodily injuries, property damage.

- ▶ Release the pressure in the hydraulic system before connecting / disconnecting: Interrupt the pressure supply and wait for a short time.

-
- ▶ Release the hydraulic coupling by hand.
 - ▶ Disconnect the hydraulic connections to the winch.
 - ▶ Close the hydraulic hoses and hydraulic lines off properly with the intended caps.
 - ▶ Bring the hydraulic hoses in park position for transport and secure them properly.

5.1.2 Disconnecting the electrical connections to the winch

- ▶ Disconnect the electrical connections to the winch.
- ▶ Close the electrical connections properly off with the intended caps.

5.1.3 Disconnecting the connections of the central lubrication system to the winch

- ▶ Disconnect the connections to the winch.
- ▶ Close the lube line connections properly off with the intended caps.

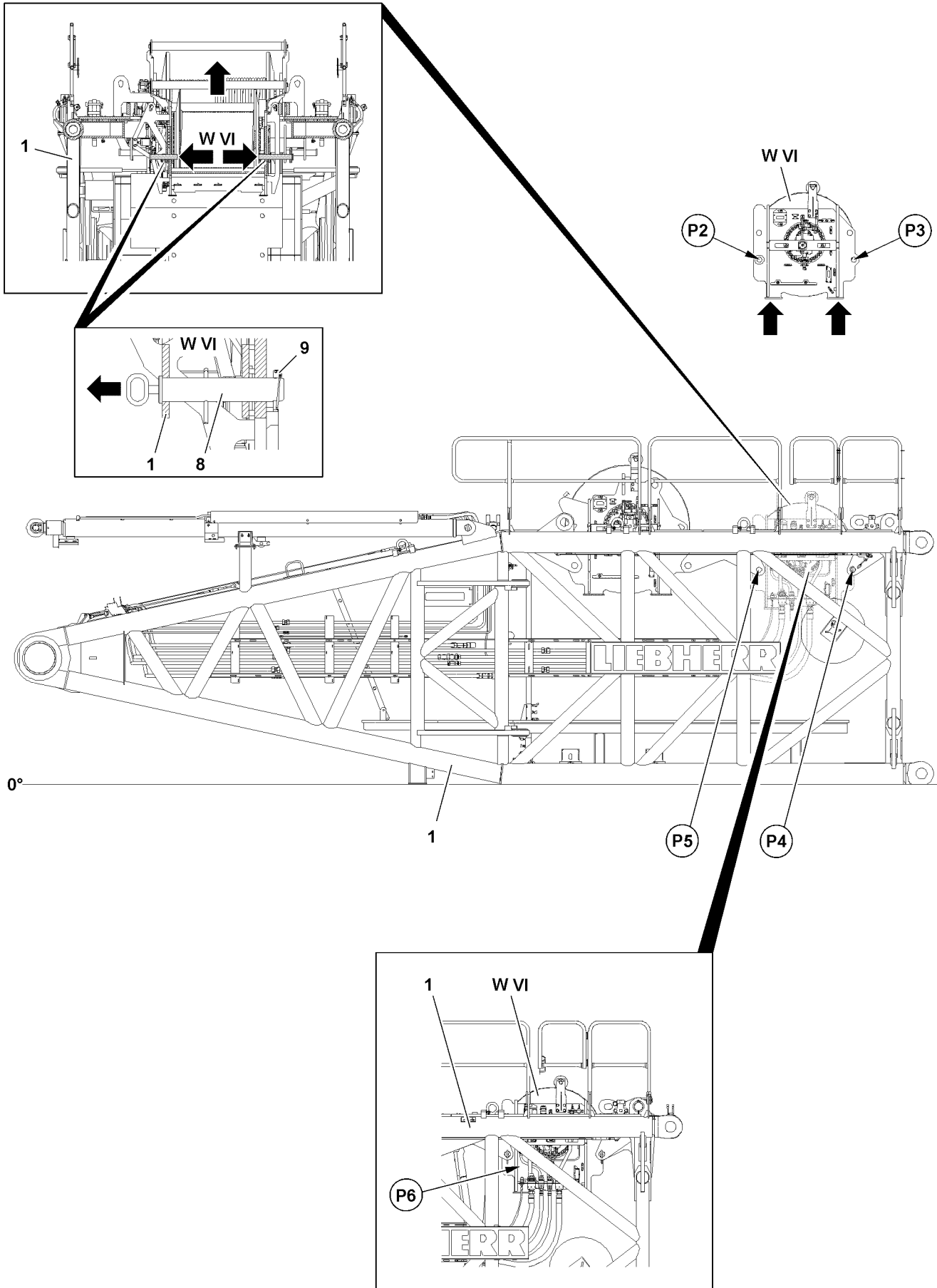

Fig.118599

LWE/LR 11000-001/23501-04-02/en

5.2 Removing winch 6

5.2.1 Unpinning winch 6

Make sure that the following prerequisites are met:

- The hydraulic connections are properly disconnected and closed off.
- The electrical connections are properly disconnected and closed off.
- The connections of the central lubrication system are properly disconnected and closed off.
- An auxiliary crane with sufficient load carrying capacity is available.



WARNING

Danger of accident due to incorrect attachment!

Life-threatening situations can arise if the winch 6 is incorrectly or improperly attached.

Death, severe bodily injuries, property damage.

- ▶ The fastening equipment may be attached on the winch only on the intended fastening points.
- ▶ Make sure that the fastening equipment is properly attached on winch 6 and that it is secured sufficiently to prevent it from loosening up.

- ▶ Attach the fastening equipment on both sides on winch 6, see section „Fastening points Winch 6“.

When the fastening equipment is properly fastened on winch 6:

- ▶ Bring the fastening equipment with the auxiliary crane carefully to „tension“.

When the fastening equipment is tensioned:

- ▶ Release pins **8** on both sides: Remove the locking pin **9** at point **P4** and point **P5**.
- ▶ Unpin pins **8** completely on both sides at point **P4** and point **P5**.

5.2.2 Lifting winch 6 from the S-pivot section

Make sure that the following prerequisites are met:

- Winch 6 is properly unpinned on the S-pivot section **1**.
- All connections to winch 6 are disconnected.



WARNING

Falling components!

When lifting the winch 6 on the S-pivot section **1**, components or winch 6 can fall down.

Death, severe bodily injuries, property damage.

- ▶ Make sure that there are no persons within the danger zone.

- ▶ Lift winch 6 carefully out with the auxiliary crane on the S-pivot section **1**.



WARNING

Toppling winch!

When setting winch 6 on the ground, the winch can sink into the ground and fall over.

Death, severe bodily injuries, property damage.

- ▶ Make sure that the ground has sufficient load bearing capacity to safely take on the weight of winch 6.

- ▶ Swing winch 6 out with the auxiliary crane and set it on the ground on a suitable support.

or

Swing winch 6 out with the auxiliary crane and set it on the flatbed trailer.

When winch 6 has been set down properly:

- ▶ Remove the auxiliary crane.

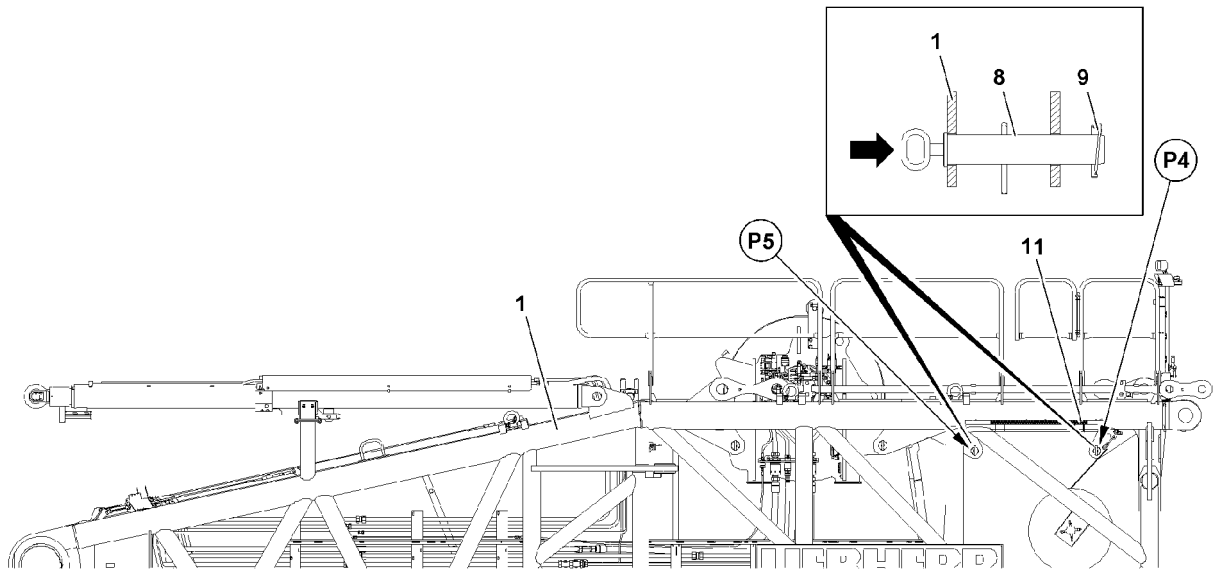

Fig.118600

5.2.3 Inserting the pins for transport

- ▶ Insert the pins 8 at point P4 and point P5 completely on both sides.
- ▶ Secure the pins 8 at point P4 and point P5 on both sides with locking pins 9.

5.2.4 Closing the assembly opening winch 6



WARNING

Falling assembly personnel!

If the assembly opening of winch 6 is not properly closed off and secured after disassembly of the winch, then assembly personnel can fall down.

Death, severe bodily injuries, property damage.

- ▶ Make sure, after disassembly of winch 6, that the assembly opening is properly closed off and secured with the catwalk 11.
- ▶ Release the catwalk 11 in transport position and swing it upward.
- ▶ Close the assembly opening winch 6: Properly pin and secure the catwalk 11 in up position.

Result:

- The assembly opening of winch 6 is closed off by the catwalk 11.

3.80 Transport of crane and crane components

1	Safety	3
2	Rigging plans	3

Fig.195219

LWE/LR 11000-001/23501-04-02/en

1 Safety

Observe and adhere to the transport safety instructions. See Crane operating instructions, chapter 2.04.

2 Rigging plans

Observe and adhere to the rigging plans, see the separate rigging plans.

Empty page!

LWE/LR 11000-001/23501-04-02/en

4 Operation of crane superstructure

LWE/LR 11000-001/23501-04-02/en

LWE/LR 11000-001/23501-04-02/en

4.01 Operating and control instruments on the crane superstructure

1	Operating and monitoring instruments	3
2	Overview Control units crane cab	10
3	Control platform	11
4	Instrument panel	12
5	Operating unit HATZ Diesel aggregate*	16
6	Operating and control unit (BKE)	16
7	LICCON computer system monitors	22
8	Camera monitoring	23
9	Pedal carrier	24
10	Touch displays	27
11	Master switch assignment MS1	31
12	Master switch assignment MS2	39
13	Master switch assignment MS3	53

Fig.195219

LWE/LR 11000-001/23501-04-02/en

1 Operating and monitoring instruments

1.1 Crane cab outside and turntable

This section describes the elements on the outside of the crane cab and on the turntable:

- Installation parts Crane cab / control cabinet outside
- Emergency equipment Crane cab outside
- Installation parts Crane cab bottom
- Installation parts rear of turntable

1.1.1 Installation parts Crane cab / control cabinet outside

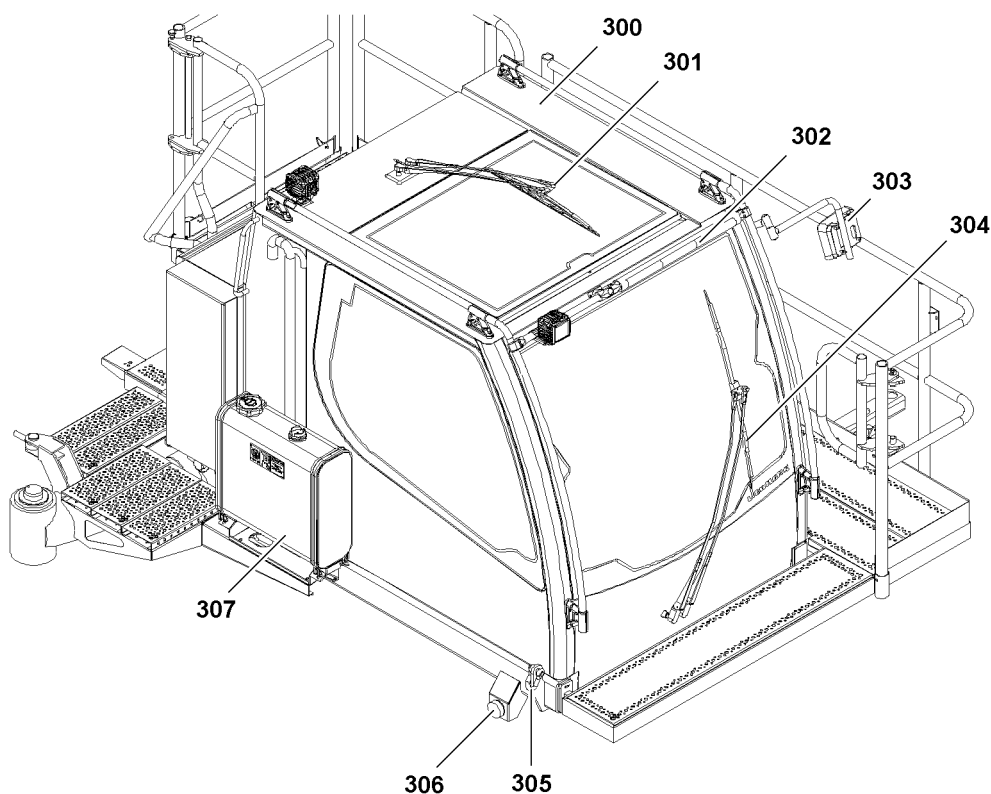

Fig.125405: Crane cab from the front

- 300** Crane cab
- 301** Windshield wiper roof window
 - With adjustable wipe speeds
- 302** LMB three color light
 - Shows the current crane utilization or the operating condition via light signals
 - Description of light signals and operating conditions, see Crane operating instructions, chapter 4.20
- 303** Rear view mirror
 - Wide angle mirror to increase the field of visibility of the crane operator
- 304** Windshield wiper front window
 - With adjustable wipe speeds
- 305** Rigging eye / shackle
 - To secure the crane cab in transport position
- 306** Bumper stop
 - As stop for the crane cab in transport position

307 Fuel container

- To supply the engine independent heater for the crane cab and / or engine preheating*

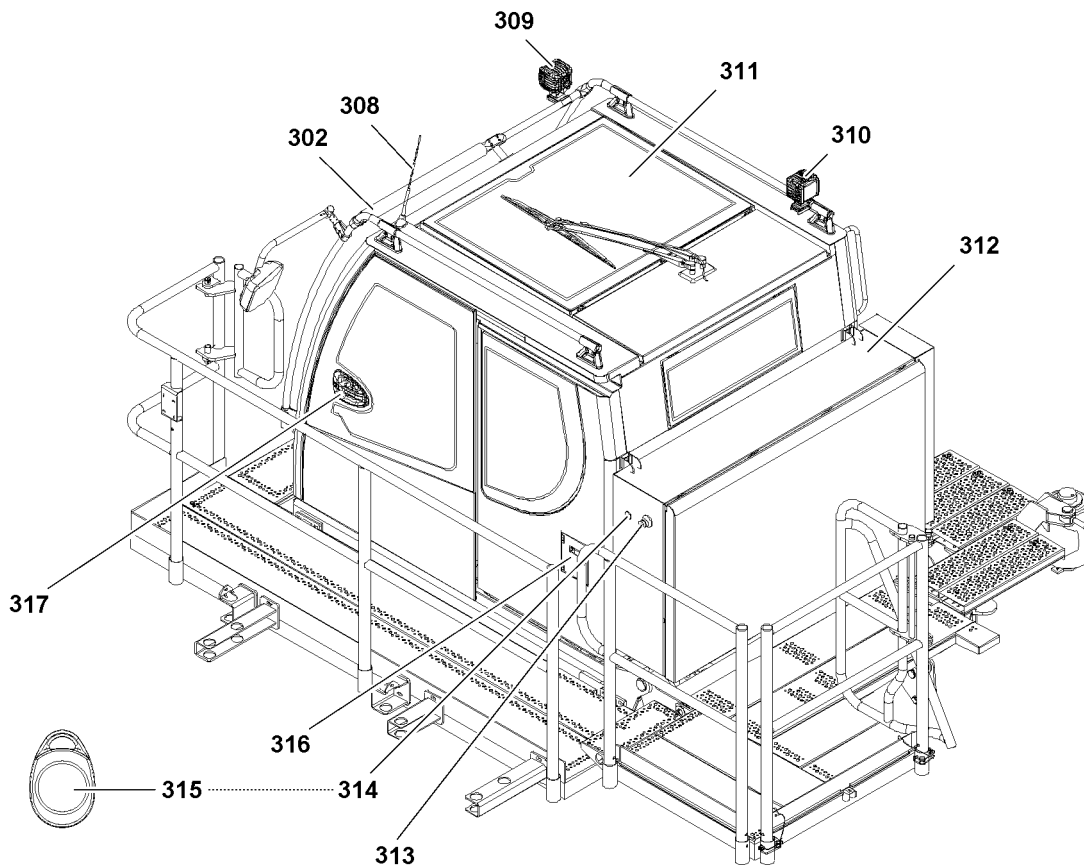

Fig.125393: Crane cab from rear

308 Antenna

- Combined roof antenna for radio and GSM module

309 Floodlight

- Outside area crane cab front

310 Floodlight

- Outside area crane cab rear

311 Roof window

- Can be moved out
- **Note:** Also provides possibility for emergency exit.

312 Control cabinet crane cab**313** EMERGENCY STOP switch**314** Sensor

- Operating element for LMB emergency operation
- Description LMB emergency operation, see Crane operating instructions, chapter 4.02 and 4.20.

315 Transponder

- For LMB emergency operation
- Control element for sensor **314**
- Description LMB emergency operation, see Crane operating instructions, chapter 4.02 and 4.20.

316 Filler port window cleaning fluid

- Filler port for container in inside of crane cab

317 Sliding door Crane cab

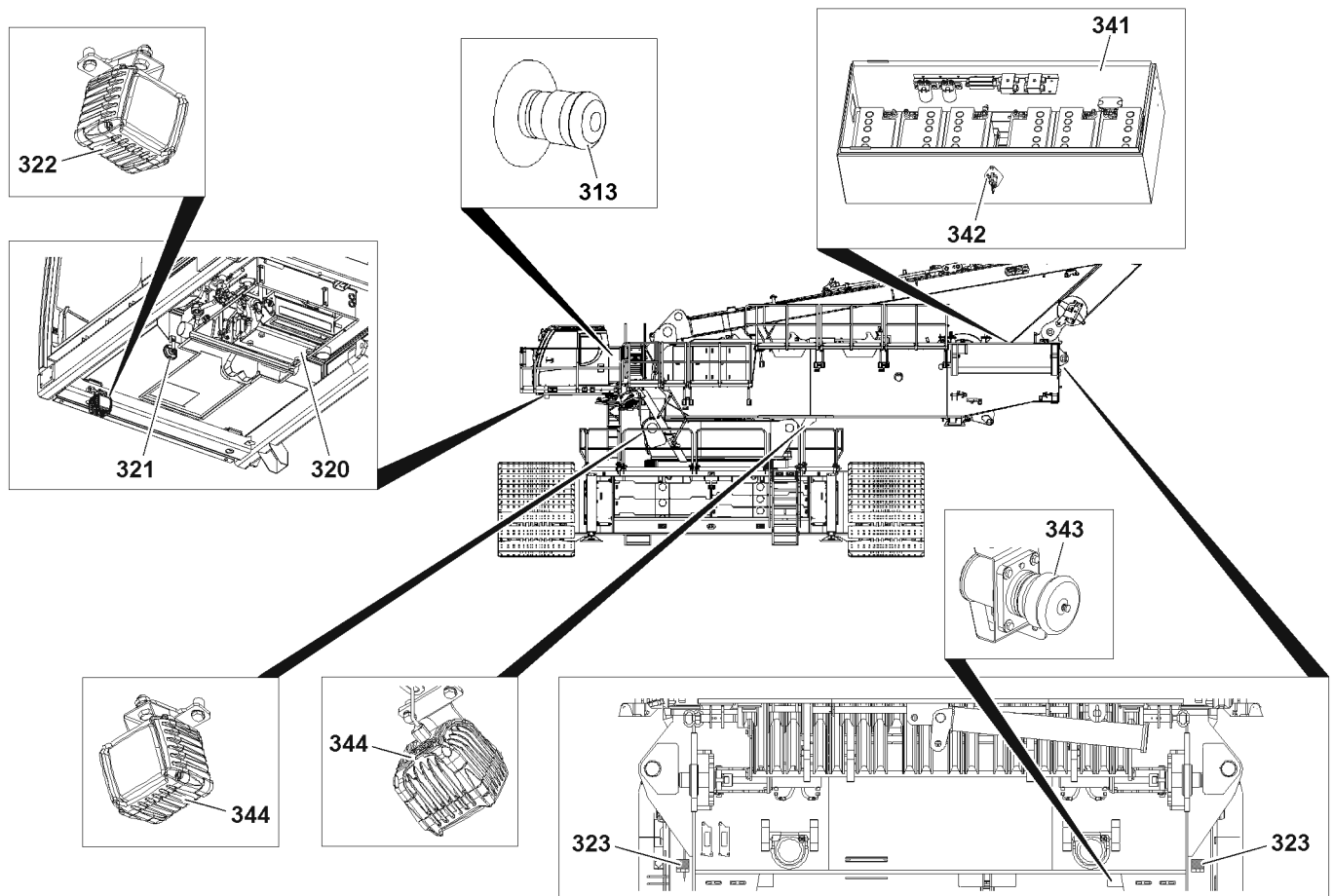

Fig.125404: Crane cab outside and turntable

1.1.2 Emergency equipment Crane cab outside

313 EMERGENCY STOP switch

1.1.3 Installation parts Crane cab bottom

320 Heater unit
 • Engine independent heater for crane cab and / or engine preheating*

321 Horn turntable
 • For acoustic warnings by crane driver or crane control

322 Floodlight
 • Lighting – turntable

1.1.4 Installation parts turntable

323 LMB warning lights
 • Active together with LMB three color light on crane cab
 Right and left each one LMB warning light

341 Battery box starter batteries

342 Disconnect switch*

• To interrupt line from plus terminal of starter batteries

Note: Thus the starter batteries no longer need to be disconnected by hand to avoid discharge during longer transport times.

343 Socket external power supply*

• For example for external start of diesel engine via the starter batteries

344 Floodlight

- Two working floodlights for illumination of turntable

**WARNING**

Disabled electrical functions!

An interruption of the line from the plus terminal by the disconnect switch* **342** is solely intended for transport of disassembled crane.

- ▶ After turning the switch, the line from the plug terminal of the starter batteries is interrupted. All electrical functions are disabled. For example, the airplane warning light is not functioning.
- ▶ The disconnect switch* **342** may solely be turned when no electrical functions are required.
- ▶ The disconnect switch* **342** may solely be turned when the LICCON computer system is shut down and the auxiliary heater has turned off.

1.2 Crane cab inside and control cabinet

This section describes the elements on the inside of the crane cab and on the control cabinet:

- Interior equipment crane cab
- Emergency equipment Crane cab inside
- Interfaces crane cab
- Control cabinet

1.2.1 Interior equipment crane cab

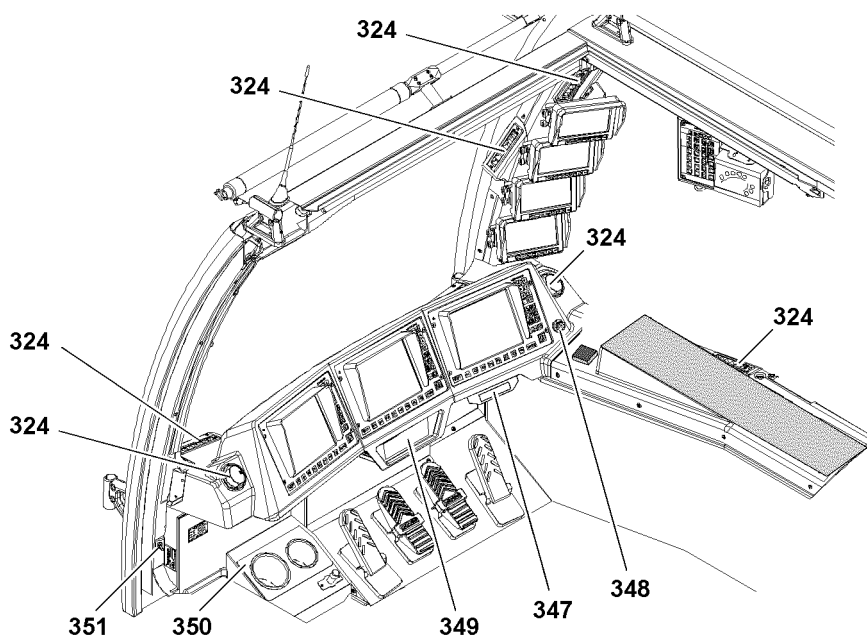

Fig.125406: Interior equipment crane cab, front section

- 324** Outlet nozzles
 - For individual control of air flow of heater / ventilation / climate control*
- 347** Ashtray
- 348** Cigarette lighter
- 349** Radio*
- 350** Drink holder
- 351** Door contact button

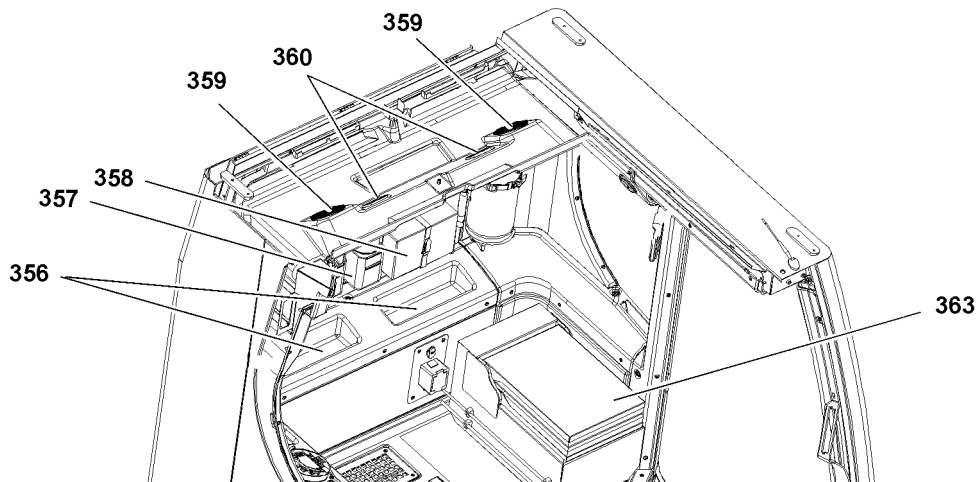

Fig.125407: Interior equipment crane cab, rear section

- 356** Compartment
- 357** Drink holder
- 359** Speaker
 - For radio*
- 360** Interior lights
- 363** Emergency seat
 - With storage compartment

1.2.2 Emergency equipment Crane cab inside

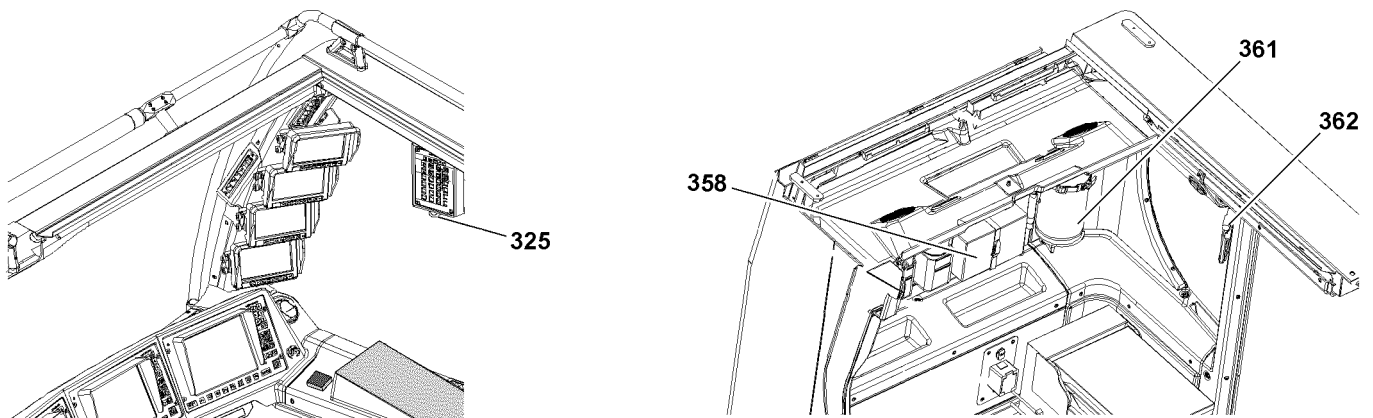

Fig.125410: Emergency equipment Crane cab inside

- 325** EMERGENCY STOP switch
- 358** First aid kit
- 361** Fire extinguisher
- 362** Emergency hammer
 - To break glass panes - for self-rescue or salvage of persons

1.2.3 Interfaces crane cab

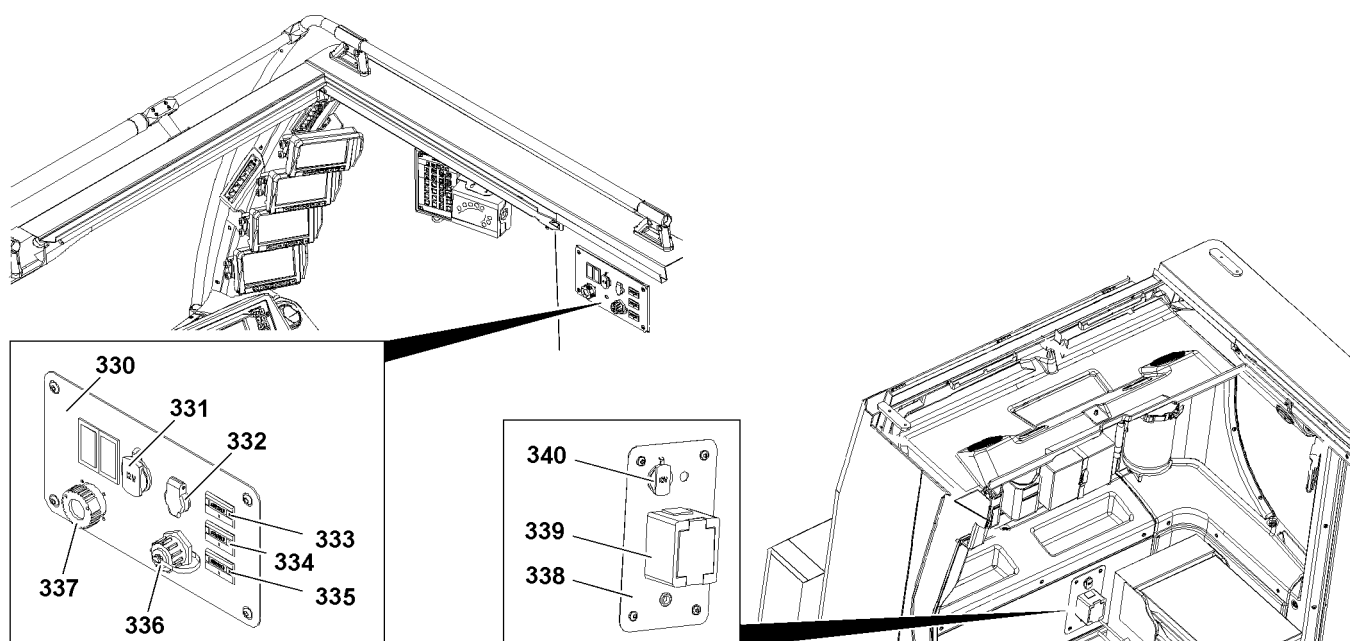

Fig.125411: Interfaces crane cab

- 330** Interface unit
- 331** Electrical socket 12 V
- 332** Electrical socket 24 V
- 333** Operating hour meter
 - Display operating hours crane / diesel engine
- 334** Operating hour meter*
 - Display operating hours winch 1
- 335** Operating hour meter*
 - Display operating hours winch 2
- 336** Ethernet interface
 - For crane control (BSE)
- 337** Diagnostic plug
 - For diagnostics diesel engine and SCR
- 338** Electrical socket unit
- 339** Electrical socket 230 V*
- 340** Electrical socket 12 V

1.2.4 Control cabinet

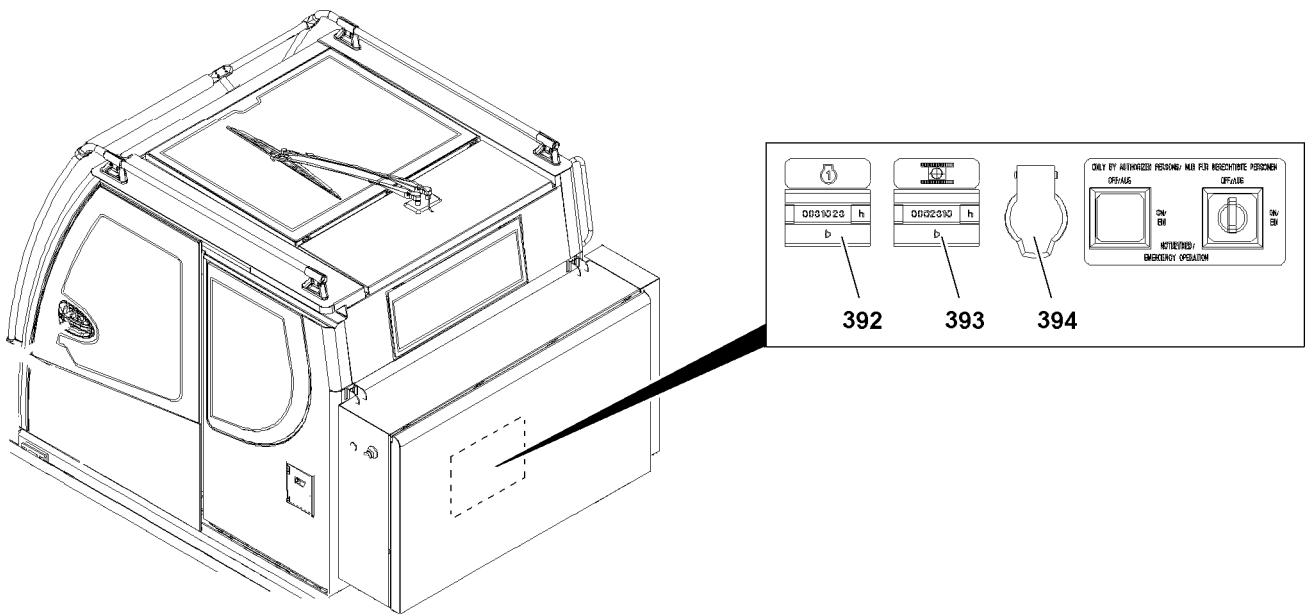

Fig.125412: Elements in control cabinet

392 Operating hour meter*

- **Note:** Assignment according to signs, for example additional display of diesel engine operating hours

393 Operating hour meter

- Display operating hours crawler

394 Electrical socket 24 V

2 Overview Control units crane cab

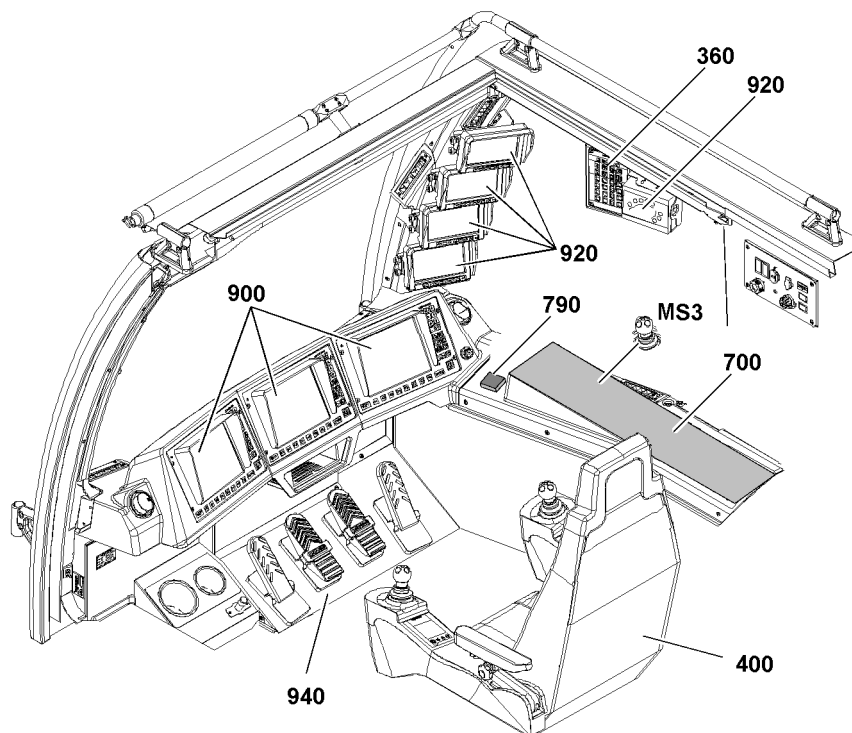

Fig.125413: Control units crane cab

The following control units are in the crane cab:

- 400** Control platform
- 700** Instrument panel
- 790** Operating unit HATZ Diesel*
 - Displayed installation location is exemplified
- 360** Operating and control unit (BKE)
- 900** LICCON monitors
 - See section „LICCON computer system monitor“
- 920** Camera monitoring
 - Monitor and operating unit, see section „camera monitoring“
- 940** Pedal carrier

3 Control platform

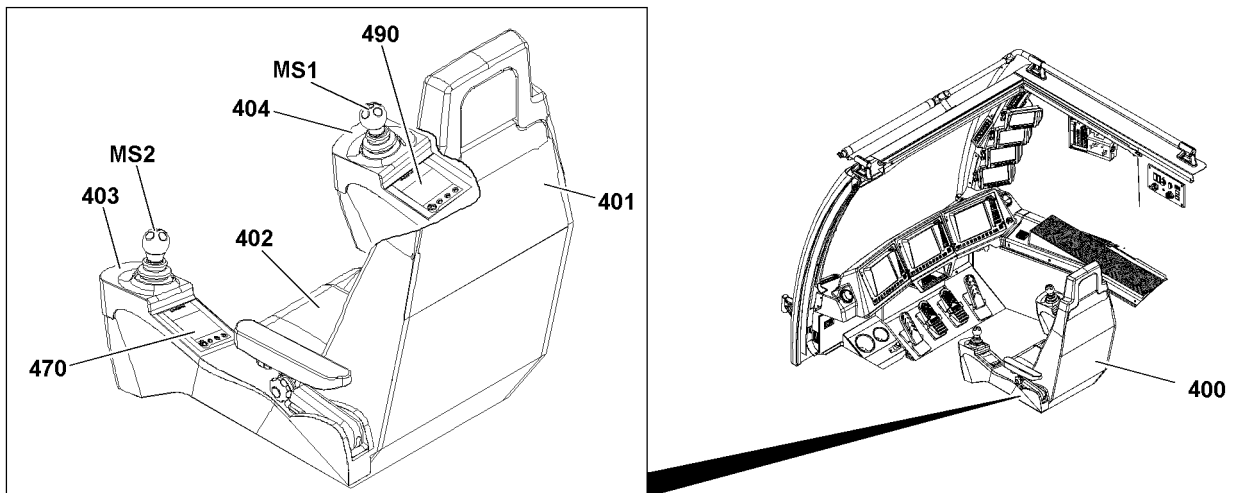

Fig.125414: Elements in control platform



Note

- For detailed description of operating elements to adjust the crane operator's seat, see Crane operating instructions, chapter 4.03!

The control platform **400** consists of the following elements:

- 401** Crane operator's seat
 - With seat contact button **402** in seat surface
- 403** Control panel, left
 - **MS2** Master switch
 - **470** Touch display (TE2)
- 404** Control panel, right
 - **MS1** Master switch
 - **490** Touch display (TE1)

4 Instrument panel

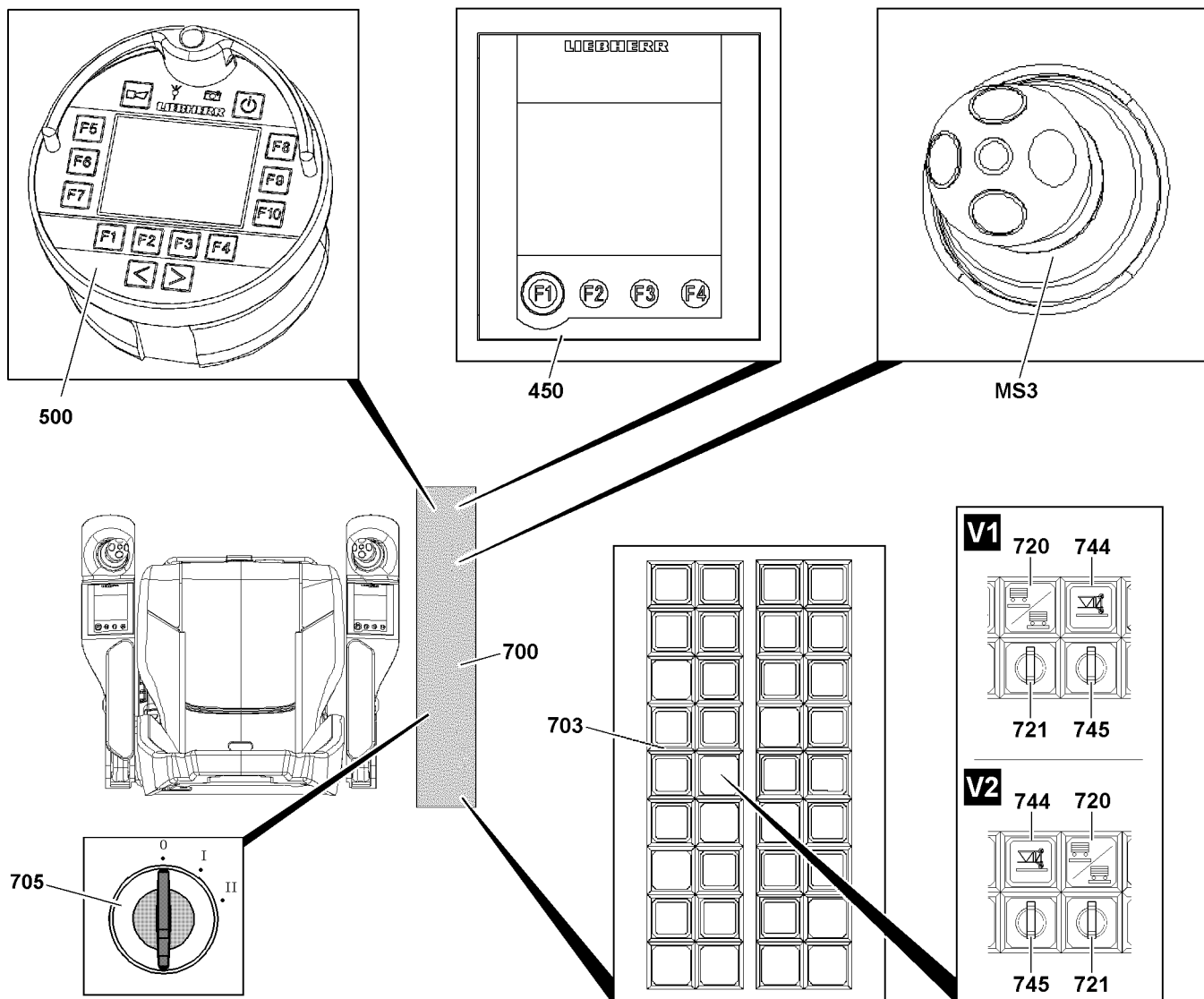

Fig.125395: Elements instrument panel

The instrument panel **700** consists of the following elements:



- **500** Bluetooth Terminal (BTT)
- **450** Touch display (TE3)
- **MS3** Master switch
- **703** Keypad
 - Key button
 - Indicator lights
 - Operating button
 - Operating button with indicator lights
 - Operating switch
 - Operating switch with indicator lights
- **705** Ignition starter switch

4.1 Key button with associated indicator lights / operating buttons / signs

Depending on the crane version, two different arrangements of key buttons with associated indicator lights / operating buttons in instrument panel are available:



V1 Arrangement variation

V2 Arrangement variation

Position	Operating element	Function	Beacon	Description
720	 <i>Derrick ballast lifted off sign</i>	–	–	To identify the <i>Derrick ballast lifted</i> key button Note: Function only for derrick ballast versions without ground contact monitoring
721	 <i>Derrick ballast lifted key button¹⁾</i>	On ²⁾	–	Turn on by pressing the key button
		Off	–	Turn off by pressing the key button



1) For a detailed description see Crane operating instructions, chapter 5.35.

2) If the *Derrick ballast lifted* key button is pressed, the derrick ballast is shown lifted in the LICCON monitor, see Crane operating instructions, chapter 4.02.









Position	Operating element	Function	Beacon	Description
744	 <i>Boom on ground indicator light</i>	–	Lights up	<i>Boom on ground</i> function is active
		–	Off	<i>Boom on ground</i> function is inactive
745	 <i>Boom on ground key button⁴⁾</i>	On	–	Turn on by pressing the on key button - <i>boom on ground</i> function is active, <i>boom on ground</i> indicator light lights up
		Off	–	Turn off by pressing the off key button - <i>boom on ground</i> function is inactive, <i>boom on ground</i> indicator light turns off









4) For a detailed description, see the Crane operating instructions, chapter 4.20.



4.2 Operating switch / operating button / indicator lights

Position	Operating element	Function	Beacon	Description
722	 <i>Operating switch Lighting instrument panel</i>	Off	–	Turn off by pressing the operating switch
		On	–	Turn on by pressing the operating switch
723	 <i>Operating switch Lighting access ladder</i>	Off	–	Turn off by pressing the operating switch
		On	–	Turn on by pressing the operating switch

LWE/LR 11000-001/23501-04-02/en

Position	Operating element	Function	Beacon	Description
724	 Operating button Ladder crane cab up	Up	–	By pressing the operating button Note: As long as the operating button is pressed, the ladder moves up until the upper end position of the ladder is reached.
725	 Operating button Ladder crane cab down	Down	–	By pressing the operating button Note: As long as the button is pressed, the ladder moves down until the lower end position of the ladder is reached.
726	 Operating button Derrick ballast down	Off	–	Releasing the operating button interrupts the movement.
		On	–	Pressing and holding the operating button lowers the derrick ballast.
727	 Operating button Derrick ballast up	Off	–	Releasing the operating button interrupts the movement.
		On	–	Pressing and holding the operating button lifts the derrick ballast.
728	 Operating button Telescope derrick ballast in	Off	–	Releasing the operating button interrupts the movement.
		On	–	Pressing and holding the operating button telescopes the derrick ballast in.
729	 Operating button Telescope the derrick ballast out	Off	–	Releasing the operating button interrupts the movement.
		On	–	Pressing and holding the operating button telescopes the derrick ballast out.
730	 Operating button block derrick ballast compensation cylinder A	Off	–	Releasing the operating button releases the compensation cylinder A on the derrick ballast.
		On	–	Pressing and holding the operating button blocks the compensation cylinder A on the derrick ballast.
731	 Operating button Block derrick ballast compensation cylinder B	Off	–	Releasing the operating button releases the compensation cylinder B on the derrick ballast.
		On	–	Pressing and holding the operating button blocks the compensation cylinder B on the derrick ballast.
732	 Operating button Move ballast trailer support cylinder in on the front	Off	–	Releasing the operating button interrupts the movement.
		On	–	Press and hold the operating button: Support cylinder moves in on the front

Position	Operating element	Function	Beacon	Description
733	 Operating button Move ballast trailer support cylinder out on the front	Off	–	Releasing the operating button interrupts the movement.
		On	–	Press and hold the operating button: Support cylinder moves out on the front
734	 Operating button Move ballast trailer support cylinder in on the rear	Off	–	Releasing the operating button interrupts the movement.
		On	–	Press and hold the operating button: Support cylinder moves in on the rear
735	 Operating button Move ballast trailer support cylinder out on the rear	Off	–	Releasing the operating button interrupts the movement.
		On	–	Press and hold the operating button: Support cylinder moves out on the rear
736	 Operating button Oil level measurement winch gear	On	–	Oil levels of all installed winches are checked. If the oil fill level is too low on one winch, then this is shown in the respective winch icon. The display remains active until the oil level sensor reports a correct fill level.
				NOTICE! Property damage! If a winch is actuated when the „oil fill level is too low“ then there is no shut off of the winch movement. An operating error message appears.
737	 Switch Drive Ballast trailer	On	On	By actuating the switch: Drive for ballast trailer is added See the Crane operating instructions, chapter 5.35.
		Off	Off	By actuating the switch: Drive for ballast trailer is turned off
738	 Operating button towing ballast trailer	On	Blinks	Press and hold the operating button: Sets the wheel sets into Towing position
			Lights up	The wheel sets are in Towing position
739	 Operating button parallel travel ballast trailer	On	Blinks	Press and hold the operating button: Turn the wheels sets into Parallel driving position
			Lights up	The wheel sets are in Parallel driving position
740	 Operating button Manual steering correction, left curve	On	Lights up	Operating mode Manual steering correction: Pressing and holding the operating button sets the wheel sets for left curves. The turntable turns when driving to the left, in reference to the crawler travel gear Function for driving in tight left curves, in tight spaces.

Position	Operating element	Function	Beacon	Description
741	 Operating button Manual steering correction, right curve	On	Lights up	Operating mode Manual steering correction: Pressing and holding the operating button sets the wheel sets for right curves. The turntable turns when driving to the right, in reference to the crawler travel gear Function for driving in tight right curves, in tight spaces.
742	 Operating button ballast trailer circular travel (cornering)	On	Blinks	Press and hold the operating button: Turn the wheels sets into Circular driving position
			Lights up	The wheel sets are in Circular driving position
411	 Indicator light Request engine stop		Lights up or blinks	In case of a warning occurrence Note: Pay attention to system error, remedy the cause of the error immediately, turn the engine off if necessary.

5 Operating unit HATZ Diesel aggregate*

The HATZ Diesel aggregate* supplies the power for auxiliary equipment* if needed.

Description of operating unit HATZ Diesel aggregate*, see Documentation of manufacturer.

6 Operating and control unit (BKE)

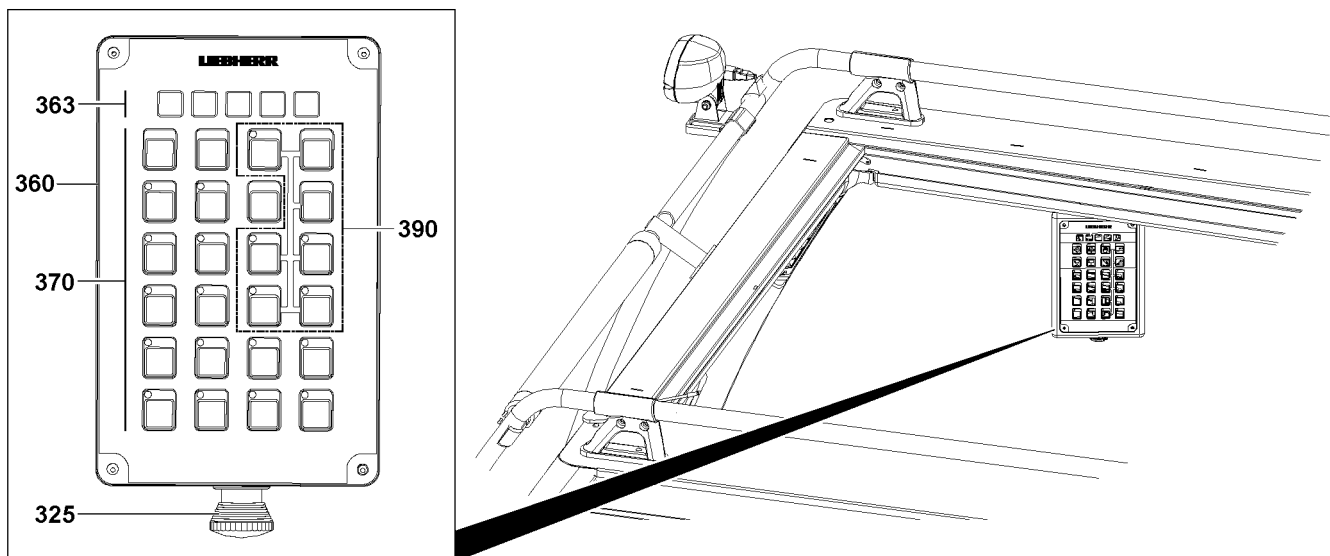

Fig.125415: Operating and control unit (BKE)

6.1 Overview Operating console







Note

► The indicator lights as well as the operating keys are described in detail in the following sections!

- 360** Operating console
 - Housing with indicator lights and buttons
- 325** EMERGENCY STOP switch
- 363** Indicator lights BKE
- 370** Operating buttons BKE
 - Standard assignment
- 390** Operating buttons on the BKE
 - Standard assignment for release controls

6.2 Indicator lights on the BKE

Here you find the description of the indicator lights **363**.

Position	Indicator light	LED	Description
364	 Engine monitoring	Orange	Engine not ready to start, engine preheating active
		Orange blinking	Engine ready to start
		Off	Engine is running (after engine has been started)
		Red	The engine is running, the alternator does not charge
		Red blinking	Engine is running in emergency operation
365	 Central lubrication 1 for: Winch 1, winch 2, winch 3, winch 5/6, Winch 4, SA-frame, pin S/D	Green + red	Functional readiness (is shown after engine start for 1.5 seconds)
		Green	Lubrication active
		Red / red blinking	Error / problem
		Off	Central lubrication not active
366	 Central lubrication 2 for: Slewing ring	Green + red	Functional readiness (is shown after engine start for 1.5 seconds)
		Green	Lubrication active
		Red / red blinking	Error / problem
		Off	
367	 Central lubrication 3 for: Ballast trailer Crawler travel gear	Green + red	Functional readiness (is shown after engine start for 1.5 seconds)
		Green	Lubrication active
		Red / red blinking	Error / problem
		Off	Central lubrication not active

LWE/LR 11000-001/23501-04-02/en



6.3 Operating keys on the BKE, Standard assignment



Here you find the description of the Operating keys, standard assignment **370**.







Note





- With the LEDs in the operating buttons, the operating conditions and problems can be recognized quickly and reliably by the crane driver!

Position	Operating button	Function	LED	Description
371	 Washer pump front window	On	–	Clean the front window: By pressing and holding the operating button
		Off	–	By releasing the operating button Note: After releasing the operating button, three additional wipe movements are carried out before the wiper blades return to their original position.
372	 Washer pump Roof window	On	–	Clean the roof window: By pressing and holding the operating button
		Off	–	By releasing the operating button Note: After releasing the operating button, three additional wipe movements are carried out before the wiper blades return to their original position.
373	 Windshield wiper front window	On	Lights up	By momentarily pressing the operating button (less than one second). By momentarily pressing it further, the interval stage changes incrementally.
		Intermittent	Lights up	There are different interval stages: 1. Interval stage: Wipe with long pauses 2. Interval stage: Wipe with short pauses 3. Wipe continuously off
		Off	Off	By pressing the operating button longer (more than one second until a beep sounds) or By pressing the operating button momentarily (several times, less than one second) until the LED turns off ¹⁾

Position	Operating button	Function	LED	Description
374	 Windshield wiper roof window	On	Lights up	By momentarily pressing the operating button (less than one second). By momentarily pressing it further, the interval stage changes incrementally.
		Intermittent	Lights up	There are different interval stages: <ol style="list-style-type: none"> 1. Interval stage: Wipe with long pauses 2. Interval stage: Wipe with short pauses 3. Wipe continuously off
		Off	Off	By pressing the operating button longer (more than one second until a beep sounds) or By pressing the operating button momentarily (several times, less than one second) until the LED turns off ¹⁾
375	 Interior lighting crane cab	On	–	By opening the door or By momentarily pressing the operating button (less than one second). By momentarily pressing it further, the dimmer stage changes incrementally.
		Dim	–	There are different dimmer stages: <ol style="list-style-type: none"> 1. Dimmer stage 75 % 2. Dimmer stage 50 % 3. Dimmer stage 25 % 4. Interior lighting continuously off
		Off	–	By pressing the operating button longer (more than one second) or By pressing the operating button momentarily (several times, less than one second) until the interior lighting turns off or If the following conditions are present simultaneously for longer than 30 seconds: <ul style="list-style-type: none"> – crane operator's seat not occupied – cab door closed – crane engine off
376	 Camera lighting	On	Lights up	By pressing the operating button
		Off	Off	By pressing the operating button
		Error	Blinks	Error / problem

LWE/LR 11000-001/23501-04-02/en

Position	Operating button	Function	LED	Description
377	 Lighting Crawler travel gear	On	Lights up	By pressing the operating button
		Off	Off	By pressing the operating button
		Error	Blinks	Error / problem
378	 Airplane warning light	On	Lights up	By pressing the button Note: To identify aviation obstructions The airplane warning light can also be actuated when the ignition is „Off“, by pressing the button longer than one second. Pressing it again switches the next shift stage. Note: The light signal illuminates or blinks depending on the airplane warning light version.
		On	Blinks (1 Hz)	By pressing the button Note: Only on crane types with switchable airplane warning light*: If the LED blinks continuously once per second, the airplane warning light is in blinking mode
		Off	Off	By pressing the button
		Error	Blinks (2 Hz)	Note: Only on crane types with airplane warning light monitoring: Error / problem: If the LED blinks continuously twice per second, there is a detected airplane warning error.
379	 Illumination outside area crane cab front / rear	On	Lights up	By pressing the operating button
		Off	Off	By pressing the operating button
		Error	Blinks	Error / problem
380	 Pressure supply auxiliary users	On	Lights up	By pressing the operating button
		Off	Off	By pressing the operating button
		Error	Blinks	Error / problem
				Note: For all functions, which are actuated with the hydraulic manual control levers, the pressure supply for the auxiliary users must be turned on.
381	 Intermediate lubrication central lubrication system	On	Lights up	By pressing the operating button, an intermediate lubrication is carried out, then the function turns off.
		Off	Off	Automatically after completion of intermediate lubrication
		Error	Blinks	Error / problem

Position	Operating button	Function	LED	Description
382		On	Lights up	By pressing the operating button
		Off	Off	By pressing the operating button
		Error	Blinks	Error / problem
383		Increase	Lights up	By pressing and holding the operating button or By momentarily pressing (less than one second) the rpm changes incrementally by 50 rpm
		Lock	Off	By releasing the operating button
		Error	Blinks	Error / problem
384		lower	Lights up	By pressing and holding the operating button or By momentarily pressing (less than one second) the rpm is lowered incrementally by 50 rpm
		Lock	Off	By releasing the operating button
		Error	Blinks	Error / problem
385		Start	Lights up	Start turned off crane engine: By pressing and holding the button until the engine is running
		Turn off	Off	Turn the started crane engine off: By pressing the operating button
		Error	Blinks	Crane engine Nominal rpm not reached
				Note: If the crane engine is turned off via this operating button when the ignition is turned on, then the stand-by mode is started in the LICCON computer system.





6.4 Operating buttons BKE for release operations

Here you find the description of the Operating keys for release actuations **390**.



Note

- ▶ The following functions require the activation of the release button.
- ▶ The release button is active for 30 seconds. If the operating key is pressed during this time, the release time is reset to 30 seconds. The release stops after 30 seconds.
- ▶ A function is triggered by activation of the release button and then pressing the corresponding operating button.
- ▶ For the listed key combinations, hold the corresponding operating button until the desired end position is reached.

Position	Key combination	Function	LED	Description
390	 Release button	On	Lights up	Press the release button, within 30 seconds the functions which require a release must now be activated.
		Off	Off	By pressing the button or Automatically after 30 seconds when no release button is pressed, a release is required.
390+391	 Lift the crane cab	On	Lights up	By pressing and holding the operating button lift the crane cab on the front to the desired position
		Lock	Off	By releasing the operating button
		Error	Blinks	Error / problem
390+392	 Lower the crane cab	On	Lights up	By pressing and holding the operating button lower the crane cab on the front to the desired position
		Lock	Off	By releasing the operating button
		Error	Blinks	Error / problem
390+393	 Swing the crane cab in	On	Lights up	Function inactive
		Off	Off	Error / problem
		Error	Blinks	The crane cab is swung in
390+394	 Swing the crane cab out	On	Lights up	Function inactive
		Off	Off	Error / problem
		Error	Blinks	The crane cab is swung out

7 LICCON computer system monitors

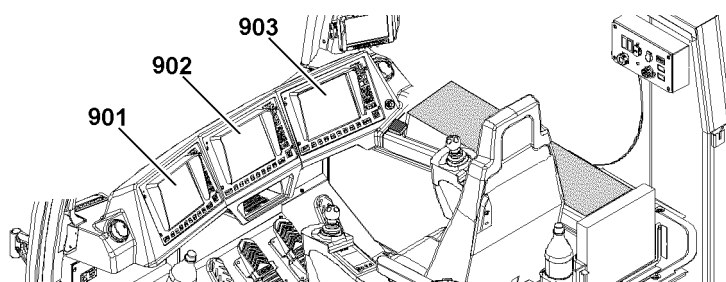

Fig.144103: LICCON computer system monitors



Note

- For detailed descriptions of the operating element and functions on the LICCON monitors, see Crane operating instructions, chapter 4.02!

- 901** LICCON monitor 2
• Also described as BSE 3
- 902** LICCON monitor 1
• Also described as BSE 2

- 903** LICCON monitor 0
 • Also described as BSE 1

8 Camera monitoring

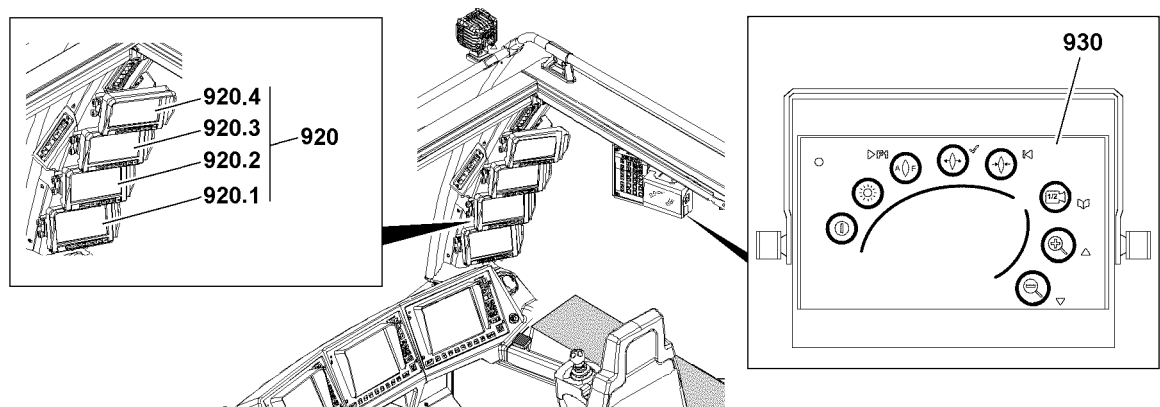

Fig.144104: Camera monitoring



WARNING

Non-available camera view!

The individual camera views in the monitors can be changed over or masked.

The camera objective can become dirty, fogged up or otherwise impaired in the sight window.

Incorrectly set or dirty floodlights can impair the camera monitoring.

- ▶ Always allow to show required camera views.
- ▶ Remedy any impairments of picture quality of camera views immediately.

Location of monitors **920** in the crane cab:

- 920.1** Monitor 1
- 920.2** Monitor 2
- 920.3** Monitor 3
- 920.4** Monitor 4

Assignment of cameras to monitors, see Electrical wiring diagram.

For a description of the monitor **920** operating buttons, see documentation from the manufacturer.

For description of the camera control unit **930**, see the documentation from the manufacturer.

9 Pedal carrier

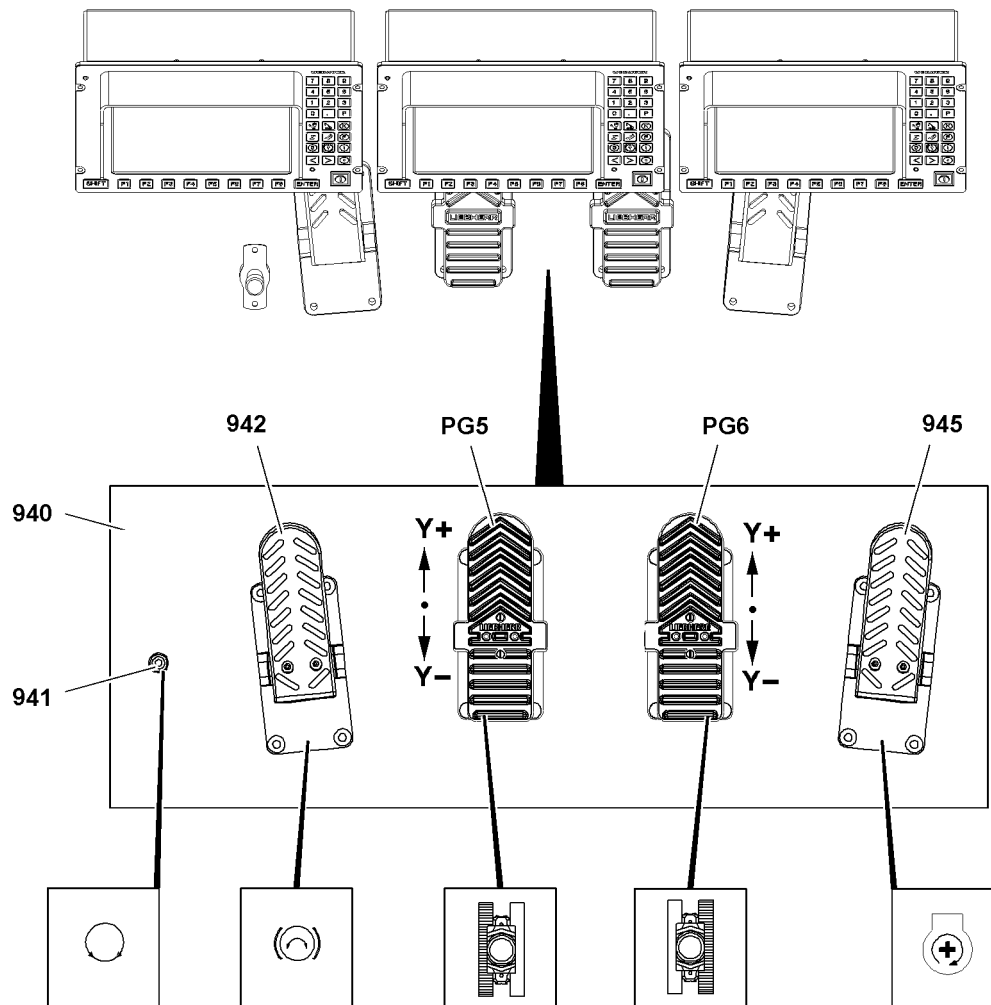

Fig.125416: Pedal carrier

- 940** Pedal carrier
- 941** Foot button
 - Freewheeling slewing gear
- 942** Pedal
 - Slewing gear brake
- PG5** Pedal sensor 5

Drive the left crawler:

Actuate the foot rocker **PG5** in direction Y+ (forward): The left crawler drives forward.
 Actuate the foot rocker **PG5** in direction Y- (backward): The left crawler drives backward.

- PG6** Pedal sensor

Drive the right crawler:

Actuate the foot rocker **PG6** in direction Y+ (forward): The right crawler drives forward.
 Actuate the foot rocker **PG6** in direction Y- (backward): The right crawler drives backward.

- 945** Pedal
 - Engine regulation

Empty page!

LWE/LR 11000-001/23501-04-02/en

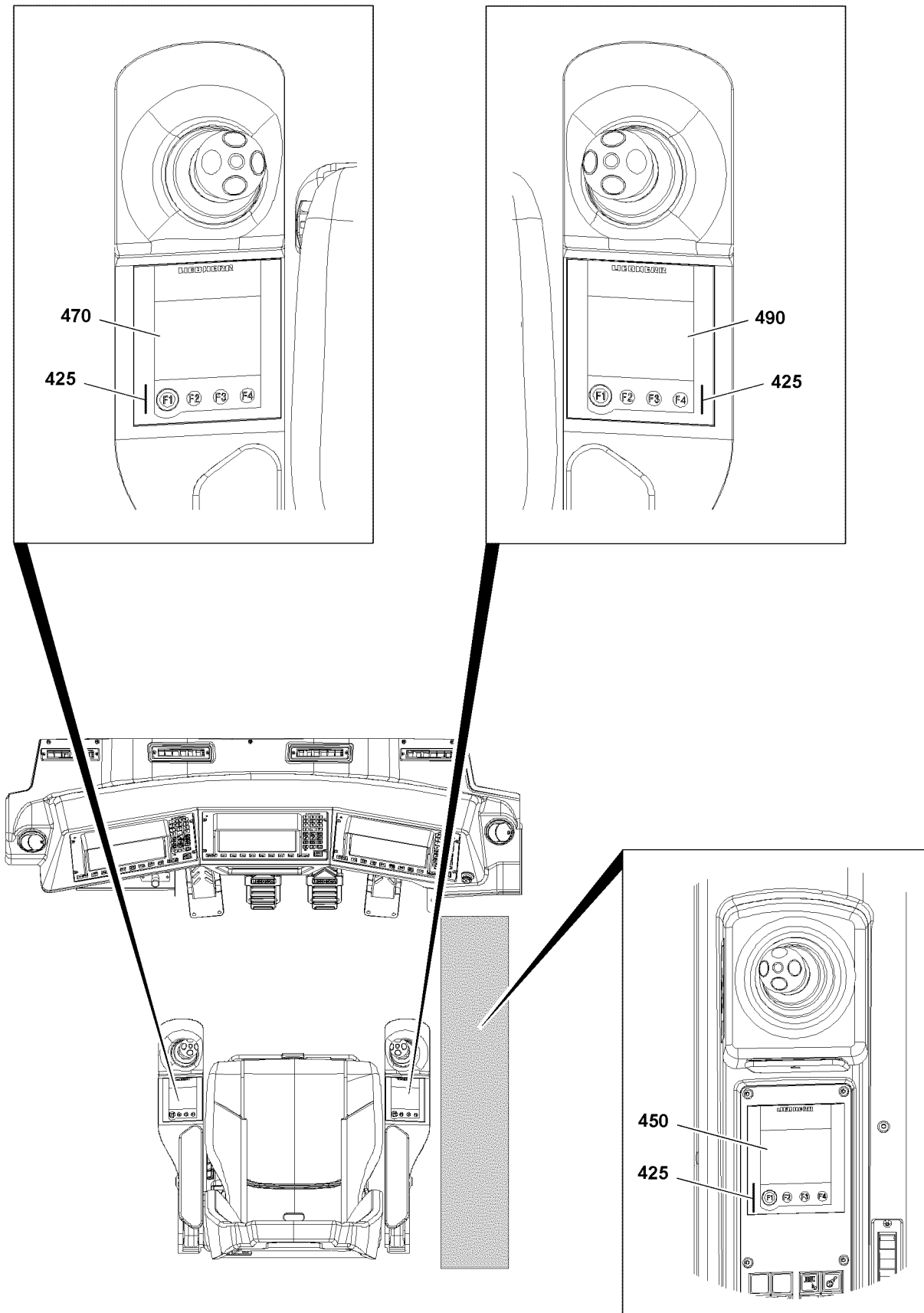

Fig.122048

LWE/LR 11000-001/23501-04-02/en

10 Touch displays

The touch displays are combined display and operating elements. The touch displays are operated using the row of function keys „F1“ to „F4“ and by direct „touch“ (fingertip) on the corresponding display icons.



Note

- ▶ The illustrations or icons in the touch displays are only examples.
- ▶ The illustrations may differ depending on the crane!
- ▶ If the F1-function key is continuously pressed, the system shifts continuously between the existing menu points.

Via the left touch display **470** and the right touch display **490**, you can call up various menus. In these menus you can select or preselect different crane functions, turn them on and off or control them directly.



Note

- ▶ In low temperatures it is possible that the touch displays initially change to the menu items delayed and that the touch functions remain deactivated for that time.
- ▶ Wait a few minutes after ignition „ON“ until the menu items are shown on the touch display.

425 Function keys

- The assignment of the function keys depends on the icons or the functions, which are visible on the individual touch displays.
- On touch display TE1 and on touch display TE2, additional functions can be called up via the menus.
- The functions are described in this chapter together with the menus.

490 Right touch display TE1

- Main menu: Master switch assignment MS1, select master switch assignment, spool assembly winch, parallel operation: Adjusting the winches
- Menu „Block winches“

470 Left touch display TE2

- Main menu: Master switch assignment MS2, slewing gear brake
- „Floodlight“ menu
- Menu „Climate control settings“
- Menu „Hydraulic oil preheating“

450 Touch display TE3, instrument panel

- Main menu: Master switch assignment MS3, drive crawler

10.1 Touch functions

10.1.1 Selecting and deselecting touch functions

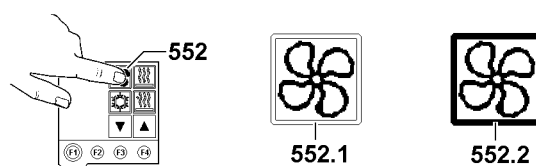

Fig.114231: Selecting and deselecting touch functions

**Note**

- ▶ Touch functions are identified by the double border (empty frame) of the touch display icons. The function in the icon is selected / deselected with the press of a finger („touch“) on the icon. Example on „Fan / blower“ icon **552**:
- ▶ „Fan / blower“ icon **552.1**: Fan / blower deselected (not active), double border (empty frame) is visible.
- ▶ „Fan / blower“ icon **552.2**: Fan / blower selected (active), double border is filled (frame filled).

10.1.2 Operating touch functions

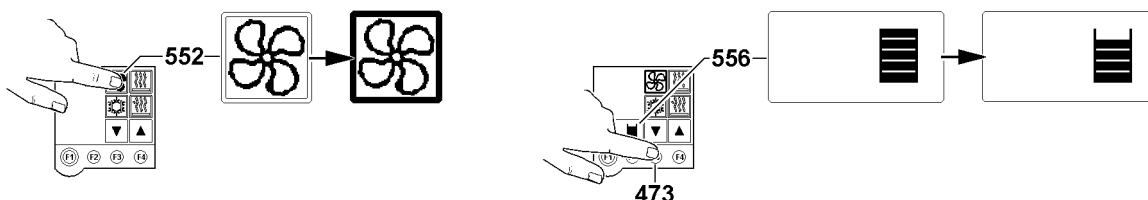

Fig.115020: Operating touch functions

**Note**

As an example, the blower stage of the heater is reduced:

- ▶ The „Fan / blower“ icon **552** is selected in the touch display by „touching“.

When the function is selected:

- ▶ The double frame area is filled out, the function „Fan / blower“ is now active.
- ▶ When the F3 key **473** is actuated, the blower stage is reduced. The status display **556** is updated.

10.2 Starting up the LICCON Computer system and the touch displays

After turning on and correct boot up of the LICCON computer system, a static crane picture appears momentarily on the touch display. From here the system automatically switches to the master switch assignment for the relevant master switch, MS1 (right), MS2 (left) and MS3 (instrument panel).

The touch display always displays the master switch assignment on the touch displays that was set or „active“ before the LICCON computer system was turned off.

Empty page!

LWE/LR 11000-001/23501-04-02/en

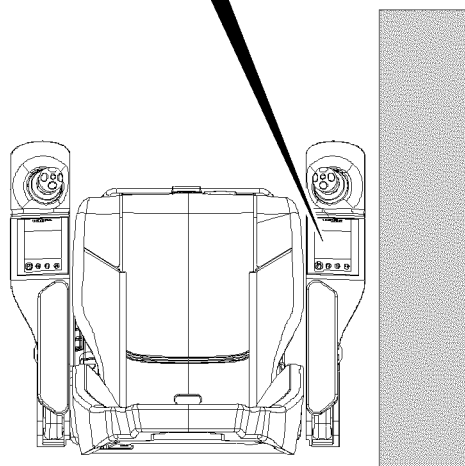
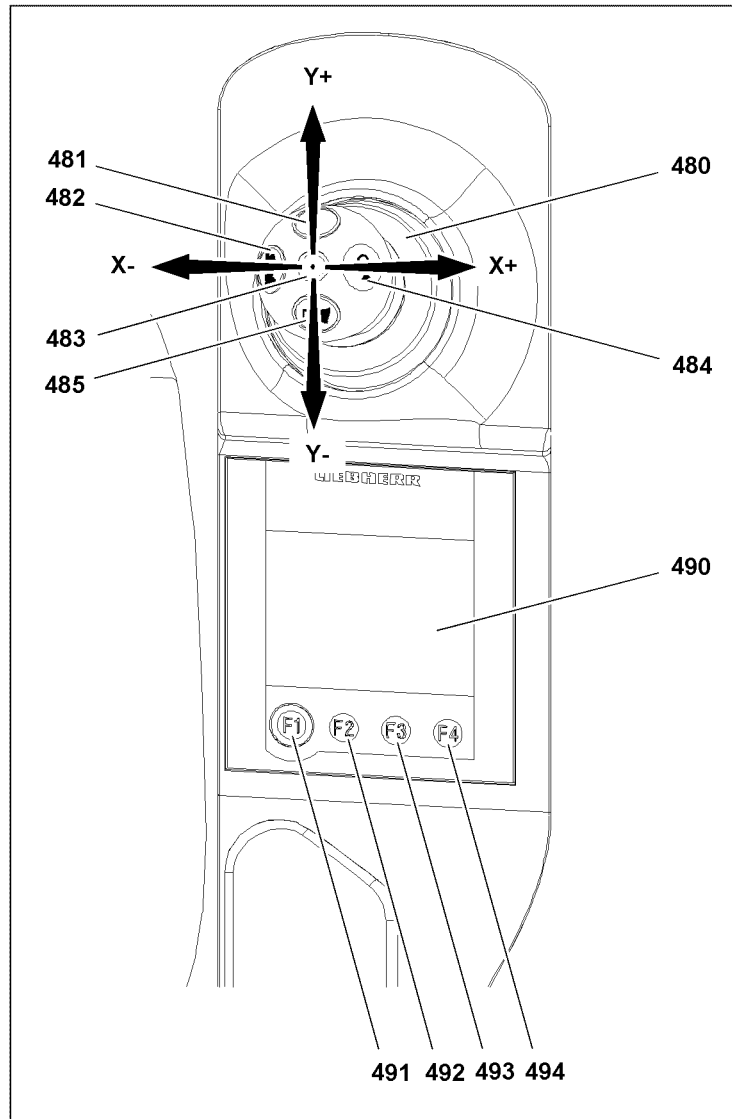

Fig.122217

LWE/LR 11000-001/23501-04-02/en

11 Master switch assignment MS1



WARNING

Change of master switch assignment!

The assignment of the master switches to the respective units on the crane can change, depending on the set up configuration and winch application.

- ▶ Select the correct master switch assignment.
- ▶ Check the assignment before actuating the master switch on the TE.



Note

- ▶ For description of function of the master switches, see Crane operating instructions, chapter 4.05.

480 Master switch right (MS1)

- The functions for the master switch MS1 depend on the set up configuration and the selected master switch assignment on TE1.

481 Button

- Bypass of the seat contact button
- **Or:** When the seat contact button is actuated: Activation of the vibration sensor **483**

482 Button

- „Power Plus“ addition, crane operation

483 Vibration sensor

- Turn sensor and winches



Note

- ▶ Pressing the button **484** will lock the engine regulation in the current position.

484 Button

- Lock the engine regulation of superstructure engine.
The idling speed can be increased up to the maximum rpm.
- Can be „overridden“ by the engine regulation (gas pedal).
- At continued actuation of the engine regulation (gas pedal), the current rpm is taken over.
- By pressing the button **484** with the engine regulation (gas pedal) **NOT actuated**, the manual throttle is cancelled.
- If the engine rpm is locked, a „+“ appears on the LICCON monitor in the „dynamic engine rpm display“ (driving mode) and the „dynamic load utilization bar display“ (crane operation).
- Delete the lock by touching the gas pedal momentarily.

485 Button

- Horn

11.1 TE1 Function key assignment

491 F1 key

- No function on TE1

492 F2 key

- Change to the menu „Lock winch“



Note

- ▶ The winch status (winch activated / blocked) can be seen on the touch display. Blocked winches are recognizable on the icon.

493 F3 key



- Change master switch assignment; identification via letter in icon.
The number of possible master switch assignments depends on the set up configuration, which was configured in the LICCON computer system.

Conditions: Master switch 1 480 (MS1), master switch 2 (MS2) and master switch 3 (MS3) are not actuated.



494 F4 key

- If a touch function of assembly winch is activated on the touch display: Spool assembly winch out, spool up or constantly spool up.
When parallel operation winch 1 || winch 2 is activated: „Adjusting the winches“





11.2 TE1 main menu: Functions and assignment





Position	Icon	Assignment TE1
1.01		Display of master switch with deflection directions: Icon visible in main menu on every touch display
1.02		Identification of master switch assignment in center of icon, for example „D“

11.2.1 TE1 Touch functions









Position	Icon	Assignment TE1 Main menu: Touch functions
1.10		Adjusting winch 1 and winch 2
1.11		Winch 1 and winch 2 are adjusted.













11.2.2 TE1 Assignment winches

Position	Icon	Assignment TE1 Main menu: Winches
1.20		Spool up winch 1
1.21		Spool winch 1 out, display of maximum winch speed in percentages
1.22		Spool up winch 1 and winch 2 in parallel operation
1.23		Spool out winch 1 and winch 2 in parallel operation, display of maximum winch speed in percentages

Position	Icon	Assignment TE1 Main menu: Winches
1.24		Winch 1 is blocked Note: If a winch is blocked, the functions „spool winch up“ and „spool winch out“ can NOT be carried out!
1.25		Parallel operation winch 1 and winch 2 is blocked Note: If the parallel operation is blocked, the functions „spool winch up“ and „spool winch out“ can NOT be carried out!
1.26		Spool up winch 4
1.27		Spool winch 4 out, display of maximum winch speed in percentages

11.2.3 TE1 Assignment boom and equipment

Position	Icon	Assignment TE1 Main menu: Boom and equipment
1.30		Luffing the main boom up
1.31		Luff main boom down; display of maximum winch speed in percentages
1.32		Luffing the luffing jib up
1.33		Luff luffing jib down; display of maximum winch speed in percentages
1.34		Luffing the main boom up
1.35		Luff main boom down; display of maximum winch speed in percentages
1.36		Luffing the main boom up
1.37		Luff main boom down; display of maximum winch speed in percentages

Position	Icon	Assignment TE1 Main menu: Boom and equipment
1.38		Luffing the luffing jib up
1.39		Luff luffing jib down; display of maximum winch speed in percentages
1.40		Luffing the main boom up
1.41		Luff main boom down; display of maximum winch speed in percentages
1.42	 	If a crane movement is blocked, the functions „luffing up“ and „luffing down“ can NOT be carried out! Note: Boom and equipment: Crane movement is blocked, example SW, „luff luffing jib up“ and „luff luffing jib down“ can NOT be carried out.
1.43		Lower derrick ballast: Extend pull cylinder A and pull cylinder B
1.44		Lift derrick ballast: Retract pull cylinder A and pull cylinder B
1.43		Lifting / lowering the derrick ballast: Lock pull cylinder A
1.44		Lifting / lowering the derrick ballast: Lock pull cylinder B
1.45		Ballast automatic* - Lower derrick ballast: Extend pull cylinder A and pull cylinder B
1.46		Ballast automatic* - Lift derrick ballast: Retract pull cylinder A and pull cylinder B

Empty page!

LWE/LR 11000-001/23501-04-02/en

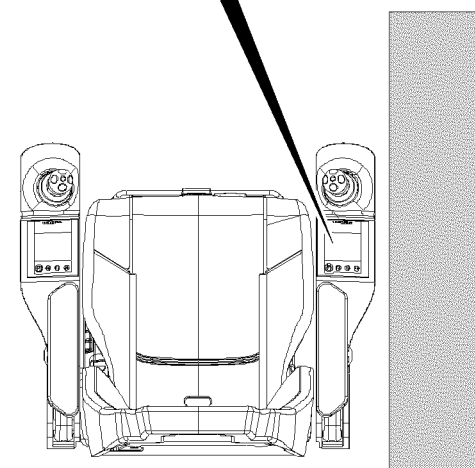
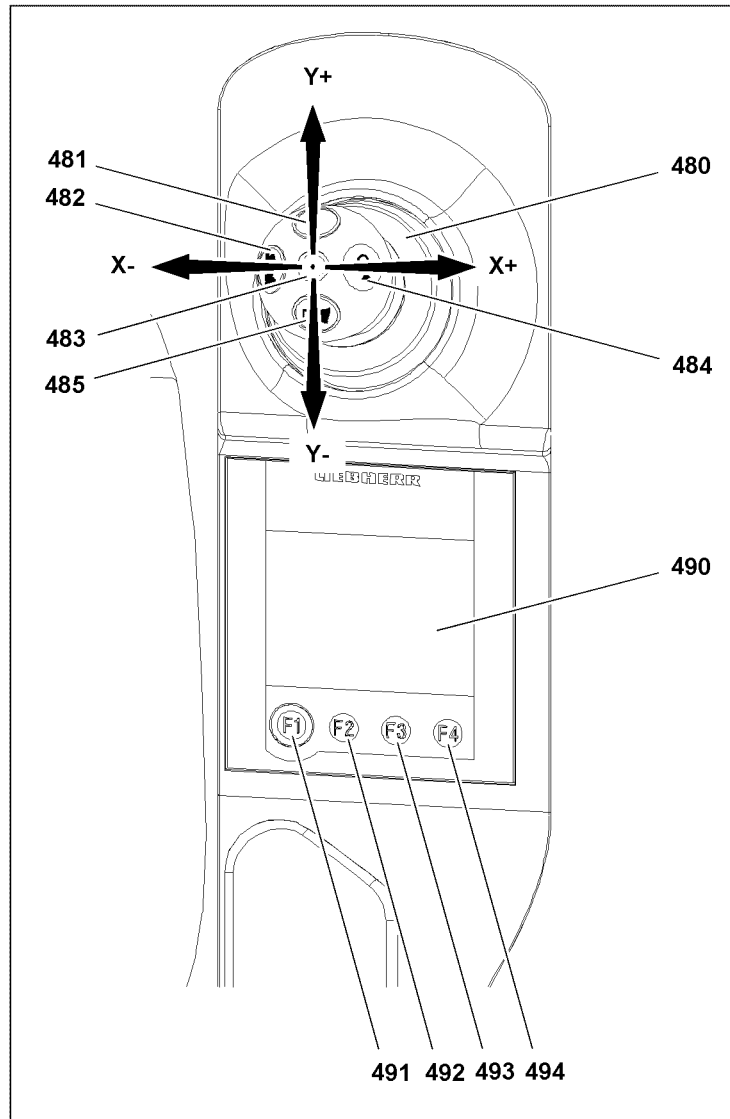

Fig.122217

11.3 TE Menu „Block winch“ (right touch display)

The crane operator has the possibility to block a winch which is not needed in the „Block winch“ menu.

LWE/LR 11000-001/23501-04-02/en

**Note**

- ▶ „Touch“ on a touch function to activate the function.
- ▶ Only an activated winch can be blocked or released with the F4 function key **494**.
- ▶ The touch display changes 20 seconds after the last button actuation to the main menu.

11.3.1 TE Menu „Block winch“ function key assignment

You can reach the „block winch“ menu via the TE1 **490**.

- 491** F1 key
 - Change to the main menu
- 492** F2 key
 - No function in this menu
- 493** F3 key
 - No function in this menu
- 494** F4 key
 - Block / release the winch: When the winch is blocked, the winch is shown as in icon **541**.

11.3.2 TE Menu „Block winch“ assignment

Position	Icon	TE Menu „Block winch“ assignment
530		Block winches which are selected

11.3.3 TE Menu „Block winch“ touch functions

Position	Icon	TE Menu „Block winch“ touch functions
535		Winch 1
536		Winch 2
537		Winch 3
538		Winch 4
539		Winch 5
540		Winch 6
541		Winch 3 is blocked

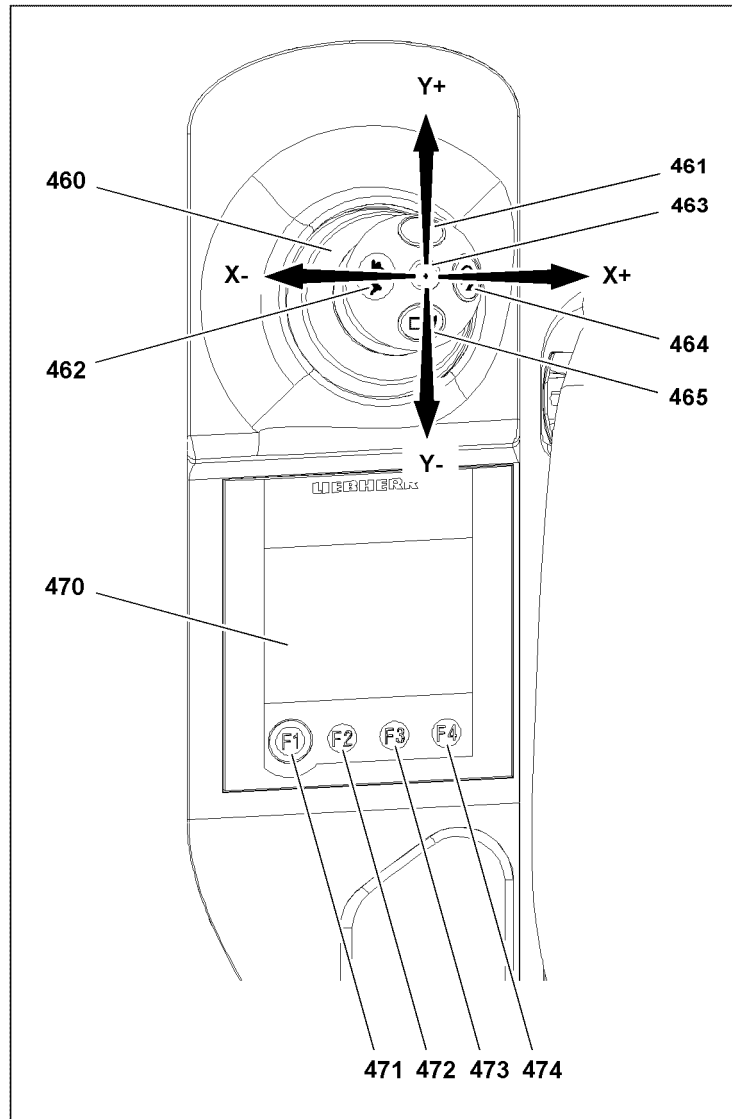

Fig.122218

LWE/LR 11000-001/23501-04-02/en

12 Master switch assignment MS2



Note

Change of master switch assignment!

The assignment of the master switches to the respective units on the crane can change, depending on the set up configuration and winch application!

► **Check the assignment before actuating the master switch on the TE!**

12.1 Functions master switch MS2



Note

► For description of function of the master switches, see Crane operating instructions, chapter 4.05.

460 Master switch left (MS1)

- The functions for the master switch MS1 depend on the set up configuration and the selected master switch assignment on TE2.

461 Button

- Bypass of the seat contact button
- **Or:** When the seat contact button is actuated: Activation of the vibration sensor **463**

462 Button

- „Power Plus“ addition, crane operation

463 Vibration sensor

- Turn sensor and winches



Note

► Pressing the button **464** will lock the engine regulation in the current position.

464 Button

- Lock the engine regulation of superstructure engine.
The idling speed can be increased up to the maximum rpm.
- Can be „overridden“ by the engine regulation (gas pedal).
- At continued actuation of the engine regulation (gas pedal), the current rpm is taken over.
- By pressing the button **464** with the engine regulation (gas pedal) **NOT actuated**, the manual throttle is cancelled.
- If the engine rpm is locked, a „+“ appears on the LICCON monitor in the „dynamic engine rpm display“ (driving mode) and the „dynamic load utilization bar display“ (crane operation).
- Delete the lock by touching the gas pedal momentarily.

465 Button

- Horn

12.2 TE2 Function key assignment

471 F1 key

- You can change to the next menu in this sequence:
 - Menu „Climate control settings“
 - „Floodlight“ menu
 - Menu „Hydraulic oil preheating“

472 F2 key

- No function in the main menu TE2

473 F3 key

- Open / close slewing gear brake
or
- Ballast automatic out / in





474 F4 key

- Spool the assembly winch out / up
- Luff in with suspended load (icon **2.14**), see Crane operating instructions, chapter 4.20



12.3 TE2 main menu: Functions and assignment



Position	Icon	Assignment TE2
2.01		Display of master switch with deflection directions: Icon visible in main menu on every touch display

12.3.1 TE2 Touch functions











Position	Icon	Assignment TE2 Main menu: Touch functions
2.14	LMB 	Luff in with suspended load
2.10		Spool the assembly winch up
2.11		Spool the assembly winch out
2.12		Spooling the assembly winch up constantly

12.3.2 TE2 Assignment winches

Position	Icon	Assignment TE2 Main menu: Winches
2.20		Spool up winch 2
2.21		Spool winch 2 out; display of maximum winch speed in percentages
2.22		Spool up winch 6

Position	Icon	Assignment TE2 Main menu: Winches
2.23		Spool winch 6 out; display of maximum winch speed in percentages
2.24	Note: If a winch is blocked, the functions „spool winch up“ and „spool winch out“ can NOT be carried out!	
		Winch 2 is blocked

12.3.3 TE2 Assignment slewing gear and equipment

Position	Icon	Assignment TE2 Main menu: Slewing gear
2.30		Turn slewing gear to the left
2.31		Turn slewing gear to the right, display of maximum slewing gear speed in percentages
2.32		Slewing gear brake is released
2.33		Slewing gear brake is applied
2.34		Ballast automatic can be turned on
2.35		Ballast automatic can be turned off
2.36		Extend the assembly cylinder
2.37		Retract the assembly cylinder
2.38		Increase radius derrick ballast
2.38		Decrease radius derrick ballast

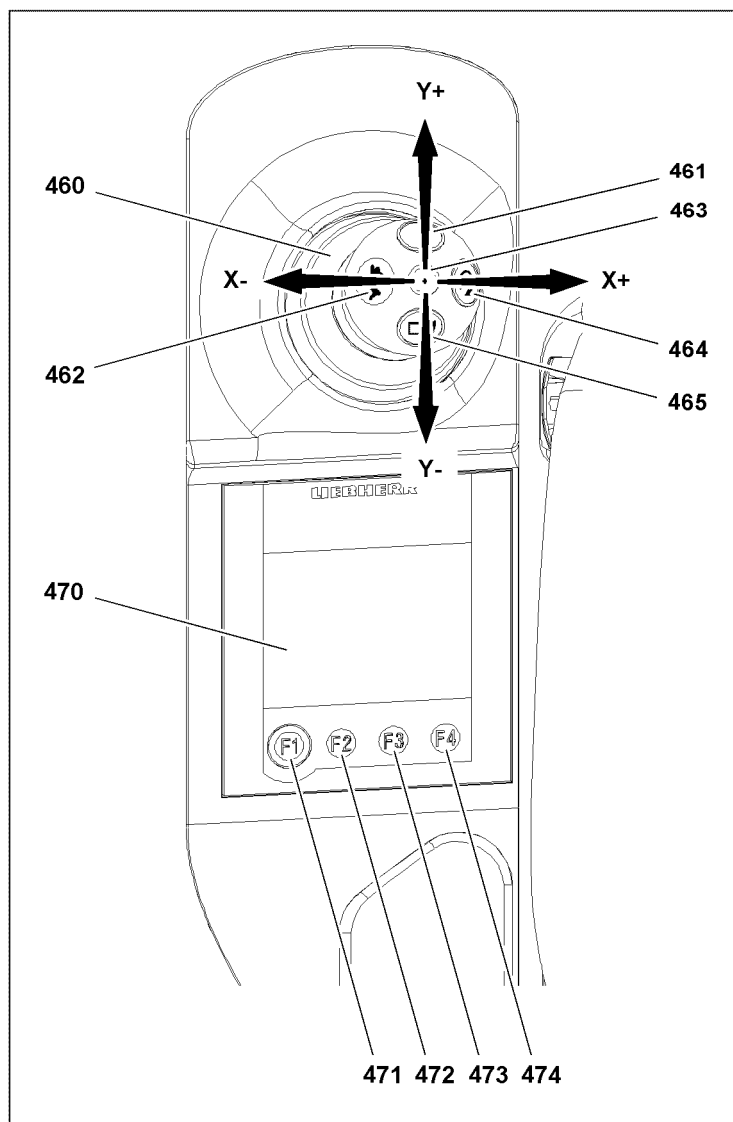

Fig.122218

12.4 TE2 Menu: „Climate control settings“ (Left touch display)

In the „Climate control settings“ menu the crane driver has the opportunity to make any heater, air conditioning and ventilation settings.



Note

- ▶ Refer to the Crane operating instructions, chapter 6.02 for a detailed description of the heater / air conditioning and ventilation settings.
- ▶ The Floodlight menu is solely available if the floodlight is installed and connected.
- ▶ „Touch“ on a touch function to activate the function.
- ▶ Only an activated function can be turned off or reduced in value with the F3 key **473**.
- ▶ Only an activated function can be turned on or increased in value with the F4 key **474**.
- ▶ The touch display changes 30 seconds after the last button actuation to the main menu.

12.4.1 TE Menu „Climate control settings“ function key assignment

- 471** F1 key
 - Change to the next menu
- 472** F2 key
 - „Minus“ - reduce stage / temperature or turn „OFF“



Note

- ▶ The **automatic climate control** can only be turned on if the climate control system **551** has been selected.

- 473** F3 key
 - „Plus“ - increase stage / temperature or turn „ON“
- 474** F4 key
 - Automatic climate control „ON“ / „OFF“

12.4.2 TE Menu „Climate control settings“ touch functions





Note





- ▶ „Touching“ a function in the „Climate control settings“ menu causes a black border to appear around the relevant icon (function selection) and at the same time the current setting, the selected stage or the on / off status („ON“ / „OFF“) for a function is displayed in the Status display **555**.
- ▶ Solely one function can be selected and edited in the „climate control settings“ menu.

Position	Icon	TE Menu „Climate control settings“ touch functions
551		Climate control system
552		Fan / blower
554		Auxiliary heater

LWE/LR 11000-001/23501-04-02/en

Position	Icon	TE Menu „Climate control settings“ touch functions
556		Air distribution
557		Recirculating air
560		Defroster

12.4.3 TE Menu „Climate control settings“ assignment

Position	Icon	TE Menu „Climate control settings“ assignment
555		Status display: The status display shows the different icons, depending on the selected function.
		Status display in this example: Automatic operation, temperature set to 15 °C.
558		Reduce temperature. After selecting a touch function: Decrease current size or conditions of a function, change current status of a function.
559		Increase temperature. After selecting a touch function: Increase current size or conditions of a function, change current status of a function.
561		Icon turned off in manual operation: Turn manual operation on.
562		Icon turned on in automatic operation: Turn automatic operation off.

Empty page!

LWE/LR 11000-001/23501-04-02/en

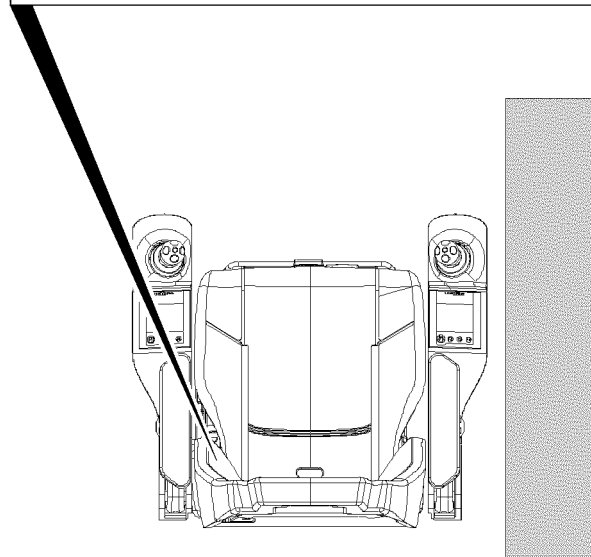
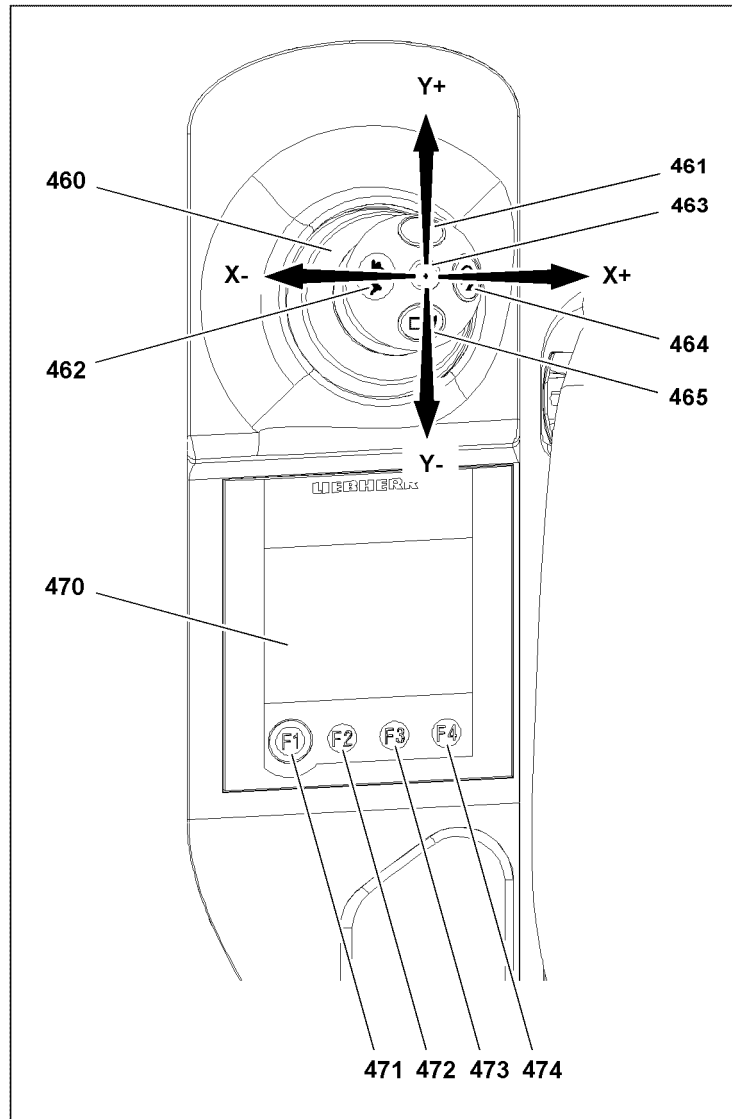

Fig.122218

LWE/LR 11000-001/23501-04-02/en

12.5 TE2 Menu „Working floodlight“ (left touch display)



Note

- ▶ The floodlight on the S-pivot section is installed together with the zoom camera on one control drive.
- ▶ The alignment and the adjustment of the working floodlight transfers automatically to the zoom camera.
- ▶ Functions of zoom camera, see section „Control unit camera monitoring“

In the floodlight menu the crane driver has the opportunity to manually align the working floodlight to suit the current load or the planned working range. In crane operation, the previously aligned floodlight changes its position according to the movement direction of the load (load-following) or the working range (fixed to working range).



Note

- ▶ The Floodlight menu is solely available if the floodlight is installed and connected.
- ▶ „Touch“ on a touch function to activate the function.
- ▶ Solely an activated function can be turned on or off with the F4 key **474**.
- ▶ The touch display changes 20 seconds after the last button actuation to the main menu.

12.5.1 TE Menu „Working floodlight“ function key assignment

- 471** F1 key
 - Change to the next menu
- 472** F2 key
 - **No** function
- 473** F3 key
 - One hook position: **No** function
 - From two hook positions: Select hook position
- 474** F4 key
 - Turning the floodlight on / off

12.5.2 „Floodlight“ TE menu assignment





Position	Icon	„Floodlight“ TE menu assignment
510		Turn the floodlight on / off.
511		From two hook positions: Select hook position.
512		Status display: The status display shows the different icons, depending on the selected function. This example shows the working floodlights turned off.
513		Status display: The status display shows the different icons, depending on the selected function. This example shows the working floodlights turned on.

12.5.3 TE Menu „Working floodlight“ touch functions

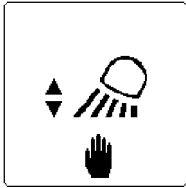

Note

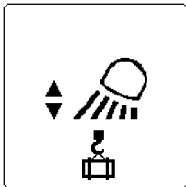
- ▶ Before the desired operating mode of the working floodlights is selected, set the initial position of the working floodlights manually.
- ▶ Set the initial position: In the operating mode „Working floodlight manual“ deflect the master switch 2 460 (MS2) left in direction Y+ or Y-.

Position	Icon	TE Menu „Working floodlight“ touch functions	Status display
515		Align the working floodlight „manually“.	
516		Set the working floodlight „following the load“ (icon shows sample setting for load position 5).	
517		Set working floodlight „fixed to working range“.	

Empty page!

LWE/LR 11000-001/23501-04-02/en

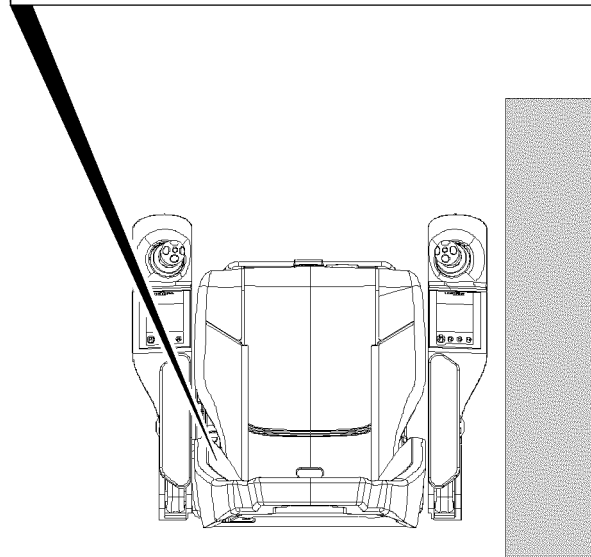
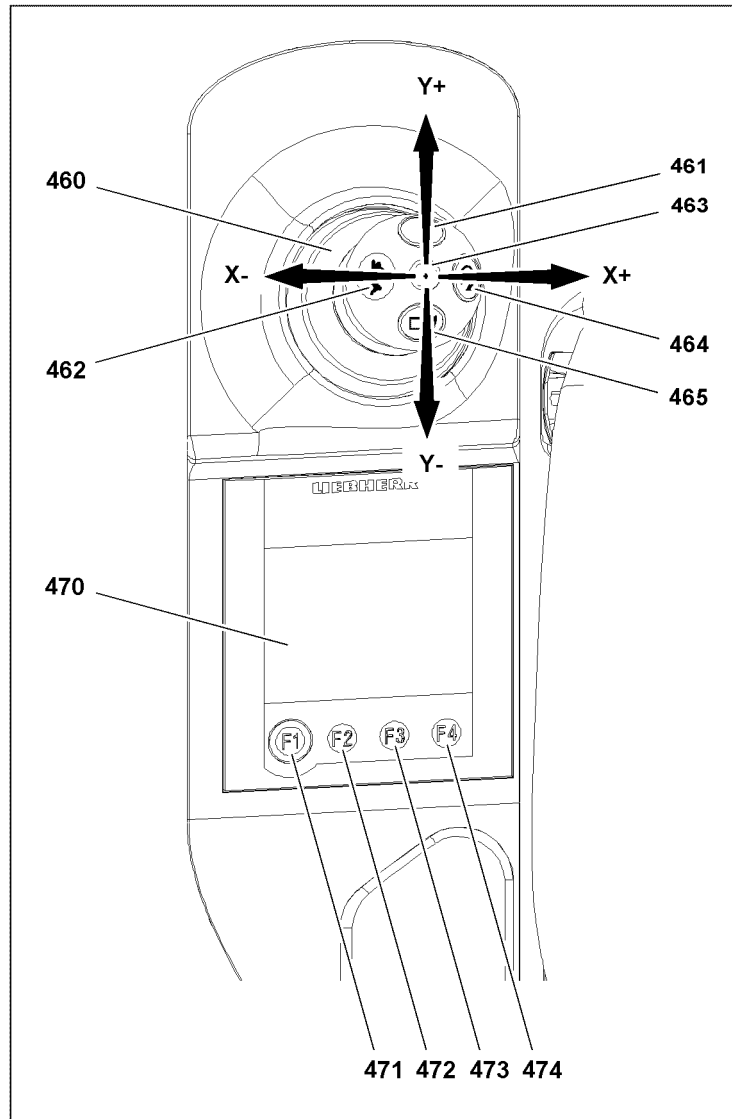

Fig.122218

LWE/LR 11000-001/23501-04-02/en

12.6 TE2 Menu: „Hydraulic oil preheating“ (Left touch display)



Note

- ▶ „Touch“ on a touch function to activate the function.
- ▶ Solely an activated function can be turned on or off with the F4 key **474**.
- ▶ The touch display changes 20 seconds after the last button actuation to the main menu.

12.6.1 „Hydraulic oil preheating“ TE menu function key assignment

- 471** F1 key
 - Change to the next menu
- 472** F2 key
 - **No** function
- 473** F3 key
 - **No** function
- 474** F4 key
 - Turn the hydraulic oil preheating on / off

12.6.2 TE Menu „Hydraulic oil preheating“ assignment

Position	Icon	TE Menu „Hydraulic oil preheating“ assignment
570		Turn the hydraulic oil preheating on / off

12.6.3 TE Menu „Hydraulic oil preheating“ touch functions

Position	Icon	TE Menu „Hydraulic oil preheating“ touch functions
575		Select / deselect hydraulic oil preheating

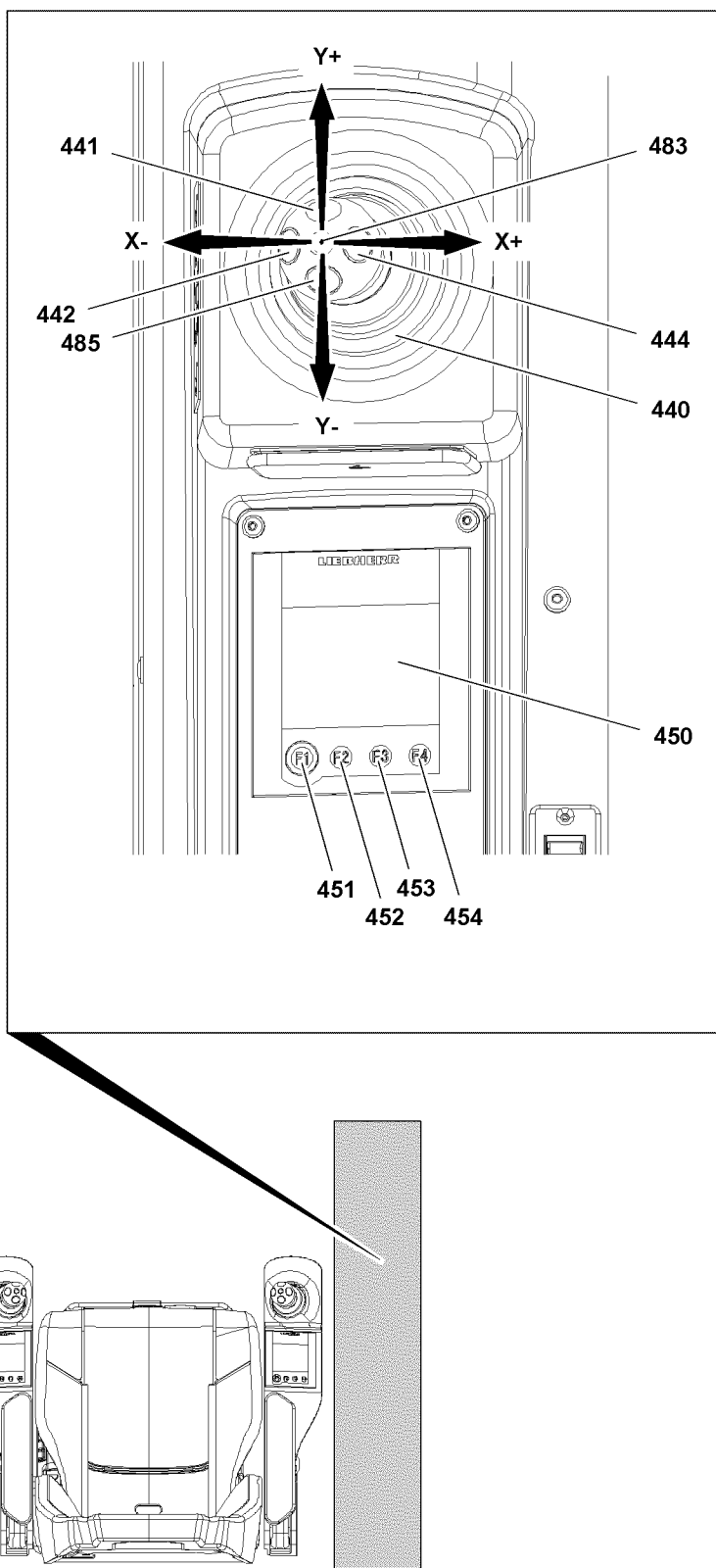

Fig.122219

LWE/LR 11000-001/23501-04-02/en

13 Master switch assignment MS3



Note

Change of master switch assignment!

The assignment of the master switches on the control platform to the respective units on the crane can change, depending on the set up configuration and winch application!

► **Check the assignment before actuating the master switch on the TE!**



Note

► For description of function of the master switches, see Crane operating instructions, chapter 4.05.

440 Master switch instrument panel (MS3)

- The functions for the master switch MS3 depend on the set up configuration and the selected master switch assignment on TE3.

441 Button

- Bypass of the seat contact button. **Or** if the seat contact button is actuated: Activation of the vibration sensor **443**

442 Button

- Addition „Power Plus“ for winch(es) and luffing up.

443 Vibration sensor

- Winch turn sensor, (vibrator) winch **or** turn sensor



Note

► Pressing the button **444** will lock the engine regulation in the current position.

444 Button

- Lock the engine regulation of superstructure engine.
The idling speed can be increased up to the maximum rpm.
- Can be „overridden“ by the engine regulation (gas pedal).
- At continued actuation of the engine regulation (gas pedal), the current rpm is taken over.
- By pressing the button **444** with the engine regulation (gas pedal) **NOT actuated**, the manual throttle is cancelled.
- If the engine rpm is locked, a „+“ appears on the LICCON monitor in the „dynamic engine rpm display“ (driving mode) and the „dynamic load utilization bar display“ (crane operation).
- Delete the lock by touching the gas pedal momentarily.

445 Button

- Horn

13.1 Function key assignment TE3

451 F1 key

- No function on TE3

452 F2 key

- No function on TE3

453 F3 key

- No function on TE3



WARNING

Incorrect travel direction!

When the travel direction is incorrectly interpreted, the crane moves in the opposite direction.

Persons and objects can be rolled over.







- Before starting to drive, make sure that the correct travel direction is actuated.
- In the case of uncertainty, monitor the travel route in both directions.
- Initiate travel movement very slowly and check the travel of direction driving as slow as possible.

- 454 F4 key
- Driving the crawler



13.2 TE3 main menu: Functions and assignment

Position	Icon	Assignment TE3
3.01		Display of master switch with deflection directions: Continuously visible icon on every touch display

13.2.1 TE3 Touch functions







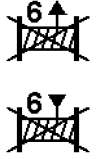

Position	Icon	TE3 main menu: Touch functions
3.10		Driving the crawler, normal travel crawler operation deactivated
		Driving the crawler, normal travel crawler operation activated, icon blinks
3.11		Driving the crawler, rapid gear crawler operation deactivated
		Driving the crawler, rapid gear crawler operation activated, icon blinks
3.12		Driving the crawler, parallel travel crawler operation deactivated
		Driving the crawler, parallel travel crawler operation activated, icon blinks



13.2.2 TE3 Assignment winches

Position	Icon	TE3 main menu: Assignment winches
3.20		Not present on all crane types. Spool winch 5 out; display of maximum winch speed in percentages
3.21		Not present on all crane types. Spool up winch 5
3.20		Spool winch 6 out; display of maximum winch speed in percentages





Position	Icon	TE3 main menu: Assignment winches
3.21		Spool up winch 6
3.22	Note: If a winch is blocked, the functions „spool winch up“ and „spool winch out“ can NOT be carried out!	
		Winch 6 blocked

13.2.3 TE3 Assignment boom and equipment

Position	Icon	TE3 main menu: Assignment Boom and equipment
3.30		Luff SW – luffing jib up
3.31		Luff SW – luffing jib down; display of maximum winch speed in percentages
3.32		Luff SW – main boom up
3.33		Luff SW – main boom down; display of maximum winch speed in percentages
3.34		Luff SD – derrick boom up
3.35		Luff SD – derrick boom down; display of maximum winch speed in percentages
3.36		Luff SDW – luffing jib up
3.37		Luff SDW – luffing jib down; display of maximum winch speed in percentages
3.38		Luff SDW – derrick boom up

Position	Icon	TE3 main menu: Assignment Boom and equipment
3.39		Luff SDW – derrick boom down; display of maximum winch speed in percentages
3.40	Note: If a crane movement is blocked, the functions „luffing up“ and „luffing down“ can NOT be carried out!	
	 	Boom and equipment: Crane movement is blocked, example SW, „luff luffing jib up“ and „luff luffing jib down“ can NOT be carried out.

13.2.4 TE3 Assignment support ballast trailer

Position	Icon	TE3 main menu: Assignment support ballast trailer
3.50		Extend the support ballast trailer at the front and at the rear. Support the ballast trailer.
3.51		Retract the support ballast trailer at the front and at the rear. Lower the ballast trailer on the wheels.
3.52		Support cylinder blocked at the front.
3.53		Support cylinder blocked at the rear.

4.02 LICCON computer system

1	General	3
2	System start of the LICCON computer system	5
3	Overview of general operating elements on the LICCON monitors	7
4	<i>Set up</i> program	12
5	The <i>Crane operation</i> program on LICCON monitor 0	71
6	The <i>Crane operation</i> program on LICCON monitor 1	157
7	The <i>Crane operation</i> program on LICCON monitor 2	179
8	Speed reduction master switch / pedal sensor	193
9	Power-Save mode and Stand-by mode in the LICCON computer system	201
10	The <i>Working range limitation</i> program	209
11	<i>Chart view</i> program: Curve illustration of load charts	216

Fig.195219

LWE/LR 11000-001/23501-04-02/en

1 General



Note

- ▶ The illustrations, icons and monitor illustrations in this chapter are only examples.
- ▶ The numerical values in the individual icons and charts do not have to necessarily match the crane exactly.
- ▶ Numbers and letters can be replaced by place holders.
- ▶ The display and assignment of the icons can deviate, depending on the set up configuration, operating status and configuration of the crane.
- ▶ In addition, many of the illustrations show the maximum configuration of the LICCON monitor with icons.
- ▶ In crane operation, an identical display will **not** appear on the LICCON monitor.

The LICCON computer system is a computer system for controlling and monitoring mobile and crawler cranes. In addition to the use of overload protection and load capacity display there are a number of application programs that can be used for controlling and monitoring the crane movements.

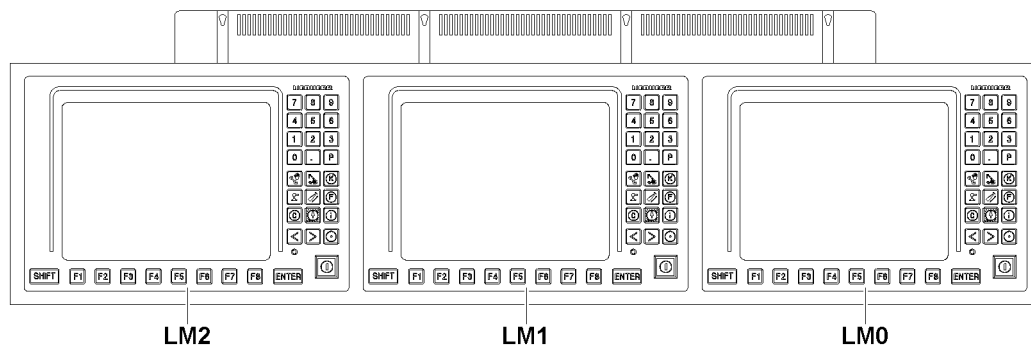

Fig.119921

The LICCON computer system is visualized among other possibilities via three LICCON monitors:

- **LM0** LICCON monitor 0
 - Placed on the right in the monitor arrangement
- **LM1** LICCON monitor 1
 - Placed in the center in the monitor arrangement
- **LM2** LICCON monitor 2
 - Placed to the left in the monitor arrangement



Note

- ▶ The electrical and electronic components are linked via data bus transmission technology (Liebherr System-Bus = LSB).

1.1 Overload protection

The overload protection includes limiters and displays (for example load capacity displays), which also alert to danger conditions via acoustical and optical warning signals.

The computer controlled part of the overload protection is called the LICCON overload protection. The LICCON overload protection is set by entering the set up configuration in the LICCON computer system.

The LICCON overload protection works, among other possibilities, according to the principle of comparing the current and actual load with the maximum load (also *Maximum load according to the load chart and reeving*) of the crane.

1.1.1 Acoustic and optical warning signals

The crane is equipped with acoustical and optical warning device to warn crane operator, auxiliary personnel and any person nearby.

Overview of acoustic / optical warnings, see Crane operating instructions, chapter 4.20.

1.1.2 Actual load

The actual load is determined by recording changing dimensions, the set up configuration and situational influences.

The **load on the crane** results from the load momentum, boom momentum as well as environmental and mechanical influences. The occurring moments and forces are measured and processed by the LICCON computer system.

The **load momentum** results from load and boom radius. The load includes load, fastening equipment and hook block / load hook. The boom radius is calculated with aid of the angle sensor information (boom angle) and the length of the boom system. This also takes into account the boom flexation due to its own weight and the weight of the load.

The **boom momentum** is calculated from the length of the boom system, the crane data (boom weights) and angle sensor information (boom angle).

Environmental and mechanical influences are recorded, determined and taken into account individually.

1.1.3 Maximum load according to load chart and reeving



Note

► The *Maximum load according to load chart and reeving* is also called *Maximum load* in the description.

The crane data such as load charts (also called load capacity charts), boom weights and geometry data are stored in the central data memory of the LICCON computer system.

The *maximum load according to load chart and reeving* value (maximum load) is constantly determined, based on the load charts, for the set up configuration, the set reeving, the calculated boom radius and additional influences.

1.1.4 Comparison

The *actual load* value and *maximum load* value are compared. When they approach the specified limit, an advance warning is issued by the overload protection. If this limit is exceeded, the overload protection turns the load moment increasing crane movements off.

1.2 Error messages

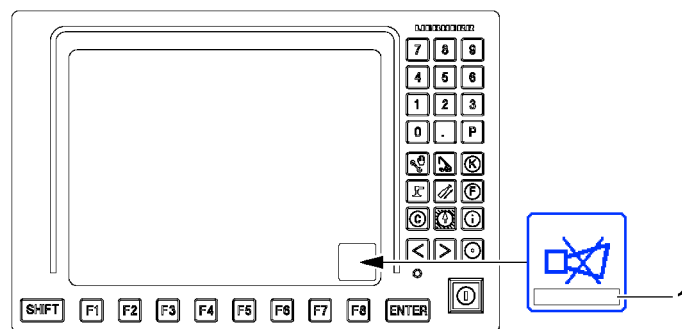

Fig.119922

The LICCON computer system monitors the crane permanently for operating and system errors.

If operating and / or system errors occur, error messages **1** are issued. Error messages appear in the *Horn* icon of the LICCON monitor.



Note

- ▶ Always pay attention to error messages **1**.
- ▶ For procedure in case of error messages, see Diagnostics manual and the respective chapter in the Crane operating instructions.

2 System start of the LICCON computer system

There are two operating modes for the LICCON computer system:

- LICCON computer system in normal mode (crane engine turned on).
- LICCON computer system in stand-by mode (crane engine turned off).

Starting in normal mode:

- System start of LICCON computer system in connection with a started crane engine.

Starting in stand-by mode:

- See Section „LICCON computer system in stand-by mode“.

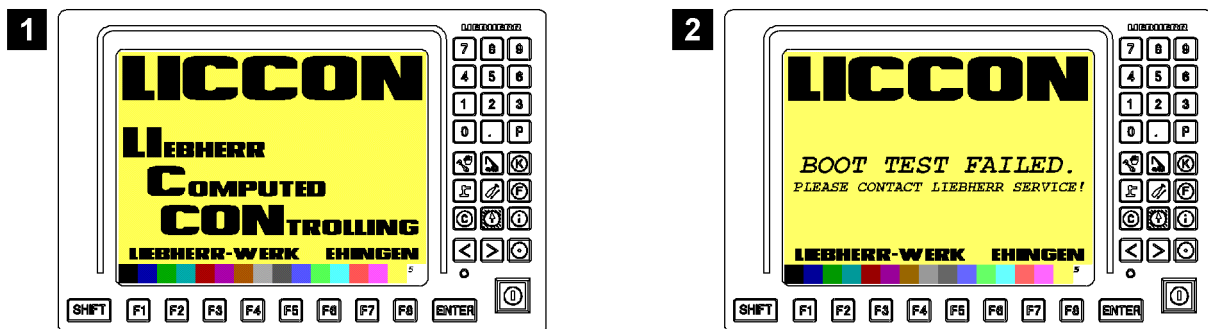

Fig.119923

All the components of the LICCON computer system run through a self-test after turning the computer on.

During the self test, the start screen of the LICCON computer system appears on all LICCON monitors, see illustration 1.



Note

Error during the system start of the LICCON computer system.

If an error is found during the system start of the LICCON computer system, then the system start procedure is interrupted, see illustration 2.

- ▶ Consult Liebherr Service if an error occurs during system start.

2.1 The LICCON monitors at system start

After successful self test and system start, every LICCON monitor changes into a separate view.

2.1.1 LICCON monitor 0

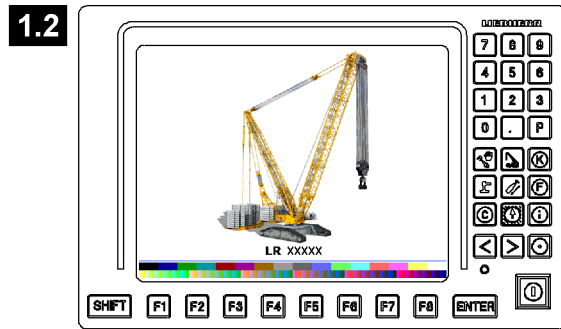
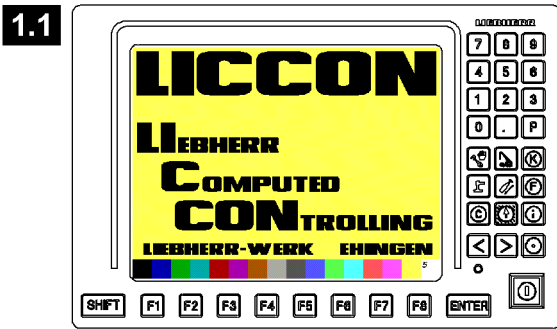

Fig.119916

During the self test, the start screen appears, illustration 1.1.

After successful starting procedure, a wall paper of the crane appears on the **LICCON monitor 0** for a few seconds, see illustration 1.2.

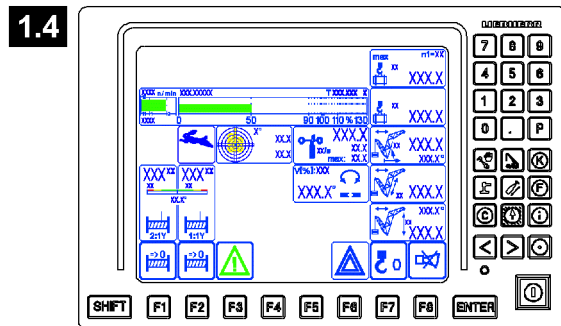
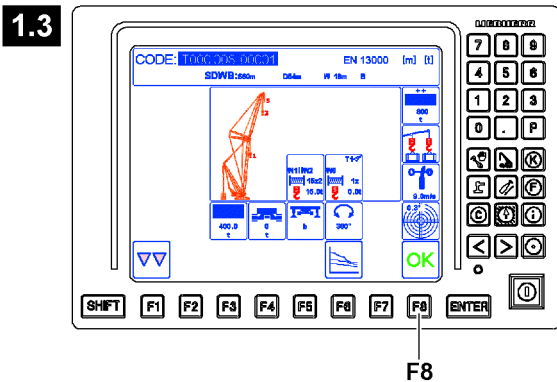

Fig.119936

When the last set up configuration appears (see example illustration 1.3), then system start on **LICCON monitor 0** is completed.

The existing set up configuration or a newly entered set up configuration must be confirmed with the function key **F8**.

Then the crane operating screen appears for **LICCON monitor 0**, see illustration 1.4.

2.1.2 LICCON monitor 1

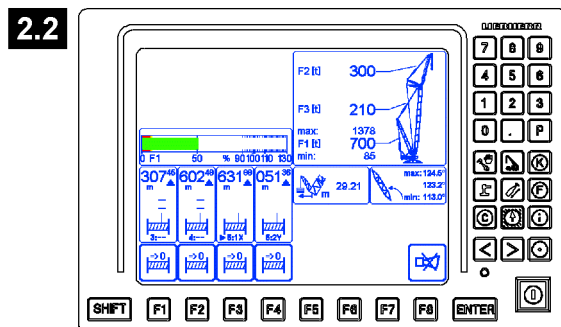

Fig.119924

During the self test, the start screen appears, illustration 2.1.

After successful starting procedure, a respective operating screen appears on **LICCON monitor 1**, see example illustration 2.2.

2.1.3 LICCON monitor 2

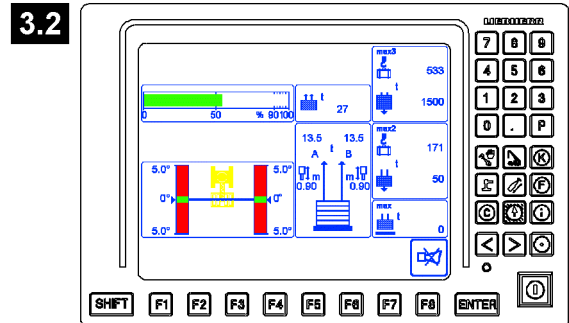
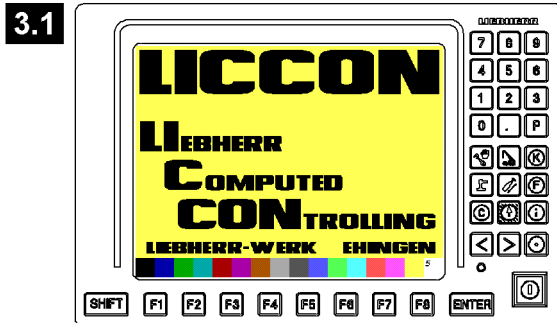

Fig.146955

During the self test, the start screen appears, illustration 3.1.

After successful starting procedure, a respective operating screen appears on **LICCON monitor 2**, see example illustration 3.2.

3 Overview of general operating elements on the LICCON monitors

All LICCON monitors are optically the same, the installation location is the deciding factor for the function of the operating elements.

In addition, the functions of the individual monitor operating elements are program-dependent and can differ, depending on the currently running LICCON program. This will be described in more detail in the description of the individual LICCON programs.

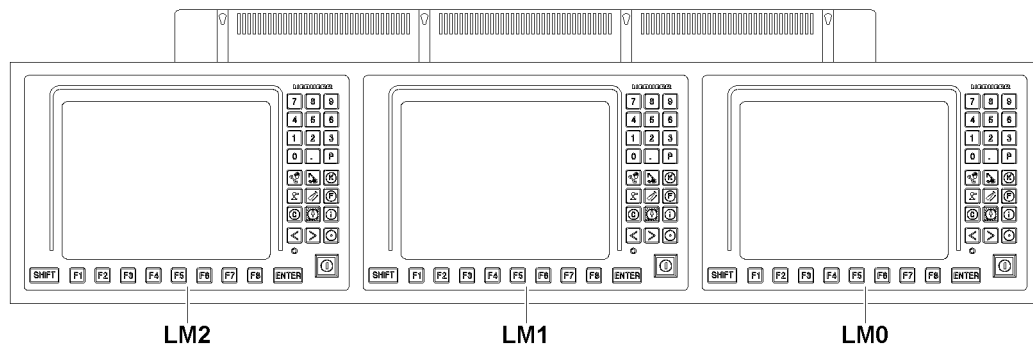

Fig.119921

- LM0** LICCON monitor 0
 - Placed on the right in the monitor arrangement
- LM1** LICCON monitor 1
 - Placed in the center in the monitor arrangement
- LM2** LICCON monitor 2
 - Placed to the left in the monitor arrangement

LWE/LR 11000-001/23501-04-02/en

3.1 General operating elements on LICCON Monitor 0

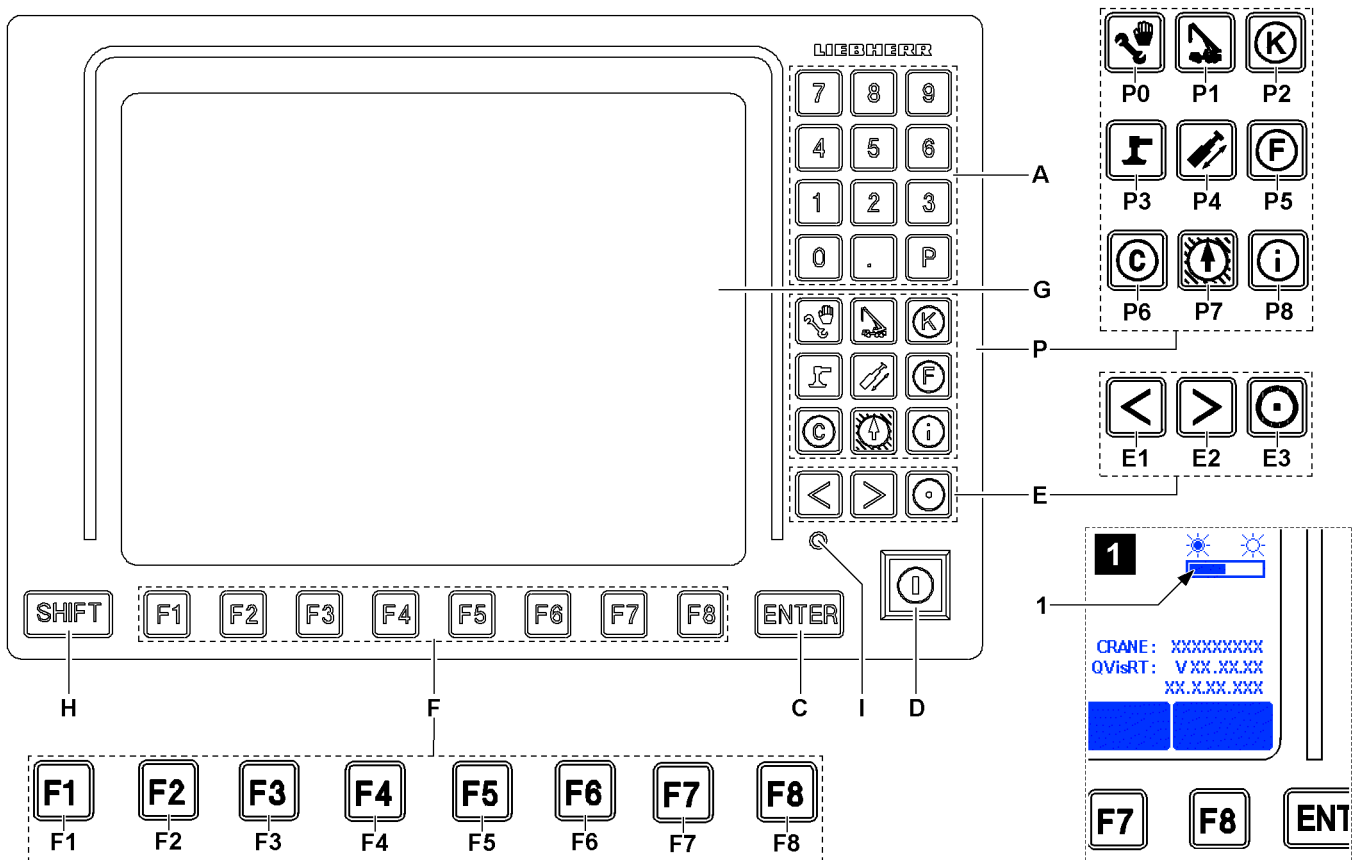

Fig.120677

- A** Keypad
 - Function is program dependent
- P** Program keys
 - Selection of the individual LICCON programs
- P0** Set up
 - Call up the *Set up* program
- P1** Crane operation
 - Call up the *Crane operation* program
- P2** Chart view
 - Call up the *Chart view* program
- P3** —
 - Program key not assigned.
- P4** —
 - Program key not assigned.
- P5** —
 - Program key not assigned.
- P6** —
 - Program key not assigned.
- P7** Working range limitation*
 - Call up the *Working range limitation* program
- P8** Test system
 - Call up the *Test system* program
 - **Note:** Test system description, see the Diagnostics manual.

- C** ENTER key
 - Confirmation of changes in running program
- D** Set up key
 - Zero position (not actuated):
Normal operation.
 - Touching:
Function *Exceedance of shut off limits of LICCON overload protection* is released and / or the hoist limit switch is bypassed

**Note**

- ▶ By actuating the set up key **D**, all erection / take down procedures can be carried out within the erection / take down charts, for which no load charts are available.

- E** Special function keys
 - Functions of the special function keys are program-dependent and are further explained in the description of the individual LICCON programs.
 - **Monitor brightness adjustment:**
 - Press **E3** (hold down) and **E1**: 6-stage night design.
 - Press **E3** (hold down) and **E2**: Brightness setting in 7 stages.
The brightness adjustment can be made from all available programs (for example: Set up, Crane operation).

**Note**

Automatic brightness adjustment of the LICCON monitor

The brightness of the LICCON monitor can be matched to the existing light conditions automatically or manually.

The current brightness setting of the LICCON monitor can be seen via the bar display in the starting screen of the test system program (illustration 1).

- ▶ In brightness setting *medium brightness* the automatic brightness adjustment is **activated**.
- ▶ In brightness setting *lowest brightness* the automatic brightness adjustment is **inactive**.
- ▶ In brightness setting *highest brightness* the automatic brightness adjustment is **inactive**.

- F** Function keys
 - The function keys should always be viewed in conjunction with the function key icon line displayed on the display **G**.
- G** Display
 - In the display appears a program-dependent operating screen
- H** SHIFT key
 - Second-level key assignments, for example Supervisory function
- I** Indicator light
 - Indicator light for the supply voltage of the monitor

3.2 General operating elements on LICCON Monitor 1

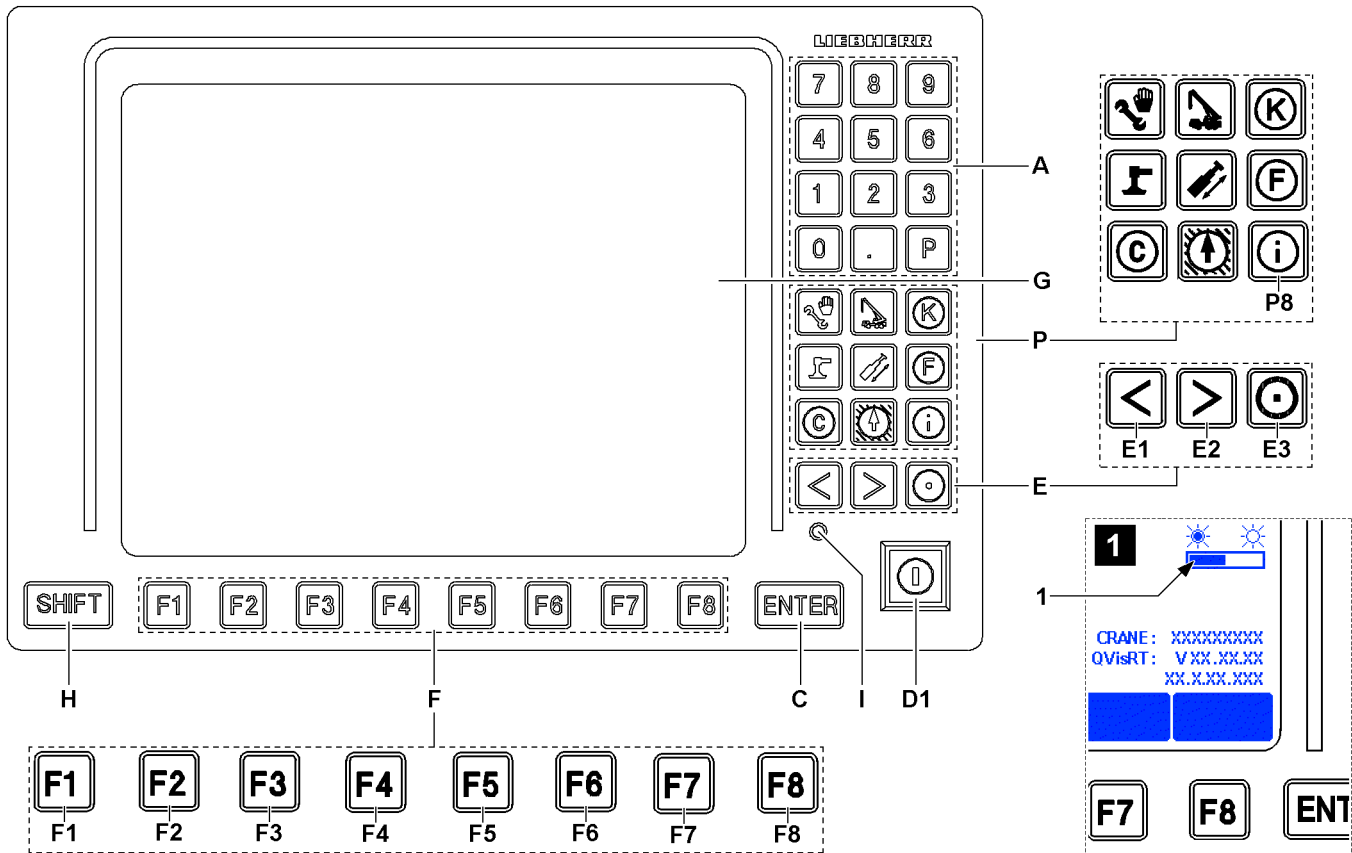

Fig.125385

- A** Keypad
 - Function is program dependent
- P** Program keys
 - Only program key Test system **P8** with function
- P8** Test system
 - Call up the *Test system* program
 - **Note:** Test system description, see the Diagnostics manual.
- C** ENTER key
 - Confirmation of changes in running program
- D1** Key button
 - No function
- E** Special function keys
 - Functions of the special function keys are program-dependent and are further explained in the description of the individual LICCON programs.
 - **Monitor brightness adjustment:**
 - Press **E3** (hold down) and **E1**: 6-stage night design.
 - Press **E3** (hold down) and **E2**: Brightness setting in 7 stages.
 - **Note:** See also section „Operating elements LICCON monitor 0“
- F** Function keys
 - The function keys should always be viewed in conjunction with the function key icon line displayed on the display **G**.
- G** Display
 - In the display appears a program-dependent operating screen
- H** SHIFT key
 - Second-level key assignments, for example Supervisory function

- I Indicator light
 - Indicator light for the supply voltage of the monitor

3.3 General operating elements on LICCON Monitor 2

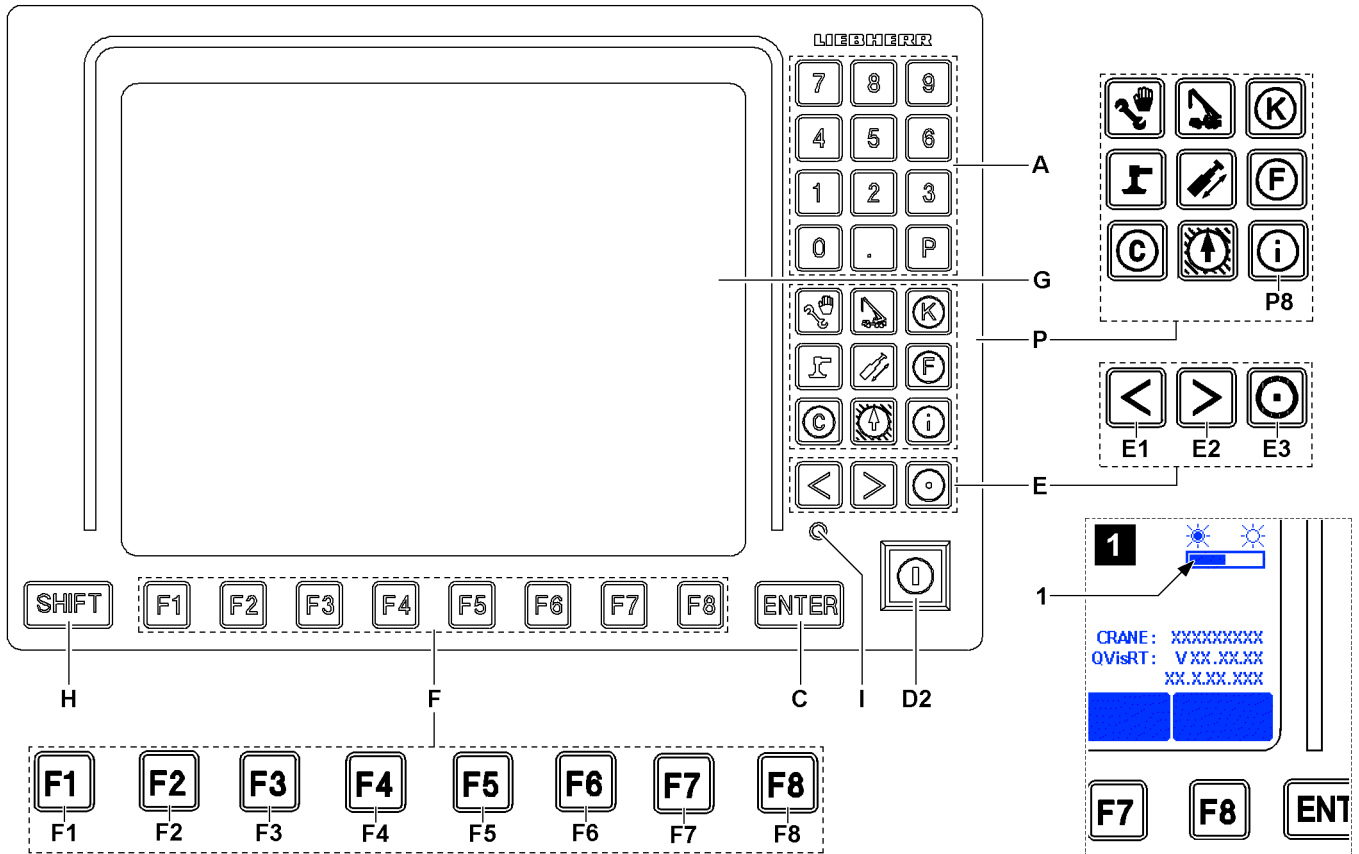

Fig.125386

- A** Keypad
 - Function is program dependent
- P** Program keys
 - Only program key *Test system P8* with function
- P8** Test system
 - Call up the *Test system* program
 - **Note:** Test system description, see the Diagnostics manual.
- C** ENTER key
 - Confirmation of changes in running program
- D2** Key button
 - Change over regulation Parallel operation winch 1 and winch 2.
 - **Note:** Only active for parallel operation of winch 1 and winch 2.
- E** Special function keys
 - Functions of the special function keys are program-dependent and are further explained in the description of the individual LICCON programs.
 - **Monitor brightness adjustment:**
 - Press **E3** (hold down) and **E1**: 6-stage night design.
 - Press **E3** (hold down) and **E2**: Brightness setting in 7 stages.
 - **Note:** See also section „Operating elements LICCON monitor 0“
- F** Function keys
 - The function keys should always be viewed in conjunction with the function key icon line displayed on the display **G**.

LWE/LR 11000-001/23501-04-02/en

- G Display
 - In the display appears a program-dependent operating screen
- H SHIFT key
 - Second-level key assignments, for example Supervisory function
- I Indicator light
 - Indicator light for the supply voltage of the monitor

4 Set up program



Note

- ▶ The monitor illustrations in this chapter are only examples.
- ▶ The numerical values in the individual icons and charts do not have to necessarily match the crane exactly.
- ▶ Numbers and letters can be replaced by place holders.
- ▶ The programmed load charts for the crane are binding.



WARNING

Danger of accident due to deviating set up configuration!

If the actual set up configuration of the crane deviates from the entries and settings in the *Set up* program, then the overload protection is not correctly set.

An incorrectly set overload protection calculates the actual load incorrectly and transmits faulty display values.

The crane can be overloaded unnoticed and topple over. Personnel can be severely injured or killed.

- ▶ The entries and settings in the *set up* program must match the actual set up configuration of the crane.

After correct system start of the LICCON computer system, it changes automatically into the *Set up* program. The set up screen is shown in the *Set up* program.

The program can also be called up via the program key, see section „Operating elements LICCON Monitor 0“.

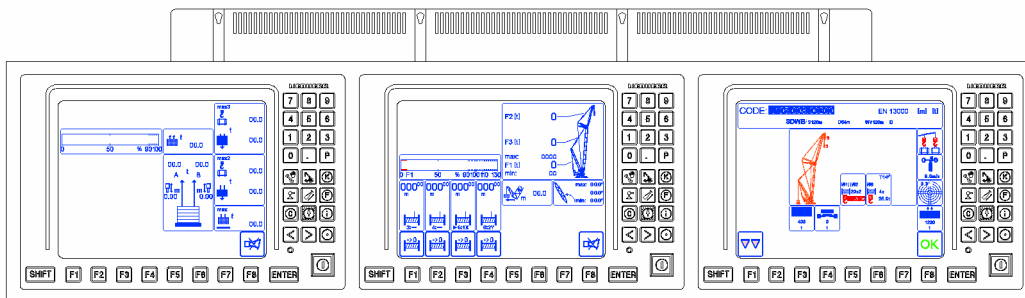

Fig.146956



Note

- ▶ All entries and settings, which are to be made by the crane operator in the *Set up* program can only be carried out on **LICCON monitor 0**.
- ▶ The LICCON monitor 0 is located on the right in the monitor arrangement.



Note

Adjustment and display of set up configuration and reeving.

- ▶ Normally, after booting up the LICCON computer system, the most recently used set up configuration and the reeving used at that time will be automatically set and displayed.

The crane operator must enter and set the actual set up configuration of the crane in the *Set up* program. The LICCON computer system will then set the overload protection accordingly with these entries and settings.

4.1 Screen display in the *Set up* program

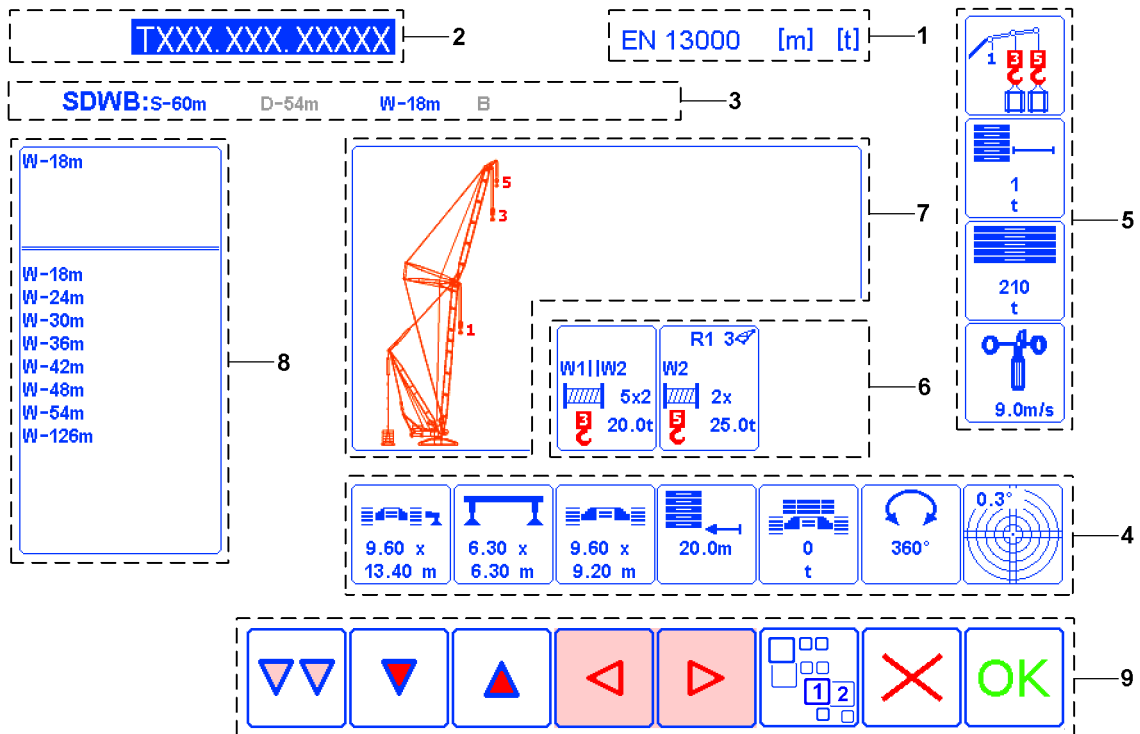

Fig.120678: Example of Screen display in the *Set up* program

The screen display in the *Set up* program consists of the following program categories:

- 1 Unit category
 - Measuring units with which the crane control works are displayed.
- 2 Chart name category
 - The set chart name (chart number) is displayed.
- 3 Operating mode category
 - The set operating mode is displayed.
- 4/5 Set up functions
 - 4 Set up completion category
 - The set values for the set up completion are displayed.
 - 5 Environmental / mechanical influence category
 - The set values for environmental / mechanical influence are displayed.
- 6 Lifting category
 - The set hoist winch operation is displayed.
 - The set hoist winch assignment is displayed.
 - The set reeving is displayed.
 - The set hook weight is displayed.

As well as program comprehensive:

- 7 Display window
 - The set operating mode is symbolized.
 - The possible hook positions are displayed.
- 8 Editing / selection window
 - Possible settings and values for editing or selecting are displayed.

9 Function key icons

- Functions assigned to the function keys are displayed as icons.

4.2 Control elements in the set up program

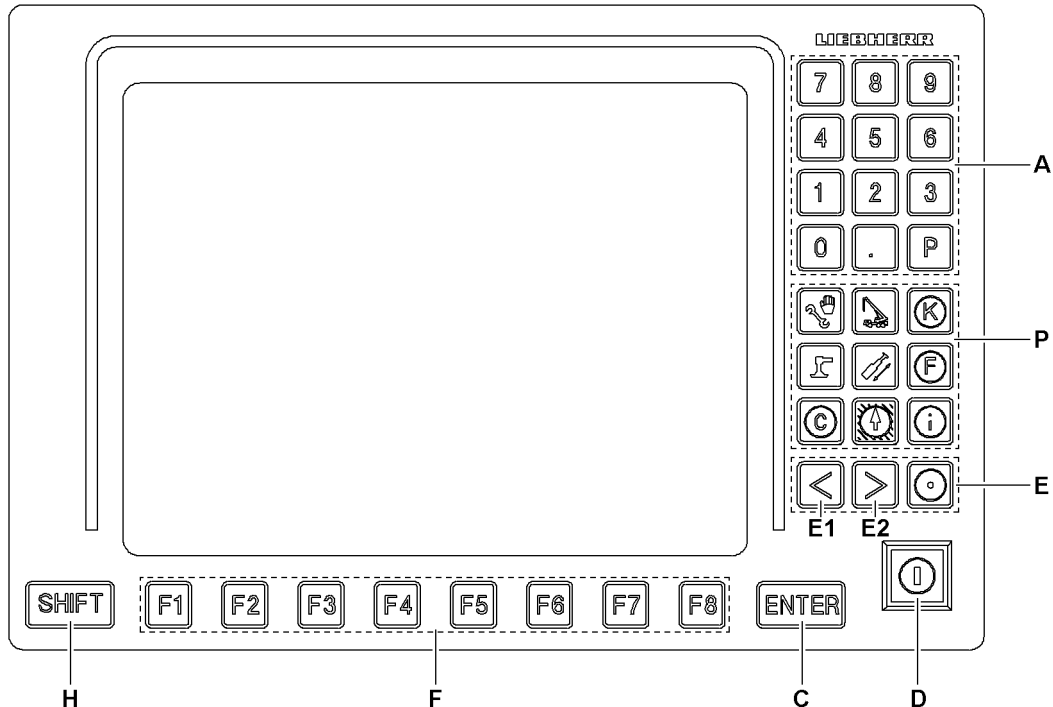

Fig.119927

A Keypad

- The keys **0** to **9** on the keypad can be used to enter the respective number directly.
- Decimal digits can be created with the key „.“
- The „P“ button has no function in the *Set up* program.

P Program keys

- Selection of individual programs. The settings in the set up program are discarded and the set up configuration, which was last confirmed with the function key **F8** (OK) is used.
- A program that is currently running **cannot** be called up again using its program key.

C ENTER key

- Entry confirmation for selections made or for edited values.
- ENTER key **C** after entering the chart name (chart number) searches the corresponding operating mode. If an error is present, a short beep sounds.
- ENTER key **C** after changing / editing within a category sets the new value

D Set up key

- Has no function in the *Set up* program

E Special function keys

- **Note:** The key **E1** in the *Set up* program has the same function as function key **F4**.
The key **E2** in the *Set up* program has the same function as function key **F5**.

F Function keys

- The function key line consists of function keys **F1** to **F8** and the function key icon bar above it.
- The function keys correspond to the various function key icons above them.

H SHIFT key

- No function

4.3 The function key line in the set up program

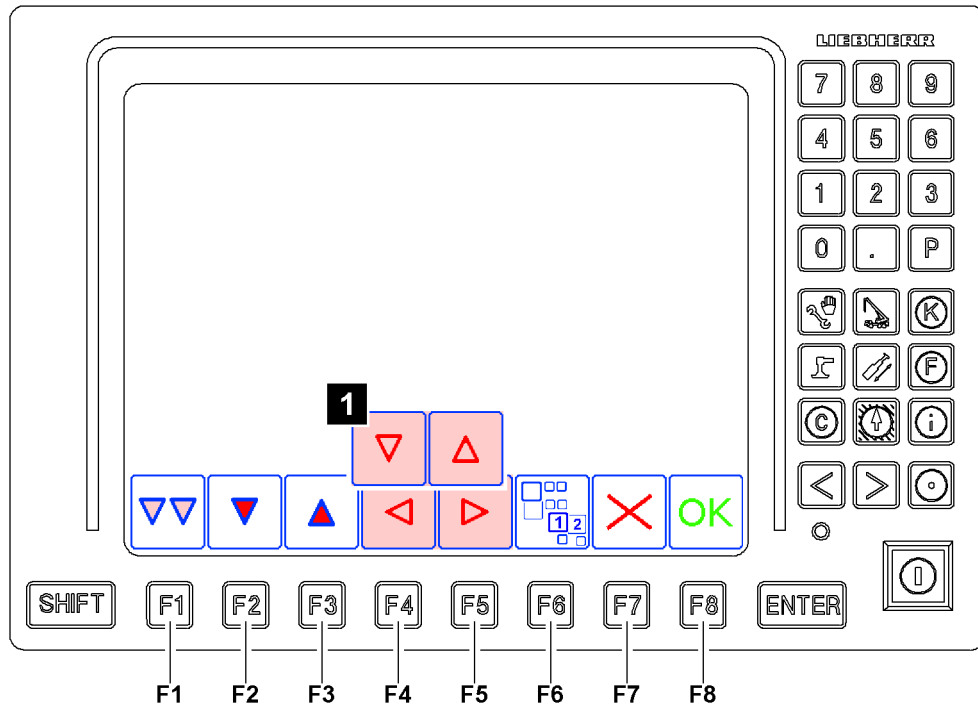

Fig.119928

The function key line consists of function keys **F1** to **F8** and the function key icon bar above it. The function keys correspond to the various function key icons above them.



Note

► Not all function keys on the LICCON monitor are always active and assigned with icons. Only when a function key is presently available is the corresponding icon shown.

- F1** Function key
 - Change to the next category by pressing the function key **F1**.
 - **Note:** The active category is highlighted in pink.
- F2** Function key
 - Navigation in Editing / selection window: change downward
 - **Note:** If it is not possible to change further downward, a short beep sounds.
- F3** Function key
 - Navigation in Editing / selection window: change upward
 - **Note:** If it is not possible to change further upward, a short beep sounds.
- F4** Function key
 - Navigation in the pink highlighted (active) program category
 - Left arrow: change within the selection to the left
 - Down arrow, Illustration 1: change within the selection downward
 - **Note:** If it is not possible to change further in the direction a short beep sounds.
- F5** Function key
 - Navigation in the pink highlighted (active) program category
 - Right arrow: change within the selection to the left
 - Up arrow, Illustration 1: change within the selection downward
 - **Note:** If it is not possible to change further in the direction a short beep sounds.
- F6** Function key
 - If additional levels are present, then they can be selected by pressing the function key **F6**.

- F7** Function key
 - Reset the *Set up* program to the last valid set up configuration
- F8** Function key
 - Take over the current settings as the new set up configuration.
 - **Note:** By pressing the function key **F8**, the *Set up* program is completed and the *Crane operation* program is called up.

4.4 Setting the set up configuration in general

Make sure that the following prerequisite is met:

- There is no load on the hook.

The set up configuration is set in the following program categories:

- Operating mode category
- Set up completion category
- Environmental / mechanical influence category
- Lifting category



WARNING

Incorrect operation in *Set up* program!

The *Set up* program is only correctly carried out when **all** program categories are set and the actual configurations for crane and environment are depicted.

Incorrect operation in the *Set up* program leads to an incorrectly set overload protection.

An incorrectly set overload protection calculates the actual load incorrectly and transmits faulty display values.

The crane can be overloaded unnoticed and topple over. Personnel can be severely injured or killed.

- ▶ In the *Set up* program, always set **all** program categories according to the actual configurations of crane and environment.
- ▶ Before taken over the settings in the *Set up* program, check all program categories.



Note

In the following sections it is described by example how it is changed from the basic setting of the crane into a more extensive operating mode.

All entries and settings can therefore be explained by example.

- ▶ If the required operating mode deviates, make your own entries and settings and do not skip required steps.

4.5 Structure of the operating mode category

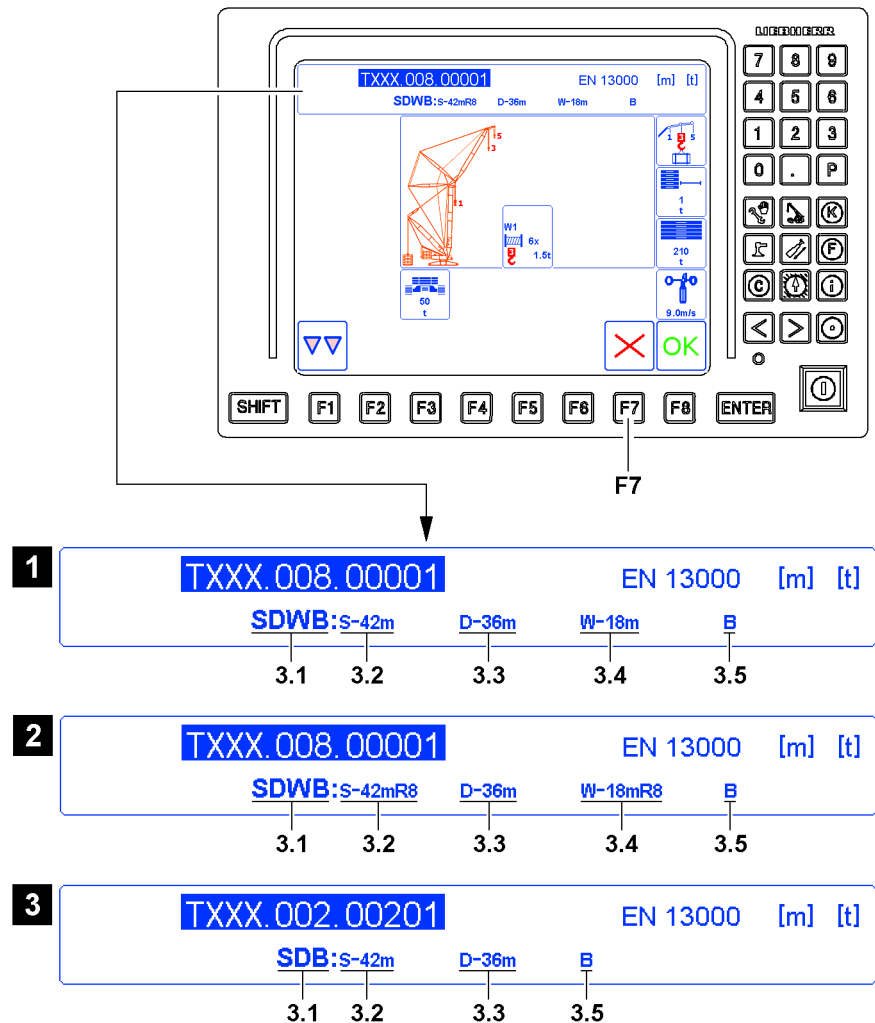

Fig.119915

The components of the boom system can be combined with each other to operating modes according to certain rules.

The individual components are coded via markers.

The operating mode consists of up to five markers, see illustration 1.

The operating mode is set in the operating mode category.

Markers for operating mode in the *Set up* program:

- 3.1** Abbreviation
 - Abbreviation of operating mode
- 3.2** Main boom
 - Type and length of main boom
 - **Note:** On some main booms various roller sets can be additionally set up, see illustration 2
- 3.3** Derrick boom
 - Length of derrick boom
 - **Note:** Appears only in corresponding operating mode.
- 3.4** Auxiliary boom / accessory
 - Type and length of auxiliary boom / accessory
 - **Note:** On some auxiliary booms various roller sets can be additionally set up, see illustration 2.

- **Note:** Appears only in corresponding operating mode.

3.5 Derrick ballast

- Version of derrick ballast
- **Note:** Appears only in corresponding operating mode.



Note

- ▶ If a marker for an operating mode does not appear, then the following markers move up, see example illustration 3.
- ▶ If the *Abort* icon appears above a function key **F7**, then the procedure can be aborted at any time. All entries and settings made up to that point are discarded.

The operating mode can be set two ways:

- Setting the operating mode via chart names (chart number)
- Setting the operating mode via the function keys

4.6 Setting the operating mode via chart name (chart number)

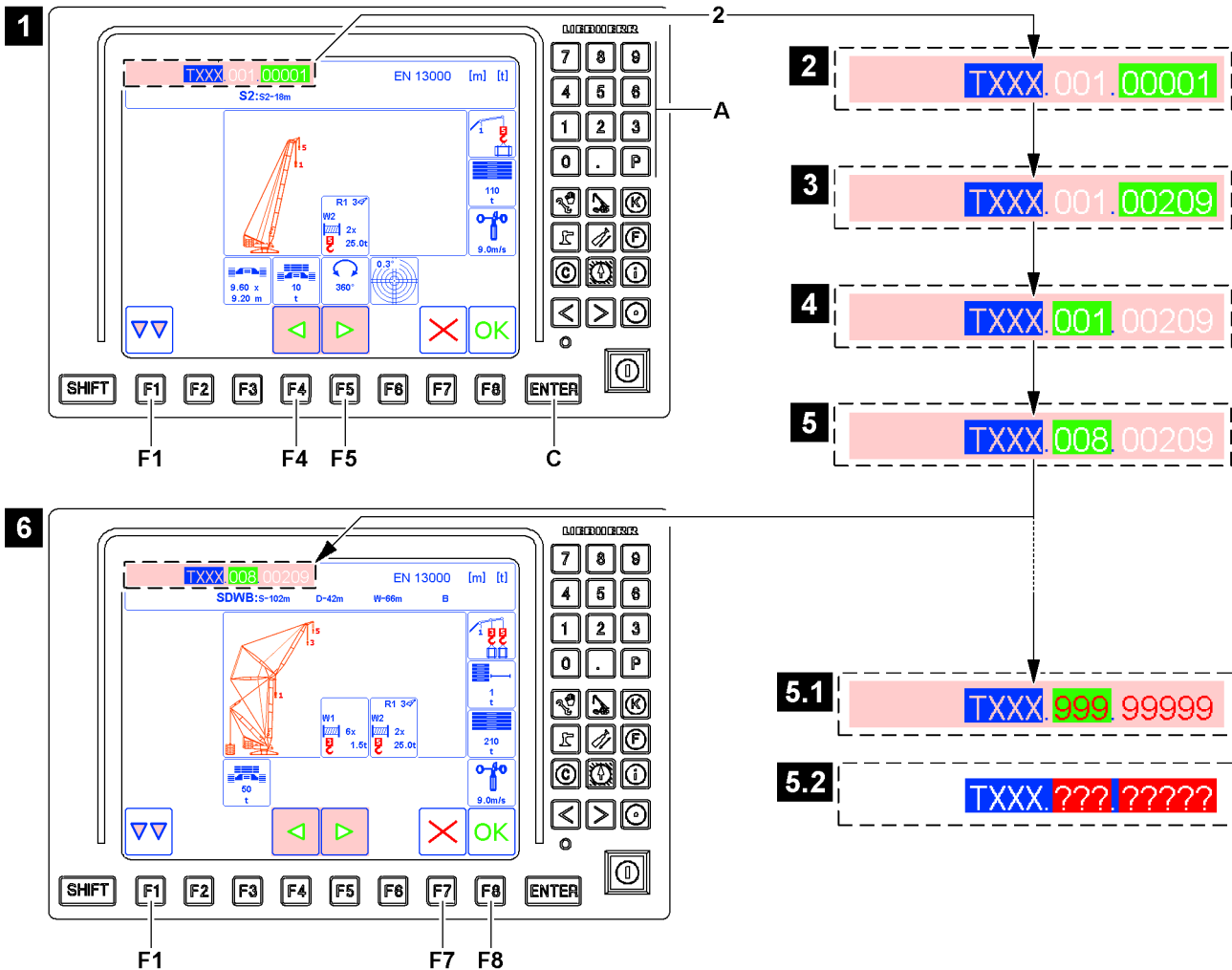

Fig.120679



Note

- The following section describes by example how a certain chart name (chart number) is entered.
- ▶ Always enter the required chart name (chart number).
- ▶ If the *Abort* icon appears above a function key **F7**, then the procedure can be aborted at any time. All entries and settings made up to that point are discarded.

LWE/LR 11000-001/23501-04-02/en

Make sure that the following prerequisites are met:

- The *Set up* program is called up.
- The required chart name (chart number) is known.

▶ Press the function key **F1** until the chart name category **2** is highlighted in pink, see illustration 1.

Result:

- The chart name category **2** is active. The editable area of the chart name (chart number) is additionally highlighted in green.



Note

Navigation in the chart name category **2**

- ▶ Press the function key **F4**: The editable area changes to the left.
- ▶ Press the function key **F5**: The editable area changes to the right.

When the rear five digits of the chart name (chart number) are highlighted in green (illustration 2):

- ▶ Enter the number sequence via the keypad **A**, in example „00209“.

Result:

- In the editable area of the chart name (chart number), the entered number sequence is shown, see illustration 3.

▶ Press the function key **F4**.

Result:

- The editable area of the chart name (chart number) changes, see illustration 4.

When the center three digits of the chart name (chart number) are highlighted in green (illustration 4):

- ▶ Enter the number sequence via the keypad **A**, in example „008“.

Result:

- In the editable area of the chart name (chart number), the entered number sequence is shown, see illustration 5.

▶ Accept the chart name (chart number) with the ENTER key **C**.

Result:

- The chart names (chart number) are accepted.
- The screen display is matched, see illustration 6.

Problem remedy

Invalid chart name (chart number)

When trying to accept an invalid number sequence, the numbers are displayed in red (illustration 5.1) or replaced by red question marks („?“) (illustration 5.2).

- ▶ Enter and accept only valid chart names (chart number).

4.7 Setting the operating mode via the function keys



Note

The following section describes by example how a certain operating mode is entered.
 ► Always enter the required operating mode.

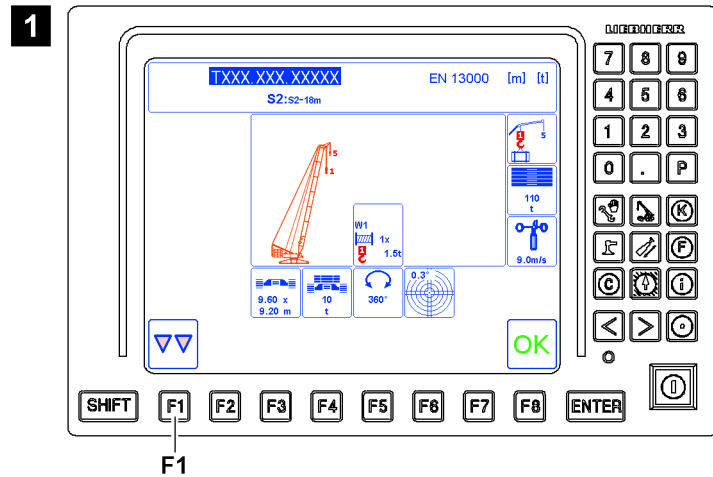

Fig.119929

Make sure that the following prerequisite is met:
 – The Set up program is called up, see illustration 1.

4.7.1 Selecting the operating mode category

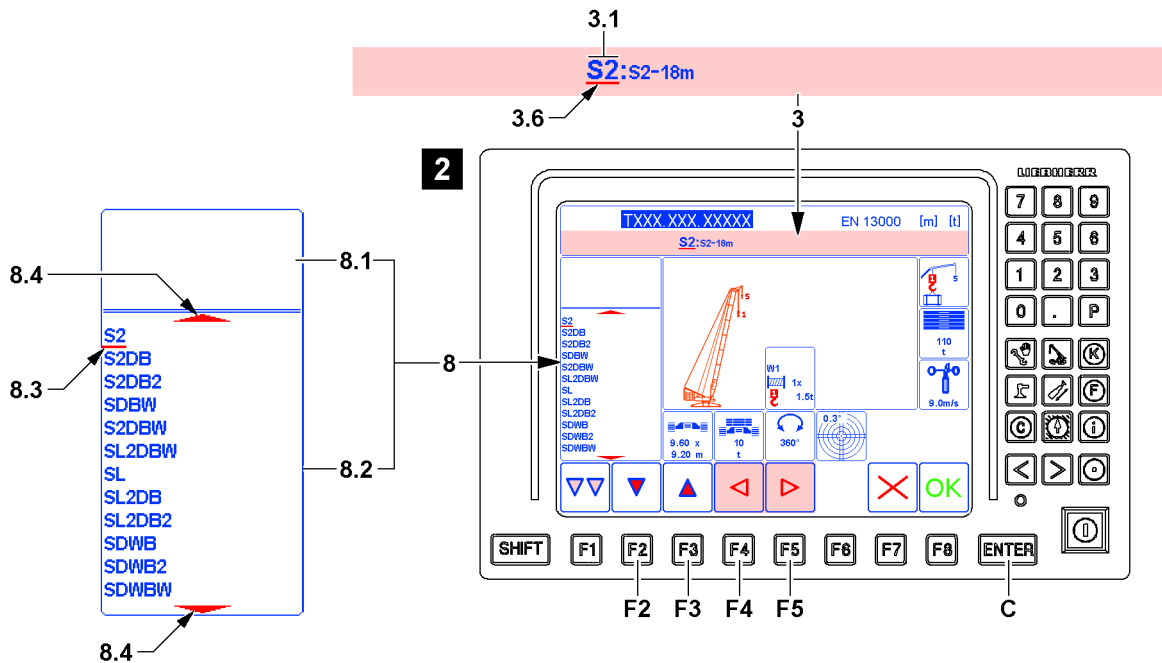

Fig.119919

► Press the function key F1 until the operating mode category 3 is highlighted in pink, see illustration 2.

Result:

- The operating mode category 3 is selected.
 The selection bar 3.6 automatically underlines the first marker: Abbreviation 3.1

- The Editing / selection window **8** appears.
- In the lower area **8.2** of the Editing / selection window **8** the abbreviations available for selection are displayed.
- Above function key **F2**, function key **F3**, function key **F4** and function key **F5** appear the icons for navigation in the individual program categories.



Note

Navigation in the operating mode category **3**

- ▶ Press the function key **F4**: The selection bar **3.6** moves to the left.
- ▶ Press the function key **F5**: The selection bar **3.6** moves to the right.



Note

Navigation in Editing / selection window **8**

- ▶ Press the function key **F2**: The selection bar **8.3** changes downward by one line.
- ▶ Press the function key **F3**: The selection bar **8.3** changes upward by one line.
- ▶ If a directional triangle **8.4** appears on the upper and lower end of a window, additional selection possibilities are present in this direction.
- ▶ When the upper area **8.1** and the lower area **8.2** are assigned: Press the ENTER **C** key and change between the upper area **8.1** and the lower area **8.2**.

4.7.2 Selecting the abbreviation for the boom system

Make sure that the following prerequisite is met:

- The operating mode category **3** is selected.
- ▶ Press the function key **F5** or function key **F4** until the abbreviation **3.1** is underlined with the selection bar **3.6** (in the example „S2“, see illustration 2).

Result:

- In the lower area **8.2** of the Editing / selection window **8** the abbreviations available for selection are displayed.

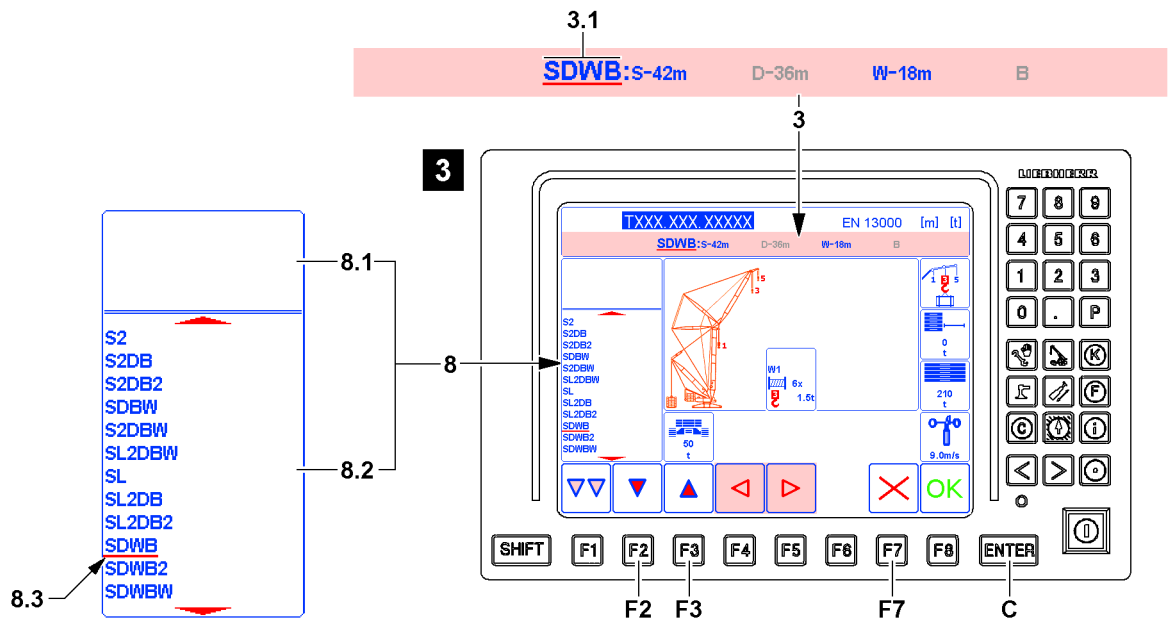

Fig.119930

- ▶ Press the function key **F2** or function key **F3** until the required abbreviation is underlined with the selection bar **8.3**. In example „SDWB“, see illustration 3.

When the required abbreviation is underlined with the selection bar **8.3**:

- ▶ Press the ENTER key **C**.

LWE/LR 11000-001/23501-04-02/en

Result:

- The abbreviation is selected (example „SDWB“).
- In the operating mode category **3** appears the newly selected abbreviation **3.1**.
- The graphic display of the crane in the display window changes accordingly.

4.7.3 Determining main boom variation

Fig.119935

At first, the main boom **3.2** must be selected in the operating mode category **3**.

- Press the function key **F5** or function key **F4** until the main boom **3.2** is underlined with the selection bar **3.6**, see illustration **4**.

Result:

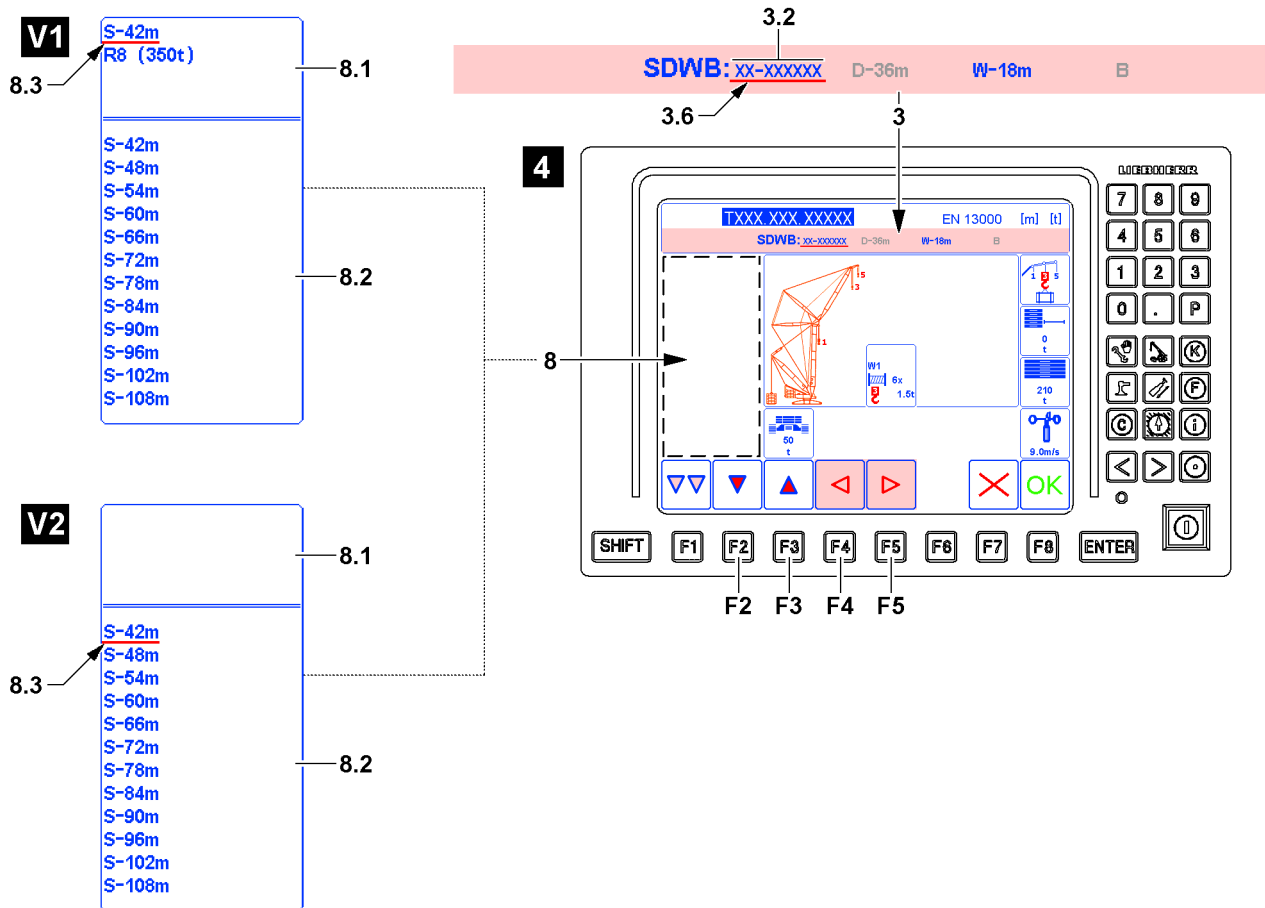
- First variation, illustration **V1**

Note: The first variation appears solely when various roller sets can be assigned to the main boom in the *Set up* program.

- The preselection possibilities are displayed in the upper area **8.1** of the Editing / selection window **8**. The first preselection possibility is automatically underlines and activated with the selection bar **8.3**.
- In the lower area **8.2** of the Editing / selection window **8** the main booms available for section are displayed.

- Second variation, illustration **V2**

Note: The second variation appears solely when no various roller sets can be assigned to the main boom in the *Set up* program.

- In the upper area **8.1** of the Editing / selection window **8** appears no selection possibility.
- In the lower area **8.2** of the Editing / selection window **8** the main booms available for section are displayed.

Depending on the view of the Editing / selection window **8** you must proceed differently:

- ▶ If the first variation is shown (illustration **V1**), proceed with section „Selecting main boom for the first variation (V1)“.
- ▶ If the second variation is shown (illustration **V2**), proceed with section „Selecting main boom for the second variation (V2)“.

4.7.4 Selecting main boom for the first variation (V1)

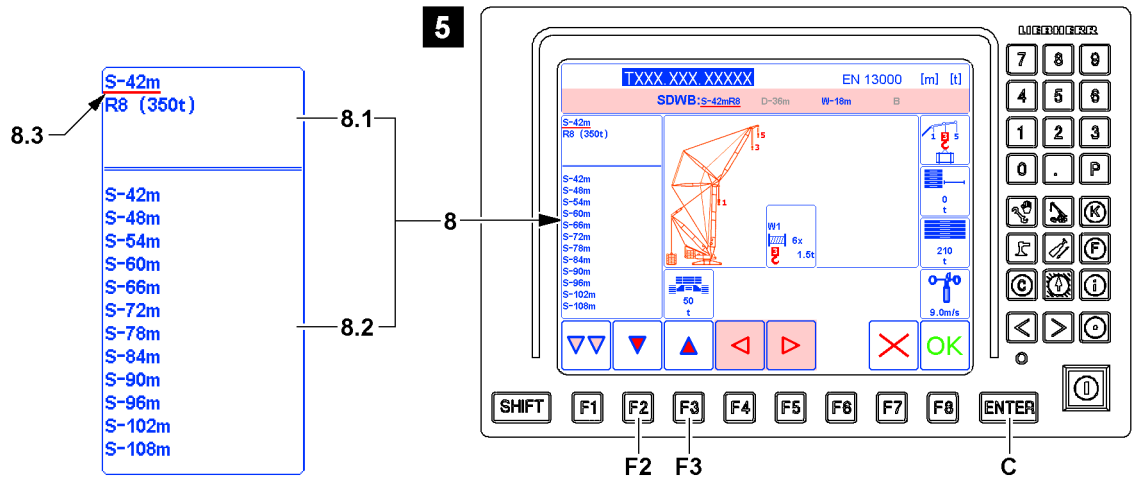

Fig.119920

- ▶ Press the function key **F2** or function key **F3** until the required preselection possibility in the upper area **8.1** is underlined with the selection bar **8.3** (in the example „S-42m“, see illustration **5**).

When the required preselection possibility is underlined with the selection bar **8.3**:

- ▶ Press the ENTER key **C**.

Result:

- The selection bar **8.3** changes in the lower area **8.2** of the Editing / selection window **8**.

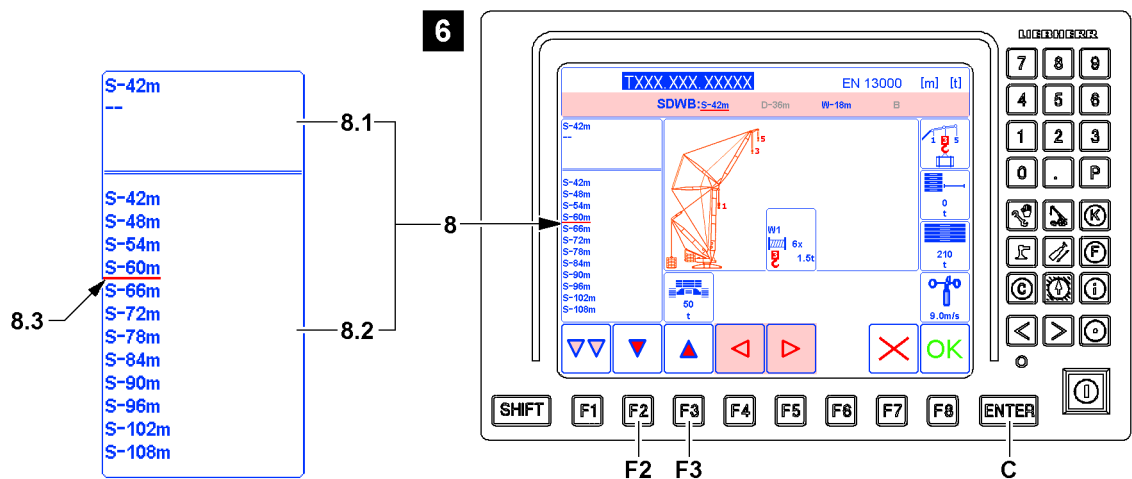

Fig.119937

- ▶ Press the function key **F2** or function key **F3** until the required main boom is underlined with the selection bar **8.3** (in the example „S60m“, see illustration **6**).

When the required main boom is underlined with the selection bar **8.3**:

- ▶ Press the ENTER key **C**.

LWE/LR 11000-001/23501-04-02/en

Result:

- The main boom is selected (in example „S60m“).
- The selection bar **8.3** changes in the upper area **8.1** of the Editing / selection window **8**.

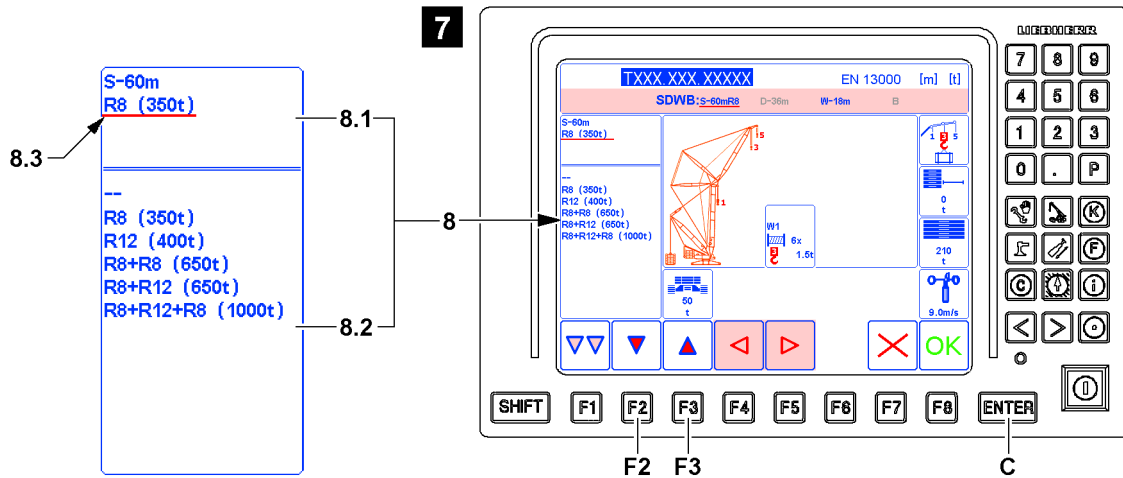

Fig.119938

- ▶ Press the function key **F2** or function key **F3** until the required preselection possibility in the upper area **8.1** is underlined with the selection bar **8.3** (in the example „R8 (350t)“), see illustration 7.

When the required preselection possibility is underlined with the selection bar **8.3**:

- ▶ Press the ENTER key **C**.

Result:

- The selection bar **8.3** changes in the lower area **8.2** of the Editing / selection window **8**.

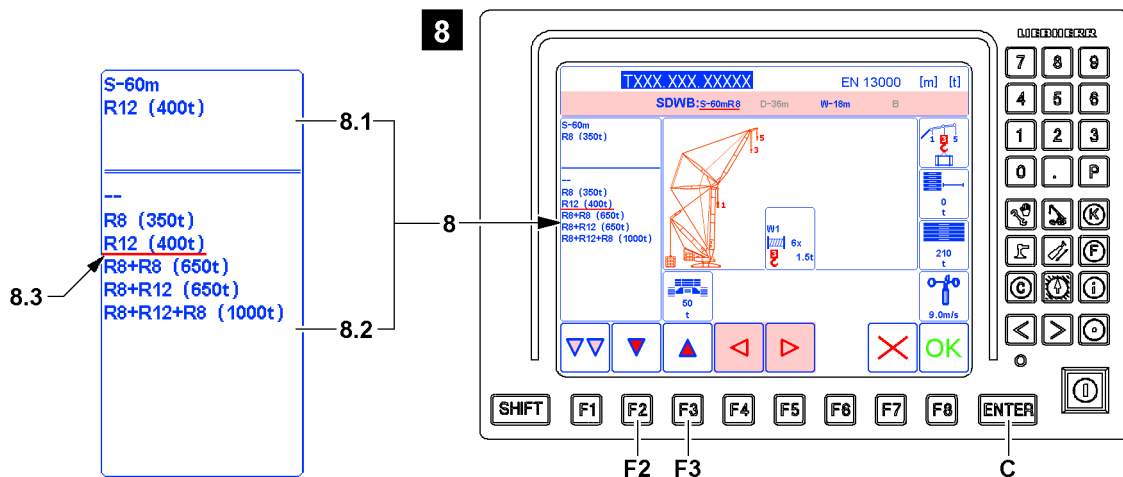

Fig.119939

- ▶ Press the function key **F2** or function key **F3** until the required roller set is underlined with the selection bar **8.3** (in the example „R12 (400t)“), see illustration 8.

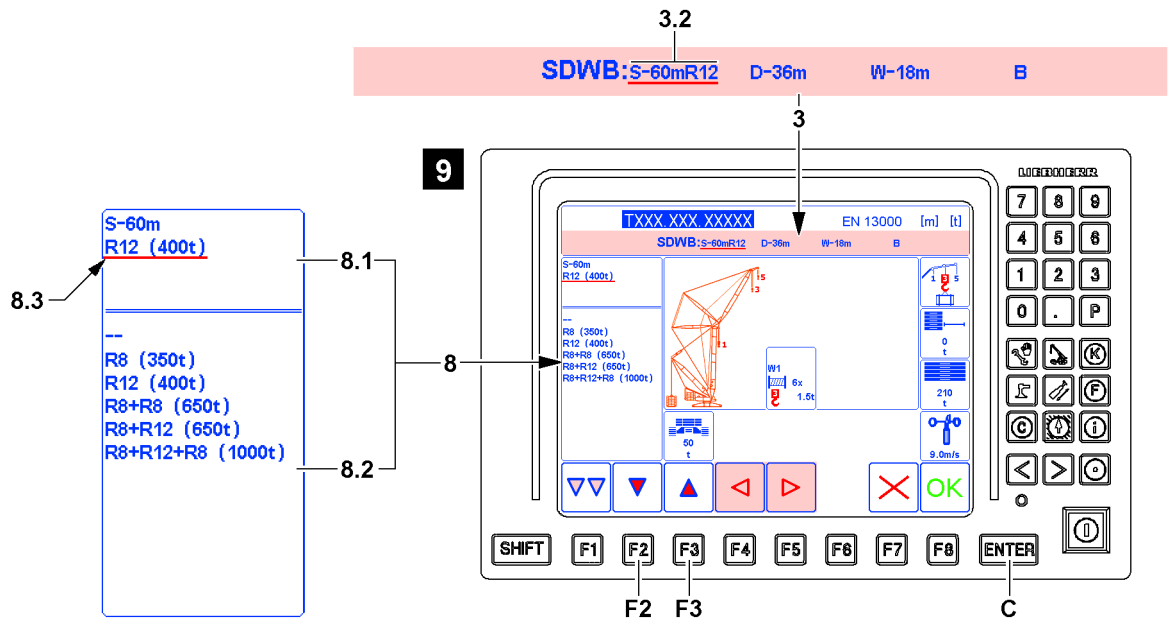

Fig.119940

When the required roller set is underlined with the selection bar 8.3:

► Press the ENTER key C.

Result:

- The roller set is selected (in example „R12 (400t)“).
- The selection bar 8.3 changes in the upper area 8.1 of the Editing / selection window 8.
- In the operating mode category 3 appears the newly selected main boom with roller set 3.2, see illustration 9.

4.7.5 Selecting the main boom for the second variation (V2)

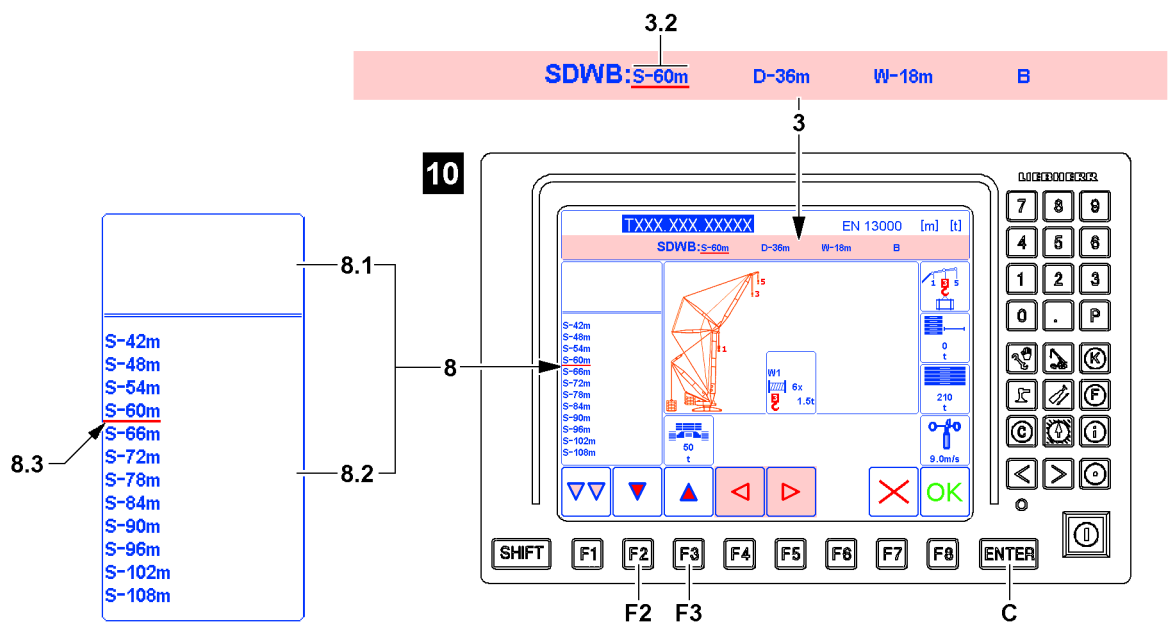

Fig.119931

► Press the function key F2 or function key F3 until the required main boom is underlined with the selection bar 8.3 (in the example „S60m“), see illustration 10.

LWE/LR 11000-001/23501-04-02/en

When the required main boom is underlined with the selection bar **8.3**:

► Press the ENTER key **C**.

Result:

- The main boom is selected (in example „S60m“).
- In the operating mode category **3** appears the newly selected main boom **3.2**.

4.7.6 Invalid chart name

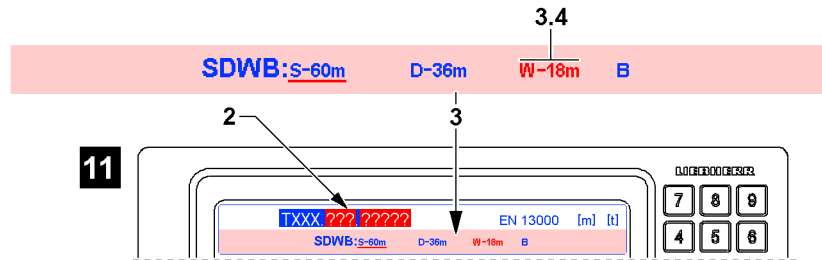

Fig.119932

► Check if the chart name **2** is displayed in blue lettering.

Problem remedy

After pressing the ENTER key **C**, the chart name **2** is replaced by the red highlighted question mark („?“- see illustration **11**)?

Additional entries and settings must be made to obtain a valid set up configuration. If a valid set up configuration is prevented by a certain marker, then this marker is highlighted in red. In the example, the marker for auxiliary boom / accessory **3.4** must still be processed.

► Continue entries and settings normally until it is the turn for the red highlighted marker.

4.7.7 Selecting the derrick boom

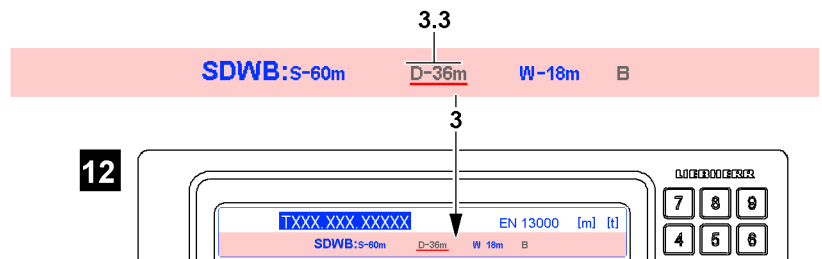

Fig.119933



Note

Illustration **12**: If the text for the derrick boom **3.3** appears in gray, then no additional entries and settings for this marker are possible.

► Correctly selected markers with gray lettering can be skipped.

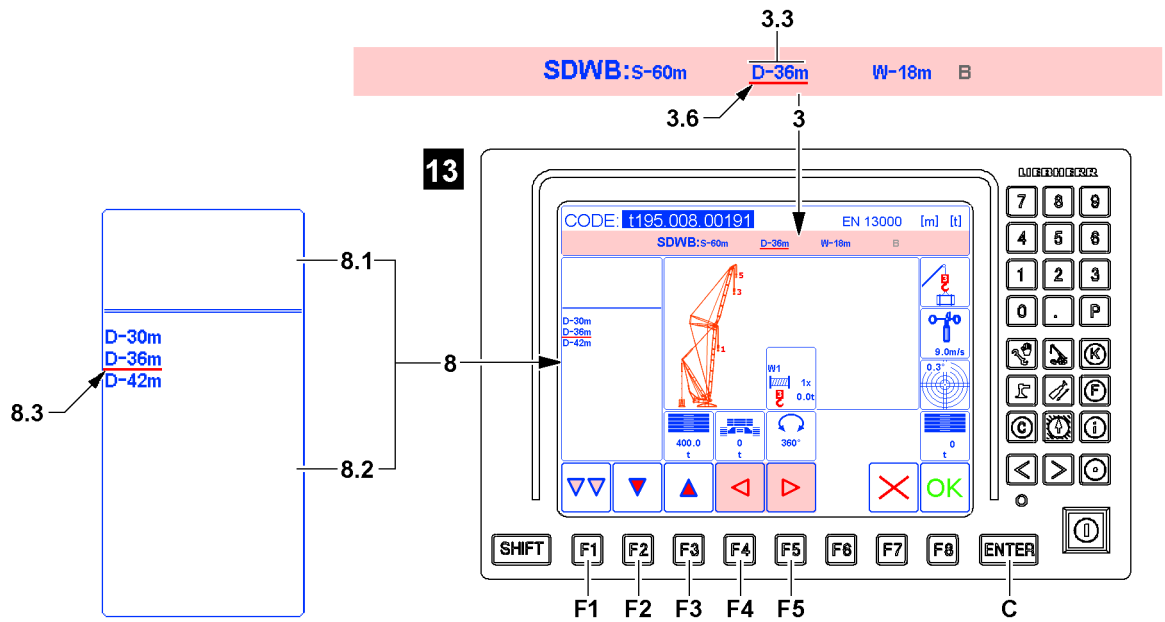

Fig.119934

**Note**

If the correct derrick boom **3.3** already appears, then the entries and settings for this marker can be skipped.

- ▶ Press the function key **F5** or function key **F4** until the next marker to be changed is underlined with the selection bar **3.6**.
- ▶ If all entries and settings in the operating mode category **3** are correct, press function key **F1** and change into the next category.

At first, the operating mode category **3** for the derrick boom **3.3** must be selected.

- ▶ Press the function key **F5** or function key **F4** until the derrick boom **3.3** is underlined with the selection bar **3.6** (in the example „D36m“), see illustration **13**.

Result:

- In the lower area **8.2** of the Editing / selection window **8** the abbreviations for derrick booms available for selection are displayed.

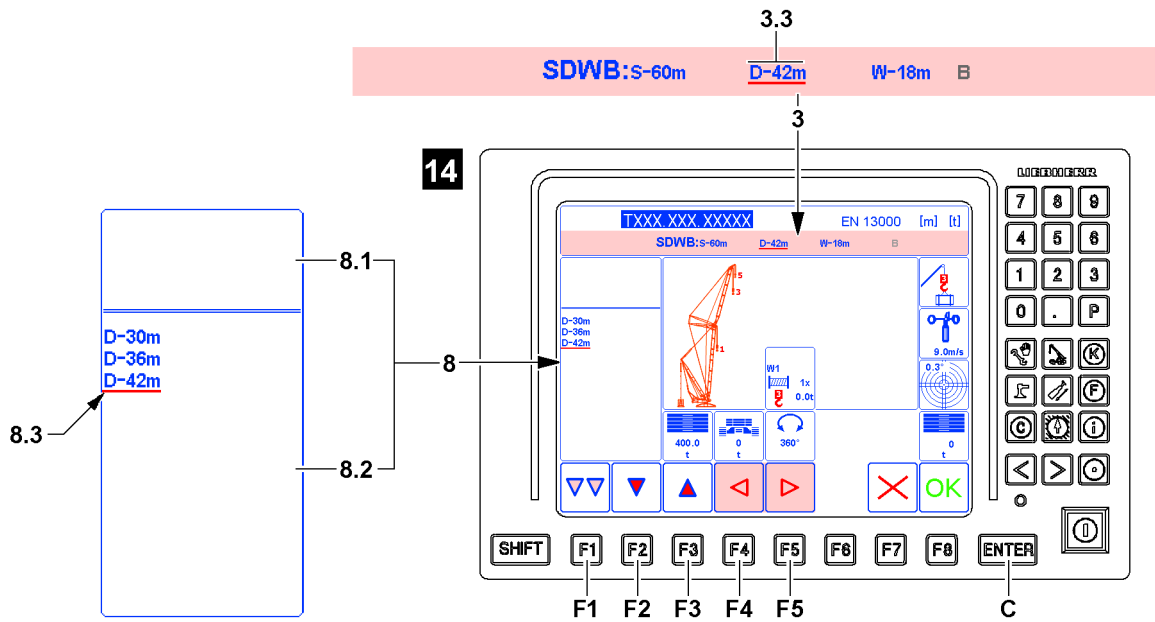

Fig.119941

- ▶ Press the function key **F2** or function key **F3** until the required derrick boom is underlined with the selection bar **8.3**. (For example „D42m“), see illustration 14.

When the required derrick boom is underlined with the selection bar **8.3**:

- ▶ Press the ENTER key **C**.

Result:

- The derrick boom is selected (example „D42m“).
- In the operating mode category **3** appears the newly selected derrick boom **3.3**.

Problem remedy

The required selection for a marker is not available in the operating mode category **3**?

The previously made entries and settings were not made correctly.

In the *Set up* program only entries and settings can be made for which load charts are available.

- ▶ Correct previously made entries and settings.

4.7.8 Selecting auxiliary boom / accessory

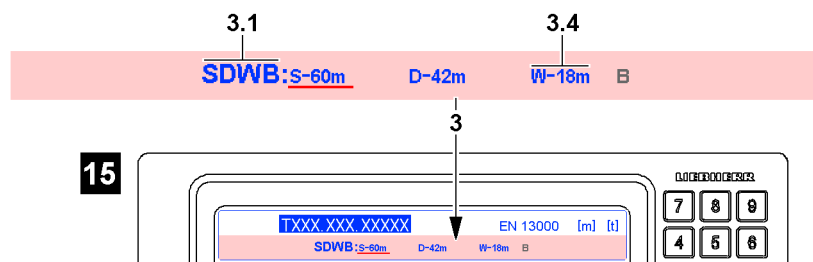

Fig.119942

The marker auxiliary boom / accessory **3.4** only appears when a corresponding abbreviation **3.1** is selected, see illustration 15.



Note

If the text for the auxiliary boom / accessory **3.4** appears in gray, then no additional entries and settings for this marker are possible.

- ▶ Correctly selected markers with gray lettering can be skipped.

LWE/LR 11000-001/23501-04-02/en

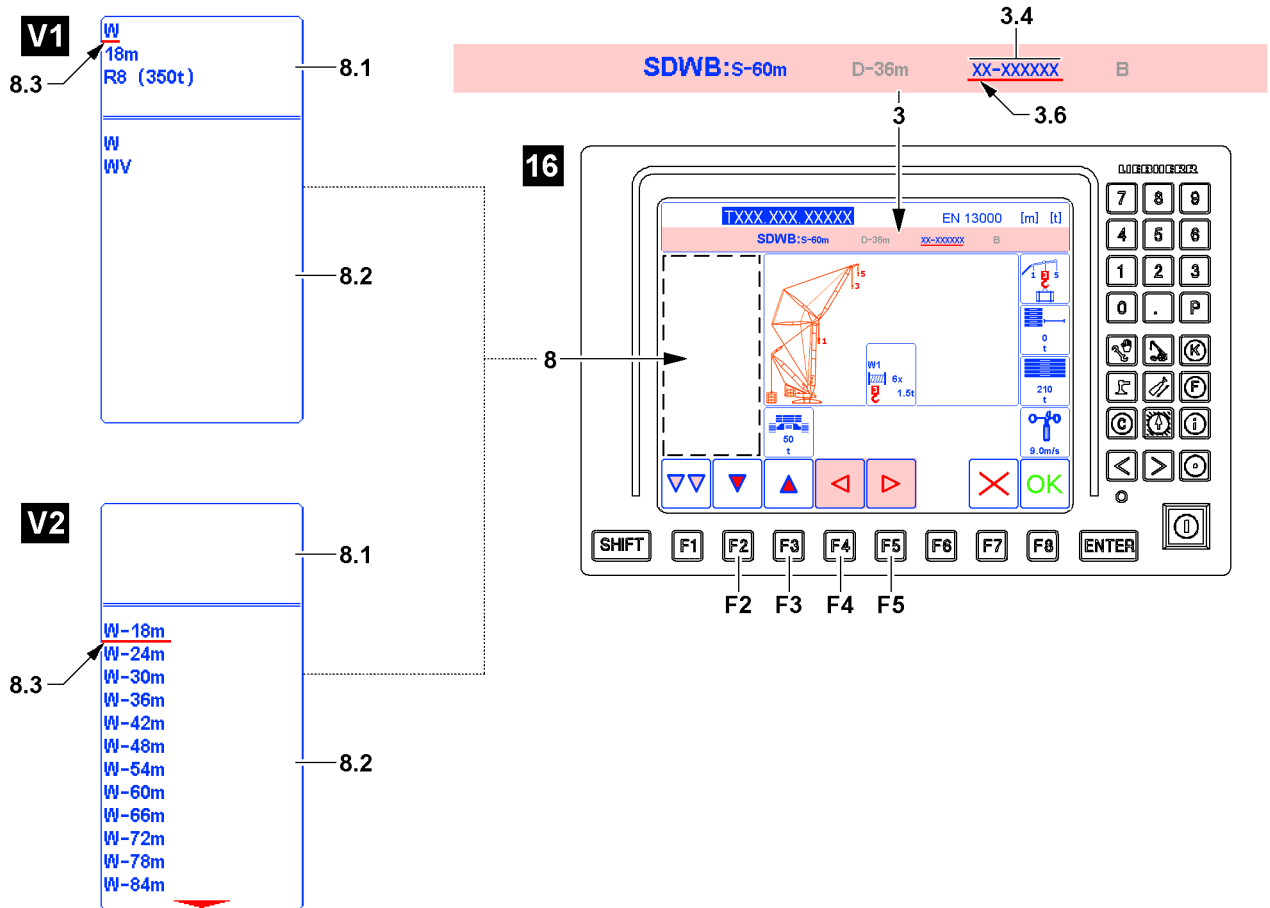

Fig.119943

**Note**

If the correct auxiliary boom / accessory 3.4 already appears, then the entries and settings for this marker can be skipped.

- ▶ Press the function key F5 or function key F4 until the next marker to be changed is underlined with the selection bar 3.6.
- ▶ If all entries and settings in the operating mode category 3 are correct, press function key F1 and change into the next category.

4.7.9 Determining variation auxiliary boom / accessory

At first, the operating mode category 3 for the auxiliary boom / accessory 3.4 must be selected.

- ▶ Press the function key F5 or function key F4 until the marker auxiliary boom / accessory 3.4 is underlined with the selection bar 3.6, see illustration 16.

Result:

- First variation, illustration V1

Note: The first variation appears solely when various operating modes and / or roller sets can be assigned to the auxiliary boom / accessory in the *Set up* program.

- The preselection possibilities are displayed in the upper area 8.1 of the Editing / selection window. 8 The first preselection possibility is automatically underlines and activated with the selection bar 8.3.
- In the lower area 8.2 of the Editing / selection window 8 the settings available for selection are displayed.

- Second variation, illustration V2

Note: The second variation appears solely when no various operating modes and roller sets can be assigned to the auxiliary boom / accessory in the *Set up* program.

- In the upper area **8.1** of the Editing / selection window **8** appears no selection possibility.
- In the lower area **8.2** of the Editing / selection window **8** the settings available for selection are displayed.

Depending on the view of the Editing / selection window **8** you must proceed differently:

- ▶ If the first variation is shown (illustration **V1**), proceed with section „Selecting auxiliary boom / accessory for the first variation (V1)“.
- ▶ If the second variation is shown (illustration **V2**), proceed with section „Selecting auxiliary boom / accessory for the second variation (V2)“.

4.7.10 Selecting auxiliary boom / accessory for the first variation (V1)

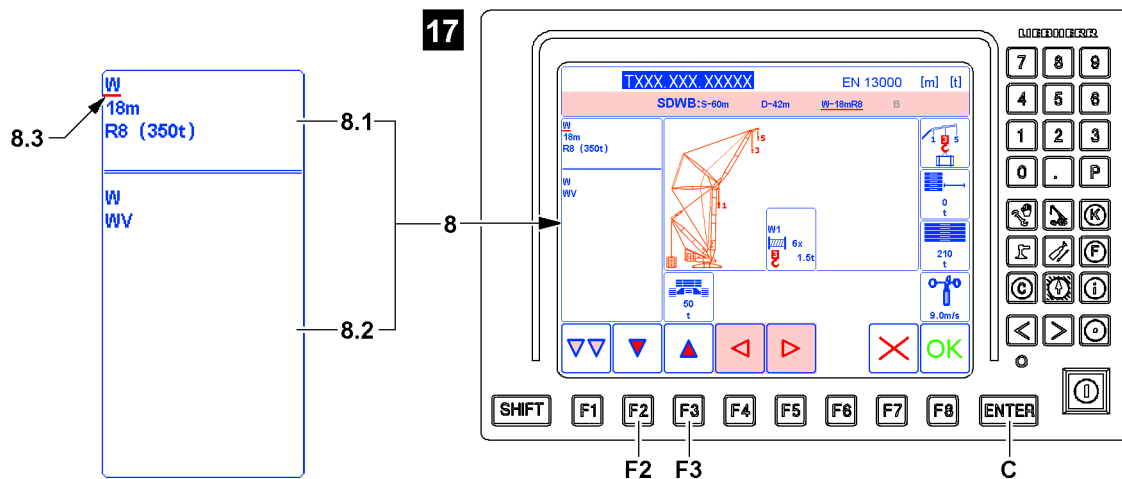

Fig.119944

- ▶ Press the function key **F2** or function key **F3** until the required preselection possibility in the upper area **8.1** is underlined with the selection bar **8.3** (in the example „W“, see illustration **17**).

When the required preselection possibility is underlined with the selection bar **8.3**:

- ▶ Press the ENTER key **C**.

Result:

- The selection bar **8.3** changes in the lower area **8.2** of the Editing / selection window **8**.

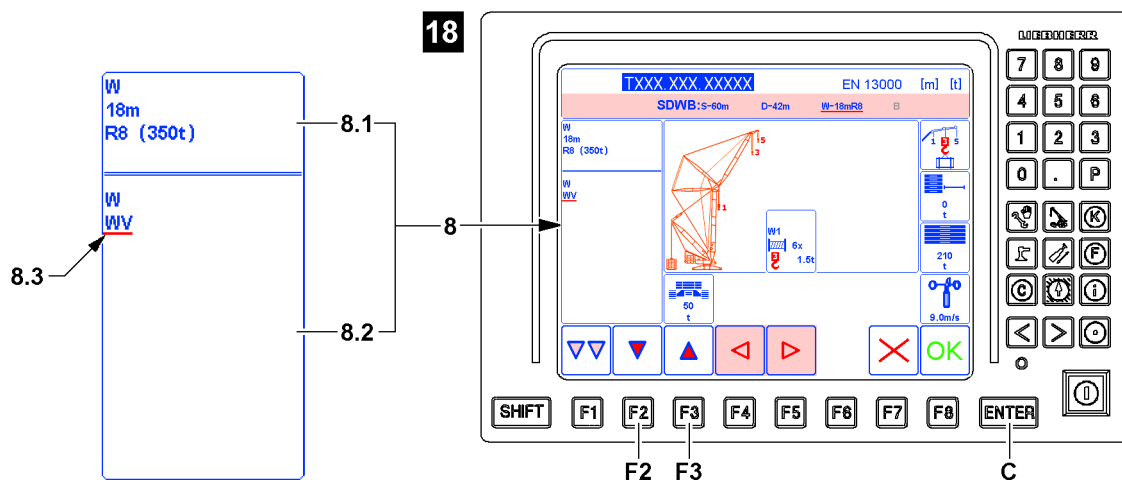

Fig.119945

- ▶ Press the function key **F2** or function key **F3** until the required setting is underlined with the selection bar **8.3** (in the example „WV“, see illustration **18**).

When the required setting is underlined with the selection bar **8.3**:

▶ Press the ENTER key **C**.

Result:

- The setting is selected.
- The selection bar **8.3** changes in the upper area **8.1** of the Editing / selection window **8**.

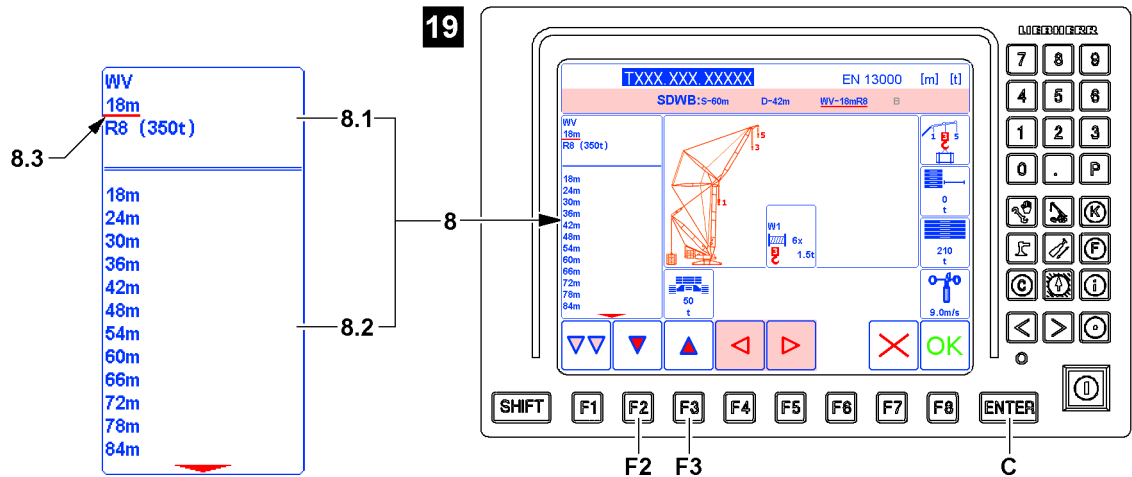

Fig.119946

▶ Press the function key **F2** or function key **F3** until the required preselection possibility in the upper area **8.1** is underlined with the selection bar **8.3** (in the example „18m“), see illustration **19**.

When the required preselection possibility is underlined with the selection bar **8.3**:

▶ Press the ENTER key **C**.

Result:

- The selection bar **8.3** changes in the lower area **8.2** of the Editing / selection window **8**.

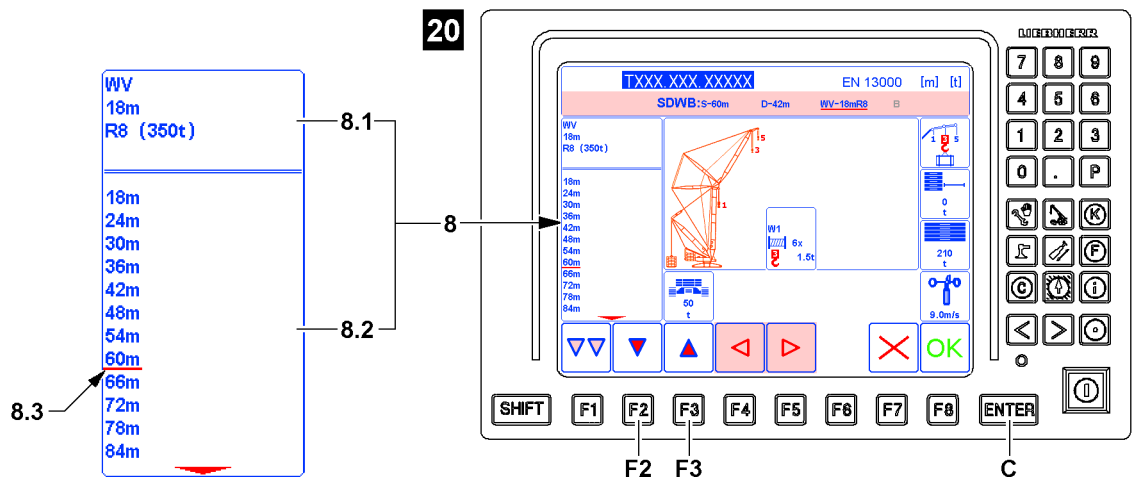

Fig.120576

▶ Press the function key **F2** or function key **F3** until the required setting is underlined with the selection bar **8.3** (in the example „60m“), see illustration **20**.

When the required roller set is underlined with the selection bar **8.3**:

▶ Press the ENTER key **C**.

Result:

- The setting is selected.

LWE/LR 11000-001/23501-04-02/en

- The selection bar **8.3** changes in the upper area **8.1** of the Editing / selection window **8**.

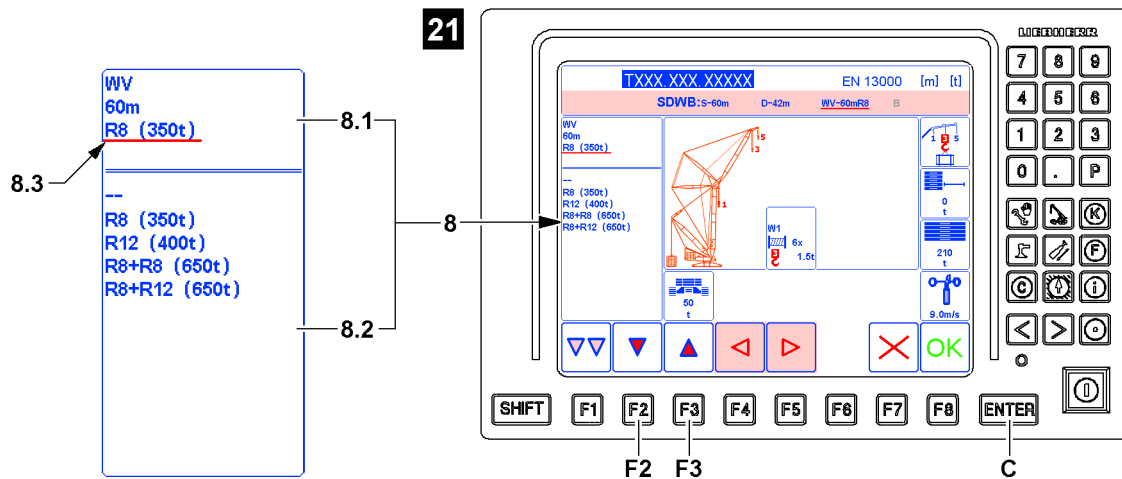

Fig.120577

- Press the function key **F2** or function key **F3** until the required preselection possibility in the upper area **8.1** is underlined with the selection bar **8.3** (in the example „R8 (350t)“, see illustration **21**).

When the required preselection possibility is underlined with the selection bar **8.3**:

- Press the ENTER key **C**.

Result:

- The selection bar **8.3** changes in the lower area **8.2** of the Editing / selection window **8**.

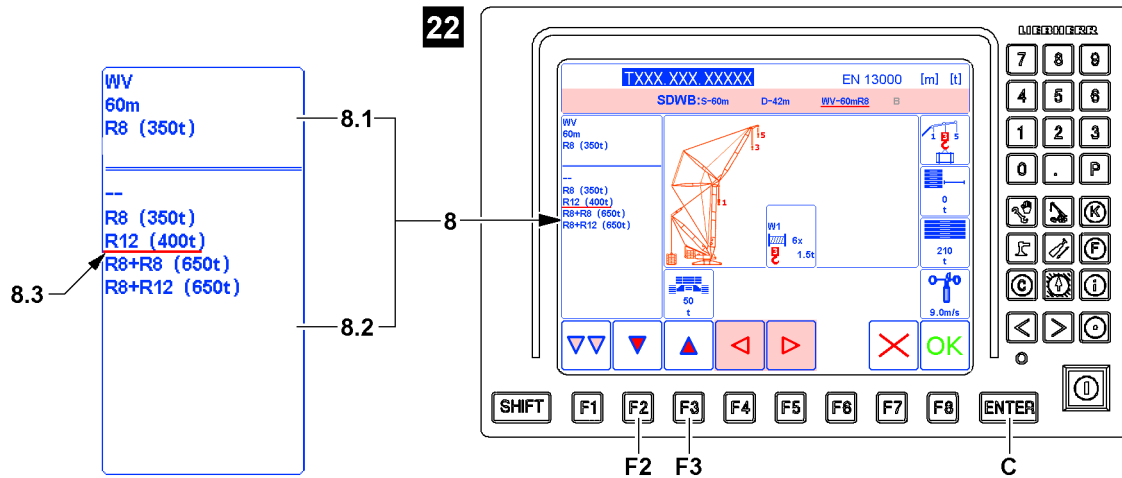

Fig.120578

- Press the function key **F2** or function key **F3** until the required setting is underlined with the selection bar **8.3** (in the example „R12 (400t)“, see illustration **22**).

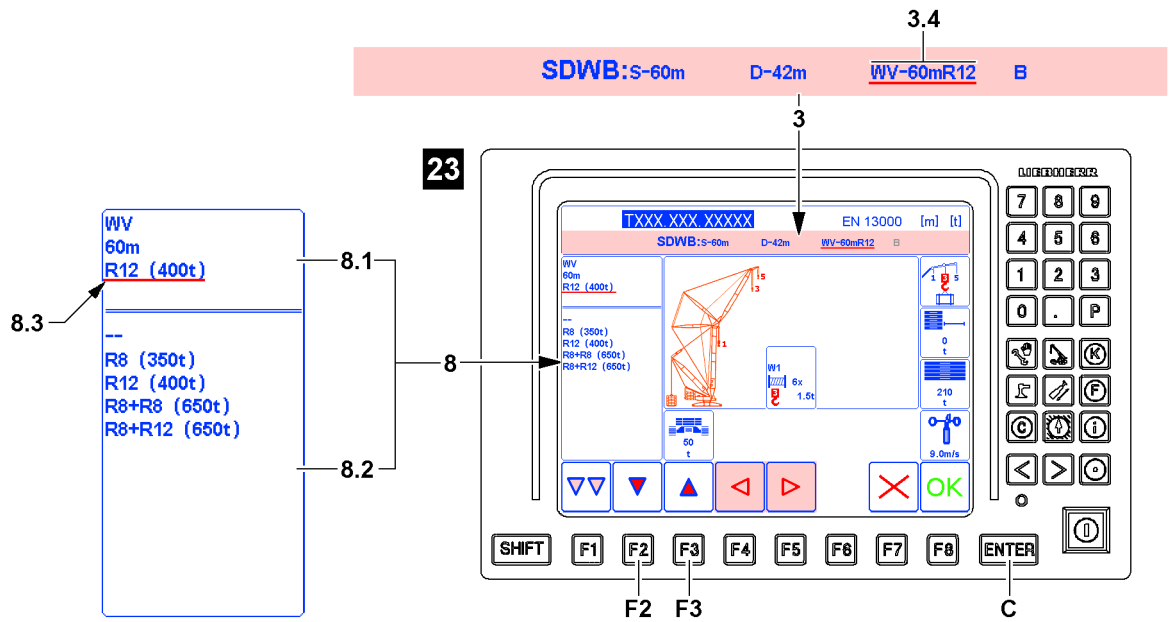

Fig.120579

When the required setting is underlined with the selection bar 8.3:

- ▶ Press the ENTER key C.

Result:

- The setting is selected.
- The selection bar 8.3 changes in the upper area 8.1 of the Editing / selection window 8.
- In the operating mode category 3 appear the selected settings for auxiliary boom / accessory 3.4, see illustration 23.

4.7.11 Selecting auxiliary boom / accessory for the second variation (V2)

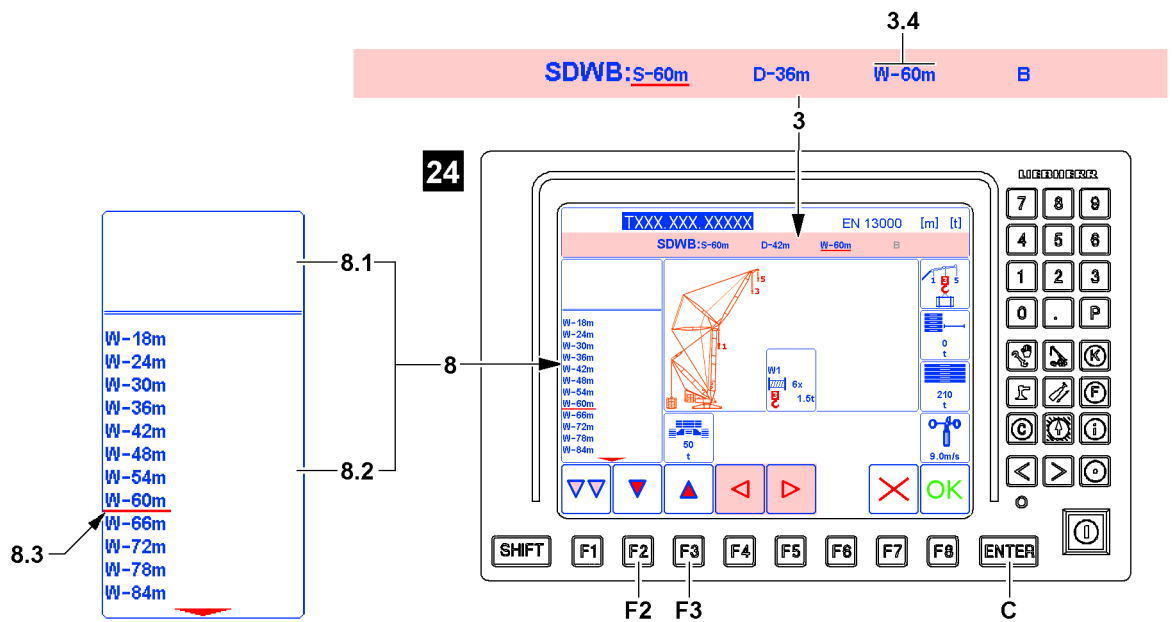

Fig.120580

- ▶ Press the function key F2 or function key F3 until the required main boom is underlined with the selection bar 8.3 (in the example „W-60m“), see illustration 24.

LWE/LR 11000-001/23501-04-02/en

When the required main boom is underlined with the selection bar **8.3**:

► Press the ENTER key **C**.

Result:

- The auxiliary boom / accessory is selected (in example „W-60m“).
- In the operating mode category **3** appear the selected settings for auxiliary boom / accessory **3.4**.

4.7.12 Selecting derrick ballast settings

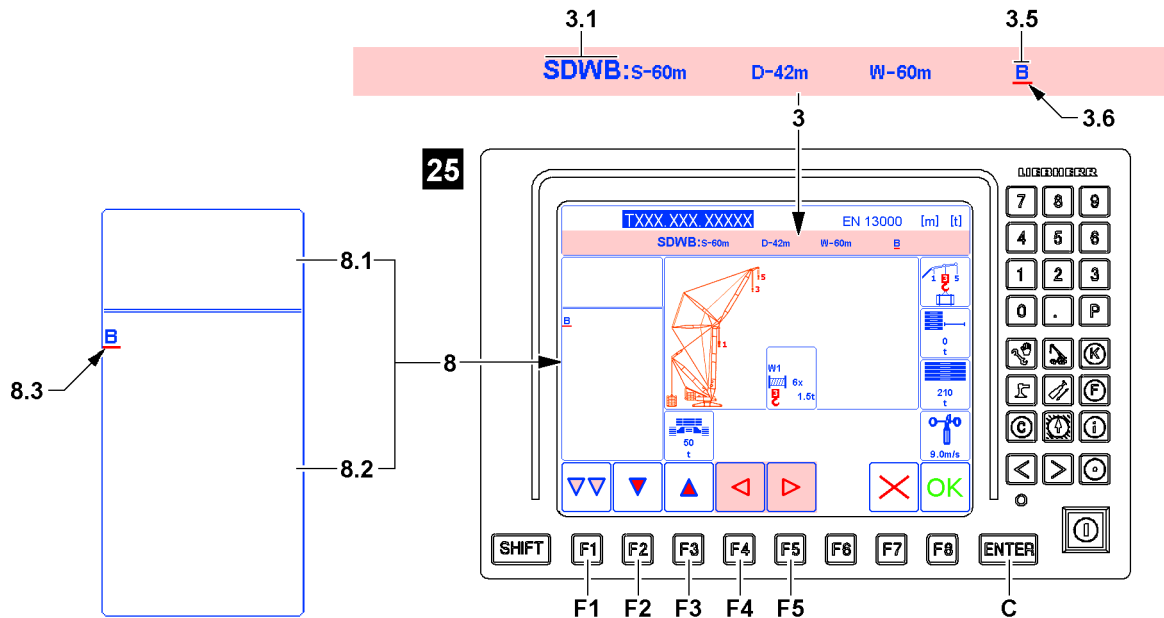

Fig.120581

The marker derrick ballast **3.5** only appears when a corresponding abbreviation **3.1** is selected.



Note

If the text for the derrick ballast **3.5** appears in gray, then no additional entries and settings for this marker are possible.

► Correctly selected markers with gray lettering can be skipped.



Note

If the correct derrick ballast **3.5** already appears, then the entries and settings for this marker can be skipped.

► Press the function key **F5** or function key **F4** until the next marker to be changed is underlined with the selection bar **3.6**.

► If all entries and settings in the operating mode category **3** are correct, press function key **F1** and change into the next category.



Note

If a suspended ballast or a ballast trailer or the operating mode with removed ballast pallet is used as a derrick ballast **3.5** depends on the selected abbreviation **3.1**.

► To change between suspended ballast, ballast trailer or the operating mode with removed ballast pallet, see section: „Selecting the abbreviation for the boom system“.

► Settings regarding the derrick ballast weight are made via the set up functions, see section „Setting the set up functions“.

At first, the operating mode category **3** for the derrick ballast **3.5** must be selected.

► Press the function key **F5** or function key **F4** until the derrick ballast **3.5** is underlined with the selection bar **3.6** (in the example „B“), see illustration **25**.

Result:

- In the lower area **8.2** of the Editing / selection window **8** the abbreviations for derrick ballast settings available for selection are displayed.

When another derrick ballast setting is available for selection:

- ▶ Press the function key **F2** or function key **F3** until the required derrick ballast setting is underlined with the selection bar **8.3**.

When the required derrick ballast setting is underlined with the selection bar **8.3**:

- ▶ Press the ENTER key **C**.

Result:

- The derrick ballast setting is selected.
- In the operating mode category **3** appears the newly selected derrick ballast **3.5**.

Problem remedy

The required selection for a entries and settings of a marker is not available in the operating mode category **3**?

The previously made entries and settings were not made correctly.

In the *Set up* program only entries and settings can be made for which load charts are available.

- ▶ Correct previously made entries and settings.

4.7.13 Accepting the entries and settings of the operating mode category

Make sure that the following prerequisites are met:

- All selected entries and settings in the operating mode category **3** are correct and complete.
- ▶ Press the function key **F1**.

Result:

- The entries and settings of the operating mode category are completed.
- The set up completion category is automatically called up.

Problem remedy

After pressing the function key **F1** it was determined that one or several markers are not correct?

By pressing the function key **F1**, the individual program categories can be switched through one after the other. After the last program category, the first is called up again.

- ▶ Press the function key **F1** until the operating mode category **3** is called up again. Then all entries and settings can be changed.

4.8 Setting the set up functions

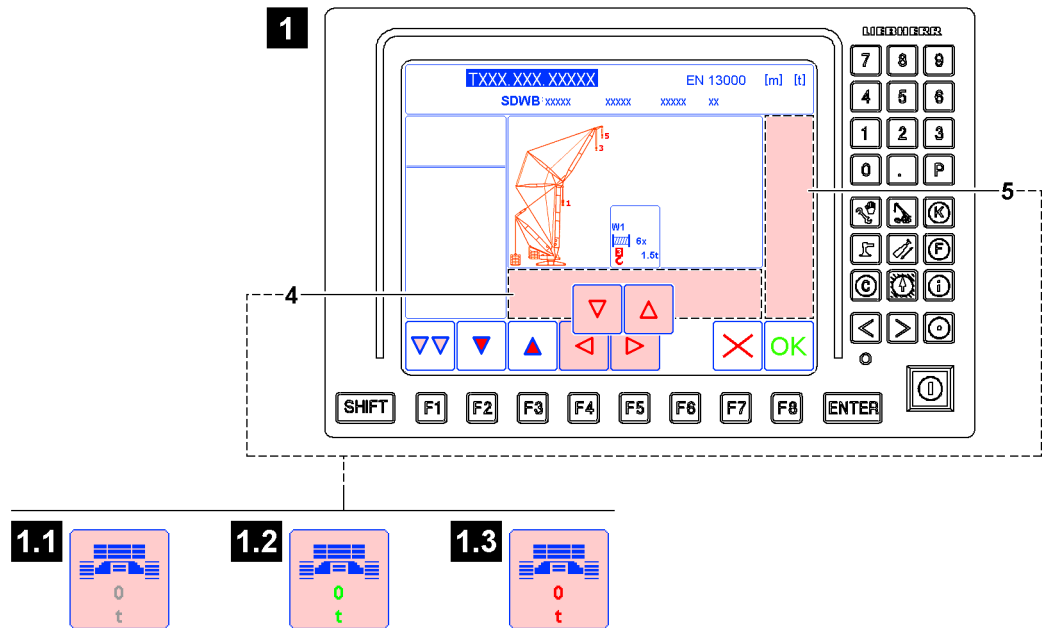

Fig.121745

The set up functions include the set up supplement category and the environmental influence / mechanical influence category.

The individual set up functions are described as markers.

- The set up supplement category 4 includes the lower area of the screen display.
- The environmental / mechanical influence category 5 includes the right area of the screen display.

Depending on the respective load chart, the individual set up functions are assigned to the respective program category.



Note

Values in gray letters

Example Illustration 1.1: If in one or several of the icons the text of the value for the entries and settings appears in gray, then no additional entries and settings for this marker are presently possible. All entries and settings are specified by the operating mode category.

- ▶ Correctly selected markers with gray lettering can be skipped.



Note

Values in green letters

Example Illustration 1.2: If in one or several of the icons the text of the value for the entries and settings appears in green, then additional entries and settings for this marker are possible.

- ▶ Correctly selected markers with green lettering can be skipped.











Note

Values in red letters

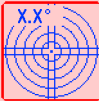
Example Illustration 1.3: If in one or several of the icons the text of the value for the entries and settings appears in red, then additional entries and settings for this marker within the chart filter are required.

- ▶ A release for the set up configuration only occurs when no values for the entries and settings appear in red.

Overview Markers of set up supplement category and the environmental / mechanical influence category	
	<p>Set up function <i>Crane chassis</i></p> <p>Adjustment option for the crane chassis (on crawler travel gear, auxiliary support or assembly support)</p> <p>Note: Adjustment option does not appear for all operating modes.</p>
	<p>Set up function <i>Derrick ballast radius</i></p> <p>Adjustment option for derrick ballast radius</p> <p>Note: Adjustment option does not appear for all operating modes.</p>
	<p>Set up function <i>Central ballast</i></p> <p>Adjustment option for central ballast</p> <p>Note: Adjustment option does not appear for all operating modes.</p>
	<p>Set up function <i>Slewing range</i></p> <p>Adjustment option for slewing range of crane superstructure</p> <p>Note: Adjustment option does not appear for all operating modes.</p>
	<p>Set up function <i>Incline range</i></p> <p>Adjustment option of incline range of load chart</p> <p>Note: Adjustment option does not appear for all operating modes.</p>
	<p>Set up function <i>Load position</i></p> <p>Adjustment option for the position of the load on the boom system</p> <p>Note: Adjustment option does not appear for all operating modes.</p>
	<p>Set up function <i>Weight derrick ballast</i></p> <p>Adjustment option for the weight of the derrick ballast on the derrick boom</p> <p>Note: Adjustment option does not appear for all operating modes.</p>
	<p>Set up function <i>Counterweight</i></p> <p>Adjustment option for the weight of the counterweight on the crane superstructure</p> <p>Note: Adjustment option does not appear for all operating modes.</p>
	<p>Set up function <i>Wind speed</i></p> <p>Adjustment option for the maximum permissible wind speed of the load chart</p> <p>Note: Adjustment option does not appear for all operating modes.</p>

4.8.1 Selecting the program category

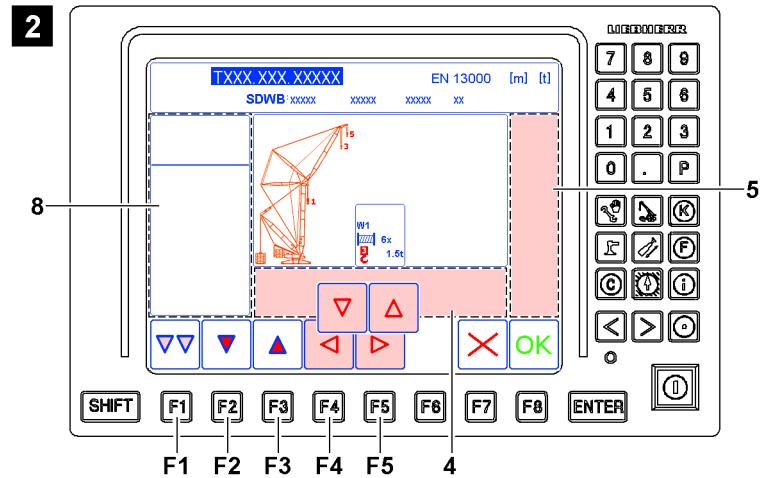

Fig.121746

Selecting the set up completion category

- ▶ Press the function key **F1** until the set up completion category **4** is highlighted in pink.

Result:

- The set up completion category **4** is selected.
A red selection frame surrounds the first marker.
- The Editing / selection window **8** appears.
- Above function key **F2**, function key **F3**, function key **F4** and function key **F5** appear the icons for navigation in the individual program categories.



Note

Navigation in the set up completion category **4**

- ▶ Press the function key **F4**: The red selection frame moves by one icon to the left.
- ▶ Press the function key **F5**: The red selection frame moves by one icon to the right.
- ▶ If the red selection frame is moved in one direction past the edge of the set up supplement category **4** then it enters again from the other direction.



Note

Navigation in Editing / selection window **8**

- ▶ Press the function key **F2**: The selection bar changes downward by one line.
- ▶ Press the function key **F3**: The selection bar changes upward by one line.

Selecting the environmental / mechanical influence category

- ▶ Press the function key **F1** until the environmental / mechanical influence category **5** is highlighted in pink.

Result:

- The environmental / mechanical influence category **5** is selected.
The red selection frame surrounds the first marker.
- The Editing / selection window **8** appears.
- Above function key **F2**, function key **F3**, function key **F4** and function key **F5** appear the icons for navigation in the individual program categories.

**Note**

Navigation in the environmental / mechanical influence category **5**

- ▶ Press the function key **F4**: The red selection frame moves down by one icon.
- ▶ Press the function key **F5**: The red selection frame moves up by one icon.
- ▶ If the red selection frame is moved in one direction past the edge of the environmental / mechanical influence category **5** then it enters again from the other direction.

**Note**

Navigation in Editing / selection window **8**

- ▶ Press the function key **F2**: The selection bar changes downward by one line.
- ▶ Press the function key **F3**: The selection bar changes upward by one line.

4.8.2 Setting the crane chassis

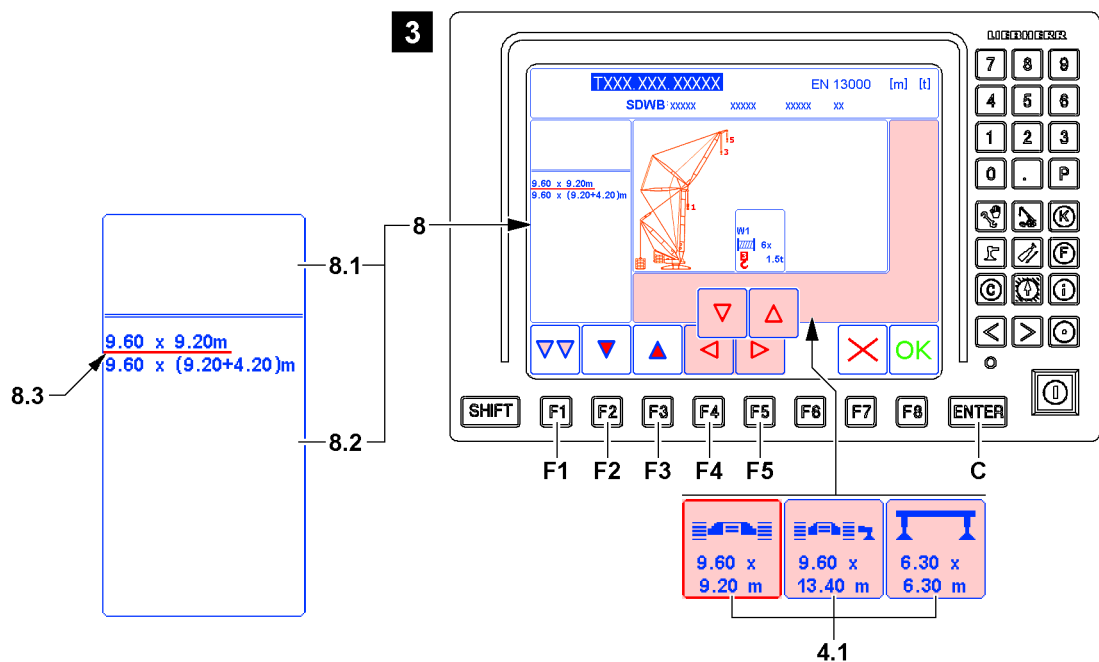

Fig.121747

**Note**



If the correct set up configuration crane chassis **4.1** already appears, then the entries and settings for this marker can be skipped.

- ▶ Press the function key **F5** or the function key **F4** and select the next marker to be changed.

**Note**

The following section describes by example how a certain set up configuration for the crane chassis is set.

- ▶ Always set the required set up configuration for the crane chassis.

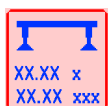
Icons <i>Set up configuration crane chassis</i>	
	Crane on crawler travel gear ¹⁾
	Crane on crawler travel gear with auxiliary support installed on one side ¹⁾
	Crane on assembly support ¹⁾

1) Only for certain crane types and / or operating modes

When the respective program category is not yet highlighted in pink:

- ▶ Press the function key **F1** until the respective program category is highlighted in pink.

When icon *Set up configuration crane chassis 4.1* is not yet bordered in red:

- ▶ Press the function key **F5** or the function key **F4** until the icon *Set up configuration crane chassis 4.1* is bordered in red.

Result:

- In the lower area **8.2** of the Editing / selection window **8** the settings available for selection are displayed, see example illustration **3**.
- ▶ Press the function key **F2** or function key **F3** until the required setting is underlined with the selection bar **8.3** (in the example „9.60m x 9.20m“).

When the required main boom is underlined with the selection bar **8.3**:

- ▶ Press the ENTER key **C**.

Result:

- The set up configuration for the crane chassis is selected, the respective icon for the set up configuration crane chassis **4.1** (in the example Crane on crawler track „9.60 x 9.20m“) appears.

4.8.3 Setting the derrick ballast radius

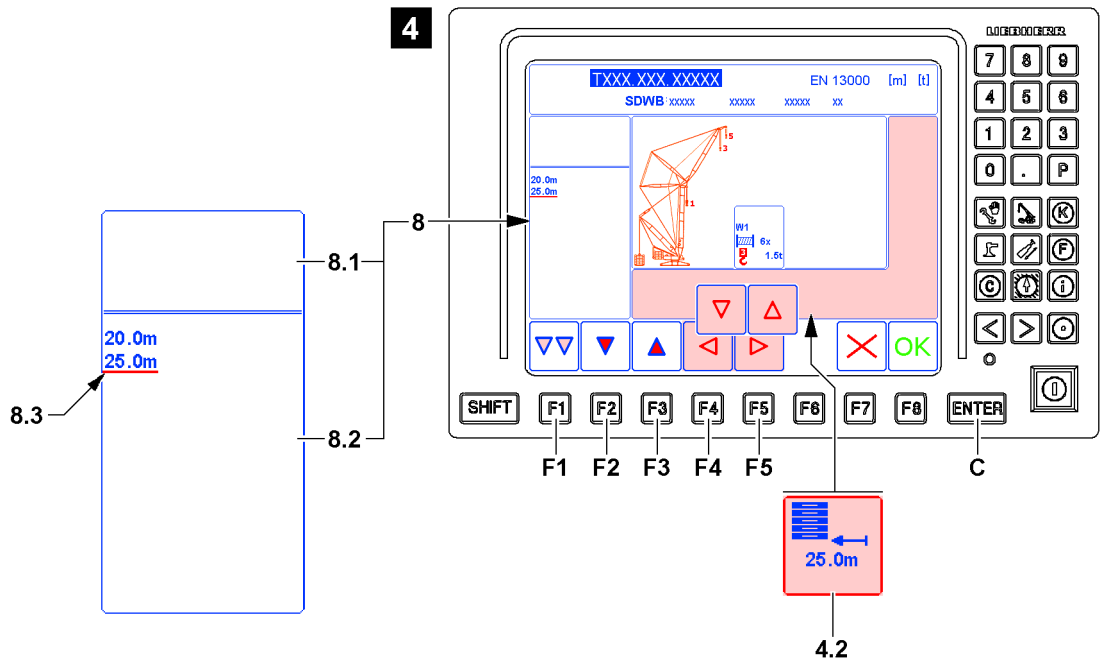

Fig.121756



Note

If the correct derrick ballast radius **4.2** already appears, then the entries and settings for this marker can be skipped.

- ▶ Press the function key **F5** or the function key **F4** and select the next marker to be changed.



Note

The following section describes by example how a certain derrick ballast radius is set.

- ▶ Always set the required derrick ballast radius.

When the respective program category is not yet highlighted in pink:

- ▶ Press the function key **F1** until the respective program category is highlighted in pink.

When icon *Derrick ballast radius 4.2* is not yet bordered in red:

- ▶ Press the function key **F5** or the function key **F4** until the icon *Derrick ballast radius 4.2* is bordered in red.

Result:

- In the lower area **8.2** of the Editing / selection window **8** the settings available for selection are displayed, see example illustration **4**.

- ▶ Press the function key **F2** or function key **F3** until the required setting is underlined with the selection bar **8.3** (in the example „25.0m“).

When the required derrick ballast radius is underlined with the selection bar **8.3**:

- ▶ Press the ENTER key **C**.

Result:

- The derrick ballast radius is selected, the respective icon *Derrick ballast radius 4.2* (in the example „25.0m“) appears.

4.8.4 Setting the central ballast

Depending on the crane type and load chart there are two possibilities to set the central ballast:

- Specified settings distances: The central ballast must be selected from a list, see section „Setting the central ballast: Specified settings distances“.
- Stepless settings distances: The central ballast must be entered within a specified range, see section „Setting the central ballast: Stepless settings distances“.

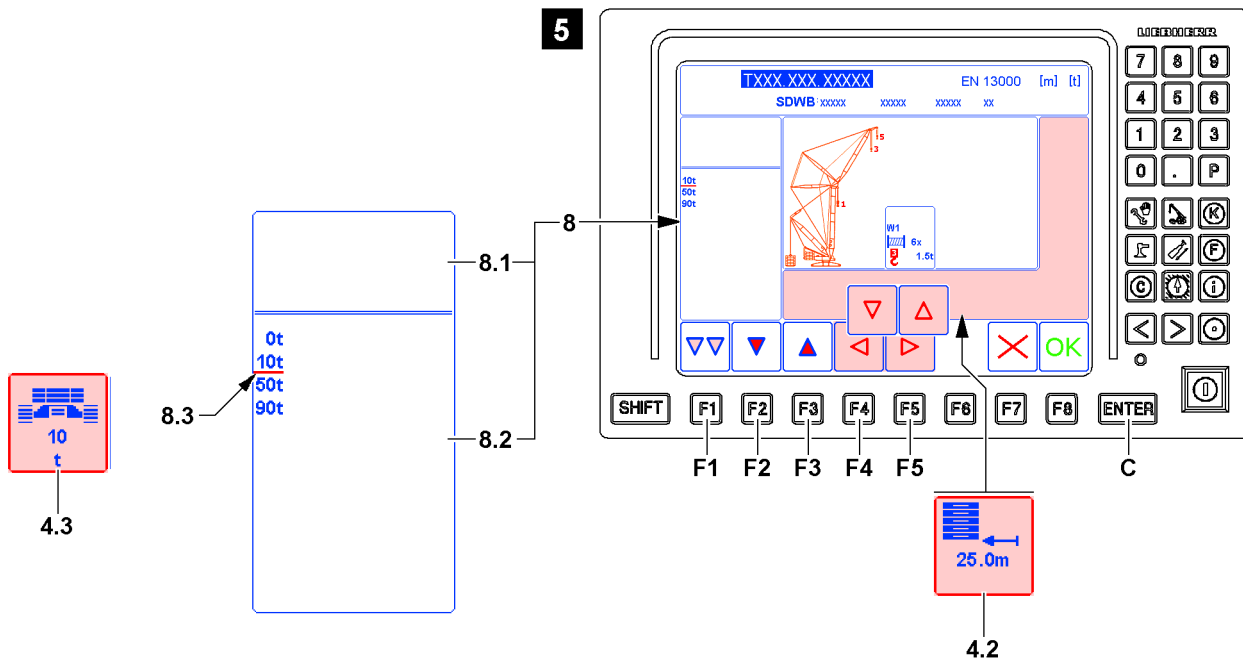

Fig.121757



Note

If the correct central ballast **4.3** already appears, then the entries and settings for this marker can be skipped.

- ▶ Press the function key **F5** or the function key **F4** and select the next marker to be changed.



Note

The following section describes by example how a certain central ballast is set.

- ▶ Always set the required central ballast.

Setting the central ballast: Specified settings distances

When the respective program category is not yet highlighted in pink:

- ▶ Press the function key **F1** until the respective program category is highlighted in pink.

When icon *Central ballast* **4.3** is not yet bordered in red:

- ▶ Press the function key **F5** or the function key **F4** until the icon *Central ballast* **4.3** is bordered in red.

Result:

- In the lower area **8.2** of the Editing / selection window **8** the settings available for selection are displayed, see example illustration **5**.

- ▶ Press the function key **F2** or function key **F3** until the required setting is underlined with the selection bar **8.3** (in the example „10t“).

When the required central ballast is underlined with the selection bar **8.3**:

- ▶ Press the ENTER key **C**.

Result:

- The central ballast is selected, the respective icon *Central ballast 4.3* (in the example „10t“) appears.

Setting the central ballast: Stepless settings distances

Fig.121758

When the respective program category is not yet highlighted in pink:

- ▶ Press the function key **F1** until the respective program category is highlighted in pink.

When icon *Central ballast 4.3* is not yet bordered in red:

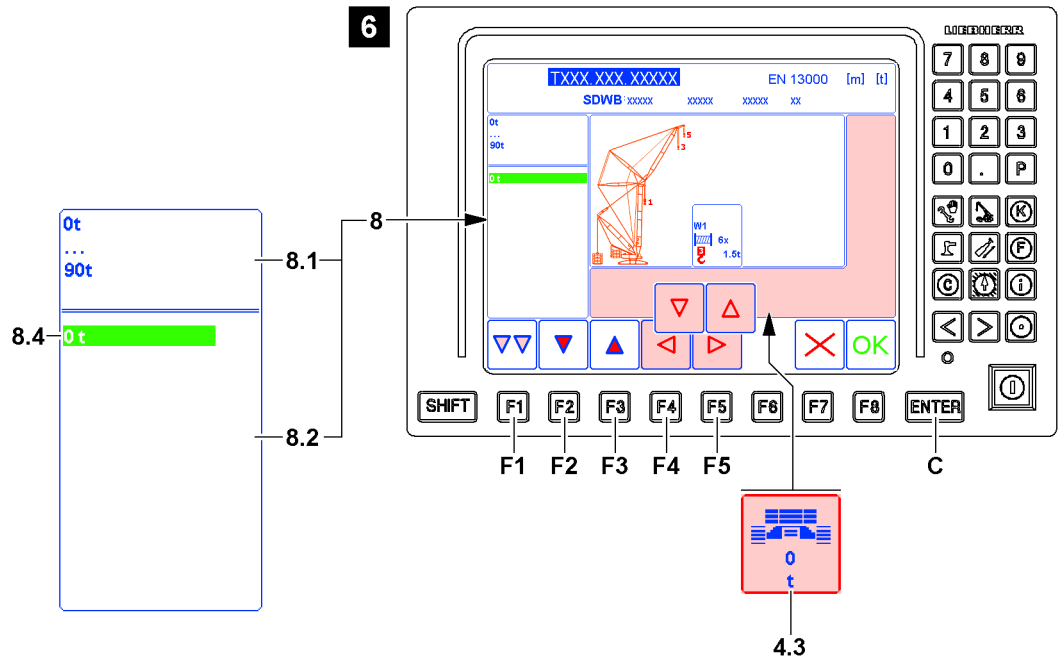
- ▶ Press the function key **F5** or the function key **F4** until the icon *Central ballast 4.3* is bordered in red.

Result:

- Illustration **6**:

- In the upper area **8.1** of the Editing / selection window **8** the permissible range of the central ballast is displayed.
- In the lower area **8.2** of the Editing / selection window **8** appears a green field **8.4** with the currently selected central ballast.

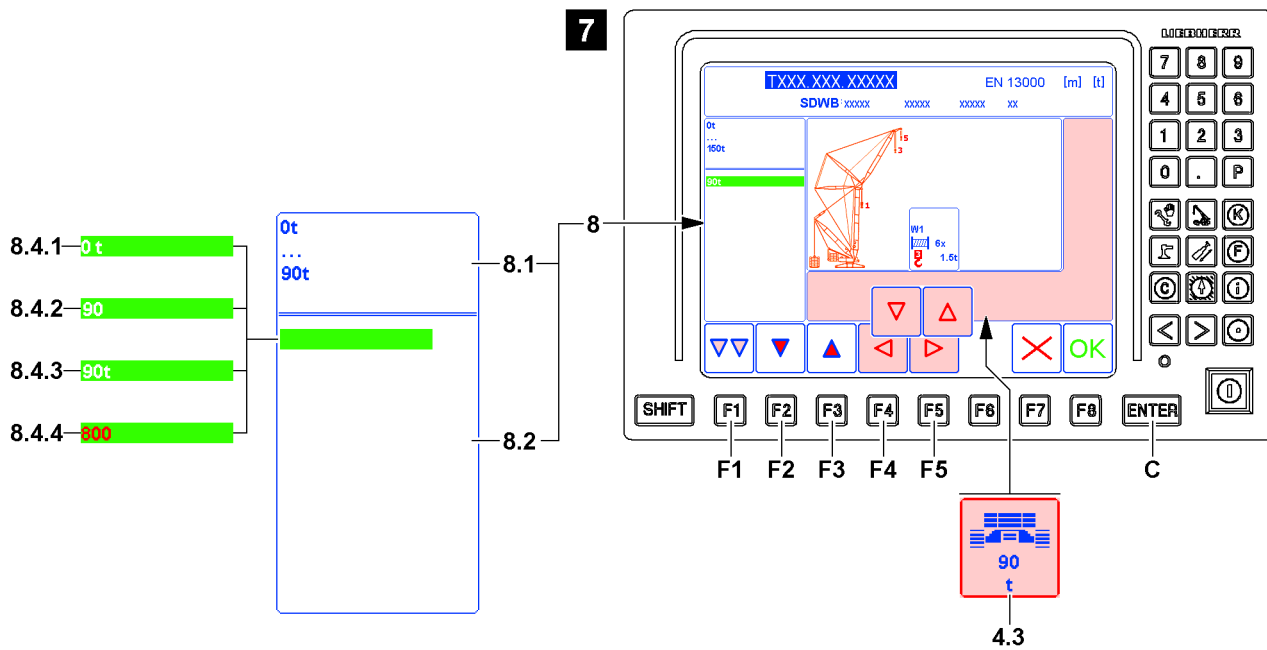

Fig.121744

Illustration 7: The entry is made without the weight unit.

► Enter the required number sequence via the keypad **A**, in example „90“.

Result:

- The original value **8.4.1** (in example „0t“) turns off.
- The entered value **8.4.2** (in example „90“) appears.

► Press the ENTER key **C**.

Result:

- The new value **8.4.3** is taken over and displayed in the icon *Central ballast* **4.3**.

Problem remedy

Invalid input value

When trying to accept an invalid input value **8.4.4** then the numbers are shown in red.

Enter only permissible values according to the specifications from the upper area **8.1** of the Editing / selection window **8**.

► Enter the permissible value via the keypad **A**.

4.8.5 Setting the slewing range

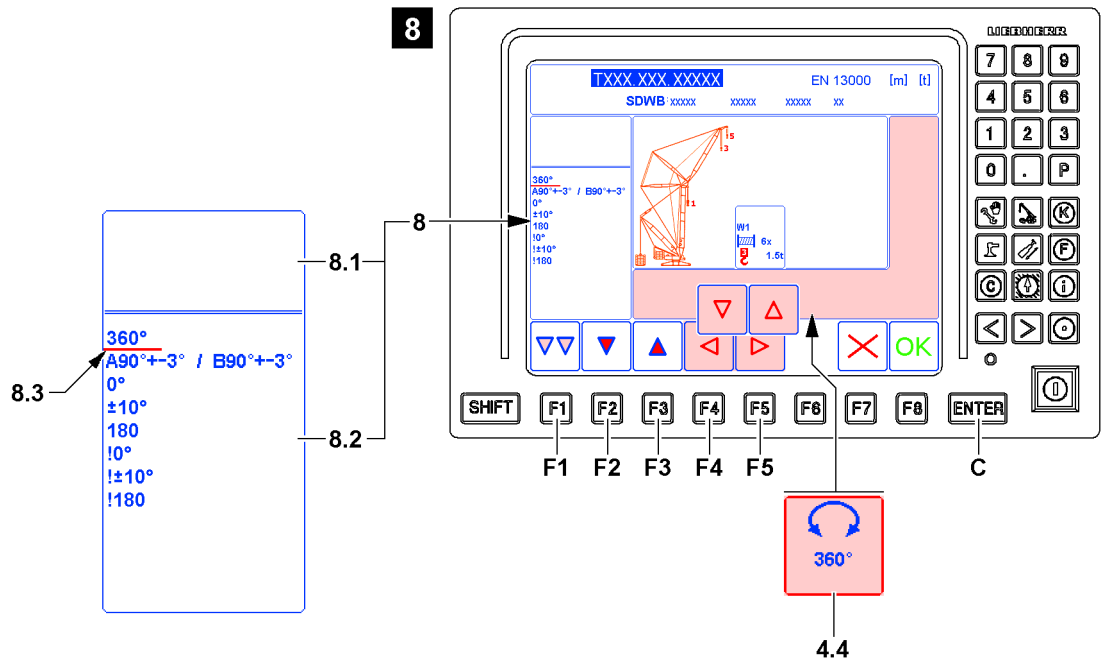

Fig.121759

The marker turning range **4.4** only appears when an alternative setting is possible.



Note

If the correct turning range **4.4** already appears, then the entries and settings for this marker can be skipped.

- ▶ Press the function key **F5** or the function key **F4** and select the next marker to be changed.



Note

The following section describes by example how a certain turning range is selected.

- ▶ Always select the required turning range.

When the respective program category is not yet highlighted in pink:

- ▶ Press the function key **F1** until the respective program category is highlighted in pink.

When icon *Slewing range* **4.4** is not yet bordered in red:

- ▶ Press the function key **F5** or the function key **F4** until the icon *Slewing range* **4.4** is bordered in red.

Result:

- In the lower area **8.2** of the Editing / selection window **8** the settings available for selection are displayed, see sample listing illustration **8**.

When another setting for the slewing range is to be set:

- ▶ Press the function key **F2** or function key **F3** until the required setting is underlined with the selection bar **8.3**, in the example „360°“.

When the required turning range setting is underlined with the selection bar **8.3**:

- ▶ Press the ENTER key **C**.

Result:

- The new value is taken over and displayed in the *Turning range* icon **4.4**.

4.8.6 Setting the incline range



WARNING

Impermissible incline exceeded!

When no incline range is shown, then $\pm 0.3^\circ$ applies as the largest permissible incline.

► Never exceed the permissible incline.

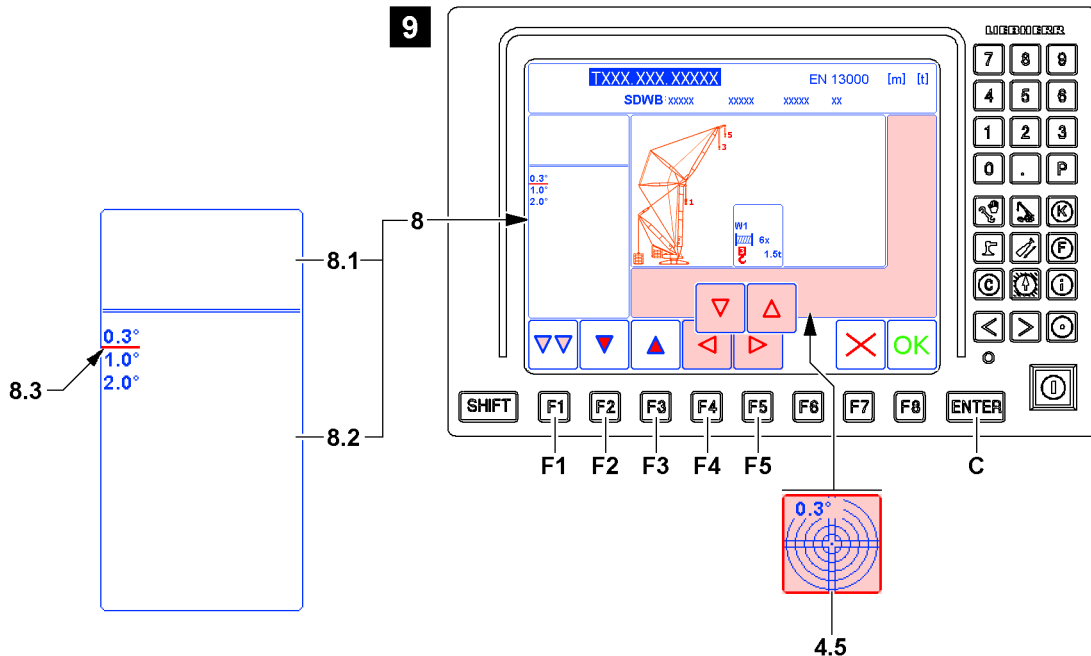

Fig. 121760

The incline range cannot be set in all operating modes. If the incline range is not adjustable, then the icon *Incline range 4.5* is not shown in some operating modes.

Depending on the crane type and load chart there are two possibilities to set the incline range:

- Specified settings distances: The incline range must be selected from a list, see section „Setting the incline range: Specified settings distances“.
- Stepless settings distances: The incline range must be entered within a specified range, see section „Setting the incline range: Stepless settings distances“.



Note

If the correct incline range **4.5** already appears, then the entries and settings for this marker can be skipped.

► Press the function key **F5** or the function key **F4** and select the next marker to be changed.



Note

The following section describes by example how a certain incline range is set.

► Always set the required incline range.

Setting the incline range: Specified settings distances

When the respective program category is not yet highlighted in pink:

► Press the function key **F1** until the respective program category is highlighted in pink.

When icon *Incline range 4.5* is not yet bordered in red:

► Press the function key **F5** or the function key **F4** until the icon *Incline range 4.5* is bordered in red.

Result:

- In the lower area **8.2** of the Editing / selection window **8** the settings available for selection are displayed, see example illustration **9**.
- ▶ Press the function key **F2** or function key **F3** until the required setting is underlined with the selection bar **8.3**, (in the example „0.3°“).

When the required incline range is underlined with the selection bar **8.3**:

- ▶ Press the ENTER key **C**.

Result:

- The incline range is selected, the respective icon *Incline range* **4.5** (in the example „0.3°“) appears.

Setting the incline range: Stepless settings distances

Fig.121761

When the respective program category is not yet highlighted in pink:

- ▶ Press the function key **F1** until the respective program category is highlighted in pink.

When icon *Incline range* **4.5** is not yet bordered in red:

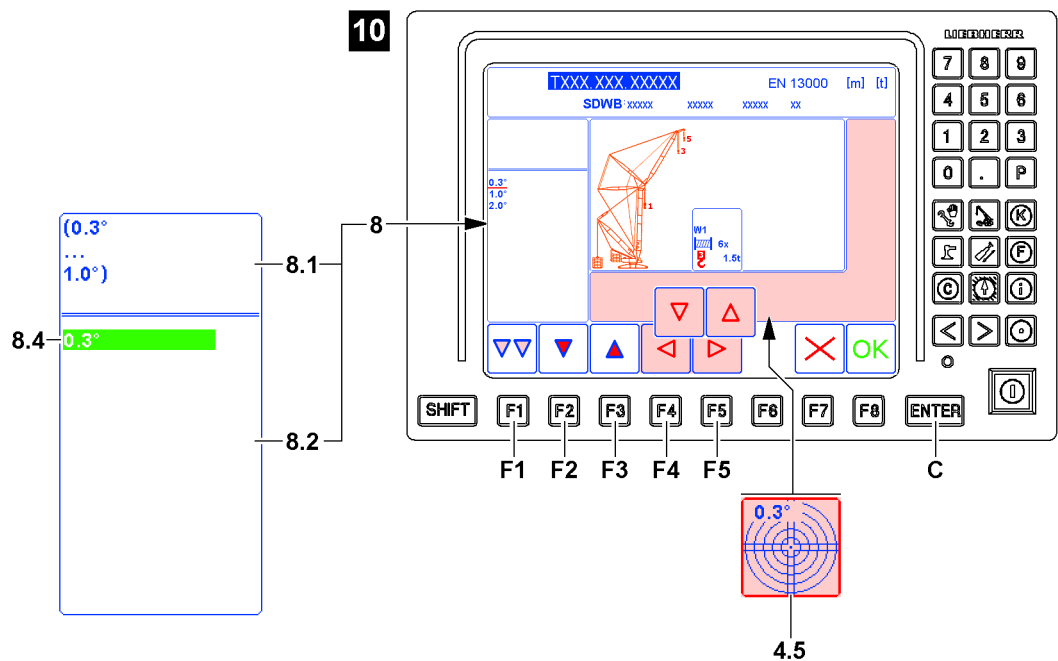
- ▶ Press the function key **F4** or the function key **F5** until the icon *Incline range* **4.5** is bordered in red.

Result:

Illustration **10**:

- In the upper area **8.1** of the Editing / selection window **8** the permissible incline range is displayed.
- In the lower area **8.2** of the Editing / selection window **8** appears a green field **8.4** with the currently selected incline range.

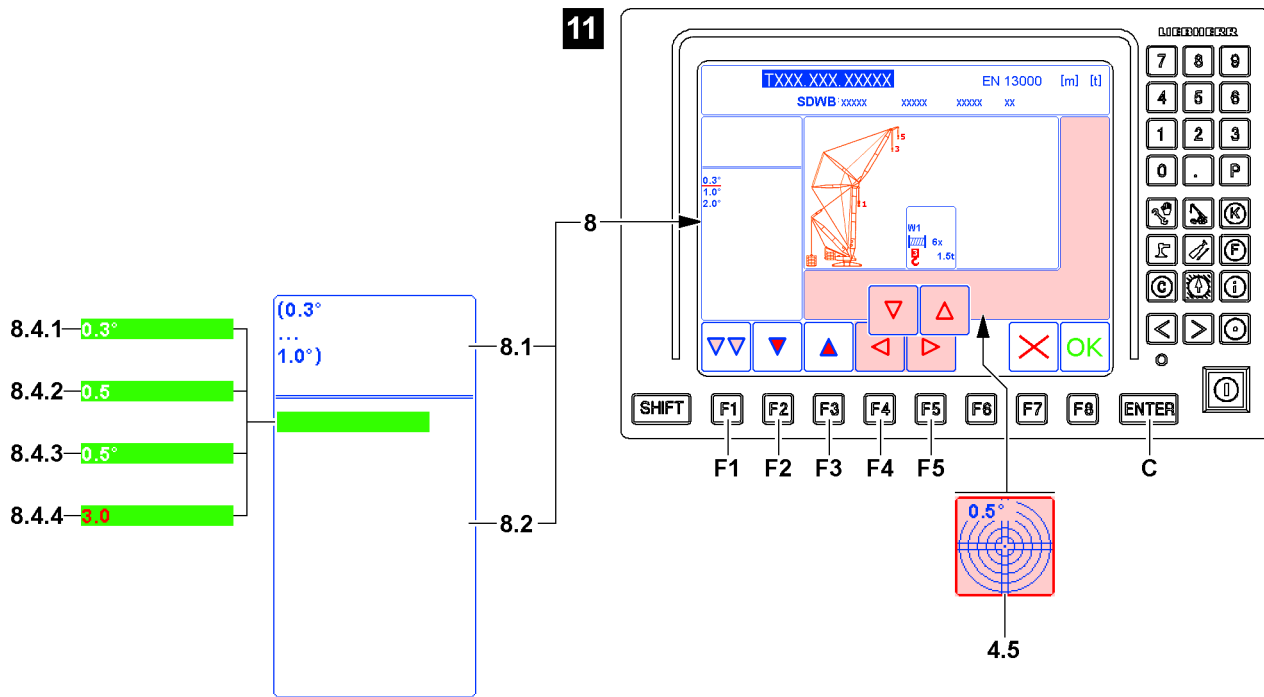

Fig.121762

Illustration 11: The entry is made without the measuring unit.

- ▶ Enter the required number sequence via the keypad **A**, in example „0.5“.

Result:

- The original value **8.4.1** (in example „0.3°“) turns off.
- The entered value **8.4.2** (in example „0.5“) appears.

- ▶ Press the ENTER key **C**.

Result:

- The new value **8.4.3** (in example „0.5°“) is taken over and shown in the icon *Incline range* **4.5**.

Problem remedy

Invalid input value

When trying to accept an invalid input value **8.4.4** then the numbers are shown in red.

Enter only values according to the specifications from the upper area **8.1** of the Editing / selection window **8**.

- ▶ Enter the permissible value via the keypad **A**.

4.8.7 Setting the load position

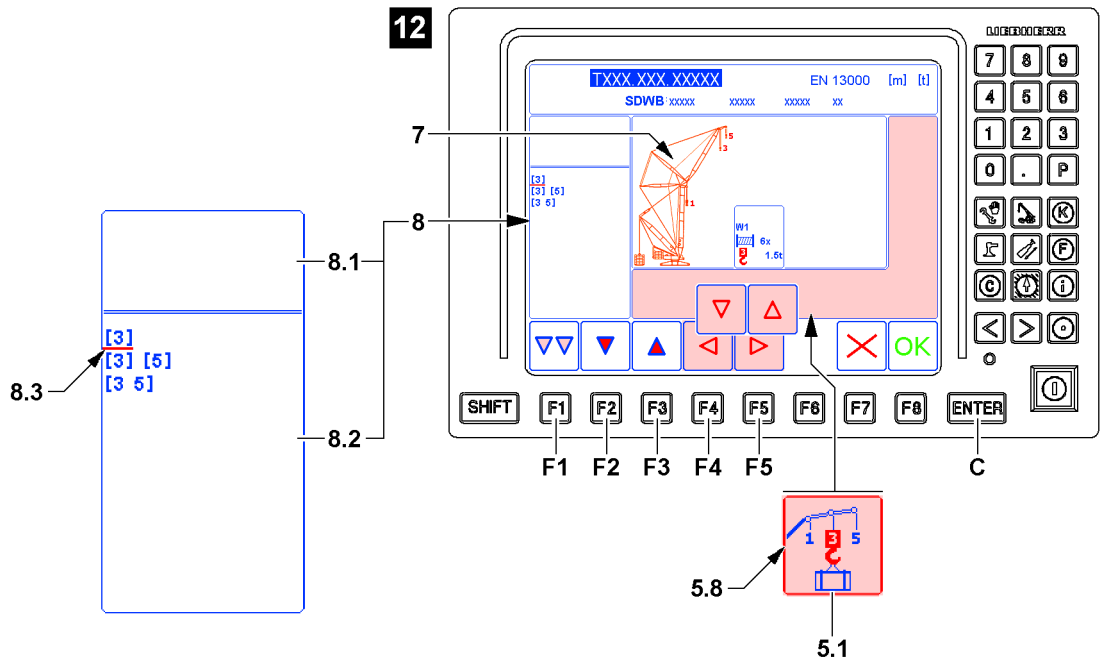

Fig.121763



Note

If the correct load position **5.1** already appears, then the settings for this marker can be skipped.
 ► Press the function key **F5** or the function key **F4** and select the next marker to be changed.



Note

The following section describes by example how a certain load position is selected.
 ► Always select the required load position.

When the respective program category is not yet highlighted in pink:

► Press the function key **F1** until the respective program category is highlighted in pink.

When icon *Load position 5.1* is not yet bordered in red:

► Press the function key **F4** or the function key **F5** until the icon *Load position 5.1* is bordered in red.

Result:

Illustration **12**:

- The *Load position* icon **5.1** is bordered in red and activated.
- In the lower area **8.2** of the Editing / selection window **8** the possible load positions are displayed.



Note

Possible load positions

- The possible load positions are visualized in the display window **7**.
- The possible load positions depend on the selected operating mode.

LWE/LR 11000-001/23501-04-02/en

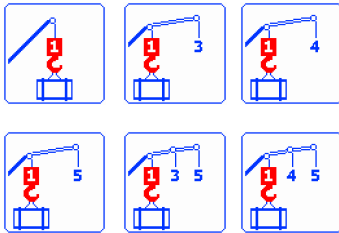
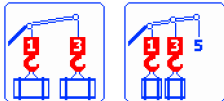
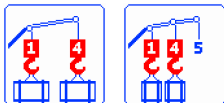
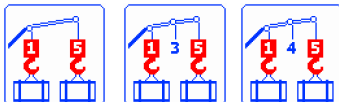
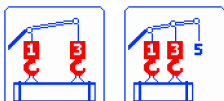
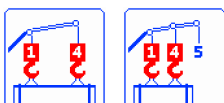
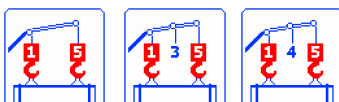
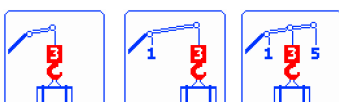
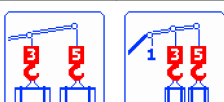
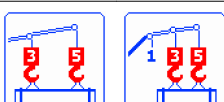
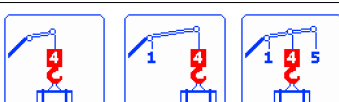
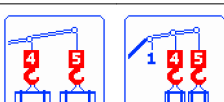
Possible load positions		
	Possible icons	Description
[1]		One hook operation: Hook 1 is reeved on load position 1. A load is fastened on hook 1.
[1] [3]		Two hook operation: Hook 1 is reeved on load position 1. Hook 3 is reeved on load position 3. First load is fastened on hook 1. Second load is fastened on hook 3.
[1] [4]		Two hook operation: Hook 1 is reeved on load position 1. Hook 4 is reeved on load position 4. First load is fastened on hook 1. Second load is fastened on hook 4.
[1] [5]		Two hook operation: Hook 1 is reeved on load position 1. Hook 5 is reeved on load position 5. First load is fastened on hook 1. Second load is fastened on hook 5.
[1 3]		Two hook operation: Hook 1 is reeved on load position 1. Hook 3 is reeved on load position 3. A combined load is fastened on hook 1 and hook 3.
[1 4]		Two hook operation: Hook 1 is reeved on load position 1. Hook 4 is reeved on load position 4. A combined load is fastened on hook 1 and hook 4.
[1 5]		Two hook operation: Hook 1 is reeved on load position 1. Hook 5 is reeved on load position 5. A combined load is fastened on hook 1 and hook 5.
[3]		One hook operation: Hook 3 is reeved on load position 3. A load is fastened on hook 3.
[3] [5]		Two hook operation: Hook 3 is reeved on load position 3. Hook 5 is reeved on load position 5. First load is fastened on hook 3. Second load is fastened on hook 5.
[3 5]		Two hook operation: Hook 3 is reeved on load position 3. Hook 5 is reeved on load position 5. A combined load is fastened on hook 3 and hook 5.
[4]		One hook operation: Hook 4 is reeved on load position 4. A load is fastened on hook 4.
[4] [5]		Two hook operation: Hook 4 is reeved on load position 4. Hook 5 is reeved on load position 5. First load is fastened on hook 4. Second load is fastened on hook 5.

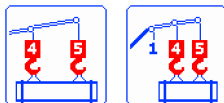
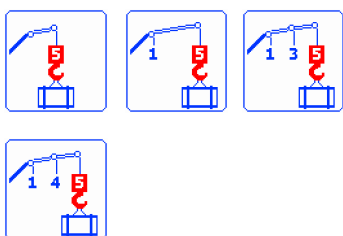
Possible load positions		
	Possible icons	Description
[4 5]		Two hook operation: Hook 4 is reeved on load position 4. Hook 5 is reeved on load position 5. A combined load is fastened on hook 4 and hook 5.
[5]		One hook operation: Hook 5 is reeved on load position 5. A load is fastened on hook 5.

- ▶ Press the function key **F2** or function key **F3** until the required load position is underlined with the selection bar **8.3**. As example „[3]“.

When the required load position is underlined with the selection bar **8.3**:

- ▶ Press the ENTER key **C**.

Result:

- The load position is selected (example „[3]“).
- The load position is accepted and shown in the icon *Load position 5.1*.

4.8.8 Setting the derrick ballast weight

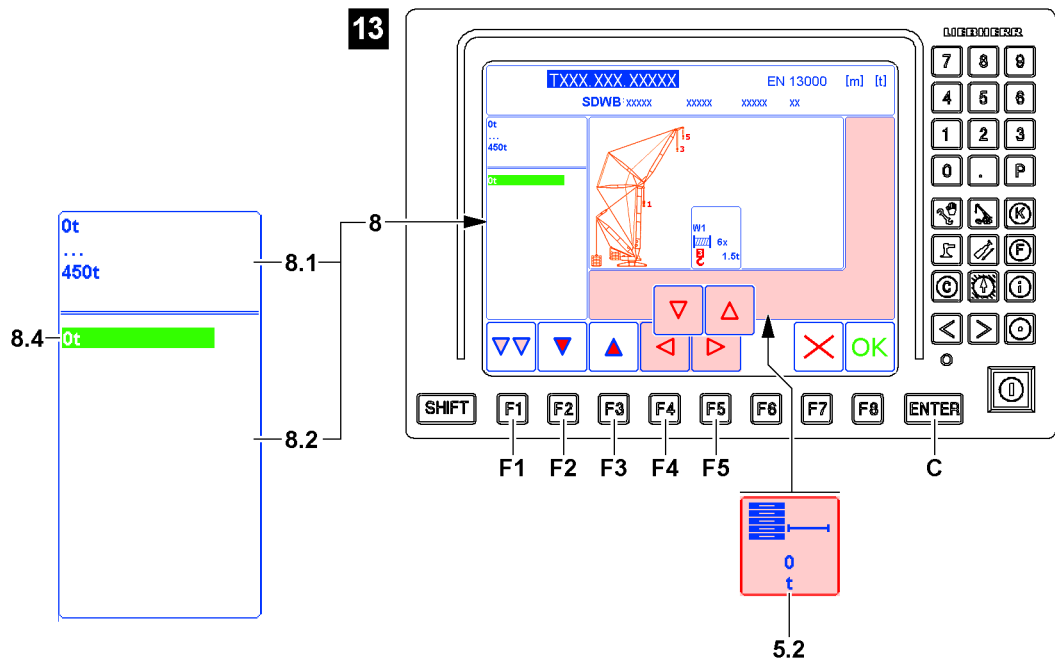

Fig.121764

The marker derrick ballast weight **5.2** only appears when a an operating mode with derrick ballast is selected.

LWE/LR 11000-001/23501-04-02/en

**Note**

If the correct derrick ballast weight **5.2** already appears, then the entries and settings for this marker can be skipped.

- ▶ Press the function key **F5** or the function key **F4** and select the next marker to be changed.

**Note**

The following section describes by example how a certain derrick ballast weight is entered.

- ▶ Always enter the required derrick ballast weight.

When the respective program category is not yet highlighted in pink:

- ▶ Press the function key **F1** until the respective program category is highlighted in pink.

When icon *Derrick ballast weight 5.2* is not yet bordered in red:

- ▶ Press the function key **F5** or the function key **F4** until the icon *Derrick ballast weight 5.2* is bordered in red, see illustration 13.

Result:

- In the upper area **8.1** of the Editing / selection window **8** the possible range of the derrick ballast weight is displayed.
- In the lower area **8.2** of the Editing / selection window **8** appears a green field **8.4** with the currently selected derrick ballast weight.

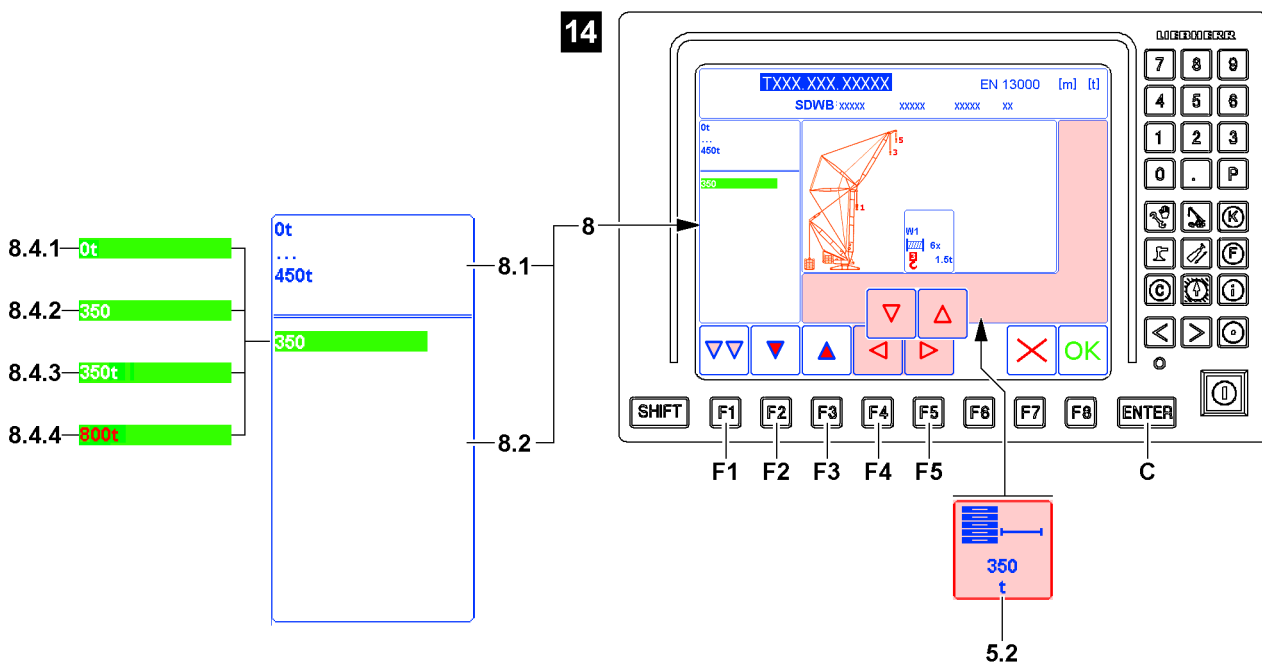

Fig.121765

Illustration 14, the entry is made without the measuring unit:

- ▶ Enter the required number sequence via the keypad **A**, in example „350“.

Result:

- The original value **8.4.1** (in example „0“) turns off.
- The entered value **8.4.2** (in example „350“) appears.

- ▶ Press the ENTER key **C**.

Result:

- The new value **8.4.3** (in example „350t“) is taken over and shown in the icon *Derrick ballast weight 5.2*.

Problem remedy

Invalid input value

When trying to accept an invalid input value **8.4.4** then the numbers are shown in red.Enter only values according to the specifications from the upper area **8.1** of the Editing / selection window **8**.

- ▶ Enter the permissible value via the keypad **A**.

4.8.9 Setting the counterweight

Depending on the crane type and load chart there are two possibilities to set the counterweight:

- Specified settings distances: The counterweight must be selected from a list, see section „Setting the counterweight: Specified settings distances“.
- Stepless settings distances: The counterweight must be entered within a specified range, see section „Setting the counterweight: Stepless settings distances“.

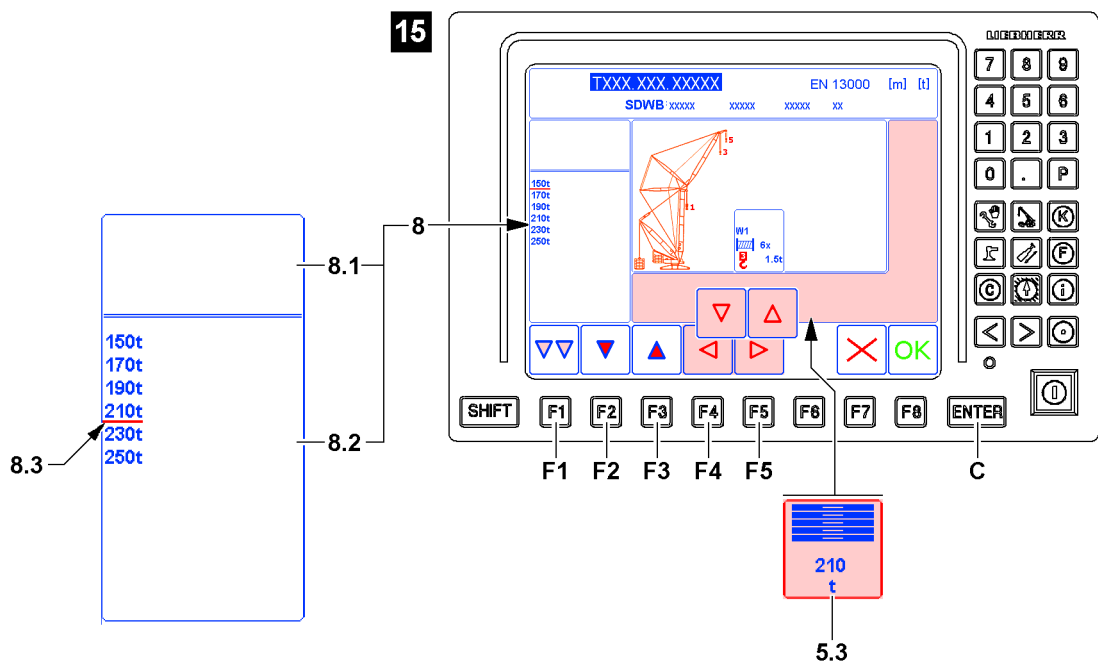

Fig.121766

**Note**If the correct counterweight **5.3** already appears, then the entries and settings for this marker can be skipped.

- ▶ Press the function key **F5** or the function key **F4** and select the next marker to be changed.

**Note**

The following section describes by example how a certain counterweight is set.

- ▶ Always set the required counterweight.

Setting the counterweight: Specified settings distances

When the respective program category is not yet highlighted in pink:

- ▶ Press the function key **F1** until the respective program category is highlighted in pink.

When icon *Counterweight* **5.3** is not yet bordered in red:

- ▶ Press the function key **F5** or the function key **F4** until the icon *Counterweight* **5.3** is bordered in red.

Result:

- In the lower area **8.2** of the Editing / selection window **8** the settings available for selection are displayed, see example illustration **15**.
- ▶ Press the function key **F2** or function key **F3** until the required setting is underlined with the selection bar **8.3** (in the example „210t“).

When the required counterweight is underlined with the selection bar **8.3**:

- ▶ Press the ENTER key **C**.

Result:

- The counterweight is selected, the respective icon *Counterweight 5.3* (in the example „210t“) appears.

Setting the counterweight: Stepless settings distances

Fig.121767

When the respective program category is not yet highlighted in pink:

- ▶ Press the function key **F1** until the respective program category is highlighted in pink.

When icon *Counterweight 5.3* is not yet bordered in red:

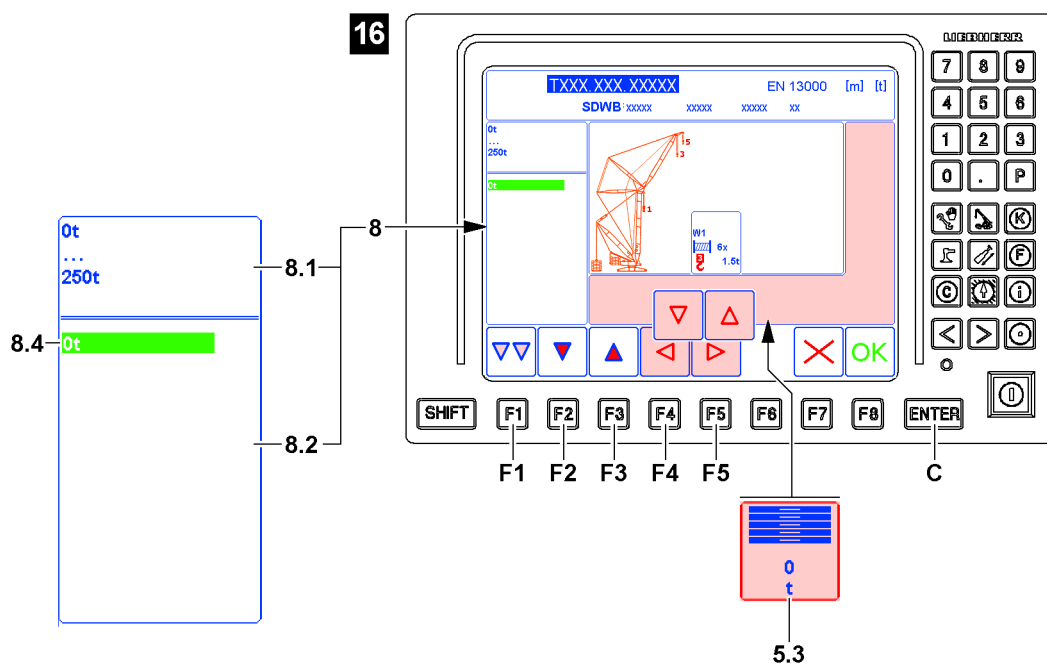
- ▶ Press the function key **F5** or the function key **F4** until the icon *Counterweight 5.3* is bordered in red.

Result:

- Illustration **16**:
 - In the upper area **8.1** of the Editing / selection window **8** the permissible range of the counterweight is displayed.
 - In the lower area **8.2** of the Editing / selection window **8** appears a green field **8.4** with the currently selected counterweight.

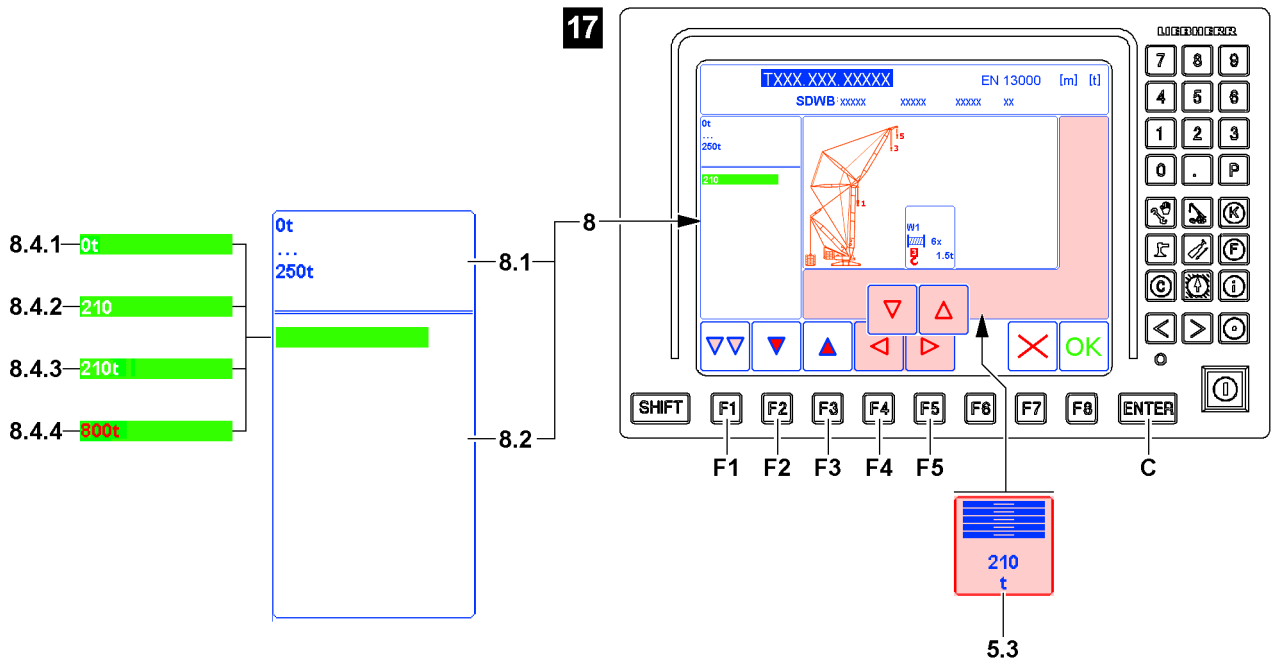

Fig.121768

Illustration 17: The entry is made without the weight unit.

► Enter the required number sequence via the keypad **A**, in example „210“.

Result:

- The original value **8.4.1** (in example „0t“) turns off.
- The entered value **8.4.2** (in example „210“) appears.

► Press the ENTER key **C**.

Result:

- The new value **8.4.3** is taken over and displayed in the icon *Counterweight 5.3*.

Problem remedy

Invalid input value

When trying to accept an invalid input value **8.4.4** then the numbers are shown in red.

Enter only permissible values according to the specifications from the upper area **8.1** of the Editing / selection window **8**.

► Enter the permissible value via the keypad **A**.

4.8.10 Setting the wind speed

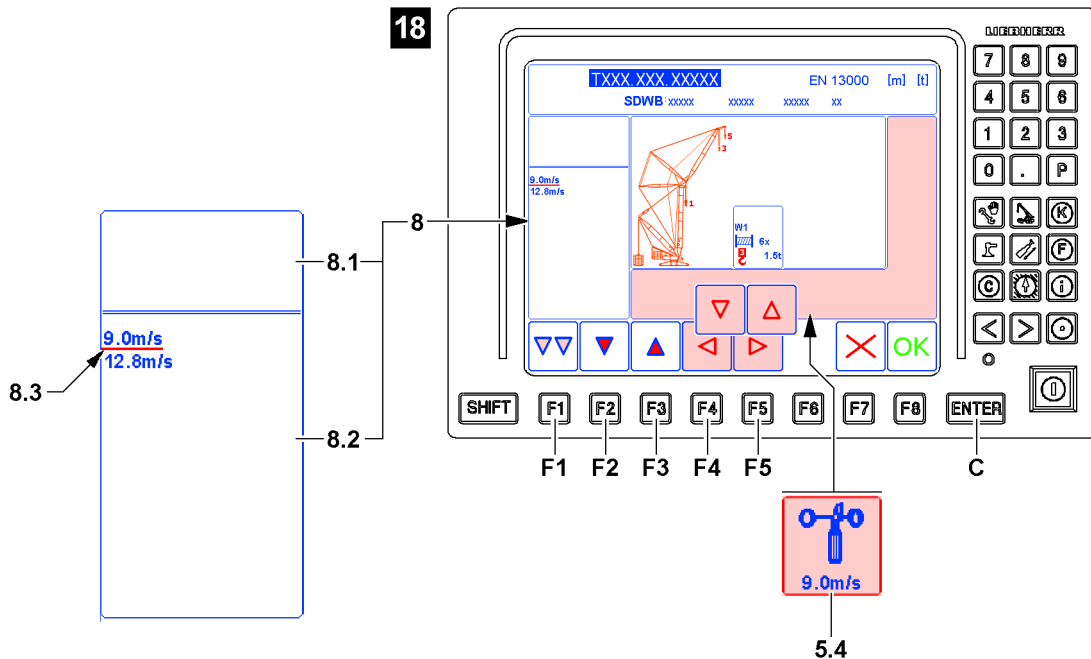

Fig.121769



Note

If the correct maximum wind speed **5.4** already appears, then the settings for this marker can be skipped.

- ▶ Press the function key **F5** or the function key **F4** and select the next marker to be changed.



Note

The following section describes by example how a certain wind speed is set.

- ▶ Always set the required wind speed.

When the respective program category is not yet highlighted in pink:

- ▶ Press the function key **F1** until the respective program category is highlighted in pink.

When icon *Wind speed* **5.4** is not yet bordered in red:

- ▶ Press the function key **F4** or the function key **F5** until the *Wind speed* icon **5.4** is bordered in red, see illustration **18**.

Result:

- In the lower area **8.2** of the Editing / selection window **8** the possible maximum wind speeds are displayed.
- ▶ Press the function key **F2** or function key **F3** until the required wind speed is underlined with the selection bar **8.3**. In example „9.0m/s“.

When the required wind speed is underlined with the selection bar **8.3**:

- ▶ Press the ENTER key **C**.

Result:

- The maximum wind speed is selected (example „9.0m/s“).
- The maximum wind speed is accepted and shown in the *Wind speed* icon **5.4**.

4.8.11 Accepting the entries and settings

Make sure that the following prerequisites are met:

- All entries and settings in the currently called up program category are correct and complete.

► Press the function key **F1**.

Result:

- Entries and settings are completed.
- The next category is automatically called up.

Problem remedy

After pressing the function key **F1** it was determined that one or several markers are not correct? By pressing the function key **F1**, the individual program categories can be switched through one after the other. After the last program category, the first is called up again.

► Press the function key **F1** until the respective program category is called up again. Then all entries and settings can be changed.

4.9 Lifting category

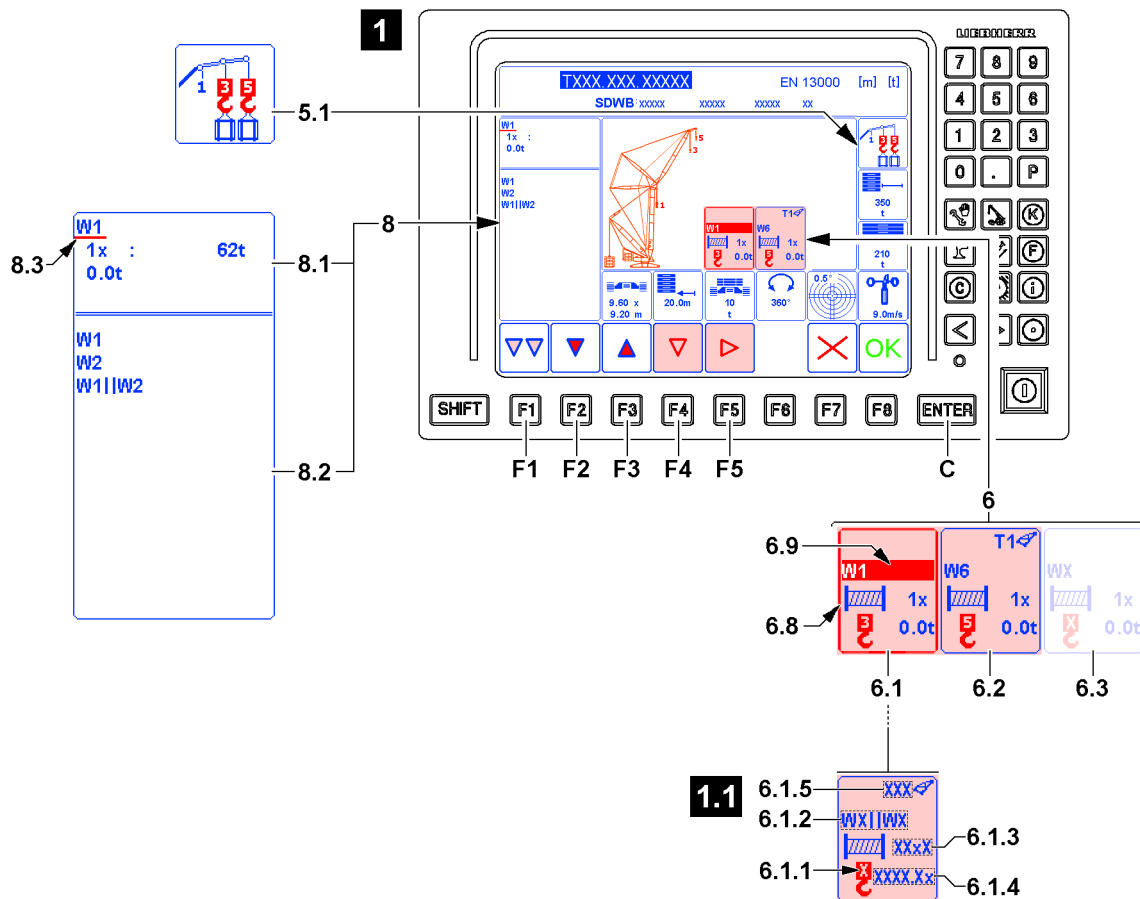

Fig.120603

The lifting category **6** includes, depending on the number of selected load positions, one to three display windows, see illustration **1**.

The display windows are always dependent on the settings for the icon *Load position* **5.1**.

- 6.1** Display window
 - Display window for the first load position
- 6.2** Display window
 - Display window for the second load position

LWE/LR 11000-001/23501-04-02/en

- **Note:** Appears only when a second load position was selected.

6.3 Display window

- Display window for the third load position
- **Note:** Appears only when a third load position was selected.

Markers in the display window of the respective load position, see illustration 1.1:

6.1.1 Load position

- Selected load position

6.1.2 Hoist winch

- Assigned hoist winch, at parallel operation both assigned hoist winches are shown.

6.1.3 Reeving

- Reeving of assigned hoist winch

6.1.4 Hook block weight

- Weight of reeved hook block

6.1.5 Fixed accessory

- Type / kind of fixed accessory
- **Note:** Appears only when fixed accessory (load position 5) was selected.

4.9.1 Selecting the lifting category



Note

If the correct hoist winch, reeving and accessory, if applicable, is already assigned to a load position, then the settings for this marker can be skipped.

- ▶ Press function key **F2** or function key **F3** until the display window for the next load position is activated.
- ▶ If no other settings are required: Change to the following section „Taking over the entries and settings from the lift category“.

- ▶ Press the function key **F1** until the lifting category **6** is highlighted in pink, see illustration 1.

Result:

- The lifting category **6** is selected.
The red selection frame **6.8** surrounds the first display window **6.1**.
The first marker in the first display window **6.1** is set to active.
The active marker is always highlighted with a red surface **6.9**.
- The Editing / selection window **8** appears.
- The preselection possibilities are displayed in the upper area **8.1** of the Editing / selection window **8**. The first preselection possibility is automatically underlined and activated with the selection bar **8.3**.
- In the lower area **8.2** of the Editing / selection window **8** the respective selection possibilities are displayed.
- Above function key **F2**, function key **F3**, function key **F4** and function key **F5** appear the icons for navigation in the individual program categories.



Note

Navigation in the lifting category **6**

Applies only when several display windows are shown.

- ▶ Press the function key **F4**: The red selection frame **6.8** moves by one icon to the left.
- ▶ Press the function key **F5**: The red selection frame **6.8** moves by one icon to the right.
- ▶ If the red selection frame **6.8** is moved in one direction past the edge of the lifting category **6** then it enters again from the other direction.



Note

Navigation in Editing / selection window **8**

- ▶ Press the function key **F2**: The selection bar **8.3** changes downward by one line.
- ▶ Press the function key **F3**: The selection bar **8.3** changes upward by one line.
- ▶ When the upper area **8.1** and the lower area **8.2** are assigned: Press the ENTER **C** key and change between the upper area **8.1** and the lower area **8.2**.

4.9.2 Assigning the hoist winch

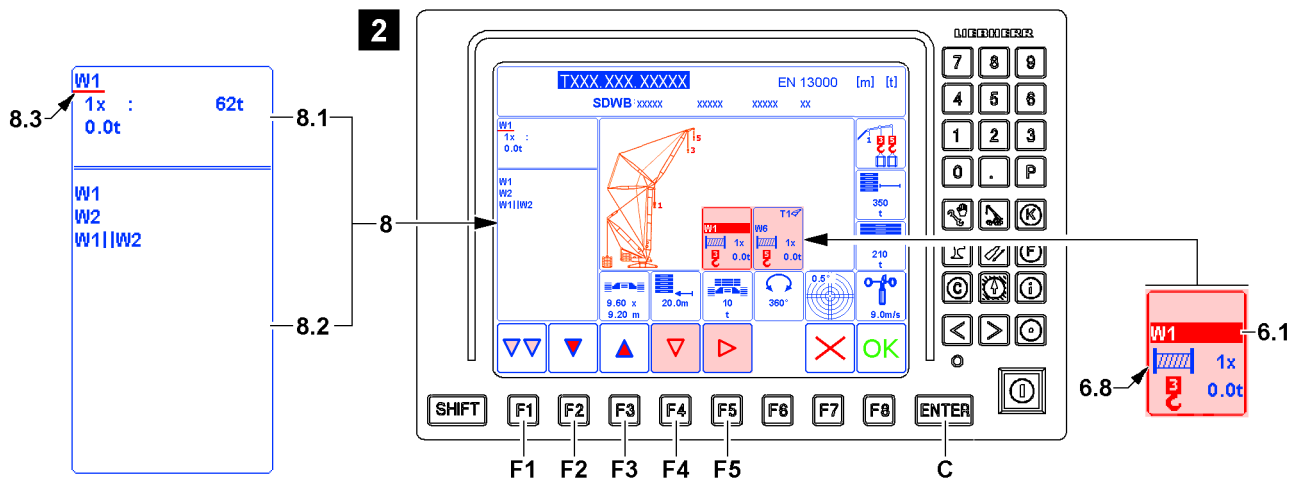

Fig.120604



Note

Assigning abbreviations for the hoist winches

- ▶ W1: Abbreviation for winch 1.
- ▶ W2: Abbreviation for winch 2.
- ▶ W6: Abbreviation for winch 6.



Note

The following section describes by means of an example how a certain hoist winch is assigned.

- ▶ Always assign the required hoist winch.

Make sure that the following prerequisite is met:

- All entries and settings in the previous program category are correct and complete.

When the desired display window is not marked with the red selection frame **6.8**:

- ▶ Press the function key **F5** or function key **F4** until the red selection frame **6.8** marks the desired display window (in example „load position 3“), see illustration **2**.

Result:

- The preselection possibilities are displayed in the upper area **8.1** of the Editing / selection window. **8** The first preselection possibility is automatically underlines and activated with the selection bar **8.3**.
- In the lower area **8.2** of the Editing / selection window **8** the respective selection possibilities are displayed.

- ▶ Press the function key **F2** or function key **F3** until the hoist winch selection in the upper area **8.1** is underlined with the selection bar **8.3**. (In example „W1“).

Result:

- In the active display window, the display for the assigned hoist winch **6.1.2** is highlighted in red.

When the hoist winch selection is underlined with the selection bar **8.3**:

► Press the ENTER key **C**.

Result:

- The selection bar **8.3** changes in the lower area **8.2** of the Editing / selection window **8**.

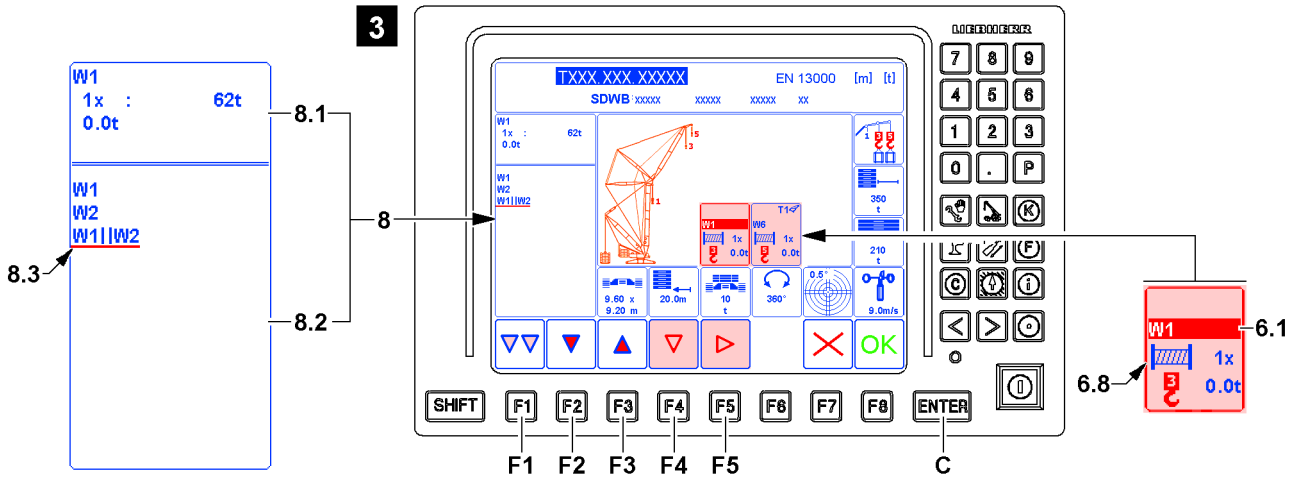

Fig.120605

► Press the function key **F2** or function key **F3** until the required selection in the upper area **8.2** is underlined with the selection bar **8.3**. (As example „Parallel operation WI and WII“), see illustration **3**.

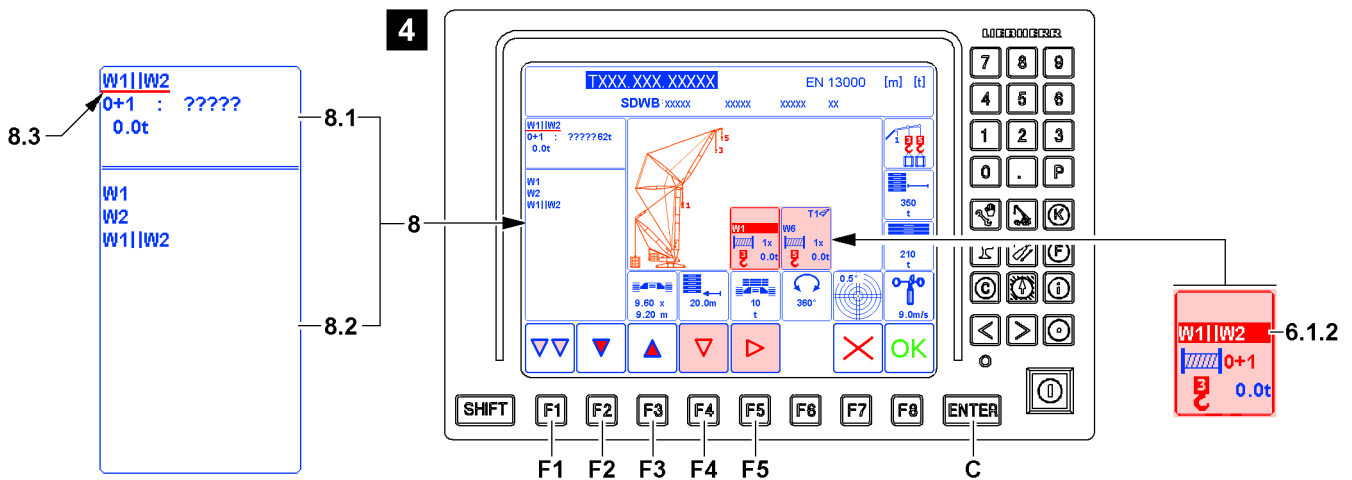

Fig.120606

When the required preselection possibility is underlined with the selection bar **8.3**:

► Press the ENTER key **C**.

Result:

- The preselection possibility is defined (In example „Parallel operation WI and WII“).
- In the icon for load position 3 appears as the new setting as assigned hoist winch **6.1.2**, see illustration **4**.
- The selection bar **8.3** changes again in the upper area **8.1** of the Editing / selection window **8**.

**Note****Effect of single / parallel operation of hoist winches for the reeving line**

Changes for values for the reeving 8.1.1 and the maximum load 8.1.2:

When changing from parallel operation of hoist winches to single operation of one hoist winch, the current reevings are added up.

When changing from single operation of one hoist winch to parallel operation of two hoist winches, the current reeving 8.1.1 is divided.

If it is not a number which can be divided, then question marks („?“) or the value „0.0“ appear instead of a maximum load 8.1.2, see illustration 4.

▶ A valid reeving must be entered.

▶ For subsequent procedure, see the following section „Assigning reeving“.

4.9.3 Assigning reeving

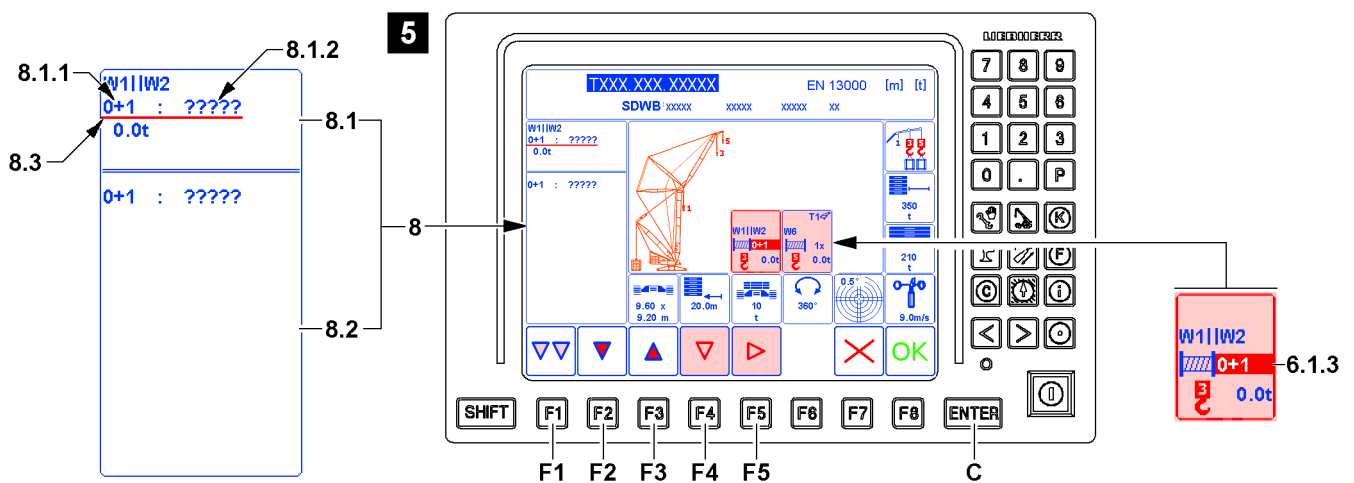

Fig.120607

**Note**

The following section describes by means of an example how a certain reeving is assigned.

▶ Always assign the required reeving.

**Note**

Illustration 5: If question marks („?“) appear behind the reeving number 8.1.1, then no valid reeving has been entered.

If the icon OK turns off above the function key F8, then an invalid selection is active.

▶ A valid reeving must now be entered.

- The preselection possibilities are displayed in the upper area 8.1 of the Editing / selection window 8. The first preselection possibility is automatically underlines and activated with the selection bar 8.3.
- In the lower area 8.2 of the Editing / selection window 8 the respective selection possibilities are displayed.

**Note**

The following section describes by means of an example how a certain reeving is entered.

▶ Always enter the required reeving.

▶ Press the function key F2 or function key F3 until the reeving in the upper area 8.1 is underlined with the selection bar 8.3. (As example „0+1 : ?????“).

Result:

- In the active display window, the display for the reeving 6.1.3 is highlighted in red.

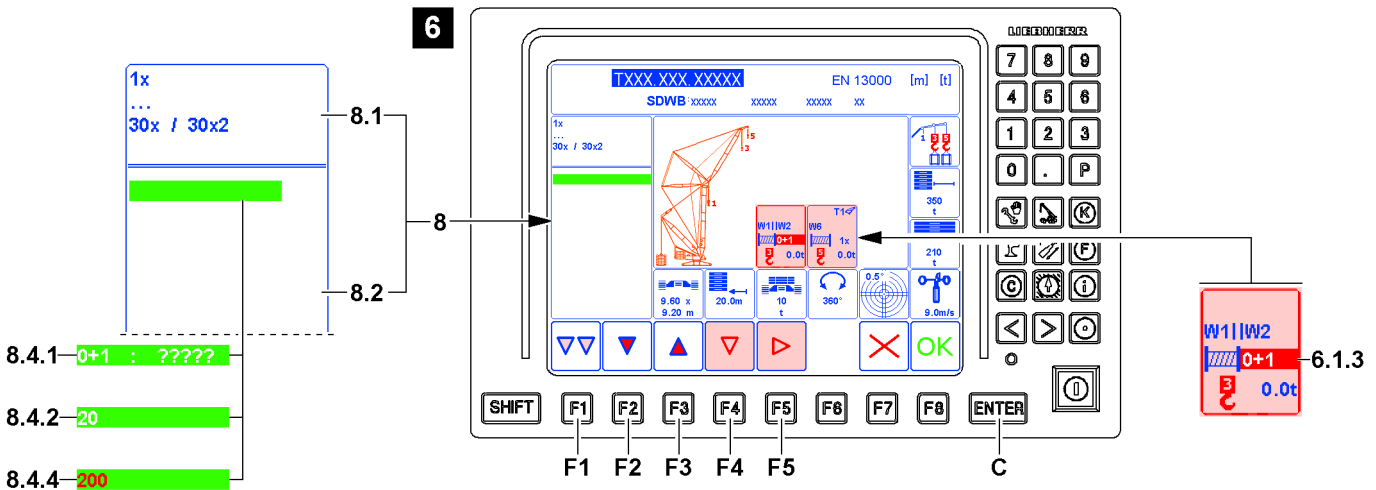

Fig.120608

When the reeving is underlined with the selection bar 8.3:

► Press the ENTER key C.

Result:

- In the upper area 8.1 of the Editing / selection window 8 the permissible reeving are displayed, see illustration 6.
- In the lower area 8.2 of the Editing / selection window 8 appears a green input field with the reeving value from the upper area 8.1.



Note

► Always only one value must be entered for the reeving. In parallel operation, the code „x2“ is automatically added to the value and the value is assigned to both hoist winches.

► Enter the required number sequence via the keypad A, in example „20“.

Result:

- The original value 8.4.1 (in example „0+1 : ?????“) turns off.
- The new value 8.4.2 (in example „20“) appears.

Problem remedy

Invalid input value

When trying to accept an invalid input value 8.4.4 then the numbers are shown in red.

Enter only values according to the specifications from the upper area 8.1 of the Editing / selection window 8.

► Enter the permissible value via the keypad A.

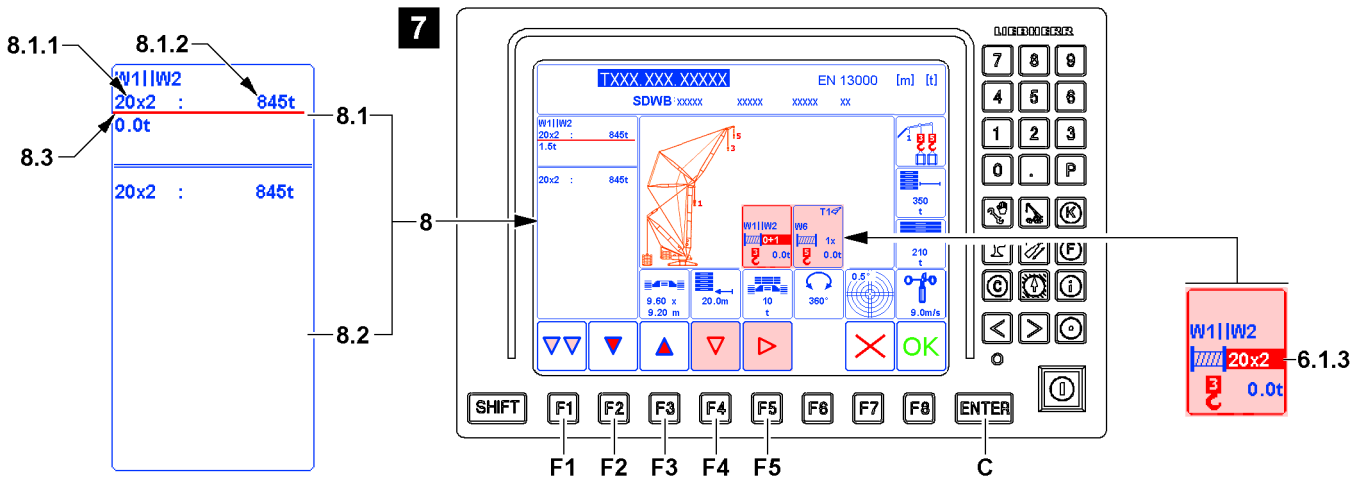

Fig.120609

► Press the ENTER key C.

Result:

- The new value is accepted and changed for parallel operation if necessary, see illustration 7.
- In the display window appears the new value for the reeving 6.1.3.
- In the upper area 8.1 appears the entered reeving 8.1.1. In addition, the maximum load 8.1.2 appears, which could be lifted with this reeving under ideal conditions.

4.9.4 Entering the hook block weight

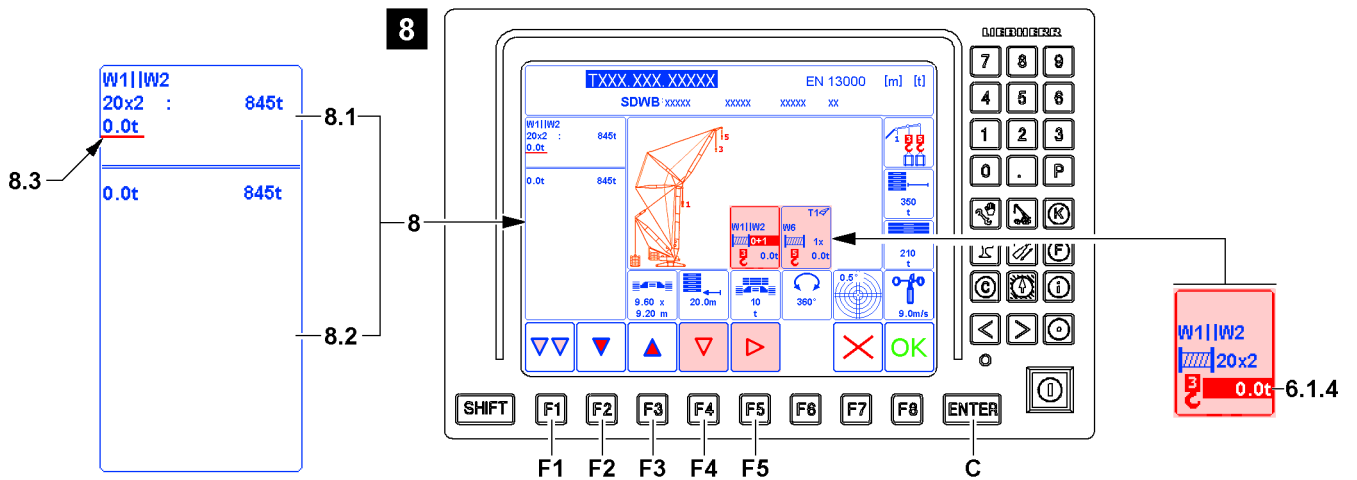

Fig.120610

LWE/LR 11000-001/23501-04-02/en

**Note**

If the correct hook block weight **6.1.4** already appears, then the settings for this marker can be skipped.

Change to the next marker (if present):

- ▶ Press the function key **F2** or function key **F3** until the next marker to be changed is underlined with the selection bar **8.3**.

Change into the next display window (if present):

- ▶ Press the function key **F5** or the function key **F4** and select the next display window.

Ending the *Set up* program (when all entries and settings are made):

- ▶ When all entries and settings in the lifting category **6** are correct, see section „Taking over entries and settings from the set up program“.

- The preselection possibilities are displayed in the upper area **8.1** of the Editing / selection window. **8** The first preselection possibility is automatically underlines and activated with the selection bar **8.3**.
- In the lower area **8.2** of the Editing / selection window **8** the respective selection possibilities are displayed.

**Note**

The following section describes by example how a certain hook block weight is entered.

- ▶ Always enter the required hook block weight.

- ▶ Press the function key **F2** or function key **F3** until the hook block weight in the upper area **8.1** is underlined with the selection bar **8.3**. (In example „0.0t“).

Result:

- In the active display window, the display for the hook block weight **6.1.4** is highlighted in red.

When the hook block weight is underlined with the selection bar **8.3**, see illustration **8**:

- ▶ Press the ENTER key **C**.

Result:

- In the upper area **8.1** of the Editing / selection window **8** the permissible hook block weight is displayed.
- In the lower area **8.2** of the Editing / selection window **8** appears a green input field with the hook block weight from the upper area **8.1**.

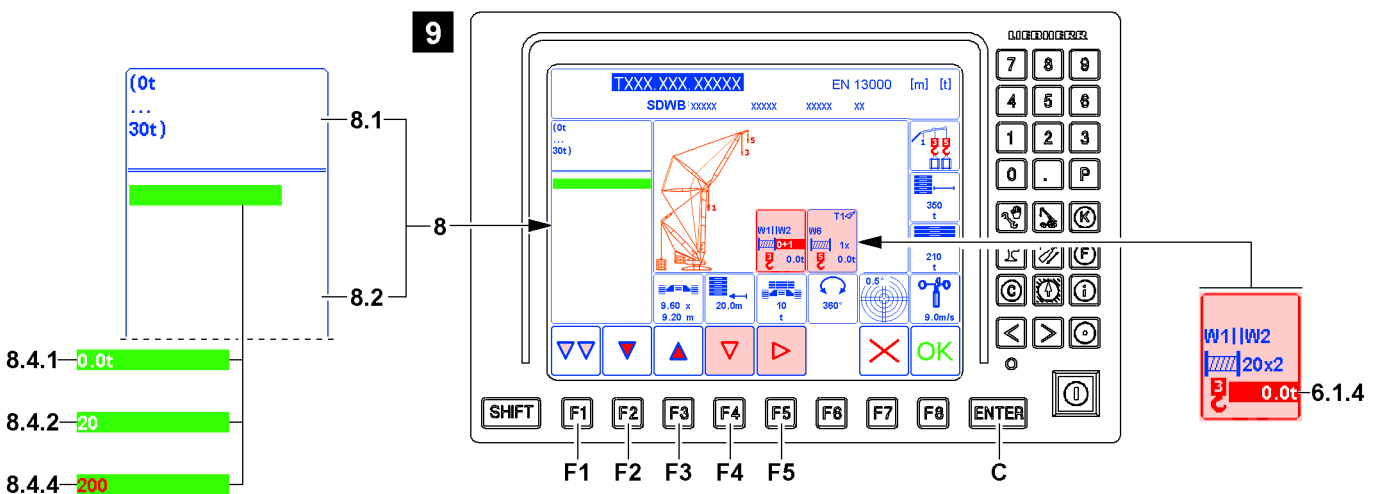

Fig.120611

The entry is made without the measuring unit:

- ▶ Enter the required number sequence via the keypad **A**, in example „20“.

Result:

Illustration 9:

- The original value **8.4.1** (in example „0t“) turns off.
- The new value **8.4.2** (in example „20“) appears.

Problem remedy

Invalid input value

When trying to accept an invalid input value **8.4.4** then the numbers are shown in red.

Enter only values according to the specifications from the upper area **8.1** of the Editing / selection window **8**.

- ▶ Enter the permissible value via the keypad **A**.

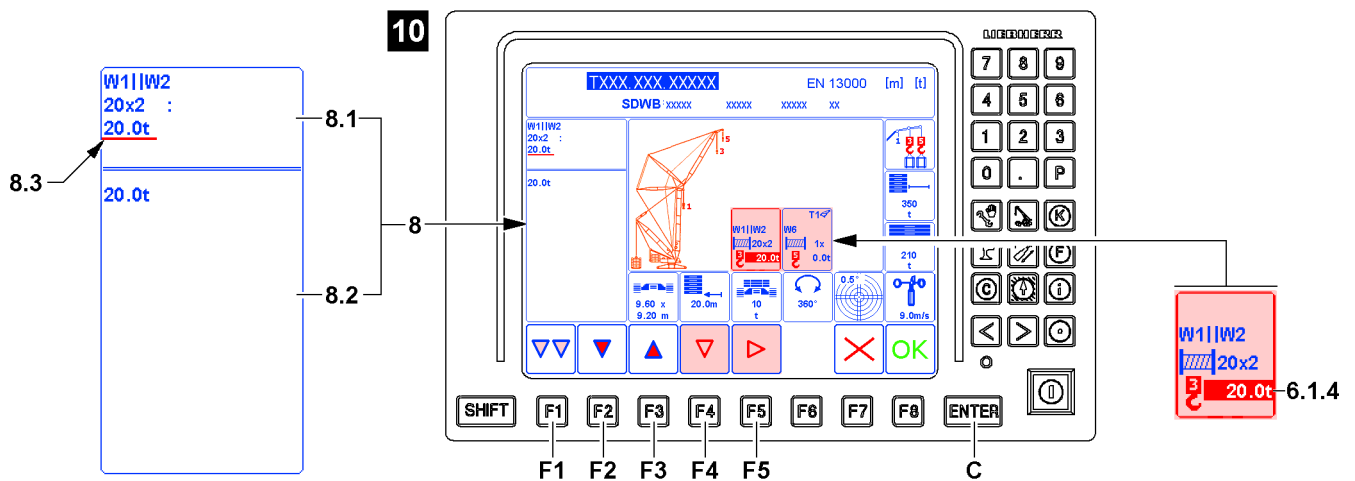

Fig.120612

- ▶ Press the ENTER key **C**.

Result:

- The new value is taken over, see illustration 10.
- In the display window appears the new value for the hook block weight **6.1.4**.
- In the upper area **8.1** appears the new value for the hook block weight.

4.9.5 Assigning fixed accessory

LWE/LR 11000-001/23501-04-02/en

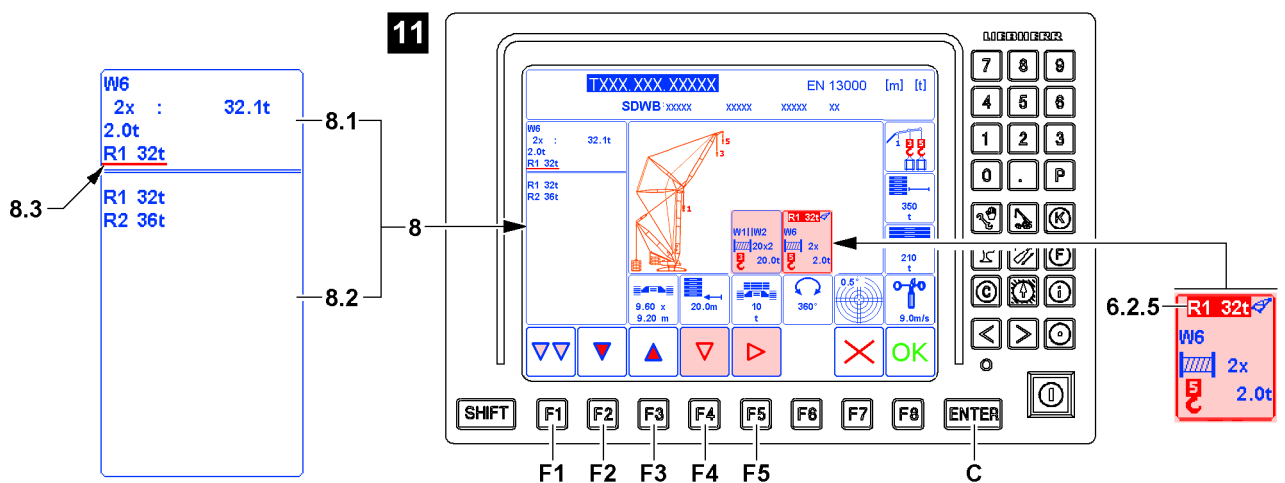

Fig.120613

The marker for the fixed accessory **6.2.5** only appears when a corresponding load position is selected.

**Note**

If the correct maximum fixed accessory **6.2.5** already appears, then the settings for this marker can be skipped.

Change to another marker (if necessary):

- ▶ Press the function key **F2** or function key **F3** until the next marker to be changed is underlined with the selection bar **8.3**.

Change into the next display window (if present):

- ▶ Press the function key **F5** or the function key **F4** and select the next display window.

Ending the *Set up* program (when all entries and settings are made):

- ▶ When all entries and settings in the lifting category **6** are correct, see section „Taking over entries and settings from the set up program“.

- The preselection possibilities are displayed in the upper area **8.1** of the Editing / selection window. **8** The first preselection possibility is automatically underlines and activated with the selection bar **8.3**.
- In the lower area **8.2** of the Editing / selection window **8** the respective selection possibilities are displayed.

**Note**

Abbreviations for fixed accessory

Only the fixed accessory is listed for which a load chart is available.

For example, the following can appear corresponding to the load chart name (chart number):

- ▶ R1: Abbreviation for boom nose 1. (Appears only when a valid load chart for boom nose 1 is available)
- ▶ R2: Abbreviation for boom nose 2. (Appears only when a valid load chart for boom nose 2 is available).

Make sure that the following prerequisite is met:

- The desired display window is marked with the red selection frame **6.8**.

When the desired display window is not marked with the red selection frame **6.8**:

- ▶ Press the function key **F5** or function key **F4** until the red selection frame **6.8** marks the desired display window (in example „load position 5“), see illustration **11**.
- ▶ Press the function key **F2** or function key **F3** until the fixed accessory in the upper area **8.1** is underlined with the selection bar **8.3**. (In example „R1 32t“).

Result:

- In the active display window, the display for the fixed accessory **6.2.5** is highlighted in red.

When the fixed accessory is underlined with the selection bar **8.3**:

- ▶ Press the ENTER key **C**.

Result:

- The selection bar **8.3** changes in the lower area **8.2** of the Editing / selection window **8**.

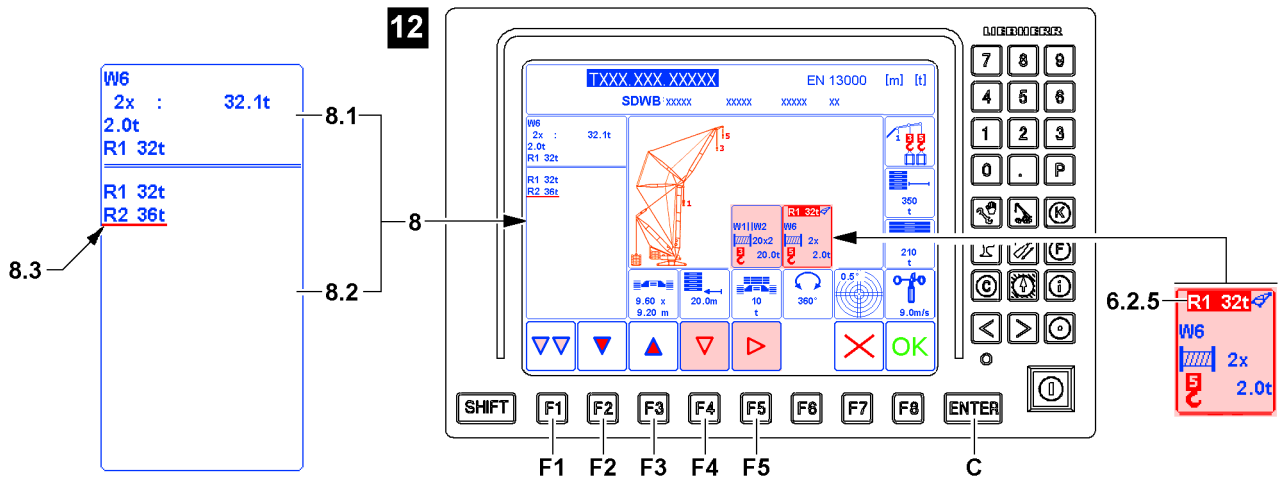

Fig.120614

- ▶ Press the function key **F2** or function key **F3** until the required selection in the upper area **8.2** is underlined with the selection bar **8.3**. (In example „R2 36t“, see illustration **12**.)

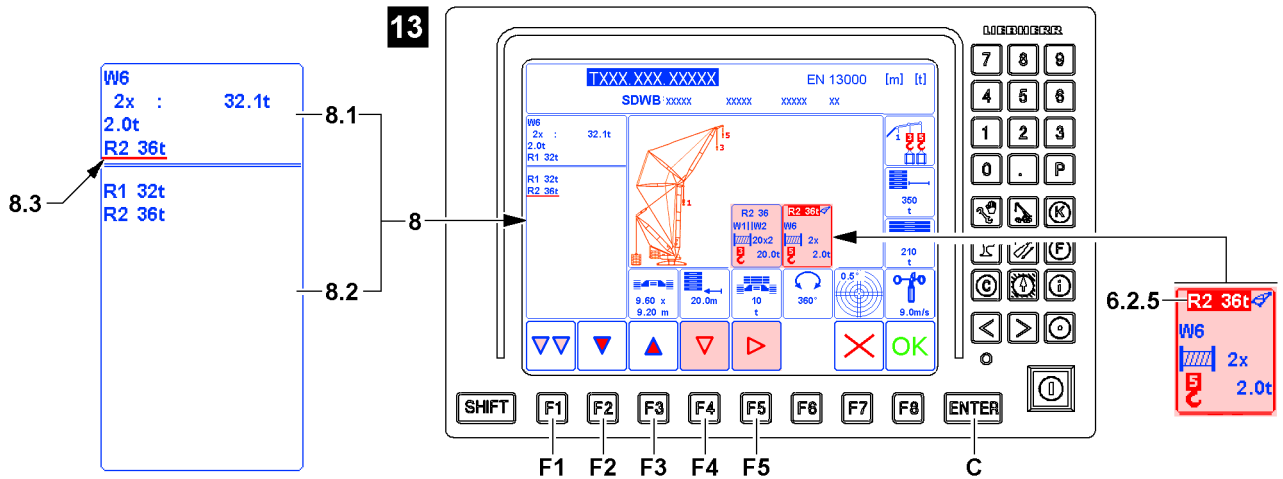

Fig.120615

- ▶ Press the ENTER key **C**.

Result:

- The selection is defined (example „R2 36t“).
- In the icon for load position 5 appears as the selected setting as fixed accessory **6.2.5**, see illustration **13**.
- The selection bar **8.3** changes again in the upper area **8.1** of the Editing / selection window **8**.

LWE/LR 11000-001/23501-04-02/en

4.9.6 Accepting the entries and settings of the lifting category

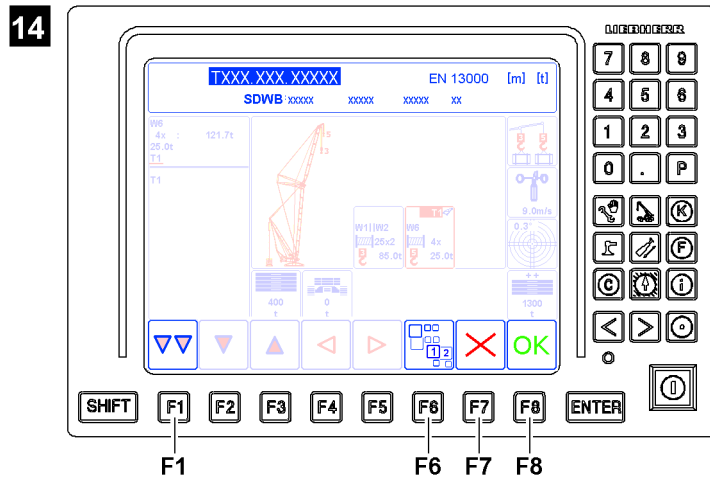

Fig.120616

Make sure that the following prerequisites are met:

- All selected entries and settings in the lifting category are correct and complete.

- ▶ Change to the following section „Taking over the entries and settings from the set up program“.

Problem remedy

It was determined that one or several markers are not correct?

By pressing the function key **F1**, the individual program categories can be switched through one after the other. After the last program category, the first is called up again.

- ▶ Press the function key **F1** until the lifting category is called up again. Then all entries and settings can be changed.

4.10 Taking over the entries and settings from the Set up program



WARNING

Danger of accident due to deviating set up configuration!

If the actual set up configuration of the crane deviates from the entries and settings in the *Set up* program, then the overload protection is not correctly set.

An incorrectly set overload protection calculates the actual load incorrectly and transmits faulty display values.

The crane can be overloaded unnoticed and topple over. Personnel can be severely injured or killed.

- ▶ The entries and settings in the *set up* program must match the actual set up configuration of the crane.

Make sure that the following prerequisite is met:

- There is no load on the hook.

- ▶ Check all entries and settings on the screen to ensure they are correct.

If the icon for additional levels appears above the function key **F6** (see illustration 14), then they must be checked also.

When the icon for additional levels appears:

- ▶ Press the function key **F6** and check all entries and settings on the screen to ensure they are correct.

When all entries and settings have been checked to ensure that they are correct:

- ▶ Press the function key **F8** (below the **OK** icon) and take over the entries and settings from the *Set up* program.

Result:

- The *Set up* program is ended.
- Entries and settings from the *Set up* program have been taken over into the crane operating screen.
- The crane operating screen is called up.

Problem remedy

It was determined that one or several markers are not correct?

By pressing the function key **F1**, the individual program categories can be switched through one after the other. After the last program category, the first is called up again.

- ▶ Press the function key **F1** until the category to be changed is called up. Then all entries and settings can be changed.

**Note**

Caution Program abort.

- ▶ By pressing the function key **F7**, the process is aborted and the last valid entries and settings from the *Set up* program are called up.
-

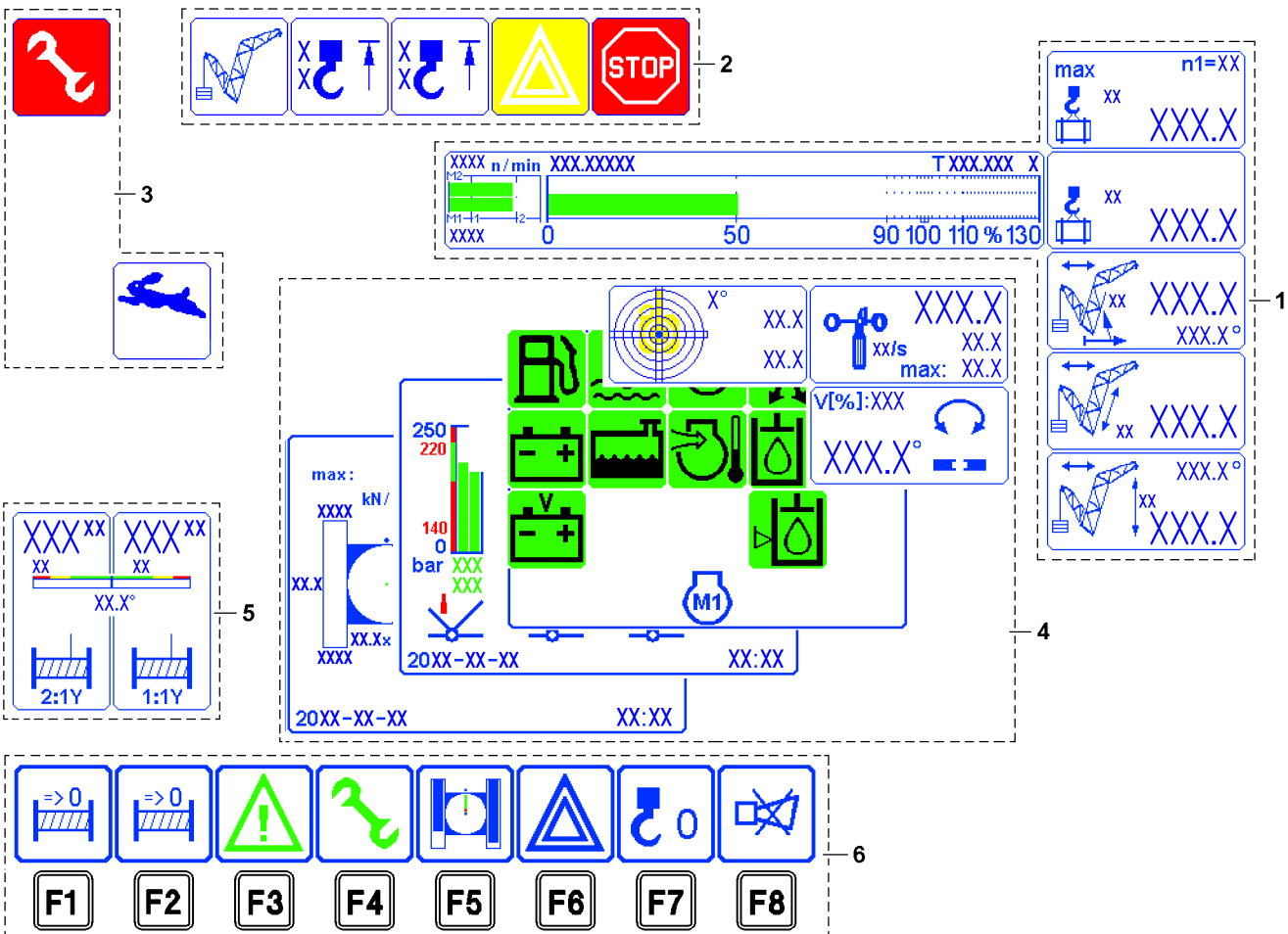
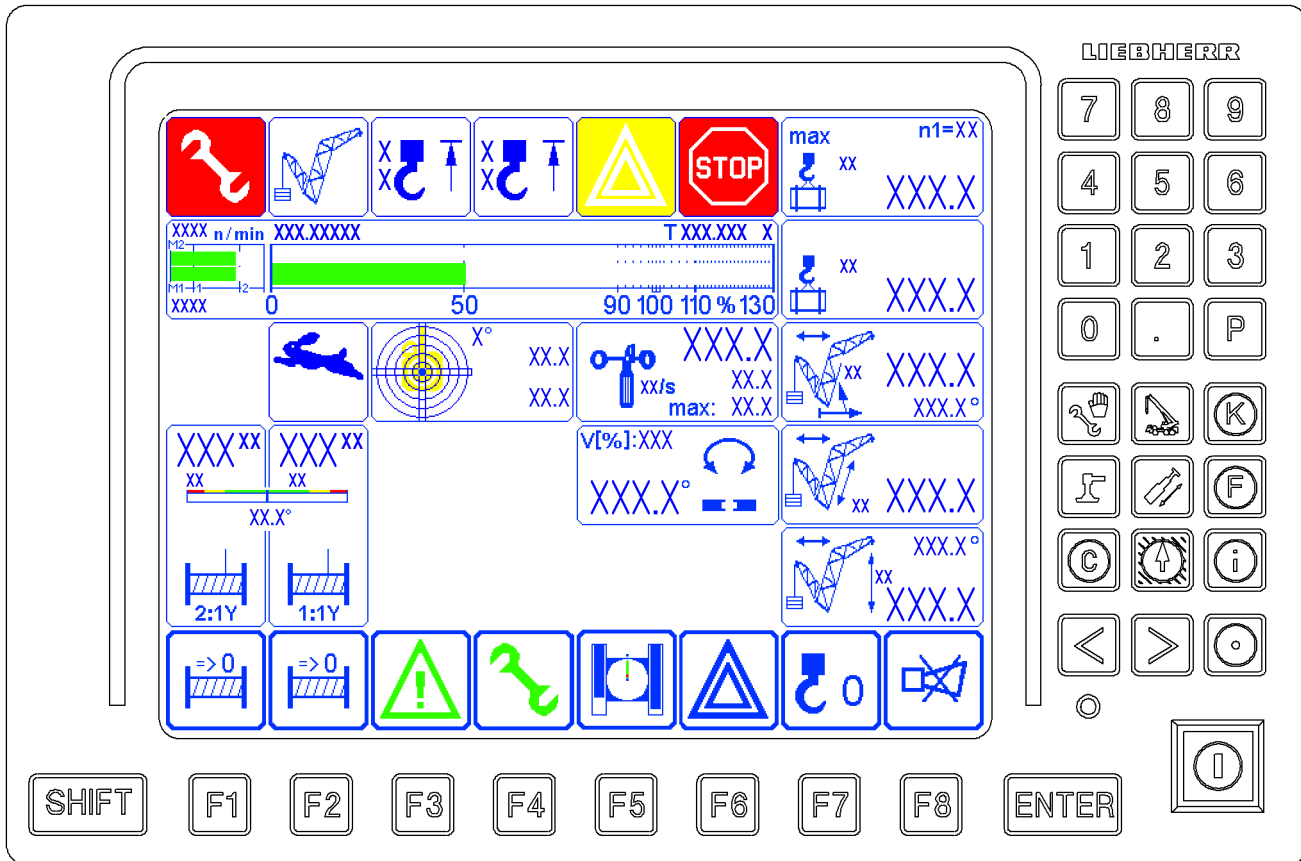

Fig.113426

LWE/LR 11000-001/23501-04-02/en

5 The *Crane operation* program on LICCON monitor 0

The *Crane operation* LICCON program assists the crane operator by displaying the data relevant for crane operation clearly on three LICCON monitors. An acoustic signal accompanies all critical displays. Depending on the equipment, a range of other icons may also be turned on as additional displays, either as required by the crane operator, or automatically in the event of a problem.

It also alerts the crane operator to imminent overload conditions. In the event of overload and many error conditions, which could be hazardous during crane operation, the system shuts off.

The LICCON monitor 0 is divided into six areas in the *Crane operation* program:

- 1 Crane geometry and load information
- 2 Alarm functions
- 3 LICCON Monitor 0 special functions
- 4 Monitoring field
 - Monitoring functions during crane operation
 - Monitoring of relapse cylinders
 - Monitoring of surface pressure and center of gravity
 - Monitored auxiliary functions
- 5 Winch display
 - Winch 1 and winch 2
- 6 Function key line
 - Function keys always refer to the icons shown directly above
 - **Note:** If no icon is shown in the line directly above the function key, then no function is assigned in the program to the function key.



Note

- ▶ The monitor illustrations in this chapter are only examples.
 - ▶ The numerical values in the individual icons and charts do not have to necessarily match the crane exactly.
 - ▶ The configuration of the LICCON monitor with icons is only descriptive.
 - ▶ An identical icon display will **not** appear during crane operation.
-

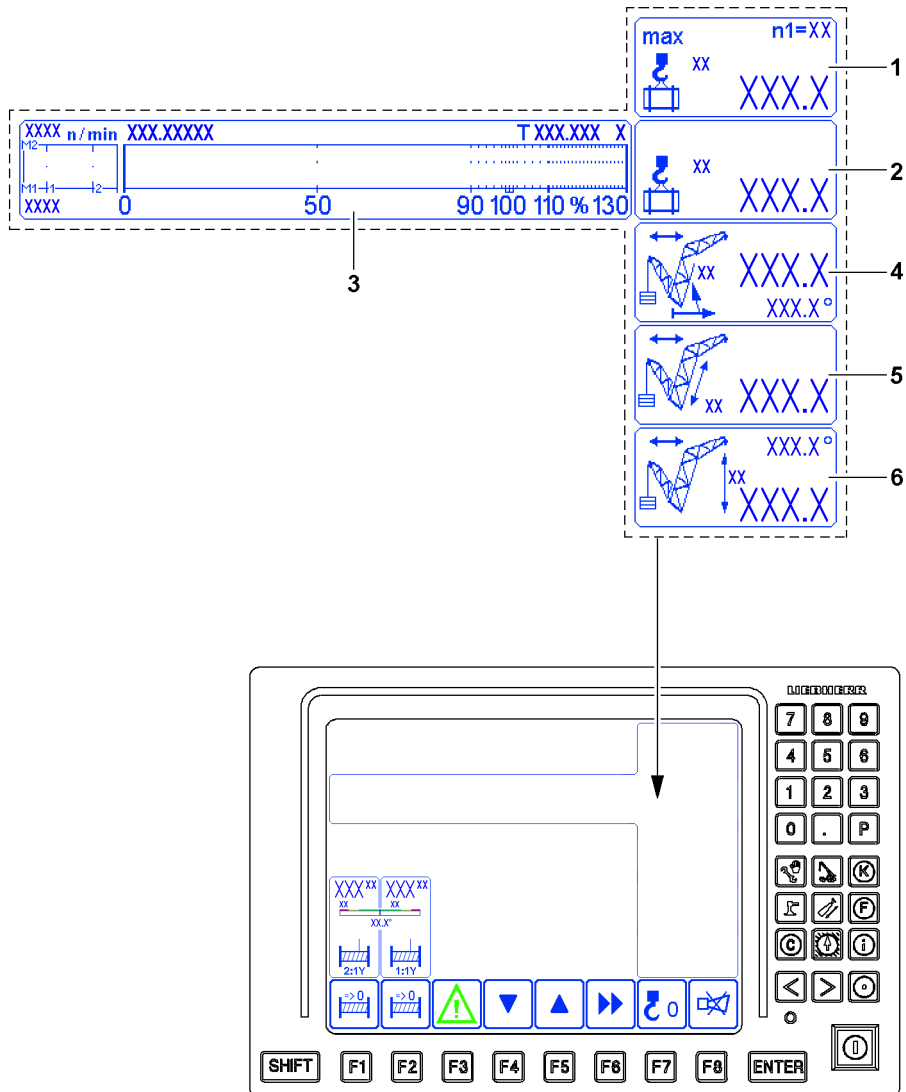

Fig.114296

5.1 Crane geometry and load information

Display on LICCON monitor 0



Note

- ▶ The crane illustrations in this section are only examples and are generalized.
 - ▶ They may differ from the crane type and equipment.
-

The information regarding crane geometry and load involves six icons:

- 1 Maximum load
- 2 Actual load
- 3 Bar diagram Utilization
- 4 Boom radius
- 5 Boom length
- 6 Pulley head height



Note

- ▶ A question mark (?) is shown instead of values when no load chart value can be accessed. Example: The crane is not in the range of the load chart.
 - ▶ A question mark (?) is shown instead of values if the value cannot be calculated / determined. Example: A sensor error can be present - pay attention to error messages.
-

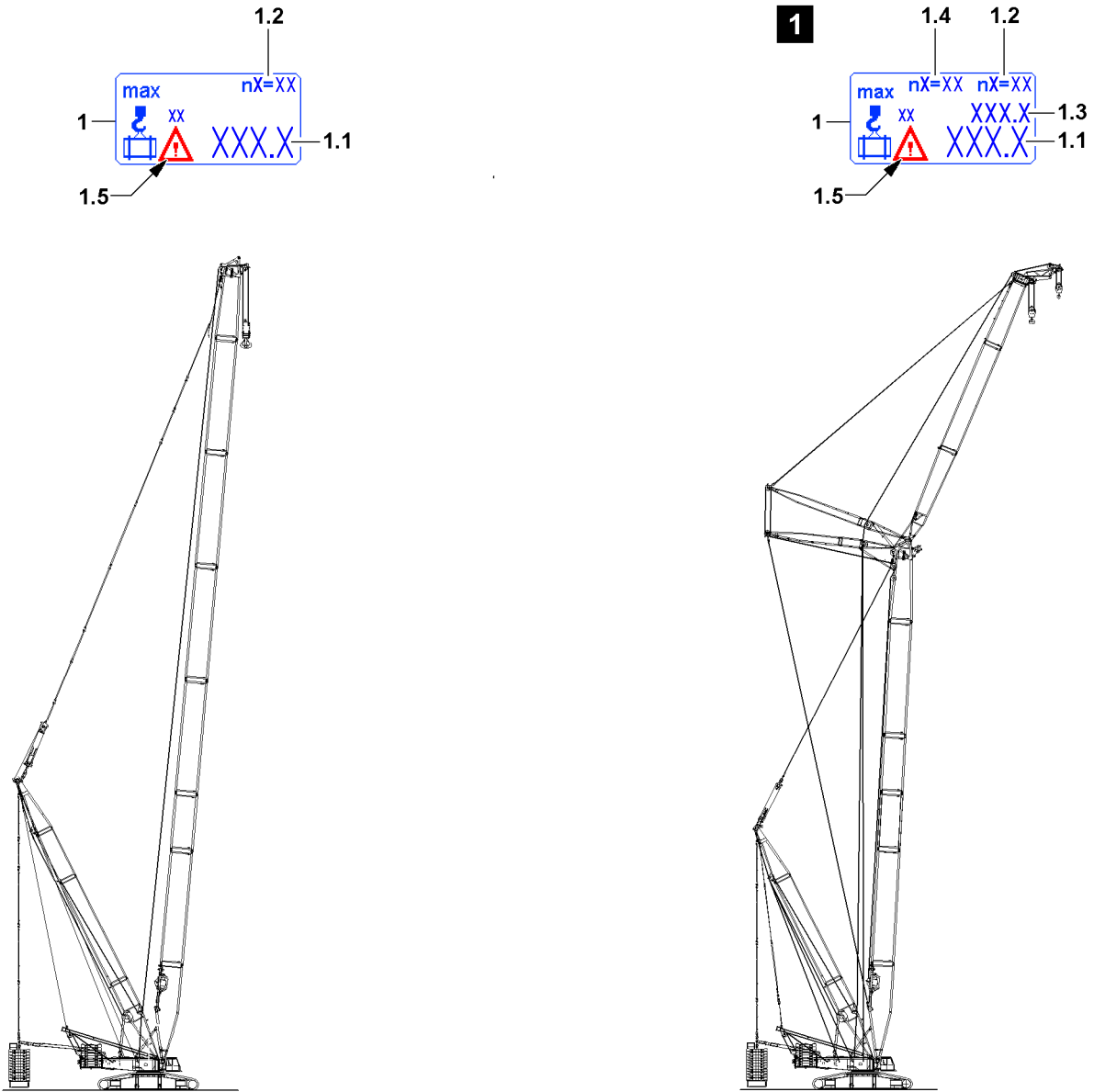

Fig.121770

LWE/LR 11000-001/23501-04-02/en

5.1.1 Maximum load

According to the set up configuration, the following changes:

- The illustration of the icon.
- The position of values in the icon, see sample illustration 1.

1 Maximum load icon

- In [t] or [lbs]

1.1 Maximum load

- Maximum load on the **first** load position
- In [t] or [lbs]

1.2 Reeving

- Reeving on the **first** load position
- Load position (n1 to n5) and assigned reeving number (settings from the *Set up* program)
 - n1= Load position 1
 - n2= Load position 2
 - n3= Load position 3
 - n4= Load position 4
 - n5= Load position 5

1.3 Maximum load

- **Note:** Appears only when a second load position is selected (settings from the *Set up* program).
- Maximum load on the **second** load position
- In [t] or [lbs]

1.4 Reeving

- Reeving on the **second** load position
- Load position (n1 to n5) and assigned reeving number (settings from the *Set up* program)
 - n1= Load position 1
 - n2= Load position 2
 - n3= Load position 3
 - n4= Load position 4
 - n5= Load position 5

1.5 Warning icon*

- **Note:** Appears solely for certain crane types.
- Appears possibly when:
 - The permissible wind speed is exceeded.
 - The permissible crane incline is exceeded.



Note

- ▶ The *Maximum load* (also *Maximum load according to the load chart and the reeving*) is the load, which the crane can lift in its current operating condition with the maximum utilized ballast / counterweight.

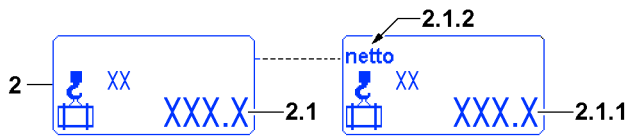

1

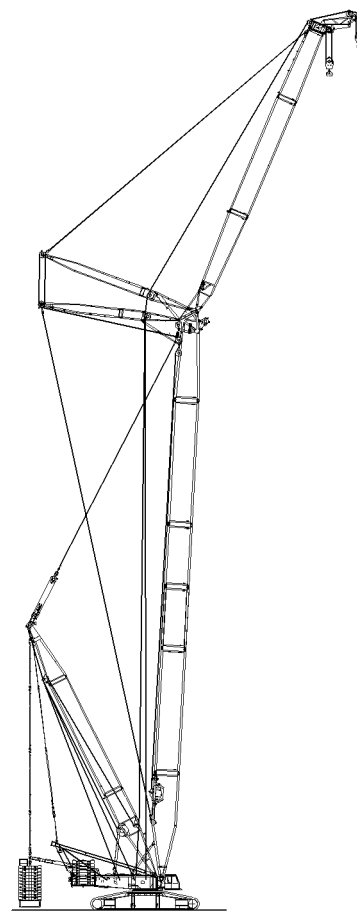
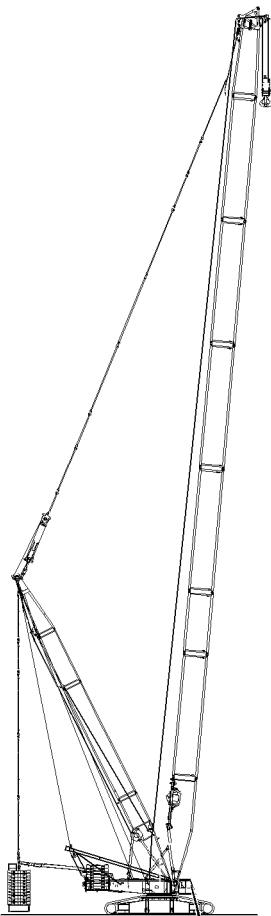
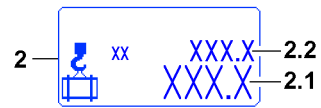

Fig.123759

LWE/LR 11000-001/23501-04-02/en

5.1.2 Actual load (current load) / net load

According to the set up configuration, the following changes:

- The illustration of the icon
- The position and number of values in the icon, see sample illustration 1.

2 Actual load / net load icon

- With text for MU [t] or [lbs]

2.1 Actual load display

- *Actual load* display = load in [t] or [lbs] that is currently suspended on the **first** load position.
- Display of the calculated total load including the weights for the load carrying, load taking on and / or fastening equipment.

2.1.1 Net load display

- *Net load* display = the *Actual load* display 2.1 can be changed at any time to *Net load* display 2.1.1 (tared) by pressing the function key **F7**.
- After pressing the function key **F7** the display value is set to zero and the word *net* 2.1.2 is shown.
- As long as net load is set, the icon above the function key **F7** is shown in red.
- If the taring is cancelled, the word *net* 2.1.2 disappears from the icon and the gross load value is displayed.

The change to net load is cancelled by the following actions:

- By pressing the function key **F7** again.
- By telescoping the boom by more than three LE (LE= 1 decimeter or 1/10 ft).
- By luffing by more than $\pm 4^\circ$.
- **Note:** This makes it possible to eliminate the weights of the load handling, load taking on and / or fastening equipment in the display value. The maximum load is not increased / adjusted.



WARNING

Incorrectly determined weight of the load!

Due to operating errors or tolerances, deviations can occur for the displayed values in the *Actual load / net load* icon 2.

- ▶ The *Actual load / Net load* display is no calibrated weighing device.
- ▶ Always observe the actual weight of the load in connection with the load charts and the set up configuration of the crane.



Note

- ▶ The *Actual load* display 2.2 for the **second** load position appears only for certain crane types with special load charts for two load positions.

2.2 Actual load display

- **Note:** Appears only when a second load position is selected (settings from the *Set up* program).
- *Actual load* display = load (in [t] or [lbs]) that is currently suspended on the **second** load position.
- Display of the calculated total load including the weights for the load carrying, load taking on and / or fastening equipment.

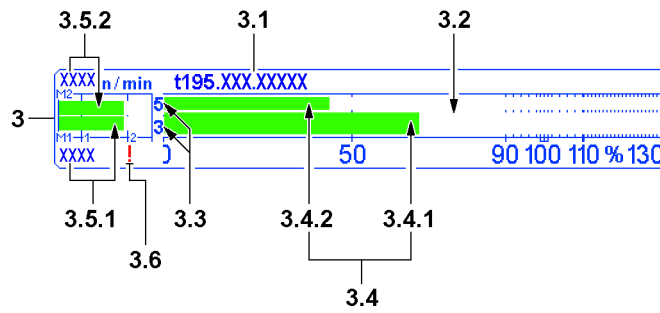

Fig.121771

5.1.3 Bar diagram Utilization

- 3 *Bar diagram Utilization* icon
 - In percent [%]
- 3.1 Chart names
 - Note to the set chart name (chart number) with associated operating mode
- 3.2 Utilization scale
 - Marking from a utilization of 90 %: LMB advance warning
 - Marking at a utilization of 100 %: LMB STOP shut off
- 3.3 Load position
 - The load position assigned to the respective utilization bar
- 3.4 Utilization bar
 - Current utilization of the crane
 - Appears in blue, green, yellow and red, depending on the situation
 - Utilization bar 3.4 blue / green: Utilization in permissible range
 - Utilization bar 3.4 yellow: Advance warning! Utilization just before impermissible range
 - Utilization bar 3.4 red: Warning! Utilization in impermissible range
 - For two load positions:
 - 3.4.1 Utilization bar for the **first** load position
 - 3.4.2 Utilization bar for the **second** load position



Note

► The set up configuration of the crane can only be changed when the utilization bar 3.4 is blue.

Utilization of the crane	
Current utilization of the crane	$= \frac{\text{Actual load}}{\text{Maximum load}}$

- 3.5 Engine rpm
 - In revolutions per minute
 - The engine rpm is always shown numerically and graphically
 - When the rpm is locked, a „+“ is shown behind the rpm value.
 - **NOTICE!** If the display is in red, an error is present.
 - **Note:** Question marks (?) appear if there is an error in the rpm recording. Then the nominal rpm for the diesel engine is set for the output regulation of the drives. The set nominal rpm is shown blinking. An error message is issued.
 - Only for crane types with two engines:
 - 3.5.1 First engine (Engine 1)
 - 3.5.2 Second engine (Engine 2)
- 3.6 Limitation of engine rpm*
 - **Note:** Only for certain crane types with ECO-Mode*.
 - If the engine rpm is limited by the ECO mode, then a „!“ is displayed behind the value for the engine rpm.

LWE/LR 11000-001/23501-04-02/en

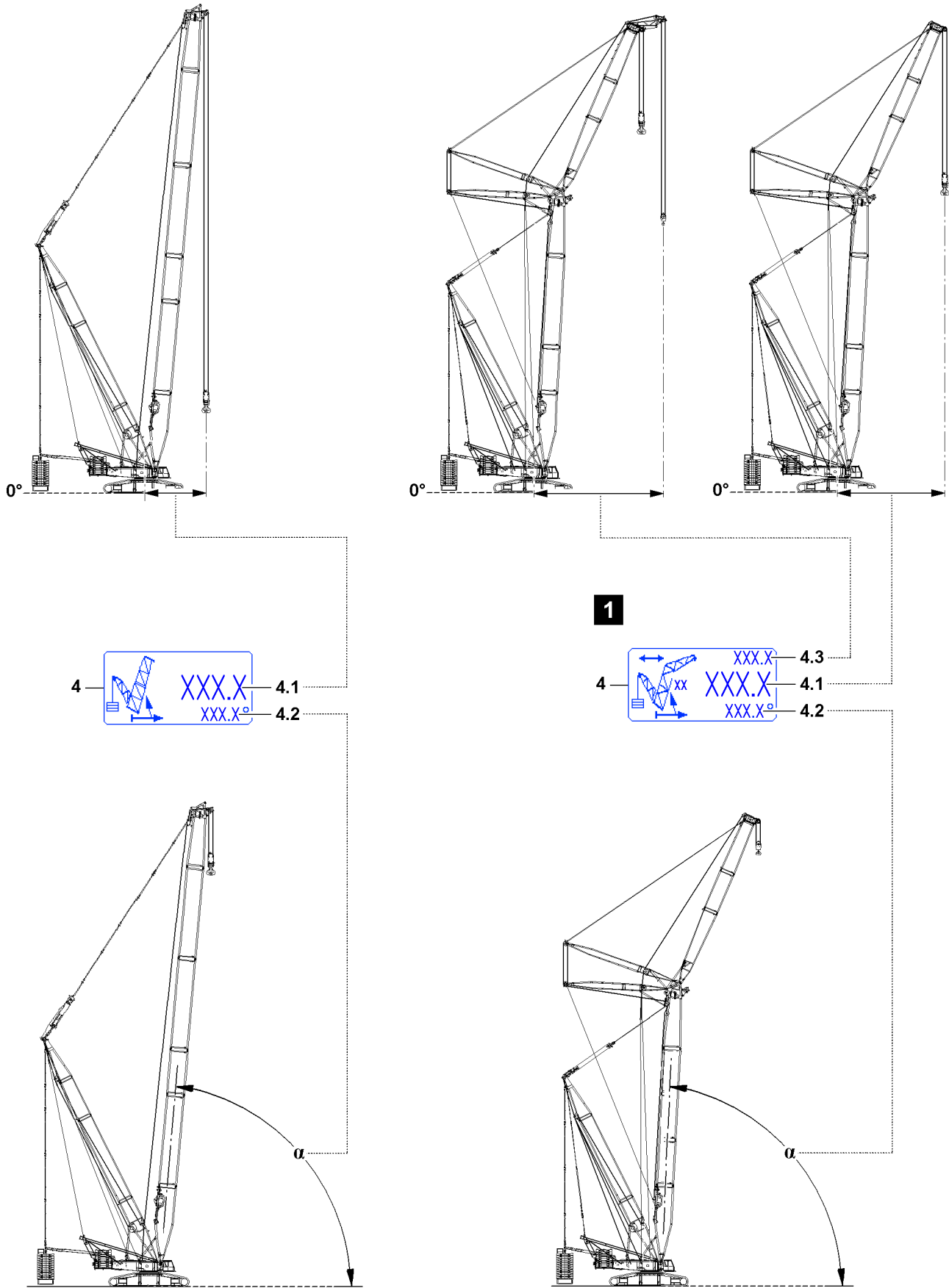

Fig.114264

LWE/LR 11000-001/23501-04-02/en

5.1.4 Boom radius

According to the set up configuration, the following changes:

- The illustration of the icon
- The position and number of values in the icon, see sample illustration 1.

4 Boom radius icon

4.1 Boom radius

- Boom radius **first** load position
- In [m] or [ft]

Denotes the horizontal distance of the load hook from the center of rotation of the crane superstructure. This also takes into account the boom flexation due to its own weight and the suspended weight of the load.

4.2 Main boom angle

- In [°]
- Displayed is the angle of the main boom (angle α) to the horizontal

4.3 Boom radius

- **Note:** Appears only when a **second** load position is selected (settings from the *Set up* program).
- Boom radius **second** load position
- In [m] or [ft]

Denotes the horizontal distance of the load hook from the center of rotation of the crane superstructure. This also takes into account the boom flexation due to its own weight and the suspended weight of the load.

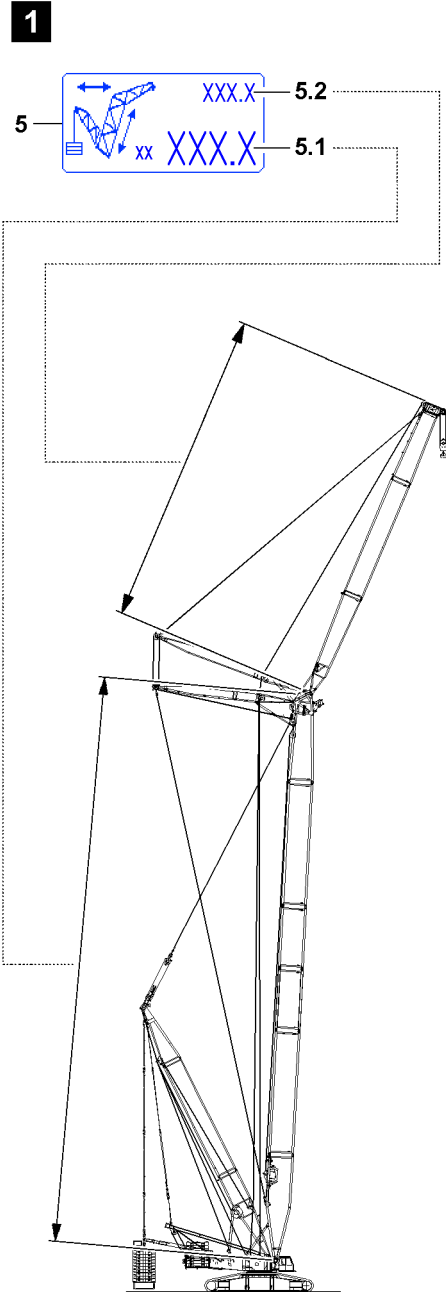
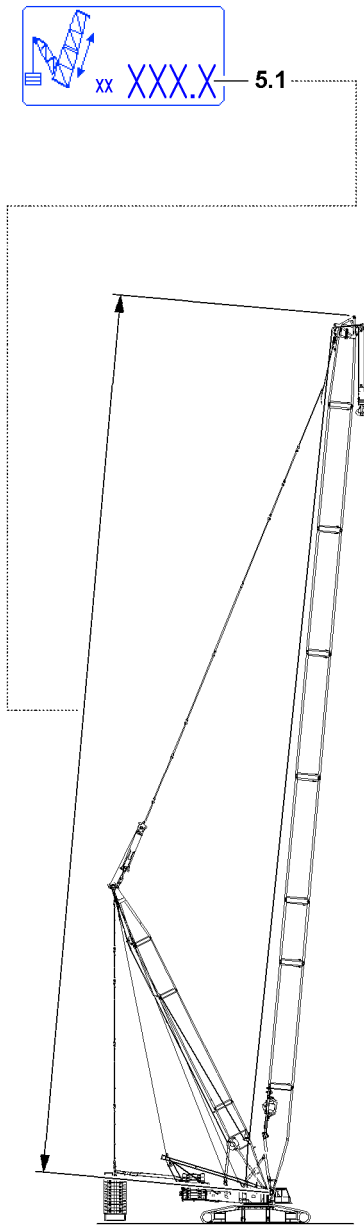

Fig.114265

LWE/LR 11000-001/23501-04-02/en

5.1.5 Boom length

According to the set up configuration, the following changes:

- The illustration of the icon
- The position of values in the icon, see sample illustration 1.

5 Boom length icon

5.1 Length of main boom

- In [m] or [ft]

5.2 Length of auxiliary boom / accessory

- In [m] or [ft]

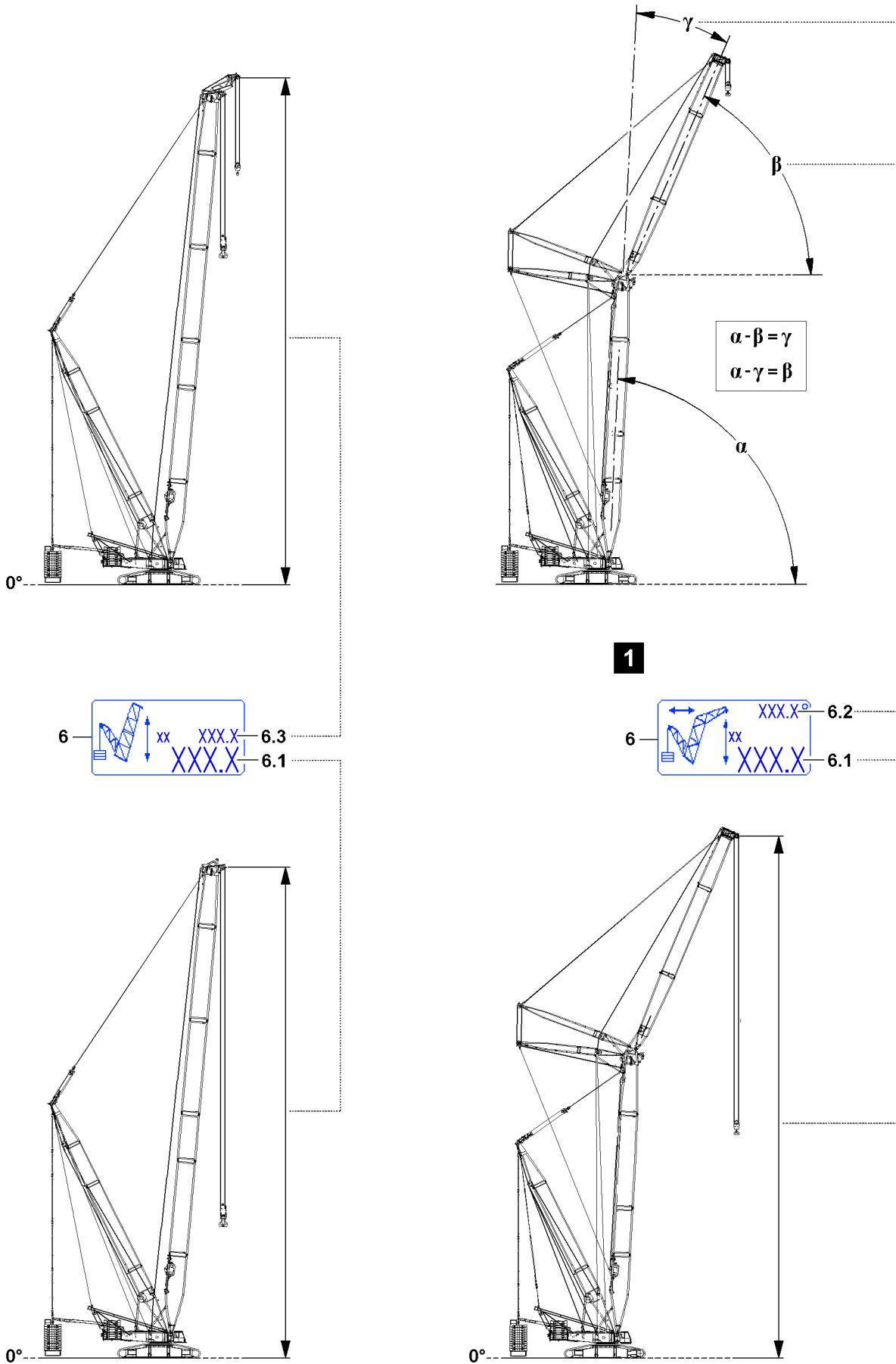

Fig.114266

LWE/LR 11000-001/23501-04-02/en

5.1.6 Pulley head height



Note

- ▶ Main boom angle α : The angle of the main boom to the horizontal.
- ▶ Angle auxiliary boom / accessory β : The angle of the auxiliary boom / accessory to the horizontal.
- ▶ Relative angle auxiliary boom / accessory γ : The angle of the auxiliary boom / accessory is determined relative to the main boom.

According to the set up configuration, the following changes:

- The illustration of the icon
- The position of values in the icon, see sample illustration 1.

6 Pulley head height icon

6.1 Pulley head height

- Pulley head height **first** load position
- In [m] or [ft]
- Marks the vertical distance from the placement surface of the crane to the selected pulley head axle.

6.2 Angle auxiliary boom / accessory

- In [°]



Note

- ▶ Depending on the set up configuration and the load chart, a differentiation is made between an absolute angle display or a relative angle display.

β Absolute angle auxiliary boom / accessory

- The angle of the auxiliary boom / accessory to the horizontal in [°]
- Display absolute angle: For operating modes with load chart for a fixed defined main boom angle.

or

γ Relative angle auxiliary boom / accessory

- Angle between the main boom and the auxiliary boom / accessory in [°]
- Display relative angle: For operating modes with load chart for a fixed defined angle auxiliary boom / accessory.

6.3 Pulley head height

- **Note:** Appears only when a second load position is selected (settings from the *Set up* program).
- Pulley head height **second** load position
- In [m] or [ft]
- Marks the vertical distance from the placement surface of the crane to the selected pulley head axle.

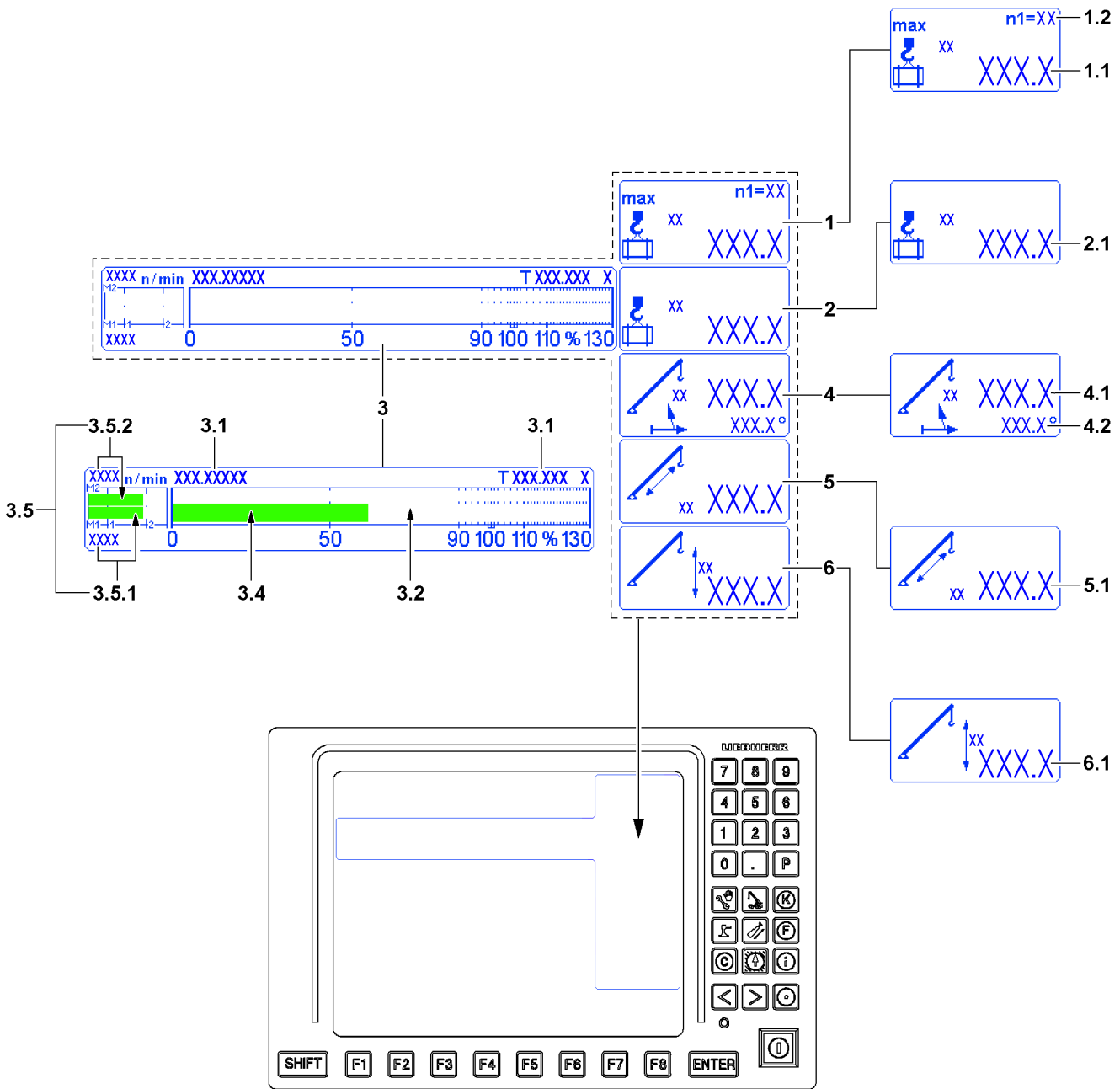

Fig.120624

LWE/LR 11000-001/23501-04-02/en

5.2 Information about crane geometry and load in the SA-operating mode

Display on LICCON monitor 0



Note

► Only for crane types with SA-operating mode.

The information about crane geometry and load in the SA-operating mode is comprised of six icons:

- 1 Maximum load
 - Maximum load **1.1** in the SA-operating mode
In [t] or [lbs]
 - **1.2** Place holder Reeving
- 2 Actual load
 - *Actual load* display **2.1** in the SA-operating mode
In [t] or [lbs]
- 3 Bar diagram Utilization
 - **3.1** Chart names
 - Note to the set chart name (chart number) with associated operating mode
 - **Note:** Depending on the crane type either in the left or right upper area of the Bar diagram Utilization **3**.
 - **3.2** Utilization scale
 - Marking from a utilization of 90 %: Advance warning
 - Marking at a utilization of 100 %: STOP shut-off
 - **3.4** Utilization bar
 - Current utilization of the crane in the SA-operating mode
 - Appears in blue, green, yellow and red, depending on the situation
 - Utilization bar **3.4** blue / green: Utilization in permissible range
 - Utilization bar **3.4** yellow: **Advance warning!** Utilization just before impermissible range
 - Utilization bar **3.4** red: **Warning!** Utilization in impermissible range
 - **3.5** Engine rpm
 - In revolutions per minute
 - The engine rpm is always shown numerically and graphically
 - When the rpm is locked, a „+“ is shown behind the rpm value.
 - **NOTICE!** If the display is in red, an error is present.
 - **Note:** Question marks (?) appear if there is an error in the rpm recording. Then the nominal rpm for the diesel engine is set for the output regulation of the drives. The set nominal rpm is shown blinking. An error message is issued.
 - Only for crane types with two engines:
 - 3.5.1** First engine (Engine 1)
 - 3.5.2** Second engine (Engine 2)

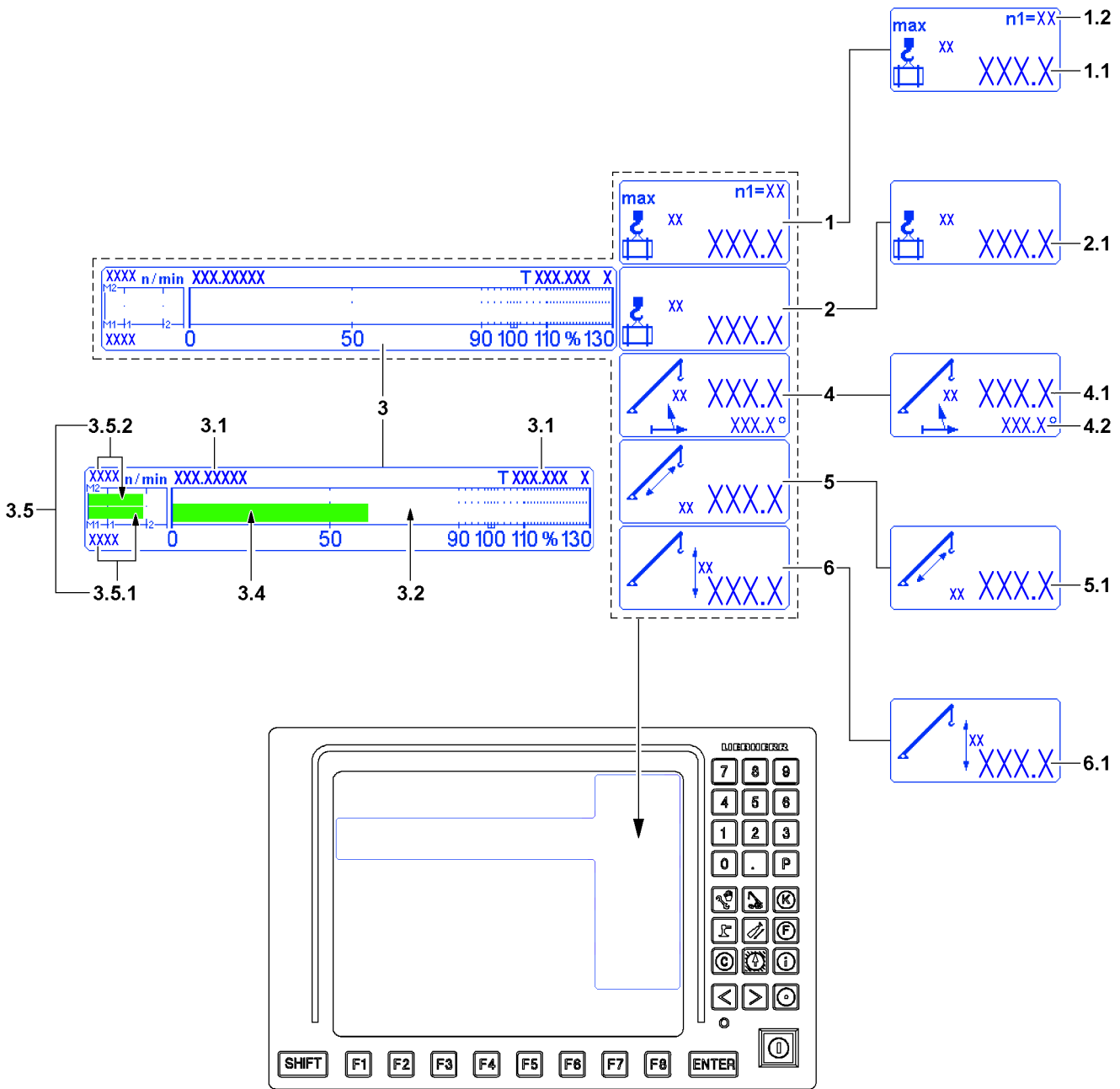

Fig.120624

4 Boom radius

- Boom radius **4.1** of SA-frame in reference to the slewing ring center
In [m] or [ft]
- Angle **4.2** of the SA-frame

5 Length

- Length **5.1** of the SA-frame between the pin point on the turntable and the pin point of the SA-assembly cylinder
In [m] or [ft]

6 Height

- Height **6.1** of the center of the pin point of the SA-assembly cylinder above the placement location of the crane
In [m] or [ft]

**WARNING**

Tolerances at *Actual load* display!

Due to tolerances, deviations can occur for the displayed values in the *Actual load* icon 2!

The *Actual load* display is not a calibrated weighing device.

- ▶ Always observe the actual weight of the load in connection with the load charts and the set up configuration of the crane.

**Note**

- ▶ A question mark (?) is shown instead of values when no load chart value can be accessed. Example: The crane is not in the range of the load chart.
- ▶ A question mark (?) is shown instead of values if the value cannot be calculated / determined. Example: A sensor error can be present - pay attention to error messages.

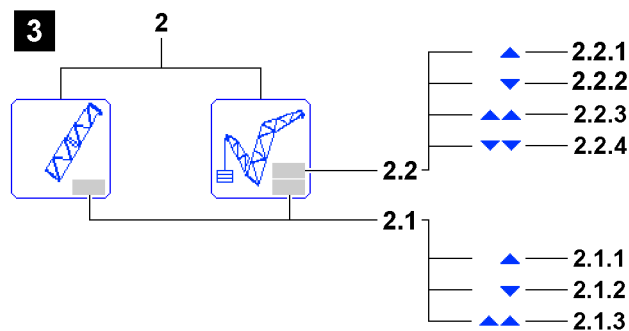
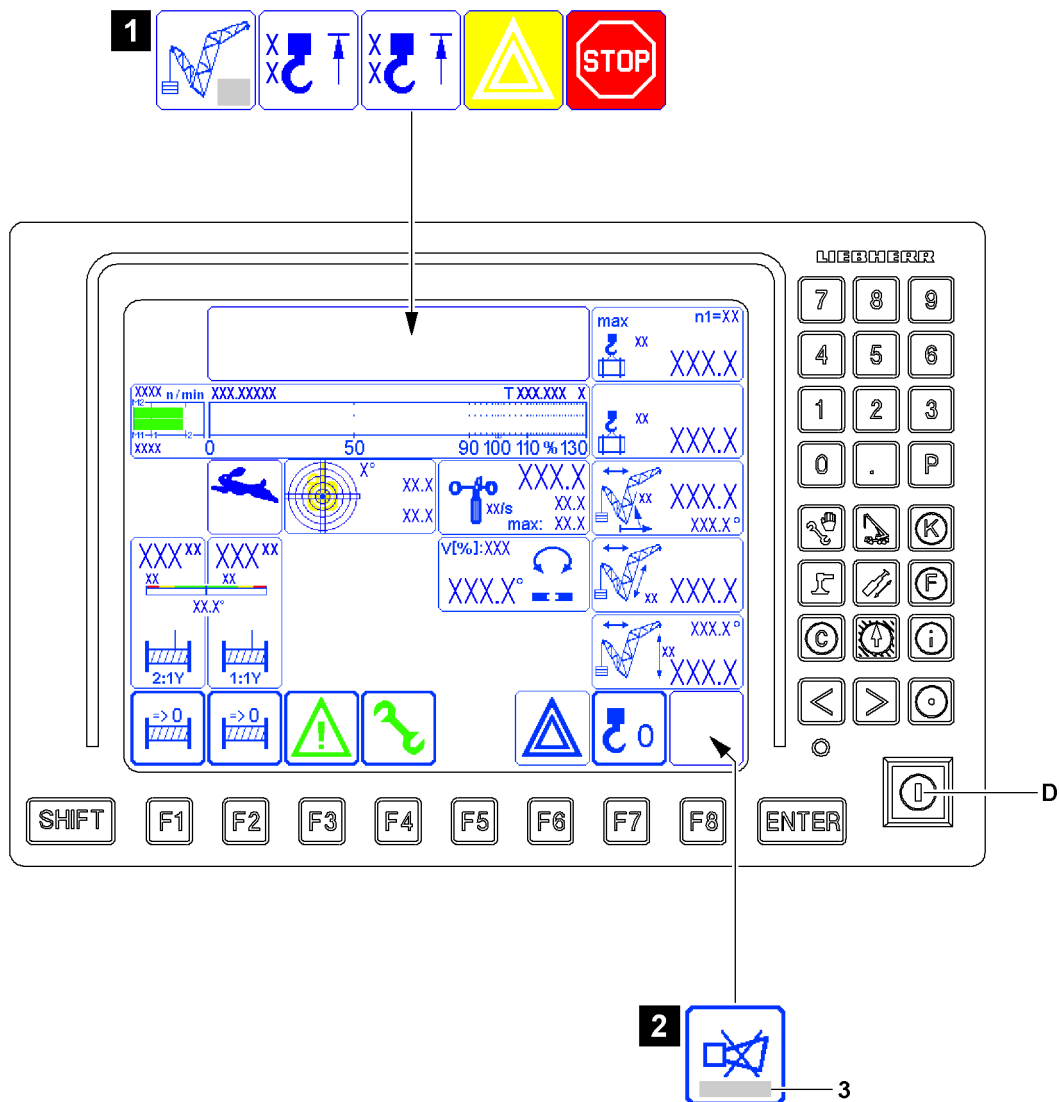

Fig.114267

5.3 Alarm functions

NOTICE

Triggered alarm function!

If an alarm function is triggered (for example an advance warning occurrence or shut off of crane movement), the cause must be determined.

- ▶ Always pay attention to triggered alarm functions.
- ▶ Alarm function can flash over the monitor.

The limit ranges of the crane movements are monitored. When the limit ranges are reached, the crane operator is warned by the alarm functions.

The alarm functions are shown by the LICCON monitor:

- Optically with icons, see illustration 1.
- Acoustically by a warning sound *Horn*, see illustration 2.

In case of a failure of the relevant sensors / limit switches, special error messages 3 are added.

5.3.1 Boom limitation

See illustration 3

Limit signs main boom



Note

- ▶ The *Boom limitation* icon 2 can change in different operating modes, but it is shown always at the same position in the LICCON monitor.
- ▶ The field *on the bottom* 2.1 refers to the main boom.
- ▶ The field *on the top* 2.2 refers to the auxiliary boom / accessory.

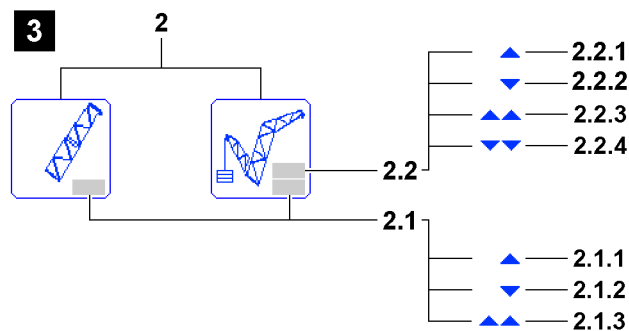
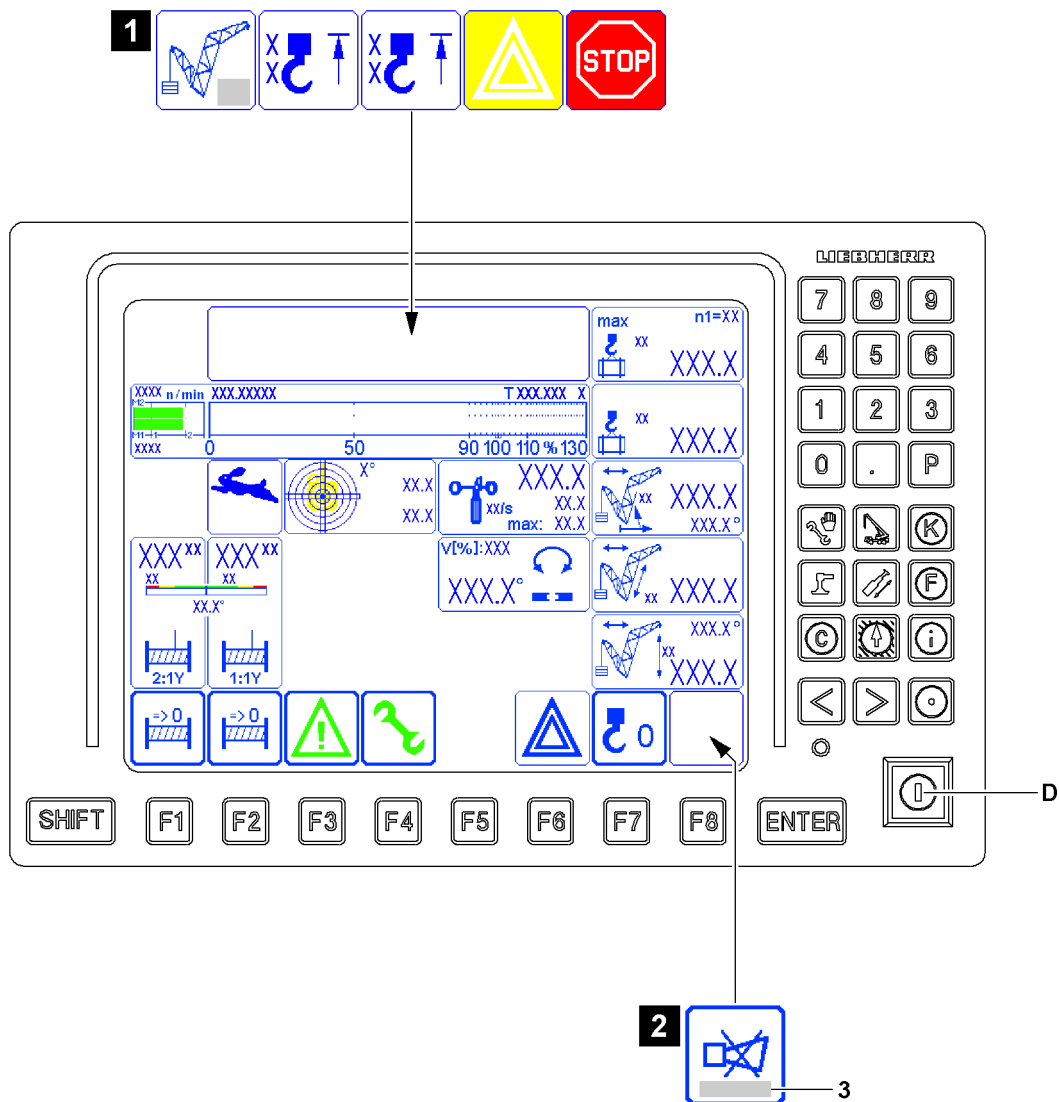



Fig.114267

2.1 Boom limitation main boom icon

- The luffing range of the main boom is limited both upward and downward.
- This icon appears if an end position determined by the load chart is reached when luffing the boom or when luffing the boom is disabled by a proximity switch.

Position	Icon	Description
2.1.1		The shut-off <i>Luffing up the main boom</i> is made by running against the upper load chart limit. or The shut off <i>Luff main boom up</i> , due to utilization, is larger than 95 % and falling load capacity when luffing main boom up occurs ¹⁾ . Note: Luffing down the main boom is still possible.
2.1.2		The shut-off <i>Luffing down the main boom</i> is made by running against the lower load chart limit. Note: Luffing up the main boom is still possible.

1) Only for certain crane types and boom systems.



WARNING

Alarm function deactivated!

When the set up key **D** is actuated, there is no shut-off of crane movement via position **2.1.1** and position **2.1.2**.

► Observe the Crane operating instructions, chapter 4.20.

Position	Icon	Description
2.1.3		The shut-off <i>Luffing up the main boom</i> is triggered by running against the block limit switch of the main boom relapse cylinders on the left / right (boom steep) or due to an error in one block limit switch of the main boom relapse cylinders. Note: Luffing down the main boom is still possible.

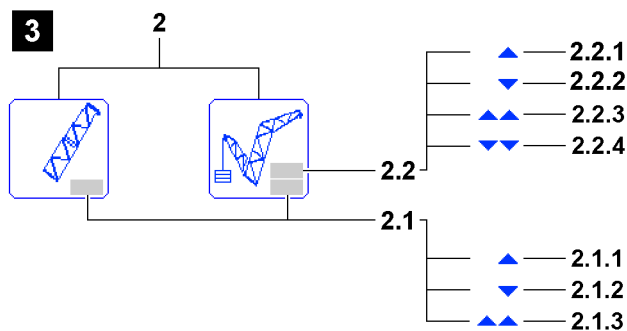
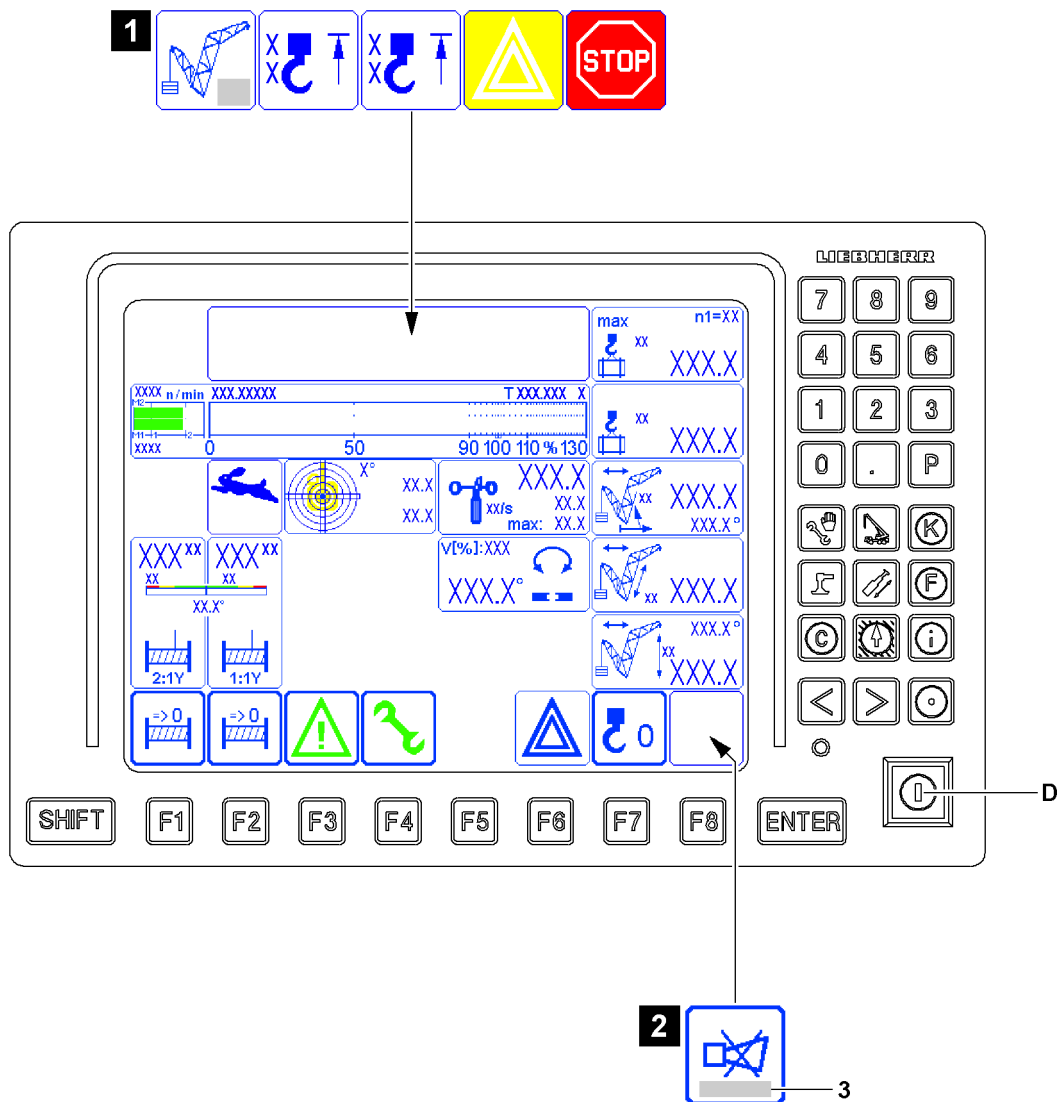

Fig.114267

Limit sign auxiliary boom / accessory



Note

- ▶ The *Boom limitation* icon **2** can change in different operating modes, but it is shown always at the same position in the LICCON monitor.
- ▶ The field *on the bottom* **2.1** refers to the limit sign main boom.
- ▶ The field *on top* **2.2** refers to the limit sign auxiliary boom / accessory.

2.2 Boom limitation Auxiliary boom / accessory icon

- The luffing range of the auxiliary boom / accessory is limited both upward and downward.
- This icon appears if an end position determined by the load chart is reached when luffing the auxiliary boom / accessory or when luffing is disabled by a limit switch.

Position	Icon	Description
2.2.1		The shut-off <i>Luffing up the auxiliary boom / accessory</i> is triggered by running against the upper load chart limit. Note: Luffing the auxiliary boom / accessory down remains possible.
2.2.2		The shut-off <i>Luffing down the auxiliary boom / accessory</i> is triggered by running against the lower load chart limit. Note: Luffing the auxiliary boom / accessory up remains possible.



WARNING

Alarm function deactivated!

When the set up key **D** is actuated, there is no shut-off of crane movement via position **2.2.1** and position **2.2.2**.

- ▶ Observe the Crane operating instructions, chapter 4.20.

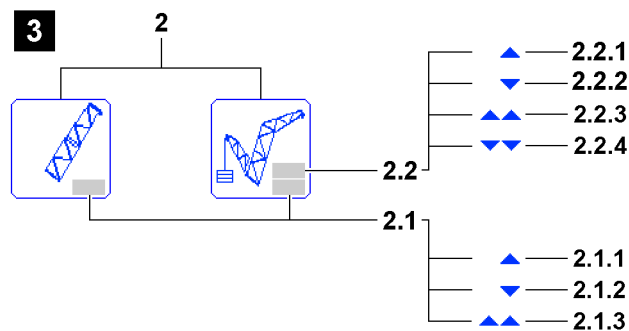
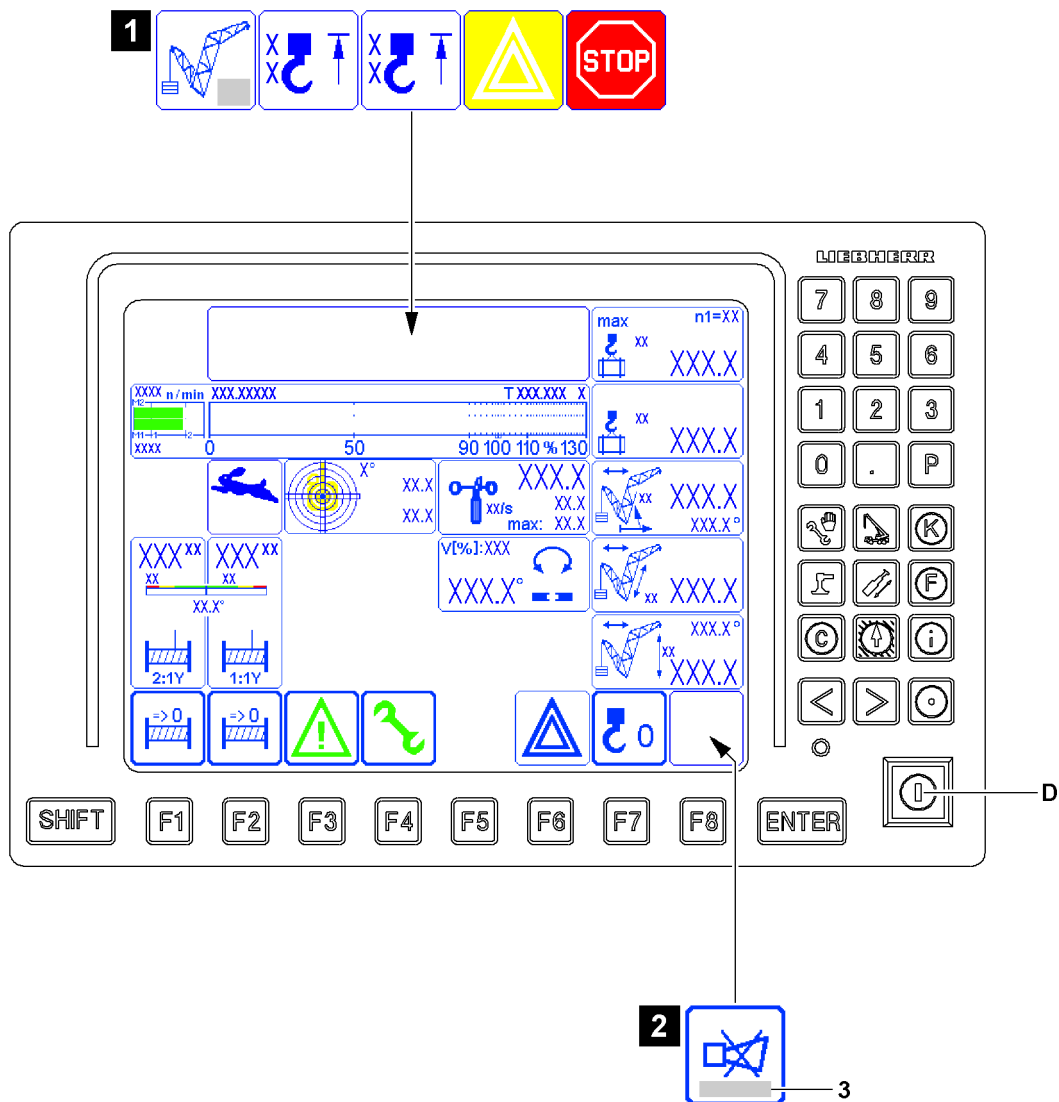



Fig.114267

Position	Icon	Description
2.2.3		<p>The shut-off <i>Luffing up the auxiliary boom / accessory</i> is triggered by running against a block limit switch of the relapse cylinders auxiliary boom / accessory</p> <p>or</p> <p>the relapse flap</p> <p>or</p> <p>an error on one limit switch occurs.</p> <p>Note: Luffing the auxiliary boom / accessory down remains possible.</p>
2.2.4		<p>The shut-off <i>Luffing down the auxiliary boom / accessory</i> is triggered by running against a block limit switch (on auxiliary boom / accessory lower left / right)</p> <p>or</p> <p>an error on one of these limit switches occurs.</p> <p>Note: Luffing the auxiliary boom / accessory up remains possible.</p>

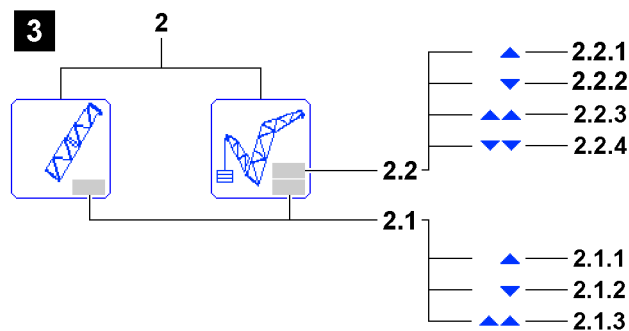
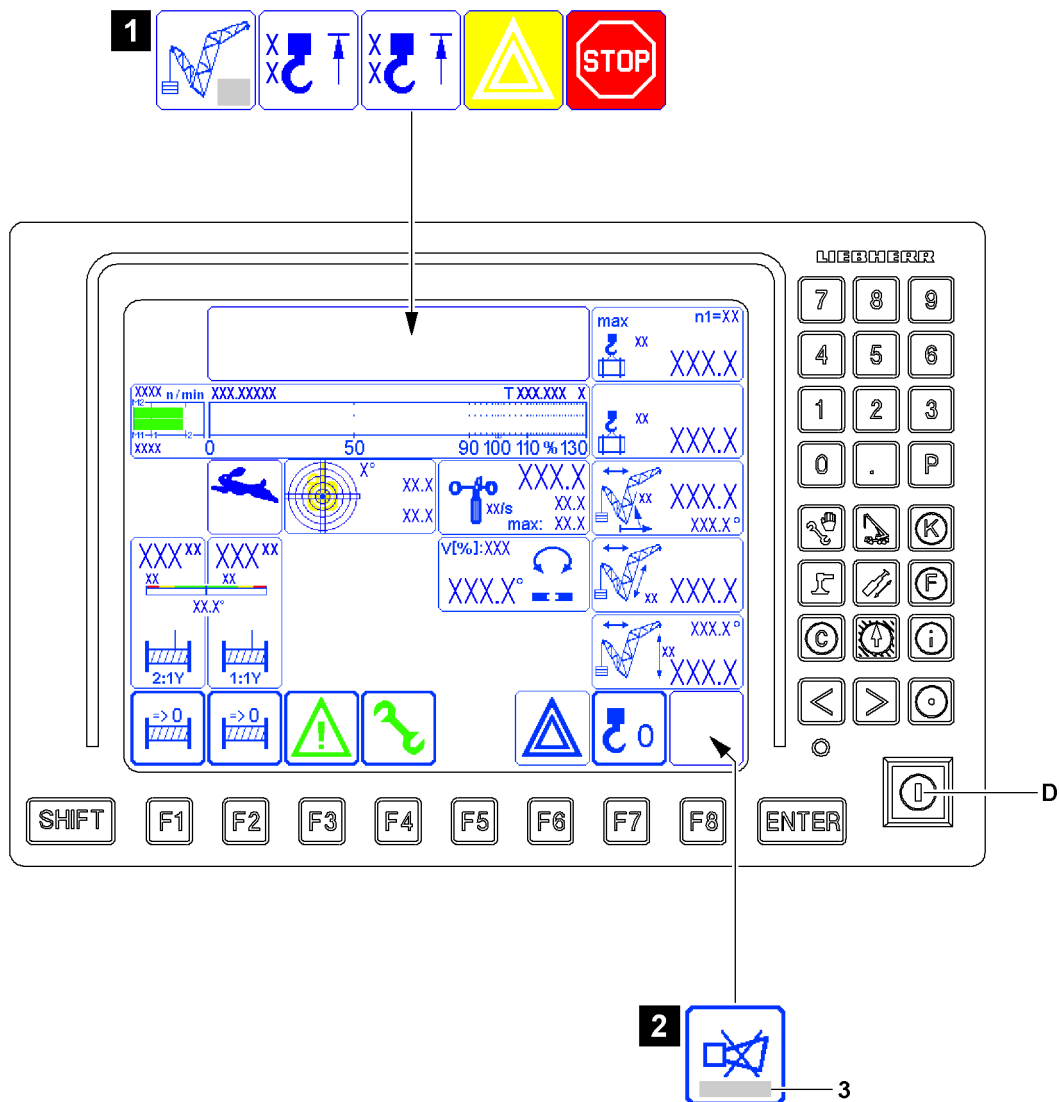

Fig.114267

LWE/LR 11000-001/23501-04-02/en

5.3.2 Failure of sensor / limit switch!

NOTICE

Failure of sensor / limit switch!

Depending on the classification of the sensor / limit switch, the crane can continue to be operated with limitation or is shut off by the control.

An error message is issued in the *Horn* icon 3, see illustration 2.

The error message shows defective sensors / limit switches, see Diagnostics manual.

- ▶ The error must be remedied immediately.
- ▶ Crane movements after a failure of a sensor / limit switch must be carried out anticipatorily and with extreme caution.

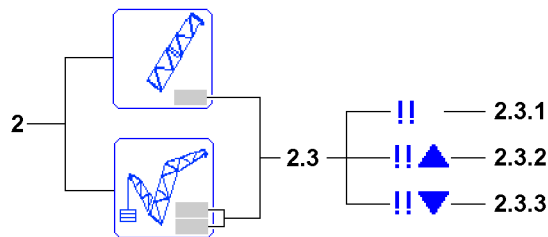

Fig.114275

Position	Icon	Description
2.3.1	!!	On the auxiliary boom / accessory, at least one associated sensor / limit switch is defective / missing. If an alarm function occurs at the same time, then the icon can be shown differently, see position 2.3.1, position 2.3.2 or position 2.3.3.
2.3.2	!!▲	
2.3.3	!!▼	



Note

- ▶ Not every failure of a sensor / limit switch on the boom is shown in the *Boom limitation* icon 2. Observe the error message in the *Horn* icon 3.
- ▶ Depending on the classification of the sensor / limit switch, the respective crane movement is shut off in case of a failure and **cannot be bypassed**.
- ▶ When deflecting the master switch, an operating error message is issued in the *Horn* icon 3. The operating error message shows defective sensors / limit switches.
- ▶ If the error cannot be remedied by yourself, contact Liebherr Service.

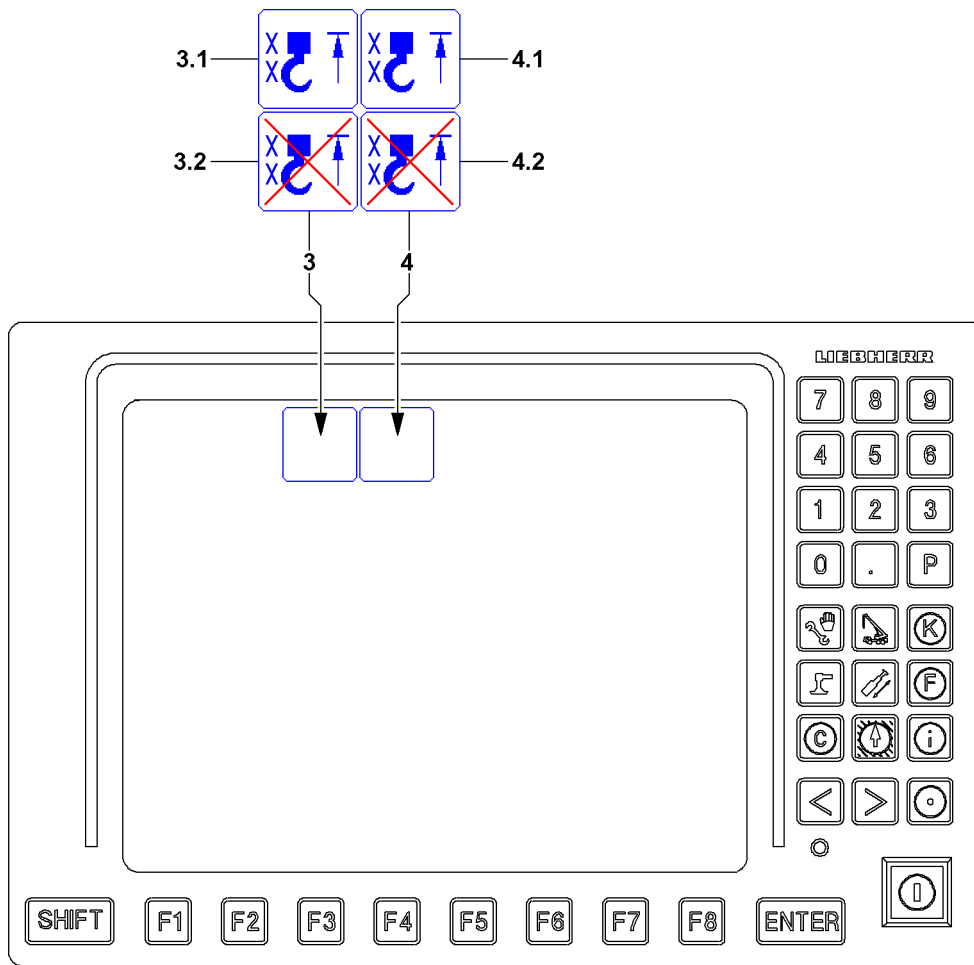

Fig.114276

5.3.3 Hoist limit switch

In order to prevent the crane from being operated without hoist limit switch (HES), the presence of the hoist limit switch is continuously monitored by the crane control. If a hoist limit switch required for a particular operating mode is not plugged in, therefore not active on the LSB bus system, the corresponding crane movements are stopped and an operating error message is also issued.

The identification of the triggered hoist limit switch (for example HES1 for hoist limit switch 1) appears in the respective icon.



WARNING

Hoist limit switch not functioning!

► Before crane operation, check the hoist limit switches for function and correct assembly.

-
- 3 *Hoist top* icon
Hoist limit switch for the first load position
 - 3.1 *Hoist top triggered* icon
 - The *Hoist top triggered* icon appears when:
 - The hook block is pulled against the hoist limit switch weight.
 - The hoist limit switch weight is not attached freely (for example on placed down boom).
 - The hoist limit switch is not recognized by the crane control, even though it is required for the operating mode.
 - The hoist limit switch has an internal error.
 - **Note:** Spool up hoist winches is turned off. Additional crane movements can be turned off.
 - 3.2 *Hoist top bypassed* icon
 - The *hoist top bypassed* icon appears if the hoist limit switch is bypassed, see section „Special functions LICCON monitor 0“.
 - 4 *Hoist top* icon
Hoist limit switch for the second load position
 - 4.1 *Hoist top triggered* icon
 - The *Hoist top triggered* icon appears when:
 - The hook block is pulled against the hoist limit switch weight.
 - The hoist limit switch weight is not attached freely (for example on placed down boom).
 - The hoist limit switch is not recognized by the crane control, even though it is required for the operating mode.
 - The hoist limit switch has an internal error.
 - **Note:** Spool up hoist winches is turned off. Additional crane movements can be turned off.
 - 4.2 *Hoist top bypassed* icon
 - The *hoist top bypassed* icon appears if the hoist limit switch is bypassed, see section „Special functions LICCON monitor 0“.

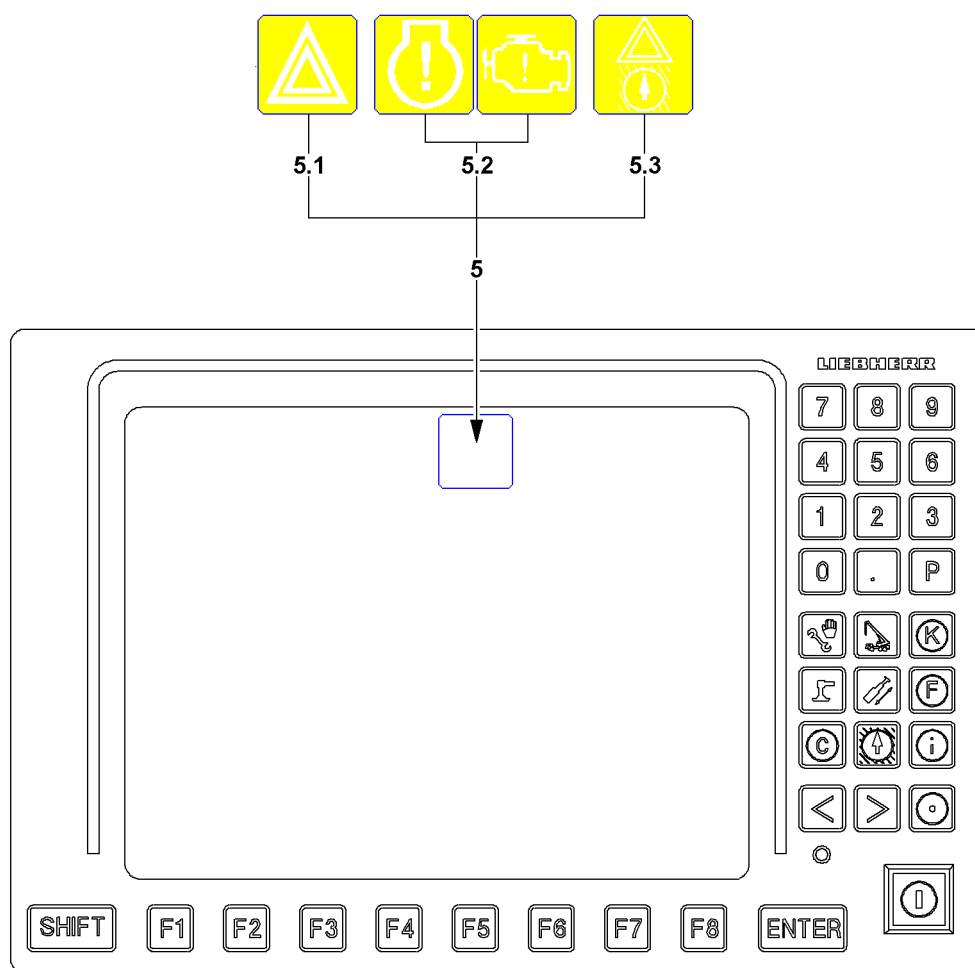

Fig.121772

5.3.4 Occurrence of an advance warning

5 Advance warning icons

5.1 Advance warning Utilization icon

- The current utilization of the crane results from the *actual load* value and the *maximum load* value.
- The *Advance warning utilization* icon appears if:
 - The current utilization of the crane exceeds the programmed limit (standard value **90 percent**) for the advance warning.

5.2 Advance warning Engine monitoring icon

- Appears if an advance warning for one or more monitoring functions in the engine monitoring occurs.
- **NOTICE!** If the Advance warning engine monitoring **5.2** appears, the monitoring functions must be checked.
- **Note:** Depending on the respective crane, either the right or the left *Advance warning engine monitoring* icon **5.2** appears.

5.3 Advance warning Working range limitation*

- Appears if an advance warning in the *Working range limitation* program occurs.
- **NOTICE!** Pay attention to the set working range.
- **Note:** Appears only on crane types with Working range limitation*.



WARNING

Non-observance of advance warnings!

If advance warnings are not observed, then it can result in a sudden shut off of the crane movement. A sudden shut off of the crane movement can result in high stress and strain for crane and load. High stress and strain for crane and load can cause accidents.

- ▶ Operate the crane in such a way that there is no shut off of crane movements by the crane control.
- ▶ Pay attention to advance warnings and approach a possible shut off of crane movements extremely cautiously.

NOTICE

Shut off engine monitoring!

Outside of the *crane operation* program, the engine monitoring is turned off.

When the engine monitoring is turned off, problems and warning occurrences are not recognized.

This could result in crane failure.

- ▶ If work is not carried out in the *Crane operation* program, then turn the crane engine off and operate the LICCON computer system in stand-by mode, see section „LICCON computer system in stand-by mode“.
- ▶ If work has to be carried out for a longer period outside of the *Crane operation* program, with the crane engine running, then switch regularly into the engine monitoring screen.

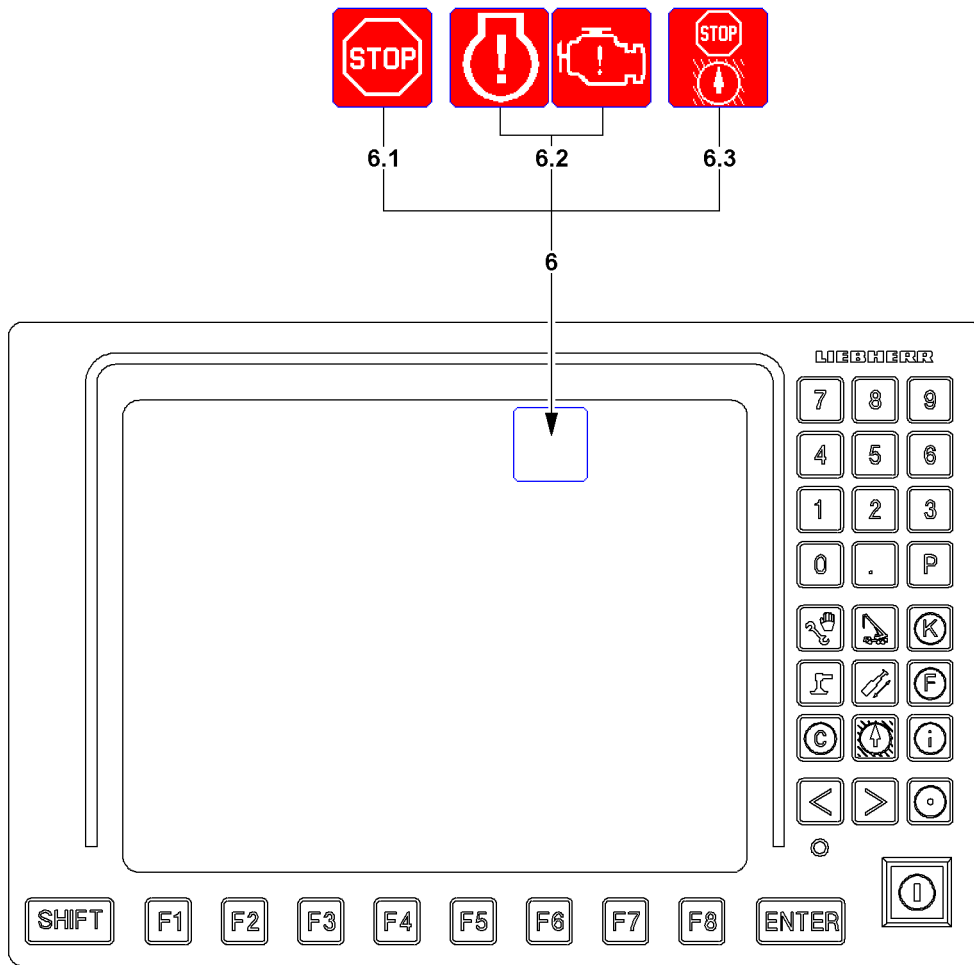

Fig.121773

LWE/LR 11000-001/23501-04-02/en

5.3.5 Shut off of crane movement

6 STOP icons

6.1 LMB-STOP icon

- The *LMB-STOP* icon appears when the crane movement is turned off.

Possible causes:

1. **Utilization of the crane:** The *LMB-STOP* icon appears when the current utilization of the crane exceeds the programmed limit for the *LMB-STOP* (Standard **100 %**).
2. **Sensor error:** The *LMB-STOP* icon appears when a sensor which is required to monitor the load chart has an error (*LMB-STOP* is actuated).
3. **No load chart:** The *LMB-STOP* icon appears if no load chart is available (*LMB-STOP* is triggered).



WARNING

Crane movements at active *LMB-STOP*!

At active *LMB-STOP 6.1*, not all crane movements are necessarily turned off. In certain circumstances, load moment decreasing crane movements are possible.

- ▶ Always remedy the cause for the *LMB-STOP 6.1* first.
- ▶ Carry out any crane movements which are still possible with extreme caution.

6.2 Engine STOP icon

- Appears if a STOP event takes place in engine monitoring.

Note: Depending on the respective crane, either the right or the left *Engine STOP* icon **6.2** appears.

6.3 Working range limitation STOP icon

- Appears when the *Working range limitation program* turns the crane movement off.



WARNING

Shut off of crane movement!

A sudden shut off of the crane movement can result in high stress and strain for crane and load. High stress and strain for crane and load can cause accidents.

- ▶ Operate the crane in such a way if possible that there is no shut off of crane movements by the crane control.
- ▶ Monitor the display instruments constantly.
- ▶ If not otherwise possible, approach a possible shut off of crane movements with extreme caution.

NOTICE

Shut off engine monitoring!

Outside of the *crane operation* program, the engine monitoring is turned off.

When the engine monitoring is turned off, problems and warning occurrences are not recognized.

This could result in crane failure.

- ▶ If work is not carried out in the *Crane operation* program, then turn the crane engine off and operate the LICCON computer system in stand-by mode, see section „LICCON computer system in stand-by mode“.
- ▶ If work has to be carried out for a longer period outside of the *Crane operation* program, with the crane engine running, then switch regularly into the engine monitoring screen.

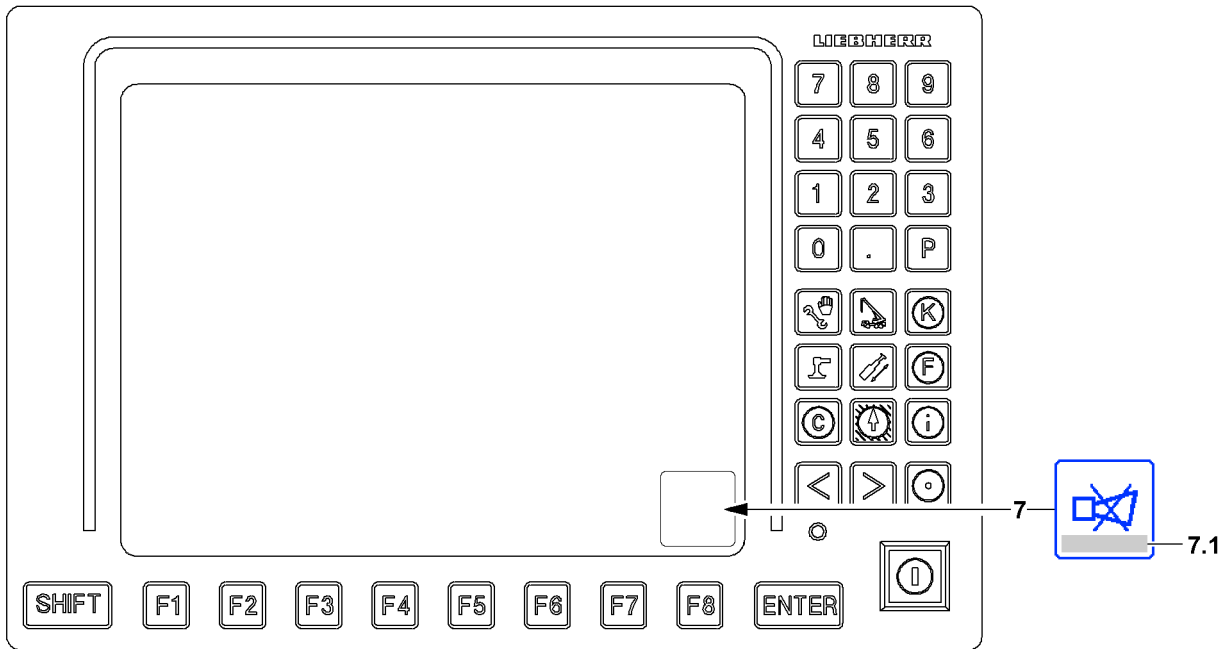

Fig.114279

5.3.6 Acoustic warning on LICCON monitor 0

Acoustic warnings on LICCON monitor 0 are indicated by the warning sound *Horn*.

The warning sound *Horn* is divided into two categories:

- *Horn* is a beeping sound of a duration of approximately 0.5 seconds, which is repeated in a second cycle.
- *Short horn* is a beeping sound of a duration of approximately 0.1 seconds, which is repeated in a second cycle.

7 *Horn* icon

- When the *Horn* icon 7 is shown in the LICCON monitor, any acoustic signals which will occur can be shut off by the LICCON monitor 0 by pressing the function key **F8**.
- If an error message is shown in the *Horn* icon 7 in field 7.1, then the present error can be determined through it. Pressing the function key **F8** twice, automatically changes to the error determination screen of the test system. The error is displayed there in documentary form.

Warning sound *Horn*

- Sounds in addition to the visual display of an error message in field 7.1 in case of operational errors are found, which lead to a shut off of a crane movement.
Operational errors are, for example:
 - Overload
 - Boom outside of the angle / boom radius range of the load chart
- In case of application errors with error number (LICCON Error Code LEC). For example sensor errors, which occur due to insufficient sensor signals or a defective sensor.

Monitored sensors are, for example:

- Length sensors
- Angle sensors
- Pressure sensors
- Pull test brackets (force test boxes)
- Inductive sensors
- Hoist limit switch
- Wind sensor
- Battery voltage

Warning sound *Short horn*

Sounds in addition to the visual display of error messages without an error number and which do not lead directly to crane movement shut off by the LICCON overload protection.

Monitored error messages are, for example:

- Maximum permissible wind speed exceeded (only with an activated wind sensor*)
- Crane utilization value for advance warning (90 %) has been reached

Priority acoustic warning

- The *Horn* warning around has higher priority than the *Short horn* warning sound, i.e. *Horn* takes preference over *Short horn*.
- The *Horn* warning sound as well as the *Short horn* warning sound become active again after shut down if a new error occurs.

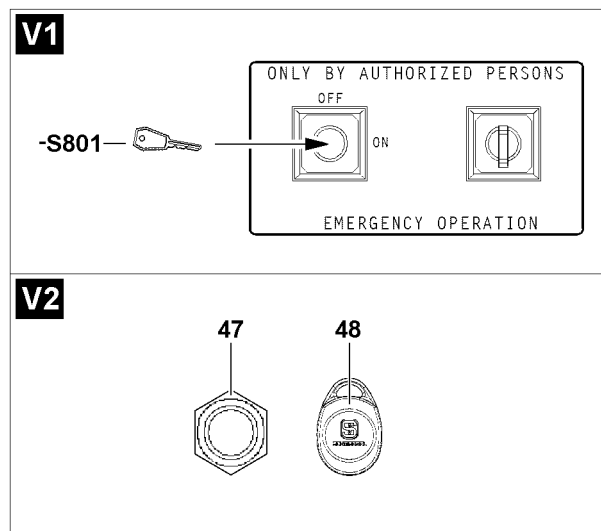
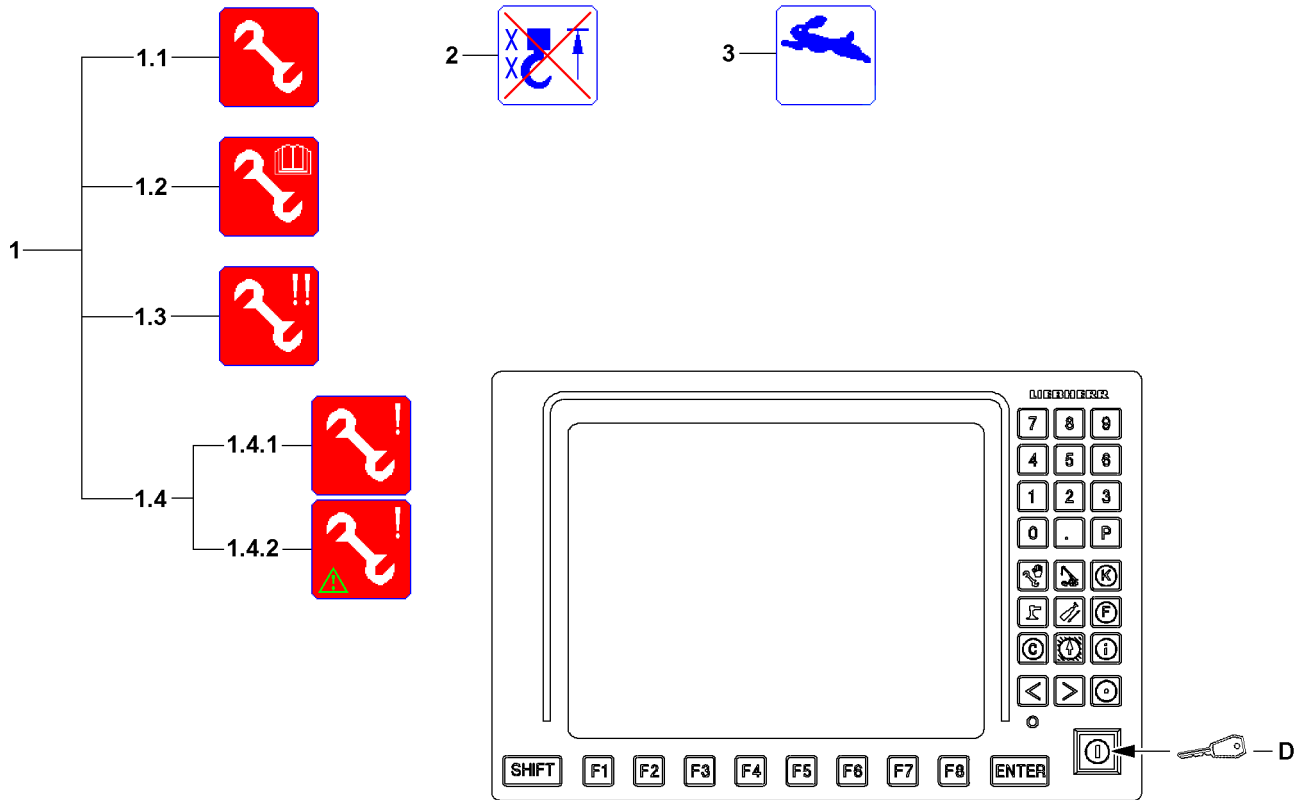

Fig.120622

5.4 LICCON Monitor 0 special functions



Note

Additional special functions

- ▶ Observe section „Special function LICCON monitor 2“.



WARNING

Danger of accident due to the *Exceedance of shut-off limits of the LICCON overload protection* function!

If the shut off limits of the LICCON overload protection are exceeded, there is no additional protection against crane overload.

Due to erroneous operation or deliberate misuse, the crane could collapse, the boom can break off or the crane can topple over.

Personnel can be severely injured or killed.

- ▶ The function *Exceedance of shut off limits of the LICCON overload protection* is only permissible in emergencies and for assembly purposes.
- ▶ The set up key **D** may only be actuated by persons who are aware of the effects of their acts regarding the function *Exceeding the shut off limits of the LICCON overload protection*.
- ▶ The *Exceedance of shut off limits of the LICCON overload protection* function requires the presence of an authorized person and must be performed with utmost caution.
- ▶ Crane operation with activated function *Exceedance of shut off limits of the LICCON overload protection* is prohibited.

Before pressing the set up key **D** make sure that:

- Operation and specifications to use the set up key **D** from the Crane operating instructions, chapter 4.20 and 7.15 are known to the crane operator and have been understood.



Note

- ▶ The various *Assembly operation* icons **1** are shown on the same position in the LICCON monitor, depending on the operating mode, illustration **2**.

5.4.1 Exceeding the shut off limits of the LICCON overload protection

1.1 Assembly icon

- The *Assembly* icon **1.1** appears when a special case for operation of the LICCON overload protection was activated, for example the shut off limits of the LICCON overload protection were bypassed by the set up key **D**.



Note

- ▶ The *Assembly* icon **1.1** appears in the LICCON monitor 2, when the difference monitoring of the derrick ballast guying is bypassed, see Crane operating instructions, chapter 5.35 / 5.36.

5.4.2 No load chart is available

1.2 Assembly - no load chart icon

- The *Assembly - no load chart* icon **1.2** appears when the shut off limits of the LICCON overload protection are bypassed via the set up key **D** and no load chart is available.
- The crane may only be operated according to the specifications of the respective chapter in the Crane operating instructions and / or the erection / take down charts.
- **Note:** By actuating the set up key **D**, all erection / take down procedures can be carried out within the erection / take down charts, for which no load charts are available.

5.4.3 Emergency operation LICCON overload protection (according to EN 13000:2010)



WARNING

Increased danger of accident during emergency operation of the LICCON overload protection! In emergency operation, the crane movements are no longer monitored by the LICCON overload protection.

- ▶ The emergency operation may only be activated by persons who are aware of the consequences of their actions.
- ▶ A shut off by the LICCON overload protection may not be circumvented by the emergency operation.
- ▶ If normal crane operation is possible, then the emergency operation may not be activated.
- ▶ All crane movements must be carried out with extreme caution and anticipatorily.

1.3 Emergency operation activated icon

- The *Emergency operation activated* icon **1.3** appears:
 - when the emergency operation of the LICCON overload protection is activated via the key button **S801** or by actuation of the transponder **48** on the sensor **47**.



Note

Activating emergency operation

- ▶ If emergency operation of the LICCON overload protection is activated via the key button **S801** or by actuation of the transponder **48** on a sensor **47** depends on the crane type. For location, see Crane operating instructions, chapter 4.01.

5.4.4 Additional emergency operating modes



WARNING

Erroneous operation of the crane!

If one of the *additional emergency operating modes* icon **1.4** appears, then there is a high danger of accidents due to erroneous operation of the crane.

Safety equipment could be deactivated.

Personnel can be killed or injured.

This could result in property damage.

- ▶ Deactivate *additional emergency operating modes* **1.4** icon again or contact Liebherr Service and coordinate further procedure.

1.4 Additional emergency operating modes icon

- *Additional emergency operating modes* icon **1.4** appears if additional emergency operating modes were activated.

5.4.5 Bypassing the difference force monitoring for derrick ballast guying



WARNING

Overload of crane!

Erroneous operation when bypassing the difference force monitoring for the derrick ballast guying.

- ▶ Observe the Crane operating instructions, chapter 5.35 / 5.36.

- D** The shut off *Difference force monitoring derrick ballast guying* is bypassed by the set up key **D**. Observe the Crane operating instructions, chapter 5.35 / 5.36.

5.4.6 Bypass of hoist limit switch

2 Hoist top bypassed icon

- The *Hoist top bypassed* icon **2** appears when the shut off *Hoist top* is bypassed by the set up key **D**.

Note: The *Crane operation* program is locked, meaning, no other program can be turned on via the program keys.

5.4.7 Rapid gear



Note

- ▶ **Crane operation without rapid gear:** The speeds of the individual crane movements are independent of each other. There is no interference of the movement speeds.
 - ▶ **Crane operation with rapid gear:** If the rapid gear is added, the individual crane movements can reach the largest possible movement speed. As a result, it can happen that during several simultaneous crane movements individual crane movements are slowed down.
-

Add the rapid gear only when:

- If the highest possible movement speed is to be made possible for individual crane movements **and**
- An interference amongst the movement speeds creates no problem.

3 *Rapid gear* icon

- The *Rapid gear* icon **3** appears if the rapid gear is enabled for one or several crane movements.

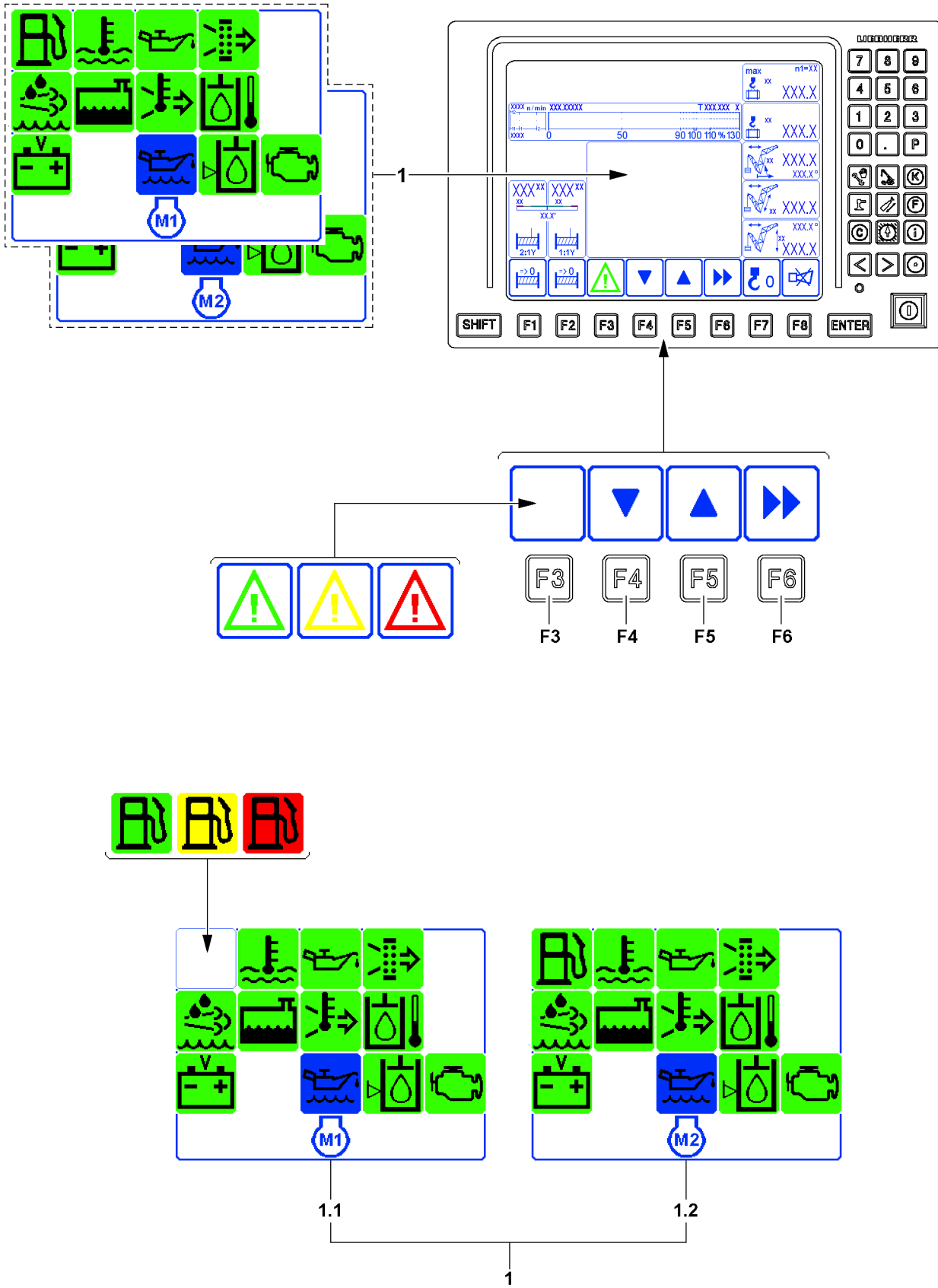

Fig.121774

5.5 Monitoring functions during crane operation

The monitoring functions **1** are always active and can be displayed in the monitoring field, if necessary. Due to the color of the icon over the function key **F3** the crane operator is automatically alerted in case of a warning occurrence.

The monitoring field has its fixed place on the LICCON monitor and can be hidden or assigned with other functions.

By pressing the function key **F3**, the monitoring functions **1** are displayed in the monitoring field.

NOTICE

There is a danger of severe damage to the engine if warnings are ignored!

If other programs are used for extended periods of time, for example the *Set up* program or *Test system* program, it is essential to switch to the crane operation screen in order to ensure that no events have occurred, which could lead to damage or destruction of the engine.

- ▶ Switch continuously into the crane operation screen and check the displays.
-

NOTICE

Danger of severe engine damage!

If the engine monitoring reports a problem and / or warning occurrence, then you must react immediately and remedy the problem.

- ▶ React to problems and / or warning occurrences immediately and remedy the problem.
 - ▶ If necessary, stop crane operation and turn the engine off.
-

NOTICE

Shut off engine monitoring!

Outside of the *crane operation* program, the monitoring functions are turned off.

When the engine monitoring is turned off, problems and warning occurrences are not recognized. This could result in crane failure.

- ▶ If work is not carried out in the *Crane operation* program, then turn the crane engine off and operate the LICCON computer system in stand-by mode, see section „LICCON computer system in stand-by mode“.
 - ▶ If work has to be carried out for a longer period outside of the *crane operation* program, with the crane engine running, then switch continuously into the engine monitoring screen and check the display values.
 - ▶ Register changes in the display values mindfully and proceed anticipatorily, for example, refuel in time.
-

Color key Warning icon above function key **F3**.

- Warning icon green: All monitoring functions are ok.
- Warning icon yellow: Advance warning for one or several monitoring functions.
- Warning icon red: Warning for one or several monitoring functions.

Monitoring functions **1**:

- Monitoring functions **1.1** Engine M1
- Monitoring functions **1.2** Engine M2

Note: Appears exclusively for crane types with two crane engines.

5.5.1 Calling up the monitoring functions

If a warning event occurs in one or more monitoring functions in the monitoring field, this is indicated by the color change of the warning icon over the function key **F3**. The warning icon is displayed statically and in the color of the monitoring function that triggered the warning event.

- ▶ Press the function key **F3** until the desired page of the monitoring functions **1** is called up.

Result:

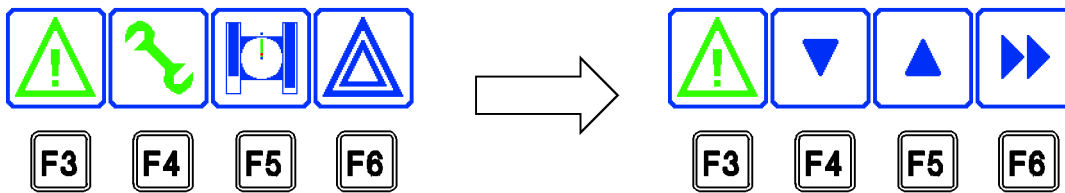

Fig.114282

- The assignment of the function key **F4**, function key **F5** and function key **F6** changes.
- The monitoring functions **1** are displayed in the monitoring field on the LICCON monitor.

For the colors for the icons of the monitoring function **1**, see the following section „Overview of icons for monitoring functions“:

- Green: Monitored function ok
- Yellow: Advance warning for the monitored function
- Red: Warning for the monitored function

Call up the individual control displays one after the other:

- ▶ Press function key **F4** or function key **F5**.

Result:

- The individual control displays appear, see the following section „Overview of individual control displays“

Mask the monitoring functions **1**:

- ▶ Press the function key **F6**.

5.5.2 Overview of icons for monitoring functions

In the monitoring field **1** appear the following monitoring functions:

	Fuel reserve
Green:	Fuel reserve more or equal to 5 %
Yellow:	Fuel reserve approx. 3 % - 4 %
Red:	Fuel reserve less than 3% NOTICE! Immediately bring the crane to a standstill, turn the engine off and remedy the problem. Pay attention to error message.

	Coolant temperature
Green:	Coolant temperature OK
Red:	Coolant temperature too high NOTICE! Immediately bring the crane to a standstill, turn the engine off and remedy the problem. Pay attention to error message.

LWE/LR 11000-001/23501-04-02/en

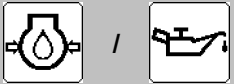
		Engine oil pressure
Green:		Engine oil pressure OK (engine on)
Red:		Engine oil pressure too low (engine on) NOTICE! Immediately bring the crane to a standstill, turn the engine off and remedy the problem. Pay attention to error message.

		Air filter Engine
Green:		Air filter OK (engine on)
Yellow		Air filter dirty (engine on) NOTICE! Immediately bring the crane to a standstill, turn the engine off and remedy the problem. Pay attention to error message.

		Charge control display¹⁾
Green:		Alternator OK (engine on)
Red:		Alternator does not charge (engine on) NOTICE! Immediately bring the crane to a standstill, turn the engine off and remedy the problem. Pay attention to error message.

1) Only for certain crane types

		Urea tank / exhaust aftertreatment¹⁾
Green:		Urea available
Yellow / red:		Urea level too low or erroneous function of exhaust aftertreatment system NOTICE! Add urea or remedy the erroneous function of the exhaust aftertreatment. Under some circumstances a power reduction or start block of the engine ¹ is triggered, pay attention to the error message.

1) Only for certain crane types

		Coolant level
Green:		Coolant level OK
Red:		Insufficient coolant NOTICE! Immediately bring the crane to a standstill, turn the engine off and remedy the problem. Pay attention to error message.

LWE/LR 11000-001/23501-04-02/en

		Charge air temperature
Green:		Charge air temperature OK
Red:		Charge air temperature too high NOTICE! Immediately bring the crane to a standstill, turn the engine off and remedy the problem. Pay attention to error message.

		Hydraulic oil temperature ¹⁾
Green:		Hydraulic oil temperature OK
Red:		Hydraulic oil temperature too high NOTICE! Immediately bring the crane to a standstill, turn the engine off and remedy the problem. Pay attention to error message.

1) Only for certain crane types

		Battery voltage
Green:		Battery voltage OK
Red:		On-board power supply over / undervoltage NOTICE! Immediately bring the crane to a standstill, turn the engine off and remedy the problem. Pay attention to error message.

		Engine oil level ¹⁾
Green:		Engine oil level OK
Blue		The engine oil level can not be checked here on the display, call up the individual indicator light
Red:		Engine oil level not OK NOTICE! Immediately bring the crane to a standstill, turn the engine off and remedy the problem. Call up individual indicator lights and adjust the engine oil according to the display - pay attention to error message.

1) Only for certain crane types

		Hydraulic oil level ¹⁾
Green:		Hydraulic oil level OK
Yellow / red:		Hydraulic oil level too low NOTICE! Immediately bring the crane to a standstill, turn the engine off and remedy the problem. Pay attention to error message.

1) Only for certain crane types

	Exhaust aftertreatment¹⁾
Green:	Exhaust aftertreatment OK
Yellow / red:	Erroneous function Exhaust aftertreatment or Urea level too low NOTICE! Add urea or remedy the erroneous function of the exhaust aftertreatment. Under some circumstances a power reduction or start block of the engine ¹ is triggered, pay attention to the error message.

1) Only for certain crane types

5.5.3 Overview of individual control displays



Note

► For some monitoring functions in the monitoring field the display values can be shown by switching through with function key **F4** or function key **F5**. The illustrated individual control displays are only examples.

Individual control display *Fuel reserve*

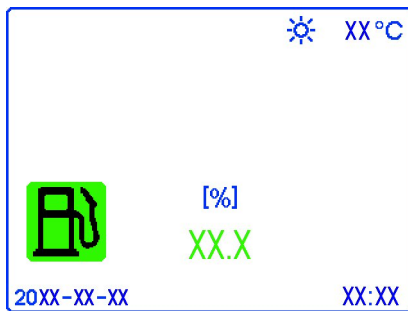

Fig.114283: Fuel reserve

Individual control display *Coolant temperature Single motor / Double motor*

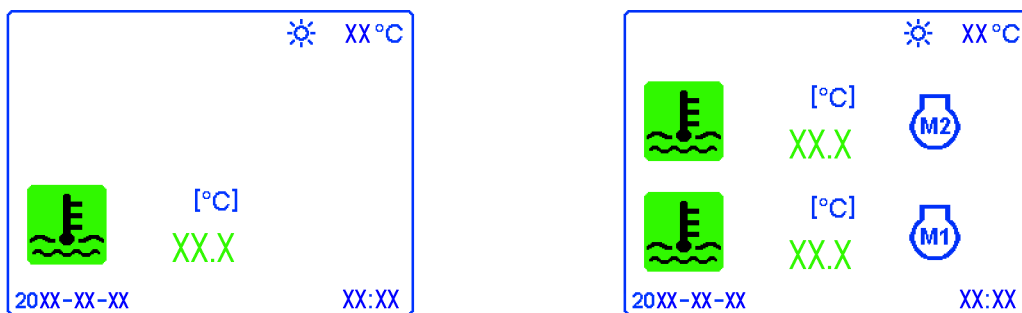

Fig.121781: Coolant temperature Single motor / Double motor

LWE/LR 11000-001/23501-04-02/en

Individual control display *Engine oil pressure*

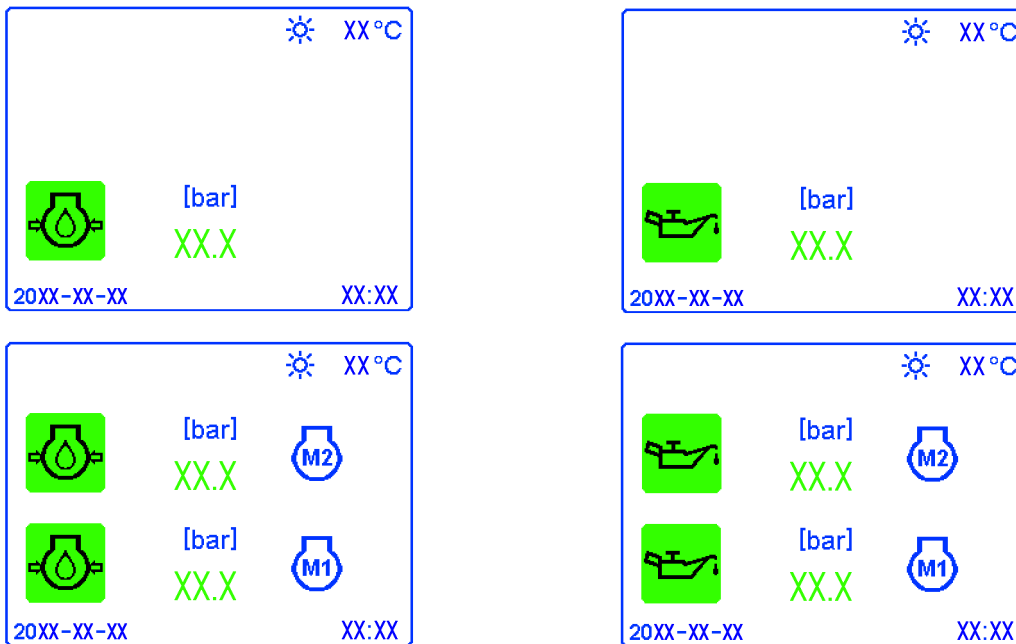

Fig.121782: Engine oil pressure Single motor / double motor (both variations of icons)

Individual control display *Urea reserve*

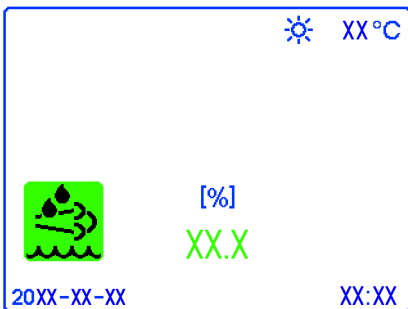

Fig.121788: Urea reserve (only for certain crane types)

Individual control display *Charge air temperature*

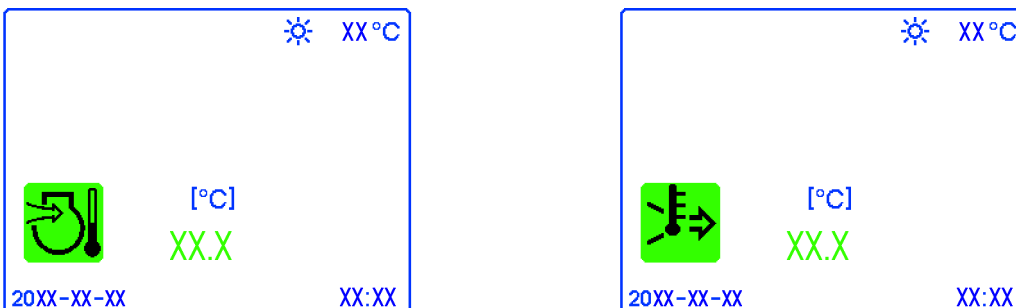

Fig.121784: Charge air temperature (both variation of icons)

LWE/LR 11000-001/23501-04-02/en

Individual control display *Hydraulic oil temperature*

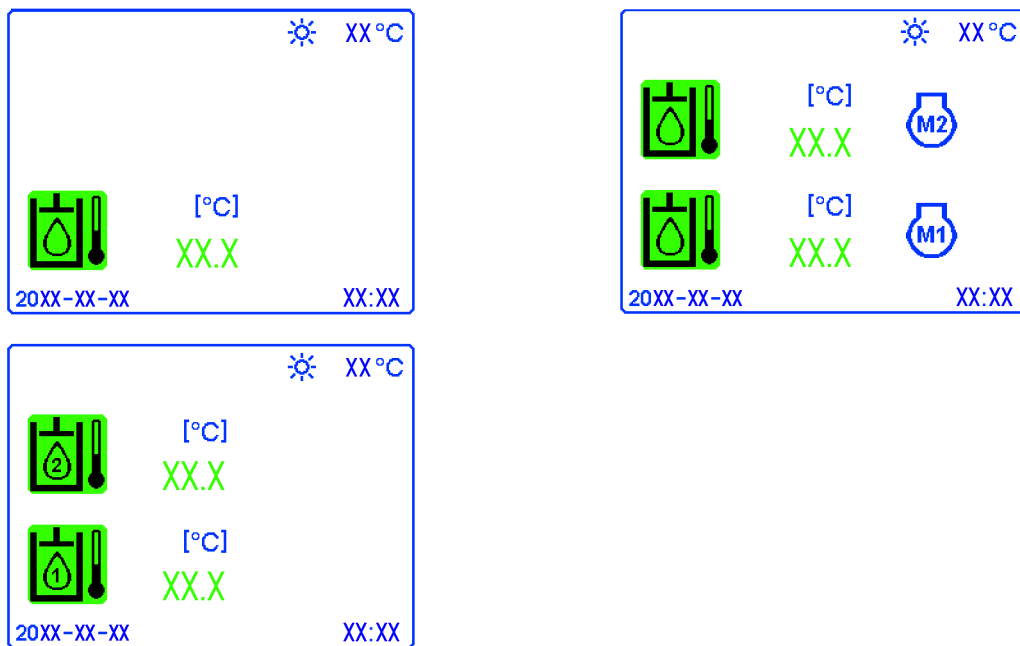

Fig.121787: Hydraulic oil temperature Single motor / double motor / two circuit (only for certain crane types)

Individual control display *Battery voltage*

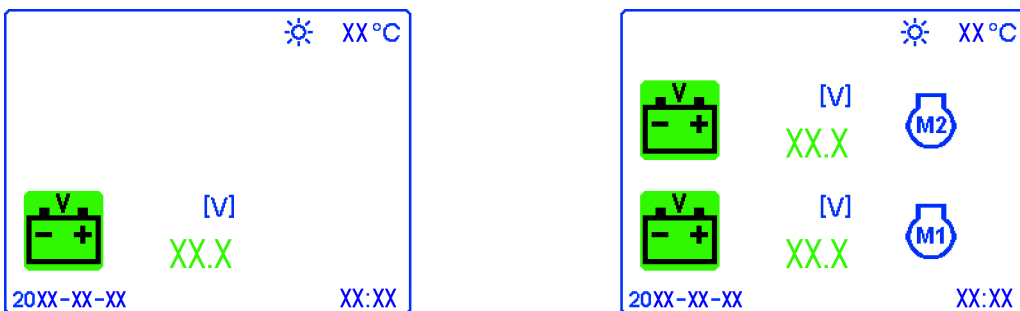

Fig.121785: Battery voltage Single motor / Double motor

Individual control display *Engine oil level*



Note

- ▶ When the engine is running an erroneous test value appears, to check the engine oil level align the crane horizontally and turn the engine off.

Engine oil level Number value

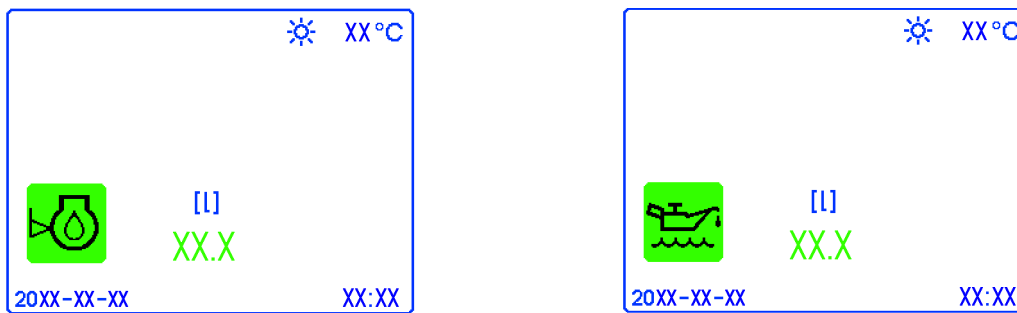

Fig.121786: Engine oil level number value over / under fill (both variations of the icons, only for certain crane types)

Engine oil level Bar diagram

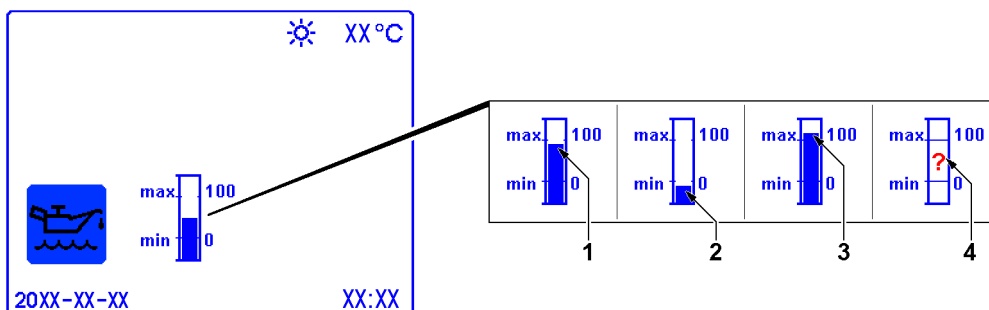

Fig.123757: Engine oil level Bar diagram fill level (only for certain crane types)

- At normal level, the bar 1 reaches a display between 0 and 100
- If underfilled, the bar 2 reaches a display under 0
- If overfilled, the bar 3 reaches a display above 100
- In case of an incorrect test value, the question mark (?) 4 appears

Individual control display Hydraulic oil level

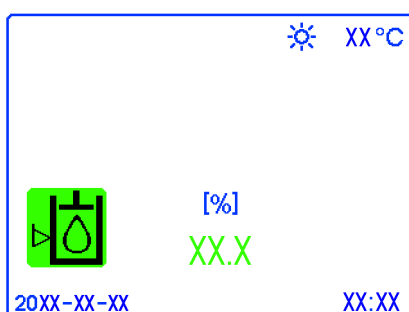









Fig.121790: Hydraulic oil level (only for certain crane types)

5.5.4 Overview of function key assignment

Function key	Function / description
 	<p>By pressing the function key F3 once, the monitoring functions of engine M1 are displayed. By pressing the function key F3 twice, the monitoring functions of engine M2 are displayed.</p> <p>Icon green: All monitoring functions are ok. Icon yellow: Advance warning for one or several monitoring functions. Icon red: Warning for one or several monitoring functions.</p> <p>NOTICE!: Always pay attention to advance warnings and act accordingly.</p>

Function key	Function / description
 	<p>By pressing the function key F4, the individual control displays are called up one after the other in sequence from the beginning.</p>

Function key	Function / description
 	<p>By pressing the function key F5, the individual control displays are called up one after the other in sequence from behind.</p>

Function key	Function / description
 	<p>Change back by one selection level by pressing the function key F6.</p>

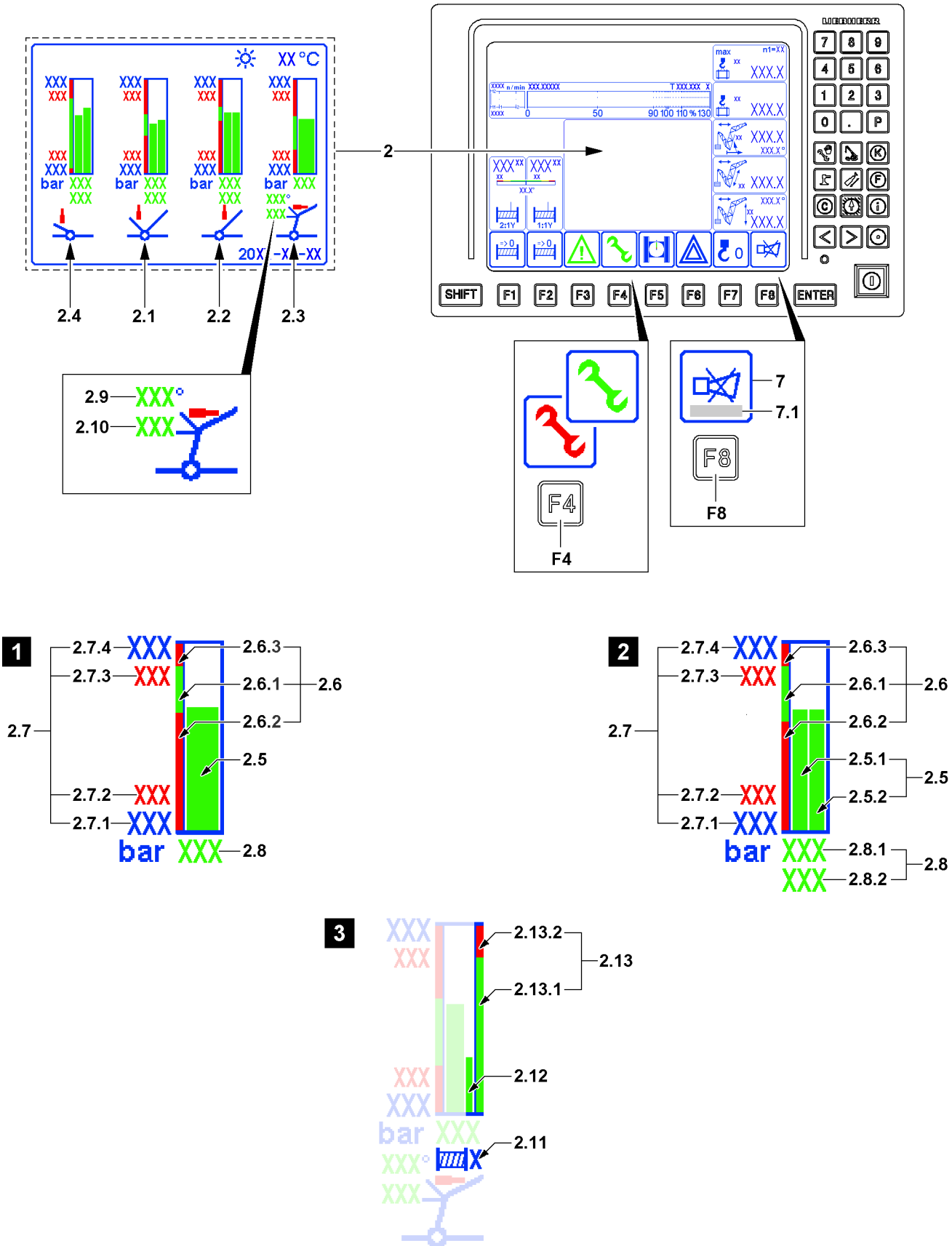

Fig.125388

5.6 Monitoring Relapse cylinder / erection cylinder

The monitoring of the relapse cylinders **2** are always active and can be displayed in the monitoring field, if necessary. Due to the color of the icon over the function key **F4** the crane operator is automatically alerted in case of a warning occurrence.

The monitoring field has its fixed place on the LICCON monitor and can be hidden or assigned with other functions.

By pressing the function key **F4**, the monitoring of the relapse cylinders **2** is displayed in the monitoring field.



WARNING

Pressure in impermissible range!

- ▶ Make sure that the pressure displays are always in the permissible range.
- ▶ Counteract an impermissible pressure immediately.



WARNING

Shut off monitoring of relapse cylinders!

- ▶ Outside of the *Crane operation* program, the monitoring of the relapse cylinders is turned off!
- ▶ When the monitoring of the relapse cylinders is turned off, warning events are not recognized!

Color key of warning icon above function key **F4**

- Warning icon green: Monitoring of relapse cylinders is ok.
- Warning icon red: Warning for one or several relapse cylinders.

- If a warning occurs, an error message **7.1** is issued in the *Horn* icon **7** for some errors. The error message **7.1** includes an acoustic signal through the LICCON monitor and an error description.
- Press the function key **F8** once: The acoustic signal is turned off.
Press the function key **F8** twice: The error description for the error message **7.1** which occurred last is called up.

2 Display field

- Depending on the set up configuration and crane type, up to four pressure displays appear.
- The individual pressure displays always refer to the relapse cylinder / erection cylinder, which are highlighted in the icon directly underneath.

2.1 Derrick relapse cylinder

2.2 Main boom relapse cylinder

2.3 Auxiliary boom / accessory relapse cylinder

2.4 SA-frame Erection cylinder

- **Note:** Only present for certain crane types



Note

- ▶ **Illustration 1:** Example of display of individual relapse cylinders
- ▶ **Illustration 2:** Example of display of double relapse cylinders
- ▶ **Illustration 3:** Example supplementary Winch pressure display* during erection procedures (only for certain crane types)

2.5 Bargraph Actual pressure

- Bar display of actual pressure on relapse cylinder
- For double relapse cylinders:
 - 2.5.1** Bargraph of first relapse cylinder
 - 2.5.2** Bargraph of second relapse cylinder
- **Note:** When the actual pressure is in the permissible range, the actual pressure bargraph **2.5** is shown in green.

Warning! When the actual pressure is in the impermissible range, the actual pressure bargraph **2.5** is shown in red. Counteract immediately to the high pressure.

- 2.6 Scale pressure display
 - 2.6.1 Ideal pressure range
 - 2.6.2 Minimum pressure range fallen below
 - Note:** Appears only if a minimum pressure is monitored.
 - 2.6.3 Highest pressure range exceeded
- 2.7 Values pressure display
 - 2.7.1 Lowest display value
 - 2.7.2 Minimum pressure value
 - Note:** Appears only if a minimum pressure is monitored.
 - 2.7.3 Highest pressure value
 - 2.7.4 Highest display value
- 2.8 Pressure relapse cylinder
 - Actual value relapse cylinder
 - For double relapse cylinders:
 - 2.8.1 Pressure of the first relapse cylinders
 - 2.8.2 Pressure of the second relapse cylinders
- 2.9 Angle WA-frame 1
- 2.10 Angle WA-frame 2

Winch pressure display* during erection procedures (only for certain crane types)

See illustration 3



Note

- ▶ The winch pressure is shown when the main boom is luffed under 10 degrees, the luffing jib was set up and no parallel operation was preselected.
- ▶ The winch moved last is always shown (winch 1 or winch 2).

2.11 Displayed winch

- Shows for which winch the winch pressure is shown

2.12 Bargraph Winch pressure

- Bargraph for winch pressure of respectively shown winch **2.11**
- **Note:** When the actual pressure is in the permissible range, the winch pressure bargraph **2.12** is shown in green.
- **Warning!** When the actual pressure is in the impermissible range, the winch pressure bargraph **2.12** is shown in red. Counteract immediately to the high pressure.

2.13 Scale pressure display

- 2.13.1 Ideal pressure range
- 2.13.2 Highest pressure range exceeded



Note

Additional display values in the display *Monitoring of relapse cylinders 2*

- ▶ Date and ambient temperature are also displayed.

Empty page!

LWE/LR 11000-001/23501-04-02/en

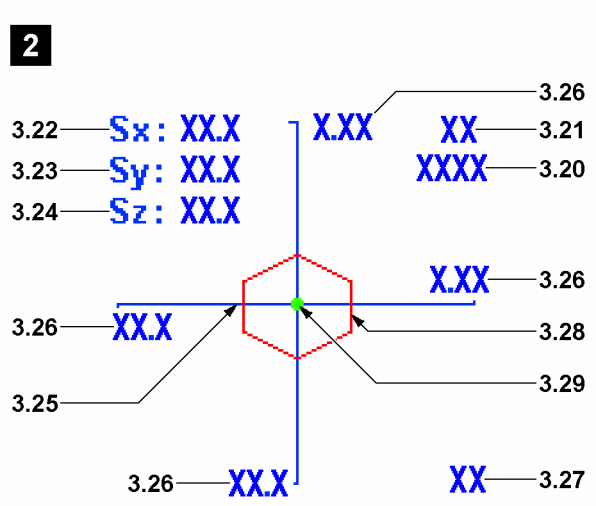
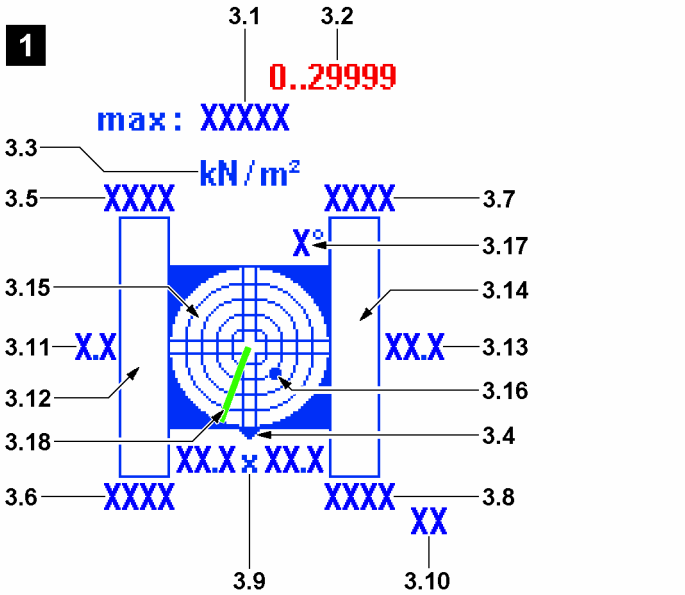
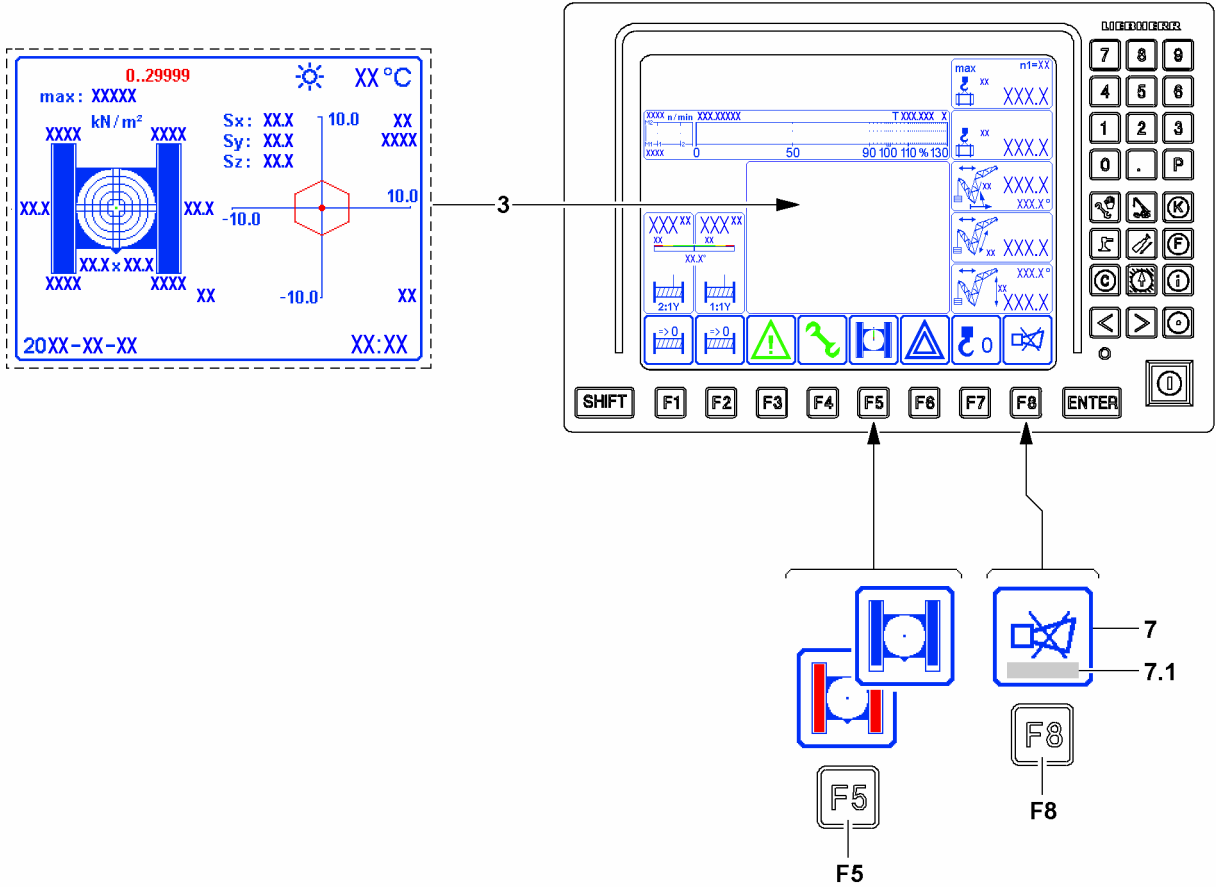

Fig.144107

5.7 Monitoring of surface pressure and center of gravity



WARNING

The crane can topple over!

When the programmed limit values are reached in the monitoring of surface pressure and center of gravity, there is no automatic shut off of crane movements.

The displayed values are calculated and are informative. Calculated values are below the tolerances and unpredictable influences, for example crane control, surrounding and environmental influences. Due to the resulting tolerance field of the values, the monitoring of surface pressure and center of gravity may not be used to determine the limit values of the crane.

If this is disregarded, then the crane can topple over.

Personnel can be severely injured or killed.

- ▶ Do not use the displayed values to determine the limit values of the crane and to utilize the crane to its tipping limit or until it sinks in.
 - ▶ Make sure that all values are within the programmed limit values.
-



WARNING

Increased surface pressure!

The calculation of the values for the display of the surface pressure in the LICCON monitor are based on ideal assumptions.

- ▶ Side deformations of the boom system due to wind, inclined position and elastic resilience of the steel structure are not taken into account but they can lead to an increase of the surface pressure.
-



WARNING

Shifting of center of gravity!

The calculation of the values for the display of the center of gravity in the LICCON monitor are based on ideal assumptions.

- ▶ Side deformations of the boom system due to wind, inclined position and elastic resilience of the steel structure are not taken into account but they can lead to a shifting of the center of gravity.
-

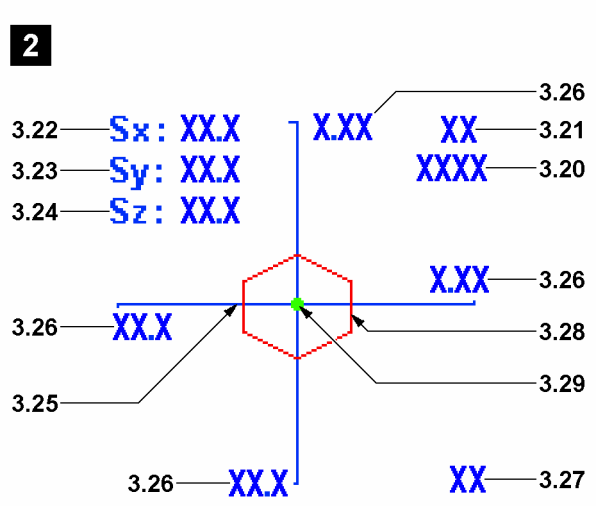
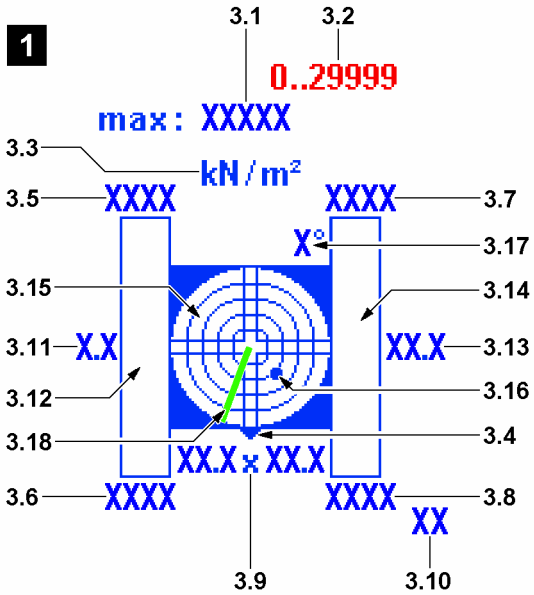
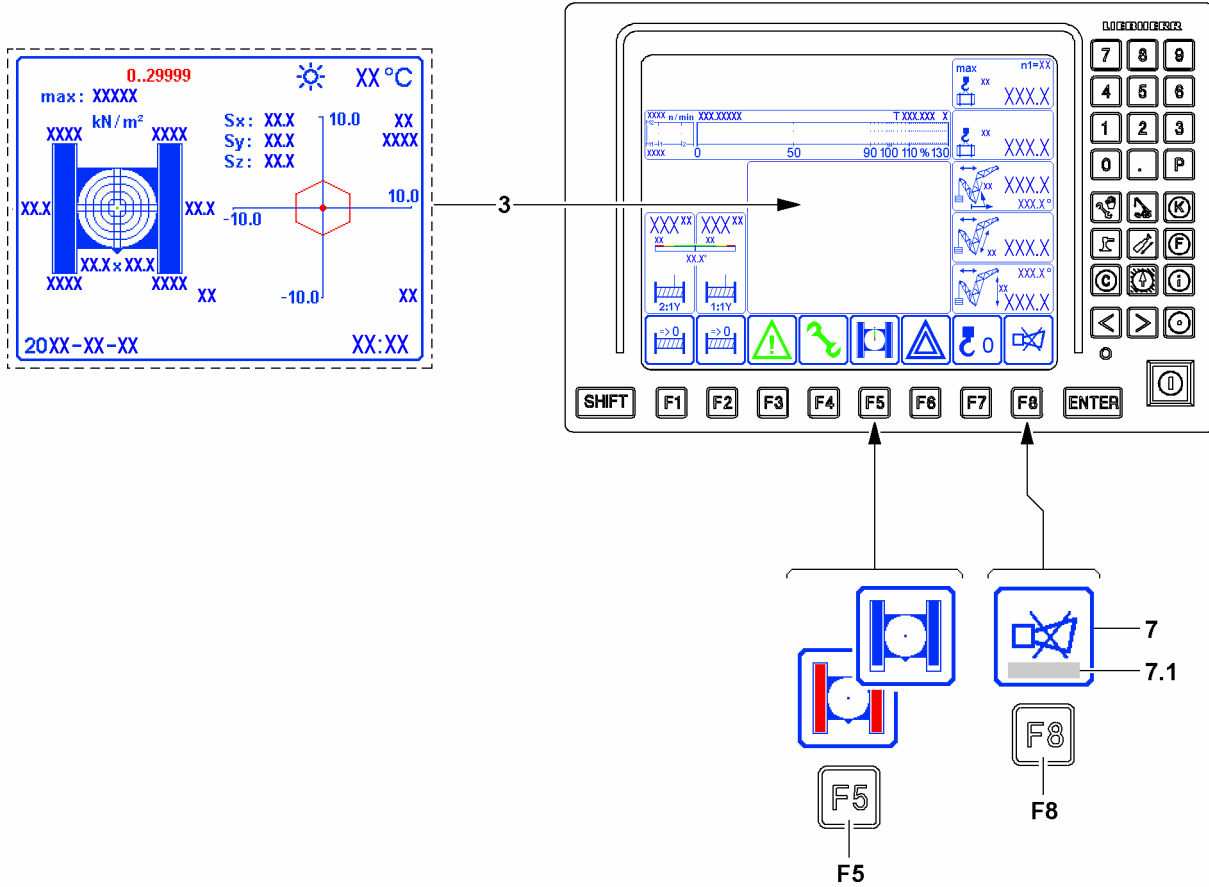

Fig.144107

The monitoring of surface pressure and center of gravity **3** is always active and can be displayed in the monitoring field, if necessary. Due to the color of the icon over the function key **F5** the crane operator is automatically alerted in case of a warning occurrence.

The monitoring field has its fixed place on the LICCON monitor and can be hidden or assigned with other functions.

By pressing the function key **F5**, the monitoring of surface pressure and center of gravity **3** is displayed in the monitoring field.



Note

Turned off monitoring of surface pressure and center of gravity.

- ▶ Outside of the *Crane operation* program, the monitoring of surface pressure and center of gravity is turned off.
- ▶ When the monitoring of surface pressure and center of gravity is turned off, warning events are not recognized.

Color key of warning icon above function key **F5**:

- Warning icon blue: Monitoring of surface pressure and center of gravity is ok.
- Crawler carrier in warning icon red: Warning for monitoring of surface pressure and center of gravity.

Error messages:

- If a warning occurs, an error message **7.1** is issued in the *Horn* icon **7** for some errors. The error message **7.1** includes an acoustic signal through the LICCON monitor and an error description.
- Press the function key **F8** once: The acoustic signal is turned off.
- Press the function key **F8** twice: The error description for the error message **7.1** which occurred last is called up.



Note

- ▶ **Illustration 1:** Display Surface pressure
- ▶ **Illustration 2:** Display *Center of gravity*

3 Display *Monitoring of surface pressure and center of gravity*

- The values are calculated depending on the set up configuration of the crane and the load.

Display Surface pressure, illustration 1:

- 3.1 Permissible surface pressure
 - The value is entered by the crane operator via the keypad.
- 3.2 Input area
 - Input area for the permissible surface pressure **3.1**.
- 3.3 Measuring unit for surface pressure
 - Measuring unit for the pressure data in the display surface pressure (illustration **1**).
- 3.4 Direction specification
 - The triangle symbolizes where the front of the crawler travel gear is in the illustration.
 - **Note:** The front on the crawler travel gear is always on the side where the chain tension devices for the crawler carriers are located. The position of the turntable has no influence on this. The position of the turntable can be derived from the boom direction **3.18**.
- 3.5 Surface pressure
 - Calculated actual value of surface pressure on the crawler travel gear, left rear.
- 3.6 Surface pressure
 - Calculated actual value of surface pressure on the crawler travel gear, left front.
- 3.7 Surface pressure
 - Calculated actual value of surface pressure on the crawler travel gear, right rear.
- 3.8 Surface pressure
 - Calculated actual value of surface pressure on the crawler travel gear, right front.

- 3.9** Travel gear base
 - Base dimensions of the crawler travel gear.
- 3.10** Measuring unit Length data
 - Measuring unit for the measuring data in the display surface pressure (illustration 1).
- 3.11** Placement surface
 - Calculated placement surface of crawler carrier right as value.
- 3.12** Placement surface
 - Calculated placement surface of crawler carrier right as graphic.
- 3.13** Placement surface
 - Calculated placement surface of crawler carrier left as value.
- 3.14** Placement surface
 - Calculated placement surface of crawler carrier left as graphic.
- 3.15** Incline display
 - The graphic display is in the form of a spirit level, with a moving dot **3.16** representing the air bubble.
 - **Note:** Incline display with number values, see section „Monitored auxiliary functions“.
- 3.16** Point
 - The center of the dot **3.16** shows the incline.
- 3.17** Resolution of view
 - This value describes the resolution of the graphic view of the incline indicator. This displayed value corresponds with the outermost ring of the spirit level. The resolution is matched automatically to the incline.
- 3.18** Boom direction
 - Current boom direction in reference to the displayed icon.
 - The boom direction corresponds to the viewing direction *to the front* from the crane cab.



Note

Example for the incline indicator **3.15**:

- ▶ **Example:** The point **3.16** lies on the second ring from the inside in the lower right quadrant. The display resolution **3.17** is 1° . Therefore an inclination of 0.4° is displayed. The highest point on the placement surface of the crawler travel gear is on the front left side. Therefore, the crane is inclined back to the right 0.4° from the point of view of the crawler travel gear.



WARNING

The crane can topple over!

If the permissible incline of the crane is exceeded, the crane can topple over.

- ▶ Do not exceed the permissible incline from the load chart.
- ▶ Do not exceed the permissible incline for driving the crane, see Crane operating instructions, chapter 4.10.

Display Center of gravity, illustration 2:

- 3.20** Weight data
 - Calculated total weight of the crane including load.
- 3.21** Weight unit
 - Weight unit for the weight data **3.20** in the display center of gravity (illustration 2).
- 3.22** Center of gravity position
 - Calculated center of gravity position in direction S_x
- 3.23** Center of gravity position
 - Calculated center of gravity position in direction S_y
- 3.24** Center of gravity position
 - Calculated center of gravity position in direction S_z

3.25 Axis of coordinates

- The axis of coordinates **3.25** is aligned according to the direction of the display surface pressure (illustration 1) centered to the slewing ring on the placement surface of the crane.

3.26 Scale value

- Scale value on the axis of coordinates **3.25**

3.27 Measuring unit

- Measuring unit in the display center of gravity (illustration 2)

3.28 Core surface

- Calculated core surface of the crane according to the set up configuration, load and ground conditions.
- **Note:** The core surface is an important reference point for the center of gravity of the crane.

3.29 Center of gravity Sx/Sy

- Calculated center of gravity displayed graphically in direction Sx/Sy
- **Note:** The actual position is in direct relation to the values center of gravity position **3.22** and center of gravity position **3.23**

**Note**

Additional display values in the Display *Monitoring of surface pressure and center of gravity 3*

- ▶ Date, time of day and ambient temperature are also displayed.

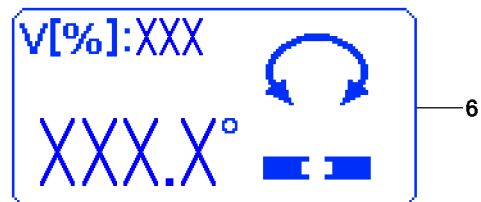
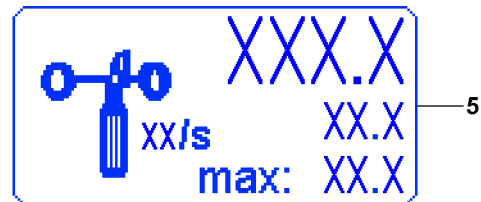
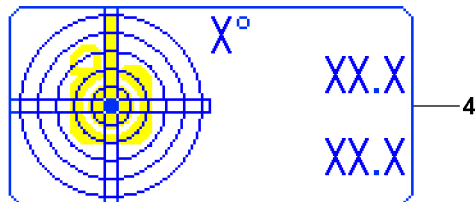
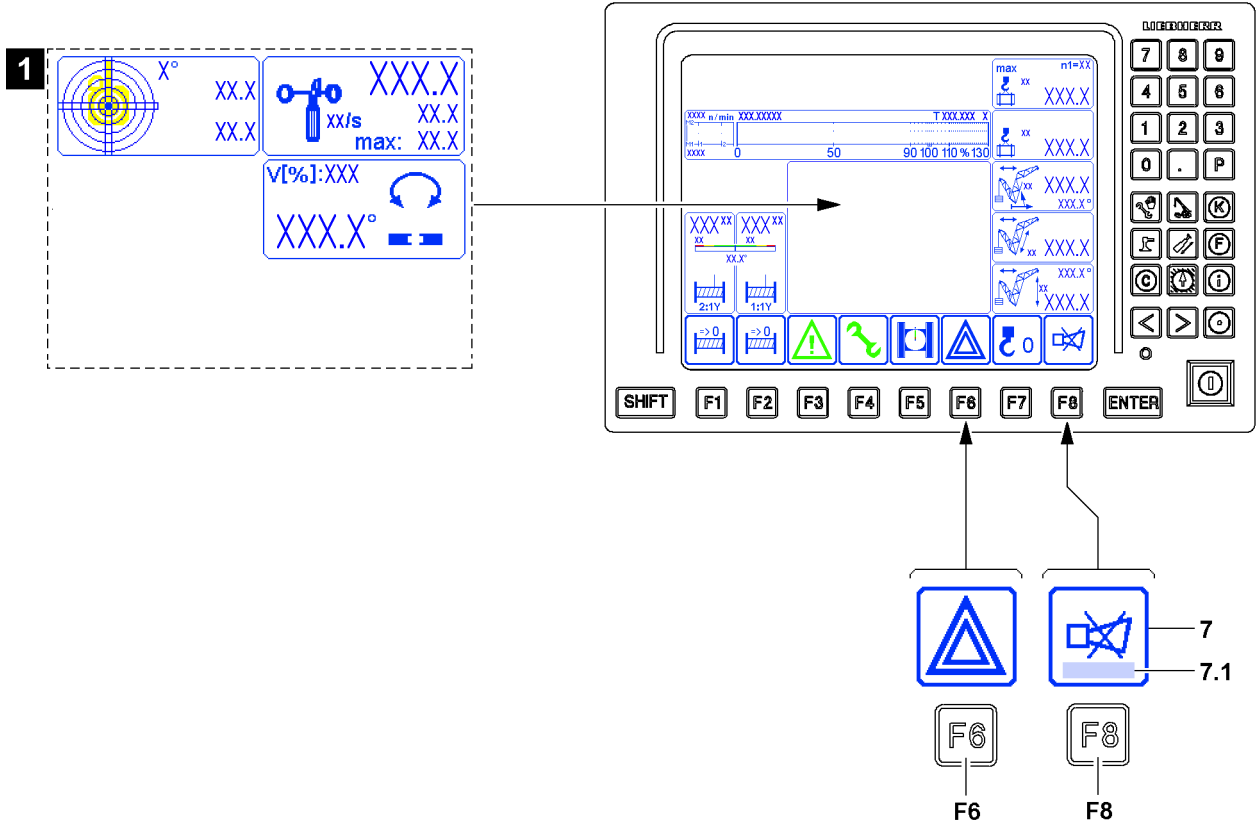

Fig.116013

5.8 Monitored auxiliary functions

The monitored auxiliary functions (illustration 1) are always active and can be displayed in the monitoring field, if necessary.

The monitoring field has its fixed place on the LICCON monitor and can be hidden or assigned with other functions.

By pressing the function key **F6**, the monitored auxiliary functions are displayed / masked in the monitoring field.



Note

Shut off *Monitored auxiliary functions*

- ▶ Outside of the *Crane operation* program, the monitored auxiliary functions are turned off.
- ▶ When the monitored auxiliary functions are turned off, warning events are not recognized.

The appearance of the icon over function key **F6** changes according to the condition:

Icon with filled out frame = auxiliary functions icons turned off

Icon with frame not filled out = auxiliary functions icons turned on

Note: If a monitored limit has been exceeded, a warning is issued the corresponding icon is displayed, even if the monitoring icons have been hidden.

Error messages:

- If a warning occurs, an error message **7.1** is issued in the *Horn* icon **7** for some errors. The error message **7.1** includes an acoustic signal through the LICCON monitor and an error description.
- Press the function key **F8** once: The acoustic signal is turned off.
- Press the function key **F8** twice: The error description for the error message **7.1** which occurred last is called up.

Auxiliary functions:

- 4 Crane incline
- 5 Wind speed
- 6 Slewing range

5.8.1 Display of auxiliary functions

The display changes depending if the monitored auxiliary functions are turned on or off via the function key **F6**.

Monitored auxiliary functions turned off:

- No error:
Icons are not shown.
- Error in one function:
Icon with error message is shown.

Monitored auxiliary functions turned on:

- Icons are displayed permanently

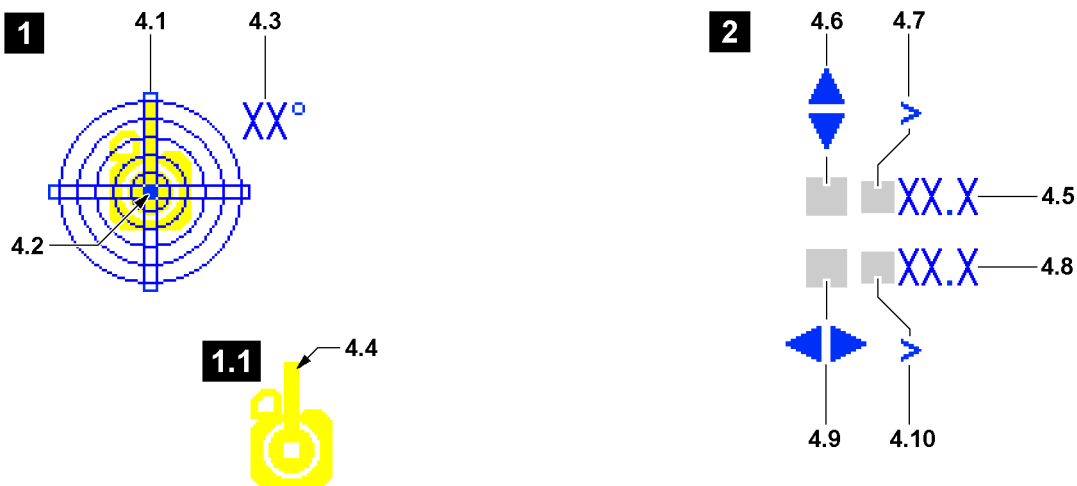
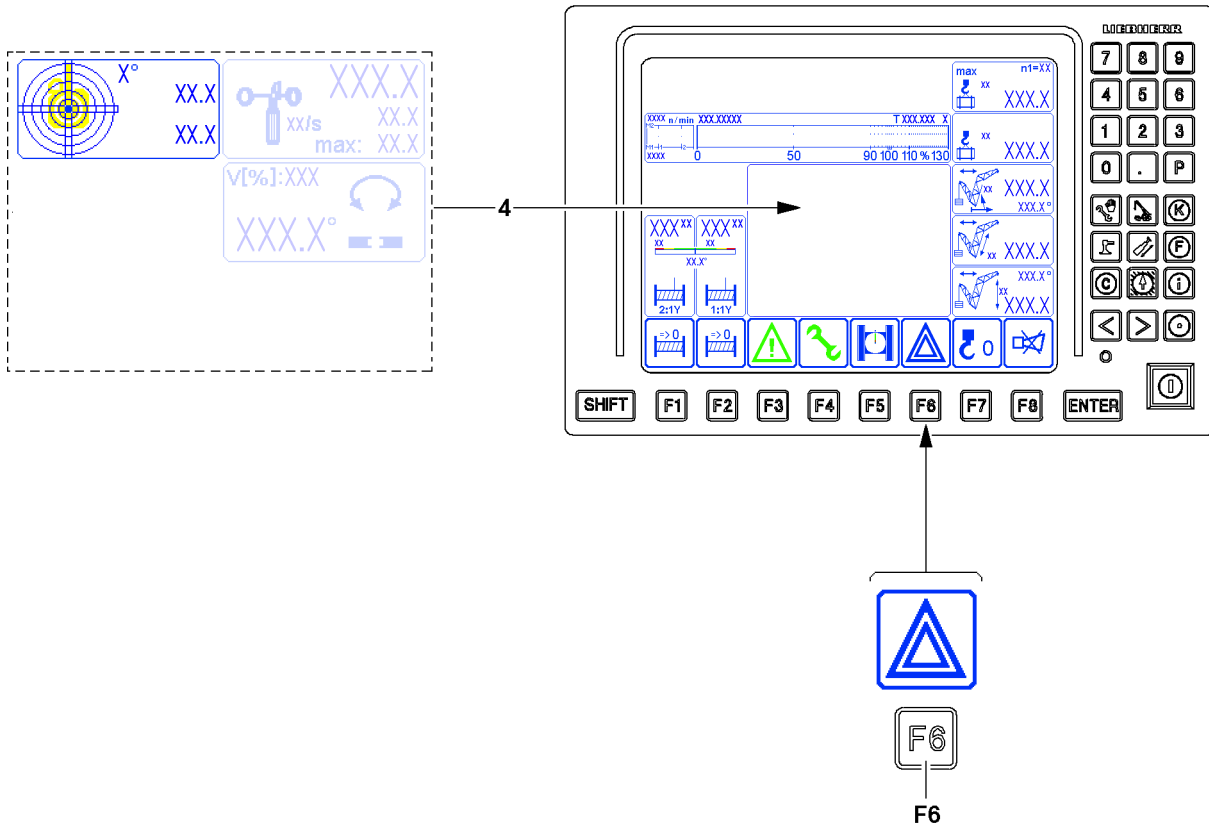

Fig.114292

5.8.2 Crane incline



WARNING

The crane can topple over!

If the permissible incline of the crane is exceeded, the crane can topple over.

The *larger than* icon shows that the crane is inclined further than can be shown.

The exact incline can then not be read.

- ▶ Do not exceed the permissible incline from the load chart.
- ▶ Do not exceed the permissible incline for driving the crane, see Crane operating instructions, chapter 4.10.

4 Inclination icon

- Display of the incline of the crane to the horizontal in longitudinal and lateral direction. The display is graphic as well as numeric.
- The display is divided in a graphic section (illustration 1) and a numeric section (illustration 2).
- The directional data refers to the direction of the crane superstructure (view from the cab).

Graphical section (illustration 1):

4.1 Graphic display

- The graphic display is in the form of a spirit level, with a moving dot 4.2 representing the air bubble.

4.2 Point

- The center of the dot 4.2 shows the incline value.

4.3 Resolution of view

- This value describes the resolution of the graphic view. The resolution is matched automatically to the incline.

4.4 Boom direction

- To the graphic view 4.1, the overhead view of the imitated crane superstructure is provided, see illustration 1.1. The main boom direction 4.4 is symbolized by a wide yellow line and is provided for orientation in the display.

Numeric section (illustration 2):

4.5 Longitudinal direction

- Incline of crane in longitudinal direction in [°].

4.6 Direction arrow

- The direction arrow shows the direction of the incline.

4.7 Display range exceeded

- If the *larger than* icon appears, then the display range is exceeded.
- **Note:** The crane is inclined further than can be shown.

4.8 Lateral direction

- Incline of crane in lateral direction in [°].

4.9 Direction arrow

- The direction arrow shows the direction of the incline.

4.10 Display range exceeded

- If the *larger than* icon appears, then the display range is exceeded.
- **Note:** The crane is inclined further than can be shown.



Note

Orientation of the crane in *Incline* icon 4.

- ▶ Observe the main boom direction 4.4.

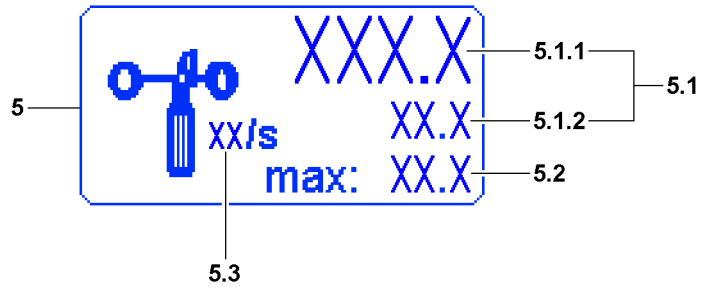
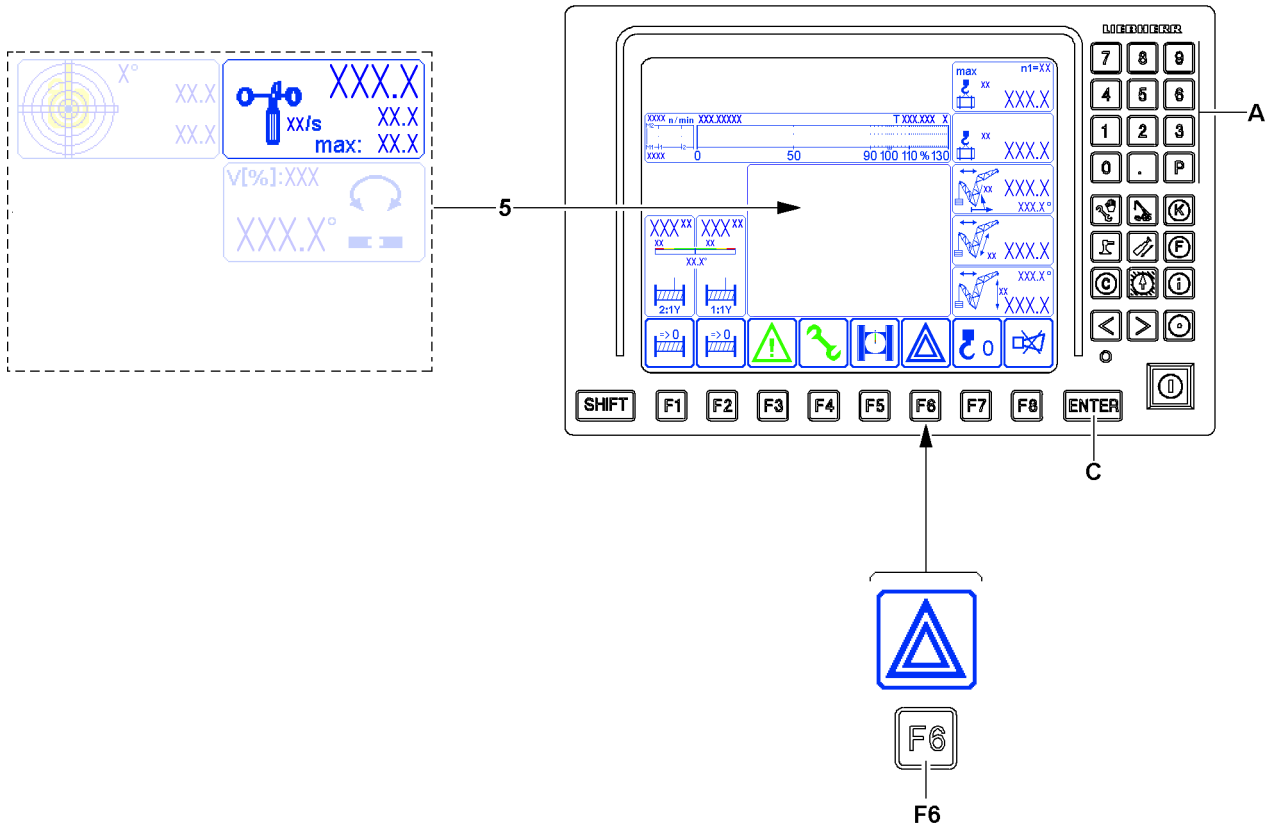

Fig.121798

5.8.3 Wind speed



WARNING

Wind speed too high!

If the maximum permissible wind speed is exceeded with an erected boom system, there is a danger of accident.

Dangerous situations can arise, such as oscillating load or shaking crane.

The crane can topple over, personnel can be severely injured or killed.

- ▶ **The crane movements will not be shut off.**
- ▶ The boom system must be taken down in time before exceeding the maximum permissible wind speed of the crane.
- ▶ The danger notes, see Crane operating instructions, chapter 2.04 must be strictly observed and adhered to.

5 Wind speed icon

5.1 Current wind speed

- **Note:** If a wind sensor is connected, then the wind speed appears at **5.1.1**. If two wind sensors are connected (Example: Crane operation with auxiliary boom / accessory), a second wind speed appears additionally at **5.1.2**
- **5.1.1** current wind speed WG1
- **5.1.2** current wind speed WG2



WARNING

Crane operation without display value of wind speed!

If a question mark (?) appears in the display of the current wind speed **5.1** instead of number values, then a wind sensor which must be present is missing or there is an error in the wind sensor.

- ▶ Before starting to work with the crane, make sure that all wind sensors which must be present are present and functioning.
- ▶ Remedy the error immediately.
- ▶ If an error cannot be remedied, then it must be ensured that the wind speed is monitored otherwise.

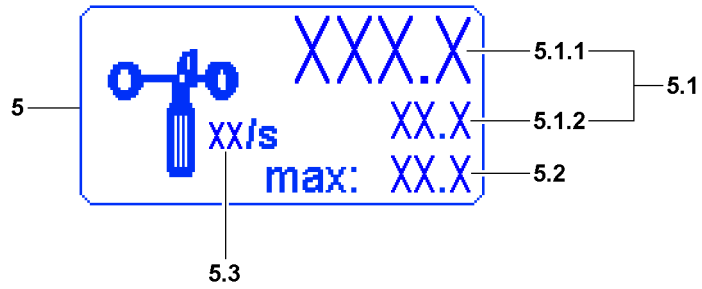
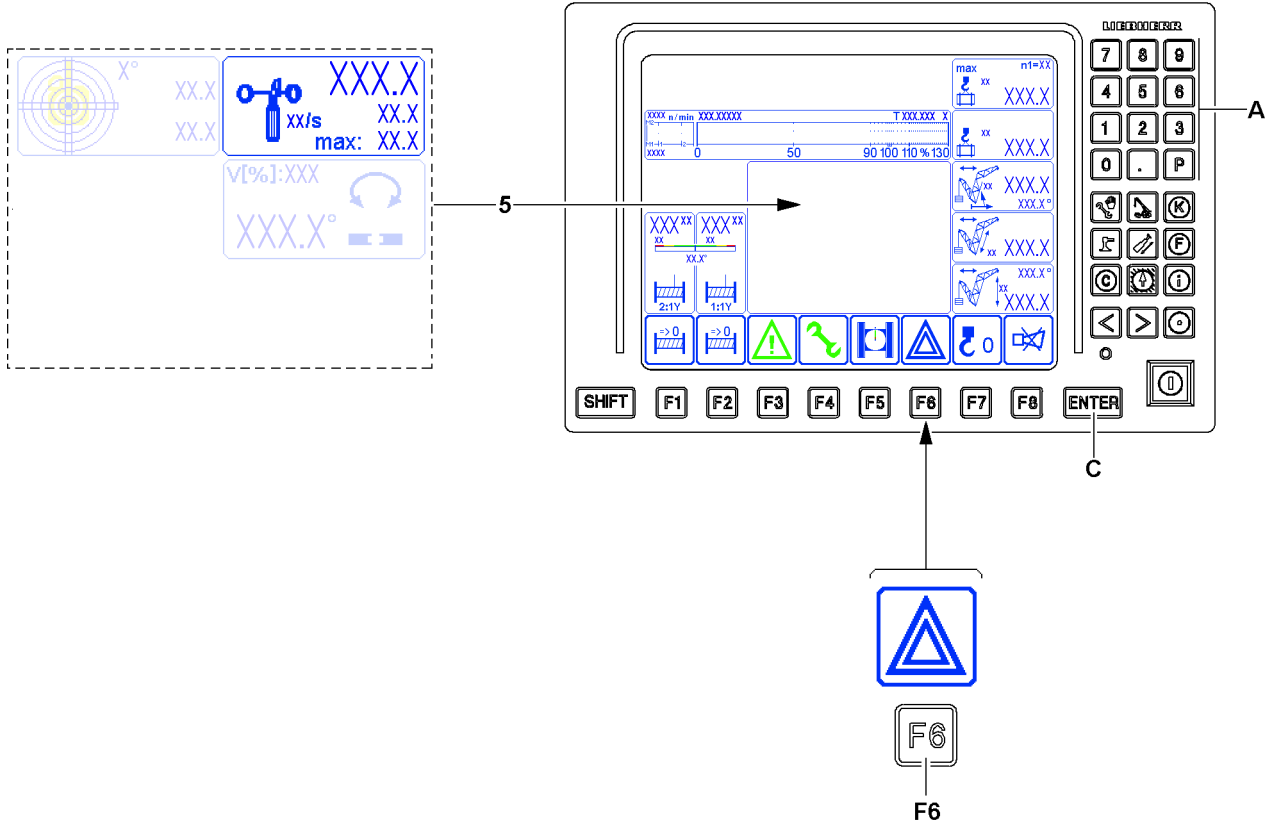

Fig.121798

**Note**

- ▶ If several wind sensors are connected, the installation location of the wind sensor determines the corresponding display in the *Wind speed* icon **5**.
- ▶ The priority depends on the installation location of the wind sensor, from outside (auxiliary boom / accessory) to inside (main boom). The wind speed for the outside wind sensor is shown independent from the inside wind sensor.

5.2 Maximum permissible wind speed

- The value depends on the operating mode and the set up configuration.
- If the current wind speed value exceeds the displayed maximum value, the maximum value starts to blink and the warning sound *Short horn* sounds.

**Note**

- ▶ If access to a load chart is not possible, then the maximum value starts to blink and the warning sound *Short horn* sounds.

5.3 Measuring unit

- [m/s] or [ft/s]

Reducing the maximum permissible wind speed***Note**

- ▶ This function is not available for all crane types.

The value for the maximum permissible wind speed **5.2** can possibly be reduced.

Ensure that the following prerequisite is met:

- The *Wind speed* icon **5** is shown.

Reduce the wind speed:

1. Press the ENTER key **C**.
2. As soon as the value for the maximum permissible wind speed **5.2** is highlighted in blue, enter the new value via the keypad **A**.
3. Press the ENTER **C** key again. The changed value for the maximum permissible wind speed **5.2** is shown in red.

Cancel reduce the wind speed:

1. Press the ENTER key **C**.
2. As soon as the value for the maximum permissible wind speed **5.2** is highlighted in blue, enter 0 (zero) as the new value via the keypad **A**.
3. Press the ENTER **C** key again. The original value from the load chart is taken over again.

**Note**

- ▶ If you try to enter a value for the maximum permissible wind speed **5.2** which is too high, then the highest possible value is taken over.

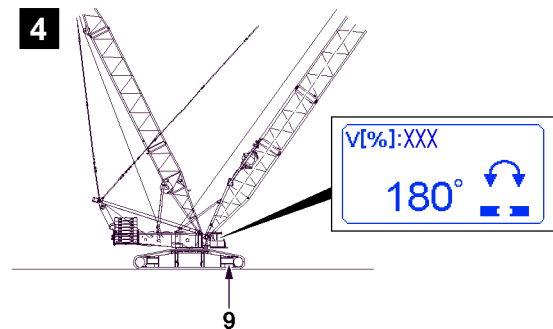
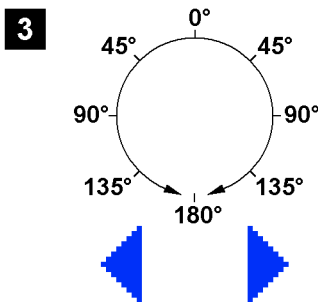
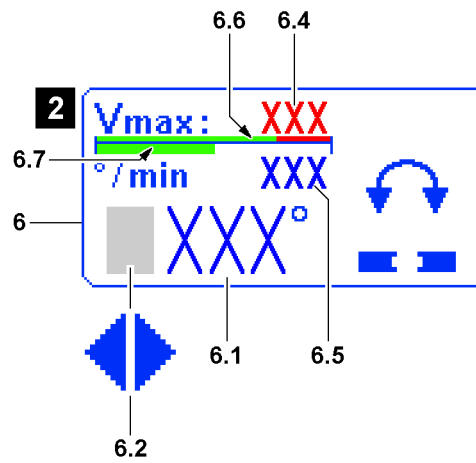
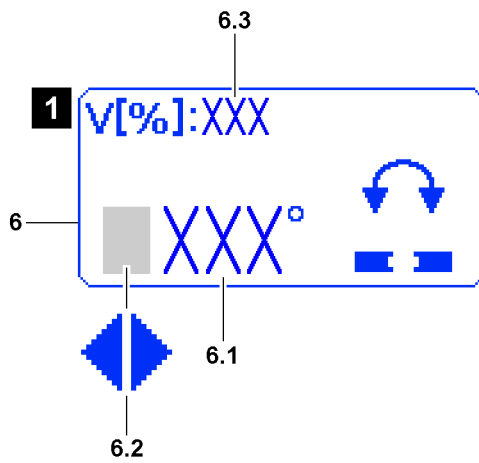
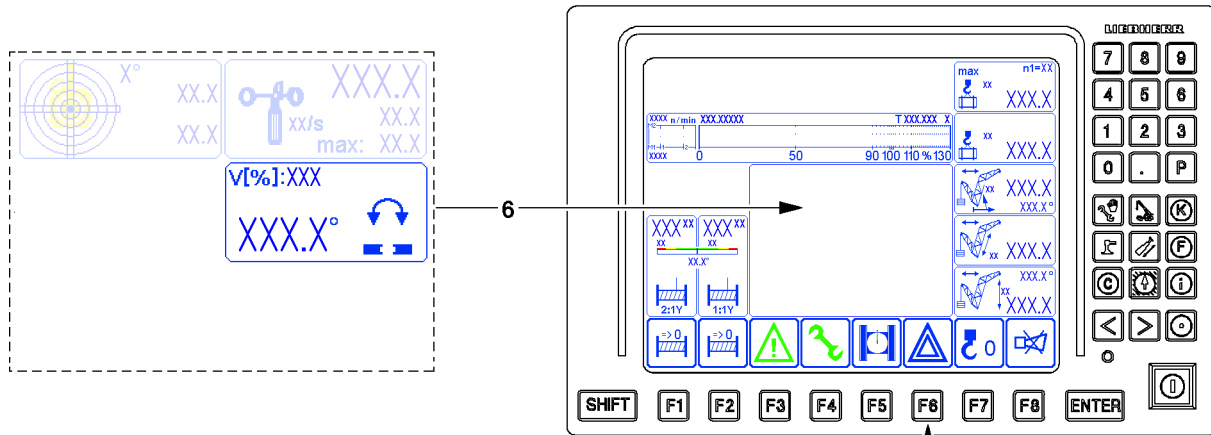

Fig.144105

LWE/LR 11000-001/23501-04-02/en

5.8.4 Slewing range

6 Slewing range icon

- depending on the crane type, either the icon illustration 1 or illustration 2 appears



WARNING

Danger of accidents in case of excessive slewing speed!

Danger of toppling or collapsing crane.

Death, severe bodily injuries, property damage.

- ▶ Observe the slewing speed according to the specifications in the load chart manual.

6.1 Slewing angle

- Slewing angle of the crane superstructure in relation to the working direction *to the rear* (0°)
- The number value can increase on both sides to the maximum value of 180°, see illustration 3
- **Note:** At display value 180°, the crane superstructure is exactly in the forward position, see illustration 4. The front of the crawler travel gear is where the chain tension devices 9 are located.

6.2 Direction of rotation

- The direction arrow in front of the value indicates the direction of rotation of the crane superstructure.
- The direction arrow is in relation to the working direction *to the rear* (0°), see illustration 3
- Arrow to the left: The crane superstructure is turned to the left.
- Arrow to the right: The crane superstructure is turned to the right.
- **Note:** If the crane superstructure is positioned exactly to the front (display value 180°) or to the rear (display value 0°) there is no direction arrow.

6.3 Slewing speed

- Only for crane types with the icon illustration 1
 - Maximum slewing speed in [%]
 - Identifies the set maximum slewing speed of the slewing gear with a fully deflected master switch, relating to the maximum attainable slewing speed of the slewing gear at a preselected speed of 100 %.
- This value can be infinitely preselected, see section „Settings window Speed reduction master switch“.

6.4 Permissible slewing speed

- Only for crane types with the icon illustration 2
- Number value for the permissible slewing speed in degrees per minute [°/min]. The permissible slewing speed is calculated depending on the current crane utilization and displayed.
- **Note:**
The permissible slewing speed is reduced depending on the load down until the permissible value indicated in the load chart manual is reached. The crane driver is responsible for making sure this value is never exceeded. The slewing speed is not reduced automatically with the help of the crane control.

6.5 Current slewing speed

- Only for crane types with the icon illustration 2
- Number value for the actual slewing speed in degrees per minute [°/min]
- Blue number value: Slewing speed in the permissible range
- Red number value (blinking): Slewing speed above the permissible range

6.6 Slewing speed scale

- Only for crane types with the icon illustration 2
- Green range: Slewing speed in the permissible range
- Red range: Slewing speed above the permissible range

6.7 Slewing speed bar diagram

- Only for crane types with the icon illustration 2
- Green bar: Slewing speed in the permissible range

- Red bar: Slewing speed above the permissible range

Empty page!

LWE/LR 11000-001/23501-04-02/en

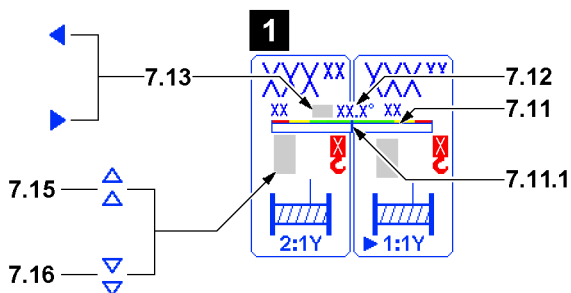
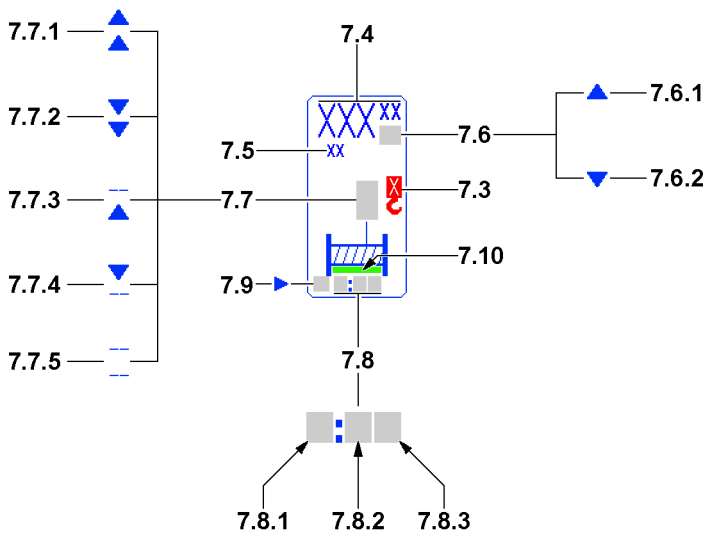
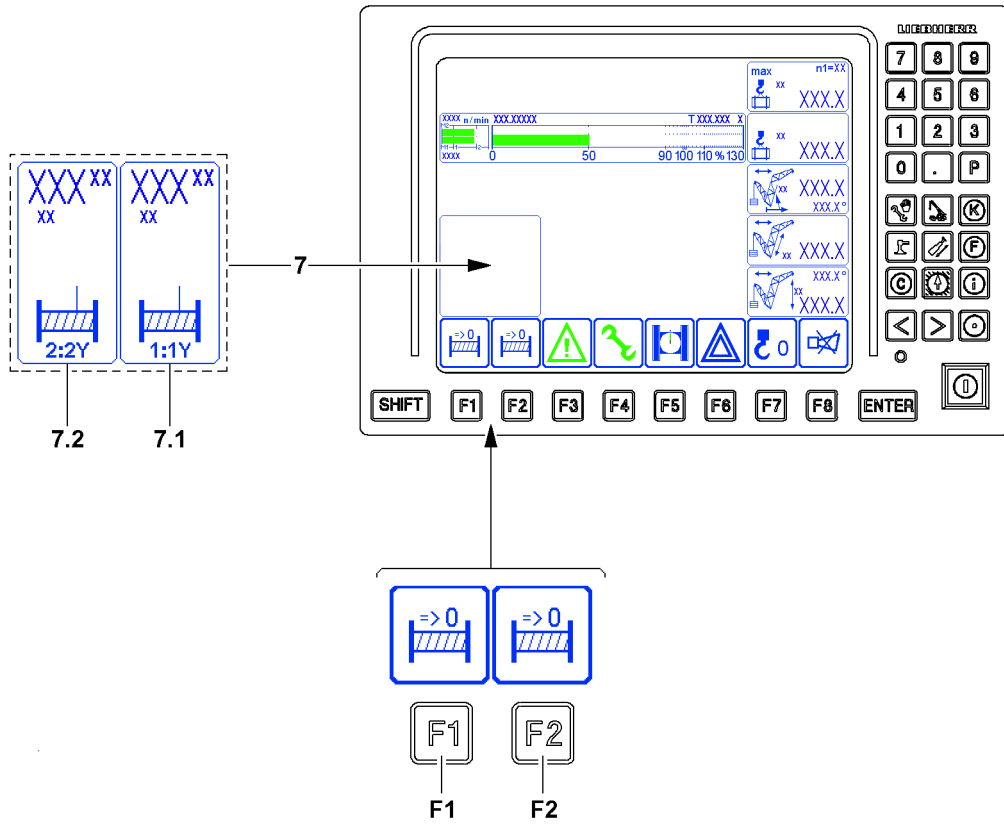

Fig.120621

LWE/LR 11000-001/23501-04-02/en

5.9 Winch display

The winch displays **7** have their fixed place on the LICCON monitor.

The current position of each winch can be set as zero point:

- Hoist winch: The completed hook path is calculated with the reeving set in the *Set up* program. A prerequisite for a correct display is that the value entered matches the entered reeving and the actual number of rope strands between the boom head and the hook block.
- Control winch: Rope length of winch spooled out / up

F1 Function key

- Above the function key **F1** appears the icon *Reset winch display*. Pressing on the button sets the display of the rope measurement to zero. The path measurement begins here.

F2 Function key

- Above the function key **F2** appears the icon *Reset winch display*. Pressing on the button sets the display of the rope measurement to zero. The path measurement begins here.

7 Winch display

7.1 Winch 1 icon

- Icon for winch 1 (WI)

7.2 Winch 2 icon

- Icon for winch 2 (WII)



Note

- ▶ The displays for winch 1 and winch 2 are identical and are explained on one icon element.

7.3 Load position

- Load position to which the winch is assigned.

7.4 Travelled distance

- In [m] or [ft], see Measuring unit **7.5**
From a zero point to be determined
- The positions before the decimal point are displayed with a maximum of three large digits. The digits after the decimal point are displayed with small digits. Setting to zero point, see also section „The function key line of LICCON monitor 0“).
- As hoist winch the following applies:
 - For single operation with the reeving set in the *set up* program: completed hook path.
 - For parallel operation with the set total reeving made in the *set up* program: distance completed by the hook block.
 - A prerequisite for a correct display is that the reeving value entered equals the actual number of rope strands between the boom head and the hook block.

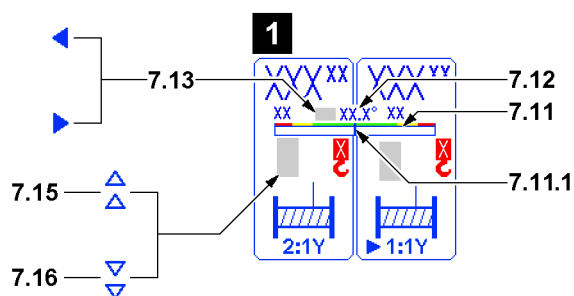
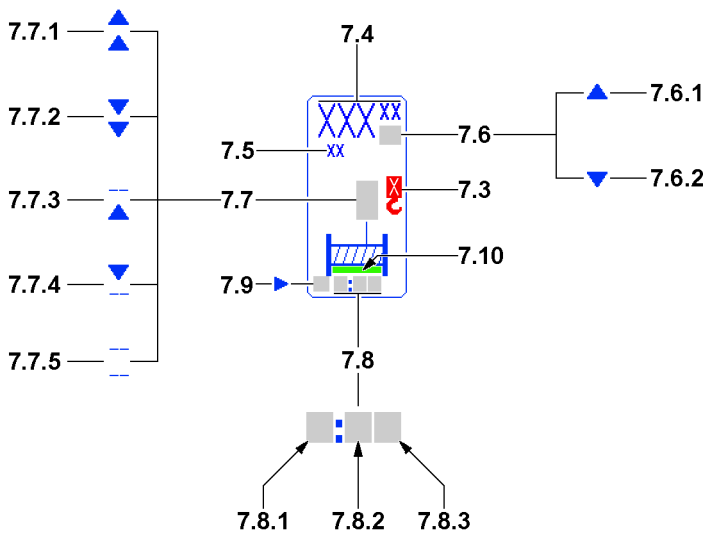
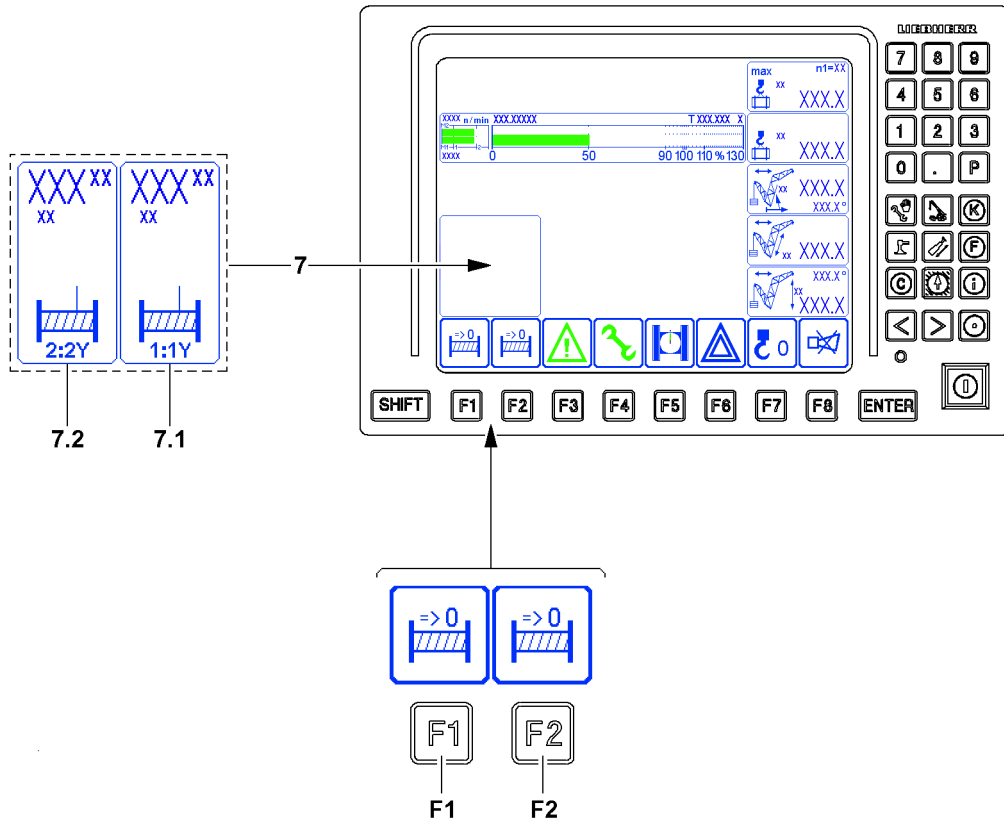

Fig.120621

LWE/LR 11000-001/23501-04-02/en

**Note**

Display area winch displays.

- ▶ The completed path 7.4 display has only three positions before the comma, any positions before that are cut off. The crane operator must evaluate for himself if, for example 200 m rope are spooled up on a winch or 1200 m. **The display in both cases would be identical with 200 m.**

For use as hoist winch:

- ▶ The hook path calculation only works accurately if the load is suspended freely and is not luffed during the lifting procedure. Not taken into account are flexation and rope expansion.
- ▶ The length display (hook path display) is only correct when the winch is calibrated.

7.5 Measuring unit

- Measuring unit of hook path display: [m] or [ft]

7.6 Direction of hook movement

- The arrows on the length value show the direction of the hook movement in relation to the zero point
- Arrow up 7.6.1: Hook moves upward from the zero point
- Arrow down 7.6.2: Hook moves downward from the zero point

7.7 Winch status display

- There are five winch condition icons, all blinking
- **Note:** If no winch status icon appears, the activated winch is inactive and is neither spooled up nor spooled out.

7.7.1 Spool out

- Winch is spooled out

7.7.2 Spool up

- Winch is spooled up

7.7.3 Spooled out

- Additional spooling out of the winch is blocked

7.7.4 Spooled up

- Additional spooling up of the winch is blocked

7.7.5 Winch deactivated

- Winch is deactivated or unplugged
- **Note:** Winch cannot be controlled.

7.8 Assignment of master switch

- **7.8.1 First digit**
 - First digit: Winch number, every winch icon is permanently assigned to a winch
- **7.8.2 Second digit**
 - Master switch number, according to the assigned master switch
 - ? : No master switch assigned
- **7.8.3 Letter**
 - Actuation direction of the master switch, see illustration
 - ? : No actuation direction assigned

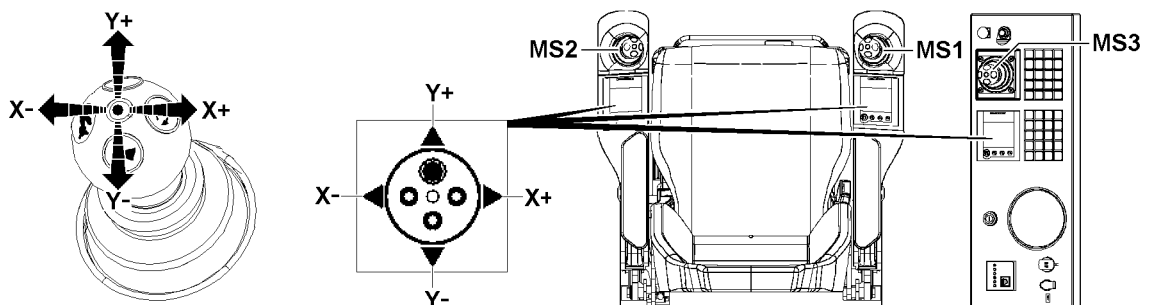

Fig.123758: Actuation directions Master switch

MS1 Master switch 1

MS2 Master switch 2

X- To the left

Y+ To the front

For continuation of legend for illustrations, see next page

MS3 Master switch 3
X+ To the right

Y- To the rear

7.9 Vibration sensor

- If the vibration sensor for a winch is added on the master switch, then an arrow appears in this winch icon for the added vibration sensor.
- **Note:** The vibration sensor is added at the first actuated crane function.

7.10 Winch speed

- **Note:** Only for certain crane types.
- If the maximum winch speed is reduced, a bar in the respective length appears on the bottom in the winch icon. Example: Half the length corresponds to a reduction of the maximum winch speed of 50 %, see example in illustration 1.1.



Note

- For detailed description of parallel operation of winch 1 and winch 2, see Crane operating instructions, chapter 4.05.

Parallel operation of Winch 1 and winch 2, illustration 1:

7.11 Incline display

- Graphic display of incline of hook block during parallel operation with winch 1 and winch 2

7.11.1 Display bar

- Appears as soon as the hook block is inclined
- The display bar 7.11.1 appears in green, yellow and red, depending on the situation
- Display bar 7.11.1 green: Incline in permissible range
- Display bar 7.11.1 yellow: **Advance warning!** Incline just before impermissible range
- Display bar 7.11.1 red: **Warning!** Incline in impermissible range

7.12 Incline value

- Incline value of hook block in parallel operation with winch 1 and winch 2.
- The incline value appears in degrees [°].

7.13 Incline direction

- Incline direction of hook block in parallel operation with winch 1 and winch 2.

7.15 Spool the winch out

- If the *Spool winch out* icon 7.15 appears in the winch display: Spool the winch out to align the hook block

7.16 Spool the winch up

- If the *Spool winch up* icon 7.16 appears in the winch display: Spool the winch up to align the hook block



WARNING

Hook block in sloped position!

If the hook block gets so far into a sloped position that the red range (example illustration 1.1) is reached in the incline display, then there is a danger of accident.

- Always correct the position of the hook block in time.
- Keep the incline of the hook block always within the green range.

Maintenance displays, illustration 1.2:

7.14 Winch overheated icon

- If the *Winch overheated* icon 7.14 appears, the temperature in the respective winch is too high.
- **Note:** Only for certain crane types with temperature sensors in the winches.

7.17 Insufficient oil icon

- If the *Insufficient oil* icon 7.17 appears after correct completion of oil level measurement *Winch gear* permanently, the oil level in the respective winch is too low.
- **Note:** Only for certain crane types.

**WARNING**

Overheated winch!

If a winch is operated further, even though the *Winch overheated* icon 7.14 appears, the winch can be severely damaged.

The winch can fail and accidents can result.

- ▶ Let the overheated winch cool off.

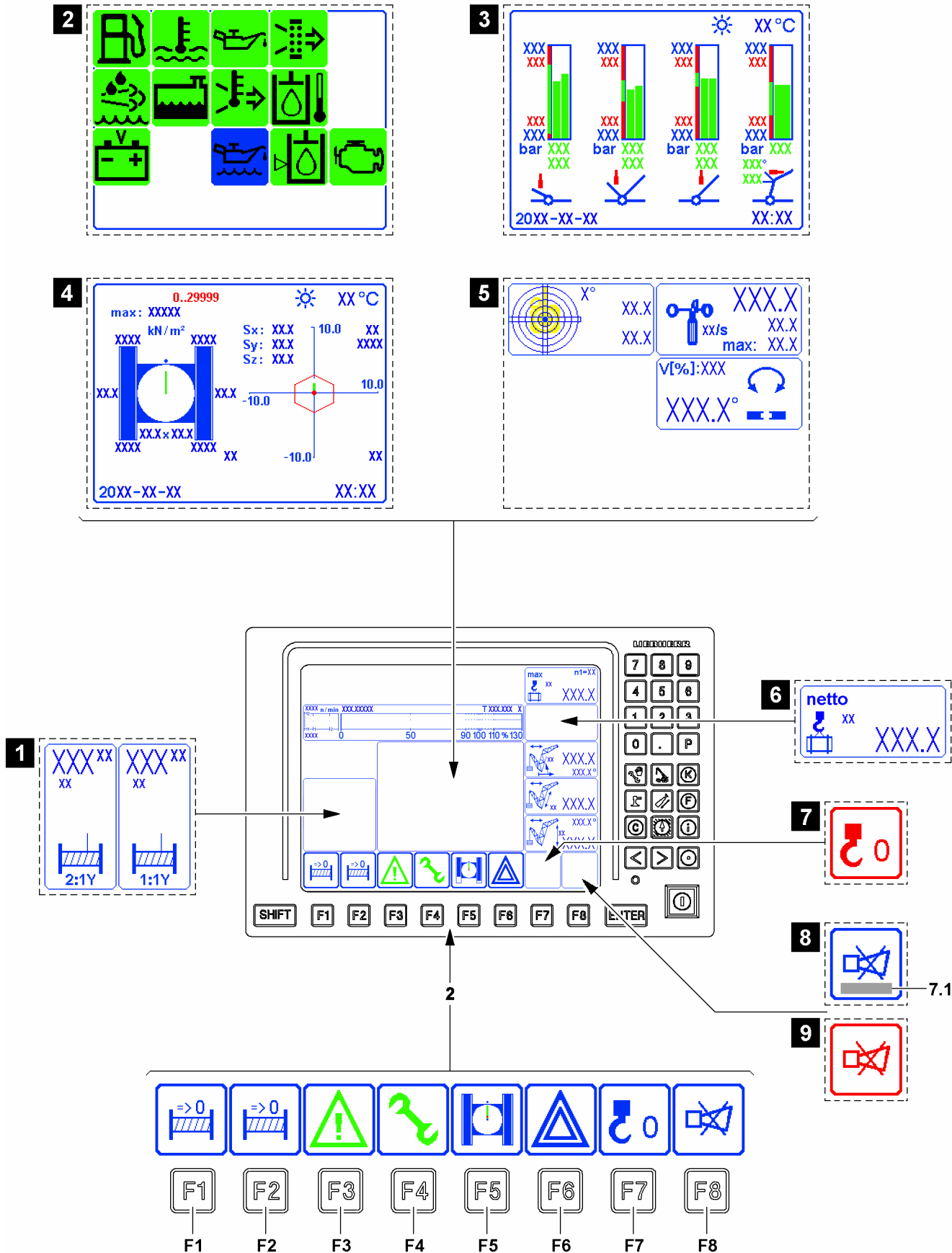

Fig.144106

5.10 The function key line of LICCON monitor 0

The function key line consists of function keys **F1** to **F8** and the function key icon bar above it. The function keys correspond to the various function key icons above them.

The function key icons always show the functions which are activated by pressing the button.

The function is called up after pressing a button. In addition, the icon above it can change its display, its meaning or its text.

Not all function keys must have assigned icons. This depends on the respective program selection.

F1 Function key

- Determine the zero point for the path display Winch 2*, see illustration 1
- Above the function key **F1** appears the icon *Reset winch display*. Pressing on the button sets the display *Completed path* to zero. The path measurement begins here.

F2 Function key

- Determine the zero point for hook path display winch 1, see illustration 1
- Above the function key **F2** appears the icon *Reset winch display*. Pressing on the button sets the display *Completed path* to zero. The path measurement begins here.
- **Note:** When winch 1 and winch 2 work in parallel operation, then the displays *completed path* of winch 1 and winch 2 can only be set together to zero with the function key **F1**.

Then the function key **F2** has no function.

F3 Function key

- Show or not show monitoring functions (illustration 2)
See also section „Monitoring functions“.

F4 Function key

- Show or not show monitoring of relapse cylinders (illustration 3)
See also section „Monitoring of relapse cylinders“

F5 Function key

- Show or not show monitoring of surface pressure and center of gravity (illustration 4)
See also section „Monitoring of surface pressure and center of gravity“

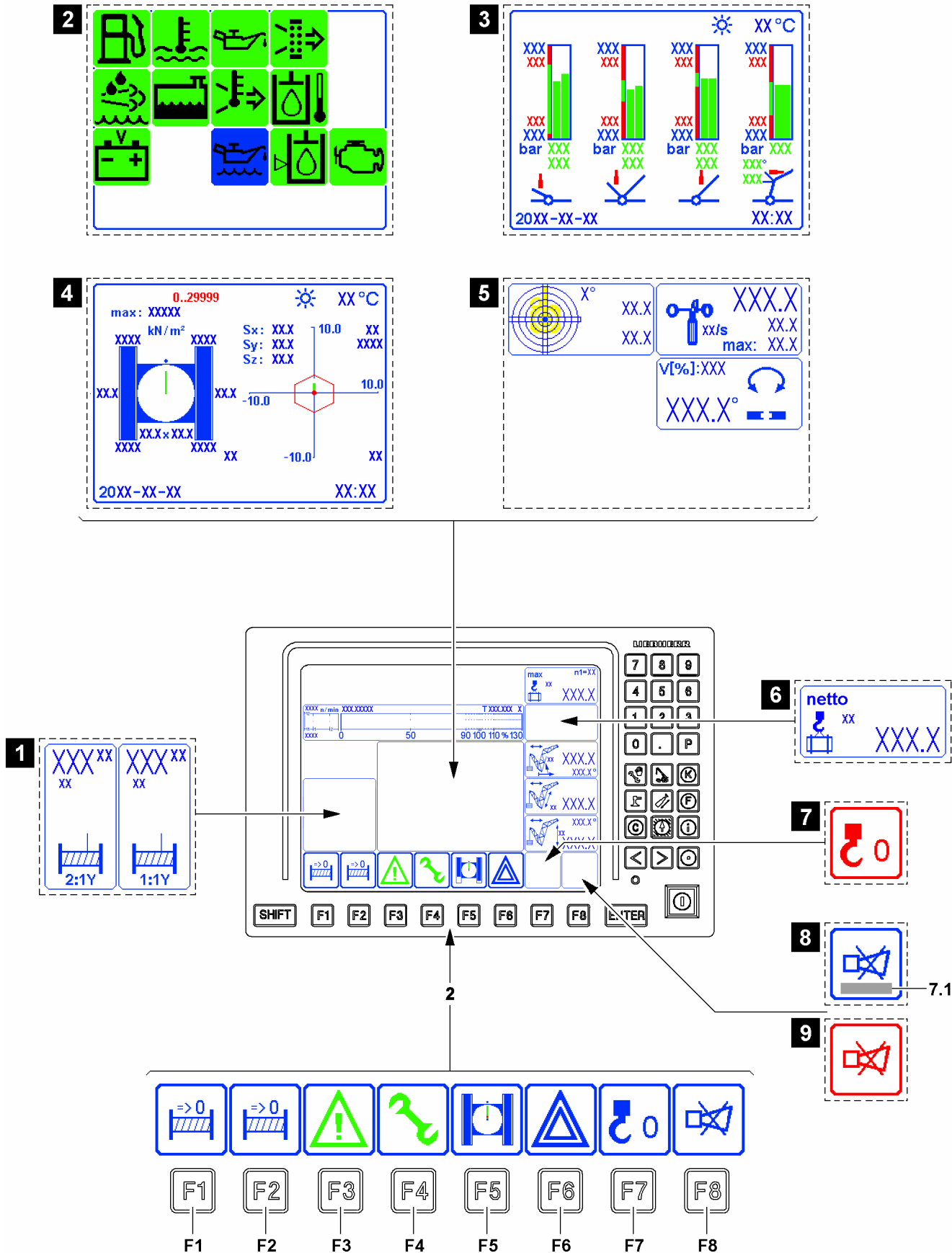

Fig.144106

F6 Function key

- Show or not show monitored auxiliary functions (illustration 6)
- The appearance of the icon changes according to the status:
thick border = auxiliary functions icons not shown
thin border = auxiliary functions icons shown

**Note**

- ▶ The monitoring of all auxiliary functions is always active, even if the monitoring icons are hidden.
- ▶ When a monitored limit is exceeded, then an acoustic warning is issued by the LICCON monitor and the respective icon is shown permanently.

F7 Function key

- Taring: When the function key **F7** is pressed, the *Actual load* display is set to zero. At the same time, the word *net* appears in the display, see illustration 6.
If the taring is cancelled again, then the word *net* disappears from the display and the gross load value is displayed.
- Taring is cancelled by one of the following two actions:
 1. By pressing the function key **F7** again.
 2. By luffing by more than $\pm 4^\circ$.

**Note**

By taring it is possible, for example, to eliminate weights of carrying equipment, load handling equipment or fastening equipment.

- ▶ Therefore the calculated weight of the load to be lifted (net load) can be displayed.
- ▶ As long as taring is active, the function key icon is shown in red, see illustration 7.

F8 Function key

- Shut off of acoustic warning and possibly calling up of error message **7.1** (illustration 8).
Press the function key **F8** once: The acoustic signal is turned off.
Press the function key **F8** twice: The error description for the error message **7.1** which occurred last is called up.
- **Note:** A new error turns the acoustic warning on again.

**WARNING**

Malfunctions in the crane control!

A special program is available for LIEBHERR crane acceptance in the LICCON computer system. This program is blocked after completion of crane acceptance.

If the function key icon displays red permanently and without a visible reason (illustration 9), then the special program is activated.

- ▶ Contact Liebherr Service immediately.
- ▶ In order to prevent error functions, access to the special program is only permitted for trained Liebherr personnel.

5.11 Other operating elements

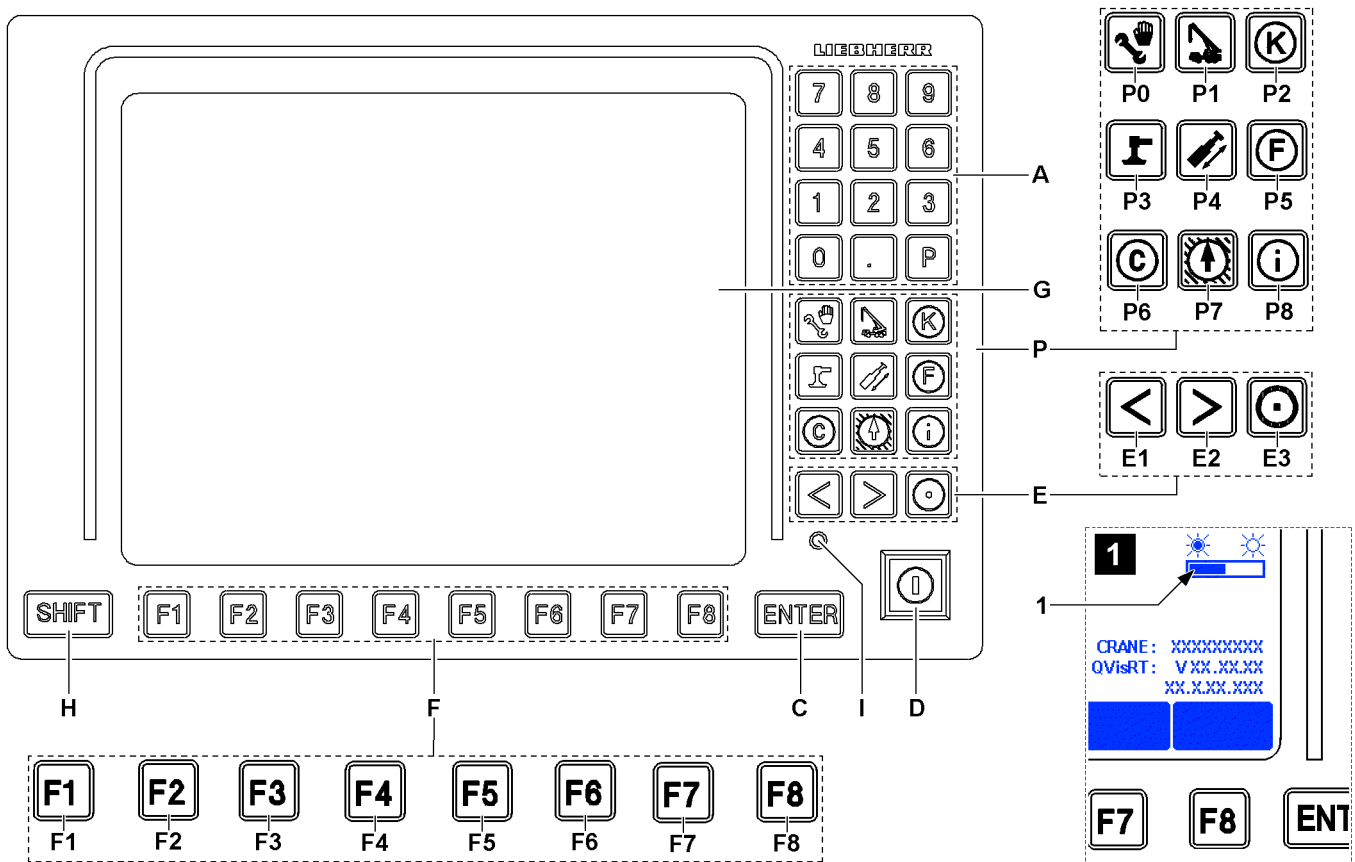

Fig.120677

The following functions are assigned to the other operating elements of the display and operating unit of the LICCON computer system in program *Crane operation*.

- A Keypad**
 - Keys „0“ to „9“, „P“ and „K“ (illustration 1) have no function in the *Crane operation* program.
- P Program keys**
 - The program keys are used to select individual programs. The program specific peculiarities must be observed, see respective sections of programs in this chapter.
 - **Note:** The program currently running **cannot** be called up again using its program key. The programs can only be called up with the program key when no functions are activated via the set up key **D** at the same time.
- C ENTER key**
 - No function in *crane operation* program
- D Set up key**
 - Zero position (not actuated):
Normal operation.
 - Touching:
Function *Exceedance of shut off limits of the LICCON overload protection* released.
 - **Exceeding the shut off limits of the LICCON overload protection**
If the shut off limits of the LICCON overload protection are exceeded, the LICCON overload protection shuts the crane movements off.
These shut offs can be exceeded by the set up key **D** in the *right touching* position. To do so, chapter 4.20 in the *Crane operating instructions* must be observed.

**Note**

Carry out the erection / take down procedures.

- ▶ By actuating the set up key **D**, all erection / take down procedures can be carried out within the erection / take down charts, for which no load charts are available.

- **Bypass of hoist limit switch**

The hoist limit switch turns the crane movement off when:

- The hook block is pulled against the hoist limit switch weight.
- The hoist limit switch weight is not attached freely (for example on placed down boom).
- The hoist limit switch has an internal error.

This shut off can be bypassed by the set up key **D** in the *right touching* position. To do so, chapter 4.20 in the Crane operating instructions must be observed.

- E** Special function keys

- Monitor brightness adjustment
 - Key combination **E3** and **E1**: Turn background illumination on / off
 - Key combination **E3** and **E2**: Brightness adjustment in three stages

**Note**

- ▶ Additional functions of the special function keys **E** are program-dependent and are further explained in the description of the individual LICCON programs.

- F** Function keys

- The function key line consists of function keys **F1** to **F8** and the function key icon bar above it.
The function keys correspond to the various function key icons above them.

- H** SHIFT key

- Second level key assignments

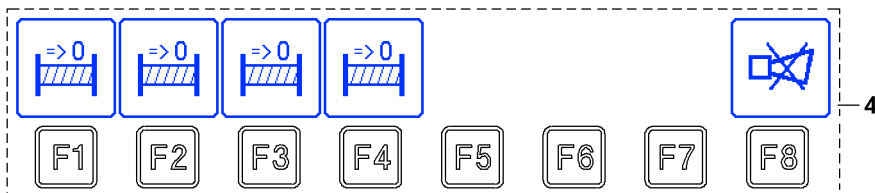
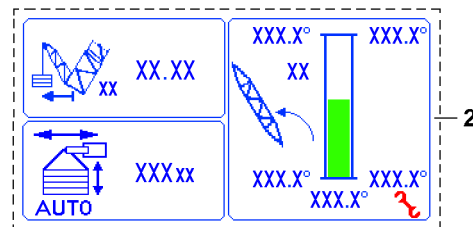
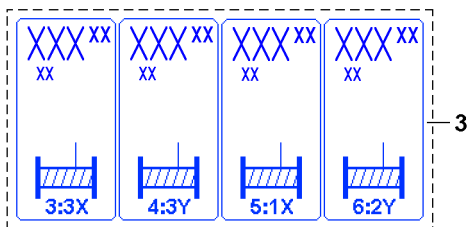
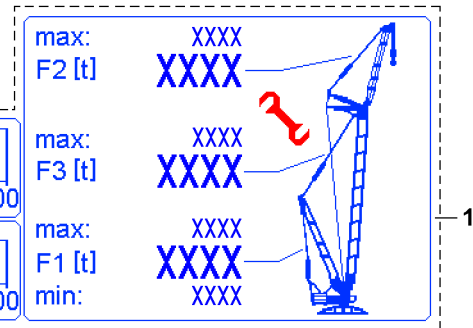
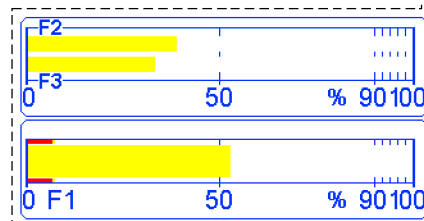
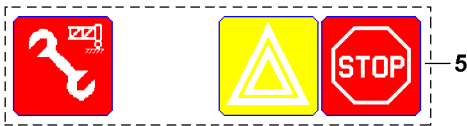
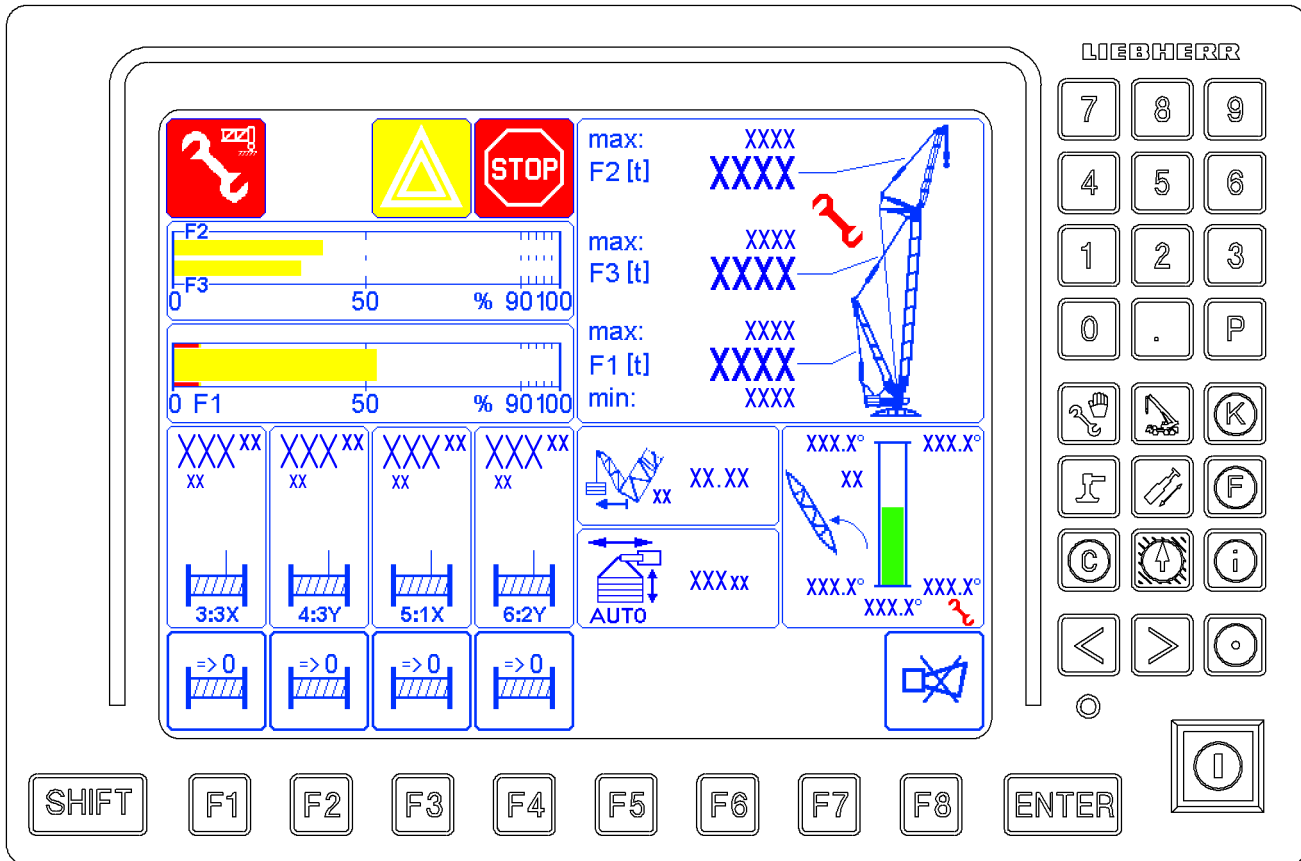

Fig.125381

LWE/LR 11000-001/23501-04-02/en

6 The *Crane operation* program on LICCON monitor 1

The *Crane operation* LICCON program assists the crane operator by displaying the data relevant for crane operation clearly on three LICCON monitors. An acoustic signal accompanies all critical displays.

The LICCON monitor 1 is divided into four areas in the *Crane operation* program:

- 1 F-load display
 - F1-load display
 - F2-load display
 - Note:** Appears only for corresponding boom system
 - F3-load display
 - Note:** Appears only for corresponding boom system
- 2 Geometry Derrick boom
 - Boom radius and angle of the derrick boom
 - Note:** Appears only for corresponding boom system
- 3 Winch display
 - Winch 3 to winch 6
- 4 Function key line
 - Function keys always refer to the icons shown directly above
 - **Note:** If no icon is shown in the line directly above the function key, then no function is assigned in the program to the function key. See for example function key F5 to function key F7.
- 5 Alarm functions
 - Alarm functions of LICCON monitor 1



Note

- ▶ The monitor illustrations in this chapter are only examples.
 - ▶ The numerical values in the individual icons and charts do not have to necessarily match the crane exactly.
 - ▶ The configuration of the LICCON monitor with icons is only descriptive.
 - ▶ An identical icon display will **not** appear during crane operation.
-



Note

- ▶ The suspended ballast and the ballast trailer* are generally referred to as the **derrick ballast**.
-

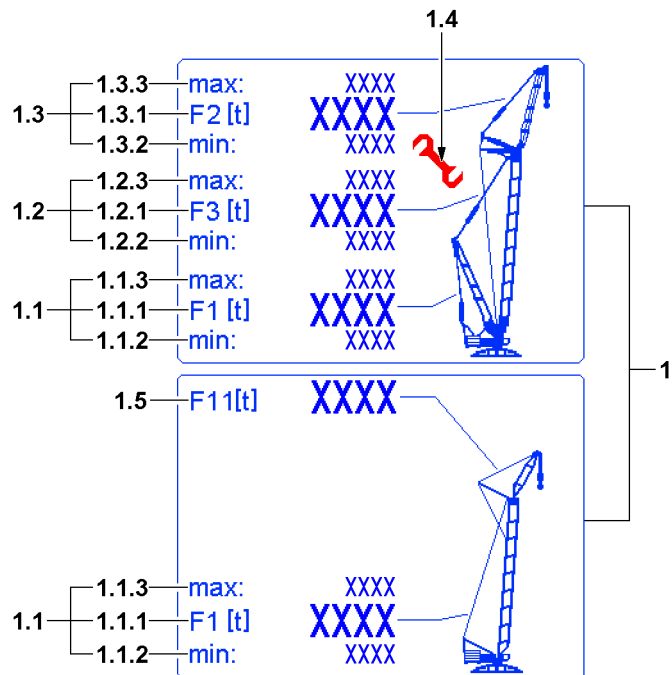
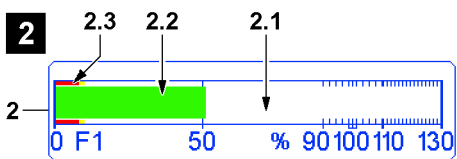
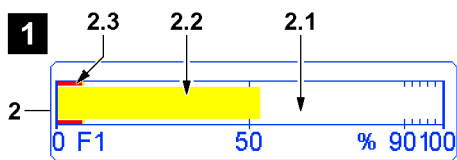
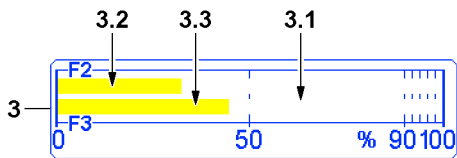
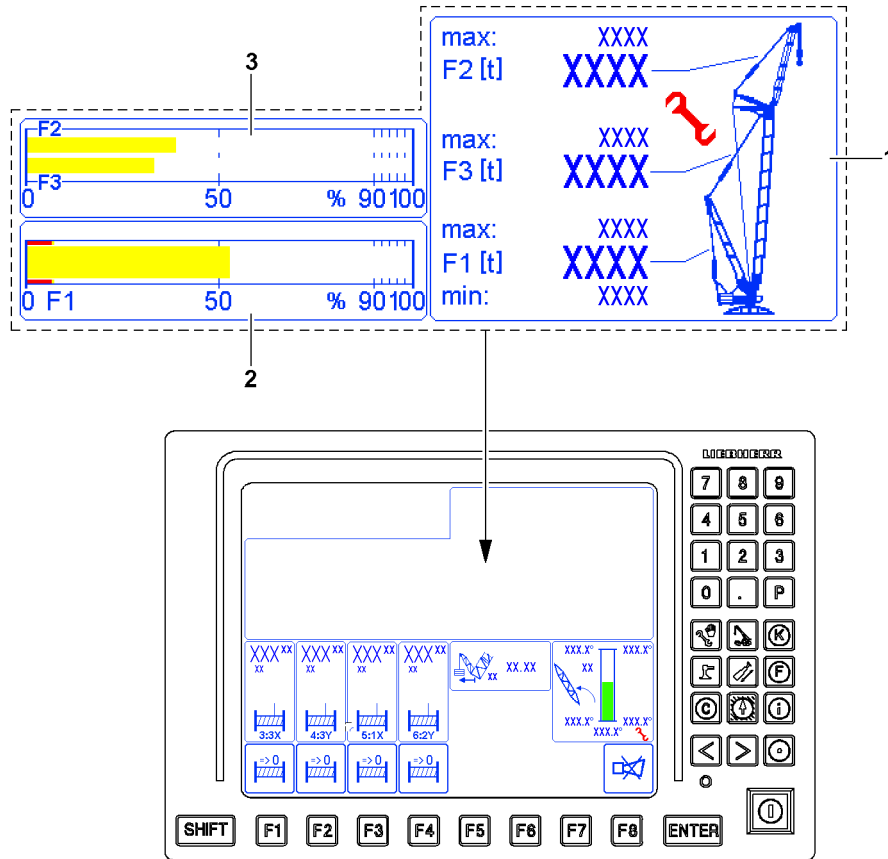

Fig.122454

6.1 F-load display

From the ratio of the operating force F_{actual} to the permissible maximum force F_{max} results the respective F-utilization.

The F-load display includes various display modes:

- Numeric displays
- Bar diagrams, when a ratio of operating force F_{actual} to the permissible maximum force F_{max} is shown.



WARNING

Damage, overload and toppling of the crane!

If the permissible values of the F-load display are exceeded / fallen below, then the crane can be damaged or overloaded and topple over.

As long as the set up boom system is not completely assembled and not all sensors, which are required for this operating mode are electrically connected, no maximum forces and minimum forces are displayed in the F-load display.

In these cases it must be determined with the assembly drawing which maximum forces are permissible in the F-load display.

These maximum forces must be monitored by the crane operator and may not be exceeded during set up / removal of the crane.

- ▶ The crane operator must ensure that the permissible values of the F-load display are not exceeded / fallen below.
- ▶ Observe and adhere to the maximum forces for the F-load display from the assembly drawings.



Note

The values of the F-load display depend on the set up configuration of the crane and the crane geometry.

The values of the F-load display change continuously when the crane is moved.

- ▶ Monitor the F-load display continuously.

6.1.1 Numeric F-load display

1 Numeric displays

- Type and scope of numeric displays depends on the set up configuration and the operating situation.

1.1 F1-display

1.1.1 F1-actual value ($F1_{\text{actual}}$)

- Actual value F1-force

1.1.2 F1-minimum ($F1_{\text{min}}$)

- Minimum value F1-force

Note: Appears only outside a load chart, at activated assembly operation or in special situations.

1.1.3 F1-maximum ($F1_{\text{max}}$)

- Maximum value F1-force

Note: Appears only outside a load chart, at activated assembly operation or in special situations.

1.2 F3-display

- **Note:** Appears only for corresponding boom system

1.2.1 F3-actual value ($F3_{\text{actual}}$)

- Actual value F3-force

1.2.2 F3-minimum ($F3_{\text{min}}$)

- Minimum value F3-force

Note: Appears only outside a load chart, at activated assembly operation or in special situations.

1.2.3 F3-maximum ($F3_{\text{max}}$)

- Maximum value F3-force

Note: Appears only outside a load chart, at activated assembly operation or in special situations.

1.3 F2-display

- **Note:** Appears only for corresponding boom system

1.3.1 F2-actual value ($F2_{\text{actual}}$)

- Actual value F2-force

1.3.2 F2-minimum ($F2_{\text{min}}$)

- Minimum value F2-force

Note: Appears only outside a load chart, at activated assembly operation or in special situations.

1.3.3 F2-maximum ($F2_{\text{max}}$)

- Maximum value F2-force

Note: Appears only outside a load chart at activated assembly operation

1.4 Assembly icon

- Appears when assembly operation is activated

1.5 F11-display

- Actual value F11-force

- **Note:** Appears only for corresponding boom system

Empty page!

LWE/LR 11000-001/23501-04-02/en

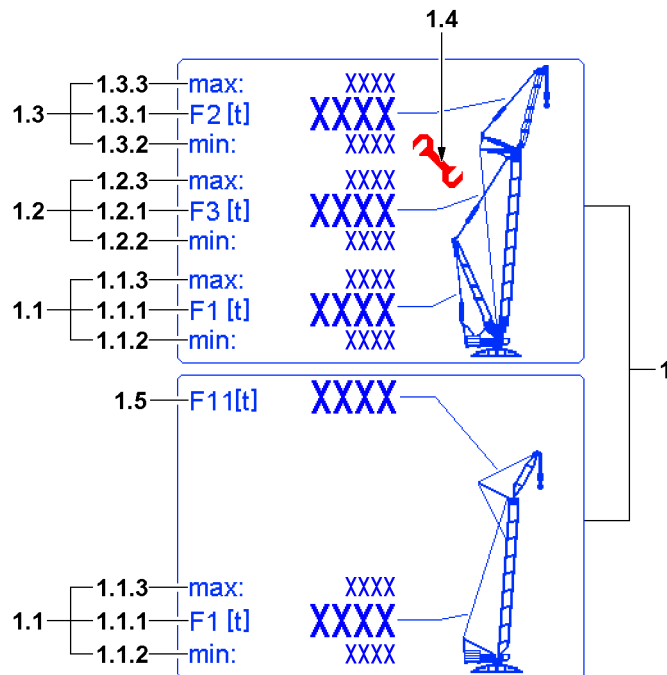
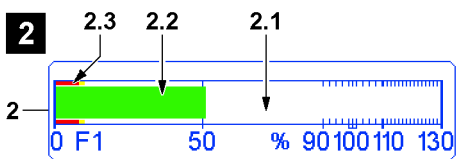
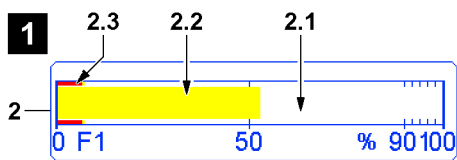
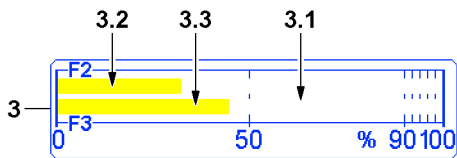
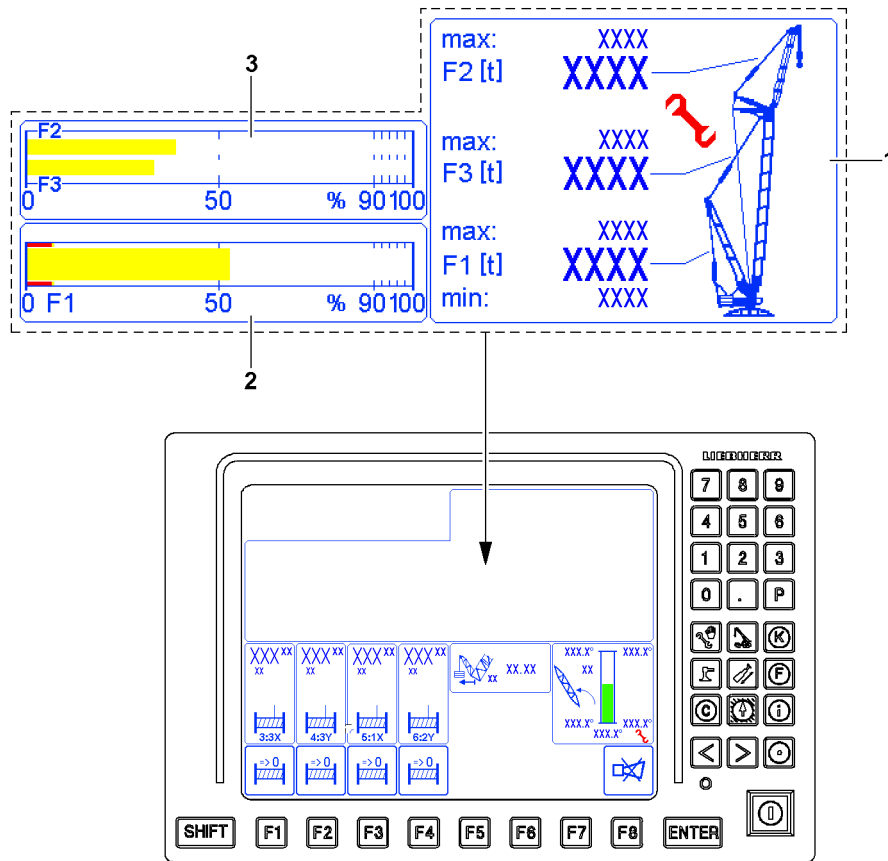

Fig.122454

LWE/LR 11000-001/23501-04-02/en

6.1.2 F1-display bar

Pull test brackets Test point 1A and 1B (F1 force) are in the A-frame guying

- F1-display bar in assembly operation: Scale from 0 % to 100 % (outside a load chart), see illustration 1
- F1-display bar in cane operation: Scale from 0 % to 130 % (within a load chart), see illustration 2

2 Display bar

- Display bar for graphic illustration of F1-force

2.1 Display scale

- Crane operation: Scale from 0 % to 130 % (within a load chart)
- Assembly operation: Scale from 0 % to 100 % (outside a load chart)

2.2 F1-bar

- Graphic illustration of the F1-actual value ($F1_{\text{actual}}$)
- Appears in green, yellow and red, depending on the situation
- F1-bar 2.2 green: $F1_{\text{is}}$ present in the permissible range and load chart
- F1-bar 2.2 yellow: **Advance warning!** $F1_{\text{is}}$ shortly before impermissible range
- **Note:** In assembly operation, the F1-bar 2.2 is also shown in yellow within the permissible range.
- F1-bar 2.2 red: **Warning!** $F1_{\text{actual}}$ in impermissible range

2.3 F1-minimum

- Graphic illustration of range $F1_{\text{min}}$
 Yellow range: $F1_{\text{min-advance warning}}$ - advance warning for F1-minimum
 Red range: $F1_{\text{min-Stop}}$ - Warning / stop for F1-minimum

6.1.3 F2/F3-display bar

Pull test brackets test point 2A and 2B (F2 force) are in the N/W-guying

Pull test brackets test point 3A and 3B (F3 force) are in the guying derrick boom / main boom on the main boom head



Note

- ▶ The F2/F3-display bar appears only in certain situations, for example at activated assembly operation and corresponding boom system.

3 Display bar

- Display bar for graphic illustration of F2/F3-force

3.1 Display scale

- Scale from 0 % to 100 %

3.2 F2-bar

- Graphic illustration of the F2-actual value ($F2_{\text{actual}}$)
- Appears in yellow and red, depending on the situation
- F2-bar 3.2 yellow: Assembly operation - $F2_{\text{actual}}$ in permissible range
- F2-bar 3.2 red: **Warning!** $F2_{\text{actual}}$ in impermissible range

3.3 F3-bar

- Graphic illustration of F3-actual value
- Appears in yellow and red, depending on the situation
- F3-bar 3.3 yellow: Assembly operation - $F3_{\text{actual}}$ in permissible range
- F3-bar 3.3 red: **Warning!** $F3_{\text{actual}}$ in impermissible range

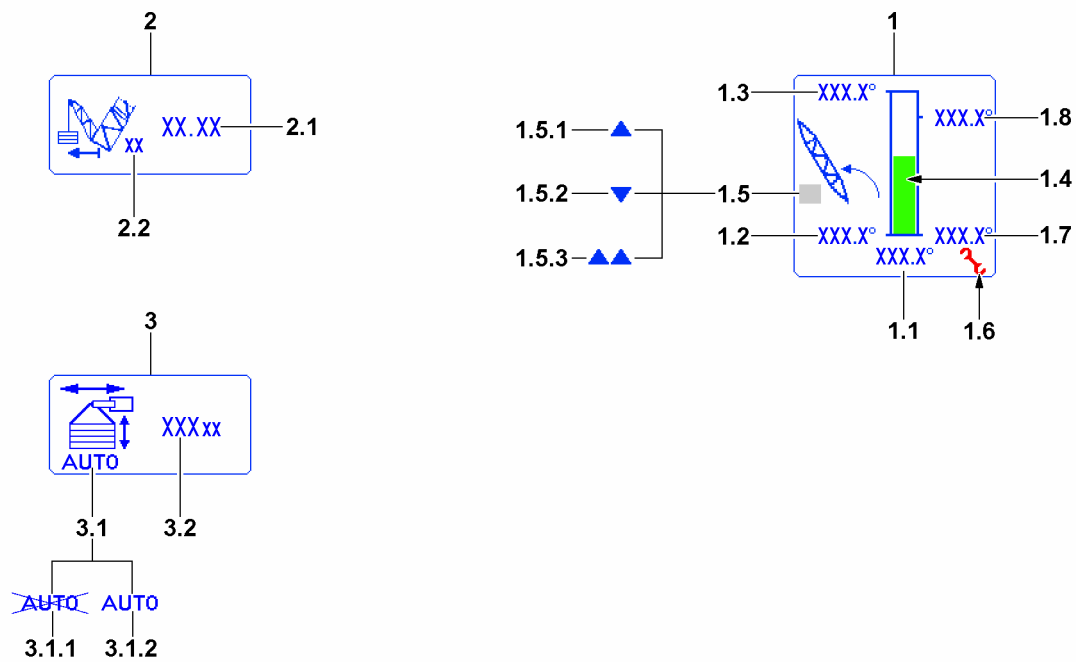
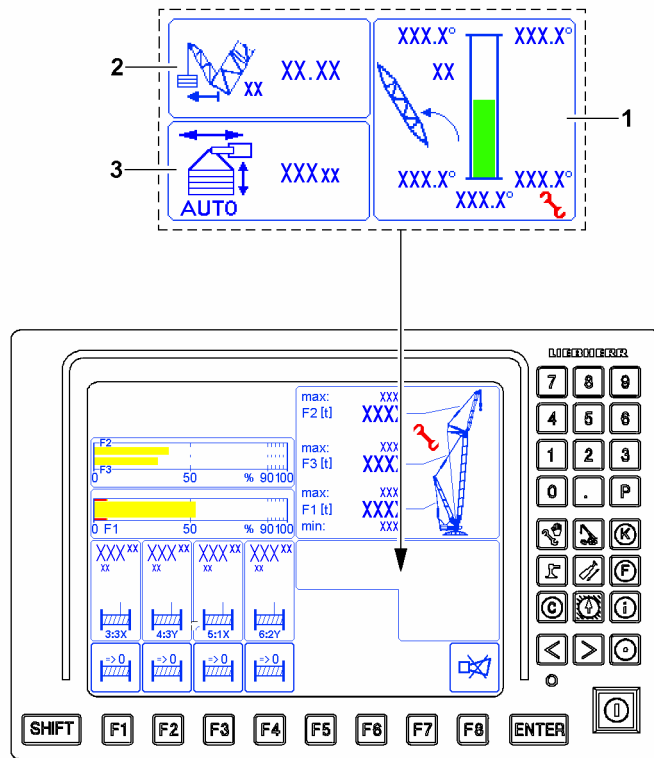

Fig.144127

LWE/LR 11000-001/23501-04-02/en

6.2 Angle display Derrick boom

- 1 Derrick angle
 - 1.1 Actual angle
 - Current actual angle of derrick boom
 - Actual angle **1.1** red: **Warning!** Angle derrick boom in impermissible range
 - 1.2 Minimum angle
 - Minimum angle Derrick boom to the front (to the horizontal)
 - 1.3 Maximum angle
 - Maximum angle Derrick boom to the front (to the horizontal)
 - 1.4 Bargraph
 - Graphic illustration of derrick angle as bargraph in relation to the minimum / maximum value.
 - Appears in green and red, depending on the situation
 - Column **1.4** green: Angle Derrick boom in permissible range
 - Column **1.4** red: **Warning!** Angle derrick boom in impermissible range
 - 1.5 Alarm function Derrick
 - **1.5.1** Arrow up: Maximum angle derrick boom exceeded
 - **1.5.2** Arrow down: Minimum derrick angle fallen below
 - **1.5.3** Double up arrow: Derrick boom relapse cylinder on block position
 - 1.6 *Assembly* icon
 - *Assembly* icon **1.6** appears when a defined angle range for the derrick boom for erection and take down of the boom system is specified.
 - 1.7 Minimum angle Assembly
 - Assembly: Minimum angle Derrick boom to the front (to the horizontal)
 - 1.8 Maximum angle Assembly
 - Assembly: Maximum angle Derrick boom to the front (to the horizontal)

6.3 Radius display Derrick ballast

- 2 Boom radius *derrick ballast*
 - 2.1 Radius value
 - Current radius value of derrick ballast
 - Measured from the center of the slewing ring to the center of the derrick ballast
 - 2.2 Measuring unit
 - Measuring unit of radius value

6.4 Ballast automatic*

After selecting the ballast automatic (F3-key on Touch-Display *TE2*, see the Crane operating instructions, chapter 4.01) the system saves the current F1-force and the ballast trailer incline.

If the ballast trailer is moved out or in, the ballast automatic automatically regulates the ballast cylinders to keep the saved value (depending on the situation F1-force or ballast trailer incline).

- 3 Ballast automatic icon
 - 3.1 Status Ballast automatic
 - **3.1.1** Ballast automatic turned off
 - **3.1.2** Ballast automatic turned on
 - 3.2 Saved value
 - Depending on the situation:
 - Saved F1-force
 - or**
 - Ballast trailer incline

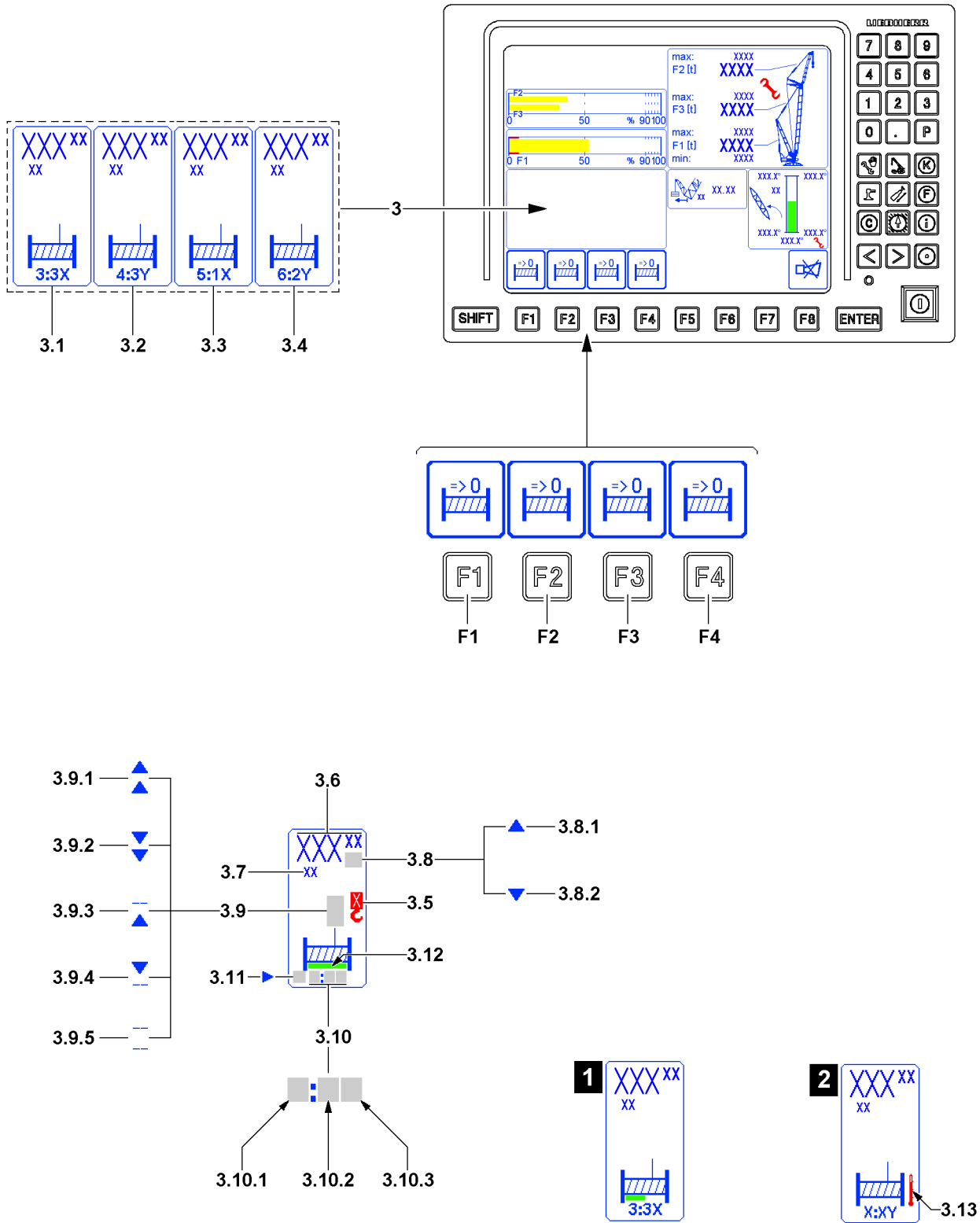

Fig.115251

6.5 Winch display

The winch displays **3** have their fixed place on the LICCON monitor.

The current position of each winch can be set as zero point:

- Hoist winch: The completed hook path is calculated with the reeving set in the *Set up* program. A prerequisite for a correct display is that the value entered matches the entered reeving and the actual number of rope strands between the boom head and the hook block.
- Control winch: Rope length of winch spooled out / up

F1 Function key

- Above the function key **F1** appears the icon *Reset winch display*. Pressing on the button sets the display of the rope measurement to zero. The path measurement begins here.

F2 Function key

- Above the function key **F2** appears the icon *Reset winch display*. Pressing on the button sets the display of the rope measurement to zero. The path measurement begins here.

F3 Function key

- Above the function key **F3** appears the icon *Reset winch display*. Pressing on the button sets the display of the rope measurement to zero. The path measurement begins here.

F4 Function key

- Above the function key **F4** appears the icon *Reset winch display*. Pressing on the button sets the display of the rope measurement to zero. The path measurement begins here.

3 Winch display

3.1 Winch 3 icon

- Icon for winch 3 (WIII)

3.2 Winch 4 icon

- Icon for winch 4 (WIV)

3.3 Winch 5 icon

- Icon for winch 5 (WV)

3.4 Winch 6 icon

- Icon for winch 6 (WVI)



Note

- ▶ The displays for winch 3 to winch 6 are identical and are explained on one icon element.

3.5 Load position

- Load position to which the winch is assigned.
- **Note:** Appears only when using it as hoist winch.

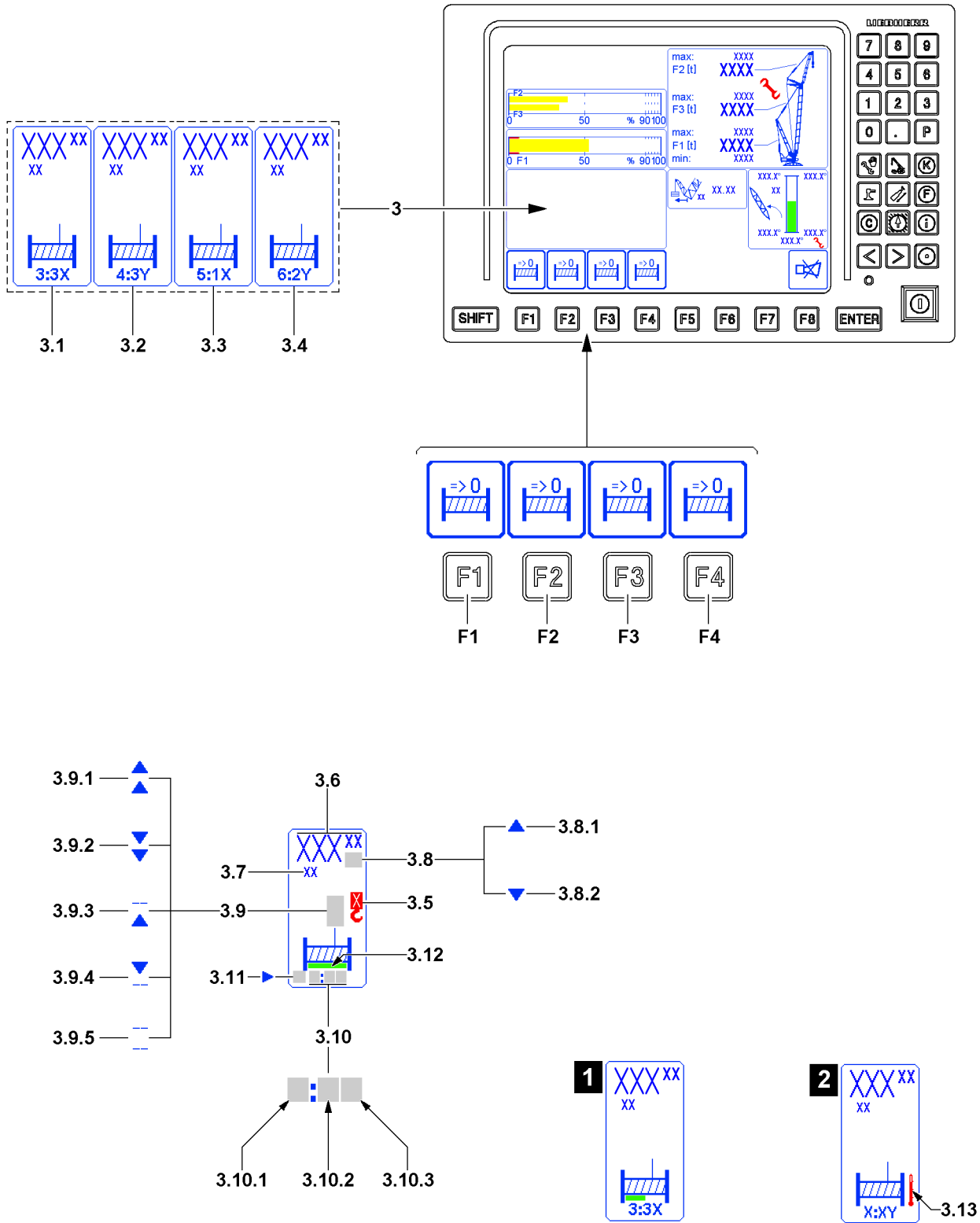

Fig.115251

3.6 Travelled distance

- In [m] or [ft], see Measuring unit **3.7**
From a zero point to be determined
- The positions before the decimal point are displayed with a maximum of three large digits. The digits after the decimal point are displayed with small digits. Setting to zero point, see also section „The function key line of LICCON monitor 0“).
- As hoist winch the following applies:
 - For single operation with the reeving set in the *set up* program: completed hook path.
 - For parallel operation with the set total reeving made in the *set up* program: distance completed by the hook block.
 - A prerequisite for a correct display is that the reeving value entered equals the actual number of rope strands between the boom head and the hook block.



Note

Display area winch displays.

- ▶ The completed path **3.6** display has only three positions before the comma, any positions before that are cut off. The crane operator must evaluate for himself if, for example 200 m rope are spooled up on a winch or 1200 m. **The display in both cases would be identical with 200 m.**

For use as hoist winch:

- ▶ The hook path calculation only works accurately if the load is suspended freely and is not luffed during the lifting procedure. Not taken into account are flexation and rope expansion.
- ▶ The length display (hook path display) is only correct when the winch is calibrated.

3.7 Measuring unit

- Measuring unit of hook path display: [m] or [ft]

3.8 Direction of hook movement

The arrows on the length value show the direction of the hook movement in relation to the zero point:

- Arrow up **3.8.1**: Hook moves upward from the zero point
- Arrow down **3.8.2**: Hook moves downward from the zero point

3.9 Winch status display

- There are five winch status icons (all blinking):

3.9.1 Spool out

- Winch is spooled out

3.9.2 Spool up

- Winch is spooled up

3.9.3 Spooled out

- Additional spooling out of the winch is blocked

3.9.4 Spooled up

- Additional spooling up of the winch is blocked

3.9.5 Winch deactivated

- Winch is deactivated or unplugged
- **Note:** Winch cannot be controlled.

3.10 Assignment of master switch

- **3.10.1** First digit
 - First digit: Winch number, every winch icon is permanently assigned to a winch
- **3.10.2** Second digit
 - Master switch number, according to the assigned master switch
 - ? : No master switch assigned
- **3.10.3** Letter
 - Actuation direction of the master switch, see illustration
 - ? : No actuation direction assigned

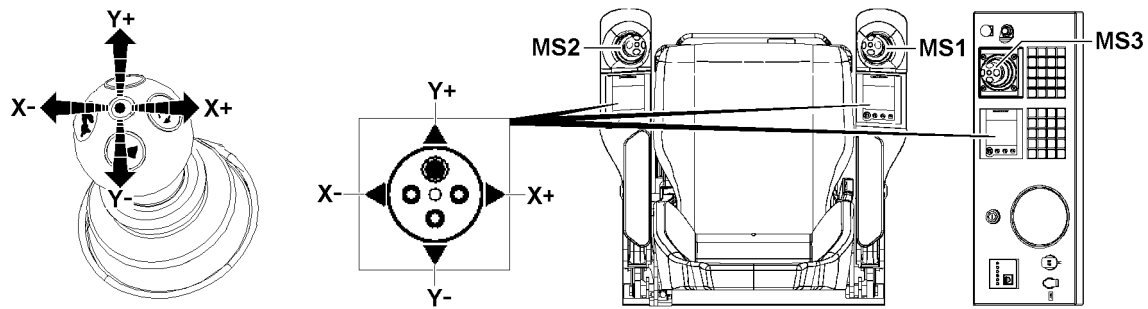

Fig.123758: Actuation directions Master switch

MS1 Master switch 1

MS2 Master switch 2

MS3 Master switch 3

X+ To the right

X- To the left

Y+ To the front

Y- To the rear

3.11 Vibration sensor

- If the vibration sensor for a winch is added on the master switch, then an arrow appears in this winch icon for the added vibration sensor.
- **Note:** The vibration sensor is added at the first actuated crane function.

3.12 Winch speed

- If the maximum winch speed is reduced, a bar in the respective length appears on the bottom in the winch icon. Example: Half the length corresponds to a reduction of the maximum winch speed of 50 %, see example in illustration 1.

Winch overheated, illustration 2:

3.13 Overheated icon

- If the *Overheated* icon 3.13 appears, the temperature in the winch is too high.

Note: Only for certain crane types with temperature sensors in the winches.



WARNING

Overheated winch!

If a winch is operated further, even though the *Overheated* icon 3.13 appears, the winch can be severely damaged.

The winch can fail and accidents can result.

- ▶ Let the overheated winch cool off.

Empty page!

LWE/LR 11000-001/23501-04-02/en

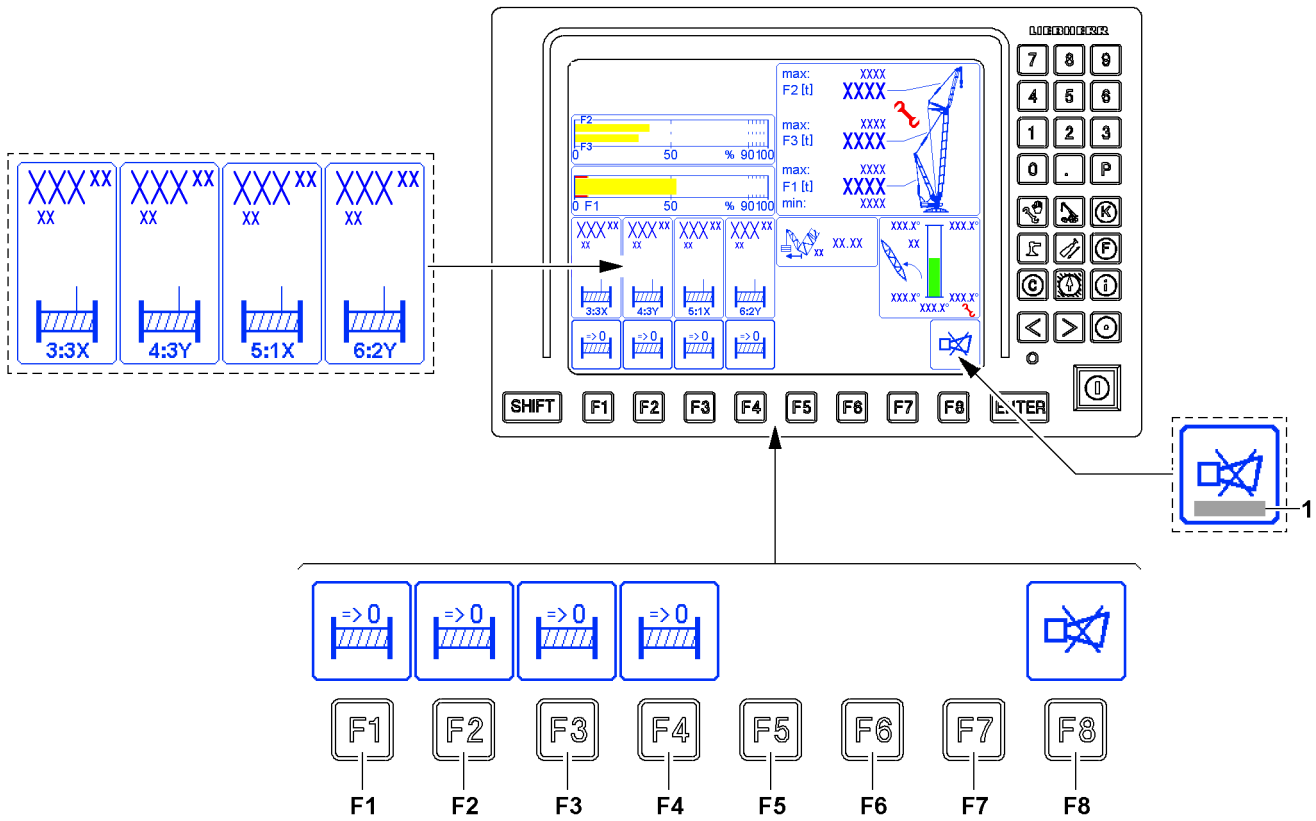

Fig.115252

6.6 The function key line of LICCON monitor 1

The function key line consists of function keys **F1** to **F8** and the function key icon bar above it. The function keys correspond to the various function key icons above them.

The function key icons always show the functions which are activated by pressing the button.

The function is called up after pressing a button. In addition, the icon above it can change its display, its meaning or its text.

Not all function keys must have assigned icons. This depends on the respective program selection.

- F1** Function key
 - Determine the zero point for path display winch 3*
 - Above the function key **F1** appears the icon *Reset winch display*. Pressing on the button sets the display *Completed path* to zero. The path measurement begins here.
- F2** Function key
 - Determine the zero point for path display winch 4
 - Above the function key **F2** appears the icon *Reset winch display*. Pressing on the button sets the display *Completed path* to zero. The path measurement begins here.
- F3** Function key
 - Determine the zero point for path display winch 5*
 - Above the function key **F3** appears the icon *Reset winch display*. Pressing on the button sets the display *Completed path* to zero. The path measurement begins here.
- F4** Function key
 - Determine the zero point for path display winch 6*
 - Above the function key **F4** appears the icon *Reset winch display*. Pressing on the button sets the display *Completed path* to zero. The path measurement begins here.
- F5** Function key
 - No function
- F6** Function key
 - No function
- F7** Function key
 - No function
- F8** Function key
 - Shut off of acoustic warning and possibly calling up of error messages **1**.
Press the function key **F8** once: The acoustic signal is turned off.
Press the function key **F8** twice: The error description for the error message **1** which occurred last is called up.
 - **Note:** A new error turns the acoustic warning on again.

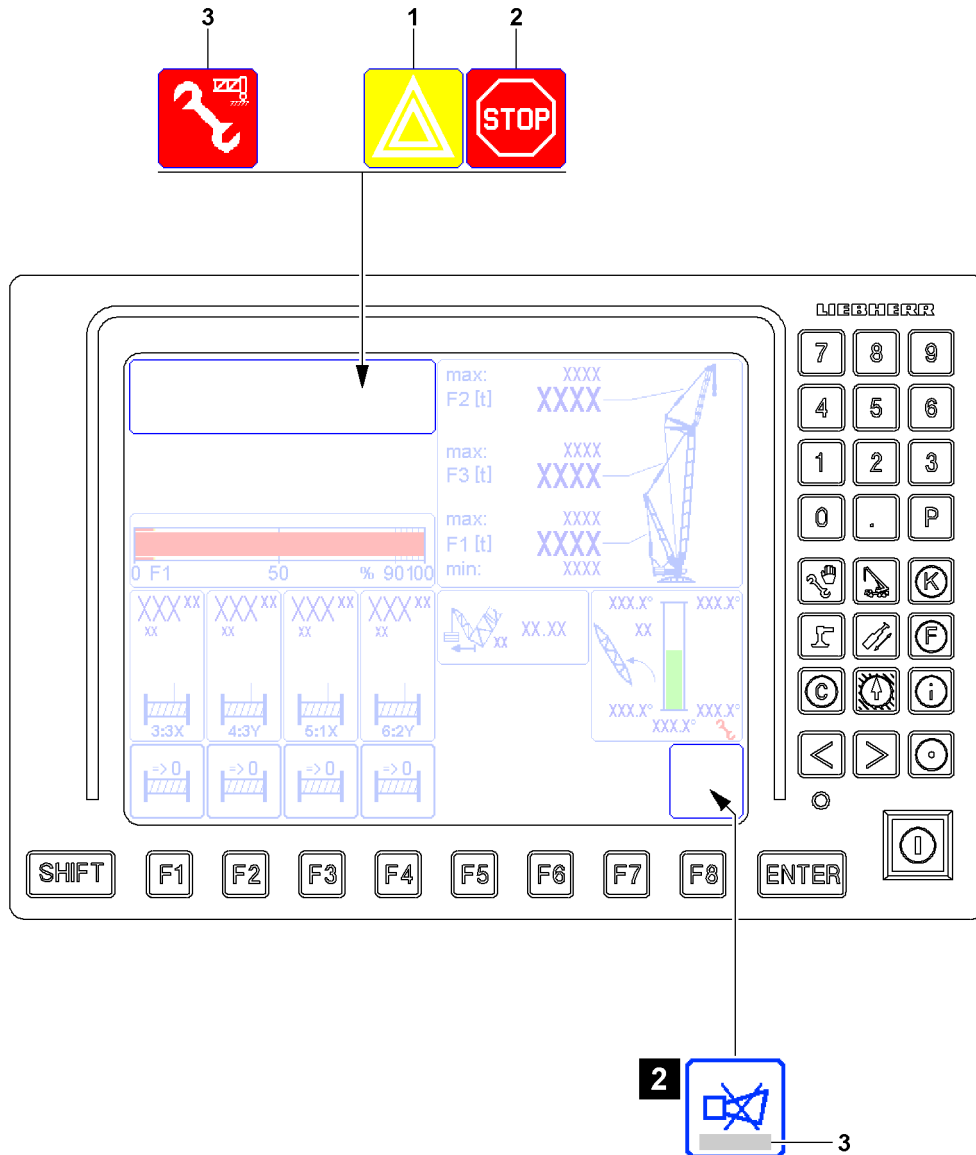

Fig.125389

6.7 Alarm functions of LICCON monitor 1



WARNING

Shut off of crane movement!

If advance warnings are not observed, then it can result in a sudden shut off of the crane movement. A sudden shut off of the crane movement can result in high stress and strain for crane and load. High stress and strain for crane and load can cause accidents.

- ▶ Operate the crane in such a way if possible that there is no shut off of crane movements by the crane control.
- ▶ Monitor the display instruments constantly.
- ▶ If not otherwise possible, approach a possible shut off of crane movements with extreme caution.



Note

Shut off delay LMB-STOP

- ▶ A LMB-STOP with shut off delay remains for a certain period of time. Possible fluctuating movements of the crane can be thereby minimized.

6.7.1 Occurrence of an advance warning

1 Advance warning icon

- If an advance warning occurs, for example: $F1_{\text{actual}}$ smaller than $F1_{\text{min-warning value}}$
- $F1_{\text{min-warning value}}$ is prioritized to $F1_{\text{min}}$ as advance warning value.
- **Example:** $F1_{\text{min}}$ plus advance warning extra (approx. 15 t) results in $F1_{\text{min-warning value}}$.

6.7.2 Shut off of crane movement

2 LMB-STOP icon

- The *LMB-STOP* icon **2** appears if a shut off limit is exceeded.
Example: $F1_{\text{actual}}$ smaller than $F1_{\text{min}}$
- **Note:** Individual crane movements are shut off. **3** Pay attention to error messages **3** and display values.

6.7.3 Boom on the ground function

3 Boom on ground icon

- The *Boom on ground* icon **3** appears when the *Boom on ground function is activated*.
- **Note:** Operating elements *Boom on ground* function, see the Crane operating instructions, chapter 4.01

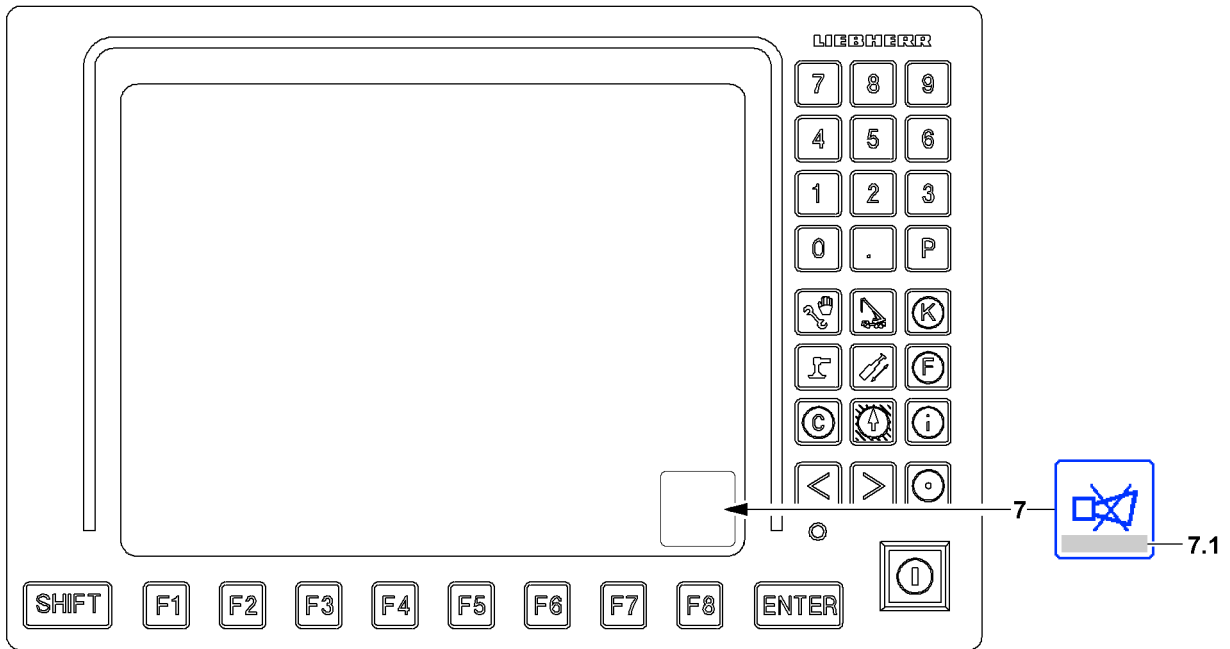

Fig.114279

6.8 Acoustic warning on LICCON monitor 1

Acoustic warnings on LICCON monitor 1 are indicated by the warning sound *Horn*.

The warning sound *Horn* is divided into two categories:

- *Horn* is a beeping sound of a duration of approximately 0.5 seconds, which is repeated in a second cycle.
- *Short horn* is a beeping sound of a duration of approximately 0.1 seconds, which is repeated in a second cycle.

7 *Horn* icon

- When the *Horn* icon **7** is shown in the LICCON monitor, any acoustic signals which will occur can be shut off by the LICCON monitor 1 by pressing the function key **F8**.
- If an error message is shown in the *Horn* icon **7** in field **7.1**, then the present error can be determined through it. Pressing the function key **F8** twice, automatically changes to the error determination screen of the test system. The error is displayed there in documentary form.

6.8.1 Warning sound *Horn*

- Sounds in addition to the visual display of an error message in field **7.1** in case of operational errors are found, which lead to a shut off of a crane movement.
Operational errors are, for example:
 - Exceeding of limit values in the F-load display
 - Exceeding of limit values in the geometry Derrick boom
- In case of application errors with error number (LICCON Error Code LEC)

6.8.2 Warning sound *Short horn*

Sounds in addition to the visual display of error messages without an error number and which do not lead directly to crane movement shut off by the LICCON overload protection.

Monitored error messages are, for example:

- Advance warning by approaching the limit values in the F-load display

6.8.3 Priority acoustic warning

- The *Horn* warning around has higher priority than the *Short horn* warning sound, i.e. *Horn* takes preference over *Short horn*.
- The *Horn* warning sound as well as the *Short horn* warning sound become active again after shut down if a new error occurs.

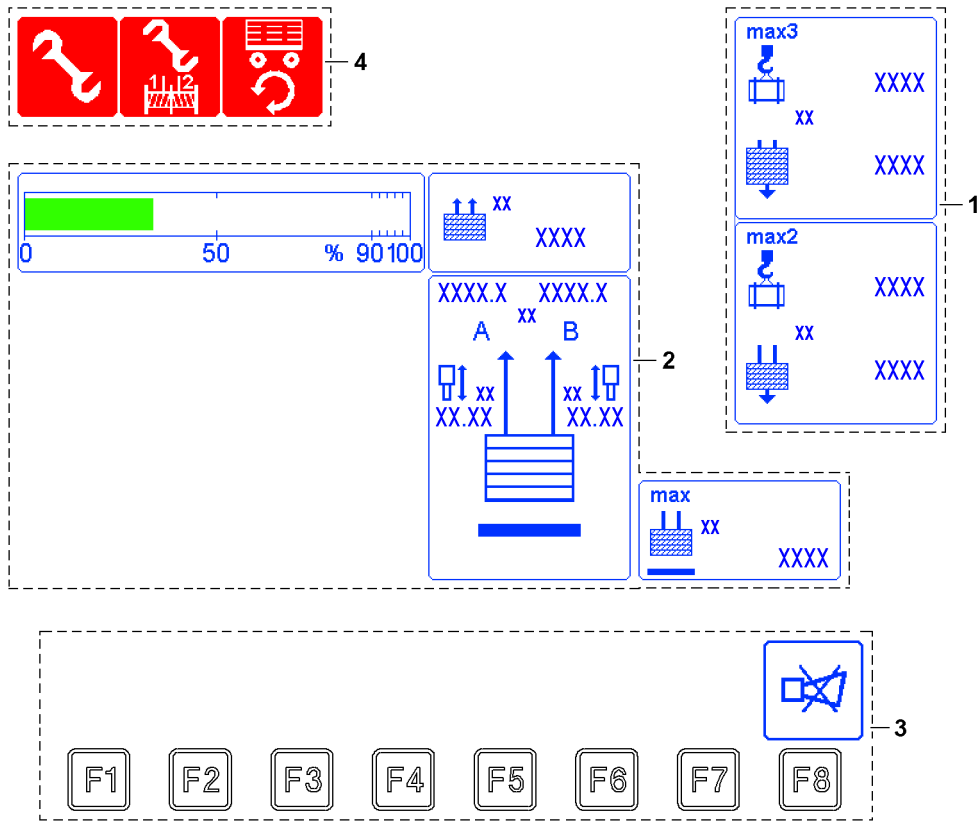
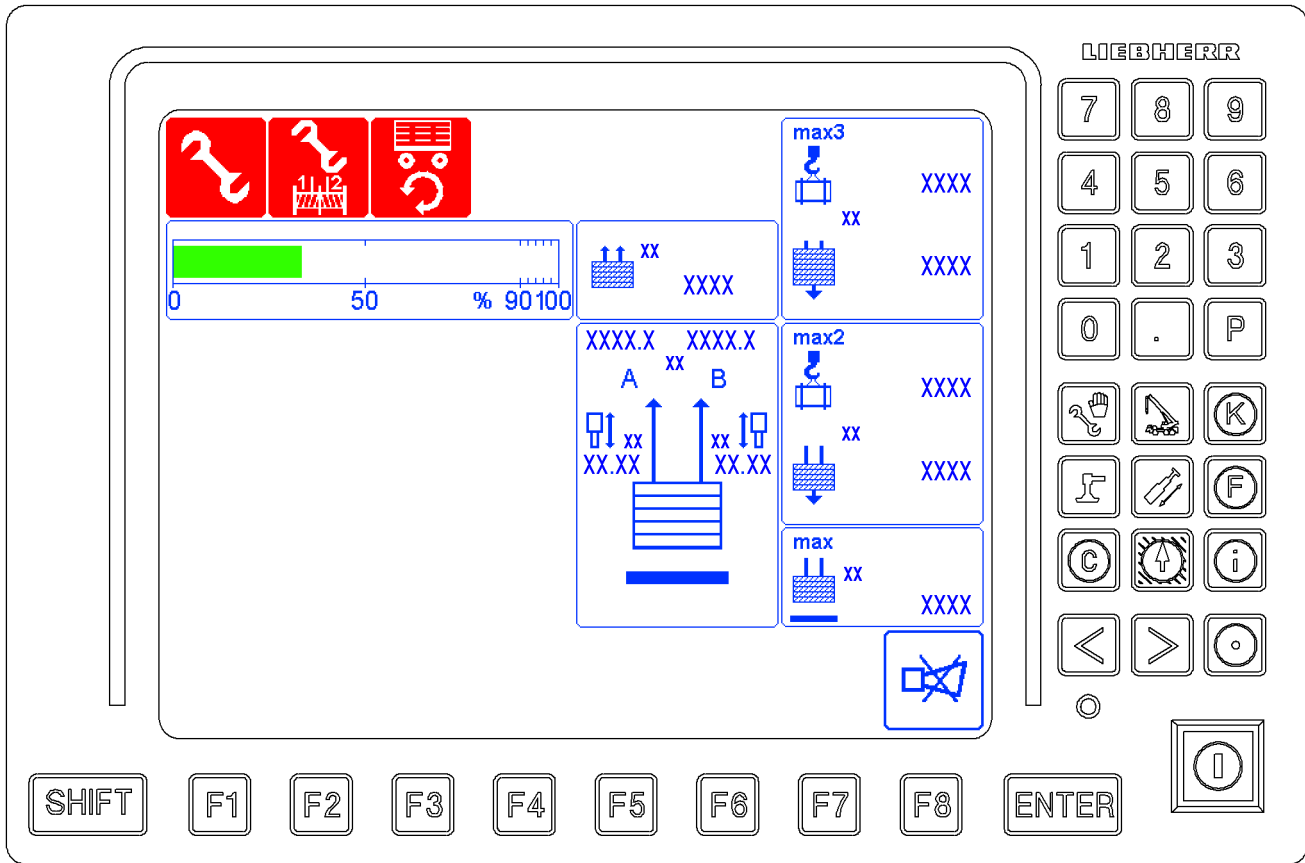

Fig.146957

LWE/LR 11000-001/23501-04-02/en

7 The *Crane operation* program on LICCON monitor 2

The *Crane operation* LICCON program assists the crane operator by displaying the data relevant for crane operation clearly on three LICCON monitors. An acoustic signal accompanies all critical displays. Depending on the equipment, a range of other icons may also be turned on as additional displays, either as required by the crane operator, or automatically in the event of a problem.

It also alerts the crane operator to imminent overload conditions. In the event of overload and many error conditions, which could be hazardous during crane operation, the system shuts off.



Note

- ▶ The suspended ballast and the ballast trailer* are generally referred to as the **derrick ballast**.
- ▶ The fixed compensation weight that is installed on the turntable is generally referred to as the **counterweight**.

The LICCON monitor 2 is divided into three areas in the *Crane operation* program:

- 1 Load max
 - Maximum load depending on the derrick ballast
- 2 Derrick ballast
 - Derrick ballast weight
 - Derrick guying forces
 - Utilization of the derrick ballast
 - Maximum liftable derrick ballast for the current crane condition, without falling below $F1_{min}$ when lifting
- 3 Function key line
 - Function keys always refer to the icons shown directly above
 - **Note:** If no icon is shown in the line directly above the function key, then no function is assigned in the program to the function key.
- 4 LICCON Monitor 2 special functions



Note

- ▶ The monitor illustrations in this chapter are only examples.
- ▶ The numerical values in the individual icons and charts do not have to necessarily match the crane exactly.
- ▶ The configuration of the LICCON monitor with icons is only descriptive.
- ▶ An identical icon display will **not** appear during crane operation.

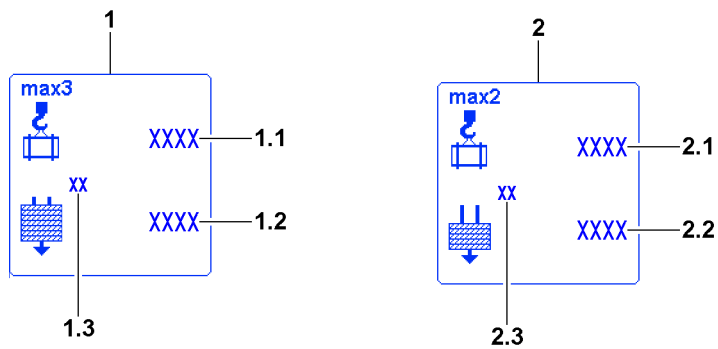
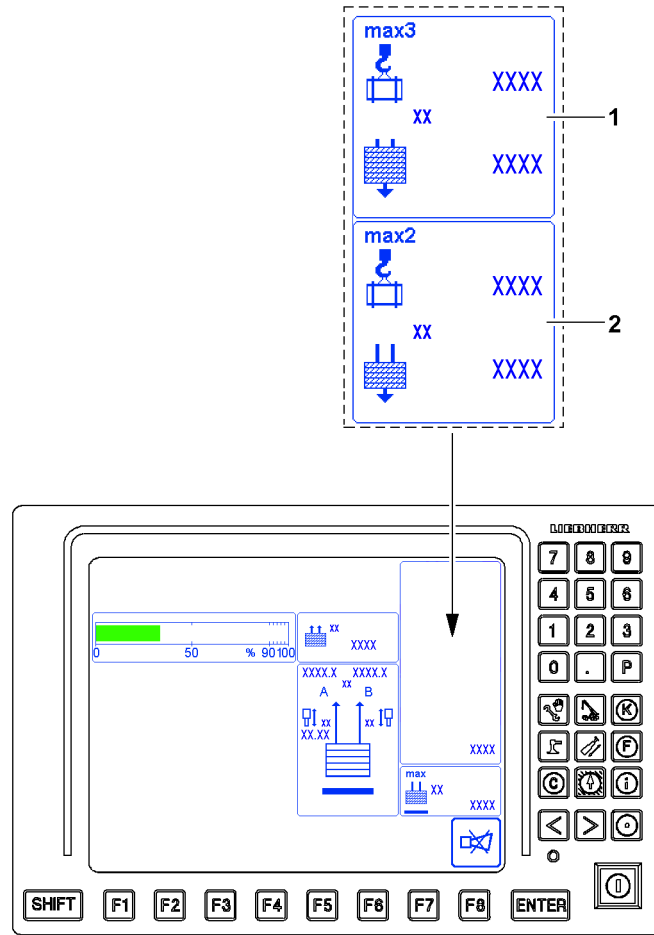

Fig.146958

LWE/LR 11000-001/23501-04-02/en

7.1 Load max

The information regarding crane geometry and load involves two icons:

1 Load max3

Note: This is hidden as soon as two hook operation is set in the *set up* program.

2 Load max2

Note: This is hidden as soon as two hook operation is set in the *set up* program.



Note

► Question marks (?) are shown instead of values if the value cannot be calculated / determined.
Example: A sensor error can be present - pay attention to error messages.

7.1.1 Load max3

The *load max3* icon **1** shows the maximum load at the maximum derrick ballast within the framework of the load chart.

The *load max3* icon **1** is hidden as soon as two hook operation is set in the *set up* program.

1 Load max3 icon

1.1 Possible load_{max3}

- Is the load which the crane could currently lift when the maximum derrick ballast according to the load chart would have been placed
- In [t] or [lbs]

1.2 Maximum derrick ballast

- Maximum derrick ballast according to load chart

1.3 Measuring unit

- Measuring unit for display values in icon *Load max3 1*: [t] or [lbs]

7.1.2 Load max2

In the icon *load max2 2* the highest possible load in the current operating status is shown (**current derrick ballast** fully utilized).

The *load max2* icon **2** is hidden as soon as two hook operation is set in the *set up* program.

2 Load max2 icon

2.1 Possible load_{max2}

- Is the maximum load, which the crane can lift in the current operating status. For that, the placed derrick ballast must be fully utilized (Derrick ballast lifted off the ground).
- In [t] or [lbs]

2.2 Placed derrick ballast

- Currently placed derrick ballast

2.3 Measuring unit

- Measuring unit for display values in icon *Load max2 2*: [t] or [lbs]

7.2 Derrick ballast



Note

► A question mark (?) is shown instead of values if the value cannot be calculated / determined.
Example: A sensor error can be present - pay attention to error messages.

The force components / load of the guying derrick ballast is recorded on guying A and guying B of the derrick ballast.

Test points guying A are:

- Test point 4A = pressure sensor ring surface left F4A
- Test point 5A = pressure sensor piston surface left F5A

Test points guying B are:

- Test point 4B = pressure sensor ring surface right F4B
- Test point 5B = pressure sensor piston surface right F5B

7.2.1 Utilization display Derrick ballast

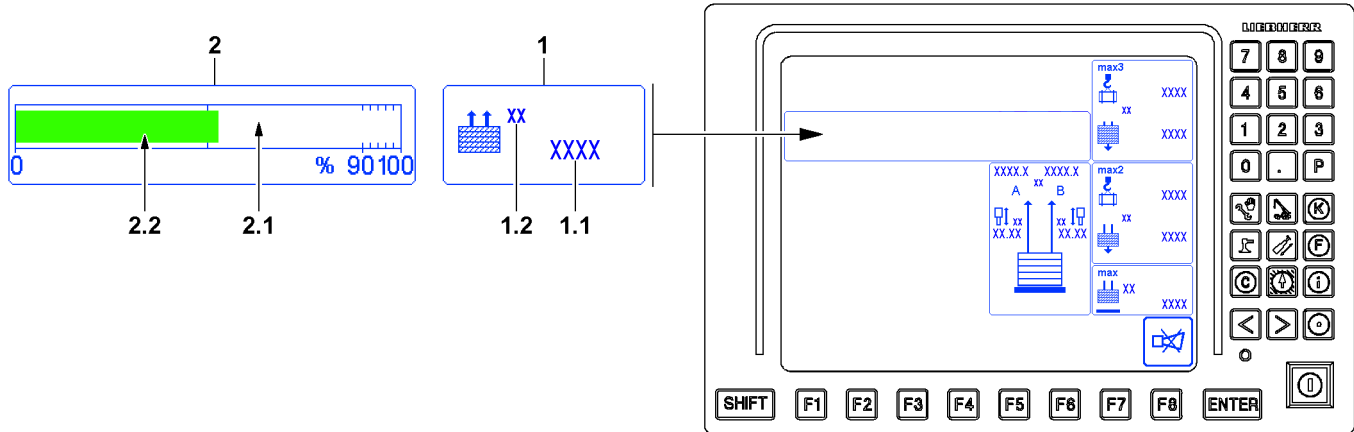

Fig.146959

In the icon *Pulled derrick ballast 1* the currently pulled derrick ballast is shown. The value results from the vertical force components / load on guying A and guying B of the derrick ballast.

- 2 *Pulled derrick ballast* icon
 - 1.1 *Pulled derrick ballast*
 - Currently pulled derrick ballast
 - Sum of forces / load from guying A and guying B
 - 1.2 *Measuring unit*
 - Measuring unit for display values in icon *Pulled derrick ballast 1*: [t] or [lbs]

The *Utilization bar Derrick ballast* icon 2 depicts the ratio of the pulled derrick ballast (BA_{pulled}) to the placed derrick ballast (BA_{placed}) in percentages.

- 2 *Utilization bar Derrick ballast* icon
 - Display bar for graphic display of utilization of derrick ballast
- 2.1 *Display scale*
 - Scale from 0 % to 100 %
- 2.2 *Pulled derrick ballast*
 - Graphic illustration of pulled derrick ballast
 - If the derrick ballast is completely pulled, the derrick ballast lifts off the ground

7.2.2 Suspended ballast*

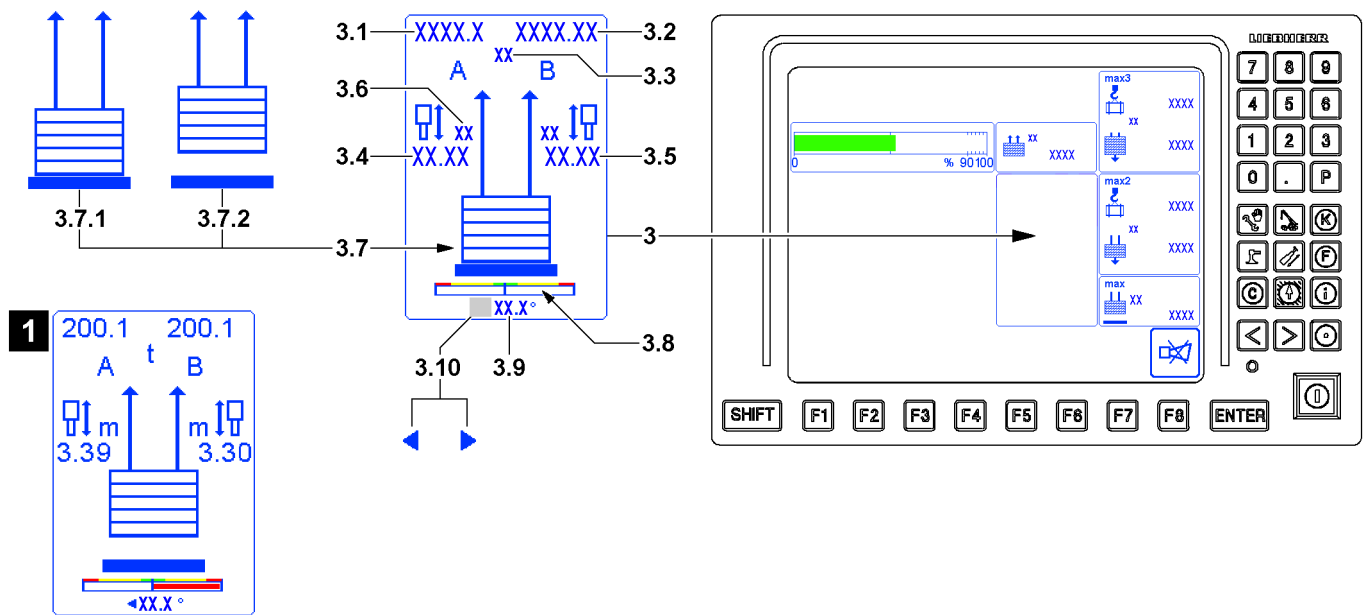

Fig. 146960

If the crane is set up with suspended ballast*, then the displays in the *Guying derrick ballast* icon 3 are automatically adapted by the LICCON computer system.



WARNING

Derrick ballast on unsuitable ground!

If the derrick ballast gets so far into a sloped position in lateral direction that the red range (example illustration 1) is reached in the incline display, then there is a danger of accident.

If the derrick ballast sinks too far into the ground, then there is a danger of accident.

- ▶ Always correct the position of the derrick ballast in time. Hold the extension length A and extension length B even.
- ▶ The derrick ballast may only be set down if the ground is sufficiently load bearing and even.

3 *Guying Derrick ballast* icon

- 3.1 *Guying A*
 - Current force / load on guying A
- 3.2 *Guying B*
 - Current force / load on guying B
- 3.3 *Measuring unit*
 - Measuring unit for display values guying A and guying B: [t] or [lbs]
- 3.4 *Extension length A*
 - Current extension length of pull cylinder of guying A
- 3.5 *Extension length B*
 - Current extension length of pull cylinder of guying B
- 3.6 *Measuring unit*
 - Measuring unit for extension length of pull cylinders of guying A and guying B: [m] or [ft]
- 3.7 *Ground contact*
 - Display for ground contact of derrick ballast
 - 3.7.1 Derrick ballast has ground contact
 - 3.7.2 Derrick ballast lifted off
- 3.8 *Incline display*
 - Graphic display of incline of derrick ballast in lateral direction
 - **Note:** Not for the suspended ballast for the *Ballast Constant* version

3.9 Incline value

- Incline value of derrick ballast in lateral direction
The incline value appears in degrees [°].



Note

- ▶ The incline direction **3.10** appears only when the derrick ballast is inclined in the lateral direction.

3.10 Incline direction

- Incline direction of derrick ballast in lateral direction
- Appears only when the derrick ballast is inclined in lateral direction

7.2.3 Ballast trailer*

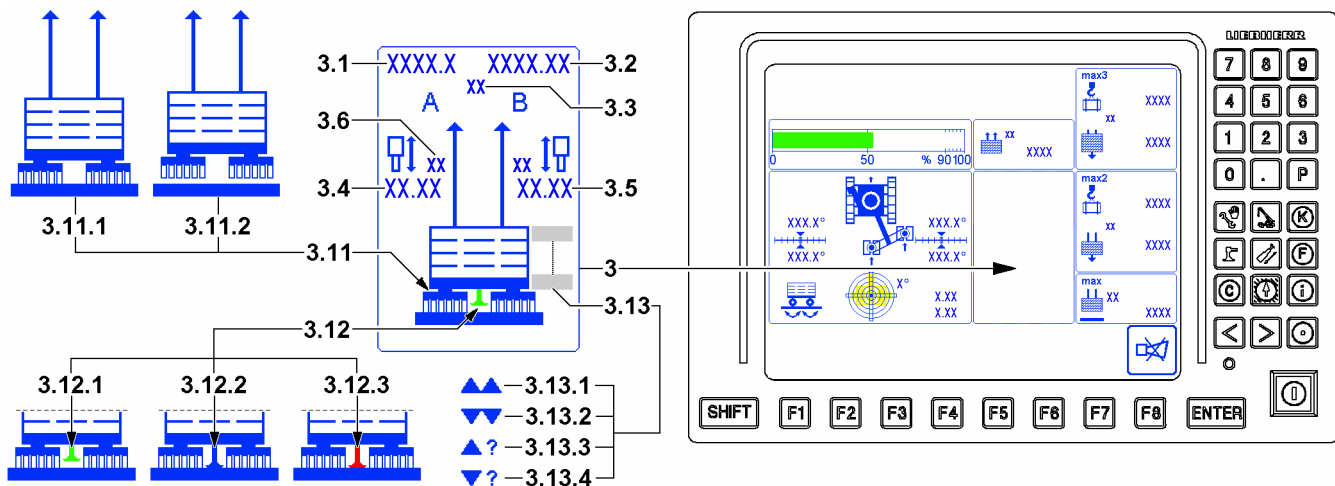

Fig.146961

If the crane is set up with a ballast trailer*, then the displays in the *Guying derrick ballast* icon **3** are automatically adapted by the LICCON computer system.



WARNING

Ballast trailer on unsuitable ground!

If the ballast trailer gets too far into an incline position, then there is a danger of accident.

If the ballast trailer sinks too far into the ground, then there is a danger of accident.

- ▶ Always correct the position of the ballast trailer in time. Hold the extension length A and extension length B even.
- ▶ The ballast trailer may only be set down if the ground is sufficiently load bearing and even.

3 Guying Derrick ballast icon

3.1 Guying A

- Current force / load on guying A

3.2 Guying B

- Current force / load on guying B

3.3 Measuring unit

- Measuring unit for display values guying A and guying B: [t] or [lbs]

3.4 Extension length A

- Current extension length of pull cylinder of guying A

3.5 Extension length B

- Current extension length of pull cylinder of guying B

3.6 Measuring unit

- Measuring unit for extension length of pull cylinders of guying A and guying B: [m] or [ft]

3.11 Ground contact

- Display for ground contact of ballast trailer

- 3.11.1 Ballast trailer has contact with the ground
- 3.11.2 Ballast trailer lifted off
- 3.12 Support Ballast trailer
 - Display for the status of the support ballast trailer
 - 3.12.1 Support retracted, ballast trailer not supported
 - 3.12.2 Support extended, ballast trailer is supported
 - 3.12.3 Support not in nominal position

Notice! Support not completely retracted and selection travel gear, slewing gear or sliding cylinder selected



Note

Ballast trailer limit signs 3.13

► The level difference between the placement surface of the crane and the ballast trailer is limited both upward and downward. In order to avoid damaging the crane or the ballast trailer, the upper and lower stop positions are monitored by limit switches. If one of the end positions, the corresponding limit sign appears. The movements on the crane, or on the ballast trailer, are turned off.

3.13 Ballast trailer limit signs

- 3.13.1 upper end position limit switch triggered (ballast trailer too far above the crane placement surface)
- 3.13.2 lower end position limit switch triggered (ballast trailer too far below the crane placement surface)
- 3.13.3 upper end position limit switch defective

Notice! There is no shut-off when reaching the upper end position. Remedy the error immediately.

- 3.13.4 lower end position limit switch defective

Notice! There is no shut-off when reaching the lower end position. Remedy the error immediately.

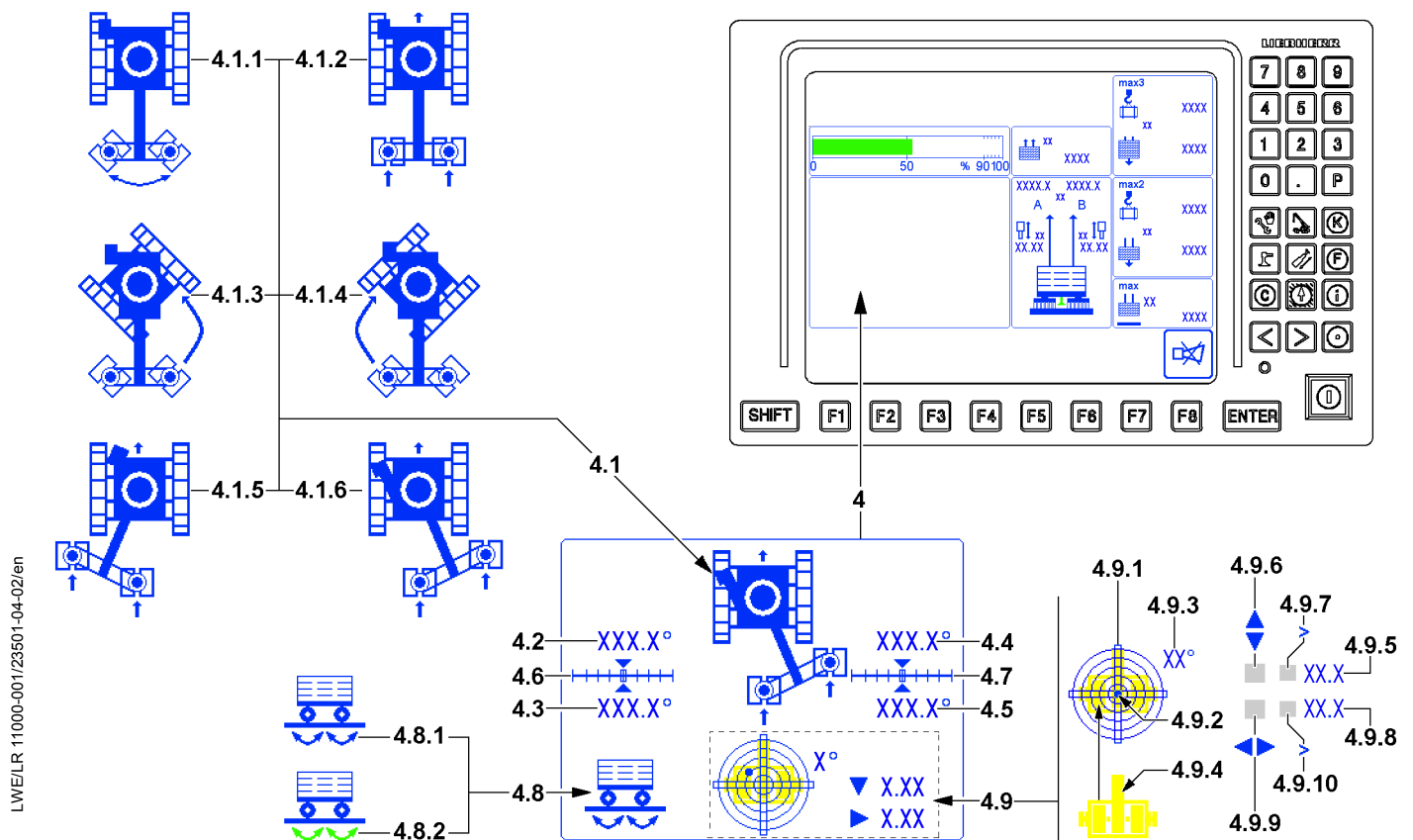

LWE/LR 11000-001/23501-04-02/en

Fig.146962

4 Ballast trailer icon

- 4.1 Steering operating modes
 - Display for a set steering operating mode
 - 4.1.1 Circular travel Ballast trailer
 - 4.1.2 Towing Ballast trailer
 - 4.1.3 Corrective steering Ballast trailer (crane drives left)
 - 4.1.4 Corrective steering Ballast trailer (crane drives right)
 - 4.1.5 Parallel travel Ballast trailer (ballast trailer offset left)
 - 4.1.6 Parallel travel Ballast trailer (ballast trailer offset right)
- 4.2 Nominal angle left
 - Nominal angle for the left wheel set
- 4.3 Actual angle left
 - Actual angle for the left wheel set
 - If the nominal angle left 4.2 is not reached:
 - The actual angle left 4.3 is shown in red
 - In the graphic display left 4.6 the position arrow *actual value* is not the same as arrow *nominal value*
- 4.4 Nominal angle right
 - Nominal angle for the right wheel set
- 4.5 Actual angle right
 - Actual angle for the right wheel set
 - If the nominal angle right 4.2 is not reached:
 - The actual angle right 4.5 is shown in red
 - In the graphic display right 4.7 the position arrow *actual value* is not the same as arrow *nominal value*
- 4.6 Graphic display left
 - Graphic display Actual angle and nominal angle for the left wheel set
- 4.7 Graphic display right
 - Graphic display Actual angle and nominal angle for the right wheel set
- 4.7 Status Drive
 - Status display for the ballast trailer drive
 - 4.8.1 Drive turned on (not active)
 - 4.8.2 Drive turned on and active
- 4.9 Display *Incline Ballast trailer*
 - Display of the incline of the ballast trailer to the horizontal in longitudinal and lateral direction.
 - The display is divided in a graphic section and a numeric section.
 - The direction data refers to the overhead view of the ballast trailer in the graphic display.

Graphic part:

- 4.9.1 Graphic display
 - The graphic display is in the form of a spirit level, with a moving dot 4.2 representing the air bubble.
- 4.9.2 Point
 - The center of the dot 4.9.2 shows the incline value.
- 4.9.3 Resolution of view
 - This value describes the resolution of the graphic view. The resolution is matched automatically to the incline.
- 4.9.4 Position Ballast trailer guide
 - An overhead view of the ballast trailer is highlighted in the graphic illustration 4.9.1. The displayed position of the ballast trailer guide 4.9.4 is serves as orientation in the display.

Numeric part:

- 4.9.5 Longitudinal direction
 - Incline of crane in longitudinal direction in [°].

- 4.9.6 Direction arrow
 - The direction arrow shows the direction of the incline.
- 4.9.7 Display range exceeded
 - If the *larger than* icon appears, then the display range is exceeded.
 - **Note:** The crane is inclined further than can be shown.
- 4.9.8 Lateral direction
 - Incline of crane in lateral direction in [°].
- 4.9.9 Direction arrow
 - The direction arrow shows the direction of the incline.
- 4.9.10 Display range exceeded
 - If the *larger than* icon appears, then the display range is exceeded.
 - **Note:** The crane is inclined further than can be shown.

**Note**

Orientation of the crane in the display *Incline Ballast trailer* 4.9.

► Pay attention to the position of the ballast trailer guide 4.9.4.

7.3 Maximum liftable derrick ballast

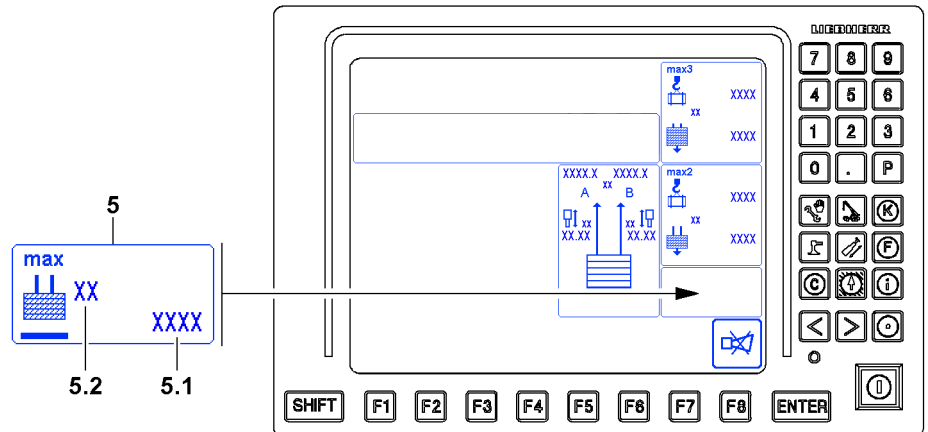

Fig.146950

The *maximum liftable derrick ballast* icon **5** displays the derrick ballast that, with reference to the current crane condition, can be lifted off the ground with the pull cylinder or off the suspended ballast palette in case of the VarioTray without falling below the $F1_{\min}$ force.

- 5** *Maximum liftable derrick ballast* icon
- 5.1** Maximum liftable derrick ballast
 - Maximum derrick ballast
- 5.2** Measuring unit
 - Measuring unit for display values in the *Pulled derrick ballast* icon **5**: [t] or [lb]

7.4 LICCON Monitor 2 special functions

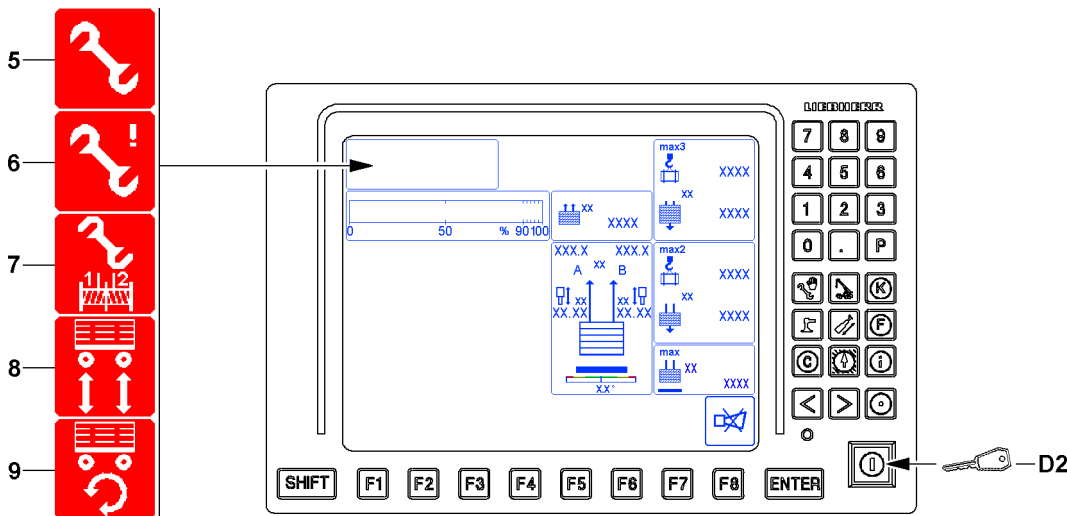

Fig.146963

7.4.1 Shut off difference force monitoring derrick ballast guying

5 Assembly icon

- The Assembly icon 5 appears when the shut off difference force monitoring derrick ballast guying is bypassed. The bypass of the shut off is made via the key button (set up key) of LICCON monitor 0 (right monitor), see section „Special functions LICCON monitor 0“.



Note

Shut off difference force monitoring derrick ballast guying

- Observe the Crane operating instructions, chapter 5.35 / 5.36.

7.4.2 Changing over regulation Parallel operation winch 1 and winch 2

The parallel operation of winch 1 and winch 2 is regulated from a pulley head height of more than 20 m via the change over pulleys. If a problem occurs, then switch over to a regulation via the winch speed sensors.



WARNING

Impermissible change over of regulation *parallel operation winch 1 and winch 2!*

- Changing the regulation *parallel operation winch 1 and winch 2* is only permissible if - due to contamination, icing or failure of the path measurement system of the test pulleys - a correct path measurement of the hoist ropes of winch 1 and winch 2 is not possible.
- Changing the regulation *parallel operation winch 1 and winch 2* is only permissible if it is not possible to immediately clean or de-ice the test pulleys or repair the path measurement system.
- As long as the regulation *parallel operation winch 1 and winch 2* is changed over, the crane driver must align the position of the hook block generally manually.

D2 Key button

- Change over regulation Parallel operation winch 1 and winch 2.
- Note:** At a pulley head height below 20 m the function is deactivated, since the system is already regulated via the winch speed sensors.
By pressing the key button **D2** again, the function is turned off.
The function is also turned off if the engine of the ignition is turned off.

7 Regulation parallel operation switched over icon

- The Regulation parallel operation switched over icon 7 appears when the regulation parallel operation winch 1 and winch 2 is switched over.

- **Note:** After turning the function off, the icon turns off.

7.4.3 Emergency operation ballast trailer

6 *Assembly* icon

- The *Assembly* icon **6** appears when the emergency operation ballast trailer is engaged, see Crane operating instructions, chapter 5.35.

8 *Emergency operation travel clear* icon

- The *Emergency operation travel clear* icon **8** appears when:
 - The emergency operation ballast trailer is engaged
 - *Emergency operation travel clear* is engaged

9 *Emergency operation turn clear* icon

- The *Emergency operation turn clear* icon **9** appears when:
 - The emergency operation ballast trailer is engaged
 - *Emergency operation turn clear* is engaged

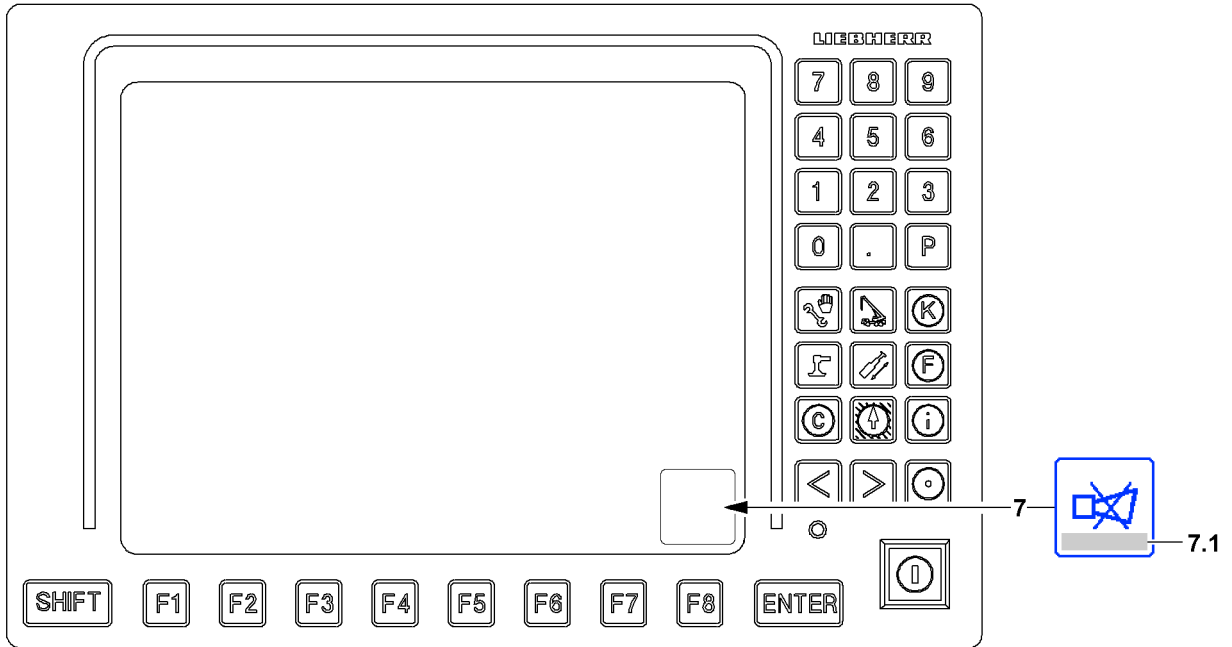

Fig.114279

7.5 Acoustic warning on LICCON monitor 2

Acoustic warnings on LICCON monitor 2 are indicated by the warning sound *Horn*.

The warning sound *Horn* is divided into two categories:

- *Horn* is a beeping sound of a duration of approximately 0.5 seconds, which is repeated in a second cycle.
- *Short horn* is a beeping sound of a duration of approximately 0.1 seconds, which is repeated in a second cycle.

7 Horn icon

- When the *Horn* icon **7** is shown in the LICCON monitor, any acoustic signals which will occur can be shut off by the LICCON monitor 2 by pressing the function key **F8**.
- If an error message is shown in the *Horn* icon **7** in field **7.1**, then the present error can be determined through it. Pressing the function key **F8** twice, automatically changes to the error determination screen of the test system. The error is displayed there in documentary form.

7.5.1 Warning sound *Horn*

1. Sounds in addition to the visual display of an error message in field **7.1** in case of operational errors are found, which lead to a shut off of a crane movement.
Operational errors are, for example:
 - Difference between *Force / load on guying A* and *Force / load on guying B* is too large
2. In case of application errors with error number (LICCON Error Code LEC)

7.5.2 Warning sound *Short horn*

Sounds in addition to the visual display of error messages without an error number and which do not lead directly to crane movement shut off by the LICCON overload protection.

Monitored error messages are, for example:

- Advance warning by approaching the limit values in the F-load display

7.5.3 Priority acoustic warning

- The *Horn* warning around has higher priority than the *Short horn* warning sound, i.e. *Horn* takes preference over *Short horn*.
- The *Horn* warning sound as well as the *Short horn* warning sound become active again after shut down if a new error occurs.

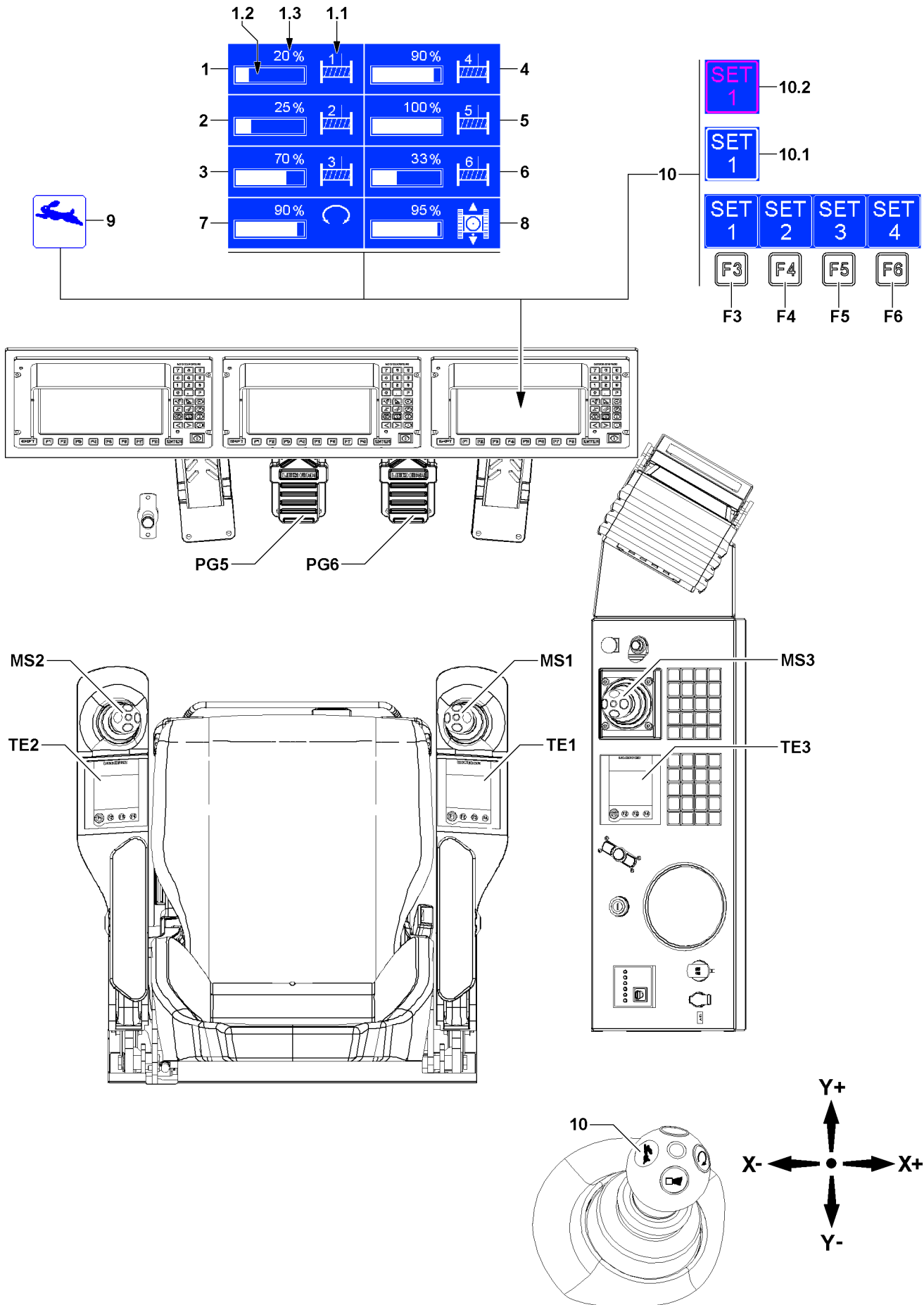

Fig.120651

8 Speed reduction master switch / pedal sensor

The speed reduction of master switches is made in the settings window. The speeds of the displayed crane movements / crane functions can be limited steplessly to the desired value.

Speed reduction of master switches is the speed of the crane function reduced to the speed set in the settings window.



WARNING

Deactivated speed reduction of master switches!

When the rapid gear **9** is engaged, the speed reductions of the master switches can be ineffective. Too high a crane speed can cause accidents.

- ▶ Turn the rapid gear **9** off when a speed reduction of the master switches is necessary.



WARNING

Danger of accident!

- ▶ Make the preselection of the slewing speed according to the specifications in the load chart manual.
- ▶ The following applies: The longer the boom and / or the greater the load, the lower the set maximum slewing speed must be.
- ▶ **Never** deflect the master switch for the slewing gear to the stop with a long boom and / or great load.

8.1 Operating elements at speed reduction of master switch / pedal sensor

- MS1** Master switch 1
- TE1** Touch display 1
- MS2** Master switch 2
- TE2** Touch display 2
- MS3** Master switch 3
- TE3** Touch display 3
- PG5** Pedal sensor 5
- PG6** Pedal sensor 6

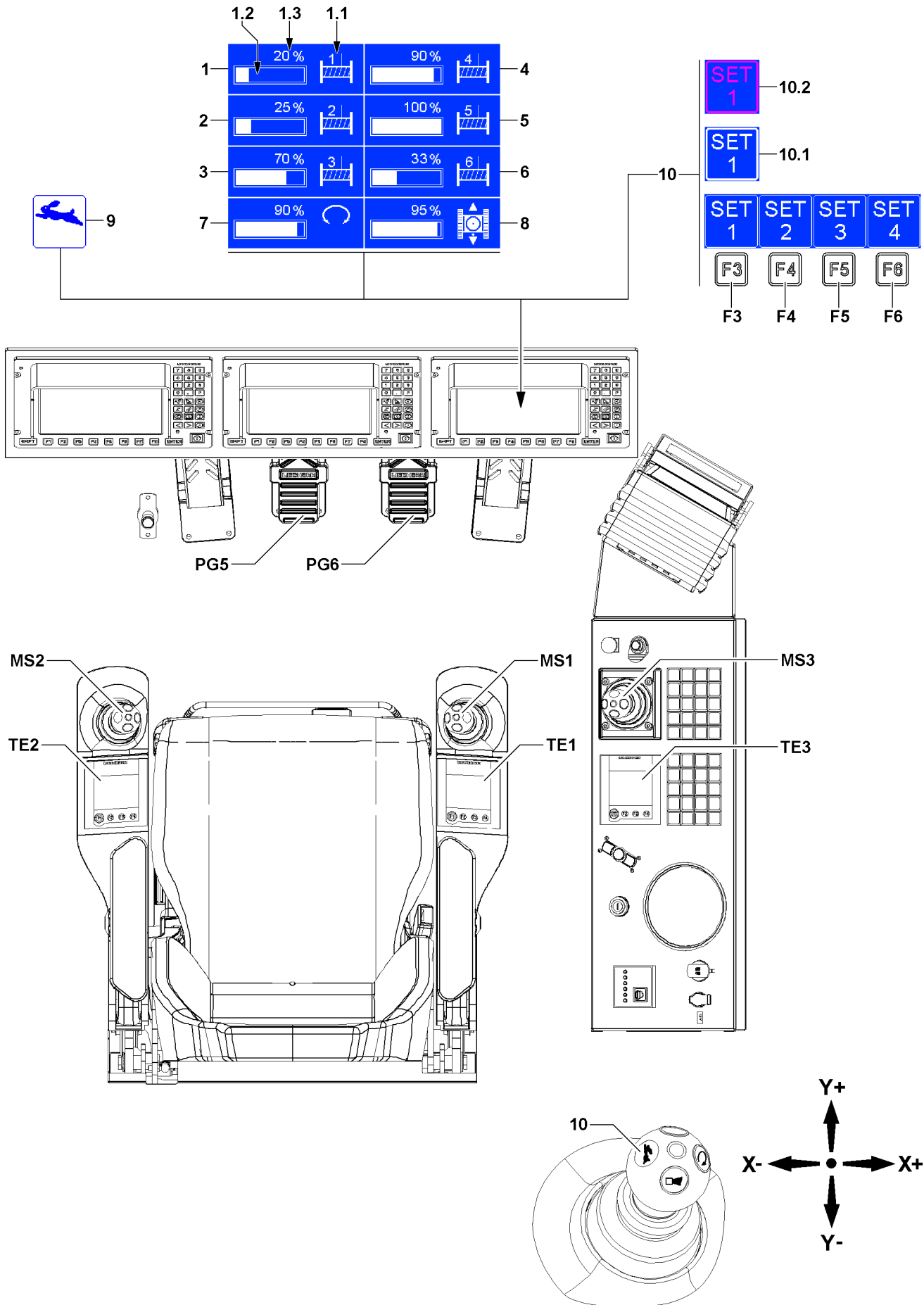

Fig.120651

LWE/LR 11000-001/23501-04-02/en

8.2 User platform in settings window for speed reduction of master switch / pedal sensor



Note

- The structure of the individual settings windows is always the same. The structure is explained based on the first settings window (setting window for winch 1).

- 1 Settings window Winch 1
 - **Note:** Appears only when the winch is active.
- 1.1 *Assignment* icon
 - Icon of assigned crane movement / crane function
 - The icon corresponds to the illustration in the respective TE- display
- 1.2 Bar display
 - Graphic illustration of current speed reduction
- 1.3 Display value
 - Numeric display of current speed reduction in [%]
- 2 Settings window Winch 2
 - **Note:** Appears only when the winch is active.
- 3 Settings window Winch 3
 - **Note:** Appears only when the winch is active.
- 4 Settings window Winch 4
 - **Note:** Appears only when the winch is active.
- 5 Settings window Winch 5
 - **Note:** Appears only when the winch is active.
- 6 Settings window Winch 6
 - **Note:** Appears only when the winch is active.
- 7 Settings window Slewing gear
- 8 Settings window for crawler
- 8 Fast setting
 - Four freely programmable fast settings are possible.

8.3 Processing the speed reduction

The procedure in the settings window *Speed reduction master switch / pedal sensor* is identical for all crane functions.

Using the example Speed reduction for winch 1, the individual steps are explained.



Note

Only the settings for the displayed crane movements / crane functions can be carried out.

- If necessary, activate required crane movements / crane functions before calling up the settings windows.

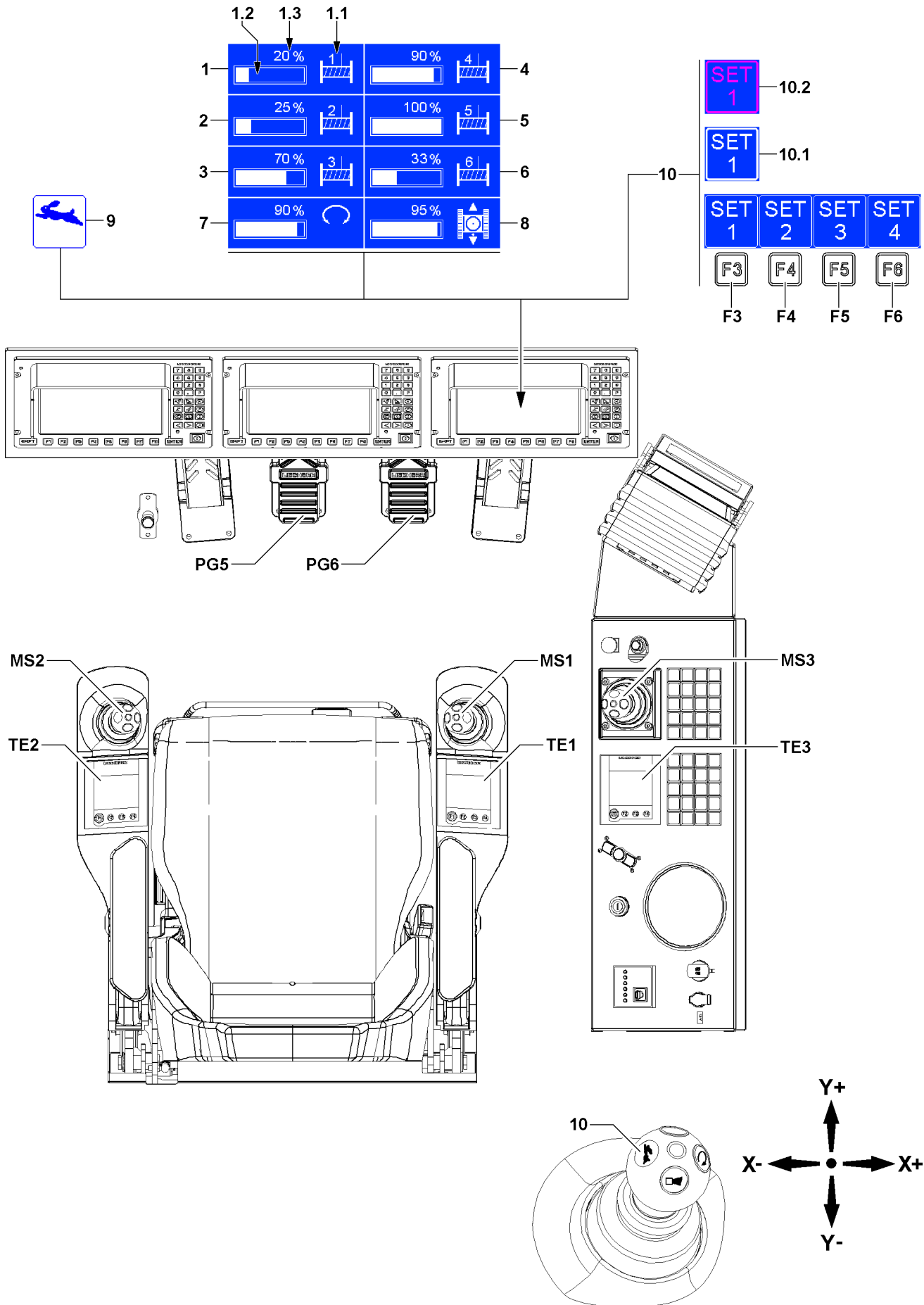

Fig.120651

LWE/LR 11000-001/23501-04-02/en

8.3.1 Displaying the settings windows

- ▶ Press the rapid gear **10** button on a master switch at least two seconds.

Result:

- The settings window for the speed reduction of the master switch / pedal sensor is shown for ten seconds.



Note

The settings window is automatically hidden after ten seconds if during that time there is no access to the speed reduction of a crane function.

- ▶ Continue in time with the next steps.

8.3.2 Procedure

The speed reduction is always set via the master switch / pedal sensor which controls the crane movement.



Note

- ▶ If the master switch / pedal sensor is deflected lightly, the value is slowly increased / reduced.
- ▶ If the master switch / pedal sensor is deflected strongly, the value is quickly increased / reduced.

Example: Set crane movement *spool winch 1*. The crane movement is carried out via the master switch **MS1**.

Reducing the value of the speed reduction:

- ▶ Move the master switch **MS1** in direction Y- (to the rear).

Result:

- The bar in the bar display **1.2** gets shorter.
- The display value **1.3** is reduced.
- The speed for crane movement *spool winch 1* is set to the new display value **1.3**.

Increasing the value of the speed reduction:

- ▶ Move master switch **MS1** in direction Y+ (forward).

Result:

- The bar in the bar display **1.2** gets longer.
- The display value **1.3** is increased.
- The speed for crane movement *spool winch 1* is set to the new display value **1.3**.

8.4 Fast settings* Speed reduction master switch / pedal sensor

Four different fast settings for the speed reduction master switch / pedal sensor can be saved and called up by pressing a button.

Make sure that the following prerequisite is met:

- The settings window is shown.

8.4.1 Programming fast settings

Operating elements:

- **F3** Function key
 - Operate fast setting 1 (SET1)
- **F4** Function key
 - Operate fast setting 2 (SET2)
- **F5** Function key
 - Operate fast setting 3 (SET3)
- **F6** Function key

- Operate fast setting 6 (SET4)

As an example in fast setting 1 (SET1) a new setting for crane movement *spool winch 1* is programmed:

- ▶ Press the function key **F3**.

Result:

- The frame around the *SET1* icon is shown in bold.

Reducing the value of the speed reduction:

- ▶ Move the master switch **MS1** in direction Y- (to the rear).

Result:

- The frame and lettering in the *SET1* icon are shown in red.
- The bar in the bar display **1.2** gets shorter.
- The display value **1.3** is reduced.
- The speed for crane movement *spool winch 1* is set to the new display value **1.3**.

Increasing the value of the speed reduction:

- ▶ Move master switch **MS1** in direction Y+ (forward).

Result:

- The frame and lettering in the *SET1* icon are shown in red.
- The bar in the bar display **1.2** gets longer.
- The display value **1.3** is increased.
- The speed for crane movement *spool winch 1* is set to the new display value **1.3**.



Note

- ▶ All settings can be changed one after the other as desired.
-

When the desired setting is reached:

- ▶ Press the function key **F3**.

Result:

- The frame and lettering in the *SET1* icon are shown in white.
- All current settings are saved as fast setting 1 (SET1).

Empty page!

LWE/LR 11000-001/23501-04-02/en

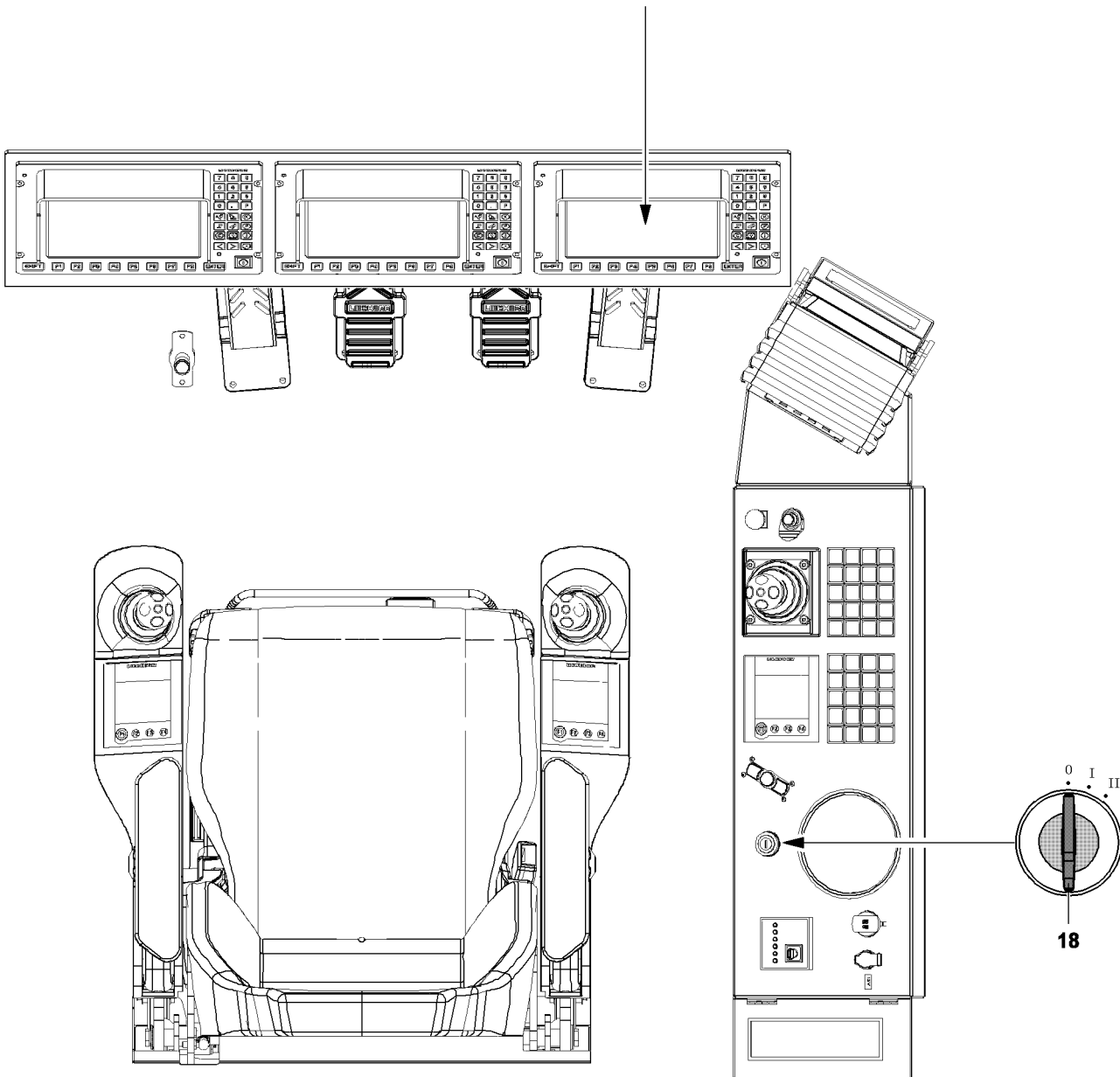
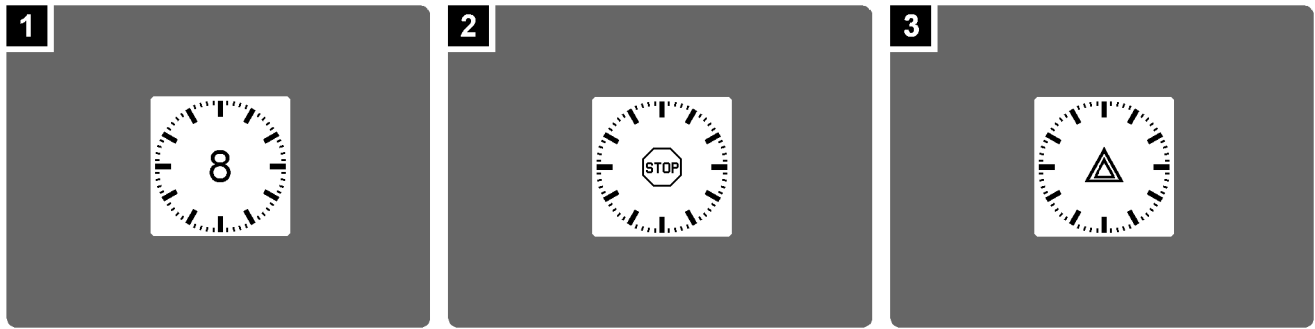

Fig.115263

LWE/LR 11000-001/23501-04-02/en

9 Power-Save mode and Stand-by mode in the LICCON computer system

9.1 The Power-Save mode

If the crane engine - by turning the ignition switch **18** - is turned off to position 0 (ignition **OFF**), the LICCON computer system changes to the Power-Save mode.

The Power-Save mode enables the crane operator - within approx. eight seconds after turning the ignition off - either to change to Stand-by mode or to start the crane engine again without having to start the LICCON computer system again.

If no program key is actuated within eight seconds, then the LICCON computer system turns off completely.



Note

▶ In the Power-Save mode, no crane movements are possible.

Turning the crane engine off

▶ Turn the ignition switch **18** to position 0 (ignition **OFF**).

Result:

- The crane engine is turned off.
 - The **Power-Save mode** is active.
 - The clock with a Power-Save run time (approx. eight seconds) appears, illustration 1.
-

**Note**

▶ After eight seconds have expired, a clock appears briefly with an integrated STOP icon, which displays the complete turning off of the LICCON computer system.

- The clock with integrated STOP icon appears for a few seconds, illustration 2.
- All processes on the LICCON computer system are stopped.
- The LICCON computer system turns off completely.

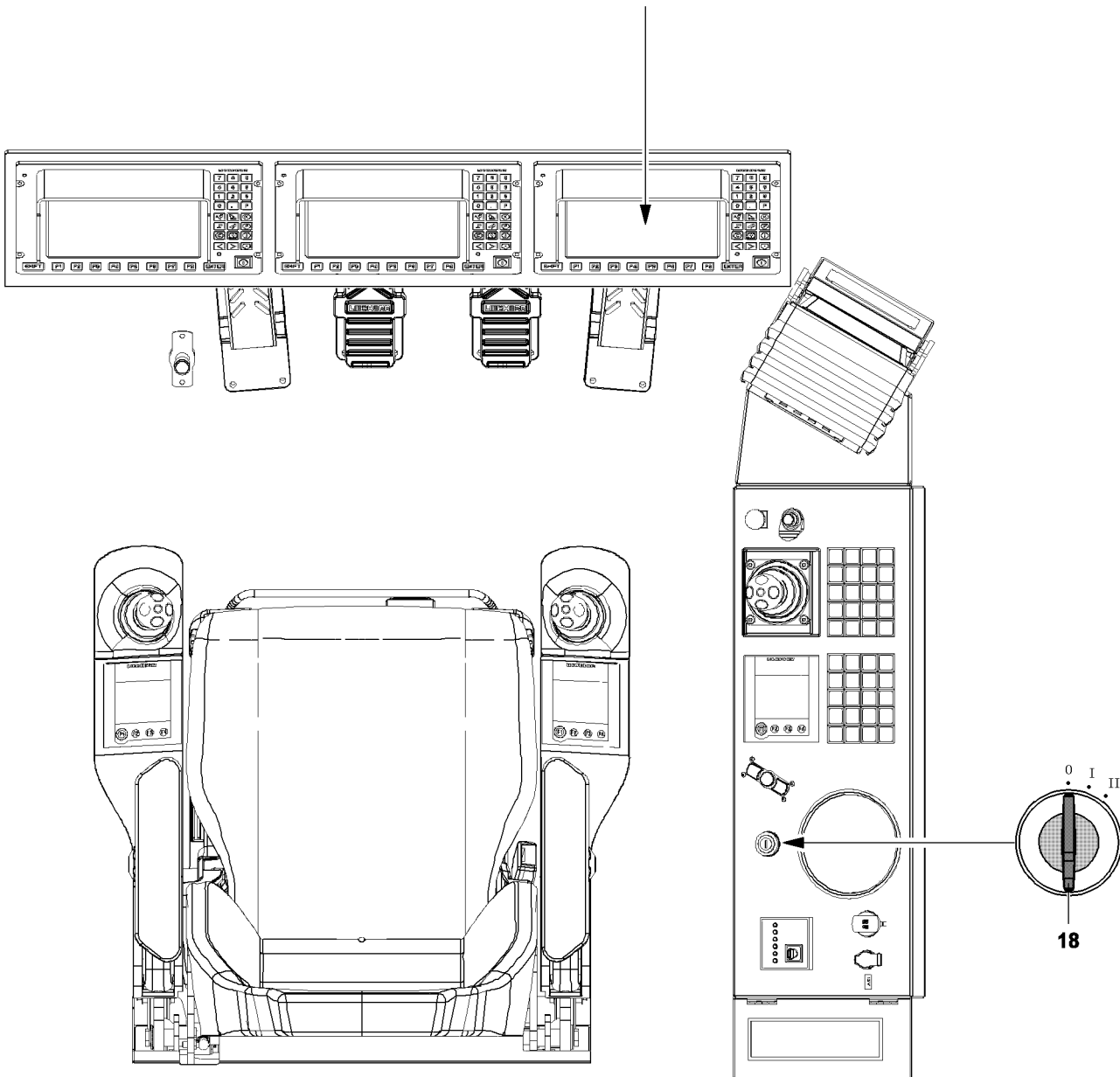
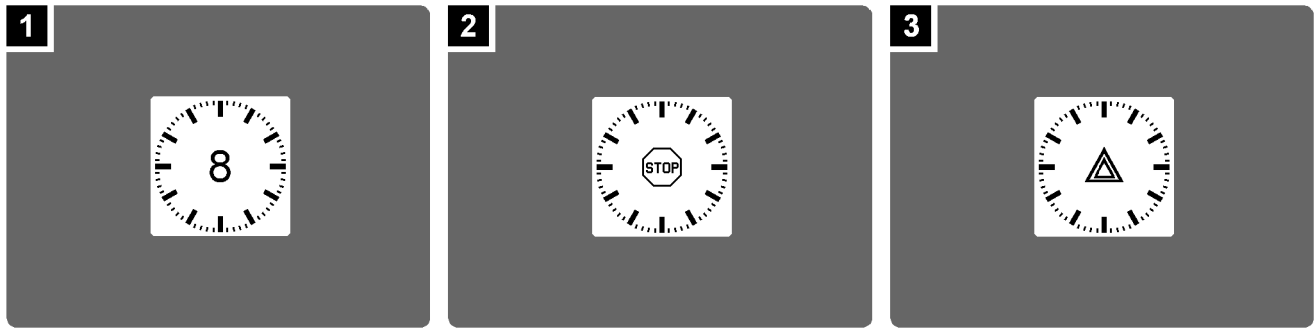

Fig.115263

LWE/LR 11000-001/23501-04-02/en

Press any key in Power-Save mode once**Note**

▶ Pressing a key in Power-Save mode once shortens the Power-Save alarm time to five seconds.

▶ Press any key.

Result:

– The Power-Save alarm time is shortened to five seconds.

Press any key in Power-Save mode twice

▶ Press any key twice in succession.

Result:

- The Power-Save alarm time is set to zero.
- The clock with integrated STOP icon appears for a few seconds, illustration 2.
- All processes on the LICCON computer system are stopped.
- The LICCON computer system turns off completely.

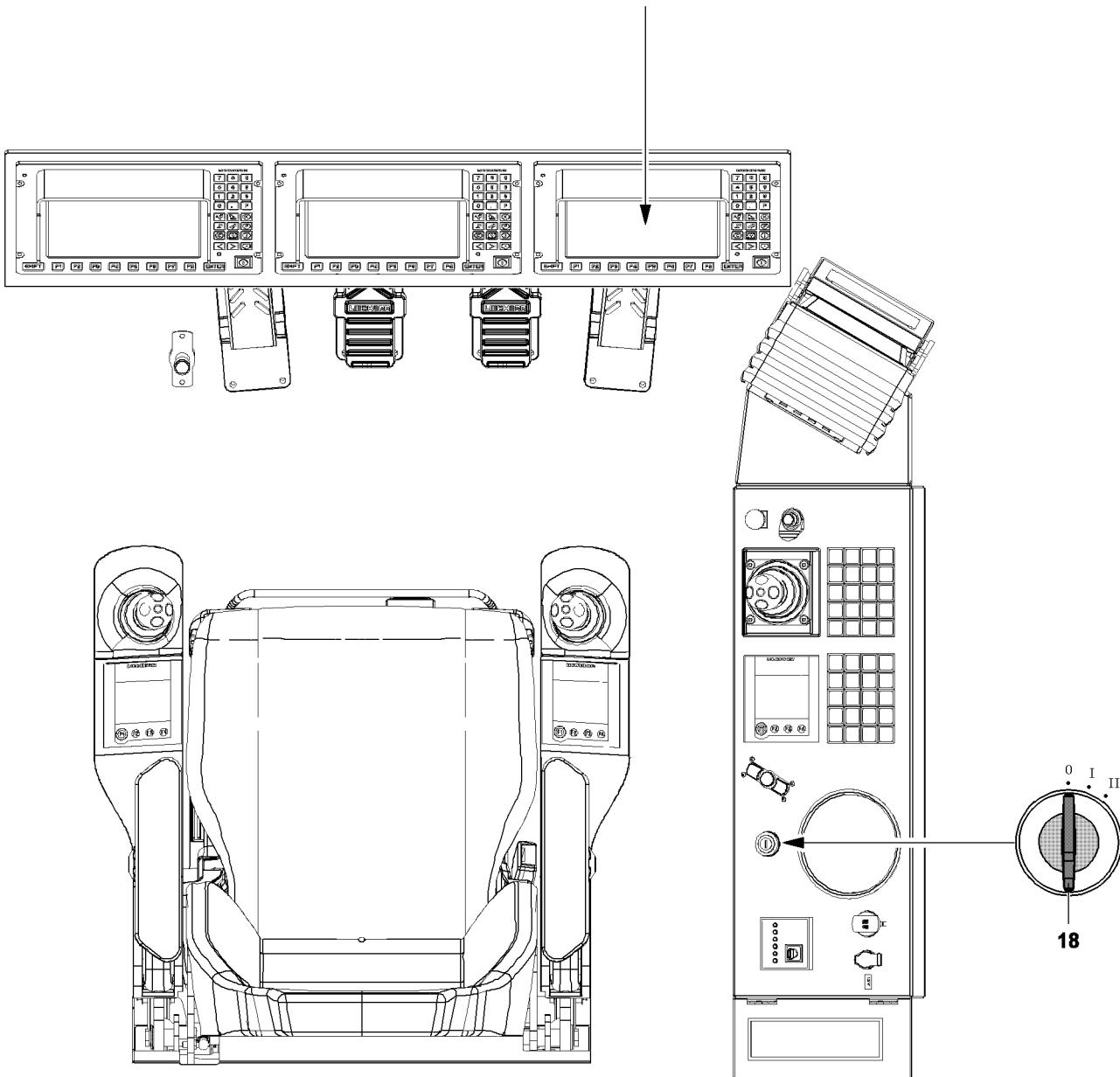
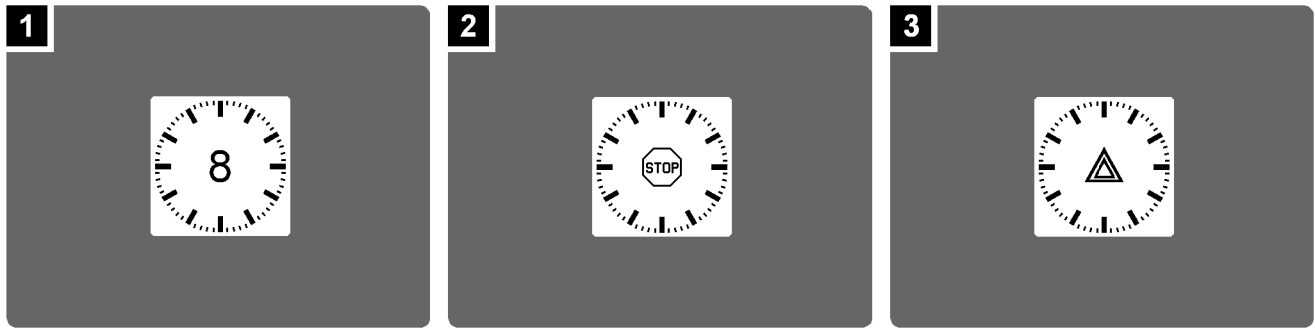

Fig.115263

LWE/LR 11000-001/23501-04-02/en

9.2 Stand-by mode

After pressing the Engine STOP key - the crane engine is turned off - on the LICCON monitor, the operating interface of the most recently active application program continues to be displayed for an additional 10 minutes, illustration 3.

After 10 minutes are over, the Stand-by mode is reached. The Stand-by mode is displayed by the Stand-by clock + warning icon on the LICCON monitor and by a repeated short acoustic signal (*short horn*) with longer intervals.



Note

- ▶ In the Stand-by mode, no crane movements are possible.

There are two ways of achieving Stand-by mode with the LICCON computer system.

Turning the crane engine off

Turning the engine off with the engine STOP key:

- ▶ Press the engine STOP key.
- ▶ Leave the ignition key **18** in position „I“.

Result:

- The crane engine is turned off.
- The ten minute time frame is over.
- ▶ Within the ten minute time frame, press **any key**.

Result:

- The ten minute time frame is reset and starts again.
- ▶ Within the ten minute time frame, press **no key**.

Result:

- After the time is over, the **Stand-by mode** is reached.
- The display area on the LICCON monitor turns black.
- The stand-by clock with a warning icon is shown, illustration 3.
- Every half a minute a repeating acoustic signal from the LICCON monitor sounds.



Note

- ▶ The Stand-by mode does not lead to any automatic shut off of the LICCON computer system.

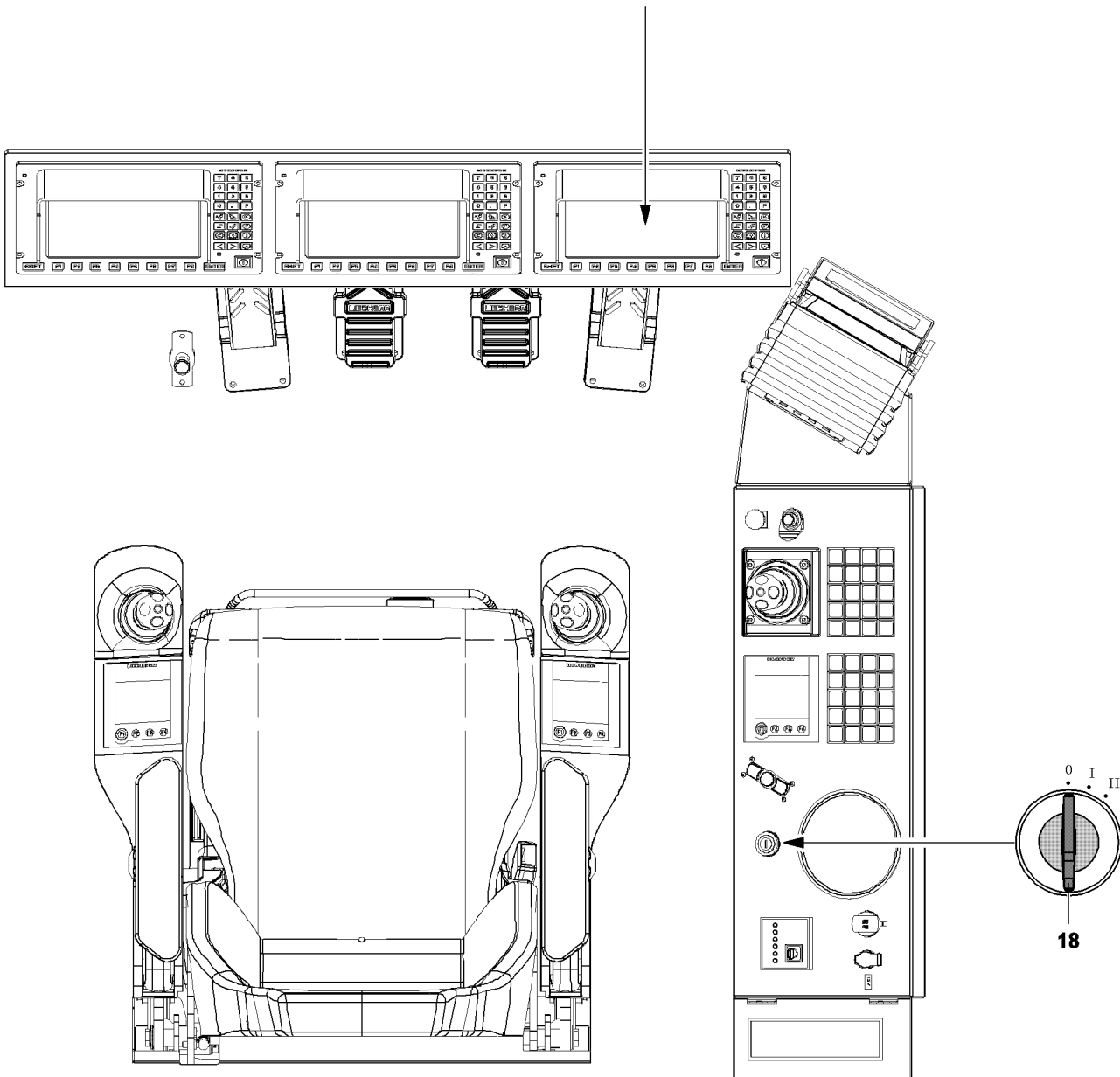
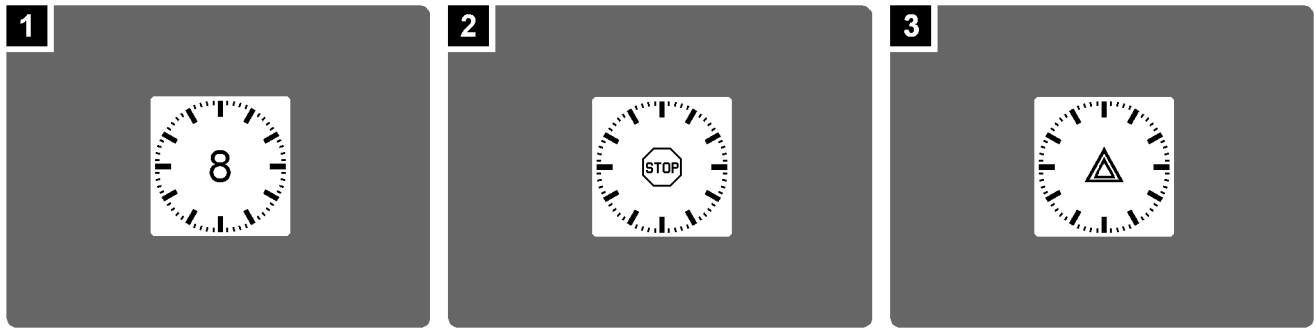

Fig.115263

LWE/LR 11000-001/23501-04-02/en

Turn the LICCON computer system off from the Stand-by mode

- ▶ Turn the ignition switch to position 0.

Result:

- The Power-Save mode is active.

**Note**

- ▶ See section „Power-Save mode“.

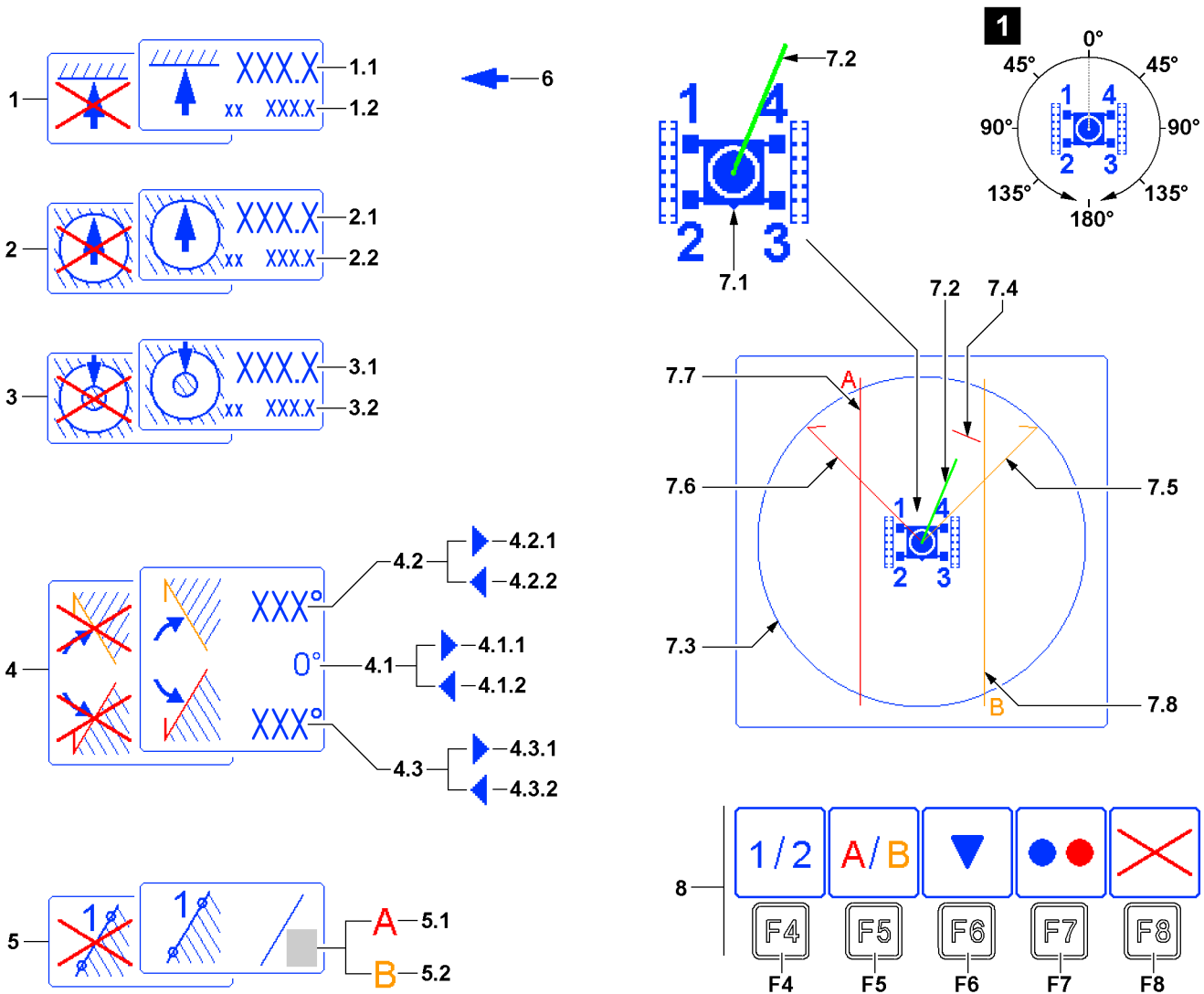
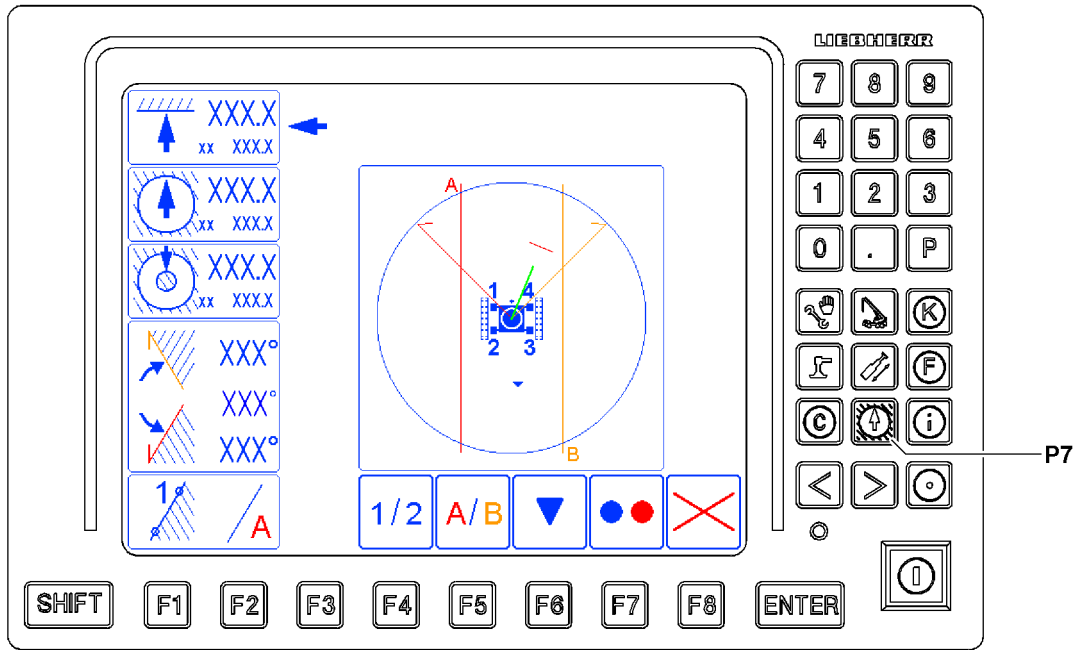

Fig.116057

LWE/LR 11000-001/23501-04-02/en

10 The *Working range limitation* program

For a detailed description of *Working range limitation* program, see separate Operating instructions for Working range limitation.

10.1 Starting the program

- ▶ Press the program key P7.

10.2 Operating interface



Note

- ▶ The limit function icons are shown crossed out if they are inactive

- 1 Pulley head height
 - Limitation of pulley head height
 - Limits the height of the load pulley to a predetermined dimension
- 1.1 Limit value
 - The limitation is made by reaching the limit value of the pulley head height
- 1.2 Actual value
 - Current pulley head height
- 2 Working radius_{max}
 - Limitation of maximum working radius (maximum boom radius)
 - Limits the working radius of the load hook to a predetermined upper limit
- 2.1 Limit value
 - The limitation is made by reaching the limit value for the maximum working radius
- 2.2 Actual value
 - Current working radius
- 3 Working radius_{min}
 - Limitation of minimum working radius (minimum boom radius)
 - Limits the working radius of the load hook to a predetermined lower limit
- 3.1 Limit value
 - The limitation is made by reaching the limit value for the minimum working radius
- 3.2 Actual value
 - Current working radius

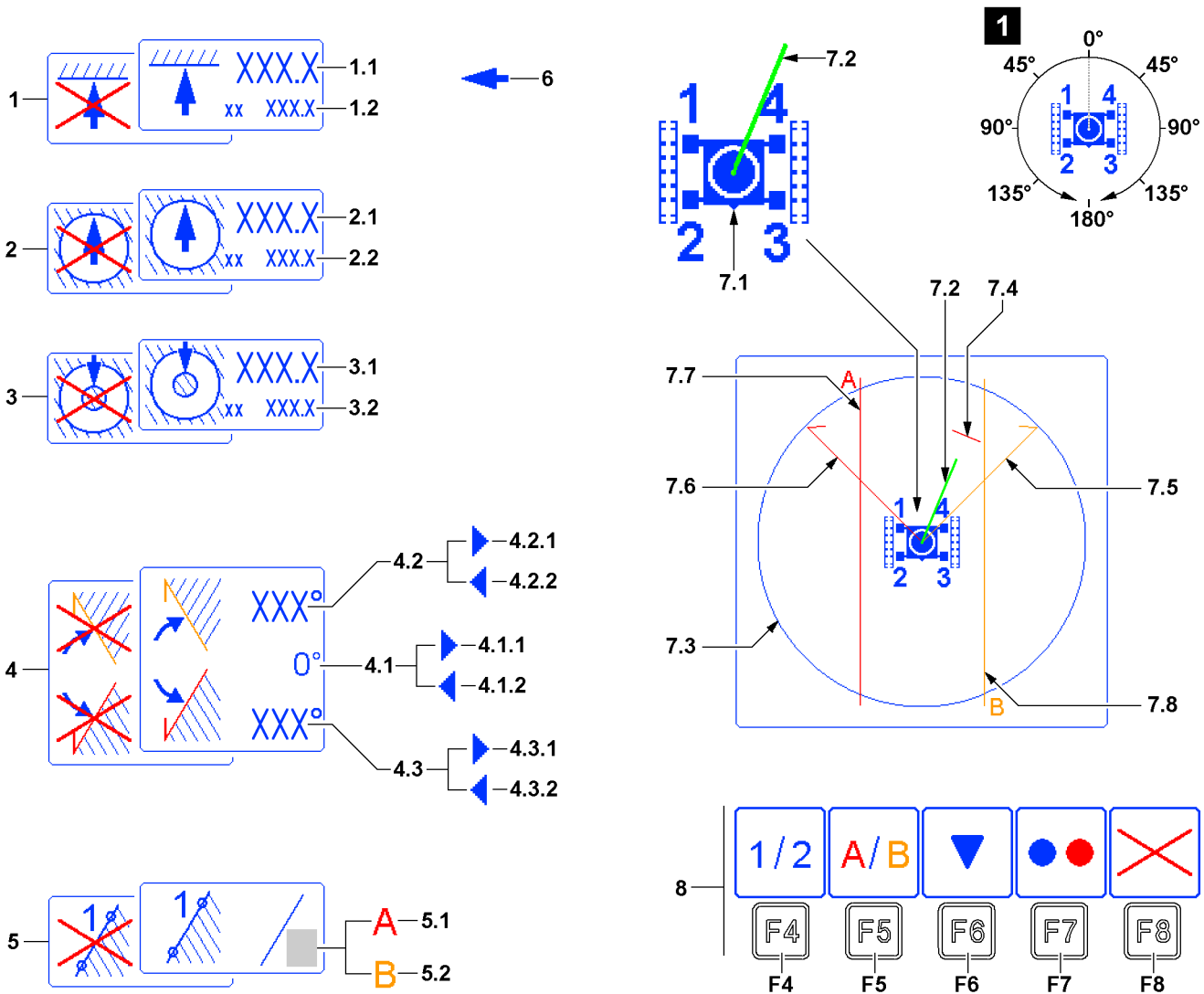
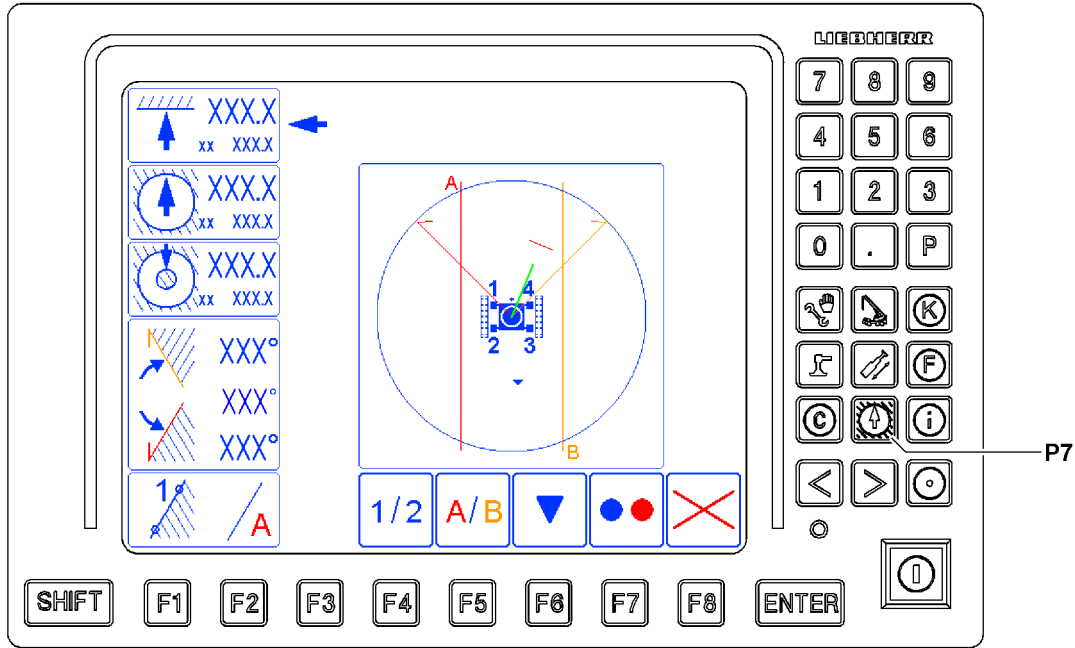

Fig.116057

LWE/LR 11000-001/23501-04-02/en

- 4 Turning limitation
 - Limitation of turning range
 - Limits the turning range of the crane superstructure to a predetermined angle range.
 - Each consists of one right limit angle **4.2** and one left limit angle **4.3**.
- 4.1 Slewing angle
 - Current slewing angle of the crane superstructure
 - Main working direction of the crane = slewing angle 0°
Slewing angle 0° is displayed when the crane superstructure is oriented exactly to the rear.
 - The slewing angle increases on both sides up to 180° when the crane superstructure is turned. When turning past 180°, the side is changed on the Scaling display, see illustration 1.
 - Arrow to the right **4.1.1**: Range *Crane superstructure turned to the right*
 - Arrow to the left **4.1.2**: Range *Crane superstructure turned to the left*
- 4.2 Limit angle right
 - The limitation is made by reaching this right limit angle
 - Arrow to the right **4.2.1**: Limit angle is in range *Crane superstructure turned to the right*
 - Arrow to the left **4.2.2** Limit angle is in range *Crane superstructure turned to the left*
- 4.3 Limit angle left
 - The limitation is made by reaching this left limit angle
 - Arrow to the right **4.3.1**: Limit angle is in range *Crane superstructure turned to the right*
 - Arrow to the left **4.3.2** Limit angle is in range *Crane superstructure turned to the left*
- 5 Edge limitation
 - Limitation of freely selectable edges (limitations)
 - Consists of up to two edges („edge A **5.1**“ and „edge B **5.2**“), which do not have to run through the center of the slewing ring.



Note

- ▶ Due to the edge limitation it is possible to determine the working range limits, which allow a rotation of 360° compared to the slewing angle limitation. If necessary, the boom radius must be shorted for turning.
-

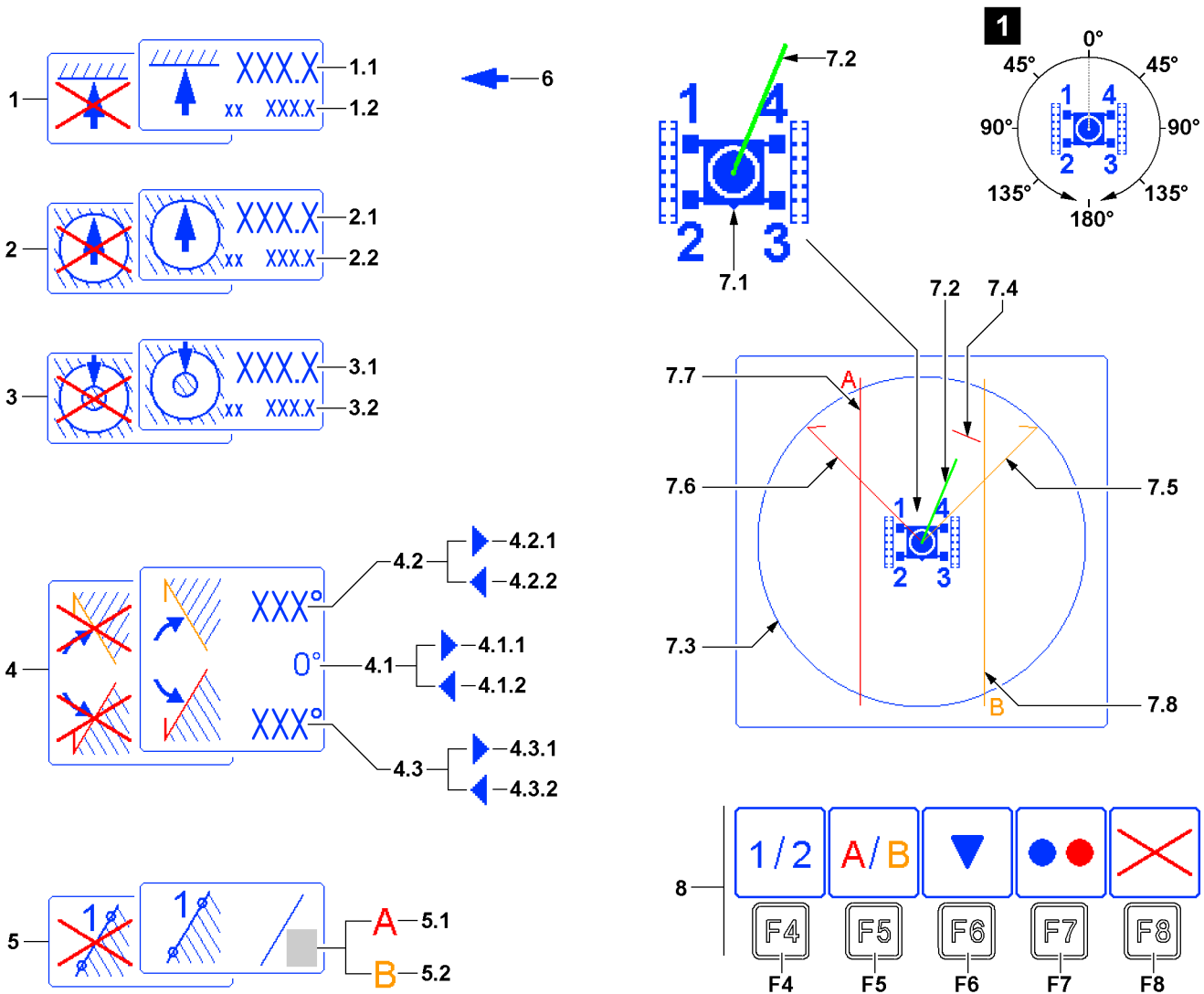
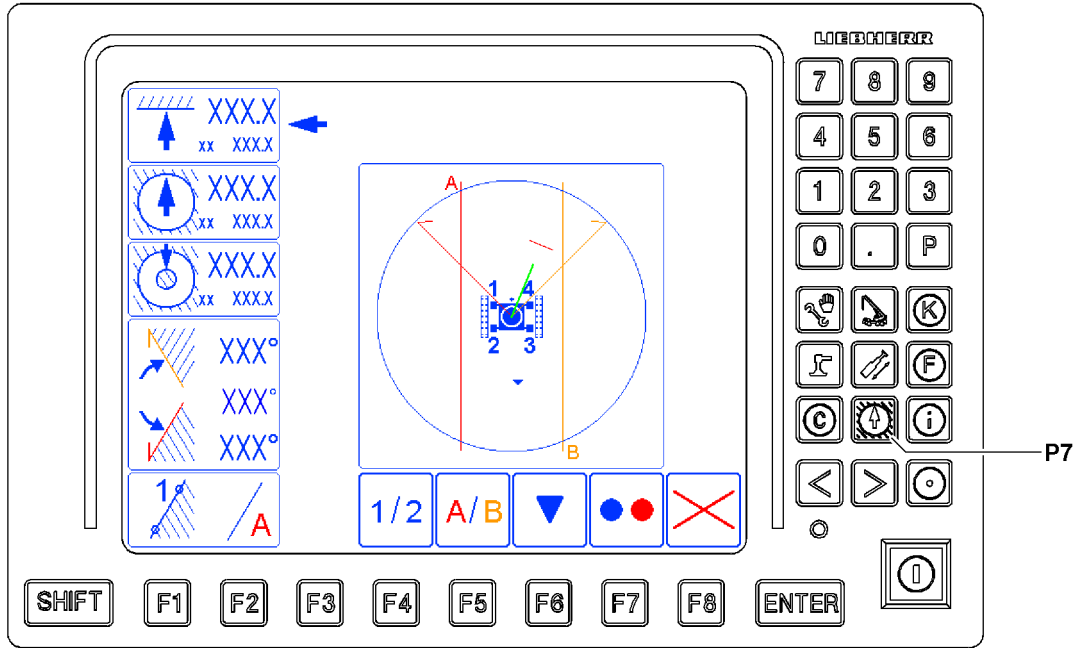

Fig.116057

LWE/LR 11000-001/23501-04-02/en

- 6 Function selector
 - To select the limitation functions (Position 1 to 5)
- 7 Graphic display
 - Graphic display of programmed working range limits viewed from above. The crawler travel gear is shown in the center.
 - The triangle 7.1 shows where the front is on the crawler travel gear.
 - The green bar 7.2 shows the current direction and boom radius of the main boom. The longer the green bar, the larger the boom radius of the crane.
- 7.3 Crane working radius
 - Graphic illustration of the maximum working radius (maximum boom radius) of the crane under ideal conditions.
 - **Note:** Setting cannot be changed in the program.
- 7.4 Working radius_{max}
 - Graphic illustration of the maximum working radius (maximum boom radius).
 - Based on the limit value 2.1 from *Working radius_{max}* icon 2
 - **Note:** If the green bar 7.2 crosses the red line of the working radius_{max} 7.4, a shut off occurs.
- 7.5 Limit angle right
 - Graphic illustration of the right limit angle.
 - Based on the limit angle right 4.2 from *Turning limit* icon 4
 - **Note:** If the green bar 7.2 and the orange line of the limit angle right 7.5 are superimposed, a shut off occurs.
- 7.6 Limit angle left
 - Graphic illustration of the left limit angle.
 - Based on the limit angle left 4.3 from *Turning limit* icon 4
 - **Note:** If the green bar 7.2 and the red line of the limit angle left 7.6 are superimposed, a shut off occurs.
- 7.7 Edge A
 - Graphic illustration of edge A
 - Based on the edge A 5.1 from *Edge limitation* icon 5
 - **Note:** If the green bar 7.2 crosses the red line of the edge A 7.7, a shut-off occurs.
- 7.8 Edge B
 - Graphic illustration of edge B
 - Based on the edge B 5.2 from *Edge limitation* icon 5
 - **Note:** If the green bar 7.2 crosses the orange line of the edge B 7.8, a shut-off occurs.

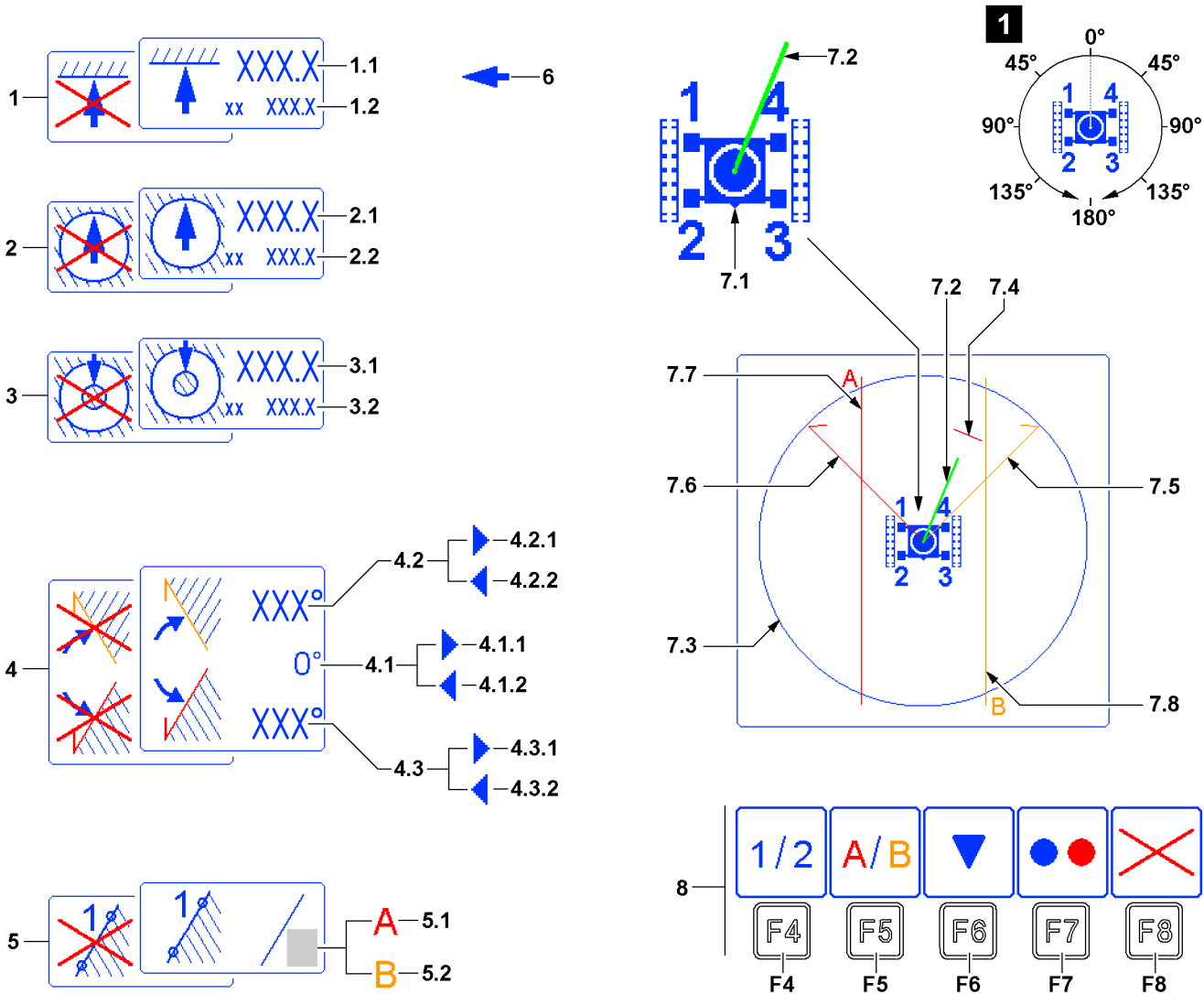
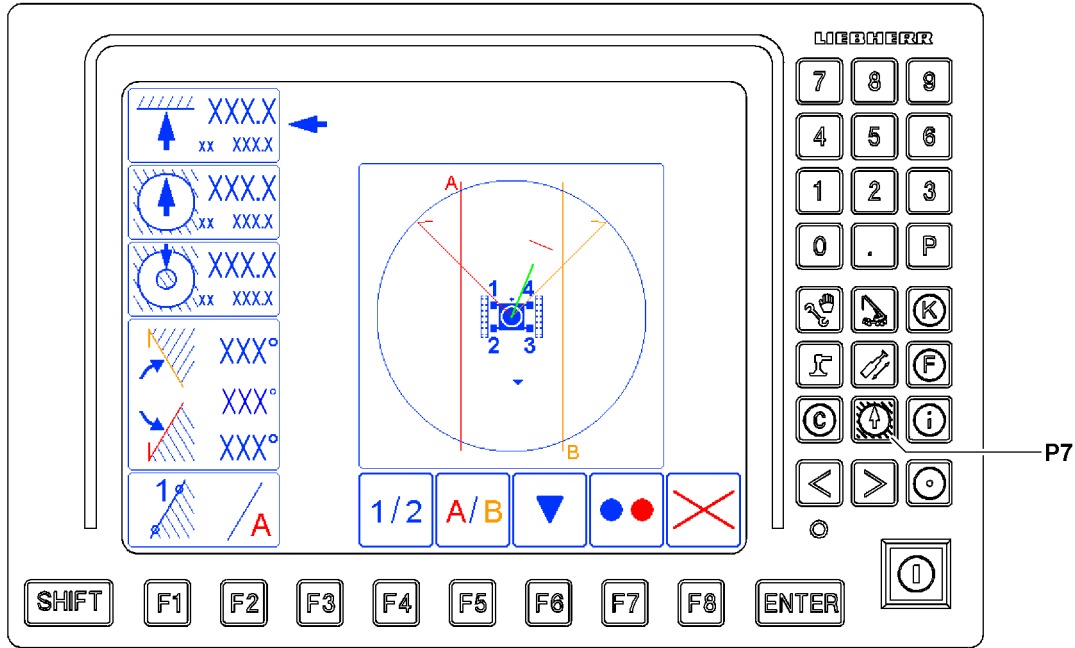

Fig.116057

LWE/LR 11000-001/23501-04-02/en

10.2.1 Function key line in the *Working range limitation* program

- F4** Function key
 - Select point 1 or 2 of selected edge A (red) or B (black)
- F5** Function key
 - Selected edge A (red) or B (black) that is being programmed
- F6** Function key
 - The function selector is moved down by one limit function
- F7** Function key
 - ON / OFF

The limitation function selected with the function selector **6** changes its status. If previously active, it will now be inactive when the function key **F7** is pressed, and vice versa. An inactive limit function is identified by a crossed out icon. If the function selector **6** shows a turning limit to the left or the right, then both limits will always be switched.

Note: For the edge limitation **5**, only the preselected edge will be switched. The edge that is not displayed can be active or inactive at the same time.



Note

- ▶ Limit functions can only be added via the function key **F7** when the boom is in the respective permissible range.

- F8** Function key
 - All limit functions become inactive

10.3 Occurrence of a shut off in the working range limitation

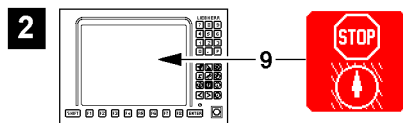

Fig.115262

If the programmed working range limitation is actuated, then this status is shown in the crane operating screen by a STOP icon **9**, see illustration **2**.

11 Chart view program: Curve illustration of load charts

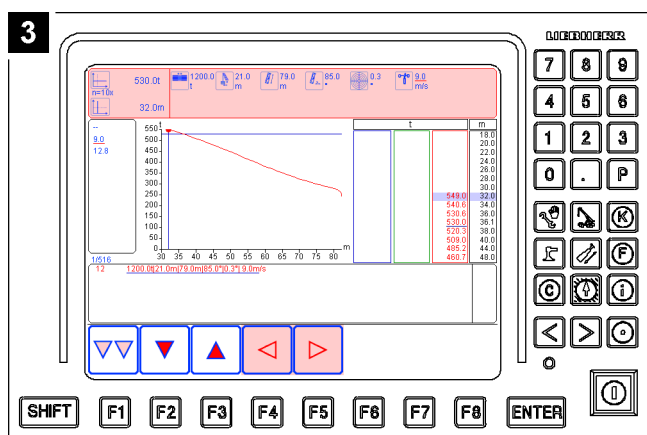
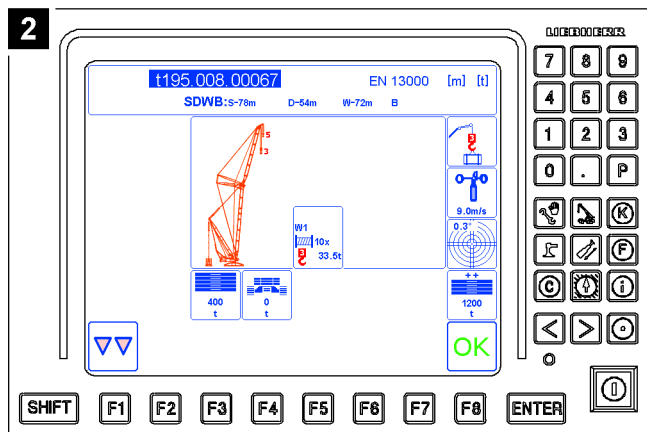
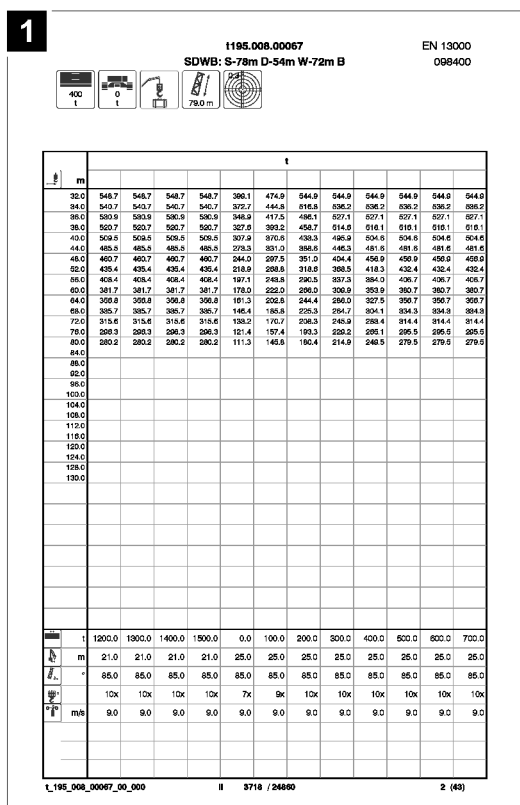

Fig.120685



Note

- The monitor illustrations in this section are only examples!
- The numerical values in the individual icons and charts do not have to necessarily match the crane exactly!
- Numbers and letters can be replaced by place holders!
- The programmed load charts for the crane are binding!

The curve illustration of the load charts is based on:

- the load charts, illustration 1
- the entries and settings in the *Set up* program, illustration 2
- the entries and settings in the *Chart view* program, illustration 3

In the *Chart view* program, the following can be carried out:

- Display of load charts as curves and as numeric values
- Filtration of load columns according to certain column criteria
- Comparison of up to three curves

11.1 Ranges of curve display of load charts

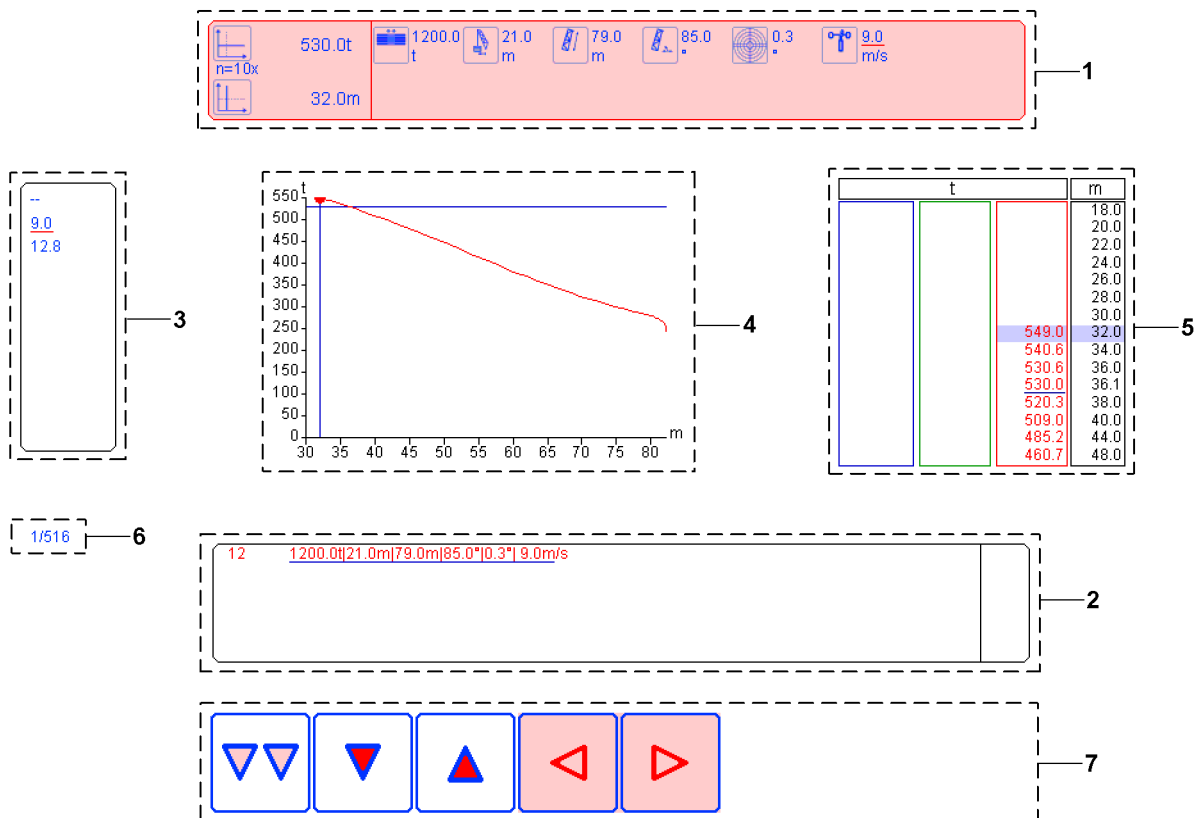

Fig.120686

The curve display window consists of the following program categories and areas:

- 1 Filter category
 - Depending on the settings in the *Set up* program, different parameters are shown
- 2 Column category
 - Depending on the parameters of the Filter category 1 load columns are shown.
- 3 Editing and selection area
 - To edit or select values
- 4 Curve display
 - Curve display of load columns from the column category 2
- 5 Numeric display
 - Number display of load columns from the column category 2
- 6 Page counter
 - Number of filtered / all columns
- 7 Function keys
 - For navigation within the screen display
 - The icons correspond to the various function keys below them

11.2 Filter category

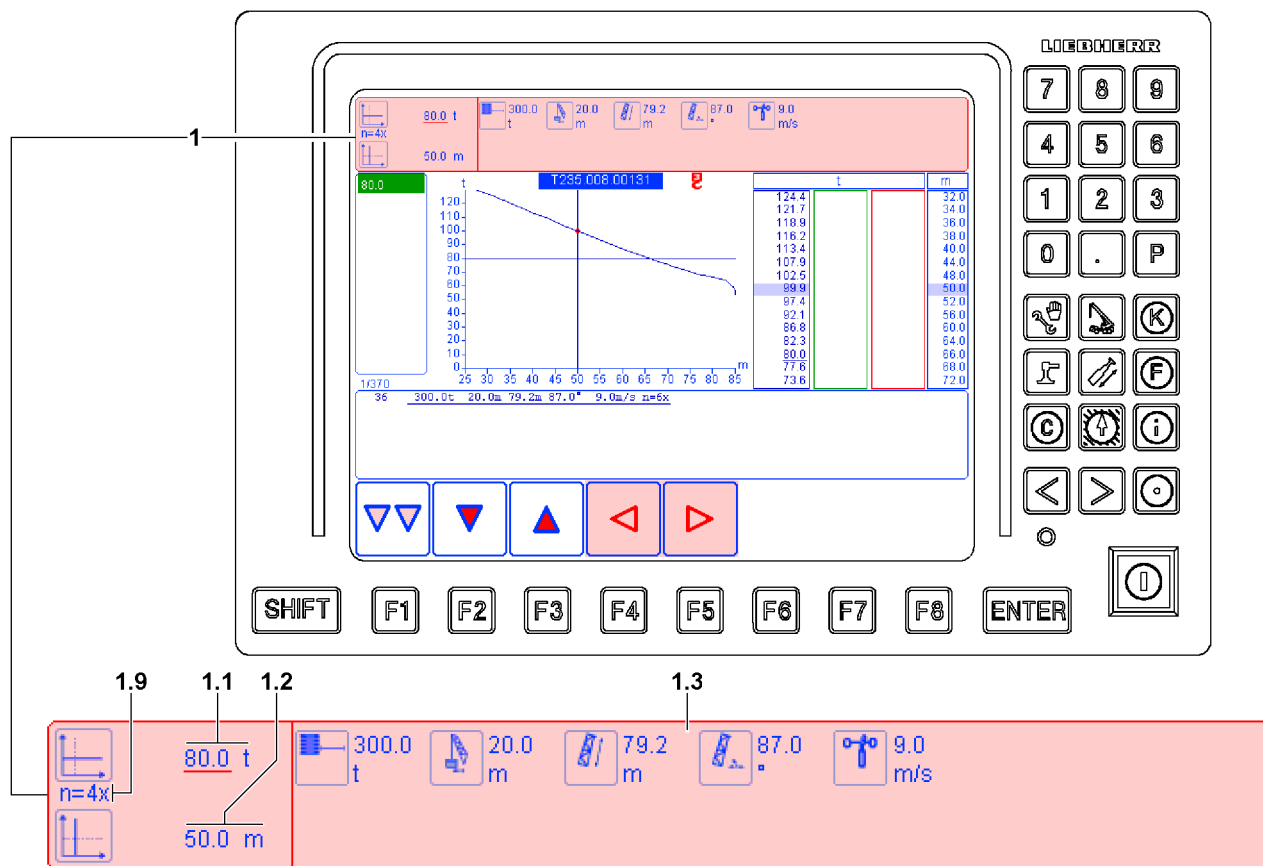

Fig.120663

The filter category 1 is divided into two areas.









- In the left area, the parameter boom radius and load can be set to analyze the displayed load curves in the numeric curve display area.
- In the right area, a filter can be set which can be used to limit the number of relevant load columns.

Depending on the settings in the *Set up* program, different parameters are shown. It is only possible to change parameters within the load chart, whose chart name is set in the *Set up* program.

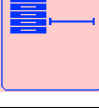
It is not possible to change the parameters within the filter category in such a way that another chart name and therefore another load chart is called up.

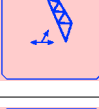
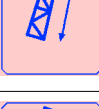
Parameters in the left area:

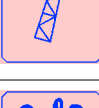
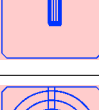
- 1.1 Load
 - Desired load on the hook
 - **Note:** In addition to load 1.1 the required reeving 1.9 is shown.
- 1.2 Boom radius
 - Desired boom radius of the crane

Parameters in the right area 1.3	
 XXX.X XXX	Counterweight: Weight of counterweight
 XXX.X XXX	Central ballast ¹⁾ : Weight of central ballast
 XXX.X XXX	Derrick ballast ¹⁾ : Weight of derrick ballast
 XXX.X XXX	Note: Depending on the crane type, one of the icons is shown.
 XXX.X XXX	Derrick radius ¹⁾ : Boom radius of the derrick boom
 XXX.X XXX	Derrick angle ¹⁾ : Angle of derrick boom to the horizontal
 XXX.X XXX	Calculation value main boom: The length display refers to a static calculation value for the main boom. The static calculation value can deviate slightly from the set up main boom length.
 XXX.X XXX	Angle main boom ²⁾ : Angle of main boom to the horizontal
 XX.X XXX	Angle accessory / auxiliary boom ²⁾ : The angle of the accessory / auxiliary boom to the horizontal
 XXX.X XXX	Wind speed ³⁾ : Maximum permissible wind speed
 XX.X	Incline range ³⁾ : Permissible maximum incline of crane to the horizontal

1) Appears solely at respective operating mode

2) Appears solely in operating modes with luffing accessory / auxiliary boom

2) Appears solely in operating modes with selection possibility for this parameter



Note

- ▶ Set the parameter, see section „Carry out parameter settings“.
- ▶ If a parameter for an operating mode does not appear, then the following parameters move up.

11.3 Column category

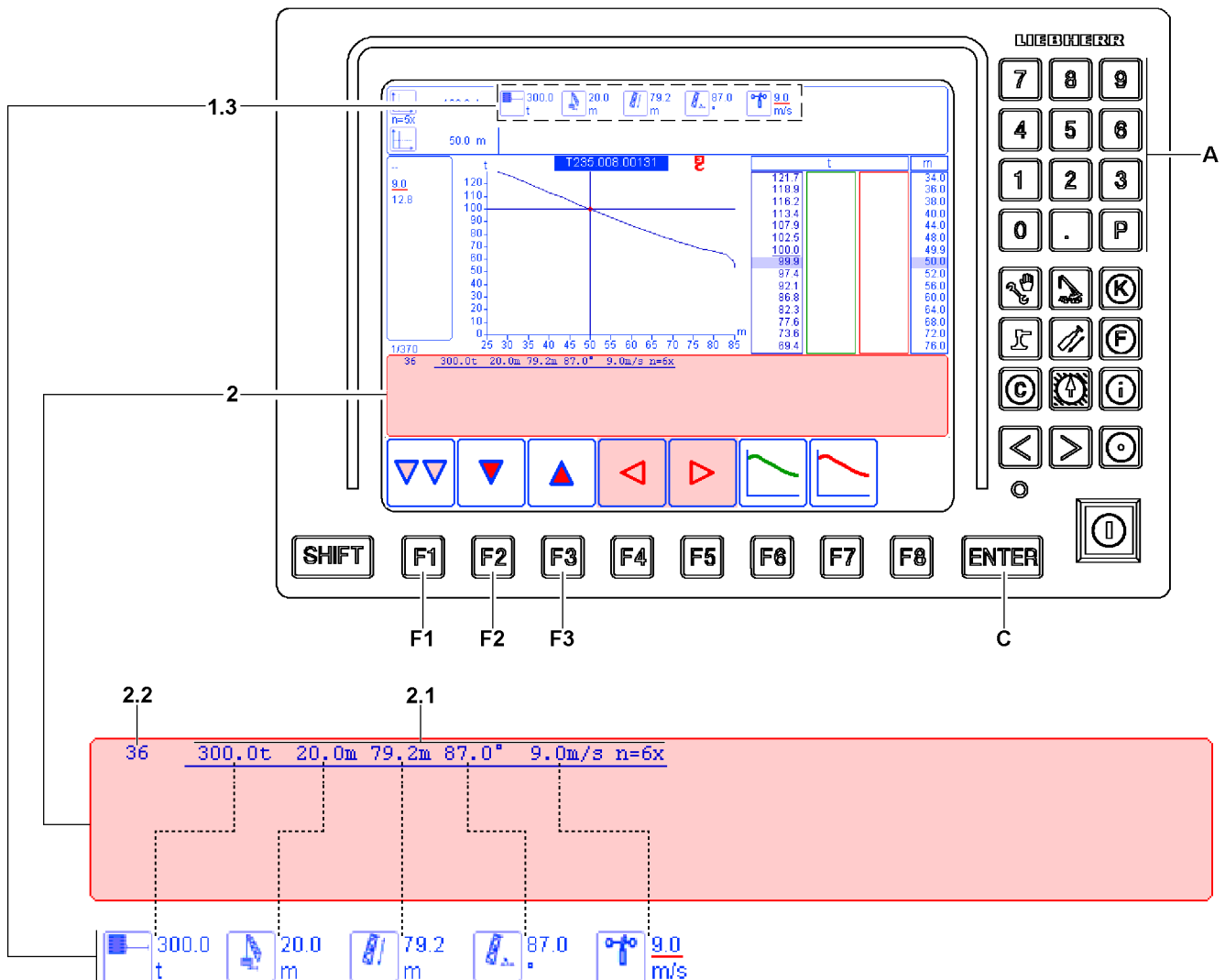

Fig.120664

For all display load columns **2.1** the values of the column parameters are combined to a text line. This happens in the same sequence as the parameters in the right area **1.3** are located in the filter category.

Every load column **2.1** is numbered and has a column number **2.2** for identification. In the column category **2** the relevant load columns **2.1** for the set operating mode are listed.

The number of load columns **2.1** can be reduced or expanded by setting the parameters in the filter category, see section „Carrying out parameter settings“.

If more than seven load columns exists in the column category **2**, then you have to page to view. To page, the column category **2** must be active.

- Set the column category to active: Press the function key **F1** until the column category **2** is highlighted in pink.
- Page in the column category: Press function key **F2** or function key **F3**.

11.4 Editing and selection area

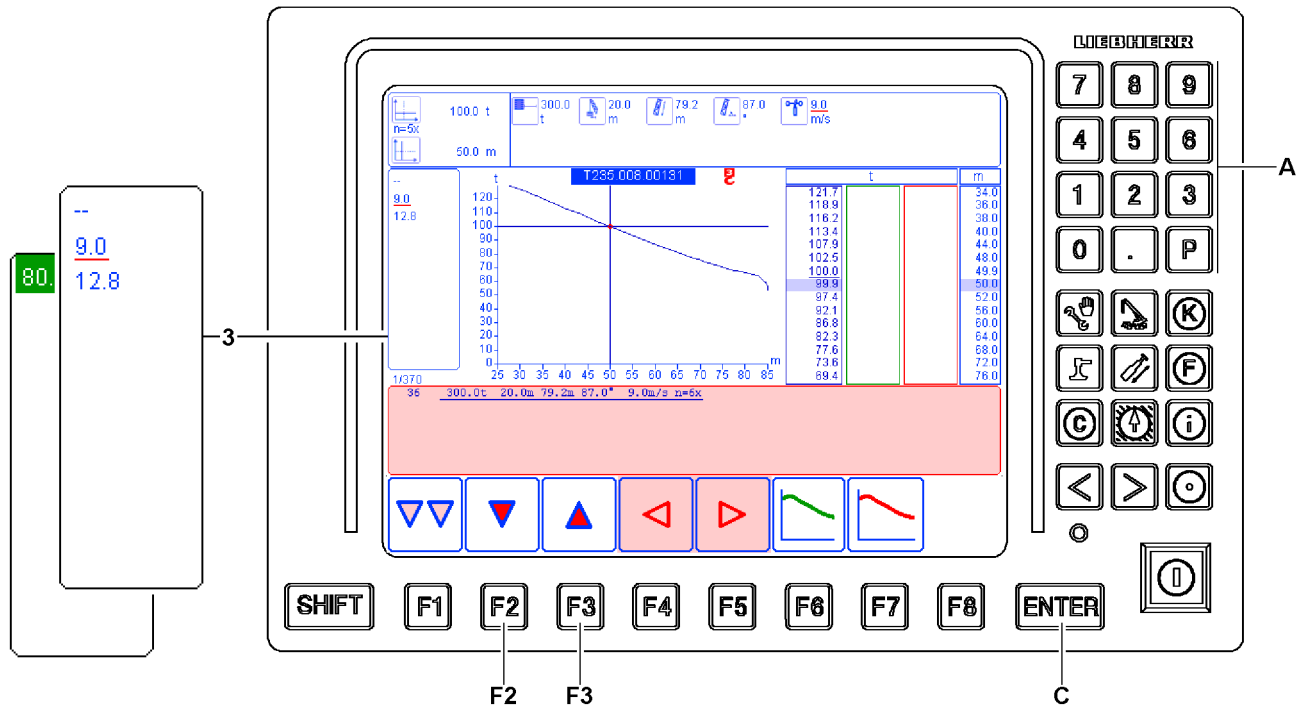

Fig.120680

If an element is selected in the filter category there are two possibilities to select the values:

- The value for this element is entered via the keypad **A**.
- The values to be selected are shown directly in the Editing and selection area **3**. The selection is made by positioning a selection bar. The positioning is made via the function key **F2** and die function key **F3**.

The respective selection possibility is specified by the program.

If the value is confirmed by pressing the ENTER key **C**, then it is accepted into the filter category.

11.5 Curve display

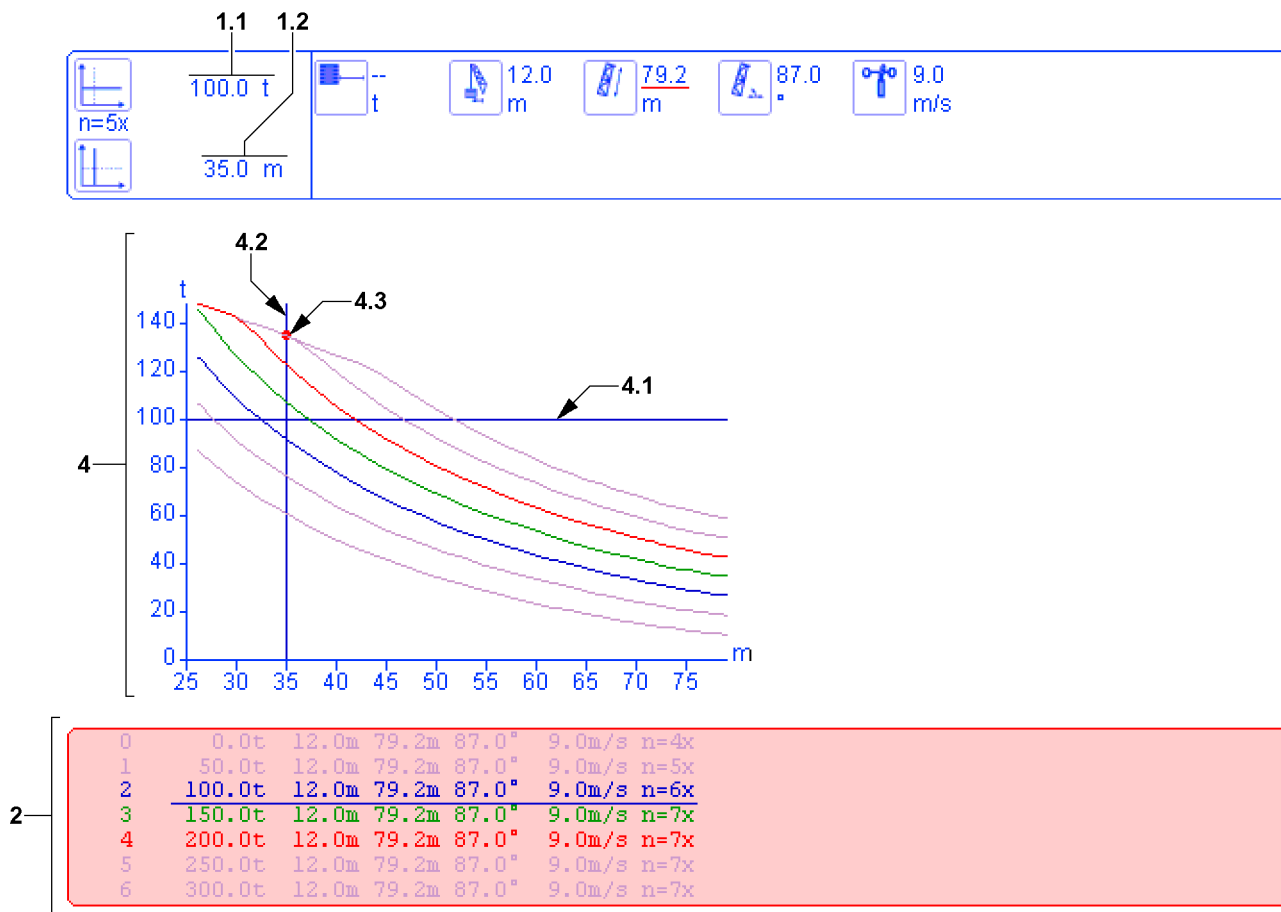

Fig.120665

Only the load columns are shown in the curve display 4, which are also shown in the column category 2.

- Up to three curves of marked load columns are displayed in red, green or blue.
- The curves of the unmarked load columns are displayed in gray.
- If a value of more than 0 is entered for the parameter load 1.1, then a horizontal line 4.1 appears.
- If a value of more than 0 is entered for the parameter boom radius 1.2, then a vertical line 4.2 appears.
- A red dot 4.3 shows the maximum load of the current load columns.

11.6 Numeric display

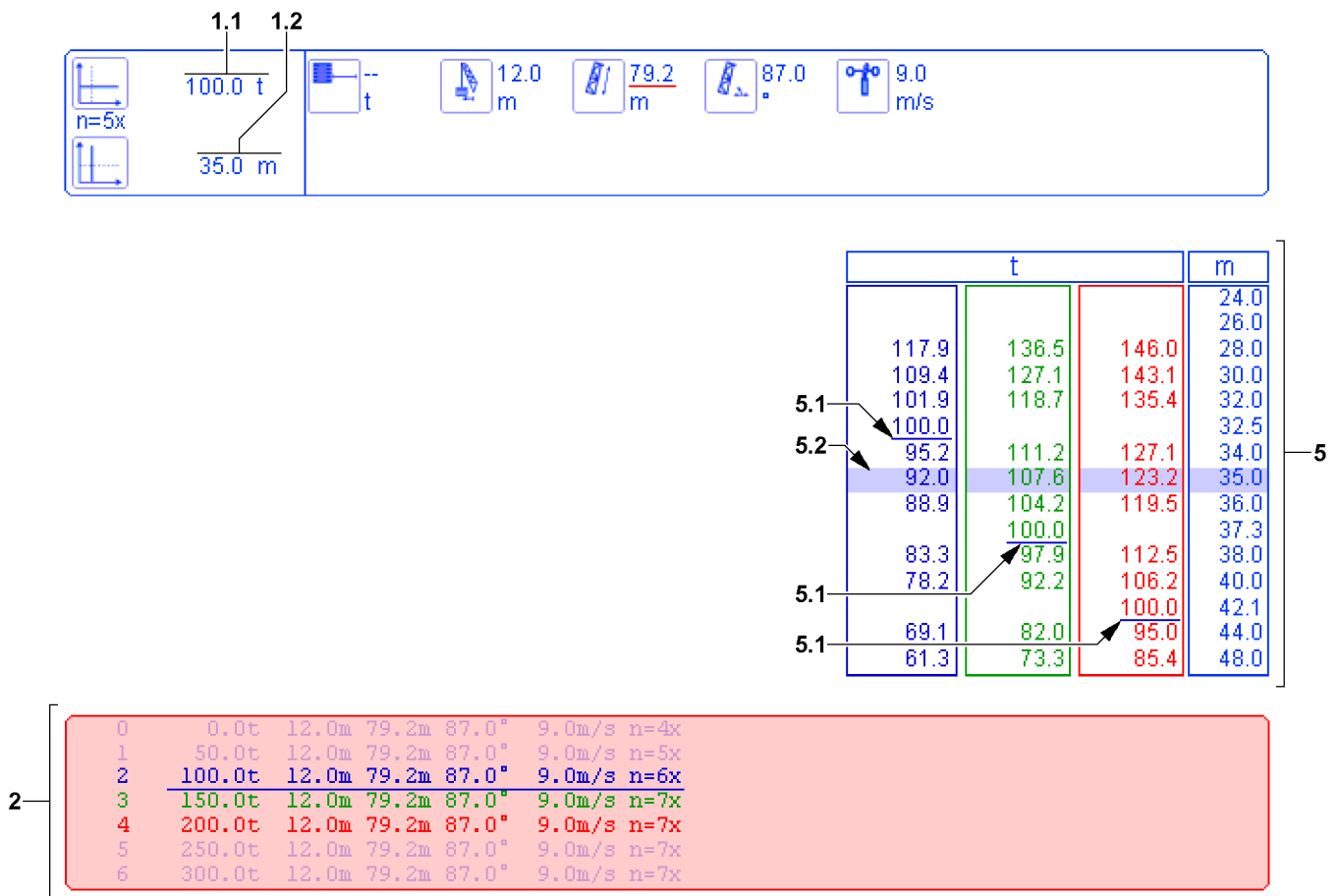

Fig.120683

For the numeric display 5 up to three load columns can be shown and compared with each other.

Only the load columns are shown in the numeric display 5, which are also shown in the column category 2.

To do so:

- The load columns are highlighted in color in the column category, see section „Highlighting load column in color“
- Enter values for the parameter load 1.1 and boom radius 1.2, see section „Carrying out the parameter settings“.

The areas of the load column correspond in color to the assigned curve display and the load column.

The parameters for Load 1.1 and Boom radius 1.2 are highlighted.

- The nominal value for the Load 1.1 is underlined in the listing with a line 5.1.
- The nominal value for the boom radius 1.2 is highlighted with a blue bar 5.2 in the listing.

11.7 Page counter

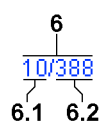

Fig.120684

The page counter 6 shows the number of the filtered columns and the total number of all columns.

LWE/LR 11000-001/23501-04-02/en

A slash separates the left numbers from the right numbers.

Layout of page counter:

- The left numbers **6.1** show the number of filtered displayable columns in the column category.
- The right numbers **6.2** show the number of all load columns relevant for this operating mode.

11.8 Function keys

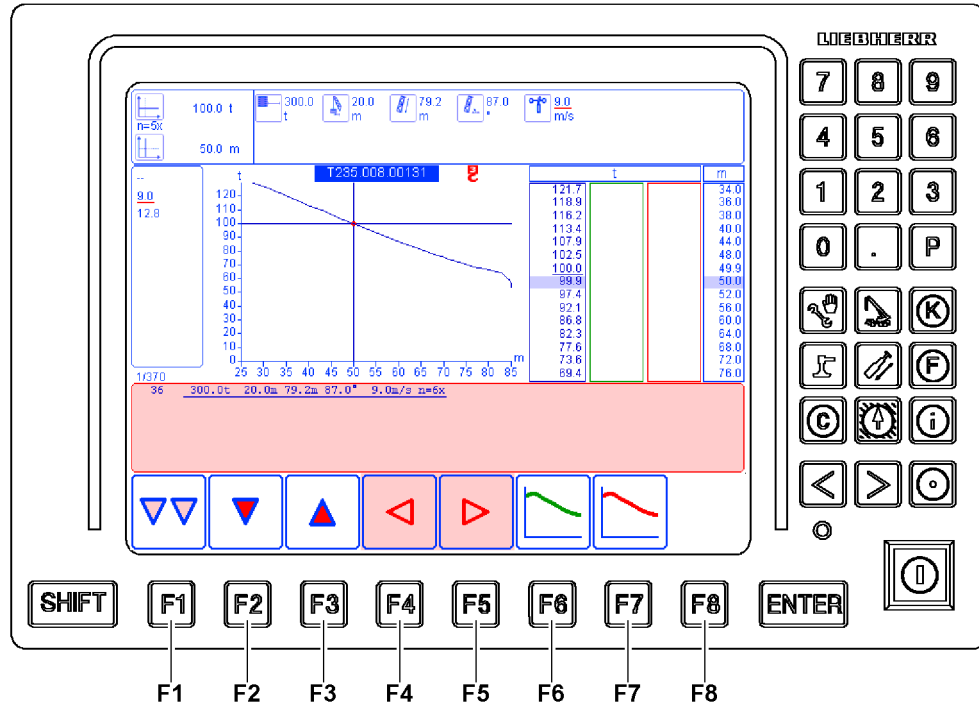

Fig.120666

The function key line consists of function keys **F1** to **F8** and the function key icon bar above it. The function keys correspond to the various function key icons above them.



Note

- Not all function keys on the LICCON monitor are always active and assigned with icons. Only when a function key is presently available is the corresponding icon shown.

F1 Function key

- Change to the next category by pressing the function key **F1**.
- **Note:** The active category is highlighted in pink.

F2 Function key

- Navigation: change downward
- **Note:** If it is not possible to change further downward, a short beep sounds.

F3 Function key

- Navigation: change upward
- **Note:** If it is not possible to change further upward, a short beep sounds.

F4 Function key

- Navigation: change to the left
- **Note:** At active column category reduce the value for the nominal boom radius.
- **Note:** If it is not possible to change further to the left, a short beep sounds.

F5 Function key

- Navigation: change to the right
- **Note:** At active column category increase the value for the nominal boom radius.
- **Note:** If it is not possible to change further to the right, a short beep sounds.

- F6** Function key
 - For active column category active curve assign the color green
- F7** Function key
 - For active column category active curve assign the color red
- F8** Function key
 - Not assigned

11.9 Operating elements for curve display of load charts

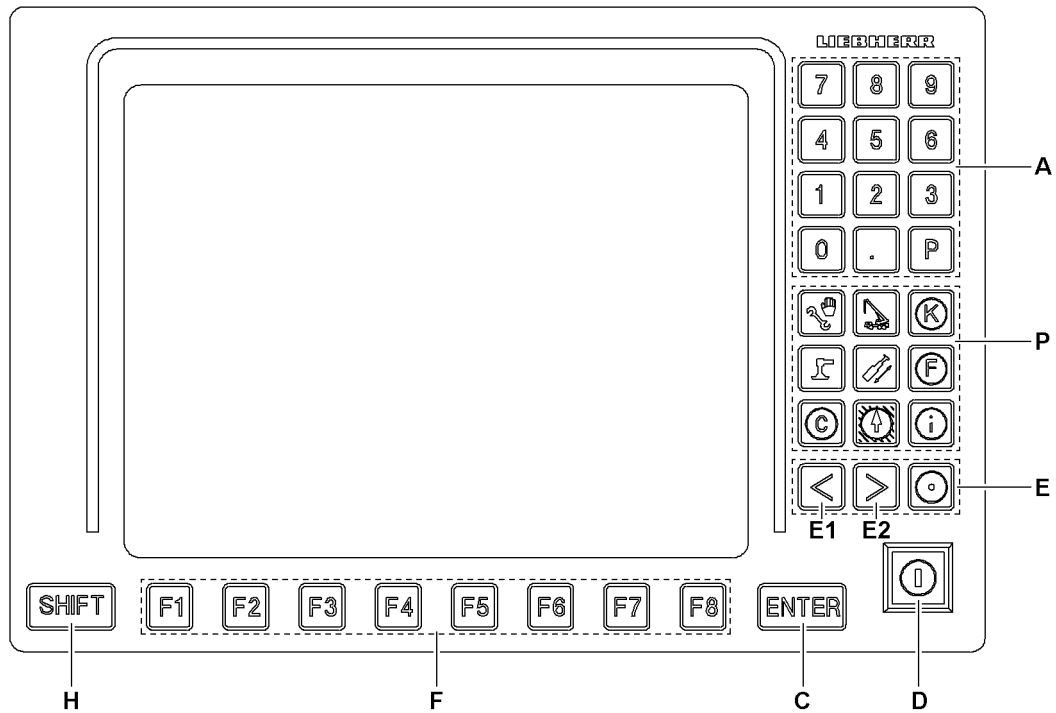

Fig.119927

- A** Keypad
 - The keys **0** to **9** on the keypad can be used to enter the respective number directly.
 - Decimal digits can be created with the key „.“
 - The key „P“ has no function in the curve display of the load charts
- P** Program keys
 - Selection of individual programs.
 - A program that is currently running **cannot** be called up again using its program key.
- C** ENTER key
 - Entry confirmation for selections made or for edited values.
 - ENTER key **C** after changing / editing within a category sets the new value
- D** Set up key
 - Has not function in the curve display of load charts
- E** Special function keys
 - **Note:** The key **E1** has the same function as function key **F4** in the curve display. The key **E2** has the same function as function key **F5** in the curve display.
- F** Function keys
 - The function key line consists of function keys **F1** to **F8** and the function key icon bar above it.
 - The function keys correspond to the various function key icons above them.
- H** SHIFT key
 - No function

11.10 Advance settings for curve display of load charts

The curve display of load charts always refers to the currently called up chart name in the *Set up* program. The currently called up chart name does not have been taken over as set up configuration in the crane operating screen. It is therefore possible to display all programmed load charts quickly in the *Chart view* program.

Possible is:

- Advance settings for curve display of the current set up configuration
- Advance settings for curve display of any desired set up configuration

11.10.1 Advance settings for curve display of the current set up configuration

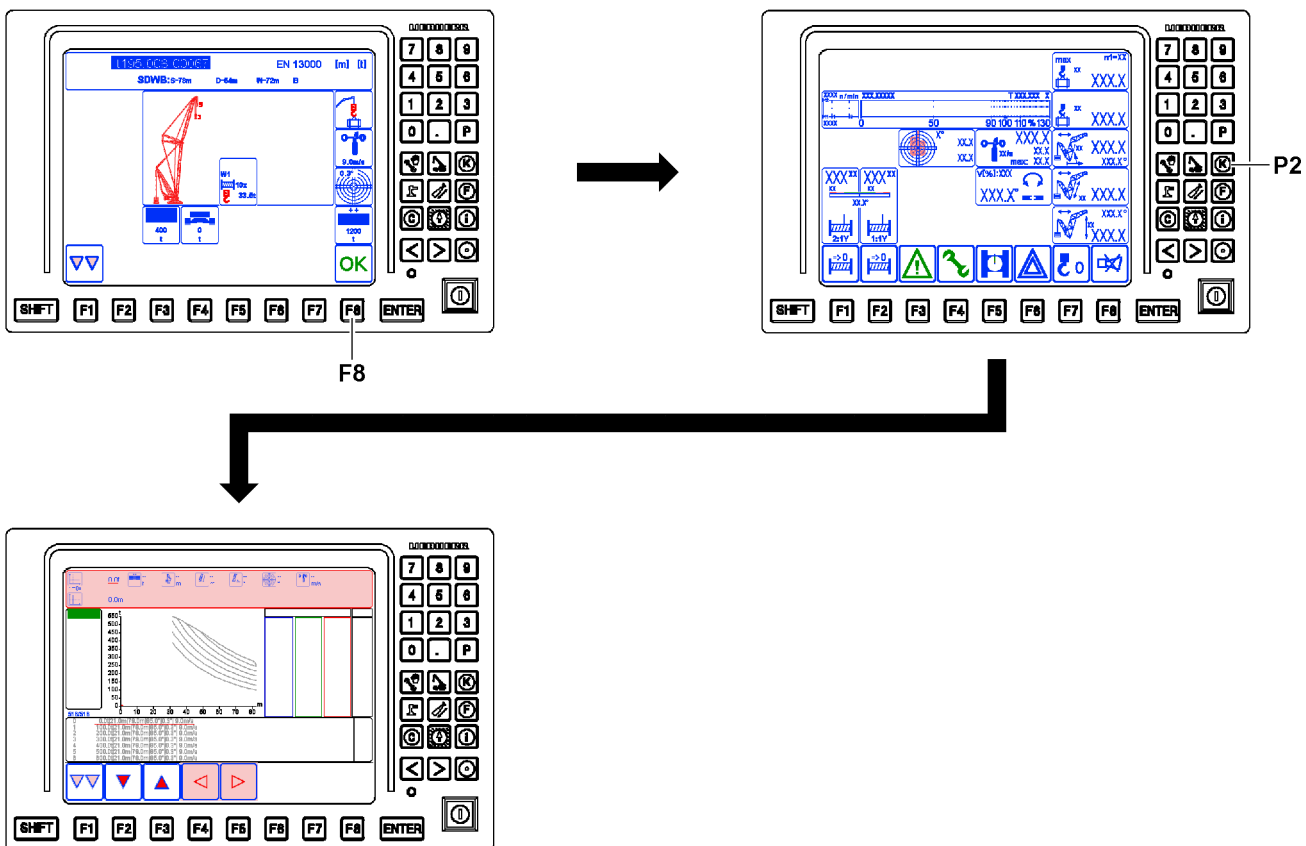

Fig.120681

Make sure that the following prerequisites are met:

- The entries and settings of the current set up configuration were entered correctly in the *Set up* program.
- The entries and settings in the *Set up* program were taken over by pressing the function key **F8** (below **OK** icon).
- The displays in the *Crane operation* program corresponds to the current set up configuration of the crane.

With the *Crane operation* program running:

- ▶ Press the program key **P2**.

Result:

- The *Chart view* program is called up with the advance settings of the current set up configuration.

11.10.2 Advance settings for curve display of any desired set up configuration

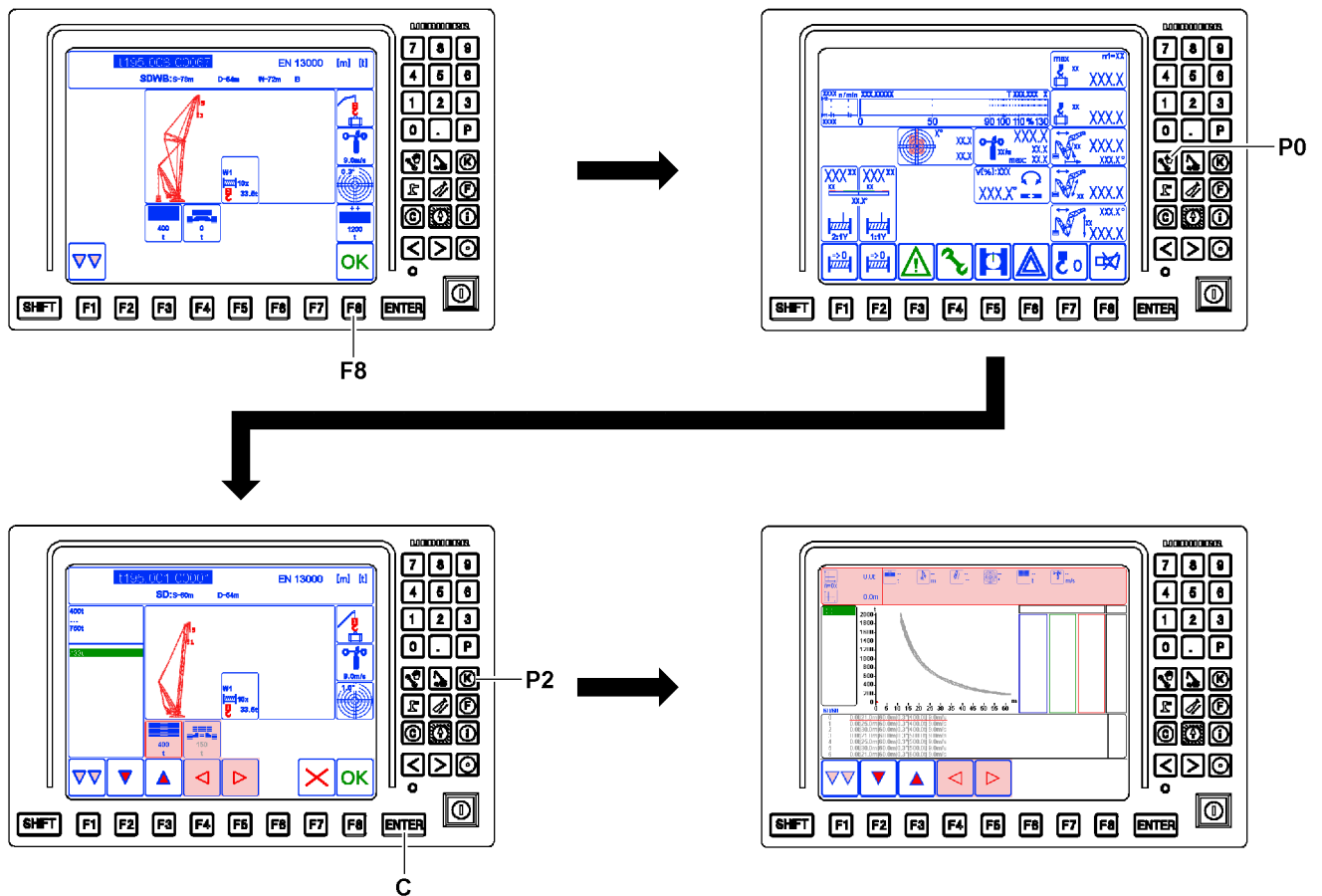

Fig.120682

Make sure that the following prerequisites are met:

- The entries and settings of the actual set up configuration are entered correctly in the *Set up* program.
- The entries and settings in the *Set up* program were taken over by pressing the function key **F8** (below *OK* icon).
- The displays in the *Crane operation* program correspond to the current set up configuration.

With the *Crane operation* program running:

- ▶ Press the program key **P0**.

Result:

- The *Set up* program is called up.



WARNING

Take over of a deviating set up configuration!

If a deviating set up configuration is taken over by pressing the function key **F8** (below *OK* icon), then the overload protection is incorrectly set.

An incorrectly set overload protection calculates the actual load incorrectly and transmits faulty display values.

The crane can be overloaded unnoticed and topple over. Personnel can be severely injured or killed.

- ▶ If any desired set up configuration is to be called up in the *Chart view* program, then it **may not** be taken over by pressing the function key **F8** (below *OK* icon).

- ▶ Set the desired set up configuration and confirm with the **ENTER** key **C**.
- ▶ **Do not** press the function key **F8** in the *Set up* program.
- ▶ Press the program key **P2**.

Result:

- The *Chart view* program is called up with the advance settings of the currently set up configuration.

11.11 Carrying out the parameter settings

**Note**

The following section describes by example how the parameter setting for selected parameters is made.

- ▶ Always carry out all required parameter settings.

The parameter settings are either carried out by entering numbers or by selection:

- Example for the number entry of a parameter setting, see section „Setting parameters via number entry“
- Example for the selection of a parameter setting, see section „Selecting parameter setting from a list“

Make sure that the following prerequisites are met:

- The advance setting for curve display of load charts was made.
- The *Chart view* program is called up.

11.11.1 Calling up the filter category

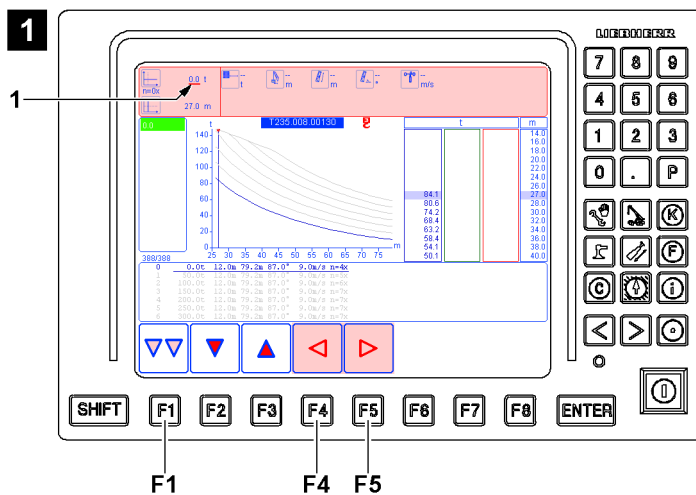

Fig. 120668

- ▶ Press the function key **F1** until the filter category is highlighted in pink, see illustration 1.

Result:

- The filter category is selected.
- The selection bar **1** underlines the first parameter.

**Note**

Navigation in the filter category

- ▶ Press the function key **F4**: The next parameter is underlined by the selection bar **1**.
- ▶ Press the function key **F5**: The previous parameter is underlined by the selection bar **1**.

11.11.2 Setting parameters via number entry

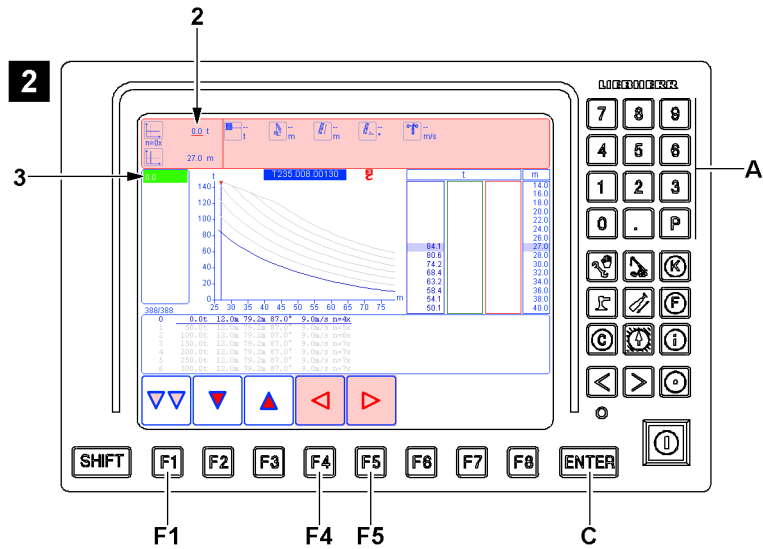

Fig.120667



Note

The following section describes by example how the parameter load is set via number entry.

► The procedure for all parameters, which are set via number entry is accordingly.

► Press function key **F4** or function key **F5** until the Parameter load **2** is underlined in red, see illustration 2.

Result:

- The Parameter load **2** is selected.
- In the Editing / selection window **3** appears a green input field.

The entry of the value is made without the weight unit.

► Enter the required number sequence via the keypad **A**, in example „120“.

► Press the ENTER key **C**.

Result:

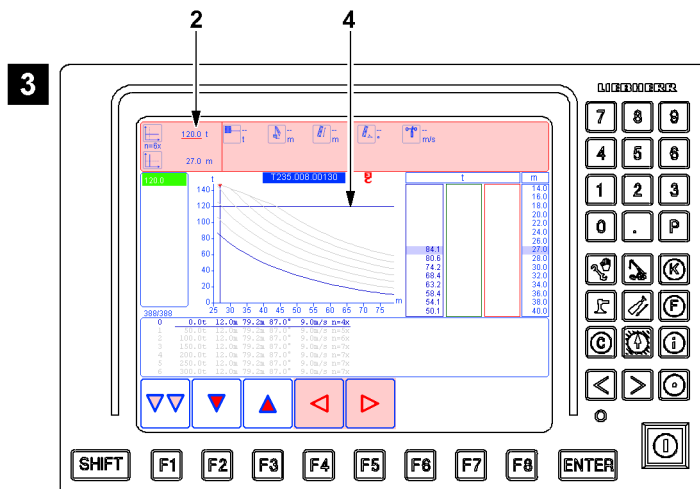

Fig.120669

- The entered value for the parameter load **2** (in example „120.0t“) appears, see illustration 3.
- The entered value is shown as a line **4** at „120.0t“ in the curve display.

LWE/LR 11000-001/23501-04-02/en

11.11.3 Selecting the parameter setting from a list

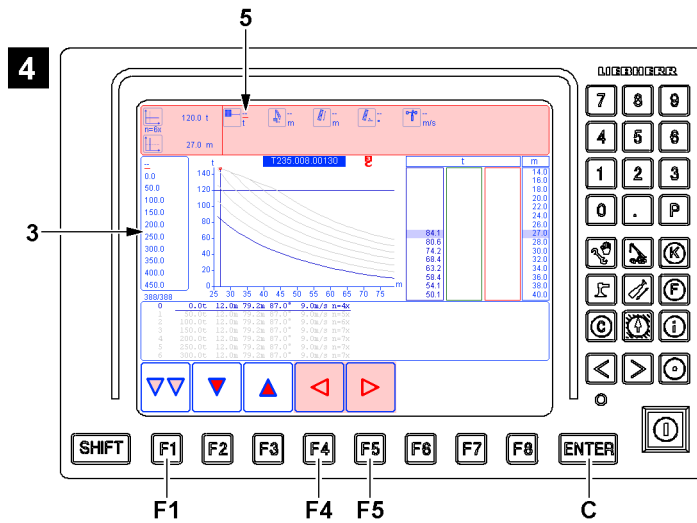

Fig.120670



Note

The following section describes by means of an example how the Derrick ballast parameter is selected from the list in the Editing / selection window 3.

- ▶ The procedure is accordingly for all parameters, which are selected from the list in the Editing / selection window 3.

- ▶ Press function key **F4** or function key **F5** until the parameter Derrick ballast 5 is underlined in red, see illustration 4.

Result:

- The parameter Derrick ballast 5 is selected.
- Shown in the Editing / selection window 3 is the derrick ballast which is available for selection.

- ▶ Press the function key **F2** or function key **F3** until the desired derrick ballast is underlined with the red line 6, as example „300.0“.
- ▶ Press the ENTER key **C**.

Result:

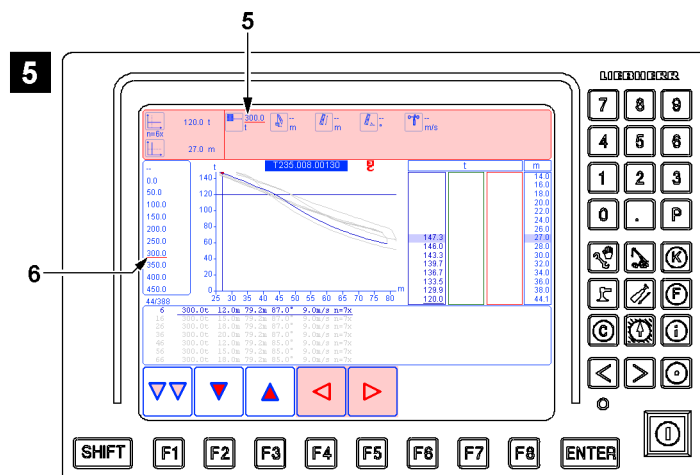

Fig.120671

- The entered value for the Derrick ballast 5 (in example „300.0t“) appears, see illustration 5.

11.12 Highlighting the load column in color

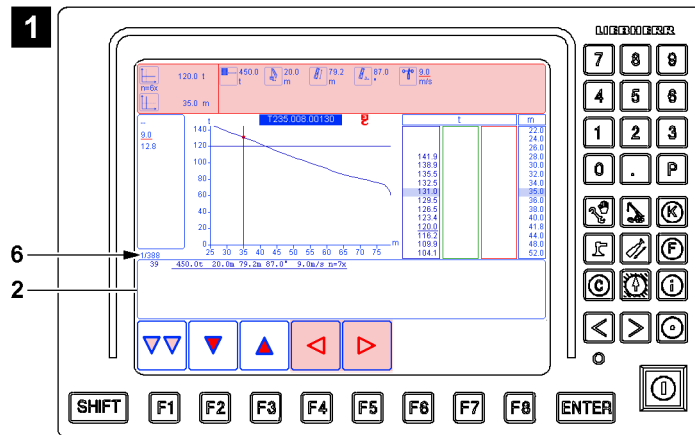

Fig.120672

- When all parameters in the filter category 1 have a value, only the current load columns in the column category 2 are listed, see example in illustration 1. In the page counter 6 it is noted that only one load column is still valid (example 1/388 = one of three hundred eighty eight load columns).

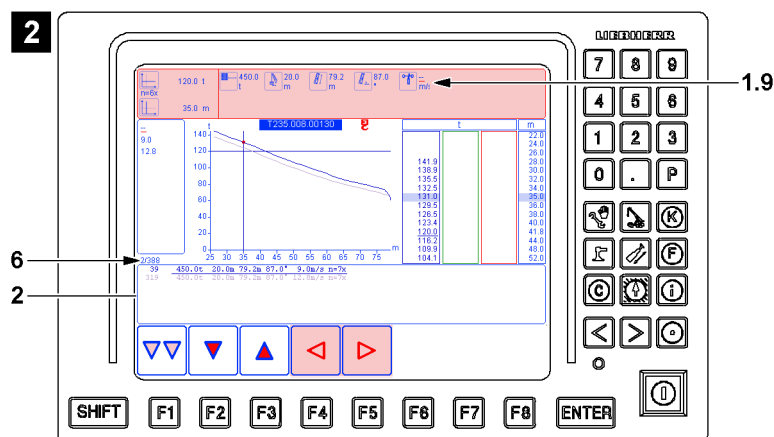

Fig.120673

- If „-“ is selected as a value on one individual parameter for the filter category, then all load columns are listed in the column category 2, which have an arbitrary value at this parameter and contain the remaining parameters, see example in illustration 2. In the page counter 6 is it noted that only certain load columns are still valid (example 2/388 = two of three hundred and eighty eight load columns). In the example (illustration 2) the parameter for the permissible wind speed is set to „-“. All respective load charts with all permissible wind speeds available for selection are listed. Then no load column is filtered out due to the permissible wind speed.

LWE/LR 11000-001/23501-04-02/en

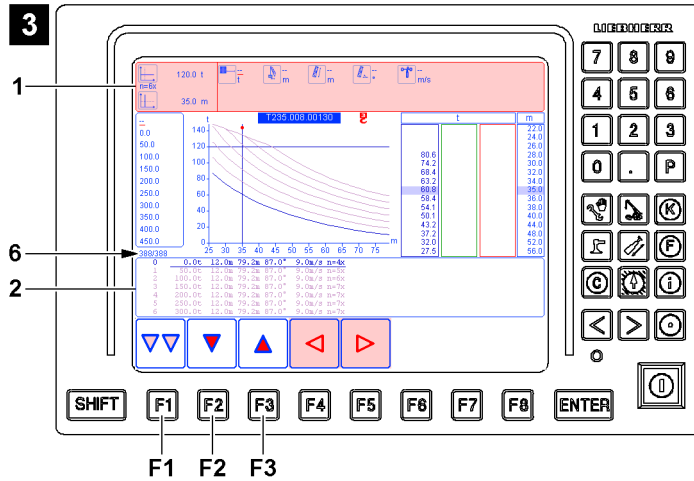

Fig.120674

- When all filter elements have a value „-“, then all load columns are listed in the column category 2, see example in illustration 3.
In the page counter 6 is it noted that all load columns are valid (example 388/388 = three hundred and eighty eight of three hundred and eighty eight load columns).
If more than seven load columns are valid, then you have to page in the column category 2 to view.
To page, the column category must be active, see section „Column category“.



Note
Change between filter category 1 and column category 2.
▶ Press the function key **F1**.
▶ The respectively active category is highlighted in pink.



Note
Navigation in the Column category 2:
▶ Press the function key **F2**: One load column down.
▶ Press the function key **F3**: One load column up.

11.12.1 Assigning a color

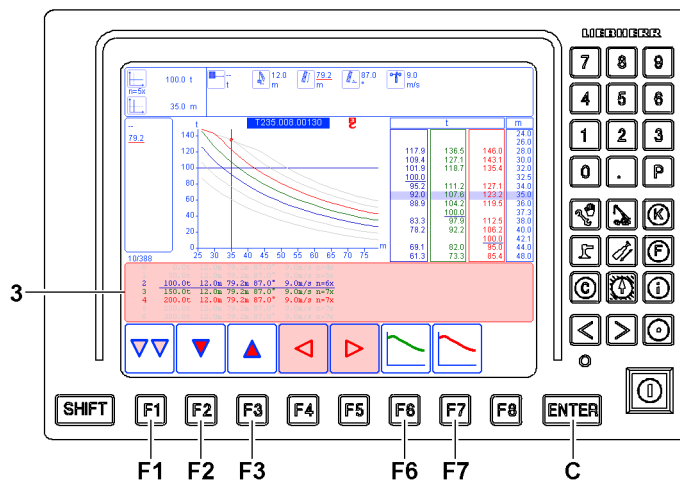

Fig.120675

Three different colors can be assigned.

- ▶ Press the function key **F1** until the column category is highlighted in pink.
- ▶ Press function key **F2** or function key **F3** until the desired load column is underlined.
- ▶ Highlight the load column in green: Press the function key **F6**.

Result:

- The load column is highlighted in green.
- The curve display of the load column is shown in green.
- The numeric display of the load column is shown in green.
- The next load column can be selected by pressing the function key **F2** or function key **F3**.

- ▶ Highlight the load column in red: Press the function key **F7**.

Result:

- The load column is highlighted in red.
- The curve display of the load column is shown in red.
- The numeric display of the load column is shown in red.
- The next load column can be selected by pressing the function key **F2** or function key **F3**.



Note

- ▶ If the same color is reissued, then the older selection is eliminated.
 - ▶ The blue color can always be used for the currently selected load column and cannot be assigned permanently.
-
- ▶ Assign the green and red color to the first two columns.
 - ▶ Highlight the third column only via the function key **F2** or function key **F3**.

11.13 Comparing the load columns

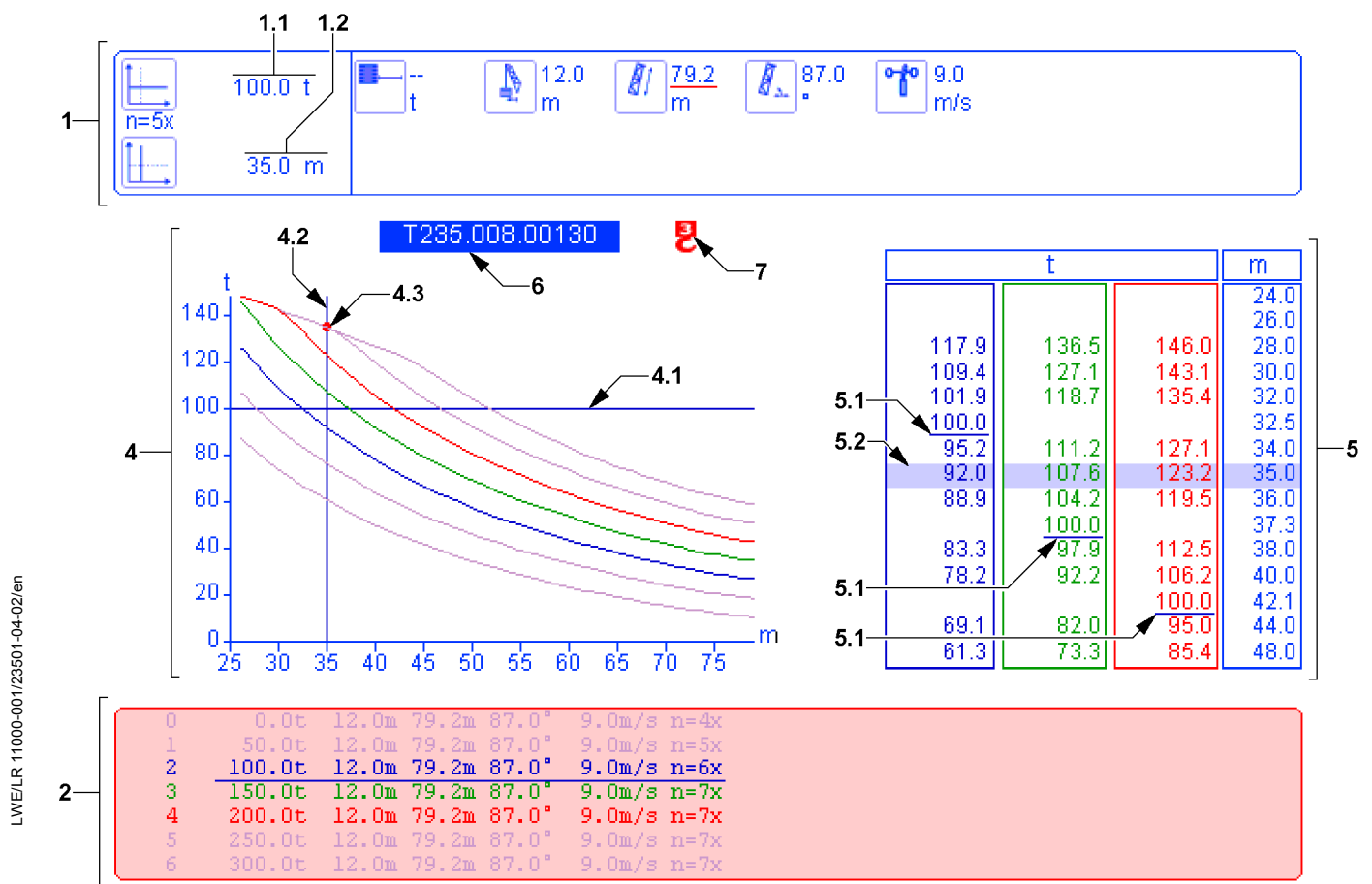

Fig.120676

If several load columns are highlighted in a color, then they can be easily compared in the curve display and the numeric display.



Note

- ▶ If the parameter in the filter category **1** are changed, then the load columns must be highlighted again.
-

Make sure that the following prerequisites are met:

- The load columns are highlighted in color, see section „Highlighting a load column“
- The correct chart number **6** and load position **7** are shown.
- The nominal values for the parameter load **1.1** and boom radius **1.2** have been entered, see section „Carrying out the parameter settings“.

The parameters for load **1.1** and Boom radius **1.2** are highlighted for comparison:

- The nominal value for the load **1.1** is:
 - displayed in the curve display **4** with a horizontal line **4.1** through the respective scale value.
 - underlined in the numeric display **5** with a line **5.1**.
- The nominal value for the boom radius **1.2** is:
 - displayed in the curve display **4** with a vertical line **4.2** through the respective scale value.
 - Highlighted in the numeric display **5** with a blue bar **5.2**.
- ▶ Load columns can be compared visually and numerically.

When the parameter boom radius **1.2** is to be changed for comparison:

- ▶ Press the function key **F1** until the column category **2** is highlighted in pink.
- ▶ Reduce the parameter for boom radius **1.2**: Press the function key **F4**.
- ▶ Increase the parameter for boom radius **1.2**: Press the function key **F5**.

4.03 Crane start up and taking the crane out of service

1	Crane commissioning	3
2	Bringing the crane operator's cab into operating position	3
3	Checks before start up	11
4	Work station - Crane operator's cab	23
5	Supply via external feed / power aggregate	35
6	Preheating the hydraulic oil with the Hydraulic oil preheating*	37
7	Starting the LICCON computer system (before engine start)	38
8	Starting and stopping the engine	41
9	Starting the LICCON computer system parallel to the engine	47
10	Load weighing and load display	49
11	Bringing the crane operator's cab into transport position	55

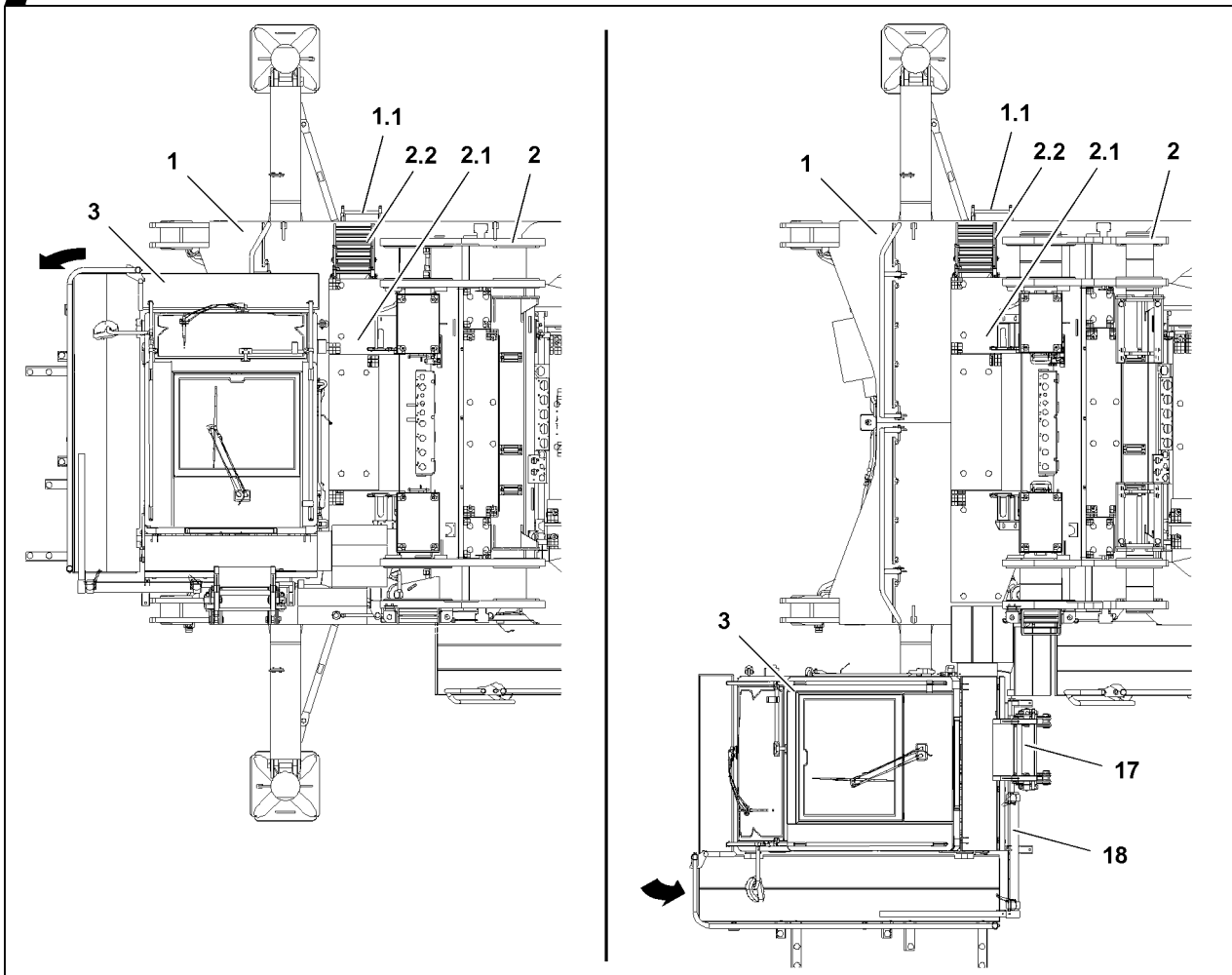
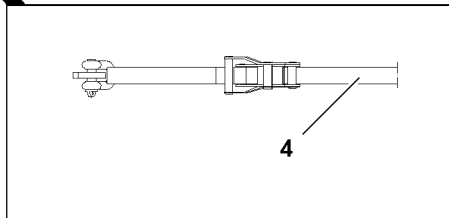
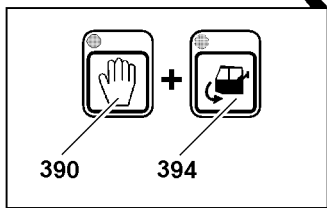
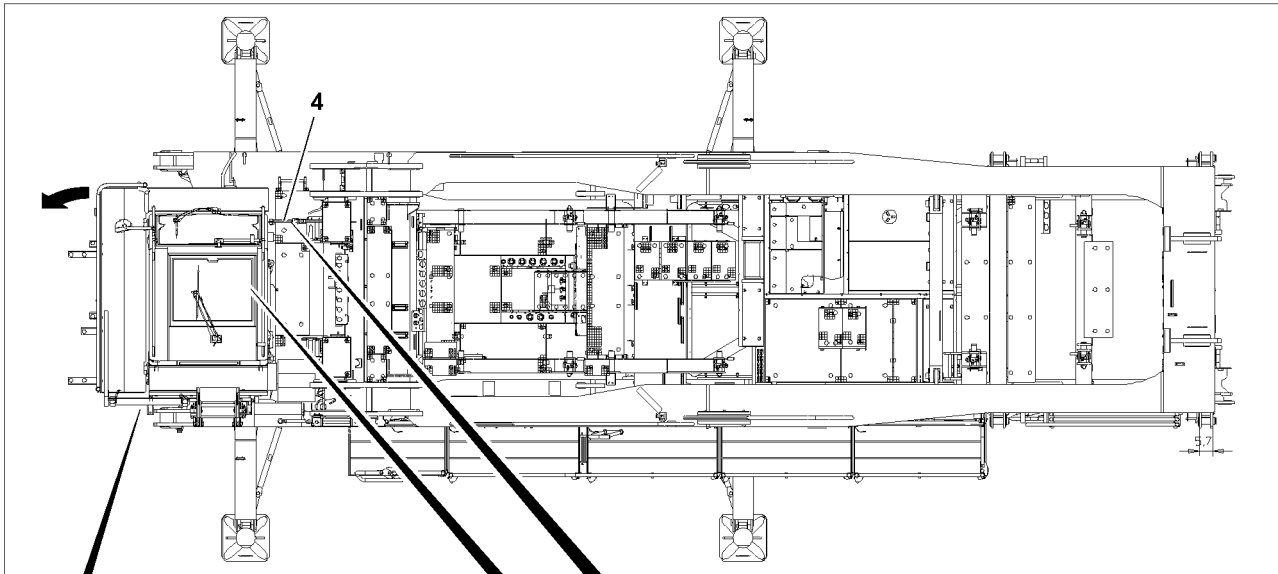

Fig.118194

LWE/LR 11000-001/23501-04-02/en

1 Crane commissioning



Note

- ▶ Before taking the crane into service, especially in low temperatures, pay attention and adhere to the Crane operating instructions, chapter 2.08.

2 Bringing the crane operator's cab into operating position



WARNING

Danger of falling!

During assembly / disassembly, inspection and maintenance work, assembly personnel must be secured with appropriate aids to prevent them from falling.

If this is not observed, assembly personnel could fall and suffer life-threatening or fatal injuries.

- ▶ The assembly personnel must always move carefully and anticipatory on the crane, the crane components or lattice sections.
 - ▶ All work aloft, where there is a danger of falling must be carried out with suitable aids.
 - ▶ If fall protection equipment is available, then it must be used.
 - ▶ If aids are not available and work cannot be carried out from the ground, then the assembly personnel must secure themselves with the approved fall arrest system to prevent falling, see Crane operating instructions, chapter 2.04.
 - ▶ The fall arrest system must be attached on the fastening and hook points as well as on the safety ropes.
 - ▶ Always secure ladders on structural parts and / or components to prevent them from falling over.
 - ▶ Only step on the aids, ladders and catwalks with clean shoes.
 - ▶ Keep aids, ladders and catwalks free of heavy dirt, snow, frost and ice.
 - ▶ Stepping or walking on crane components and lattice sections, which have an incline of more than 20° is prohibited.
-
- The crawler center section **1** is laying properly on the support.
 - The extension ladders **1.1** are properly hooked on the crawler center section **1**.
 - The railings on the crawler center section **1** are in operating position.
 - The catwalks and railings on the turntable frame main section **2** are in operating position.
 - The turntable frame main section **2** is properly installed and secured on the turntable frame lower section.
 - The ladder **2.2** on the main boom assembly platform **2.1** is in operating position.

2.1 Releasing the tension belt from the crane operator's cab

- ▶ Climb on the crawler center section **1** via the extension ladder **1.1**.
- ▶ Secure with the fall arrest system on the retaining ropes on the turntable frame lower section to prevent falling, see Crane operating instructions, chapter 2.06.
- ▶ Bring the ladder **2.2** on the main boom assembly platform **2.1** into operating position, see Crane operating instructions, chapter 2.06.
- ▶ Release and remove the tension belt **4** between the crane operator's cab **3** and the turntable frame main section **2**.

Result:

- The crane operator's cab **3** is released.

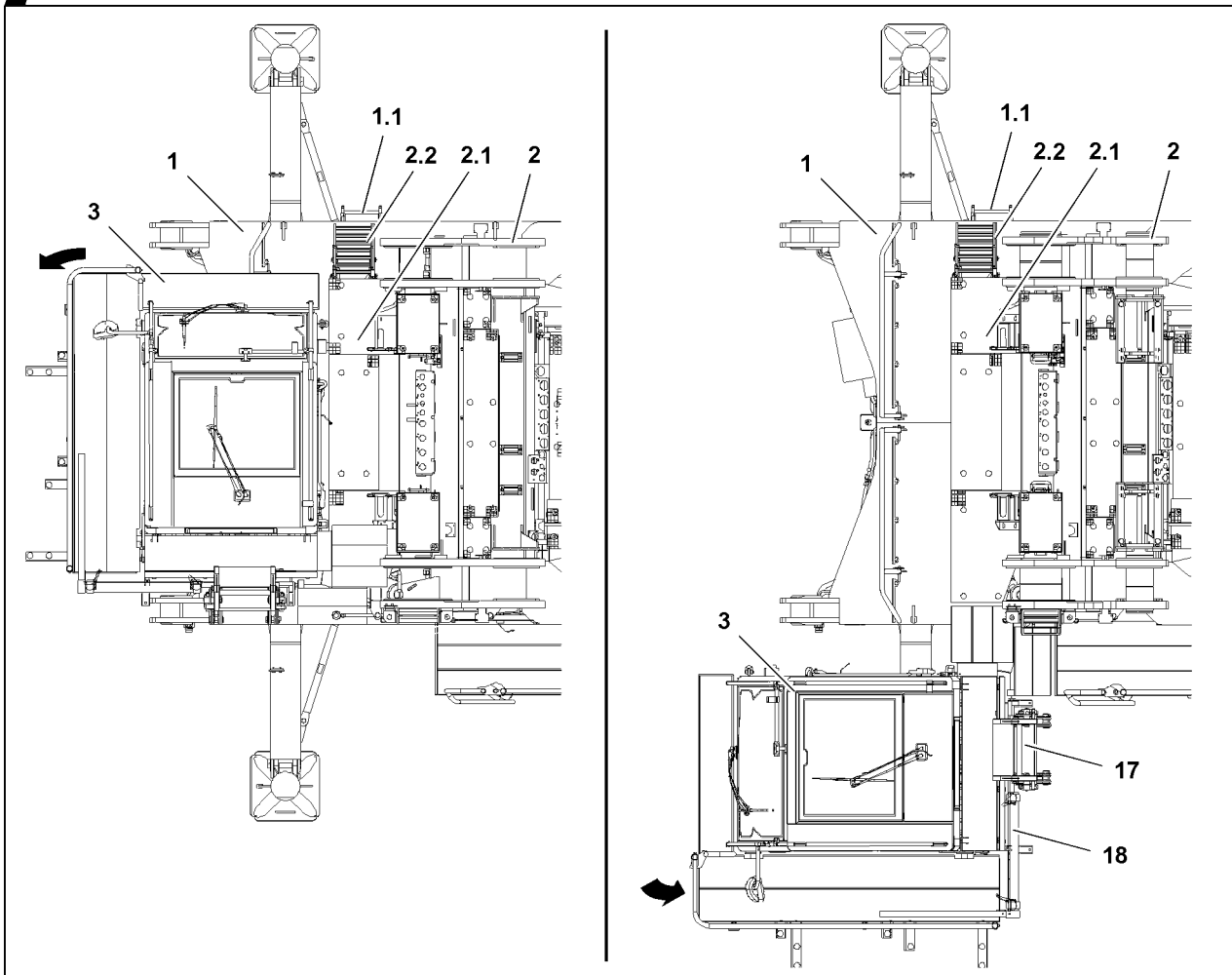
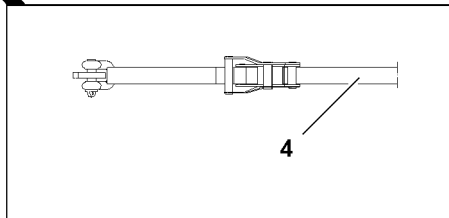
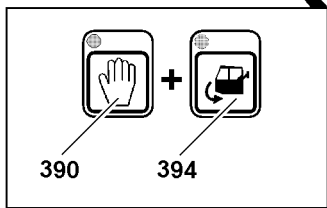
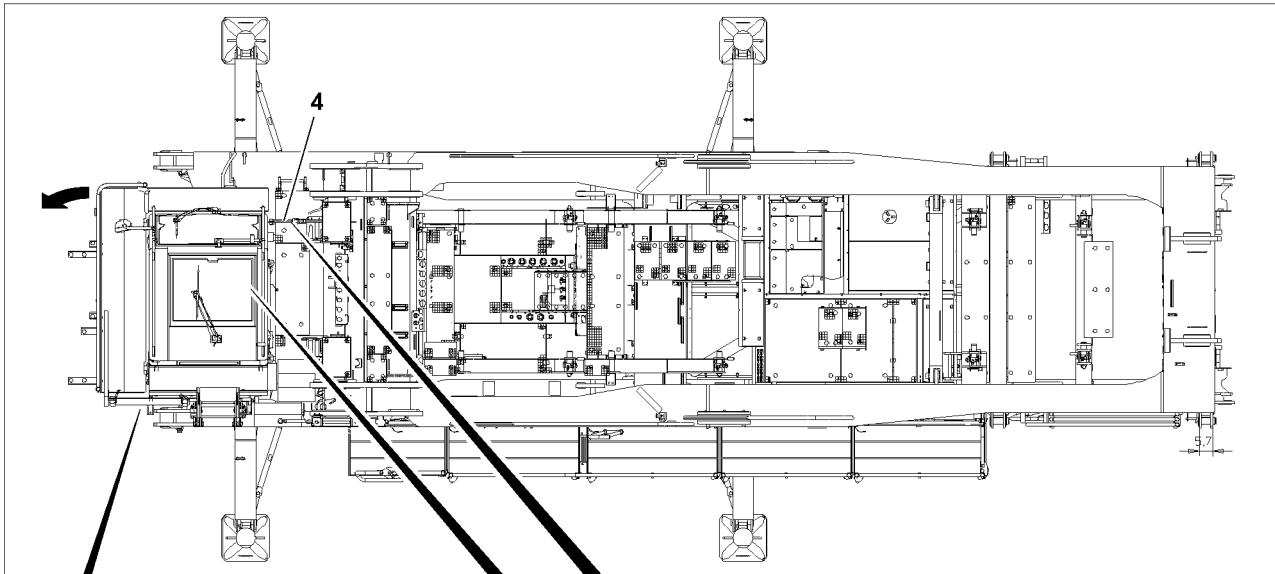

Fig.118194

LWE/LR 11000-001/23501-04-02/en

2.2 Swinging the crane operator's cab into operating position

Make sure that the following prerequisites are met:

- The tension belt **4** is removed.
- The access stairs **17** are in transport position.



WARNING

Fatal injury when swinging the crane operator's cab out!

- ▶ Make sure that there are no persons within the danger zone during the swing out procedure of the crane operator's cab **3**.

- ▶ Start the engine, see section „Starting the engine“.

When the engine is running:

- ▶ Swing the crane operator's cab **3** out: Press the button **390** and button **394**.

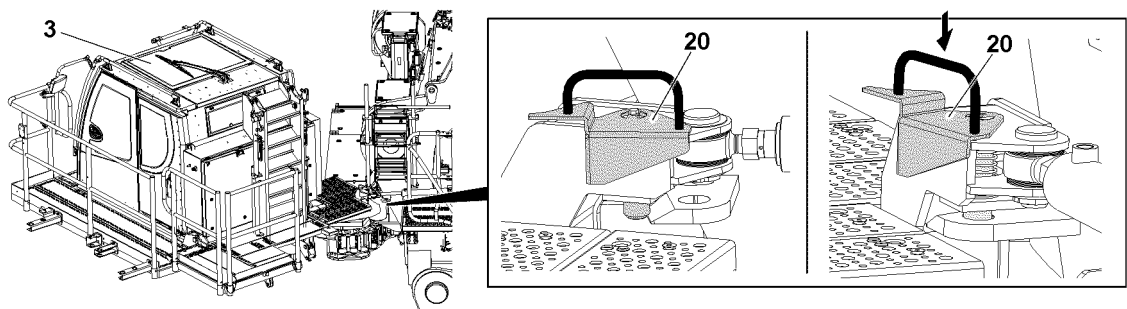

Fig.124499



Note

- ▶ Lock **20** is spring-loaded.
- ▶ When the crane operator's cab **3** reaches the operating position, it is automatically held in position the lock **20**.

- ▶ Swing the crane operator's cab **3** out further until the lock **20** engages.

When the crane operator's cab **3** is held in place in operating position:

- ▶ Release the button **390** and button **394**.



Note

- ▶ The crane operator's cab **3** can be swung out by the BTT, see Crane operating instructions, chapter 5.31.

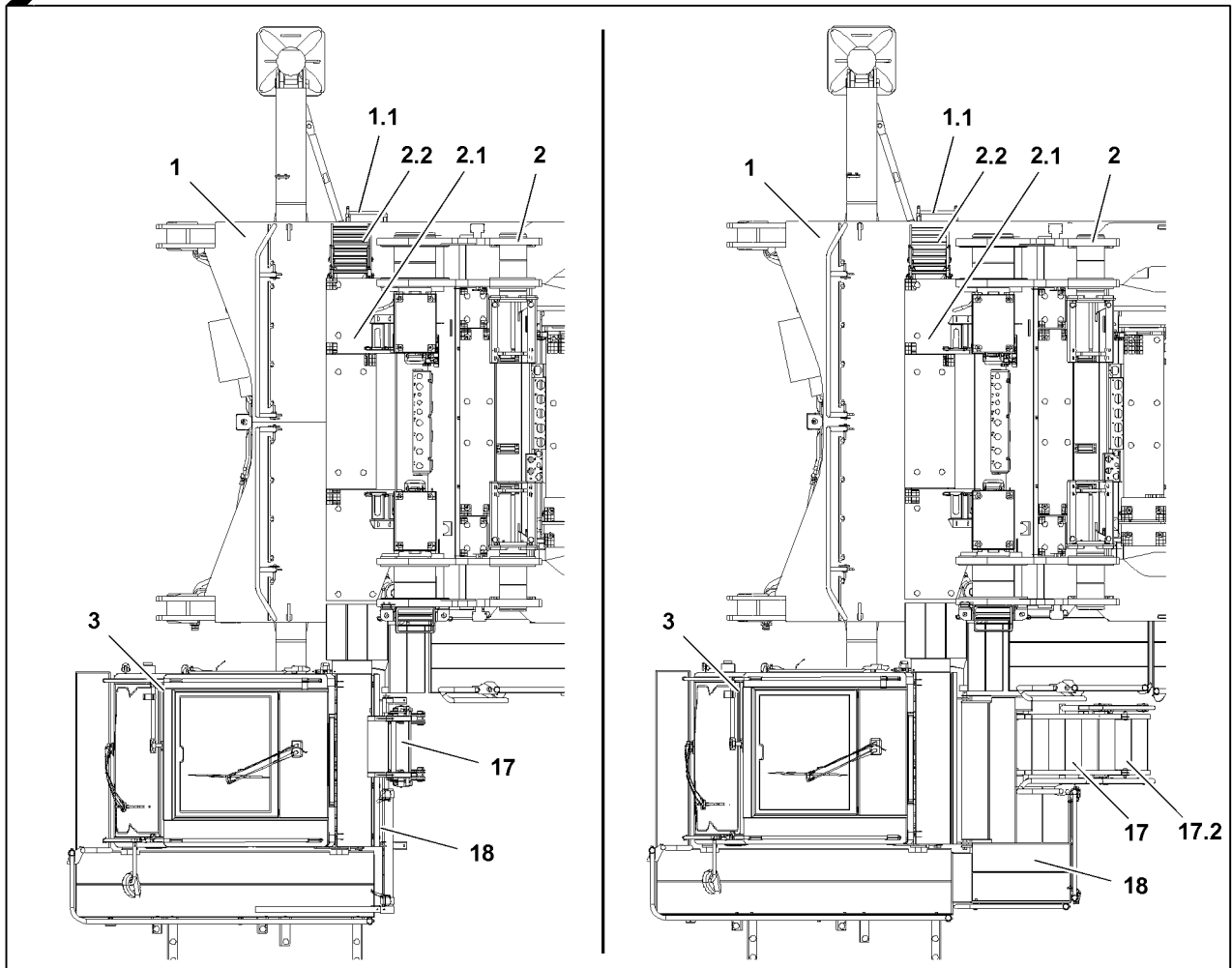
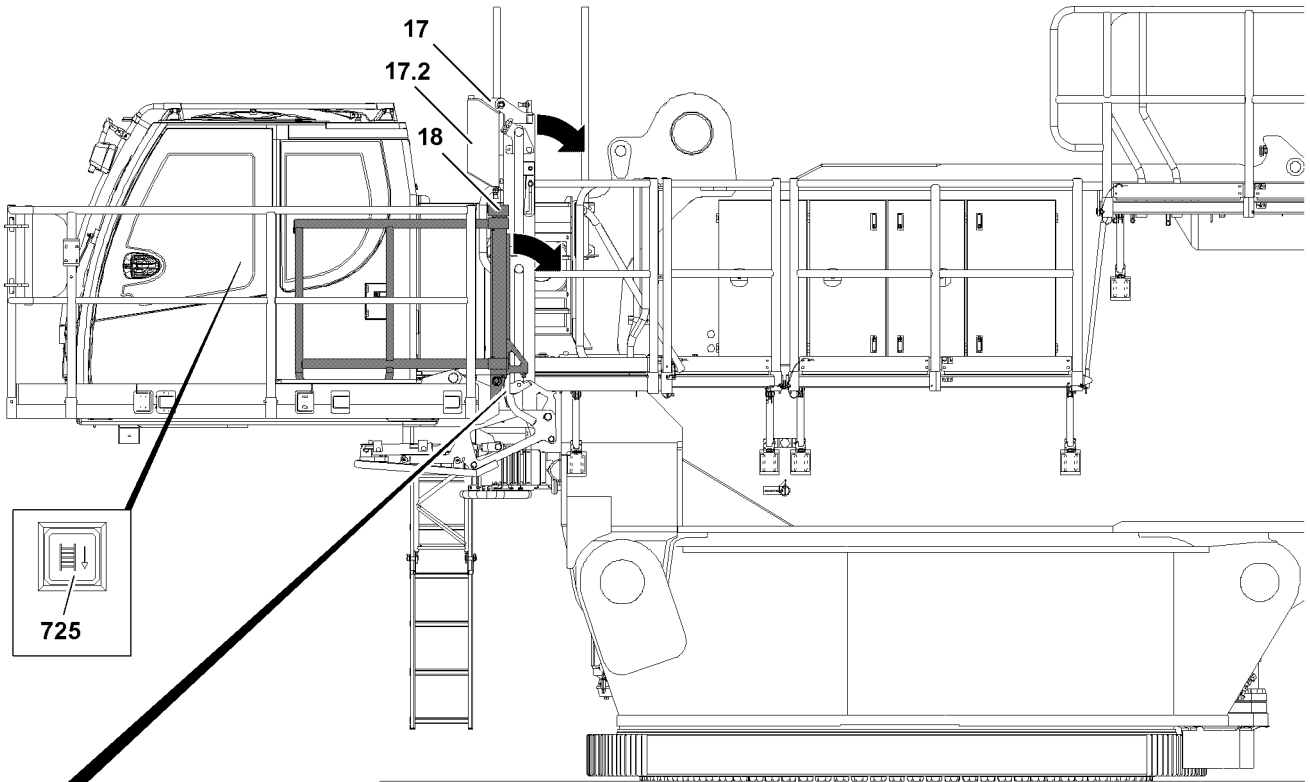

Fig.118195

LWE/LR 11000-001/23501-04-02/en

2.3 Bringing the access stairs / cab platform into operating position

Make sure that the following prerequisites are met:

- The crane operator's cab **3** is in operating position.
- The engine is running.

2.3.1 Swinging the access stairs into operating position



WARNING

Danger of accidents due to access stairs!

When lowering the access stairs personnel can be severely injured or killed.

- ▶ Make sure that no persons are within the swing range of the access stairs **17**.
- ▶ Step on the cab platform **18** and access stairs **17** only when they are in operating position.

- ▶ Press the button **725** on the instrument panel and hold.

Result:

- The access stairs **17** and cab platform **18** lower into operating position.



WARNING

Danger of falling!

When the access stairs **17** and cab platform **18** are in operating position, the operating or assembly personnel can fall from the cab platform.

Personnel can be severely injured or killed.

- ▶ The operating and / or assembly personnel must secure themselves with an approved fall arrest system when stepping on the cab platform.
- ▶ Install the railings on the cab platform immediately, see Crane operating instructions, chapter 2.06.

When the access stairs **17** and cab platform **18** are in operating position:

- ▶ Release the button **725**.



Note

- ▶ The access stairs can be operated from the BTT, see Crane operating instructions, chapter 5.31.

2.3.2 Assembling the railings on the cab platform

Make sure that the following prerequisites are met:

- The access stairs **17** and cab platform **18** are in operating position.



Note

- ▶ Install the railings on the cab platform, see Crane operating instructions, chapter 2.06.

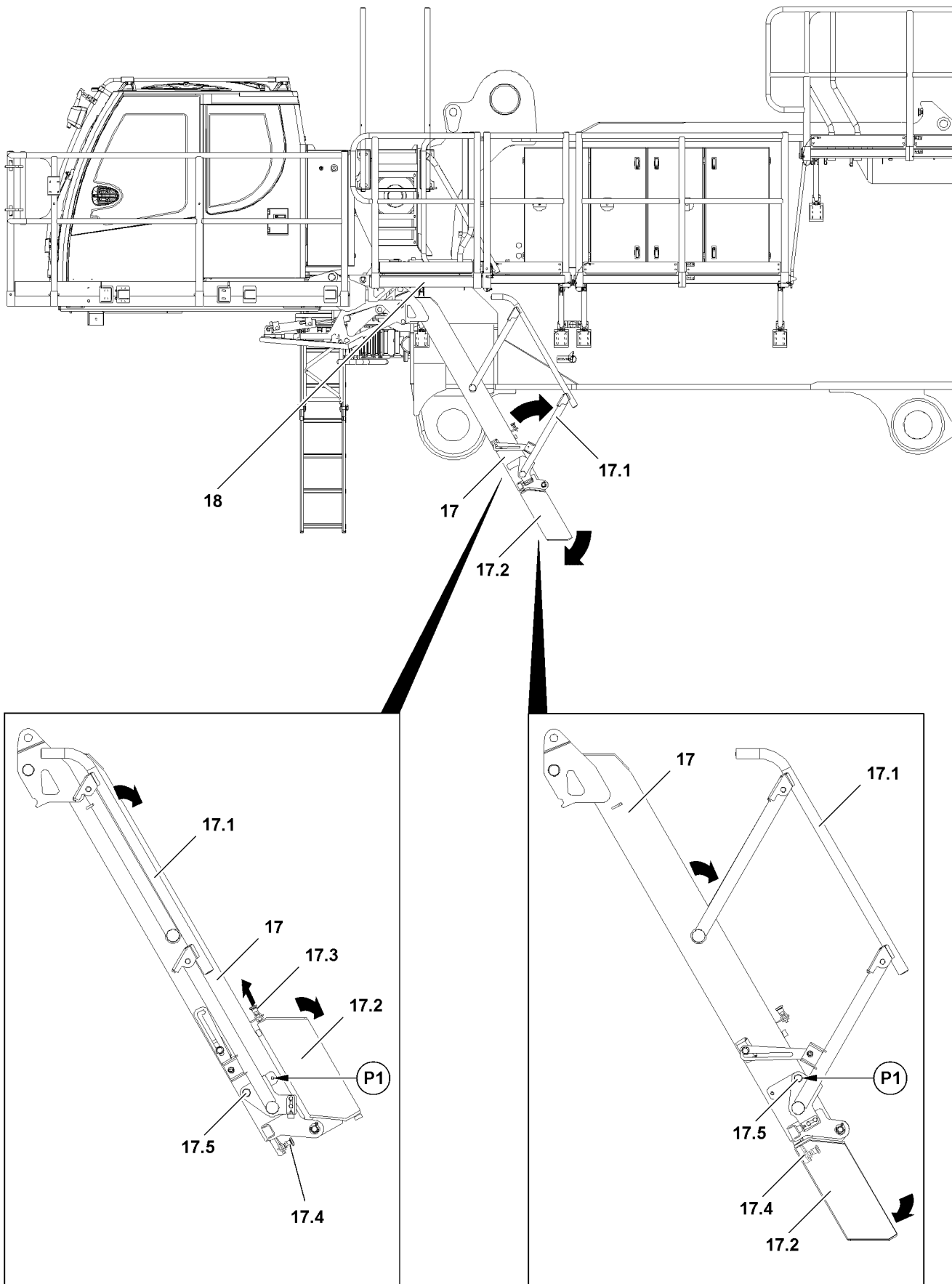

Fig.118196

LWE/LR 11000-001/23501-04-02/en

2.3.3 Swinging the stair folding section into operating position

Make sure that the following prerequisites are met:

- The access stairs **17** and cab platform **18** are in operating position.
- The railings on the cab platform are in operating position, see Crane operating instructions, chapter 2.06.
- The crawler carriers are properly installed and secured on the crawler center section, see Crane operating instructions, chapter 3.01.
- The catwalks and stairs on the crawler travel gear are properly installed and secured, see Crane operating instructions, chapter 2.06.



WARNING

Danger of crushed limbs!

When swinging the stair folding section **17.2**, fingers and hands can be crushed.

- ▶ Do not reach with your hands into the danger zone.

- ▶ Pull the detent pin **17.3** up and hold.

Result:

- The stair folding section **17.2** is released.

- ▶ Fold the stair folding section **17.2** completely down until the detent pin **17.4** engages.

Result:

- The stair folding section **17.2** is in operating position.

2.3.4 Bringing the handrails into operating position

Make sure that the following prerequisite is met:

- The stair folding section **17.2** is in operating position.



WARNING

Danger of crushed limbs!

When swinging the handrails **17.1**, fingers and hands can be crushed!

- ▶ Do not reach with your hands into the danger zone.

- ▶ Pull and hold the detent pin **17.5**.

- ▶ Move the first handrail **17.2** into operating position until the detent pin **17.5** engages at point **P1**.

Result:

- The first handrail **17.2** is in operating position.

- ▶ Bring the second handrail **17.2** into operating position.

Fig.195219

LWE/LR 11000-001/23501-04-02/en

3 Checks before start up

Various checks must be performed every time before operating the crane.

If an item is low or lacking during an inspection, then it must be refilled or brought to normal status before operating the crane.

If the inspection shows a very dirty filter, then it must be replaced before operating the crane.



WARNING

Operating safety of the crane!

Defects on components, missing quantities or dirty filters affect the operating safety of the crane.

- ▶ If a defect on a component is found during the check, the defect must be remedied before operating the crane.
- ▶ If an item is low or lacking during an inspection, then it must be refilled or brought to normal status before operating the crane.
- ▶ If the inspection shows a very dirty filter, then it must be replaced before operating the crane.



WARNING

Heated crane components!

When the engine is running, crane components can heat up significantly! This applies especially to exhaust system, the engine, the coolant circuit and the respective gears in the crane chassis and in the crane superstructure.

Touching heated crane components can cause severe injuries.

- ▶ Carry out the checks before starting the crane, when the crane components are cold.
- ▶ Let already heated components cool off before checking.
- ▶ Proceed with special caution near heated crane components.



WARNING

Emergency devices not operational!

If emergency devices, such as the EMERGENCY STOP switch, ladders etc. are not accessible or operational, then they cannot be used in case of an emergency.

Personnel can be injured or killed because the emergency devices are not operational.

- ▶ Check emergency devices before start up for accessibility or operational readiness.
- ▶ Open or remove anti-theft devices, such as locks on the emergency devices.



Note

- ▶ The illustrations, icons and monitor illustrations in this chapter are only examples.
- ▶ The numerical values in the individual icons and charts do not have to necessarily match the crane exactly.
- ▶ Numbers and letters can be replaced by place holders.
- ▶ The display and assignment of the icons can deviate, depending on the set up configuration, operating status and configuration of the crane.
- ▶ In addition, many of the illustrations show the maximum configuration of the LICCON monitor with icons.
- ▶ In crane operation, an identical display will **not** appear on the LICCON monitor.



Note

- ▶ For fill quantities, service items and lubricants, see Service fill and Crane operating instructions, chapter 7.06 and chapter 7.07!

Make sure that the following prerequisites are met:

- The ignition switches are in position „I“.
- The engine is off.
- The engine is at ambient temperature.
- The LICCON computer system is in stand-by mode.

3.1 Checking the general condition of the crane



WARNING

Danger of accident due to falling parts!

Loose parts, such as pins, spring retainers or ice, which are on the boom or crane superstructure can fall down during crane operation and hit personnel.

Personnel can be killed or seriously injured.

► Before starting crane operation, make sure that there are no loose parts on the boom and crane superstructure.

- Check the crane for visible damage before starting crane operation.
- Carry out a function test of available safety equipment.
- Make sure that the crane is standing on level, load bearing ground.
- Make sure that the crane is properly supported and horizontally aligned.
- Make sure that the gear ring of the slewing ring connection is clean and greased.
- Make sure that the air supply to the oil and water cooler is clear.
- Make sure that side covers are closed and locked.
- Make sure that no persons or objects are within the danger zone of the crane.
- Make sure that the cable, hose and rope drum as well as the limit switches are free of snow, frost and ice.
- Make sure that there are no loose parts on the boom and the crane superstructure.

3.2 Performing a visual inspection



WARNING

Avoidable missing amounts / problems can cause critical situations unnecessarily.

► Carry out visual inspections thoroughly, conscientiously and completely.

Make sure that the following prerequisites are met:

- The engine is off.
- The engine is at ambient temperature.

3.2.1 Checking the engine oil level

For detailed description of checking the oil levels, see Crane operating instructions, chapter 7.05.

For detailed description of the crane engine, see Operating instructions of the engine manufacturer.

► Check the engine oil level.

3.2.2 Checking the winch oil level

By pressing the button **736** in the instrument panel, all oil level sensors for the winches installed on the crane are checked. If all oil levels of the winches are in the permissible range, then the oil level displays **7.17** on all winch icons turn off after releasing the button **736** again. If the oil level of one or several winches is below the permissible range, then the oil level display **7.17** in the winch icons of the affected winches remains on until the oil level has been brought to the required level.

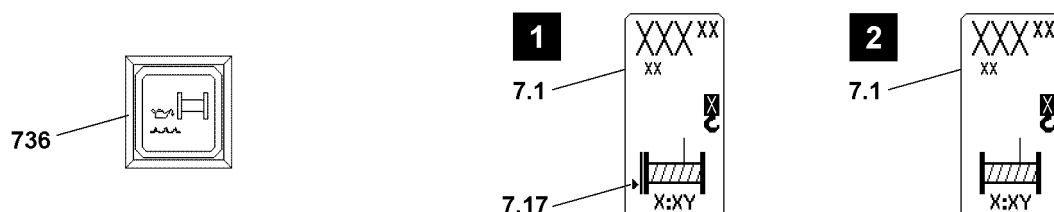

Fig.119737: Button Oil level monitoring **736** and Winch icon **7.1** with and without oil level display **7.17**

**Note**

- ▶ The winch icon **7.1** is an example and takes the place for all winches installed on the crane.
- ▶ The oil level icon **7.17** is identical on all winch icons **7.1**.
- ▶ When checking the oil level, pay attention to the installation position of the winches.

- ▶ Press the button **736** on the instrument panel.

Result:

When the oil levels of the winches are in the permissible range:

- The oil level icon **7.17** is masked on the winch icons after releasing the button **736** again.

When the oil level of one or several installed winches is **not** in the permissible range:

- The oil level icon **7.17** remains shown on the respective winch icon **7.1** until the oil level sensor of the respective winch reports the correct fill level.

NOTICE

Damage to winch(es)!

If missing oil on the winches is not replenished, the winches can be severely damaged.

Longer downtimes of the crane and associated costs can be the result.

- ▶ Make sure that the winches are only operated when they show a correct oil level.
- ▶ Make sure that the oil level icons **7.17** turn off after the oil level check in the respective winch icon **7.1**.

When the oil level icon **7.17** on a winch is shown:

- ▶ Replenish the oil on the respective winch, see Crane operating instructions, chapter 7.05, until the oil level icon **7.17** turns off.

3.2.3 Checking the hydraulic tank

For detailed description of checking the filters on the hydraulic tank, see Crane operating instructions, chapter 7.05.

Checking the oil level in the hydraulic tank

- ▶ Check the oil level in the hydraulic tank on the sight gauge.

Checking the filter for the hydraulic tank

- ▶ Check the filter for the hydraulic tank.

3.2.4 Checking the coolant level**WARNING**

Danger of injury due to scalding of the skin!

- ▶ Check the coolant level only when the engine is cold.
- ▶ Never open the cap on the coolant reservoir as long as the engine is warm. The cooling system is under pressure.
- ▶ To protect face, hands and arms from hot steam of hot coolant, cover the cap with a large rag when opening.

The coolant expansion tanks must be filled up to overflow on the filler neck.

- ▶ Check the coolant level on the engine.

If the coolant level is too low:

- ▶ Add coolant, see Crane operating instructions, chapter 7.05.

3.2.5 Checking the central lubrication systems

NOTICE

Damage of crane components!

Missing or insufficient lubrication can cause damage on the crane components.

Expensive and extensive repairs can result.

- ▶ Make sure that the grease containers for the central lubrication system always show a sufficient fill level.
- ▶ Replace missing lubricant.

The grease container must be filled at all times with sufficient lubricant.

- ▶ Check the grease container.

If the fill level on the grease container is too low:

- ▶ Add lubricant, see Crane operating instructions, chapter 7.04 and chapter 7.05.

3.2.6 Checking the window cleaning fluid

NOTICE

Frozen window cleaning fluid!

If the window cleaning fluid is not frost resistant, then the windshield washer system can freeze during the cold time of the year.

Failure of the windshield washer system is the result.

The windshield washer system can be damaged.

- ▶ Change the window cleaning fluid in time to a frost resistant type.

Before the start of the cold season:

- ▶ Empty the container for the window cleaning fluid and refill it with a commercially available, frost resistant window cleaning fluid.

3.3 Calling up and checking the monitoring functions of the LICCON computer system

If a control value has reached a limit value, then the monitoring functions are automatically called up in the Crane operation program and the error or problem are pointed out.

The monitoring functions do not replace the visual inspections:

- Approaching missing amounts can be recognized through visual inspections.
- Imminent problems can be recognized better through visual inspections.

The monitoring functions react in general only when a missing amount / problem is present. Avoidable missing amounts / problems impede crane operation and cause unnecessary delays and / or down-time.

Make sure that the following prerequisites are met:

- The ignition switch in the crane operator's cab is in position „I“.
- The engine is off.
- The engine is at ambient temperature.
- The LICCON computer system is in stand-by mode.
- The LICCON computer system is in the „Crane operation“ program.



Note

- ▶ For a detailed description of the displays in the LICCON monitor, see Crane operating instructions, chapter 4.02.
- ▶ For a detailed description of the safety equipment, see Crane operating instructions, chapter 4.04.

3.3.1 Checking the fuel level



WARNING

Danger of fire and explosion!

- ▶ Turn the engine independent heater* off approx. 3 minutes before refueling the fuel tank.
- ▶ Before refueling the fuel tank, turn the engine off.



Note

Fuel tank empty!

If the fuel tank has run dry, then the fuel system must be bled!

- ▶ Refuel in time.

Make sure that the following prerequisite is met:

- The LICCON computer system is booted up and in the „Crane operation“ program.

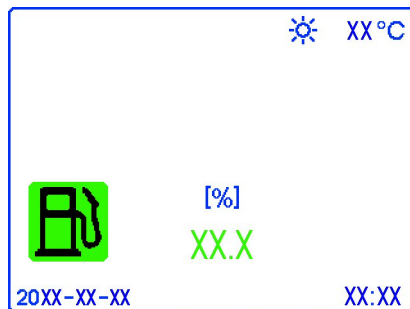

Fig.114283: Fuel level in percentages

On the LICCON monitor, the amount in the tank is given in the form of a numerical display in percent [%].

For a detailed description, see Crane operating instructions, chapter 4.02.

- ▶ Call up the screen display monitoring functions in the LICCON computer system and check the fuel level.

3.3.2 Checking the urea reserve



WARNING

Power reduction or starting block of the engine!

Insufficient urea reserve can trigger a power reduction or starting block of the engine.

Crane and / or travel operation can be limited.

- ▶ Add Urea in time.

Make sure that the following prerequisite is met:

- The LICCON computer system is booted up and in the „Crane operation“ program.



Fig.118203: Urea reserve in percentages

On the LICCON monitor, the Urea reserve is given in the form of a numerical display in percent [%].

For a detailed description, see Crane operating instructions, chapter 4.02.

- ▶ Call up the screen display monitoring functions in the LICCON computer system and check the Urea level.

3.3.3 Checking the engine oil level

Make sure that the following prerequisite is met:

- The LICCON computer system is booted up and in the „Crane operation“ program.

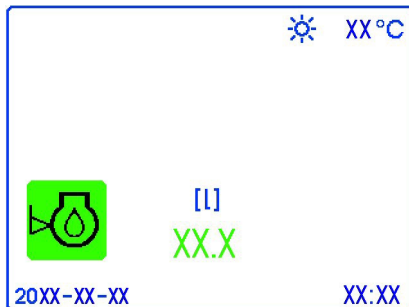

Fig.118206: Engine oil level in liters

On the LICCON monitor, the engine oil level is indicated in liters.

- ▶ Call up the screen display monitoring functions in the LICCON computer system and check the engine oil level.

The engine oil level can be read on the analog display:

- If „0.0“ is shown on the analog display, then the engine oil level is ok.
- If „-1.0“ is shown on the analog display, then 1 liter of engine oil must be drained.
- If „+1.5“ is shown on the analog display, then 1.5 liter of engine oil must be added.

- ▶ Adjust the engine oil, if necessary.

3.3.4 Check the hydraulic oil level

Make sure that the following prerequisite is met:

- The LICCON computer system is booted up and in the „Crane operation“ program.

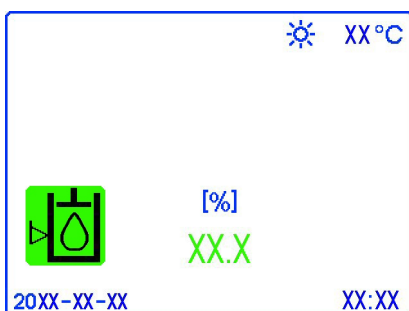

Fig.118207: Hydraulic oil level in percentages

On the LICCON monitor, the fill level of the hydraulic oil tank is given in the form of a numerical display in percent [%].

For a detailed description, see Crane operating instructions, chapter 4.02.

- ▶ Call up the screen display monitoring functions in the LICCON computer system and check the hydraulic oil level.

3.3.5 Checking the battery voltage

When the crane has been „out of operation“ for a longer period of time and users, such as the airplane warning light are turned on, the batteries can discharge significantly.

At low ambient temperatures, there is a greater power requirement opposed by reduced battery power.

- The battery voltage must be checked in regular intervals and the batteries must be recharged, if necessary.
- At low ambient temperatures, pay attention that the batteries are well charged.

Checking the battery voltage on LICCON monitor

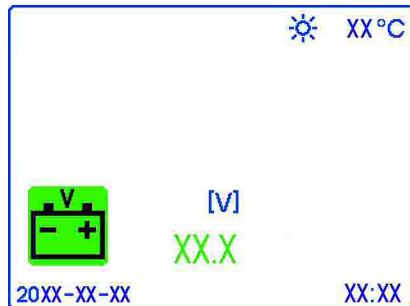

Fig.118204: Battery voltage

The battery voltage is shown in Volt on the LICCON monitor.

For a detailed description, see Crane operating instructions, chapter 4.02.

- ▶ Call up the screen display monitoring functions in the LICCON computer system and check the battery voltage.
- or**

Check the battery voltage on the batteries:

See Crane operating instructions, chapter 7.05.

Checking the battery voltage on the batteries



Note

- ▶ See Crane operating instructions, chapter 7.05.

3.3.6 Checking the display for the center of gravity on the LICCON monitor



WARNING

Shifting of center of gravity!

The calculation of the values for the display of the center of gravity in the LICCON monitor are based on ideal assumptions.

- ▶ Side deformations of the boom system due to wind, inclined position and elastic resilience of the steel structure are not taken into account but they can lead to a shifting of the center of gravity.

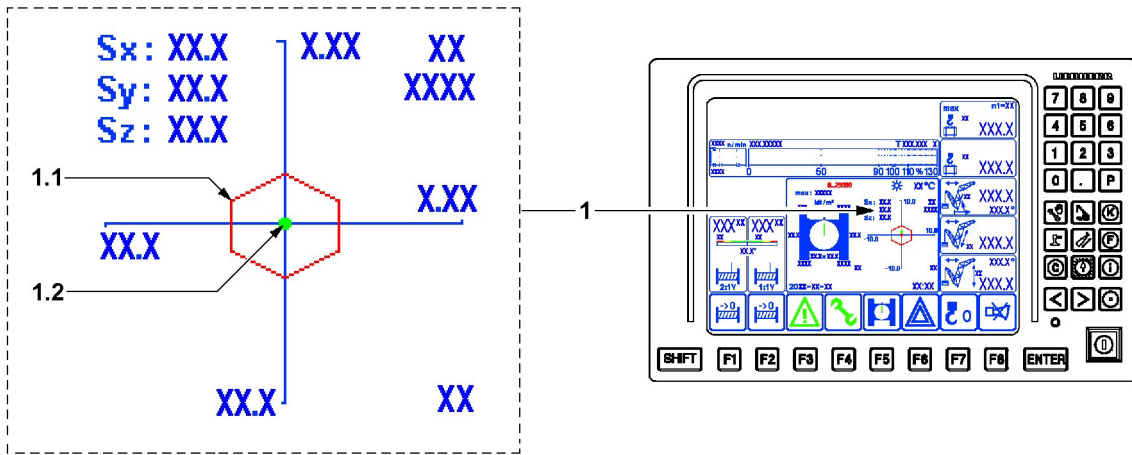

Fig.115325

Display Center of gravity	
Position	Description
1.1	Core surface
1.2	Center of gravity



WARNING

Center of gravity of the crane is outside the core area!
 If the center of gravity 1.2 of the crane is outside the core area 1.1, then the crane can topple over. Personnel can be severely injured or killed.
 ► The center of gravity 1.2 must always be within the core area 1.1.



Note

► If the center of gravity 1.2 of the crane is within the core area 1.1, then the center of gravity 1.2 is shown in green.
 ► If the center of gravity 1.2 of the crane is outside the core area 1.1, then the center of gravity 1.2 is shown in red.

3.3.7 Checking the display for the surface pressure in the LICCON monitor



WARNING

Increased surface pressure!
 The calculation of the values for the display of the surface pressure in the LICCON monitor are based on ideal assumptions.
 ► Side deformations of the boom system due to wind, inclined position and elastic resilience of the steel structure are not taken into account but they can lead to an increase of the surface pressure.

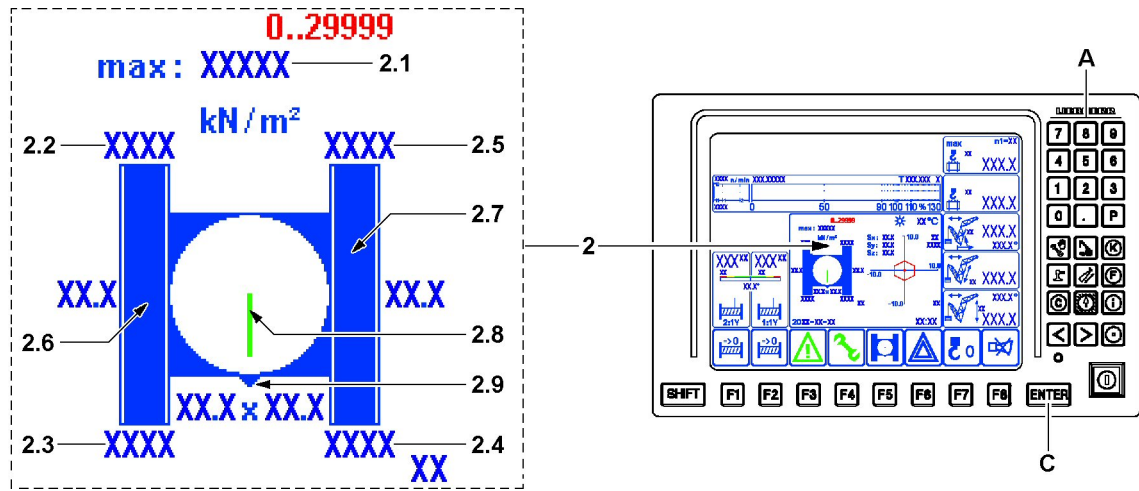

Fig.115326

Display Surface pressure	
Position	Description
2.1	Maximum surface pressure
2.2	Surface pressure right rear
2.3	Surface pressure right front
2.4	Surface pressure left front
2.5	Surface pressure left rear
2.6	Placement of crawler carrier right
2.7	Placement of crawler carrier left
2.8	Boom position ¹⁾
2.9	Marker „Front side of crawler carrier“ ⁽²⁾

1) The boom position corresponds to the „viewing direction to the front“ from the crane cab.
 2) The front on the crawler travel gear is always on the side where the chain tension device for the crawler carriers is located.



WARNING

Surface pressure too high!
 If the maximum surface pressure 2.1 is exceeded, the crane can topple over.
 Personnel can be severely injured or killed.
 ► Do not exceed the maximum value for the surface pressure.



Note

► The placement of the crawler carriers is shown graphically.
 ► If the resulting surface pressure can be distributed so that the maximum surface pressure is not exceeded **and** the resulting forces can be transferred safely into the ground, then the stability of the crane is ensured.

The following specifications and instructions must be observed:

- The highest possible surface pressure, which may be obtained on the travel route must be entered as the maximum surface pressure 2.1.

Entering / changing the maximum permissible surface pressure

Make sure that the following prerequisite is met:

- The Crane operation program is called up.
- The maximum permissible surface pressure of the ground is known.

LWE/LR 11000-001/23501-04-02/en

- ▶ Press the enter key **C**.

Result:

- The value for the maximum surface pressure **2.1** can be changed.

- ▶ Enter the value for the maximum permissible surface pressure via the keypad **A**.
- ▶ Press the enter key **C**.

Result:

- The new value for the maximum surface pressure **2.1** appears.
- ▶ Check the value for the maximum permissible surface pressure.

3.3.8 Checking the display for the incline in the LICCON monitor

Display of the incline of the crane to the horizontal in longitudinal and lateral direction. The display is graphic as well as numeric.

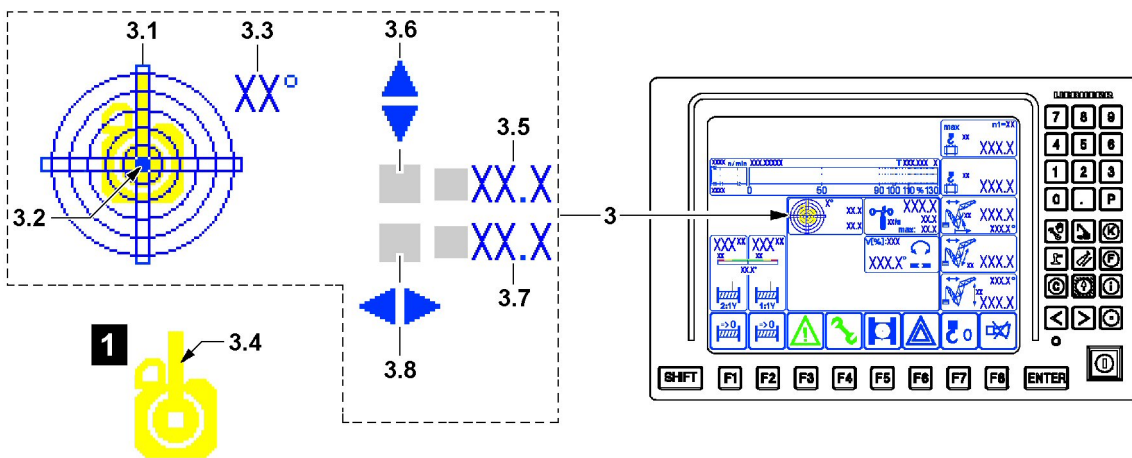

Fig.115327

Display Surface pressure	
Position	Description
3.1	Sight gauge
3.2	Bubble
3.3	Resolution of view
3.4	Boom position ³⁾
3.5	Incline in longitudinal direction
3.6	Incline direction
3.7	Incline in lateral direction
3.8	Incline direction

3) The boom position in the sight gauge **3.1** is highlighted as orientation aid, see detail **1**. The boom position corresponds to the „viewing direction to the front“ from the crane cab in relation to the sight gauge **3.1**.



WARNING

The crane can topple over!
 If the permissible inclines are exceeded, the crane can topple over.
 Personnel can be severely injured or killed.

- ▶ Make sure that the permissible inclines are never exceeded.

Empty page!

LWE/LR 11000-001/23501-04-02/en

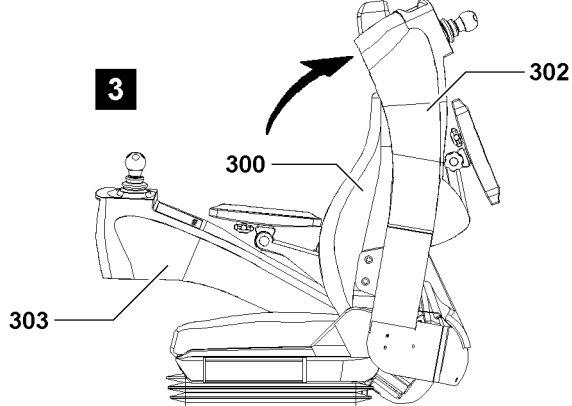
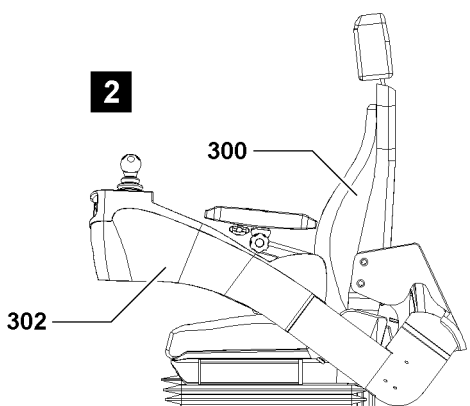
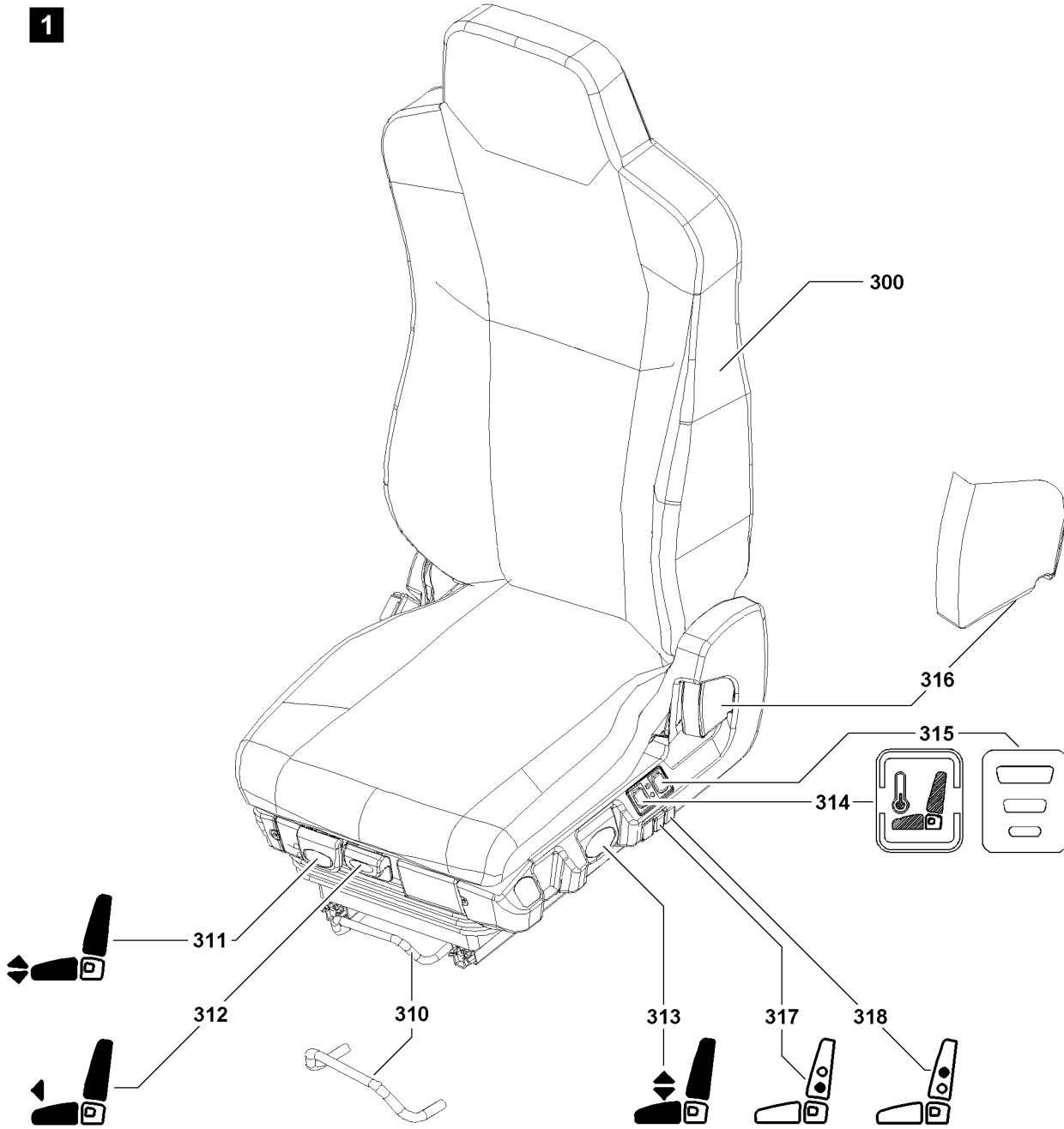

Fig.110462

LWE/LR 11000-001/23501-04-02/en

4 Work station - Crane operator's cab

4.1 Adjusting the crane operator's seat



WARNING

Danger of injury!

At inclined crane operator's cab and when the crane is standing on an incline, the crane operator's seat can move suddenly when adjusting it.

Limbs can be caught and injured.

- ▶ Carry out adjustments on the crane operator's seat only when the crane operator's cab is in horizontal position.

Adjust the seat position

- ▶ With the bar **310** adjust the seat in horizontal direction by moving it back or forth.
- ▶ With the lever **311** adjust the seat incline.
- ▶ With the lever **312** adjust the position of the seat cushion.
- ▶ With the lever **313** adjust height of seat.
- ▶ With the lever **316** adjust the angle of the backrest.
- ▶ With the button **317** adjust the lumbar area support „on the bottom“.
- ▶ With the button **318** adjust the lumbar area support „on top“.

Turn the seat heater* / seat climate control* on.

The seat heater or climate control is turned on / off with the switch* **314**.

There are three switch positions:

- Center position: Seat heater and seat climate control turned off.
 - Pushed on top: Seat heater turned on (red light).
 - Pushed on the bottom: Seat climate control turned on (blue light).
- ▶ Select the seat heater / seat climate control on with switch* **314**.
 - ▶ Adjust the seat heater / seat climate control with switch* **315**.

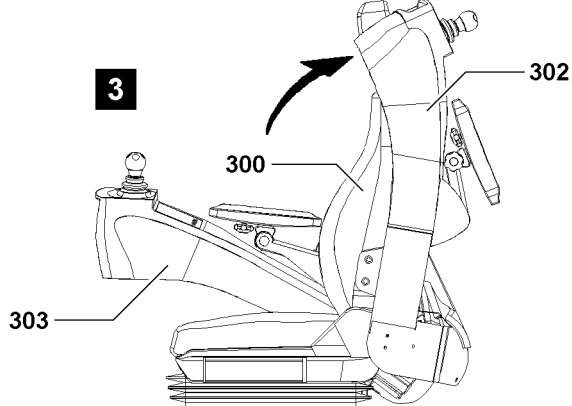
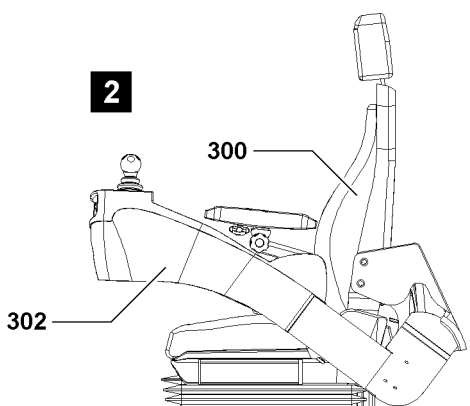
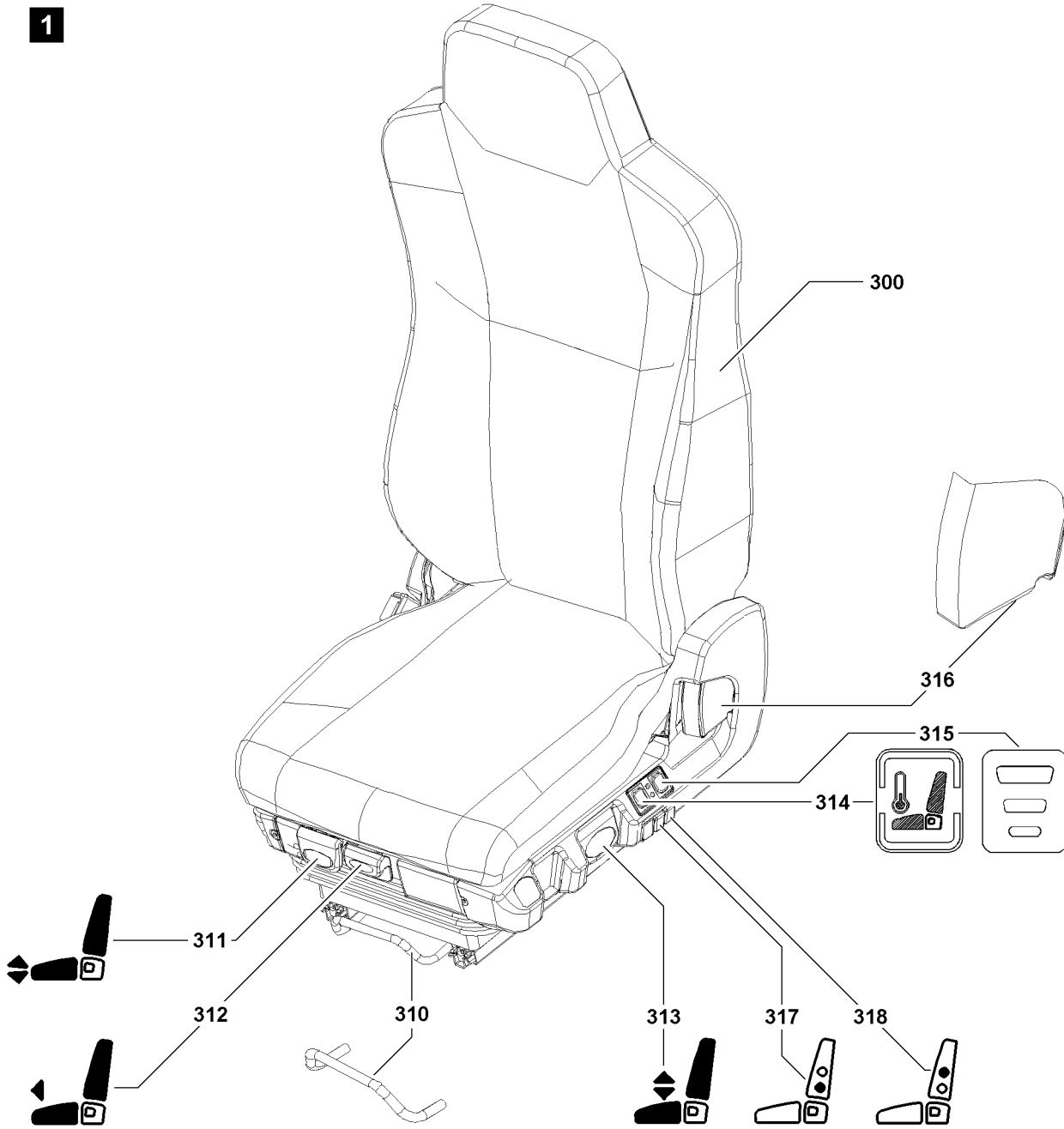

Fig.110462

LWE/LR 11000-001/23501-04-02/en

4.2 Adjusting the consoles

The control platform, with the consoles on the left and right hand side of the crane operator's seat **300** allows the crane driver to adjust the consoles to suit his body size optimally.

Two different console positions are possible:

- Crane operating position (both consoles down), see illustration **2**.
- Position Entering / exiting, see illustration **3**.



WARNING

Danger of accident!

A raised console (for example console **302** in entering / existing position), can swing down uncontrolled in case of jolting (for example due to sudden braking action).

Injuries to persons and property damage can result.

- ▶ Driving the crane and crane operation with raised consoles is prohibited.
 - ▶ Always bring the consoles into „Crane operating position“ immediately.
 - ▶ Hold the consoles when swinging them until the respective end position is reached.
-

The consoles can be brought into another position by swinging them up:

- Move the console **302** (left) from „crane operating position“ to „enter / exit“ position by swinging it up.
 - Move the console **303** (right) from „crane operating position“ to „Up“ position by swinging it up.
-



Note

- ▶ If the consoles are swung down, the last set positions are used.
-

4

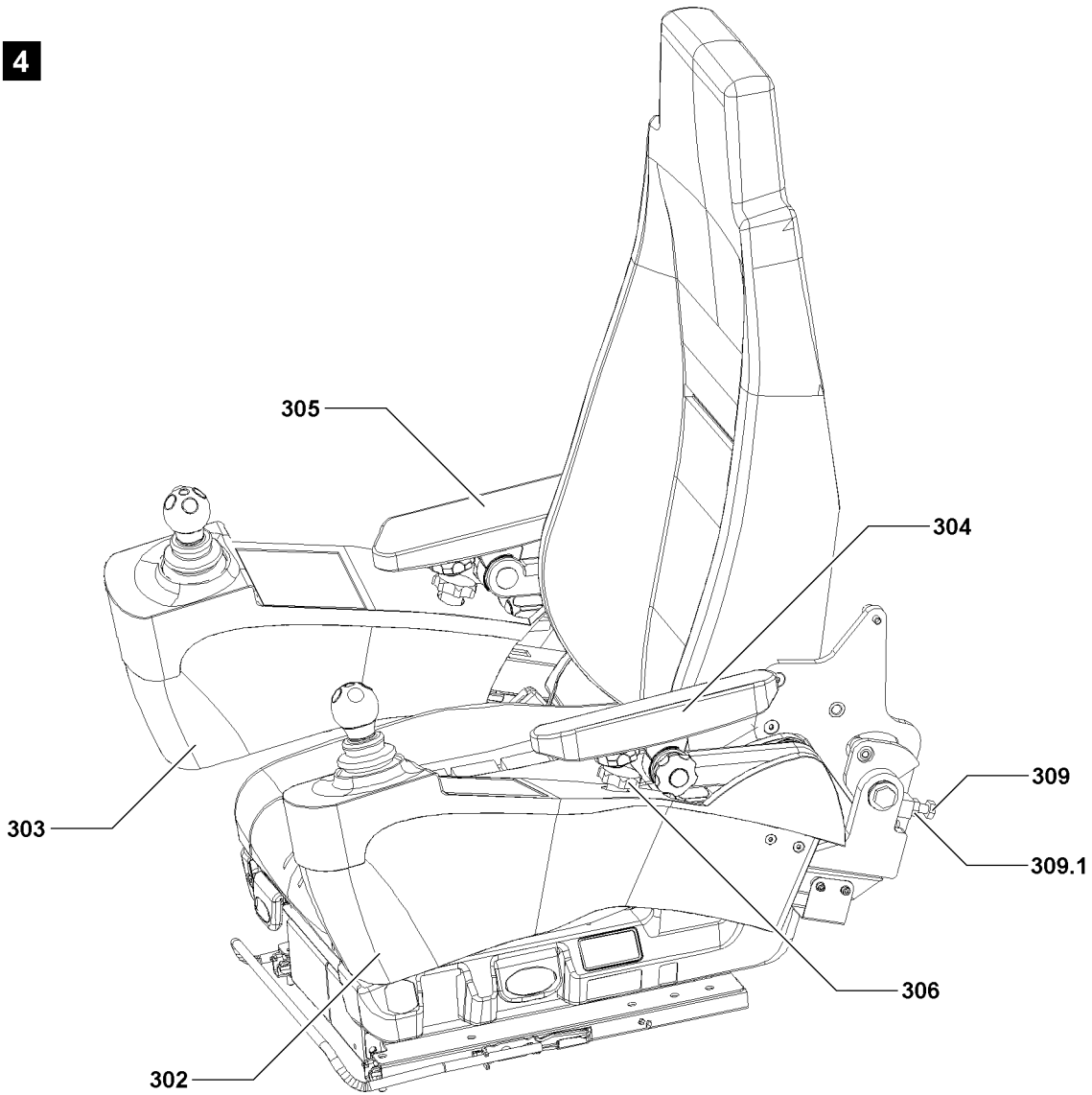

5

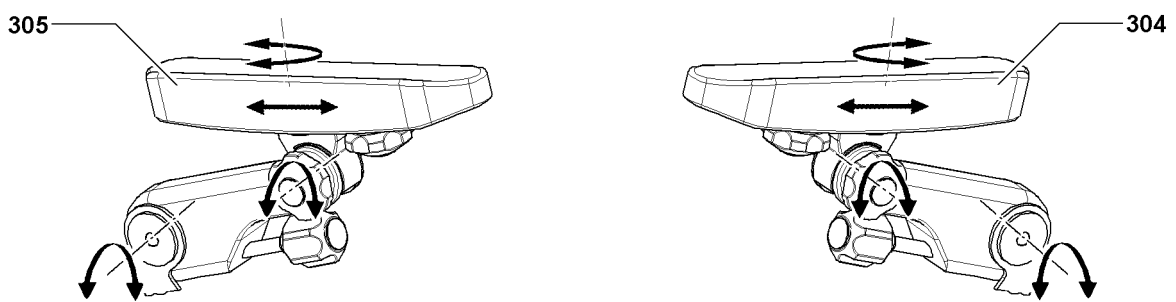

Fig.110463

LWE/LR 11000-001/23501-04-02/en

4.2.1 Adapting the consoles to the crane operator



Note

- ▶ The consoles can be adjusted individually to suit. Every crane operator can set his work place optimally to his body size.
- ▶ The left console **302** and the right console **303** can be adjusted independently of each other.



Note

- ▶ The consoles can be adjusted to suit the crane operator as described for the left console **302**, see illustration **4**.
- ▶ The procedure for the right console **303** is accordingly.

Adjusting the incline of the console

- ▶ Release the nut **309.1**.
- ▶ Adjust the stop screw **309** until the console **302** has reached the desired incline.
- ▶ Secure the stop screw **309** with nut **309.1**.

Move the console horizontally

- ▶ Fold the armrest **304** up.
- ▶ Pull the locking pin **306** until the console **302** can be moved.
- ▶ Adjust the horizontal position of the console **302** by moving it forward / backward.
- ▶ Release the locking pin **306** and let it engage.
- ▶ Fold the armrest **304** down.

Result:

- The console **302** is adjusted.

4.2.2 Armrests

The left armrest **304** and the right armrest **305** offer a multitude of adjustment possibilities, see illustration **5**.



Note

- ▶ To ensure fatigue free and concentrated work with the crane, the armrests should be adjusted in such a way that you can comfortably reach and operate the master switches.
- ▶ The left armrest **304** and the right armrest **305** can be adjusted with the adjustment screws, see illustration **5**.

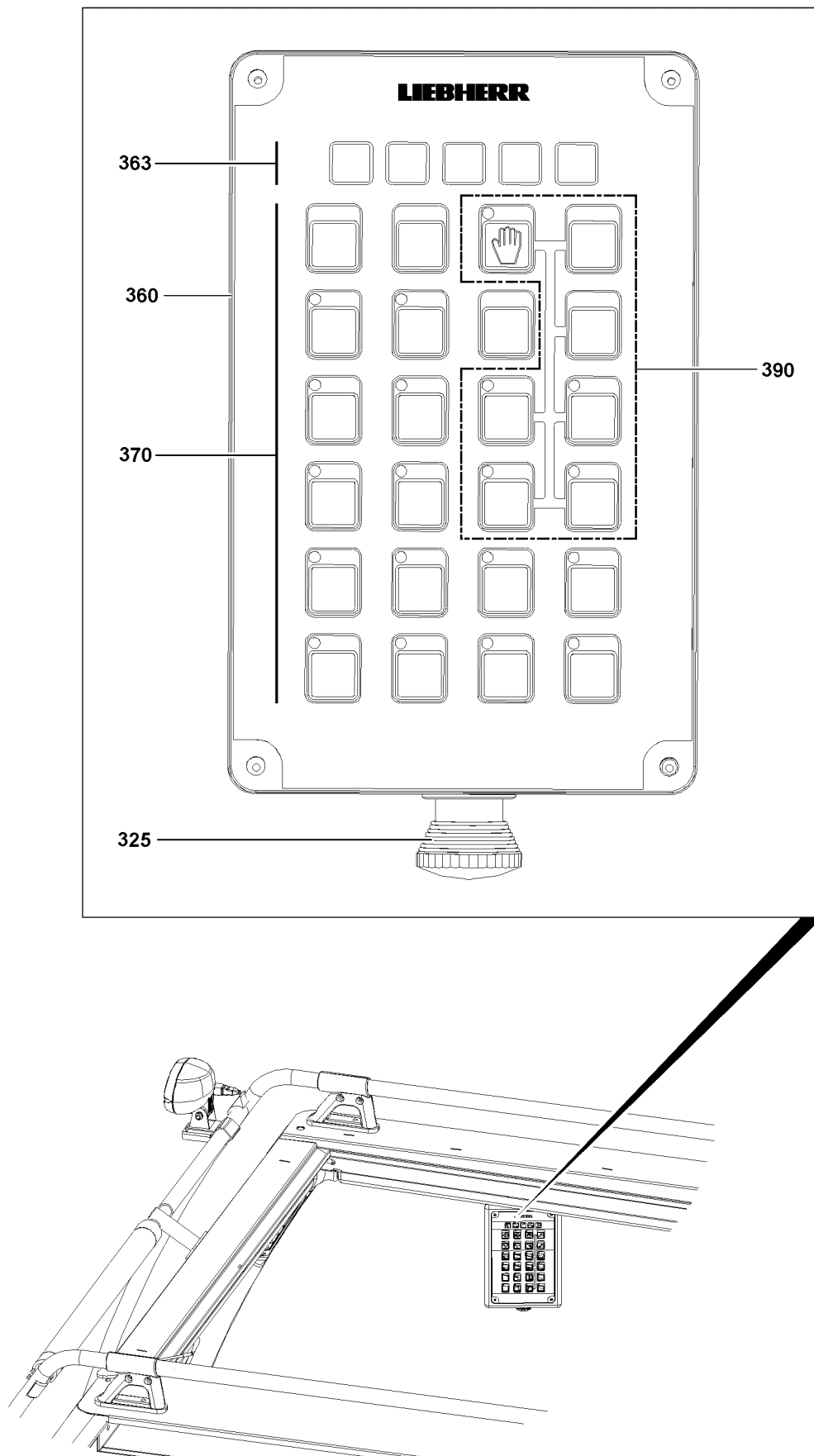

Fig.117705

LWE/LR 11000-001/23501-04-02/en

4.3 Tilting the crane operator's cab*

To give the crane driver a better field of vision, the crane operator's cab can be tilted up.

When the crane operator's cab is tilted up, the catwalk around the cab is also inclined.

The incline of the crane operator's cab can be adjusted via the function keys on the operating and control unit (BKE).



WARNING

Danger of accident!

When the crane operator's cab is tilted or tilting, personnel which move freely in the cab can fall.

When the crane operator's cab is tilted or tilting, the cab door can start to move suddenly when opening it.

Injuries to persons and property damage can result.

- ▶ Tilt the crane operator's cab only when properly seated in the crane operator's seat.
- ▶ Before getting up from the crane operator's seat, set the crane operator's cab into horizontal position.
- ▶ After completion of working with the crane, return the crane operator's cab to horizontal position.

When the cab door must be opened with tilted crane operator's cab:

- ▶ Grasp the cab door handle safely and carefully open the cab door.



WARNING

Inclined catwalk!

If persons are on a tilted or tilting catwalk, they can fall.

Personnel can be severely injured or killed.

- ▶ It is prohibited for anyone to remain under the catwalk when tilting the crane cab.
- ▶ It is prohibited for anyone to remain on a tilted catwalk.
- ▶ Before stepping on the catwalk, set it to horizontal position.

After completion of working with the crane, return the crane operator's cab to horizontal position.

Make sure that the following prerequisite is met:

- There are no persons in the incline range of the crane operator's cab and the catwalk.

4.3.1 Tilting the cab upward



Fig.117719

- ▶ Activate the release key **390** and then press the control button **391**.

Result:

- The cab swings upward.

4.3.2 Setting the cab to horizontal position



Fig.117720

- ▶ Activate the release key **390** and then press the control button **392**.

Result:

- The cab swings downward.

4.4 Windshield wiper / windshield washer system

4.4.1 Operating the windshield wiper

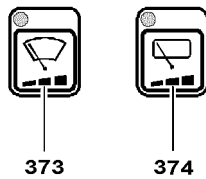

Fig. 118205

The windshield wipers on the front and roof window can be operated via the function buttons on the operating and control unit (BKE), see illustration. Each window is assigned its own button.

Turn the windshield wiper on

There are four different wipe stages.

Pressing the button **373** or the button **374** (less than 0.5 seconds) reduces the wiper speed incrementally:

1. Continuous operation
2. Short interval
3. Long interval
4. Wiper off

- When the wipe stage „Wiper off“ is reached, an acoustical signal sounds on the BKE.

To activate the windshield wiper on the front window:

- ▶ Press the button **373** until the desired wipe stage is reached.
- or**

To activate the windshield wiper on the roof window:

- Press the button **374** until the desired wipe stage is reached.

Turn the windshield wiper off

- ▶ Press the button **373** or the button **374** for at least one second.
- or**

- Press the Taste **373** or Taste **374** until an acoustical signal sounds on the BKE (0.5 seconds).

4.4.2 Operating the windshield washer system

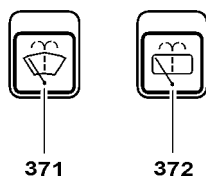

Fig. 118214

The windshield washer system on the front and roof window can be operated via the function buttons on the operating and control unit. Each window is assigned its own button.

The wiper motor and the water pump run as long as the button **371** or button **372** is pressed down.

After pressing the button **371** or the button **372**, three additional wipe movements are carried out before the wiper arms return to their original position.

To activate the windshield washer system for the front window:

- ▶ Press the button **371**.
- or

To activate the windshield washer system for the roof window:
Press the button **372**.

4.4.3 Filling the windshield washer system

For the location of the reservoir for the window cleaning fluid, see Crane operating instructions, chapter 4.01!

NOTICE

Frozen window cleaning fluid!

If the window cleaning fluid is not frost resistant, then the windshield washer system can freeze during the cold time of the year.

Failure of the windshield washer system is the result.

The windshield washer system can be damaged.

- ▶ Change the window cleaning fluid in time to a frost resistant type.

Before the start of the cold season:

- ▶ Fill the reservoir with a frost resistant window cleaning fluid.

4.5 Checking the horn



WARNING

Improper use of horn!

If the horn is used outside of danger situations, then it can lose its warning effect.

If the horn loses its warning effect, then severe injuries can occur as a result.

If the horn is to be checked:

- ▶ Notify all personnel in the vicinity that the horn is being checked for function.

When the horn test is completed:

- ▶ Notify all personnel in the vicinity that the testing of the horn has been completed.
- ▶ Do not use the horn unnecessarily.

Make sure that the following prerequisite is met:

- Any personnel in the vicinity has been notified that the horn is being checked for function.

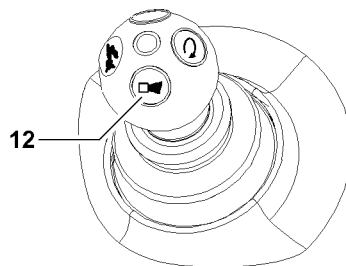

Fig.115322: Horn button

Before starting to work, check that the horn is functioning:

- ▶ Press the button **12** on any desired master switch.

Result:

- The horn sounds.

Problem remedy

The horn does not sound?

The horn is defective or is dysfunctional.

- ▶ Repair the horn before starting crane operation.

After successful testing of the horn:

- ▶ Notify any personnel in the vicinity that the testing of the horn has been completed.

4.6 Opening / closing cab doors and cab windows

Unsecured or unlocked cab doors or cab windows can move suddenly if, for example:

- The crane is driven / slowed down.
- The cab or the entire crane is at an incline.

**WARNING**

Danger of accident!

Unsecured or unlocked cab doors or cab windows which move suddenly can catch personnel and cause accidents.

If the crane is driven with open window or open crane door, the crane cab can be damaged.

- ▶ Secure or lock cab doors or cab windows to prevent them from moving suddenly.

**WARNING**

Danger of crushing!

When closing the cab door and cab windows, hands and / or other limbs can be crushed.

- ▶ When closing the cab door and cab windows, make sure that no limbs are injured.

Open the cab door:

- ▶ Unlock and open the cab door.

Close the cab door:

- ▶ Pull the cab door closed and lock.

Open the cab window:

- ▶ Unlock and open the cab window.

Close the cab window:

- ▶ Pull the cab window closed and lock.

4.7 Opening / closing the roof window

4.7.1 Opening the roof window

**WARNING**

Hands can get trapped!

- ▶ Watch your hands when closing the roof window.

A pair of nitrogen gas cylinders support the lifting movement of the roof window.

- ▶ Open the window lock.
 - ▶ To open from inside, press on the roof window.
- or**

If you only want to partly open the roof window:

Adjust the window in the desired position with the provided perforated belt.

4.7.2 Closing the roof window



WARNING

Hands can get trapped!

▶ Watch your hands when closing the roof window.

▶ To close the roof window, pull the window down on the locking handle.

When the roof window is closed:

▶ Close the window lock.

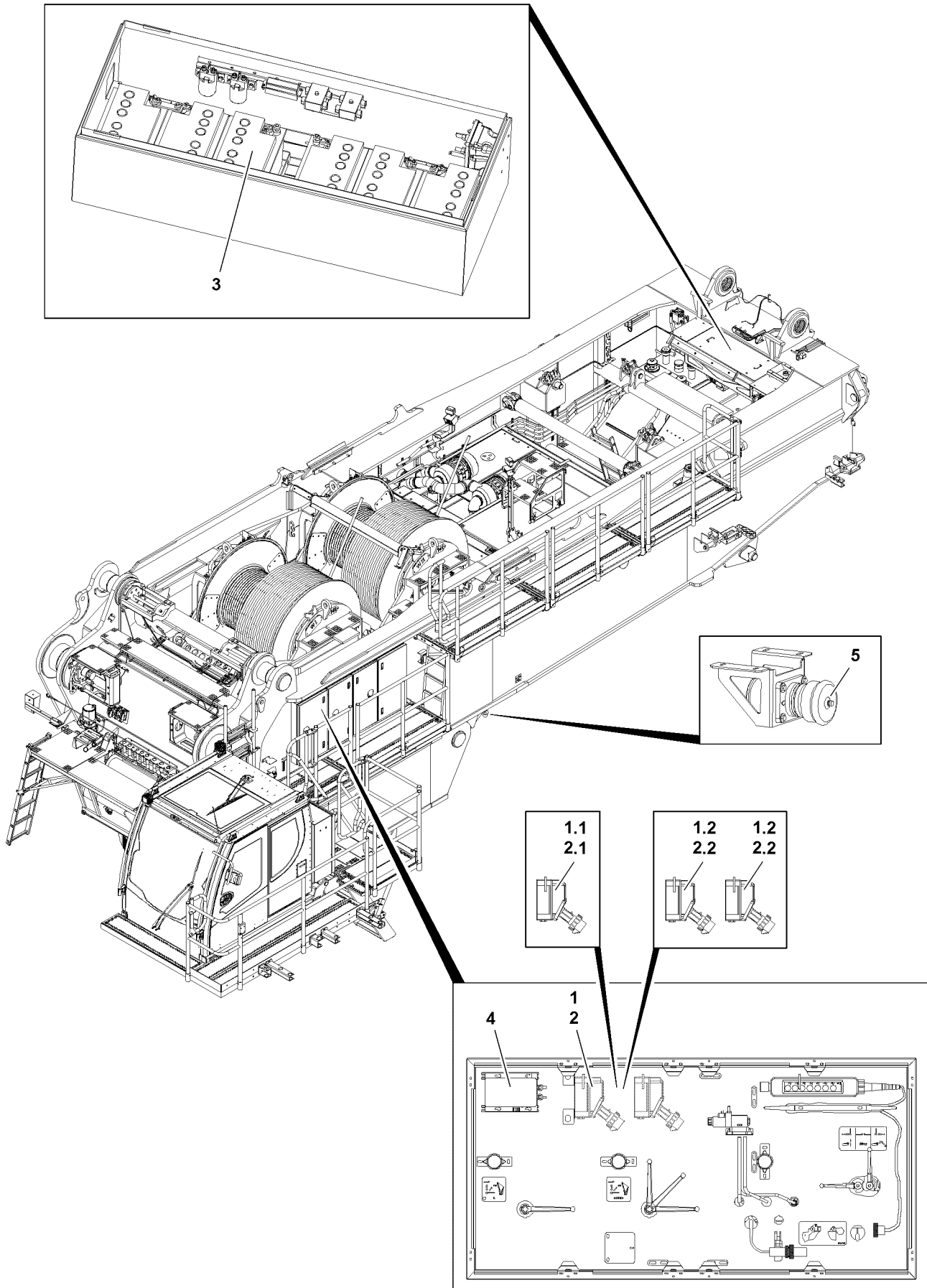

Fig.118208

LWE/LR 11000-001/23501-04-02/en

5 Supply via external feed / power aggregate

The following types of supply are available:

- Supply via plug connection for external feed from power supply system

Position	Description
1	Plug connection(s) External feed
1.1	Plug connection for external feed (230 V)
1.2*	Plug connections for external feed (2 x 110 V)
2	Circuit breaker
2.1	Circuit breaker for external feed (230 V)
2.2*	Circuit breaker for external feed (2 x 110 V)
3	Battery system
4	Battery charger
5	Feed for external start

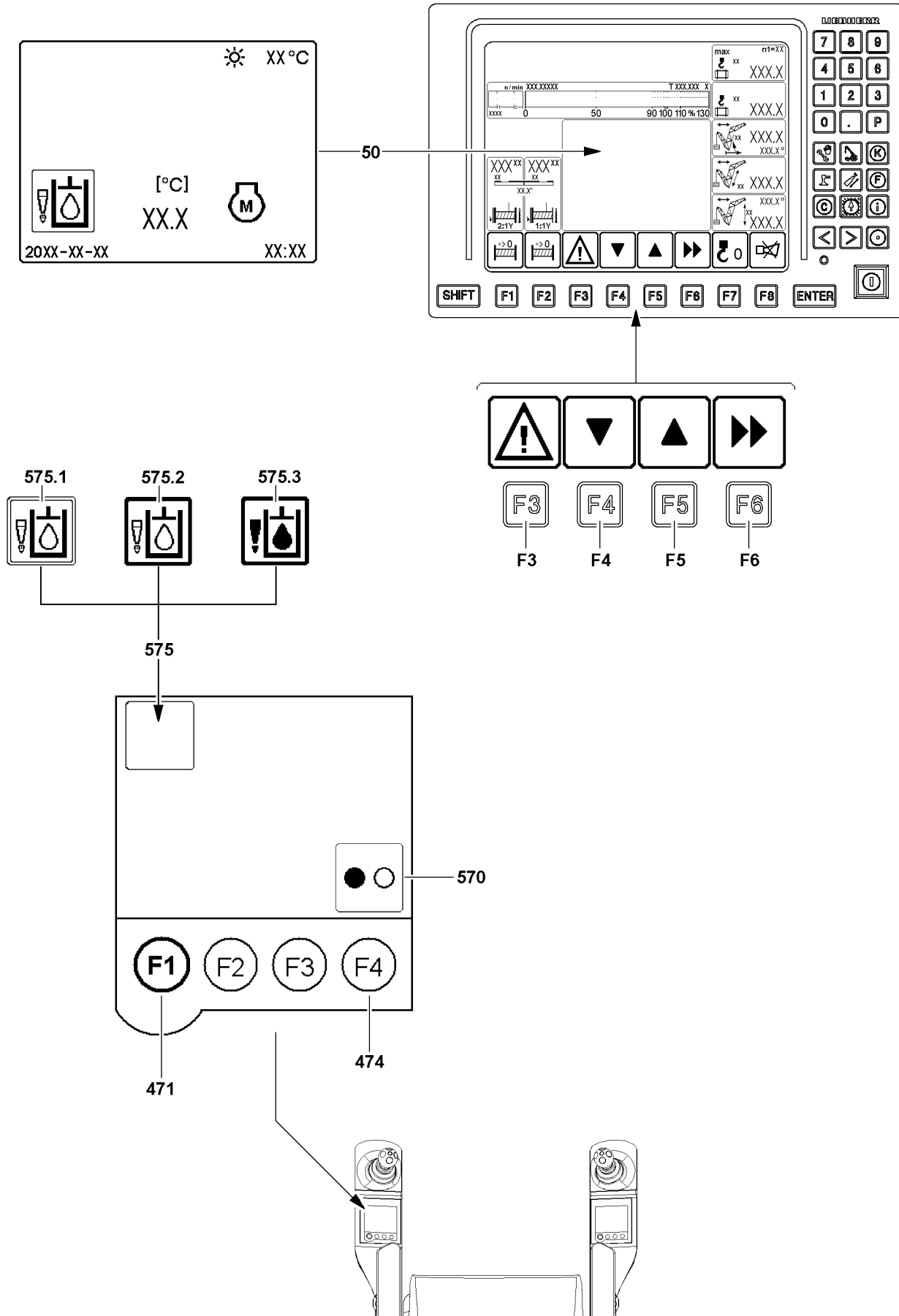

Fig.118213

LWE/LR 11000-001/23501-04-02/en

6 Preheating the hydraulic oil with the Hydraulic oil preheating*

The hydraulic oil can be preheated with the Hydraulic oil preheating*.

NOTICE

Damage of hydraulic crane components!

If the required measures are not carried out for use of the crane at low temperatures, then the crane or crane components can be damaged.

Extensive repairs and / or downtime can result.

- ▶ Engage the Hydraulic oil preheating*.
- ▶ Warm up crane components according to Crane operating instructions, chapter 2.08.



Note

- ▶ Always preheat the hydraulic oil at low ambient temperatures.
- ▶ From a hydraulic oil temperature above 25 °C , do not turn the Hydraulic oil preheating* on.
- ▶ The current hydraulic oil temperature can be called up via the individual control display on the LICCON monitor.

6.1 Turning the Hydraulic oil preheating* on

Make sure that the following prerequisite is met:

- The crane engine is running.



Note

When the Hydraulic oil preheating* is turned on, various crane movements are turned off.

- ▶ If necessary, turn the Hydraulic oil preheating* off.

- ▶ In the „Crane operation“ program, press the function key **F3**.

Result:

- The monitoring area with its monitoring functions is displayed on the LICCON monitor.

- ▶ Press the function key **F4** until the individual control display for the hydraulic oil temperature is shown on the LICCON monitor.

Result:

- The current hydraulic oil temperature can be read.

- ▶ Press the F1 function key **471** on the left touch display until the „Hydraulic oil preheating“ menu appears.

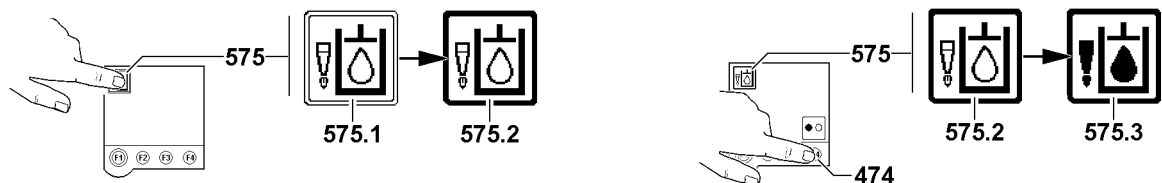

Fig.115320

- ▶ Select the function „Hydraulic oil preheating“ **575** by touching the icon **575.1** on the display.

Result:

- Icon **575.1** changed to icon **575.2** (icon bordered in black)

- ▶ Press the F4 key **474**.

Result:

- Icon **575.2** changes to icon **575.3** (icon filled out)
- The hydraulic oil preheating is turned on.

When the hydraulic oil temperature in the individual control display **50** has reached the operating temperature:

- ▶ Press the F4 key **474**.

Result:

- The hydraulic oil preheating is turned off.
- Icon **575.2** appears (icon not filled out)

- ▶ Press the function key **F3**.
- or**
- Press the function key **F6** twice.

Result:

- The monitoring field with monitoring functions is not displayed.

7 Starting the LICCON computer system (before engine start)

There are two operating modes for the LICCON computer system:

- LICCON computer system in stand-by mode (crane engine turned off).
- LICCON computer system in normal mode (crane engine turned on).

7.1 System start of the LICCON computer system

After the ignition is turned on, the LICCON computer system boots up and carries out a self-test, see Crane operating instructions, chapter 4.02.

Make sure that the following prerequisite is met:

- Do not operate any operating elements during the system start of the LICCON computer system.

**Note**

During the boot up phase, if an operating element is actuated (for example the master switch is moved from the zero position), the system start may be aborted as a result.

- ▶ After an abort at system start: Turn the engine and ignition off and start again.

- ▶ Wait for the boot up phase.

Result:

- The set up screen appears on the LICCON monitor.
- Normally the previously selected set up configuration is displayed.
- ▶ Check the set up configuration.

Problem remedy

The LICCON monitor does not show the required set up configuration?

- ▶ Set the required set up configuration, see section „Changing the set up configuration“.

Problem remedy

An error message appears on the LICCON monitor?

- ▶ Turn the engine and ignition off and start again.

When an error message appears again:

- ▶ Contact Liebherr Service.

7.2 Taking over the previously set set up configuration

Make sure that the following prerequisite is met:

- The entries and settings in the set up program match the actual set up configuration of the crane.

When the entries and settings in the set up program are correct:

- ▶ Press function key **F8**.

Result:

- The entries and settings are taken over and the „Set up“ program is ended. The crane operation program is called up and the crane operating screen is shown.

7.3 Changing the set up configuration

The entries and settings for the set up configuration can be changed in the Set up program.

- ▶ Call up the set up program and make the entries and settings for the set up configuration.



Note

- ▶ For detailed description of the entries and settings in the Set up program, see Crane operating instructions, chapter 4.02.
-

When the entries and settings in the set up program are correct:

- ▶ Press function key **F8**.

Result:

- The entries and settings are taken over and the „Set up“ program is ended. The crane operation program is called up and the crane operating screen is shown.

7.4 Setting the speed reduction master switch



Note

- ▶ For detailed description to set the speed reduction master switch, see Crane operating instructions, chapter 4.02.
-

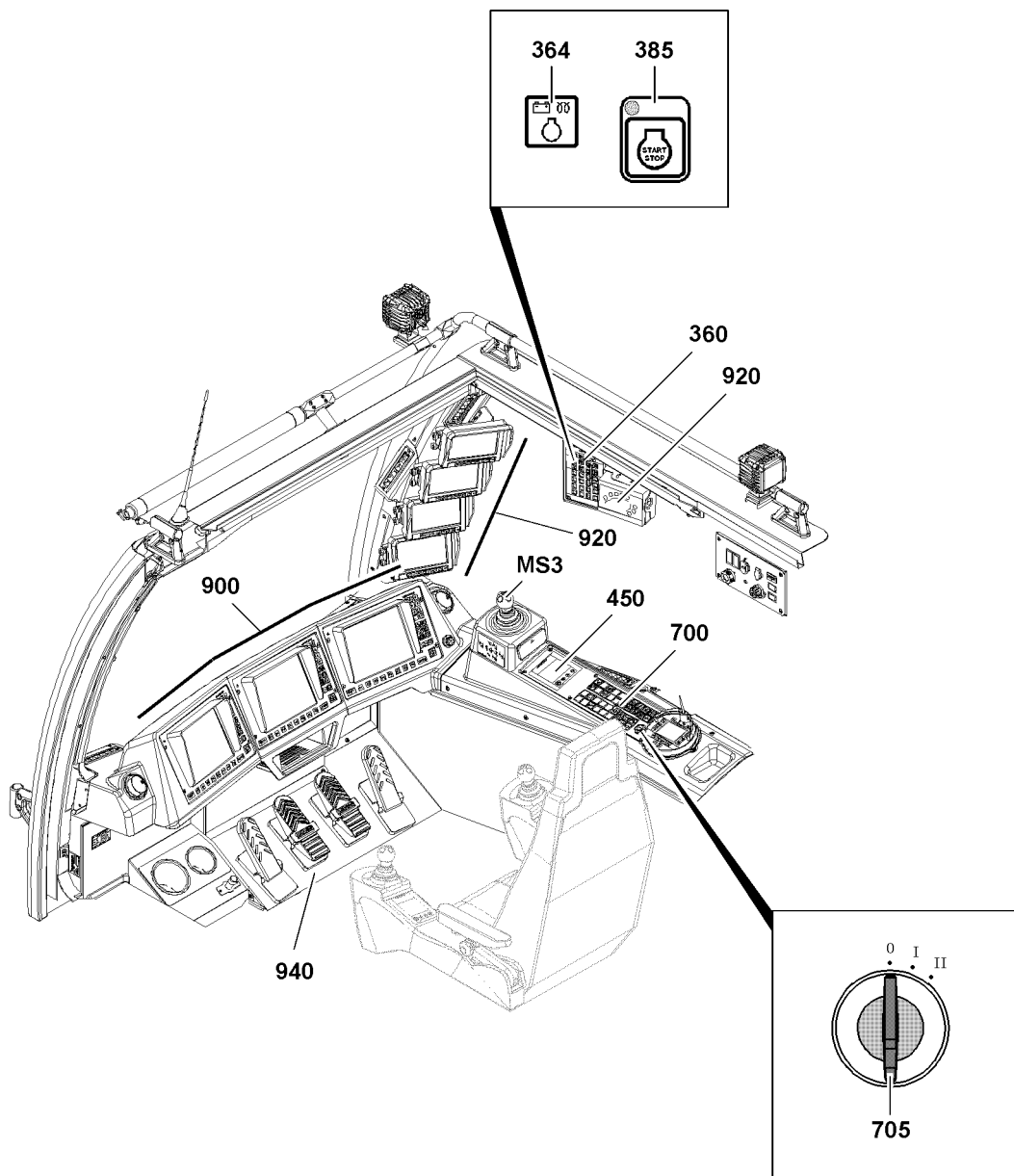

Fig.118209

LWE/LR 11000-001/23501-04-02/en

8 Starting and stopping the engine

Operate the engine according to the manufacturer's specifications, see separate operating instructions of the engine manufacturer.



Note

- ▶ As long as the indicator light **364** lights up yellow, the engine preheating is active.
-

Make sure that the following prerequisites are met:

- The ignition switch **705** is in position „I“.
 - In the LICCON computer system, the Crane operation program is called up and the crane operation screen is shown.
 - Indicator light **364** blinks yellow (1 Hz).
-

NOTICE

Danger of property damage!

- ▶ Start the engine only when the indicator light **364** blinks yellow.
 - ▶ Do not press down on the gas pedal during starting.
 - ▶ Do not actuate the starter too long and pause in between starting attempts, see Operating instructions from the engine manufacturer.
 - ▶ Let the engine warm up before subjecting the engine to a full load, see Operating instructions from the engine manufacturer.
-

8.1 Starting the engine

When the indicator light **364** blinks yellow (1 Hz), the engine is ready to start.

- ▶ Press the control button **385** „Engine START / STOP“.

Result:

- The engine starts.
- ▶ Check the instruments after starting the engine.

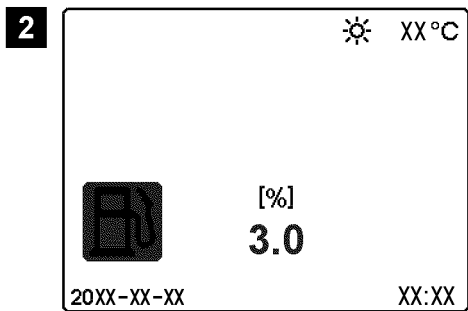
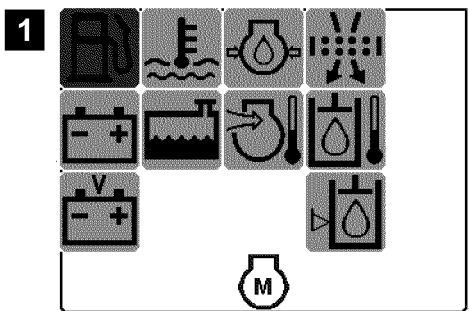
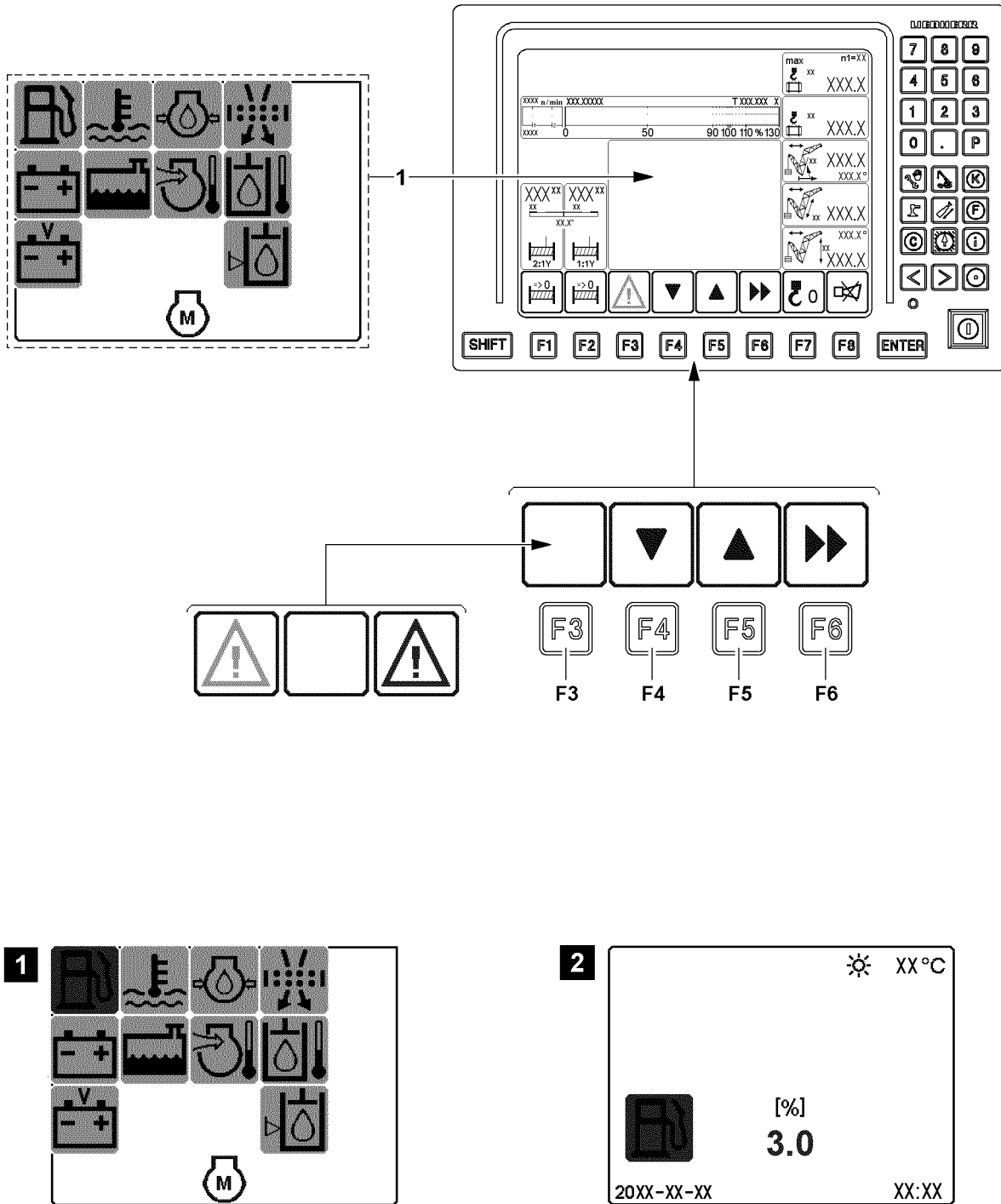

Fig.118212

8.2 Checking the operating and control instruments after start

- LICCON Monitor: If a control value has reached a limit value, then the monitoring functions are automatically called up in the Crane operation program and the error or problem are pointed out.
- Operating and control unit (BKE): If an error or a problem occurs, then the error or the problem are pointed out.



Note

- ▶ For detailed description of the operating and control instruments, see Crane operating instructions, chapter 4.01.

8.2.1 Checking the monitoring functions on the LICCON monitor

If a control value has reached a limit value, then the monitoring functions are automatically called up in the Crane operation program and the error or problem are pointed out.

- The monitoring functions react in general only when an error or problem is present. Avoidable missing amounts / problems impede crane operation and cause unnecessary delays and / or down-time.
- If the warning icon of the function key **F3** is „yellow“ or „red“, then there is an error or a problem on the crane.

- ▶ Check the warning icon of the function key **F3**.

When the warning icon for the function key **F3** is shown in „yellow“ or „red“ and the monitoring functions **1** are not automatically shown:

- ▶ Press the function key **F3**.

Result:

- The monitoring functions **1** on LICCON monitor are called up.
- The erroneous function is displayed in the monitoring field in „yellow“ or „red“ (see example illustration **1**).

When the warning icon of the function key **F3** is shown in „red“:

- ▶ Turn the engine off immediately and remedy the error or the problem.



Note

- ▶ For a detailed description of monitoring functions, see Crane operating instructions, chapter 4.02.

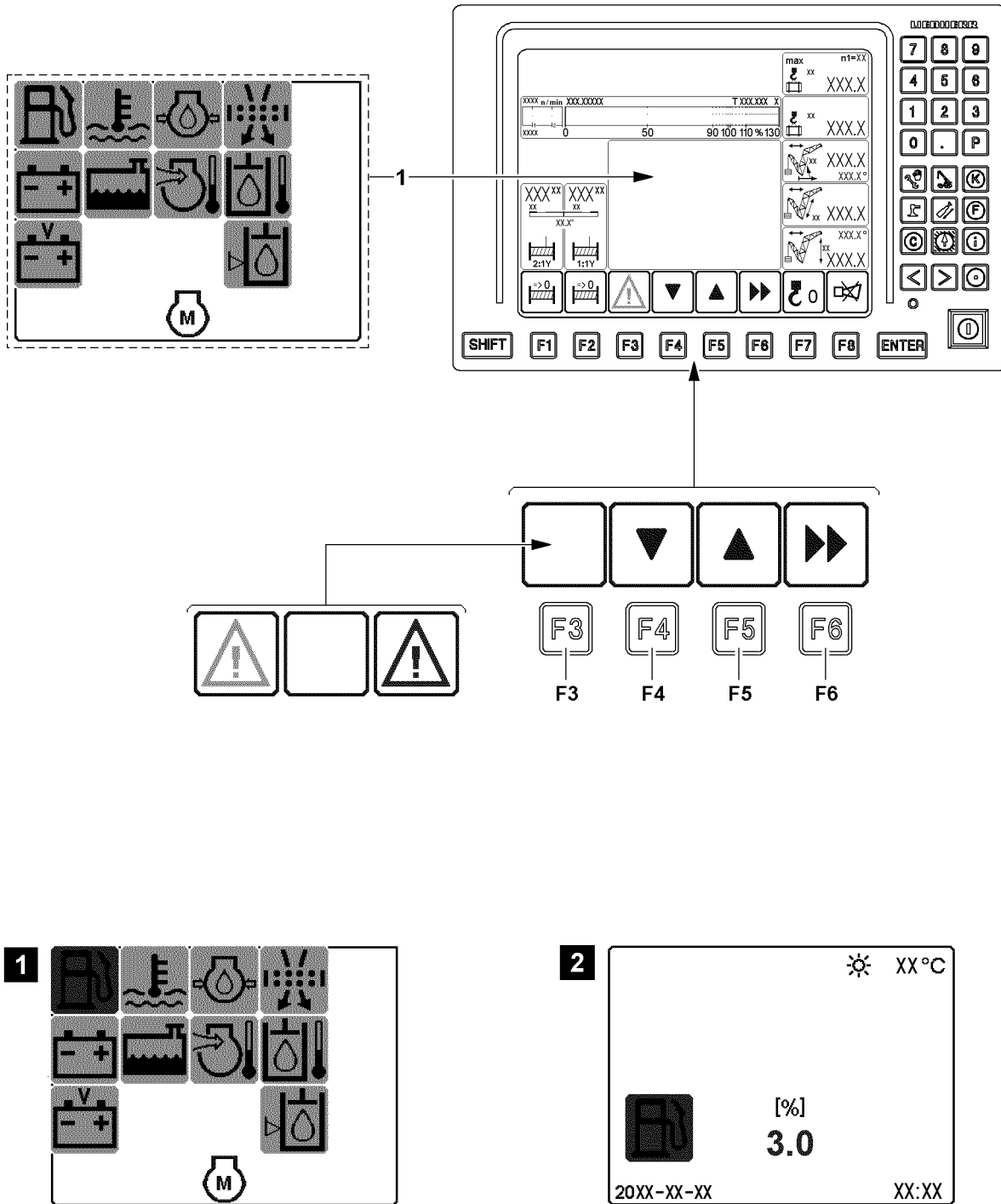

LWE/LR 11000-001/23501-04-02/en

Fig.118212

8.2.2 Calling up and checking the individual control displays

The relevant values for some monitoring functions in the monitoring field can be displayed.

In the example, the fuel reserve is low and:

- The monitoring functions report an error or a problem.
- The fuel reserve icon is shown in the monitoring field in „red“, see example illustration 1.
- ▶ Press the function key **F4** or function key **F5** and call up the individual control displays for the fuel reserve.

Result:

- The individual control display with the current fuel reserve is displayed, see example illustration 2.
- The fuel reserve is 3 % and would have to be replenished immediately.

By continuing to press the function key **F4** or function key **F5**, all additional individual control displays can be switched through one after the other.

Change back to the monitoring field using the function key **F6**.

- ▶ Press the function key **F6**.

Result:

- The monitoring field is shown again.

The monitoring field can be exited using the function key **F3**.

- ▶ Press the function key **F3**.

Result:

- The monitoring field is faded out.

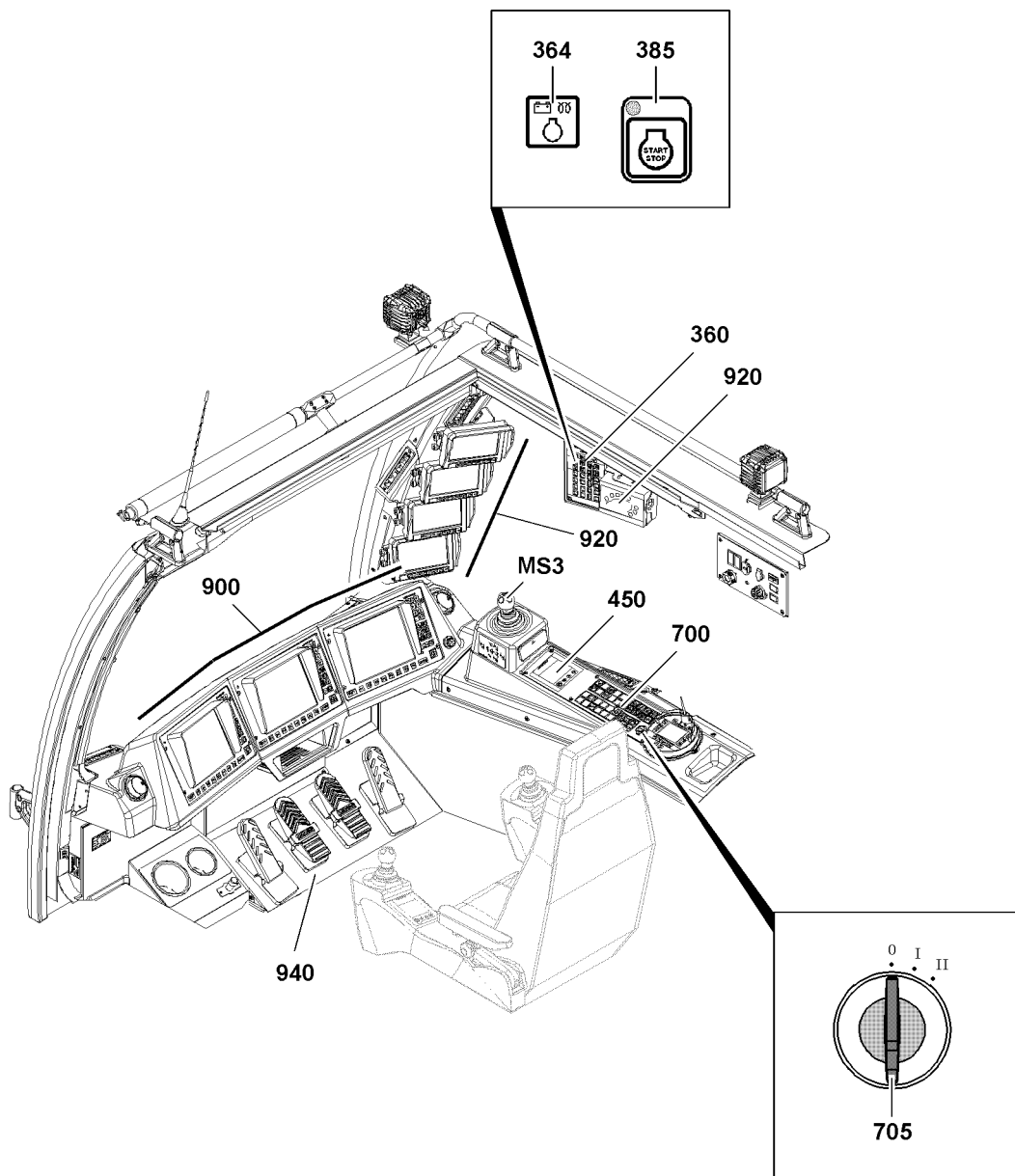

Fig.118209

LWE/LR 11000-001/23501-04-02/en

8.3 Turning the engine off

NOTICE

Increased engine wear!

If the engine is suddenly turned off after operation with full engine load or in case of increased coolant temperature (above 95 °C), then this can lead to increased wear over time.

- ▶ Before turning the engine off, let the engine run for approximately three to five minutes at idling speed without a load.



Note

LICCON computer system in stand-by mode

- ▶ If the engine is turned off, the LICCON computer system can continue to be operated in Stand-by mode, see Crane operating instructions, chapter 4.02.

8.3.1 Turning the engine off

To turn the engine off use the operating and control unit (BKE).

When the engine is running:

- ▶ Press the control button **385** „Engine START / STOP“.

Result:

- The engine turns off.
- ▶ Release the control button **385**.

8.3.2 Turning the engine off in the event of danger

NOTICE

Improper use of the EMERGENCY STOP switch!

Repeated improper use of the EMERGENCY STOP switch can cause increased wear on the crane!

- ▶ Use of the EMERGENCY STOP switch for normal operation is not permitted!
- ▶ Use the EMERGENCY STOP switch only in emergency situations!

If an emergency situation occurs:

- ▶ Actuate the EMERGENCY STOP switch.

Result:

- The crane is turned off.

After pressing an EMERGENCY STOP switch it is possible that the LICCON computer system must be reset.

Reset the LICCON computer system after EMERGENCY STOP:

- ▶ Release the actuated EMERGENCY STOP switch.
- ▶ Turn the ignition switch **705** momentarily to position „0“ and then again to position „I“.

9 Starting the LICCON computer system parallel to the engine



Note

If the engine was started with the ignition switch **705** without having started the LICCON computer system first, then the system start of the LICCON computer system starts parallel to the engine start.

- ▶ Start the LICCON computer system first, see section „Starting the LICCON computer system (before engine start)“

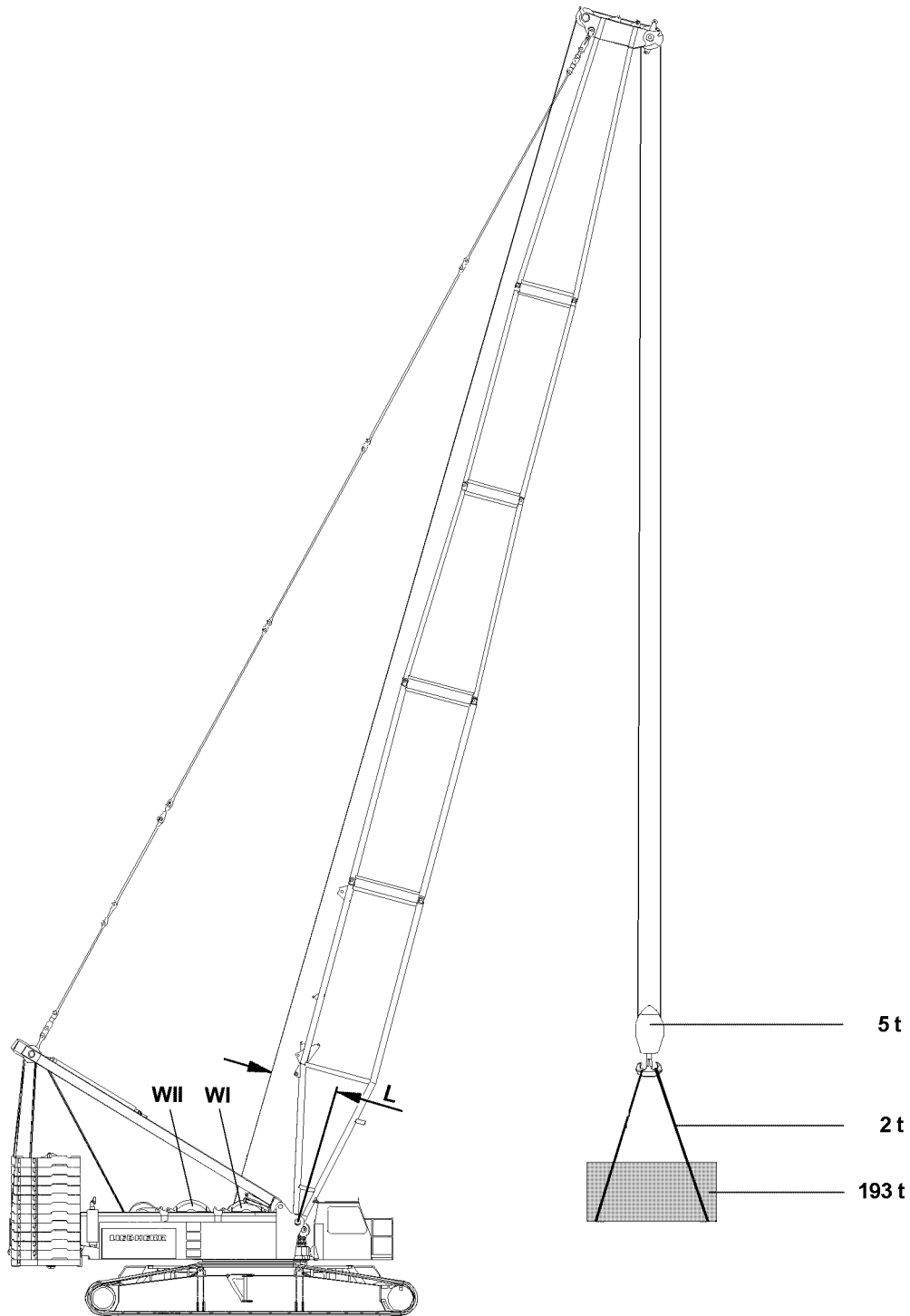

Fig.103667

LWE/LR 11000-001/23501-04-02/en

10 Load weighing and load display

In the loads stated in the load chart, the weight of the lifting equipment (hoist rope at nominal reeving) has been taken into account.



DANGER

Lifting unknown loads!

When lifting unknown loads, there is a danger of unrecognized overloading of the crane!

- ▶ The crane operator must know the weight, the center of gravity and the dimensions of the load to be lifted before operating the crane.
- ▶ Before crane operation, the crane operator must know the radii of the crane for the entire covered distance of the load to be lifted.
- ▶ The crane driver must check, before lifting the load, if he may even lift and transfer the load according to the data in the load chart.
- ▶ No deviation from the load charts may occur, even if the load display shows deviating values (for example inaccurate load weighing or load display).

10.1 Load reduction

Load reduction

- The weight of the hook block and the weights of the fastening equipment must be subtracted from the load given in the load chart.
- If higher than the nominal reeving of the load chart is reeved, then the load capacity is reduced by the weight of the additional strands of the hoist rope (additional load carrying equipment weight).
- If a deviating pulley head with more pulleys is installed, then the load capacity is reduced by the additional pulley head weight.

Example 1 (at nominal reeving):		
Maximum permissible load according to chart		200 t
Weight of the hook block	5 t	- 5 t
Deduction for load carrying equipment at nominal reeving	0 t	- 0 t
Weight of the fastening rope	2 t	- 2 t
Actual load capacity of the crane		= 193 t

In this case, the load to be lifted may not exceed **193 t**, see illustration.

Example 2 (at nominal reeving + 10 strands):		
Maximum permissible load according to chart		200 t
Weight of the hook block	5 t	- 5 t
Deduction for load carrying equipment at nominal reeving	1 t	- 1 t
Weight of the fastening rope	2 t	- 2 t
Actual load capacity of the crane		= 192 t

In this case, the load to be lifted may not exceed **192 t**.

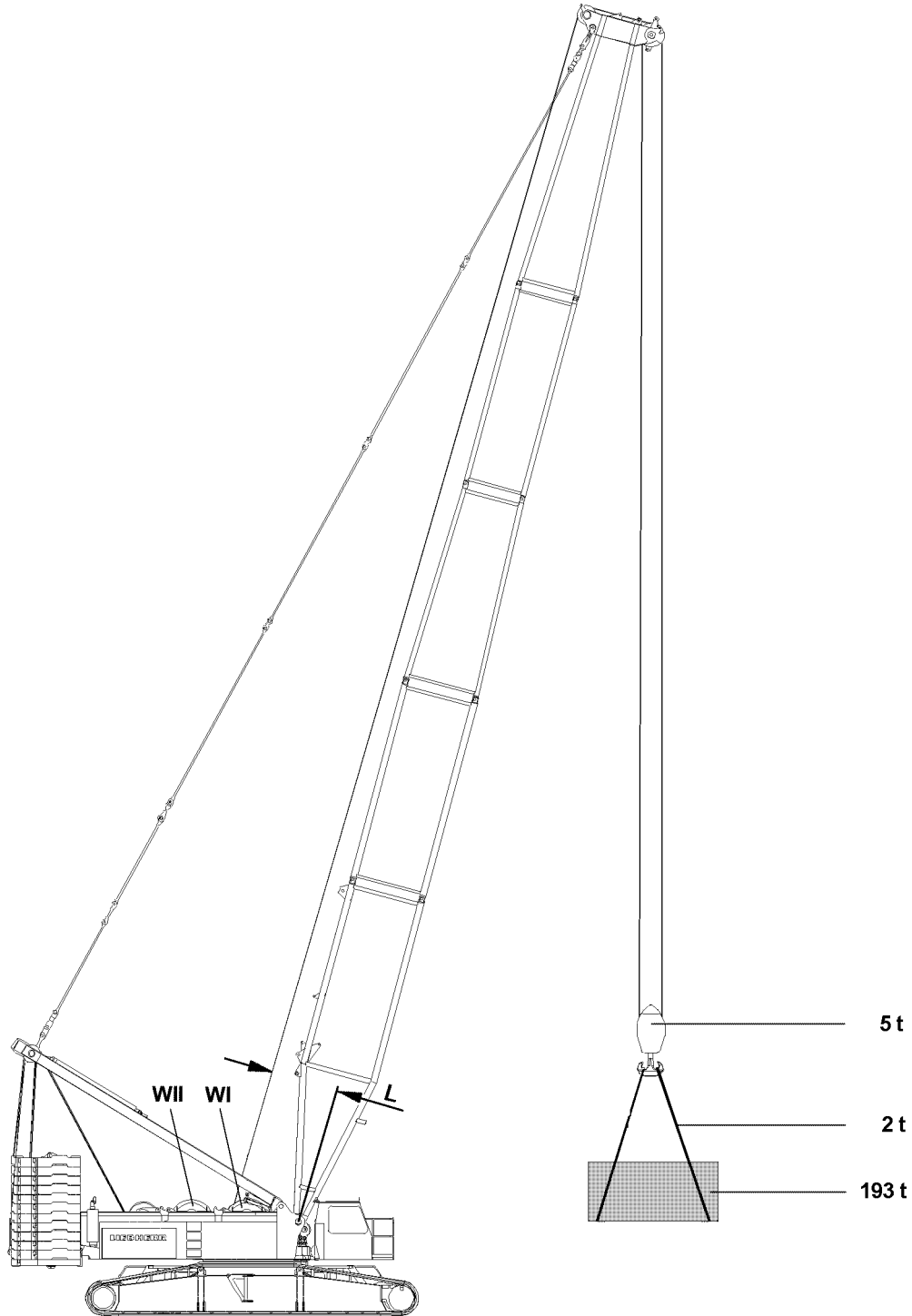

Fig.103667

LWE/LR 11000-001/23501-04-02/en

10.2 Load weighing

Make sure that the following prerequisites are met:

- The crane is operational, fully functioning and in a proper and safe operating condition.
- On the entire boom system there may be no block position of cylinders and / or crane components.



Note

- ▶ On the entire boom system there may be no block position.
- ▶ A block position can cause weighing errors.
- ▶ If an error or a problem is present, an error message is issued. Load display and load weighing can send erroneous or inexact values. Possibly the values cannot even be determined.

10.2.1 Possible weighing errors



WARNING

Tolerances at actual load display!

Due to tolerances, deviations can occur for the displayed values of the actual load display. The actual load display is not a calibrated weighing device and can have weighing errors.

- ▶ Always observe the actual weight of the load in connection with the load charts and the set up configuration.

The weighing error can occur, among others, when:

- The incorrect hoist winch is used.
- The reeving is incorrect.



WARNING

Danger of accident due to deviating set up configuration!

If the actual set up configuration of the crane deviates from the entries and settings in the Set up program, then the overload protection is not correctly set.

An incorrectly set overload protection calculates the actual load incorrectly and transmits faulty display values.

The crane can be overloaded unnoticed and topple over.

Personnel can be severely injured or killed.

- ▶ The entries and settings in the set up program must match the actual set up configuration of the crane.

10.2.2 Adjustment of reeving

The number of reeving must be correctly set on the LICCON monitor. The reeving should not be higher than the nominal reeving, otherwise the load is increased above the nominal reeving of the reeved hoist rope.



Note

- ▶ The nominal reeving determines for which reeving the load chart values of a load chart are valid.

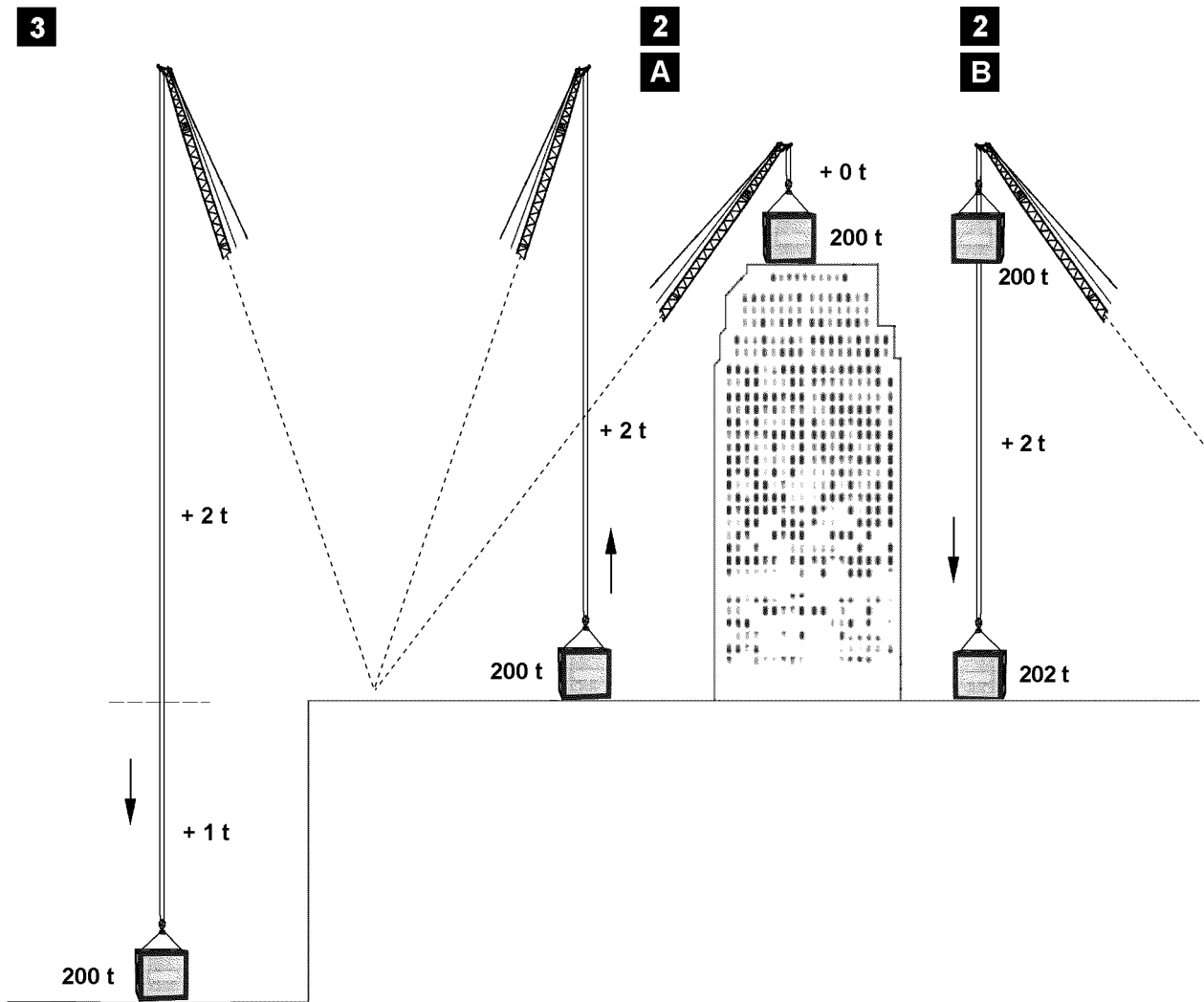
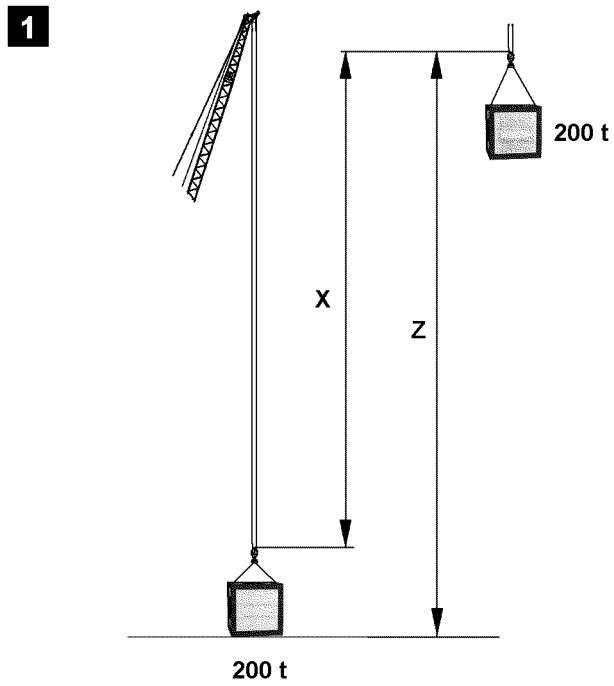

Fig.103643

LWE/LR 11000-001/23501-04-02/en

10.3 Load display

10.3.1 Lifting, illustration 1

For the calculation of the displayed actual load, the weight of the hoist rope up to the height of the slewing ring is deducted from the total load **Z**, which hangs on the pulley head **X**, see illustration 1.

In that case the nominal reeving of the hoist rope is taken into account.



Note

- ▶ If the load is raised far above the ground, see illustration 1, then the load display is too small by the weight of the hoist rope from the load to the ground.

10.3.2 Lifting above ground level, illustration 2A

When the load is raised above the crane level (high rise), then the hoist rope to the ground is always deducted anyway for the display, therefore the load seems increasing lighter when lifting than it did on the ground.

Therefore a somewhat larger load can be lifted in large heights than on the ground, without triggering the LMB overload shut off at 100 %.

This poses no danger because the load stress for the crane is the same if, for example 200 t if load on the bottom and 2 t rope or 202 t load on top and 0 t rope hang on the pulley head.

10.3.3 Load take up on high rise, illustration 2B

When a load is taken up on the high rise on top (=100 %), for example 200 t, and then lowered to the ground, the weight of the hoist rope below the high rise level is calculated as load and displayed.

10.3.4 Lifting below ground, illustration 3

When a load is lowered below the crane level (excavation), then the hoist rope below the crane level is calculated as load and displayed.



DANGER

Danger of accidents due to overload!

It must be noted that the load display in illustration 2B and illustration 3 is correct, the overload of the crane is also shown in the utilization bar, but no shut off of the lowering movement occurs.

- ▶ At LMB overload, all crane movements are shut off, which would increase the danger of overload, however, lowering the load at 100 % -LMB shut off remains clear because one normally assumes that the overload was caused by lifting the load.
- ▶ However, the crane can also be overloaded by lowering the load, especially in case of high reeving with high hoist rope weight on the pulley head. The crane driver must know this, so that he can relieve the crane by careful lifting again in this special case, even though the lifting and not the lowering of the load is automatically shut off.

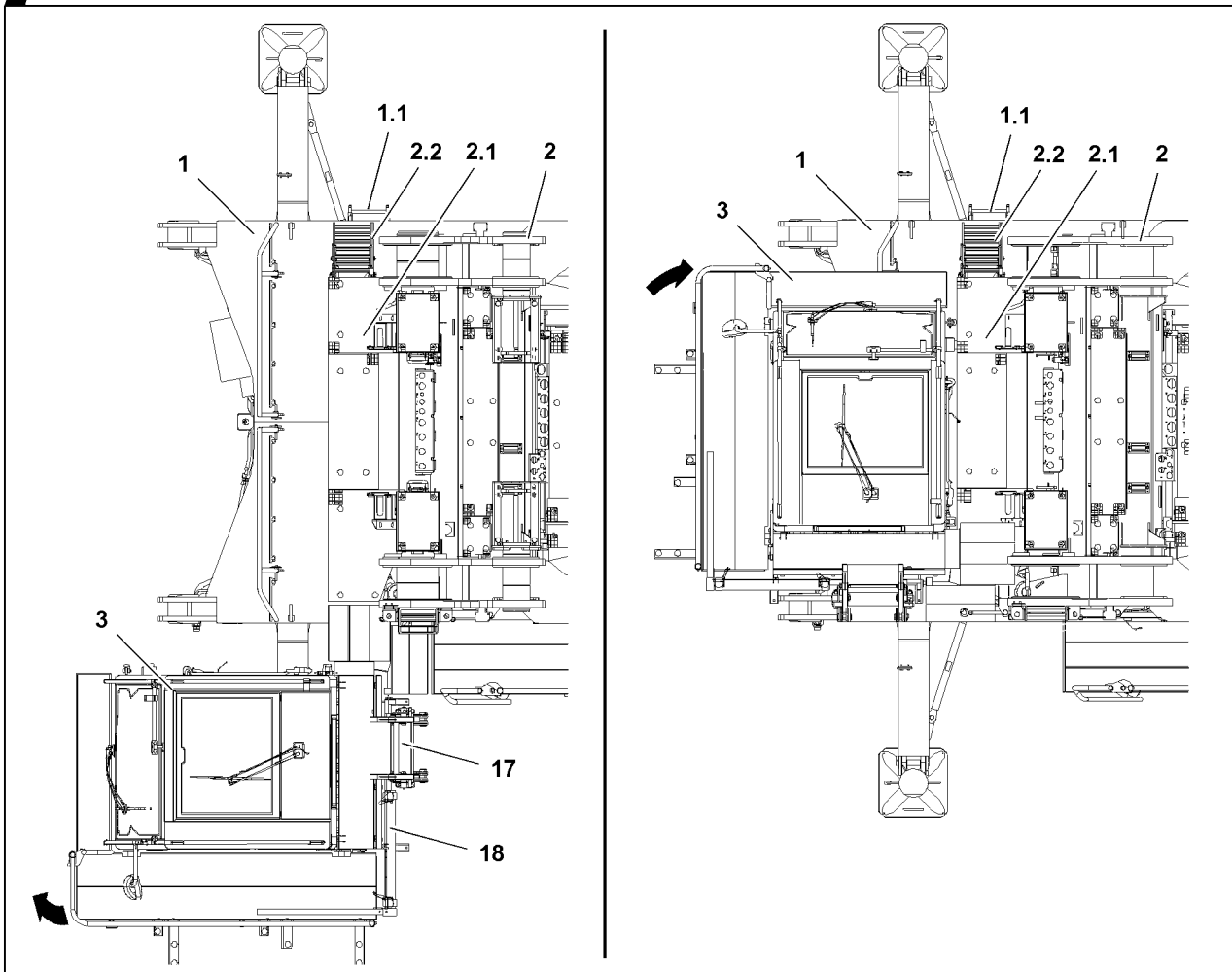
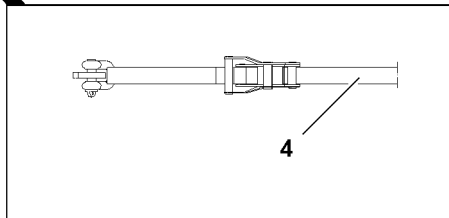
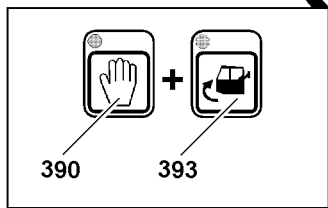
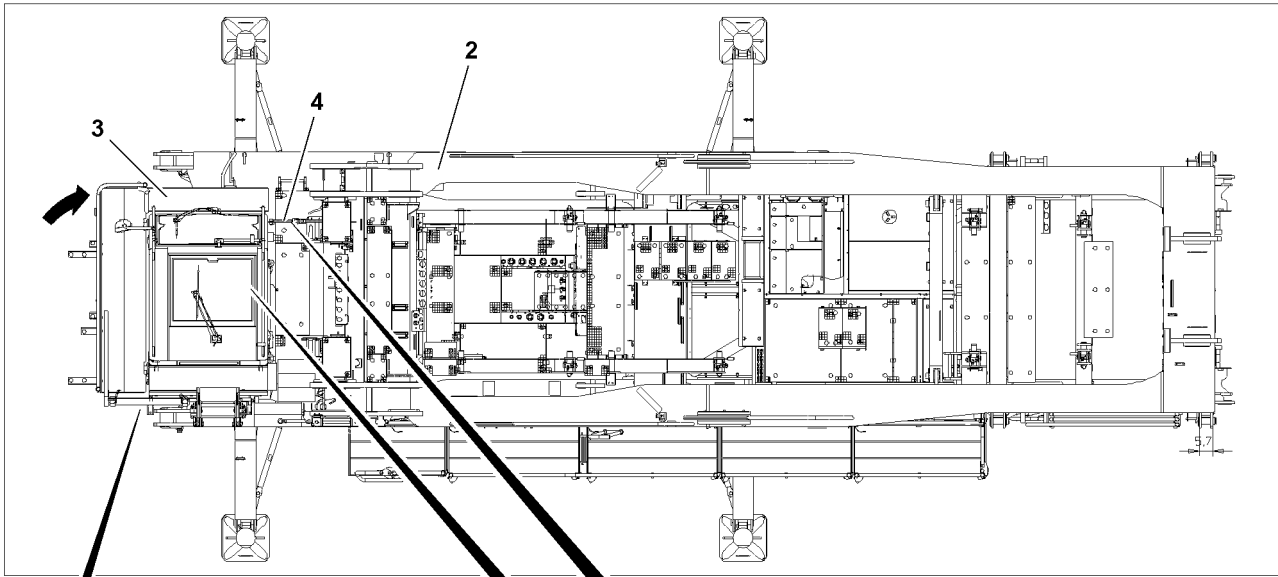

Fig.118199

LWE/LR 11000-001/23501-04-02/en

11 Bringing the crane operator's cab into transport position



WARNING

Danger of falling!

During assembly / disassembly, inspection and maintenance work, assembly personnel must be secured with appropriate aids to prevent them from falling.

If this is not observed, assembly personnel could fall and suffer life-threatening or fatal injuries.

- ▶ The assembly personnel must always move carefully and anticipatory on the crane, the crane components or lattice sections.
- ▶ All work aloft, where there is a danger of falling must be carried out with suitable aids.
- ▶ If fall protection equipment is available, then it must be used.
- ▶ If aids are not available and work cannot be carried out from the ground, then the assembly personnel must secure themselves with the approved fall arrest system to prevent falling, see Crane operating instructions, chapter 2.04.
- ▶ The fall arrest system must be attached on the fastening and hook points as well as on the safety ropes.
- ▶ Always secure ladders on structural parts and / or components to prevent them from falling over.
- ▶ Only step on the aids, ladders and catwalks with clean shoes.
- ▶ Keep aids, ladders and catwalks free of heavy dirt, snow, frost and ice.
- ▶ Stepping or walking on crane components and lattice sections, which have an incline of more than 20° is prohibited.

-
- The crawler carriers are removed on the crawler travel gear.
 - The crawler center section **1** is laying properly on the support.
 - The extension ladders **1.1** are properly hooked on the crawler center section **1**.
 - The catwalks and railings on the turntable frame main section **2** are in operating position.
 - The turntable frame main section **2** is properly installed and secured on the turntable frame lower section.
 - The ladder **2.2** on the main boom assembly platform **2.1** is in operating position.

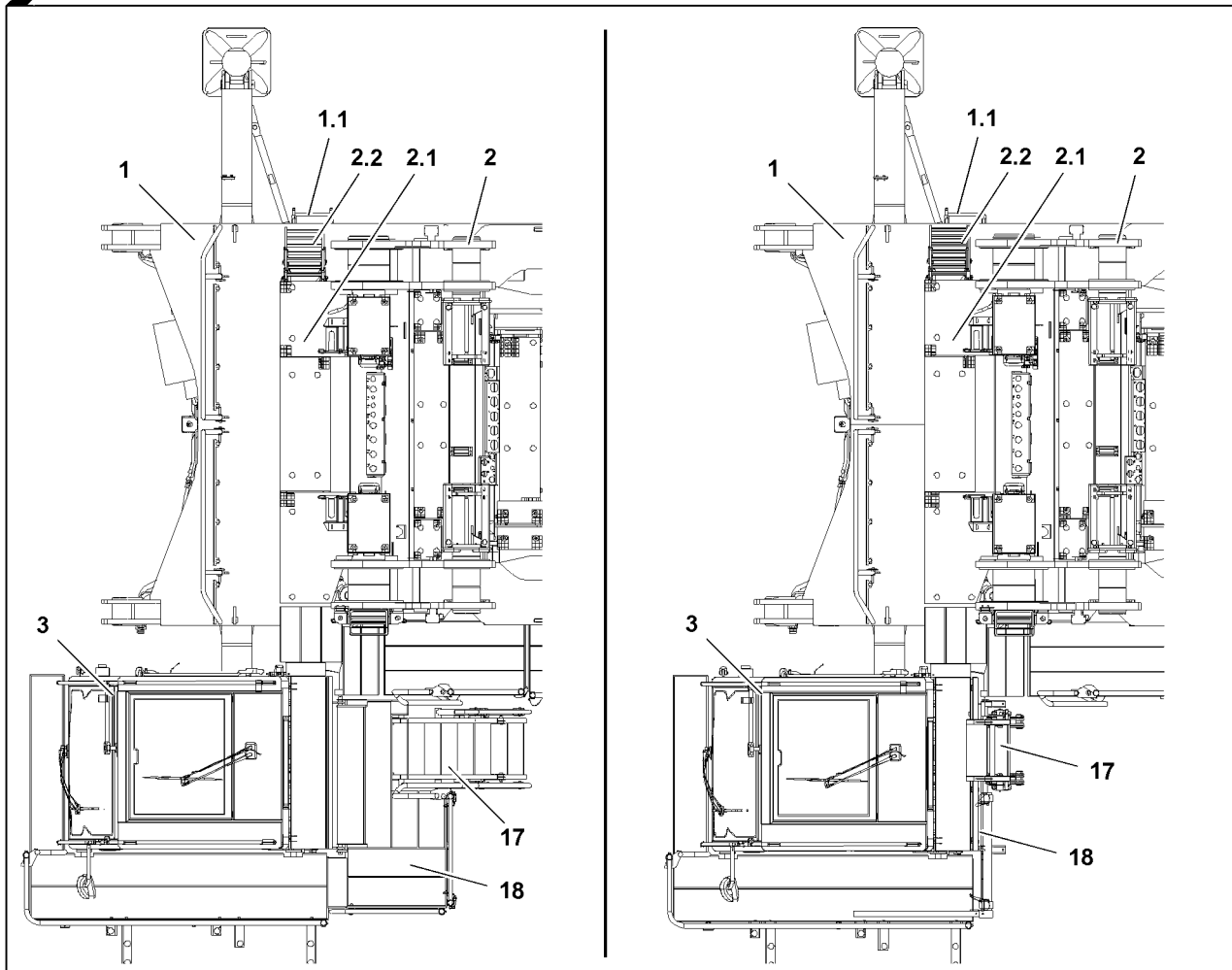
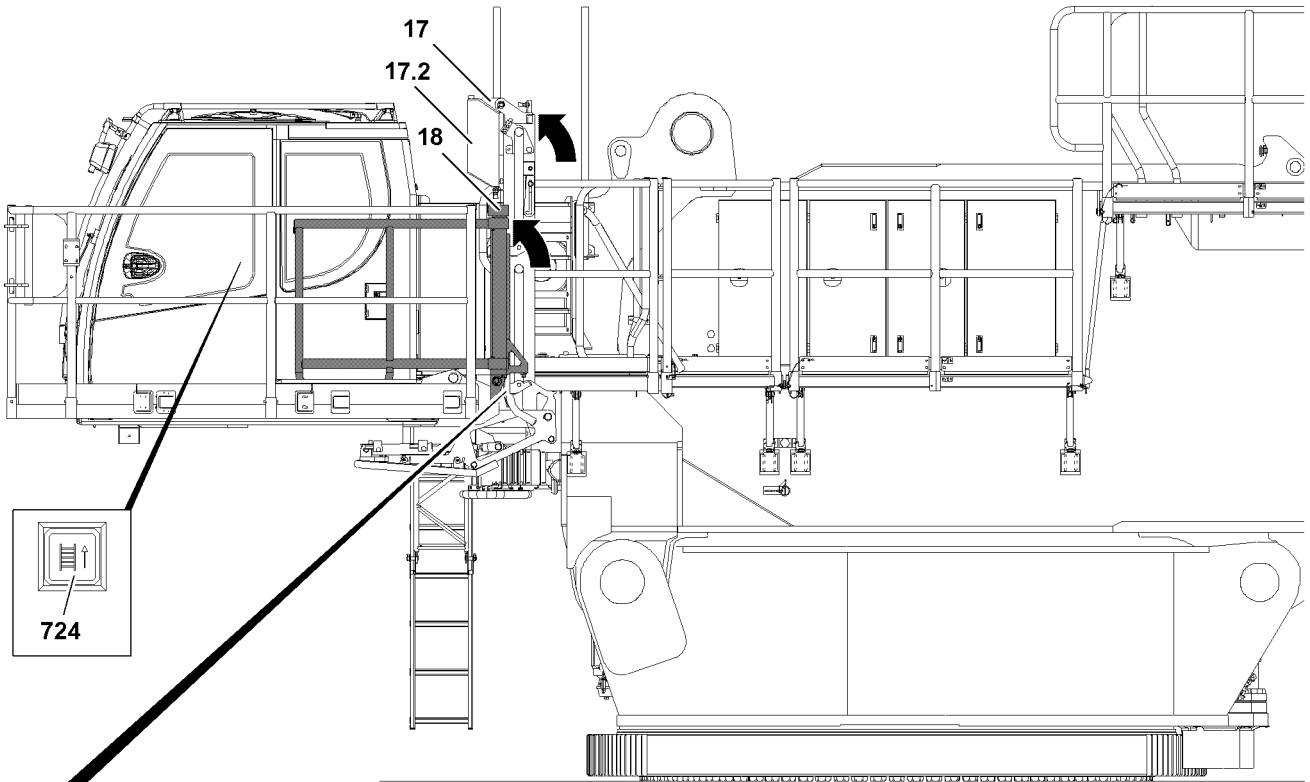

Fig.118198

LWE/LR 11000-001/23501-04-02/en

11.1 Bringing the access stairs into transport position

Make sure that the following prerequisites are met:

- The crane operator's cab **3** is in operating position.
- The engine is running.

11.1.1 Bringing the hand rails into transport position

Make sure that the following prerequisite is met:

- The stair folding section **17.2** is in operating position.



WARNING

Danger of crushed limbs!

When swinging the handrails **17.1**, fingers and hands can be crushed!

- ▶ Do not reach with your hands into the danger zone.
-

- ▶ Pull and hold the detent pin **17.5**.

- ▶ Move the first handrail **17.2** into transport position until the detent pin **17.5** engages at point **P2**.

Result:

- The first handrail **17.2** is in transport position.

- ▶ Bring the second handrail **17.2** into transport position.

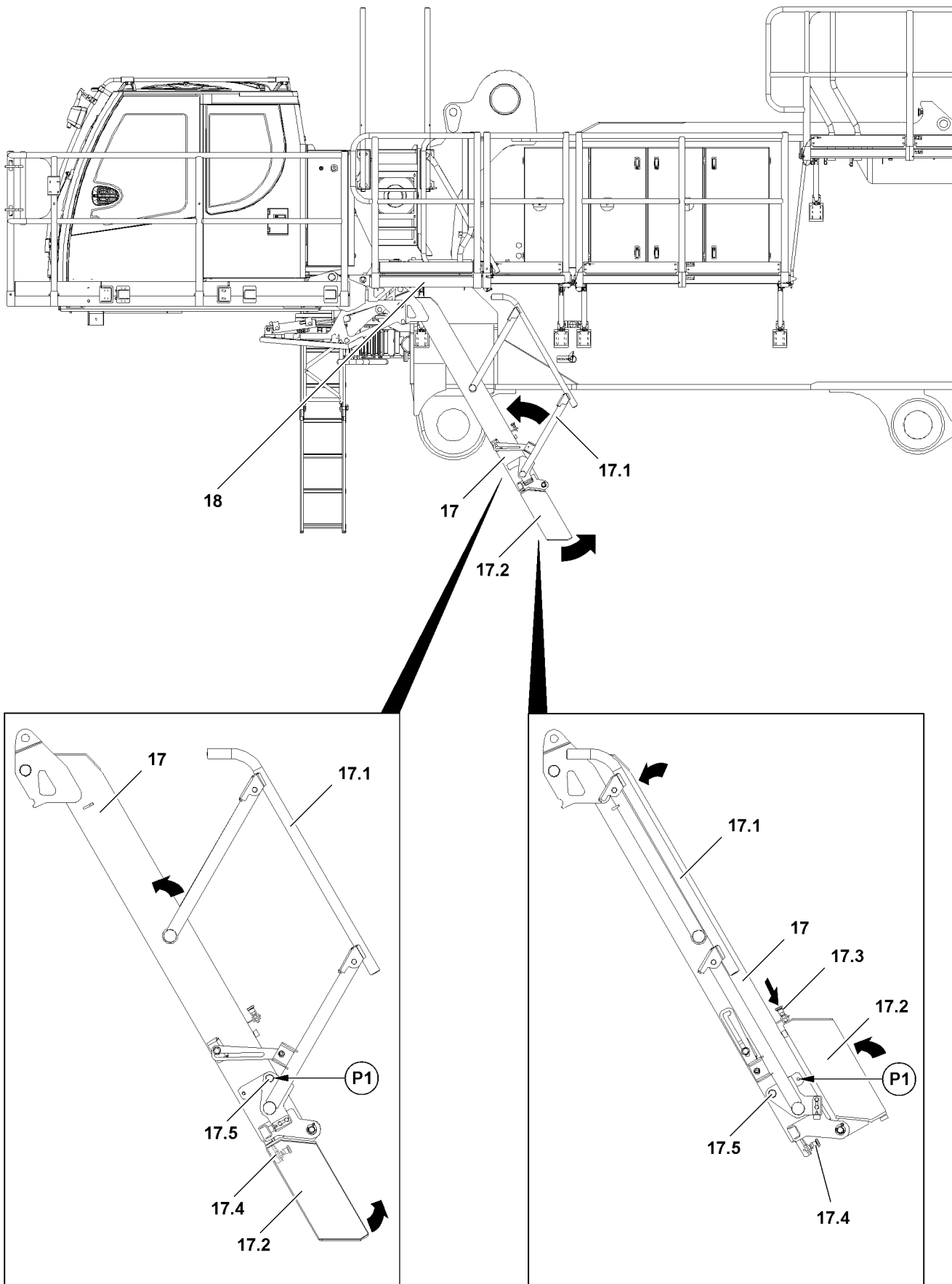

Fig.118197

LWE/LR 11000-001/23501-04-02/en

11.1.2 Swinging the stair folding section into transport position

Make sure that the following prerequisite is met:

- The hand rails **17.2** are in transport position.



WARNING

Danger of crushed limbs!

When swinging the stair folding section **17.2**, fingers and hands can be crushed.

- ▶ Do not reach with your hands into the danger zone.

-
- ▶ Pull the detent pin **17.4** up and hold.

Result:

- The stair folding section **17.2** is released.

- ▶ Fold the stair folding section **17.2** completely up until the detent pin **17.3** engages completely.

Result:

- The stair folding section **17.2** is in transport position.

11.1.3 Removing the railings on the cab platform

Make sure that the following prerequisites are met:

- The access stairs **17** and cab platform **18** are in operating position.



Note

- ▶ Remove the railings on the cab platform, see Crane operating instructions, chapter 2.06.
-

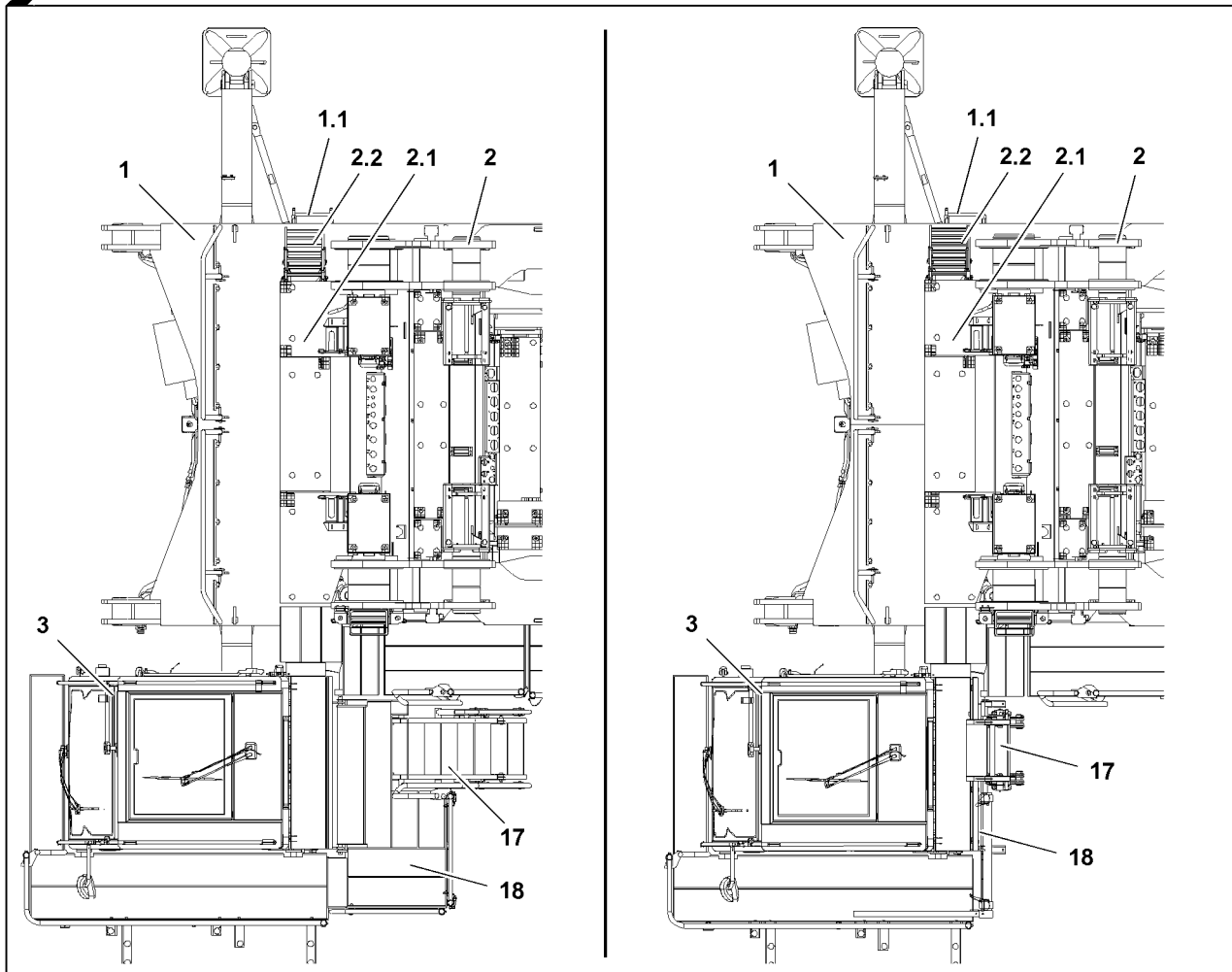
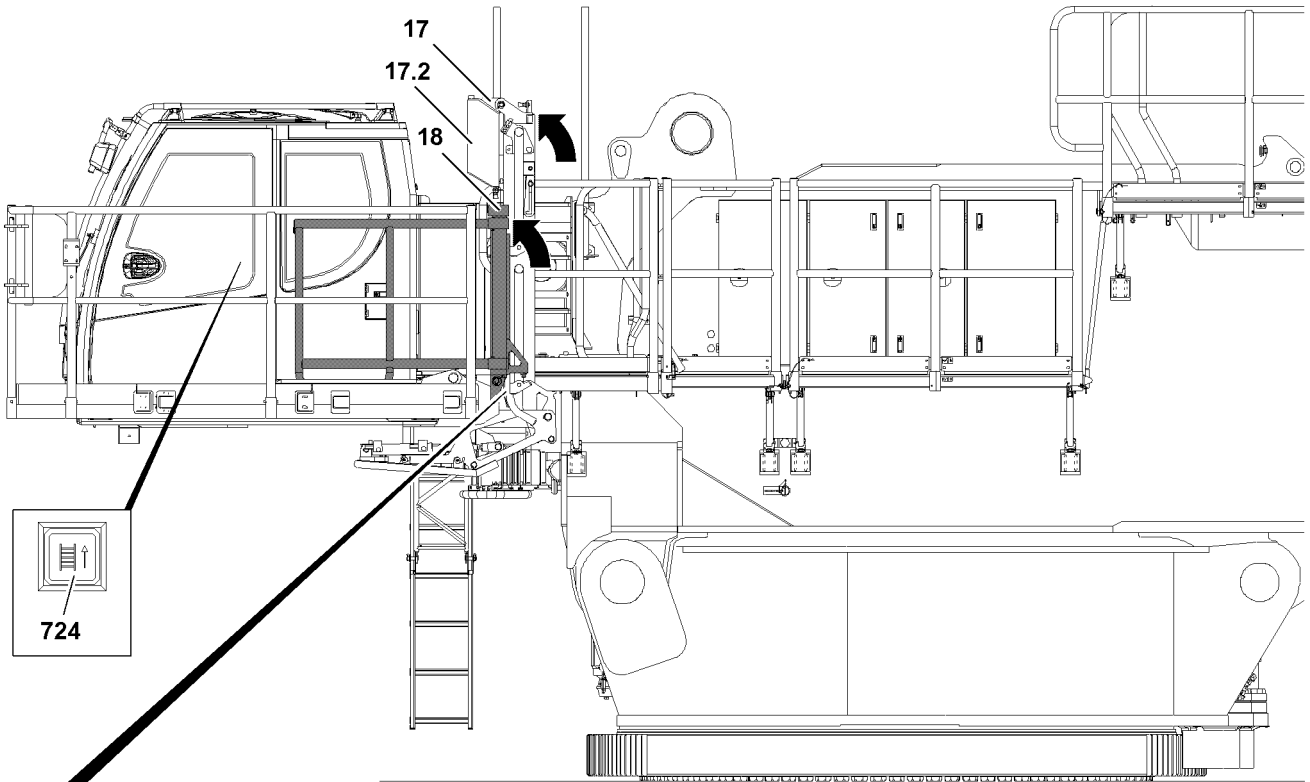

Fig.118198

LWE/LR 11000-001/23501-04-02/en

11.1.4 Swinging the access stairs into transport position



WARNING

Danger of accidents due to access stairs!

When lifting the access stairs personnel can be severely injured or killed.

Due to the folding mechanism of the access stairs, personnel can be caught below the switch cabinet and the cab platform and be killed.

- ▶ Make sure that no persons are within the swing range of the access stairs **17** and the cab platform **18**.

-
- ▶ Press the button **724** on the instrument panel and hold.

Result:

- The access stairs **17** are raised.

When the access stairs **17** and cab platform **18** are in operating position:

- ▶ Release the button **724**.



Note

- ▶ The access stairs can be operated from the BTT, see Crane operating instructions, chapter 5.31.
-

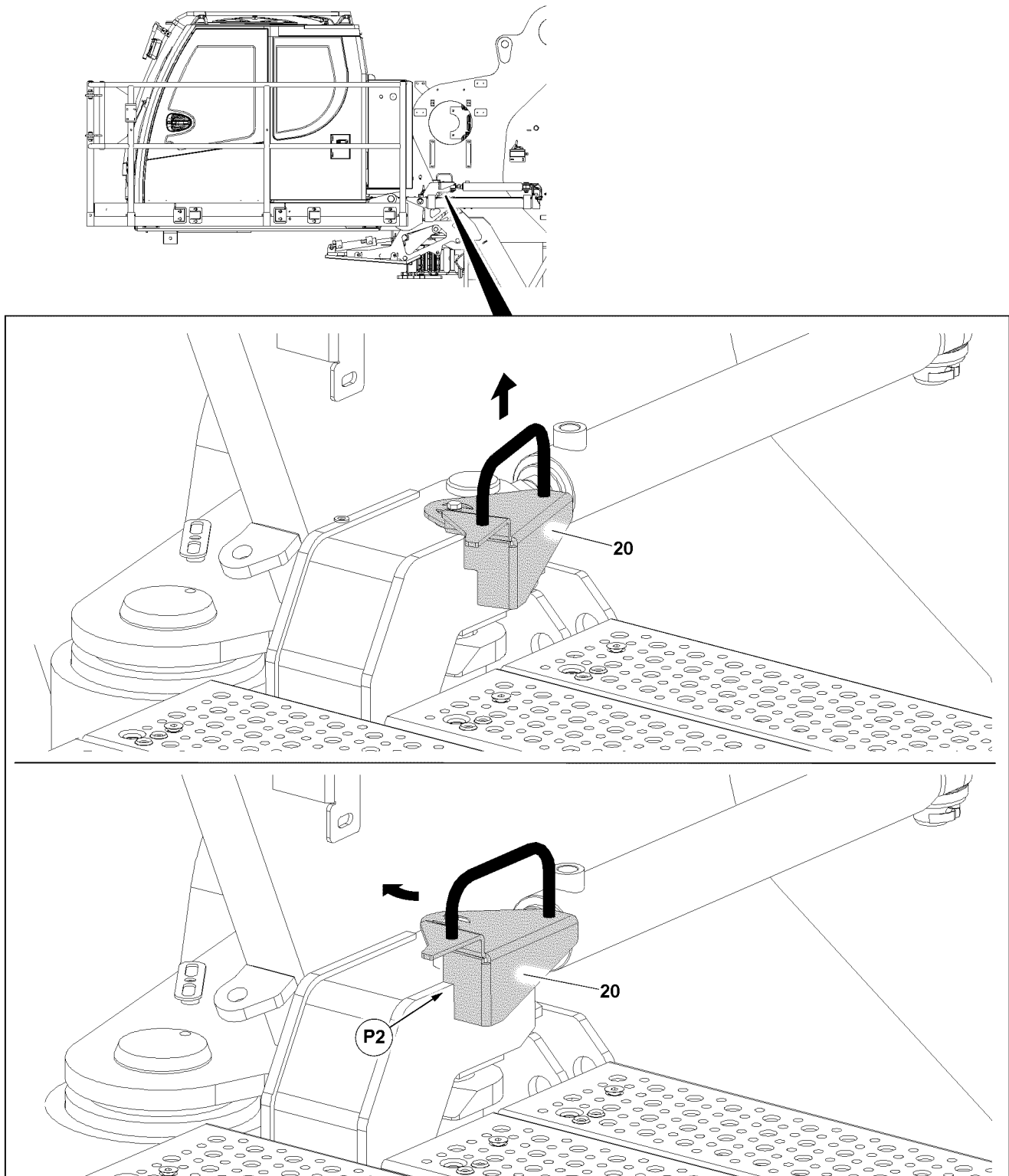

Fig.124497

11.2 Bringing the crane operator's cab into transport position

Make sure that the following prerequisite is met:

- The access stairs 17 are in transport position.
- ▶ Unlock the crane operator's cab: Pull the lock 20 up.
- ▶ Swing the lock 20 to the turntable.

- ▶ Set the lock **20** with the recess at point **P2** on the steel structure of the turntable.

Result:

- The lock **20** is held in place in the uppermost position.
- The crane operator's cab can be swung.

**Note**

- ▶ Lock **20** is spring-loaded.
- ▶ The lock **20** is automatically reset by the reset mechanism when the crane operator's cab is swung.

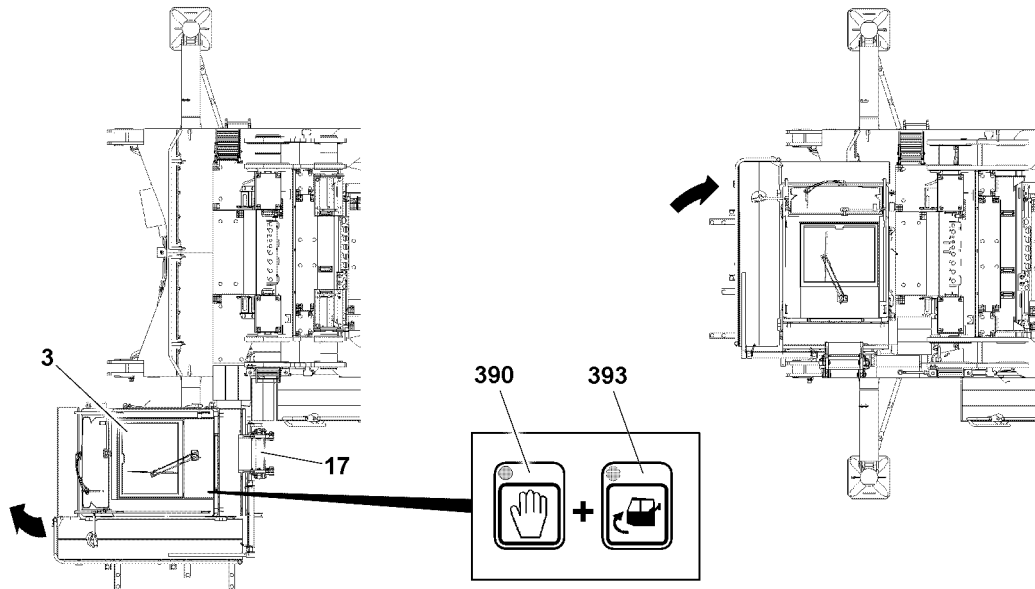

Fig.124498

- ▶ Start the engine, see section „Starting the engine“.

When the motor is running:

- ▶ Swing the crane operator's cab in: Press the button **390** and button **393**.

When the crane operator's has reached the transport position:

- ▶ Release the button **390** and button **393**.

**Note**

- ▶ The crane operator's cab can be swung out by the BTT, see Crane operating instructions, chapter 5.31.

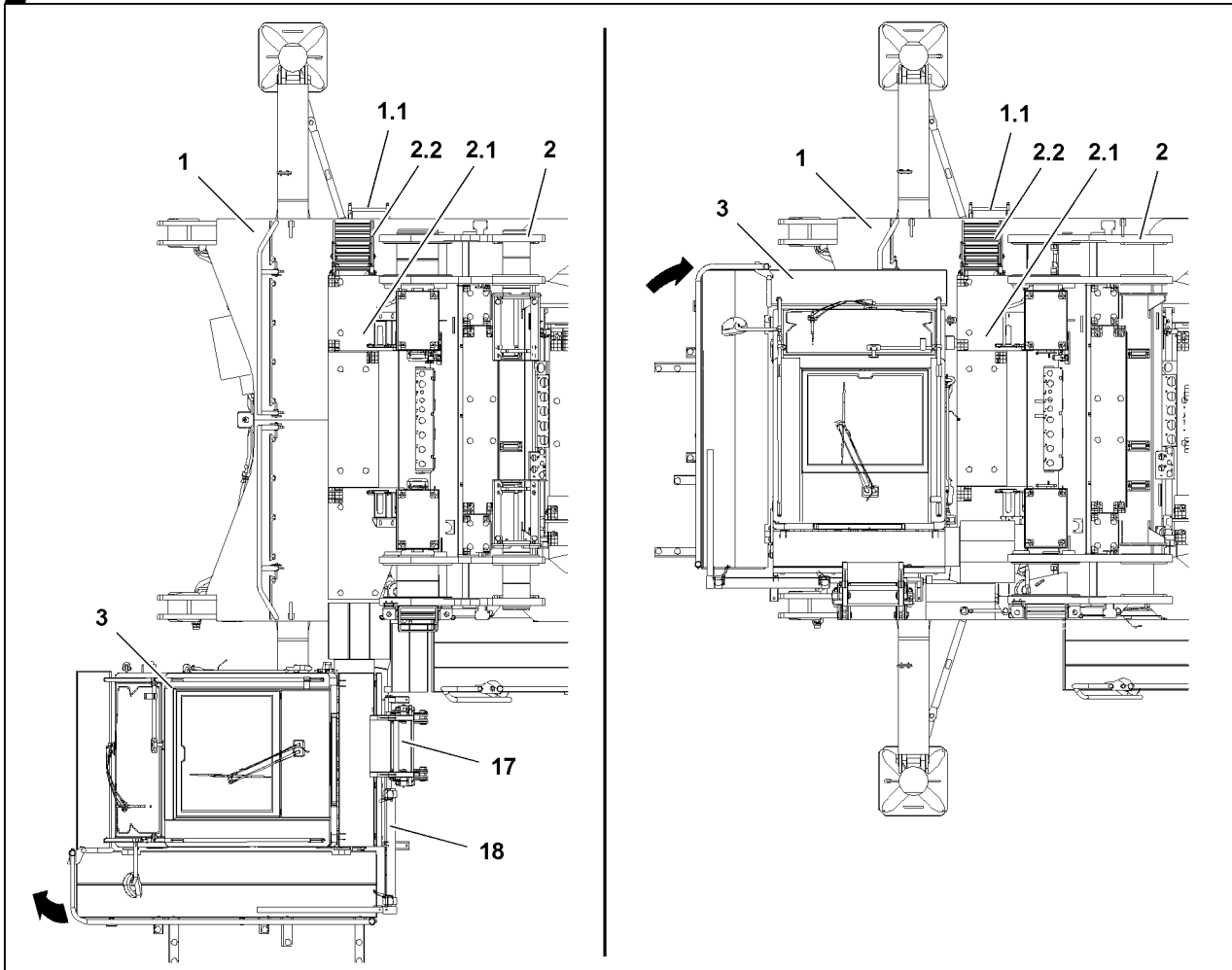
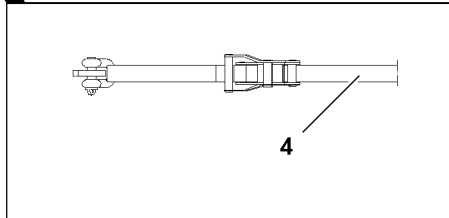
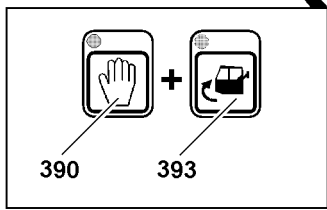
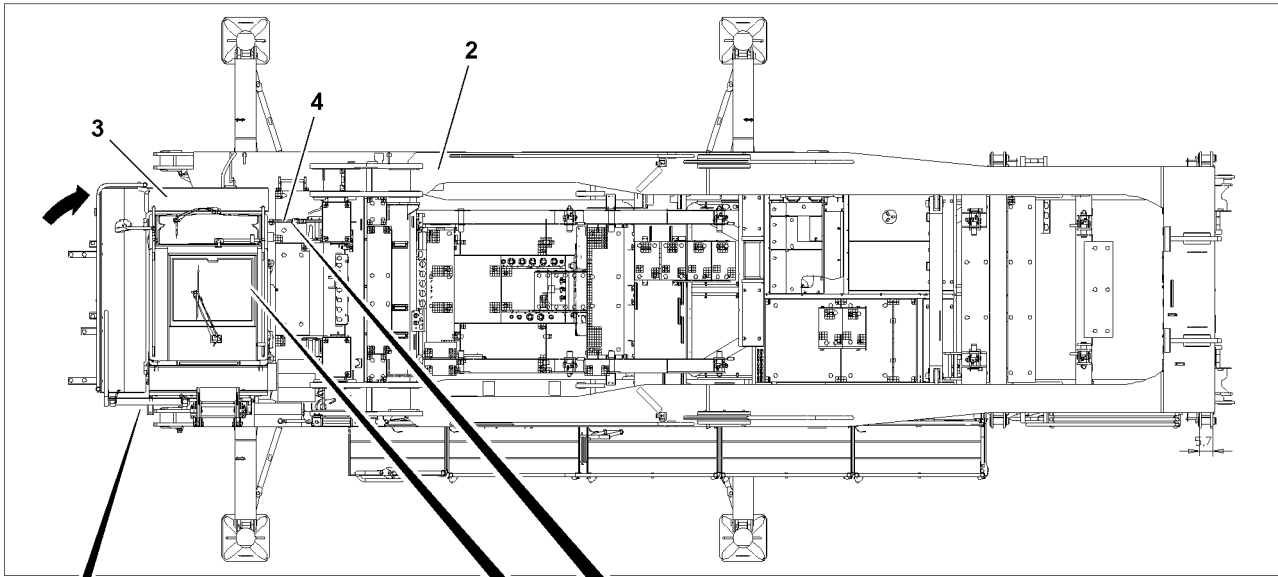

Fig.118199

LWE/LR 11000-001/23501-04-02/en

11.3 Securing the crane operator's cab with the tension belt in transport position

- ▶ Guide the tension belt **4** through the shackle on the crane operator's cab **3** and on the turntable frame main section **2**.
- ▶ Rig the crane operator's cab **3** on the turntable frame main section **2** with the tension belt **4**.

Result:

- The crane operator's cab **3** is secured in transport position.

Empty page!

LWE/LR 11000-001/23501-04-02/en

4.04 Safety equipment

1	General	3
2	Quick test Crane geometry	3
3	Quick test Overload protection	3
4	LICCON computer system	3
5	Safety systems on the crane	9

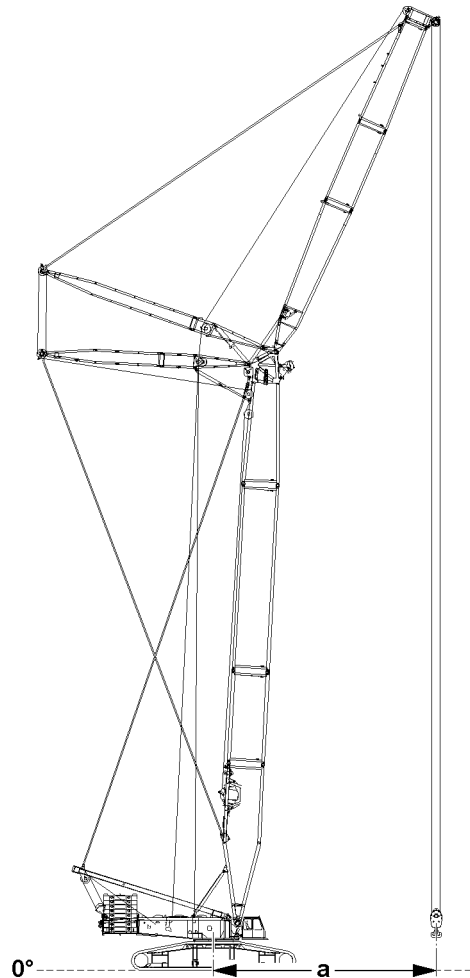
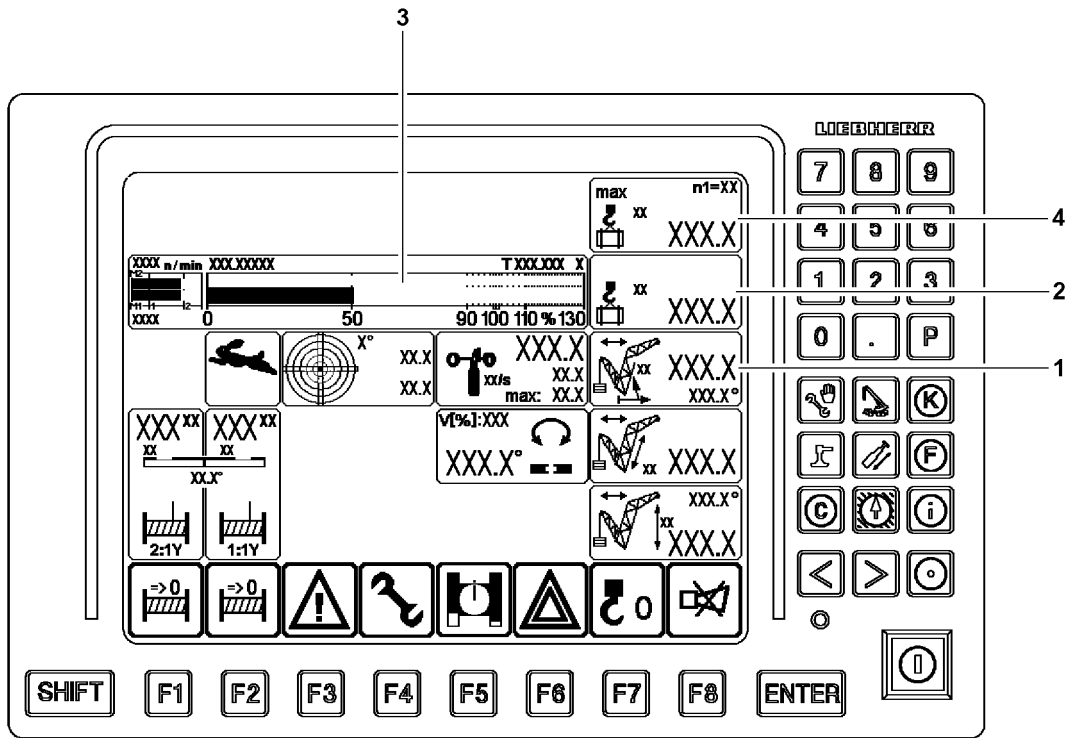

Fig.115293

LWE/LR 11000-001/23501-04-02/en

1 General

The crane operator is obligated before every crane operation to ensure that the warning and safety equipment are functioning.



WARNING

Danger of accident due to defective warning and safety systems!

If the crane is operated with defective warning and safety equipment, then there is a danger of accidents!

Personnel can be killed or seriously injured!

This could result in property damage!

- ▶ Make sure that all warning and safety equipment are functioning.
- ▶ Make sure that the overload protection is functioning.

2 Quick test Crane geometry

Make sure that the following prerequisites are met:

- The crane is aligned in horizontal direction.
- The set up configuration has been entered correctly into the LICCON computer system.
- There is no load on the hook.

Measure the horizontal distance of the load hook from the center of rotation of the crane superstructure on the ground:

- The value display radius **1** must match the measured value **a**.

3 Quick test Overload protection

Fasten a known weight, for example a counterweight plate. Then lift the counterweight plate completely and then set it down.

Make sure that the following prerequisite is met:

- The crane is aligned in horizontal direction.

The respective displayed values must be plausible:

- **2** Actual load display
- Utilization bar **3**: Ratio of value of Actual load display **2** to maximum load value **4**
- Example:

Value Actual load display **2** is 100 t.

Maximum load value **4** is 200 t.

Utilization bar **3** shows 50 %.

4 LICCON computer system

The LICCON computer system is a system for controlling and monitoring mobile cranes. In addition to the LICCON overload safety device (Load torque limiter = LMB), there are a number of application programs that can be used for controlling and monitoring the crane movements. For a detailed description see Crane operating instructions, chapter 4.02 and chapter 4.20.

4.1 LICCON overload safety device

The LICCON overload safety device is programmed to **shut off** the crane movements if the permissible load moment is exceeded (LMB-STOP).

The LICCON overload safety device may not be used as an operational shut off device for crane movements of any kind.

An overload protection cannot detect all occurring conditions by itself. Careful and diligent crane operation by the crane operator is important.

The basis for the calculation of the utilization of the crane are:

- The currently data and values recorded by the crane control.
- The set up configuration entered by the crane operator.

Direct influence is taken, among others:

- Failure of a test device (for example: Pull test brackets, angle sensor, pressure sensor).
- A set up configuration incorrectly or deviating entered by the crane operator.
- Environmental influences not considered (such as wind influence, ground with insufficient load bearing capability).
- Assembly and operating errors.



WARNING

Danger of accident due to assembly and operating errors!

Due to assembly and operating errors it is possible that the overload protection is not effective or shut off is delayed!

A set up configuration which deviates from the load chart cannot be detected by the overload protection!

Environmental influences which are not considered cannot be detected by the overload protection!

Dangerous situations and accidents can result!

Personnel can be killed or seriously injured!

This could result in property damage!

- ▶ Always assemble and operate the crane carefully!



WARNING

Operational utilization of the overload protection!

If the LICCON overload safety device is utilized as an operational shut off device for crane movements, then there is a danger of accidents!

For example, crane movements can be shut off abruptly or uncontrolled!

The behavior of load and crane cannot be foreseen in such a case!

Personnel can be killed or seriously injured!

This could result in property damage!

- ▶ Do not use the LICCON overload safety device as an operational shut off device for crane movements!



WARNING

Lifting of unknown loads!

The presence of the overload protection does not relieve the crane operator of his obligation for care and attention!

The crane may not only be operated according to the displays of the LICCON overload safety device!

Lifting of loads with unknown weight and unknown properties can lead to accidents!

Personnel can be killed or seriously injured!

This could result in property damage!

- ▶ Before lifting a load, its weight and properties must be known to the crane operator!
- ▶ The crane operator must check with the load chart if the crane is able to carry out the work safely!

The LICCON computer system detects various values, which result in optical and acoustical warnings if exceeded:

Within the crane operator's cab:

- Acoustic warning „Horn / short horn“ on the LICCON monitor
- Optical warning „blinking value / display“ on the LICCON monitor

Outside the crane operator's cab:

- Acoustic warning via the horn on the turntable
- Optical warning via the warning light on the turntable

All warnings, even those which do not lead to an immediate shut off must be noted by the crane operator and personnel within the danger zone.

The overload protection can **not** detect (examples of cases):

- The hooking of the load or the load handling equipment
- Excessive retarding forces
- Loads falling onto the rope
- Angular pulling
- Driving the crane on ground with large slope
- Collapsing ground

4.1.1 Failure of the overload protection



WARNING

Crane operation without overload protection!

If the LICCON overload safety device is no longer functioning properly because of one or more errors, then there is a danger of accidents if crane operation is continued!

Due to operation of the crane with failed LICCON overload safety device, the crane can be overloaded and collapse!

Personnel can be killed or seriously injured!

This could result in property damage!

- ▶ Crane operation without overload protection is prohibited!
- ▶ Place the boom system down if necessary according to the specification in the crane documentation!
- ▶ Do not take up crane operation again until the overload protection is functioning again!

A failed overload protection:

- Must be repaired before the crane can be operated again.
- May only be bypasses in emergency cases or emergency situations.

4.2 Bypass of overload protection

The overload protection can be bypassed in case of:

- Failure of the overload protection
- In an emergency situation (according to EN 13000:2010)

4.2.1 Bypass of overload protection: Failure of the overload protection



Note

- ▶ Applies **not** for cranes with configuration according to EN 13000:2010!

To bring the crane into safe condition after failure of a component required for the overload protection, it can be necessary that the overload protection has to be bypassed.



WARNING

Bypassed overload protection!

If the overload protection is bypassed, crane movements are no longer monitored!

The crane can be overloaded and collapse!

Personnel can be killed or seriously injured!

This could result in property damage!

- ▶ Then carry out only crane movements in the range of a valid load chart!
- ▶ Place the boom system down if necessary according to the specification in the crane documentation!

4.2.2 Bypass of overload protection: Failure of overload protection (according to EN 13000:2010)



Note

► Applies **only** for cranes with configuration according to EN 13000:2010!

To bring the crane into safe condition after failure of a component required for the overload protection, it can be necessary that the overload protection has to be bypassed.

With the specification that:

- The bypass is automatically reset at engine stop.
- The bypass is automatically reset after no later than 30 minutes.
- The bypass of the overload protection limits the working speed to no more than maximum 15 %.



WARNING

Bypassed overload protection!

If the overload protection is bypassed, crane movements are no longer monitored!

The crane can be overloaded and collapse!

Personnel can be killed or seriously injured!

This could result in property damage!

- Then carry out only crane movements in the range of a valid load chart!
- Place the boom system down if necessary according to the specification in the crane documentation!

4.2.3 Bypass of overload protection: Emergency situation (according to EN 13000:2010)

In an emergency situation, a bypass of the overload protection may become necessary.

With the specification that:

- The bypass is automatically reset at engine stop.
- The bypass is automatically reset after no later than 30 minutes.
- The bypass of the overload protection limits the working speed to no more than maximum 15 %.



DANGER

Overload of crane!

After a bypass of the overload protection, the crane movements are no longer shut off in case of a danger of overload of the crane!

An overload of the crane can result in severe damage or collapse!

Personnel can be killed or seriously injured!

This could result in property damage!

- Do not subject the crane to such a load that it collapses!
- Clear and secure the danger zone of the crane!



Note

► Location of bypass device, see Crane operating instructions, chapter 4.01 and chapter 4.02.

Empty page!

LWE/LR 11000-001/23501-04-02/en

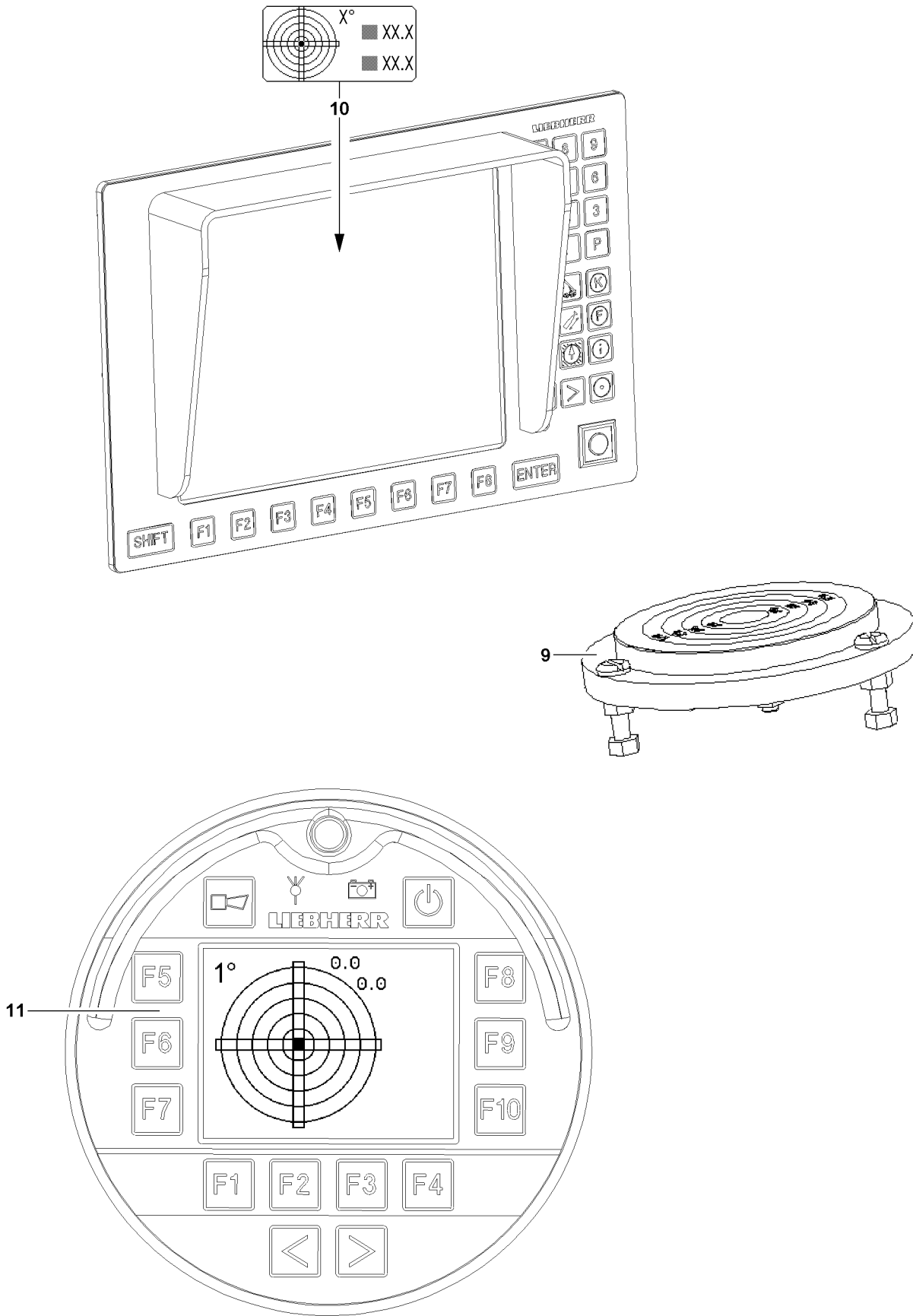

LWE/LR 11000-001/23501-04-02/en

Fig.115294

5 Safety systems on the crane

5.1 Leveling instruments

To ensure the working safety of the crane, the crane must be aligned on level ground with sufficient load bearing capacity according to the load chart.

The current values are continuously shown in the Incline icon **10**, see Crane operating instructions, chapter 4.02.

The incline is shown manually in the sight gauge **9** on the crawler travel gear.



WARNING

The crane can topple over!

If the leveling instruments are defective or incorrectly adjusted, there is a danger that the crane is not aligned according to the load chart!

A crane which is not aligned according to the load chart can topple over!

Personnel can be killed or seriously injured!

This could result in property damage!

► Make sure to align the crane according to the load chart!

5.1.1 Leveling instruments in the LICCON monitor

The incline of the crane is shown in the Incline icon **10** graphically as well as numerically, see Crane operating instructions, chapter 4.02.

5.1.2 Leveling instrument in the Bluetooth™ Terminal (BTT)



Note

► Applies only for cranes with Bluetooth™ Terminal (BTT).

The incline of the crane is shown in the Incline display menu **11** graphically as well as numerically, see Crane operating instructions, chapter 3.05 and 5.31.

5.1.3 Quick test Leveling instrument



Note

The horizontal alignment of the crane can be checked with a spirit level on the top of the slewing ring, for example.

► The alignment of the top of the slewing ring is the determining factor for the incline display.

Make sure that the following prerequisites are met:

- The crane is aligned in horizontal direction.
- There is no load on the hook.

For horizontally aligned crane:

- The sight gauge **9** on the crawler travel gear must show 0°.
- In the incline icon **10** 0° must always be shown.

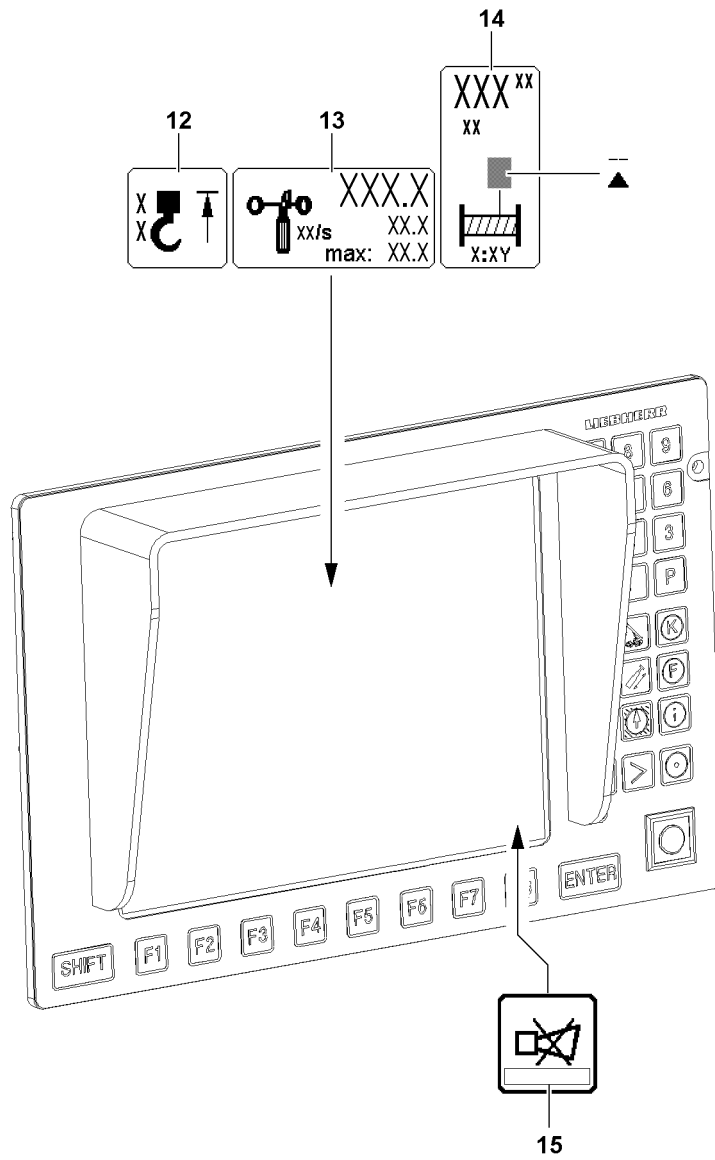

Fig.115295

5.2 Acoustic and optical warning devices



Note

► Overview of acoustic and optical warnings, see Crane operating instructions, chapter 4.20.

- The acoustic and optical warning devices must be functioning and operational.
- Take care of any possible detriments in function, such as snow on the warning lights.

5.3 Hoist limit switch „Hoist top“

The hoist limit switch is intended to prevent the hook block from running against the boom head.

Before every crane application, the function of the hoist limit switch must be checked by running against the switch weight with the hook block.

For installation purposes and in emergency cases, the hoist limit switch can be bypassed, see Crane operating instructions, chapter 4.20.



WARNING

Falling load and property damage!

If the hoist limit switch is defective, there is the danger that the hook block or the load hook is pulled against the pulley head!

Falling load and property damage can result!

Personnel can be severely injured or killed!

- Crane operation without or with defective hoist limit switch is prohibited!
- Repair or replace a defective hoist limit switch!

The hoist limit switch must actuate when the hoist limit switch weight is lifted by the load hook / hook block:

- When the hoist limit switch is actuated, the icon **12** „Hoist top“ appears in the operating screen. The crane movement „Spool winch up“ as well as other crane movements which have an influence on the hoist rope are shut off.

5.3.1 Quick test Hoist limit switch

When the hoist limit switch weight is lifted:

- The icon **12** „Hoist top“ must appear in the operating screen.
- The actuated crane movement must be shut off.

5.4 Error messages by the LICCON computer system

Two types are differentiated (all crane types except LR1400/2):

- Operating errors
 - Displayed in field **15** by error number / LEC: B.....
- System errors in LICCON computer system
 - Displayed in field **15** by error number / LEC: E.....

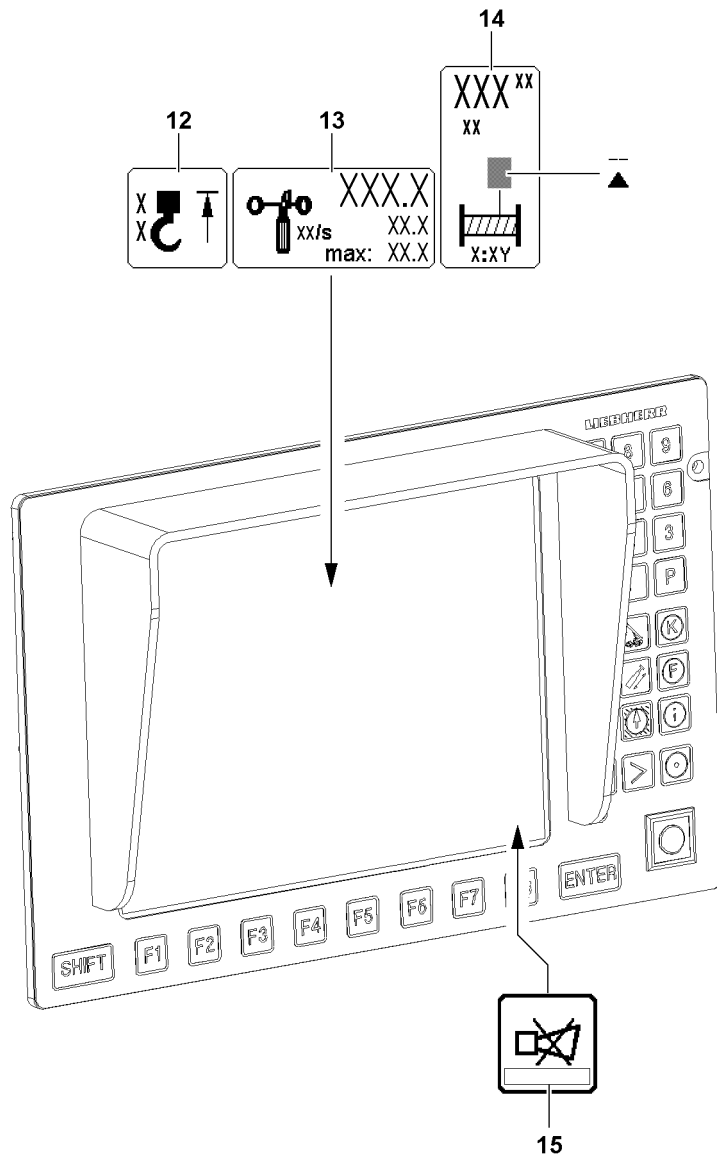

Fig.115295

LWE/LR 11000-001/23501-04-02/en

5.5 Wind speed sensor

The wind warning by the wind speed sensor appears in the operating screen of the LICCON computer system.



WARNING

The crane can topple over!

If the crane is operated with a defective wind speed sensor, then there is the danger that excessively high wind speeds are not recognized!

The crane can topple over!

Personnel can be killed or seriously injured!

This could result in property damage!

- ▶ Crane operation with a defective wind speed sensor is prohibited!
- ▶ Repair / replace a defective wind speed sensor!

If wind occurs, then the wind speed sensor must report it speed:

- If the actual wind speed value exceeds the displayed maximum value, the value in the icon **13** „Wind speed“ starts to blink and the acoustic alarm „Short horn“ sounds on the LICCON monitor. But there is **no shut off** of crane movements.



Note

- ▶ To set the wind speed, see Crane operating instructions, chapter 4.02.

5.5.1 Quick test Wind speed sensor

When blowing in the cups:

- The wind speed sensor must start to move.
- An actual value must be shown in the icon **13** „Wind speed“.

5.6 Limit switch winch spooled out

The limit switches for the winches are adjusted at the factory. If used properly, the winches will not need readjustment.



Note

Minimum rope coils on the shut off point!

For the winches, a minimum of three rope coils are set for each drum.

- ▶ The shut off must occur **before** reaching the third minimum rope coil.



WARNING

The load can fall off!

If the limit switch „Winch spooled out“ does not turn off **before** three minimum rope coils are reached, then there is the danger, when it is further spooled out, that the rope mounting locks are ripped out and the load falls down!

Falling load can cause the crane to sway and / or topple over!

Personnel can be severely injured or killed!

This could result in property damage!

- ▶ Crane operation with an incorrectly or non-adjusted winch is strictly prohibited!
- ▶ If the winch falls below the three minimum rope coils per winch, have it readjusted by **Liebherr Service!**

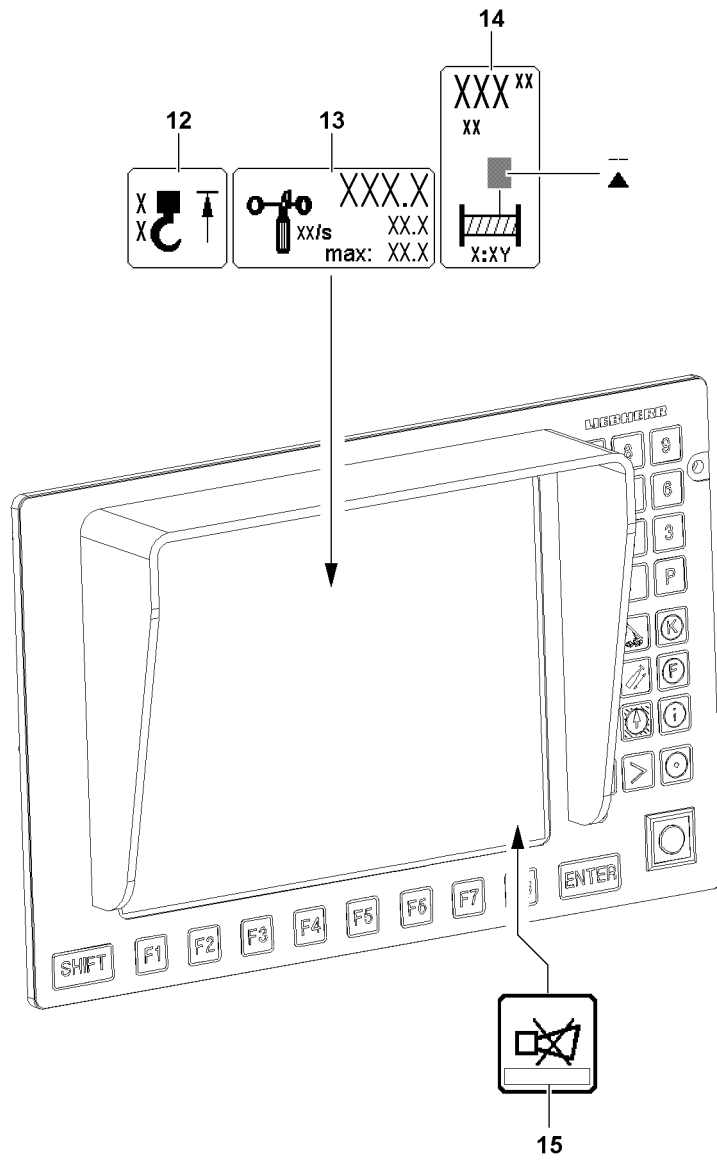

Fig.115295

**WARNING**

The load can fall off!

If the rope is not spooled up or out properly, then the adjustment of the limit switch „Winch spooled out“ is changed!

If the adjustment of the limit switch „Winch spooled out“ has changed, then the minimum rope coils are fallen below!

The load can fall down!

Falling load can cause the crane to sway and / or topple over!

Personnel can be severely injured or killed!

This could result in property damage!

- ▶ **Never** pull the end of rope underneath the winch by spooling up the rope winch!
- ▶ **Never** pull the rope from the „stationary“ winch!
- ▶ If you suspect that the limit switch „Winch spooled out“ is not adjusted correctly: Check the shut off without a load on the hook!

The limit switch „Winch spooled out“ must shut off when the minimum rope coils for the winch are reached:

- When the minimum rope coil for the winch is reached, then the display „Winch spooled out“ appears in the Winch icon **14**, see illustration. The crane movement „Spool winch out“ is shut off.

5.6.1 Quick test Limit switch winch

When the minimum rope coil is reached:

- The display „Winch spooled out“ must appear in the Winch icon **14**.
- The crane movement „Spool winch out“ must be shut off.

5.7 Servo oil pressure monitoring in the winches

- If no servo oil pressure is present when the master switch is actuated, a corresponding error message appears in field **15**.

5.8 Pressure monitoring in the relapse cylinders

Pressure sensors are installed in the hydraulic cylinders. The pressure measured with the pressure sensor is shown on the LICCON monitor, see Crane operating instructions, chapter 4.02.

**WARNING**

Danger of accident due to crane toppling over or destruction of the crane!

If the pressure drops, the relapse cylinder can no longer stabilize the boom!

The crane can topple over or be destroyed!

Personnel can be severely injured or killed!

- ▶ During crane operation: Constantly monitor the pressure in the relapse cylinders!

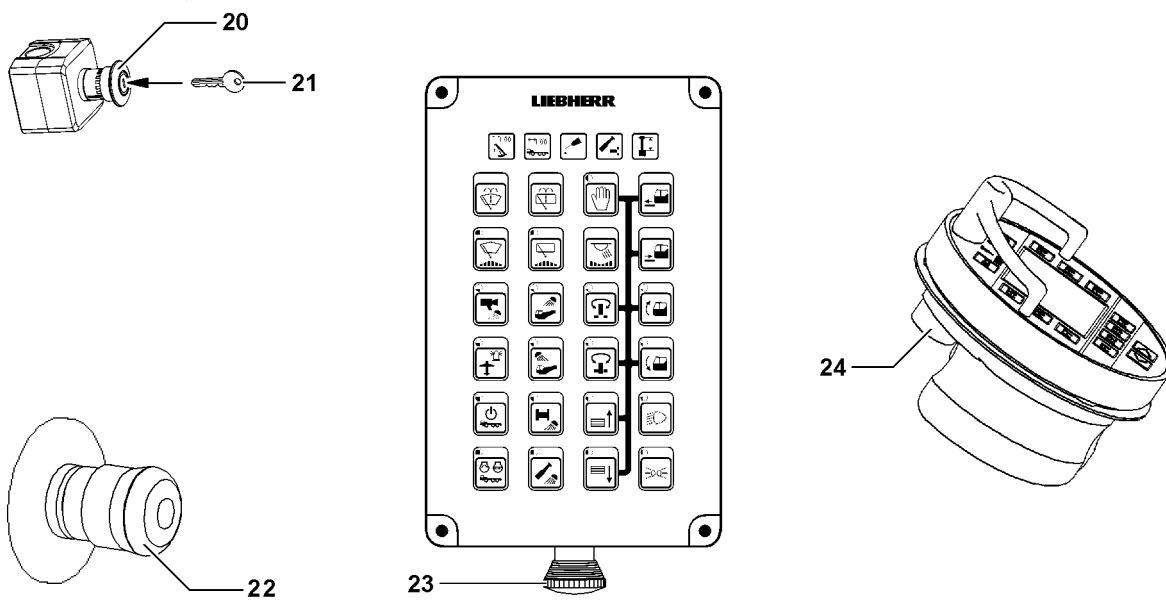
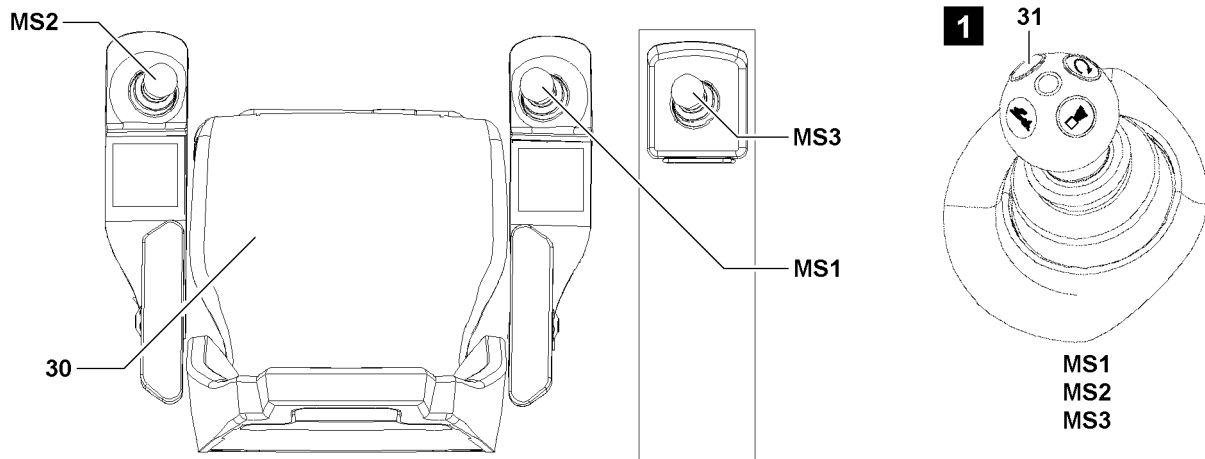

Fig.115296

LWE/LR 11000-001/23501-04-02/en

5.9 EMERGENCY STOP switch / EMERGENCY OFF switch

If an EMERGENCY STOP switch / EMERGENCY OFF switch is actuated, then the crane movement can be stopped with it.



WARNING

Defective EMERGENCY STOP switch / EMERGENCY OFF switch!

If the crane is operated with a defective EMERGENCY STOP switch / EMERGENCY OFF switch, then the crane movement cannot be stopped by actuating the EMERGENCY STOP switch!

This could result in accidents!

Personnel can be killed or seriously injured!

This could result in property damage!

▶ Crane operation with a defective EMERGENCY STOP switch / EMERGENCY OFF switch is prohibited!

▶ Repair or replace a defective EMERGENCY STOP switch / EMERGENCY OFF switch!

NOTICE

Operational actuation of the EMERGENCY STOP switch / EMERGENCY OFF switch

Actuation of the EMERGENCY STOP switch / EMERGENCY OFF switch causes the crane movement to stop abruptly!

Abruptly stopping the crane movement can cause the load to swing!

Swinging loads can cause accidents!

▶ Do not use the EMERGENCY STOP switch / EMERGENCY OFF switch operationally!

▶ Use the EMERGENCY STOP switch / EMERGENCY OFF switch only in emergency situations!

The EMERGENCY STOP switch / EMERGENCY OFF switch is available in various versions, depending on the crane type:

- After actuation of a switch of version* **20**, the release is only obtained by an authorized person with key **21** and by subsequently turning the ignition „Off - On“ momentarily.
- After actuation of the switch of version* **22**, the release is obtained by turning and unlocking the knob and subsequently turning the ignition „Off - On“ momentarily.
- After actuation of the switch of version* **23**, the release is obtained by turning and unlocking the knob and subsequently turning the ignition „Off - On“ momentarily.
- After actuation of the switch of version* **24**, the release is obtained by turning and unlocking the knob and subsequently turning the ignition „Off - On“ momentarily.



Note

▶ Which EMERGENCY STOP switch / EMERGENCY OFF switch is on the crane depends on the crane type.

▶ The switch **24** on the BTT is only activated when working with the BTT.

5.9.1 Quick test EMERGENCY STOP switch / EMERGENCY OFF switch

After actuation of the EMERGENCY STOP switch / EMERGENCY OFF switch:

- The crane movements must be stopped.
- No crane movements must be possible until the release was issued by turning and unlocking the knob and then turning the ignition „Off - On“ momentarily.

5.10 Control release

The control release can be made via the following switches:

- **30** Seat contact button
- Button **31** on master switch **MS1** and **MS2** and **MS3**.

The seat contact button **30** shuts down the crane control as soon as the crane operator gets up from the seat.

This prevents unintended crane movements by accidentally touching the master switch, for example when getting in or out of the cab.

Each one of the buttons **31** on master switch **MS1**, **MS2** and **MS3** bypasses the seat contact button **30** if needed, for example when it is necessary to work while standing up.

5.11 Hydraulic safety valves

A differentiation is made between three types:

- Pressure limiting valves
 - Prevent pipe and hose bursts due to excessive pressure.
- Shut off valves
 - Control and secure the working cylinders.
- Check valves
 - Control and secure the flow direction.



Note

▶ See separate Hydraulic schematic.

5.12 Gravity actuated relapse retainer



Note

▶ Only for cranes with luffing accessories.

The gravity actuated relapse retainer (oscillation guard / flap / relapse support) prevent luffing accessory from tipping to the rear in „steepest position“.



WARNING

The crane can topple over!

If the gravity actuated relapse retainer (oscillation guard / flap / relapse support) is hard to move, then it will no longer function!

Shut off and limit functions can be set out of service!

The crane can be overloaded and topple over!

Personnel can be killed or seriously injured!

This could result in property damage!

▶ Before erecting the crane, check the relapse retainer for easy movement!

▶ Crane operation with hard to move relapse retainer is prohibited!

5.13 Angle sensors



Note

▶ See separate Electrical diagram.

5.14 Test brackets (force test boxes)



Note

▶ See separate Electrical diagram.

5.15 Limit switch Boom system



WARNING

Danger of toppling or destroying the crane!

If the crane movement is stopped by the block limit switches, then the load forces cannot be absorbed and calculated by the control!

The crane can be overloaded and topple over!

Personnel can be hit and killed or seriously injured!

This could result in property damage!

- ▶ Do **not** use the hoist limit switch as an operational shut off device!
 - ▶ Do not actuate the block limit switches!
-

Empty page!

LWE/LR 11000-001/23501-04-02/en

4.05 Crane operation

1	LICCON computer system	3
2	Master switch functions	5
3	Lifting and lowering	17
4	Luffing	39
5	Turning	47

Fig.195219

LWE/LR 11000-001/23501-04-02/en

1 LICCON computer system



WARNING

Danger of accidents due to overload!

Death, severe bodily injuries, property damage.

- ▶ Constantly monitor the displays on the LICCON monitor.
- ▶ Observe changing utilization conditions and forces.



WARNING

Danger of accident!

Death, severe bodily injuries, property damage.

- ▶ The crane driver must evaluate constantly if the data shown on the operating screen can even be correct. He may not rely blindly on the LICCON system but must think for himself and must recognize a possible error or overload conditions.

For detailed description of the operation of the LICCON computer system, refer to Crane operating instructions, chapter 4.02.

Make sure that the following prerequisites are met:

- The crane is horizontally aligned.
- The ground is able to carry the weight of the crane, the load and the load handling equipment.
- The counterweight is attached and secured according to the data in the load chart.
- The Diesel engine is running.
- The crawler operation is turned off.
- The hook block is correctly reeved in according to the reeving plan.
- All safety equipment has been adjusted according to the data in the load chart.
- The winches are correctly assigned to the respective load positions, see Crane operating instructions, chapter 4.02.
- The crane is properly put into operation, see Crane operating instructions, chapter 4.03.
- The set up configuration has been entered in the LICCON computer system and all displays are within the permissible range, see the Crane operating instructions, chapter 4.02.
- There are no persons or objects in the danger zone.

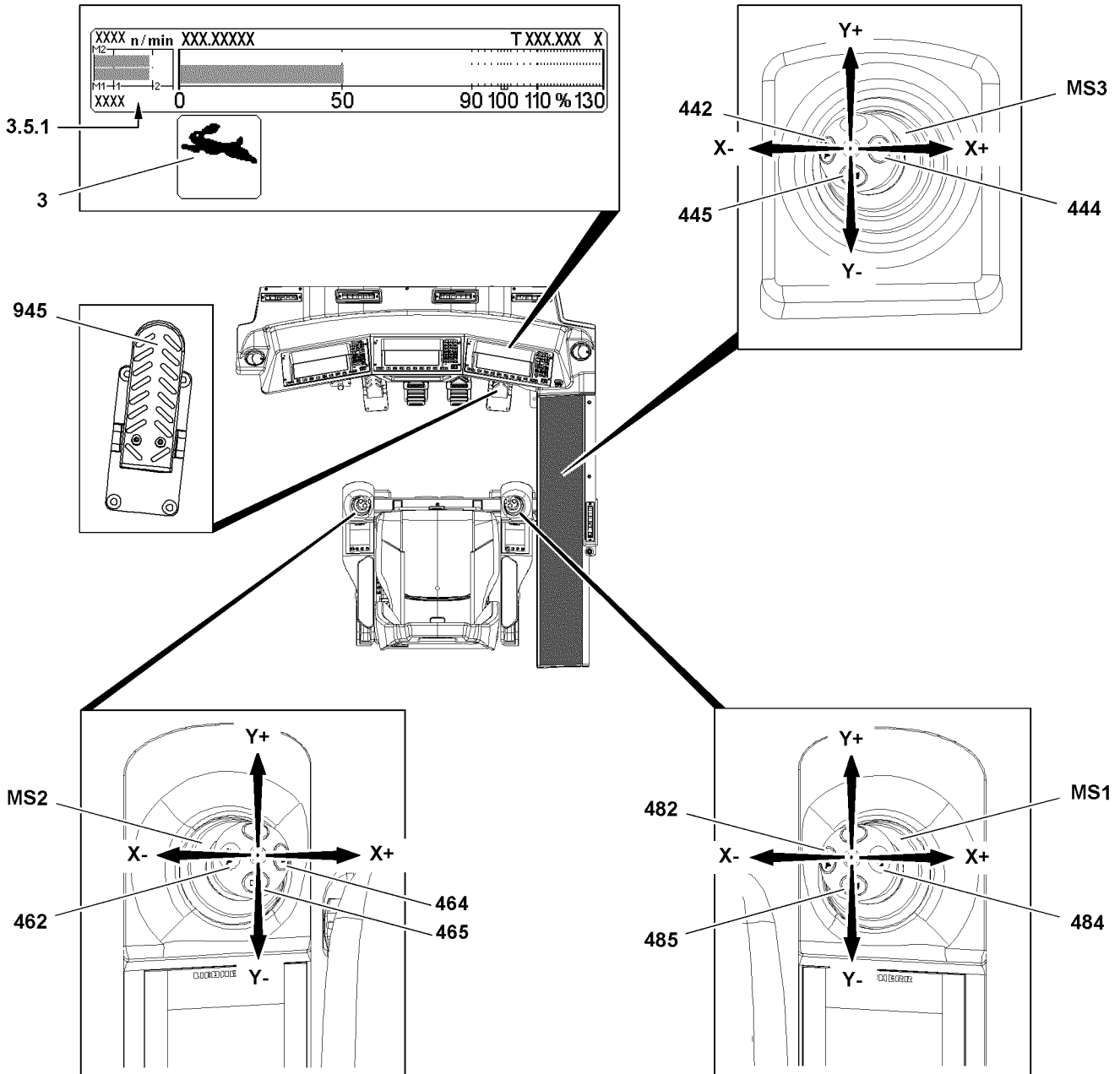

Fig.122227

LWE/LR 11000-001/23501-04-02/en

2 Master switch functions



WARNING

Danger of fatal injury!

Death, severe bodily injuries, property damage.

- ▶ It is prohibited for personnel to remain in the danger zone.
- ▶ Make sure that there are no obstacles within the working area of the crane.
- ▶ Give a short warning signal (horn) before starting a crane movement.
- ▶ Observe the danger notes for crane operation, see Crane operating instructions, chapter 5.01.



Note

Change of master switch assignment!

The assignment of the master switches to the respective units on the crane can change, depending on the set up configuration and winch application.

- ▶ **Check the assignment before actuating the master switch on the TE.**



Note

- ▶ In order to protect the crane and reduce the danger of accidents always use the master switch slowly and sensitively.

2.1 Giving a warning signal



WARNING

Crane movement without warning signal!

Without warning signals, personnel within the danger zone of the crane can be surprised by a crane movement.

Death, severe bodily injuries, property damage.

- ▶ Before initiating a crane movement, give a warning signal (horn).

- ▶ Press the button **485** on the master switch **MS1**.
or
Press the button **465** on the master switch **MS2**.
or
Press the button **445** on the master switch **MS3**.

Result:

- Warning signal sounds.

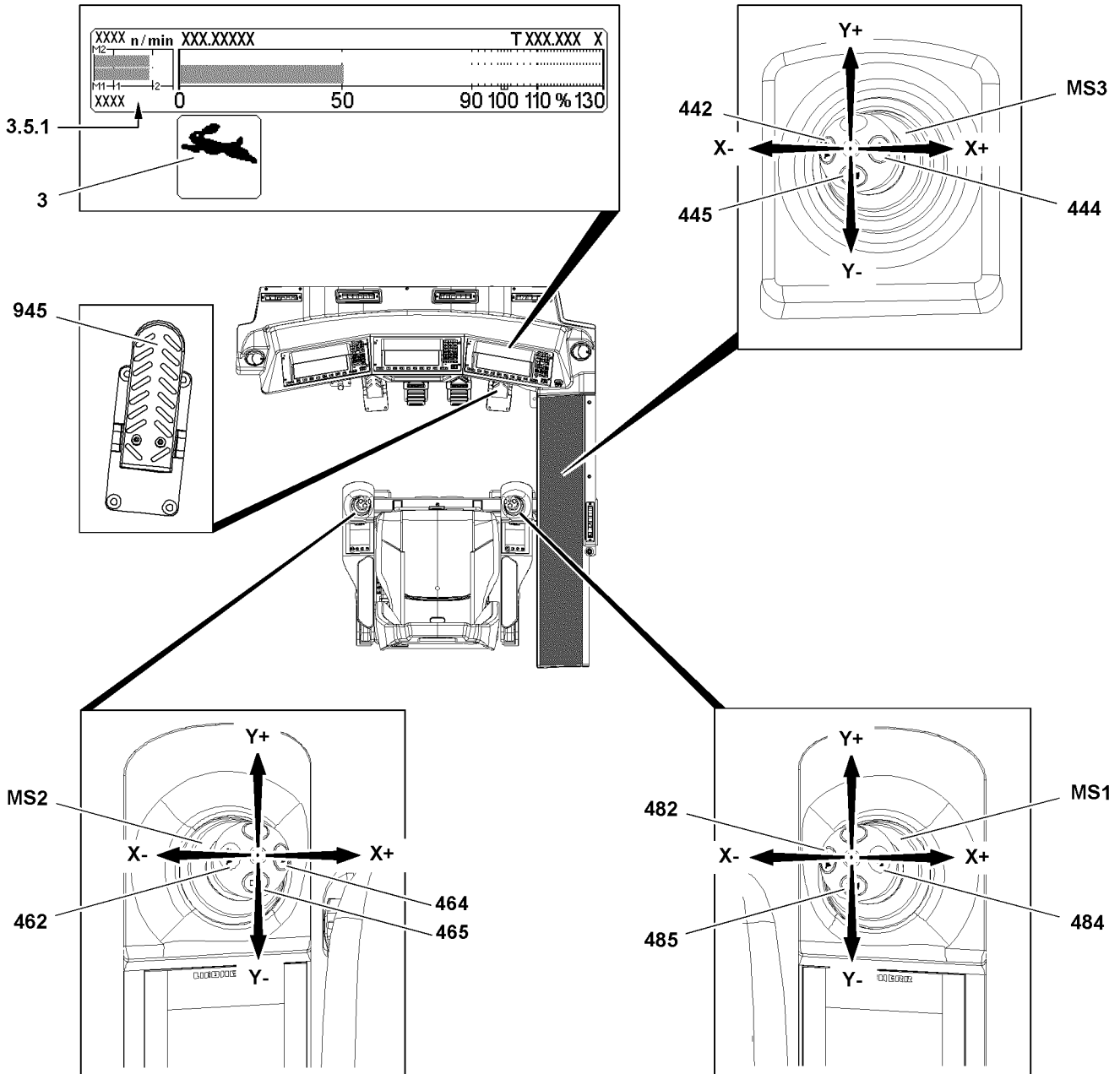

Fig.122227

LWE/LR 11000-001/23501-04-02/en

2.2 Engine rpm

2.2.1 Locking the engine rpm

Locking the engine rpm relieves the crane operator if he needs to work for an extended period with constant rpm. The engine regulation can be locked in any position.

- ▶ Press the pedal **945** for the engine regulation down until the desired rpm is reached.
- ▶ Press the button **484**.
 - or
 - Press the button **464**.
 - or
 - Press the button **444**.

Result:

- The pedal **945** is locked and the engine rpm is saved.
- The icon „+“ appears behind the rpm display **3.5.1** on the LICCON monitor.



Note

- ▶ The locked engine rpm can be overridden by pressing the pedal **945**. If the button **484**, the button **464** or the button **444** is pressed during the override, the current rpm will be used.

2.2.2 Releasing the engine rpm lock

Make sure that the following prerequisite is met:

- The pedal **945** is not actuated.

When the engine rpm is locked:

- ▶ Press the button **484**.
 - or
 - Press the button **464**.
 - or
 - Press the button **444**.
 - or
 - Tap the pedal **945** momentarily.

Result:

- The engine rpm lock is revoked.
- The icon „+“ turns off behind the rpm display **3.5.1** on the LICCON monitor.

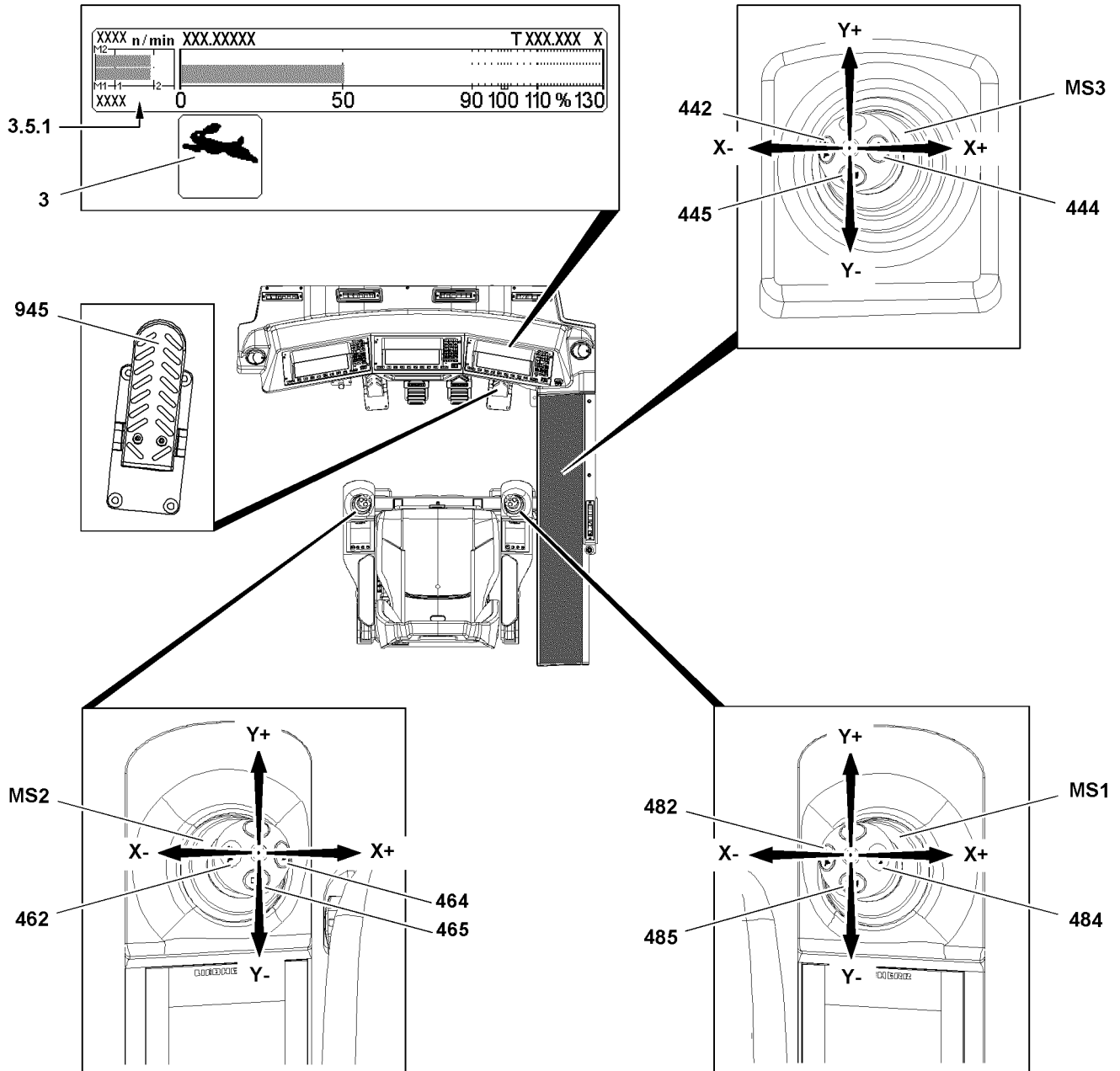

Fig.122227

2.3 „Power Plus“ rapid gear

Using the button **482**, the button **462** or the button **442** will increase the speed of the crane movement for „luffing up“, „luffing down“ and „lifting / lowering“.



WARNING

Danger of accident in the event of one to three strand reeving!

Death, severe bodily injuries, property damage.

- ▶ Do **NOT** turn the rapid gear on if the crane is loaded to more than 50 % of its maximum permitted load bearing capacity for the respective boom radius.



Note

When „Power Plus“ is turned on, observe the following:

- ▶ If the total power requirement of all actuated crane movements is larger than the available power, then the crane movements that require the most power are reduced.
- ▶ If another crane movement is added or taken back to one or more actuated crane movements then this has an influence on the other movements. For that reason we recommend in situations in which an interference of the individual crane movements is troublesome, not to add the „Power Plus“ or to turn the „Power Plus“ off.



Note

- ▶ The effectiveness of the rapid gear function „Power Plus“ depends on the size of the „speed reduction master switch“. If a small value is set for the speed reduction, then the rapid gear function „Power Plus“ is accordingly low.
- ▶ When the „Power Plus“ rapid gear is active and various crane movements are actuated at the same time, then speed reductions can occur.

2.3.1 Turning on „Power Plus“ rapid gear

- ▶ Press the button **482**.
or
Press the button **462**.
or
Press the button **442**.

Result:

- The rapid gear is switched on.
- The icon **3** appears on the LICCON monitor.

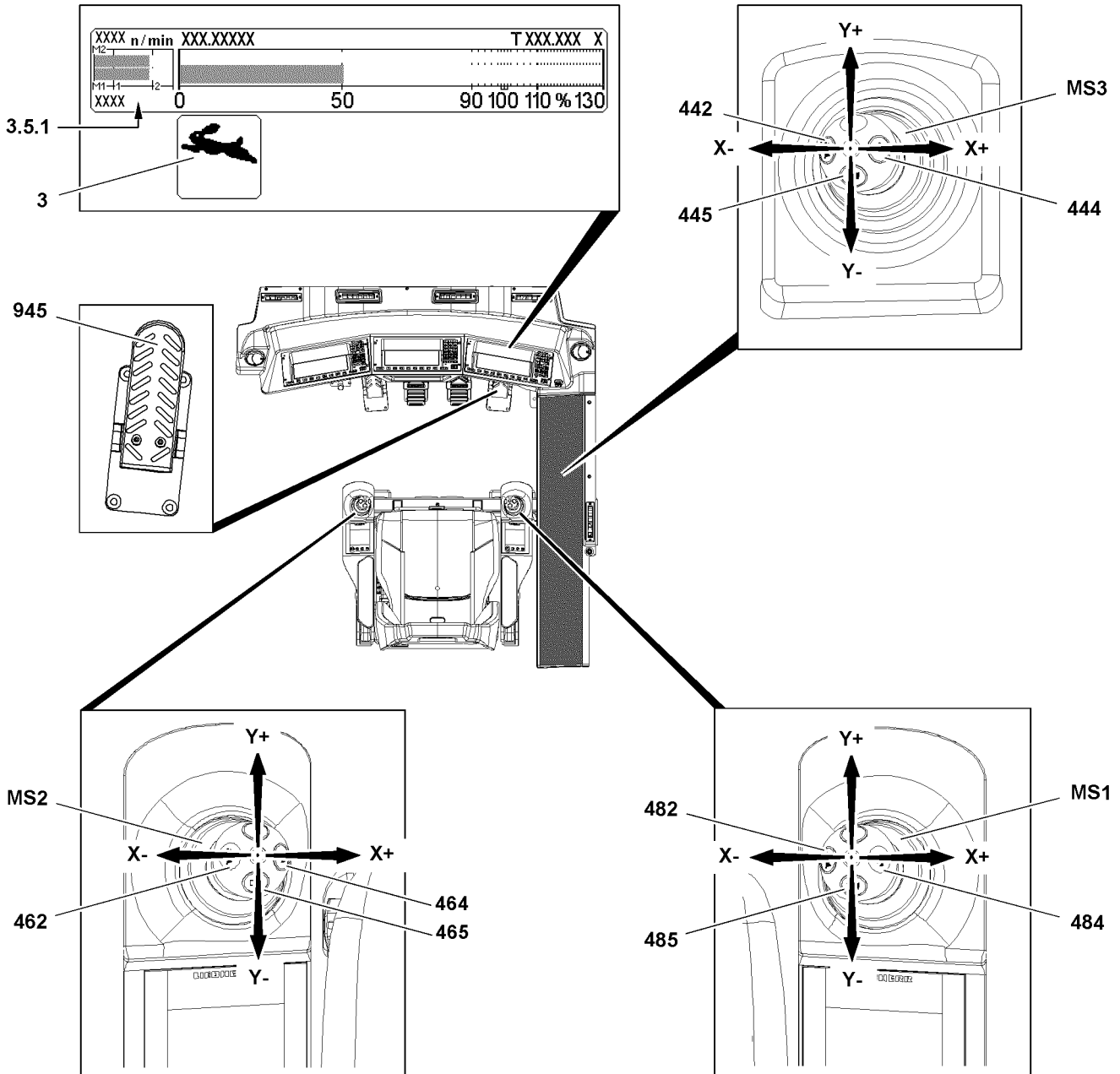

Fig.122227

LWE/LR 11000-001/23501-04-02/en

2.3.2 Turning off „Power Plus“ rapid gear

When the rapid gear is turned on:

- ▶ Press the button **482**.
- or**
- Press the button **462**.
- or**
- Press the button **442**.

Result:

- The rapid gear is turned off.
- The icon **3** turns off on the LICCON monitor.

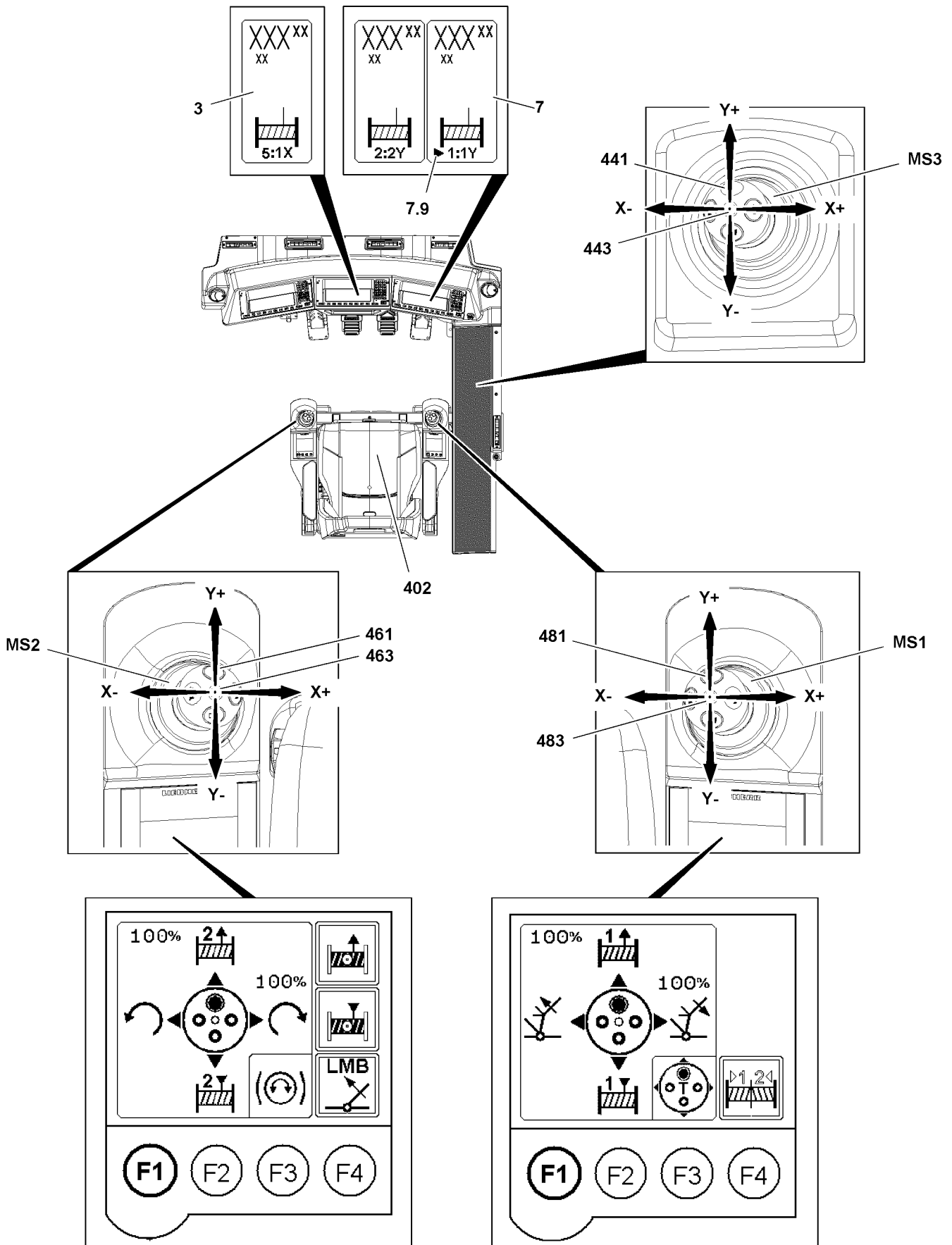

LWE/LR 11000-001/23501-04-02/en

Fig.122228

2.4 Vibration sensor

By adding on the vibration sensor, crane movements also can be detected via master switch vibration.



Note

- ▶ After the vibration sensor on the master switch is activated, the vibration sensor can be assigned to a deflection axle. To assign the vibration sensor to another deflection axle, the master switch must first be brought back into zero position. Then the master switch must be deflected in the other deflection axle.

Make sure that the following prerequisite is met:

- The seat contact button **402** is actuated.

2.4.1 Vibration sensor winches

This section applies for the deflection axles for hoist winches and for the control winches on the master switches:

- **MS1** Master switch
- **MS2** Master switch
- **MS3** Master switch



Note

When the vibration sensor is activated on one master switch:

- ▶ For very winch, which is assigned to the master switch, the icon **7.9** before every winch display appears on the LICCON monitors, see example for winch 1 in the illustration.
- ▶ The vibration sensor is activated on one master switch exclusively for the movement axle that was deflected first.
- ▶ When a movement axle is deflected and a winch is actuated, the icon **7.9** for the other winches turns off on the winch displays.
- ▶ For description of winch displays on the LICCON monitors, see sections „Winch display“, Crane operating instructions, chapter 4.02.

Adding the vibration sensor winch 1

This example shows how the vibration sensor for winch 1 is added, master switch **MS1** at master switch assignment „T“.

- ▶ Press the button **481**.

Result:

- The vibration sensor **483** on the master switch **MS1** is turned on.
- In the winch display **7** for winch 1 and in the winch display **3** for winch 5, luffing jib, appears the icon **7.9**, see illustration.

- ▶ Deflect the master switch **MS1** in Y-direction.

Result:

- In the winch display **7** for winch 1, the icon **7.9** remains visible, the other icons turn off.
- The vibration sensor for winch 1 is activated.

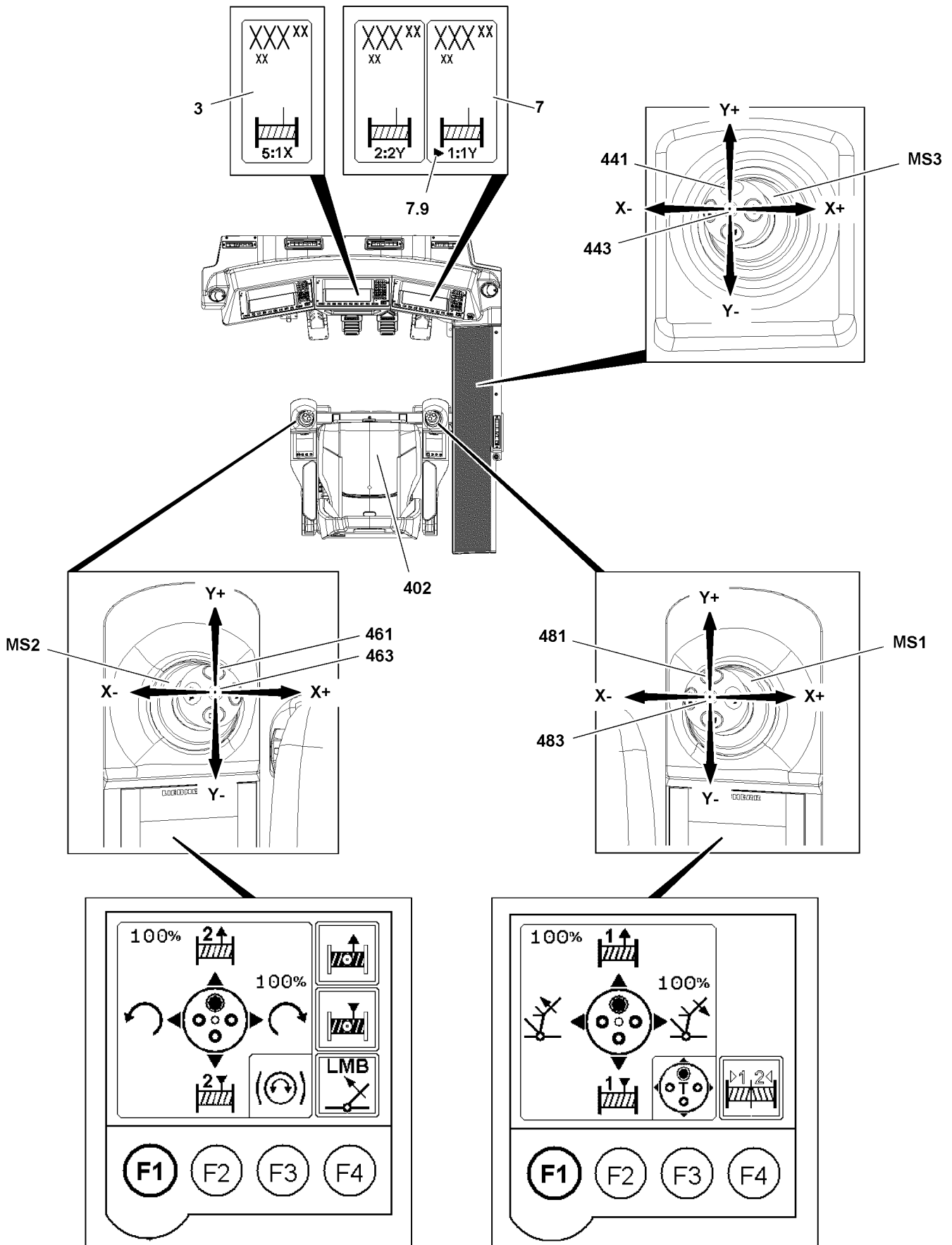

Fig.122228

LWE/LR 11000-001/23501-04-02/en

Turning the vibration sensor winch 1 off

When the vibration sensor **483** for winch 1 is turned on:

- ▶ Press the button **481**.

Result:

- The vibration sensor **483** on the master switch **MS1** is deactivated and turned off.
- The icon **7.9** turns off in the winch display **7** for winch 1.

2.4.2 Vibration sensor slewing gear

This section applies for the deflection axle for the slewing gear on master switch **MS2**.



Note

- ▶ The vibration sensor for the slewing gear is **NOT** displayed by an icon on the LICCON monitor.
- ▶ The vibration sensor is activated on one master switch exclusively for the movement axle that was deflected first.
- ▶ If a movement for the slewing gear is deflected, then the icons **7.9** for the winches on the winch displays turn off.

Adding the vibration sensor for the slewing gear

This example shows how the vibration sensor for the slewing gear is added, master switch **MS2** at master switch assignment „T“.

- ▶ Press the button **461**.

Result:

- The vibration sensor **463** on the master switch **MS2** is turned on.
- ▶ Deflect the master switch **MS2** in X-direction.

Result:

- The vibration sensor for the slewing gear is activated.

Turning the vibration sensor for the slewing gear off

When the vibration sensor **463** for the slewing gear is turned on:

- ▶ Press the button **461**.

Result:

- The vibration sensor **463** on the master switch **MS2** is deactivated and turned off.

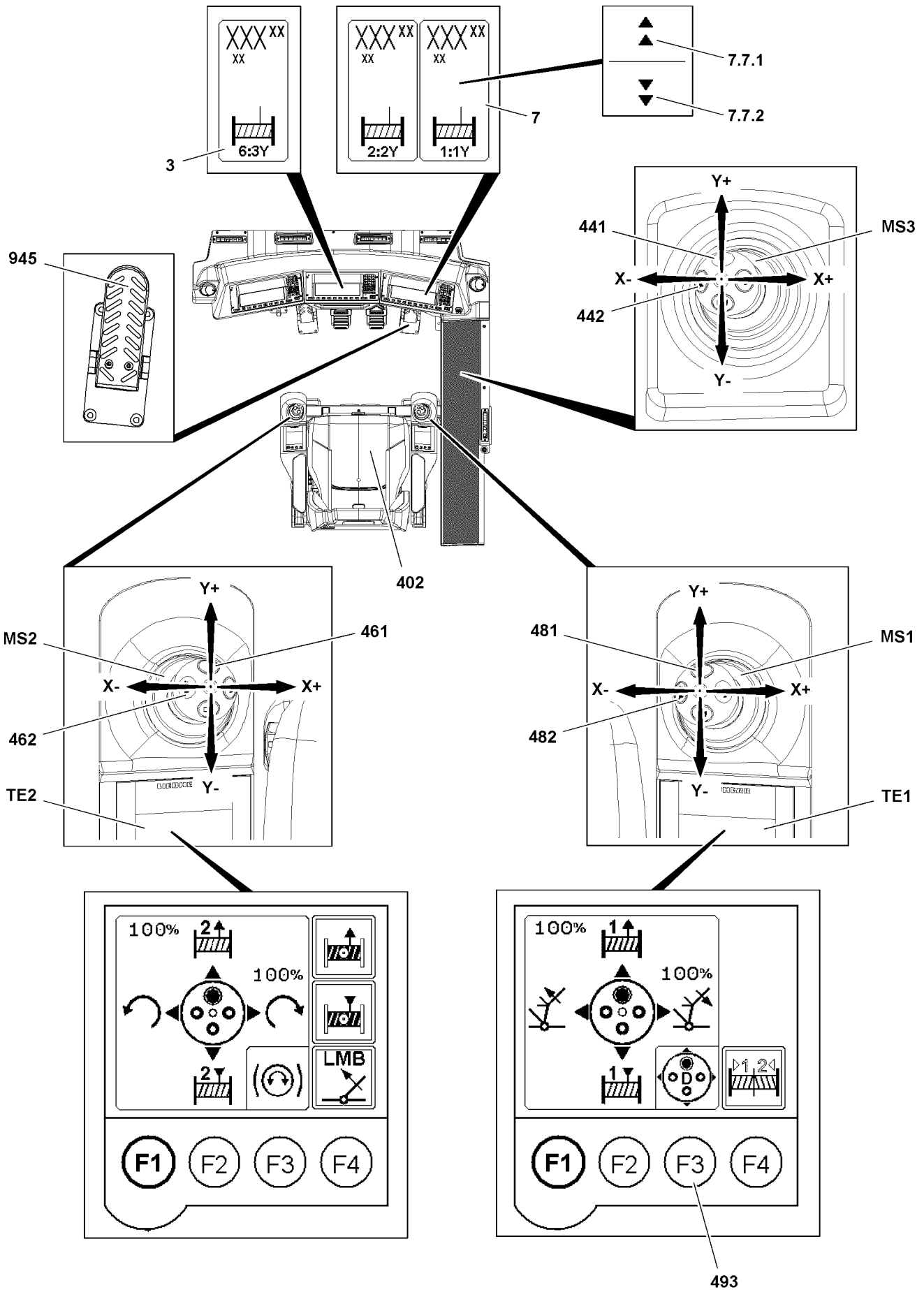

Fig.122229

LWE/LR 11000-001/23501-04-02/en

3 Lifting and lowering

The speed of crane movement „lifting and lowering“ is controlled via the deflection of the corresponding master switch and via the pedal **945** of the engine regulation.

The maximum winch speed can be reduced or increased in the „Speed reduction master switch“ menu, see Crane operating instructions, chapter 4.02.

Every winch can be blocked or released, see section „TE1 Menu block winch“, Crane operating instructions, chapter 4.01.



Note

- ▶ The seat contact button **402** in the crane operator's seat can be bypassed by the button **481** on the master switch **MS1** or the button **461** on the master switch **MS2** or the button **441** on the master switch **MS3**.
 - ▶ For description of winch displays on the LICCON monitors, see Crane operating instructions, chapter 4.02.
 - ▶ For description of the touch functions and the icons on the individual touch displays, see Crane operating instructions, chapter 4.01.
-



Note

- ▶ With the button **482**, the button **462** or the button **442** the speed of the crane movement „lift / lower“ is increased, see section „Rapid gear Power Plus“.
-

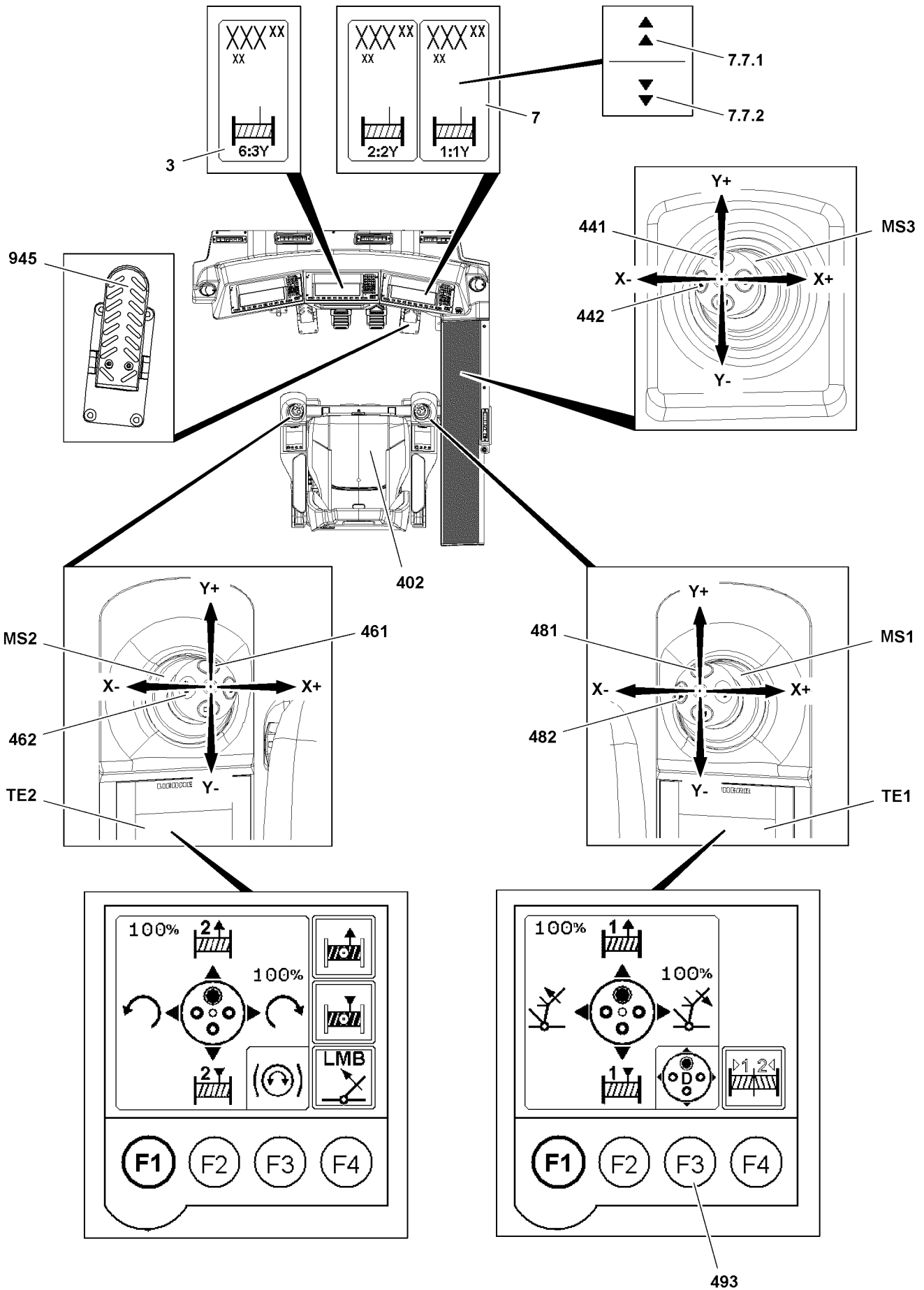

Fig.122229

LWE/LR 11000-001/23501-04-02/en

3.1 Spooling the hoist winches up and out



Note

Change of master switch assignment!

The assignment of the master switches to the respective units on the crane can change, depending on the set up configuration and winch application.

► **Check the assignment before actuating the master switch on the TE.**

This section is valid for the following winches:

- Winch 1 and winch 2
- Winch 6 as hoist winch

In the winch display **7** and in the winch display **3** on the LICCON monitors is shown that the winch is turning, even if no hook movement is visible due to multiple reeving and low speed:

- Winch display **7** for winch 1 and winch 2
- Winch display **3** for winch 6 and the control winches

Make sure that the following prerequisites are met:

- The master switches are in the neutral position.
- The crane is at a standstill.
- On the touch displays, the assignment of the main menu is visible.
- The seat contact button **402** is activated or the button **481**, button **461** or button **441** is pressed.

3.1.1 Spooling the hoist winch out

This example shows how the winch 1 is spooled out, master switch **MS1** at master switch assignment „D“.

In this assignment, winch 2 on master switch **MS2** and winch 6 on master switch **MS3** are spooled out the same way.

- Select the master switch assignment: Press the F3-key **493** on the touch display **TE1** until the master switch assignment „D“ appears.
- Deflect the master switch **MS1** in direction Y+.

Result:

- The icon **7.7.1** appears in the winch display and blinks.
- The winch spools out, the load is lowered.

Problem remedy

Winch blocked?

When a winch is blocked, then the crane movement is also blocked.

- Release the winch, see section „Blocking the winch (touch display right)“, Crane operating instructions, chapter 4.01.

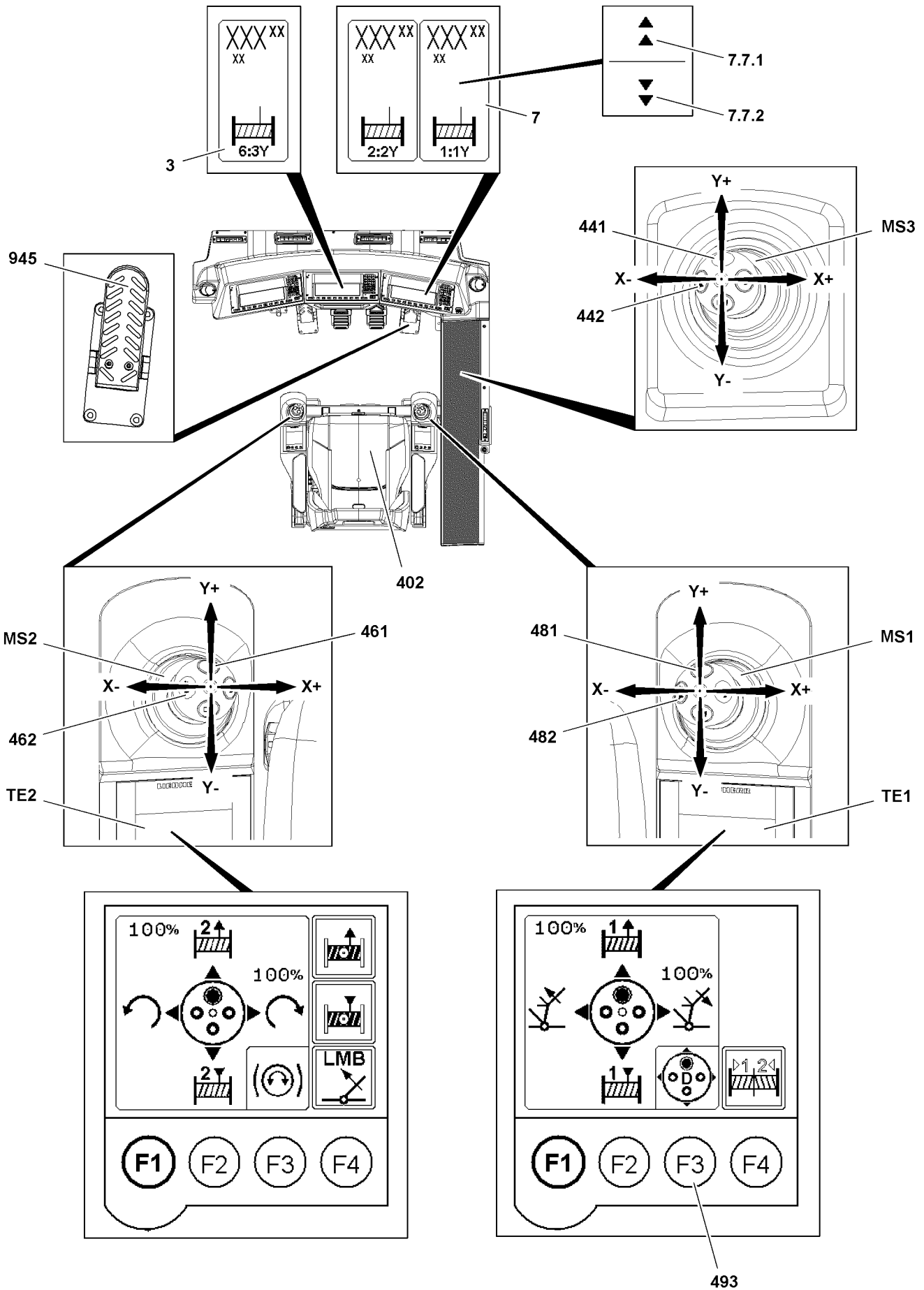

Fig.122229

LWE/LR 11000-001/23501-04-02/en

3.1.2 Spooling the hoist winch up

This example shows how the winch 1 is spooled out, master switch **MS1** at master switch assignment „D“.

In this assignment, winch 2 on master switch **MS2** and winch 6 on master switch **MS3** are spooled out the same way.

- ▶ Deflect the master switch **MS1** in direction Y-.

Result:

- The icon 7.7.2 appears in the winch display and blinks.
- Winch spools up and the load is lifted.

3.2 Setting up parallel operation

For parallel operation, winch 1 and winch 2 are used.

In parallel operation, winch 1 and winch 2 are actuated simultaneously with the master switch **MS1**.

Make sure that the following prerequisites are met:

- All rope pulleys, change over pulleys and test pulleys on the boom system are free of contamination, snow, frost and ice.
- The pulley blocks of the hook block are installed together, see Crane operating instructions, chapter 5.19 or separate operating instructions.
- The pulley blocks of the hook block are reeved according to the load charts.
- The pulley blocks of the hook block are properly reeved according to the reeving plan, see separate reeving plan.
- The minimum reeving according to the reeving plan may not be fallen below.
- The total reeving has been entered on the LICCON monitor.
- The number of the reeving of the hoist ropes for every winch must be identical and even.



WARNING

Danger of accident!

Death, severe bodily injuries, property damage.

- ▶ The number of the reeving of the hoist ropes for every winch in parallel operation must be identical and even.
- ▶ Make sure to unpin the transport pins on the roller blocks before the horizontal alignment and before crane operation.
- ▶ Make sure that the danger zone of the hook blocks is free of any personnel.

3.2.1 Adapting to the wind speed

In the case of rope reevings > 2 x 20-way, the wind speed must be reduced to 70 %.

- ▶ Call up the setting window Speed reduction Master switch / pedal sensor, see Crane operating instructions, chapter 4.02
- ▶ Reduce the master switch for crane movement *Spooling winch 1/12 up / out* to 70 %.

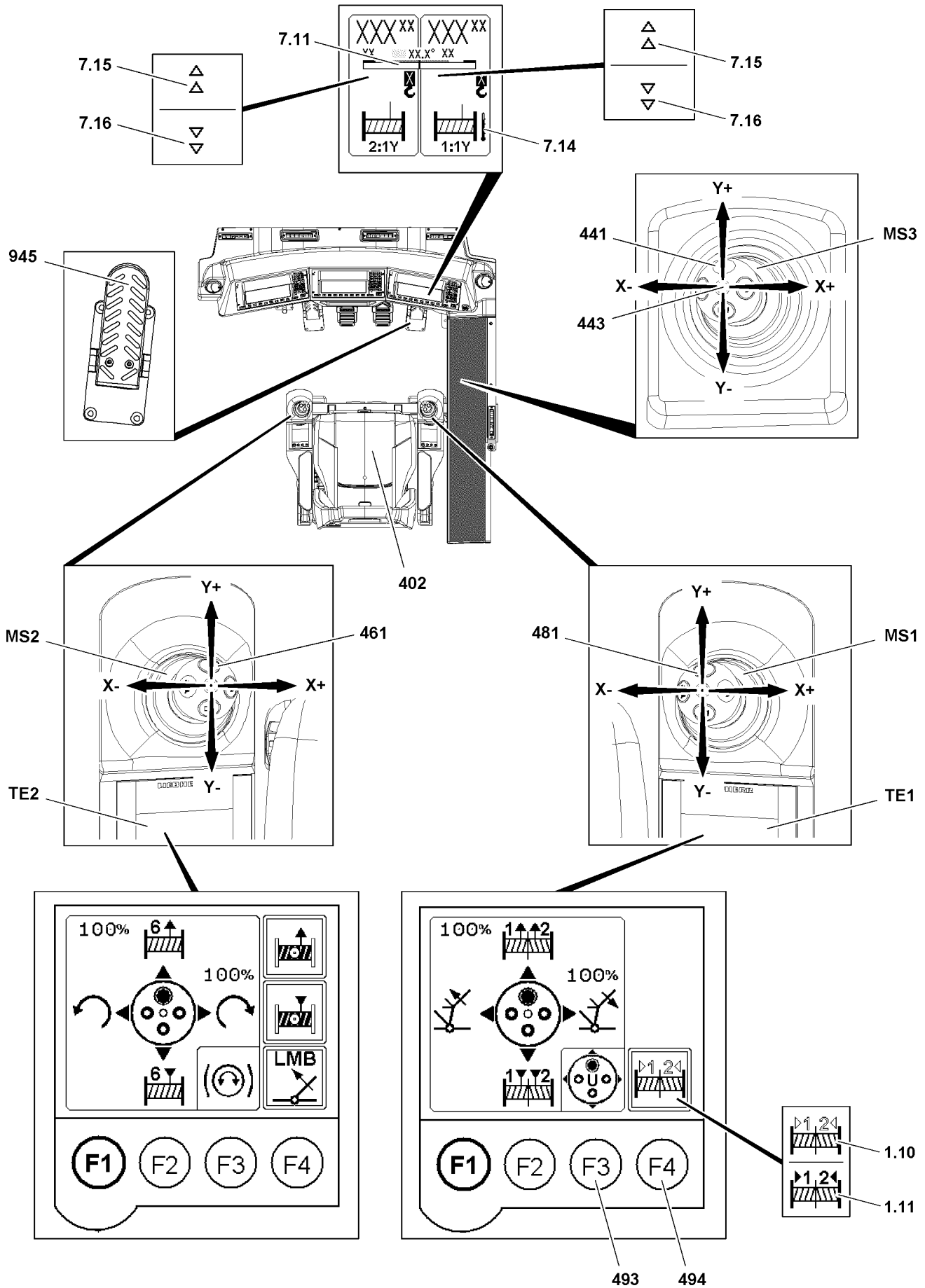

Fig.145930

LWE/LR 11000-001/23501-04-02/en

3.2.2 Horizontally aligning the hook block

Make sure that the following prerequisite is met:

- Winch 1 and winch 2 are **NOT** adjusted.

The hook blocks align horizontally through visual check and the icons on the winch display.

To align the hook blocks horizontally, proceed depending on the icons in the winch display **7**:

- If the icon **7.15** appears in the winch display, you have to spool the corresponding winch out.
- If the icon **7.16** appears in the winch display, you have to spool the corresponding winch up.

Set individual operation for winch 1 and winch 2:

- ▶ Press the F3 key **493** until the master switch assignment for individual operation of winch 1 and winch 2 is displayed.

Winch 1 can only be controlled if the seat contact switch **402 and** the button **481** are actuated at the same time:

- ▶ Spool winch 1 out or up until the hook block is aligned horizontally.
- or**

Winch 2 can only be controlled if the seat contact switch **402 and** the button **461** are actuated at the same time:

Spool winch 2 out or up until the hook block is aligned horizontally.



Note

- ▶ In order to horizontally align winch 1 or winch 2 for the alignment of the hook block, the seat contact switch **402 and** the button **481** must be actuated at the same time.

-
- ▶ Press the F3 key **493** until the master switch assignment for the parallel operation of winch 1 and winch 2 is displayed.

Result:

- Winch 1 and winch 2 can be adjusted.

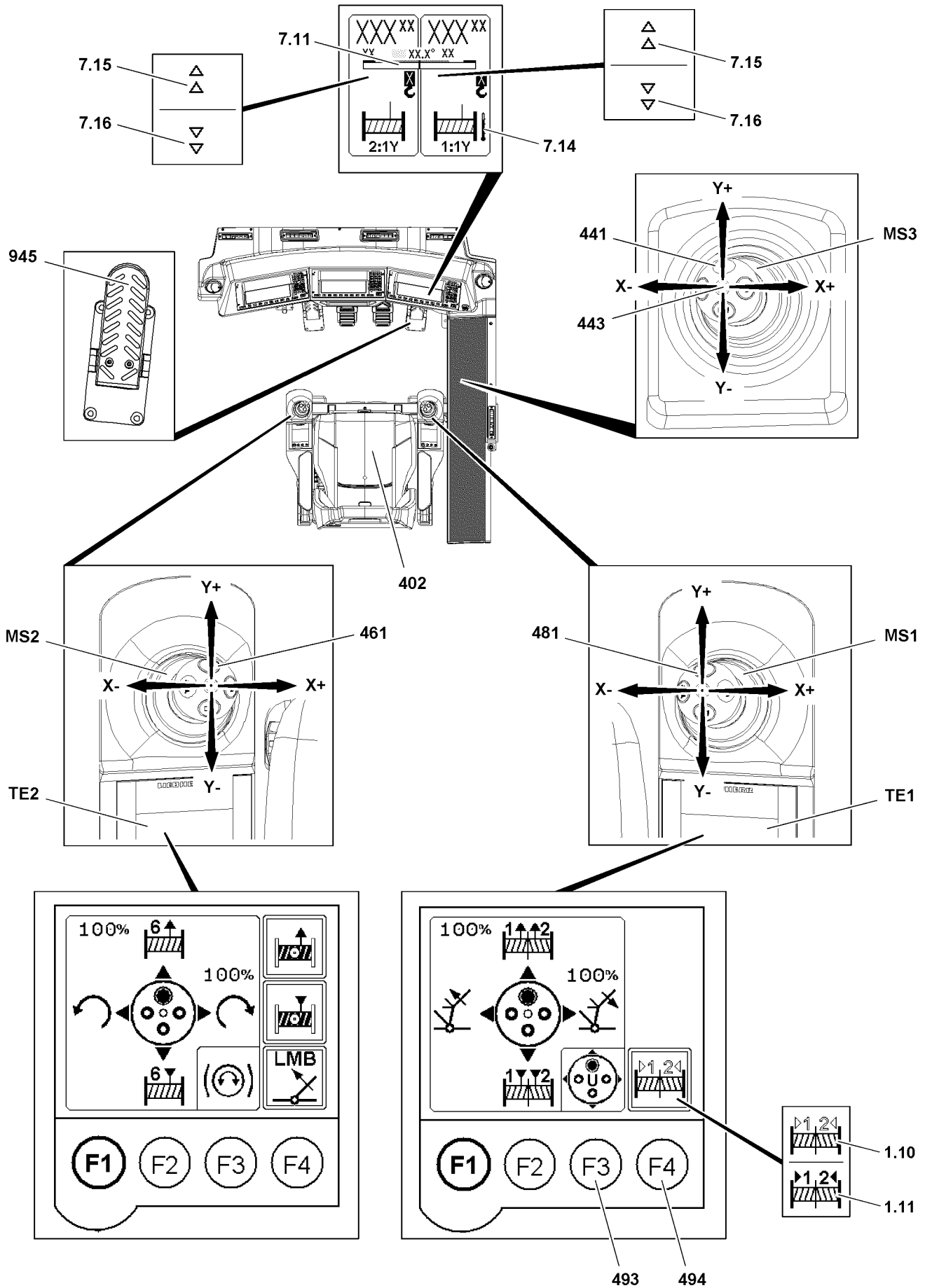

Fig.145930

LWE/LR 11000-001/23501-04-02/en

3.2.3 Adjusting winch 1 and winch 2

**Note**

- ▶ At master switch assignment with parallel operation of winch 1 and winch 2 both winches can **NOT** be spooled up or out individually.
- ▶ In parallel operation, the winch display **7** changes. For description of winch displays on the LIC-CON monitors, see Crane operating instructions, chapter 4.02.

Make sure that the following prerequisites are met:

- The hook blocks are horizontally aligned, check visually.
- A master switch assignment with parallel operation winch 1 and winch 2 is set on the touch display **TE1**.

The icon **1.10** is located on the touch display **TE1**.

- ▶ Preselect the touch function „Adjust winch 1 and winch 2“ by „touching“ the icon **1.10**.

Result:

- The icon **1.10** is bordered in black.
- ▶ Activate the touch function „Adjust winch 1 and winch 2“: Press the F4 key **494** on the touch display **TE1**.

Result:

- Instead of the icon **1.10**, the icon **1.11** is shown.
- Winch 1 and winch 2 are adjusted.

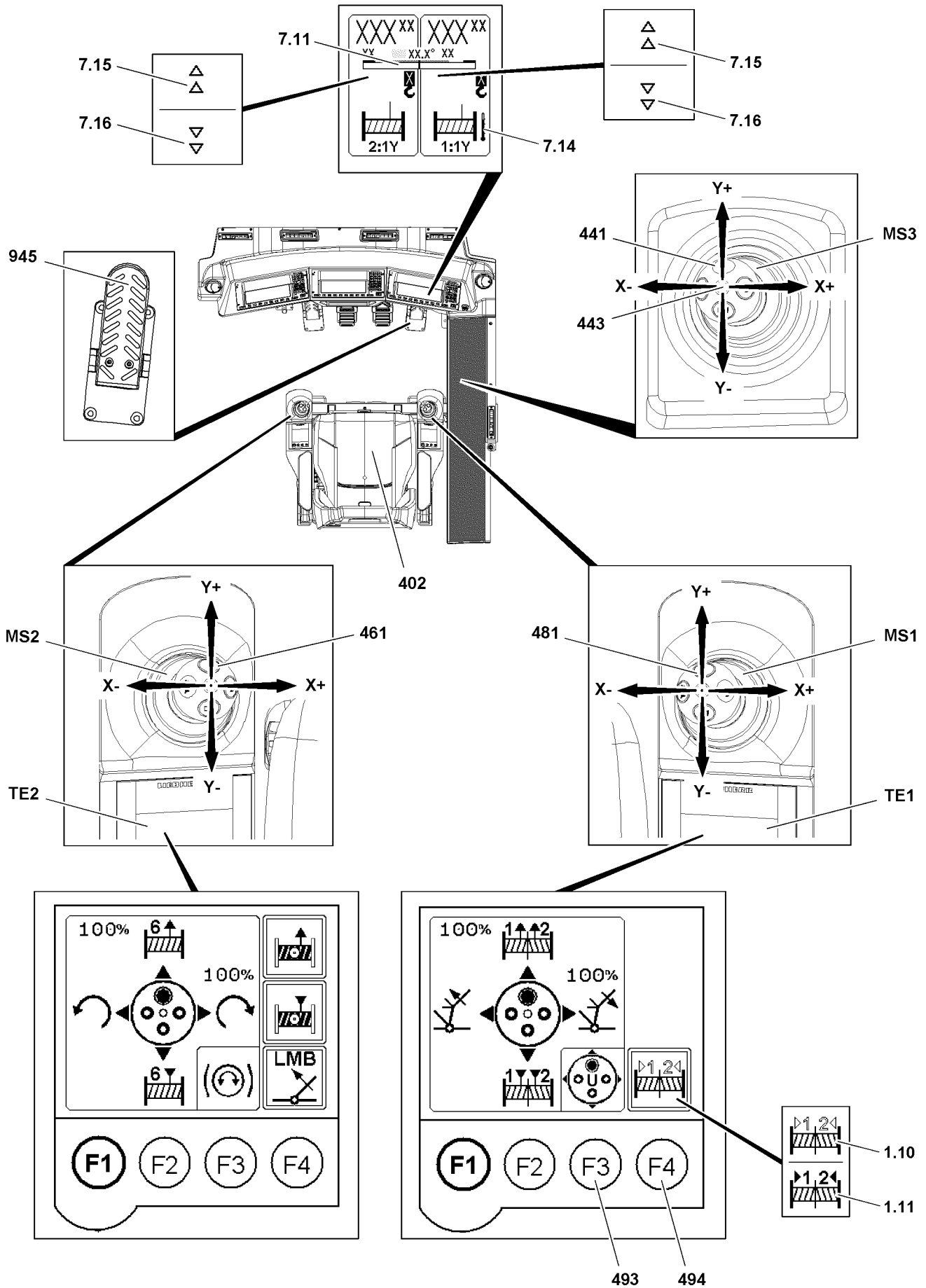

Fig.145930

LWE/LR 11000-001/23501-04-02/en

3.3 Parallel operation: Spooling the hoist winches up and out



WARNING

Incline position of the hook block!

If the balance bar on the roller blocks is inclined, then the load on the individual roller blocks is significantly increased. The boom, hook block or ropes can be overloaded.

Death, severe bodily injuries, property damage.

- ▶ Make sure that the number of reevings on winch 1 and winch 2 is identical and even.
- ▶ Unpin the transport pin on the roller blocks before crane operation.
- ▶ Make sure that the balance bar is always aligned horizontally on the roller blocks. Visual inspection hook block.
- ▶ Always correct the position of the hook block in time.



WARNING

Hook block in sloped position!

If the hook block gets so far into a sloped position that the red range is reached in the incline display, then there is a danger of accident.

Death, severe bodily injuries, property damage.

- ▶ The incline of the hook block is displayed in the winch display 7 on the LICCON monitor.
- ▶ When the incline display 7.11 of the hook block is in the red range, then there is a danger of accidents.
- ▶ Make sure that the incline display 7.11 of the hook block is always in the green range.



Note

- ▶ The LICCON computer system monitors in parallel operation the rope length of winch 1 and winch 2 with the aid of test pulleys.



WARNING

Hook block in sloped position!

Due to dirty or iced-up test pulleys it is possible that the rope length of winch 1 and winch 2 is incorrectly measured.

This incorrect measurement causes the hook block to move into an impermissible incline position and the winches are not automatically stopped.

Death, severe bodily injuries, property damage.

- ▶ Make sure that the test pulleys on the boom end section are free of dirt, snow, frost and ice.

The crane operator must ensure that the hook block is always aligned in parallel operation:

- ▶ Monitor the incline display of the hook block on the LICCON computer system.
- ▶ Monitor the hook block.

If incline position is present:

- ▶ Stop the winch movement and align the hook block.

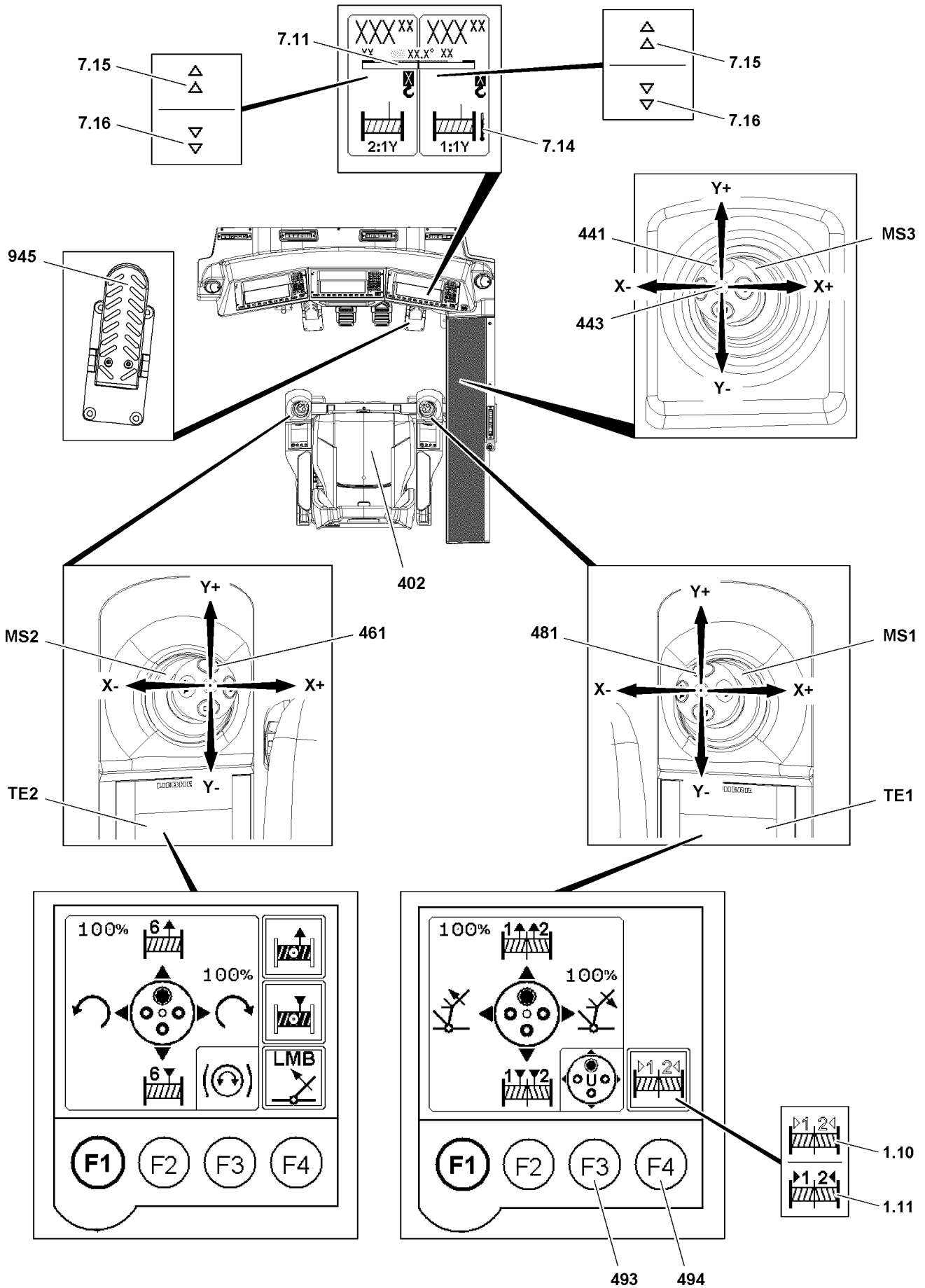

Fig.145930

LWE/LR 11000-001/23501-04-02/en

**Note**

- ▶ In parallel operation, the winch display changes. For description of winch displays on the LICCON monitors, see Crane operating instructions, chapter 4.02.
- ▶ There are several master switch assignments, in which parallel operation is possible.
- ▶ In the master switch assignment „U“, you can actuate winch 1 and winch 2 simultaneously (parallel), winch 6 can be actuated with the master switch **MS2** independent of master switch **MS1**.

Make sure that the following prerequisites are met:

- The parallel operation is set, see section „Setting up parallel operation“
- The total reeving has been entered on the LICCON monitor.
- Winch 1 and winch 2 are adjusted.
- The seat contact button **402** is activated or the button **481**, button **461** or button **441** is pressed.

3.3.1 Parallel operation: Spooling the hoist winches up

This example shows how the hoist winches are spooled up parallel, master switch **MS1** at master switch assignment „U“.

- ▶ Deflect the master switch **MS1** in direction Y-.

Result:

- Winch 1 and winch 2 spool up simultaneously: The load is lifted.

Problem remedy

Parallel operation is blocked?

Winch 1 and / or winch 2 is blocked.

- ▶ Release the winches, see section „Blocking the TE1 winches“, Crane operating instructions, chapter 4.01.

Problem remedy

Incline of hook block in red range of winch display?

When the incline value of the hook block is in the red range, there is an increased danger of damage to persons and property.

- ▶ Stop parallel operation.
- ▶ Align the hook block horizontally.
- ▶ Adjust winch 1 and winch 2.

Problem remedy

Path measurement in parallel operation is faulty?

- ▶ Switch the regulation for the path measurement over, see Crane operating instructions, chapter 4.02.

Problem remedy

The icon 7.14 „Winch overheated“ appears in the winch display?

The Winch is overheated.

- ▶ Let the winch cool off.

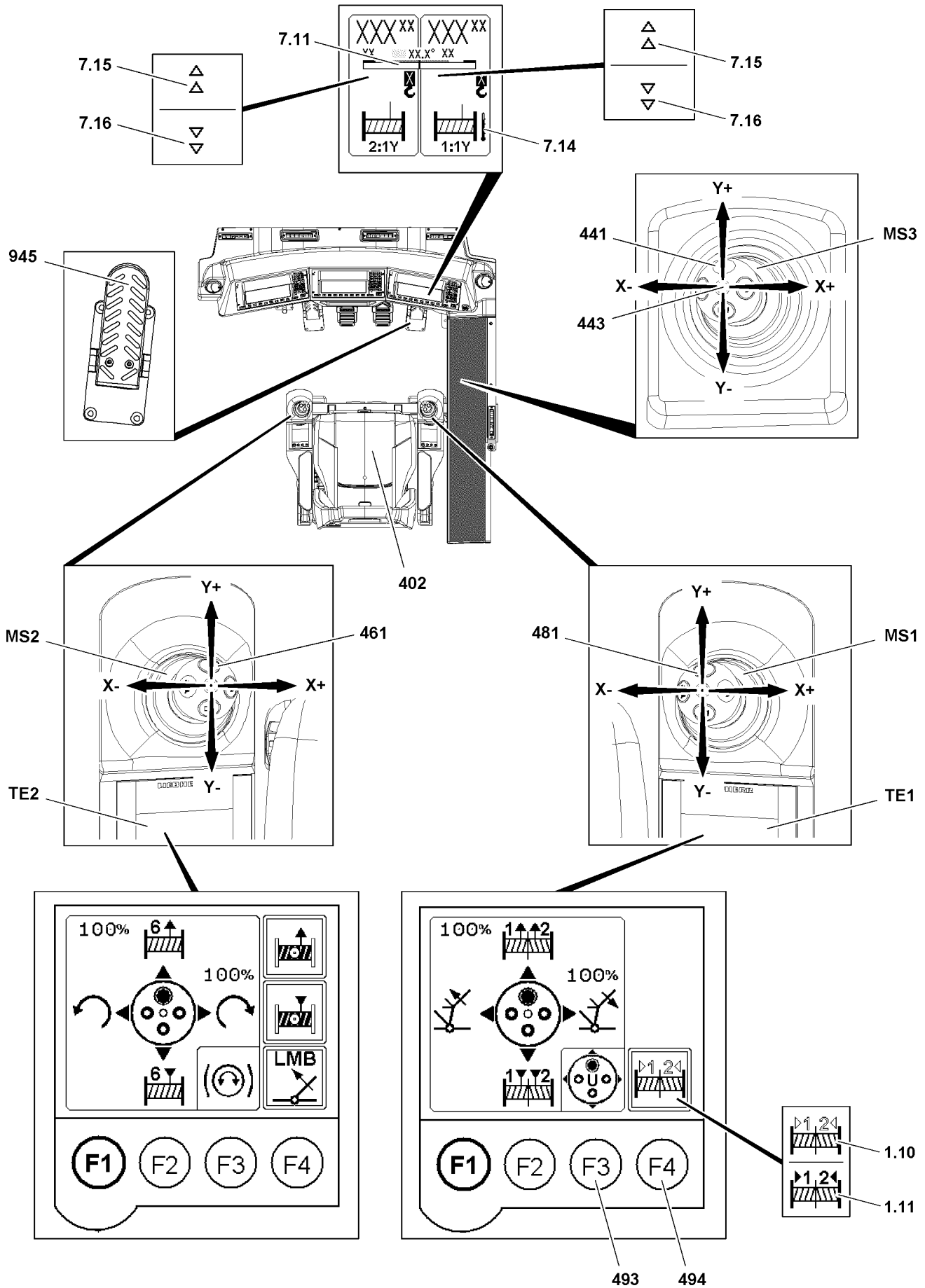

Fig.145930

LWE/LR 11000-001/23501-04-02/en

3.3.2 Parallel operation: Spool the hoist winches out.

Notes for problem remedy are in section „Parallel operation: Spooling the hoist winches up“.

This example shows how the hoist winches are spooled out parallel, master switch **MS1** at master switch assignment „U“.

- ▶ Deflect the master switch **MS1** in direction Y+.

Result:

- Winch 1 and winch 2 spool out simultaneously: The load is lowered.

3.3.3 Changing over regulation Parallel operation winch 1 and winch 2

The parallel operation of winch 1 and winch 2 is regulated from a pulley head height of more than 20 m via the change over pulleys. If there is a problem, the regulation can be switched over by the winch speed sensors, see Crane operating instructions, chapter 4.02.



WARNING

Impermissible change over of regulation *parallel operation winch 1 and winch 2*!

- ▶ Changing the regulation *parallel operation winch 1 and winch 2* is only permissible if - due to contamination, icing or failure of the path measurement system of the test pulleys - a correct path measurement of the hoist ropes of winch 1 and winch 2 is not possible.
- ▶ Changing the regulation *parallel operation winch 1 and winch 2* is only permissible if it is not possible to immediately clean or de-ice the test pulleys or repair the path measurement system.
- ▶ As long as the regulation *parallel operation winch 1 and winch 2* is changed over, the crane driver must align the position of the hook block generally manually.

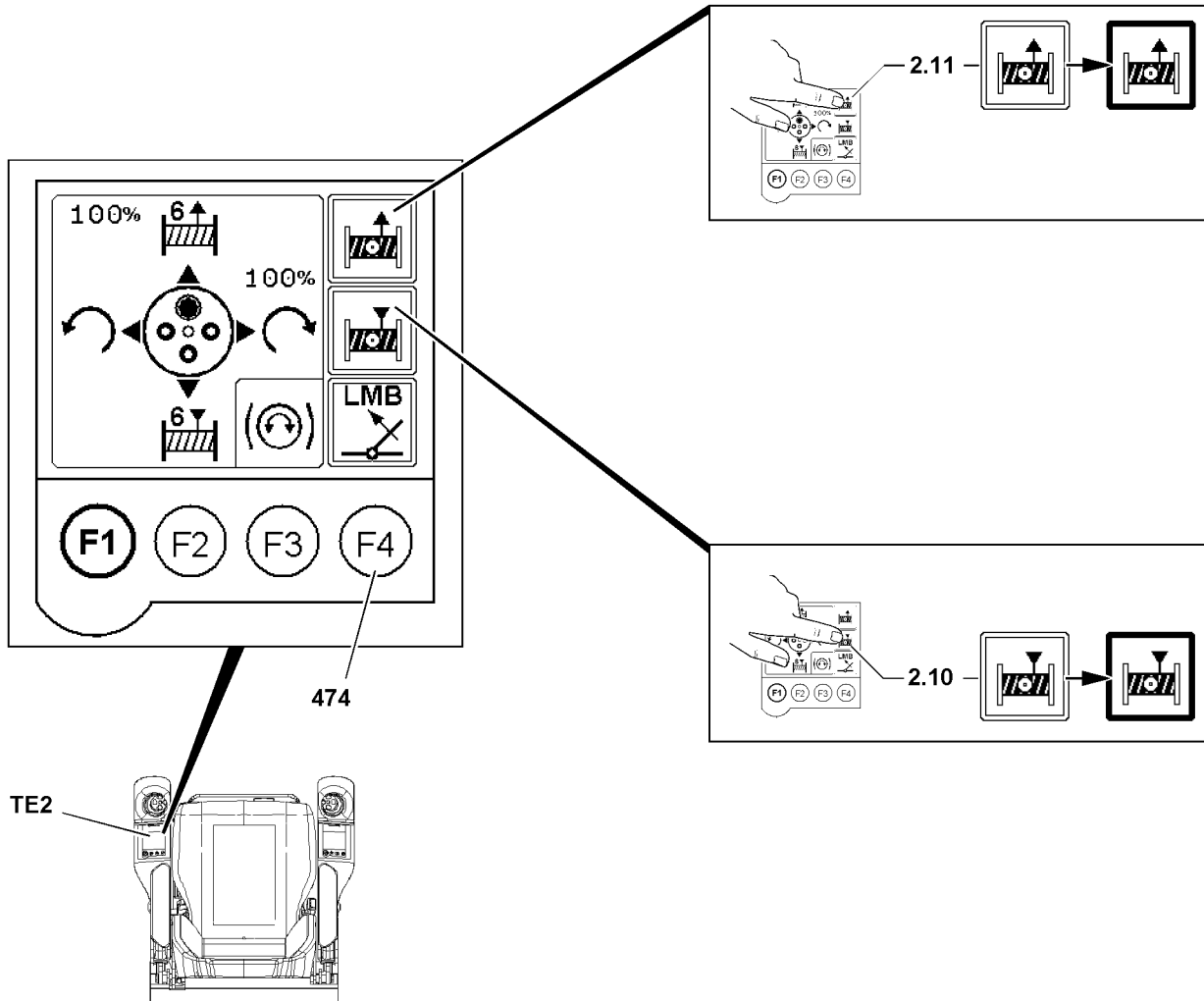

Fig.123993

3.4 Spooling the assembly winch up and out



WARNING

Overload of assembly winch!

When the assembly winch is used for hoisting work, then the assembly winch can be overloaded. Death, severe bodily injuries, property damage.

- ▶ Use the assembly winch only for reeving work.

The assembly winch is installed on the turntable front side.

The assembly winch is actuated from the crane operator's cab.



Note

- ▶ The assembly winch is operated with the touch display **TE2**.

Make sure that the following prerequisite is met:

- The touch functions for the assembly winch are visible on the touch display **TE2**, see illustration.

3.4.1 Spool the assembly winch out

- ▶ Select the touch function „Spooling the assembly winch out“ by „touching“ the icon **2.11**.

Result:

- The icon **2.11** is bordered in black.

The assembly winch is spooled out as long as the F4 key **474** is actuated.

- ▶ Press the F4 key **474**.

Result:

- The winch in the icon **2.11** blinks as long as the F4-key **474** is actuated.

Deselect the touch function „Spooling the assembly winch out“

- ▶ Deselect the touch function „Spooling the assembly winch out“ by „touching“ the icon **2.11**.
or
Select other touch functions on the touch display **TE2**.

Result:

- The icon **2.11** is no longer bordered in black.

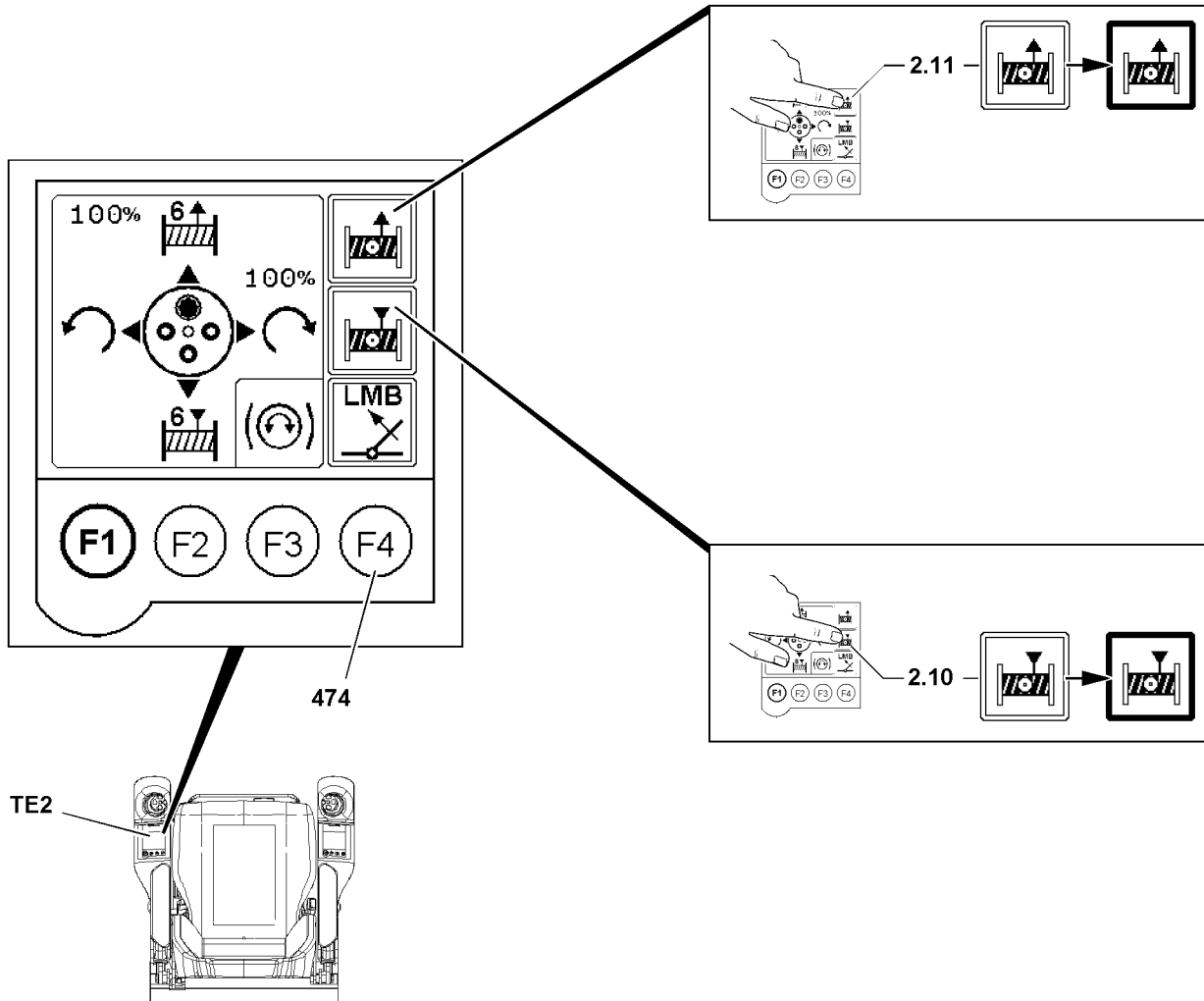

Fig.123993

3.4.2 Spool the assembly winch up

- ▶ Select the touch function „Spooling the assembly winch up“ by „touching“ the icon **2.10**.

Result:

- The icon **2.10** is bordered in black.

The assembly winch is spooled up as long as the function key **474** is actuated.

- ▶ Press the function key **474**.

Result:

- The winch in the icon **2.10** blinks as long as the function key **474** is actuated.

Deselect the touch function „Spooling the assembly winch up“

- ▶ Deselect the touch function „Spooling the assembly winch up“ by „touching“ the icon **2.10**.
or
Select other touch functions on the touch display **TE2**.

Result:

- The icon **2.10** is no longer bordered in black.

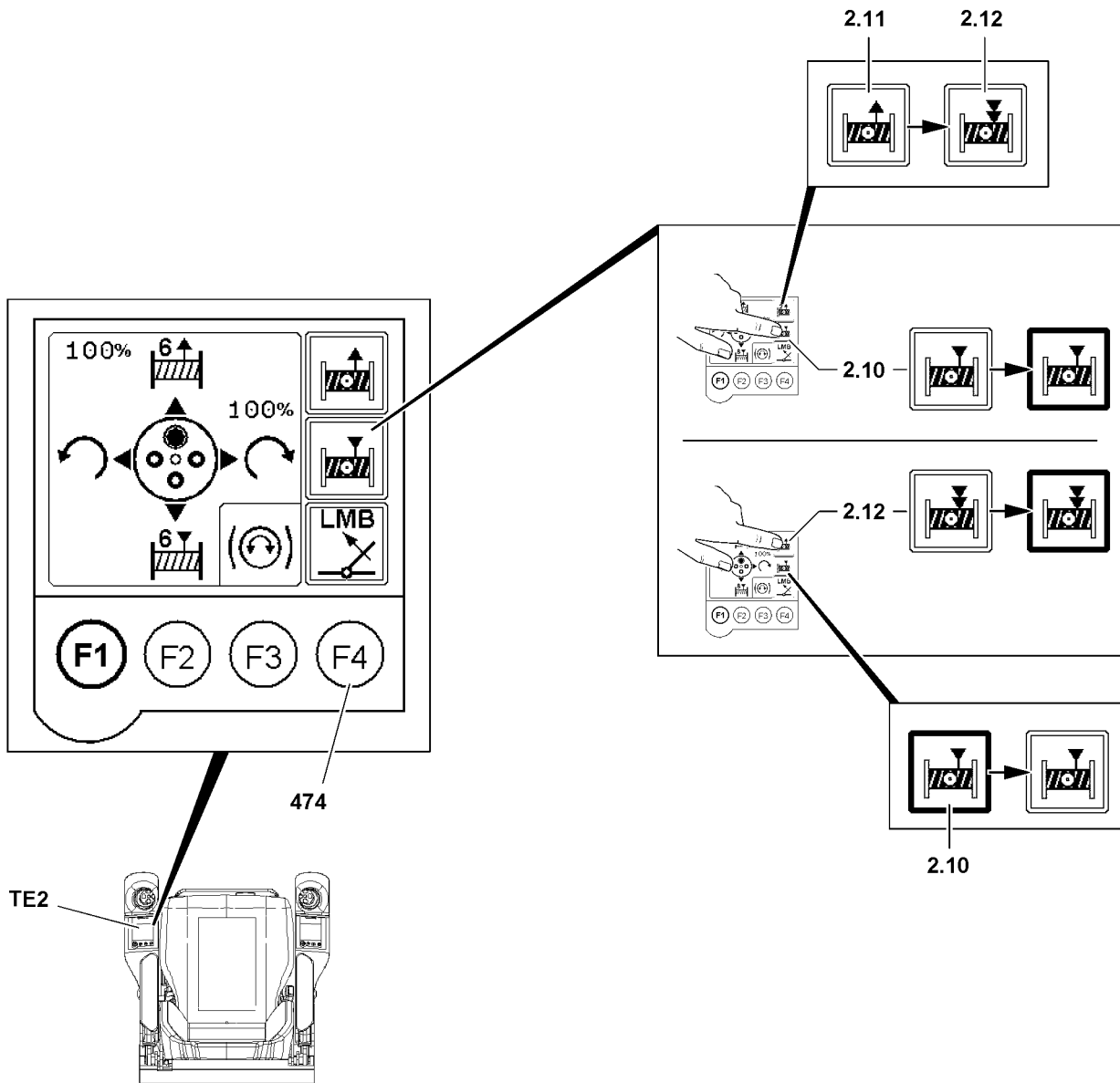

Fig.119696

3.4.3 Spooling the assembly winch up constantly

- ▶ Call up touch function „Spool the assembly winch up constantly“: Press the icon **2.10** for at least 1.5 s.

Result:

- The icon **2.10** is bordered in black.
- Instead of the icon **2.11**, the icon **2.12** is shown.

- ▶ Select the touch function „Spooling the assembly winch up constantly“ by „touching“ the icon **2.12**.

Result:

- The icon **2.12** is bordered in black.
- The icon **2.10** is no longer bordered in black.

- ▶ Press the function key **474** for at least 1 s.

Result:

- The assembly winch is spooled up constantly.
- The winch in the icon **2.12** blinks.

Stop the constant spooling up of the assembly winch

- ▶ Deselect the touch function „Spooling the assembly winch up constantly“ by „touching“ the icon **2.12**.

Result:

- The assembly winch is no longer spooled up.
- The icon **2.12** is no longer bordered in black.

or

- ▶ Press the function key **474**.

Result:

- The assembly winch is no longer spooled up.
- The icon **2.12** remains bordered in black.

or

- ▶ Select other touch functions on the touch display **TE2**.

Result:

- The assembly winch is no longer spooled up.
- The icon **2.12** is no longer bordered in black.

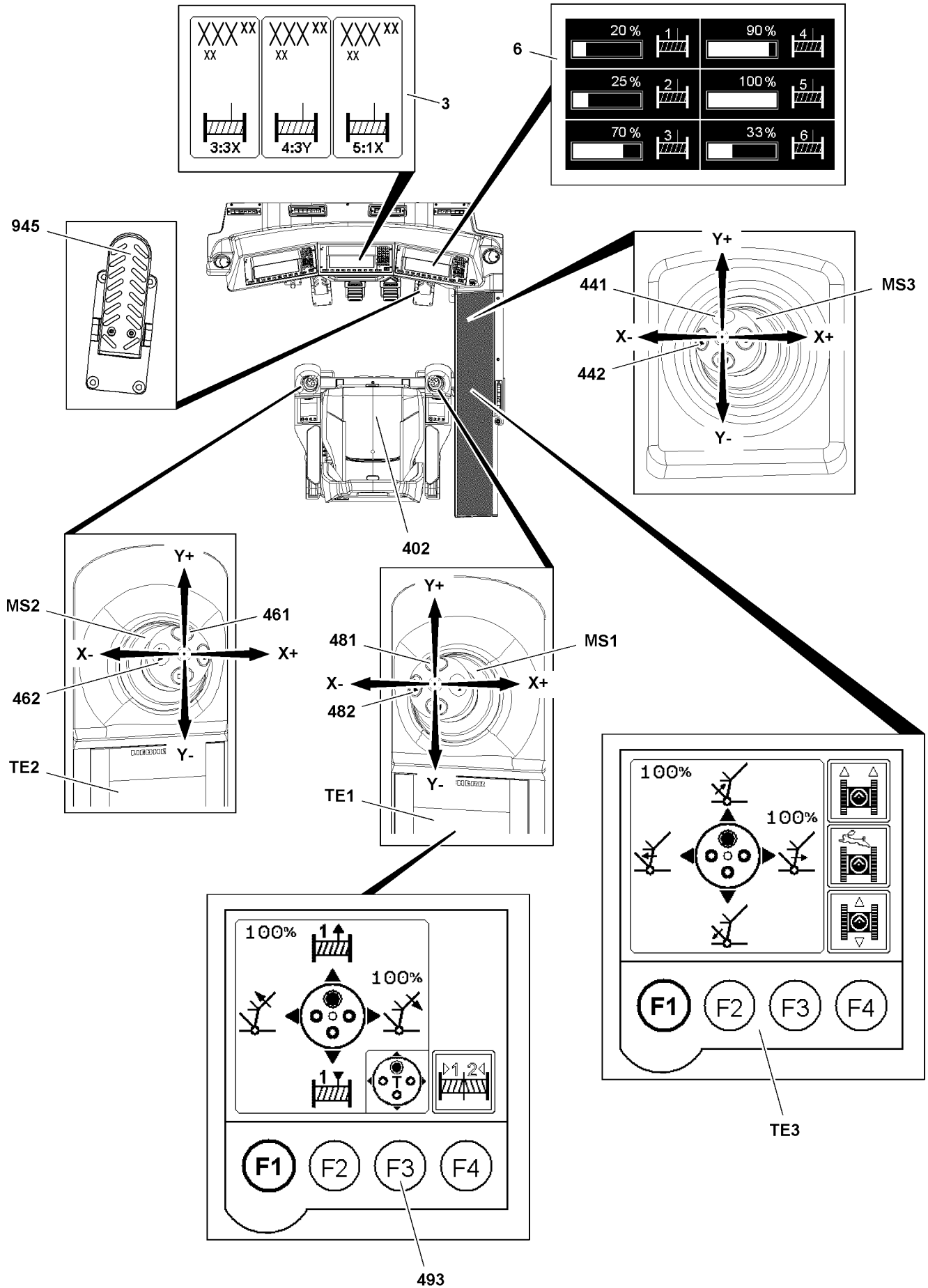

Fig.122231

LWE/LR 11000-001/23501-04-02/en

4 Luffing



WARNING

Luffing the boom up!

If the LICCON overload protection turns off while trying to lift the load with the winch, then a subsequent luffing movement can cause the crane to topple over or damage it.

Death, severe bodily injuries, property damage.

- ▶ Do **NOT** luff up the boom to lift a load off the ground.

The speed of crane movement „luffing“ is controlled by the deflection of the corresponding master switch and via the pedal **945** of the engine regulation.

The maximum winch speed can be reduced or increased in the „Speed reduction master switch“ menu, see Crane operating instructions, chapter 4.02.

Every winch can be blocked or released, see section „TE1 Menu block winch“, Crane operating instructions, chapter 4.01.



Note

- ▶ The seat contact button **402** in the crane operator's seat can be bypassed by the button **481** on the master switch **MS1** or the button **461** on the master switch **MS2** or the button **441** on the master switch **MS3**.
- ▶ For description of winch displays on the LICCON monitors, see Crane operating instructions, chapter 4.02.
- ▶ For description of the touch functions and the icons on the individual touch displays, see Crane operating instructions, chapter 4.01.



Note

- ▶ With the button **482**, the button **462** or the button **442** the speed of the crane movement „luffing up“ and „luffing down“ is increased, see section „Rapid gear Power Plus“.

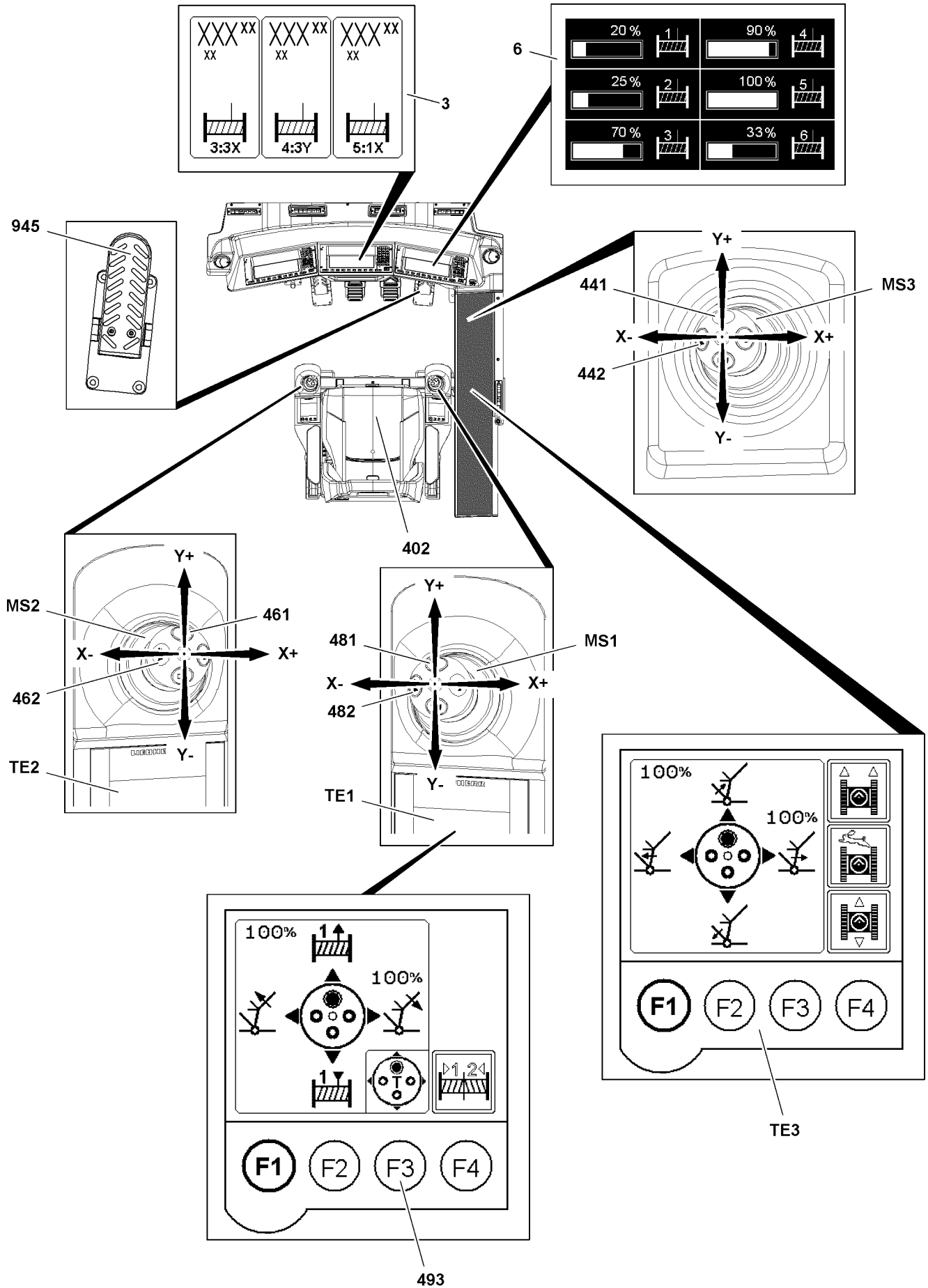

Fig.122231

LWE/LR 11000-001/23501-04-02/en

4.1 Luffing the main boom



Note

Change of master switch assignment!

The assignment of the master switches to the respective units on the crane can change, depending on the set up configuration and winch application.

- ▶ **Check the assignment before actuating the master switch on the TE.**
- ▶ The following sections describe the luffing movement in the master switch assignment „T“.

The maximum luffing speed of the main boom can be preselected in the setting window „Speed reduction master switch“ **6**, see Crane operating instructions, chapter 4.02.

Make sure that the following prerequisites are met:

- The master switch is in the zero position.
- The seat contact button **402** is activated or the button **481**, button **461** or button **441** is pressed.

4.1.1 Luffing the main boom up

This example shows how the main boom is luffed up, master switch **MS3** at master switch assignment „T“.

- ▶ Press the F3-key on the touch display **TE1** until the master switch assignment „T“ appears.
- ▶ Deflect the master switch **MS3** in direction X-.

Result:

- The main boom is luffed up.

4.1.2 Luffing the main boom down

This example shows how the main boom is luffed down, master switch **MS3** at master switch assignment „T“.

- ▶ Deflect the master switch **MS3** in direction X+.

Result:

- The main boom is luffed down.

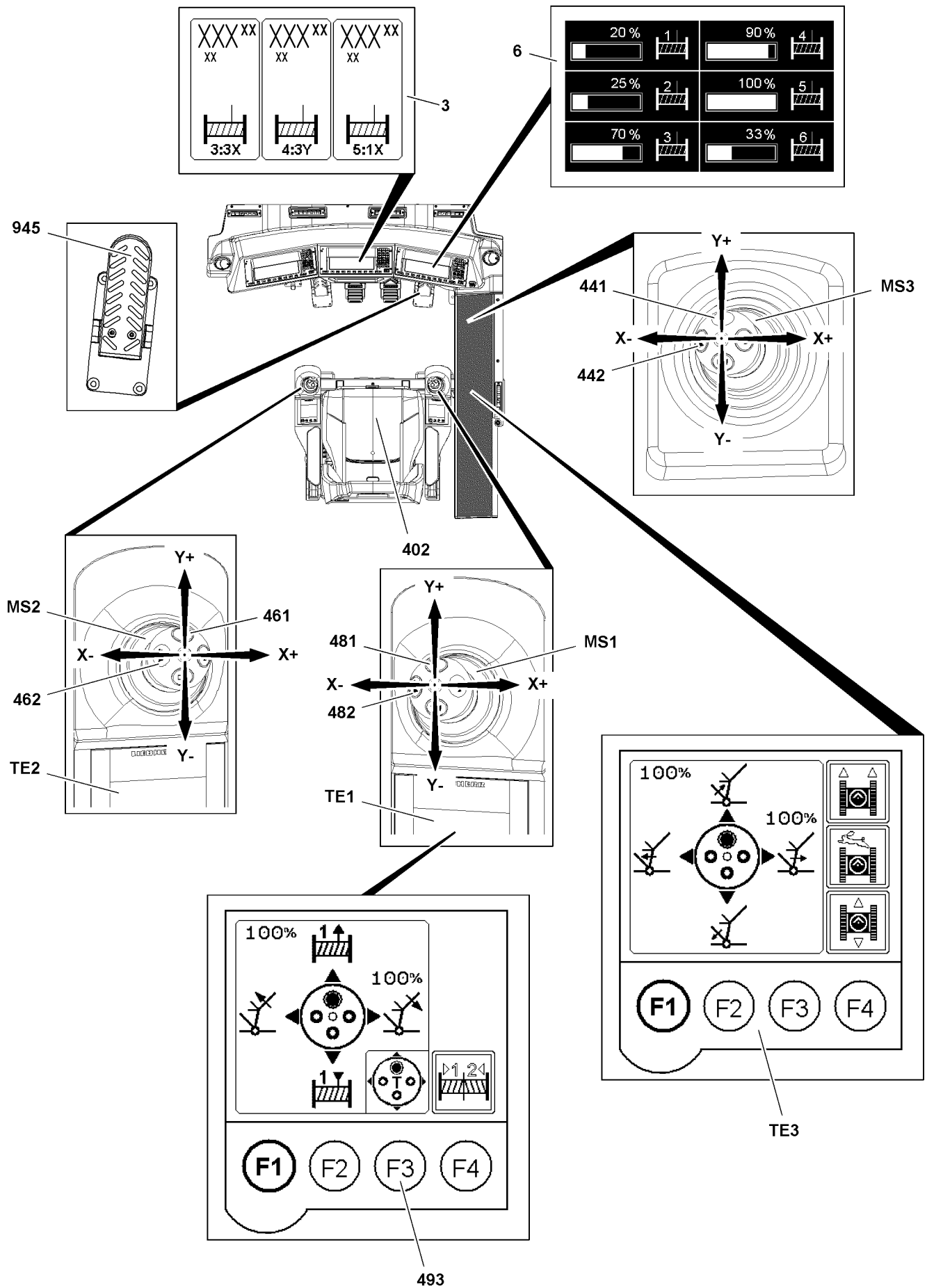

Fig.122231

LWE/LR 11000-001/23501-04-02/en

4.2 Luffing the derrick boom



Note

Change of master switch assignment!

The assignment of the master switches to the respective units on the crane can change, depending on the set up configuration and winch application.

- ▶ **Check the assignment before actuating the master switch on the TE.**
- ▶ The following sections describe the luffing movement in the master switch assignment „T“.

The maximum luffing speed of the derrick boom can be preselected in the setting window „Speed reduction master switch“ **6**, see Crane operating instructions, chapter 4.02.

Make sure that the following prerequisites are met:

- The master switch is in the zero position.
- The seat contact button **402** is activated or the button **481**, button **461** or button **441** is pressed.

4.2.1 Luffing the derrick boom up

This example shows how the derrick boom is luffed up, master switch **MS3** at master switch assignment „T“.

- ▶ Press the F3-key on the touch display **TE1** until the master switch assignment „T“ appears.
- ▶ Deflect the master switch **MS3** in direction Y+.

Result:

- The derrick boom is luffed up.

4.2.2 Luffing the derrick boom down

This example shows how the derrick boom is luffed down, master switch **MS3** at master switch assignment „T“.

- ▶ Deflect the master switch **MS3** in direction Y-.

Result:

- The derrick boom is luffed down.

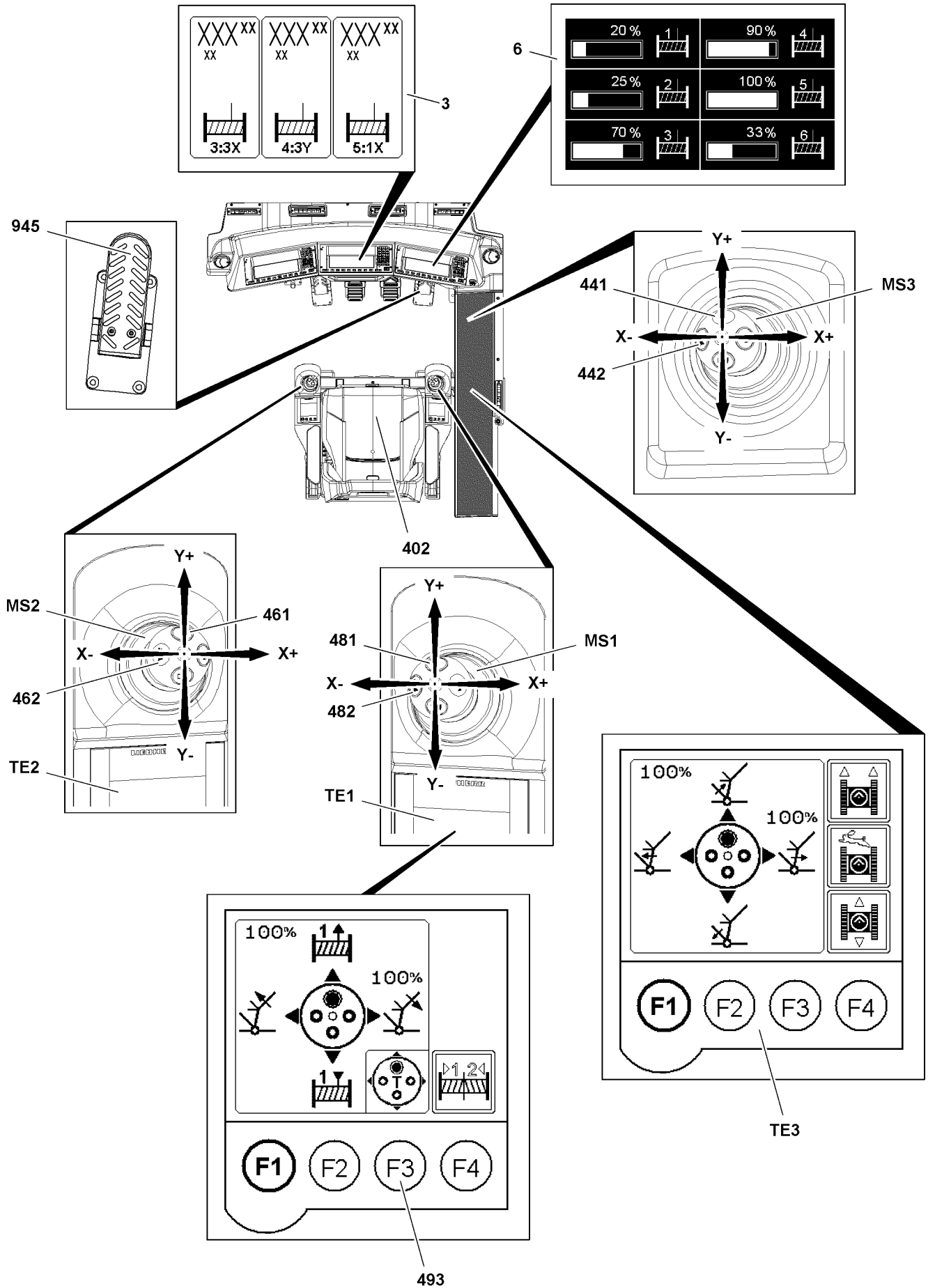

Fig.122231

LWE/LR 11000-001/23501-04-02/en

4.3 Luffing the luffing jib



Note

Change of master switch assignment!

The assignment of the master switches to the respective units on the crane can change, depending on the set up configuration and winch application.

▶ **Check the assignment before actuating the master switch on the TE.**

▶ The following sections describe the luffing movement in the master switch assignment „T“.

The maximum luffing speed of the luffing jib can be preselected in the setting window „Speed reduction master switch“ **6**, see Crane operating instructions, chapter 4.02.

Make sure that the following prerequisites are met:

- The master switch is in the zero position.
- The seat contact button **402** is activated or the button **481**, button **461** or button **441** is pressed.

4.3.1 Luffing the luffing jib up

This example shows how the luffing jib is luffed up, master switch **MS1** at master switch assignment „T“.

▶ Press the F3-key on the touch display **TE1** until the master switch assignment „T“ appears.

▶ Deflect the master switch **MS1** in direction X-.

Result:

- The luffing jib is luffed up.

4.3.2 Luffing the luffing jib down

This example shows how the luffing jib is luffed down, master switch **MS1** at master switch assignment „T“.

▶ Deflect the master switch **MS1** in direction X+.

Result:

- The luffing jib is luffed down.

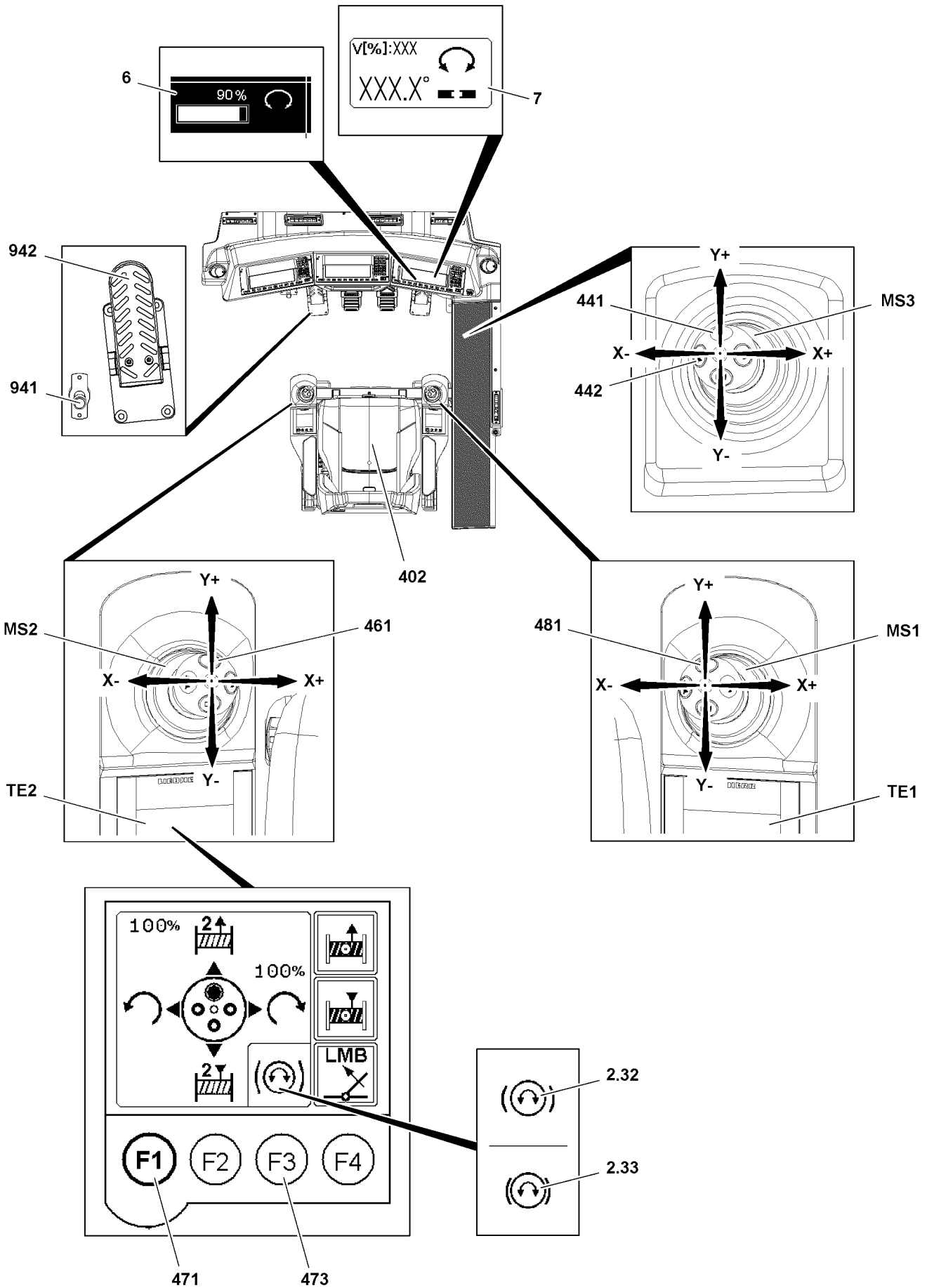

Fig.122232

LWE/LR 11000-001/23501-04-02/en

5 Turning

The slewing gear can be operated with the parking brake **released** or **applied**, see section „Parking brake slewing gear“.



WARNING

Uncontrolled turning of the crane superstructure!

As long as the „parking brake of the slewing gear“ is released, the slewing gear can turn in an uncontrolled manner due to wind, incline position or angular pull.

Death, severe bodily injuries, property damage.

- ▶ Close the „parking brake slewing gear“ by pressing the F3-key **473** on the touch display **TE2**.



Note

- ▶ Once the parking brake is released, it remains released, regardless of whether the slewing gear is actuated with the master switch **MS2** or if it is not actuated. This is to prevent a sudden stop.
- ▶ If the parking brake is applied, it is released as soon as the master switch **MS2** is deflected. The parking brake engages again as soon as the master switch **MS2** is moved to the zero position and the slewing gear is **NO** longer actuated.



Note

- ▶ The seat contact button **402** in the crane operator's seat can be bypassed by the button **481** on the master switch **MS1** or the button **461** on the master switch **MS2** or the button **441** on the master switch **MS3**.
- ▶ For description of winch displays on the LICCON monitors, see Crane operating instructions, chapter 4.02.
- ▶ For description of the touch functions and the icons on the individual touch displays, see Crane operating instructions, chapter 4.01.

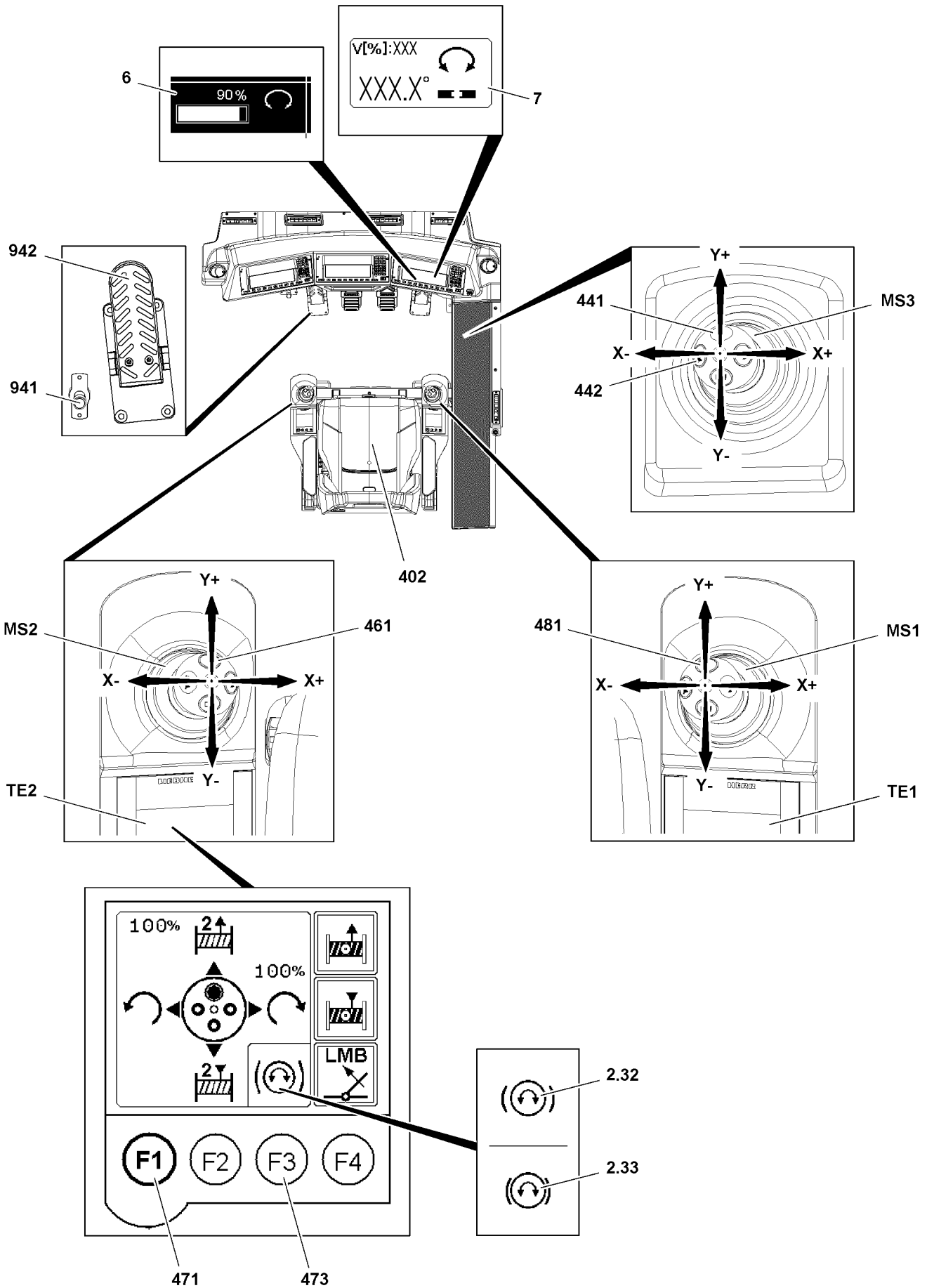

Fig.122232

LWE/LR 11000-001/23501-04-02/en

5.1 Opening and closing the parking brake slewing gear

The parking brake of the slewing gear can be „applied“ or „released“ with the F3-key **473** on the touch display **TE2**.

The status of the parking brake can be seen on the icon on the touch display **TE2**:

- Icon **2.32** shows that the parking brake is released.
- Icon **2.33** shows that the parking brake is applied.

The parking brake closes automatically if:

- The crane operator gets up from the crane operator's seat (seat contact button **402** no longer actuated).
- The Diesel engine is turned off.

The parking brake can **NOT** be released if:

- The working range limitation is active.
- A load chart with limited slewing range is selected.

5.1.1 Releasing the parking brake

Make sure that the following prerequisites are met:

- The parking brake is applied.
- The icon **2.33** appears on the touch display **TE2**.
- The seat contact button **402** or button **441** or button **461** or button **481** is actuated.
- The Diesel engine is running

▶ Press the F3 key **473**.

Result:

- The parking brake is released.
- Icon **2.32** appears on the touch display **TE2**.

5.1.2 Applying the parking brake

Make sure that the following prerequisites are met:

- The parking brake is released.
- The icon **2.32** appears on the touch display **TE2**.

▶ Press the F3 key **473**.

or

Turn the Diesel engine off.

or

Do not actuate the seat contact button **402** or button **441** or button **461** or button **481** any longer.

Result:

- The parking brake is applied.
- Icon **2.33** appears on the touch display **TE2**.

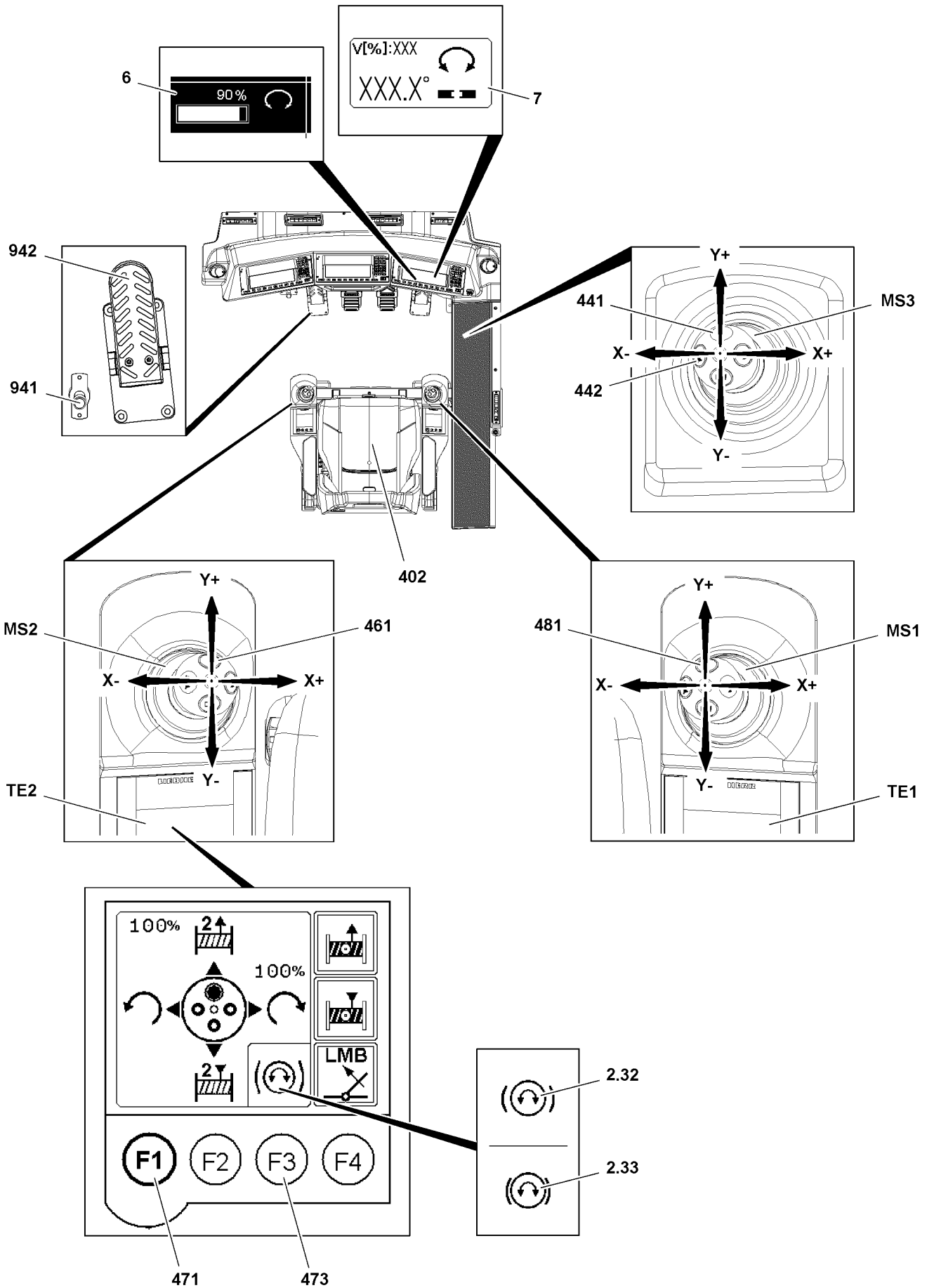

Fig.122232

LWE/LR 11000-001/23501-04-02/en

5.2 Actuating the slewing gear brake with the pedal



CAUTION

Risk of damaging the slewing gear or the roller ring connection!

The slewing gear brake cannot brake the full turning momentum. Failure to comply with the following instructions could damage the slewing gear or roller ring connection.

- ▶ Use the pedal **942** only at minimum rotation speeds, in other words with master switch **MS2** almost at the zero position.
- ▶ Do **NOT** abruptly brake the turning movement of the crane by moving the master switch **MS2** back to the zero position and by simultaneously applying the pedal **942**.

Use the pedal **942** to actuate the slewing gear brake only in the following cases:

- Starting out with a strong side wind
- Stopping the slewing movement with a strong side wind

5.2.1 Starting out with a strong side wind

When turning against the wind with a strong side wind and with a long boom system, the superstructure will turn to the opposite direction due to leaks in the hydraulic motor.

This can be avoided as follows:

- ▶ Actuate the pedal **942** and deflect the master switch **MS2** into the desired turning direction.
- ▶ Slowly release the pedal **942** until the superstructure turns in the desired turning direction.

5.2.2 Stopping the slewing movement with a strong side wind

- ▶ Slow down the crane with master switch **MS2** to minimum slewing speed.
- ▶ Apply the pedal **942** carefully, until the crane has come to a standstill at the desired position.

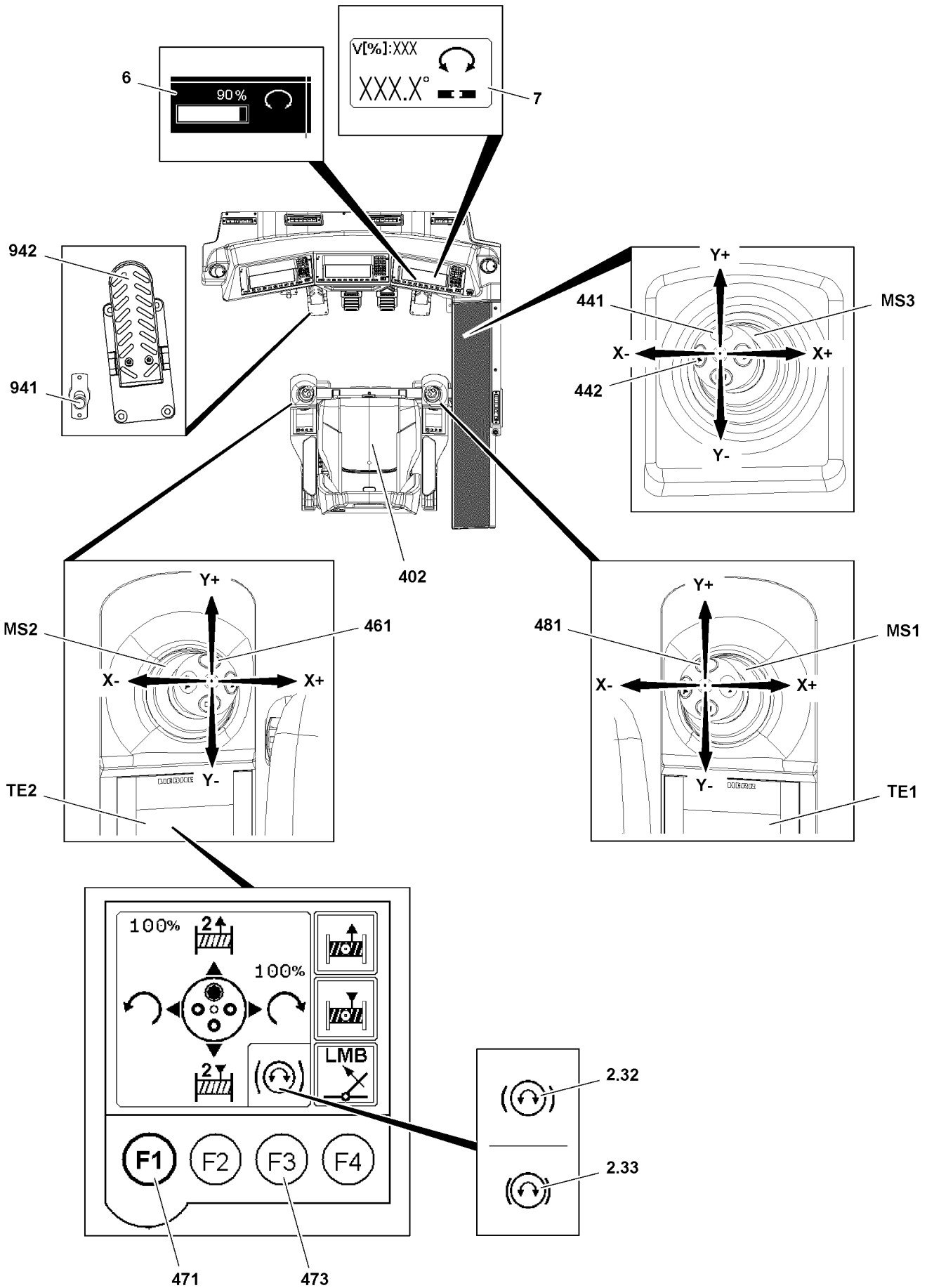

Fig.122232

LWE/LR 11000-001/23501-04-02/en

5.3 Switching the slewing gear to freewheeling

In order to position the boom over the load more easily, the slewing gear can be switched to freewheeling.

Make sure that the following prerequisites are met:

- The seat contact button **402** or button **441** or button **461** or button **481** is actuated.
- The Diesel engine is running
- The master switch **MS2** is **NOT** deflected.



Note

The activation of the freewheel and actuation of the slewing movement via the master switch **MS2** are mutually exclusive.

- ▶ When the master switch **MS2** is deflected, the slewing gear cannot be switched to freewheeling via the foot button **941**.
- ▶ When pressing the foot button **941**, the slewing movement can **NOT** be carried out by deflecting the master switch **MS2**.

The slewing gear can **NOT** be switched to freewheel / coasting if:

- A load chart with limited slewing range is selected.
 - The working range limitation is active.
- ▶ Press the foot button **941**.

Result:

- The slewing gear is switched to freewheeling.

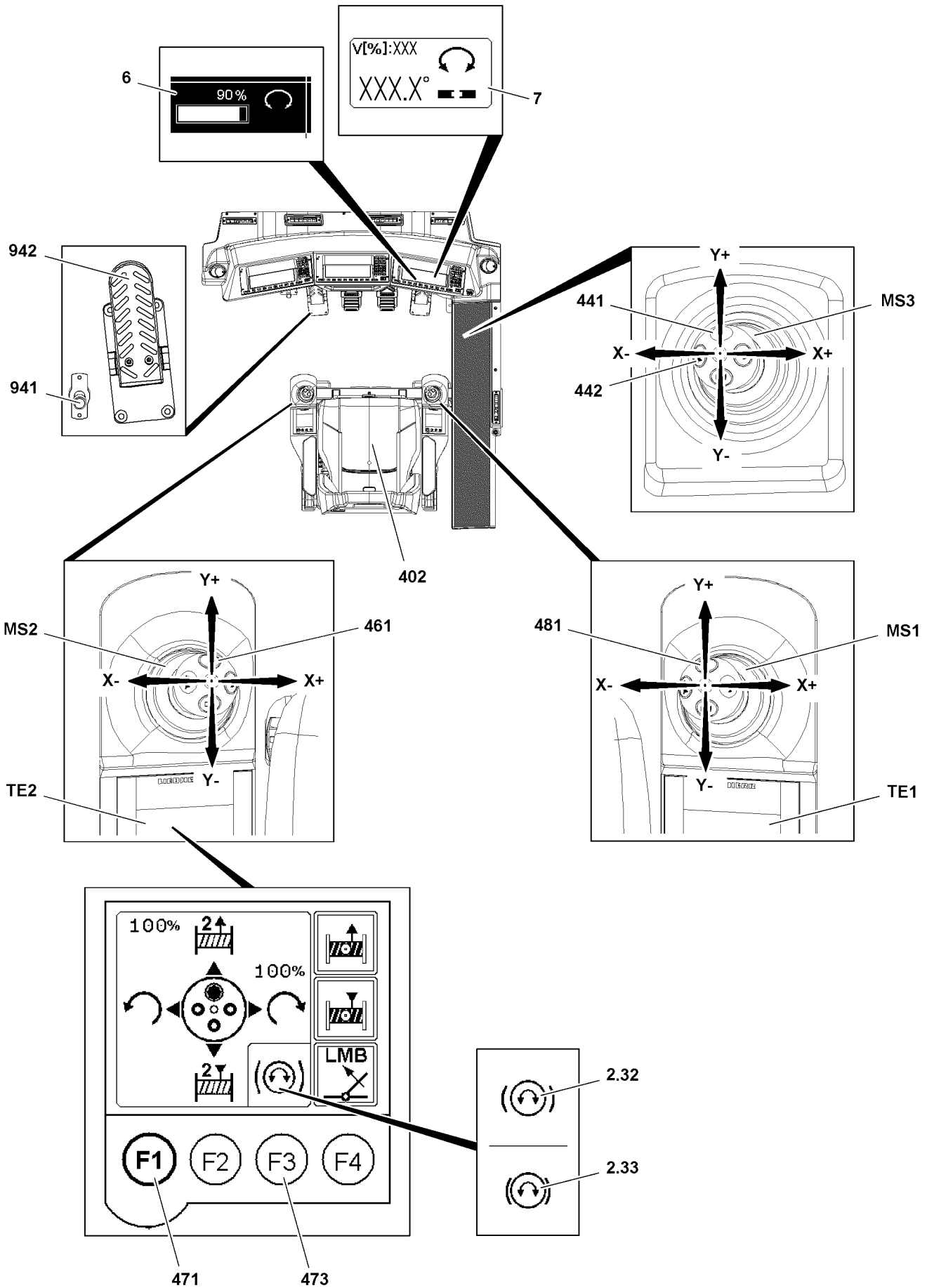

Fig.122232

LWE/LR 11000-001/23501-04-02/en

5.4 Turning the crane superstructure

5.4.1 Preselection of slewing speed



WARNING

Slewing speed too high for actual operating conditions!

Toppling crane, failure of crane structure.

Death, severe bodily injuries, property damage.

- ▶ Adhere to the permissible slewing speed in the load charts.
- ▶ When selecting the slewing speed, take the actual operating conditions also into account.
- ▶ Select the slewing speed depending on the actual operating conditions.

The load chart manual lists the maximum slewing speeds in percentages for **ideal conditions**.

The maximum permissible slewing speeds can be set on the LICCON computer system in the „Speed reduction master switch“ setting window **6**, see the Crane operating instructions, chapter 4.02.

Basic rule: With a longer boom and a larger load, you have to turn with a slower speed.

5.4.2 Turning the crane superstructure



WARNING

Persons or obstacles within the danger zone!

Death, severe bodily injuries, property damage.

- ▶ It is prohibited for personnel to remain in the danger zone.
- ▶ Make sure that there are no obstacles within the working area of the crane.
- ▶ Give a short warning signal (horn) before starting a crane movement.
- ▶ When turning with a load: Initiate and slow down a turning movement extremely sensitively.



WARNING

Oscillating loads!

If the slewing speed is exceeded, there is the danger that the loads start to swing. The crane can be damaged or topple over.

Death, severe bodily injuries, property damage.

- ▶ Turning with a load: Initiate and slow down a turning movement extremely sensitively.
- ▶ Longer boom and larger load: Operate the crane with lower slewing speed.
- ▶ Observe and adhere to the values in the load chart manual.

The maximum rotational speed is shown in the slewing range **7** on the LICCON monitor, see Crane operating instructions, chapter 4.02.

Make sure that the following prerequisite is met:

- The maximum permissible slewing speed is set on the LICCON computer system in the „Speed reduction master switch“ setting window **6**, see the Crane operating instructions, chapter 4.02.
- The seat contact button **402** is activated or the button **481**, button **461** or button **441** is pressed.

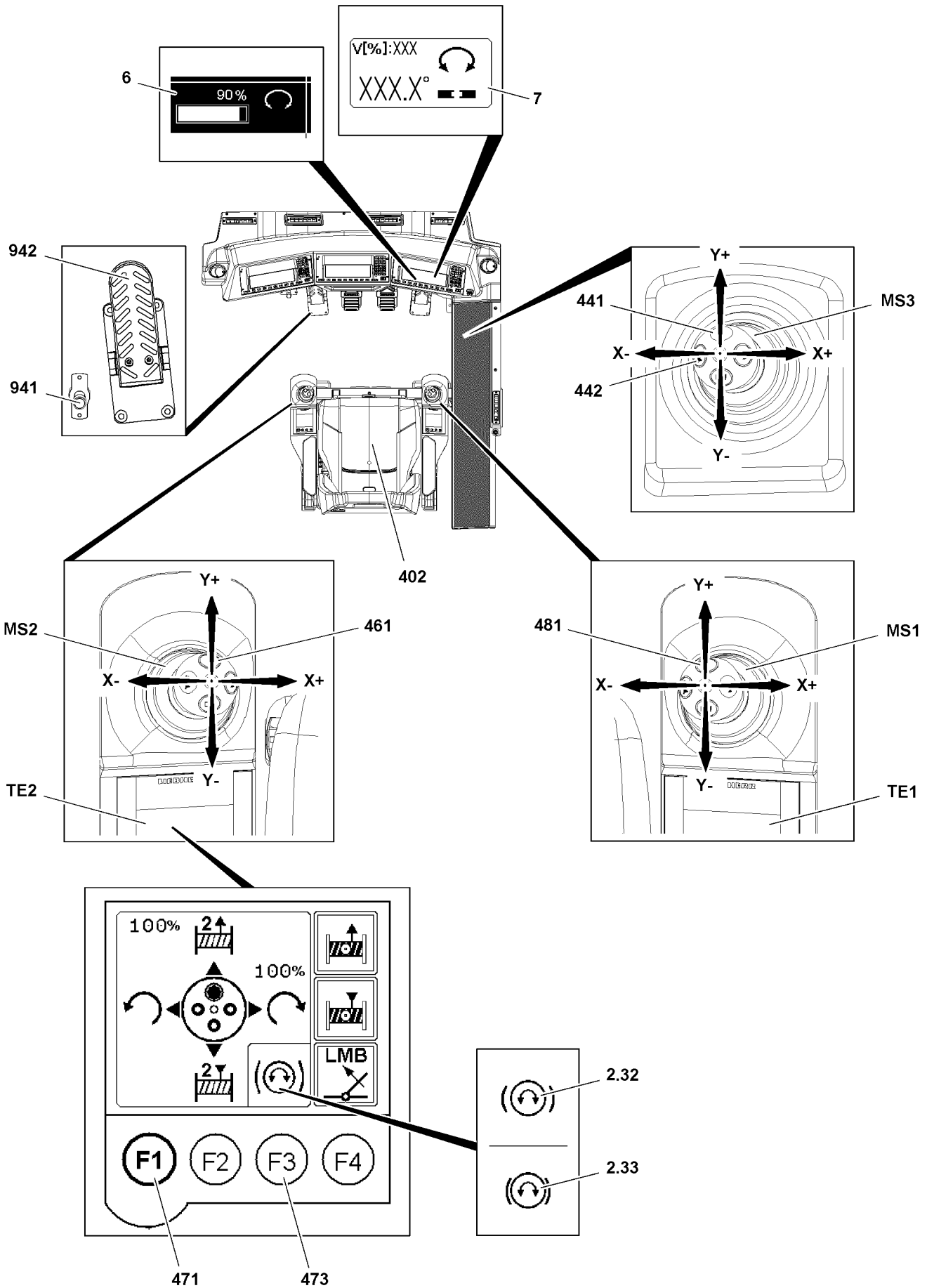

Fig.122232

LWE/LR 11000-001/23501-04-02/en

Turning crane superstructure to the right

- ▶ Press the F1-key **471** on the touch display **TE2** until the TE2 menu the „master switch assignment“ appears.
- ▶ Deflect the master switch **MS2** in direction X+.

Result:

- The crane superstructure turns to the right.

Turning the crane superstructure to the left

- ▶ Press the F1-key **471** on the touch display **TE2** until the TE1 menu the „master switch assignment“ appears.
- ▶ Deflect the master switch **MS2** in direction X-.

Result:

- The crane superstructure turns to the left.

Empty page!

4.06 Rope reeving

1	Wire ropes and rope end connections	3
2	Reeving in the hoist rope	5
3	Reeving the hook block in and out	8
4	Reeving in / reeving out the hook block, L-shaped rope end connection (LR 11000 only)	11
5	Attaching and removing the load hook*	16
6	Attaching / removing the hoist limit switch weight	19
7	Assembling / disassembling the wedge lock	21
8	Rope reeving	22

Fig.195219

LWE/LR 11000-001/23501-04-02/en

1 Wire ropes and rope end connections

1.1 Wire ropes

Check if a **rotating resistant** or a **non-rotating** rope is required for the application. The selected type of rope then requires the corresponding rope end connections, see Crane operating instructions, chapter 8.04.



Note

- ▶ Correct choice and use of the wire rope and the rope end connections are a decisive precondition for proper and accident-free crane operation.



DANGER

Incorrect rope type!

Danger of severe injuries to personnel and property damage.

- ▶ **Never** use rotation-resistant ropes with a rotating rope end connection.
- ▶ **Never** install a twist compensator / swivel.

1.2 Rope end connections

Rope end connections are grouped into:

- Rope end connections with locking clamp or locking cast sleeve
- The L-shaped rope end connection with locking clamp or locking cast sleeve (LR 11000 only)
- Rope end connection **without** locking clamp or locking cast sleeve



Note

- ▶ The locking clamp **8** is pressed on the rope.
- ▶ The locking cast sleeve **8** is cast with the rope.

1.2.1 Rope end connections with locking clamp or locking cast sleeve

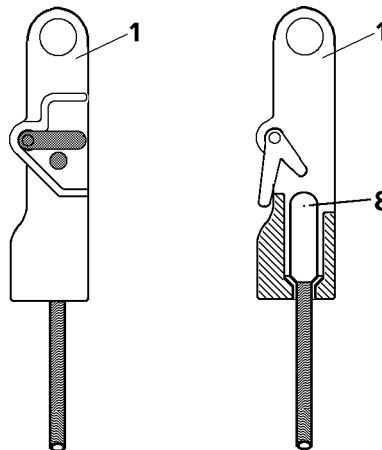

Fig.144019: Rope end connections with locking clamp **8** or locking cast sleeve **8**

- Rope end connections **with** locking clamp **8** or locking cast sleeve **8**.
A rope end connection **1** or an L-shaped rope end connection **24** should be used for this.

1.2.2 The L-shaped rope end connection with locking clamp or locking cast sleeve (LR 11000 only)



WARNING

Load can be ripped off!

Death, severe bodily injuries, property damage.

- ▶ The L-shaped rope end connection **24** is only permitted for use on LR 11000.
- ▶ It is prohibited to use the L-shaped rope end connection **24** on other crane types.
- ▶ Make sure that the L-shaped rope end connection is only used for **reeving with an even number of strands**.

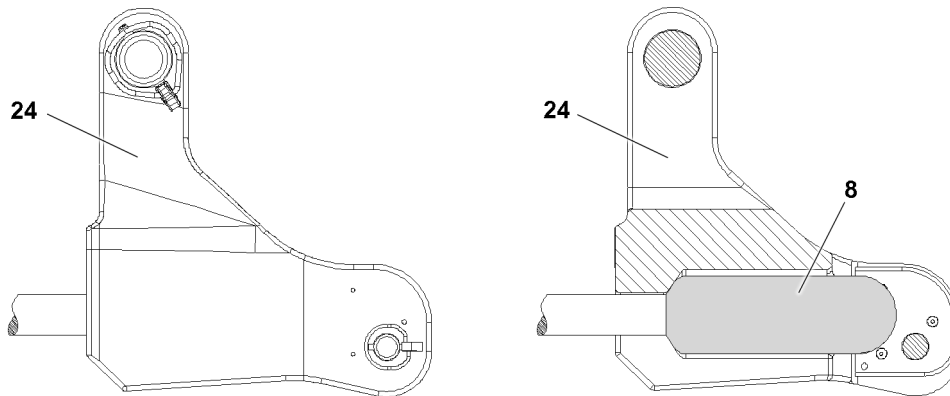

Fig.144020: L-shaped rope end connection **24** with locking clamp **8** or locking cast sleeve **8**

- Rope end connections **with** locking clamp **8** or locking cast sleeve **8**.
An L-shaped rope end connection **24** or a rope end connection **1** should be used for this.

1.2.3 Rope end connection without locking clamp or locking cast sleeve

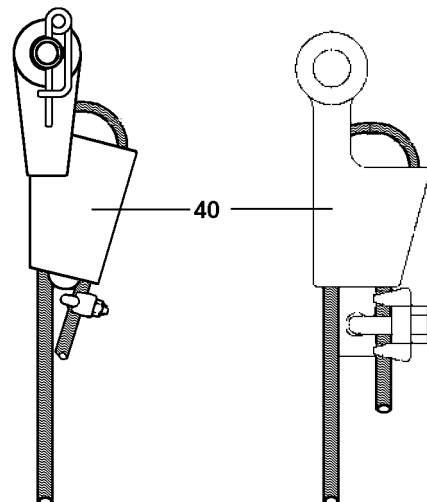

Fig.144021: Rope end connection without locking clamp or locking cast sleeve

- Rope end connections **without** locking clamp **8** or locking cast sleeve **8**.
For that, use a wedge lock **40**.

2 Reeving in the hoist rope



WARNING

Slipping at assembly work!

Danger of falling.

Death, severe injury, property damage.

- ▶ The boom system may only be accessed if the assembly personnel is protected with suitable safety measures to prevent them from falling.
- ▶ If retaining ropes are present on the boom system, then the assembly personnel must hang an approved fall arrest system to the retaining ropes of the boom system on the left and right with both snap hooks and secure themselves to prevent them from falling.
- ▶ Without appropriate safety measures it is **strictly** prohibited to step on the boom system.
- ▶ If railings are present for the crane, then they must be brought into the corresponding position and secured for assembly / disassembly.
- ▶ Carry out all assembly work from a safe location.
- ▶ Observe the assembly guidelines in the Crane operating instructions, chapter 5.01.

Make sure that the following prerequisites are met:

- The ground is level and of sufficient load carrying capacity.
- **Only for cranes with crane support:** The crane is properly supported.
- The crane is horizontally aligned.
- The crane is ballasted according to the load chart.
- The LICCON overload protection has been set according to the load chart.
- The slewing gear brake is applied.
- The boom end section is just above the ground.

2.1 Reeving in the hoist rope with the assembly winch

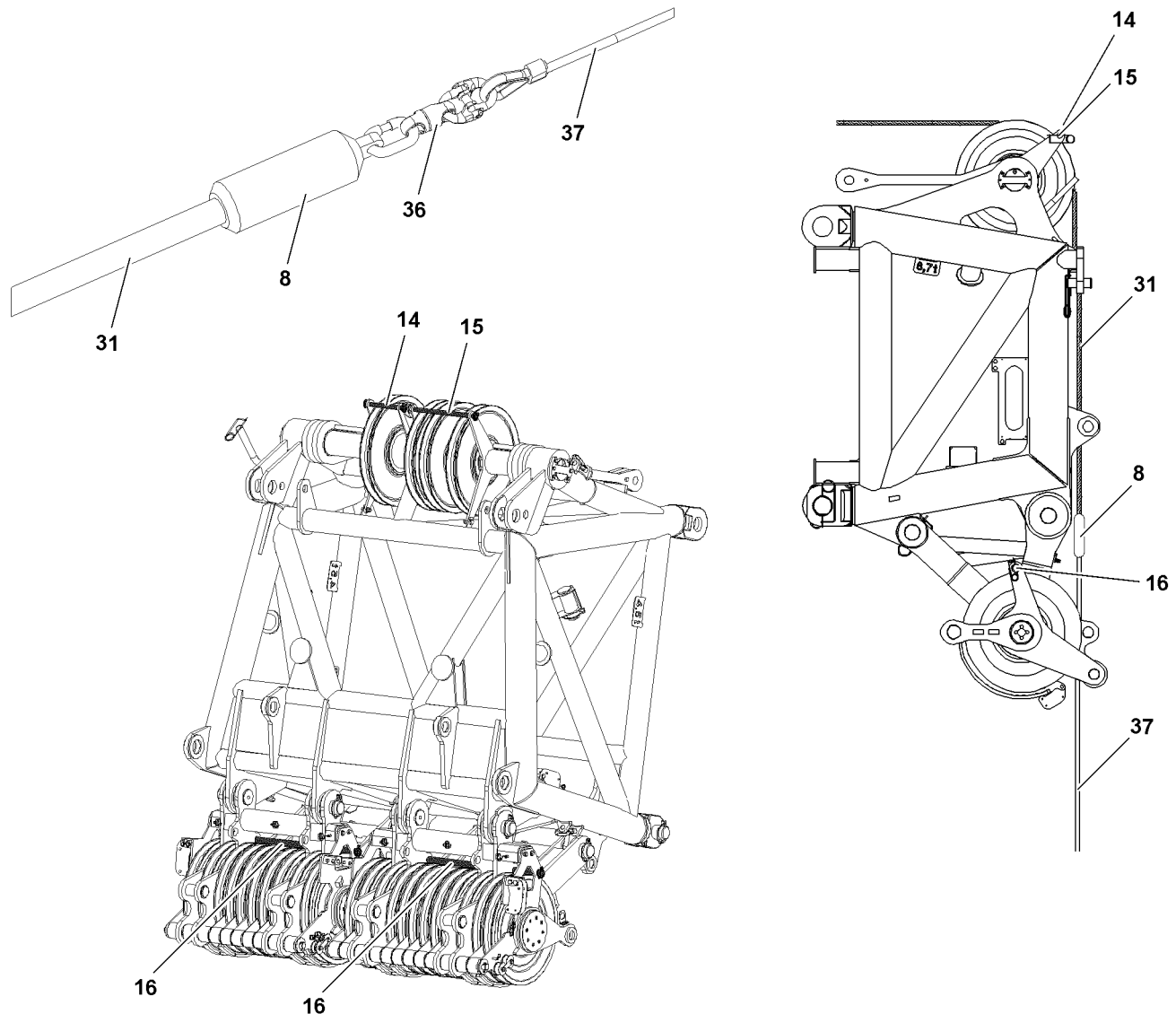

Fig.121853: Reeving in with assembly winch

- ▶ Wear approved fall arrest system and protective equipment, see Crane operating instructions, chapter 2.04.
- ▶ Bring the fall protection equipment on the crane superstructure and on the lattice boom in operating position and secure, see Crane operating instructions, chapter 2.06.
- ▶ Properly hang the fall arrest system on the intended safety ropes and / or fastening points.
- ▶ Switch the assembly winch to freewheeling.
- ▶ Remove the rope retaining pin **14**, rope retaining pin **15** and rope retaining pin **16**.
- ▶ Connect the auxiliary rope **37** with the auxiliary reeving rope (hemp rope).
- ▶ Reeve in the auxiliary rope **37** in the reverse direction between the hook block and the pulley head.
- ▶ Bring the auxiliary rope **37** with the auxiliary reeving rope (hemp rope) upward over the back pulley, which is to be reeved according to the reeving plan.
- ▶ Pull the auxiliary rope **37** to the rear to the hoist winch.
- ▶ Release the auxiliary reeving rope (hemp rope) from the auxiliary rope **37**.

When the auxiliary rope is on the hoist winch:

- ▶ Connect the auxiliary rope **37** with the hoist rope **31**: Open the connecting link **36**, connect it with the eyehook of the lock clamp **8** and close the connecting link **36**.
- ▶ Turn the freewheeling off on the assembly winch.

NOTICE

Hoist rope tension too low!

Slack rope formation.

- ▶ Permit no slack rope on the hoist winch and the assembly winch.

-
- ▶ Reeve in the hoist rope **31**: Spool the hoist rope **31** from the hoist winch and simultaneously spool up the auxiliary rope **37** on the assembly winch.

When the hoist rope **31** is reeved:

- ▶ Release the auxiliary rope **37** from the hoist rope **31**.
- ▶ Spool the auxiliary rope on the assembly winch.
- ▶ Pin and secure the rope retaining pin **14**, rope retaining pin **15** and rope retaining pin **16**.
- ▶ Hang the hoist rope properly in on the rope lock, see section „Hanging the hoist rope in on the rope lock“.

When the hoist rope is properly hung in on the rope lock:

- ▶ Attach the hoist limit switch weight, see section „Attaching the hoist limit switch weight“.

**Note**

Parallel operation of winch 1 and winch 2!

- ▶ Repeat the above described reeving procedure with the second hoist rope.
 - ▶ Observe the reeving plan.
-

3 Reeving the hook block in and out

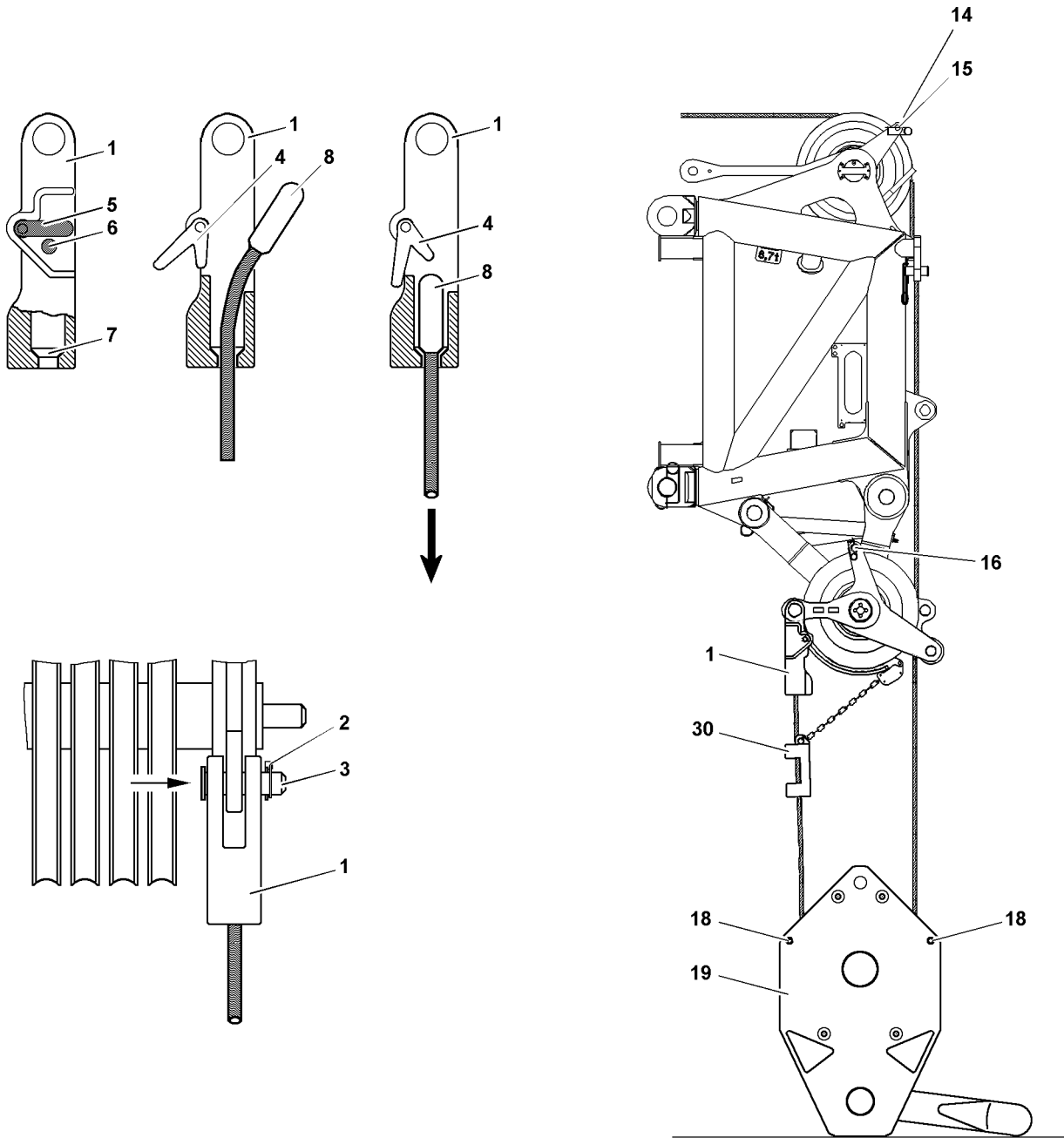

Fig.144024: Details Reeving Hook block

LWE/LR 11000-001/23501-04-02/en

3.1 Reeving in the hook block



WARNING

Toppling of hook block!

If the retaining pins are **not** pinned in the roller block / the pulley blocks of the hook block before placing the hook block down, then the pulley blocks / the hook block can topple over when unreeving the hoist rope.

Death, severe injury, property damage.

- ▶ Pin the retaining pins, see Crane operating instructions, chapter 5.19 or separate operating instructions.

3.1.1 Preparing the hook block

Make sure that the following prerequisites are met:

- The crane is horizontally aligned.
- The slewing gear brake is applied.
- The hook block is set down on the ground properly.
- The boom is luffed down to the point where the pulley head is above the hook block.
- An assistant is present to guide the hoist rope.



WARNING

Danger of accident due to side wind!

If the slewing gear brake is released after reeving in / reeving out the hook block / the load hook, then the crane can turn uncontrolled in strong side wind.

Death, severe injury, property damage.

The crane can collide with close-by structures or objects.

- ▶ Make sure that the current wind speed does not exceed the values from the wind speed chart when releasing the slewing gear brake.

NOTICE

Hook block incorrectly reeved!

Damage to the hoist rope.

- ▶ Carry out the reeving of the hoist rope according to the reeving plan.
- ▶ Select the rope fixed point on the hook block in such a way that the last strand runs parallel to the remaining rope strands, as much as possible.
- ▶ Set the required hook block under the boom head.
- ▶ At the hook block **19**, remove the spring retainers **18** for both rope retaining pins and pull them both out.



WARNING

Slipping at assembly work!

Danger of falling.

Death, severe injury, property damage.

- ▶ The boom system may only be accessed if the assembly personnel is protected with suitable safety measures to prevent them from falling.
- ▶ If retaining ropes are present on the boom system, then the assembly personnel must hang an approved fall arrest system to the retaining ropes of the boom system on the left and right with both snap hooks and secure themselves to prevent them from falling.
- ▶ Without appropriate safety measures it is **strictly** prohibited to step on the boom system.
- ▶ If railings are present for the crane, then they must be brought into the corresponding position and secured for assembly / disassembly.
- ▶ Carry out all assembly work from a safe location.
- ▶ Observe the assembly guidelines in the Crane operating instructions, chapter 5.01.

- ▶ Reeve the hook block.
- ▶ Insert the rope retaining pins again and secure with spring retainers.

3.1.2 Hooking the hoist rope on the rope lock

NOTICE

Hoist rope is incorrectly installed!
Damage to the hoist rope.

- ▶ Always insert the pins **3** from „inside to outside“ and secure from the outside.
- ▶ The rope lock **1** must be pinned in either at the pulley head or on the hook block and secured with locking pins **2**, depending on reeving.
- ▶ On the rope lock **1**, push the safety pin **6** in.
- ▶ Swing the lever **5** „down“ and hold it in this position.

Result:

- The latch **4** is swung „downward“.
- ▶ Attach the rope end with the locking clamp **8** in the rope lock **1** and pull „down“ firmly (in direction of arrow), until the locking clamp **8** is touching in the cone **7**.



WARNING

Locking clamp is incorrectly installed!
Danger of accident.
Death, severe injuries, property damage.

- ▶ The locking clamp **8** must touch on the cone **7** after hanging it into the rope lock **1** and must be secured by the latch **4**.

- ▶ Release the lever **5**.

Result:

- The lever **5** returns to the initial position and is locked by the safety pin **6**.
- ▶ Check the rope retainer. Visual check.

3.2 Unreeving the hook block



WARNING

Toppling of hook block!
If the retaining pins are **not** pinned in the roller block / the pulley blocks of the hook block before placing the hook block down, then the pulley blocks / the hook block can topple over when unreeving the hoist rope.

Death, severe injury, property damage.

- ▶ Pin the retaining pins, see Crane operating instructions, chapter 5.19 or separate operating instructions.

Make sure that the following prerequisites are met:

- The ground is level and of sufficient load carrying capacity.
- **Only for cranes with crane support:** The crane is properly supported.
- The crane is horizontally aligned.
- The crane is ballasted according to the load chart.
- The LICCON overload protection has been set according to the load chart.
- The slewing gear brake is applied.
- The boom end section is just above the ground.



WARNING

Danger of accident due to side wind!

If the slewing gear brake is released after reeving in / reeving out the hook block / the load hook, then the crane can turn uncontrolled in strong side wind.

Personnel can be severely injured or killed.

The crane can collide with close-by structures or objects.

- ▶ Make sure that the current wind speed does not exceed the values from the wind speed chart when releasing the slewing gear brake.

3.2.1 Lowering the hook block



WARNING

Crushing of hands!

When unreeving the hook block, it can topple over.

Death, severe injury, property damage.

- ▶ Use the handles in the safe area of the hook block.
- ▶ Make sure the hook block is safely positioned.

- ▶ Lower the hook block and set it on the ground.
- ▶ Remove the hoist limit switch weight.

3.2.2 Detaching the hoist rope

- ▶ On the rope lock **1**, push the safety pin **6** in.
- ▶ Swing the lever **5** „down“ and hold it in this position.

Result:

- The latch **4** is swung downward.
- The locking clamp **8** is released.
- ▶ Push the hoist rope up and detach the locking clamp **8**.
- ▶ Release and unpin the rope retaining pin on the hook block.
- ▶ Unreeve the hoist rope from the hook block and the pulley head.
- ▶ Insert the rope retaining pins again and secure with spring retainers.

4 Reeving in / reeving out the hook block, L-shaped rope end connection (LR 11000 only)



WARNING

Load can be ripped off!

Death, severe bodily injuries, property damage.

- ▶ The L-shaped rope end connection **24** is only permitted for use on LR 11000.
- ▶ It is prohibited to use the L-shaped rope end connection **24** on other crane types.
- ▶ Make sure that the L-shaped rope end connection is only used for **reeving with a even number of strands**.

Depending on the number of rope strands, with the even reeving of the hook block, the L-shaped rope end connection must be installed on one of the pin points (pin point **P1** to pin point **P4**) on the roller set / roller sets.

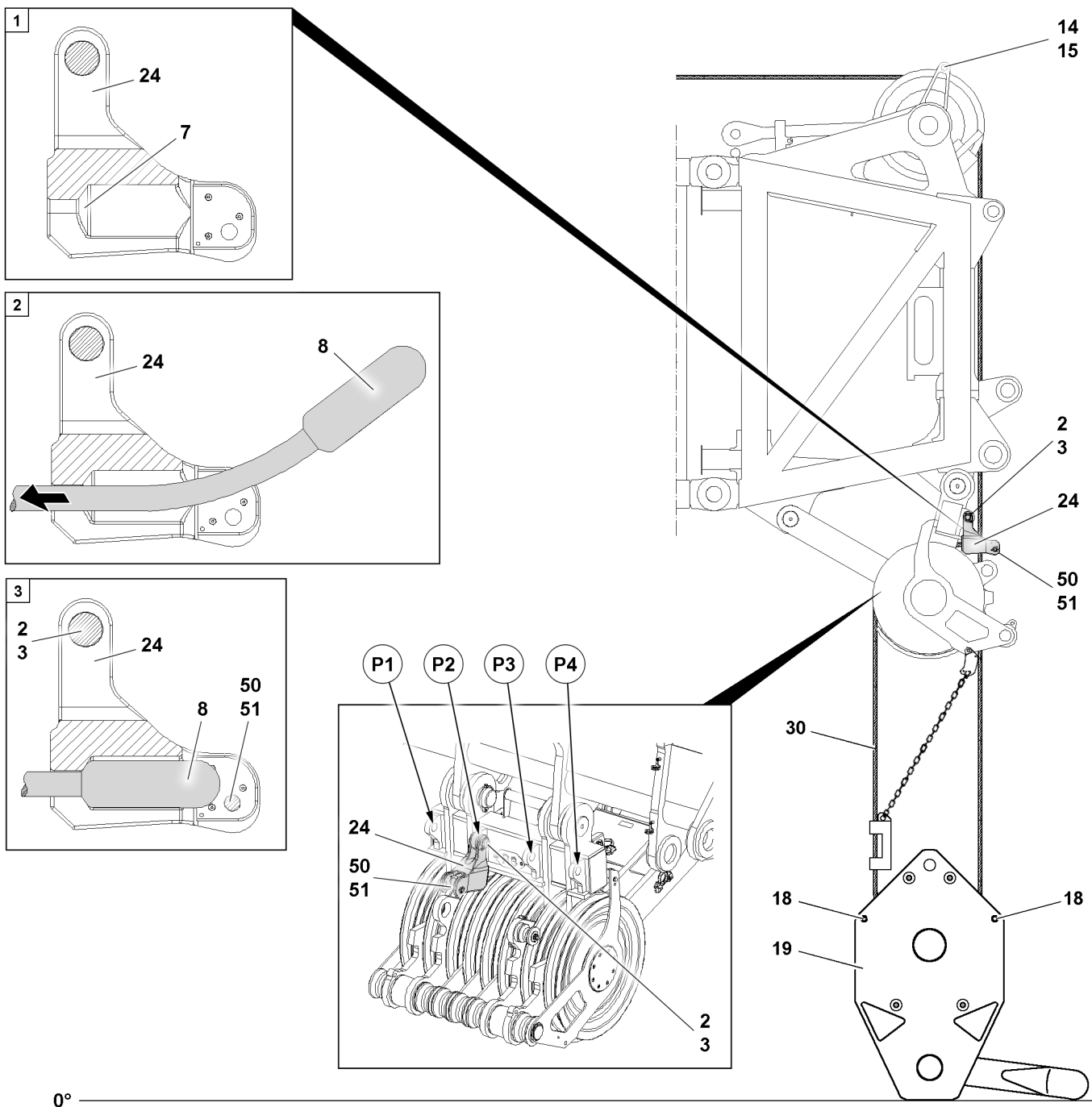

0°

Fig.144022: Details reeving hook block, L-shaped rope end connection 24

LWE/LR 11000-001/23501-04-02/en

4.1 Reeving in the hook block



WARNING

Toppling of hook block!

If the retaining pins are **not** pinned in the roller block / the pulley blocks of the hook block before placing the hook block down, then the pulley blocks / the hook block can topple over when unreeving the hoist rope.

Death, severe injury, property damage.

- ▶ Pin the retaining pins, see Crane operating instructions, chapter 5.19 or separate operating instructions.

4.1.1 Preparing the hook block

Make sure that the following prerequisites are met:

- The crane is horizontally aligned.
- The slewing gear brake is applied.
- The hook block is set down on the ground properly.
- The boom is luffed down to the point where the pulley head is above the hook block.
- An assistant is present to guide the hoist rope.



WARNING

Danger of accident due to side wind!

If the slewing gear brake is released after reeving in / reeving out the hook block / the load hook, then the crane can turn uncontrolled in strong side wind.

Death, severe injury, property damage.

The crane can collide with close-by structures or objects.

- ▶ Make sure that the current wind speed does not exceed the values from the wind speed chart when releasing the slewing gear brake.

NOTICE

Hook block incorrectly reeved!

Damage to the hoist rope.

- ▶ Carry out the reeving of the hoist rope according to the reeving plan.
- ▶ Select the rope fixed point on the hook block in such a way that the last strand runs parallel to the remaining rope strands, as much as possible.
- ▶ Set the required hook block under the boom head.
- ▶ At the hook block **19**, remove the spring retainers **18** for both rope retaining pins and pull them both out.



WARNING

Slipping at assembly work!

Danger of falling.

Death, severe injury, property damage.

- ▶ The boom system may only be accessed if the assembly personnel is protected with suitable safety measures to prevent them from falling.
- ▶ If retaining ropes are present on the boom system, then the assembly personnel must hang an approved fall arrest system to the retaining ropes of the boom system on the left and right with both snap hooks and secure themselves to prevent them from falling.
- ▶ Without appropriate safety measures it is **strictly** prohibited to step on the boom system.
- ▶ If railings are present for the crane, then they must be brought into the corresponding position and secured for assembly / disassembly.
- ▶ Carry out all assembly work from a safe location.
- ▶ Observe the assembly guidelines in the Crane operating instructions, chapter 5.01.

- ▶ Reeve the hook block.
- ▶ Insert the rope retaining pins again and secure with spring retainers.

4.1.2 Fitting the hoist rope on the rope lock, L-shaped rope end connection

NOTICE

Hoist rope is incorrectly installed!
Damage to the hoist rope.

- ▶ Always insert the pins **50** from „inside to outside“ and secure from the outside.
- ▶ Only pin the rope lock **24** on the roller set / roller sets and secure with a locking pin **2**.
- ▶ On the rope lock **24**, release and unpin the retaining pin **50**.
- ▶ Fit the rope end with the locking clamp **8** in the rope lock **24** and pull the rope firmly in the direction of the arrow, until the locking clamp **8** contacts the cone **7**.



WARNING

Locking clamp is incorrectly installed!
Danger of accident.
Death, severe injuries, property damage.

- ▶ The locking clamp **8** must touch on the cone **7** after fitting it into the rope lock **24** and must be secured by the retaining pin **50**.
- ▶ Insert the retaining pin **50** and secure properly with the retaining element **51**.
- ▶ Check the rope retainer. Visual check.

4.2 Unreeving the hook block



WARNING

Toppling of hook block!

If the retaining pins are **not** pinned in the roller block / the pulley blocks of the hook block before placing the hook block down, then the pulley blocks / the hook block can topple over when unreeving the hoist rope.

Death, severe injury, property damage.

- ▶ Pin the retaining pins, see Crane operating instructions, chapter 5.19 or separate operating instructions.

Make sure that the following prerequisites are met:

- The ground is level and of sufficient load bearing capacity.
- **Only for cranes with crane support:** The crane is properly supported.
- The crane is horizontally aligned.
- The crane is ballasted according to the load chart.
- The LICCON overload protection has been set according to the load chart.
- The slewing gear brake is applied.
- The boom end section is just above the ground.



WARNING

Danger of accident due to side wind!

If the slewing gear brake is released after reeving in / reeving out the hook block / the load hook, then the crane can turn uncontrolled in strong side wind.

Personnel can be severely injured or killed.

The crane can collide with close-by structures or objects.

- ▶ Make sure that the current wind speed does not exceed the values from the wind speed chart when releasing the slewing gear brake.

4.2.1 Lowering the hook block



WARNING

Crushing of hands!

When unreeving the hook block, it can topple over.

Death, severe injury, property damage.

- ▶ Use the handles in the safe area of the hook block.
- ▶ Make sure the hook block is safely positioned.

- ▶ Lower the hook block and set it on the ground.
- ▶ Remove the hoist limit switch weight.

4.2.2 Detaching the hoist rope

- ▶ On the rope lock **24**, release and unpin the retaining pin **50**.

Result:

- The locking clamp **8** is released.
- ▶ Push the hoist rope forward and detach the locking clamp **8**.
- ▶ Release and unpin the rope retaining pin on the hook block.
- ▶ Unreeve the hoist rope from the hook block and the pulley head.
- ▶ Insert the rope retaining pins again and secure with spring retainers.

5 Attaching and removing the load hook*

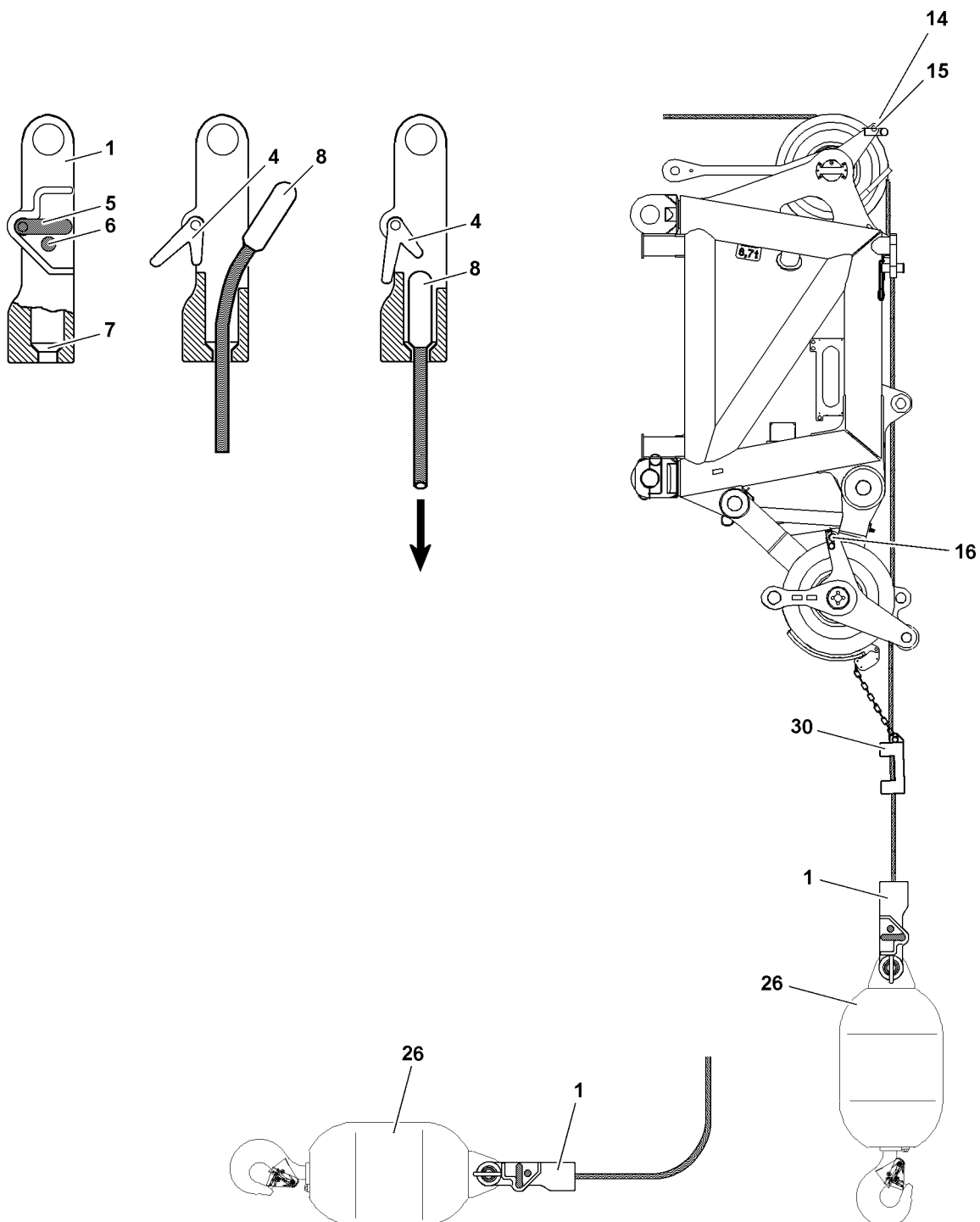

Fig.121854: Fastening load hook

5.1 Fastening the load hook*

5.1.1 Assembling the load hook*

- ▶ Place the load hook under the pulley head of the boom.
- ▶ Release and unpin the rope retaining pins on the back pulley and on the pulley head.

**WARNING**

Slipping at assembly work!

Danger of falling.

Death, severe injury, property damage.

- ▶ The boom system may only be accessed if the assembly personnel is protected with suitable safety measures to prevent them from falling.
- ▶ If retaining ropes are present on the boom system, then the assembly personnel must hang an approved fall arrest system to the retaining ropes of the boom system on the left and right with both snap hooks and secure themselves to prevent them from falling.
- ▶ Without appropriate safety measures it is **strictly** prohibited to step on the boom system.
- ▶ If railings are present for the crane, then they must be brought into the corresponding position and secured for assembly / disassembly.
- ▶ Carry out all assembly work from a safe location.
- ▶ Observe the assembly guidelines in the Crane operating instructions, chapter 5.01.

- ▶ Place the hoist rope over the back pulley on the boom head.
- ▶ Insert the rope retaining pins again and secure with spring retainers.
- ▶ Pin the rope lock **1** in the load hook **26** and secure with spring retainers.

5.1.2 Fastening the hoist rope

Make sure that the following prerequisites are met:

- The crane is horizontally aligned.
- The slewing gear brake is applied.
- The hook block is set down on the ground properly.
- The boom is luffed down to the point where the pulley head is above the hook block.
- An assistant is present to guide the hoist rope.

**WARNING**

Danger of accident due to side wind!

If the slewing gear brake is released after reeving in / reeving out the hook block / the load hook, then the crane can turn uncontrolled in strong side wind.

Personnel can be severely injured or killed.

The crane can collide with close-by structures or objects.

- ▶ Make sure that the current wind speed does not exceed the values from the wind speed chart when releasing the slewing gear brake.
- ▶ On the rope lock **1**, push the safety pin **6** in.
- ▶ Swing the lever **5** „down“ and hold it in this position.

Result:

- The latch **4** is swung „downward“.
- ▶ Attach the rope end with the locking clamp **8** in the rope lock and pull „down“ firmly (in direction of arrow), until the locking clamp **8** is touching in the cone **7**.

**WARNING**

Locking clamp is incorrectly fastened!

Damage to locking clamp.

Death, severe injuries, property damage

- ▶ The locking clamp **8** must touch on the cone **7** after hanging it into the rope lock **1** and must be secured by the latch **4**.

- ▶ Release the lever **5**.

Result:

- The lever **5** returns to the initial position and is locked by the safety pin **6**.

5.2 Removing the load hook*

Make sure that the following prerequisites are met:

- The ground is level and of sufficient load carrying capacity.
- **Only for cranes with crane support:** The crane is properly supported.
- The crane is horizontally aligned.
- The slewing gear brake is applied.
- The load hook is prepared for assembly.
- An assistant is present to guide the hoist rope.

5.2.1 Lowering the load hook



WARNING

Crushing of hands!

When unreeving the hook block, it can topple over.
Death, severe injury, property damage.

- ▶ Use the handles in the safe area of the hook block.
- ▶ Make sure the hook block is safely positioned.

- ▶ Place the load hook **26** on the ground.
- ▶ Remove the hoist limit switch weight.

5.2.2 Detaching the hoist rope



WARNING

Danger of accident due to side wind!

If the slewing gear brake is released after reeving in / reeving out the hook block / the load hook, then the crane can turn uncontrolled in strong side wind.

Death, severe injury, property damage.

The crane can collide with close-by structures or objects.

- ▶ Make sure that the current wind speed does not exceed the values from the wind speed chart when releasing the slewing gear brake.

- ▶ On the rope lock **1**, push the safety pin **6** in.
- ▶ Swing the lever **5** „down“ and hold it in this position.

Result:

- The latch **4** is swung „downward“.
- The locking clamp **8** is released.
- ▶ Push the hoist rope in the direction of the load hook and detach the locking clamp **8**.
- ▶ Remove the rope retaining pins on the pulley head and on the back pulley.
- ▶ Lift the hoist rope from the rope pulleys.
- ▶ Insert the rope retaining pins again and secure with spring retainers.

6 Attaching / removing the hoist limit switch weight

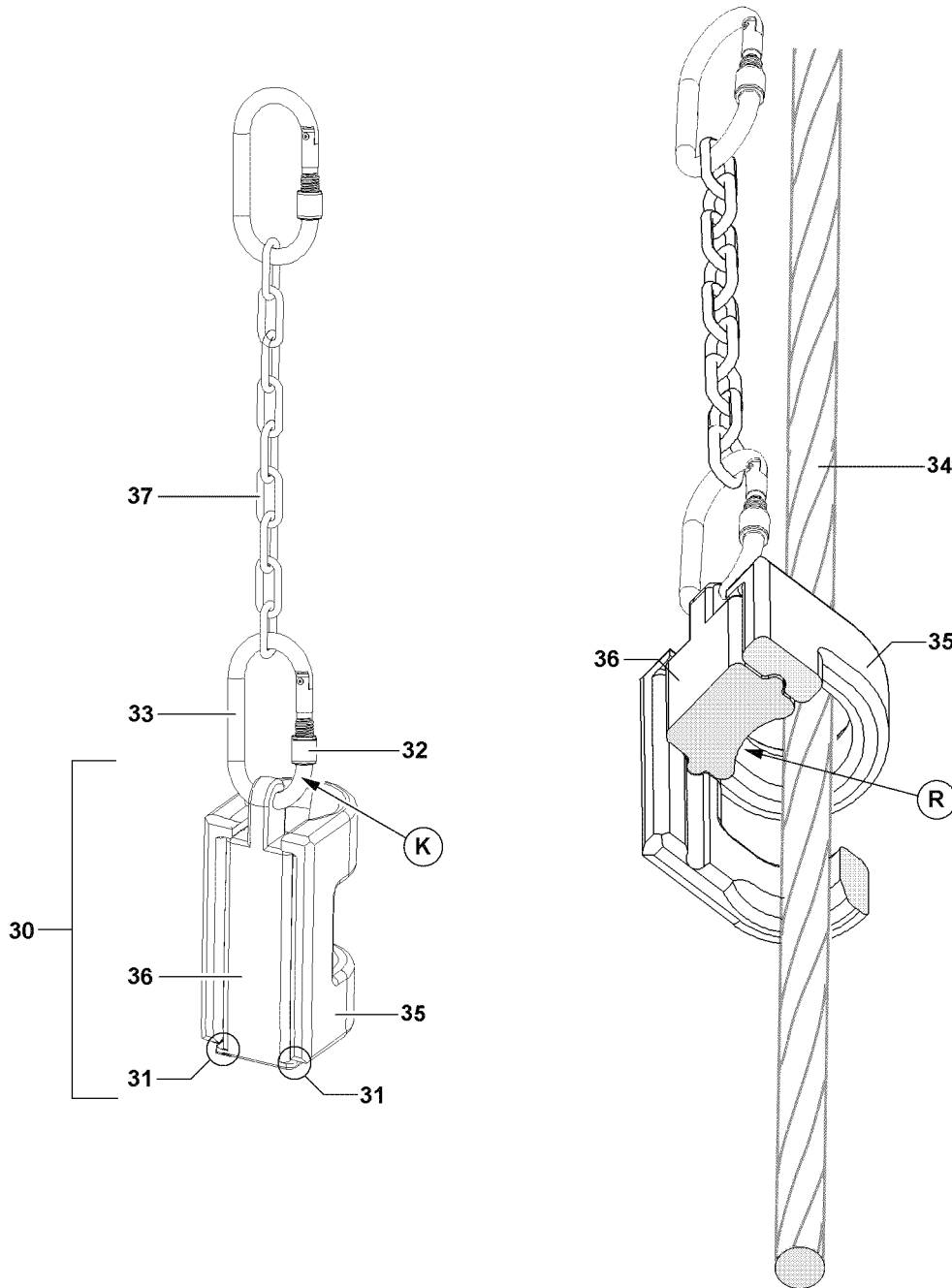

Fig.122728: Details Hoist limit switch weight

6.1 Attaching the hoist limit switch weight

The hoist limit switch weight **30** consists of two parts, which are pushed into each other:

- The weight **35**
- The carrier section **36**

► Loosen and open the screw retainer **32**.

**WARNING**

Hoist limit switch weight is incorrectly installed!

Hoist limit switch weight can fall down. Death, severe injuries.

- ▶ Do not replace the snap hook **33** with other parts, such as a shackle or similar.
- ▶ When detaching or attaching the hoist limit switch weight **30** make sure that the weight **35** and the carrier section **36** do not fall down.
- ▶ Make sure that the curvature **R** of the carrier section **36** points to the hoist rope **34**.
- ▶ Make sure that the noses **31** of the carrier section **36** is placed on the weight **35**.
- ▶ Make sure that the screw retainer **32** can be turned to be closed from top to bottom, point **K**.

The attachment of the hoist limit switch weight **30** depends on the position of the rope fixed point.

Rope fixed point on the pulley head:

- In the event of multiple hoist rope reeving, the hoist limit switch weight **30** must always be laid around the „stationary rope strand“, in other words around the rope strand that leads directly to the cable lock.

Rope fixed point on hook block:

- The hoist limit switch weight **30** is laid around the outer strand which shows the least angular pull, i.e. the one with the smallest angle between the hanging hoist limit switch weight and the hoist rope.

**Note**

- ▶ The chain **37** must be attached in full length during crane operation and may not be shortened.
- ▶ Push the weight **35** with one hand on the hoist rope **34** and hold.
- ▶ With the other hand, guide the carrier section **36** behind the hoist rope **34** and under the weight **35**. The curvature **R** of the carrier section **36** must point to the hoist rope **34**.
- ▶ Push the weight **35** on the carrier section **36**.
- ▶ Hang in the hoist limit switch weight **30** with the carrier section **36** in the snap hook **33**.

The snap hook **33** must be secured with the screw retainer **32**.

- ▶ Screw the screw retainer **32** closed on the snap hook **33**.

6.2 Removing the hoist limit switch weight

**WARNING**

Hoist limit switch weight is incorrectly installed!

Hoist limit switch weight can fall down. Death, severe injuries.

- ▶ When detaching or attaching the hoist limit switch weight **30** make sure that the weight **35** and the carrier section **36** do not fall down.
- ▶ It is prohibited to remain within the danger zone.
- ▶ Release and open the screw retainer **32** on the snap hook **33**.
- ▶ Detach the hoist limit switch weight **30** from the snap hook **33**.
- ▶ Hold the weight **35** with one hand and with the other hand, push the carrier section **36** from the weight **35**.
- ▶ Store the weight **35** and carrier section **36** safely.

7 Assembling / disassembling the wedge lock

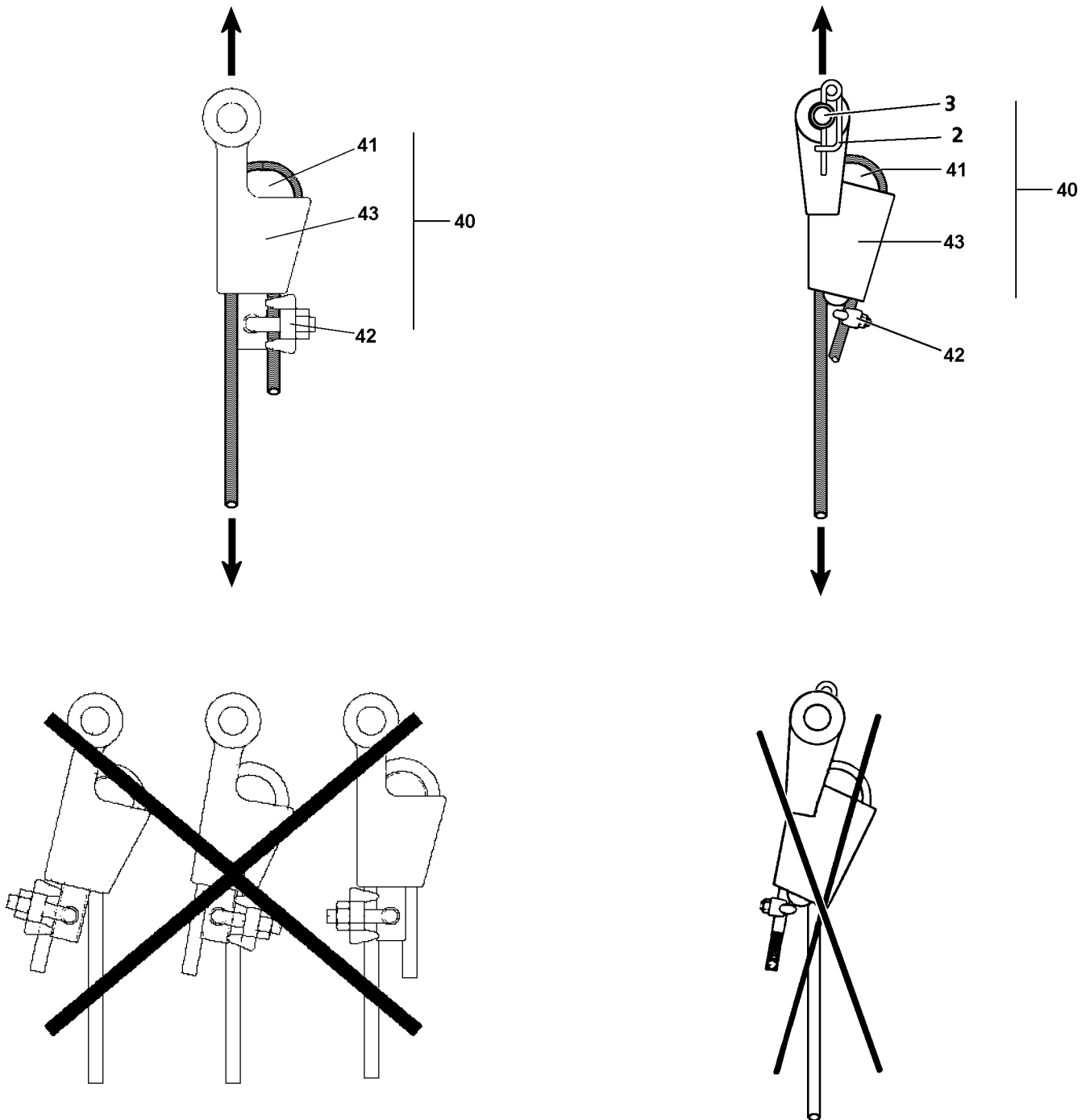

Fig.122729: Wedge lock

Make sure that the following prerequisites are met:

- The rope clamp is cut off on the hoist rope.
- The hook block or the load hook is ready for assembly.

LWE/LR 11000-001/23501-04-02/en

7.1 Installing the wedge lock



WARNING

Wedge lock is incorrectly installed!

Hook block or load can fall down. Death, severe injuries, property damage.

- ▶ Use only a wedge lock **40** approved by Liebherr-Werk Ehingen.
- ▶ Install the wedge lock **40** correctly.
- ▶ Place the hoist rope with the wedge **41** into the housing **43** in such a way that the rope strand runs in the pull axle of the wedge lock **40**.
- ▶ The dead end of the rope must be secured by the clamp **42** to prevent it from being pulled through.
- ▶ It is prohibited for personnel to remain in the danger zone.

- ▶ Take a matching wedge lock **40** from the tool box.
- ▶ Place the hoist rope with the wedge **41** into the housing **43**.
- ▶ If possible, assemble the clamp **42** through the wedge **41** on the dead end of the rope.

NOTICE

Damage to the hoist rope!

If the pin **3** has been assembled incorrectly, the hoist rope may rub against the pin **3** or on the lynch pin **2**.

- ▶ Always insert the pins **3** from „inside to outside“ and secure from the outside.
- ▶ Pin and secure the wedge lock **40** on the fixed point of the pulley head or on the fixed point of the hook block or on the load hook, depending on the reeving plan.

7.2 Removing the wedge lock

- ▶ Unpin the wedge lock **40** on the fixed point.
- ▶ Remove the clamp **42** and pull the hoist rope with the wedge from the housing.
- ▶ Store the wedge lock **40**.

8 Rope reeving



Note

- ▶ See separate reeving plans.

4.07 Counterweight

1	Component overview	3
2	Fastening points	3
3	Permissible counterweight assemblies	5
4	Installing the counterweight	6
5	Removing the counterweight	15

Fig.195219

LWE/LR 11000-001/23501-04-02/en

1 Component overview



Note

- ▶ Dimensions and weights, see Crane operating instructions, chapter 1.03.
- ▶ The components are marked with their own weight.

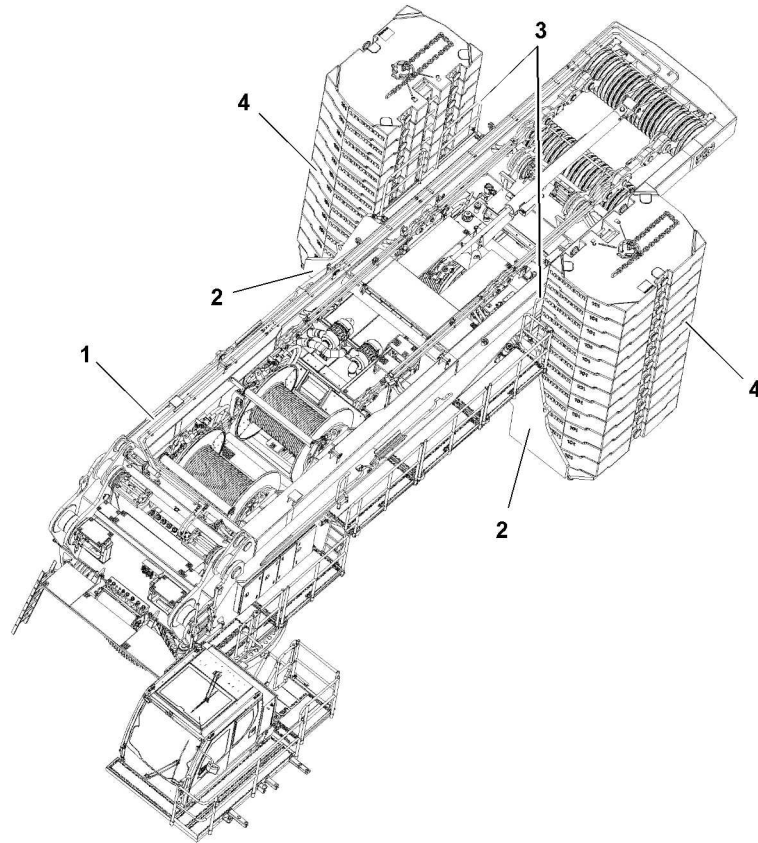

Fig.144010

Position	Component description
1	Turntable
2	Counterweight bracket
3	Railings
4	Counterweight plate

2 Fastening points



Note

- ▶ Pay attention to the labels of the fastening points on the counterweight brackets 2.



WARNING

Falling counterweight bracket!

Death, severe bodily injuries, property damage.

- ▶ Fasten the counterweight bracket 2 on the fastening points (fastening points **P1** and fastening points **P2**) only in connection with shackles with sufficient load carrying capacity 5.

LWE/LR 11000-001/23501-04-02/en

2.1 Fastening points Counterweight bracket



WARNING

Tipping of counterweight bracket!

Death, severe bodily injuries, property damage.

- ▶ Make sure that the fastening equipment is fastened on the correct fastening points, pay attention to the labels.
- ▶ Make sure that the fastening ropes **6** have a length of at least 4 m.
- ▶ Make sure that there are no persons or obstacles within the danger zone.

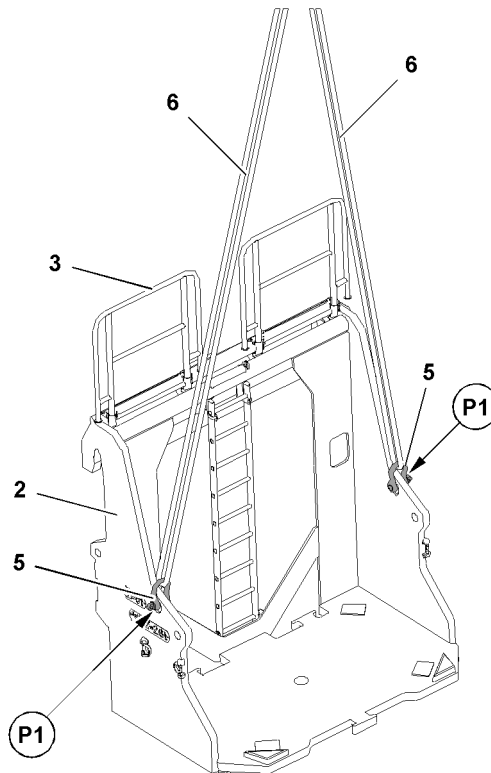

Fig.144009: Fastening points Counterweight bracket

Fastening points	
P1	Counterweight bracket

2.2 Fastening points counterweight bracket with counterweight plates



WARNING

Tipping of counterweight bracket!

If the counterweight bracket **2** is fastened on the auxiliary crane with more than the maximum permissible two counterweight plates **4**, then the counterweight bracket **2** can tip over.

The counterweight plates **4** can fall down.

Death, severe bodily injuries, property damage.

- ▶ Make sure that the assembly of the counterweight bracket **2** is carried out with maximum two inside counterweight plates **4**.
- ▶ Make sure that the fastening equipment is fastened on the correct fastening points, pay attention to the labels.
- ▶ Make sure that the fastening ropes **6** have a length of at least 4 m.
- ▶ Make sure that there are no persons or obstacles within the danger zone.

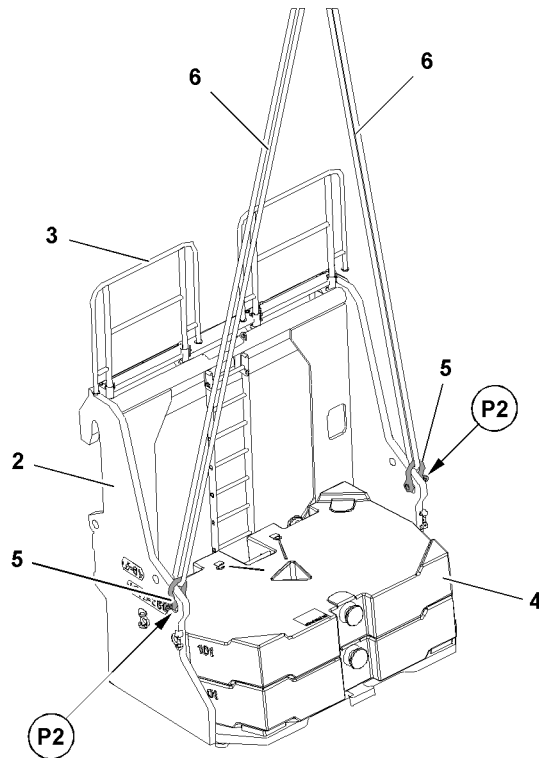

Fig.144013: Fastening points counterweight bracket with counterweight plates

Fastening points	
P2	Counterweight bracket with counterweight plates ¹⁾

1) Maximum permissible: 2 x 10.0 t

3 Permissible counterweight assemblies



WARNING

Overload fastening points counterweight assemblies!

If more than the permissible number of counterweights are lifted together, then the fastening points can be overloaded.

The counterweights **4** and components can fall down.

Death, severe bodily injuries, property damage.

▶ Attach only the maximum permissible number of counterweights **4** per lift.

LWE/LR 11000-001/23501-04-02/en

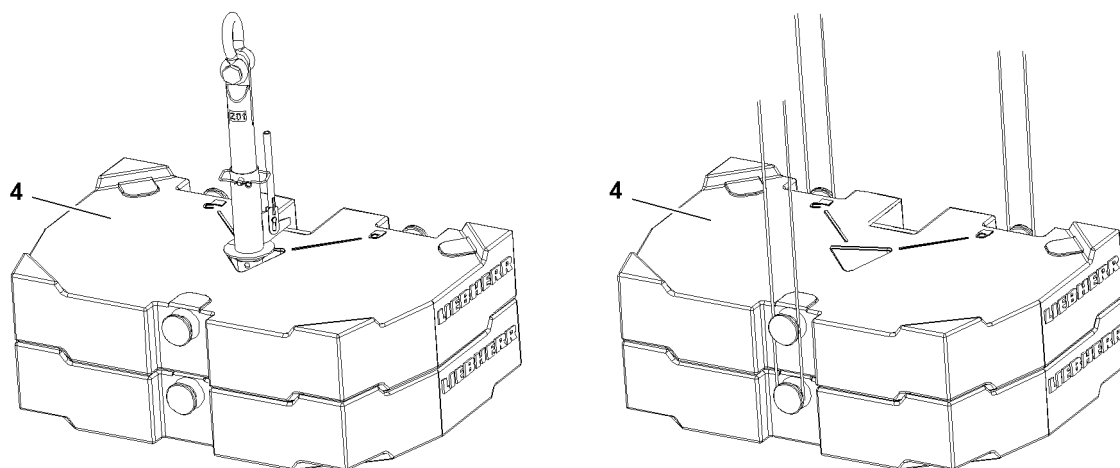

Fig.118980

Individual weight Counterweight plate	Maximum number of same counterweight plates per lift over	
	Twistlock	Bitt
5.0 t	2	1
7.5 t	2	2
10.0 t	2	2

4 Installing the counterweight

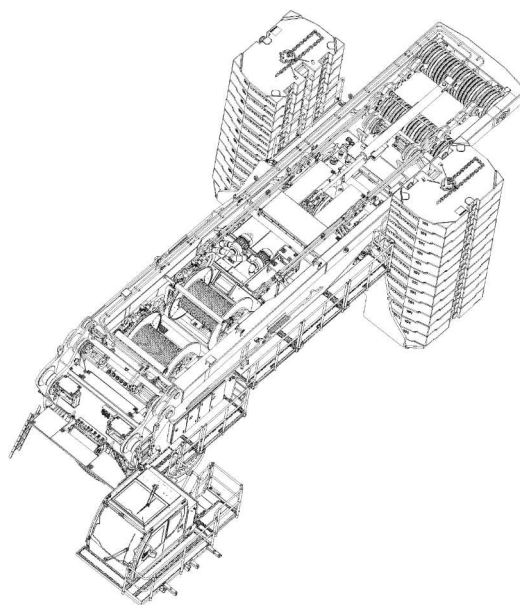

Fig.144011: Installing the counterweight

Make sure that the following prerequisite is met:

- The crane is horizontally aligned.



WARNING

Danger of falling!

During assembly / disassembly, inspection and maintenance work, personnel must be secured with appropriate aids to prevent them from falling.

Death, severe bodily injuries, property damage.

- ▶ All work aloft, where there is a danger of falling must be carried out with suitable aids.
- ▶ If aids are not available and work cannot be carried out from the ground, then the assembly personnel must secure themselves with the supplied fall arrest system to prevent falling, see Crane operating instructions, chapter 2.04.
- ▶ If fall protection equipment is available, then it must be used, see Crane operating instructions, chapter 2.06.
- ▶ When lifting, lowering, swinging crane parts in and out, no persons may remain in the danger zone.
- ▶ If railings are present on the components, then they must be brought into the corresponding position and secured for assembly / disassembly work.
- ▶ Only step on the aids, ladders and catwalks with clean shoes.
- ▶ Keep aids, ladders and catwalks free of heavy dirt, snow and ice.
- ▶ During all assembly and disassembly work, maintenance work and inspections, travel or crane operation is prohibited.
- ▶ Remaining on a suspended load is prohibited.
- ▶ Stepping or walking on crane components and lattice sections, which have an incline of more than 20° is prohibited.
- ▶ For all assembly work, the crane operator of the main crane must be in voice contact with the crane operator / crane operators of the auxiliary crane / auxiliary cranes.
- ▶ For assembly / disassembly tasks, the crane operator may only initiate crane movements when the responsible guide has explicitly released the movement.



WARNING

Components not pinned and secured!

If a component is released from the auxiliary crane before having been pinned and secured, the component can slip and fall down.

Death, severe bodily injuries, property damage.

- ▶ Do not disengage the auxiliary crane until the corresponding component is pinned and secured.



WARNING

Danger of impact / crushing!

When installing / removing crane components with the auxiliary crane, crane components can start to swing back and forth.

When lifting / lowering and positioning crane components, there is an increased danger of impacts / crushing.

Death, severe bodily injuries, property damage.

- ▶ Make sure that personnel cannot be caught by components.
- ▶ When working in danger zones: Use aids to protect limbs.
- ▶ Guide components with suitable aids to minimize oscillation.

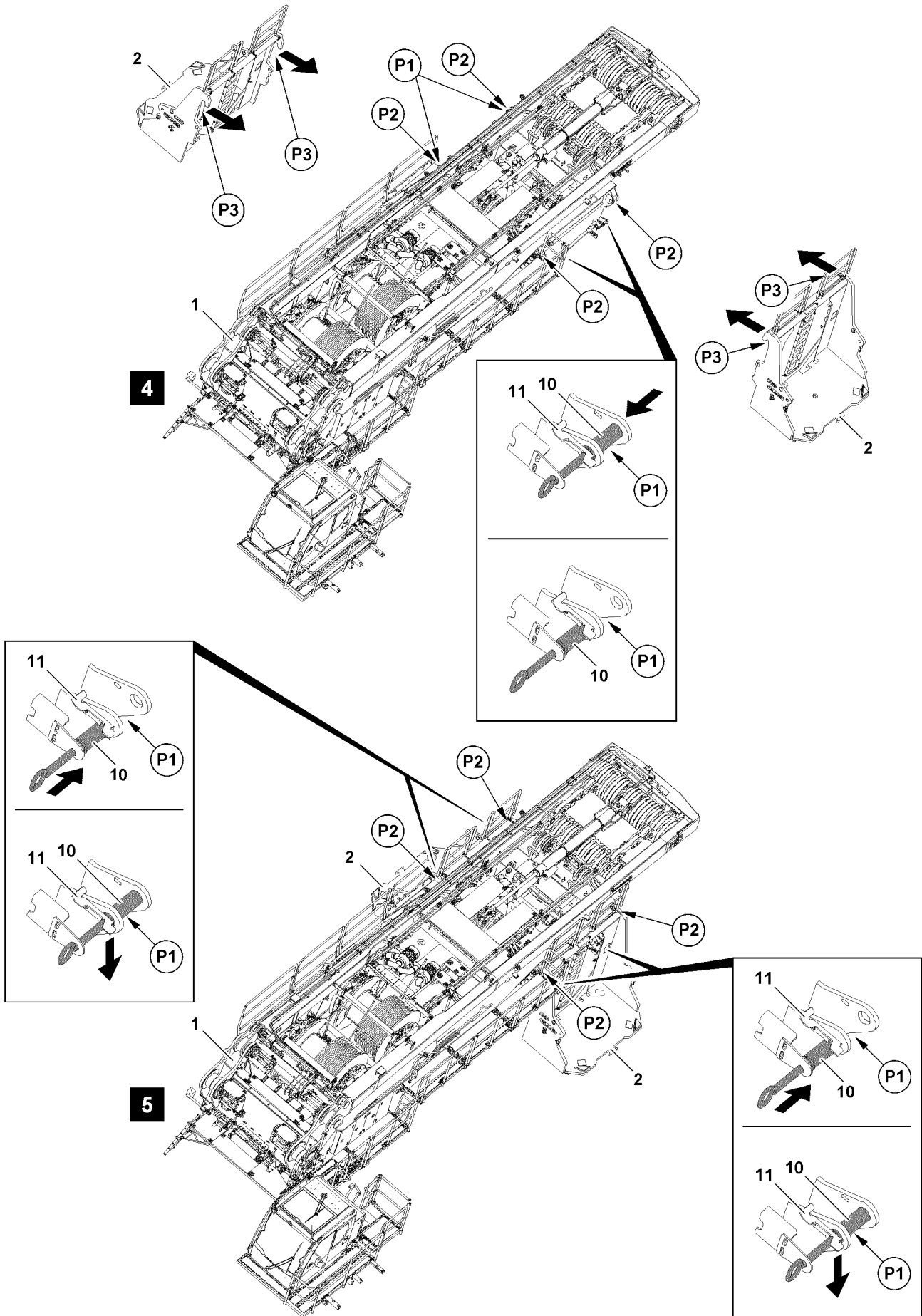

Fig.118982

LWE/LR 11000-001/23501-04-02/en

4.1 Bringing the railings on the counterweight brackets into operating position



Note

- ▶ The assembly / disassembly of the railings is described in the Crane operating instructions, chapter 2.06.



WARNING

Danger of falling for assembly personnel!

- ▶ Assemble / disassemble the railings only according to the description in the Crane operating instructions, chapter 2.06.

4.2 Assembling the counterweight brackets on the turntable

Make sure that the following prerequisites are met:

- The retaining pins **10** are completely unpinned on both sides on the turntable **1**.
- The railings **3** are properly installed and secured on the counterweight brackets **2**.

4.2.1 Installing the counterweight brackets



Note

- ▶ The assembly / disassembly of the counterweight brackets **2** is explained on an example without inside counterweight plates.

- ▶ Fasten the counterweight bracket **2** on the auxiliary crane, see section „Fastening points“.



WARNING

Tipping of counterweight bracket!

When lifting the counterweight bracket **2** with maximum two inside counterweight plates **4**, then the counterweight bracket **2** tips to the rear by approx. 5° to 8° - due to the position of the center of gravity.

- ▶ Make sure that the assembly of the counterweight bracket **2** is carried out with maximum two inside counterweight plates **4**.
- ▶ Make sure that the fastening ropes have a length of at least 4 m.
- ▶ Make sure that there are no persons within the danger zone when lifting the counterweight bracket **2**.

- ▶ Swing the counterweight bracket **2** in with the auxiliary crane to the hook pins (points **P2**), on the turntable.
- ▶ Hang the counterweight bracket **2** with the hangers (point **P3**) on the hook pins (points **P2**) on the side on the turntable **1**.
- ▶ Lower the counterweight bracket **2** completely on the hook pins (points **P2**).

When the counterweight bracket **2** is properly hooked on the hook pins:

- ▶ Insert the retaining pin **10** on both sides at point **P1** and secure.

Result:

- The counterweight bracket **2** is pinned with the turntable **1**.
- ▶ Make sure that retaining pins **10** are secured with retaining clamps **11**.
- ▶ Release the fastening equipment **6** on the counterweight bracket **2** and remove the auxiliary crane.



Note

- ▶ The procedure to install the second counterweight bracket **2** is identical with the above procedure.
- ▶ Install the second counterweight bracket **2**.

4.3 Placing the counterweight plates



WARNING

The crane can topple over!

If the placed counterweight deviates from the specified data in the erection / take down charts, the load charts or the assembly conditions, then the crane can be damaged or topple over.

Death, severe bodily injuries, property damage.

- ▶ Always place the counterweight plates symmetrically on the counterweight brackets **2**.
- ▶ Place the counterweight according to the data in the erection / take down charts as well as the load chart.
- ▶ Before placing the counterweight plates check the maximum permissible counterweight depending on the assembly conditions, see Crane operating instructions, chapter 3.06.

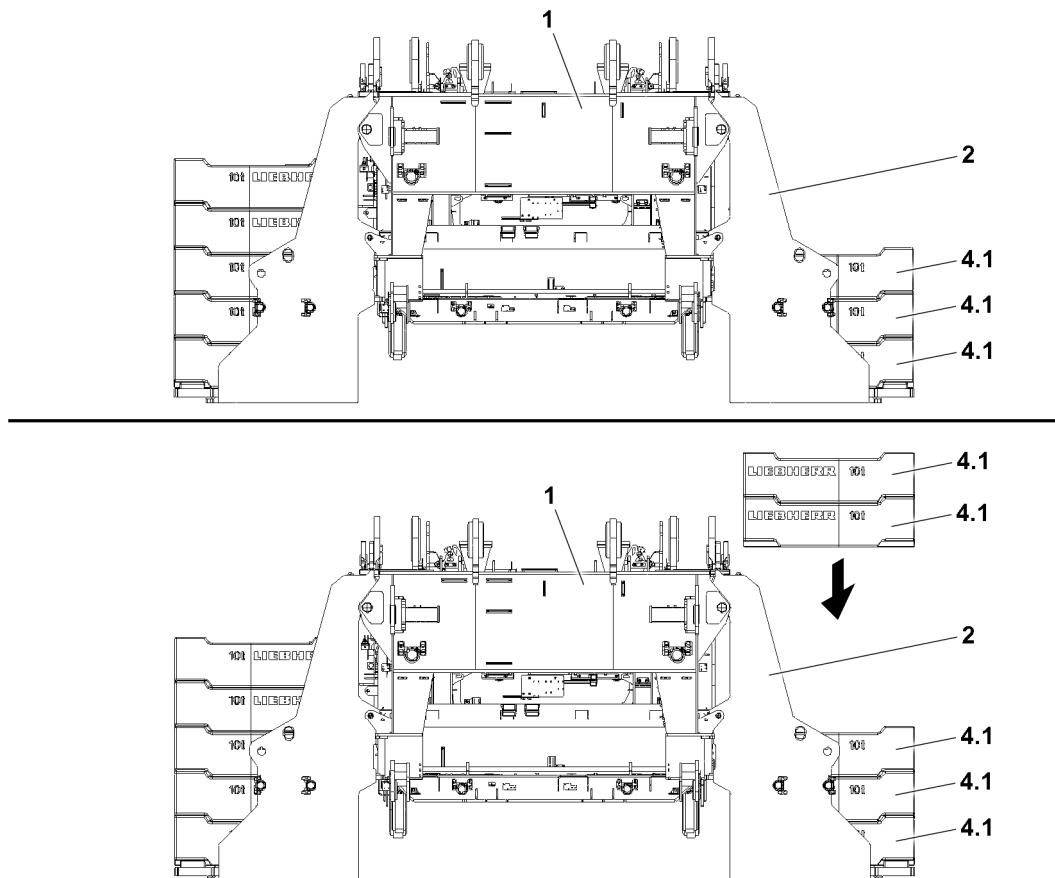

Fig.144008: Placing the counterweight plates



WARNING

The crane can topple over!

When ballasting the crane up / down, a weight difference of more than 20 t between the left and right turntable side can cause the crane to topple over.

Death, severe bodily injuries, property damage.

- ▶ A weight difference between the left and right turntable side of more than 20 t is prohibited.
- ▶ Alternately place no more than maximum 20 t counterweight assemblies on the counterweight stacks, alternately symmetrically on the left and right.

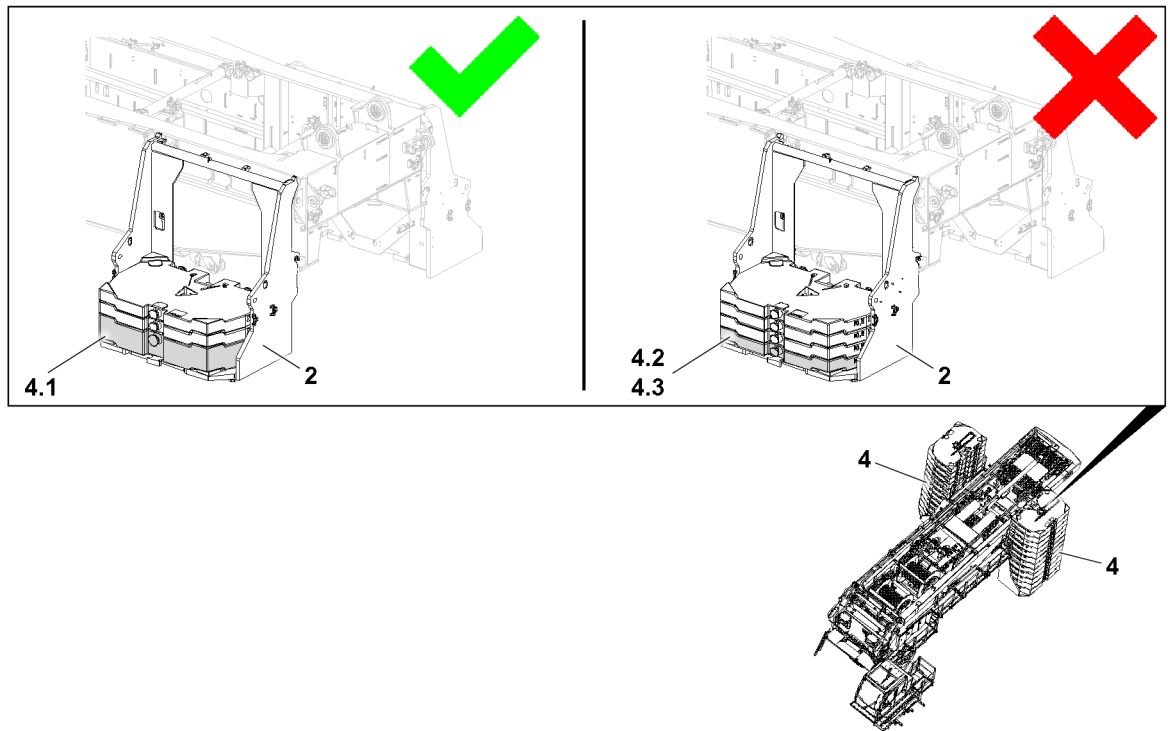

Fig.144007: Ballasting the counterweight stack



WARNING

Falling counterweight plates!

If the ballasting sequence is not adhered to when placing the counterweights on the counterweight brackets **2**, the counterweight plates located at the bottom of the counterweight stack may be damaged.

The counterweight plates can fall down from the counterweight stack.

Death, severe bodily injuries, property damage.

- ▶ Make sure that the counterweight stack is only started with 10 t counterweight plates **4.1**.
- ▶ Make sure that the counterweight stack is never started with 5.0 t counterweight plates **4.3** or 7.5 t counterweight plates **4.2**.
- ▶ Further ballasting from the first 10 t counterweight plates **4.1** in the counterweight stack can be continued with 5.0 t or 7.5 t counterweight plates.

Make sure that the following prerequisites are met:

- The counterweight brackets **2** are properly pinned and secured on the turntable.
- There are no obstacles, objects or personnel in the danger zone.

4.3.1 Placing the counterweight plates, fastening system: „Twistlock“

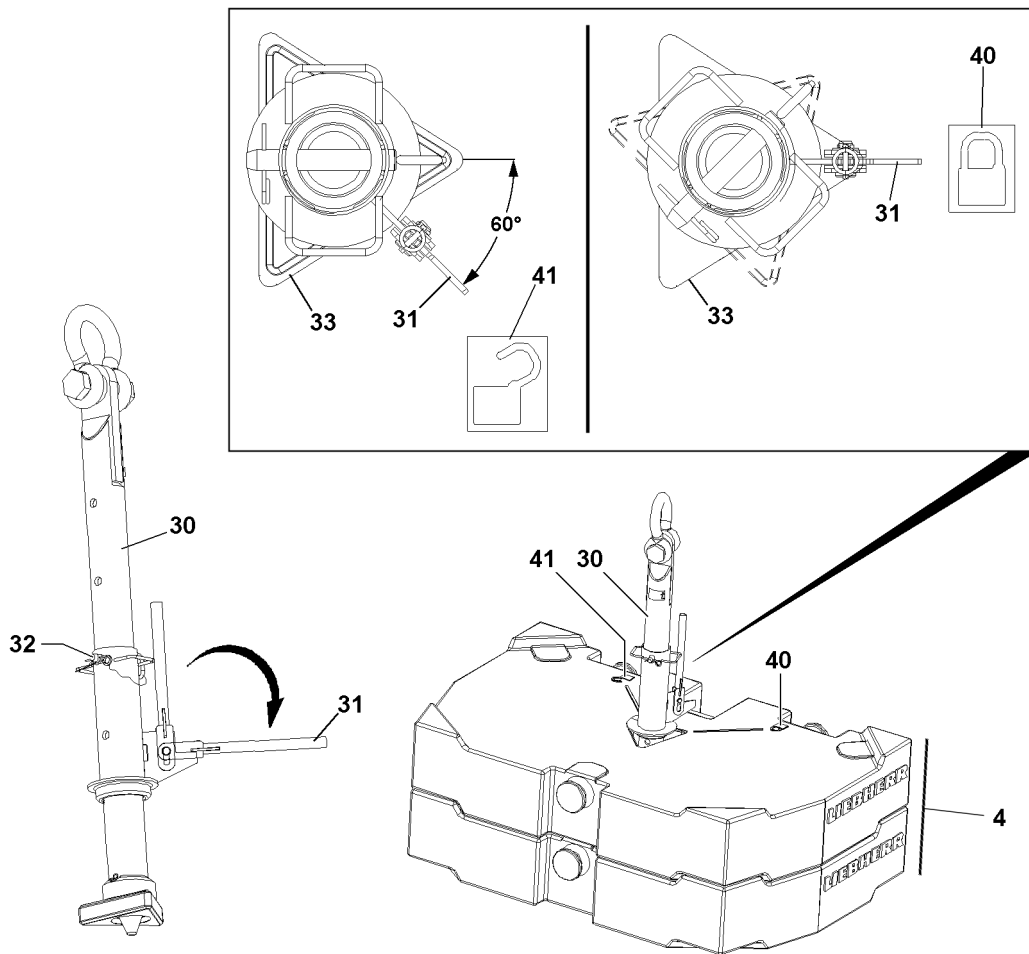

Fig.128757: Placing the counterweight plates 4, fastening system: „Twistlock“



WARNING

Danger of accident!

If more than the permissible two counterweight plates 4 are lifted with the receptacle stud, the receptacle stud will be overloaded and can be damaged.

Death, severe bodily injuries, property damage.

- ▶ Make sure that the counterweight plates 4 are placed correctly in the centerings.
- ▶ Replace damaged counterweight plates 4.

To stack the counterweight plate(s) 2, use the receptacle stud 30.

Before the receptacle stud 30 is guided into the counterweight plates 4, it must be ensured that the length of the receptacle stud 30 is set correctly. The length of the receptacle stud 30 can be adjusted with the pin 32.

If the length of the receptacle stud 30 is to be adjusted:

- ▶ Release and unpin the pin 32.
- ▶ Adjust the length of the receptacle stud by moving the receptacle stud 30.
- ▶ Insert the pin 32 and secure with the spring retainer.
- ▶ Attach the receptacle stud 30 on the auxiliary crane and guide it into the counterweight plate(s).
- ▶ Pull the lever 31 up and fold it down.
- ▶ Turn the lever 31 by 60° until the lever 31 points to the icon 40.

Result:

- The receptacle stud 30 is locked with the counterweight plate.

- ▶ Lift the counterweight plate(s) with the receptacle stud **30** and place carefully onto the centerings on the counterweight bracket **2** or on another counterweight plate.

When the counterweight plate(s) are placed on the counterweight bracket **2** or on another counterweight plate:

- ▶ Turn the lever **31** by 60° until the lever **31** points to the icon **41**.

Result:

- The receptacle stud **30** is unlocked.
- ▶ Carefully pull the receptacle stud **30** from the counterweight plate / the counterweight plates.
- ▶ Stack the counterweight plates **4** according to the erection / take down charts or the load charts.

4.3.2 Placing the counterweight plates, fastening points: Bitt

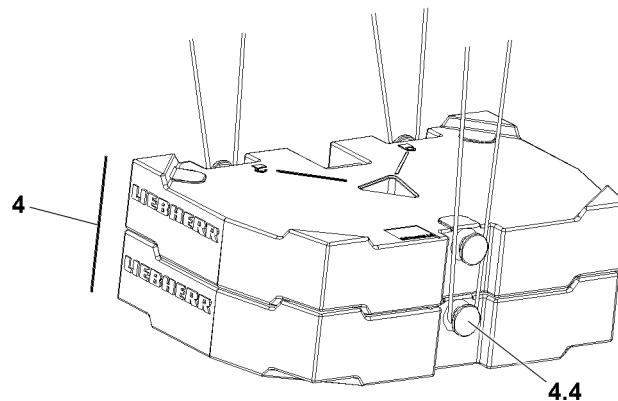

Fig.128758: Placing the counterweight plates, fastening points: Bitt



WARNING

Falling counterweight plates!

If more than the permissible loads are lifted, then the bits **4.4** are overloaded and the counterweight plates **4** can fall down.

Death, severe bodily injuries, property damage.

- ▶ Lift no more than maximum 20 t with the ropes, 3 fastening points.
- ▶ Replace damaged counterweight plates **4** immediately.



WARNING

Incorrect handling of the fastening equipment!

If fastening equipment cannot be attached correctly and if it is not secured sufficiently to prevent it from loosening up, loads can fall down.

Death, severe bodily injuries, property damage.

- ▶ Make sure that the fastening equipment is correctly attached on the bits **4.4** and that it is secured sufficiently to prevent it from loosening up.



Note

- ▶ Place the counterweight plates **4** individually or as a counterweight assembly, maximum 20 t.
- ▶ Weight difference between the counterweight stacks, no more than maximum 20 t.
- ▶ 20 t counterweight assembly.

- ▶ Attach the counterweight plate **4** or counterweight assembly on the auxiliary crane and place it on both sides on the counterweight brackets **2** or on the already placed counterweight plates **4**.

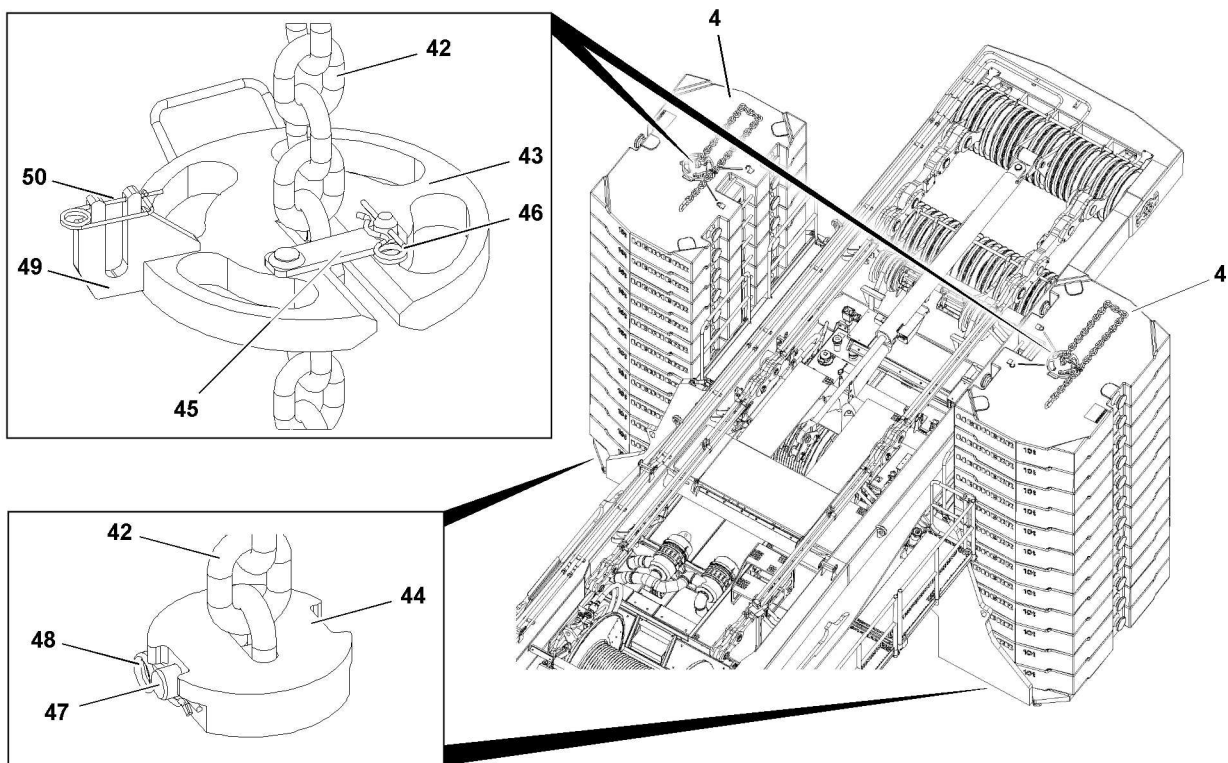

Fig.144014

4.4 Securing the counterweight

Make sure that the following prerequisite is met:

- The counterweight has been stacked according to the load chart and the operating instructions.



WARNING

Danger of accident when securing the counterweight plates **4**!

If the counterweight is not properly secured, then it can fall down from the counterweight brackets. Death, severe bodily injuries, property damage.

- ▶ Before starting crane operation, the complete counterweight must be secured.

- ▶ Guide the retaining chain **42** with the auxiliary crane from the top through the counterweight assembly.
- ▶ Pin the retaining chain **42** on the bottom with the retaining plate **44**: Insert the pin **47** and secure with the spring retainer **48**.
- ▶ Carefully tighten the retaining chain **42** with the auxiliary crane.
- ▶ Secure the retaining chain **42** on top with the retaining plate **43**.
- ▶ Secure the retaining plate **43** with the retaining plate **45**.
- ▶ Secure the retaining plate **45** with spring retainer **46**.



WARNING

Danger of accidents due to chain overhang!

On a partial ballast, the chain overhang can fall down on the side of the counterweight stack! Death, severe bodily injuries, property damage.

- ▶ In case of a chain overhang, hang in the retaining chain **42** into the fork **49** and secure with spring retainer **50** to prevent it from falling down.
- ▶ Secure the retaining chain to prevent it from falling down.

5 Removing the counterweight

Make sure that the following prerequisite is met:

- The crane is horizontally aligned.



WARNING

Danger of falling!

During assembly / disassembly, inspection and maintenance work, personnel must be secured with appropriate aids to prevent them from falling.

Death, severe bodily injuries, property damage.

- ▶ All work aloft, where there is a danger of falling must be carried out with suitable aids.
- ▶ If aids are not available and work cannot be carried out from the ground, then the assembly personnel must secure themselves with the supplied fall arrest system to prevent falling, see Crane operating instructions, chapter 2.04.
- ▶ If fall protection equipment is available, then it must be used, see Crane operating instructions, chapter 2.06.
- ▶ When lifting, lowering, swinging crane parts in and out, no persons may remain in the danger zone.
- ▶ If railings are present on the components, then they must be brought into the corresponding position and secured for assembly / disassembly work.
- ▶ Only step on the aids, ladders and catwalks with clean shoes.
- ▶ Keep aids, ladders and catwalks free of heavy dirt, snow and ice.
- ▶ During all assembly and disassembly work, maintenance work and inspections, travel or crane operation is prohibited.
- ▶ Remaining on a suspended load is prohibited.
- ▶ Stepping or walking on crane components and lattice sections, which have an incline of more than 20° is prohibited.
- ▶ For all assembly work, the crane operator of the main crane must be in voice contact with the crane operator / crane operators of the auxiliary crane / auxiliary cranes.
- ▶ For assembly / disassembly tasks, the crane operator may only initiate crane movements when the responsible guide has explicitly released the movement.



WARNING

Components not pinned and secured!

If a component is released from the auxiliary crane before having been pinned and secured, the component can slip and fall down.

Death, severe bodily injuries, property damage.

- ▶ Do not disengage the auxiliary crane until the corresponding component is pinned and secured.



WARNING

Danger of impact / crushing!

When installing / removing crane components with the auxiliary crane, crane components can start to swing back and forth.

When lifting / lowering and positioning crane components, there is an increased danger of impacts / crushing.

Death, severe bodily injuries, property damage.

- ▶ Make sure that personnel cannot be caught by components.
- ▶ When working in danger zones: Use aids to protect limbs.
- ▶ Guide components with suitable aids to minimize oscillation.

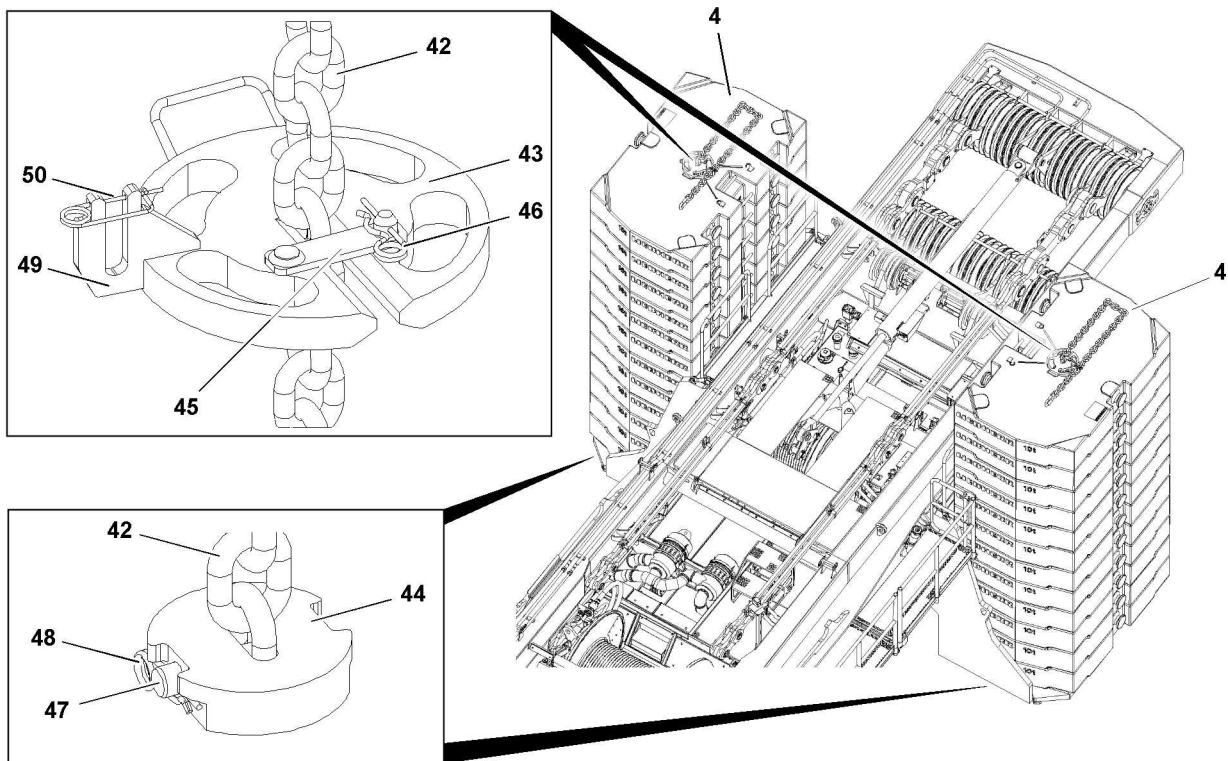

Fig.144014

5.1 Releasing the counterweight

If necessary:

- ▶ Remove the spring retainer **50**.
- ▶ Attach the retaining chain **42** on the auxiliary crane and secure it to prevent it from falling.
- ▶ Remove the retaining plate **44**: Release and unpin the pin **47**.
- ▶ Pull the retaining chain **42** with the auxiliary crane from the counterweight assembly and place it on a suitable base or on the ground.
- ▶ Release the retaining plate **45** and remove the retaining plate **43**.
- ▶ Remove the counterweight plates **4**.

5.2 Removing the counterweight plates

Make sure that the following prerequisite is met:

- The retaining chains are removed.



Note

- ▶ The counterweight plates **4** are marked with their own weights.



WARNING

The crane can topple over!

When ballasting the crane up / down, a weight difference of more than 26 t between the left and right turntable side can cause the crane to topple over.

Death, severe bodily injuries, property damage.

- ▶ A weight difference between the left and right turntable side of more than 26 t * is prohibited.
- ▶ Alternately remove no more than maximum 20 t counterweight assemblies from the counterweight stacks, alternately symmetrically on the left and right.

5.2.1 Removing the counterweight plates, fastening system: „Twistlock“

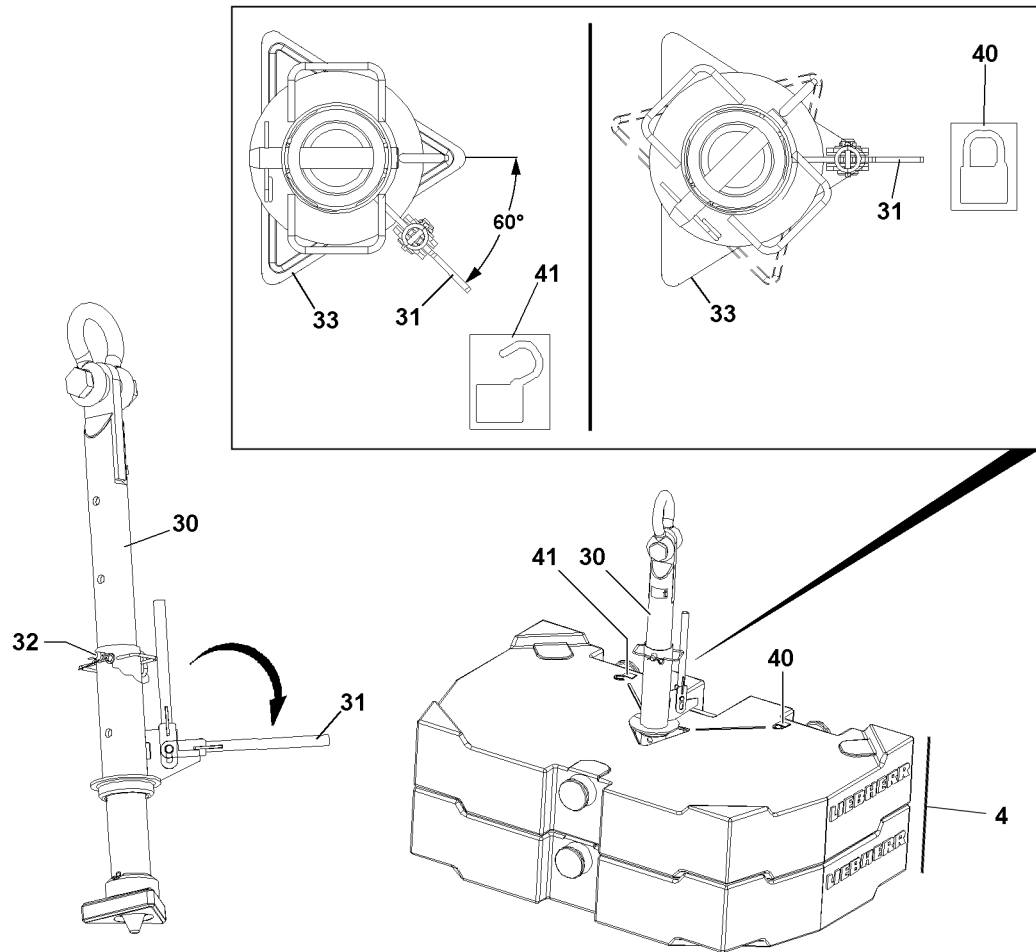

Fig.128757: Removing the counterweight plates, fastening system: „Twistlock“



DANGER

Danger of accident!

If more than the permissible two counterweight plates **4** are lifted with the receptacle stud, the receptacle stud will be overloaded and can be damaged.

Death, severe bodily injuries, property damage.

- ▶ Make sure that the counterweight plates **4** are placed correctly in the centerings.
- ▶ Replace damaged counterweight plates **4**.

To remove the counterweight plate(s) **2**, use the receptacle stud **30**.

Before the receptacle stud **30** is guided into the counterweight plates **4**, it must be ensured that the length of the receptacle stud **30** is set correctly. The length of the receptacle stud **30** can be adjusted with the pin **32**.

If the length of the receptacle stud **30** is to be adjusted:

- ▶ Release and unpin the pin **32**.
- ▶ Adjust the length of the receptacle stud by moving the receptacle stud **30**.
- ▶ Insert the pin **32** and secure with the spring retainer.
- ▶ Attach the receptacle stud **30** on the auxiliary crane and guide it into the counterweight plate(s).
- ▶ Pull the lever **31** up and fold it down.
- ▶ Turn the lever **31** by 60° until the lever **31** points to the icon **40**.

Result:

- The receptacle stud **30** is locked with the counterweight plate.

- ▶ Lift the counterweight plate with the receptacle stud **30** and remove it from the counterweight stack or the counterweight brackets **2**.
- ▶ Turn the lever **31** by 60° until the lever **31** points to the icon **41**.

Result:

- The receptacle stud **30** is unlocked from the counterweight plate.
- ▶ Carefully pull the receptacle stud **30** from the counterweight plate.
- ▶ Alternately remove the counterweight plates **4** from both sides.

5.2.2 Removing the counterweight plates, fastening points: Bitt

Fig.128758: Removing the counterweight plates, fastening points: Bitt

**WARNING**

Falling counterweight plates **4**!

If more than the permissible loads are lifted, then the bits **4.4** are overloaded and the counterweight plates **4** can fall down.

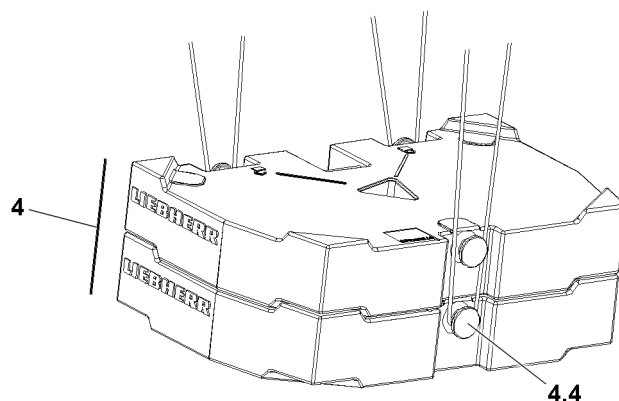
Death, severe bodily injuries, property damage.

- ▶ Lift no more than maximum 20 t with the ropes, 3 fastening points.
- ▶ Replace damaged counterweight plates **4** immediately.

**WARNING**

Incorrect handling of the fastening equipment!

If fastening equipment cannot be attached correctly and if it is not secured sufficiently to prevent it from loosening up, loads can fall down.

Death, severe bodily injuries, property damage.

- ▶ Make sure that the fastening equipment is correctly attached on the bits **4.4** and that it is secured sufficiently to prevent it from loosening up.

**Note**

- ▶ Remove the counterweight plates **4** individually or as a counterweight assembly, maximum 20 t.
- ▶ Weight difference between the counterweight stacks, maximum 20 t.
- ▶ Lift the counterweight plate **4** or the counterweight assembly and remove it from the counterweight stack or the counterweight brackets **2**.

Empty page!

LWE/LR 11000-001/23501-04-02/en

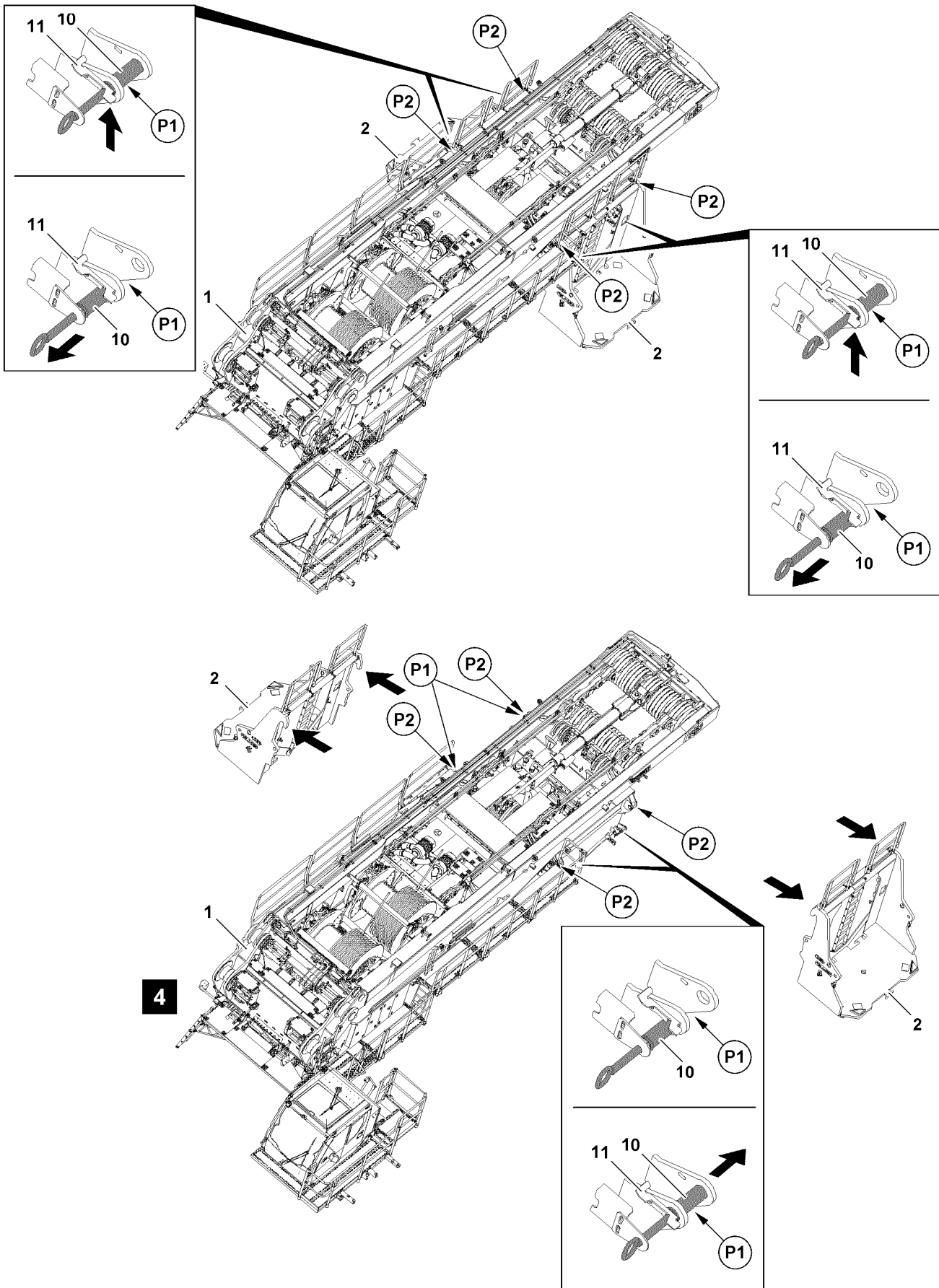

Fig.118985

5.3 Removing the counterweight brackets on the turntable



Note

- ▶ The assembly / disassembly of the counterweight brackets **2** is explained on an example without inside counterweight plates.

Make sure that the following prerequisites are met:

- The railings **3** are in the operating position.
 - The retaining pins **10** are unpinned completely on both sides.
 - Maximum two 10 t counterweight plates **4** are on one counterweight bracket **2**.
- ▶ Fasten the counterweight bracket **2** on the auxiliary crane, see section „Fastening points“.



WARNING

Tipping of counterweight bracket!

When lifting the counterweight bracket **2** with maximum two inside counterweight plates **4**, the counterweight bracket **2** tips to the rear by approx. 5° to 8° due to the position of the center of gravity.

- ▶ Make sure that the disassembly of the counterweight bracket **2** is carried out with maximum two inside counterweight plates **4**.
- ▶ Make sure that the fastening ropes have a length of at least 4 m.
- ▶ Make sure that there are no persons within the danger zone when lifting the counterweight bracket **2**.

- ▶ Release the retaining pin **10**: Fold the retaining bar **11** up and hold.
- ▶ Unpin the retaining pins **10** on both sides.

When the retaining pins **10** are completely unpinned on both sides:

- ▶ Lift the counterweight bracket **2** with the auxiliary crane and swing out.
- ▶ Set the counterweight bracket **2** on a load bearing support or on a flatbed trailer.
- ▶ Depending on the disassembly status of the counterweight bracket **2**: Remove the remaining counterweight plates **4**.

When the counterweight bracket **2** is properly set on the support or on the flatbed trailer:

- ▶ Remove the fastening equipment and the auxiliary crane.

5.4 Bringing the railings on the counterweight brackets into transport position



Note

- ▶ The assembly / disassembly of the railings is described in the Crane operating instructions, chapter 2.06.



WARNING

Danger of falling for assembly personnel!

- ▶ Assemble / disassemble the railings only according to the description in the Crane operating instructions, chapter 2.06.

Empty page!

LWE/LR 11000-001/23501-04-02/en

4.08 Working with a load

1	Safety guidelines	3
2	Checks before starting to work with the crane	4
3	Crane movement - Telescoping	5
4	Taking on a load	7
5	Crane operation	13
6	Crane rope pretension	15

Fig.195219

LWE/LR 11000-001/23501-04-02/en

1 Safety guidelines

In addition, observe the general technical safety instructions in chapter 2.04.

In steep boom positions for which no loads are specified in the load charts, there is a danger of tipping to the rear to the counterweight side.

The danger of tipping to the rear exists especially in case of:

- Crane operation on tires
- Supported, with retracted sliding beams
- Reduced support base



WARNING

Crane operation in steep boom positions for which no loads are specified in the load charts!

The crane can tip to the rear and fatally injure personnel.

- ▶ Comply with the boom radius specified in the load chart.
- ▶ Crane operation outside the permissible set up configurations, boom radii and slewing ranges according to the load chart is prohibited.



WARNING

Incorrect reeving number set up!

If the reeving number on the pulley head is less than the reeving number set on the LICCON computer system, it can result in an overload of the hoist rope.

The hoist rope can rip. The load can fall down and fatally injure personnel.

- ▶ Comply with the reeving numbers specified in the load chart for maximum loads.
- ▶ Make sure that the reeving on the pulley head and the reeving set on the LICCON computer system match.

The minimum rope coils must remain on the rope winches. The number of minimum rope coils depends on if the rope winch is equipped with a cam limit switch or a winch speed sensor.



WARNING

Minimum rope coils fallen below!

The rope will be ripped out. The load falls down.

Personnel can be killed.

- ▶ Make sure that the minimum rope coils remain on the rope winch.
- ▶ Observe and comply with the number of the minimum rope coils in chapter 5.01.



WARNING

Lift the load by luffing up!

The crane can topple over and fatally injure personnel.

- ▶ Lift the load with the hoist gear.

Always comply with the maximum loads specified in the load chart.

The weight of the hook block according the load chart must be taken into account. Subtract the weight of the hook block from the load chart value. The minimum hook block weight must be determined according to the reeving number and the data in the load charts.

For the lift, use the hook block which is suited best for the existing set up configuration in connection with the load chart.

Initiate all crane movements carefully. Also slow down the crane movements carefully. That way you can avoid a swinging or pendulum motion in the suspended load.

2 Checks before starting to work with the crane

Before starting work with the crane, the crane operator must carry out a further inspection to satisfy himself about the crane's operational safety:

- Check that the crane is properly supported and level.
- Check that the set up configuration set in the control matches the actual set up configuration.
- Check that all values in the load chart that apply to the current equipment configuration have been entered and met.
- Ensure that there are no people or objects within the danger zone of the crane.



WARNING

Persons in the slewing range!
Crushing danger, death, severe bodily injuries.

- ▶ Monitor the slewing range.
- ▶ Make sure that there are **no** persons within the slewing range.
- ▶ Block off the slewing range if necessary.



WARNING

Obstacle in the slewing range!
Property damage on crane and on obstacle.

- ▶ Make sure that there are **no** obstacles within the turning range of the crane and the crane components.

2.1 Visual check for damage



WARNING

Danger of accident!

If the crane is operated despite existing defects, personnel can be severely injured or killed.

- ▶ In the event of deficiencies which threaten operational safety, stop crane operation immediately.

The following deficiencies threaten the crane's operational safety:

- Damage to load-bearing parts of the crane design, such as booms, supports etc.
- Failure of the hoist gear brake and consequent slipping of the load
- Functional failures in the crane control system
- Functional defects in the indicator and warning lights
- Damage to the hoist ropes
- Safety defects in the safety equipment
- Leaks on safety relevant components of the crane hydraulic

Inform the appropriate supervisor about the deficiencies on the crane and also inform your relief when crane operators are changed.

2.2 Telescopic boom distortion because of sunshine on one side

A temperature difference occurs between the side facing the sun and the side facing away from the sun for cranes with telescopic booms. This causes telescopic boom side distortion, which can reduce the load bearing capacity of the telescopic boom.

For example, a temperature difference between the two boom sides of 30 °C and a boom length of 60 m results in a length difference caused by the temperature difference between the two sides of the telescopic boom of approximately 22 mm. With narrow boom parts, this causes the profiles to bend sideways.

If the maximum load is being utilized when a telescopic boom extension such as a fixed lattice jib, luffing lattice jib or folding jib is being used, then it must be ensured through a visual inspection before picking up the load that the boom is not showing signs of side deformation due to one-sided sun exposure.

**WARNING**

Danger of accident due to component overload!

If the telescopic boom has become distorted because of one-sided sunlight, this can cause component overload and therefore accidents.

- ▶ Turn the crane so that both sides of the boom are heated up equally, eliminating side deformation due to temperature difference.

3 Crane movement - Telescoping

If the telescopic boom is telescoped with the jib boom or telescopic boom extension, before the telescoping procedure, ensure that:

- The crane is properly supported and horizontally aligned.
- The telescopic boom is evenly warmed up by solar radiation.
- There is no strong side wind.

**WARNING**

Damage to the telescopic boom or the hoist rope!

If these 3 factors are not adhered to, damage of the telescopic boom or the hoist rope can occur and lead to accidents.

- ▶ Support the crane properly and align it horizontally.
- ▶ Keep both sides of the boom at about the same temperature.
- ▶ Telescope only to the permissible wind speed according to the load chart.
- ▶ If the actual wind speed is higher than the permissible wind speed noted on the load chart, telescoping is prohibited.

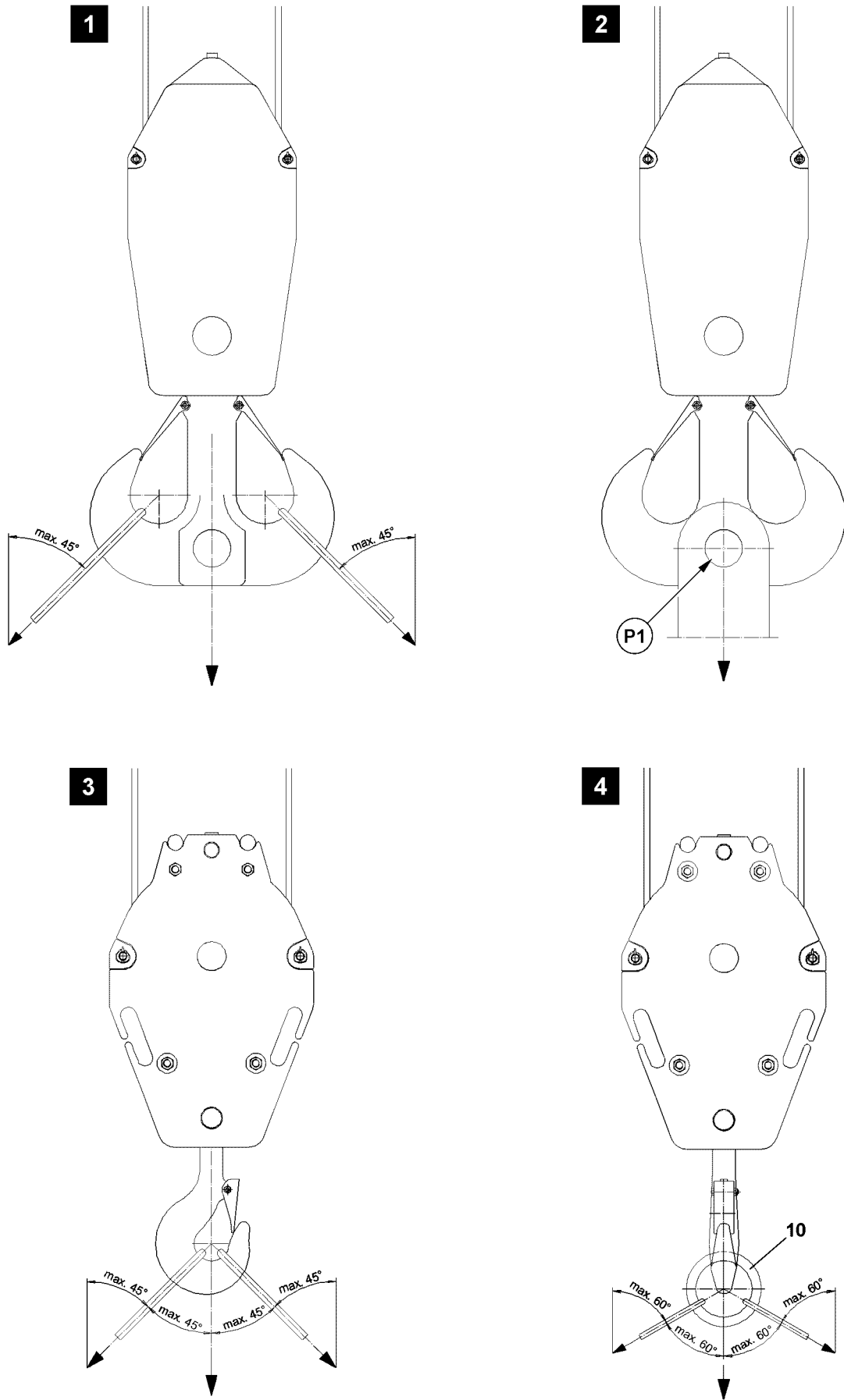

Fig.121650

LWE/LR 11000-001/23501-04-02/en

4 Taking on a load

The crane must always be operated in such a way that its load-bearing parts are not destroyed or damaged and its stability is ensured.

Make sure that the following prerequisites are met:

- The crane is supported and horizontally aligned.
- The LICCON overload protection has been set according to the load chart and the set up configuration.
- The LICCON overload protection is active.
- In the case of cranes with central ballast: The central ballast is installed according to the load chart.
- The counterweight is installed according to the load chart.
- In the case of cranes with derrick ballast: The derrick ballast is installed according to the load chart.
- The hook block or the load hook is correctly reeved.

4.1 Fastening the load



WARNING

Load can be ripped off!

If impermissible fastening and / or load handling equipment is used when taking on a load on the centric bore on the double hook at point **P1** (illustration **2**), then the double hook as well as the hook block can be damaged.

The load can rip off and fall down.

Personnel can be severely injured or killed.

- ▶ Lift the load via the centric bore on the double hook (point **P1**): For the technical requirements and the technical design of the fastening and / or load handling equipment contact the hook block manufacturer.



WARNING

The crane can topple over!

If the following conditions are not met, the crane can topple over.

Personnel can be severely injured or killed.

This could result in high property damage.

- ▶ Pay attention to the own weight of the load handling equipment.
- ▶ Pay attention to the load bearing capacity of the load handling equipment!
- ▶ The maximum permissible incline of the strands fastened on the single or double hook in the hook jaws is 45°. See illustration **1** and illustration **3**.

If necessary for the single hook:

- ▶ Use fastening equipment with a suspension link **10**. The maximum permissible incline in this case is 60°. See illustration **4**.
- ▶ Load a single and double hook symmetrically. A maximum deviation of $\pm 3^\circ$ from the direction of the center of gravity is permissible.

If necessary:

- ▶ Use cross beam or two cranes for taking on the load.

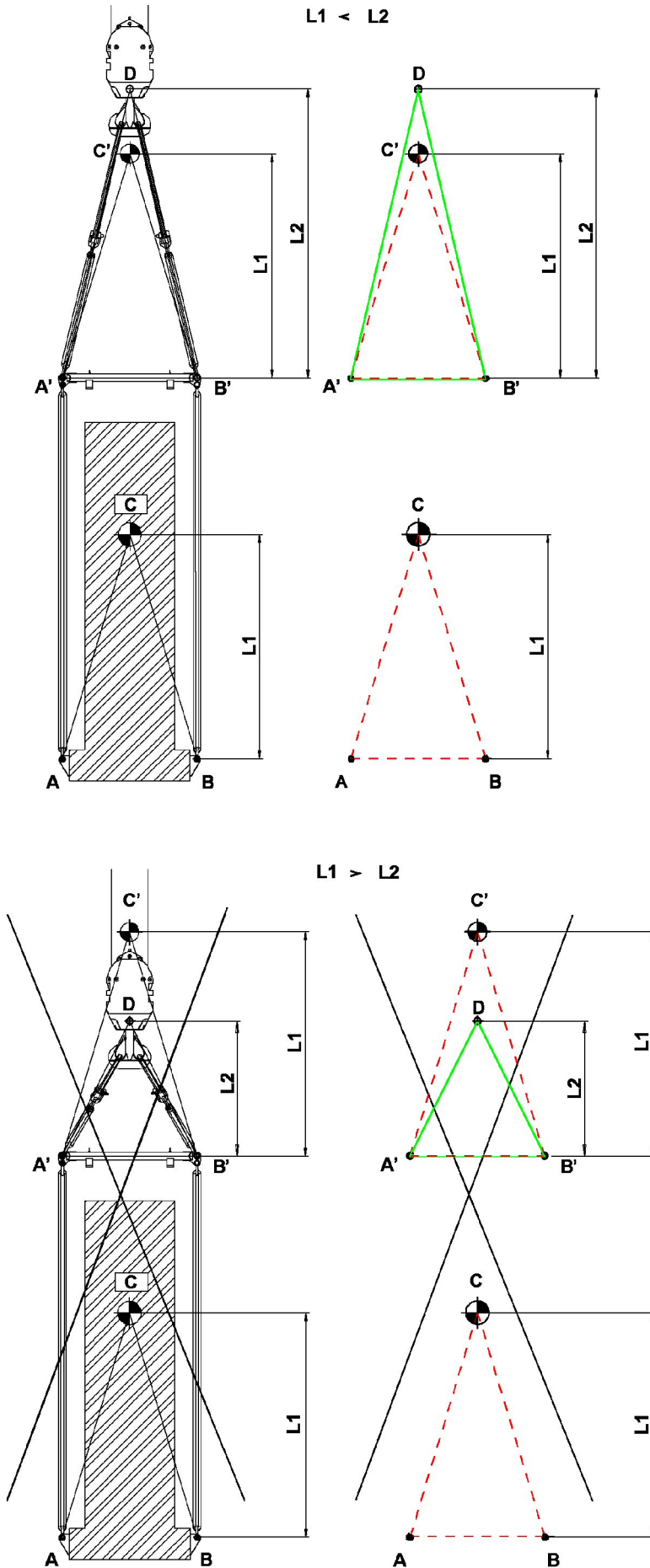

Fig.116274

LWE/LR 11000-001/23501-04-02/en

4.2 Taking on a load with cross beam

Cross beam are load handling equipment between crane hook and load.

The distance of the center of gravity **L1** is the vertical dimension from the fastening point of the load to the center of gravity of the load.

The cross beam height **L2** is the vertical dimension from the point of rotation of the crane hook to the next lower linkage point of the cross bar.



WARNING

Tipping of load to the side!

If fastening ropes are used which are too short, so that the load center of gravity is above the fastening point, then there is a danger of the load tipping to the side.

Personnel can be severely injured or killed.

- ▶ The load center of gravity must be below the crane hook.
- ▶ The distance of the center of gravity **L1** must be smaller than the cross beam height **L2** ($L1 < L2$).
- ▶ The triangle **A'B'C'** must be within the triangle **A'B'D**.

4.3 Transporting the hook block



WARNING

Danger of accident!

If a hook block is fastened incorrectly for transport, personnel can be injured.

- ▶ Fasten the hook block for transport on the fixed point in the center.
- ▶ Fastening the complete hook block on the auxiliary weights is prohibited.
- ▶ When setting down, secure the hook block against falling over.
- ▶ Prevent the load hook from rolling away.

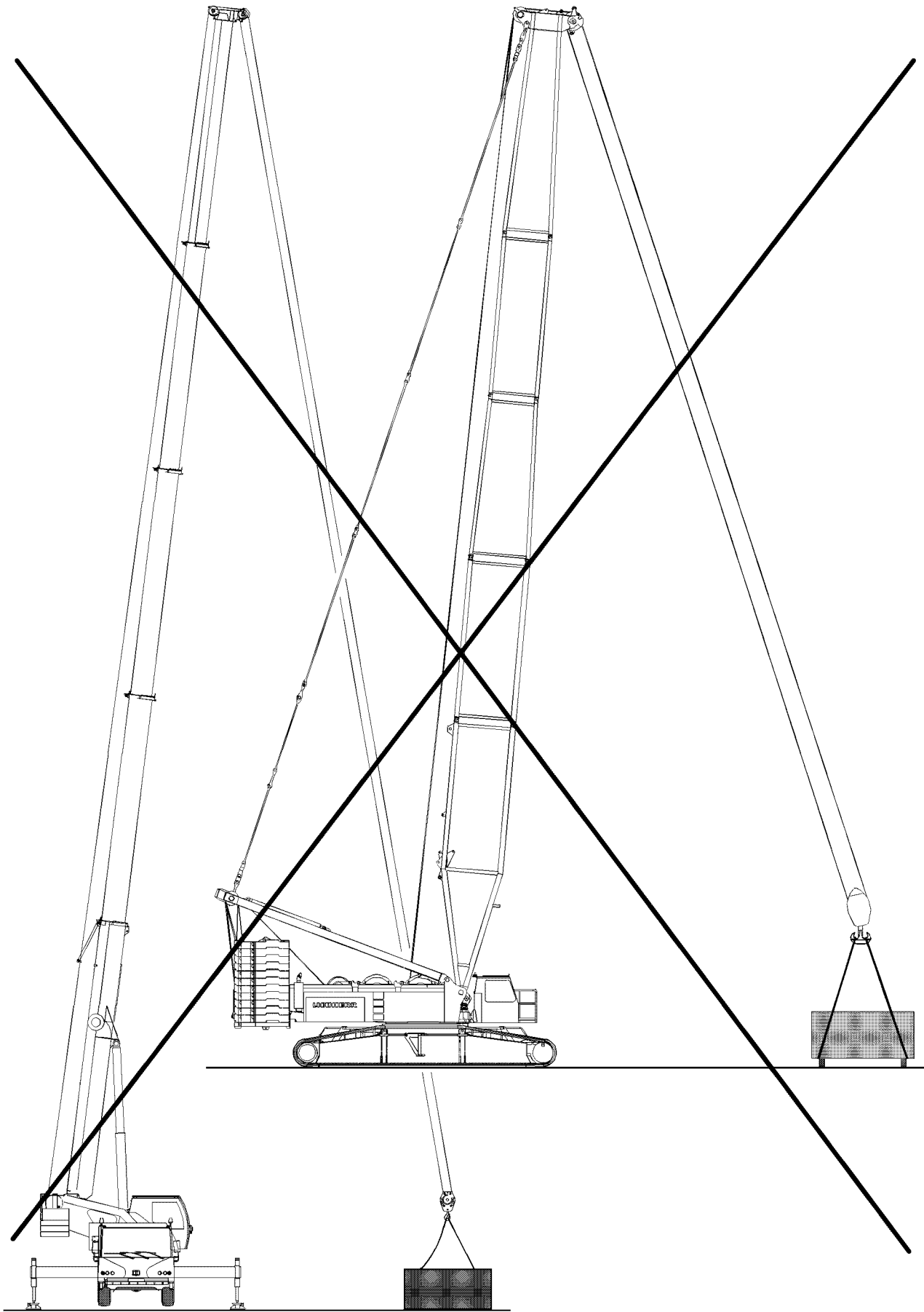

LWE/LR 11000-001/23501-04-02/en

Fig.102716

4.4 Lifting the load



WARNING

Danger of crushing for people in the load zone!

If personnel is located between the load to be lifted and a possible interfering edge (such as a wall of a building or similar) when the load is lifted, personnel can be severely injured or killed.

- ▶ Before lifting the load it must be ensured that there are no persons within the danger zone.
- ▶ It is prohibited to remain in the danger zone.
- ▶ It is prohibited for anyone to be under the load. Maintain a safe distance.
- ▶ Swinging the load is prohibited.
- ▶ Exercise extreme caution when lifting a load.



WARNING

The crane can topple over!

If an attempt to lift a load over the hoist gear causes the LICCON overload protection to turn off, then the load may not be lifted by luffing up the boom. This causes overload or toppling the crane. Personnel can be severely injured or killed.

- ▶ Do not lift the load by luffing up the boom off the ground.



Note

When using the assembly winch* observe the following:

- ▶ Use the assembly winch* only for assembly and not for lifting loads.
- ▶ Lifting of loads with the auxiliary winch is prohibited.

If the fastening rope is manually attached by an assistant to the load to be lifted:

- Make sure that the assistant's hands are not crushed by the tightened ropes between the load and the fastening rope.
- Make sure that the assistant's body parts (hands, legs etc.) are not crushed by a swaying movement of the load during lifting.

4.5 Angular pulling



WARNING

The crane can topple over!

Angular pulling can destroy the crane or cause it to topple over.

Personnel can be severely injured or killed.

- ▶ Fasten (hang) the hook block always vertically over the center of gravity of the load to be lifted.
- ▶ Do not use the slewing gear to pull and set up loads.
- ▶ When lifting, compensate for boom deflection.
- ▶ Angular pull is prohibited.

The crane is designed only to lift loads vertically. During angular pulling, regardless of whether this is done in the same direction as the boom or laterally, horizontal forces are generated from the load in addition to the vertical forces, for which the boom is not designed.

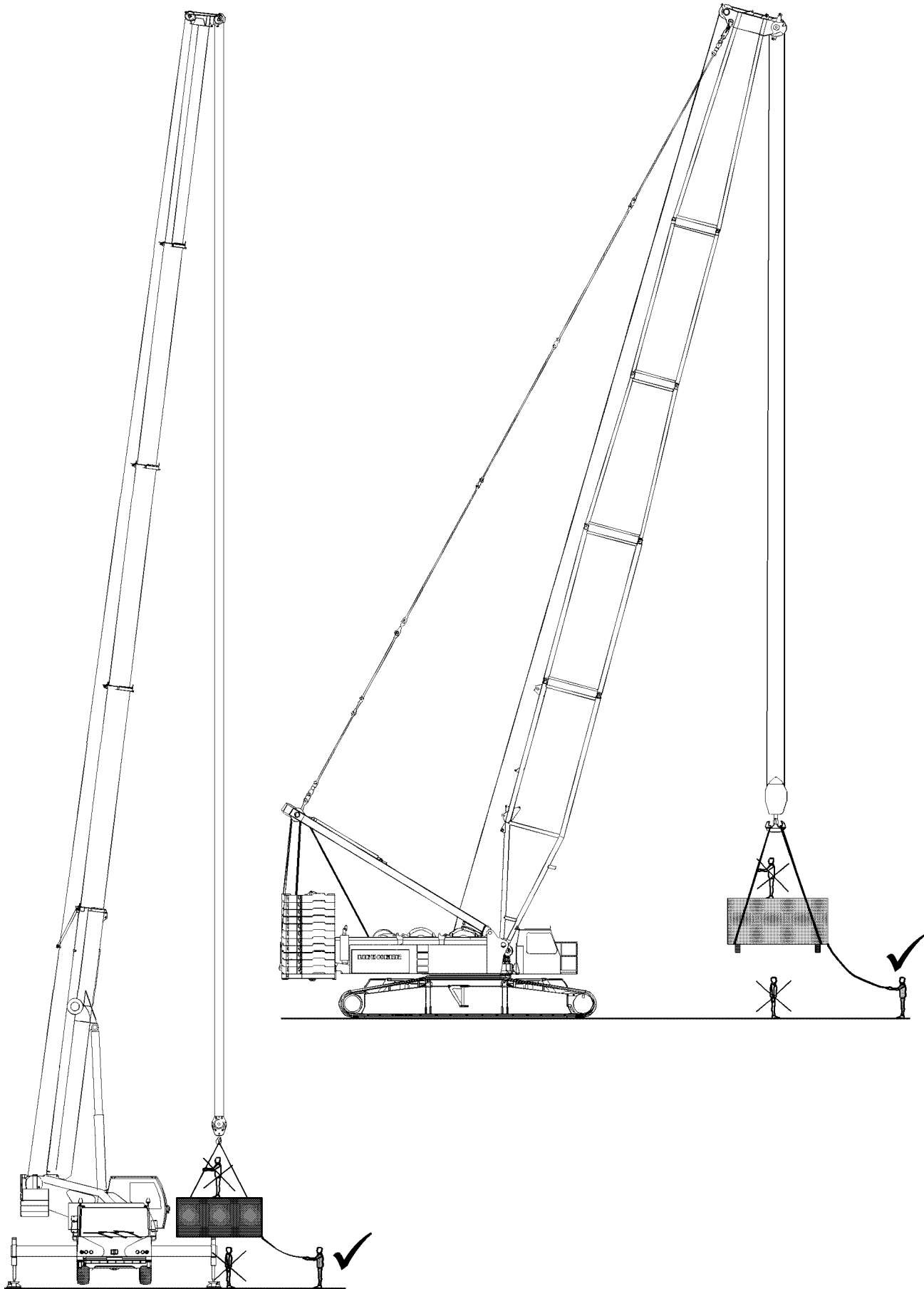

Fig.102717

LWE/LR 11000-001/23501-04-02/en

4.6 Breaking away fixed loads



WARNING

The crane can topple over!
Ripping stuck loads free can destroy the crane or cause it to topple over.
Personnel can be severely injured or killed.
▶ Ripping stuck loads free is prohibited.

5 Crane operation

The maximum load capacity of the crane is not just limited by the stability, but in many cases a load-bearing component breaks when the crane is overloaded **before** the crane topples over. Components that are susceptible to buckling such as the telescopic boom may fail suddenly **without showing signs of distortion beforehand** if the crane is overloaded.



WARNING

Danger of accidents for cranes with luffing cylinders!
When the luffing cylinder is on block position, the overload protection is not functioning.
▶ Crane operation at block position of luffing cylinders is prohibited.

5.1 General

A suspended load must always be kept under control. A fundamental requirement for this is the safe and delicate control of the crane's functions.



WARNING

Danger of accident due to swaying loads!
A swaying load can damage the crane and cause it to topple.
▶ All crane movements must be executed slowly and delicately.
▶ Initiate all crane movements slowly.
▶ Apply the brakes slowly in all crane movements.
▶ Crane operation with swaying load is prohibited.

NOTICE

Damage of rope pulleys!
▶ Place down hook blocks, booms, folding jibs, jib booms and boom noses in such a way that the rope pulleys do not lie on the ground and are damaged.

5.2 Guiding the load

The use of guide ropes is recommended to help the crane operator manage the load more precisely and to prevent the load from swaying. This will prevent undesirable movements of the load and consequent damage.

5.3 Danger of crushing



WARNING

Danger of fatal injury!

Extreme care is needed when lowering a load. Danger of fatal injury exists for personnel in the immediate area of the load being lowered.

Personnel can be severely injured or killed.

- ▶ Standing under a suspended loads is strictly prohibited.
- ▶ Observe the danger of tipping when setting down the load. For example, small support surfaces or unsuitable ground.

5.4 Danger of falling



WARNING

Danger of fatal injury!

If persons are on the suspended load, then they can fall down and be severely injured or killed.

- ▶ Remaining on a suspended load is strictly prohibited.
- ▶ Remaining on or within crane components (for example: At assembly of boom sections, lattice sections) which are moved during lifting, lowering, turning or closing procedures is strictly prohibited.

5.5 Working in the vicinity of electricity transmission lines

If there are electricity transmission lines in the immediate vicinity of the building site, then the electrical transmission lines must be turned off by qualified electricians. If this is not possible, the danger area must be covered over or cordoned off.



WARNING

Danger of current transfer!

If electricity transmission lines are not shut off nor covered nor blocked off, then there is an increased danger of accident due to current transfer.

- ▶ For rated voltages to 500 kV AC: Adhere to a safety distance of 8 m.

If the crane becomes electrified despite having taken all necessary precautions, proceed as follows:

- ▶ Remain calm!
- ▶ Do not leave the crane cab.
- ▶ Warn people outside: Stay in place and do not touch the crane.
- ▶ Move the crane away from the danger zone.

5.6 Ram work or pulling sheet piles

Vibration can be transmitted to the supporting steel structure of the crane during ram work or when pulling sheet piles with the crane. This vibration can cause premature fatigue of the material and therefore cracks in the supporting steel structure.



DANGER

Important instructions for „ram work“ or „pulling sheet piles“.

If the crane is used for ram work or pulling sheet piles, then the following instructions must be followed. Failure to follow the instructions can result in damage to the crane.

- ▶ The ramming equipment may not pass on vibrations into the boom.
- ▶ When pulling sheet piles, the maximum pull force of the crane is limited according to the load chart. Restricting the maximum pull force via the crane overload protection **only** is prohibited. The pull force must be additionally checked by measuring.

6 Crane rope pretension

Damage that can occur with multi layer spooling:

- Friction
- Broken wires and loop formation
- Flattenings, deformations

NOTICE

Crane rope pretension too low!

Loosely coiled rope layers.

Rope damage. Reduced service life of the crane rope.

Cutting of the crane rope into the lower rope layers. The load can not be lowered any further.

- ▶ To maximize the service life of the crane rope, carry out the measures in the following sections.
-



Note

- ▶ Liebherr recommends to shorten crane ropes with damage in the cross over area of the coils, in order to lengthen the service life. Shortening the crane rope, see Crane operating instructions, chapter 7.05.50.
-

6.1 Working with a high rope pull

If multiple lifts are performed with a high rope pull, loosen the lower rope layers that are rarely or never spooled out.

NOTICE

Loosely spooled out rope layers!

Rope damage.

Upper rope layers with a high rope pull deform the lower rope layers in the cross over area of the crane rope.

Spooling deformed rope sections over rope pulleys reduces the service life of the crane rope.

- ▶ Place a shorter crane rope.

When the lower rope layers are **not** used during repeat work:

- ▶ Increase the pretension of the lower rope layers: Spool out the entire rope length and then spool back up with the highest rope pull possible. See section „Increasing the hoist rope pretension“.
-

6.1.1 Placing a shorter crane rope



Note

- ▶ Liebherr recommends using the entire rope length.
-

Unused rope sections cause the loosening of the lower rope layers.

When only a part of the crane rope length is used for a longer period of time:

- ▶ Place a shorter crane rope.

6.1.2 Reducing rope unwinding

Telescopic boom

When telescoping out less, then the smallest amount of fixed coiled up crane rope is spooled out.

- ▶ Telescope out as little as possible.

Picking up the fastening equipment

If the fastening equipment with a flat boom system must be picked up, then the smallest possible amount of crane rope is spooled up loose.

- ▶ Establish a flat boom system: Telescope out or luff up the boom.
- ▶ Pick up the fastening equipment.

6.1.3 Restoring hoist rope pretension

Brief description

If a multi-pulley hook block is reeved, then the entire hoist rope length can be spooled out from the rope drum.

- ▶ Spool the hoist rope out until three safety coils.
- ▶ Create 10 % maximum strand pull: Attach the load.

While the hoist rope is spooled up:

- Hold the load just off the ground.
 - In the permissible range of the load chart of the relevant set up configuration: Increase the load radius by luffing down.
- ▶ Spool the hoist rope up.

Description using the example LR 1600-2, SL3F

This section explains the procedure with the help of the set up configuration for LR 1600-2 with boom system SL3F.

The crane-specific parameters ensure that rope is spooled out until four rope coils and as many rope coils with pretension as possible can be spooled up.

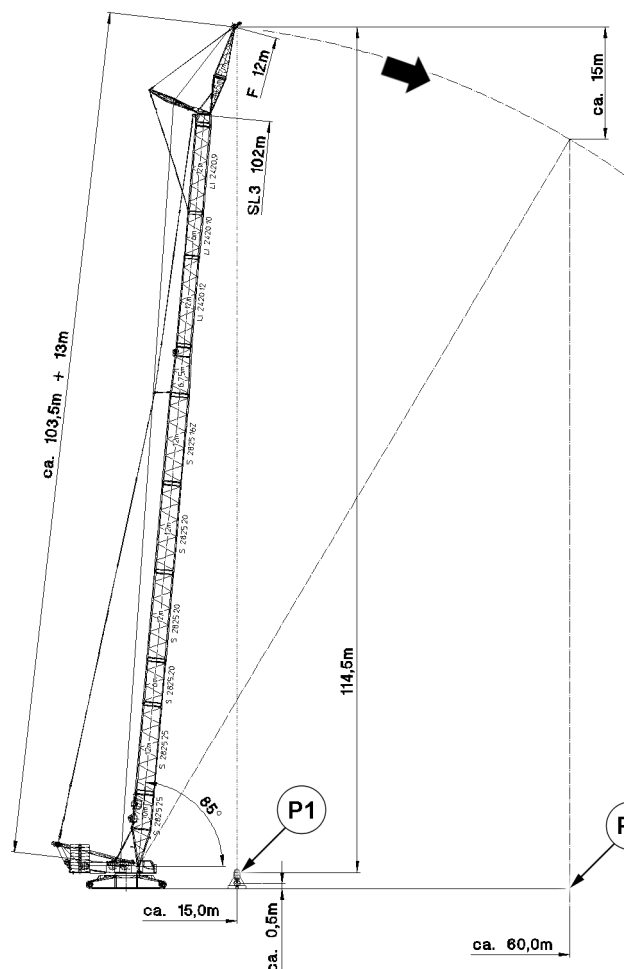

Fig.127131: LR 1600-2, SL3F: Spooling up hoist rope with pretension

Boom radius	Load	10 % of maximum strand pull
60 m	14.4 t	1.8 t

Load example: LR 1600-2, SL3 102, F12, according to the load charts

Hoist rope for this example:

- Hoist rope with a length of 1050 m

Hook block for this example:

- Hook block 200 DM, 5-pulley, reeved 8 times
- The weight of the hook block with ten auxiliary weights is 7.0 t

To reach sufficient rope pull, another load must be hung in addition to the hook block.

Make sure that the following prerequisites are met when hanging the load:

- Load is hung as short as possible.
- For a boom radius of 15.0 m, the hoist rope can be spooled out on the winch until four coils.
- The load is suspended over the ground.

- ▶ Pick up the load with 7.4 t.
- ▶ Set the boom system to boom radius 15.0 m.
- ▶ Spool the hoist rope out.

Result:

- In position **P1** there are 9 m of hoist rope (four coils) on the hoist winch:

Spoiled out rope section	Length
8-way reeving, distance of ground to the F-jib with boom radius 15 m	8 x 114,5 m = 916,0 m
Winch to FA-frame	103.5 m
F-head	13.0 m
Rope pulleys	7.5 m
Total of spoiled out hoist rope	1040.0 m

Rope lengths in position P1

While the hoist rope is spooled up:

- Hold the load just off the ground.
- In the permissible range of the load chart of the relevant set up configuration: Increase the load radius by luffing down.
- ▶ Spool up the hoist rope and luff down the boom at the same time until boom radius 60.0 m is reached.
- ▶ Set down the load.

Result:

- The pretension of the first and second position of the rope coils is restored.
- In position **P2** there are 130 m of hoist rope (23 coils) on the hoist winch:

Spoiled up rope section	Length
Four coils initial situation	9 m
8-way reeving, F-jib height difference with boom radius 60 m	8 x 15 m = 120 m
Total of spoiled up hoist rope	130 m

Rope lengths in position P2

- ▶ Make sure that the hoist rope on the winch remains pretensioned: Reeve out the hook block and reeve in with slower reeving. See Reeving plan.

6.2 Picking up and lowering overhead loads

The load is picked up overhead in the following application examples:

- Repowering wind power plants
- Disassembly of slewing tower cranes

NOTICE

Load picked up overhead with loosely coiled rope layers!

The rope pull increases when the load is picked up. The rope coils in the lower rope layers move laterally and are compressed. The hoist rope can cut into the lower rope layers.

- ▶ Spool up the hoist rope without a load only with rope pretension.
-

NOTICE

Load lowered with cut in rope layers!

The hoist rope is pulled jerkily from the lower rope layers. Vibrations are introduced into the crane system.

Cut in hoist rope clamped between the lower rope layers. The load can **not** be lowered any further.

- ▶ To prevent the cutting in of the hoist rope, carry out the measures in the following sections.
-

6.2.1 Increasing the reeving number

NOTICE

Higher reeving number than indicated on the load chart!

Slack rope formation.

The crane load drops due to additional weight from the rope strands and hook block.

If a higher reeving number is not considered in the set up configuration, the load display on the LIC-CON monitor no longer corresponds.

- ▶ Redetermine the hook block weight according to the load chart manual and adjust if necessary.
 - ▶ Check if the crane load is sufficient for higher reeving.
 - ▶ After telescoping out, check if the hook block can still reach the desired position for putting down the load.
-

A higher reeving number reduces the rope pull. A lower rope pull prevents the cutting in of the hoist rope in the lower rope layers.

- ▶ Select the highest reeving number possible for the hoist rope.

6.2.2 Increasing the hook block weight

NOTICE

Lift the hook block without a load!

The hoist rope is spooled up with a low rope pull. The rope layers are spooled up loose on the rope pulley.

- ▶ Increase the rope pull: Increase the hook block weight.
-

A higher hook block weight increases the rope pull.

- ▶ Increase the hook block weight.

If the crane load is sufficient:

- ▶ Attach an auxiliary weight between the load and hook block.

6.2.3 Pretensioning the hoist rope with pretensioning ballast with two hook operation

The pretensioning ballast is **not** included in the Liebherr scope of delivery.

NOTICE

Lift the hook block without a load!

The hoist rope is spooled up with a low rope pull. The rope layers are spooled up loose on the rope drum.

- ▶ Pretension the hoist rope with pretensioning ballast with two hook operation.
-

Make sure that the following prerequisites are met:

- The crane is equipped for two hook operation.
- The pretensioning ballast is present.

Properties of the pretensioning ballast:

- Developed by Liebherr.
- The weight is 4 t.
- Special tow coupling

- ▶ Fasten the pretensioning ballast on the main hook and on the auxiliary hook.

The pretensioning ballast is lifted with the main hook, the auxiliary hook is carried along without a load.

- ▶ Lift the pretensioning ballast.

When the main hook has reached the required height:

- ▶ Stop the main hook.

After the load is completely transferred to the auxiliary hook, the main hook fastening ropes release automatically.

- ▶ Lift the auxiliary hook until the pretensioning ballast hangs completely on the auxiliary hook.

When the main hook fastening ropes have released:

- ▶ Lower the pretensioning ballast with the auxiliary hook and place it on the ground.

Result:

- The full load is present on the main hook.

Empty page!

LWE/LR 11000-001/23501-04-02/en

4.10 Driving from the crane operator's cab

1	Prerequisites for driving the crane (crawler operation)	3
2	Displays in LICCON monitor	7
3	Preparing for driving the crane	13
4	Driving the crane: Load chart available	16
5	Driving the crane: No load chart is available	17
6	Driving the crane: Ballast trailer installed	21
7	Driving the crawler crane	22

Fig. 199898

1 Prerequisites for driving the crane (crawler operation)

For driving the crane (crawler operation) the situations of the travel route are the deciding factor.

- For **ground inclines within the area of a valid load chart Driving with load** is possible at slow speed. The ground must be sufficiently level and capable of supporting the load. The addendums to the load charts for driving the crane must be observed.
- For **ground inclines outside the area of a valid load chart Driving without load** is possible at slow speed up to certain incline ranges. The ground must be sufficiently level and capable of supporting the load.

Driving the crane: Load chart available

- valid and regular load chart available
- with load on the hook
- without load on the hook

Driving the crane: No load chart is available

- only without load on the hook
- only without derrick ballast
- with specifications and limitations for the set up configuration of the crane



WARNING

The crane can topple over!

If the permissible inclines of the crane are exceeded, the crane can topple over.

If the permissible surface pressures of the travel route are exceeded, the crane can topple over.

Personnel can be severely injured or killed.

- ▶ Do not exceed the permissible inclines of the crane.
- ▶ Do not exceed the permissible surface pressures for the travel route.



WARNING

The crane can topple over!

If the following specifications, instructions and prerequisites are not observed, then the crane can topple over or be overloaded.

Personnel can be severely injured or killed.

- ▶ The crane operator is responsible for adhering to all specifications, instructions and prerequisites in the crane documentation.
- ▶ The crane operator may not drive the crane if not all specifications, instructions and prerequisites in the crane documentation can be adhered to.
- ▶ The crane operator is responsible for the correct and complete data entry into the LICCON computer system and into the LICCON job planner, if applicable.
- ▶ All acceleration and delay maneuvers must be initiated with extreme caution and at the least possible speed.
- ▶ Depending on the situation, additional observers, who are acoustically or visually connected with the crane operator (for example by radio or sight), may have to support the crane operator with shared responsibility.



WARNING

Combined crane movements at crawler operation!

- ▶ In crawler operation, do not carry out any additional crane movements.
- ▶ Carry out additional crane movements while the crane is at a standstill, if possible.

Make sure that the following prerequisites are met:

- No personnel or objects are within the danger zone.
- The crane is in operational condition.
- The crane is in a set up configuration permitted for travel operation.
- Installed ballast (central ballast, counterweight and derrick ballast) is locked and secured.
- There are no loose objects on the crane.

- The assembly brackets of the crawler carriers are folded down.

1.1 Travel route



WARNING

The crane can topple over!

If the following specifications, instructions and prerequisites are not observed, then the crane can topple over or be overloaded.

Personnel can be severely injured or killed.

- ▶ The transfer from the horizontal into an uphill slope and from the uphill slope into the horizontal must be made evenly, i.e.: There may be no edges which can cause the crane to topple over. Any incline changes must be made continuously.
- ▶ If the travel route cannot safely take on the surface pressure, then measures must be taken to be able to safely induce the forces into the ground.
- ▶ If measures were taken to induce the forces into the ground, then they must be checked by an expert before starting to drive for proper execution and sufficient supportability.
- ▶ An insufficient ground condition can cause accidents, for example the crane can slide away to the side and as a result get into an impermissible incline position.

Make sure that the following prerequisites are met:

- Before starting to drive, the travel route was determined.
- Before starting to drive, the condition of the ground has been checked.
- The entire travel route can safely absorb the surface pressure.
- All inclines occurring on the travel route can be driven safely by the crane.
- The entire travel route is free of obstacles.
- The friction coefficient between crawler track and ground is sufficiently large to absorb the occurring drive forces or to eliminate the crane from slipping away in an incline position.
- Possible environmental influences for driving the crane (among others precipitation and wind) were taken into account for the travel route.
- The travel route was selected and prepared in such a way that the boom system can be taken down at any time.
- Select the travel route in such a way that no steering movements are required, if possible.
- With load on the hook: Setting down the load is possible at any time.
- The entire travel route is secured as a danger zone.
- The travel route has been selected in such a way that a sufficient distance to local facilities (among others power lines) can be retained.

For falling terrain gradients outside the range of a valid load chart, the following applies additionally:

- Before starting to drive, the travel route was checked in connection with the actual set up configuration of the crane on the LICCON job planner.
- Before starting to drive, the optimum positions for the boom system were determined to obtain as even a surface pressure as possible - the LICCON job planner can be used for this purpose.



Note

- ▶ For a detailed description of the LICCON job planner on the crane, see the operating instructions LICCON job planner.
- ▶ For a detailed description of the computer program LICCON job planner, see separate description.

1.1.1 Optimizing measures for travel route

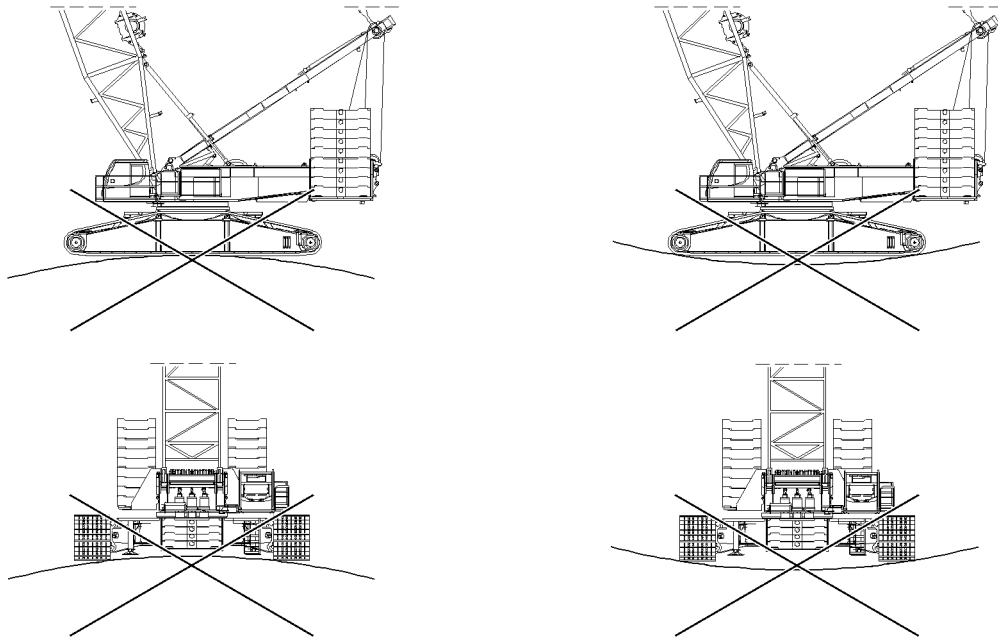

Fig.119598: Depressions, crests, track grooves and other uneven areas of the travel route cause punctiform strain to the track.

NOTICE

Damage to the track!

Continuous punctiform strain to the track causes increased wear. Continuous increased wear can cause damage to the track.

- ▶ Set up the travel routes in such a way that the track is not subjected to continuous punctiform strain.
 - ▶ For extended travel operation shorten the maintenance intervals.
-

Through the following configuration features of the travel route, wear on the track can be minimized:

- Shapings of the travel route (such as depressions, crests, track grooves) have been eliminated via suitable measures.
- Lay out the travel route in such a way that no steering movements are required, if possible.

1.2 Calculation of required length of transfers in uphill / downhill slopes

The required length **L** for transfers results from the existing uphill angle α and the length of the crawlers **LC**.

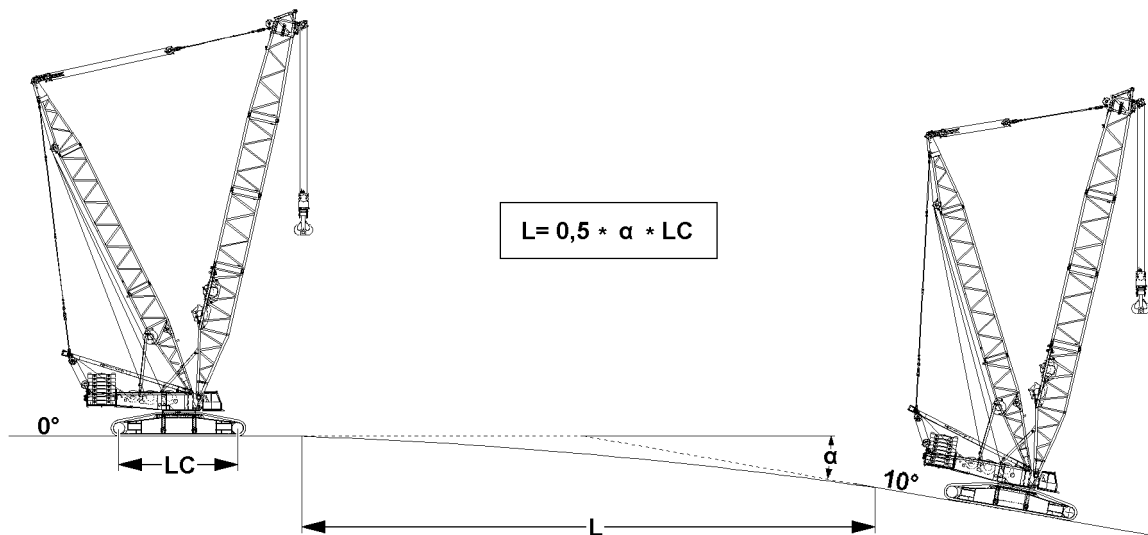

Fig.119612

Abbreviation	Description
L	Required length of transfers
α	Angle Rising / falling inclines in degrees
LC	Length of crawlers between drive wheels / steering wheels

1.2.1 Calculation example

Given:

$$\alpha = 10^\circ$$

LC = 17.3 m (use only the actual value of the crane!)

Wanted:

$$L = ?$$

Calculation formula						
L	=	0,5	*	α	*	LC
L	=	0,5	*	10	*	17.3 m
L	=	86.5 m				

1.3 Travel gears / hydraulic motors / track rollers

NOTICE

Damage to the travel gear, hydraulic motors and track rollers!

On longer travel routes and / or when driving uphill / downhill, the travel gears, hydraulic motors and / or track rollers can be overheated and damaged.

- ▶ Make sure that the travel gears - before driving the crane - are on maximum fill level.
- ▶ With suitable measuring devices make sure that the maximum permissible temperature of the travel gears, hydraulic motors and / or track rollers in travel operation over longer distances is below 90 °C. For a short time (**maximum** 10 minutes), the temperature may increase to a value between 90 °C and 100 °C.
- ▶ As soon as the maximum permissible temperature on one position is exceeded, take a break for cooling off.
- ▶ The crane operator is responsible for any damage on travel gears, hydraulic motors and / or track rollers.

When the maximum permissible temperature range on a travel gear and / or hydraulic motor is reached:

- ▶ Take a break until the temperature on travel gear(s), hydraulic motor(s) and / or track rollers had dropped considerably.

Maximum permissible temperature range on travel gear(s) / hydraulic motor(s)		
	to 90 °C	between 90 °C and 100 °C
Duration of exposure	continuous	not longer than 10 minutes

When the temperature has dropped on all travel gears / hydraulic motors under 90 °C:

- ▶ Travel operation is permissible again.

2 Displays in LICCON monitor



WARNING

Danger of accident due to deviating set up configuration!

If the actual set up configuration of the crane deviates from the entries and settings in the Set up program, then the overload protection is not correctly set.

An incorrectly set overload protection calculates the actual load incorrectly and transmits faulty display values.

The crane can be overloaded without noticing it and topple over or collapse as a result.

Personnel can be severely injured or killed.

- ▶ The entries and settings in the set up program must match the actual set up configuration of the crane.



WARNING

Incorrect display values!

If the display values do not increase correspondingly when lifting known weights, an erroneous display value may be present.

If the crane is operated with erroneous display values, then the crane can be overloaded.

This could result in serious accidents.

- ▶ When lifting the hook block off the ground check if the display value for the actual load increases correspondingly.
- ▶ When lifting the derrick ballast off the ground check if the display value for the pulled derrick ballast BA_{pulled} increases correspondingly.
- ▶ When lifting the load off the ground check if the display value for the actual load increases correspondingly.

Make sure that the following prerequisites are met:

- The actual set up configuration of the crane matches with the entries and settings in the set up program.
- The assignment of the crane to the displays in the LICCON monitor is clear.
- All displays function flawlessly.



Note

- For a detailed description of the displays in the LICCON monitor, see Crane operating instructions, chapter 4.02.
- For a detailed description of the safety devices, see Crane operating instructions, chapter 4.04.

2.1 Display for the center of gravity in the LICCON monitor



WARNING

Shifting of center of gravity!

The calculation of the values for the display of the center of gravity in the LICCON monitor are based on ideal assumptions.

- Side deformations of the boom system due to wind, inclined position and elastic resilience of the steel structure are not taken into account but they can lead to a shifting of the center of gravity.

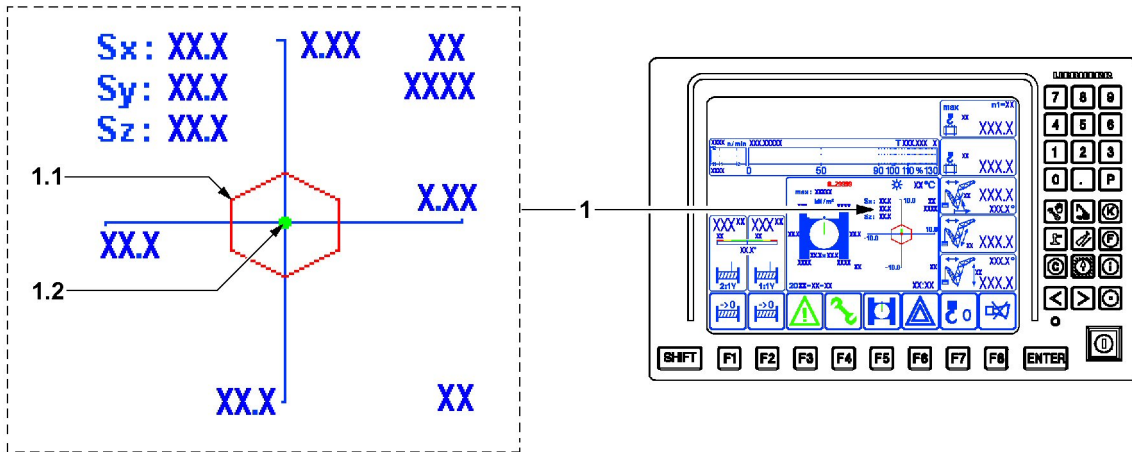

Fig.115325

Display Center of gravity 1	
Position	Description
1.1	Core surface
1.2	Center of gravity



WARNING

Center of gravity of the crane is outside the core area!

If the center of gravity 1.2 of the crane is outside the core area 1.1, then the crane can topple over. Personnel can be severely injured or killed.

- To drive the crane, the center of gravity 1.2 must always be within the core area 1.1.
- If the center of gravity 1.2 is outside of the core area 1.1, then it is prohibited to drive the crane.

The following specifications and instructions must be observed:

- By luffing the boom system up and down, the position of the center of gravity 1.2 must be corrected in such a way that the overall center of gravity remains within the core area 1.1.

2.2 Display for surface pressure in the LICCON monitor



WARNING

Increased surface pressure!

The calculation of the values for the display of the surface pressure in the LICCON monitor are based on ideal assumptions.

- ▶ Side deformations of the boom system due to wind, inclined position and elastic resilience of the steel structure are not taken into account but they can lead to an increase of the surface pressure.

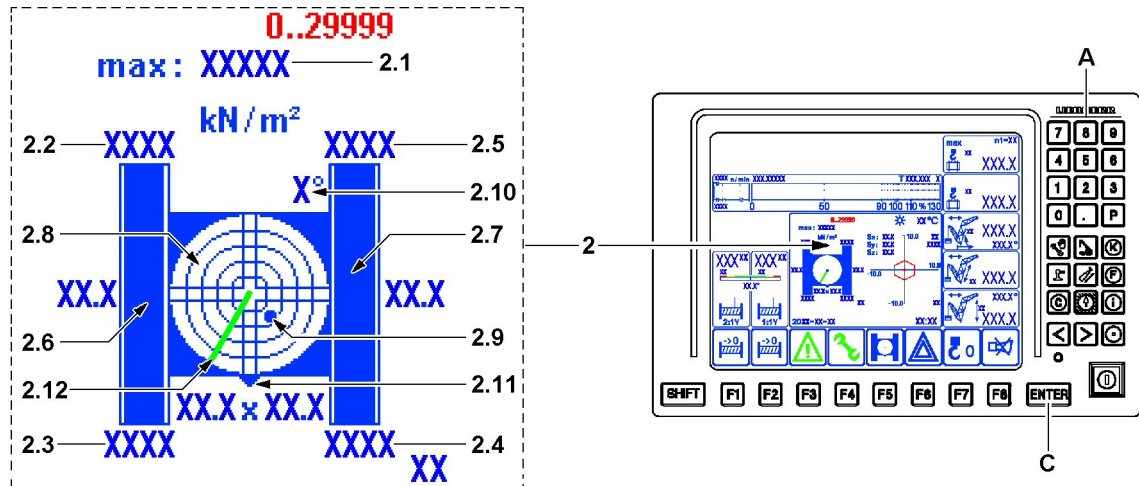

Fig.119613

Display Surface pressure 2	
Position	Description
2.1	Maximum surface pressure
2.2	Surface pressure right rear
2.3	Surface pressure right front
2.4	Surface pressure left front
2.5	Surface pressure left rear
2.6	Placement surface Track right
2.7	Placement surface Track left
2.8	Incline display ¹⁾
2.9	Point ¹⁾
2.10	Display resolution ²⁾
2.11	Marker „Front side of crawler carrier“ ³⁾
2.12	Boom direction ⁴⁾

1) The graphic display is in the form of a spirit level with a moving dot **2.9** representing the air bubble.

2) This value describes the resolution of the graphic view. The resolution is matched automatically to the incline.

3) The front on the crawler travel gear is always on the side where the chain tension devices for the crawler carriers are located.

4) Current boom direction in reference to the displayed icon.

**WARNING**

Surface pressure too high!

If the maximum surface pressure is exceeded, the crane can topple over.

Personnel can be severely injured or killed.

- ▶ Do not exceed the maximum surface pressure.
- ▶ The value entered in the LICCON computer system for the maximum surface pressure **2.1** must match the actual conditions of the travel route.

**WARNING**

The crane can topple over!

If the permissible incline of the crane is exceeded, the crane can topple over.

- ▶ Do not exceed the permissible incline from the load chart.
- ▶ Do not exceed the permissible incline for driving the crane, see the following sections.

**Note**

- ▶ The placement surface of the crawler carriers is graphically shown in the display of the surface pressure.
- ▶ If the resulting surface pressure can be distributed so that the maximum surface pressure of the travel route is not exceeded **and** the resulting forces can be transferred safely into the ground, then the stability of the crane is ensured.
- ▶ Incline display **2.8** with number values, see section „Display of incline in LICCON monitor“.

The following specifications and instructions must be observed:

- The maximum surface pressure, which may be reached, must be entered as the maximum surface pressure **2.1**.
- By luffing the boom system up and down, the resulting surface pressure must be distributed in such a way that the maximum surface pressure of the travel route is not exceeded.
- Inclines, which are reached on the travel route are known and are taken into account.
- As soon as the crane shows the tendency that the permissible incline could be exceeded, the load must be set down. If necessary, driving the crane must be interrupted.

2.2.1 Entering the maximum permissible surface pressure

Make sure that the following prerequisites are met:

- The Crane operation program is called up.
- The maximum permissible surface pressure of the travel route is known.

- ▶ Press the enter key **C**.

Result:

- The value for the maximum surface pressure **2.1** can be changed.

- ▶ Enter the value for the maximum permissible surface pressure via the keyboard **A**.

- ▶ Press the enter key **C**.

Result:

- The new value for the maximum surface pressure **2.1** appears.

- ▶ Check the value for the maximum permissible surface pressure.

2.3 Display for the incline in the LICCON monitor

The display of the incline is additionally shown at the monitored auxiliary functions.

Display of the incline of the crane to the horizontal in longitudinal and lateral direction. The display is graphic as well as numeric.

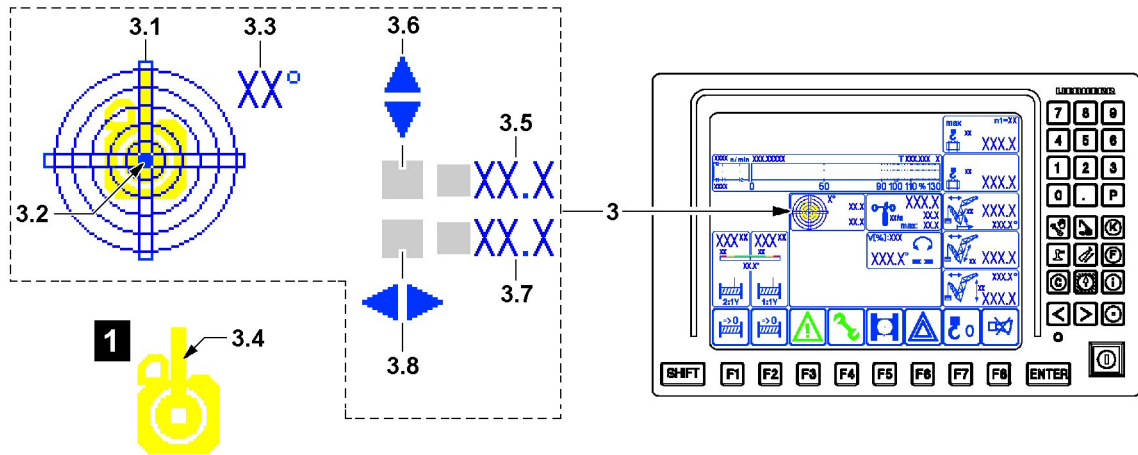

Fig.115327

Display Incline 3	
Position	Description
3.1	Sight gauge
3.2	Bubble
3.3	Resolution of view
3.4	Boom position ³⁾
3.5	Incline in longitudinal direction
3.6	Incline direction
3.7	Incline in lateral direction
3.8	Incline direction

3) The boom position in the sight gauge 3.1 is highlighted as orientation aid, see detail 1. The boom position corresponds to the „viewing direction to the front“ from the crane cab in relation to the sight gauge 3.1.



WARNING

The crane can topple over!

If the permissible incline of the crane is exceeded, the crane can topple over.

- ▶ Do not exceed the permissible incline from the load chart.
- ▶ Do not exceed the permissible incline for driving the crane, see the following sections.

The following specifications and instructions must be observed:

- Inclines, which are reached on the travel route, are known and are taken into account.
- As soon as the crane lets the tendency to be known that the permissible incline could be exceeded, the load on the hook and / or the suspended ballast must be set down.

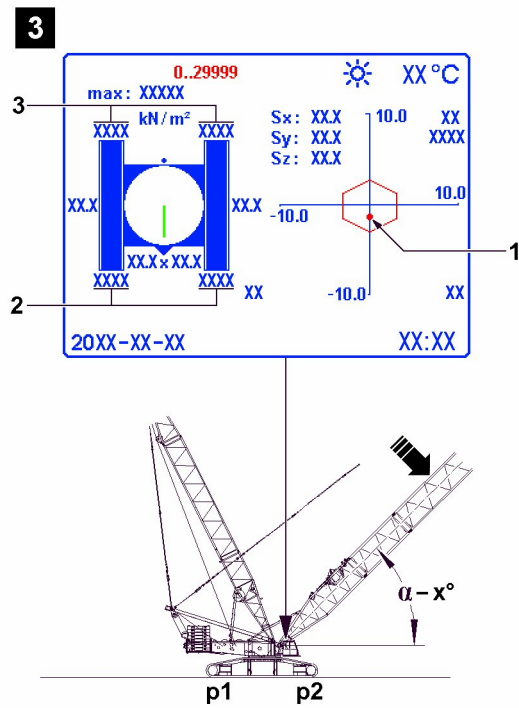
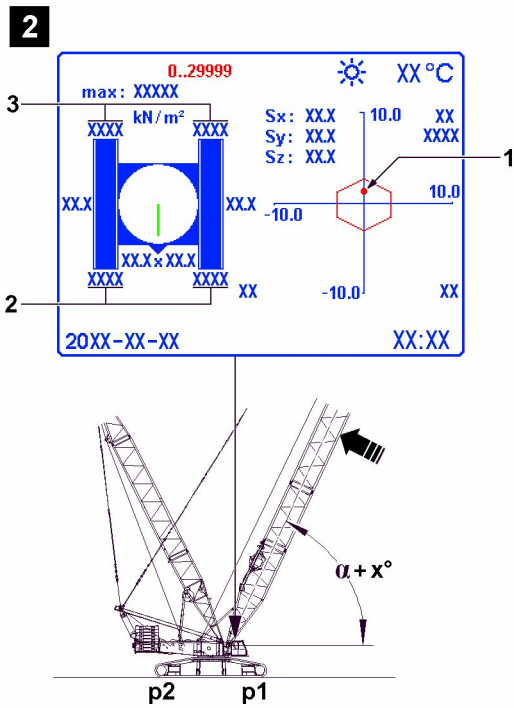
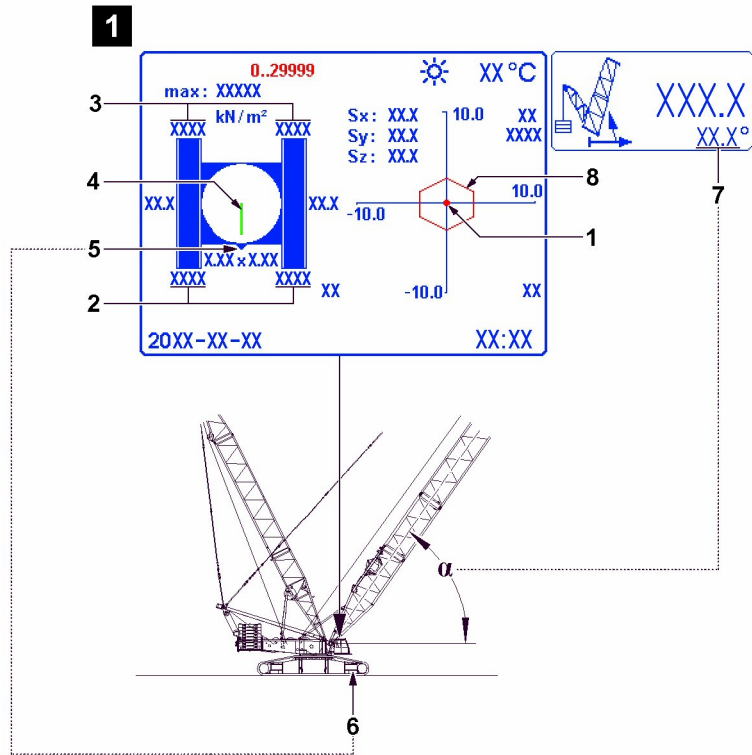

Fig.119635

LWE/LR 11000-001/23501-04-02/en

3 Preparing for driving the crane

3.1 Distribution of surface pressure

While driving, pay attention in all driving conditions to the ratio of the surface pressure between the front and the rear sides of both crawlers.

In the following examples it is assumed that the crawler travel gear and the turntable are oriented to the front.

Distribution of surface pressure	
Position	Description
1	Center of gravity
2	Surface pressure front
3	Surface pressure rear
4	Boom position ¹⁾
5	Marker „Front side of crawler carrier“ ⁽²⁾
6	Chain tension device Crawler carrier
7	Display angle main boom
8	Core surface
α	Angle main boom

1) The boom position corresponds to the „viewing direction to the front“ from the crane cab.

2) The front on the crawler travel gear is always on the side where the chain tension device for the crawler carriers is located.

Before driving the crane it is required to position the boom in such a way that a suitable distribution of surface pressure for driving is obtained.

3.1.1 Examples for the distribution of surface pressure

The center of gravity **1** is in the center, illustration 1

- The surface pressure on the front **2** is the same as the surface pressure on the rear **3**.

The center of gravity **1** is in the rear, illustration 2

- The main boom was luffed up.
- The surface pressure on the rear **3** is higher.

The center of gravity **1** is in the front, illustration 3

- The main boom was luffed down.
- The surface pressure on the front **2** is higher.

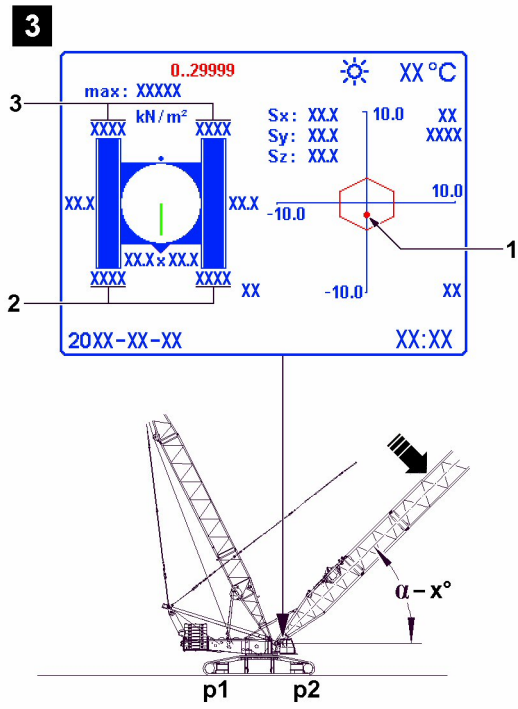
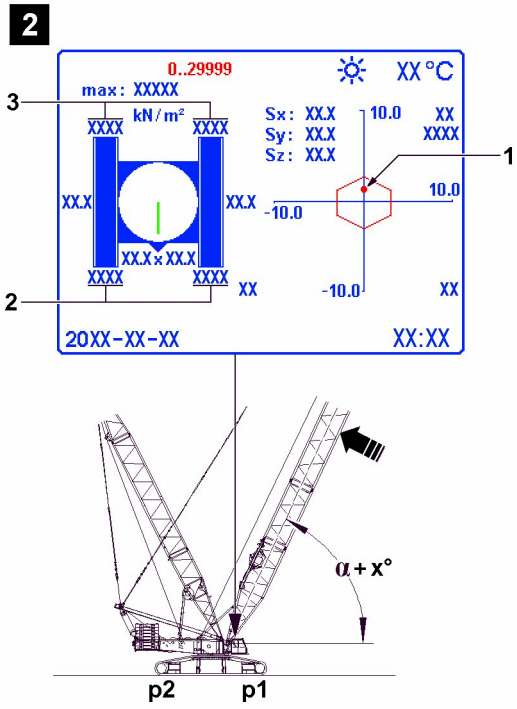
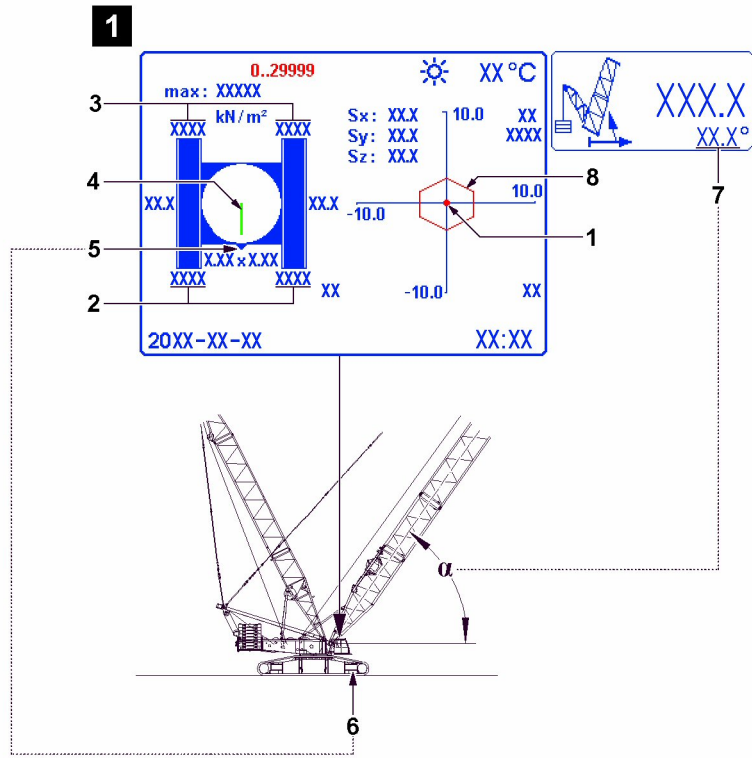

Fig.119635

LWE/LR 11000-001/23501-04-02/en

3.2 Suitable distribution of surface pressure

If the distribution of the surface pressure is even (surface pressure front **2** and surface pressure rear **3** approx. the same value), then steering is difficult or not possible at all.

For the suitable distribution of surface pressure, the following applies:

- p1 = Surface pressure on the side of the two tracks which has the lower load
- p2 = Surface pressure on the side of the two tracks which has the higher load
- The center of gravity **1** must however always be within the core area **8**

Distribution of surface pressure p1 to p2			
p1	/	p2	= should be greater than 0.3

In case of unfavorable distribution of surface pressure it is required to position the boom system in such a way that a suitable distribution of the surface pressure is reached for driving.

- ▶ The turntable should be turned while at a standstill: The boom system should be luffed in such a way that the crawlers are subjected to a load as evenly as possible.
- ▶ Driving uphill: The boom system should be luffed in such a way that the side of the two crawlers which has less of a load is on the rear.
- ▶ Driving downhill: The boom system should be luffed in such a way that the side of the two crawlers which has less of a load is on the front.



Note

- ▶ The side with the higher surface pressure should be within the field of vision of the crane operator or the auxiliary personnel. To ensure that it is recognized early on that the crawler carriers sink in and the respective countermeasures can be initiated.

3.3 Steering ability



Note

High load on the crane!

When driving the crane, steering movements cause a high load on the crane travel gear.

- ▶ If possible, forego steering movements with load on the hook and / or derrick ballast.
- ▶ Select the travel route in such a way that no steering movements are required, if possible.
- ▶ If not otherwise possible, before initiating a steering movement, set down the load and / or derrick ballast.

The steering ability depends on the following factors:

- Friction conditions under the chains
- Evenness of the ground:
 - Steering is not possible if the crawler travel gear is only making contact with the ground at the front and rear.
- Load bearing capacity of the ground:
 - If the crawler travel gear sinks into the ground, then the steering ability is significantly restricted.
- Position of the total center of gravity:
 - If the total center of gravity - under consideration of the suspended load - is at the center of the crane, then steering is hard or not possible at all.

The steering ability can be improved by:

- Placing metal sheeting, sand, gravel, water underneath.
- By taking the load bearing capacity of the ground and the position of the center of gravity into account: Changing the center of gravity.

4 Driving the crane: Load chart available



WARNING

The crane can topple over!

If the following conditions are not observed, the crane can topple over.

Personnel can be severely injured or killed.

- ▶ The ground must be sufficiently level and within the range of permissible incline.
- ▶ The ground must be able to safely take on the maximum occurring surface pressures.



WARNING

The crane can topple over!

If the permissible inclines of the load charts are exceeded when driving the crane, then the crane can topple over or be overloaded.

If the permissible wind speeds of the load charts are exceeded when driving, then the crane can topple over or be overloaded.

Personnel can be severely injured or killed.

- ▶ If the inclines are too large then driving the crane is prohibited.
- ▶ If the wind speeds are too large then driving the crane is prohibited.

Make sure that the following prerequisites are met:

- The permissible inclines from the load charts are adhered to.
- The maximum permissible wind speeds from the load charts are adhered to.
- The maximum permissible travel speed are adhered to.
- Straight forward driving: The turntable is aligned parallel to the crawler track, 0° or 180° position.
- Turning: The slewing gear freewheeling is actuated.

Permissible inclines	
Overall incline	Load charts for incline $\pm 0.3^\circ$
Overall incline ¹⁾	Load charts for incline $\pm 1.0^\circ$

1) Only certain boom systems

Permissible wind speeds	
Wind speeds	See load charts

Driving with a load is possible under specifications of the regular load chart:

- The permissible inclines from the load charts apply for driving.
- Take the maximum permissible wind speeds from the load charts.
- Take the maximum permissible driving speed from the following sections!

4.1 Driving with a load on the hook and / or derrick ballast



WARNING

The crane can topple over!

If the load on the hook or the suspended ballast collide with the crane, the ground or obstacles when driving, then the crane can be damaged and topple over.

Personnel can be severely injured or killed.

- ▶ Make sure that the load on the hook or the suspended ballast do not collide with anything when driving.

**WARNING**

Danger of accident!

If the suspended load or the suspended derrick ballast starts to swing, then the crane operator can lose control over the crane.

If the following prerequisites are not observed, the crane can topple over.

This could result in serious accidents.

- ▶ Do not exceed the maximum permissible driving speed.
- ▶ Avoid jerky driving movements.
- ▶ The attached load and suspended derrick ballast must be secured to prevent it from swinging. If oscillating movements should occur, set the load / derrick ballast as fast as possible down on the ground. Hereby pay attention to the limit values of the load moment display and the F-load display.
- ▶ Driving and steering the crawler at the same time with suspended load and / or installed derrick ballast is prohibited.

Make sure that the following prerequisites are met:

- The permissible inclines from the load charts are adhered to.
- Without derrick ballast: The travel speed may **not** exceed 0.1 m/s **or** 6 m/min **or** 0.36 km/h
- With derrick ballast: The travel speed may **not** exceed 0.05 m/s **or** 3 m/min **or** 0.18 km/h
- The rapid gear crawler operation may not be engaged.
- The attached load hangs freely.
- The attached load must be secured to prevent it from swinging back and forth, if necessary.
- Hold the attached load close to the ground.
- Hold the attached load at a small radius.
- For derrick ballast: The suspended ballast hangs freely.
- For derrick ballast: The suspended ballast is lifted off the ground no more than maximum 250 mm.
- For derrick ballast: The derrick ballast must also be secured to prevent it from swinging back and forth.

4.2 Driving without a load on the hook and without derrick ballast

Make sure that the following prerequisites are met:

- The crane is driving according to the inclines from the load charts.
- Take the maximum permissible wind speeds from the load charts.
- the travel speed may not exceed 0.4 m/s **or** 24 m/min **or** 1.44 km/h
- The hook block is secured to prevent it from swinging back and forth.

5 Driving the crane: No load chart is available

**WARNING**

The crane can topple over!

If the following note is not observed, the crane can topple over.

Personnel can be severely injured or killed.

- ▶ Driving uphill must always be anticipatory, with upmost caution and at the slowest speed.
- ▶ Drive on starting rising and falling inclines (for example ramps) at a right angle.
- ▶ It is prohibited to let the crane tip over an edge.

**WARNING**

The crane can topple over!

If the crane is driven outside the load chart with a load or with the derrick ballast, accidents can occur.

The crane can topple over or be overloaded.

Personnel can be severely injured or killed.

- ▶ Driving the crane with a load outside the load chart is prohibited.
- ▶ Driving the crane with derrick ballast outside the load chart is prohibited.

Make sure that the following prerequisites are met:

- There is no load on the hook.

- No derrick ballast is installed.
- The oil level of the crane engine is at maximum fill level.
- The oil level in the hydraulic oil tank must be lowered by extending the cylinders so that an overflow is not possible.
- The contents of the fuel tank must be reduced so that an overflow is not possible, even at the largest crane incline.
- The travel speed may **not** exceed 0.1 m/s **or** 6 m/min **or** 0.36 km/h
- Straight forward driving: The turntable is aligned parallel to the crawler track, 0° or 180° position.
- Turning: The slewing gear freewheeling is actuated.
- The maximum permissible wind speed of 9 m/s is adhered to.
- The permissible lateral incline when driving without a load is adhered to.
- The permissible longitudinal incline when driving without a load is adhered to.

Permissible lateral incline when driving without load and without derrick ballast		
Overall length main boom	Maximum permissible lateral incline	For longitudinal incline
Shorter / equal to 96 m	± 3°	± 0,3°
97 m to 150 m	± 2°	± 0,3°

Permissible longitudinal incline when driving without load and without derrick ballast		
Overall length main boom	Maximum permissible longitudinal incline	For lateral incline
To 150 m	± 10°	± 0,3°

5.1 Driving uphill / downhill



WARNING

The crane can topple over!

If the following notes are not observed, the crane can topple over.

Personnel can be severely injured or killed.

- ▶ Deciding for driving uphill are the exact knowledge of operational conditions on the jobsite.
- ▶ Specifications, instructions and prerequisites in this chapter must be adhered to.
- ▶ Driving uphill / downhill must always be anticipatory, with utmost caution and at the slowest speed.



WARNING

The crane can topple over!

If the crane is driven uphill / downhill with a load or derrick ballast, the crane can topple over.

If the angle of the boom system is not matched to the incline when driving the crane in uphill inclines, then the crane can topple over.

- ▶ Match the angle of the boom system to the uphill slope.
- ▶ Driving uphill with a load and / or derrick ballast is prohibited!



WARNING

The crane can topple over!

If the turntable is not parallel to the crawler travel gear when driving the crane in uphill or downhill inclines, then the crawler crane can topple over or be overloaded.

- ▶ For downhill gradients of more than 0.3° ,make sure that the turntable is aligned parallel to the crawler track in 0° or 180° position before moving the crawler crane!

**WARNING**

The crane can topple over!

At falling gradients of more than $\pm 0.3^\circ$ the travel direction may not be changed.

- ▶ At falling gradients of more than $\pm 0.3^\circ$ plan the travel route in such a way that a travel direction change is not necessary.

**WARNING**

The crane can topple over!

Longitudinal incline of more than $\pm 0.3^\circ$ and lateral incline of more than $\pm 0.3^\circ$ may not be combined.

- ▶ For a longitudinal incline of more than $\pm 0.3^\circ$ a maximum lateral incline of $\pm 0.3^\circ$ always applies. For a lateral incline of more than $\pm 0.3^\circ$ a maximum longitudinal incline of $\pm 0.3^\circ$ always applies.

Make sure that the following prerequisites are met:

- The turntable is aligned parallel to the crawler track, 0° or 180° position.
- Uphill / downhill slopes with more than $\pm 0.3^\circ$ can be driven without travel direction change.
- The maximum side incline of $\pm 0.3^\circ$ is adhered to.

There are two different possibilities for driving crawler cranes on uphill / downhill slopes:

- By adjusting the angle of the boom system.
- Without adjusting the angle of the boom system.

5.1.1 Maximum climbing ability

The maximum climbing ability of the crawler crane is limited by the following criteria:

- The location of the center of gravity for the complete crawler crane
- The friction coefficient between roadway and track pads
- The transit between the horizontal and the uphill slope
- The maximum uphill incline of 10° up to a boom length of 150 m

5.1.2 Driving uphill / downhill by changing the angle of the boom system

The following specifications and instructions must be observed:

- On level ground, set the optimum angle of the boom system regarding the center of gravity and the surface pressure.
- Uphill / downhill slopes: As soon as the value of the displays for the center of gravity and the surface pressure become more unfavorable, match the boom angle in the permissible range.

**WARNING**

The crane can topple over!

If the limit values for the center of gravity and the surface pressure are exceeded, then the crane can topple over or be overloaded.

- ▶ Driving without display values for the center of gravity and the surface pressure is only permissible when the center of gravity and the surface pressure are otherwise monitored and ensured.

**Note**

Driving without display values for center of gravity and surface pressure!

- ▶ On level ground, set the optimum angle of the boom system regarding the center of gravity and the surface pressure.
- ▶ When driving into an uphill incline, during the transition between the horizontal into the incline, the original angle of the boom system must be changed continuously in such a way that the same angle ratio always remains between the boom system and the horizontal. This angle must be retained in the uphill incline.
- ▶ When driving out from an uphill incline, at the transition from incline into the horizontal, change the angle of the boom system continuously so that always the same angle ratio is retained.
- ▶ As a rule, the center of gravity and the surface pressure of the crane must be taken into account.

Positive longitudinal incline



Note

- ▶ When driving in positive longitudinal inclines (uphill), the main boom must usually be luffed down.

Status	Transition	Boom angle
Driving horizontally	after uphill incline	match
Driving in uphill incline		
Driving in uphill incline	after horizontal	match
Driving horizontally		

Negative longitudinal incline



Note

- ▶ When driving in negative longitudinal inclines (downhill), the main boom must usually be luffed up.

Status	Transition	Boom angle
Driving horizontally	after downhill slope	match
Driving downhill		
Driving downhill	after horizontal	match
Driving horizontally		

5.1.3 Prerequisites for driving uphill / downhill without changing the angle of the boom system

The following specifications and instructions must be observed:

- Make sure that with the selected position of the boom system, the center of gravity and the surface pressure is within the permissible range.



WARNING

The crane can topple over!

If the limit values for the center of gravity and the surface pressure are exceeded, then the crane can topple over or be overloaded.

Personnel can be severely injured or killed.

- ▶ Before driving into uphill and downhill slopes, check the change of the center of gravity and the surface pressure and ensure that it is permissible.
- ▶ Before driving the crane, determine if the crane may drive on the intended route without changing the boom system.
- ▶ If the intended uphill / downhill slope cannot be driven without changing the angle of the boom system, then the boom angle must be changed to be able to drive on the uphill / downhill slope.

5.2 Driving at side inclines



WARNING

The crane can topple over!

At falling gradients of more than $\pm 0.3^\circ$ the travel direction may not be changed.

- ▶ At falling gradients of more than $\pm 0.3^\circ$ plan the travel route in such a way that a travel direction change is not necessary.

**WARNING**

The crane can topple over!

Longitudinal incline of more than $\pm 0.3^\circ$ and lateral incline of more than $\pm 0.3^\circ$ may not be combined.

- ▶ For a longitudinal incline of more than $\pm 0.3^\circ$ a maximum lateral incline of $\pm 0.3^\circ$ always applies. For a lateral incline of more than $\pm 0.3^\circ$ a maximum longitudinal incline of $\pm 0.3^\circ$ always applies.

Make sure that the following prerequisites are met:

- The turntable is aligned parallel to the crawler track (in 0° or 180° position).
- Side slopes with more than $\pm 0.3^\circ$ can be driven without travel direction change.
- The maximum longitudinal incline of $\pm 0.3^\circ$ is adhered to.

6 Driving the crane: Ballast trailer installed

**WARNING**

The crane can topple over if the level of the roadway differs!

Due to impermissible level differences between the ballast trailer roadway and the crane placement level, the entire crane system can be pulled back suddenly.

The relapse cylinders can run to block position. The relapse cylinders and the boom system can be damaged.

Personnel can be severely injured or killed.

- ▶ Do not exceed or fall below the permissible level difference between the ballast trailer roadway and the crane placement level.
- ▶ The travel path of the crane or the circular path of the ballast trailer must be level and of sufficient load bearing capacity.
- ▶ The permissible level difference of the ballast trailer travel path and crane travel path for „towing“ and „parallel driving“ may be no more than maximum 250 mm.
- ▶ The permissible level difference of the ballast trailer path and the crane travel path in relation to the crane travel path for circular driving may be no more than maximum 250 mm - based on a constant uphill incline or constant downhill incline on a 90° turning range.

**WARNING**

Mortal danger if the permissible travel speed is exceeded!

If the permissible travel speed is exceeded, the tires can be damaged.

Personnel can be severely injured or killed.

As a result, significant property damage can occur on the crane and on the ballast trailer.

- ▶ The travel speed of the ballast trailer for turning and driving with more than 80 % of the maximum ballast may be no more than 0.05 m/s or 0.18 km/h.

NOTICE

Danger of damage to the crane and the ballast trailer!

Due to steering movements on the crawler tracks during parallel travel, the crane and the ballast trailer can be significantly damaged.

- ▶ For parallel travel, steering the crawler track is prohibited.
- ▶ For parallel travel, the side tire distortion on the wheel sets must be observed by an instructed person over the entire travel route of the crane. If the tires distort by more than 100 mm, then the position of the wheel sets must be corrected.

**WARNING**

Danger of accident when driving the crane with ballast trailer!

When driving the crane - this also applies for „circular travel“ - and the ballast trailer is raised due to ground unevenness, the force on test point 1 (F1-load display) increases immediately and the crane will be overloaded.

If the ballast trailer sinks while driving due ground unevenness, the force on test point 1 (F1-load display) drops and the ballast trailer lifts off the ground, or the entire boom system is pulled backward.

The crane can topple over and personnel can be severely injured or killed.

- ▶ The crane operator must constantly observe the displays on the LICCON monitor while driving the crawler crane.
- ▶ The crane operator must act anticipatorily. Already when an advance warning on test point 1 (F1-load display) occurs, he must act accordingly: By actuating the pull cylinders of the derrick ballast, correct the load / force on test point 1 (F1-load display) until it is in a permissible operating range. The permissible extension lengths of the pull cylinders must be observed.

Make sure that the following prerequisite is met:

- All specifications and notes in chapters 2.15 and 5.35 of the Crane operating instructions are observed and adhered to.

In principle the following must be observed:

- If the derrick ballast is raised due to external influences, then this leads to a relief of the guying between the derrick head and the derrick ballast (force on test point 4/5 drops). This leads to an increased load on the guying between the derrick head and the A-frame (force on test point 1 increases).
- If the derrick ballast loses contact with the ground due to external influences, then this leads to a higher load of the guying between the derrick head and the derrick ballast (force on test point 4/5 increases). This leads to a relief of the guying between the derrick head and the A-frame (force on test point 1 drops).

7 Driving the crawler crane

**WARNING**

Danger of accident in inclined position!

When the slewing gear brake is open, the crane superstructure can turn uncontrolled to the side.

As a result the crane can topple over.

Personnel can be severely injured or killed.

- ▶ In inclined position, crane operation or crawler operation or with opened slewing gear is prohibited.
- ▶ In inclined position, the slewing gear brake must be closed.

**WARNING**

The crane can topple over!

If the permissible incline of the crane is exceeded, the crane can topple over.

In impermissible inclines, the LICCON computer system does **not** turn the travel operation off.

The crane operator carries the sole responsibility for possible risks or dangers when working with impermissible inclines.

- ▶ Do not exceed the permissible incline from the load chart.
- ▶ Do not exceed the permissible incline for driving the crane.
- ▶ While driving the crane, monitor the displays for center of gravity, surface pressure and incline in the LICCON monitor constantly.

**WARNING**

The crane can topple over!

If the crane is driving too fast, then the crane can topple over.

This applies especially if the crane is driven too fast with a load and / or derrick ballast.

Personnel can be severely injured or killed.

- ▶ Observe the permissible highest speeds for driving the crawler crane.
- ▶ For the travel speed, take the actual operating conditions also into account.
- ▶ The data for permissible highest speeds for driving the crawler crane is based on ideal conditions. When the conditions are not ideal, then the travel speed of the crane must be reduced accordingly.
- ▶ Driving with a load and / or derrick ballast in rapid gear is prohibited.
- ▶ Driving and steering the crawler at the same time with suspended load and / or installed derrick ballast is prohibited.

**WARNING**

Personnel in danger zone!

Personnel within the danger zone of the crane can be severely injured or killed.

- ▶ An additional monitor, who is connected by radio contact with the crane operator must ensure that there are no persons or objects within the danger zone of the crane.
- ▶ The observer may not remain in the danger zone of the crane.

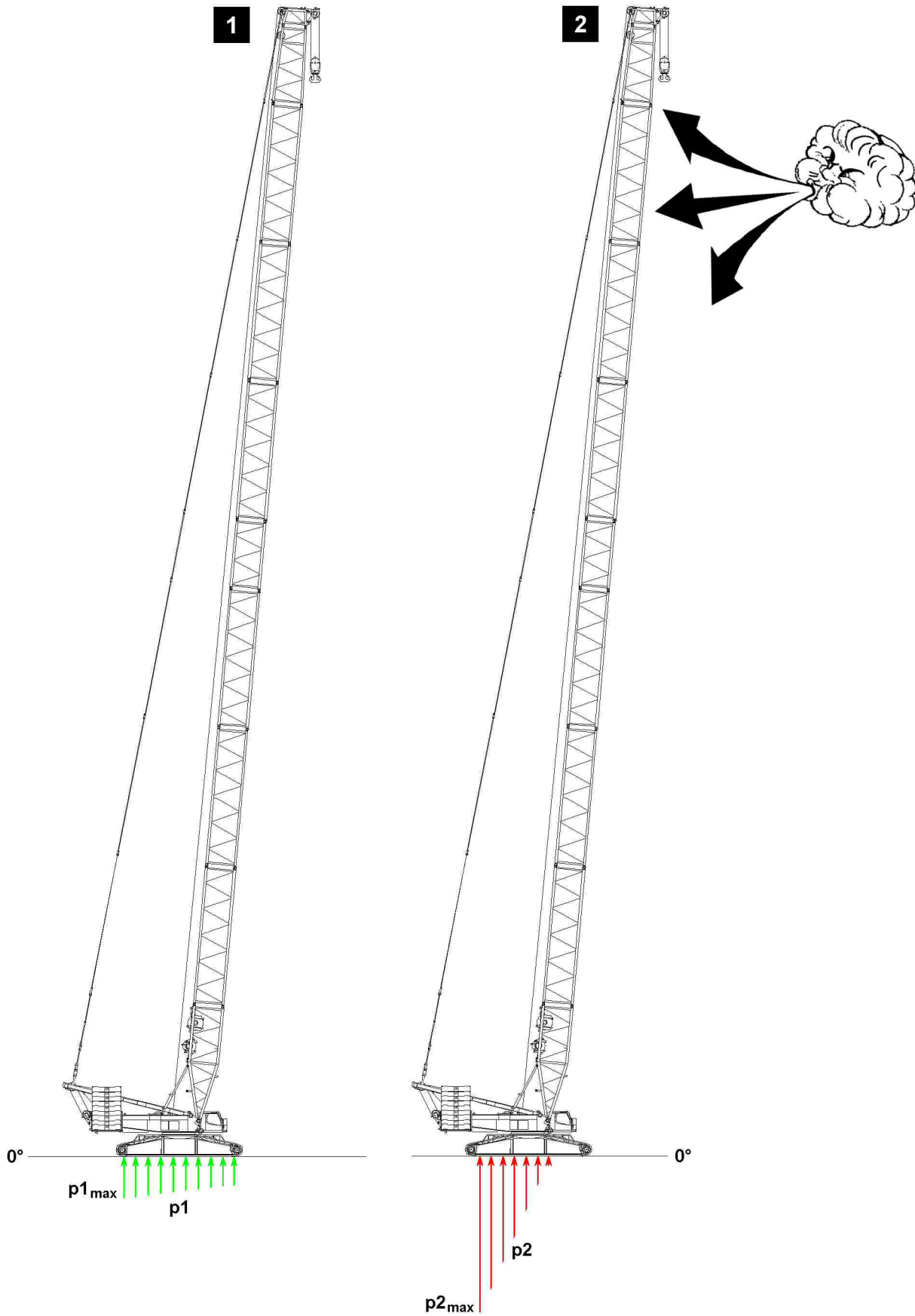

Fig.117599: $p2_{max}$ larger than $p1_{max}$

LWE/LR 11000-001/23501-04-02/en

7.1 Surface pressures and force distribution when driving the crane



WARNING

The crane can topple over!

When driving crawler cranes, surface pressures can significantly increase or change due to different factors.

This can cause the crane to topple over.

Personnel can be severely injured or killed.

- ▶ Make sure that the ground has sufficient load bearing capacity in the entire working range and / or over the entire travel route, to be able to safely take on even increased surfaces pressures of the crane.
- ▶ Make sure that the center of gravity is always within the core surface, see section „Prerequisites for crawler operation“ and LICCON job planner.

7.1.1 Surface pressures in case of wind load on boom



WARNING

The crane can topple over!

When driving the crane with long boom lengths and / or when driving with large sized loads and / or at high wind speeds, the surface pressures can increase significantly.

This can cause the crane to topple over.

Personnel can be severely injured or killed.

- ▶ Make sure that the entire travel route of the crane is sufficiently load bearing to be able to take on even increase surface pressures - for example if „wind is coming front the front on the boom“.
- ▶ Change of surface pressures on crawler track under wind load, see opposite graphic.

Illustration 1:

- Surface pressures **p1** on crawler track without wind load

Illustration 2:

- Surface pressures **p2** on crawler track in case of wind load from the front

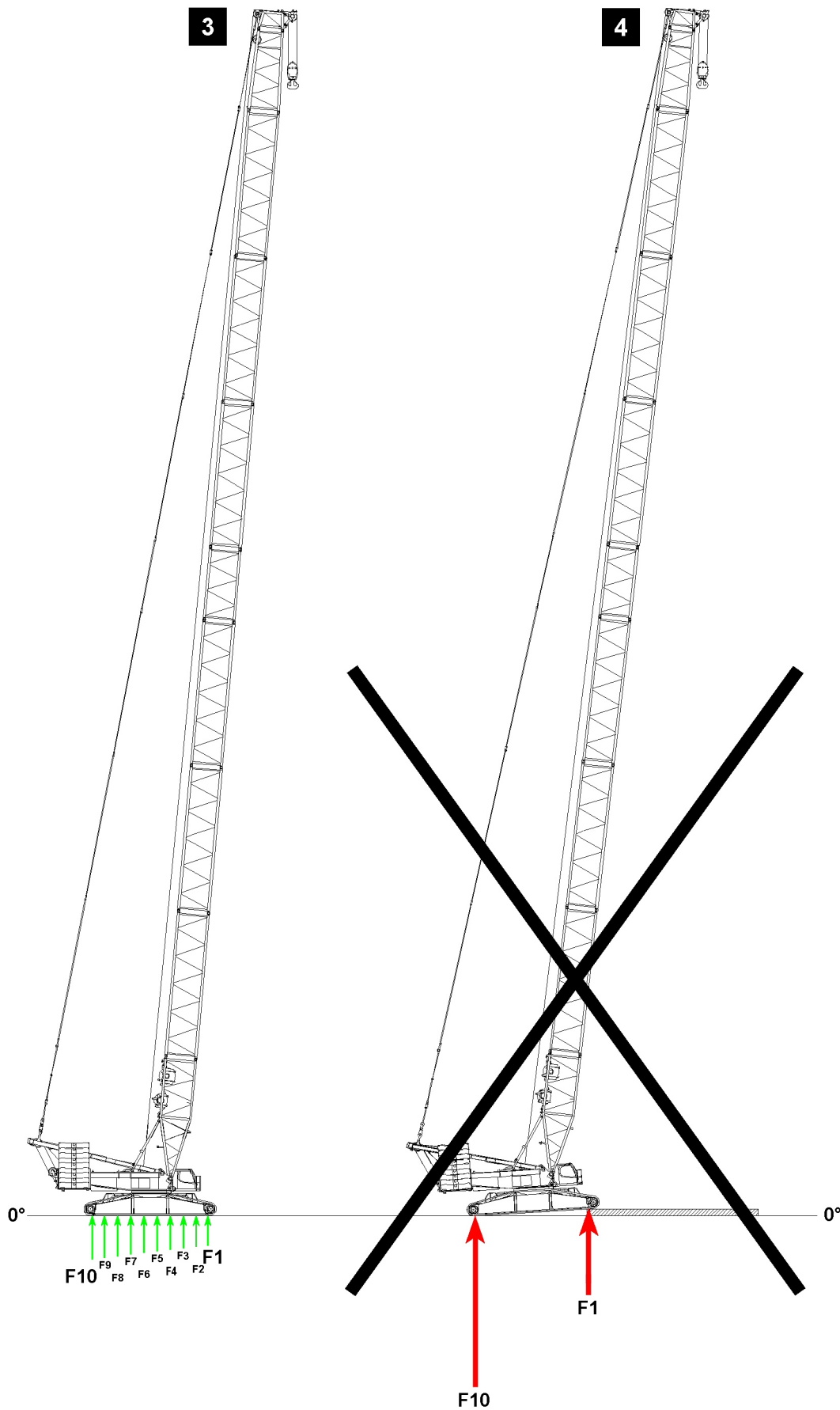

LWE/LR 11000-001/23501-04-02/en

Fig.117600: Force distribution in normal operation // driving on pressure distributor plates

7.1.2 Force distribution when driving on pressure distributor plates



WARNING

The crane can topple over!

When driving the crane on pressure distributor plates, a movement of forces occurs due to the reduction of the ground contact surfaces on the crawler track. The forces concentrate at force **F1** and force **F10**, see illustration 4.

This can cause the crane to topple over.

Personnel can be severely injured or killed.

- ▶ Make sure, before driving the crane on pressure distributor plates, that a load bearing transfer (height equalization) was established, see section „Calculation of required length of transfers“.
- ▶ Driving the crane on pressure distributor plates without transfer (height equalization) is prohibited.

Illustration 3:

- Force distribution on crawler track of crane (normal operation)
 - Without wind influence

Illustration 4:

- Not permissible

Make sure that the following prerequisites are met:

- The crane is ready to drive.
- The crane engine is running.
- The set up configuration of the crane has been entered correctly into the LICCON computer system.
- The displays for incline, surface pressure and center of gravity are shown.
- There are no persons or objects in the danger zone.

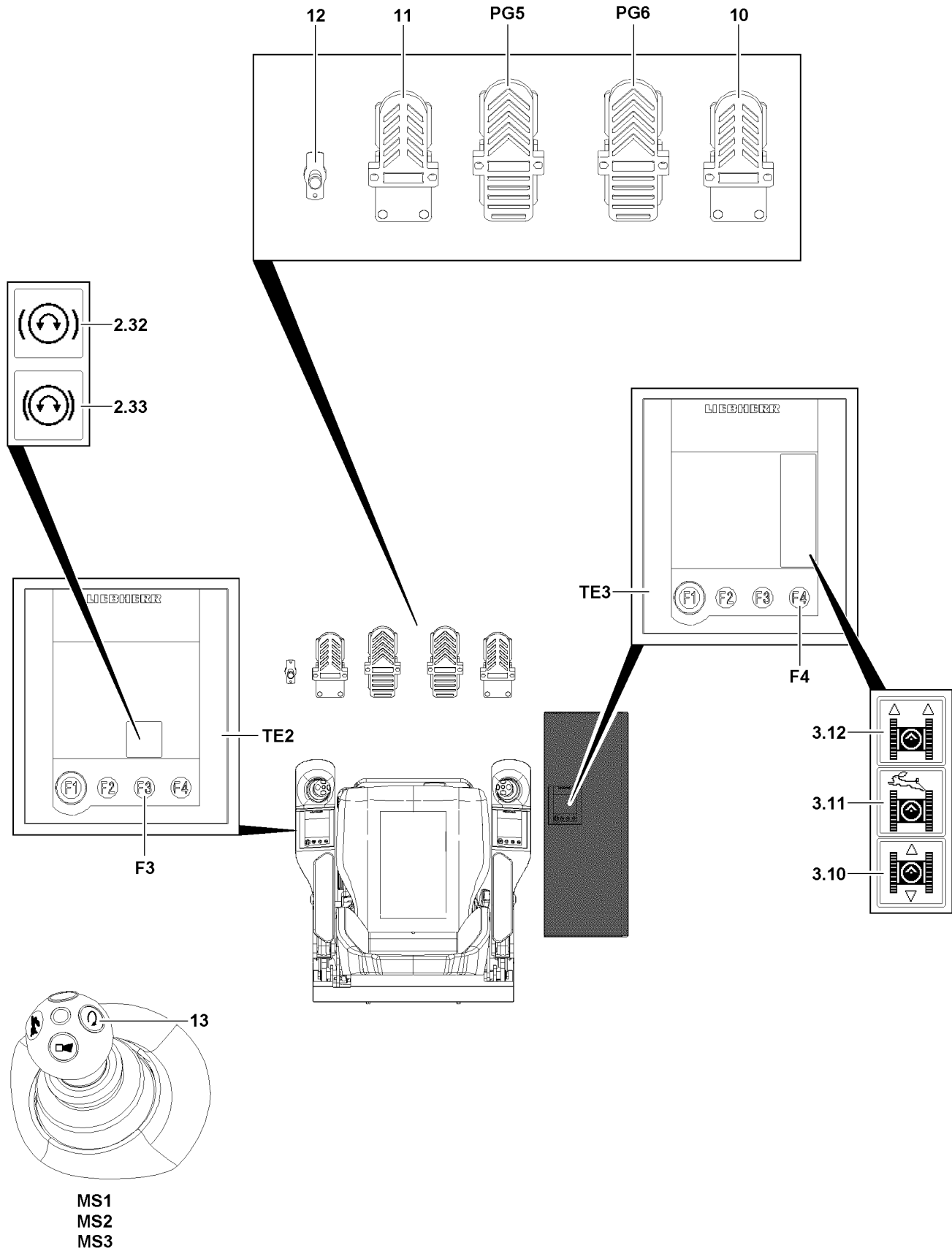

Fig.122233

LWE/LR 11000-001/23501-04-02/en

7.2 Operating elements for the crawler operation

7.2.1 Pedal carrier

- **10** Pedal for engine regulation
- **11** Pedal Slewing gear brake
- **12** Foot button for freewheeling slewing gear
 - **Note:** The foot button for freewheeling slewing gear **12** is only available on certain crane types.
- **PG5** Foot rocker (pedal sensor 5)
- **PG6** Foot rocker (pedal sensor 6)

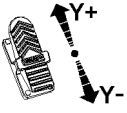
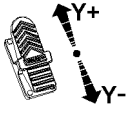
Crawler operating mode	Pedal carrier	
	 Foot rocker PG5	 Foot rocker PG6
Normal travel	Left track forward / backward: PG5 direction Y+ / Y-	Right track forward / backward: PG6 direction Y+ / Y-
Parallel travel	Steer both tracks ¹⁾ : PG5 direction Y+ / Y-	Forward / backward both tracks: PG6 direction Y+ / Y-

1) Only for crane types with steering function in added parallel travel

Engine regulation

The rpm of the crane engine is controlled with the Pedal for the engine regulation **10**. For crawler operation, a certain rpm can be locked in, see Crane operating instructions, chapter 4.05.

- ▶ Locking the current rpm of the crane engine: Press the button **13** on master switch **MS1** or master switch **MS2**.

Result:

- Behind the rpm display in the LICCON monitor appears a „+“.
- The current rpm of the crane engine is locked.
- The rpm can be increased further via the pedal for the engine regulation **10**.

- ▶ Releasing the rpm lock: Press the button **13** on master switch **MS1** or master switch **MS2** again.

Result:

- The „+“ behind the rpm display turns off.

7.2.2 Slewing gear brake

Operating elements slewing gear brake:

- **11** Pedal Slewing gear brake
- **12** Foot button for freewheeling slewing gear
- Button **F3**: Slewing gear brake in TE2 (parking brake)
- ▶ Regulate the slewing gear brake steplessly: Press down the slewing gear brake pedal **11**.



Result:

- The slewing gear brake is regulated according to the pedal position: The further the pedal is pressed down, the stronger the slewing gear brake brakes.

- ▶ Adding the coasting function of the slewing gear: Actuate the foot button for freewheeling the slewing gear **12**.

Result:

- Freewheeling the slewing gear is engaged as long as the foot button for freewheeling the slewing gear **12** is pressed down.

Touch display 2 TE2		
Position	Icon	Description of function
2.32		Nominal status slewing gear brake released, icon remains even when the slewing gear brake is applied with the slewing gear brake pedal 11 .
2.33		Nominal status slewing gear applied, icon remains even when the slewing gear brake is automatically released by the control.

- ▶ Apply the slewing gear brake (parking brake): Press the button **F3** on the touch display 2 **TE2**.





Result:



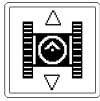

- Icon „Slewing gear brake applied“ appears.
- ▶ Release the slewing gear brake (parking brake): Press the button **F3** on the touch display 2 **TE2** again.

Result:

- The „slewing gear brake released“ icon appears.

7.2.3 Icons Crawler operating modes in touch display 3

Touch display 3 TE3		
Position	Icon	Description of function
3.10		Normal travel Crawler operation turned off
		Normal travel Crawler operation preselected
		Normal travel Crawler operation engaged, icon blinks
3.11		Rapid gear Crawler operation turned off
		Rapid gear Crawler operation preselected

Touch display 3 TE3		
Position	Icon	Description of function
		Rapid gear Crawler operation engaged, icon blinks
3.12		Parallel travel Crawler operation turned off
		Parallel travel Crawler operation preselected
		Parallel travel Crawler operation engaged, icon blinks

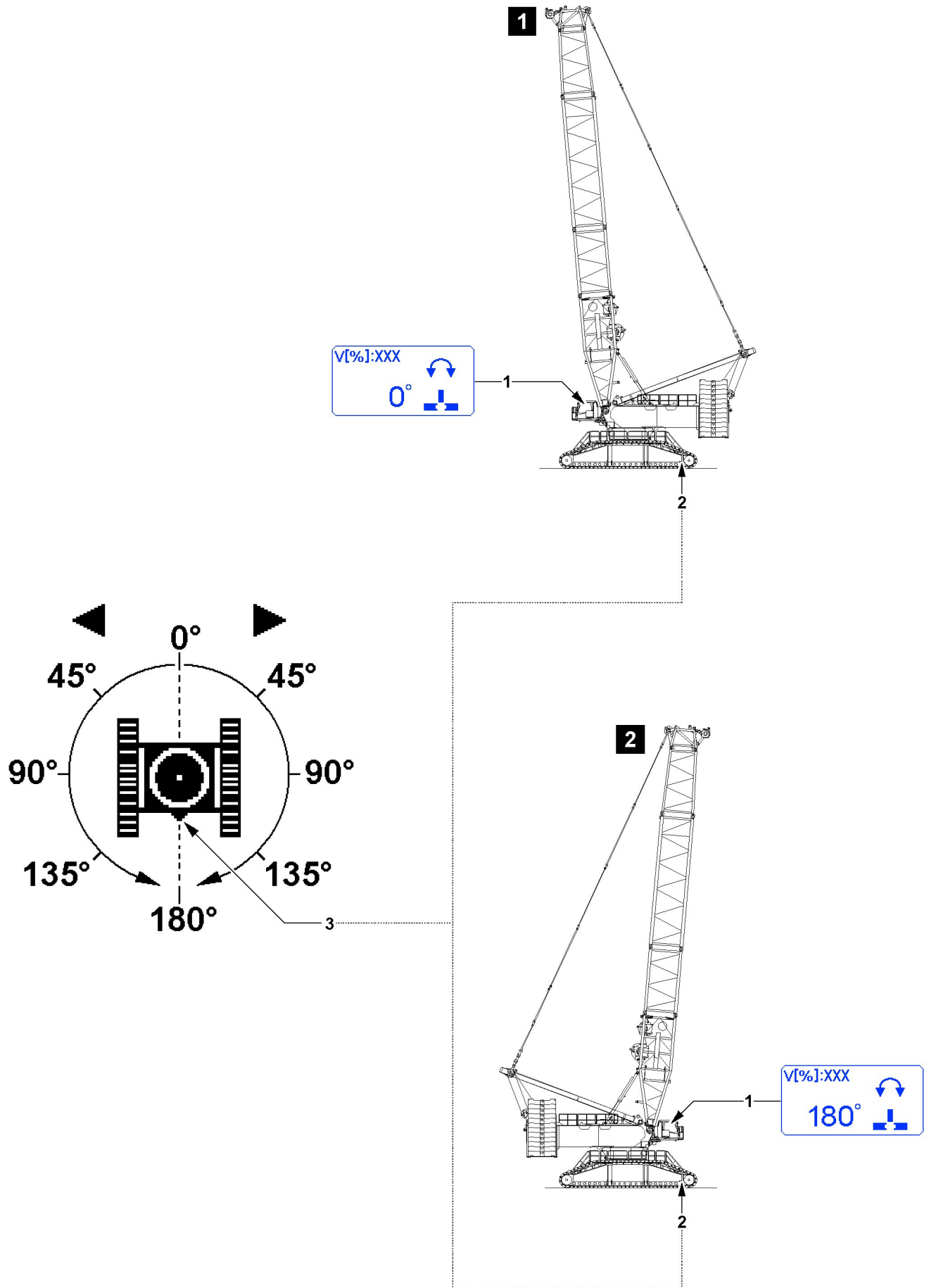

Fig.119625

LWE/LR 11000-001/23501-04-02/en

7.3 Assignment of the crane superstructure to the travel direction

The travel direction of the crane is continuously assigned to the position of the crane superstructure.

The position of the crane superstructure to the crawler travel gear can be read with one glance on the slewing range icon **1**:

- At display value 0° in slewing range icon **1** the crane superstructure is exactly in position „to the rear“, see illustration **1**.
- At display value 180° in slewing range icon **1** the crane superstructure is exactly in position „to the front“, see illustration **2**.

Note: The front on the crawler travel gear is always on the side where the chain tension device **2** for the crawler carriers is located. In the LICCON view of the crawler travel gear, the front side is marked by a directional triangle **3**.

- At display value 0° in the slewing range icon **1** the crane superstructure is exactly in position „to the rear“.
- The apex for the assignment of the crane superstructure is at display value 90° in the slewing range icon **1**. At display values from 0° to 90° the crane superstructure is positioned „to the rear“. At display values from 90° to 180° the crane superstructure is positioned „to the front“.
- If the crane superstructure is turned over / under the display value 90° in the slewing range icon **1**, then the running direction of the crawler carriers changes to actuation direction of the foot rockers. The change happens only when the foot rockers are in position 0 (not actuated).
- If the crane superstructure is turned while driving over / under the display value 90° in the slewing range icon **1**, then the running direction of the crawler carriers and therefore the travel direction remains until the respective foot rocker is „returned“ to zero position. The new assignment of the travel direction becomes only active after the foot rockers are the next time in position 0 (not actuated).



WARNING

Change of travel direction after turning the crane superstructure!

If the crane superstructure is turned while driving over / under the display value 90° in the slewing range icon **1**, then the running direction of the crawler carriers only remains until the respective foot rocker is „returned“ to zero position. If the foot rocker is actuated again in the same direction, the crane is driven into the opposite direction.

- ▶ Pay attention to the assignment of the crane superstructure to the travel direction when turning the crane superstructure while driving the crane.
- ▶ After turning the crane superstructure, check the travel route in both directions for persons and obstacles. Initiate travel movements with utmost caution.

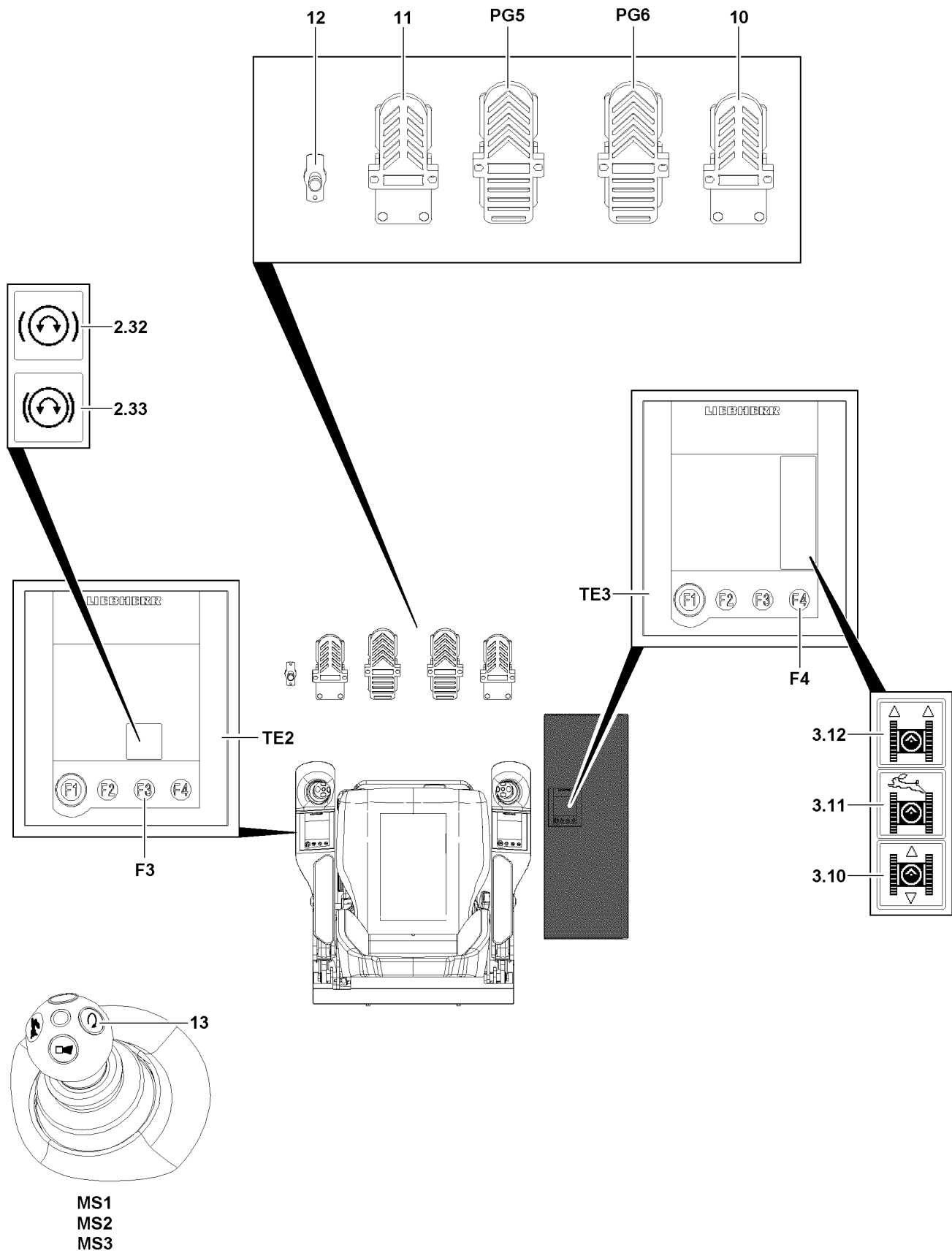

Fig.122233

7.4 Turning crawler operating modes on / off

The crawler crane can be driven with various crawler operating modes:

- Normal travel crawler operation
 - Classic crawler operation, every track is controlled via a separate foot pedal
- Parallel travel crawler operation
 - The steering movement is controlled by a separate foot pedal
 - The travel direction is controlled by a separate foot pedal

To obtain a higher travel speed, the rapid gear can be activated.

7.4.1 Selecting the function in the touch display

Select a function in the touch display on example „Parallel operation Crawler“.



Fig.119615

- ▶ Example „Parallel travel crawler operation“: Select parallel operation by touching the icon **3.12** on the touch display **3 TE3**, see illustration **1**.

Result:

- Icon „Parallel travel Crawler operation“ is bordered all over.
- Parallel travel Crawler operation is preselected.

- ▶ Press the key **F4** on the touch display **3 TE3**, see illustration **2**.

Result:

- Icon „Parallel operation Crawler“ blinks.
- Parallel operation is activated.

7.4.2 Turning normal travel crawler operation on / off

The normal travel crawler operation is the prerequisite to drive the crane and must generally be activated.

Normal travel Engage crawler operation:

- ▶ Select normal travel crawler operation by touching the icon **3.10** on the touch display **3 TE3**.

Result:

- Icon **3.10** is bordered all over
- Normal travel crawler operation is preselected.

- ▶ Press the key **F4** on touch display **3 TE3**.

Result:

- Icon **3.10** blinks.
- Normal travel Crawler operation is activated.

Turn normal travel crawler operation off:

- ▶ Press the key **F4** on touch display **3 TE3**.

Result:

- Icon **3.10** no longer blinks.

- Normal travel crawler operation is turned off.
- ▶ Deselect normal travel crawler operation by touching the icon **3.10** on the touch display **3 TE3**.

Result:

- The border around icon **3.10** disappears.
- Preselection of normal travel crawler operation is cancelled.

7.4.3 Turning parallel travel crawler operation on / off

Make sure that the following prerequisites are met:

- Normal travel crawler operation is activated
- The tracks are at a standstill.

Engage parallel travel crawler operation:

- ▶ Select parallel travel crawler operation by touching the icon **3.12** on the touch display **3 TE3**.

Result:

- Icon **3.12** is bordered all over.
- Parallel travel Crawler operation is preselected.

- ▶ Press the key **F4** on touch display **3 TE3**.

Result:

- Icon **3.12** blinks.
- Parallel travel Crawler operation is activated.

Turn parallel travel crawler operation off:

- ▶ Press the key **F4** on touch display **3 TE3**.

Result:

- Icon **3.12** no longer blinks.
- Parallel travel Crawler operation is turned off.

- ▶ Deselect parallel travel crawler operation by touching the icon **3.12** on the touch display **3 TE3**.

Result:

- The border around icon **3.12** disappears.
- Preselection of parallel travel crawler operation is cancelled.

7.4.4 Turning rapid gear crawler operation on / off**WARNING**

Travel speed too high!

If the travel speed is too high, the crane can topple over.

Personnel can be severely injured or killed.

- ▶ Driving with a load or derrick ballast in rapid gear crawler operation is prohibited.
- ▶ Observe the permissible highest speeds for driving the crawler crane.

Make sure that the following prerequisite is met:

- Normal travel crawler operation is activated
- or**
- the parallel travel crawler operation is turned on.

Activate the rapid gear crawler operation:

- ▶ Select rapid gear crawler operation by touching the icon **3.11** on the touch display **3 TE3**.

Result:

- Icon **3.11** is bordered all over.
- Rapid gear Crawler operation is preselected.

- ▶ Press the key **F4** on touch display 3 **TE3**.

Result:

- Icon **3.11** blinks.
- Rapid gear Crawler operation is activated.

Deactivate the rapid gear crawler operation:

- ▶ Press the key **F4** on touch display 3 **TE3**.

Result:

- Icon **3.11** no longer blinks.
- Rapid gear Crawler operation is turned off.

- ▶ Deselect rapid gear crawler operation by touching the icon **3.12** on the touch display 3 **TE3**.

Result:

- The border around icon **3.11** disappears.
- Preselection of rapid gear crawler operation is cancelled.

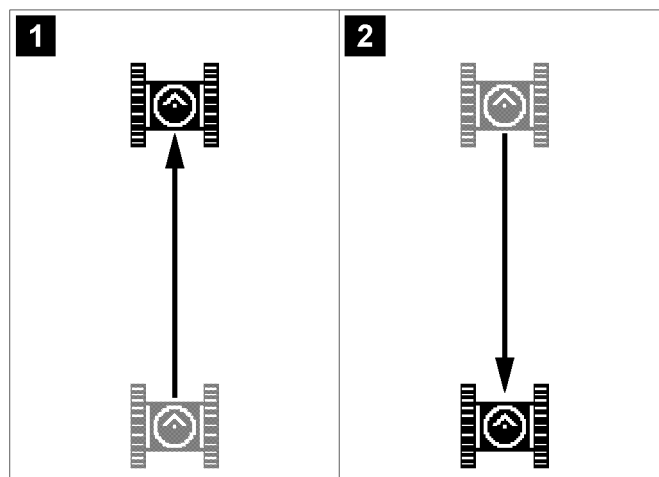
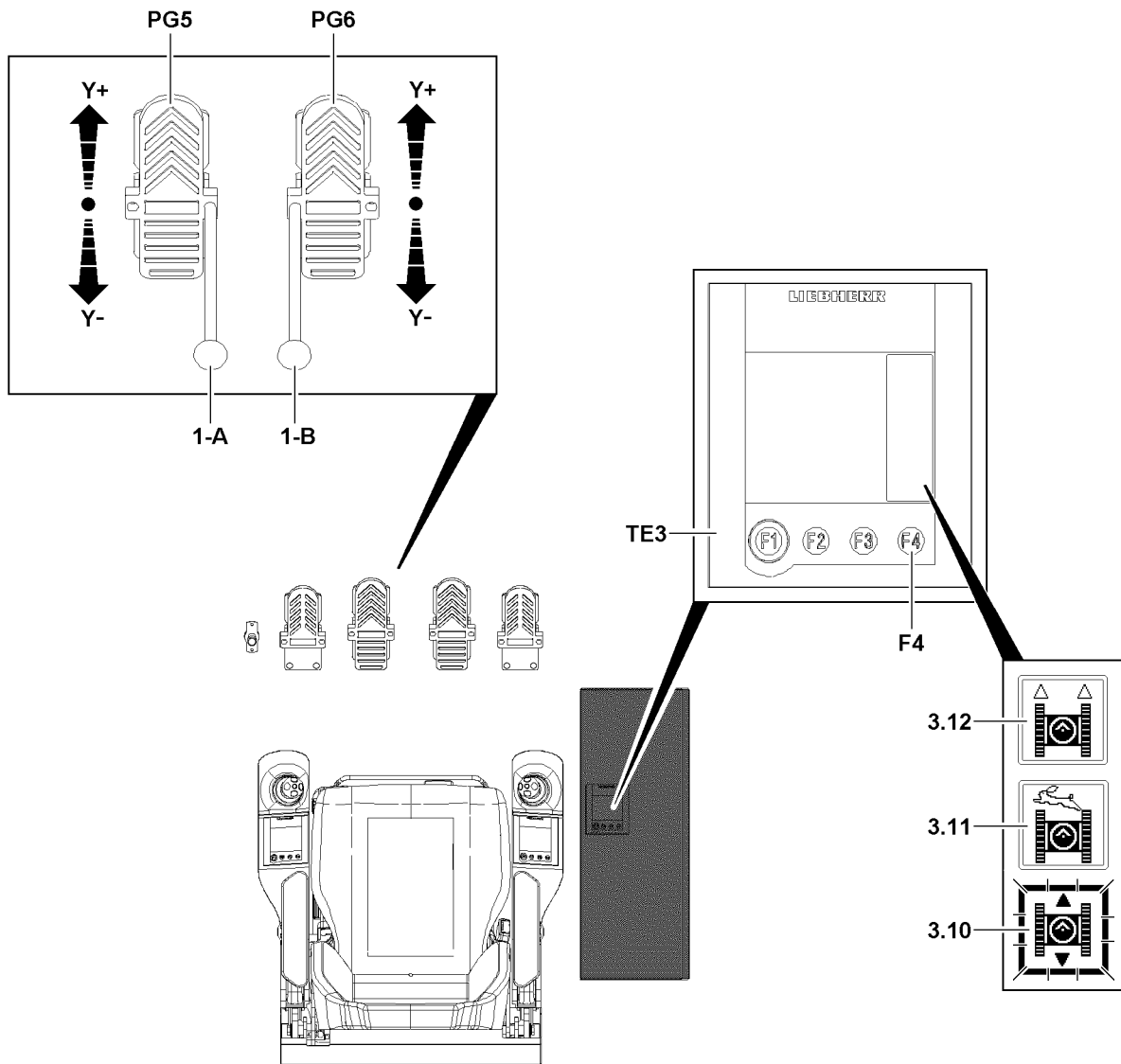

Fig.122234

LWE/LR 11000-001/23501-04-02/en

7.5 Driving the crawler crane in normal travel

NOTICE

Increased wear on the crawler travel gear!

When steering in small radii, high friction forces are created which lead to increased wear.

- ▶ If possible, always drive in curves with large radii.
- ▶ Avoid turning over a stationary track, if possible.
- ▶ Avoid counterrotation, if possible.

Make sure that the following prerequisites are met:

- A travel direction change may only be done from the standstill.
- The desired rpm of the crane engine is set.
- Normal travel crawler operation is selected, icon **310** blinks



Note

Special hand levers can be attached on the foot rockers. The hand levers are used for delicate driving maneuvers.

The hand levers are stored in a transport retainer in the crane cab.

The technical design of the hand lever **1-A** and the hand lever **1-B** is completely identical. The differentiation of the two hand levers is only in their assignment to the corresponding foot rockers in assembled (pushed on) condition.

- ▶ Use the hand levers to control the crane especially sensitively.

7.5.1 Driving forward

See illustration 1.

- ▶ Deflect the left foot rocker **PG5** and the right foot rocker **PG6** synchronously forward (direction **Y+**).

Result:

- The crane drives forward.

7.5.2 Driving in reverse

See illustration 2.

- ▶ Deflect the left foot rocker **PG5** and the right foot rocker **PG6** synchronously backward (direction **Y-**).

Result:

- The crane drives backward.

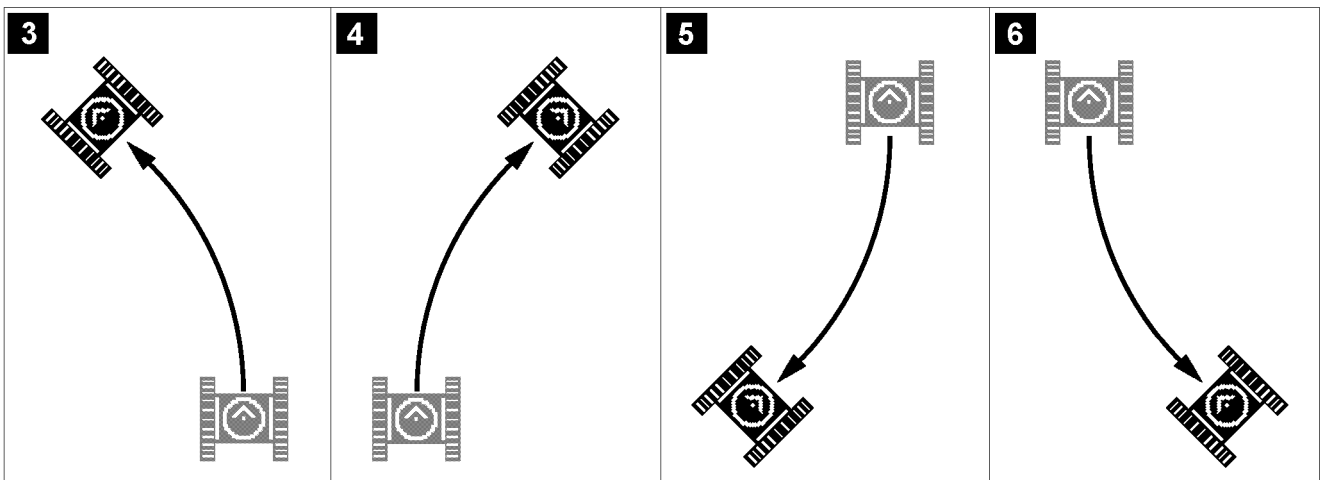
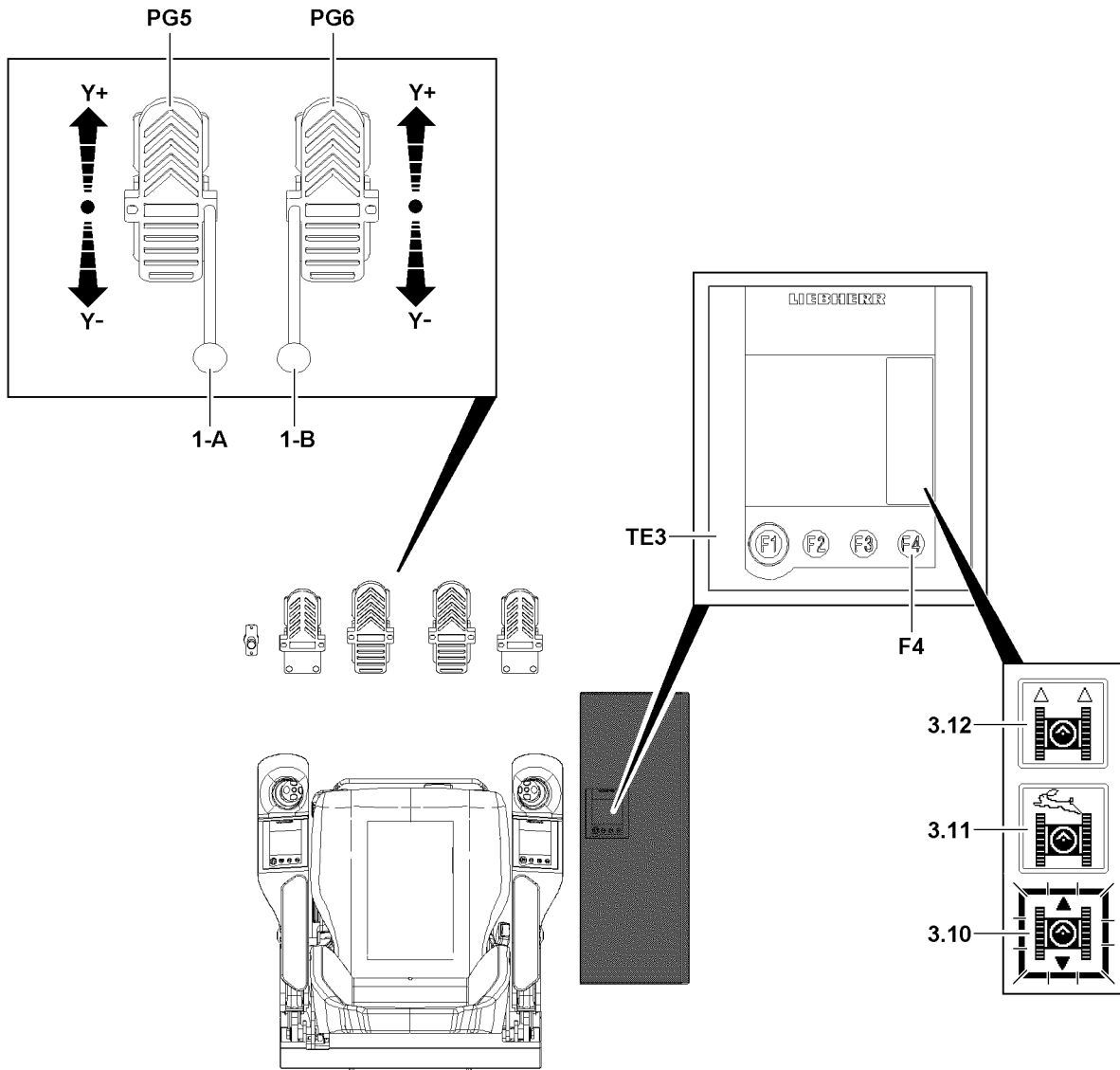

Fig.122235

7.5.3 Driving in curves forward to the left

See illustration 3.

- ▶ Actuate the left foot rocker **PG5** reduced to the front (direction **Y+**) and the right foot rocker **PG6** stronger to the front (direction **Y+**).

Result:

- The crane drives a forward curve to the left.

7.5.4 Driving in curves forward to the right

See illustration 4.

- ▶ Actuate the left foot rocker **PG5** stronger to the front (direction **Y+**) and the right foot rocker **PG6** reduced to the front (direction **Y+**).

Result:

- The crane drives a forward curve to the right.

7.5.5 Driving in curves reverse to the left

See illustration 5.

- ▶ Actuate the left foot rocker **PG5** reduced to the rear (direction **Y-**) and the right foot rocker **PG6** stronger to the rear (direction **Y-**).

Result:

- The crane drives a reverse curve to the left.

7.5.6 Driving in curves reverse to the right

See illustration 6.

- ▶ Actuate the left foot rocker **PG5** stronger to the rear (direction **Y-**) and the right foot rocker **PG6** reduced to the rear (direction **Y-**).

Result:

- The crane drives a reverse curve to the right.

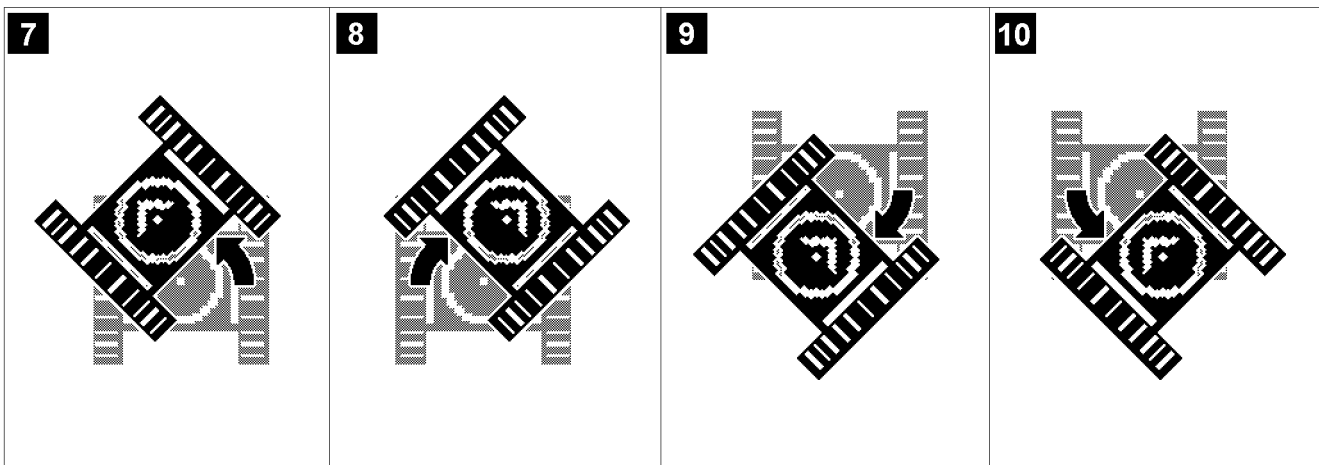
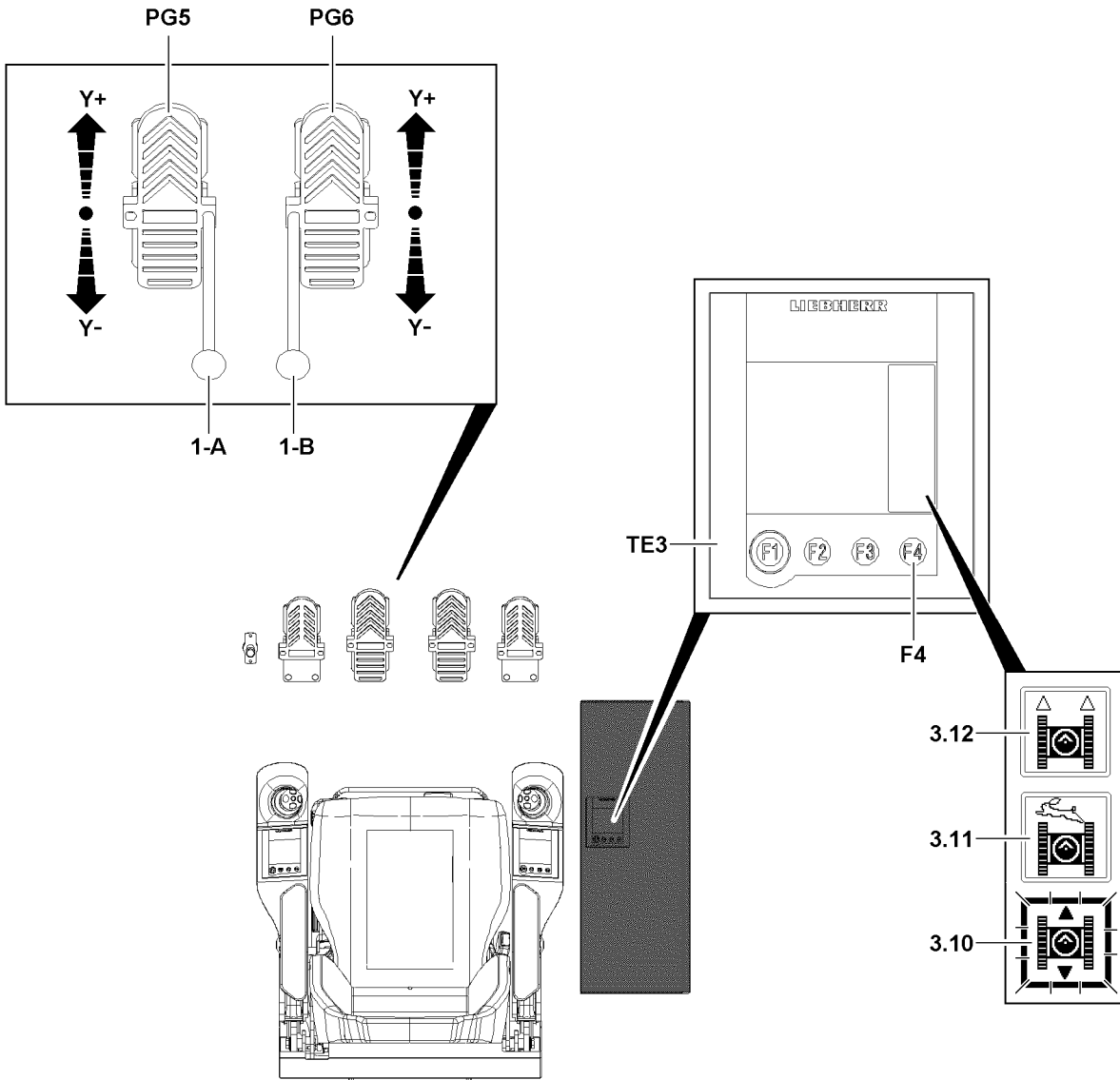

Fig.122236

LWE/LR 11000-001/23501-04-02/en

7.5.7 Turning forward to the left

See illustration 7.

- ▶ Actuate the right foot rocker **PG6** forward (direction **Y+**).

Result:

- The crane is turned forward to the left.

7.5.8 Turning forward to the right

See illustration 8.

- ▶ Actuate the left foot rocker **PG5** forward (direction **Y+**).

Result:

- The crane is turned forward to the right.

7.5.9 Turning backward to the left

See illustration 9.

- ▶ Actuate the right foot rocker **PG6** backward (direction **Y-**).

Result:

- The crane is turned backward to the left.

7.5.10 Turning backward to the right

See illustration 10.

- ▶ Actuate the left foot rocker **PG5** backward (direction **Y-**).

Result:

- The crane is turned backward to the right.

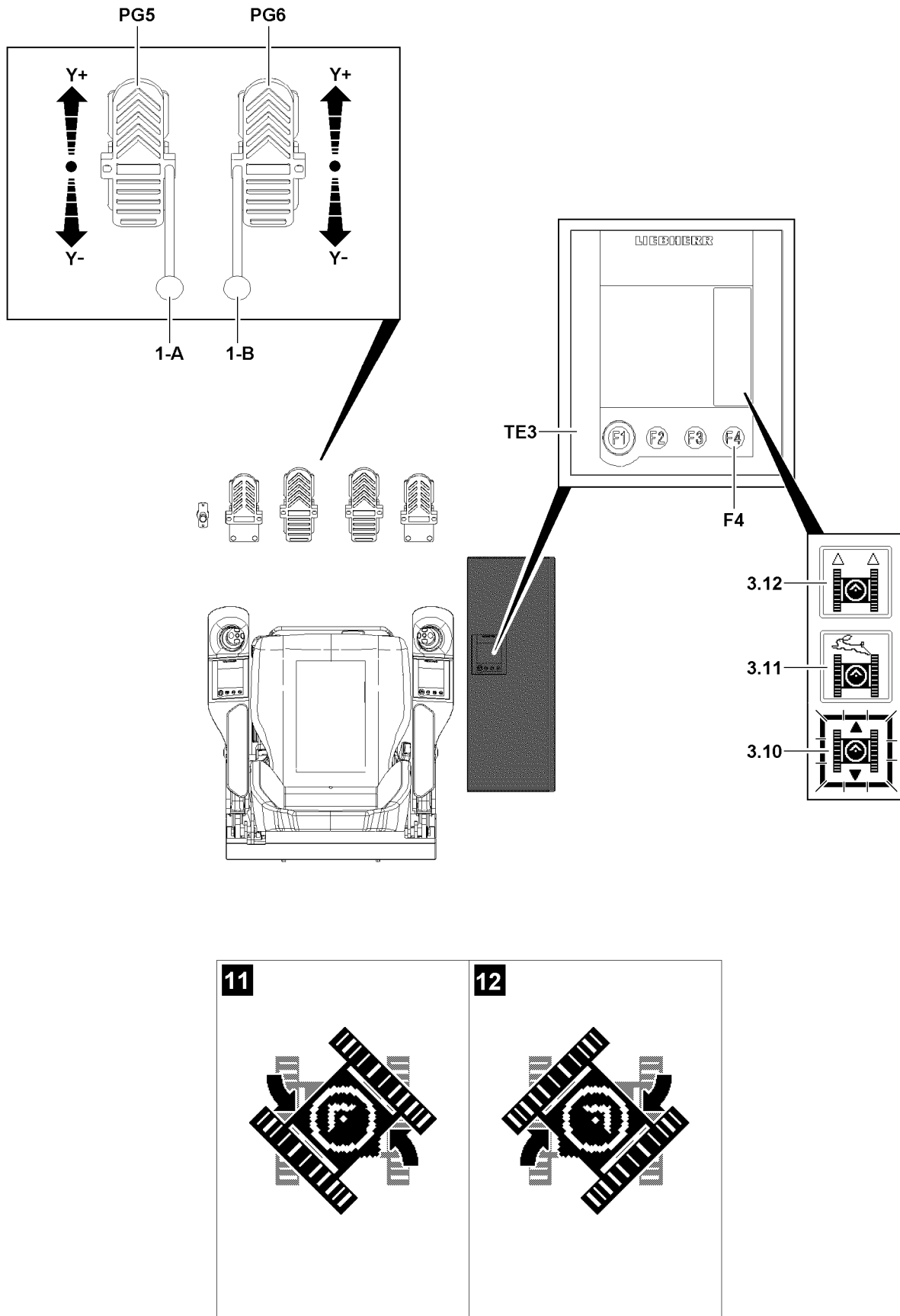

Fig.122237

7.5.11 Counterrotation to the left (counterclockwise direction)

See illustration 11.

- ▶ Actuate the left foot rocker **PG5** to the rear (direction **Y-**) and the right foot rocker **PG6** to the front (direction **Y+**).

Result:

- The crane is turned to the left.

7.5.12 Counterrotation to the right (clockwise direction)

See illustration 12.

- ▶ Actuate the left foot rocker **PG5** to the front (direction **Y+**) and the right foot rocker **PG6** to the rear (direction **Y-**).

Result:

- The crane is turned to the right.

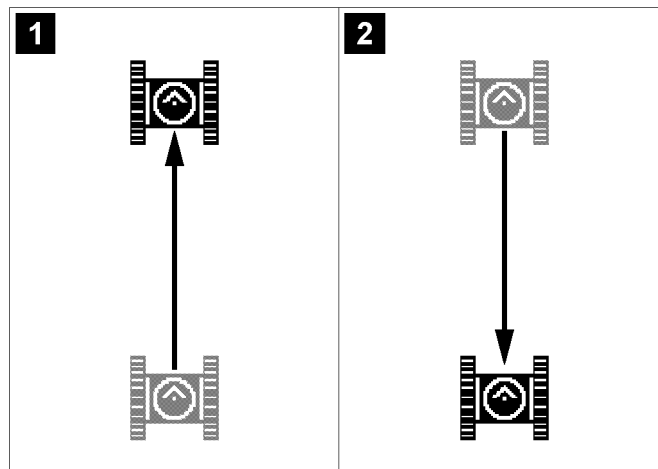
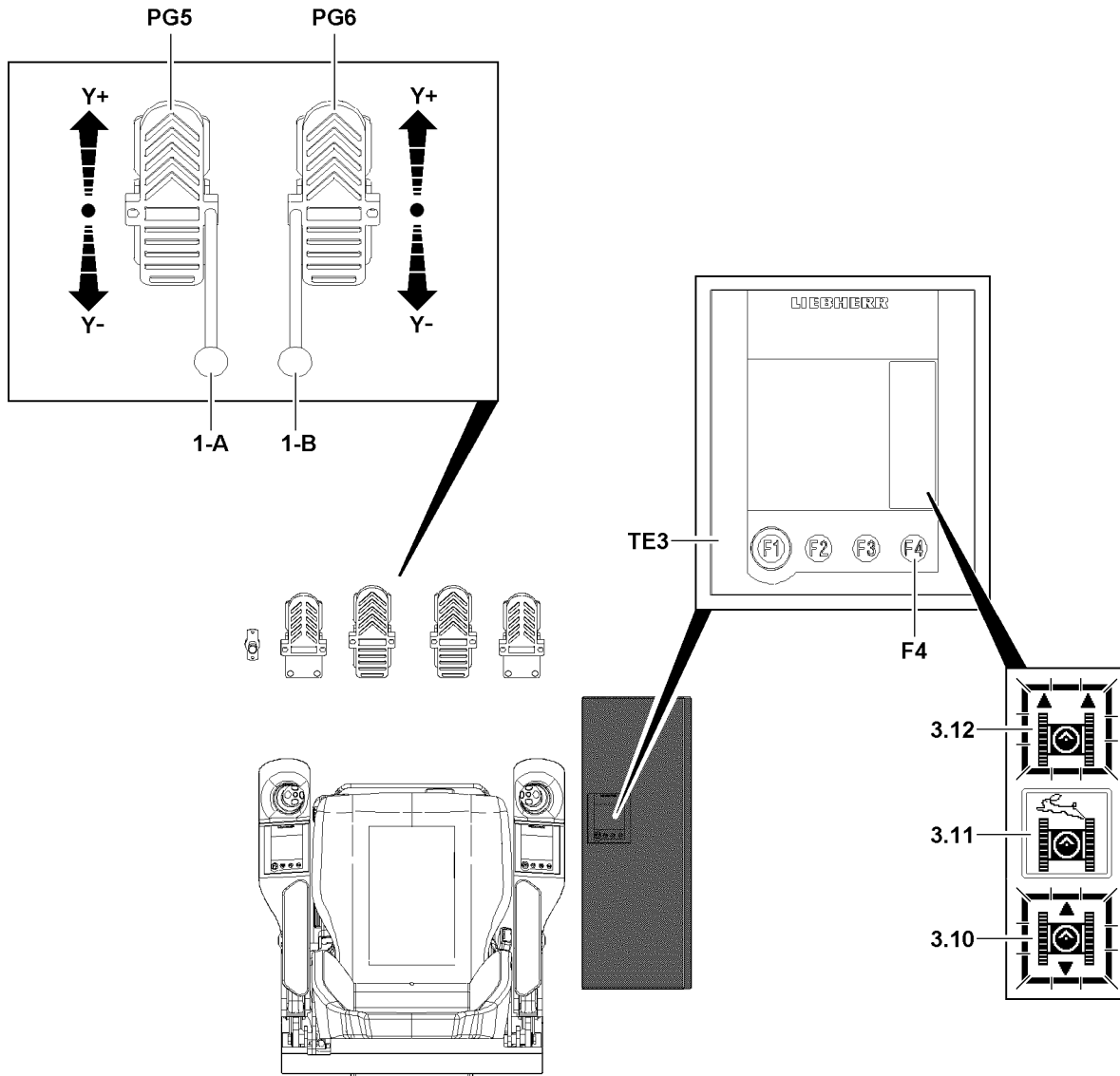

Fig.122238

LWE/LR 11000-001/23501-04-02/en

7.6 Driving the crawler crane in parallel travel

NOTICE

Increased wear on the crawler travel gear!

When steering in small radii, high friction forces are created which lead to increased wear.

- ▶ If possible, always drive in curves with large radii.
- ▶ Avoid turning over a stationary track, if possible.

Make sure that the following prerequisites are met:

- The desired rpm of the crane engine is set.
- Parallel travel crawler operation is selected, icon **310** and icon **312** blink



Note

- ▶ Special hand levers **1-A** and hand levers **1-B** can be inserted into the foot rockers. These hand levers **1-A** and hand levers **1-B** are used for delicate driving maneuvers. The operation is identical to that for the foot rockers.
- ▶ Hand lever **1-A** and hand lever **1-B** are placed in the transport retainer on the left of the crane operator's seat.
- ▶ The technical design of the hand lever **1-A** and the hand lever **1-B** is completely identical. The differentiation of the two hand levers is only in their assignment to the corresponding foot rockers in assembled (pushed on) condition.

Turning the crawler travel gear in counterrotation is not possible in parallel travel.

7.6.1 Driving forward

See illustration 1.

- ▶ Deflect the right foot rocker **PG6** forward (direction **Y+**).

Result:

- The crane drives forward.



Note

- ▶ The further the foot rockers are actuated forward (direction **Y+**) the higher the speed.

7.6.2 Driving in reverse

See illustration 2.

- ▶ Deflect the right foot rocker **PG6** backward (direction **Y-**).

Result:

- The crane drives backward.



Note

- ▶ The further the foot rockers are actuated forward (direction **Y+**) the higher the speed.

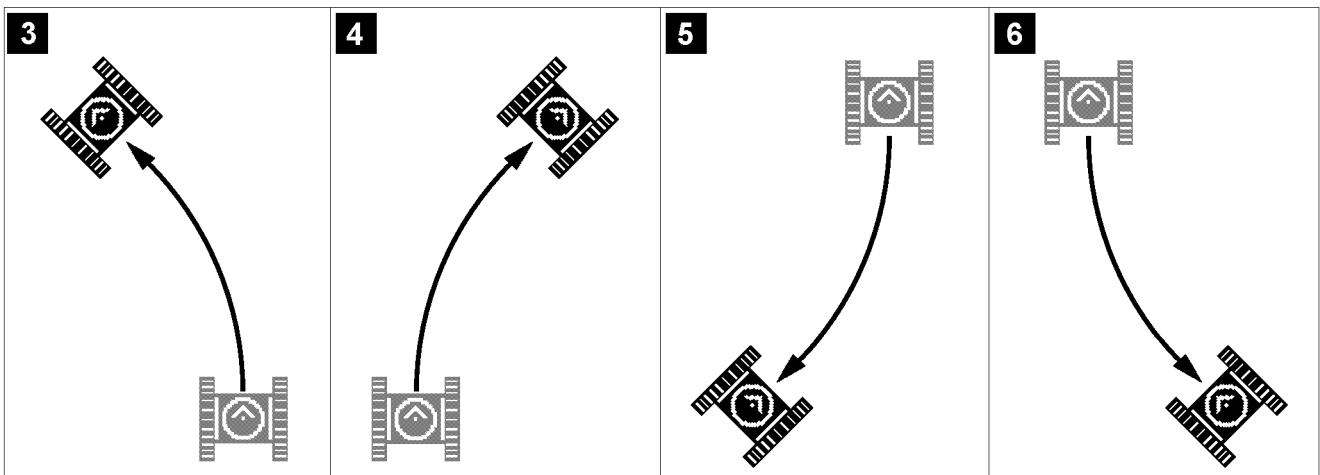
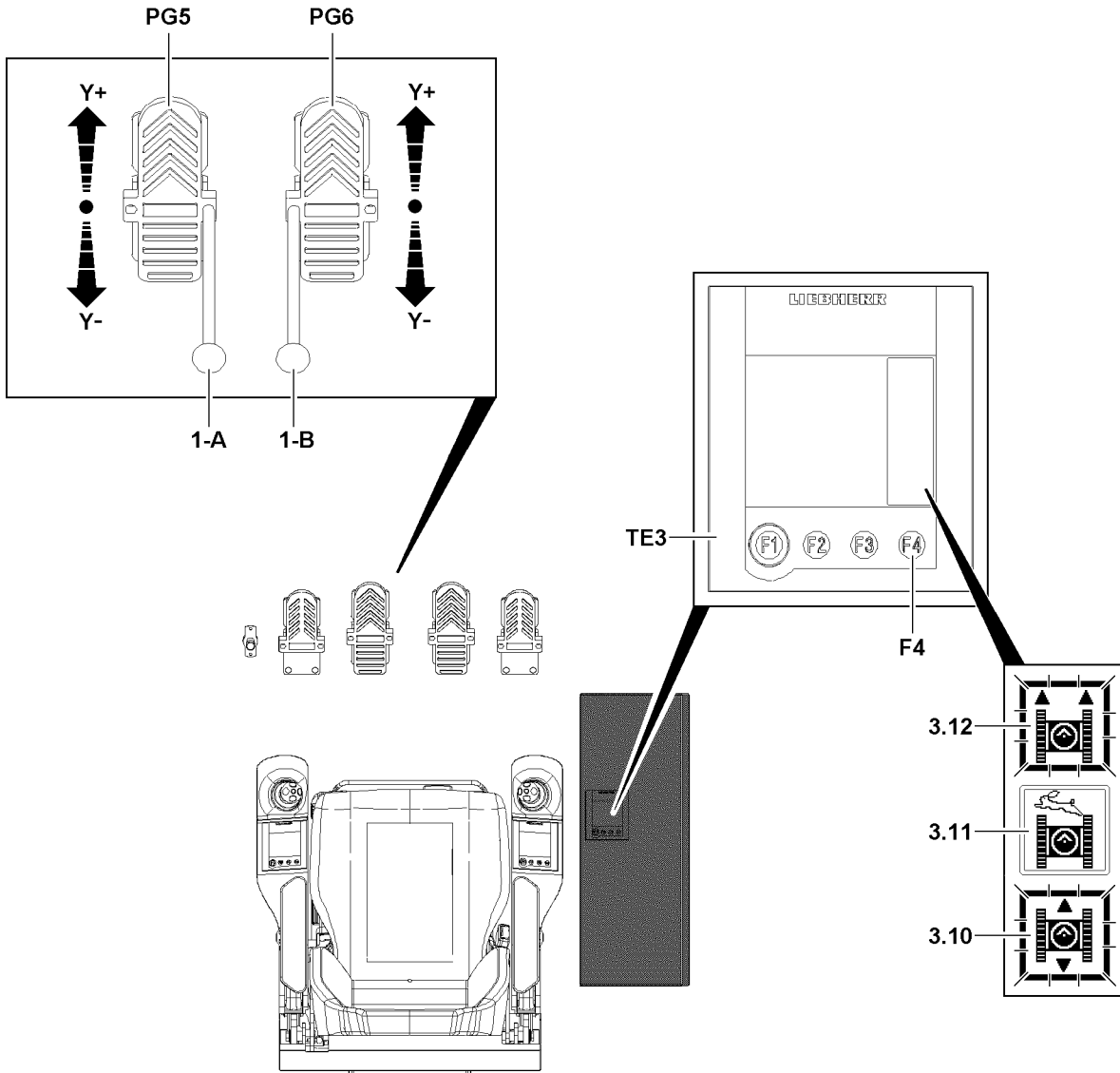

Fig.122239

LWE/LR 11000-001/23501-04-02/en

7.6.3 Driving in curves forward to the left

See illustration 3.

- ▶ Actuate the left foot rocker **PG5** reduced to the rear (direction **Y-**) and the right foot rocker **PG6** to the front (direction **Y+**).

Result:

- The crane drives a forward curve to the left.



Note

- ▶ The further the right foot rocker **PG6** is actuated forward (direction **Y+**) the higher the speed of driving a curve.
 - ▶ If the left foot rocker **PG5** is pushed fully to the rear (direction **Y-**), the left track stops.
-

7.6.4 Driving in curves forward to the right

See illustration 4.

- ▶ Actuate the left foot rocker **PG5** reduced to the front (direction **Y+**) and the right foot rocker **PG6** to the front (direction **Y+**).

Result:

- The crane drives a forward curve to the right.



Note

- ▶ The further the right foot rocker **PG6** is actuated forward (direction **Y+**) the higher the speed of driving a curve.
 - ▶ If the left foot rocker **PG5** is pushed fully to the front (direction **Y+**), the right track stops.
-

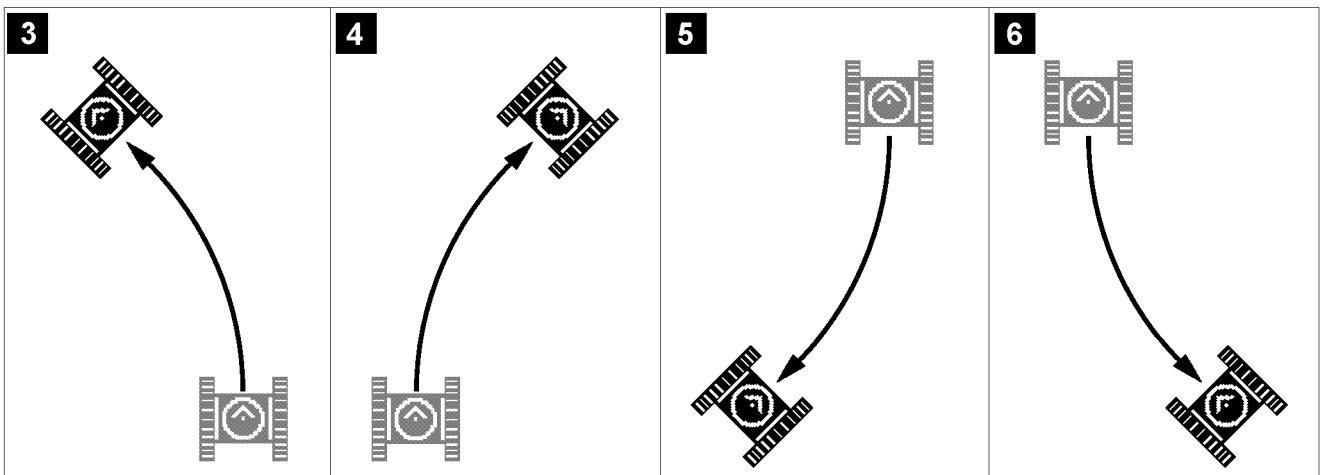
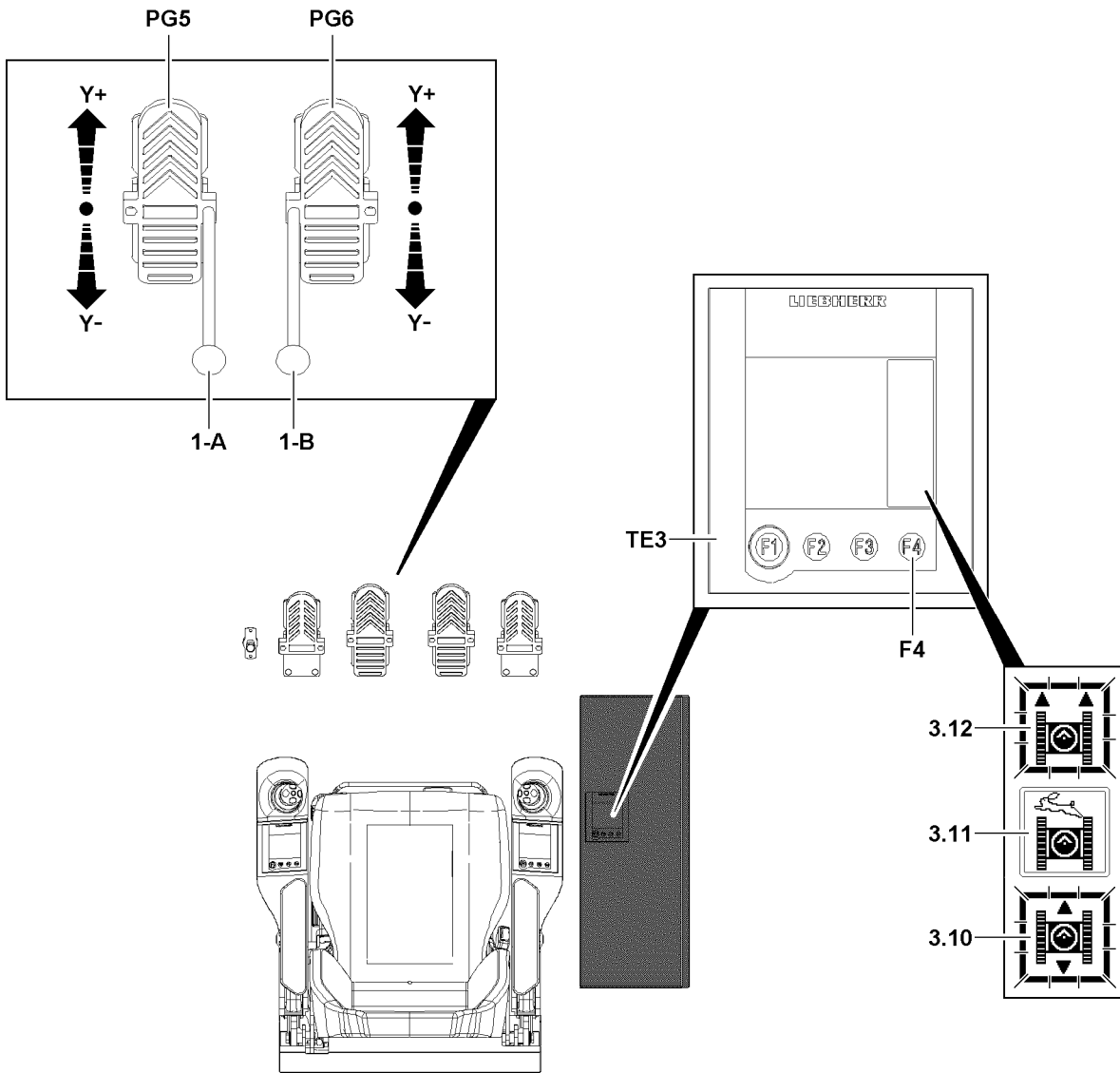

Fig.122239

LWE/LR 11000-001/23501-04-02/en

7.6.5 Driving in curves reverse to the left

See illustration 5.

- ▶ Actuate the left foot rocker **PG5** reduced to the rear (direction **Y-**) and the right foot rocker **PG6** to the rear (direction **Y-**).

Result:

- The crane drives a reverse curve to the left.



Note

- ▶ The further the right foot rocker **PG6** is actuated backward (direction **Y-**) the higher the speed of driving a curve.
 - ▶ If the left foot rocker **PG5** is pushed fully to the rear (direction **Y-**), the left track stops.
-

7.6.6 Driving in curves reverse to the right

See illustration 6.

- ▶ Actuate the left foot rocker **PG5** reduced to the front (direction **Y+**) and the right foot rocker **PG6** to the rear (direction **Y-**).

Result:

- The crane drives a reverse curve to the right.



Note

- ▶ The further the right foot rocker **PG6** is actuated backward (direction **Y-**) the higher the speed of driving a curve.
 - ▶ If the left foot rocker **PG5** is pushed fully to the front (direction **Y+**), the right track stops.
-

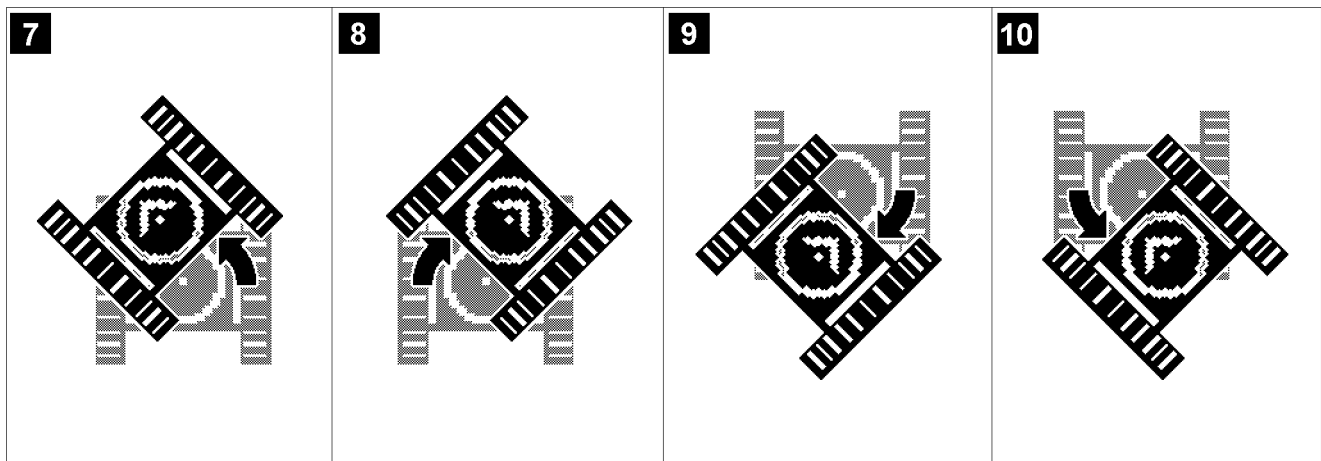
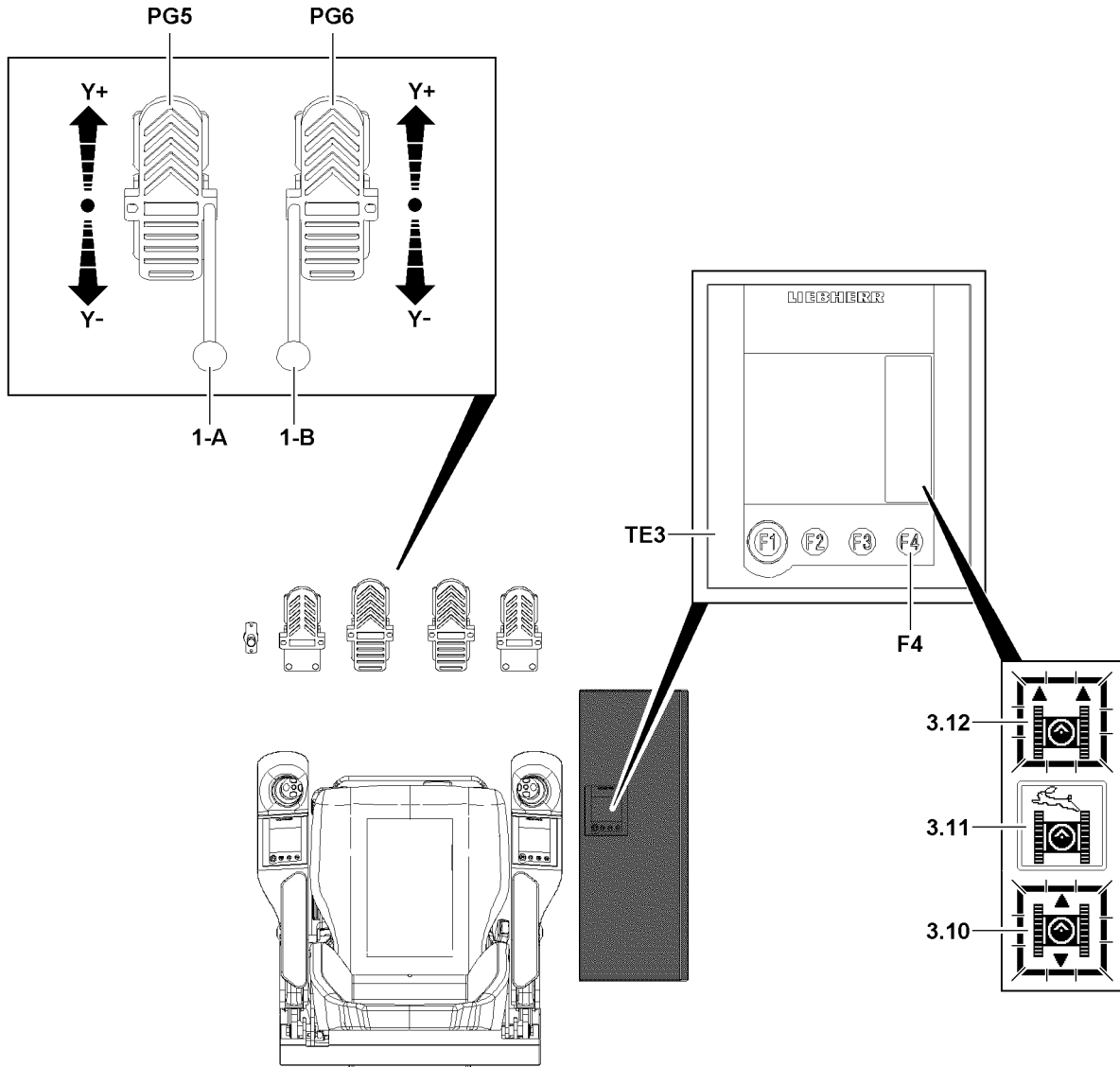

Fig.122240

LWE/LR 11000-001/23501-04-02/en

7.6.7 Turning forward to the left

See illustration 7.

- ▶ Push through and hold the left foot rocker **PG5** fully to the rear (direction **Y-**).
- ▶ Actuate the right foot rocker **PG6** forward (direction **Y+**).

Result:

- The crane is turned forward to the left.



Note

- ▶ The further the right foot rocker **PG6** is actuated forward (direction **Y+**) the higher the speed of the turning movement.

7.6.8 Turning forward to the right

See illustration 8.

- ▶ Push through and hold the left foot rocker **PG5** fully to the front (direction **Y+**).
- ▶ Actuate the right foot rocker **PG6** forward (direction **Y+**).

Result:

- The crane is turned forward to the right.



Note

- ▶ The further the right foot rocker **PG6** is actuated forward (direction **Y+**) the higher the speed of the turning movement.

7.6.9 Turning backward to the left

See illustration 9.

- ▶ Push through and hold the left foot rocker **PG5** fully to the rear (direction **Y-**).
- ▶ Actuate the right foot rocker **PG6** backward (direction **Y-**).

Result:

- The crane is turned backward to the left.



Note

- ▶ The further the right foot rocker **PG6** is actuated backward (direction **Y-**) the higher the speed of the turning movement.

7.6.10 Turning backward to the right

See illustration 10.

- ▶ Push through and hold the left foot rocker **PG5** fully to the front (direction **Y+**).
- ▶ Actuate the right foot rocker **PG6** backward (direction **Y-**).

Result:

- The crane is turned backward to the right.



Note

- ▶ The further the right foot rocker **PG6** is actuated backward (direction **Y-**) the higher the speed of the turning movement.

Empty page!

LWE/LR 11000-001/23501-04-02/en

4.20 Procedure for shut off of crane movements

1	General	3
2	Instructions for resuming crane movement	17

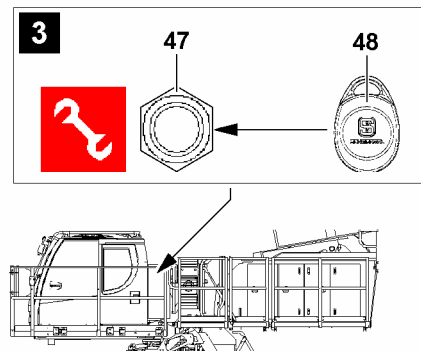
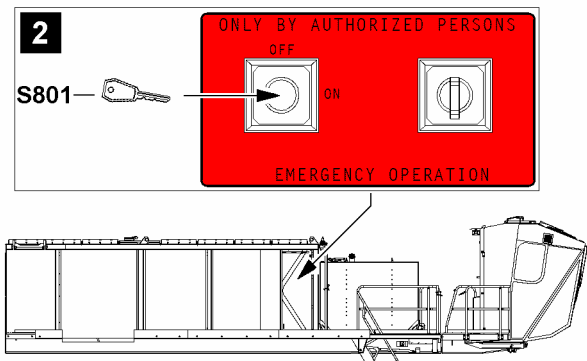
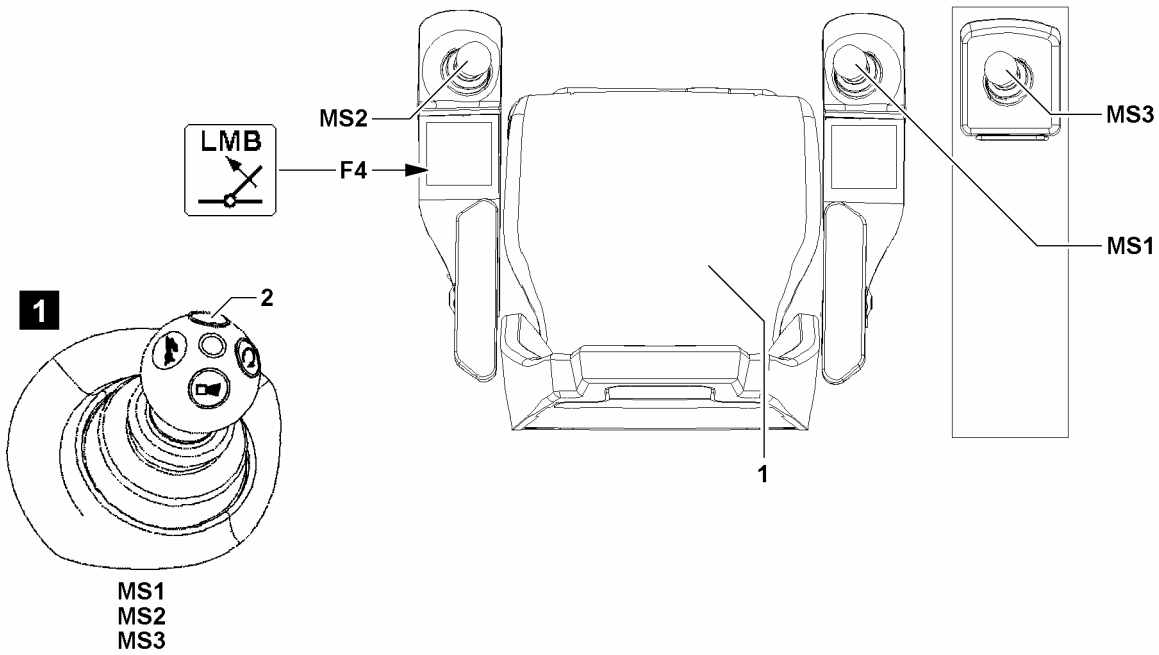
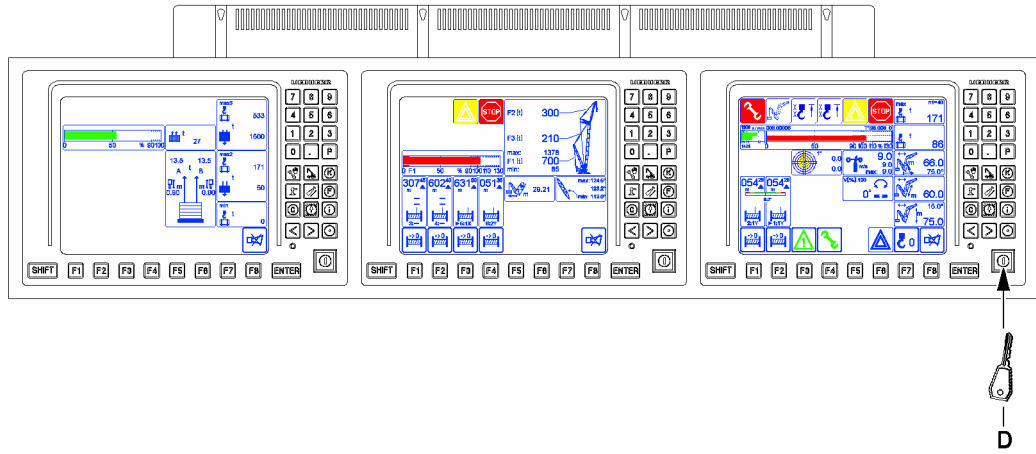

Fig.144109

LWE/LR 11000-001/23501-04-02/en

1 General



Note

- ▶ The monitor illustrations in this chapter are only examples.
- ▶ The numerical values in the individual icons and charts do not have to necessarily match the crane exactly.
- ▶ Numbers and letters can be replaced by place holders.
- ▶ The display and assignment of the icons can deviate, depending on the set up configuration, operating status and configuration of the crane.
- ▶ In addition, many of the illustrations show the maximum configuration of the LICCON monitor with icons.
- ▶ In crane operation, an identical display will **not** appear on the LICCON monitor.

For monitoring the crane, three LICCON monitors are available in the instrument panel.

LICCON monitor 0

- Placed on the right in the monitor arrangement

LICCON monitor 1

- Placed in the center in the monitor arrangement

LICCON monitor 2

- Placed to the left in the monitor arrangement

If a crane movement is to be carried out with a master switch (MS1, MS2 or MS3), then at least one of the following buttons must be pressed:

- **1** Seat contact button
 - Is actuated by sitting properly on the seat.
- **2** Button
 - To bypass the seat contact button **1**, to be able to work while standing up, if necessary.
 - Each master switch (MS1, MS2 or MS3) has a button **2**, see illustration **1**



Note

- ▶ Load hook and hook block are also generally described as hooks.

1.1 Operating elements for special cases at operation of the LICCON overload protection

Within the crane operator's cab, two buttons are installed as operating elements for „Special cases at operation of the LICCON overload protection“:

- Button **F4** on the left control panel
- Set up key **D** on LICCON monitor 0

Depending on the crane configuration, an additional operating element can be installed outside the crane operator's cab for „Special cases at operation of the LICCON overload protection“.

Depending on the crane type, either:

- Key button **S801** in the control cabinet, see illustration **2**
- or
- Sensor **47** and transponder **48** on the outside of the control cabinet, see illustration **3**

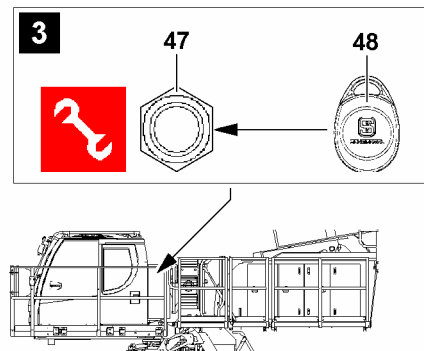
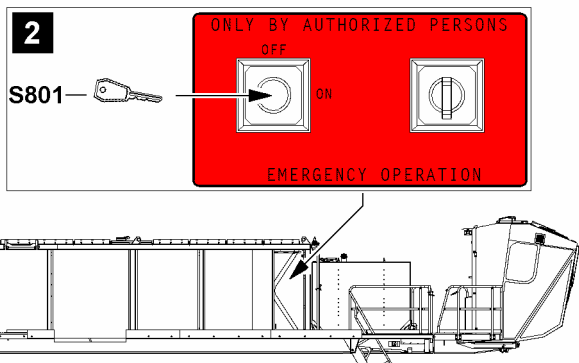
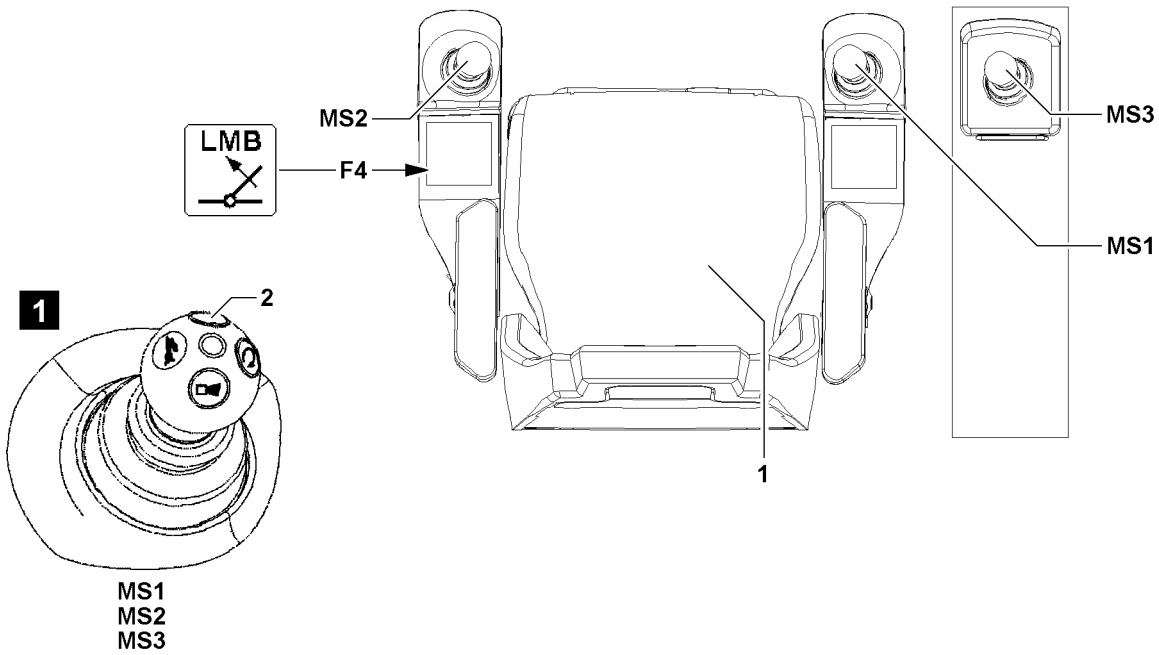
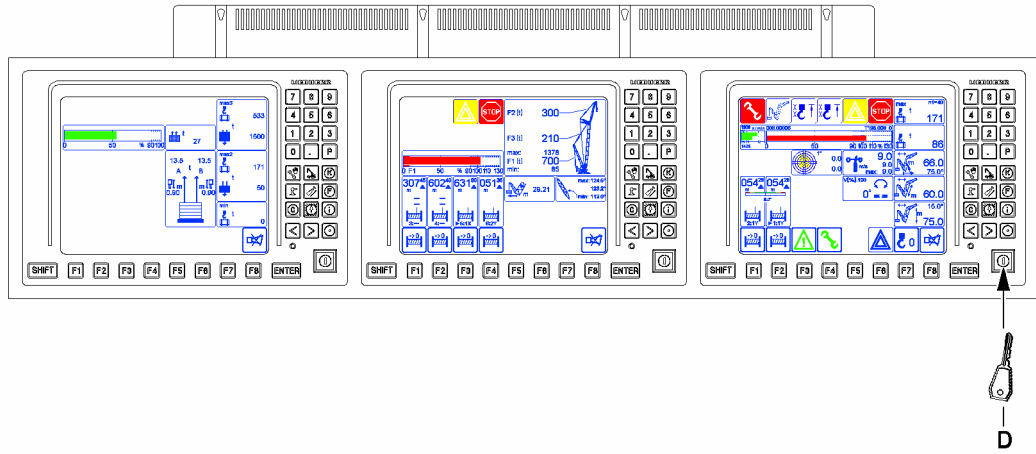

Fig.144109

LWE/LR 11000-001/23501-04-02/en

1.2 Special cases at operation of the LICCON overload protection

When special cases at operation of the LICCON overload protection occur, then the functionality of the LICCON overload protection is accessed.



WARNING

Access the functionality of the LICCON overload protection!

If the functionality of the LICCON overload protection is accessed by pressing the key **F4**, set up key **D**, the key switch **S801** or sensor **47** via transponder **48**, then the LICCON overload protection is entirely deactivated, bypassed or limited.

It is possible to exceed several shut-off limits of the LICCON overload protection simultaneously or one after the other.

It is possible to carry out crane movements that are not monitored by the LICCON overload protection. Without the LICCON overload protection, no additional protection against overload of the crane via the crane control is present.

- ▶ When accessing the functionality of the LICCON overload protection, take into account that the LICCON overload protection is deactivated totally or limited.
- ▶ Access the functionality of the LICCON overload protection exclusively according to the specifications in the crane documentation.

Possible limitation in the crane control:

- During certain „Special cases at operation of the LICCON overload protection“, the working speed of the crane is significantly reduced.
- During certain „Special cases at operation of the LICCON overload protection“, the possibility to control the crane is limited in time.
- During certain „Special cases at operation of the LICCON overload protection“, the individual display instruments show no values.

1.2.1 Special operating conditions

If a special operating condition occurs, such as self-blocking of overload protection („Deadlock“), pressing key **F4** or set up key **D** can provide a remedy.

By pressing the key **F4** you can:

- Luff in with suspended load

By pressing the set up key **D**, the function „Exceeding the shut-off limits of the LICCON overload protection“ is activated. This makes it possible:

- To exceed the maximum permissible load moment.
- To exceed the maximum value of the F-load display in crane operation.
- To make it possible to carry out some limited crane movements after shut-off *LMB-STOP* due to sensor errors, if the erroneous sensor is not required for monitoring by the LICCON overload protection.



Note

- ▶ If there is no sensor defect and a load chart is available, then the display values remain for the crane utilization (load capacity display).
- ▶ Depending on the crane configuration, exceeding the maximum permissible load moment is limited to 110 %.

1.2.2 Assembly / disassembly procedures

By pressing the set up key **D** you can:

- Bypass the LICCON overload protection to carry out erection / take down procedures and assembly procedures.
- Bypass *hoist top* shut-off (erection / take down procedures and assembly procedures)

**Note**

- ▶ For assembly / disassembly procedures, depending on the circumstances there may not be any display values or they may be significantly reduced.
- ▶ The display of the required display values or determination of required values is ensured when proceeding correctly.

1.2.3 Failure of components

**WARNING**

Erroneous operation of the crane!

If the LICCON overload protection turns the crane movement off due to failure of components, then the exact cause for the shut-off must be determined.

After a failure of components, no normal operating condition can be reached. No normal crane operation is possible.

- ▶ For the procedure, see Crane operating instructions, chapter 4.04.
- ▶ Assume normal crane operation only when the cause for the shut-off has been remedied and the crane control is fully functioning.

Depending on the crane configuration, a shut-off due to a failure of components can be bypassed by:

- Press the set up button **D**.
- or
- Actuate the key switch **S801**.
- or
- Actuate the sensor **47** through the transponder **48**.

The activated function includes the following:

- Allows crane movements in case of failure of components, for example sensors which are required for monitoring by the LICCON overload protection.

1.2.4 Emergency situations

**WARNING**

Overload of crane!

If the LICCON overload protection is bypassed, then the LICCON overload protection is entirely deactivated.

If the LICCON overload protection is bypassed, there is no further protection against crane overload. There is no longer a load torque limiter.

If the LICCON overload protection is bypassed, the crane can be overloaded readily.

Overloading the crane can lead to accidents.

During accidents, personnel could be killed or seriously injured.

- ▶ If the LICCON overload protection is bypassed, take into account that the LICCON overload protection is entirely deactivated.
- ▶ If the LICCON overload protection is bypassed, the crane operator assumes the full responsibility for his actions.

Depending on the crane configuration, the LICCON overload protection can be bypassed as follows:

- Press the set up button **D**.
- or
- Actuate the key switch **S801**.
- or
- Actuate the sensor **47** through the transponder **48**.

The activated function includes the following:

- Allowing crane movements in emergency situations without monitoring by the LICCON overload protection

**Note**

- ▶ Installation location of key switch **S801** or sensor **47**, see illustration. The transponder **48** (when sensor **47** is installed) is supplied at crane delivery and must be accessible to the respective personnel (for example the crane operator).
- ▶ For the procedure, see Crane operating instructions, chapter 4.04.

1.3 Operating condition of crane

A „**normal operating condition**“ can only be reached if all of the following statements apply:

- The crane is in a proper condition.
- The crane is set up according to the specifications in the crane documentation.
- The set up configuration of the crane has been entered correctly into the LICCON computer system.
- The crane is in the range of a valid load chart.
- The crane utilization is in the range of 0 % to 100 %.
- The F-load display is in the permissible range.
- All required displays in the LICCON monitors provide the correct display values.
- All required display instruments are functioning.
- The local conditions meet the specifications for crane application.

„**The operating condition is not normal**“, among others, if one or more of the following statements apply:

- The crane has defects that compromise operational safety.
- The crane is not set up according to the specifications in the crane documentation.
- The set up configuration of the crane deviates from the entries in the LICCON computer system.
- The limit values from the load charts are exceeded.
- The maximum permissible load moment is exceeded.
- The *hoist top* shut-off is bypassed.
- The limit values from the F-load display are exceeded.
- Required displays in the LICCON monitors provide no correct display values.
- Required display instruments are not functioning.
- The functionality of the LICCON overload protection has been accessed by pressing the key **F4**, set up key **D** or key switch **S801** or sensor **47** via transponder **48**.
- Crane movements are carried out without functioning overload protection.
- Crane movements are carried out outside of the load charts.
- A special case at operation of the LICCON overload protection has occurred.

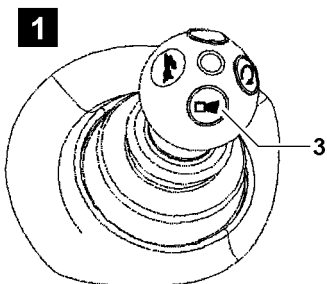
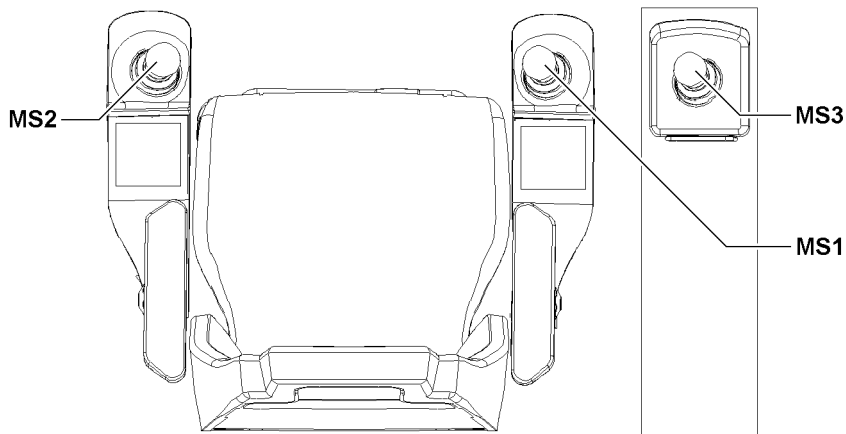
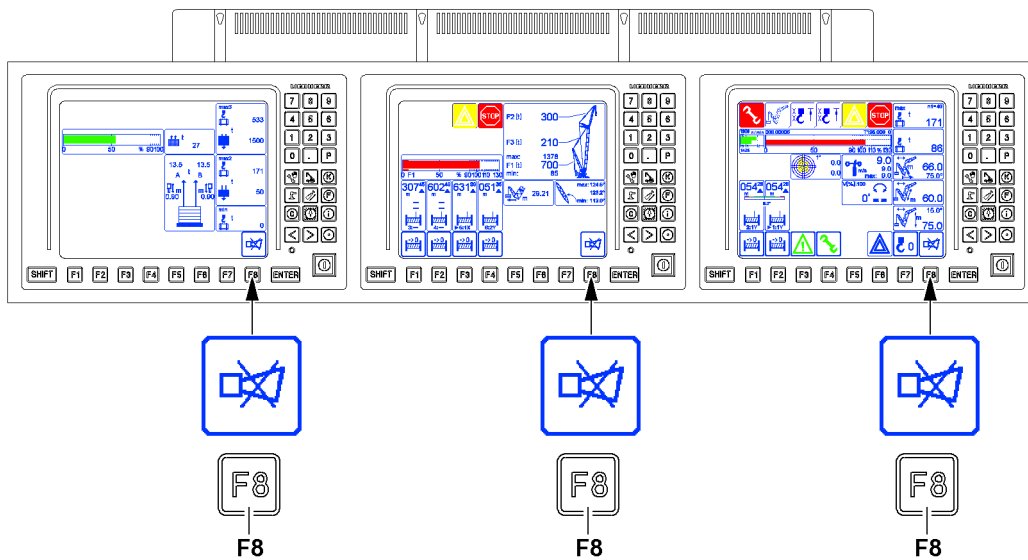
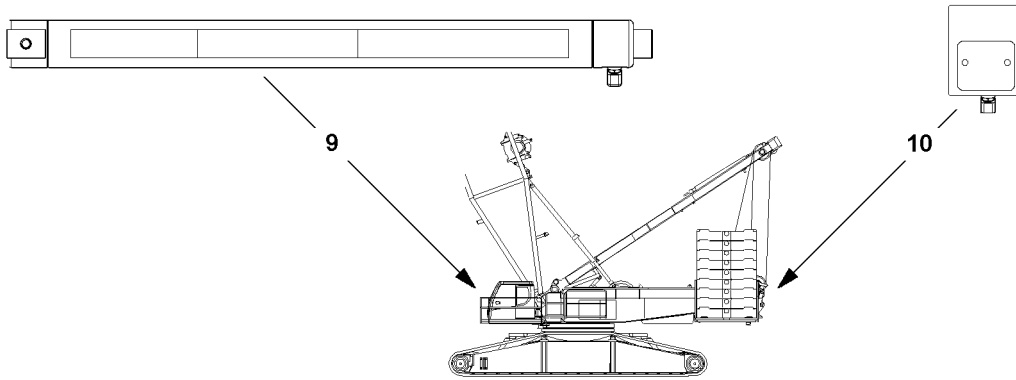

MS1
MS2
MS3

Fig.144108

LWE/LR 11000-001/23501-04-02/en

1.4 Overview of acoustic / optical warnings

- The acoustic warnings are issued to the crane operator via the signal sounds of the LICCON monitors.
- The acoustic warnings are issued to the crane surrounding area via a horn on the turntable.
- The optical warnings are issued to the crane operator via warning icons in the LICCON monitors.
- The LMB warning lights (three color light **9** on the crane cab and warning light **10** on the rear of the turntable) are used to issue optical warnings to the crane surrounding area.
- The acoustic warnings within the crane operator's cab are turned off by pressing the button **F8** on the corresponding LICCON monitor.
- The acoustic warnings outside the crane operator's cab are turned off by pressing the button **3**. Each master switch (MS1, MS2 or MS3) has a button **3**, see illustration 1

1.4.1 General notes regarding the acoustic / optical warnings to the crane surrounding area



WARNING

Disregard of acoustic or optical warnings!

If persons in the crane surrounding area are not informed about the meaning of acoustic / optical warnings of the crane, then there is a danger of accidents.

- ▶ Only persons who have been informed about how to proceed correctly according to the acoustic / optical warnings may be in the crane surrounding area.

In reference to the horn on the turntable, the following applies:

- An intermittent sound is heard: A special case in the operation of the LICCON overload protection has occurred or the overload protection has turned the crane movement off.

In reference to the three color light **9**, the following applies:

- The three color light **9** lights up green: The crane is in normal operating condition.
- The three color light **9** lights up yellow: The crane is still in normal operating condition, an advance warning for upcoming shut-off exists.
- The three color light **9** lights up red: The crane movement was turned off by the overload protection.
- The three color light **9** blinks yellow: A special case at operation of the LICCON overload protection has occurred.
- The three color light **9** blinks red: A special case at operation of the LICCON overload protection has occurred.

In reference to the warning light **10** on the rear of the turntable, the following applies:

- The warning light **10** lights up red: The crane movement was shut off.
- The warning light **10** blinks red: A special case at operation of the LICCON overload protection has occurred.

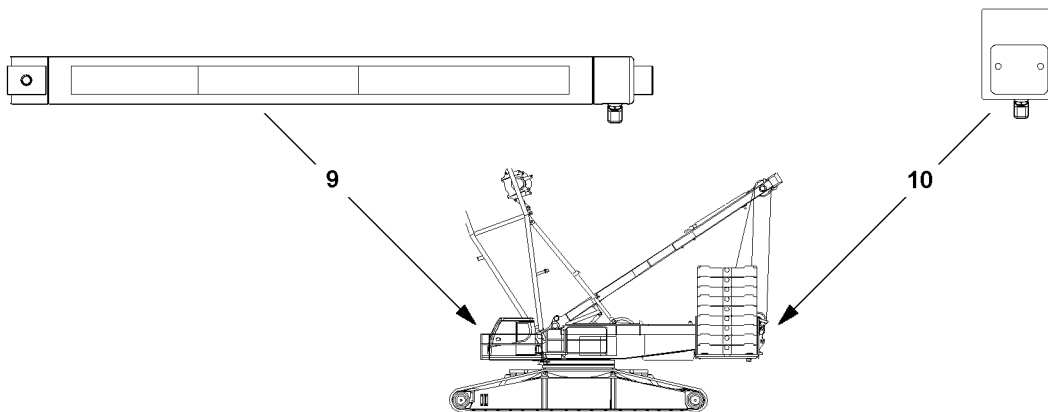
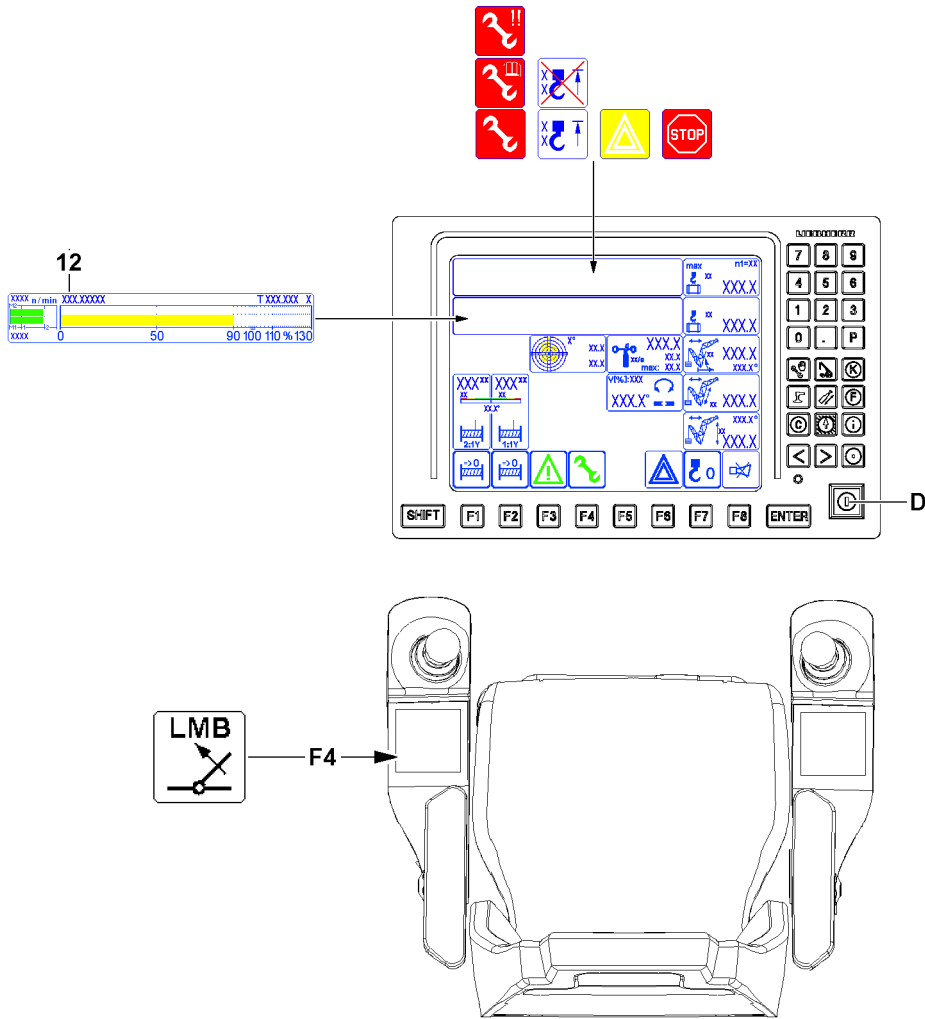

Fig.115284

LWE/LR 11000-001/23501-04-02/en

1.4.2 Description of acoustic / visual warnings

The occurrence of acoustic / optical warnings in crane operation is explained via sample situations. The situation numbers from the chart „Overview of possible situations“ is valid for the following charts in this chapter:

- Acoustic / visual warnings on the LICCON monitor
- LMB warning lights
- Horn on the turntable



Note

- ▶ The percentage values in the chart „Overview of possible situations“ refers to the crane utilization according to the display in the bar diagram for utilization **12**.

Overview of possible situations	
Situation number	Sample description of the situation
Situation 001	Normal operating condition with crane utilization of 0 % to 100 %.
Situation 003	The crane movement was turned off due to a crane utilization above 100 % - shut-off <i>LMB-STOP</i> was triggered.
Situation 004	The crane movement was turned off even though the crane utilization is below 100 % - shut-off <i>LMB-STOP</i> was triggered.
Situation 005	The crane movement „luffing in with suspended load“ is carried out at a crane utilization above 100 % via the F4 key.
Situation 006	Failure of components
Situation 010	The shut-off limits of the LICCON overload protection are deactivated / exceeded with the set up key D .
Situation 011	An actuated hoist limit switch (<i>hoist top</i> shut-off) is bypassed via the set up key D .
Situation 020	The assembly operation was activated via the set up key D to erect / take down the boom. No load chart is available.

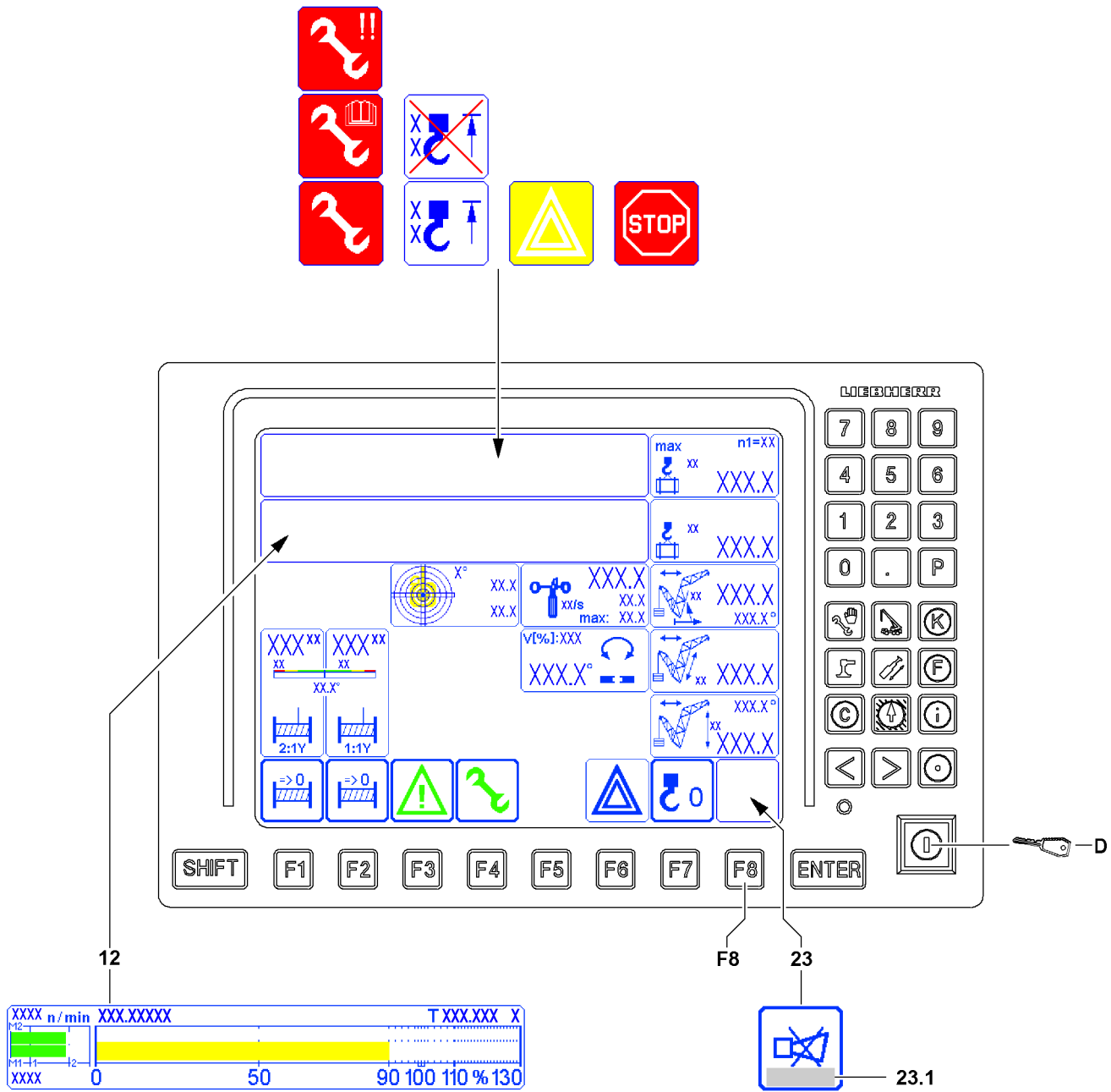

Fig.115267

1.4.3 Acoustic / visual warnings within the crane operator's cab



Note

- ▶ For description of the situations assigned to the situation numbers, see chart „Overview of possible situations“
- ▶ The percentage values refer to the crane utilization according to the display in the bar diagram for utilization **12**.



WARNING

Erroneous operation of the crane!

- ▶ In relation with acoustic / optical warnings in the *Horn* icon **23**, observe the notes regarding error messages **23.1**.

Acoustic / visual warnings on the LICCON monitor							
Situation number	Acoustic warning		Visual warning LICCON monitor				
	Horn short ²⁾	Horn long ²⁾	Warning signs		Special signs		
Situation 001	From 90 %	-	From 90 %	-	-	-	-
Situation 003	From 90 %	From 101 %	From 90 %	From 101 %	-	-	-
Situation 004	-	Always	-	Always	-	-	-
Situation 005	-	From 101 %	From 101 %	From 101 %			
Situation 006				Always		Always ³⁾	
Situation 010	From 90 %	From 101 %	From 90 %	From 101 %	Always	-	-
Situation 011¹⁾	-	Always	-	-	-	-	Always
Situation 020	-	Always	-	-	-	Always	-

1) Is in part superseded by other warnings

2) Can be turned off immediately on the LICCON monitor key **F8**

3) Depending on the crane configuration, a similar icon appears, in which two exclamation marks (upper right) appear, see also Crane operating instructions, chapter 4.02

LWE/LR 11000-001/23501-04-02/en

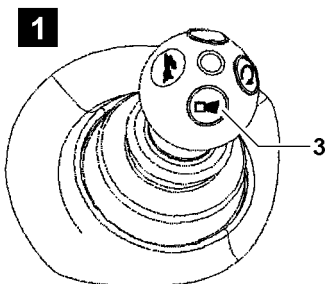
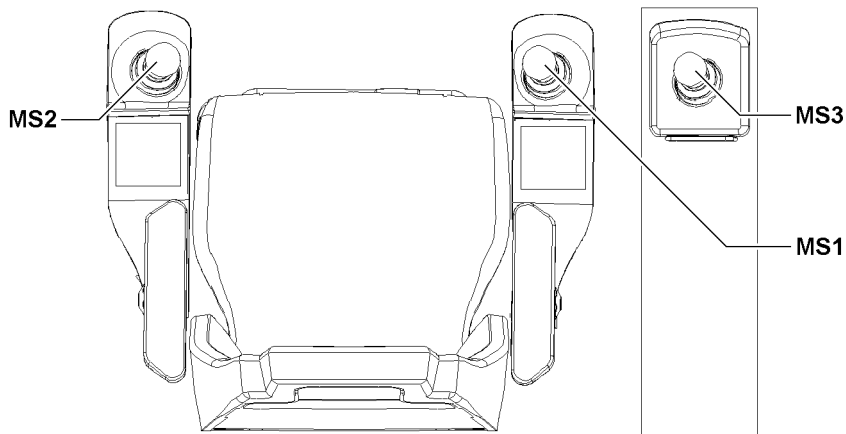
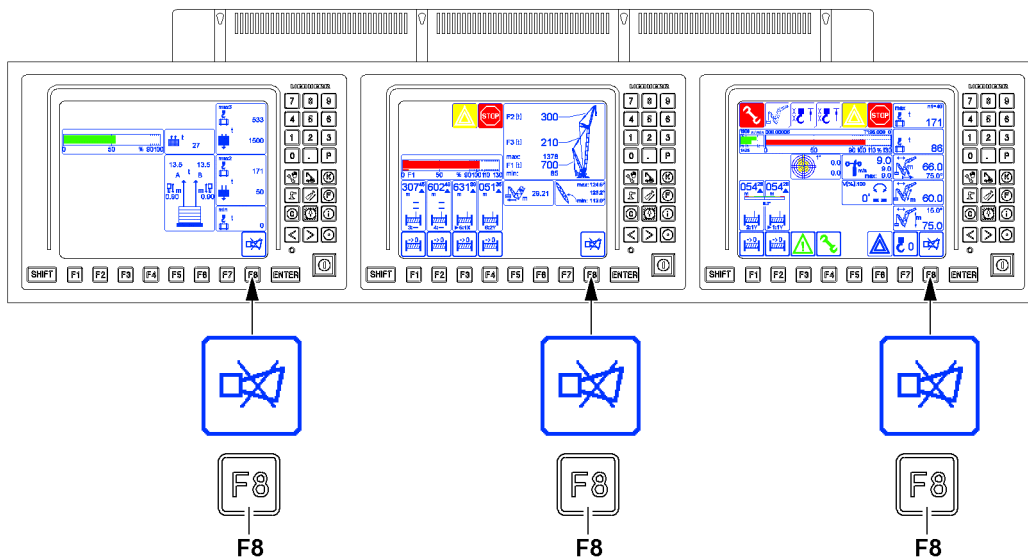
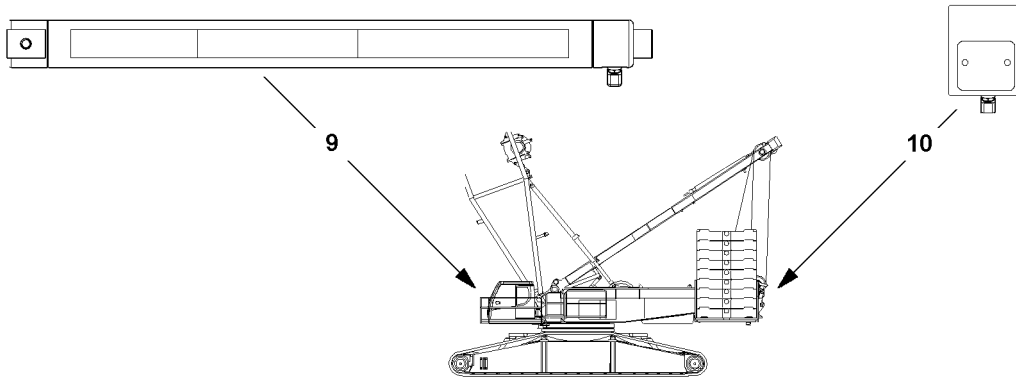

MS1
MS2
MS3

Fig.144108

LWE/LR 11000-001/23501-04-02/en

1.4.4 Acoustic / visual warnings outside the crane operator's cab



Note

- ▶ For description of the situations assigned to the situation numbers, see chart „Overview of possible situations“
- ▶ The percentage values refer to the crane utilization according to the display in the crane operating screen.

LMB warning lights					
Situation number	At utilization of crane	Three color light 9			Warning light 10
		Green	Yellow	Red	Red
Situation 001	0 % to 89 %	Lights up			
	90 % to 100 %		Lights up		
Situation 003	From 101 %			Lights up	Lights up
Situation 004	Always			Lights up	Lights up
Situation 005	From 101 %			Blinks	Blinks
Situation 006	Always			Blinks	Blinks
Situation 010 ⁴⁾	0 % to 89 %	Lights up			
	90 % to 100 %		Lights up		
	101 % to 110 %		Blinks		
	From 111 %			Lights up	Lights up
Situation 010	0 % to 89 %	Lights up			
	90 % to 100 %		Lights up		
	From 101 %			Blinks	Blinks
Situation 011 ¹⁾	Always		Blinks		
Situation 020	No display value		Blinks		

1) Is in part superseded by other warnings

4) Cranes according to EN13000:2010

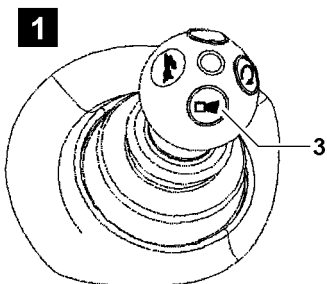
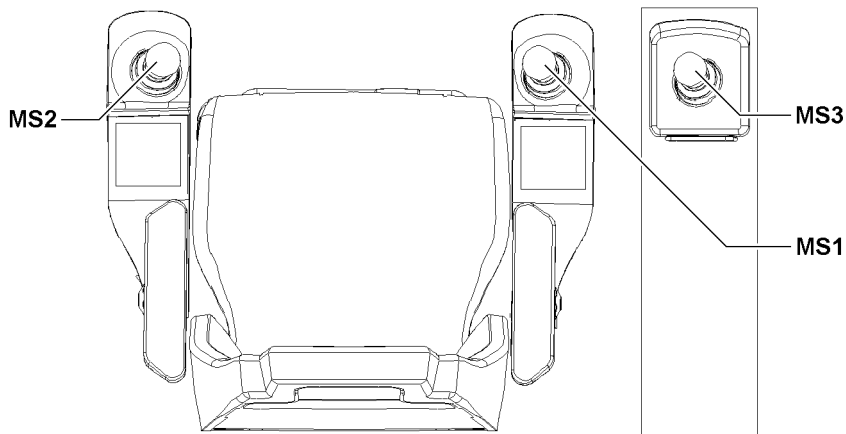
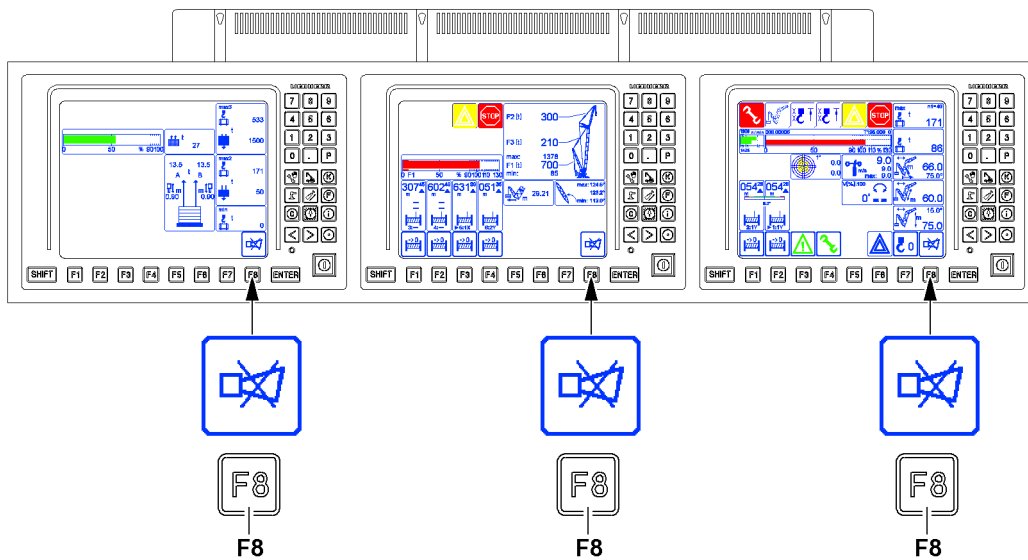
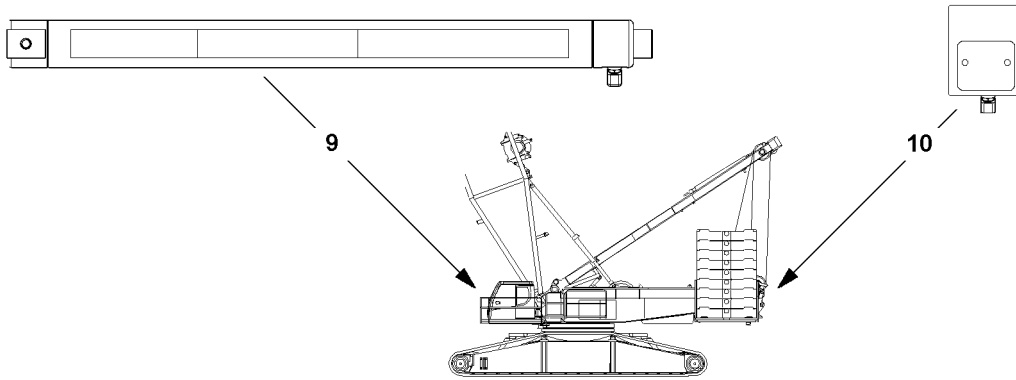

MS1
MS2
MS3

Fig.144108

LWE/LR 11000-001/23501-04-02/en

**Note**

- ▶ For description of the situations assigned to the situation numbers, see chart „Overview of possible situations“
- ▶ The percentage values refer to the crane utilization according to the display in the crane operating screen.

Acoustical signals on the turntable that can be shut off by actuating a button **3** (illustration **1**). The signal shut-off is effective no earlier than after five seconds.

Signal turntable		
Situation number	At utilization of crane	Signal type
Situation 001	0 % to 89 %	-
Situation 002	90 % to 100 %	-
Situation 003	From 101 %	Intermittent sound, can be shut off after five seconds
Situation 004	Always	-
Situation 005	From 101 %	Intermittent sound, can be shut off after five seconds
Situation 006	Always	Intermittent sound
Situation 010	From 111 %	Intermittent sound, can be shut off after five seconds
Situation 011 ¹⁾	Always	Intermittent sound, can be shut off after five seconds
Situation 020	No display value	-

1) Is in part superseded by other warnings

2 Instructions for resuming crane movement

**WARNING**

Danger of accident!

If the following points are not observed, personnel can be severely injured or killed.

- ▶ The crane operator bears the sole and full responsibility for the adherence to measures to be taken in case of shut-off of crane movement.

2.1 Overview Load chart

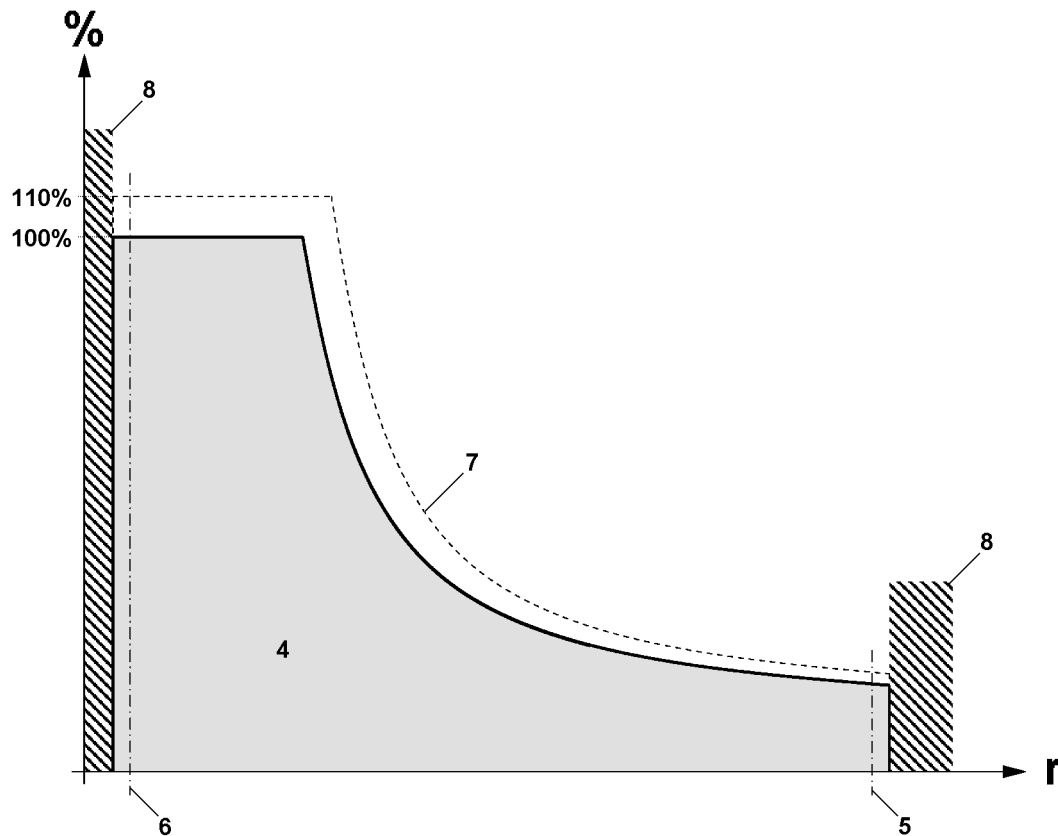

Fig.125392: Sample overview of a load chart

Axle	Description
r	Boom radius (working radius)
%	Utilization of the crane in percentages

Position	Description
4	Range „Load chart available“
5	Lower limit angle load chart
6	Upper limit angle load chart
7	Curve utilization 110 %
8	Range „No load chart available“

2.2 Shut-off of crane movement

The LICCON computer system carries out the following shut-offs if a limit value is exceeded in crane operation:

- Shut-off *overload*
- Shut-off *luffing the main boom up / down*
- Shut-off *luffing the auxiliary boom / accessory up / down*
- Shut off *maximum / minimum value F-load display*
- Shut-off *spooling the winch up / out*
- Shut-off hoist top

- Shut-off *luffing the derrick boom up / down*
- Shut-off *parallel operation winch 1 and winch 2*
- Shut-off *difference force monitoring of derrick ballast guying*
- Shut-off due to error message

**Note**

- ▶ For detailed description of the individually listed icons, see Crane operating instructions, chapter 4.02.

**WARNING**

Erroneous operation of the crane!

If the LICCON overload protection turns the crane movement off, then the exact cause for the shut-off must be determined first.

- ▶ Determine the cause for the shut-off and remedy it if possible without pressing the key **F4** „Luffing in with suspended load“ or the set up key **D**.
- ▶ If it is not possible to reset the crane movement causing the shut-off, see section „Procedure for special cases at operation of the LICCON overload protection“.

2.2.1 Shut-off overload

Fig.115274

In the bar diagram utilization **12** the utilization bar **12.1** exceeds the 100 % mark. The LICCON overload protection has turned off the crane movement, *LMB-STOP* icon **19** appears. The actual load **13** has exceeded the maximum load **14**.

- ▶ Wait for a short time until the crane movement has come to a complete standstill.

When the bar diagram utilization **12** shows less or equal 100 %:

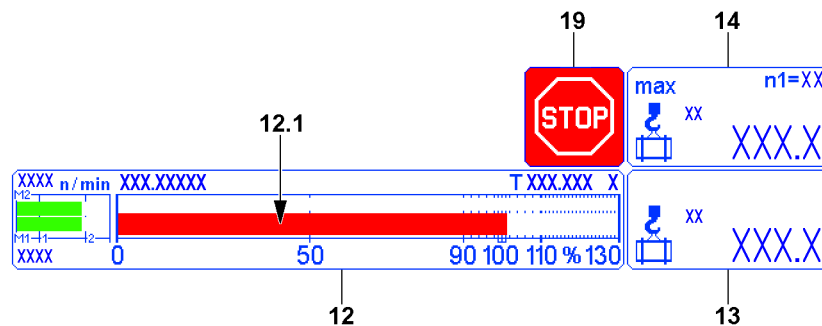
- ▶ Carry out crane movements in such a way that no repeated shut-off by the LICCON overload protection occurs.

When the bar diagram utilization **12** shows more than 100 %:

- ▶ Check if there are permissible tasks, which positively influence the utilization of the crane.

When necessary and possible:

- ▶ Set down the load.

**Note**

It is possible that the following tasks can positively influence the utilization of the crane:

- ▶ Set down the load and reduce the boom radius by driving the crane.
- ▶ Set down the load and reduce.
- ▶ Set down the load and reconfigure the crane to obtain higher load chart values.
- ▶ Carry out permissible tasks that positively influence the utilization of the crane.

Problem remedy

The crane operation is limited because the maximum load **14** is seemingly too low or reached too soon?

- ▶ Make sure that the load bearing capacity of the crane is sufficient for the upcoming crane application.
- ▶ Make sure that a valid set up configuration has been entered on the LICCON computer system.
- ▶ Make sure that the crane is assembled according to the specifications in the crane documentation.
- ▶ Make sure that the actual set up configuration and the entered set up status of the crane match.
- ▶ Make sure that all attachment parts and guy rods on the boom system, which are not needed, have been removed (weight).
- ▶ Make sure that the boom system is free of snow and ice (weight).
- ▶ Make sure that the environmental influences (for example wind influence) onto the crane are not too great.
- ▶ Contact Liebherr Service.

When the shut-off cannot be remedied despite the observance of all points listed here:

- ▶ Change to section „Procedure for special cases at operation of the LICCON overload protection“.

2.2.2 Shut-off luffing the main boom up / down**Note**

- ▶ The illustration of icon **15** depends on the set up configuration of the crane.

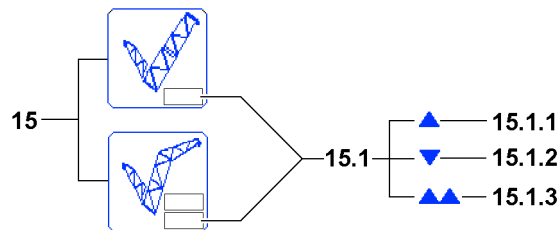

Fig.115275

In the icon **15** the arrow **15.1.1** or arrow **15.1.2** blinks and the LICCON overload protection has shut off the crane movement.

„Luffing the main boom up“ (arrow **15.1.1**) or „Luffing the main boom down“ (arrow **15.1.2**) was shut off because the upper / lower limit angle of the selected load chart was exceeded / fallen below.

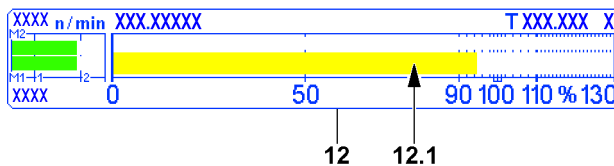

Fig.115276

**Note**

- ▶ If the utilization of the crane is more than 95 % (in bar diagram utilization **12** the utilization bar **12.1** exceeds 95 %) and the maximum load according to the load chart (falling load capacity) drops by continuing to luff up the boom, then the arrow **15.1.1** also appears and the crane movement „Luffing the main boom up“ is turned off.

If the double arrow **15.1.3** appears, then:

- **either** it was luffed up to a limit switch or the limit switch has turned off the crane movement „Luffing the main boom up“
- **or** there is an error on one of the limit switches „Main boom top“

The arrow **15.1.1** appears and the crane movement „Luffing the main boom up“ was turned off:

- ▶ Luff the main boom down.

Result:

- Crane operation is possible again.

The arrow **15.1.2** appears and the crane movement „Luffing the main boom down“ was turned off:

- ▶ Luff the main boom up.

Result:

- Crane operation is possible again.

The double arrow **15.1.3** appears and the crane movement „Luffing the main boom up“ was turned off:

- ▶ Luff the main boom down.

Result:

- Crane operation is possible again.

Problem remedy

The double arrow **15.1.3** appears continuously?

If a double arrow **15.1.3** appears without having luffed the main boom up to a limit switch, then there may be an error in the limit switches / sensors.

- ▶ Check if there is an error message from the LICCON computer system, see the Diagnostics manual.
 - ▶ If yes: Remedy the error immediately.
-



WARNING

Limited warning functions!

If one of the double version limit switches / sensors is not OK and the crane is continued to be operated, then the warning functions of the LICCON overload protection are limited.

- ▶ The crane can only be operated in an emergency after failure of a double version limit switch.
 - ▶ Carry out crane movements in such a way that no repeated shut-off by the LICCON overload protection occurs.
-

2.2.3 Shut-off luffing the auxiliary boom / accessory up / down



Note

- ▶ Only in operating modes with auxiliary boom / accessory
 - ▶ The illustration of icon **15** depends on the set up configuration of the crane.
 - ▶ The description „auxiliary boom / accessory“ comprises all boom types which can be luffed and are installed on the main boom.
-

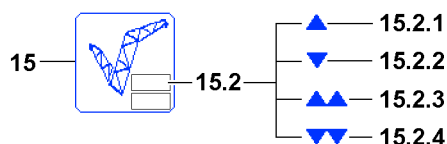

Fig.115277

In the icon **15** (upper field) the arrow **15.2.1** or arrow **15.2.2** blinks and the LICCON overload protection has shut off the crane movement.

„Luffing the equipment up“ (arrow **15.2.1**) or „Luffing the equipment down“ (arrow **15.2.2**) was shut off because the upper / lower limit angle of the selected load chart was exceeded or fallen below.

If the double arrow **15.2.3** appears, then:

- **either** it was luffed up to a limit switch or the limit switch has turned off the crane movement „Luffing the auxiliary boom / accessory up“

- **or** the mechanical relapse support has turned off the crane movement „Luffing the auxiliary boom / accessory up“
- **or** there is an error on one of the limit switches „Auxiliary boom / accessory top“.

If the double arrow **15.2.4** appears, then:

- **either** it was luffed down to a limit switch „Auxiliary boom / accessory bottom“ and the limit switch has turned off the crane movement „Luffing the auxiliary boom / accessory up“
- **or** there is an error on one of the limit switches „Auxiliary boom / accessory bottom“

The arrow **15.2.1** appears and the crane movement „Luffing the auxiliary boom / accessory up“ was turned off:

- ▶ Luff the auxiliary boom / accessory down.

Result:

- Crane operation is possible again.

The arrow **15.2.2** appears and the crane movement „Luffing the auxiliary boom / accessory down“ was turned off:

- ▶ Luff the auxiliary boom / accessory up.

Result:

- Crane operation is possible again.

The double arrow **15.2.3** appears and the crane movement „Luffing the auxiliary boom / accessory up“ was turned off:

- ▶ Luff the auxiliary boom / accessory down.

Result:

- Crane operation is possible again.

Problem remedy

The double arrow **15.2.3** appears continuously?

If a double arrow **15.2.3** appears without having luffed up to a limit switch, then there may be an error in the limit switches „Auxiliary boom / accessory top“.

- ▶ Check if there is an error message from the LICCON computer system, see the Diagnostics manual.
- ▶ If yes: Remedy the error immediately.

The double arrow **15.2.4** appears and the crane movement „Luffing the auxiliary boom / accessory down“ was turned off:

- ▶ Luff the auxiliary boom / accessory up.

Result:

- Crane operation is possible again.

Problem remedy

The double arrow **15.2.4** appears continuously?

If a double arrow **15.2.4** appears without having luffed down to a limit switch, then there may be an error in the limit switches / sensors.

- ▶ Check if there is an error message from the LICCON computer system, see the Diagnostics manual.
- ▶ If yes: Remedy the error immediately.

**WARNING**

Limited warning functions!

If one of the double version limit switches / sensors is not OK and the crane is continued to be operated, then the warning functions of the LICCON overload protection are limited.

- ▶ The crane can only be operated in an emergency after failure of a double version limit switch / sensor.
-
- ▶ Carry out crane movements in such a way that no repeated shut-off by the LICCON overload protection occurs.

2.2.4 Shut off *maximum / minimum value F-load display*

The illustration of the F-load display **17** depends on the set up configuration of the crane and can vary. The values for test point 2 (force F2) and test point 3 (force F3) are possibly shown.

**Note**

- ▶ The force determined on test point 1 is generally described as $F1_{\text{actual}}$ (actual value F1).
- ▶ In the icon **17** (F-load display), the force ratio is shown in number values as well as a bar display (called F-bar display).
- ▶ The value $F1_{\text{max}}$ **17.3** corresponds to 100 % in the F1-bar display.
- ▶ The F1-utilization bar **17.1** shows the relationship $F1_{\text{actual}}$ **17.2** to $F1_{\text{max}}$ **17.3**.
- ▶ The illustration of the F-load display **17** depends on the set up configuration of the crane and can vary.

Shut off *maximum value F1 in crane operation*

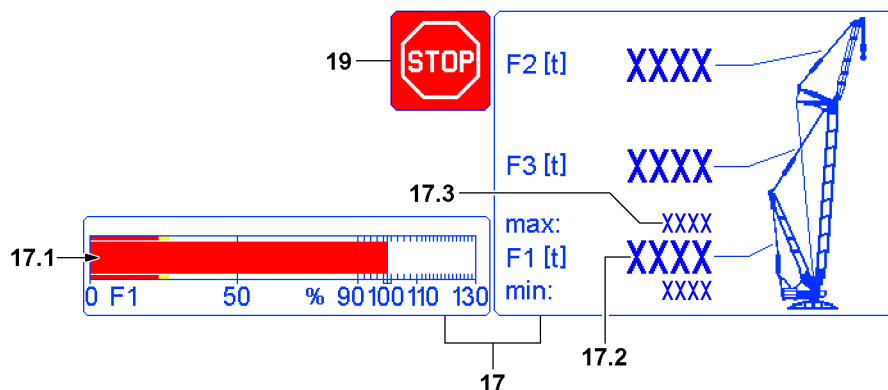

Fig. 115278

In the F-load display **17** the F1-utilization bar **17.1** exceeds the 100 % mark and the LICCON overload protection has shut off the crane movement. The value $F1_{\text{actual}}$ **17.2** has exceeded the value $F1_{\text{max}}$ **17.3**.

All other movements, which lead to a decline of the force ratio in the F-load display **17** are turned off.

- ▶ Reverse any crane movement that has caused the shut-off.
or
Alternatively initiate a crane movement that improves the force ratio in the F-load display **17**.

Result:

- Crane operation is possible again.
- ▶ Carry out crane movements in such a way that no repeated shut-off by the LICCON overload protection occurs.

Problem remedy

The crane operation is limited because the value $F1_{max}$ 17.3 apparently is being reached too early?

- ▶ Make sure that a valid set up configuration has been entered on the LICCON computer system.
- ▶ Make sure that the crane is assembled according to the specifications in the crane documentation.
- ▶ Make sure that the actual set up configuration and the entered set up status of the crane match.
- ▶ Make sure that all attachment parts and guy rods on the boom system, which are not needed, have been removed (weight).
- ▶ Make sure that the boom system is free of snow and ice (weight).
- ▶ Make sure that the wind influence on the crane is not too great.

If no irregularities can be found:

- ▶ Contact Liebherr Service.

When the shut-off cannot be remedied despite the observance of all points listed here:

- ▶ Change to section „Procedure for special cases at operation of the LICCON overload protection“.

Shut off *minimum value F1* in crane operation**Note**

- ▶ A shut-off *minimum value F1* ($F1_{min}$) only occurs in operating modes with derrick ballast. The status $F1_{actual} = F1_{min}$ cannot be reached in all other operating modes.

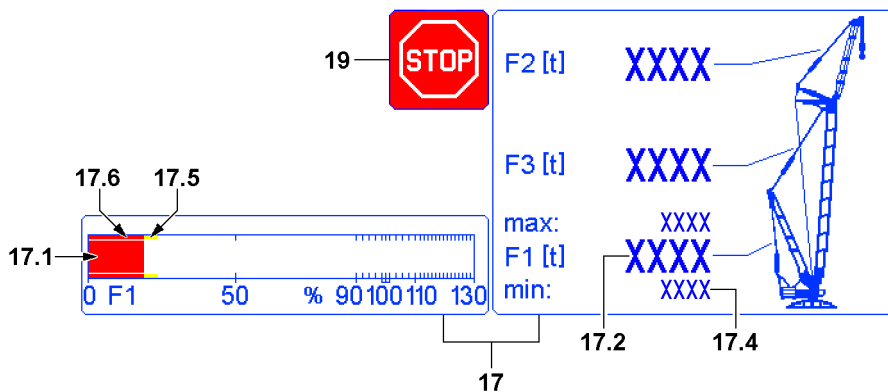

Fig.115279

In the F-load display 17, when falling below the $F1_{min}$ advance warning bar 17.5, a warning of the upcoming shut-off is issued by the F1-utilization bar 17.1.

If the F1-utilization bar 17.1 falls below the $F1_{min}$ -STOP bar 17.6, then the LICCON overload protection shuts off the crane movement. The value $F1_{actual}$ 17.2 has fallen below the value $F1_{min}$ 17.4.

All other movements, which lead to a decline of the force ratio in the F-load display 17 are turned off.

- ▶ Reverse any crane movement that has caused the shut-off.
or
Initiate an alternative crane movement that increases the force F1 (value $F1_{actual}$ 17.2).

Result:

- Crane operation is possible again.
- ▶ Carry out crane movements in such a way that no repeated shut-off by the LICCON overload protection occurs.

Problem remedy

The crane operation is limited because the value $F1_{min}$ **17.4** apparently is being reached too early?

- ▶ Make sure that a valid set up configuration has been entered on the LICCON computer system.
- ▶ Make sure that the crane is assembled according to the assembly drawings.
- ▶ Make sure that the actual set up configuration and the entered set up status of the crane match.
- ▶ Make sure that all attachment parts and guy rods on the boom system, which are not needed, have been removed (weight).
- ▶ Make sure that the boom system is free of snow and ice (weight).
- ▶ Make sure that the wind influence on the crane is not too great.

If no irregularities can be found:

- ▶ Contact Liebherr Service.

When the shut-off cannot be remedied despite the observance of all points listed here:

- ▶ Change to section „Procedure for special cases at operation of the LICCON overload protection“.

2.2.5 Shut-off *spooling the winch up / out*

**Note**

- ▶ Applies independently for winch 1 to winch 6.
- ▶ For detailed description of winch 1 to winch 6, see Crane operating instructions, chapter 4.02.

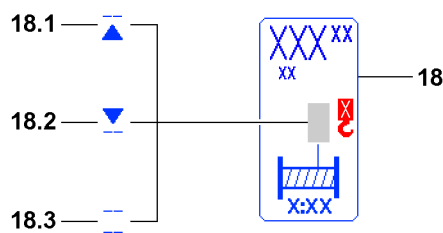

Fig.115280

In the icon **18**, the line / arrow **18.1**, arrow / line **18.2** or line / line **18.3** appears and the LICCON overload protection has shut off the crane movement.

„Spooling the winch out“ (line / arrow **18.1**) or „Spooling the winch up“ (arrow / line **18.2**) was shut off because the upper / lower limit value of the rope for the selected winch was exceeded or fallen below.

If line / line **18.3** appears blinking in the icon **18**, then the affected winch is deactivated.

The line / arrow **18.1** appears and the crane movement „Spooling the winch out“ was turned off:

- ▶ Spool the winch up.

Result:

- Crane operation is possible again.

The arrow / line **18.2** appears and the crane movement „Spooling the winch up“ was turned off:

- ▶ Spool the winch out.

Result:

- Crane operation is possible again.

The line / line **18.3** appears and the winch is deactivated:

- ▶ Activate the winch, see Crane operating instructions, chapter 4.02.

Result:

- Crane operation is possible again.

2.2.6 Shut off *hoist top*

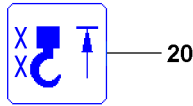

Fig.115281

The *hoist top* icon **20** appears in the LICCON monitor and the LICCON overload protection has turned off crane movement.

Spooling the hoist winch up was turned off because the hook (hook block / load hook) has touched a hoist limit switch weight during the upward movement and the affected hoist limit switch was triggered.



WARNING

Property damage / falling load!

- ▶ After shut-off *spool hoist winch up (hoist top)*, for every further crane movement, the distance between the hook (hook block / load hook) and the boom head must be checked.



Note

- ▶ After a *hoist top* shut-off occurred, further crane movements that affect the length of the hoist rope are also shut off.

- ▶ Spool the hoist winch out.

Result:

- Crane operation is possible again.

2.2.7 Shut-off *luffing the derrick boom up / down*



Note

- ▶ Only in operating modes with derrick boom.

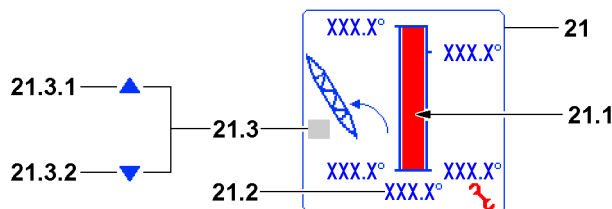

Fig.115282

In icon **21**, the column diagram **21.1** of the derrick angle has reached the minimum / maximum value. The actual angle **21.2** has left the permissible angle range.

Arrow **21.1** or arrow **21.2** appears and the movement of the derrick boom is turned off.

„Luffing the derrick boom up“ (arrow **21.1**) or „Luffing the derrick boom down“ (arrow **21.2**) was shut off because the upper / lower limit angle was reached.

The arrow **21.1** appears and „Luffing the derrick boom up“ was turned off:

- ▶ Luffing the derrick boom down.

Result:

- The shut off is nullified.

The arrow **21.2** appears and the crane movement „Luffing the derrick boom down“ was turned off:

- ▶ Luff the derrick boom up.

Result:

- The shut off is nullified.

Problem remedy

The derrick boom is to be placed down?

- ▶ See Crane operating instructions, chapter 5.05.

2.2.8 Shut-off *parallel operation winch 1 and winch 2*

Fig.122459

**WARNING**

Impermissible change over of regulation *parallel operation winch 1 and winch 2*!

- ▶ Changing the regulation *parallel operation winch 1 and winch 2* is only permissible if - due to contamination, icing or failure of the path measurement system of the test pulleys - a correct path measurement of the hoist ropes of winch 1 and winch 2 is not possible.
- ▶ Changing the regulation *parallel operation winch 1 and winch 2* is only permissible if it is not possible to immediately clean or de-ice the test pulleys or repair the path measurement system.
- ▶ As long as the regulation *parallel operation winch 1 and winch 2* is changed over, the crane driver must align the position of the hook block generally manually.

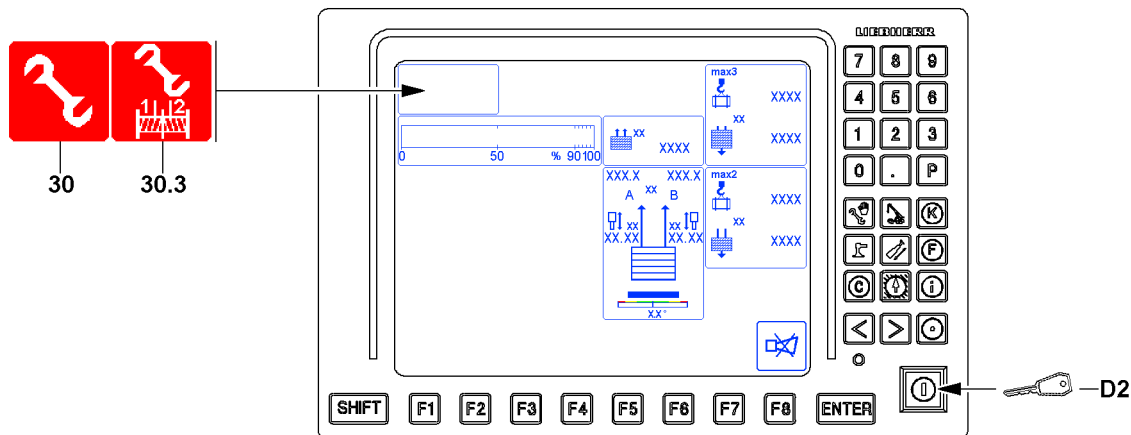
If a correct path measurement of the hoist ropes of winch 1 and winch 2 is not possible via the LIC-CON computer system, then spooling the winches is shut off and an error message is issued.

If an immediate cleaning or de-icing of the test pulleys or repair of the path measurement system is not possible:

- ▶ Reestablish parallel operation of winches, see Crane operating instructions, chapter 4.05.

Change over the regulation Parallel operation winch 1 and winch 2:

- ▶ Actuate the key button **D2**.

Result:

- The regulation of the parallel operation winch 1 and winch 2 is switched over by the change over pulleys to the winch speed sensors.
- Assembly icon **30.3** and possibly assembly icon **30** appear.
- ▶ Remedy the problem as quickly as possible.
- ▶ Turn the regulation off again via the winch speed sensors: Actuate the key button **D2** again.

Result:

- Assembly icon **30.3** and possibly assembly icon **30** turn off.

**Note**

- ▶ If the engine or the ignition is turned off, the regulation is also turned off via the winch speed sensors.

2.2.9 Shut-off *difference force monitoring of derrick ballast guying*

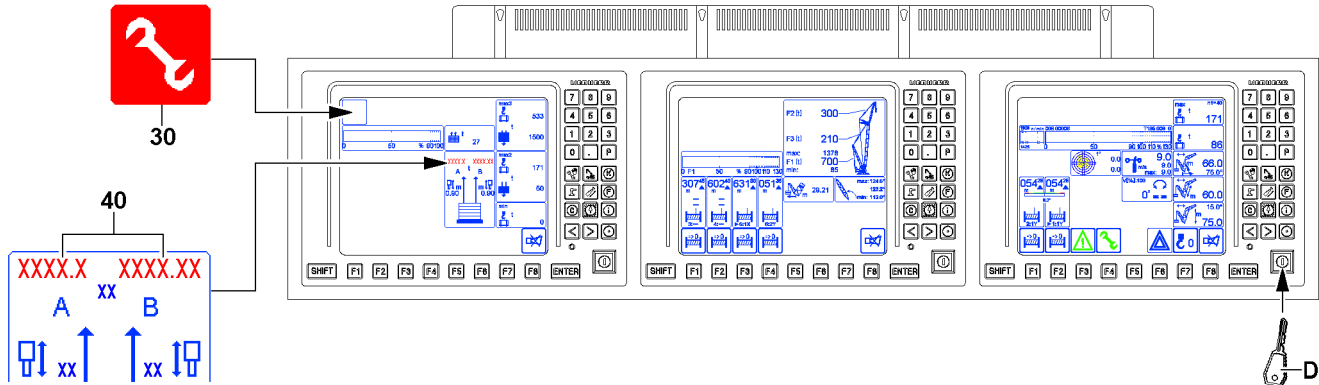

Fig.125390

**WARNING**

Danger of accident!

If the forces in the derrick ballast guying A and B are too high, then this can lead to an overload of the crane. Components can fail and severe accidents can be the result.

- ▶ Load the derrick ballast guying A and B evenly.

After reaching the specified limit value of the difference force threshold, the displays *guying A/B 40* blink and turn red, the function *ballast up / down* is stopped. The difference force must be lowered again.

The assembly icon **30** appears when the shut-off *difference force monitoring - derrick ballast guying* is bypassed. The shut-off is bypassed via the set up key **D** (right monitor).

Shut-off *difference force monitoring derrick ballast guying*:

- ▶ Observe the Crane operating instructions, chapter 5.35 / 5.36.

2.2.10 Shut-off due to error message

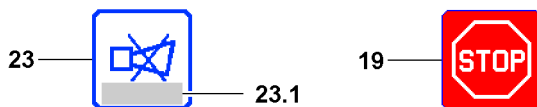

Fig.115283

In the icon **23** appears an error message, the icon **19** appears in the LICCON monitor and the LICCON overload protection has turned off crane movement.

- ▶ Determine the existing error with the help of the error message from the error field **23.1** in icon **23**, see Diagnostics manual.
- ▶ Rectify the error.

If the error cannot be remedied:

- ▶ Contact Liebherr Service.

Problem remedy

The erection of the crane, for example after assembly on a new job site or with another set up configuration, is not possible due to an error message?

- ▶ Evaluate the error message.
 - ▶ Make sure that all electrical connections are established correctly.
 - ▶ Check if all sensors or dummy plugs with integrated electric have been connected properly.
-

**Note**

If there is a defect on an involved sensor of the load torque limiter (LMB), then the crane can no longer be operated in normal operating condition.

- ▶ Fix / replace the sensor, contact Liebherr Service if necessary.
-

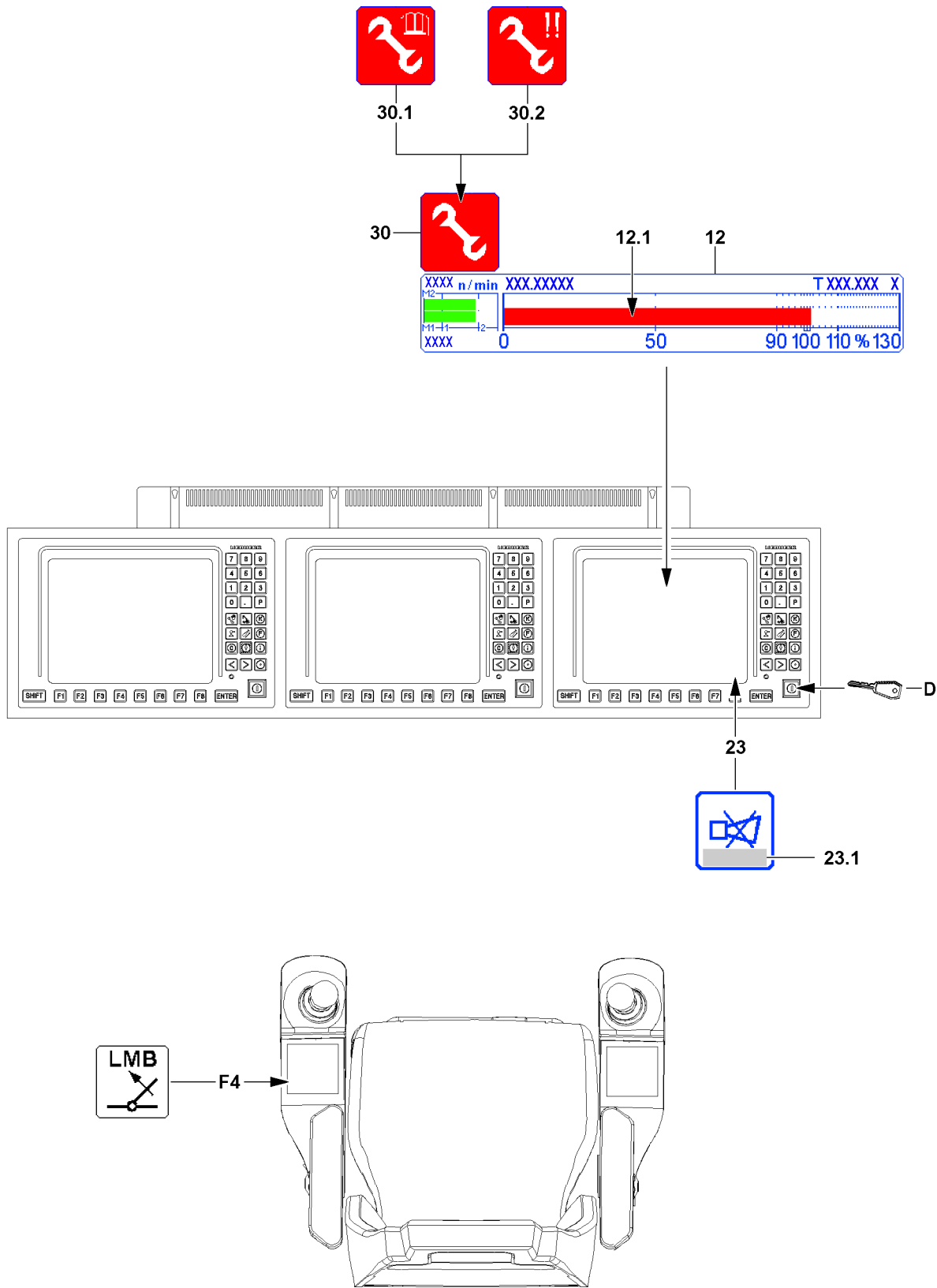

Fig.115285

LWE/LR 11000-001/23501-04-02/en

2.3 Procedure for special cases at operation of the LICCON overload protection

Within the crane operator's cab, the following operating elements available for Special cases at operation of the LICCON overload protection:

- Button **F4** on the left control panel
- Set up key **D** on the right LICCON monitor

By pressing key **F4** and set up key **D** the functionality of the LICCON overload protection is accessed. If the set up key **D** is actuated, the assembly icon **30** appears in the LICCON monitor 0.

The assembly icon **30** appears, depending on the situation, also as:

- Assembly icon **30.1** - no load chart / assembly condition / sensor defect
- Assembly icon **30.2** - emergency operation (also with only one exclamation mark)

The *horn* icon **23** possibly displays error messages **23.1**:

- Observe and evaluate the error messages **23.1**, see also Diagnostics manual.



WARNING

Risk of overloading and toppling of the crane!

If the functionality of the LICCON overload protection is accessed without knowing the exact cause for the shut-off, then the crane can be overloaded and topple over.

Personnel can be severely injured or killed.

- ▶ Before accessing the functionality of the LICCON overload protection, determine the exact cause for the shut-off.
- ▶ Observe and evaluate the error messages **23.1**.



WARNING

Access the functionality of the LICCON overload protection!

When accessing the functionality of the LICCON overload protection, the LICCON overload protection is deactivated totally or limited.

It is possible to exceed several shut-off limits of the LICCON overload protection simultaneously or one after the other.

It is possible to carry out crane movements that are not monitored by the LICCON overload protection. Without the LICCON overload protection, no additional protection against overload of the crane via the crane control is present.

- ▶ When accessing the functionality of the LICCON overload protection, take into account that the LICCON overload protection is deactivated totally or limited.
- ▶ Access the functionality of the LICCON overload protection exclusively according to the specifications in the crane documentation.
- ▶ Outside of the load charts, the data in the erection / take-down charts is binding.



WARNING

Leaving the load chart!

If the set up key **D** is actuated, it is possible that the crane leaves the range of the load charts.

Without a load chart, various display values are no longer displayed on the crane operating screen.

A load on the hook can no longer be monitored by the LICCON overload protection.

Severe accidents due to crane overload can result.

Personnel can be severely injured or killed.

- ▶ Do not leave the range of the load charts.

**WARNING**

Danger of accident due to incorrect procedure!

Due to erroneous operation or deliberate misuse, the crane could collapse, the boom can break off or the crane can topple over.

Key **F4** „Luffing in at suspended load“ and set up key **D** may only be actuated when it is ensured that without their actuation no normal operating status (see section „operating status of the crane“) can be reached.

- ▶ Actuate the set up key **D** only when no normal operating status can be reached with the key **F4** „Luffing in with suspended load“.
- ▶ The set up key **D** may only be actuated by persons who are aware of the effects of their acts regarding the access into the functionality of the LICCON overload protection.
- ▶ Accessing the functionality of the LICCON overload protection requires the presence of an authorized person and must be performed with utmost caution.
- ▶ Accessing the functionality of the LICCON overload protection is prohibited in normal crane operation.

**WARNING**

Expanded working / danger zone of the crane!

Due to an access the functionality of the LICCON overload protection it is possible that the working / danger zone of the crane is significantly expanded.

If these circumstances are not observed, collisions and accidents can occur.

Personnel can be severely injured or killed.

- ▶ During a special case at operation of the LICCON overload protection take an expanded working / danger zone of the crane into account and monitor it.

**WARNING**

Overload of crane!

Luffing in / pulling in of a load standing on the ground is not permissible.

When taking on a load by luffing the boom up, the crane can be overloaded.

This could result in serious accidents.

- ▶ Taking on load by luffing up the boom is prohibited.
- ▶ Take on a load solely via the hoist gear.

**WARNING**

Self-blockade of overload protection (Deadlock)!

After activation of the function „exceeding the shut-off limits of the LICCON overload protection“, if no crane movements that lead immediately to a normal operating status (see section „operating status of the crane“) are initiated, then the overload protection can be self-blocked (Deadlock).

At a self-blocked overload protection it is no longer possible to control the crane.

- ▶ After activation of the function „exceeding the shut-off limits of the LICCON overload protection“ initiate crane movements that lead immediately to a normal operating condition (see section „operating condition of the crane“).

NOTICE

Danger of mix up!

The individual functions of the set up key **D** can only be activated with this key button.

The key buttons on the other LICCON monitors are not assigned with this function.

- ▶ Do not mix up the set up key **D** with the other key buttons.
- ▶ In case of mix up: Deactivate the activated function immediately.

Possible limitation in the crane control during certain „Special cases at operation of the LICCON overload protection“:

- During certain „Special cases at operation of the LICCON overload protection“ the shut-off limits of the overload protection can be exceeded by pressing the set up key **D** maximum to 110 %.
- During certain „Special cases at operation of the LICCON overload protection“, the working speed of the crane is significantly reduced.

- During certain „Special cases at operation of the LICCON overload protection“, the possibility to control the crane is limited in time.
- During certain „Special cases at operation of the LICCON overload protection“, the individual display instruments show no values.



Note

Depending on the number of load positions, the display in the bar diagram utilization **12** changes.

- ▶ If an additional utilization bar appears next to the utilization bar **12.1**, then the description applies accordingly.
 - ▶ For a detailed description of the Bar diagram utilization **12**, see Crane operating instructions, chapter 4.02.
-

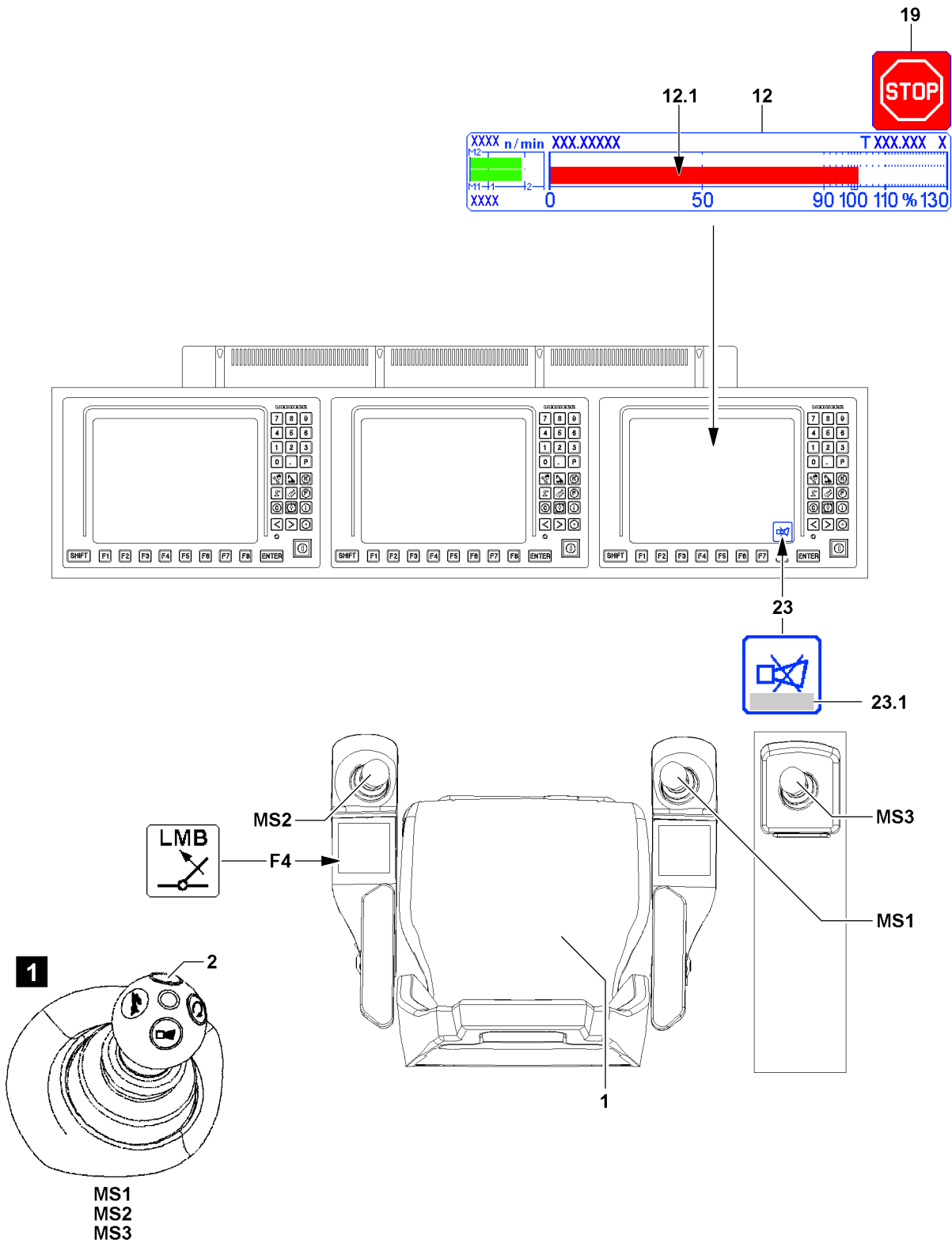

Fig.115286

LWE/LR 11000-001/23501-04-02/en

2.3.1 Luff in with suspended load

If the maximum permissible load torque is exceeded, the LICCON overload protection turns off all crane movements that increase the load torque.

In the bar diagram utilization **12** (load moment display) the utilization bar **12.1** has exceeded the 100 % mark and in the LICCON monitor appears the icon **19**

This shut-off limit can be exceeded by actuating the button **F4** „Luffing in with suspended load“.

Make sure that the following prerequisites are met:

- The load hangs freely.
- The load hook / hook block and boom system have no ground contact.
- Either the seat contact button **1** or one of the buttons **2** (illustration **1**) of the master switches (MS1, MS2, MS3) is actuated.



Note

If the load is reduced by luffing up or the values in the bar diagram utilization **12** are exceeded too far, then the key **F4** „Luffing in with suspended load“ is possibly not functioning.

- ▶ Pay attention to notes regarding error messages **23.1** occurring in the *horn* icon **23**.
- ▶ For the procedure when the key **F4** „Luffing in with suspended load“ is not functioning, see section „Exceedance of maximum permissible load moment“.

- ▶ Press the key **F4** „Luffing in with suspended load“ and hold it.

Result:

- The LICCON overload protection is inactive.

- ▶ Luff the load in.

Result:

- If the crane reaches a normal operation condition, then the icon **19** turns off, normal crane operation is possible again.

The function „Luffing in with suspended load“ is deactivated:

- When the key **F4** „Luffing in with suspended load“ is not longer actuated.
- When neither the seat contact button **1** nor one of the buttons **2** of the master switches (MS1, MS2, MS3) is actuated.

The function „Luffing in with suspended load“ is deactivated:

- The LICCON overload protection is active.
- ▶ Carry out crane movements in such a way that no repeated shut-off by the LICCON overload protection occurs.

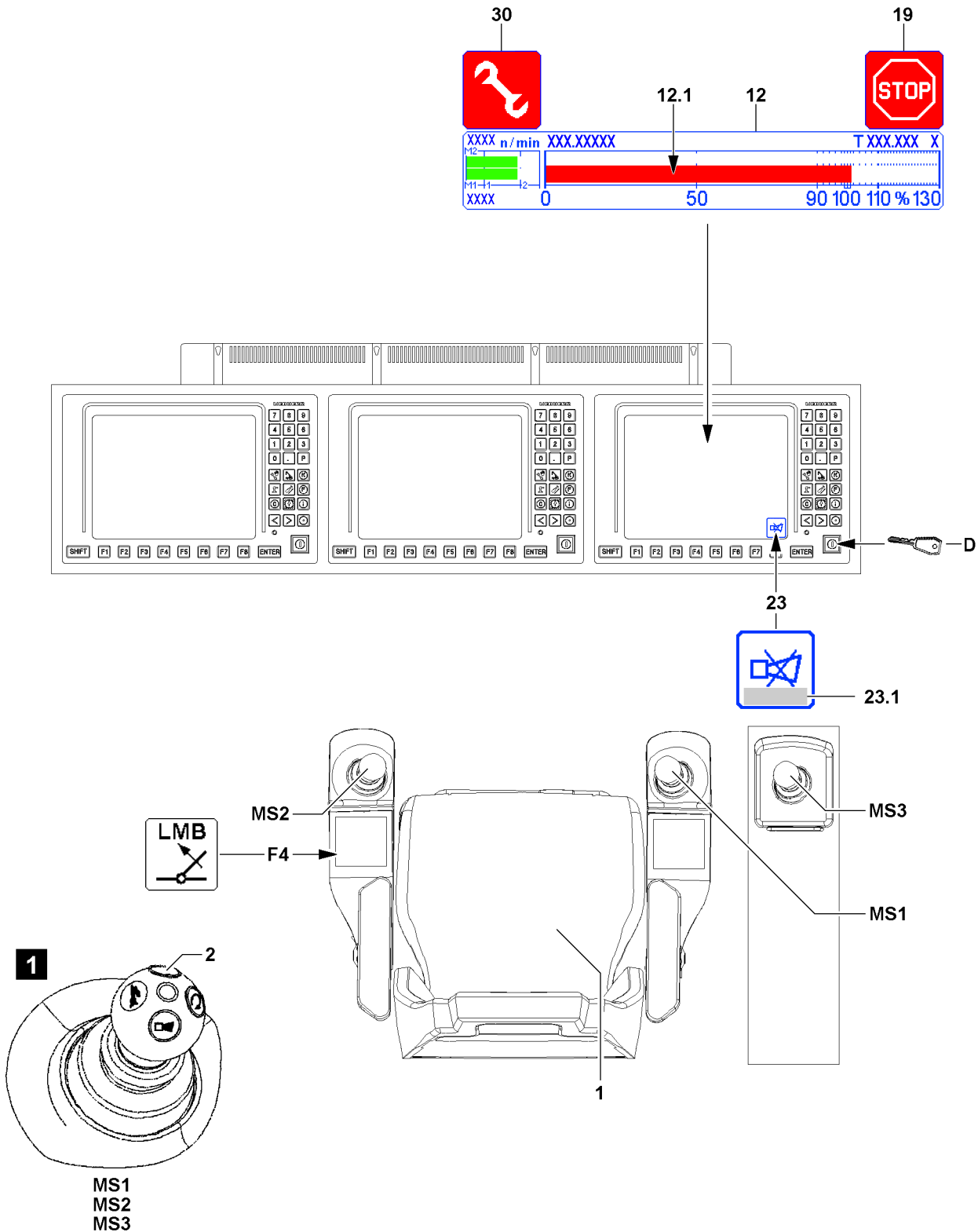

Fig.115287

LWE/LR 11000-001/23501-04-02/en

2.3.2 To exceed the maximum permissible load moment.

If the maximum permissible load torque is exceeded, the LICCON overload protection turns off all crane movements that increase the load torque.

In the bar diagram utilization **12** (load moment display) the utilization bar **12.1** has exceeded the 100 % mark and in the LICCON monitor appears the icon **19**

This limit value can be exceeded by the set up key **D** in the „right touching“ position.



WARNING

Shut off safety device!

If the function „Exceedance of shut-off limits of LICCON overload protection“ is activated by actuating the set up key **D** then it is possible to exceed the maximum permissible load torque.

► All notes regarding the „Special cases at operation of LICCON overload protection“ must be observed.

The set up key **D** on the LICCON monitor has two positions:

- Operating position (not actuated): Crane is in normal operation.
- Position to right (touching): The function „Exceedance of shut-off limits of the LICCON overload protection“ is activated, the assembly icon **30** appears in the LICCON monitor.

Make sure that the following prerequisites are met:

- With the button **F4** „Luffing in with suspended load“ no normal operating condition (utilization below 100 % and no active shut-off) can be reached.
- All master switches (MS1, MS2, MS3) are in the zero position (not deflected).
- Either the seat contact button **1** or one of the buttons **2** (illustration **1**) of the master switches (MS1, MS2, MS3) is actuated.
- The crane is in the range of a load chart.



Note

If the values in the bar diagram utilization **12** are exceeded too far, then the functionality of the set up key **D** may be disabled.

► Pay attention to notes regarding error messages **23.1** occurring in the *horn* icon **23**.

► Turn the set up key **D** to the right (touching).

Result:

- The LICCON overload protection is inactive.
- The assembly icon **30** appears in the LICCON monitor.

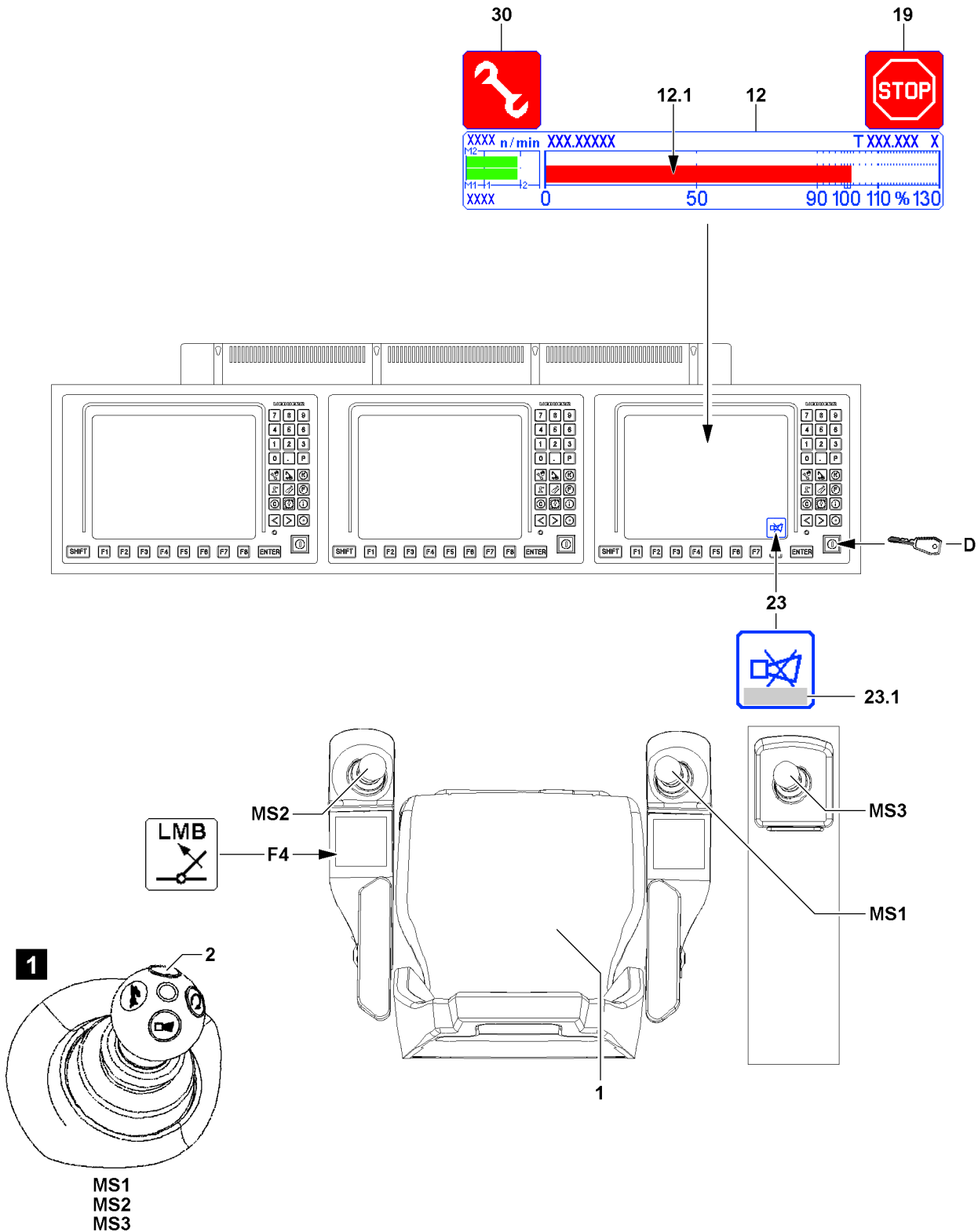

Fig.115287

LWE/LR 11000-001/23501-04-02/en

- ▶ Initiate crane movements which lead immediately to a normal operating condition (see section „operating condition of the crane“).

Result:

- If the crane reaches a normal operating condition, the function „Exceeding the shut-off limits of the LICCON overload protection“ turns off - the assembly icon **30** turns off.

The function „Exceedance of shut-off limits of LICCON overload protection“ turns off immediately also:

- If the set up key **D** is actuated again.
- If all master switches (MS1, MS2, MS3) are in zero position for 10 seconds.
- When neither the seat contact button **1** nor one of the buttons **2** of the master switches (MS1, MS2, MS3) is actuated.
- When a *hoist top* shut-off occurs.

**Note**

- ▶ The function „Exceedance of shut-off limits of the LICCON overload protection“ is only turned off when the assembly icon **30** in the LICCON monitor turns off.
- ▶ If the function „Exceedance of shut-off limits of the LICCON overload protection“ does not turn off after pressing the set up key **D** once, then press the set up key **D** again until the assembly icon **30** in the LICCON monitor turns off.

The function „Exceedance of shut-off limits of the LICCON overload protection“ has / was shut off:

- The assembly icon **30** in the LICCON monitor turns off.
- The working speed is possibly reduced until all master switches (MS1, MS2, MS3) are in the zero position at the same time.
- ▶ Make sure that the assembly icon **30** no longer appears in the LICCON monitor.
- ▶ Carry out crane movements in such a way that no repeated shut-off by the LICCON overload protection occurs.

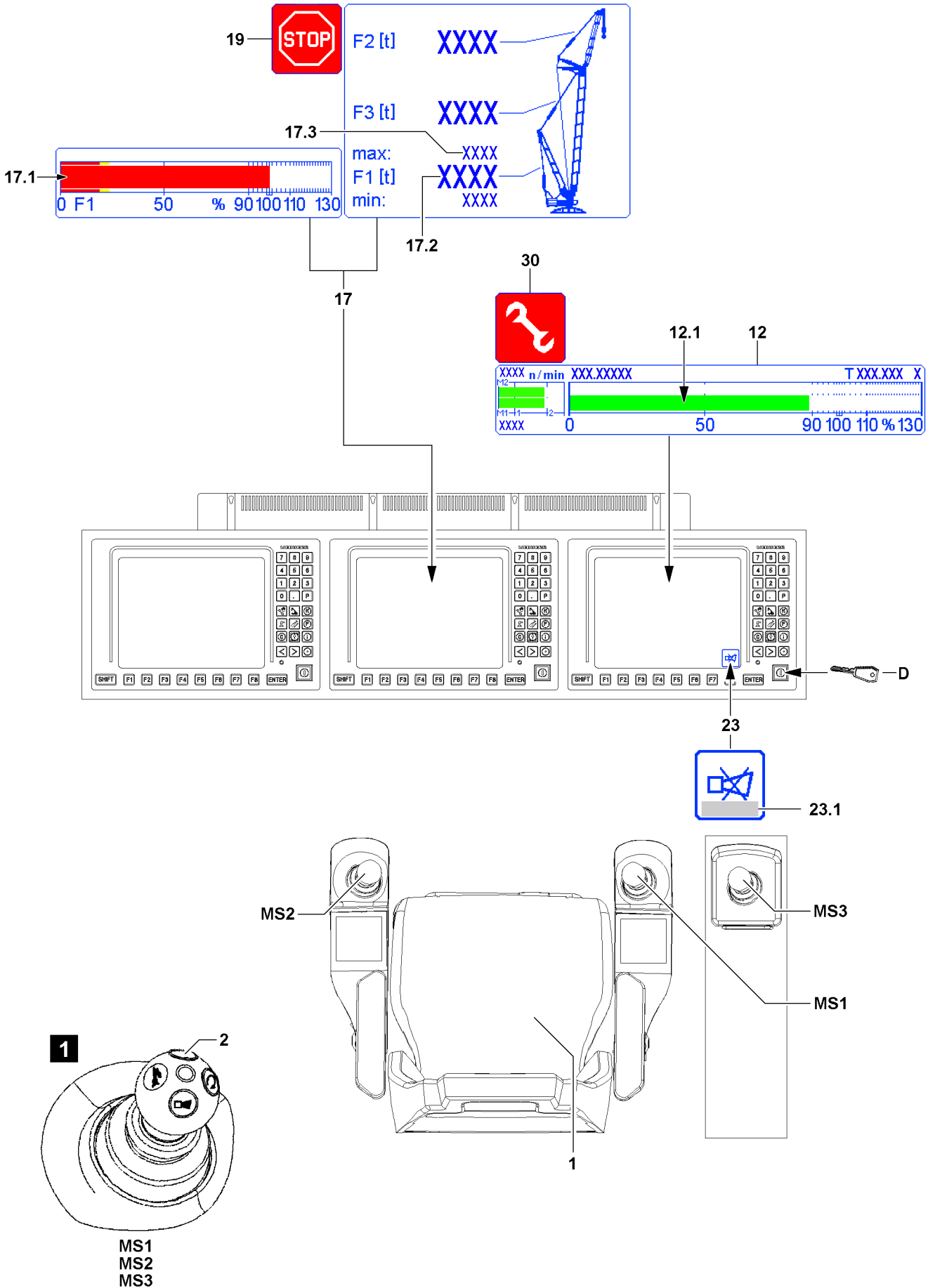

Fig.115288

LWE/LR 11000-001/23501-04-02/en

2.3.3 To exceed the maximum value of the F-load display in crane operation.

The illustration of the F-load display **17** depends on the set up configuration of the crane and can vary. The values for test point 2 (force F2) and test point 3 (force F3) are possibly shown.



WARNING

Shut off safety device!

By pressing the set up key **D** if the maximum value of the F-load display is exceeded, then the function „Exceedance of shut-off limits of the LICCON overload protection“ is automatically activated. Thus there is no shut-off if the maximum permissible load moment is exceeded.

- ▶ All notes regarding the „Special cases at operation of LICCON overload protection“ must be observed.
- ▶ The utilization bar **12.1** of the bar diagram utilization **12** must be observed.
- ▶ The F1-utilization bar **17.1** of the F-load display **17** must be observed.



Note

- ▶ The force determined on test point 1 is generally described as $F1_{actual}$ (actual value F1).
- ▶ In the F1-load display **17**, the force ratio is shown as number values as well as a bar display (called F1-bar display).
- ▶ The value $F1_{max}$ **17.3** corresponds to 100 % in the F1-bar display.
- ▶ The F1-utilization bar **17.1** shows the relationship $F1_{actual}$ **17.2** to $F1_{max}$ **17.3**.



Note

- ▶ See also section „Minimum values or maximum values of F-load display reached“.

In the F1-load display **17** the utilization bar $_{actual}$ **17.1** exceeds the 100 % mark and the LICCON overload protection has shut off the crane movement. The value $F1_{actual}$ **17.2** has exceeded the value $F1_{max}$ **17.3**.

All other movements, which lead to a decline of the force ratio in the F-load display **17** are turned off.

The LICCON monitor with the derrick operating screen displays the icon **19**.



Note

If the values in the F-load display **17** or in the bar diagram utilization **12** are outside the permissible range, then the functionality of the set up key **D** may be disabled.

- ▶ Pay attention to notes regarding error messages **23.1** occurring in the *horn* icon **23**.

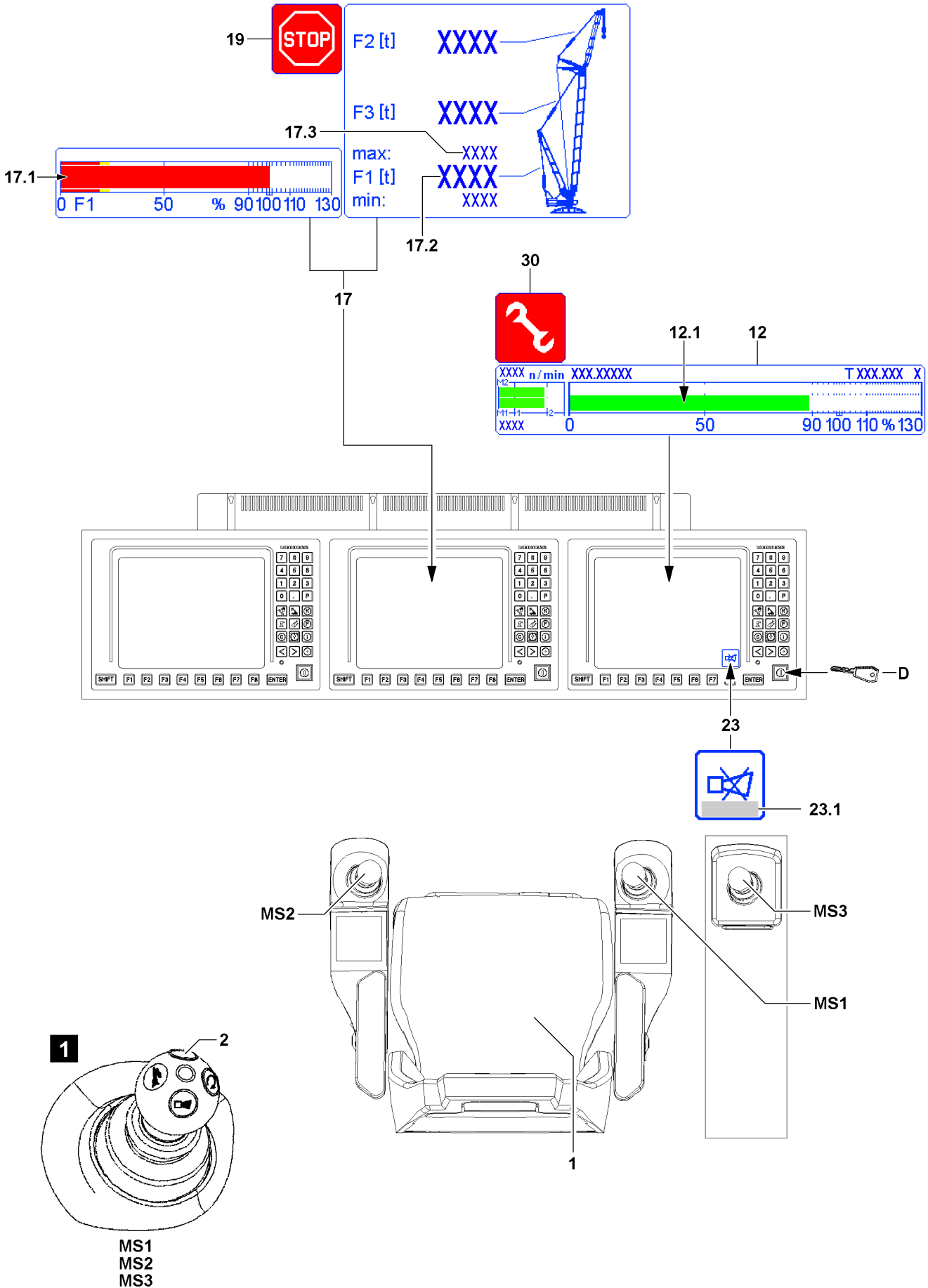

Fig.115288

LWE/LR 11000-001/23501-04-02/en

Make sure that the following prerequisites are met:

- All master switches (MS1, MS2, MS3) are in the zero position (not deflected).
- Either the seat contact button **1** or one of the buttons **2** (illustration **1**) of the master switches (MS1, MS2, MS3) is actuated.
- The crane is in the range of a load chart.
- ▶ Turn the set up key **D** to the right (touching).

Result:

- The function „Exceedance of shut-off limits of the LICCON overload protection“ is activated. As a result the maximum value of the F-load display can be exceeded.
- The assembly icon **30** appears.
- $F_{1_{\max}}$ **17.3** can be exceeded.

- ▶ Initiate crane movements which lead immediately to a normal operating condition (see section „operating condition of the crane“).

Result:

- If the crane reaches a normal operating condition, the function „Exceeding the shut-off limits of the LICCON overload protection“ turns off - the assembly icon **30** turns off.

The function „Exceedance of shut-off limits of LICCON overload protection“ turns off immediately also:

- If the set up key **D** is actuated again.
- If all master switches (MS1, MS2, MS3) are in the zero position for 10 seconds (with load chart available).
- When neither the seat contact button **1** nor one of the buttons **2** of the master switches (MS1, MS2, MS3) is actuated.
- When a *hoist top* shut-off occurs.



Note

- ▶ The function „Exceedance of shut-off limits of the LICCON overload protection“ is only turned off when the assembly icon **30** in the LICCON monitor turns off.
- ▶ If the function „Exceedance of shut-off limits of the LICCON overload protection“ does not turn off after pressing the set up key **D** once, then press the set up key **D** again until the assembly icon **30** in the LICCON monitor turns off.

The function „Exceedance of shut-off limits of the LICCON overload protection“ has / was shut off:

- The assembly icon **30** in the LICCON monitor turns off.
- The working speed is possibly reduced until all master switches (MS1, MS2, MS3) are in the zero position at the same time.
- ▶ Make sure that the assembly icon **30** no longer appears in the LICCON monitor.
- ▶ Carry out crane movements in such a way that no repeated shut-off by the LICCON overload protection occurs.

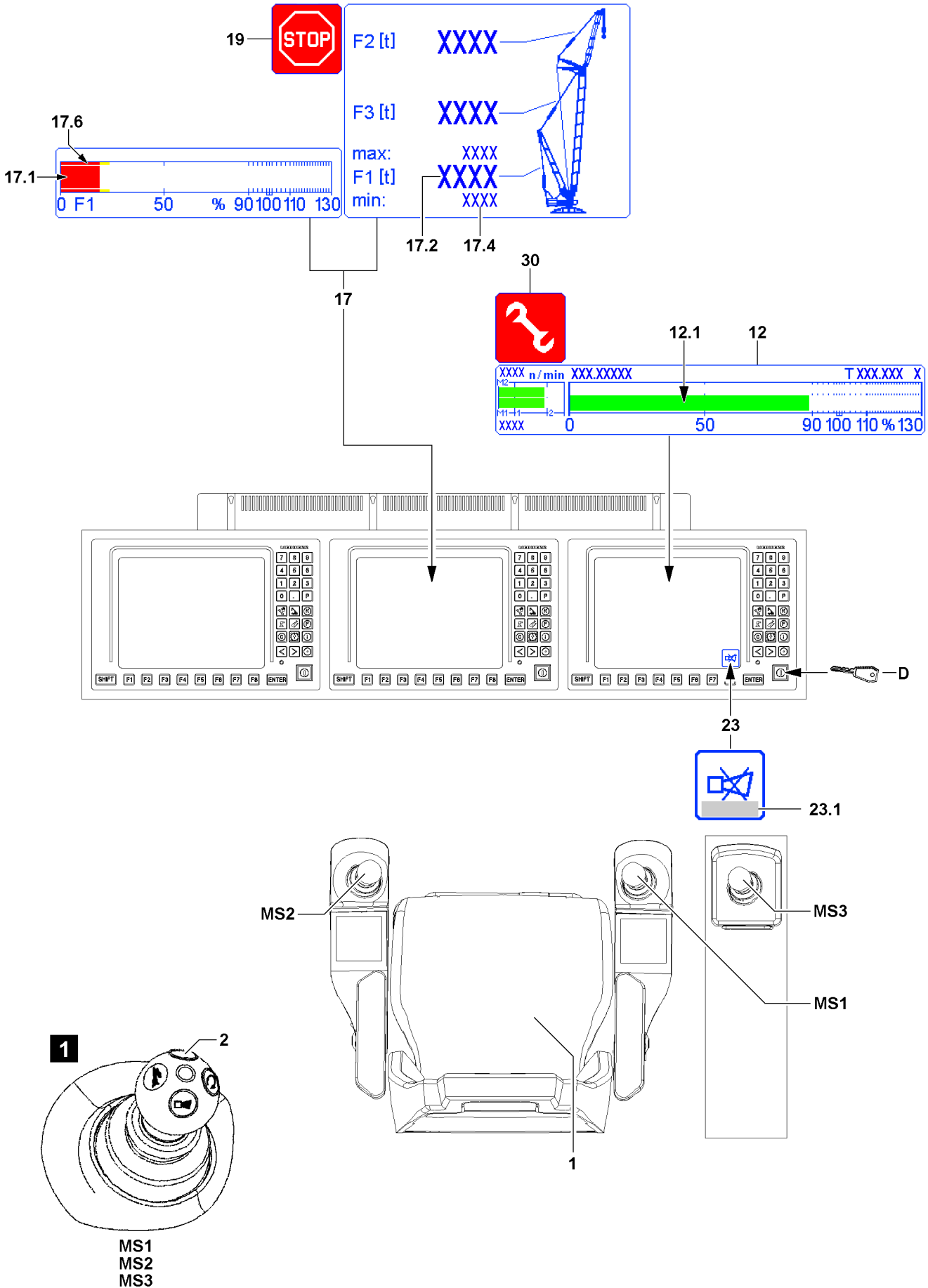

Fig.115307

LWE/LR 11000-001/23501-04-02/en

2.3.4 Falling below the minimum value of the F-load display in crane operation

The illustration of the F-load display **17** depends on the set up configuration of the crane and can vary. The values for test point 2 (force F2) and test point 3 (force F3) are possibly shown.



WARNING

Shut off safety device!

By pressing the set up key **D** if the minimum value of the F-load display is fallen below, then the function „Exceedance of shut-off limits of the LICCON overload protection“ is automatically activated. Thus there is no shut-off if the maximum permissible load moment is exceeded.

- ▶ All notes regarding the „Special cases at operation of LICCON overload protection“ must be observed.
- ▶ The utilization bar **12.1** of the bar diagram utilization **12** must be observed.
- ▶ The F1-utilization bar **17.1** of the F-load display **17** must be observed.



Note

- ▶ The force determined on test point 1 is generally described as $F1_{actual}$ (actual value F1).
- ▶ In the F1-load display **17**, the force ratio is shown as number values as well as a bar display (called F1-bar display).
- ▶ The value $F1_{max}$ **17.3** corresponds to 100 % in the F1-bar display.
- ▶ The F1-utilization bar **17.1** shows the relationship $F1_{actual}$ **17.2** to $F1_{max}$ **17.3**.



Note

- ▶ See also section „Minimum values or maximum values of F-load display reached“.

In the F1-load display **17** the utilization bar $_{actual}$ **17.1** falls below the $F1_{min}$ -STOP-Bar **17.6** and the LICCON overload protection has shut off the crane movement. The value $F1_{actual}$ **17.2** has fallen below the value $F1_{min}$ **17.4**.

All other movements, which lead to a decline of the force ratio in the F-load display **17** are turned off.

The LICCON monitor with the derrick operating screen displays the icon **19**.



Note

If the values in the F-load display **17** or in the bar diagram utilization **12** are outside the permissible range, then the functionality of the set up key **D** may be disabled.

- ▶ Pay attention to notes regarding error messages **23.1** occurring in the *horn* icon **23**.

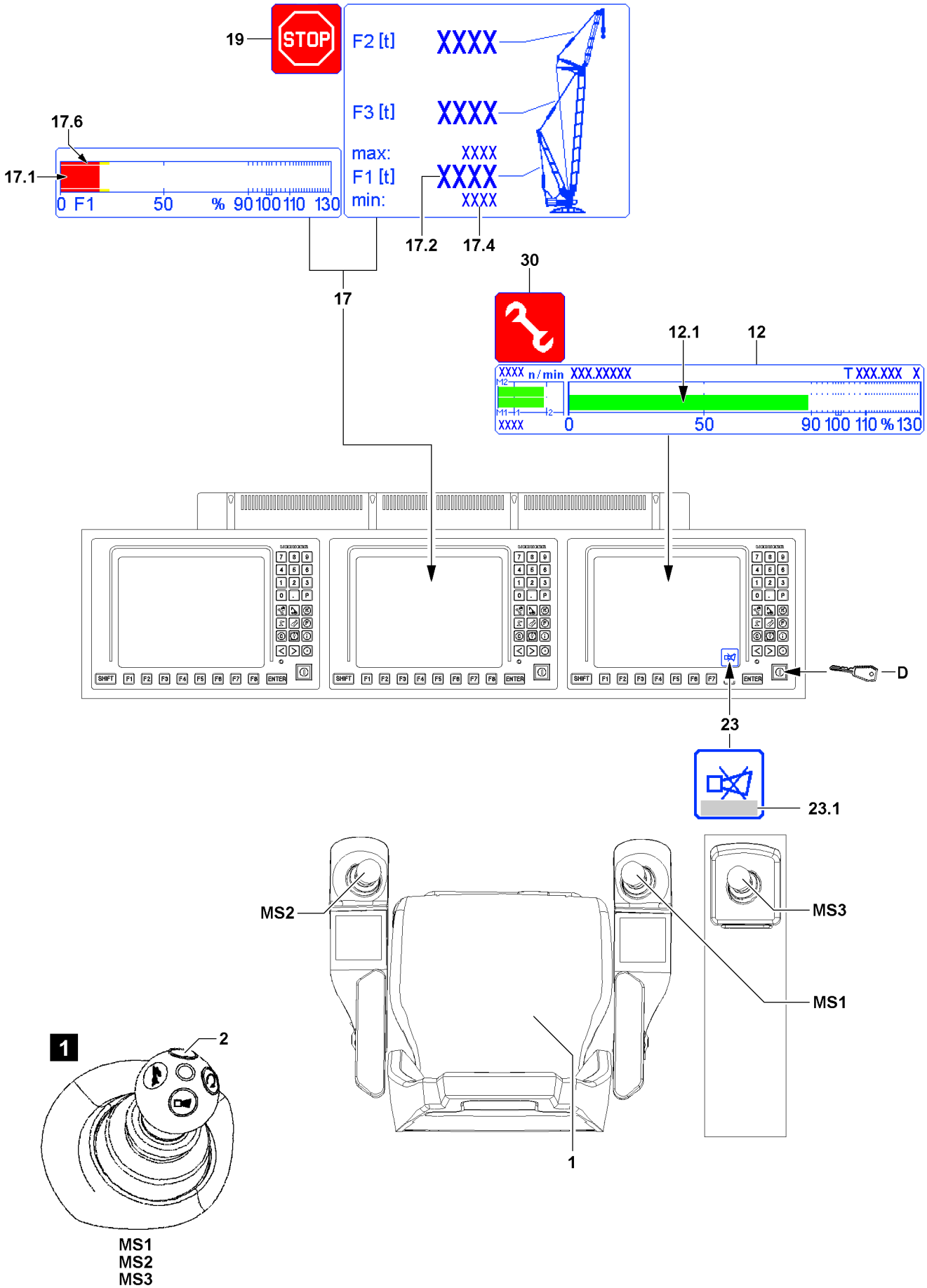

Fig.115307

LWE/LR 11000-001/23501-04-02/en

Make sure that the following prerequisites are met:

- All master switches (MS1, MS2, MS3) are in the zero position (not deflected).
- Either the seat contact button **1** or one of the buttons **2** (illustration **1**) of the master switches (MS1, MS2, MS3) is actuated.
- The crane is in the range of a load chart.
- ▶ Turn the set up key **D** to the right (touching).

Result:

- The function „Exceedance of shut-off limits of the LICCON overload protection“ is activated. As a result the minimum value of the F-load display can be fallen below.
- The assembly icon **30** appears.
- $F_{1_{\min}}$ **17.4** can be fallen below.

- ▶ Initiate crane movements which lead immediately to a normal operating condition (see section „operating condition of the crane“).

Result:

- If the crane reaches a normal operating condition, the function „Exceeding the shut-off limits of the LICCON overload protection“ turns off - the assembly icon **30** turns off.

The function „Exceedance of shut-off limits of LICCON overload protection“ turns off immediately also:

- If the set up key **D** is actuated again.
- If all master switches (MS1, MS2, MS3) are in the zero position for 10 seconds (with load chart available).
- When neither the seat contact button **1** nor one of the buttons **2** of the master switches (MS1, MS2, MS3) is actuated.
- When a *hoist top* shut-off occurs.



Note

- ▶ The function „Exceedance of shut-off limits of the LICCON overload protection“ is only turned off when the assembly icon **30** in the LICCON monitor turns off.
- ▶ If the function „Exceedance of shut-off limits of the LICCON overload protection“ does not turn off after pressing the set up key **D** once, then press the set up key **D** again until the assembly icon **30** in the LICCON monitor turns off.

The function „Exceedance of shut-off limits of the LICCON overload protection“ has / was shut off:

- The assembly icon **30** in the LICCON monitor turns off.
- The working speed is possibly reduced until all master switches (MS1, MS2, MS3) are in the zero position at the same time.
- ▶ Make sure that the assembly icon **30** no longer appears in the LICCON monitor.
- ▶ Carry out crane movements in such a way that no repeated shut-off by the LICCON overload protection occurs.

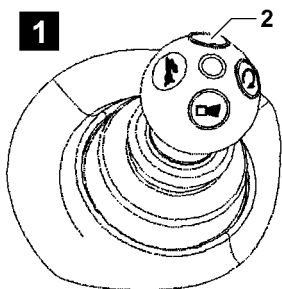
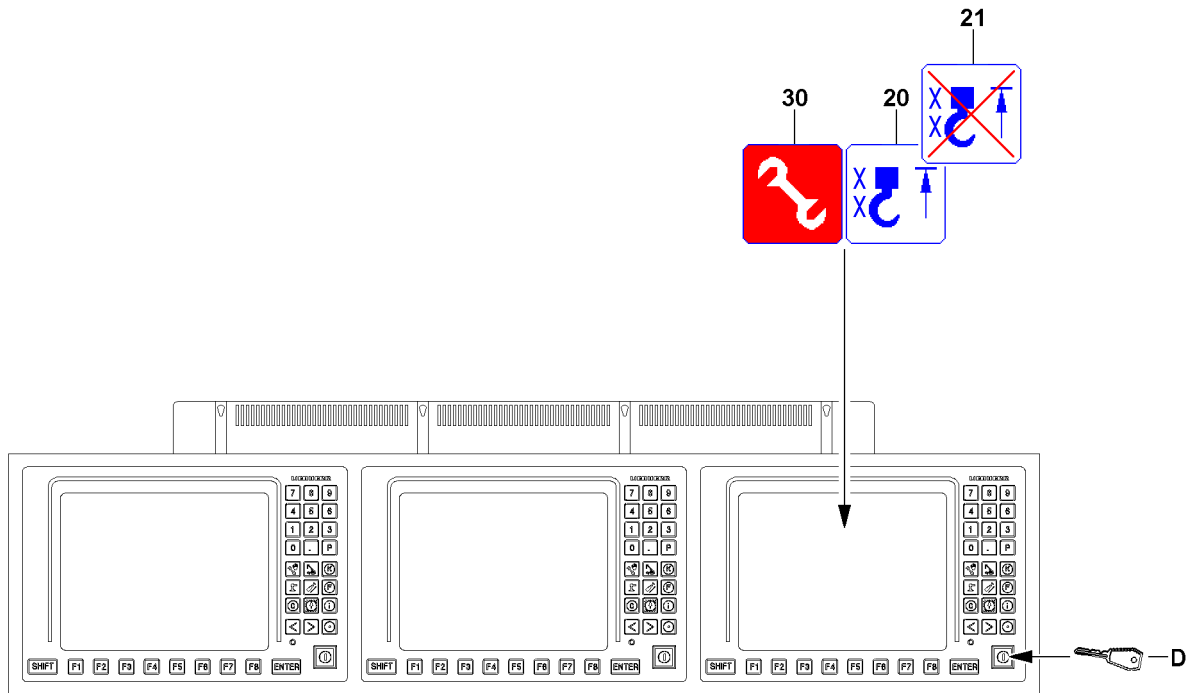

MS1
MS2
MS3

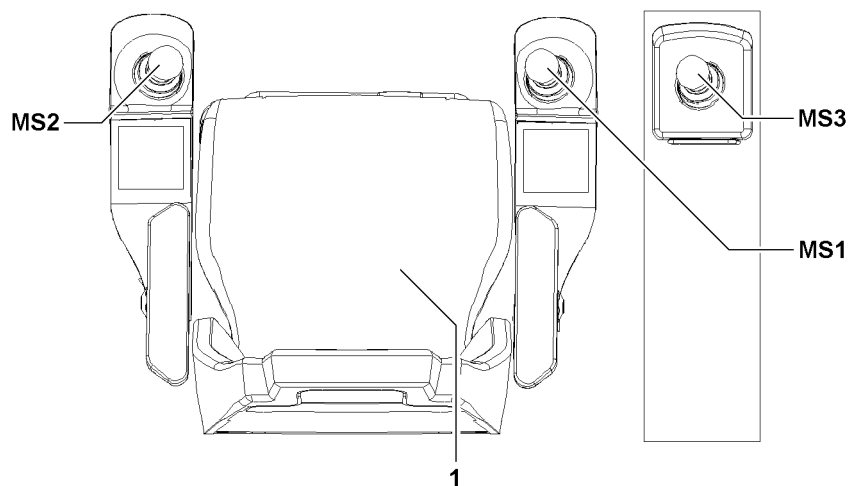

Fig.115289

LWE/LR 11000-001/23501-04-02/en

2.4 Bypassing the *hoist top* shut-off



WARNING

Improper use of the function „Bypass of hoist top shut-off“!

- ▶ The function „Bypass of hoist top shut-off“ may never be used to increase the lifting height during crane operation.



WARNING

Property damage and falling load!

If the function „Bypass of hoist top shut off“ is activated, there is the danger that the hook (hook block / load hook) is pulled against the pulley head.

This danger exists especially when the hoist winch is continued to be spooled up and for crane movements which have an influence on the hoist rope, for example luffing the boom, the auxiliary boom / accessory or the derrick boom.

Property damage and falling load can result.

Personnel can be severely injured or killed.

- ▶ The function „Bypass of hoist top shut-off“ may only be carried out by an authorized person, along with a guide. The guide must be in direct contact with the crane operator and must continually monitor the distance between the hook block / load hook and the boom head.
- ▶ Carry out all crane movements with utmost caution.



Note

- ▶ A bypass of the *hoist top* shut-off is only possible when the shut-off has already occurred due to a triggered hoist limit switch.
- ▶ With actuated set up key **D** (assembly icon **30** appears in the LICCON monitor) if a hoist limit switch is triggered, then there is a new shut-off of crane movements.
- ▶ For assembly purposes or in emergency cases, if the activation of the function „Bypass of hoist top shut-off“ **and** activation of the function „Exceedance of shut-off limits of the LICCON overload protection“ is necessary, then the set up key **D** must be actuated until the icon **21** and assembly icon **30** appear.

Spooling the hoist winch up was turned off because the hook (hook block / load hook) has touched a hoist limit switch weight during the upward movement and the affected hoist limit switch was triggered.

Make sure that the following prerequisites are met:

- A *hoist top* shut-off has occurred, the *hoist top* icon **20** appears in the LICCON monitor.
- Either the seat contact button **1** or one of the buttons **2** (illustration **1**) of the master switches (MS1, MS2, MS3) is actuated.
- All master switches (MS1, MS2, MS3) are in the zero position (not deflected).

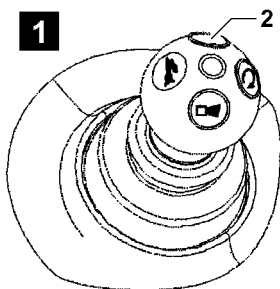
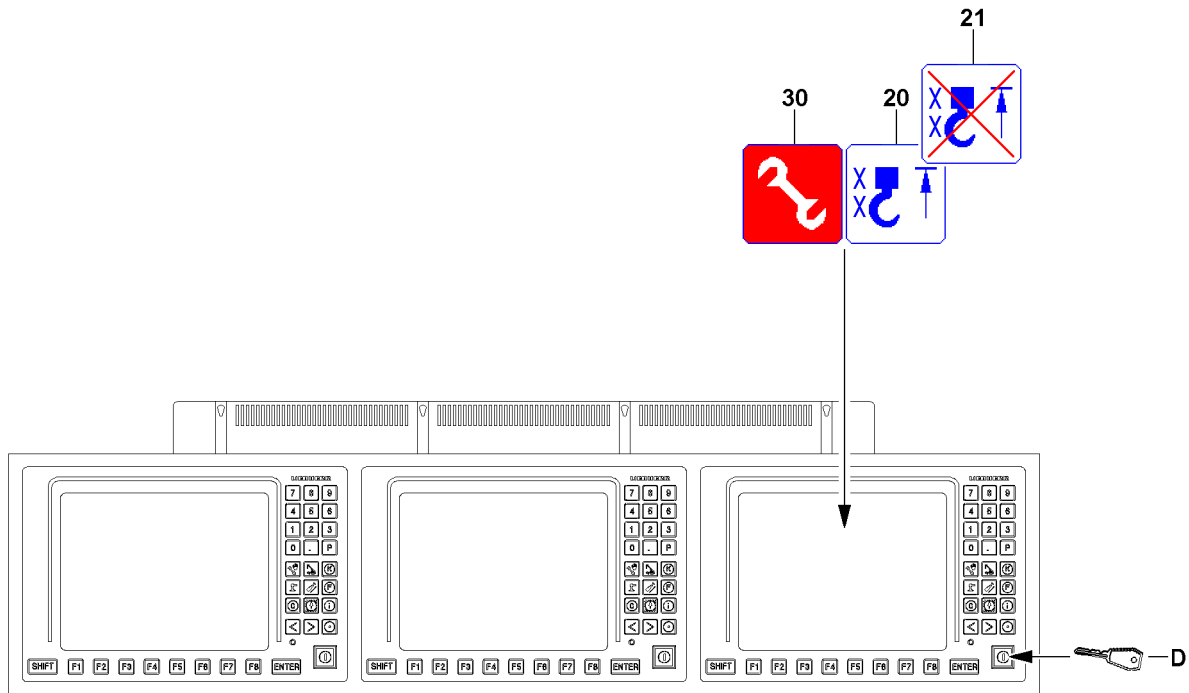

MS1
MS2
MS3

Fig.115289

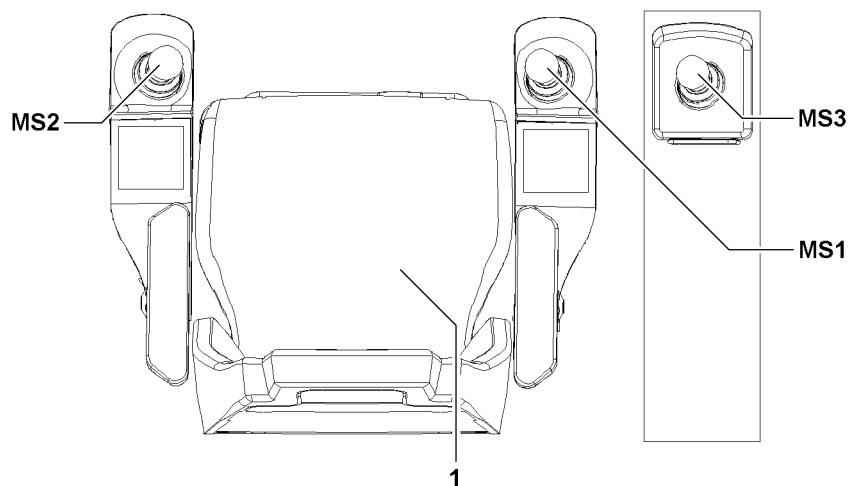

LWE/LR 11000-001/23501-04-02/en

- To bypass the *hoist top* shut-off, a combined actuation of the set up key **D** and at least one master switch is required.
- ▶ Turn the set up key **D** to the right (touching).

Result:

- The assembly icon **30** (assembly operation) appears in the LICCON monitor.
- The *hoist top* icon **20** in the LICCON monitor changes to the icon **21**.

Within 10 seconds, if the master switch to lift the hoist gear is deflected, the hoist limit switches are bypassed. The bypass of the *hoist top* shut-off remains active only as long as the master switch is deflected.

- ▶ Carry out a crane movement with utmost caution and by taking the safety guidelines into account.

The function „Bypass of the hoist top shut-off“ turns off:

- If the set up key **D** is actuated again.
- When no master switch (MS1, MS2, MS3) was deflected for 10 seconds.
- When neither the seat contact button **1** nor one of the buttons **2** of the master switches (MS1, MS2, MS3) is actuated.
- If there is no longer a shut-off of a hoist limit switch.

The function „Bypass of the hoist top shut-off“ has / was turned off:

- The assembly icon **30** (assembly operation) in the LICCON monitor turns off.
- The icon **21** on the LICCON monitor turns off.
- ▶ Make sure that the assembly icon or the assembly icon **30** (assembly operation) as well as the icon **21** no longer appear in the LICCON monitor.
- ▶ Carry out the crane movements in such a way that no repeated *hoist top* shut-off occurs.

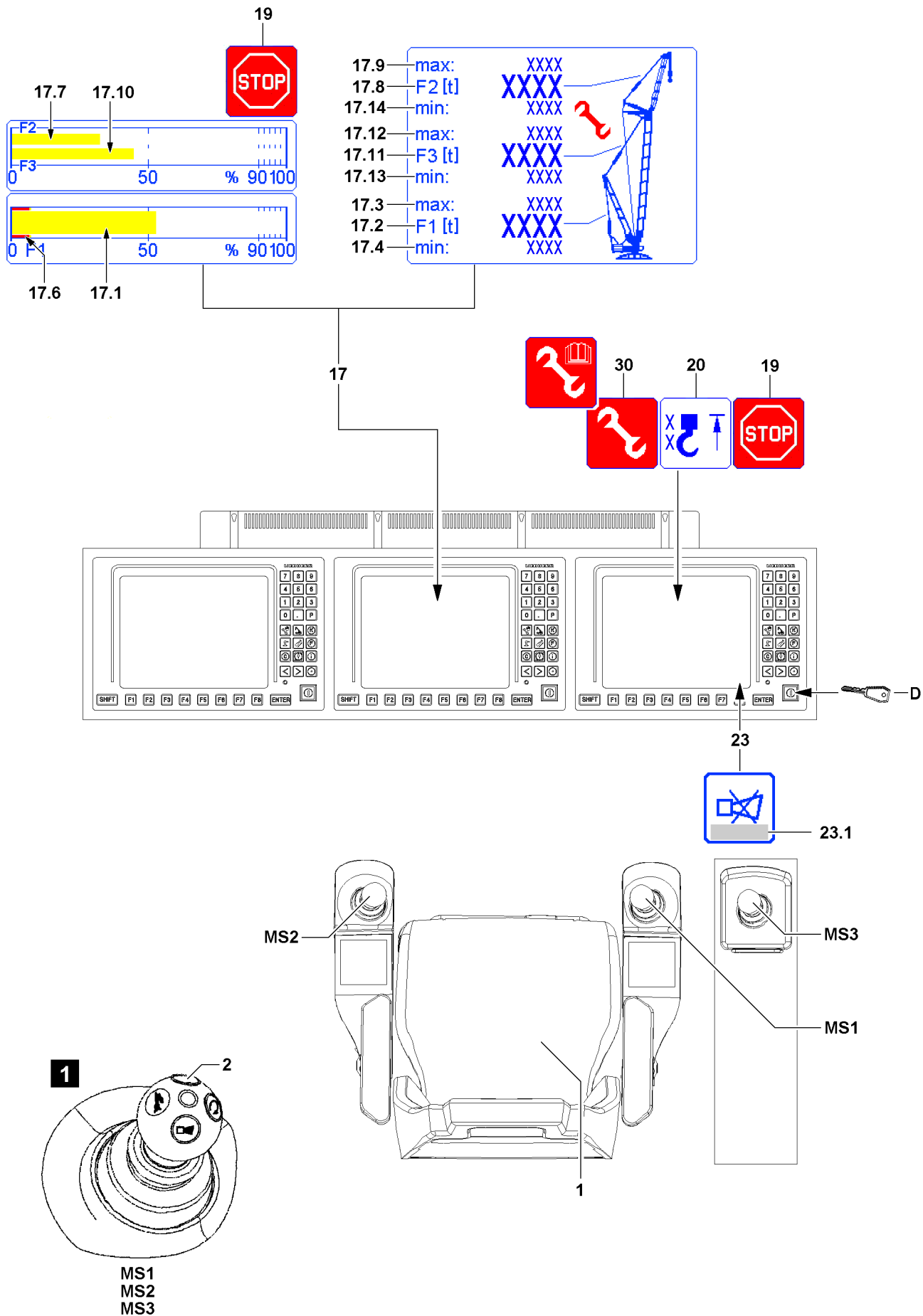

Fig.122457

2.5 Carrying out the erection / take down procedures

To carry out the erection / take down procedures and assembly procedures, the LICCON overload protection can be bypassed by the set up key **D**.



Note

- ▶ If the crane is in the range „No load chart available“ then there is a shut-off of the crane control by the LICCON overload protection. The icon **19** appears in the LICCON monitor.
- ▶ By pressing the set up key **D** all erection / take down procedures and assembly procedures can be carried out according to the specifications in the crane documentation.



WARNING

Danger of accident during erection / take down procedures!

If the specifications of the crane documentation are not observed, the crane can collapse, the boom can break off or the crane can topple over.

Personnel can be severely injured or killed.

- ▶ Make sure to adhere to all specifications in the crane documentation.
- ▶ Make sure to observe the data in the crane documentation (for example erection / take-down charts and assembly instructions).
- ▶ Press the set up key **D** only when the set up configuration has been entered correctly in the LICCON computer system and matches the actual situation.



WARNING

Damage, overload and toppling of the crane!

If the permissible values of the F-load display **17** are exceeded / fallen below, then the crane can be damaged or overloaded and topple over.

As long as the set up boom system is not completely assembled and not all sensors, which are required for this operating mode are electrically connected, no maximum forces and minimum forces are displayed in the F-load display **17**.

In these cases it must be determined with the assembly drawing which maximum forces are permissible in the F-load display **17**.

These maximum forces must be monitored by the crane operator and may not be exceeded during set up / take down of the crane.

- ▶ The crane operator must ensure that the permissible values of the F-load display **17** are not exceeded / fallen below.
- ▶ Observe and adhere to the maximum forces for the F-load display **17** from the assembly drawings.

Display area of F-load display **17**:

- F1-load display
The force determined on test point 1 is generally described as $F1_{actual}$.
- F2-load display
The force determined on test point 2 is generally described as $F2_{actual}$.
Note: Appears only for the corresponding boom system.
The F2-utilization bar **17.7** only appears in assembly operation (no load chart available and set up key **D** actuated).
- F3-load display
The force determined on test point 3 is generally described as $F3_{actual}$.
Note: Appears only for the corresponding boom system.
The F3-utilization bar **17.10** only appears in assembly operation (no load chart available and set up key **D** actuated).

**Note**

In the F-load display **17**, the force ratio is shown as number values as well as a bar display (called F-bar display).

The permissible maximum value corresponds to 100 % in the bar display.

- ▶ The F1-utilization bar **17.1** shows the relationship $F1_{\text{actual}}$ **17.2** to $F1_{\text{max}}$ **17.3**.
- ▶ The value $F1_{\text{min}}$ **17.4** corresponds to the $F1_{\text{min}}$ -STOP-bar **17.6**.
- ▶ The F2-utilization bar **17.7** shows the relationship $F2_{\text{actual}}$ **17.8** to $F2_{\text{max}}$ **17.9**.
- ▶ The F3-utilization bar **17.10** shows the relationship $F3_{\text{actual}}$ **17.11** to $F3_{\text{max}}$ **17.12**.
- ▶ The value $F3_{\text{min}}$ **17.13** appears solely in special situations, for example during the erection of the derrick boom. The value $F2_{\text{min}}$ **17.14** appears solely for certain crane types in special situations. If no minimum values F_{min} appear, then the data in the crane documentation (for example erection / take-down charts and assembly instructions) must be observed.
- ▶ When leaving the range „load chart available“ the display of the assembly icon **30** changes.

Empty page!

LWE/LR 11000-001/23501-04-02/en

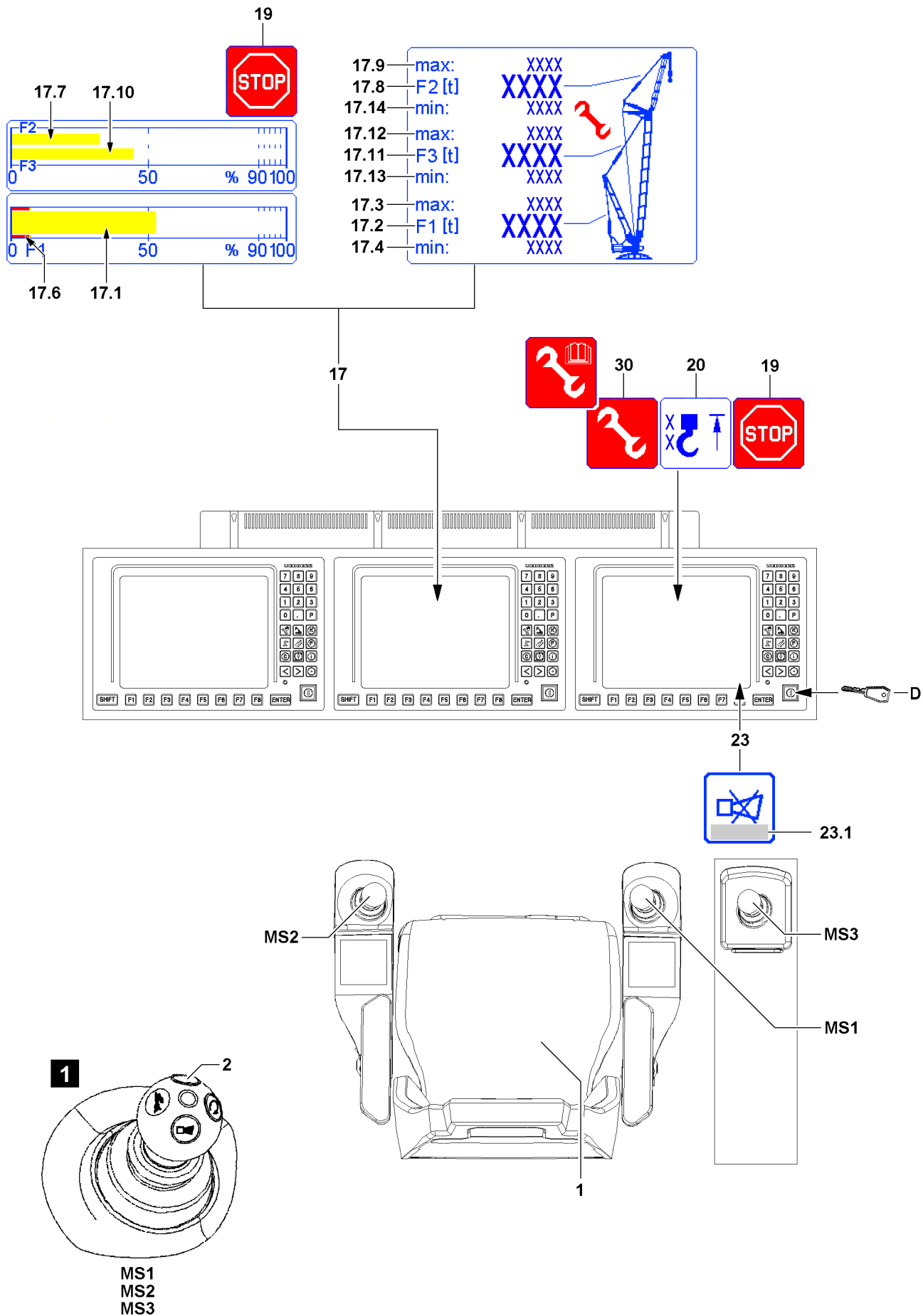

Fig.122457

LWE/LR 11000-001/23501-04-02/en

2.5.1 Carrying out erection procedures

Make sure that the following prerequisites are met:

- The set up configuration corresponds to the specifications in the crane documentation.
- The set up configuration has been entered correctly into the LICCON computer system.
- All master switches (MS1, MS2, MS3) are in the zero position (not deflected).
- Either the seat contact button **1** or one of the buttons **2** (illustration **1**) of the master switches (MS1, MS2, MS3) is actuated.



Note

- ▶ Depending on the situation, the *hoist top* shut-off (icon **20** appears) must be bypassed at the same time.

- ▶ Turn the set up key **D** to the right (touching).

Result:

- The assembly icon **30** appears.
- The erection procedure can be carried out.

Problem remedy

The functionality of the set up key **D** is disabled by the crane control?

- ▶ Pay attention to notes regarding error messages **23.1** occurring in the *horn* icon **23**.
- ▶ Check the electrical connections.
- ▶ Check if all sensors or dummy plugs with integrated electric have been connected properly.

- ▶ Luff the boom according to the specifications of the crane documentation.
- ▶ Monitor the F-load display **17**, all values must be within the minimum values and the maximum values.

Problem remedy

The erection / take down procedure cannot be carried out due to exceeding of the minimum or maximum values?

- ▶ See section „Minimum values or maximum values of F-load display reached“.

The „Bypass of the LICCON overload protection“ via the set up key **D** turns off:

- If the set up key **D** is actuated again.
- When an range with existing load chart is reached (erection procedure).
- If all master switches (MS1, MS2, MS3) are in the zero position for 10 seconds (with „Load chart available“).
- When neither the seat contact button **1** nor one of the buttons **2** of the master switches (MS1, MS2, MS3) is actuated.

The function „Exceedance of shut-off limits of the LICCON overload protection“ has / was shut off:

- The assembly icon **30** in the LICCON monitor turns off.
- ▶ After completion of the erection / take down procedures, make sure that the assembly icon **30** no longer appears in the LICCON monitor.

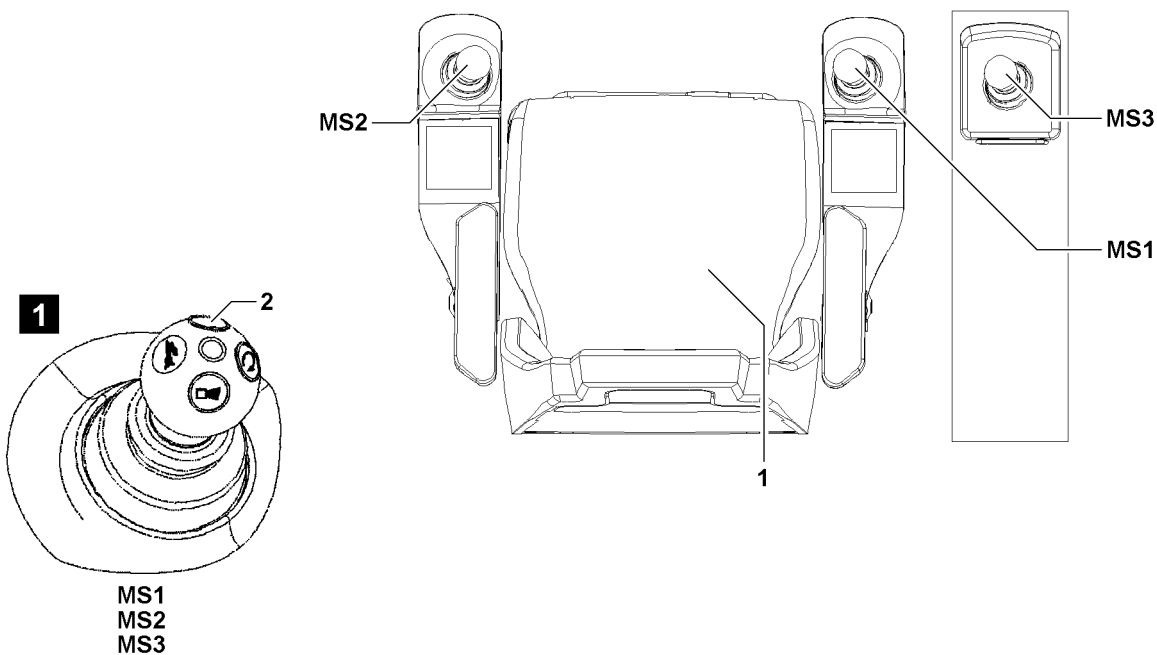
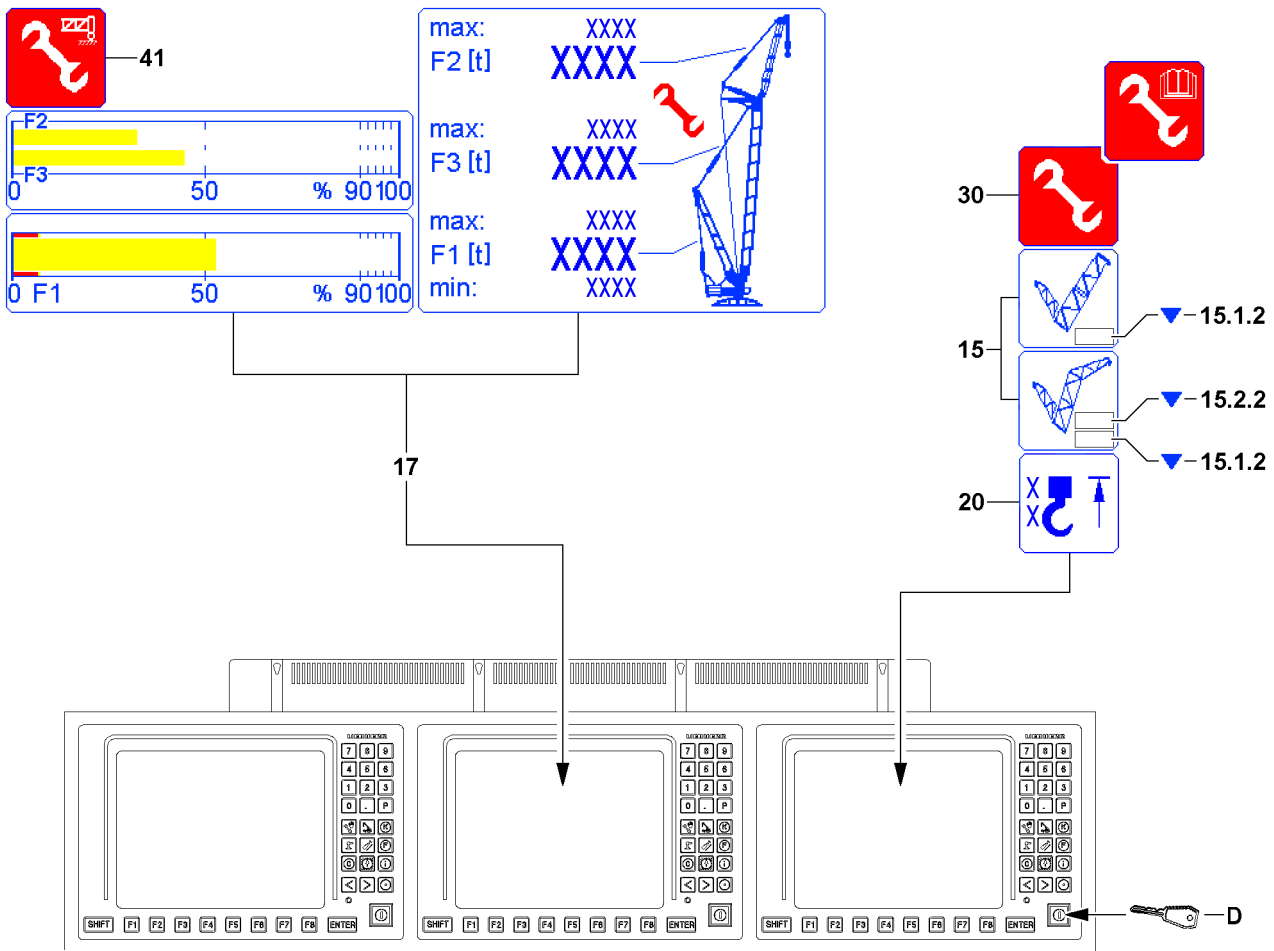

Fig.125391

2.5.2 Carrying out take down procedures



WARNING

Danger of accidents when taking the boom system down!

When the shut-off *luffing the main boom / auxiliary boom / accessory down* is bypassed, then the LICCON overload protection as a whole is deactivated, bypassed or limited.

The main boom and / or auxiliary boom / accessory can be luffed from the range of the load chart.

In case of deviations from the specifications of the crane documentation, severe accidents can be the result.

Personnel can be severely injured or killed.

- ▶ Always proceed according to the specifications of the crane documentation.
- ▶ Carry out all crane movements with utmost caution.

Make sure that the following prerequisites are met:

- With installed main boom / auxiliary boom / accessory: In the icon **15** the arrow **15.1.2** or arrow **15.2.2** appears and the LICCON overload protection has shut off the crane movement.
- Either the seat contact button **1** or one of the buttons **2** (illustration **1**) of the master switches (MS1, MS2, MS3) is actuated.
- All master switches (MS1, MS2, MS3) are in the zero position (not deflected).
- There is no load on the hook (hook block / load hook).
- If necessary, the hook (hook block / load hook) is placed on the ground.
- The set up configuration corresponds to the specifications in the crane documentation.
- The set up configuration has been entered correctly into the LICCON computer system.



Note

- ▶ When leaving the range „load chart available“, the limit values and utilization displays for value F2 and value F3 will possibly appear.
- ▶ When leaving the range „load chart available“ the display of the assembly icon **30** changes.

- ▶ Turn the set up key **D** to the right (touching).

Result:

- The assembly icon **30** appears in the LICCON monitor.
- The take down procedure can be carried out.
- ▶ Luff the boom according to the specifications of the crane documentation.
- ▶ Monitor the F-load display **17**, all values must be within the minimum values and the maximum values.

Problem remedy

The erection / take down procedure cannot be carried out due to exceeding of the minimum or maximum values?

- ▶ See section „Minimum values or maximum values of F-load display reached“.

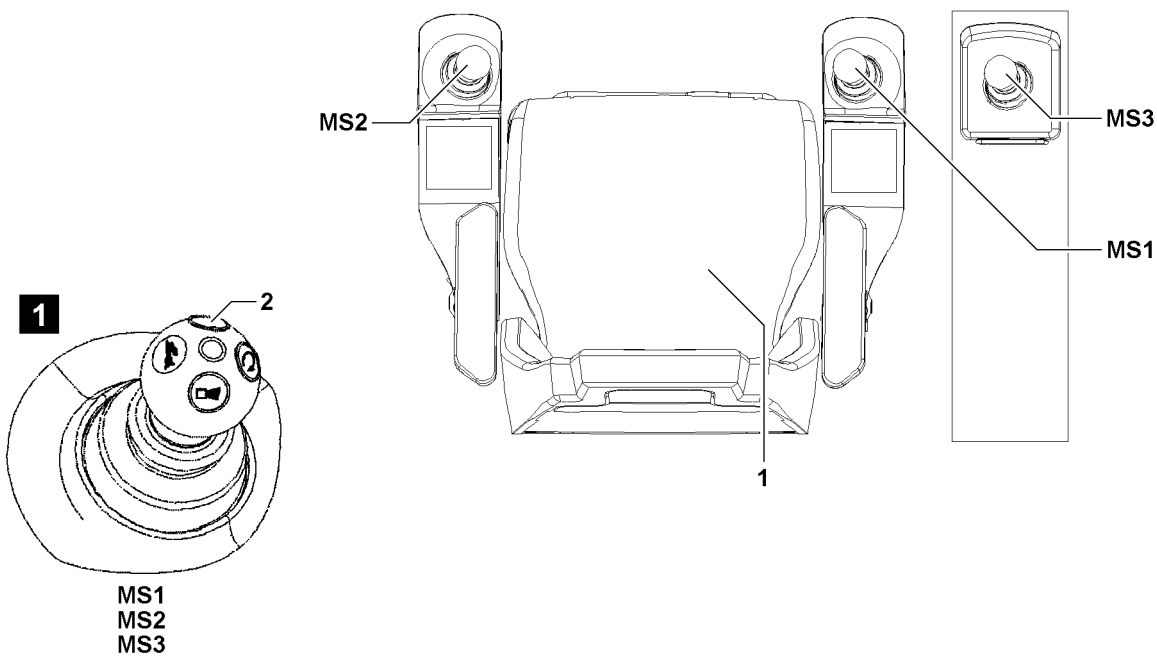
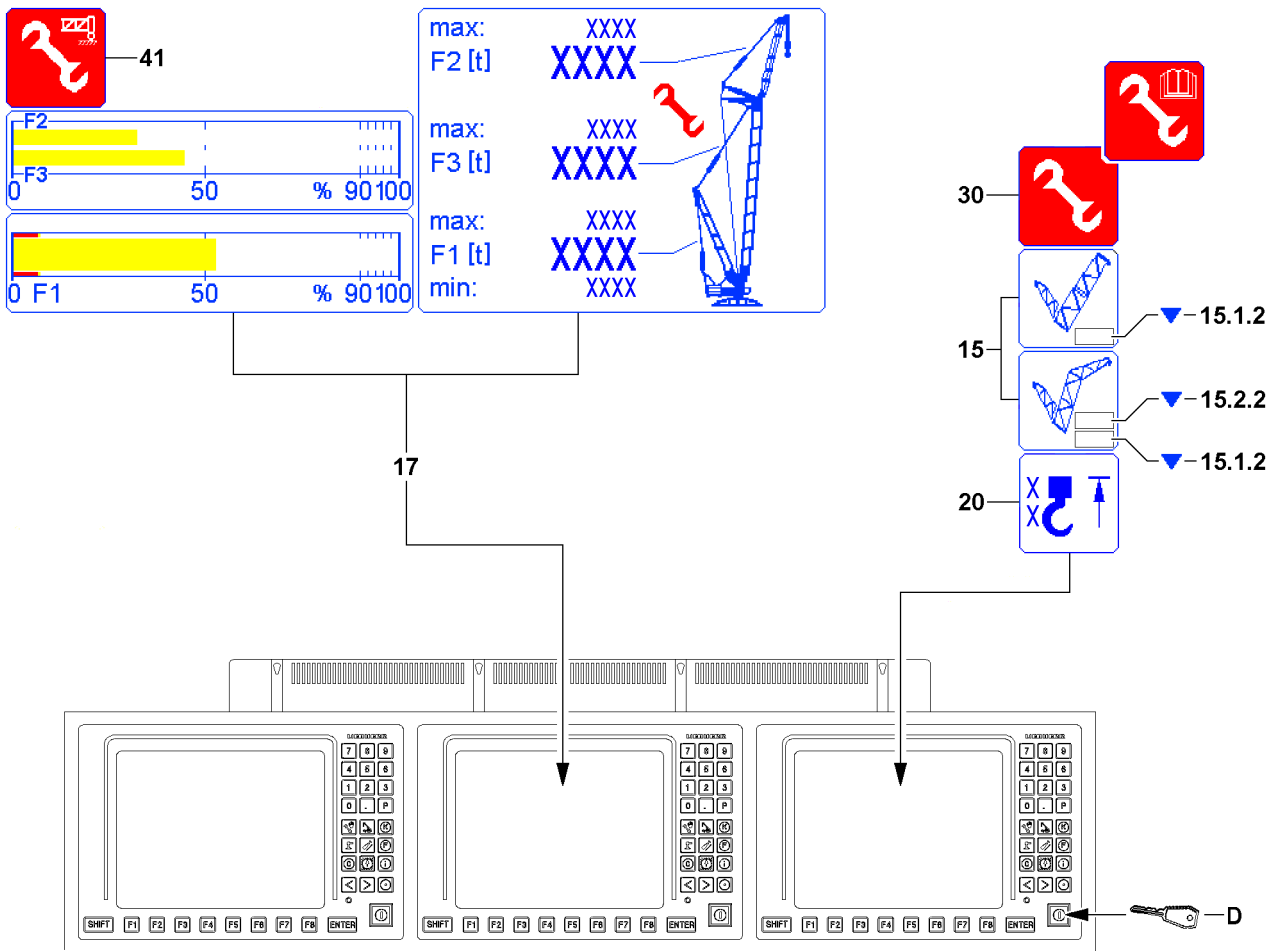

Fig.125391

LWE/LR 11000-001/23501-04-02/en

**Note**

- ▶ Depending on the situation, the *hoist top* shut-off (icon **20** appears) must be bypassed at the same time.

The „Bypass of the LICCON overload protection“ via the set up key **D** turns off:

- If the set up key **D** is actuated again.
- When neither the seat contact button **1** nor one of the buttons **2** of the master switches (MS1, MS2, MS3) is actuated.
- When an area with existing load chart is reached.

The bypass of the LICCON overload protection is / was turned off:

- The assembly icon **30** in the LICCON monitor turns off.
- ▶ Make sure that the assembly icon **30** no longer appears in the LICCON monitor.

2.5.3 Carrying out the assembly procedures

**WARNING**

Danger of accident during assembly procedures!

In case of deviations from the specifications of the crane documentation for the assembly procedures, severe accidents can be the result.

Personnel can be severely injured or killed.

- ▶ Always proceed according to the specifications of the crane documentation.
- ▶ **If you cannot proceed according to the crane documentation, contact Liebherr Service before carrying out any subsequent steps and agree on the procedure.**

Make sure that the following prerequisites are met:

- The set up configuration corresponds to the specifications in the crane documentation.
- The set up configuration has been entered correctly into the LICCON computer system.
- ▶ Actuate the set up key **D** only according to the corresponding specifications in the crane documentation.

2.5.4 Key button *Boom on the ground*

With the aid of the key button *Boom on the ground*, a shut-off can be bypassed in the lowest angle range of the boom, when:

- The boom has contact with the ground.
- At least 12.5 % of the boom weight is taken up by the ground contact.

Make sure that the following prerequisites are met:

- The set up configuration corresponds to the specifications in the crane documentation.
- The set up configuration has been entered correctly into the LICCON computer system.
- ▶ Actuate the key button *Boom on the ground* and erect / take-down the boom.

Result:

- Icon **41** appears as long as the shut-off is bypassed.

**Note**

- ▶ The key button *Boom on the ground* is on the instrument panel, see Crane operating instructions, chapter 4.01.

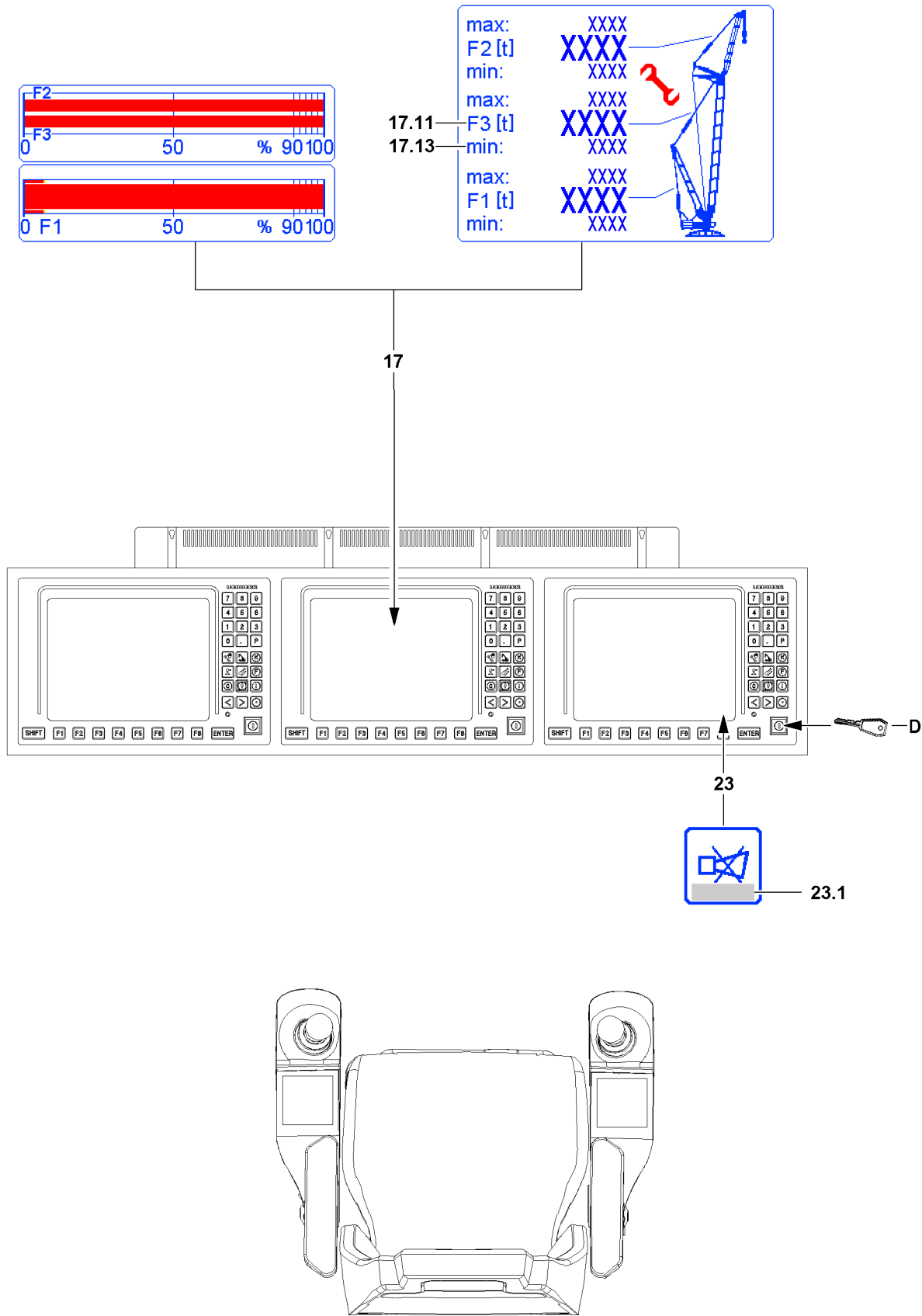

Fig.122458

2.6 Minimum values or maximum values of F-load display reached



Note

- ▶ The display and assignment of the F-load display **17** can deviate depending on the set up configuration, operating condition and configuration of the crane, see Crane operating instructions, chapter 4.02.

In the F-load display **17** the minimum and maximum values were reached.

Make sure that the following prerequisites are met:

- The crane is assembled according to the specifications in the crane documentation.
- A valid set up configuration has been entered on the LICCON computer system (Set up program).
- The actual set up configuration has been entered on the LICCON computer system (Set up program).
- The hook block / load hook is correctly installed and reeved in.
- All attachment parts and guy rods on the boom system, which are not needed, have been removed (weight).
- The boom system is free of snow and ice (weight).
- The wind influence on the crane is not too great.
- The local conditions (terrain incline) are in the permissible range.
- The notes regarding error messages **23.1** appearing in the *horn* icon **23** were observed.

2.6.1 Improvement of force ratio in the guying of the boom system

- ▶ Check if a crane movement was initiated, which leads to an improvement of the force ratio in the F-load display **17**.



Note

In the permissible framework of specifications of the crane documentation, a positive influence of the force ratio in the F-load display **17** can be reached by:

- ▶ Changing the pulled derrick ballast.
- ▶ Changing the derrick ballast radius (luffing the derrick boom up / down).
- ▶ Erecting the main boom: Carry the hook (hook block / load hook) along.
- ▶ Erection of the main boom with installed luffing jib: Spool the control winch for the luffing jib out to shift the weight of the guy rods more favorably.
- ▶ In difficult local conditions (terrain incline): Support the placed down boom system to obtain more favorable angle conditions.
- ▶ In difficult local conditions (terrain incline): Support the placed down boom system to reduce flexation.

2.6.2 Minimum value F3-load display during erection of the derrick boom fallen below

If the guying between the derrick boom and the main boom is not sufficiently tensioned, then it is possible that the value $F3_{\min}$ **17.13** is fallen below. The value $F3_{\min}$ **17.13** appears possibly only during the erection procedure of the derrick boom in steep boom position.



Note

- ▶ By targeted spooling winch 3 up / out during the erection procedure, the guying between the derrick boom and the main boom can be slightly pretensioned depending on the circumstances and the value $F3_{\text{actual}}$ **17.11** can be increased / held.
- ▶ Pretension the guying slightly between the derrick boom and the main boom so that the value $F3_{\min}$ **17.13** is not fallen below. A collision of the luffing pulley block / guy rods with the crane (for example during the erection procedure of the derrick boom) may not occur.

When $F3_{\min}$ **17.13** was fallen below and the movements winch 3 and winch 4 are fully or partially shut-off:

- ▶ Press the set up key **D** again at activated assembly operation.

Result:

- The value for $F3_{\min}$ **17.13** is reduced slightly once.
 - ▶ Spool winch 3 up to increase the value $F3_{\text{actual}}$ **17.11**.
-

Problem remedy

The value for $F3_{\min}$ **17.13** is fallen below again:

It is not possible to reduce the value for $F3_{\min}$ **17.13** again.

- ▶ By spooling out winch 4 the derrick boom can be moved forward until the $F3_{\min}$ **17.13** is masked again and winch 3 can be spooled up / out again.
-

5 Equipment

LWE/LR 11000-001/23501-04-02/en

LWE/LR 11000-001/23501-04-02/en

5.01 Safety technical notes for assembly and disassembly

1	Rope pulleys	3
2	Ropes	3
3	Control measures	4
4	Relapse cylinder	6
5	Pneumatic springs	7
6	Manual rope winches	7
7	Weights	7
8	Guy rods	8
9	Auxiliary guying	8
10	Bypassing the overload protection	9
11	Bypassing the hoist top shut off	11
12	Pin connections	11
13	Retaining elements	14
14	Assembly / disassembly	22
15	Erection / take down	67

Fig.195219

LWE/LR 11000-001/23501-04-02/en

1 Rope pulleys



WARNING

Danger of crushing due to rotating rope pulleys!

Arms and legs can be caught and crushed or severed between the rope pulley and the rope due to rotating rope pulleys.

- ▶ It is prohibited to touch the ropes or rope pulleys during operation.
- ▶ Adhere to the safety distance to ropes and rotating rope pulleys.

2 Ropes



WARNING

Danger of accident!

- ▶ The ropes must be checked by an expert before assembly and checks must be performed at regular intervals in order to detect possible damage or wear and tear at an early stage. See Crane operating instructions, chapter 8.04.

The ropes must be removed immediately if any of the following damage is detected:

- Breakage of a strand
- Wire breaks
- Broken wire nests
- Reduction in the rope diameter by 10 % or more of the nominal size
- Rope deformations

2.1 Placing the hoist rope or the control rope

In order to guarantee safety and operating characteristics, only original Liebherr replacement parts or parts approved by Liebherr may be used.

NOTICE

Damage to the hoist rope or the control rope!

If a hoist rope or control rope is placed with worn rope pulleys, damage can occur.

- ▶ Before placing a rope, check the rope pulleys. See the Operating instructions, chapter 8.01.
- ▶ Replace worn or damaged rope pulleys.

2.2 Minimum rope coils

NOTICE

If the following notes are not observed, the cam limit switch / winch speed sensor must be readjusted!

- ▶ When the hoist rope is spooled up, the end of the hoist rope must remain in front of the winch and may not be pulled over the winch.
- ▶ Pull the hoist rope end never under the winch by spooling the winch up.
- ▶ Pull the hoist rope never off from the „stationary“ winch.
- ▶ The winch speed sensor must also be readjusted, if it is determined during operation or when changing the hoist rope that the winch does not turn off when the minimum rope coils are reached.

2.2.1 Cranes with cam limit switch

The cam limit switch is adjusted at the factory that it turns off before the minimum rope coils are reached (three hoist rope coils on the winch).

**WARNING**

Danger of accident due to falling load!

If the following instructions are not observed, the hoist rope end attachment may be torn out, causing the load to topple.

- ▶ If a new hoist rope is used, the cam limit switch must be reset.
- ▶ The cam limit switch must be adjusted so that it turns off when only 3 hoist rope coils remain on the winch.

2.2.2 Cranes with winch speed sensor

The winch speed sensor is adjusted at the factory that it turns off before the minimum rope coils are reached (four hoist rope coils on the winch). If used properly, the winch turn sensor will not need readjustment.

**WARNING**

Danger of accident due to falling load!

If the following instructions are not observed, the hoist rope end attachment may be torn out, causing the load to topple.

- ▶ If a new hoist rope is placed, the winch speed sensor must be checked.
- ▶ The winch speed sensor must be set to turn off when only 4 hoist rope coils remain on the winch.

3 Control measures

**WARNING**

The crane can topple over!

If the control measures are not carried out before crane operation, then accidents can occur. The crane can topple over, be overloaded or damaged.

Personnel can be killed or injured.

- ▶ Crane operation with safety equipment which are **not** functioning correctly is strictly prohibited.
- ▶ Start crane operation only after all safety equipment have been checked and are functioning correctly.
- ▶ Start crane operation only if the overload protection has been set according to the data in the load chart.
- ▶ Start crane operation only if the crane is properly supported and horizontally aligned.

**WARNING**

Interruption of crane operation!

If the following specifications for interruption of crane operation are not observed, accidents can occur.

- ▶ If the crane operator leaves the crane cab even if for just a short time, the crane must be secured to prevent unauthorized access.
- ▶ Before starting to work again with the crane, the crane operator is obligated to check the operating mode settings and to reset them, if necessary.

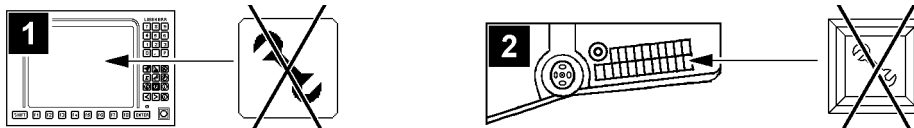

Fig.113437: Control displays

Make sure that the following prerequisites are met:

- The overload protection is not bypassed.
- No assembly operation is activated.

3.1 General controls before crane operation

- Make sure that no visible damage is present on the crane.
- Make sure that there are no loose parts on the boom, crane chassis and crane superstructure.
- Make sure that exposed rope pulleys are free of snow, frost and ice.
- Make sure that the cable / rope drums as well as the limit switches are free of snow and ice.
- Make sure that the gear ring of the slewing ring connection is clean and greased.
- Make sure that the air supply to the oil and water cooler is clear.
- Make sure that steps, ladders and platforms are in the correct position for crane operation.
- Make sure that all tool boxes, compartments, coverings, covers and cabinet doors are closed.
- Make sure that no persons or objects are within the danger zone of the crane.
- Make sure that the crane is standing on level, load bearing ground.
- Make sure that the crane is sufficiently supported depending on the load case and the ground conditions.
- Make sure that there is a sufficient safety distance to excavations and slopes.
- Make sure that no obstacles are within the working range of the crane, which obstruct the required crane movements.
- Make sure that the crane has sufficient distance to live power lines.
- Make sure that the LICCON overload protection is set according to the data in the load chart.
- Make sure that the overload protection is set according to the actual set up configuration of the crane.
- Make sure that the electrical connections, the connector plug, the pull release, the cables and the protective insulation function. Replace missing or defective parts.
- Make sure that the cable routings on the electrical connections are seated tightly. If necessary, tighten loose screw connections.
- Make sure that the existing safety equipment is functioning.
- Make sure that the overload protection is functioning.
- Make sure that the hoist limit switches are functioning.
- Make sure that the limit switch boom „steepest position“ is functioning.
- Make sure that the wind speed sensor easily moves and is functioning.

3.2 Additional controls for cranes with crane support

- Make sure that the folding / sliding beams are secured with pins to prevent them from sliding.
- Make sure that the support plates are secured in the operating position.
- Make sure that the crane is properly supported.
- Make sure that the crane is horizontally aligned.
- Make sure that the axle suspension is blocked (mobile crane).
- Make sure that the tires have no contact to the ground (mobile crane).
- Make sure that the track chains are secured to prevent them from sagging (crawler crane).

3.3 Additional controls for cranes on tires on the front and supported on the rear

- Make sure that the rear folding / sliding beams are secured with pins to prevent them from sliding.
- Make sure that the rear support plates are secured in the operating position.
- Make sure that the crane is properly supported on the rear.
- Make sure that the axle pressure compensation is correctly switched.
- Make sure that the axle suspension is blocked.
- Make sure that the tires of the rear axle group have no contact with the ground.
- Make sure that a sufficient tire pressure is present in the tires.
- Make sure that the ground for the front axle group is sufficiently level and has a sufficient load bearing capacity.

3.4 Additional controls for cranes supported on the front and on tires on the rear

- Make sure that the front folding / sliding beams are secured with pins to prevent them from sliding.

- Make sure that the front support plates are secured in the operating position.
- Make sure that the crane is properly supported on the front.
- Make sure that the axle pressure compensation is correctly switched.
- Make sure that the axle suspension is blocked.
- Make sure that the tires of the front axle group have no contact with the ground.
- Make sure that a sufficient tire pressure is present in the tires.
- Make sure that the ground for the rear axle group is sufficiently level and has a sufficient load bearing capacity.

3.5 Additional controls for freestanding crane operation (on tires)

- Make sure that all prerequisites for freestanding crane operation are met.
- Make sure that sufficient tire pressure is in all tires for crane operation on tires.
- Make sure that the ground is sufficiently level for crane operation on tires and has a sufficient load bearing capacity.

3.6 Additional controls for cranes with a derrick boom

- Make sure that the shut off via the limit switch - derrick is functioning.
- Make sure that the entire slewing range of the suspended ballast / ballast trailer is free of personnel and obstacles.

3.7 Additional controls for cranes with luffing auxiliary boom / accessories

- Make sure that the shut off via the limit switch luffing auxiliary boom / accessories „steepest position“ is functioning.
- Make sure that the shut off via the limit switch luffing auxiliary boom / accessories „lowest position“ is functioning.
- Make sure that the shut off via the limit switch flap in „steepest position“ position is functioning.
- Make sure that the pendulum of the mechanical relapse retainer moves easily over the entire slewing range and is functioning.

3.8 Additional controls for certain crawler cranes

For existing crawler assembly key button:

- Make sure that the crawler assembly key button is turned off.

4 Relapse cylinder

4.1 Block position of the relapse cylinders when setting down the load

NOTICE

Damage to the boom or the relapse cylinders!

If the block position of the relapse cylinders is triggered by the boom or the derrick with attached, freely suspended load, then there is a danger of damaging the boom or the relapse cylinders when setting the load on the ground. By setting down the load, the crane is relieved, and this movement causes the boom system to move to the rear.

There is no shut-off of the hoist gear lowering function.

- ▶ Actuate the opposite direction of movement which caused the block position and eliminate the block position.
-

5 Pneumatic springs

Pneumatic springs are installed on various crane components to simplify the assembly of these components.



WARNING

Danger of crushing!

Defective pneumatic springs no longer provide the supporting properties on the movable components. Due to falling components, personnel can be killed or severely injured.

High danger of accident.

- ▶ Always check pneumatic springs for damage before actuating the corresponding components.
- ▶ Do not use components with defective pneumatic springs. Replace defective pneumatic springs immediately.
- ▶ Make sure that no persons or objects are in the movement range of the moving components which is supported by the pneumatic spring.
- ▶ It is strictly prohibited to remain or place any objects in the movement or other danger zone of the moving crane components which are supported by the pneumatic spring.

6 Manual rope winches

Manual rope winches are installed on various components to simplify the assembly or disassembly of these components.



WARNING

Danger of crushing!

Defective manual rope winches no longer provide the supporting action on the movable components. Due to falling components, personnel can be killed or severely injured.

High danger of accident.

- ▶ Always check manual rope winches for external and functional damage before actuating the respective components.
- ▶ Check the rope of the manual rope winch for damage.
- ▶ At least two rope coils must always remain on the rope drum.
- ▶ Do not use components with defective manual rope winches. Replace defective manual rope winches.
- ▶ It is strictly prohibited for personnel or objects to remain within the movement range of the components, which are supported by the manual rope winch.
- ▶ It is prohibited for personnel or objects to remain within the danger zone of the moveable components.

7 Weights



Note

- ▶ The weight of each component is specified in the chapter 1.03 or the respective chapter in the Crane operating instructions or is stated on the tag attached to the corresponding component.
- ▶ If components are pushed into one another (for example the boom intermediate sections) or folded together (for example the folding jib), then the total weight is given by the sum of the individual components.

NOTICE

False estimation of weights

- ▶ Contact the Service department at **Liebherr-Werk Ehingen GmbH** if the weight of the respective component is not stated on the tag or in the Crane operating instructions.
- ▶ Use an auxiliary crane with sufficient load carrying capacity including judicious reserve.

8 Guy rods

**WARNING**

Boom can break off!

The arrangement of the guy rods for the boom or boom systems is stipulated in the rod plan. If the arrangement of the guy rods according to the rod plan is not observed, the crane can collapse, the boom can break off or the crane can topple over.

Personnel can be severely injured or killed.

- ▶ Always carry out the arrangement of the guy rods according to the rod plan.
- ▶ If an auxiliary guying is required for a certain boom length, then it must always be installed according to the rod plan on the position defined in the rod plan.

**WARNING**

Unutilized guy rods on boom!

If guy rods are on the lattice sections which are not used for operation, then there is a danger of accidents.

Unused guy rods can loosen up and fall down.

Personnel can be severely injured or killed.

The load chart is invalid.

The load display of the LICCON computer system shows an incorrect value.

The weight of the boom is too large for erection.

- ▶ Disassemble and remove the guy rods which are not needed on the transport retainers before erecting the boom.

**Note**

- ▶ Inspection and maintenance of guy rods, see Crane operating instructions, chapter 8.15.
- ▶ In reference to the guy rods, observe section „Erection / take down“.

9 Auxiliary guying

The auxiliary guying is of significant importance for safe crane operation.

The auxiliary guying is a deciding factor in relieving the boom, or the boom system during erection and take down as well as during crane operation.

**WARNING**

The crane can topple over!

If the auxiliary guying is not installed or not installed on the position specified in the rod plan, then the crane can collapse, the boom can break off or the crane can topple over.

- ▶ If an auxiliary guying is specified in the rod plan for the required boom length, then it must be installed on the respective position.
- ▶ Make sure that the auxiliary guying is always completely installed and that all pins are properly pinned and secured.

10 Bypassing the overload protection



Fig.113438: Bypassing the overload protection

- Illustration 1: LICCON monitor (only certain crane types).
- Illustration 2: Indicator light „Assembly“ in instrument panel crane cab (only certain crane types).

The overload protection is considered bypassed for:

- all types of assembly operations.
- all types of exceeded shut off limits of the overload protection.
- all types of emergency operation.
- all types of crane operation with deactivated or defective sensors and limit switches.
- all types of deviation from specified set up configuration of the crane.



DANGER

Increased danger of accident due to bypass of the overload protection!

Proper and destined use of the crane is ensured due to the construction of the overload protection system and observance of the information in the Crane operating instructions. All **sensibly foreseeable erroneous operations** of the crane have been taken into consideration.

Impermissible crane operation with bypassed overload protection – with the aim of increasing the maximum load bearing capacity of the crane above the rated value in the load chart or of extending the designated working range of the crane – does not constitute a **reasonably foreseeable erroneous operation**, rather **deliberate improper use with high danger of accident**.

The possible risks and consequences of such improper use are detailed in the Crane operating instructions.

Such deliberate improper use can neither be prevented by means of the structural design nor by means of information in the Crane operating instructions.

- ▶ Bypass the overload protection only according to the Crane operating instructions.
- ▶ Exceed the shut off limits of the overload protection only according to the Crane operating instructions.
- ▶ Any other use of the crane with bypassed overload protection than that described in the Crane operating instructions is prohibited.

If the maximum permissible load moment is exceeded, the overload protection turns all load moment increasing crane movements off.

This shut off can be bypassed or exceeded various ways, for example:

- exceeding the shut off limits (utilization more than 100 % or leaving the load chart).
- activating an assembly operation.
- activating an emergency operation.

The displays of the LICCON overload protection remain functioning when all associated sensors and limit switches are active and a load chart is available.

**WARNING**

Increased danger of accident due to bypass of the overload protection!

If the overload protection is bypassed, there is no longer any protection against crane overload.

In the event of improper use, the crane could collapse, the boom can break off or the crane can topple over.

Personnel can be killed.

This could result in high property damage.

- ▶ It is only permitted to bypass the overload protection for assembly or in emergencies.
- ▶ The bypass of the overload protection may only be carried out by persons who are aware of the effects of their acts.
- ▶ Bypassing the overload protection requires the presence of a person authorized by the crane operator and must be performed with utmost caution.
- ▶ It is strictly prohibited to operate the crane when the overload protection is bypassed.

10.1 Bypassing the LICCON overload protection

**Note**

- ▶ Applies only for cranes with LICCON overload protection.

Depending on the crane version, one or more operating elements are available to bypass the overload protection:

- Button in the control panel.
- Key button on the LICCON monitor.
- Key button in the instrument panel.
- Key button in the control cabinet.
- Sensor for transponder on the crane cab.

The functions of the operating elements are described in chapter 4.20.

- ▶ Actuate the respective operating element.

Result:

- The LICCON overload protection is bypassed / inactive.
- The „Assembly“ icon appears on the LICCON monitor.
- Depending on the circumstances, acoustic and / or optical warning signals (blinkers, flashing lights, bells and horns) sound.

If the LICCON overload protection is to be reactivated:

- ▶ No longer actuate the respective operating element or reset.

Result:

- The LICCON overload protection is active.
- The „Assembly“ icon no longer appears on the LICCON monitor.
- The acoustic and / or optical warning signals which were triggered by the bypass are turned off again.

10.2 Bypassing the PAT overload protection

**Note**

- ▶ Applies only for cranes with PAT overload protection.

- ▶ Actuate the bypass key button and turn the PAT overload protection off.

Result:

- The PAT overload protection is bypassed / inactive.
- ▶ Actuate the bypass key button and turn the PAT overload protection on.

Result:

- The PAT overload protection is active.

11 Bypassing the hoist top shut off

**Note**

- ▶ Applies only for cranes with hoist limit switch.

If the hook block touches the hoist limit switch weight during the upward movement, the hoist limit switch reacts. The crane movements „Spool up winches“, „Luff boom down“ and „Telescope telescopic boom out“ are turned off. The shut off can be bypassed.

**WARNING**

Danger of accidents due to bypass of Hoist top shut off!

When bypassing the hoist top shut off, there is a risk that the hook block may be pulled against the pulley head when continuing to lift or luffing down the boom. This may damage the pulleys and cause the loads to fall.

- ▶ The bypass of the hoist top shut off in crane operation with a load may only be carried out by a person authorized by the crane operator with the aid of a „Guide“. The guide must be in direct contact with the crane operator and must continually monitor the distance between the hook block and the boom head.
- ▶ Carry out all crane movements with maximum care and minimum speed.

12 Pin connections

**WARNING**

Pin connections **not** lubricated!

If pins or pin connections are not properly greased or lubricated before assembly, then they can corrode.

The pins can be stuck in the pin bores and be damaged.

During the unpinning procedure, the pins can suddenly release.

Death, severe bodily injuries, property damage.

- ▶ Make sure that all pins, which are not supplied with grease via the central lubrication system are sufficiently greased before assembly.
- ▶ Make sure that all lube points, which are equipped with a grease fitting, are properly greased at assembly and according to the respective interval specification.
- ▶ Never insert or unpin pins by force.

**WARNING**

Pin **not** secured to prevent it from loosening up by itself!

The pin connection could loosen up suddenly.

Death, severe bodily injuries, property damage.

- ▶ Secure all pins with retaining elements against loosening up by itself.

**WARNING**

Distorted pin!

Angular pull or excessive or low hoisting force of the auxiliary crane may result in distortion of the pins. Distorted parts can suddenly fly off when the pins are unpinned.

Death, severe bodily injuries, property damage.

- ▶ When the pins are unpinned, the lifting force of the auxiliary crane must be adapted to the weight of the components being lifted.
- ▶ Do **not** remove difficult to remove pins by force.
- ▶ Remedy the cause of the distortion.

12.1 Pinning the collar pin

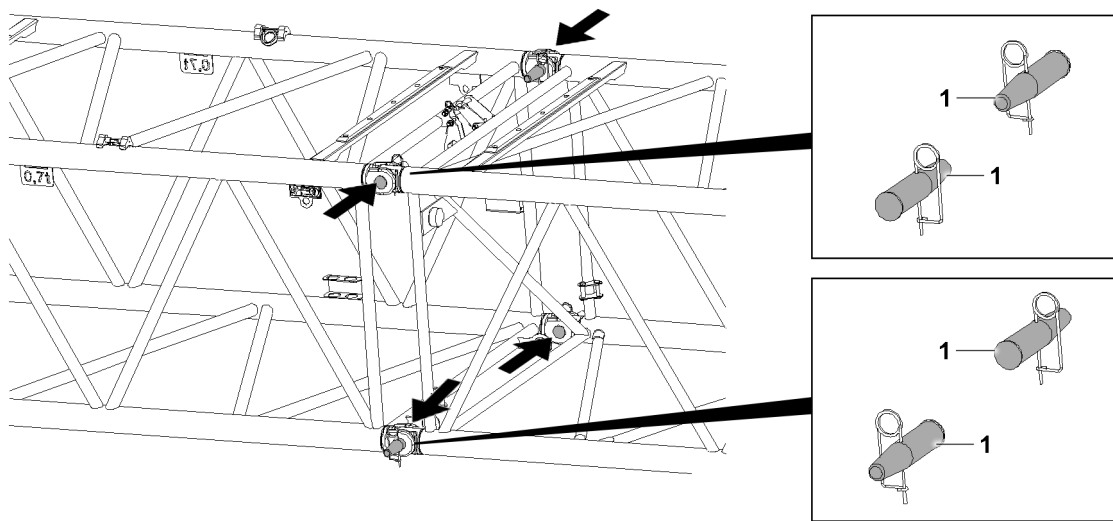

Fig.143114: Pinning the collar pin

**WARNING**

The collar pin is incorrectly pinned!

Death, severe bodily injuries, property damage.

- ▶ Pin or unpin both pins at the same horizontal level, i.e. **left and right**.
- ▶ Pin the upper collar pin **1** from the **outside to the inside** and unpin from the **inside to the outside**.
- ▶ Pin the lower collar pin **1** from the **inside to the outside** and unpin from the **outside to inside**.

12.2 Assembling the double cone pins horizontally

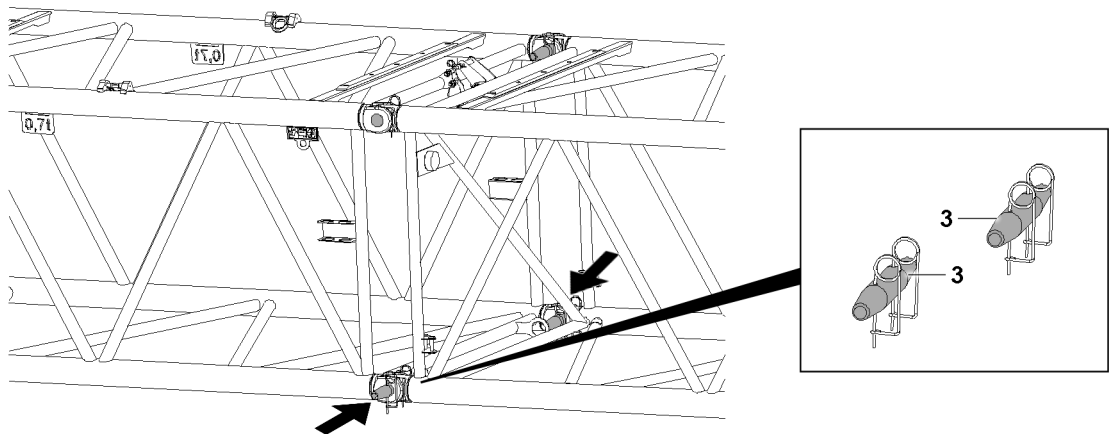

Fig.143115: Pinning the double cone pins horizontally



WARNING

Double cone pins incorrectly pinned!

Death, severe bodily injuries, property damage.

- ▶ Pin or unpin both pins at the same horizontal level, i.e. **left and right**.
- ▶ Pin and unpin horizontally installable double cone pins **3** from the **outside to the inside**.

12.3 Assembling the double cone pins vertically

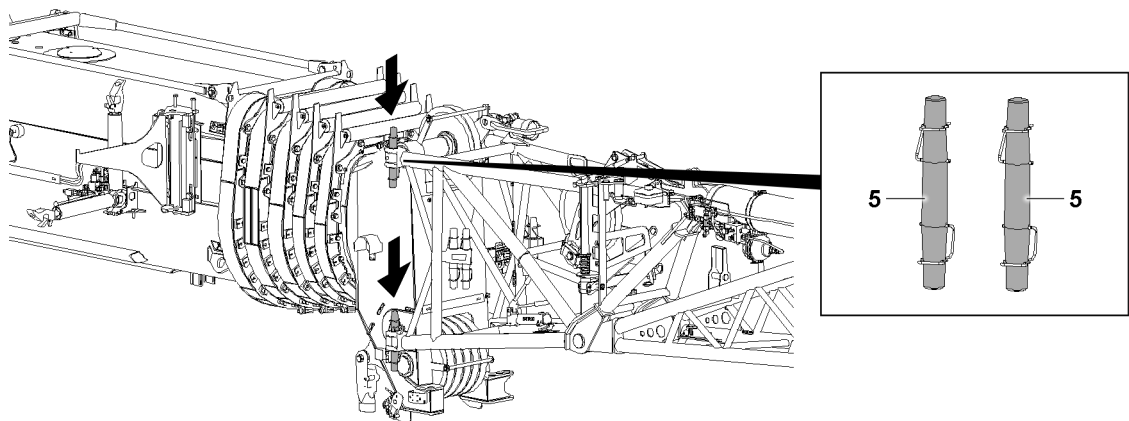

Fig.143116: Assembling the double cone pins vertically



WARNING

Double cone pins incorrectly pinned!

Death, severe bodily injuries, property damage.

- ▶ Pin or unpin both pins at the same vertical level, i.e. **above and below**.
- ▶ Pin and unpin vertically installable double cone pins **5** from the **top to the bottom**.

13 Retaining elements

13.1 Checking the retaining elements

Retaining elements are used to secure the pins. Due to mechanical damage / distortion, the function of the retaining elements can be compromised. In addition, the spring force of the retaining elements can be reduced significantly. Do **not** re-use retaining elements if there is insufficient spring force. The pin retainer must be secured with a correctly **functioning** retaining element.



WARNING

Mechanical damage or deformation of the retaining element!

The retaining elements can fail.

The pin can unpin by itself.

Death, severe bodily injury, property damage.

► Use exclusively functioning retaining elements in a proper condition.

► Replace defective retaining elements.

13.2 Overview of the retaining elements

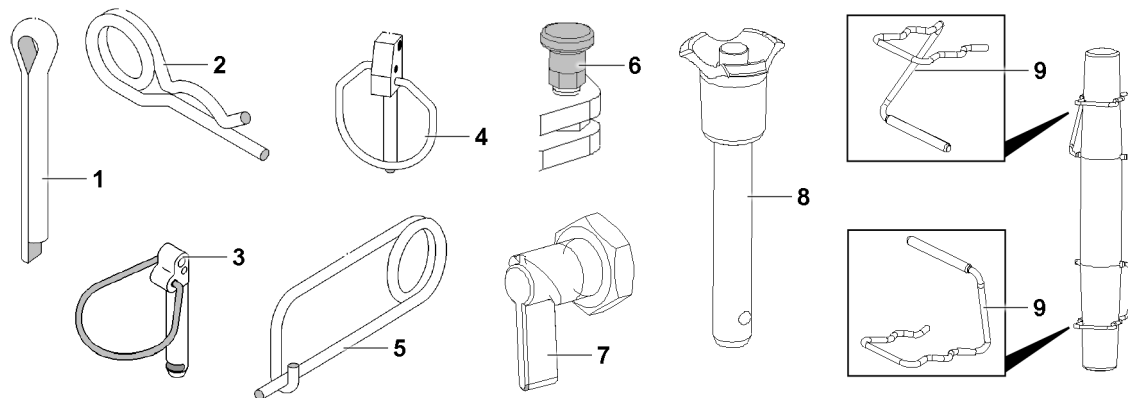

Fig.143102: Retaining elements

- | | | | |
|---|--------------------|---|------------------|
| 1 | Split pin | 6 | Detent pin |
| 2 | Cotter pin | 7 | Latch |
| 3 | Safety locking pin | 8 | Ball locking pin |
| 4 | Linch pin | 9 | Retaining clip |
| 5 | Spring retainer | | |

13.3 Split pin

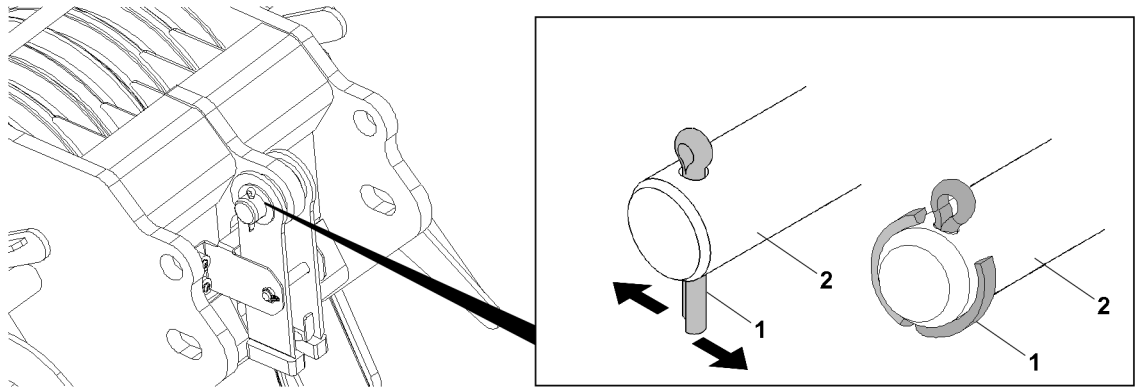

Fig.143105: Split pin

1 Split pin

2 Pin



WARNING

Multiple use of a split pin 1!
The split pin 1 can break.

- ▶ Assemble the split pin 1 only once.
- ▶ Use a correctly sized split pin 1.

- ▶ Secure the pin 2: Insert the split pin 1.
- ▶ Bend the end of the split pin 1 toward the outside.

Problem remedy

Split pin 1 defective!

- ▶ Replace the split pin 1.

13.4 Cotter pin

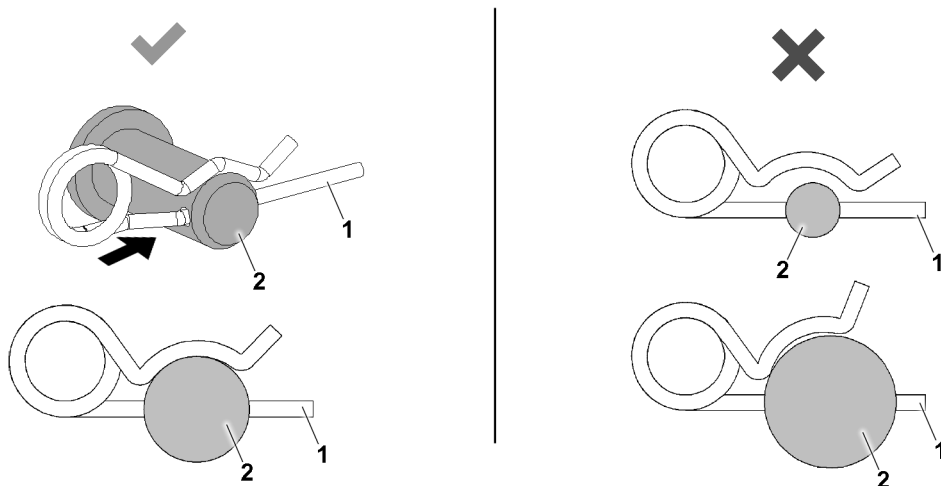

Fig.143106: Cotter pin, correct and incorrect dimensions

1 Cotter pin

2 Pin

LWE/LR 11000-001/23501-04-02/en

**WARNING**

Improper dimensions of the cotter pin 1!

The cotter pin 1 can loosen up by itself.

- ▶ Use a correctly sized cotter pin 1.
-
- ▶ Secure the pin 2: Insert the cotter pin 1.

Problem remedy

Spring tension is too low?

The cotter pin 1 is defective.

- ▶ Replace the cotter pin 1.

13.5 Safety locking pin

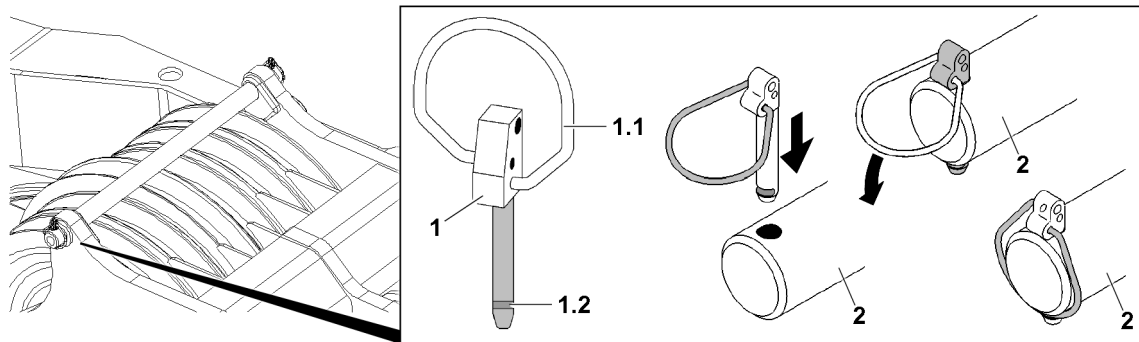

Fig.143103: Safety locking pin

1 Safety locking pin

1.2 Groove

1.1 Spring clip

2 Pin

Increased effort is necessary for opening the safety locking pin 1.

**WARNING**

Spring clip 1.1 **not** engaged!

The safety locking pin 1 can loosen up by itself.

- ▶ Engage the spring clip 1.1 completely in the groove 1.2.
-
- ▶ Secure the pin 2: Insert the safety locking pin 1.
 - ▶ Close the spring clip 1.1 and engage it completely in the groove 1.2.

Problem remedy

The spring clip 1.1 does **not** engage completely?

Tension of the spring clip 1.1 is too low.

- ▶ Replace the safety locking pin 1.

13.6 Linch pin

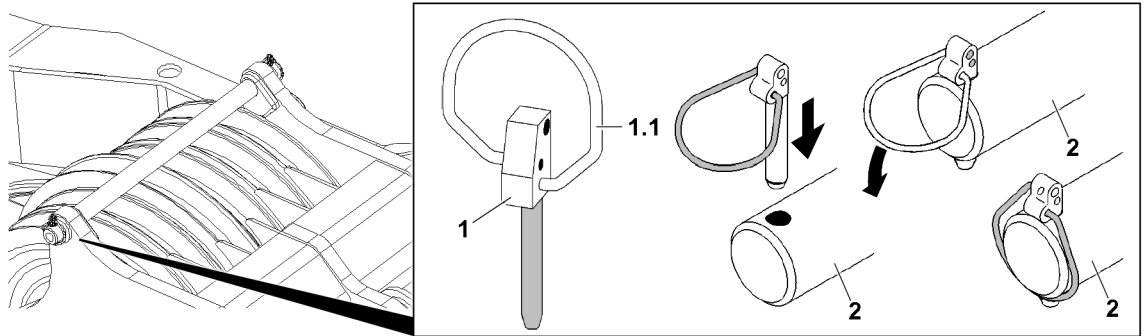

Fig.143104: Linch pin

1 Safety locking pin
1.1 Spring clip

2 Pin



WARNING

The locking pin 1 is **not** completely closed!
The locking pin 1 can loosen up by itself.
▶ Close the spring clip 1.1 completely.

▶ Secure the pin 2: Insert the locking pin 1.
▶ Close the spring clip 1.1 completely.

Problem remedy

The spring clip 1.1 does not close completely?
Tension of the spring clip 1.1 is too low.
▶ Replace the locking pin 1.

13.7 Spring retainer

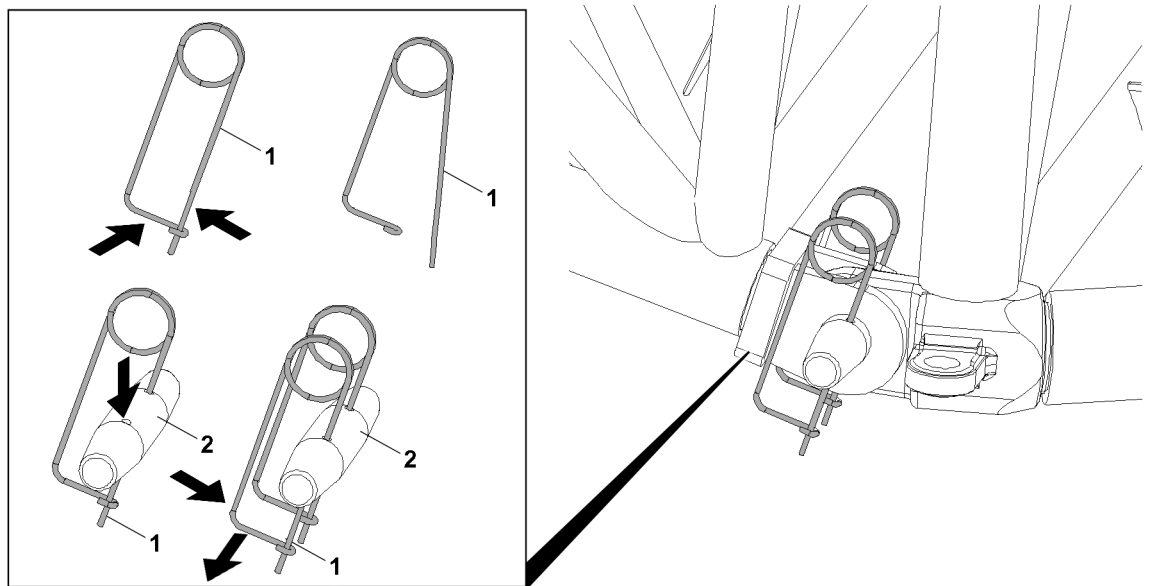

Fig.143108: Spring retainer

1 Spring retainer

**WARNING**

The spring retainer **1** is **not** closed!
The spring retainer **1** can loosen up by itself.
▶ Close the spring retainer **1**.

- ▶ Secure the pin **2**: Insert the spring retainer **1**.
- ▶ Close the spring retainer **1**.

Problem remedy

Spring tension is too low?
The spring retainer **1** is defective.
▶ Replace the spring retainer **1**.

13.8 Detent pin

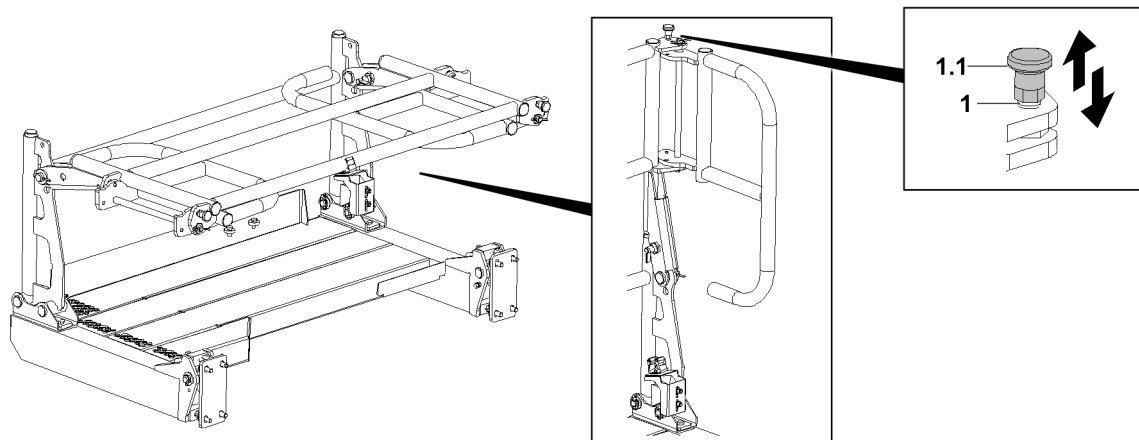

Fig.143110: Detent pin

1 Detent pin

1.1 Handle

**WARNING**

The handle **1.1** is **not** locked!
The detent pin **1** can loosen up by itself.
▶ Lock the detent pin **1**.

- ▶ Pull the handle **1.1**.

Result:

– The detent pin **1** is unlocked.

- ▶ Insert the detent pin **1**: Release the handle **1.1**.

Result:

– The detent pin **1** is pinned.

Problem remedy

The handle **1.1** cannot be pulled.
The detent pin **1** is defective.
▶ Replace the detent pin **1**.

13.9 Latch

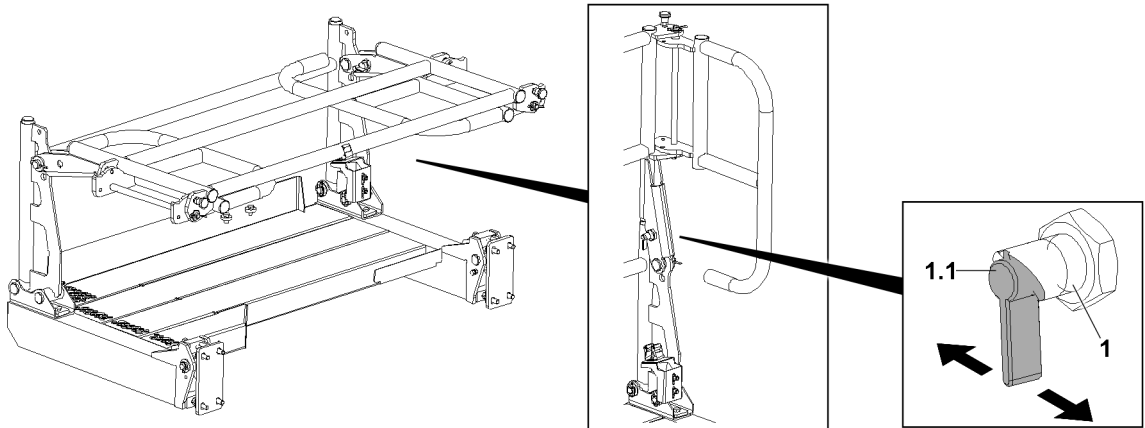

Fig.143111: Latch

1 Latch

1.1 Lever



WARNING

The latch **1** is **not** locked!
The latch **1** can loosen up by itself.
▶ Lock the latch **1**.

▶ Operate the lever **1.1**.

Result:

– The latch **1** is unlocked.

▶ Insert the latch **1**: Release the lever **1.1** and swing the railing until the latch is pinned.

Problem remedy

The lever **1.1** cannot be actuated?

The latch **1** is defective.

▶ Replace the latch **1**.

13.10 Ball locking pin

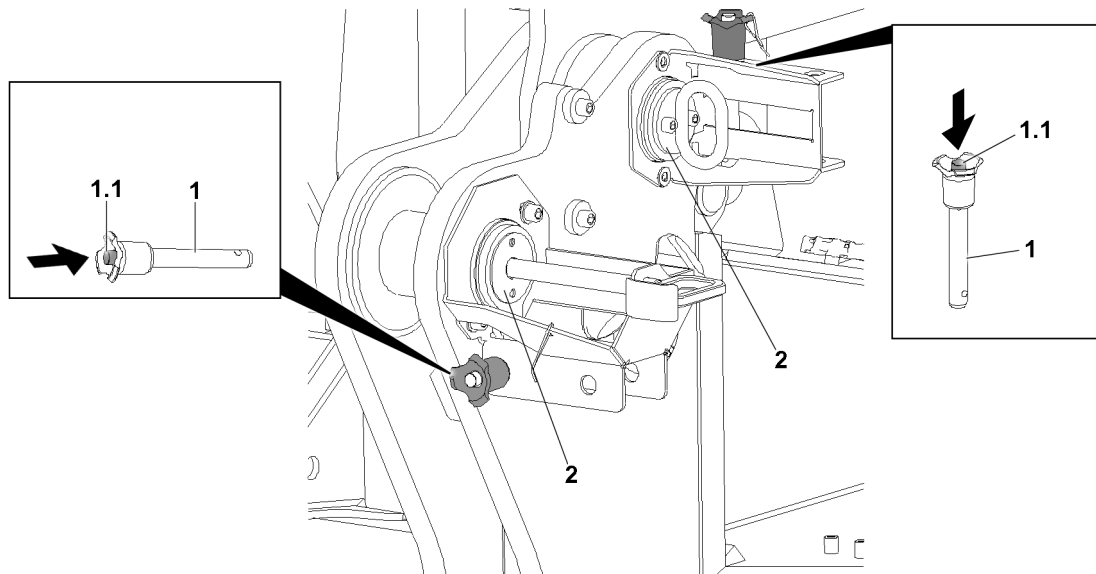

Fig.143109: Ball locking pin

1 Ball locking pin
1.1 Press button

2 Pin



WARNING

The ball locking pin **1** is **not** locked!
The ball locking pin **1** can loosen up by itself.

▶ Lock the ball locking pin **1**.

▶ Secure the pin **2**: Actuate the press button **1.1**.

Result:

– The ball locking pin **1** is unlocked.

▶ Pin the ball locking pin **1** and release the press button **1.1**.

Result:

– The ball locking pin **1** is pinned and secured.

Problem remedy

The press button **1.1** cannot be actuated?

The ball locking pin **1** is defective.

▶ Replace the ball locking pin **1**.

13.11 Retaining clips

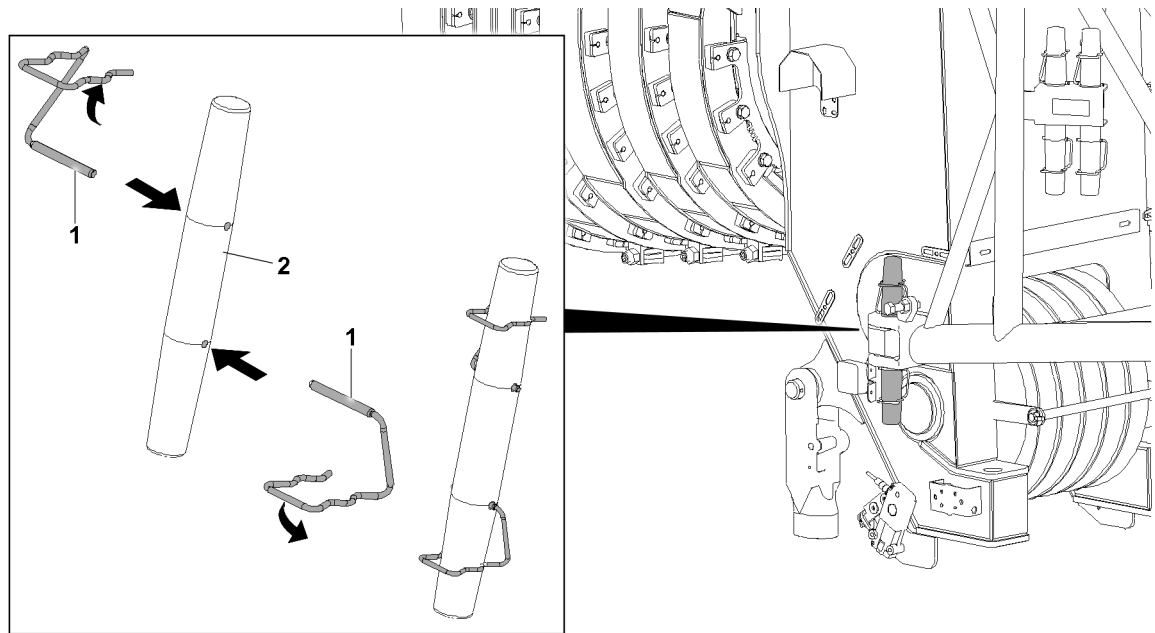

Fig.143107: Retaining clips 1

1 Retaining clip

2 Pin



WARNING

Incorrect retaining element!
Shearing off of the retaining element.

- ▶ To secure the folding jib pinning: Use retaining clips 1.
- ▶ The use of other retaining elements is **prohibited**.



WARNING

Retaining clip **not** engaged!
The retaining clip 1 can loosen up by itself.

- ▶ Engage the retaining clip 1.
- ▶ Secure the pin 2: Insert the retaining clip 1.
- ▶ Engage the retaining clip 1.

Problem remedy

Retaining clip 1 defective?
The spring force of the retaining clip 1 is too low.

- ▶ Replace the retaining clip 1.

14 Assembly / disassembly



WARNING

Danger of fatal injury due to incorrect assembly or disassembly!

The assembly / disassembly of lattice sections and / or components may never be performed by untrained personnel.

An erroneous assembly / disassembly of lattice sections and / or components can cause damage on load carrying crane structures.

Crane components can fail due to improper assembly / disassembly.

Death, severe bodily injuries, property damage.

- ▶ Make sure that the assembly / disassembly of lattice sections and / or components is carried out only by authorized and trained expert personnel.
- ▶ Make sure that the fastening equipment on lattice sections and / or components is always fastened properly.
- ▶ Make sure that lattice sections and / or components are always properly pinned and secured at assembly.
- ▶ For assembly / disassembly of individual components, also observe the chapters relating to those components.
- ▶ The boom combinations must be assembled according to the separately supplied rod plans.
- ▶ All components which must be transported separately must be transported with suitable auxiliary cranes and fastening equipment near ground level.



WARNING

Failure of auxiliary winch!

- ▶ Only use the auxiliary winch (assembly or reeving winch) for assembly and not to lift loads.
- ▶ Lifting of loads with the auxiliary winch is prohibited.



WARNING

Danger of impact / crushing!

When installing / removing crane components with the auxiliary crane, crane components can start to swing back and forth.

When lifting / lowering and positioning crane components, there is an increased danger of impacts / crushing.

Death, severe bodily injuries, property damage.

- ▶ Make sure that personnel cannot be caught by components.
- ▶ Make sure that the crane is horizontally aligned.
- ▶ When working in danger zones: Use aids to protect limbs.
- ▶ Guide components with suitable aids to minimize oscillation.
- ▶ During assembly / disassembly no one may be in the dangerous area around or underneath the suspended components before the load has been secured.

Part of the category „Aids for working at a height“ are, for example:

- Lifting platforms
- Scaffolding
- Auxiliary cranes
- Ladders

**WARNING**

Danger of falling!

During assembly / disassembly, inspection and maintenance work, assembly personnel must be secured with appropriate aids to prevent them from falling.

Death, severe bodily injuries, property damage.

- ▶ All work at a height, where there is a danger of falling must be carried out with suitable aids.
- ▶ If aids are not available and work cannot be carried out from the ground, then the assembly personnel must secure themselves with the supplied fall arrest system to prevent falling, see the Crane operating instructions, chapter 2.04.
- ▶ If fall protection equipment is available, then it must be used, see Crane operating instructions, chapter 2.06.
- ▶ When lifting, lowering, swinging crane parts in and out, no persons may remain in the danger zone.
- ▶ When closing or opening boom systems during boom assembly or boom disassembly, no persons may remain on the boom system or in the danger zone.
- ▶ If railings are present on the components, then they must be brought into the corresponding position and secured for assembly / disassembly work.
- ▶ Only step on the aids, ladders and catwalks with clean shoes.
- ▶ Keep aids, ladders and catwalks free of heavy dirt, snow, frost and ice.
- ▶ During all assembly and disassembly work, maintenance work and inspections, travel or crane operation is prohibited.
- ▶ Remaining on a suspended load is prohibited.
- ▶ Stepping and walking on crane components and lattice sections, which have an incline of more than 20° is prohibited.
- ▶ For all assembly work, the crane driver of the main crane must be in voice contact with the crane driver / crane drivers of the auxiliary crane / auxiliary cranes.
- ▶ For all assembly work, the crane driver of the main crane must be in voice contact with the assembly personnel.
- ▶ For assembly tasks, the crane driver may only initiate crane movements when the responsible guide has explicitly released the movement.

**DANGER**

The components can fall down!

If the corresponding component is disengaged from the auxiliary crane before the corresponding component is pinned, then the corresponding component can fall down.

Death, severe bodily injuries, property damage.

- ▶ Do not disengage the auxiliary crane and the fastening equipment until the respective component is pinned and secured.

**WARNING**

The components can fall down!

If the corresponding component is unpinned without being secured by an auxiliary crane, the corresponding component can fall down.

Death, severe bodily injuries, property damage.

- ▶ Do not unpin the components until they are secured by an auxiliary crane.

**WARNING**

Falling components and tools!

Whenever working at a height, for example on the crane or on an aerial platform, components or tools can fall down.

Death, severe bodily injuries, property damage.

- ▶ Make sure that the danger zone under the work area is blocked off and marked and that no personnel is located within it.

14.1 Assembly drawings



WARNING

Use of assembly drawings!

Due to sole use of assembly drawings, dangerous situations can arise up to toppling of the crane. Death, severe bodily injuries, property damage.

- ▶ Assembly drawings should only be considered to be **additional** and **supplementary** information.
- ▶ The respective chapters in the crane operating instructions are decisive for the assembly and disassembly of crane structures, lattice sections or crane components.
- ▶ The detailed information and danger notes in the respective chapters must be observed.

14.2 Guiding crane structures, lattice sections or crane components



WARNING

Danger due to oscillating load!

During the assembly of crane structures, lattice sections or crane components with the auxiliary crane, they can start to swing back and forth.

Death, severe bodily injuries, property damage.

- ▶ To guide and position crane structures, lattice sections or crane components always use a guide rope.
- ▶ Make sure that there are no persons or obstacles within the danger zone.
- ▶ Make sure that the guide rope is long enough.

14.3 Assembly / disassembly of electrical lines



WARNING

The crane can topple over!

If mechanical crane components, which have electrical connections are not immediately electrically connected after installation, then the limit switches and / or electrical sensors are not functioning.

Safety relevant shut offs are not recognized by the LICCON computer system.

Any errors or safety relevant messages which might occur are not shown on the LICCON computer system.

Death, severe bodily injuries, property damage.

- ▶ Make sure that the electrical connections are made immediately after installation of the respective crane components on the crane.
- ▶ Make sure that the procedure to make the electrical connections to the boom end sections in the respective assembly and set up chapters are observed.

NOTICE

Danger of damage to the electrical connections!

If the following measures are not adhered to, the electrical connections can be damaged.

- ▶ Do not plug in the plug connection or unplug them under tension.
- ▶ Do not pinch or crush electrical connections.

When pulling the cable out:

- ▶ Hold the plug and not the cable. Do not pull on the cable to release the plug connection.
- ▶ Relieve the electrical connections in operating condition.
- ▶ In case of defective or faulty electrical lines, contact Customer Service at Liebherr-Werk Ehingen GmbH.

**WARNING**

Malfunction if dummy plugs are not installed!

If the dummy plugs on the non-required electrical connections are not installed, then malfunctions or functional limitations can occur on the crane.

- ▶ Make sure that all non-required electrical connections, which have a dummy plug, are closed off with dummy plugs.
- ▶ Pay attention to the Electrical wiring diagram.

NOTICE

Property damage due to dirt and / or corrosion!

The plug connections are only protected when plugged in. If the plug connections are not plugged in, then the contact surfaces can corrode.

This could result in malfunctions.

- ▶ Always plug or screw the plug connections together properly.
- ▶ Keep plug connections clean and dry. Clean contact surfaces provide the best signal transfer.
- ▶ Close off the plug connections that are not used with dust caps.

- ▶ Establish the electrical connections to the installed crane components properly.

- ▶ As a rule, close off on-required electrical connections (for example for accessories which are not installed) with the respective dummy plugs.

- ▶ Properly close off electrical connections, which have no dummy plugs, with the corresponding protective dust or cover caps.

If a pull release for the cable drum is present:

- ▶ Hang the pull release in on the fixed point and relieve the plug connections from the pull strain.

After installing the plug connections:

- ▶ Check all plug connections for proper connection.

If a plug connection is not properly connected:

- ▶ Plug or screw the plug connection together properly.

After removing the plug connections:

- ▶ Protect the electrical connections with protective dust or cover caps or place them in intended storage retainers.
- ▶ After unplugging the electrical plug connections, install the dummy plugs, see Electrical wiring diagram.

If locking brackets are present:

- ▶ Close the locking bracket.

14.4 Assembling / disassembling of hydraulic lines

When connecting and releasing hydraulic lines with quick couplings, make sure that the coupling procedure is carried out correctly.

**WARNING**

Danger of accident due to loss of pressure or leakage!

Incorrectly coupled or self-loosening quick couplings (particularly return lines) can result in serious accidents due to component failure.

Death, severe bodily injuries, property damage.

- ▶ Check the quick couplings after assembly for correct connection.
- ▶ Make sure that the sleeve and plug after fastened after assembly with the knurled nut.

**WARNING**

Pressure in the hydraulic lines!

If the pressure supply is not interrupted before releasing the hydraulic lines, the hydraulic oil can escape with high pressure.

Death, severe bodily injuries, property damage.

- ▶ Release the pressure in the hydraulic system before releasing. Interrupt the pressure supply and wait for a short time.
-
- ▶ Release the pressure in the hydraulic system before connecting or disconnecting: Turn the engine off and wait for short time.
 - ▶ Connect the coupling components (sleeve and connector) and screw together with the knurled nut.
 - ▶ Tighten the hydraulic coupling by hand. Rotate the knurled nut until it reaches a tangible, fixed stop position.

14.5 Bypass at assembly / disassembly Crawler

**Note**

- ▶ Applies only for cranes with crawler assembly key button.

**WARNING**

High danger of accident in case of actuated crawler assembly key button!

If the crawler assembly key button is actuated, the overload protection is bypassed. No shut off at overload will occur in assembly operation nor in crane operation.

In the event of misuse, the crane can topple over.

Death, severe bodily injuries, property damage.

- ▶ The crawler assembly key button may only be actuated for assembly tasks.
- ▶ All other usage of the crawler assembly key button other than as described in the operating instructions is prohibited.
- ▶ Operating the crane with the crawler assembly key button enabled is strictly prohibited.

14.5.1 Activating the bypass at crawler assembly and crawler disassembly

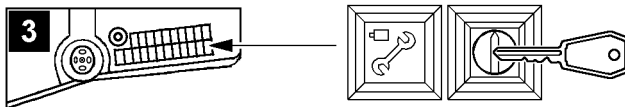

Fig.113441: Activating the bypass

- Illustration 3: Crawler assembly key button and indicator light *Crawler assembly* with touch function *Crawler assembly off*

- ▶ Actuate the crawler assembly key button.

Result:

- The LICCON overload protection is inactive.
- The indicator light *Crawler assembly* lights up.

14.5.2 Deactivating the bypass at crawler assembly and crawler disassembly

Make sure that the following prerequisites are met:

- The LICCON overload protection is bypassed / inactive and the „Bypass at assembly and disassembly“ is activated.
- The indicator light *Crawler assembly* lights up.

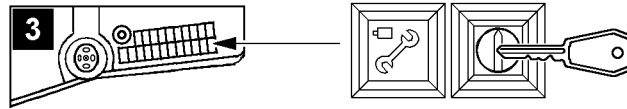

Fig.113441: Deactivating the bypass

If the bypass at crawler assembly is to be turned off:

- ▶ Turn the crawler assembly off by pressing the off button *Crawler assembly off*.

Result:

- The indicator light in the button *Crawler assembly* turns off.

14.6 Bypass at assembly / disassembly

Depending on the crane version, the „Bypass at assembly and disassembly“ is activated by:

- The set up button (key button) on the LICCON monitor.
- The assembly key button in the instrument panel.



Note

- ▶ Applies only for cranes with LICCON overload protection.
- ▶ Indicator light *Assembly* is only present in the instrument panel for certain crane types.



WARNING

High danger of accident at crane operation with activated „Bypass at assembly and disassembly“! At activated „Bypass at assembly and disassembly“ the overload protection and possibly bypassed hoist limit switches.

In the event of improper use, the crane could collapse, the boom can break off or the crane can topple over.

Personnel can be killed.

This could result in high property damage.

- ▶ The activation of the „Bypass at assembly and disassembly“ is only permissible for assembly and disassembly purposes.
- ▶ All other usage of the „Bypass at assembly and disassembly“ other than as described in the operating instructions is prohibited.
- ▶ The „Bypass at assembly and disassembly“ may only be activated by persons who are aware of the consequences of a bypass.
- ▶ Crane operation with activated „Bypass at assembly and disassembly“ is strictly prohibited.
- ▶ The „Bypass at assembly and disassembly“ must be deactivated immediately after assembly and disassembly work.
- ▶ The crane operator or a person authorized by him must make sure that no misuse of the bypass device is possible (remove the key and store it safely, if necessary).

14.6.1 Activating the bypass at assembly and disassembly



Fig.113438: Activating the bypass at assembly and disassembly

- Illustration 1: LICCON monitor (only certain crane types).
- Illustration 2: Indicator light „Assembly“ in instrument panel crane cab (only certain crane types).
- ▶ Actuate the respective operating element.

Result:

- The LICCON overload protection is bypassed / inactive and the „Bypass at assembly and disassembly“ is activated.
- The „Assembly“ icon appears in the LICCON monitor and / or the indicator light „Assembly“ in the instrument panel lights up.
- Depending on the circumstances, acoustic and / or optical warning signals (blinkers, flashing lights, bells and horns) sound.

14.6.2 Bypass at assembly and disassembly

Fig.113437: Bypass at assembly and disassembly

- ▶ No longer actuate the respective operating element or reset.

Result:

- The LICCON overload protection is active and the „Bypass at assembly and disassembly“ is deactivated.
- The „Assembly“ icon turns off in the LICCON monitor and / or the indicator light „Assembly“ in the instrument panel no longer lights up.
- The acoustic and / or optical warning signals which were triggered by the bypass are turned off again.

14.7 Actuation of winch and / or crane movements during assembly / disassembly**Note**

- ▶ The winches and / or crane movements can be controlled from the crane cab or, depending on the crane set up configuration, with the Bluetooth™ Terminal (BTT) or the radio remote control*.
- ▶ Observe the Crane operating instructions, chapter 4.05, chapter 5.31 and chapter 6.08.

**WARNING**

Uncoordinated procedure for assembly tasks!
Death, severe bodily injuries, property damage.

- ▶ Before starting the assembly tasks, define the course of action and agree on all steps with all involved personnel.
- ▶ Monitor all steps and continuously check the course of action.
- ▶ In the case of unforeseen events, stop the course of action and agree on the new situation with all involved personnel.
- ▶ Make sure that winches and / or crane movements are only controlled by people who are aware of the effects on the crane and / or boom system as well as the connected dangers.
- ▶ Make sure that no persons, objects or obstacles are within the danger zone of the crane.
- ▶ Prewarn persons within the surrounding area of the crane, for example via a horn signal.
- ▶ Perform all winch and / or crane movements anticipatorily and at a low speed.

14.8 Assembly / disassembly of booms



WARNING

The crane can topple over!

Angular pull can overload the crane.

Overload can cause destruction of the crane or cause it to topple over.

Death, severe bodily injuries, property damage.

- ▶ The hook block must always be attached (hooked) vertically over the center of gravity of the load to be lifted.
- ▶ Angular pull is prohibited.

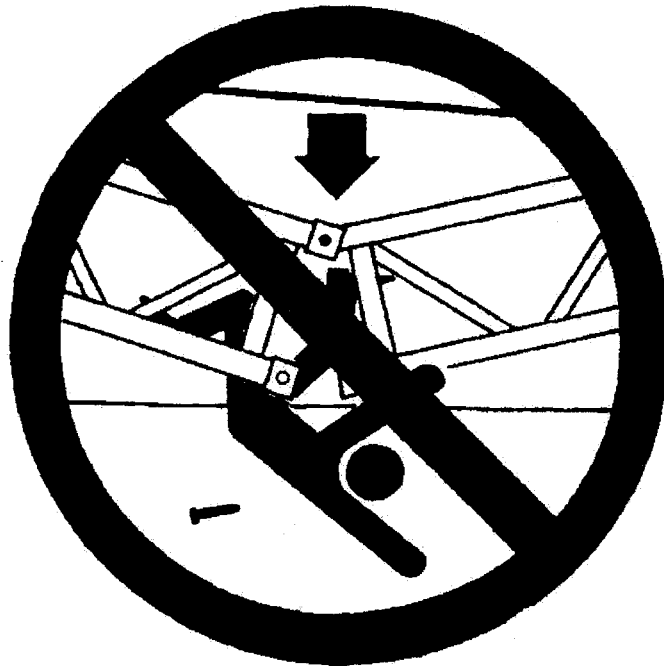

Fig.113444: Danger of accident during assembly / disassembly



WARNING

Danger of accident at assembly / disassembly of booms!

When you disassemble unsecured or unsupported booms, they can fall down.

Death, severe bodily injuries, property damage.

- ▶ Never unpin the pins under unsecured or unsupported booms.
- ▶ Never unpin the connecting pins on unsecured or unsupported booms.
- ▶ Do not stand under the booms or within the complete danger zone during the pinning and unpinning procedure of the booms.
- ▶ Secure the pins in the storage locations and in the receptacles.
- ▶ The railing at assembly and disassembly of booms must be horizontal.
- ▶ Do not lean the ladder against the component being disassembled.

Make sure that the following prerequisites are met for the closing assembly:

- If parts of the equipment (for example lattice sections) are not in contact with the ground during assembly / disassembly, then they must be supported with suitable, stable materials.
- Take down the parts of the equipment with rope pulleys in such a way that the rope pulleys are not damaged.
- During disassembly make sure that the auxiliary crane can lift the load vertically.
- Have an auxiliary crane with sufficient load carrying capacity available to be able to hold the load at a respective radius.

14.9 Fastening positions for assembly / disassembly of the lattice jib



WARNING

Danger of fatal accidents due falling components!

The maximum permissible tensile load on the fastening eye is engraved on the fastening eye.

The maximum permissible fastening load of the respective components can differ to the maximum permissible tensile load of the fastening eye.

Components can be damaged at overload and fall down during lifting.

- ▶ Observe the maximum permissible fastening load according to the operating instructions and the tags on the components.
- ▶ Fasten the lattice jib only according to the following descriptions.
- ▶ Do not overload the components.

14.9.1 Closing the end section

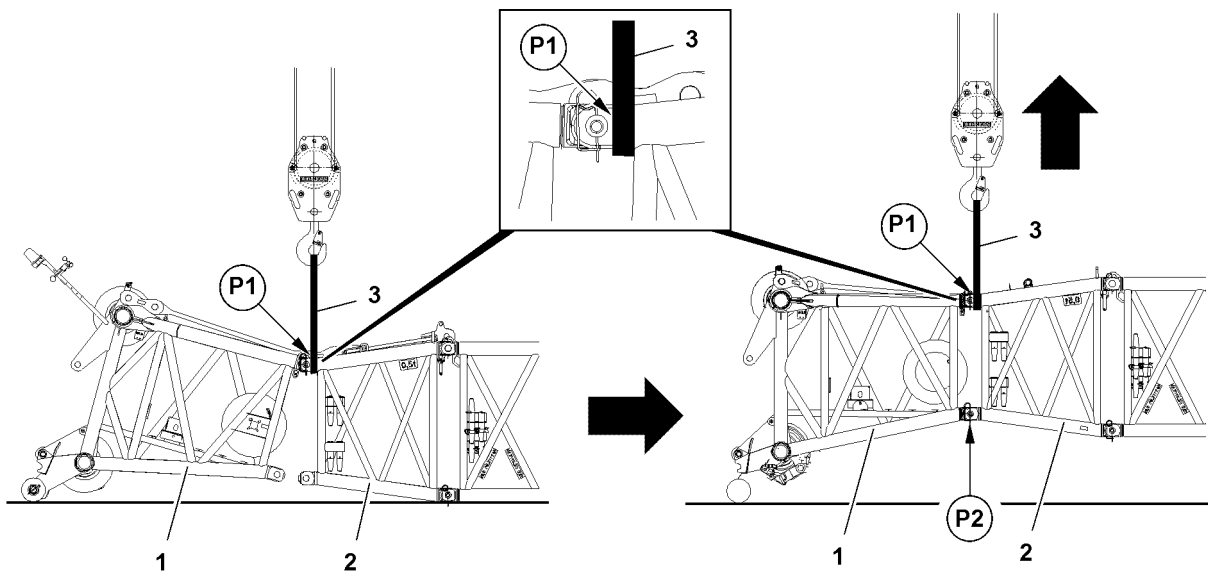

Fig.117840: Closing the end section

For closing the end section, observe the following:

- Use textile type fastening equipment **3**.
- Loop the textile type fastening equipment **3** on the left and right around on the pin points.

Before fastening:

- ▶ Check the position of the spring retainers and correct, if necessary.
- ▶ Fasten the textile type fastening equipment **3** on the upper pin points **P1** between the end section **1** and the pinned components **2**.
- ▶ Lift the lattice jib until the lower pin points **P2** align between the end section **1** and components **2**.
- ▶ Pin the end section **1** and components **2** on the lower pin points **P2** on the left and right.

After pinning:

- ▶ Remove the textile type fastening equipment **3**.

14.9.2 Placing the lattice jib into the roller cart



Note

- ▶ The following illustrations are examples and may not match your crane exactly.

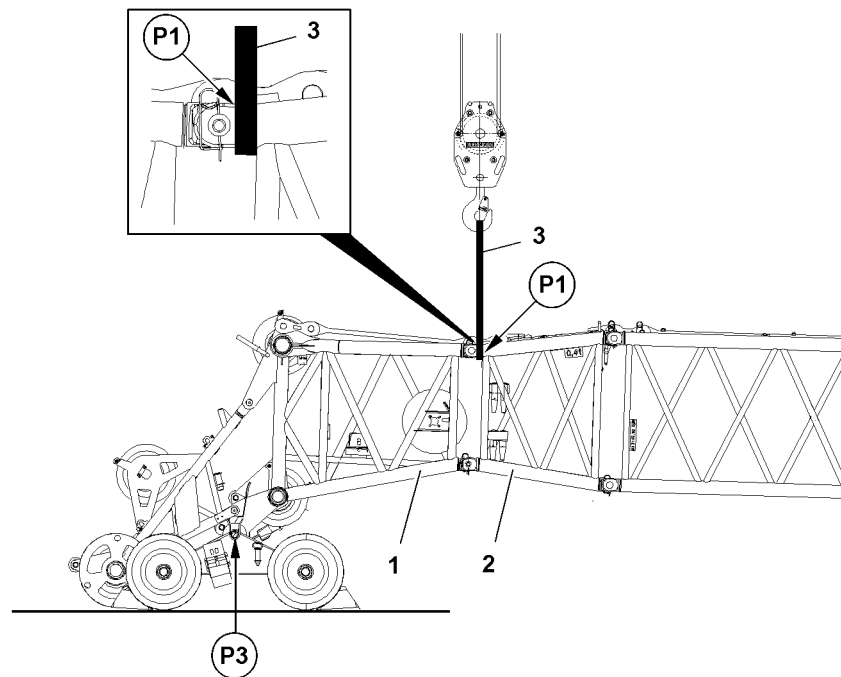

Fig.117842: Placing the lattice jib into the roller cart (telescopic crane with lattice jib)

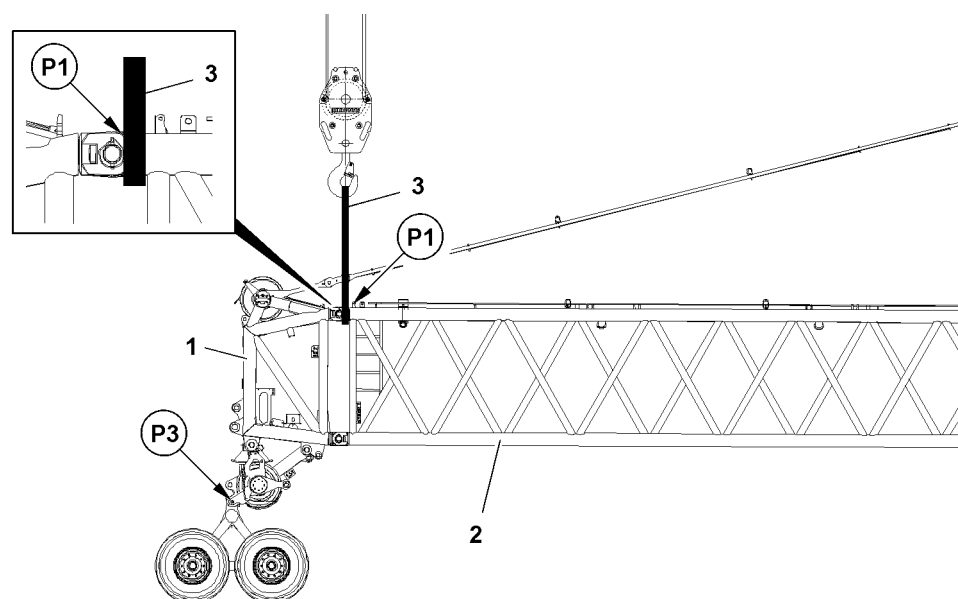

Fig.121550: Placing the lattice jib into the roller cart (crane with lattice mast)

When placing it into the roller cart, observe the following:

- The end section 1 is completely installed.
- Use textile type fastening equipment 3.
- Loop the textile type fastening equipment 3 on the left and right around on the pin points.

Before fastening:

- ▶ Check the position of the spring retainers and correct, if necessary.
- ▶ Fasten the textile type fastening equipment 3 on the upper pin points P1 between the end section 1 and the pinned components 2.
- ▶ Lift the lattice jib and place it in the roller cart 4.
- ▶ Pin the end section 1 with the roller cart 4 on the pin points P3 on the left and right.
- ▶ Remove the textile type fastening equipment 3.

**Note**

- ▶ The disassembly and removal of the pulley cart 4 is handled accordingly.

14.9.3 Opening the end section

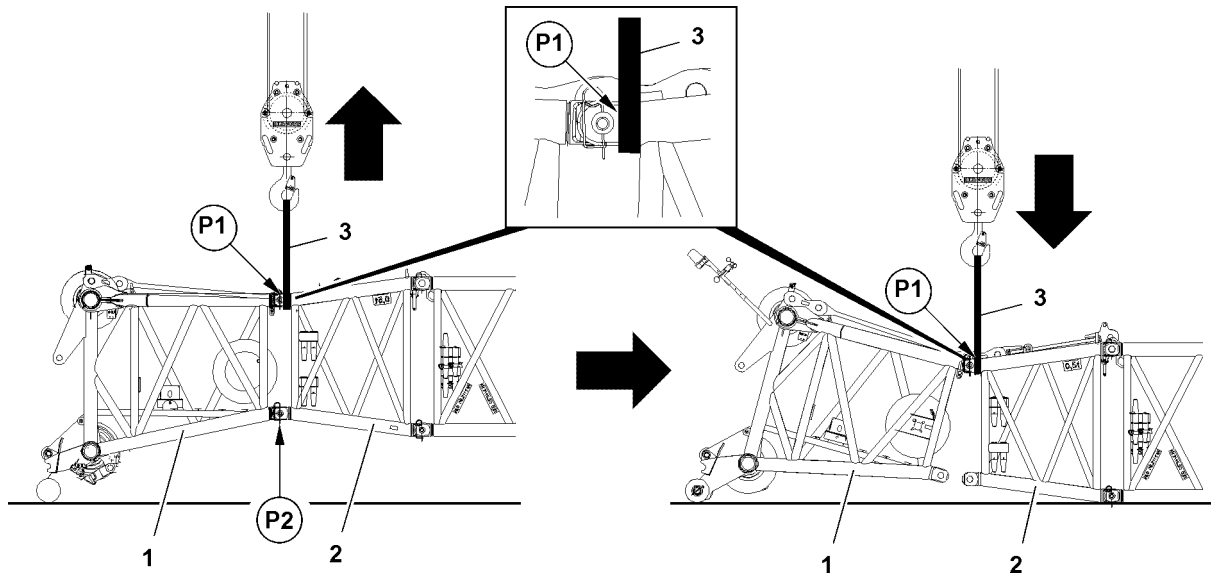

Fig.117841: Opening the end section

For opening the end section, observe the following:

- The roller cart is disassembled and removed.
- Use textile type fastening equipment 3.
- Loop the textile type fastening equipment 3 on the left and right around on the pin points.

Before fastening:

- ▶ Check the position of the spring retainers and correct, if necessary.
- ▶ Fasten the textile type fastening equipment 3 on the upper pin points P1 between the end section 1 and the pinned components 2.
- ▶ Lift the lattice jib and relieve the pins on the lower pin points P2.
- ▶ Unpin the end section 1 and components 2 on the lower pin points P2 on the left and right.
- ▶ Take down the lattice jib on the ground.
- ▶ Remove the textile type fastening equipment 3.

14.9.4 Holding the luffing lattice jib

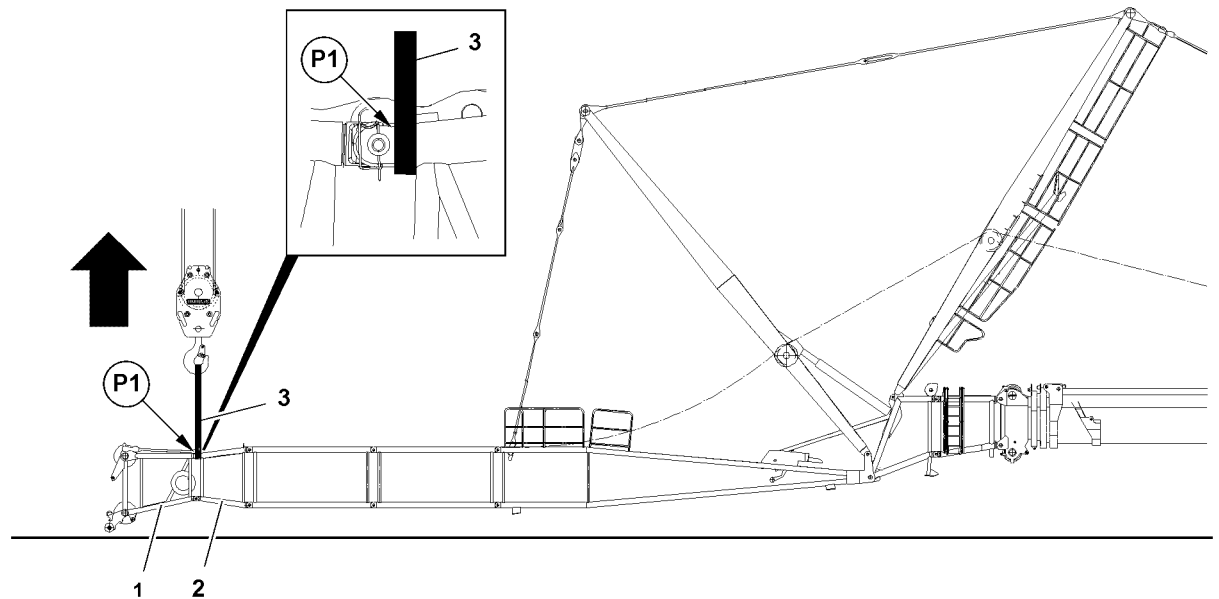

Fig.117843: Holding the luffing lattice jib

To be able to install or remove the guy rods and "flying assembly", the luffing lattice jib must be held on the upper pin points **P1**.

When holding the luffing lattice jib, observe the following:

- The lattice jib has been completely assembled.
- Use textile type fastening equipment **3**.
- Loop the textile type fastening equipment **3** on the left and right around on the pin points.

Before fastening:

- ▶ Check the position of the spring retainers and correct, if necessary.
- ▶ Fasten the textile type fastening equipment **3** on the upper pin points **P1** between the end section **1** and the pinned components **2**.
- ▶ Lift the lattice jib and install the guy rods.

When the guy rods are installed:

- ▶ Remove the textile type fastening equipment **3**.



Note

- ▶ The removal of the guy rods is handled accordingly.

14.9.5 Assembling the fixed lattice jib on the TF-adapter



WARNING

Mortal danger if the lattice jib tilts over!

Due to unfavorable center of gravity, only certain lattice jib lengths can be installed / removed as an assembled lattice jib.

If a lattice jib length cannot be installed / removed as an assembled lattice jib, then they must be installed / removed individually in flying mode.

- ▶ Check if the respective lattice jib length can be installed / removed as an assembled lattice jib. See charts in the Crane operating instructions, chapter 5.01.10.

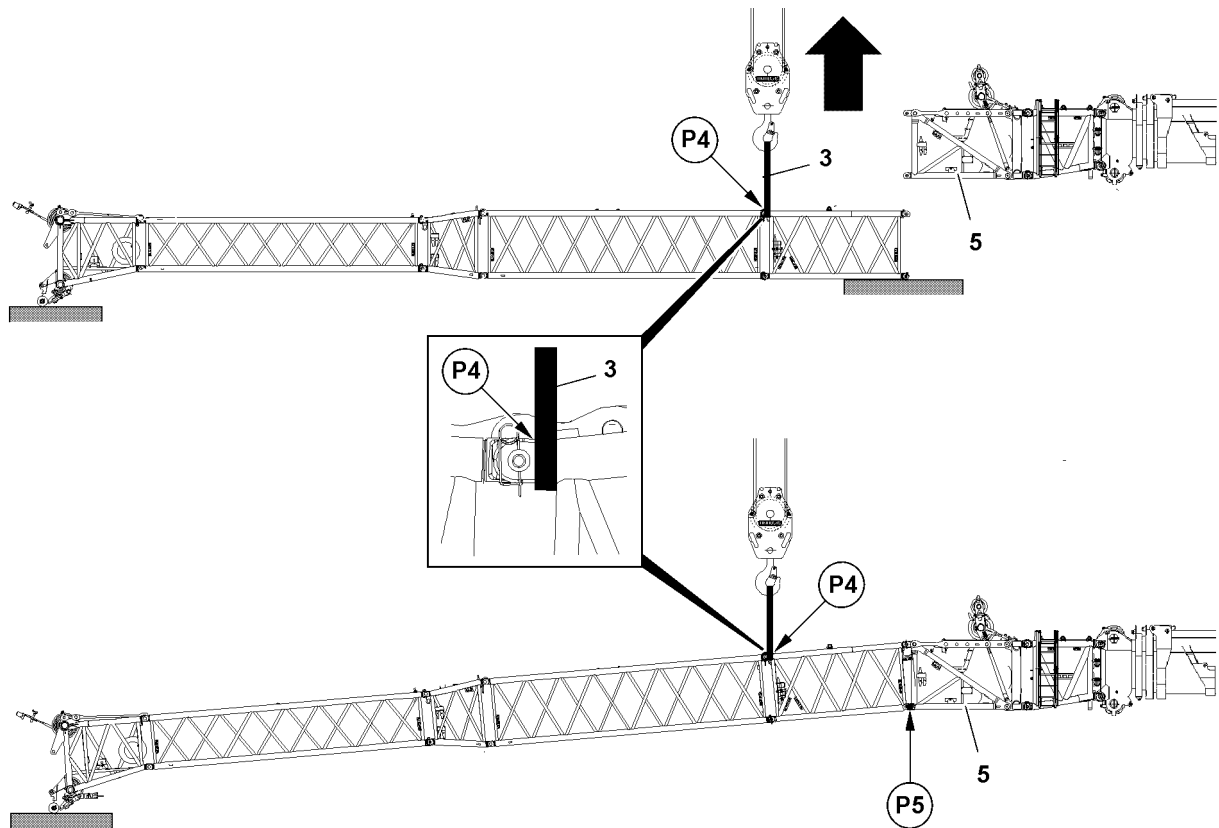

Fig.117844: Assembling the lattice jib on the TF-adapter

For installation on the TF-adapter, observe the following:

- The lattice jib has been assembled.
- The TF-adapter **5** is installed.
- Use textile type fastening equipment **3**.
- Loop the textile type fastening equipment **3** on the left and right around on the pin points.

Before fastening:

- ▶ Check the position of the spring retainers and correct, if necessary.

Fasten between the lattice sections, which are installed directly on the TF-adapter.

- ▶ Fasten the textile type fastening equipment **3** on the upper pin points **P4**.
- ▶ Lift the lattice jib and affix on the lower pin point **P5** on the TF-adapter **5**.
- ▶ Pin the lattice jib on the lower pin point **P5** with the TF-adapter **5**.

After pinning:

- ▶ Remove the textile type fastening equipment **3**.



WARNING

Mortal danger if the lattice jib tilts over!

- ▶ Make sure to always observe the permissible lattice jib length at disassembly.
- ▶ Disassemble accordingly.

14.9.6 Closing the fixed lattice jib

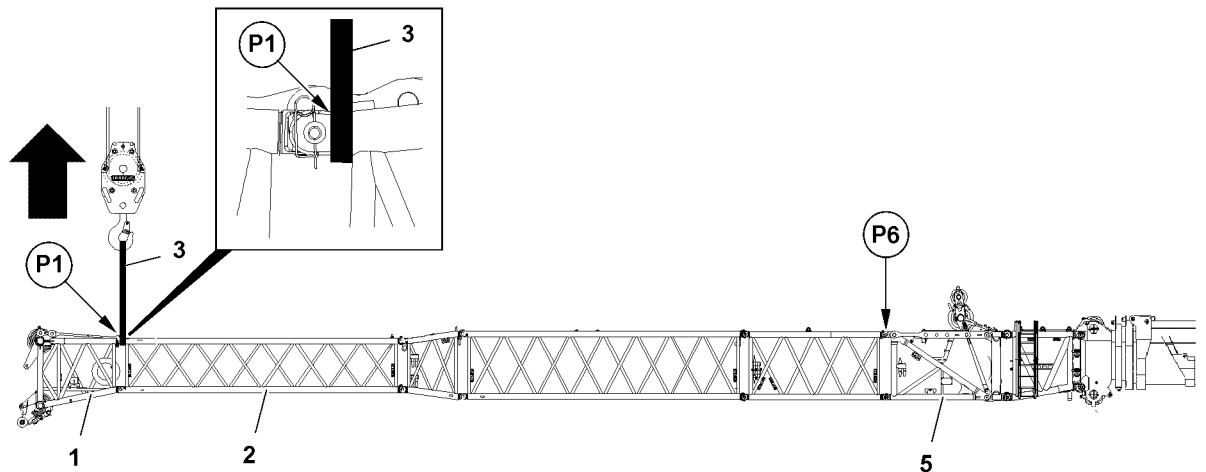

Fig.117850: Closing the lattice jib

For installation on the TF-adapter, observe the following:

- The lattice jib is pinned on the lower pin points of the TF-adapter **5**.
- Use textile type fastening equipment **3**.
- Loop the textile type fastening equipment **3** on the left and right around on the pin points.

Before fastening:

- ▶ Check the position of the spring retainers and correct, if necessary.
- ▶ Fasten the textile type fastening equipment **3** on the upper pin points **P1** between the end section **1** and the pinned components **2**.
- ▶ Lift the lattice jib and affix on the upper pin point **P6** on the TF-adapter **5**.
- ▶ Pin the lattice jib on the upper pin point **P6** with the TF-adapter **5**.

After pinning:

- ▶ Remove the textile type fastening equipment **3**.



Note

- ▶ Disassemble accordingly.

14.9.7 Angle adjustment on the fixed lattice jib with mechanical adjustment

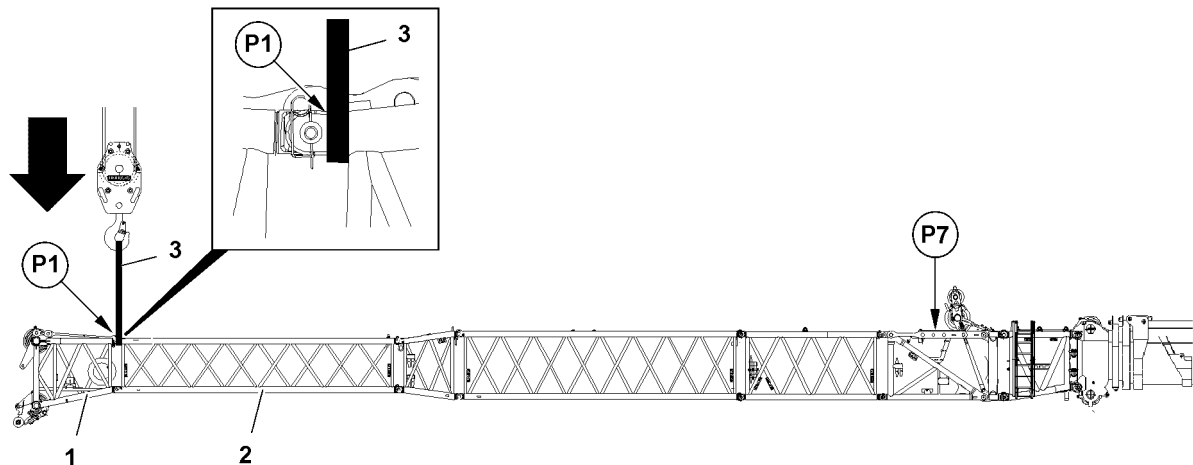

Fig.117851: Angle adjustment on the fixed lattice jib

For the angle adjustment on the fixed lattice jib, observe the following:

- The lattice jib has been completely assembled.
- Use textile type fastening equipment 3.
- Loop the textile type fastening equipment 3 on the left and right around on the pin points.

Before fastening:

- ▶ Check the position of the spring retainers and correct, if necessary.
- ▶ Fasten the textile type fastening equipment 3 on the upper pin points P1 between the end section 1 and the pinned components 2.
- ▶ Lift the lattice jib and relieve the pins on the angle adjustment P7.
- ▶ Unpin the angle adjustment P7, see Crane operating instructions, chapter 5.03.
- ▶ Set and pin a New angle on the angle adjustment P7, see Crane operating instructions, chapter 5.03.
- ▶ Lower the lattice jib.

After lowering:

- ▶ Remove the textile type fastening equipment 3.

14.9.8 Loading the preassembled lattice jib

For loading the lattice jib, observe the following:

- The lattice jib has been preassembled.
- Use textile type fastening equipment.
- Loop the textile type fastening equipment on the left and right around on the pin points.

Before fastening:

- ▶ Check the position of the spring retainers and correct, if necessary.
- ▶ Fasten the preassembled lattice jib according to the fastening points in the Crane operating instructions, chapter 5.03.

Empty page!

LWE/LR 11000-001/23501-04-02/en

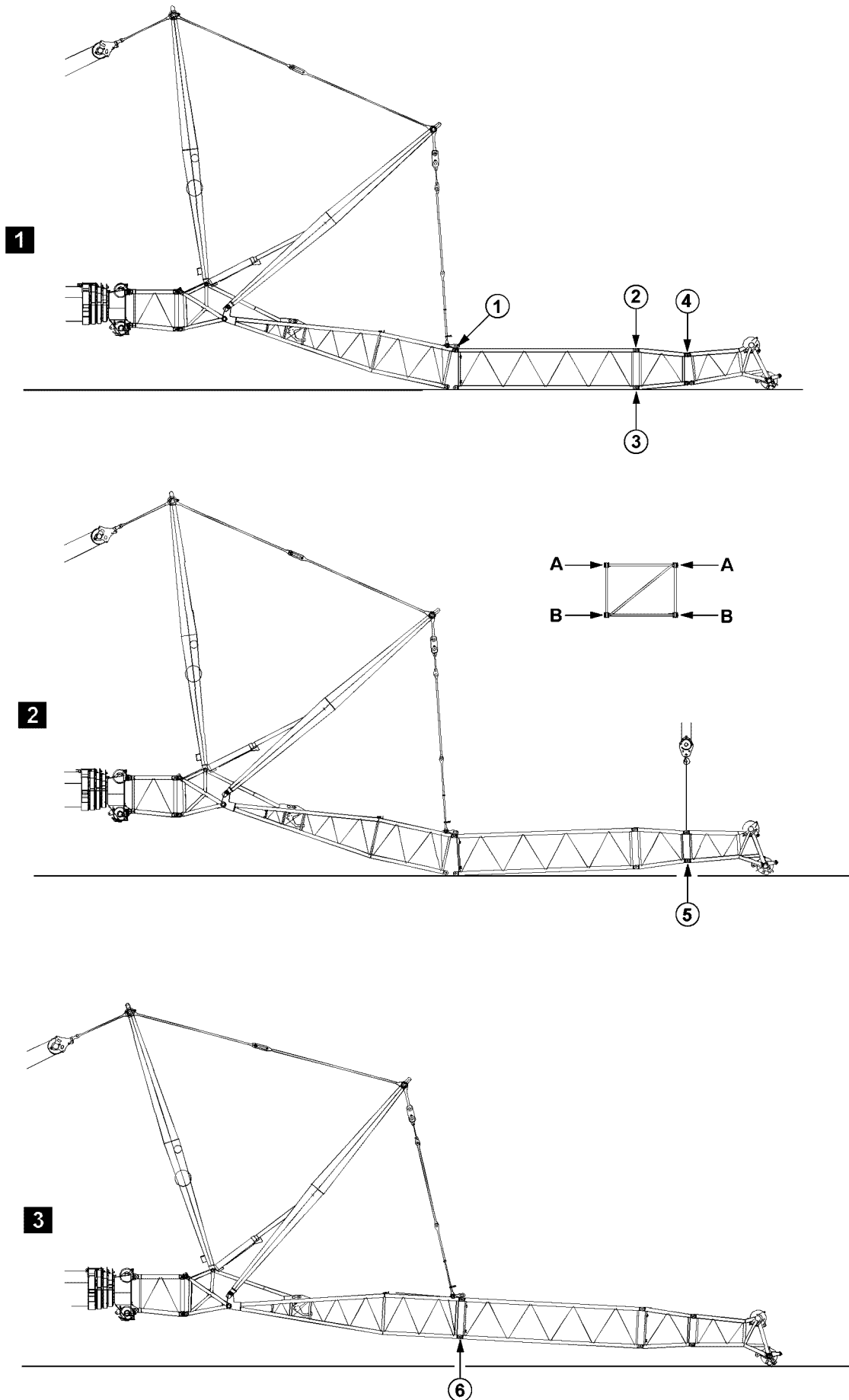

Fig.197718: Example for cranes with telescopic boom

LWE/LR 11000-001/23501-04-02/en

14.10 Assembling / disassembling the lattice sections on telescopic cranes with a luffing lattice jib

14.10.1 Assembling the lattice sections on a luffing lattice jib

The illustrations serve as examples. The illustrations may differ depending on the crane.



WARNING

Danger of fatal injury when assembling auxiliary booms!

If the pins are not pinned in the given sequence, then lattice sections may suddenly fold down or fall down.

Death, severe bodily injuries, property damage.

▶ Pins must be pinned in the order specified.

- ▶ Pin and secure pins at both sides (level **A**) at point **1**, illustration 1.
- ▶ Pin and secure pins at both sides (level **A**) at point **2**, illustration 1.
- ▶ Pin and secure pins at both sides (level **B**) at point **3**, illustration 1.
- ▶ Pin and secure pins at both sides (level **A**) at point **4**, illustration 1.
- ▶ Close the end section with the auxiliary crane, illustration 2.
- ▶ Pin and secure pins at both sides (level **B**) at point **5**, illustration 2.
- ▶ Lift the lattice sections, illustration 3.
- ▶ Pin and secure pins at both sides (level **B**) at point **6**, illustration 3.

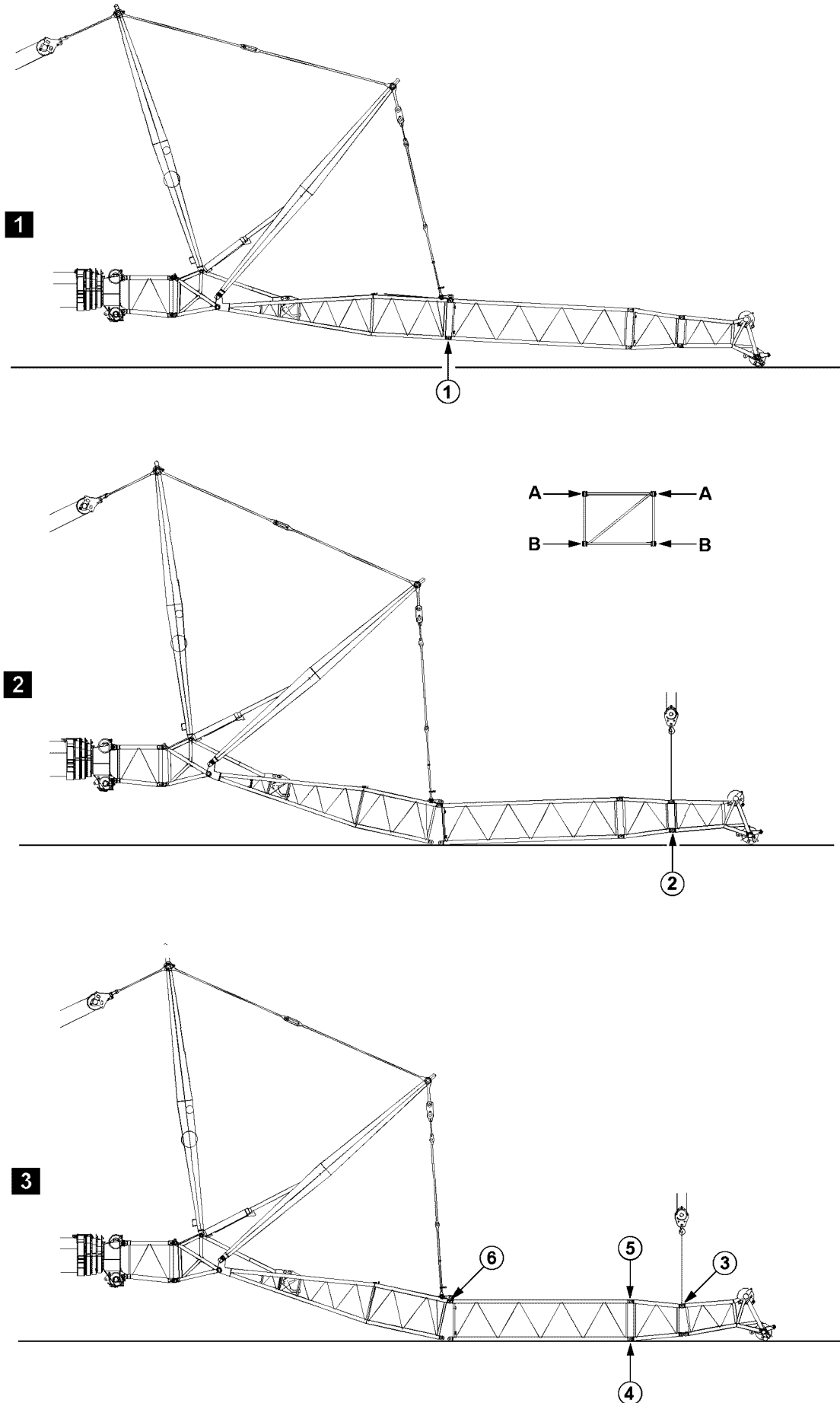

Fig.197719: Example for cranes with telescopic boom

LWE/LR 11000-001/23501-04-02/en

14.10.2 Disassembling the lattice sections on a luffing lattice jib

The illustrations serve as examples. The illustrations may differ depending on the crane.



WARNING

Danger of fatal injury when disassembling auxiliary booms!

If the pins are not unpinned in the given sequence, then lattice sections may suddenly fold down or fall down.

Death, severe bodily injuries, property damage.

▶ Pins must be unpinned in the order specified.

- ▶ Luff the boom down until the end section touches the ground slightly, illustration 1.
- ▶ Guy the boom with NA-frame I, illustration 1.
- ▶ Release and unpin the pins on both sides (level **B**) at point 1, illustration 1.
- ▶ Open the boom with the NA-frame I and completely take down the boom, illustration 2.
- ▶ Lift the end section with the auxiliary crane, illustration 2.
- ▶ Release and unpin the pins on both sides (level **B**) at point 2, illustration 2.
- ▶ Release and unpin the pins on both sides (level **A**) at point 3, illustration 3.
- ▶ Release and unpin the pins on both sides (level **B**) at point 4, illustration 3.
- ▶ Release and unpin the pins on both sides (level **A**) at point 5, illustration 3.
- ▶ Release and unpin the pins on both sides (level **A**) at point 6, illustration 3.

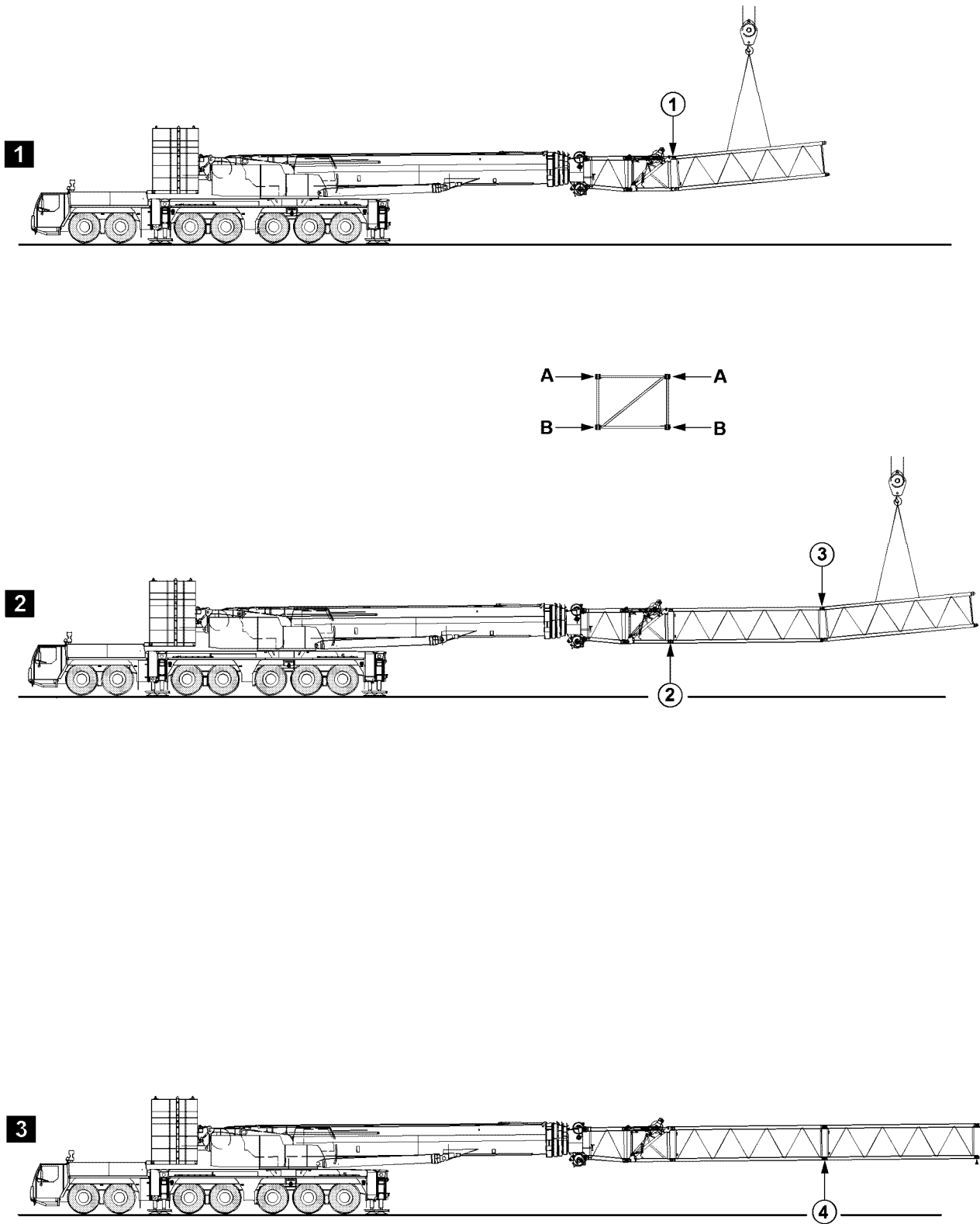

Fig.197705: Example for cranes with telescopic boom

14.11 Assembling / disassembling the lattice sections on telescopic cranes with an auxiliary boom, with an auxiliary crane

14.11.1 Assembling the lattice sections on an auxiliary boom with an auxiliary crane

The illustrations serve as examples. The illustrations may differ depending on the crane.



WARNING

Danger of fatal injury when assembling auxiliary booms!

If the pins are not pinned in the given sequence, then lattice sections may suddenly fold down or fall down.

Death, severe bodily injuries, property damage.

▶ Pins must be pinned in the order specified.

- ▶ Pin and secure pins at both sides (level **A**) at point **1**, illustration 1.
- ▶ Pin and secure pins at both sides (level **B**) at point **2**, illustration 2.
- ▶ Pin and secure pins at both sides (level **A**) at point **3**, illustration 2.
- ▶ Pin and secure pins at both sides (level **B**) at point **4**, illustration 3.

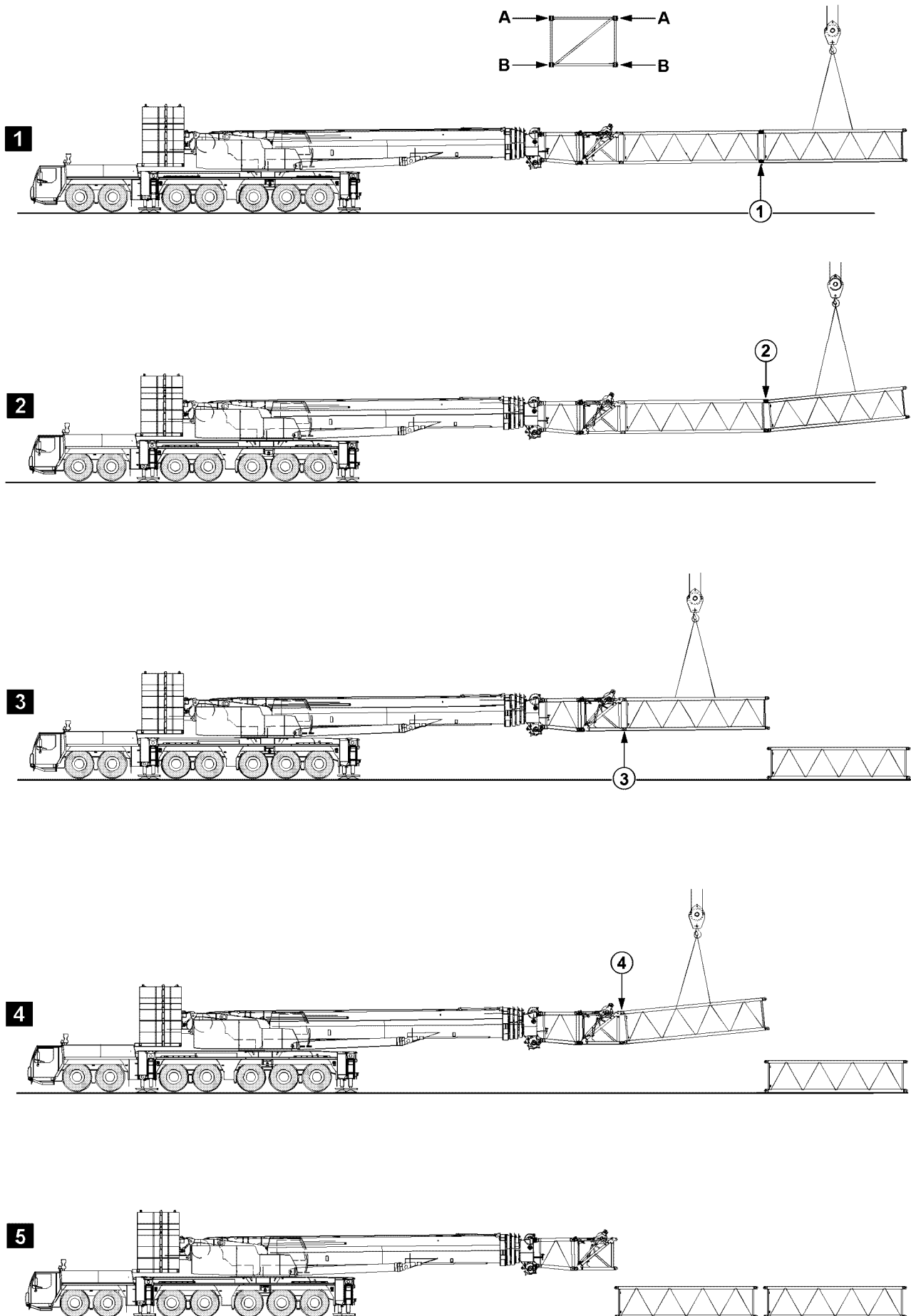

Fig.105510: Example for cranes with telescopic boom

14.11.2 Disassembling the lattice sections on an auxiliary boom with an auxiliary crane

The illustrations serve as examples. The illustrations may differ depending on the crane.



WARNING

Danger of fatal injury when disassembling auxiliary booms!

If the pins are not unpinned in the given sequence, then lattice sections may suddenly fold down or fall down.

Death, severe bodily injuries, property damage.

▶ Pins must be unpinned in the order specified.

- ▶ Release and unpin the pins on both sides (level **B**) at point **1**, illustration **1**.
- ▶ Release and unpin the pins on both sides (level **A**) at point **2**, illustration **2**.
- ▶ Release and unpin the pins on both sides (level **B**) at point **3**, illustration **3**.
- ▶ Release and unpin the pins on both sides (level **A**) at point **4**, illustration **4**.

1**2****3**

Fig.197712: Example for cranes with telescopic boom

14.12 Assembling / disassembling the lattice sections on telescopic cranes with an auxiliary boom, without an auxiliary crane

14.12.1 Assembling the lattice sections on an auxiliary boom without an auxiliary crane

The illustrations serve as examples. The illustrations may differ depending on the crane.

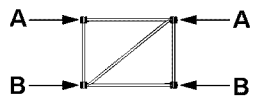
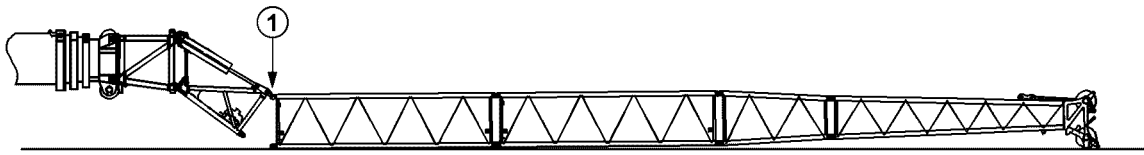
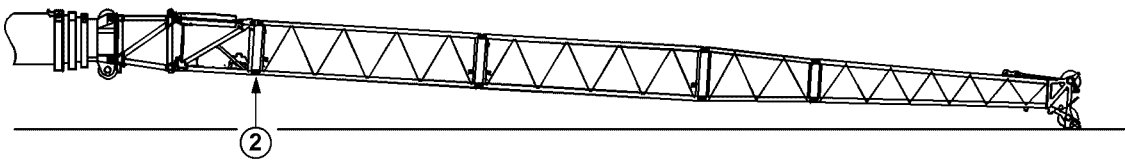
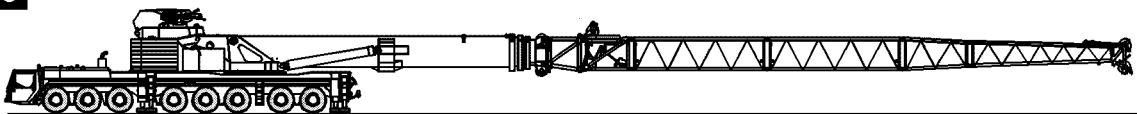

WARNING

Danger of fatal injury when assembling auxiliary booms!

If the pins are not pinned in the given sequence, then lattice sections may suddenly fold down or fall down.

Death, severe bodily injuries, property damage.

▶ Pins must be pinned in the order specified.

For cranes with hydraulic angle adjustment and self-supporting auxiliary boom, the assembly / disassembly of additional lattice sections may be performed using the crane itself.

In order to do so, proceed as follows.

- ▶ Assemble the lattice sections to the required length.
- ▶ Pin and secure pins at both sides (level **A**) at point **1**, illustration **1**.
- ▶ Close the auxiliary boom until the pins can be pinned at point **2**, illustration **2**.
- ▶ Pin and secure pins at both sides (level **B**) at point **2**, illustration **2**.

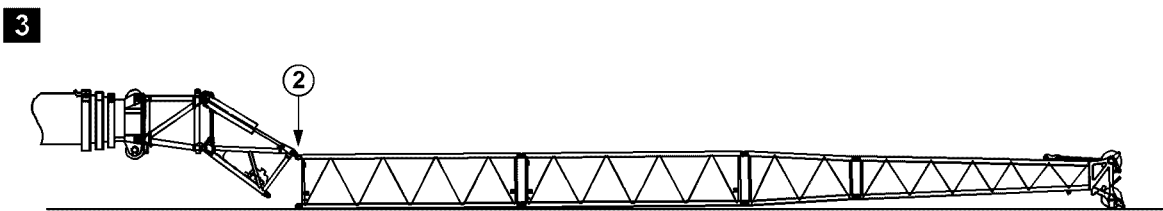
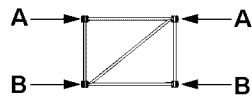
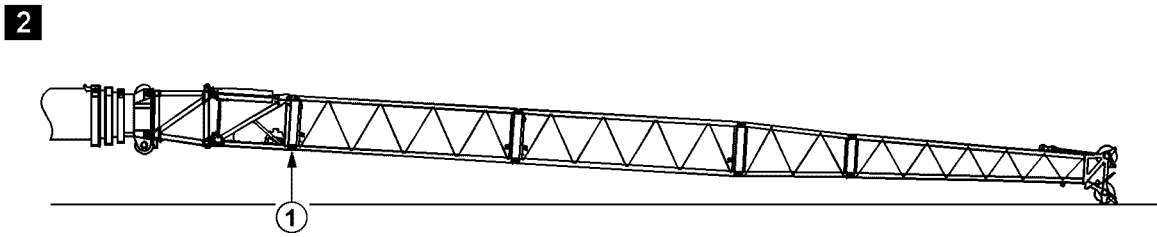
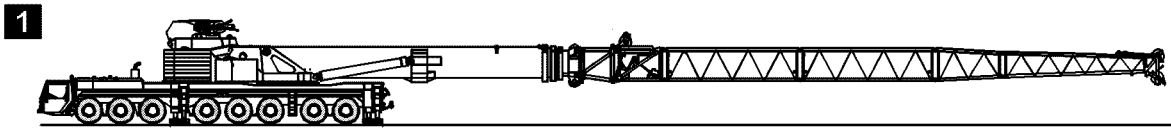

Fig.197713: Example for cranes with telescopic boom

14.12.2 Disassembling the lattice sections on an auxiliary boom without an auxiliary crane

The illustrations serve as examples. The illustrations may differ depending on the crane.



WARNING

Danger of fatal injury when disassembling auxiliary booms!

If the pins are not unpinned in the given sequence, then lattice sections may suddenly fold down or fall down.

Death, severe bodily injuries, property damage.

- ▶ Pins must be unpinned in the order specified.

For cranes with hydraulic angle adjustment and self-supporting auxiliary boom, the assembly / disassembly of additional lattice sections may be performed using the crane itself.

In order to do so, proceed as follows.

NOTICE

Damage of hydraulic cylinders on the TF-adapter!

- ▶ As soon as the lattice jib is placed, stop the luff down movement.
- ▶ It is prohibited to set down the fixed lattice jib „hard“.

- ▶ Luff the main boom down until the end section touches the ground slightly, illustration 2.

If it is not possible to luff down that far:

- ▶ Adjust the TF-adapter until the end section touches the ground slightly, illustration 2.
- ▶ Release and unpin the pins on both sides (level **B**) at point 1, illustration 2.

NOTICE

Damage of hydraulic cylinders on the TF-adapter.

- ▶ As soon as the lattice jib is placed, stop the opening movement.

- ▶ Open the auxiliary boom until the lattice sections to be removed are laying completely on the ground, illustration 3.
- ▶ Release and unpin the pins on both sides (level **A**) at point 2, illustration 3.
- ▶ Completely remove the auxiliary boom.

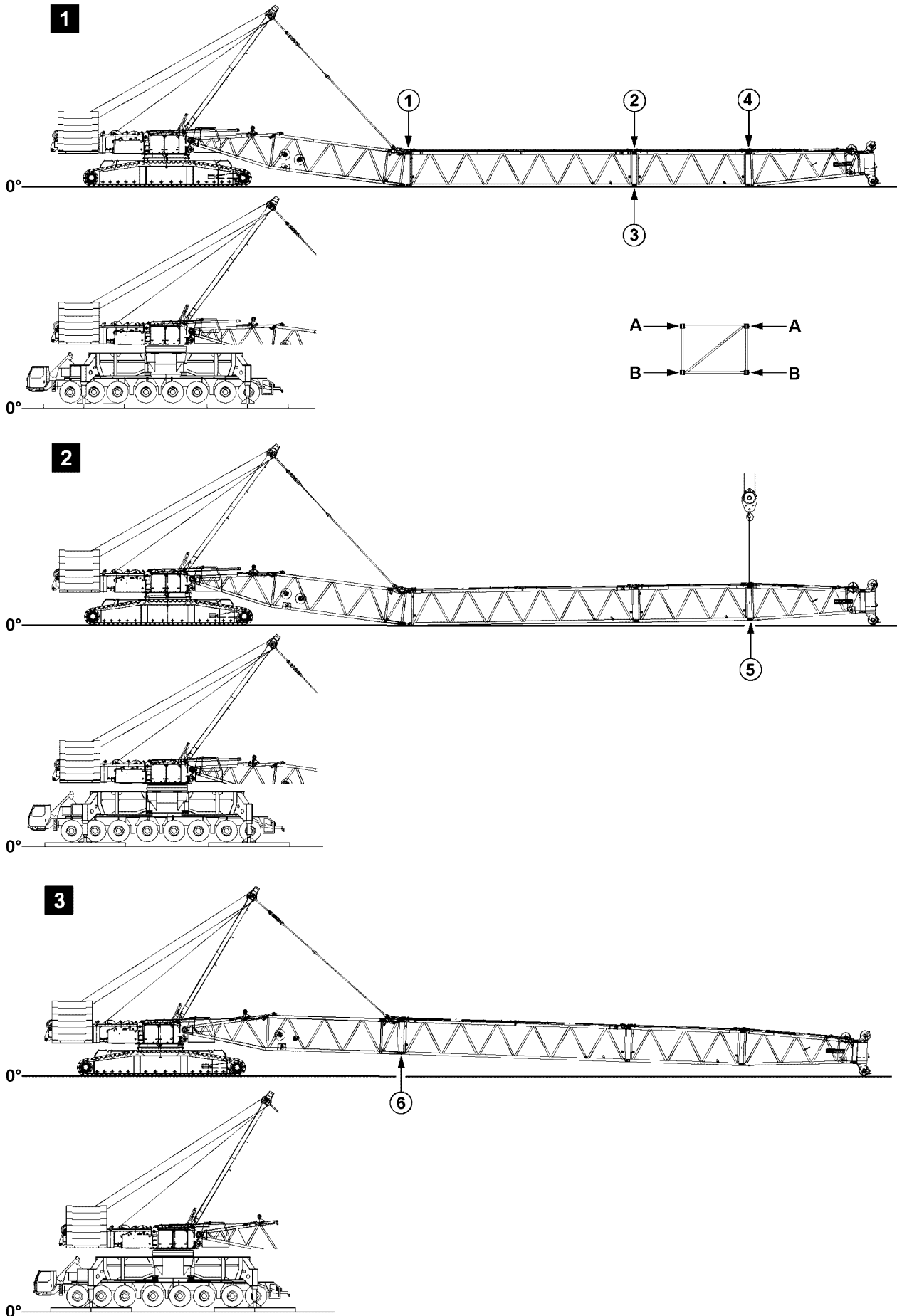

Fig.121633: Example for cranes with lattice mast booms

LWE/LR 11000-001/23501-04-02/en

14.13 Assembly / disassembly of lattice sections for lattice mast cranes

14.13.1 Assembly of lattice sections

The illustrations serve as examples. The illustrations may differ depending on the crane.



WARNING

Danger of fatal injury when assembling booms!

If the pins are not pinned in the given sequence, then lattice sections may suddenly fold down or fall down.

Personnel can be killed or seriously injured.

▶ Pins must be pinned in the order specified.

- ▶ Pin and secure pins at both sides (level **A**) at point **1**, illustration **1**.
- ▶ Pin and secure pins at both sides (level **A**) at point **2**, illustration **1**.
- ▶ Pin and secure pins at both sides (level **B**) at point **3**, illustration **1**.
- ▶ Pin and secure pins at both sides (level **A**) at point **4**, illustration **1**.
- ▶ Lift the end section with the auxiliary crane, illustration **2**.
- ▶ Pin and secure pins at both sides (level **B**) at point **5**, illustration **2**.
- ▶ Close the boom system with the SA-frame, illustration **3**.
- ▶ Pin and secure pins at both sides (level **B**) at point **6**, illustration **3**.

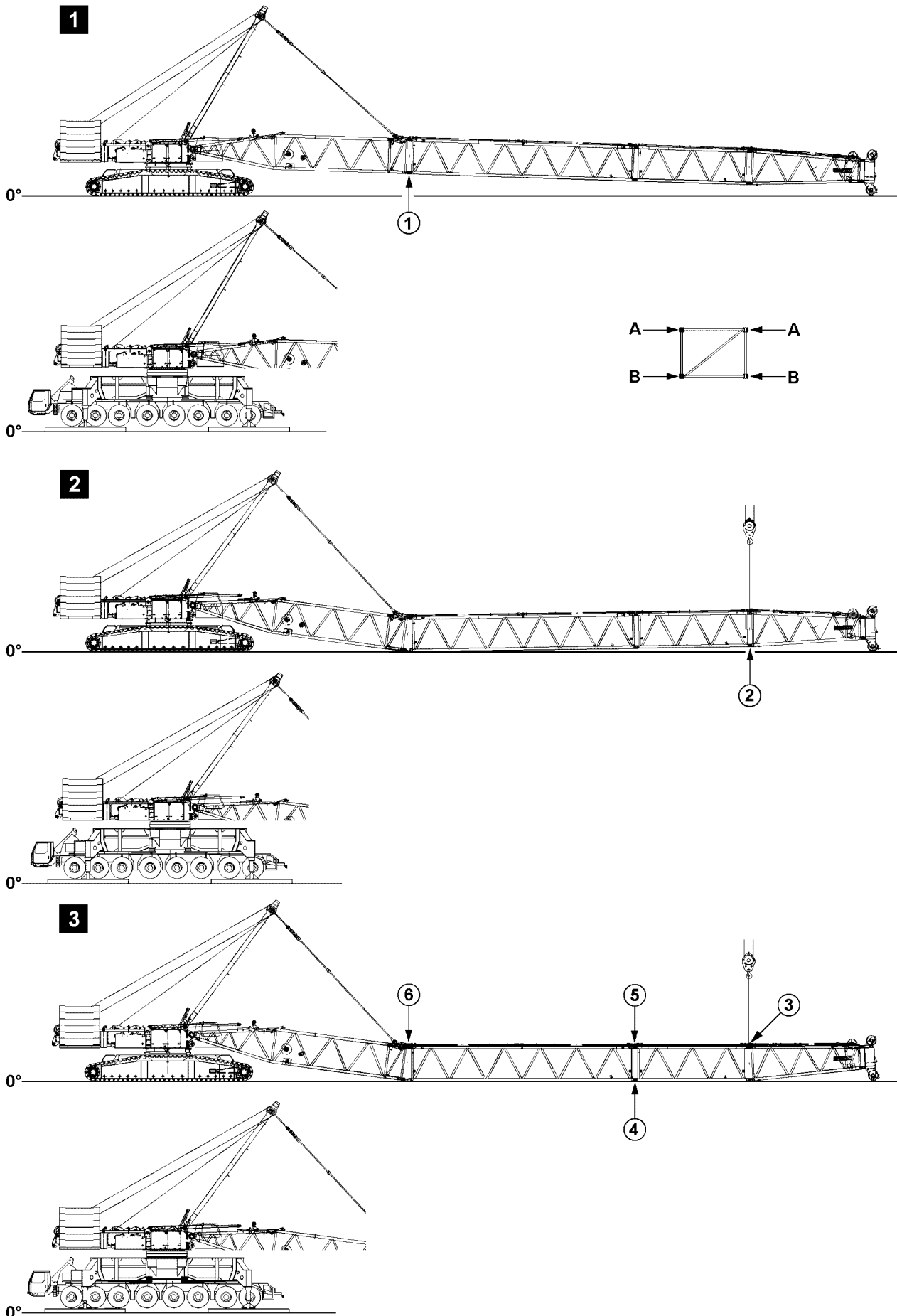

Fig.121634: Example for cranes with lattice mast booms

LWE/LR 11000-001/23501-04-02/en

14.13.2 Disassembly of lattice sections

The illustrations serve as examples. The illustrations may differ depending on the crane.



WARNING

Danger of fatal injury when disassembling booms!

If the pins are not unpinned in the given sequence, then lattice sections may suddenly fold down or fall down.

Personnel can be killed or seriously injured.

- ▶ Make sure that the SA-frame guying is tensioned before the pins are unpinned at point **1**, see illustration **1**.
 - ▶ Pins must be unpinned in the order specified.
-
- ▶ Luff the boom down until the end section touches the ground slightly, illustration **1**.
 - ▶ Guy the boom with SA-frame, illustration **1**.
 - ▶ Release and unpin the pins on both sides (level **B**) at point **1**, illustration **1**.
 - ▶ Open the boom system with the SA-frame, illustration **2**.
 - ▶ Completely remove the lattice sections, illustration **2**.
 - ▶ Lift the end section with the auxiliary crane, illustration **2**.
 - ▶ Release and unpin the pins on both sides (level **B**) at point **2**, illustration **2**.
 - ▶ Release and unpin the pins on both sides (level **A**) at point **3**, illustration **3**.
 - ▶ Release and unpin the pins on both sides (level **B**) at point **4**, illustration **3**.
 - ▶ Release and unpin the pins on both sides (level **A**) at point **5**, illustration **3**.
 - ▶ Release and unpin the pins on both sides (level **A**) at point **6**, illustration **3**.

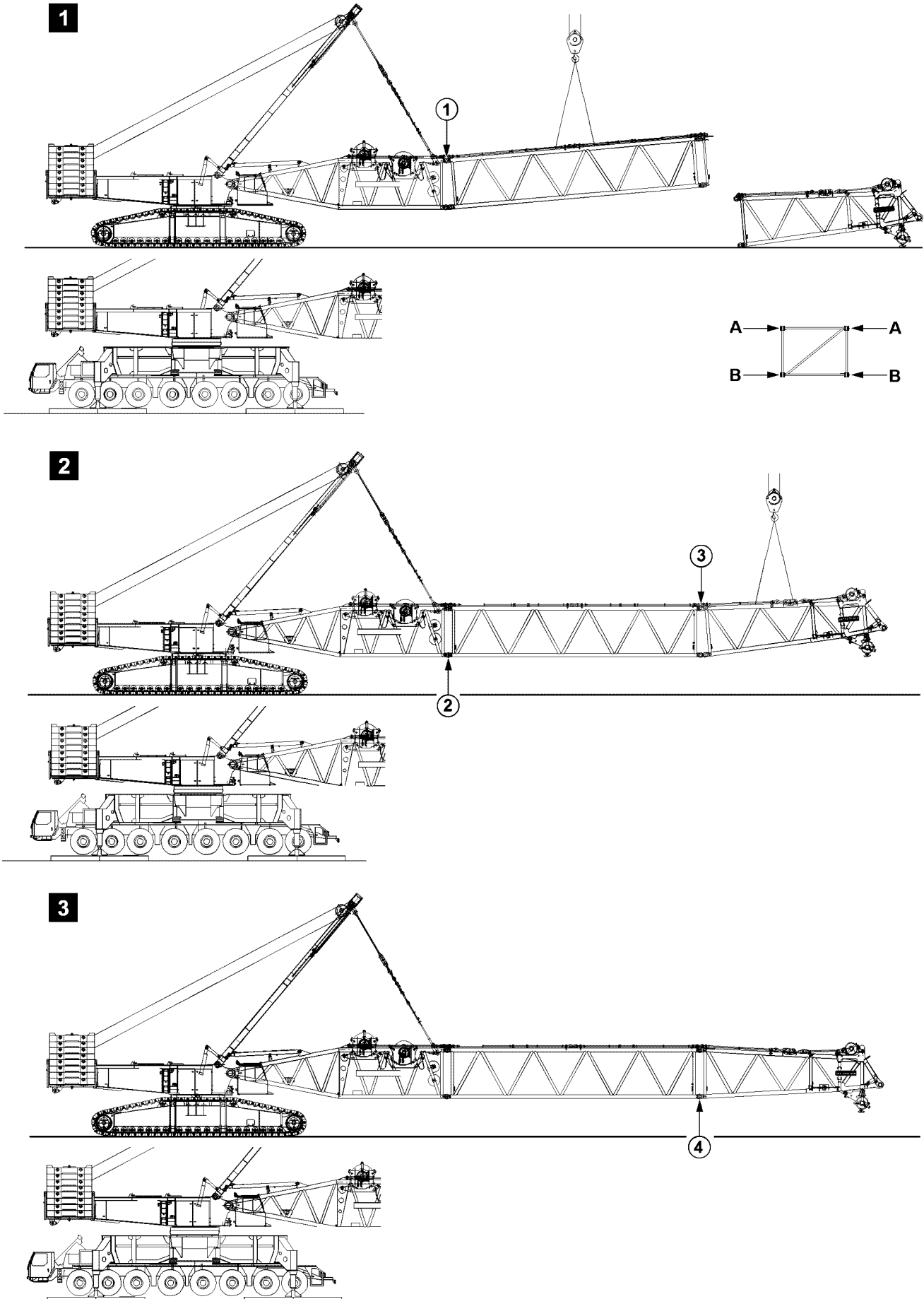

Fig.198182: Example for cranes with lattice mast booms

LWE/LR 11000-001/23501-04-02/en

14.14 Flying assembly / disassembly of lattice sections

14.14.1 Flying assembly of lattice sections

The illustrations serve as examples. The illustrations may differ depending on the crane.



WARNING

Danger of fatal injury when assembling booms!

If the pins are not pinned in the given sequence, then lattice sections may suddenly fold down or fall down.

Personnel can be killed or seriously injured.

▶ Pins must be pinned in the order specified.

- ▶ Pin and secure pins at both sides (level **A**) at point **1**, illustration **1**.
- ▶ Pin and secure pins at both sides (level **B**) at point **2**, illustration **2**.
- ▶ Pin and secure pins at both sides (level **A**) at point **3**, illustration **2**.
- ▶ Pin and secure pins at both sides (level **B**) at point **4**, illustration **3**.

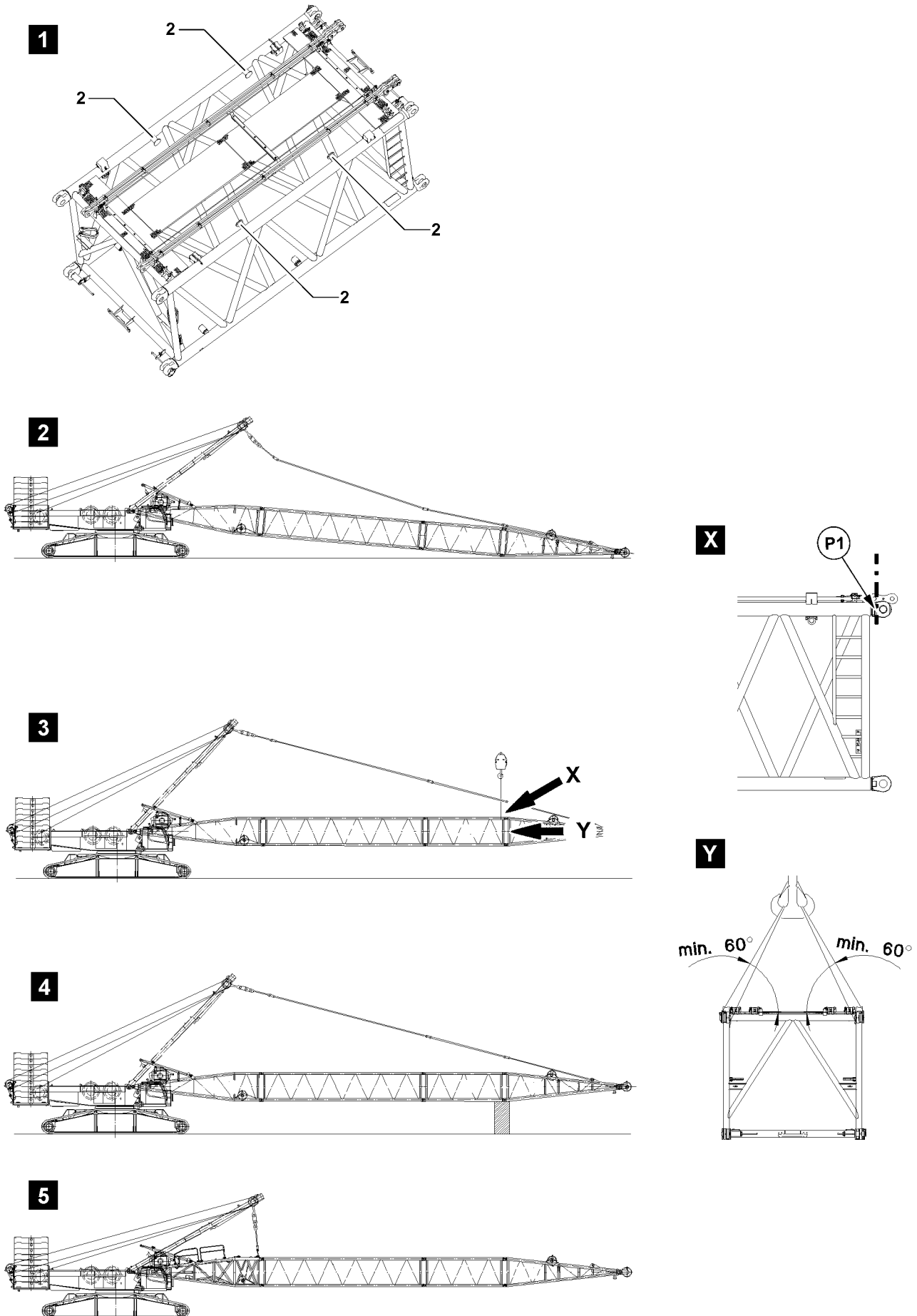

Fig.111448: Guying the pivot section with the SA-frame

LWE/LR 11000-001/23501-04-02/en

14.14.2 Flying disassembly of lattice sections

The illustrations serve as examples. The illustrations may differ depending on the crane.

The flying disassembly of lattice sections can be used on:

- Derrick boom
- Main boom

Make sure that the following prerequisite is met:

- Before guying the pivot section, secure the boom properly to prevent it from falling down!

Guying the pivot section in flying mode with the SA-frame

There are three ways to change the guying point for flying disassembly:

- Take down the boom on the ground.
 - Secure the boom with the auxiliary crane.
 - Support the boom.
- ▶ Take down the boom on the ground, see illustration 2.
or



WARNING

Lattice section incorrectly attached!

If the fastening equipment is attached on the bits **2** when securing the boom, then the bits will be overloaded. The lattice section will be damaged.

The boom can fall down.

Personnel can be severely injured or killed.

If an auxiliary crane is used to secure the boom for flying disassembly:

- ▶ Do **not** fasten the lattice section on the bits **2**, see illustration 1.
- ▶ Attach the fastening equipment in the area of point **P1** on both sides on the lattice section, see detail **X**.
- ▶ Make sure that the long fastening equipment is used, so that the angle between the cross section of the lattice section and guyed fastening equipment is at least 60°, see detail **Y**.

Secure the boom with the auxiliary crane, see illustration 3.

or



WARNING

Falling boom!

If the boom is not properly and securely supported from below, then the boom can fall down.

- ▶ Support the boom properly and safely with suitable material.

Support the boom, see illustration 4.

Result:

- The guy rods can be disassembled.
- ▶ Place down, secure and disassemble the guy rods.
- ▶ Pin and secure the guy rods SA-frame on the pivot section.
- ▶ Tighten the guy rods SA-frame until the boom is in horizontal position.

Result:

- Pivot section is guyed in flying mode with the SA-frame, see illustration 5.
- The lattice sections can be disassembled in flying mode.

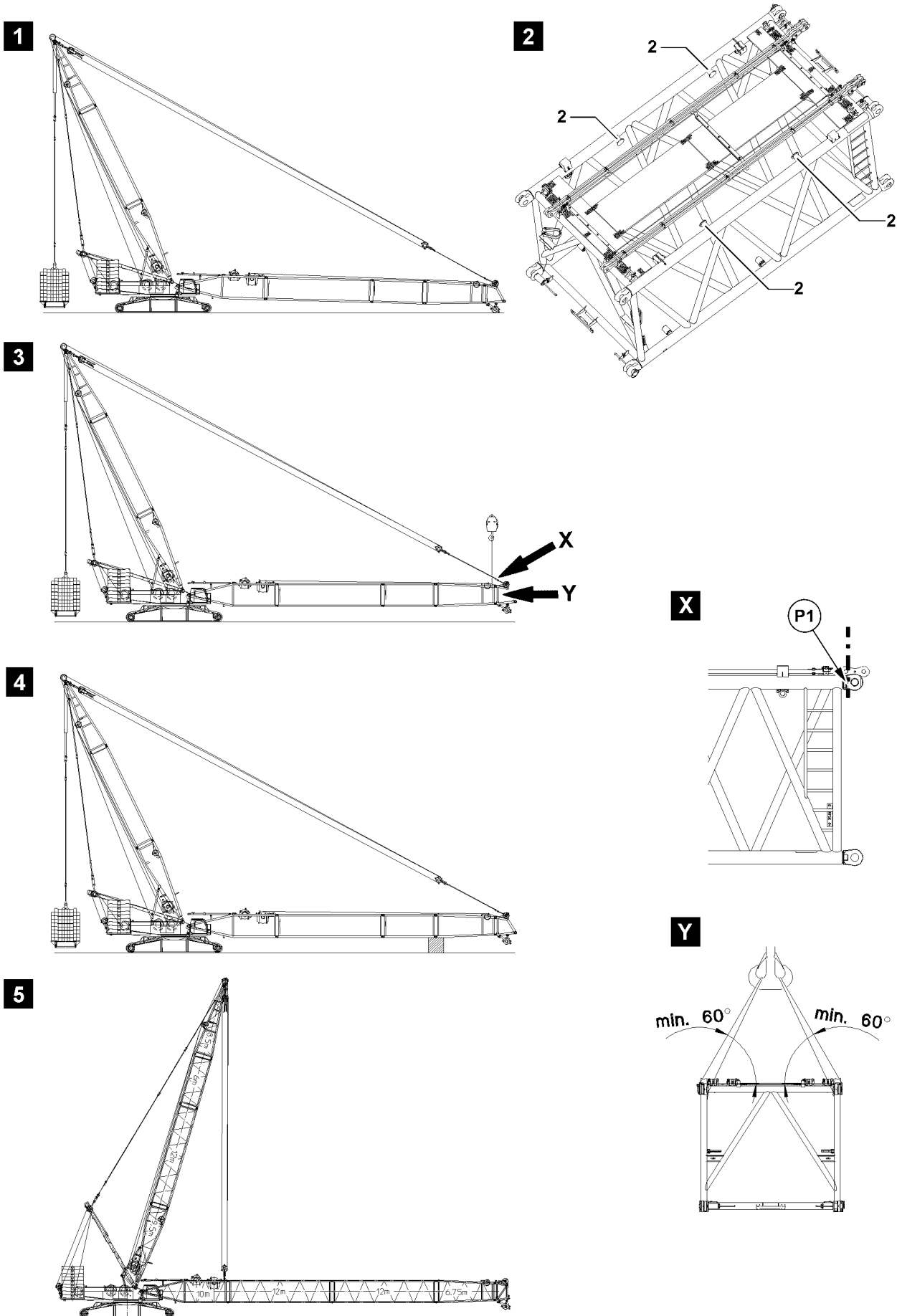

Fig.111449: Guying the pivot section with the derrick boom

LWE/LR 11000-001/23501-04-02/en

Guying the pivot section in flying mode with the derrick boom

There are three ways to change the guying point for flying disassembly:

- Take down the boom on the ground.
 - Secure the boom with the auxiliary crane.
 - Support the boom.
- ▶ Take down the boom on the ground, see illustration 1.
or



WARNING

Lattice section incorrectly attached!

If the fastening equipment is attached on the bitts **2** when securing the boom, then the bitts will be overloaded. The lattice section will be damaged.

The boom can fall down.

Personnel can be severely injured or killed.

If the auxiliary crane is used to secure the boom for flying disassembly:

- ▶ Do **not** fasten the lattice section on the bitts **2**, see illustration 2.
- ▶ Attach the fastening equipment in the area of point **P1** on both sides on the lattice section, see detail **X**.
- ▶ Make sure that the long fastening equipment is used, so that the angle between the cross section of the lattice section and guyed fastening equipment is at least 60°, see detail **Y**.

Secure the boom with the auxiliary crane, see illustration 3.

or



WARNING

Falling boom!

If the boom is not properly supported from below, then the boom can fall down.

- ▶ Support the boom properly and safely with suitable material.

Support the boom, see illustration 4.

Result:

- The guy rods can be disassembled.
- ▶ Place down, secure and disassemble the guy rods.
 - ▶ Pin and secure the luffing pulley block on the pivot section.
 - ▶ Tighten the control rope until the boom is in horizontal position.

Result:

- Pivot section is guyed in flying mode with the derrick boom, see illustration 5.
- The lattice sections can be disassembled in flying mode.

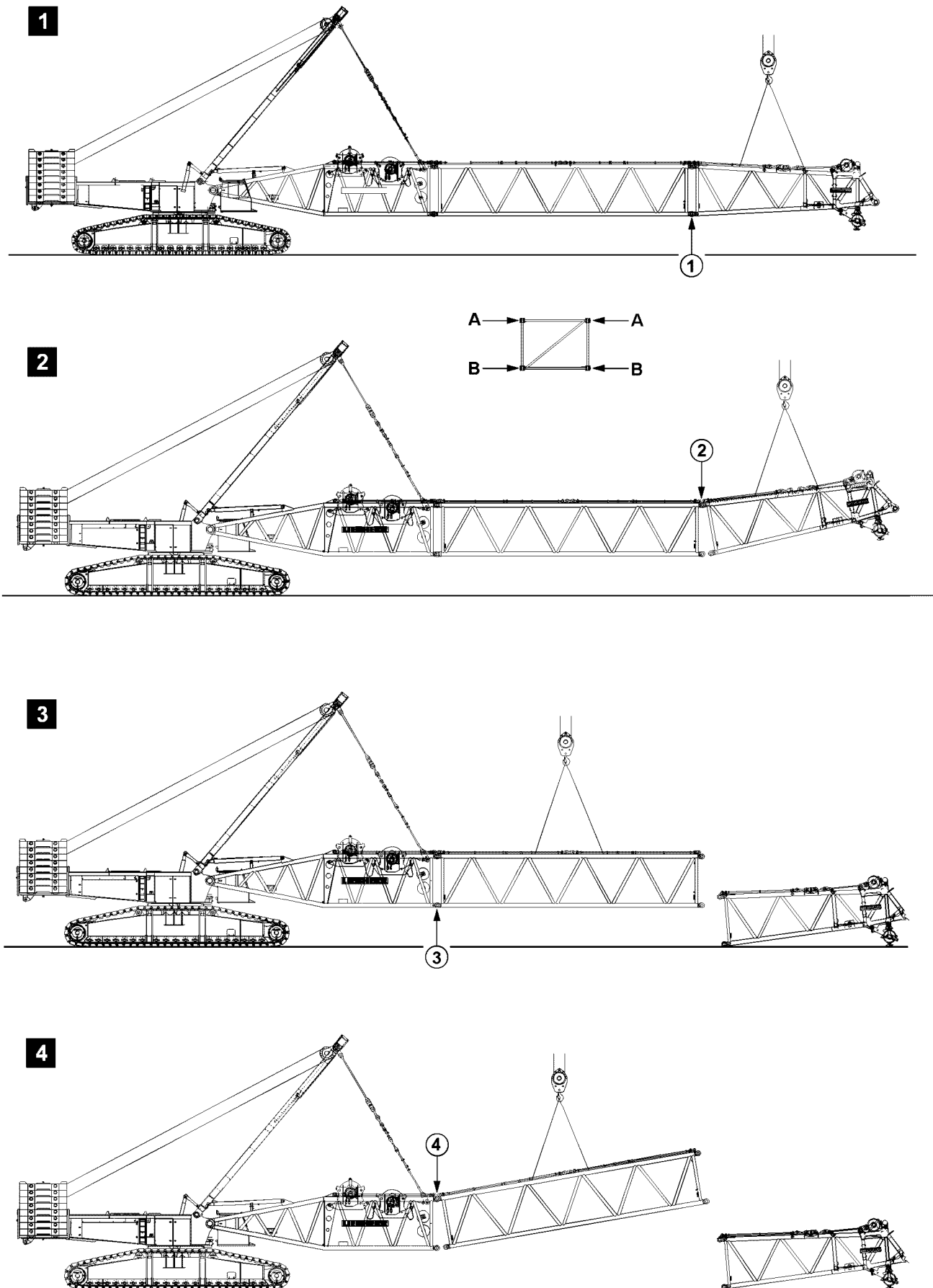

Unpinning the lattice components



WARNING

Danger of fatal injury when disassembling booms!

If the pins are not unpinned in the given sequence, then lattice sections may suddenly fold down or fall down.

Personnel can be killed or seriously injured.

▶ Pins must be unpinned in the order specified.

- ▶ Release and unpin the pins on both sides (level **B**) at point **1**, illustration 1.
- ▶ Release and unpin the pins on both sides (level **A**) at point **2**, illustration 2.
- ▶ Release and unpin the pins on both sides (level **B**) at point **3**, illustration 3.
- ▶ Release and unpin the pins on both sides (level **A**) at point **4**, illustration 4.

14.15 Assembly / disassembly of boom systems for supporting on ascending terrain (assembly / disassembly schematic)



Note

- ▶ The following assembly steps are simplified and are examples and may not match your crane exactly.



WARNING

Danger of fatal injury when assembling / disassembling booms!

If the pins are not pinned / unpinned in the specified sequence, then lattice sections may suddenly fold down or fall down.

Personnel can be killed or seriously injured.

- ▶ Pin / unpin pins in the specified sequence, see section „Assembly of lattice sections“.
- ▶ Observe all safety technical notes in section „Assembly / disassembly“.
- ▶ Make sure that there are no persons within the danger zone.



WARNING

Horizontal movement of the boom!

- ▶ Make sure that there are no persons within the danger zone.

14.15.1 Assembly of boom systems on ascending terrain

Make sure that the following prerequisites are met:

- An auxiliary crane with sufficient load bearing capacity is available.

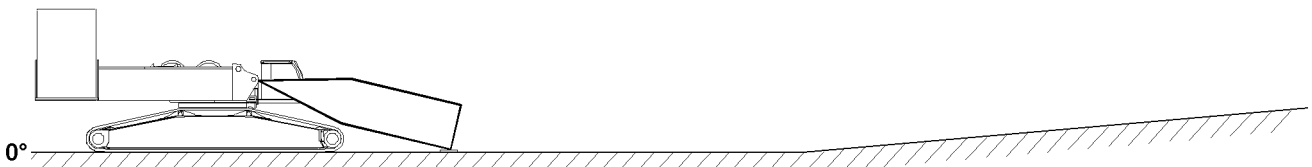

Fig. 121635: Boom - pivot section installed on turntable and placed on the ground

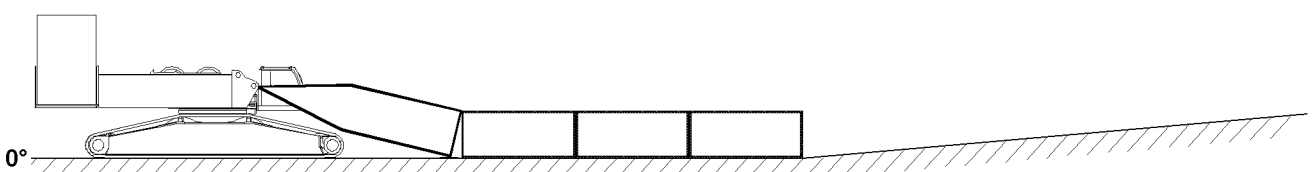

Fig. 121636: Boom - intermediate sections installed on boom - pivot section and placed on the ground

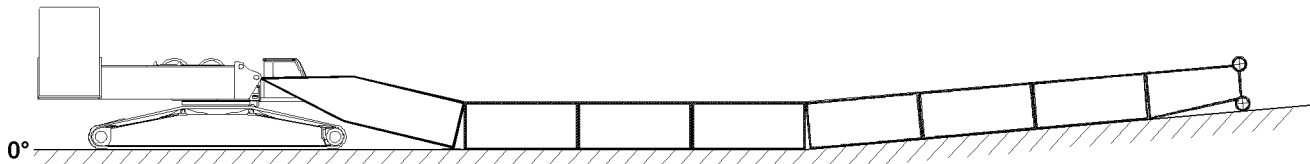

Fig.121637: Boom - intermediate sections installed and placed in ascending terrain

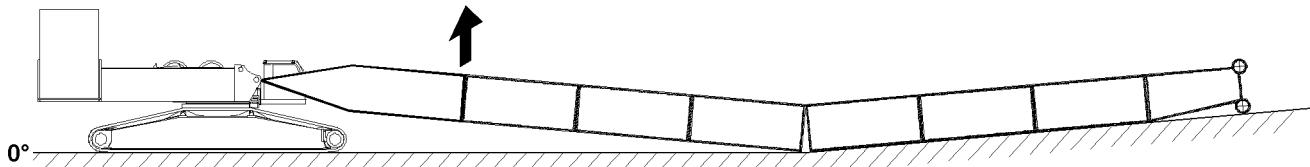

Fig.121638: Lifting and close the boom system in the area of the boom - pivot section

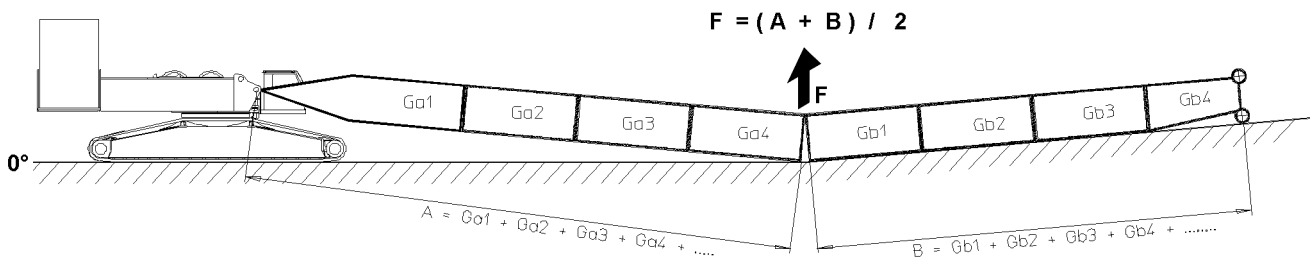

Fig.145512: Calculation of force for the closing procedure of the boom system



Note

- ▶ The abbreviations Ga1, Ga2, ... and Gb1, Gb2, ... are for the weights of the individual lattice sections.
- ▶ The weights of the lattice sections are noted on the welded on weight tags on the lattice sections.

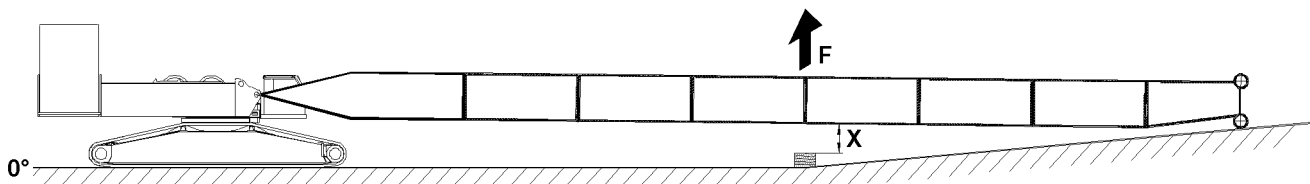

Fig.121639: Lifting and close the boom system // Support the boom system



Note

- ▶ The height of the substructure or dimension X is noted on the respective boom assembly chapter, see Crane operating instructions, chapter 5.38 or chapter 5.39.
- ▶ Support the boom system properly after the closing procedure.

14.15.2 Disassembly of boom systems on ascending terrain

Make sure that the following prerequisites are met:

- An auxiliary crane with sufficient load bearing capacity if available.

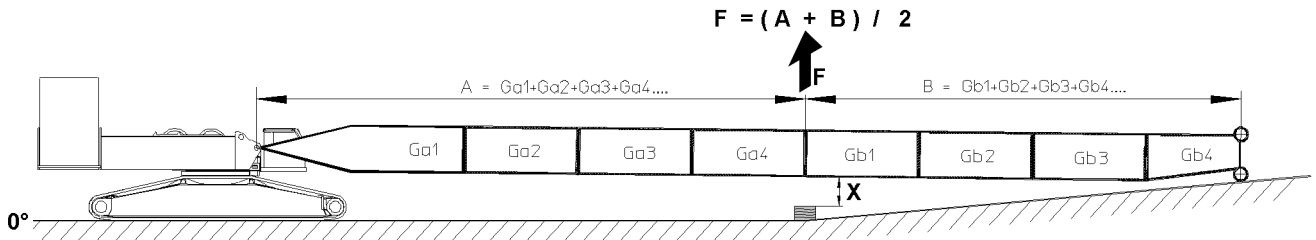

Fig.145513: Calculation of force for opening the boom system // Lift the boom system // Remove the substructure // Open the boom system



Note

- ▶ The abbreviations Ga1, Ga2, ... and Gb1, Gb2, ... are for the weights of the individual lattice sections.
- ▶ The weights of the lattice sections are noted on the welded on weight tags on the lattice sections.

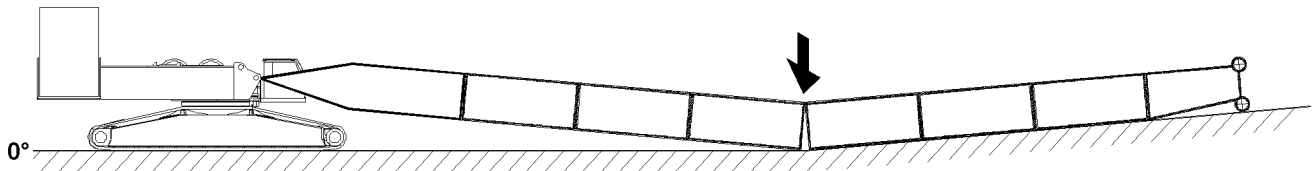

Fig.121657: Placing the boom system down

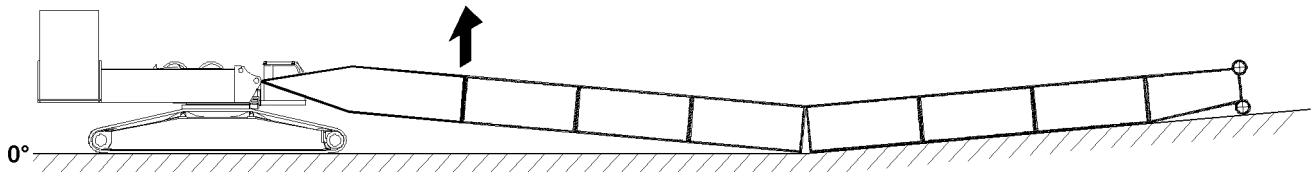

Fig.121652: Lifting and opening the boom system

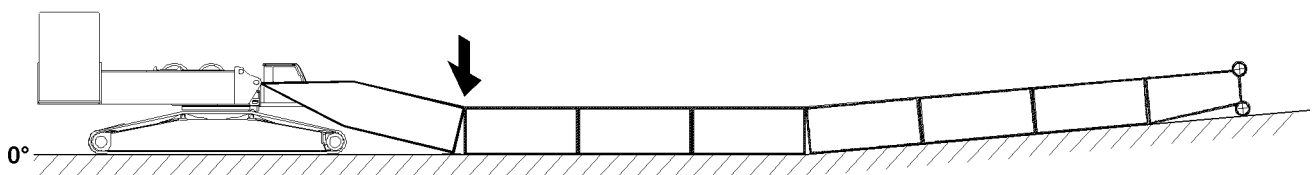

Fig.121653: Placing the boom system down

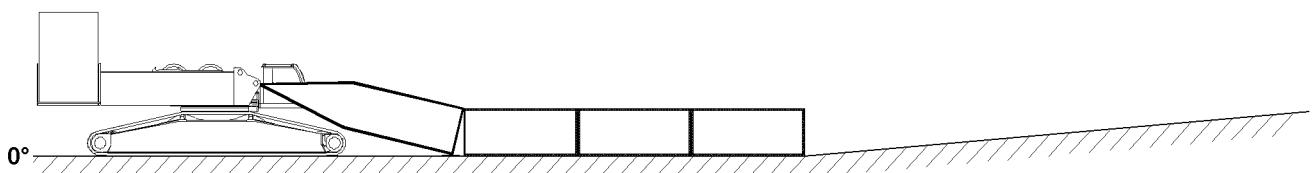

Fig.121636: Disassembling and removing the boom - intermediate sections with the end section

LWE/LR 11000-001/23501-04-02/en

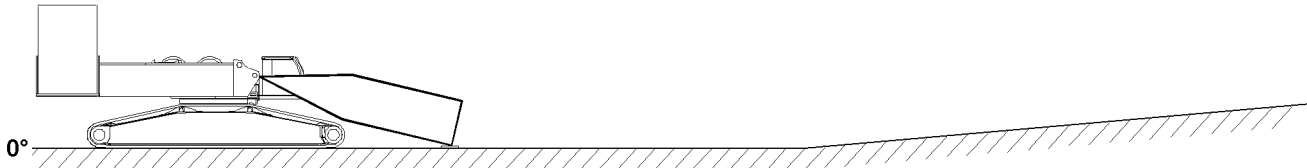

Fig.121635: Disassembling and removing the boom - intermediate sections to the boom - pivot section

- ▶ Disassemble and remove the boom - pivot section.

14.16 Assembly / disassembly of boom systems for supporting on descending terrain (assembly / disassembly schematic)



Note

- ▶ The following assembly steps are simplified and are examples and may not match your crane exactly.



WARNING

Danger of fatal injury when assembling / disassembling booms!

If the pins are not pinned / unpinned in the specified sequence, then lattice sections may suddenly fold down or fall down.

Personnel can be killed or seriously injured.

- ▶ Pin / unpin pins in the specified sequence, see section „Assembly of lattice sections“.
- ▶ Observe all safety technical notes in section „Assembly / disassembly“.
- ▶ Make sure that there are no persons within the danger zone.

14.16.1 Assembly of boom systems on descending terrain

Make sure that the following prerequisites are met:

- The lattice sections are properly assembled.
- An auxiliary crane with sufficient load bearing capacity if available.

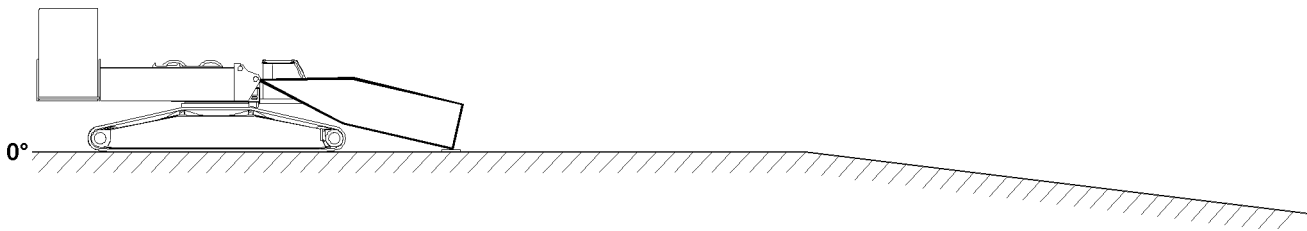

Fig.121640: Boom - pivot section installed on turntable and placed on the ground

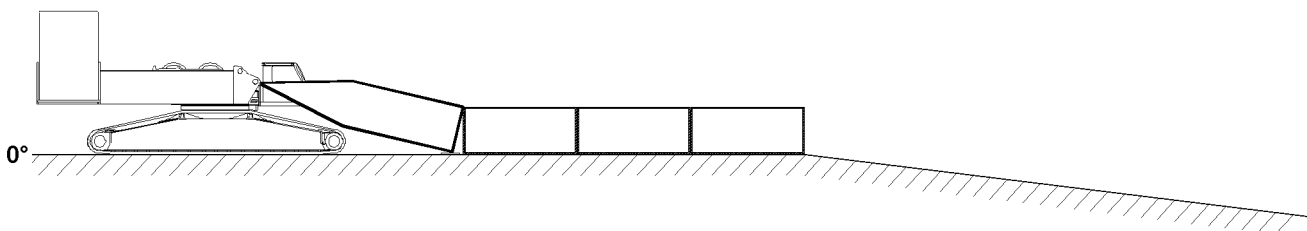

Fig.121641: Boom - intermediate sections installed on boom - pivot section and placed on the ground

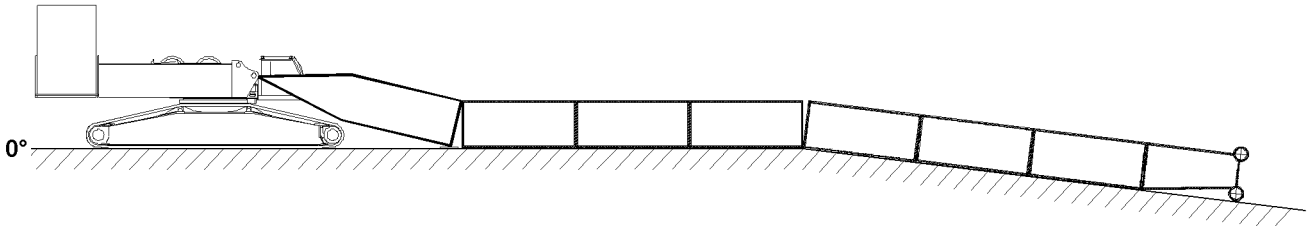

Fig.121642: Boom - intermediate sections installed and placed in descending terrain

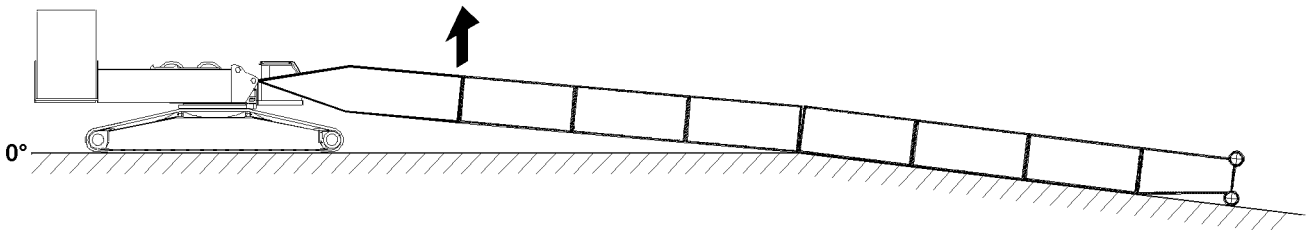

Fig.121643: Lifting and close the boom system in the area of the boom - pivot section

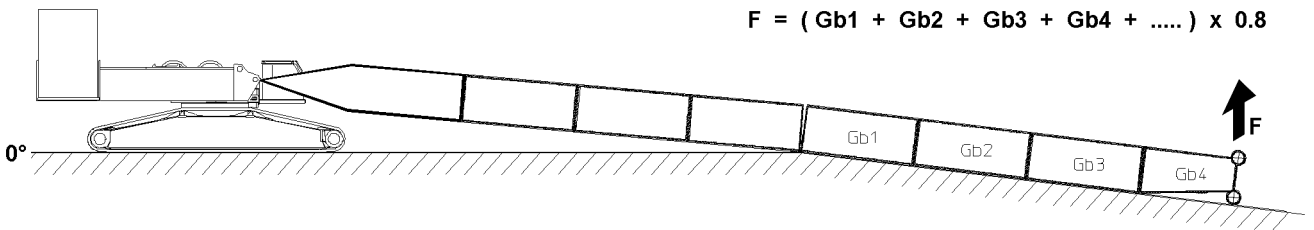

Fig.145514: Calculation of force for the closing procedure of the boom system



Note

- ▶ The abbreviations Gb1, Gb2, ... are for the weights of the individual lattice sections.
- ▶ The weights of the lattice sections are noted on the welded on weight tags on the lattice sections.

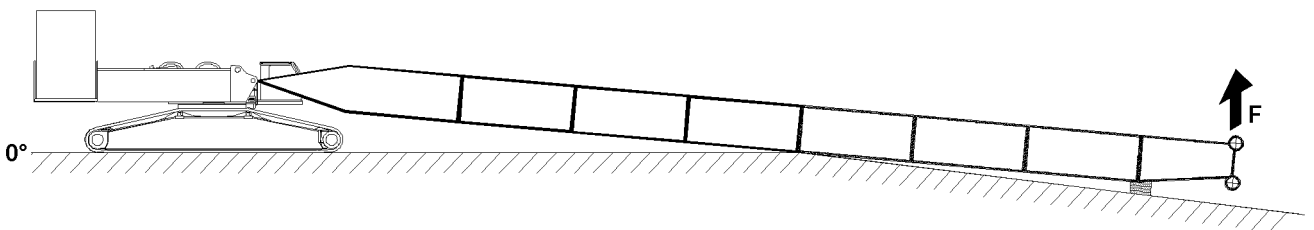

Fig.121644: Lifting and close the boom system // Support the boom system



Note

- ▶ The height of the substructure depends on the lay of the terrain and the resulting incline of the boom system.
- ▶ Support the boom system properly after the closing procedure.

14.16.2 Disassembly of boom systems on descending terrain

Make sure that the following prerequisite is met:

- An auxiliary crane with sufficient load bearing capacity if available.

LWE/LR 11000-001/23501-04-02/en

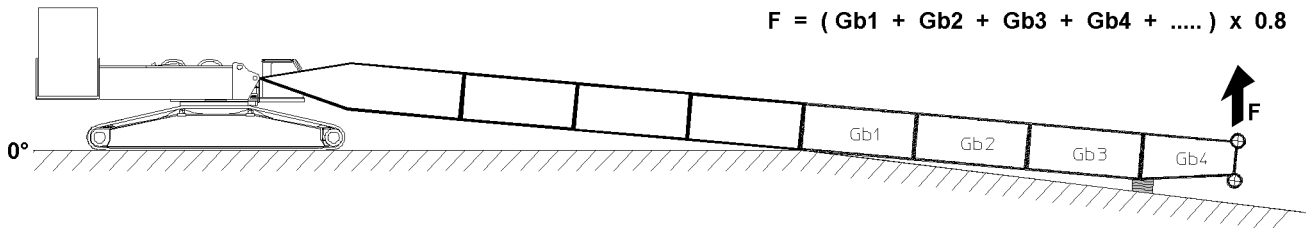

Fig.145515: Calculation of force for opening the boom system // Lift the boom system // Remove the substructure // Open the boom system



Note

- ▶ The abbreviations Gb1, Gb2, ... are for the weights of the individual lattice sections.
- ▶ The weights of the lattice sections are noted on the welded on weight tags on the lattice sections.

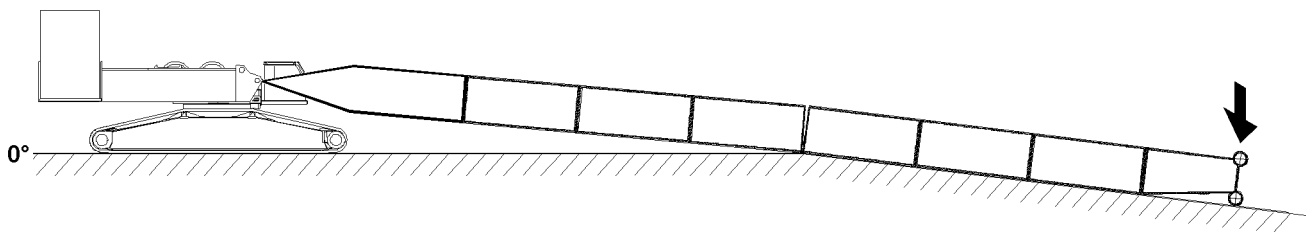

Fig.121658: Placing the boom system down

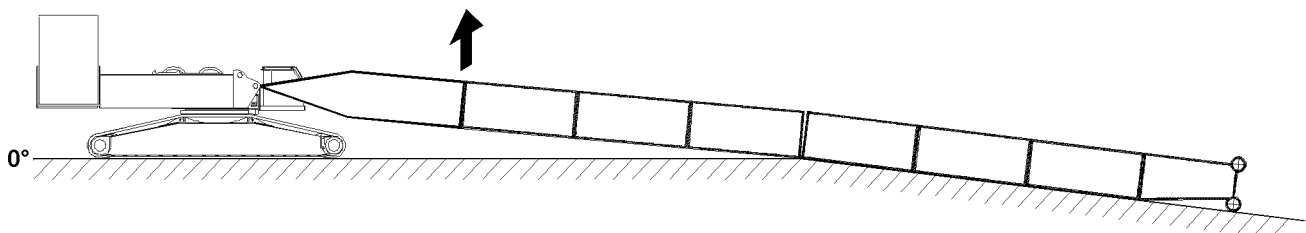

Fig.121655: Lifting and opening the boom system

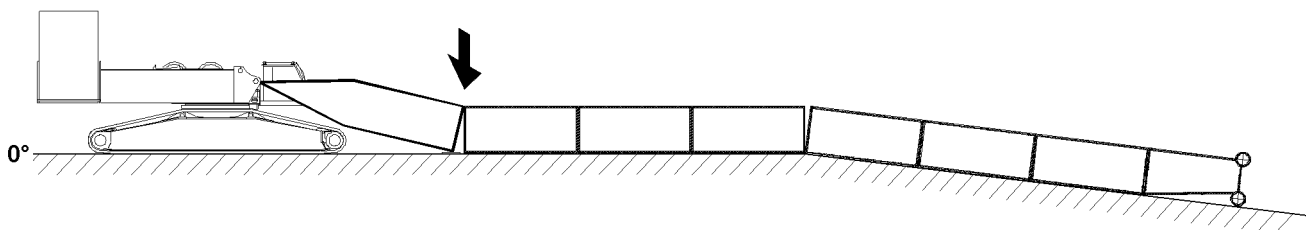

Fig.121656: Placing the boom system down

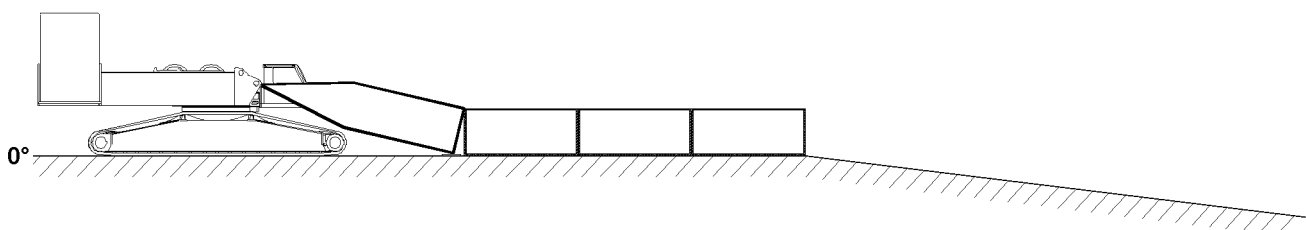

Fig.121641: Disassembling and removing the boom - intermediate sections with the end section

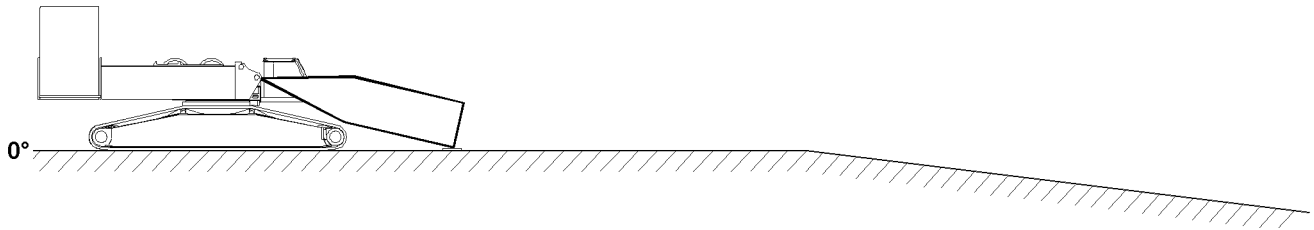

Fig.121640: Disassembling and removing the boom - intermediate sections to the boom - pivot section

- ▶ Disassemble and remove the boom - pivot section.

15 Erection / take down



WARNING

The crane can topple over!

Due to an unforeseen occurrence, for example: Sudden strong wind or storm can lead to dangerous operating situations, up to toppling the crane.

Personnel can be severely injured or killed.

- ▶ The boom must be able to be placed down at any time with its current equipment, observe the erection and take down charts. Observe the job planner.
- ▶ The counterweights and / or ballasts required for this must always be in direct vicinity of the crane.
- ▶ The crane operator must ensure that the required counterweight and / or the required ballast is carried along when driving the crane with the equipment in place and that the boom can be placed down at any time.



WARNING

Danger of fatal injury!

- ▶ Incorrectly installed or non-functioning limit switches as well as falling parts (pins, cotter pins, ice etc.) can cause accidents.

15.1 Erection / take down for mobile cranes

Make sure that the following prerequisites are met:

- The crane is properly supported.
 - The crane is horizontally aligned.
 - The counterweight has been installed on the turntable according to the load chart or the erection / take down charts.
 - In the case of cranes with derrick ballast: The derrick ballast (suspended ballast or ballast trailer ballast) is installed according to the load chart or the erection / take down charts.
 - For cranes with a telescopic boom: The telescopic boom is telescoped in all the way.
 - The boom has been installed according to the load chart and the Crane operating instructions.
 - The hoist rope has been correctly placed in the rope pulleys and prevented from jumping out with the rope retaining pins.
 - All limit switches have been correctly installed and are fully operational.
 - All pin connections are secured.
 - No persons in the danger zone.
 - No loose parts on the boom or the auxiliary boom.
 - The exposed rope pulleys are free of snow and ice.
 - The boom and its components (limit switches, cable drums, airplane warning light, wind speed sensor etc.) must be kept free of ice and snow.
- ▶ Check if all prerequisites have been met.

15.2 Erection / take down for crawler cranes

Make sure that the following prerequisites are met:

- Comply with the maximum permissible incline of the crane specified in the load chart manual.
 - For cranes with a support: The crane is properly supported.
 - For cranes with a support: The crane is horizontally aligned.
 - The counterweight has been installed on the turntable according to the load chart.
 - The central ballast is installed according to the load chart.
 - The counterweight is installed according to the load chart or the erection / take down charts.
 - In the case of cranes with derrick ballast: The derrick ballast (suspended ballast or ballast trailer ballast) is installed according to the load chart or the erection / take down charts.
 - For cranes with a telescopic boom: The telescopic boom is telescoped in all the way.
 - The boom has been installed according to the load chart and the Crane operating instructions.
 - The hoist rope has been correctly placed in the rope pulleys and prevented from jumping out with the rope retaining pins.
 - All limit switches have been correctly installed and are fully operational.
 - All pin connections are secured.
 - No persons in the danger zone.
 - No loose parts on the boom or the auxiliary boom.
 - The exposed rope pulleys are free of snow and ice.
 - The boom and its components (limit switches, cable drums, airplane warning light, wind speed sensor etc.) must be kept free of ice and snow.
- ▶ Check if all prerequisites have been met.

15.3 Rigging the guy rods on lattice booms on placed down boom system



WARNING

Danger of fatal injury due to damaged guy rods!

If the boom system is placed on the ground or a load bearing substructure in strong wind or longer downtime, the guy rods can be damaged due to wind influence on the boom guying. This wind influenced oscillations can lead to fatigue on the guy rods.

As a result, the guy rods could break or rip off under load - for example when erecting the boom system or in crane operation. The boom system can therefore fall uncontrolled forward onto the ground. Personnel can be severely injured or killed.

- ▶ Make sure that the guy rods are placed completely on the lattice sections and relieved when the boom systems are placed on the ground.
- ▶ Make sure that freely suspended guy rods are rigged on the lattice boom.
- ▶ Make sure that the upper pulley block is rigged on the lattice boom in Derrick operating modes.
- ▶ Make sure, that the guying on the luffing lattice jib is removed on lattice mast cranes.
- ▶ Make sure that the guy rods are inspected before resuming crane operation and that no damage or cracks are present.
- ▶ Make sure that the maintenance intervals of the guy rods are adhered to.



Note

- ▶ In case of strong wind or longer downtimes of the crane, the boom system must be placed on the ground or on a load bearing substructure.
- ▶ The guying must be relieved and the guy rods must be placed on the transport receptacles.
- ▶ The following illustrations are examples and may not match your crane exactly.

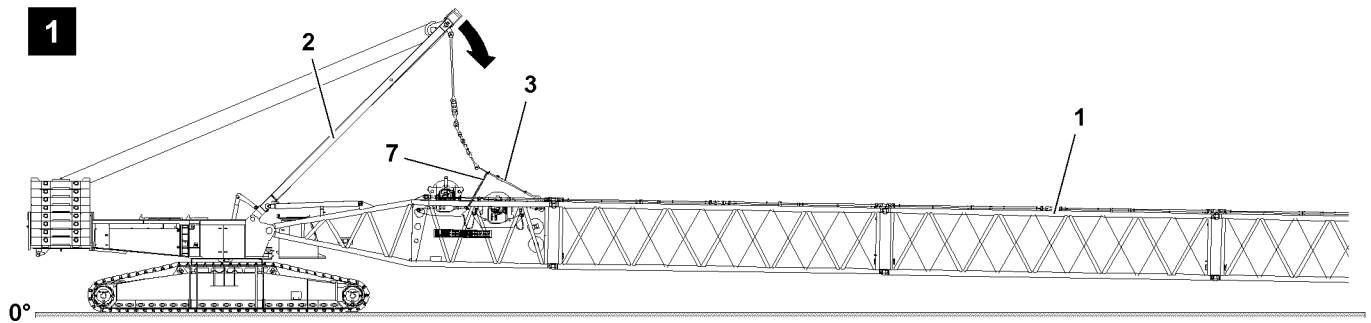

Fig.120722: Guying placed in transport receptacle and SA-frame guying relieved

- ▶ Place the guy rods on the lattice sections 1: Luff the SA-frame 2 to the front until the guying is placed completely in the transport receptacles on the lattice sections and the SA-frame guying 3 is relieved, see illustration 1.
- ▶ To minimize side oscillation of the SA-frame guying 3 due to wind influence: Rig the SA-frame guying 3 with suitable rigging straps / ropes 7 against the boom, see illustration 1.

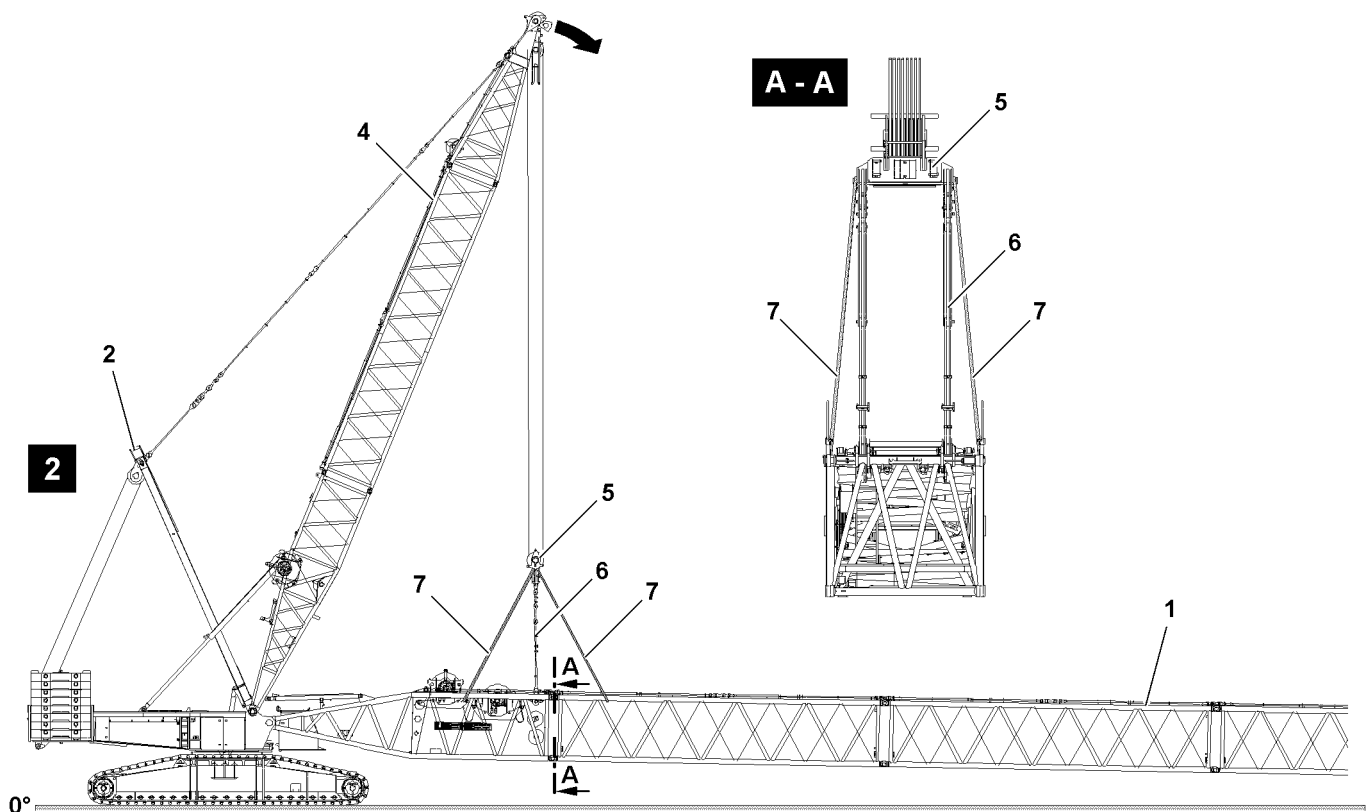

Fig.120771: Guying placed in transport receptacle and upper pulley block rigged against the boom

- ▶ Place the boom system down and - if present - release the derrick guying to the derrick ballast.
- ▶ Place the guy rods on the lattice sections 1: Luff the D-boom 4 down to the front until the main boom guying is placed completely in the transport receptacles on the lattice sections and the upper pulley block 5 is positioned over the S-pivot section, see illustration 2.
- ▶ To minimize side oscillation of the upper pulley block 5 due to wind influence: Rig the upper pulley block 5 with suitable rigging straps / ropes 7 against the boom, see illustration 2.

For lattice mast cranes with luffing lattice jib the following applies:

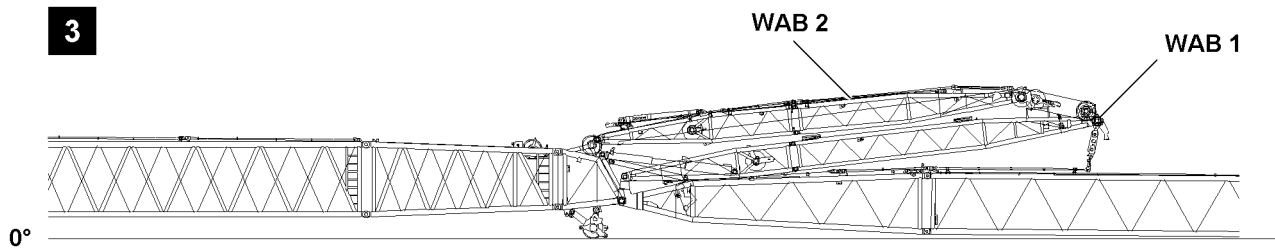

Fig.120821: Guying in transport receptacle(s) and WA-frames placed down to the front (example crane with lattice mast)



WARNING

Danger of accident when removing the W-guying!

When placing down and removing the guying dangerous situations can arise.

- ▶ Make sure that the danger notes in the respective chapter of the Crane operating instructions are observed.

- ▶ Remove the guy rods on the luffing lattice jib and place them into the transport receptacles.
- ▶ Place the WA-frames (WA-frame 1 **WAB 1** and WA-frame 2 **WAB 2**) down to the front.

For telescopic cranes with luffing lattice jib the following applies:

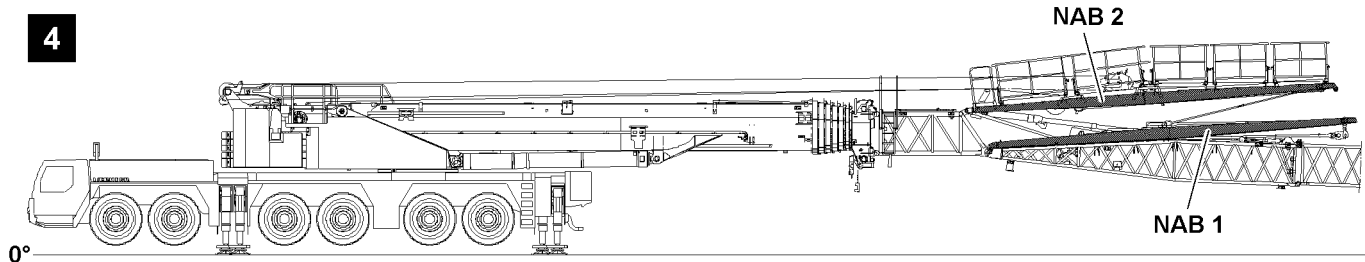

Fig.121261: Guying in transport receptacle(s) and NA-frames placed down to the front (example telescopic crane)



WARNING

Danger of accident when placing the NA-frames down!

When placing the guy rods as well as the NA-frames down dangerous situations can arise.

- ▶ Make sure that the danger notes in the respective chapter of the Crane operating instructions are observed.

- ▶ Spool the jib control winch out and take the NA-frames down to the front so that the guy rods are relieved.

5.02 SA-frame

1 SA-frame

3

LWE/LR 11000-001/23501-04-02/en

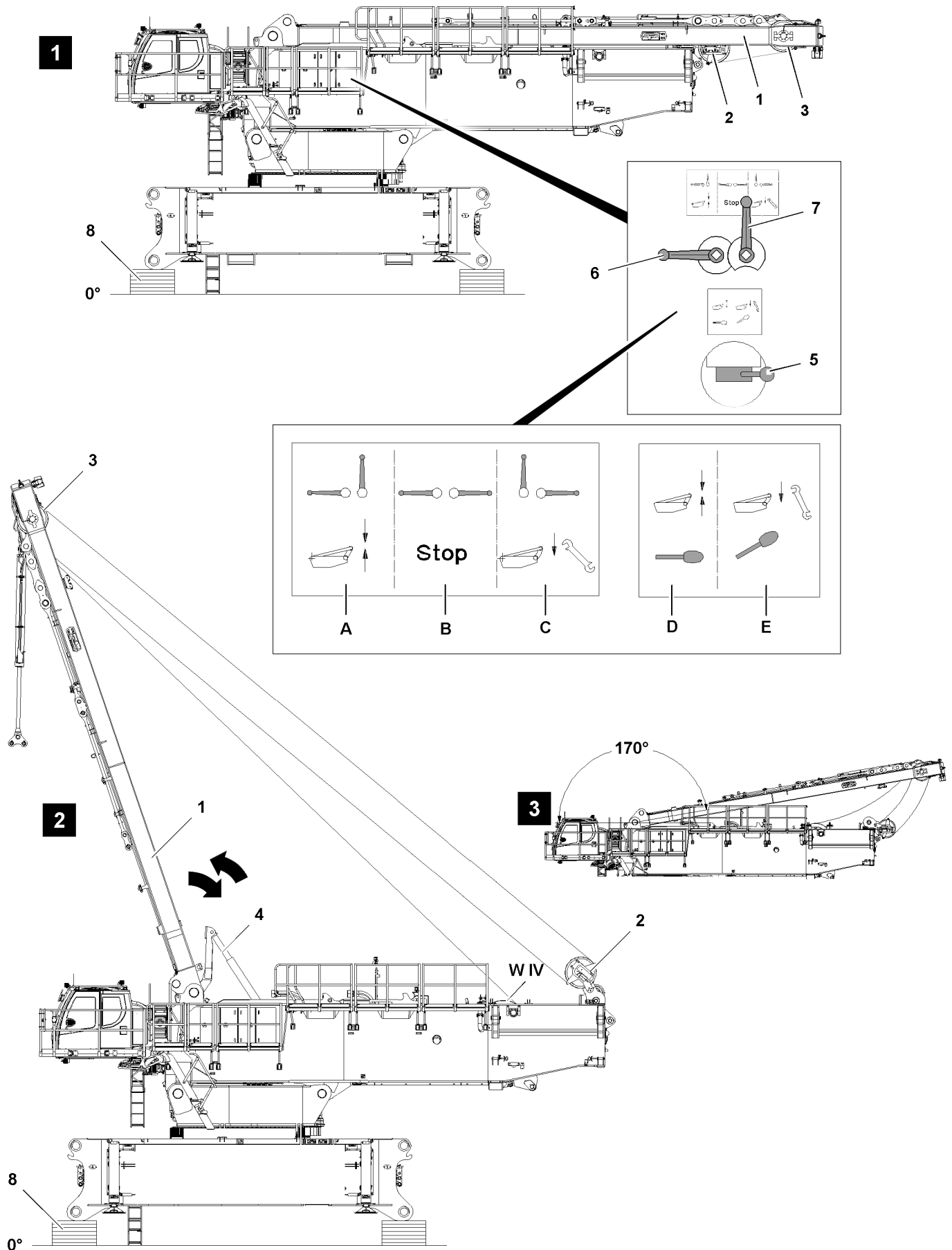

Fig.124466

LWE/LR 11000-001/23501-04-02/en

1 SA-frame



Note

- ▶ The SA-frame is used in assembly operation to install the crawler travel gear, see Crane operating instructions, chapter 3.01!
- ▶ In addition, the SA-frame is used in assembly operation for closing boom systems and for guying the boom in flying assembly of lattice sections, see Crane operating instructions, chapter 5.38.

Switch positions of ball valves (ball valve 6 / ball valve 7)		
Switch position	Function	Use
A	Erecting the SA-frame	Assembly and crane operation
B	SA-frame stop, cylinder stop	Block erection cylinder
C	Lower the SA-frame	Lower the SA-frame into transport position

Switch position Hand lever 5		
Switch position	Function	Use
D ¹⁾	Erecting the SA-frame	Assembly, crane operation
E ²⁾	Lower the SA-frame	Lower the SA-frame into transport position

1) Hand lever 5 is in zero / basic position (not actuated)

2) Ball valve 6 and ball valve 7 are in switch position C

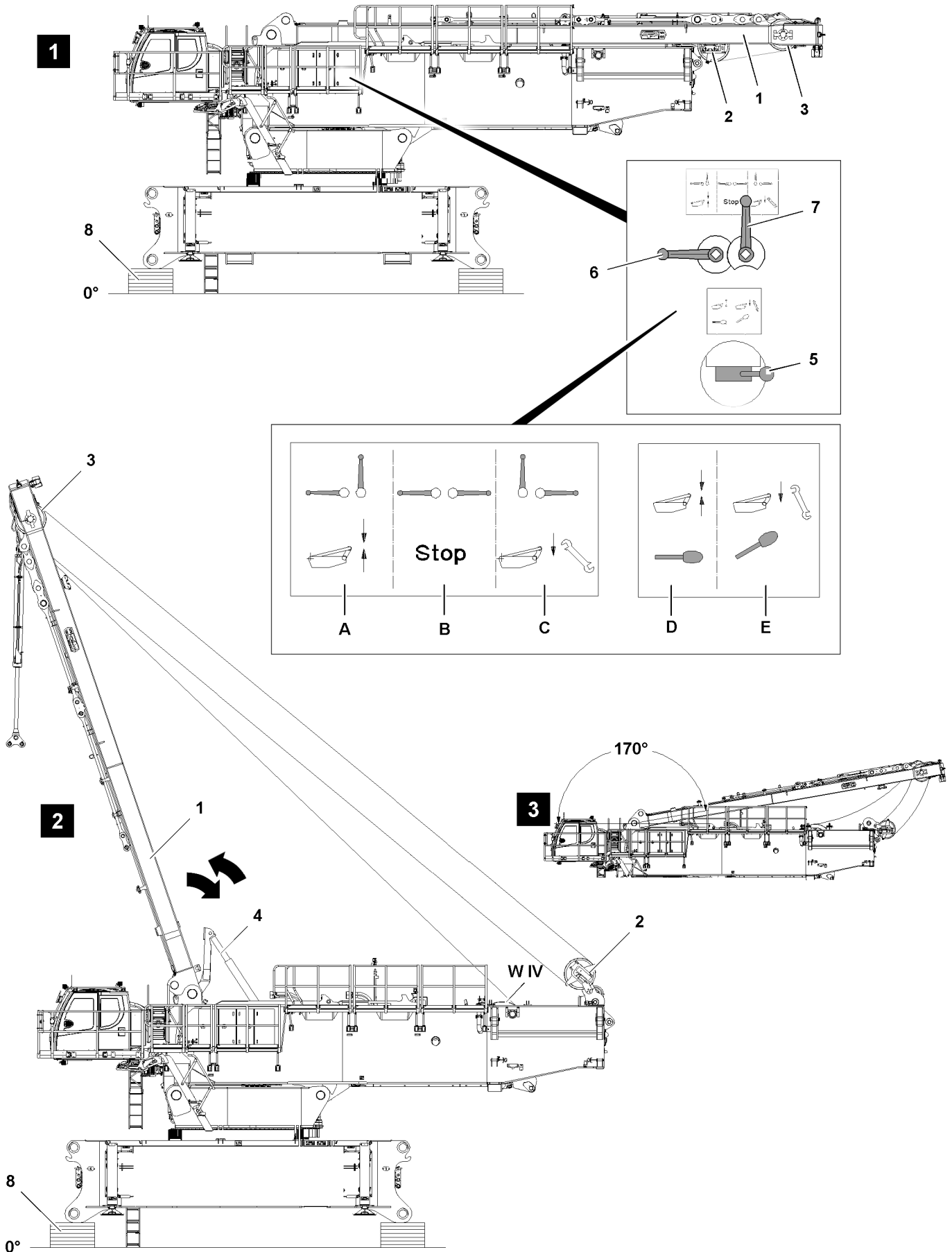

Fig.124466

LWE/LR 11000-001/23501-04-02/en

1.1 Erecting the SA-frame

1.1.1 Erection procedure

Make sure that the following prerequisites are met:

- The crawler center section is sitting on the supports **8**.
- The SA-frame is in transport position.
- There is no counterweight on the turntable.
- Winch 4 is reeved on the pulley set **3** of the SA-frame **1**.
- The engine is running.
- The shut off limits of the LICCON overload safety device are exceeded, see Crane operating instructions, chapter 4.02.
- The SA-operating mode has been set and confirmed on the LICCON computer system.



WARNING

Danger of accident when exceeding the LICCON overload safety device!

If the shut off limits of the LICCON overload safety device are exceeded, there is no additional protection against overload!

Due to erroneous operation or deliberate misuse, the crane could collapse, the SA-frame can collapse or the crane can topple over!

Personnel can be severely injured or killed!

This could result in high property damage!

- ▶ The function „Exceedance of the LICCON overload safety device“ may only be activated or used in emergencies and for assembly purposes.
- ▶ The function „Exceedance of the LICCON overload safety device“ may only be activated or used by an authorized person who knows the effects of the bypass exactly.
- ▶ The „Exceedance of the LICCON overload safety device“ may only be carried out „anticipatorily“ and with utmost caution.
- ▶ The „Exceedance of the LICCON overload safety device“ is only permissible if the set up configuration of the crane has been entered correctly into the LICCON computer system and has been confirmed!

NOTICE

Danger of slack rope formation!

If winch 4 is spooled out too quickly during the erection procedure of the SA-frame **1**, slack rope can form!

- ▶ The intake rope of winch 4 must be tensioned during the entire erection procedure!
- ▶ The spool out speed of winch 4 must be matched to the erection speed of the erection cylinder **4**!

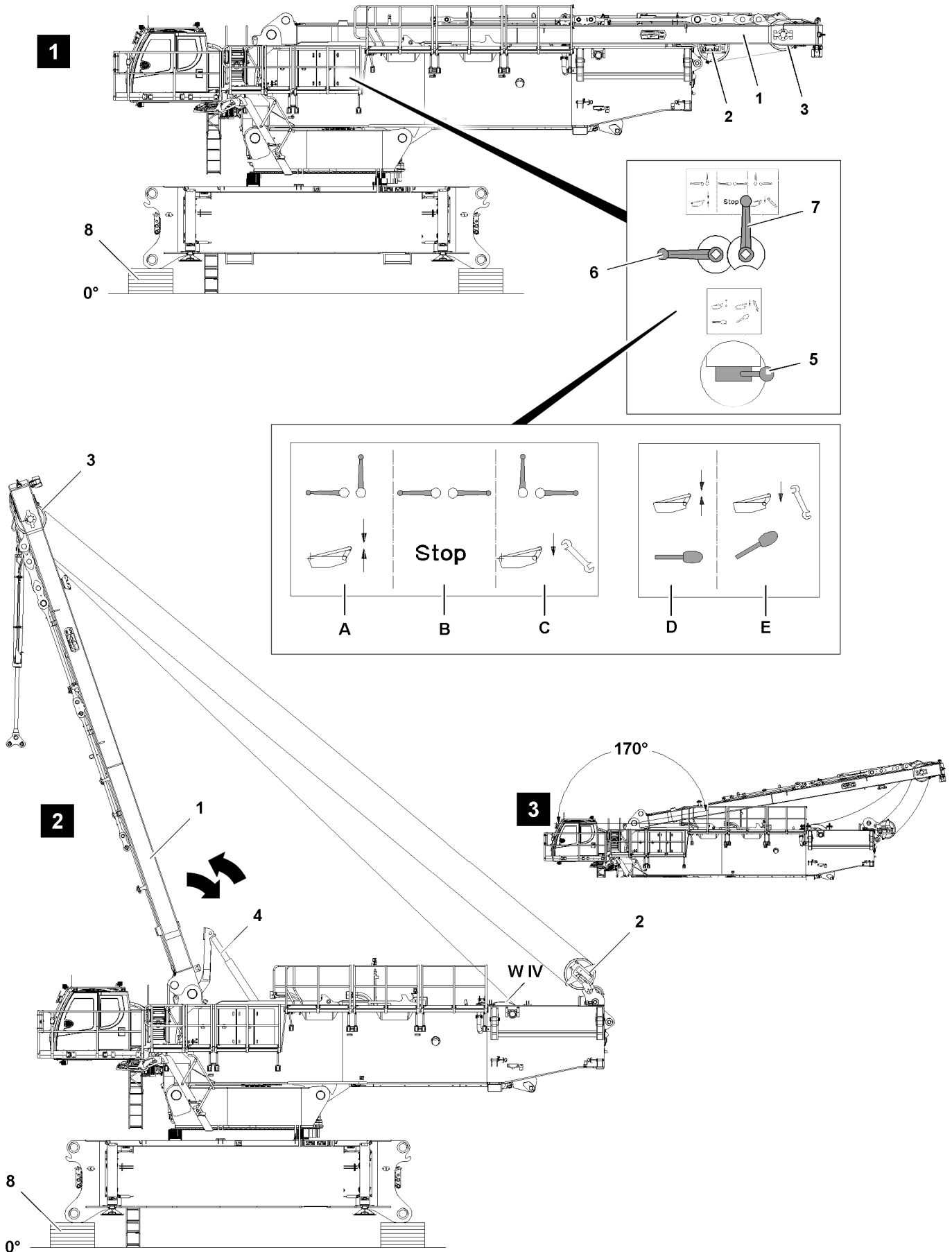

Fig.124466

LWE/LR 11000-001/23501-04-02/en

**WARNING**

Independent lowering of the SA-frame!

Due to incorrect ball valve positions during the erection procedure, the SA-frame **1** can lower backward by itself!

Personnel can be severely injured or killed!

It can result in slack rope build up!

- ▶ Ball valve **6** and ball valve **7** must be in position **A** during assembly and crane operation!
- ▶ Ball valve position **C** „lower“ and ball valve position **B** „stop“ are only permissible when lowering the SA-frame onto the turntable (transport position)!

- ▶ Set the ball valve **6** and ball valve **7** in position **A**, see illustration **1**.

Result:

- The SA-frame **1** is pushed upward by the erection cylinders **4** until the ropes are tensioned between the pulley support **2** and the pulley set **3**.

NOTICE

Damage to ropes!

- ▶ Check the rope pulleys visually!
- ▶ The ropes must be laying correctly in the corresponding rope pulleys!

**Note**

- ▶ Functions of master switch MS1, see Crane operating instructions, chapter 4.05.

- ▶ Move master switch MS1 in direction X+.

Result:

- Winch 4 spools out and the SA-frame **1** is erected forward by the erection cylinders **4**, see illustration **2**.
- The „???“ turn off and the SA-operating mode is shown.

- ▶ Move master switch MS1 in direction X+.

Result:

- The SA-frame is lowered to the front and is now in the operating range of SA-operating mode, see illustration **2**.

**WARNING**

The crane can topple over!

If the shut off limits of the LICCON overload safety device are exceeded, there is no additional protection against overload!

Due to erroneous operation or deliberate misuse, the crane could collapse, the SA-frame can collapse or the crane can topple over!

Personnel can be severely injured or killed!

This could result in high property damage!

- ▶ When the operating range is reached, turn off / deactivate the function „Exceedance of the LICCON overload safety device“ immediately!

- ▶ Turn off / deactivate the function „Exceedance of the LICCON overload safety device“ immediately.

Result:

- The LICCON overload safety device is active.

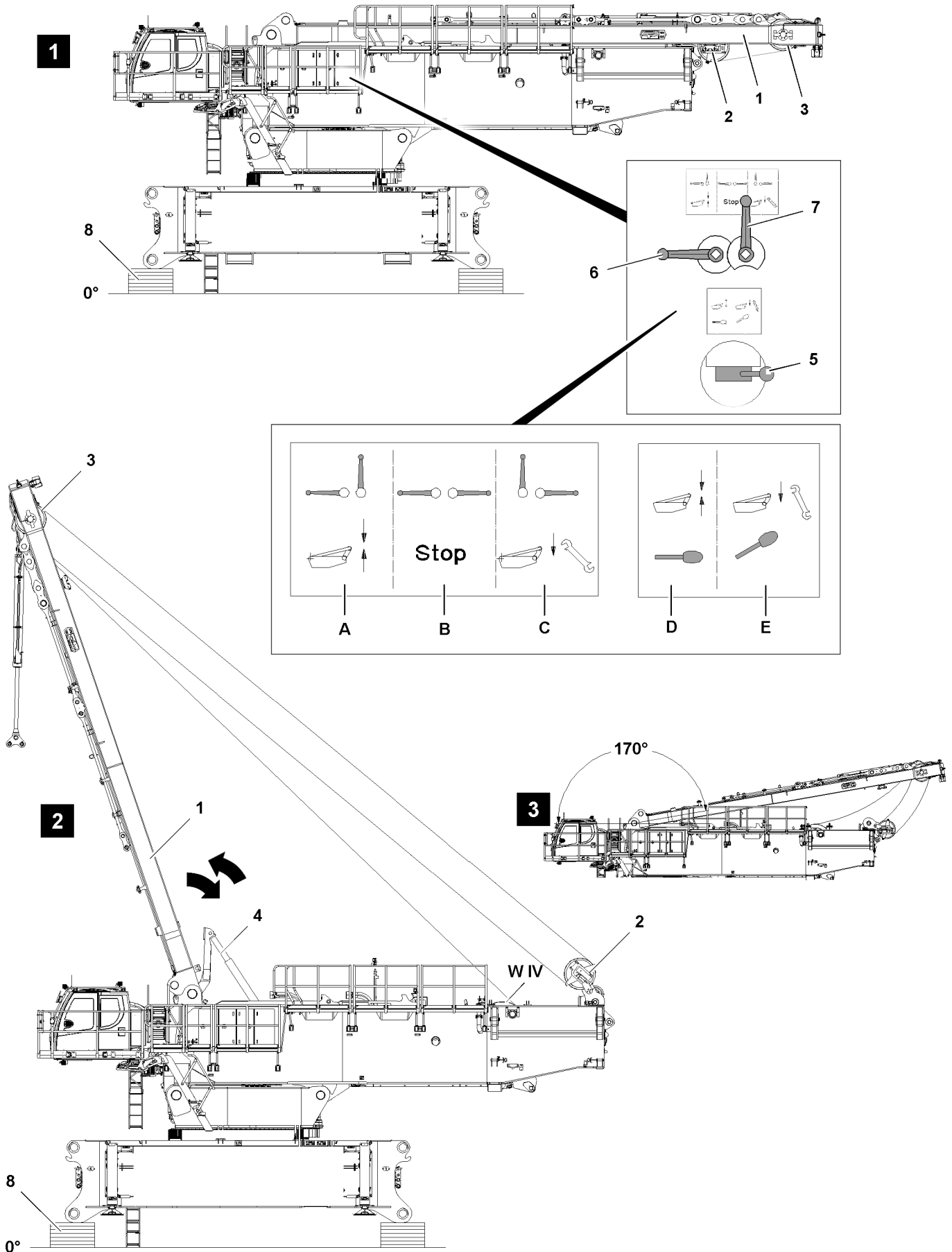

Fig.124466

LWE/LR 11000-001/23501-04-02/en

**Note**

- ▶ Due to the own weight of the SA-frame and by spooling out winch 4 simultaneously, the SA-frame is lowered to the front.
- ▶ When the SA-frame leaves the operating range, an error message appears on the LICCON monitor and LMB stop is initiated.
- ▶ „Spooling out“ winch 4 is turned off.
- ▶ „Luffing down“ the SA-frame is blocked.
- ▶ „Luffing up“ the SA-frame is only possible when the shut off limits of the LICCON overload safety device are exceeded.
- ▶ If the minimum or maximum pressure is reached in the erection cylinders, winch 4 turns off. An error is shown.

**WARNING**

Danger of accident!

Ball valve **6** and ball valve **7** must be in position **A** during assembly and crane operation.

Ball valve position **C** and ball valve position **B** are only permissible when lowering the SA-frame onto the turntable (transport position)!

- ▶ Secure the ball valves immediately after assembly with a lock to prevent unauthorized access.
- ▶ Secure the ball valves.

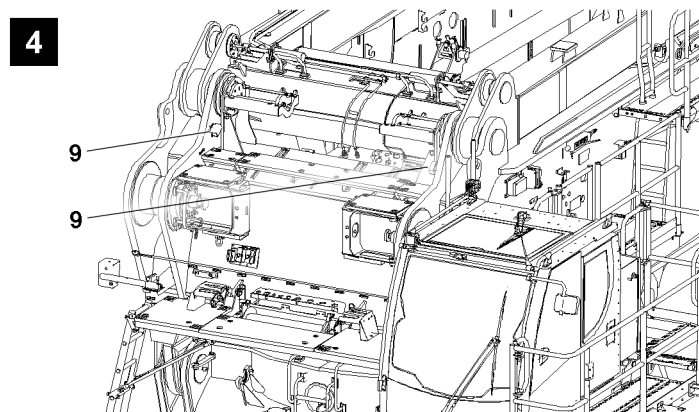

Fig.124467

**Note**

- ▶ The limit switch functions must be checked individually for the erection of the SA-frame, see illustration **4**.

- ▶ Cover limit switches **9** individually with a metal plate.

Result:

- The spool out function of winch 4 turns off.

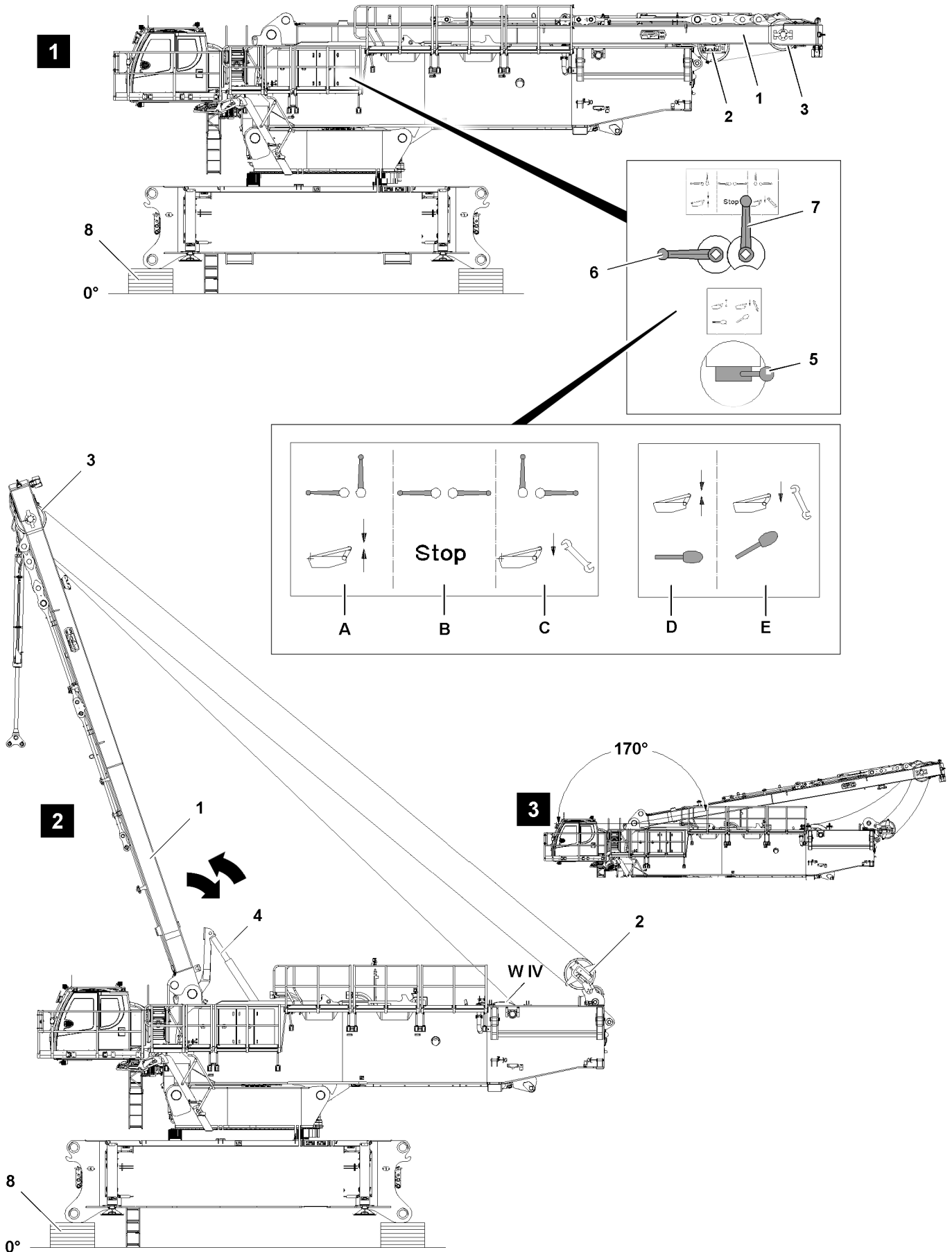

Fig.124466

LWE/LR 11000-001/23501-04-02/en

1.2 Placing the SA-frame onto the turntable

1.2.1 Take down procedure

Make sure that the following prerequisites are met:

- The SA-operating mode has been set and confirmed on the LICCON computer system.
- Ball valve **6** and ball valve **7** are in position **A**
- The SA-frame is in the operating range.



Note

- ▶ Functions of master switch MS1, see Crane operating instructions, chapter 4.05.

- ▶ Move master switch MS1 in direction X-.

Result:

- Winch 4 spools up.
- The SA-frame is pulled back against the pressure in the erection cylinders, see illustration 2.



Note

- ▶ When the SA-frame leaves the operating range when luffing up, an **error message** and **LMB STOP** is shown on the LICCON monitor.
- ▶ Spooling up of winch 4 is turned off.



WARNING

Danger of accident when exceeding the LICCON overload safety device!

If the shut off limits of the LICCON overload safety device are exceeded, there is no additional protection against overload!

Due to erroneous operation or deliberate misuse, the crane could collapse, the SA-frame can collapse or the crane can topple over!

Personnel can be severely injured or killed!

This could result in high property damage!

- ▶ The function „Exceedance of the LICCON overload safety device“ may only be activated or used in emergencies and for assembly purposes.
- ▶ The function „Exceedance of the LICCON overload safety device“ may only be activated or used by an authorized person who knows the effects of the bypass exactly.
- ▶ The „Exceedance of the LICCON overload safety device“ may only be carried out „anticipatorily“ and with utmost caution.
- ▶ The „Exceedance of the LICCON overload safety device“ is only permissible if the set up configuration of the crane has been entered correctly into the LICCON computer system and has been confirmed!

- ▶ Exceeding the LICCON overload safety device, see Crane operating instructions, chapter 4.02.

Result:

- No further protection against overload of the crane is present.
- The assembly icon appears on the LICCON monitor, see Crane operating instructions, chapter 4.02.



WARNING

Danger of fatal injury from SA-frame!

During the take down of the SA-frame, personnel can be severely injured or killed!

- ▶ Make sure that no persons or objects are within the danger zone.

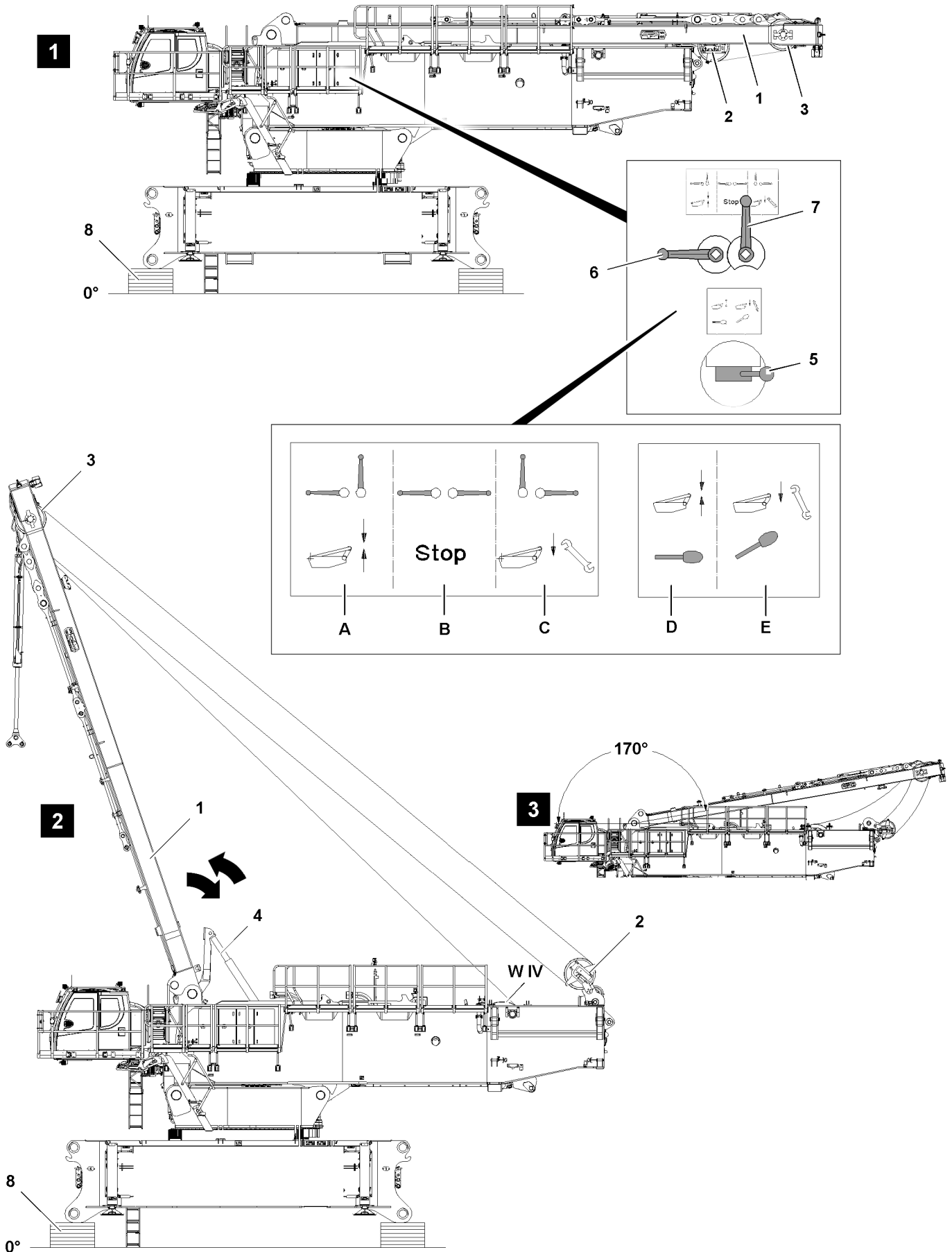

Fig.124466

LWE/LR 11000-001/23501-04-02/en

**WARNING**

Independent lowering of the SA-frame!

Due to an incorrect ball valve position, the SA-frame can lower backward by itself!

Personnel can be severely injured or killed!

It can result in slack rope build up and to destruction of crane components!

- ▶ Ball valve **6** and ball valve **7** must be in position **A** during assembly and crane operation!
- ▶ The ball valve position **C** and ball valve position **B** are only permissible when lowering the SA-frame onto the turntable (transport position)!

**Note**

- ▶ Functions of master switch MS1, see Crane operating instructions, chapter 4.05.

When the LICCON overload safety device is exceeded:

- ▶ Move master switch MS1 in direction X-.

Result:

- Due to the own weight of the SA-frame **1** and by spooling up winch 4 simultaneously, the SA-frame is lowered to the rear against the pressure in the erection cylinders **4**, see illustration **2**.

**Note**

- ▶ Spooling up of winch 4 is shut off from an angle of the SA-frame of approx. 170°, see illustration **3**.

NOTICE

Damage to crane!

The ball valve position **B** and the ball valve position **C** are only permissible when lowering the SA-frame from 170° onto the turntable (transport position)!

- ▶ If this is not observed, parts of the crane will be destroyed.

NOTICE

SA-frame damage!

At a forward incline of the crane, the SA-frame or the rope pulleys can be damaged before the shut off is reached.

- ▶ Make sure that the SA-frame and the rope pulley are not moved together too far.
- ▶ Always use a guide when placing the SA-frame down.

When the SA-frame has reached an angle of approx. 170° and winch 4 is turned off:

- ▶ Turn off / deactivate the function „Exceedance of the LICCON overload safety device“.

Result:

- The LICCON overload safety device is active.
- Winch 4 can be actuated again.
- ▶ Lower the SA-frame **1** onto the turntable: Move the hand lever **5** to position **E**.

Result:

- The erection cylinders move in.
- The SA-frame **1** lowers.

When the SA-frame **1** is lowered completely on the turntable, see illustration **1**:

- ▶ Return the hand lever **5** to zero position **D** and set the ball valve **6** and ball valve **7** to position **B** and secure.
- ▶ Secure the ball valves immediately after assembly with a lock to prevent unauthorized access.

Empty page!

LWE/LR 11000-001/23501-04-02/en

5.03 Boom systems

1	Boom components	3
2	Arrangement of intermediate sections on the boom	3
3	Auxiliary guying	7

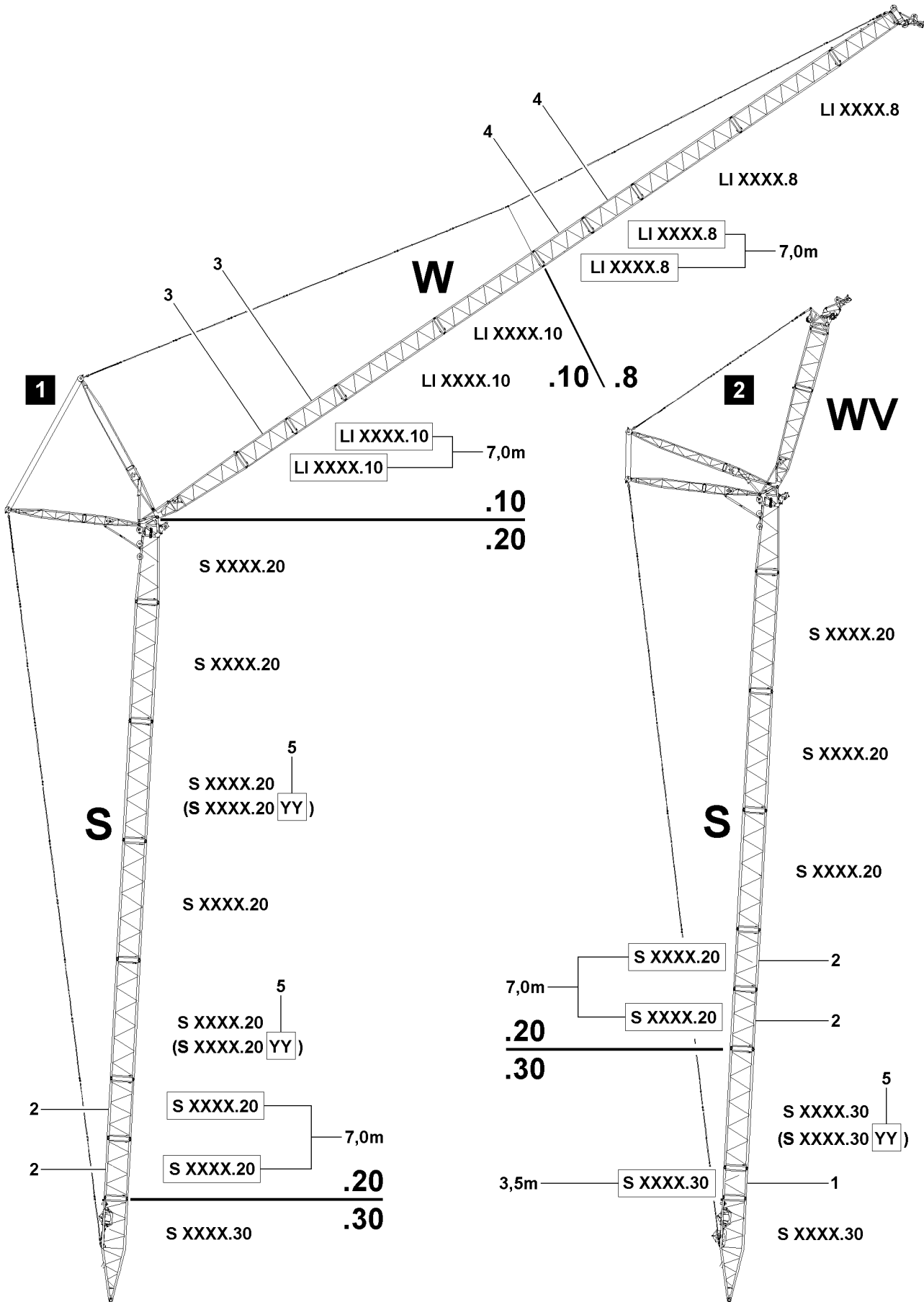

Fig.116151

LWE/LR 11000-001/23501-04-02/en

1 Boom components



Note

- ▶ For boom components including associated system dimensions, lengths and component weights refer to the Crane operating instructions, chapter 1.03.

2 Arrangement of intermediate sections on the boom



Note

- ▶ The following description is an example and may not exactly match to your crane.
- ▶ Lengths, weights and system dimensions of the intermediate sections are examples and may differ from the data on your crane.
- ▶ For exact crane data refer to the respective rod plan.
- ▶ For dimensions and weights of crane components, see Crane operating instructions, chapter 1.03.



WARNING

Boom can break off!

The arrangement of the intermediate sections on booms or boom systems are based on extensive static calculations. If the arrangement of the intermediate sections according to the rod plan is not observed, the crane can collapse, the boom can break off or the crane can topple over.

Death, severe bodily injuries, property damage.

- ▶ Always carry out the arrangement of the intermediate sections according to the rod plan.
- ▶ If an auxiliary guying is required for a certain boom length, then it must always be installed according to the rod plan on the position defined in the rod plan.

General specifications for the configuration of booms or boom systems:

- With the same system dimension, two short intermediate sections with a length of 3.5 m are heavier than one single intermediate section with a length of 7.0 m.
- With the same system dimension, two short intermediate sections with a length of 7.0 m are heavier than one single intermediate section with a length of 14.0 m.
- With the same system dimension, two short intermediate sections with a length of 3.5 m can be replaced by one single intermediate section with a length of 7.0 m.
- With the same system dimension, two short intermediate sections with a length of 7.0 m can be replaced by one single intermediate section with a length of 14.0 m.
- For intermediate sections with the same system dimension but different lengths, always install the short intermediate sections on the bottom in the boom, due to their weight, in direction of the slewing ring, see also illustration 1 and illustration 2.
- The heavier one intermediate section is, the higher is the value of the last two digits on the system dimension plate.
- Pay attention to the last two letters following the letter combinations (YY) 5 on the last two letters on the system dimension plate and observe them.

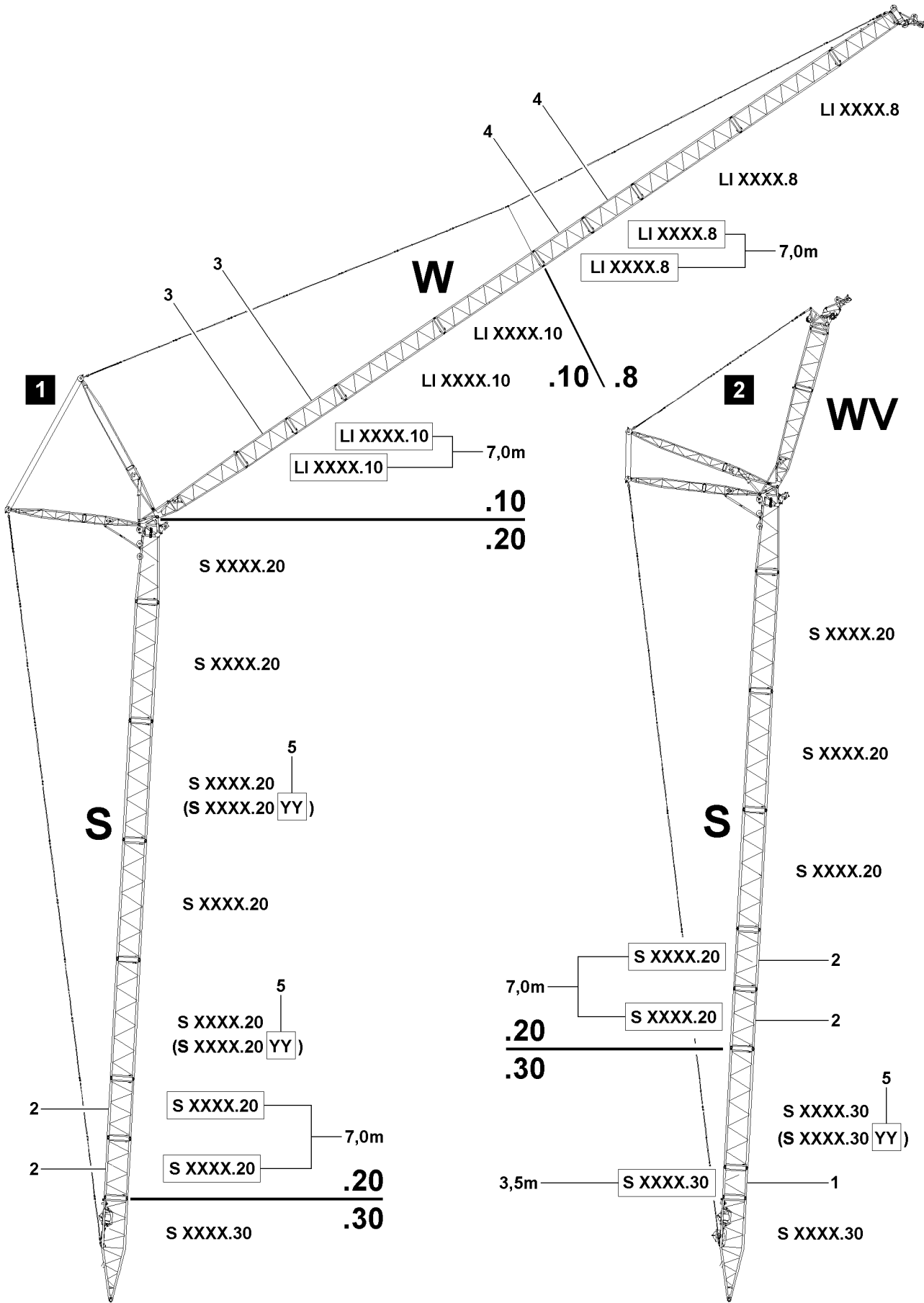

Fig.116151

LWE/LR 11000-001/23501-04-02/en

System dimensions and assignment				
Position	System		Heavy	Light
1	S XXXX	.30	X	
2	S XXXX	.20		X
3	LI XXXX	.10	X	
4	LI XXXX	.8		X
5	S XXXX	.40 YY	X	

2.1 Arrangement of intermediate sections



WARNING

Danger of accidents due to incorrectly assembled intermediate sections!

- ▶ Any other arrangement of the intermediate sections and guy rods than specified in the operating instructions or the rod plans is prohibited.
- ▶ There is the danger that intermediate sections are mixed up, they are differently sized and do not differ externally.
- ▶ The intermediate sections differ externally only by the welded on plates (.8, .10, .12, .16, .20, .25, .30, .40 YY).
- ▶ When assembling the boom, it must be ensured that the intermediate sections are arranged and installed according to their description as stated on the rod plan.
- ▶ Observe and adhere to the additional letter combinations (YY) **5** on the system dimension plate of the intermediate sections at assembly of the intermediate sections.



WARNING

Arrangement of intermediate sections!

If the arrangement of the intermediate sections is not carried out according to the rod plan, then the boom can be overloaded, bend down and break off.

Death, severe bodily injuries, property damage.

This could result in high property damage.

- ▶ For intermediate sections with the same system dimension but different length the shorter intermediate sections must always be installed on the bottom in the boom, in direction of the rotary connection, except if another installation position is specified in the rod plan.
- ▶ The specifications in the rod plan must be adhered to in any case.

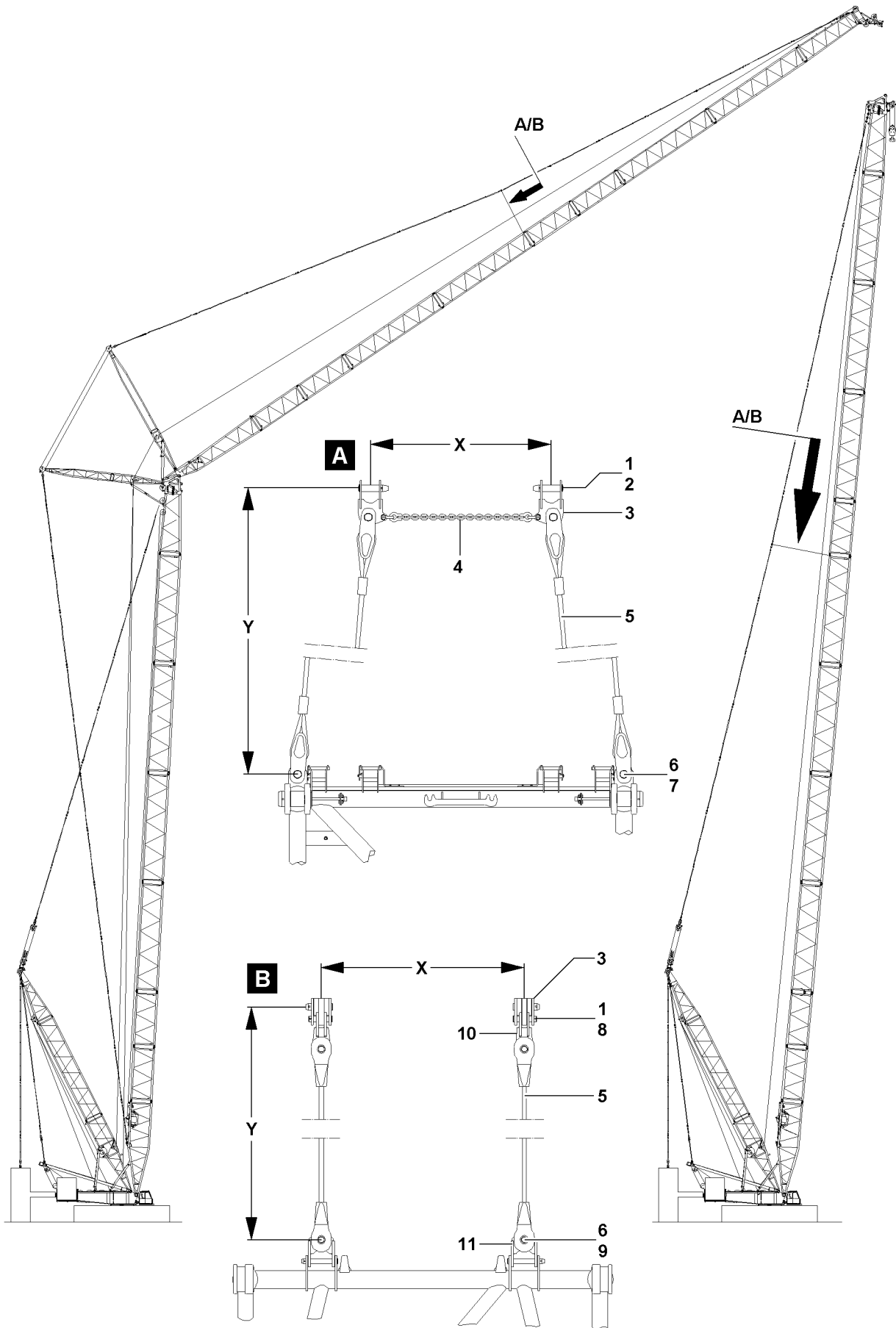

Fig.112270

LWE/LR 11000-001/23501-04-02/en

3 Auxiliary guying



Note

- ▶ The following description is an example and may not exactly match to your crane.
- ▶ For exact crane data refer to the respective rod plan.

3.1 Installing the auxiliary guying

The auxiliary guying, in regards to safe crane operation - especially for long boom systems - is of vital importance.

The auxiliary guying is a deciding factor in relieving the boom, or the boom system during erection and take down as well as during crane operation.



WARNING

The crane can topple over!

If the auxiliary guying is not installed or not installed on the position specified in the rod plan, then the crane can collapse, the boom can break off or the crane can topple over.

- ▶ If an auxiliary guying is specified in the rod plan for the required boom length, then it must be installed on the respective position.
- ▶ Make sure that the auxiliary guying is always completely installed and that all pins are properly pinned and secured.



Note

- ▶ The boom lengths, for which an auxiliary guying is required, can be seen in the rod plan.
- ▶ Depending on the crane type: To install the auxiliary guying, remove the standard lugs and install the „Lugs for the auxiliary guying“.

Components of auxiliary guying, illustration A	
Position	Description
1	Pin
2	Spring retainer
3	Bracket
4	Chain
5	Rope
6	Pin
7	Spring retainer

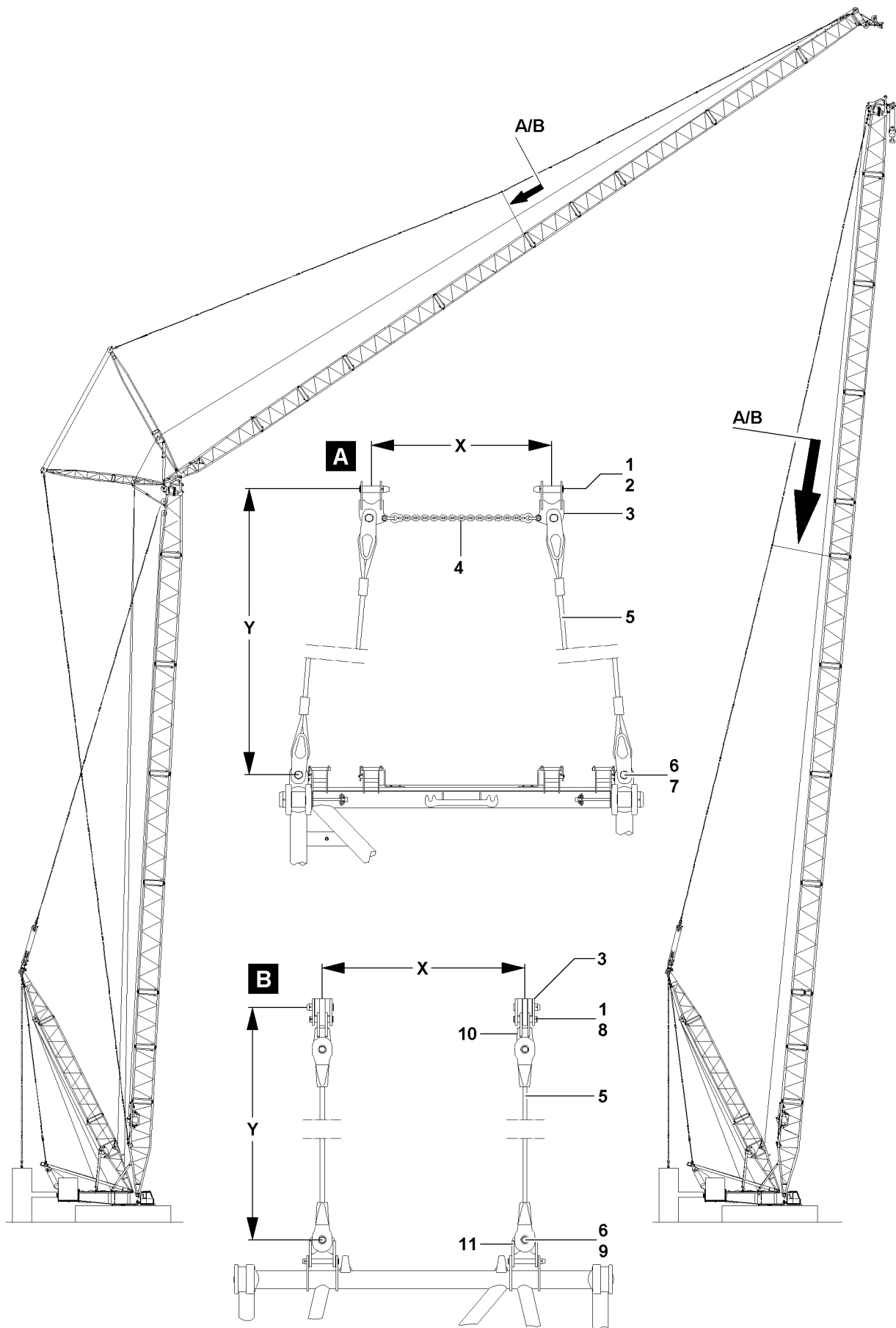

Fig.112270

LWE/LR 11000-001/23501-04-02/en

Components of auxiliary guying, illustration B	
Position	Description
1	Pin
3	Bracket
5	Rope
6	Pin
8	Locking pin
9	Locking pin
10	Cross-shaped lug
11	Cross-shaped lug

The lugs **3** must be installed in the guying instead of the standard lugs. The auxiliary guying is installed on the lugs **3**.

The guy ropes **5** are pinned on top on the lugs **3** of the guying or on the cross-shaped lugs **10**. The guy ropes **5** are pinned on the bottom on the lugs / connector points on the boom, see illustration **A** or on the cross-shaped lugs **11**, see illustration **B**.

- ▶ Install the guy ropes: Pin the guy ropes on top on the guying with pin **1** and secure with spring retainer **2**, see illustration **A**.

or

- Install the guy ropes: Pin the guy ropes on top on the guying with pin **1** and secure with locking pin **8**, see illustration **B**.

When the guy ropes **5** are pinned and secured on the lugs **3** of the guying or on the cross-shaped lugs **10**:

- ▶ Pin the guy ropes **5** on the lugs / connection points on the boom, see illustration **A** with pin **6** and secure with locking spring **7**.

or

- Pin the guy ropes **5** on the cross-shaped lugs **11** on the boom, see illustration **B** with pin **6** and secure with locking pin **9**.



WARNING

The crane can topple over!

If the chain **4** is not installed in connection with the auxiliary guying, then the guying can be damaged, the boom can break off and the crane can topple over.

Personnel can be severely injured or killed.

- ▶ The auxiliary guying must be installed according to the rod plans.
- ▶ If a chain **4** is specified in the rod plan, then it must always be installed in connection with the auxiliary guying, otherwise the guy rods will be pulled apart.

- ▶ Recheck the proper and complete assembly of the auxiliary guying before erecting the boom / boom system.

Empty page!

LWE/LR 11000-001/23501-04-02/en

5.05 D-boom

1	Component overview	3
2	Fastening points for derrick components	3
3	D-boom assembly on the crane	7
4	Erecting the D-boom	35
5	D-boom assembly on the ground	42
6	Flying D-boom assembly	44
7	Disassembling	49
8	D-boom disassembly on the ground	75
9	Flying D-boom disassembly	77

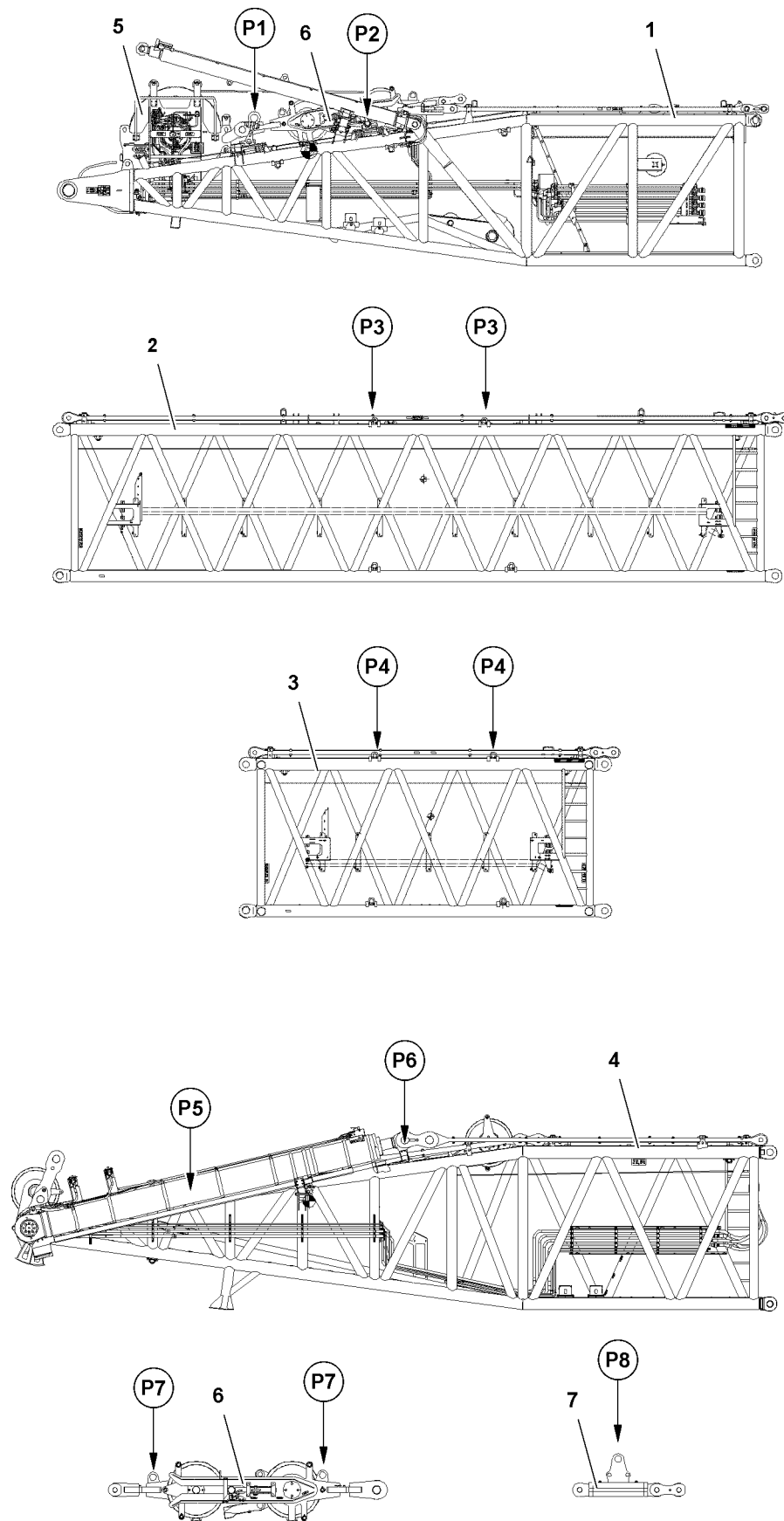

LWE/LR 11000-001/23501-04-02/en

Fig.116964

1 Component overview



Note

- ▶ The assembly sections are marked with their own weight.



Note

- ▶ Dimensions and weights, see the Crane operating instructions, chapter 1.03.

Position	Component
1	D-pivot section
2	D-intermediate section 2825.20 12 m
3	D-intermediate section 2825.25 6 m
4	D-end section
5	Winch 3
6	S-luffing pulley block
7	Auxiliary weight

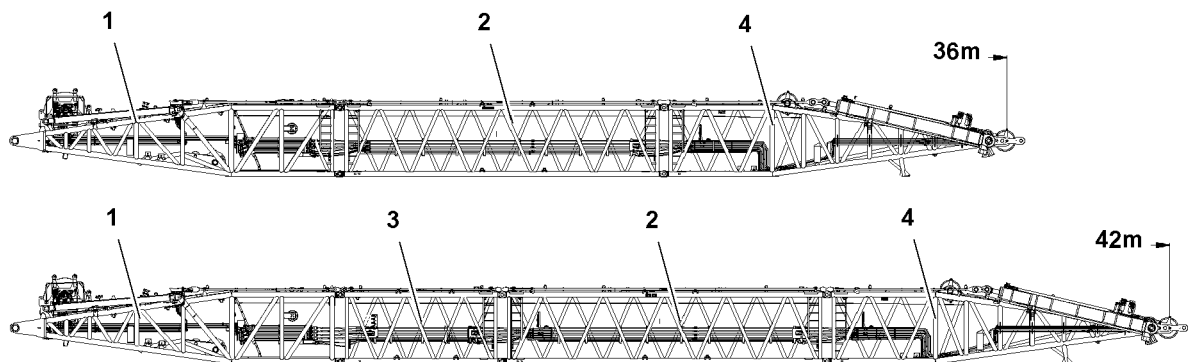

Fig.116965: Derrick boom combination

2 Fastening points for derrick components



WARNING

Component incorrectly fastened!
Death, severe bodily injuries, property damage.

- ▶ Fasten the components only on the intended fastening points on both sides.
- ▶ Fastening of components and description of fastening points, see Crane operating instructions, chapter 5.01.

2.1 Fastening points D-pivot section

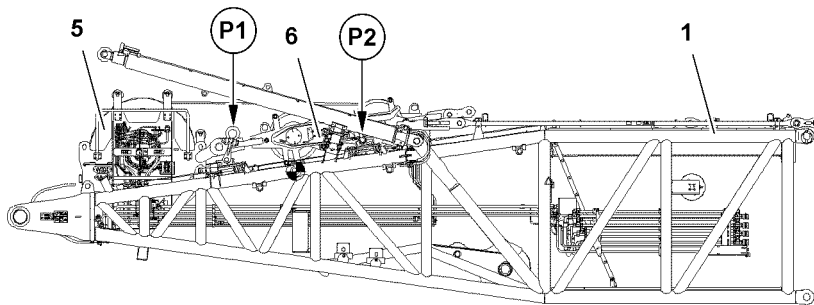

Fig.122782: Fastening points D-pivot section

Fastening points	
P1 and P2	D-pivot section

2.2 Fastening points D-intermediate section 2825.20 12 m

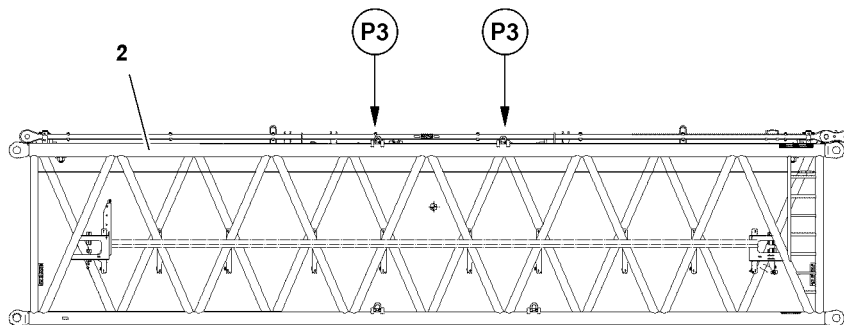

Fig.122783: Fastening points D-intermediate section 2825.20 12 m

Fastening points	
P3	D-intermediate section 2825.20 12 m

2.3 Fastening points D-intermediate section 2825.25 6 m

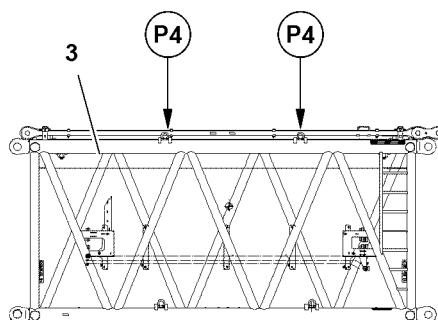

Fig.122784: Fastening points D-intermediate section 2825.25 6 m

Fastening points	
P4	D-intermediate section 2825.25 6 m

2.4 Fastening points D-end section

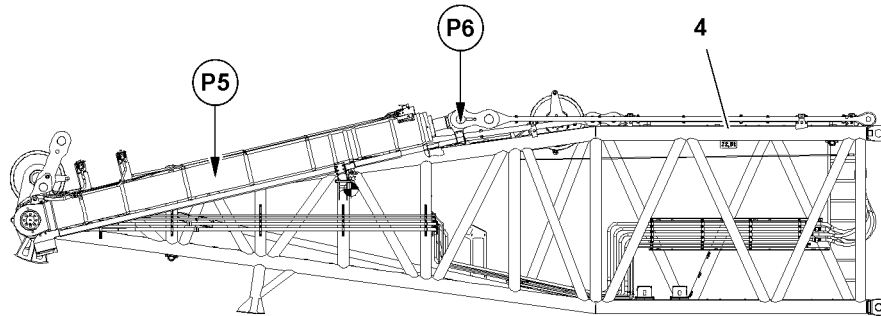

Fig.122785: Fastening points D-end section

Fastening points	
P5 and P6	D-end section

2.5 Fastening points S-luffing pulley block

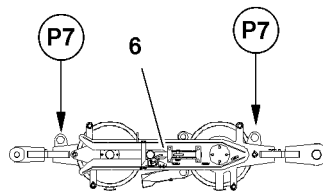

Fig.122786: Fastening points S-luffing pulley block

Fastening points	
P7	S-luffing pulley block

2.6 Fastening points Auxiliary weight

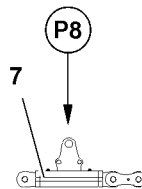

Fig.122787: Fastening points Auxiliary weight

Fastening points	
P8	Auxiliary weight

LWE/LR 11000-001/23501-04-02/en

Fig.195219

LWE/LR 11000-001/23501-04-02/en

3 D-boom assembly on the crane



WARNING

Danger of falling!

During assembly / disassembly, inspection and maintenance work, personnel must be secured with appropriate aids to prevent them from falling.

If this is not observed, assembly personnel could fall and be killed or seriously injured.

- ▶ All work at a height, when there is a danger of falling, must be carried out with suitable aids.
- ▶ If aids are not available and work cannot be carried out from the ground, then assembly personnel must secure themselves with the supplied fall arrest system to prevent falling, see the Crane operating instructions, chapter 2.04.
- ▶ If fall protection equipment is available, then it must be used, see the Crane operating instructions, chapter 2.06.
- ▶ When lifting, lowering, swinging crane parts in and out, no persons may remain in the danger zone.
- ▶ If railings are present on the components, then they must be brought into the corresponding position and secured for assembly / disassembly work.
- ▶ Only step on the aids, ladders and catwalks with clean shoes.
- ▶ Keep aids, ladders and catwalks free of heavy dirt, snow and ice.
- ▶ During all assembly and disassembly work, maintenance work and inspections, travel or crane operation is prohibited.
- ▶ Remaining on a suspended load is prohibited.
- ▶ Stepping or walking on crane components and lattice sections, which have an incline of more than 20° is prohibited.
- ▶ For all assembly work, the crane operator of the main crane must be in voice contact with the crane operator / crane operators of the auxiliary crane / auxiliary cranes.
- ▶ For assembly / disassembly tasks, the crane operator may only initiate crane movements when the responsible guide has explicitly released the movement.



WARNING

Danger of impact / crushing!

When installing / removing crane components with the auxiliary crane, crane components can start to swing back and forth.

When lifting / lowering and positioning crane components, there is an increased danger of impacts / crushing.

Death, severe bodily injuries, property damage.

- ▶ Make sure that personnel cannot be caught by components.
- ▶ When working in danger zones: Use aids to protect limbs.
- ▶ Guide components with suitable aids to minimize oscillation.

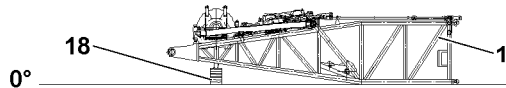

Fig.144113: D-pivot section with substructure



WARNING

Danger of tipping over!

If the D-pivot section is placed on the ground before assembly, then it must be supported accordingly. If the D-pivot section is not supported, then it can tip forward.

Death, severe bodily injuries, property damage.

- ▶ Only set the D-pivot section 1 down on a proper substructure 18.

**DANGER**

The components can fall down!

If the corresponding components are disengaged from the auxiliary crane before the corresponding component is pinned, the corresponding component can fall down and fatally injure personnel.

- ▶ Do not disengage the auxiliary crane until the respective component is pinned and secured.

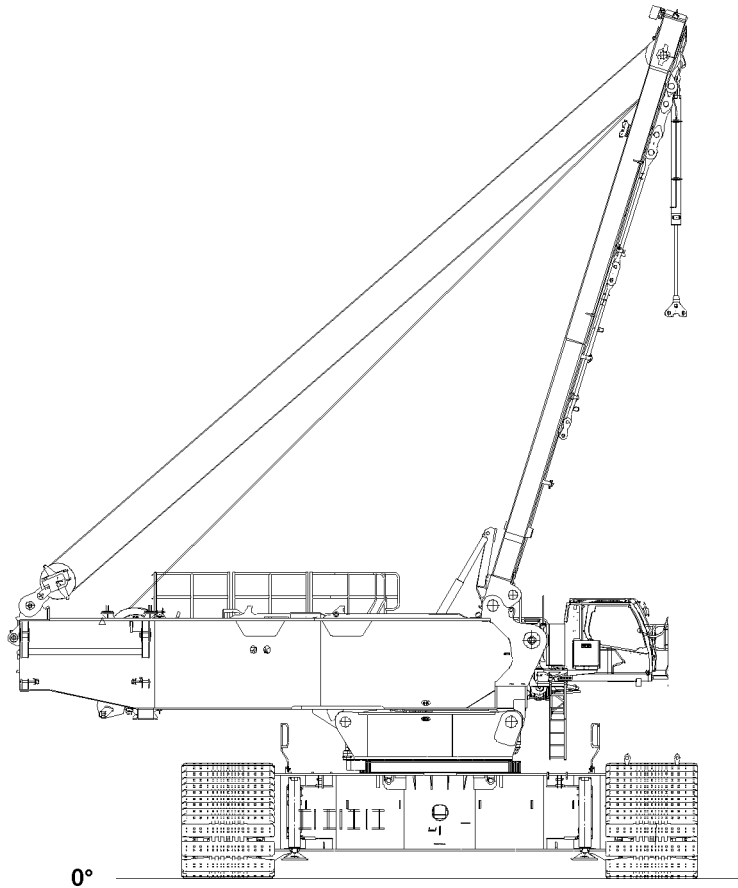

Fig.122720

**WARNING**

The lattice sections can fall down!

If the lattice sections are not pinned and secured correctly, then they can fall down and fatally injure personnel.

- ▶ Pin or unpin both pins at the same horizontal level, i.e. **left and right**.
- ▶ Do not stand under the lattice sections or within the entire danger zone during the pinning and unpinning procedure of the boom.
- ▶ Safely secure the pins in the storage locations as well as in the receptacles.
- ▶ It is prohibited to lean the auxiliary ladder against the component being disassembled.

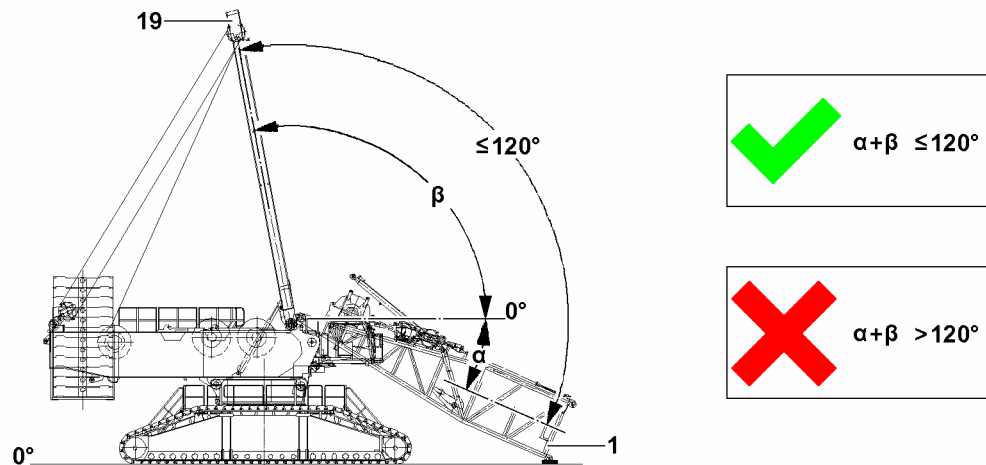

Fig.144110: The difference angle between the D-pivot section and the SA-frame may not exceed 120°

NOTICE

Damage of derrick boom and SA-frame!

Upon assembly / disassembly, if a difference angle between the D-pivot section 1 and the SA-frame 19 of 120° is exceeded, this can cause damage.

- ▶ Make sure that an angle of more than 120° is never reached between the SA-frame 19 and the D-pivot section 1.

NOTICE

Damage of derrick boom and SA-frame!

If the SA-frame is pulled by winch 4 (intake gear) to the rear in direction of the turntable, then the derrick boom and the SA-frame can be severely damaged.

Expensive and extensive repairs can result.

- ▶ As long as the guying between the SA-frame and the assembled D-pivot section or between the SA-frame and the assembled D-boom is **not** assembled and guyed, do not pull the SA-frame to the rear in direction of the turntable.



Note

- ▶ The assembly and disassembly of the derrick boom with 36 m corresponds to the assembly and disassembly of the derrick boom with 42 m, but without the derrick auxiliary guying.
- ▶ The assembly and disassembly of the derrick boom is described based on the example of the derrick boom with 42 m.

Make sure that the following prerequisites are met:

- The crane is horizontally aligned.
- An auxiliary crane is available.
- An assembly scaffolding / work platform is available.
- The required counterweight is installed, see the Crane operating instructions, chapter 3.06.
- The target set up configuration (completely erected crane) is set in the set up program.
- No main boom is assembled on the turntable.
- The assembly cylinder on the SA-frame is pinned and secured in the transport position.

3.1 Turning the turntable into the assembly position



DANGER

The crane can topple over!

If the following conditions are not met before turning the turntable - **without** installed D-boom, the crane can topple over.

Death, severe bodily injuries, property damage.

- ▶ Observe the specifications in the erection and take-down charts.
- ▶ Observe the assembly conditions for operation on crawlers, see Crane operating instructions, chapter 3.06.

- ▶ Turn the turntable in lengthwise direction of the crawler travel gear.

3.2 Exceeding the shut off limits of the LICCON overload protection for assembly operation



WARNING

Danger of accident due to function „Exceeding the shut-off limits of the LICCON overload protection“. If the shut off limits of the LICCON overload protection are exceeded, there is no additional protection against crane overload.

Due to erroneous operation or deliberate misuse, the crane could collapse, the boom can break off or the crane can topple over.

Death, severe bodily injuries, property damage.

- ▶ The function „Exceedance of shut off limits of the LICCON overload protection“ is only permissible in emergencies and for assembly purposes.
- ▶ The function „Exceeding the shut off limits of the LICCON overload protection“ may only be actuated by persons who know the effects of their actions regarding the function „Exceeding the shut off limits of the LICCON overload protection“.
- ▶ The function „Exceedance of shut off limits of the LICCON overload protection“ requires the presence of an authorized person and must be performed with utmost caution.
- ▶ Crane operation with activated function „Exceedance of shut off limits of the LICCON overload protection“ is prohibited.

- ▶ Exceeding the shut off limits of the LICCON overload protection: Engage assembly operation.

Result:

- The shut off limits of the LICCON overload protection are exceeded.
- The assembly icon appears on the LICCON monitor.



Note

- ▶ See the Crane operating instructions, chapter 4.02 and chapter 4.20.

Empty page!

LWE/LR 11000-001/23501-04-02/en

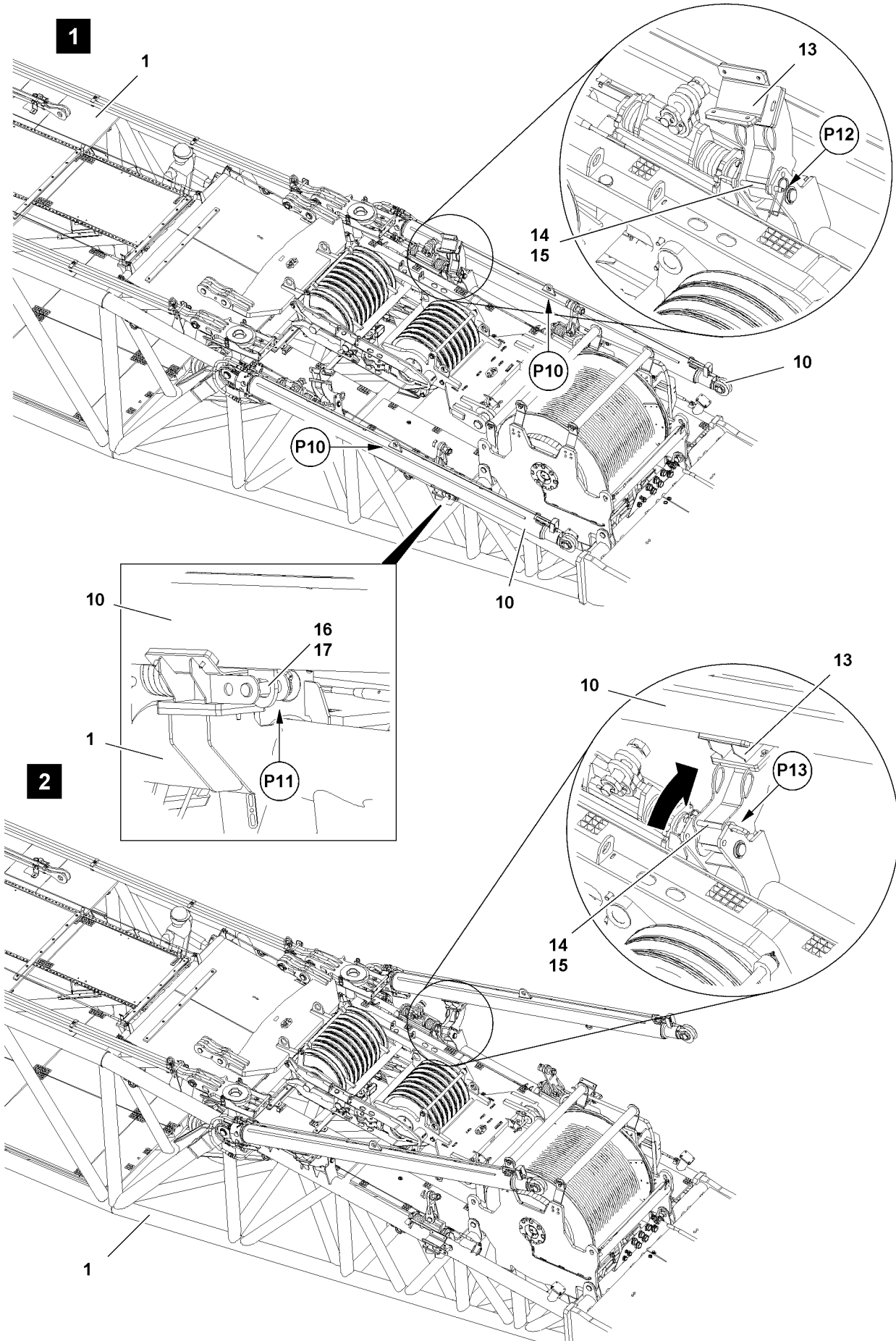

Fig.116967

LWE/LR 11000-001/23501-04-02/en

3.3 Installing the D-boom in sections

3.3.1 Erecting the D-relapse cylinder

- ▶ Remove the safety locking pin **17** at point **P11** and unpin the pin **16**, see illustration 1.

Result:

- The D-relapse cylinder **10** is released.
- ▶ Fasten the D-relapse cylinder **10** to the auxiliary crane at point **P10**, see illustration 1.
- ▶ Lift the D-relapse cylinder **10** with the auxiliary crane.
- ▶ Insert the pin **16** again at point **P11** and secure with the safety locking pin **17**.
- ▶ Remove the spring retainer **15** at point **P12** and unpin the grip pin **14**, see illustration 1.

Result:

- The support **13** is released.



WARNING

Danger of crushed limbs!

When swinging the support **13**, fingers and hands can be crushed.

- ▶ Do not reach with your hands into the danger zone.
- ▶ Swing the support **13** up to the stop.
- ▶ Insert the grip pin **14** at point **P13** and secure with the spring retainer **15**, see illustration 2.

Result:

- The support **13** is secured in operating position.



WARNING

Danger of crushed limbs!

When placing the D-relapse cylinder **10** down, fingers and hands can be crushed.

- ▶ Do not reach with your hands into the danger zone.
- ▶ Place the D-relapse cylinder **10** with the auxiliary crane on the support **13**.
- ▶ Remove the fastening equipment at point **P10**.
- ▶ Swing the second support into operating position.

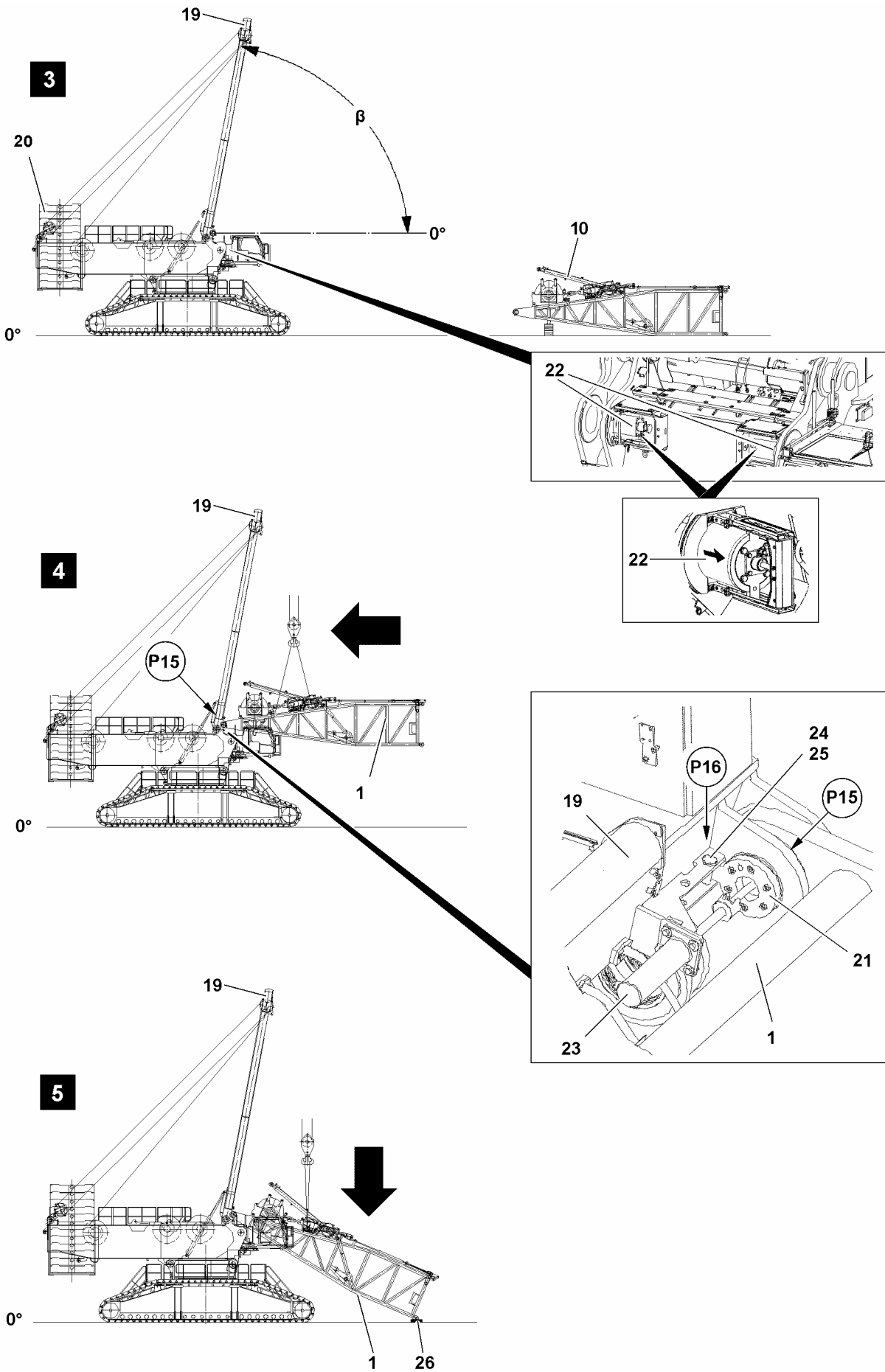

Fig.144114

LWE/LR 11000-001/23501-04-02/en

3.3.2 Pinning the D-pivot section on the SA-frame



DANGER

Danger of fatal injury due falling components!

If the pin connections are not visually inspected, the pins can loosen up by themselves and cause components to fall down.

Death, severe bodily injuries, property damage.

- ▶ All pins must be secured after assembly with the intended safety elements. Check visually.
- ▶ The guy rods must be inspected regularly, see the Crane operating instructions, chapter 8.15.

NOTICE

Danger of property damage!

If the SA-frame **19** with an installed and unguyed D-pivot section **1** is erected further than 90° (angle β), components can be seriously damaged.

- ▶ Do not erect the SA-frame **19** with an installed and unguyed D-pivot section **1** too far.

Make sure that the following prerequisites are met:

- The SA-frame **19** is erected to approx. 80° (angle β), see illustration **3**
- The D-relapse cylinders **10** are erected, see illustration **3**.
- The connector pins **22** on the S-pivot section are completely unpinned, see illustration **3**.
- The required counterweight **20** is installed, see the Crane operating instructions, chapter 3.06.
- The crane engine is running.



Note

- ▶ Fastening points, see section „Fastening points for derrick components“.

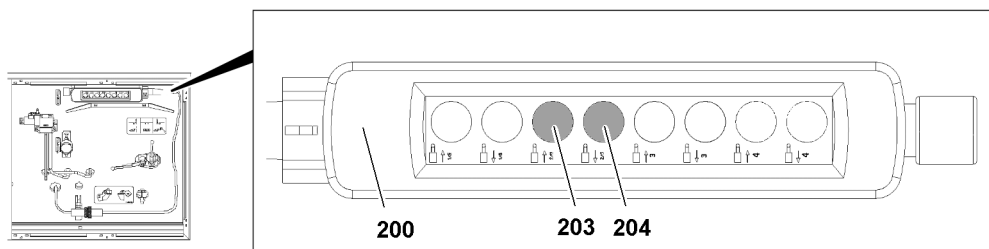

Fig.123563: Control panel

When the connector pins **21** for the D-pivot section **1** are pinned:

- ▶ Unpin the connector pins **21** on both sides: Press the button **204** on the control panel **200** and „hold it down“ until the connector pins **21** are completely unpinned.
- ▶ Fasten the D-pivot section **1** to the auxiliary crane and swing in to the pin points **P15** on the SA-frame **19**, see illustration **4**.



WARNING

Falling D-pivot section!

Due to non-secured or insufficiently secured connector pins, the D-pivot section can fall down.

Death, severe bodily injuries, property damage.

- ▶ The connector pins **21** must be secured after the pinning procedure on the SA-frame with the retaining pins **24**.

- ▶ Insert the connector pins **21** on both sides: Press the button **203** on the control panel **200** and „hold it down“ until the connector pins **21** are completely pinned, see illustration **4**.

When the connector pins **21** are completely pinned on both sides:

- ▶ Secure the connector pins **21** with retaining pins **24**.
- ▶ Insert the retaining pin **24** at point **P16** to the stop and secure with the spring retainer **25** see illustration **4**.

NOTICE

Incorrect take-down of the D-pivot section!

Property damage can occur by incorrectly taking down the assembled D-pivot section 1.

- ▶ Make sure that the D-pivot section is not placed down below the alignment level.
- ▶ When taking the D-pivot section down, always use a sufficiently load bearing and large enough substructure.

**Note**

D-pivot section substructure

If the SA-frame 19 is adjusted, also the pinned D-pivot section 1 is adjusted.

- ▶ Support the D-pivot section 1 so that when adjusting the SA-frame 19, the D-pivot section 1 does not slide away from the substructure.

NOTICE

Danger of property damage!

If the pins of the S-boom are in the **pinned** position when taking the D-pivot section 1 down in the turntable, components can be severely damaged.

- ▶ Make sure that the pins 22 on the turntable are in **unpinned** position when taking down the D-pin 1.
- ▶ Take down the D-pivot section 1 carefully with the auxiliary crane on the substructure 26, see illustration 5.
- ▶ Remove the auxiliary crane.

3.3.3 Establishing the hydraulic connections to the D-pivot section

The hydraulic connections are made with quick couplings.

NOTICE

Danger of property damage!

If the hydraulic lines are not connected with the turntable before lowering the SA-frame 19 to the front, then they will be crushed when lowering the SA-frame.

- ▶ Make sure, before lowering the SA-frame 19 to the front, that the hydraulic lines are connected with the turntable.

When connecting hydraulic lines with quick couplings, make sure that the coupling procedure is carried out correctly.

**WARNING**

Pressure in the hydraulic lines!

If the pressure supply is not interrupted before connecting / releasing the hydraulic lines, the hydraulic oil can escape with high pressure.

Death, severe bodily injuries, property damage.

- ▶ Release the pressure in the hydraulic system before connecting / disconnecting: Interrupt the pressure supply and wait for a short time.

**WARNING**

Loss of pressure or leakage!

Incorrectly coupled or self-loosening quick couplings (particularly return lines) can result in serious accidents due to component failure.

- ▶ Check that the quick couplings have been properly connected before using the crane.
- ▶ Connect the coupling components (sleeve and connector) and screw together with the knurled nut.
- ▶ Tighten the hydraulic coupling by hand. Rotate the knurled nut until it reaches a tangible, fixed stop position.
- ▶ Establish the hydraulic connections, see Hydraulic diagram.

3.3.4 Establishing the electrical connections to the D-pivot section

NOTICE

Danger of damage to the electrical connections!

If the electrical connection between the terminal box and the D-pivot section and the cable drum in the D-pivot section is established before the boom end section is installed and electrically connected, then the electric connection can be damaged.

- ▶ Make sure that the electric connection between the terminal box in the D-pivot section and the cable drum in the D-pivot section is only established **after** assembly and the connection of the electric wiring for the boom end section.



Note

- ▶ To establish the electrical connections on the D-pivot section: Use the Electric wiring diagram.

Make sure that the following prerequisite is met:

- The D-pivot section is completely assembled and placed on the substructure
- ▶ Establish the electrical connections.
- ▶ Make sure that all electrical connections to the D-pivot section have been established.



WARNING

Malfunction if dummy plugs are not installed!

If the dummy plugs on the non-required electrical connections are not installed, then malfunctions or functional limitations can occur on the crane.

- ▶ Make sure that all non-required electrical connections that have a dummy plug are closed off with dummy plugs.
- ▶ Pay attention to the Electrical wiring diagram.
- ▶ As a rule, close off on-required electrical connections (for example for accessories which cannot be installed) with the respective dummy plugs.

NOTICE

Property damage due to dirt and / or corrosion!

If non-required electrical connections are not closed off with the respective protective caps, then dirt and / or corrosion can damage the electrical connections.

This could result in malfunctions.

- ▶ Make sure that all non-required electrical connections are always closed off properly.
- ▶ Pay attention to the Electrical wiring diagram.
- ▶ Close electrical connections, which have no dummy plugs, properly off with the corresponding protective caps.

3.3.5 Lowering the SA-frame

Make sure that the following prerequisite is met:

- The hydraulic connections to the D-pivot section are established.

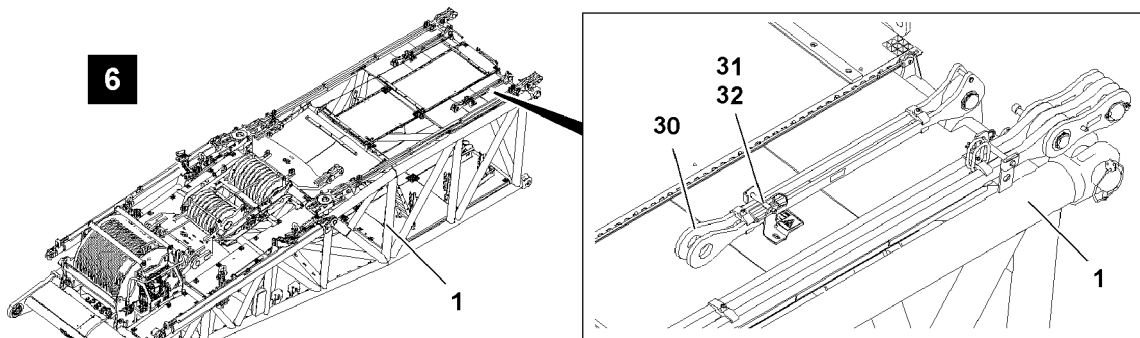

Fig. 144116: Rods for flying assembly

- Release the rods for flying assembly **30**: Remove the spring retainer **32** and unpin the pin **31**, see illustration **6**.

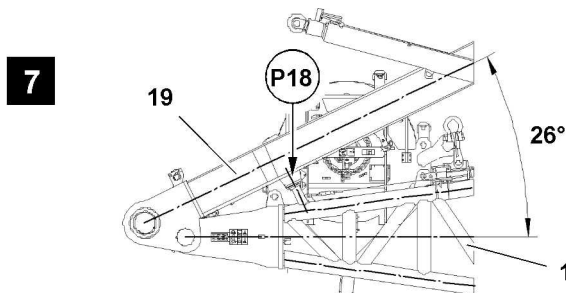

Fig. 144117: SA-frame on stop D-pivot section

NOTICE

Danger of slack rope formation!

At an angle of 26° between the SA-frame and the D-pivot section, the SA-frame **19** touches at point **P18** on the stop of the D-pivot section **1**, see illustration **7**.

This block position is not monitored with control technology. If winch **4** is spooled out further in this situation, slack rope may form.

- Make sure that winch **4** is not spooled out any further when the block position is reached.

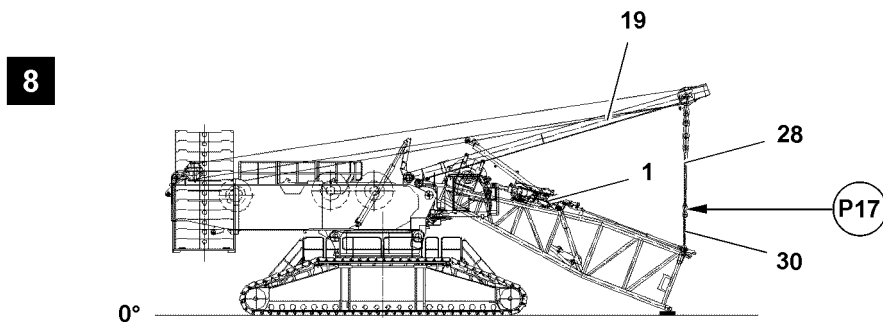

Fig. 144115: SA-frame on stop D-pivot section

- Lower the SA-frame **19** to the front: Spool out winch **4**.
- Connect the guy rods **28** of the SA-frame **19** with the rods for flying assembly **30** in point **P17**, see illustration **8**. Insert the pin and secure with the locking pin.
- Erecting the SA-frame: Spool winch **4** up until the guy rods are tensioned.

Empty page!

LWE/LR 11000-001/23501-04-02/en

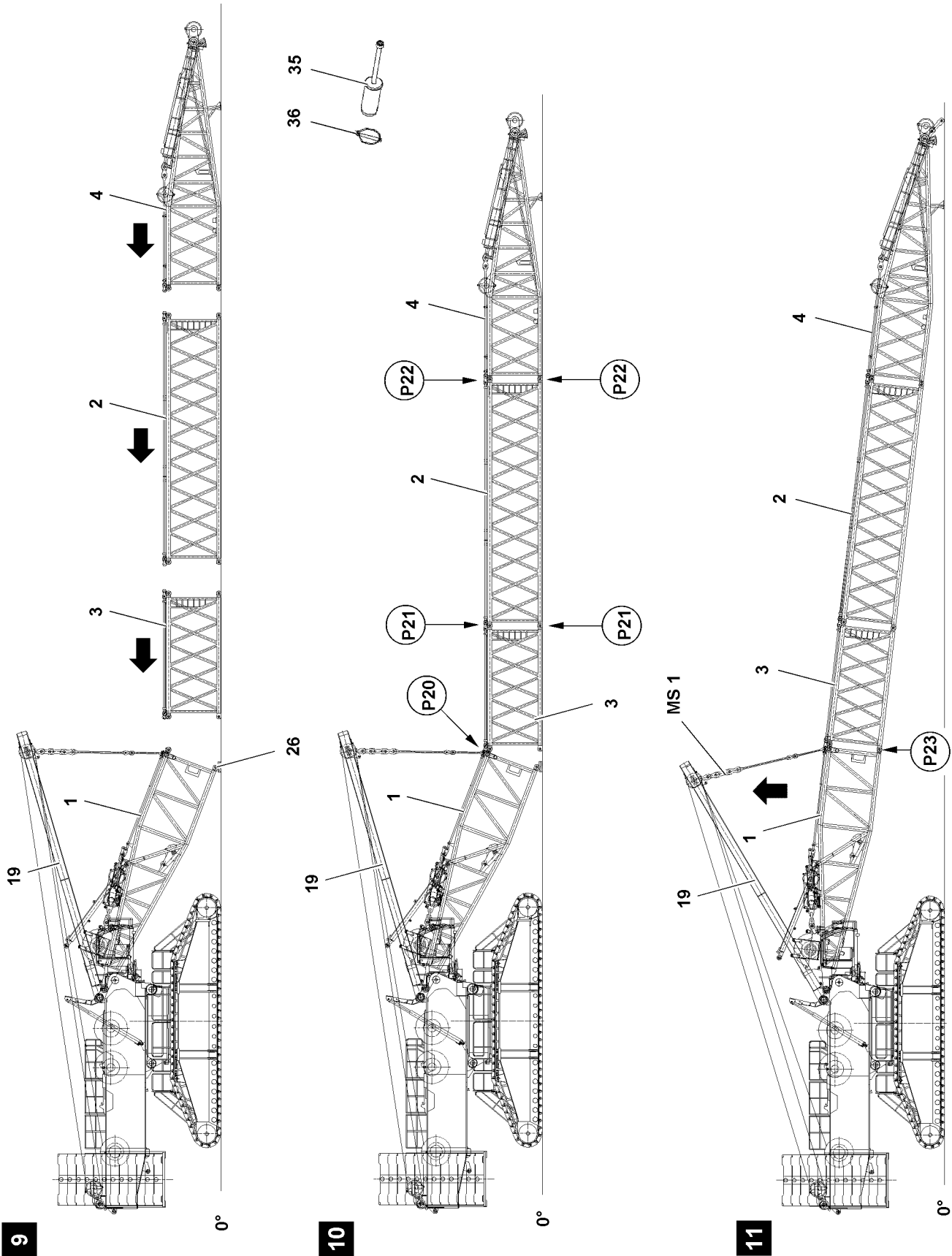

Fig.116979

LWE/LR 11000-001/23501-04-02/en

3.3.6 Assembling the D-lattice sections

Make sure that the following prerequisites are met:

- The D-pivot section is pinned and secured on the SA-frame.
- The D-pivot section is placed on the substructure **26**, see illustration **9**



Note

- ▶ Always support the D-lattice sections sufficiently for easier assembly.
- ▶ Pin and unpin the D-lattice sections with the pin pulling device, see Crane operating instructions, chapter 5.30.



Note

- ▶ Fastening points, see section „Fastening points for derrick components“.

Pin the D-intermediate section **3** on the D-pivot section **1** at point **P20** on top.

- ▶ Hang the D-intermediate section **3** on the auxiliary crane and align on the D-pivot section **1**.

When the pin bores on the D-pivot section **1** and on the D-intermediate section **3** align at point **P20**:

- ▶ Insert the pin **35** at point **P20** and secure with the locking pin **36**, see illustration **10**.
- ▶ Hang the D-intermediate section **2** on the auxiliary crane and align on the D-intermediate section **3**.

When the pin bores on the D-intermediate section **2** and on the D-intermediate section **3** align at points **P21**:

- ▶ Insert the pin **35** at the points **P21** on top and bottom and secure with locking pin **36**, see illustration **10**.
- ▶ Attach the D-end section **4** to the auxiliary crane and align with the D-intermediate section **2**.

When the pin bores on the D-intermediate section **2** and on the D-end section **4** align at points **P22**:

- ▶ Insert the pin **35** at the points **P22** on top and bottom and secure with locking pin **36**, see illustration **10**.

3.3.7 „Closing“ the D-boom

Make sure that the following prerequisites are met:

- The transport retainers for the guy rods on the SA-frame are released.
- The D-lattice sections are pinned and secured.
- The guy rods of the SA-frame are connected with the rods for flying assembly on the D-pivot section.



WARNING

Danger of accident!

- ▶ The maximum permissible total force on test point MS1 of 45 t may not be exceeded.

Erect the SA-frame **19** until the pin bores on the D-pivot section **1** and on the D-intermediate section **3** „on the bottom“ align at point **23**, see illustration **11**:

- ▶ Insert the pin **35** on both sides at point **P23** and secure with the locking pin **36**.

3.3.8 Establishing the hydraulic connections on the D-boom

The hydraulic connections are made with quick couplings.

Make sure that the following prerequisite is met:

- The D-lattice sections are pinned and secured.

When connecting hydraulic lines with quick couplings, make sure that the coupling procedure is carried out correctly.

**WARNING**

Pressure in the hydraulic lines!

If the pressure supply is not interrupted before connecting / releasing the hydraulic lines, the hydraulic oil can escape with high pressure.

Death, severe bodily injuries, property damage.

- ▶ Release the pressure in the hydraulic system before connecting / disconnecting: Interrupt the pressure supply and wait for a short time.

**WARNING**

Loss of pressure or leakage!

Incorrectly coupled or self-loosening quick couplings (particularly return lines) can result in serious accidents due to component failure.

- ▶ Check that the quick couplings have been properly connected before using the crane.
- ▶ Connect the coupling components (sleeve and connector) and screw together with the knurled nut.
- ▶ Tighten the hydraulic coupling by hand. Rotate the knurled nut until it reaches a tangible, fixed stop position.
- ▶ Establish the hydraulic connections, see Hydraulic diagram.

3.3.9 Establishing the electrical connections on the D-boom

**Note**

- ▶ To establish the electrical connections on the D-boom: Use the Electric wiring diagram.
- ▶ Establish the electrical connections.

3.3.10 Setting the ball valve on the pull cylinder to the „crane operation“ position

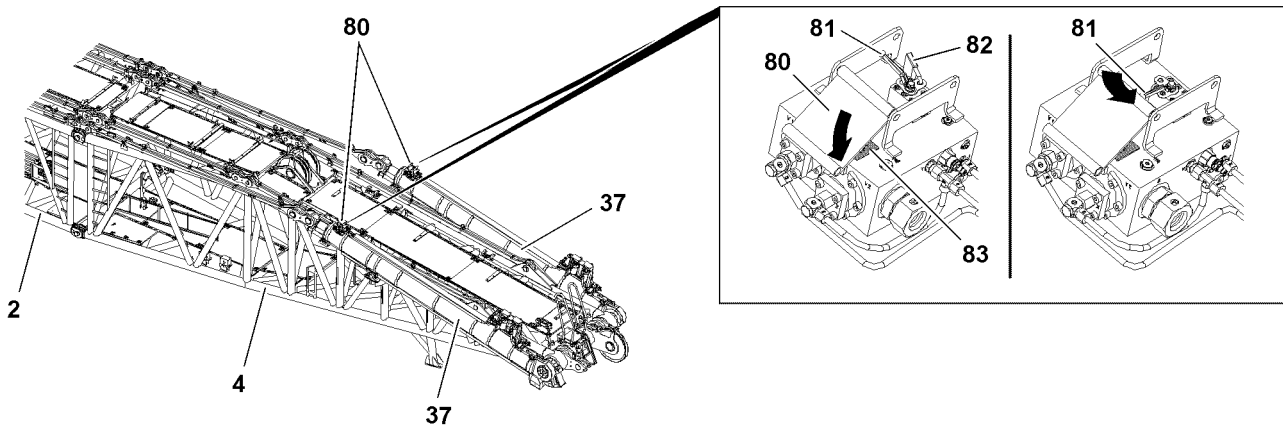

Fig.122780: Ball valve 81 on the pull cylinder 37

**WARNING**

Ball valve open!

When the ball valve is open in crane operation with derrick ballast, then the derrick ballast can lower itself uncontrolled.

The crane can topple over.

Death, severe bodily injuries, property damage.

- ▶ Make sure that the ball valve 81, before starting crane operation, is in the „crane operation“ position.

**Note**

- ▶ The following tasks must be carried out on both pull cylinders.

The ball valve **81** is located under the flap **80** on the pull cylinder **37**.

- ▶ Open the flap **80**.
- ▶ Remove the safety lock **82**.
- ▶ Change the ball valve **81** to the „crane operation“ position, see sign **83**.

When the ball valve **81** is in the „crane operation“ position:

- ▶ Attach the safety lock **82** and secure the ball valve **81** to prevent it from turning.
- ▶ Close the flap **80** and secure it properly.

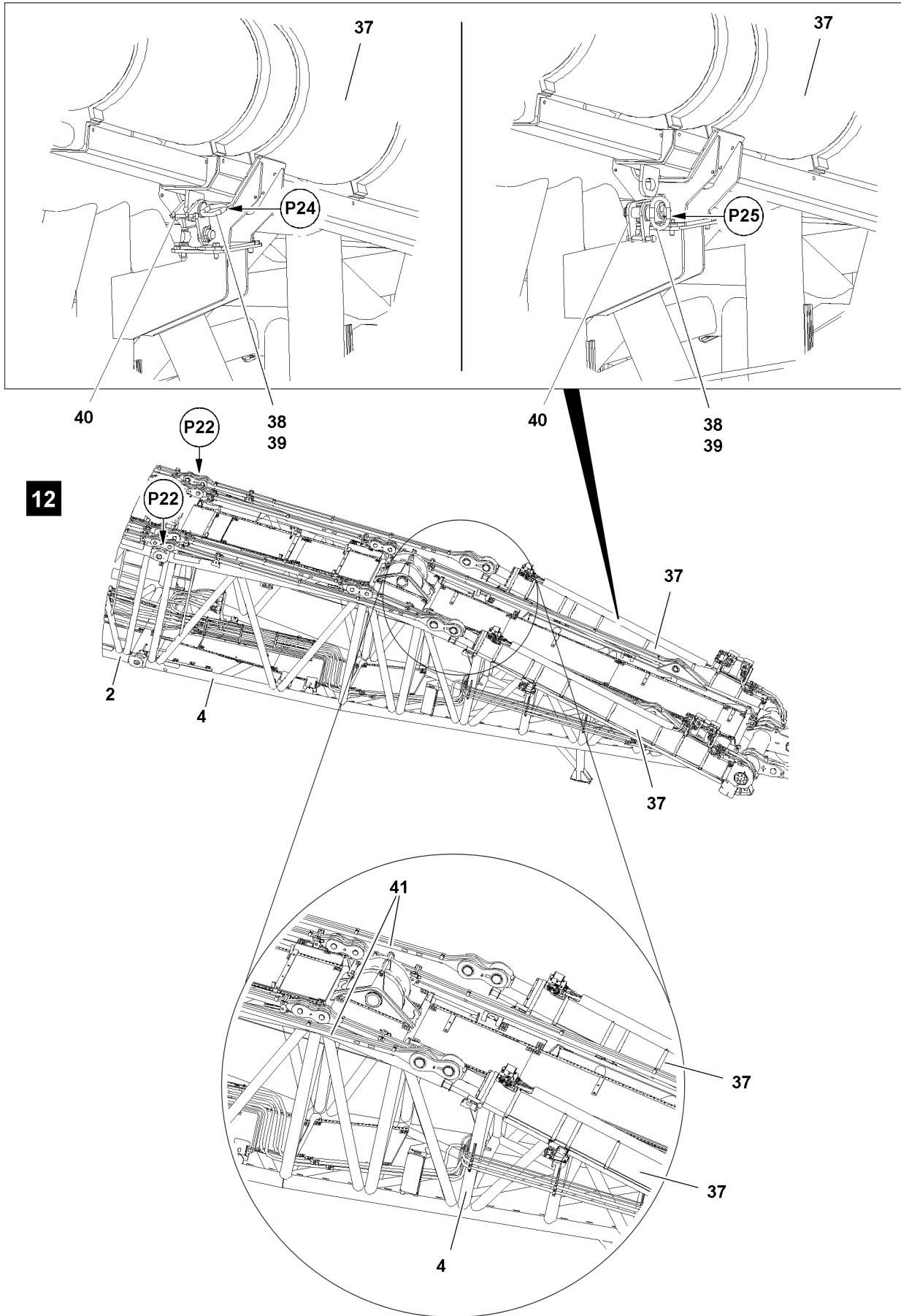

LWE/LR 11000-001/23501-04-02/en

Fig.144118

3.3.11 Releasing the pull cylinder

Both pull cylinders **37** of the D-end section **4** must be released, see illustration **12**.

- ▶ Remove the safety locking pin **39** at point **P24** and unpin the grip pin **38**.

Result:

- The pull cylinder **37** is released.
- ▶ Swing the retainer **40** downward.
- ▶ Secure the retainer **40**: Insert the grip pin **38** at point **P25** and secure with the safety locking pin **39**, see illustration **12**.

3.3.12 Extending the pull cylinder

To be able to unpin the guy rods **41**, the pull cylinders **37** must be extended, see illustration **12**.



Note

- ▶ Extend the pull cylinder (radio remote control*), see the radio remote control* operating instructions.
- ▶ Extend the pull cylinder (crane cab), see the Crane operating instructions, chapter 4.01.
- ▶ Extend the pull cylinder **37** (150-200 mm), until the guy rods of the D-end section **4** align with the guy rods of the D-intermediate section **2** on the upper points **P22**.

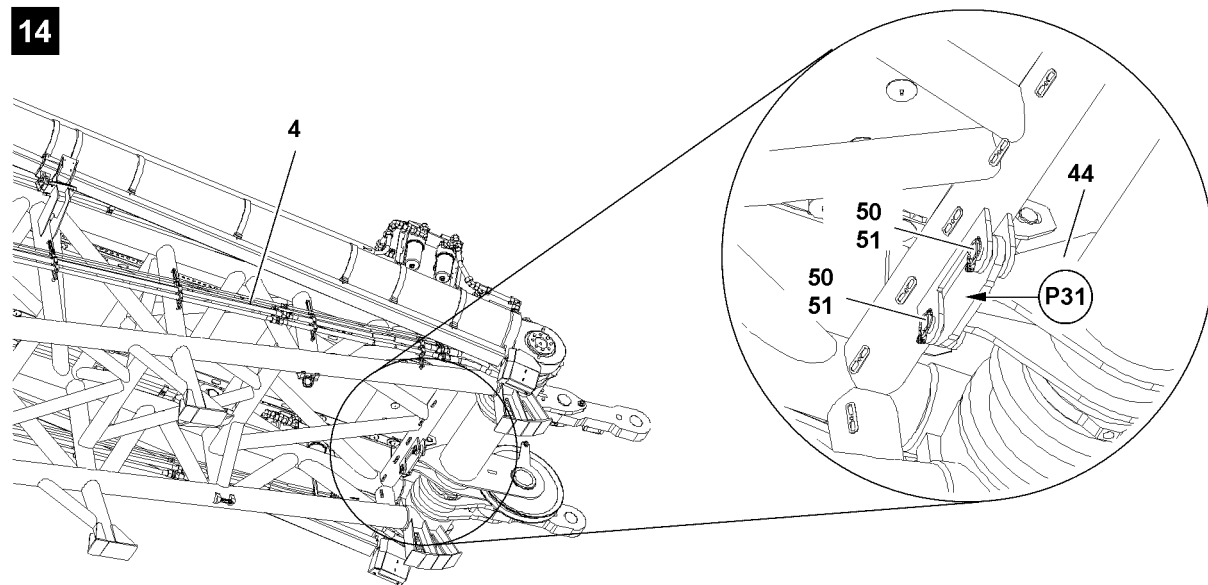
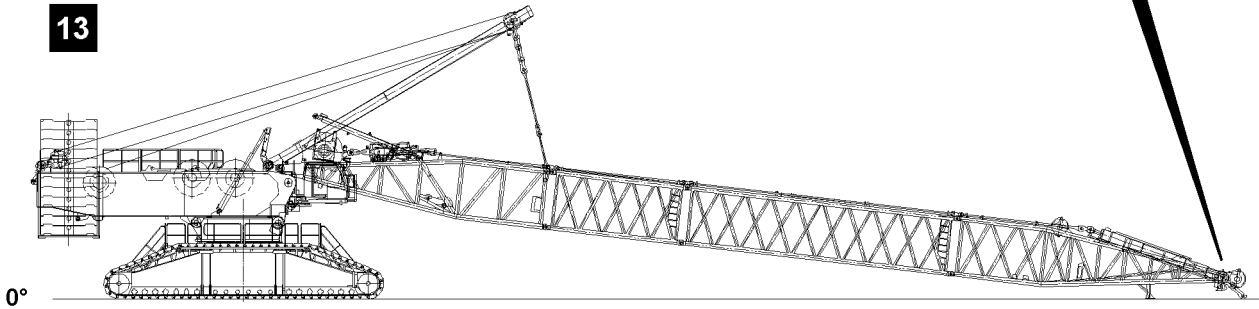
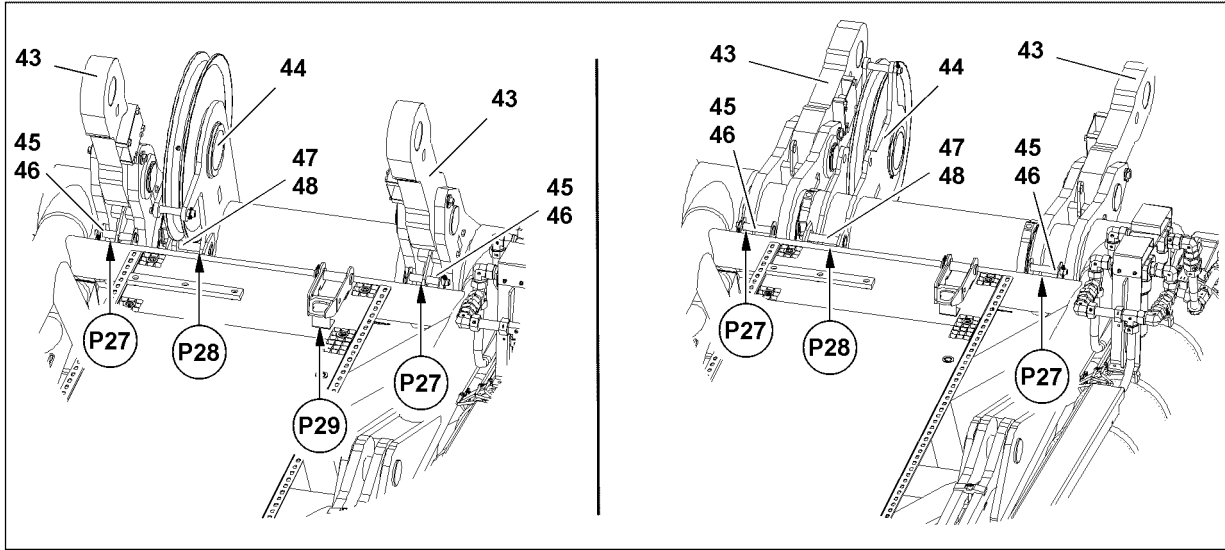

Fig.116969

LWE/LR 11000-001/23501-04-02/en

3.3.13 Bringing the pull test brackets into operating position

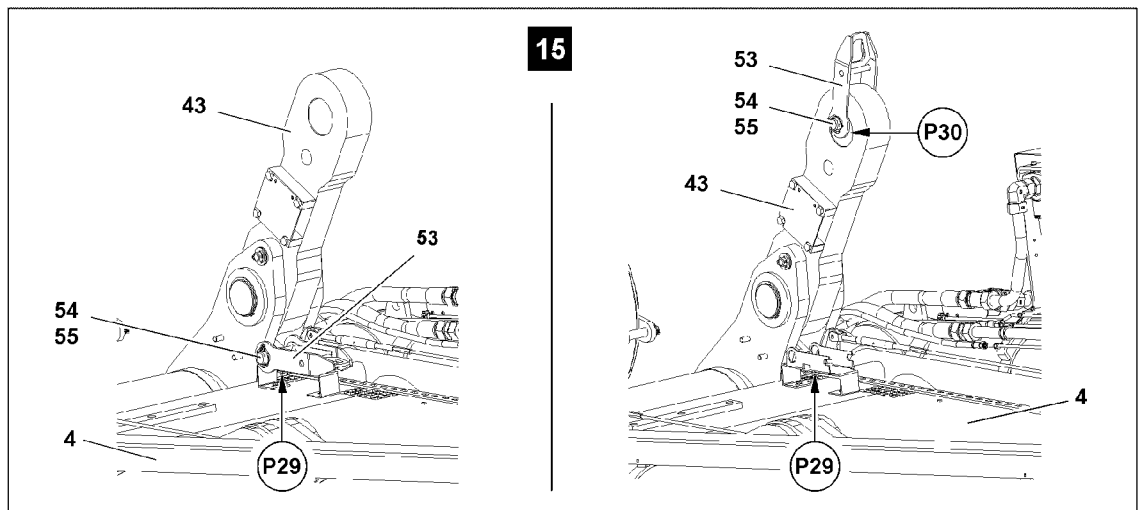

Fig.116970: Swinging the auxiliary bracket

- ▶ Remove the safety locking pin **55** at point **P29** and unpin the pin **54**, see illustration **13** and illustration **15**.
- ▶ Take the auxiliary bracket **53** from the transport retainer.

NOTICE

Danger of property damage!

- ▶ The pull test bracket **43** may only be fastened to the auxiliary crane via the auxiliary bracket **53**.
- ▶ Connect the auxiliary bracket **53** with the pull test bracket **43**: Insert the pin **54** at point **P30** and secure with the safety locking pin **55**, see illustration **15**.
- ▶ Fasten the auxiliary bracket **53** to the auxiliary crane.



WARNING

Danger of fatal injury due to the pull test bracket!

If the pull test brackets are not secure with an auxiliary crane during the swing procedure, they can swing forward due to their weight.

Death, severe bodily injuries, property damage.

- ▶ Swing the pull test bracket **43** into the operating position only with the aid of an auxiliary crane.
- ▶ Swinging the pull test bracket without an auxiliary crane is **prohibited**.

- ▶ Tension the fastening equipment.
- ▶ Remove the safety locking pin **46** on the transport retainer at point **P29** and unpin the retaining pin **45**.
- ▶ Swing the pull test bracket **43** forward with the auxiliary crane.

When the pull test bracket **43** is swung forward completely:

- ▶ Remove the auxiliary crane.
- ▶ Disconnect the auxiliary bracket **53** from the pull test bracket **43**.
- ▶ Insert the retaining pin **45** again in transport position at point **P27** and secure with the safety locking pin **46**.
- ▶ Swing the second pull test bracket **43** into the operating position.
- ▶ Fasten the auxiliary bracket **53** in transport position at point **P29**.

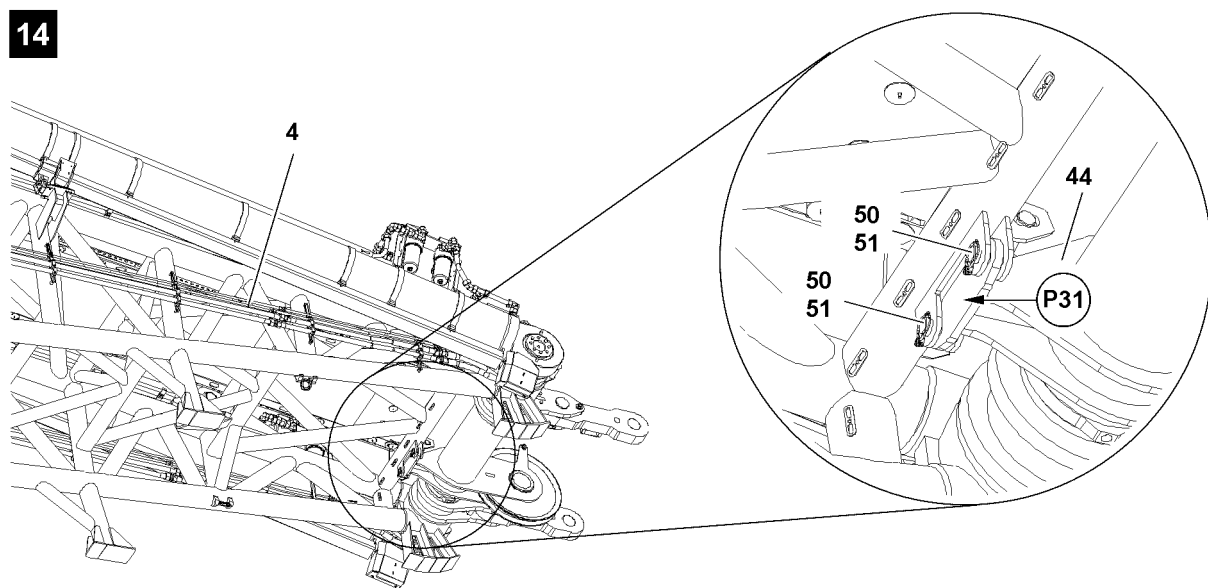
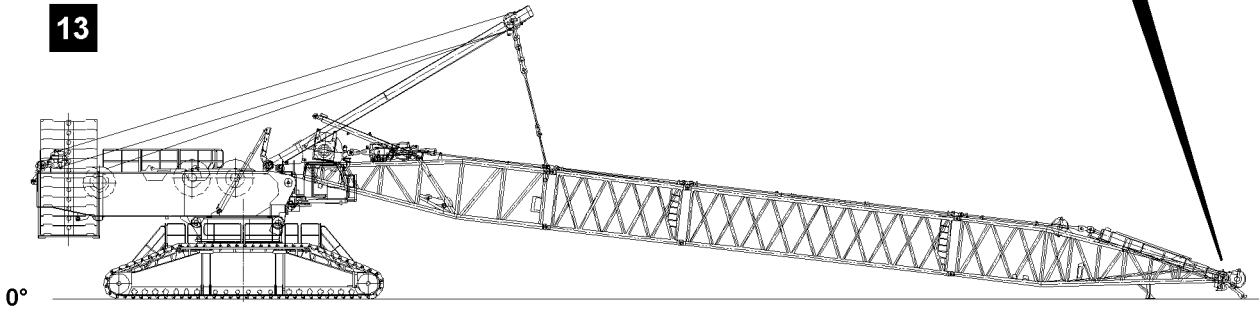
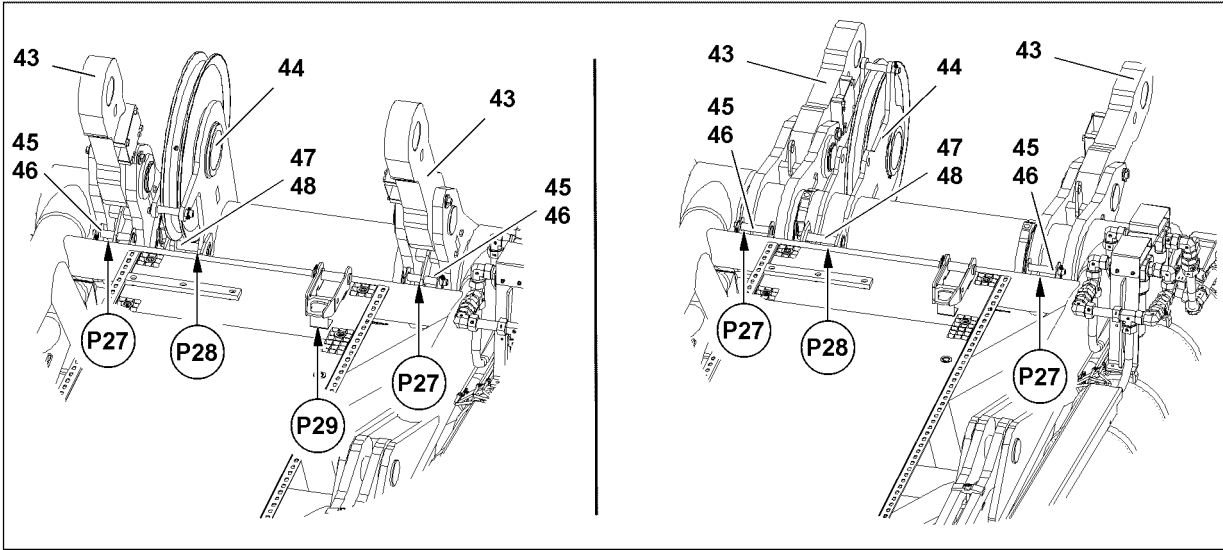

Fig.116969

LWE/LR 11000-001/23501-04-02/en

3.3.14 Bringing the pulley retainers into the operating position



WARNING

Mortal danger due to pulley retainer!

If the pulley retainer is not secure with an auxiliary crane during the swing procedure, then it can swing forward due to its weight.

Death, severe bodily injuries, property damage.

- ▶ Swing the pulley retainer **44** into operating position only with the aid of an auxiliary crane.
- ▶ Swinging the pulley retainer without an auxiliary crane is **prohibited**.

- ▶ Fasten the pulley retainer **44** to the auxiliary crane.

When the pulley retainer **44** is secured with the auxiliary crane:

- ▶ Tension the fastening equipment.
- ▶ Remove the spring retainer **48** on the transport retainer at point **P28** and unpin the retaining pin **47**, see illustration **13**.
- ▶ Remove the safety locking pin **51** at points **P31** and unpin the pin **50**, see illustration **14**.
- ▶ Swing the pulley retainer **44** forward with the auxiliary crane.

When the pulley retainer is in operating position:

- ▶ Insert the pin **50** in the operating position of the pulley retainer **44** at points **P31** and secure with the safety locking pin.
- ▶ Remove the auxiliary crane.
- ▶ Insert the retaining pin **47** again in transport position at point **P28** and secure with the spring retainer **48**.

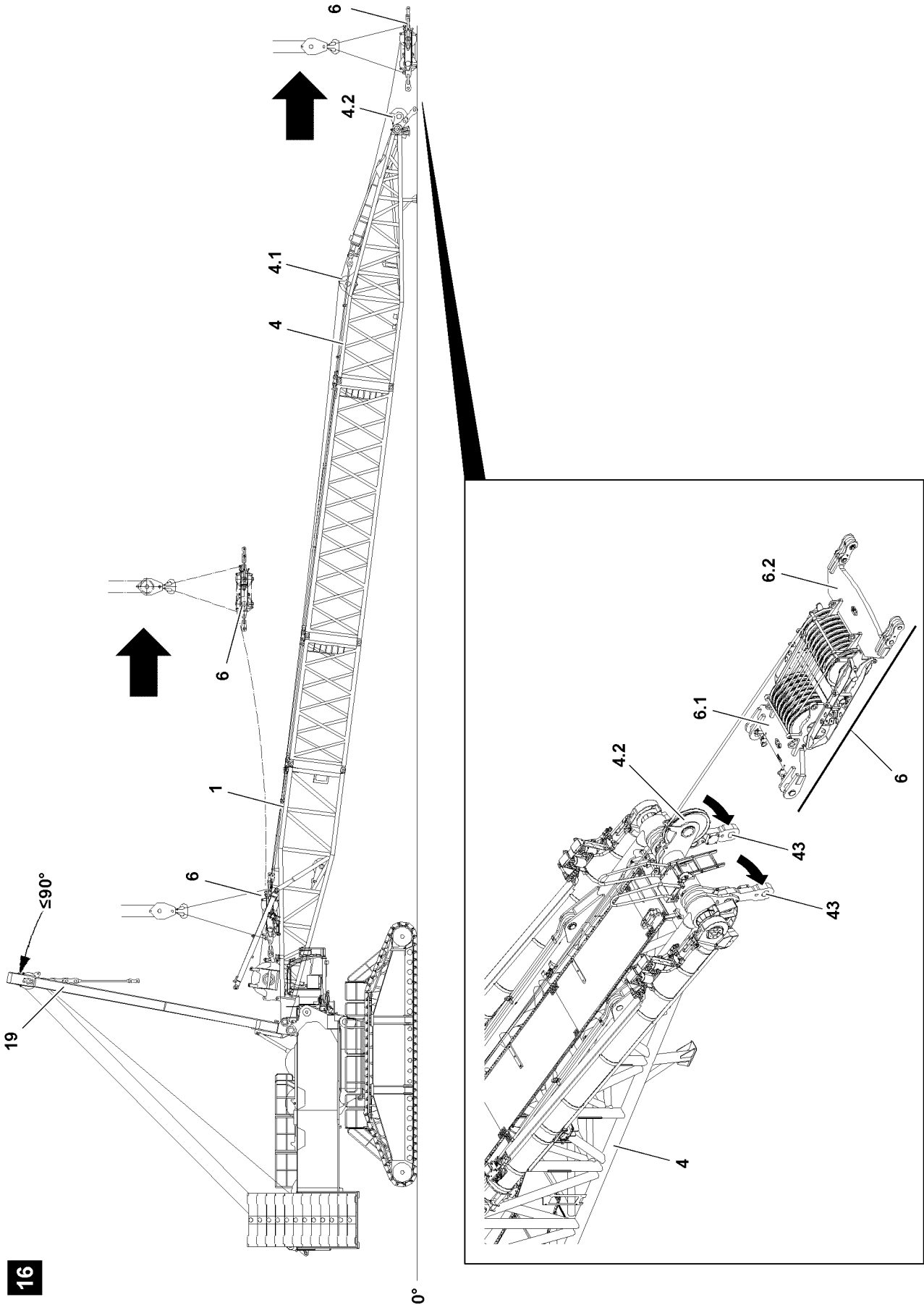

Fig.144119

LWE/LR 11000-001/23501-04-02/en

3.3.15 Pulling the luffing pulley block to the D-end section and taking it down on the ground

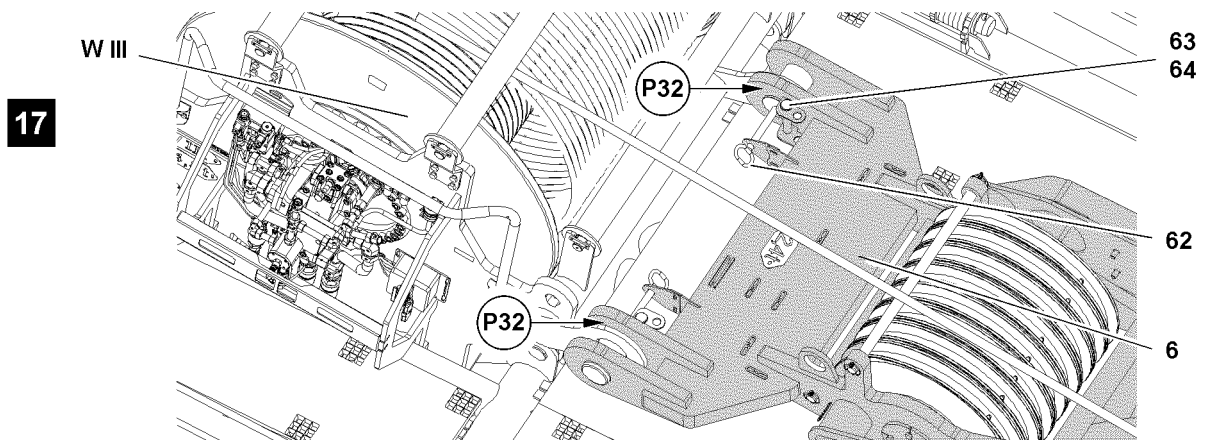

Fig.116971: Unpin the luffing pulley block on winch 3

- ▶ Disconnect the guy rods of the SA-frame **19** from the rods for flying assembly of the D-pivot section.

NOTICE

Danger of property damage!

If the SA-frame **19** with an installed and unguyed D-pivot section **1** is erected further than 90°, components can be seriously damaged.

- ▶ Do not erect the SA-frame **19** with an installed and unguyed D-pivot section **1** too far.
- ▶ Erect the SA-frame maximum to 90°, see illustration **16**.



WARNING

Slipping luffing pulley block!

By unpinning the luffing pulley block **6** on winch 3, the pulley block can start to slip. Death, severe bodily injuries, property damage.

- ▶ The luffing pulley block must be secured by an auxiliary crane before unpinning it on winch 3.



Note

- ▶ Fastening points, see section „Fastening points for derrick components“.

- ▶ Fasten the luffing pulley block **6** to the auxiliary crane.
- ▶ Unpin the luffing pulley block **6** on winch 3 at point **P32**: Remove the safety locking pin **64** on both sides and unpin the retaining pin **63** on both sides, see illustration **17**.
- ▶ Unpin the pins **62** on both sides.

NOTICE

Rope damage!

- ▶ When spooling winch 3 out, make sure that no slack rope forms.
- ▶ Pull the luffing pulley block **6** with the auxiliary crane to the D-end section **4** while spooling out winch 3 at the same time, see illustration **16**.
- ▶ Take down the luffing pulley block **6** with the auxiliary crane in front of the D-end section **4**.
- ▶ Properly insert and secure the control rope from winch 3 on the rope pulley **4.1** and the rope pulley **4.2**.
- ▶ Remove the auxiliary crane.

3.3.16 Releasing the upper pulley block on the lower pulley block

Make sure that the following prerequisites are met:

- The luffing pulley block **6** is laying on the ground or on a load-bearing substructure.
- The auxiliary crane is removed.

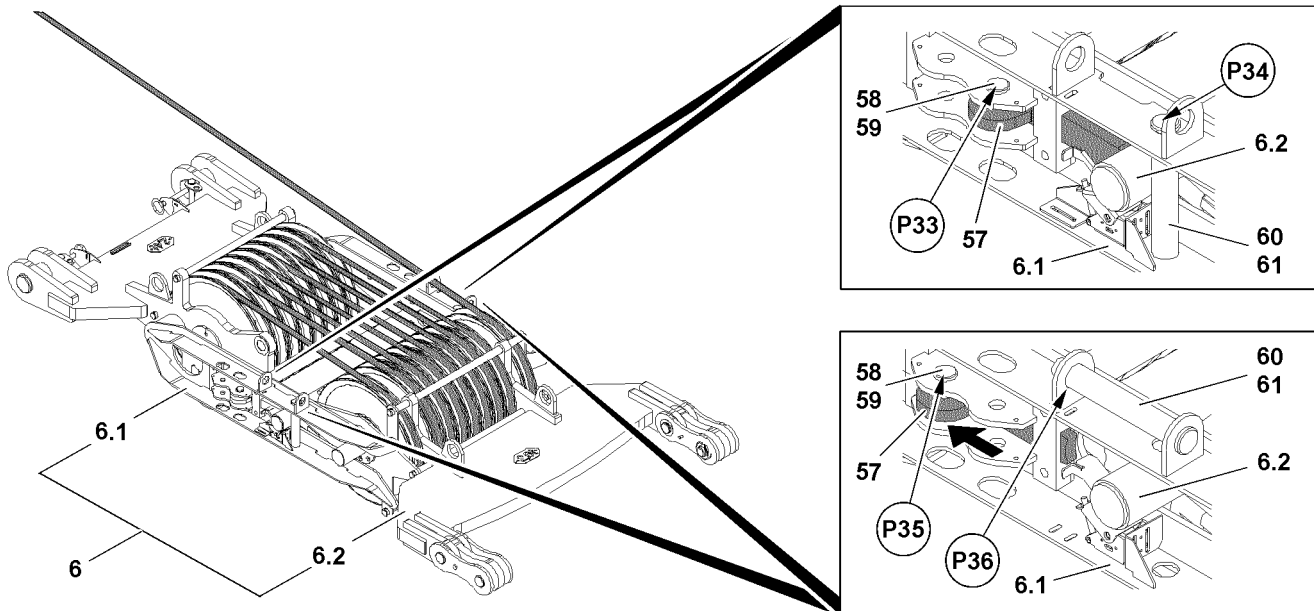

Fig. 122964: Releasing the upper pulley block on the lower pulley block

- ▶ Remove the safety locking pin **59** on both sides at point **P33** and unpin the pin **58**.
- ▶ Move the latch **57** until it can be pinned at point **P35**.

When the bores align:

- ▶ Insert the pin **58** at point **P35** and secure with the safety locking pin **59**.
- ▶ Remove the safety locking pin **61** on both sides at point **P34** and unpin the pin **60**.

Result:

- The transport retainer between the upper pulley block **6.2** and the lower pulley block **6.1** is removed.

When the upper pulley block **6.2** and lower pulley block **6.1** are released:

- ▶ Insert the pins **60** on both sides in park position at point **P36** and secure with the safety locking pin **61**.

3.3.17 Assembling the D-guy rods



WARNING

Neglected guy rod inspection and maintenance!

If the regular inspection and maintenance of the guy rods is not carried out or is carried out only at irregular intervals, then severe accidents can occur due to existing and unrecognized damage to the guy rods.

Death, severe bodily injuries, property damage.

- ▶ The guy rods must be checked before every assembly, see Crane operating instructions, chapter 8.15.



Note

- ▶ The D-guy rods must be assembled and secured according to the separately supplied assembly drawings. The numbering on the assembly drawings must be identical to the numbering on the guy rods.

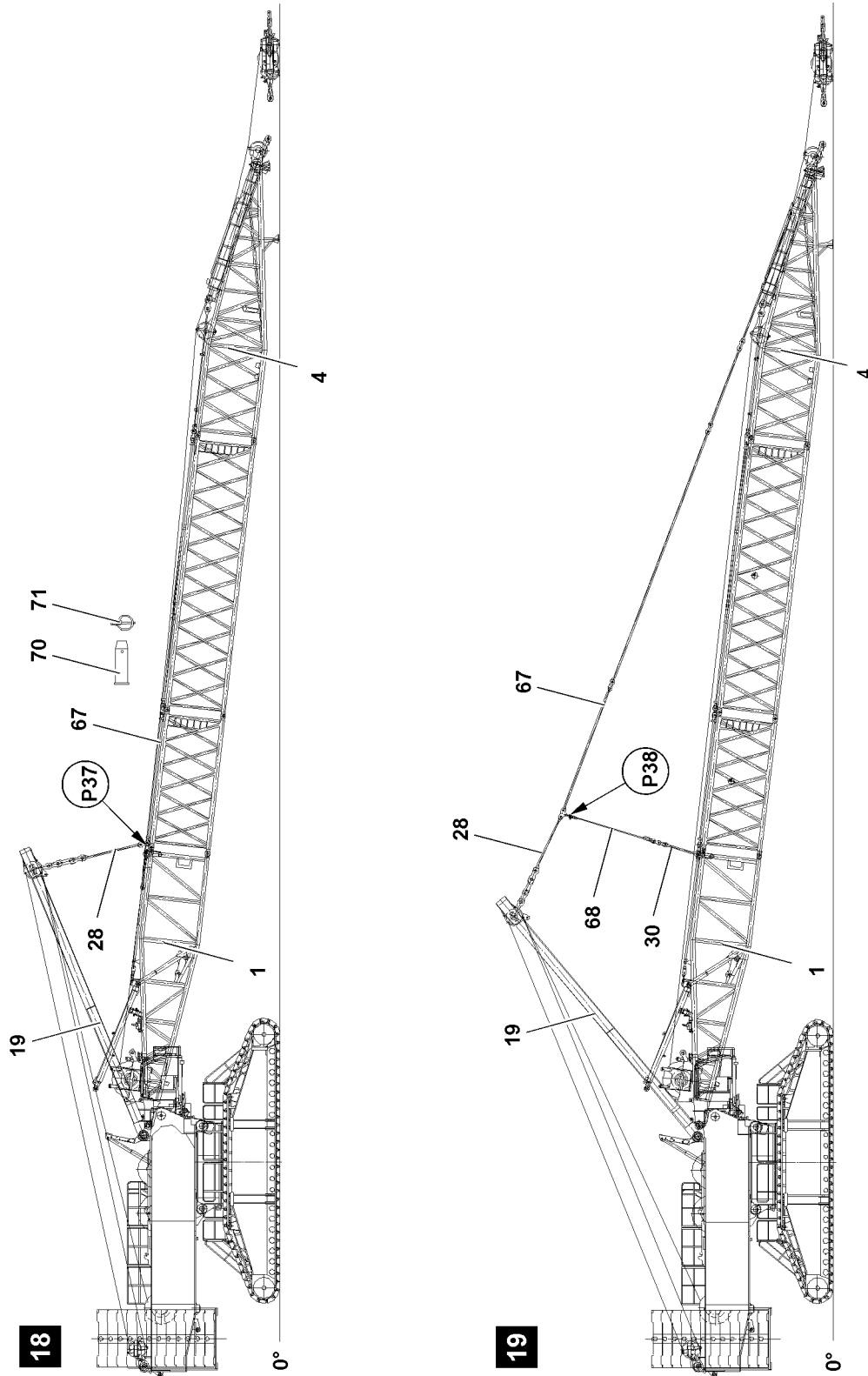

Fig.122967: Assembling the D-guy rods

The D-guy rods are taken down and secured for transport on the D-lattice sections. Before assembly, the transport retainers must be released.

- ▶ Release the transport retainers on the guy rods.
- ▶ Lower the SA-frame to the front.

LWE/LR 11000-001/23501-04-02/en

**DANGER**

Danger of accident!

- ▶ The pins **70** of the Derrick guy rods may only be pinned from the „inside“ to the „outside“.

Pin the guy rods **28** of the SA-frame with the guy rods **67** on the D-pivot section at point **P37**, see illustration **18**.

- ▶ Insert the pin **70** and secure with the safety locking pin **71**.

Pin the guy rods of the D-intermediate sections with each other.

- ▶ Insert the pin **70** and secure with the safety locking pin **71**.

Pin the guy rods of the D-intermediate sections with the guy rods on the D-end section.

- ▶ Insert the pin **70** and secure with the safety locking pin **71**.

**Note**

- ▶ The derrick auxiliary guying is only required / possible at a derrick boom length of 42 m.

- ▶ Pin the rods for flying assembly **30** of the D-pivot section **1** with the guy rope **68**: Insert the pin **70** and secure with the safety locking pin **71**, see illustration **19**.

- ▶ Connect the auxiliary guying with the D-guying: Insert the pin **70** at point **P38** and secure with the spring retainer **71**, see illustration **19**.

When the guy rods are pinned and secured to each other:

- ▶ Actuate winch 4 until the guy rods are tensioned between the SA-frame and the D-end section.

**DANGER**

General danger note!

If the following conditions are not met before erecting the D-boom, the hoist rope can fall down due to its own weight.

Death, severe bodily injuries, property damage.

- ▶ Enough hoist rope must be guided over the rope pulleys so that the hoist rope is **not** pulled back and falls down when erecting the D-boom.

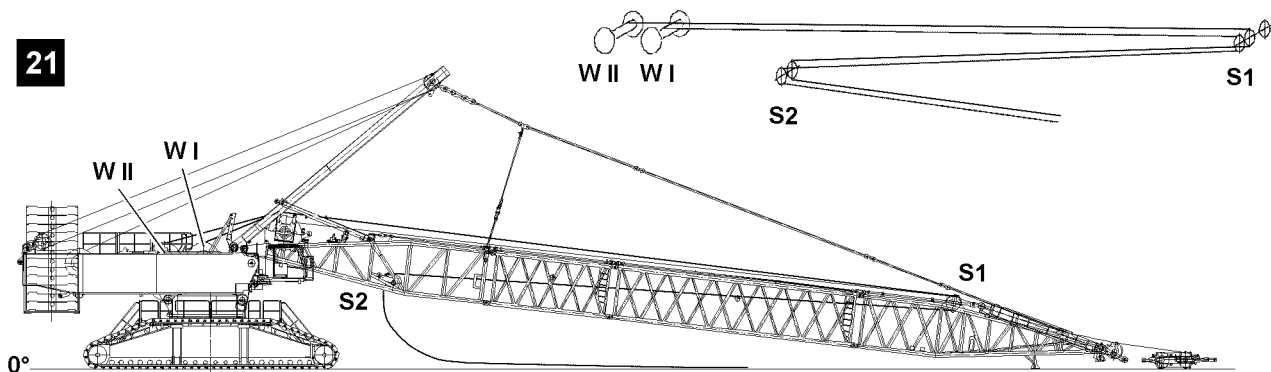

Fig.122968: Hoist rope reeving(s) on the D-boom

**Note**

- ▶ Hoist rope reevings: See the Crane operating instructions, chapter 4.06.

**WARNING**

Danger due to falling hoist ropes!

Death, severe bodily injuries, property damage.

- ▶ Make sure that the hoist ropes are properly secured when erecting the D-boom to prevent them from falling down.

- ▶ Pull the hoist ropes over the rope pulley **S1** in the D-end section and over the rope pulley **S2** in the D-pivot section, see illustration **21**.
- ▶ Erect the D-boom.

4 Erecting the D-boom

23

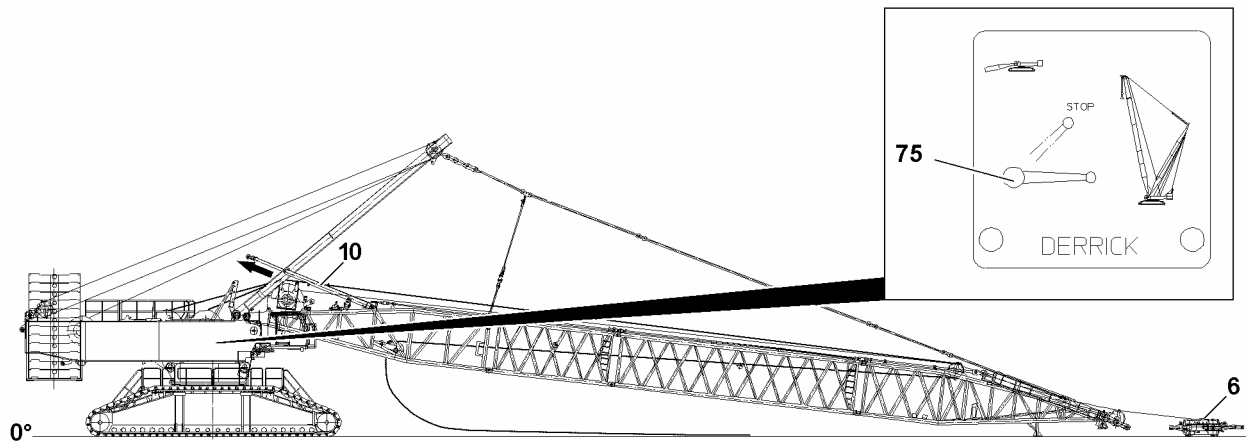

Fig.144120

**DANGER**

The crane can topple over!

- ▶ It is not permitted to turn the crane during the erection procedure.
- ▶ Observe the specifications in the erection and take down charts.

**WARNING**

The crane can topple over!

If the following conditions are not met before erecting the D-boom, the crane can topple over. Death, severe bodily injuries, property damage.

- ▶ Observe the technical safety instructions, see the Crane operating instructions, chapter 5.01.
- ▶ Extend the D-relapse cylinder **10** before erection.
- ▶ Do not allow slack rope to build up on the control winch (winch 3).
- ▶ The ball valve cabinet must be locked. Always pull the key and hand it to an authorized person.

**WARNING**

Falling hoist rope!

If the hoist rope before the erection procedure is not properly secured onto the corresponding length on the D-boom, it can fall down backward on the basis of its own weight. Death, severe bodily injuries, property damage.

- ▶ Reeve the hoist rope before the erection procedure with sufficient length on the D-boom.
- ▶ The hoist rope must be constantly monitored during erection.
- ▶ Do not step into the danger zone.

NOTICE

Damage of control rope and the luffing pulley block!

At slack guying at the derrick boom angle of 76° the luffing pulley block is laying on the D-end section. If winch 3 is further actuated from a derrick boom angle of 76° then the D-end section or the luffing pulley block can be damaged.

- ▶ Winch 3 is therefore turned off from a derrick boom angle of 76°.
- ▶ Make sure that winch 3 is no longer actuated from a derrick boom angle of 76°.

Make sure that the following prerequisites are met:

- The crane is horizontally aligned.
- All electrical connections have been made.
- All limit switches are functioning.
- The counterweight has been installed on the turntable according to the load chart.
- All pin connections have been secured.
- The relapse cylinders are touching the supports.
- The hoist rope has been correctly placed in the rope pulleys and is prevented from jumping out with the rope retaining pins.
- The LICCON overload protection has been set according to the data in the load chart.
- The LICCON overload protection is exceeded.
- The assembly icon is visible on the LICCON monitor.
- No personnel is within the danger zone.

4.1 Extending the D-relapse cylinder



WARNING

Danger of fatal injury due to the D-boom!

If the D-relapse cylinders **10** are not completely extended before erecting the D-boom, then the D-boom can fall backward.

Death, severe bodily injuries, property damage.

- ▶ The D-relapse cylinders must be extended before erection of the D-boom.
- ▶ The ball valve must be secured during crane operation to prevent unintended actuation.

The piston rods on the D-relapse cylinders must be completely extended prior to erection, see illustration **23**.

Ball valve positions	
Horizontal	Crane operation, extend the piston rod
Vertical	Assembly, retract the piston rod
45°	STOP (the piston rod cannot be retracted / extended)

Make sure that the following prerequisite is met:

- All hydraulic connections have been made.
- ▶ Move the ball valve **75** into horizontal position.

Result:

- The piston rods of the D-relapse cylinders **10** extend.



Note

- ▶ The ball valve is secured by closing the cabinet door and removing the key.
- ▶ Close the cabinet door and pull out the key.
- ▶ Hand the key to an authorized person.

4.2 Erection procedure

Make sure that the following prerequisites are met:

- The piston rods of the D-relapse cylinders **10** are fully extended before erection.
- The D-guying is properly assembled and secured.
- **Only in the case of a D-boom 42 m:**, the auxiliary guying on the D-boom is properly assembled and secured.
- The control rope of winch 3 is properly placed and secured on the rope pulleys of the D-end section, see the Reeving plan.
- The control rope of winch 3 is properly reeved in on the luffing pulley block and properly secured on the rope fixed point, see the Reeving plan.
- The luffing pulley block **6** is laying on the ground with sufficient „rope reserve“.
- The connector pins between the upper pulley block and the lower pulley block are unpinned, see section „Releasing the upper pulley block on the lower pulley block“.

4.2.1 Erecting the D-boom to the horizontal

Make sure that the following prerequisites are met:

- Sufficient control rope (winch 3) is spooled out.
- The pull test brackets are folded to the front in operating position.



WARNING

The crane can topple over!

- ▶ It is prohibited to turn the crane superstructure during the erection procedure.
- ▶ Erect the D-boom carefully and at low speed maximum to the horizontal.

NOTICE

Damage of control rope and the luffing pulley block!

When lifting the D-boom, the control rope or the luffing pulley block can be damaged.

- ▶ When lifting the D-boom, carefully spool out winch 3 so that the luffing pulley block remains on the ground.
 - ▶ Check the rope run on the D-end section, carry out a visual inspection.
 - ▶ Make sure that no slack rope on winch 3 forms when lifting the D-boom.
- ▶ Erect the D-boom carefully and at low speed to the horizontal (0°).

4.2.2 Pinning the luffing pulley block on the pull test brackets



Note

- ▶ The following illustrations are shown in part without the control rope (winch 3).

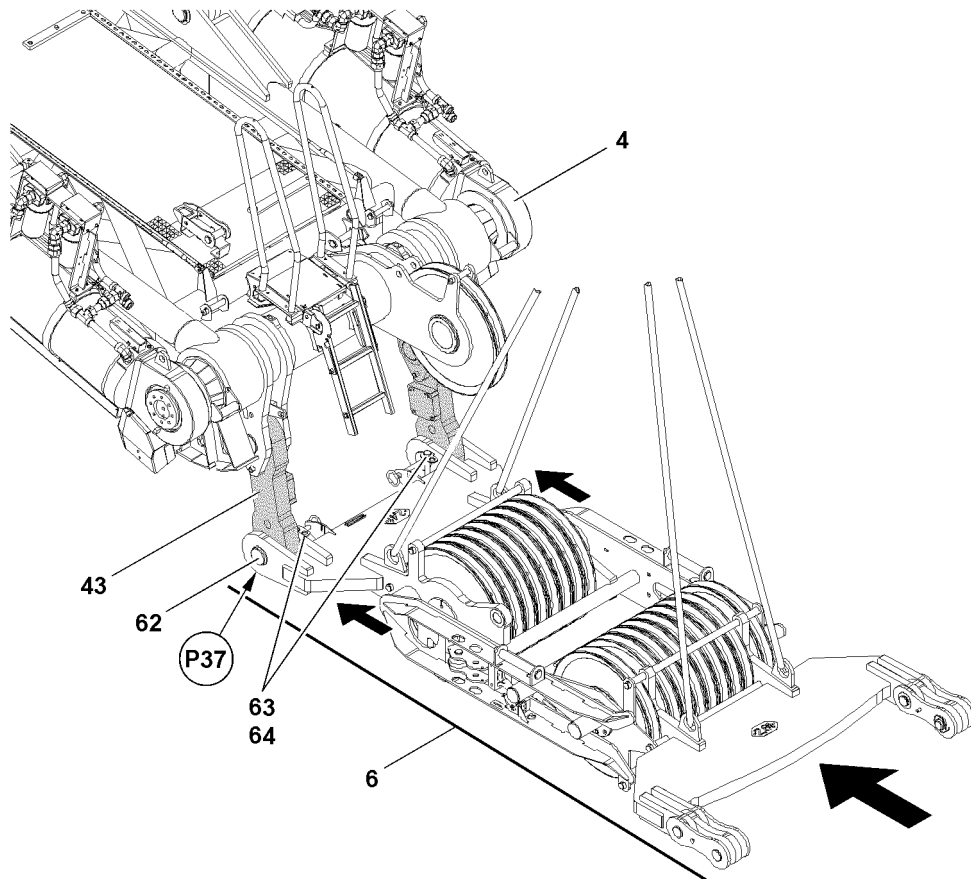

Fig.122965: Pinning the luffing pulley block on the pull test brackets

Make sure that the following prerequisites are met:

- The D-boom is erected to the horizontal position.
- The pull test brackets are in the operating position.
- The pins **62** are unpinned on both sides.

Pin the luffing pulley block **6** on the D-end section **4** with the pull test brackets **43**.

- ▶ Fasten the luffing pulley block **6** properly to the auxiliary crane.

NOTICE

Danger of slack rope formation!

When swinging the luffing pulley block on the D-end section in, slack rope can form on winch 3.

- ▶ When swinging the luffing pulley block in to the D-end section, slowly and carefully spool up winch 3.

When the luffing pulley block **6** is properly fastened to the auxiliary crane:

- ▶ Lift the luffing pulley block with the auxiliary crane and swing it in to the pull test brackets **43** on the D-end section **4**.
- ▶ Align the luffing pulley block **6** with the pull test brackets **43** until the pin bores align.
- ▶ Insert the pins **62** completely on both sides.

When the pins **62** are fully pinned on both sides:

- ▶ Insert the retaining pins **63** on both sides and secure with safety locking pin **64**.

When the pins **62** are properly secured on both sides:

- ▶ Lower the luffing pulley block **6** carefully with the auxiliary crane until the pulley block **6** hangs vertically.

4.2.3 Establishing the electrical connections to the luffing pulley block



Note

- ▶ To establish the electrical connections on the luffing pulley block: Use the Electric wiring diagram.
- ▶ Establish the electrical connections.

4.2.4 Assembling the auxiliary weight on the upper pulley block

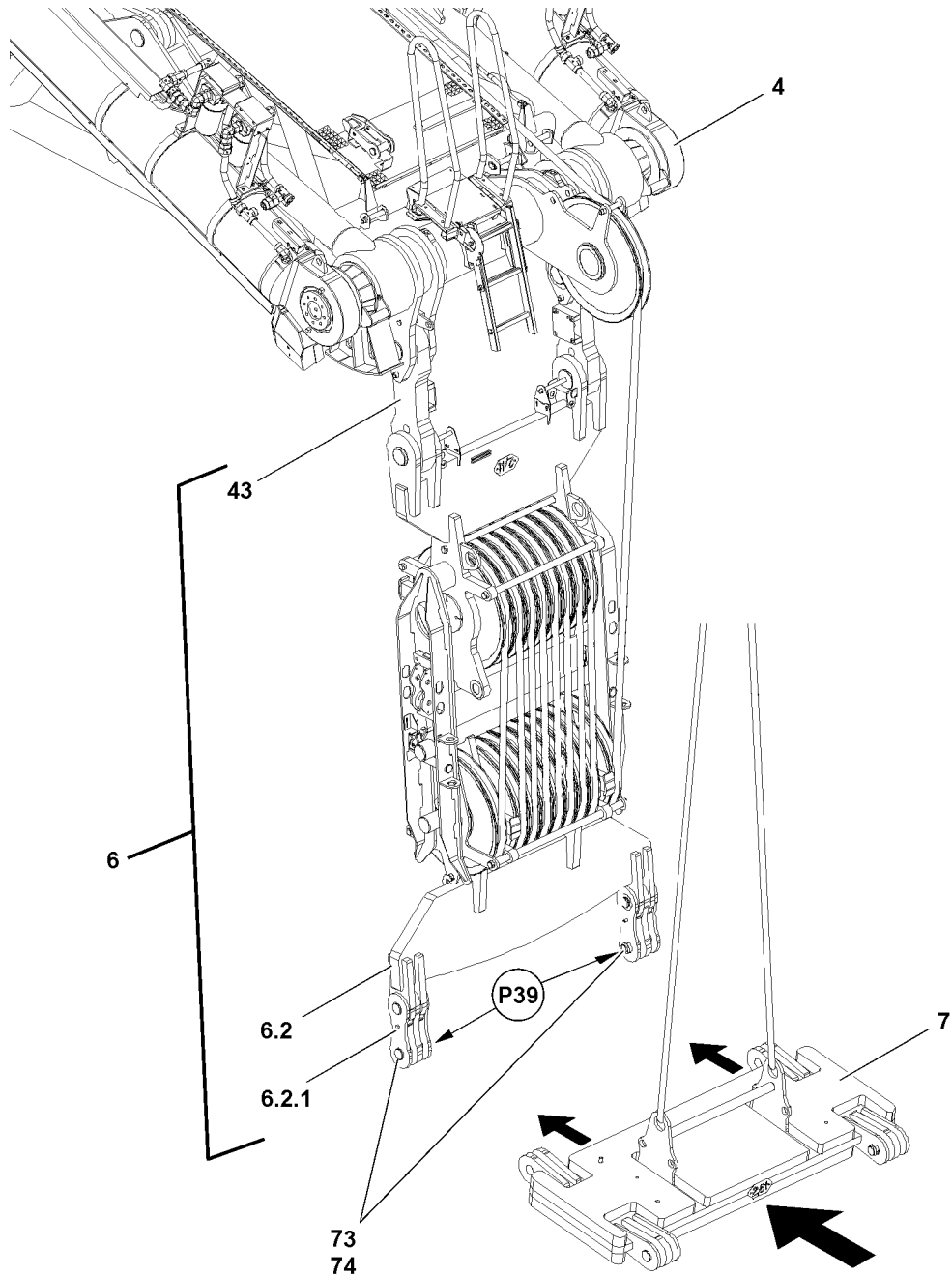

Fig.122966: Pinning the auxiliary weight on the lower pulley block

LWE/LR 11000-001/23501-04-02/en

Make sure that the following prerequisites are met:

- The luffing pulley block **6** is properly installed and secured on the pull test brackets **43**.
- The luffing pulley block hangs down vertically.
- The auxiliary crane is removed.
- The pins **73** on the brackets **6.2.1** of the upper pulley block **6.2** are unpinned on both sides.



Note

- ▶ Fastening points, see section „Fastening points for derrick components“.

- ▶ Fasten the auxiliary weight **7** to the auxiliary crane.
- ▶ Swing the auxiliary weight **7** in to the hanging luffing pulley block **6**.
- ▶ Align the auxiliary weight **7** on the brackets **6.2.1** of the upper pulley block **6.2** until the pin bores align on both sides at point **P39**.
- ▶ Insert the pins **73** at point **P39** on both sides and secure with the safety locking pin **74**.

When the auxiliary weight **7** is properly pinned and secured on the upper pulley block **6.2**:

- ▶ Lower the auxiliary weight **7** with the auxiliary crane.
- ▶ Remove the auxiliary crane.

4.2.5 Checking the function of the safety equipment



WARNING

Malfunctioning safety equipment!

If the function of the safety equipment is defective, personnel can be severely injured or killed.

- ▶ Crane operation with non-functioning safety equipment is **prohibited**.



Note

- ▶ The function of the individual limit switches must be checked before erection.
- ▶ The function of the limit switch initiators must be checked in the test system, see the separate „Diagnostics manual“.



Note

- ▶ If a function check on the limit switches or on the safety equipment does not lead to the desired shut-offs, then the plug connections on the connector boxes or the components themselves must be checked.
- ▶ If no visible connection errors or component defects can be found, contact **LIEBHERR** Service.

Make sure that the following prerequisites are met:

- All electrical connections have been made.
- The crane engine is running.
- The corresponding operating mode is set on the LICCON monitor.

Limit switch D-boom, relapse cylinder

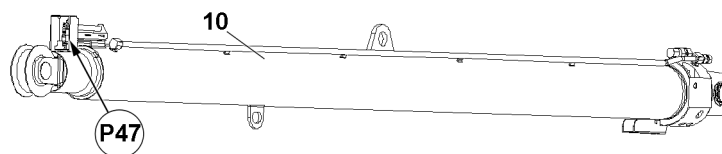

Fig.144124: Limit switch initiators of the D-relapse cylinders **10**



Note

- ▶ The limit switch functions have to be checked individually before erection.
- ▶ Cover the limit switch initiators of the D-relapse cylinders **10** at point **P47** individually with a metal plate, see the Crane operating instructions, chapter 8.12.

Result:

- The spooling up of winch 4 (control winch) turns off in upward movement.
- The „derrick boom angle“ icon appears on LICCON monitor 1, see the Crane operating instructions, chapter 4.02.

Luffing pulley block limit switch

Fig.144122: Limit switch initiators of the luffing pulley block 6

**Note**

- ▶ The limit switch functions have to be checked individually before erection.
- ▶ Cover the limit switch initiators of the luffing pulley block 6 at point P45 individually with a metal plate.

Result:

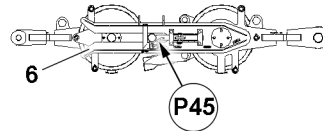
- The spooling up of winch 3 turns off.

Pull cylinder limit switch

Fig.144123: Limit switch initiators of the pull cylinders 37

**Note**

- ▶ The limit switch functions have to be checked individually before erection.
- ▶ Cover the limit switch initiators of the pull cylinders 37 at point P46 individually with a metal plate.

Result:

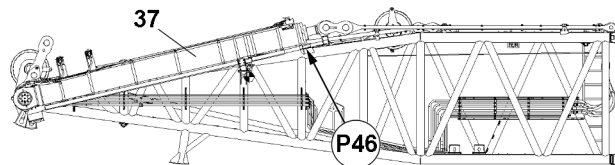
- The retraction of the pull cylinder is turned off.

4.2.6 Erecting the D-boom to maximum 85°

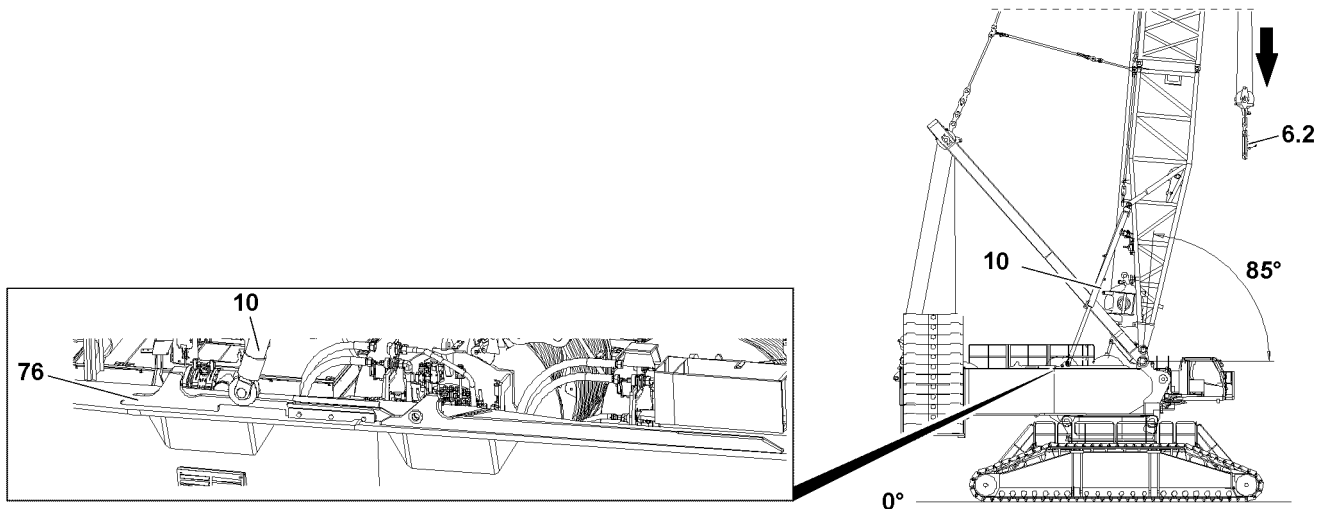

Fig.144121: Initiator limit switch

The erection of the D-boom to maximum 85° is required in order to make space in the assembly area of the S-pivot section and permit the assembly of the S-pivot section without a problem.



WARNING

The crane can topple over!

Death, severe bodily injuries, property damage.

- ▶ It is prohibited to turn the crane superstructure during the erection procedure.
- ▶ Make sure during the erection procedure of the D-boom that the D-relapse cylinders **10** engage in the stop rail **76** of the D-relapse retainer.
- ▶ Make sure that no slack rope forms on winch 3.
- ▶ Do not erect the D-boom further than maximum 85° to the horizontal.

NOTICE

Danger of property damage!

- ▶ Make sure that the upper pulley block **6.2** is lowered during the erection procedure of the D-boom.
- ▶ Make sure that the upper pulley block **6.2** is located at the height of the D-pivot section (see illustration), before the D-boom reaches the boom angle setting of 76°.



Note

- ▶ Winch 3 is turned off completely from a D-boom angle of 76°. It is no longer possible to lift / lower the upper pulley block **6.2**.

When luffing up the D-boom, lower the upper pulley block **6.2** continuously:

- ▶ Actuate winch 4 and erect the D-boom to an angle range of maximum 85°.

Result:

- The upper pulley block **6.2** is located at the height of the D-pivot section, see illustration

5 D-boom assembly on the ground



Note

- ▶ For D-boom assembly „on the ground“ the D-pivot section, D-intermediate sections and D-end section can be pinned and secured as a preassembled unit with the auxiliary crane directly on the SA-frame.

**WARNING**

Danger of accident!

Death, severe bodily injuries, property damage.

- ▶ Assembly of the D-boom „on the ground“ is only described as an example, for the detailed assembly process, see section „Assembling the D-boom in sections“.
- ▶ Observe the danger notes in section „Assembling the D-boom in sections“.

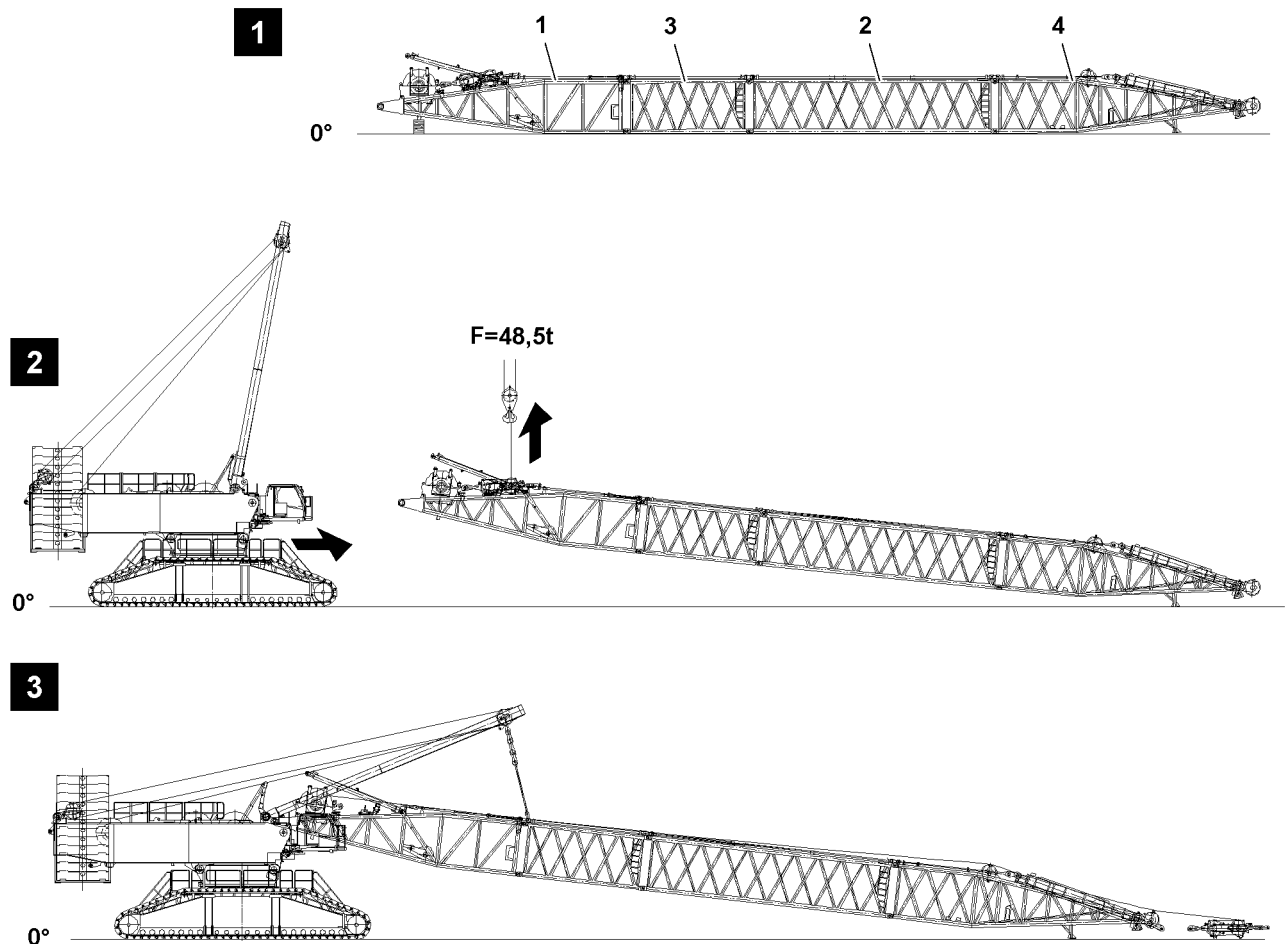

Fig.122969: Preassembling the D-boom on the ground

Make sure that the following prerequisites are met:

- The crane is horizontally aligned.
- The counterweight has been installed on the turntable according to the load chart.
- The central ballast has been installed on the turntable according to the load chart.
- The LICCON overload protection has been set according to the data in the load chart.
- The LICCON overload protection settings have been compared with the actual set up configuration.

5.1 Preassembling the D-boom on the ground

**WARNING**

Danger due to lattice sections!

Death, severe bodily injuries, property damage.

- ▶ Make sure that the D-boom sections are properly pinned and secured.
- ▶ Pin and secure the D-pivot section, D-intermediate sections and D-end section with each other on the ground, see section „Assembling the D-boom in sections“, see illustration 1.

5.2 Assembling the D-boom on the SA-frame

Make sure that the following prerequisites are met:

- The travel route of the crane is level and horizontal.
- The ground in the area of the travel route is able to safely take on the weight of the crane.
- There are no persons and / or obstacles on the travel route.
- The D-relapse cylinders are in operating position.



WARNING

Driving crane!

Death, severe bodily injuries, property damage.

- ▶ Make sure that there are no persons or obstacles within the danger zone when driving the crane in to the D-boom.

- ▶ Fasten the D-boom to the auxiliary crane.
- ▶ Lift the D-boom with the auxiliary crane, see illustration 2.
- ▶ Retract the crane carefully to the pin location, see illustration 2.

When the pin bores between the SA-frame and the D-pivot section align, see illustration 3:

- ▶ Insert the pin and secure with the spring retainer, see section „Pinning the D-pivot section on the SA-frame“.

When the D-boom is properly pinned and secured on the SA-frame:

- ▶ Remove the auxiliary crane on the D-boom.

NOTICE

Danger of property damage!

Damage of hydraulic lines.

- ▶ Make sure that the hydraulic connections from the turntable to the D-pivot section are established before the SA-frame is lowered to the front.
- ▶ Establish the hydraulic connections from the turntable to the D-pivot section properly.

5.3 Completing the D-boom assembly

Make sure that the following prerequisites are met:

- The D-boom is properly pinned and secured on the SA-frame.
- The hydraulic connections to the D-pivot section are properly established.
- ▶ Lower the SA-frame to the front and assemble the D-guying, see section „Assembling the D-guy rods“.
- ▶ Check the safety equipment, see section „Checking the function of the safety equipment.“
- ▶ Erect the boom, see section „Erecting the D-boom.“

6 Flying D-boom assembly



Note

- ▶ To assemble the D-boom in „flying“ mode, the D-intermediate sections and the D-end section can be pinned and secured as a preassembled unit with auxiliary cranes on the D-pivot section.



WARNING

Danger of accident!

Death, severe bodily injuries, property damage.

- ▶ Do not exceed the maximum permissible total force on test point MS 1 of 145 t.
- ▶ The assembly of the D-boom in „flying“ mode is only described as an example, for the detailed assembly process, see section „Assembling the D-boom in sections“.
- ▶ Observe the danger notes in section „Assembling the D-boom in sections“.

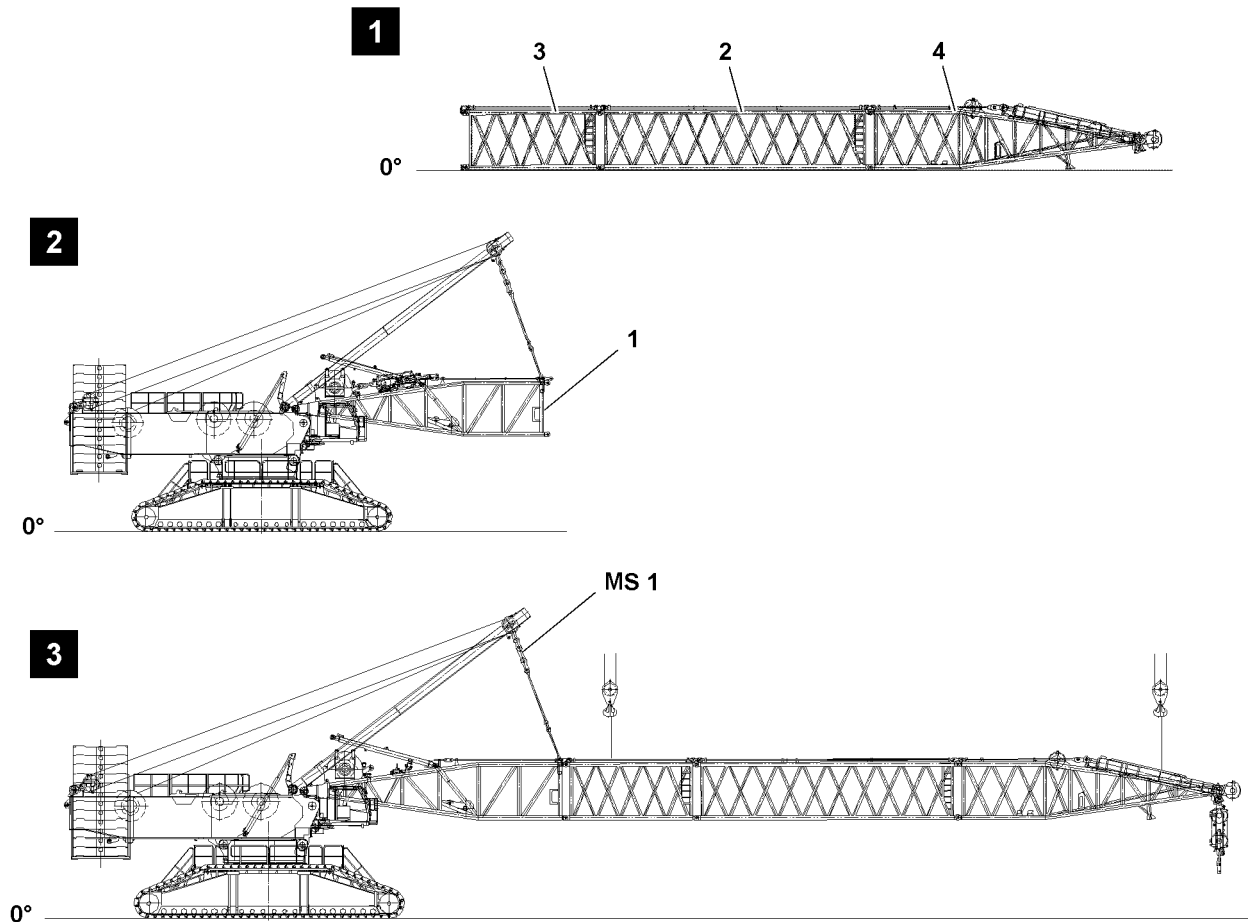

Fig.122970: Flying assembly of the D-boom

Make sure that the following prerequisites are met:

- The crane is horizontally aligned.
- The counterweight has been installed on the turntable according to the load chart.
- The central ballast has been installed on the turntable according to the load chart.
- The LICCON overload protection has been set according to the data in the load chart.
- The LICCON overload protection settings have been compared with the actual set up configuration.

6.1 Preassembling the D-boom on the ground



WARNING

Danger due to lattice sections!

Death, severe bodily injuries, property damage.

► Make sure that the D-boom sections are properly pinned and secured.

► Properly pin and secure the D-intermediate sections and D-end section with each other on the ground, see section „Assembling the D-boom in sections“, see illustration 1.

6.2 Assembling the D-pivot section on the SA-frame

- Fasten the D-pivot section 1 to the auxiliary crane.
- Swing the D-pivot section 1 in with the auxiliary crane to the SA-frame.

When the pin bores between the SA-frame and the D-pivot section align:

- Properly pin and secure the D-pivot section 1 on the SA-frame, see section „Pinning the D-pivot section on the SA-frame“, see illustration 2.

NOTICE

Danger of property damage!

Damage of hydraulic lines.

- ▶ Make sure that the hydraulic connections from the turntable to the D-pivot section are established before the SA-frame is lowered to the front.

-
- ▶ Establish the hydraulic connections from the turntable to the D-pivot section properly.

When the D-pivot section is properly pinned and secured on the SA-frame:

- ▶ Lower the SA-frame to the front in direction of the D-pivot section.
- ▶ Assemble the flying assembly guying between the SA-frame and the D-pivot section.

When the guying between the SA-frame and the D-pivot section is properly assembled and secured:

- ▶ Remove the auxiliary crane on the D-pivot section **1**, see illustration **2**.

6.3 Assembling the D-boom on the D-pivot section

- ▶ Fasten the D-boom to the auxiliary crane.
- ▶ Lift the D-boom with the auxiliary crane.
- ▶ Swing the preassembled D-boom in to the pin points on the D-pivot section, see illustration **3**.

When the pin bores between the D-pivot section and the D-boom align:

- ▶ Insert the pin and secure with spring retainer, see section „Assembling the D-boom in sections“, see illustration **3**.

When the D-boom is properly pinned and secured on the D-pivot section:

- ▶ Remove the auxiliary crane.

6.4 Completing the D-boom assembly

Make sure that the following prerequisite is met:

- The D-boom is properly pinned and secured on the D-pivot section.

- ▶ Take the D-boom down on the ground or on the substructure.
- ▶ Lower the SA-frame to the front and assemble the D-guying, see section „Assembling the D-guy rods“.
- ▶ Check the safety equipment, see section „Checking the function of the safety equipment.“
- ▶ Erect the boom, see section „Erecting the D-boom.“

Empty page!

LWE/LR 11000-001/23501-04-02/en

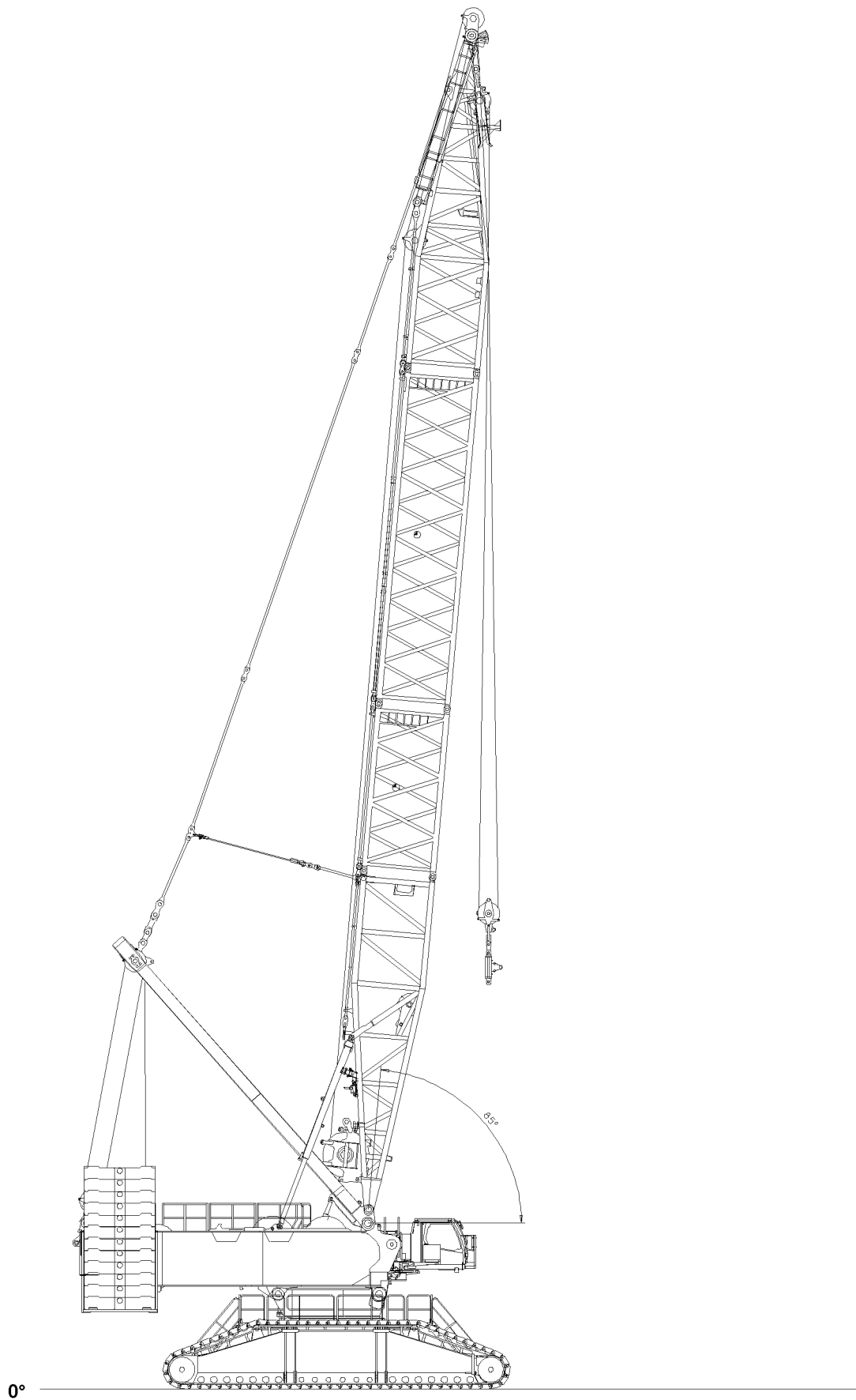

LWE/LR 11000-001/23501-04-02/en

Fig.122722

7 Disassembling



WARNING

Danger of falling!

During assembly / disassembly, inspection and maintenance work, personnel must be secured with appropriate aids to prevent them from falling.

If this is not observed, assembly personnel could fall and be killed or seriously injured.

- ▶ All work at a height, when there is a danger of falling, must be carried out with suitable aids.
- ▶ If aids are not available and work cannot be carried out from the ground, then assembly personnel must secure themselves with the supplied fall arrest system to prevent falling, see the Crane operating instructions, chapter 2.04.
- ▶ If fall protection equipment is available, then it must be used, see the Crane operating instructions, chapter 2.06.
- ▶ When lifting, lowering, swinging crane parts in and out, no persons may remain in the danger zone.
- ▶ If railings are present on the components, then they must be brought into the corresponding position and secured for assembly / disassembly work.
- ▶ Only step on the aids, ladders and catwalks with clean shoes.
- ▶ Keep aids, ladders and catwalks free of heavy dirt, snow and ice.
- ▶ During all assembly and disassembly work, maintenance work and inspections, travel or crane operation is prohibited.
- ▶ Remaining on a suspended load is prohibited.
- ▶ Stepping or walking on crane components and lattice sections, which have an incline of more than 20° is prohibited.
- ▶ For all assembly work, the crane operator of the main crane must be in voice contact with the crane operator / crane operators of the auxiliary crane / auxiliary cranes.
- ▶ For assembly / disassembly tasks, the crane operator may only initiate crane movements when the responsible guide has explicitly released the movement.



WARNING

Danger of impact / crushing!

When installing / removing crane components with the auxiliary crane, crane components can start to swing back and forth.

When lifting / lowering and positioning crane components, there is an increased danger of impacts / crushing.

Death, severe bodily injuries, property damage.

- ▶ Make sure that personnel cannot be caught by components.
- ▶ When working in danger zones: Use aids to protect limbs.
- ▶ Guide components with suitable aids to minimize oscillation.



DANGER

The components can fall down!

If the corresponding components are disengaged from the auxiliary crane before the corresponding component is pinned, the corresponding component can fall down and fatally injure personnel.

- ▶ Do not disengage the auxiliary crane until the respective component is pinned and secured.



WARNING

The lattice sections can fall down!

If the lattice sections are not pinned and secured correctly, then they can fall down and fatally injure personnel.

- ▶ Pin or unpin both pins at the same horizontal level, i.e. **left and right**.
- ▶ Do not stand under the lattice sections or within the entire danger zone during the pinning and unpinning procedure of the boom.
- ▶ Safely secure the pins in the storage locations as well as in the receptacles.
- ▶ It is prohibited to lean the auxiliary ladder against the component being disassembled.

**Note**

- ▶ The assembly and disassembly of the derrick boom with 36 m corresponds to the assembly and disassembly of the derrick boom with 42 m, but without the derrick auxiliary guying.
- ▶ The assembly and disassembly of the derrick boom is described based on the example of the derrick boom with 42 m.

Make sure that the following prerequisites are met:

- The crane is horizontally aligned.
- An auxiliary crane is available.
- An assembly scaffolding / work platform is available.
- The counterweight has been installed on the turntable according to the load chart.
- The central ballast has been attached according to the load chart.
- The LICCON overload protection has been set according to the data in the load chart.
- The LICCON overload protection settings have been compared with the actual set up configuration.
- The main boom has been removed.

7.1 Turning the turntable to the disassembly position

**DANGER**

The crane can topple over!

Death, severe bodily injuries, property damage.

- ▶ After disassembly of the D-boom, observe the assembly conditions for operation on crawlers, see Crane operating instructions, chapter 3.06.

- ▶ Turn the turntable in lengthwise direction of the crawler travel gear.

7.2 Exceeding the shut off limits of the LICCON overload protection for assembly operation

**WARNING**

Danger of accident due to function „Exceedance of shut-off limits of the LICCON overload protection“! If the shut off limits of the LICCON overload protection are exceeded, there is no additional protection against crane overload.

Due to erroneous operation or deliberate misuse, the crane could collapse, the boom can break off or the crane can topple over.

Death, severe bodily injuries, property damage.

- ▶ The function „Exceedance of shut off limits of the LICCON overload protection“ is only permissible in emergencies and for assembly purposes.
- ▶ The function „Exceeding the shut off limits of the LICCON overload protection“ may only be actuated by persons who know the effects of their actions regarding the function „Exceeding the shut off limits of the LICCON overload protection“.
- ▶ The function „Exceedance of shut off limits of the LICCON overload protection“ requires the presence of an authorized person and must be performed with utmost caution.
- ▶ Crane operation with activated function „Exceedance of shut off limits of the LICCON overload protection“ is prohibited.

- ▶ Exceeding the shut off limits of the LICCON overload protection: Engage assembly operation.

Result:

- The shut off limits of the LICCON overload protection are exceeded.
- The assembly icon appears on the LICCON monitor.

**Note**

- ▶ See the Crane operating instructions, chapter 4.02 and chapter 4.20.

7.3 Removing the D-boom in sections



WARNING

Falling boom!

If the D-boom is not properly supported before disassembly or held with an auxiliary crane, then the D-boom can fall down when it is unpinned.

Death, severe bodily injuries, property damage.

- ▶ Before supporting the D-boom, the ground condition must be checked regarding load bearing capacity and level.

If the ground condition is not classified as sufficient:

- ▶ Support the D-boom properly and safely with suitable material.
-

7.3.1 Luffing the D-boom down

NOTICE

Damage to the luffing pulley block!

If the D-boom is lowered too quickly „forward“, significant damage can occur on the luffing pulley block and on the D-end section.

- ▶ Lower the D-boom forward carefully and at a slow speed.
 - ▶ Make sure that the upper pulley block **6.2** does not run on the ground when lowering the D-boom.
 - ▶ Make sure that the upper pulley block **6.2** does not collide uncontrolled with the lower pulley block **6.1** when spooling up winch 3.
-

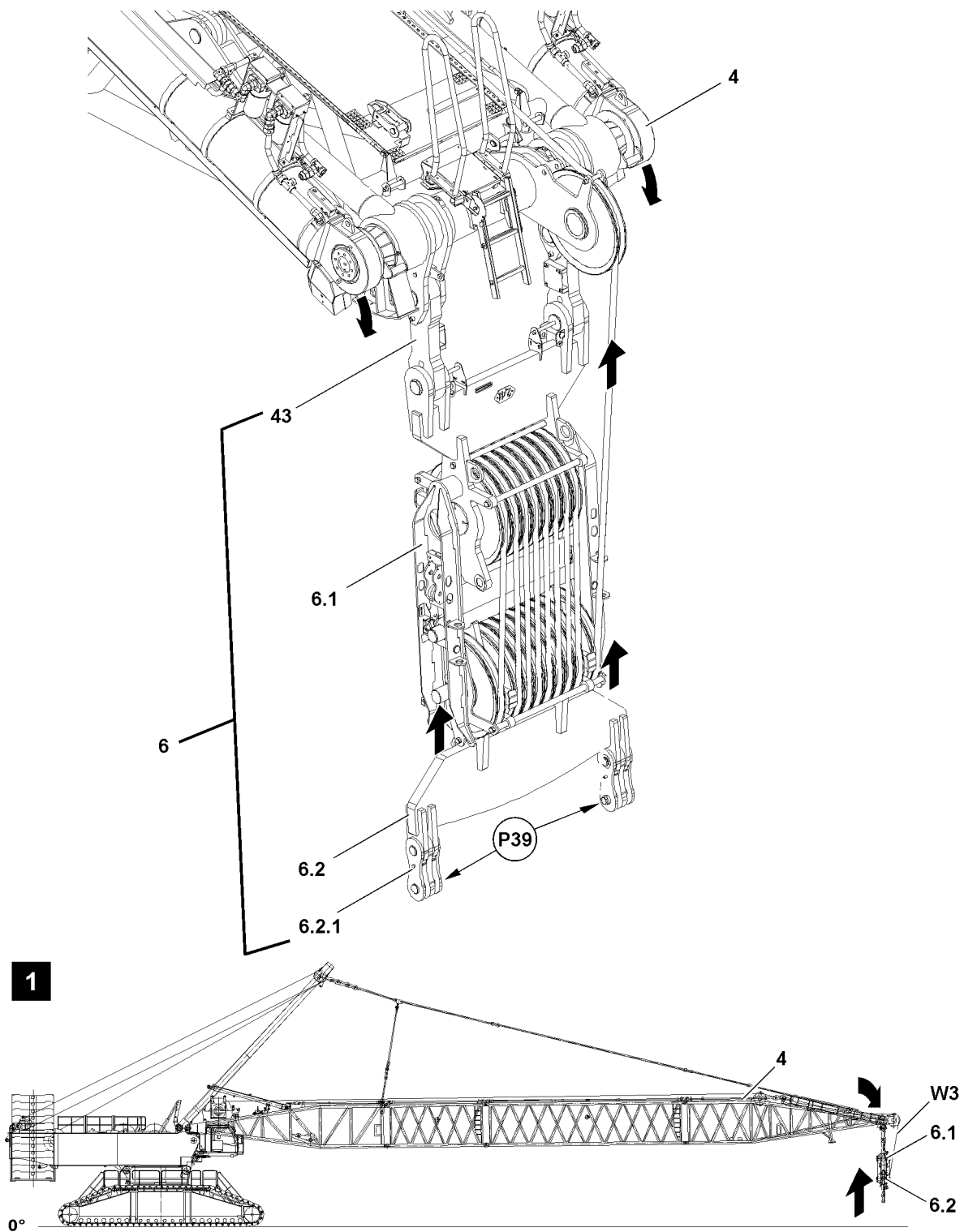

Fig.123558: Luffing the D-boom down and spool up winch 3

- ▶ Lower the D-boom to the front to the horizontal and spool winch 3 up at the same time, see illustration 1.

When the upper pulley block **6.2** approaches the lower pulley block **6.1**:

- ▶ Align the upper pulley block **6.2** on the bracket of the lower pulley block **6.1**.

When the upper pulley block is aligned:

- ▶ Move the upper pulley block **6.2** in by spooling up winch 3 in the link to the limit switches.

Result:

- „Lift“ winch 3 (pulling the luffing pulley block together) turns off.
- „Lower“ winch 4 (luffing the D-boom down) turns off.
- ▶ Pin the luffing pulley block **6** for transport, see section „Pinning the upper pulley block with the lower pulley block“.

7.3.2 Pinning the upper pulley block with the lower pulley block

Make sure that the following prerequisites are met:

- The luffing pulley block hangs in a reeved in condition on the D-end section.
- The pin **60** is in park position at point **P36**.

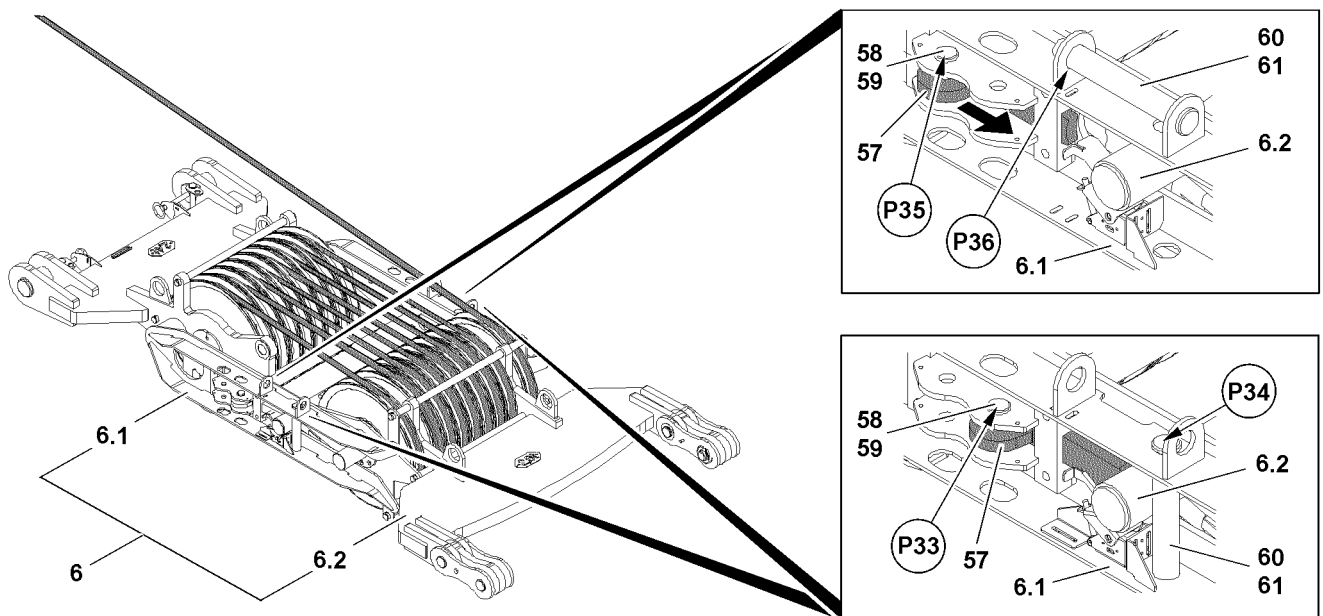

Fig.123559: Pinning the upper pulley block with the lower pulley block for transport

The upper pulley block **6.2** must be pinned with the lower pulley block **6.1** before the complete luffing pulley block **6** can be placed in the transport receptacle on the D-pivot section.

- ▶ Remove the safety locking pin **59** at point **P35** and unpin the pin **58** on both sides.
- ▶ Move the latch **57** until it can be pinned at point **P33**.
- ▶ Insert the pins **58** on both sides at point **P33** and secure with the safety locking pin **59**.

NOTICE

Danger of property damage on the luffing pulley block!

If the D-boom is luffed down too fast and winch 3 is spooled up too fast, then significant property damage can occur on the upper as well as the lower pulley block.

- ▶ Carry out all crane movements slowly and with utmost caution.

- ▶ Unpin the pins **60** in park position on both sides: Release the safety locking pin **61** and unpin the pin **60** at point **P36**.
- ▶ Insert the pin **60** on both sides on the bracket of the lower pulley block **6.1** at point **P34** and secure with the safety locking pin **61**.

Result:

- The upper pulley block **6.2** is connected with the lower pulley block **6.1** and now forms the „transport unit“ luffing pulley block **6**.

Problem remedy

The pin **60** cannot be inserted at point **P34**?

- ▶ Fasten the upper pulley block **6.2** on both sides to the auxiliary crane and lift carefully to the stop on the latch **57**.
 - ▶ Insert the pin **60** on both sides on the bracket of the lower pulley block **6.1** at point **P34** and secure with the safety locking pin **61**.
-

7.3.3 Disconnecting the electrical connections to the luffing pulley block

Make sure that the following prerequisites are met:

- The D-boom is in the „horizontal“ position.
- The upper pulley block **6.2** has been secured to the lower pulley block **6.1** on both sides with pins **60**.

**Note**

- ▶ Disconnect the electrical connections, use the Electric wiring diagram.
-

- ▶ Disconnect the electrical connections from the luffing pulley block to the terminal box on the D-end section.

When the electrical connections from the luffing pulley block to the terminal box are disconnected:

- ▶ Close the electrical connections off properly with dummy plugs, protective caps or caps.

7.3.4 Unpinning the luffing pulley block and taking it down on the ground

Make sure that the following prerequisites are met:

- The electrical connections to the luffing pulley block are disconnected.
- The dummy plugs are properly assembled.
- An auxiliary crane is on hand.

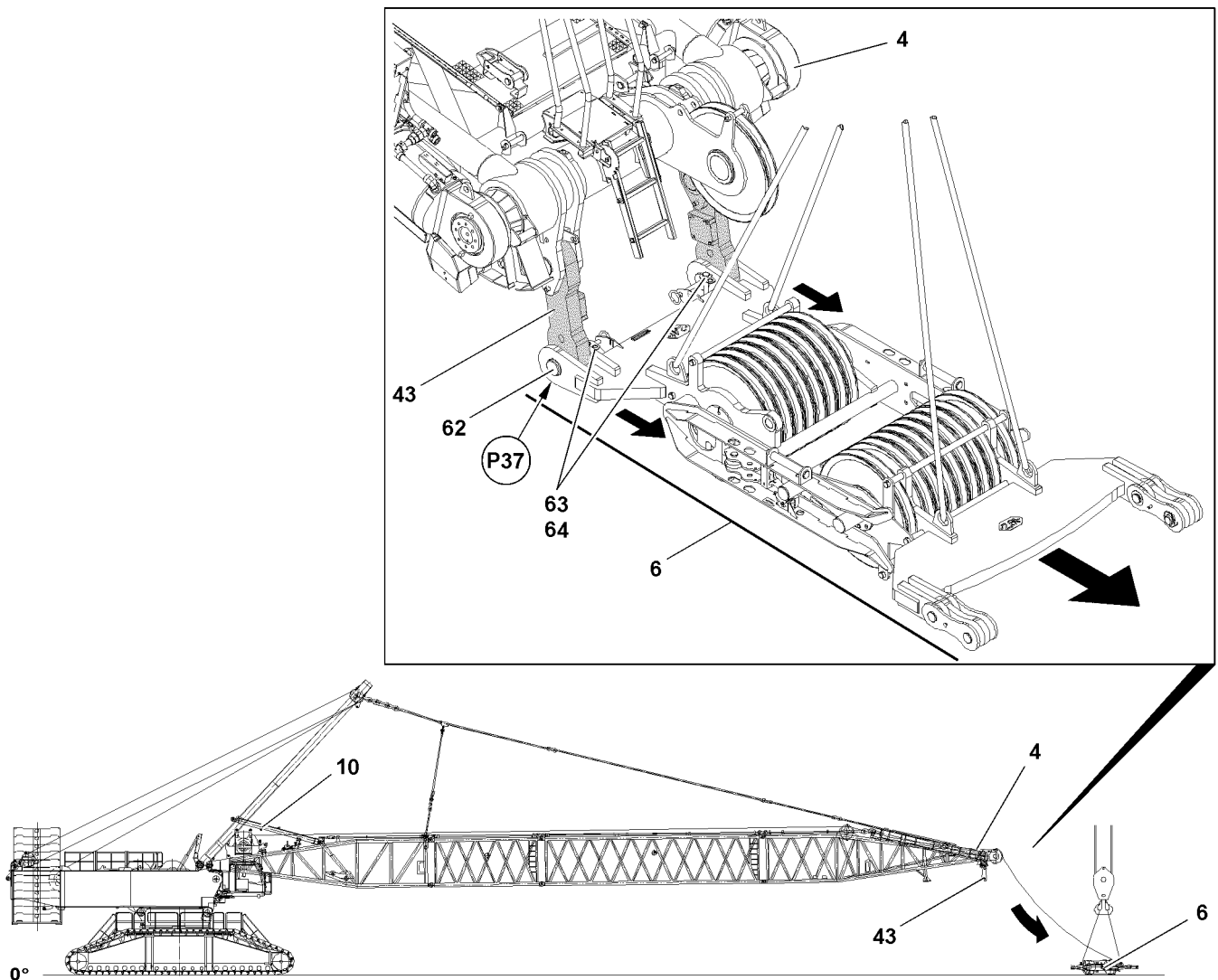

Fig.123560: Unpin the luffing pulley block on the pull test brackets and take it down on the ground

- ▶ Fasten the luffing pulley block **6** properly to the auxiliary crane.
- ▶ Lift the luffing pulley block **6** with the auxiliary crane to the horizontal.

Disassemble the luffing pulley block **6** on the pull test brackets **43** and take it down on the ground at a sufficient distance.

When the luffing pulley block **6** hangs horizontally on the auxiliary crane:

- ▶ Remove the safety locking pin **64** at point **P37** and unpin the pin **63** on both sides.
- ▶ Unpin the pins **62** on both sides.

Result:

- The luffing pulley block **6** is unpinned.

NOTICE

Danger of slack rope formation!

- ▶ Make sure that no slack rope on winch 3 forms when swinging the luffing pulley block out.

When the luffing pulley block **6** is unpinned on both sides:

- ▶ Swing the luffing pulley block **6** out with the auxiliary crane and spool winch 3 out at the same time.
- ▶ Take the luffing pulley block **6** down on the ground with the auxiliary crane.
- ▶ Remove the auxiliary crane.

7.3.5 Bringing the pulley retainer on the D-end section into transport position

Make sure that the following prerequisite is met:

- The luffing pulley block is disassembled on the D-end section and taken down on the ground.
- ▶ Unpin the pulley retainer **44** in the operating position: Remove the safety locking pin **51** at point **P31** and unpin the pin **50** on both sides.
- ▶ Unpin the retaining pin **47** in the transport position of the pulley retainer **44** at point **P28**: Remove the spring retainer **48** and unpin the retaining pin **47**.

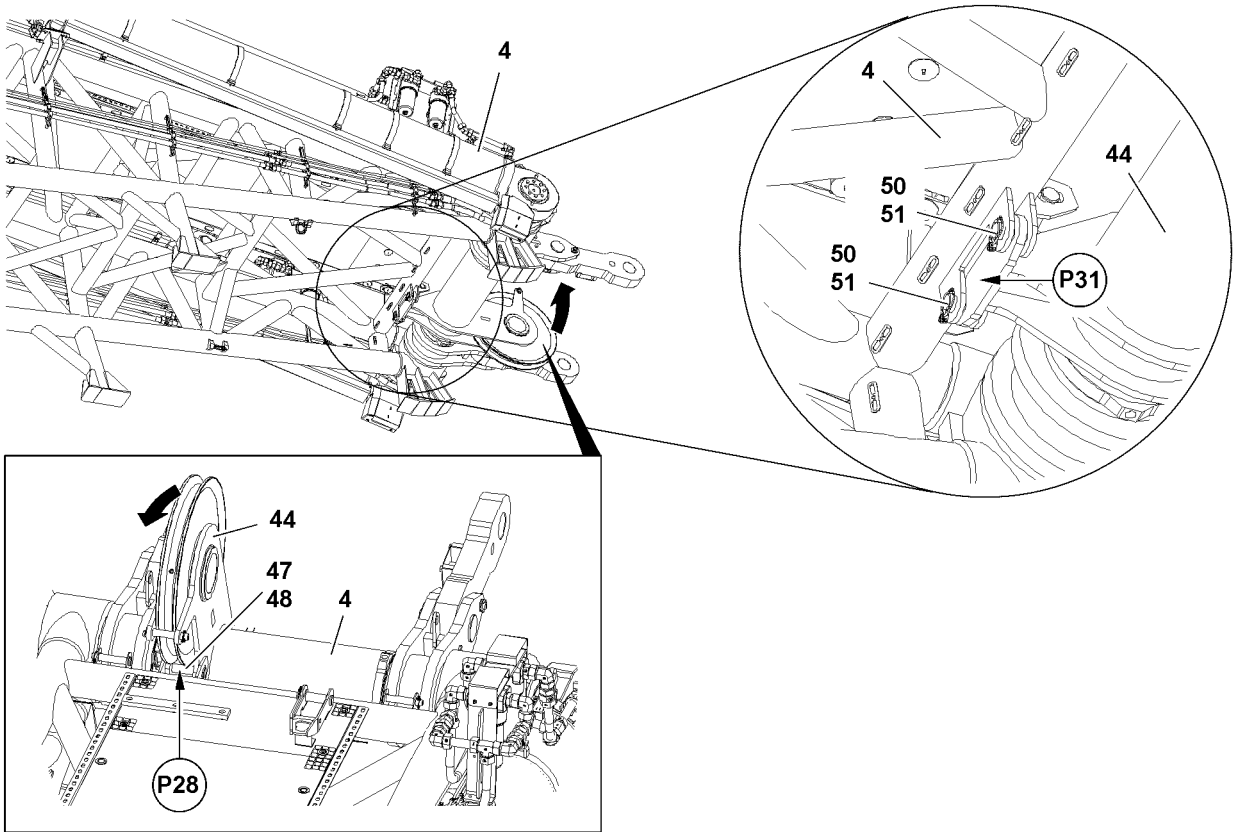

Fig.123561: Bringing the pulley retainer into the transport position



WARNING

Mortal danger due to pulley retainer!

If the pulley retainer is not secured with an auxiliary crane during the swing procedure, it can swing forward with a large momentum due to its weight.

Death, severe bodily injuries, property damage.

- ▶ Swing the pulley retainer into transport position only with the aid of an auxiliary crane.
- ▶ Swinging the pulley retainer without an auxiliary crane is **prohibited**.

- ▶ Fasten the pulley retainer **44** to the auxiliary crane.
- ▶ Swing the pulley retainer **44** upward with the auxiliary crane into transport position.

When the pulley retainer **44** is in transport position:

- ▶ Insert the retaining pin **47** at point **P28** and secure with the spring retainer **48**.

When the pulley retainer **44** is pinned and secured in the transport position:

- ▶ Remove the auxiliary crane.
- ▶ Insert the pin **50** again on both sides at point **P31** and secure with the safety locking pin **51**.

7.3.6 Bringing the pull test brackets into transport position

- ▶ Remove the safety locking pin **55** at point **P29** and unpin the pin **54**.

- ▶ Take the auxiliary bracket **53** from the transport retainer.

NOTICE

Danger of property damage!

- ▶ The pull test bracket **43** may only be lifted with the auxiliary crane via the auxiliary bracket **53**.

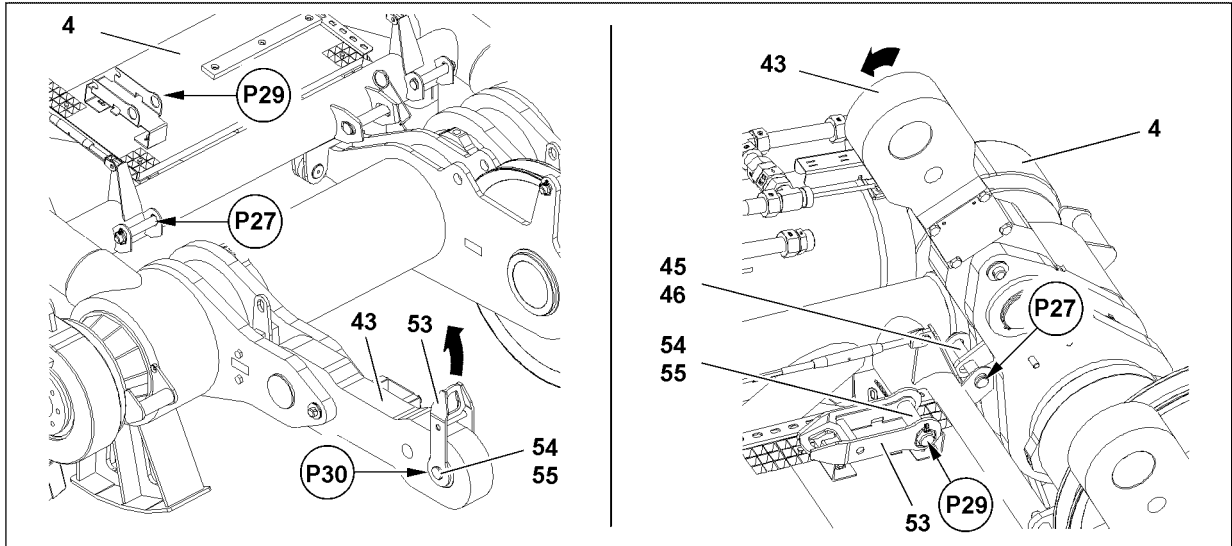

Fig.123562: Bringing the pull test brackets into transport position

- ▶ Connect the auxiliary bracket **53** with the pull test bracket **43**: Insert the pin **54** at point **P30** and secure with the safety locking pin **55**.
- ▶ Fasten the auxiliary bracket to the auxiliary crane.

**WARNING**

Danger of fatal injury due to the pull test bracket!

If the pull test bracket **43** is not secured with an auxiliary crane during the swing procedure, then it can swing forward due to its weight.

Death, severe bodily injuries, property damage.

- ▶ Swing the pull test bracket **43** into operating position or transport position only with the aid of an auxiliary crane.
- ▶ Swinging the pull test bracket without an auxiliary crane is **prohibited**.

- ▶ Tension the fastening equipment carefully.
- ▶ Remove the safety locking pin **46** on the transport retainer at point **P27** and unpin the retaining pin **45**.
- ▶ Swing the pull test bracket **43** to the rear with the auxiliary crane until it can be pinned at point **P27**.
- ▶ Insert the retaining pin **45** in the transport position at point **P27** and secure with the safety locking pin **46**.

When the pull test bracket is secured:

- ▶ Remove the auxiliary crane.
- ▶ Disconnect the auxiliary bracket **53** from the pull test bracket **43**.
- ▶ Swing the second pull test bracket into the transport position.
- ▶ Fasten the auxiliary bracket **53** in transport position at point **P29**.

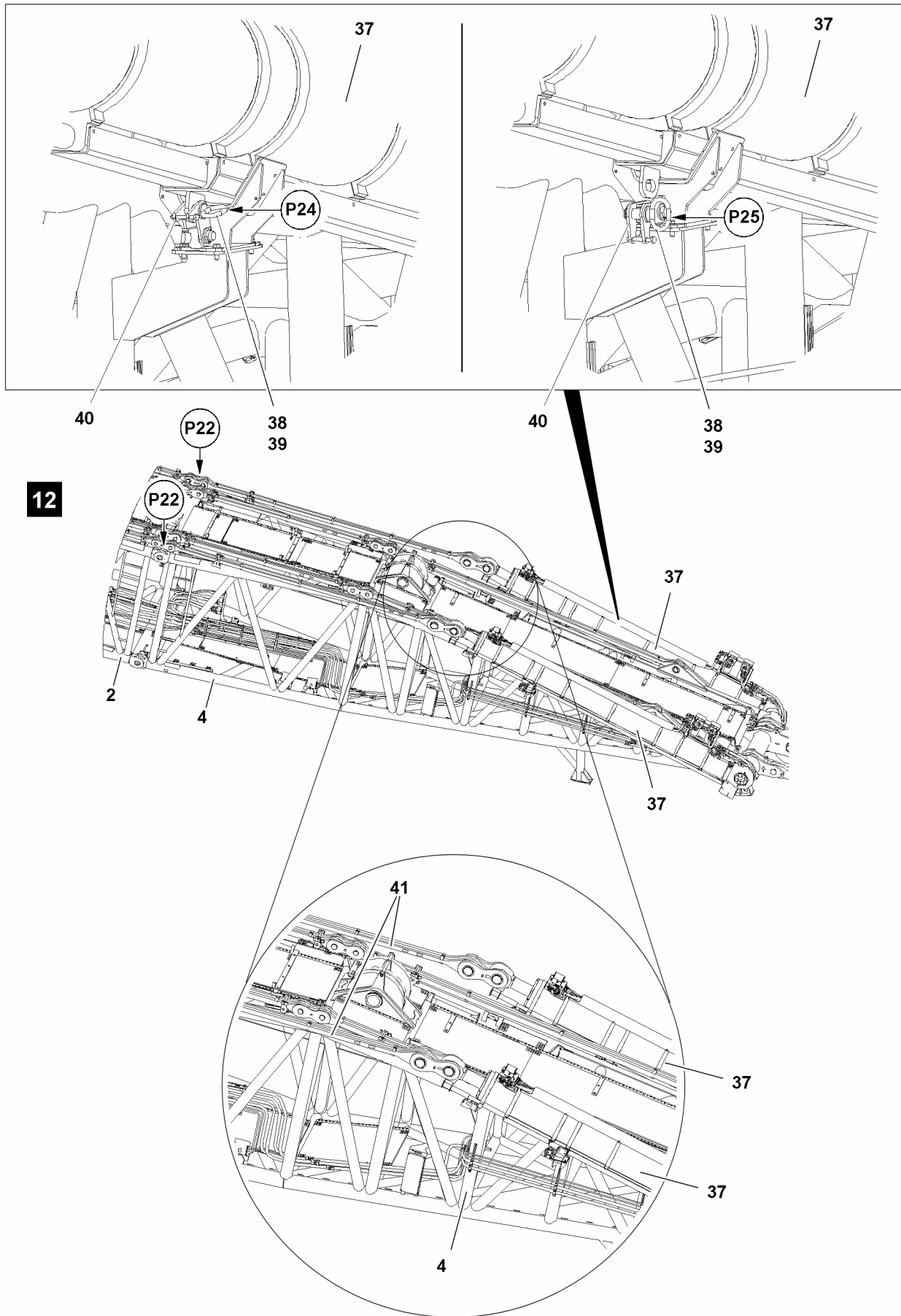

Fig.144118

7.3.7 Retracting and securing the pull cylinder

Make sure that the following prerequisite is met:

- The guy rods are taken down.
- The guy rods are separated at point **P22**.



Note

- ▶ The pull cylinders can only be retracted completely when the angle of the D-boom is less than 5°.
- ▶ Retract the pull cylinder (radio remote control*), see the radio remote control* operating instructions.
- ▶ Retract the pull cylinder (crane cab), see the Crane operating instructions, chapter 4.01.

Both pull cylinders **37** must be completely retracted and secured.

- ▶ Retract the pull cylinder **37** completely.
- ▶ Remove the safety locking pin **39** at point **P25** and unpin the grip pin **38**, see illustration **13**.
- ▶ Swing the retainer **40** upward, see illustration **12**.
- ▶ Insert the grip pin **38** at point **P24** and secure with the safety locking pin **39**, see illustration **12**.

Result:

- The pull cylinder **37** is secured in transport position.

7.3.8 Setting the ball valve on the pull cylinder to the „transport and storage“ position



Note

- ▶ The following tasks must be carried out on both pull cylinders.

The ball valve **81** is located under the flap **80** on the pull cylinder **37**.

- ▶ Open the flap **80**.

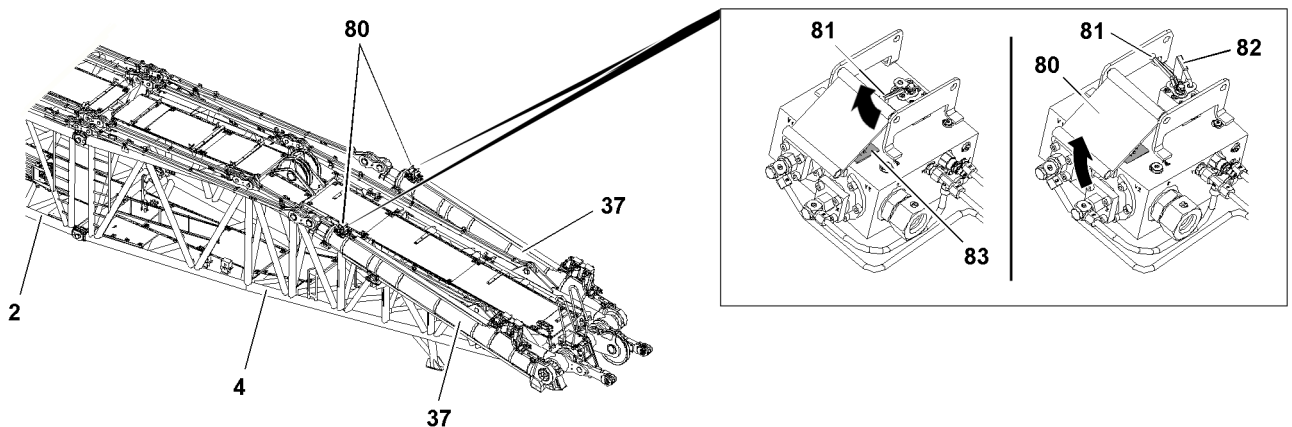
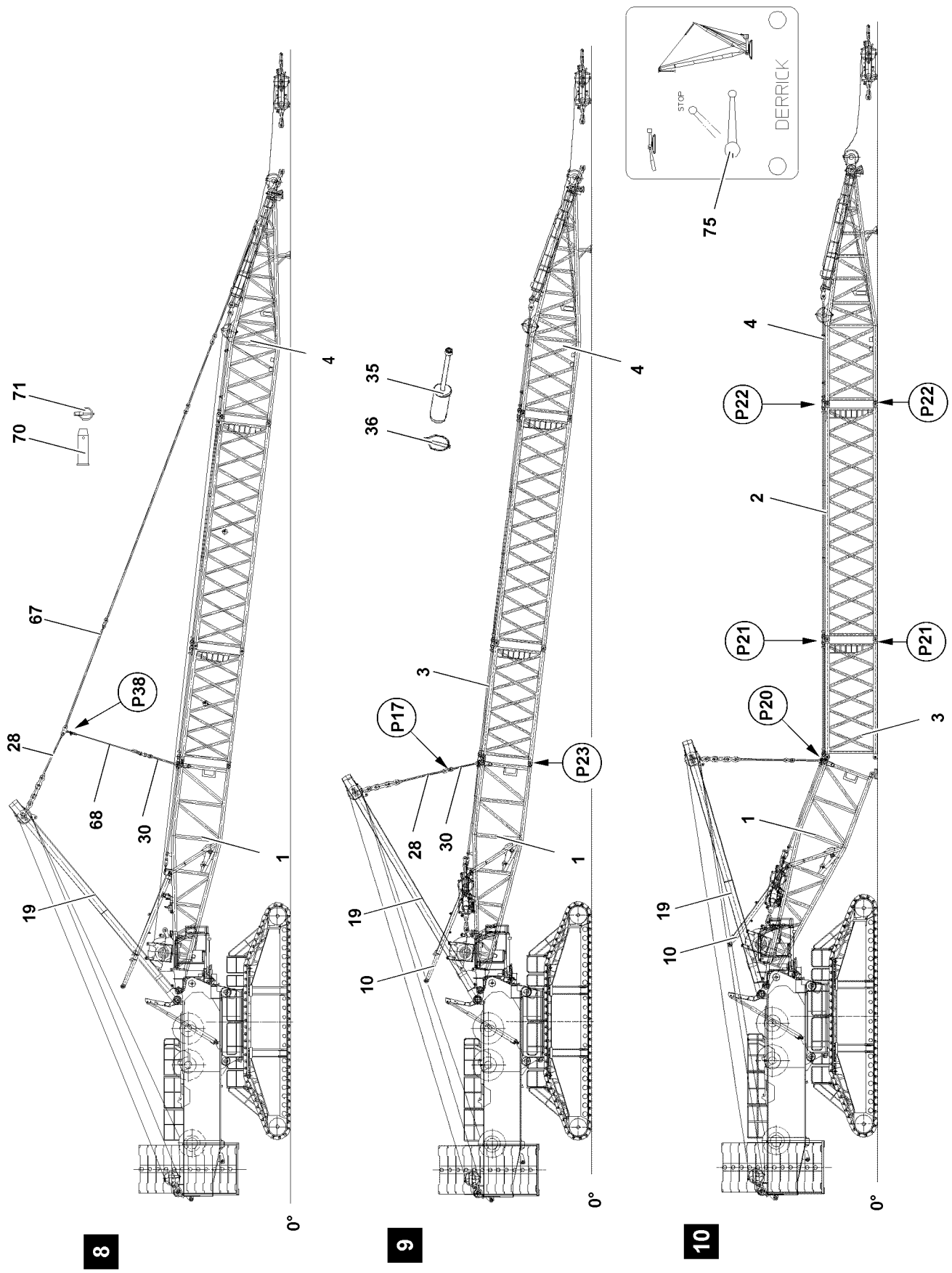

Fig.122781: Ball valve **81** on the pull cylinder **37**

- ▶ Change the ball valve **81** to the „transport and storage“ position, see sign **83**.

When the ball valve **81** is in the „transport and storage“ position:

- ▶ Attach the safety lock **82** and secure the ball valve **81** to prevent it from turning.
- ▶ Store the key safely.
- ▶ Close the flap **80** and secure it properly.



8

9

10

Fig.123557

LWE/LR 11000-001/23501-04-02/en

7.3.9 Disassembling the D-guy rods

- ▶ Place the guy rods into the transport retainers of the D-intermediate sections: Lower the SA-frame to the front.
- ▶ Pin and secure the guy rods **67** in the transport retainers.
- ▶ Unpin the guy rods **28** of the SA-frame and the guy rods **67** of the D-intermediate section: Remove the safety locking pin **71** and unpin the pin **70**.
- ▶ Unpin the guy rope **68** at point **P38** and remove, see illustration **8**.

7.3.10 Reeving the hoist rope out

- ▶ Reeve out the hoist ropes: Spool up winch 1 and winch 2.

7.3.11 Disconnecting the hydraulic connections on the D-boom

The hydraulic connections are made with quick couplings.

When disconnecting hydraulic lines with quick couplings, make sure that the coupling procedure is carried out correctly.



WARNING

Pressure in the hydraulic lines!

If the pressure supply is not interrupted before connecting / releasing the hydraulic lines, the hydraulic oil can escape with high pressure.

Death, severe bodily injuries, property damage.

- ▶ Release the pressure in the hydraulic system before connecting / disconnecting: Interrupt the pressure supply and wait for a short time.

- ▶ Release the hydraulic coupling by hand.
- ▶ Disconnect the hydraulic connections, see Hydraulic diagram.
- ▶ Protect the hydraulic connections from contamination with caps.

7.3.12 Disconnecting the electrical connections on the D-boom

- ▶ Disconnect the electrical connections, see Electric wiring diagram.
- ▶ Close the electrical connections off properly with dummy plugs or protective caps.

7.3.13 „Opening“ the D-boom and taking it down

NOTICE

Danger of property damage!

If the pins of the S-boom are in the **pinned** position when taking the D-pivot section down in the turntable, components can be severely damaged.

- ▶ Make sure that the pins on the turntable are in the **unpinned** position.



Note

- ▶ For disassembly of the D-boom, the guying of the guy rods **28** of the SA-frame **19** must be pinned with the rods for flying assembly **30** on the D-pivot section so that the D-boom can be lowered over the SA-frame and removed.

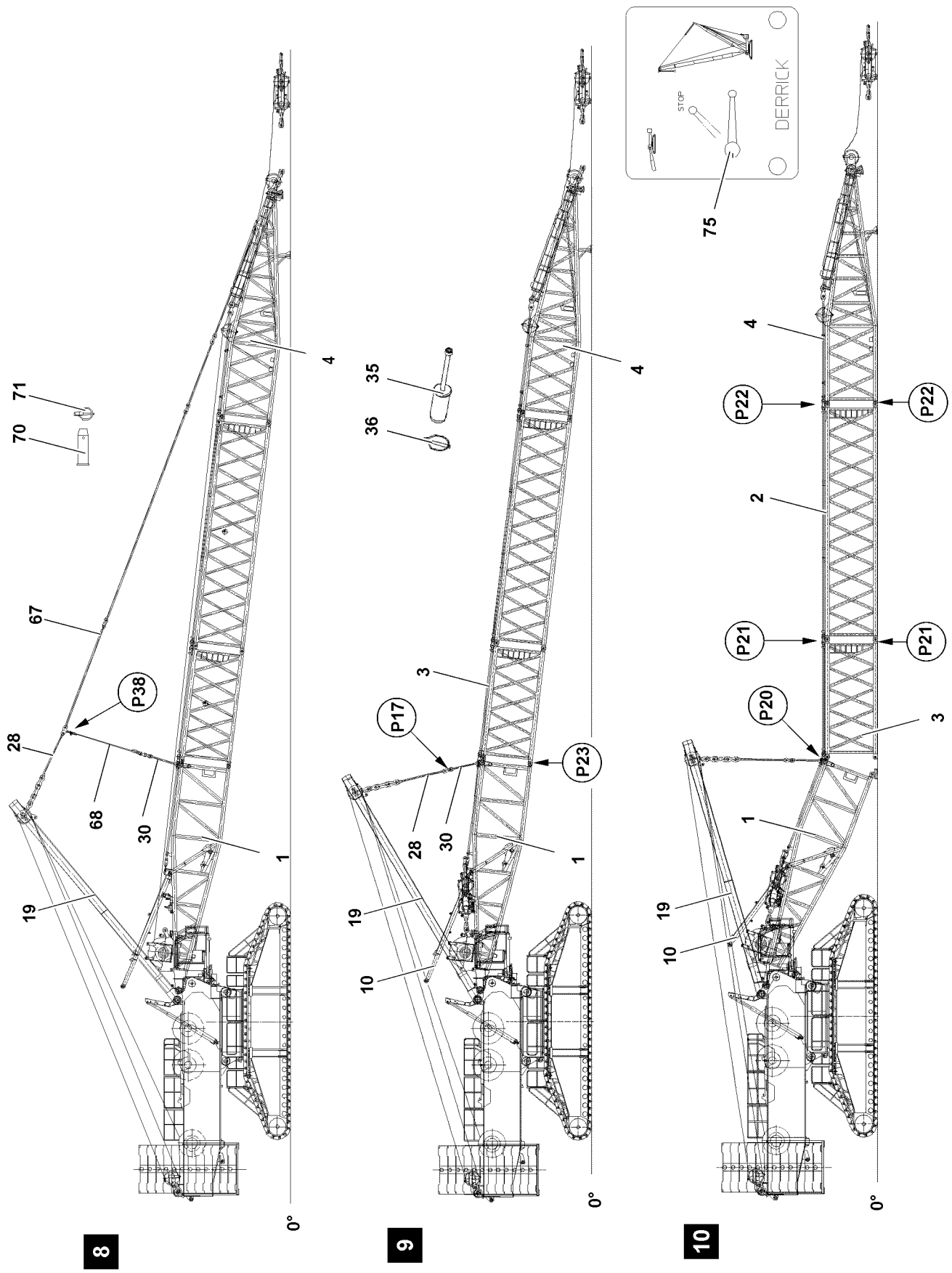

8

9

10

Fig.123557

LWE/LR 11000-001/23501-04-02/en

When the boom guying between the guy rods **28** of the SA-frame and the guy rods **67** of the D-intermediate section is unpinned:

- ▶ Pin the guy rods of the SA-frame **19** and the rods for flying assembly **30** of the D-pivot section **1** at point **P17**, insert the pins and secure with safety locking pins, see illustration **9**.
- ▶ Luff the SA-frame **19** up until the guying between the SA-frame and the D-pivot section is tensioned.



WARNING

Falling D-boom!

When unpinning the D-boom on the D-pivot section, the D-boom can fall down.

Death, severe bodily injuries, property damage.

- ▶ It is prohibited for anyone to remain under the D-boom during the unpinning procedure.
- ▶ Make sure that the D-boom is safely held by the guying.

-
- ▶ Unpin the D-pivot section **1** on the D-intermediate section **3**: Release the safety locking pins **36** on both sides at point **P23** and unpin the pins **35**.

When the pins **35** are unpinned on both sides at point **P23**:

- ▶ Luff the SA-frame down and take the D-boom down on the ground, see illustration **10**.
- ▶ Luff the SA-frame down until the guying is relieved.
- ▶ Unpin the guying: Release and unpin the pin.

NOTICE

Danger of property damage!

If the SA-frame **19** with an installed and unguyed D-pivot section **1** is erected further than 90°, components can be seriously damaged.

- ▶ Do not erect the SA-frame **19** with an installed and unguyed D-pivot section **1** too far.

-
- ▶ Luff the SA-frame up to maximum 90°.

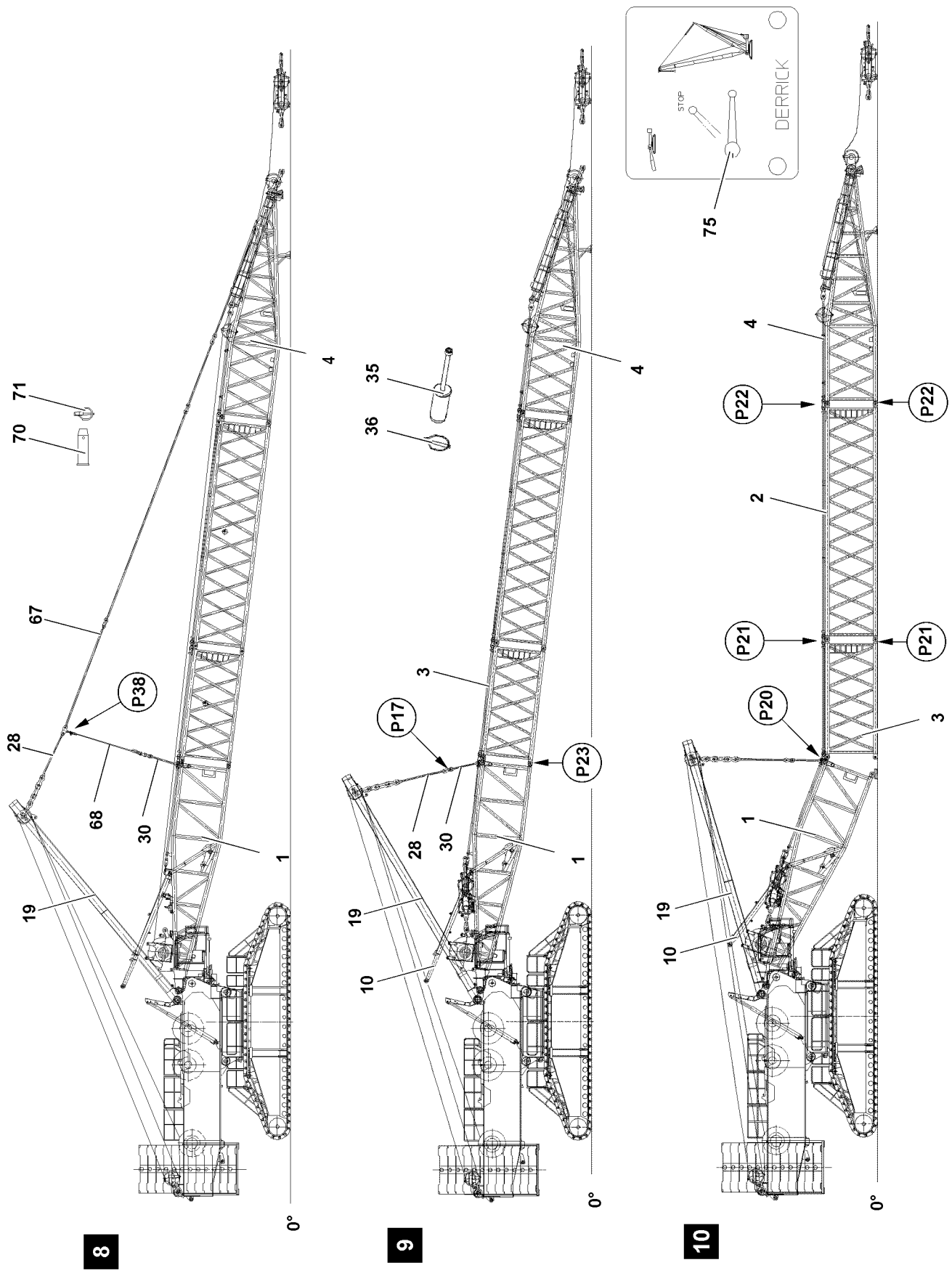

8

9

10

Fig.123557

LWE/LR 11000-001/23501-04-02/en

7.3.14 Retracting the D-relapse cylinder



WARNING

Danger of fatal injury due to the D-boom!
Death, severe bodily injuries, property damage.

- ▶ The ball valve must be secured during crane operation to prevent unintended actuation.

The piston rod on the D-relapse cylinder **10** must be retracted by actuating the ball valve **75**, see illustration **10**.

Ball valve positions	
Horizontal	Crane operation, extend the piston rod
Vertical	Assembly, retract the piston rod
45°	STOP (the piston rod cannot be retracted / extended)

Make sure that the following prerequisite is met:

- All hydraulic connections have been made.

- ▶ Move the ball valve **75** into vertical position.

Result:

- The piston rods of the D-relapse cylinders **10** retract.



Note

- ▶ The ball valve is secured by closing the cabinet door and removing the key.

- ▶ Close the cabinet door and pull out the key.
- ▶ Hand the key to an authorized person.

11

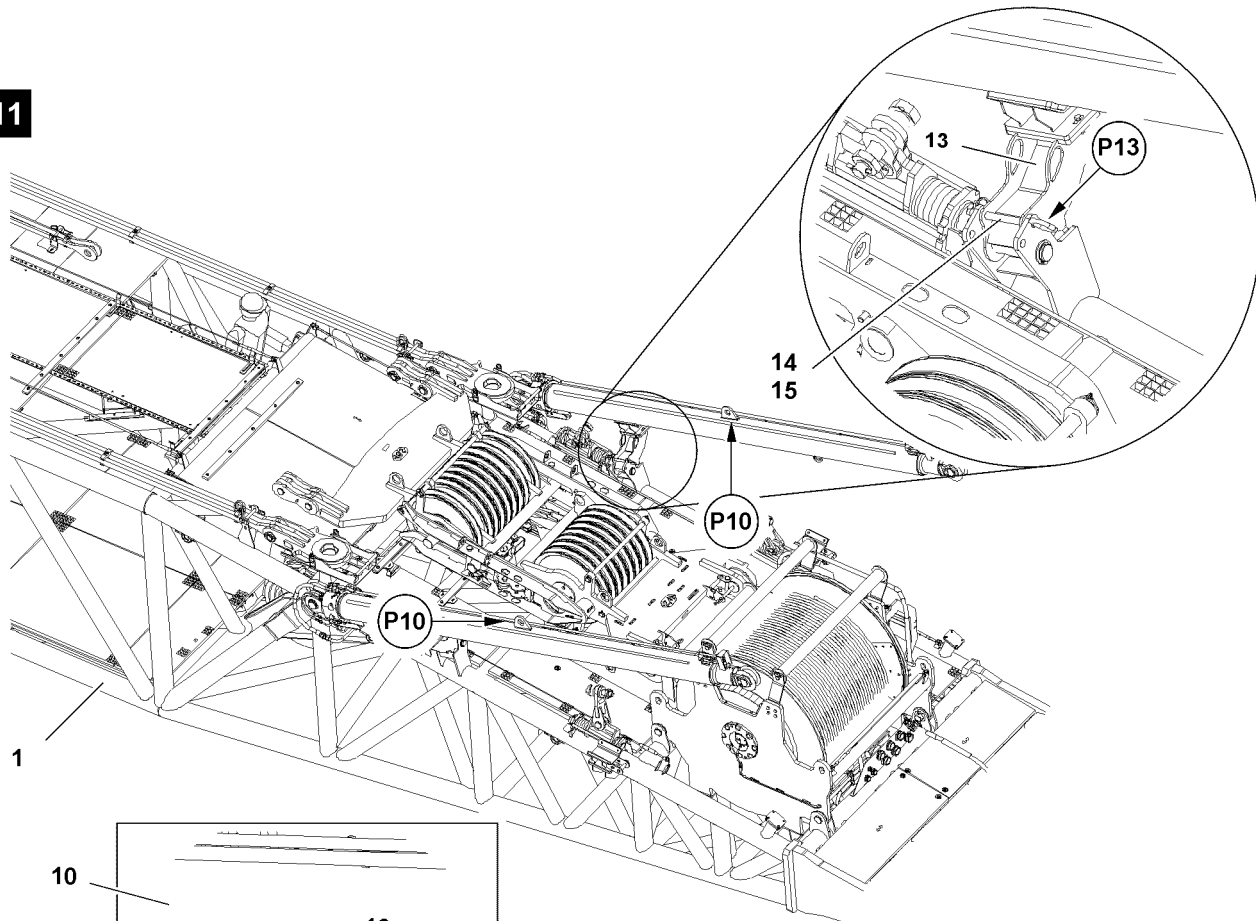

12

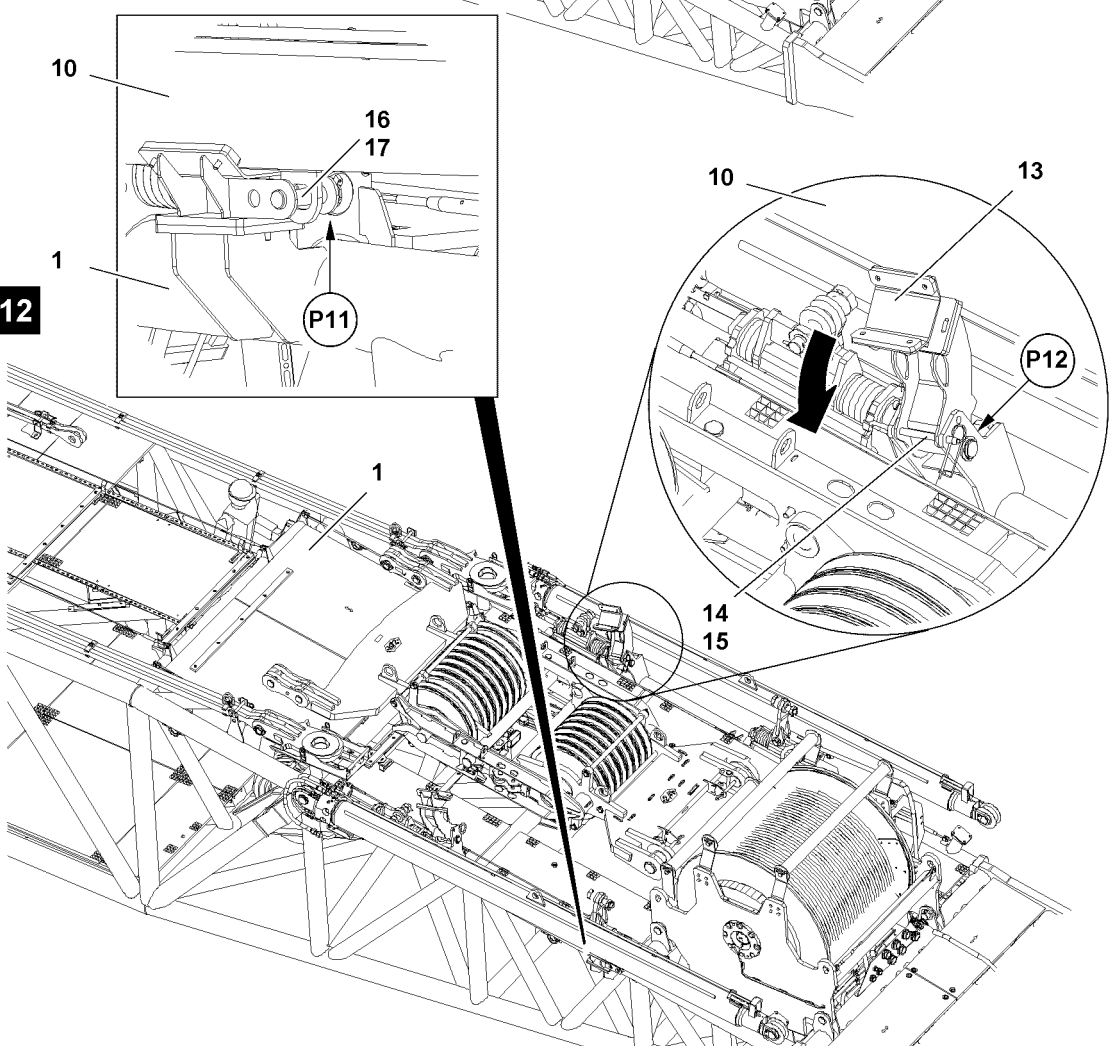

Fig.116973

LWE/LR 11000-001/23501-04-02/en

7.3.15 Taking the D-relapse cylinder down and securing it

- ▶ Remove the safety locking pin **17** at point **P11** and unpin the pin **16**, see illustration **12**.
- ▶ Fasten the D-relapse cylinder **10** to the auxiliary crane at point **P10**, see illustration **11**.
- ▶ Lift the D-relapse cylinder with the auxiliary crane.
- ▶ Remove the spring retainer **15** at point **P13** and unpin the grip pin **14**, see illustration **11**.



WARNING

Danger of crushed limbs!

When swinging the support **13**, fingers and hands can be crushed.

- ▶ Do not reach with your hands into the danger zone.

- ▶ Swing the support **13** down to the stop.
- ▶ Insert the grip pin **14** at point **P12** and secure with the spring retainer **15**, see illustration **12**.

Result:

- The support **13** is secured in the transport position.



WARNING

Danger of crushed limbs!

When placing the D-relapse cylinder **10** down, fingers and hands can be crushed.

- ▶ Do not reach with your hands into the danger zone.

- ▶ Take the D-relapse cylinder **10** down with the auxiliary crane.
- ▶ Remove the fastening equipment at point **P10**.
- ▶ Insert the pin **16** at point **P11** and secure with the safety locking pin **17**.

Result:

- The D-relapse cylinder **10** is secured in the transport position.
- ▶ Swing the second support into operating position.

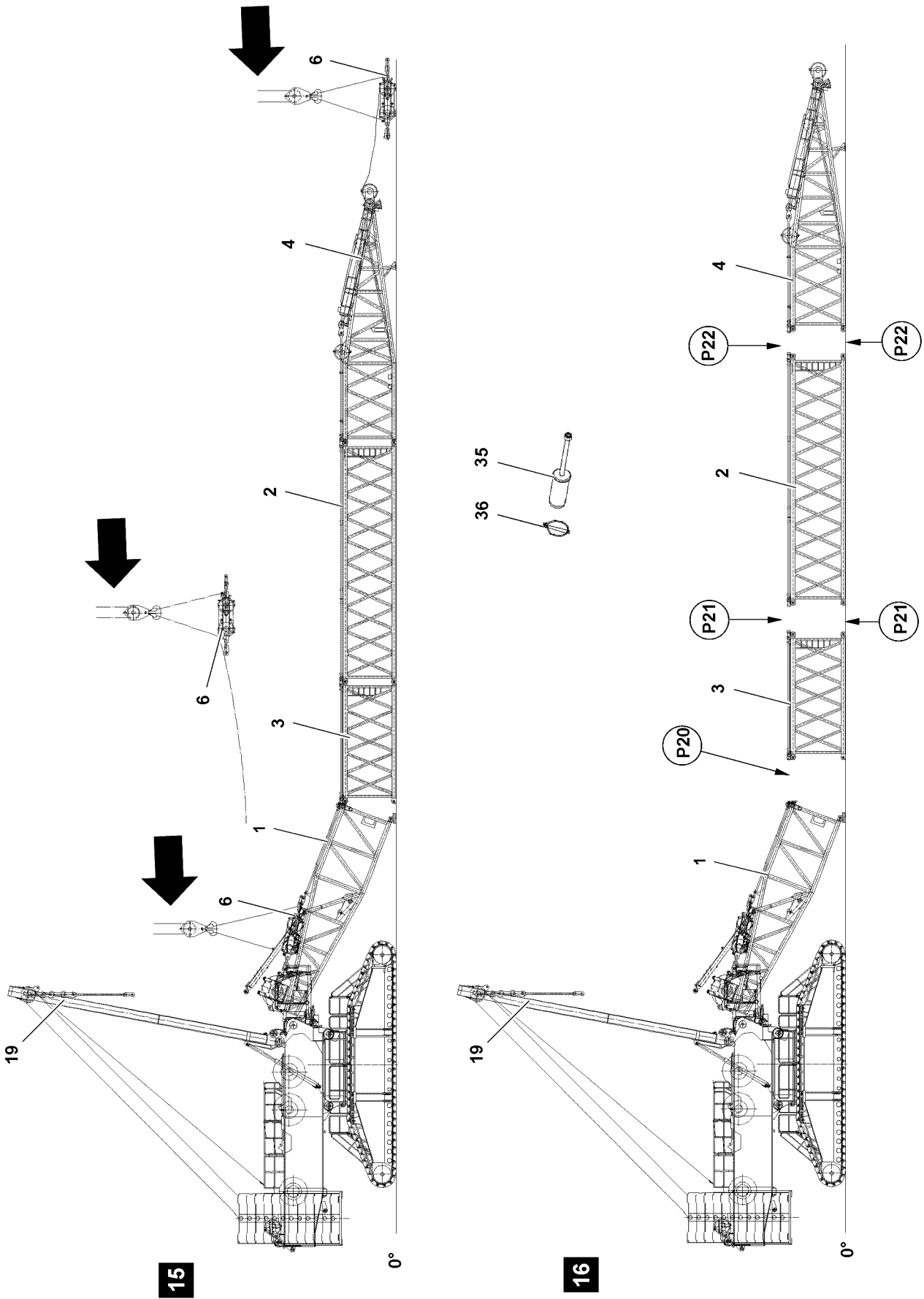

Fig.116993

LWE/LR 11000-001/23501-04-02/en

7.3.16 Taking the luffing pulley block down into the transport receptacle on the D-pivot section

Make sure that the following prerequisites are met:

- The lower and the upper pulley block are pinned together as a „transport unit“ luffing pulley block **6**.
 - The rope retaining pins on the D-end section are released and unpinned.
 - The guy rods are taken down in the transport retainers and secured.
 - The SA-frame is luffed up to approx. 100°.
 - The D-boom is laying fully on the ground (on the substructure).
 - The electrical connections are disconnected.
 - The electrical connections are closed off with dummy plugs, protective caps or caps.
- ▶ Fasten the luffing pulley block **6** to the auxiliary crane.
 - ▶ Tension the fastening equipment between the luffing pulley block and the hook block of the auxiliary crane.

NOTICE

Slack rope formation!

- ▶ Hold the control rope of winch 3 always slightly tensioned.
-
- ▶ Pull the luffing pulley block **6** with the auxiliary crane to the D-pivot section while spooling up winch 3 at the same time, see illustration **15**.

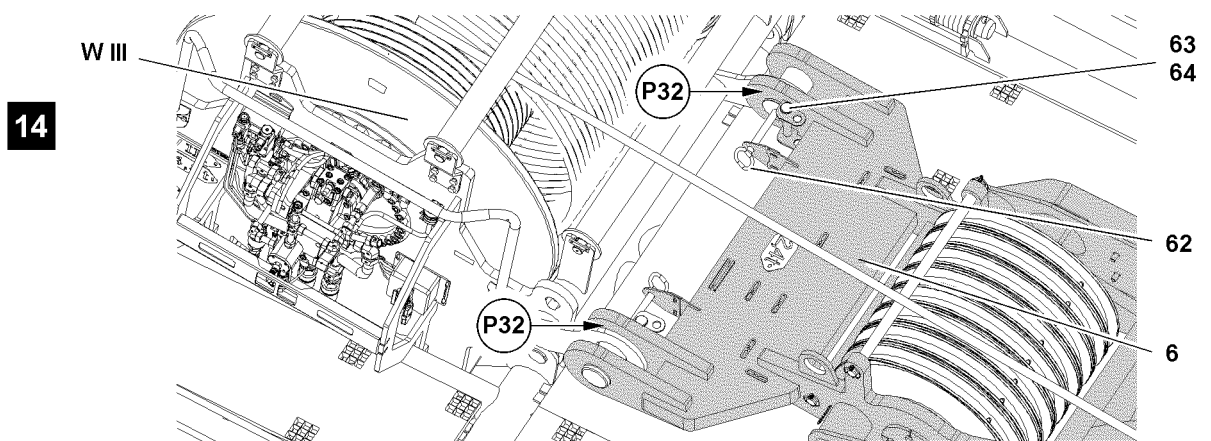

Fig.116994: Pinning the luffing pulley block

- ▶ Place the luffing pulley block **6** in the transport receptacle on the D-pivot section.
- ▶ Pin and secure the luffing pulley block **6** on the D-pivot section with winch 3 at point **P32**: Insert the pin **62** and secure with the retaining pin **63** and spring retainer **64**, see illustration **14**.

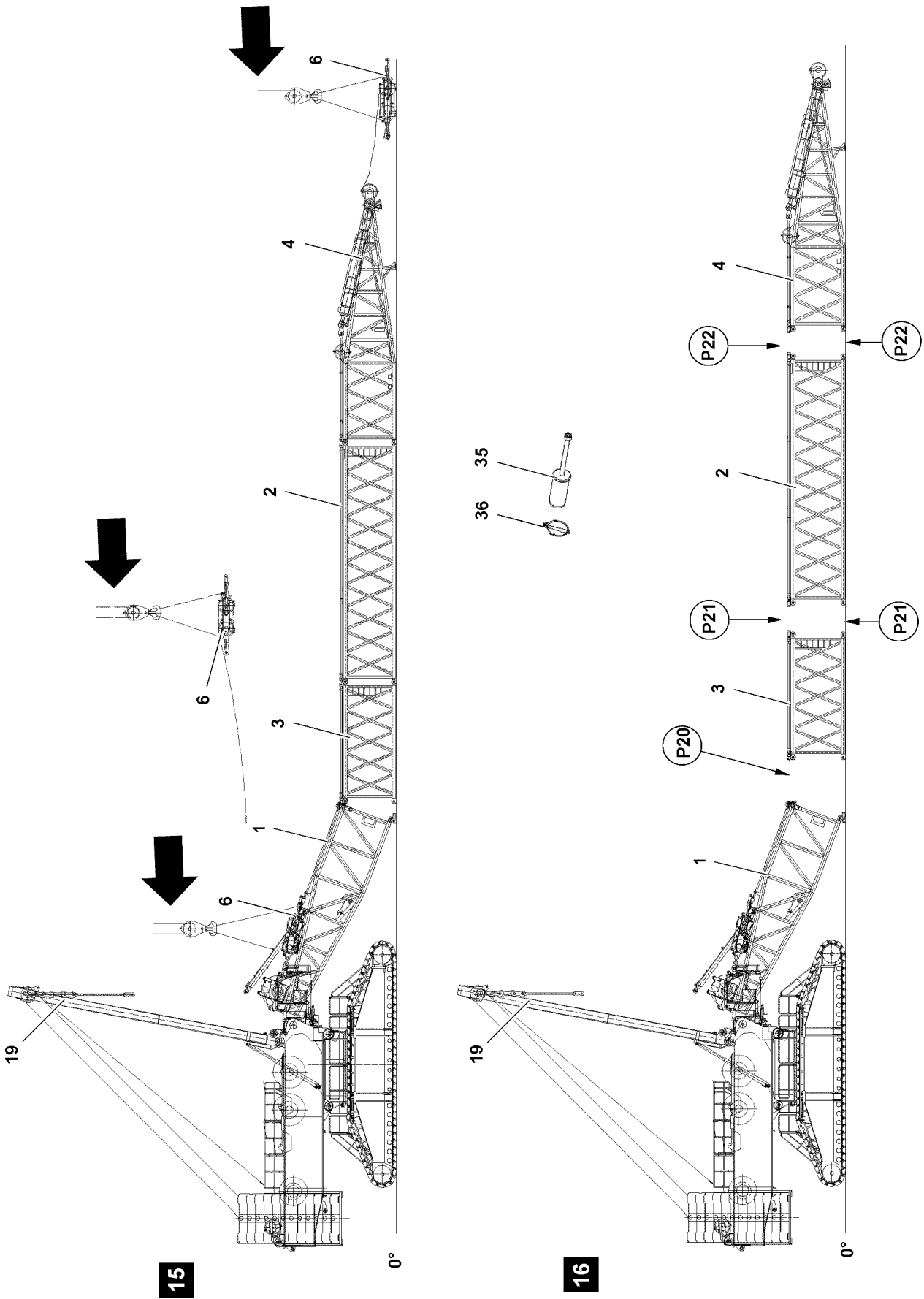

Fig.116993

7.3.17 Disassembling the D-lattice sections



WARNING

Tipping lattice sections!

When the lattice sections are unpinned, they can tip over, depending on the ground or the substructure.

Death, severe bodily injuries, property damage.

- ▶ The lattice sections must be safely held by the auxiliary crane before unpinning them.
- ▶ The fastening equipment must be tensioned before unpinning.



Note

- ▶ Always support the D-lattice sections sufficiently for easier disassembly.
- ▶ Pin and unpin the D-lattice sections with the pin pulling device, see Crane operating instructions, chapter 5.30.



Note

- ▶ Fastening points, see section „Fastening points for derrick components“.

Make sure that the following prerequisite is met:

- The luffing pulley block is pinned and secured on winch 3.

- ▶ Fasten the D-end section **4** to the auxiliary crane.

When the D-end section is being held by the auxiliary crane:

- ▶ Release the pin **35** at points **P22** and unpin.
- ▶ Remove the D-end section with the auxiliary crane, see illustration **16**.
- ▶ Fasten the D-intermediate section **2** to the auxiliary crane.

When the D-intermediate section is being held by the auxiliary crane:

- ▶ Release the pin **35** at points **P21** and unpin.
- ▶ Remove the D-intermediate section with the auxiliary crane, see illustration **16**.
- ▶ Fasten the D-intermediate section **3** to the auxiliary crane.

When the D-intermediate section is being held by the auxiliary crane:

- ▶ Release the pin **35** at point **P20** and unpin.
- ▶ Remove the D-intermediate section with the auxiliary crane, see illustration **16**.

7.3.18 Disconnecting the hydraulic connections to the D-pivot section

The hydraulic connections are made with quick couplings.

When disconnecting hydraulic lines with quick couplings, make sure that the coupling procedure is carried out correctly.



WARNING

Pressure in the hydraulic lines!

If the pressure supply is not interrupted before connecting / releasing the hydraulic lines, the hydraulic oil can escape with high pressure.

Death, severe bodily injuries, property damage.

- ▶ Release the pressure in the hydraulic system before connecting / disconnecting: Interrupt the pressure supply and wait for a short time.

- ▶ Release the hydraulic coupling by hand.
- ▶ Disconnect the hydraulic connections, see Hydraulic diagram.
- ▶ Protect the hydraulic connections from contamination with caps.

7.3.19 Disconnecting the electrical connections to the D-pivot section

- ▶ Disconnect the electrical connections, see Electric wiring diagram.
- ▶ Close the electrical connections off properly with dummy plugs or protective caps.

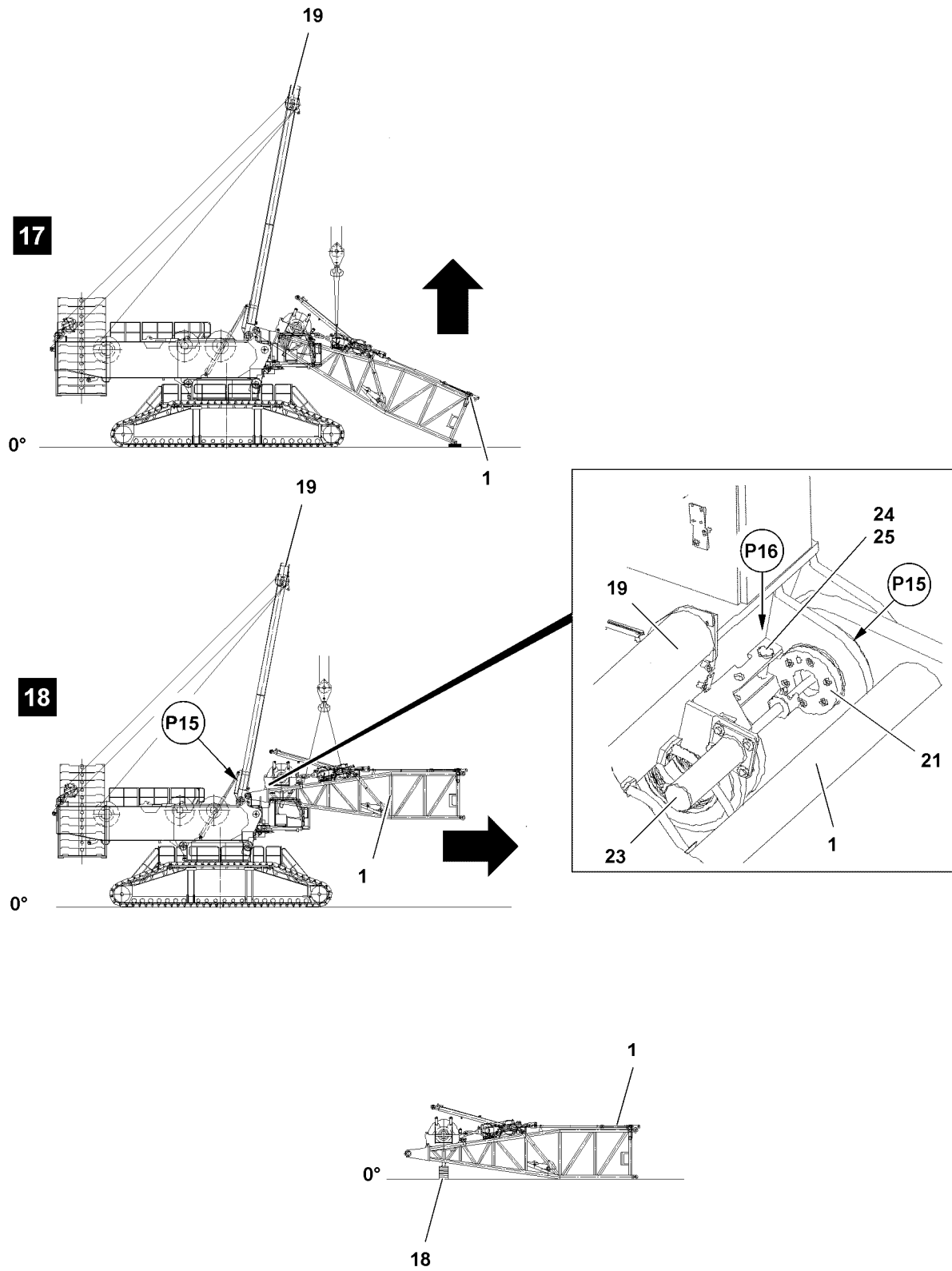

Fig.116995

7.3.20 Unpinning the D-pivot section on the SA-frame

Make sure that the following prerequisites are met:

- The D-lattice sections are removed.
- The crane engine is running.
- ▶ Fasten the D-pivot section **1** to the auxiliary crane.
- ▶ Lift the D-pivot section **1** with the auxiliary crane off the ground, see illustration **17**.

When the D-pivot section **1** is lifted off the ground:

- ▶ Release the electrical and hydraulic connections from the turntable to the D-pivot section, see section „Disconnecting the hydraulic and electrical connections“.
- ▶ Release the connector pin **21**: Remove the spring retainer **25** at point **P16** and unpin the retaining pin **24**, see illustration **18**.

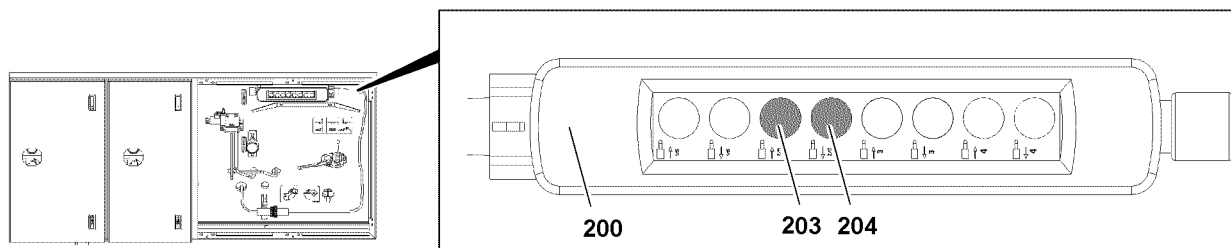

Fig.123564: Control panel

- ▶ Unpin the connector pins **21** with the hydraulic pin pulling device at point **P15**.
- ▶ Unpin the connector pins **21** on both sides: Press the button **204** on the control panel **200** and „hold it down“ until the connector pins **21** are completely unpinned.



WARNING

Danger of tipping over!

If the D-pivot section is taken down on the ground, then it must be supported accordingly.

If the D-pivot section is not properly supported, then it can tip forward.

Death, severe bodily injuries, property damage.

- ▶ Support properly.
 - ▶ Only set the D-pivot section **1** down on a proper substructure **18**.
-
- ▶ Remove the D-pivot section with the auxiliary crane and put it down on the substructure **18**.

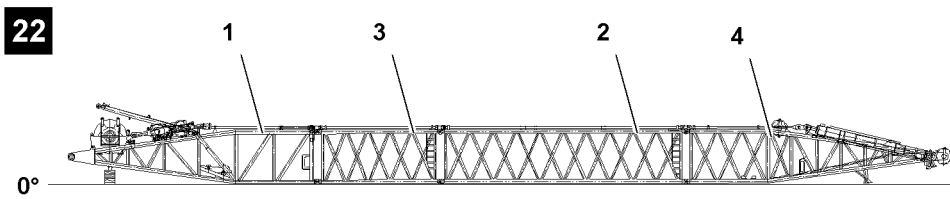
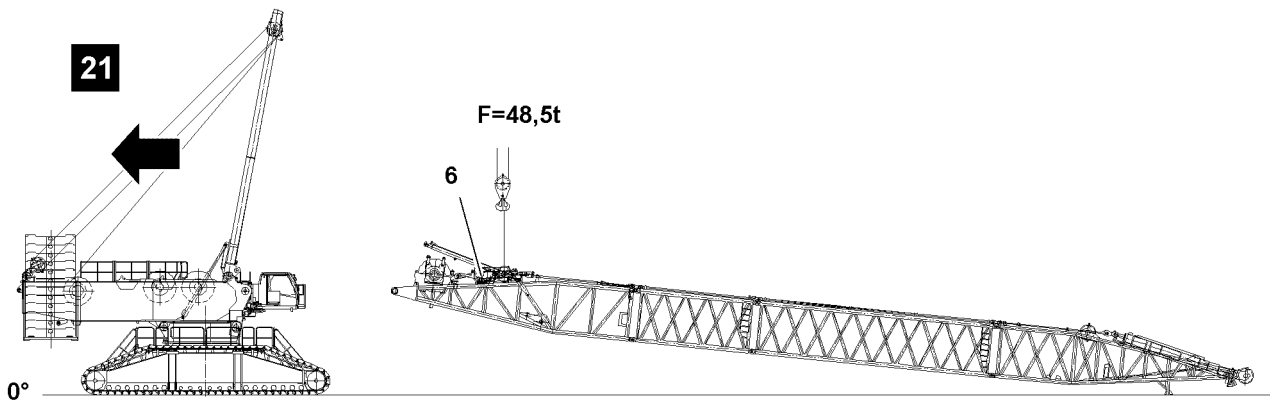
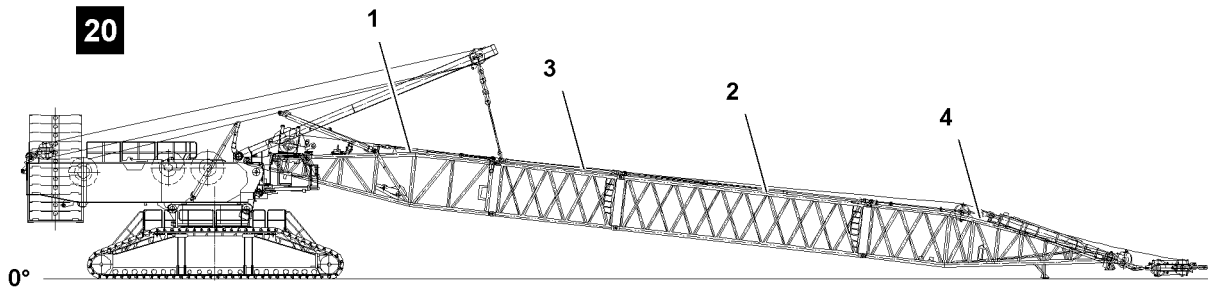

Fig.116997

LWE/LR 11000-001/23501-04-02/en

8 D-boom disassembly on the ground

8.1 Disassembling the D-boom on the ground



Note

- ▶ For disassembly „on the ground“, the D-pivot section, D-intermediate sections and D-end section can be unpinned and removed as a preassembled unit directly on the crane.



WARNING

Danger of accident!

If the following conditions are not observed, personnel can be severely injured or killed.

- ▶ Disassembly of the D-boom „on the ground“ is only described as an example, for the detailed disassembly process, see section „Disassembling the D-boom in sections“.

Make sure that the following prerequisites are met:

- The crane is properly supported and horizontally aligned.
- The counterweight has been installed on the turntable according to the load chart.
- The LICCON overload protection has been set according to the data in the load chart.
- The LICCON overload protection settings have been compared with the actual set up configuration.
- The hydraulic and electrical connections are disconnected.
- The luffing pulley block is pinned and secured on the D-pivot section.
- The hoist ropes are reeved out.

- ▶ Erect the SA-frame.
- ▶ Fasten the D-boom to the auxiliary crane.
- ▶ Tension the fastening equipment.
- ▶ Unpin the D-boom: Unpin the pin on the SA-frame, see section „Disassembling the D-boom in sections.“

When the D-boom is unpinned:

- ▶ Move the crane carefully away from the pin location, see illustration **21**.
- ▶ Take the D-boom down on the ground with the auxiliary crane, see illustration **22**.
- ▶ Disassemble the D-lattice sections, see section „Disassembling the D-boom in sections.“

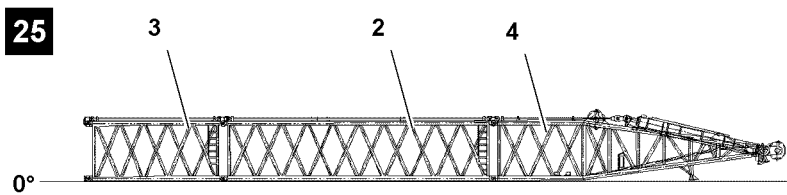
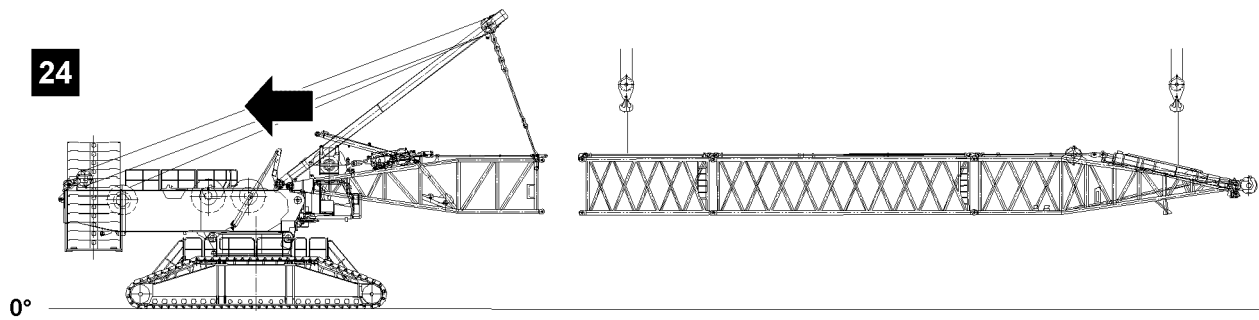
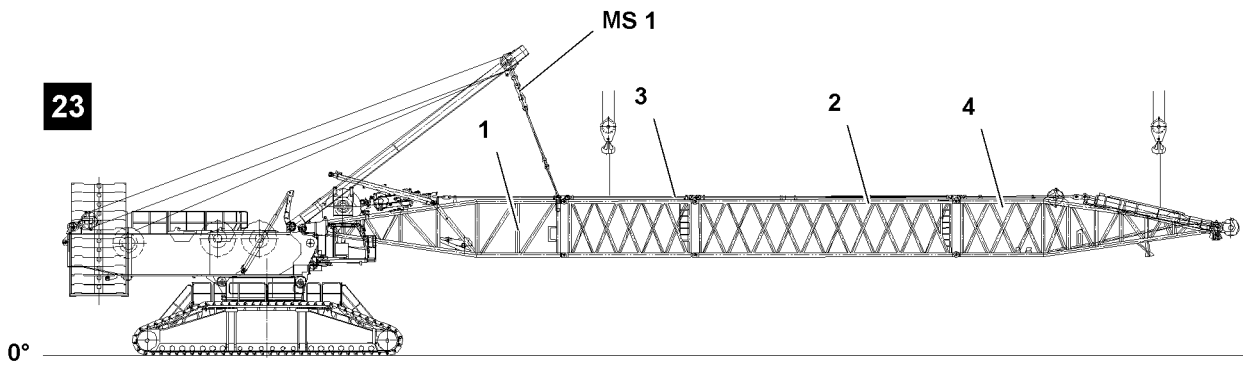

Fig.116998

LWE/LR 11000-001/23501-04-02/en

9 Flying D-boom disassembly

9.1 Flying disassembly of the D-boom



Note

- ▶ For „flying“ disassembly, the D-intermediate sections and D-end section can be unpinned and removed as a preassembled unit with auxiliary cranes on the D-pivot section.



WARNING

Danger of accident!

If the following conditions are not met, personnel can be severely injured or killed.

- ▶ The maximum permissible total force on test point MS1 of -145 t may not be exceeded.
- ▶ Disassembly of the D-boom in „flying mode“ is only described as an example, for the detailed disassembly process, see section „Disassembling the D-boom in sections“.

Make sure that the following prerequisites are met:

- The crane is properly supported and horizontally aligned.
 - The counterweight has been installed on the turntable according to the load chart.
 - The LICCON overload protection has been set according to the data in the load chart.
 - The LICCON overload protection settings have been compared with the actual set up configuration.
 - The hydraulic and electrical connections are disconnected.
 - The hoist ropes are reeved out.
- ▶ Fasten the D-boom to the auxiliary cranes, see illustration **23**.
 - ▶ Tension the fastening equipment.
 - ▶ Unpin the D-boom on the D-pivot section: Unpin the pin, see section „Disassembling the D-boom in sections.“

When the D-boom is unpinned:

- ▶ Move the crane carefully away from the pin location, see illustration **24**.
- ▶ Take the D-boom down on the ground with the auxiliary cranes, see illustration **25**.
- ▶ Disassemble the D-lattice sections, see section „Disassembling the D-boom in sections.“
- ▶ Take the D-pivot section down and remove it, see section „Disassembling the D-boom in sections.“

Empty page!

LWE/LR 11000-001/23501-04-02/en

5.07 SW/SDW boom combination

1	Component overview	3
2	Fastening points	6
3	Assembling	13
4	Erecting the boom	59
5	Crane operation	65
6	Disassembling	67

Fig.195219

LWE/LR 11000-001/23501-04-02/en

1 Component overview



Note

► The assembly sections are marked with their own weight.



Note

► Dimensions and weights, see the Crane operating instructions, chapter 1.03.

1.1 Assembly unit I

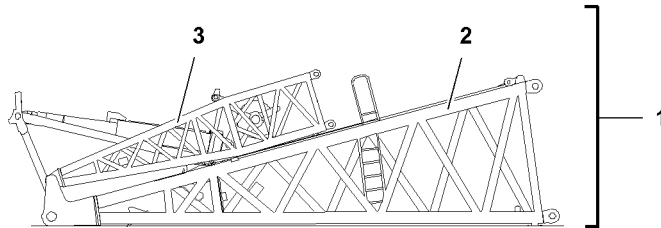

Fig.124286: Assembly unit I

Position	Component
1	Assembly unit I
2	W-pivot section
3	WA-frame 1, pivot section

1.2 Assembly unit II

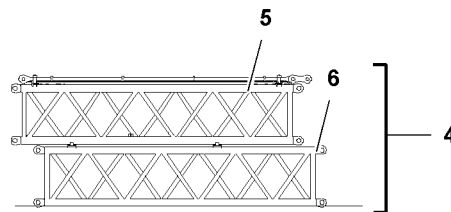

Fig.124287: Assembly unit II

Position	Component
4	Assembly unit II
5	WA-frame 2 intermediate section
6	WA-frame 1 intermediate section

1.3 Assembly unit III

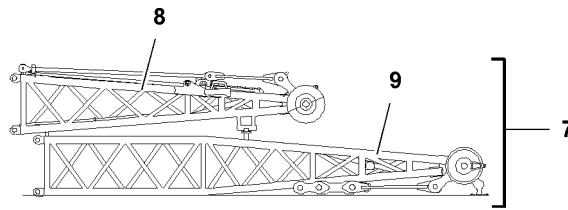

Fig.124288: Assembly unit III

Position	Component
7	Assembly unit III
8	WA-frame 2, end section
9	WA-frame 1, end section

1.4 Assembly unit IV

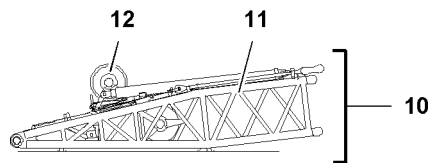

Fig.124289: Assembly unit IV

Position	Component
10	Assembly unit IV
11	WA-frame 2, pivot section
12	Change over pulley

1.5 S-intermediate section 12 m

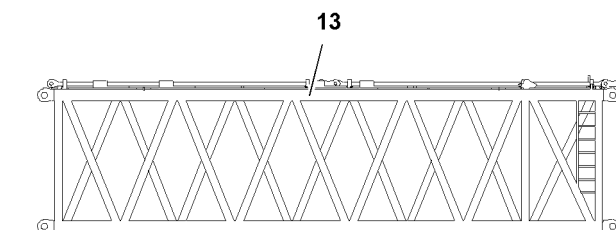

Fig.124290: S-intermediate section 12 m

Position	Component
13	S-intermediate section 12 m

1.6 SL-reducer section

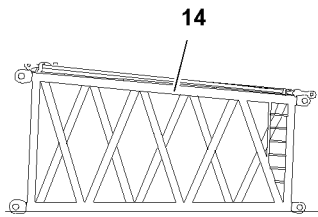

Fig.124291: SL-reducer section

Position	Component
14	SL-reducer section

1.7 L-intermediate section 12 m

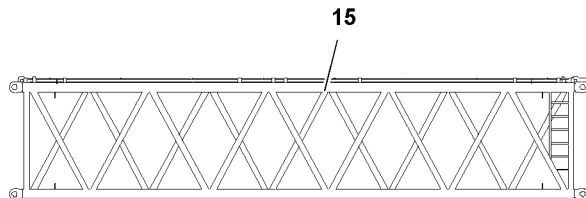

Fig.124292: L-intermediate section 12 m

Position	Component
15	L-intermediate section 12 m

1.8 L-end section

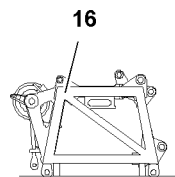

Fig.124293: L-end section

Position	Component
16	L-end section

2 Fastening points



WARNING

Lattice component not properly fastened!

If the lattice component is not properly fastened on the specified fastening positions, then the lattice component can fall down.

Death, severe bodily injuries, property damage.

► Make sure that the fastening equipment is properly fastened on the specified fastening positions.



WARNING

Selection of incorrect fastening equipment!

Death, severe bodily injuries, property damage.

► Select fastening equipment according to the weight labels on the respective crane components.

2.1 Fastening points Assembly unit I

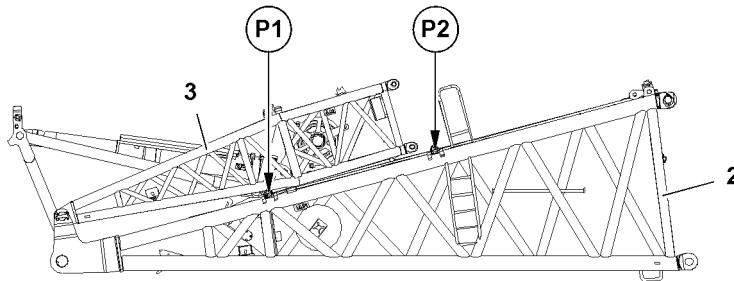

Fig.122181: Fastening points Assembly unit I

Fastening points	
P1 and P2	Assembly unit I

2.2 Fastening points Assembly unit II

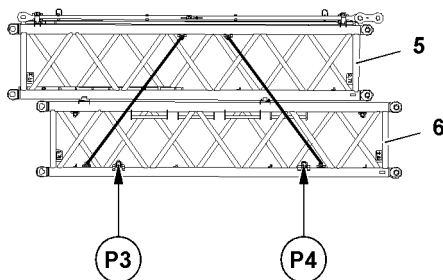

Fig.117015: Fastening points Assembly unit II

Fastening points	
P3 and P4	Assembly unit II

2.3 Fastening points Assembly unit III

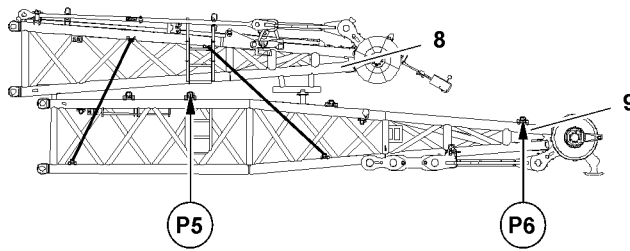

Fig.117016: Fastening points Assembly unit III

Fastening points	
P5 and P6	Assembly unit III

2.4 Fastening points Assembly unit IV

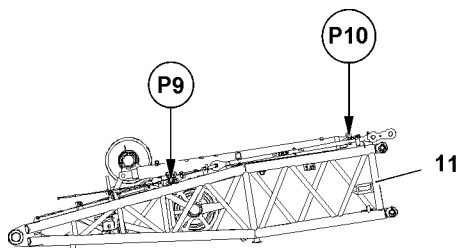

Fig.117017: Fastening points Assembly unit IV

Fastening points	
P9 and P10	Assembly unit IV

2.5 Fastening points Assembly unit V



Note

► Assembly unit V consists of the assembled assembly unit II and assembly unit III.

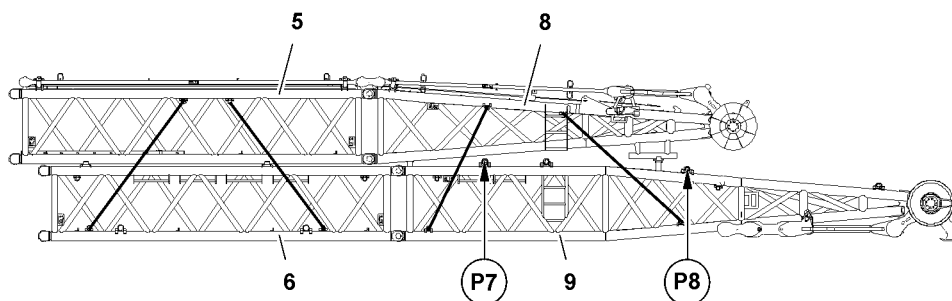

Fig.117022: Fastening points Assembly unit V

Fastening points	
P7 and P8	Assembly unit V

LWE/LR 11000-001/23501-04-02/en

2.6 Fastening points S-intermediate section 12 m

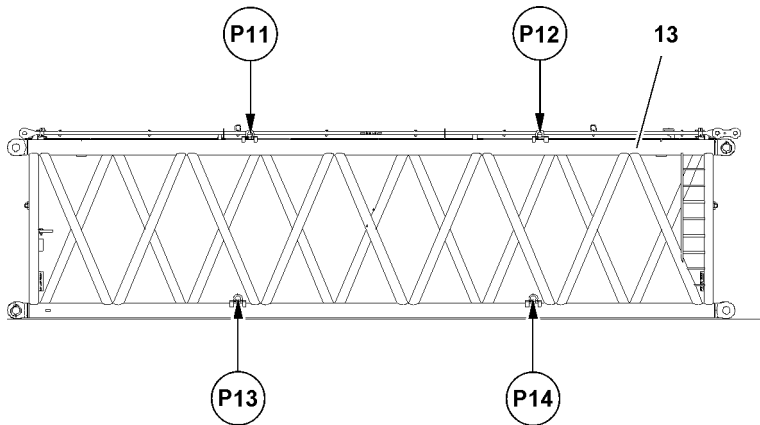

Fig.117018: Fastening points S-intermediate section 12 m

Fastening points	
(P11 and P12) or (P13 and P14)	S-intermediate section 12 m

2.7 Fastening points SL-reducer section

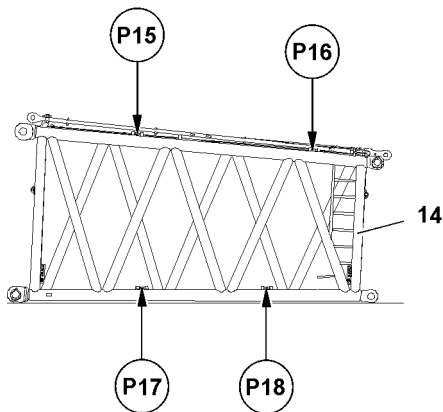

Fig.117019: Fastening points SL-reducer section

Fastening points	
(P15 and P16) or (P17 and P18)	SL-reducer section

LWE/LR 11000-001/23501-04-02/en

2.8 Fastening points L-intermediate section 12 m

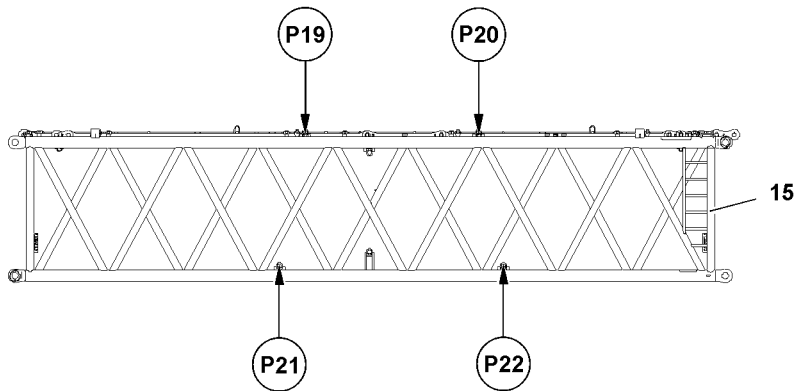

Fig.117020: Fastening points L-intermediate section 12 m

Fastening points	
(P19 and P20) or (P21 and P22)	L-intermediate section 12 m

2.9 Fastening points L-end section

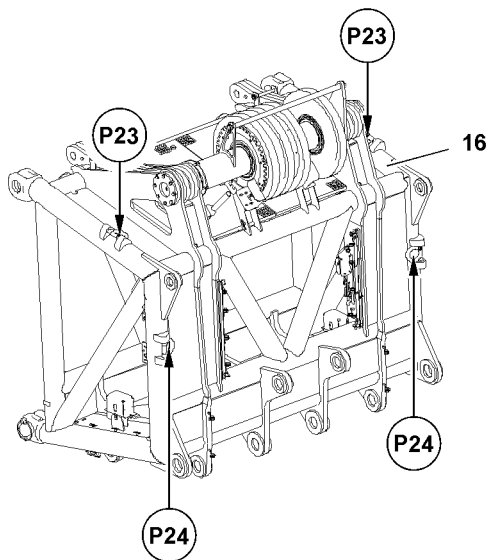

Fig.117021: Fastening points L-end section

Fastening points	
P23 or P24	L-end section

LWE/LR 11000-001/23501-04-02/en

2.10 Fastening points Change over pulley

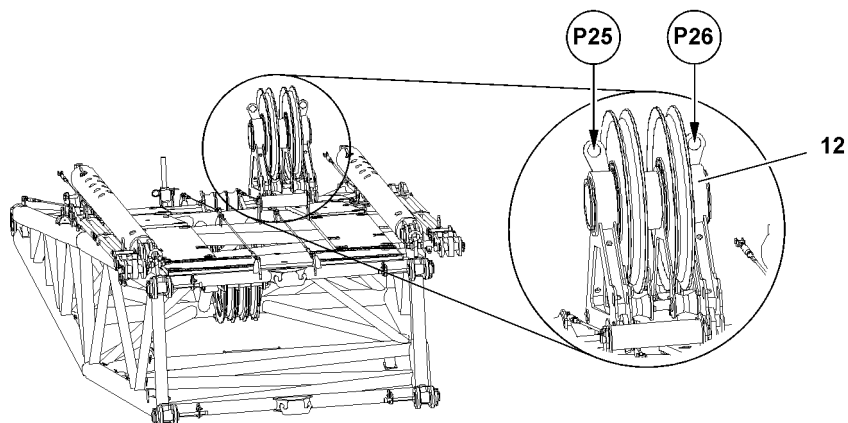

Fig.117023: Fastening points Change over pulley

Fastening points	
P25 and P26	Change over pulley

Empty page!

LWE/LR 11000-001/23501-04-02/en

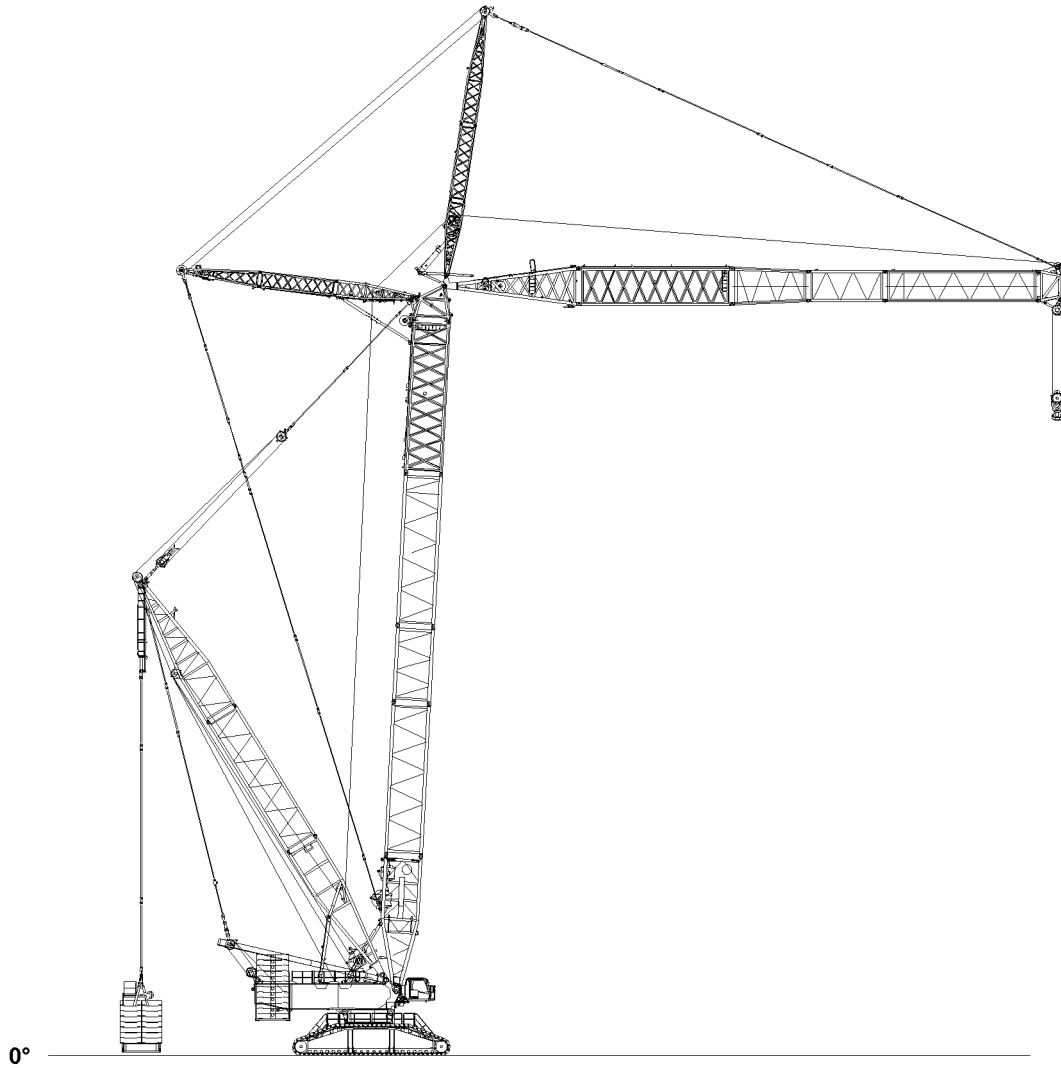

Fig.121038: Assembling

LWE/LR 11000-001/23501-04-02/en

3 Assembling



WARNING

Danger of falling!

During assembly / disassembly, inspection and maintenance work, assembly personnel must be secured with appropriate aids to prevent them from falling.

Death, severe bodily injuries, property damage.

- ▶ All work at a height, when there is a danger of falling, must be carried out with suitable aids.
- ▶ If aids are not available and work cannot be carried out from the ground, then assembly personnel must secure themselves with the supplied fall arrest system to prevent falling, see the Crane operating instructions, chapter 2.04.
- ▶ If fall protection equipment is available, then it must be used, see the Crane operating instructions, chapter 2.06.
- ▶ When lifting, lowering, swinging crane parts in and out, no persons may remain in the danger zone.
- ▶ When closing or opening boom systems during boom assembly or boom disassembly, no persons may remain on the boom system or in the danger zone.
- ▶ If railings are present on the components, then they must be brought into the corresponding position and secured for assembly / disassembly work.
- ▶ Only step on the aids, ladders and catwalks with clean shoes.
- ▶ Keep aids, ladders and catwalks free of heavy dirt, snow and ice.
- ▶ During all assembly and disassembly work, maintenance work and inspections, travel or crane operation is prohibited.
- ▶ Remaining on a suspended load is prohibited.
- ▶ Stepping or walking on crane components and lattice sections, which have an incline of more than 20° is prohibited.
- ▶ For all assembly work, the crane driver of the main crane must be in voice contact with the crane driver / crane drivers of the auxiliary crane / auxiliary cranes.
- ▶ For assembly tasks, the crane driver may only initiate crane movements when the responsible guide has explicitly released the movement.



WARNING

The lattice sections can fall down!

If the lattice sections are not pinned and secured correctly, then they can fall down.

Death, severe bodily injuries, property damage.

- ▶ Pin or unpin both pins at the same horizontal level, i.e. **left and right**.
- ▶ Do not stand under the lattice sections or within the entire danger zone during the pinning and unpinning procedure of the boom.
- ▶ Safely secure the pins in the storage locations as well as in the receptacles.
- ▶ It is prohibited to lean the auxiliary ladder against the component being disassembled.



WARNING

Danger of impact / crushing!

When installing / removing crane components with the auxiliary crane, crane components can start to swing back and forth.

When lifting / lowering and positioning crane components, there is an increased danger of impacts / crushing.

Death, severe bodily injuries, property damage.

- ▶ Make sure that personnel cannot be caught by components.
- ▶ Make sure that the crane is horizontally aligned.
- ▶ When working in danger zones: Use aids to protect limbs.
- ▶ Guide components with suitable aids to minimize oscillation.

**WARNING**

Danger of accident!

If no guide is present during assembly work who has voice connection to the crane operator as well as to the drivers of the auxiliary units, then there is a great danger of accidents.

Crane movements, which are carried out without the approval of the guide, can cause accidents. Death, severe bodily injuries, property damage.

- ▶ For all assembly work, observe the instructions of the guide.
- ▶ Make sure that the danger zone can be seen completely by the crane operator and / or the guide.

**DANGER**

The components can fall down!

Death, severe bodily injuries, property damage.

- ▶ Do not disengage the auxiliary crane until the respective component is pinned and secured.

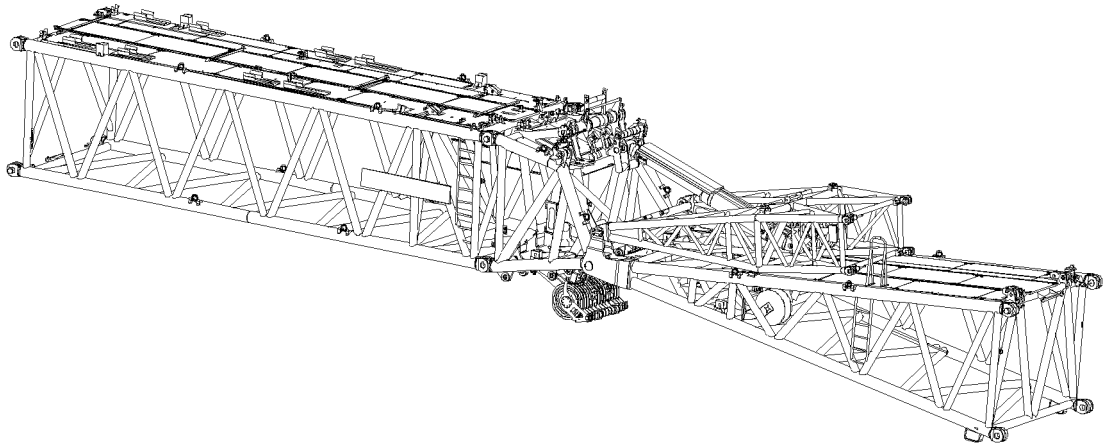

Fig.122798: Assembly - W-assembly unit

**WARNING**

Collision between S-end section and W-pivot section!

During the entire assembly procedure it must be ensured that the S-end section does not collide with the W-pivot section.

Death, severe bodily injuries, property damage.

- ▶ Make sure that no collision occurs during assembly.

Make sure that the following prerequisites are met:

- The crane is placed on ground with a sufficient load bearing capacity.
- The crane is horizontally aligned.
- The S-boom is completely assembled and aligned in horizontal direction.
- The counterweight is attached on the turntable according to the load chart and placed on the suspended ballast / ballast trailer.
- The LICCON overload protection has been set according to the data in the load chart.
- All electrical connections on the S-boom have been established.
- The limit switches have been checked for their mechanical function.
- An auxiliary crane is available.

3.1 Assembling the WA-frames

3.1.1 Exceeding the LICCON overload protection for assembly



WARNING

Danger of accident due to function „Exceedance of shut-off limits of the LICCON overload protection“! If the shut off limits of the LICCON overload protection are exceeded, there is no additional protection against crane overload.

Due to erroneous operation or deliberate misuse, the crane could collapse, the boom can break off or the crane can topple over.

Death, severe bodily injuries, property damage.

- ▶ The function „Exceedance of shut off limits of the LICCON overload protection“ is only permissible in emergencies and for assembly purposes.
- ▶ The function „Exceeding the shut off limits of the LICCON overload protection“ may only be actuated by persons who know the effects of their actions regarding the function „Exceeding the shut off limits of the LICCON overload protection“.
- ▶ The function „Exceedance of shut off limits of the LICCON overload protection“ requires the presence of an authorized person and must be performed with utmost caution.
- ▶ Crane operation with activated function „Exceedance of shut off limits of the LICCON overload protection“ is prohibited.

- ▶ Exceeding the shut off limits of the LICCON overload protection: Engage assembly operation.

Result:

- The shut off limits of the LICCON overload protection are exceeded.
- The assembly icon appears on the LICCON monitor.



Note

- ▶ See Crane operating instructions, chapter 4.02.

3.1.2 Preparatory work

Assembling the change over pulley

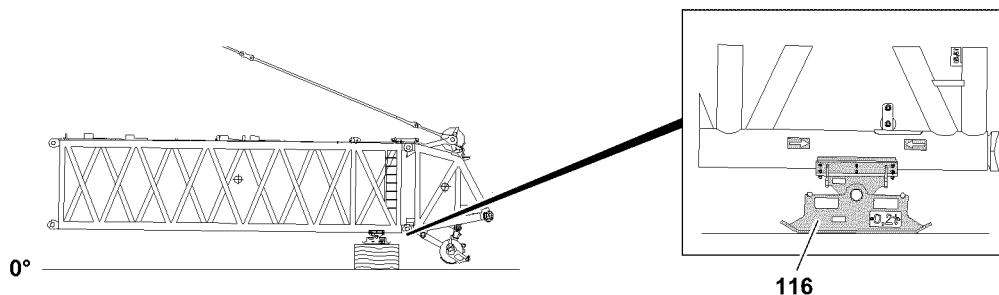

Fig.121049: Assembling the change over pulley - substructure

Make sure that the following prerequisites are met:

- The main boom is aligned parallel to the ground.
- The main boom is placed on the substructure.
- The assembly shoe **116** is set within the arrows.
- An auxiliary crane is available.

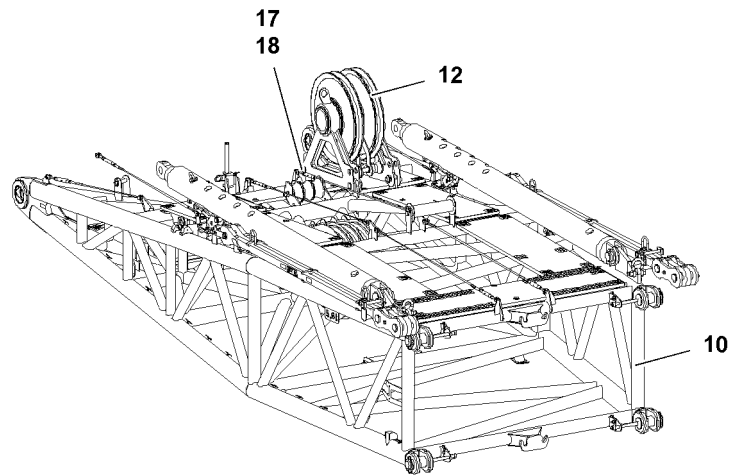

Fig. 121046: Assembling the change over pulley - Unpinning the change over pulley

- ▶ Fasten the change over pulley 12 to the auxiliary crane, see section „Fastening points“.
- ▶ Unpin the change over pulley 12 on the assembly unit IV 10: Remove the four safety locking pins 18 and unpin the pins 17.

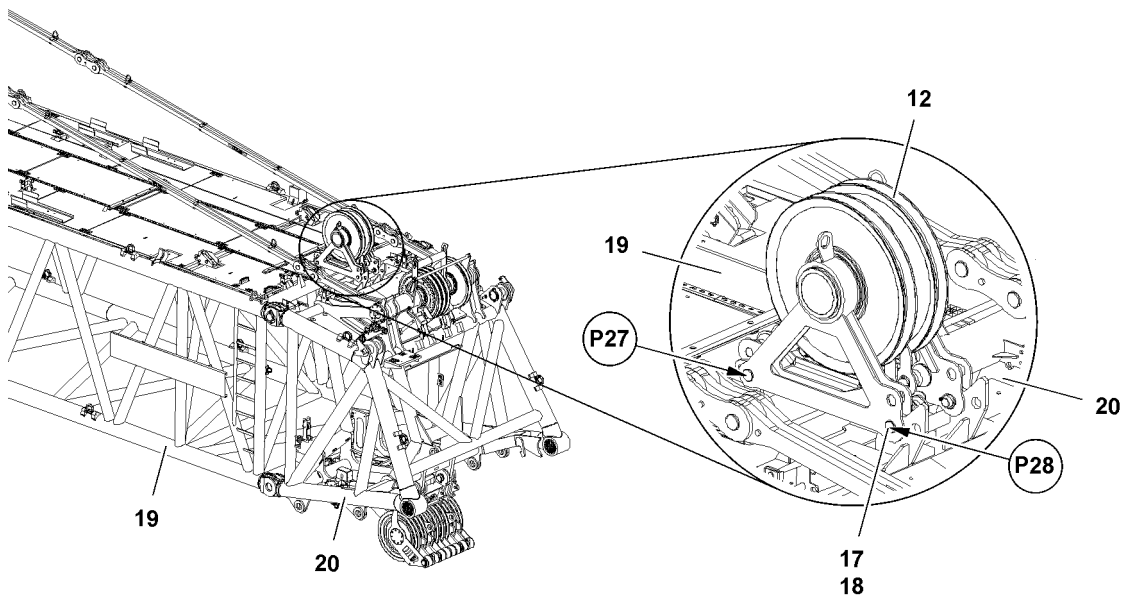

Fig. 117025: Assembling the change over pulley - Assembling the change over pulley in the assembly position

- ▶ Lift the change over pulley 12 with the auxiliary crane and position it on the S-end section 20 so it can be pinned on points P27 and points P28.
- ▶ Pin the change over pulley 12 with the S-end section 20: Insert the pins 17 on both sides on points P28 and secure with safety locking pins 18.
- ▶ Pin the change over pulley 12 with the S-adapter 19: Insert the pins 17 on both sides on points P27 and secure with safety locking pins 18.

Placing additional guy rods



Note

- ▶ Depending on the set up configuration, additional guy rods are required. Check the rod plan for the required guy rods.

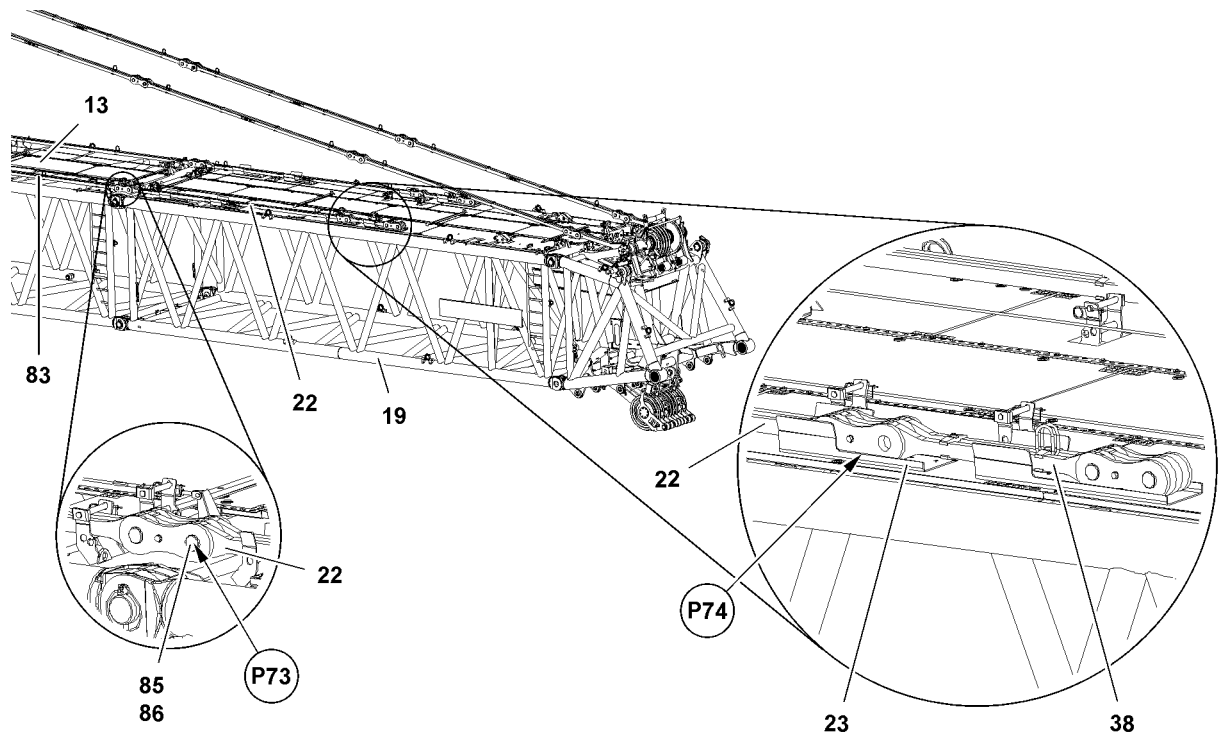

Fig.117027: Placing additional guy rods - Short WA-frames

When the short WA-frames are installed:

- ▶ Place 6 m guy rods **22** on both sides and pin with the guy rods **83** of the S-intermediate section **13**: Insert the pins **85** on both sides on points **P73** and secure with safety locking pins **86**.

When the short WA-frames are installed and additional guy rods **38** are required:

- ▶ Place additional guy rods **38** on point **P74** on both sides on the rack **23** of the S-adapter **19**.
- ▶ Pin and secure the guy rods **38** on both sides with the 6 m guy rods **22**.

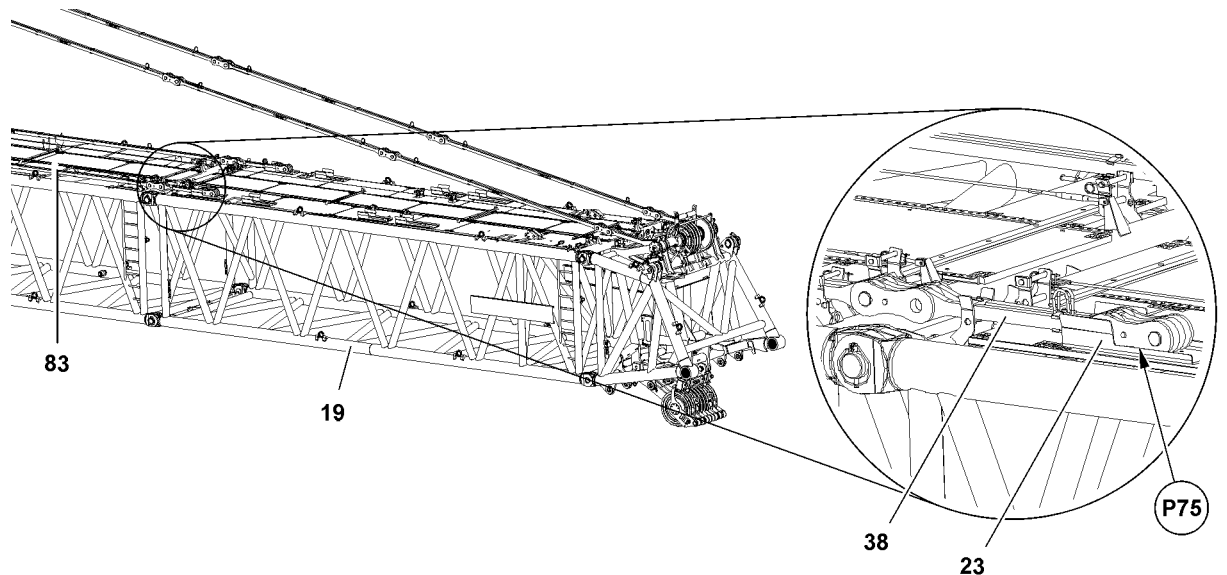

Fig.117051: Placing additional guy rods - Long WA-frames

When the long WA-frames are installed and additional guy rods **38** are required:

- ▶ Place additional guy rods **38** on point **P75** on both sides on the rack **23** of the S-adapter **19**.
- ▶ Pin the guy rods **38** on both sides with the guy rods **83** and secure.

Installing the wind speed sensor

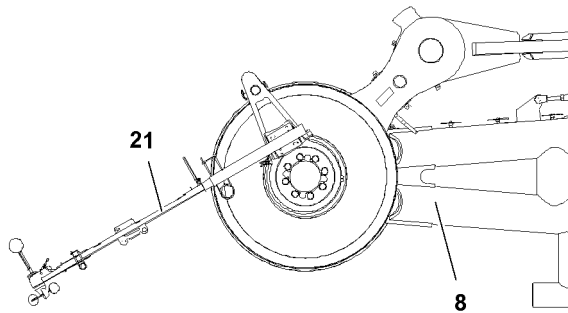

Fig.117026: Installing the wind speed sensor

- ▶ Install the wind sensor **21** on WA-frame 2 end section **8**.

Assembling the WA-frame intermediate sections with the WA-frame end sections

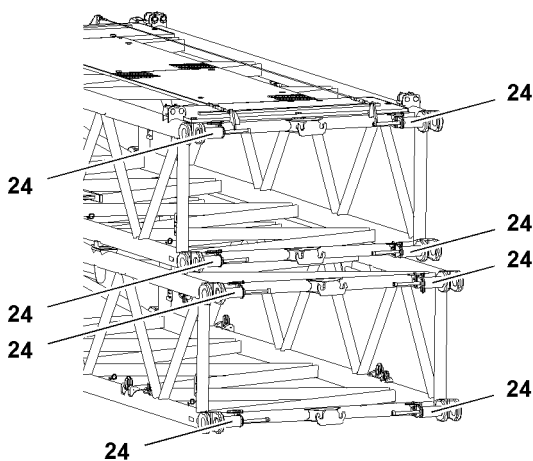

Fig.117028: Assembling the WA-frame intermediate sections with the WA-frame end sections - pin points



Note

- ▶ If the long WA-frames are required, the intermediate sections are installed first with the end sections. For the short WA-frames this step is not required.

Make sure that the following prerequisites are met:

- The WA-frame intermediate sections (assembly unit II) are on hand.
- All pins **24** on the WA-frame intermediate sections are unpinned.
- An auxiliary crane is available.

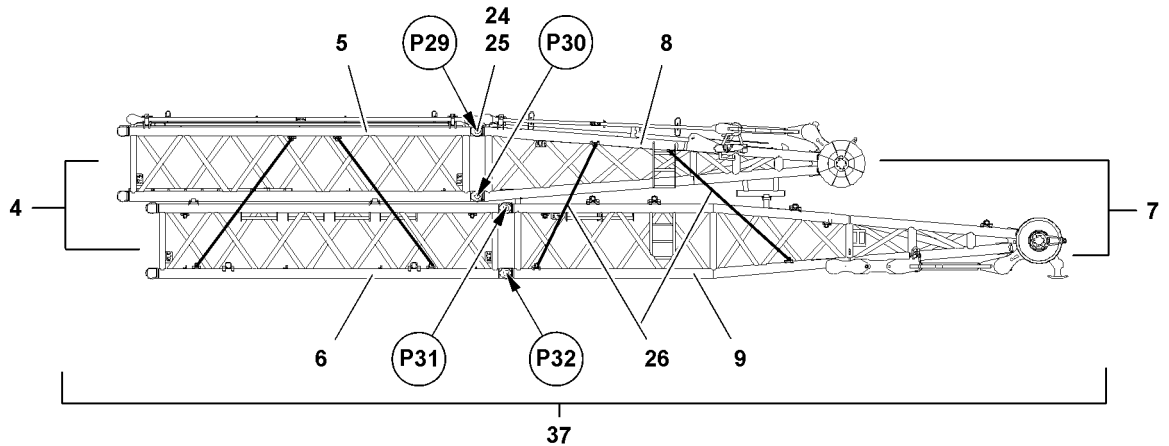

Fig.121047: Assembling the WA-frame intermediate sections with the WA-frame end sections - Assembly procedure



Note

- ▶ The WA-frame components are pinned with the pin pulling cylinder, see Crane operating instructions, chapter 5.30.
- ▶ Attach the auxiliary crane on assembly unit III 7, see section „Fastening points“.
- ▶ Lift assembly unit III 7 and position it in such a way that it can be pinned on both sides on point P29.
- ▶ Pin assembly unit III 7 with assembly unit II 4: Insert the pins 24 on both sides on point P29 and secure with safety locking pin 25.
- ▶ Pin assembly unit III 7 with assembly unit II 4: Insert the pins 24 on both sides on point P30 and secure with safety locking pin 25.
- ▶ Pin assembly unit III 7 with assembly unit II 4: Insert the pins 24 on both sides on point P31 and secure with safety locking pin 25.
- ▶ Pin assembly unit III 7 with assembly unit II 4: Insert the pins 24 on both sides on point P32 and secure with safety locking pin 25.

Result:

- Assembly unit V 37 completed for assembly.

3.1.3 Assembling assembly unit I on the S-end section

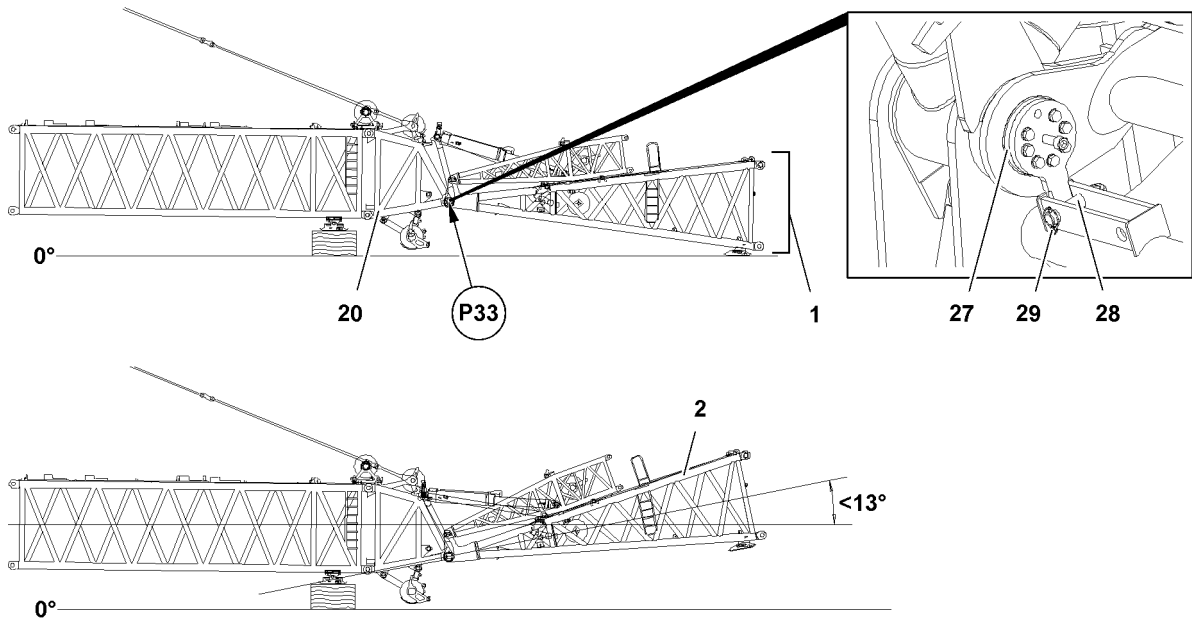

Fig.121050: Assembling assembly unit I on the S-end section - pinning procedure of W-pivot section

Make sure that the following prerequisites are met:

- The main boom is aligned parallel to the ground to 0°.
- The pins 27 on point P33 are completely unpinned on both sides.
- An auxiliary crane is available.
- The pin pulling cylinder is installed on point P33 in center detent position.



WARNING

Exceeding the maximum angle between the main boom and the W-pivot section!

If the maximum angle of 13° between the main boom and the W-pivot section is exceeded, a collision will occur. Damaged crane components can cause an accident later during operation.

Death, severe bodily injuries, property damage.

- ▶ Make sure that the angle between the main boom and the W-pivot section is always less than 13°.



WARNING

Danger of crushing!

If any persons are within the danger zone while lifting the load or during the pin procedure, then these persons can be severely injured or killed.

- ▶ Make sure, when swinging the W-pivot section in to the pin points, that no persons are within the danger zone.
- ▶ Swinging the load is prohibited.
- ▶ Make sure that no personnel is within the danger zone when operating the pin pulling device.
- ▶ Operate the pin pulling device with utmost caution from the pin pulling aggregate.

- ▶ Fasten the assembly unit I 1 to the auxiliary crane, see section „Fastening points“.

The assembly unit I 1 can not be installed, when the angle between the W-pivot section 2 and S-boom is larger than 13°.

- ▶ Position the assembly unit I 1 in such a way that the S-end section 20 can be pinned on point P33.



Note

- ▶ The assembly unit I 1 is pinned with the pin pulling cylinder, see Crane operating instructions, chapter 5.30.

Since the stroke of the pin pulling cylinder is not sufficient it must be reset to insert the pin completely.

- ▶ Pin the assembly unit I 1 with the S-end section 20: Insert the pins 27 on both sides on point P33 with the pin pulling device and secure with retaining elements (pin 28 and safety locking pin 29).
- ▶ Place the assembly unit I 1 with the auxiliary crane on the ground.
- ▶ Remove the auxiliary crane.

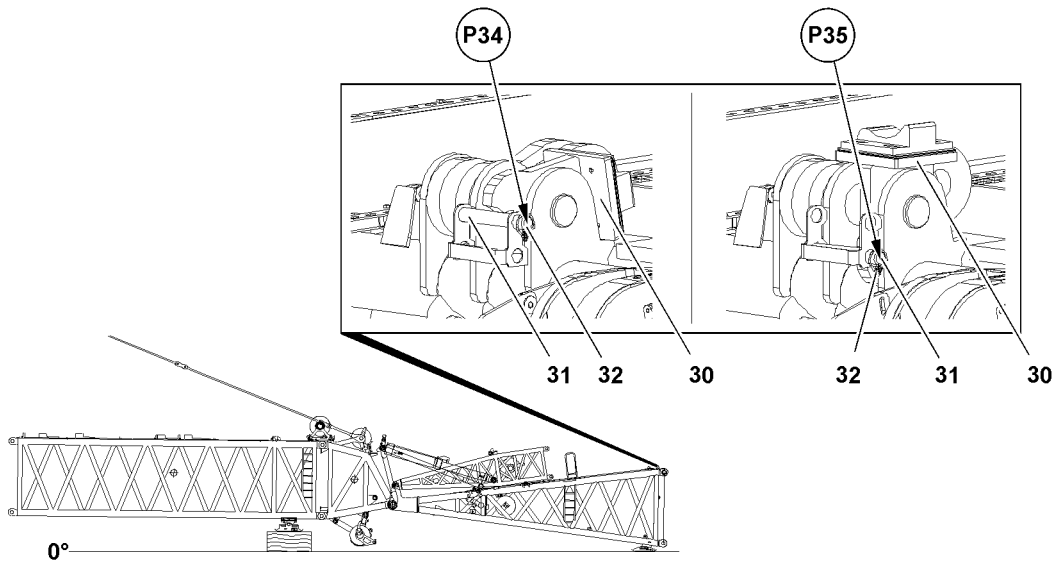

Fig.121051: Assembling the assembly unit I on the S-end section - Installing the racks in operating position

- ▶ Release the rack 30 in transport position: Release the pin 31 on point P34 and unpin.
- ▶ Align the placement surfaces upward.
- ▶ Secure the rack 30 in operating position: Insert the pin 31 on point P35 and secure with safety locking pin 32.
- ▶ Repeat the procedure the same way for the second rack 30.

3.1.4 Aligning the assembly unit I on the S-end section

Make sure that the following prerequisite is met:

- The assembly unit I 1 is fully assembled.

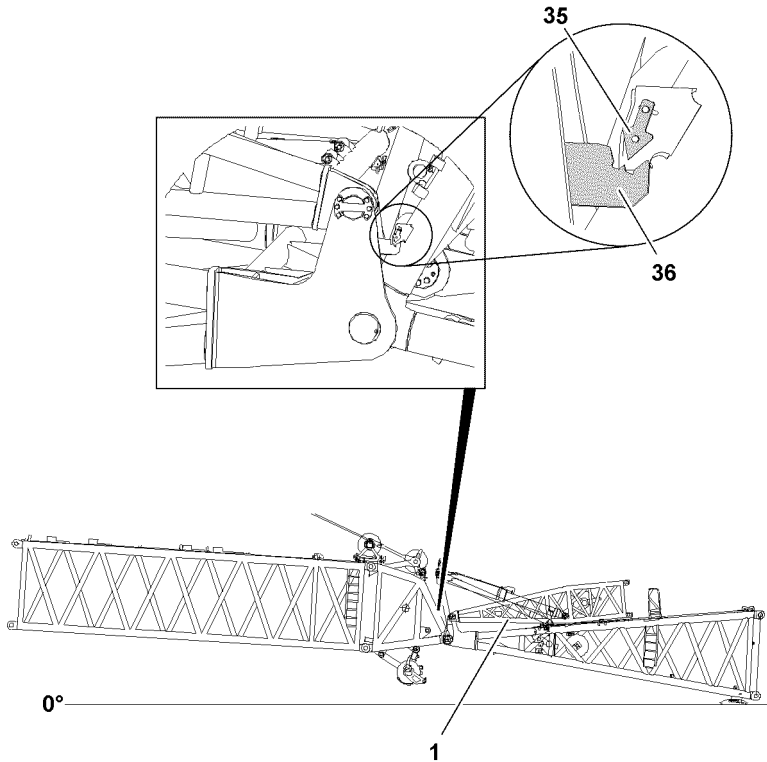

Fig.121043: Aligning the assembly unit I on the S-end section - positioning



WARNING

Damage of crane due to incorrect position of the WA-frame 2 pivot section 11!

If the mark 35 and the mark 36 do not align, then crane components can be damaged and cause an accident later during operation.

Death, severe bodily injuries, property damage.

► Make sure that the mark 35 and the mark 36 align.

► Check if the mark 35 and mark 36 are aligned.

Problem remedy

The mark 35 does not align with the mark 36?

► Lift or lower the main boom until the mark 35 and the mark 36 align.

3.1.5 Establishing the electrical connections to the assembly unit I



Note

► To establish the electrical connections to the terminal box on the W-assembly unit: Pay attention to the Electrical wiring diagram.

Make sure that the following prerequisite is met:

- The W-assembly unit is fully assembled.



WARNING

Malfunction if dummy plugs are not installed!

If the dummy plugs on the non-required electrical connections are not installed, then malfunctions or functional limitations can occur on the crane.

- Make sure that all non-required electrical connections that have a dummy plug are closed off with dummy plugs.
- Pay attention to the Electrical wiring diagram.

- ▶ As a rule, close off on-required electrical connections (for example for accessories which cannot be installed) with the respective dummy plugs.

NOTICE

Property damage due to dirt and / or corrosion!

If non-required electrical connections are not closed off with the respective protective caps, then dirt and / or corrosion can damage the electrical connections.

This could result in malfunctions.

- ▶ Make sure that all non-required electrical connections are always closed off properly.
 - ▶ Pay attention to the Electrical wiring diagram.
-
- ▶ Close electrical connections, which have no dummy plugs, properly off with the corresponding protective caps.
 - ▶ Establish the electrical connections to the W-pivot section.
 - ▶ Establish the electrical connections to the WA-frame 1 pivot section.
 - ▶ Make sure that all electrical connections to the W-assembly unit have been established.

3.1.6 Assembling the WA-frames

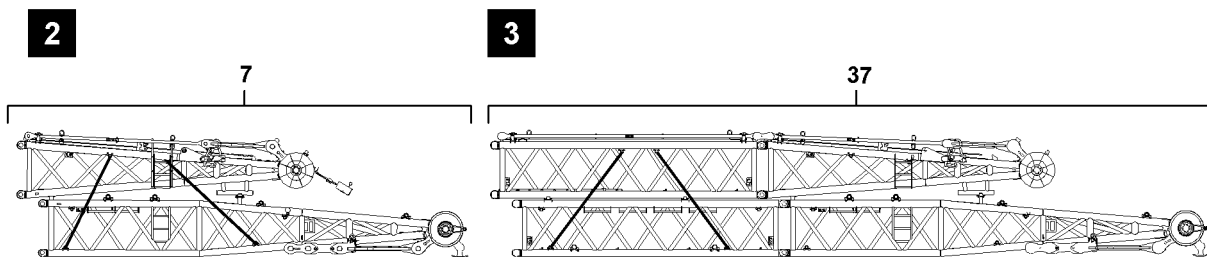

Fig.121044: Assembling the WA-frames - prerequisites

Make sure that the following prerequisites are met:

- The pins **24** are completely unpinned on both sides at point **P39** and point **P40**.
- The assembly unit I is fully assembled.
- An auxiliary crane is available.
- The mark **35** and the mark **36** align.
- When the short WA-frames are installed, then the assembly unit III **7** is rigged on both WA-frame end sections, see illustration **2**.
- When the long WA-frames are installed, then the assembly unit V **37** is completely installed.
- When the long WA-frames are installed, then the assembly unit V **37** is rigged on both WA-frame intermediate sections, see illustration **3**.

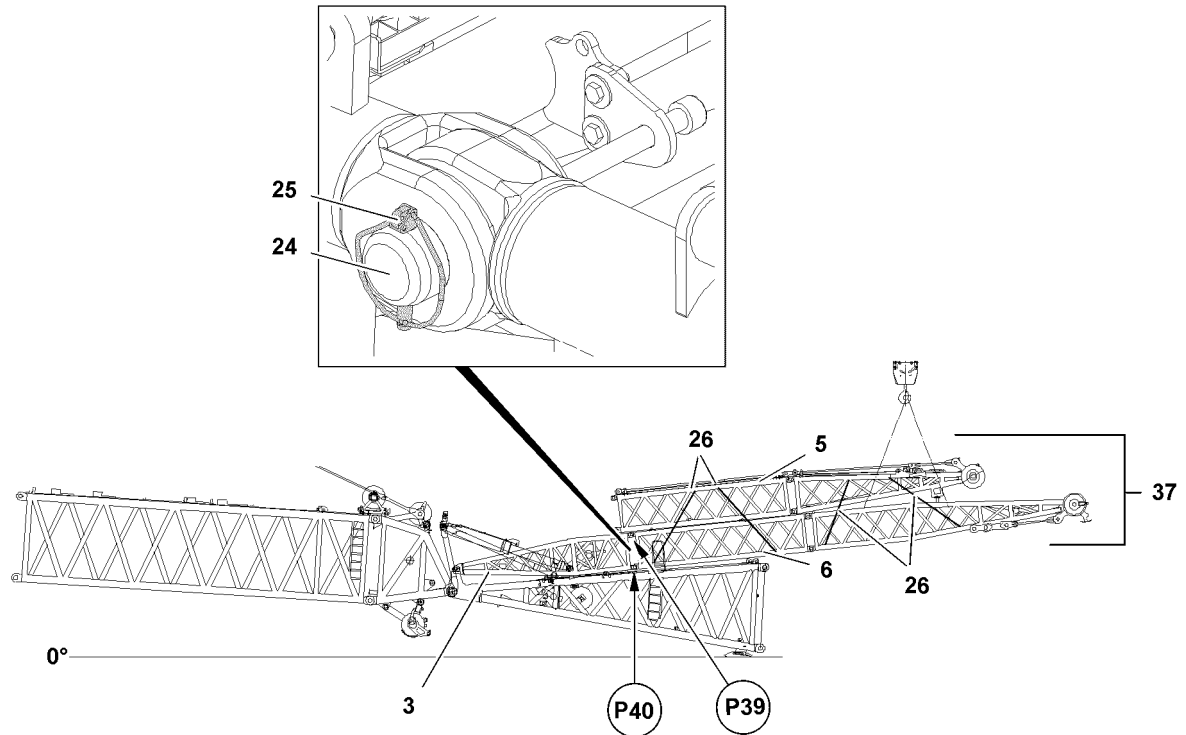

Fig.121041: Assembling the WA-frames - pinning procedure



Note

► The assembly procedure is described as an example on the long WA-frames. The assembly procedure for the short WA-frames is handled the same way.

- Fasten the assembly unit V 37 to the auxiliary crane, see section „Fastening points“.
- Install the pin pulling device on point P39.
- Lift the assembly unit V 37 with the auxiliary crane and position it in such a way that it can be pinned on point P39.
- Pin the assembly unit V 37 with WA-frame 1 pivot section 3: Insert the pins 24 on both sides on point P39 and secure with safety locking pin 25.
- Lift the assembly unit V 37 with the auxiliary crane until it can be pinned on point P40.
- Pin the assembly unit V 37 with WA-frame 1 pivot section 3: Insert the pins 24 on both sides on point P40 and secure with safety locking pin 25.
- Remove the auxiliary crane.



WARNING

Removed tension belts!
Death, severe bodily injuries, property damage.

- Loosen the transport tension belts 26 but do not remove them.
- Loosen the transport tension belts 26.

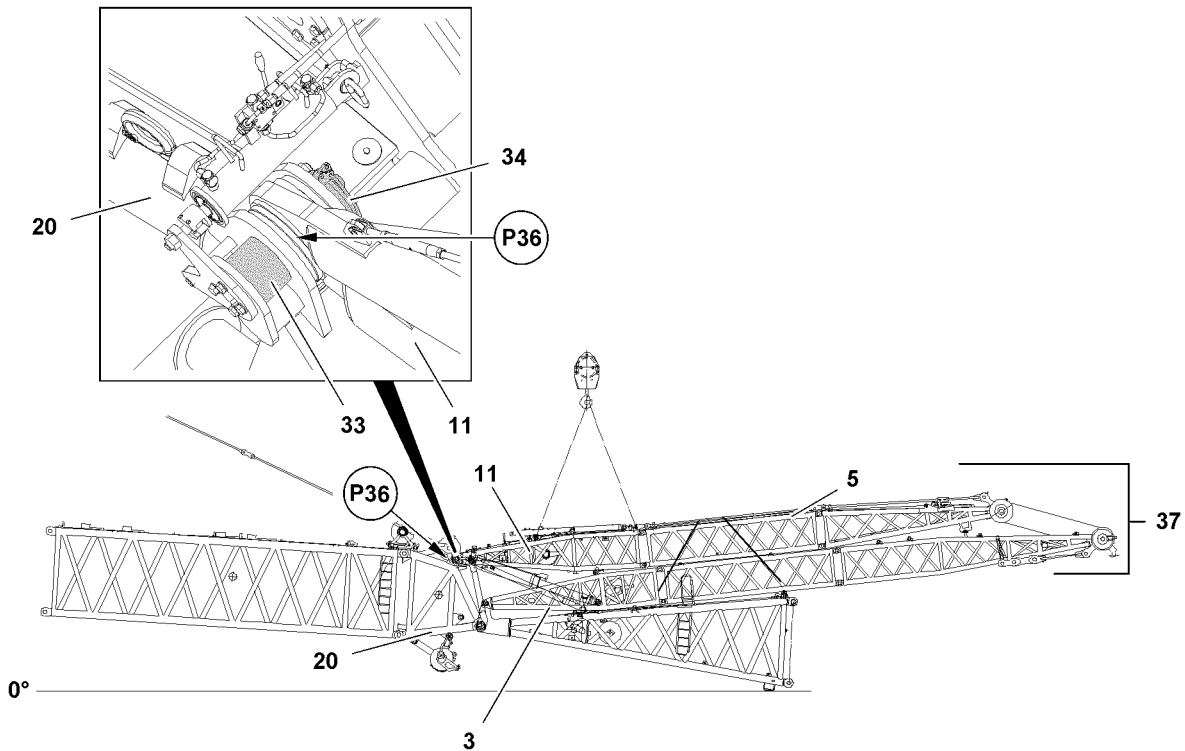

Fig.121042: Assembling the WA-frames - pinning procedure

- ▶ Fasten the WA-frame 2 pivot section 11 to the auxiliary crane, see section „Fastening points“.
- ▶ Position the WA-frame 2 pivot section 11 in such a way that it can be pinned on both sides on point P36 of the S-end section 20.



Note

- ▶ The WA-frame 2 pivot section 11 is pinned with the pin pulling cylinder, see Crane operating instructions, chapter 5.30.

When the pin points of the WA-frame 2 pivot section 11 align with those of the S-end section 20:

- ▶ Pin the WA-frame 2 pivot section 11 with the S-end section 20: Insert the pins 33 on both sides on point P36 and secure with safety locking pin 34.
- ▶ Lay the WA-frame 2 pivot section 11 completely down with auxiliary crane.
- ▶ Remove the auxiliary crane.

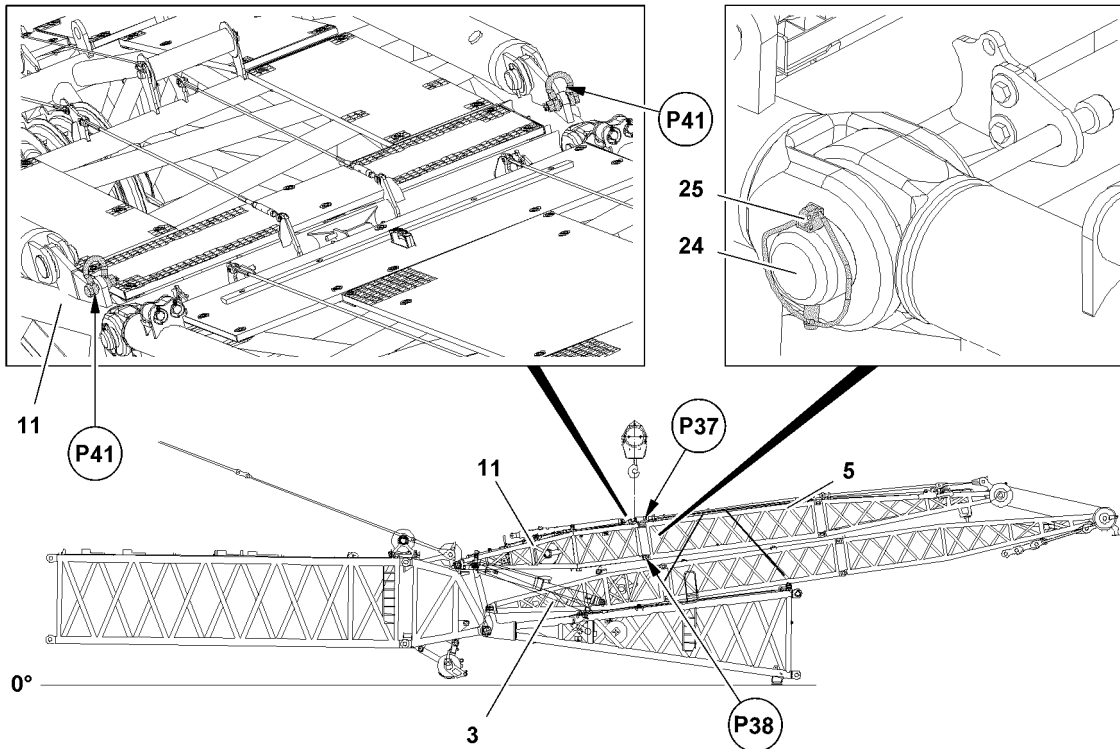

Fig.121045: Assembling the WA-frames - pinning procedure

- ▶ Lower the main boom until the pin bores align on point **P37**.
- ▶ Pin the assembly unit **V 37** with WA-frame 2 pivot section **11**: Insert the pins **24** on both sides on point **P37** and secure with safety locking pin **25**.
- ▶ Remove the auxiliary crane on assembly unit **V 37**.
- ▶ Remove all transport tension belts **26** between WA-frame 1 intermediate section **6** and WA-frame 2 intermediate section **5**.
- ▶ Install the pin pulling device on point **P38**.
- ▶ Fasten the auxiliary crane on both sides on points **P41** of the WA-frame 2 pivot section **11**.



DANGER

Do not stay in danger zone!

Death, severe bodily injuries, property damage.

- ▶ While the WA-frame 2 is lifted, it is prohibited for anyone to remain in the danger zone.
- ▶ Lift the WA-frame 2 pivot section **11** with the auxiliary crane until the pin bores on point **P38** align.
- ▶ Pin the assembly unit **V 37** with WA-frame 2 pivot section **11**: Insert the pins **24** on both sides on point **P38** and secure with safety locking pin **25**.
- ▶ Remove the auxiliary crane.



Note

- ▶ To establish the electrical connections, observe the Electric wiring diagram.
- ▶ Establish the electrical connections to the WA-frame 2 pivot section.
- ▶ Establish the electrical connections to the WA-frame 1 end section.

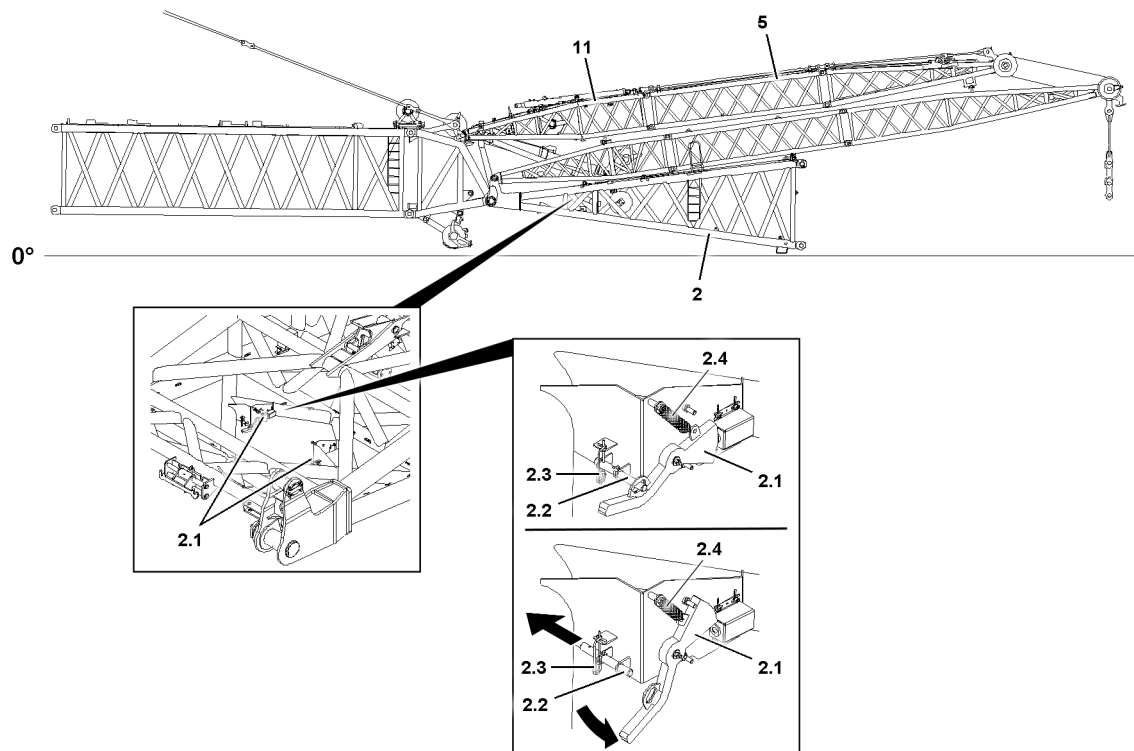

Fig.124282: Bringing the cantilevers „jib down“ into operating position

Bring the cantilevers **2.1** „jib down“ into operating position by removing the transport retaining pins on both sides.



WARNING

Spring actuated component!

When releasing the cantilever **2.1** it moves suddenly and at high speed down due to the pull spring **2.4**.

Limbs can be crushed or severed.

► Before unpinning the cantilever **2.1**, hold the cantilever **2.1** with one hand.

- Remove the spring retainer **2.3**.
- Hold the cantilever **2.1** with one hand.

When the cantilever **2.1** is held safely:

- Unpin the pin **2.2** in direction of the arrow to the stop.
- Move the cantilever **2.1** in the spring loaded direction (operating position).

When the cantilever **2.1** is in operating position:

- Release the cantilever **2.1**.
- Insert the pin **2.2** with spring retainer in position „unpinned“.

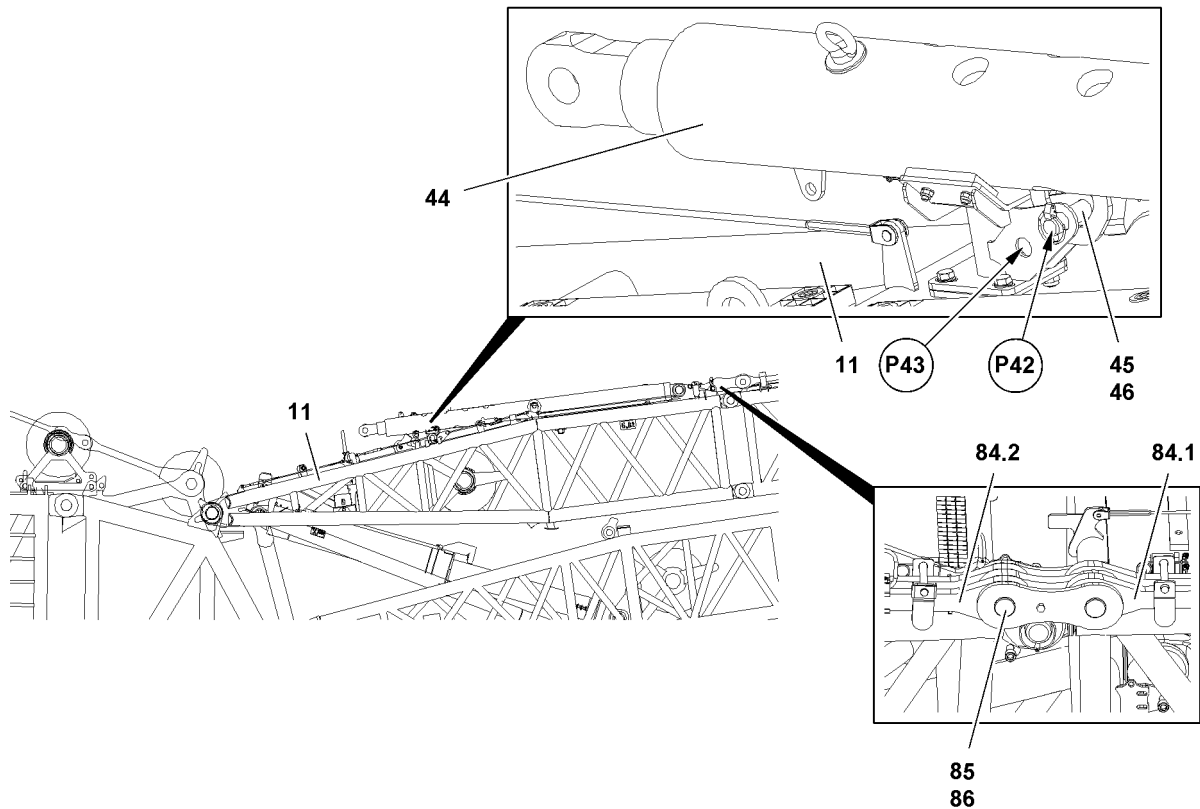

Fig.117038: Assembling WA-frames - Releasing the transport retainer of the relapse support and pinning the guy rods

- ▶ Unpin the relapse supports **44** on both sides on WA-frame 2 pivot section **11**: Release pins **45** on points **P42** and unpin.
- ▶ Insert the pins **45** on both sides in park position on point **P43** and secure with safety locking pin **46**.
- ▶ Pin the guy rods **84.1** with the guy rods **84.2**: Insert the pins **85** on both sides and secure with safety locking pin **86**.

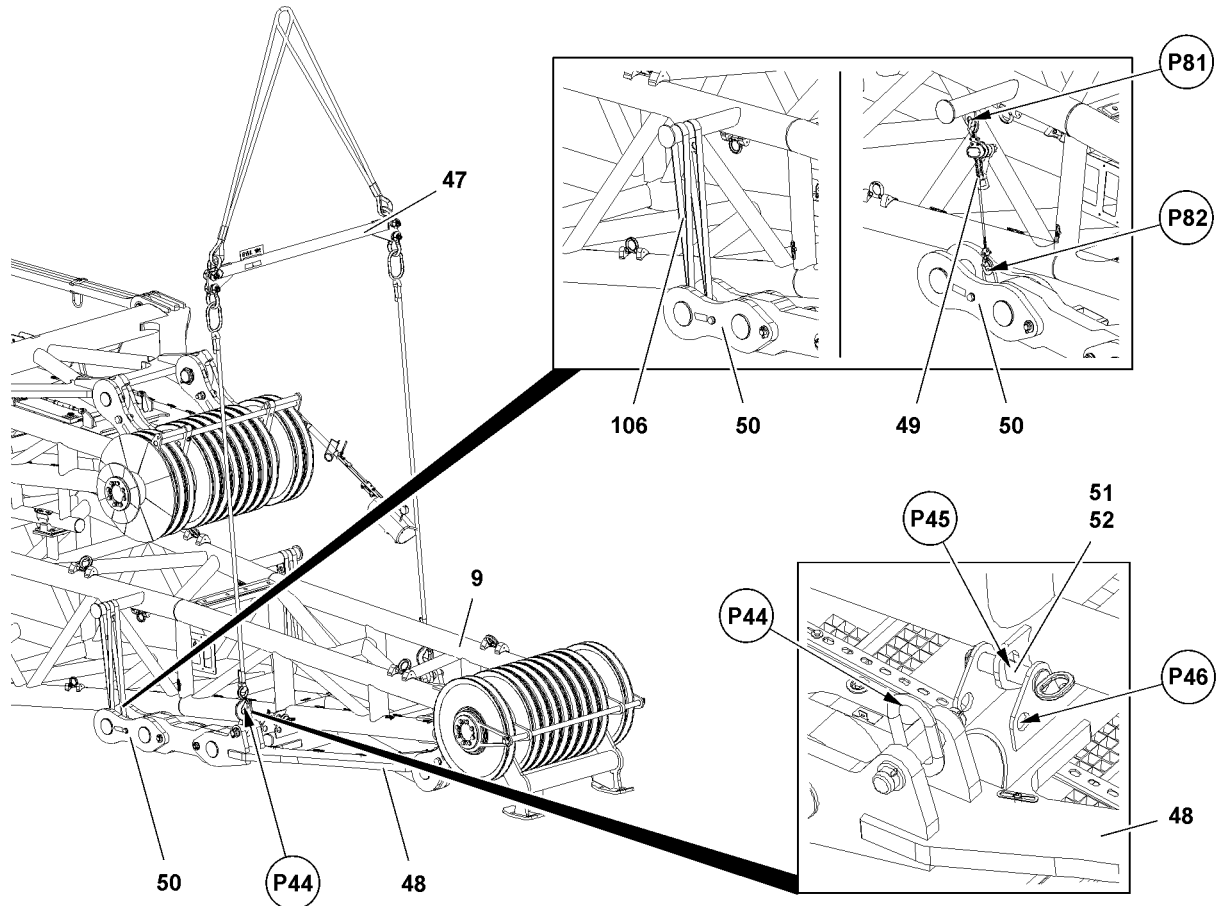

Fig.117039: Assembling the WA-frames - Lowering the WA-frame 1 swing

To lower the brackets **50**, use the chain pulls **49**.

- ▶ Hang the chain pull **49** on point **P81** and point **P82**.
- ▶ Tighten the chain pull **49** until the round sling **106** is loose and can be removed.
- ▶ Remove the round sling **106**.
- ▶ Lower the bracket **50** with the chain pull **49**.
- ▶ Remove the chain pull **49**.
- ▶ Repeat the procedure on the other side the same way as described above.
- ▶ Attach the cross beam **47** on both sides on points **P44**.
- ▶ Tighten the fastening equipment of the cross beam **47** until the pins **51** have some play.
- ▶ Unpin the swing **48** on the WA-frame 1 end section **9**: Release the pins **51** on both sides on point **P45** and unpin.
- ▶ Insert the pins **51** on both sides in the park position on point **P46** and secure with safety locking pin **52**.
- ▶ Lower the swing **48**.
- ▶ Remove the cross beam **47**.

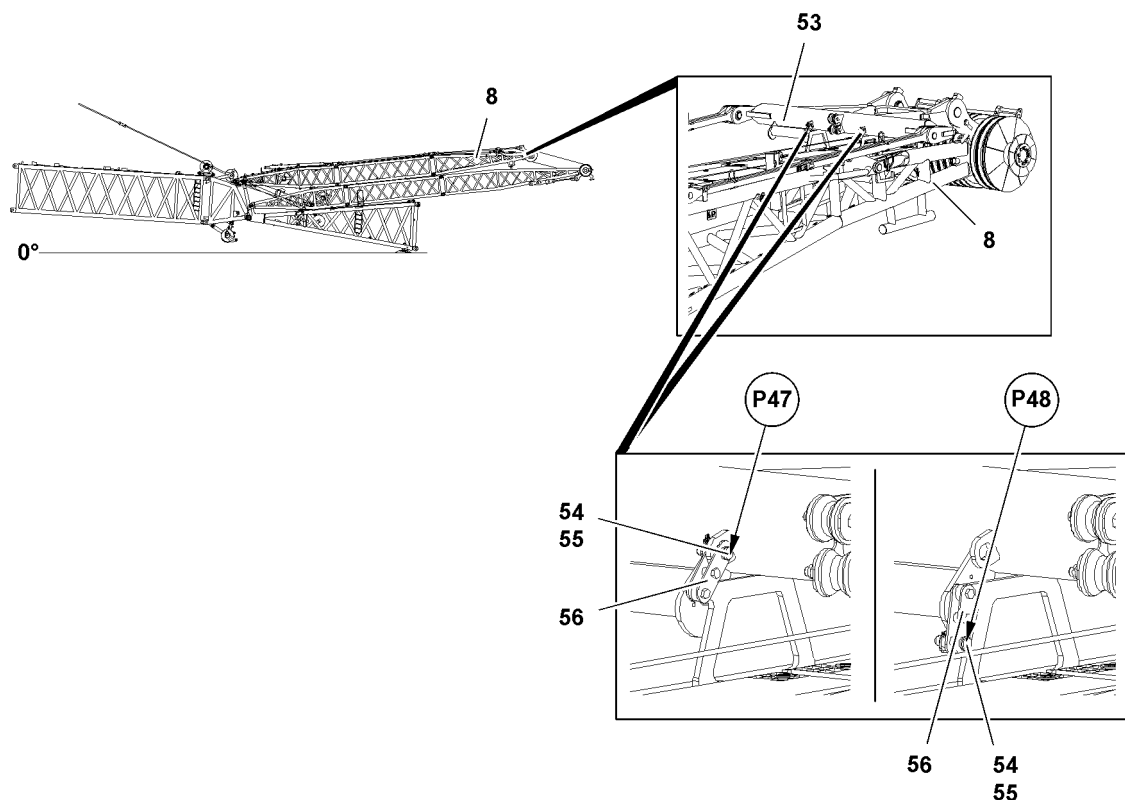

Fig.117041: Assembling the WA-frames - Releasing the transport retainer for the WA-frame 2 cross beam

- ▶ Unpin the cross beam **53** on the WA-frame 2 end section **8**: Release the pins **54** on both sides on points **P47** and unpin.
- ▶ Fold the brackets **56** down.
- ▶ Insert the pin **54** in park position: Insert the pins **54** on both sides on points **P48** and secure with safety locking pins **55**.

Result:

- ▷ The transport retainer for the cross beam **53** is completely released.

3.2 Reeving the W-control rope in and pulling the hoist ropes forward to the S-end section

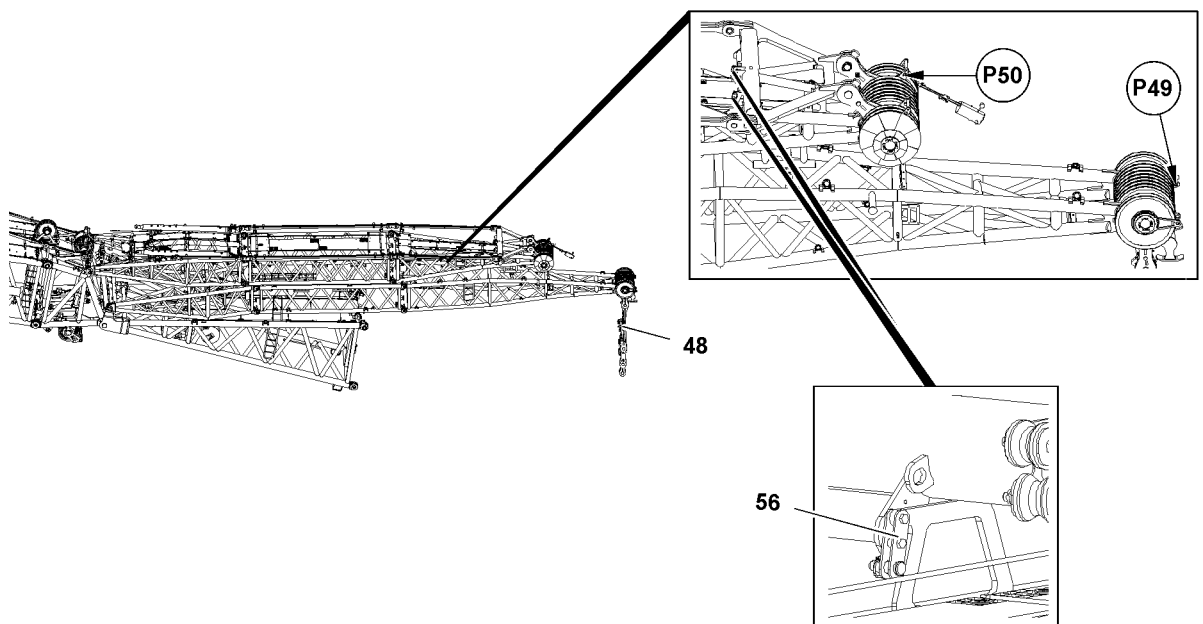

Fig.117042: Reeving the W-control rope in and pulling the hoist ropes forward to the S-end section - Prerequisites

NOTICE

Slack rope formation!

Due to slack rope formation, the hoist rope and the W-control rope can be damaged. This could result in high property damage.

- ▶ When spooling the hoist rope or the W-control rope up or out, allow no slack rope formation.
- ▶ When spooling up or out, hold the hoist rope and the W-control rope taut.



WARNING

Danger of accident!

Death, severe bodily injuries, property damage.

- ▶ It is prohibited to remain within the danger zone of the running ropes.
- ▶ Radio contact is available between crane operator and assembly personnel.

Make sure that the following prerequisite is met:

- The WA-frames are completely assembled.
- The swing **48** of WA-frame 1 is in operating position.
- The transport retainers **56** of the swing of WA-frame 2 are completely released.
- The rope guard of WA-frame 1 end section is removed on point **P49**.
- The rope guard of WA-frame 2 end section is removed on point **P50**.

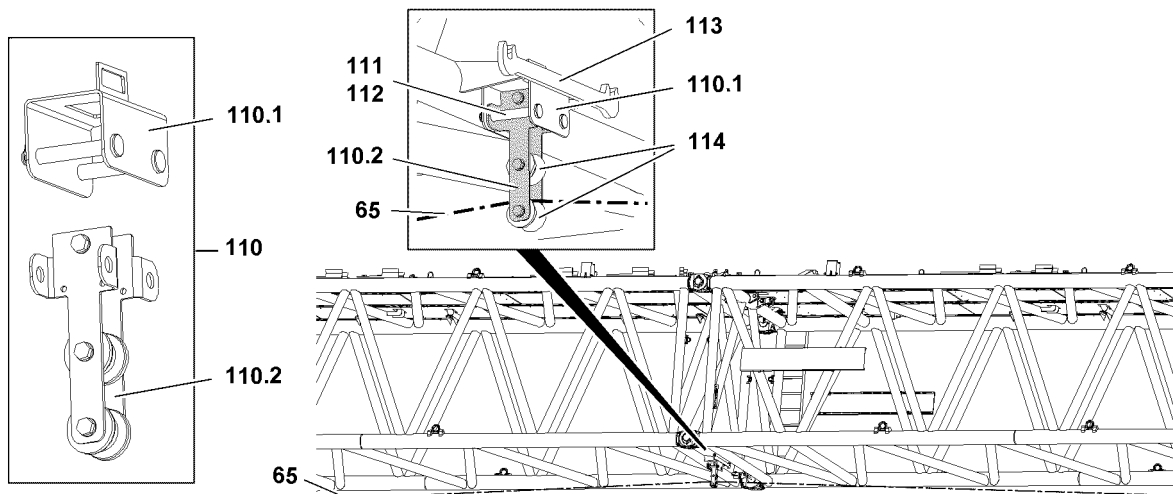

Fig.121048: Reeving the W-control rope in and pulling the hoist ropes forward to the S-end section - Installing the complete retainer



Note

- ▶ The complete retainer **110** is part of the assembly aid.
- ▶ Position the complete retainer **110** in the S-boom in such a way that the auxiliary rope does not scrape on the S-boom when pulling it in.

- ▶ Take the complete retainer **110** apart: Remove the safety locking pin **112** and unpin the pin **113**.
- ▶ Set the part **110.1** in the retainer **113** for the pin pulling device.
- ▶ Position the part **110.2** on part **110.1** so that they can be pinned with each other.

When the pin bores align:

- ▶ Insert the pin **113** and secure with the safety locking pin **112**.
- ▶ Pull the auxiliary rope **65** forward to the complete retainer **110**.
- ▶ Guide the auxiliary rope **65** between the change over pulleys **114**.

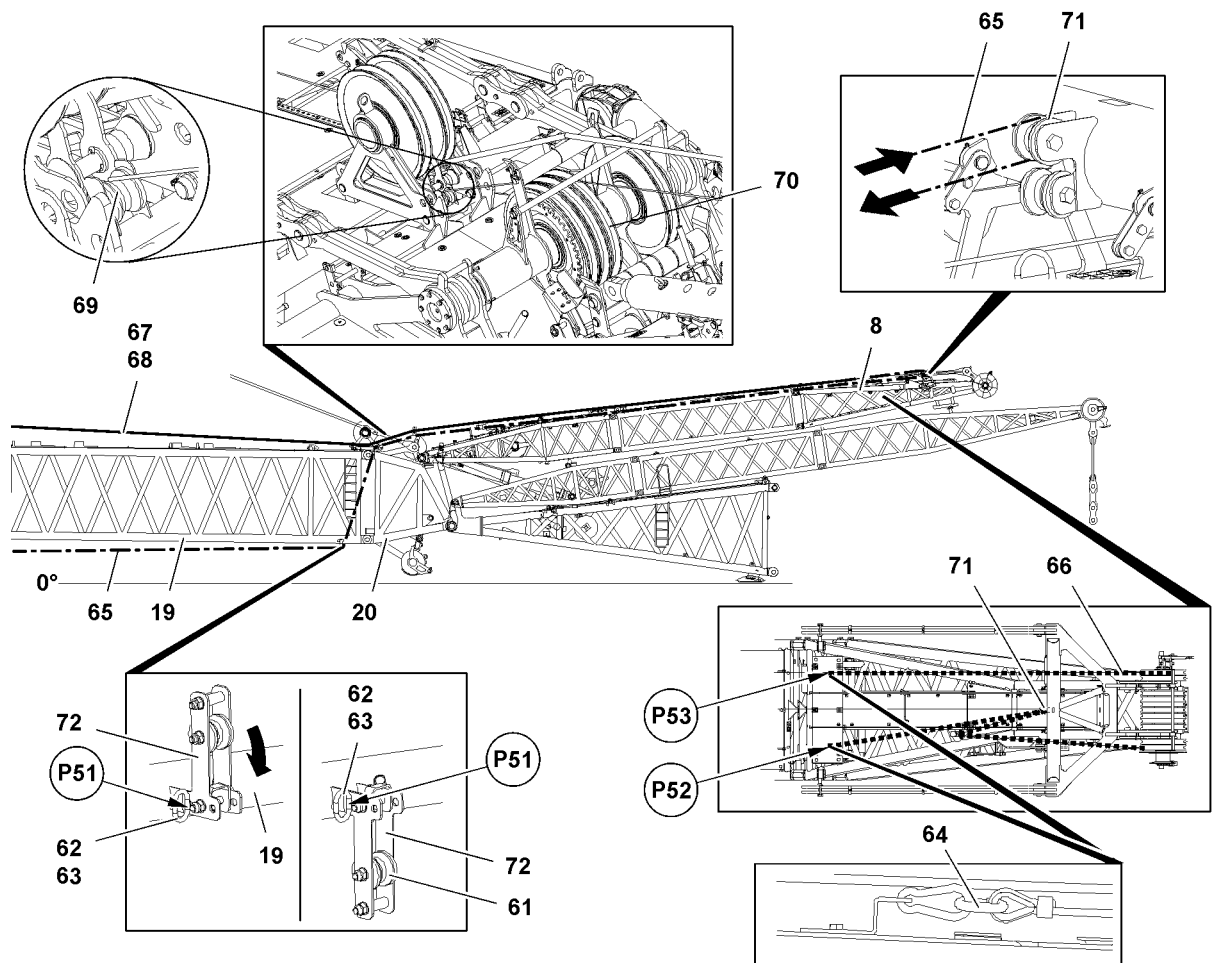

Fig.117043: Reeving the W-control rope in and pulling the hoist ropes forward to the S-end section - Assembly procedure

- ▶ Unpin the change over pulley retainer 72 on S-adaptor 19: Release the pin 62 on point P51 and unpin.
- ▶ Swing the change over pulley retainer 72 downward.
- ▶ Pin the change over pulley retainer 72 with the S-adaptor 19: Insert the pin 62 on point P51 and secure with safety locking pin 63.
- ▶ Pull the auxiliary rope 65 forward to the change over pulley 61.
- ▶ Guide the auxiliary rope 65 over the change over pulley 61.
- ▶ Guide the auxiliary rope 65 over the change over pulley 69.
- ▶ Guide the auxiliary rope 65 over the end pulley 70.
- ▶ Pull the auxiliary rope 65 to the change over pulley 71 of the WA-frame 2 end section 8.
- ▶ Remove the forerunner rope 66 on point P52.
- ▶ Remove the forerunner rope 66 from the change over pulley 71.

The auxiliary rope 65 is guided in from top.

- ▶ Guide the auxiliary rope 65 over the upper change over pulley 71.
- ▶ Pull the auxiliary rope 65 to winch 1.
- ▶ Connect the auxiliary rope 65 with the hoist rope 68: Place the connecting link 64 in between hoist rope 68 and auxiliary rope 65.
- ▶ Pull the hoist rope 68 forward with the aid of the auxiliary rope 65 to the S-end section 20.
- ▶ Remove the auxiliary rope 65 from the hoist rope 68.

When a second hoist rope 68 is required:

- ▶ Pull the second hoist rope 68 the same way to the S-end section 20 as described before.
- ▶ Pull the auxiliary rope 65 to winch 5.

- ▶ Connect the auxiliary rope **65** with the W-control rope **67**: Place the connecting link **64** in between W-control rope **67** and auxiliary rope **65**.
- ▶ Pull the W-control rope **67** with the aid of the auxiliary rope **65** to park position (point **P53**) of the forerunner rope **66**.
- ▶ Remove the auxiliary rope **65** from the W-control rope **67**.
- ▶ Remove the auxiliary rope **65** from the upper change over pulley **71** and position it in such a way that the end of the auxiliary rope **65** is laying on point **P52**.
- ▶ Remove the forerunner rope **66** on park position (point **P53**).

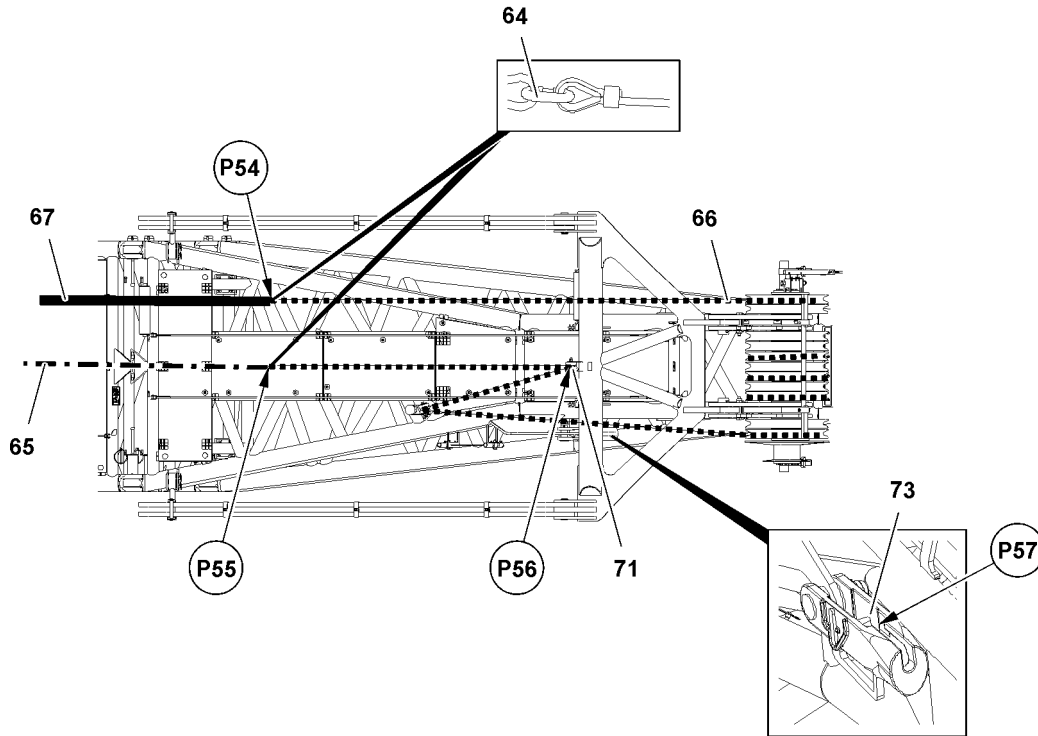

Fig.117044: Reeving the W-control rope in and pulling the hoist ropes forward to the S-end section - Pulling in the W-control rope

- ▶ Connect the forerunner rope **66** with the W-control rope **67**: Place the connecting link **64** in on point **P54** between the forerunner rope **66** and W-control rope **67**.
- ▶ Place the forerunner rope **66** on point **P56** over the upper change over pulley **71**.
- ▶ Connect the forerunner rope **66** with the auxiliary rope **65**: Place the connecting link **64** in on point **P55** between the forerunner rope **66** and auxiliary rope **65**.
- ▶ Pull the auxiliary rope **65** in and slowly spool the W-control rope **67** out until it can be affixed in the rope lock **73** on point **P57**.



WARNING

Danger of crushing if winch 5 moves!

If the W-control rope winch (winch 5) is actuated while affixing the W-control rope **67**, personnel can be severely injured or killed.

Fingers, hands and arms can be crushed or severed.

- ▶ Do not actuate winch 5 during the assembly procedure.
 - ▶ Radio contact is available between crane operator and assembly personnel.
-
- ▶ Affix the W-control rope **67** on point **P57** on the rope lock **73**.

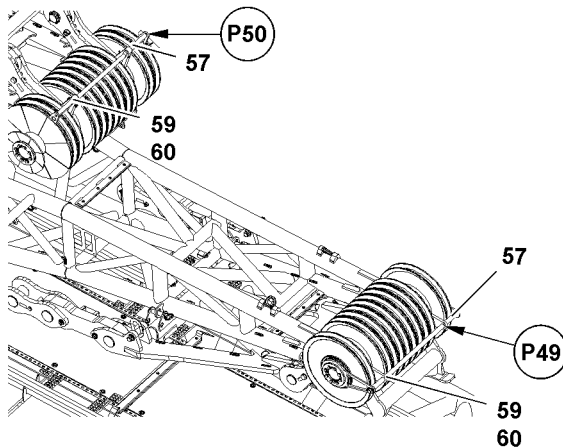

Fig.117046: Reeving the W-control rope in and pulling the hoist ropes forward to the S-end section - Installing the rope guard

- ▶ Install the rope guard **57** on point **P49** and point **P50** and secure with retaining elements (pin **59** and safety locking pin **60**).

3.3 Checking the limit switches for the relapse cylinder for function

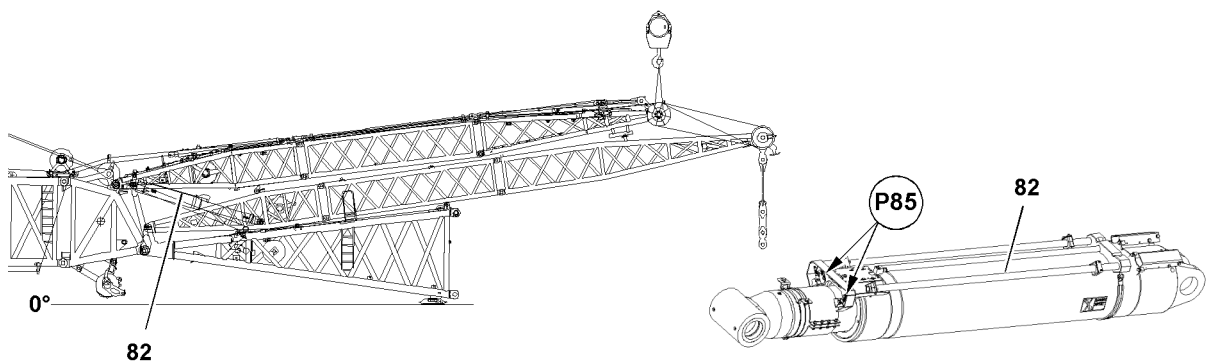

Fig.117070: Checking the limit switches for the relapse cylinder for function

NOTICE

Damage to relapse cylinder **82**!

Before erecting the WA-frame 1, the electrical connection for the limit switches of the relapse cylinder **82** must be established. If this is **NOT** the case, the WA-frame 1 can be pulled back over the mechanical stop of the relapse cylinder **82**, which may damage the relapse cylinder **82**.

- ▶ Establish the electrical connection for the limit switches of the relapse cylinder **82**.
- ▶ Make sure that the electrical connection for the limit switches of the relapse cylinder **82** is established.
- ▶ Cover the limit switch initiators of the relapse cylinder **82** individually at points **P85** with a metal plate.

Result:

- The icon appears on the LICCON monitor.
- The **spool up function** of the W-control winch turns off.

3.4 Guying and erecting the WA-frame 2

Make sure that the following prerequisites are met:

- The WA-frame 2 is laying on WA-frame 1.
- The W-control rope is fully assembled.
- The limit switches were checked for proper function.
- The pressure of the relapse cylinder was checked.

3.4.1 Assembling the erection ropes

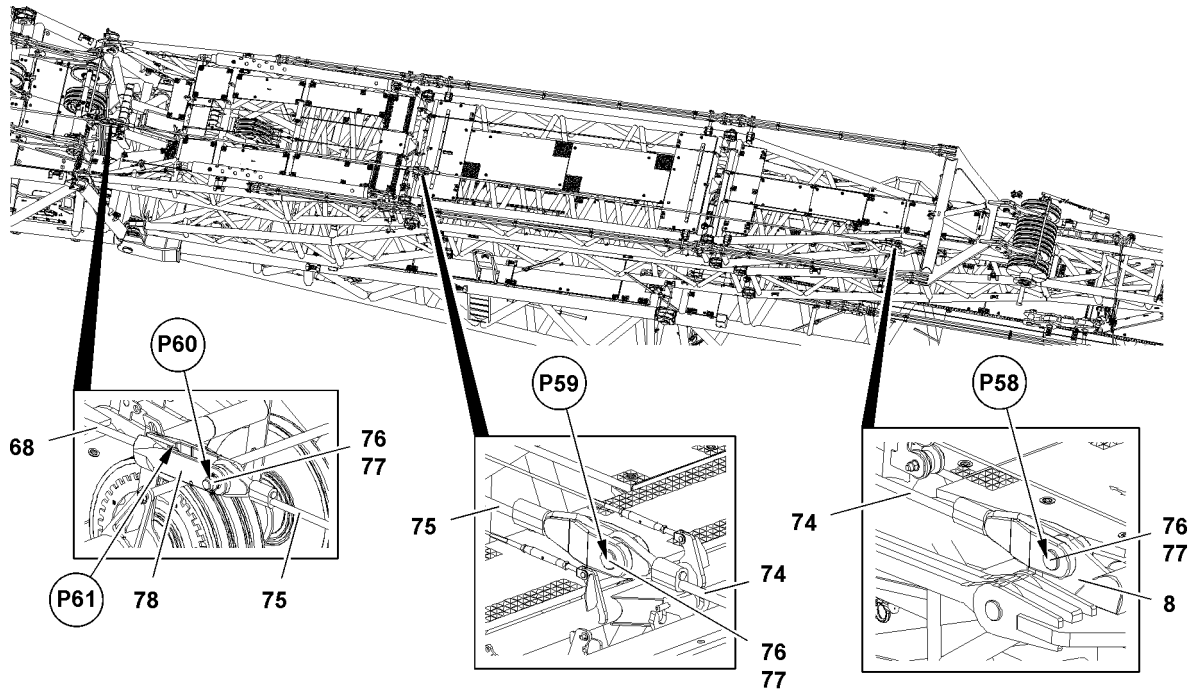

Fig.117045: Assembling the erection ropes

- ▶ Place a 9.3 m erection rope **74** on the WA-frame 2 to be able to pin on point **P58**.
- ▶ Pin the 9.3 m erection rope **74** with the WA-frame 2 end section **8**: Insert the pin **76** on point **P58** and secure with safety locking pin **77**.



Note

- ▶ For short WA-frames, the 6 m erection rope is not installed.
- ▶ Place a 6 m erection rope **75** lengthwise on the WA-frame 2 to be able to pin on point **P59**.
- ▶ Pin the 6 m erection rope **75** with the 9.3 m erection rope **74**: Insert the pin **76** on point **P59** and secure with safety locking pin **77**.
- ▶ Pin the rope lock **78** with the 6 m erection rope **75**: Insert the pin **76** on point **P60** and secure with safety locking pin **77**.
- ▶ Affix the hoist rope **68** on point **P61** in rope lock **78**.

3.4.2 Opening the transport retainers of the guy rods

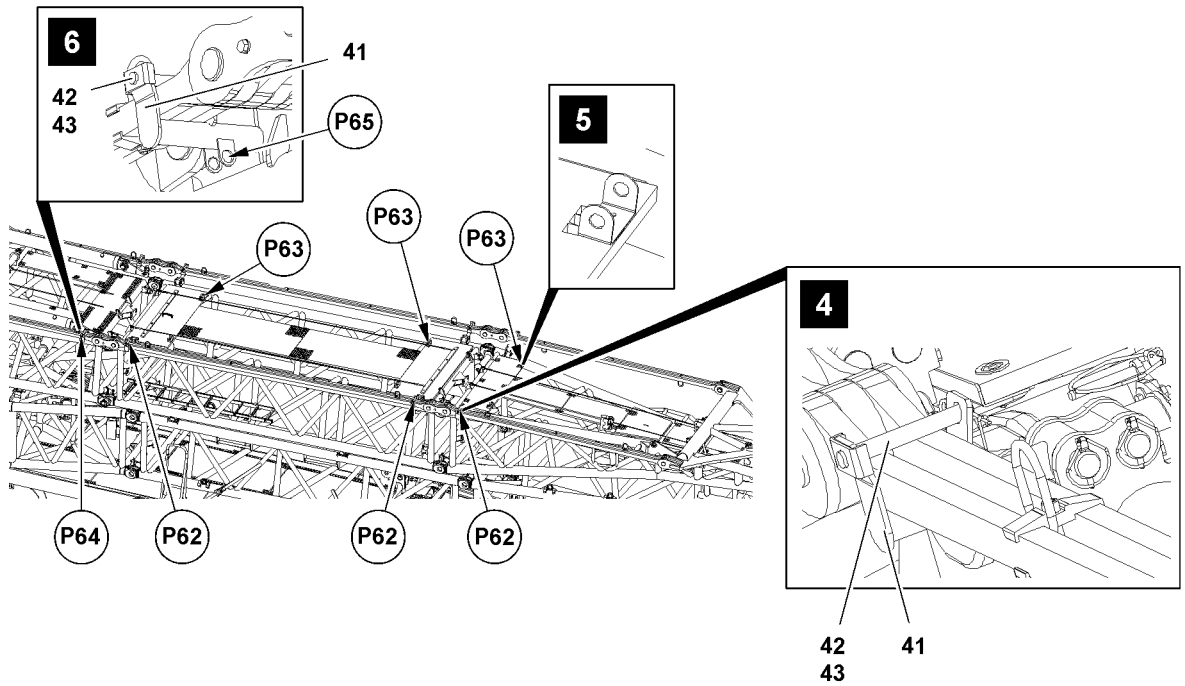

Fig.117037: Opening the transport retainers of the guy rods

- ▶ Open the transport retainers 41 (illustration 4) on points P62 on both sides: Remove the safety locking pin 43 and unpin the pin 42.
- ▶ Insert the pins 42 on both sides on points P63 in park positions (illustration 5).
- ▶ Open the transport retainers 41 (illustration 6) on both sides on point P64: Remove the safety locking pin 43 and unpin the pin 42.
- ▶ Insert the pins 42 in park positions (point P65) and secure with safety locking pin 43.

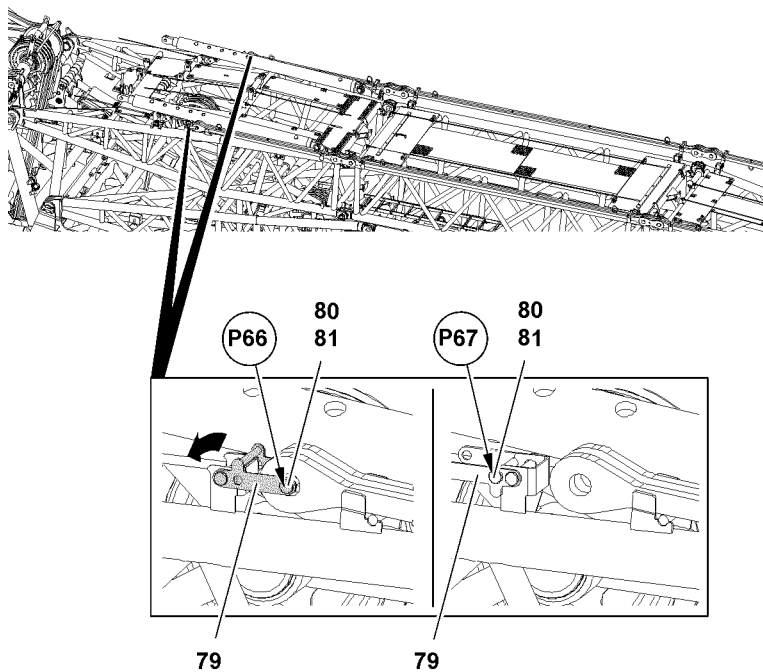

Fig.117047: Opening the transport retainers of the guy rods

- ▶ Release the pins 80 on both sides on points P66 and unpin.

LWE/LR 11000-001/23501-04-02/en

- ▶ Fold the transport retainer **79** over.
- ▶ Secure the transport retainer **79** in park position: Insert the pins **80** on both sides on points **P67** and secure with safety locking pins **81**.

3.4.3 Erecting the WA-frame 2

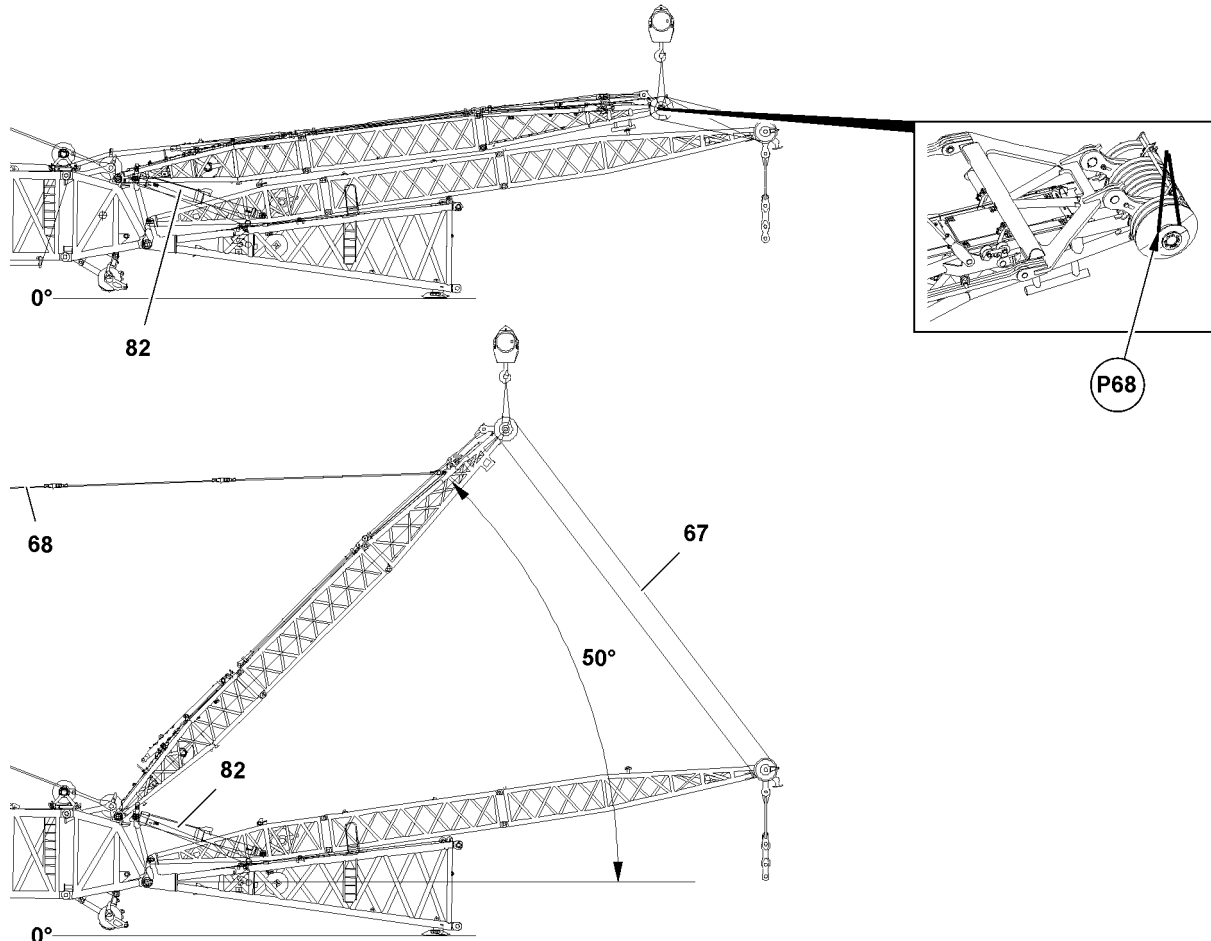

Fig.121053: Erecting the WA-frame 2 - Erection procedure 50°

- ▶ Fasten the auxiliary crane on point **P68**.



WARNING

Danger of accident!

Up to an angle of 50°, the WA-frame 2 may only be lifted with an auxiliary crane. The hoist rope **68** may not be subjected to a load.

If the following notes are not observed and adhered to, personnel can be severely injured or killed.

- ▶ It is prohibited to remain in the danger zone.
- ▶ Maintain a safe distance.
- ▶ The spooling procedure must be monitored by a guide.
- ▶ Lift the WA-frame 2 only with the auxiliary crane to approx. 50°.
- ▶ Allow no slack rope formation on the W-control rope and on the hoist rope.
- ▶ Make sure that the WA-frame 1 remains in a position during the entire erection procedure in which the W-control rope is tensioned.
- ▶ During the entire assembly procedure, the WA-frame 1 must be raised with the W-control rope **67** to approx. 15° so that the relapse cylinder **82** is under pressure.

NOTICE

Slack rope formation!

Due to slack rope formation, the hoist rope **68** and the W-control rope **67** can be damaged.

This could result in high property damage.

- ▶ When spooling the hoist rope **68** or the W-control rope **67** up or out, allow no slack rope formation.
- ▶ When spooling up or out, hold the hoist rope **68** and the W-control rope **67** taut.

- ▶ Lift the WA-frame 2 solely with the auxiliary crane to approx. 50° and simultaneously spool the hoist rope **68** up and the W-control rope **67** out.

When the WA-frame 2 has reached an approximate angle of 50°:

- ▶ Tension the hoist rope **68** until the WA-frame is held by the hoist rope **68**.
- ▶ Remove the auxiliary crane.
- ▶ Lift the WA-frame 2 with the hoist rope to about 90° and simultaneously spool out the W-control rope.

3.4.4 Long WA-frames: Pining the guy rods with each other and installing the relapse supports in operating position

**WARNING**

Danger of accident!

If the following notes are not observed and adhered to, personnel can be severely injured or killed.

- ▶ It is prohibited to remain in the danger zone.
- ▶ Maintain a safe distance.
- ▶ The spooling procedure must be monitored by a guide.
- ▶ Allow no slack rope formation on the W-control rope and on the hoist rope.
- ▶ Make sure that the WA-frame 1 remains in a position during the entire erection procedure in which the W-control rope is tensioned.
- ▶ During the entire assembly procedure, raise the WA-frame 1 with the W-control rope **67** to approx. 15° so that the relapse cylinder **82** is under pressure.

Make sure that the following prerequisites are met:

- The long version of the WA-frame is installed.
- The WA-frame 2 is held by the hoist rope.
- The function of the relapse cylinder is ensured.
- The required guy rods are installed according to the rod plan.
- The transport retainers of the guy rods on the WA-frame 2 are unpinned.
- The transport retainer of the relapse support is unpinned.

Pinning the guy rods with each other

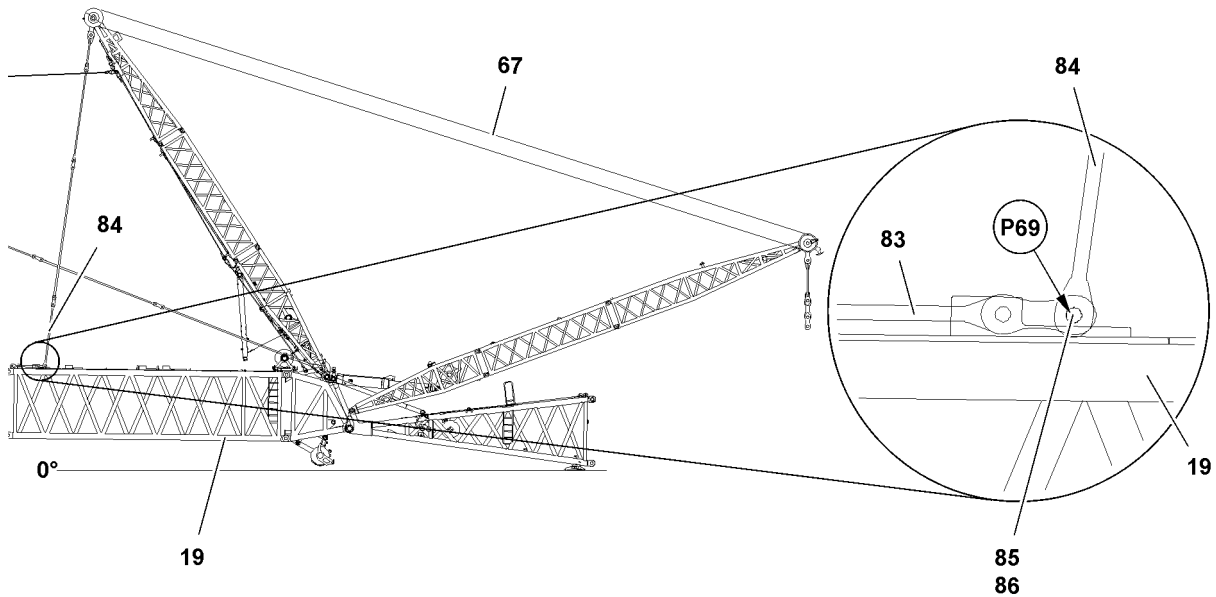

Fig. 117049: Long WA-frames: Pinning the guy rods with each other

The WA-frame is pulled back until the hanging guy rods **84** are positioned in such a way that the guy rods **83** of the S-adapter **19** can be installed. This position is approx. at 120°.

- ▶ Lift the WA-frame 2 by spooling up the hoist rope and simultaneously spooling out the W-control rope **67** until the guy rods **84** can be pinned with the guy rods **83**.
- ▶ Pin the guy rods **84** with the guy rods **83**: Insert the pins **85** on both sides on points **P69** and secure with safety locking pins **86**.

Installing the relapse supports in operating position

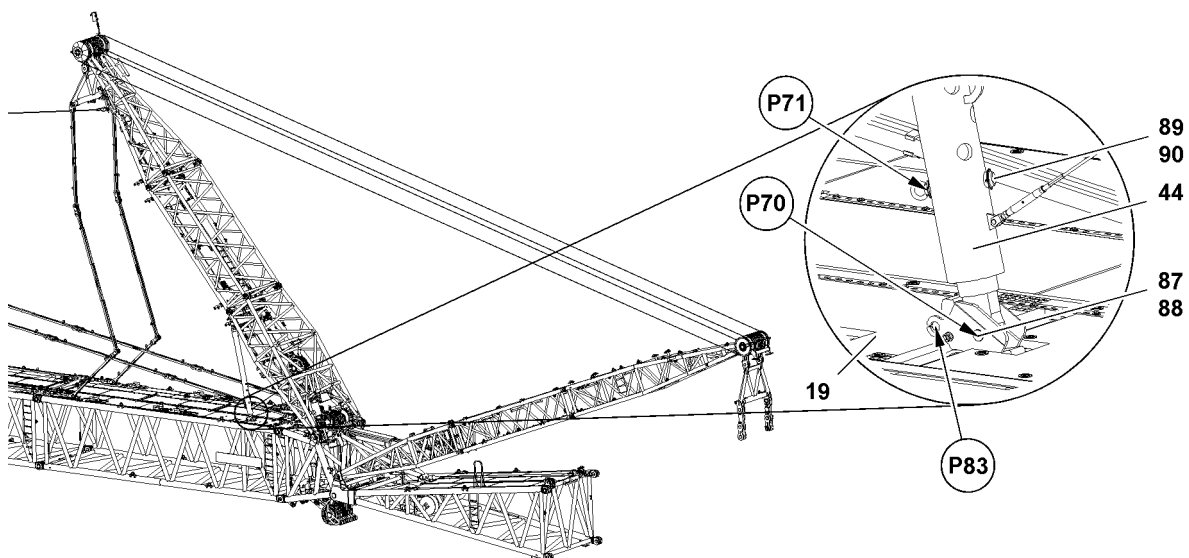

Fig. 117050: Long WA-frames: Installing the relapse supports in operating position

Make sure that the following prerequisite is met:

- The pins **87** are pinned in park positions (point **P83**)
- ▶ Align the WA-frame 2 with the hoist winch in such a way that the relapse supports **44** can be pinned on point **P70**.

- ▶ Pin the relapse supports **44** with the S-adapter **19**: Insert the pins **87** on both sides on points **P70** and secure with safety locking pins **88**.
- ▶ Release and unpin the locking pin **90** on both relapse supports **44** on points **P71**.

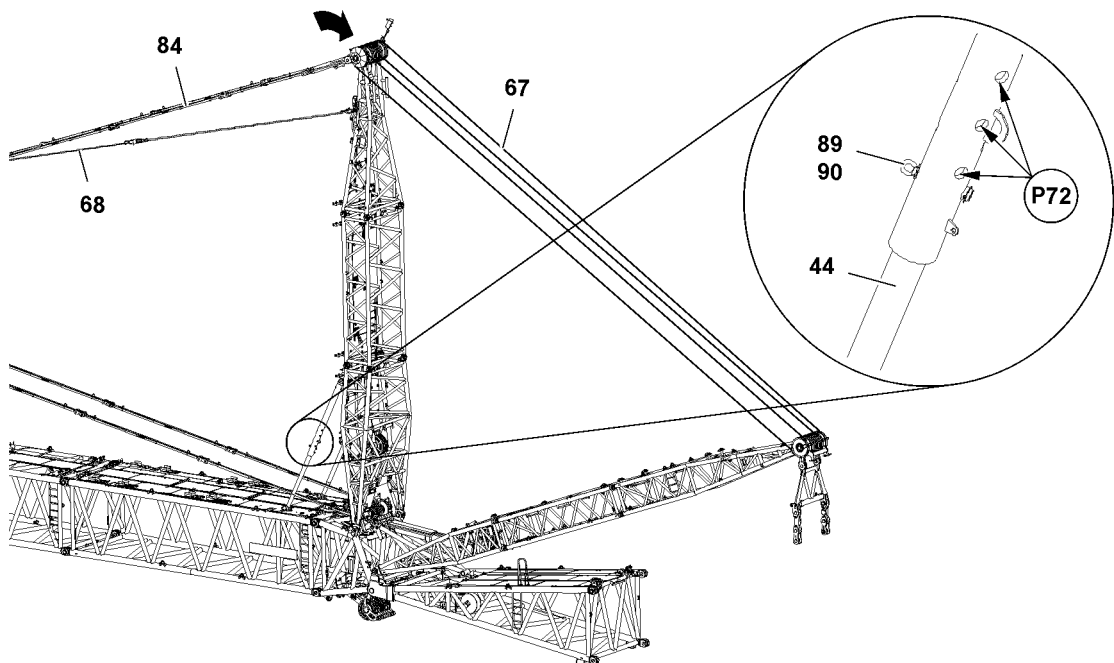

Fig.117052: Long WA-frames: Installing the relapse support with locking pins in operating position

- ▶ Erect WA-frame 2 with W-control rope **67** and at the same time, spool the hoist rope **68** out until the guy rods **84** are tensioned.

The locking pins **89** must be set in such a way that the relapse supports **44** are pinned in the maximum possible length.

When the guy rods **84** are tensioned:

- ▶ Secure the locking pins **89** on both sides as far down as possible on the points **P72** and secure with the safety locking pin **90**.

3.4.5 Short WA-frames: Assembling the relapse supports in operating position and pinning the guy rods with each other



WARNING

Danger of accident!

If the following notes are not observed and adhered to, personnel can be severely injured or killed.

- ▶ It is prohibited to remain in the danger zone.
- ▶ Maintain a safe distance.
- ▶ The spooling procedure must be monitored by a guide.
- ▶ Allow no slack rope formation on the W-control rope and on the hoist rope.
- ▶ Make sure that the WA-frame 1 remains in a position during the entire erection procedure in which the W-control rope is tensioned.
- ▶ During the entire assembly procedure, raise the WA-frame 1 with the W-control rope **67** to approx. 15° so that the relapse cylinder **82** is under pressure.

Make sure that the following prerequisites are met:

- The short version of the WA-frame is installed.
- The WA-frame 2 is held by the hoist rope.
- The function of the relapse cylinder is ensured.
- The required guy rods are installed according to the rod plan.
- The transport retainers of the guy rods on the WA-frame 2 are unpinned.
- The transport retainer of the relapse support is unpinned.
- The pins for the relapse supports on the pin point of the S-adapter are pinned in park position.

Pinning the relapse supports on the S-adapter

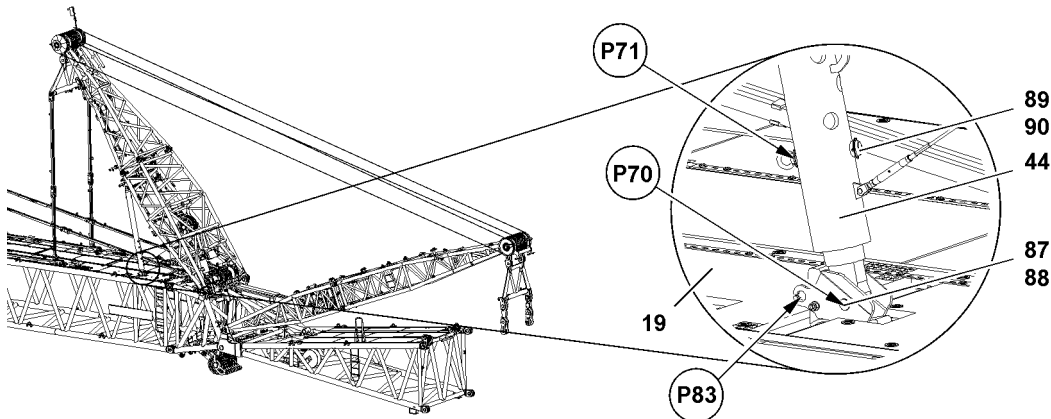

Fig.117053: Short WA-frames: Pinning the relapse supports on the S-adapter

Make sure that the following prerequisite is met:

- The pins **53** are pinned in park positions (point **P83**)
- ▶ Align the WA-frame 2 with the hoist winch in such a way that the relapse supports **44** can be pinned on point **P70**.
 - ▶ Pin the relapse supports **44** with the S-adapter **19**: Insert the pins **87** on both sides on points **P70** and secure with safety locking pins **88**.
 - ▶ Release and unpin the locking pin **90** on both relapse supports **44** on points **P71**.

Pinning the guy rods with each other

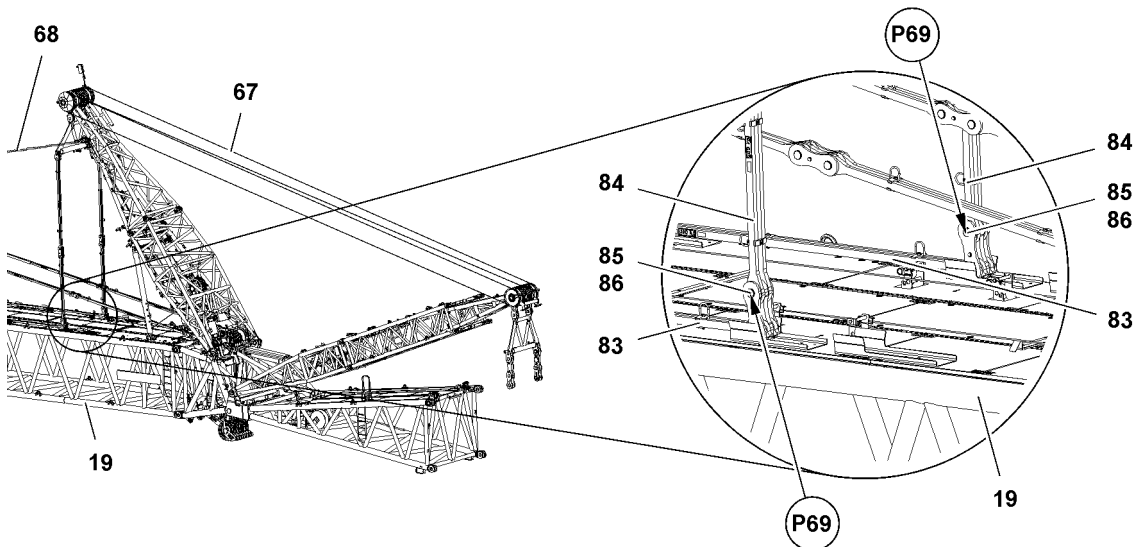

Fig.117054: Short WA-frames: Pinning the guy rods with each other

- ▶ Fasten the guy rods to the auxiliary crane.
- ▶ Position the guy rods **83** with the auxiliary crane in such a way that pinning on point **P69** is possible.
- ▶ Pin the guy rods **84** with the guy rods **83**: Insert the pin **85** on point **P69** and secure with safety locking pin **86**.
- ▶ Repeat the procedure on the other side for the guy rods the same way as described above.

Installing the relapse supports in operating position

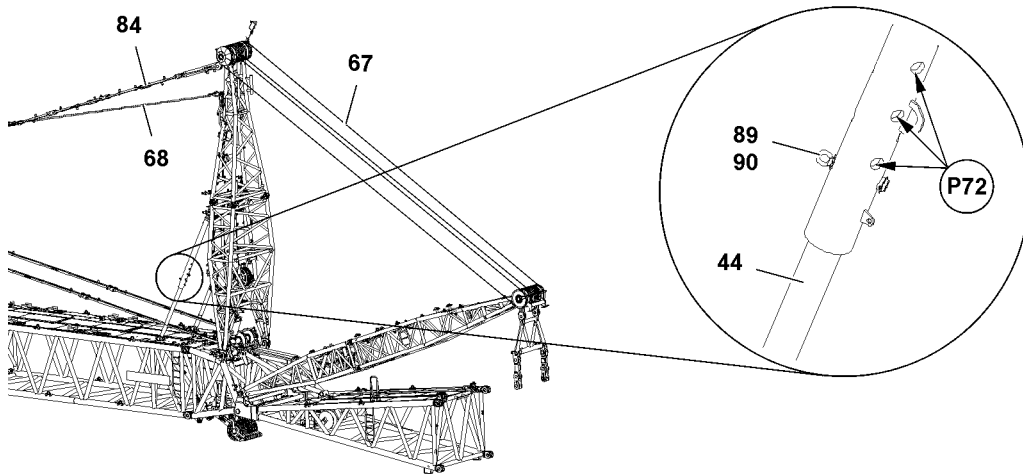

Fig.117055: Short WA-frames: Installing the relapse supports in operating position

The locking pins **89** must be set in such a way that the relapse supports **44** are pinned in the maximum possible length.

- ▶ Erect WA-frame 2 with W-control rope **67** and at the same time, spool the hoist rope **68** out until the guy rods **84** are tensioned.

When the guy rods **84** are tensioned:

- ▶ Secure the locking pins **89** on both sides as far down as possible one of the points **P72** and secure with safety locking pin **90**.

3.5 Securing the ropes in park position

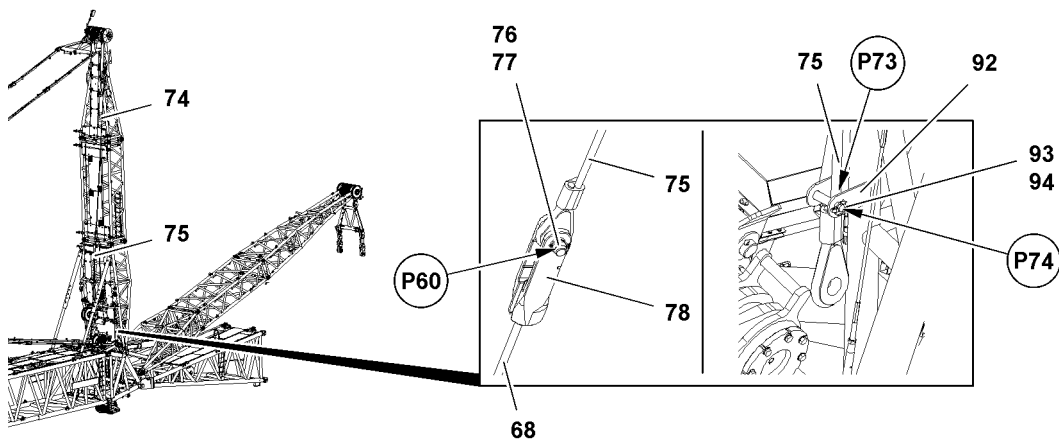

Fig.117056: Securing the ropes in park position

- ▶ Lower the 6 m erection rope **75** and 9.3 m erection rope **74** with the hoist winch.
- ▶ Remove the hoist rope **68** from the rope lock **78**.
- ▶ Remove the safety locking pin **77** on point **P60** and unpin the pin **76**.

- ▶ Remove the rope lock **78**.
- ▶ Remove the safety locking pin **94** on point **P74** and unpin the pin **93**.
- ▶ Place the 6 m erection rope **75** on point **P73** in the retainer **92**.
- ▶ Insert the pin **93** on point **P74** and secure with safety locking pin **94**.

Result:

- The 6 m erection rope **75** and the 9.3 m erection rope **74** are secured in park position.

3.6 Pulling the hoist ropes forward to the W-pivot section

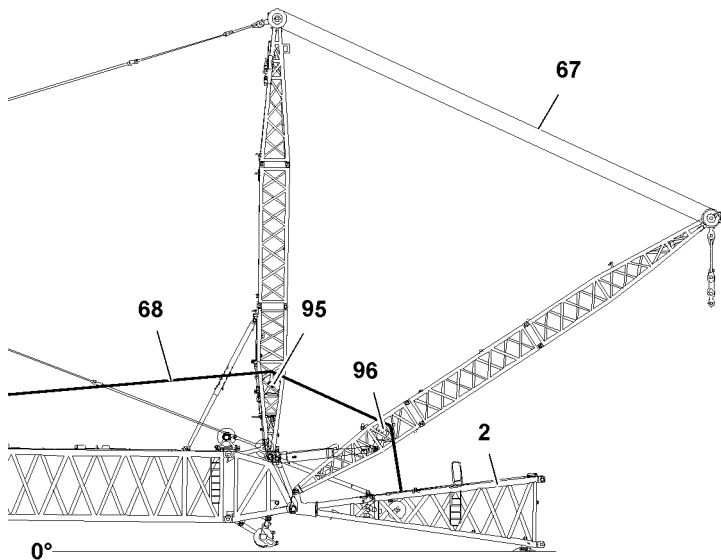

Fig.117057: Pulling the hoist ropes forward to the W-pivot section

NOTICE

Slack rope formation!

Due to slack rope formation, the hoist rope **68** and the W-control rope **67** can be damaged. This could result in high property damage.

- ▶ When spooling the hoist rope **68** or the W-control rope **67** up or out, allow no slack rope formation.
- ▶ When spooling up or out, hold the hoist rope **68** and the W-control rope **67** taut.



WARNING

Danger of accident!

Death, severe bodily injuries, property damage.

- ▶ It is prohibited to remain within the danger zone of the running ropes.
 - ▶ Radio contact is available between crane operator and assembly personnel.
-
- ▶ Pull the hoist rope **68** over the change over pulley **95** and change over pulley **96** and place down on the W-pivot section **2**.

3.7 Assembling the WA-frame 1 guy rods

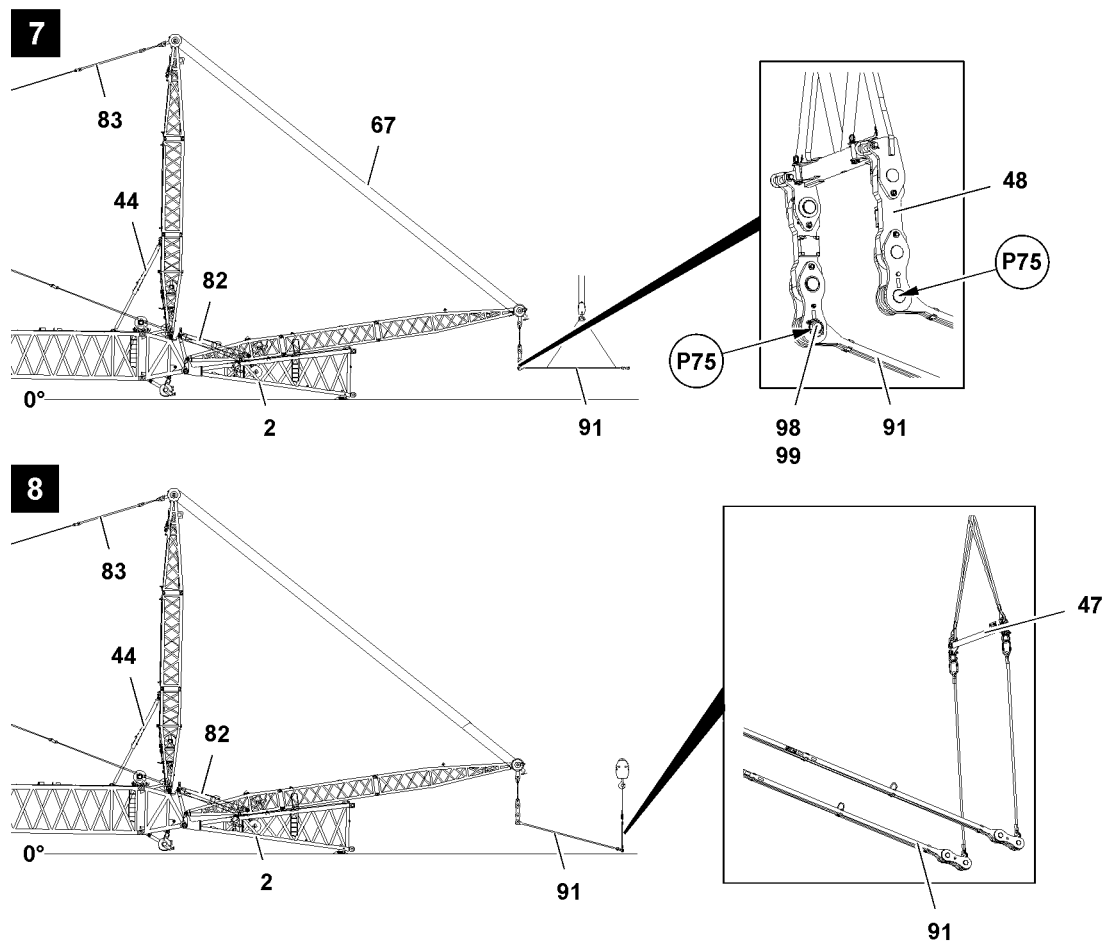

Fig.117058: Assembling the WA-frame 1 guy rods

Make sure that the following prerequisites are met:

- The WA-frame 2 guying **83** is completely assembled.
- The relapse supports **44** are installed in operating position.
- The WA-frame 1 is laying on the W-pivot section **2**.
- The function of the relapse cylinder **82** is ensured

Select the required guy rods according to the rod plan and install with the auxiliary crane.

- ▶ Fasten the guy rods **91** to the auxiliary crane.
- ▶ Lift the guy rods **91** with the auxiliary crane and pin on the swing **48**: Insert the pins **98** on both sides on points **P75** and secure with safety locking pin **99**, see illustration 7.
- ▶ Place the guy rods **91** down with the auxiliary crane.
- ▶ Fasten the cross beam **47** on the guy rods **91**, see illustration 8.

When erecting the WA-frame 1, the guy rods **91** are carried along by the auxiliary crane and the cross beam **47** so that the guy rods **91** are not laying on the ground.

- ▶ Erect the WA-frame 1 via the W-control rope **67** until the guy rods **91** hang vertically.

If additional guy rods **91** must be installed according to the rod plan:

- ▶ Install the guy rods **91** the same way as described before.

3.8 Assembling the W-lattice jib on the W-pivot section

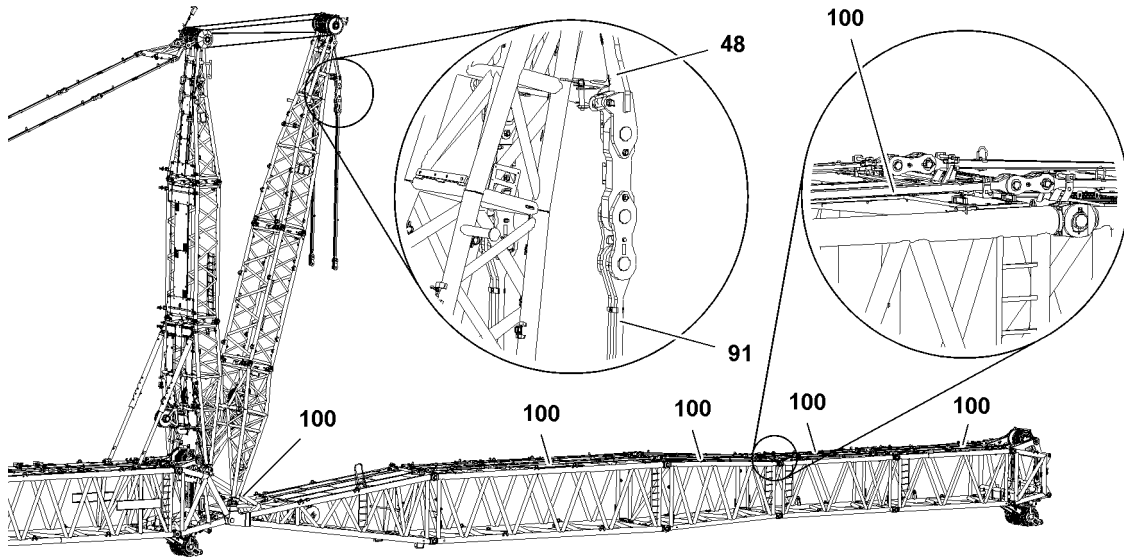

Fig.117059: Assembling the W-lattice jib on the W-pivot section



WARNING

Danger of crushing for people in the load zone!
If personnel are located between the load to be lifted and a possible interfering edge when lifting a load, personnel can be severely injured or killed.

- ▶ Before lifting the load it must be ensured that there are no persons within the danger zone.
- ▶ It is prohibited to remain in the danger zone.
- ▶ It is prohibited for anyone to be under the load.
- ▶ Maintain a safe distance.
- ▶ Swinging the load is prohibited.
- ▶ Exercise extreme caution when lifting a load.



DANGER

General danger notes!

- ▶ Support the W-lattice jib at assembly and disassembly properly with the assembly shoes, see Crane operating instructions, chapter 5.62.
- ▶ All pins must be secured after the assembly.
- ▶ The guy rods must be checked regularly, see Crane operating instructions, chapter 8.15.



DANGER

Overload of boom!

If several lattice sections are preassembled after the W-pivot section, which exceed the total length of 37.5 m, then the lattice sections will be overloaded.

Death, severe bodily injuries, property damage.

- ▶ Assemble lattice sections to a total length of maximum 37.5 m, without supporting them again.



Note

- ▶ During assembly of the W-lattice jib, adhere to the pin sequence, see Crane operating instructions, chapter 5.01.

Make sure that the following prerequisites are met:

- The guy rods **91** are installed on the swing **48**.
- The function of the relapse cylinder **82** is ensured.
- The WA-frame 2 is guyed.
- The required guy rods **100** are laying on the lattice sections to be installed.

To pin the W-lattice jib with the pin pulling device, see Crane operating instructions, chapter 5.30.

The assembly of the W-lattice jib is the same as the assembly of the boom, see Crane operating instructions, chapter 5.39.

Refer to the rod plan for the sequence and the number of the individual lattice sections.

- ▶ Assemble the W-lattice jib to the required length.

3.9 Assembling the WA-frame 1 guy rods

3.9.1 Long WA-frames: Pinning the guy rods with each other

Assembling the 9 m guy rod and 3 m guy rod

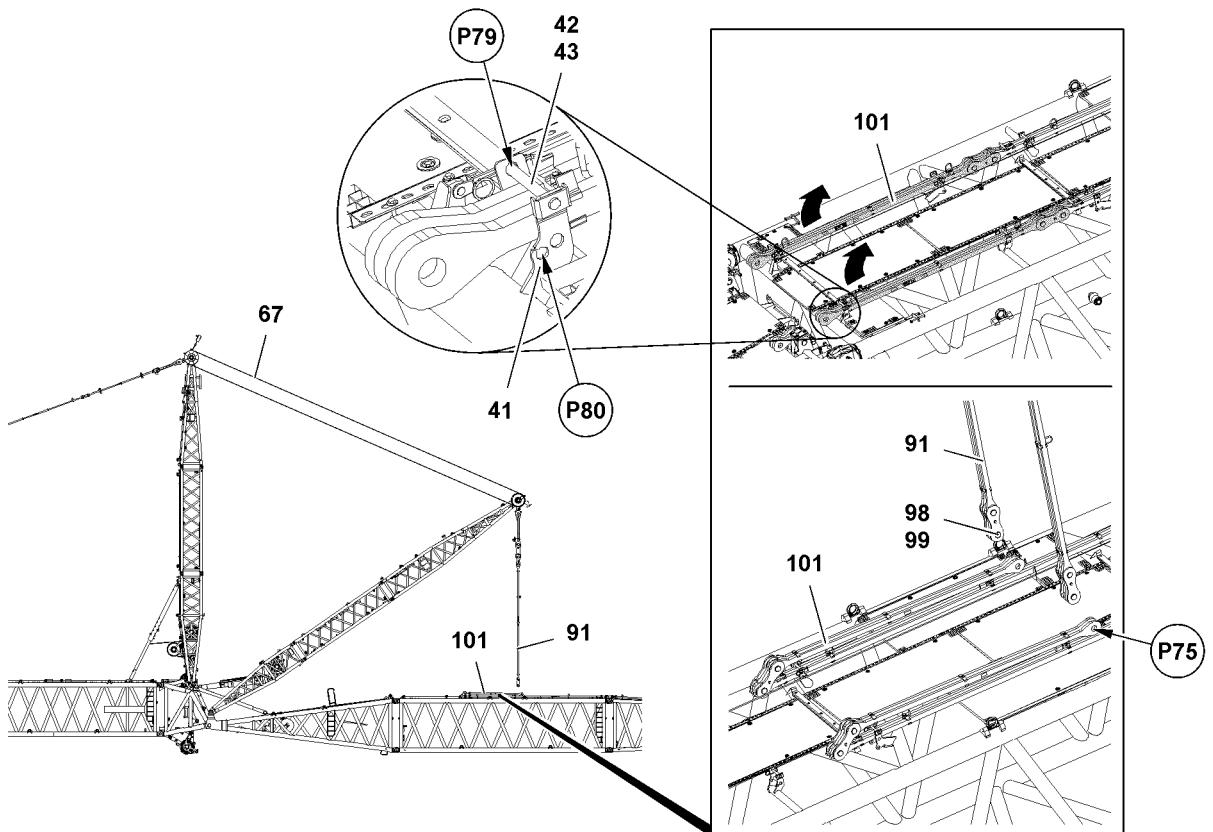

Fig.117061: Long WA-frames: Assembling the 9 m guy rod and 3 m guy rod

- ▶ Open all transport retainers **41**: Remove the spring retainer **43** on both sides on points **P79** and unpin the pin **42**.
- ▶ Insert the pins **42** on both sides on points **P80** in park position and secure with spring retainer **43**.
- ▶ Fold the 3 m guy rods **101** over.
- ▶ Lower the WA-frame 1 via the W-control rope **67** until the guy rods **91** can be pinned with the guy rods **101**.
- ▶ Pin the guy rods **91** with the guy rods **101**: Insert the pins **98** on both sides on point **P75** and secure with safety locking pin **99**.

Assembling the 12 m guy rod

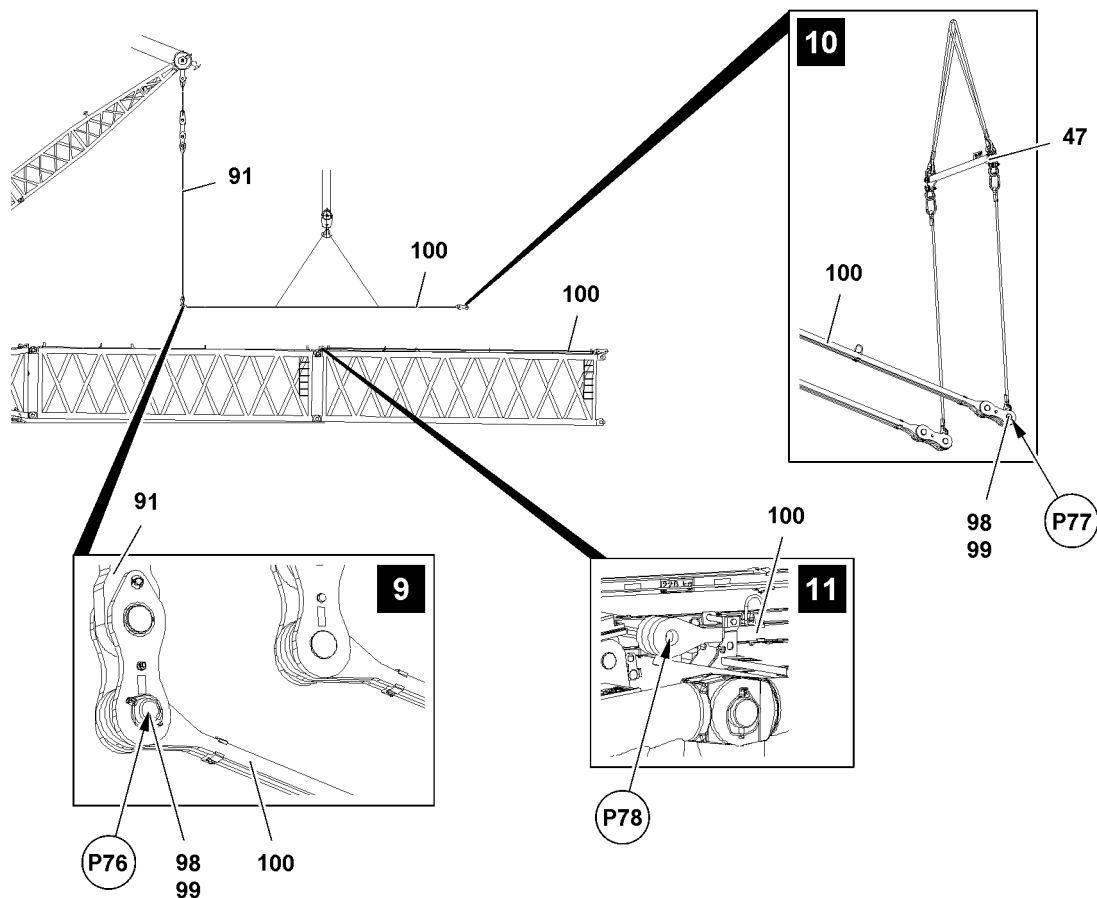

Fig.117060: Long WA-frames: Assembling the 12 m guy rods

Fasten the guy rods **100** on the auxiliary crane which are laying on the first intermediate section after the W-pivot section.

- ▶ Fasten the guy rod **100** to the auxiliary crane.
- ▶ Lift the guy rod **100** with the auxiliary crane and position it in such a way that it can be pinned on point **P76**, see illustration **9**.
- ▶ Pin the guy rod **100** with the guy rod **91**: Insert the pin **98** on point **P76** and secure with safety locking pin **99**, see illustration **9**.
- ▶ Place the guy rod **100** down on the lattice section.
- ▶ Remove the auxiliary crane.
- ▶ Repeat the procedure the same way for the second guy rod **100**.
- ▶ Pin the cross beam **47** on both sides on points **P77** with guy rods **100**, see illustration **10**.
- ▶ Lift the WA-frame 1 and carry the guy rods **100** along with the auxiliary crane and the cross beam until the guy rods **100** can be pinned with the guy rods **100** on point **P78**, see illustration **11**.
- ▶ Pin the guy rods **100** with the guy rods **100**: Insert the pins **98** on both sides on points **P78** and secure with safety locking pin **99**, see illustration **11**.

3.9.2 Short WA-frames: Pinning the guy rods with each other

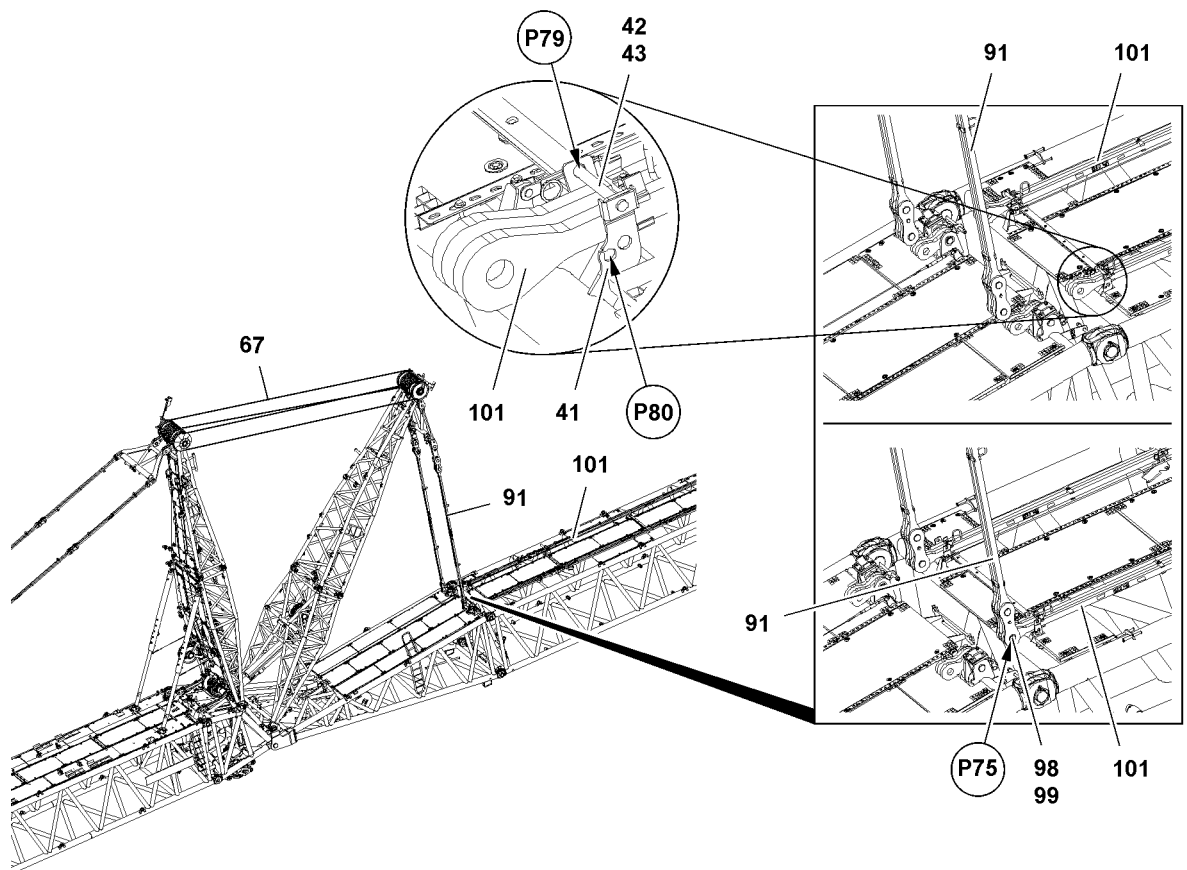

Fig.117062: Short WA-frames: Pinning the guy rods with each other

- ▶ Lower the WA-frame 1 via the W-control rope **67** until the guy rods **91** can be pinned with the guy rods **101**.
- ▶ Open all transport retainers **41**: Remove the spring retainer **43** on both sides on points **P79** and unpin the pin **42**.
- ▶ Insert the pins **42** on both sides on points **P80** in park position and secure with spring retainer **43**.
- ▶ Pin the guy rods **91** with the guy rods **101**: Insert the pins **98** on both sides on point **P75** and secure with safety locking pin **99**.

3.9.3 Installing the auxiliary guying

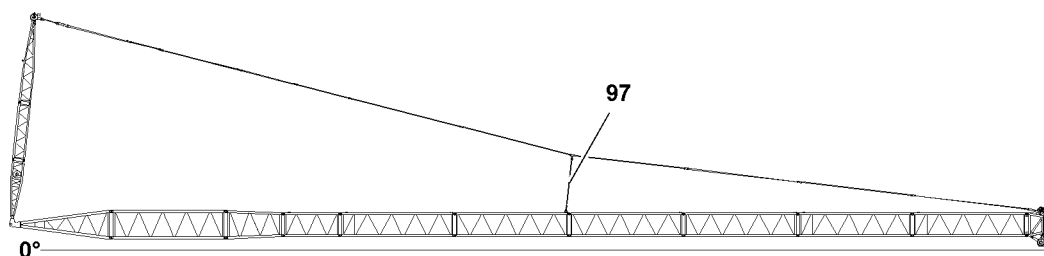

Fig.117064: Installing the auxiliary guying

**Note**

- ▶ Auxiliary guying **97** is not required for every system. Refer to the rod plans if an auxiliary guying **97** is required.
 - ▶ Assembly of the auxiliary guying **97**, see rod plans. The numbering on the rod plans must be identical to the numbering on the guy rods.
 - ▶ For assembly procedure of auxiliary guying **97**, see Crane operating instructions, chapter 5.03.
-
- ▶ Lower the WA-frame 1 until the auxiliary guying **97** can be installed.
 - ▶ Assembling the auxiliary guying **97**, see Crane operating instructions, chapter 5.03.

3.10 Erecting the WA-frame 1

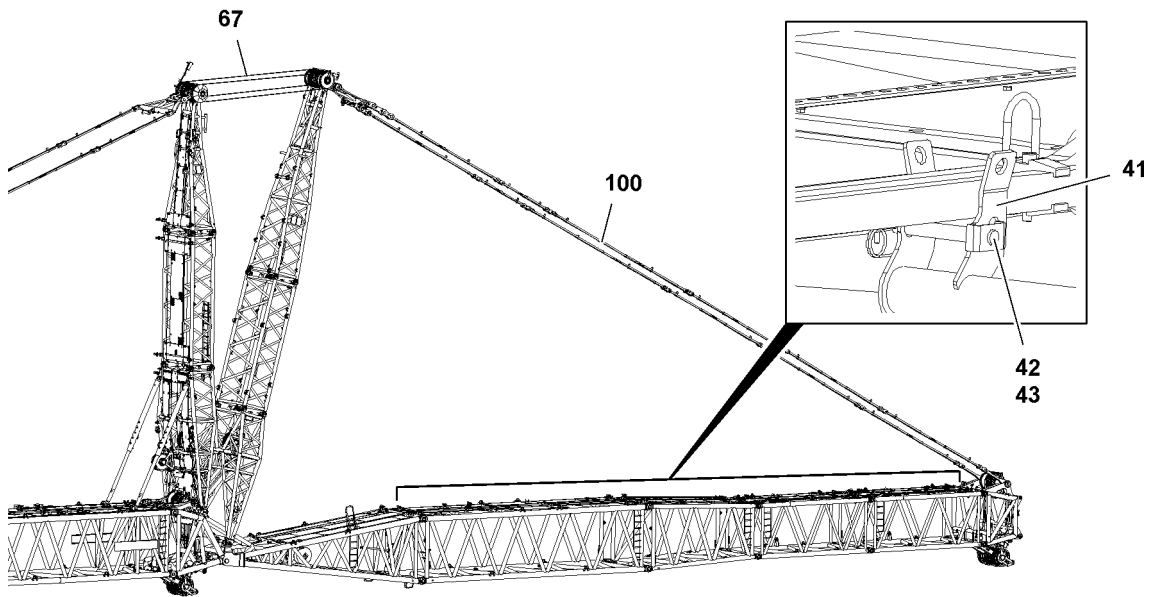

Fig.117063: Erecting the WA-frame 1

Make sure that the following prerequisites are met:

- The function of the relapse cylinder is ensured.
 - All pins **42** of the transport retainers **41** are in park position and are secured with spring retainers **43**.
- ▶ Erect the WA-frame 1 with W-control rope **67** until the guy rods **100** are tensioned or the WA-frame 1 is moved to block.

3.11 Installing the roller set

**Note**

- ▶ The assembly of the roller set is described in the Crane operating instructions, chapter 5.14.

When the roller set is properly installed on the end section:

- ▶ Route the hoist limit switch from the end section forward on the roller set, observe the Electrical wiring diagram.

3.12 Assembling the roller cart on the W-lattice jib

3.12.1 Preparing the assembly of the roller cart

Make sure that the following prerequisites are met:

- The W-lattice jib is fully assembled.
- The W-guying is properly installed.
- The WA-frame 1 is erected.
- The roller set is assembled on the L-end section.
- An auxiliary crane with sufficient load bearing capacity is available.
- The W-lattice jib is properly fastened on the auxiliary crane, see Crane operating instructions, chapter 5.01.

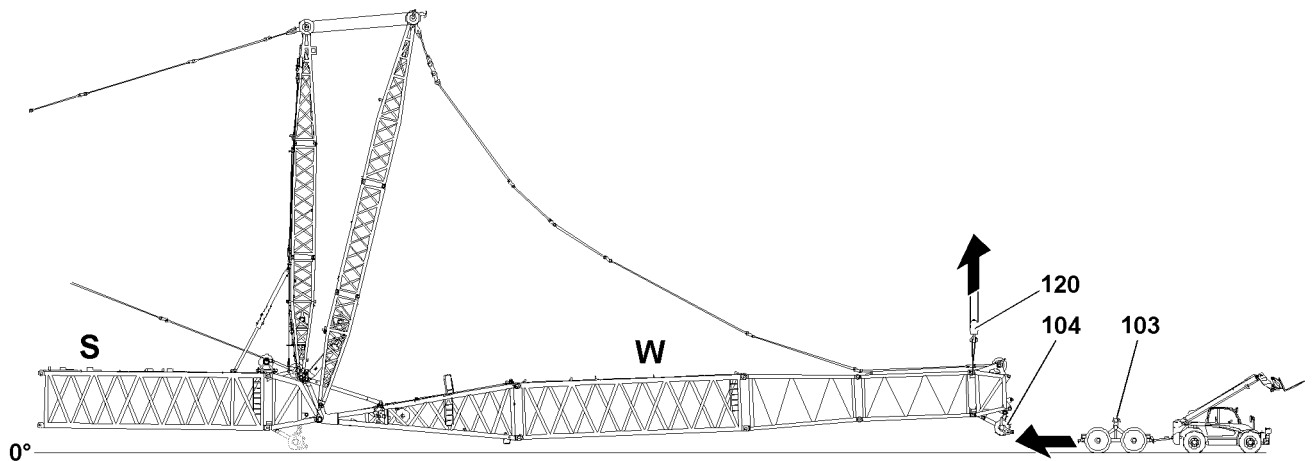

Fig.12225: Position the roller cart **103** on the roller set **104**



WARNING

Danger of accident due to W-lattice jib.
Death, severe bodily injuries, property damage.

- ▶ Make sure that an auxiliary crane with sufficient load bearing capacity is available for the assembly tasks. Observe the head weights of the W-lattice jibs, see the following charts.
 - ▶ Make sure that the W-lattice jib is properly fastened on the auxiliary crane, see Crane operating instructions, chapter 5.01.
 - ▶ Improvisations are prohibited.
-
- ▶ Lift the W-lattice jib with the auxiliary crane.
 - ▶ Position the roller cart **103** under the roller set **104**.

3.12.2 Head weights W-lattice jib

	Lattice jib length W					
	18 m	24 m	30 m	36 m	42 m	48 m
Head weight for W	18 t	20 t	23 t	25 t	27 t	28 t

	Lattice jib length W					
	54 m	60 m	66 m	72 m	78 m	84 m
Head weight for W	30 t	31 t	33 t	35 t	37 t	38 t

	Lattice jib length W					
	90 m	96 m	102 m	108 m	114 m	—
Head weight for W	40 t	41 t	43 t	45 t	47 t	—

3.12.3 Head weights W1-lattice jib

	Lattice jib length W1					
	18 m	24 m	30 m	36 m	42 m	48 m
Head weight for W1	18 t	20 t	23 t	25 t	27 t	28 t

	Lattice jib length W1					
	54 m	60 m	66 m	72 m	78 m	84 m
Head weight for W1	30 t	31 t	33 t	34 t	36 t	38 t

3.12.4 Head weights W2-lattice jib

	Lattice jib length W2					
	18 m	24 m	30 m	36 m	42 m	48 m
Head weight for W2	18 t	22 t	23 t	26 t	29 t	32 t

	Lattice jib length W2					
	54 m	60 m	66 m	72 m	78 m	84 m
Head weight for W2	34 t	37 t	37 t	40 t	43 t	46 t

	Lattice jib length W2					
	90 m	96 m	—	—	—	—
Head weight for W2	49 t	52 t	—	—	—	—

3.12.5 Head weights W3-lattice jib

	Lattice jib length W3					
	18 m	24 m	30 m	36 m	42 m	48 m
Head weight for W3	18 t	22 t	26 t	29 t	31 t	34 t

	Lattice jib length W3					
	54 m	60 m	66 m	72 m	78 m	84 m
Head weight for W3	35 t	38 t	38 t	41 t	44 t	46 t

	Lattice jib length W3					
	90 m	96 m	—	—	—	—
Head weight for W3	50 t	52 t	—	—	—	—

3.12.6 Installing the roller cart

- ▶ Lift the W-lattice jib with the auxiliary crane off the ground.



Note

- ▶ The assembly of the roller cart is described in the Crane operating instructions, chapter 5.61.
- ▶ Install the roller cart properly.

3.13 Pulling the hoist ropes in

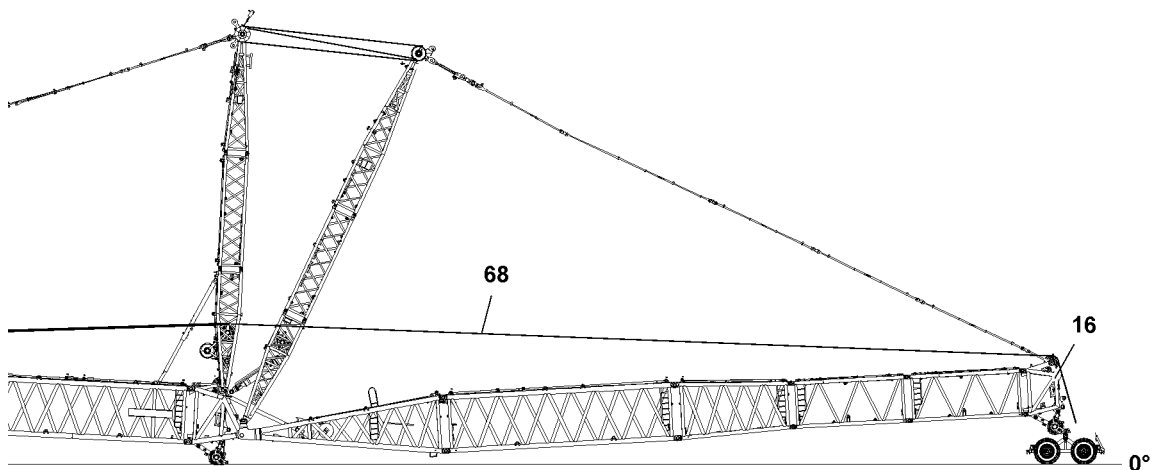

Fig.117065: Pulling the hoist ropes in

NOTICE

Slack rope formation!

Due to slack rope formation, the hoist rope **68** and the W-control rope **67** can be damaged. This could result in high property damage.

- ▶ When spooling the hoist rope **68** or the W-control rope **67** up or out, allow no slack rope formation.
- ▶ When spooling up or out, hold the hoist rope **68** and the W-control rope **67** taut.



WARNING

Danger of accident!

Death, severe bodily injuries, property damage.

- ▶ It is prohibited to remain within the danger zone of the running ropes.
- ▶ Radio contact is available between crane operator and assembly personnel.

- ▶ Spool the hoist rope **68** out and pull it to the L-end section **16**, see Reeving plan.

If additional hoist ropes **68** are used:

- ▶ Pull the hoist ropes **68** the same way to the L-end section **16** as described before.

3.14 Establishing the electrical connections on the end section of the W-boom

Make sure that the following prerequisites are met:

- The W-boom is properly assembled on the ground and secured.
- The W-guy rods are completely assembled and are in operating position.
- The electrical connections to the S-end section have been established.
- The airplane warning light, wind speed sensor and all sensors are properly installed and secured on the L-end section.
- The hoist limit switches are properly installed and secured on the pulley head / pulley heads.

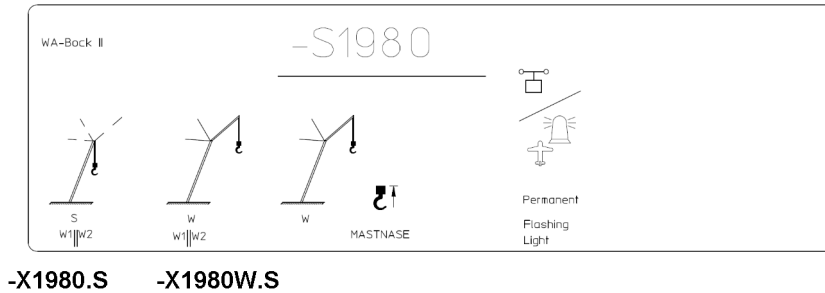

Fig.124470: Terminal box „-S1980“



Note

Before erecting the crane it must be ensured on which end section the parallel operation with winch 1 and winch 2 is operated, pay attention to the Electric wiring diagram.

- ▶ At parallel operation of the S-end section, connect the cable „W1911A“ in the terminal box „-S1980“ in socket „-X1980.S“.
- ▶ At parallel operation of the W-end section, connect the cable „W1911A“ in the terminal box „-S1980“ in socket „-X1980W.S“.

NOTICE

Danger of damage to the electrical connections!

If the electrical connection from the terminal box on the W-pivot section to the cable drum on the W-pivot section is established first before the connection from the cable drum to the terminal box on the L-end section, then the electrical connection will be damaged when spooling out the cable drum.

- ▶ Establish first the electrical connection from the cable drum on the W-pivot section to the terminal box on the L-end section and then the electrical connection from the terminal box on the W-pivot section to the cable drum.



Note

▶ To establish the electrical connections on the end section of the W-boom: Pay attention to the Electrical wiring diagram.

- ▶ Establish the electrical connections.
- ▶ Make sure that all electrical connections on the boom are established.



WARNING

Malfunction if dummy plugs are not installed!

If the dummy plugs on the non-required electrical connections are not installed, then malfunctions or functional limitations can occur on the crane.

- ▶ Make sure that all non-required electrical connections that have a dummy plug are closed off with dummy plugs.
- ▶ Pay attention to the Electrical wiring diagram.
- ▶ As a rule, close off on-required electrical connections (for example for accessories which cannot be installed) with the respective dummy plugs.

NOTICE

Property damage due to dirt and / or corrosion!

If non-required electrical connections are not closed off with the respective protective caps, then dirt and / or corrosion can damage the electrical connections.

This could result in malfunctions.

- ▶ Make sure that all non-required electrical connections are always closed off properly.
- ▶ Pay attention to the Electrical wiring diagram.

- ▶ Close electrical connections, which have no dummy plugs, properly off with the corresponding protective caps.

3.15 Checking the function of the safety equipment

Make sure that the following prerequisites are met:

- All electrical connections have been established.
- The appropriate operating mode is set.

3.15.1 Wind speed sensor*

- ▶ Check the movement and the function of the wind speed sensor.

3.15.2 Airplane warning light*

- ▶ Turn the airplane warning light on and visually check the function.

3.15.3 Oscillation guard

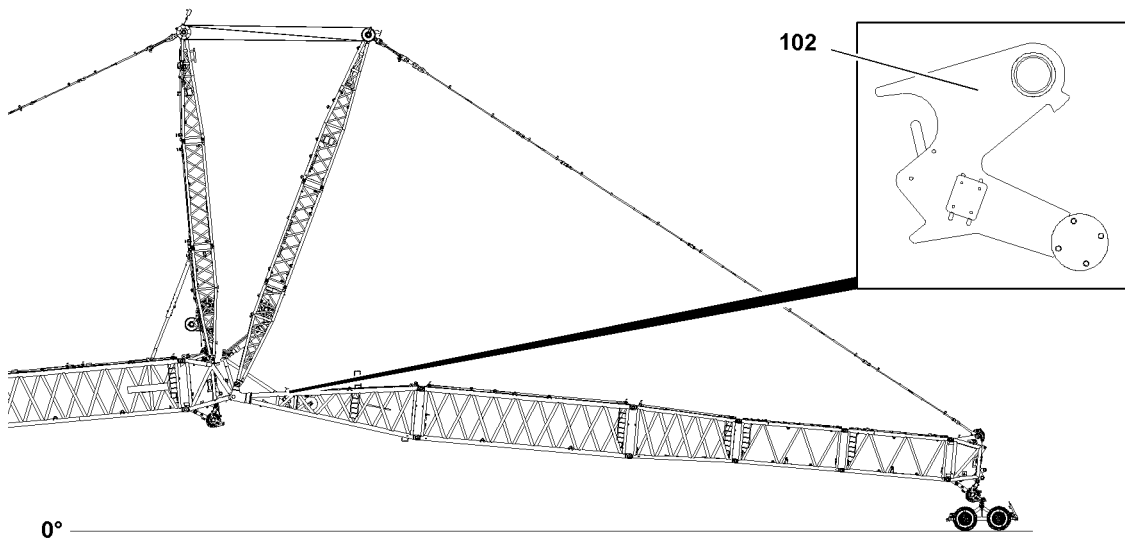

Fig.117066: Oscillation guard

**DANGER**

Danger of tipping over if the oscillation guard is hard to move!

If the oscillation guard **102** is hard to move, the mechanical relapse retainer will no longer function. The W-lattice jib can tip backwards uncontrolled and cause the crane to topple over.

- ▶ Crane operation with hard to move oscillation guard **102** is prohibited.
- ▶ Check the oscillation guard **102** for easy movement.

3.15.4 Limit switch, general

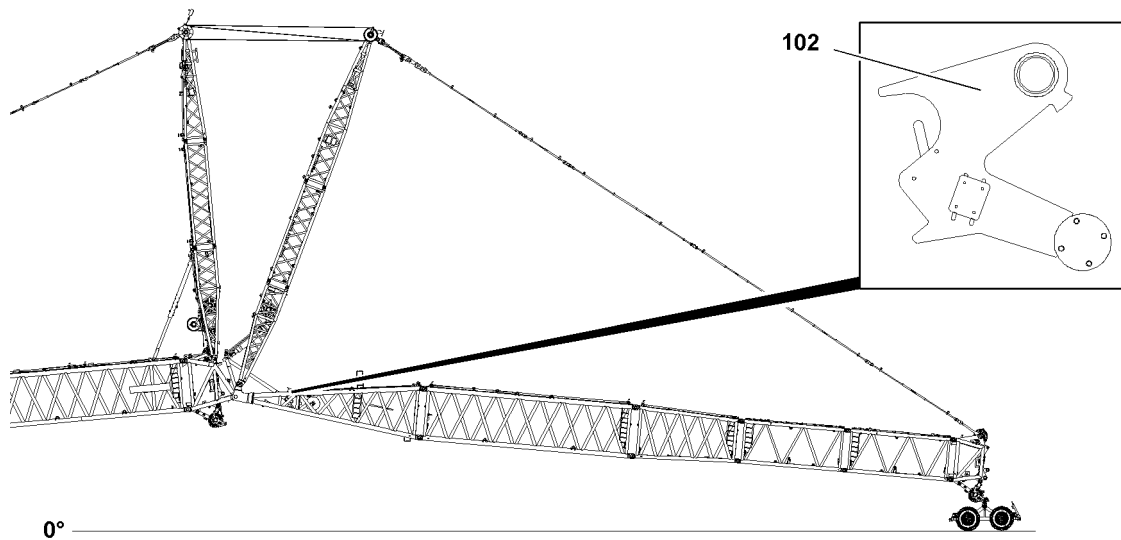

Fig.117066: Limit switch, general



WARNING

The crane control does not turn off in time!

- ▶ The limit switch functions have to be checked individually before erection.



Note

- ▶ The limit switch initiators are checked manually as follows.
- ▶ Check the limit switch initiators, see also Crane operating instructions, chapter 8.12.

3.15.5 Hoist limit switch

When replacing or changing the hoist limit switch (HES), the HES must have the correct bus address and the correct software version in order to be recognized again by the bus system (LSB).

- ▶ Actuate the hoist limit switch manually.

Result:

- The icon appears on the LICCON monitor.
- The **spool up** function of the hoist winch turns off.

3.15.6 Limit switch on relapse cylinder, „W-lattice jib steepest position“

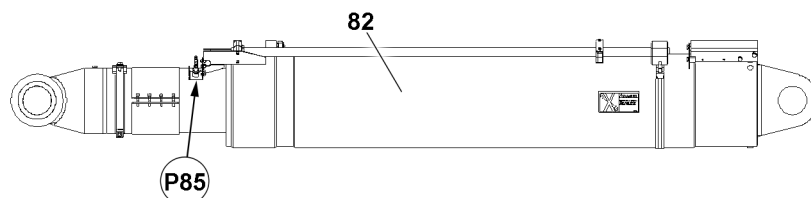

Fig.124472: Limit switch on relapse cylinder

- ▶ Cover the limit switch initiators „W-lattice jib steepest position“ at points **P85** individually with a metal plate.

Result:

- The icon appears on the LICCON monitor.
- The **spool up function** of the W-control winch turns off.

3.15.7 Limit switch on W-pivot section

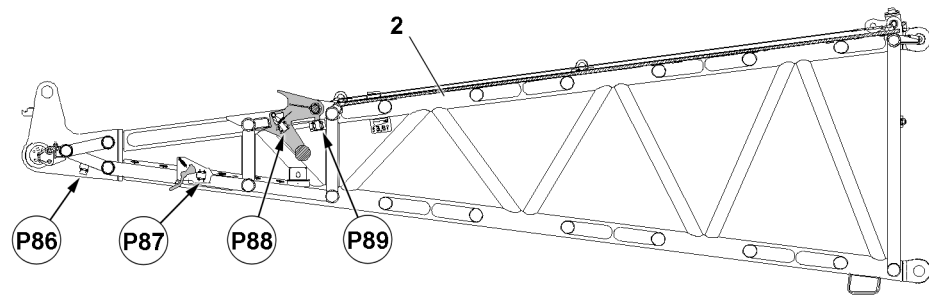

Fig.124471: Limit switch on W-pivot section

Limit switch on W-pivot section, position „W-lattice jib on bottom 45°“, S-boom without roller set

- ▶ Cover the limit switch initiators „W-lattice jib bottom 45°“ at points **P86** individually with a metal plate.

Result:

- The icon appears on the LICCON monitor.
- The **spool up function** of the W-control winch turns off.

Limit switch on W-pivot section, position „W-lattice jib on bottom 80°“, S-boom with roller set

- ▶ Cover the limit switch initiators „W-lattice jib bottom 80°“ at points **P87** individually with a metal plate.

Result:

- The icon appears on the LICCON monitor.
- The **spool out function** of the W-control winch turns off.

Limit switch on flap, position „W-lattice jib in steepest position“, mechanical relapse support in flap

- ▶ Cover the limit switch initiators „W-lattice jib steepest position“ at points **P88** individually with a metal plate.

Result:

- The icon appears on the LICCON monitor.
- The **spool up function** of the W-control winch turns off.

Limit switch on W-pivot section, position „flap in position“

- ▶ Cover the limit switch initiators „flap in position“ individually at points **P89** with a metal plate.

Result:

- The icon appears on the LICCON monitor.
- The **spool up function** of the W-control winch turns off.

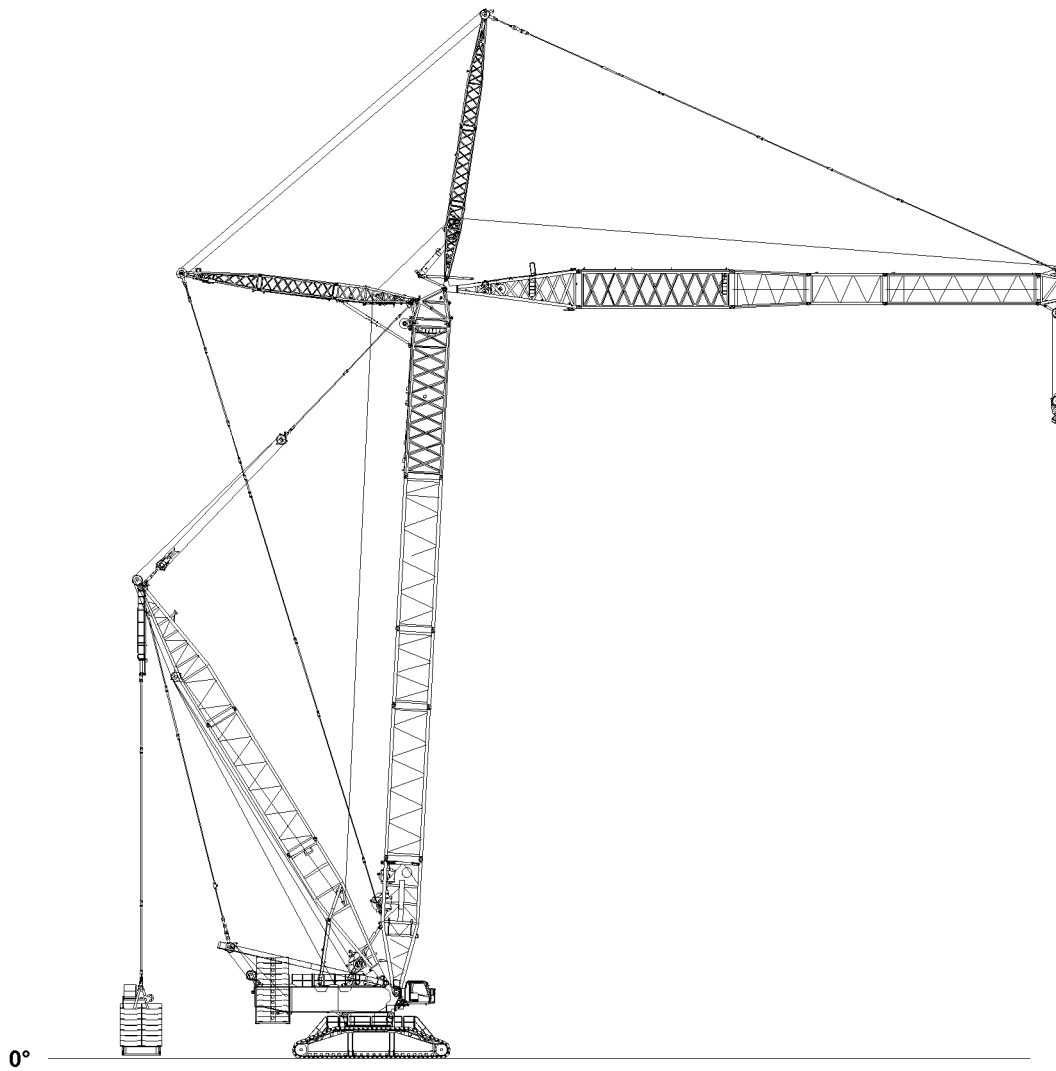

Fig.121038: Erecting the boom

LWE/LR 11000-001/23501-04-02/en

4 Erecting the boom



DANGER

The crane can topple over!

- ▶ It is not permitted to turn the crane during erection.
- ▶ Observe the technical safety instructions, see Crane operating instructions, chapter 5.01.
- ▶ Observe the specifications in the erection and take-down charts.
- ▶ Extend the relapse cylinder before erection.



DANGER

Tipping lattice jib!

If the easy movement on the pendulum of the mechanical relapse support is not checked before erection or not reestablished, if necessary, then the mechanical relapse support will not engage in the steep lattice jib position. As a result, the lattice jib can tip to the rear.

Death, severe bodily injuries, property damage.

- ▶ Check the easy movement of the pendulum of the mechanical relapse support before erection.
- ▶ If the pendulum does not move easily: Make the pendulum easy to move.



WARNING

The crane can topple over!

If the following conditions are not met before erecting the boom, the crane can topple over.

Death, severe bodily injuries, property damage.

- ▶ The lattice jib must roll on the ground with its entire weight.
- ▶ Spool the lattice jib adjustment out in such that guy rods sag slightly.
- ▶ Do not allow slack rope to form on the W-control winch.



WARNING

Unutilized guy rods on boom!

If guy rods are on the lattice sections which are not used for operation, then there is a danger of accidents.

Death, severe bodily injuries, property damage.

Guy rods can fall down.

The load chart is invalid.

The load display of the LICCON computer system shows the incorrect value.

- ▶ Removed unutilized guy rods before erecting the boom.

Make sure that the following prerequisites are met:

- The W-lattice jib is fully assembled.
- The roller cart is assembled on the L-end section.
- The crane is horizontally aligned.
- The guy rods are properly assembled.
- The guy rods which are not required have been removed from the lattice sections.
- All electrical connections have been made.
- All hydraulic connections have been made.
- The function checks were carried out properly.
- All limit switches and warning devices are functioning.
- Crane ballasting (counterweight, central ballast, derrick ballast and / or auxiliary ballast) is carried out according to the load charts and / or the erection and take-down charts.
- The crane has been set up according to the load charts and / or the erection and take-down charts.
- The LICCON overload protection has been set according to the data in the load charts and / or the erection and take-down charts.
- The LICCON overload protection settings have been checked for completeness and correctness.
- Assembly operation of the crane control is activated: the assembly icon is visible on the LICCON monitor.
- All pin connections have been secured.
- The hoist rope has been correctly placed in the rope pulleys and is prevented from jumping out with the rope retaining pins.
- The hoist rope has been pulled with the respective length over the L-end section.
- There are no loose parts on the boom system.
- The boom system and the safety equipment are free from snow, frost and ice.
- No personnel or obstacles are within the danger zone.

4.1 Erection procedure

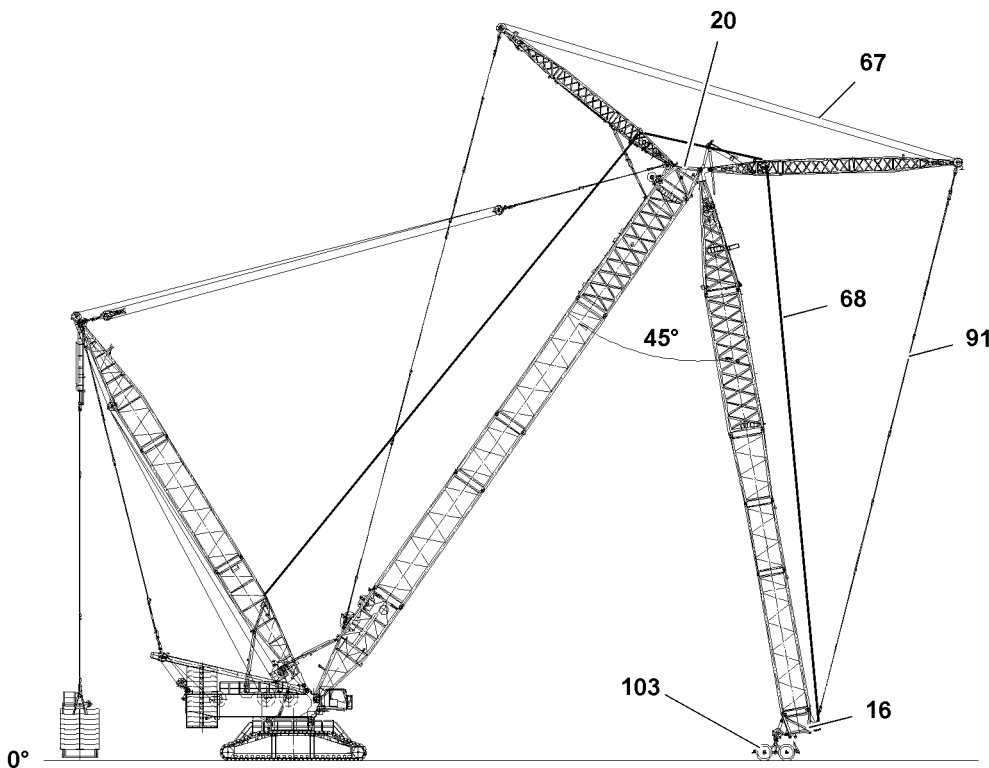

Fig.122177: Erection procedure

LWE/LR 11000-001/23501-04-02/en

**WARNING**

Falling hoist rope!

If the hoist rope **68** is not pulled with the respective length over the L-end section **16** before the erection procedure, then it can fall backward due to its own weight.

Death, severe bodily injuries, property damage.

- ▶ Pull the hoist rope **68** before the erection procedure with sufficient length over the L-end section **16** and place on the ground.
- ▶ During the erection walk along with the roller cart and constantly monitor the hoist rope: The hoist rope may not lift off the ground.
- ▶ The hoist rope **68** must be constantly monitored during erection.
- ▶ Do not step into the danger zone.

**DANGER**

The crane can topple over!

Death, severe bodily injuries, property damage.

When the roller cart **103** is installed on the L-end section **16** and the guy rods **91** are tensioned:

- ▶ Spool the W-lattice jib control up until the guy rods **91** hang through slightly.

While the S-boom is luffed down:

- ▶ Spool the W-lattice jib control up in such a way that the guy rods **91** always hang through slightly.
- ▶ The W-lattice jib must roll on the ground with its entire weight.
- ▶ Allow no slack rope formation on the W-control rope **67**.

**Note**

- ▶ Depending on the set up configuration of the boom system, one of the following listed erection variations must be selected.

4.1.1 Erecting the boom system without a roller set on the S-end section

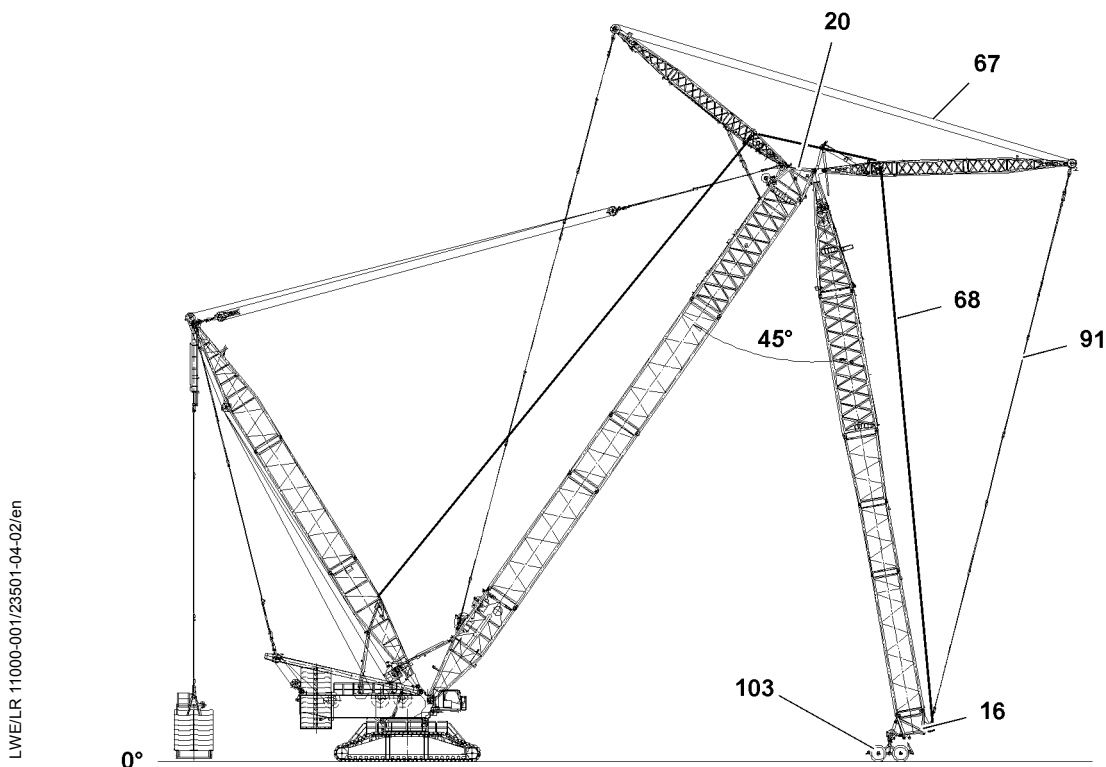

Fig.122177: Erecting the boom system without a roller set on the S-end section

When **NO** roller set **104** is installed on the S-end section **20**:

- ▶ Luff up the S-boom and simultaneously spool the W-control winch out to keep the lattice jib with the L-end section **16** placed on the roller cart **103** on the ground. Continue with this process until the S-boom and the W-lattice jib form an angle of approximately 45° , **Switch position W-lattice jib down** or until the W-boom points down almost vertically or until the WA-frame 1 is in **bottom** position.

Problem remedy

The erection procedure was turned off as a result of falling below the value $F3_{\min}$?

- ▶ See the Crane operating instructions, chapter 4.02 and chapter 4.20.

4.1.2 Erecting the boom system without a roller set on the S-end section and long W-lattice jib



Note

- ▶ On this boom system, the W-lattice jib is significantly longer than the S-boom.

When **NO** roller set **104** is installed on the S-end section **20**, without illustration:

- ▶ Luff up the S-boom and simultaneously spool the W-control winch out to keep the lattice jib with the L-end section **16** placed on the roller cart **103** on the ground. Carry out this procedure until the S-boom has reached the 87° position.

Problem remedy

The erection procedure was turned off as a result of falling below the value $F3_{\min}$?

- ▶ See the Crane operating instructions, chapter 4.02 and chapter 4.20.

4.1.3 Erecting the boom system with a roller set on the S-end section

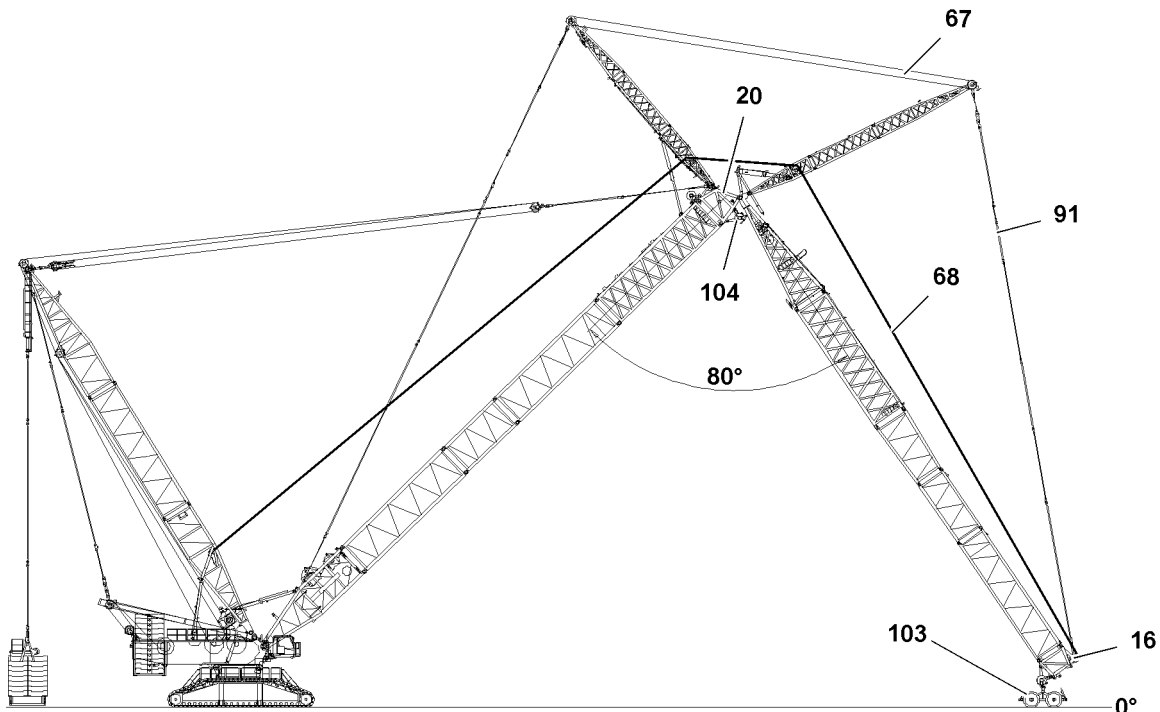

Fig. 122178: Erecting the boom system with a roller set on the S-end section

When **ONE** roller set **104** is installed on the S-end section **20**:

- ▶ Luff up the S-boom and simultaneously spool the W-control winch out to keep the lattice jib with the L-end section **16** placed on the roller cart **103** on the ground. Continue with this process until the S-boom and the W-lattice jib form an angle of approximately 80° , **Switch position W-lattice jib**

down or until the W-boom points down almost vertically or until the WA-frame 1 is in **bottom** position.

Problem remedy

The erection procedure was turned off as a result of falling below the value $F3_{min}$?

- ▶ See the Crane operating instructions, chapter 4.02 and chapter 4.20.

4.1.4 Continuing the erection procedure

Make sure that the following prerequisite is met:

- The L-end section of the W-lattice jib is placed in the roller cart
- ▶ Release and remove the roller cart **103**, see Crane operating instructions, chapter 5.61.
- ▶ Luff the S-boom up until the L-end section **16** is over the hook block **105**.



WARNING

Danger of accident due to side wind!

If the slewing gear brake is released after reeving in / reeving out the hook block / load hook, then the crane can turn uncontrolled if there is a strong side wind.

Death, severe bodily injuries, property damage.

The crane can collide with close-by structures or objects.

- ▶ Make sure that the current wind speed does not exceed the values from the wind speed chart when releasing the slewing gear brake.

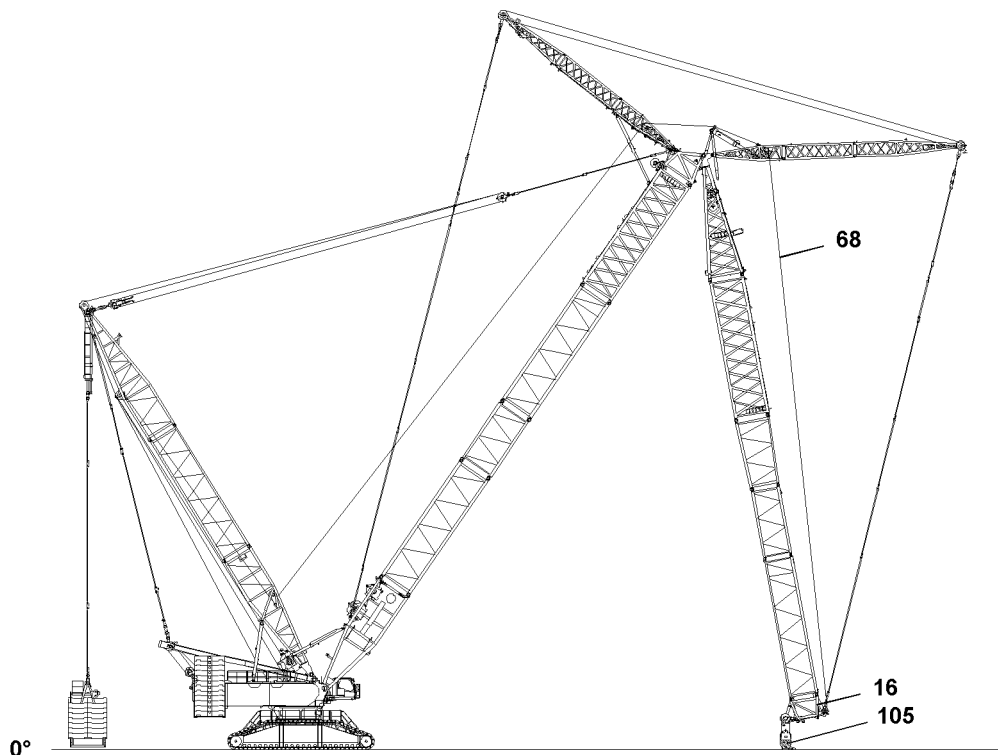

Fig.144149: Reeving in the hook block / load hook

- ▶ Reeve in the hook block **105** properly, see Crane operating instructions, chapter 4.06 and reeving plan.
- or**
- ▶ Pin the load hook, see Crane operating instructions, chapter 4.06.
- ▶ Check the actual load on the LICCON monitor.

Problem remedy

The actual load on the LICCON monitor is greater than 0.0 t.

- ▶ Observe the notes for input of hook block weight, see Crane operating instructions, chapter 4.02.

- ▶ Attach the hoist limit switch weight.

- ▶ Enter the weight of the hook block **105** in the LICCON computer system.

NOTICE

Damage to crane!

- ▶ Operate the hoist rope only when the W-boom is in horizontal position.

- ▶ Luff up the S-boom to the operating position.

**WARNING**

The crane can topple over!

In crane operation with exceeded LICCON overload protection, the crane can topple over.

Death, severe bodily injuries, property damage.

- ▶ The radii listed in the load chart may not be exceeded or fallen below, even if there is no load on the hook.

If required in the erection and take down chart:

- ▶ Carry the hook block **105** along with the auxiliary crane.

**Note**

- ▶ When the lowest operating position of the W-lattice jib is reached, the set load chart of the LICCON overload protection is activated.

- ▶ In the maximum load icon appears a load number in „t“ instead of the display „???“.

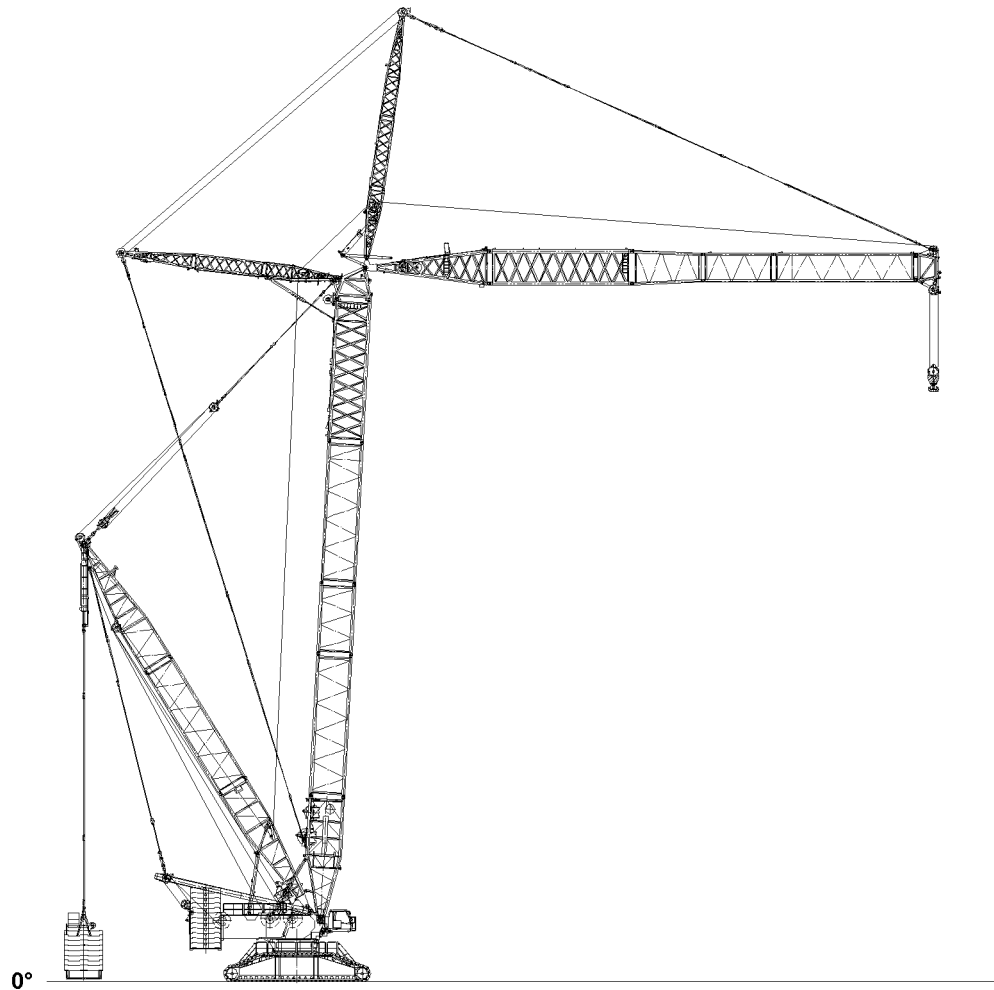

Fig.122180

- ▶ Luff the boom up to the lowest operating position.

When the boom has reached the lowest operating position:

- ▶ Make sure that the assembly icon on the LICCON monitor turns off.

Result:

- The LICCON overload protection is active.
- ▶ Luff the boom up to the required main boom angle according to the load chart.

5 Crane operation



Note

- ▶ Observe the notes, see Crane operating instructions, chapter 4.05, Crane operating instructions, chapter 4.08 and Crane operating instructions, chapter 5.01.

Make sure that the following prerequisites are met:

- The LICCON overload protection is active.
- The LICCON overload protection has been set according to the data in the load chart.
- The main boom is in the specified angle position according to the load chart.



WARNING

The crane can topple over!

Death, severe bodily injuries, property damage.

- ▶ Check the horizontal position of the crane before and during operation.
 - ▶ If the crane operator leaves the cab, even for a short time, the operating mode setting must be checked and reset if necessary before resuming crane operation.
-

5.1 Checking the settings

- ▶ Check the function of the overload protection by running against the operating positions „on top“ and „bottom“.
- ▶ Check the hoist limit switch by running against the hoist limit switch weight.

6 Disassembling

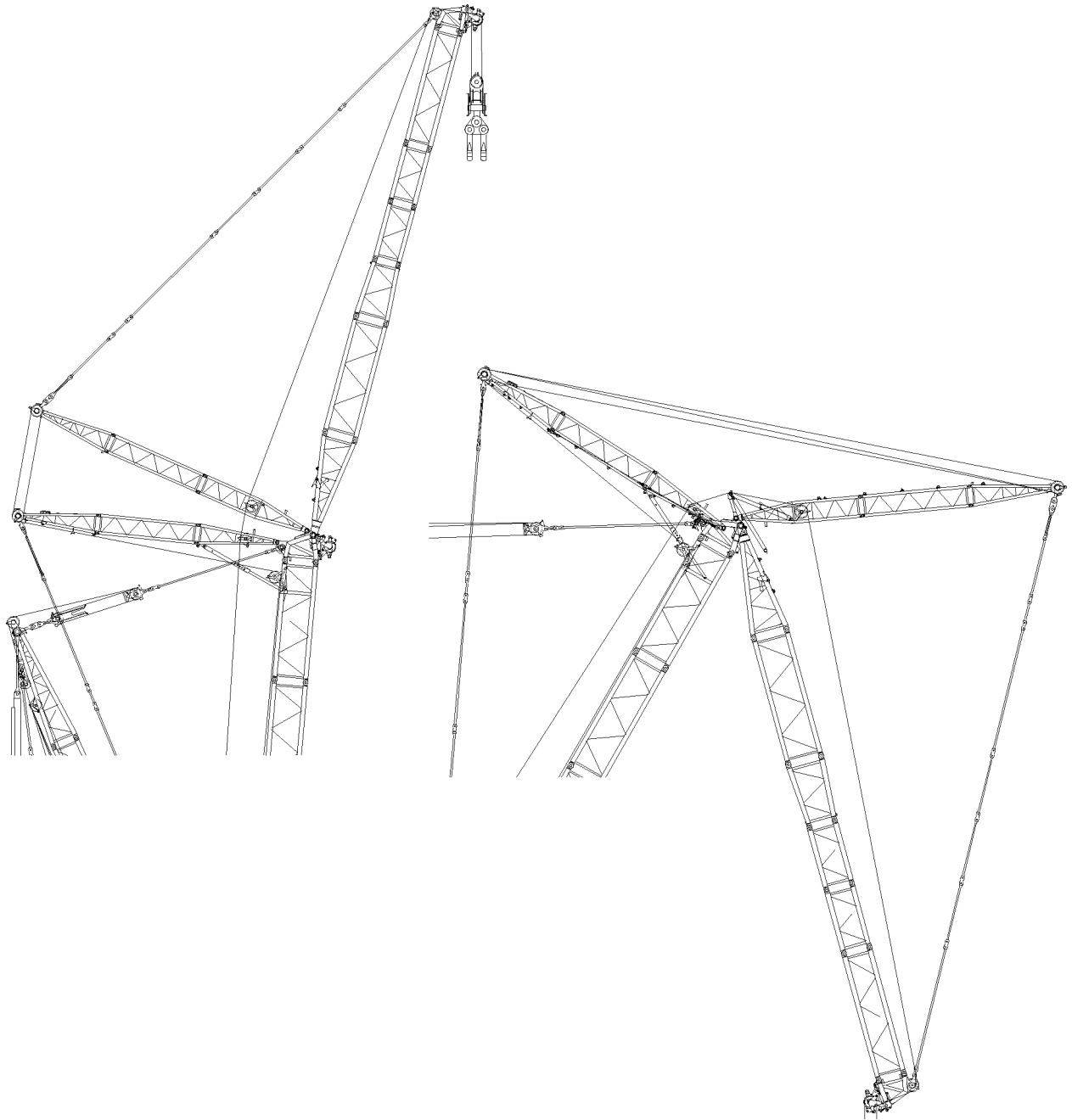

Fig.116106: Disassembling

LWE/LR 11000-001/23501-04-02/en

**WARNING**

Danger of falling!

During assembly / disassembly, inspection and maintenance work, assembly personnel must be secured with appropriate aids to prevent them from falling.

Death, severe bodily injuries, property damage.

- ▶ All work at a height, when there is a danger of falling, must be carried out with suitable aids.
- ▶ If aids are not available and work cannot be carried out from the ground, then assembly personnel must secure themselves with the supplied fall arrest system to prevent falling, see the Crane operating instructions, chapter 2.04.
- ▶ If fall protection equipment is available, then it must be used, see the Crane operating instructions, chapter 2.06.
- ▶ When lifting, lowering, swinging crane parts in and out, no persons may remain in the danger zone.
- ▶ When closing or opening boom systems during boom assembly or boom disassembly, no persons may remain on the boom system or in the danger zone.
- ▶ If railings are present on the components, then they must be brought into the corresponding position and secured for assembly / disassembly work.
- ▶ Only step on the aids, ladders and catwalks with clean shoes.
- ▶ Keep aids, ladders and catwalks free of heavy dirt, snow and ice.
- ▶ During all assembly and disassembly work, maintenance work and inspections, travel or crane operation is prohibited.
- ▶ Remaining on a suspended load is prohibited.
- ▶ Stepping or walking on crane components and lattice sections, which have an incline of more than 20° is prohibited.
- ▶ For all assembly work, the crane driver of the main crane must be in voice contact with the crane driver / crane drivers of the auxiliary crane / auxiliary cranes.
- ▶ For assembly tasks, the crane driver may only initiate crane movements when the responsible guide has explicitly released the movement.

**WARNING**

The lattice sections can fall down!

If the lattice sections are not pinned and secured correctly, then they can fall down.

Death, severe bodily injuries, property damage.

- ▶ Pin or unpin both pins at the same horizontal level, i.e. **left and right**.
- ▶ Do not stand under the lattice sections or within the entire danger zone during the pinning and unpinning procedure of the boom.
- ▶ Safely secure the pins in the storage locations as well as in the receptacles.
- ▶ It is prohibited to lean the auxiliary ladder against the component being disassembled.

**WARNING**

Danger of impact / crushing!

When installing / removing crane components with the auxiliary crane, crane components can start to swing back and forth.

When lifting / lowering and positioning crane components, there is an increased danger of impacts / crushing.

Death, severe bodily injuries, property damage.

- ▶ Make sure that personnel cannot be caught by components.
- ▶ Make sure that the crane is horizontally aligned.
- ▶ When working in danger zones: Use aids to protect limbs.
- ▶ Guide components with suitable aids to minimize oscillation.

**WARNING**

Danger of accident!

If no guide is present during assembly work who has voice connection to the crane operator as well as to the drivers of the auxiliary units, then there is a great danger of accidents.

Crane movements, which are carried out without the approval of the guide, can cause accidents.

Death, severe bodily injuries, property damage.

- ▶ For all assembly work, observe the instructions of the guide.
- ▶ Make sure that the danger zone can be seen completely by the crane operator and / or the guide.

**DANGER**

The components can fall down!

If the corresponding components are disengaged from the auxiliary crane before the corresponding component is pinned and secured, the corresponding component can fall down and fatally injure personnel.

- ▶ Do not disengage the auxiliary crane until the respective component is pinned and secured.

6.1 Taking down the boom

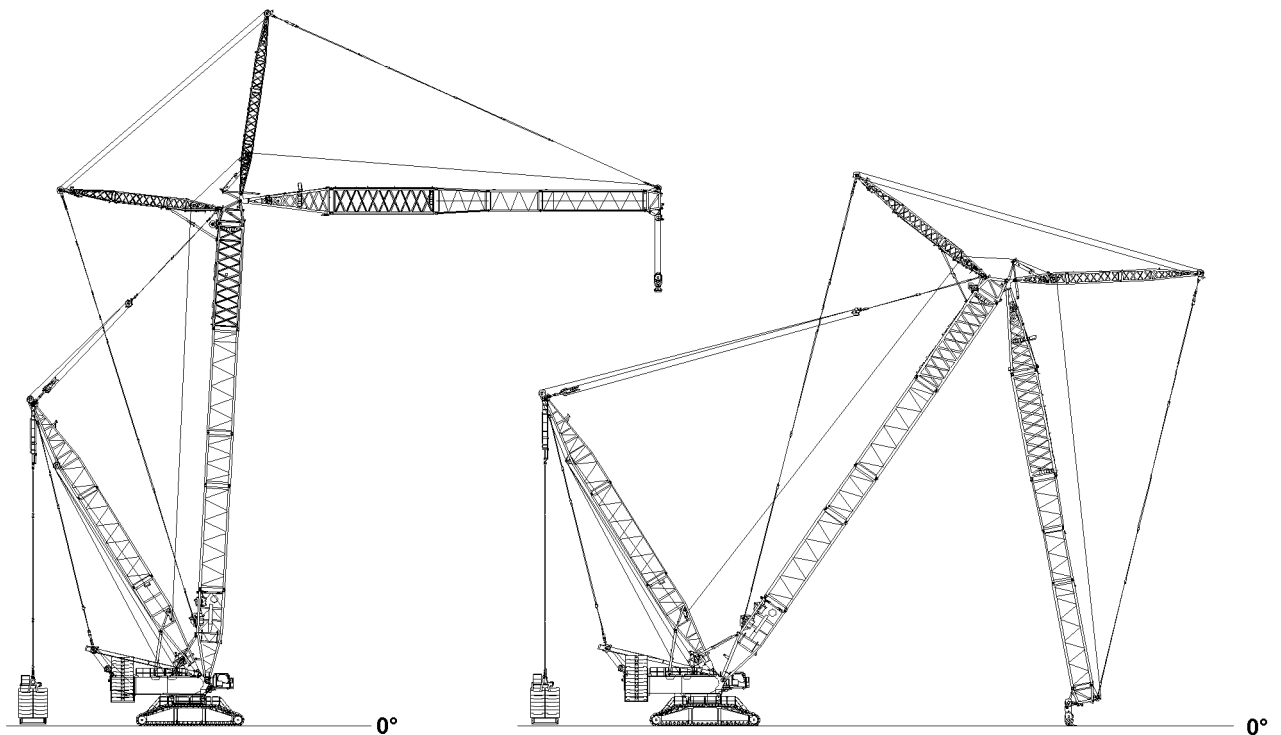

Fig.144150: Taking down the boom

**DANGER**

The crane can topple over!

If the following conditions are not met before taking down the boom, the crane can topple over and fatally injure personnel.

- ▶ Observe the technical safety instructions, see Crane operating instructions, chapter 5.01.
- ▶ Observe the specifications in the erection and take-down charts.

Make sure that the following prerequisite is met:

- The S-boom is in the steepest position

- ▶ Luff the W-lattice jib down to the **lowest** operating position.

When the lowest operating position is reached the luff down movement is shut off.

The load value in the „maximum load“ icon disappears and question marks appear (????).

The following alarm functions become active:

- „STOP“
- „Horn“ and acoustical signal



WARNING

Danger of accident due to function „Exceedance of shut-off limits of the LICCON overload protection“! If the shut off limits of the LICCON overload protection are exceeded, there is no additional protection against crane overload.

Due to erroneous operation or deliberate misuse, the crane could collapse, the boom can break off or the crane can topple over.

Death, severe bodily injuries, property damage.

- ▶ The function „Exceedance of shut off limits of the LICCON overload protection“ is only permissible in emergencies and for assembly purposes.
- ▶ The function „Exceeding the shut off limits of the LICCON overload protection“ may only be actuated by persons who know the effects of their actions regarding the function „Exceeding the shut off limits of the LICCON overload protection“.
- ▶ The function „Exceedance of shut off limits of the LICCON overload protection“ requires the presence of an authorized person and must be performed with utmost caution.
- ▶ Crane operation with activated function „Exceedance of shut off limits of the LICCON overload protection“ is prohibited.

When the W-lattice jib has reached the „lowest“ operating position:

- ▶ Exceeding the shut off limits of the LICCON overload protection: Engage assembly operation.

Result:

- The shut off limits of the LICCON overload protection are exceeded.
- The assembly icon appears on the LICCON monitor.



Note

- ▶ See the Crane operating instructions, chapter 4.02.

Empty page!

LWE/LR 11000-001/23501-04-02/en

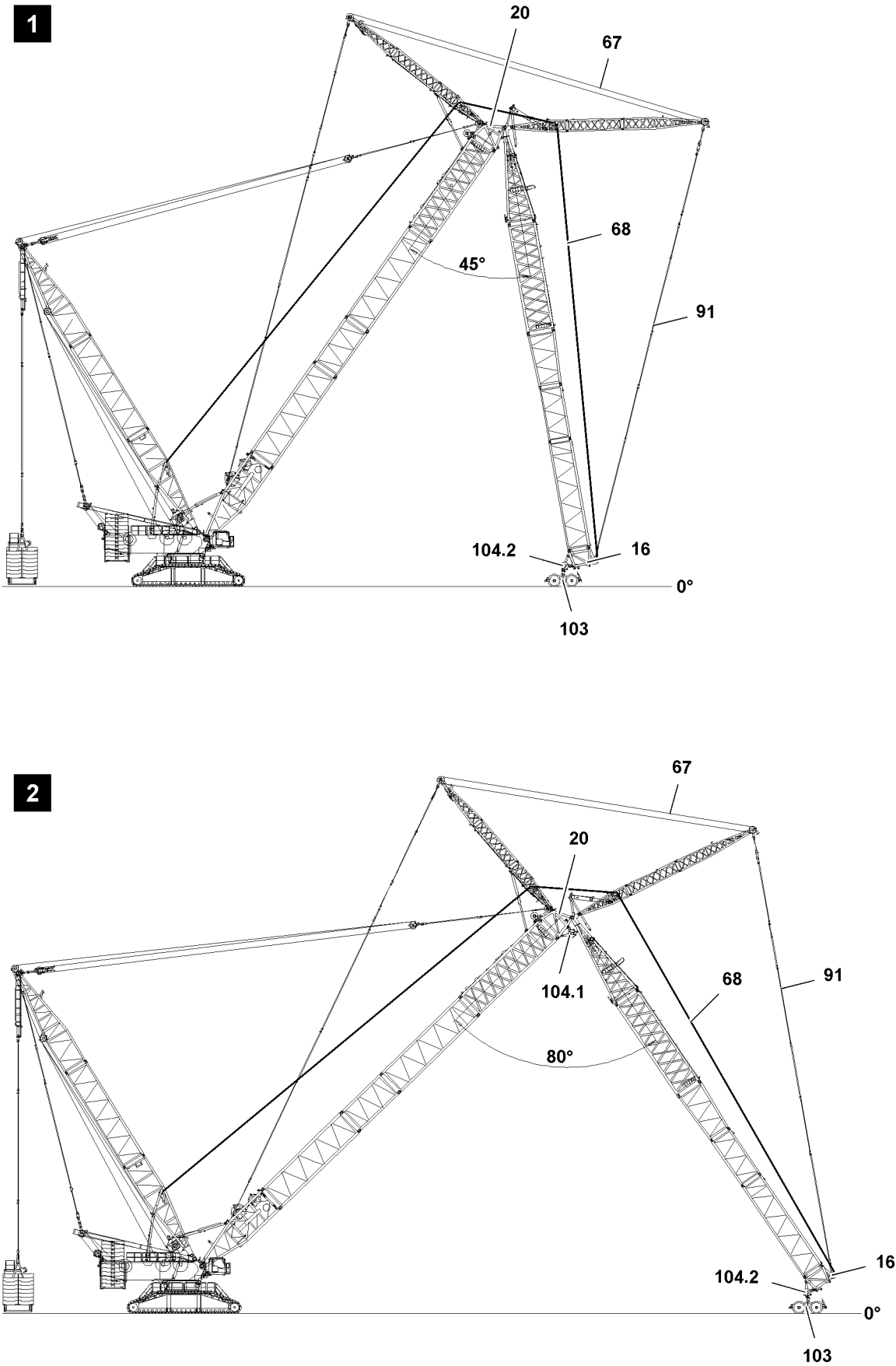

LWE/LR 11000-001/23501-04-02/en

Fig.117072: Taking the boom down - Luff down procedure

When **NO** roller set **104.1** is installed on the S-end section **20**, see illustration **1**:

- ▶ Luff down the W-lattice jib until an angle of approximately 45° is reached between the S-boom and the W-lattice jib or the hook block touches the ground.

Result:

- The switch position „W-lattice jib bottom“ is reached.
- The luff down procedure of the W-lattice jib will be ended.

When **ONE** roller set **104.1** is installed on the S-end section **20**, see illustration **2**:

- ▶ Luff down the W-lattice jib until an angle of approximately 80° is reached between the S-boom and the W-lattice jib or the hook block touches the ground.

Result:

- The switch position „W-lattice jib bottom“ is reached.
- The luff down procedure of the W-lattice jib will be ended.

NOTICE

Damage to crane!

When the hoist rope **68** is not spooled out during the luff down procedure, a collision of the hook block with the L-end section **16** can occur.

This could result in high property damage.

- ▶ Luff down the S-boom and simultaneously spool the hoist winch out to prevent the hook block from colliding with the L-end section **16**.

-
- ▶ Luff the S-boom down until the hook block touches the ground.
 - ▶ Remove the hoist limit switch weight and reeve the hook block out.
 - ▶ Luff the S-boom down until the placement pins can be installed on the roller set **104.2**.
 - ▶ Place the roller set **104.2** on the roller cart **103**.
 - ▶ Install the roller set **104.2** on the roller cart **103**, see Crane operating instructions, chapter 5.61.



DANGER

The crane can topple over!

Death, severe bodily injuries, property damage.

When the roller cart **103** is installed on the L-end section **16** and the guy rods **91** are tensioned:

- ▶ Spool the W-lattice jib control out until the guy rods **91** hang through slightly.

While the S-boom is luffed down:

- ▶ Spool the W-lattice jib control out in such a way that the guy rods **91** always hang through slightly.
 - ▶ The W-lattice jib must roll on the ground with its entire weight.
 - ▶ Allow no slack rope formation on the W-control rope **67**.
-

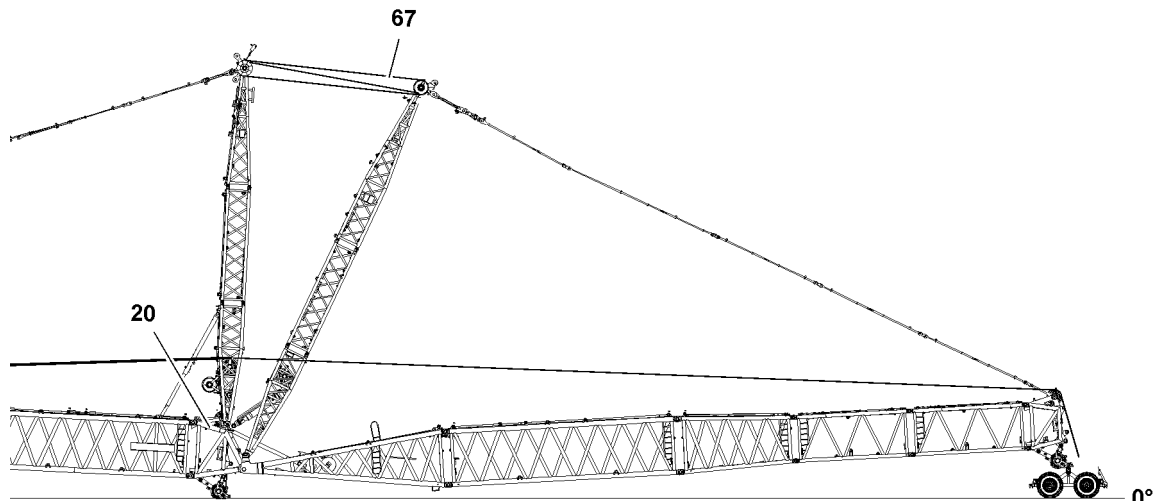

Fig.117073: Taking the boom down — Luffing the S-boom down

- ▶ Luff the S-boom down and spool the W-control rope **67** up simultaneously until the S-end section **20** is laying on the substructure on the ground.

6.2 Removing the hoist ropes

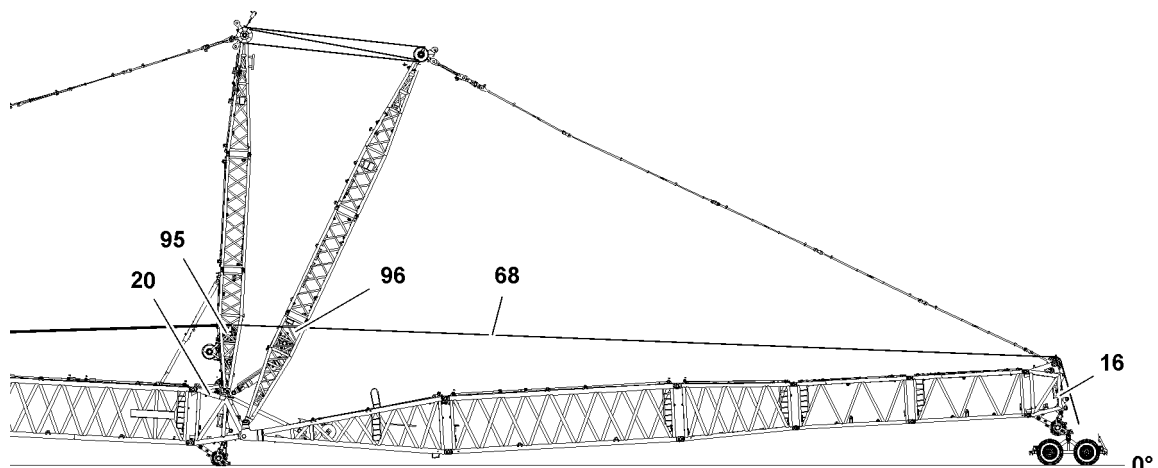

Fig.117078: Removing the hoist ropes

Make sure that the following prerequisite is met:

- All rope retainers are removed on the L-end section **16**.

NOTICE

Slack rope formation!

The hoist rope **68** can be damaged if slack rope forms.

This could result in high property damage.

- ▶ When spooling the hoist rope **68** up or out, allow no slack rope formation.
- ▶ Hold the hoist rope **68** taut when spooling it up or out.



WARNING

Danger of accident!

Death, severe bodily injuries, property damage.

- ▶ It is prohibited to remain within the danger zone of the running ropes.
- ▶ Radio contact is available between crane operator and assembly personnel.

- ▶ Slowly spool the hoist rope **68** up and pull it over the rope pulley **96** and the rope pulley **95** which are within the WA-frames.
- ▶ Spool the hoist rope **68** up until the end of the rope can be placed down on the S-end section **20**.
- ▶ Take the hoist rope **68** down.
- ▶ Secure the hoist rope **68** to prevent it from falling.

If additional hoist ropes **68** must be removed:

- ▶ Remove the hoist ropes **68** the same way as described before.

6.3 Removing the auxiliary guying

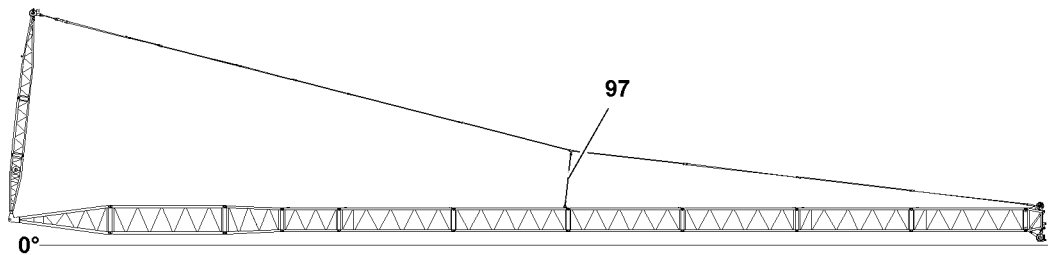

Fig.117064: Removing the auxiliary guying

When one auxiliary guying **97** is installed:

- ▶ Lower the WA-frame 1 until the auxiliary guying **97** can be removed.
- ▶ For disassembly of the auxiliary guying **97**, see Crane operating instructions, chapter 5.03.

6.4 Releasing the WA-frame 1 guy rods

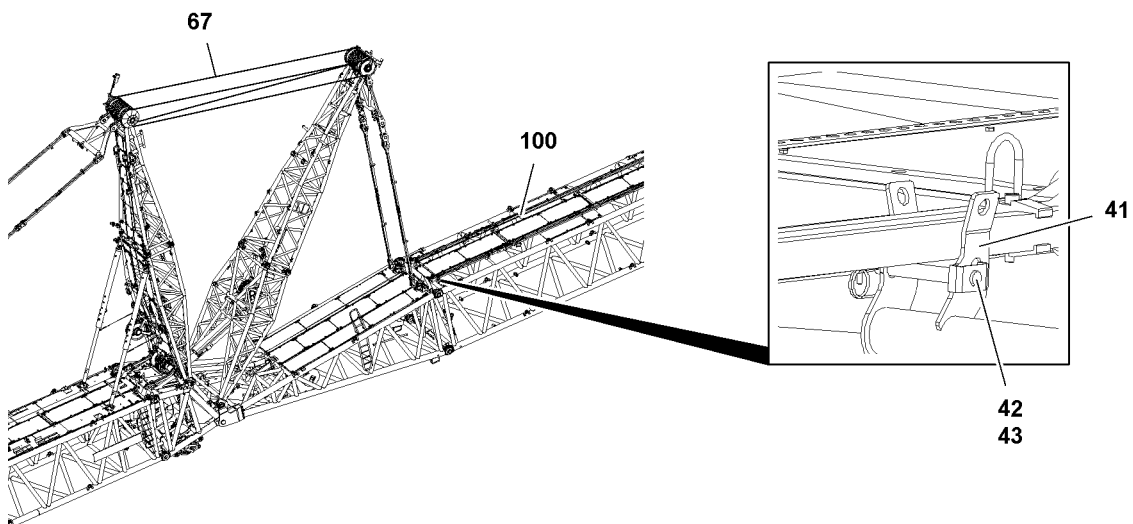

Fig.117074: Releasing the WA-frame 1 guy rods

Make sure that the following prerequisites are met:

- The function of the relapse cylinder is ensured.
- All pins **42** of the transport retainers **41** are in park position and are secured with spring retainers **43**.
- ▶ Place the WA-frame 1 down with the W-control rope **67** until the guy rods **100** are laying on the W-boom.

6.5 Removing the WA-frame 1 guying

6.5.1 Long WA-frames: Unpinning the guy rods

Disassembling the 9 m guy rod

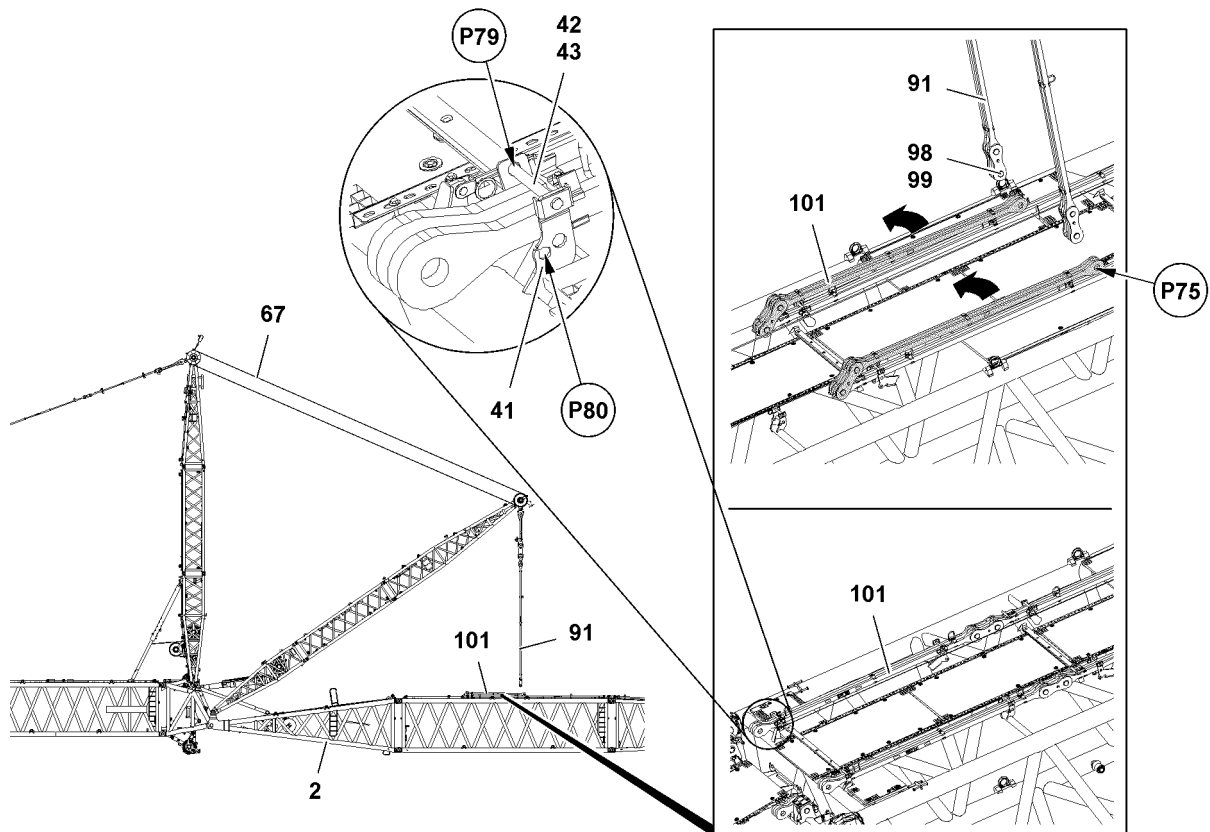

Fig.117076: Disassembling the 9 m guy rod

- ▶ Lower the WA-frame 1 via the W-control rope **67** until the guy rods **91** on the 3 m guy rods **101** can be unpinned on points **P75**.
- ▶ Unpin the 3 m guy rods **101** on guy rods **91**: Remove the safety locking pins **99** on both sides on points **P75** and unpin the pins **98**.
- ▶ Erect the WA-frame 1 until the guy rods **91** hang over the W-pivot section **2**.
- ▶ Fold the 3 m guy rods **101** over.
- ▶ Close all transport retainers **41** on the W-boom: Release and remove the pins **42** on both sides in park positions (point **P80**). Insert the pins **42** on both sides on points **P79** and secure with spring retainer **43**, see illustration **4**.

Disassembling the 12 m guy rod

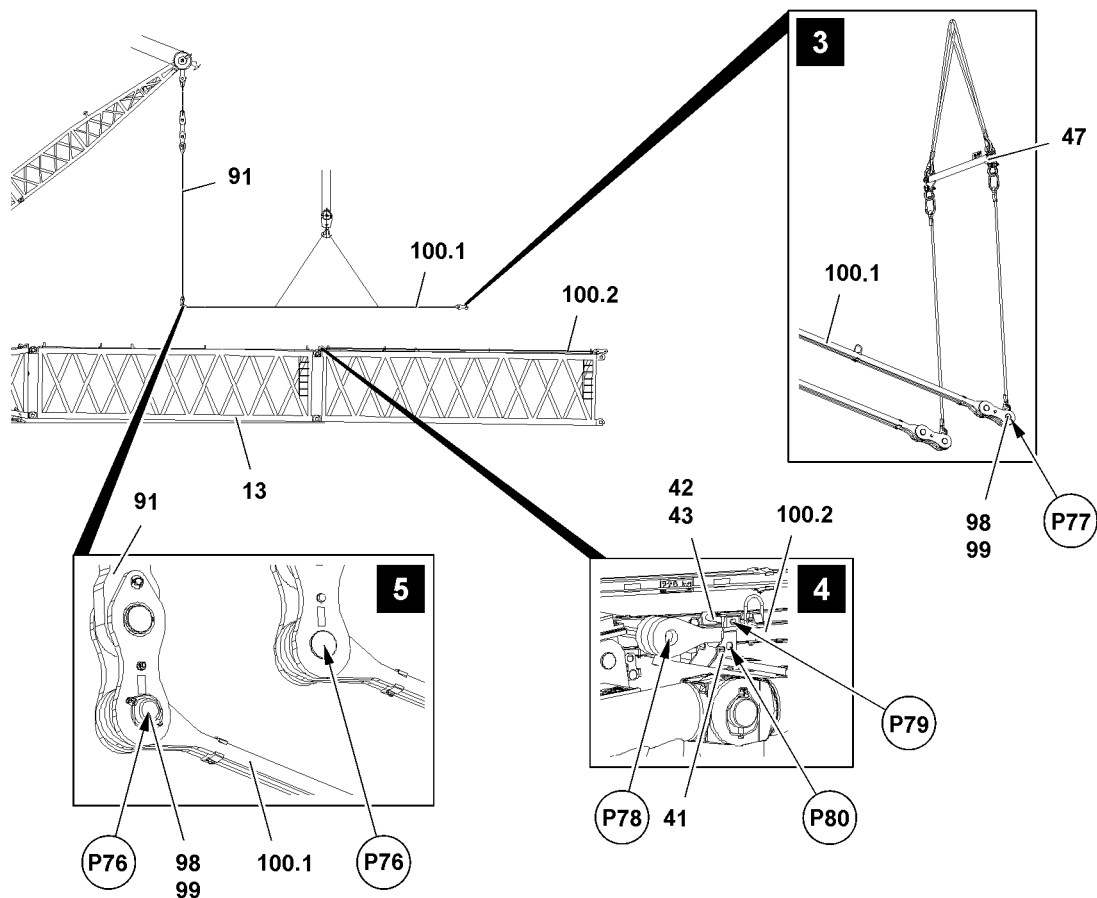

Fig.117075: Disassembling the 12 m guy rod

- ▶ Unpin the guy rods **100.1** on the guy rods **100.2**: Release the pins **98** on both sides on points **P78** and unpin, see illustration **4**.
- ▶ Pin the cross beam **47** on both sides on points **P77** with guy rods **100.1**, see illustration **3**.
- ▶ Lift the guy rods **100.1** with the cross beam **47** until they are horizontal.
- ▶ Lower the WA-frame 1 and carry the guy rods **100.1** along with the cross beam **47** until the guy rods **100.1** are laying on the lattice section.
- ▶ Unpin the cross beam **47** on both sides on points **P77**.
- ▶ Remove the cross beam **47**.
- ▶ Unpin guy rod **100.1** on guy rod **91**: Remove the safety locking pins **99** on both sides and unpin the pins **98** on points **P76**, see illustration **5**.
- ▶ Fasten the guy rod **100.1** to the auxiliary crane.
- ▶ Take the guy rod **100.1** down with the auxiliary crane on the S-intermediate section **13** in such a way that all transport retainers **41** can be closed.
- ▶ Remove the auxiliary crane.
- ▶ Close all transport retainers **41** on the W-boom: Release and remove the pins **42** on both sides in park positions (point **P80**). Then insert the pins **42** on both sides on points **P79** and secure with spring retainers **43**.

6.5.2 Short WA-frames: Disassembling the guy rods

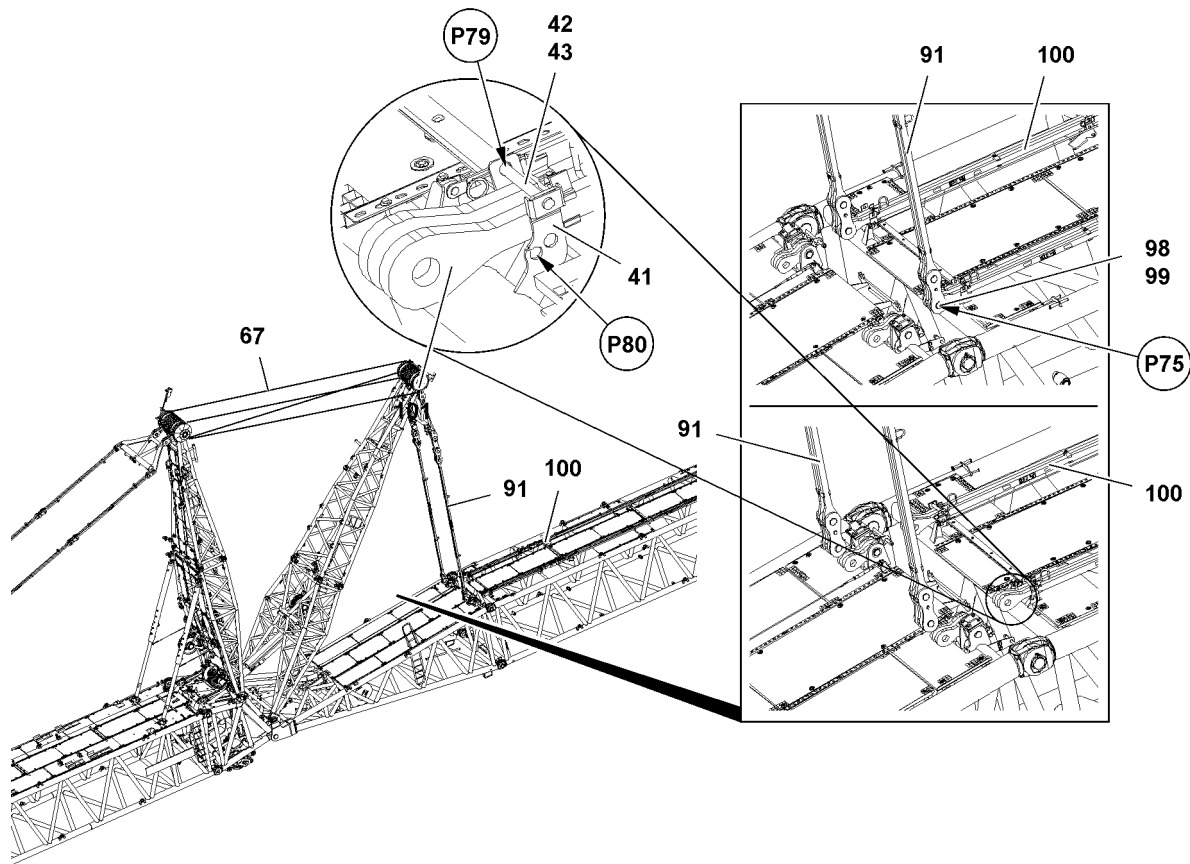

Fig.117077: Short WA-frames: Disassembling the guy rods

- ▶ Lower the WA-frame 1 via the W-control rope **67** until the guy rods **91** can be unpinned on the guy rods **100** and on points **P75**.
- ▶ Unpin the guy rods **100** on the guy rods **91**: Remove the safety locking pins **99** on both sides and unpin the pins **98** on points **P75**.
- ▶ Close all transport retainers **41** on the W-boom: Release and remove the pins **42** on both sides in park positions (point **P80**). Then insert the pins **42** on both sides on points **P79** and secure with spring retainers **43**.

6.6 Disassembling the W-lattice jib

6.6.1 Disassembling the roller cart on the W-lattice jib

Preparing the disassembly of the roll cart

Make sure that the following prerequisites are met:

- The W-guying is properly removed.
- An auxiliary crane with sufficient load bearing capacity is available.
- The W-lattice jib is properly fastened on the auxiliary crane, see Crane operating instructions, chapter 5.01.

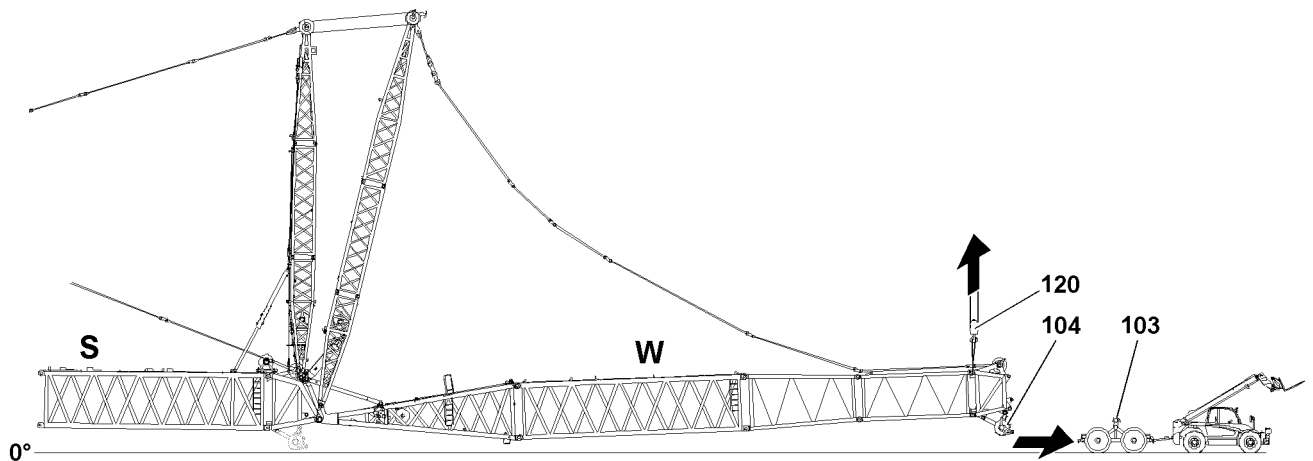

Fig.122226: Removing the roller cart 103 on the roller set 104



WARNING

Danger of accident due to W-lattice jib.
Death, severe bodily injuries, property damage.

- ▶ Make sure that an auxiliary crane with sufficient load bearing capacity is available for the disassembly tasks. Observe the head weights of the W-lattice sections, see charts in section „Assembling the roller cart on the W-lattice jib“.
 - ▶ Make sure that the W-lattice jib is properly fastened on the auxiliary crane, see Crane operating instructions, chapter 5.01.
 - ▶ Improvisations are prohibited.
-
- ▶ Lift the W-lattice jib with the auxiliary crane.
 - ▶ Remove the roller cart 103 on the roller set 104.

Disassembling the roller cart

- ▶ Lift the W-lattice jib with the auxiliary crane off the ground.



Note

- ▶ The disassembly of the roller cart is described in the Crane operating instructions, chapter 5.61.
- ▶ Remove the roller cart properly.

6.6.2 Disconnecting the electrical connections

NOTICE

Damage to cable drum or cable!

If the electrical connection between the terminal box W-pivot section and cable drum is not separated before spooling up the cable drum, the electrical connection will be damaged.

If the cable of the cable drum is not properly spooled up on the cable drum after unplugging on the L-end section, then the cable drum or the cable can be significantly damaged.

- ▶ Release the electrical connection first from the terminal box of the W-pivot section to the cable drum and then the electrical connection from the cable drum to the L-end section.
 - ▶ After unplugging, spool the cable onto the cable drum.
-
- ▶ Disconnect the electrical connections.
 - ▶ After unplugging, spool the cable onto the cable drum and secure it to prevent it from spooling out inadvertently.
 - ▶ Secure the cable: Reestablish the electrical connection between the terminal box and the cable drum on the W-pivot section.

NOTICE

Property damage due to dirt and / or corrosion!

If non-required electrical connections are not closed off with the respective protective caps, then dirt and / or corrosion can damage the electrical connections.

This could result in malfunctions.

- ▶ Make sure that all non-required electrical connections are always closed off properly.
 - ▶ Pay attention to the Electrical wiring diagram.
-
- ▶ Close electrical connections, which have no dummy plugs, properly off with the corresponding protective caps.
 - ▶ Secure all electrical connections with protective caps to prevent any dirt infiltration.

6.6.3 Disassembling the roller set



Note

- ▶ The disassembly of the roller set is described in the Crane operating instructions, chapter 5.14.



DANGER

Overload of boom!

If several lattice sections are located preassembled after the W-pivot section, which exceed the total length of 37.5 m, then the lattice sections will be overloaded.

Death, severe bodily injuries, property damage.

- ▶ Place lattice sections down to a total length of maximum 37.5 m, without supporting them.
-
- ▶ Route the hoist limit switch from the end section to the roller set, observe the Electrical wiring diagram.
 - ▶ Disassemble the roller set.

6.6.4 Disassembling the W-lattice jib to the W-pivot section



WARNING

Danger of crushing for people in the load zone!

If personnel are located between the load to be lifted and a possible interfering edge when lifting a load, personnel can be severely injured or killed.

- ▶ Before lifting the load it must be ensured that there are no persons within the danger zone.
- ▶ It is prohibited to remain in the danger zone.
- ▶ It is prohibited for anyone to be under the load.
- ▶ Maintain a safe distance.
- ▶ Swinging the load is prohibited.
- ▶ Exercise extreme caution when lifting a load.



DANGER

General danger notes!

- ▶ Support the W-lattice jib at assembly and disassembly properly with the assembly shoes, see Crane operating instructions, chapter 5.62.
- ▶ All pins must be secured after the assembly.
- ▶ The guy rods must be checked regularly, see Crane operating instructions, chapter 8.15.



DANGER

Overload of boom!

If several lattice sections are located preassembled after the W-pivot section, which exceed the total length of 37.5 m , then the lattice sections will be overloaded.

Death, severe bodily injuries, property damage.

- ▶ Place lattice sections down to a total length of maximum 37.5 m , without supporting them.



Note

- ▶ During disassembly of the W-lattice jib, adhere to the unpinning sequence, see Crane operating instructions, chapter 5.01.

To unpin the W-lattice jib with the pin pulling device, see Crane operating instructions, chapter 5.30.

The disassembly of the W-lattice jib is the same as the disassembly of the S-boom, see Crane operating instructions, chapter 5.39.

- ▶ Disassemble the W-lattice jib to the W-pivot section.

6.7 Disassembling the WA-frame 1 guy rods

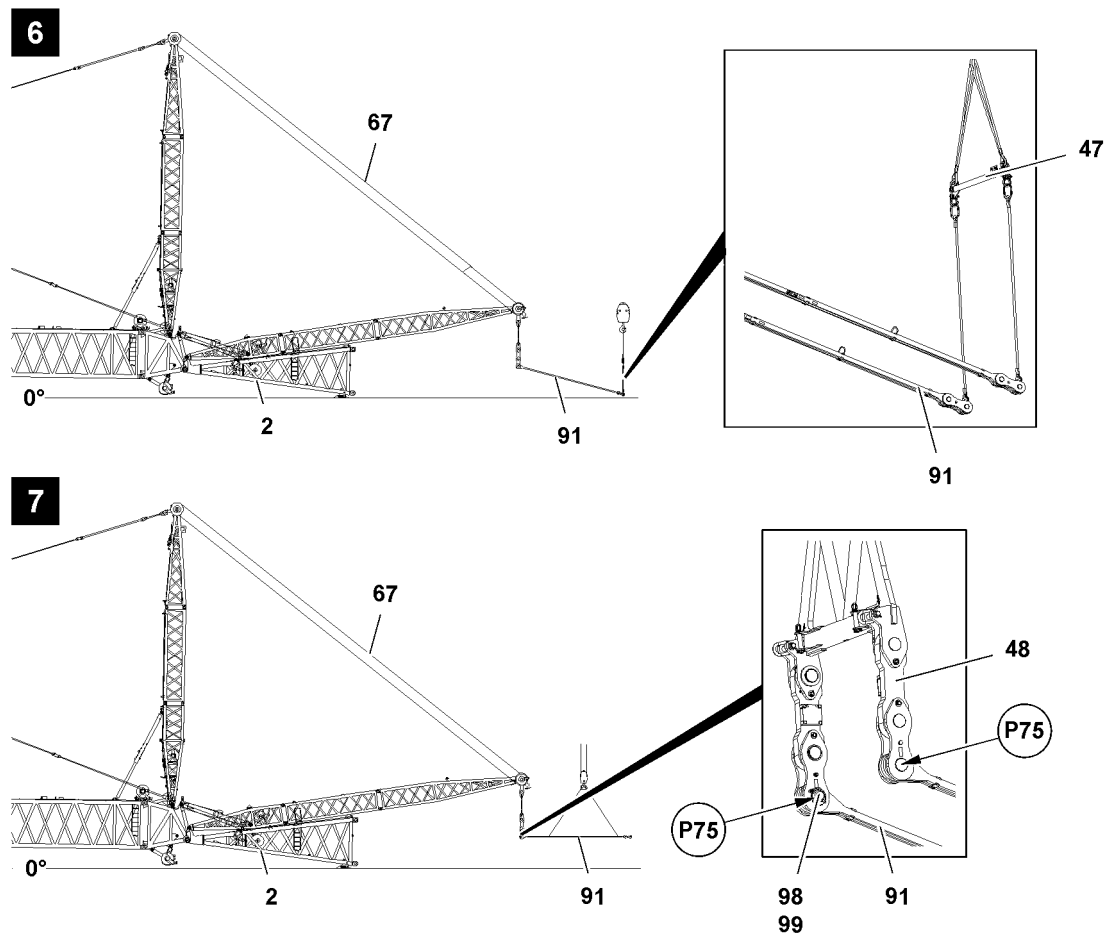

Fig.117079: Disassembling the WA-frame 1 guy rods

Make sure that the following prerequisite is met:

- The guy rods **91** hang vertically on the WA-frame 1.

- ▶ Pin the cross beam **47** on both sides with the guy rods **91**, see illustration **6**.

NOTICE

Slack rope formation!

The W-control rope **67** can be damaged if there is slack rope.

This could result in high property damage.

- ▶ When spooling the W-control rope **67** up or out, allow no slack rope formation.
- ▶ When spooling up or out, hold the W-control rope **67** taut.

- ▶ Lower the WA-frame 1 and carry the guy rods **91** along with the cross beam **47** until the WA-frame 1 is laying on the W-pivot section **2**.
- ▶ Unpin and remove the cross beam **47**.
- ▶ Fasten the guy rods **91** to the auxiliary crane.
- ▶ Unpin the guy rods **91** on the swing **48**: Remove the safety locking pins **99** on both sides and unpin the pins **98** on points **P75**, see illustration **7**.
- ▶ Take the guy rod **91** down with the auxiliary crane in a suitable storage location.
- ▶ Remove the auxiliary crane.

6.8 Placing the WA-frame 2 down



WARNING

Danger of accident!

If the following notes are not observed and adhered to, personnel can be severely injured or killed.

- ▶ It is prohibited to remain in the danger zone.
- ▶ Maintain a safe distance.
- ▶ The spooling procedure must be monitored by a guide.
- ▶ Allow no slack rope formation on the W-control rope and on the hoist rope.
- ▶ Make sure that the WA-frame 1 remains in a position during the entire erection procedure in which the W-control rope is tensioned.
- ▶ During the entire disassembly procedure, raise the WA-frame 1 with the W-control rope to approx. 15° so that the relapse cylinder is under pressure.

NOTICE

Slack rope formation!

The hoist rope can be damaged if slack rope forms.

This could result in high property damage.

- ▶ When spooling the hoist rope up or out, allow no slack rope formation.
- ▶ Hold the hoist rope taut when spooling it up or out.



WARNING

Danger of accident!

Death, severe bodily injuries, property damage.

- ▶ It is prohibited to remain within the danger zone of the running ropes.
- ▶ Radio contact is available between crane operator and assembly personnel.

Make sure that the following prerequisites are met:

- The function of the relapse cylinder is ensured.
- All guy rods on the WA-frame 1 are removed.
- The W-boom is fully disassembled.

6.8.1 Installing the hoist rope on the erection ropes

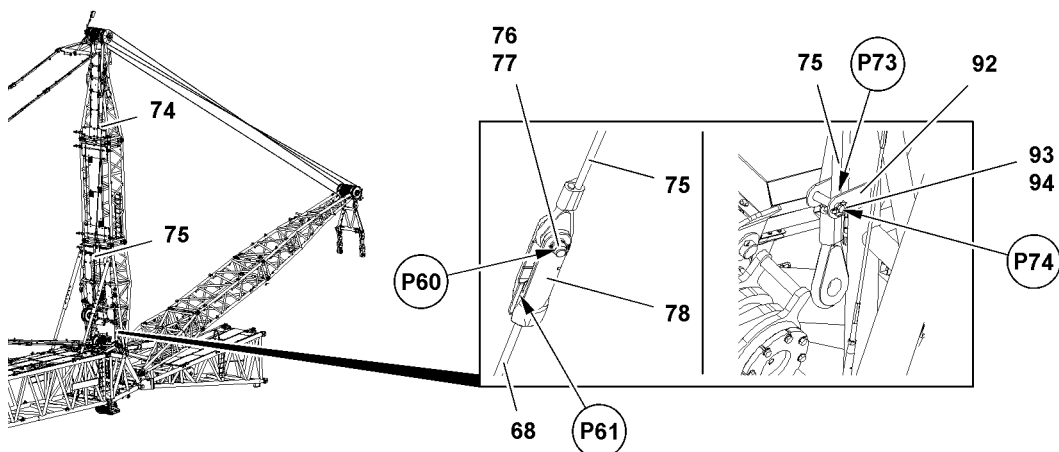

Fig.117080: Installing the hoist rope on the erection ropes

- ▶ Remove the safety locking pin **94** on point **P74** and unpin the pin **93**.
- ▶ Take the 6 m erection rope **75** on point **P73** from the retainer **92**.
- ▶ Insert the pin **93** on point **P74** and secure with safety locking pin **94**.
- ▶ Pin the rope lock **78** with the 6 m erection rope **75**: Insert the pin **76** on point **P60** and secure with safety locking pin **77**.
- ▶ Affix the hoist rope **68** on point **P61** in rope lock **78**.

- ▶ Pull the hoist rope **68** in until the hoist rope **68** and the erection ropes are slightly tensioned.

6.8.2 Long WA-frames: Installing the relapse supports in transport position and removing the guy rods

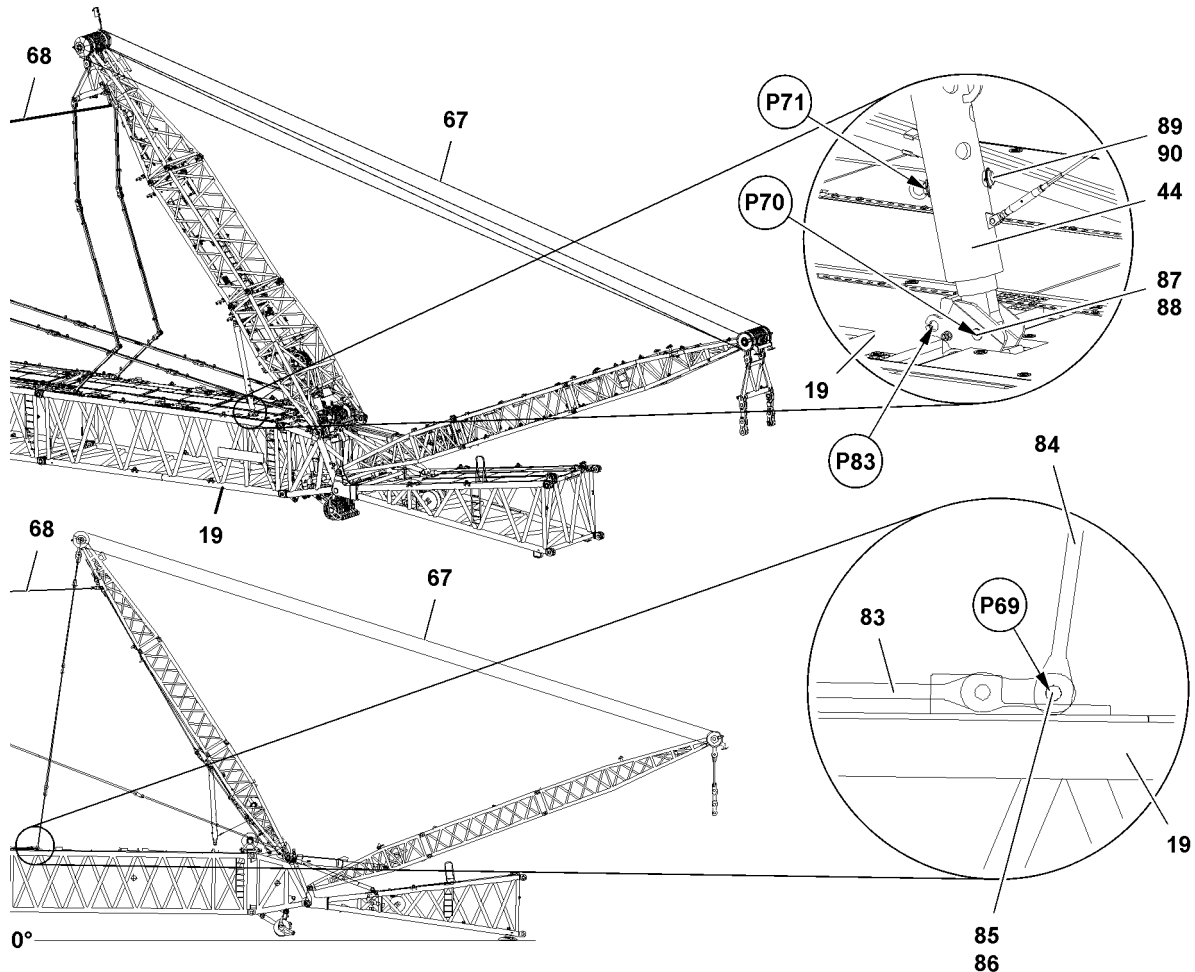

Fig. 117081: Long WA-frames: Installing the relapse supports in transport position and removing the guy rods

Make sure that the following prerequisites are met:

- The function of the relapse cylinder is ensured.
 - The WA-frame 1 is approx. at 15°.
 - The W-control rope is tensioned.
- ▶ Release and unpin the locking pins **89** on both sides.
 - ▶ Pull the WA-frame 2 back with the hoist rope **68** and simultaneously spool the W-control rope **67** out until the relapse supports **44** are completely pushed together and the locking pins **89** can be pinned at point **P71**.
 - ▶ Insert the locking pins **89** on both sides on points **P71** and secure with safety locking pins **90**.
 - ▶ Unpin the relapse supports **44** on the S-adaptor **19**: Release the pins **87** on both sides on points **P70** and unpin.
 - ▶ Insert the pins **87** on both sides in park position (point **P83**) and secure with safety locking pin **88**.
 - ▶ Erect the WA-frame 2 until the guy rods **84** can be unpinned on points **P69**.
 - ▶ Unpin the guy rods **84** on the guy rods **83**: Release the pins **85** on both sides on points **P69** and unpin.
 - ▶ Erect the WA-frame 2 to approx. 90°.

6.8.3 Short WA-frames: Removing the guy rods and installing the relapse supports in the transport position

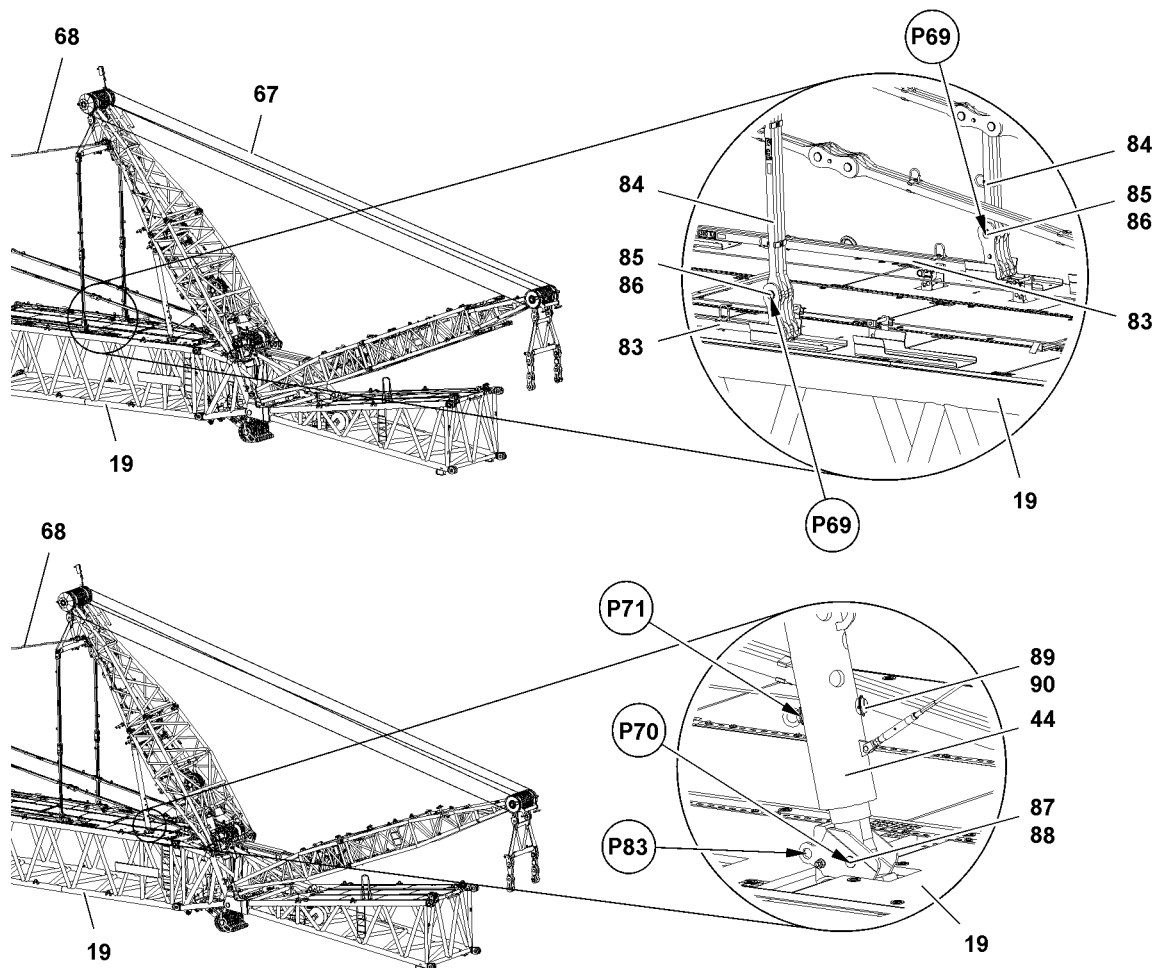

Fig.117082: Short WA-frames: Removing the guy rods and installing the relapse supports in the transport position

Make sure that the following prerequisites are met:

- The function of the relapse cylinder is ensured.
 - The WA-frame 1 is approx. at 15°.
 - The W-control rope is tensioned.
 - An auxiliary crane is available.
- ▶ Release and unpin the locking pins **89** on both sides.
 - ▶ Pull the WA-frame 2 back with the hoist rope **68** and simultaneously spool out the W-control rope **67** until the guy rods **84** can be unpinned on points **P69**.
 - ▶ Fasten the guy rods **83** to the auxiliary crane.
 - ▶ Unpin the guy rods **84** on the guy rods **83**: Release the pins **85** on both sides on points **P69** and unpin.
 - ▶ Place the guy rods **83** down with the auxiliary crane.
 - ▶ Pull the WA-frame 2 back with the hoist rope **68** and simultaneously spool the W-control rope **67** out until the relapse supports **44** are completely pushed together and the locking pins **89** can be pinned at point **P71**.
 - ▶ Insert the locking pins **89** on both sides on points **P71** and secure with safety locking pins **90**.
 - ▶ Unpin the relapse supports **44** on the S-adapter **19**: Release the pins **87** on both sides on points **P70** and unpin.
 - ▶ Insert the pins **87** on both sides in park position (point **P83**) and secure with safety locking pin **88**.
 - ▶ Erect the WA-frame 2 to approx. 90°.

6.8.4 Placing the WA-frame 2 on WA-frame 1

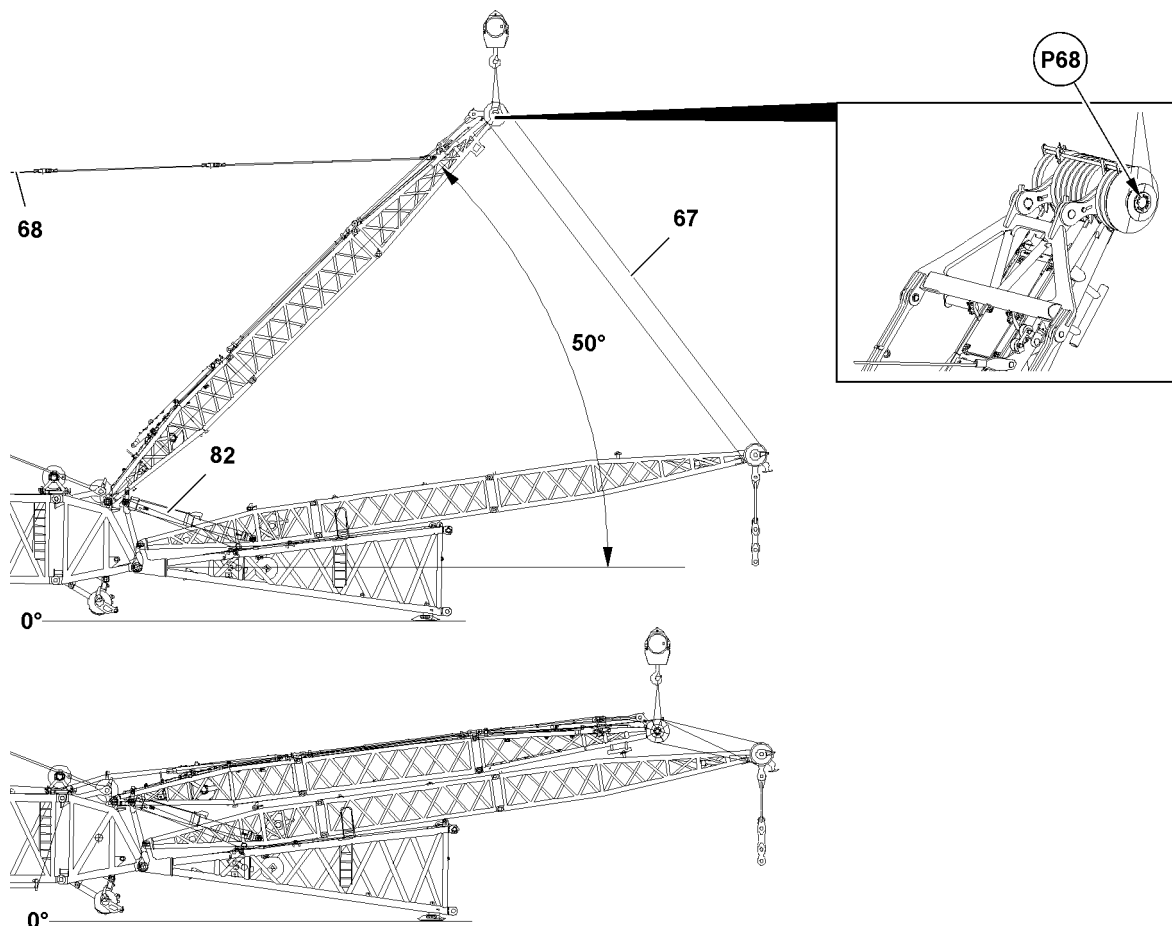

Fig.121054: Placing the WA-frame 2 on WA-frame 1



WARNING

Danger of accident!

Up to an angle of 50°, WA-frame 2 may only be held with an auxiliary crane. The hoist rope **68** may not be subjected to a load.

If the following notes are not observed and adhered to, personnel can be severely injured or killed.

- ▶ It is prohibited to remain in the danger zone.
- ▶ Maintain a safe distance.
- ▶ The spooling procedure must be monitored by a guide.
- ▶ From an angle of less than 50°, take the WA-frame 2 down only with an auxiliary crane.
- ▶ Make sure that the WA-frame 1 remains in a position during the entire erection procedure in which the W-control rope is tensioned.
- ▶ During the entire disassembly procedure, raise the WA-frame 1 with the W-control rope **67** to approx. 15° so that the relapse cylinder **82** is under pressure.

NOTICE

Slack rope formation!

Due to slack rope formation, the hoist rope **68** and the W-control rope **67** can be damaged.

This could result in high property damage.

- ▶ When spooling the hoist rope **68** or the W-control rope **67** up or out, allow no slack rope formation.
- ▶ When spooling up or out, hold the hoist rope **68** and the W-control rope **67** taut.
- ▶ Luff the WA-frame 2 down until an angle of approx. 50° is reached: Spool the W-control rope **67** up and simultaneously spool out the hoist rope **68**.
- ▶ Fasten the auxiliary crane on point **P68** and tension with fastening equipment.

- ▶ Relieve the hoist rope **68**.
- ▶ Place the WA-frame **2** only with the auxiliary crane on the WA-frame **1**: Spool the W-control rope **67** up and simultaneously spool out the hoist rope **68**.

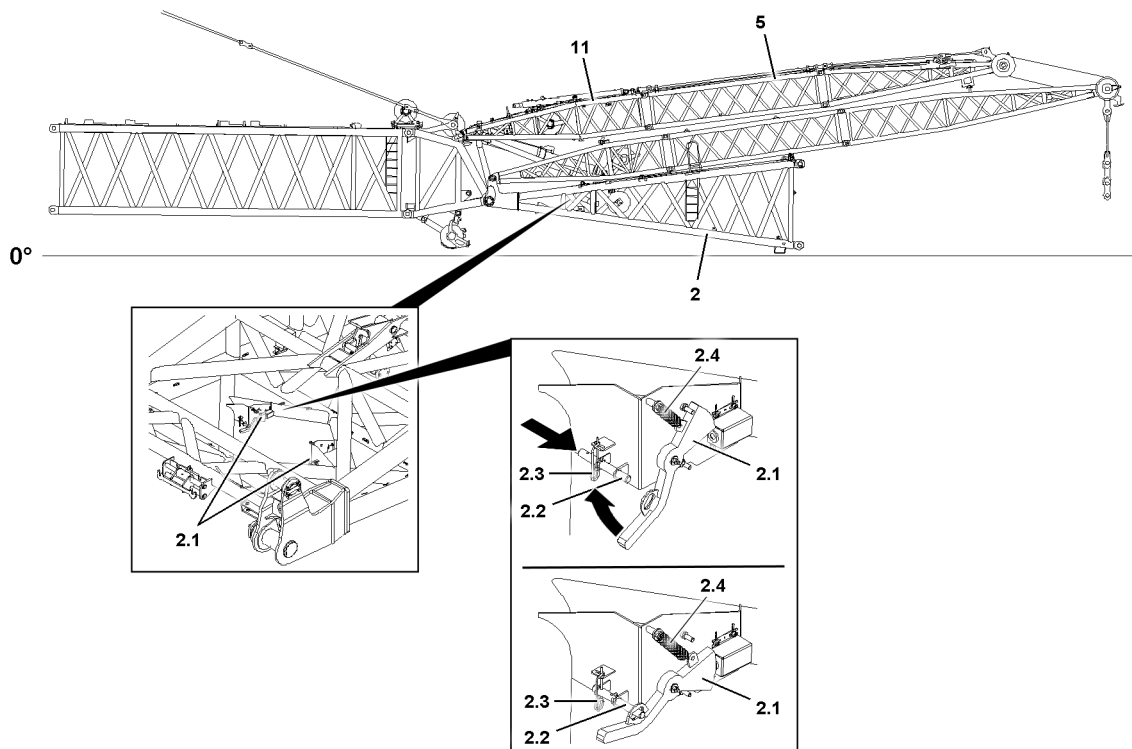

Fig.124283: Bringing the cantilevers „jib down“ into the transport position

Bring the cantilevers **2.1** „jib down“ into the transport position by pinning the transport retaining pins on both sides.



WARNING

Spring actuated component!

When pinning the cantilever **2.1** in the transport position, the cantilever can move down suddenly and at a high speed due to the pull spring **2.4**.

Limbs can be crushed or severed.

- ▶ Make sure, before releasing the cantilever **2.1** in the transport position, that the pin **2.2** is properly pinned and secured.

- ▶ Remove the spring retainer **2.3**.
- ▶ Hold the cantilever **2.1** with one hand.
- ▶ Pull the cantilever **2.1** up to the stop.

When the cantilever **2.1** touches on the stop „on top“:

- ▶ Insert the pin **2.2** in direction of the arrow to the stop.

When the cantilever **2.1** is pinned in the transport position:

- ▶ Secure the cantilever **2.1** in the „pinned“ position with spring retainer **2.3**.

6.8.5 Securing the relapse supports on the WA-frame 2

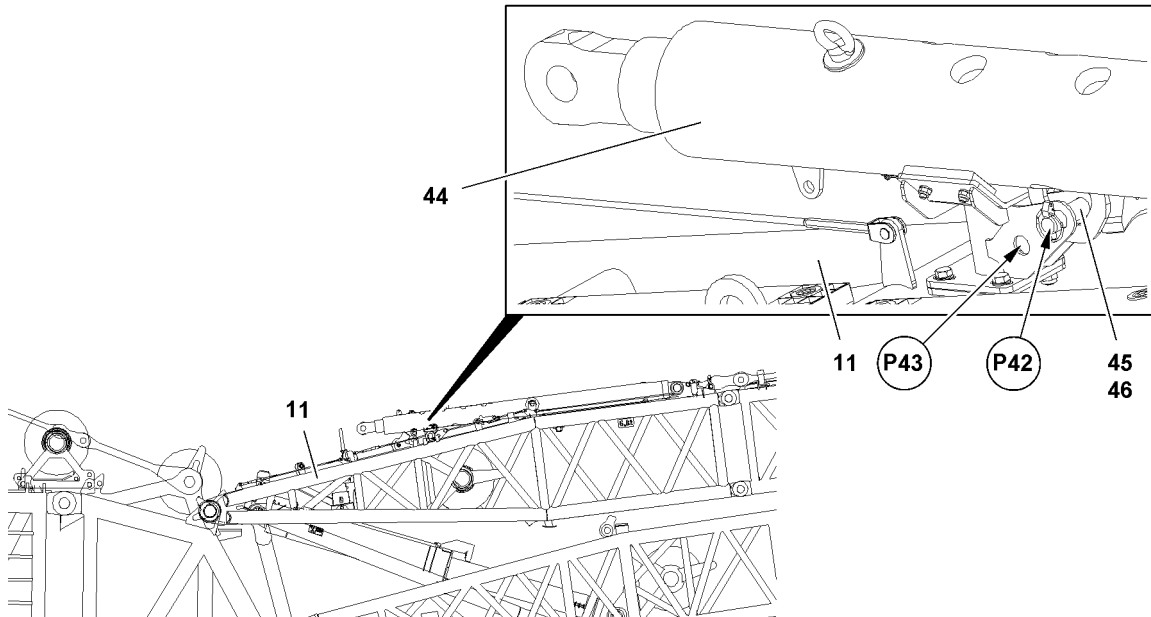

Fig.117084: Securing the relapse supports on the WA-frame 2

- ▶ Release the pins 45 on both sides on park position (point P43) and unpin.
- ▶ Pin the relapse supports 44 with WA-frame 2 pivot section 11: Insert the pins 45 on both sides on points P42 and secure with safety locking pins 46.

6.8.6 Closing the transport retainers of the guy rods

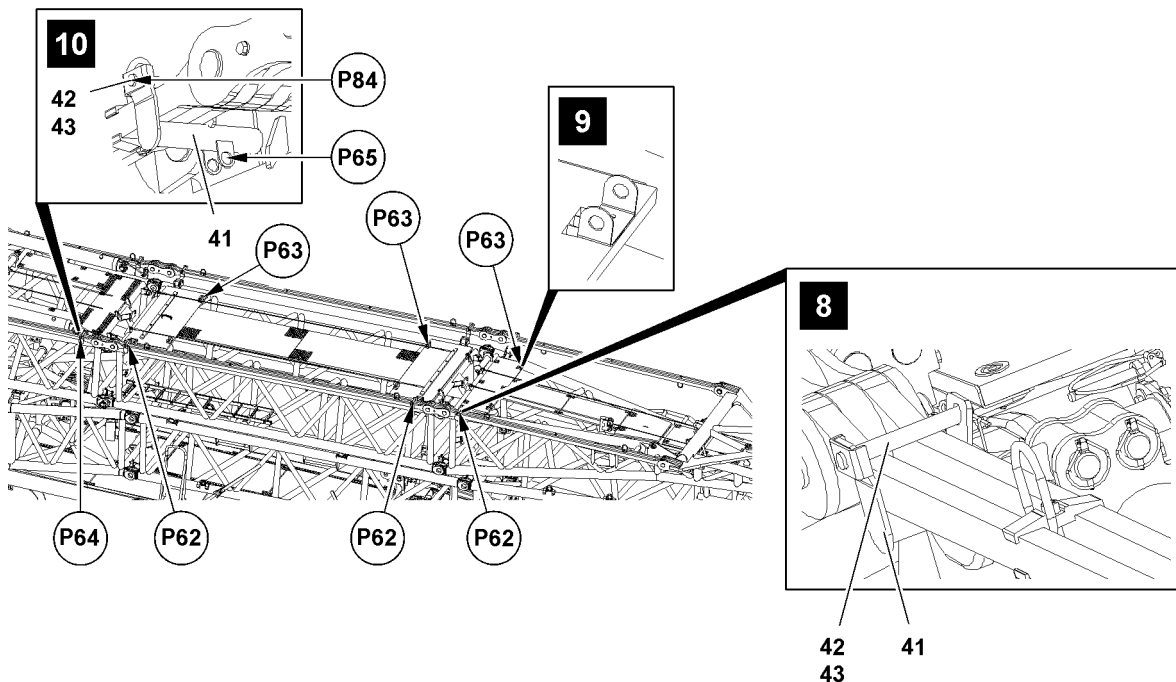

Fig.117085: Closing the transport retainers of the guy rods - Placement surfaces

- ▶ Release the pins 42 on both sides on park positions (points P63) and unpin, see illustration 9.
- ▶ Close the transport retainers 41 on points P62 on both sides: Insert the pin 42 and secure with the safety locking pin 43, see illustration 8.

- ▶ Release the pins **42** on both sides on points **P65** on park positions (point **P65**) and unpin, see illustration **10**.
- ▶ Close the transport retainers **41** on points **P64** on both sides: Insert the pins **42** on both sides on points **P84** and secure with safety locking pin **43**, see illustration **10**.

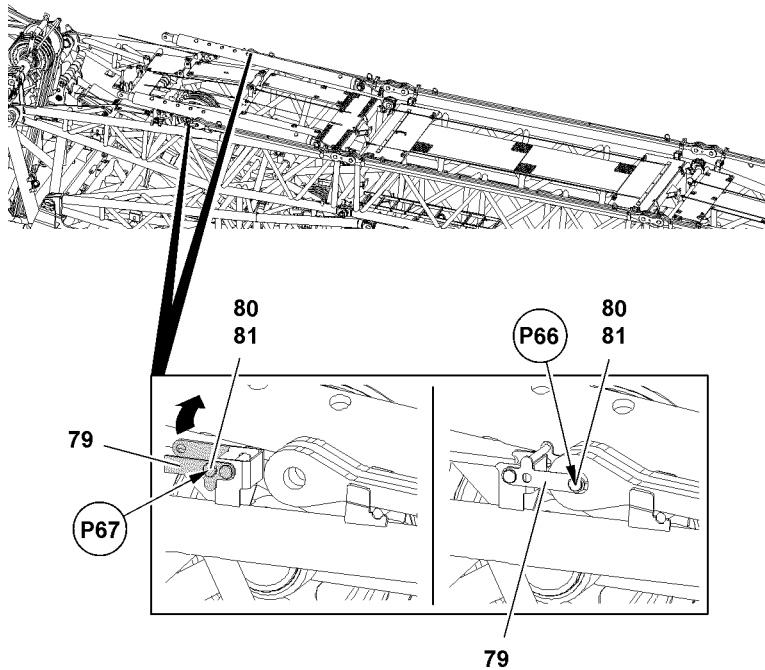

Fig.117086: Closing the transport retainers of the guy rods - Securing the guy rod end

- ▶ Release the pins **80** on both sides on points **P67** and unpin.
- ▶ Fold the transport retainer **79** over.
- ▶ Close the transport retainer **79**: Insert the pins **80** on both sides on points **P66** and secure with safety locking pins **81**.

6.8.7 Closing the transport retainer of the cross beam

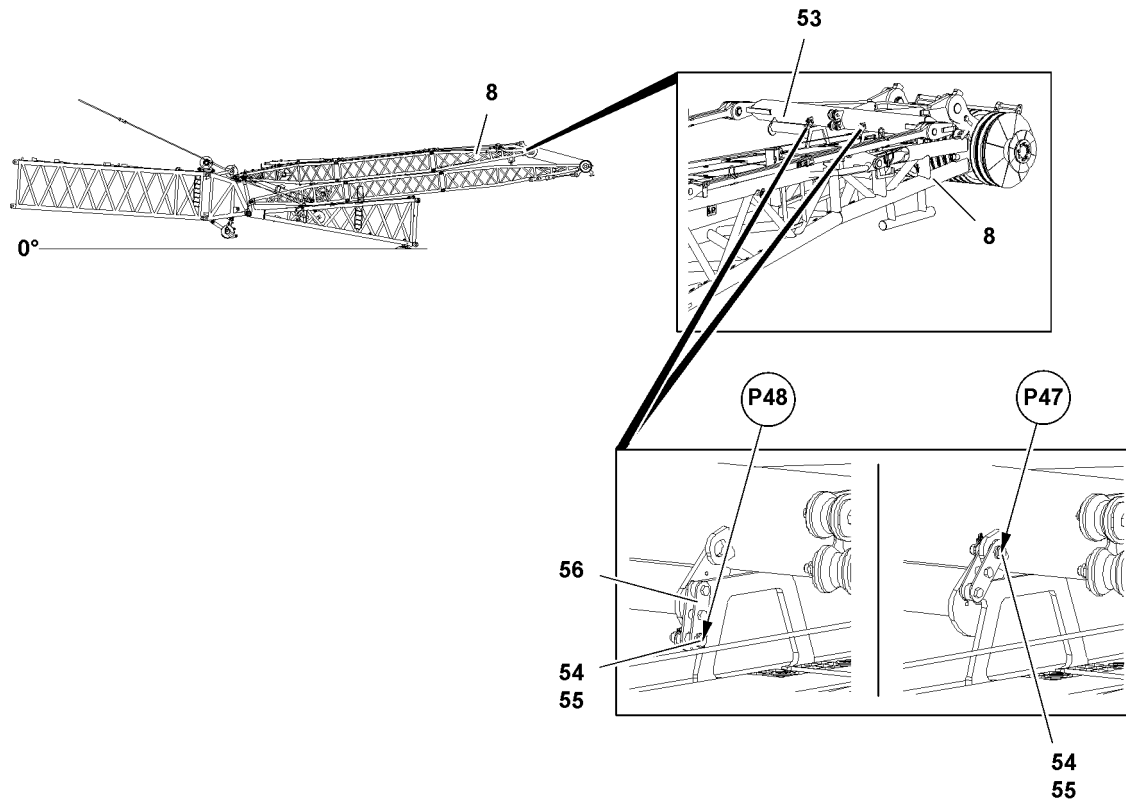

Fig.117087: Closing the transport retainer of the cross beam

- ▶ Release the pins **54** on both sides on points **P48** and unpin.
- ▶ Fold the brackets **56** up.
- ▶ Close the transport retainer: Insert the pins **54** on both sides on points **P47** and secure with safety locking pins **55**.

Result:

- ▷ The cross beam **53** is completely secured.

6.9 Disassembling the WA-frames

6.9.1 Removing the erection ropes

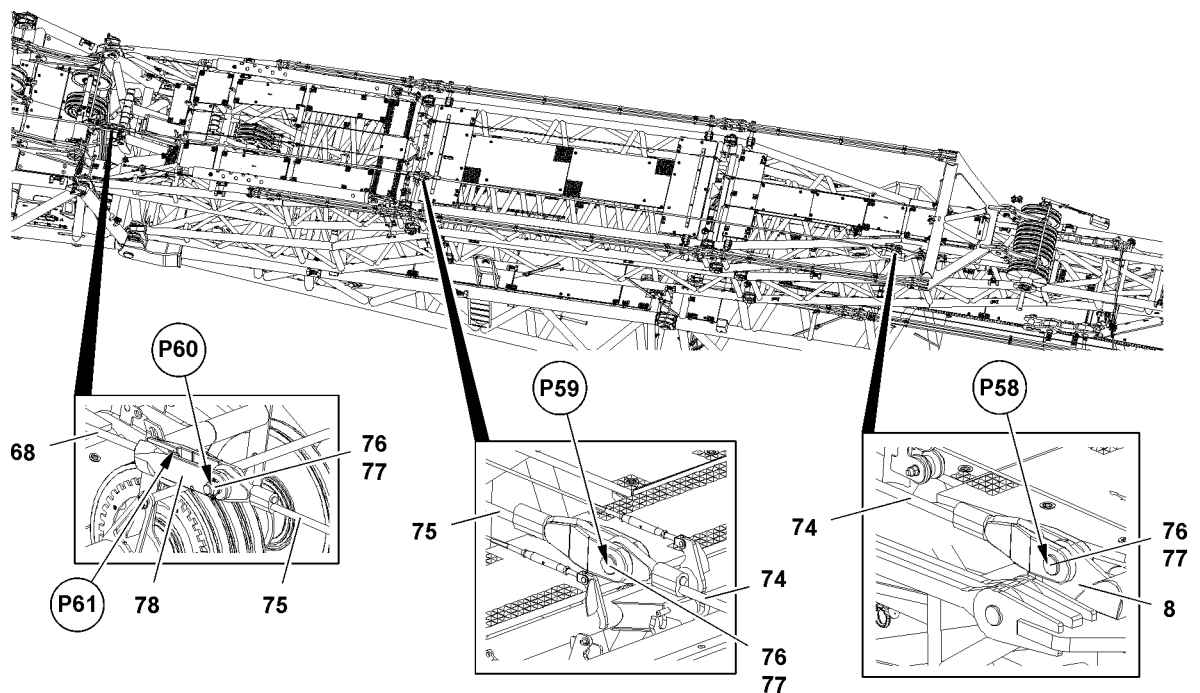

Fig.117088: Removing the erection ropes

- ▶ Remove the hoist rope **68** on point **P61** of the rope lock **78**.
- ▶ Unpin the rope lock **78** on the 6 m erection rope **75**: Release the pin **76** on point **P60** and unpin.
- ▶ Unpin the 6 m erection rope **75** on the 9.3 m erection rope **74**: Release the pin **76** on point **P59** and unpin.
- ▶ Unpin the 9.3 m erection rope **74** on the WA-frame 2 end section **8**: Release the pin **76** on point **P58** and unpin.
- ▶ Take the 6 m erection rope **75** and 9,3 m erection rope **74** down with the auxiliary crane in a suitable location.

6.9.2 Removing the W-control rope and hoist ropes

NOTICE

Slack rope formation!

Due to slack rope formation, the hoist rope and the W-control rope can be damaged.

This could result in high property damage.

- ▶ When spooling the hoist rope or the W-control rope up or out, allow no slack rope formation.
- ▶ When spooling up or out, hold the hoist rope and the W-control rope taut.



WARNING

Danger of accident!

Death, severe bodily injuries, property damage.

- ▶ It is prohibited to remain within the danger zone of the running ropes.
- ▶ Radio contact is available between crane operator and assembly personnel.

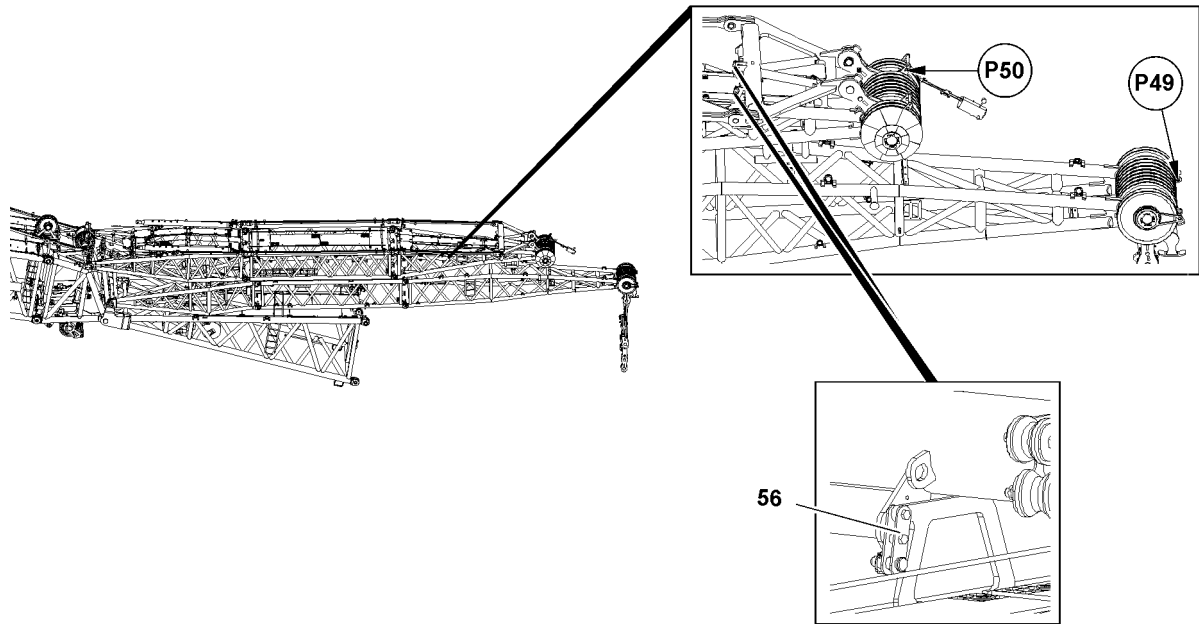

Fig. 117089: Removing the W-control rope and hoist ropes - Prerequisites

Make sure that the following prerequisites are met:

- The transport retainers **56** of the swing of WA-frame 2 are closed.
- The rope guard of WA-frame 1 end section is removed on point **P49**.
- The rope guard of WA-frame 2 end section is removed on point **P50**.

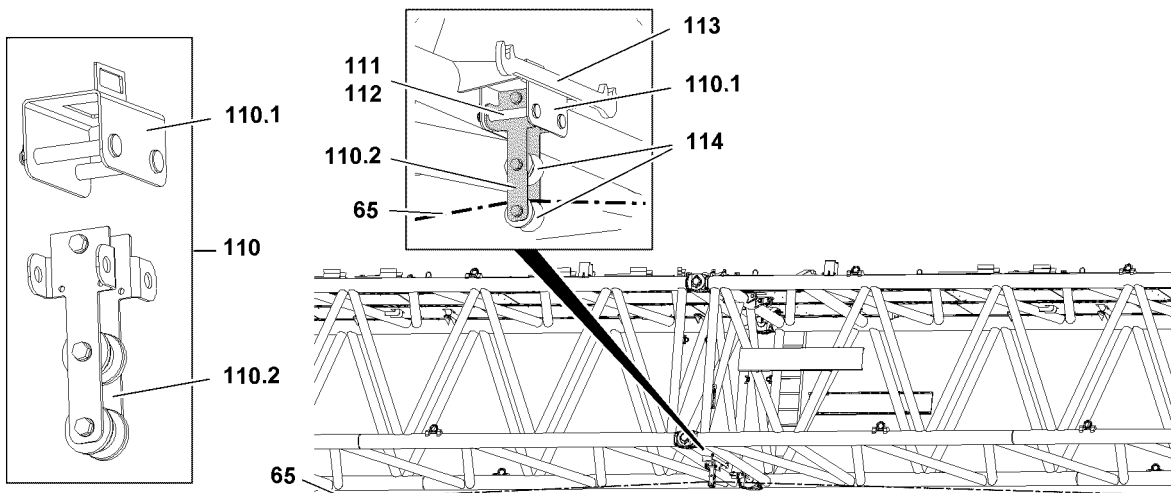

Fig. 121048: Reeving the W-control rope in and pulling the hoist ropes forward to the S-end section - Installing the complete retainer



Note

- ▶ The complete retainer **110** is part of the assembly aid.
- ▶ Position the complete retainer **110** in the S-boom in such a way that the auxiliary rope does not scrape on the S-boom when pulling it in.
- ▶ Take the complete retainer **110** apart: Remove the safety locking pin **112** and unpin the pin **113**.
- ▶ Set the part **110.1** in the retainer **113** for the pin pulling device.
- ▶ Position the part **110.2** on part **110.1** so that they can be pinned with each other.

When the pin bores align:

- ▶ Insert the pin **113** and secure with the safety locking pin **112**.
- ▶ Pull the auxiliary rope **65** forward to the complete retainer **110**.

- ▶ Guide the auxiliary rope **65** between the change over pulleys **114**.

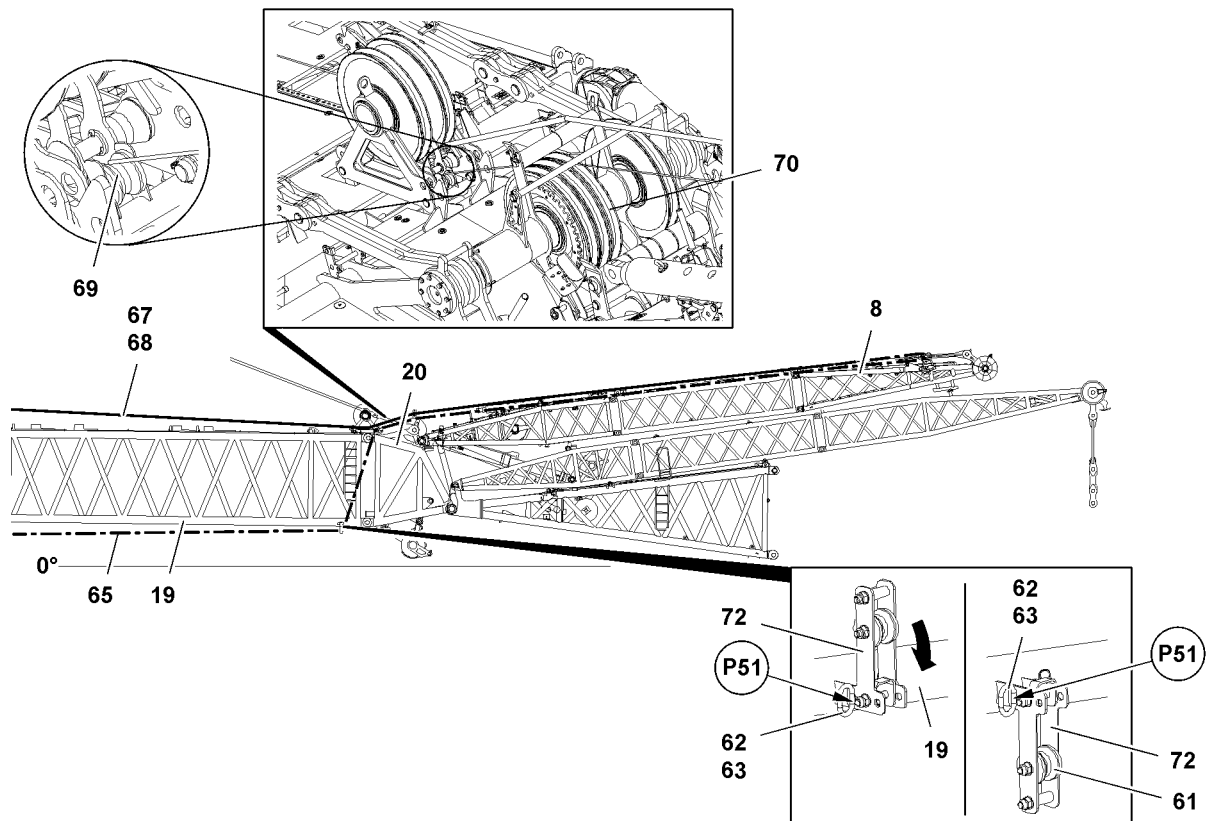

Fig.117090: Disassembling the W-control rope and hoist ropes - Installing the auxiliary rope

- ▶ Unpin the change over pulley retainer **72** on S-adapter **19**: Release the pin **62** on point **P51** and unpin.
- ▶ Swing the change over pulley retainer **72** downward.
- ▶ Pin the change over pulley retainer **72** with the S-adapter **19**: Insert the pin **62** on point **P51** and secure with safety locking pin **63**.
- ▶ Pull the auxiliary rope **65** forward to the change over pulley **61**.
- ▶ Guide the auxiliary rope **65** over the change over pulley **61**.
- ▶ Guide the auxiliary rope **65** over the change over pulley **69**.
- ▶ Guide the auxiliary rope **65** over the end pulley **70**.

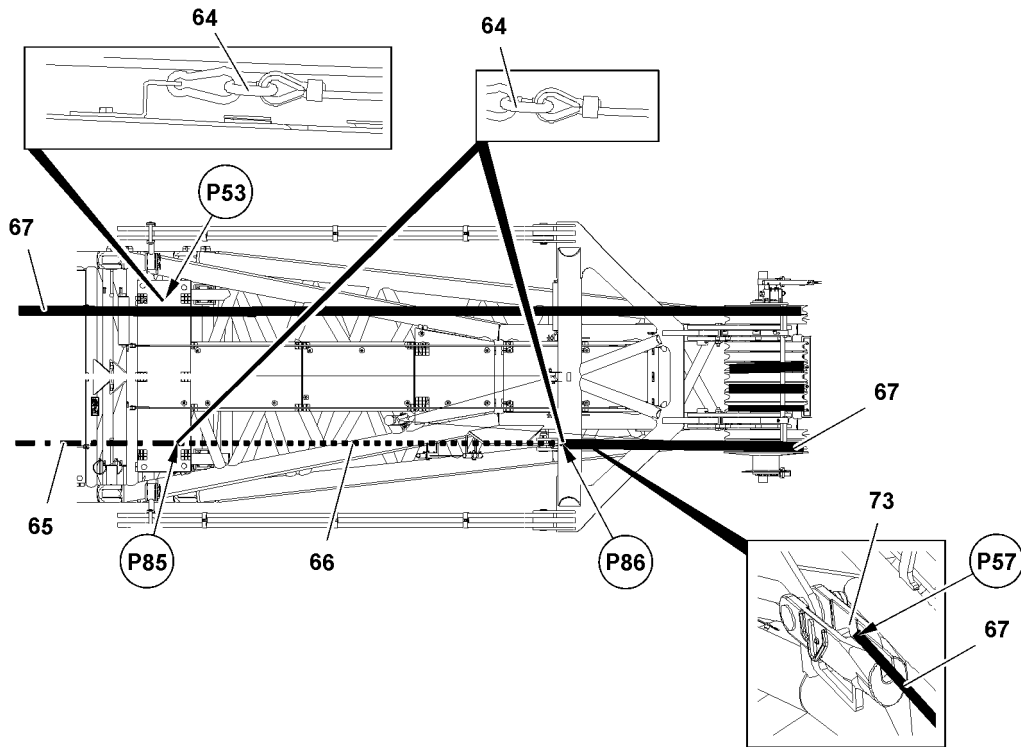

Fig.117091: Disassembling the W-control rope and hoist ropes - Pulling in the W-control rope

- ▶ Connect the forerunner rope **66** with the auxiliary rope **65**: Place the connecting link **64** in on point **P85** between the forerunner rope **66** and auxiliary rope **65**.



WARNING

Danger of crushing if winch 5 moves!

If the W-control rope winch (winch 5) is actuated while releasing the W-control rope **67**, personnel can be severely injured or killed.

Fingers, hands and arms can be crushed or severed.

- ▶ Do not actuate winch 5 during the disassembly procedure.
- ▶ Radio contact is available between crane operator and assembly personnel.

- ▶ Remove the W-control rope **67** on point **P57** on the rope lock **73**.
- ▶ Connect the forerunner rope **66** with the W-control rope **67**: Place the connecting link **64** in on point **P86** between the forerunner rope **66** and W-control rope **67**.
- ▶ Slowly pull the W-control rope **67** in and counter with the auxiliary rope **65** until the forerunner rope **66** can be attached on point **P53**.
- ▶ Remove the forerunner rope **66** from the W-control rope **67**.
- ▶ Install the forerunner rope **66** on park position (point **P53**).

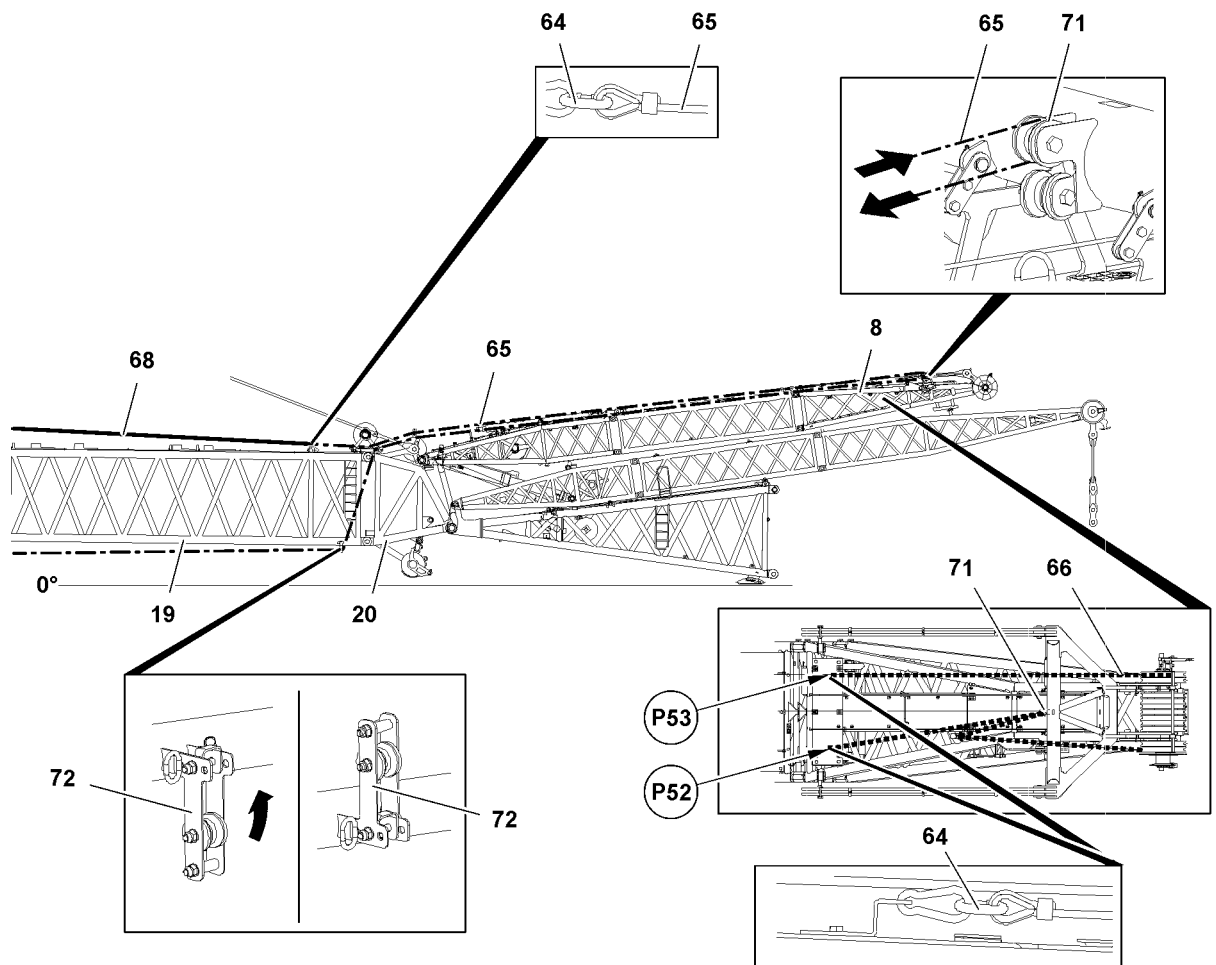

Fig.117092: Disassembling the W-control rope and hoist ropes - Pulling in the hoist ropes

- ▶ Remove the forerunner rope **66** on the auxiliary rope **65**.
- ▶ Place the forerunner rope **66** in such a way that the upper change over pulley **71** can be covered with the auxiliary rope **65**.
- ▶ Pull the auxiliary rope **65** to the change over pulley **71** of the WA-frame 2 end section **8**.

The auxiliary rope **65** is guided in from top.

- ▶ Guide the auxiliary rope **65** over the upper change over pulley **71**.
- ▶ Pull the auxiliary rope **65** to the hoist rope end.
- ▶ Connect the auxiliary rope **65** with the hoist rope **68**: Place the connecting link **64** in between hoist rope **68** and auxiliary rope **65**.
- ▶ Pull the hoist rope **68** back to the hoist winch and counter with the auxiliary rope **65**.
- ▶ Remove the auxiliary rope **65** on the hoist rope **68**.

When a second hoist rope **68** must be pulled back:

- ▶ Pull the second hoist rope **68** back to the hoist winch the same way as described before.
- ▶ Spool the auxiliary rope **65** up on the auxiliary winch.
- ▶ Place the forerunner rope **66** over the change over pulley **71**.
- ▶ Install the forerunner rope **66** on park position (point **P52**).
- ▶ Install the change over pulley retainer **72** in the park position.

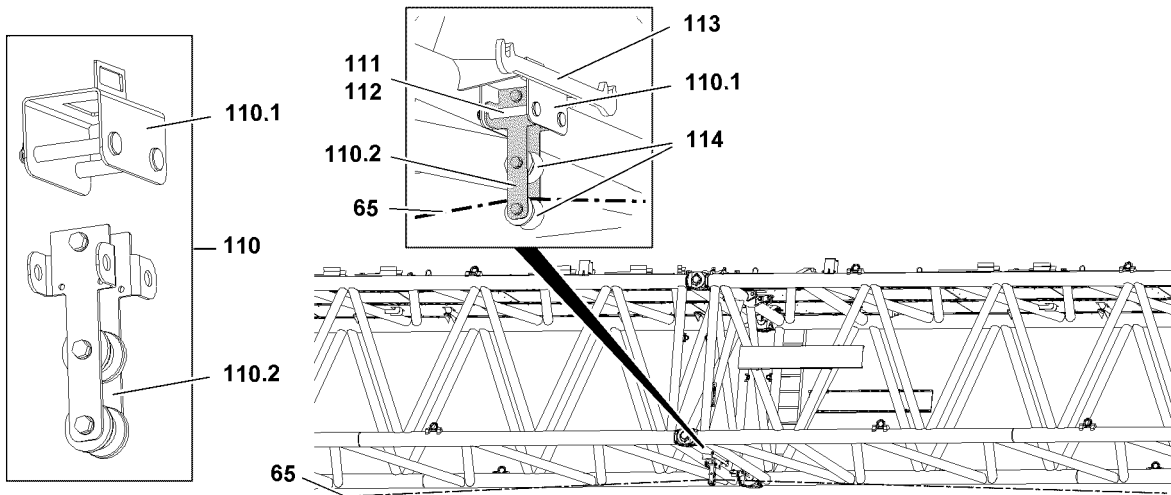

Fig.121048: Disassembling the W-control rope and hoist ropes - Removing the complete retainer



Note

- ▶ The complete retainer **110** is part of the assembly aid.
- ▶ Remove the safety locking pin **112** and unpin the pin **113**.
- ▶ Remove the part **110.2**.
- ▶ Remove the part **110.1** from the retainer **113** for the pin pulling device.
- ▶ Assemble the complete retainer **110** again: Position the part **110.2** on part **110.1** so that they can be pinned with each other.

When the pin bores align:

- ▶ Insert the pin **113** and secure with the safety locking pin **112**.

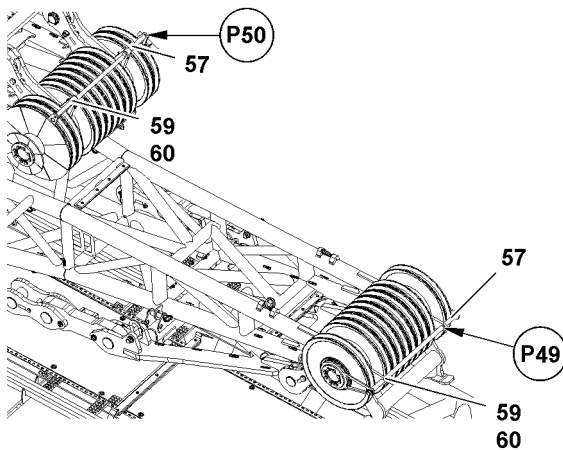

Fig.117093: Disassembling the W-control rope and hoist ropes - Installing the rope guard

- ▶ Install the rope guard **57** on point **P49** and point **P50** and secure with retaining elements (pin **59** and safety locking pin **60**).

6.9.3 Pinning the swing from the WA-frame 1 in transport position

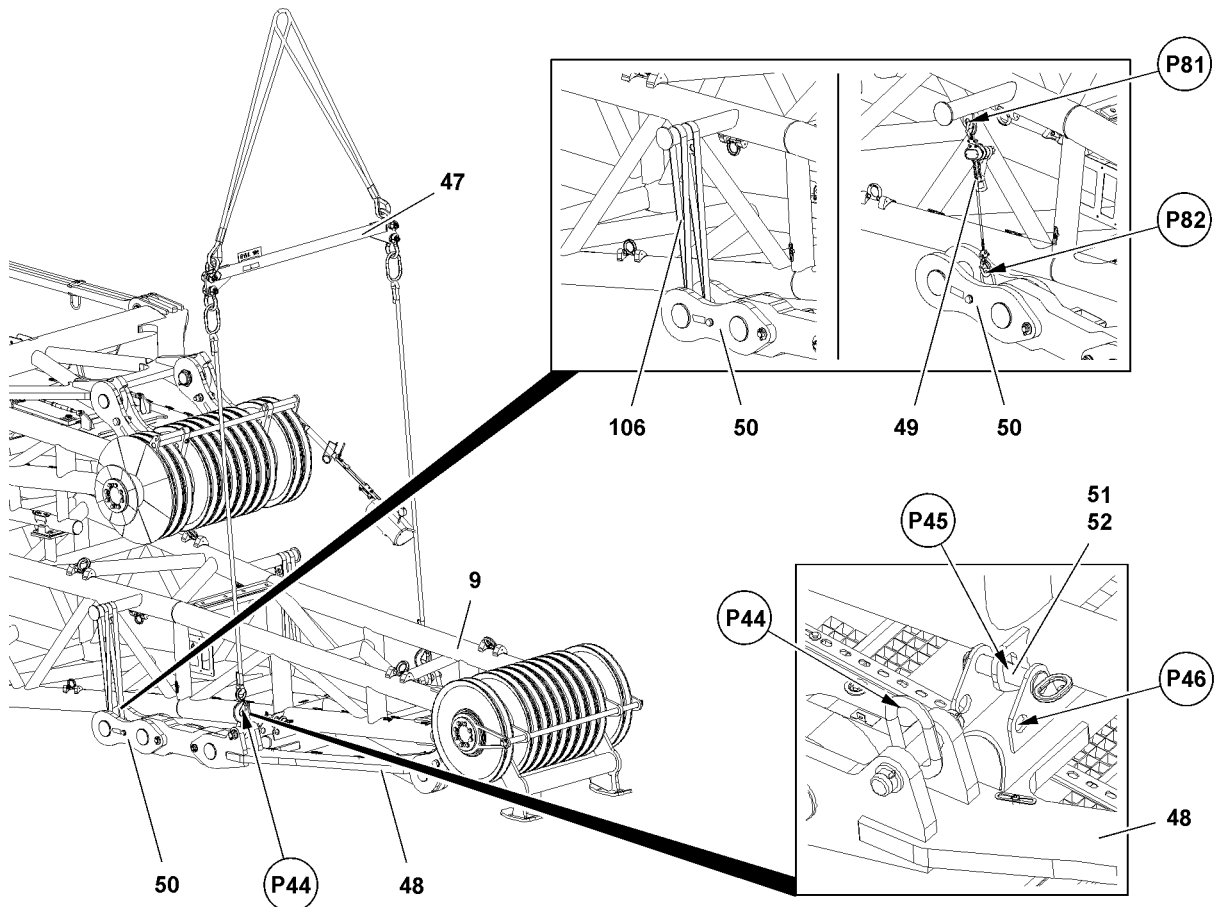

Fig.117094: Pinning the swing from the WA-frame 1 in transport position

- ▶ Attach the cross beam **47** on both sides on points **P44**.
- ▶ Lift the swing **48** with the cross beam **47** until the swing **48** can be pinned on both sides on points **P45**.
- ▶ Release pins **51** on both sides on park position (point **P46**) and unpin.
- ▶ Pin the swing **48** with the WA-frame 1 end section **9**: Insert the pins **51** on both sides on point **P45** and secure with safety locking pin **52**.

To secure the brackets **50**, use the chain pulls **49**.

- ▶ Hang the chain pull **49** on point **P81** and point **P82**.
- ▶ Tighten the chain pull **49** until the round sling **106** can be placed.
- ▶ Place the round sling **106**.
- ▶ Lower the bracket **50** with the chain pull **49**.
- ▶ Remove the chain pull **49**.
- ▶ Repeat the procedure on the other side the same way as described above.
- ▶ Remove the cross beam **47**.

6.9.4 Disassembling the assembly unit V

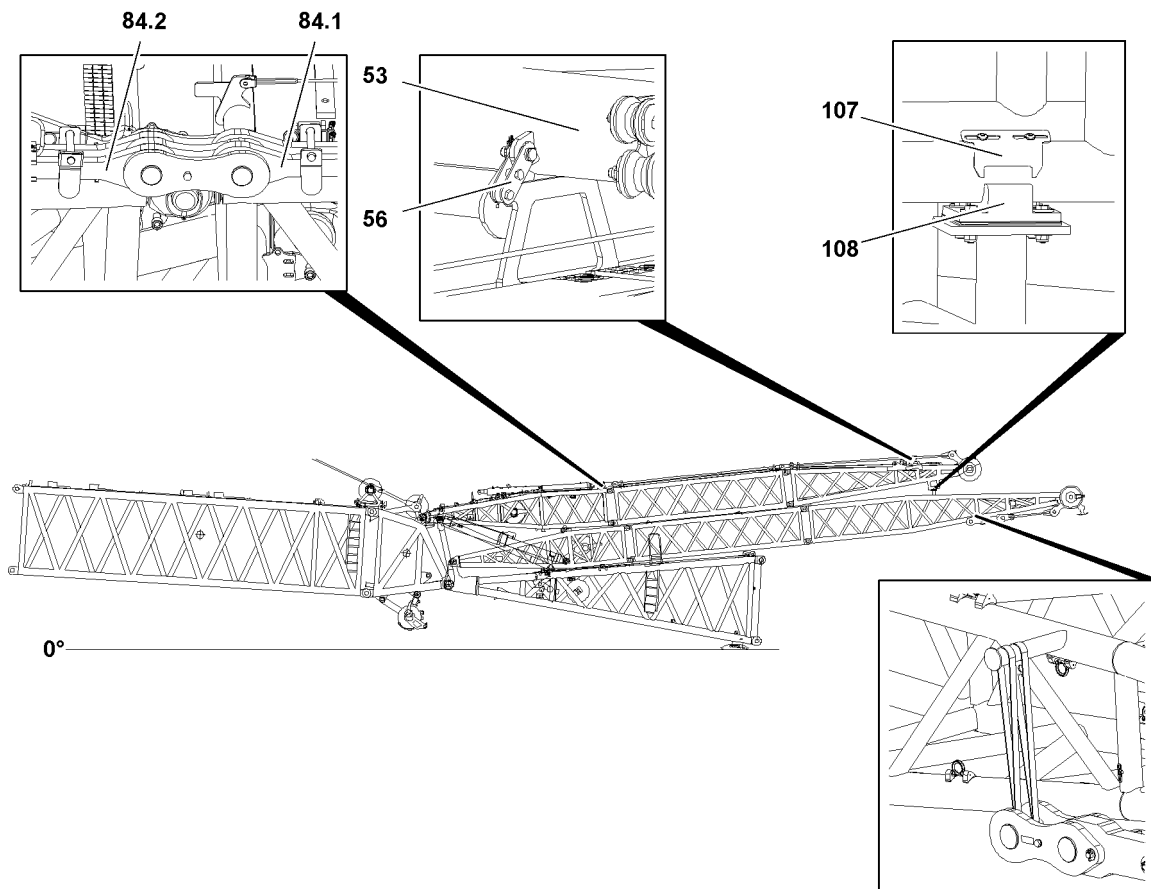

Fig.117095: Disassembling the assembly unit V - Prerequisites

Make sure that the following prerequisites are met:

- The transport retainers **56** of the cross beam **53** of WA-frame 2 are closed.
- The swing **48** of WA-frame 1 is pinned and secured with round slings.
- The guy rods **84.2** are unpinned from guy rods **84.1**.
- All transport retainers of the guy rods **84** on the WA-frame 2 are closed.
- The mark **107** and the mark **108** align.

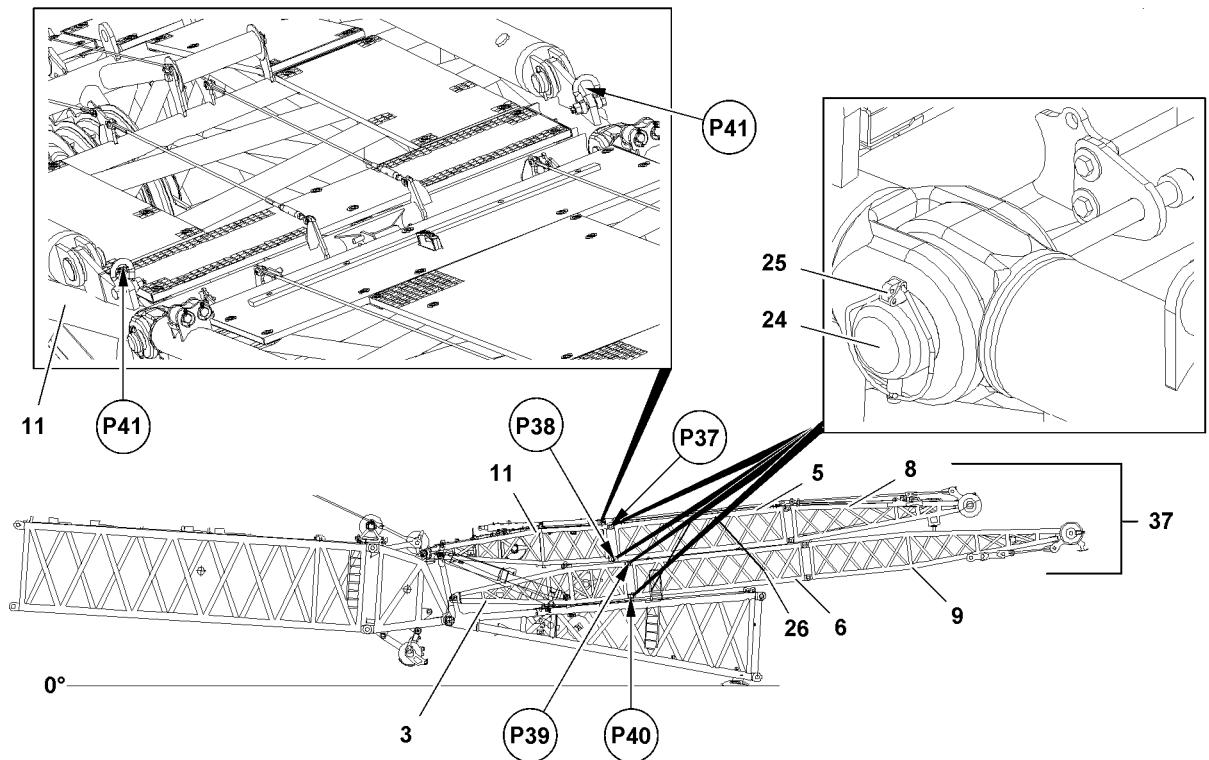

Fig.117096: Disassembling the assembly unit V - Disassembly procedure



Note

- ▶ The disassembly procedure is described as an example on the long WA-frames. The disassembly procedure for the short WA-frames is handled the same way.

- ▶ Fasten the auxiliary crane on both sides on points **P41** of the WA-frame 2 pivot section **11**.



DANGER

Do not stay in danger zone!
Death, severe bodily injuries, property damage.

- ▶ While the WA-frame 2 is lowered, it is prohibited for anyone to remain in the danger zone.

- ▶ Tension the fastening equipment until the WA-frame 2 is being held.
- ▶ Install the pin pulling device on point **P38**.
- ▶ Unpin the WA-frame 2 intermediate section **5** on WA-frame 2 pivot section **11**: Release the pins **24** on both sides on point **P38** and unpin.
- ▶ Take the WA-frame 2 pivot section **11** down with the auxiliary crane until the WA-frame 2 intermediate section **5** is laying on the WA-frame 1 intermediate section **6**.
- ▶ Remove the auxiliary crane on points **P41**.

When the long WA-frames are installed:

- ▶ Place all transport tension belts **26** between WA-frame 1 intermediate section **6** and WA-frame 2 intermediate section **5** and tension.

When the short WA-frames are installed:

- ▶ Place all transport tension belts **26** between WA-frame 1 end section **9** and WA-frame 2 end section **8** and tension.
- ▶ Unpin the WA-frame 2 intermediate section on WA-frame 2 pivot section **11**: Release the pins **24** on both sides on point **P37** and unpin.
- ▶ Fasten the assembly unit V **37** to the auxiliary crane, see section „Fastening points“.
- ▶ Tension the fastening equipment until the assembly unit V **37** is being held.
- ▶ Install the pin pulling device on point **P40**.
- ▶ Unpin the assembly unit V **37** on WA-frame 1 pivot section **3**: Release the pins **24** on both sides on point **P40** and unpin.

- ▶ Install the pin pulling device on point **P39**.
- ▶ Unpin the assembly unit **V 37** on WA-frame 1 pivot section **3**: Release the pins **24** on both sides on point **P39** and unpin.
- ▶ Lift the assembly unit **V 37** with the auxiliary crane and take it down on a suitable storage location.
- ▶ Remove the auxiliary crane.

6.9.5 Disassembling the WA-frame 2 pivot section

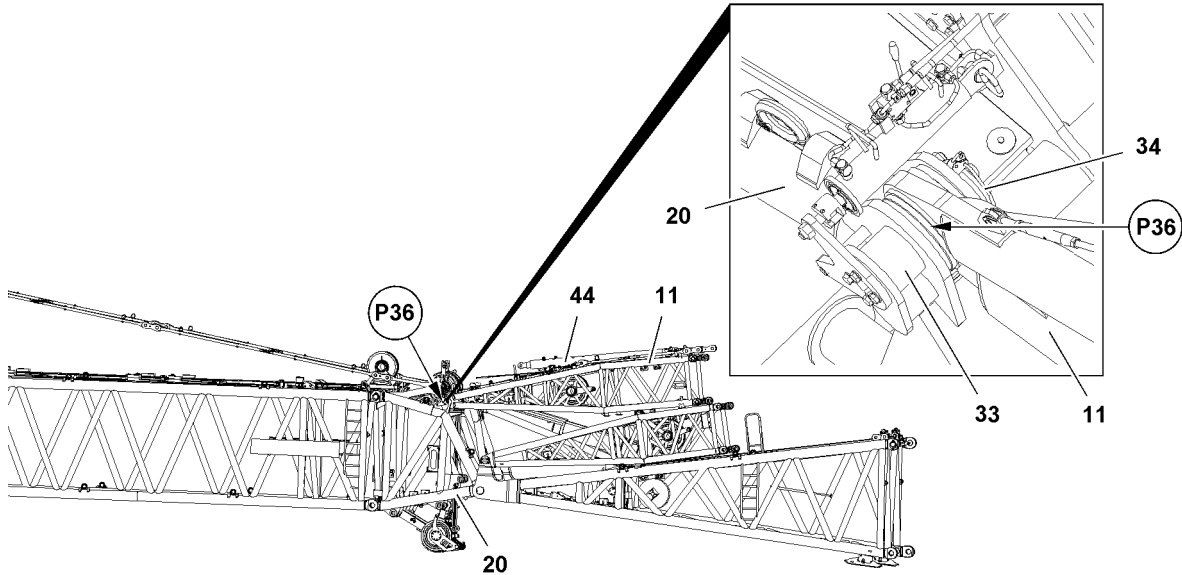

Fig.117097: Disassembling the WA-frame 2 pivot section

Make sure that the following prerequisites are met:

- The assembly unit **V** is completely removed.
- The relapse supports **44** are secured.
- The guy rods on the WA-frame 2 pivot section **11** are secured.

- ▶ Fasten the WA-frame 2 pivot section **11** to the auxiliary crane, see section „Fastening points“.



Note

- ▶ The WA-frame 2 pivot section **11** is unpinned with the pin pulling cylinder, see Crane operating instructions, chapter 5.30.
- ▶ Unpin the WA-frame 2 pivot section **11** on the S-end section **20**: Release the pins **33** on both sides on points **P36** and unpin.
- ▶ Take the WA-frame 2 pivot section **11** down with the auxiliary crane in a suitable storage location.
- ▶ Remove the auxiliary crane.

6.9.6 Disassembling the assembly unit I on the S-end section

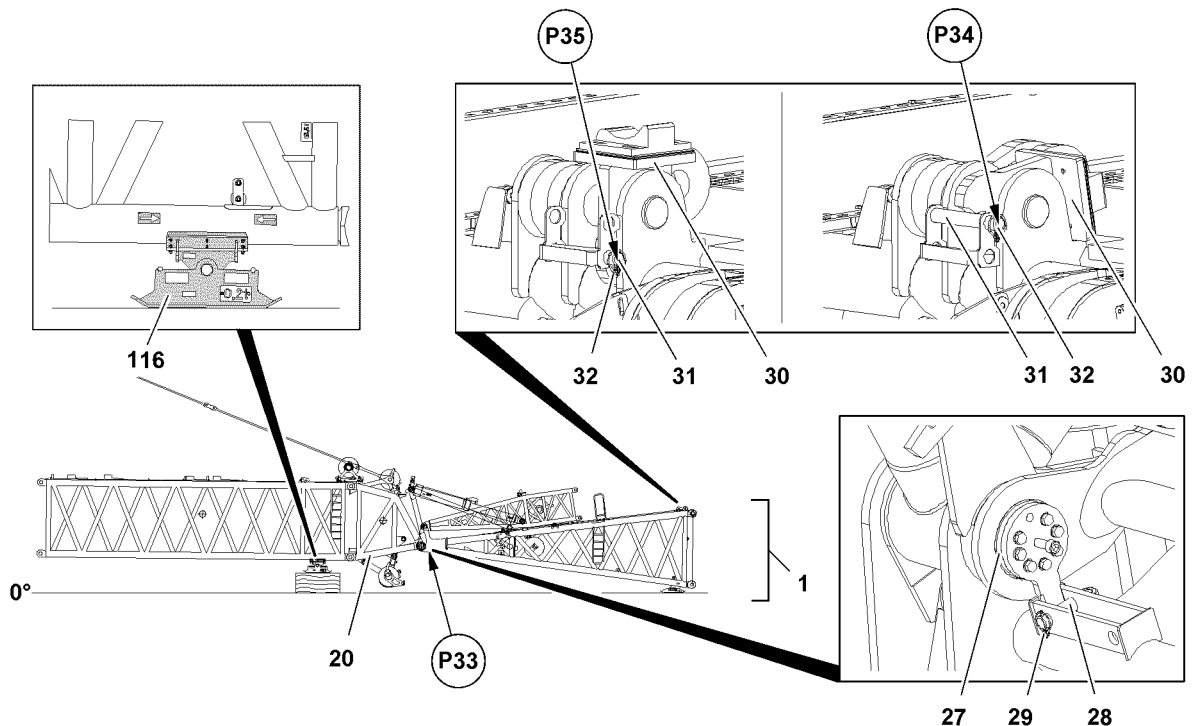

Fig.121052: Disassembling the assembly unit I on the S-end section

Make sure that the following prerequisites are met:

- The main boom is aligned parallel to the ground.
- The main boom is placed on the substructure.
- The assembly shoe **116** is set within the arrows.
- The WA-frame 2 pivot section is completely disassembled.
- The pin pulling cylinder is installed on point **P33** in front detent position
- An auxiliary crane is available.

- ▶ Release the rack **30** in operating position: Release the pin **31** on point **P35** and unpin.
- ▶ Align the placement surfaces to the side.
- ▶ Secure the rack **30** in transport position: Insert the pin **31** on point **P34** and secure with safety locking pin **32**.
- ▶ Repeat the procedure the same way for the second rack **30**.
- ▶ Fasten the assembly unit I **1** to the auxiliary crane, see section „Fastening points“.



Note

- ▶ The assembly unit I **1** is unpinned with the pin pulling cylinders, see Crane operating instructions, chapter 5.30.

The stroke of the pin pulling cylinder is not sufficient and it must be reset to insert the pin completely.

- ▶ Unpin the assembly unit I **1** on the S-end section **20**: Release the pins **27** on both sides on points **P33** and unpin with the pin pulling device.



WARNING

Danger of crushing!

Death, severe bodily injuries, property damage.

- ▶ Make sure, when swinging the W-pivot section in to the pin points, that no persons are within the danger zone.
- ▶ Swinging the load is prohibited.
- ▶ Make sure that no personnel is within the danger zone when operating the pin pulling device.
- ▶ Operate the pin pulling device with utmost caution from the pin pulling aggregate.

- ▶ Take the assembly unit I 1 down with the auxiliary crane in a suitable storage location.
- ▶ Remove the auxiliary crane.

6.9.7 Final tasks

Removing the wind speed sensor

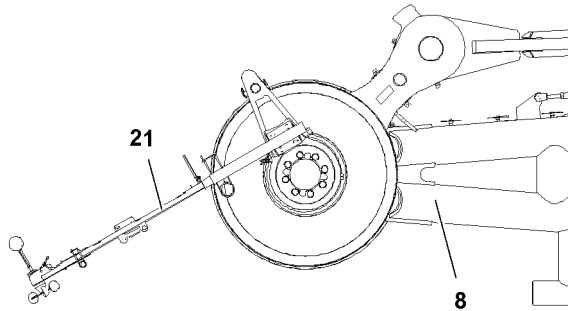

Fig.117026: Removing the wind speed sensor

- ▶ Remove the wind sensor 21 on WA-frame 2 end section 8.

Disassembling the WA-frame end sections on the WA-frame intermediate sections



Note

- ▶ If the short WA-frames are installed, then this step is not required.

Make sure that the following prerequisite is met:

- An auxiliary crane is available.

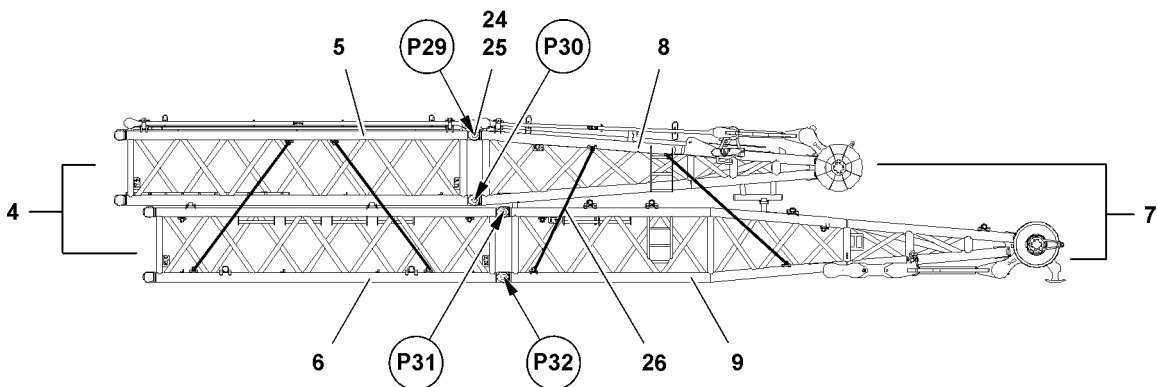

Fig.117029: Disassembling the WA-frame end sections on the WA-frame intermediate sections



WARNING

Missing tension belts!

Death, severe bodily injuries, property damage.

- ▶ The transport tension belts 26 between WA-frame 1 intermediate section 6 and WA-frame 2 intermediate section 5 must be tensioned.
 - ▶ The transport tension belts 26 between WA-frame 1 end section 6 and WA-frame 2 end section 8 must be tensioned.
-
- ▶ Install all transport tension belts 26 on assembly unit III 7 (WA-frame 1 end section 9 and WA-frame 2 end section 8).

**Note**

- ▶ The WA-frame components are unpinned with the pin pulling cylinders, see Crane operating instructions, chapter 5.30.
- ▶ Attach the auxiliary crane on assembly unit III 7, see section „Fastening points“.
- ▶ Unpin the assembly unit III 7 on assembly unit II 4: Release the pins 24 on both sides on points P32 and unpin.
- ▶ Unpin the assembly unit III 7 on assembly unit II 4: Release the pins 24 on both sides on points P31 and unpin.
- ▶ Unpin the assembly unit III 7 on assembly unit II 4: Release the pins 24 on both sides on points P30 and unpin.
- ▶ Unpin the assembly unit III 7 on assembly unit II 4: Release the pins 24 on both sides on points P29 and unpin.
- ▶ Lift the assembly unit III 7 with the auxiliary crane and take it down in a suitable storage location.

Removing additional guy rods

Fig.117027: Removing additional guy rods - Short WA-frames

When the short WA-frames were installed:

- ▶ Unpin the 6 m guy rods 22 on both sides on the guy rods 83 of the S-intermediate section 13: Release pins 85 on both sides on points P73 and unpin.

When the short WA-frames with additional guy rods 38 were installed:

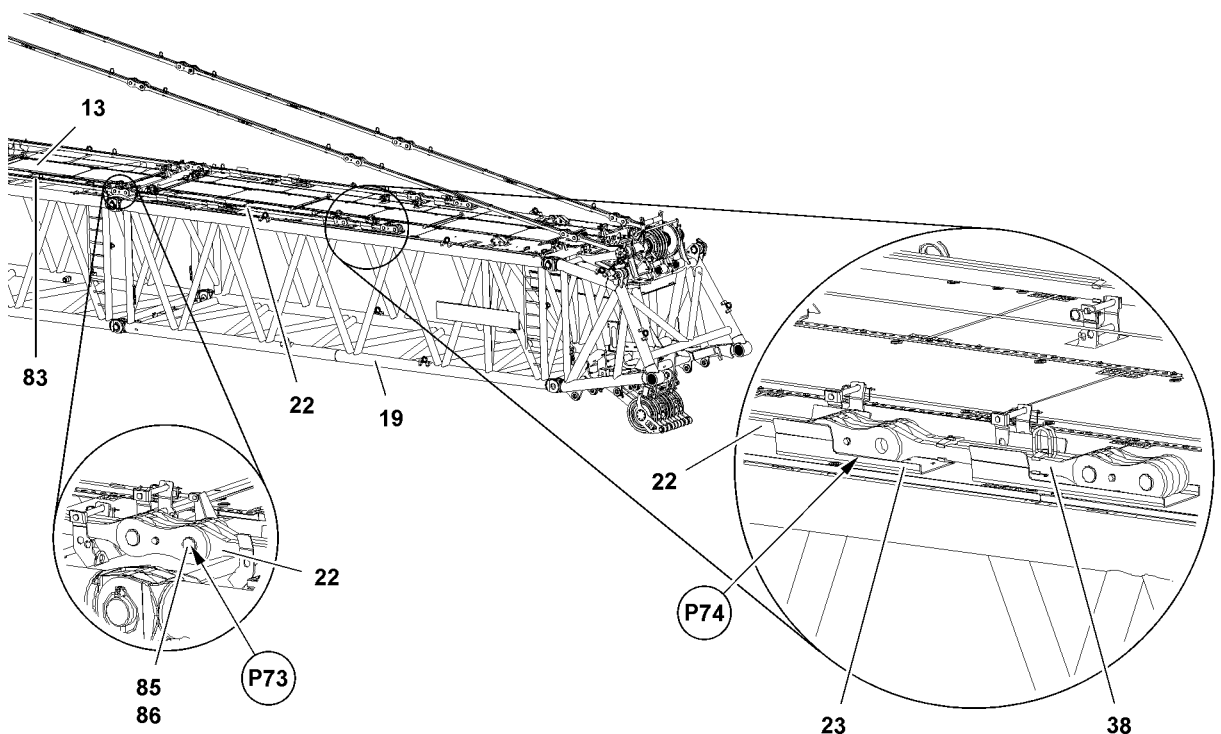
- ▶ Unpin the guy rods 38 on both sides on the 6 m guy rods 22: Release pins 85 on both sides on points P74 and unpin.

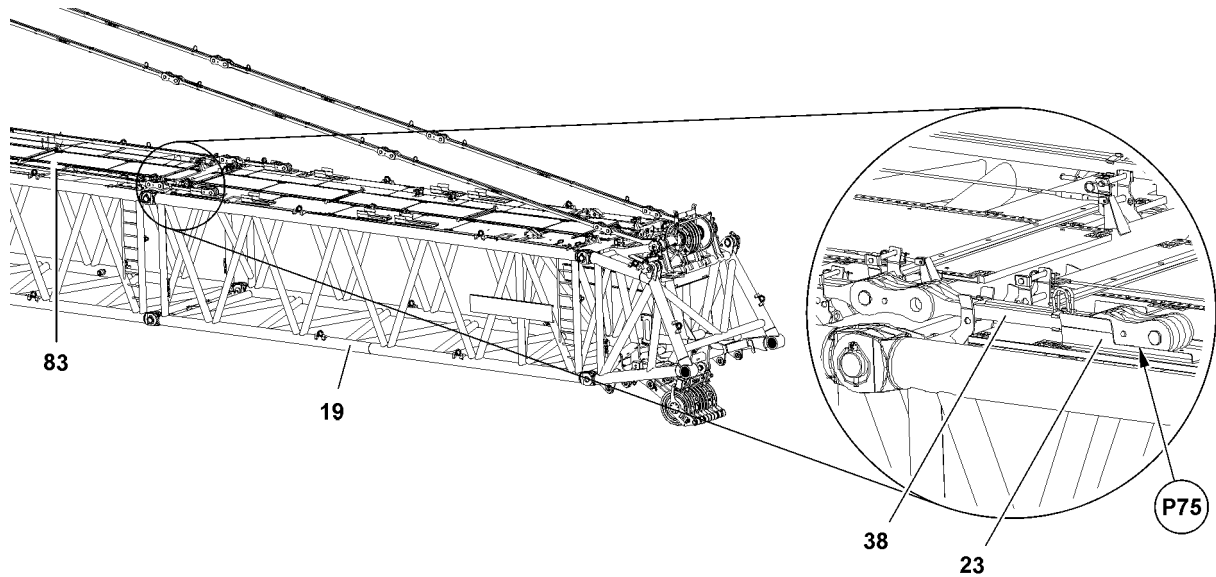

Fig.117051: Removing additional guy rods - Long WA-frames

When the long WA-frames with additional guy rods **38** were installed:

- ▶ Unpin the guy rods **38** on both sides on the guy rods **83**. Release pins **85** on both sides on points **P75** and unpin.
- ▶ Fasten all additional guy rods to the auxiliary crane and remove.

Installing the change over pulley in the transport position

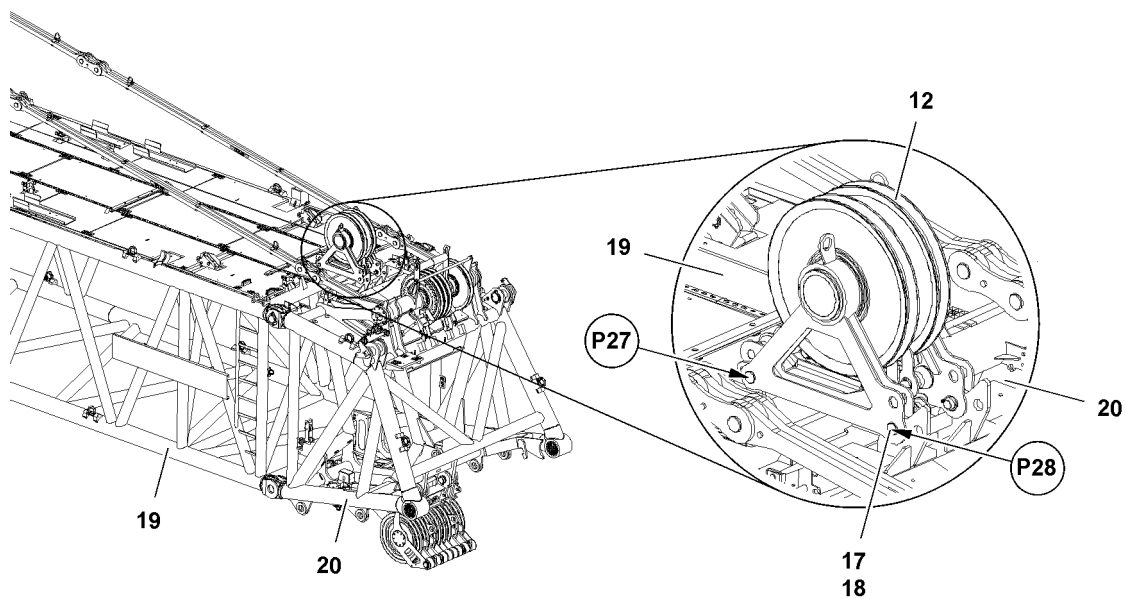

Fig.117025: Installing the change over pulley in the transport position - Unpinning the change over pulley in the operating position

- ▶ Fasten the change over pulley **12** to the auxiliary crane, see section „Fastening points“.
- ▶ Unpin the change over pulley **12** on the S-adaptor **19**: Release pins **17** on both sides on points **P27** and unpin.
- ▶ Unpin the change over pulley **12** on the S-end section **20**: Release pins **17** on both sides on points **P28** and unpin.

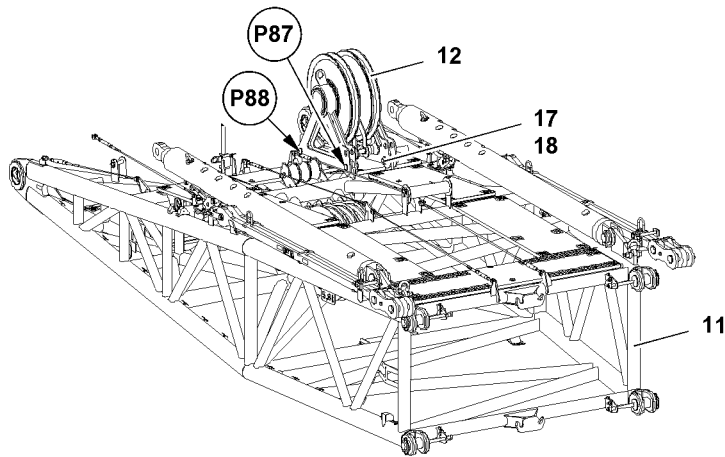

Fig.117099: Installing the change over pulley in the transport position - Pinning the change over pulley in the transport position

- ▶ Lift the change over pulley **12** with the auxiliary crane and position it on the WA-frame 2 pivot section **11** so it can be pinned on points **P87** and points **P88**.
- ▶ Pin the change over pulley **12** on the WA-frame 2 pivot section **11**: Insert the four pins **17** and secure with the safety locking pin **18**.

Empty page!

LWE/LR 11000-001/23501-04-02/en

5.10 Boom nose lattice boom

1	Component overview	3
2	Fastening points for boom nose 32 t	4
3	Installing the boom nose 32 t	7
4	Crane operation	21
5	Disassembling the 32 t boom nose	23

Fig.195219

LWE/LR 11000-001/23501-04-02/en

1 Component overview



Note

- ▶ The boom nose is marked with its own weight.
- ▶ Dimensions and weights, see Crane operating instructions, chapter 1.03.

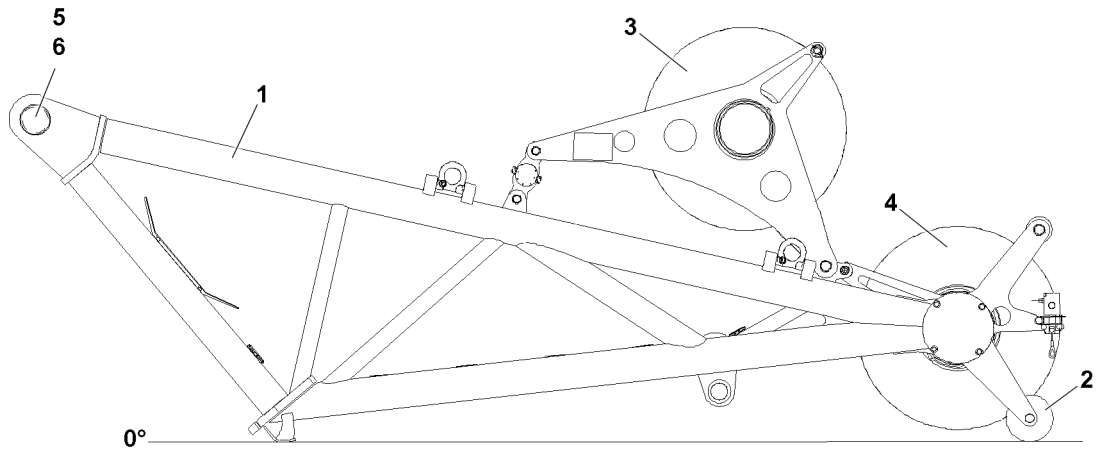

Fig.124473: Boom nose 32 t

Position	Component
1	Boom nose 32 t
2	Base roller
3	Rope pulley I
4	Rope pulley II
5	Pin
6	Safety locking pin

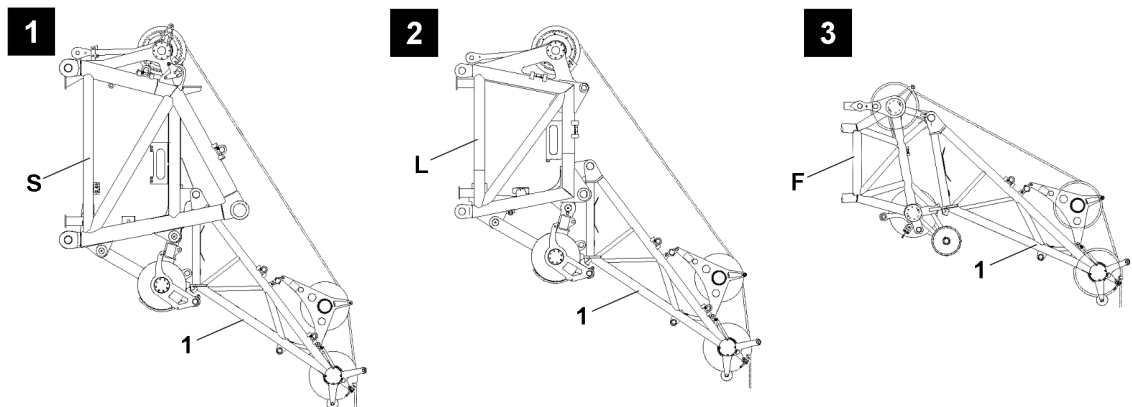

Fig.124475: Installation possibilities of the boom nose

LWE/LR 11000-001/23501-04-02/en

Installation possibilities of the boom nose	
Illustration	Boom
1	S-boom with end section
2	L-boom with end section
3	F-jib with end section

**WARNING**

Load capacity of boom nose!

For boom variation with F-jib, the permissible load capacity of the boom nose is limited to 20 t. Death, severe bodily injuries, property damage.

► Make sure that the load capacity of the boom nose does not exceed 20 t.

2 Fastening points for boom nose 32 t

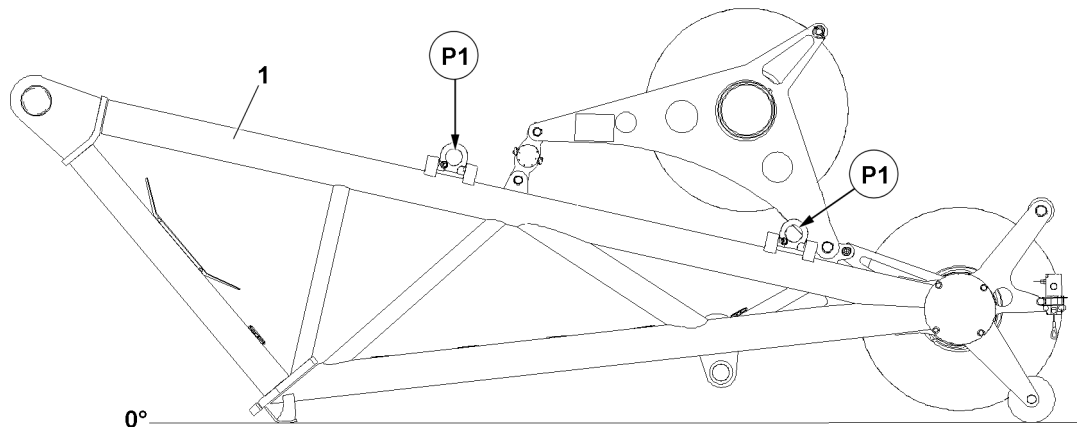

Fig.124474

**WARNING**

Component incorrectly fastened!

Death, severe bodily injuries, property damage.

- Fasten the components only on the intended fastening points on both sides.
- Fastening of components and description of fastening points, see Crane operating instructions, chapter 5.01.

Fastening points	
P1 and P2	Boom nose

Empty page!

LWE/LR 11000-001/23501-04-02/en

Fig.195219

LWE/LR 11000-001/23501-04-02/en

3 Installing the boom nose 32 t



WARNING

Danger of falling!

During assembly / disassembly, inspection and maintenance work, personnel must be secured with appropriate aids to prevent them from falling.

Death, severe bodily injuries, property damage.

- ▶ All work aloft, where there is a danger of falling must be carried out with suitable aids.
- ▶ If aids are not available and work cannot be carried out from the ground, then the assembly personnel must secure themselves with the supplied fall arrest system to prevent falling, see Crane operating instructions, chapter 2.04.
- ▶ If fall protection equipment is available, then it must be used, see Crane operating instructions, chapter 2.06.
- ▶ When lifting, lowering, swinging crane parts in and out, no persons may remain in the danger zone.
- ▶ If railings are present for the crane, then they must be brought into the corresponding position and secured for assembly / disassembly work.
- ▶ Only step on the aids, ladders and catwalks with clean shoes.
- ▶ Keep aids, ladders and catwalks free of heavy dirt, snow and ice.
- ▶ During all assembly and disassembly work, maintenance work and inspections, travel or crane operation is prohibited.
- ▶ Remaining on a suspended load is prohibited.
- ▶ Stepping or walking on crane components and lattice sections, which have an incline of more than 20° is prohibited.
- ▶ For all assembly work, the crane operator of the main crane must be in voice contact with the crane operator / crane operators of the auxiliary crane / auxiliary cranes.
- ▶ For assembly / disassembly tasks, the crane operator may only initiate crane movements when the responsible guide has explicitly released the movement.



WARNING

Danger of impact / crushing!

When installing / removing crane components with the auxiliary crane, crane components can start to swing back and forth.

When lifting / lowering and positioning crane components, there is an increased danger of impacts / crushing.

Death, severe bodily injuries, property damage.

- ▶ Make sure that personnel cannot be caught by components.
- ▶ When working in danger zones: Use aids to protect limbs.
- ▶ Guide components with suitable aids to minimize oscillation.



DANGER

The components can fall down!

If the corresponding component is disengaged from the auxiliary crane before the corresponding component is pinned, then the corresponding component can fall down.

Death, severe bodily injuries, property damage.

- ▶ Do not disengage the auxiliary crane until the corresponding component is pinned and secured.

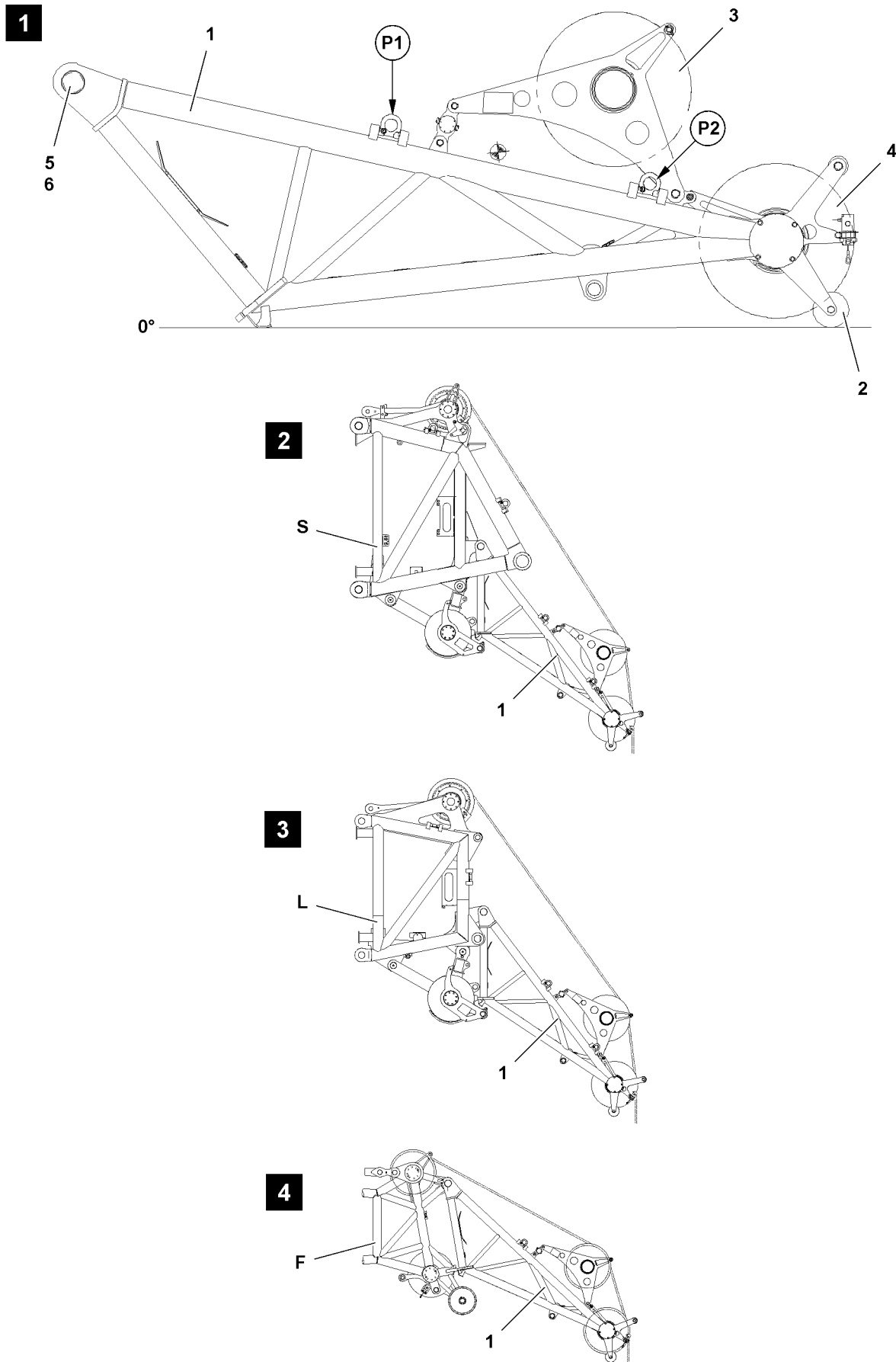

Fig.119036

LWE/LR 11000-001/23501-04-02/en

**WARNING**

Danger of accident due to function „Exceeding the shut off limits of the LICCON overload safety device“!

If the shut off limits of the LICCON overload safety device are exceeded, there is no additional protection against crane overload.

Due to erroneous operation or deliberate misuse, the crane could collapse, the boom can break off or the crane can topple over.

Death, severe bodily injuries, property damage.

- ▶ The function „Exceeding the shut off limits of the LICCON overload safety device“ is only permissible in emergencies and for assembly purposes.
- ▶ The function „Exceeding the shut off limits of the LICCON overload safety device“ may only be actuated by persons who know the effects of their actions regarding the function „Exceeding the shut off limits of the LICCON overload safety device“.
- ▶ The function „Exceeding the shut off limits of the LICCON overload safety device“ requires the presence of an authorized person and must be performed with utmost caution.
- ▶ Crane operation with activated function „Exceeding the shut off limits of the LICCON overload safety device“ is prohibited.

Make sure that the following prerequisites are met:

- The crane is aligned in horizontal direction.
- The boom including the respective end section are installed.
- The boom is placed on a load-bearing support.
- The counterweight has been installed on the turntable according to the load chart.
- The LICCON overload safety device has been set according to the data in the load chart.
- The LICCON overload safety device is exceeded.
- The assembly icon is visible on the LICCON monitor.
- An auxiliary crane is available.

5

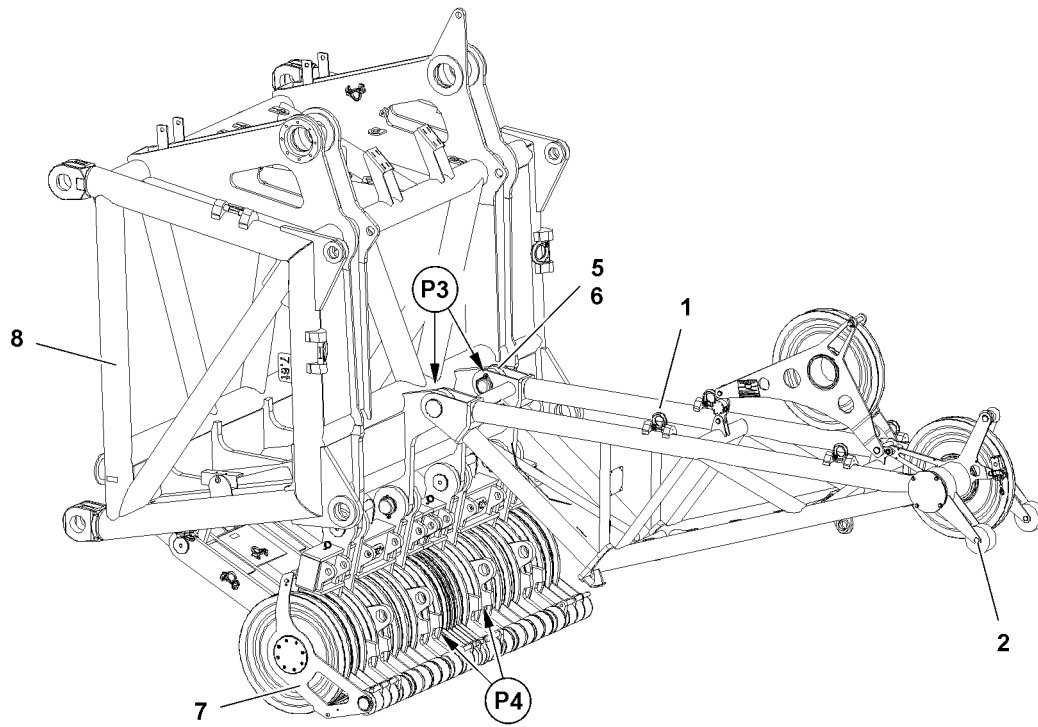

6

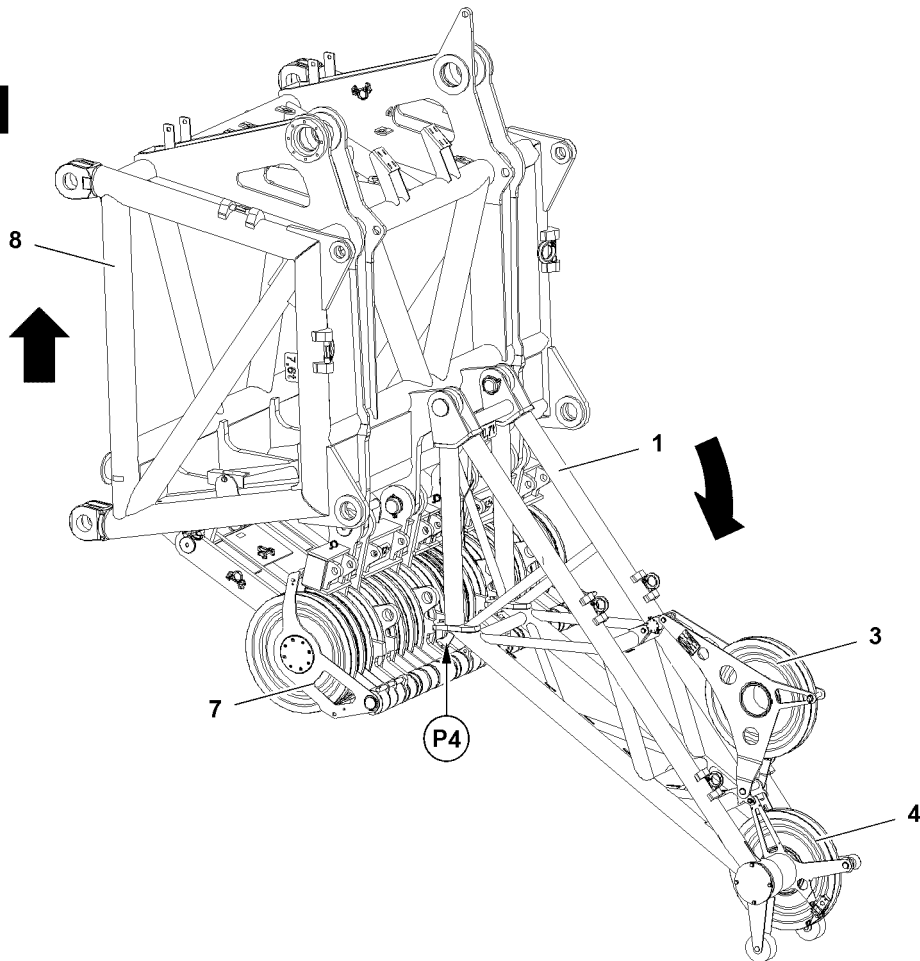

Fig.119037

LWE/LR 11000-001/23501-04-02/en

3.1 Assembly procedure

Make sure that the following prerequisite is met:

- The boom end section is laying on the ground.



Note

- ▶ For assembly of the boom nose on the end section, the assembly procedure and the process are identical for all boom variations.
 - ▶ The assembly of the boom nose is described therefore on a variation with L-boom.
-
- ▶ Attach the boom nose **1** on the auxiliary crane.
 - ▶ Lift the boom nose **1** with the auxiliary crane and swing it to the boom end section **8**.
 - ▶ Position the boom nose **1** at points **P3**, see illustration **5**.



WARNING

The pins can loosen up by themselves!

If the pins are not secured with the safety locking pins, the axles can release during crane operation. This can cause the crane to topple over.

Death, severe bodily injuries, property damage.

- ▶ Make sure that all pins are inserted and secured.

The boom nose is pinned on two points.

- ▶ Pin the boom nose **1** at points **P3** with the boom end section **8** „on top“: Insert the pin **5** and secure with safety locking pin **6**, see illustration **5**.
- ▶ Place the boom nose **1** with the auxiliary crane on the base rollers **2** on the ground.
- ▶ Remove the auxiliary crane.



Note

- ▶ Reeve in the hoist rope according to the Reeving plan, see Reeving plan.

5

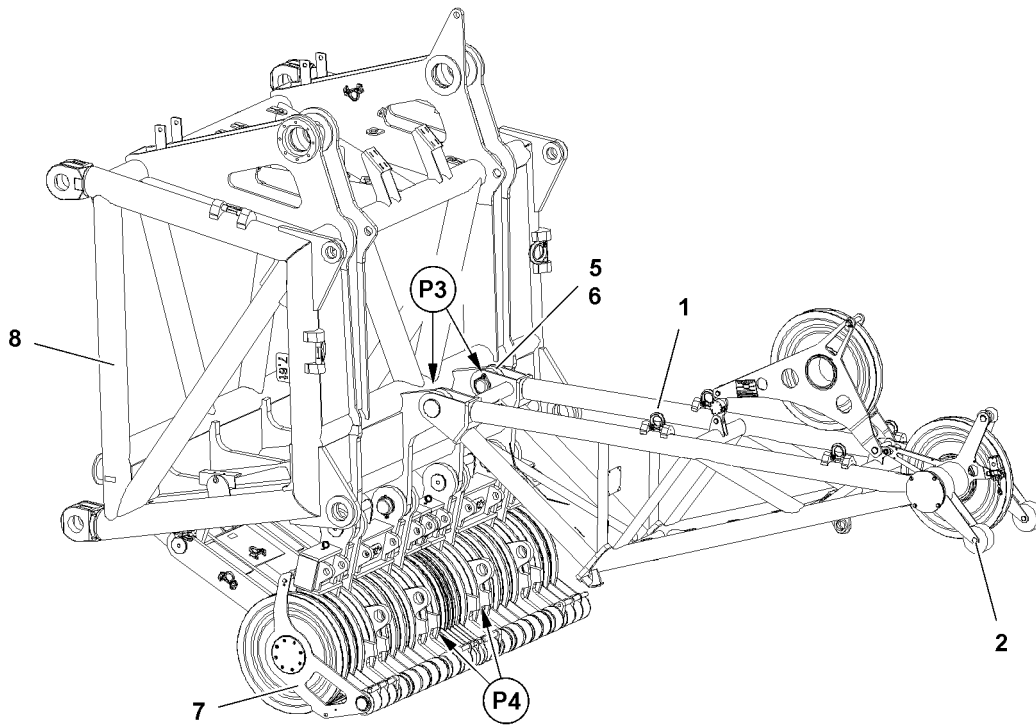

6

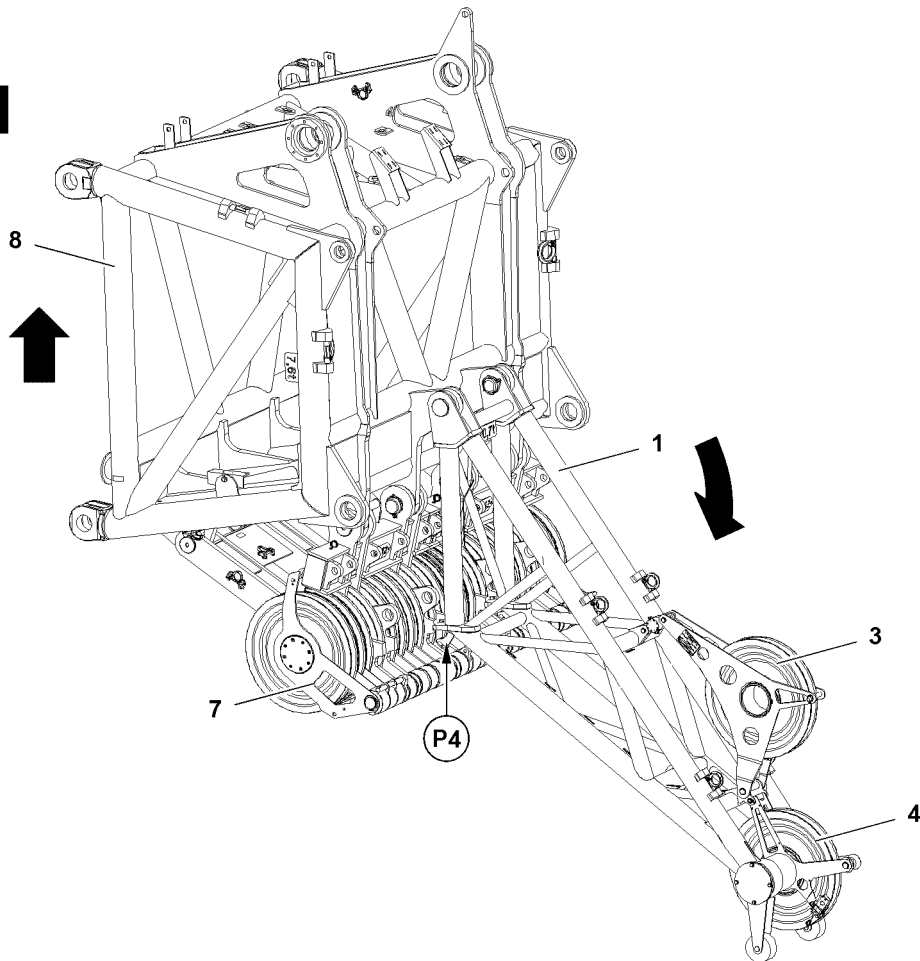

Fig.119037

LWE/LR 11000-001/23501-04-02/en

- ▶ Pull the hoist rope over the rope pulley I **3** and rope pulley II **4**.
- ▶ Luff the boom up until the boom nose **1** is touching on the boom end section **8** „on the bottom“ in the receptacle at points **P4**, see illustration **5** and illustration **6**.



WARNING

Falling hoist rope!

If the hoist rope is not properly secured with a corresponding length on the boom nose before the erection procedure, then it can fall backward due to its own weight.

Death, severe bodily injuries, property damage.

- ▶ Reeve in the hoist rope with sufficient length on the boom nose before the erection process.
- ▶ The hoist rope must be constantly monitored during erection.
- ▶ Do not step into the danger zone.



WARNING

Danger of accident due to side wind!

If the slewing gear brake is released after reeving / unreeving the hook block / the load hook, then the crane can turn uncontrolled in strong side wind.

Death, severe bodily injuries, property damage.

The crane can collide with close-by structures or objects.

- ▶ Make sure that the current wind speed does not exceed the values from the wind speed chart when releasing the slewing gear brake.
-
- ▶ Apply the slewing gear brake before reeving in the hook block.
 - ▶ Reeve the hook block properly and attach the hoist limit switch weight.

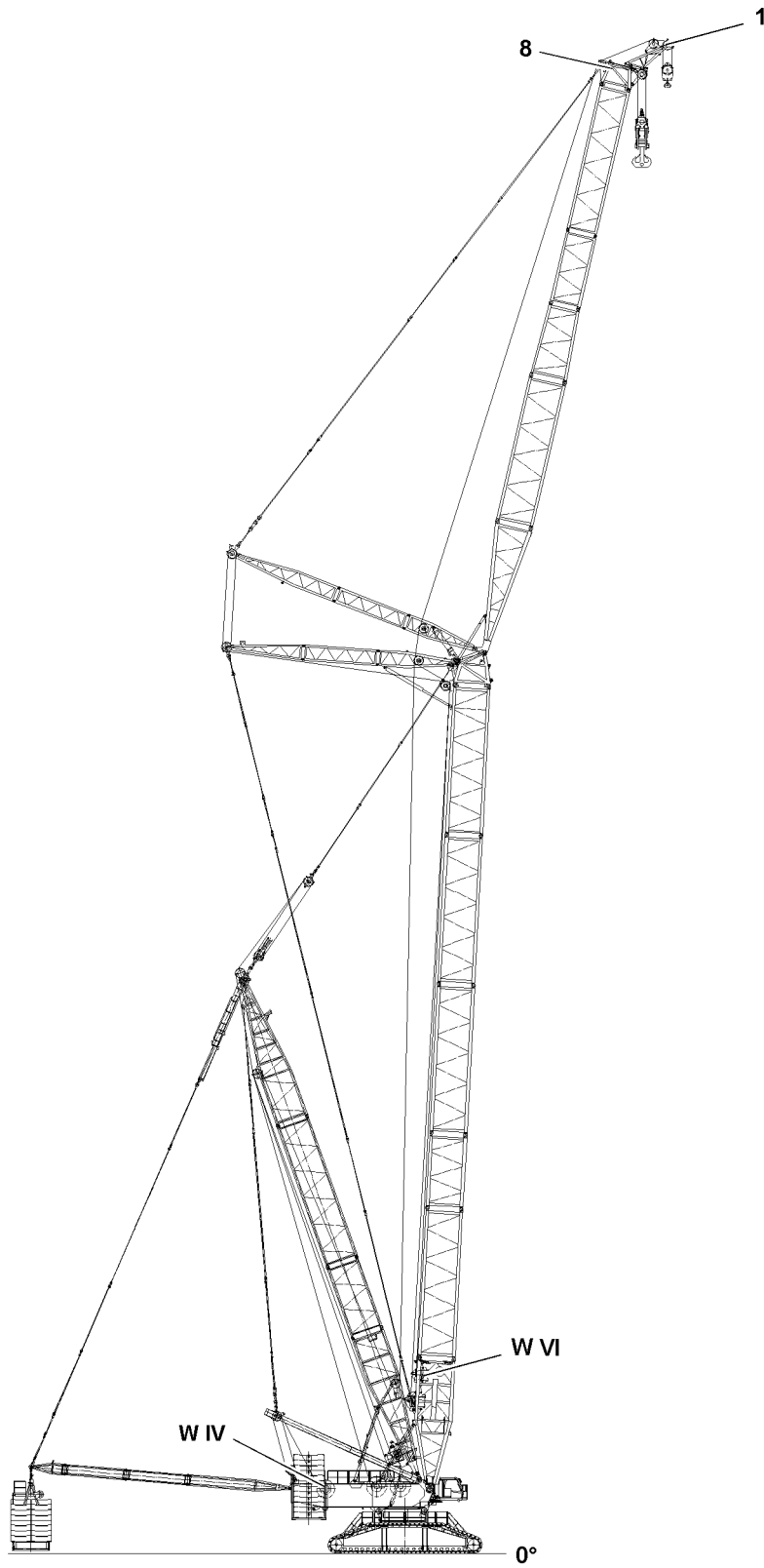

Fig.119038

LWE/LR 11000-001/23501-04-02/en

3.2 Establishing the electrical connections

NOTICE

Damage to the electrical connection on the cable drum!

If the electrical connection from the cable drum on the L-pivot section to the terminal box on the L-pivot section is established first before the connection to the terminal box on the respective end section, then the electrical connection can be damaged when spooling out the cable drum.

- ▶ Establish first the electrical connection from the cable drum in the L-pivot section to the terminal box on the respective end section and then the electrical connection from the terminal box in the L-pivot section to the cable drum in the L-pivot section.



Note

- ▶ To establish the electrical connections, see Electric wiring diagram.

Make sure that the following prerequisites are met:

- The boom is fully assembled.
- The airplane warning light and the wind speed sensor are assembled.
- ▶ Establish the electrical connections.
- ▶ Make sure that all electrical connections on the boom are established.

3.3 Function check



WARNING

Non-functioning safety equipment!

If the function of the safety equipment is defective, personnel can be severely injured or killed.

- ▶ Crane operation with non-functioning safety equipment is **prohibited**.



Note

- ▶ The function of the individual limit switches must be checked before erection.
- ▶ The function of the limit switch initiators must be checked in the test system, see Diagnostics manual.



Note

- ▶ If a function check on the limit switches or on the safety equipment does not lead to the desired shut offs, then the plug connections on the terminal boxes or the components itself must be checked.
- ▶ If no visible connection errors or component defects can be found, contact **LIEBHERR** Service.

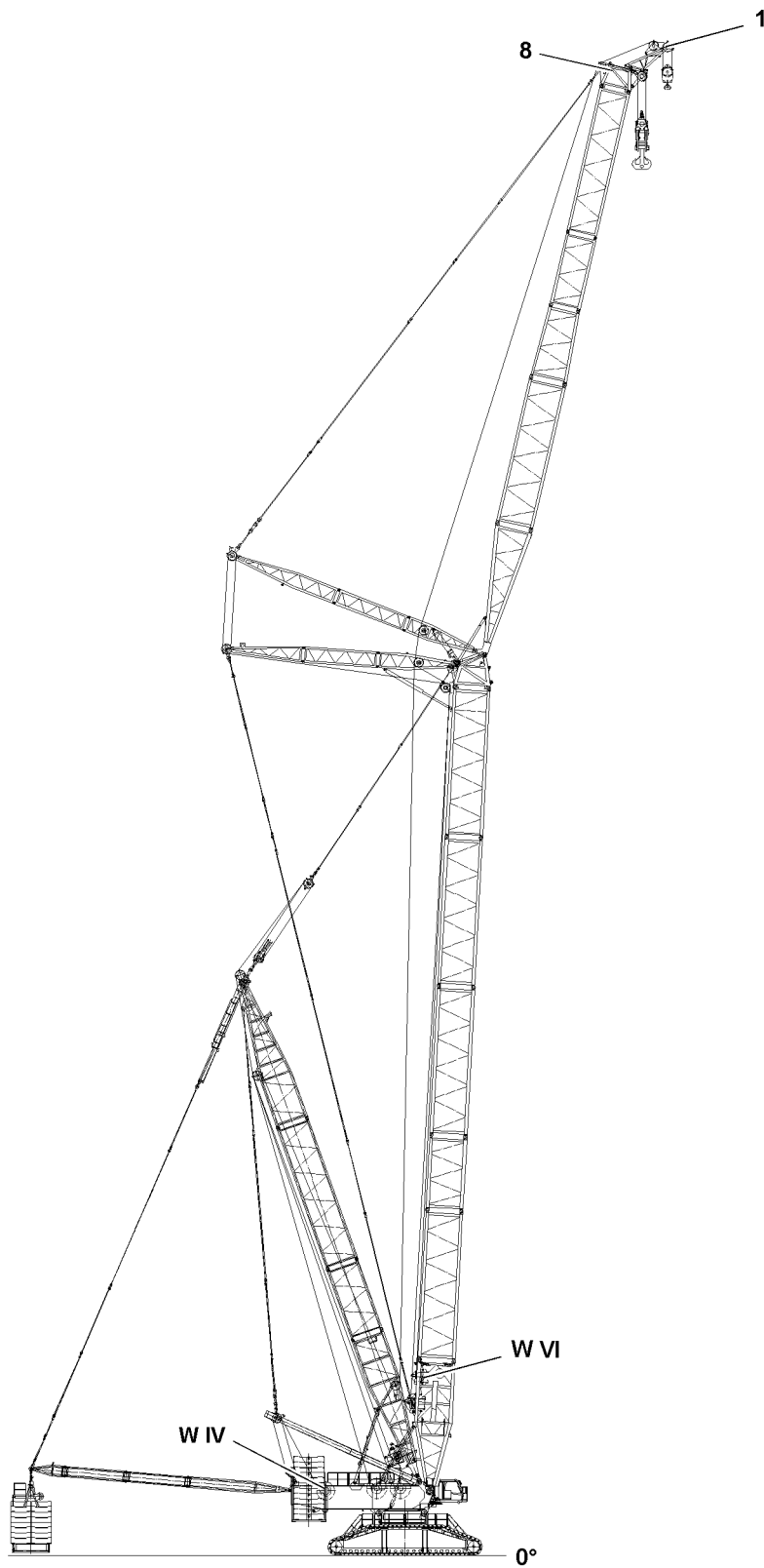

Fig.119038

LWE/LR 11000-001/23501-04-02/en

Make sure that the following prerequisites are met:

- All electrical connections have been made.
- The crane engine is running.
- The corresponding operating mode is set on the LICCON monitor.

3.3.1 Checking the wind speed sensor

- ▶ Check the movement and the function of the wind speed sensor.

3.3.2 Checking the airplane warning light

- ▶ Turn the airplane warning light on.
- ▶ Check the function visually.

3.3.3 Checking the hoist limit switch on the pulley head



Note

- ▶ When replacing or changing a hoist limit switch (HES), the corresponding hoist limit switch must have the correct bus address and the correct software version in order to be detected again by the bus system (LSB).
-

- ▶ Actuate the hoist limit switch manually on the pulley head.

Result:

- The spool up function of the hoist winch turns off.
- The icon „Hoist top“ appears on the LICCON monitor 0.
- The limit switch is functioning.

3.3.4 Checking the limit switches in general



Note

- ▶ The limit switch functions have to be checked individually before erection.
 - ▶ To check the limit switches, see corresponding chapter for respective boom system in the Crane operating instructions.
-

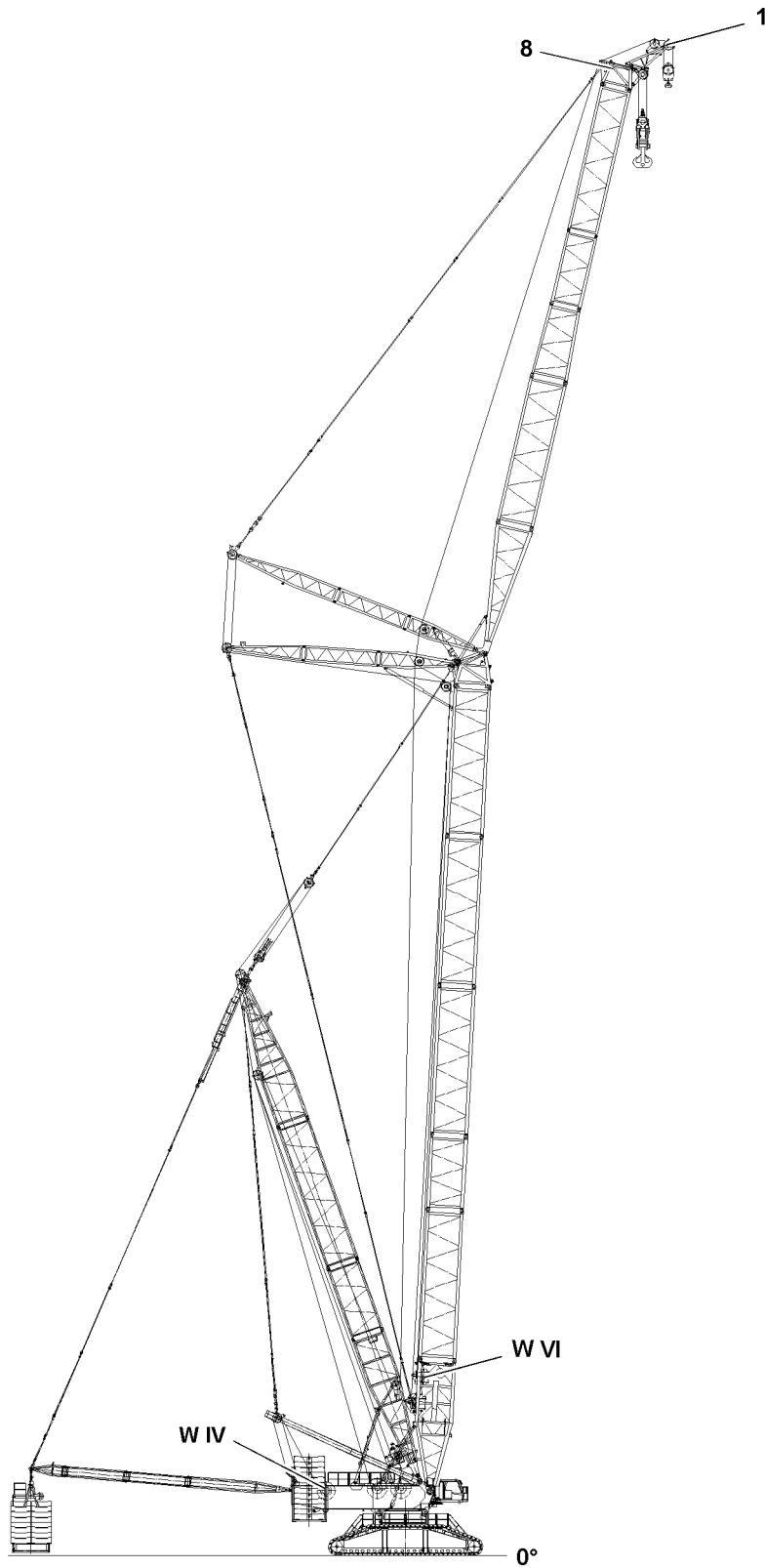

LWE/LR 11000-001/23501-04-02/en

Fig.119038

3.4 Erecting the boom



WARNING

The crane can topple over!

If the following conditions are not met before erecting the boom, the crane can topple over.

Death, severe bodily injuries, property damage.

- ▶ Observe and adhere to the safety technical notes, see Crane operating instructions, chapter 5.01.
- ▶ Observe the specifications in the erection and take down charts.
- ▶ Extend the relapse cylinder before erection.

Make sure that the following prerequisite is met:

- The LICCON overload safety device is exceeded.



WARNING

The crane can topple over!

In crane operation with exceeded LICCON overload safety device, the crane can topple over.

Death, severe bodily injuries, property damage.

- ▶ The radii listed in the load chart may not be exceeded or fallen below, even if there is no load on the hook.



Note

- ▶ When the lowest operating position of the boom is reached, the set load chart of the LICCON overload safety device is activated.
- ▶ In the maximum load icon appears a load number in „t“ instead of the display „???“.

- ▶ Luff the S-boom up to the lowest operating position.
- ▶ When the boom has reached the lowest operating position: Make sure that the assembly icon turns off on the LICCON monitor.

Result:

- The LICCON overload safety device is active.

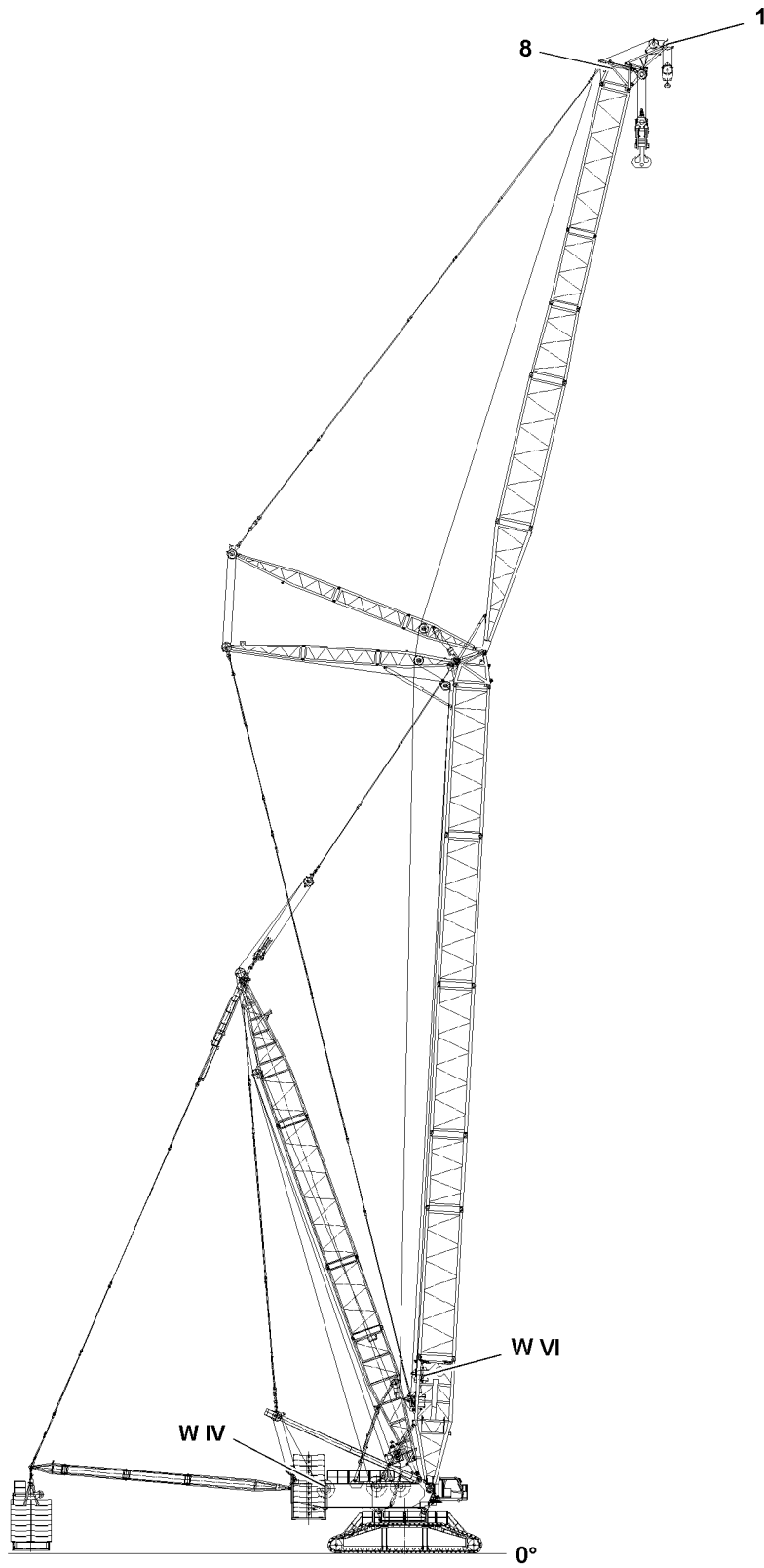

LWE/LR 11000-001/23501-04-02/en

Fig.119038

4 Crane operation

Observe the instructions in chapter 4.05, chapter 4.08 and chapter 5.01.

Make sure that the following prerequisites are met:

- The LICCON overload protection has been set according to the data in the load chart.
- The LICCON overload safety device is active.
- The assembly icon on the LICCON monitor is off, see Crane operating instructions, chapter 4.02.



WARNING

Load reduction!

During crane operation with installed boom nose, the value in the load charts is reduced by the own weight of the boom nose.

Death, severe bodily injuries, property damage.

- ▶ Observe the load charts.
-



WARNING

The crane can topple over!

Death, severe bodily injuries, property damage.

- ▶ Check the horizontal position of the crane before and during operation.
 - ▶ If the crane operator leaves the cab, even for a short time, the operating mode setting must be checked and reset, if necessary, before resuming crane operation.
-

4.1 Checking the settings

- ▶ Check the function of the overload protection by running against the operating positions on top and bottom.
- ▶ Check the hoist limit switch by running against the hoist limit switch weight.
- ▶ Check the function of the force test bracket on the boom nose.

Fig.195219

LWE/LR 11000-001/23501-04-02/en

5 Disassembling the 32 t boom nose



WARNING

Danger of falling!

During assembly / disassembly, inspection and maintenance work, personnel must be secured with appropriate aids to prevent them from falling.

Death, severe bodily injuries, property damage.

- ▶ All work aloft, where there is a danger of falling must be carried out with suitable aids.
- ▶ If aids are not available and work cannot be carried out from the ground, then the assembly personnel must secure themselves with the supplied fall arrest system to prevent falling, see Crane operating instructions, chapter 2.04.
- ▶ If fall protection equipment is available, then it must be used, see Crane operating instructions, chapter 2.06.
- ▶ When lifting, lowering, swinging crane parts in and out, no persons may remain in the danger zone.
- ▶ If railings are present for the crane, then they must be brought into the corresponding position and secured for assembly / disassembly work.
- ▶ Only step on the aids, ladders and catwalks with clean shoes.
- ▶ Keep aids, ladders and catwalks free of heavy dirt, snow and ice.
- ▶ During all assembly and disassembly work, maintenance work and inspections, travel or crane operation is prohibited.
- ▶ Remaining on a suspended load is prohibited.
- ▶ Stepping or walking on crane components and lattice sections, which have an incline of more than 20° is prohibited.
- ▶ For all assembly work, the crane operator of the main crane must be in voice contact with the crane operator / crane operators of the auxiliary crane / auxiliary cranes.
- ▶ For assembly / disassembly tasks, the crane operator may only initiate crane movements when the responsible guide has explicitly released the movement.



WARNING

Danger of impact / crushing!

When installing / removing crane components with the auxiliary crane, crane components can start to swing back and forth.

When lifting / lowering and positioning crane components, there is an increased danger of impacts / crushing.

Death, severe bodily injuries, property damage.

- ▶ Make sure that personnel cannot be caught by components.
- ▶ When working in danger zones: Use aids to protect limbs.
- ▶ Guide components with suitable aids to minimize oscillation.



DANGER

The components can fall down!

If the corresponding component is disengaged from the auxiliary crane before the corresponding component is pinned, then the corresponding component can fall down.

Death, severe bodily injuries, property damage.

- ▶ Do not disengage the auxiliary crane until the corresponding component is pinned and secured.

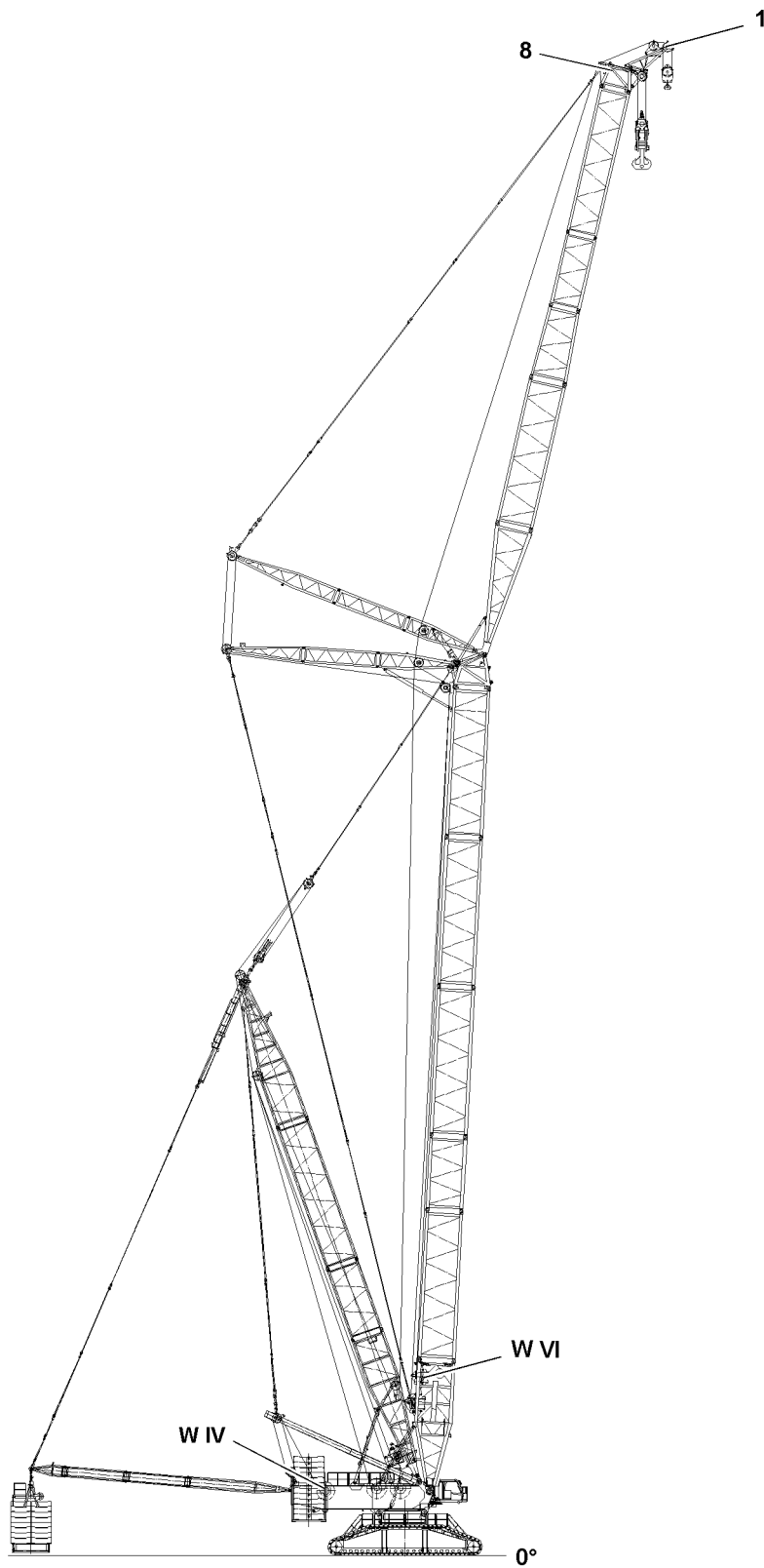

Fig.119038

LWE/LR 11000-001/23501-04-02/en

**WARNING**

Danger of accident due to function „Exceeding the shut off limits of the LICCON overload safety device“!

If the shut off limits of the LICCON overload safety device are exceeded, there is no additional protection against crane overload.

Due to erroneous operation or deliberate misuse, the crane could collapse, the boom can break off or the crane can topple over.

Death, severe bodily injuries, property damage.

- ▶ The function „Exceeding the shut off limits of the LICCON overload safety device“ is only permissible in emergencies and for assembly purposes.
- ▶ The function „Exceeding the shut off limits of the LICCON overload safety device“ may only be actuated by persons who know the effects of their actions regarding the function „Exceeding the shut off limits of the LICCON overload safety device“.
- ▶ The function „Exceeding the shut off limits of the LICCON overload safety device“ requires the presence of an authorized person and must be performed with utmost caution.
- ▶ Crane operation with activated function „Exceeding the shut off limits of the LICCON overload safety device“ is prohibited.

Make sure that the following prerequisites are met:

- The crane is properly supported and horizontally aligned.
- An auxiliary crane is available.
- The counterweight has been installed on the turntable according to the load chart.
- The LICCON overload safety device has been set according to the data in the load chart.
- The LICCON overload safety device settings have been compared with the actual set up configuration.

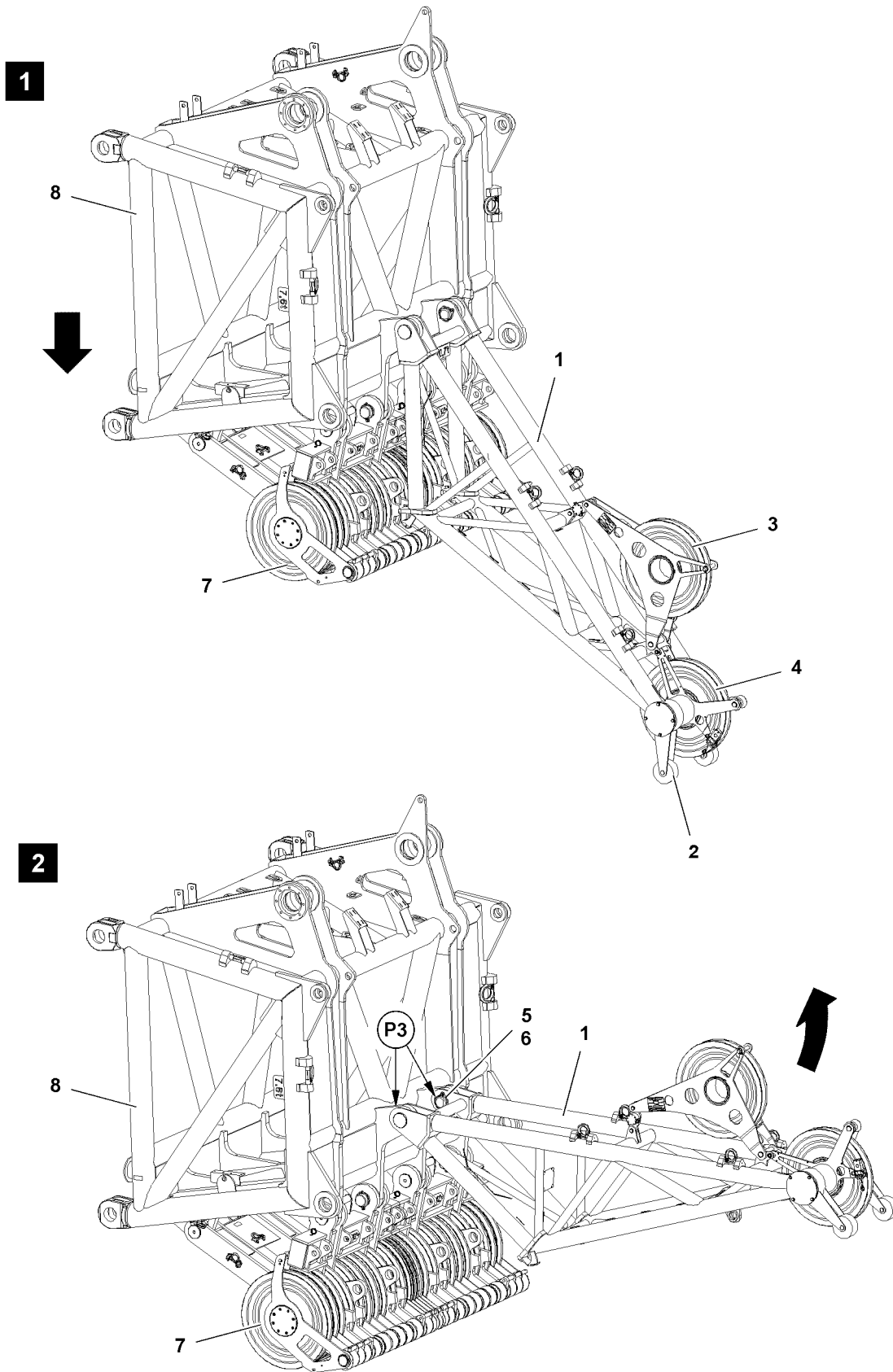

Fig.119039

LWE/LR 11000-001/23501-04-02/en

5.1 Placing the boom down



WARNING

The crane can topple over!

If the following conditions are not met before taking down the boom, the crane can topple over and fatally injure personnel.

Death, severe bodily injuries, property damage.

- ▶ Observe and adhere to the safety technical notes, see Crane operating instructions, chapter 5.01.
- ▶ Observe the specifications in the erection and take down charts.

NOTICE

Damage of boom components!

Taking down the boom system can lead to a collision between the hook block and the pulley head.

Boom components can be severely damaged.

- ▶ Luff the boom system down at the same time and spool the hoist winch out.



WARNING

The crane can topple over!

If the danger notes for take down of the boom or the boom systems in the following chapters are not observed, then the crane can topple over.

Death, severe bodily injuries, property damage.

Boom nose assembled on the end section:

- ▶ Observe and adhere to the danger notes in the Crane operating instructions, chapter 5.38, chapter 5.39 or chapter 5.07.

- ▶ Luff the boom down according to the instructions in the above chapters.



WARNING

Danger of accident due to function „Exceeding the shut off limits of the LICCON overload safety device“!

If the shut off limits of the LICCON overload safety device are exceeded, there is no additional protection against crane overload.

Due to erroneous operation or deliberate misuse, the crane could collapse, the boom can break off or the crane can topple over.

Death, severe bodily injuries, property damage.

- ▶ The function „Exceeding the shut off limits of the LICCON overload safety device“ is only permissible in emergencies and for assembly purposes.
- ▶ The function „Exceeding the shut off limits of the LICCON overload safety device“ may only be actuated by persons who know the effects of their actions regarding the function „Exceeding the shut off limits of the LICCON overload safety device“.
- ▶ The function „Exceeding the shut off limits of the LICCON overload safety device“ requires the presence of an authorized person and must be performed with utmost caution.
- ▶ Crane operation with activated function „Exceeding the shut off limits of the LICCON overload safety device“ is prohibited.

- ▶ At the same time, spool the hoist winch out and luff the boom down until the hook block touches the ground.
- ▶ Remove the hoist limit switch weight and unreeve the hook block.
- ▶ Luff the boom down until the end section and the boom nose are laying on the base rollers **2** on the ground, see illustration **1**.
- ▶ Remove the hoist rope.

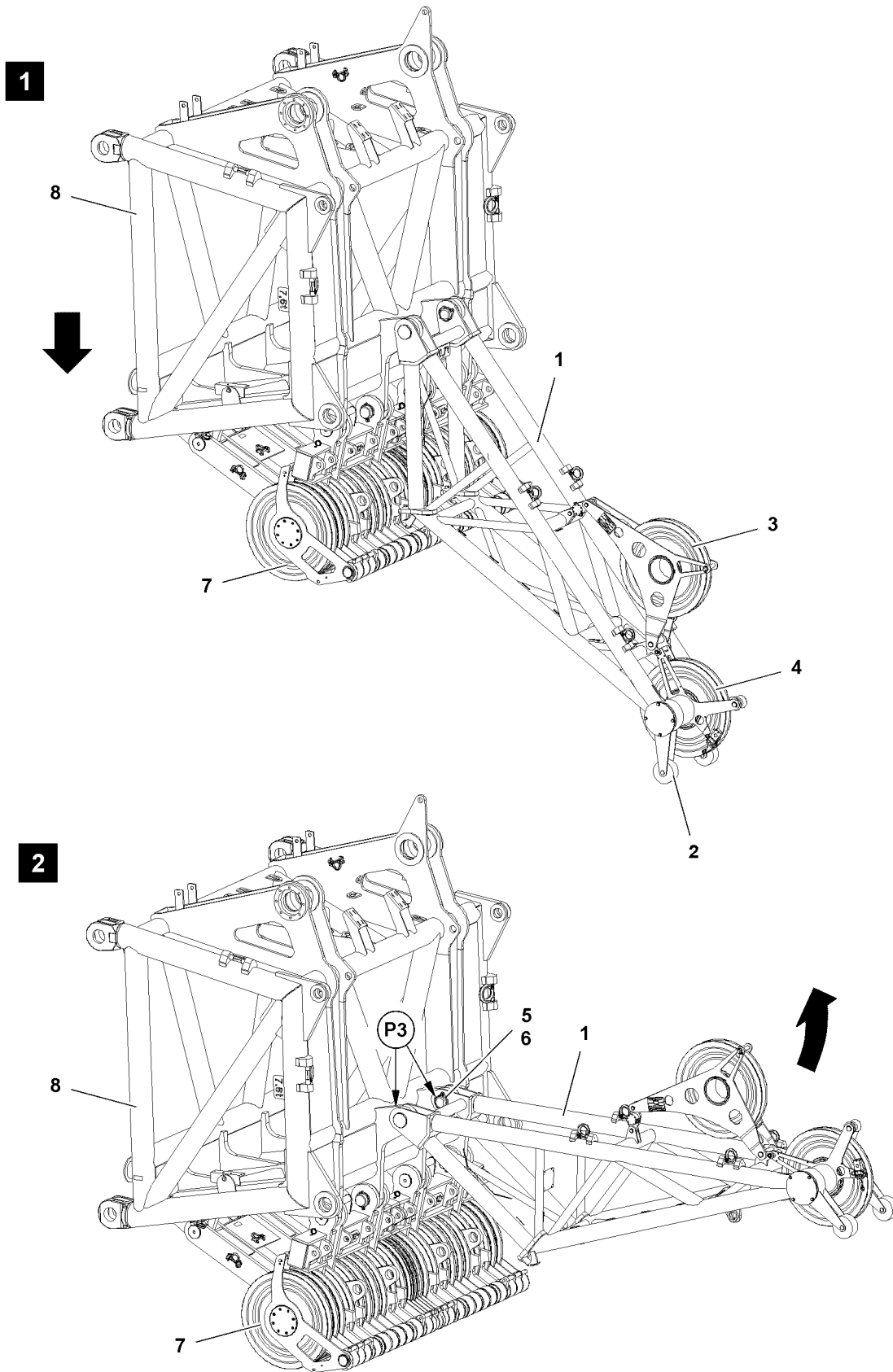

Fig.119039

LWE/LR 11000-001/23501-04-02/en

5.2 Disconnecting the electrical connections

Make sure that the following prerequisite is met:

- The boom is properly placed down as specified.

NOTICE

Damage to the electrical connections on the cable drum!

If the electrical connection from the cable drum on the L-pivot section to the terminal box on the respective end section is disconnected and spooled up, then the electrical connection from the cable drum to the terminal box on the L-pivot section can be damaged.

- ▶ Disconnect the electrical connection from the cable drum to the terminal box on the L-pivot section first and then the electrical connection from the terminal box to the respective end section.
-
- ▶ Store the cable from the terminal box on the L-pivot section properly.
 - ▶ Spool the cable drum up and secure it to prevent inadvertent spooling out.

5.3 Disassembly procedure

Make sure that the following prerequisites are met:

- The boom end section and the boom nose are laying on the ground.
 - The electrical connections are properly disconnected.
- ▶ Attach the boom nose **1** on the auxiliary crane.
 - ▶ Swing the boom nose **1** with the auxiliary crane up, see illustration **2**.

The boom nose is pinned on two points.

- ▶ Release the safety locking pin **6** „on top“ at points **P3** and unpin the pin **5** on the end section **8**, see illustration **2**.
- ▶ Remove the boom nose **1** with the auxiliary crane and place it on the ground.
- ▶ Remove the auxiliary crane.

Empty page!

LWE/LR 11000-001/23501-04-02/en

5.13 SLF-boom combination

1	Component overview	3
2	Fastening points for the F-jib	5
3	Assembling the F-jib	8
4	Assembly variation V1 — Assembling the F-jib in parts	11
5	Assembly variant V2 — Assembling the complete F-jib (maximum length of 12 m) on the ground	23
6	Assembly variant V3 — Assembling the complete F-jib (maximum length of 12 m) in flying mode	33
7	Assembly variant V4 — Assembling the complete F-jib (maximum length of 12 m) in flying mode	43
8	Establishing the electrical connections	45
9	Checking the function of the safety equipment	45
10	Erecting the boom	46
11	Operating the crane	48
12	Disassembling the F-jib	49

Fig.195219

LWE/LR 11000-001/23501-04-02/en

1 Component overview



Note

► The assembly sections are marked with their own weight.



Note

► Dimensions and weights, see the Crane operating instructions, chapter 1.03.

1.1 F-pivot section

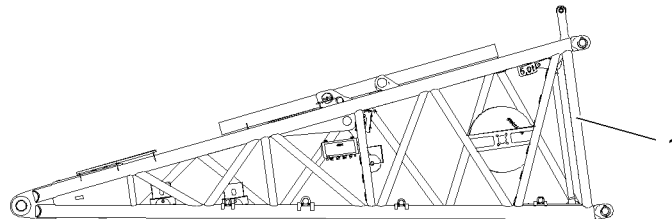

Fig.124501: F-pivot section

Position	Component
1	F-pivot section

1.2 F-end section

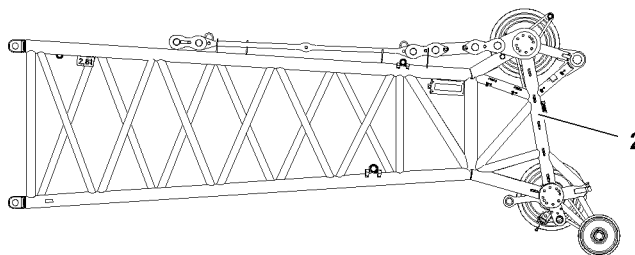

Fig.124503: F-end section

Position	Component
2	F-end section

1.3 F-intermediate section 6 m

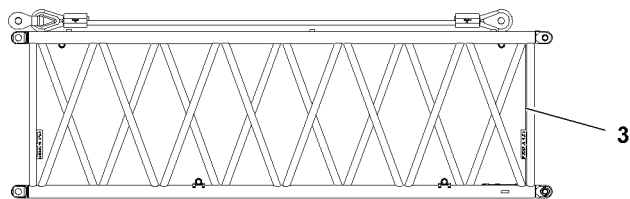

Fig.124505: F-intermediate section 6 m

Position	Component
3	F-intermediate section 6 m

1.4 F-intermediate section 12 m

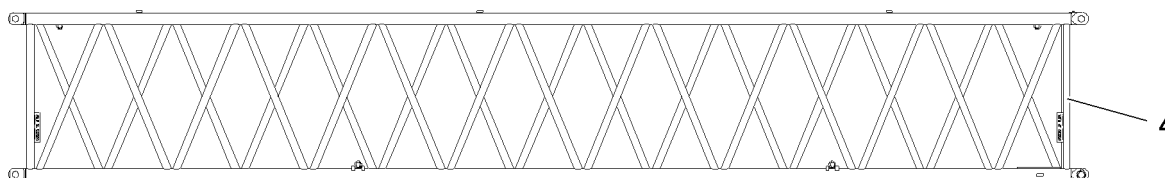

Fig.124507: F-intermediate section 12 m

Position	Component
4	F-intermediate section 12 m

1.5 F-assembly unit

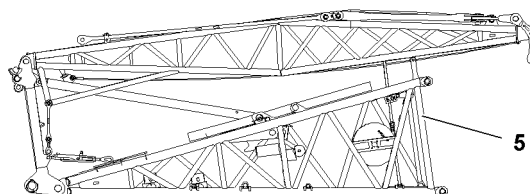

Fig.124509: F-assembly unit

Position	Component
5	F-assembly unit

1.6 F-assembly unit with F-end section

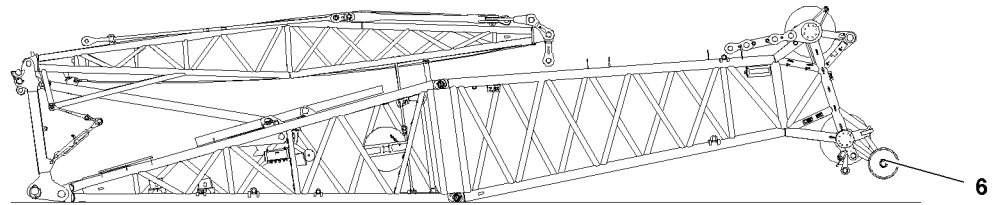

Fig.127641: F-assembly unit with F-end section

Position	Component
6	F-assembly unit with F-end section

2 Fastening points for the F-jib



WARNING

Falling lattice sections!

Death, severe bodily injuries, property damage.

- ▶ Make sure that the lattice sections are properly fastened on the respective fastening points.
- ▶ Make sure that the fastening equipment has the appropriate length and a sufficient load bearing capacity.
- ▶ Pay attention and adhere to the labels on the fastening points on the lattice sections and crane components.

2.1 F-pivot section

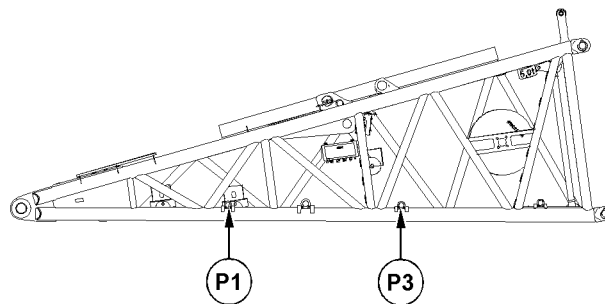

Fig.127913: F-pivot section

Fastening points	
P1 and P3	F-pivot section

2.2 F-end section

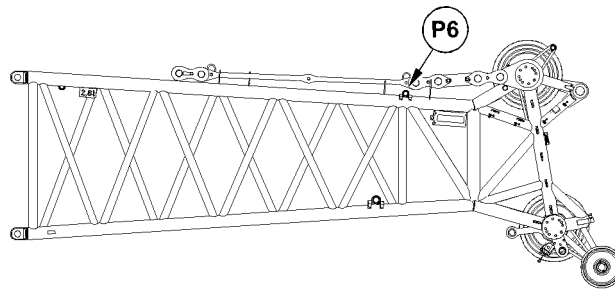

Fig.127914: F-end section

Fastening points	
P6	F-end section

2.3 F-intermediate section 6 m

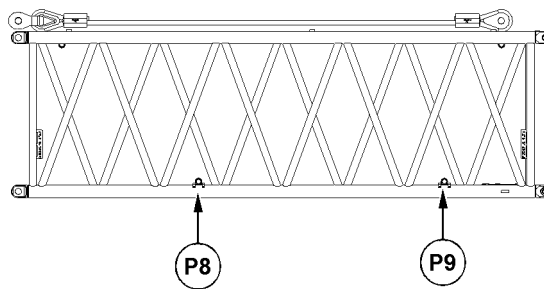

Fig.124506: F-intermediate section 6 m

Fastening points	
P8 and P9	F-intermediate section 6 m

2.4 F-intermediate section 12 m

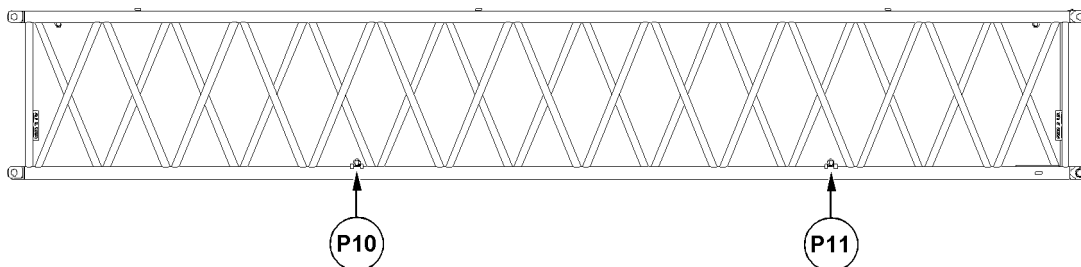

Fig.124508: F-intermediate section 12 m

Fastening points	
P10 and P11	F-intermediate section 12 m

LWE/LR 11000-001/23501-04-02/en

2.5 F-assembly unit

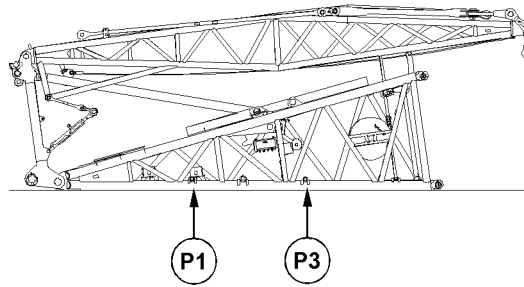

Fig.127642: F-assembly unit

Fastening points	
P1 and P3	F-assembly unit

2.6 F-assembly unit with F-end section

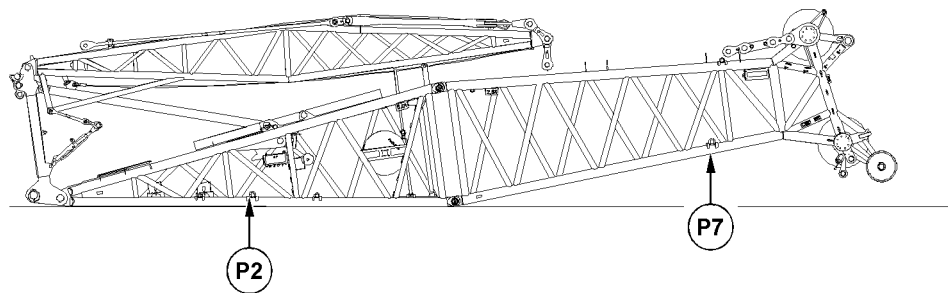

Fig.127643: F-assembly unit with F-end section

Fastening points	
P2 and P7	F-assembly unit with F-end section

LWE/LR 11000-001/23501-04-02/en

3 Assembling the F-jib



WARNING

Danger of falling!

During assembly / disassembly, inspection and maintenance work, personnel must be secured with appropriate aids to prevent them from falling.

Death, severe bodily injuries, property damage.

- ▶ All work at a height, when there is a danger of falling, must be carried out with suitable aids.
- ▶ If aids are not available and work cannot be carried out from the ground, then assembly personnel must secure themselves with the supplied fall arrest system to prevent falling, see the Crane operating instructions, chapter 2.04.
- ▶ If fall protection equipment is available, then it must be used, see the Crane operating instructions, chapter 2.06.
- ▶ When lifting, lowering, swinging crane parts in and out, no persons may remain in the danger zone.
- ▶ If railings are present on the components, then they must be brought into the corresponding position and secured for assembly / disassembly work.
- ▶ It is prohibited to lean the auxiliary ladder against the component being disassembled.
- ▶ Only step on the aids, ladders and catwalks with clean shoes.
- ▶ Keep aids, ladders and catwalks free of heavy dirt, snow and ice.
- ▶ During all assembly and disassembly work, maintenance work and inspections, travel or crane operation is prohibited.
- ▶ Remaining on a suspended load is prohibited.
- ▶ Stepping or walking on crane components and lattice sections, which have an incline of more than 20° is prohibited.
- ▶ For all assembly work, the crane operator of the main crane must be in voice contact with the crane operator / crane operators of the auxiliary crane / auxiliary cranes.
- ▶ For assembly / disassembly tasks, the crane operator may only initiate crane movements when the responsible guide has explicitly released the movement.



WARNING

Danger of impact / crushing!

When installing / removing crane components with the auxiliary crane, crane components can start to swing back and forth.

When lifting / lowering and positioning crane components, there is an increased danger of impacts / crushing.

Death, severe bodily injuries, property damage.

- ▶ Make sure that personnel cannot be caught by components.
- ▶ When working in danger zones: Use aids to protect limbs.
- ▶ Guide components with suitable aids to minimize oscillation.



DANGER

The components can fall down!

If the corresponding components are disengaged from the auxiliary crane before the corresponding component is pinned, the corresponding component can fall down and fatally injure personnel.

- ▶ Do not disengage the auxiliary crane until the respective component is pinned and secured.



WARNING

The lattice sections can fall down!

If the lattice sections are not pinned and secured correctly, then they can fall down and fatally injure personnel.

- ▶ Pin or unpin both pins at the same horizontal level, i.e. **left and right**.
- ▶ Do not stand under the lattice sections or within the entire danger zone during the pinning and unpinning procedure of the boom.
- ▶ Safely secure the pins in the storage locations as well as in the receptacles.
- ▶ It is prohibited to lean the auxiliary ladder against the component being disassembled.

**Note**

- ▶ The F-jib is **not** adjustable during crane operation.
- ▶ This crane can be equipped with an F-jib. The F-jib can be assembled at an angle of 10°, 15° or 30° to the SL-boom. Lengths of 12 m to 42 m are possible.
- ▶ The assembly and disassembly of the F-jibs from 12 m to 42 m is described using the example of only one length.

Make sure that the following prerequisites are met:

- The SL-boom is installed and luffed down to the substructure.
- The L-end section **or** the F-connector head is installed, pinned and secured on the SL-boom.
- The LICCON overload protection has been set according to the data in the load chart.
- The LICCON overload protection settings have been compared with the actual set up configuration.
- The LICCON overload protection is exceeded.
- The assembly icon is visible on the LICCON monitor.

3.1 Assembling the F-jib — assembly variants

**Note**

- ▶ The F-jib can be assembled, depending on the required operating mode for the crane application, either on the L-end section or on the F-connector head.
- ▶ Observe and adhere to the Rod plan.

**WARNING**

Maximum permissible assembly lengths!

If the maximum permissible assembly lengths are not complied with when assembling the F-jib, then dangerous situations can arise.

Death, severe bodily injuries, property damage.

- ▶ Make sure that the maximum permissible assembly lengths are adhered to.

**WARNING**

Non-compliance with the assembly descriptions!

Death, severe bodily injuries, property damage.

- ▶ The following assembly variants are possible depending on the circumstances at the job site!
- ▶ The F-jib must always be assembled in accordance with the respective description in the respective section.
- ▶ Make sure that the danger notes in the respective assembly description are observed.

3.1.1 Assembly variant V1

Assembling the F-jib in parts

- For assembly variant V1, the F-jib is assembled in individual parts.

3.1.2 Assembly variant V2

Assemble the complete F-jib (maximum length of 12 m) on the ground

- For assembly variant V2, assembly takes place using a hoist rope.

3.1.3 Assembly variant V3

Assemble the complete F-jib (maximum length of 12 m) in flying mode

- For assembly variant V3, flying assembly takes place using the assembly winch rope.

3.1.4 Assembly variant V4

Assemble the complete F-jib (maximum length of 12 m) in flying mode

- For assembly variant V4, flying assembly takes place using a hoist rope.

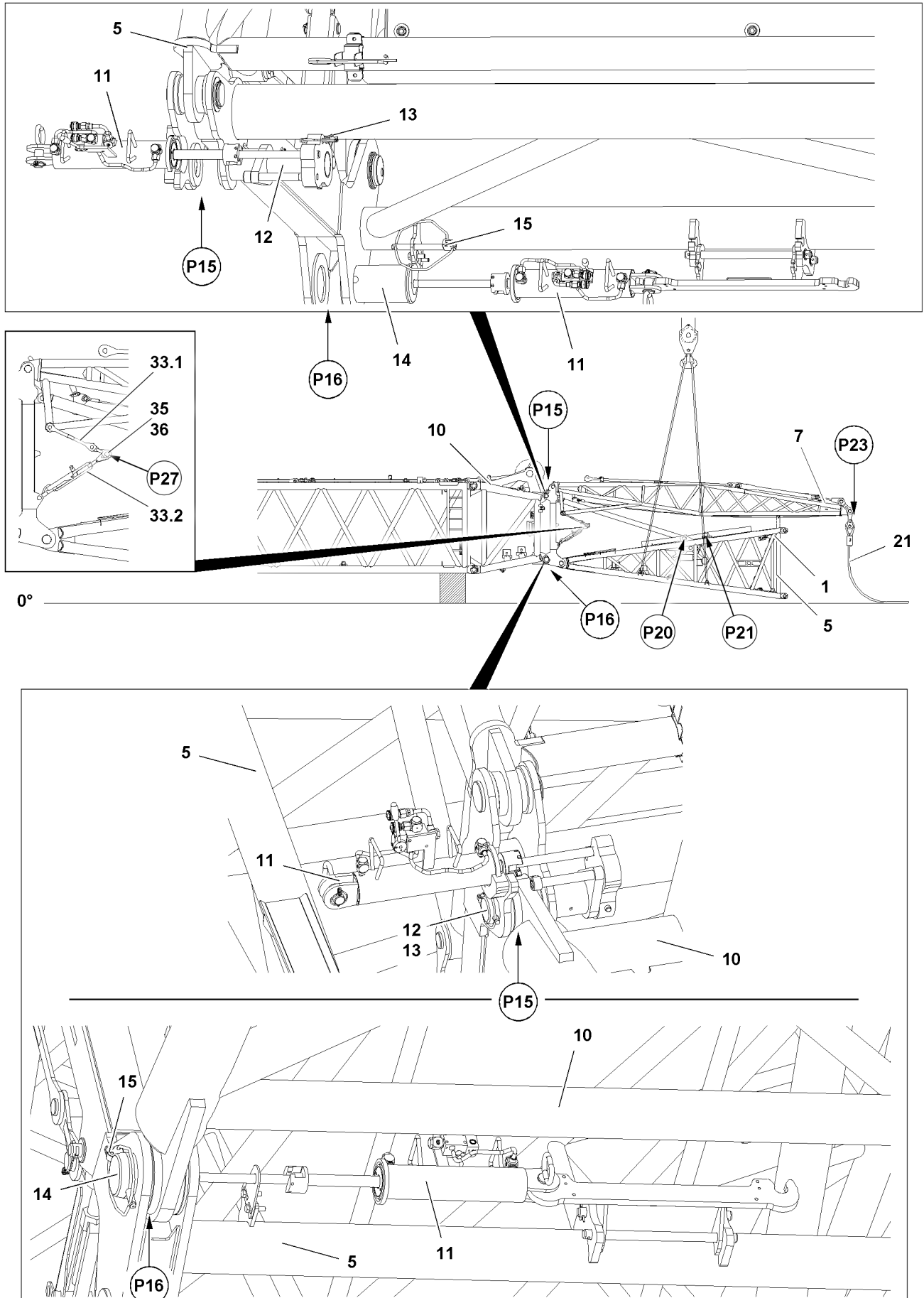

Fig.127477

LWE/LR 11000-001/23501-04-02/en

4 Assembly variation V1 — Assembling the F-jib in parts

4.1 Assembling the F-assembly unit

- ▶ Fasten the F-assembly unit **5** to the auxiliary crane.
- ▶ Remove the rigging belts between the F-pivot section **1** and FA-frame **7**.

The F-assembly unit **5** is pinned four times on L-end section or on the F-connector head. Every pin point is present on both sides of the component on one level.

- ▶ Set the pin pulling cylinder **11** at pin point **P15** and unpin the pin **12**.
- ▶ Set the pin pulling cylinder **11** at pin point **P16** and unpin the pin **14**.
- ▶ Position the F-assembly unit **5** with the auxiliary crane on the L-end section or on the F-connector head so that it can be pinned at point **P15** and at point **P16**.
- ▶ Set the pin pulling cylinder **11** at pin point **P15** and pin the pin **12** on both sides.

When the pins **12** are completely pinned:

- ▶ Secure the pins **12** with retaining elements **13** on both sides.



WARNING

Crushing / shearing of limbs!

While performing boom system assembly tasks, limbs can be crushed and / or sheared off.

Death, severe bodily injuries, property damage.

- ▶ Make sure that no crane movements are performed while pinning in the area of the lower pin points **P16**.

- ▶ Set the pin pulling cylinder **11** at pin point **P16** and pin the pin **14** on both sides.

When the pins **14** are completely pinned:

- ▶ Secure the pins **14** with retaining elements **15** on both sides.

4.2 Releasing the F-relapse support

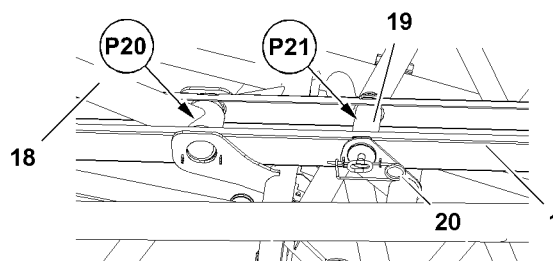

Fig.127478: F-relapse support in the transport position

Release the F-relapse support **18** from the transport position:

- ▶ Remove the retaining element **20** at point **P20** and unpin the pin **19**.
- ▶ Insert pin **19** in the stop position at point **P21** and secure with retaining element **20**.

4.3 Separating the FA-frame relapse retainers



WARNING

Falling and swinging FA-frame relapse retainer!

The FA-frame relapse retainer consists of guy rods **33.1** and a turnbuckle **33.2**.

The guy rod **33.1** of the FA-frame relapse retainer can fall down due to its own weight during unpinning.

The guy turnbuckle **33.2** of the FA-frame relapse retainer can fall down due to its own weight during unpinning.

Death, severe bodily injuries, property damage.

- ▶ Make sure when unpinning the FA-frame relapse retainer, the guy rods **33.1** and turnbuckle **33.2** are safely held.
- ▶ Assembly personnel must be at the side of the assembly unit.

NOTICE

Danger of property damage!

If the FA-frame relapse retainers are not separated, then they will be damaged during erection of the FA-frame.

- ▶ Make sure that the FA-frame relapse retainers are separated during the erection of the FA-frame.

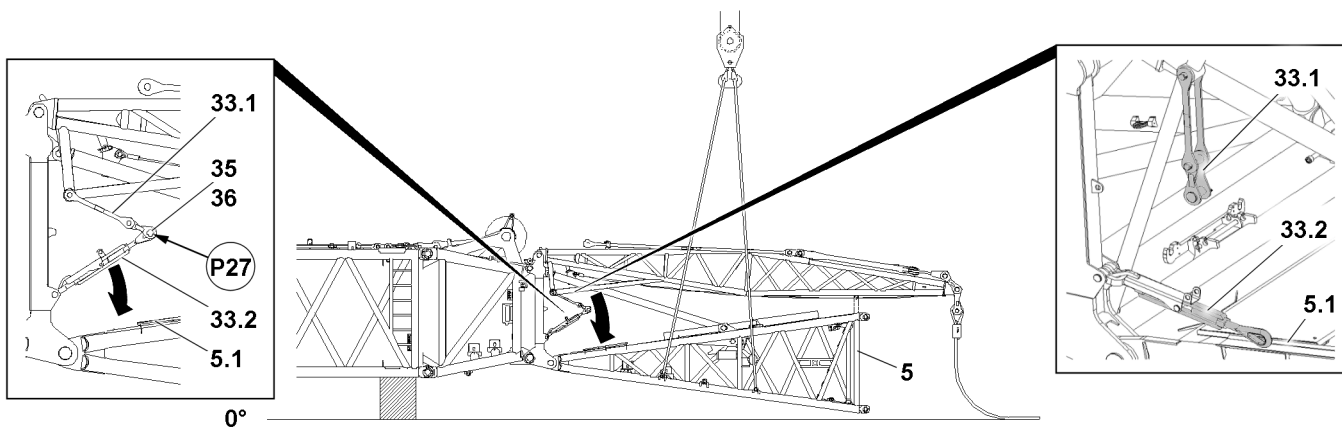

Fig.127481: Separating the FA-frame relapse retainers

Separate the FA-frame relapse retainer **33** at point **P27**:

- ▶ Remove the retaining element **36** at point **P27** and unpin the pin **35**.
- ▶ Place the turnbuckle **33.2** in the receptacle **5.1**.
- ▶ Guide the guy rods **33.1** after the position *downward* and let them hang.
- ▶ Insert the pin **35** again at point **P27** and secure with the retaining element **36**.

When the FA-frame relapse retainer **33** is separated:

- ▶ Slowly lower the F-pivot section **5**.
- ▶ Remove the auxiliary crane.

4.4 Assembling the F-guy ropes



WARNING

F-guy ropes ripping off!

If the F-guy ropes **21** are installed twisted in longitudinal axis, then the load bearing capacity can be significantly reduced as a result and the F-guy ropes can rip off.

Death, severe bodily injuries, property damage.

- ▶ Make sure that the F-guy ropes **21** are **never** kinked, knotted or twisted.
- ▶ Make sure the kinked, knotted or twisted F-guy ropes **21** are **never** installed.
- ▶ Make sure that F-guy ropes **21** are never pulled over the ground or sharp edges.
- ▶ Make sure that no damaged F-guy ropes **21** are being installed.
- ▶ Make sure that the numbering in the rod plan is identical to the numbering on the F-guy ropes.
- ▶ Make sure that the maximum bending radius of $20 \times$ rope diameter on the F-guy ropes **21** is **never** fallen below.
- ▶ Check the F-guy ropes before every assembly.
- ▶ When using fiber guy ropes: Inspect the fiber guy rods regularly, see Crane operating instructions, chapter 8.16.

Connect the F-guy ropes **21** with the brackets **22** of the FA-frame **7**.

- ▶ Fasten the F-guy rope **21** to the auxiliary crane and swing it in from the transport device directly to the assembly position.



WARNING

Load can be ripped off!

If the F-guy ropes are installed / assembled with a twist in the longitudinal axis, then the load bearing capacity is significantly reduced.

Death, severe bodily injuries, property damage.

- ▶ Make sure that the F-guy ropes are not twisted at assembly. Pay attention to the twist display - marker line along the longitudinal axis of the rope braid.

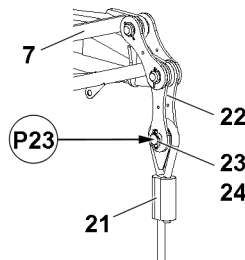

Fig.127479: Pinning the F-guy rope **21** on the FA-frame

- ▶ Pin the F-guy rope **21**: Insert the pin **23** at point **P23** and secure with the retaining element **24**.

When the first F-guy rope **21** is properly installed and secured:

- ▶ Assemble the second F-guy rope **21**.

4.5 Preparing the rope pulley retainer for the assembly of the F-jib



WARNING

Falling rope pulley retainer!

The rope pulley retainer **25** can fall down due to its own weight when unpinning it.

Death, severe bodily injuries, property damage.

- ▶ Make sure that the rope pulley retainer **25** is held during unpinning.

Release the rope pulley retainer **25** from the FA-frame **7**:

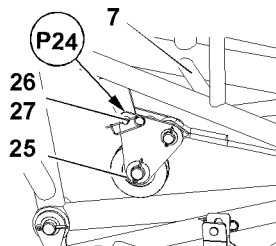

Fig.127480: Releasing the rope pulley retainer 25 from the FA-frame 7

- ▶ Remove the retaining element 27 at point P24 and unpin the pin 26.
- ▶ Take the rope pulley retainer 25 down with the rope on the open end of the F-assembly unit.

4.6 Erecting the FA-frame



WARNING

Automatic swinging of the FA-frame!

If the fastening rope 16 on the FA-frame 7 is not held under tension during assembly, the FA-frame 7 can swing suddenly to the side.

Death, severe bodily injury, property damage.

- ▶ Make sure that there are no persons within the danger zone.
- ▶ Make sure that the fastening rope 16 never sags during assembly / disassembly operations.

Make sure that the following prerequisite is met:

- The FA-frame relapse retainers **33** are separated.

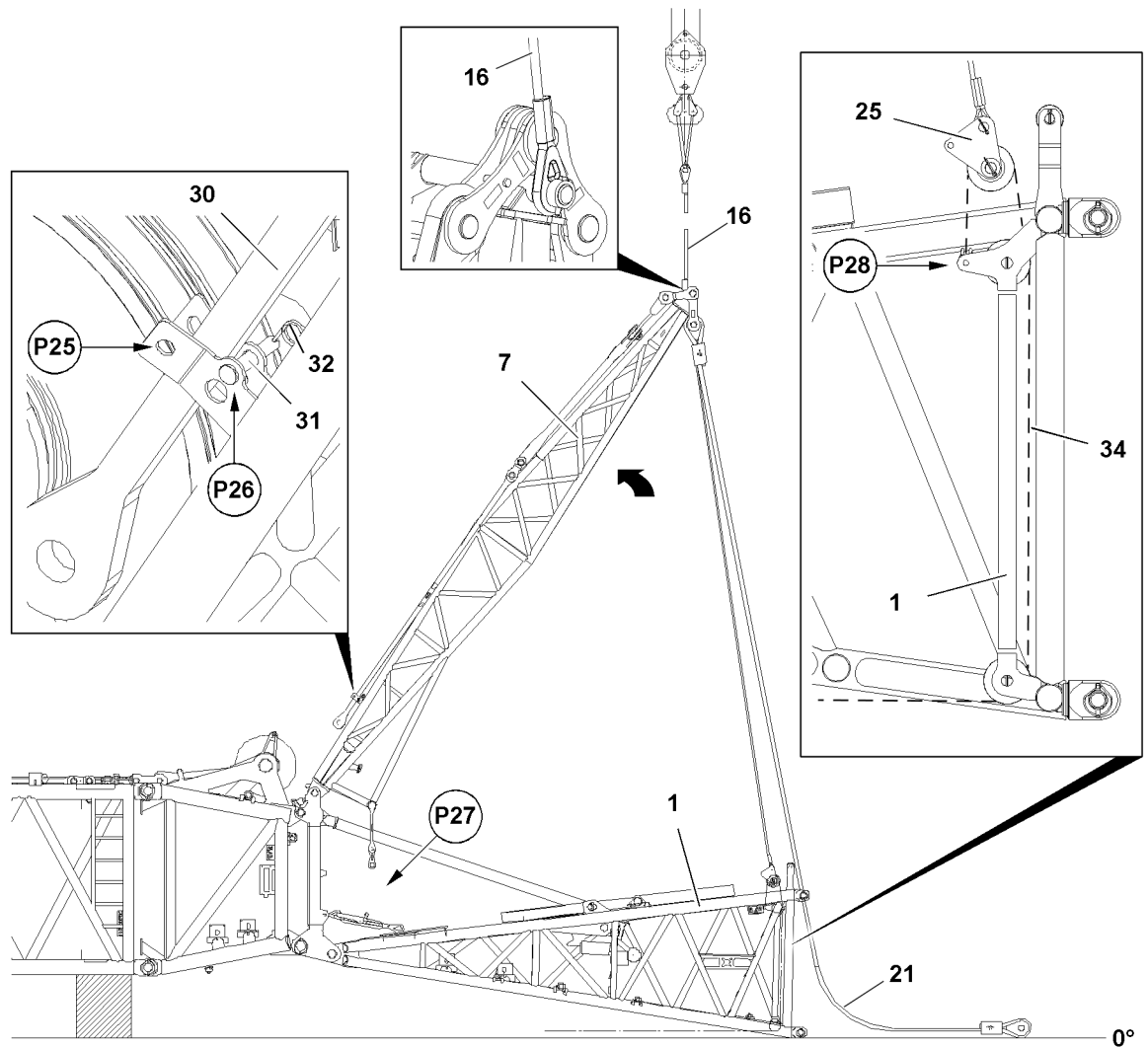

Fig.127482: Erecting the FA-frame

- ▶ Release the fastening rope **16** from the transport retainer on the FA-frame **7**.
- ▶ Fasten the FA-frame **7** with the fastening rope **16** to the auxiliary crane.
- ▶ Lift FA-frame **7** with auxiliary crane.
- ▶ Reeve the assembly winch rope **34** at the rope pulley retainer **25** and secure on the F-pivot section **1** at point **P28**.

Release the FAB-guy rods **30** on both sides:

- ▶ Remove the retaining element **32** at point **P25** and unpin the pin **31**.
- ▶ Insert the pin **31** at point **P26** in the park position and secure with the retaining element **32**.

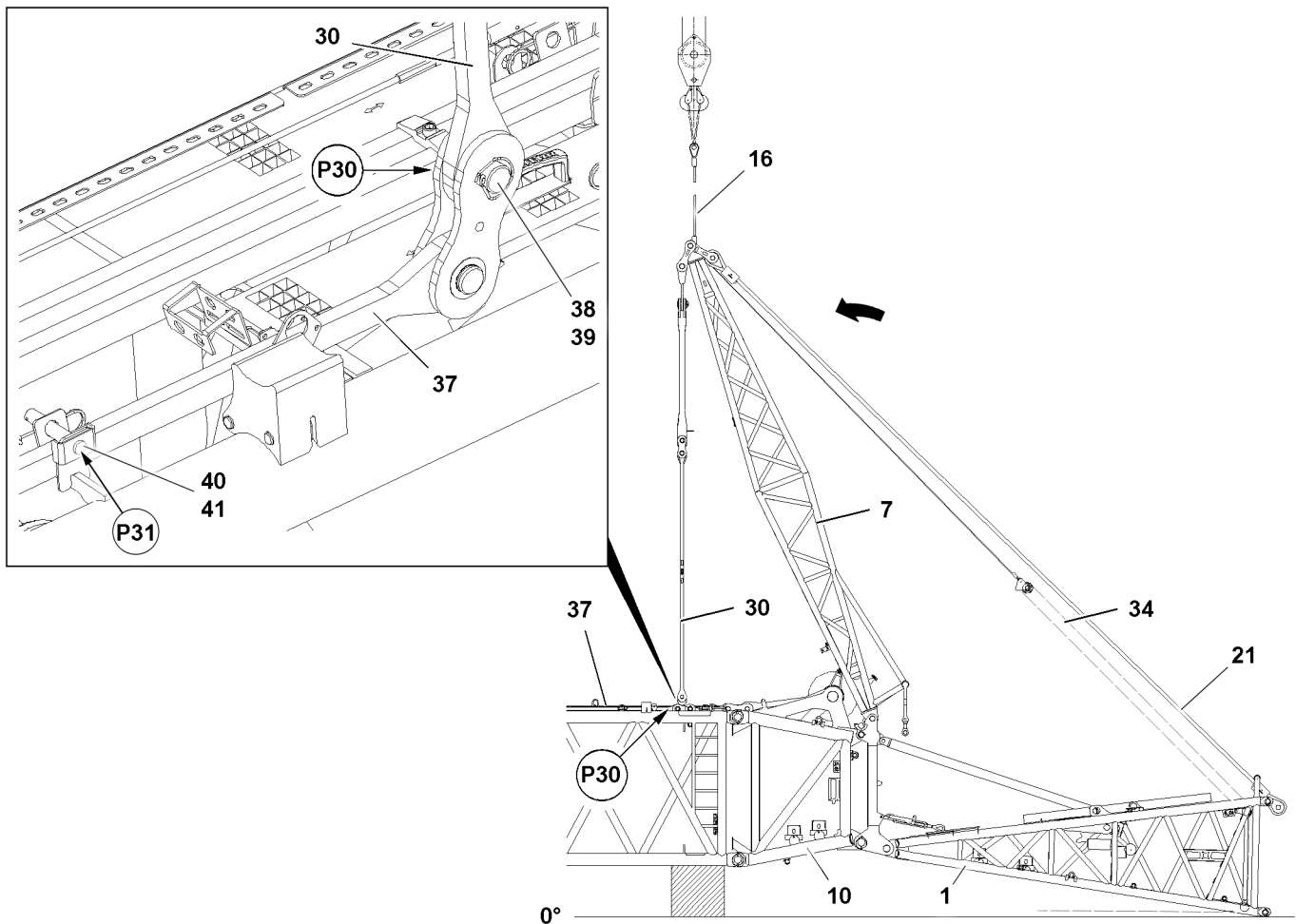

Fig.127483: Pinning the FAB-guy rods

NOTICE

Danger of property damage!

When swinging the FA-frame 7 in the direction of the main boom, damage may occur to the FA-frame 7, the F-connector head 10, as well as the rope pulley retainer 25.

- ▶ Make sure that a guide supervises the swinging process of the FA-frame.
- ▶ Make sure that the guide is constantly in visual and acoustic contact with the crane operator!
- ▶ Make sure that the assembly winch rope 34 is spooled out during the swinging process of the FA-frame 7.

- ▶ Carefully swing the FA-frame 7 with the auxiliary crane in direction of the main boom and spool the assembly winch rope 34 out at the same time until it can be pinned at point P30.

Pin the FAB-guy rods 30 with the FAB-guy rods 37 of the L-intermediate section:

- ▶ Insert the pin 38 at point P30 and secure with the retaining element 39.

Release the FAB-guy rods 37 in the transport receptacle:

- ▶ Remove the retaining element 41 at points P31 and unpin pin 40.

4.7 Placing the FA-frame in the operating position

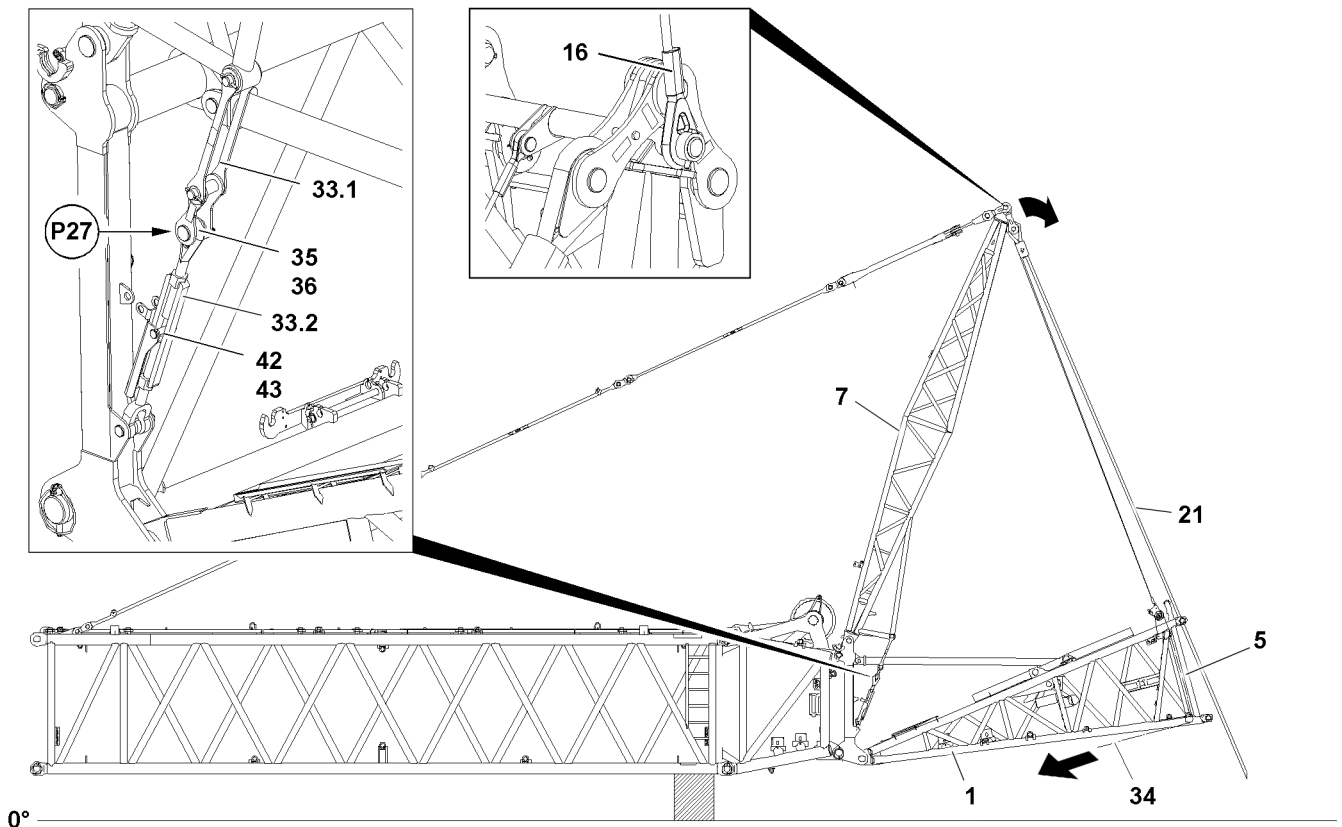

Fig.127644: Bringing the FA-frame into operating position

Make sure that the following prerequisite is met:

- The FAB-guy rods are properly pinned and secured.

► Pull the FA-frame 7 with the assembly winch rope 34 in direction of the F-pivot section 1.

Pin the FA-frame relapse retainer 33:

► Pin the rods 33.1 and turnbuckle 33.2 at point P27 with pin 35 and secure properly with the retaining element 36.

When the FA-frame relapse retainer 33 is properly pinned and secured:

- Fasten the turnbuckle evenly on both sides and secure it to prevent turning.
- Insert the pin 42 and secure it with the retaining element 43.

Result:

- The turnbuckle is secured to prevent it from twisting in crane operation.
- Affix the FA-frame 7 in the operating position

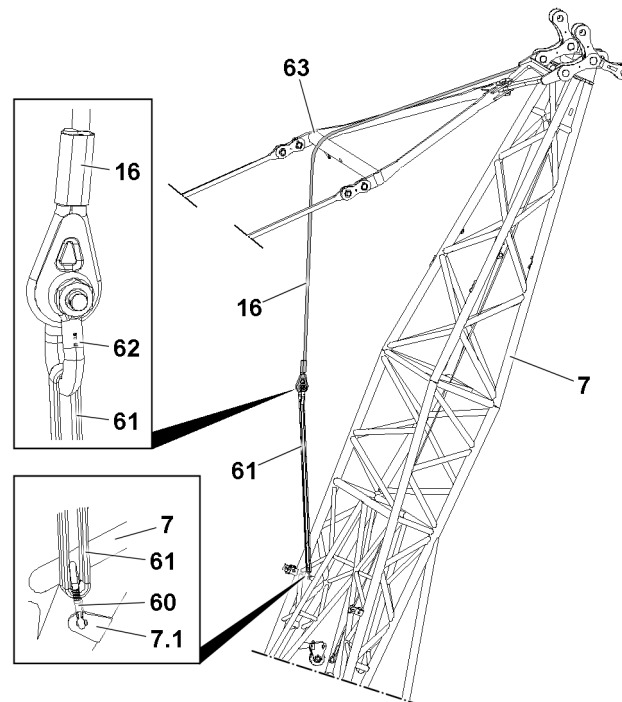

Fig.124500: Securing the fastening rope on the FA-frame for crane operation

NOTICE

Swinging fastening rope!

If the fastening rope **16** is not properly secured, then the fastening rope **16** can start to swing back and forth in crane operation and damage components.

- ▶ Make sure that the fastening rope **16** is properly secured on the FA-frame before starting to work with the crane.
- ▶ Place the fastening rope **16** over the linkage **63**.
- ▶ Connect the fastening rope **16** with the roundslings **61** with the shackle **62**.
- ▶ Fasten the roundslings **61** with the carabiner **60** on bracket **7.1** of the FA-frame.

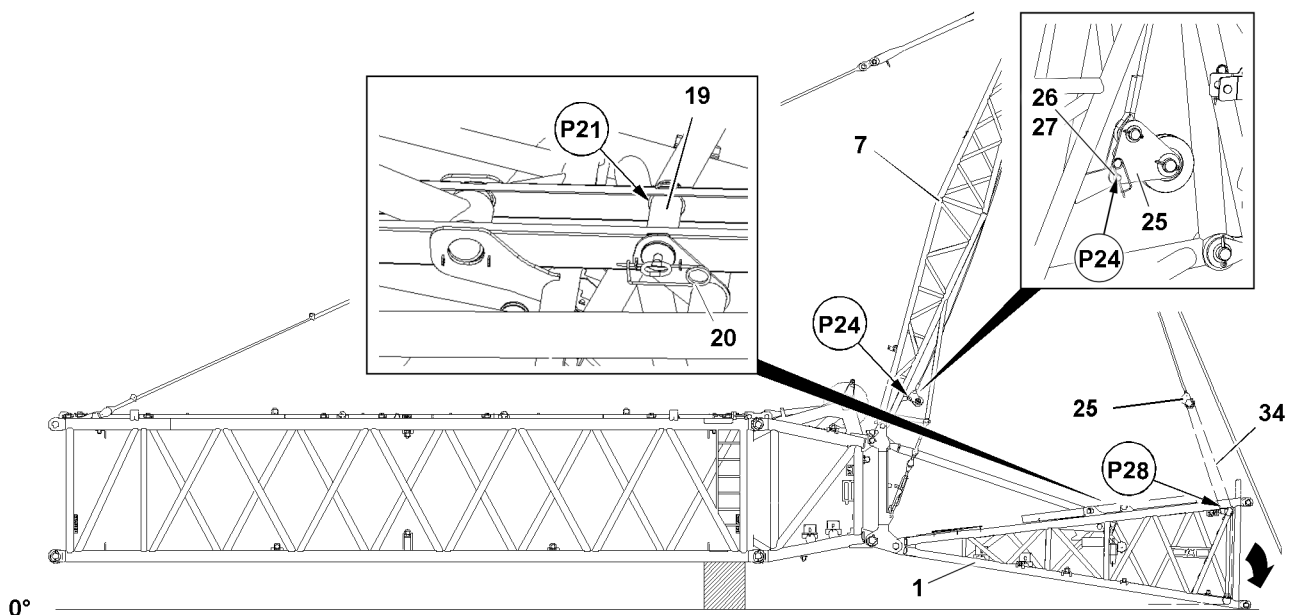

Fig.127645: Placing the F-pivot section on the ground

Lower the F-pivot section **1**:

- ▶ Spool out the assembly winch rope **34**.
- ▶ Release and reeve out the assembly winch rope **34** at point **P28**.

Pin the rope pulley retainer **25** on the FA-frame **7**:

- ▶ Insert the pin **26** at point **P24** and secure with the retaining element **27**.
- ▶ Leave the pin **19** for the crane operation in the stop position **P21**.

4.8 Assembling the lattice sections

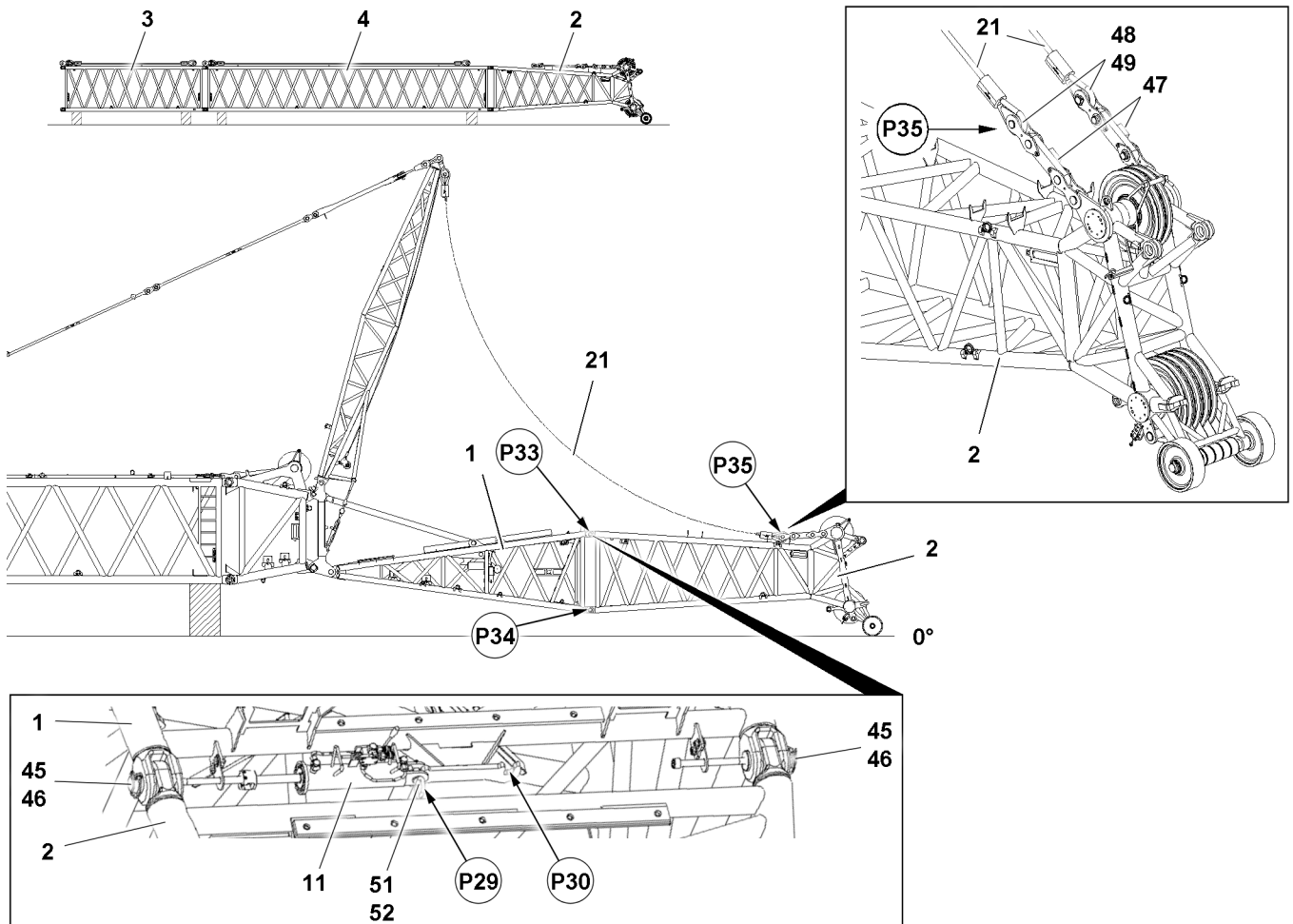

Fig.127647: Assembling the lattice sections

- ▶ Properly install the F-end section **2** and also the F-intermediate sections (F-intermediate section **3** and / or F-intermediate section **4**) to the auxiliary crane and pin on the F-pivot section **1**.

The F-end section **2** is pinned four times on F-pivot section **1**. Every pin point is present on both sides of the component on one level.

- ▶ Insert the pin pulling cylinder **11** at point **P29** / point **P30** in the pin pulling device.
- ▶ Insert the pins **45** at the pin point **P33** on both sides.
- ▶ Secure the pins **45** on both sides with the retaining element **46**.



Note

- ▶ Procedure for pinning the lattice sections on the pin points **P34** is identical as the process for pinning on pin points **P33**.

- ▶ Insert the pin **45** at pin point **P34** on both sides and secure.

**Note**

- ▶ If the F-intermediate sections are installed, then the additional guy ropes for the F-intermediate sections must be assembled, pinned and secured.
 - ▶ For the combination of the guy rope refer to the rod plan.
-
- ▶ Pin the F-guy ropes **21** on the F-end section **2** at point **P35** with pin **48** and secure with the retaining element **49**.

Empty page!

LWE/LR 11000-001/23501-04-02/en

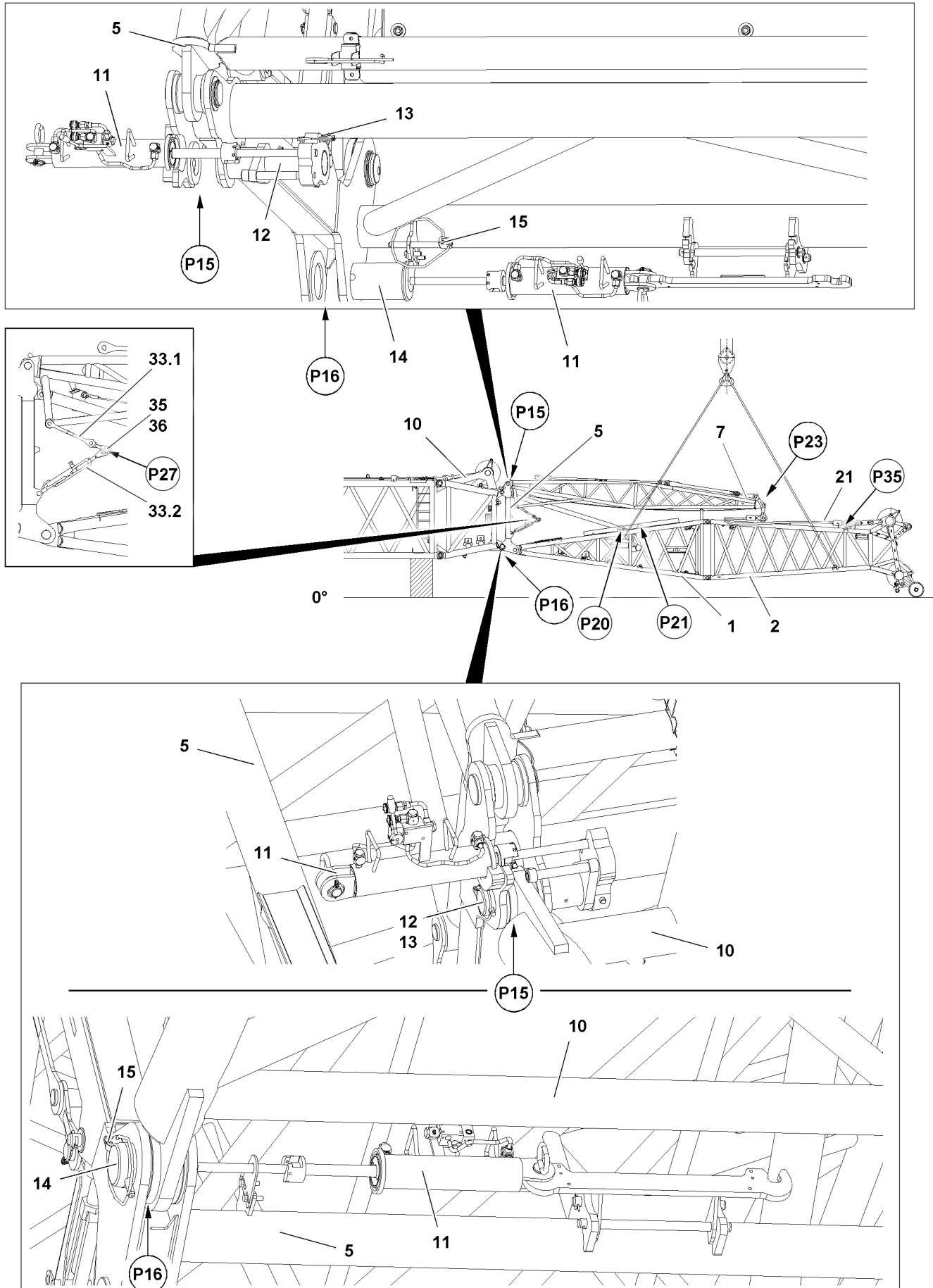

Fig.127646

LWE/LR 11000-001/23501-04-02/en

5 Assembly variant V2 — Assembling the complete F-jib (maximum length of 12 m) on the ground



WARNING

Impermissible F-assembly length(s)!

Death, severe bodily injuries, property damage.

- ▶ Make sure that the assembly of the F-jib as a complete F-assembly unit with the F-end section does not exceed 12 m.
- ▶ During assembly, no hook block may be reeved on the F-jib!

5.1 Assembling the F-assembly unit with F-end section

- ▶ Fasten the F-assembly unit **5** with the F-end section **6** to the auxiliary crane.
- ▶ Remove the rigging belts between the F-pivot section **1** and FA-frame **7**.

The F-assembly unit **5** is pinned four times on L-end section or on the F-connector head. Every pin point is present on both sides of the component on one level.

- ▶ Set the pin pulling cylinder **11** at pin point **P15** and unpin the pin **12**.
- ▶ Set the pin pulling cylinder **11** at pin point **P16** and unpin the pin **14**.
- ▶ Position the F-assembly unit **5** with the F-end section **6** with the auxiliary crane on the L-end section or on the F-connector head so that it can be pinned at point **P15** and at point **P16**.
- ▶ Set the pin pulling cylinder **11** at pin point **P15** and pin the pin **12** on both sides.

When the pins **12** are completely pinned:

- ▶ Secure the pins **12** with retaining elements **13** on both sides.



WARNING

Crushing / shearing of limbs!

While performing boom system assembly tasks, limbs can be crushed and / or sheared off.

Death, severe bodily injuries, property damage.

- ▶ Make sure that no crane movements are performed while pinning in the area of the lower pin points **P16**.

- ▶ Set the pin pulling cylinder **11** at pin point **P16** and pin the pin **14** on both sides.

When the pins **14** are completely pinned:

- ▶ Secure the pins **14** with retaining elements **15** on both sides.
- ▶ Remove the auxiliary crane.

5.2 Assembling the F-guy ropes

- ▶ Make sure that the two F-guy ropes **21** are properly pinned and secured with the brackets of the FA-frame **7** and the F-end section **2** at point **P23** and point **P35**.

5.3 Releasing the F-relapse support

Release the F-relapse support **18** from the transport position:

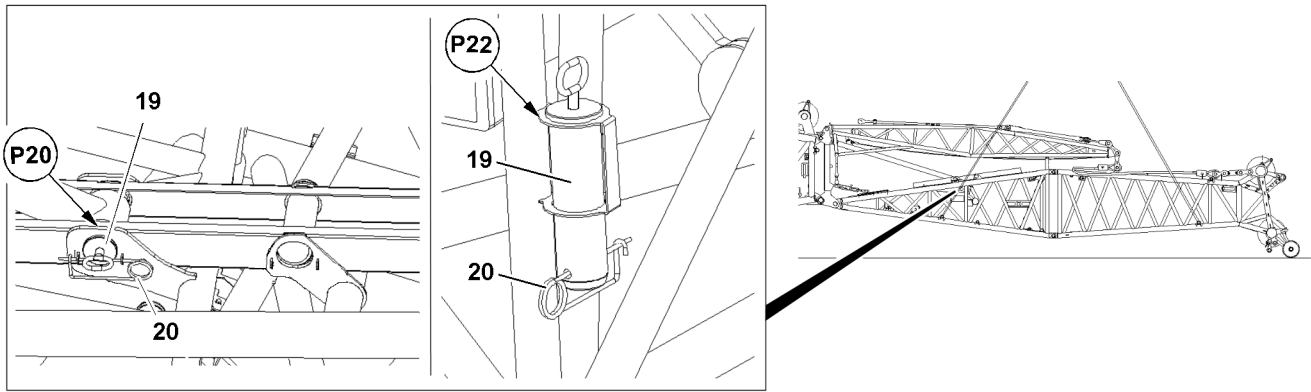

Fig. 127649: Position of the F-relapse support

- ▶ Remove the retaining element **20** at point **P20** and unpin the pin **19**.
- ▶ Insert pin **19** in the park position at point **P22** and secure with retaining element **20**.

5.4 Separating the FA-frame relapse retainers



WARNING

Falling and swinging FA-frame relapse retainer!

The FA-frame relapse retainer consists of guy rods **33.1** and a turnbuckle **33.2**.

The guy rod **33.1** of the FA-frame relapse retainer can fall down due to its own weight during unpinning.

The guy turnbuckle **33.2** of the FA-frame relapse retainer can fall down due to its own weight during unpinning.

Death, severe bodily injuries, property damage.

- ▶ Make sure when unpinning the FA-frame relapse retainer, the guy rods **33.1** and turnbuckle **33.2** are safely held.
- ▶ Assembly personnel must be at the side of the assembly unit.

NOTICE

Danger of property damage!

If the FA-frame relapse retainers are not separated, then they will be damaged when pulling up the F-jib.

- ▶ Make sure that the FA-frame relapse retainers are separated during the erection of the FA-frame.

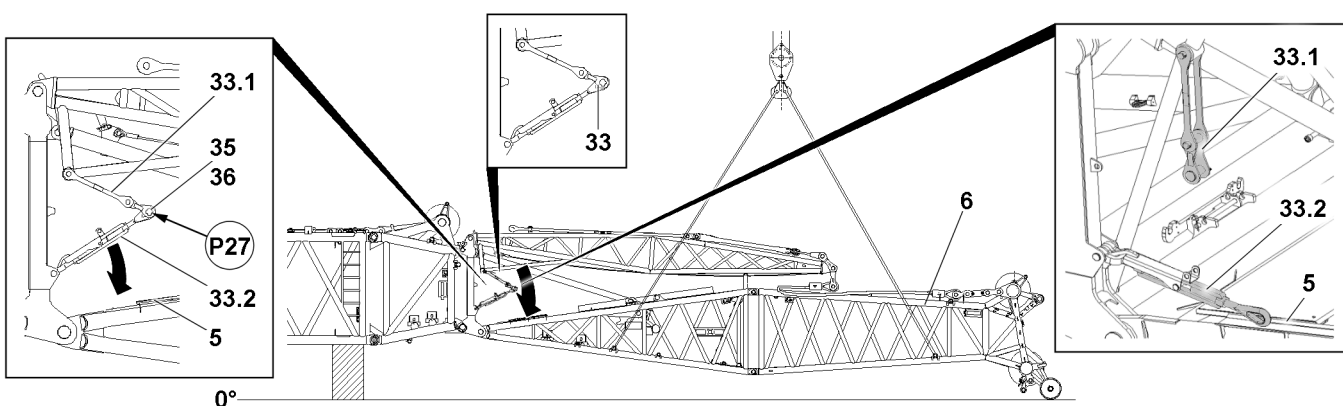

Fig. 127648: Separating the FA-frame relapse retainers

Separate the FA-frame relapse retainer **33** at point **P27**:

- ▶ Remove the retaining element **36** at point **P27** and unpin the pin **35**.
- ▶ Place the turnbuckle **33.2** in the receptacle **5.1**.
- ▶ Guide the guy rods **33.1** after the position *downward* and let them hang.

- ▶ Insert the pin **35** again at point **P27** and secure with the retaining element **36**.

When the FA-frame relapse retainer **33** is separated:

- ▶ Lower the F-jib slowly on the ground.

5.5 Erecting the FA-frame

NOTICE

Danger of property damage!

If the FA-frame relapse retainers **33** are not separated, then they will be damaged during erection of the FA-frame.

- ▶ Make sure that the FA-frame relapse retainers **33** are separated during the erection of the FA-frame.

Make sure that the following prerequisites are met:

- The F-guy ropes are properly installed and secured between the FA-frame and the F-end section.
- The FA-frame relapse retainer is separated.

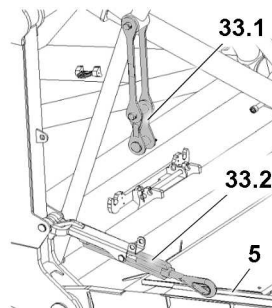

Fig.127650: Separated FA-frame relapse retainer

- ▶ Fasten the auxiliary crane properly to the eyehooks of the F-end section **6**.

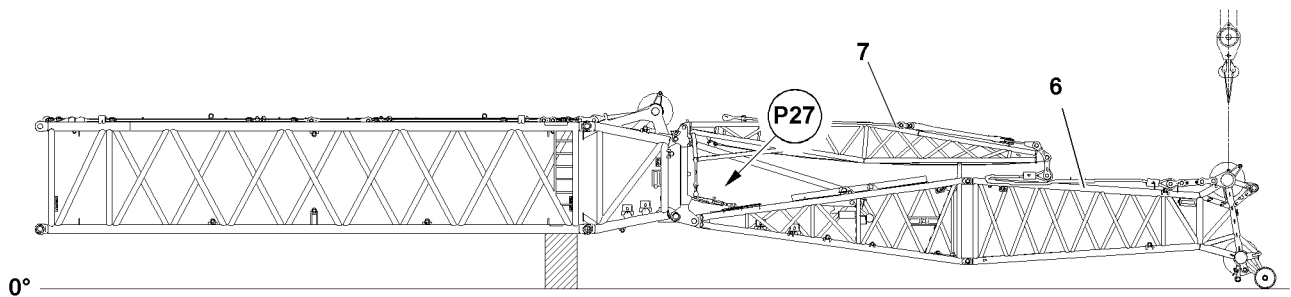

Fig.127671: Fastening the F-end section to the auxiliary crane.

- ▶ Pull up the F-assembly unit with the auxiliary crane on the F-end section **6** until the angle between the FA-frame **7** and the horizontal is at least 40° .

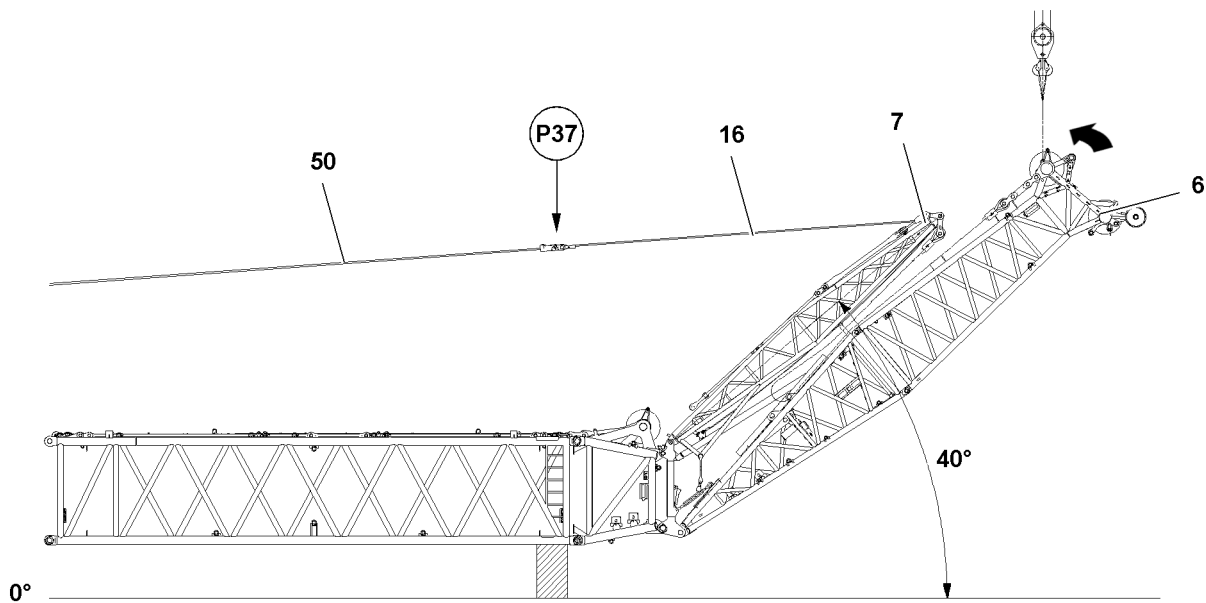

Fig.127672: Lifting the F-assembly unit on the F-end section

- ▶ Connect the fastening rope **16** of the FA-frame **7** using the link of the hoist rope **50** at point **P37** with the hoist rope **50**.
- ▶ Spool up the hoist rope **50** until the FA-frame **7** is held in the 40° position by the hoist rope.

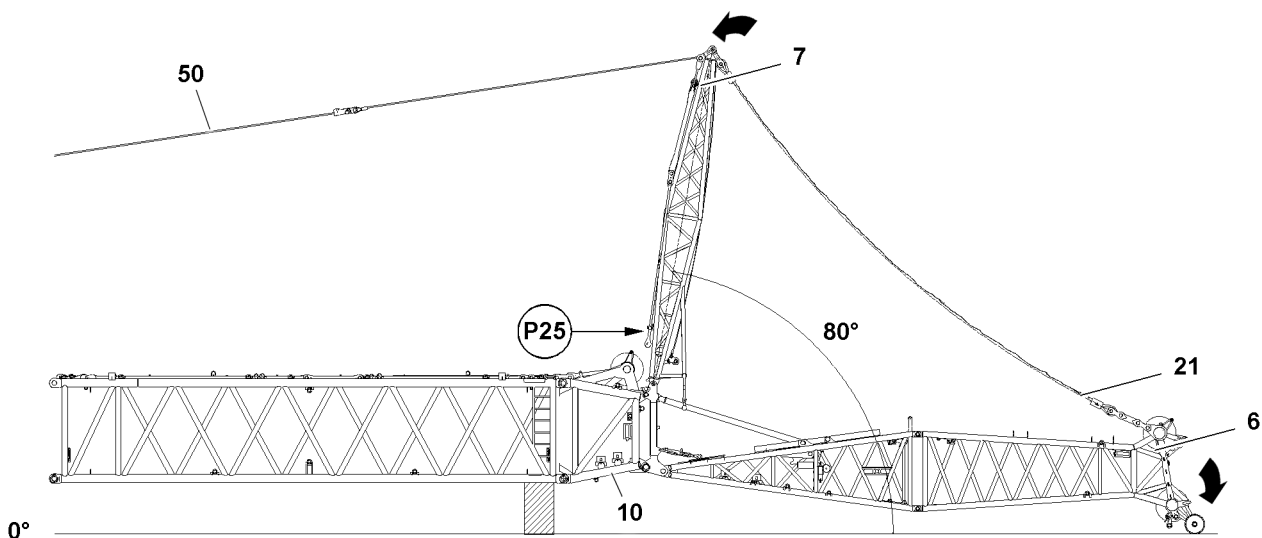

Fig.127673: Lowering the F-jib with the auxiliary crane

- ▶ Lower the F-jib with the auxiliary crane to the horizontal.

NOTICE

Danger of property damage!

When swinging the FA-frame **7** in direction of the main boom there is a danger of collision of the FA-frame with the attachment parts of the L-end section or the F-connector head.

- ▶ When swinging the FA-frame, a guide must be used.
- ▶ The guide must be in constant visual and acoustic contact with the crane operator.

NOTICE

Hoist rope contact with cross binders of the main boom auxiliary guying!

- ▶ Make sure that the hoist rope does not scrape the cross binder of the main boom auxiliary guying when erecting the FA-frame.

If the hoist rope scrapes:

- ▶ Place the main boom on the ground or on a load bearing substructure.
 - ▶ Release the main boom guying and unhook the cross binder of the auxiliary guying.
-
- ▶ Pull the FA-frame **7** further with the hoist rope **50** in direction of the main boom until the angle between the FA-frame **7** and the horizontal is maximum 80°.

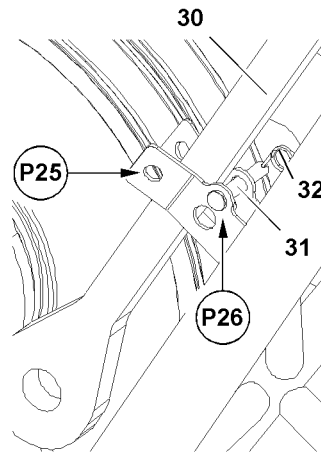

Fig.127674: Released FAB-guy rods

Release the FAB-guy rods **30** in the transport retainers on both sides:

- ▶ Remove the retaining element **32** at point **P25** and unpin the pin **31**.
- ▶ Insert the pin **31** at point **P26** in the park position and secure with the retaining element **32**.
- ▶ Lower the F-jib with the auxiliary crane until the F-guy ropes **21** are tensioned.
- ▶ Unhook and remove the fastening equipment (fastening rope) of the auxiliary crane.

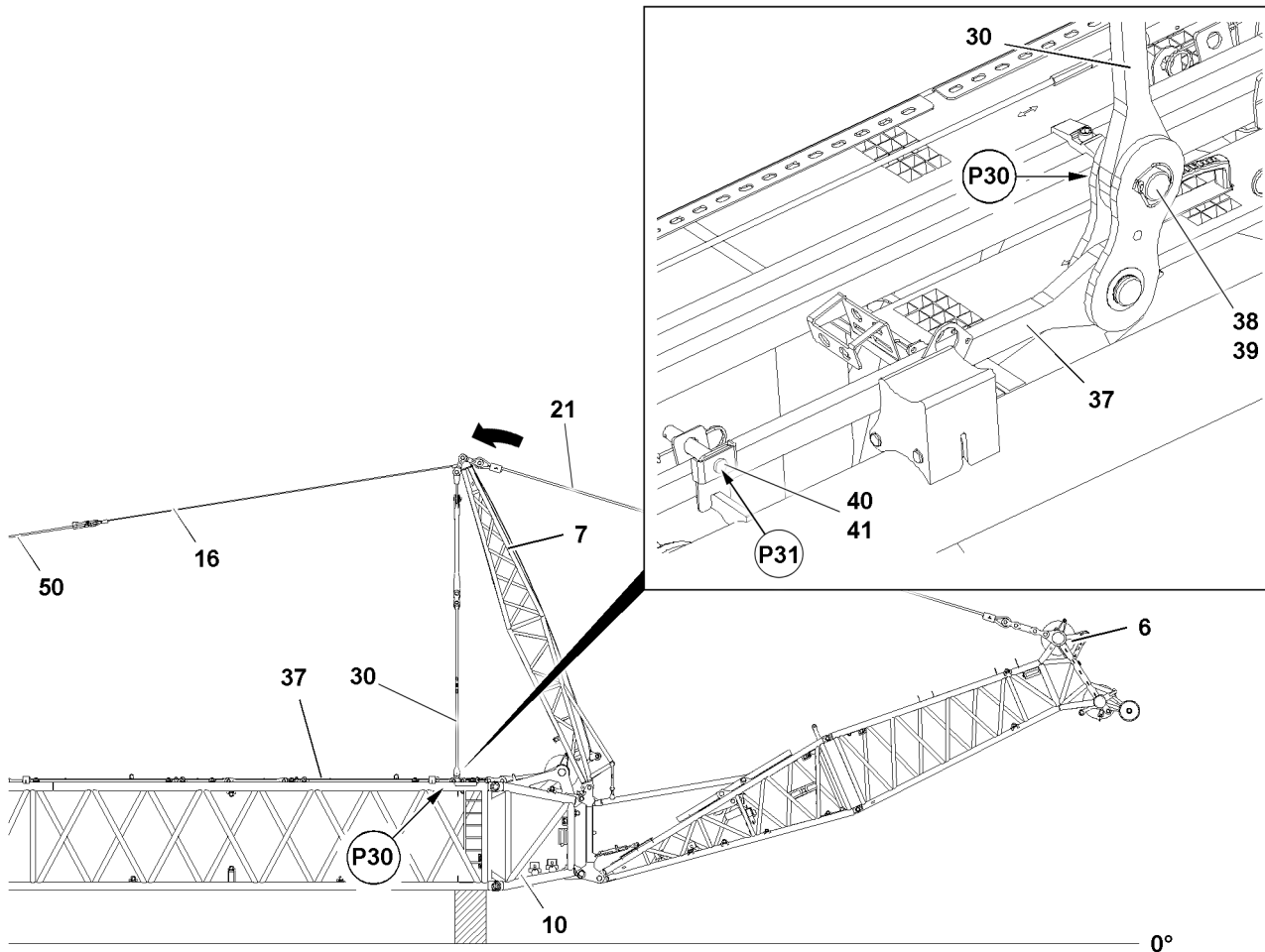

Fig.127675: Pinning the FAB-guy rods

- ▶ Continue to swing the FA-frame 7 further with the hoist rope 50 in direction of the main boom until it can be pinned at point P30.

Pin the FAB-guy rods 30 with the FAB-guy rods 37 of the L-intermediate section:

- ▶ Insert the pin 38 at point P30 and secure with the retaining element 39.

Release the FAB-guy rods 37 in the transport receptacle:

- ▶ Remove the retaining element 41 at points P31 and unpin pin 40.

5.6 Placing the FA-frame in the operating position

Make sure that the following prerequisite is met:

- The FAB-guy rods are properly pinned and secured.

NOTICE

Danger of slack rope formation!

- ▶ When spooling the hoist rope out, make sure that no slack rope forms.
- ▶ Lower the FA-frame 7 to the operating position (to the front): Spool out the hoist rope 50 up until the FAB-guying is tensioned.
- ▶ Continue to spool out the hoist rope until the fastening rope 16 is completely relieved.
- ▶ Separate the hoist rope 50 and the fastening rope 16.

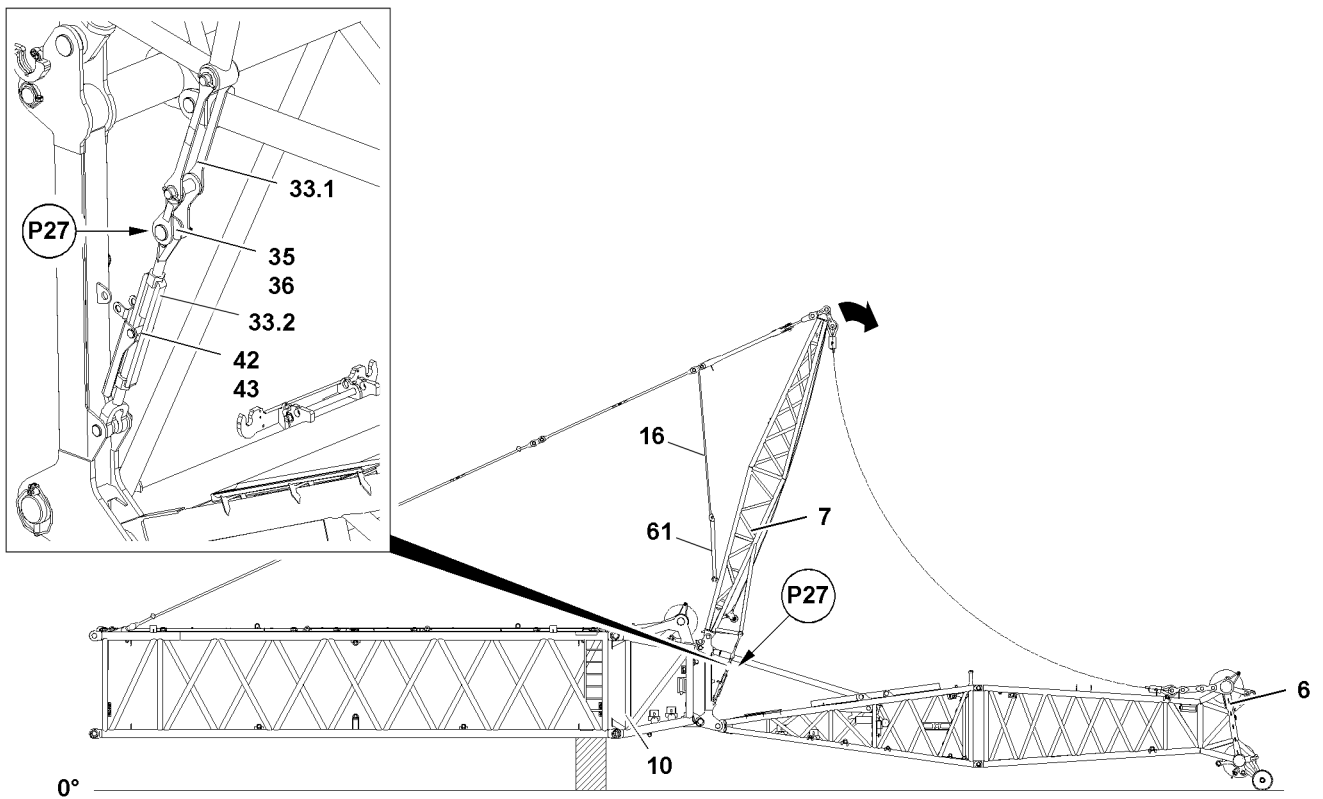

Fig.127676: Bringing the FA-frame into operating position // Assembling the FA-frame relapse retainer

Pin the FA-frame relapse retainer 33:

- ▶ Pin the rods 33.1 and turnbuckle 33.2 at point P27 with pin 35 and secure properly with the retaining element 36.

When the FA-frame relapse retainer 33 is properly pinned and secured:

- ▶ Fasten the turnbuckle evenly on both sides and secure it to prevent turning.
- ▶ Insert the pin 42 and secure it with the retaining element 43.

Result:

- The turnbuckle is secured to prevent it from twisting in crane operation.

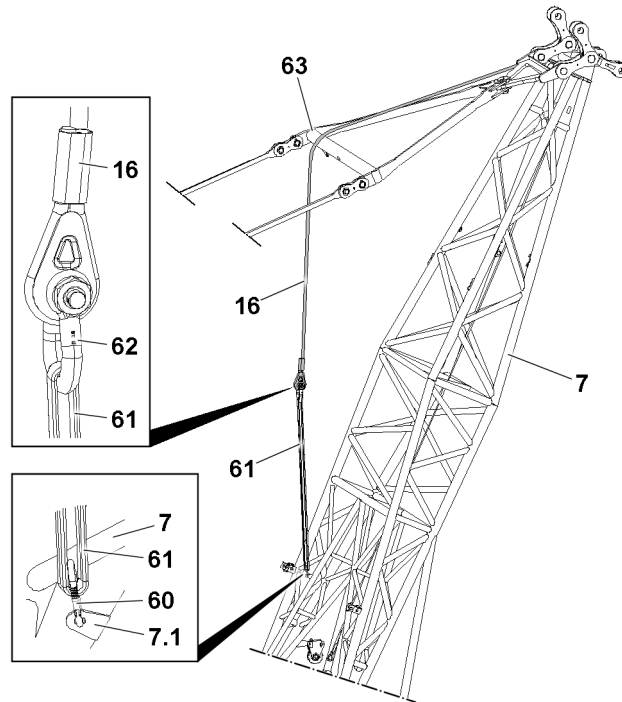

Fig.124500: Securing the fastening rope on the FA-frame for crane operation

NOTICE

Swinging fastening rope!

If the fastening rope **16** is not properly secured, then the fastening rope **16** can start to swing back and forth in crane operation and damage components.

- ▶ Make sure that the fastening rope **16** is properly secured on the FA-frame before starting to work with the crane.
-
- ▶ Place the fastening rope **16** over the linkage **63**.
 - ▶ Connect the fastening rope **16** with the roundsling **61** with the shackle **62**.
 - ▶ Fasten the roundsling **61** with the carabiner **60** on bracket **7.1** of the FA-frame.

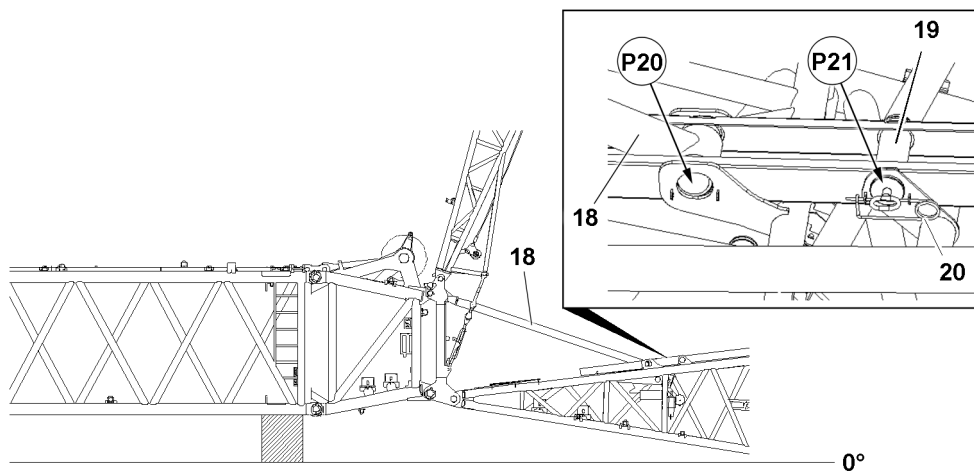
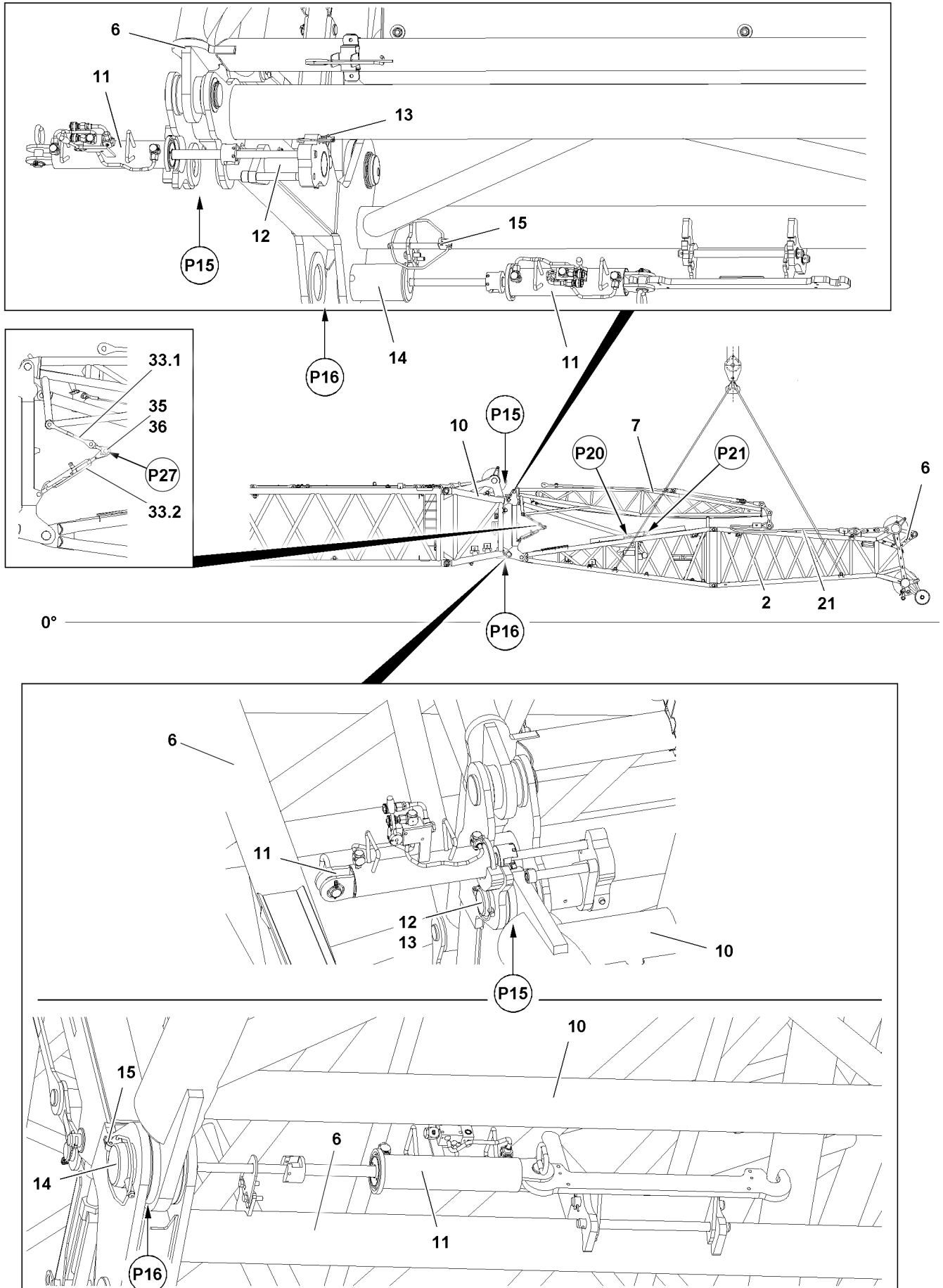

Fig.127677: Inserting pin **19** of the F-relapse retainer in the stop position and securing

- ▶ Insert the pin **19** for crane operation in the stop position **P21** and secure properly.
- ▶ Properly hang the cross binder of the main boom auxiliary guying and secure.

Empty page!

LWE/LR 11000-001/23501-04-02/en



LWE/LR 11000-001/23501-04-02/en

Fig.127678

6 Assembly variant V3 — Assembling the complete F-jib (maximum length of 12 m) in flying mode



WARNING

Impermissible F-assembly length(s)!

Death, severe bodily injuries, property damage.

- ▶ Make sure that the flying assembly length of the F-jib as a complete F-assembly unit with the F-end section does not exceed 12 m.
- ▶ During assembly, no hook block may be reeved on the F-jib!

6.1 Assembling the F-assembly unit with F-end section

- ▶ Fasten the F-assembly unit with the F-end section **6** to the auxiliary crane.
- ▶ Remove the rigging belts between the F-pivot section **1** and FA-frame **7**.

The F-assembly unit **6** is pinned four times on L-end section or on the F-connector head. Every pin point is present on both sides of the component on one level.

- ▶ Set the pin pulling cylinder **11** at pin point **P15** and unpin the pin **12**.
- ▶ Set the pin pulling cylinder **11** at pin point **P16** and unpin the pin **14**.
- ▶ Position the F-assembly unit with the F-end section **6** with the auxiliary crane on the L-end section or on the F-connector head so that it can be pinned at point **P15** and at point **P16**.
- ▶ Set the pin pulling cylinder **11** at pin point **P15** and pin the pin **12**.
- ▶ Secure the pins **12** with retaining elements **13** on both sides.



WARNING

Crushing / shearing of limbs!

While performing boom system assembly tasks, limbs can be crushed and / or sheared off. Death, severe bodily injuries, property damage.

- ▶ Make sure that no crane movements are performed while pinning in the area of the lower pin points **P16**.

- ▶ Set the pin pulling cylinder **11** at pin point **P16** and pin the pin **14**.

When the pins **14** are fully pinned on both sides:

- ▶ Secure the pins **14** with retaining elements **15** on both sides.

6.2 F-relapse support

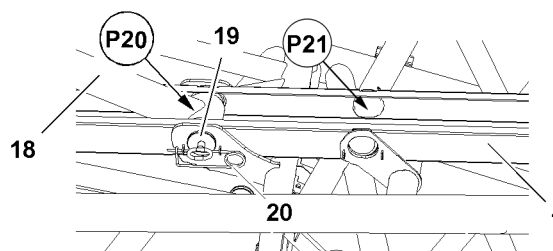

Fig.127680: Pinned F-relapse support

**WARNING**

Automatic swinging of the F-jib!

If the pin **19** of the F-relapse support is unpinned at point **P20**, before the F-guy rope **21** is properly assembled and secured, the F-jib could fall down by itself.

Death, severe bodily injuries, property damage.

- ▶ Make sure that the F-relapse support remains pinned at point **P20** until the F-guy rope **21** is properly pinned and secured on the FA-frame **7** and on the F-end section **6**.
- ▶ Do **not** unpin the F-relapse support **18** at point **P20**.

- ▶ Make sure that the F-relapse support **18** is properly pinned and secured in the transport position at point **P20** with pin **19**.

6.3 Separating the FA-frame relapse retainers

**WARNING**

Falling and swinging FA-frame relapse retainer!

The FA-frame relapse retainer consists of guy rods **33.1** and a turnbuckle **33.2**.

The guy rod **33.1** of the FA-frame relapse retainer can fall down due to its own weight during unpinning.

The guy turnbuckle **33.2** of the FA-frame relapse retainer can fall down due to its own weight during unpinning.

Death, severe bodily injuries, property damage.

- ▶ Make sure when unpinning the FA-frame relapse retainer, the guy rods **33.1** and turnbuckle **33.2** are safely held.
- ▶ Assembly personnel must be at the side of the assembly unit.

NOTICE

Danger of property damage!

If the FA-frame relapse retainers are not separated, then they will be damaged during erection of the FA-frame.

- ▶ Make sure that the FA-frame relapse retainers are separated during the erection of the FA-frame.

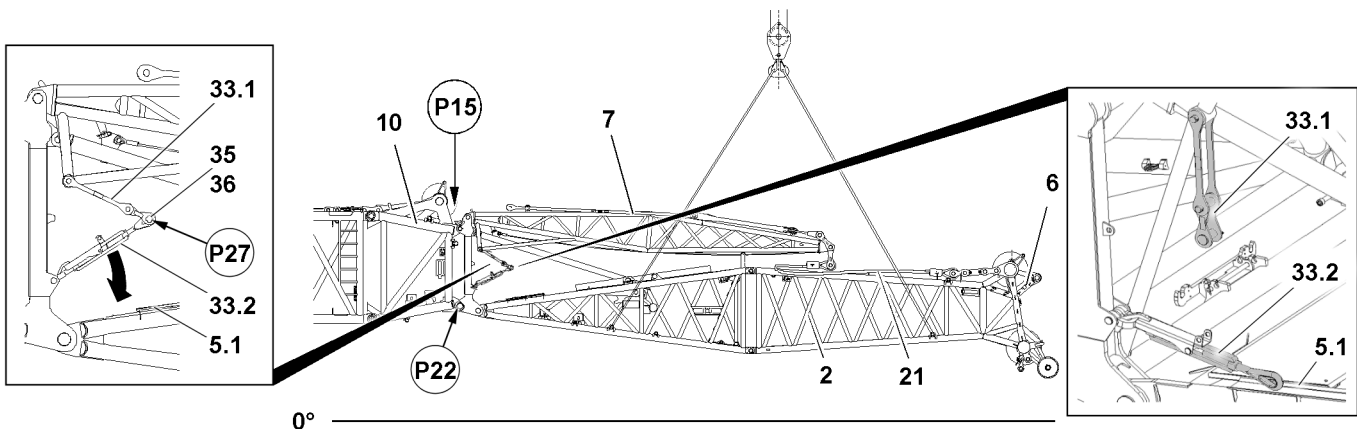

Fig.127679: Separating the FA-frame relapse retainers

Separate the FA-frame relapse retainer **33** at point **P27**:

- ▶ Remove the retaining element **36** at point **P27** and unpin the pin **35**.
- ▶ Place the turnbuckle **33.2** in the receptacle **5.1**.
- ▶ Guide the guy rods **33.1** after the position *downward* and let them hang.
- ▶ Insert the pin **35** again at point **P27** and secure with the retaining element **36**.

6.4 Preparing the rope pulley retainer for the assembly of the F-jib



WARNING

Falling rope pulley retainer!

The rope pulley retainer **25** can fall down due to its own weight when unpinning it.

Death, severe bodily injuries, property damage.

► Make sure that the assembly winch rope **25** is secured against falling down when unpinning.

Release the rope pulley retainer **25** from the FA-frame **7**:

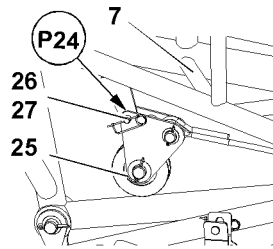

Fig.127480: Releasing the rope pulley retainer **25** from the FA-frame:

- Remove the retaining element **27** at point **P24** and unpin the pin **26**.
- Take the rope pulley retainer **25** down with the rope on the open end of the F-assembly unit.

6.5 Erecting the FA-frame

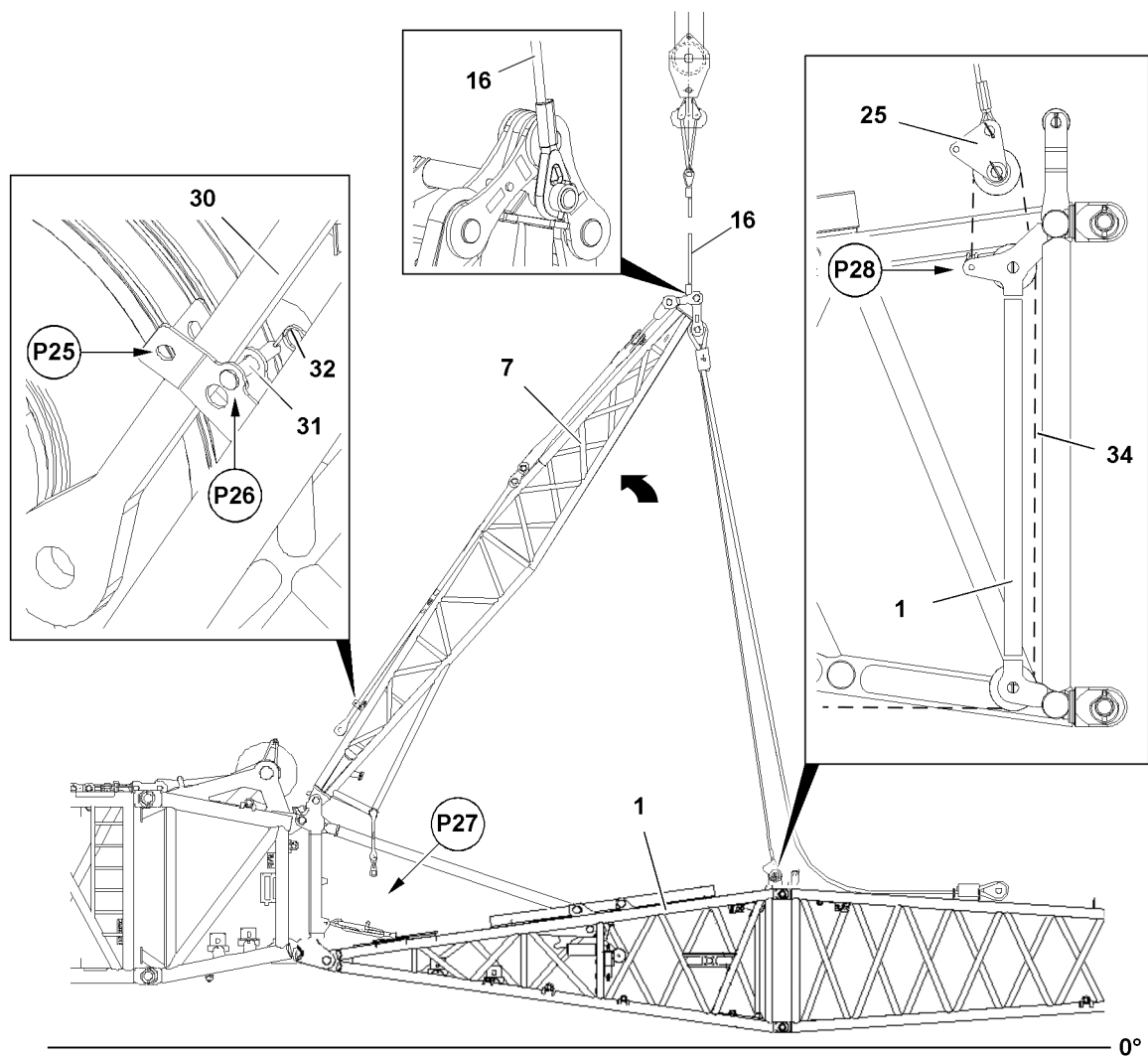

Fig.127681: Erecting the FA-frame

Make sure that the following prerequisite is met:

- The FA-frame relapse retainers **33** are separated at point **P27**.

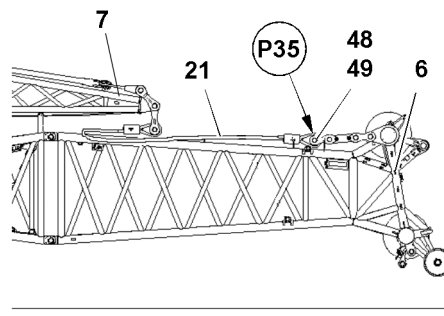

Fig.127683: Releasing the F-guy rope **21** on the F-end section **6** at point **P35**

- ▶ Unpin the F-guy rope **21** on the F-end section at point **P35**: Remove the retaining element **49** on both sides and unpin the pin **48** on both sides.
- ▶ Release the fastening rope **16** in the transport position on the FA-frame **7**.
- ▶ Fasten the FA-frame **7** with the fastening rope **16** to the auxiliary crane.
- ▶ Lift FA-frame **7** with auxiliary crane.

- ▶ Reeve the assembly winch rope **34** at the rope pulley retainer **25** and secure on the F-pivot section **1** at point **P28**.

Release the FA-guy rods **30** on both sides:

- ▶ Remove the retaining element **32** at point **P25** and unpin the pin **31**.
- ▶ Insert the pin **31** at point **P26** in the park position and secure with the retaining element **32**.

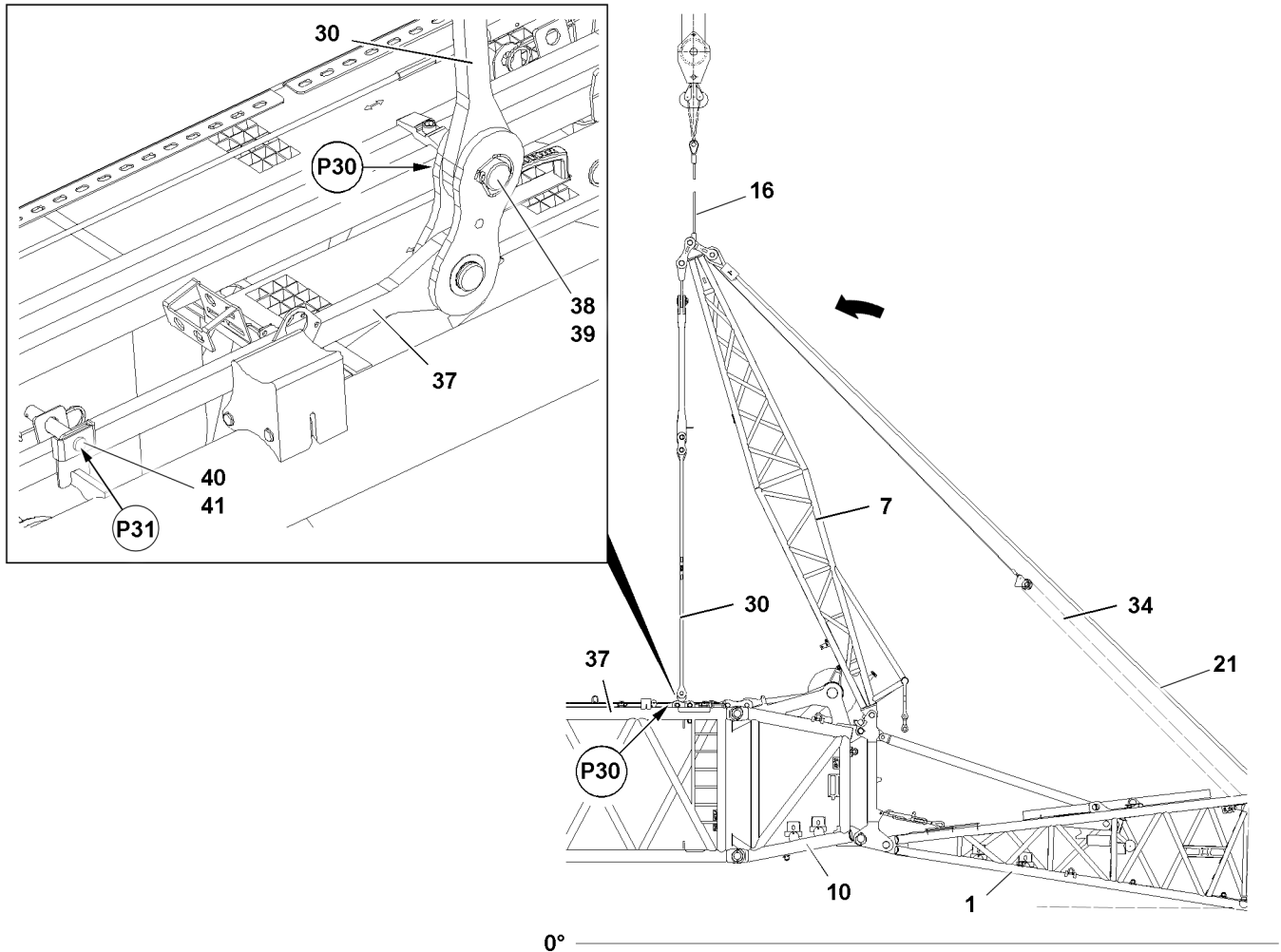

Fig.127684: Pinning the FAB-guy rods

NOTICE

Danger of property damage!

When swinging the FA-frame **7** in the direction of the main boom, damage may occur to the FA-frame, the F-connector head **10** or the L-end section **10**, as well as the rope pulley retainer **25**.

- ▶ Make sure that a guide supervises the swinging process of the FA-frame.
- ▶ Make sure that the guide is constantly in visual and acoustic contact with the crane operator!
- ▶ Make sure that the assembly winch rope **34** is spooled out during the swinging process of the FA-frame **7**.

- ▶ Carefully swing the FA-frame **7** with the auxiliary crane in direction of the main boom and spool the assembly winch rope **34** out at the same time until it can be pinned at point **P30**.

Pin the FAB-guy rods **30** with the FAB-guy rods **37** of the L-intermediate section:

- ▶ Insert the pin **38** at point **P30** and secure with the retaining element **39**.

Release the FAB-guy rods **37** in the transport receptacle:

- ▶ Remove the retaining element **41** at points **P31** and unpin pin **40**.

6.6 Placing the FA-frame in the operating position

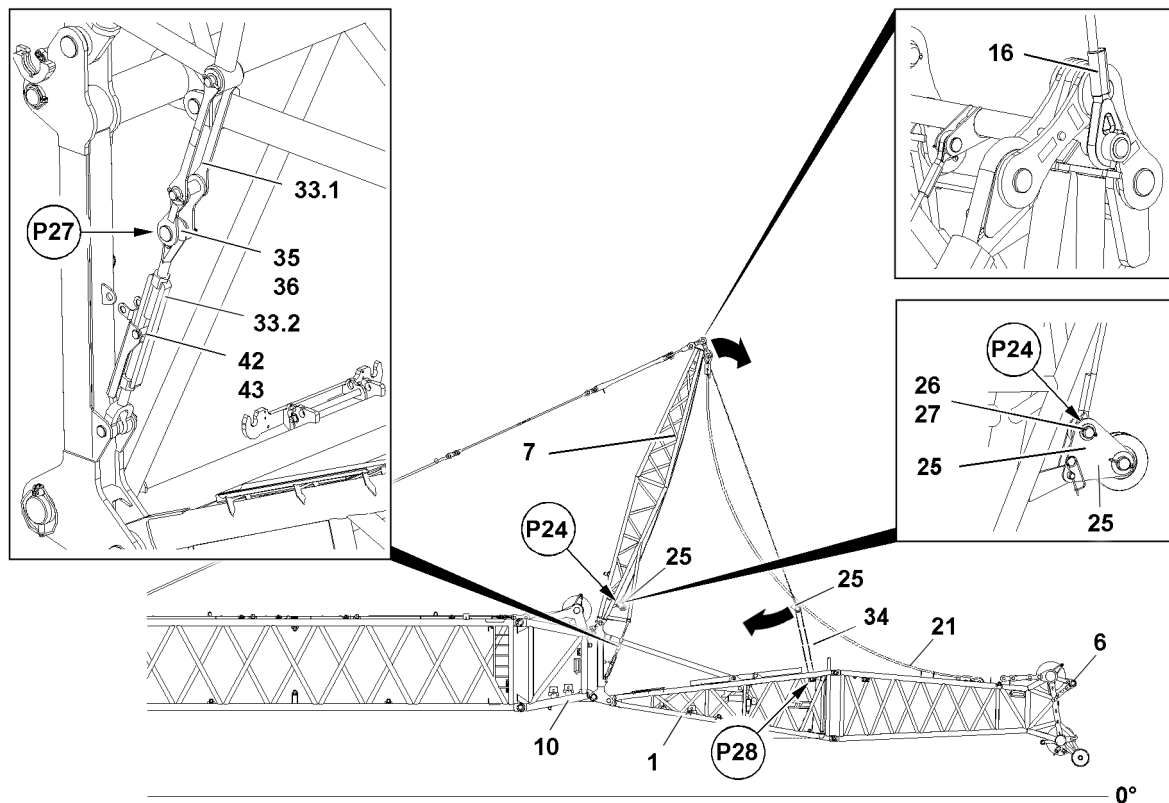

Fig.127685: Bringing the FA-frame into operating position

Make sure that the following prerequisite is met:

- The FAB-guy rods are properly pinned and secured.
- ▶ Pull the FA-frame 7 with the assembly winch rope 34 in direction of the F-pivot section 1.
- ▶ Pin the FA-frame relapse retainer 33:
- ▶ Pin the rods 33.1 and turnbuckle 33.2 at point P27 with pin 35 and secure properly with the retaining element 36.

When the FA-frame relapse retainer 33 is properly pinned and secured:

- ▶ Fasten the turnbuckle evenly on both sides and secure it to prevent turning.
- ▶ Insert the pin 42 and secure it with the retaining element.

Result:

- The turnbuckle is secured to prevent it from twisting in crane operation.
- Affix the FA-frame 7 in the operating position.

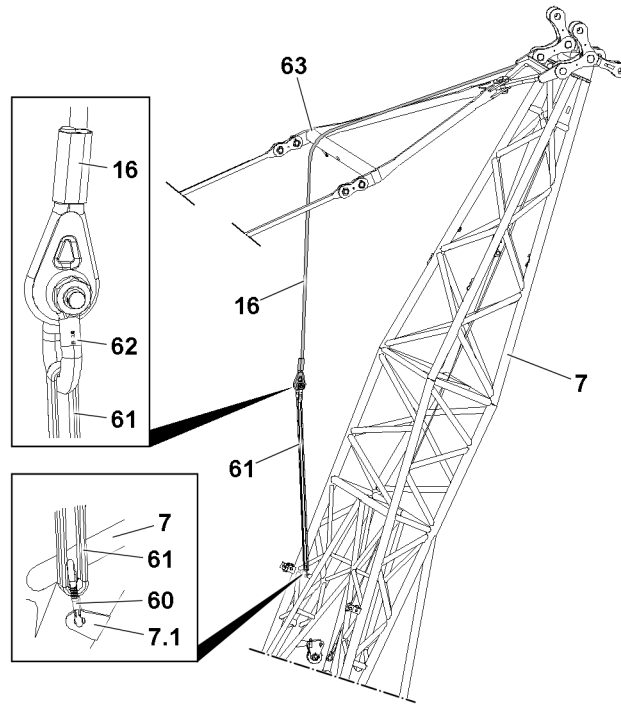

Fig.124500: Securing the fastening rope on the FA-frame for crane operation

NOTICE

Swinging fastening rope!

If the fastening rope 16 is not properly secured, then the fastening rope 16 can start to swing back and forth in crane operation and damage components.

► Make sure that the fastening rope 16 is properly secured on the FA-frame before starting to work with the crane.

► Place the fastening rope 16 over the linkage 63.

► Connect the fastening rope 16 with the roundslings 61 with the shackle 62.

► Fasten the roundslings 61 with the carabiner 60 on bracket 7.1 of the FA-frame.

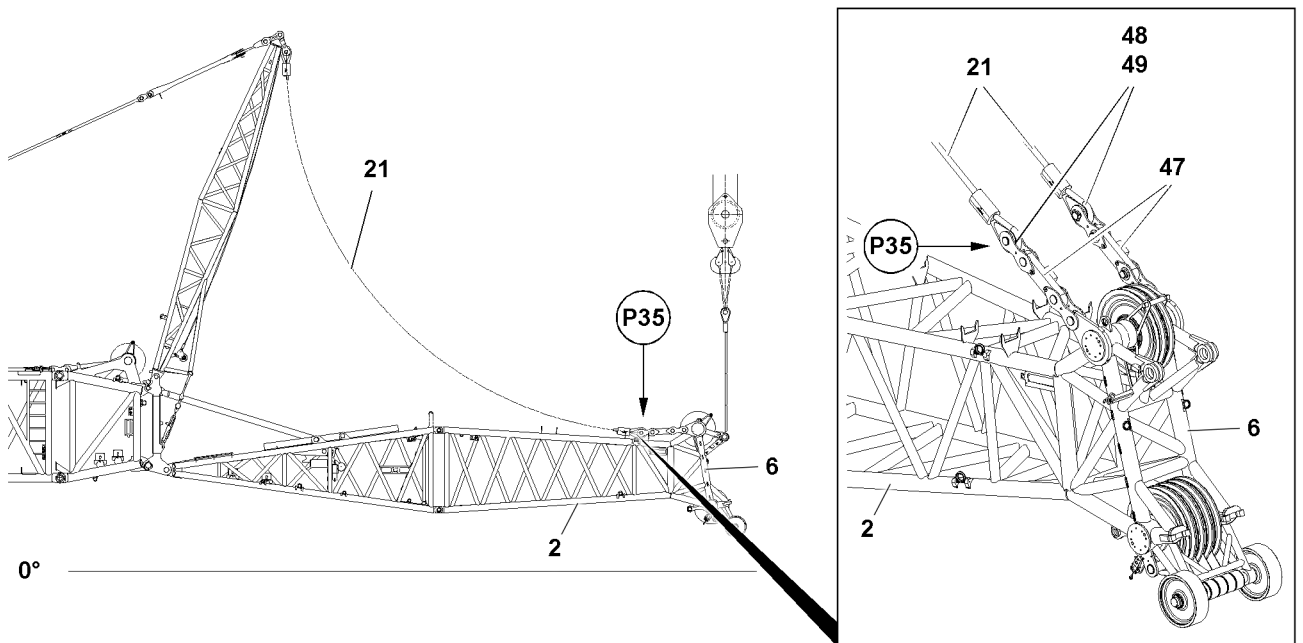

Fig.127686: Assembling the F-guy rope on the F-end section

LWE/LR 11000-001/23501-04-02/en

- ▶ Fasten the F-jib **2** to the auxiliary crane.
- ▶ Carefully tension the fastening equipment.

When the fastening equipment is tensioned:

- ▶ Release and reeve out the assembly winch rope **34** at point **P28**.

Pin the rope pulley retainer **25** on the FA-frame **7**:

- ▶ Insert the pin **26** at point **P24** and secure with the retaining element **27**.
- ▶ Pin the F-guy ropes **21** on the F-end section **2** at point **P35** with pin **48** and secure with the retaining element **49**.

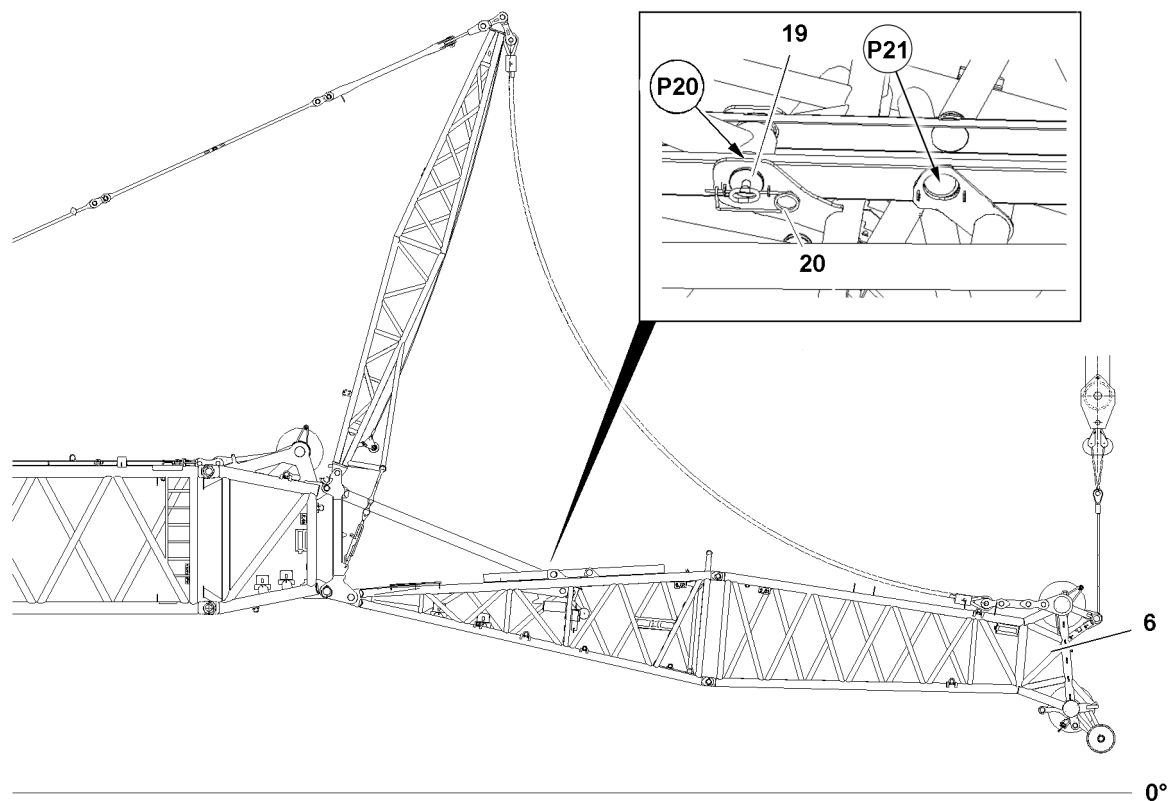

Fig.127687: Unpinning the F-relapse support

Unpin the F-relapse support **18** in the transport position.

When the F-jib **6** is safely held by the auxiliary crane:

- ▶ Remove the retaining element **20** at point **P20** and unpin the pin **19**.
- ▶ Insert the pin **19** in the stop position at point **P21** and secure with retaining element **20**.
- ▶ Lower the F-assembly unit **6** slowly on the ground with the auxiliary crane.

When the F-jib is laying on the ground:

- ▶ Remove the auxiliary crane.

Empty page!

LWE/LR 11000-001/23501-04-02/en

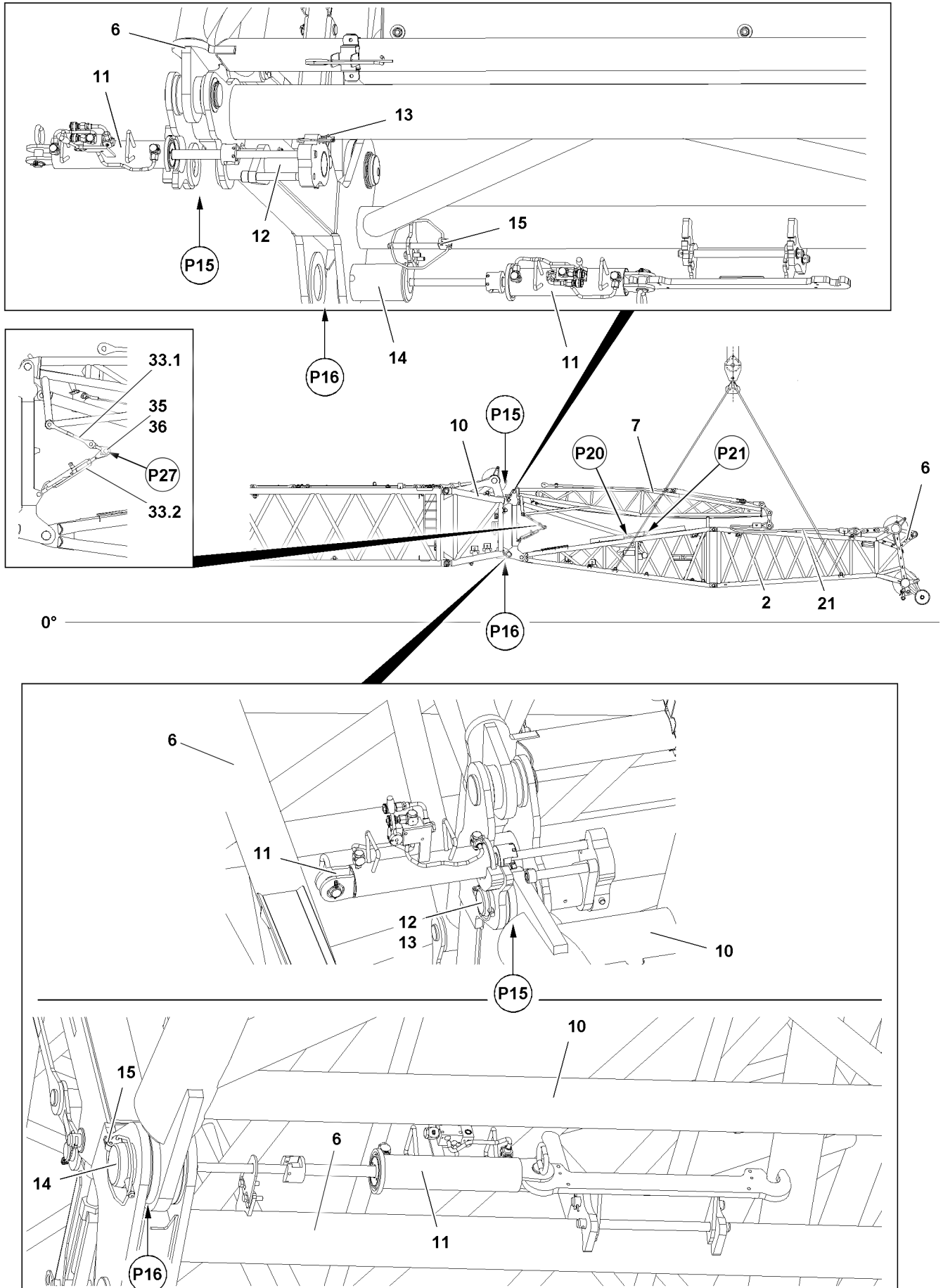

Fig.127678

LWE/LR 11000-001/23501-04-02/en

7 Assembly variant V4 — Assembling the complete F-jib (maximum length of 12 m) in flying mode



WARNING

Impermissible F-assembly length(s)!

Death, severe bodily injuries, property damage.

- ▶ Make sure that the assembly of the F-jib as a complete F-assembly unit with the F-end section does not exceed 12 m.
- ▶ During assembly, no hook block may be reeved on the F-jib!

7.1 Assembling the F-assembly unit with F-end section

- ▶ Fasten the F-assembly unit with the F-end section **6** to the auxiliary crane.
- ▶ Remove the rigging belts between the F-pivot section **1** and FA-frame **7**.

The F-assembly unit is pinned four times on L-end section or on the F-connector head. Every pin point is present on both sides of the component on one level.

- ▶ Set the pin pulling cylinder **11** at pin point **P15** and unpin the pin **12**.
- ▶ Set the pin pulling cylinder **11** at pin point **P16** and unpin the pin **14**.
- ▶ Position the F-assembly unit **5** with the F-end section **6** with the auxiliary crane on the L-end section or on the F-connector head so that it can be pinned at point **P15** and at point **P16**.
- ▶ Set the pin pulling cylinder **11** at pin point **P15** and pin the pin **12** on both sides.

When the pins **12** are completely pinned:

- ▶ Secure the pins **12** with retaining elements **13** on both sides.



WARNING

Crushing / shearing of limbs!

While performing boom system assembly tasks, limbs can be crushed and / or sheared off.

Death, severe bodily injuries, property damage.

- ▶ Make sure that no crane movements are performed while pinning in the area of the lower pin points **P16**.

- ▶ Set the pin pulling cylinder **11** at pin point **P16** and pin the pin **14** on both sides.

When the pins **14** are completely pinned:

- ▶ Secure the pins **14** with retaining elements **15** on both sides.
- ▶ Remove the auxiliary crane.

7.2 Assembling the F-guy ropes

- ▶ Make sure that the F-guy ropes **21** are properly pinned and secured with the brackets of the FA-frame **7** and the F-end section **2** at point **P23** and point **P35**.

7.3 Releasing the F-relapse support

Make sure that the following prerequisites are met:

- The F-assembly unit **6** is properly pinned and secured on L-end section or on the F-connector head with the F-end section.
- The F-guy ropes **21** are properly pinned and secured between the FA-frame **7** and the F-end section **2**.
- The F-jib is, on the F-end section **2**, properly fastened on the auxiliary crane.

Release the F-relapse support **18** from the transport position.

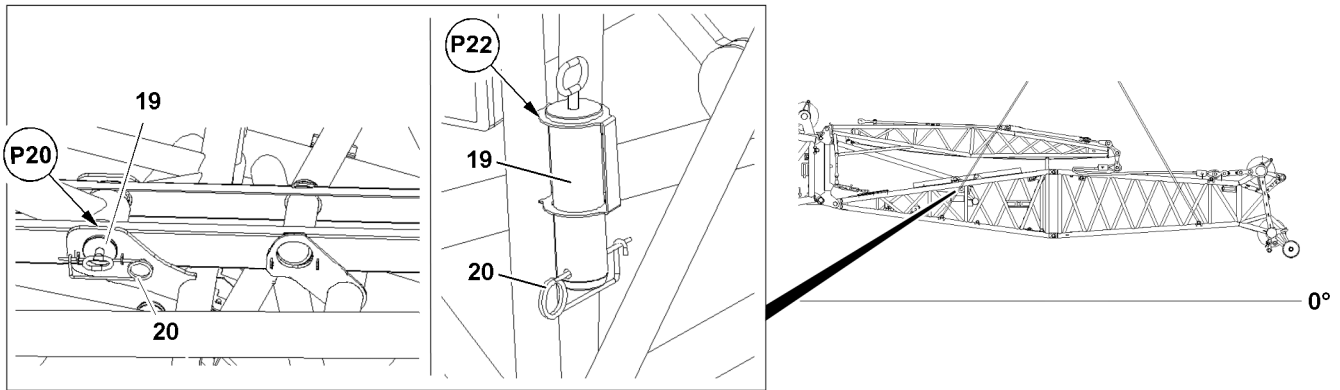

Fig. 127912: Position of the F-relapse support

If the prerequisites for releasing the F-relapse support are fulfilled:

- ▶ Remove the retaining element **20** at point **P20** and unpin the pin **19**.
- ▶ Insert pin **19** in the park position at point **P22** and secure with retaining element **20**.

7.4 Separating the FA-frame relapse retainers



Note

- ▶ Separate the „FA-frame relapse retainer“, see description of assembly variant V2.



WARNING

Nonobservance of safety guidelines!

If the safety guidelines are not observed, dangerous situations can arise.

Death, severe bodily injuries, property damage.

- ▶ Make sure that all danger notes in the section „Separating the FA-frame relapse retainer“ are observed.

7.5 Erecting the FA-frame



Note

- ▶ Erect the „FA-frame“, see description of assembly variant V2.



WARNING

Nonobservance of safety guidelines!

If the safety guidelines are not observed, dangerous situations can arise.

Death, severe bodily injuries, property damage.

- ▶ Make sure that all danger notes in the section „Erecting the FA-frame“ are observed.

7.6 Placing the FA-frame in the operating position



Note

- ▶ Place the „FA-frame in the operating position“, see description of assembly variant V2.



WARNING

Nonobservance of safety guidelines!

If the safety guidelines are not observed, dangerous situations can arise.

Death, severe bodily injuries, property damage.

- ▶ Make sure that all danger notes in the section „Placing the FA-frame in the operating position“ are observed.

8 Establishing the electrical connections

Make sure that the following prerequisites are met:

- The F-jib is completely assembled.
- The airplane warning light and the wind speed sensor are installed.

NOTICE

Damage to the electrical connection on the cable drum!

If the electrical connection from the cable drum on the F-pivot section to the terminal box on the L-end section or on the F-connector head is established first before the connection to the terminal box on the F-end section, the electrical connection can be damaged when spooling out the cable drum.

- ▶ Establish the electrical connection from the cable drum on the F-pivot section to the terminal box on the F-end section first and then the electrical connection from the terminal box on the F-connector head or on the L-end section to the cable drum on the F-pivot section.



Note

- ▶ Establish the electrical connections to the F-jib, see Electrical wiring diagram.

- ▶ Establish the electrical connections.
- ▶ Make sure that all electrical connections on the boom are established.

9 Checking the function of the safety equipment



WARNING

Malfunctioning safety equipment!

Death, severe bodily injuries, property damage.

- ▶ Crane operation with non-functioning safety equipment is **prohibited**.



Note

- ▶ The function of the individual limit switches must be checked before erection of the boom system.
- ▶ The function of the limit switch initiators must be checked in the test system, see the „Diagnostics manual“.



Note

- ▶ If a function check on the limit switches or on the safety equipment does not lead to the desired shut-offs, then the plug connections on the connector boxes or the components themselves must be checked. If no visible connection errors or component defects can be found, contact **Liebherr Service**.

Make sure that the following prerequisites are met:

- All electrical connections have been made.
- The crane engine is running.
- The corresponding operating mode is set on the LICCON monitor.

9.1 Checking the wind speed sensor

- ▶ Check the movement and the function of the wind speed sensor.

9.2 Checking the airplane warning light

- ▶ Turn the airplane warning light on in the crane operator's cab, see Crane operating instructions, chapter 4.01.
- ▶ Check the function visually.

9.3 Checking the hoist limit switch on the pulley head



Note

- ▶ When replacing or changing a hoist limit switch (HES), the corresponding hoist limit switch must have the correct bus address and the correct software version in order to be detected again by the bus system (LSB).

- ▶ Actuate the hoist limit switch manually on the pulley head.

Result:

- The spool up function of the hoist winch turns off.
- The icon „Hoist top“ appears on the LICCON monitor 0.
- The limit switch is functioning.

9.4 Checking the limit switches in general



Note

- ▶ The limit switch functions have to be checked individually before erection.
- ▶ To check the limit switches, see corresponding chapter in the Crane operating instructions.

10 Erecting the boom



WARNING

The crane can topple over!

For certain boom lengths, the mechanical auxiliary supports must be assembled, see Erection and take down charts.

Death, severe bodily injuries, property damage.

- ▶ Observe the specifications in the erection and take down charts.



WARNING

The crane can topple over!

If the following conditions are not met before erecting the boom, the crane can topple over.

Death, severe bodily injuries, property damage.

- ▶ Observe the technical safety instructions, see the Crane operating instructions, chapter 5.01.
- ▶ Extend the relapse cylinder before erection.
- ▶ Do not allow slack rope formation on the control winch.



WARNING

Falling hoist rope!

If the hoist rope before the erection procedure is not properly secured onto the end section, it can fall down backward on the basis of its own weight.

Death, severe bodily injuries, property damage.

- ▶ Secure the hoist rope properly on the end section before the erection procedure.

Make sure that the following prerequisites are met:

- The crane is horizontally aligned.
- The guy rods are properly assembled.
- The guy rods which are not required have been removed from the lattice sections.
- All electrical connections have been made.
- All hydraulic connections have been made.
- The function checks were carried out properly.
- All limit switches and warning devices are functioning.
- Crane ballasting (counterweight, central ballast, derrick ballast and / or auxiliary ballast) is carried out according to the load charts and / or the erection and take-down charts
- The crane has been set up according to the load charts and / or the erection and take-down charts.
- The LICCON overload protection has been set according to the data in the load charts and / or the erection and take-down charts.
- The LICCON overload protection settings have been checked for completeness and correctness.
- Assembly operation of the crane control is activated: the assembly icon is visible on the LICCON monitor.
- All pin connections have been secured.
- The hoist rope has been correctly placed in the rope pulleys and is prevented from jumping out with the rope retaining pins.
- There are no loose parts on the boom system.
- The boom system and the safety equipment are free from snow, frost and ice.
- No personnel or obstacles are within the danger zone.

10.1 Erection procedure



WARNING

The crane can topple over!

Death, severe bodily injuries, property damage.

- ▶ It is prohibited to turn the crane superstructure while erecting the boom.
- ▶ Observe the data in the Erection and take down charts.

10.1.1 Reeving in the hook block

Make sure that the following prerequisites are met:

- The crane is horizontally aligned.
- The slewing gear brake is applied.



WARNING

Danger of accident due to side wind!

If the slewing gear brake is released after reeving in / reeving out the hook block / load hook, then the crane can turn uncontrolled if there is a strong side wind.

Death, severe bodily injuries, property damage.

The crane can collide with close-by structures or objects.

- ▶ Make sure that the current wind speed does not exceed the values from the wind speed chart when releasing the slewing gear brake.
- ▶ Luff up the boom until the F-jib lifts off the ground.
- ▶ Reeve in the hook block properly, see Crane operating instructions, chapter 4.06 and the separate reeving plans.
- ▶ Properly secure the hoist rope on the rope fixed point, see the Crane operating instructions, chapter 4.06.
- ▶ Attach the hoist limit switch weight, see the Crane operating instructions, chapter 4.06.

10.1.2 Erecting the boom



DANGER

The crane can topple over!
Death, severe bodily injuries, property damage.

- ▶ The radii listed in the load chart may not be exceeded or fallen below, even if there is no load on the hook.



Note

- ▶ When the lowest operating position of the boom is reached, the set load chart of the LICCON overload protection is activated.
- ▶ In the maximum load icon appears a load number in „t“ instead of the display „???“.

- ▶ Luff the boom up to the lowest operating position.

When the boom has reached the lowest operating position:

- ▶ Make sure that the assembly icon on the LICCON monitor turns off.

Result:

- The LICCON overload protection is active.

11 Operating the crane

11.1 Preparing for crane operation



Note

- ▶ Observe the notes, see Crane operating instructions, chapter 4.05, chapter 4.08 and chapter 5.01.

Make sure that the following prerequisites are met:

- The LICCON overload protection is active.
- The LICCON overload protection has been set according to the data in the load chart.



WARNING

The crane can topple over!
Death, severe bodily injuries, property damage.

- ▶ Check the horizontal position of the crane before and during operation.
- ▶ If the crane operator leaves the crane cab, even for a short time, the operating mode setting must be checked and reset, if necessary, before resuming crane operation.

11.2 Checking the settings

- ▶ Check the function of the overload protection by running against the operating positions „on top“ and „bottom“.
- ▶ Check the hoist limit switch by running against the hoist limit switch weight.

12 Disassembling the F-jib



WARNING

Danger of falling!

During assembly / disassembly, inspection and maintenance work, personnel must be secured with appropriate aids to prevent them from falling.

Death, severe bodily injuries, property damage.

- ▶ All work at a height, when there is a danger of falling, must be carried out with suitable aids.
- ▶ If aids are not available and work cannot be carried out from the ground, then assembly personnel must secure themselves with the supplied fall arrest system to prevent falling, see the Crane operating instructions, chapter 2.04.
- ▶ If fall protection equipment is available, then it must be used, see the Crane operating instructions, chapter 2.06.
- ▶ When lifting, lowering, swinging crane parts in and out, no persons may remain in the danger zone.
- ▶ If railings are present on the components, then they must be brought into the corresponding position and secured for assembly / disassembly work.
- ▶ It is prohibited to lean the auxiliary ladder against the component being disassembled.
- ▶ Only step on the aids, ladders and catwalks with clean shoes.
- ▶ Keep aids, ladders and catwalks free of heavy dirt, snow and ice.
- ▶ During all assembly and disassembly work, maintenance work and inspections, travel or crane operation is prohibited.
- ▶ Remaining on a suspended load is prohibited.
- ▶ Stepping or walking on crane components and lattice sections, which have an incline of more than 20° is prohibited.
- ▶ For all assembly work, the crane operator of the main crane must be in voice contact with the crane operator / crane operators of the auxiliary crane / auxiliary cranes.
- ▶ For assembly / disassembly tasks, the crane operator may only initiate crane movements when the responsible guide has explicitly released the movement.



WARNING

Danger of impact / crushing!

When installing / removing crane components with the auxiliary crane, crane components can start to swing back and forth.

When lifting / lowering and positioning crane components, there is an increased danger of impacts / crushing.

Death, severe bodily injuries, property damage.

- ▶ Make sure that personnel cannot be caught by components.
- ▶ When working in danger zones: Use aids to protect limbs.
- ▶ Guide components with suitable aids to minimize oscillation.



WARNING

The components can fall down!

If the corresponding component is disengaged from the auxiliary crane before the corresponding component is pinned, then the corresponding component can fall down.

Death, severe bodily injuries, property damage.

- ▶ Do not disengage the auxiliary crane until the respective component is pinned and secured.



WARNING

The lattice sections can fall down!

If the lattice sections are not pinned and secured correctly, then they can fall down.

Death, severe bodily injuries, property damage.

- ▶ Pin or unpin both pins at the same horizontal level, i.e. **left and right**.
- ▶ Do not stand under the lattice sections or within the entire danger zone during the pinning and unpinning procedure of the boom.
- ▶ Safely secure the pins in the storage locations as well as in the receptacles.
- ▶ It is prohibited to lean the auxiliary ladder against the component being disassembled.

Make sure that the following prerequisites are met:

- The S-boom is luffed down to the „lowest“ operating position.
- The LICCON overload protection has been set according to the data in the load chart.
- The LICCON overload protection is exceeded.
- The assembly icon is visible on the LICCON monitor.
- The auxiliary crane is available.

12.1 Taking the S-boom down



WARNING

The crane can topple over!

If the following conditions are not met before taking down the boom, the crane can topple over. Death, severe bodily injuries, property damage.

- ▶ Observe the technical safety instructions, see the Crane operating instructions, chapter 5.01.
- ▶ Observe the specifications in the erection and take-down charts.

NOTICE

Damage of boom components!

Taking down the boom system can lead to a collision between the hook block and the pulley head. Boom components can be severely damaged.

- ▶ Luff the boom system down and at the same time spool the hoist winch out.

12.1.1 Luffing the S-boom down



Note

- ▶ The luff down movement is turned off as soon as the lowest operating position is reached.
- ▶ When the lowest operating position of the S-boom is reached, the load display in the maximum load icon turns off and instead of the load display appears the display „???“.
- ▶ In the crane operating screen appear alarm functions.

- ▶ Luff the S-boom down to the „lowest“ operating position.

Result:

- The luff down movement is turned off.
- The „STOP“ icon appears on the LICCON monitor.
- The horn icon appears on the LICCON monitor.



WARNING

The crane can topple over!

In assembly operation the LICCON overload protection is deactivated.

In the event of deliberate improper use, the crane could collapse, the boom can break off or the crane can topple over.

Death, severe bodily injuries, property damage.

- ▶ Activate the assembly operation only when the consequences are known.
- ▶ Enter the set up configuration correctly into the LICCON computer system.
- ▶ Observe the erection / take down charts.
- ▶ Crane operation with deactivated LICCON overload protection is prohibited.
- ▶ In assembly operation only load torque reducing crane movements may be carried out until a permissible operating and load range.
- ▶ The crane operator carries complete and sole responsibility for his actions if the LICCON overload protection is deactivated.

When the boom has reached the „lowest“ operating position:

- ▶ Activate assembly operation, see Crane operating instructions, chapter 4.02.

Result:

- The LICCON overload protection is deactivated.

- The assembly icon appears on the LICCON monitor.
- ▶ At the same time, luff down the boom system and spool out the hoist winch until the hook block touches the ground.

When the hook block touches the ground:

- ▶ Properly take down / set down the hook block onto the floor or a suitable substructure.

When the hook block is properly set down:

- ▶ Remove the hoist limit switch weight.
- ▶ Reeve out the hook block, see Crane operating instructions, chapter 4.06.
- ▶ Carefully spool the hoist rope up.
- ▶ Remove the hook block with the auxiliary crane.

NOTICE

Damage to the boom system!

- ▶ Make sure that the boom system is carefully luffed down at a slow speed.
 - ▶ When the F-jib comes into contact with the ground, carefully luff the boom system down further until the main boom lies on a load bearing substructure.
-

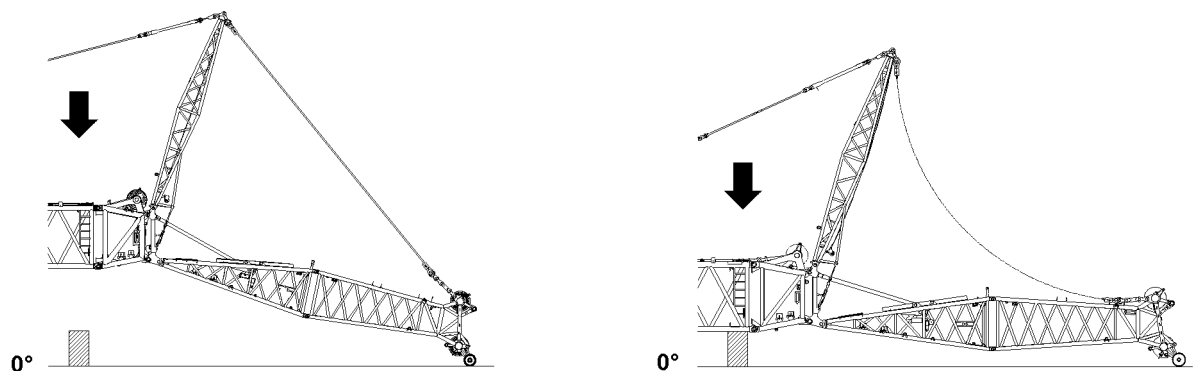

Fig.120188: Taking the boom system down

When the hook block is removed under the F-jib:

- ▶ Carefully luff the boom system down until the F-jib comes into contact with the ground.

12.2 Disconnecting the electrical connections

Make sure that the following prerequisite is met:

- The boom system is properly taken down.

NOTICE

Damage to the electrical connection on the cable drum!

If the electrical connection between the F-connector head or the L-end section **and** the F-pivot section is not separated before spooling up the cable drum, the electrical connection will be damaged.

If the cable of the cable drum is not properly spooled up on the cable drum after unplugging the F-end section, then the cable drum or the cable can be significantly damaged.

- ▶ Disconnect the electrical connection from the cable drum on the F-pivot section to the terminal box on the L-connector head or the L-end section first **and** then the electrical connection from the terminal box on the F-end section to the cable drum.
 - ▶ After unplugging, spool up the cable onto the cable drum.
-
- ▶ Properly disconnect the electrical connections.
 - ▶ After unplugging, spool up the cable onto the cable drum and secure it to prevent it from spooling out inadvertently.
 - ▶ Secure the cable: Reestablish the electrical connection between the F-connector head or the L-end section and the cable drum.

12.3 Disassembling the F-jib in parts

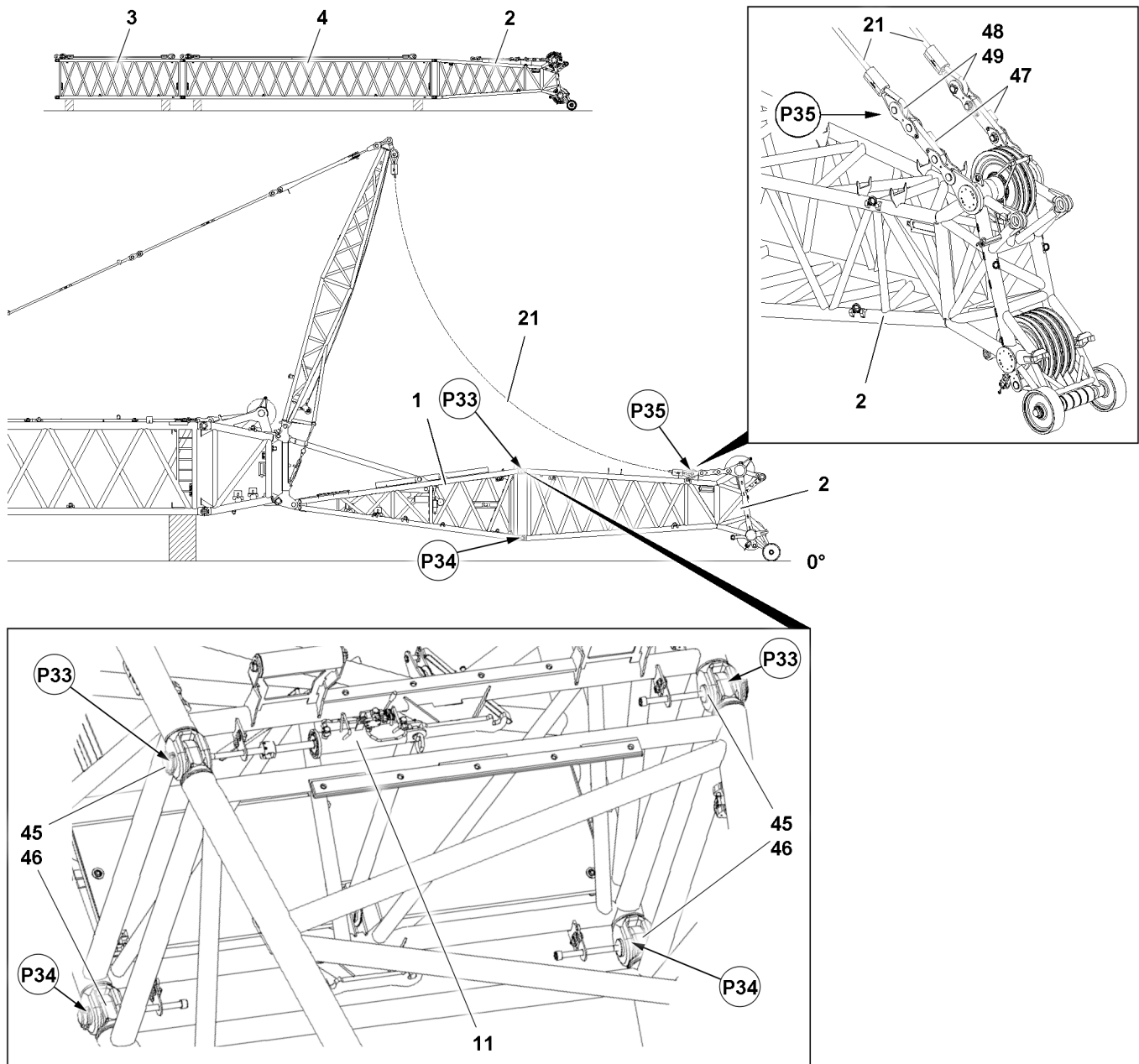

Fig.127688: Disassembling the lattice sections

LWE/LR 11000-001/23501-04-02/en

12.3.1 Disassembling the lattice sections



WARNING

F-guy ropes ripping off!

If the F-guy ropes **21** are installed twisted in longitudinal axis, then the load bearing capacity can be significantly reduced as a result and the F-guy ropes can rip off.

Death, severe bodily injuries, property damage.

- ▶ Make sure that the F-guy ropes **21** are **never** kinked, knotted or twisted.
- ▶ Make sure the kinked, knotted or twisted F-guy ropes **21** are **never** installed.
- ▶ Make sure that F-guy ropes **21** are never pulled over the ground or sharp edges.
- ▶ Make sure that no damaged F-guy ropes **21** are being installed.
- ▶ Make sure that the numbering in the rod plan is identical to the numbering on the F-guy ropes.
- ▶ Make sure that the maximum bending radius of **20 x** rope diameter on the F-guy ropes **21** is **never** fallen below.
- ▶ Check the F-guy ropes before every assembly.
- ▶ When using fiber guy ropes: Inspect the fiber guy rods regularly, see Crane operating instructions, chapter 8.16.

Unpin the F-guy ropes **21** at point **P35** on the F-end section **2**:

- ▶ Remove the retaining element **49** and unpin the pin **48**.



Note

- ▶ If F-intermediate sections are installed on the F-jib, then the additional guy ropes for the F-intermediate sections must be removed.

- ▶ Fasten the F-end section **2** and the F-intermediate sections (if applicable) to the auxiliary crane and disassemble.

The F-end section **2** is pinned four times on F-pivot section **1**. Every pin point is present on both sides of the component on one level.

- ▶ Remove the retaining element **46** at the pin point **P34**.
- ▶ Set the pin pulling cylinder **11** at pin point **P34** and unpin the pin **45**.
- ▶ Remove the retaining element **46** at the pin point **P33**.
- ▶ Set the pin pulling cylinder **11** at pin point **P33** and unpin the pin **45**.

When all connector pins are properly unpinned:

- ▶ Swing out the F-end section **2** and the F-intermediate section (if applicable) with the auxiliary crane and take it down on a load bearing substructure.
- ▶ Take the F-pivot section **1** down on the ground or on a load bearing substructure.

12.3.2 Unpinning the guy rods

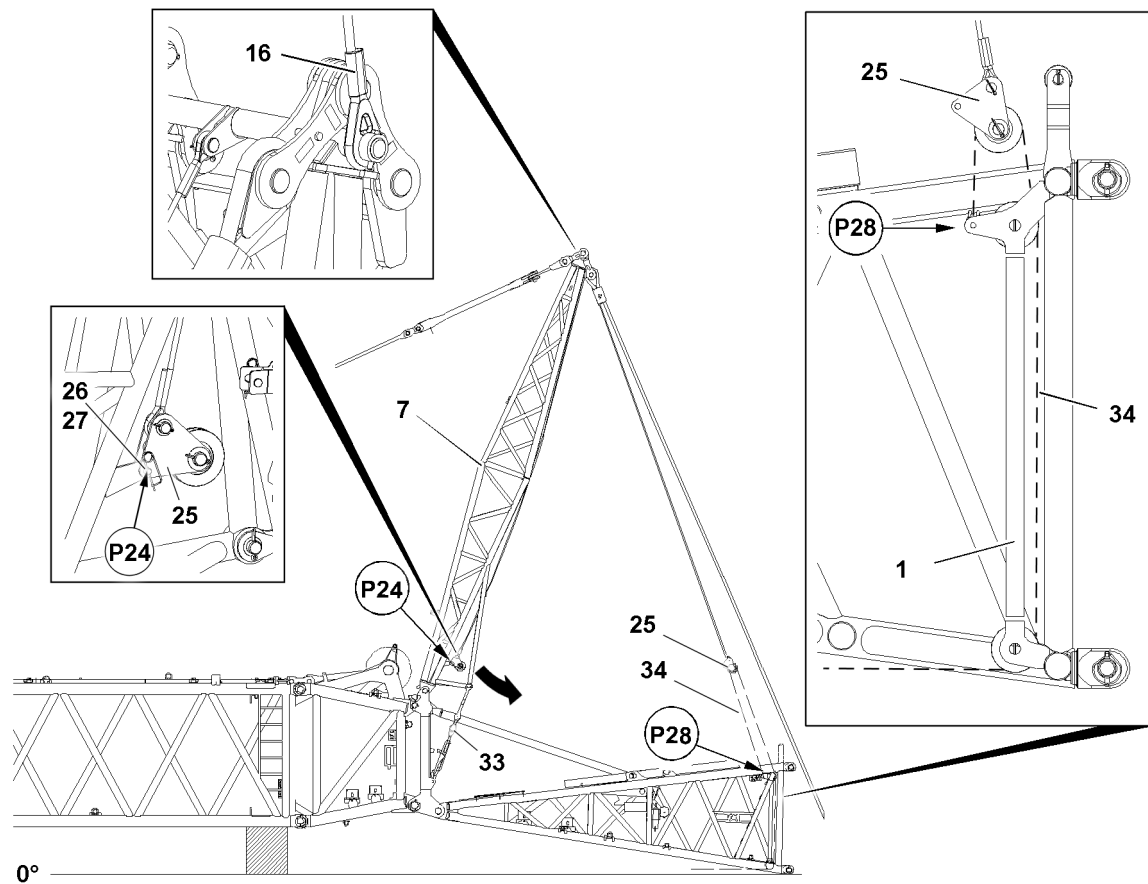

Fig.127690

- ▶ Release the fastening rope **16** on the FA-frame **7**.
- ▶ Fasten the fastening rope **16** to the auxiliary crane.
- ▶ Position the auxiliary crane over the FA-frame **7** and carefully tension the fastening rope **16**.



WARNING

Swinging rope pulley retainer!

The rope pulley retainer **25** can swing due to its own weight when unpinning it. Death, severe bodily injuries, property damage.

- ▶ Make sure that the rope pulley retainer **25** is held during unpinning.

Release the rope pulley retainer **25** on the FA-frame: **7**

- ▶ Remove the retaining element **27** at point **P24** and unpin the pin **26**.
- ▶ Swing the rope pulley retainer **25** to point **P28**.
- ▶ Reeve the assembly winch rope **34** on the rope pulley retainer **25** and secure on the F-pivot section **1** at point **P28**.

NOTICE

Danger of property damage!

If the FA-frame relapse retainers **33** are not separated, then they will be damaged during erection of the FA-frame **7**.

- ▶ Make sure that the FA-frame relapse retainers are properly separated during the erection of the FA-frame.

**WARNING**

Falling and swinging FA-frame relapse retainer!

The FA-frame relapse retainer consists of guy rods **33.1** and a turnbuckle **33.2**.

The guy rod **33.1** of the FA-frame relapse retainer can fall down due to its own weight during unpinning.

The guy turnbuckle **33.2** of the FA-frame relapse retainer can fall down due to its own weight during unpinning.

Death, severe bodily injuries, property damage.

- ▶ Make sure when unpinning the FA-frame relapse retainer, the guy rods **33.1** and turnbuckle **33.2** are safely held.
- ▶ Assembly personnel must be at the side of the assembly unit.

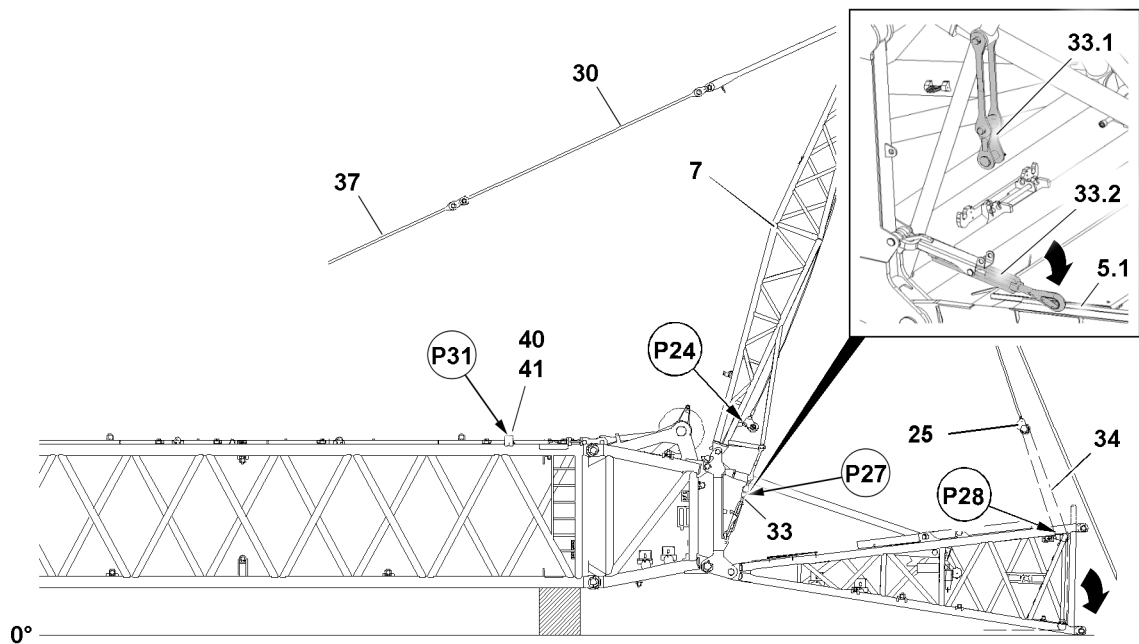

Fig.127689: Separating the FA-frame relapse retainers

Separate the FA-frame relapse retainer at point **P27**:

- ▶ Carefully spool up assembly winch rope **34**.

Result:

- The F-pivot section is pulled in the direction of the FA-frame **7** and lifted off the ground.
- The FA-frame relapse retainer **33** is relieved.

When the FA-frame relapse retainer **33** is relieved:

- ▶ Remove the retaining element **36** at point **P27** and unpin the pin **35**.
- ▶ Take down the FA-frame relapse retainer.
- ▶ Insert the pin **35** again at point **P27** and secure with the retaining element **36**.

Unpin the retaining pin in the transport receptacle for the FAB-guy rods.

- ▶ Remove the retaining element **41** at point **P31** and unpin the pin **40**.

Result:

- The FAB-guy rods **37** can be placed on the LI-intermediate section.

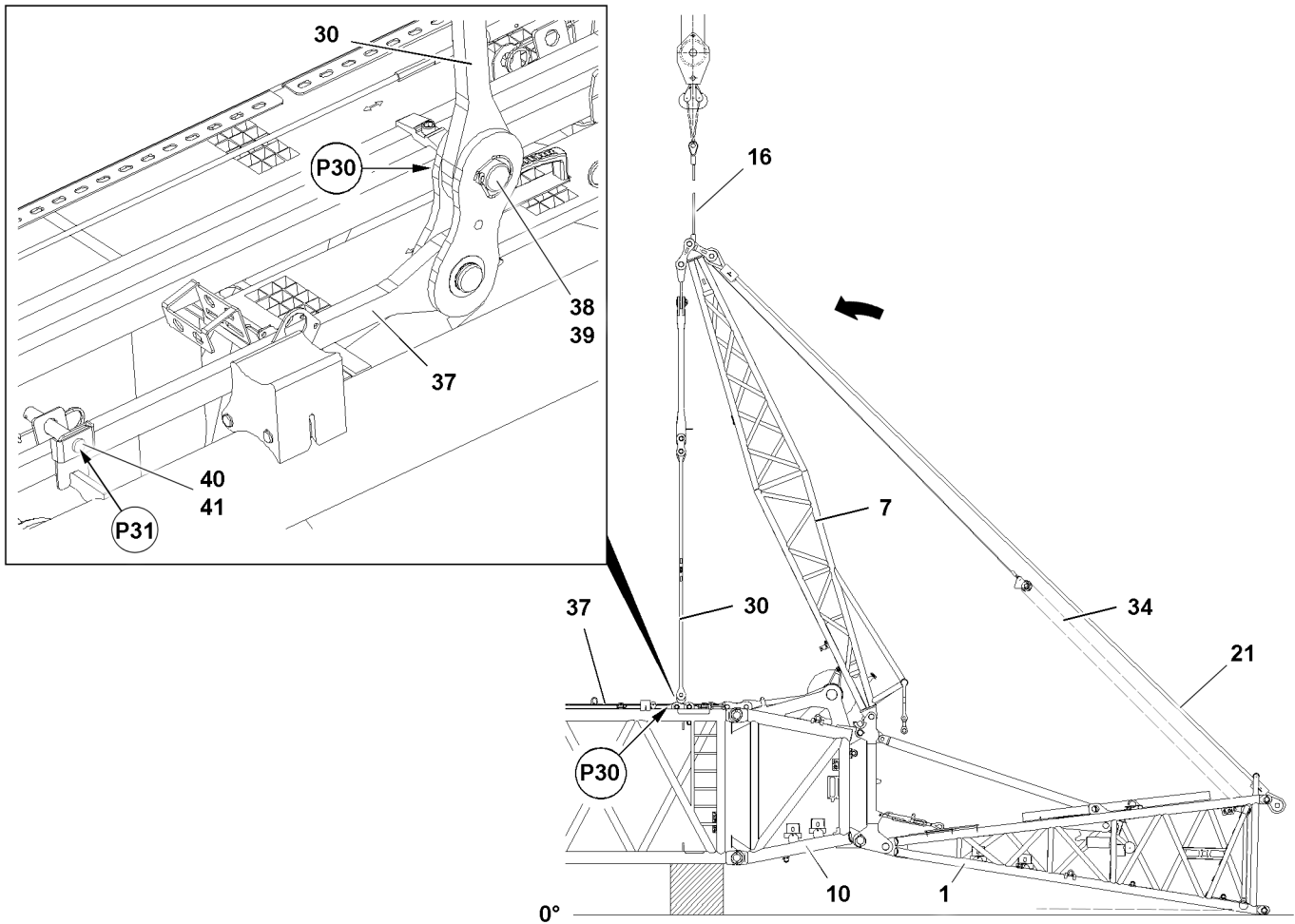

Fig.127483: Unpinning the FAB-guy rods

NOTICE

Danger of property damage!

When swinging the FA-frame 7 in the direction of the main boom, damage may occur to the FA-frame 7, the F-connector head 10, as well as the rope pulley retainer 25.

- ▶ Make sure that a guide supervises the swinging process of the FA-frame.
- ▶ Make sure that the guide is constantly in visual and acoustic contact with the crane operator!
- ▶ Make sure that the assembly winch rope 34 is spooled out during the swinging process of the FA-frame.

- ▶ Carefully swing the FA-frame 7 with the auxiliary crane in direction of the main boom and spool out the assembly winch rope 34 at the same time until it can be unpinned at point P30.

Unpin the FAB-guy rods 30 from the FAB-guy rods 37:

- ▶ Remove the retaining element 39 at point P30 and unpin the pin 38.

Secure the FAB-guy rods 37 in the transport receptacles:

- ▶ Insert the pin 40 at point P31 and secure with the retaining element 41.



WARNING

Automatic swinging of the FA-frame!

If the fastening rope 16 on the FA-frame 7 is not held under tension during assembly, the FA-frame 7 can swing suddenly to the side.

Death, severe bodily injury, property damage.

- ▶ Make sure that there are no persons within the danger zone.
- ▶ Make sure that the fastening rope 16 never sags during assembly / disassembly operations.

- ▶ Pull the FA-frame 7 with the assembly winch rope 34 forward in the direction of the F-pivot section until the FAB-guy rods 30 lie on the FA-frame 7.

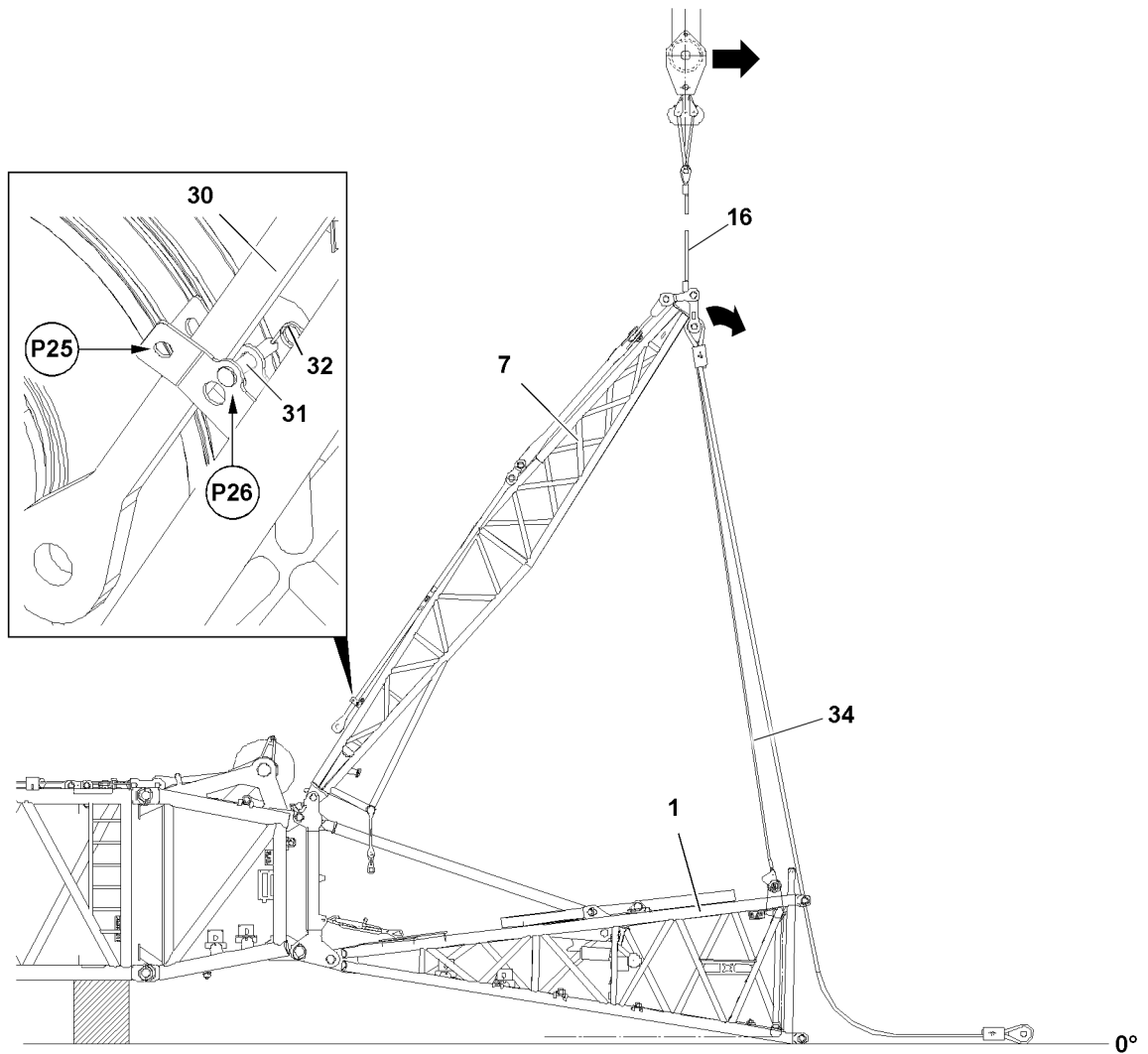

Fig.127691: Swinging the FA-frame 7 in direction of the F-pivot section 1 and securing the FAB-guy rods

- ▶ Pull the FA-frame 7 with the assembly winch rope 34 in direction of the F-pivot section 1.
- ▶ Guide the auxiliary crane.

Secure the FAB-guy rods 30 on both sides:

When the FAB-guy rods 30 lie on the transport receptacles:

- ▶ Remove the retaining element 32 at point P26 on both sides and unpin the pin 31 from the park position.
- ▶ Insert the pins 31 at point P25 on both sides and secure with the retaining element 32.

12.3.3 Taking the FA-frame down

NOTICE

Damage to the fiber guy ropes!

Depending on the degree of severity, a damaged fiber guy rope can rip off in crane operation.

- ▶ Make sure that the fiber guy ropes **21** are not kinked, crushed or damaged in any other way when taking down the FA-frame **7**.
- ▶ If visible slight damage is determined on a fiber guy rope **21**, observe the Crane operating instructions, chapter 8.16 and thoroughly inspect the rope.
- ▶ Make sure that a damaged fiber guy rope will only continued to be used, depending on the scope of the damage, after it has been thoroughly inspected and released by the rope manufacturer.

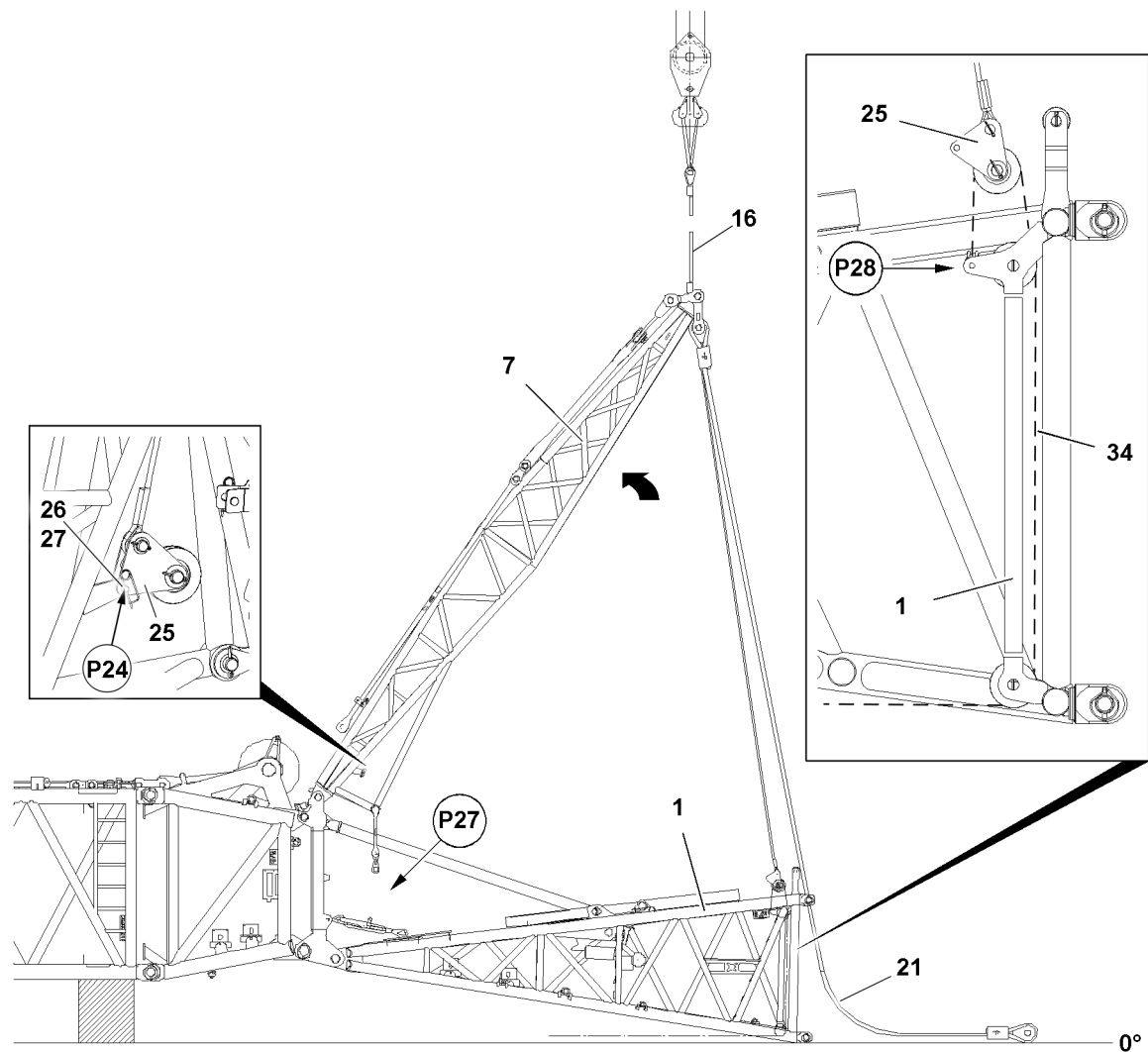

Fig.127692

- ▶ Release and reeve out the assembly winch rope **34** at point **P28**.

Pin the rope pulley retainer **25** on the FA-frame **7**:

- ▶ Insert the pin **26** at point **P24** and secure with the retaining element **27**.
- ▶ Spool the assembly winch rope **34** up.
- ▶ Take down the FA-frame **7** with the auxiliary crane on the F-pivot section **1**.
- ▶ Remove the auxiliary crane.

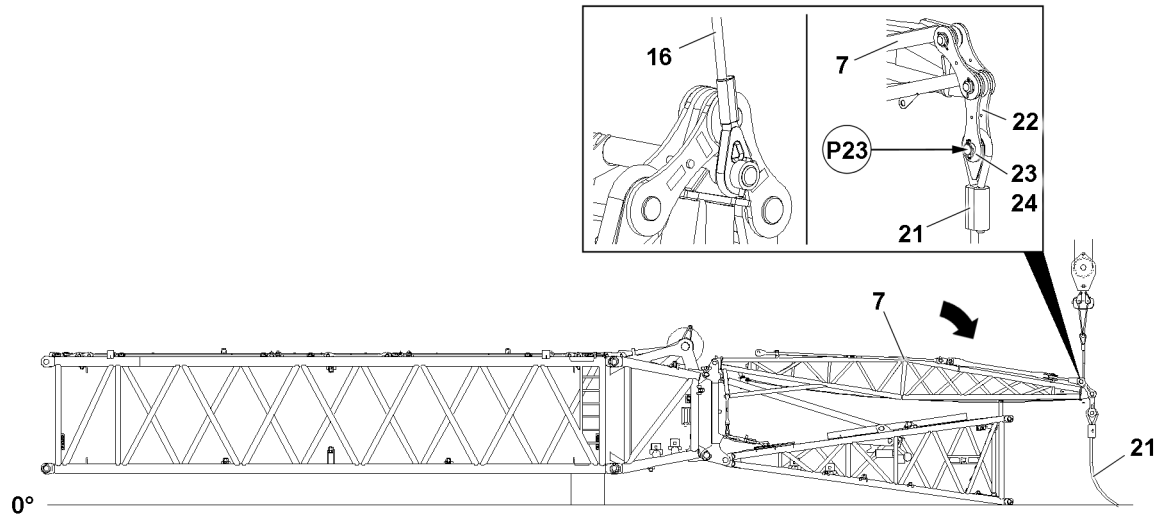

Fig. 127693: Position of the F-relapse support

► Attach the fastening rope **16** on the FA-frame **7**.

Unpin F-guy ropes **21** at point **P23** on the F-frame **7**:

► Remove the retaining element **24** and unpin the pin **23**.

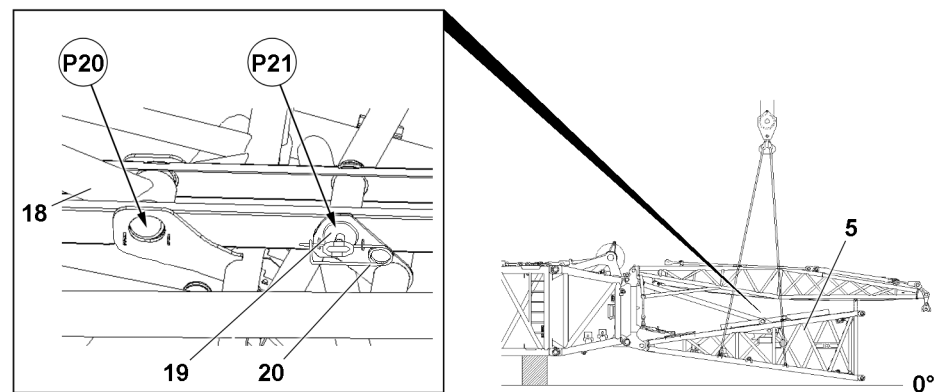

Fig. 127694: Position of the F-relapse support

► Fasten the F-assembly unit **5** to the auxiliary crane.

► Lift the F-assembly unit **5** with the auxiliary crane until the F-relapse support **18** can be pinned at point **P20** in transport position.

► Remove the retaining element **20** at point **P21** and unpin the pin **19**.

Secure the F-relapse support **18** in the transport position:

► Insert the pin **19** at point **P20** and secure with the retaining element **20**.

12.3.4 Disassembling the F-assembly unit

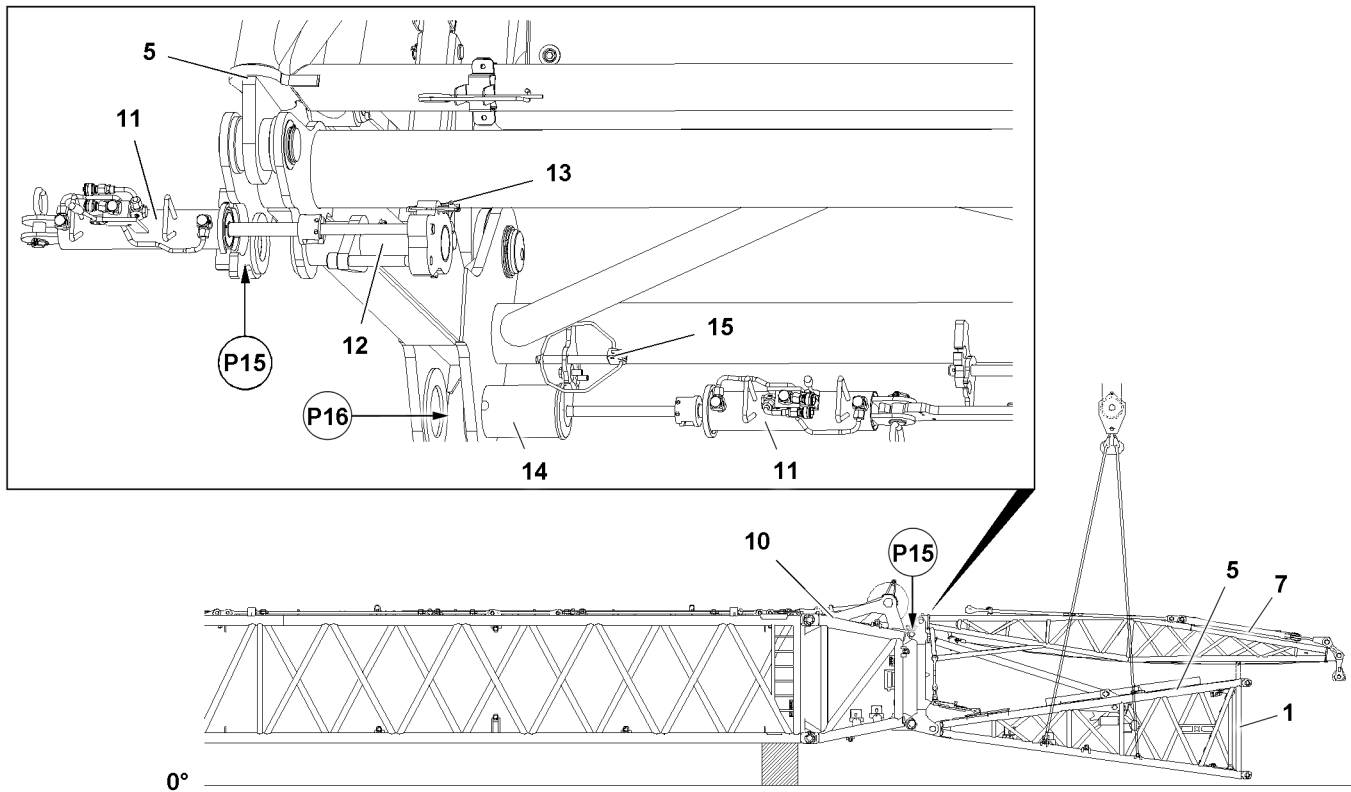

Fig.127695: Unpinning the F-assembly unit 5 at point P15.

Make sure that the following prerequisite is met:

- The F-assembly unit 5 is properly fastened on the auxiliary crane.
- The fastening equipment is tensioned.
- ▶ Release the pins 12 at point P15 on both sides: Remove the retaining element 13.
- ▶ Properly hang the pin pulling cylinder 11 in the pin pulling device at point P15.

When the pin pulling cylinder 11 is properly hung in the pin pulling device:

- ▶ Unpin the pins 12 on both sides.

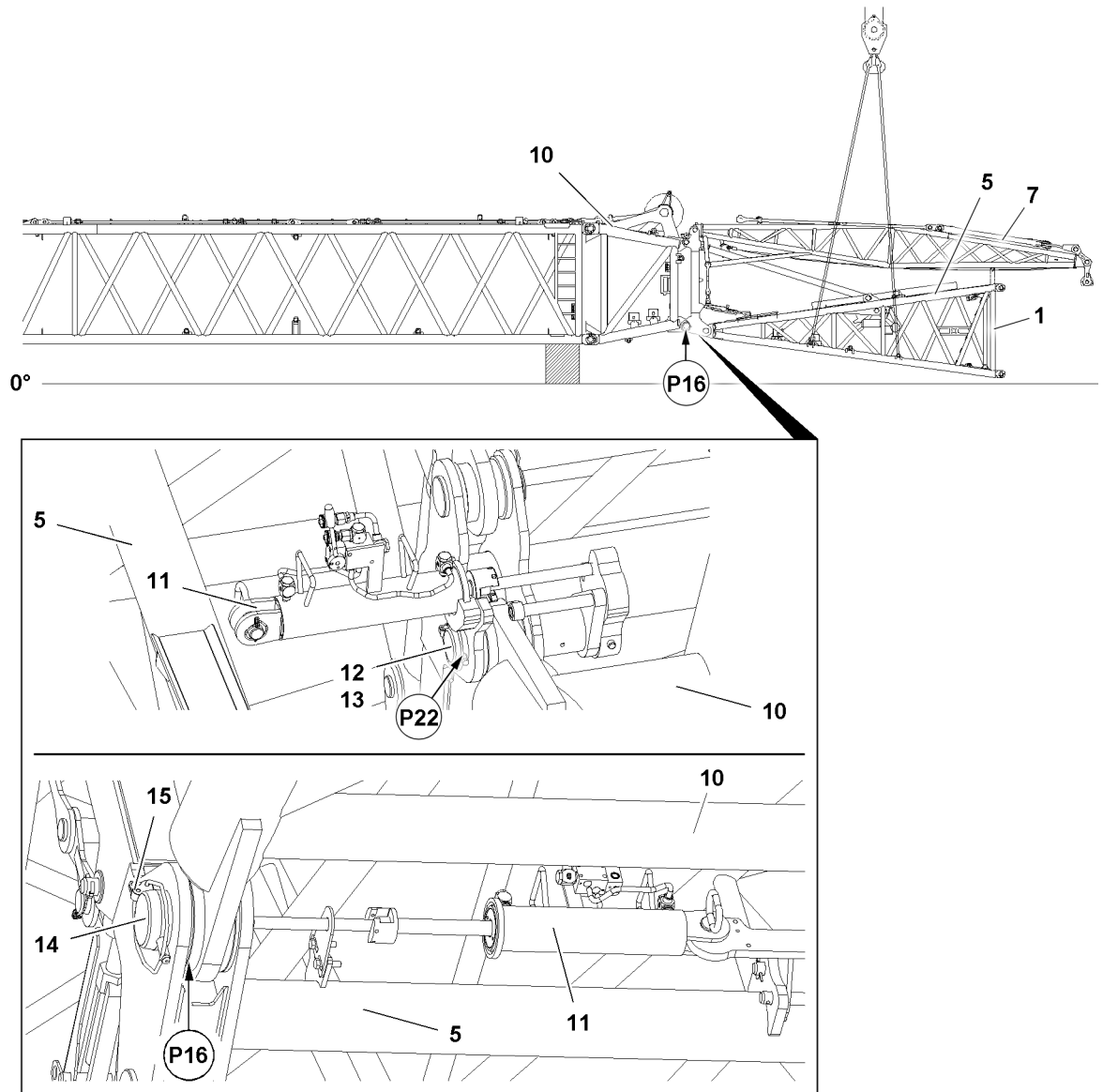

Fig.127901: Unpinning the F-assembly unit 5 at point P16.

- ▶ Release the pins 14 at point P16 on both sides: Remove the retaining element 13.
- ▶ Properly hang the pin pulling cylinder 11 in the pin pulling device at point P15.

When the pin pulling cylinder 11 is properly hung in the pin pulling device:

- ▶ Unpin the pins 14 on both sides.

If the pin 12 and pin 14 are unpinned on both sides:

- ▶ Swing out the F-assembly unit 5 with the auxiliary crane and take it down on the ground or on a load bearing substructure.
- ▶ Attach the rigging belts between the F-pivot section 1 and FA-frame 7.
- ▶ Reinsert the pin 14 at point P16 and point 12 at point P15 and secure.

12.4 Disassembling the F-jib completely as the F-assembly unit with the F-end section (maximum length 12 m)

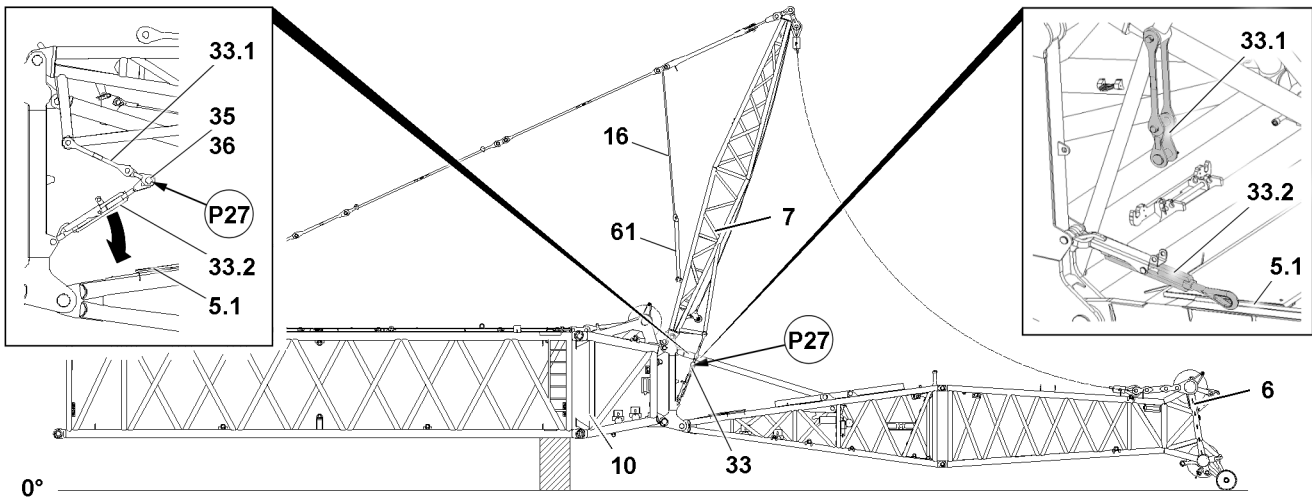

Fig.127902: Disassembling the F-jib



WARNING

Impermissible assembly length(s)!
Death, severe bodily injuries, property damage.

- ▶ Make sure that the assembly of the F-jib as a complete F-assembly unit with the F-end section does not exceed 12 m.
- ▶ During disassembly, no hook block may be reeved on the F-jib.

12.4.1 Unpinning the FAB-guy rods

NOTICE

Damage of F-relapse support!

If the pin **19** is not unpinned before disassembling the FAB-guy rods from the stop position **P21**, the F-relapse retainer can be damaged.

- ▶ Make sure that the pin **19** is unpinned before disassembling the FAB-guy rods from the stop position **P21**.
- ▶ Unpin the pin **19** from the stop position **P21** and insert it in the park position at point **P22** and secure.

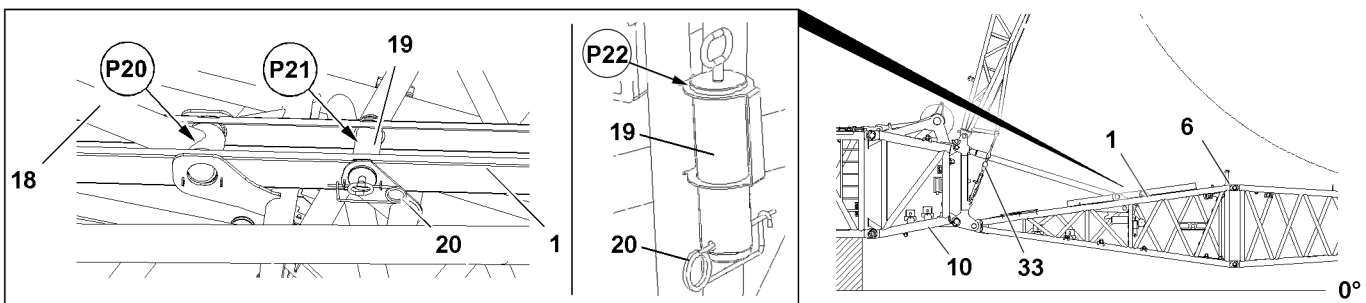

Fig.127907

NOTICE

Danger of property damage!

If the FA-frame relapse retainers **33** are not separated, then they will be damaged during erection of the FA-frame.

- ▶ Make sure that the FA-frame relapse retainers are separated during the erection of the FA-frame.

**WARNING**

Falling and swinging FA-frame relapse retainer!

The FA-frame relapse retainer consists of guy rods **33.1** and a turnbuckle **33.2**.

The guy rod **33.1** of the FA-frame relapse retainer can fall down due to its own weight during unpinning.

The guy turnbuckle **33.2** of the FA-frame relapse retainer can fall down due to its own weight during unpinning.

Death, severe bodily injuries, property damage.

- ▶ Make sure when unpinning the FA-frame relapse retainer, the guy rods **33.1** and turnbuckle **33.2** are safely held.
- ▶ Assembly personnel must be at the side of the assembly unit.

Separate the FA-frame relapse retainer **33** at point **P27**:

- ▶ Remove the retaining element **36** at point **P27** and unpin the pin **35**.
- ▶ Place the turnbuckle **33.2** in the receptacle **5.1**.
- ▶ Insert the pin **35** again at point **P27** and secure with the retaining element **36**.

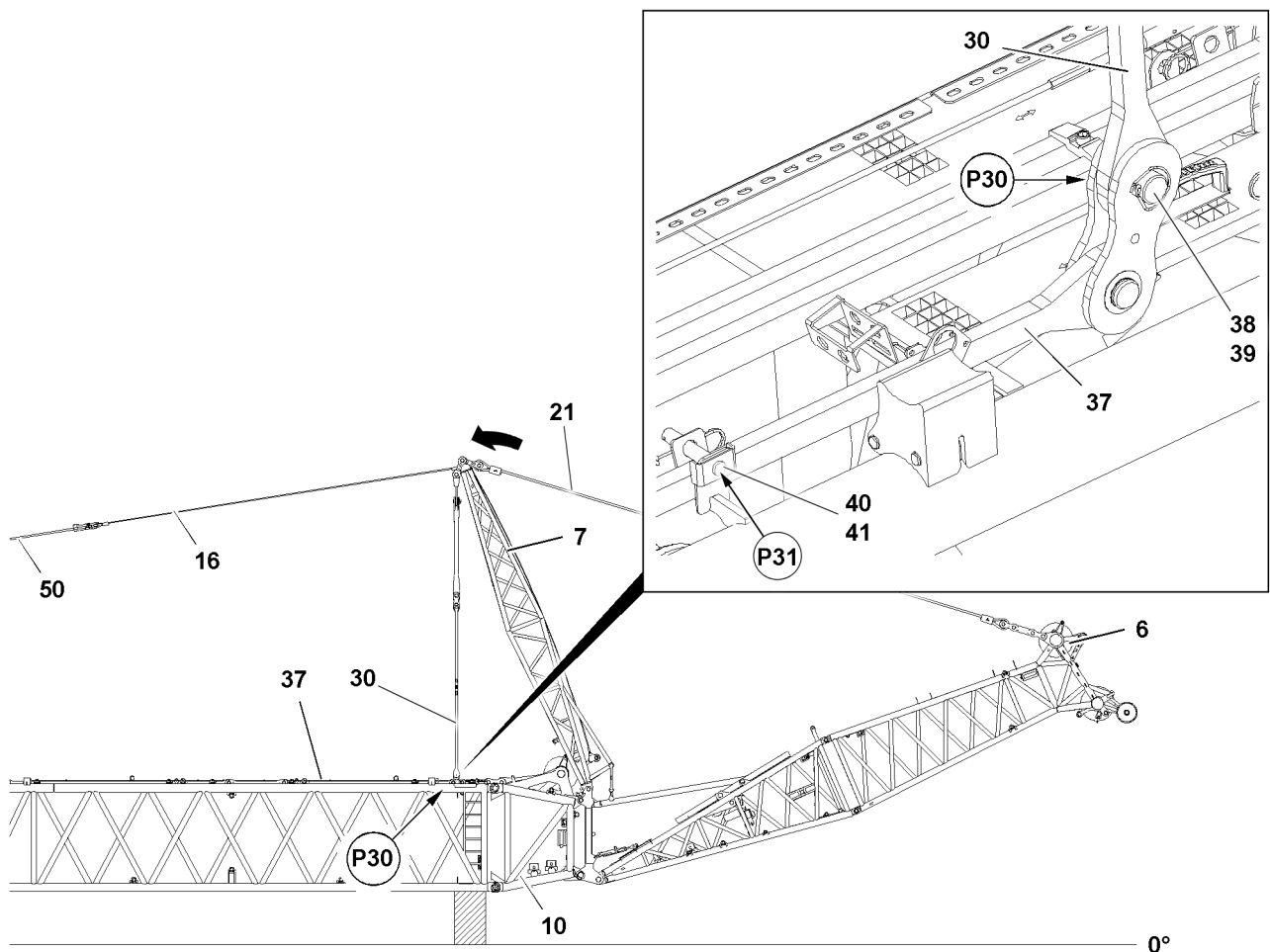

LWE/LR 11000-001/23501-04-02/en

Fig.127675: Taking the guy rods **37** down in the transport retainers

- ▶ Release the fastening rope **16** on the FA-frame **7**.
- ▶ Connect the fastening rope **16** of the FA-frame **7** using the link with the hoist rope **50**.

- ▶ Remove the retaining element **41** at point **P31** and unpin the pin **40**.

NOTICE

Danger of property damage!

When swinging the FA-frame **7** in direction of the main boom there is a danger of collision of the FA-frame with the attachment parts of the L-end section **10** or the F-connector head.

- ▶ When swinging the FA-frame, a guide must be used.
- ▶ The guide must be in constant visual and acoustic contact with the crane operator.

- ▶ Spool the hoist rope **50** up until the FAB-guy rods **37** are completely in the transport receptacles.

When the FAB-guy rods **37** are completely in the transport receptacles:

- ▶ Insert the pin **40** at point **P31** and secure with the retaining element **41**.

Result:

- The FAB-guy rods **37** are secured in the transport receptacles:

When the FAB-guy rods **37** are properly secured in the transport receptacles:

- ▶ Separate the FA-guy rods **37** at point **P30**: Release and unpin the pin **38**.

12.4.2 Taking the FA-frame down

NOTICE

Damage to the fiber guy ropes!

Depending on the degree of severity, a damaged fiber guy rope can rip off in crane operation.

- ▶ Make sure that the fiber guy ropes **21** are not kinked, crushed or damaged in any other way when taking down the FA-frame **7**.
- ▶ If visible slight damage is determined on a fiber guy rope **21**, observe the Crane operating instructions, chapter 8.16 and thoroughly inspect the rope.
- ▶ Make sure that a damaged fiber guy rope will only continued to be used, depending on the scope of the damage, after it has been thoroughly inspected and released by the rope manufacturer.

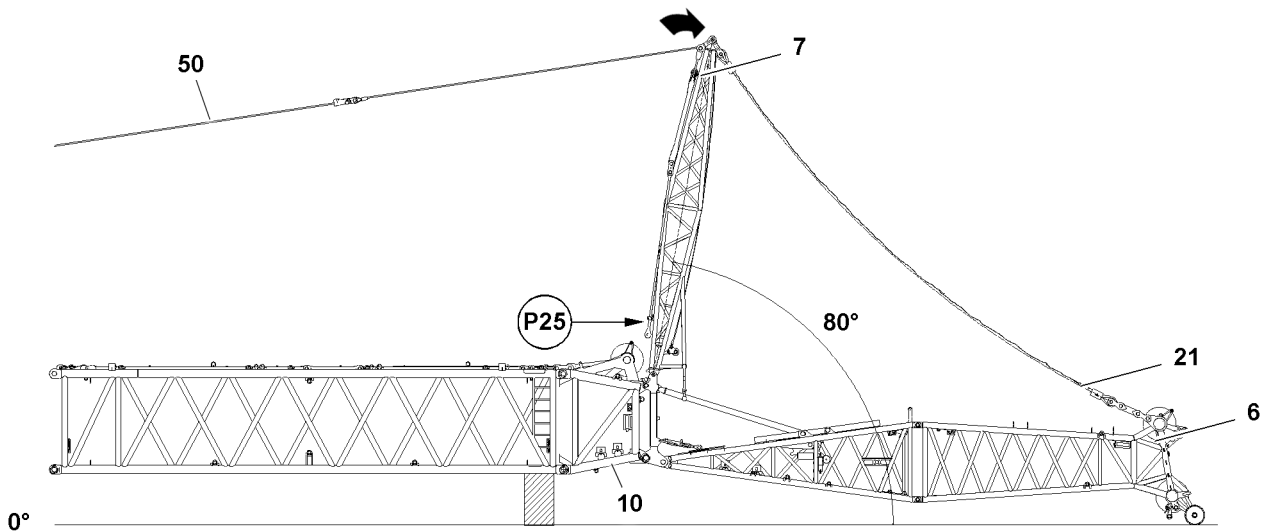

Fig.127904: Lowering the FA-frame **7** to the front in direction of the F-pivot section

Make sure that the following prerequisites are met:

- The FAB-guy rods are separated.
- The FAB-guy rods **37** are properly pinned and secured in the transport retainers
- ▶ Lower the FA-frame **7** with the hoist rope **50** in direction of the F-jib until the angle between the FA-frame and the horizontal is approx. 80° and the F-jib lies on the ground.

Result:

- The FAB-guy rods **30** rest in the transport receptacle on the FA-frame **7**.

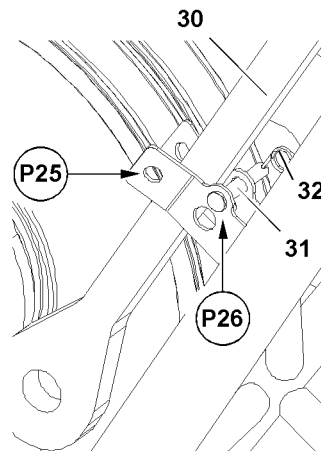

Fig.127674: Securing the FAB-guy rods on the FA-frame

Secure the FAB-guy rods **30** on both sides:

- ▶ Remove the retaining element **32** at point **P30** and unpin the pin **31** from the park position.
- ▶ Insert the pins **31** at point **P25** and secure with the retaining element **32**.
- ▶ Lower the FA-frame **7** with the hoist rope **50** in direction of the F-jib until the angle between the FA-frame **7** and the horizontal is approx. 40° .
- ▶ Fasten the F-jib properly to the auxiliary crane.
- ▶ Pull up the F-jib with the auxiliary crane to the FA-frame **7**.

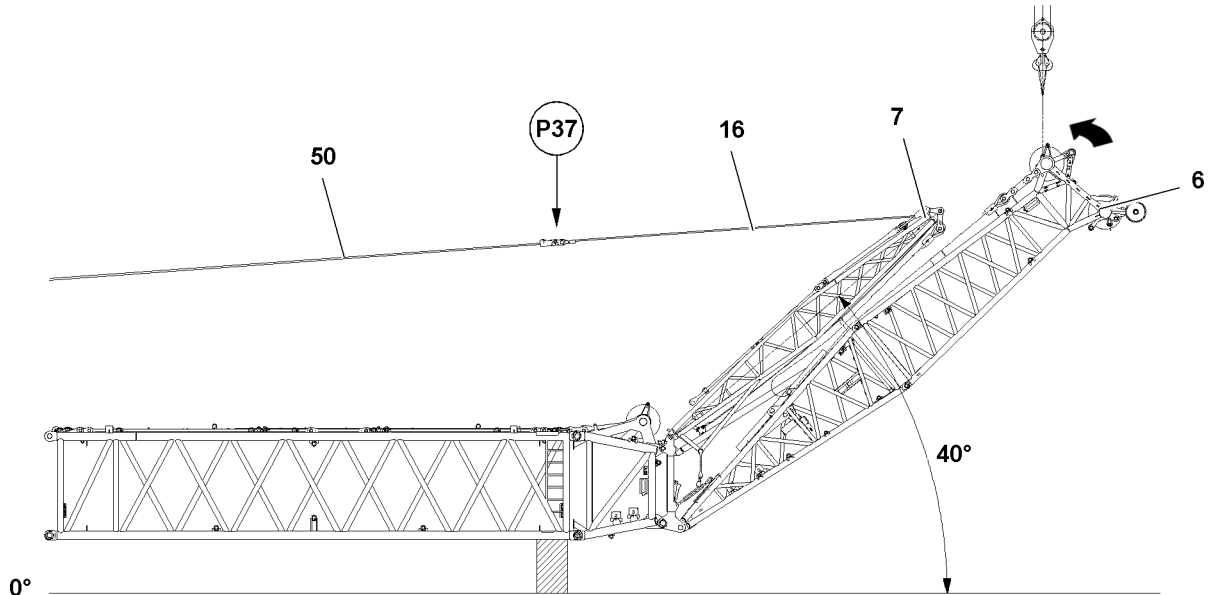

Fig.127672: Lifting the assembly unit on the F-end section

NOTICE

Danger of slack rope formation!

When spooling the hoist rope **50** out, slack rope can form.

- ▶ When spooling out the hoist rope **50**, make sure there is no slack rope.

When the F-jib is safely held with the auxiliary crane:

- ▶ Spool the hoist rope **50** out until the hoist rope **50** is relieved.
- ▶ Separate the hoist rope **50** and the fastening rope **16**.

- ▶ Fasten the fastening rope **16** on the transport retainer on the FA-frame **7**.
- ▶ Take down the F-assembly unit **6** on the ground with the auxiliary crane.

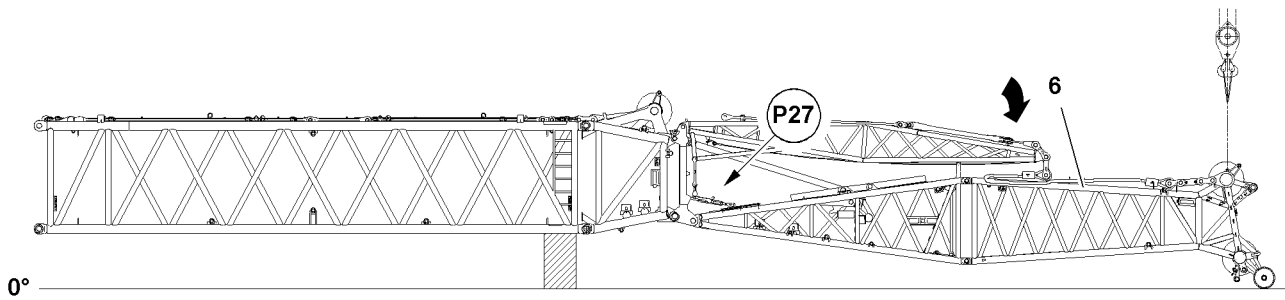

Fig.127906: Taking down the F-assembly unit on the ground with the auxiliary crane.

- ▶ Remove the auxiliary crane on the F-end section.

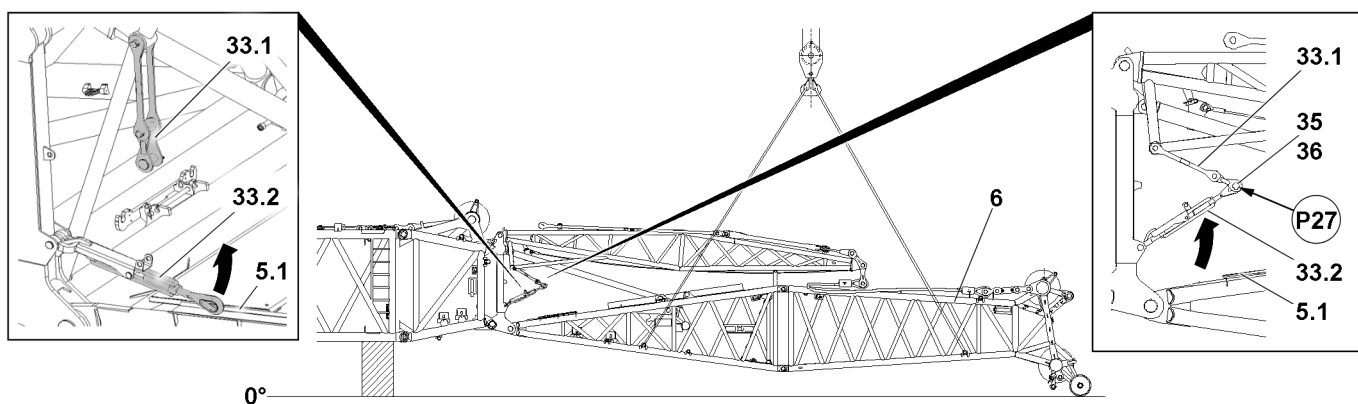

Fig.127905

- ▶ Fasten the F-assembly unit **6** with the F-end section on the corresponding fastening points for the assembly, see section Fastening points.

When the F-assembly unit **6** is properly fastened with the F-end section on the fastening points on the auxiliary crane:

- ▶ Lift the F-assembly unit **6** with the auxiliary crane until the pin bores of the F-relapse support **18** align on the pin point **P20**.
- ▶ Pin the FA-frame relapse retainer **33** on both sides: Pin the guy rod **33.1** with the turnbuckle **33.2** at point **P27** with pin **35** and secure with the retaining element **36**.

12.4.3 Disassembling the F-assembly unit with F-end section

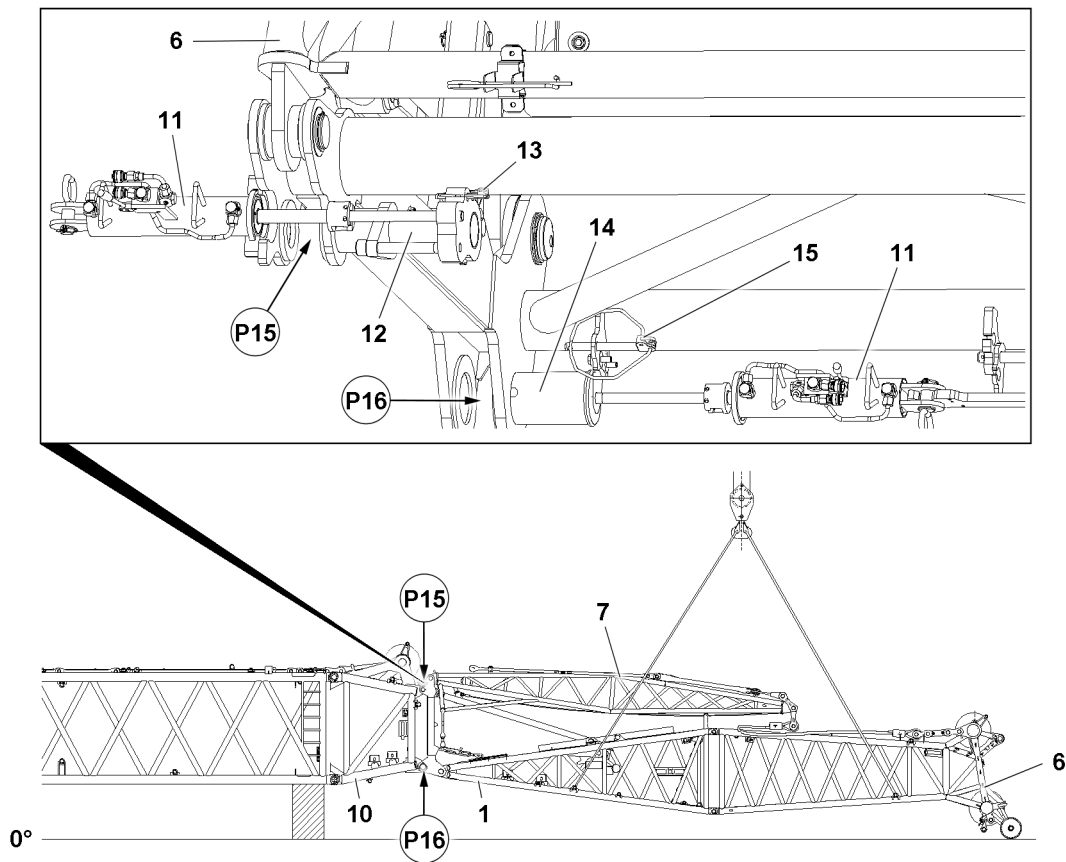

Fig.127909: Unpinning the F-assembly unit with the F-end section 6 on the L-end section or on the F-connector head on top

- ▶ Lift the F-assembly unit with the F-end section 6 with the auxiliary crane until the pin bore of the F-relapse support 18 can be pinned at point P20 in the transport position.

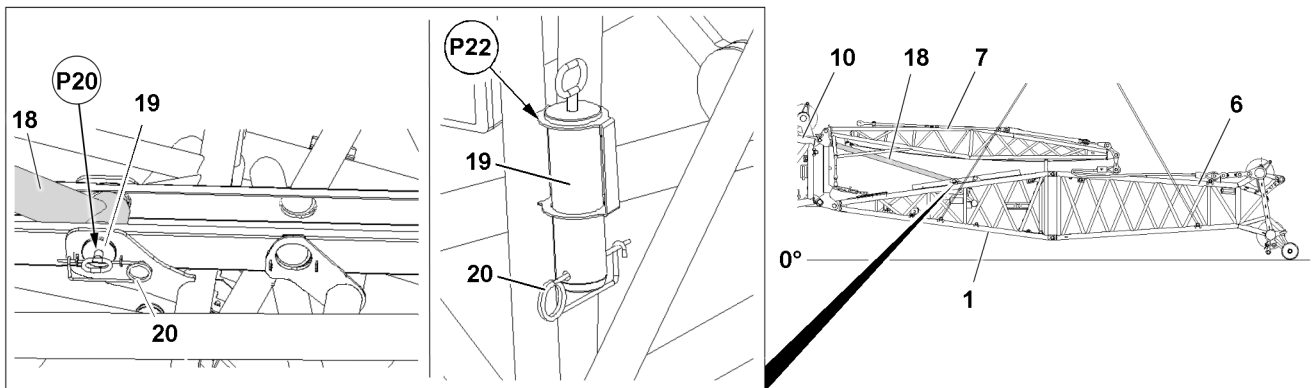

Fig.127908: Pinning the F-relapse support 18 in the transport position

When the pin bore of the F-relapse support 18 aligns with the pin hole at point P20:

- ▶ Remove the retaining element 20 at point P22 and unpin the pin 19

Secure the F-relapse support 18 in the transport position:

- ▶ Insert the pin 19 at point P20 and secure with the retaining element 20.

LWE/LR 11000-001/23501-04-02/en

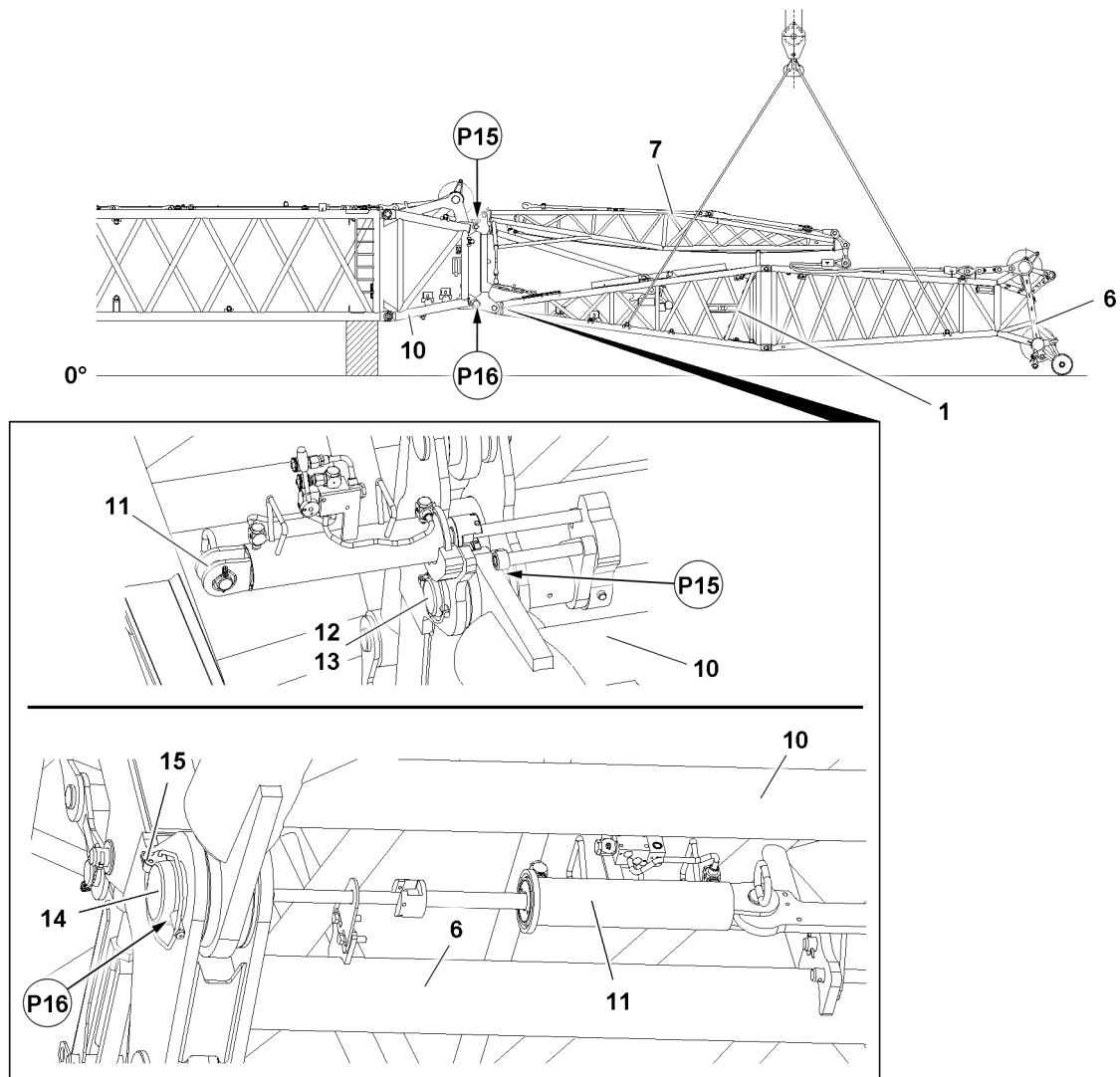

Fig.127910: Unpinning the F-assembly unit with the F-end section 6 on the L-end section or on the F-connector head on the bottom

When the F-assembly unit with the F-end section 6 is safely held in position by the auxiliary crane:

- ▶ Release pins 14 on both sides: Remove the retaining element 15.
- ▶ Set the pin pulling cylinder 11 at pin point P16 and unpin the pin 14.
- ▶ Release the pin 12 at point P15: Remove the retaining element 13.
- ▶ Set the pin pulling cylinder 11 at pin point P15 and unpin the pin 12.

When all four pins between the F-assembly unit with the F-end section 6 and L-end section or F-connector head are unpinned:

- ▶ Swing out the F-assembly unit with F-end section 6 with the auxiliary crane and take it down.
- ▶ Remove the auxiliary crane.
- ▶ Attach the rigging belts properly between the F-pivot section 1 and FA-frame 7.
- ▶ Tighten the rigging belts.
- ▶ Insert the pin 12 at point P15 on both sides and secure.
- ▶ Insert the pin 14 at point P16 on both sides and secure.

5.14 Roller set

1	Roller sets overview	3
2	Component overview	3
3	Fastening points for roller set	4
4	Assembly rack for roller set	4
5	Boom configurations	5
6	Combinations End section - Roller set	7
7	Assembling the roller set / roller sets	8
8	Removing the roller set / roller sets	15

Fig.195219

LWE/LR 11000-001/23501-04-02/en

1 Roller sets overview



Note

- ▶ The roller sets are marked with their own weight.
- ▶ Dimensions and weights, see Crane operating instructions, chapter 1.03.

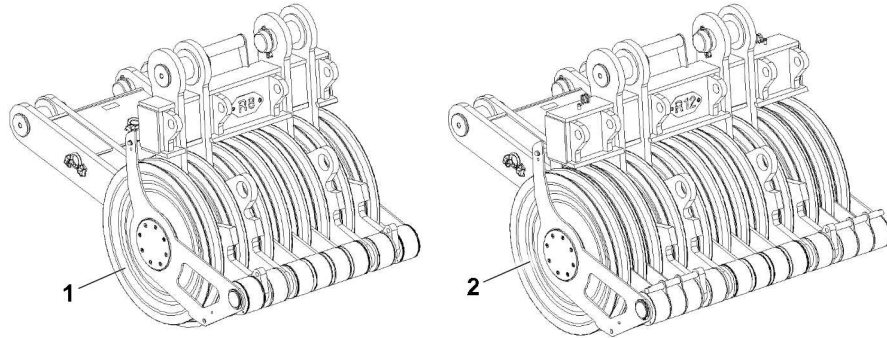

Fig.124476: Roller sets overview

Position	Component	Description
1	Roller set 350 t	R8
2	Roller set 400 t	R12

Roller sets overview

2 Component overview



Note

- ▶ Component view is shown as an example on one roller set R8 350 t.

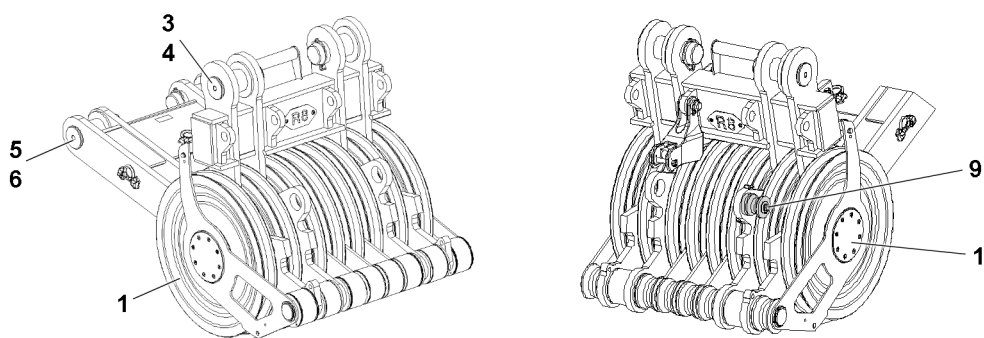

Fig.144157: Component overview roller set

Position	Component
1	Roller set R8
3	Connector pin
4	Retaining element

LWE/LR 11000-001/23501-04-02/en

Position	Component
5	Connector pin
6	Retaining element
9	Rope guide pulley

Component overview roller set R8 350 t

3 Fastening points for roller set



WARNING

Component incorrectly fastened!

Life-threatening situations can arise due to improper or incorrect attachment of the corresponding components.

Death, severe bodily injuries, property damage.

- ▶ Fasten the components only on the intended fastening points on both sides.
- ▶ Fastening of components and description of fastening points, see Crane operating instructions, chapter 5.01.

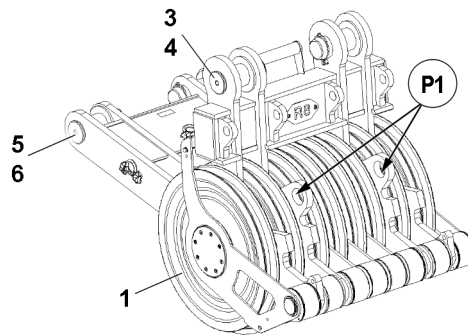

Fig.124477: Fastening points roller set R8 350 t

Point	Component
P1	Roller set R8

Fastening points roller set R8 350 t

4 Assembly rack for roller set

The assembly rack 9 is used for the simple and safe assembly of the roller set 1 on the boom head.



WARNING

Falling components!

Death, severe bodily injuries, property damage.

- ▶ Make sure that the roller set is properly placed and secured in the assembly rack 9.
- ▶ Make sure that the assembly rack 9 is picked up properly with the forklift and secured against "slipping".

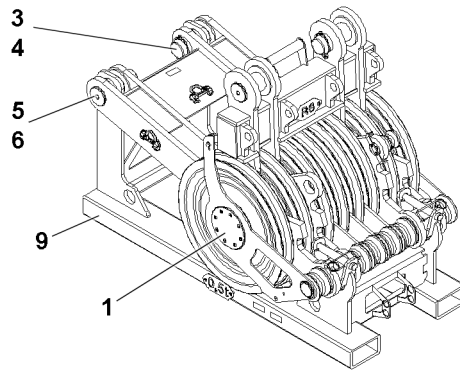

Fig.144158: Roller set R8 350 t 1 placed in the assembly rack 9

5 Boom configurations

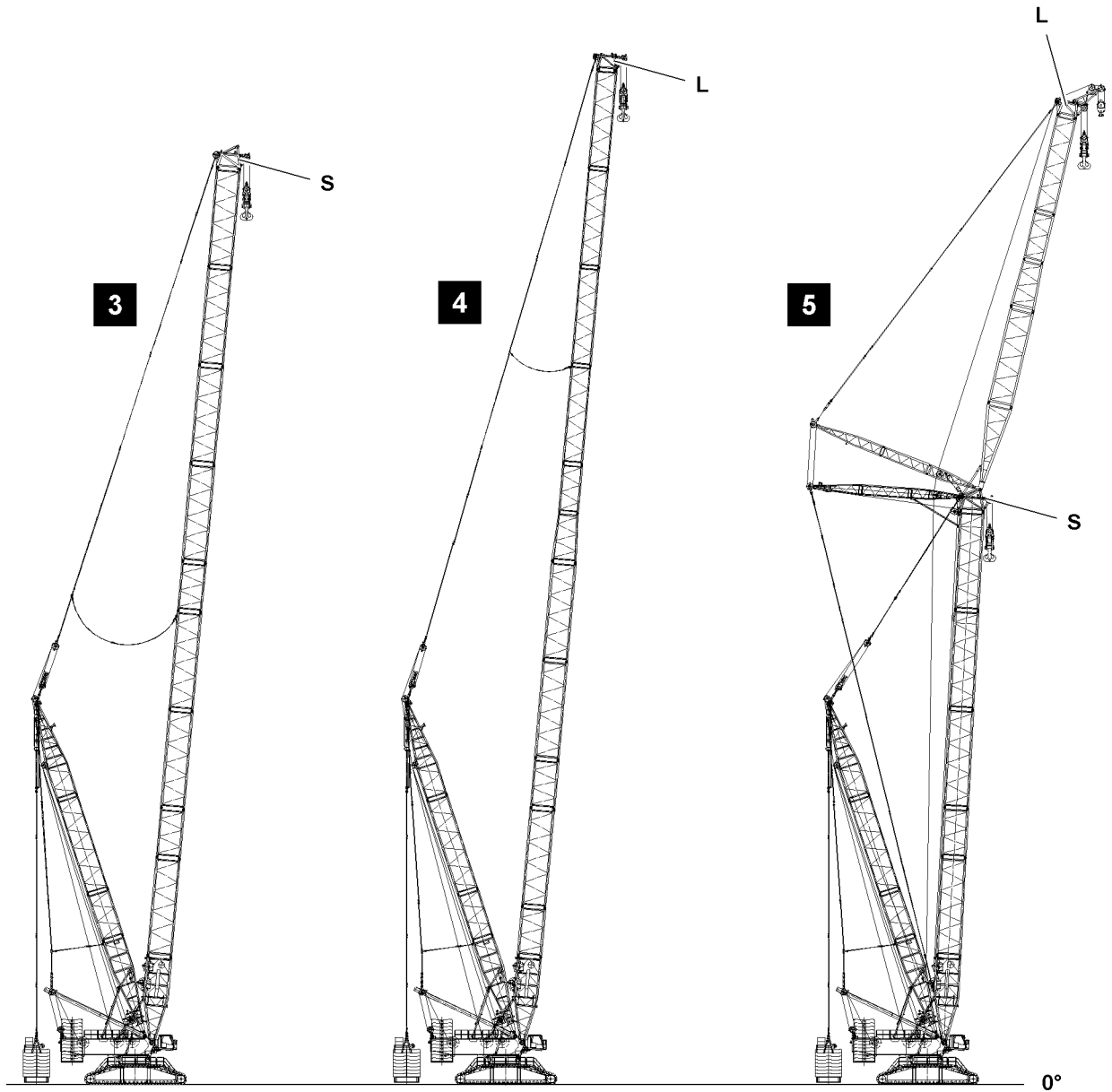

Fig.119042: Boom systems (example)

LWE/LR 11000-001/23501-04-02/en

**WARNING**

Load reduction!

For the installation of an additional roller set - in reference to the following operating modes, the value in the load chart is reduced by the own weight of this roller set.

Death, severe bodily injuries, property damage.

- ▶ Select the number of roller sets according to the operating modes.
- ▶ Observe the Erection and take down charts.
- ▶ Observe the load charts.

Boom	Operating modes	End section	Number of roller sets
S without jib boom	SDB/B2/BW	S	R8+R8
S with jib boom	SW1 SDWB/B2/BW SDW2B/BW	S	0
P without jib boom	PDB/B2/BW	S	R8+R8
P with jib boom	PDW3B/B2/BW	S	0
SL	SL S2 SL2DB/B2/BW S2DB/B2/BW	L	R12
W, W1, W2, W3	SW1 SDWB/B2/BW SDW2B/B2/BW PDW3B/B2/BW	L	R12
SL with fixed jib Two hook operation	SLF SL2DFB/BW	L	0
S in SDW Two hook operation	SD(W)B	S	0
SL with fixed jib	SL4DFB/B2 SL3F	F-connector head	—

Boom configurations for the calculation of load charts and associated erection charts

6 Combinations End section - Roller set

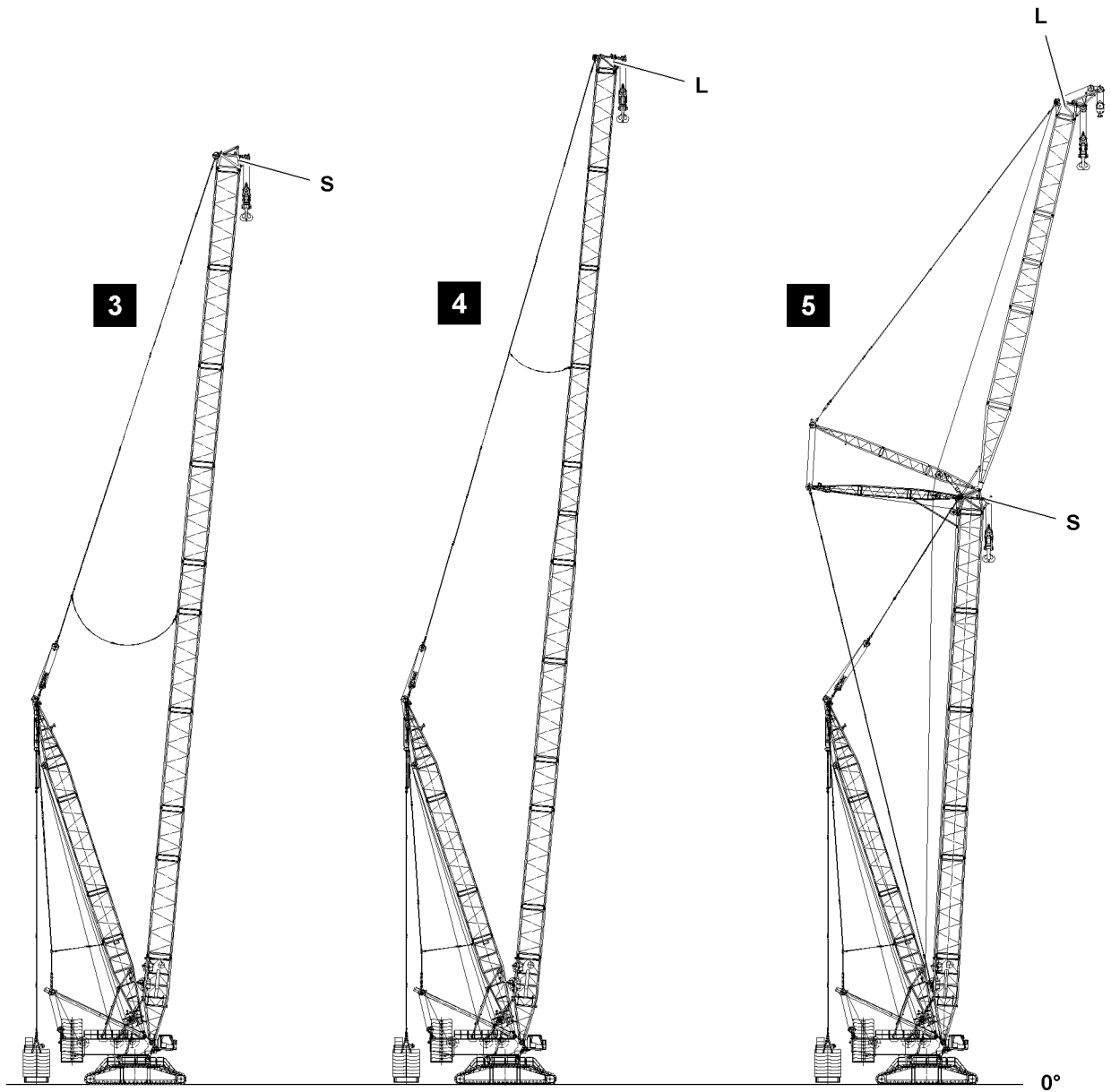

Fig.119042: Boom systems (example)

	Roller sets				
S-end section	R8	R12	R8+R8	R8+R12	R8+R8+R12

Combination S-end section 1000 t with roller sets, see illustration 3

	Roller sets				
L-end section	R8	R12	R8+R8	R8+R12	—

Combination L-end section 650 t with roller sets, see illustration 4

LWE/LR 11000-001/23501-04-02/en

	Roller sets				
L-end section	R8	R8+R8	R8	R8	R8+R8
S-end section	—	—	R8	R12	R12

Combination S-end section 1000 t and L-end section 650 t with roller sets, see illustration 5

	Roller sets				
L-end section	R8	R8+R12	R8+R12	R12	R12
S-end section	R8+R12	—	R8	—	R8

Combination S-end section 1000 t and L-end section 650 t with roller sets, see illustration 5

	Roller sets				
L-end section	R12	—	—	—	—
S-end section	R8+R8	—	—	—	—

Combination S-end section 1000 t and L-end section 650 t with roller sets, see illustration 5

7 Assembling the roller set / roller sets

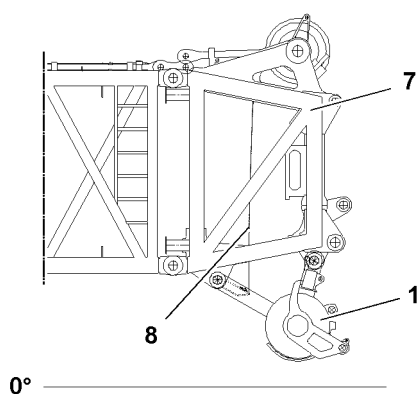

Fig.144151: Assembling roller set / roller sets 1

**WARNING**

Danger of falling!

During assembly / disassembly, inspection and maintenance work, personnel must be secured with appropriate aids to prevent them from falling.

Death, severe bodily injuries, property damage.

- ▶ All work aloft, where there is a danger of falling must be carried out with suitable aids.
- ▶ If aids are not available and work cannot be carried out from the ground, then the assembly personnel must secure themselves with the supplied fall arrest system to prevent falling, see Crane operating instructions, chapter 2.04.
- ▶ If fall protection equipment is available, then it must be used, see Crane operating instructions, chapter 2.06.
- ▶ When lifting, lowering, swinging crane parts in and out, no persons may remain in the danger zone.
- ▶ If railings are present on the components, then they must be brought into the corresponding position and secured for assembly / disassembly work.
- ▶ It is prohibited to lean the auxiliary ladder against the component being disassembled.
- ▶ Only step on the aids, ladders and catwalks with clean shoes.
- ▶ Keep aids, ladders and catwalks free of heavy dirt, snow and ice.
- ▶ During all assembly and disassembly work, maintenance work and inspections, travel or crane operation is prohibited.
- ▶ Remaining on a suspended load is prohibited.
- ▶ Stepping or walking on crane components and lattice sections, which have an incline of more than 20° is prohibited.
- ▶ For all assembly work, the crane operator of the main crane must be in voice contact with the crane operator / crane operators of the auxiliary crane / auxiliary cranes.
- ▶ For assembly / disassembly tasks, the crane operator may only initiate crane movements when the responsible guide has explicitly released the movement.

**WARNING**

Danger of impact / crushing!

When installing / removing crane components with the auxiliary crane, crane components can start to swing back and forth.

When lifting / lowering and positioning crane components, there is an increased danger of impacts / crushing.

Death, severe bodily injuries, property damage.

- ▶ Make sure that personnel cannot be caught by components.
- ▶ When working in danger zones: Use aids to protect limbs.
- ▶ Guide components with suitable aids to minimize oscillation.

**DANGER**

The components can fall down!

If the corresponding component is disengaged from the auxiliary crane before the corresponding component is pinned, then the corresponding component can fall down.

Death, severe bodily injuries, property damage.

- ▶ Do not disengage the auxiliary crane until the respective component is pinned and secured.

**WARNING**

Falling roller sets!

If the roller sets are not pinned and secured correctly, then they can fall down.

Death, severe bodily injuries, property damage.

- ▶ Pin or unpin both pins, which are laying in one horizontal level.
- ▶ It is prohibited to stand under the roller sets or within the complete danger zone during the pinning and unpinning procedure of the roller sets.
- ▶ Safely secure the pins in the storage locations as well as in the receptacles.

**WARNING**

Overload of boom system!

If only one roller set is used and the roller set is assembled off center of the end section, then the boom system can be overloaded.

Death, severe bodily injuries, property damage.

- ▶ Observe the installation position of the roller set / the roller sets on the respective boom end section, see Reeving plan.

**WARNING**

The crane can topple over!

If the roller set / roller sets are improperly assembled, the crane can topple over.

Death, severe bodily injuries, property damage.

- ▶ Select roller set / roller sets according to the operating modes, as specified in the load charts.
- ▶ Observe the Erection and take down charts.
- ▶ Observe the load charts.
- ▶ Pay attention to the description on the roller sets.

7.1 Assembling the roller sets R8/R12 on the L- or S-end section

**Note**

- ▶ The assembly / disassembly of the roller sets R8 or R12 is identical and is described on the example of roller set R8.
- ▶ The assembly / disassembly of the roller sets on the L-end section or on the S-end section is identical and is described on the example of the L-end section.

**Note**

- ▶ For the assembly / disassembly of the roller sets on the main boom, the main boom can be held by its own main boom guying. But Liebherr-Werk Ehingen GmbH recommends to additionally secure the main boom at assembly of the roller sets with an auxiliary crane with sufficient load bearing capacity.
- ▶ For the assembly / disassembly of the roller sets on the luffing lattice jib (W-boom), the W-boom **must** be supported with materials with a load bearing capacity. If supporting is not possible: Lift the W-boom with the auxiliary crane with sufficient load bearing capacity. Observe the following danger notes.

**WARNING**

Working under suspended load!

The boom can fall down.

Death, severe bodily injuries, property damage.

- ▶ Make sure that the auxiliary crane **10** is properly supported and horizontally aligned.
- ▶ Make sure that the utilization of the **auxiliary crane 10** is **maximum 90 %**.
- ▶ Make sure that the motor of the auxiliary crane **10** is turned off for assembly of the roller sets.

**WARNING**

Impermissible fastening equipment!

The boom can fall down.

Death, severe bodily injuries, property damage.

- ▶ Use only inspected fastening equipment.

Make sure that the following prerequisites are met:

- The crane is horizontally aligned.
- The L-end section **7** is approx. 2.00 m above the ground.
- The boom system is supported with materials with load bearing capacity.
- **or**
- The boom system is safely held by the auxiliary crane **10**.
- An assembly scaffolding / work platform is available.
- The connector pins are unpinned on the roller set **R8 1** at points **P2** and at points **P4**.

7.1.1 Installing roller set R8 with the forklift and assembly rack

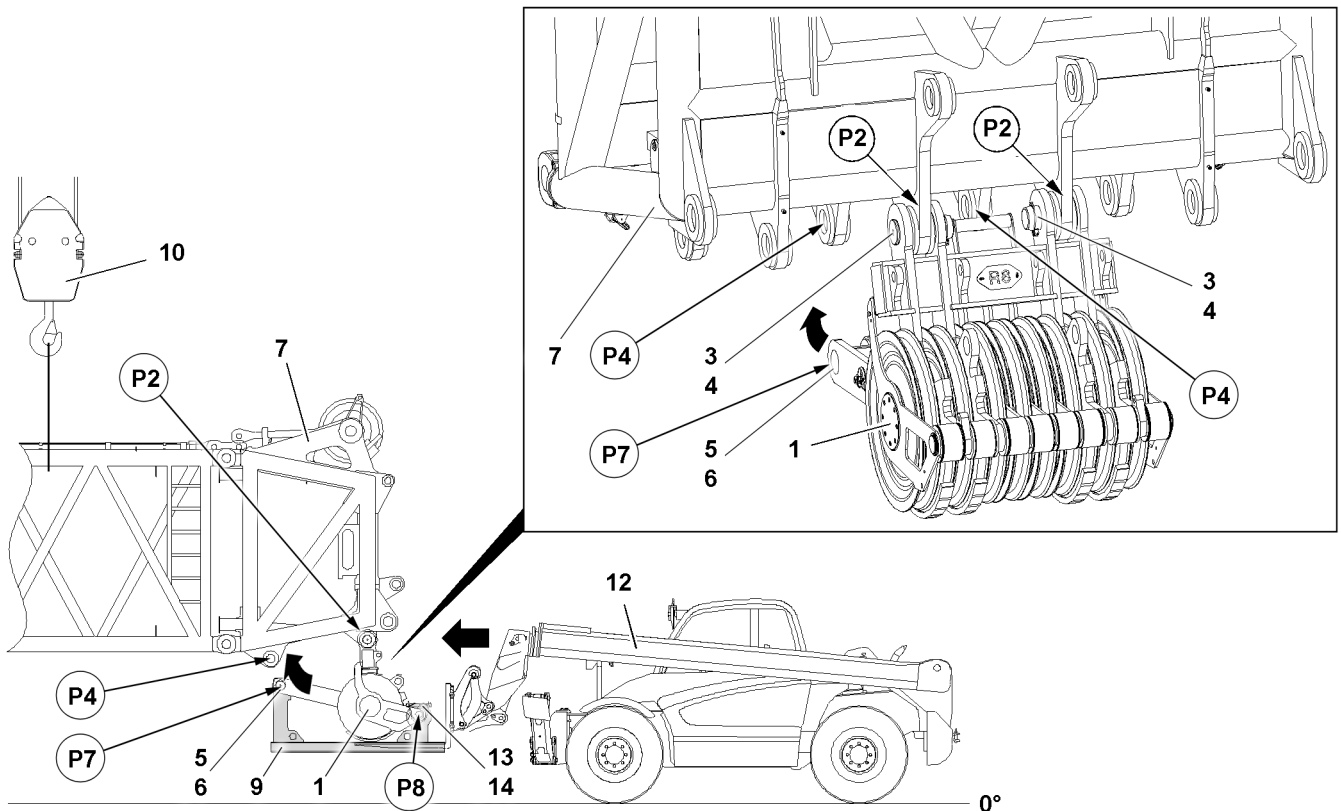

Fig.144155: Installing roller set R8 1 with the forklift and assembly rack 9

Make sure that the following prerequisites are met:

- A forklift **12** is available.
- Roller set **1** is properly placed and secured in the assembly rack **9**.
- ▶ Retract the forklift **12** properly in the receptacles of the assembly rack **9**.
- ▶ Lift the roller set **R8 1** with the forklift **12** and retract it into the pin points **P2**.
- ▶ Align the roller set **R8 1** with the forklift **12** on the pin bores at points **P2**.

The roller set **R8 1** is pinned on four points.

- ▶ Pin the roller set **R8 1** at points **P2** on the L-end section **7** twice: Insert connector pin **3** on both sides and secure with the retaining element **4**.

NOTICE

Danger of property damage!

If the roller set is moved uncontrolled with the forklift to the pin position, crane components can be damaged.

- ▶ Make sure that a guide supervises the assembly procedure.

When the roller set **R8 1** is properly pinned on the pin points **P2** and secured with connector pins **3**:

- ▶ Release and unpin the connector pin **5** on the assembly rack **9**.

When the connector pins **5** are properly unpinned on the assembly rack **9**:

- ▶ Drive the forklift forward until the pin bores **P4** on the L-end section **7** align with the pin bores of the roller set **P7**.
- ▶ Insert connector pin **5** on both sides and secure with the retaining element **6**.

Result:

- Roller set R8 **1** is properly installed and secured on the L-end section **7**.
- ▶ Release and unpin the pin **13** on the assembly rack **9** at point **P8** on both sides.

When the pins **13** are released and unpinned on both sides:

- ▶ Lower and extend the assembly rack **9** with the forklift.



Note

- ▶ At assembly, pay attention to the correct position of the hoist limit switch, see Electric wiring diagram.

- ▶ Install the hoist limit switch and hoist limit switch weight on the roller set R8 **1** properly.

7.1.2 Installing the roller set R8 with the auxiliary crane

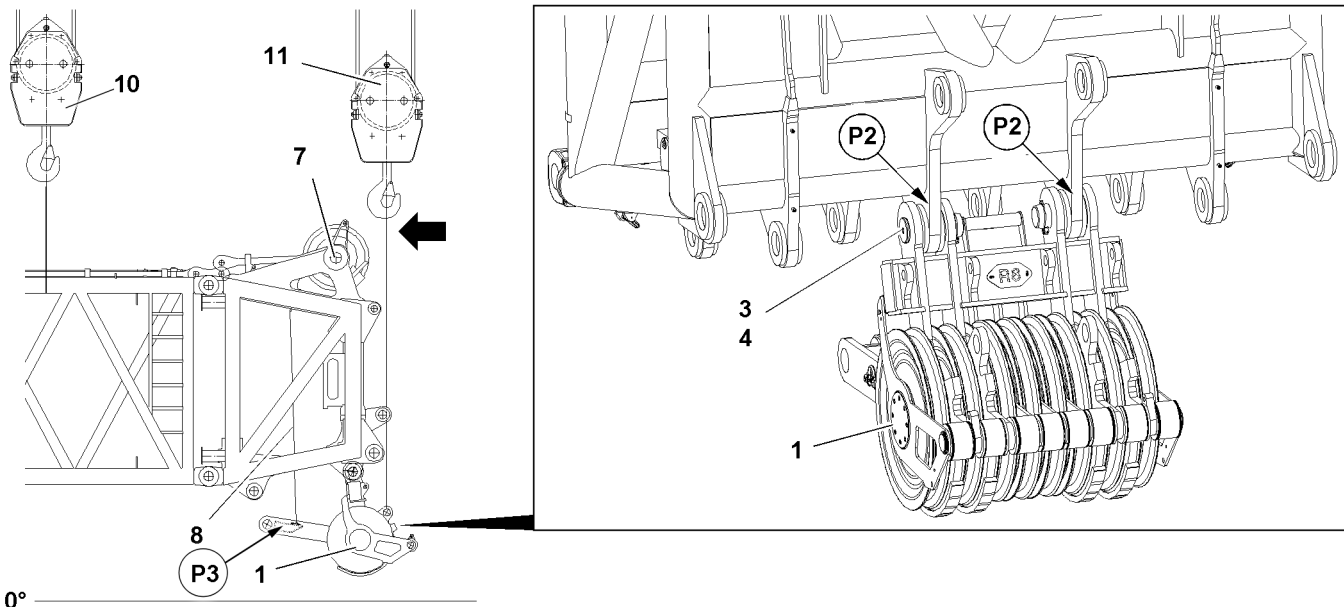

Fig.144153: Installing the roller set R8 with the auxiliary crane

Make sure that the following prerequisite is met:

- A second auxiliary crane **11** is available.
- ▶ Fasten the roller set R8 **1** on the auxiliary crane **11** and swing it to the pin points **P2**.
- ▶ Align the roller set R8 **1** with the auxiliary crane **11** on the pin bores at points **P2**.

The roller set R8 **1** is pinned on four points.

- ▶ Pin the roller set R8 **1** at points **P2** with the L-end section **7** twice: Insert the connecting pin **3** and secure it with a retaining element **4**.

When the roller set R8 **1** is pinned and secured:

- ▶ Remove the auxiliary crane **11**.

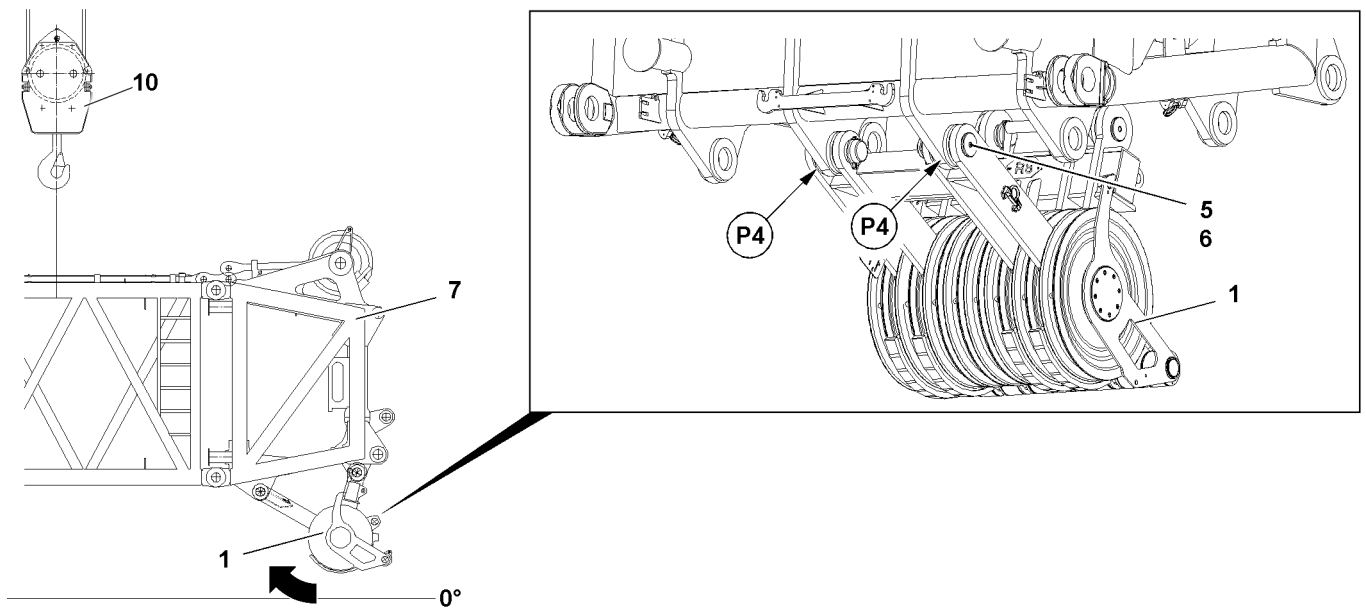

Fig.144154

- ▶ Connect the roller set R8 1 with the manual chain pull 8 at point P3.
- ▶ Swing the roller set R8 1 with the manual chain pull 8 to the pin bores at points P4.
- ▶ Pin the roller set R8 1 at points P4 with the L-end section 7 twice: Insert the connecting pin 5 and secure it with a retaining element 6.
- ▶ Release the manual chain pull 8 at point P3 and remove.

**Note**

- ▶ At assembly, pay attention to the correct position of the hoist limit switch, see Electric wiring diagram.
- ▶ Install the hoist limit switch and hoist limit switch weight on the roller set R8 1 properly.

7.2 Installing the rope guide pulley on the roller set / roller sets

NOTICE

Danger of property damage!

If the rope guide pulleys are not correctly installed, the steel structure of the roller set can be damaged when erecting the boom system and while spooling out the hoist rope.

- ▶ Make sure that the rope guide pulley(s) are properly installed on the roller set before erecting the boom system.
- ▶ Observe the installation direction of the rope guide pulley(s).

**Note**

- ▶ The following illustrations are examples and may not match your crane exactly.
- ▶ The following illustrations show the roller set R8 / roller sets R8.
- ▶ The use of the rope guide pulley(s) on roller set R12 / roller sets R12 is identical to its use on roller sets R8.

Make sure that the following prerequisites are met:

- The roller set / the roller sets are properly installed and secured on the boom head.
- The hoist limit switch and hoist limit switch weight are assembled.

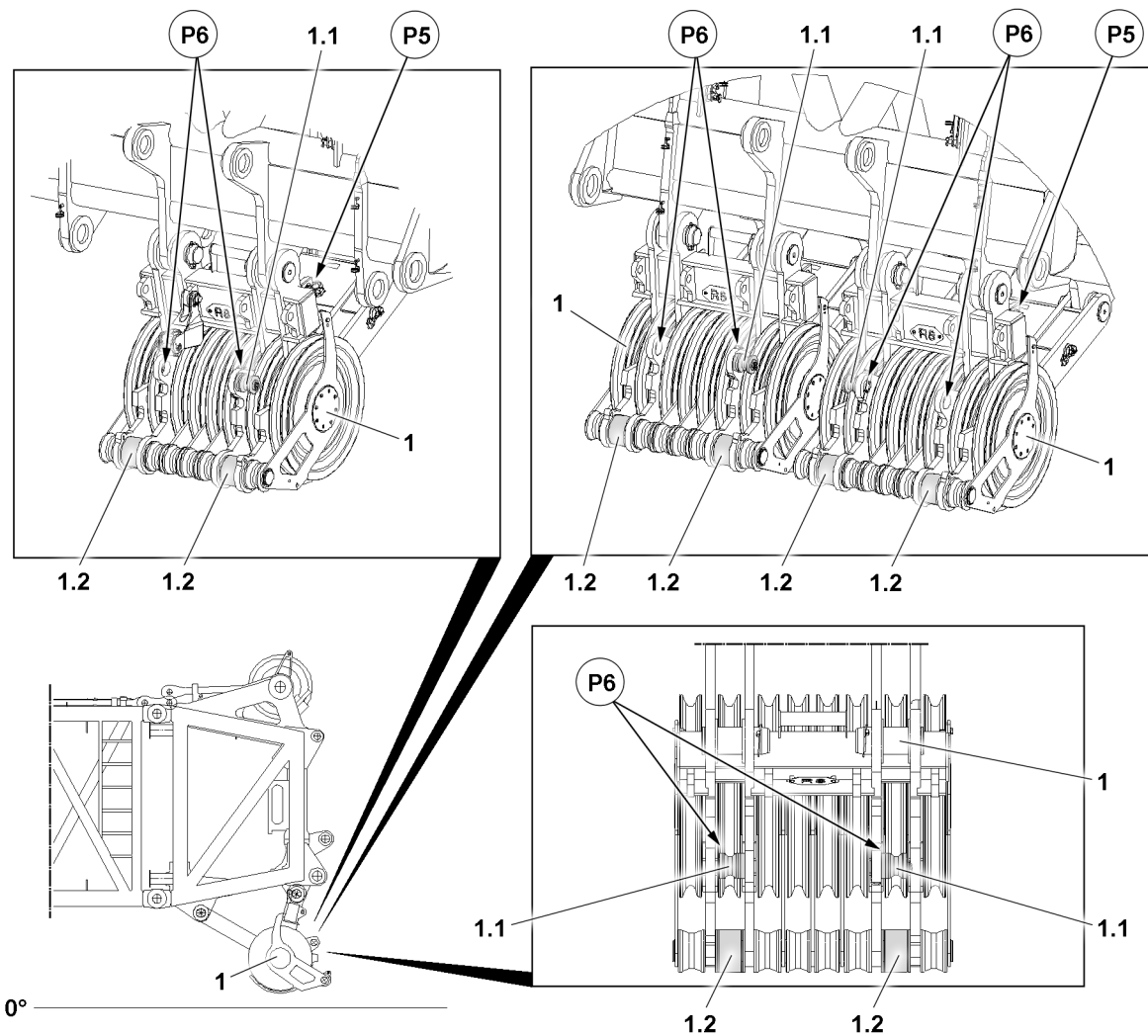

Fig.144023: Installing the rope guide pulley(s) 1.1 on the roller set 1

7.2.1 Reeving the hoist rope / installing the rope guide pulley

NOTICE

Incorrectly installed rope guide pulley!

- ▶ Make sure that the rope guide pulley(s) are again properly installed on the roller set after reeving in the hoist rope.
- ▶ The rope guide pulley 1.1 must be installed respectively over the pulley 1.2.

To reeve in the hoist rope, the rope guide pulley on the roller set must be unpinned out of the operating position **P6** and pinned in the parking position **P5**.

- ▶ Release the rope guide pulley 1.1 on point **P6** and remove.
- ▶ Insert the rope guide pulley 1.1 on point **P5** in the park position and secure.
- ▶ Reeve in the hoist rope correctly, see the Reeving plan.

When the hoist rope is properly reeved:

- ▶ Release the rope guide pulley 1.1 on point **P5** in the park position and remove.
- ▶ Insert the rope guide pulley 1.1 on point **P6** and secure.

8 Removing the roller set / roller sets

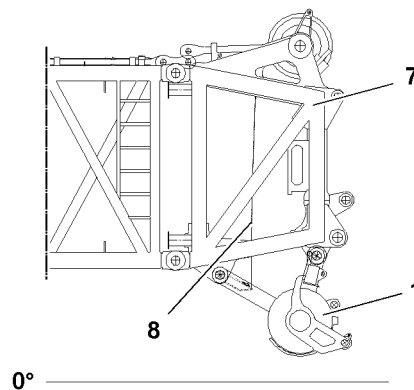

Fig.144151: Removing the roller set / roller sets



WARNING

Danger of falling!

During assembly / disassembly, inspection and maintenance work, personnel must be secured with appropriate aids to prevent them from falling.

Death, severe bodily injuries, property damage.

- ▶ All work aloft, where there is a danger of falling must be carried out with suitable aids.
- ▶ If aids are not available and work cannot be carried out from the ground, then the assembly personnel must secure themselves with the supplied fall arrest system to prevent falling, see Crane operating instructions, chapter 2.04.
- ▶ If fall protection equipment is available, then it must be used, see Crane operating instructions, chapter 2.06.
- ▶ When lifting, lowering, swinging crane parts in and out, no persons may remain in the danger zone.
- ▶ If railings are present on the components, then they must be brought into the corresponding position and secured for assembly / disassembly work.
- ▶ It is prohibited to lean the auxiliary ladder against the component being disassembled.
- ▶ Only step on the aids, ladders and catwalks with clean shoes.
- ▶ Keep aids, ladders and catwalks free of heavy dirt, snow and ice.
- ▶ During all assembly and disassembly work, maintenance work and inspections, travel or crane operation is prohibited.
- ▶ Remaining on a suspended load is prohibited.
- ▶ Stepping or walking on crane components and lattice sections, which have an incline of more than 20° is prohibited.
- ▶ For all assembly work, the crane operator of the main crane must be in voice contact with the crane operator / crane operators of the auxiliary crane / auxiliary cranes.
- ▶ For assembly / disassembly tasks, the crane operator may only initiate crane movements when the responsible guide has explicitly released the movement.



WARNING

Danger of impact / crushing!

When installing / removing crane components with the auxiliary crane, crane components can start to swing back and forth.

When lifting / lowering and positioning crane components, there is an increased danger of impacts / crushing.

Death, severe bodily injuries, property damage.

- ▶ Make sure that personnel cannot be caught by components.
- ▶ When working in danger zones: Use aids to protect limbs.
- ▶ Guide components with suitable aids to minimize oscillation.

**DANGER**

The components can fall down!

If the corresponding component is disengaged from the auxiliary crane before the corresponding component is pinned, then the corresponding component can fall down.

Death, severe bodily injuries, property damage.

► Do not disengage the auxiliary crane until the respective component is pinned and secured.

8.1 Removing the rope guide pulley on the roller set / roller sets

Make sure that the following prerequisites are met:

- The L-end section is approx. 2.00 m above the ground.
- The boom system is supported with materials with load bearing capacity.
- The pulley head of the L-end sections is located above the hook block.
- **or**
- The boom system is safely held by the auxiliary crane.
- An assembly scaffolding / work platform is available.

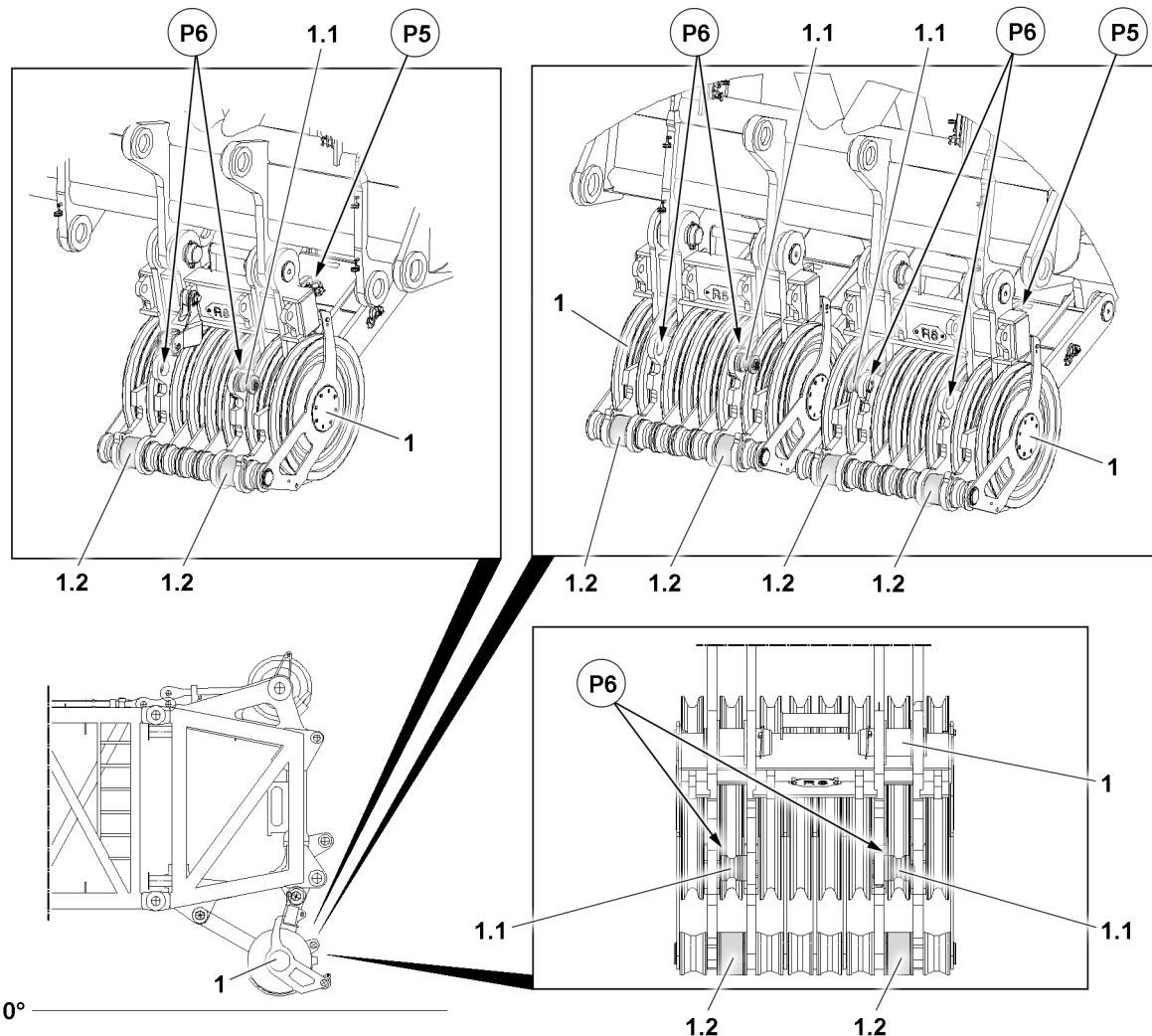

Fig.144023: Removing the rope guide pulley(s) 1.1 on the roller set 1

8.1.1 Reaving out the hoist rope / removing the rope guide pulley

To reeve out the hoist rope, the rope guide pulley on the roller set must be unpinned out of the operating position P6 and pinned in the parking position P5.

► Release the rope guide pulley 1.1 on point P6 and remove.

- ▶ Insert the rope guide pulley **1.1** on point **P5** in the park position and secure.
- ▶ Reeve the hoist rope out correctly.

When the hoist rope is properly reeved out:

- ▶ Release the rope guide pulley **1.1** on point **P5** in the park position and remove.
- ▶ Insert the rope guide pulley **1.1** on point **P6** and secure.

8.2 Disassembling the roller sets R8/R12 on the L- or S-end section



Note

- ▶ The assembly / disassembly of the roller sets R8 or R12 is identical and is described on the example of roller set R8.
- ▶ The assembly / disassembly of the roller sets on the L-end section or on the S-end section is identical and is described on the example of the L-end section.



Note

- ▶ For the assembly / disassembly of the roller sets on the main boom, the main boom can be held by it's own main boom guying. But Liebherr-Werk Ehingen GmbH recommends to additionally secure the main boom at assembly of the roller sets with an auxiliary crane with sufficient load bearing capacity.
- ▶ For the assembly / disassembly of the roller sets on the luffing lattice jib (W-boom), the W-boom **must** be supported with materials with a load bearing capacity. If supporting is not possible: Lift the W-boom with the auxiliary crane with sufficient load bearing capacity. Observe the following danger notes.



WARNING

Working under suspended load!

The boom can fall down.

Death, severe bodily injuries, property damage.

- ▶ Make sure that the auxiliary crane **10** is properly supported and horizontally aligned.
- ▶ Make sure that the utilization of the auxiliary crane **10** is maximum 90 %.
- ▶ Make sure that the motor of the auxiliary crane **10** is turned off during assembly of the roller sets.



WARNING

Impermissible fastening equipment!

The boom can fall down.

Death, severe bodily injuries, property damage.

- ▶ Use only inspected fastening equipment.

Make sure that the following prerequisites are met:

- The crane is horizontally aligned.
- The L-end section **7** is approx. 2.00 m above the ground.
- The boom system is supported with materials with load bearing capacity.
- **or**
- The boom system is safely held by the auxiliary crane **10**.
- An assembly scaffolding / work platform is available.
- The hoist rope has been reeved out.

8.2.1 Removing roller set R8 with the forklift and assembly rack

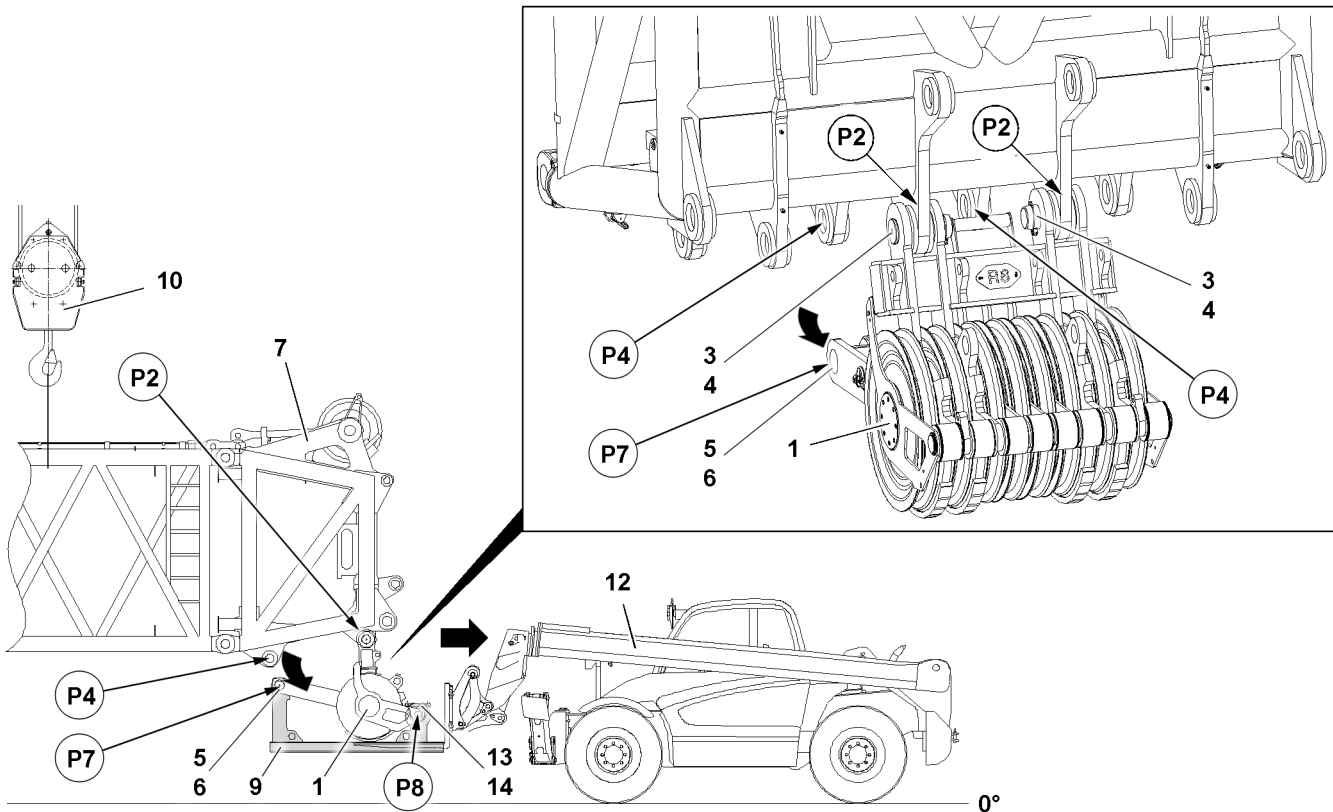

Fig.144160: Removing roller set R8 1 with the forklift and assembly rack 9

Make sure that the following prerequisites are met:

- A forklift 12 is available.
- The assembly rack 9 is available.
- The hoist limit switch weight and the hoist limit switch are properly removed on roller set R8 1.

- ▶ Retract the forklift 12 properly in the receptacles of the assembly rack 9.
- ▶ Align the assembly rack 9 with the forklift 12 under the roller set 1.
- ▶ Lift the assembly rack 9 with the forklift 12 and roller set 1 on the receptacles at point P8.

When the roller set 1 is properly pinned and secured in the receptacles of the assembly rack 9:

- ▶ Unpin the roller set R8 1 on the pin points P4 on both sides.

When the roller set R8 1 is properly unpinned on the pin points P4:

- ▶ Move the forklift 12 away from the L-end section slowly.

Result:

- The roller set R8 1 lowers into the receptacles of the assembly rack 9.
- ▶ Secure roller set R8 1 in the receptacles of the assembly rack 9.

When the roller set R8 1 is completely lowered into the receptacles of the assembly rack 9:

- ▶ Release and unpin the roller set R8 1 on the points P2 on the L-end section 7 on both sides.

When the roller set R8 1 is properly unpinned on the pin points P2 on both sides:

- ▶ Lower the assembly receptacle 9 with the forklift and extend the forklift.

8.2.2 Removing the roller set R8 with the auxiliary crane

Make sure that the following prerequisite is met:

- A second auxiliary crane 11 is available.
- ▶ Disassemble the hoist limit switch weight and hoist limit switch.

- ▶ Connect the roller set R8 1 with the manual chain pull 8 at point P3.

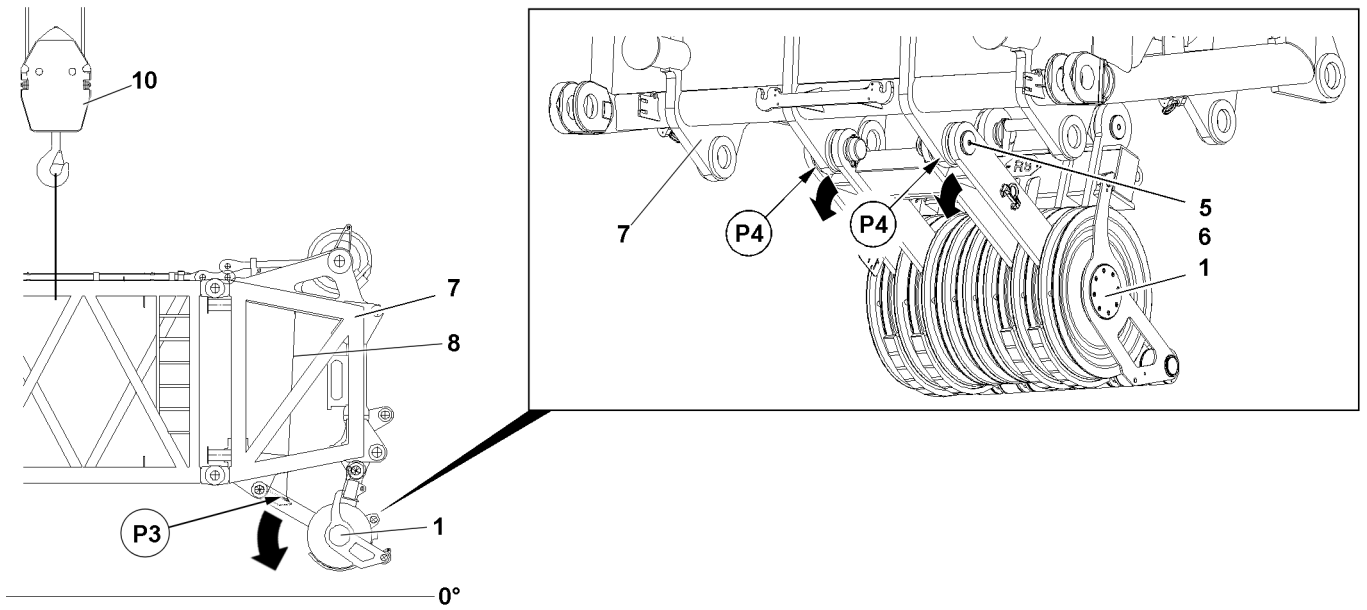

Fig.144162



WARNING

Roller set swinging down!

The roller set R8 1 can swing down by itself due to its own weight when unpinning on points P4. Death, severe bodily injuries, property damage.

- ▶ Make sure, before unpinning, that the roller set R8 1 is connected with the manual chain pull 8 at point P3.
 - ▶ Do not reach with your hands into the danger zone.
-
- ▶ Unpin the roller set R8 1 at points P4 from the L-end section 7 twice: Remove the retaining element 6 and unpin the connecting pin 5.
 - ▶ Swing the roller set R8 1 with the manual chain pull 8 down.
 - ▶ Release the manual chain pull 8 at point P3 and remove.

LWE/LR 11000-001/23501-04-02/en

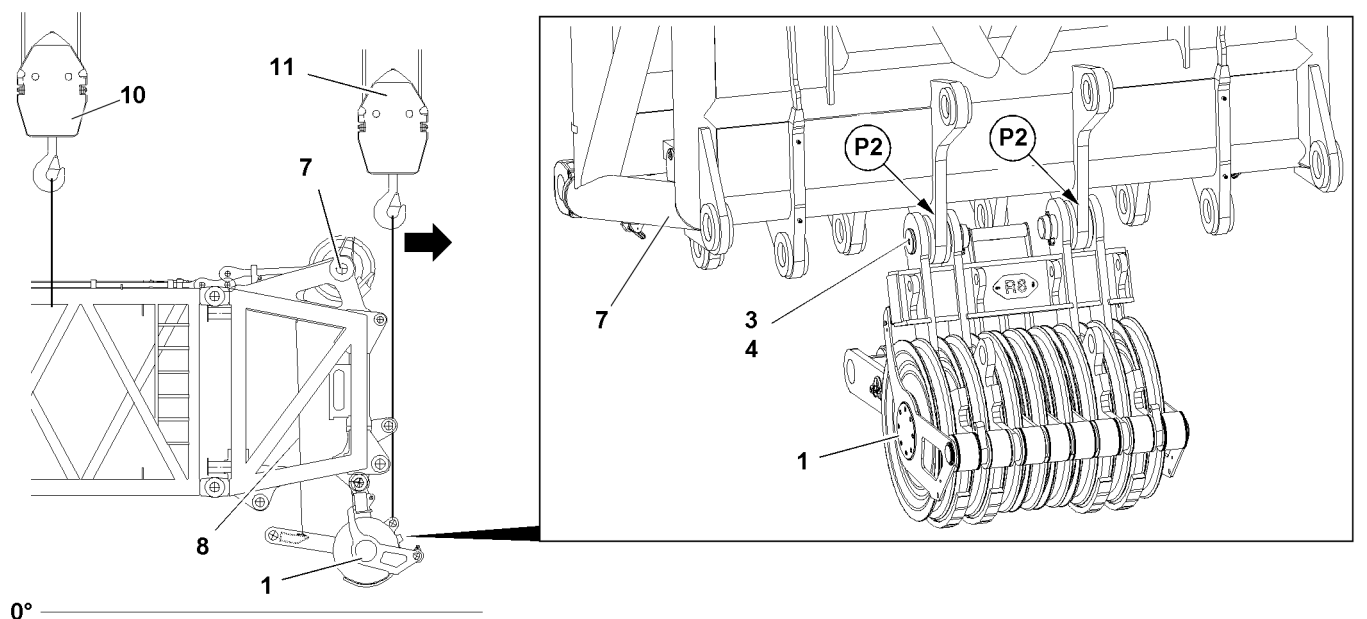

Fig.144161: Removing the roller set on the L-end section

- ▶ Fasten the roller set R8 1 on the auxiliary crane 11.



WARNING

Roller set falling down!

The roller set R8 1 can fall down by itself due to its own weight when unpinning at points P2. Death, severe bodily injuries, property damage.

- ▶ Make sure, before unpinning, that the roller set R8 1 is held with the auxiliary crane 11.
-

When the roller set R8 1 is safely held by the auxiliary crane 11:

- ▶ Unpin the roller set R8 1 at points P2 from the L-end section 7 twice: Remove the retaining element 4 and unpin the connecting pin 3.
- ▶ Remove roller set R8 1 with the auxiliary crane 11 and place down.
- ▶ Remove the auxiliary crane 11.

5.19 Hook blocks

1	Hook blocks	3
2	Radio sending unit for the incline display hook block	3
3	Procedure in case of slack rope	3

Fig.195219

LWE/LR 11000-001/23501-04-02/en

1 Hook blocks



Note

- ▶ For assembly and disassembly of hook blocks, see the separate operating instructions.

2 Radio sending unit for the incline display hook block



Note

- ▶ For the assembly and disassembly of the radio sending unit observe the Crane operating instructions, chapter 5.19.10.

3 Procedure in case of slack rope



Note

- ▶ If the hook block can no longer be lowered due to slack rope formation, then the following steps must be carried out!

3.1 Spooling up loose hoist rope

- ▶ Spool up loose hoist rope between the boom head and the winch carefully onto the winch.



Note

- ▶ A slight rope slack must remain between the boom head and the winch!

3.2 Luffing the boom down

NOTICE

Danger of collision!

When luffing the boom down, the hoist rope length can shorten and pull the hook block against the boom head.

- ▶ Monitor the distance of the hook block to the boom head.

- ▶ Luff the boom down carefully.

Result:

- The hoist rope between the boom head and the winch is tensioned.

3.3 Lowering the hook block

- ▶ Lower the hook block carefully with the hoist gear.

Empty page!

LWE/LR 11000-001/23501-04-02/en

5.19.10 Hook block incline sensors

1	Assembling the receiver-incline sensor*	3
2	Assembling the sending unit-incline sensor* on the hook block	6

Fig.195219

LWE/LR 11000-001/23501-04-02/en

1 Assembling the receiver-incline sensor*

The installation of the radio receiver on the respective boom head is required to provide an additional aid for the crane driver in parallel operation of winch 1 and winch 2 (11I2) to manually monitor the incline of the hook block via the incline display in the respective winch icons.



Note

- ▶ The assembly of the radio receiver is described in this chapter as an example and may not apply exactly to your crane.
- ▶ The representation of the various mounting positions of the radio receiver are examples and may not apply exactly to your crane.
- ▶ Depending on the crane type and / or equipment, the assembly plate of the radio receiver may be constructed with a different design, see variation 1 and variation 2.



Note

- ▶ When using the radio receiver, the sender batteries must be sufficiently charged.



Note

- ▶ The LICCON computer system monitors in parallel operation the incline / incline position of the hook block, see the Crane operating instructions chapter 4.02 and chapter 4.05.



WARNING

Load ripping off!

If the hook block gets into an impermissible incline / incline position in parallel operation of winch 1 and winch 2 (11I2), then the hook block can be overloaded.

Death, severe bodily injuries, property damage.

- ▶ Make sure that the radio receiver is properly installed on the boom head / lattice section.
- ▶ Make sure that the incline display in the LICCON computer system is constantly monitored in crane operation, see Crane operating instructions, chapter 4.02.

1.1 Variation 1: Installing / removing the radio receiver on the boom end section / lattice section

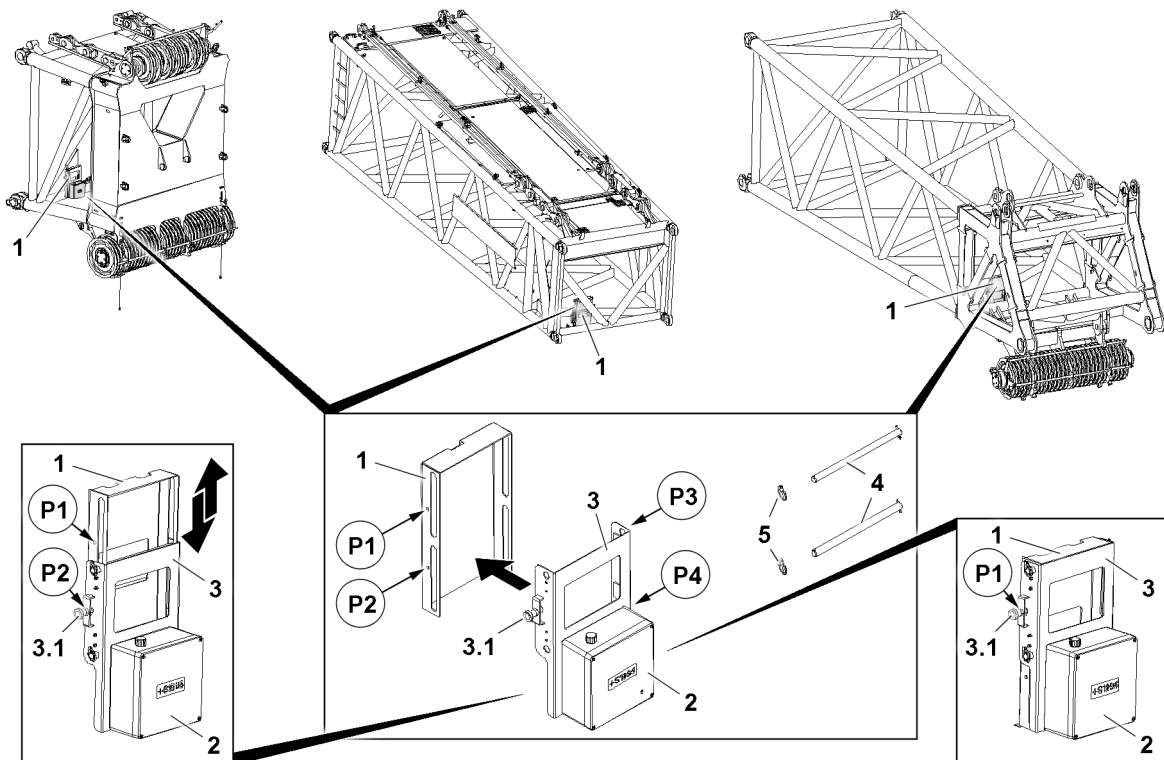

Fig.128140: Variation 1: Installing the radio receiver 2 on the boom end section / lattice section

Point **P1** = transport position lock

Point **P2** = operating position lock

The radio receiver 2 is screwed firmly with the assembly plate 3.

If the assembly plate 3 is assembled properly on the boom end section / lattice section, then the radio receiver 2 can be moved and locked twice within the slotted holes on the support 1.

1.1.1 Assembling the radio receiver

- Pull the detent pin 3.1 on the assembly plate 3 and position and hold the radio receiver 2 with the assembly plate 3 on the support 1.

When the assembly plate 3 is properly set on the support 1:

- Release the detent pin 3.1 and make sure that the detent pin 3.1 is properly locked in point **P1**.
- Properly insert the pins 4 at the points (point **P3** and point **P4**) and secure with the retaining element 5.

Result:

- The radio receiver 2 is properly pinned and secured on the support 1.
- The radio receiver 2 is properly locked in the transport position at point **P1**.

When the radio receiver 2 is properly pinned and locked:

- Connect the radio receiver 2 electrically, see Electric wiring diagram.

NOTICE

Damage of the radio receiver 2!

- Make sure that the radio receiver 2, when handling and / or placing down the respective boom end section / lattice section on the ground, is always in the transport position, see the section „Bringing the radio receiver to the transport position from the operating position“.

- ▶ Protect the radio receiver **2** from damage.

1.1.2 Bringing the radio receiver to the operating position from the transport position



WARNING

Interruption of radio connection!

If the radio receiver **2** is left in the transport position during crane operation, the radio connection can break off.

- ▶ Make sure that the radio receiver **2** is in the operating position during crane operation.

The radio receiver **2** must be brought to the operating position before erecting the boom system and locked at point **P2**.

- ▶ Hold the radio receiver **2**, pull the detent pin **3.1** and slowly lower the radio receiver **2** in the operating position until the detent pin **3.1** engages at point **P2**.

Result:

- The radio receiver **2** is in the operating position.

1.1.3 Bringing the radio receiver to the transport position from the operating position

The radio receiver **2** must be brought to the transport position before disassembling the boom system and locked at point **P1**.

- ▶ Hold the radio receiver **2**, pull the detent pin **3.1** and slowly push the radio receiver **2** up to the transport position until the detent pin **3.1** engages at point **P1**.

Result:

- The radio receiver **2** is in the transport position.

1.1.4 Disassembling the radio receiver

- ▶ Disconnect the electrical connection between the terminal box and the radio receiver **2**.
- ▶ Properly store the electrical connection.

When the electrical connection is properly disconnected:

- ▶ Remove the retaining element **5** on the pins **4**.
- ▶ Hold the radio receiver **2** and unpin the pin **4**.
- ▶ Pull the detent pin **3.1** lift the radio receiver **2** with the assembly plate **3** from the support **1**.
- ▶ Insert the pin **4** on the assembly plate **3** and secure properly with the retaining element **5**.

1.2 Variation 2: Installing the radio receiver on the boom end section

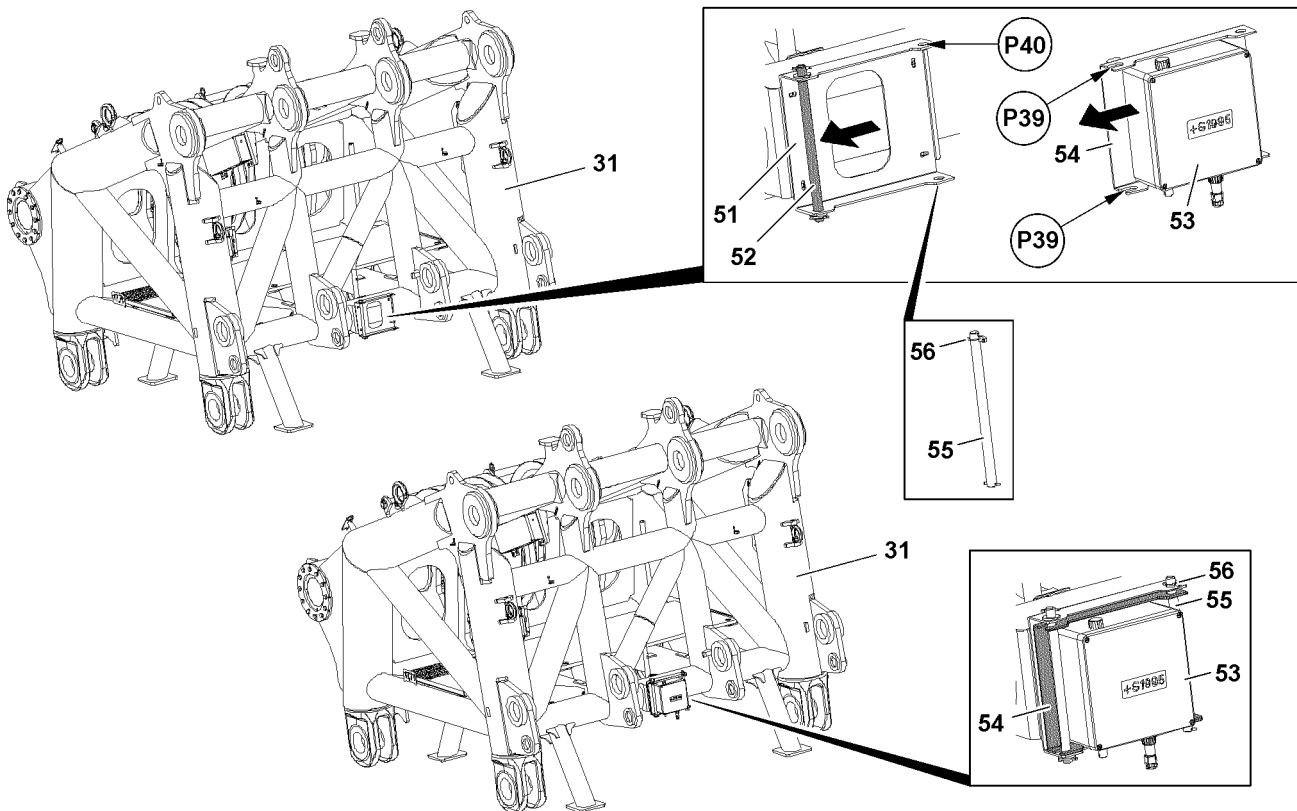

Fig.120089: Variation 2: **53**Installing the radio receiver **53** on the boom end section

The radio receiver **53** is screwed on the assembly plate **54**.

- ▶ Move the assembly plate **54** of the radio receiver **53** with the fork connections at point **P39** on the axle **52** of the retainer **51**.

When the assembly plate **54** of the radio receiver **53** is properly in the retainer **51**:

- ▶ Insert the pin **55** at point **P40** and secure properly with the locking pin **56**.
- ▶ Connect the radio receiver **53** electrically, see Electric wiring diagram.

NOTICE

Damage of the radio receiver **53**!

- ▶ Make sure that the radio receiver **53** is not damaged when handling and / or setting down the respective boom head on the ground.
- ▶ Protect the radio receiver **53** from damage.

2 Assembling the sending unit-incline sensor* on the hook block

So that the inclination of the hook block can be recorded in parallel operation by the crane control, the radio sending unit must be properly assembled on the hook block.

**Note**

- ▶ The assembly of the radio sending unit is described in this chapter as an example and may not apply exactly to your crane.
- ▶ The representation of the various mounting positions of the hook blocks are examples and may not apply exactly to your crane.

**Note**

- ▶ The LICCON computer system monitors in parallel operation the incline / incline position of the hook block, see the Crane operating instructions chapter 4.02 and chapter 4.05.

**WARNING**

Load ripping off!

If the hook block gets into an impermissible incline / incline position in parallel operation of winch 1 and winch 2 (11I2), then the hook block can be overloaded.

Death, severe bodily injuries, property damage.

- ▶ Make sure that the radio sending unit is properly installed on the hook block.
- ▶ Make sure that the incline display in the LICCON computer system is constantly monitored in crane operation, see Crane operating instructions, chapter 4.02.

2.1 Assembling the radio sending unit on the hook block

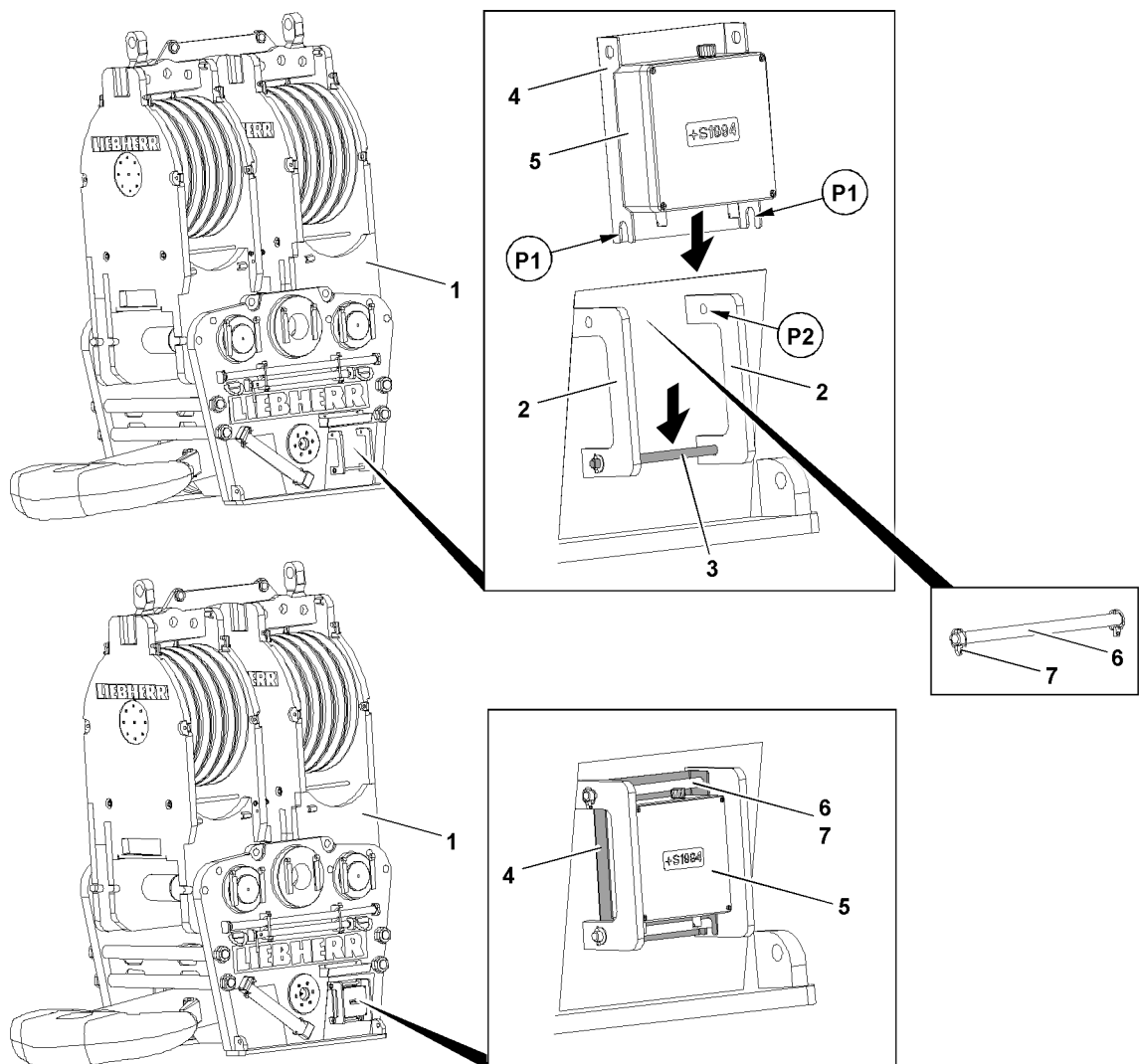

Fig.120141: Assembly of the radio sending unit 5 on the hook block

The installation of the radio sending unit **5** on the respective hook block is required to be able to ensure in parallel operation of winch 1 and winch 2 (11I2) via the incline display in the respective winch icons that the hook block does not get into an impermissible incline position.

Make sure that the following prerequisites are met:

- The hook block is standing on the ground.
- The hook block has the required retainer **2** for the assembly of the radio sending unit.
- The radio sending unit batteries are sufficiently charged.



Note

- ▶ An impermissible incline position of the hook block in parallel operation of winch 1 and winch 2 (11I2) does **not** result in a **shut-off** of winch movements by the LICCON computer system.



WARNING

Load ripping off!

If the hook block gets into an impermissible incline position in parallel operation of winch 1 and winch 2 (11I2), then the hook block can be overloaded.

The load can rip off and fall down.

Death, severe bodily injuries, property damage.

- ▶ Make sure that the radio sending unit **5** is properly installed on the hook block.
- ▶ Make sure that the incline display in the LICCON computer system is constantly monitored in crane operation, see Crane operating instructions, chapter 4.02.



Note

- ▶ The assembly of the radio sending unit **5** on the respective hook block is described as an example.
- ▶ The example assembly of the radio sending unit **5** is identical to the assembly of the radio sending unit **5** on additional hook blocks approved for parallel operation.

The radio sending unit **5** is screwed on the assembly plate **4**.

- ▶ Move the assembly plate **4** of the radio sending unit **5** with the fork connections at point **P1** on the axle **3** of the retainer **2**.

When the assembly plate **4** of the radio sending unit **5** is properly in the retainer **2**:

- ▶ Insert the pin **6** at point **P2** and secure properly with the locking pin **7**.

NOTICE

Damage of the radio sending unit **5**!

- ▶ Make sure that the radio sending unit **5** is not damaged when handling with the hook block.
- ▶ Protect the radio sending unit **5** from damage.

2.2 Disassembling the radio sending unit on the hook block

Make sure that the following prerequisite is met:

- The hook block is standing on the ground.
- ▶ Release the radio sending unit **5**: Remove the locking pin **7** and unpin the pin **6** at point **P2**.
- ▶ Lift the radio sending unit **5** and store it properly.
- ▶ Insert the pin **6** again at point **P2** and secure properly with locking pin **7**.

5.30 Pin pulling device

1 Pinning and unpinning with pin pulling device

3

LWE/LR 11000-001/23501-04-02/en

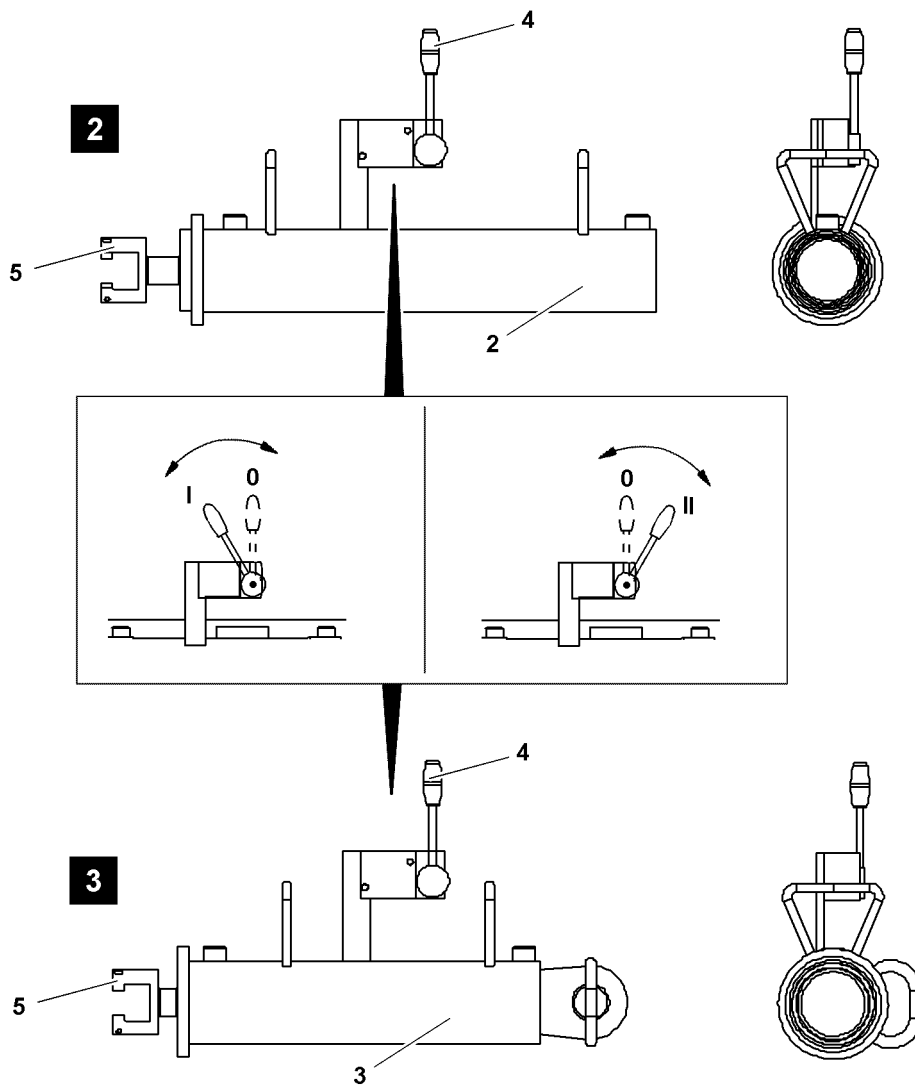
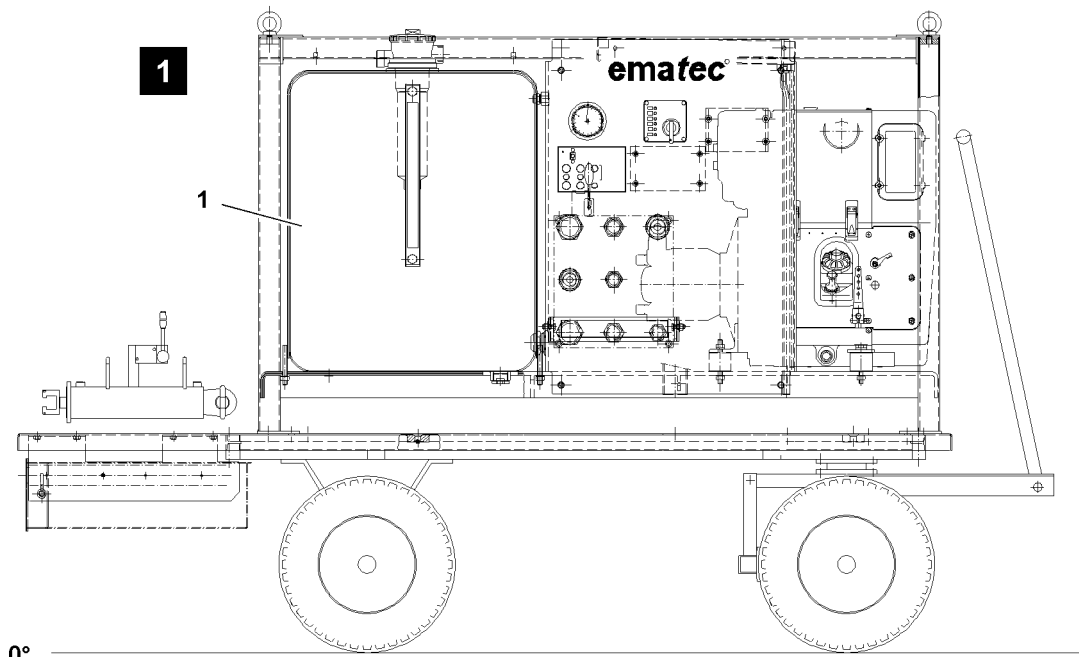

Fig.119040

LWE/LR 11000-001/23501-04-02/en

1 Pinning and unpinning with pin pulling device

The pin pulling device consists of the hydraulic aggregate and the pin pulling cylinders. The connector pins on the crawler crane and on the lattice sections are pinned and unpinned with these pin pulling cylinders.



Note

- ▶ The pin pulling cylinder **2** is used for pinning and unpinning on the chassis.



Note

- ▶ The pin pulling cylinder **3** is used for pinning and unpinning on the lattice sections.



DANGER

Danger of accident!

When you disassemble unsecured or unsupported crane parts, they can fall down!

Personnel can be severely injured or killed!

- ▶ Never stand **under** unsecured or unsupported crane parts and unpin the pins!
- ▶ Never unpin the connecting pins on unsecured or unsupported booms!
- ▶ Do not stand under the crane parts or within the complete danger zone during the pinning and unpinning procedure!
- ▶ Do not lean the ladder against the crane part being disassembled!



WARNING

Pressure in the hydraulic lines!

If the pressure supply is not interrupted before connecting / releasing the hydraulic lines, the hydraulic oil can escape with high pressure!

Personnel can be severely injured or killed!

- ▶ Release the pressure in the hydraulic system before connecting / disconnecting: Interrupt the pressure supply and wait for a short time!



WARNING

Loss of pressure or leakage!

Incorrectly coupled or self-loosening quick-release couplings (particularly return lines) can result in serious accidents due to component failure!

- ▶ Check that the quick couplings have been properly connected before using the crane!
- ▶ Assemble coupling components (sleeve and connector) and screw together with the hand-tightened nut!
- ▶ Tighten the hydraulic coupling by hand. Rotate hand-tightened nut until it reaches a tangible, fixed stop position!

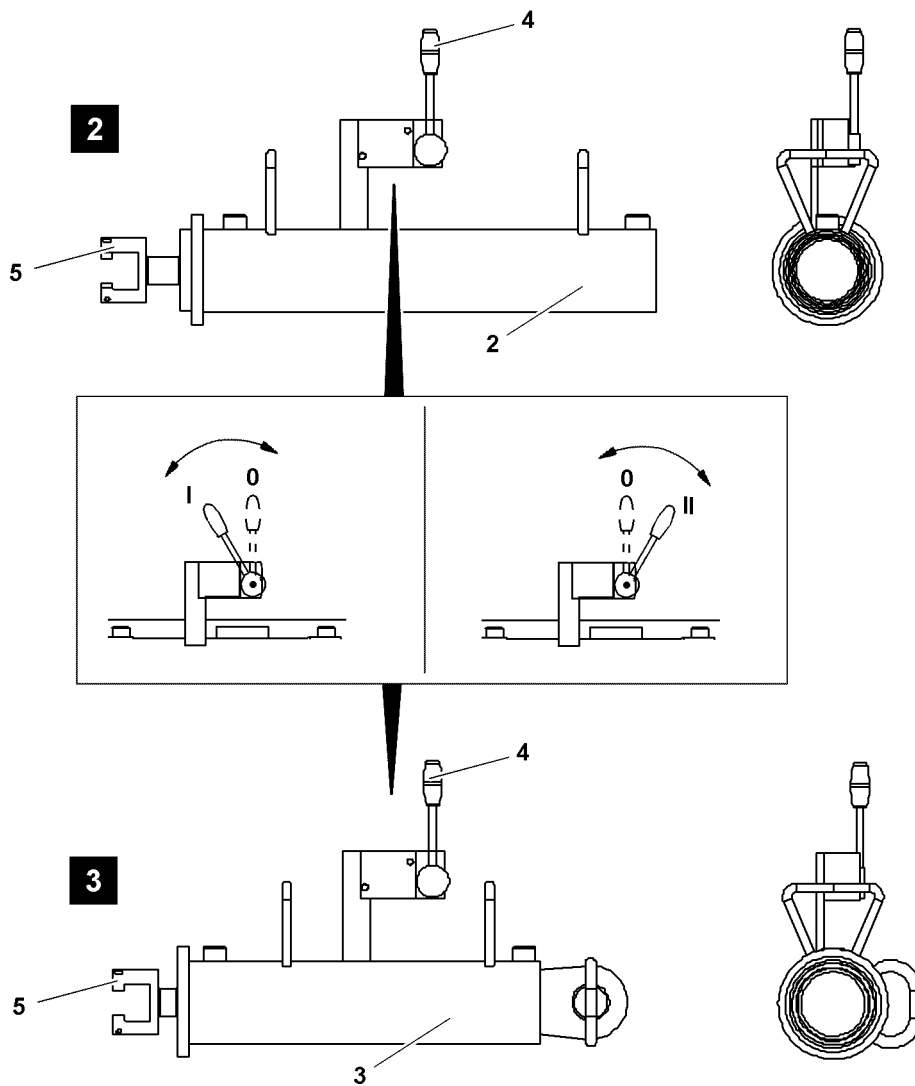
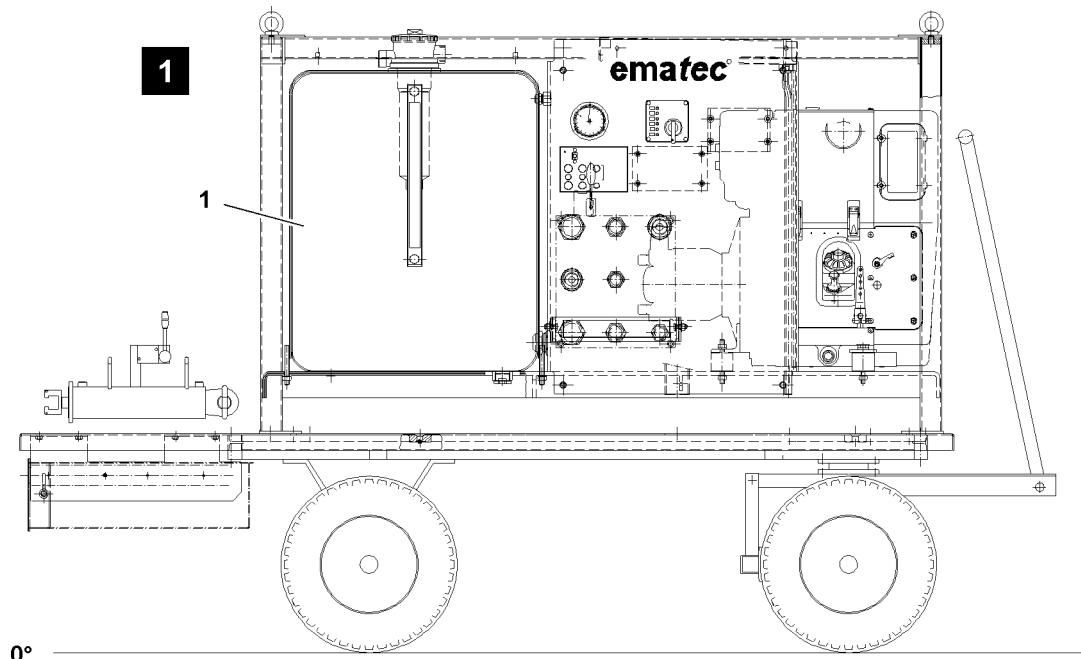

Fig.119040

LWE/LR 11000-001/23501-04-02/en

1.1 Hydraulic oil level



Note

- ▶ The hydraulic oil tank is filled when starting the hydraulic aggregate.
- ▶ Check the hydraulic oil level, see Operating and maintenance instructions for the Hydraulic aggregate.

NOTICE

Emerging hydraulic oil!

When the hydraulic aggregate is changed and / or the operational crane hydraulic is connected, then there is a danger that the hydraulic oil is supplied during the working process into the hydraulic tank circuit and thus forwarded into the hydraulic tank of the hydraulic aggregate.

The forwarded hydraulic oil quantity exceeds the tank volume of the hydraulic aggregate. Hydraulic oil runs over and contaminates the environment.

- ▶ Make sure that the hydraulic aggregate is separated from the hydraulic circuit of the crane before hydraulic components are actuated via the crane hydraulic.
- ▶ Make sure, before the hydraulic aggregate is separated from the crane, that the working process is ended with the same hydraulic aggregate.
- ▶ Make sure that the identical amount of hydraulic oil is in the hydraulic oil tank of the hydraulic aggregate after application than before.

1.2 Pin and unpin the pin with the pin pulling cylinder 2.

1.2.1 Preparatory work

Make sure that the following prerequisites are met:

- The hydraulic aggregate **1** is not yet started.
- The lever **4** is in **0-position**.
- ▶ Connect the hydraulic hoses of the required pin pulling cylinder on the pin pulling aggregate **1**.
- ▶ Hang or pin the pin pulling cylinder in the retainer on the component.
- ▶ Connect the piston rod head **5** with the screw on the pin.

1.2.2 Pinning or unpinning pins



Note

- ▶ Operate the hydraulic aggregate, see Operating and maintenance instructions for the Hydraulic aggregate.

- ▶ Start the hydraulic aggregate **1**.
- ▶ Set the engine rpm on the hydraulic aggregate **1**.
- ▶ Operate the lever **4** on the pin pulling cylinder **2**.



Note

- ▶ **I-position**, insert the pin, see illustration **2** and illustration **3**.
- ▶ **II-position**, unpin the pin, see illustration **2** and illustration **3**.
- ▶ Pin or unpin the pin.

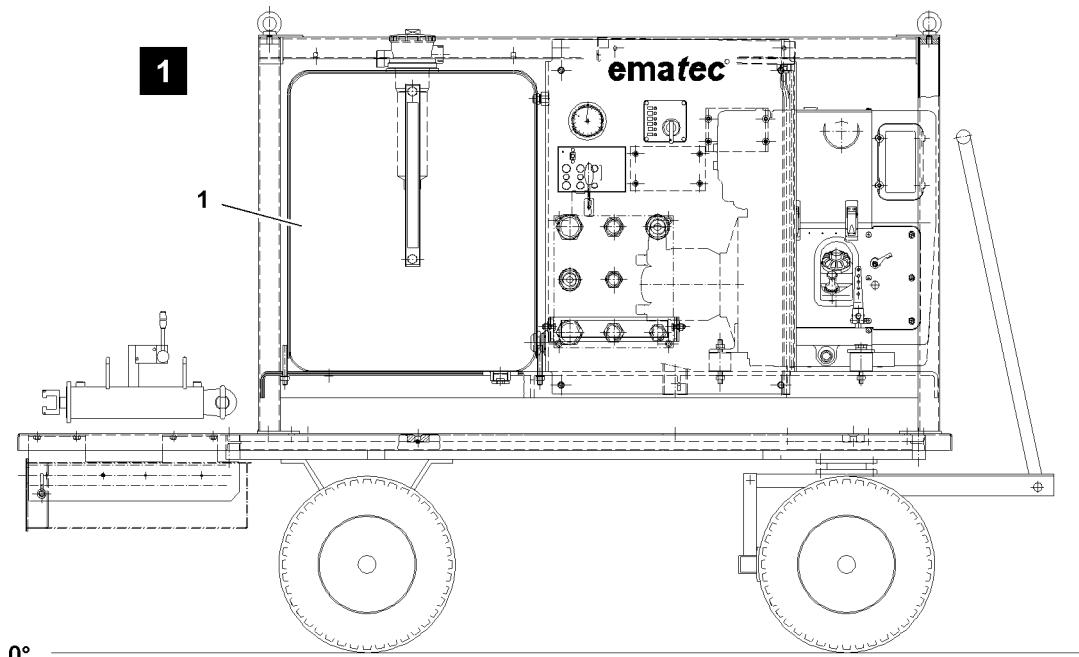

0°

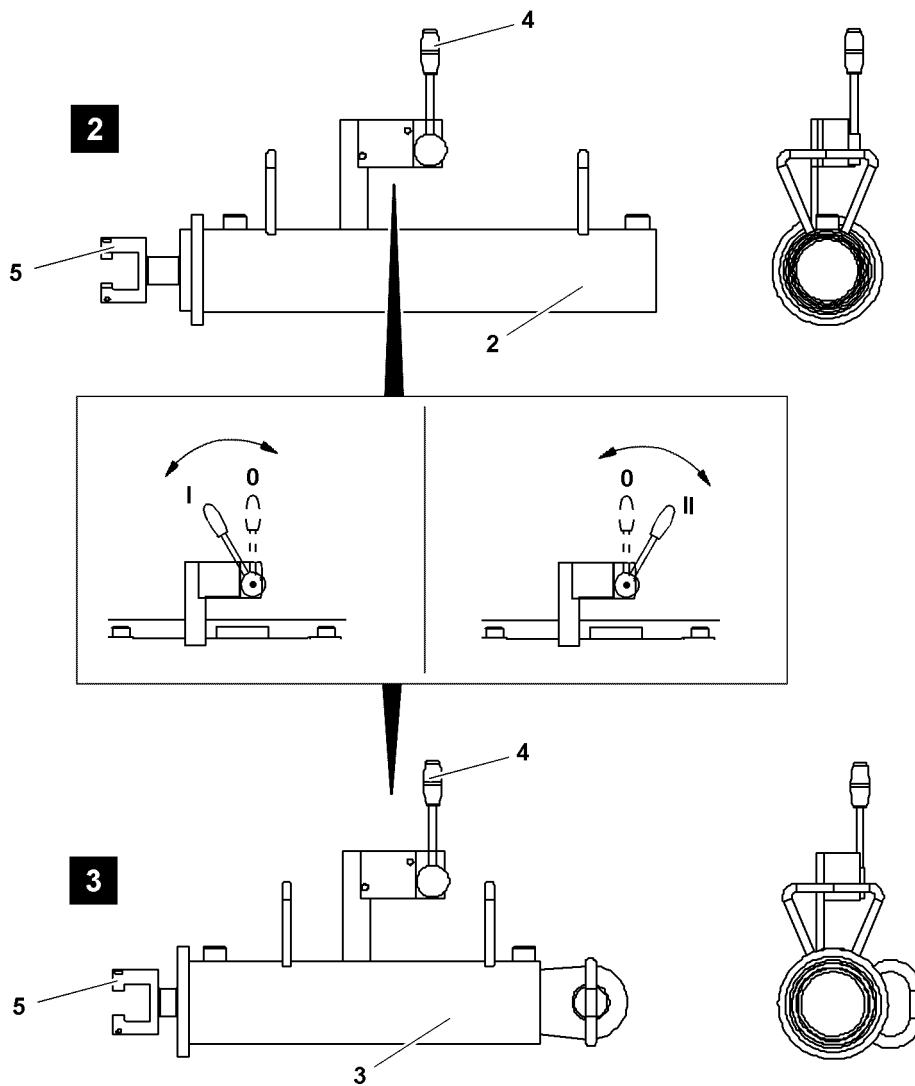

Fig.119040

LWE/LR 11000-001/23501-04-02/en

1.3 Pin and unpin the pin with the pin pulling cylinder 3.

1.3.1 Preparatory work

Make sure that the following prerequisites are met:

- The hydraulic aggregate **1** is not yet started.
- The lever **4** is in **0-position**.
- ▶ Connect the hydraulic hoses of the required pin pulling cylinder on the pin pulling aggregate **1**.
- ▶ Hang or pin the pin pulling cylinder in the retainer on the component.
- ▶ Connect the piston rod head **5** with the screw on the pin.

1.3.2 Pinning or unpinning pins



Note

- ▶ The pin pulling cylinder **3** is actuated for safety reasons on the hydraulic aggregate **1**!
- ▶ Before pinning and unpinning the lattice sections, engage the lever **4** in **I-position** or **II-position**.
- ▶ Engage the lever **4** on the pin pulling cylinder **3** in **I-position** or **II-position**, see illustration **3**.



Note

- ▶ **I-position**, insert the pin, see illustration **2** and illustration **3**.
- ▶ **II-position**, unpin the pin, see illustration **2** and illustration **3**.



Note

- ▶ Operate the hydraulic aggregate, see Operating and maintenance instructions for the Hydraulic aggregate.
- ▶ Start the hydraulic aggregate **1**.
- ▶ Set the engine rpm on the hydraulic aggregate **1**.
- ▶ Operate the change over lever on the hydraulic aggregate **1**.

Result:

- The piston rod of the pin pulling cylinder **3** moves in or out.

Empty page!

LWE/LR 11000-001/23501-04-02/en

5.31 Bluetooth Terminal (BTT)

1	Display / operating element BTT	3
2	Start menu of the BTT	12
3	Settings and status displays on the BTT	15
4	<i>Engine operation</i> menu	17
5	Menu <i>Crane cab / stepladder</i>	29
6	<i>Test system</i> menu	35
7	Operation BTT	37
8	Measures in case of problems	39

Fig.195219

LWE/LR 11000-001/23501-04-02/en

1 Display / operating element BTT

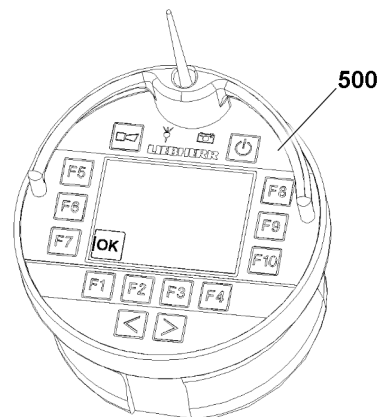

Fig.124478



Note

- ▶ The Bluetooth Terminal is described as BTT in the description.
- ▶ The Bluetooth Basis is described as BTB in the description.

The BTT is a combined display / operating element for the crane. Selected crane movements can be carried out. The data exchange is made via the BTB on the crane. The data exchange can also be made wireless as well as via a connector cable.

The BTT is operated using function keys F1 - F10 and two changeover buttons



Note

- ▶ The illustrations or icons in the monitor display of the BTT are only examples.
- ▶ They may differ from the crane.

Via the BTT **500** you can call up various menus. Various crane functions can be selected or preselected, turned on or off, or directly activated in these menus.

If the turned on BTT is pulled from the charging cradle, the following menu points can be selected:

- *Engine operation* menu
- *Crane cab* menu
 - Swinging the crane cab
 - Positioning the stepladder

The operation of the BTT **500** via the function keys and changeover buttons:

- Function keys
 - The function of the function keys is menu dependent. For exact description, see the respective menu section.
- Changeover buttons
 - The function of the changeover buttons is menu dependent. For exact description, see the respective menu section.

NOTICE

Destruction of the BTT!

- ▶ Under no circumstances clean the BTT **500** with a jet of water or a steam cleaner.

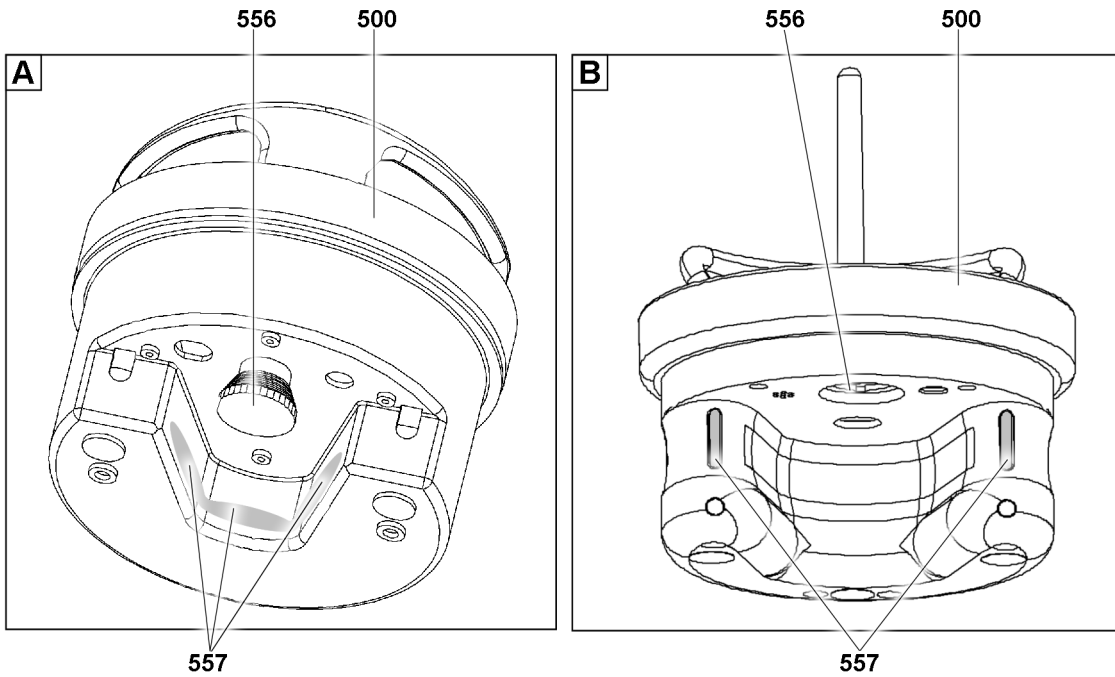
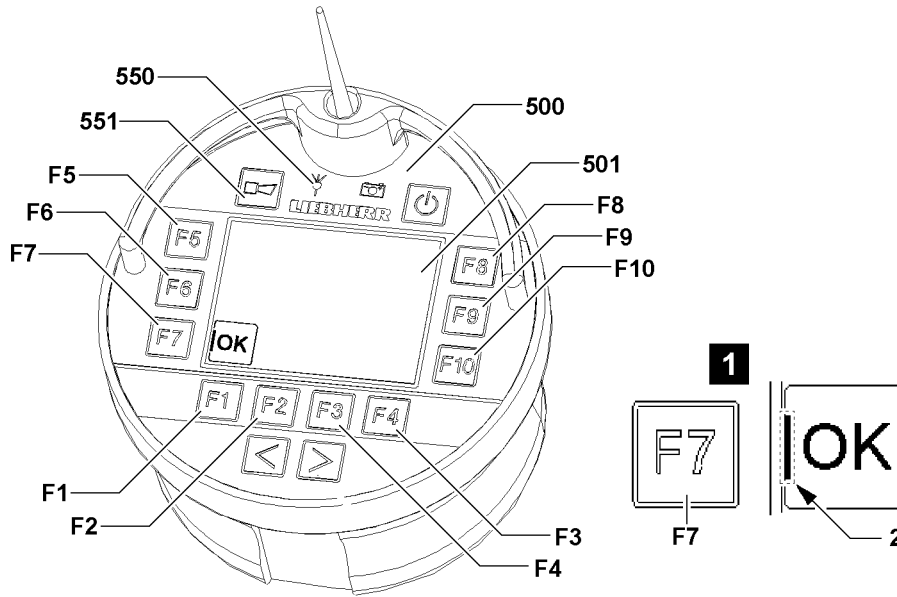

Fig. 146318

- A** 2-hand keypad: On the inner surface
- B** 2-hand keypad: Button on the front side of the curvature



Note

► One of the described BTTs is used depending on the delivery condition of the crane.

LWE/LR 11000-001/23501-04-02/en

1.1 Important information about the BTT

The following important information must be observed for operation with the BTT **500**:

- The machine number on the data tag of the crane cab must match the machine number on the BTT display **501**.
- The BTT can only be turned on when the EMERGENCY STOP switch **556** on the rear of the BTT is **not** actuated.
- The rechargeable battery of the BTT is only charged if the EMERGENCY STOP switch **556** on the rear of the BTT is **not** actuated when plugging it into the charging module.
- When a function is selected via a function key, the corresponding icon is surrounded with a black border. In some case, additional icons are shown on the BTT display.
- The operation of the BTT must be made with two hands for safety reasons, see section „Release of button block on the BTT“.
- During crane operation via the BTT **500**, the complete crane must be in the field of visibility of the operator.
- Before any movement, which is controlled via the BTT **500**, the horn **551** must be actuated.
- As soon as the reception of the radio signal deteriorates, the indicator light **550** lights up orange.
- The reach of the radio signal can fluctuate due to local conditions.
- If the radio contact between the BTT **500** and the BTB is interrupted or the EMERGENCY STOP switch **556** on the rear of the BTT **500** is actuated, the crane movement stops.
- Keep the BTT **500** and the charging module clean.
- Protect the BTT **500** from direct sun exposure.
- Protect the BTT **500** from dirt and moisture.



Note

Function keys **F1** to **F10**

- ▶ Icons are assigned to the individual function keys. A small bar **2** marks the assigned button, see illustration 1: Example for function key **F7**.

1.2 Releasing the button block on the BTT

To prevent inadvertent crane operation, movements to be carried out on the BTT are secured by a button block. The 2-Hand keypad **557** can be activated by finger touch. The button block is removed.

After selecting a function, the actual movement (operation) is only released after activation of the 2-hand keypad **557**. Released icons are highlighted with the color **purple**.

If the icon is released and the respective function key is pressed, the movement is carried out.



Note

- ▶ Any actuation of the 2-hand keypad **557** is stored for 30 seconds. If no movement is actuated within these 30 seconds or if the 2-hand keypad **557** is actuated again, then the button block is activated and a signal tone sounds.

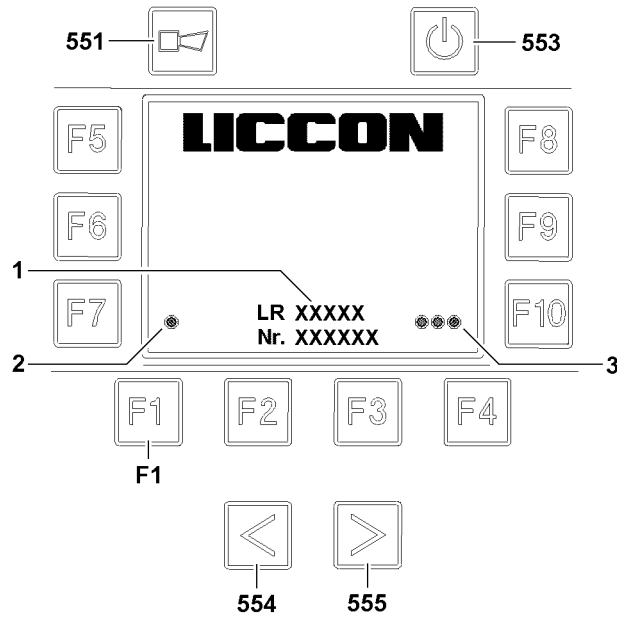

Fig.119599

1.3 Connecting the BTB and the BTT



Note

- ▶ If crane type and crane number **2** do not match, a connection between BTB and BTT is not possible.

To be able to control the crane via the BTT a connection to the BTB must be established.

The connection is based on a pairing process and a code calibration.

1.3.1 Pairing process

If the BTT is plugged into the charging module when the ignition is turned on, then a pairing process is carried out automatically with the BTB.

Carry out the pairing process by hand:

To do so, the turned on BTT must be plugged into the charging module. Various connecting parameters are compared and checked for a match via an infrared interface.

When the pairing process is completed successfully, the indicator light **1** lights up green.



Note

- ▶ If the pairing process does not run successfully, contact your **Liebherr Service location** or **Liebherr-Werk Ehingen**.

1.3.2 Code calibration

If the BTT is plugged into the charging module when the ignition is turned on, then the code calibration is made automatically.

Carry out the code calibration by hand:

One after the other, press the button **554**, then the button **555** and then the function key **F1**.

When the code calibration is completed successfully, all indicator lights **3** light up green.

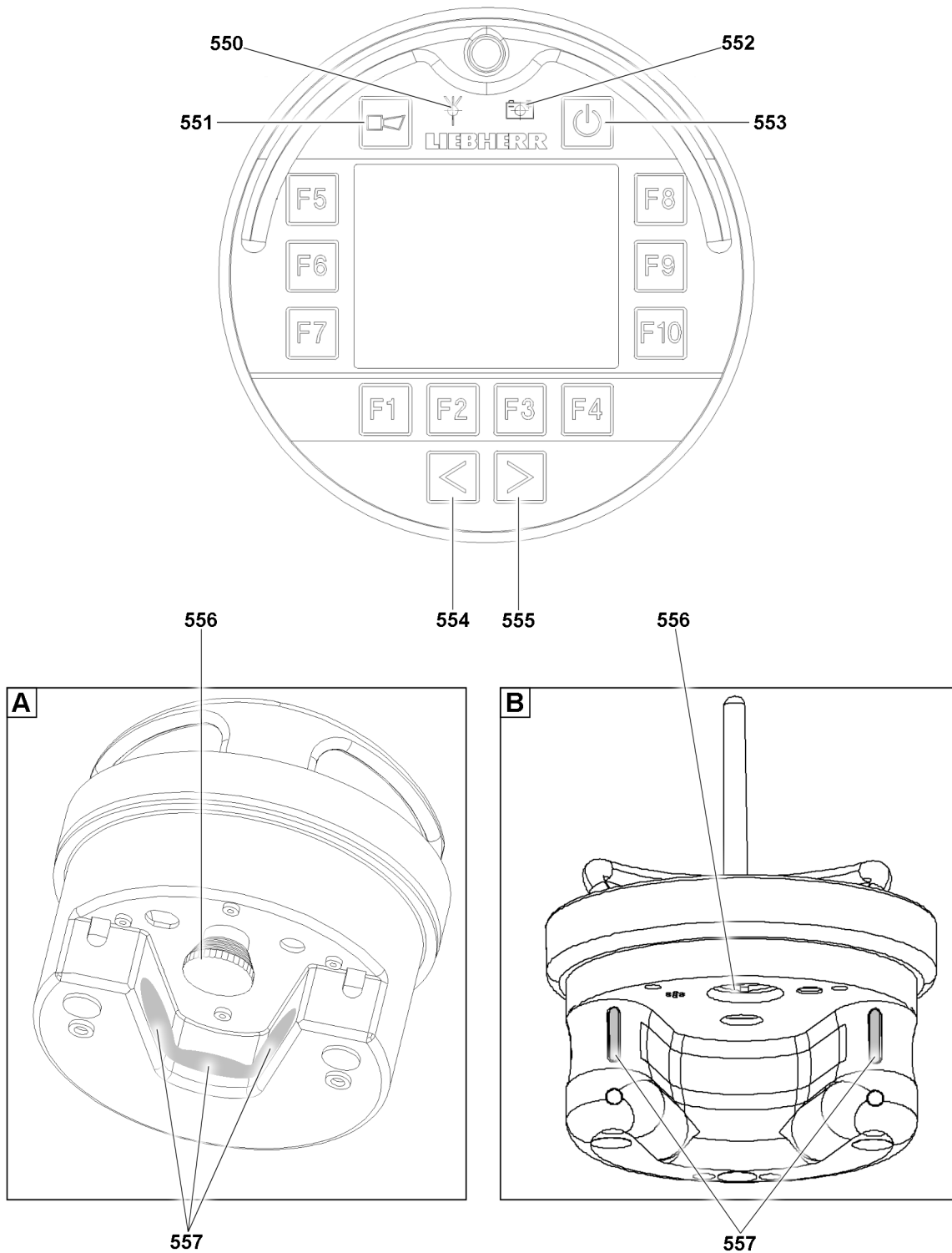

Fig.146316

- A** 2-hand keypad: On the inner surface
- B** 2-hand keypad: Button on the front side of the curvature

LWE/LR 11000-001/23501-04-02/en

1.4 General information regarding the BTT

550 Indicator light

Transmission signal for BTT:

- Green: Transmission signal ok
- Yellow: Transmission signal about to be lost
- Red: Transmission signal not available

551 Button

- Operate the acoustic signal of the crane (horn)

552 Indicator light

Charge condition of rechargeable battery on the BTT:

- Green: Rechargeable battery fully charged
- Yellow: Rechargeable battery almost discharged
- Red: Rechargeable battery discharged



Note

- ▶ To recharge the rechargeable battery, the BTT **500** must be plugged into the charging cradle.

553 Button

- ON / OFF button: Turn the BTT on / off
- ON / OFF button: End stand-by of the BTT

554 Button

- Changeover button (menu dependent)

555 Button

- Changeover button (menu dependent)

556 EMERGENCY STOP switch

- **Note:** The EMERGENCY STOP switch **556** is on the underside of the BTT.

557 2-hand keypad

- **Note:** The 2-hand keypad **557** must be actuated in order to be able to actuate a movement with the BTT.

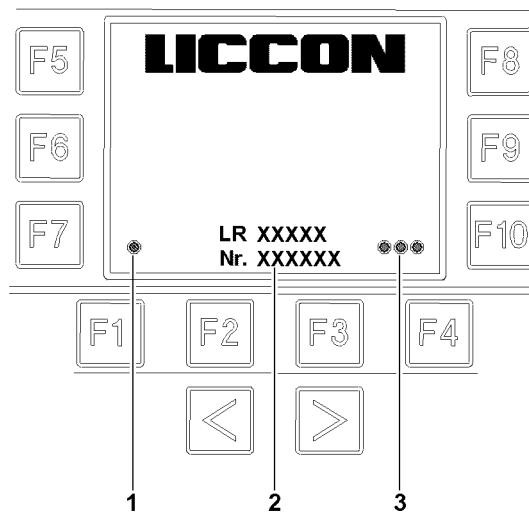
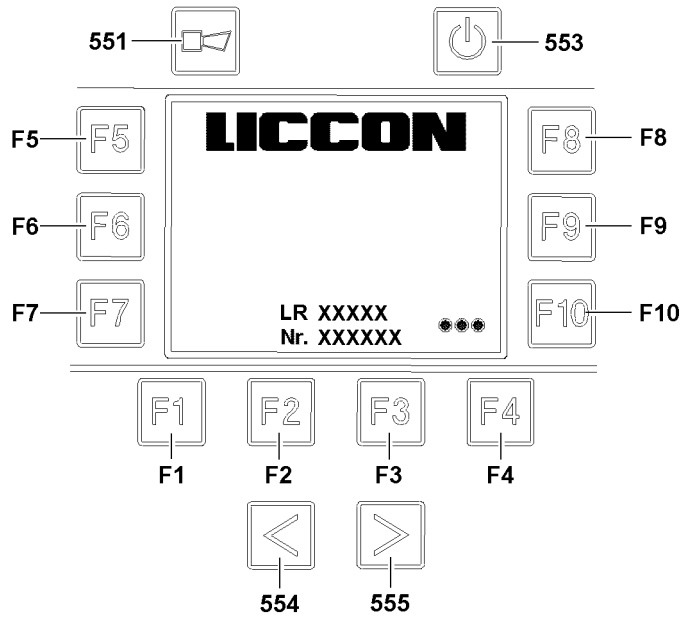

Fig.119600

LWE/LR 11000-001/23501-04-02/en

1.5 Start screen BTT

1.5.1 Icon explanation Start screen BTT

1 Indicator light

Status display connection to BTT receiver

- Yellow / red: not connected
- Yellow: Transmission signal being build up or severed
- Green / magenta: Connection prepared
- Green: Connection established
- Red: No connection between BTT and BTB

Note: If necessary, the pairing process must be repeated, see section „Connecting the BTB and BTT“

2 Crane type and crane number

3 Indicator lights

Condition display Code entry:

- Green: Code entry OK
- Red: No code entered, code entry incorrect

F1- F10 Function key

- **Note:** Once the code has been successfully entered, press any function key **F1-F10** to switch back to the selection overview.

2 Start menu of the BTT

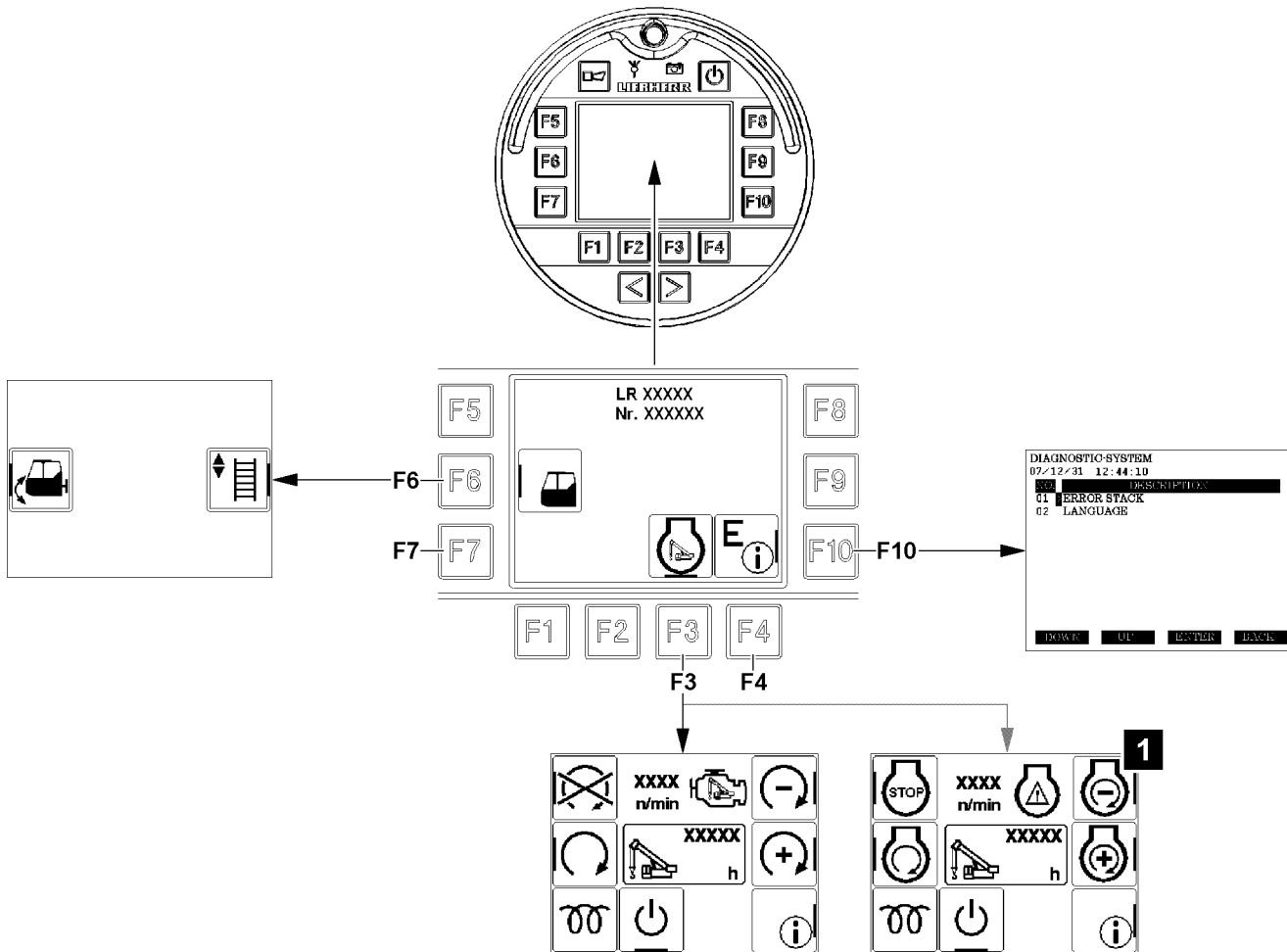

Fig.123749

F3	Menu <i>Engine operation</i> ¹⁾
>> F1	-Back to the start menu-
>> F2	Turn the ignition crane superstructure on / off ²⁾
>> F5	Turn the engine off
>> F6	Turn the engine on
>> F8	Decrease engine rpm
>> F9	Increase the engine rpm
>> F10	Call up the test system

1) Illustration of individual icons can vary, depending on the crane programming, see example illustration 1

2) Function only present for certain crane types

F4	Turn off disengageable acoustic warning signal
<p>Note: After an error message of the LICCON computer system the BTT issues an <i>acoustic warning signal</i>. Depending on the error message (for example operating error or system error), the warning signal can be turned off directly via the F4 function key or it remains and additional steps are required.</p>	

F5	Menu <i>Crane cab / stepladder</i>
>> F1	-Back to the start menu-
>> F6	Swinging the crane cab
>> F9	Positioning the stepladder ²⁾

2) Function only present for certain crane types

F10	Test system
Note: The test system can be called up at any time. If an error message of the LICCON computer system is present, then an error text can be viewed	

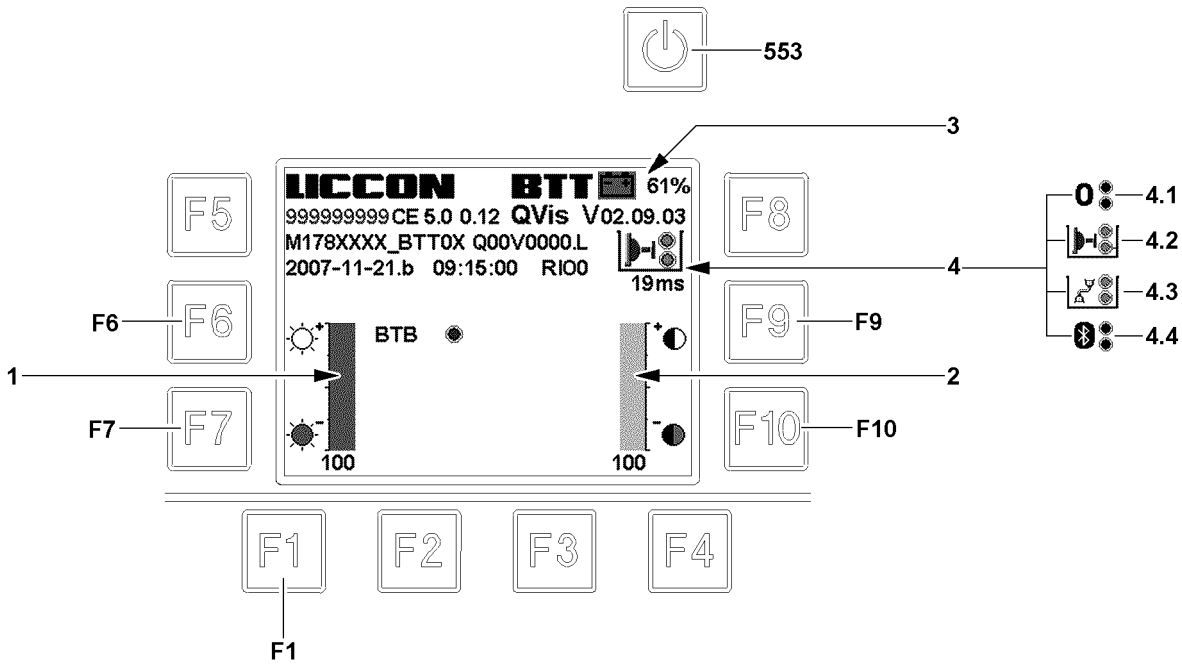

Fig.117976

3 Settings and status displays on the BTT

In the system screen of the BTT, settings can be made and status displays can be read.

3.1 Calling up / closing the system screen

Make sure that the following prerequisite is met:

– The start menu is displayed.

▶ Select the system screen: Press the button **553** momentarily until the system screen appears (max. 1 second).



Note

▶ When the button **553** is pressed too long, the BTT turns off.

▶ To change back to the System menu: Press the function key **F1**.

3.2 Setting the brightness on the BTT display

The current setting stage for brightness can be read on the bar diagram 1.

▶ BTT display brighter: Press the function key **F6**.

▶ BTT display darker: Press the function key **F7**.

3.3 Setting the contrast on the BTT display



Note

▶ Only available for certain crane types.

The current setting stage for the contrast can be read on the bar diagram 2.

▶ BTT display more contrast: Press the function key **F9**.

▶ BTT display less contrast: Press the function key **F10**.

3.4 Determining the exact charge condition of the rechargeable battery

The exact charge condition of the rechargeable battery can be read on the charge condition display 3.

▶ Read the charge condition, if necessary recharge the BTT by inserting it in the charging bay.

3.5 Checking the connection type

The connection type can be read on the connection type display 4.

▶ Read the connection type.

Result:

- **4.1** No connection
- Infrared **4.2** (only in the charging bay)
- **4.3** Cable
- **4.4** tooth

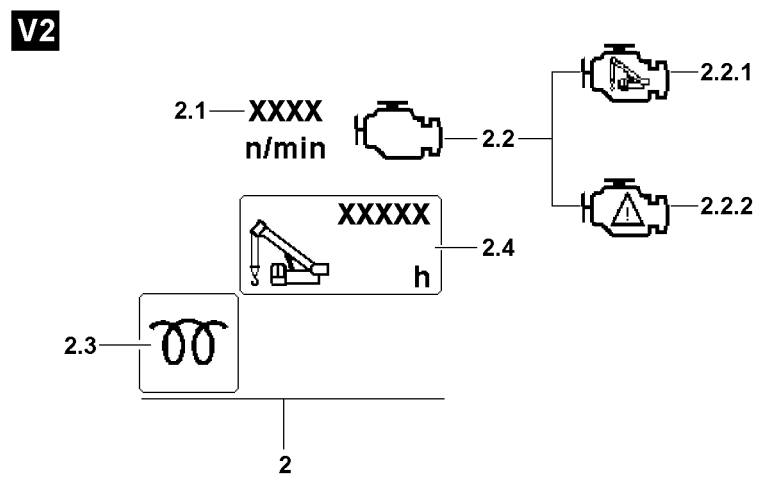
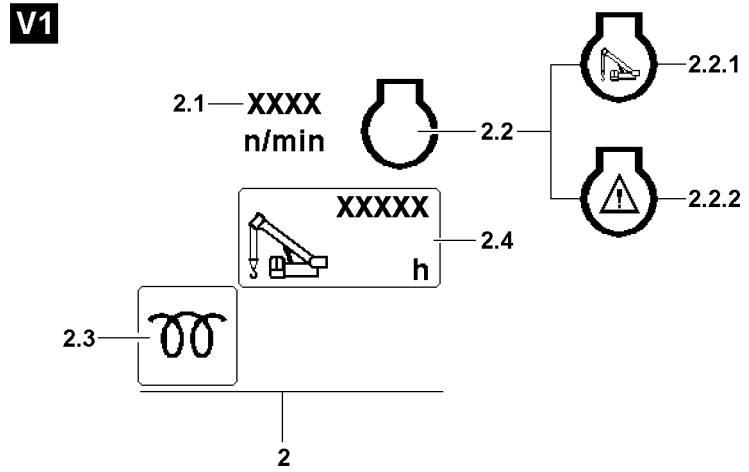

Fig.122498

LWE/LR 11000-001/23501-04-02/en

4 Engine operation menu

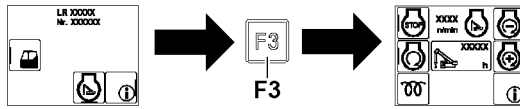

Fig.119602: Changing from the start menu to engine operation menu



Note

The depiction of the *Engine operation* icons **2** depends on the crane programming.

► Either the variation **V1** or variation **V2** icons appear.

4.1 Icon explanation in *Engine operation* menu

2 Engine operation icons

2.1 Engine rpm

- Actual engine speed in rpm

2.2 Engine monitoring

- If icon **2.2.1** appears, then there is no engine warning present.
- If warning icon **2.2.2** appears, then an engine warning is present.

• NOTICE:

Call up *Engine* monitoring functions and evaluate.

2.3 Control display

- The control display lights up green: The crane superstructure engine is ready to start.
- The control display lights up yellow: Crane superstructure engine preheating is active.
- The control display lights up red: The crane superstructure engine is not ready to start.

2.4 Operating hour meter

- Operating hours of crane engine

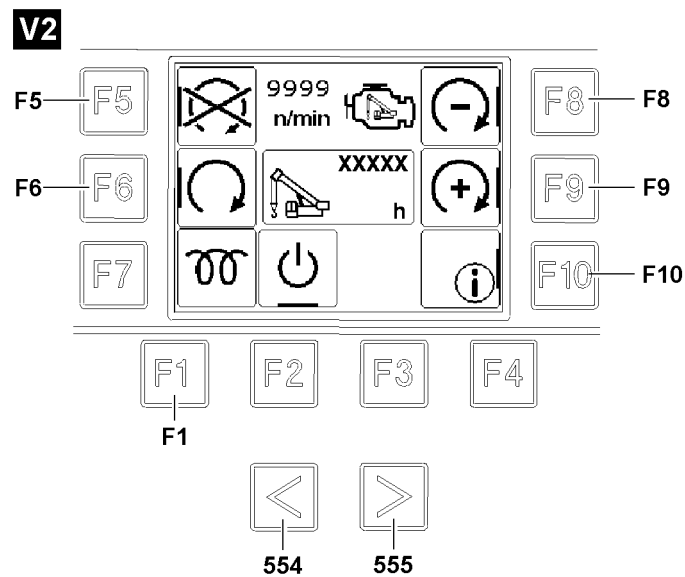
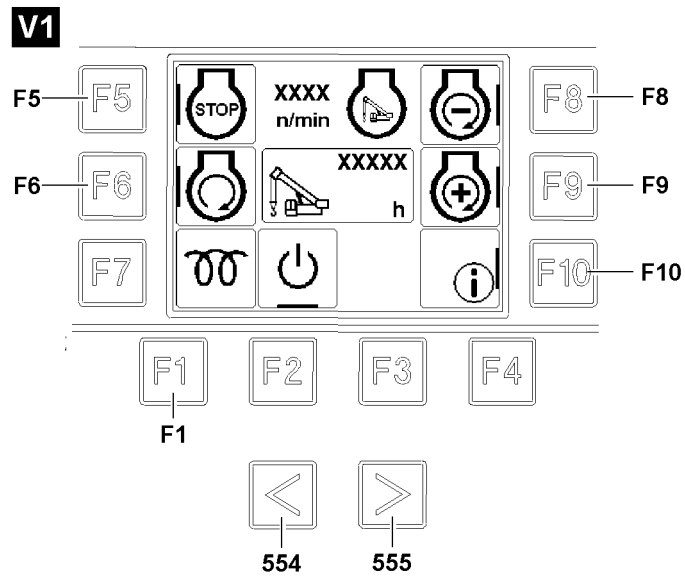

Fig.122499

4.2 The function keys



Note

The depiction of the *Engine operation* icons depends on the crane programming.
 ► Either the variation **V1** or variation **V2** icons appear.

- 554** Button
 - Call up *Engine* monitoring functions
- 555** Button
 - Call up *Engine* monitoring functions
- F1** Function key
 - Back to the start menu
- F2** Function key
 - Turn the ignition crane chassis on / off
 - **Note:** Appears only for certain crane types
- F5** Function key
 - Press momentarily (less than 0.5 seconds): Reset settings in the *Engine operation* menu
 - Press long: Turn the engine off
 - **Note:** The control release must have been made by touching the 2-Hand keypad in the rear of the BTT, see section „Release of button block on BTT“
- F6** Function key
 - Turn the engine on
- F8** Function key
 - Decrease engine rpm
 - **Note:** The control release must have been made by touching the 2-Hand keypad in the rear of the BTT, see section „Release of button block on BTT“
- F9** Function key
 - Increase the engine rpm
 - **Note:** The control release must have been made by touching the 2-Hand keypad in the rear of the BTT, see section „Release of button block on BTT“
- F10** Function key
 - Change to the test system

4.3 Engine monitoring functions

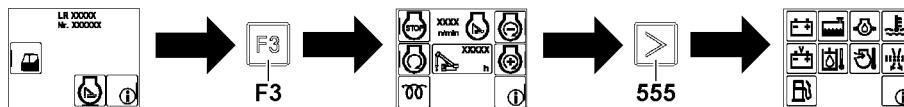

Fig. 119603: Change from the start menu to the Engine monitoring functions:



WARNING

Messages / warnings of the engine monitoring functions ignored!

If messages / warnings of the engine monitoring functions are ignored, problems can occur.

If problem is not immediately rectified, the crane can fail and dangerous situations may occur.

Personal injury and property damage can result.

► Remedy the malfunction immediately.

**WARNING**

Triggers power reduction or start block of engine!

If the urea level is too low or if there is a malfunction in the exhaust aftertreatment, then a power reduction or starting block of the engine can be triggered.

The crane operation, assembly operation and travel operation can be limited or disabled.

- ▶ Replenish the Urea level in time.
- ▶ Remedy the faulty function of the exhaust aftertreatment immediately.
- ▶ Observe any valid national / regional regulations and the vehicle configuration.

Messages / warnings of the engine monitoring functions can be displayed by:

- warning symbols
and / or
- audio warnings
and / or
- automatic, situation-related switching to the engine monitoring functions

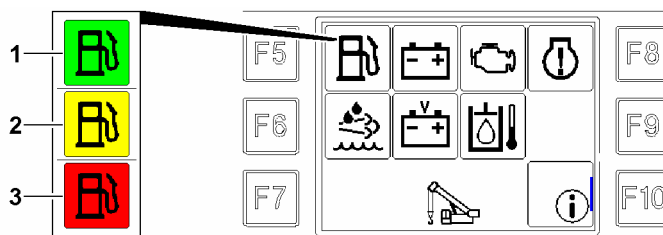

Fig.128017: Example for the colors in the icons

The colors in the icons for the engine monitoring functions mean:

- If a function is highlighted **green** (example icon 1), then the function is operating correctly.
- If a function is highlighted **orange** (example icon 2), then the respective function has an error. An advance warning is active for the *Engine monitoring functions*.
- If a function is highlighted **red** (example icon 3), then the respective function has a problem. A warning is active for the *Engine monitoring functions*.

4.3.1 Function keys in the Engine monitoring functions

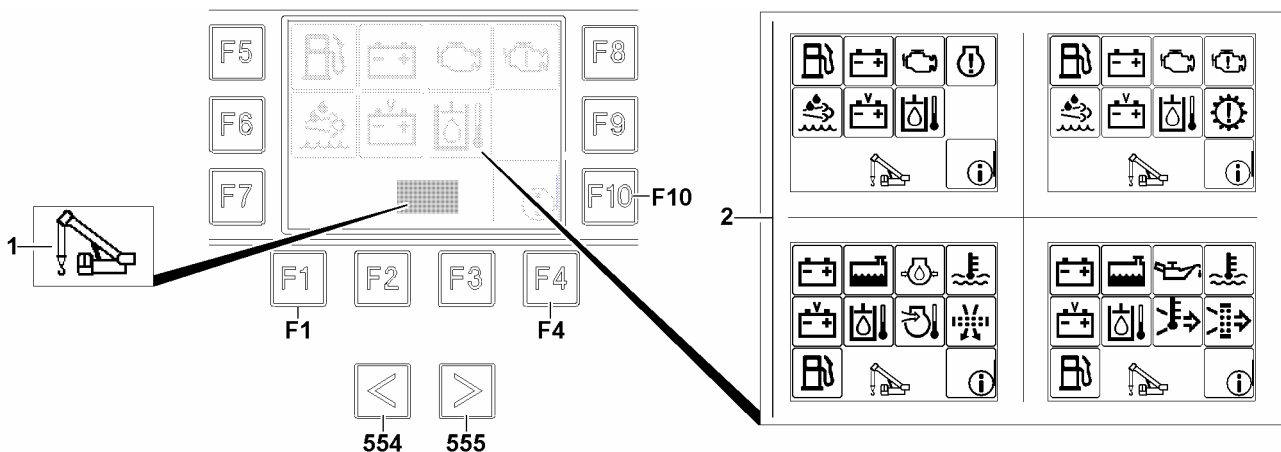

Fig.128018: Function keys Monitoring functions Engine

1 Crane superstructure icon

Depending on crane type, the depiction of the icons *Monitoring function Engine 2* can vary.

- 554** Button
 - Call up the *Engine operation* menu
- 555** Button
 - Call up the *Engine operation* menu

- F1** Function key
 - Back to the start menu
- F4** Function key
 - After an error message, turn off the disengageable *acoustic warning signal* of the BTT
- F10** Function key
 - Change to the test system

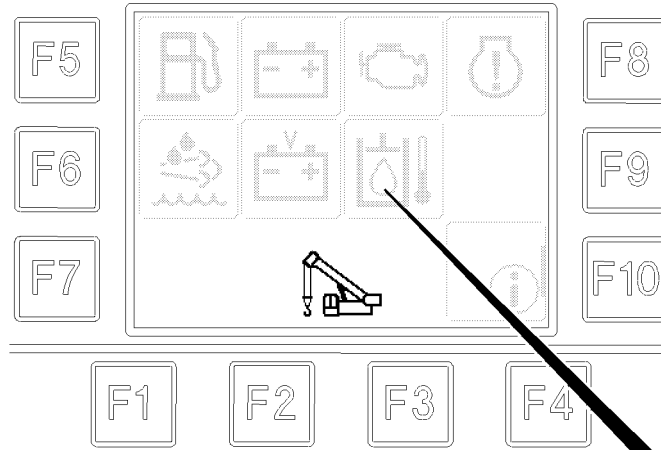

1

1.1

1.2

2

2.1

1.2

LWE/LR 11000-001/23501-04-02/en

Fig.122500

4.3.2 Icons in the Engine monitoring functions



Note

- ▶ Engines **with SCR system** for exhaust aftertreatment - Display in BTT display, see illustrations 1. Depending on the crane programming, either icons illustration 1.1 or illustration 1.2 appear.
- ▶ Engines **without SCR system** - Display in BTT display, see illustrations 2. Depending on the crane programming, either icons illustration 2.1 or illustration 2.2 appear.
- ▶ If a function is highlighted **green**, this function is operating correctly.
- ▶ If a function is highlighted **red** or **orange**, then this function has an error.





Note



The scope of the monitoring functions depends on the crane type and crane configuration. The depiction of the icon depends on the crane programming. If two icons are depicted for one function, then only one of the two appears.

- ▶ Not all crane types have all listed monitoring functions.

	Fuel reserve
Green:	Fuel reserve is at the fill level, an exact display value can be seen on the LIC-CON monitor
Yellow:	Fuel reserve is short, check the display value on the LICCON monitor and add to the fuel reserve if necessary
Red:	Fuel reserve low / depleted / system error NOTICE! Immediately bring the crane to a standstill, turn the engine off and remedy the problem (add to the fuel reserve immediately / remedy the system error). Pay attention to error message.

	Coolant temperature
Green:	Coolant temperature OK
Red:	Coolant temperature too high / system error NOTICE! Immediately bring the crane to a standstill, turn the engine off and remedy the problem. Pay attention to error message.

	Engine oil pressure
Green:	Engine oil pressure OK (engine on)
Red:	Engine oil pressure too low (engine on) / system error NOTICE! Immediately bring the crane to a standstill, turn the engine off and remedy the problem. Pay attention to error message.

 / 	Air filter Engine
Green:	Air filter OK (engine on)
Yellow / red	Air filter dirty (engine on) / system error NOTICE! Immediately bring the crane to a standstill, turn the engine off and remedy the problem. Pay attention to error message.



	Charge control indicator (alternator)
Green:	Charge control OK (engine on)
Red:	Charge control has a problem (engine on) / system error NOTICE! Immediately bring the crane to a standstill, turn the engine off and remedy the problem. Pay attention to error message.

	Urea tank / exhaust aftertreatment¹⁾
Green:	Urea is at the fill level, an exact display value can be seen on the LICCON monitor
Yellow	Urea is short, check the display value on the LICCON monitor and add to the fuel reserve if necessary
Yellow / red:	Urea level too low or malfunction / problem of exhaust aftertreatment system / system error NOTICE! Add urea or remedy the malfunction / problem of the exhaust aftertreatment. Under some circumstances a power reduction or start block of the engine ²⁾ is triggered, pay attention to the error message.

1) Valid only for engines equipped with an SCR system with exhaust aftertreatment.

2) The type and scope of a power reduction of the engine depends on the respectively valid national / regional regulations and the crane configuration. The engine can possibly not be started any longer (starting block).

	Coolant level
Green:	Coolant level OK
Red:	Insufficient coolant / system error NOTICE! Immediately bring the crane to a standstill, turn the engine off and remedy the problem. Pay attention to error message.

 / 	Charge air temperature
Green:	Charge air temperature OK
Red:	Charge air temperature too high / system error NOTICE! Immediately bring the crane to a standstill, turn the engine off and remedy the problem. Pay attention to error message.

	Hydraulic oil temperature
Green:	Hydraulic oil temperature OK
Red:	Hydraulic oil temperature too high / system error NOTICE! Immediately bring the crane to a standstill, turn the engine off and remedy the problem. Pay attention to error message.

	Battery voltage
Green:	Battery voltage OK
Red:	On-board power supply over / undervoltage / system error NOTICE! Immediately bring the crane to a standstill, turn the engine off and remedy the problem. Pay attention to error message.



	Engine oil level
Green:	Engine oil level OK
Blue	The engine oil level can not be checked here on the display, call up the individual indicator light
Red:	Engine oil level not OK / System error NOTICE! Immediately bring the crane to a standstill, turn the engine off and remedy the problem. Call up individual indicator lights and adjust the engine oil according to the display - pay attention to error message.

	Hydraulic oil level
Green:	Hydraulic oil level OK
Red:	Hydraulic oil level too low / error / system error NOTICE! Immediately bring the crane to a standstill, turn the engine off and remedy the problem. Pay attention to error message.

	Exhaust aftertreatment ¹⁾
Green:	Exhaust aftertreatment OK
Yellow / red:	Malfunction Exhaust aftertreatment or Urea level too low / system error NOTICE! Add urea or remedy the malfunction / problem of the exhaust aftertreatment. Under some circumstances a power reduction or start block of the engine ²⁾ is triggered, pay attention to the error message.

1) Valid only for engines equipped with an SCR system with exhaust aftertreatment.

2) The type and scope of a power reduction of the engine depends on the respectively valid national / regional regulations and the crane configuration. The engine can possibly not be started any longer (starting block).

 / 	Collective warning
Green:	No warning messages present
Yellow:	An advance warning / system error is present NOTICE! Determine the cause with the error message or on the LICCON monitor.
Red:	A warning is present / system error NOTICE! Immediately bring the crane to a standstill, turn the engine off and remedy the problem. Determine the cause with the error message or on the LICCON monitor.

	Information field
B / E:	If a <i>B (operating error)</i> or <i>E (system error)</i> appears in the information field, then at least one error message is present. Call up and evaluate the error message by pressing function key F10 on the BTT, see also Diagnostics Manual.

**Note****Triggers power reduction or start block of engine**

If the urea level is too low or if there is a malfunction / problem in the exhaust aftertreatment, then a power reduction or starting block of the engine can be triggered.

The crane operation and travel operation can be limited or disabled.

- ▶ Replenish the Urea level in time.
- ▶ Remedy the malfunction / problem of the exhaust aftertreatment immediately.
- ▶ Observe any valid national / regional regulations and the crane configuration.

Empty page!

LWE/LR 11000-001/23501-04-02/en

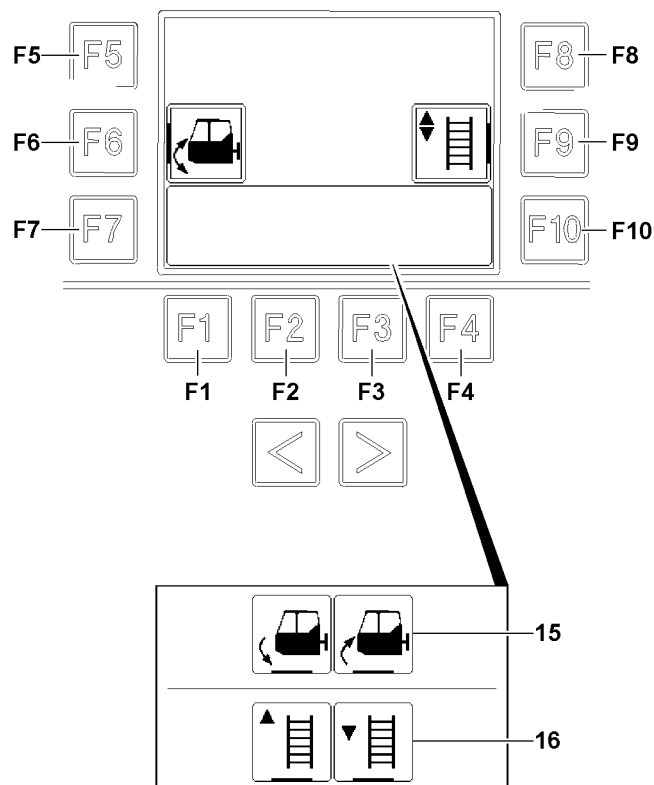

Fig.118723

LWE/LR 11000-001/23501-04-02/en

5 Menu *Crane cab / stepladder*

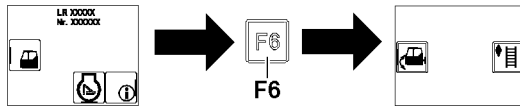

Fig.119604: Changing from start menu to Crane cab / stepladder menu

5.1 Function keys in *Crane cab / stepladder* menu

- 554** Key
 - Call up engine operation
- 555** Key
 - Call up engine operation
- F1** Function key
 - Back to the start menu
- F2** Function key
 - -No function-
- F2** Function key
 - -No function-
- F3** Function key
 - -No function-
- F5** Function key
 - -No function-
- F6** Function key
 - Selection / deselection of swinging the crane cab
 - After selection, the operating icons **15** appear additionally
- F7** Function key
 - -No function-
- F8** Function key
 - -No function-
- F9** Function key
 - Selection / deselection of positioning the stepladder
 - After selection, the operating icons **16** appear additionally
 - **Note:** Function only present for certain crane types
- F10** Function key
 - -No function-

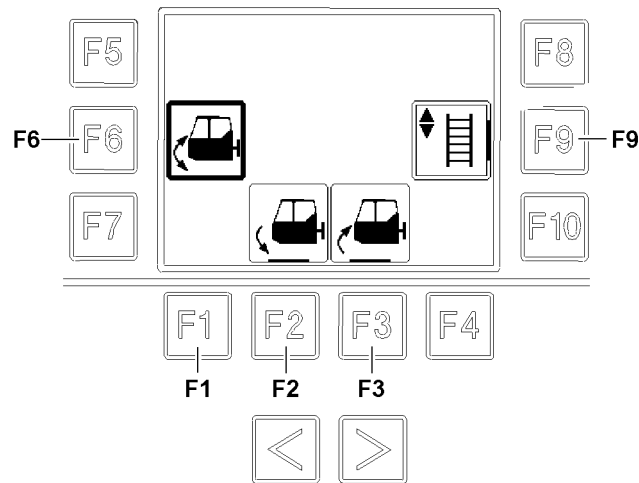

Fig.118726

LWE/LR 11000-001/23501-04-02/en

5.2 Swinging the crane cab

- **Selection / deselection of swinging the crane cab:**
 - Press the function key **F6**.
 - **Result:** When the selection has been made, the border on the icon on the right of function key **F6** is bolded. The icons above the function key **F2** and function key **F3** appear.
- **Control release:**
 - The control release is made by touching the 2-Hand keyboard in the rear of the BTT, see section „Release of button block on BTT“
 - After completed control release, the icons over the function key **F2** and function key **F3** are highlighted in purple.



Note

- ▶ To control the functions, a control release must be issued: The corresponding icons must be highlighted in purple.
-

- **Swing the crane cab out:**
 - Press the function key **F2**.
- **Swing the crane cab in:**
 - Press the function key **F3**.
- **Leave the menu:**
 - Press the function key **F1**.

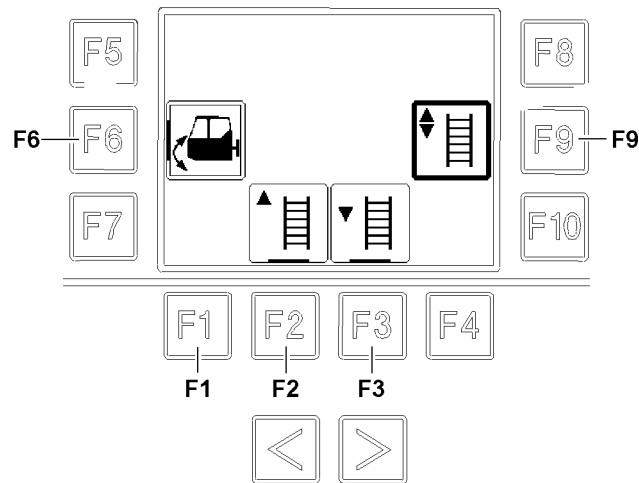

Fig.118727

5.3 Positioning the stepladder



Note

► Function only present for certain crane types.

– Selection / deselection of positioning the stepladder:

- Press the function key **F9**.
 - **Result:** When the selection has been made, the border on the icon on the right of function key **F9** is bolded. The icons above the function key **F2** and function key **F3** appear.

– Control release:

- The control release is made by touching the 2-Hand keyboard in the rear of the BTT, see section „Release of button block on BTT“
- After completed control release, the icons over the function key **F2** and function key **F3** are highlighted in purple.



Note

► To control the functions, a control release must be issued: The corresponding icons must be highlighted in purple.

– Stepladder up:

- Press the function key **F2**.

– Stepladder down:

- Press the function key **F3**.

– Leave the menu:

- Press the function key **F1**.

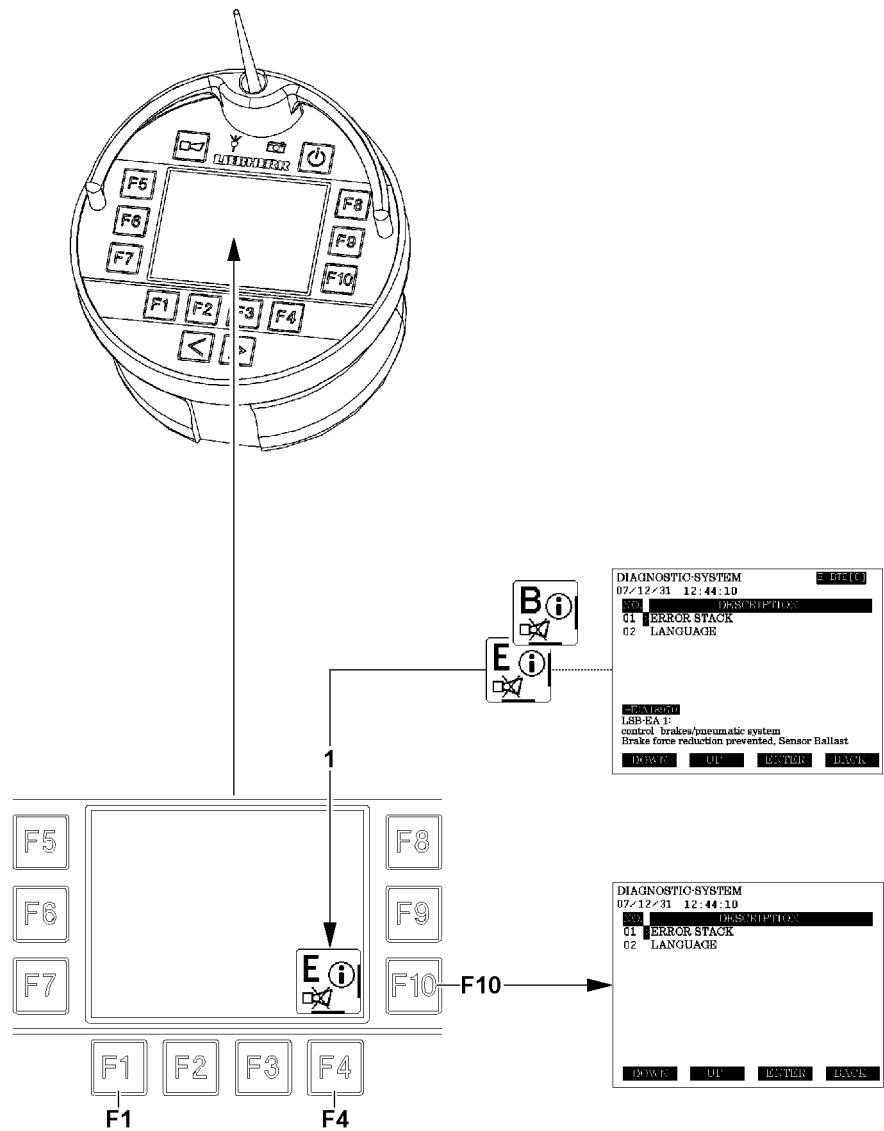

Fig.117975

6 Test system menu

If an error message is issued for the LICCON control:

- a „B“ or „E“ is shown in the information field 1, see illustration
- an acoustic warning signal of the radio remote control is issued

6.1 Function keys in the Test system menu

F1 Function key

- Back to the start menu

F4 Function key

- When a note for an error message appears and a horn is shown in the information field 1:
Press 1x: acoustic warning signal of the radio remote control, which can be shut off, is shut off in the case of operating / system errors
Press 2x: Call up the test system

F10 Function key

- Call up the test system

6.2 Operating the test system

– **Turn acoustic warning signal off:**

- Press the function key **F4**.
 - **Result:** Acoustic warning signal of the radio remote control, which can be shut off in case of operating / system errors is shut off.

– **Call up the test system:**

- Press function key **F4** again.
or
- Press the function key **F10**.
 - **Result:** Start page of test system is called up.

– **Close the test system:**

- Press the function key **F1**.



Note

- ▶ For detailed description of the test system, see Diagnostics Manual.
-

1

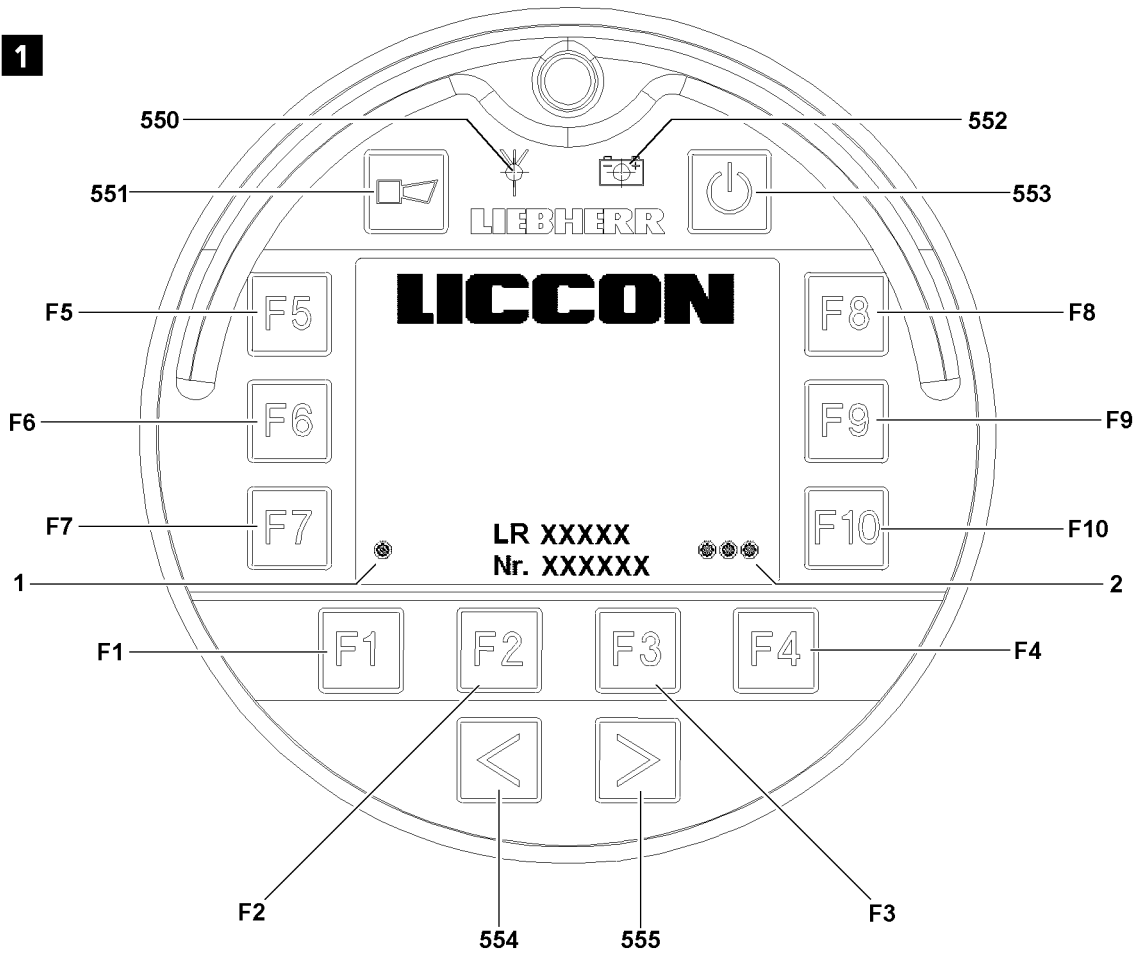

2

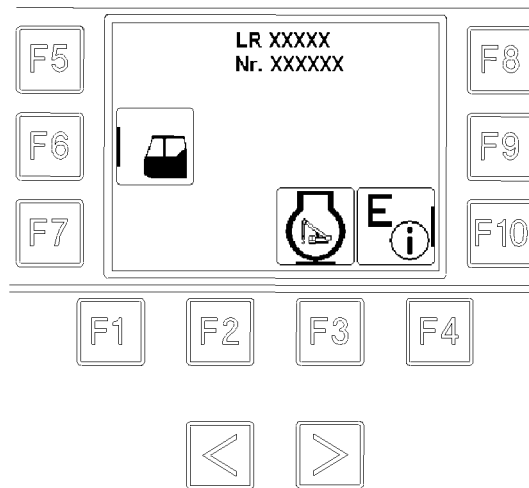

Fig.119605

LWE/LR 11000-001/23501-04-02/en

7 Operation BTT

There are two ways to turn the BTT:

- Turning the BTT on using the ignition switch
- Turning the BTT on using the ON / OFF button

7.1 Turning the BTT on using the ignition switch

Make sure that the following prerequisite is met:

- The BTT is in the charging cradle.
- ▶ Turn the ignition for the crane engine on: Actuate the ignition switch, see Crane operating instructions, chapter 4.01.

Result:

- The BTT turns itself on.
- After completion of the starting procedure, the indicator light **550** and indicator light **552** light up green, see illustration 1.
- The start screen is shown before the display changes to the start menu, see illustration 2.

7.2 Turning the BTT on using the ON / OFF button

Make sure that the following prerequisite is met:

- The BTT is pulled off the charging cradle
- ▶ Turn the ignition for the crane engine on: Actuate the ignition switch, see Crane operating instructions, chapter 4.01.
- ▶ Turn the BTT on: Press the button **553** (ON / OFF button).

Result:

- The BTT turns itself on.
- The indicator light **550** and indicator light **552** light up in orange.
- The start screen is displayed, see illustration 1.
- ▶ Enter the turn on key sequence: Press button **554**, then button **555** and then function key **F1**.

Result:

- The indicator light **550** and indicator light **552** light up in green.
- The indicator light **1** and indicator light **2** light up green.
- The connection between the BTT and the receiver is established.

- ▶ Press any function key.

Result:

- The start menu of the BTT appears on the BTT, see illustration 2.
- ▶ Select the menu with the appropriate function key, see the relevant technical chapter.

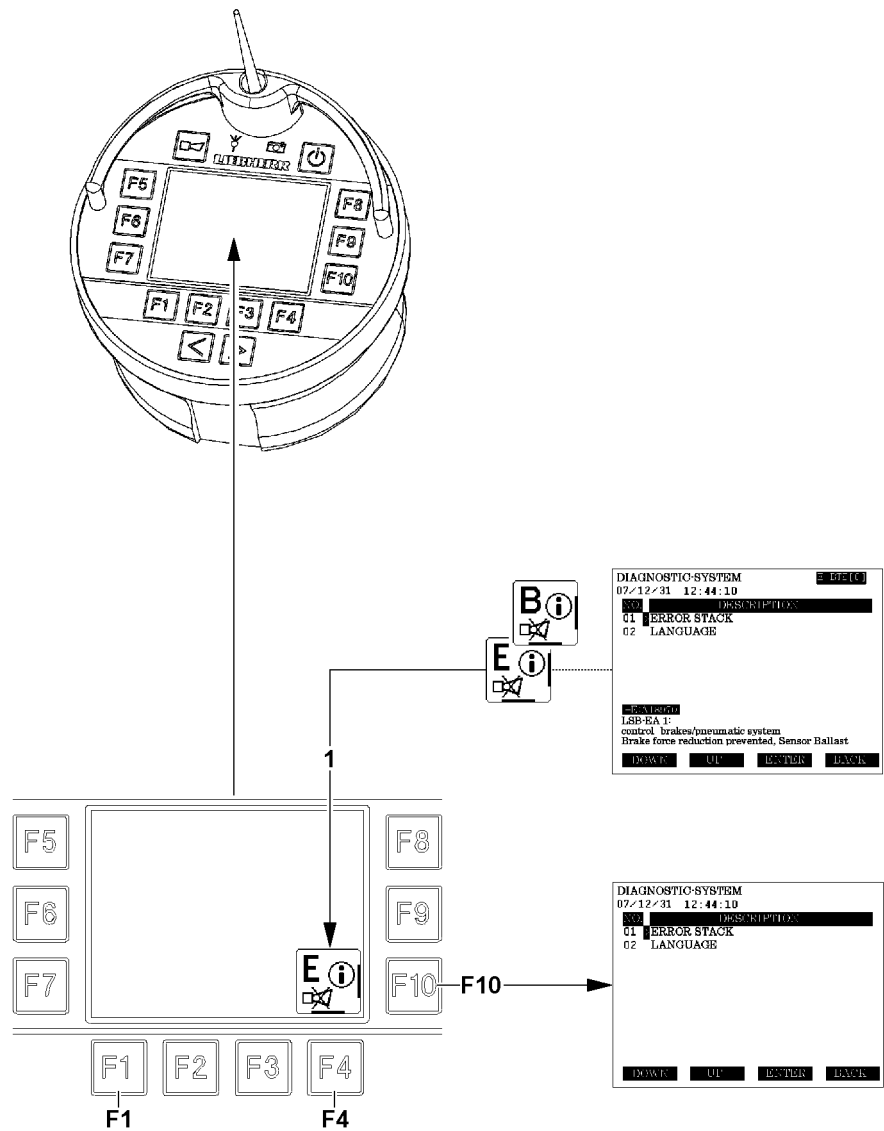

Fig.117975

8 Measures in case of problems

8.1 Did an error message occur?

If an event occurs which leads to the display of an error message, a „B“ or „E“ are shown on icon 1, see illustration.



WARNING

Danger of accident!

If the displayed errors in the icon 1 are ignored, there is a danger of accidents.

- ▶ Take the crane out of service and remedy the cause of the error.
 - ▶ Do not put the crane back into operation before the cause of the error has been remedied.
-

- ▶ Press the function key **F4**.

Result:

- Acoustic warning signal of the radio remote control, which can be shut off in case of operating / system errors is shut off.

- ▶ Press the function key **F10**.

Result:

- The *Test system* program (error determination screen) is called up.
-



Note

- ▶ To be able to find the cause of the problem, the error or errors must be read in the error determination screen / error stack of the BTT **500**, see Diagnostics manual.
-

Close the *Test system* program (error determination screen):

- ▶ Press the function key **F1**.

Result:

- The *Test system* program (error determination screen) is closed.

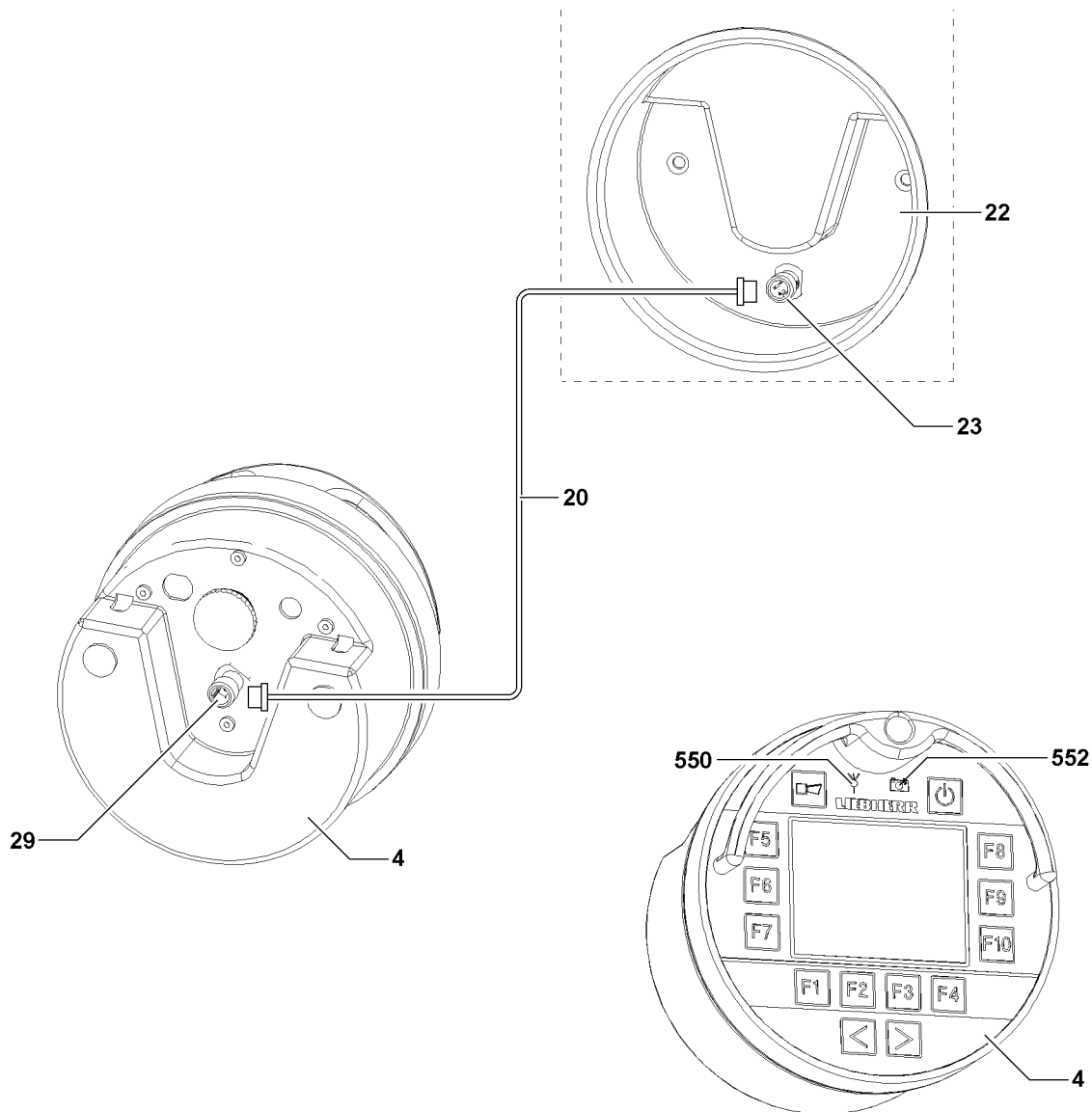

Fig.112952

8.2 The BTT display remains dark?



Note

- ▶ Indicator light Charge condition **552** shows the charge condition.
- ▶ Indicator light Transmission signal **550** shows the quality of the radio contact connection.

When the indicator light charge condition **552** does not light up or lights up red:

- ▶ Plug the BTT **4** into the charging module **22**.

When the LED **552** does not light up with the BTT **4** plugged in or the BTT **4** cannot be turned on:

- ▶ Contact Liebherr Service to determine the cause of the problem and further procedure.

8.3 Is the radio connection faulty?

If the radio contact connection to the BTT **4** is faulty or interrupted (Indicator light Transmission signal **550** lights up red), then it can be bypassed with line **20**.

The radio connection to the BTT **4** can become faulty or interrupted through the following occurrences:

- by interference signals from a nearby radio tower

- The radio module on the BTT **4** or on the BTB is defective
- The rechargeable battery in the BTT **4** is discharged.
- Due to bad selection of the placement location by the operator.

8.3.1 Bypassing the radio connection

Make sure that the following prerequisites are met:

- The line **20** to bypass the radio communication has been removed from the control cabinet of the crane cab.
- The BTT **4** has been removed from the charging module **22** and is turned on.
- The caps on the plug connection **23** and the plug connection **29** have been removed.
- ▶ Screw the line **20** on the charging module **22** onto the plug connection **23**.
- ▶ Screw the line **20** on the BTT **4** onto the plug connection **29**.

Result:

- The radio communication is bypassed.



Note

If the BTT **4** does not turn on, even though the line **20** is connected with the charging module **22**, then the rechargeable battery may be defective.

- ▶ Contact Liebherr Service to determine the cause of the problem and further procedure.
-

Empty page!

LWE/LR 11000-001/23501-04-02/en

5.35.10 Derrick ballast - ballast trailer

1	Product description	3
2	Component overview	4
3	Fastening points	5
4	Ballast trailer radii	7
5	Stability and tipping safety	9
6	Operating elements on the control panels	13
7	Assembling / disassembling the ballast trailer with the BTT-E	15
8	Pre-assembling the ballast trailer	15
9	Assembling the ballast trailer on the turntable	35
10	Working with the ballast trailer	51
11	Disassembling the ballast trailer	99
12	Removing the ballast trailer	114
13	Emergency operation in case of a defective control module of the ballast trailer control	134
14	Maintenance intervals / maintenance instructions for the ballast trailer	137

Fig.195219

LWE/LR 11000-001/23501-04-02/en

1 Product description

This chapter describes the following derrick ballast variations:

- Ballast trailer
Ballasting consisting of ballast plates on a ballast trailer.

This crane type has additional derrick ballast variations, which will be described in other chapters of these operating instructions:

- Suspended ballast *special design*: Ballast Constant
Ballasting consisting of directly suspended ballast plates (without a ballast pallet)
- Suspended ballast
Ballasting consisting of ballast plates on a ballast pallet
- Suspended ballast *special design*: Ballasting LTR crane and / or ballast plates
Ballasting consisting of an LTR crane and / or ballast plates on a ballast pallet



Note

Designation of the ballast types

- ▶ The suspended ballast and the ballast trailer are generally described as derrick ballast.
- ▶ The ballast installed on the turntable is generally referred to as the counterweight.
- ▶ The ballast installed on the crawler travel gear is generally referred to as the central ballast.

1.1 Function

The D-guying contains two pull cylinders (pull cylinder A and pull cylinder B). These pull cylinders are used to pull, lift or lower the derrick ballast.

All relevant data regarding the derrick ballast is displayed on the LICCON monitors.

The required derrick ballast radius is set using the telescopeable ballast trailer guide.

In addition, the setting range of the ballast trailer guide can be changed by inserting or removing intermediate sections.

Possible ballast trailer radius: 13 m to 30 m.

The ballast trailer has steering, and has the following steering programs:

- Towing, circular travel, parallel travel, manual corrective steering and manual operation

The two wheel sets of the ballast trailer are oscillating mounted.

2 Component overview

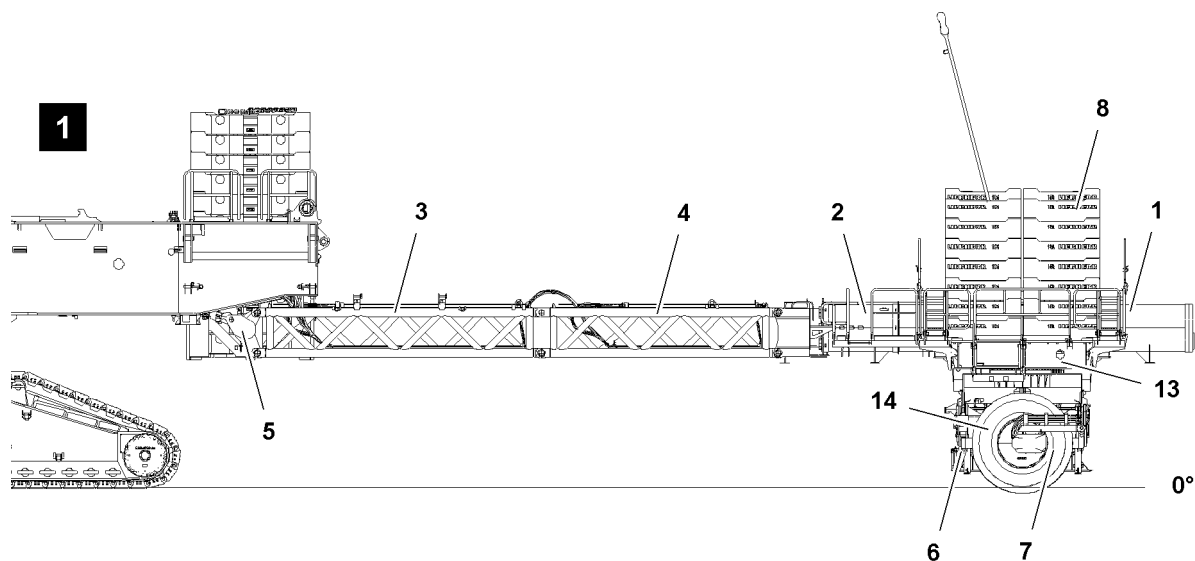

Fig.120219: Component overview



Note

- ▶ The assembly sections are marked with their own weight.
- ▶ Dimensions and weights, see chapter 1.03.

Position	Component
1	Ballast trailer (frame 13)
2	Ballast trailer guide
3	Intermediate section 6 m
4	Intermediate section 5 m
5	Adapter
6	Support
7	Wheel set
8	Ballast plates

Component overview

3 Fastening points

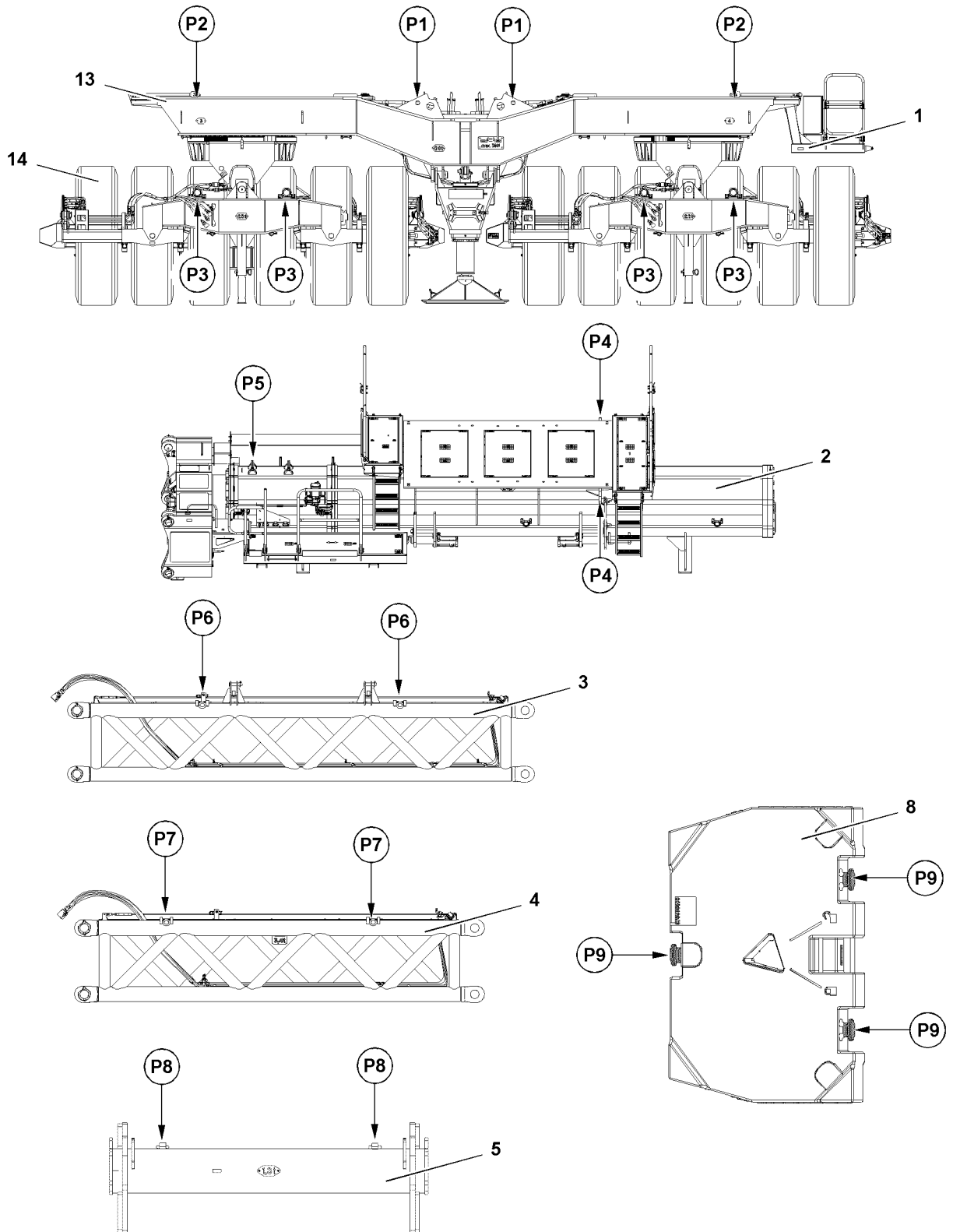

Fig.120224: Fastening points

LWE/LR 11000-001/23501-04-02/en

**WARNING**

Component incorrectly fastened!

Life-threatening situations can arise due to improper or incorrect attachment of the corresponding components.

Death, severe bodily injuries, property damage.

- ▶ Fasten the components only on the intended fastening points on both sides.
- ▶ Fastening of components and description of fastening points, see chapter 5.01.

Fastening points	
P1 and P2	Ballast trailer 1
P3	Wheel set 14
P4 and P5	Ballast trailer guide 2
P6	Intermediate section 3
P7	Intermediate section 4
P8	Adapter 5
P9	Ballast plate 8

Fastening points

4 Ballast trailer radii

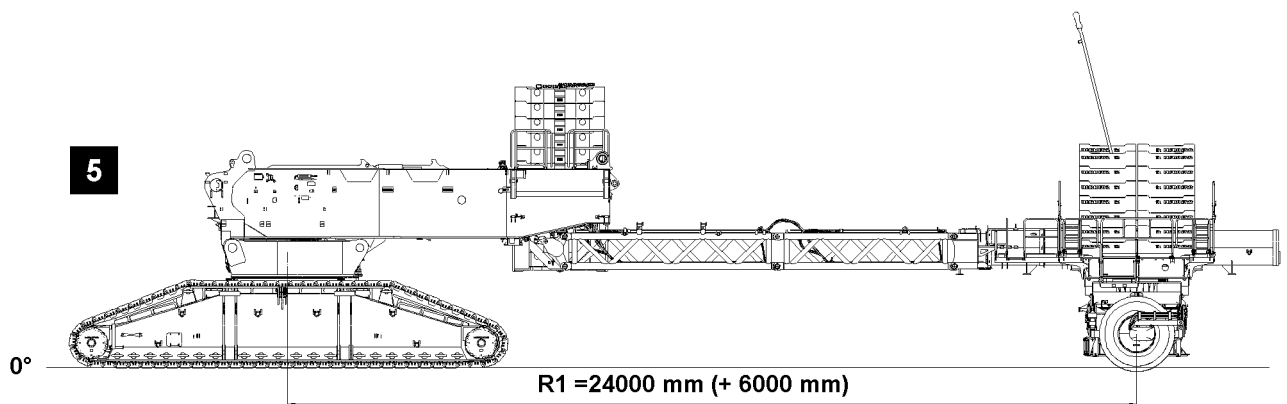
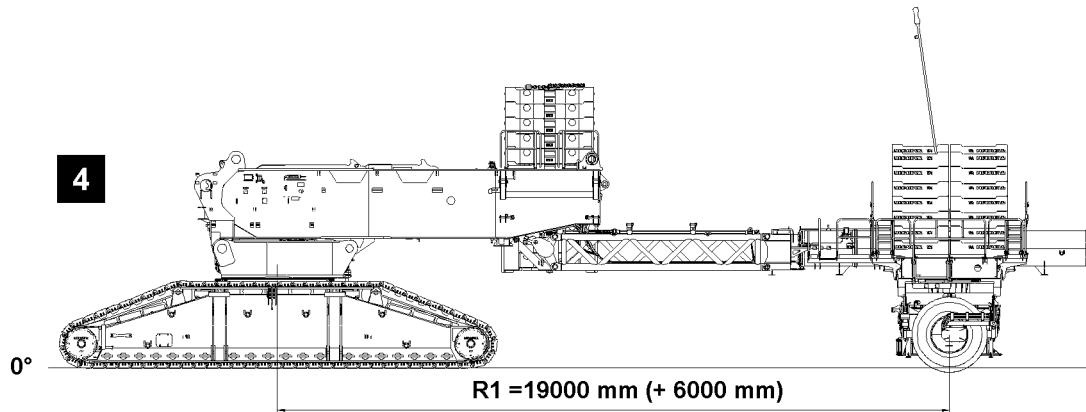
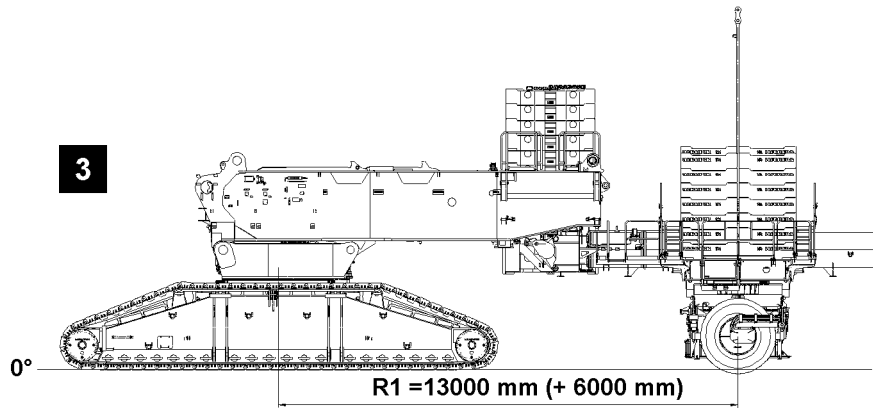

Fig.120218: Ballast trailer radii

LWE/LR 11000-001/23501-04-02/en

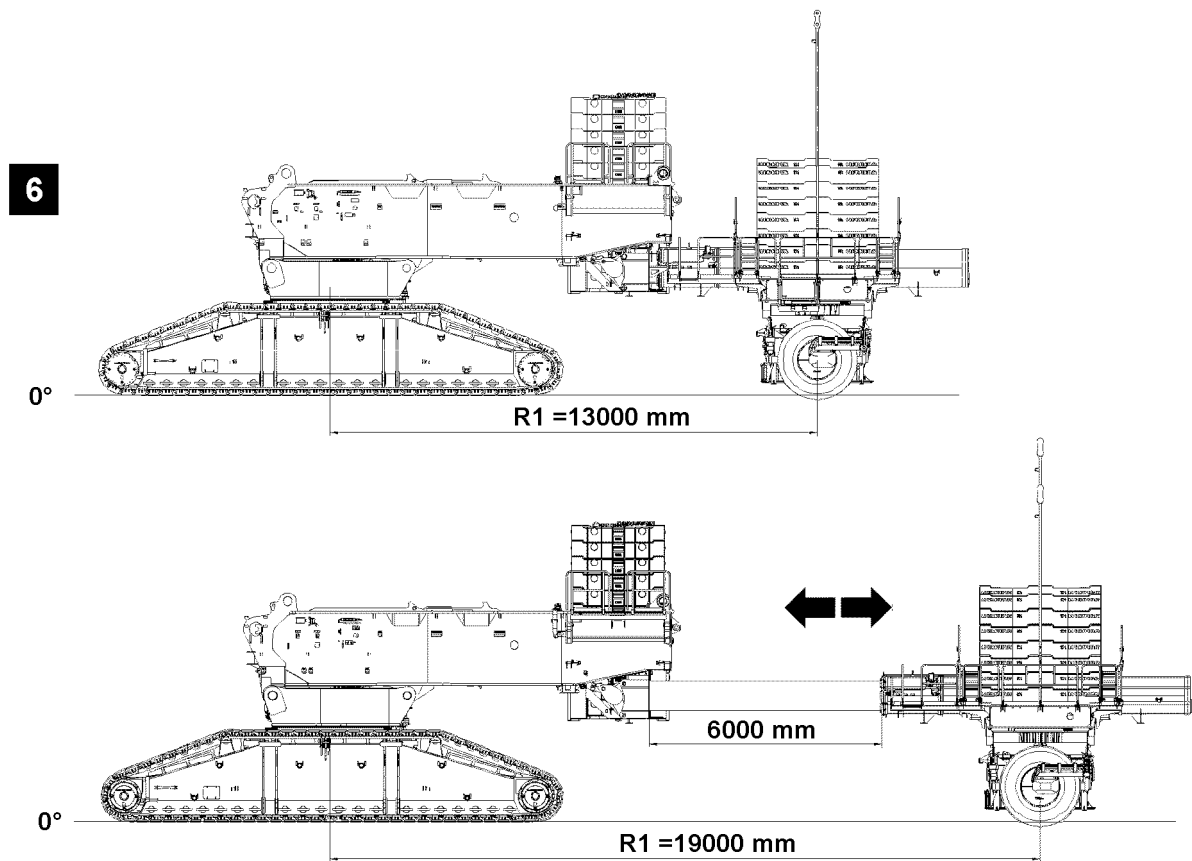

Fig.120220: Telescoping the ballast trailer

	Ballast trailer	Intermediate section 6 m	Intermediate section 5 m
36 m derrick boom	1	1	0
Derrick boom 42 m	1	1	1

Derrick boom and counterweight combination

	Ballast trailer radius = R1	Intermediate section 6 m	Intermediate section 5 m
Radius range 1	13000 mm + 6000 mm	0	0
Radius range 2	19000 mm + 6000 mm	1	0
Radius range 3	24000 mm + 6000 mm	1	1

Radius ranges

Ballast trailer radius = R1 can be reached by adjusting the telescopic guide and by installation of an intermediate section of 13 m to 30 m , see illustration 3 to illustration 6 and chart.

5 Stability and tipping safety

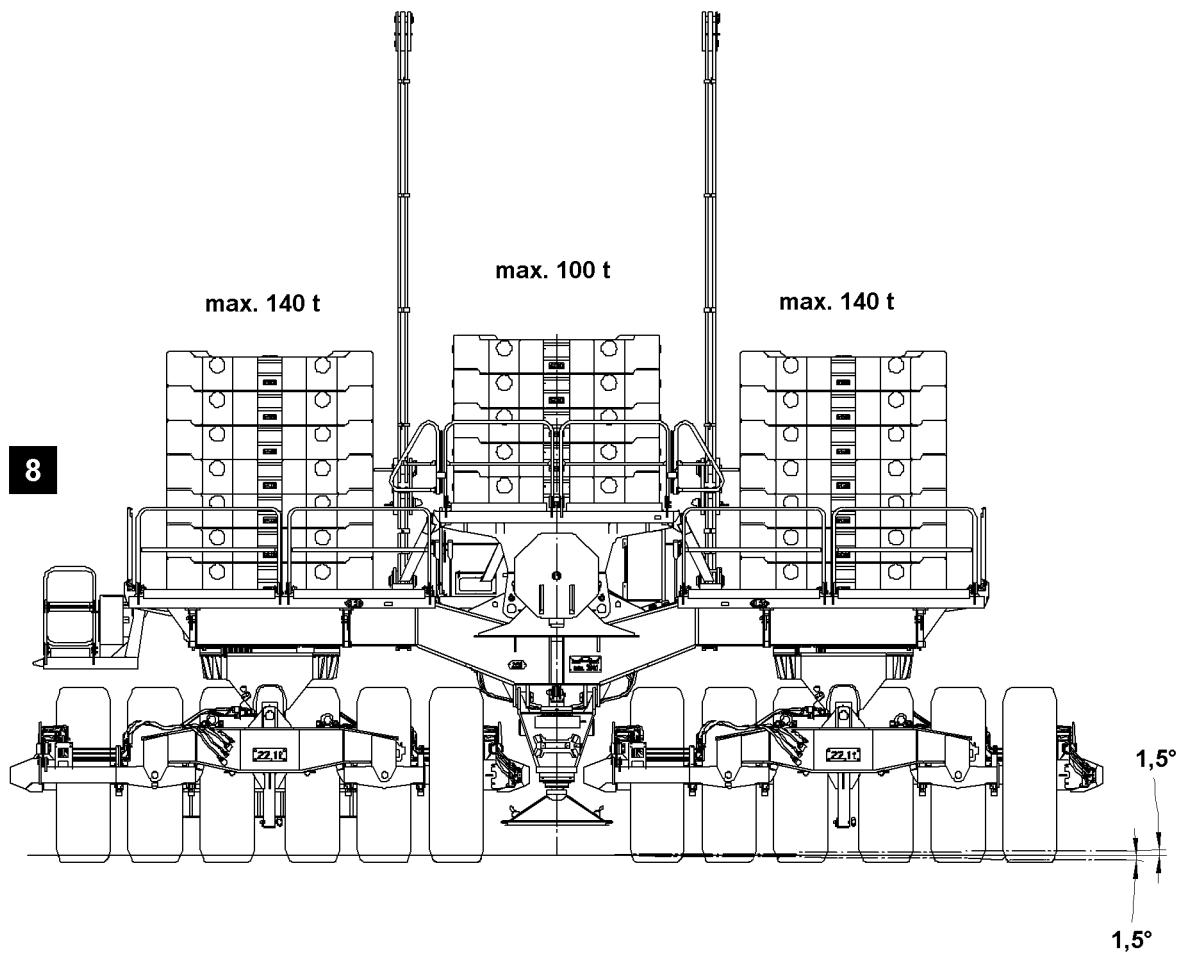
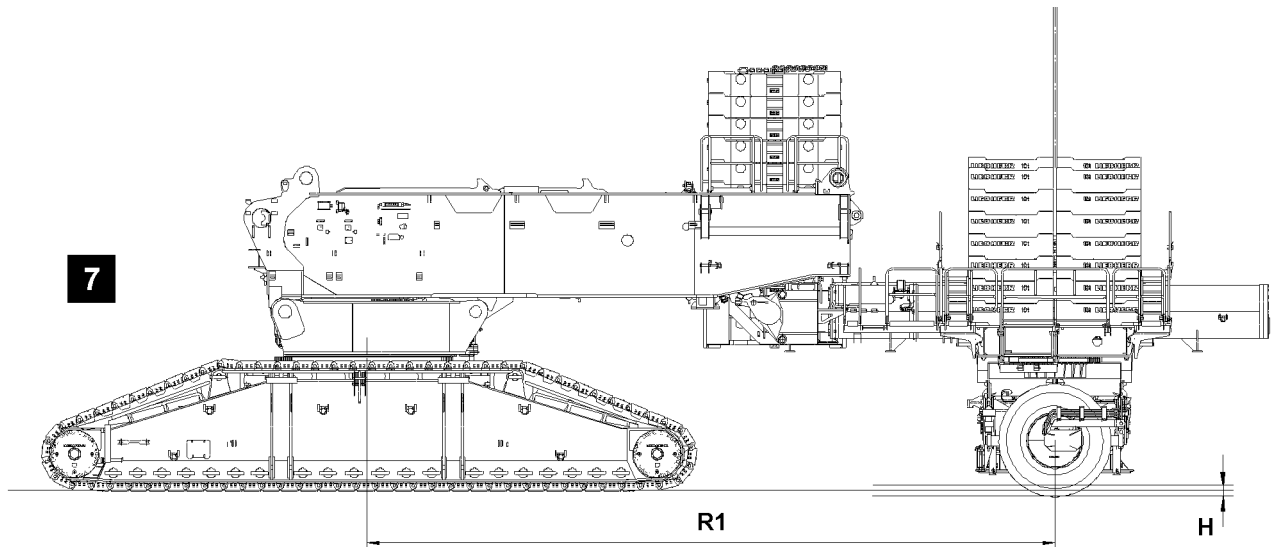

Fig.120221: Uneven ground

LWE/LR 11000-001/23501-04-02/en

5.1 Uneven ground



WARNING

The crane can topple over!

If the maximum permissible values for the uneven ground are exceeded, then the crane can topple over.

Death, severe bodily injuries, property damage.

- ▶ The permissible ground unevenness may not be exceeded.

Ballast trailer radius = R1	Level difference = H
13000 mm	+50/-200 mm
19000 mm	+100/-400 mm
25000 mm	+150/-500 mm
30000 mm	+200/-500 mm

Permissible level difference

Permissible level difference between crane placement surface and ballast trailer placement surface, see chart and illustration 7.



WARNING

The crane can topple over!

If the maximum permissible side incline of the ballast trailer is exceeded, the crane can topple over. Death, severe bodily injuries, property damage.

- ▶ Do not exceed the maximum permissible side incline of the ballast trailer.

Permissible side incline of the ballast trailer is $\pm 1.5^\circ$, see illustration 8.



WARNING

Toppling crane or ballast trailer!

If the maximum permissible weight of the ballast plates is exceeded, the crane or the ballast trailer can topple over.

Death, severe bodily injuries, property damage.

- ▶ The permissible total weight of the ballast plates may not be exceeded.

The permissible total weight of the ballast plates is 380 t, see illustration 8.

5.2 Stopping the ballast trailer

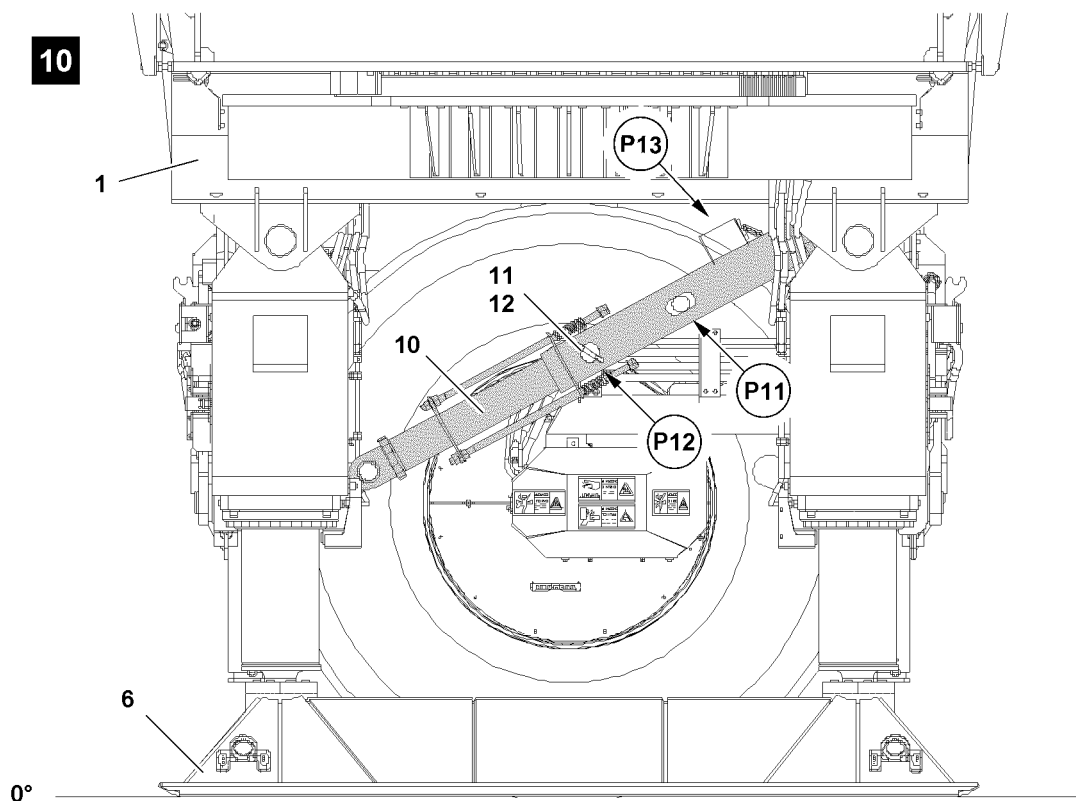
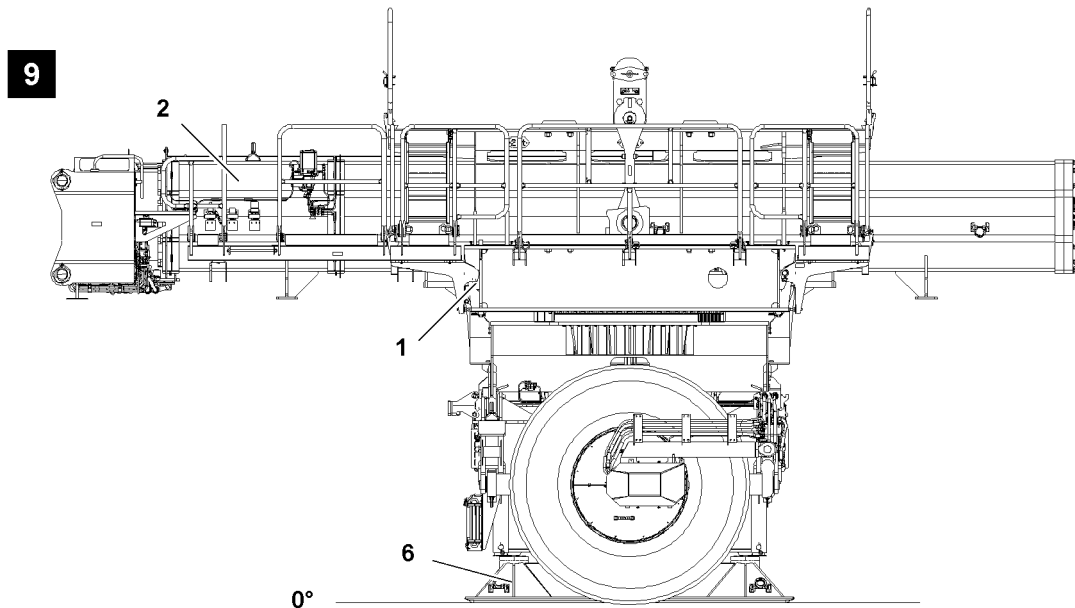

Fig.120223: Ballast trailer support

Make sure that the following prerequisites are met, see illustration 9:

- The ballast trailer guide is hydraulically fully retracted.
- The ballast trailer is supported and horizontally aligned.

**WARNING**

Ballast trailer tipping danger!

If the ballast trailer is not installed on the turntable and the ballast trailer guide is not fully retracted, the ballast trailer can tip over.

Death, severe bodily injuries, property damage.

- ▶ Before removal of the ballast trailer on the turntable, the locking pin **11** must be pinned on strut **10** of the ballast trailer at point **P12** and secured with the spring retainer **12**, see illustration **10**.
- ▶ The ballast trailer guide must be retracted completely before stopping the ballast trailer.
- ▶ The support **6** is extended to the point where the tires are relieved, see illustration **9** and illustration **10**.

Listed in the following chart are the possible pin points on the strut **10**, see illustration **10**:

- Pin point **P11**: When the support is actuated, while the ballast trailer is pinned on the crane (for example: Lift to turn the wheel sets).
- Pin point **P12**: When the ballast trailer is to be separated from the crane (for example: for transport).
- Pin point **P13**: Park position.

6 Operating elements on the control panels

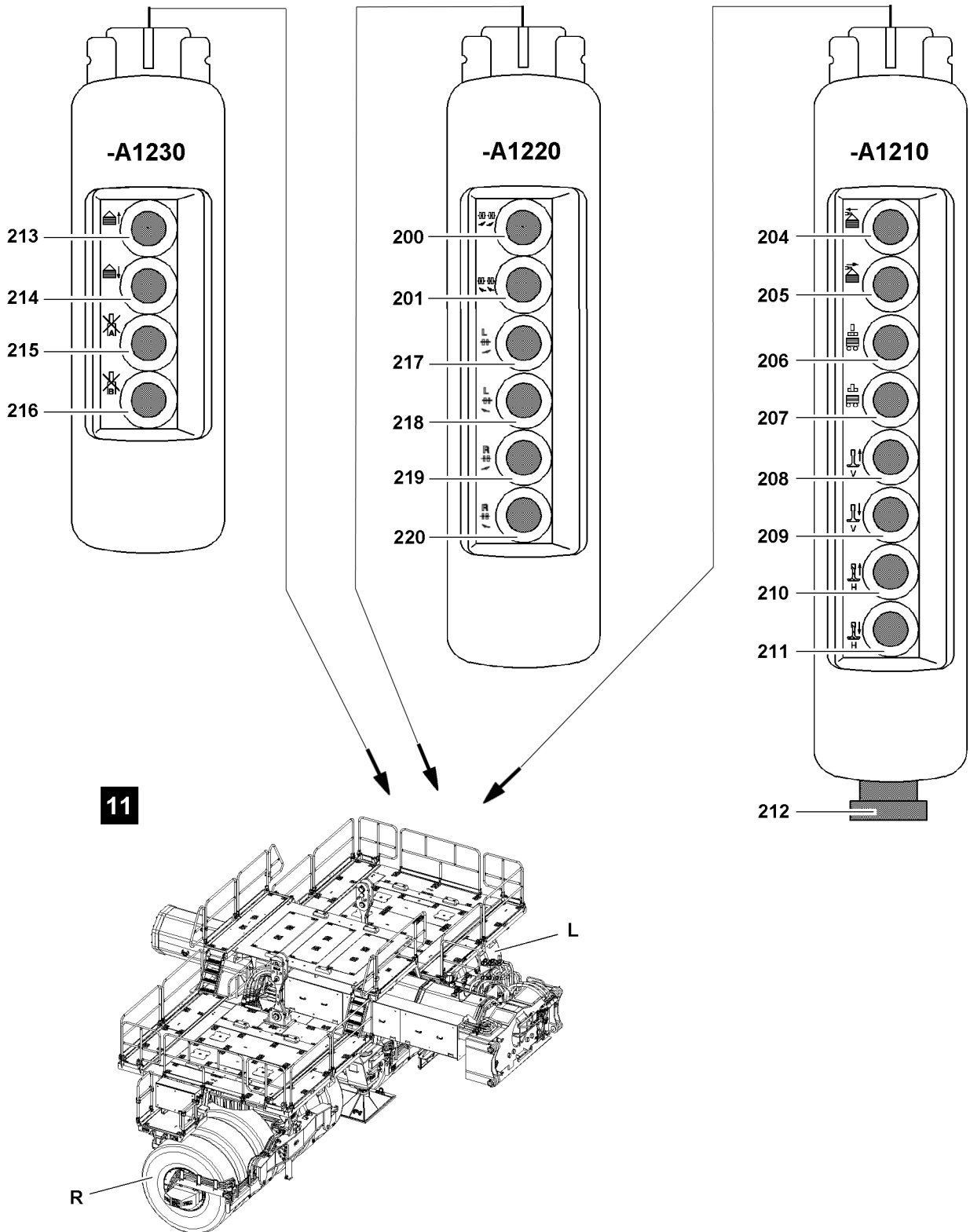

11

Fig.126313: Control panels

LWE/LR 11000-001/23501-04-02/en

Control panel - A1220

200	Button	• Corrective steering, turn wheel sets to left
201	Button	• Corrective steering, turn wheel sets to right
217	Button	• Turn the wheel set on the left side „L“ to the right
218	Button	• Turn the wheel set on the left side „L“ to the left • Manual operation for assembly or emergency operation
219	Button	• Turn the wheel set on the right side „R“ to the right
220	Button	• Turn the wheel set on the right side „R“ to the left • Manual operation for assembly or emergency operation

The designation „R“ or „L“ on the wheel sets refers to the travel direction of the crane, see illustration 11:

- „R“ - Right wheel set
- „L“ - Left wheel set

Control panel - A1210

204	Button	• Ballast trailer, move the guide cylinder in
205	Button	• Ballast trailer, move the guide cylinder out
206	Button	• Ballast trailer on turntable - unpin
207	Button	• Ballast trailer on turntable - pin
208	Button	• Retracting the front support cylinder
209	Button	• Extending the front support cylinder
210	Button	• Move the rear support cylinder in
211	Button	• Move the rear support cylinder out
212	Switch	• EMERGENCY OFF

Control panel - A1230

213	Button	• Retract both pull cylinders, lift the ballast trailer
214	Button	• Extend both pull cylinders, lower the ballast trailer
215	Button	• Stop pull cylinder A Note: The button 213 or button 214 must be pressed.
216	Button	• Stop pull cylinder B Note: The button 213 or button 214 must be pressed.

7 Assembling / disassembling the ballast trailer with the BTT-E



Note

- ▶ During the assembly / disassembly of the ballast trailer, various functions can be controlled using the BTT-E (radio remote control). See the radio remote control operating instructions.



WARNING

The crane can topple over!

Death, severe bodily injuries, property damage.

- ▶ Make sure that all danger notes are observed during radio operation.
- ▶ Make sure that there are no persons within the crane danger zone.

8 Pre-assembling the ballast trailer



WARNING

Danger of falling!

During assembly / disassembly, inspection and maintenance work, personnel must be secured with appropriate aids to prevent them from falling.

If this is not observed, the assembly personnel can fall down.

Death, severe bodily injuries, property damage.

- ▶ All work at a height, when there is a danger of falling, must be carried out with suitable aids.
- ▶ If aids are not available and work cannot be carried out from the ground, then assembly personnel must secure themselves with the supplied fall arrest system to prevent falling, see chapter 2.04.
- ▶ If fall protection equipment is available, then it must be used, see chapter 2.06.
- ▶ When lifting, lowering, swinging crane parts in and out, no persons may remain in the danger zone.
- ▶ If railings are present on the components, then they must be brought into the corresponding position and secured for assembly / disassembly work.
- ▶ Only step on the aids, ladders and catwalks with clean shoes.
- ▶ Keep aids, ladders and catwalks free of heavy dirt, snow and ice.
- ▶ During all assembly and disassembly work, maintenance work and inspections, travel or crane operation is prohibited.
- ▶ Remaining on a suspended load is prohibited.
- ▶ Stepping or walking on crane components and lattice sections, which have an incline of more than 20° is prohibited.
- ▶ For all assembly work, the crane operator of the main crane must be in voice contact with the crane operator / crane operators of the auxiliary crane / auxiliary cranes.
- ▶ For assembly / disassembly tasks, the crane operator may only initiate crane movements when the responsible guide has explicitly released the movement.



WARNING

Danger of impact / crushing!

When installing / removing crane components with the auxiliary crane, crane components can start to swing back and forth.

When lifting / lowering and positioning crane components, there is an increased danger of impacts / crushing.

Death, severe bodily injuries, property damage.

- ▶ Make sure that personnel cannot be caught by components.
- ▶ When working in danger zones: Use aids to protect limbs.
- ▶ Guide components with suitable aids to minimize oscillation.

**DANGER**

The components can fall down!

If the corresponding components are disengaged from the auxiliary crane before the corresponding component is pinned, the corresponding component can fall down and fatally injure personnel.

- ▶ Do not disengage the auxiliary crane until the respective component is pinned and secured.

**WARNING**

Ballast trailer tipping danger!

Due to improperly carried out assembly or improper assembly conditions, the ballast trailer can tip over.

Death, severe bodily injuries, property damage.

- ▶ The assembly of the ballast trailer may only be carried out by authorized personnel.
- ▶ Carry out the assembly of the ballast trailer only on level ground of sufficient load bearing capacity.
- ▶ The ballast trailer has **no** brake system. The ballast trailer must be supported with the support cylinders if it is **not** pinned on the turntable.

**Note**

- ▶ Park the ballast trailer for assembly of the ballast trailer guide on level ground with sufficient load bearing capacity in the vicinity of the crane.
- ▶ Observe the safety guidelines, see chapter 2.15.

Make sure that the following prerequisites are met:

- The ground is level and of sufficient load carrying capacity.
- An auxiliary crane is available.

8.1 Assembling the frame on the wheel sets

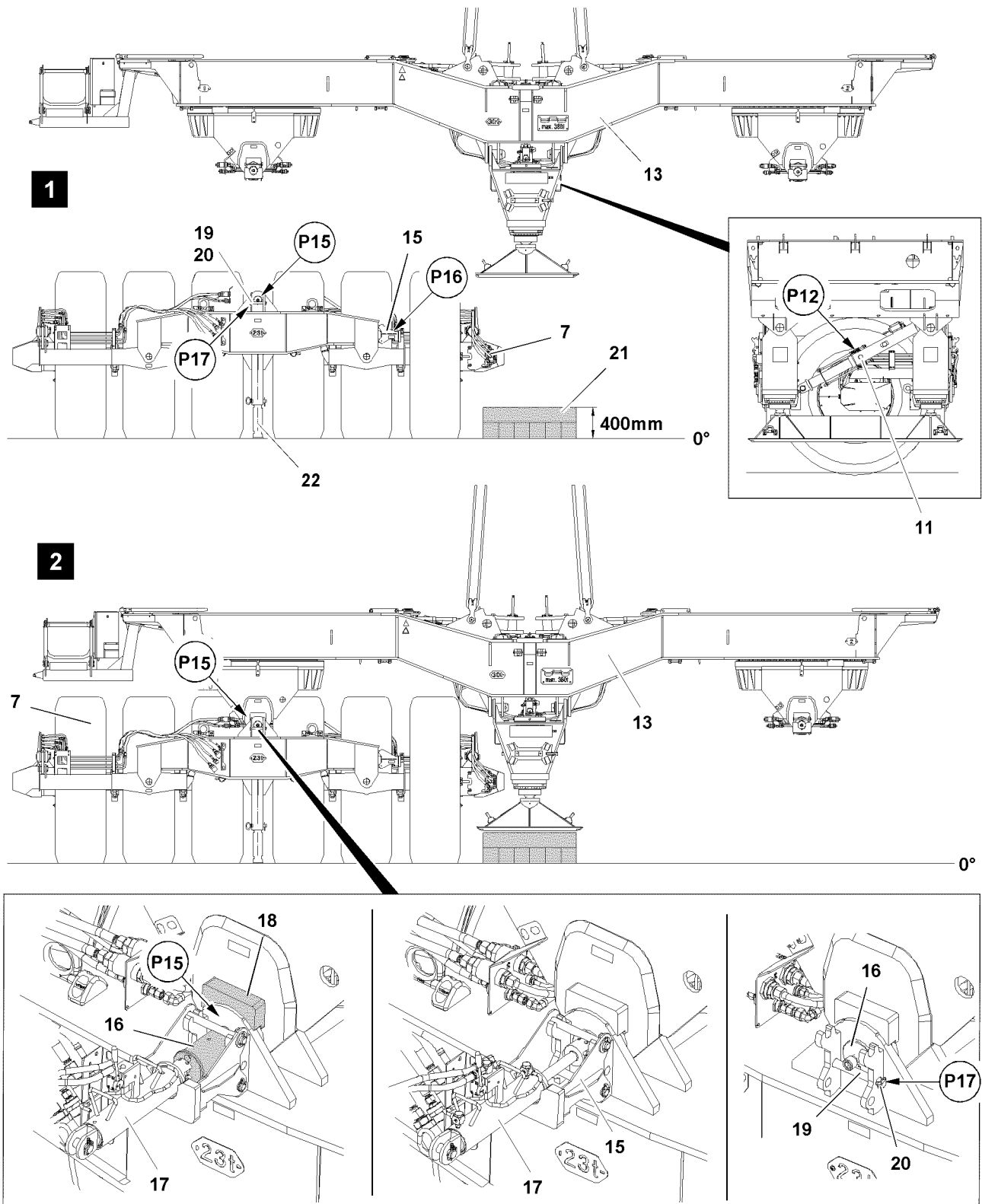

Fig.121986: Assembling the first wheel set

LWE/LR 11000-001/23501-04-02/en

8.1.1 Assembling the first wheel set



Note

- ▶ Frame and wheel set are pinned with each other on two pin points **P15**.
- ▶ The pinning procedure is described based on the example of one pin point.

- ▶ Fasten the first wheel set **7** to the auxiliary crane and set it down on level ground, see illustration **1**.
- ▶ Pull the extendable auxiliary supports **22** out and secure, see illustration **1**.

Result:

- The first wheel set **7** is secured to prevent it from tipping over.
- ▶ Remove the auxiliary crane.
- ▶ Remove the safety locking pin **20** at point **P17** and unpin the pin **19**, see illustration **1**.
- ▶ Release the retainer **15** for pin pulling device **17** at point **P16**.
- ▶ Hang the retainer **15** up at pin point **P15** and secure, see illustration **1** and illustration **2**.
- ▶ Build up the substructure **21** for frame **13** approx. 400 mm high, see illustration **1**.
- ▶ Fasten the frame **13** to the auxiliary crane.
- ▶ Swing the frame **13** with the auxiliary crane to the pin points **P15**.
- ▶ Align the frame **13** with centerings **18** at points **P15** and set it on the wheel set **7**.
- ▶ Insert the pin **16** with the pin pulling device **17** at point **P15**, see illustration **2**.
- ▶ Remove the retainer **15** and fasten at point **P16**.
- ▶ Insert the pin **19** at point **P17** and secure with the safety locking pin **20**, see illustration **2**.

Result:

- The pin **16** is secured.



WARNING

Danger of tipping over!

If the locking pin **11** is not inserted at point **P12**, the ballast trailer can tip over.

Death, severe bodily injuries, property damage.

- ▶ Make sure that the locking pin **11** is pinned and secured at point **P12** before setting down the frame **13**.

- ▶ Insert the locking pin **11** at point **P12** and secure.
- ▶ Set the frame **13** with the auxiliary crane on the substructure **21**.
- ▶ Remove the auxiliary crane.

8.1.2 Assembling the second wheel set

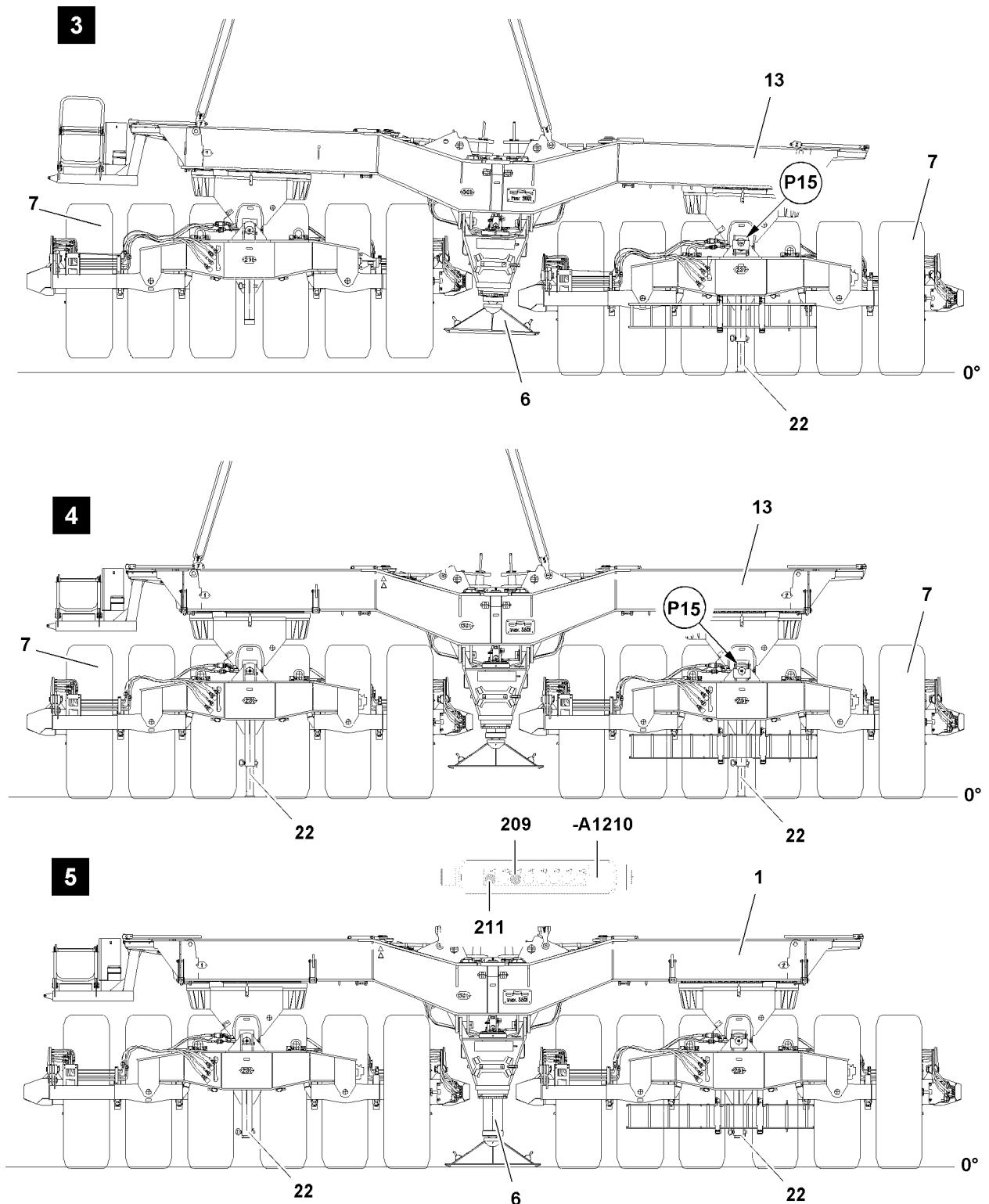

Fig.121987: Assembling the second wheel set

Make sure that the following prerequisite is met:

- The first wheel set is pinned and secured with frame.

LWE/LR 11000-001/23501-04-02/en

**Note**

- ▶ The assembly of the first wheel set is identical to the assembly of the second wheel set.
- ▶ Setting down the second wheel set, see section „Assembling the first wheel set“.

- ▶ Fasten the second wheel set **7** to the auxiliary crane and set it down on level ground.
- ▶ Secure the second wheel set **7** to prevent it from tipping over, see illustration **3**.

When the second wheel set **7** is set up and secured to prevent it from tipping over:

- ▶ Fasten the frame **13** with the first wheel set **7** to the auxiliary crane, see illustration **3**.
- ▶ Swing the frame **13** with the first wheel set **7** to the pin points **P15**.

**Note**

- ▶ The assembly of the first wheel set is identical to the assembly of the second wheel set.
- ▶ Assembly of the second wheel set, see section „Assembling the first wheel set“.

- ▶ Align the frames **13** with the first wheel set **7** with centerings at points **P15** and set it on the second wheel set **7**, see illustration **3**.
- ▶ Pin and secure the frames **13** together with the first wheel set **7** and second wheel set **7**, see section „Assembling the first wheel set“.

When the frames **13** are pinned and secured together with the first wheel set **7** and second wheel set **7**:

- ▶ Set the ballast trailer down, see illustration **4**.
- ▶ Pull the extendable auxiliary supports **22** out of the first wheel set **7** and secure, see illustration **4**.
- ▶ Relieve the fastening equipment.
- ▶ Connect the ballast trailer on the external hydraulic system.

or

Connect the ballast trailer using the electrical extension cable and the hydraulic extension hoses to the crane turntable, see the electric wiring diagram and the hydraulic diagram.

When the electrical and hydraulic connections have been established:

- ▶ Press the button **209** and button **211** on the control panel **-A1210**.

Result:

- The support **6** extends.
- ▶ Extend the support **6** until the tires are relieved, see illustration **5**.

Result:

- The ballast trailer **1** is secured to prevent it from tipping over.
- ▶ Move the extendable auxiliary supports **22** in on both wheel sets **7** and secure, see illustration **5**.
- ▶ Remove the fastening equipment.

8.1.3 Installing the extension ladder on the ballast trailer

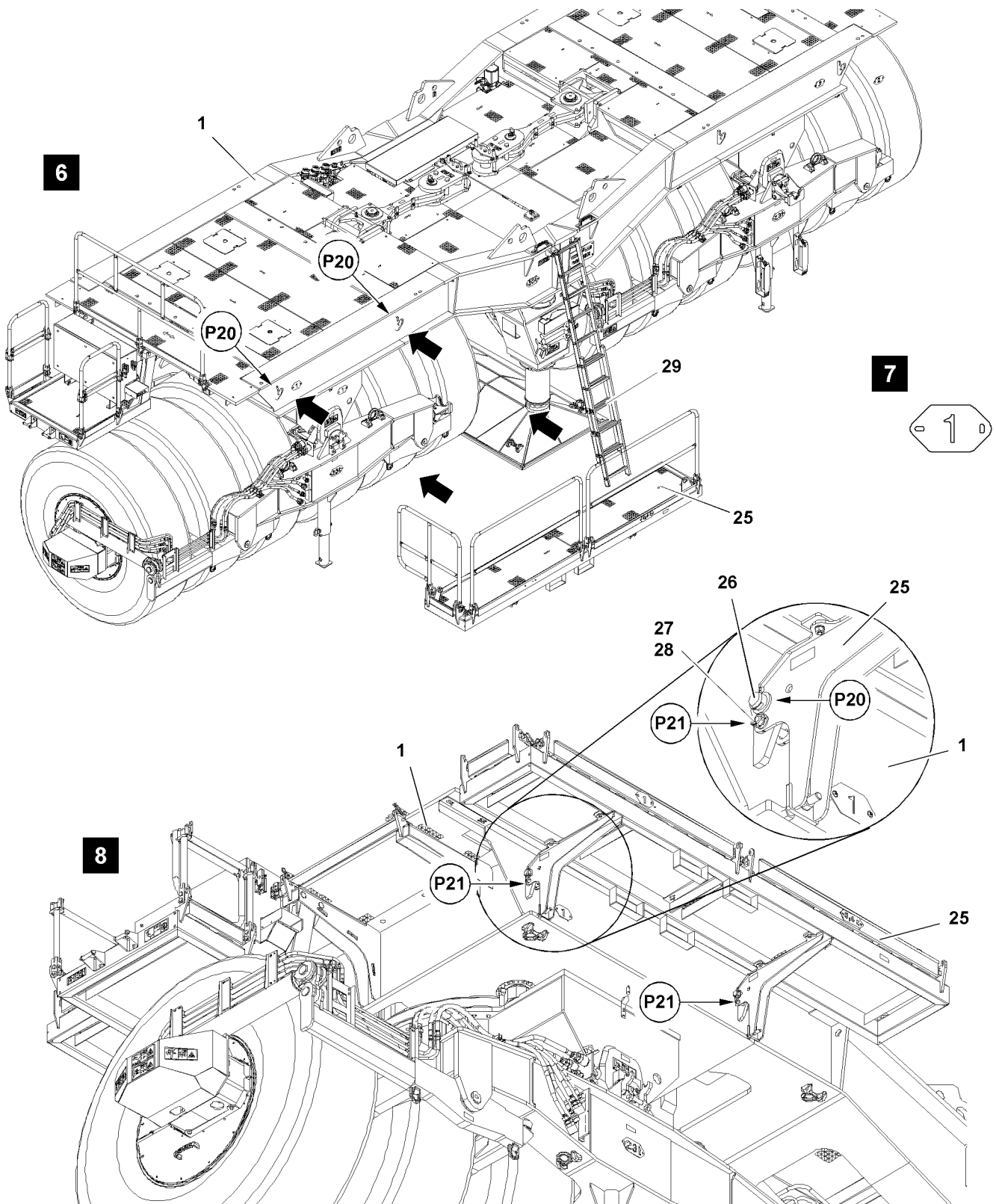

Fig.120225: Assembling the platforms



Note

- ▶ Position of extension ladder 29 see illustration 6.
- ▶ Assembly of the extension ladder 29, see chapter 2.06.

LWE/LR 11000-001/23501-04-02/en

8.1.4 Establishing the connections

Establishing the hydraulic connection



DANGER

Danger of accident due to loss of pressure or leakage!

Incorrectly coupled or self-loosening quick couplings (particularly return lines) can result in serious accidents due to component failure.

- ▶ Check that the quick couplings have been properly connected before using the crane.
-
- ▶ Release the pressure in the hydraulic system before connecting or disconnecting: Turn the engine off and wait a short time.
 - ▶ Connect the coupling components (sleeve and connector) and screw together with the knurled nut.
 - ▶ Tighten the hydraulic coupling by hand: Rotate the knurled nut until it reaches a tangible, fixed stop position.

Establishing the electrical connection

- ▶ Establish the electrical connections, see the Electric wiring diagram.

8.1.5 Assembling the platforms



Note

- ▶ The ballast trailer is equipped with four separate platforms.
- ▶ The ballast trailer sides and platforms **25** are marked with numbers, see illustration 7.
- ▶ Pay attention to identification on ballast trailer and on platform at assembly.



Note

- ▶ The assembly of the platforms is described on the example of one platform.

- ▶ Fasten the platform **25** to the auxiliary crane.
- ▶ Swing the platform **25** with the auxiliary crane to the points **P20**.
- ▶ Hang the platform **25** with pins **26** at points **P20** on ballast trailer.

The platform **25** is pinned on two points:

- ▶ Insert the pin **27** at point **P21** and secure with the safety locking pin **28**, see illustration 8.
- ▶ Remove the auxiliary crane.
- ▶ Install all platforms on the ballast trailer.

8.1.6 Installing the railing on the ballast trailer



Note

- ▶ Railing assembly, see chapter 2.06.

8.1.7 Erecting the pull brackets

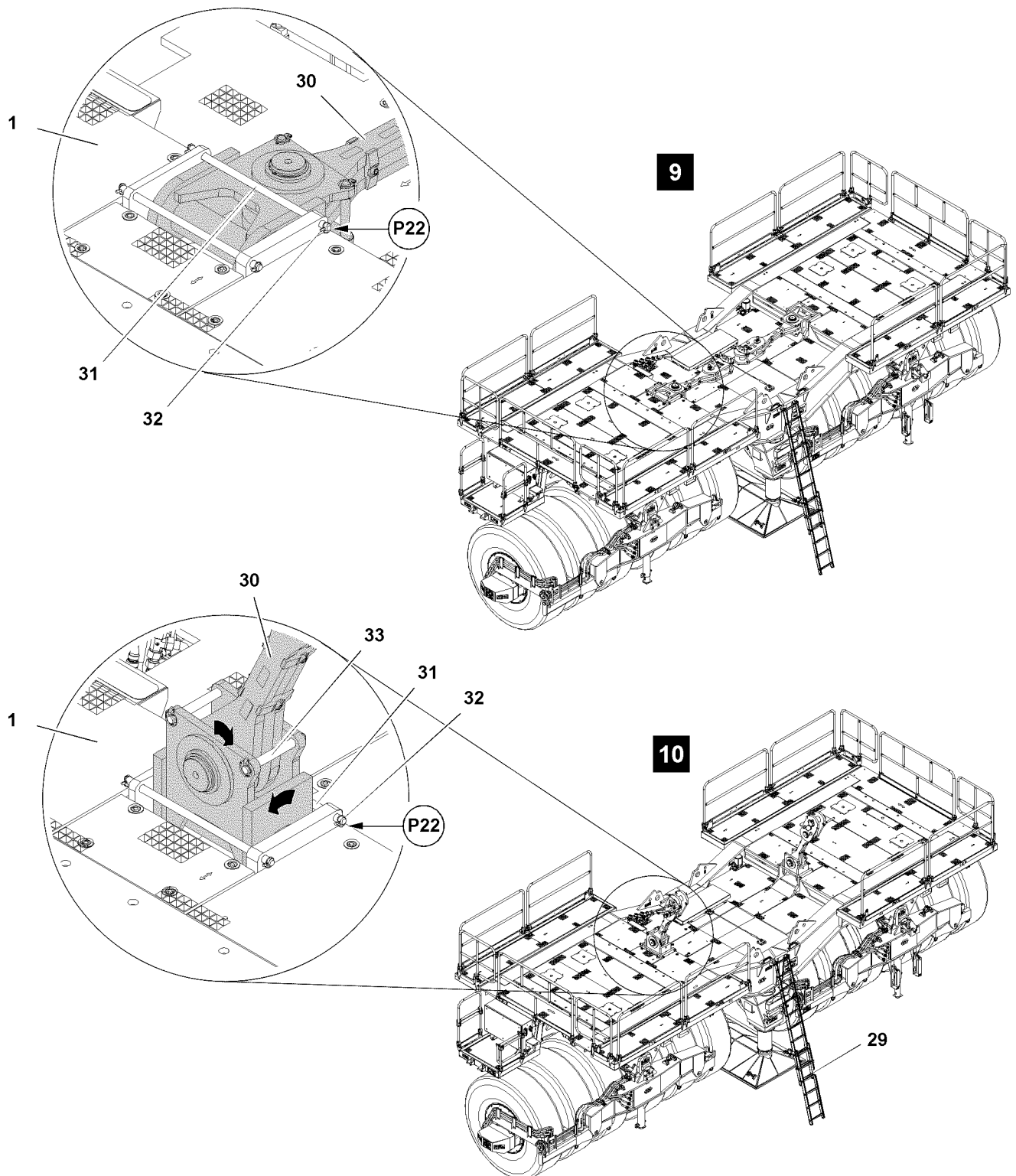

Fig.120226: Erecting the pull brackets

- ▶ Fasten the pull bracket **30** to the auxiliary crane.
- ▶ Release the pull bracket **30** from transport position: Remove the safety locking pin **32** at point **P22** and unpin the pin **31**, see illustration **9**.
- ▶ Raise the pull bracket **30** with the auxiliary crane.

- ▶ Secure the pull bracket **30** in operating position: Insert the pin **31** at point **P22** and secure with safety locking pin **32**, see illustration **10**.



WARNING

Swinging pull bracket!

When releasing the pull bracket from the auxiliary crane, it can swing uncontrolled forward or backward.

Death, severe bodily injuries, property damage.

- ▶ Make sure that pull bracket **30** is first placed on pin **33** and then released from the auxiliary crane.
-
- ▶ Swing the pull bracket **30** with the auxiliary crane until it is placed on the pin **33**, see illustration **10**.
 - ▶ Remove the auxiliary crane.
 - ▶ Erect the second pull bracket.

8.1.8 Removing the extension ladder on the ballast trailer



Note

- ▶ Position of extension ladder **29** see illustration **10**.
 - ▶ Disassembly of the extension ladder **29**, see chapter 2.06.
-

8.2 Assembling the ballast trailer guide

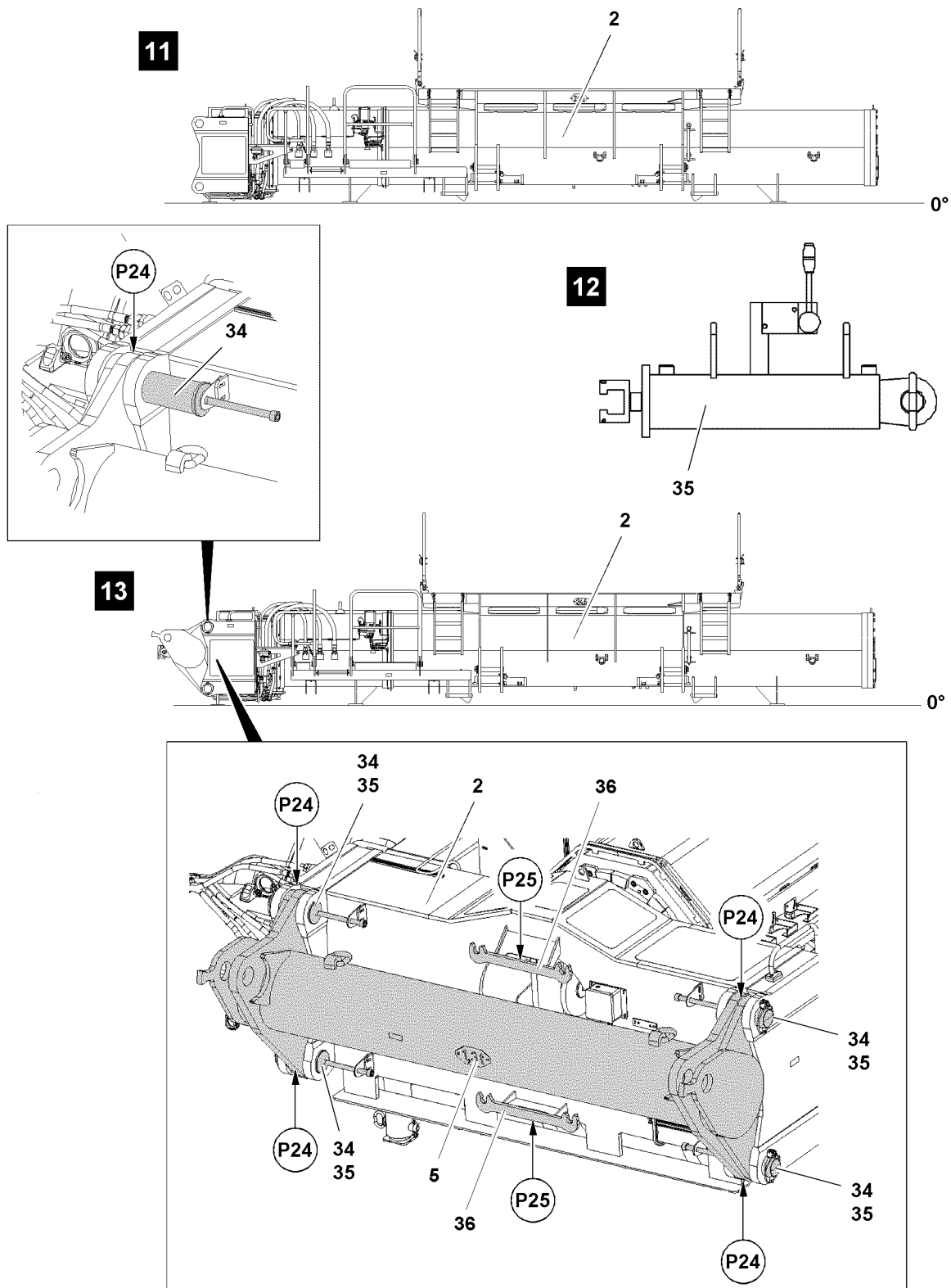

Fig.120228: Assembling the ballast trailer guide with ballast trailer radius 13-19 m

Make sure that the following prerequisites are met:

- The ballast trailer guide 2 is moved in all the way see illustration 11.
- The connector pins 34 are unpinned.
- The ballast trailer guide 2 is laying on the ground, see illustration 11.

8.2.1 Installing the ladder and railing on the ballast trailer guide



Note

- ▶ Position of ladder and railing, see illustration 11.
- ▶ For the assembly of the ladder and the railing, see chapter 2.06.

8.2.2 Assembling the ballast trailer guide with ballast trailer radius 13-19 m

- ▶ Fasten the adapter 5 to the auxiliary crane.



WARNING

Danger of crushed limbs!

When aligning the adapter, fingers and hands can be crushed.

- ▶ Do not reach with your hands into the danger zone.

The adapter 5 is pinned four times on the ballast trailer guide. Every pin point is present on both sides of the component on one level.

- ▶ Swing the adapter 5 with the auxiliary crane to the pin points P24, see illustration 13.
- ▶ Hang the pin pulling cylinder 35 on the retainer 36 at point P25 and on the screw head, see illustration 12 and illustration 13.
- ▶ Establish the hydraulic connection of the pin pulling cylinder 35, see chapter 5.30.

When the pin bores align:

- ▶ Actuate the lever on the pin pulling cylinder 35 and insert the connector pin 34.



WARNING

The connector pins can loosen up by themselves!

If the pins are not secured with the safety locking pins, the pins can release during crane operation.

This can cause the crane to topple over.

Death, severe bodily injuries, property damage.

- ▶ Make sure that connector pins are inserted and secured.

- ▶ Secure the connector pins 34 with safety locking pins 35, see illustration 13.

When all four connector pins 34 are pinned in and secured:

- ▶ Remove the auxiliary crane.

8.2.3 Assembling the ballast trailer guide with ballast trailer radius 19-25 m

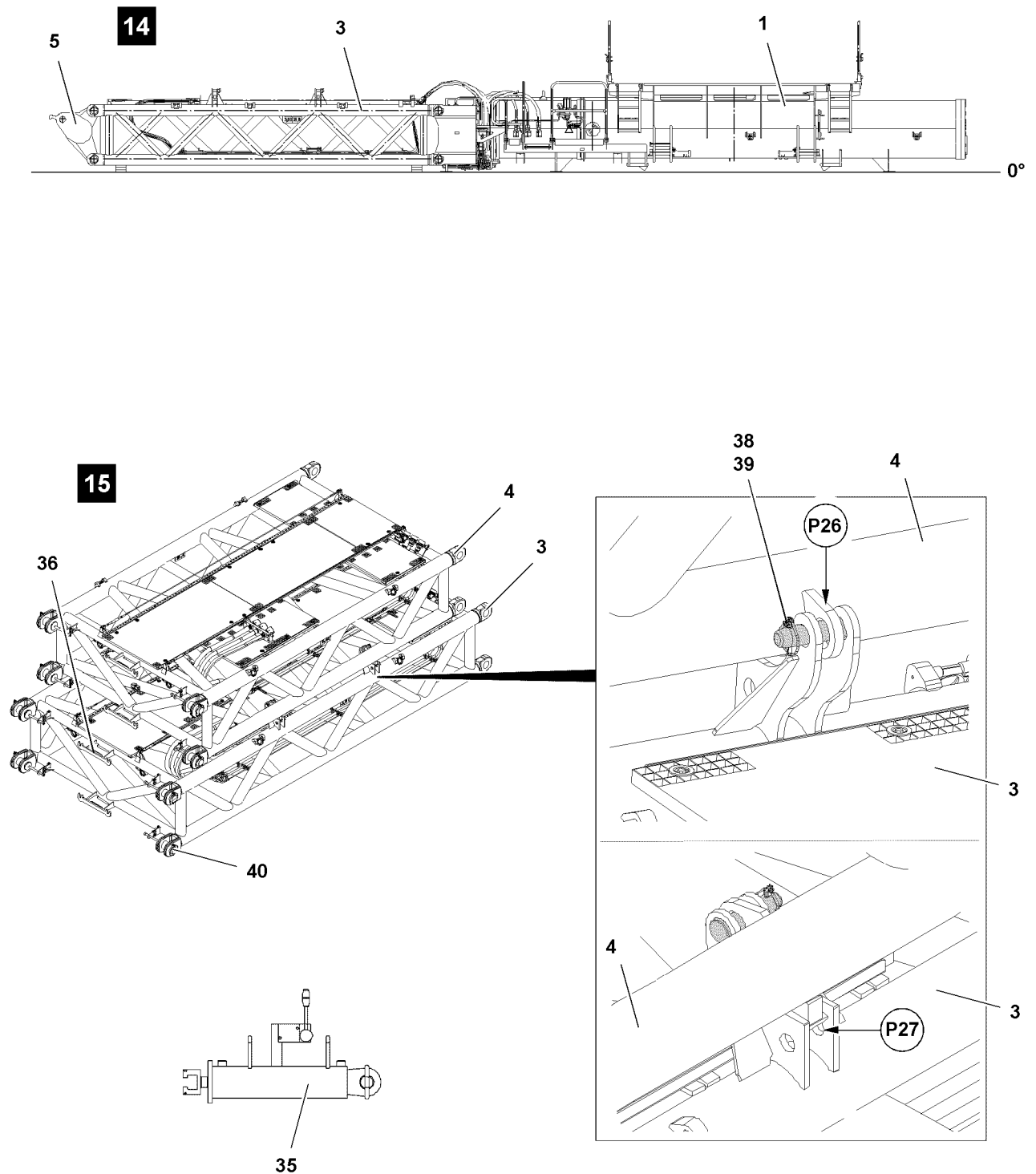

Fig.121988: Assembling the ballast trailer guide with ballast trailer radius 19-25 m

The intermediate sections are pinned with each other on four points in transport position. The unpinning procedure is described on the example for one pin, see illustration 15.

- ▶ Fasten the intermediate section 4 to the auxiliary crane.
- ▶ Remove the safety locking pin 39 at point P26 and unpin the pin 38, see illustration 15.

- ▶ Insert the pin **38** in park position at point **P27** and secure with safety locking pin **39**, see illustration **15**.
- ▶ Lift the intermediate section **4** with the crane and remove.
- ▶ Hang the pin pulling cylinder **35** on the retainer **36** and on the screw head, see illustration **15**.
- ▶ Establish the hydraulic connection of the pin pulling cylinder **35**, see chapter 5.30.
- ▶ Release the connector pin **40**.
- ▶ Actuate the lever on the pin pulling cylinder **35** and unpin the connector pin **40**.
- ▶ Fasten the intermediate section **3** to the auxiliary crane.
- ▶ Lift the intermediate section **3** with the crane and swing it to the ballast trailer guide **1**, see illustration **14**.

**Note**

- ▶ Pinning the intermediate section **3** on the ballast trailer guide **1** is identical with pinning the adapter **5** on the ballast trailer guide **1**.
- ▶ For pin procedure, see section „Assembling the ballast trailer guide with ballast trailer radius 13–19 m “.

The intermediate section **3** is pinned four times on the ballast trailer guide **1**.

- ▶ Pin the intermediate section **3** on ballast trailer guide **1**, see illustration **14**.

**Note**

- ▶ Pinning the adapter **5** on the intermediate section **3** is identical with pinning the adapter **5** on the ballast trailer guide **1**.
- ▶ For pin procedure, see section „Assembling the ballast trailer guide with ballast trailer radius 13–19 m “.

The adapter **5** is pinned four times on the intermediate section **3**.

- ▶ Pin the adapter **5** on intermediate section **3**, see illustration **14**.

8.2.4 Establishing the connections

Establishing the hydraulic connection

**DANGER**

Danger of accident due to loss of pressure or leakage!

Incorrectly coupled or self-loosening quick couplings (particularly return lines) can result in serious accidents due to component failure.

- ▶ Check that the quick couplings have been properly connected before using the crane.
- ▶ Release the pressure in the hydraulic system before connecting or disconnecting: Turn the engine off and wait a short time.
- ▶ Connect the coupling components (sleeve and connector) and screw together with the knurled nut.
- ▶ Tighten the hydraulic coupling by hand: Rotate the knurled nut until it reaches a tangible, fixed stop position.

Establishing the electrical connection

- ▶ Establish the electrical connections, see the Electric wiring diagram.

8.2.5 Assembling the ballast trailer guide with ballast trailer radius 24-30 m

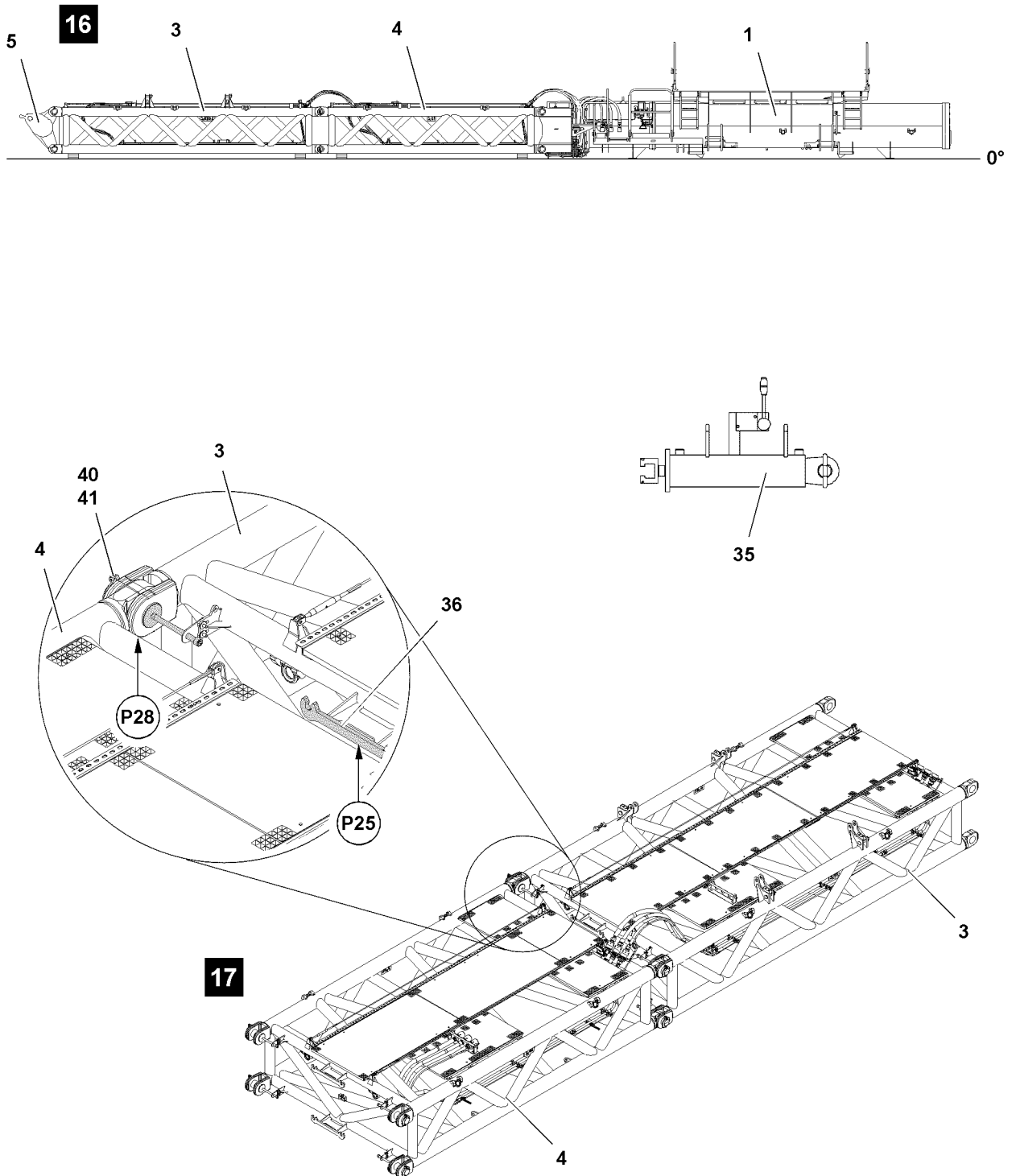

Fig.120229: Assembling the ballast trailer guide with ballast trailer radius 24-30 m

The intermediate sections are pinned with each other on four points in transport position.

- ▶ Fasten the intermediate section 4 to the auxiliary crane.
- ▶ Unpin the intermediate section 4 and lift with the crane, see section „Assembling the ballast trailer guide with ballast trailer radius 19-25 m “.

- ▶ Swing the intermediate section **4** to the pin points **P28** on the intermediate section **3**.

The intermediate section **4** is pinned four times on the intermediate section **3**. Every pin point is present on both sides of the component on one level.

- ▶ Align the intermediate section **4** with the crane so that the pin bores are aligned.
- ▶ Hang the pin pulling cylinder **35** on the retainer **36** at point **25** and on the screw head, see illustration **17**.

When the pin bores align:

- ▶ Actuate the lever on the pin pulling cylinder **35** and insert the connector pin **40**.



WARNING

The connector pins can loosen up by themselves!

If the pins are not secured with the safety locking pins, the axles can release during crane operation. This can cause the crane to topple over.

Death, severe bodily injuries, property damage.

- ▶ Make sure that connector pins are inserted and secured.

- ▶ Secure the connector pins **40** with safety locking pins **41**, see illustration **17**.

When all four connector pins **40** are pinned in and secured at pin points **P28**:

- ▶ Remove the auxiliary crane.
- ▶ Fasten the intermediate section **3** and intermediate section **4** to the auxiliary crane, lift and swing to the ballast trailer guide **1**, see illustration **16**.



Note

- ▶ Pinning the extension (intermediate section **3** and intermediate section **4**) on the ballast trailer guide **1** is identical with pinning the adapter **5** on ballast trailer guide **1**.
- ▶ For pin procedure, see section „Assembling the ballast trailer guide with ballast trailer radius 13–19 m“.

The extension is pinned four times on the ballast trailer guide **1**.

- ▶ Pin the extension on ballast trailer guide **1**, see illustration **16**



Note

- ▶ Pinning the adapter **5** on the intermediate section **3** is identical with pinning the adapter **5** on the ballast trailer guide **1**.
- ▶ For pin procedure, see section „Assembling the ballast trailer guide with ballast trailer radius 13–19 m“.

The adapter **5** is pinned four times on the intermediate section **3**.

- ▶ Pin the adapter **5** on intermediate section **3**, see illustration **16**.

8.2.6 Establishing the connections



Note

- ▶ Making the connections, see section „Assembling the ballast trailer guide with ballast trailer radius 19-25 m“.

8.3 Assembling the ballast trailer guide on the ballast trailer

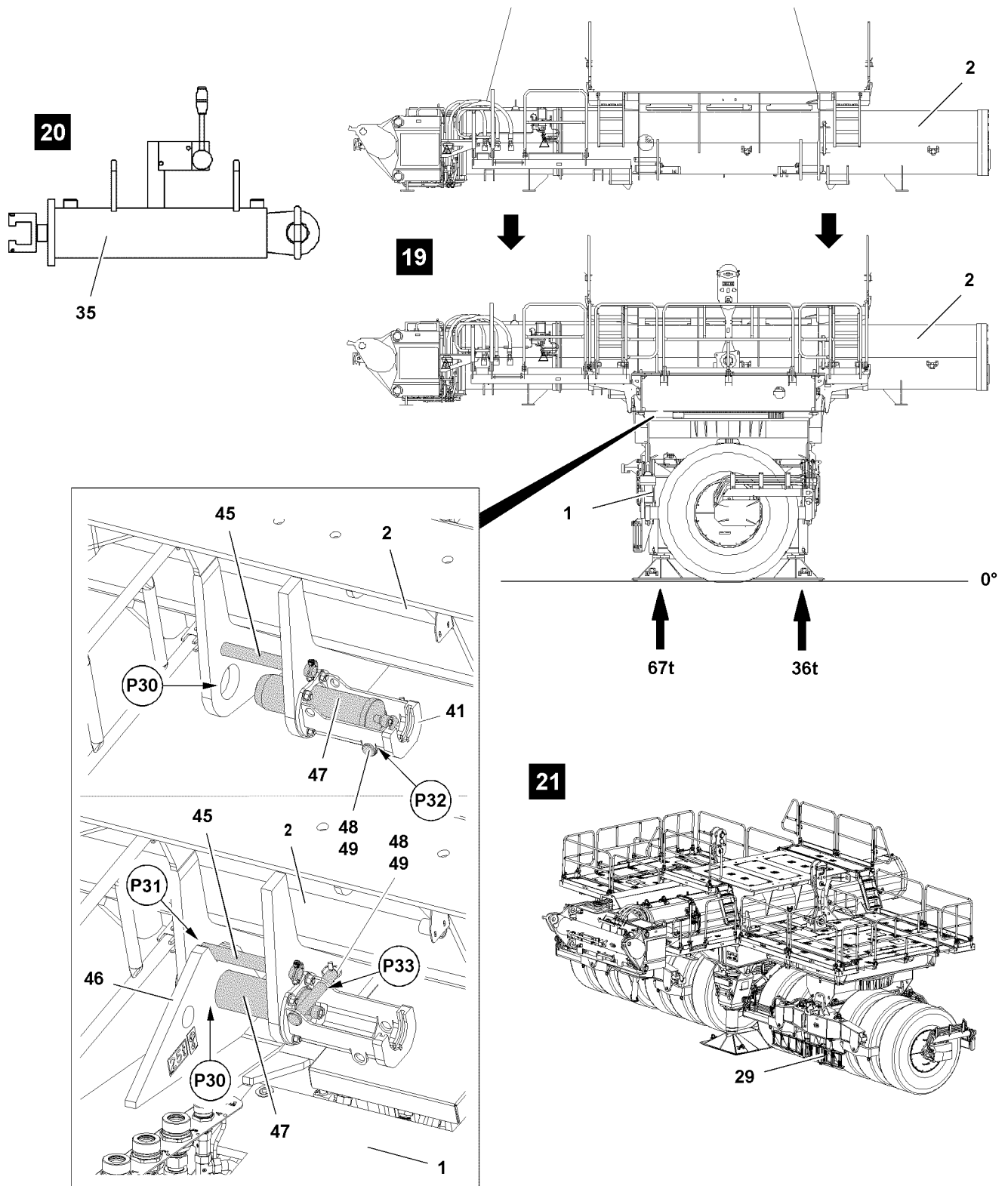

Fig.120227: Assembling the ballast trailer guide

Make sure that the following prerequisite is met:

- The locking pin is pinned and secured in the strut at point **P12**, see section „Ballast trailer not installed on the turntable“

LWE/LR 11000-001/23501-04-02/en

8.3.1 Installing the extension ladder on the ballast trailer guide



Note

- ▶ Position of extension ladder **29**, see illustration **21**.
- ▶ Assembly of the extension ladder **29**, see chapter 2.06.

8.3.2 Assembling the ballast trailer guide with ballast trailer radius 13-19 m on the ballast trailer



WARNING

Danger of fatal injury due to tipping ballast trailer!

If the ballast trailer is insufficiently ballasted, then the ballast trailer can tip over when placing the ballast trailer guide **2**.

Death, severe bodily injuries, property damage.

- ▶ Make sure that the ballast trailer guide **2** is telescoped in.
- ▶ Make sure, at assembly of the ballast trailer guide **2**, that the ballast trailer is ballasted according to the corresponding ballast trailer radius, see the following chart.
- ▶ Make sure that the ground is prepared according to the ground pressure, see illustration **19**.

	Ballast trailer radius R 13-19 m
Weight of the ballast plates (min)	0 t

Minimum weight of ballast plates

- ▶ Fasten the ballast trailer guide **2** to the auxiliary crane and swing in to the pin points **P30** on the ballast frame **1**, see illustration **19**.
- ▶ Lower the ballast trailer guide **2** with the auxiliary crane until the pins **45** are laying on the receptacle **46** of the ballast trailer at point **P31**, see illustration **19**.
- ▶ Hang the pin pulling cylinder **35**, see illustration **20**, on the retainer **50** and on the screw head.
- ▶ Establish the hydraulic connection of the pin pulling cylinder **35** to the hydraulic aggregate, see chapter 5.30.

When the ballast trailer guide **2** is lying completely on the receptacles **46** and the pin bores align, see illustration **19**:

- ▶ Actuate the lever on the pin pulling cylinder **35** and insert the connector pin **47** at point **P30**.



WARNING

Danger of fatal injury due to tipping ballast trailer!

Due to unsecured or insufficiently secured connector pins, the ballast trailer guide can loosen up from the ballast frame and the ballast trailer can tip over.

Death, severe bodily injuries, property damage.

- ▶ Make sure before starting any crane work with the ballast trailer, that all **four** connector pins **47** are properly pinned and secured.

- ▶ Secure the connector pin **47**: Insert the retaining pin **48** at point **P33** and secure with the safety locking pin **49**, see illustration **19**.

When all four connector pins **47** are pinned in and secured:

- ▶ Remove the auxiliary crane.

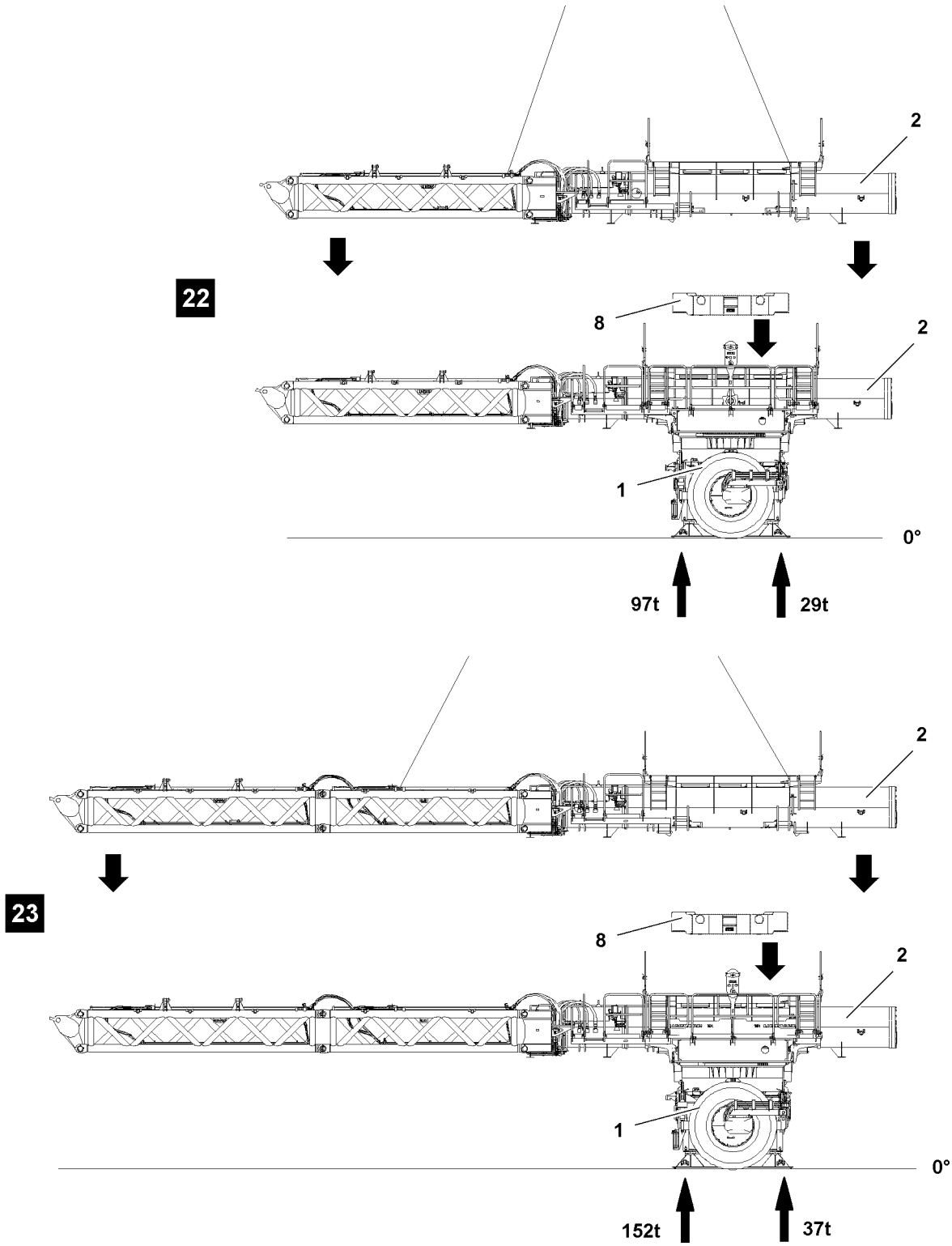

Fig.121989: Assembling the ballast trailer guide

LWE/LR 11000-001/23501-04-02/en

8.3.3 Assembling the ballast trailer guide with ballast trailer radius 19–25 m or with ballast trailer radius 24–30 m on the ballast trailer



WARNING

Danger of fatal injury due to tipping ballast trailer!

If the ballast trailer is insufficiently ballasted, then the ballast trailer can tip over when placing the ballast trailer guide **2**.

Death, severe bodily injuries, property damage.

- ▶ Make sure that the ballast trailer guide **2** is telescoped in.
- ▶ Make sure, at disassembly of the ballast trailer guide **2**, that the ballast trailer is ballasted according to the corresponding ballast trailer radius, see the following chart.
- ▶ Make sure that the ground is prepared according to the ground pressure, see illustration **22** and illustration **23**.

	Ballast trailer radius R 19-25 m	Ballast trailer radius R 24-30 m
Weight of the ballast plates (min)	20 t	80 t

Minimum weight of ballast plates



Note

- ▶ The assembly of the ballast trailer guide **2** with ballast trailer radius 19–25 m **or** with ballast trailer radius 24–30 m on the ballast trailer is identical with the assembly of the ballast trailer guide **2** with ballast trailer radius 13–19 m.
 - ▶ For assembly of the ballast trailer guide **2** with ballast trailer radius 19–25 m **or** with ballast trailer radius 24–30 m, see section „Assembling the ballast trailer guide with ballast trailer radius 13–19 m on ballast trailer“.
-
- ▶ To ballast the ballast trailer **1**, see section „Ballasting the ballast trailer“.
 - ▶ Fasten the ballast trailer guide **2** to the auxiliary crane and swing in to the pin points on the ballast frame **1**, see illustration **22** or illustration **23**.
 - ▶ Pin and secure the ballast trailer guide **2** with ballast trailer **1**, see illustration **22** or illustration **23**.

9 Assembling the ballast trailer on the turntable



WARNING

Danger of falling!

During assembly / disassembly, inspection and maintenance work, personnel must be secured with appropriate aids to prevent them from falling.

If this is not observed, the assembly personnel can fall down.

Death, severe bodily injuries, property damage.

- ▶ All work at a height, when there is a danger of falling, must be carried out with suitable aids.
- ▶ If aids are not available and work cannot be carried out from the ground, then assembly personnel must secure themselves with the supplied fall arrest system to prevent falling, see chapter 2.04.
- ▶ If fall protection equipment is available, then it must be used, see chapter 2.06.
- ▶ When lifting, lowering, swinging crane parts in and out, no persons may remain in the danger zone.
- ▶ If railings are present on the components, then they must be brought into the corresponding position and secured for assembly / disassembly work.
- ▶ Only step on the aids, ladders and catwalks with clean shoes.
- ▶ Keep aids, ladders and catwalks free of heavy dirt, snow and ice.
- ▶ During all assembly and disassembly work, maintenance work and inspections, travel or crane operation is prohibited.
- ▶ Remaining on a suspended load is prohibited.
- ▶ Stepping or walking on crane components and lattice sections, which have an incline of more than 20° is prohibited.
- ▶ For all assembly work, the crane operator of the main crane must be in voice contact with the crane operator / crane operators of the auxiliary crane / auxiliary cranes.
- ▶ For assembly / disassembly tasks, the crane operator may only initiate crane movements when the responsible guide has explicitly released the movement.



WARNING

Danger of impact / crushing!

When installing / removing crane components with the auxiliary crane, crane components can start to swing back and forth.

When lifting / lowering and positioning crane components, there is an increased danger of impacts / crushing.

Death, severe bodily injuries, property damage.

- ▶ Make sure that personnel cannot be caught by components.
- ▶ When working in danger zones: Use aids to protect limbs.
- ▶ Guide components with suitable aids to minimize oscillation.



DANGER

The components can fall down!

If the corresponding components are disengaged from the auxiliary crane before the corresponding component is pinned, the corresponding component can fall down and fatally injure personnel.

- ▶ Do not disengage the auxiliary crane until the respective component is pinned and secured.



WARNING

Ballast trailer tipping danger!

Due to improperly carried out assembly or improper assembly conditions, the ballast trailer can tip over.

Death, severe bodily injuries, property damage.

- ▶ The assembly of the ballast trailer may only be carried out by authorized personnel.
- ▶ Carry out the assembly of the ballast trailer only on level ground of sufficient load bearing capacity.
- ▶ The ballast trailer has **no** brake system. The ballast trailer must be supported with the support cylinders if it is **not** pinned on the turntable.

**Note**

- ▶ Park the ballast trailer for assembly of the ballast trailer guide on level ground with sufficient load bearing capacity in the vicinity of the crane.
- ▶ Observe the safety guidelines, see chapter 2.15.

Make sure that the following prerequisites are met:

- The counterweight has been installed on the turntable according to the load chart.
- The ballast trailer is ballasted according to the assembly conditions, see section „Assembly conditions ballast trailer“.
- The locking pin is pinned and secured in the strut at point **P12**, see section „Ballast trailer not installed on the turntable“.

9.1 Installing the ballast trailer on the turntable

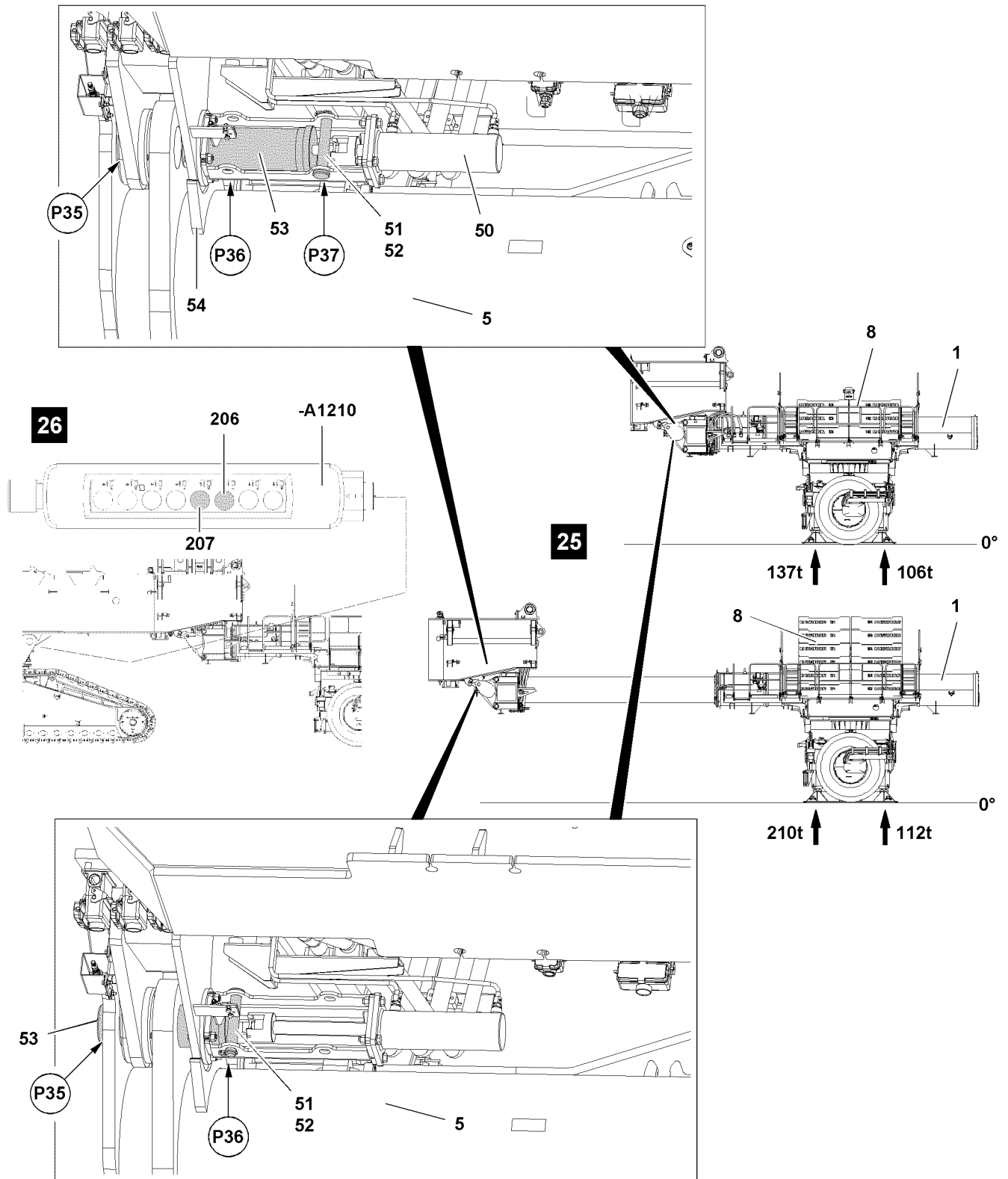

Fig.121018: Pinning the ballast trailer on the turntable

LWE/LR 11000-001/23501-04-02/en

9.1.1 Pinning the ballast trailer on the turntable



WARNING

Danger of fatal injury due to tipping ballast trailer!

If the ballast trailer is insufficiently ballasted, then the ballast trailer can tip over when pinning the ballast trailer guide **2** on the turntable.

Death, severe bodily injuries, property damage.

- ▶ Make sure, when pinning the ballast trailer guide **2**, that the ballast trailer is ballasted with appropriately selected ballast trailer radius, see chart.
- ▶ Make sure that the ground is prepared according to the ground pressure, see illustration **25**.

	Ballast trailer radius R 13-19 m		Ballast trailer radius R 19-25 m		Ballast trailer radius R 24-30 m	
	R 13 m	R 19 m	R 19 m	R 25 m	R 24 m	R 30 m
Weight of the ballast plates (min)	140 t	220 t	180 t	280 t	240 t	Not permissible

Minimum weight of ballast plates

Make sure that the following prerequisites are met:

- The ballast trailer is supported and ballasted symmetrically according to the ballast trailer radius.
- The adapter is pinned.
- The locking pin is pinned and secured in the strut at point **P12**, see section „Ballast trailer not installed on the turntable“.

Pinning the ballast trailer with ballast trailer radius 13–19 m on the turntable

- ▶ To ballast the ballast trailer **1**, see section „Ballasting the ballast trailer“.

NOTICE

Damage to the pin pulling device!

If the connector pins **53** are not unpinned before the pinning procedure, the pin pulling device can be damaged.

- ▶ Make sure that the connector pins **53** are released and unpinned before pinning.

Release and unpin the connector pins **53** on both sides:

- ▶ Remove the safety locking pin **52** at point **P36** and unpin the retaining pin **51**, see illustration **25**.
- ▶ Insert the retaining pin **51** at point **P37**.
- ▶ Press button **206** on the control panel **-A1210**, see illustration **26**.

Result:

- The pin pulling cylinders **50** retract.
- The connector pins **53** move in and the ballast trailer can be aligned on the turntable.

- ▶ Move the crane to the pin points on the ballast trailer guide.



Note

- ▶ To be able to align the pin bores between the turntable and the ballast trailer guide, it may be necessary to „swing“ the turntable somewhat, check visually.

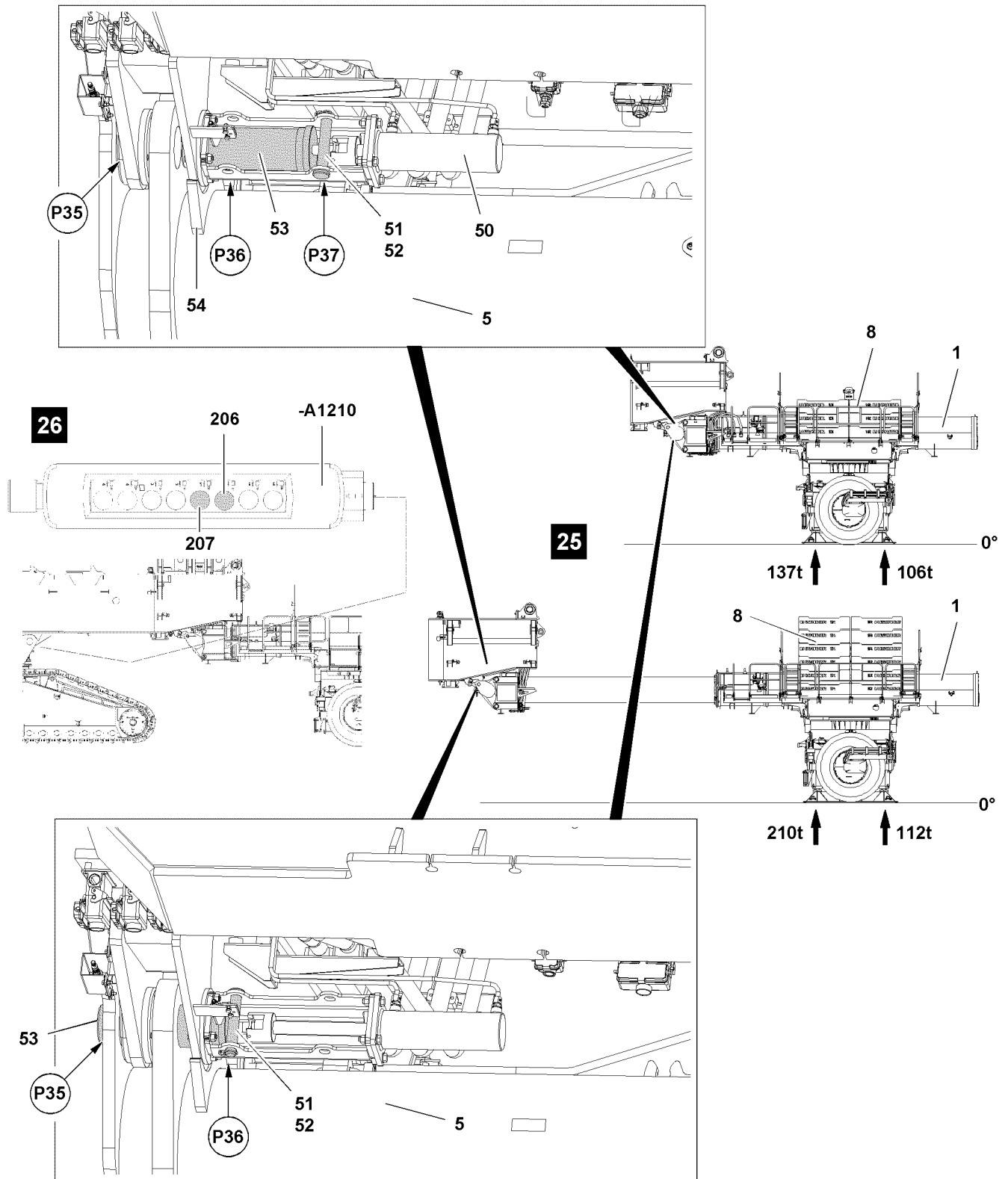

Fig.121018: Pinning the ballast trailer on the turntable



DANGER

Danger due to operating error!

When „swinging“ the turntable, severe accidents can occur.

Death, severe bodily injuries, property damage.

- ▶ Initiate all movements with utmost caution and at the least possible speed.
- ▶ It is prohibited to stand in the danger zone while „swinging“.

LWE/LR 11000-001/23501-04-02/en

- ▶ Place the ballast trailer on the centerings **54** of the turntable by lifting or lowering it, see illustration **25**.

Result:

- Align the pin bores.

Pin the ballast trailer with the turntable:

- ▶ Press button **207** on the control panel **-A1210**, see illustration **26**.

Result:

- The pin pulling cylinders **50** move out.
- The connector pins **53** move out and the ballast trailer is pinned on the turntable.

**Note**

- ▶ The crane control system recognized with the left and right limit switch initiators of the pin points, if the connector pins **47** on the turntable are fully pinned.
- ▶ If both connector pins **53** are fully and correctly pinned, the crane control, via the limit switch initiators receives the message, „Ballast trailer installed on left“ and „Ballast trailer installed on right.“ Which means: The turntable can no longer be turned and the crawler cannot be moved.
- ▶ After pinning, it must be checked again if the electrical and hydraulic connector lines are fully and correctly connected.
- ▶ The control release for the crane is only made when the wheels sets are in one of the required positions, „Circular travel“, „Towing“ or „Parallel travel“.

**DANGER**

Danger due to operating error!

If only one connector pin **53** is pinned and if the crane control therefore has only one message „Ballast trailer installed“ from a limit switch initiator, then the turntable can be turned anyway and the crane can be moved.

Death, severe bodily injuries, property damage.

The crane or the ballast trailer can be severely damaged.

- ▶ All movements are to be operated with extreme caution and at the smallest possible speed.

Secure the connector pin **53**:

- ▶ Unpin retaining pin **51** at point **P37**.
- ▶ Insert the retaining pin **52** at point **P36** and secure with safety locking pin **52**, see illustration **25**.

Problem remedy

The second connector pin **53** cannot be pinned?

You did not align the ballast trailer exactly before assembly.

- ▶ Slightly lift or lower the ballast trailer via the support cylinder.
- ▶ Carefully telescope the ballast trailer guide in or out.
- ▶ Carefully swing the turntable after.

When the second pin bore aligns between the turntable and ballast trailer guide align:

- ▶ Pin the second connector pin **53**.

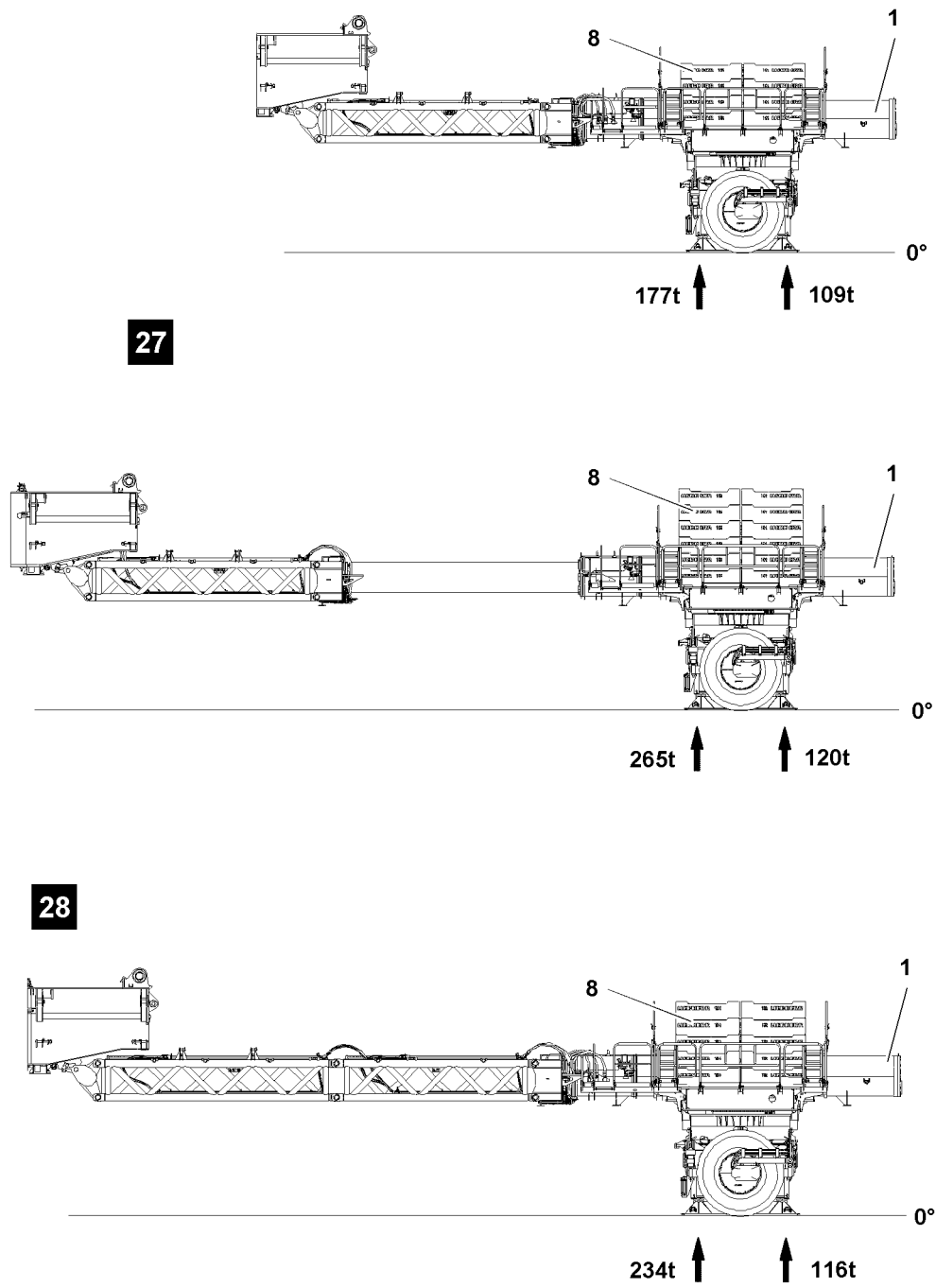

Fig.121990: Pinning the ballast trailer on the turntable

LWE/LR 11000-001/23501-04-02/en

Pinning the ballast trailer with ballast trailer radius 19–25 m on the turntable or pin the ballast trailer with ballast trailer radius 24–30 m on the turntable



WARNING

Danger of fatal injury due to tipping ballast trailer!

If the ballast trailer is insufficiently ballasted, then the ballast trailer can tip over when pinning the ballast trailer guide **2** on the turntable.

Death, severe bodily injuries, property damage.

- ▶ Make sure, when pinning the ballast trailer guide **2**, that the ballast trailer is ballasted with appropriately selected ballast trailer radius, see chart.
- ▶ Make sure that the ground is prepared according to the ground pressure, see illustration **27** and see illustration **28**.

	Ballast trailer radius R 13-19 m		Ballast trailer radius R 19-25 m		Ballast trailer radius R 24-30 m	
	R 13 m	R 19 m	R 19 m	R 25 m	R 24 m	R 30 m
Weight of the ballast plates (min)	140 t	220 t	180 t	280 t	240 t	Not permissible

Minimum weight of ballast plates

Make sure that the following prerequisites are met:

- The ballast trailer is supported and ballasted symmetrically according to the ballast trailer radius.
- The adapter is pinned.
- The locking pin is pinned and secured in the strut at point **P12**, see section „Ballast trailer not installed on the turntable“.



Note

- ▶ The pinning of the ballast trailer **1** with ballast trailer radius 19–25 m **or** with ballast trailer radius 24–30 m on the turntable is identical with the pinning of the ballast trailer **1** with ballast trailer radius 13–19 m.
 - ▶ Pinning the ballast trailer **1** with ballast trailer radius 19–25 m **or** with ballast trailer radius 24–30 m, see section „Pinning the ballast trailer with ballast trailer radius 13–19 m on turntable“.
-
- ▶ To ballast the ballast trailer **1**, see section „Ballasting the ballast trailer“.
 - ▶ Pin and secure the ballast trailer **1** with turntable, see illustration **27** or illustration **28**.

9.1.2 Assembling the ballast trailer guying

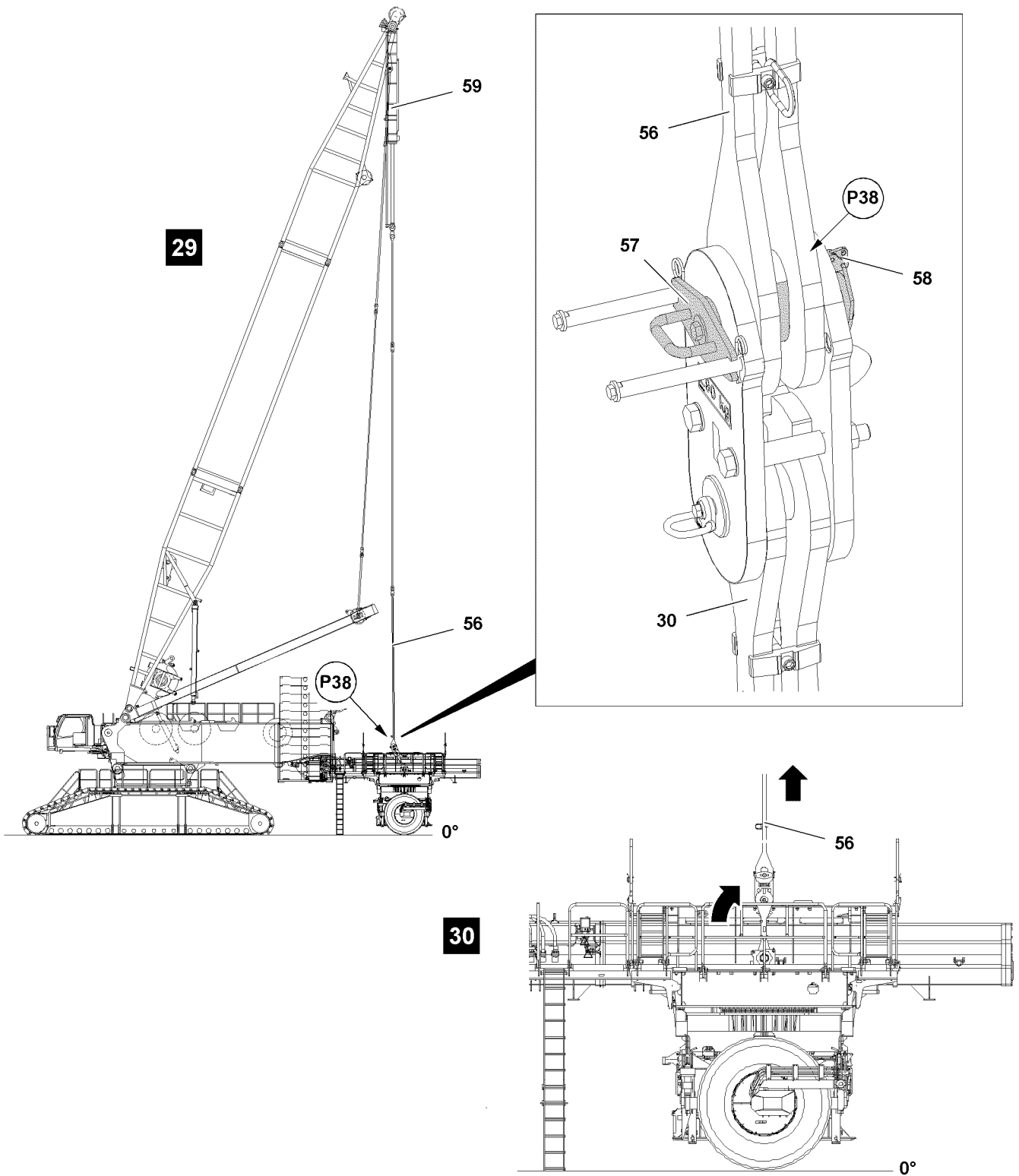

Fig.120232: Ballast trailer guying



Note

- ▶ The ballast trailer guy rods must be assembled and secured according to the data in the Rod plan. The numbering in the rod plan must be identical to the numbering on the guy rods.

LWE/LR 11000-001/23501-04-02/en

**Note**

- ▶ Set the derrick boom and the derrick ballast to the same radius.
- ▶ If this is not possible, pull the guy rods **56** with the auxiliary crane to the pin point.

Make sure that the following prerequisites are met:

- The pull brackets **30** on the ballast trailer are in operating position and pinned and secured, see section „Erecting the pull brackets“.
- The guy rods **56** on the derrick boom are pinned and secured.

The guy rods **53** of the derrick boom are to be pinned with the pull brackets **30** on the ballast trailer. The connector pins **57** are held in „pulled“ condition by the Allen screws, see illustration **29**.

- ▶ Unpin the connector pin **57**: Remove the safety locking pin **58** and unpin connector pins **57** on both sides.
- ▶ Position the guy rods **56** over the pull brackets **30** by extending the pull cylinders **59**.

**Note**

Retract / extend the pull cylinder **59**

- ▶ Control the pull cylinders **59** from the crane cab or with the control panel, see section „lifting and lowering the ballast trailer with the pull cylinders“.
- ▶ Operate the pull cylinder **59** with the radio remote control, see the „radio remote control operating instructions“.

- ▶ Align the guy rods **56** on the pull brackets **30** at point **P38**.
- ▶ Pin the guy rods **56** on both sides with the pull brackets **30**, point **P38**: Insert the connector pins **57**.
- ▶ Secure the connector pins **57** with safety locking pins **58**, see illustration **29**.
- ▶ When the guy rods **56** are pinned and secured with the pull brackets **30** on both sides:
- ▶ Retract the pull cylinder **59**.

Result:

- The ballast trailer guying is tensioned, see illustration **30**.

9.2 Establishing the electrical connection from the ballast trailer to the turntable

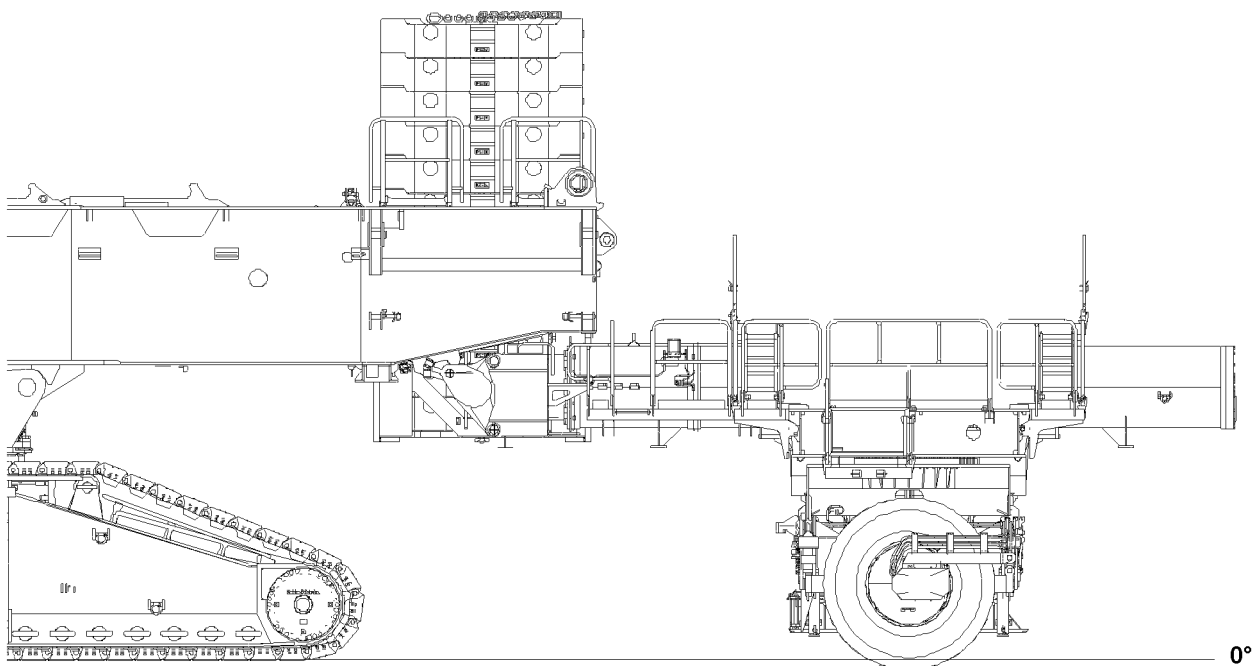

Fig.121017: Ballast trailer

**Note**

- ▶ For assembly of the ballast trailer, the electrical connection from the ballast trailer to the turntable must be established to be able to control the support cylinders, if necessary.
- ▶ The „Ballast UP / DOWN“ release is independent of whether the ballast trailer is attached, providing the conditions in the shut off diagram are fulfilled.
- ▶ The „Ballast UP“ release allows the retraction of the pull cylinder and support cylinder.
- ▶ The „Ballast DOWN“ release allows the extension of the pull cylinder and support cylinder.
- ▶ This means that the support cylinder and the pull cylinder can be moved, even if the „Ballast trailer pinned“ signal is not yet present.

**Note**

- ▶ Establish the electrical connections, see the Electric wiring diagram.
- ▶ Establish the electrical connections.

9.3 Establishing the hydraulic connection from the ballast trailer to the turntable

When connecting and releasing hydraulic lines with quick couplings, make sure that the coupling procedure is carried out correctly.

**DANGER**

Danger of accident due to loss of pressure or leakage!

Incorrectly coupled or self-loosening quick couplings (particularly return lines) can result in serious accidents due to component failure.

- ▶ Check that the quick couplings have been properly connected before using the crane.
- ▶ Release the pressure in the hydraulic system before connecting or disconnecting: Turn the engine off and wait a short time.
- ▶ Connect the coupling components (sleeve and connector) and screw together with the knurled nut.
- ▶ Tighten the hydraulic coupling by hand: Rotate the knurled nut until it reaches a tangible, fixed stop position.

9.4 Retracting the support cylinders

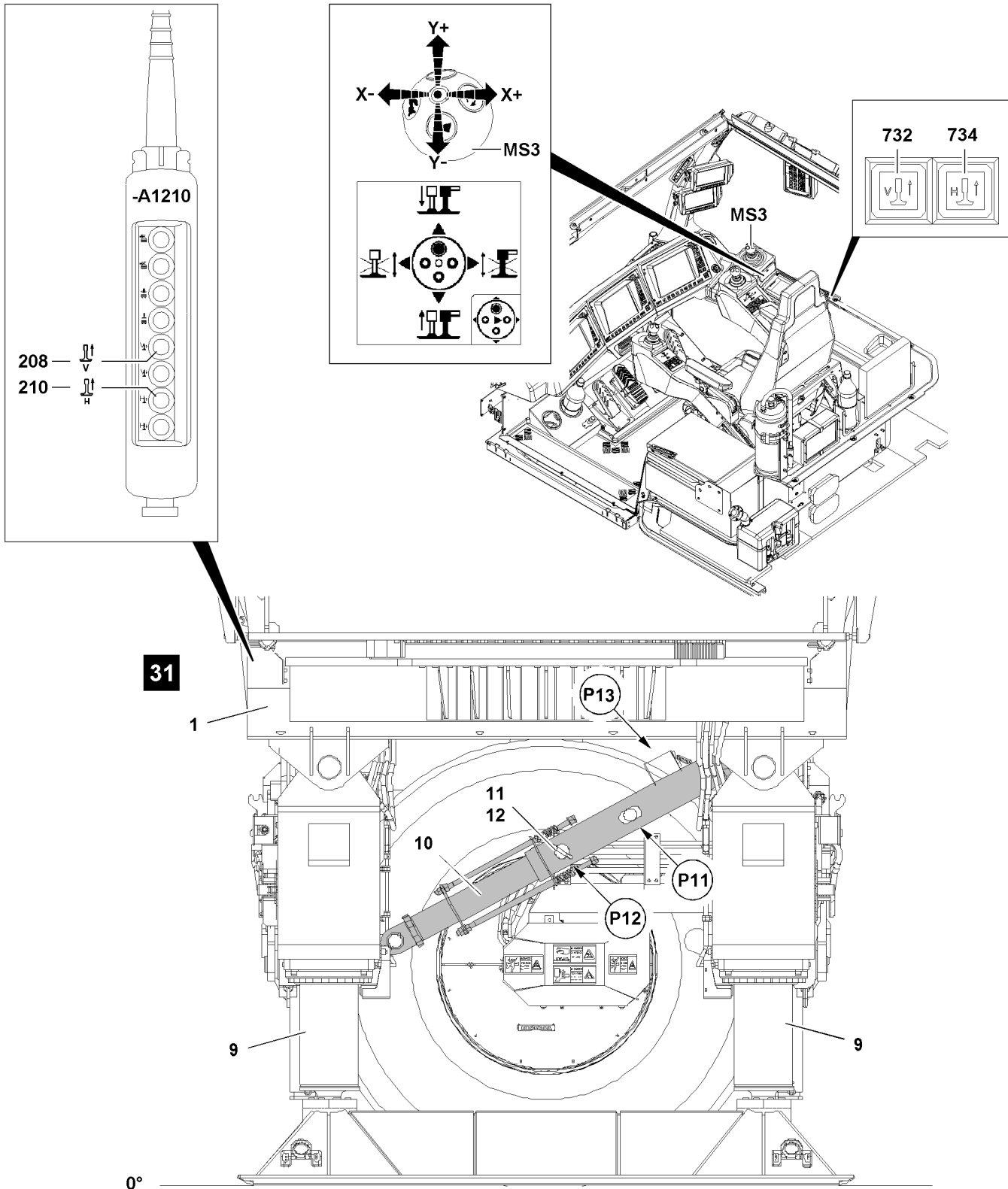

Fig.144130: Ballast trailer support

The support cylinders 9 can be retracted via the control panel -A1210, or via the corresponding button on the instrument panel of the crane cab.

LWE/LR 11000-001/23501-04-02/en

**Note**

- ▶ When the pinning procedure between the ballast trailer and the turntable is completed, move the support cylinders **9** in, see illustration **31**.

Make sure that the following prerequisites are met:

- The ballast trailer is pinned and secured on the turntable on both sides.
- The electrical and hydraulic connections are connected.

Retract the support cylinders 9 completely on the front and rear:

- ▶ Press the button **732** and button **734** in the crane cab, see illustration **31**.
or
Press the button **208** and button **210** on the control panel **-A1210**, see illustration **31**.
or

When the corresponding master switch assignment is selected:

Move the master switch 3 **MS3** in direction **Y-**.

Result:

- The support cylinders **9** retract.

**Note**

- ▶ The locking pin **11** can only be unpinned if the support cylinders **9** are relieved.

When the support cylinders **9** are relieved:

- ▶ Release and unpin the locking pin **11** on the strut **10** at point **P12**, see illustration **31**.
- ▶ Insert the locking pin **11** at point **P11** and secure with spring retainer **12**, see illustration **31**.

NOTICE

Damage of the ballast trailer!

If the following notes are not observed, the support cylinders of the ballast trailer can be significantly damaged.

- ▶ Unpin the locking pins **11** as soon as the ballast trailer is assembled on the turntable and the support is relieved.
- ▶ When the ballast trailer is assembled and ballasted on the turntable, then the locking pin **11** **must** be unpinned so that the level between the strut **10** and the support cylinders **9** can be adjusted.
- ▶ Supporting the ballasted ballast trailer with pinned strut **10** at point **P12** is prohibited.

- ▶ Retract the support cylinders **9** completely.

Result:

- A visual display appears on LICCON monitor LM2.

9.5 Ballasting the ballast trailer

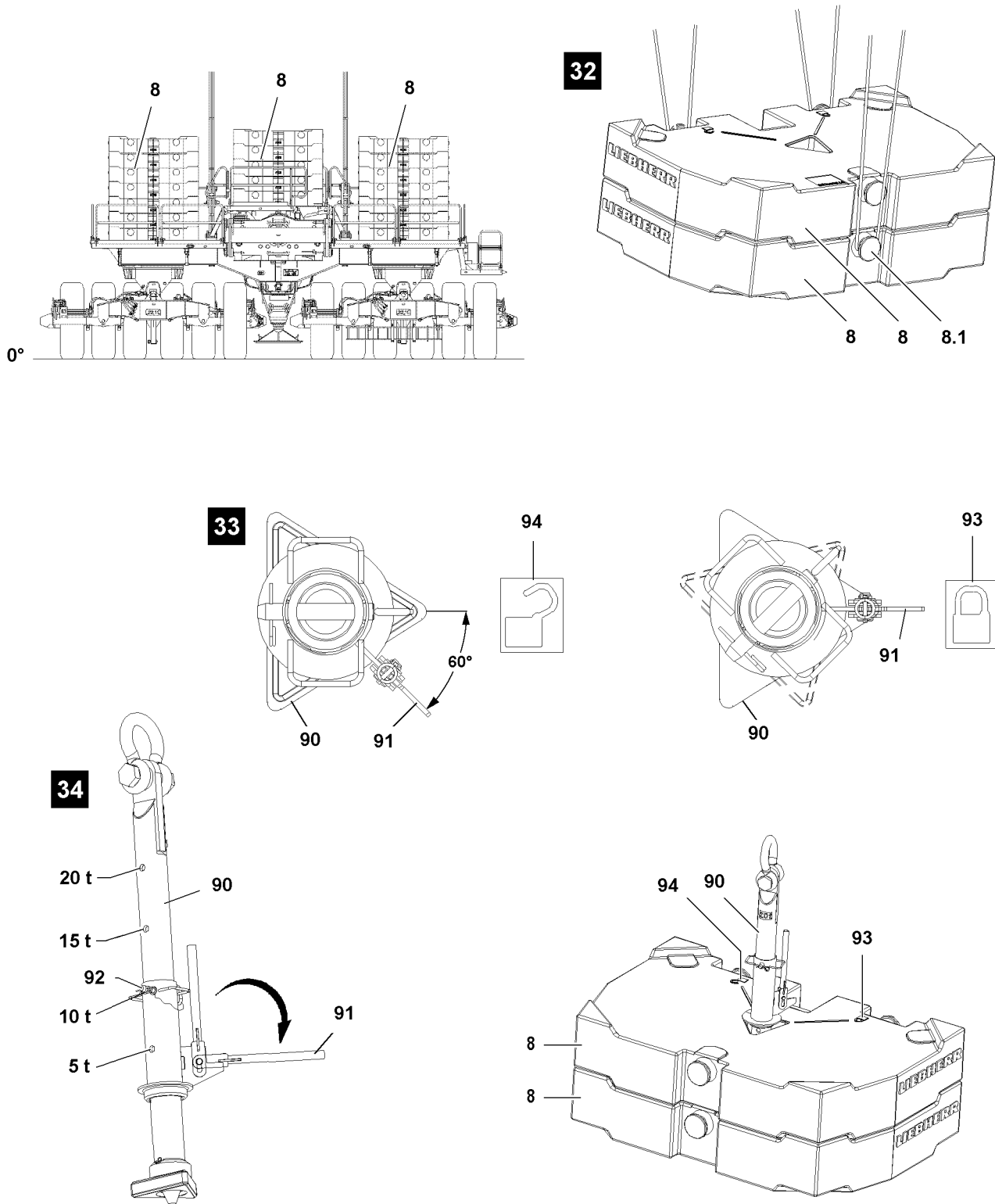

Fig.120230: Stacking the ballast plates on the ballast trailer



Note

► The ballast plates are marked with their own weights.

LWE/LR 11000-001/23501-04-02/en

**WARNING**

The crane can topple over!

If the following danger notes are not observed, the ballast plates or the ballast stack can slip on the ballast trailer and fall down.

The crane can topple over.

Death, severe bodily injuries, property damage.

- ▶ The ground on which the ballast trailer is ballasted must be level and have adequate load-bearing capacity.
- ▶ Always place the ballast plates symmetrically, in reference to the longitudinal axis.
- ▶ The outer ballast stacks must always weigh the same and be the same height after ballasting.
- ▶ The ballast stacks may only be stacked to three times the height of the ballast plate width.
- ▶ The outer ballast stacks can differ in stack height from the inner ballast stacks.
- ▶ The maximum permissible total weight of the ballast trailer may not exceed 450 t.
- ▶ Secure all ballast plates so they cannot move and fall down.
- ▶ Replace damaged ballast plates immediately with new ballast plates.

Make sure that the following prerequisites are met:

- The ballast trailer is pinned and secured on the turntable on both sides.
- The ballast trailer is properly pinned and secured to the Derrick ballast guying.
- An auxiliary crane is on hand.

9.5.1 Stacking the ballast plates on the ballast trailer, fastening system „Twistlock“

**WARNING**

Danger of accident!

If more than the permissible two ballast plates are lifted with the receptacle stud, the receptacle stud will be overloaded and can be damaged.

Death, severe bodily injuries, property damage.

- ▶ Make sure that the ballast plates are placed correctly in the centerings.
- ▶ Replace damaged ballast plates.

To stack the ballast plate(s) **8**, use the receptacle stud **90**.

Before the receptacle stud **90** is guided into the ballast plates, it must be ensured that the length of the receptacle stud is set correctly. The length of the receptacle stud **90** can be adjusted with the pin **92**, see illustration **34**.

If the length of the receptacle stud **90** is to be adjusted:

- ▶ Release and unpin the pin **92**.
- ▶ Adjust the length of the receptacle stud by moving the receptacle stud **90**, see illustration **34**.
- ▶ Insert the pin **92** and secure with the spring retainer.
- ▶ Fasten the receptacle stud **90** to the auxiliary crane and guide it into the ballast plate(s).
- ▶ Pull the lever **91** up and fold it down.
- ▶ Turn the lever **91** by 60° until the lever points to the icon **93**, see illustration **33**.

Result:

- The receptacle stud **90** is locked with the ballast plate.
- ▶ Lift always one ballast plate with the receptacle stud **90** and place it carefully on the centerings on the ballast trailer or on another ballast plate **8**.
- ▶ Turn the lever **91** by 60° until the lever **91** points to the icon **94**, see illustration **33**.

Result:

- The receptacle stud **90** is unlocked.
- ▶ Carefully pull the receptacle stud **90** from the ballast plate.
- ▶ Stack the ballast plates **8** according to the load chart, observe the danger notes.

9.5.2 Stacking the ballast plates on the ballast trailer, fastening points: Bitt



WARNING

Falling ballast plates!

If more than the permissible loads are lifted, then the bits **8.1** are overloaded and the ballast plates can fall down.

Death, severe bodily injuries, property damage.

- ▶ Lift no more than maximum 20 t with the ropes, 3 fastening points.
- ▶ Replace damaged ballast plates immediately.



WARNING

Incorrect handling of the fastening equipment!

If fastening equipment cannot be attached correctly and if it is not secured sufficiently to prevent it from loosening up, loads can fall down.

Death, severe bodily injuries, property damage.

- ▶ Make sure that the fastening equipment is correctly attached on the bits **8.1** and that it is secured sufficiently to prevent it from loosening up.



Note

- ▶ Place the ballast plates individually or as a ballast assembly, maximum 20 t.
 - ▶ The weight difference between the outer ballast stacks no more than maximum 20 t.
 - ▶ 20 t ballast assembly, see illustration **32**.
-
- ▶ Use the auxiliary crane to evenly distribute the ballast plates **8** on the ballast trailer and center them on the centering points.
 - ▶ Stack the ballast plates according to the load chart.

10 Working with the ballast trailer

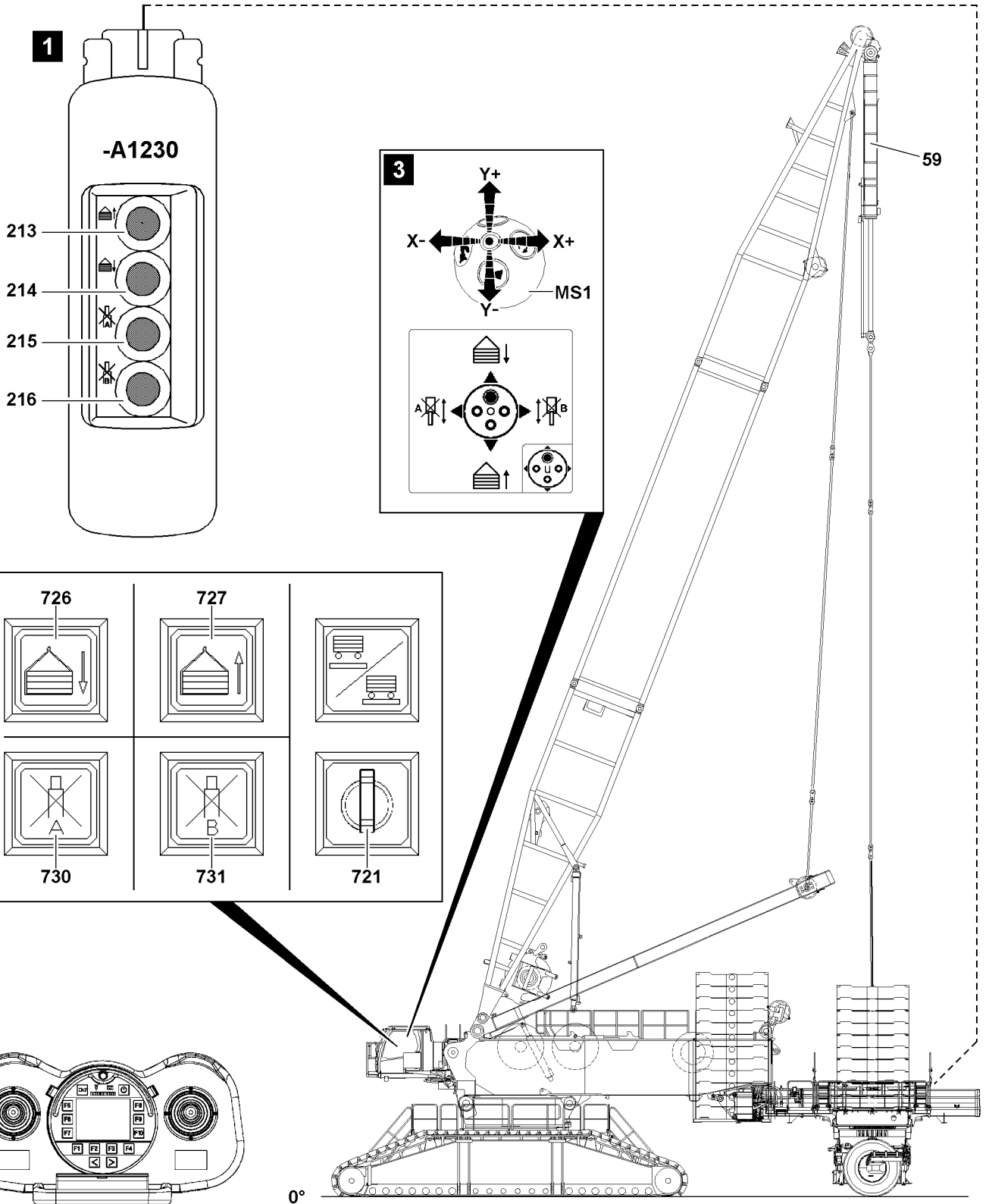

Fig.144131

LWE/LR 11000-001/23501-04-02/en

10.1 Lifting and lowering the ballast trailer with the pull cylinders

The pull cylinders **59** in the derrick ballast guying can be operated in different ways:

- Operation with control panel -A1230, see illustration 1
- Operation with operating buttons on the instrument panel, see illustration 2
- Operation with master switch **MS1** in the corresponding master switch assignment, see illustration 3
 - Select the master switch assignment for master switch MS1, see chapter 4.01.

There is an additional operating option in assembly operation:

- Operation with the radio remote control (BTT-E), see illustration 4
 - Operation with the manual control lever in the corresponding assembly menu, see the radio remote control operating instructions.



Note

- ▶ If the ballast trailer is raised or lowered using the pull cylinder **59**, then the horizontal alignment of the ballast trailer is automatically regulated by both length sensors of the pull cylinder **59**.
- ▶ For a ballast utilization of **more than** or **equal to** 90 percent, the level sensor regulates the pull cylinder **59** to a difference of 1 cm.
- ▶ With a ballast utilization of **less than** 90 percent, the level sensor monitors the ballast trailer level to $\pm 2.5^\circ$. This makes it possible to set the ballast trailer down to a ground slope of 2.5° .
- ▶ As soon as the ballast trailer has been lifted completely off the ground and hangs freely, by turning on the "Derrick ballast lifted" function (key button **721**), the turning and driving functions can be released independently of the steering program.
- ▶ From a ground slope of $\pm 1.5^\circ$, driving with the ballast trailer is no longer possible or only with limits.



DANGER

Danger of accident!

Death, severe bodily injuries, property damage.

- ▶ When lifting or lowering the ballast trailer, pay attention to the horizontal alignment of the ballast trailer.
- ▶ When lifting or lowering the ballast trailer, the forces in the ballast guyings must be regularly checked on the LICCON monitor. If the difference of forces between „derrick ballast guying A“ and „derrick ballast guying B“ is too large, an acoustic warning sounds and the values on the LICCON monitor blink, see section „Differential force monitoring of ballast guying“.
- ▶ When adjusting the pull cylinder **59** manually (block pull cylinder A or pull cylinder B) the regulation is deactivated and the ballast trailer can be inclined within the limited angle range. This is only permitted when setting down the ballast trailer on uneven ground and applying utmost caution.



WARNING

The crane can topple over!

If the ballast trailer is lifted off the ground past the **maximum permissible** 250 mm, then the crane can topple over to the rear if the load rips off.

Death, severe bodily injuries, property damage.

- ▶ Do not lift the ballast trailer by more than 250 mm off the ground.

10.1.1 Lifting the ballast trailer

- ▶ Press the button **727**.
or
Press the button **213**.
or
Deflect the master switch **MS1** in direction **Y-**.

Result:

- The piston rods of the pull cylinder **59** (pull cylinder A and pull cylinder B) retract together.

- The ballast trailer is raised.

10.1.2 Lowering the ballast trailer

- ▶ Press the button **726**.
or
Press the button **214**.
or
Deflect the master switch **MS1** in direction **Y+**.

Result:

- The piston rods of the pull cylinder **59** (pull cylinder A and pull cylinder B) extend together.
- The ballast trailer is lowered.

10.1.3 Equalizing the ballast trailer position

The position of the ballast trailer can be equalized with different extension lengths of the pull cylinders **59** (pull cylinder A and pull cylinder B).

Block the pull cylinder (A) when lifting:

- ▶ Press the button **727** and the button **730**.
or
Press the button **213** and the button **215**.
or
Deflect the master switch **MS1** diagonally in direction **X-** and direction **Y-**.

Result:

- The piston rod of the pull cylinder (A) stops.
- The piston rod of pull cylinder (B) moves in.
- Side (B) of the ballast trailer lifts up.

Block the pull cylinder (B) when lifting:

- ▶ Press the button **727** and the button **731**.
or
Press the button **213** and the button **216**.
or
Deflect the master switch **MS1** diagonally in direction **X+** and direction **Y-**.

Result:

- The piston rod of the pull cylinder (B) stops.
- The piston rod of pull cylinder (A) moves in.
- Side (A) of the ballast trailer lifts up.

Block the pull cylinder (A) when lowering:

- ▶ Press the button **726** and the button **730**.
or
Press the button **214** and the button **215**.
or
Deflect the master switch **MS1** diagonally in direction **X-** and direction **Y+**.

Result:

- The piston rod of the pull cylinder (A) stops.
- The piston rod of pull cylinder (B) moves out.
- Side (B) of the ballast trailer lowers.

Block the pull cylinder (B) when lowering:

- ▶ Press the button **726** and the button **731**.
- or**
- Press the button **214** and the button **216**.
- or**
- Deflect the master switch **MS1** diagonally in direction **X+** and direction **Y+**.

Result:

- The piston rod of the pull cylinder (B) stops.
- The piston rod of pull cylinder (A) moves out.
- Side (A) of the ballast trailer lowers.

10.2 Setting the ballast trailer radii

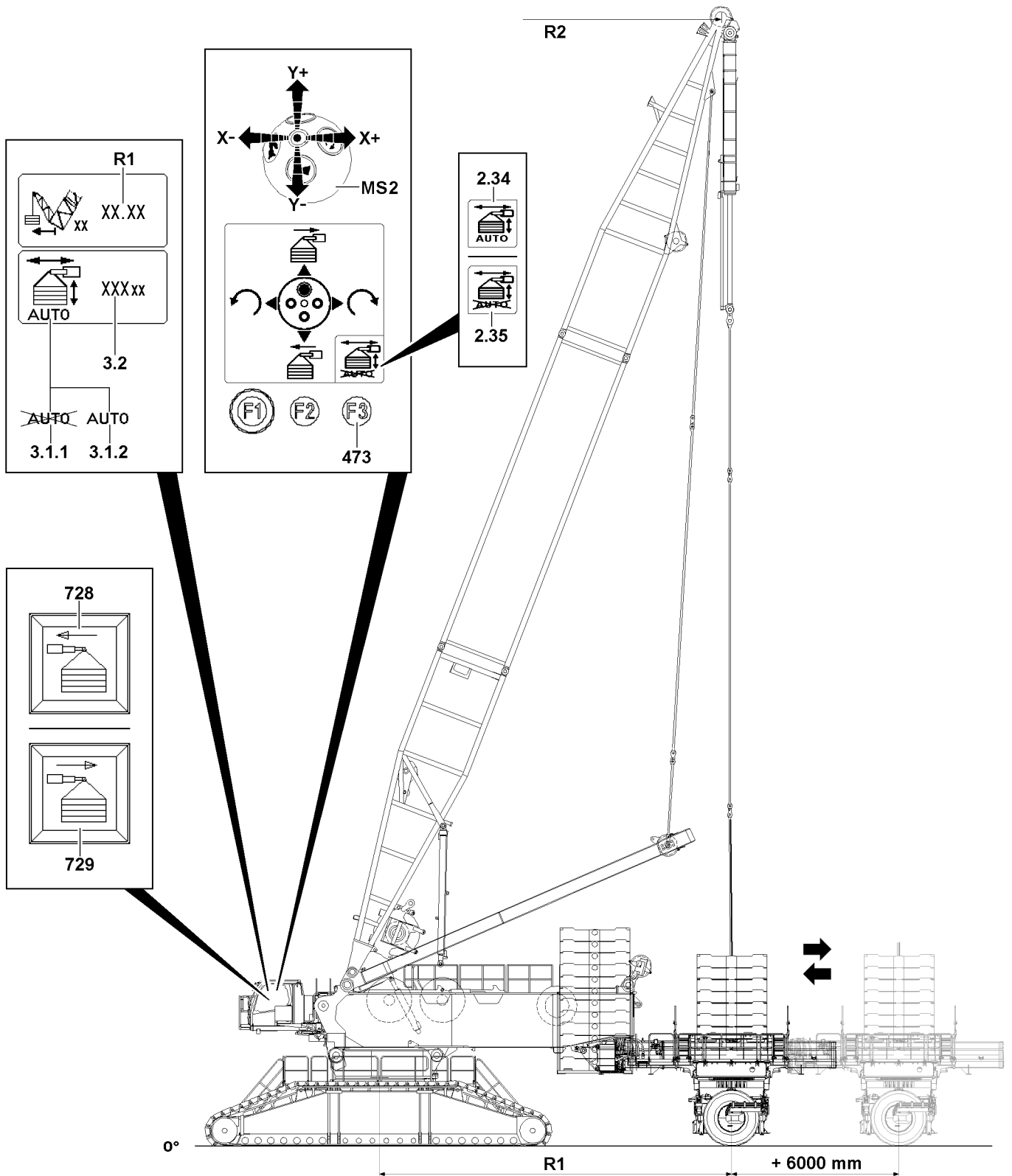

Fig.144132

The ballast trailer radius can be adjusted steplessly across a path of 6000 mm.

The ballast trailer is equipped with a telescopic ballast trailer guide. This allows the derrick ballast radius to be adjusted to suit the environment or type of lifting work. The set derrick ballast radius **R1** is displayed on the LICCON monitor.

LWE/LR 11000-001/23501-04-02/en

Pay attention to the difference between the derrick ballast radius **R1** and the derrick radius **R2**.

The ballast trailer radius can be adjusted:

- With master switch MS2 (crane cab)
 - Manual adjustment
 - Ballast automatic
- With the operating buttons on the instrument panel (crane cab)
 - Manual adjustment only
- With control panel -A1230
 - Manual adjustment only
 - See section „Operating elements on the control panels“.
- With the radio remote control (BTT-E)
 - Manual adjustment only
 - See the radio remote control operating instructions



Note

- ▶ The release for telescoping the ballast trailer guide out and in is only given when the wheel sets are in „towing“ mode, see section „Towing“.
- ▶ If the ballast trailer is supported for assembly on the turntable, then it is possible to telescope the ballast trailer guide out and in with reduced pressure.
- ▶ When telescoping the ballast trailer guide out, monitor the derrick ballast radius **R1** on the LICCON monitor constantly.
- ▶ The crane operator may not blindly rely on the derrick ballast radius measurement, he must think for himself and check if the length sensor measure functions correctly, see chapter 4.02.

10.2.1 Telescoping the ballast trailer guide out

By telescoping the ballast trailer guide out, the ballast trailer radius is enlarged.

Make sure that the following prerequisite is met:

- The wheel sets of the ballast trailer are in the „Towing“ position

Telescoping the ballast trailer guide out with the ballast automatic

Make sure that the following prerequisite is met:

- The master switch **MS2** has the master switch assignment to control the ballast automatic, see illustration.

- ▶ Press the F3 key **473**.

Result:

- The *ballast automatic can be turned on* icon **2.34** disappears, the *ballast automatic can be turned off* icon **2.35** appears.
- The ballast automatic status **3.1.2** appears.
- The ballast automatic is activated.

- ▶ Deflect the master switch **MS2** in direction **Y-**.

Result:

- The ballast trailer guide moves out.
- The ballast automatic regulates the pull cylinder automatically in order to keep the saved value **3.2** (depending on the situation F1-force or ballast trailer incline).

To turn the ballast automatic back off:

- ▶ Press the F3 key **473** again **473**

Result:

- The *ballast automatic can be turned off* icon **2.35** disappears, the *ballast automatic can be turned on* icon **2.34** appears.

- The ballast automatic status **3.1.1** appears.
- The ballast automatic is turned off.

Telescoping the ballast trailer guide out manually (operating buttons in the instrument panel)

- ▶ Press the button **729**.

Result:

- The ballast trailer guide moves out.
- ▶ Observe the force display in the derrick guying $F1_{min}$ - $F1_{max}$ and the ballast trailer incline.

Telescoping the ballast trailer guide out manually (master switch MS2)

Make sure that the following prerequisite is met:

- Ballast automatic is turned off, the ballast automatic status **3.1.1** appears.
- ▶ Deflect the master switch **MS2** in direction **Y-**.

Result:

- The ballast trailer guide moves out.
- ▶ Observe the force display in the derrick guying $F1_{min}$ - $F1_{max}$ and the ballast trailer incline.

10.2.2 Telescoping the ballast trailer guide in

By telescoping the ballast trailer guide in, the ballast trailer radius is reduced.

Make sure that the following prerequisite is met:

- The wheel sets of the ballast trailer are in the „Towing“ position.

Telescoping the ballast trailer guide in with the ballast automatic

Make sure that the following prerequisite is met:

- The master switch **MS2** has the master switch assignment to control the ballast automatic, see illustration.
- ▶ Press the F3 key **473**.

Result:

- The *ballast automatic can be turned on* icon **2.34** disappears, the *ballast automatic can be turned off* icon **2.35** appears.
- The ballast automatic status **3.1.2** appears.
- The ballast automatic is activated.
- ▶ Deflect the master switch **MS2** in direction **Y+**.

Result:

- The ballast trailer guide moves in.
- The ballast automatic regulates the pull cylinder automatically in order to keep the saved value **3.2** (depending on the situation F1-force or ballast trailer incline).

To turn the ballast automatic back off:

- ▶ Press the F3 key **473** again

Result:

- The *ballast automatic can be turned off* icon **2.35** disappears, the *ballast automatic can be turned on* icon **2.34** appears.
- The ballast automatic status **3.1.1** appears.
- The ballast automatic is turned off.

Telescoping the ballast trailer guide in manually (operating buttons in the instrument panel)

- ▶ Press the button **728**.

Result:

- The ballast trailer guide moves in.
- ▶ Observe the force display in the derrick guying $F_{1_{min}}-F_{1_{max}}$ and the ballast trailer incline.

Telescoping the ballast trailer guide in manually (master switch MS2)

Make sure that the following prerequisite is met:

- Ballast automatic is turned off, the ballast automatic status **3.1.1** appears.

- ▶ Deflect the master switch **MS2** in direction **Y+**.

Result:

- The ballast trailer guide moves in.
- ▶ Observe the force display in the derrick guying $F_{1_{min}}-F_{1_{max}}$ and the ballast trailer incline.

10.3 Steering programs

**WARNING**

Danger when moving the wheel sets on the ballast trailer!

Death, severe bodily injuries, property damage.

- ▶ The crane operator as well as any operating personnel must make sure that there are no persons in the danger zone.
- ▶ It is prohibited for anyone to remain between the wheel sets for all setting / adjustment work on the ballast trailer.
- ▶ It is prohibited to anyone to remain between the wheel sets when selecting the various steering programs.

10.3.1 Overview of the steering programs

The crane has the following computer controlled steering programs.

Towing steering program

Fig.144284: Example for crane in the Towing steering program

Parallel travel steering program

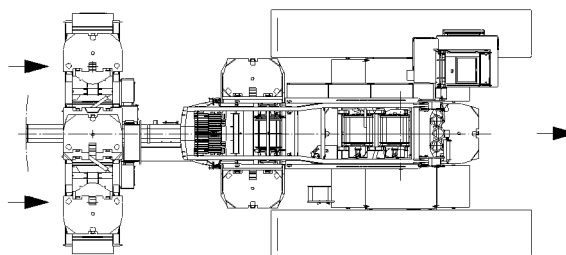
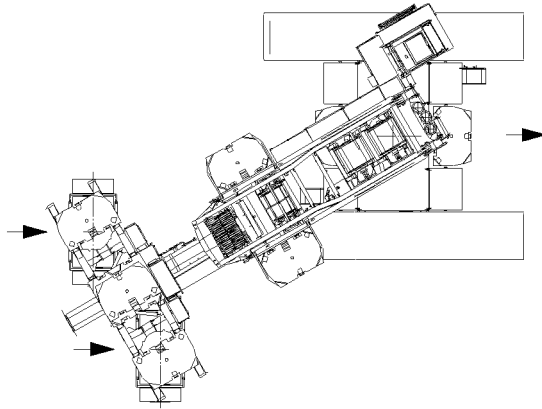

Fig.144285: Example for crane in the Parallel travel steering program

Circular travel steering program

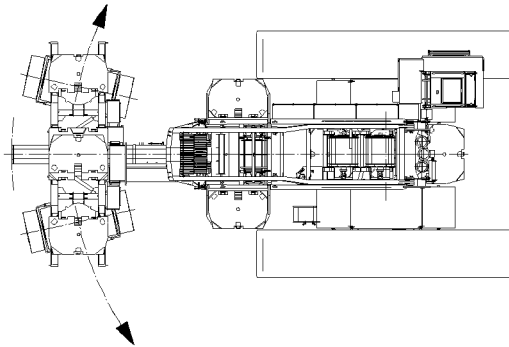

Fig.144286: Example for crane in the Circular travel steering program

Corrective steering steering program

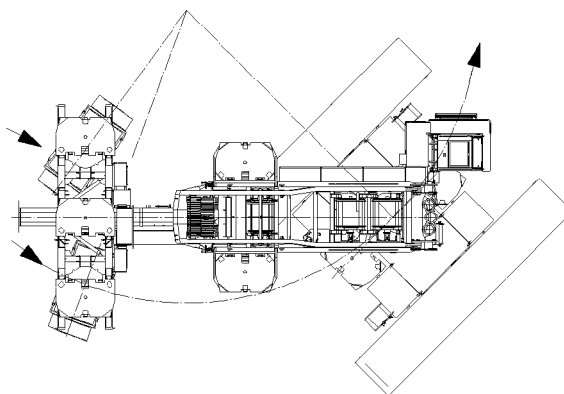

Fig.144287: Example for crane in the „Corrective steering“ steering program

10.3.2 Selecting the steering program

If an incorrect steering program is activated on the ballast trailer, necessary crane functions cannot be carried out and / or controlled.

In order to carry out necessary crane functions, the following is necessary:

- either all steering programs must be deactivated (all steering program indicator lights are off)

or:

- a certain steering program must be activated (steering program indicator light on)

In order to operate the crane functions, it may be necessary to activate the necessary steering program for the desired crane function.

- Driving the crawler requires towing steering program
- Telescoping the ballast trailer guide in / out requires the towing steering program
- Turning the turntable requires circular travel steering program

10.3.3 Wheel set adjustment procedure for the steering programs

The adjustment procedure for the various steering programs is identical.

Pressing the steering program buttons automatically adjust the wheel sets.

The wheel sets are steered correctively from the crane cab, or from the control panel on the ballast trailer.

The manual change of the wheel sets for assembly purposes is only possible with control panel on the ballast trailer.



Note

- ▶ If the ballast trailer is **not loaded**, the wheel sets can be adjusted without relieving the tires.
- ▶ If the ballast trailer is **loaded**, the ballast trailer must be raised first with the support cylinders until the tires are relieved.

10.3.4 Supporting the ballast trailer to align the wheel sets with the support cylinders

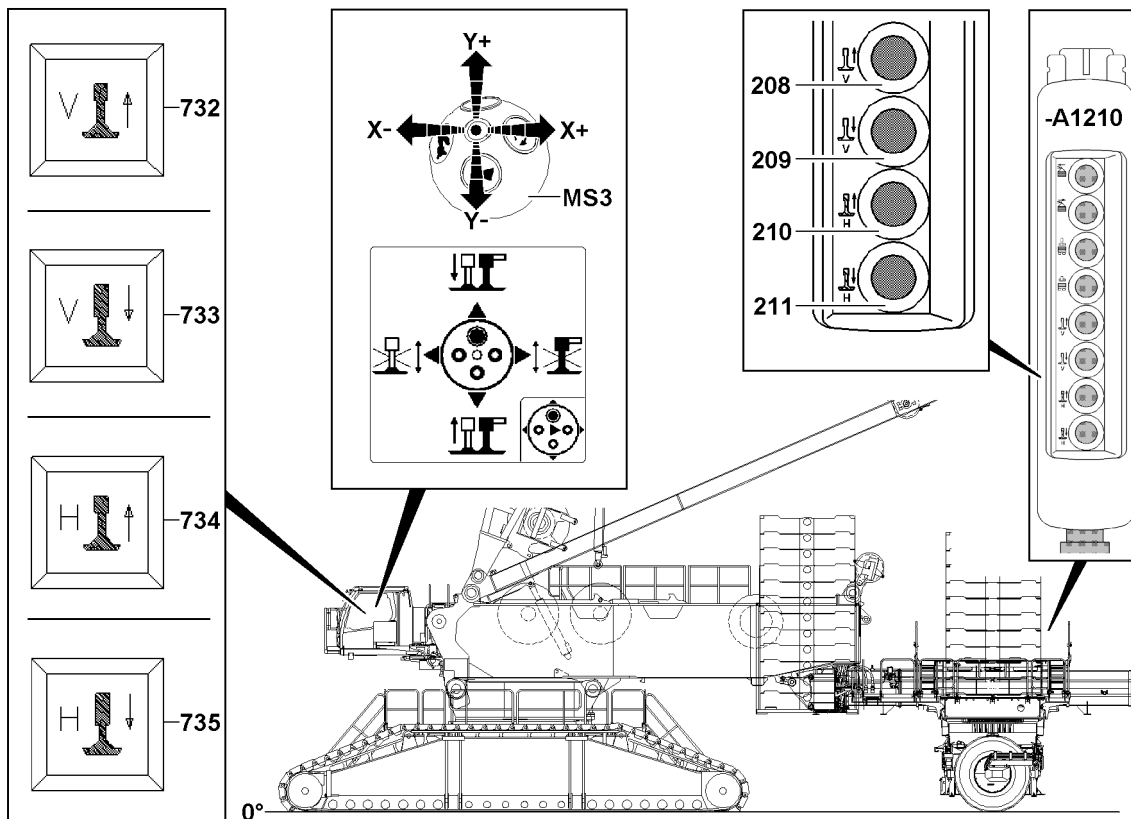

Fig.144135

**DANGER**

Danger of accident due to crane overload!

By raising the ballast trailer with the support cylinders, the force at test point 1 (MS1) can increase to the permissible maximum value. The extension of the support cylinders is then turned off.

- ▶ Monitor the display of test point 1 (F1-force) on the LICCON monitor and stop the extending of the support cylinders in time before the shut-off, see chapter 4.02.

**Note**

Ballast trailer support cylinders extended until the maximum value of test point 1 (F1-Kraft) is reached:

Release the test point 1 (F1-force):

- ▶ If possible, for example: Increase the pulled derrick ballast or luff up the main boom / accessory or place down the load.

**Note**

- ▶ By selecting the corresponding master switch assignment, the support cylinders of the ballast trailer can also be operated with the master switch **MS3**.

Lifting the ballast trailer with the support cylinders

**Note**

- ▶ The support cylinders of the ballast trailer must always be moved out evenly.
- ▶ Keep the actual value test point 1 (F1-force) in the permissible range.

- ▶ Press the button **733** and button **735** in the crane cab.
or
Press the button **209** and button **211** on the control panel **-A1210**.
or
Move the master switch **MS3** forward (direction **Y+**).

Operating the support cylinders individually

To compensate for the incline position or uneven ground, the support cylinders can be operated individually.

Retracting the front support cylinder

- ▶ Press the button **732** in the crane cab.
or
Press the button **208** on the control panel **-A1210**.
or
Move the master switch **MS3** to the left rear (direction **X-Y-**).

Extending the front support cylinder

- ▶ Press the button **733** in the crane cab.
or
Press the button **209** on the control panel **-A1210**.
or
Move the master switch **MS3** to the left front (direction **X-Y+**).

Retracting the rear support cylinder

- ▶ Press the button **734** in the crane cab.
or
Press the button **210** on the control panel **-A1210**.
or
Move the master switch **MS3** to the right rear (direction **X+Y-**).

Extending the rear support cylinder

- ▶ Press the button **735** in the crane cab.
- or
- Press the button **211** on the control panel **-A1210**.
- or
- Move the master switch **MS3** to the right front (direction **X+Y+**).

Lowering the ballast trailer with the support cylinders



Note

- ▶ The support cylinders of the ballast trailer must always be moved in evenly.

Retract the support cylinders completely on the front and rear:

- ▶ Press the button **732** and button **734** in the crane cab.
- or
- Press the button **208** and button **210** on the control panel **-A1210**.
- or
- Move the master switch **MS3** to the rear (direction **Y-**).

Result:

- The support cylinders retract.
- ▶ Fully retract both support cylinders.

Result:

- A visual display appears on LICCON monitor LM2.

10.3.5 Towing

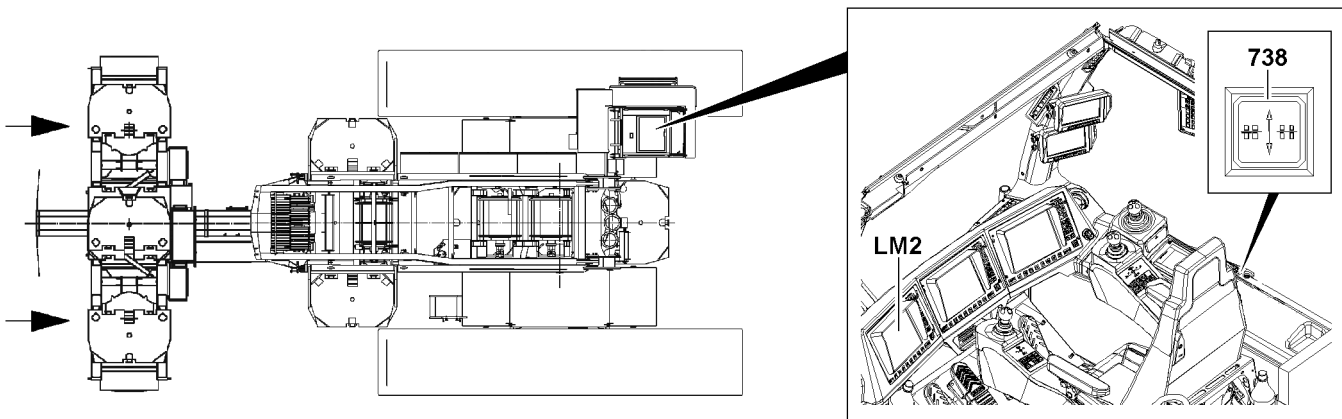

Fig.144136

Aligning the wheel sets in the towing position

Make sure that the following prerequisite is met:

- The ballast trailer is raised via the support cylinders to the point where the wheel sets are relieved.
- ▶ Press the button **738**.

Result:

- The wheel sets of the ballast trailer are aligned in towing position.
- During the turning procedure of the wheel sets, the indicator light in the button **738 blinks**.
- When the towing position is reached, the indicator light in the button **738 lights up**.
- A visual display appears on the LICCON monitor **LM2**.

**Note**

- ▶ The release to drive the crane in the „Towing“ steering program is only made when both wheel sets are in the travel direction (neutral position) and the support cylinders are fully retracted.
- ▶ Check the settings of the wheel sets and the support cylinders before driving the crane.

- ▶ Retract the support cylinders completely, see section „Supporting the ballast trailer to align the wheel sets with the support cylinders.“
- ▶ Check the visual display on the LICCON monitor **LM2**.

**Note**

- ▶ If one of the wheel sets deviates from the specified angle, the indicator light in the button **738** blinks and the wheel sets must be aligned again.

When the indicator light in the button **738** blinks.:

- ▶ Check the parallel position of the wheel sets on the visual display on the LICCON monitor **LM2**.
- ▶ Re-aligning the wheel sets in the towing position.

Corrective steering of the wheel sets

Observe the special section „Corrective steering“.

NOTICE

Damage of the ballast trailer!

Through corrective steering of wheel sets while at a standstill, the ballast trailer can be damaged.

- ▶ If the ballast trailer is ballasted, the corrective steering of the wheel sets at a standstill is **prohibited**.
- ▶ When the ballast trailer is ballasted, the corrective steering of the wheel sets is only permissible while driving.
- ▶ Monitor the distortion of the tires.

**Note**

- ▶ Changing from the steering program „Towing“ into the steering program „Corrective steering“ and back is possible while driving the crawler!
- ▶ If the steering program „Corrective steering“ is switched into the steering program „Towing operation“ then the indicator light **blinks** on the „button“ **738** until the towing operation position of the wheel sets is reached.
- ▶ If one of the wheel sets deviates from the specified limit angle, the „indicator light in the button“ **738** blinks and the wheel sets must be reset as described above.
- ▶ **In general, the following applies:** The wheel sets only move if either the button **741**, the button **740**, or the button **738** in the crane cab, or the button **200** or the button **201** on the control panel is pressed in the respective steering program or if the crawler is driven.

10.3.6 Circular travel

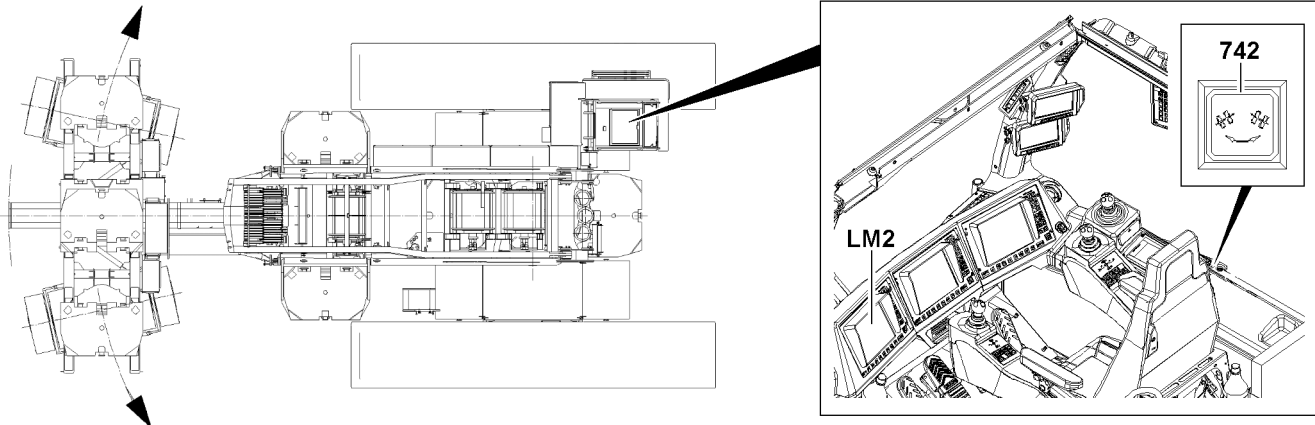

Fig.144137

Make sure that the following prerequisite is met:

- The ballast trailer guide is telescoped out to the required derrick ballast radius.

Aligning the wheel sets in the circular travel position

Make sure that the following prerequisite is met:

- The ballast trailer is raised via the support cylinders to the point where the wheel sets are relieved.

- ▶ Press the button **742**.

Result:

- The ballast trailer wheel sets are aligned in the circular travel position.
- During the turning procedure of the wheel sets, the indicator light in the button **742** blinks.
- When the circular travel position is reached, the indicator light in the button **742** lights up.
- A visual display appears on the LICCON monitor **LM2**.



Note

- ▶ The release for turning the turntable in the „Circular travel“ steering program is only made when both wheel sets are in the turning position (circular travel) and the support cylinders are completely retracted.
- ▶ Check the settings for the wheel sets and support cylinders before inspecting turning of the turntable.

- ▶ Retract the support cylinders completely, see section „Supporting the ballast trailer to align the wheel sets with the support cylinders.“

- ▶ Check the visual display on the LICCON monitor **LM2**.



Note

- ▶ If one of the wheel sets deviates from the specified angle, the indicator light in the button **742** blinks and the wheel sets must be aligned again.

When the indicator light in the button **742** blinks.:

- ▶ Check the circular travel position of the wheel sets on the visual display on the LICCON monitor **LM2**.
- ▶ Re-aligning the wheel sets in the circular travel position.

10.3.7 Parallel travel

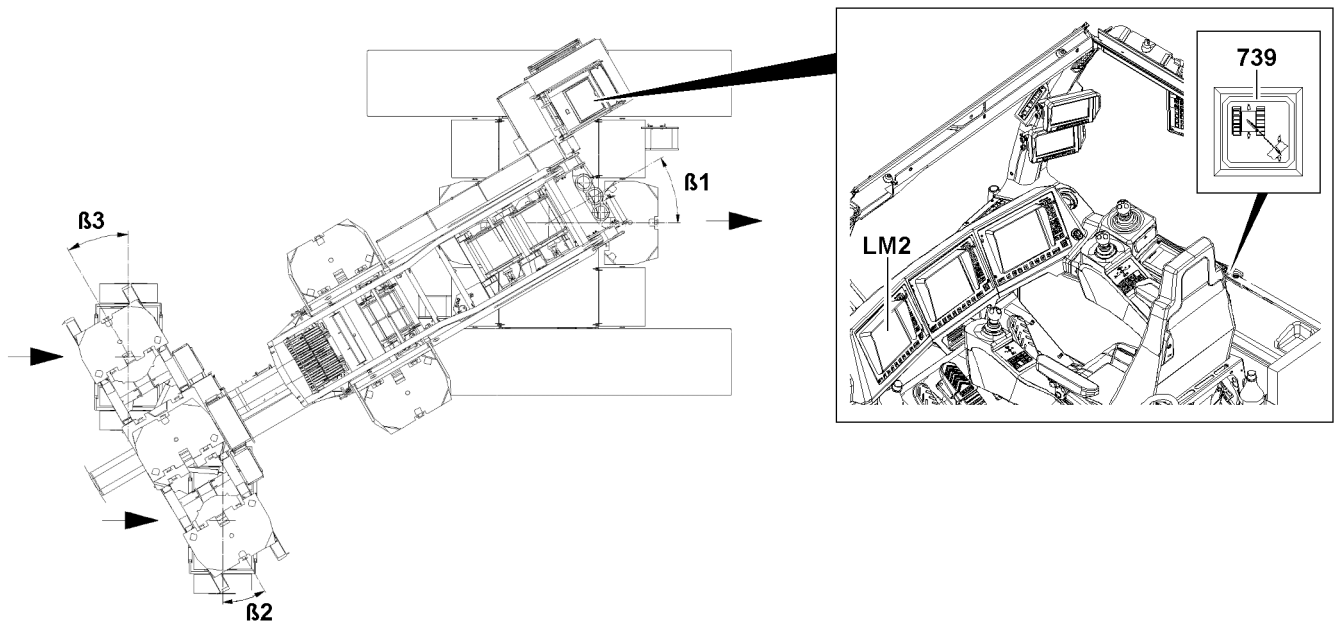

Fig.144138

NOTICE

Danger of damage to the crane and the ballast trailer!

Due to steering movements on the crawler track during parallel travel, the crane and the ballast trailer can be significantly damaged.

- ▶ For parallel travel, steering the crawler track is **prohibited**.
- ▶ Driving the crane in parallel travel is only permissible when „Parallel travel crawler“ is selected, otherwise there is no release of the travel gear.
- ▶ For parallel travel, the side tire distortion on the wheel sets must be observed by an instructed person over the entire travel route of the crane. If the tires distort by more than 100 mm, then the position of the wheel sets must be corrected.



Note

- ▶ Independently of whether the ballast trailer stands on the ground or is lifted off the ground, the wheel sets must always stand in a „Parallel travel“ position.
- ▶ In deviating position for the wheel sets, the control turns itself off.
- ▶ To drive the crane with the ballast trailer in the parallel travel steering program, „parallel travel crawler operation“ must be selected on the crane.



Note

- ▶ The travel drive of the crawler is locked until the wheel sets are in the parallel travel position.
- ▶ When driving the crawler, the slewing gear brake of the crane remains applied, the hydraulic coasting is opened.
- ▶ If the angles β_2 and β_3 deviate in relation to β_1 , by more than the permissible tolerance, the crawler travel gear is stopped, the indicator light in the button **739** blinks.
- ▶ Only through renewed alignment of the wheel sets to the required specified angle can the crawler travel gear be driven again.
- ▶ If „Crawler Parallel travel“ is selected, the crawler and the ballast trailer move straight forward on appropriate terrain.

Aligning the wheel sets in the parallel travel position

Make sure that the following prerequisite is met:

- The ballast trailer is raised via the support cylinders to the point where the wheel sets are relieved.

- ▶ Press the button **739**.

Result:

- The ballast trailer wheel sets are aligned in the parallel travel position.
 - During the turning procedure of the wheel sets, the indicator light in the button **739** **blinks**.
 - When the parallel travel position is reached, the indicator light in the button **739** **lights up**.
 - A visual display appears on the LICCON monitor **LM2**.
- ▶ Retract the support cylinders completely, see section „Supporting the ballast trailer to align the wheel sets with the support cylinders.“
 - ▶ Check the visual display on the LICCON monitor **LM2**.



Note

- ▶ If one of the wheel sets deviates from the specified angle, the indicator light in the button **739** blinks and the wheel sets must be aligned again.

When the indicator light in the button **739** blinks.:

- ▶ Check the parallel position of the wheel sets on the visual display on the LICCON monitor **LM2**.
- ▶ Re-aligning the wheel sets in the parallel travel position.

10.3.8 Corrective steering

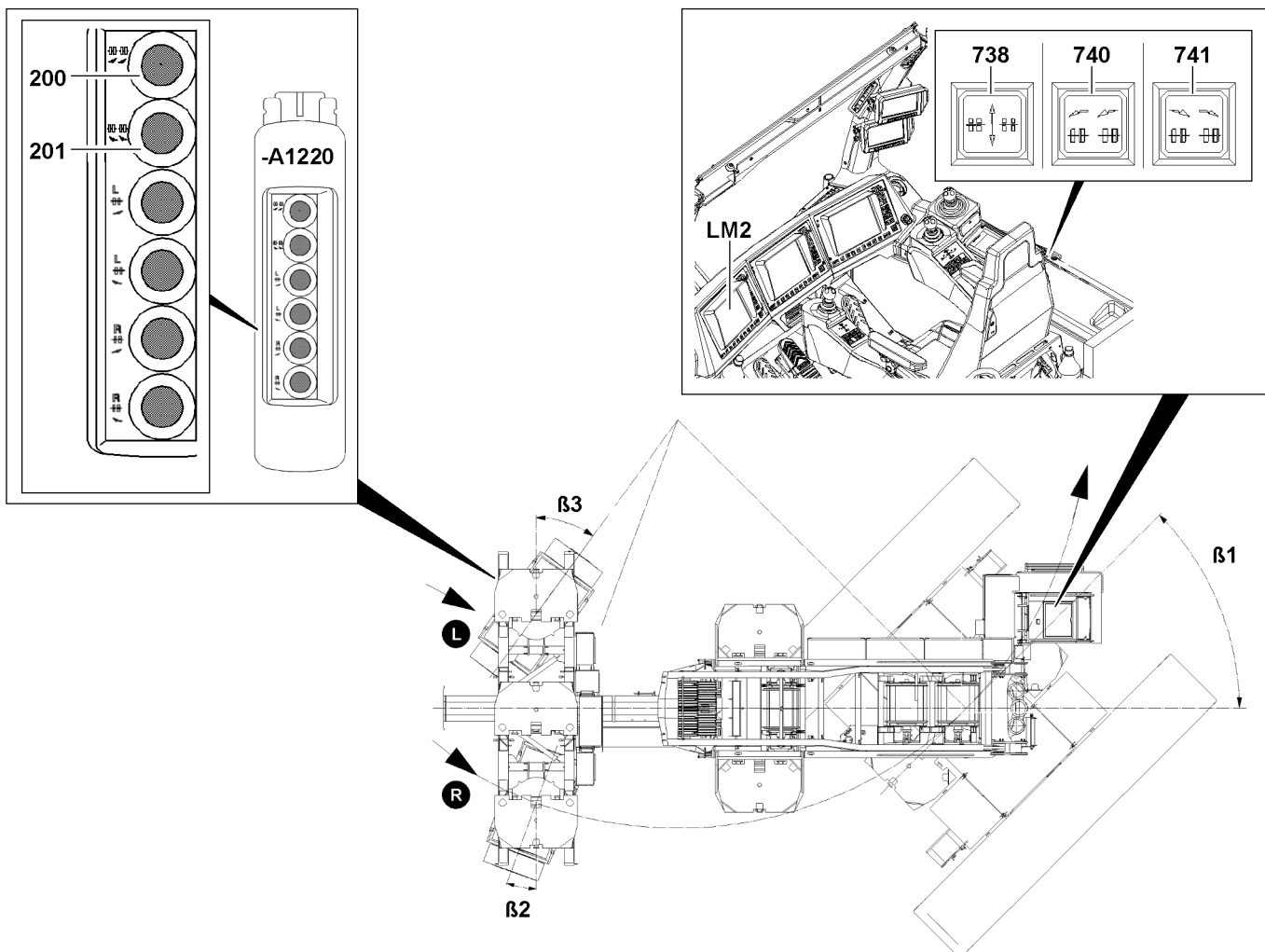

Fig.144139

Make sure that the following prerequisite is met:

- Crawler operation is turned on.

Observe the special section „Towing“.

Steering and corrective steering of the wheel sets

Make sure that the following prerequisites are met:

- The steering program „Towing“ is selected **and** the wheel sets are in the towing position.
- Control light in button **738** illuminates.

Turn wheel sets to the right:

- ▶ Press the button **741** in the crane cab.
or
Press the button **200** on the control panel **-A1220**.

Turn wheel sets to the left:

- ▶ Press the button **740** in the crane cab.
or
Press the button **201** on the control panel **-A1220**.

The right wheel set is regulated by the computer-controlled steering program so that there is always a center steering position. The angle β_1 is determined by the travel of the crawler and the angle β_3 is determined by the steering of the operator, whereby the angle β_2 is continually corrected. Switching from the steering program „Corrective steering“ into the steering program „Towing“ and back, after achieving the towing position, is possible while driving the crawler! If the steering program „Corrective steering“ is selected from the steering program „Towing“ the indicator light in the button **741** and the indicator light in the button **740** lights up.



Note

- ▶ The left wheel set can be steered to the specified limit angle β_3 . It is not possible to steer beyond this limit angle.
- ▶ The right wheel set is corrected to follow the center steering position. If the right correctively steered wheel set cannot follow the left wheel set, then the left wheel set is stopped until the right correctively steered wheel set has caught up.
- ▶ If the right wheel set still deviates from the specified limit angle, the indicator light in the button **741** and the indicator light in the button **740** blinks and you must begin again with „Towing“.
- ▶ If the crawler is driven and exceeds the angle β_1 , the turntable automatically switches the specified value into the steering program „Towing“. The axles are swung back to the initial towing position (0° or 180°). The indicator light in the button **741**, the indicator light in the button **740** and the indicator light in the button **738** blink.
- ▶ When the towing position is reached, manual corrective steering can continue. The indicator light in the button **738** lights up, also a visual display appears on the LICCON monitor LM2.
- ▶ **In general, the following applies:** The wheel sets only move during corrective steering if either the button **741** or the button **740** from the crane cab, **or** the button **200** or the button **201** on the control panel is pressed in the respective steering program or if the crawler is driven.

- ▶ Check the settings.

10.3.9 Wheel set manual operation for assembly / emergency operation

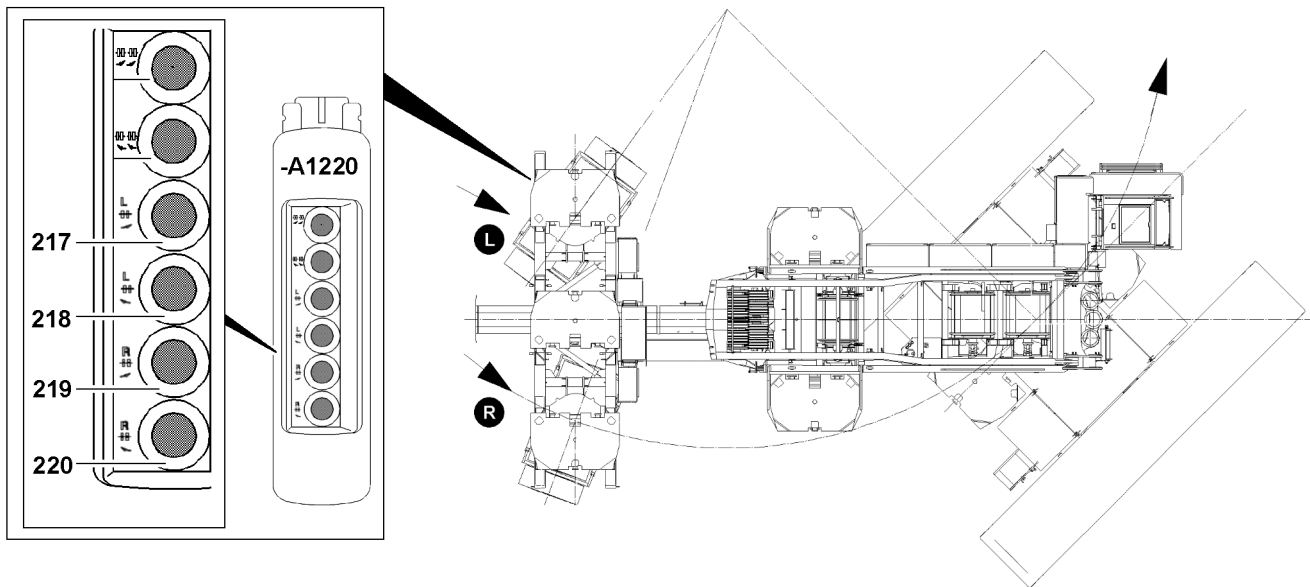

Fig.144141

The ballast trailer is equipped with a program which allows for each wheel set to be turned individually at assembly / emergency operation.

Make sure that the following prerequisite is met:

- The ballast trailer is raised via the support cylinders to the point where the wheel sets are relieved.

Turning the wheel sets individually

To set the wheel sets, the buttons on the control panel **-A1220** must be pressed.

- ▶ Press the button **217** on the control panel **-A1220**.

Result:

- Turn left wheel set to right.

- ▶ Press the button **218** on the control panel **-A1220**.

Result:

- Turn left wheel set to the left.

- ▶ Press the button **219** on the control panel **-A1220**.

Result:

- Turn right wheel set to right.

- ▶ Press the button **220** on the control panel **-A1220**.

Result:

- Turn right wheel set to the left.

10.3.10 Deactivating steering programs for assembly / disassembly purposes

If an incorrect steering program is activated on the ballast trailer, crane functions that are necessary for assembly / disassembly purposes may not be carried out and / or controlled.



Note

- ▶ When both ballast trailer guide / turntable connection pins are correctly pinned, both limit switches are actuated. If the limit switches are actuated, only the crane functions released by the steering program can be carried out. If the correct steering program is not selected, certain crane movements are not possible.
- ▶ If the ballast trailer guide / turntable connection pin points do not align, the crane and the ballast trailer must be aligned with each other correctly.



WARNING

Ballast trailer guide / turntable connection only partially pinned!

If only one pin of the ballast trailer guide / turntable connection is correctly pinned, crane function monitoring is limited.

If no steering program is turned on, the turntable can be turned, the crane can be driven and the ballast trailer guide can be telescoped.

It is possible to operate the crane incorrectly and damage it.

- ▶ The crane driver is responsible for ensuring compliance with the specifications of the operating instructions regarding ballast trailer assembly / disassembly.
- ▶ Always carry out the crane movements with extreme caution and at the lowest possible speed.

In order to carry out crane functions necessary for assembly / disassembly purposes, the following is necessary:

- either all steering programs must be deactivated (all steering program indicator lights are off)
- or:**
- a certain steering program must be activated (steering program indicator light on)
- Turning the turntable requires circular travel, driving the crane and telescoping the ballast trailer guide require towing

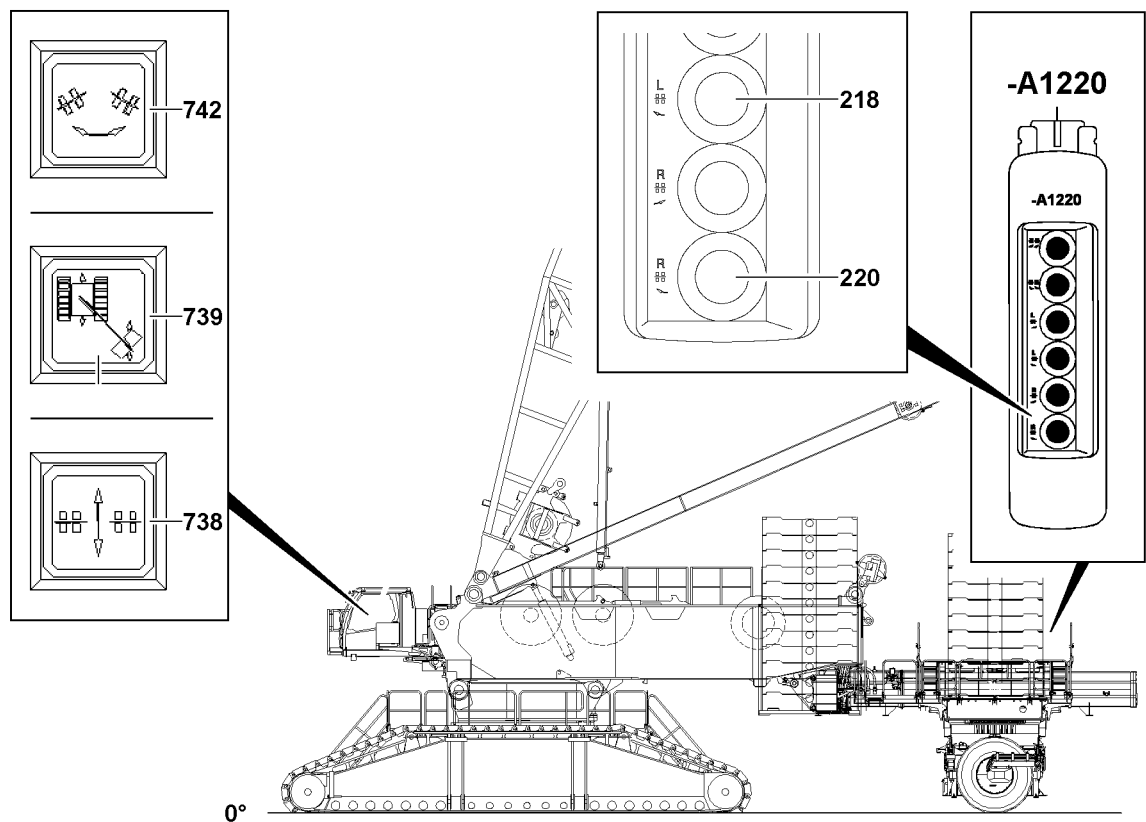

Fig.144134

LWE/LR 11000-001/23501-04-02/en

**Note**

Deactivate a steering program (crane cab)

No steering program is activated when there is no illuminated steering program indicator light.

- ▶ Crane cab: A steering program is deactivated by briefly pressing (less than one second) a button for another steering program. If the indicator light of another steering program lights up permanently as a result, then this steering program is active and must also be turned off.
- ▶ Control panel **-A1220**: Press the button **218** or button **220** to switch to manual operation and deactivate all steering programs.

Deactivating the towing steering program

On the control panel **-A1220**:

- ▶ Briefly press the button **218** or button **220** (for one second).

Result:

- The towing steering program is deactivated.
- No steering program is active.

or:

In the crane cab:

- ▶ Briefly press the *circular travel* button **742** (less than one second).

Result:

- When the *towing* button **738** indicator light is off: The towing steering program is deactivated.
- The *circular travel* button **742** indicator light must also remain off. Otherwise, deactivate the circular travel steering program.

Deactivating the parallel travel steering program

On the control panel **-A1220**:

- ▶ Briefly press the button **218** or button **220** (for one second).

Result:

- The parallel travel steering program is deactivated.
- No steering program is active.

or:

In the crane cab:

- ▶ Briefly press the *circular travel* button **742** (less than one second).

Result:

- When the *parallel travel* button **739** indicator light is off: The parallel travel steering program is deactivated.
- The *circular travel* button **742** indicator light must also remain off. Otherwise, deactivate the circular travel steering program.

Deactivating the circular travel steering program

On the control panel **-A1220**:

- ▶ Briefly press the button **218** or button **220** (for one second).

Result:

- The circular travel steering program is deactivated.
- No steering program is active.

or:

In the crane cab:

- ▶ Briefly press the *towing* button **738** (less than one second).

Result:

- When the *circular travel* button **742** indicator light is off: The circular travel steering program is deactivated.
- The *towing* button **738** indicator light must also remain off. Otherwise, deactivate the towing steering program.

10.4 Driving the ballast trailer

When the ballast trailer has ground contact, it is driven using various crane movements / steering programs:

- Through towing when driving the crane
- Through parallel travel when driving the crane
- Through circular travel when turning the crane superstructure
- Through corrective steering when driving the crane



Note

- ▶ It is only permitted to drive the ballast trailer on level ground capable of supporting the load.
- ▶ Driving over obstacles is not permitted.



DANGER

The crane can topple over!

In case of non-permissible level difference between the ballast trailer travel route and the crane position level, the entire crane system can be pulled back suddenly.

The relapse cylinders can thereby run into the mechanical block position and be significantly damaged.

The crane can topple over.

Death, severe bodily injuries, property damage.

- ▶ Do not exceed or fall below the permissible level difference between the ballast trailer roadway and the crane placement level.

NOTICE

Piston rod on block!

If the piston rod of the extension cylinder is already on block through telescoping out or in of the ballast trailer guide, there is no pressure protection. In this situation, the pressure relief valves on the piston and ring side are ineffective.

The extension cylinder can be significantly damaged.

- ▶ It is prohibited to move the piston rod in or out up to the block position.

10.4.1 Safety guidelines

Case 1: The boom system is pulled to the rear

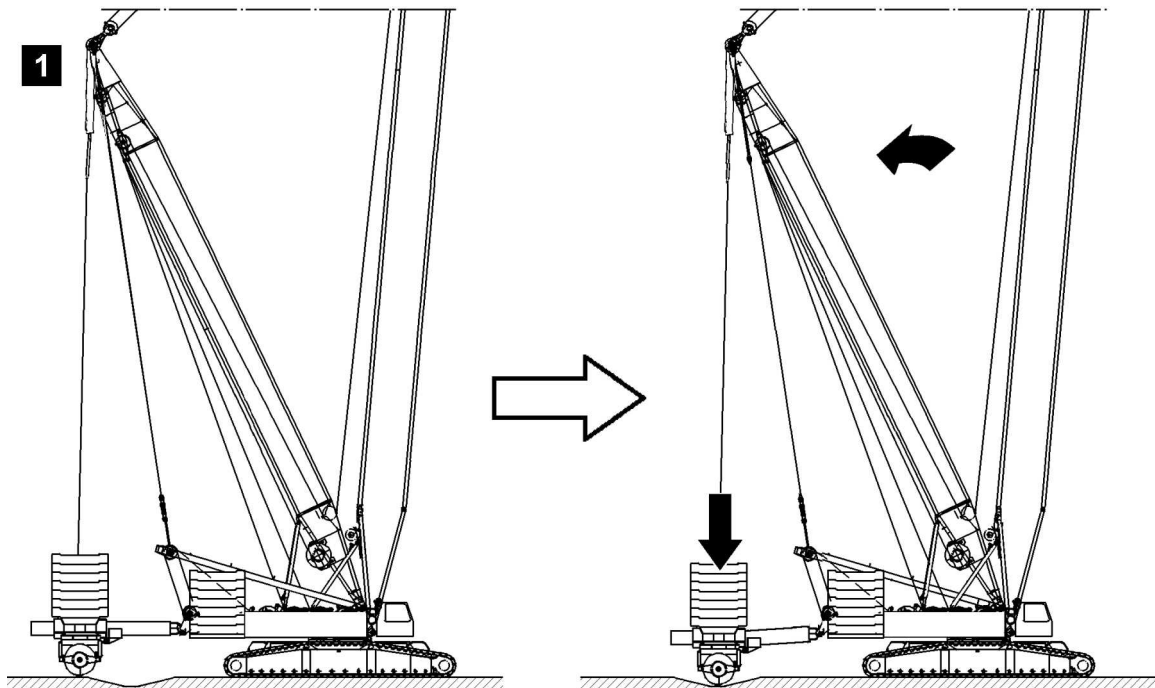

Fig.144148

Example illustration 1: When driving the crane or turning the crane superstructure, the ballast trailer lowers due to the level differences (depressions). In this way, the crane stays at its level. As a result, the entire boom system can pull back in an uncontrolled manner.

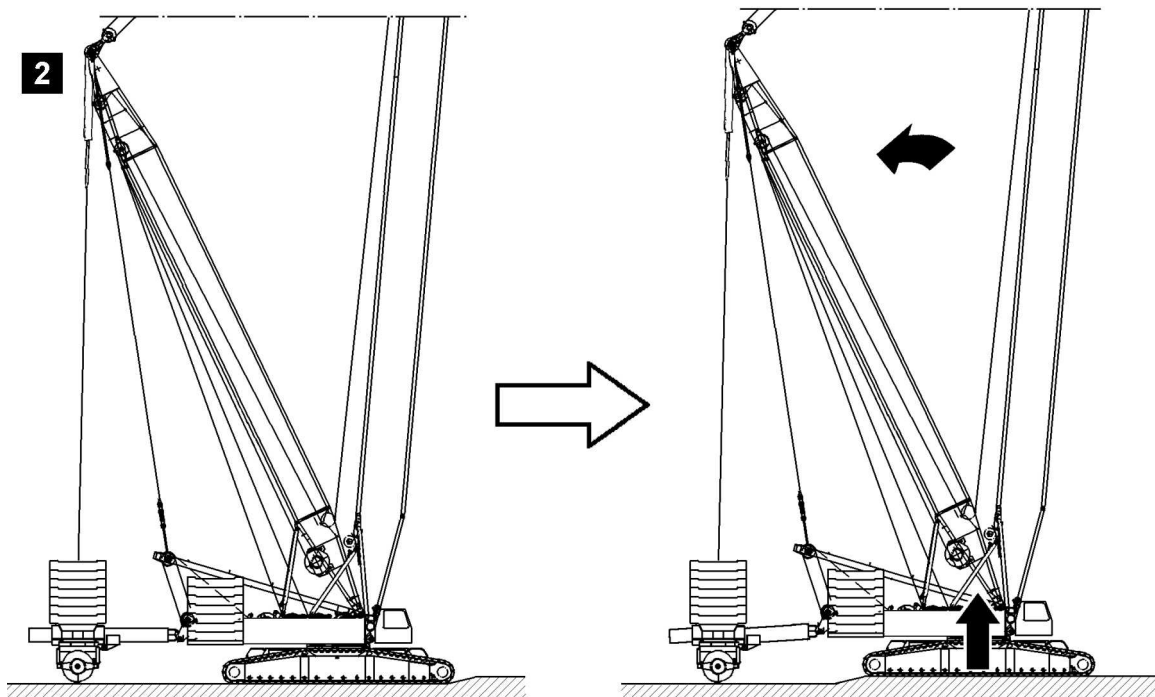

Fig.145921

Example illustration 2: When driving the crane, the crane lifts up due to the level differences (elevations). In this way, the ballast trailer stays at its level. As a result, the entire boom system can pull back in an uncontrolled manner.

Examples of possible consequences of a pulled back boom system:

- In the case of a steeply positioned boom system, block positions / damage to the relapse cylinder can result
- The minimum force $F1^{\min}$ (test point 1) may not be fallen below
- The force in the ballast trailer guying increases, the pulled derrick ballast lifts up
- The limit angles of the load chart can be exceeded



Note

- ▶ Due to the shut offs „Main boom relapse cylinder on block“ or „Derrick relapse cylinder on block“, in crane operation with ballast trailer, the „driving the crawler“ and „crane superstructure turning“ movements are automatically turned off.
- ▶ Due to the shut-off „minimum force F1 (test point 1) fallen below“, in crane operation with ballast trailer, the „driving the crawler“ and „turning“ movements are **not** turned off.

Case 2: The ballast trailer guying is relieved

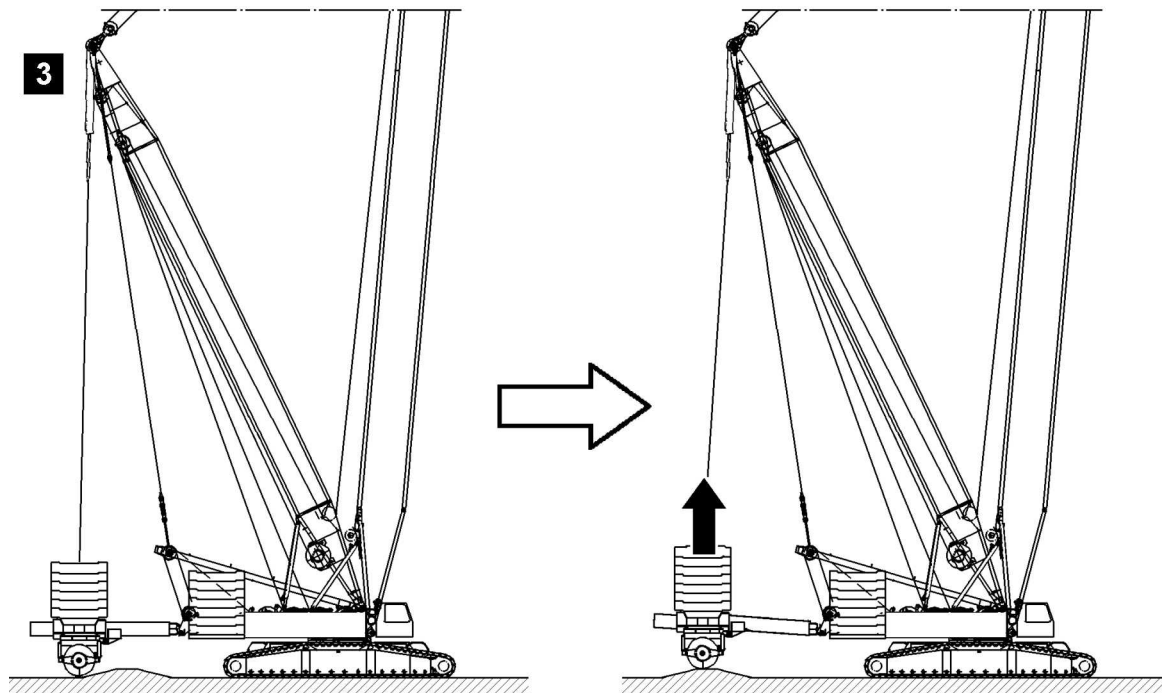

Fig.145923

Example illustration 3: When driving the crane or turning the crane superstructure, the ballast trailer lifts up due to the level differences (elevations). In this way, the crane stays at its level. As a result, the ballast trailer guying is released in an uncontrolled manner.

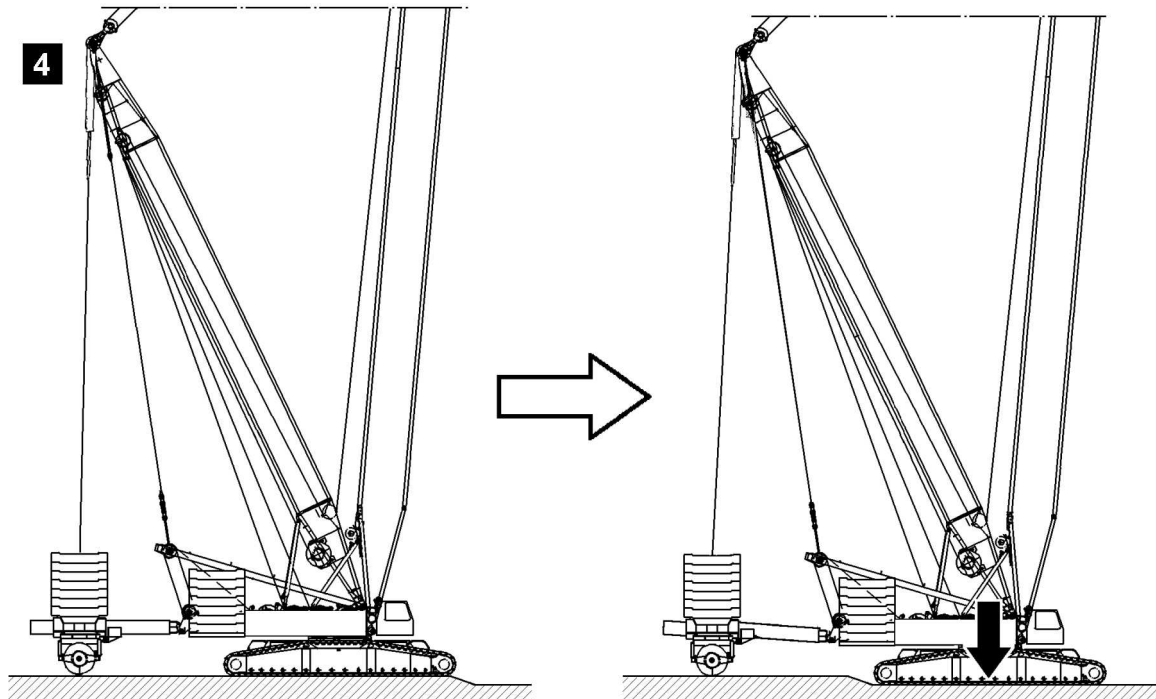

Fig.145924

Example illustration 4: When driving the crane, the crane is lowered due to the level differences (depressions). In this way, the ballast trailer stays at its level. As a result, the ballast trailer guying is released in an uncontrolled manner.

Examples of possible consequences of a releasing the ballast trailer guying:

- The maximum force $F1^{\max}$ (test point 1) can be exceeded
- The limit angles of the load chart can be exceeded



Note

- ▶ Due to the shut-off „maximum force $F1^{\max}$ (test point 1) exceeded“, in crane operation with ballast trailer, the „driving the crawler“ and „turning“ movements are **not** turned off.

Case 3: The load torque is increased

Fig.145925

Example illustration 5: The load torque is increased when picking up the load. The crane and boom system are loaded more.

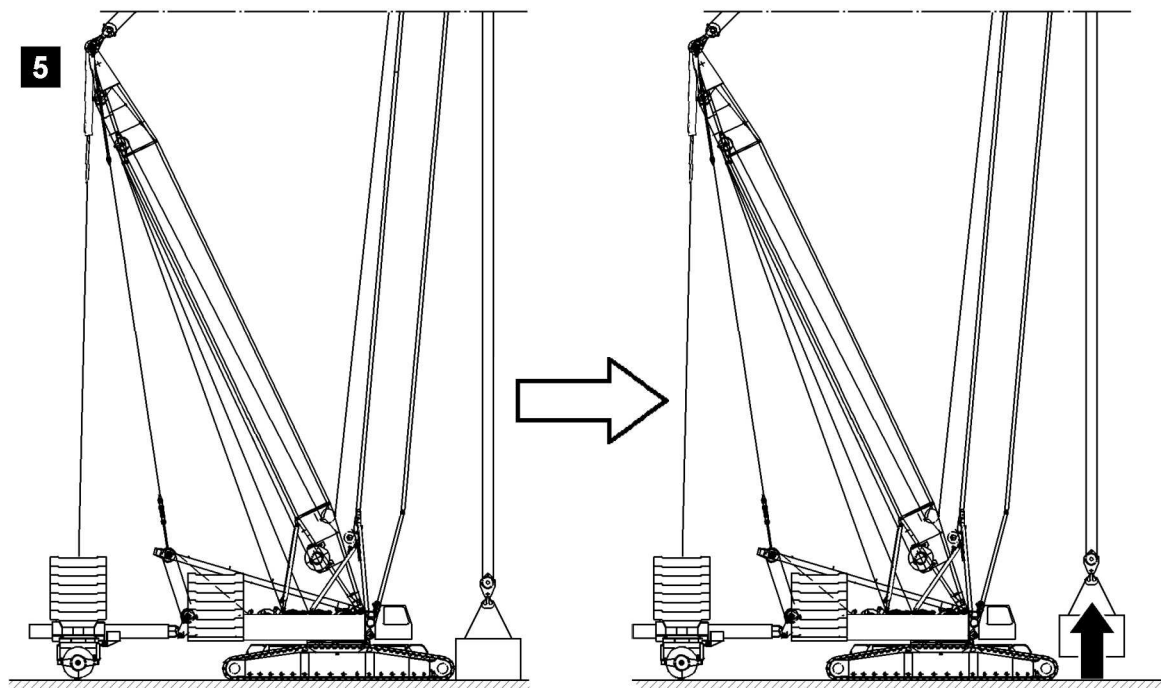
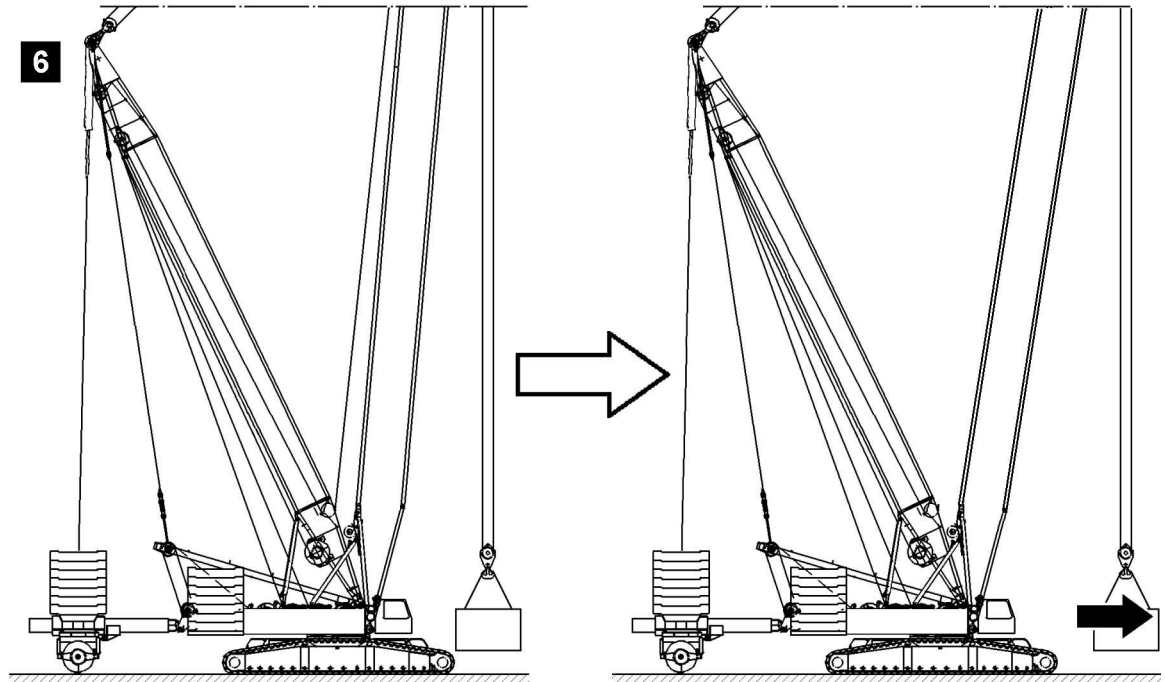

Fig.145928

Example illustration 6: The load torque is increased when the boom radius of the load is increased. The crane and boom system are loaded.

Examples of possible consequences of an increased load torque:

- The maximum force $F1^{\max}$ (test point 1) can be exceeded
- The force in the ballast trailer guying increases, the pulled derrick ballast lifts up
- The limit angles of the load chart can be exceeded

**Note**

- Due to the shut-off „maximum force $F1_{max}$ (test point 1) exceeded“, in crane operation with ballast trailer, the „driving the crawler“ and „turning“ movements are **not** turned off.

Case 4: The load torque is decreased

Fig.145922

Example illustration 7: When the load is set down, the crane and boom system are relieved. The load torque is decreased. As a result, the boom system can move backward.

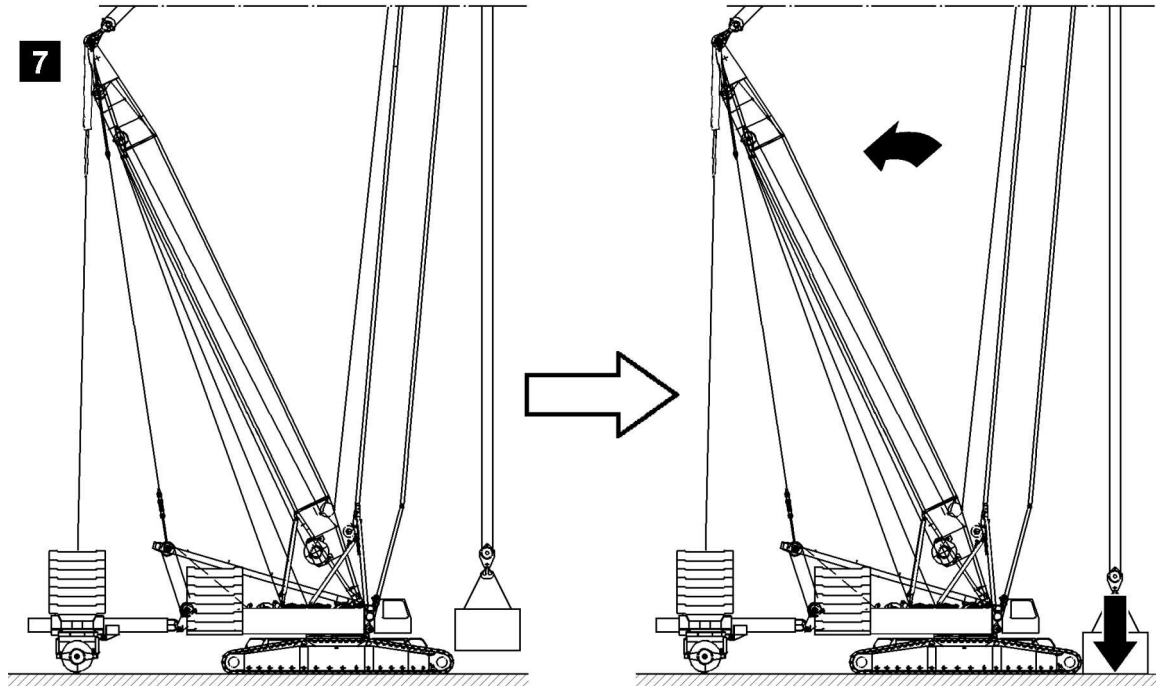
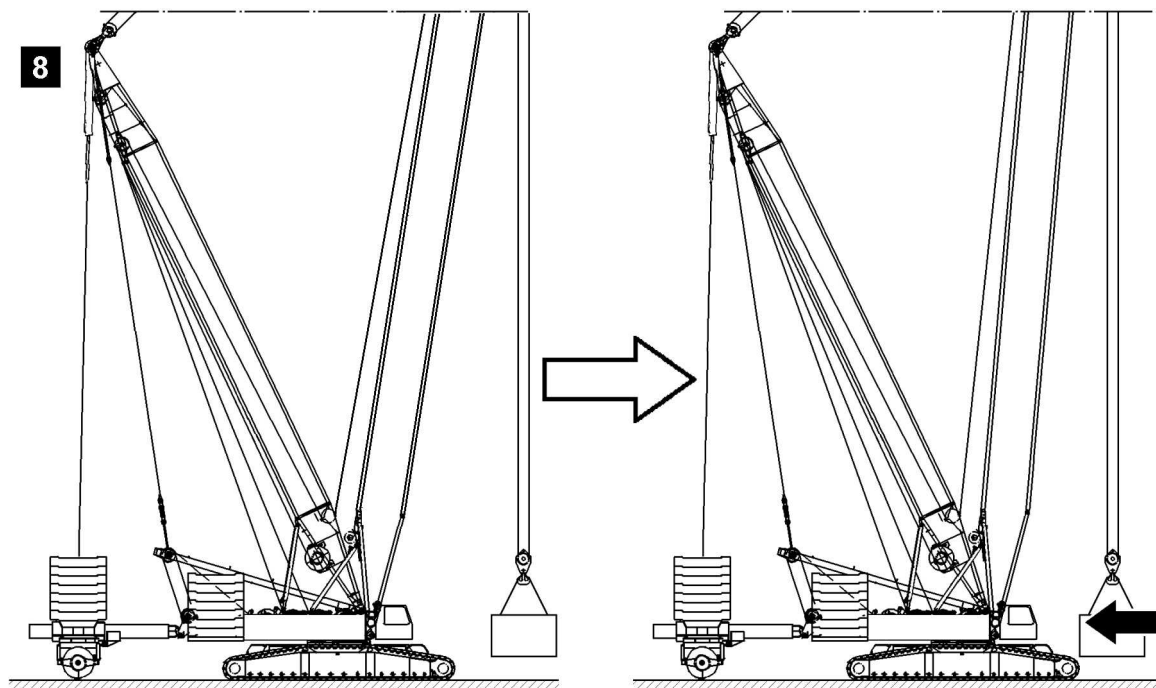

Fig.145929

Example illustration 8: When decreasing the load boom radius, the crane and boom system are relieved. The load torque is decreased. The crane and boom system are loaded less by the load.

Examples of possible consequences of an decreased load torque:

- The minimum force $F1^{\min}$ (test point 1) can be fallen below
- The pulled derrick ballast is reduced
- The limit angles of the load chart can be exceeded

10.4.2 Test point 1 (F1-Load display)



WARNING

Danger of accident when driving the crane with load and ballast trailer!

When driving the crane with a load - this also applies for „circular travel“ - and the ballast trailer is raised due to ground unevenness, the force on test point 1 (F1-load display) increases immediately and the crane will be overloaded.

If the ballast trailer sinks while driving due ground unevenness, the force on test point 1 (F1-load display) drops and the ballast trailer lifts off the ground, or the entire boom system is pulled backward. The crane can topple over and personnel can be severely injured or killed.

- ▶ The crane operator must constantly observe the displays on the LICCON monitor while driving the crane.
- ▶ The crane operator must act anticipatorily. Already when an advance warning on test point 1 (F1-load display) occurs, he must act accordingly: By actuating the pull cylinders of the derrick ballast, correct the load / force on test point 1 (F1-load display) until it is in a permissible operating range. The permissible extension lengths of the pull cylinders must be observed.

10.4.3 Relapse cylinder

When the steepest operating position of the main boom is reached, luffing up is turned off by the LICCON overload protection in all operating modes.



Note

- ▶ However, in certain cases the movement of the entire crane system to the rear can cause the relapse cylinders to mechanically latch in the block position.

Block position relapse cylinders

NOTICE

Damage to the relapse cylinder and the boom!

Through level difference between the ballast trailer and crane route, the boom can suddenly be pulled backward and the relapse cylinder can go into the block position.

The relapse cylinder or the boom can be damaged.

- ▶ Make sure before taking up the travel mode, or before turning the crane superstructure, that the travel route of the crane or the ballast trailer circular path is even and capable of supporting the load.

In normal crane operation without bypass of the LICCON overload protection, a block position is not possible. Should a block position still occur, the movement is shut off and the boom limitation icon shown on the operating screen indicates which block position has been started up.

With this boom limitation icon it is to be determined which limit switch on which relapse cylinder has been actuated. Reverse the last movement which was carried out until the corresponding limit switch is released again.

10.4.4 Maximum permissible ground unevenness



WARNING

The crane can topple over!

By exceeding the maximum permissible value for ground unevenness while driving the crane, the crane can topple.

Death, severe bodily injuries, property damage.

- ▶ The permissible ground unevenness may not be exceeded.

Level change between placement surface of the crane and the ballast trailer during towing, parallel and circular travel may not exceed a maximum permissible value.



Note

- ▶ The level difference of the ballast trailer route in relation to the crane routing during **towing** and **parallel travel**, may be no more than ± 250 mm - with a constant uphill or downhill slope over a 20 m route.
- ▶ The level difference of the ballast trailer route in relation to the crane route during **circular travel** may be no more than ± 250 mm - with a constant uphill or downhill slope over a 90° slewing range.
- ▶ Regardless of the level difference, the permissible side incline of the crane and / or the ballast trailer must be adhered to.

Compensating for ground unevenness

The maximum permissible ground unevenness can be compensated by lifting and lowering the ballast trailer.



Note

- ▶ See section „Lifting and lowering the ballast trailer with the pull cylinders“.

Ballast trailer drive



Note

- ▶ Only on crane types with a ballast trailer drive*.

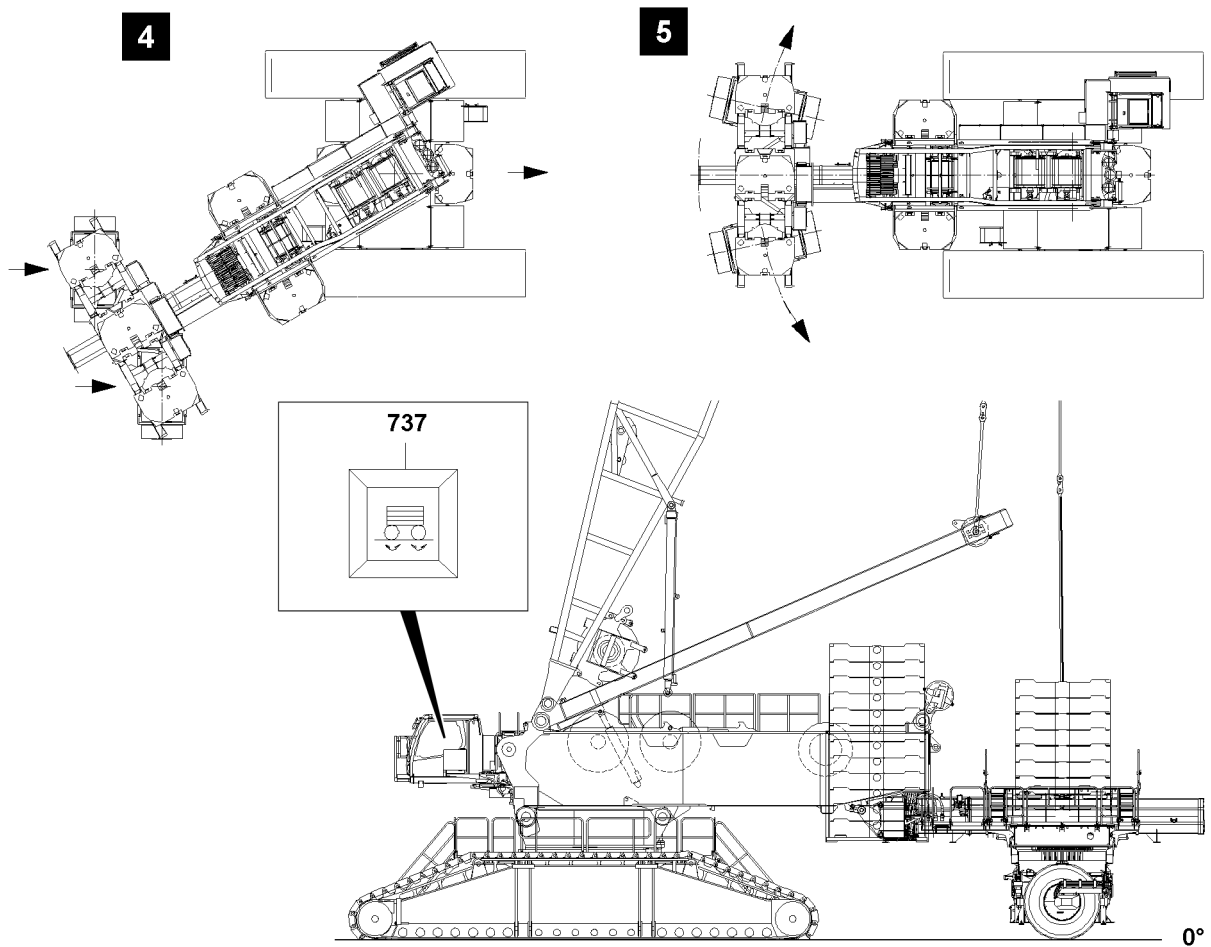

Fig.120242

A ballast trailer is equipped with a wheel set with its own drive. The drive is added in the crane cab. The drive is a proportionally adjustable drive which is regulated depending on the turning or travel speed.

If the ballast utilization is more than 90 %, then the drive is turned off to prevent the wheels from slipping.

**Note**

- ▶ The addition of the drive is only possible in circular and parallel travel, see illustration 4 and illustration 5.
- ▶ The additional drive may be required when driving over uneven ground.

If the road surface is level, no additional drive is required.

Add the drive only when no turning / travel movement occurs when the control lever is deflected.

Turn the drive on with the switch **737** in the crane cab.

**Note**

- ▶ Turn the drive off as soon as the unlevel ground has been passed.
- ▶ Turn the drive off with switch **737** in the crane operator's cab.

10.4.5 Derrick ballast lifted off key button

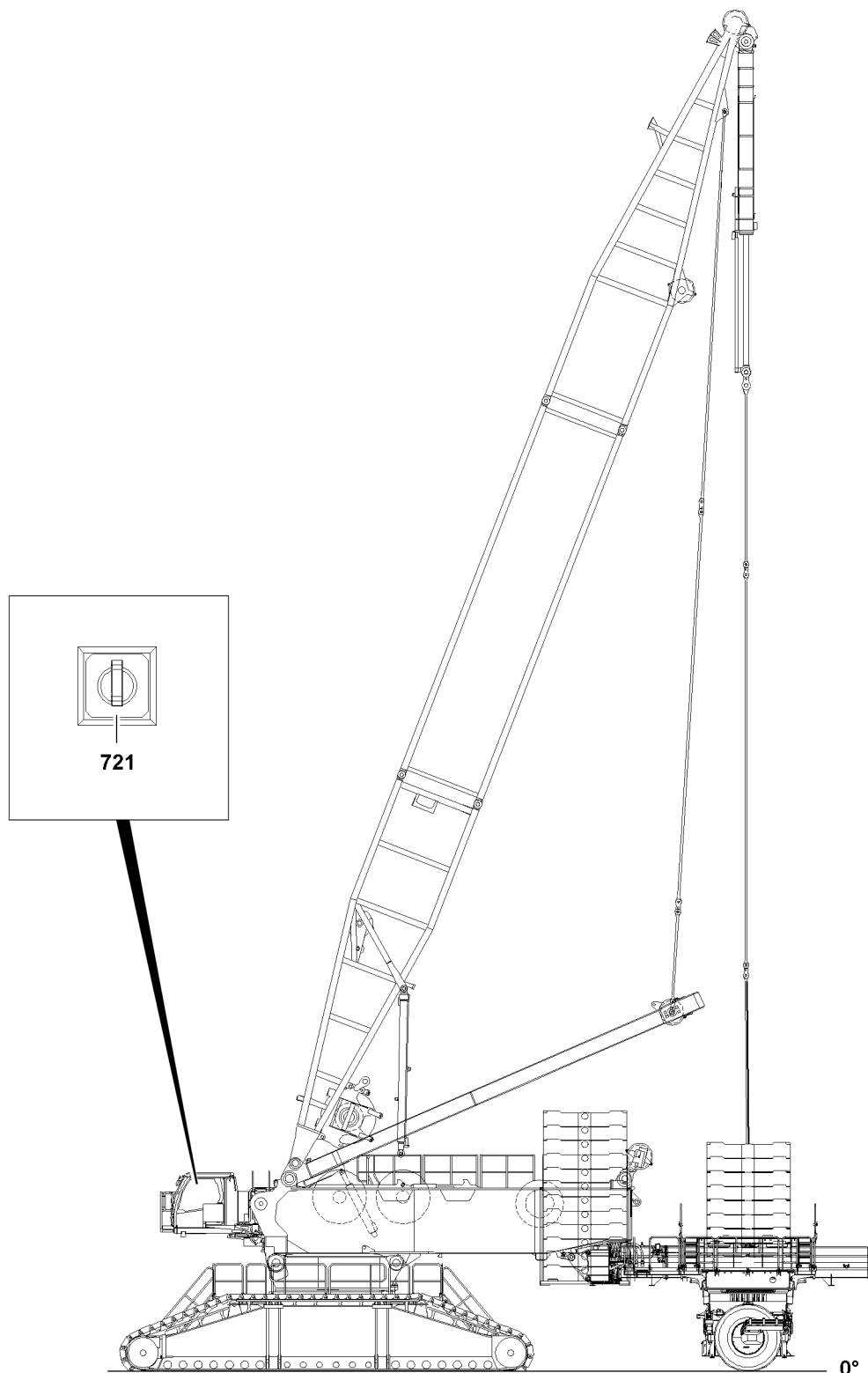

Fig.120243

With „driving the crawler“ and *derrick ballast lifted* key button **721** not pressed, that is „ballast trailer not lifted“, the slewing gear brake as well as the hydraulic slewing gear coasting are opened. When proceeding with „driving the crawler“ with **lifted off ballast trailer** (constant visual check), the *derrick ballast lifted* key button **721** must be used to turn on the „derrick ballast lifted“ function.

**DANGER**

Danger of accident!

If the ballast trailer is lifted off the ground during „driving the crawler“ in the „towing“ steering program, the danger exists that the wind turns the turntable to the side.

- ▶ After lifting the ballast trailer off, the derrick ballast lifted **721 key button** must be turned on immediately, so that the slewing gear brake remains closed for „driving the crawler“, however the hydraulic coasting remains open.
- ▶ However, if the wheel sets of the ballast trailer are not aligned accordingly, the ballast trailer or the crane will be damaged.

NOTICE

Danger of accidents when turning or driving!

If the lifted off ballast trailer scrapes on the ground - with the *derrick ballast lifted* key button **721** turned on - when turning or driving the crane, then the ballast trailer and the crane can be significantly damaged.

- ▶ If the ballast trailer has been lifted off the ground and *derrick ballast lifted* key button **721** is actuated, then it must be checked that the wheels do **not scrape on the ground**. An instructed person must check visually.
- ▶ It is prohibited to remain in the danger zone.

**Note**

- ▶ If the ballast trailer is suspended above the ground, the wheel sets can be in any position. If the „derrick ballast lifted“ function is turned on, the crane turning and driving are possible.

**Note**

- ▶ When the „derrick ballast lifted“ function is turned on, it is possible to turn the turntable or to drive the crane even though the wheel sets of the ballast trailer are not set to „Circular travel“, „Towing“ or „Parallel travel“.

Activate the „Derrick ballast lifted“function:

- ▶ Press the *derrick ballast lifted* key button **721**.

Result:

- A visual display appears on LICCON monitor LM2.

**Note**

- ▶ A visual display on the LICCON monitor LM2 shows the current status.

Turn off the „Derrick ballast lifted“function:

- ▶ Press the *derrick ballast lifted* key button **721** again.

Result:

- A visual display appears on LICCON monitor LM2.

10.4.6 Defined ballast trailer operation**DANGER**

Danger of accident!

If the ballast trailer is operated in an undefined condition, it can result in severe accidents up to toppling of the crane.

Death, severe bodily injuries, property damage.

- ▶ The ballast trailer must always be in a defined condition.
- ▶ Operation of the ballast trailer in an undefined state is prohibited.

The ballast trailer may not be raised or set down when driving, rather this be done **before** starting to travel.

Ballast trailer lifted off

„Ballast trailer defined lifted from the ground“ means:

The ballast trailer is lifted from the ground and the *derrick ballast lifted* key button **721** is pressed. This does **not** open the slewing gear brake when „driving the crawler“. It should be ensured that the wind cannot turn the turntable.

Make sure that the following prerequisites are met:

- The ballast trailer has been completely lifted off the ground.
- The *derrick ballast lifted* key button **721** is pressed.
- A visual display appears on LICCON monitor LM2.

Ballast trailer on the ground

„Ballast trailer defined on the ground“ means:

That the ballast trailer and its residual load are resting on the ballast trailer tires and the *derrick ballast lifted* key button **721** is **not** pressed. This residual load is large enough to prevent the wind from turning the turntable, if the slewing gear brake is opened when actuating „Crawler travel“.

Make sure that the following prerequisites are met:

- The ballast trailer is positioned with a residual load on the ground.
- The *derrick ballast lifted* key button **721** is **not** pressed.

10.4.7 Undefined ballast trailer operation



DANGER

Danger of accident!

If the ballast trailer is operated in an undefined condition, it can result in severe accidents up to toppling of the crane.

Death, severe bodily injuries, property damage.

- ▶ The ballast trailer must always be in a defined condition.
- ▶ Operation of the ballast trailer in an undefined state is prohibited.

Ballast trailer lifted off



Note

- ▶ Only operate the ballast trailer in a defined condition.

„Ballast trailer undefined lifted off the ground“ means:

That the ballast trailer with a residual load of approx 1 t is placed on the ballast trailer tires and the *derrick ballast lifted* key button **721** is pressed. As a result, the slewing gear brake does **not** open when cornering the „crawler“ and the ballast trailer tires or the slewing gear brake slip.

Ballast trailer on the ground



Note

- ▶ Only operate the ballast trailer in a defined condition.



DANGER

Swinging load!

Severe accidents can occur due to swinging loads.

Death, severe bodily injuries, property damage.

- ▶ Operation of the ballast trailer in an undefined state is prohibited.

„Ballast trailer undefined on the ground“ means: That the ballast trailer with a residual load of approx 1 t is placed on the ballast trailer tires and the *derrick ballast lifted* key button **721** is **not** pressed. This residual load is so small that the wind can turn the turntable, if the slewing gear brake opens when actuating „Crawler travel“.

10.5 Crane operation with the derrick ballast

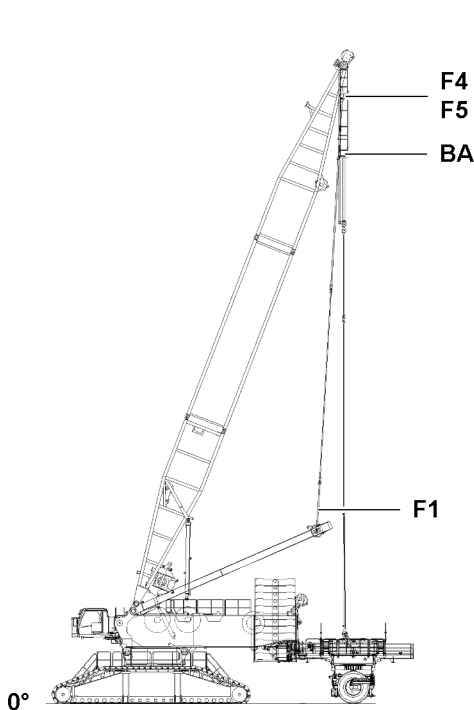
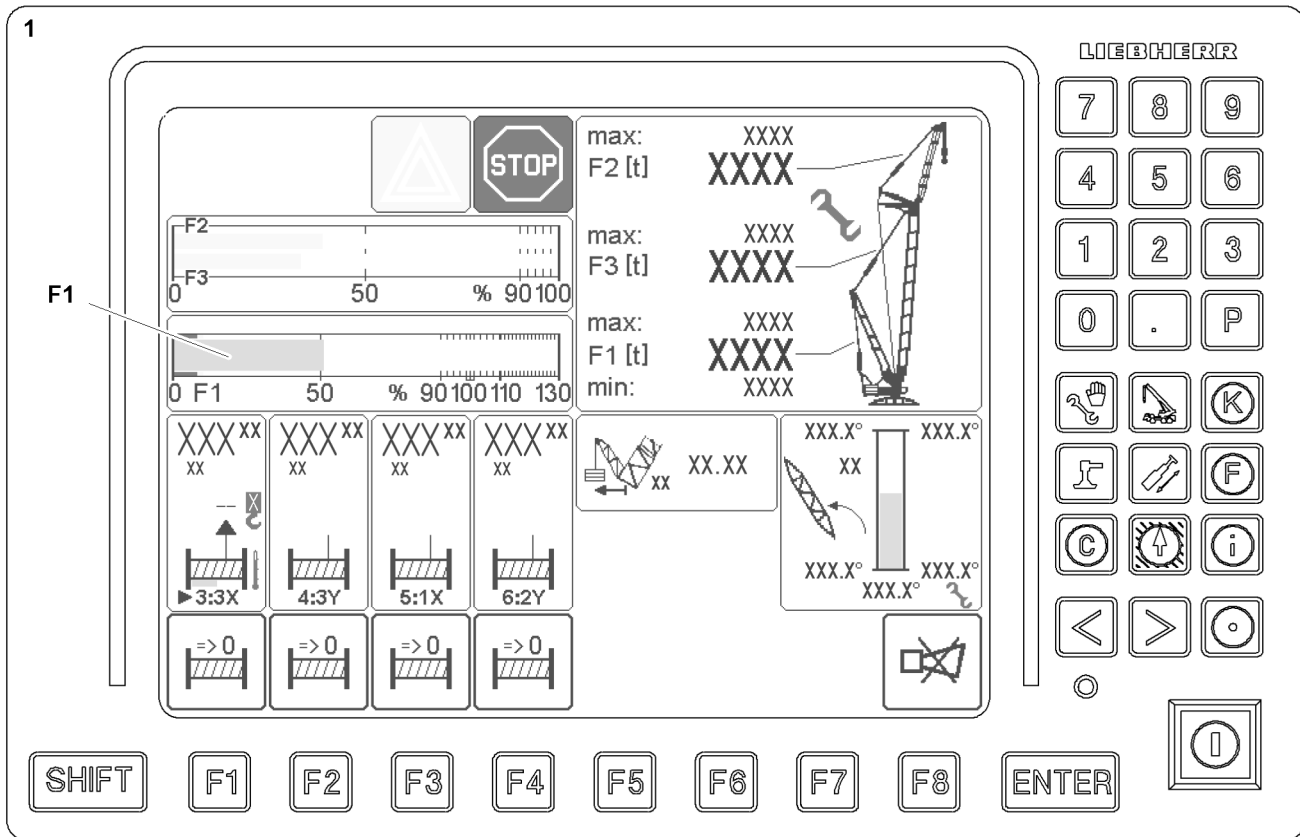
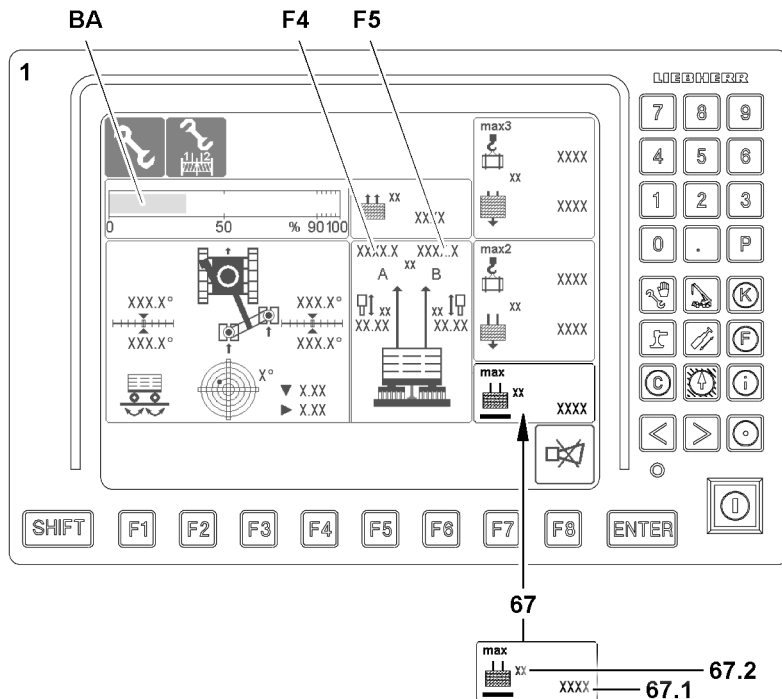

Fig.146971



LWE/LR 11000-001/23501-04-02/en

10.5.1 Safety guidelines



Note

- ▶ The test points must be checked for function before taking on crane operation.
- ▶ The weight of the load to be lifted must be known.
- ▶ There may be no obstacles within the slewing range of the crane, the suspended derrick ballast and the load.
- ▶ The lift off of the derrick ballast must be monitored by the crane operator or a guide.
- ▶ Before setting down the load and the suspended derrick ballast, the crane operator must make sure that a safe placement is ensured.
- ▶ The placement level of the ballast trailer, at the end of the load lift, must be level, horizontal and have sufficient load bearing capacity to safely take on the weight of the ballast trailer.



DANGER

Danger of accidents due to angular pull!

The crane can topple over by angular pulling of the load.

Death, severe bodily injuries, property damage.

- ▶ Angular pull is prohibited.
- ▶ When taking up the load, it must be ensured that the derrick ballast, the center of rotation of the turntable and the load are in one line.

When lifting the load, the guying between the derrick ballast and derrick end section must be relieved to the point where the actual force $F1$ ($F1_{\text{actual}}$) is larger than the $F1$ minimum force ($F1_{\text{min}}$).



DANGER

Danger of accident!

If the guying between the SA-frame and the derrick end section is without force ($F1_{\text{min}}$ is fallen below), then this can lead to uncontrolled movements of the boom system and cause the crane to topple over.

- ▶ The guying between the SA-frame and the derrick end section, test point 1 **F1**, may never be without power.
- ▶ The $F1$ -minimum force ($F1_{\text{min}}$) may not be fallen below.

10.5.2 LICCON overload protection

On cranes with derrick ballast, during operation also under load, by increasing or reducing the derrick ballast, the maximum load or the minimum load required for the balance of the crane, can be increased or decreased.



Note

- ▶ The suspended ballast and the ballast trailer are generally referred to as the **derrick ballast**.
- ▶ The fixed compensation weight that is installed on the turntable is generally referred to as the **counterweight**.

Make sure that the following prerequisites are met:

- The required derrick ballast according the load chart is placed and exactly entered and confirmed in the LICCON overload protection.
- The D-boom is in crane operating position.

Presettings

- ▶ Set the LICCON overload protection according to the data in the load chart and confirm.



Note

- ▶ Enter the actually present derrick ballast weight in the LICCON overload protection.
- ▶ Enter the actually present reeving in the LICCON overload protection.
- ▶ Enter the derrick ballast weight and derrick ballast radius into the LICCON overload protection, see chapter 4.02 and chapter 4.03.

**DANGER**

Danger of accident due to set-up parameters!

Dangerous operational situations can occur due to an incorrect ballast entry.

Death, severe bodily injuries, property damage.

- ▶ The set derrick ballast must match the actually placed derrick ballast weight.
- ▶ All settings carried out in the „Set up“ program must agree with the actual settings on the crane.

- ▶ Check the settings.

Crane operation**Note**

- ▶ For crane operation with derrick ballast, the data must be observed and adhered to, see chapter 4.02.

**WARNING**

Danger of toppling the crane!

The jerky execution / braking of turning maneuvers can cause the load or suspended derrick ballast to swing.

This can cause the boom to break or the crane to topple over.

Death, severe bodily injuries, property damage.

- ▶ There may be no persons or obstacles within the slewing range of the crane and the ballast trailer.
- ▶ While turning, a guide must watch the main boom, D-boom and derrick ballast for a danger of collision.
- ▶ The turning movement or braking must be initiated extremely carefully when turning with a load and suspended derrick ballast.

**Note**

- ▶ For crane operation, observe the section „lifting and lowering the ballast trailer with pull cylinders“ and „ballasting guying differential force monitoring“.
- ▶ Observe the extension condition of the pull cylinder and the inclination of the ballast trailer.

10.5.3 Determination of forces in operating mode with derrick ballast

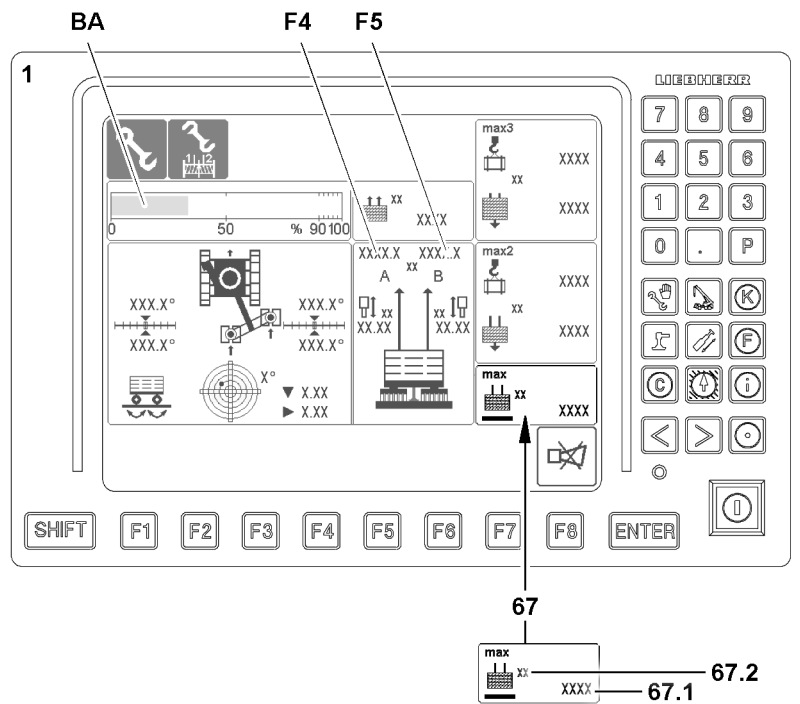
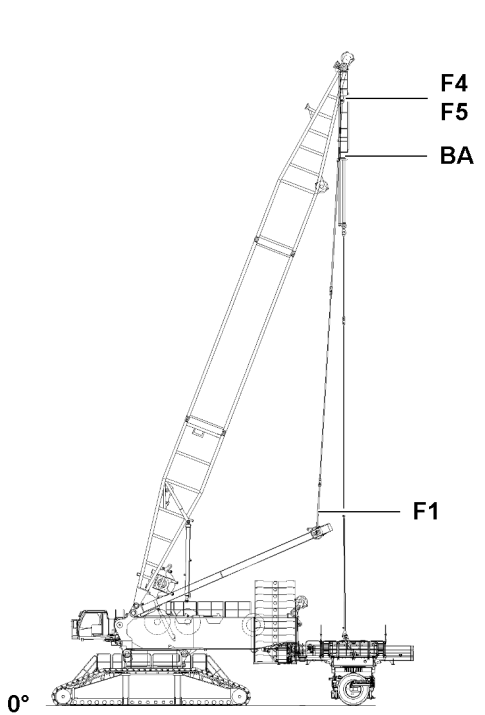
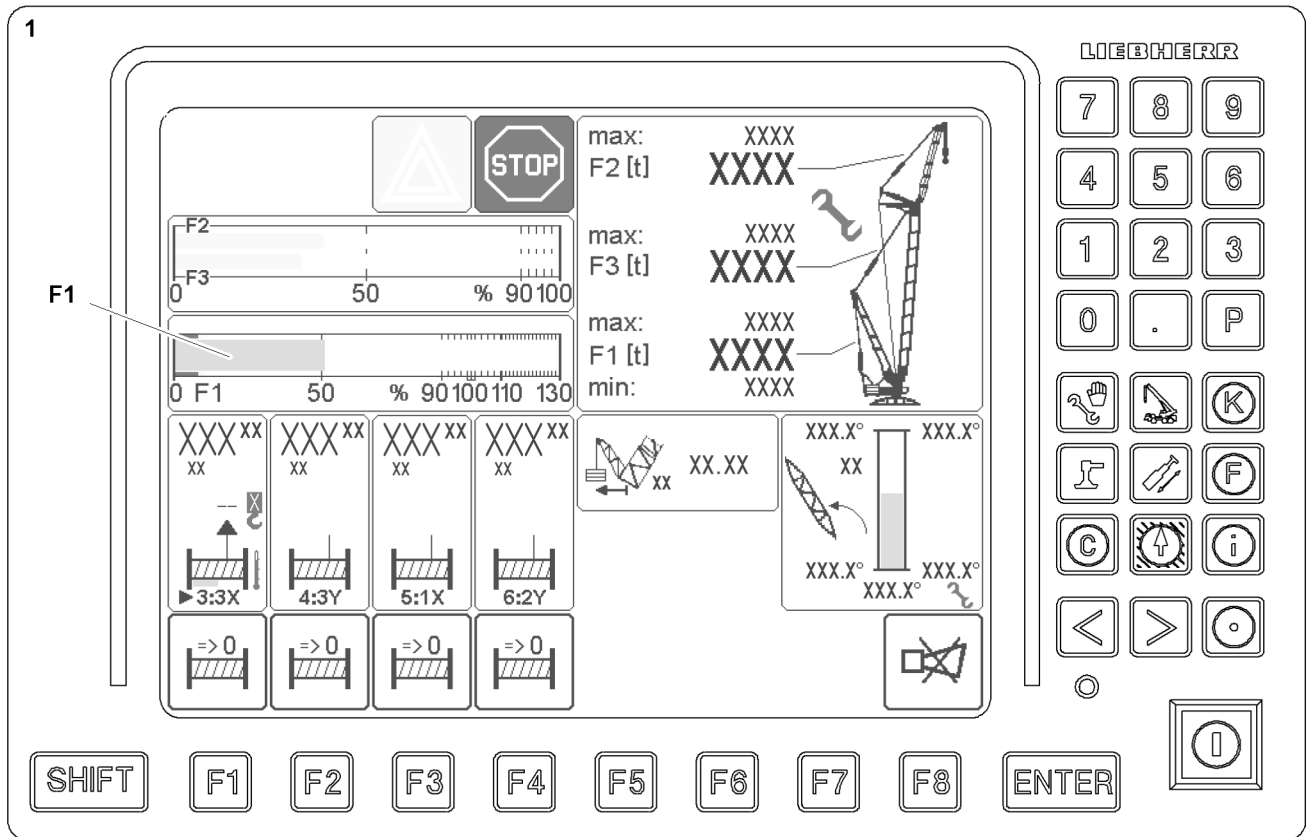

Fig.146971

In all operating modes with derrick ballast, the load is divided between the guy rods from the derrick head to the SA-frame (F1) and the derrick ballast (F4/5).

LWE/LR 11000-001/23501-04-02/en

**Note**

► See chapter 4.02.

Force F1 (test point 1) between guying SA-frame - derrick end section

The force F1 (test point 1) is determined in the guy rods from the SA-frame to the derrick head by 2 force test boxes and is shown on the LICCON monitor as total force of the guying.

From the „Operating force“ (F1) and the „Maximum operating force“ ($F1_{\text{max-operation}}$) results the F1-utilization. This is shown on the LICCON monitor on the utilization bar in percent.

Force F4/F5 (test point 4/5) guying derrick ballast - derrick end section

The forces F4/F5 (test point 4/5) are effective in the guy rods from the derrick ballast to the derrick head.

The existing forces in the guy rods (A = left and B = right) are calculated from the several pressure sensors, which are installed on the pull cylinders and shown in the LICCON monitor as individual forces.

The pulled ballast is calculated from the forces of the individual guying, which means the part of the ballast pulled up by the guying. The remaining part is laying on the ground. The derrick ballast utilization results from the pulled ballast and the placed ballast. This is shown on the LICCON monitor with a utilization bar (BA in %).

Pull cylinder on block

**DANGER**

The crane can topple over!

By completely moving one or both pull cylinders in (block position moved in), the pressure increases strongly on the ring surface of the pull cylinder and the ballast weighing of the currently pulled derrick ballast is incorrectly calculated and displayed.

Death, severe bodily injuries, property damage.

- If the pull cylinders are „retracted“ in the block position, **crane operation is explicitly prohibited**.
- The forces in the derrick ballast guying A and B must be carefully monitored on the LICCON monitor.
- Potentially occurring error messages must be observed.

Maximum liftable derrick ballast

The *maximum liftable derrick ballast 67* refers to the current crane condition and indicates the maximum derrick ballast that can be lifted off the ground with the pull cylinder or off the suspended ballast palette in case of the VarioTray without falling below the $F1_{\text{min}}$ force.

- **67** *Maximum liftable derrick ballast* icon
- **67.1** Maximum liftable derrick ballast
 - Maximum derrick ballast
- **67.2** Measuring unit
 - Measuring unit for display values in the *Pulled derrick ballast* icon **67**: [t] or [lb]

Monitoring of minimum force F1

If more than 50 percent of the set derrick ballast is being pulled (ballast utilization bar > 50 percent) and the minimum force $F1_{\text{min}}$ (test point 1) is fallen below, all crane movements that **increase load torque** are turned off.

**DANGER**

Danger of accident!

It is prohibited to fall below the minimum force $F_{1_{min}}$ (test point 1) if more than 50 % of the derrick ballast is pulled. If this is not observed, in case of loose guying from test point 1 (F1) and **derrick ballast on the ground**, the derrick ballast can suddenly lift off the ground due to the increased load moment and the boom system can suddenly move forward. This causes the load to swing back and forth too much, which could damage the boom and the crane.

- ▶ Do not fall below the minimum force - $F_{1_{min}}$.

If more than 90 % of the set derrick ballast is being pulled (ballast utilization bar greater than 90 %) and the force drops below the minimum value $F_{1_{min}}$ (test point 1) fall below, all crane **movements that increase the load moment** and all **crane movements that decrease the load moment** are turned off. This also turns the „spooling winch out“ movement of the hoist winches off.

**DANGER**

Danger of accident!

It is prohibited to fall below the minimum force $F_{1_{min}}$ (test point 1) if more than 90 % of the derrick ballast is pulled. If this is not observed and the load torque is decreased when the guying is slack at test point 1 (F1) and the derrick ballast is suspended, the derrick ballast can drop to the ground, causing the boom system to move backwards. As a result, the relapse cylinders can be pressed on the block and be overloaded. There is the danger that the cylinders of the relapse cylinders on the boom and D-boom will be damaged.

- ▶ Do not fall below the minimum force - $F_{1_{min}}$.

**Note**

- ▶ By switching on the assembly operation, the test point 1 - minimum force ($F_{1_{min}}$) is reduced by a few tons, which allows one to reverse the movement and drive out from the situation in which the $F_{1_{min}}$ shut-off occurred.
- ▶ This is the only exception on the crane, where, after a shut off, a load torque increasing movement can still be driven by activating the assembly operation.

**DANGER**

Danger of accident!

If the LICCON overload protection is bypassed / exceeded, there is no further protection against crane overload.

There is an increased danger of accidents.

Death, severe bodily injuries, property damage.

- ▶ The crane driver bears the complete and sole responsibility when bypassing the LICCON overload protection.

After a shut-off via $F_{1_{min}}$, the force F1 on test point 1 must be increased by a movement. This can be obtained for example by reducing the pulled ballast. The LICCON overload protection is / exceeded and the F1-force continues to drop below the minimum force $F_{1_{min}}$ which was reduced by bypass / exceedance, then the $F_{1_{min}}$ shut off can no longer be bypassed.

10.5.4 Overload monitoring in operating mode with derrick ballast

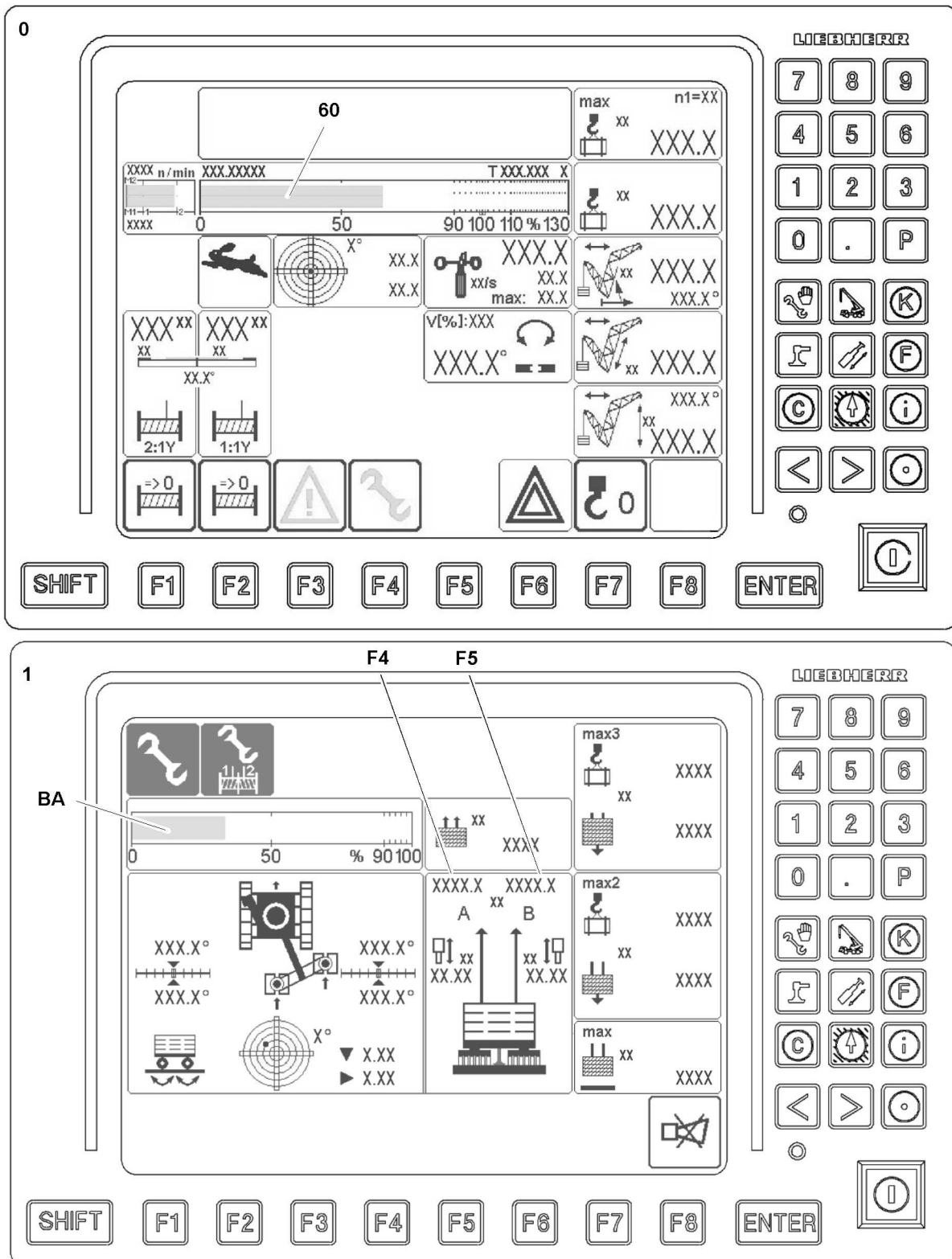

Fig.146970

In operating modes with derrick ballast, the „maximum load for the current crane condition“ is monitored two ways:

1. Monitoring of maximum load on the LICCON monitor 0
2. Monitoring of test point 1-operational maximum force LICCON monitor 1.

Monitoring of maximum load on the LICCON monitor 0

It monitors the „maximum load according to load chart and reeving“.

In operating modes with derrick ballast, this is the maximum load of the current crane condition. It is shown on LICCON monitor 0. The current utilization of the crane results from the load utilization bar (1) on LICCON monitor 0.

If the load utilization bar reaches 90 %, an advance warning is given in the form of a „notice icon“ and a „SHORT HORN“ on LICCON monitor 0.

At 100 % on the load utilization bar, the shut-off of all load moment increasing movements with the „stop icon“ and the acoustical warning „HORN“ occurs on LICCON monitor 0.



Note

- ▶ The „maximum load of the current crane condition“ can possibly be increased further, refer to section „utilization conditions“.

Monitoring of test point 1-operational maximum force (= $F1_{max}$ operation)

It is shown on LICCON monitor 1. When $F1$ is greater than $F1_{max-shut-off\ value}$, a shut off of all movements which could increase load torque occurs with the „stop icon“ and the acoustic warning „HORN“ by LICCON monitor 1.



Note

- ▶ The maximum load can be safely monitored by the „LICCON overload protection“ itself.
- ▶ The „ $F1_{max}$ monitoring“ is an additional monitoring function, which prevents the overload of the crane parallel to the „LICCON overload protection“.
- ▶ When the permissible maximum load can not be lifted because a „ $F1_{max}$ shut-off“ has stopped the crane before, then the current „F1-force“ must be reduced by increasing the pulled ballast.
- ▶ Make sure that the ballast weighing and the shut off to the maximum load function reliably.

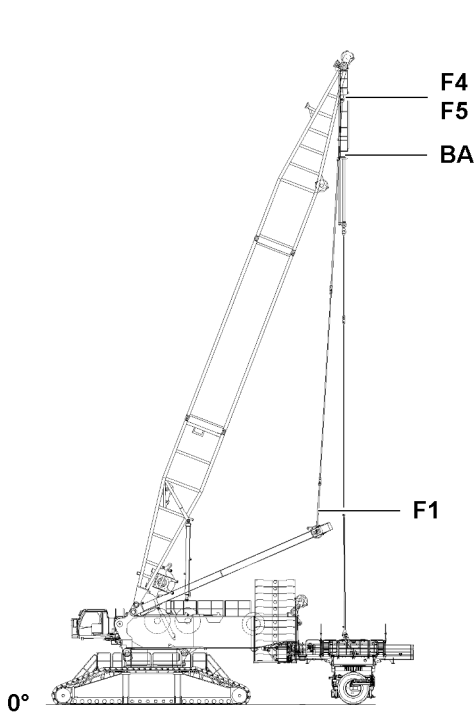
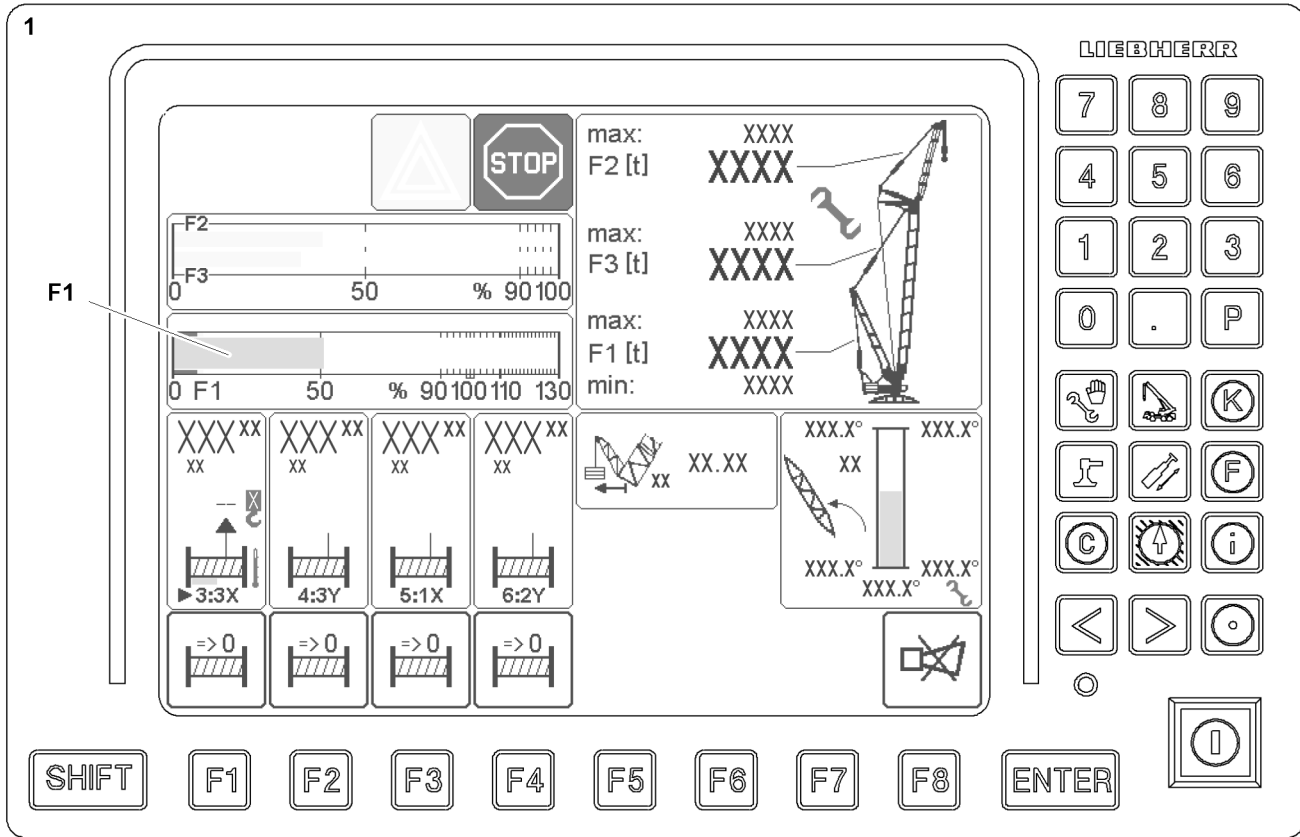
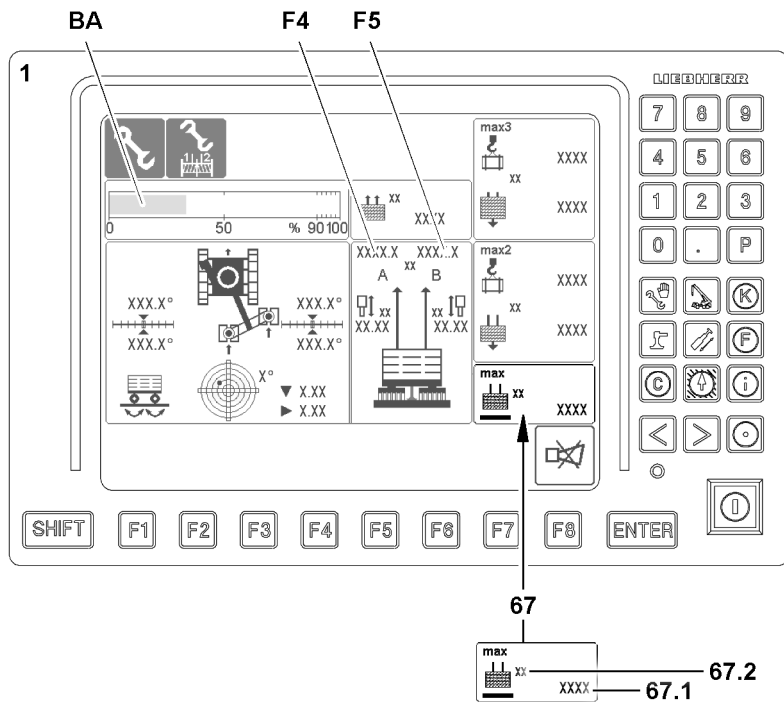

Fig.146971



LWE/LR 11000-001/23501-04-02/en

**WARNING**

Danger of accident!

- ▶ The test point 1-Operation-Maximum force not only depends on the current set up configuration but also on the force measured with the pressure sensors in the pull cylinders.
- ▶ If the pulled derrick ballast is larger, then the maximum permissible $F_{1_{max}}$ force is generally reduced and vice versa.
- ▶ Monitor the ballast weighing and the value for the pulled derrick ballast exactly.

**DANGER**

The crane can topple over!

If the pulled derrick ballast value has been incorrectly determined and is too low, the calculated $F_{1_{max}}$ may be too high and the crane could be overloaded or topple over without this becoming evident.

- ▶ Carefully monitor the displays on the LICCON monitor.

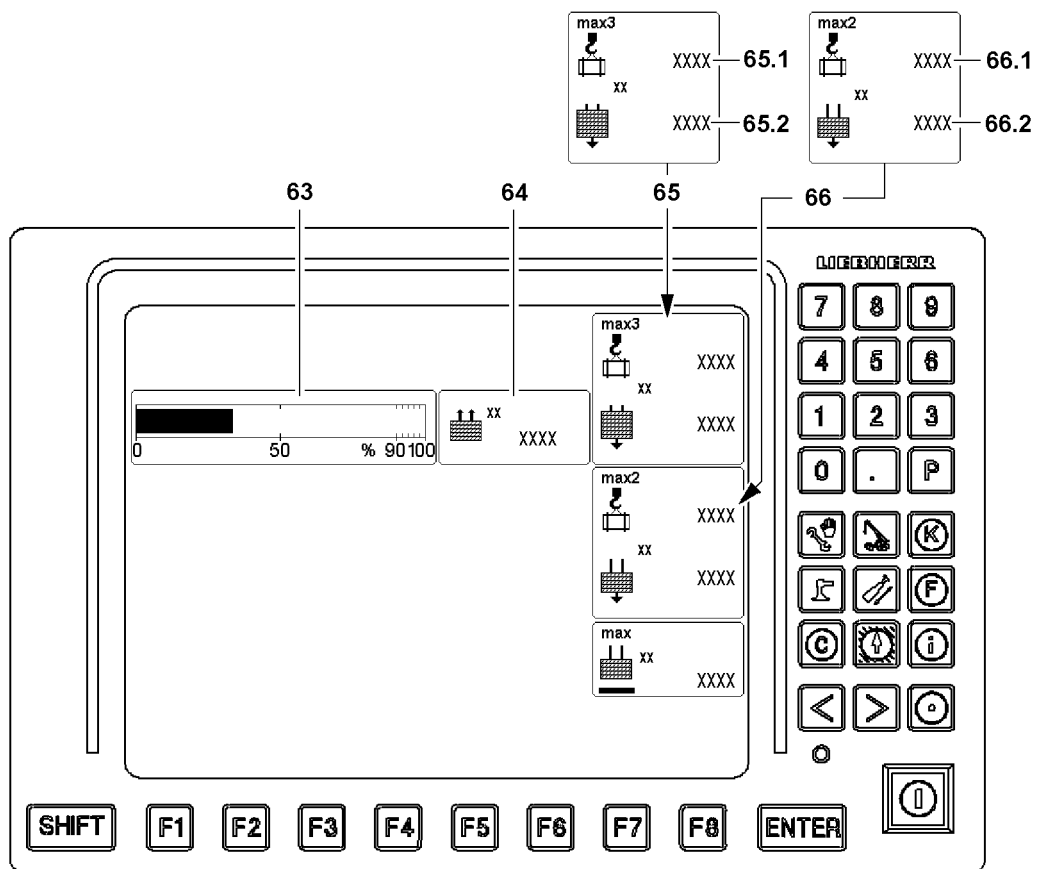
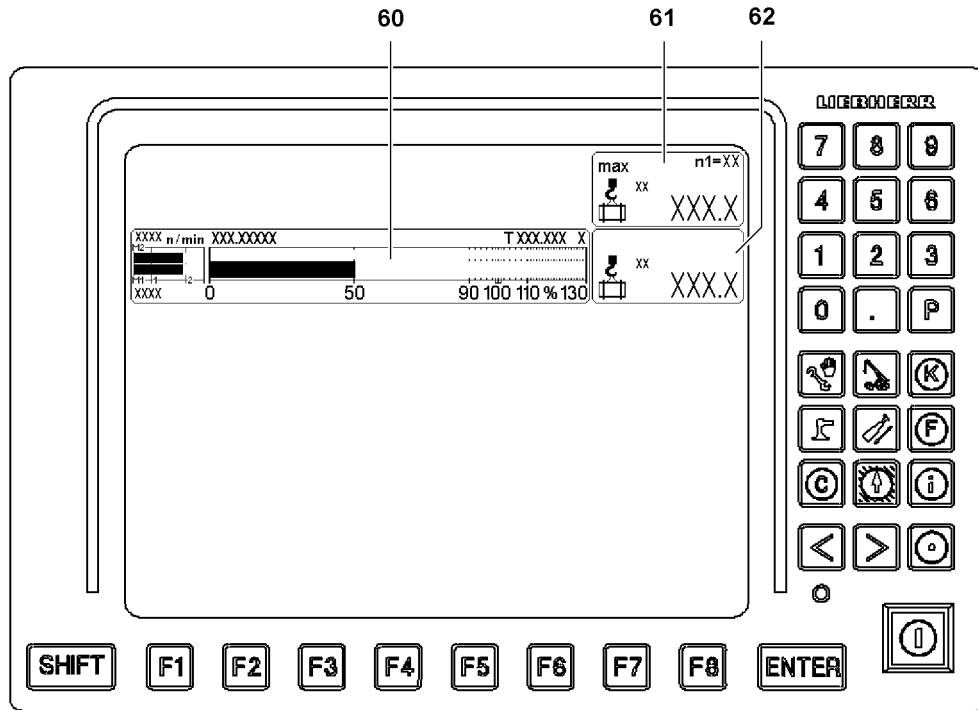

Fig.146969

LWE/LR 11000-001/23501-04-02/en

Utilization conditions

The current percentage utilization of the crane is displayed as „bar diagram utilization“ **61** in the right LICCON monitor.

Additional displays:

- **66** „Load max2“ icon
 - Currently placed derrick ballast = BA_{placed} (Input value in set up program) **66.2**
 - Possible load with currently placed derrick ballast = $\text{Load}_{\text{max2}}$ **66.1**
- **65** „Load max3“ icon
 - Maximum derrick ballast according to load chart = BA_{max} **65.2** (Highest value in Set up program)
 - Possible load with maximum derrick ballast according to load chart = $\text{Load}_{\text{max3}}$ **65.1**

Maximum load, right LICCON monitor:

- The maximum load in the current operating condition is reached when the utilization bar shows 100 % in the „bar diagram utilization“ **60**.
This is the case when the „utilization of the crane according to the load chart and reeving“ reaches 100 % (Values in icon „Maximum load“ **61** and in icon „actual“ **62** are equal).
When the „Maximum load“ **61** is smaller or the same as the $\text{load}_{\text{max2}}$ **66.1**, then an increase might possibly be obtained:
 - By increasing the pulled derrick ballast BA_{pulled} **64**, if the utilization bar derrick ballast **63** is not yet at 100 % (derrick ballast not suspended).
 - By increasing the derrick ballast when the BA_{placed} **66.2** is smaller than BA_{max} **65.2**.
 - By changing the derrick ballast radius within the permissible range, see load chart manual or LICCON job planner.

max2-load, icon „load max2“ **66**:

- The highest possible load in current operating condition „**max2-load**“ is reached when in the „bar diagram utilization“ **60** 100 % is shown **and** the utilization bar derrick ballast **63** is at 100 % (Derrick ballast is completely lifted off the ground).
This is the case when the value in icon „Actual load“ **62** is the same as the $\text{load}_{\text{max2}}$ **66.1**.
When the $\text{load}_{\text{max2}}$ **66.1** is smaller or the same as the $\text{load}_{\text{max3}}$ **65.1**, then an increase might possibly be obtained:
 - By increasing the derrick ballast by loading additional ballast plates (increase BA_{placed} **66.2** to BA_{max} **65.2**).

max3-load, icon „load max3“ **65**:

- The highest possible load at the maximum derrick ballast in current operating condition „**max3-load**“ is reached when the „bar diagram utilization“ **60** displays 100 % **and** the utilization bar derrick ballast **63** is at 100 % (Derrick ballast according to load chart is placed and is completely lifted off the ground).
This is the case when the value in icon „Actual load“ **62** is the same as the $\text{load}_{\text{max3}}$ **65.1**.
- The maximum derrick ballast according to the load chart is placed and completely pulled.
Further increase of the derrick ballast is impermissible.

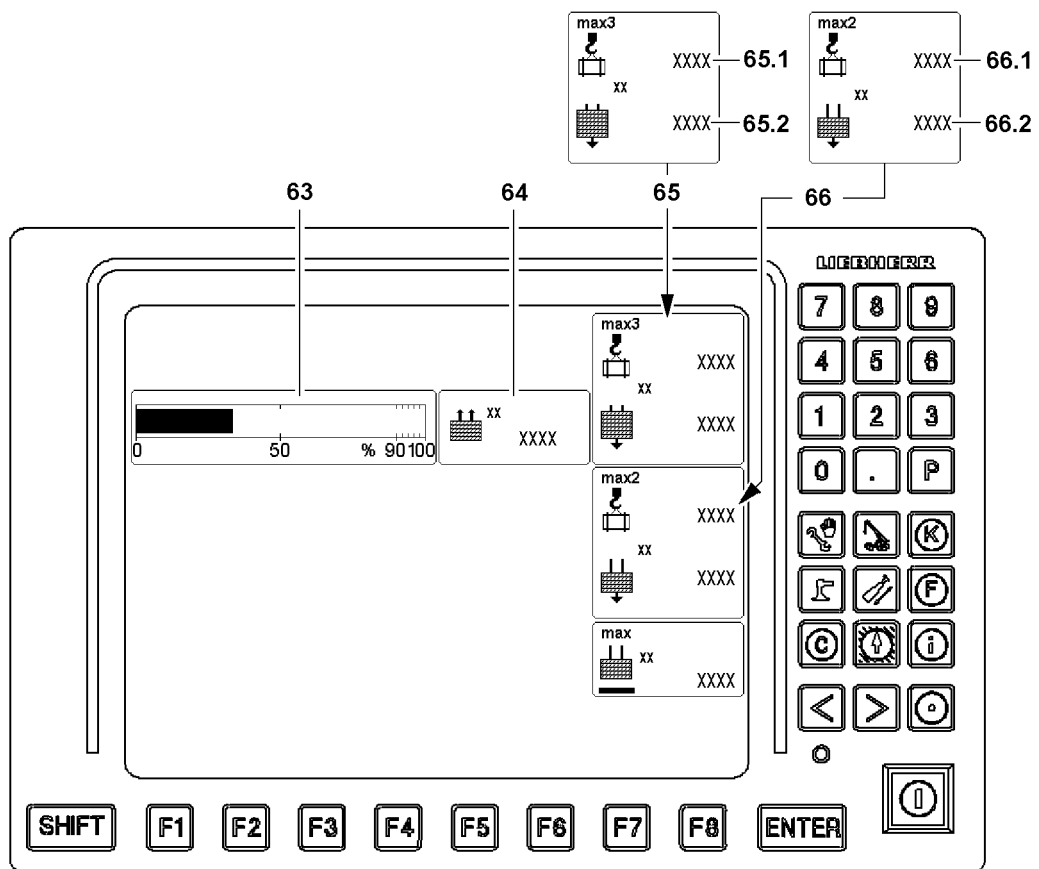
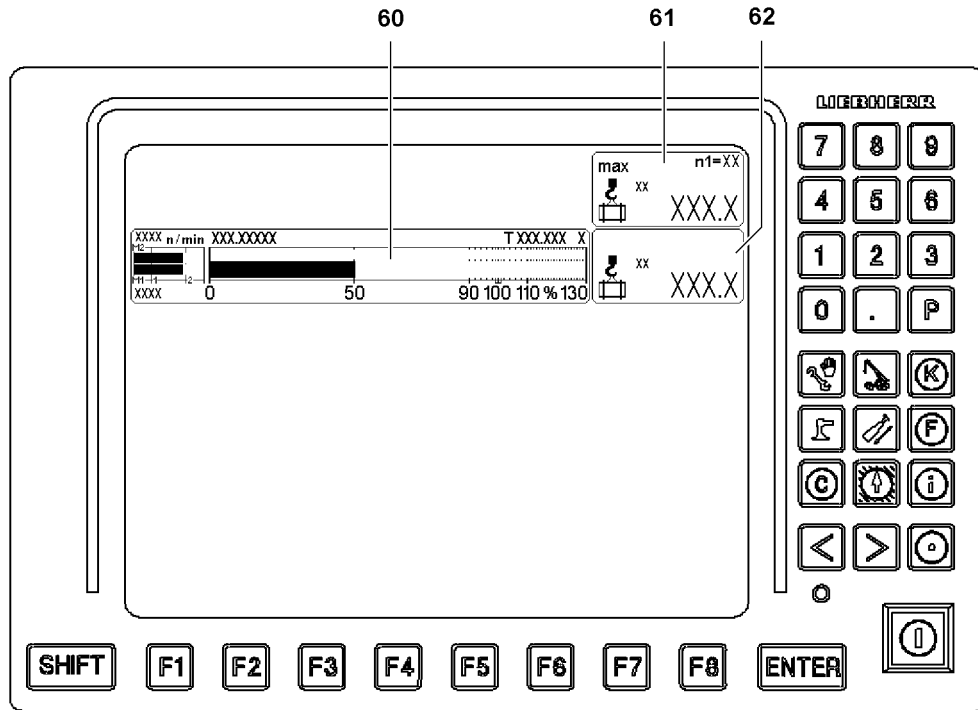

Fig.146969

The bypass of the maximum load according to the load chart and reeving (crane utilization bar 60 is at 100 percent) can be bypassed by activating the assembly operation.

Activate assembly operation, see chapter 4.02.



Note

- ▶ The test point 1-assembly - maximum force shut-off (= F1 max-assembly) cannot be bypassed.



WARNING

Danger of accident when bypassing / exceeding the LICCON overload protection!

If the shut off limits of the LICCON overload protection are bypassed / exceeded, there is no additional protection against overload.

Due to erroneous operation or deliberate misuse, the crane could collapse, the boom can break off or the crane can topple over.

Death, severe bodily injuries, property damage.

- ▶ The function „Exceedance of shut off limits of the LICCON overload protection“ may only be activated or used in emergencies and for assembly purposes.
- ▶ The function „Exceedance of shut off limits of the LICCON overload protection“ may only be activated or used by an authorized person who knows the effects of the bypass exactly.
- ▶ The „Exceedance of the shut off limits of the LICCON overload protection“ may only be carried out „anticipatorily“ and with utmost caution!
- ▶ The „Exceedance of shut off limits of the LICCON overload protection“ is only permissible if the set up configuration of the crane has been entered correctly into the LICCON computer system and has been confirmed.

10.5.5 Checking the length sensor value on the ballast trailer



CAUTION

Danger of accident!

If the derrick ballast radius is measured incorrectly, the false radius value will result in the calculated maximum lifted load and F1-Operation-max-force being too high.

The crane will be overloaded unnoticed and can topple over.

Death, severe bodily injuries, property damage.

- ▶ The crane driver may not rely blindly on the derrick ballast radius measurement, but he must think for himself and check, if the measurement is still working correctly.
- ▶ If the derrick ballast is fully telescoped out or in, the display „Derrick ballast radius“ must show almost the end position of the radius 13 m or 19 m.
- ▶ Depending on the installed intermediate sections, the end positions also change.



Note

- ▶ When telescoping the ballast trailer guide, the indicator must change the display „Derrick ballast radius“ on the LICCON monitor corresponding to the movement of the derrick ballast. If this is not the case, the crane operator can immediately recognize that if the length sensor rope drum jams when spooling in or out.
- ▶ When telescoping out and in and no length change on the rope length sensor occurs, then an error is issued.
- ▶ If a length change is recognized without actuation, then the pressure supply for the ballast trailer is turned off, the error must be remedied.
- ▶ When telescoping the derrick ballast in and out, the „Derrick ballast radius“ display must be observed carefully on the LICCON monitor.

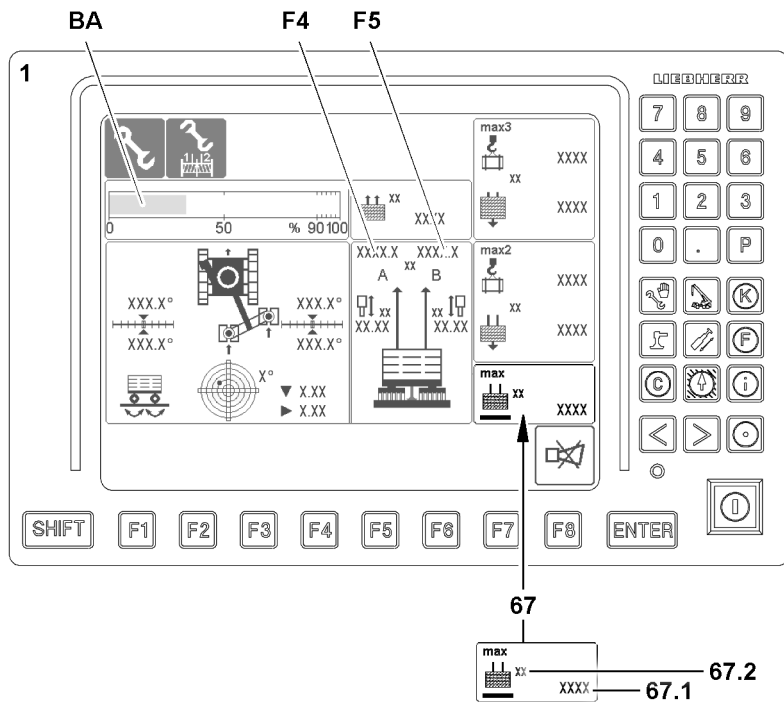
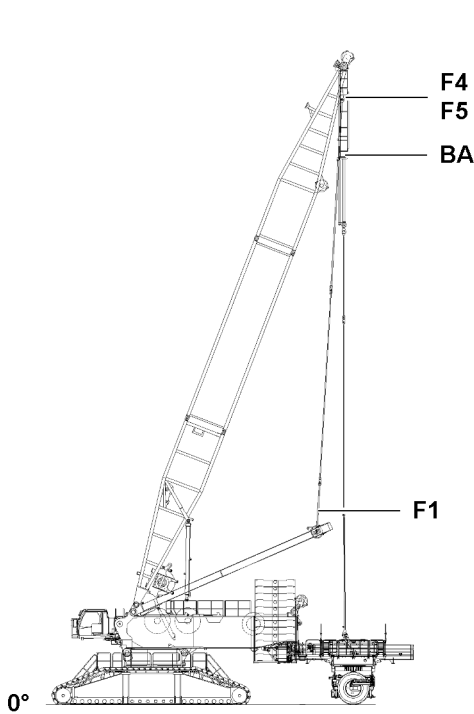
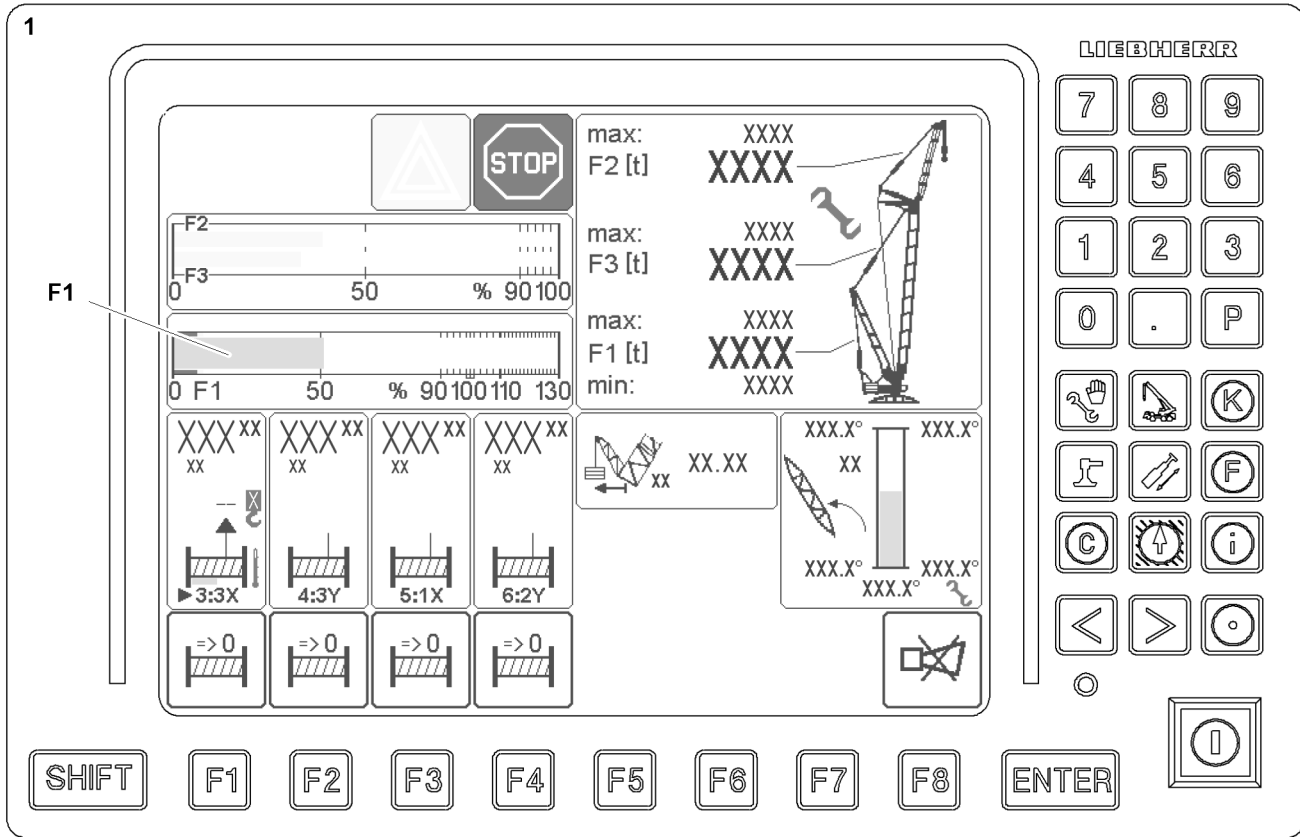

Fig.146971

10.5.6 Difference force monitoring of ballast guying

In operating modes with derrick ballast, the difference between the forces on derrick guying A and B is monitored on LICCON monitor 1. If the difference exceeds a permissible value, an acoustic warning is issued and the two force values blink.

LWE/LR 11000-001/23501-04-02/en

**WARNING**

Danger of accident due to damaged crane components!

Too high a difference in the derrick ballast guying A and B can have the result that the derrick ballast moves in an impermissible inclined position, and thereby the derrick end section, the ballast guide or other crane components may be damaged.

Death, severe bodily injuries, property damage.

- ▶ The forces in the derrick ballast guying A and B must be carefully monitored on the LICCON monitor.

Exceeding the limit value can have the following causes:

- Picking up the load by:
 - Relieving the tires on the ballast trailer or flexing of the turntable.
- The ground under the derrick ballast is uneven.
- The crane is leaning to one side.
- The derrick ballast is loaded one-sided.
- The force measurement in one derrick ballast guying is incorrect.

The crane driver must recognize the correct cause and take countermeasures:

- Error message appears.
- The error, which caused the one-sided force, must be remedied.
- The following measures are permitted providing the ground is only slightly uneven:
 - Lock one pull cylinder and with the other pull cylinder lift the derrick ballast or „Derrick ballast lower“ activate until the difference between the forces A and B is smaller.
- If the sensor values are implausible: Check if the pressure sensors for the ballast weighing supply plausible values and replace them, if necessary.

11 Disassembling the ballast trailer

**WARNING**

Danger of falling!

During assembly / disassembly, inspection and maintenance work, personnel must be secured with appropriate aids to prevent them from falling.

If this is not observed, the assembly personnel can fall down.

Death, severe bodily injuries, property damage.

- ▶ All work at a height, when there is a danger of falling, must be carried out with suitable aids.
- ▶ If aids are not available and work cannot be carried out from the ground, then assembly personnel must secure themselves with the supplied fall arrest system to prevent falling, see chapter 2.04.
- ▶ If fall protection equipment is available, then it must be used, see chapter 2.06.
- ▶ When lifting, lowering, swinging crane parts in and out, no persons may remain in the danger zone.
- ▶ If railings are present on the components, then they must be brought into the corresponding position and secured for assembly / disassembly work.
- ▶ Only step on the aids, ladders and catwalks with clean shoes.
- ▶ Keep aids, ladders and catwalks free of heavy dirt, snow and ice.
- ▶ During all assembly and disassembly work, maintenance work and inspections, travel or crane operation is prohibited.
- ▶ Remaining on a suspended load is prohibited.
- ▶ Stepping or walking on crane components and lattice sections, which have an incline of more than 20° is prohibited.
- ▶ For all assembly work, the crane operator of the main crane must be in voice contact with the crane operator / crane operators of the auxiliary crane / auxiliary cranes.
- ▶ For assembly / disassembly tasks, the crane operator may only initiate crane movements when the responsible guide has explicitly released the movement.

**WARNING**

Danger of impact / crushing!

When installing / removing crane components with the auxiliary crane, crane components can start to swing back and forth.

When lifting / lowering and positioning crane components, there is an increased danger of impacts / crushing.

Death, severe bodily injuries, property damage.

- ▶ Make sure that personnel cannot be caught by components.
- ▶ When working in danger zones: Use aids to protect limbs.
- ▶ Guide components with suitable aids to minimize oscillation.

**WARNING**

The crane can topple over!

If the following danger notes are not observed, the ballast plates or the ballast stack can slip on the ballast trailer and fall down.

The crane can topple over.

Death, severe bodily injuries, property damage.

- ▶ The ground on which the ballast trailer is ballasted must be level and have adequate load-bearing capacity.
- ▶ Remove the ballast plates always symmetrically, in reference to the longitudinal axis.
- ▶ The outer ballast stacks must always weigh the same and be the same height after ballasting.
- ▶ The maximum permissible weight of the ballast trailer is 450 t.
- ▶ Secure all ballast plates so they cannot move and fall down during take down.
- ▶ Replace damaged ballast plates immediately with new ballast plates.

**WARNING**

Ballast trailer tipping danger!

Due to improperly carried out assembly or improper assembly conditions, the ballast trailer can tip over.

Death, severe bodily injuries, property damage.

- ▶ The assembly of the ballast trailer may only be carried out by authorized personnel.
- ▶ The ballast trailer has **no** brake system. The ballast trailer must be supported with the support cylinders if it is **not** pinned on the turntable.
- ▶ Before unpinning the ballast trailer on the turntable it must be ensured that the stability and tipping safety of the ballast trailer is ensured, see section „Stability and tipping safety for ballast trailers not assembled on the turntable“.

**Note**

- ▶ Observe the information in the erection and take-down charts when taking down the boom equipment.

Make sure that the following prerequisites are met:

- The boom equipment is placed down.
- An auxiliary crane and a lifting platform are available.
- The ballast retainers are removed.
- The ballast trailer steering program(s) are deactivated, see section „Deactivating steering programs for assembly / disassembly purposes“.

11.1 Installing the extension ladder on the ballast trailer guide

**Note**

- ▶ Assembly of the extension ladder, see chapter 2.06.

11.2 Ballasting the ballast trailer down

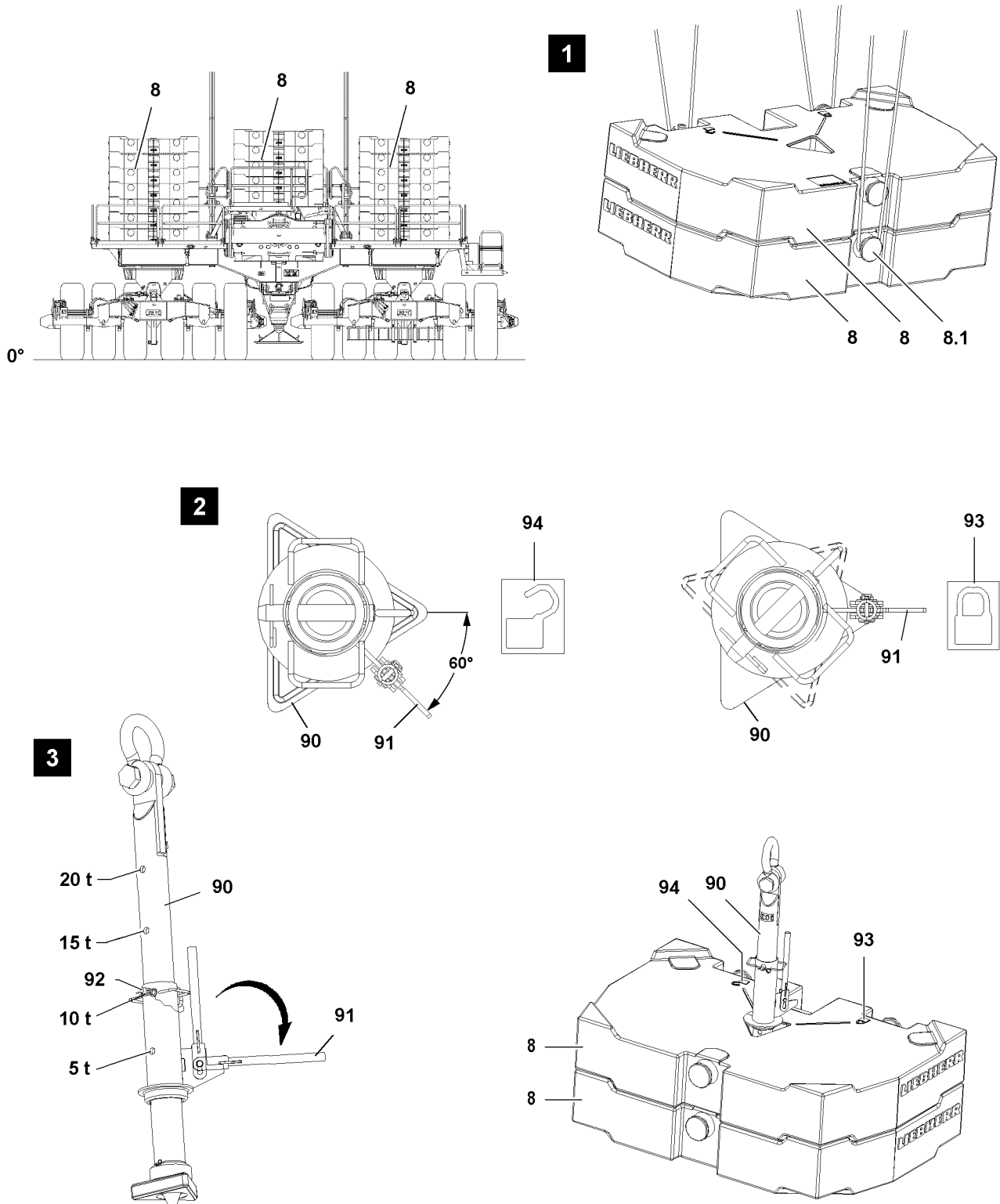

Fig.121945: Ballast plates

LWE/LR 11000-001/23501-04-02/en

**WARNING**

Toppling ballast trailer!

Death, severe bodily injuries, property damage.

- ▶ Make sure that only a quantity of ballast plates are removed from the ballast trailer in order to guarantee **at all times** the stationary stability of the ballast trailer after unpinning on the turntable.

**WARNING**

The crane can topple over!

If more than 20 t are removed with one lift from a ballast stack or if the ballast is removed asymmetrically, then the crane can topple over.

Death, severe bodily injuries, property damage.

- ▶ A weight difference between the right and left ballast stack of more than 20 t * is prohibited.
- ▶ Alternately remove no more than maximum 20 t ballast assemblies from the ballast stack, symmetrically on the left and right.

**Note**

- ▶ The ballast plates are marked with their own weights.

11.2.1 Removing the ballast plates, fastening system: „Twistlock“

**DANGER**

Danger of accident!

If more than the permissible two ballast plates are lifted with the receptacle stud, the receptacle stud will be overloaded and can be damaged.

Death, severe bodily injuries, property damage.

- ▶ Make sure that the ballast plates are placed correctly in the centerings.
- ▶ Replace damaged ballast plates.

To remove the ballast plate(s) **8**, use the receptacle stud **90**.

Before the receptacle stud **90** is guided into the ballast plates, it must be ensured that the length of the receptacle stud **90** is set correctly. The length of the receptacle stud **90** can be adjusted with the pin **92**, see illustration **3**.

If the length of the receptacle stud **90** is to be adjusted:

- ▶ Release and unpin the pin **92**.
- ▶ Adjust the length of the receptacle stud by moving the receptacle stud **90**.
- ▶ Insert the pin **92** and secure with the spring retainer.
- ▶ Attach the receptacle stud **90** on the auxiliary crane and guide it into the ballast plate(s).
- ▶ Pull the lever **91** up and fold it down.
- ▶ Turn the lever **91** by 60° until the lever **91** points to the icon **93**. See illustration **2**.

Result:

- The receptacle stud **90** is locked with the ballast plate.
- ▶ Lift the ballast plate with the receptacle stud **90** and remove it from the ballast stack or the ballast pallet.
- ▶ Turn the lever **91** by 60° until the lever **91** points to the icon **94**. See illustration **2**.

Result:

- The receptacle stud **90** is unlocked from the ballast plate.
- ▶ Carefully pull the receptacle stud **90** from the ballast plate.
- ▶ Alternately remove the ballast plates on both sides.

11.2.2 Removing the ballast plates, fastening points: Bitt



WARNING

Falling ballast plates!

If more than the permissible loads are lifted, then the bitts **8.1** are overloaded and the ballast plates can fall down.

Death, severe bodily injuries, property damage.

- ▶ Lift no more than maximum 20 t with the ropes, 3 fastening points.
- ▶ Replace damaged ballast plates immediately.



WARNING

Incorrect handling of the fastening equipment!

If fastening equipment cannot be attached correctly and if it is not secured sufficiently to prevent it from loosening up, loads can fall down.

Death, severe bodily injuries, property damage.

- ▶ Make sure that the fastening equipment is correctly attached on the bitts **8.1** and that it is secured sufficiently to prevent it from loosening up.



Note

- ▶ Remove the ballast plates individually or as a ballast assembly, maximum 20 t.
 - ▶ The weight difference between the outer ballast stacks no more than maximum 20 t.
 - ▶ 20 t ballast assembly, see illustration **1**.
-
- ▶ Lift the ballast plate **8** or ballast assembly, see illustration **1** and remove it from the ballast stack or the ballast pallet.

11.3 Supporting the ballast trailer

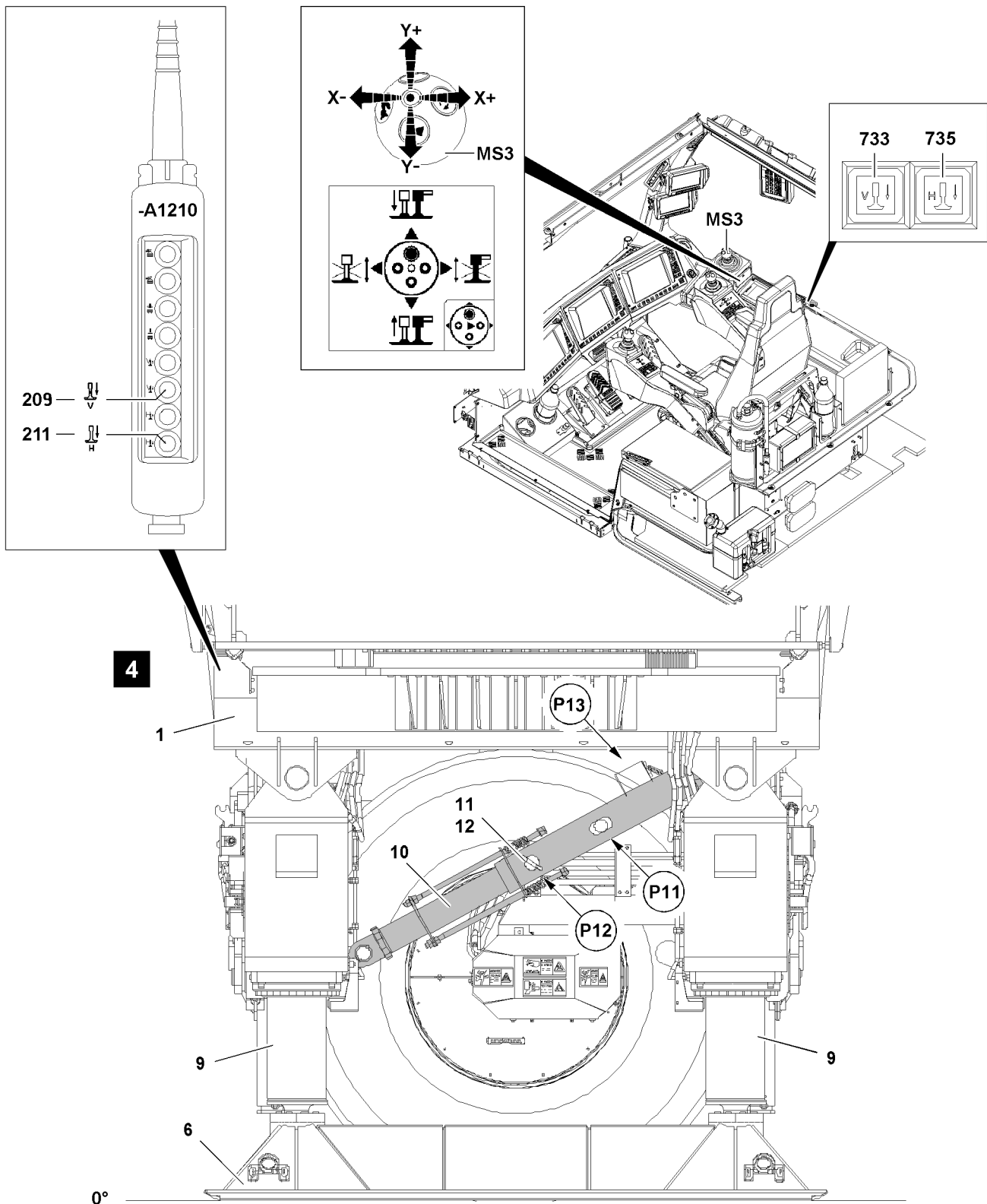

Fig.145926: Ballast trailer support

The support cylinders **9** can be operated via the control panel **-A1210**, or via the corresponding button on the instrument panel of the crane cab.

The ballast trailer must be supported before unpinning it from the turntable.

Make sure that the following prerequisites are met:

- Pay attention to the „assembly condition of the ballast trailer“.
- The ballast trailer guide is retracted until the shut-off caused by the control.
- The crane is horizontally aligned.

11.3.1 Pinning the strut on the ballast trailer



WARNING

Ballast trailer tipping danger!

If the ballast trailer is not installed on the turntable and the ballast trailer guide is not fully retracted, the ballast trailer can tip over.

Death, severe bodily injuries, property damage.

- ▶ Before removal of the ballast trailer on the turntable, the locking pin **11** must be pinned on strut **10** of the ballast trailer at point **P12** and secured with the spring retainer **12**, see illustration **4**.
 - ▶ The support **6** is extended to the point where the tires are relieved, see illustration **4**.
-
- ▶ Release the locking pin **11** at point **P11** and unpin.
 - ▶ Insert the locking pin **11** in transport position at point **P12** and secure with spring retainer **12**, see illustration **4**.

11.3.2 Extending the support cylinders

Move the front and rear support cylinders out:

- ▶ Press the button **733** and button **735** in the crane cab.
or
Press the button **209** and button **211** on the control panel **-A1210**.
or

When the corresponding master switch assignment is selected:

- ▶ Move the master switch **MS3** in direction **Y+**.
- ▶ Visually inspect the extended support cylinder.

11.4 Removing the ballast trailer on the turntable

11.4.1 Extending the supply lines between the turntable and the ballast trailer

Depending on the local circumstances at the job location of the crane, it may be necessary when assembling / disassembling the ballast trailer to extend the electrical lines between the turntable and the ballast trailer with the extension lines.

This can ensure that after unpinning the ballast trailer guides from the turntable, they can be retracted enough so that the slewing range of the turntable is not limited by the ballast trailer guide.



WARNING

Danger of accident due to loss of pressure or leakage!

Death, severe bodily injuries, property damage.

- ▶ Make sure that the specifications for establishing and disconnecting hydraulic and electrical connections are observed.
-
- ▶ Assemble the electrical extension lines between the turntable and the ballast trailer.
 - ▶ Assemble the hydraulic extension lines between the turntable and the ballast trailer.

11.4.2 Disassembling the ballast trailer guying

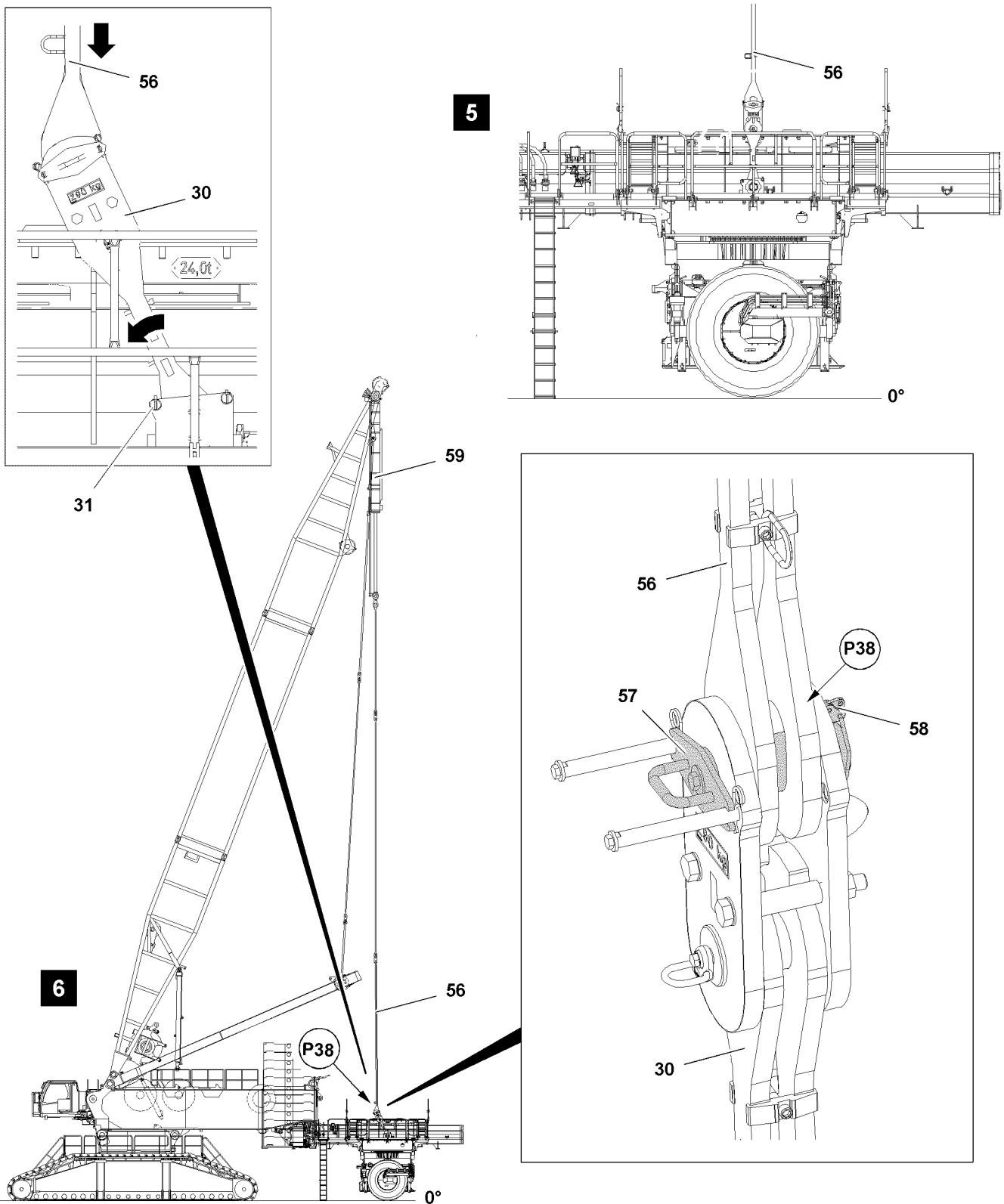

Fig.121014: Ballast trailer guying

Unpinning the guy rods

Make sure that the following prerequisite is met:

- The guy rods are relieved.

- ▶ Extend the pull cylinder **59** until the pull brackets **30** are placed on the pin **31**, see illustration **6**.

**Note**

Retract / extend the pull cylinder **59**

- ▶ Control the pull cylinders **59** from the crane cab or with the control panel, see section „lifting and lowering the ballast trailer with the pull cylinders“.
- ▶ Operate the pull cylinder **59** with the radio remote control, see the „radio remote control operating instructions“.

The guy rods **56** of the derrick boom are to be unpinned on the pull brackets **30**. The connector pins **57** are held in „pulled“ condition by the cylinder screws of the pin guide, see illustration **6**.

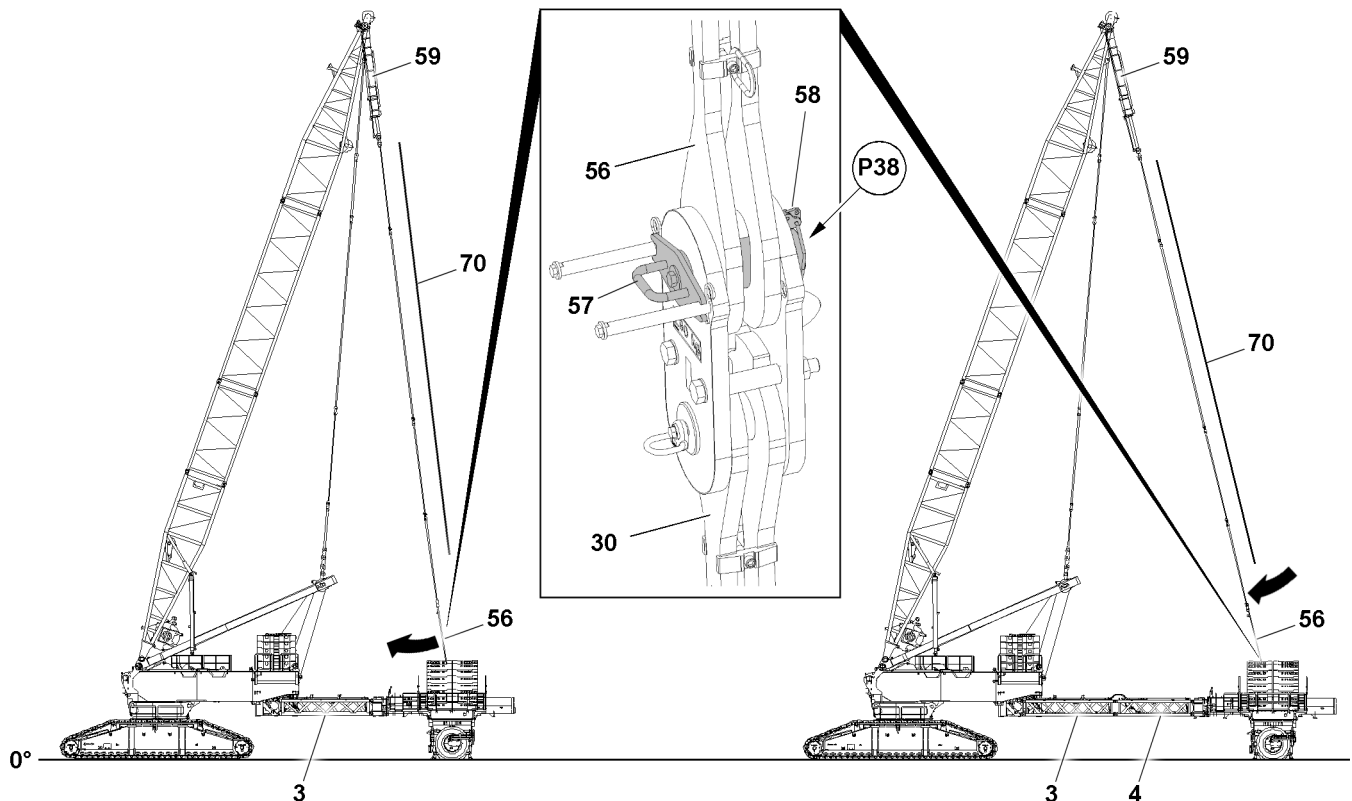

Fig.144265: Unpinning the guying **70** on the pull brackets **30**

**WARNING**

Danger of accident due to oscillating guy rods!
The guying **70** can sway during the unpinning procedure.
Death, severe bodily injuries, property damage.

- ▶ Before unpinning the guying, set the derrick ballast to the derrick boom radius by retracting the ballast trailer guide.
- ▶ If this is not possible due to the extension(s) mounted on the ballast trailer guide, use the auxiliary crane to properly secure the guying **70** on the pull brackets **30** before unpinning.
- ▶ Use the auxiliary crane to slowly and carefully swing the unpinned guying **70** in the direction of the derrick boom until the guying **70** hangs vertically.

If the derrick ballast radius does not correspond to the derrick boom radius:

- ▶ Use the auxiliary crane to properly secure the guying **70** just above the pull brackets **30**.

When the first guying is secured with the auxiliary crane:

- ▶ Unpin the guy rods **56** at point **P38** on the pull brackets **30**: Remove the safety locking pin **58** and unpin the connector pin **57**.

When the guy rods **56** are properly unpinned:

- ▶ Use the auxiliary crane to swing the guying **70** in a vertical position to the derrick boom.

When the guying **70** is in a vertical position:

- ▶ Insert the connector pin **57** again and secure with safety locking pin **58**.
- ▶ Properly disassemble and take-down the guy rods **56** on the guying **70**.
- ▶ Retract the pull cylinder **59** and pull up the guying **70**.

When the first guying is unpinned at point **P38** and hangs vertically on the derrick boom head:

- ▶ Remove the auxiliary crane.

**Note**

- ▶ The second guying is unpinned in an identical manner to the unpinning procedure used for the first guying.

-
- ▶ Properly unpin the second guying.

11.4.3 Unpinning the ballast trailer on the turntable

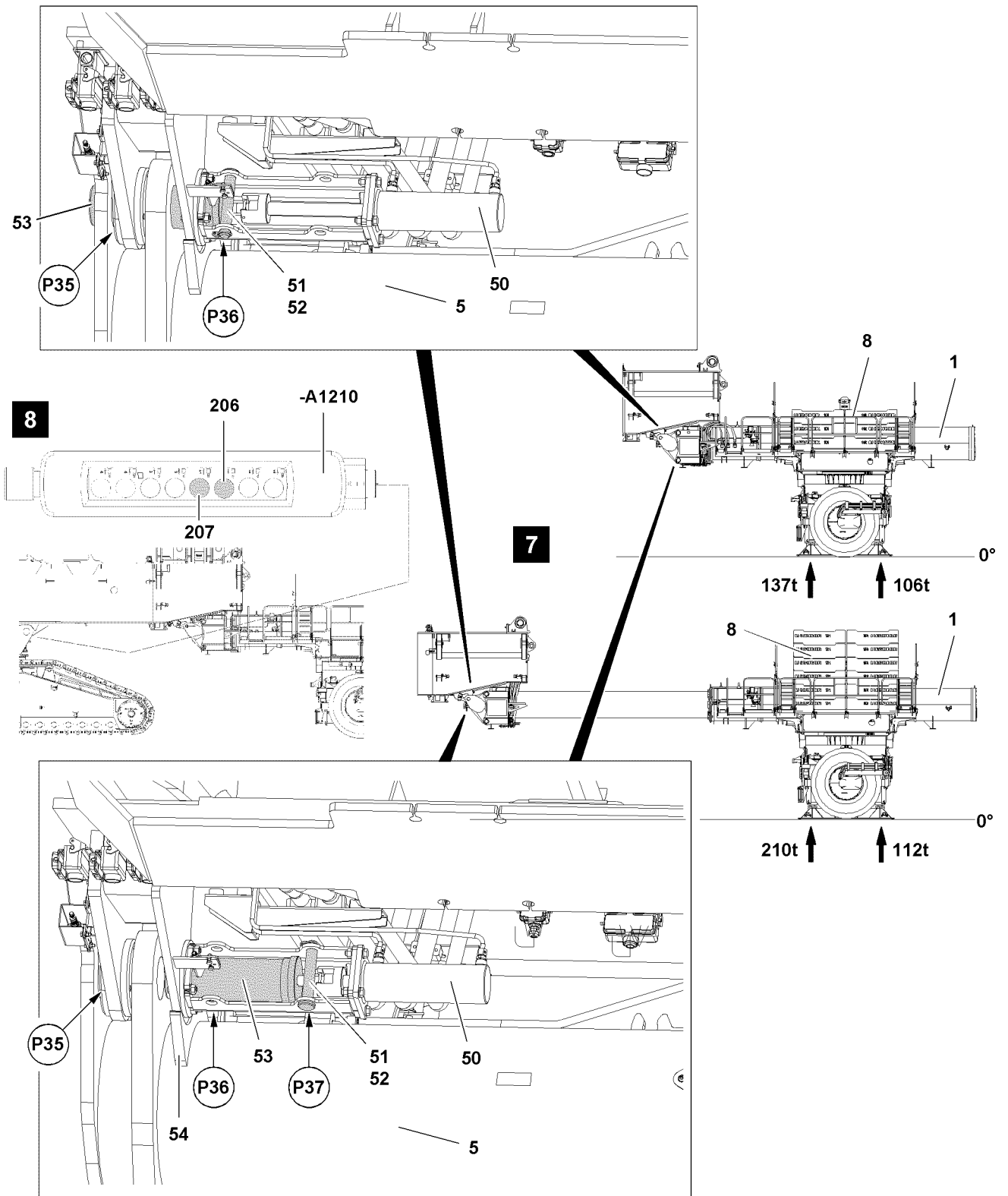

Fig.121020: Unpinning the ballast trailer on the turntable

LWE/LR 11000-001/23501-04-02/en

Unpinning the ballast trailer with ballast trailer radius 13–19 m on the turntable



WARNING

Danger of fatal injury due to tipping ballast trailer!

If the ballast trailer is insufficiently ballasted, then the ballast trailer can tip over when unpinning the ballast trailer guide **2** on the turntable.

Death, severe bodily injuries, property damage.

- ▶ Make sure, when unpinning the ballast trailer guide **2**, that the ballast trailer is ballasted with appropriately selected ballast trailer radius, see chart.
- ▶ Make sure that the ground is prepared according to the ground pressure, see illustration **7**.

	Ballast trailer radius R 13-19 m	
	R 13 m	R 19 m
Weight of the ballast plates (min)	140 t	220 t

Minimum weight of ballast plates

Make sure that the following prerequisites are met:

- The ballast trailer is supported.
- The ballast trailer is ballasted symmetrically according to the ballast trailer radius.
- The locking pin **11** on the strut **10** is pinned in transport position at point **P12** and secured with spring retainer **12**.

Release the connector pins **53** on both sides and unpin at point **P35**:

- ▶ Remove the safety locking pin **52** at point **P36** and unpin the retaining pin **51**, see illustration **7**.
- ▶ Insert the retaining pin **51** at point **P37** and secure.
- ▶ Press button **206** on the control panel **-A1210**, see illustration **8**.

Result:

- The pin pulling cylinders **50** retract.
- The connector pins **53** are unpinned on the turntable.



Note

- ▶ For disassembly of the ballast trailer, if the functions „turning“ or „driving“ are required to unpin the ballast trailer, the respective active ballast trailer operating mode „turning released“, „driving released“ or „parallel driving released“ must be deactivated.
- ▶ When the ballast trailer is installed the stated releases are not activated, i.e. turning and driving the crane is possible until both limit switches report that the ballast trailer is pinned.

NOTICE

Damage to the ballast trailer or to the turntable!

When unpinning the ballast trailer, only one connector pin **53** can be unpinned on the turntable due to distortions, (signal „Ballast trailer installed“ is no longer present), then the crane control no longer recognizes that the ballast trailer is installed, even though the ballast trailer is still connected with the turntable via the second connector pin **53**.

Due to the missing signal, „Ballast trailer installed“, it is possible to turn the turntable, to drive the crane or to telescope the ballast trailer guide out or in.

This could significantly damage the crane or the ballast trailer.

- ▶ All crane movements are to be limited to a „minimum degree“ and must be driven with extreme caution and the least possible speed.
- ▶ After unpinning of the second connector pin **53**, it must again be checked of both connector pins are completely unpinned.

- ▶ Perform a visual inspection.

When both connector pins are uninned:

- ▶ Remove the crane.

Unpinning the ballast trailer with ballast trailer radius 19–25 m on the turntable or unpinning the ballast trailer with ballast trailer radius 24–30 m on the turntable

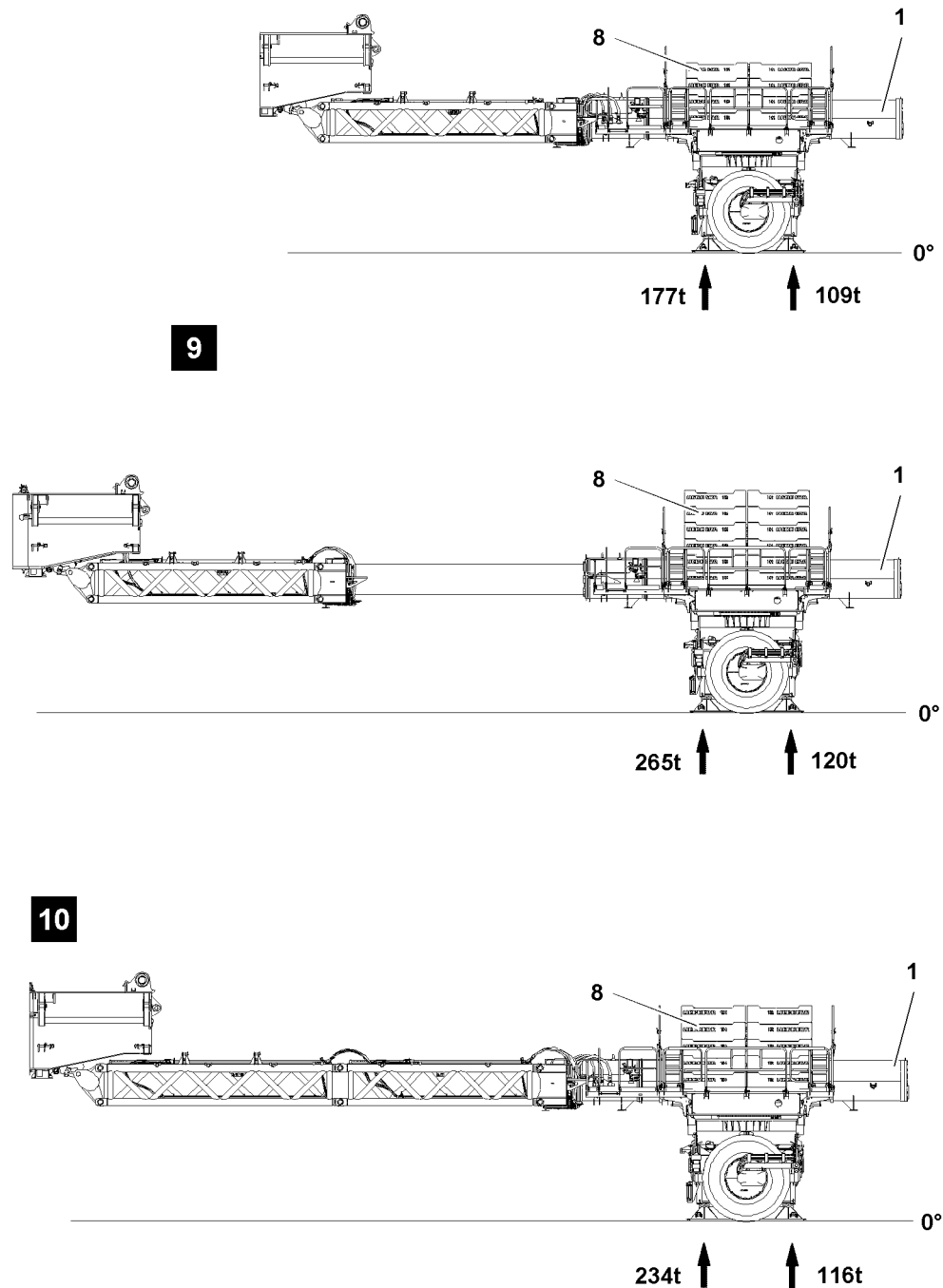

Fig.121991: Unpinning the ballast trailer on the turntable

**WARNING**

Danger of fatal injury due to tipping ballast trailer!

If the ballast trailer is insufficiently ballasted, then the ballast trailer can tip over when unpinning the ballast trailer guide **2** on the turntable.

Death, severe bodily injuries, property damage.

- ▶ Make sure, when unpinning the ballast trailer guide **2**, that the ballast trailer is ballasted with appropriately selected ballast trailer radius, see chart.
- ▶ Make sure that the ground is prepared according to the ground pressure, see illustration **7**.

	Ballast trailer radius R 19-25 m		Ballast trailer radius R 24-30 m	
	R 19 m	R 25 m	R 24 m	R 30 m
Weight of the ballast plates (min)	180 t	280 t	240 t	Not permissible

Minimum weight of ballast plates

Make sure that the following prerequisites are met:

- The ballast trailer is supported.
- The ballast trailer is ballasted symmetrically according to the ballast trailer radius.
- The locking pin **11** on the strut **10** is pinned in transport position at point **P12** and secured with spring retainer **12**.

**Note**

- ▶ The pinning of the ballast trailer **1** with ballast trailer radius 19–25 m **or** with ballast trailer radius 24–30 m on the turntable is identical with the unpinning of the ballast trailer **1** with ballast trailer radius 13–19 m.
 - ▶ Unpinning the ballast trailer **1** with ballast trailer radius 19–25 m **or** with ballast trailer radius 24–30 m, see section „Unpinning the ballast trailer with ballast trailer radius 13–19 m on turntable“.
-
- ▶ Unpin the ballast trailer **1** on the turntable.

11.5 Releasing the electrical connection from the ballast trailer to the turntable

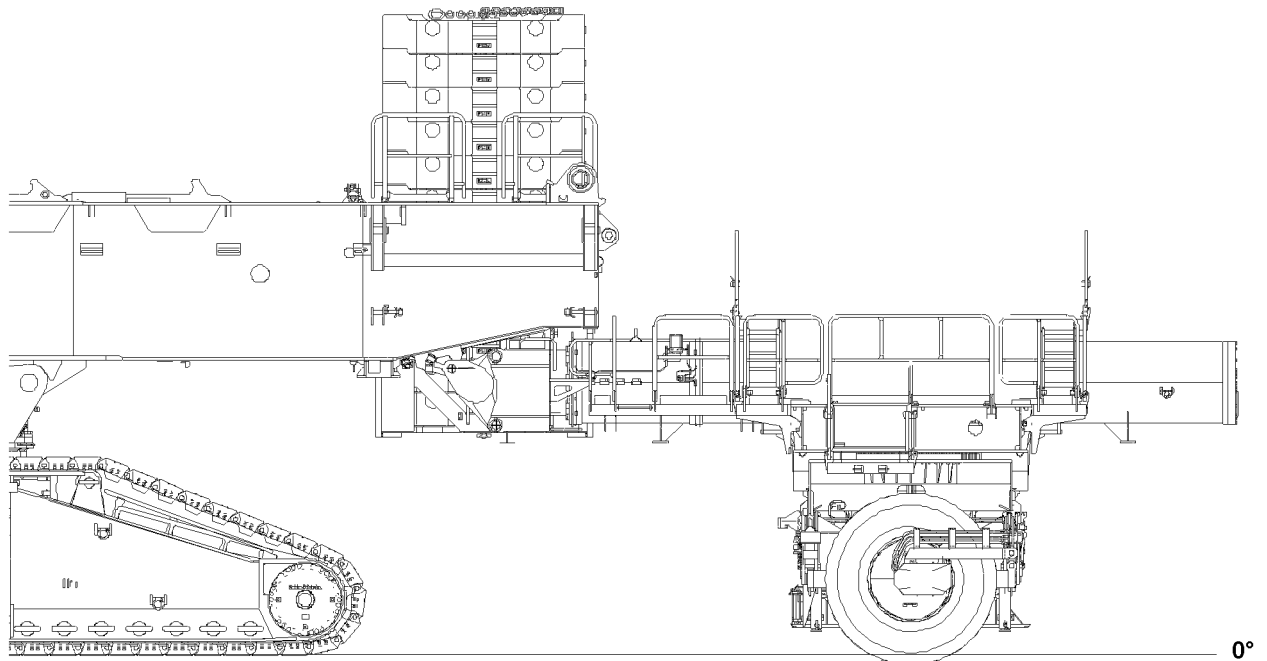

Fig. 121017

Make sure that the following prerequisite is met:

- The ballast trailer is supported.



Note

- ▶ Disconnect the electrical connections, see Electric wiring diagram.
- ▶ Disconnect the electrical connections and store properly on the ballast trailer.

11.6 Releasing the hydraulic connections from the ballast trailer to the turntable

When connecting and releasing hydraulic lines with quick couplings, make sure that the coupling procedure is carried out correctly.



DANGER

Danger of accident due to loss of pressure or leakage.

Incorrectly coupled or self-loosening quick couplings (particularly return lines) can result in serious accidents due to component failure.

- ▶ Check that the quick couplings have been properly connected before using the crane.
- ▶ Release the pressure in the hydraulic system before connecting or disconnecting. Turn the engine off and wait for short time.
- ▶ Install the coupling components (sleeve and connector) with the knurled nut.
- ▶ Disconnect the coupling sections.
- ▶ Store hydraulic hoses on the ballast trailer properly.
- ▶ Protect the coupling sections with caps to prevent contamination and damage.

12 Removing the ballast trailer



WARNING

Danger of falling!

During assembly / disassembly, inspection and maintenance work, personnel must be secured with appropriate aids to prevent them from falling.

If this is not observed, the assembly personnel can fall down.

Death, severe bodily injuries, property damage.

- ▶ All work at a height, when there is a danger of falling, must be carried out with suitable aids.
- ▶ If aids are not available and work cannot be carried out from the ground, then assembly personnel must secure themselves with the supplied fall arrest system to prevent falling, see chapter 2.04.
- ▶ If fall protection equipment is available, then it must be used, see chapter 2.06.
- ▶ When lifting, lowering, swinging crane parts in and out, no persons may remain in the danger zone.
- ▶ If railings are present on the components, then they must be brought into the corresponding position and secured for assembly / disassembly work.
- ▶ Only step on the aids, ladders and catwalks with clean shoes.
- ▶ Keep aids, ladders and catwalks free of heavy dirt, snow and ice.
- ▶ During all assembly and disassembly work, maintenance work and inspections, travel or crane operation is prohibited.
- ▶ Remaining on a suspended load is prohibited.
- ▶ Stepping or walking on crane components and lattice sections, which have an incline of more than 20° is prohibited.
- ▶ For all assembly work, the crane operator of the main crane must be in voice contact with the crane operator / crane operators of the auxiliary crane / auxiliary cranes.
- ▶ For assembly / disassembly tasks, the crane operator may only initiate crane movements when the responsible guide has explicitly released the movement.



WARNING

Danger of impact / crushing!

When installing / removing crane components with the auxiliary crane, crane components can start to swing back and forth.

When lifting / lowering and positioning crane components, there is an increased danger of impacts / crushing.

Death, severe bodily injuries, property damage.

- ▶ Make sure that personnel cannot be caught by components.
- ▶ When working in danger zones: Use aids to protect limbs.
- ▶ Guide components with suitable aids to minimize oscillation.



WARNING

The crane can topple over!

If the following danger notes are not observed, the ballast plates or the ballast stack can slip on the ballast trailer and fall down.

The crane can topple over.

Death, severe bodily injuries, property damage.

- ▶ The ground on which the ballast trailer is ballasted must be level and have adequate load-bearing capacity.
- ▶ Remove the ballast plates always symmetrically, in reference to the longitudinal axis.
- ▶ The outer ballast stacks must always weigh the same and be the same height after ballasting.
- ▶ The maximum permissible weight of the ballast trailer is 450 t.
- ▶ Secure all ballast plates so they cannot move and fall down during take down.
- ▶ Replace damaged ballast plates immediately with new ballast plates.

**WARNING**

Ballast trailer tipping danger!

Due to improperly carried out assembly or improper assembly conditions, the ballast trailer can tip over.

Death, severe bodily injuries, property damage.

- ▶ The assembly of the ballast trailer may only be carried out by authorized personnel.
- ▶ The ballast trailer has **no** brake system. The ballast trailer must be supported with the support cylinders if it is **not** pinned on the turntable.
- ▶ Before unpinning the ballast trailer on the turntable it must be ensured that the stability and tipping safety of the ballast trailer is ensured, see section „Stability and tipping safety for ballast trailers not assembled on the turntable“.

**Note**

- ▶ Observe the information in the erection and take-down charts when taking down the boom equipment.

Make sure that the following prerequisites are met:

- The ballast trailer is in a level and horizontal position.
- The ballast trailer is properly supported.
- The ballast trailer guide is fully retracted.
- The ballast plates are completely removed from the ballast trailer.
- The ballast retainers are removed.

12.1 Removing the ballast trailer guide on the ballast trailer

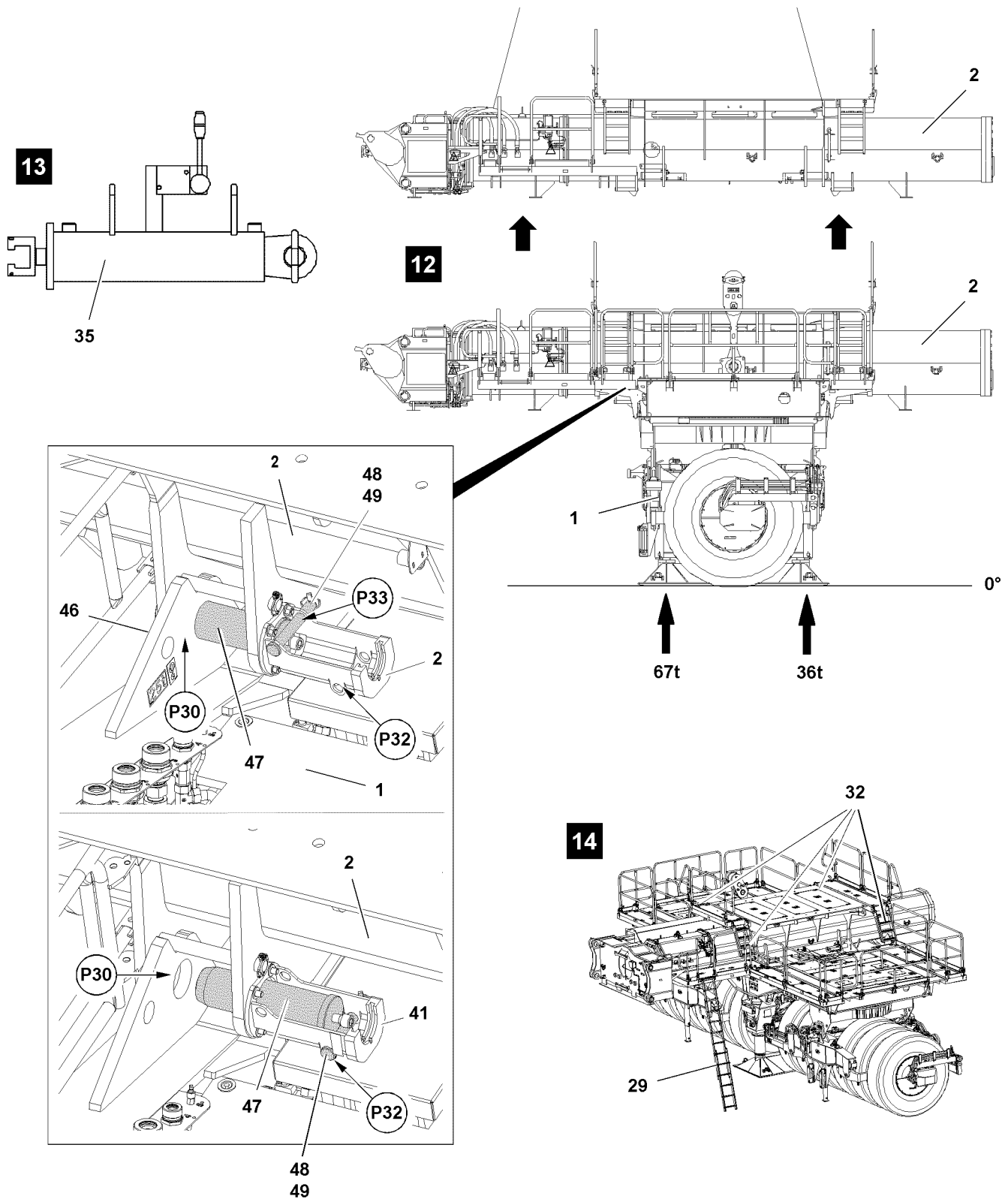

Fig.121022: Disassembling the ballast trailer guide

Make sure that the following prerequisite is met:

- The ballast trailer is supported.

LWE/LR 11000-001/23501-04-02/en

12.1.1 Installing the extension ladder on the ballast trailer guide



Note

- ▶ Position of extension ladder **29**, see illustration **14**.
- ▶ Assembly of the extension ladder **29**, see chapter 2.06.

12.1.2 Disassembling the ballast trailer guide with ballast trailer radius 13-19 m on the ballast trailer



WARNING

Danger of fatal injury due to tipping ballast trailer!

If the ballast trailer is insufficiently ballasted, then the ballast trailer can tip over disassembly of the ballast trailer guide **2**.

Death, severe bodily injuries, property damage.

- ▶ Make sure that the ballast trailer guide **2** is telescoped in.
- ▶ Make sure, at disassembly of the ballast trailer guide **2**, that the ballast trailer is ballasted according to the ballast trailer radius, see the following chart.
- ▶ Make sure that the ground is prepared according to the ground pressure, see illustration **19**.

	Ballast trailer radius R 13-19 m
Weight of the ballast plates (min)	0 t

Minimum weight of ballast plates

- ▶ Fasten the ballast trailer guide **2** to the auxiliary crane, see illustration **12**.
- ▶ Remove the safety locking pin **49** at point **P33** and unpin the retaining pin **48**.

Result:

- The connector pin **47** is released.
- ▶ Insert the retaining pin **48** at point **P33** and secure with safety locking pin **49**.
- ▶ Hang the pin pulling cylinder **35**, see illustration **13**, on the retainer **50** and on the screw head.
- ▶ Establish the hydraulic connection of the pin pulling cylinder **35** to the hydraulic aggregate, see chapter 5.30.
- ▶ Actuate the lever on the pin pulling cylinder **35** and unpin the connector pin **47** at point **P30**.
- ▶ Unpin all four connector pins **47**.

When all four connector pins **47** are unpinned:

- ▶ Lift the ballast trailer guide **2** with auxiliary crane and remove.

12.1.3 Disassembling the ballast trailer guide with ballast trailer radius 19–25 m or with ballast trailer radius 24–30 m on the ballast trailer

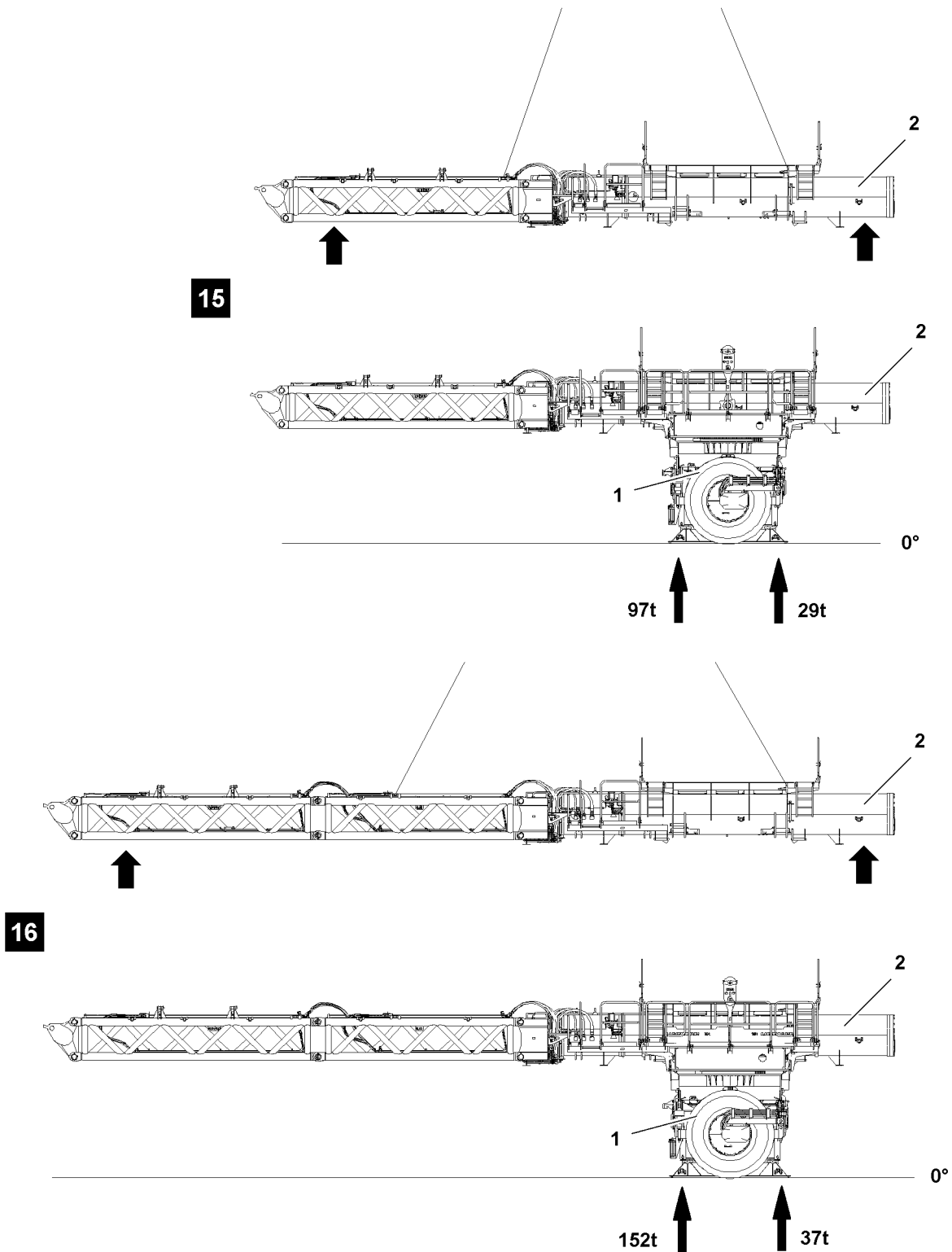

Fig.121992: Disassembling the ballast trailer guide

**WARNING**

Danger of fatal injury due to tipping ballast trailer!

If the ballast trailer is insufficiently ballasted, then the ballast trailer can tip over disassembly of the ballast trailer guide **2**.

Death, severe bodily injuries, property damage.

- ▶ Make sure that the ballast trailer guide **2** is telescoped in.
- ▶ Make sure, at disassembly of the ballast trailer guide **2**, that the ballast trailer is ballasted according to the ballast trailer radius, see the following chart.
- ▶ Make sure that the ground is prepared according to the ground pressure, see illustration **15** and illustration **16**.

	Ballast trailer radius R 19-25 m	Ballast trailer radius R 24-30 m
Weight of the ballast plates (min)	20 t	80 t

Minimum weight of ballast plates

**Note**

- ▶ The disassembly of the ballast trailer guide **2** with ballast trailer radius 19–25 m **or** with ballast trailer radius 24–30 m on the ballast trailer is identical with the disassembly of the ballast trailer guide **2** with ballast trailer radius 13–19 m.

**Note**

- ▶ For disassembly of the ballast trailer guide **2** with ballast trailer radius 19–25 m **or** with ballast trailer radius 24–30 m, see section „Disassembling the ballast trailer guide with ballast trailer radius 13–19 m on ballast trailer“.
- ▶ Fasten the ballast trailer guide **2** to the auxiliary crane, see illustration **15** or illustration **16**.
- ▶ Unpin the ballast trailer guide **2** on ballast trailer **1**, see illustration **15** or illustration **16**.

12.2 Placing the pull brackets down

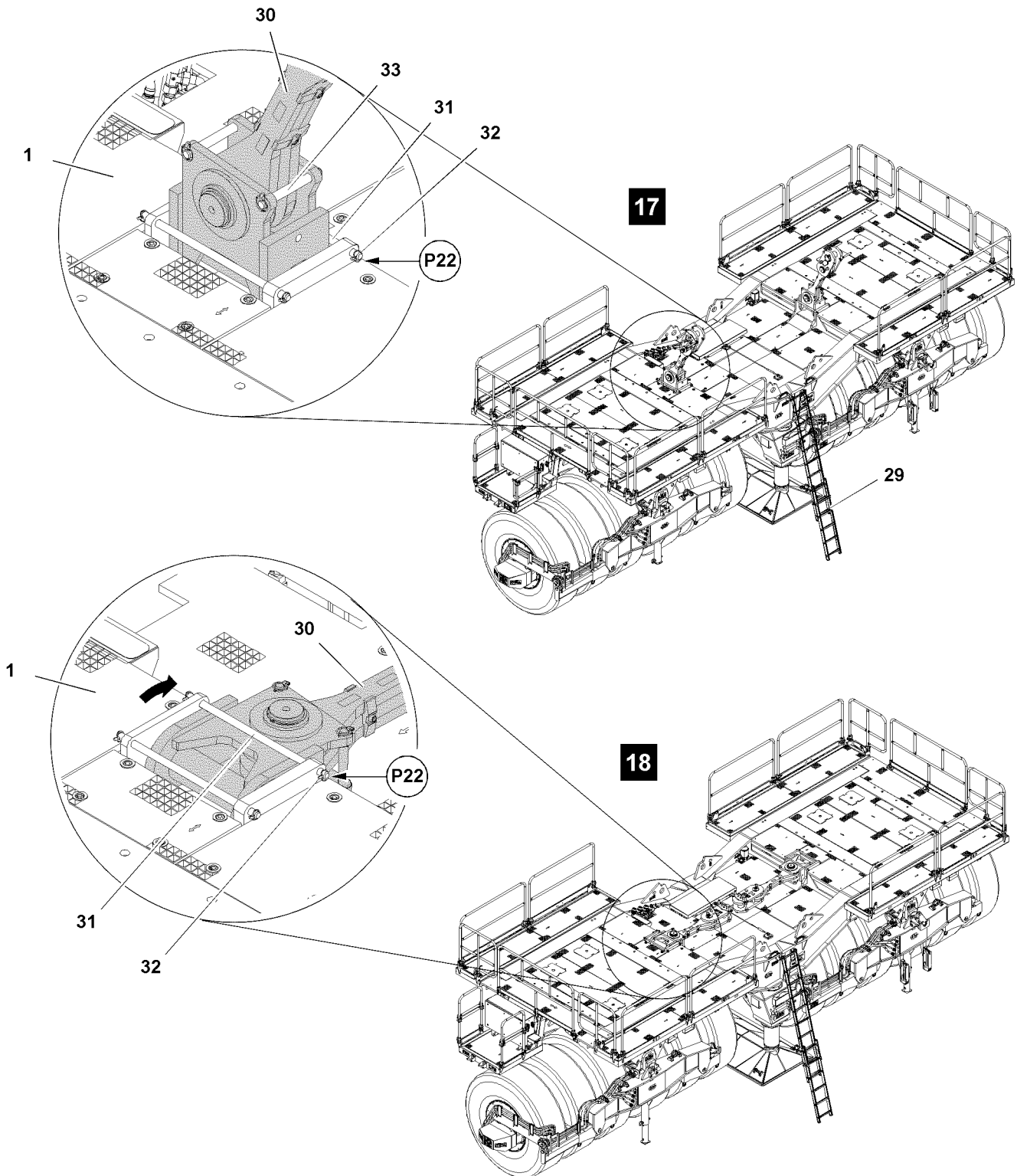

Fig.121015: Placing the pull brackets down

LWE/LR 11000-001/23501-04-02/en

12.2.1 Installing the extension ladder on the ballast trailer



Note

- ▶ Position of extension ladder **29** see illustration **17**.
- ▶ Assembly of the extension ladder **29**, see chapter 2.06.

12.2.2 Placing the pull brackets down

Make sure that the following prerequisites are met:

- The guy rods are unpinned.
- The ballast trailer guide has been disassembled.
- ▶ Fasten the pull bracket **30** to the auxiliary crane.



WARNING

Pull bracket swinging down!

The pull bracket **20** can swing down by itself due to its own weight when unpinning the pin **31**.
Death, severe bodily injuries, property damage.

- ▶ Make sure that the pull bracket is held by the auxiliary crane during unpinning.
 - ▶ Make sure that no persons reach into the danger zone during the entire procedure.
-
- ▶ Release the pull bracket **30** from operating position: Remove the safety locking pin **32** at point **P22** and unpin the pin **31**, see illustration **17**.
 - ▶ Place the pull bracket **30** down with the auxiliary crane.
 - ▶ Secure the pull bracket **30** in transport position: Insert the pin **31** at point **P22** and secure with safety locking pin **32**, see illustration **18**.
 - ▶ Remove the auxiliary crane.
 - ▶ Take down the second pull bracket.

12.2.3 Removing the railing on the ballast trailer



Note

- ▶ Disassembly of the railing, see chapter 2.06.

12.3 Disassembling the platforms

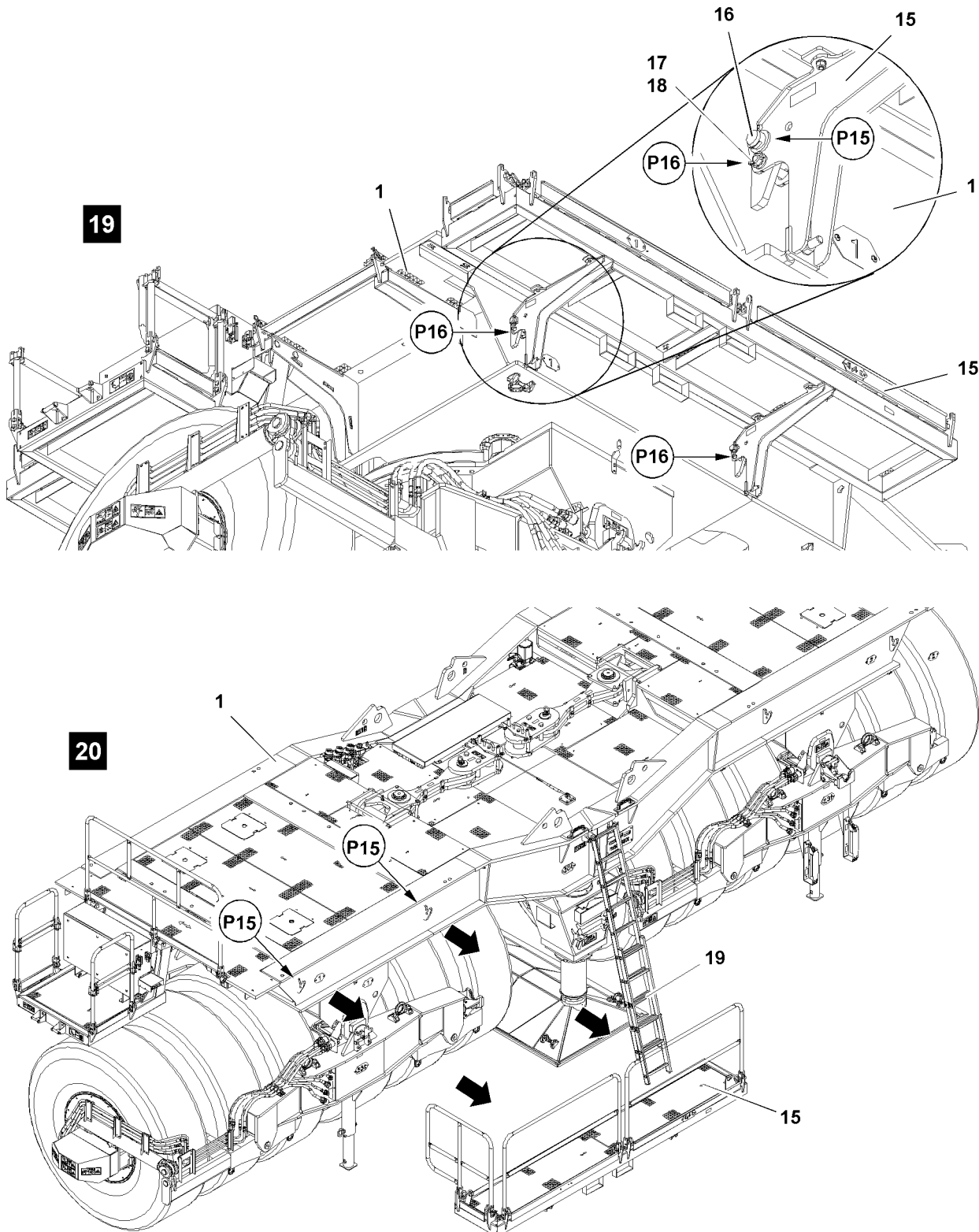

Fig.121944: Disassembling the platforms



Note

- ▶ The ballast trailer is equipped with four separate platforms.
- ▶ The ballast trailer sides and platforms **15** are marked with numbers.

**Note**

▶ The disassembly of the platforms is described on the example of one platform.

▶ Fasten the platform **15** to the auxiliary crane.

The platform **15** is pinned on two points:

When the platform is safely held by the auxiliary crane:

▶ Remove the safety locking pin **18** at point **P16** and unpin the pin **17**, see illustration **19**.

▶ Unhook the platform **15** with the auxiliary crane at points **P15** on the ballast trailer, see illustration **20**.

▶ Swing the platform **15** with the auxiliary crane and place it down.

▶ Remove the auxiliary crane.

▶ Remove all platforms on the ballast trailer.

12.4 Disassembling the ballast trailer guide

12.4.1 Disassembling the ballast trailer guide with ballast trailer radius 13-19 m

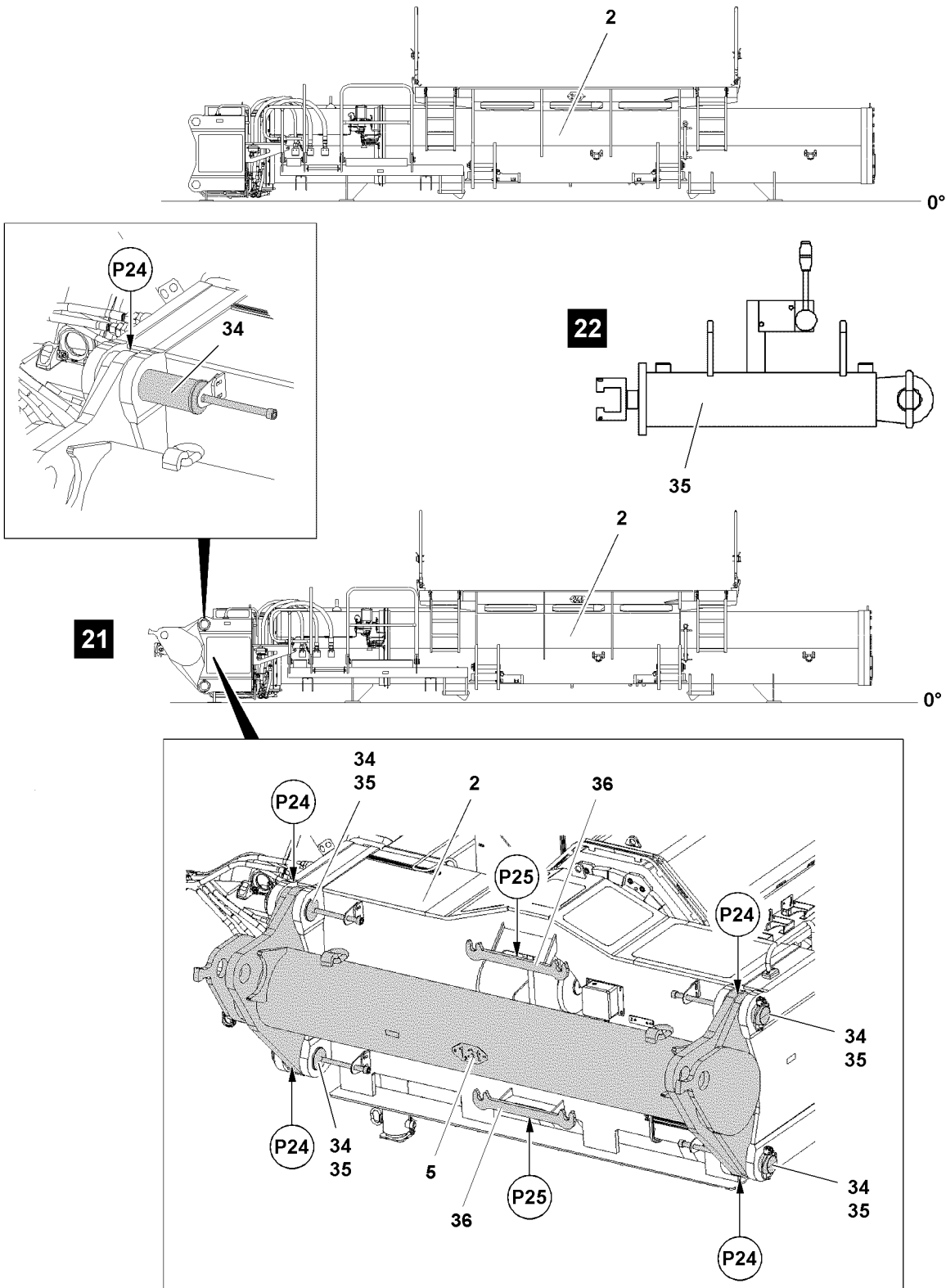

Fig.121021: Disassembling of ballast trailer guide with ballast trailer radius 13-19 m

LWE/LR 11000-001/23501-04-02/en

Make sure that the following prerequisites are met:

- The ballast trailer guide **2** is moved in all the way see illustration **21**.
 - The ballast trailer guide **2** is laying on the ground, see illustration **21**.
- ▶ Fasten the adapter **5** to the auxiliary crane.



WARNING

Danger of crushed limbs!

When unpinning the adapter, fingers and hands can be crushed.

- ▶ Do not reach with your hands into the danger zone.
-

The adapter **5** is pinned four times on the ballast trailer guide. Every pin point is present on both sides of the component on one level.

- ▶ Hang the pin pulling cylinder **35** on the retainer **36** at point **25** and on the screw head, see illustration **21**.
- ▶ Establish the hydraulic connection of the pin pulling cylinder **35**, see chapter 5.30.
- ▶ Release the connector pin **34** at point **P24**: Remove the safety locking pin **35**.
- ▶ Actuate the lever on the pin pulling cylinder **35** and unpin the connector pin **34**, see illustration **21**.
- ▶ Unpin all connector pins.

When all four connector pins **34** are unpinned:

- ▶ Remove the adapter **5** with the auxiliary crane and place down.
- ▶ Remove the auxiliary crane.

12.4.2 Disconnecting the connections

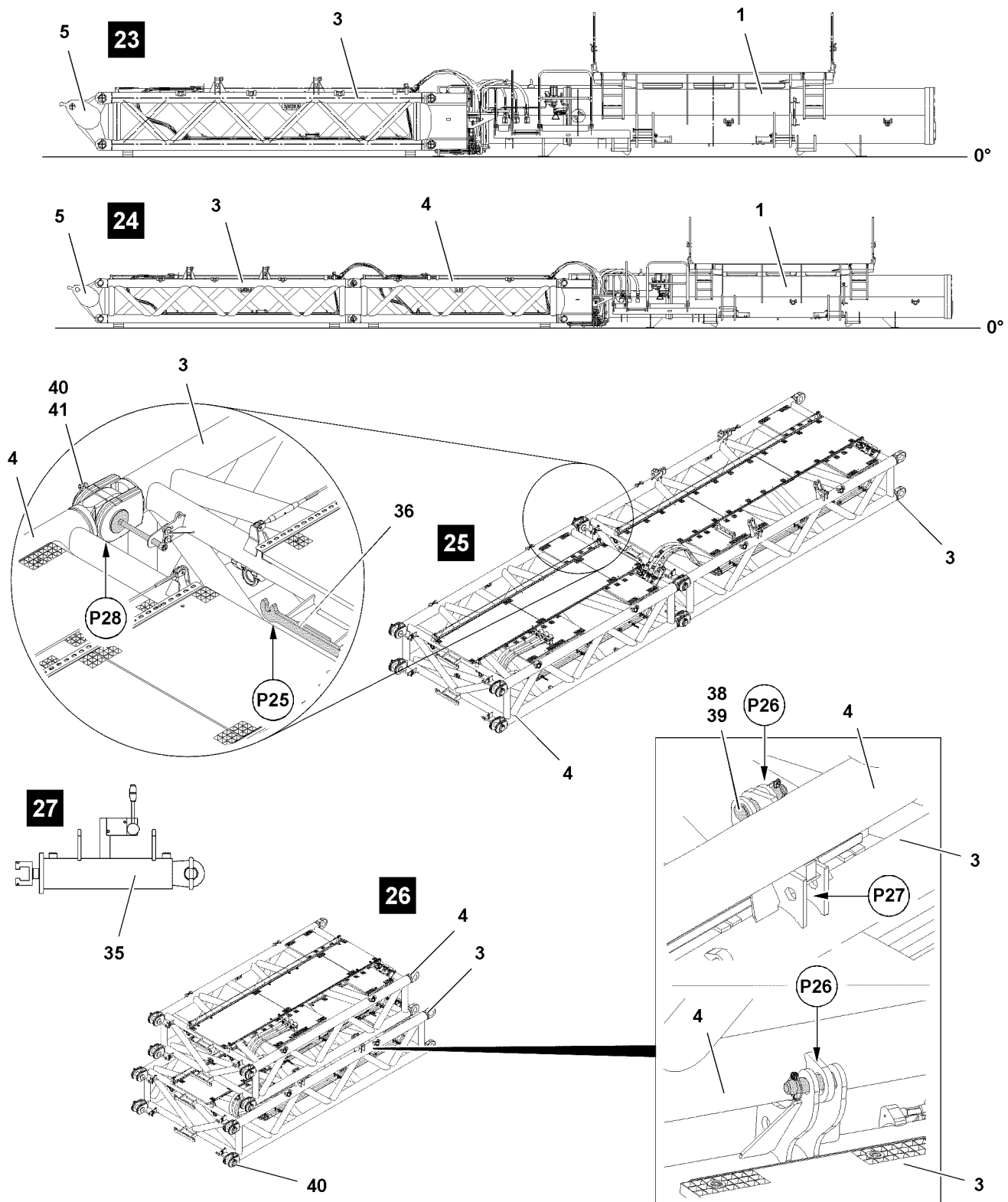

Fig.121993: Disassembling the ballast trailer guide with ballast trailer radius 19–25 m or ballast trailer guide with ballast trailer radius 24–30 m

Disconnecting the hydraulic connections

The hydraulic connections are made with quick couplings.

When disconnecting hydraulic lines with quick couplings, make sure that the coupling procedure is carried out correctly.



WARNING

Pressure in the hydraulic lines!

If the pressure supply is not interrupted before connecting / releasing the hydraulic lines, the hydraulic oil can escape with high pressure.

Death, severe bodily injuries, property damage.

- ▶ Release the pressure in the hydraulic system before connecting / disconnecting: Interrupt the pressure supply and wait for a short time.

- ▶ Release the hydraulic coupling by hand.
- ▶ Disconnect the hydraulic connections, see Hydraulic diagram.
- ▶ Protect the hydraulic connections from contamination with caps.

Disconnecting the electrical connections

- ▶ Disconnect the electrical connections, see Electric wiring diagram.

Disconnecting the connection to the central lubrication system

- ▶ Disconnect the connection to the central lubrication system.
- ▶ Protect the connections of the central lubrication system with caps from contamination.

12.4.3 Disassembling the ballast trailer guide with ballast trailer radius 19-25 m



Note

- ▶ Unpinning the adapter **5** on the intermediate section **3** is identical with unpinning the adapter **5** on the ballast trailer guide **1**.
- ▶ For unpinning procedure, see section „Disassembling the ballast trailer guide with ballast trailer radius 13–19 m “.

- ▶ Remove the adapter **5**.

Intermediate section **3** is pinned on four points. The unpinning procedure is described on the example for one pin, see illustration **23**.

- ▶ Fasten the intermediate section **3** to the auxiliary crane.



Note

- ▶ Unpinning the intermediate section **3** on the ballast trailer guide **2** is identical with unpinning the adapter **5** on the ballast trailer guide **2**.
- ▶ For unpinning procedure, see section „Disassembling the ballast trailer guide with ballast trailer radius 13–19 m “.

- ▶ Disassemble the intermediate section **3**.

12.4.4 Disassembling the ballast trailer guide with ballast trailer radius 24-30 m

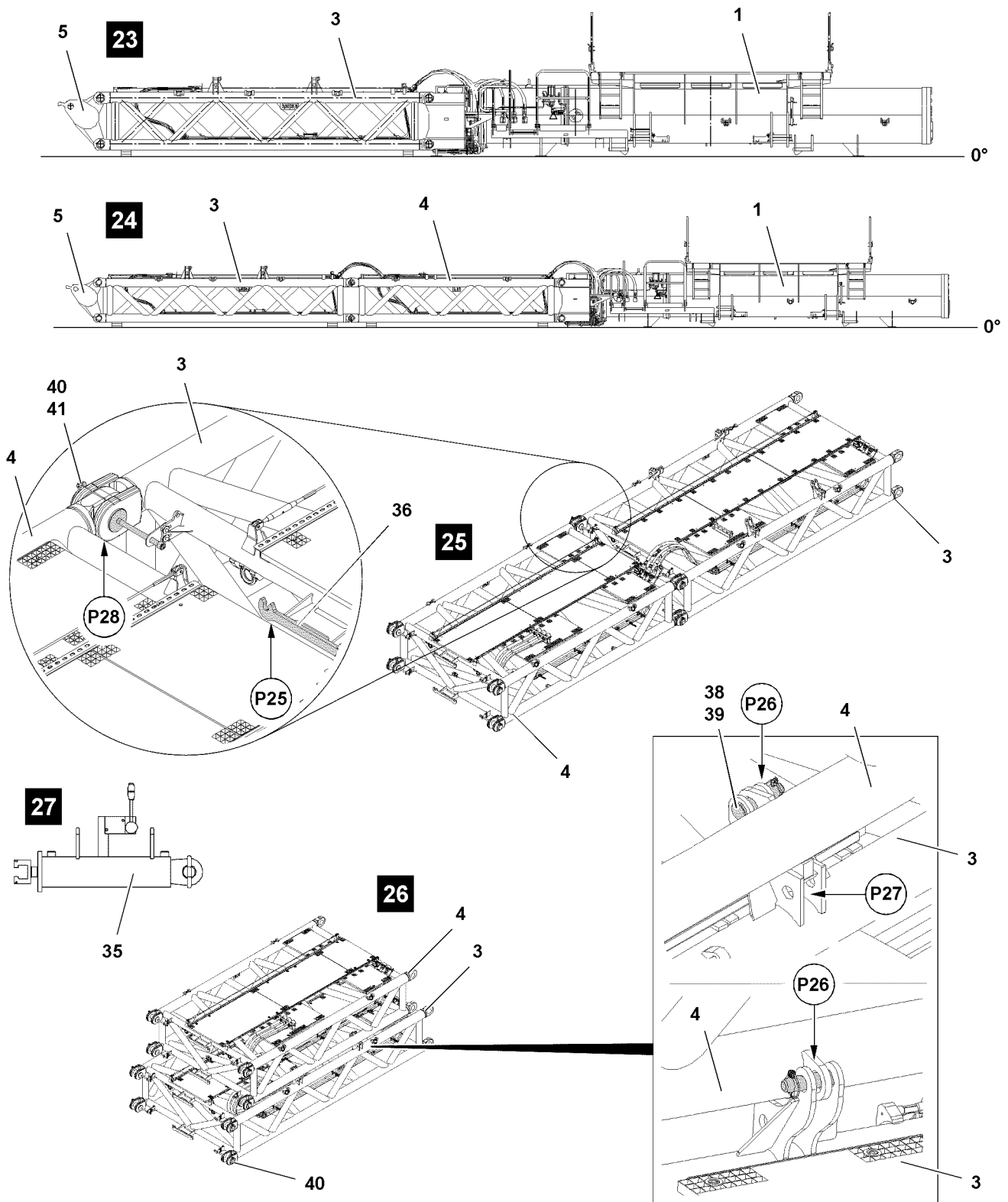

Fig.121993: Disassembling the ballast trailer guide with ballast trailer radius 19–25 m or ballast trailer guide with ballast trailer radius 24–30 m

LWE/LR 11000-001/23501-04-02/en

**Note**

- ▶ Disconnect the connections, see section „Disassembling the ballast trailer guide with ballast trailer radius 19-25 m “.

**Note**

- ▶ Unpinning the adapter **5** on the intermediate section **3** is identical with unpinning the adapter **5** on the ballast trailer guide **1**.
- ▶ For unpinning procedure, see section „Disassembling the ballast trailer guide with ballast trailer radius 13–19 m “.

- ▶ Remove the adapter **5**.

The intermediate section **4** is pinned four times on the intermediate section **3**. Every pin point is present on both sides of the component on one level, see illustration **24**.

- ▶ Fasten the intermediate section **4** to the auxiliary crane.
- ▶ Hang the pin pulling cylinder **35** on the retainer **36** at point **25** and on the screw head, see illustration **25**.
- ▶ Remove the safety locking pin **41** at point **P28**, see illustration **25**.
- ▶ Actuate the lever on the pin pulling cylinder **35** and unpin the connector pin **40**.
- ▶ Remove the intermediate section **4** with the auxiliary crane.

Intermediate section **3** is pinned on four points. The unpinning procedure is described on the example for one pin, see illustration **26**.

- ▶ Fasten the intermediate section **3** to the auxiliary crane.

**Note**

- ▶ Unpinning the intermediate section **3** on the ballast trailer guide **1** is identical with unpinning the adapter **5** on the ballast trailer guide **1**.
- ▶ For unpinning procedure, see section „Disassembling the ballast trailer guide with ballast trailer radius 13–19 m “.

- ▶ Disassemble the intermediate section **3**.
- ▶ Place the intermediate section **4** on intermediate section **3** in transport position, see illustration **26**.

When the pin bores align at point **P26**:

- ▶ Unpin the pin **38** from park position at point **P27**.
- ▶ Insert the pin **38** at point **P26** and secure with the safety locking pin **39**, see illustration **26**.

Result:

- The intermediate section **3** is pinned and secured with intermediate section **4** in transport position.

12.5 Disassembling the frame

12.5.1 Disassembling the first wheel set

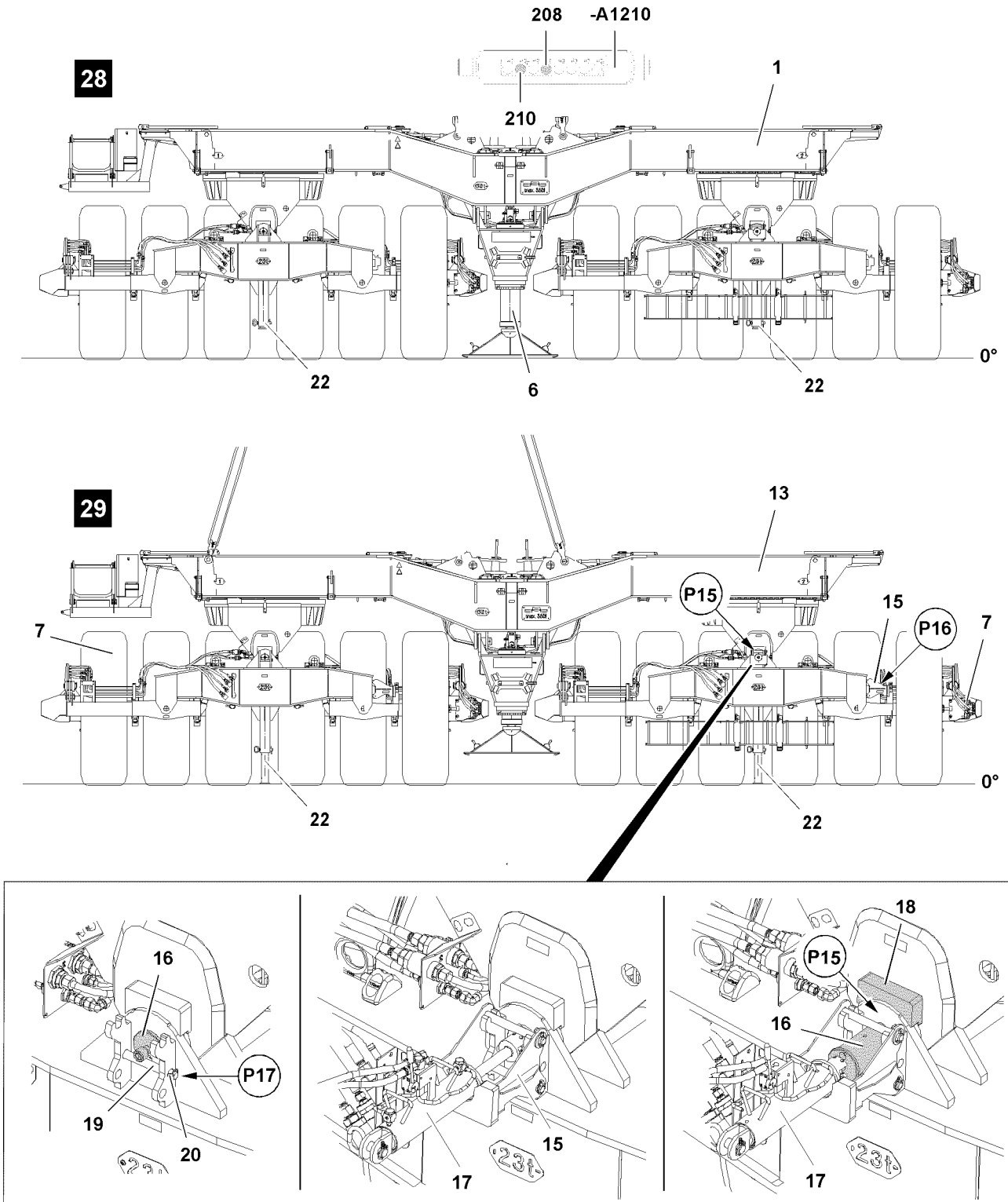

Fig.121994: Disassembling the first wheel set

LWE/LR 11000-001/23501-04-02/en

Make sure that the following prerequisites are met:

- The ground must be level and have adequate load bearing capacity.
- An auxiliary crane is available.
- ▶ Pull the extendable auxiliary supports **22** out and secure, see illustration **28**.
- ▶ Connect the ballast trailer on the external hydraulic aggregate.

or

Connect the ballast trailer using the electrical extension cable and the hydraulic extension hoses to the crane turntable, see the electric wiring diagram and the hydraulic diagram.

- ▶ Fasten the frame **13** to the auxiliary crane, see illustration **29**.

When extendable auxiliary supports **22** are extended and secured:

- ▶ Press the button **208** and button **210** on the control panel **-A1210**.

Result:

- The support **6** retracts.



Note

- ▶ Frame and wheel set are pinned with each other on two pin points **P15**.
 - ▶ The pinning procedure is described based on the example of one pin point.
-
- ▶ Remove the safety locking pin **20** at point **P17** and unpin the pin **19**, see illustration **29**.
 - ▶ Release the retainer **15** for pin pulling device **17** at point **P16**.
 - ▶ Hang the retainer **15** up at pin point **P15** and secure, see illustration **29**.
 - ▶ Unpin the pin **16** with the pin pulling device **17** at point **P15**, see illustration **29**.

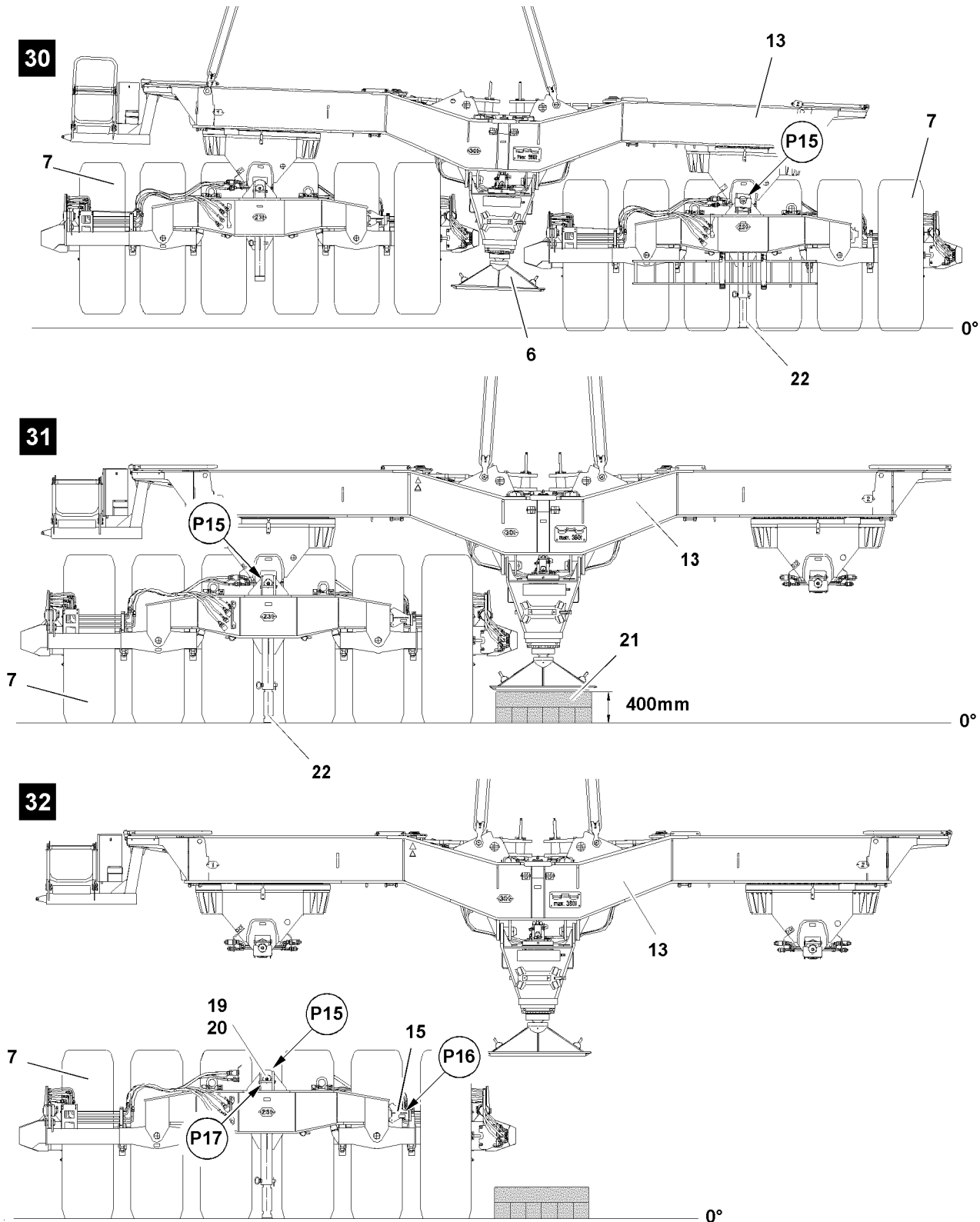

Fig.121995: Disassembling the second wheel set

- ▶ Build up the substructure 21 for frame 13 approx. 400 mm high, see illustration 31.
- ▶ Lift the frame 13 with the first wheel set 7 with the auxiliary crane and set it down on level ground and on the substructure 21, see illustration 31.
- ▶ Insert the pin 16 with the pin pulling device 17 again at point P15 for transport.
- ▶ Remove the retainer 15 and fasten again at point P16.

12.5.2 Disassembling the second wheel set

Make sure that the following prerequisite is met:

- The frame with the first wheel set is placed on the substructure and is secured to prevent it from tipping over.
- ▶ Fasten the frame **13** to the auxiliary crane, see illustration **31**.



Note

- ▶ The disassembly of the first wheel set is identical with the disassembly of the second wheel set.
 - ▶ Disassembly of the second wheel set, see section „Disassembling the first wheel set“.
-
- ▶ Unpin the frame **13** at point **P15**.
 - ▶ Lift the frame **13** with the auxiliary crane and set it down on level ground.

13 Emergency operation in case of a defective control module of the ballast trailer control

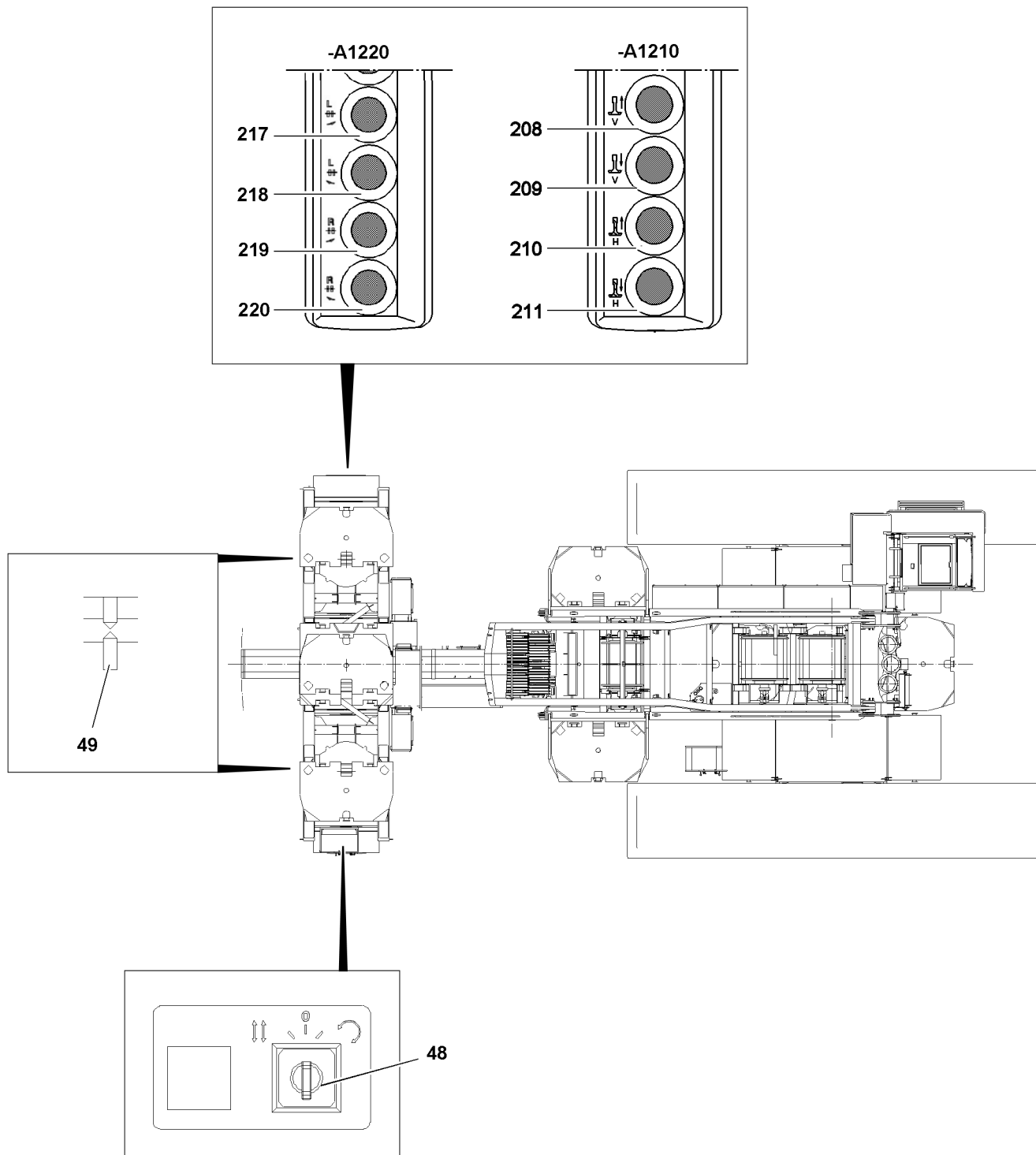

Fig.121013: Emergency operation of ballast trailer

13.1 Emergency operation of ballast trailer

In case of a defect in the control module of the ballast trailer control, the electronic steering of the ballast trailer can no longer be actuated.

The signals „Towing“ and „circular travel“ are no longer transmitted by the ballast trailer control to the crane control.

However, by actuating the key switch **48** in the control cabinet on the ballast trailer, the ballast trailer control can be bypassed.

Key switch positions

- 0 (center) = no emergency operation
- I (left) = emergency operation towing
- II (right) = emergency operation circular travel

NOTICE

Damage of the ballast trailer!

By activating the key switch **48** the signal „Towing“ or „Circular travel“ is released in the crane control, even though the wheel sets could potentially be incorrectly aligned.

This can result in severe damage on the ballast trailer or on the crane.

- ▶ Operate the key switch **48** only if the electronic fails.
 - ▶ Before driving the crane, check the alignment of the wheel sets.
 - ▶ All travel movements may only be conducted with utmost caution, minimum acceleration and careful braking.
 - ▶ If the key switch **48** is activated, then the crane operator bears the full and sole responsibility for his actions.
-



WARNING

Danger of accident due to faulty operation!

If the key switch **48** is activated, there is an increased danger of accidents due to the bypassed ballast trailer control.

Death, severe bodily injuries, property damage.

- ▶ It is prohibited to remain within the danger zone of the ballast trailer.
 - ▶ The alignment of wheel sets is to be monitored manually, visual inspection.
 - ▶ Emergency operation should only be carried out by authorized personnel. They must be aware of all related supervisory tasks and hazards.
 - ▶ If the key switch **48** is activated, then the crane operator bears the full and sole responsibility for his actions.
-

13.2 Emergency operation - towing

Make sure that the following prerequisites are met:

- The ballast trailer is properly assembled.
- Crawler operation is activated.

13.2.1 Lifting the ballast trailer with the support cylinders



Note

- ▶ The support cylinders of the ballast trailer must always be moved out evenly.
-

Move the front and rear support cylinders out:

- ▶ Press the button **209** and the button **211**.

13.2.2 Aligning the wheel sets in the towing position

To be able to align the wheel sets in towing position, the ballast trailer must be lifted with the support cylinders.

Make sure that the following prerequisite is met:

- The ballast trailer is raised via the support cylinders to the point where the wheel sets are relieved.
- ▶ Turn the key switch **48** on the ballast trailer to the „left“.



Note

- ▶ By activating the key switch **48** into position „left“, the order „Towing“ is passed on to the crane and emergency operation is turned on.

When the wheel sets are relieved:

- ▶ Press the button **217** or button **218** on the control panel **-A1220** and align the left wheel set into towing position.
- ▶ Press the button **219** or button **220** on the control panel **-A1220** and align the right wheel set into towing position.
- ▶ Check the settings.

13.2.3 Lowering the ballast trailer with the support cylinders



Note

- ▶ The support cylinders of the ballast trailer must always be moved in evenly.

Retract the support cylinders completely on the front and rear:

- ▶ Press the button **208** and the button **210**.

Result:

- The support cylinders retract.
- ▶ Retract the support cylinders completely.

13.2.4 Towing

Make sure that the following prerequisite is met:

- The wheel sets are in the towing position.

NOTICE

Damage of the ballast trailer!

If the angle settings on the wheel sets are not monitored during driving in emergency operation, it can lead to significant damage on the wheel sets.

- ▶ The angle alignment **49** on the wheel sets must be constantly checked.
- ▶ Constantly monitor the alignment of the wheel sets while driving.
- ▶ If the wheel sets become excessively deformed, then they must be realigned.

13.3 Emergency operation - circular travel

Make sure that the following prerequisite is met:

- The ballast trailer is properly assembled.

13.3.1 Lifting the ballast trailer with the support cylinders



Note

- ▶ The support cylinders of the ballast trailer must always be moved out evenly.

Move the front and rear support cylinders out:

- ▶ Press the button **209** and the button **211**.

13.3.2 Aligning the wheel sets in the circular travel position

To be able to align the wheel sets in circular travel position the ballast trailer must be lifted with the support cylinders.

Make sure that the following prerequisite is met:

- The ballast trailer is raised via the support cylinders to the point where the wheel sets are relieved.
- ▶ Turn the key switch **48** on the ballast trailer to the „right“.



Note

- ▶ By actuating the key switch **48** in position „right“, the command „Circular travel“ is transmitted to the crane and emergency operation is turned on.
- ▶ During emergency operation the support can only be actuated from the control panel **-A1210** on the ballast trailer.

When the wheel sets are relieved:

- ▶ Press the button **217** or button **218** on the control panel **-A1220** and align the left wheel set into circular driving position.
- ▶ Press the button **219** or button **220** on the control panel **-A1220** and align the right wheel set into circular driving position.
- ▶ Check the settings.

13.3.3 Lowering the ballast trailer with the support cylinders



Note

- ▶ The support cylinders of the ballast trailer must always be moved in evenly.

Retract the support cylinders completely on the front and rear:

- ▶ Press the button **208** and the button **210**.

Result:

- The support cylinders retract.
- ▶ Retract the support cylinders completely.

13.3.4 Circular travel

Make sure that the following prerequisite is met:

- The wheel sets are in the circular travel position.

NOTICE

Damage of the ballast trailer!

If the angle settings on the wheel sets are not monitored during driving in emergency operation, it can lead to significant damage on the wheel sets.

- ▶ The angle alignment **49** on the wheel sets must be constantly checked.
- ▶ Constantly monitor the alignment of the wheel sets while driving.
- ▶ If the wheel sets become excessively deformed, then they must be realigned.

14 Maintenance intervals / maintenance instructions for the ballast trailer



Note

- ▶ See chapter 7.02.50 and chapter 7.04.50.

Empty page!

LWE/LR 11000-001/23501-04-02/en

5.36.10 Derrick ballast - suspended ballast

1	Product description	3
2	Component overview	4
3	Fastening points	8
4	Pull cylinder extension conditions	12
5	Derrick ballast radii	15
6	Assembling the suspended ballast	21
7	Assembling the suspended ballast with suspended ballast guide	28
8	Ballasting the ballast pallet	57
9	Crane operation with the derrick ballast	62
10	Crawler operation with derrick ballast	96
11	Disassembling the suspended ballast	97
12	Disassembling the suspended ballast with the suspended ballast guide	111
13	Removing the ballast pallet	137

Fig.195219

1 Product description

This chapter describes the following derrick ballast variations:

- Suspended ballast
Ballasting consisting of ballast plates on a ballast pallet

This crane type has additional derrick ballast variations, which will be described in other chapters of these operating instructions:

- Suspended ballast *special design*: Ballast Constant
Ballasting consisting of directly suspended ballast plates (without a ballast pallet)
- Ballast trailer
Ballasting consisting of ballast plates on a ballast trailer
- Suspended ballast *special design*: Ballasting LTR crane and / or ballast plates
Ballasting consisting of an LTR crane and / or ballast plates on a ballast pallet



Note

Designation of the ballast types

- ▶ The suspended ballast and the ballast trailer are generally described as derrick ballast.
- ▶ The ballast installed on the turntable is generally referred to as the counterweight.
- ▶ The ballast installed on the crawler travel gear is generally referred to as the central ballast.

1.1 Function

The D-guying contains two pull cylinders (pull cylinder A and pull cylinder B). These pull cylinders are used to pull, lift or lower the derrick ballast.

All relevant data regarding the derrick ballast is displayed on the LICCON monitors.

1.2 Variations

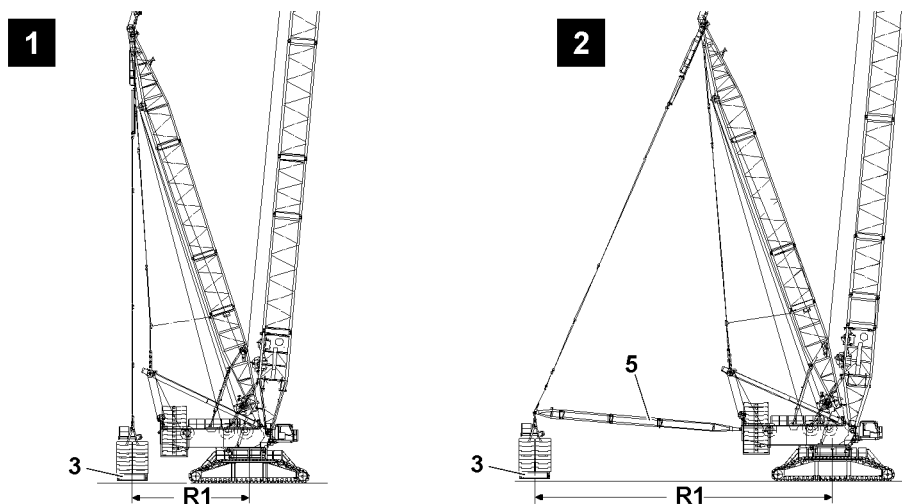

Fig.145947: Suspended ballast variations

LR 11000 has two suspended ballast variations:

- Ballast pallet **3** **without** suspended ballast guide, see illustration 1
 - The derrick ballast radius **R1** can be set by adjusting the derrick boom.
- Ballast pallet **3** **with** suspended ballast guide **5**, see illustration 2.
 - The derrick ballast radius **R1** requires the conversion of the suspended ballast guide **5**.

2 Component overview

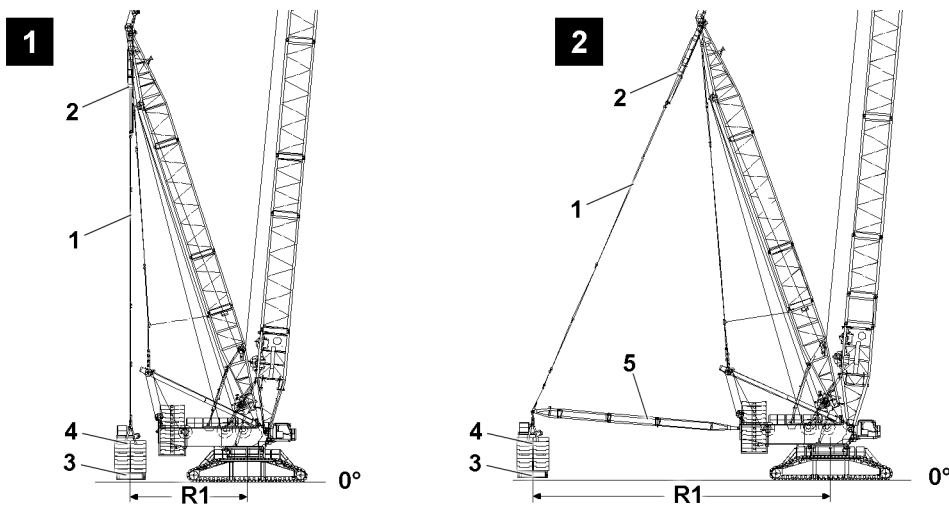

Fig.124479: Suspended ballast variations



Note

- ▶ The assembly sections are marked with their own weight.
- ▶ Dimensions and weights, see the Crane operating instructions, chapter 1.03.

Position	Component
1	D-guying
2	Pull cylinder
3	Ballast pallet
4	Ballast plates
5	Suspended ballast guide B2

2.1 Component overview - Ballast pallet

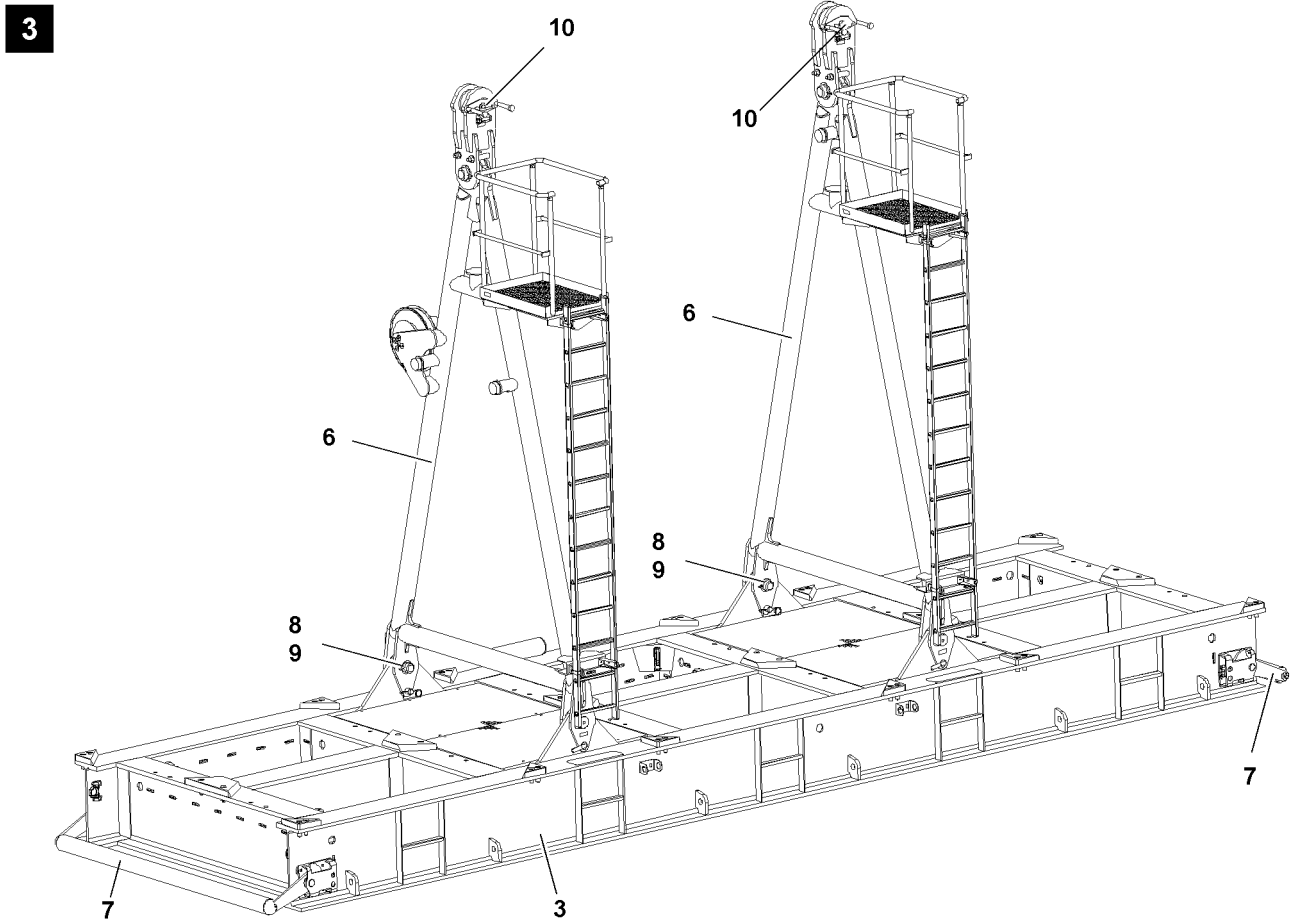

Fig.145950: Ballast pallet operating position

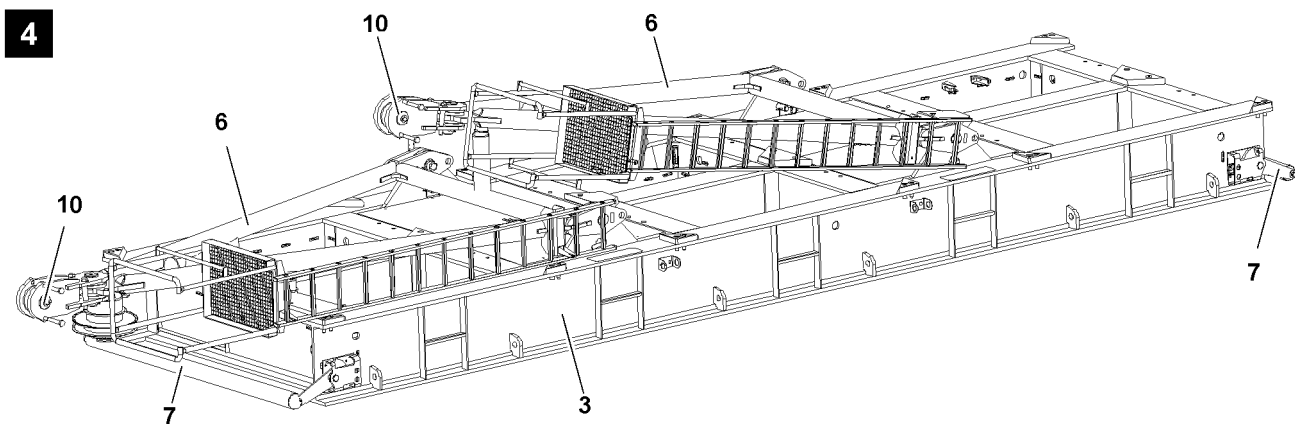

Fig.145951: Ballast pallet transport position



Note

- ▶ The assembly sections are marked with their own weight.
- ▶ Dimensions and weights, see the Crane operating instructions, chapter 1.03.

2.1.1 Ballast pallet

Position	Component
3	Ballast pallet
6	Erection rack
7	Ground contact roller
8	Retaining pin
9	Safety spring
10	Connector pin

2.1.2 Lashing lugs

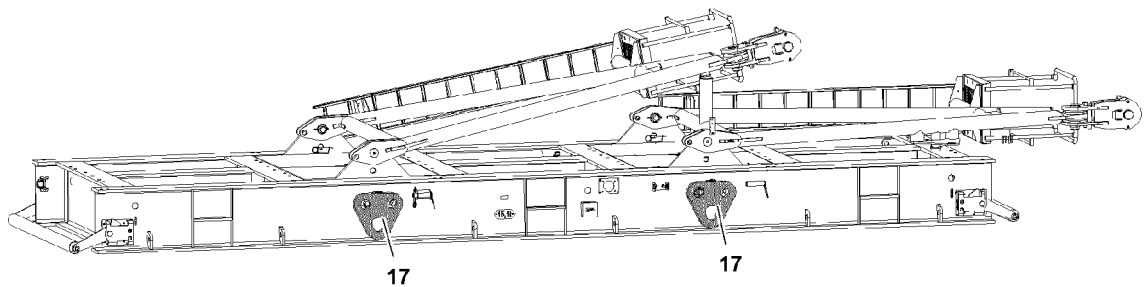

Fig.119014: Lashing lugs

Position	Component
17	Lashing lugs



Note

- ▶ Lashing lugs for fastening and transferring the ballast pallet with the auxiliary crane.

2.2 Component overview Suspended ballast guide



Note

- ▶ The assembly sections are marked with their own weight.
- ▶ Dimensions and weights, see the Crane operating instructions, chapter 1.03.

2.2.1 Pivot section

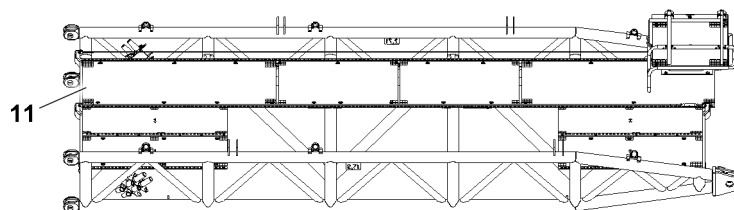

Fig.124480: Pivot section

Position	Component
11	Pivot section

2.2.2 Intermediate section

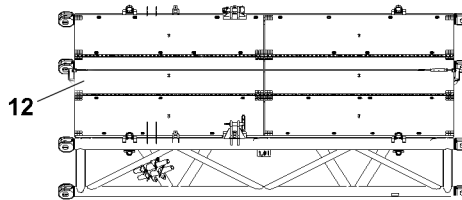

Fig.124481: Intermediate section

Position	Component
12	Intermediate section

2.2.3 Intermediate section

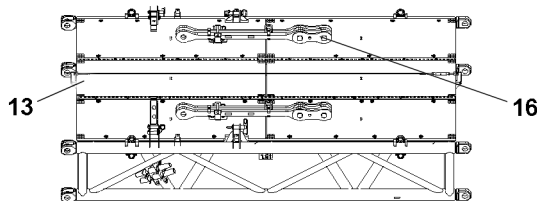

Fig.124482: Intermediate section

Position	Component
13	Intermediate section
16	Pull rods

2.2.4 End section

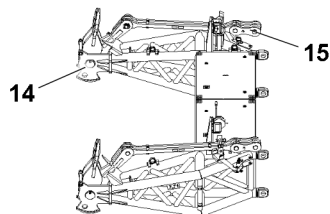

Fig.124483: End section

LWE/LR 11000-001/23501-04-02/en

Position	Component
14	End section
15	Pull rods - end section

2.2.5 Suspended ballast guide „Transport position“

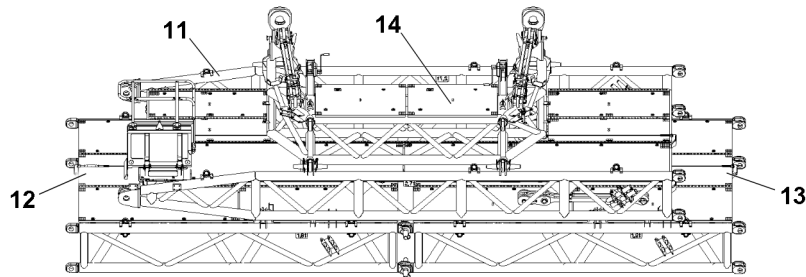

Fig.124484: Suspended ballast guide „Transport position“



Note

- Transport position, see illustration.

3 Fastening points



WARNING

Falling lattice sections!

Death, severe bodily injuries, property damage.

- Make sure that the lattice sections are properly fastened on the respective fastening points.
- Make sure that the fastening equipment has the appropriate length and a sufficient load bearing capacity.
- Pay attention and adhere to the labels on the fastening points on the lattice sections and crane components.

3.1 Fastening points for suspended ballast components

3.1.1 Ballast pallet

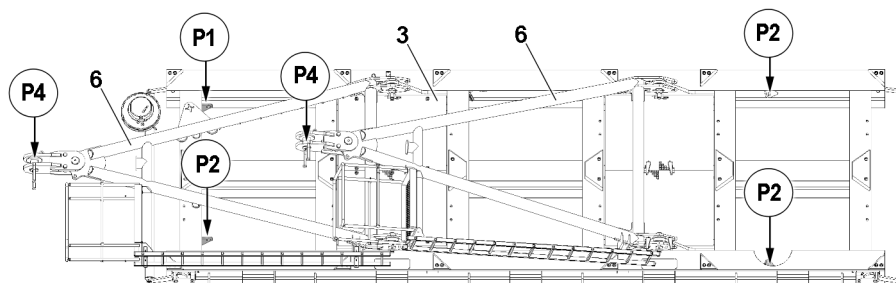

Fig.124490: Ballast pallet

Fastening points	
P1 and P2	Ballast pallet
P4	Erection rack

3.1.2 Ballast plates

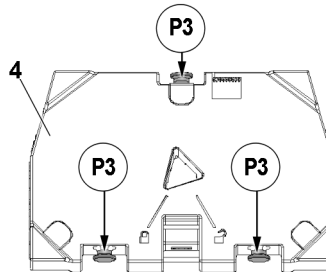

Fig.124491: Ballast plates

Fastening points	
P3	Ballast plates

3.2 Fastening points for suspended ballast guide components

3.2.1 End section

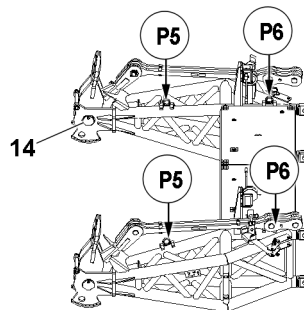

Fig.124488: End section

Fastening points	
P5 and P6	End section

LWE/LR 11000-001/23501-04-02/en

3.2.2 Intermediate section

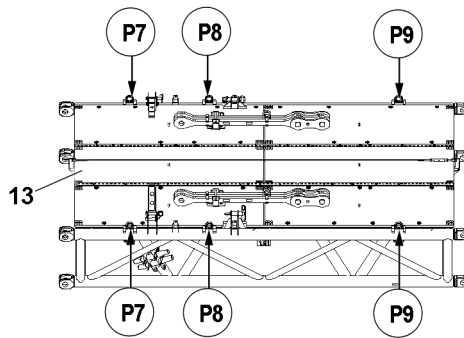

Fig.124487: Intermediate section

Fastening points	
P7 and P9	Intermediate section

3.2.3 Intermediate section

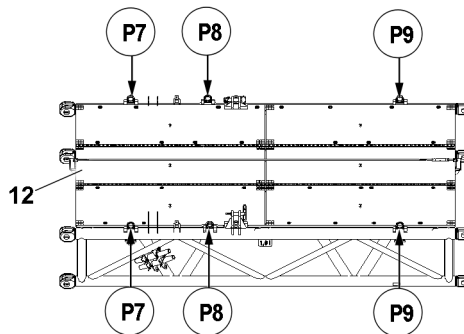

Fig.124486: Intermediate section

Fastening points	
P7 and P9	Intermediate section

3.2.4 Pivot section

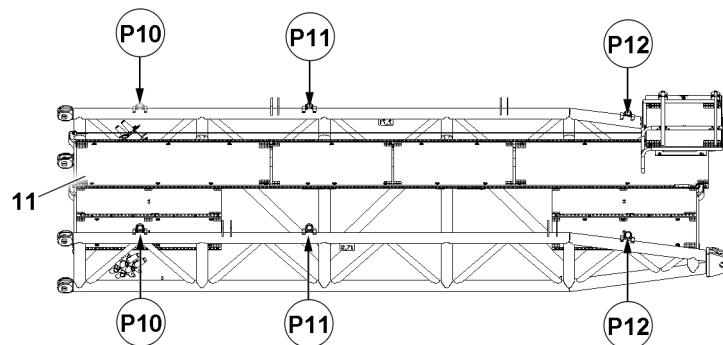

Fig.124485: Pivot section

LWE/LR 11000-001/23501-04-02/en

Fastening points	
P10 and P12	Pivot section

3.3 Suspended ballast guide (transport)

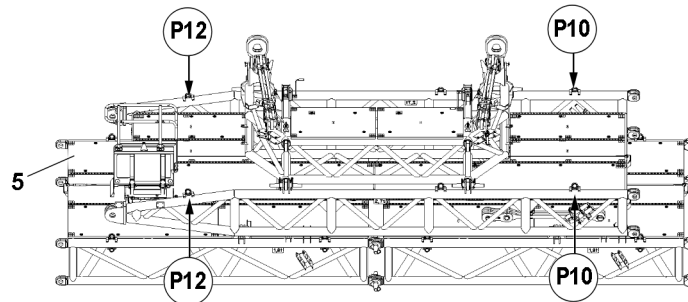

Fig.124489: Suspended ballast guide (transport)

Fastening points	
P10 and P12	Suspended ballast guide (transport)

3.4 Suspended ballast guide (assembly)

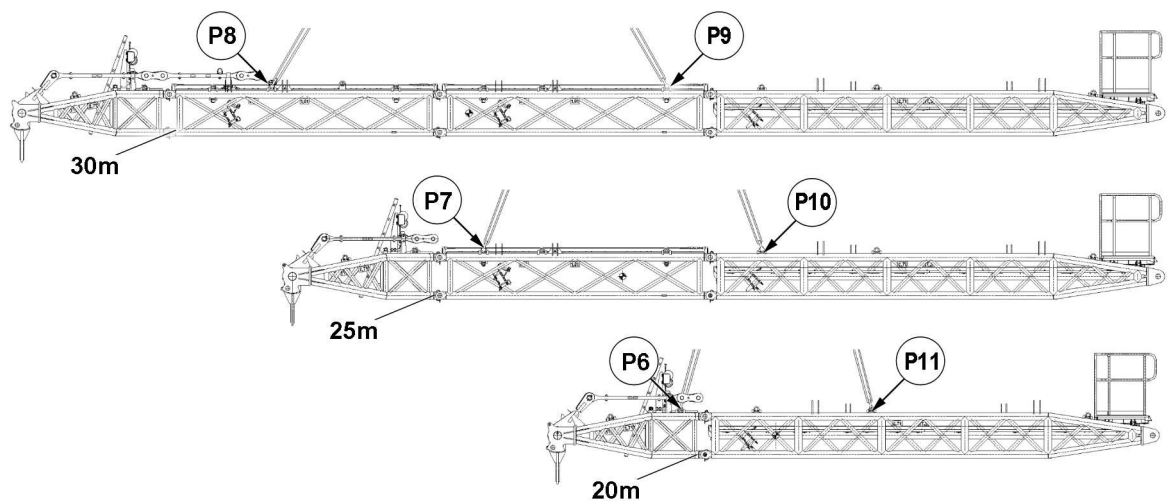

Fig.124492: Suspended ballast guide (assembly)

Fastening points	
P8 and P9	Suspended ballast guide 30 m
P7 and P10	Suspended ballast guide 25 m
P6 and P11	Suspended ballast guide 20 m

LWE/LR 11000-001/23501-04-02/en

4 Pull cylinder extension conditions

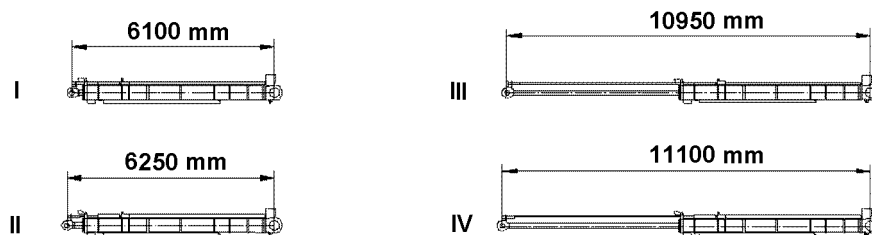

Fig.119003: Pull cylinder extension conditions

Extension conditions	
I	Block position „Retracted“
II	Switch position „Retracted“
III	Switch position „Extended“
IV	Block position „Extended“

Empty page!

LWE/LR 11000-001/23501-04-02/en

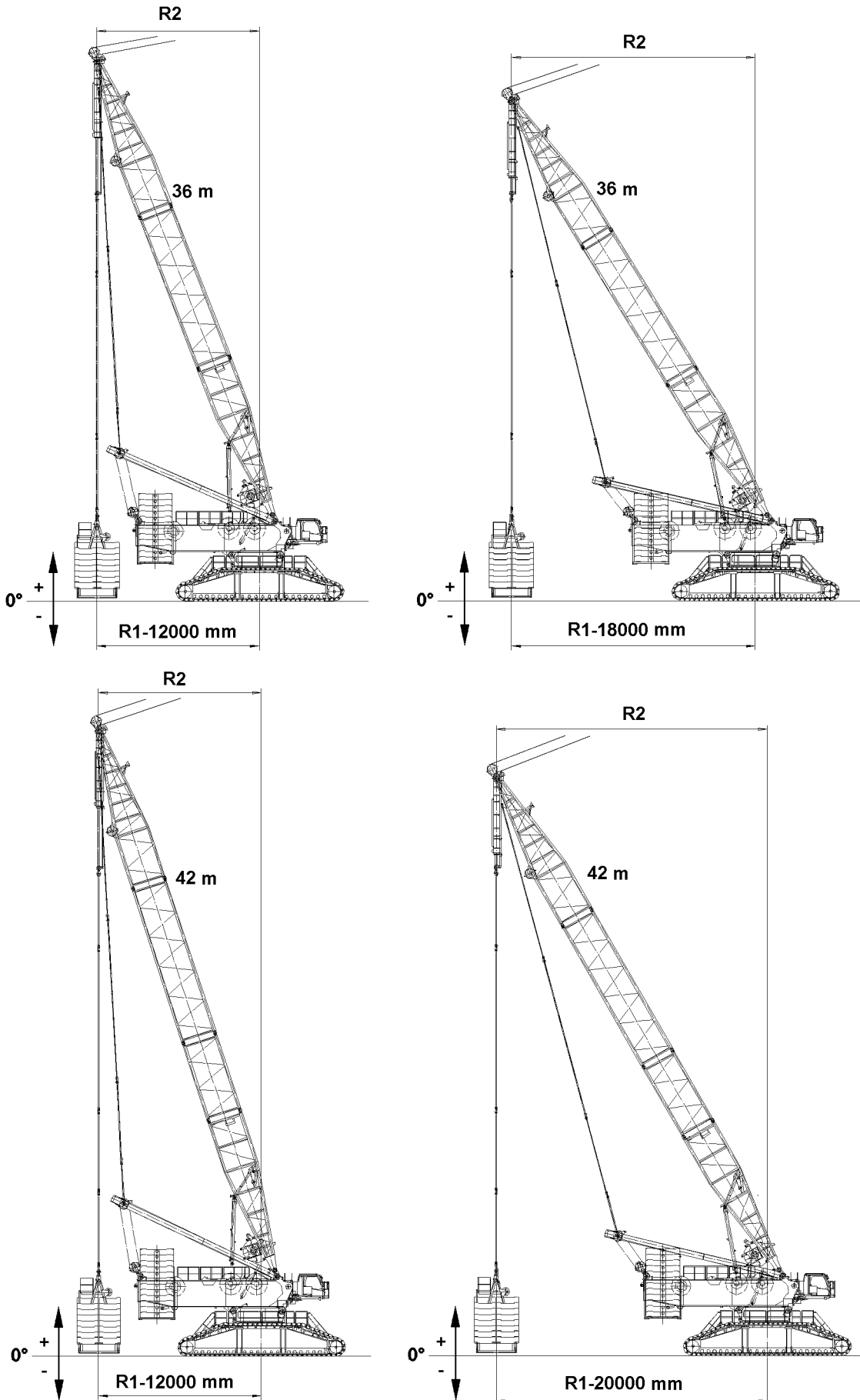

Fig.119004

LWE/LR 11000-001/23501-04-02/en

5 Derrick ballast radii

5.1 Derrick ballast without suspended ballast guide

5.1.1 36 m derrick boom

Note

- ▶ No suspended ballast guide is installed between the turntable and the ballast pallet.
- ▶ The derrick ballast radius **R1** and the derrick radius **R2** are identical, see illustration.

With the 36 m derrick, the following derrick ballast radii are possible: R1= 12 m and R1 =18 m.

Radius R1 = 12 m	
Above base	+3896 mm
Below base	-804 mm

Radius R1 = 18 m	
Above base	+919 mm
Below base	-3781 mm

5.1.2 Derrick boom 42 m

Note

- ▶ No suspended ballast guide is installed between the turntable and the ballast pallet.
- ▶ The derrick ballast radius **R1** and the derrick radius **R2** are identical, see illustration.

With the 42 m derrick, the following derrick ballast radii are possible: R1= 12 m and R1= 20 m.

Radius R1 = 12 m	
Above base	+4261 mm
Below base	-439 mm

Radius R1 = 20 m	
Above base	+709 mm
Below base	-3991 mm

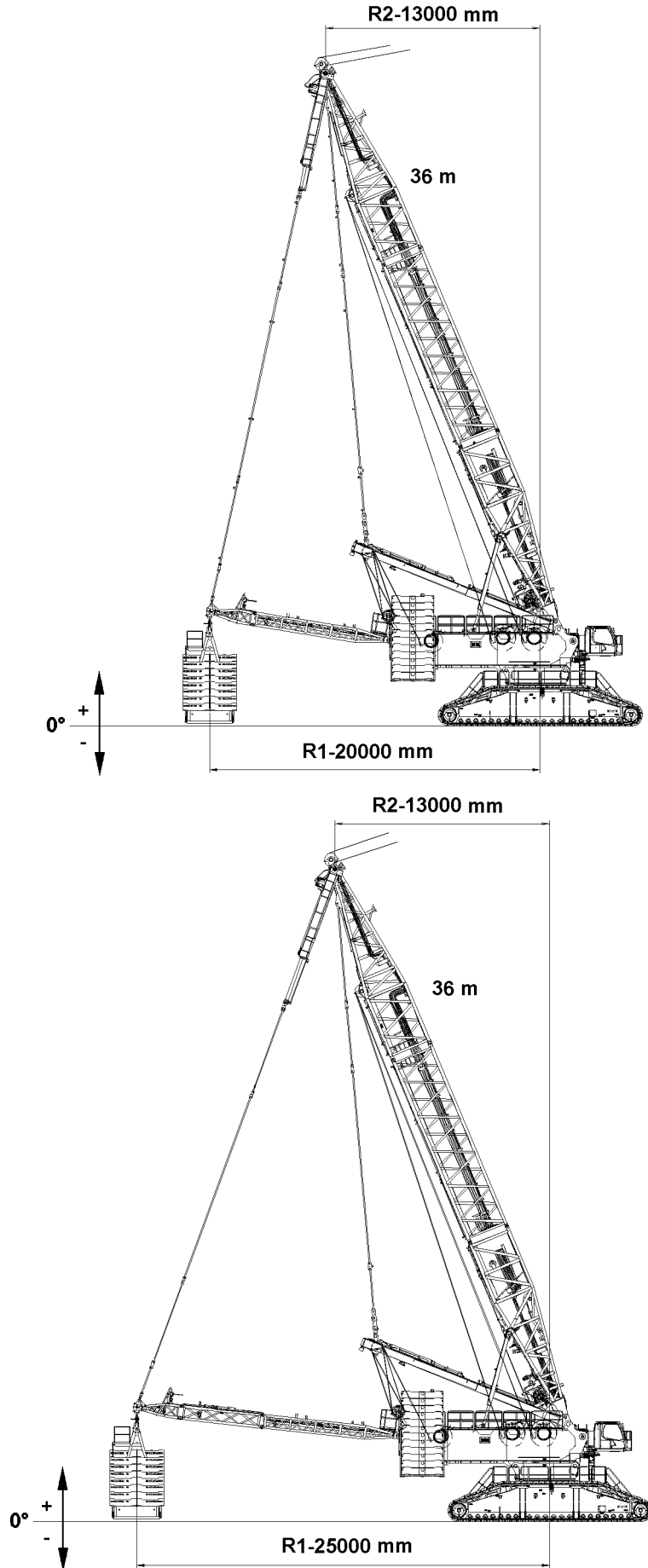

Fig.120208

LWE/LR 11000-001/23501-04-02/en

5.2 Derrick ballast with suspended ballast guide

5.2.1 36 m derrick boom



Note

- ▶ **One** suspended ballast guide is installed between the turntable and the ballast pallet.
- ▶ The derrick ballast radius **R1** and the derrick radius **R2** are **not** identical, see illustration.

Derrick radius with the 36 m derrick is $R_2 = 13$ m.

With the 36 m derrick, the following derrick ballast radii are possible: $R_1 = 20$ m and $R_1 = 25$ m.

Radius R1 = 20 m	
Above base	+1000 mm
Below base	-1000 mm

Radius R1 = 25 m	
Above base	+1000 mm
Below base	-1000 mm

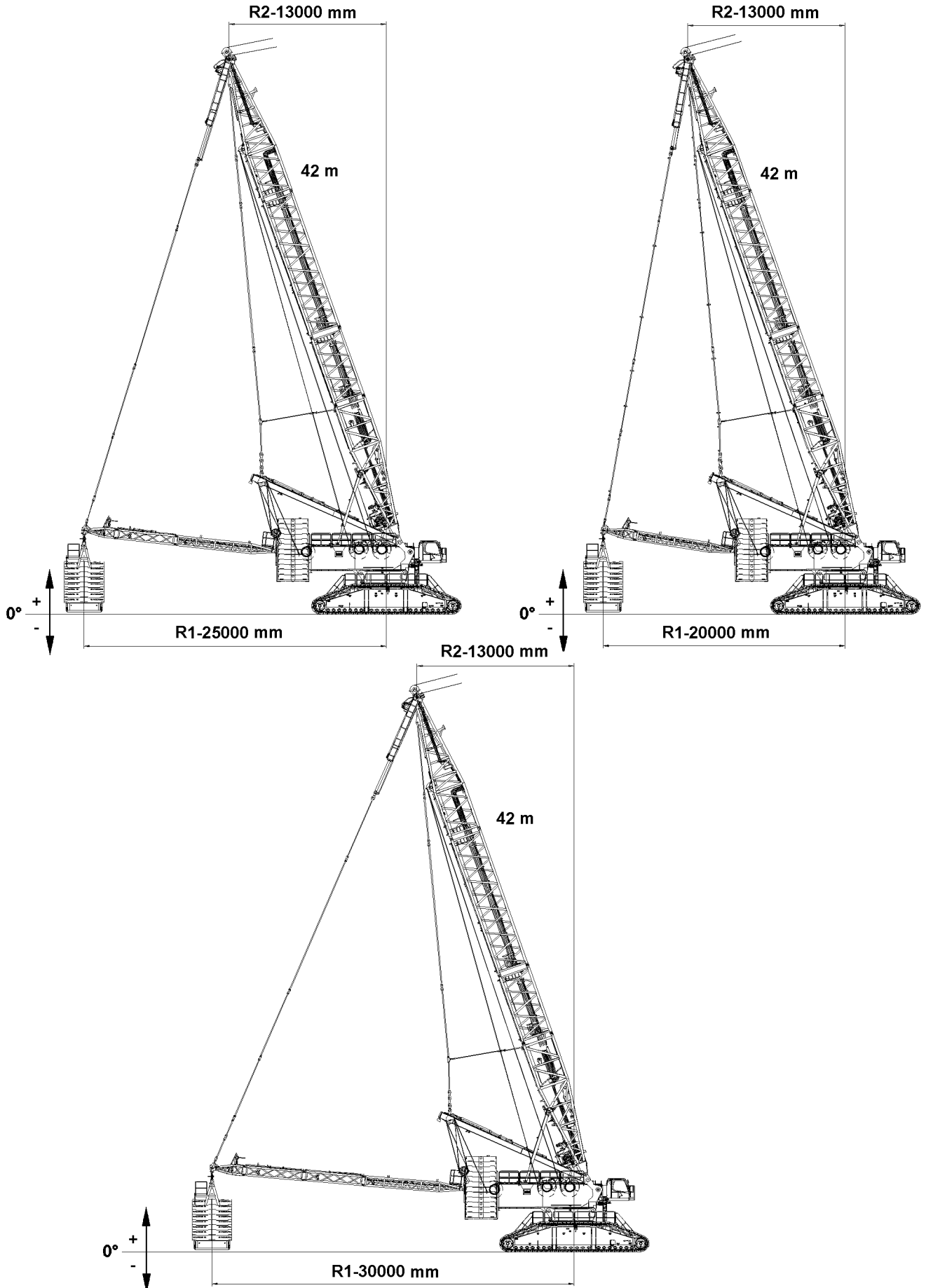

Fig.120209

LWE/LR 11000-001/23501-04-02/en

5.2.2 Derrick boom 42 m



Note

- ▶ **One** suspended ballast guide is installed between the turntable and the ballast pallet.
- ▶ The derrick ballast radius **R1** and the derrick radius **R2** are **not** identical, see illustration.

Derrick radius with the 42 m derrick is $R2 = 13$ m.

With the 42 m derrick, the following derrick ballast radii are possible: $R1 = 20$ m, $R1 = 25$ m and $R1 = 30$ m.

Radius R1 = 20 m	
Above base	+1000 mm
Below base	-1000 mm

Radius R1 = 25 m	
Above base	+1000 mm
Below base	-1000 mm

Radius R1 = 30 m	
Above base	+1000 mm
Below base	-1000 mm

Fig.195219

LWE/LR 11000-001/23501-04-02/en

6 Assembling the suspended ballast



WARNING

Danger of falling!

During assembly / disassembly, inspection and maintenance work, personnel must be secured with appropriate aids to prevent them from falling.

Death, severe bodily injuries, property damage.

- ▶ All work at a height, when there is a danger of falling, must be carried out with suitable aids.
- ▶ If aids are not available and work cannot be carried out from the ground, then assembly personnel must secure themselves with the supplied fall arrest system to prevent falling, see the Crane operating instructions, chapter 2.04.
- ▶ If fall protection equipment is available, then it must be used, see the Crane operating instructions, chapter 2.06.
- ▶ When lifting, lowering, swinging crane parts in and out, no persons may remain in the danger zone.
- ▶ If railings are present on the components, then they must be brought into the corresponding position and secured for assembly / disassembly work.
- ▶ Only step on the aids, ladders and catwalks with clean shoes.
- ▶ Keep aids, ladders and catwalks free of heavy dirt, snow and ice.
- ▶ During all assembly and disassembly work, maintenance work and inspections, travel or crane operation is prohibited.
- ▶ Remaining on a suspended load is prohibited.
- ▶ Stepping or walking on crane components and lattice sections, which have an incline of more than 20° is prohibited.
- ▶ For all assembly work, the crane operator of the main crane must be in voice contact with the crane operator / crane operators of the auxiliary crane / auxiliary cranes.
- ▶ For assembly / disassembly tasks, the crane operator may only initiate crane movements when the responsible guide has explicitly released the movement.



WARNING

Danger of impact / crushing!

When installing / removing crane components with the auxiliary crane, crane components can start to swing back and forth.

When lifting / lowering and positioning crane components, there is an increased danger of impacts / crushing.

Death, severe bodily injuries, property damage.

- ▶ Make sure that personnel cannot be caught by components.
- ▶ When working in danger zones: Use aids to protect limbs.
- ▶ Guide components with suitable aids to minimize oscillation.



DANGER

The components can fall down!

If the corresponding components are disengaged from the auxiliary crane before the corresponding component is pinned, the corresponding component can fall down and fatally injure personnel.

- ▶ Do not disengage the auxiliary crane until the respective component is pinned and secured.

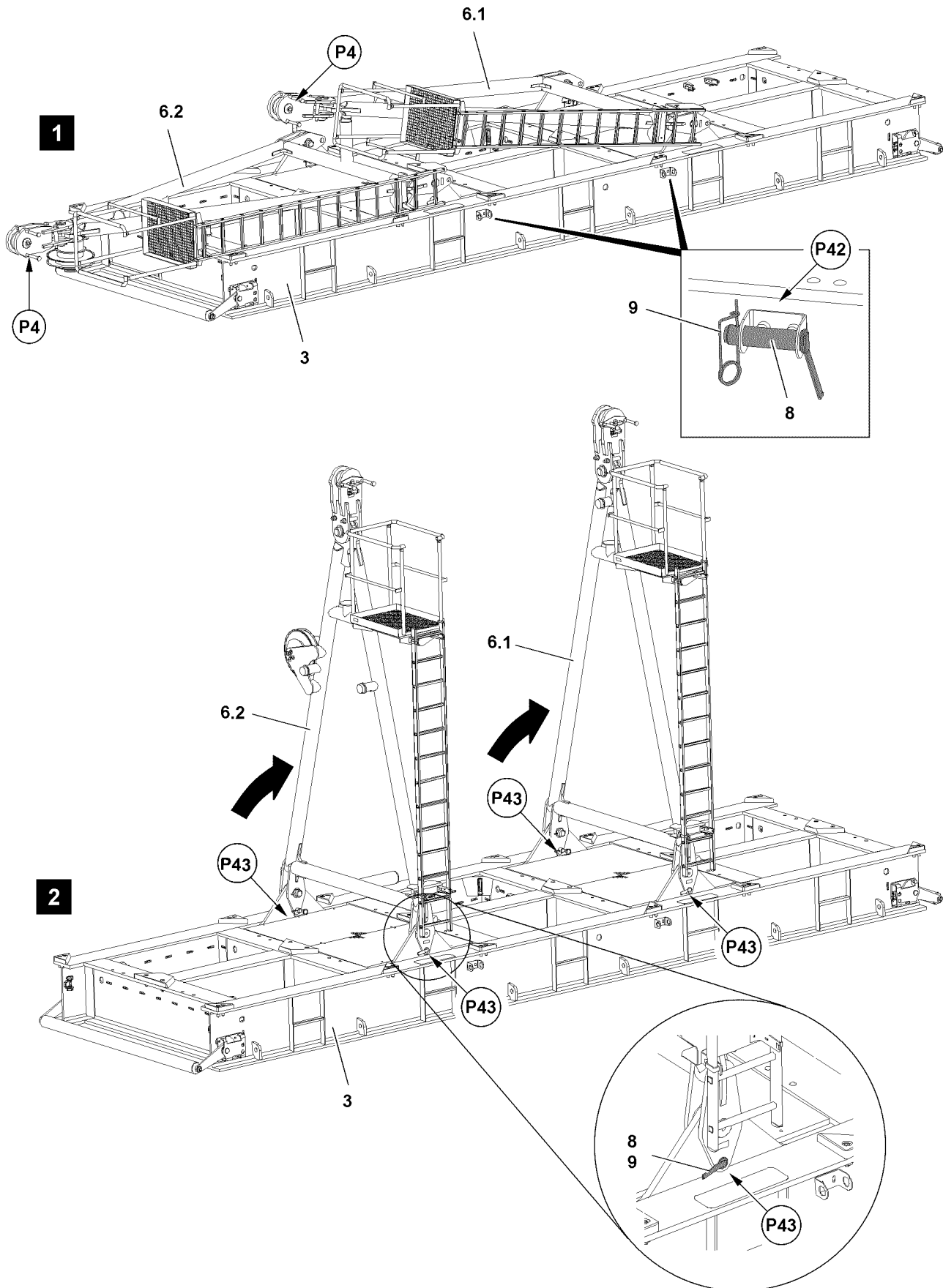

Fig.120206

LWE/LR 11000-001/23501-04-02/en

Make sure that the following prerequisites are met:

- The crane is properly supported and horizontally aligned.
- An auxiliary crane is available.
- The derrick is properly assembled on the turntable.
- The boom is properly assembled on the turntable.
- The derrick is in the crane operating position.
- The boom is laying on the substructure on the ground.
- The central ballast has been installed on the turntable according to the load chart.
- The counterweight has been installed on the turntable according to the load chart.
- The LICCON overload protection has been set according to the data in the load chart.
- The LICCON overload protection settings have been compared with the actual set up configuration.

6.1 Installing the ballast pallet



DANGER

Danger of accident during assembly / disassembly of the erection racks!

The disassembly of unsecured or unsupported erection racks can cause the erection racks to fall down and kill or severely injure personnel.

- ▶ Never unpin the retaining pins under unsecured or unsupported erection racks.
- ▶ It is prohibited for anyone to remain under the erection racks or within the complete danger zone during the pinning and unpinning procedure.

6.1.1 Setting the ballast pallet in the assembly position

- ▶ Set the derrick to the required radius.



Note

- ▶ Fastening points, see section „Fastening points for suspended ballast parts“.

- ▶ Hang the ballast pallet **3** on the auxiliary crane and position it within the slewing range of the crane under the guy rods on the derrick.



Note

- ▶ Set down the ballast pallet **3** in the lengthwise direction of the turntable for easier assembly to the guy rods.
- ▶ Align the ballast pallet **3** horizontally.

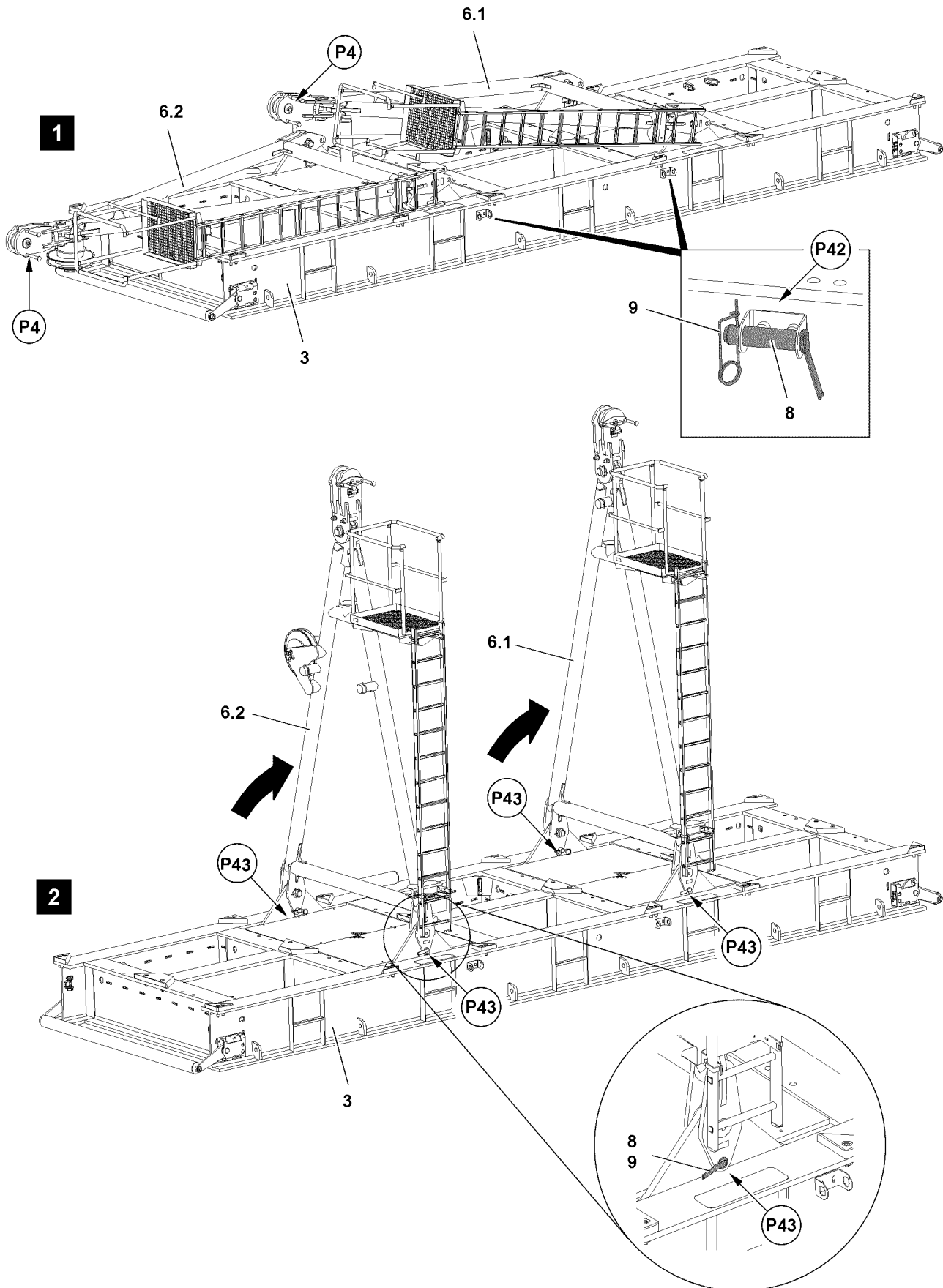

Fig.120206

6.1.2 Erecting the erection racks



Note

- ▶ The assembly of the erection racks is described based on the example of one erection rack.

The erection rack is pinned on two points. The pin procedure is described for one pin as an example.

- ▶ Hang the erection rack **6.1** on the auxiliary crane at point **P4**, see illustration **1**.
- ▶ Remove the spring retainer **9** on both sides at point **P42** and unpin the retaining pin **8** from the park position, see illustration **1**.



DANGER

Danger of accident during assembly / disassembly of the erection racks!

The erection racks must hang securely on the auxiliary crane, otherwise they could fall down and kill or severely injure personnel.

- ▶ The two erection racks must be locked and secured in a vertical position with retaining pins **8**. Only then may the auxiliary crane be removed.
- ▶ Never unpin the retaining pins of unsecured or unsupported erection racks.
- ▶ It is prohibited for anyone to remain under the erection racks or within the complete danger zone during the pinning and unpinning procedure.

- ▶ Position the erection rack **6.1** vertically with the auxiliary crane, see illustration **2**.
- ▶ Insert the retaining pin **8** at point **P43** on both sides and secure with the spring retainer **9** see illustration **2**.

When the erection rack is set up and secured:

- ▶ Remove the auxiliary crane.
- ▶ Erect the second erection rack **6.2**.

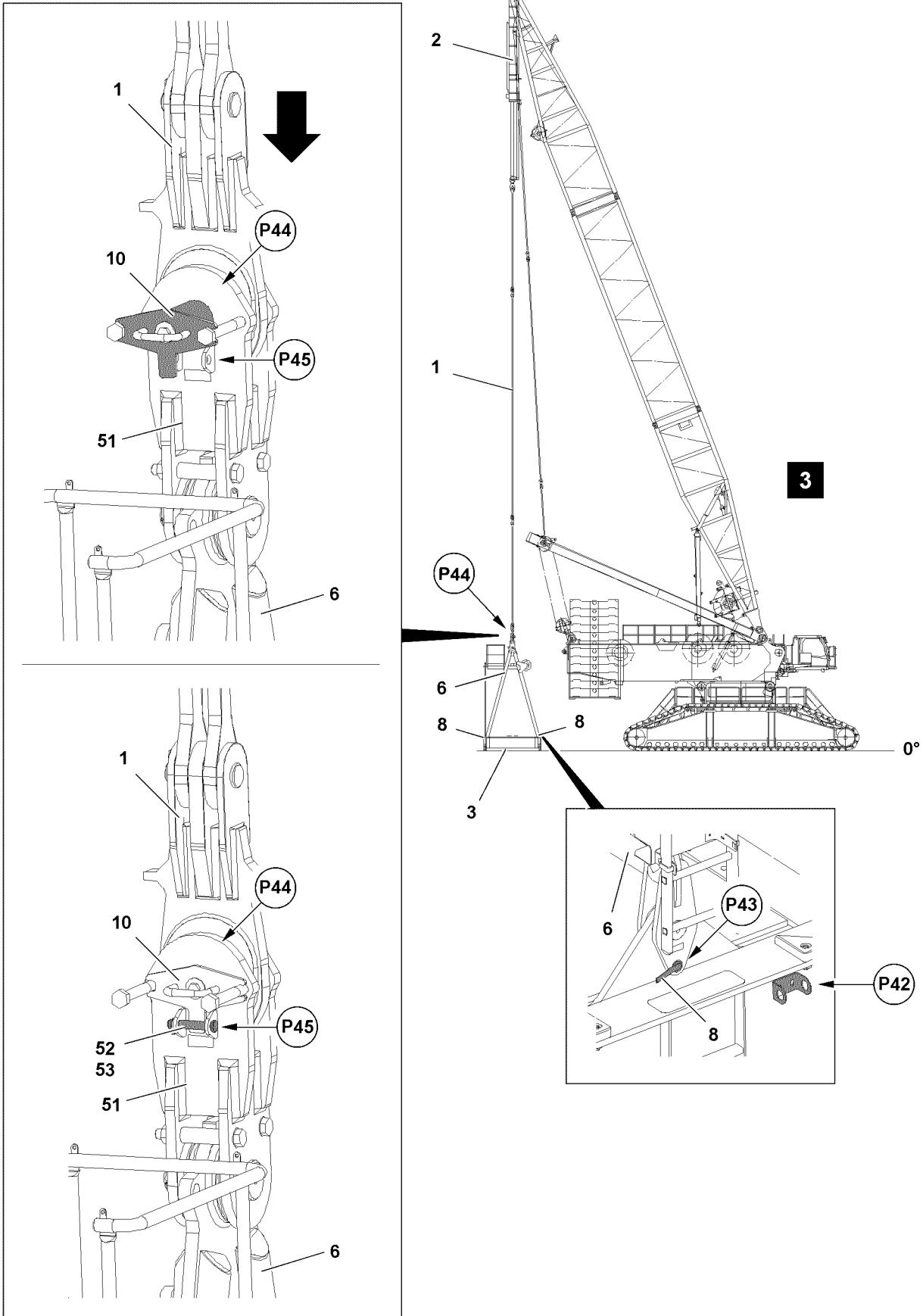

Fig.119006

LWE/LR 11000-001/23501-04-02/en

6.2 Assembling the D-guy rods on the erection racks

Make sure that the following prerequisites are met:

- The guy rods hang above the brackets of the erection racks.
 - The erection racks are set up and secured with retaining pins.
 - The derrick is set to the required radius.
- ▶ Remove the safety locking pin **53** at point **P45** and unpin the retaining pin **52**.
 - ▶ Unpin the connector pin **10** at point **P44**, see illustration **3**.
 - ▶ Position the guy rods **1**, by extending the piston rods on the pull cylinders **2**, between the brackets **51** of the erection rack **6**.



Note

Retract / extend the pull cylinder **2**

- ▶ Control the pull cylinders **2** from the crane cab, see the section „Lifting and lowering the derrick ballast using the pull cylinders“.
- ▶ Operate the pull cylinder **2** with the radio remote control, see the „radio remote control operating instructions“.

- ▶ Pin the guy rods **1** on the brackets **51** and secure.
- ▶ Insert the connector pin **10** at point **P44**.



WARNING

Danger of accident!

If the connector pins are not secured with the retaining pin, then they can loosen up by themselves during crane operation.

This can cause the crane to topple over.

Death, severe bodily injuries, property damage.

- ▶ Make sure that the connector pins are secured.

- ▶ Insert the retaining pin **52** at point **P45** and secure with the safety locking pin **53**, see illustration **3**.
- ▶ Pin the second erection rack on the D-guy rod **1**.



WARNING

Uncontrolled oscillation of the ballast pallet!

When the ballast plate **3** is raised, it can start to swing.

Death, severe bodily injuries, property damage.

- ▶ It is prohibited to remain in the danger zone.
- ▶ Secure the ballast pallet with auxiliary rope.

- ▶ Lift the empty ballast pallet **3** with the pull cylinders **2** and set down again.

Result:

- The ballast pallet **3** is thereby precisely placed vertically under the derrick head.
- ▶ Align the ballast pallet **3** horizontally.

NOTICE

Damage to the retaining pins!

If the retaining pins **8** are not unpinned before crane operation, then they can be damaged in crane operation.

- ▶ Unpin the retaining pins **8** before starting crane operation.

When the ballast pallet **3** is pinned and secured on the D-guying:

- ▶ Release and unpin the retaining pins **8** on the erection racks on both sides.
- ▶ Insert and secure the retaining pin **8** at point **P42** in the park position, see illustration **3**.

6.3 Establishing the electrical connection from the suspended ballast to the turntable



Note

- ▶ Establish the electrical connections from the suspended ballast to the turntable, see Electric wiring diagram.
- ▶ Establish the electrical connections.

7 Assembling the suspended ballast with suspended ballast guide



WARNING

Danger of falling!

During assembly / disassembly, inspection and maintenance work, personnel must be secured with appropriate aids to prevent them from falling.

Death, severe bodily injuries, property damage.

- ▶ All work at a height, when there is a danger of falling, must be carried out with suitable aids.
- ▶ If aids are not available and work cannot be carried out from the ground, then assembly personnel must secure themselves with the supplied fall arrest system to prevent falling, see the Crane operating instructions, chapter 2.04.
- ▶ If fall protection equipment is available, then it must be used, see the Crane operating instructions, chapter 2.06.
- ▶ When lifting, lowering, swinging crane parts in and out, no persons may remain in the danger zone.
- ▶ If railings are present on the components, then they must be brought into the corresponding position and secured for assembly / disassembly work.
- ▶ Only step on the aids, ladders and catwalks with clean shoes.
- ▶ Keep aids, ladders and catwalks free of heavy dirt, snow and ice.
- ▶ During all assembly and disassembly work, maintenance work and inspections, travel or crane operation is prohibited.
- ▶ Remaining on a suspended load is prohibited.
- ▶ Stepping or walking on crane components and lattice sections, which have an incline of more than 20° is prohibited.
- ▶ For all assembly work, the crane operator of the main crane must be in voice contact with the crane operator / crane operators of the auxiliary crane / auxiliary cranes.
- ▶ For assembly / disassembly tasks, the crane operator may only initiate crane movements when the responsible guide has explicitly released the movement.



WARNING

Danger of impact / crushing!

When installing / removing crane components with the auxiliary crane, crane components can start to swing back and forth.

When lifting / lowering and positioning crane components, there is an increased danger of impacts / crushing.

Death, severe bodily injuries, property damage.

- ▶ Make sure that personnel cannot be caught by components.
- ▶ When working in danger zones: Use aids to protect limbs.
- ▶ Guide components with suitable aids to minimize oscillation.



DANGER

The components can fall down!

If the corresponding components are disengaged from the auxiliary crane before the corresponding component is pinned, the corresponding component can fall down and fatally injure personnel.

- ▶ Do not disengage the auxiliary crane until the respective component is pinned and secured.

Empty page!

LWE/LR 11000-001/23501-04-02/en

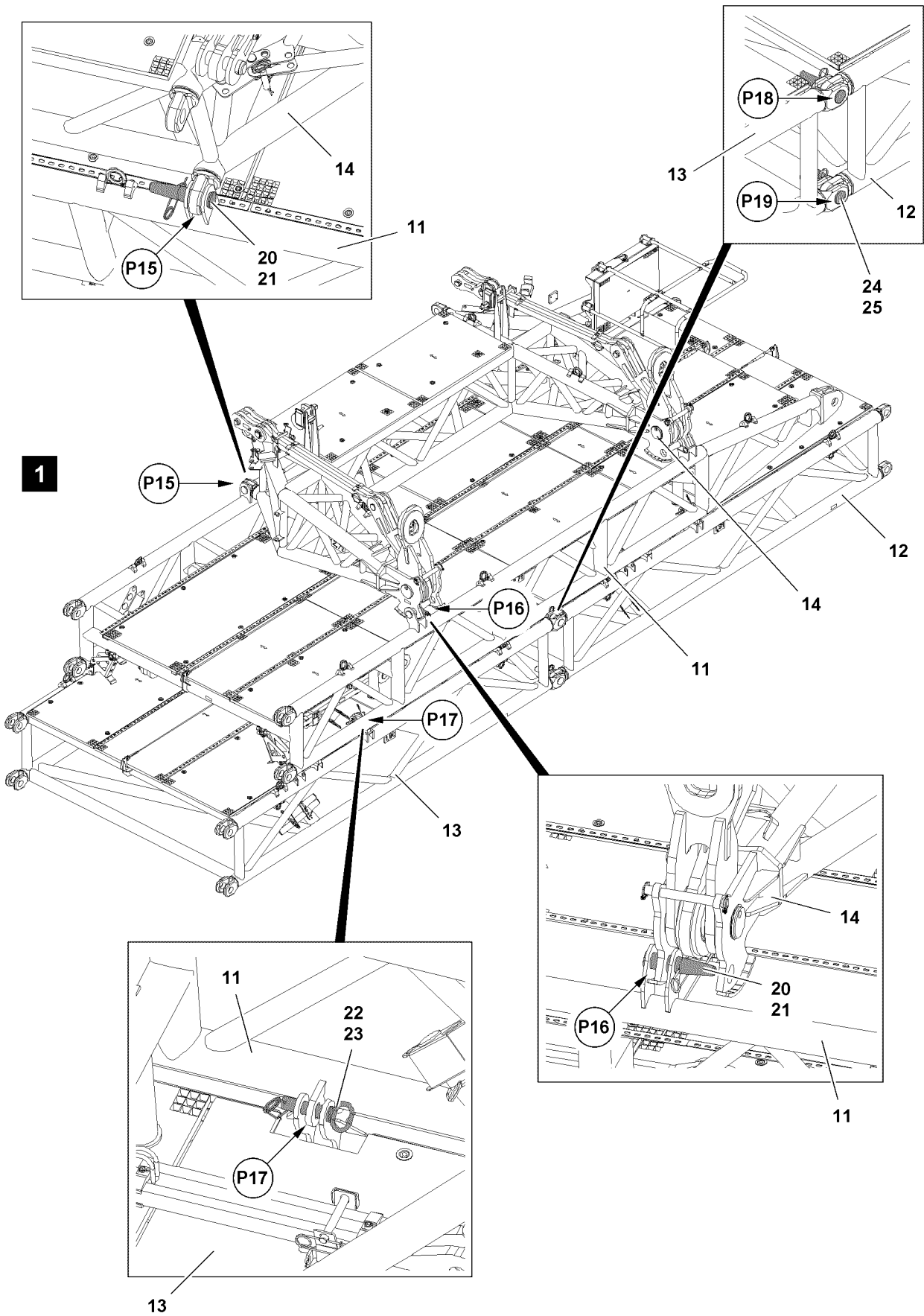

Fig.122801

LWE/LR 11000-001/23501-04-02/en

Make sure that the following prerequisites are met:

- The crane is properly supported and horizontally aligned.
- An auxiliary crane is available.
- The boom and the derrick are installed on the turntable.
- The boom and the derrick are in the crane operating position.
- The counterweight has been installed on the turntable according to the load chart.
- The LICCON overload protection has been set according to the data in the load chart.
- The LICCON overload protection settings have been compared with the actual set up configuration.

7.1 Assembling the suspended ballast guide

The suspended ballast guide makes different derrick ballast radii possible.

The derrick ballast radius determines the number of intermediate section, which must be installed.

Derrick ballast radius	Number of intermediate sections
20 m	0
25 m	1
30 m	2

7.1.1 Removing the transport unit

Make sure that the following prerequisite is met:

- The transport unit is on the transport vehicle.

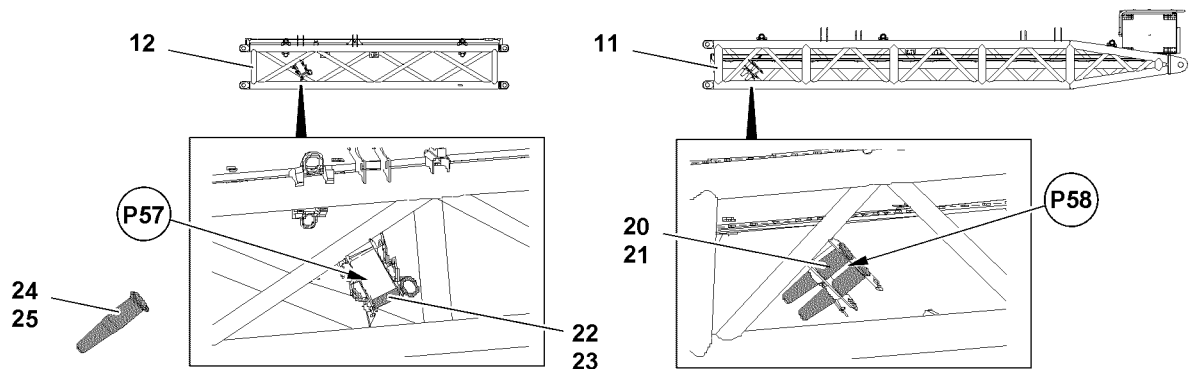

Fig.122802: Park position for pin



Note

- ▶ Park position **P57** for pin **24** and pin **22**.
- ▶ Park position **P58** for pin **20**.



WARNING

Falling pins!

Death, severe bodily injuries, property damage.

- ▶ Make sure that all pins are properly secured in the park positions with the respective retaining elements.

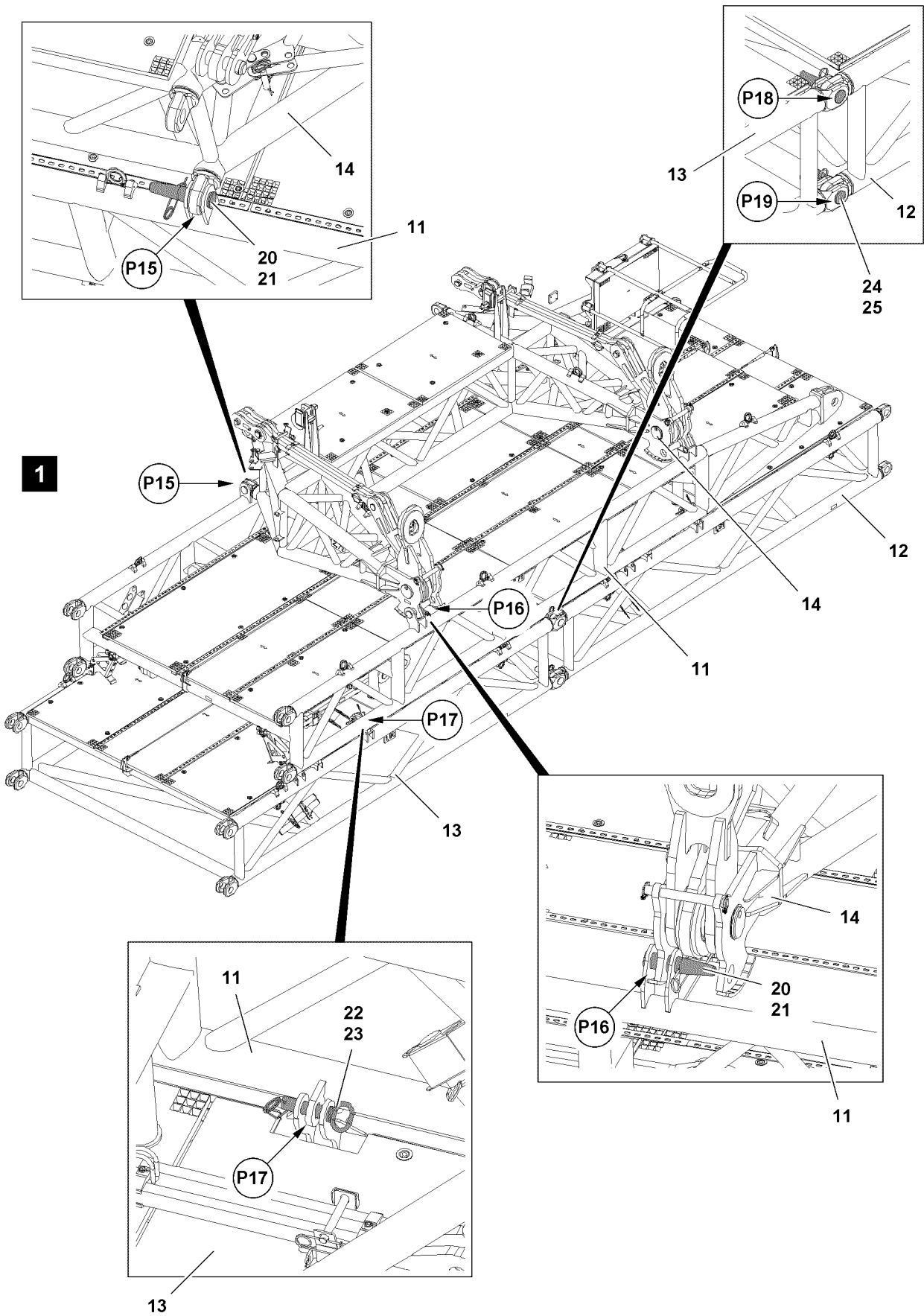

Fig.122801

LWE/LR 11000-001/23501-04-02/en

Disassembling the end section

- ▶ Release and remove the riggings on the transport vehicle.

The end section is unpinned at four points. Every point is present on both sides of the component on one level, see illustration 1.

- ▶ Fasten the auxiliary crane to the end section **14**.
- ▶ Unpin the end section **14** at points **P15**: Remove spring retainers **21** and unpin pins **20**.
- ▶ Unpin the end section **14** at points **P16**: Remove spring retainers **21** and unpin pins **20**.
- ▶ Take the end section **14** down on the ground with the auxiliary crane.

Disassembling the pivot section

The pivot section is unpinned at four points. Every point is present on both sides of the component on one level, see illustration 1.

- ▶ Fasten the auxiliary crane to the pivot section **11**.
- ▶ Unpin the pivot section **11** at points **P17**: Remove spring retainers **23** and unpin pins **22**.
- ▶ Take the pivot section **11** down on the ground with the auxiliary crane.

Disassembling the intermediate section

For a suspended ballast with a 25 m suspended ballast radius, the intermediate sections must be unpinned apart. The intermediate section is unpinned on four points. Every point is present on both sides of the component on one level, see illustration 1.

- ▶ Fasten the auxiliary crane on intermediate section **12**.
- ▶ Unpin the intermediate section **12** at points **P19**: Remove spring retainers **25** and unpin pins **24**.
- ▶ Unpin the intermediate section **12** at points **P18**: Remove spring retainers **25** and unpin pins **24**.
- ▶ Take the intermediate section **12** down on the ground with the auxiliary.

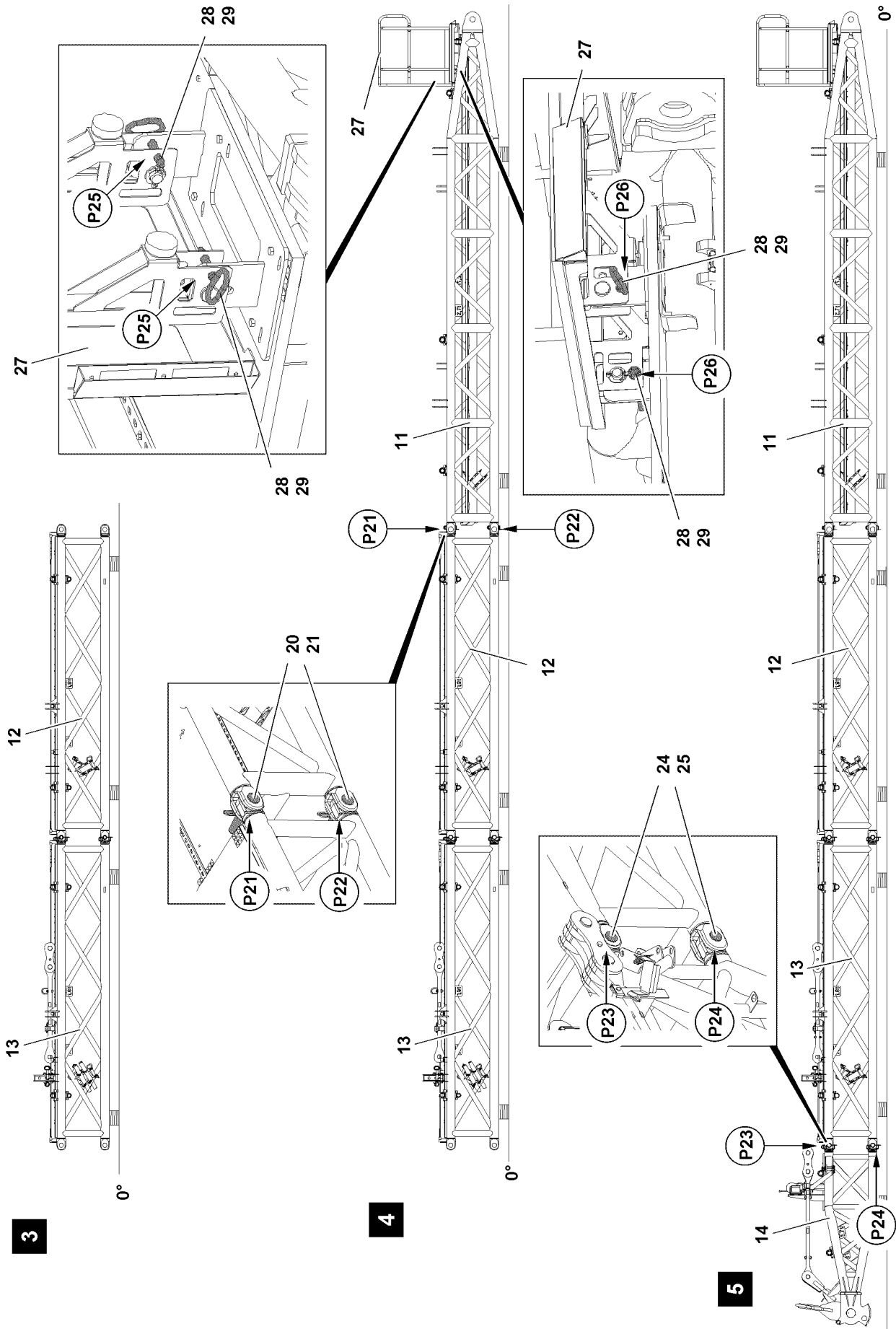

Fig.122803

LWE/LR 11000-001/23501-04-02/en

7.1.2 Assembling the suspended ballast guide with a suspended ballast radius of 30 m



Note

- ▶ The assembly of the suspended ballast guide is described based on the example of a suspended ballast guide with a 30 m suspended ballast radius.

Make sure that the following prerequisites are met:

- The pivot section has been removed from the transport unit.
- The end section has been removed from the transport unit.

Assembling the intermediate sections

For the suspended ballast guide with a 30 m suspended ballast radius only two intermediate sections are installed.

- ▶ Support the ground in such a way that the intermediate sections can be placed down horizontally.
- ▶ Place the intermediate sections with the auxiliary crane on the substructure, see illustration 3.
- ▶ Remove the fastening equipment.

Assembling the pivot section

- ▶ Fasten the pivot section 11 to the auxiliary crane.
- ▶ Position the pivot section 11 with the auxiliary crane on the intermediate section 12 at point P21 until the pin points align.
- ▶ Support the pivot section 11.

The pivot section and the intermediate section are pinned together in four points. Every point is present on both sides of the component on one level, see illustration 4.

- ▶ Pin the pivot section 11 on both sides at point P21 with the intermediate section 12: Insert the pins 20 and secure with the spring retainers 21.
- ▶ Pin the pivot section 11 on both sides at point P22 with the intermediate section 12: Insert the pins 20 and secure with the spring retainers 21.
- ▶ Remove the fastening equipment.

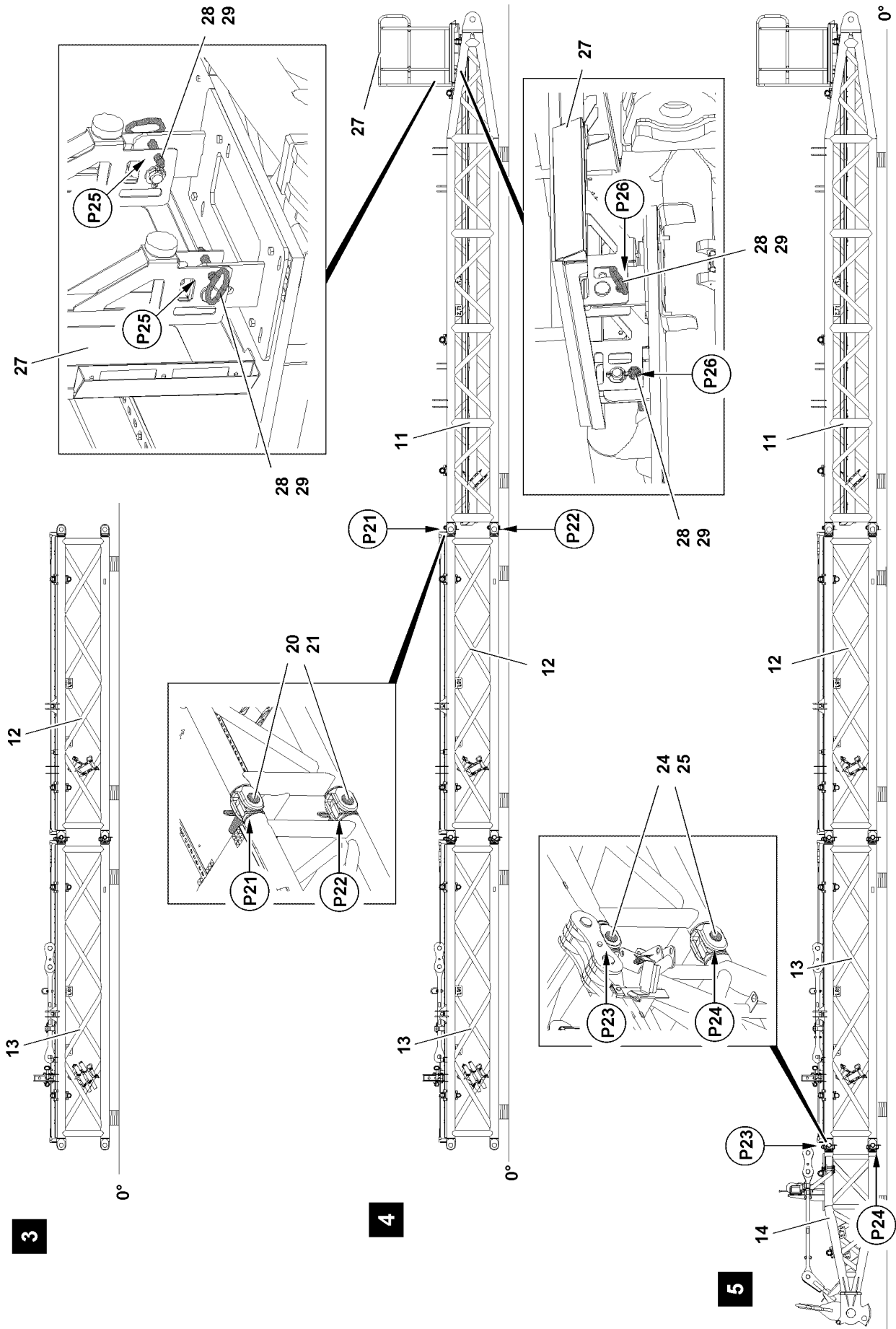

Fig.122803

LWE/LR 11000-001/23501-04-02/en

- ▶ Fasten the platform **27** to the auxiliary crane.



WARNING

Platform swinging down!

The platform can swing down by itself due to its own weight when unpinning it at points **P25**.

Death, severe bodily injuries, property damage.

Fingers and hands can be crushed.

- ▶ Make sure that the platform is safely held by the auxiliary crane.
- ▶ Do not reach with your hands into the danger zone.
- ▶ Use personal protective equipment.

-
- ▶ Set the platform **27** into operating position, see illustration 4: Remove the safety locking pin **29** at points **P25** and unpin the grip pin **28**.
 - ▶ Swing the platform **27** with the auxiliary crane.
 - ▶ Insert the grip pin **28** at points **P26** and secure with safety locking pin **29**.
 - ▶ Remove the auxiliary crane.

Assembling the end section

- ▶ Fasten the end section **14** to the auxiliary crane.
- ▶ Position the end section **14** with the auxiliary crane on the intermediate section **13** at point **P23** until the pin points align.
- ▶ Support the end section **14**.

The end section and the intermediate section are pinned together in four points. Every point is present on both sides of the component on one level, see illustration 5.

- ▶ Pin the end section **14** on both sides at point **P23** with the intermediate section **13**: Insert the pins **24** and secure with the spring retainers **25**.
- ▶ Pin the end section **14** on both sides at point **P24** with the intermediate section **13**: Insert the pins **24** and secure with the spring retainers **25**.
- ▶ Remove the fastening equipment.

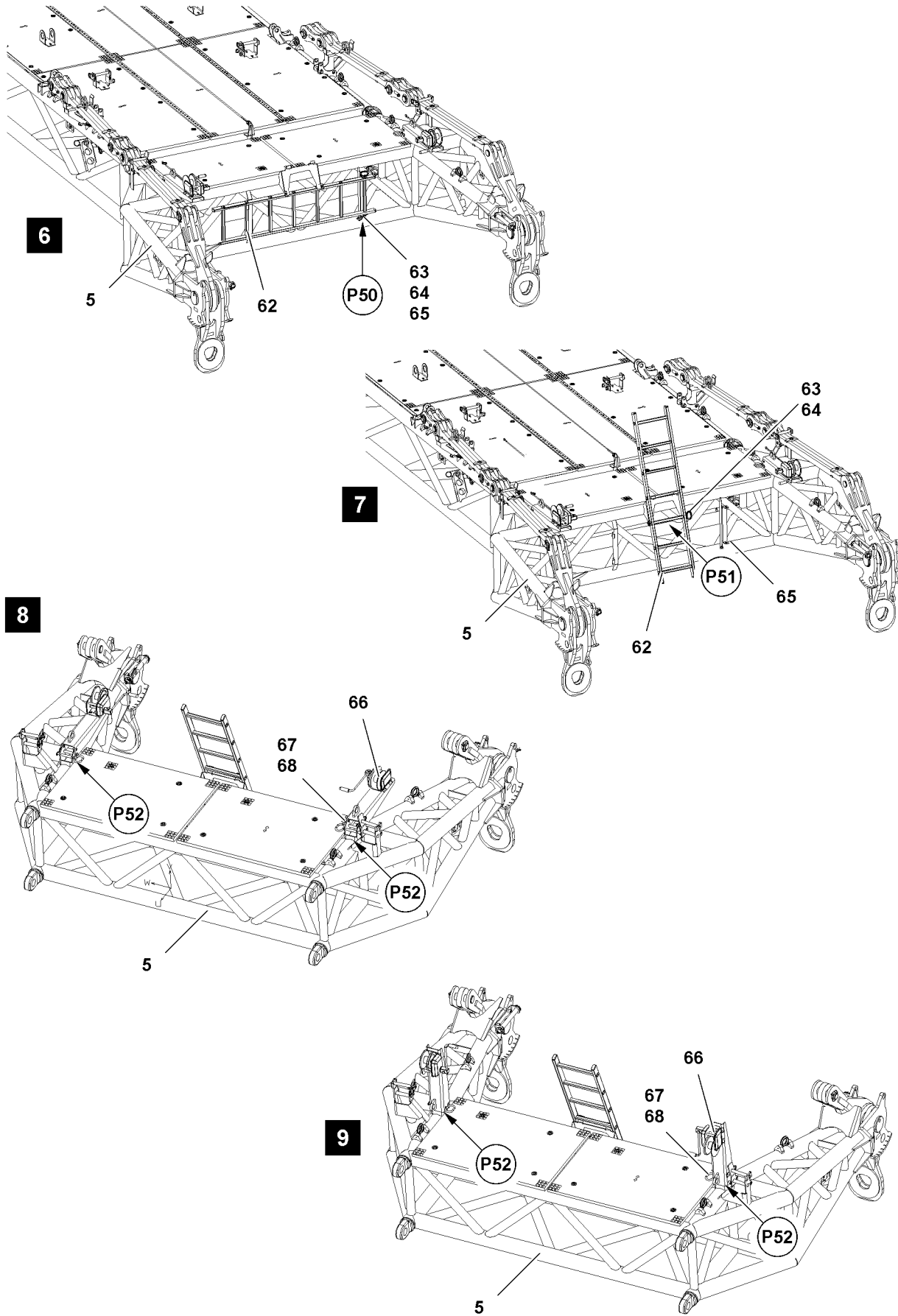

Fig.120205

LWE/LR 11000-001/23501-04-02/en

Assembling the ladder



WARNING

Falling ladder!

The ladder can fall down by itself due to its own weight when it is unpinned.

Death, severe bodily injuries, property damage.

Fingers and hands can be crushed.

- ▶ When unpinning the pin connection, hold the ladder.
 - ▶ Do not reach with your hands into the danger zone.
-
- ▶ Release the ladder **62** from the transport retainer: Remove the lock **65** at point **P50** and unpin the grip pin **63**, see illustration **6**.
 - ▶ Remove the safety locking pin **64** at point **P50** from park position, see illustration **6**.
 - ▶ Attach the lock **65** at point **P50** in the park position, see illustration **6**.



WARNING

Danger of crushed limbs!

When hanging the ladder up, fingers and hands can be crushed.

- ▶ Do not reach with your hands into the danger zone.
-
- ▶ Get the ladder **62** from the transport retainer and hang it up at point **P51**, see illustration **7**.
 - ▶ Secure the ladder **62** in operating position: Insert the grip pin **63** at point **P51** and secure with safety locking pin **64**, see illustration **7**.

Assembling the manual rope winch



WARNING

Danger of crushed limbs!

When setting up the manual rope winch, fingers and hands can be crushed.

- ▶ Do not reach with your hands into the danger zone.



WARNING

Falling manual rope winch!

The manual rope winch can fall down by itself due to its own weight when setting it up.

Death, severe bodily injuries, property damage.

Fingers and hands can be crushed.

- ▶ When unpinning the pin connection, hold the ladder.
 - ▶ Do not reach with your hands into the danger zone.
-
- ▶ Set up the manual rope winch **66**, see illustration **9**.
 - ▶ Secure the manual rope winch **66** in operating position: Insert the grip pin **67** at point **P52** and secure with safety locking pin **68**, see illustration **9**.

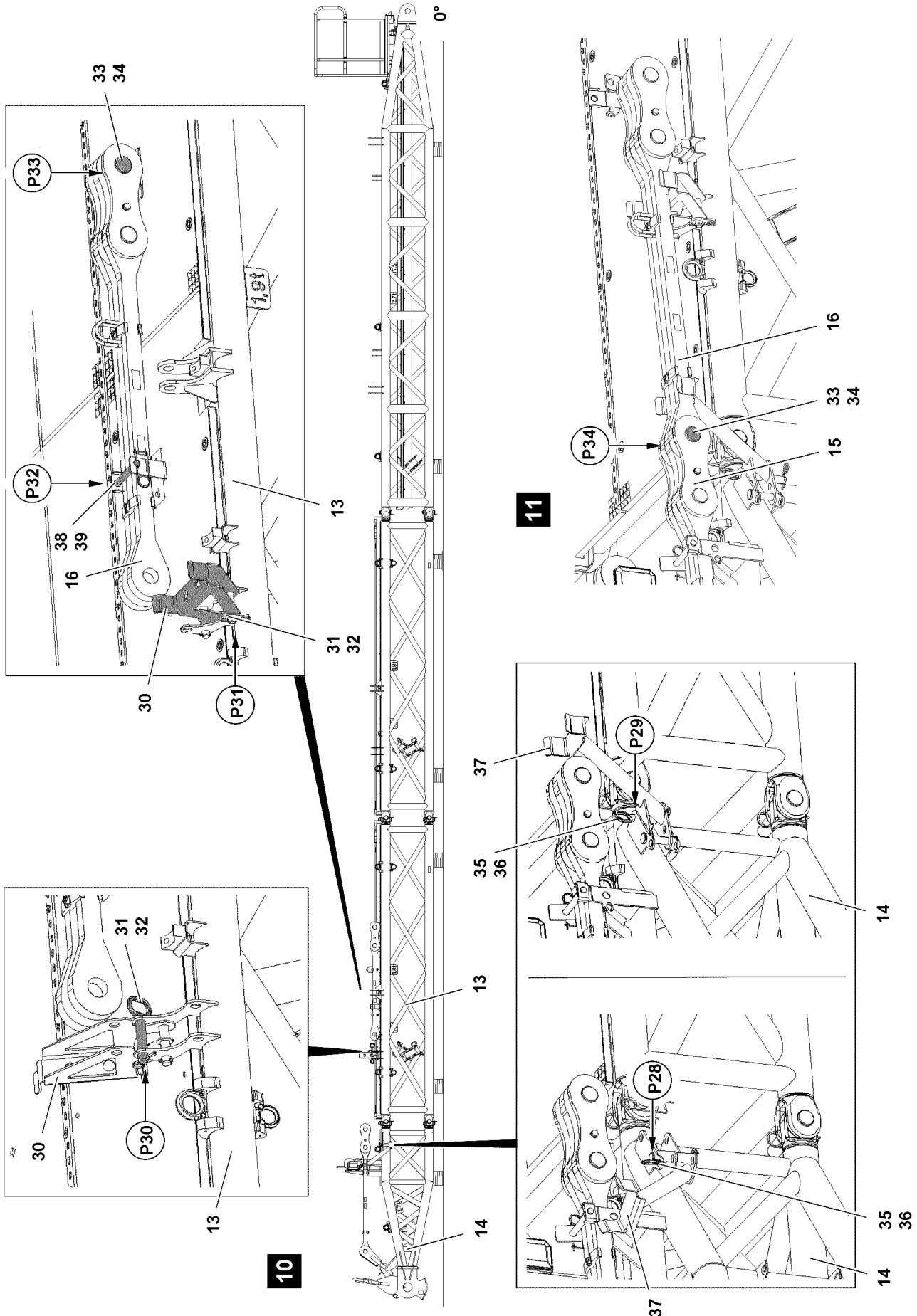

Fig.122804

LWE/LR 11000-001/23501-04-02/en

Assembling the pull rods

- ▶ Release the bracket **37** from the transport position: Remove the spring retainer **36** at point **P28** and unpin the socket pin **35**, see illustration **10**.

**WARNING**

When swinging the bracket, fingers and hands can be crushed.

- ▶ Do not reach with your hands into the danger zone.

- ▶ Swing the bracket **37** until it can be pinned at point **P29**.
- ▶ Insert the socket pins **35** at point **P29** and secure with spring retainer **36**, see illustration **10**.

Result:

- The bracket **37** is secured in the operating position.

- ▶ Release the retainer **30** from the transport position: Remove the spring retainer **32** at point **P30** and unpin the socket pin **31**, see illustration **10**.

**WARNING**

When swinging the retainer, fingers and hands can be crushed.

- ▶ Do not reach with your hands into the danger zone.

- ▶ Swing the retainer **30** until it can be pinned at point **P31**.
- ▶ Secure the retainer **30** in operating position: Insert the socket pins **31** at point **P31** and secure with spring retainer **32**, see illustration **10**.

Result:

- The retainer **30** is secured in the operating position.

- ▶ Release the pull rods **16** from the transport position: Remove the spring retainer **39** at point **P32** and unpin the pin **38**, see illustration **10**.
- ▶ Remove the safety locking pin **34** at point **P33** and unpin the pin **33**, see illustration **10**.
- ▶ Fasten the auxiliary crane to the pull rod **16**.
- ▶ Place the pull rod **16** down with the auxiliary crane in operating position on the retainer **30** and align at point **P34** on bores, see illustration **11**.
- ▶ Pin the pull rod **16** with the pull rod end section **15**: Insert the pin **33** at point **P34** and secure with the safety locking pin **34**, see illustration **11**.
- ▶ Remove the auxiliary crane.
- ▶ Insert the pin **38** in park position and secure with spring retainer **39**.
- ▶ Release the pull rod **15** from the transport position.

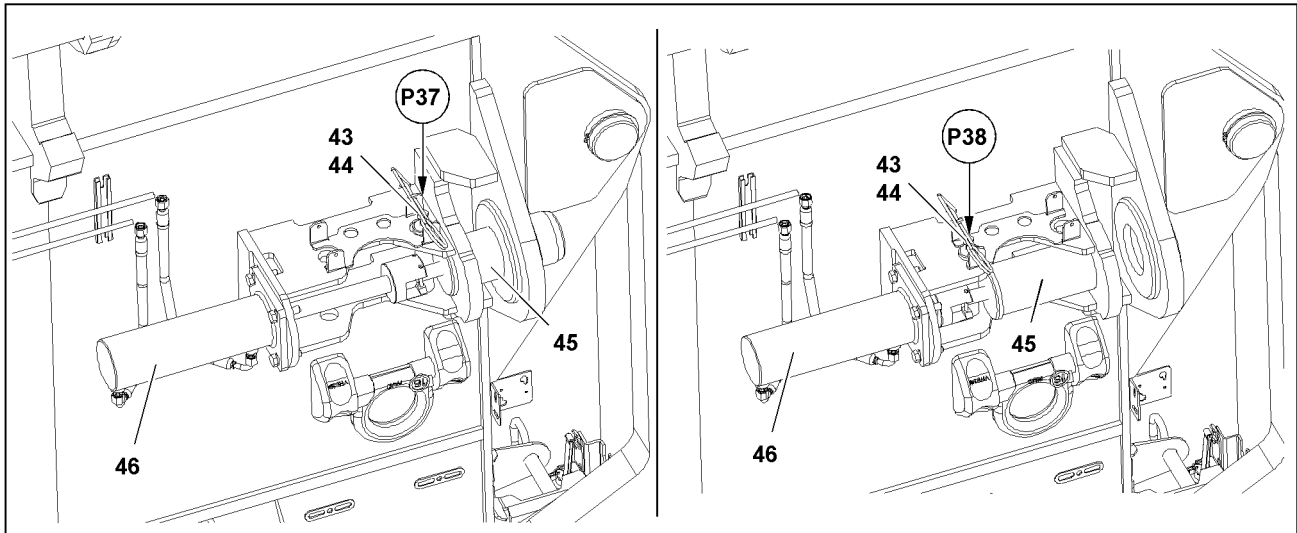

12

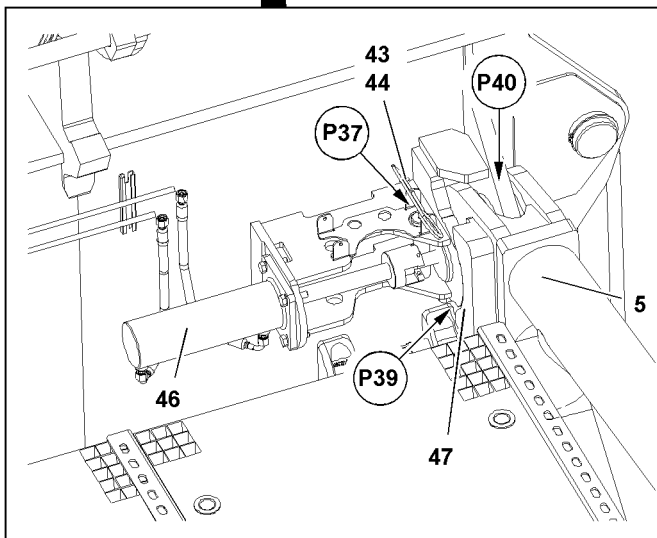
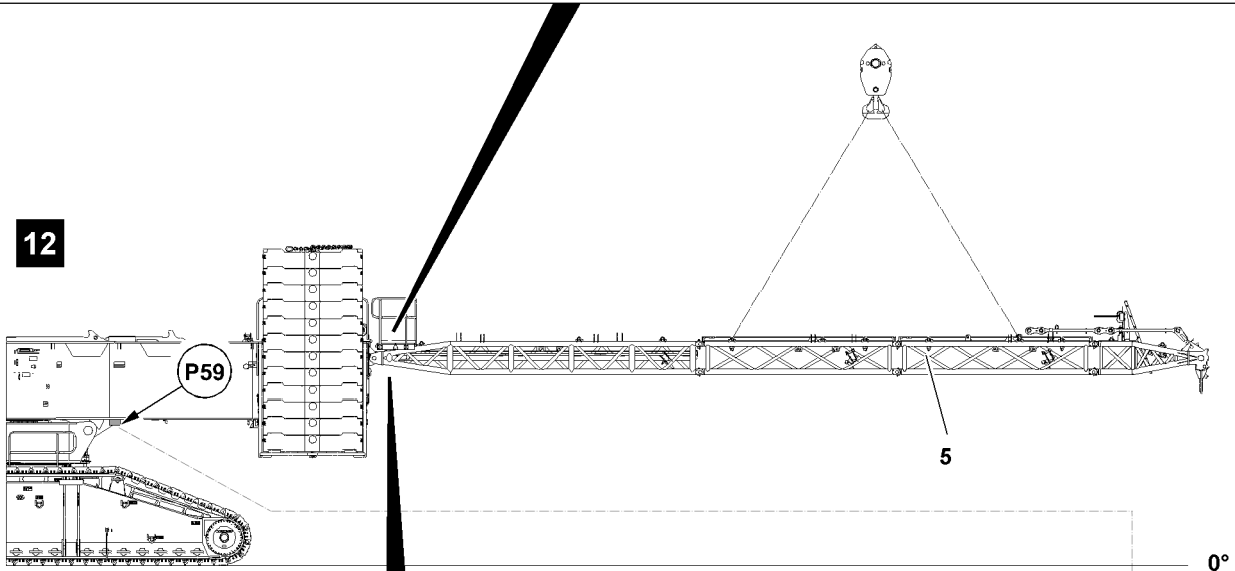

13

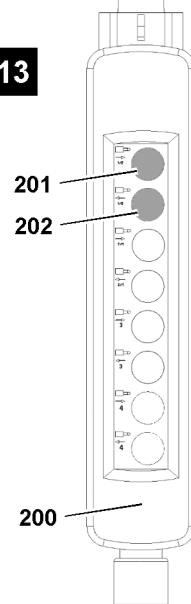

Fig.122805

LWE/LR 11000-001/23501-04-02/en

Swinging the brackets

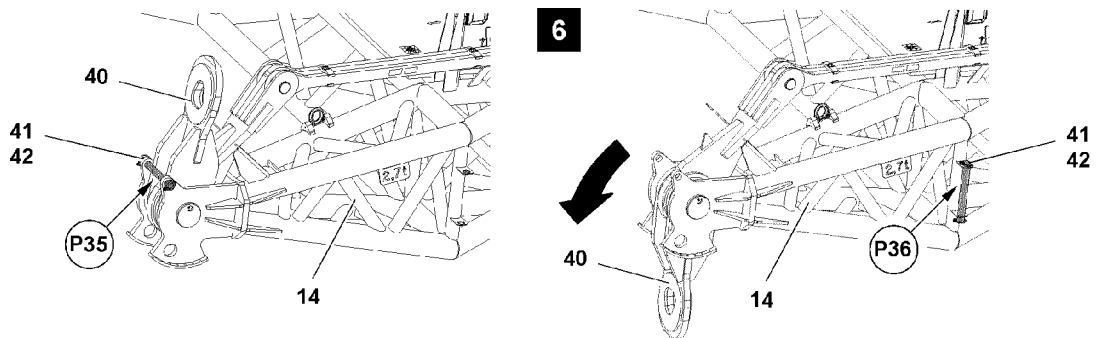

Fig.119028: Swinging the bracket

- ▶ Fasten the bracket 40 to the auxiliary crane.



WARNING

Bracket swinging down!

The bracket can swing down by itself due to its own weight when unpinning it at point P25, see illustration.

Death, severe bodily injuries, property damage.

Fingers and hands can be crushed.

- ▶ Make sure that the platform is held by the auxiliary crane.
- ▶ Do not reach with your hands into the danger zone.

- ▶ Remove the safety locking pin 42 at point P35 and unpin the pin 41, see illustration 14.
- ▶ Swing the bracket 40 downward with the auxiliary crane.
- ▶ Insert the pin 41 in park position at point P36 and secure with safety locking pin 42, see illustration 14.

7.1.3 Assembling the suspended ballast guide on the turntable frame

Make sure that the following prerequisites are met:

- A lifting platform or other aids are available.
- An auxiliary crane is available.
- The control panel is connected on the „turntable rear“ socket , point P59.

The suspended ballast guide 5 is pinned on two points. The pin procedure is described for one pin as an example:

- ▶ Release the pin 45: Remove the spring retainer 44 at point P37 and unpin the retaining pin 43, see illustration 12.
- ▶ Insert the retaining pin 43 at point P38 and secure with spring retainer 44 see illustration 12.
- ▶ Plug the control panel on the turntable in on the rear, see illustration 13.
- ▶ Unpin the pin 45: Press button 202 on the control panel 200, see illustration 13.

Result:

- The pin 45 moves out.

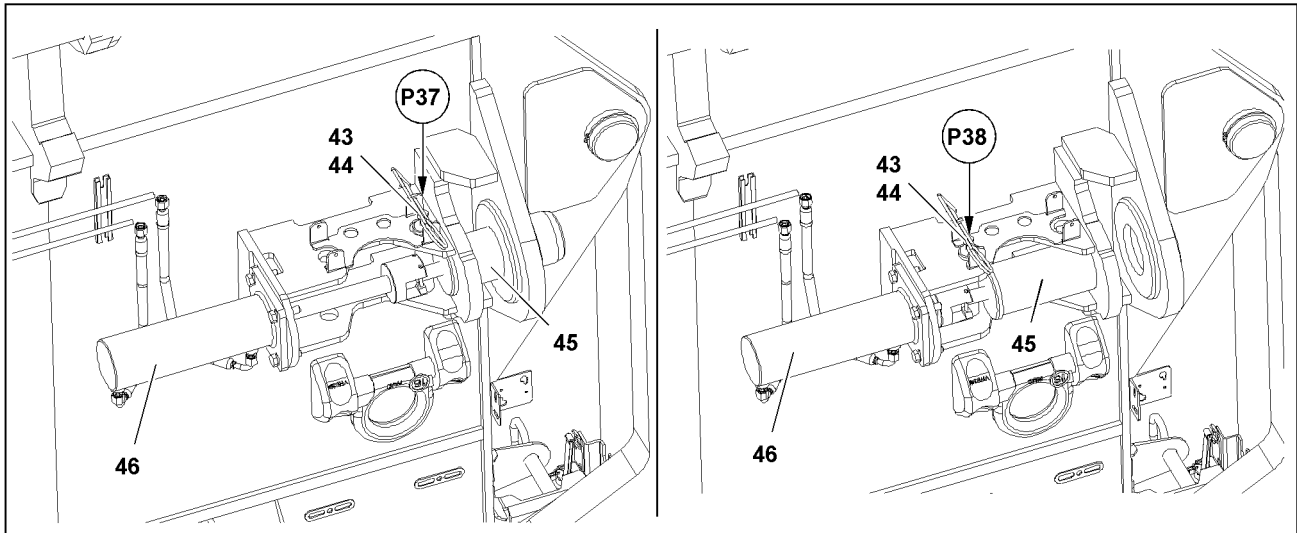

12

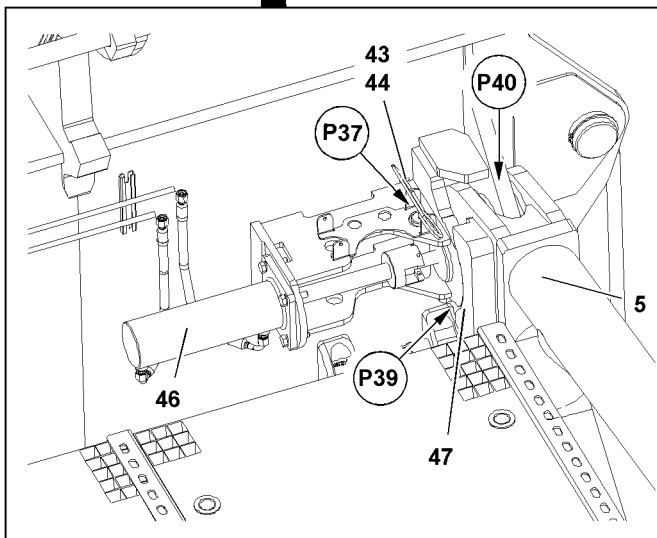
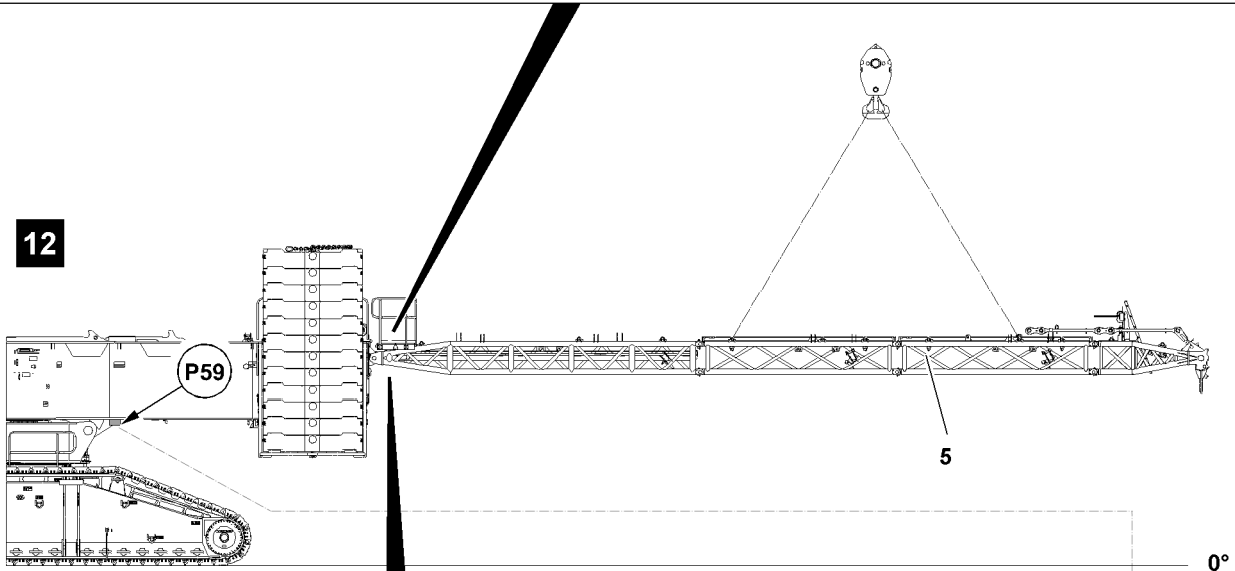

13

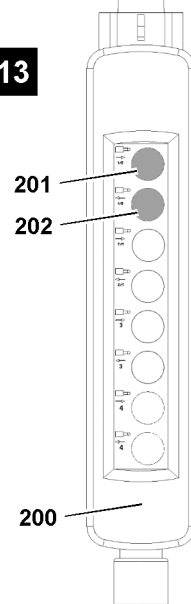

Fig.122805

LWE/LR 11000-001/23501-04-02/en

- ▶ Attach the suspended ballast guide **5** on the auxiliary crane.
- ▶ Lift the suspended ballast guide **5** to the pin points **P40** on the rear of the turntable, see illustration **12**.
- ▶ Set the suspended ballast guide **5** on the centering **47** on points **P39** of the turntable, see illustration **12**.

Result:

- Align the pin bores.

- ▶ Insert the pin **45**: Press button **201** on the control panel **200**, see illustration **13**.

Result:

- The pin **45** moves in.

**WARNING**

Danger of accident!

If the pins are not secured with the retaining pin, then the connector pins can loosen up by themselves during crane operation.

This can cause the crane to topple over.

Death, severe bodily injuries, property damage.

- ▶ Make sure that the connector pins are secured.

- ▶ Secure the pin **45**: Insert the retaining pin **43** at point **P37** and secure with spring retainer **44** see illustration **12**.

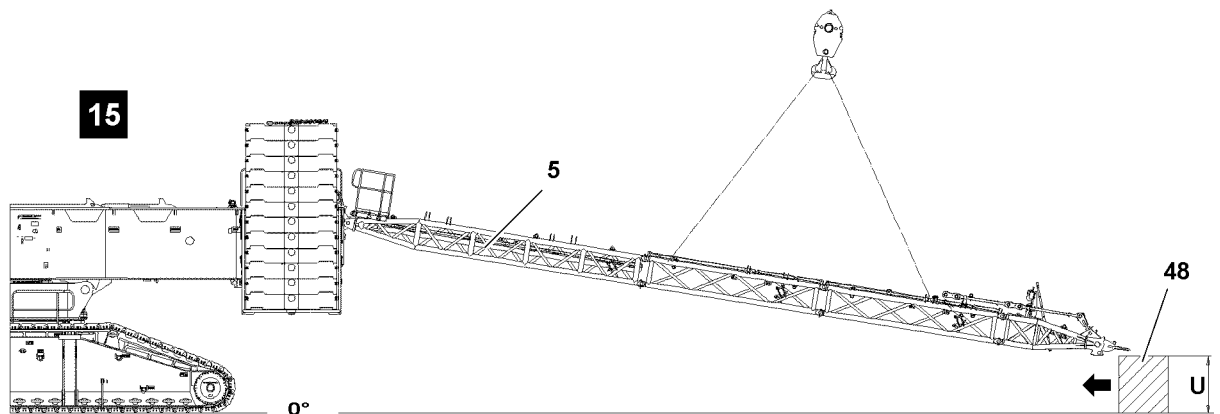

Fig.120203: Substructure

Suspended ballast guide	R30	R25	R20
Substructure height „U“	0 m	1.6 m	2.0 m

- ▶ Take the suspended ballast guide **5** down on the substructure with the auxiliary crane, see illustration **15** and chart.

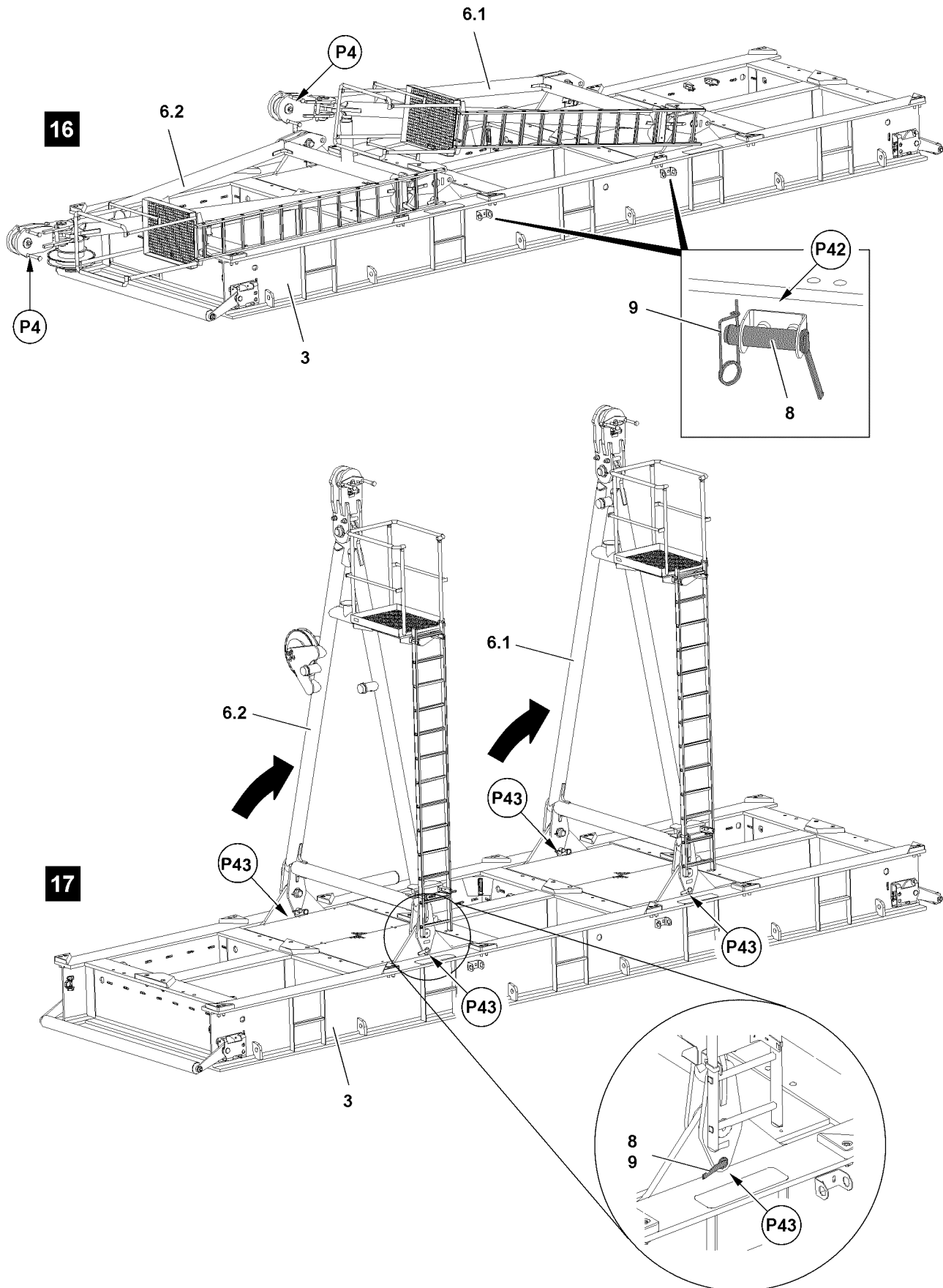

Fig.119005

LWE/LR 11000-001/23501-04-02/en

7.2 Installing the ballast pallet



DANGER

Danger of accident during assembly / disassembly of the erection racks!

The disassembly of unsecured or unsupported erection racks can cause the erection racks to fall down and kill or severely injure personnel.

- ▶ Never unpin the retaining pins under unsecured or unsupported erection racks.
- ▶ It is prohibited for anyone to remain under the erection racks or within the complete danger zone during the pinning and unpinning procedure.

7.2.1 Setting the ballast pallet in the assembly position

- ▶ Set the derrick to the required radius.



Note

- ▶ Fastening points, see section „Fastening points for suspended ballast parts“.

- ▶ Hang the ballast pallet **3** on the auxiliary crane and position it within the slewing range of the crane under the guy rods on the derrick.



Note

- ▶ Set down the ballast pallet **3** in the lengthwise direction of the turntable for easier assembly to the guy rods.

- ▶ Align the ballast pallet **3** horizontally.

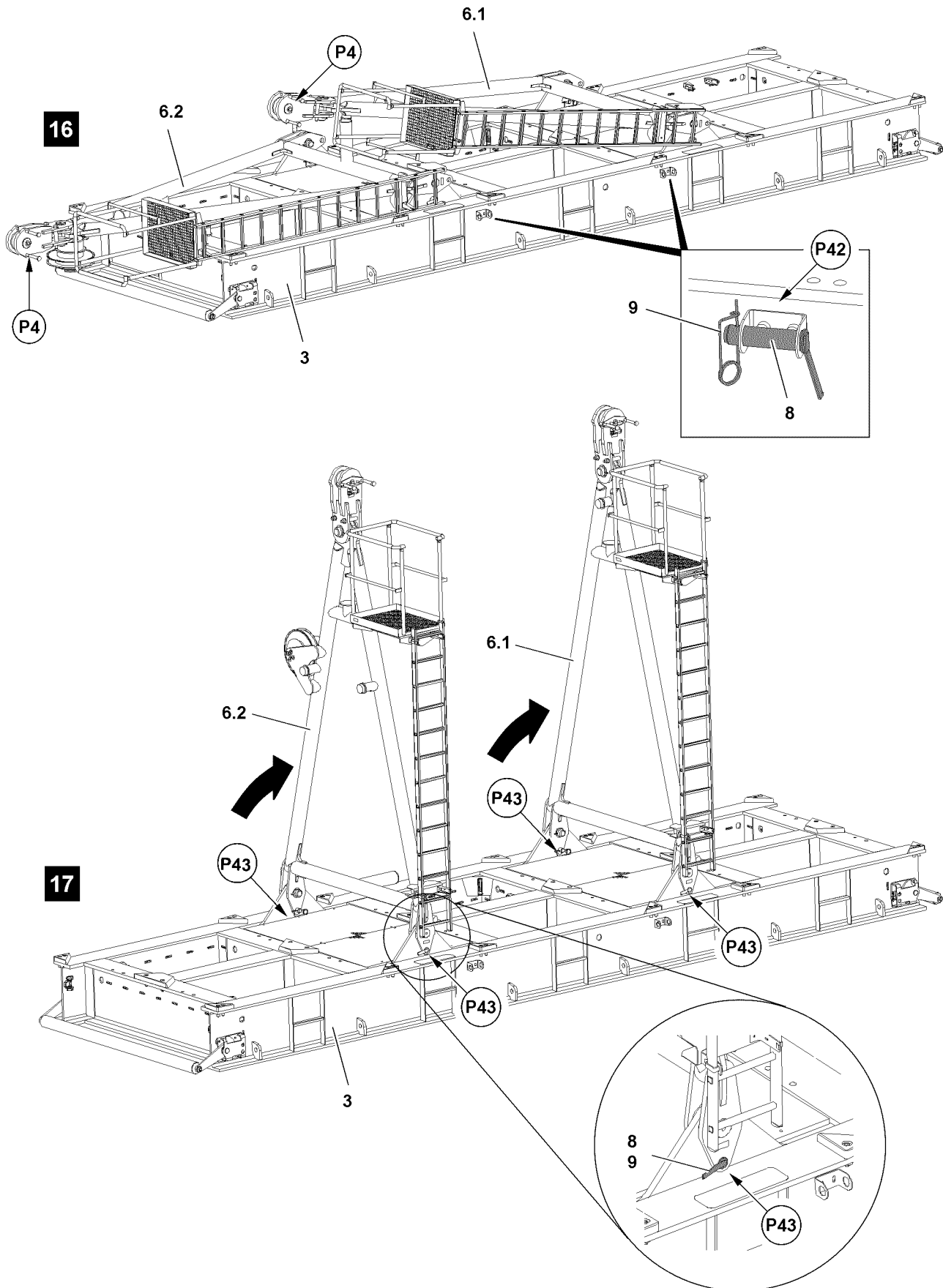

Fig.119005

LWE/LR 11000-001/23501-04-02/en

7.2.2 Erecting the erection racks



Note

- ▶ The assembly of the erection racks is described based on the example of one erection rack.

The erection rack is pinned on two points. The pin procedure is described for one pin as an example.

- ▶ Hang the erection rack **6.1** on the auxiliary crane at point **P4**, see illustration **16**.
- ▶ Remove the spring retainer **9** on both sides at point **P42** and unpin the retaining pin **8** from the park position.



DANGER

Danger of accident during assembly / disassembly of the erection racks!

The erection racks must hang securely on the auxiliary crane, otherwise they could fall down and kill or severely injure personnel.

- ▶ The two erection racks must be locked and secured in a vertical position with retaining pins **8**. Only then may the auxiliary crane be removed.
- ▶ Never unpin the retaining pins of unsecured or unsupported erection racks.
- ▶ It is prohibited for anyone to remain under the erection racks or within the complete danger zone during the pinning and unpinning procedure.

- ▶ Position the erection rack **6.1** vertically with the auxiliary crane, see illustration **13**.
- ▶ Insert the retaining pin **8** at point **P43** on both sides and secure with the spring retainer **9** see illustration **17**.

When the erection rack **6.1** is set up and secured:

- ▶ Remove the auxiliary crane.
- ▶ Erect the second erection rack **6.2**.

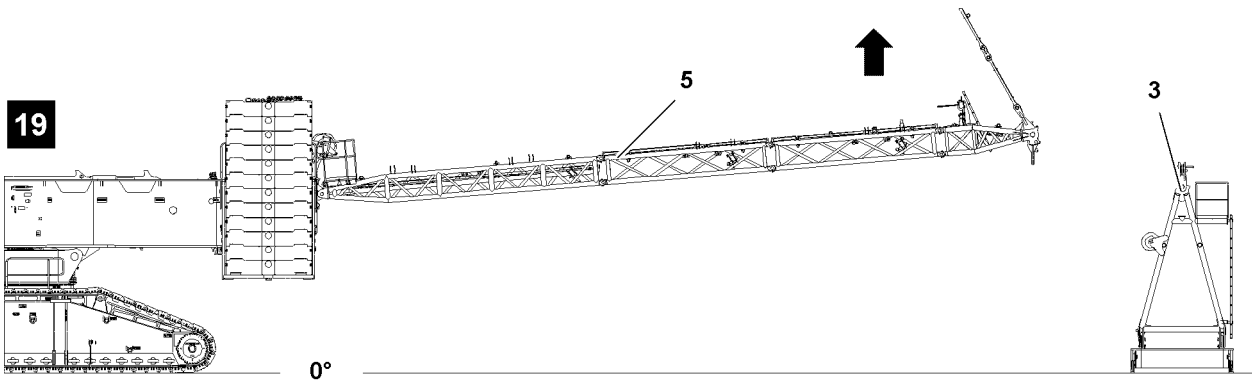
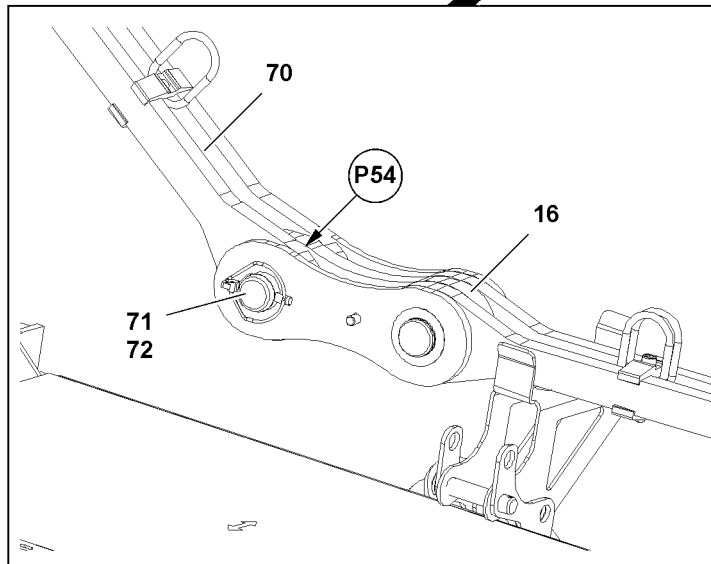
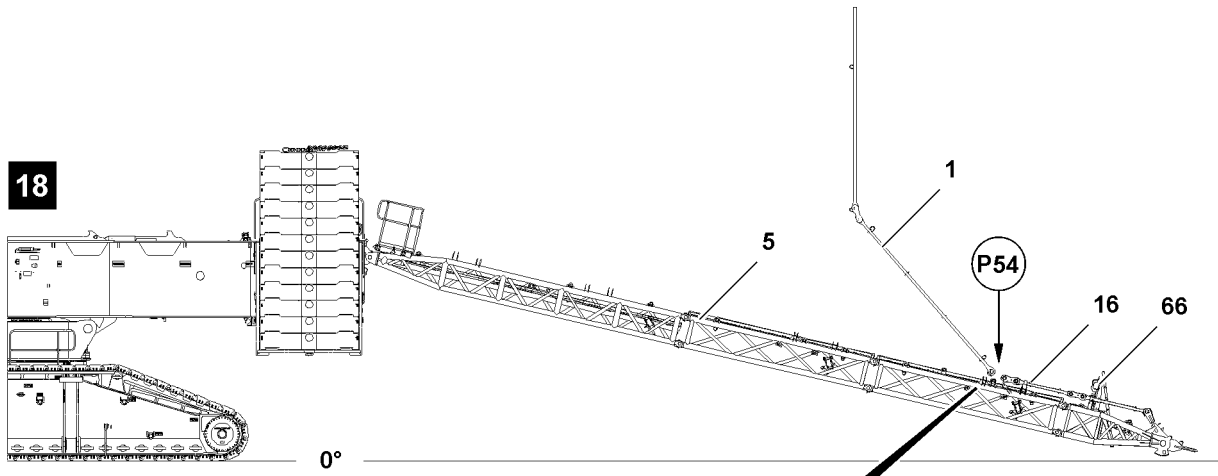

Fig.120204

LWE/LR 11000-001/23501-04-02/en

7.3 Pinning the suspended ballast guide with the ballast pallet

Make sure that the following prerequisites are met:

- The D-guy rods hang over the lugs of the suspended ballast guide.
- The manual rope winches are set up and secured.
- The erection racks are set up and secured with retaining pins.

7.3.1 Pinning the D-guy rods with the pull rods of the suspended ballast guide

- ▶ Connect the rope of the manual rope winch **66** with the D-guy rods **1**.

The D-guy rods **1** are pinned on both sides on the suspended ballast guide **5**. The pin procedure is described on the example for one D-guy rod.

- ▶ Pull the D-guy rods **1** with the manual rope winch **66** to the pull rods **16** and luff the derrick down at the same time until it can be pinned on point **P54**.



WARNING

Danger of accident!

If the connector pins are not secured with the retaining pin, then they can loosen up by themselves during crane operation.

This can cause the crane to topple over.

Death, severe bodily injuries, property damage.

- ▶ Make sure that the connector pins are secured.
-

When the pin bores align:

- ▶ Insert the pin **71** at point **P54** and secure with the safety locking pin **72**, see illustration **18**.
- ▶ Lift the suspended ballast guide **4** with the derrick, see illustration **19**.

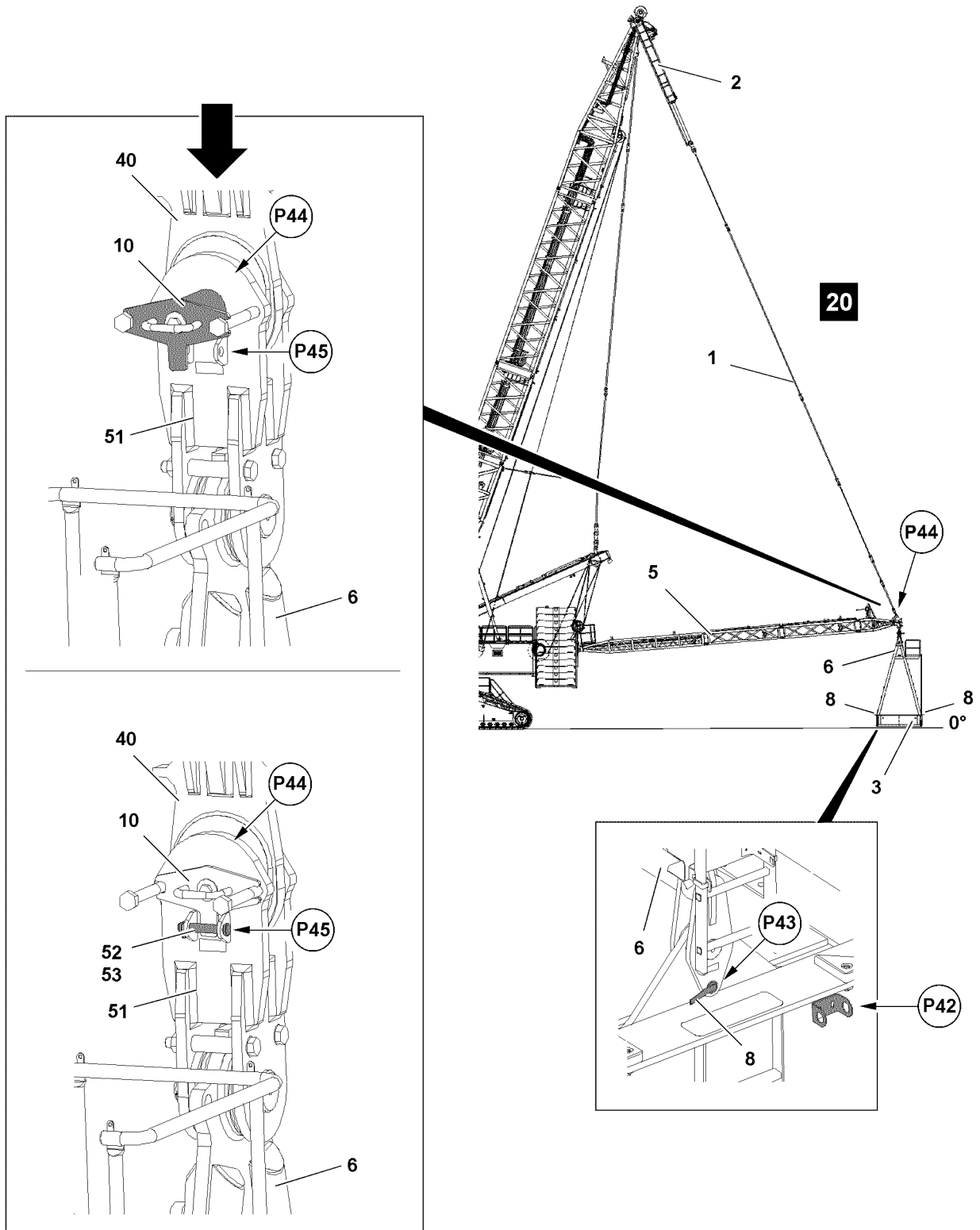

Fig.120207

LWE/LR 11000-001/23501-04-02/en

7.3.2 Pinning the suspended ballast guide on the ballast pallet

Make sure that the following prerequisite is met:

- The derrick is set to the required radius.

The ballast pallet **3** is pinned in two points. The pin procedure is described for one pin as an example.

- ▶ Position the suspended ballast guide **5** over the ballast pallet **3**.
- ▶ Remove the safety locking pin **53** at point **P45** and unpin the retaining pin **52**.
- ▶ Unpin the connector pin **10** at point **P44**.
- ▶ Lower the brackets **40** of the suspended ballast guide by extending the piston rods on the pull cylinders **2** into the brackets **51** until the pin bores align.



Note

Retract / extend the pull cylinder **2**

- ▶ Control the pull cylinders **2** from the crane cab, see the section „Lifting and lowering the derrick ballast using the pull cylinders“.
- ▶ Operate the pull cylinder **2** with the radio remote control, see the „radio remote control operating instructions“.

Pin and secure the brackets **40** on the brackets **51**, see illustration **20**.

- ▶ Insert the connector pin **10** at point **P44**.



WARNING

Danger of accident!

If the connector pins are not secured with the retaining pin, then they can loosen up by themselves during crane operation.

This can cause the crane to topple over.

Death, severe bodily injuries, property damage.

- ▶ Make sure that the connector pins are secured.

- ▶ Insert the retaining pin **52** at point **P45** and secure with the safety locking pin **53**, see illustration **20**.

- ▶ Pin the second erection rack **7** on the suspended ballast guide **5**.



WARNING

Uncontrolled oscillation of the ballast pallet!

When the ballast plate **3** is raised, it can start to swing.

Death, severe bodily injuries, property damage.

- ▶ It is prohibited to remain in the danger zone.
- ▶ Secure the ballast pallet with auxiliary rope.

- ▶ Lift the empty ballast pallet **3** with the pull cylinders **2** and set down again.

Result:

- The ballast pallet **3** is vertically aligned.

- ▶ Align the ballast pallet **3** horizontally.

NOTICE

Damage to the retaining pins!

If the retaining pins **8** are not unpinned before crane operation, then they can be damaged in crane operation.

- ▶ Unpin the retaining pins **8** before starting crane operation.

When the ballast pallet **3** is pinned and secured on the suspended ballast guide:

- ▶ Release and unpin the retaining pins **8** on the erection racks on both side on points **P43**.
- ▶ Insert and secure the retaining pin **8** at point **P42** in the park position, see illustration **20**.

7.4 Establishing the electrical connection from the suspended ballast to the turntable



Note

- ▶ Establish the electrical connections from the suspended ballast to the turntable, see Electric wiring diagram.
-
- ▶ Establish the electrical connections.

Empty page!

LWE/LR 11000-001/23501-04-02/en

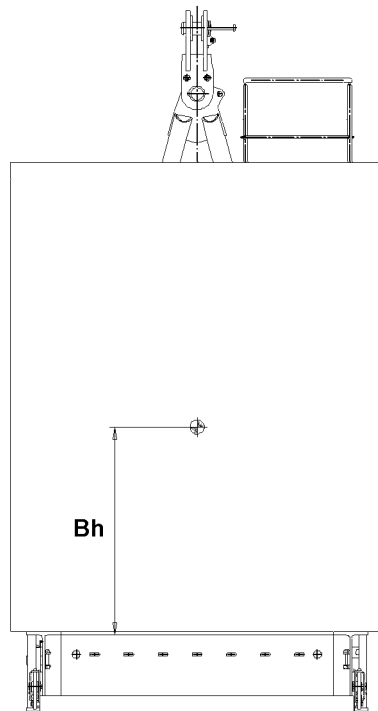
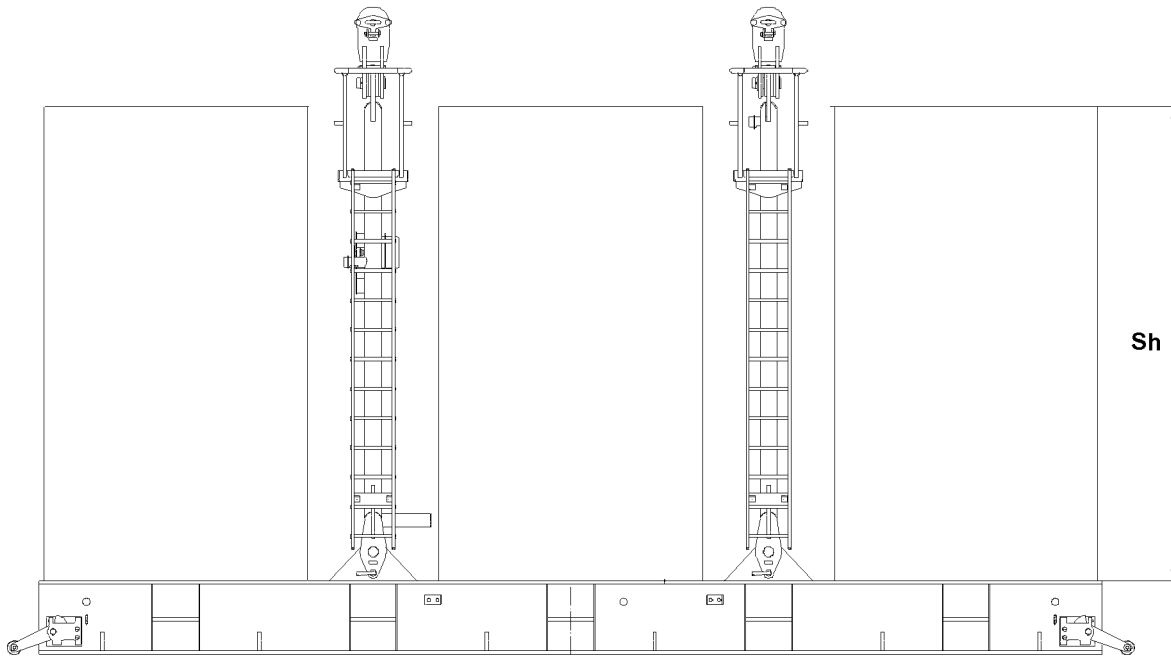

Fig.119007

LWE/LR 11000-001/23501-04-02/en

8 Ballasting the ballast pallet



WARNING

The crane can topple over!

If the following danger notes are not observed, the ballast plates or the ballast stack can slip on the ballast pallet and fall down.

The crane can topple over.

Death, severe bodily injuries, property damage.

- ▶ The ground on which the ballast pallet is ballasted must be level and have an adequate load bearing capacity.
- ▶ Always place the ballast plates symmetrically, in reference to the longitudinal axis.
- ▶ Do **not** start with the two outer ballast stacks. For ballasting, start in the center.
- ▶ For ballasting, at first only maximum 20 t ballast may be placed per stack.
- ▶ After the first ballast plate is placed, the difference per stack may be maximum 25 t.
- ▶ For ballasting with double stacks, the difference between front and rear may be maximum 10 t for a double stack.
- ▶ The outer ballast stacks must always weigh the same and be the same height after ballasting.
- ▶ The two center ballast stacks must always weigh the same and be the same height after ballasting.
- ▶ The outer ballast stacks can differ in stack height from the inner ballast stacks.
- ▶ The maximum permissible ballast center of gravity height **Bh** of 2000 mm may not be exceeded.
- ▶ The permissible stack height **Sh** of 4500 mm may not be exceeded.
- ▶ The maximum permissible total weight of the suspended ballast may **not** exceed 455 t.
- ▶ Secure all ballast plates so they cannot move and fall down.
- ▶ Replace damaged ballast plates immediately with new ballast plates.

Make sure that the following prerequisites are met:

- The ballast pallet is properly assembled and secured on the D-guying.
- An auxiliary crane is available.

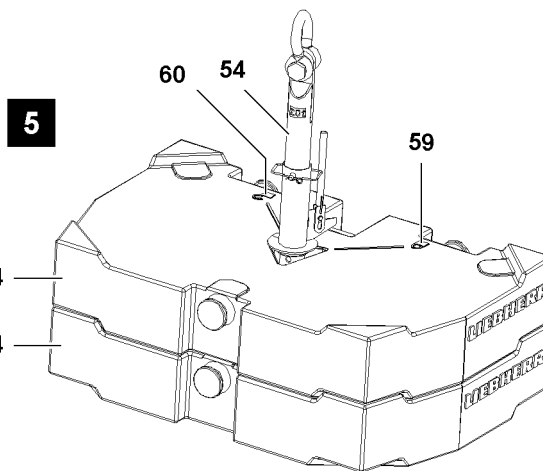
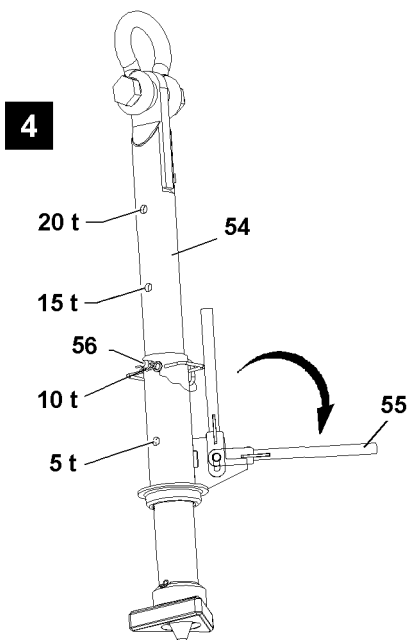
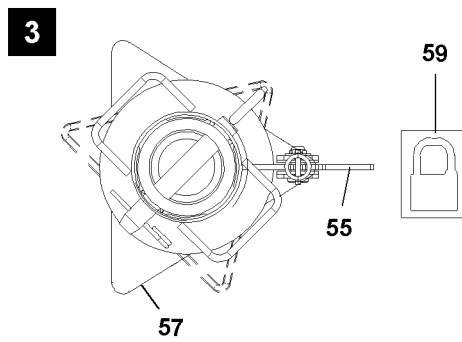
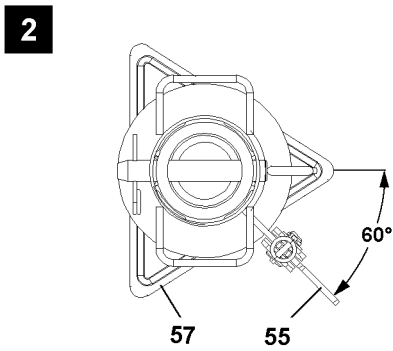
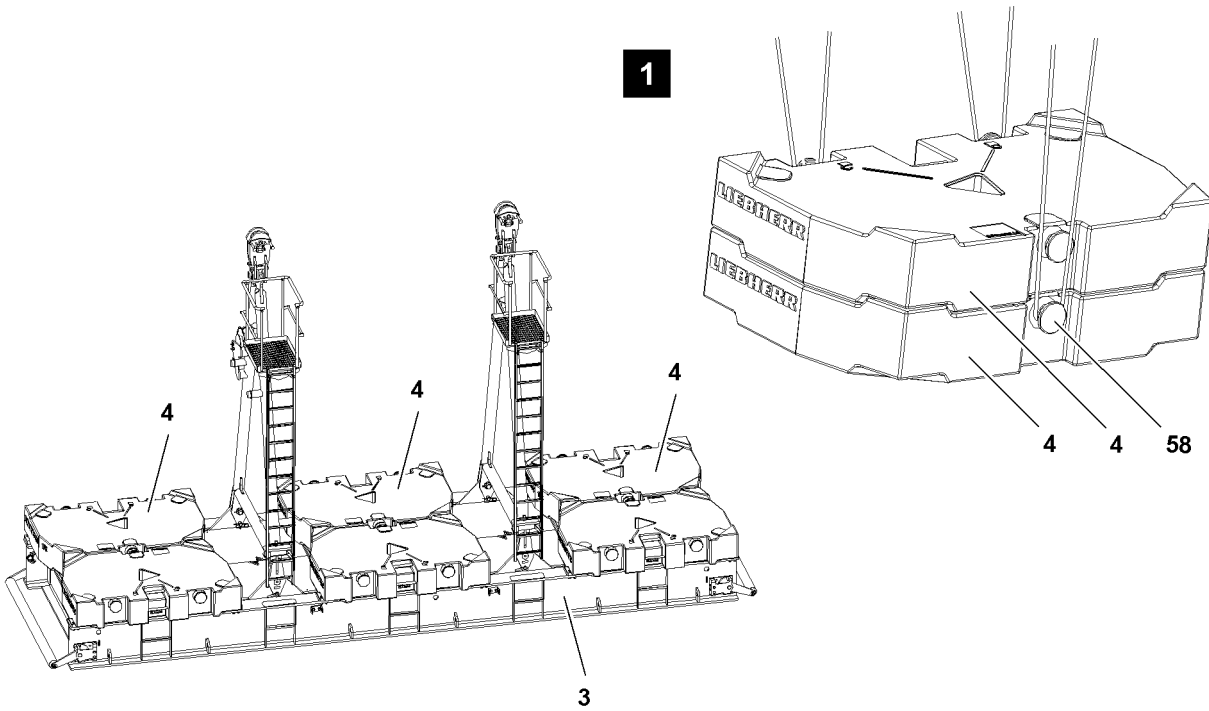

Fig.119008

LWE/LR 11000-001/23501-04-02/en

8.1 Placing the ballast plates, fastening system: „Twistlock“



WARNING

Danger of accident!

If more than the permissible two ballast plates are lifted with the receptacle stud, the receptacle stud will be overloaded and can be damaged.

Death, severe bodily injuries, property damage.

- ▶ Make sure that the ballast plates are placed correctly in the centerings.
- ▶ Replace damaged ballast plates.

To stack the ballast plate(s) **4**, use the receptacle stud **54**.

Before the receptacle stud **54** is guided into the ballast plates, it must be ensured that the length of the receptacle stud **54** is set correctly. The length of the receptacle stud **54** can be adjusted with the pin **56**.

If the length of the receptacle stud **54** is to be adjusted:

- ▶ Release and unpin the pin **56**.
- ▶ Adjust the length of the receptacle stud by moving the receptacle stud **54**, see illustration **4**.
- ▶ Insert the pin **56** and secure with the spring retainer.
- ▶ Fasten the receptacle stud **54** to the auxiliary crane and guide it into the ballast plate(s).
- ▶ Pull the lever **55** up and fold it down.
- ▶ Turn the lever **55** by 60° until the lever **55** points to the icon **59**, see illustration **2** and illustration **3**.

Result:

- The receptacle stud **54** is locked with the ballast plate.
- ▶ Lift always one ballast plate with the receptacle stud **54** and take it down carefully on the outer centerings of the ballast pallet **3**.

When the ballast plate has been taken down on the outer centerings of the ballast pallet **4**:

- ▶ Turn the lever **55** by 60° until the lever **55** points to the icon **60**, see illustration **2**.

Result:

- The receptacle stud **54** is unlocked.
- ▶ Carefully pull the receptacle stud **54** from the ballast plate.
- ▶ Stack the ballast plates according to the load chart, observe the danger notes.

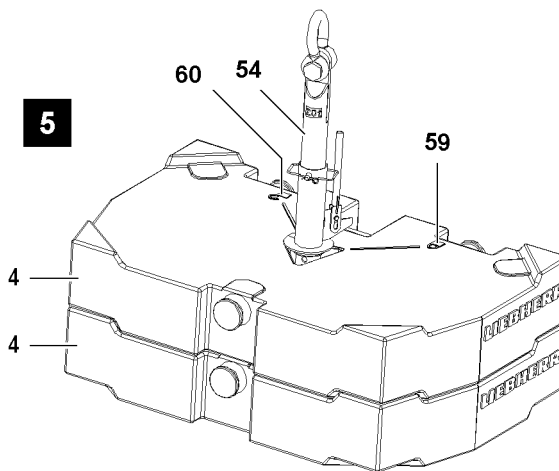
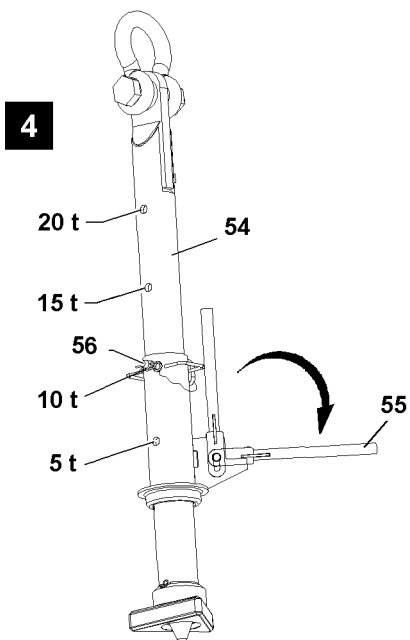
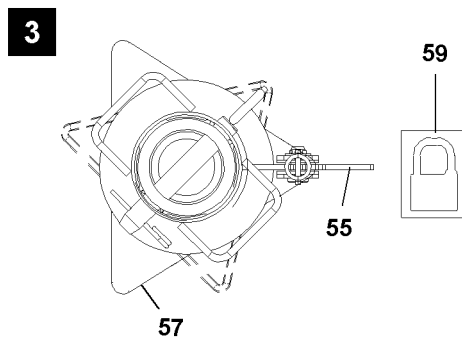
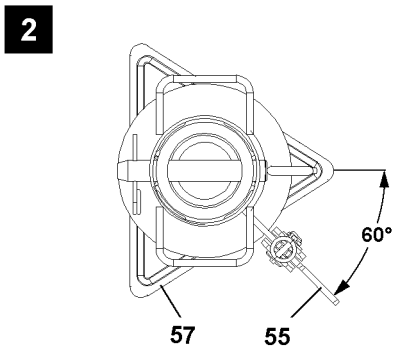
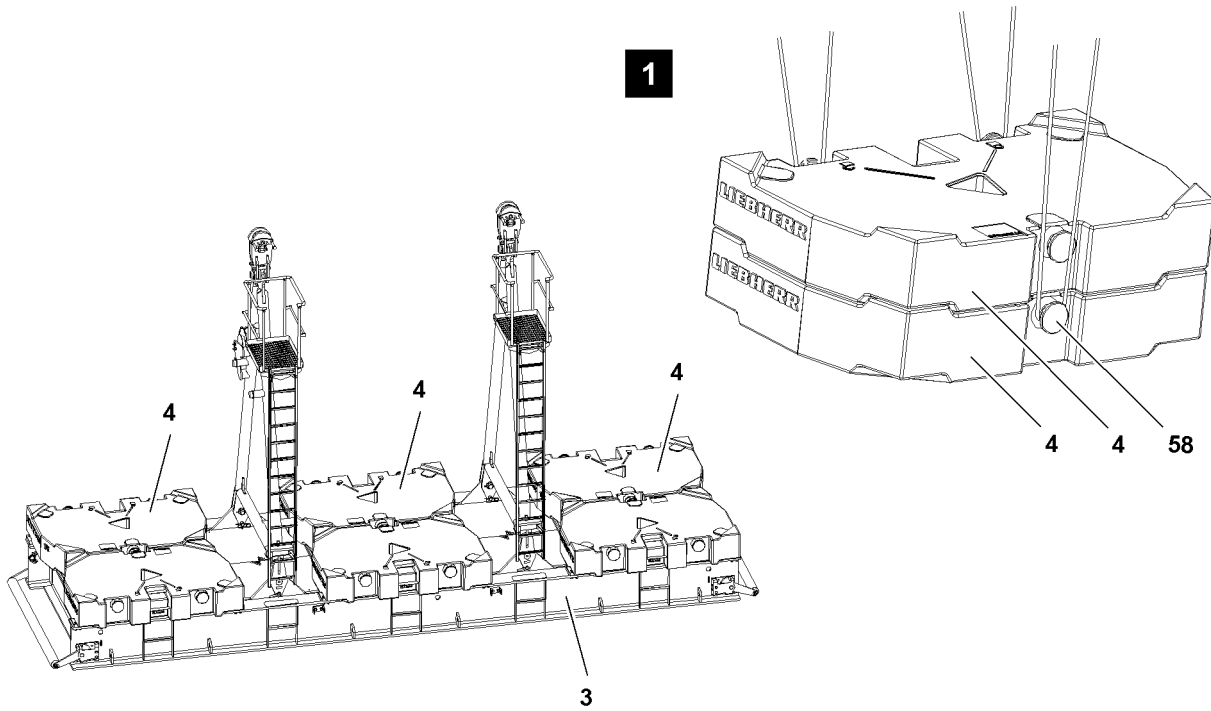

Fig.119008

LWE/LR 11000-001/23501-04-02/en

8.2 Placing the ballast plates, fastening points: „Bitt“



WARNING

Falling ballast plates!

If more than the permissible loads are lifted, then the bits **58** are overloaded and the ballast plates can fall down.

Death, severe bodily injuries, property damage.

- ▶ Lift no more than maximum 20 t with the ropes, 3 fastening points.
- ▶ Replace damaged ballast plates immediately.



WARNING

Incorrect handling of the fastening equipment!

If fastening equipment is not attached correctly and if it is not secured sufficiently to prevent it from loosening up, loads can fall down.

Death, severe bodily injuries, property damage.

- ▶ Make sure that the fastening equipment is correctly attached on the bits **58** and that it is secured sufficiently to prevent it from loosening up.



Note

- ▶ Place the ballast plates individually or as a ballast assembly, maximum 20 t.
- ▶ 20 t ballast assembly, see illustration 1.

- ▶ Place always only one ballast plate on the outer centerings on the ballast pallet.

When a ballast plate has been placed on the outer centerings of the ballast pallet:

- ▶ Place the ballast plates individually or as an assembly of maximum two plates alternately on the left and right with the auxiliary crane.
- ▶ Stack the ballast plates according to the load chart, observe the danger notes.

9 Crane operation with the derrick ballast

9.1 Function check of the ground contact switch

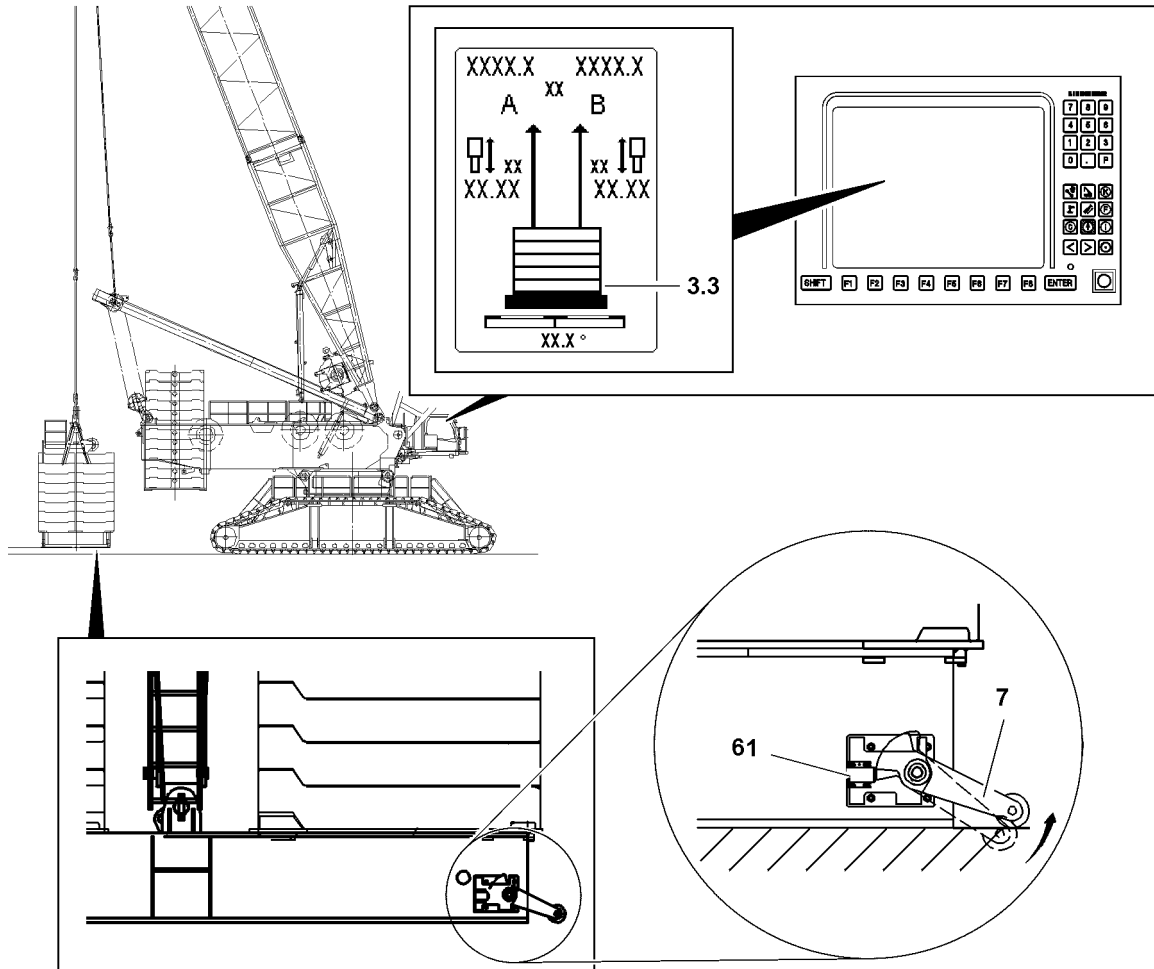

Fig.145935

Make sure that the following prerequisites are met:

- The electrical connection between the derrick ballast and the turntable has been established.
- The cable drum pull release is fastened to the turntable.



DANGER

Danger of accident if the derrick ballast touches the ground unintentionally!

If the terrain is very uneven, the danger exists that the derrick ballast rests on the ground even if a ground contact switch **61** was not actuated.

- ▶ If the ballast pallet touches the ground, **at least one** ground contact switch **61** must be actuated via the ground contact roller **7**.

- ▶ Check the ease of movement of the ground contact roller **7**.
- ▶ Manually operate the ground contact roller **7**.

Result:

- The ground contact switch **61** is actuated.
- The LICCON monitor displays derrick ballast has ground contact **3.3** - the „turning the turntable“ and „driving the crawler“ crane movements are deactivated.

9.2 Lifting and lowering the derrick ballast using the pull cylinders

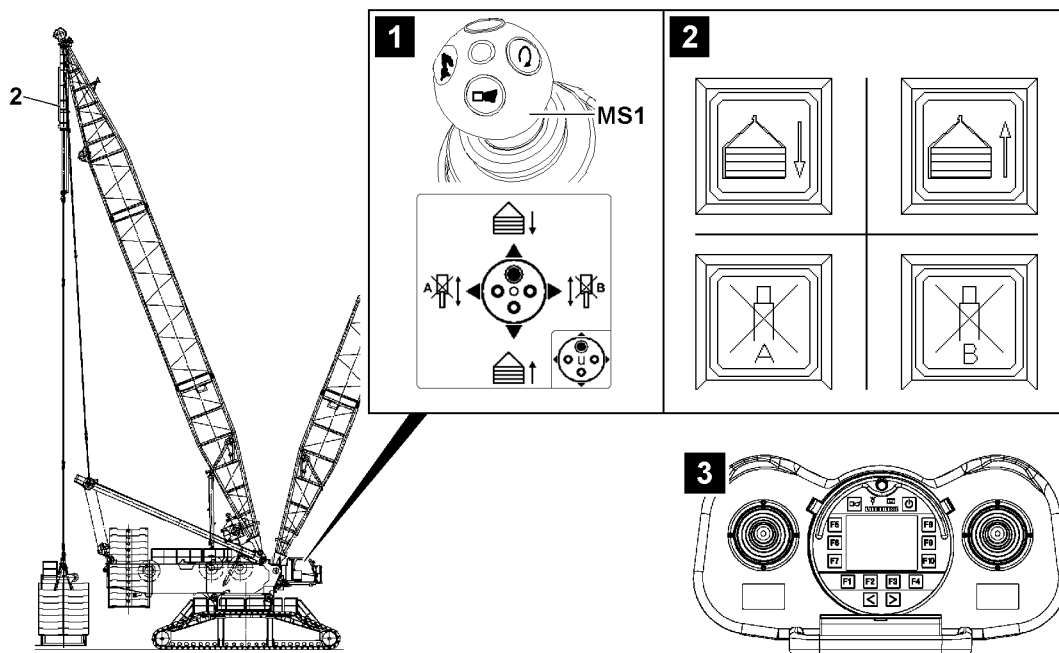

Fig.145937

The pull cylinders **2** in the derrick ballast guying can be operated in different ways:

- Operation with master switch **MS1** in the corresponding master switch assignment, see illustration 1
 - Select the master switch assignment for master switch MS1, see chapter 4.01.
- Operation with operating buttons on the instrument panel, see illustration 2

There is an additional operating option in assembly operation:

- Operation with the radio remote control (BTT-E), see illustration 3
 - Operation with the manual control lever in the corresponding assembly menu, see the radio remote control operating instructions.



Note

- ▶ If the derrick ballast is raised or lowered using the pull cylinder **2**, then the horizontal alignment of the derrick ballast is automatically regulated by both length sensors of the pull cylinder **2**.
- ▶ For a ballast utilization of **more than or equal to 90 percent**, the level sensor regulates the pull cylinder **2** to a difference of 1 cm.
- ▶ With a ballast utilization of **less than 90 percent**, the level sensor monitors the derrick ballast level to $\pm 2.5^\circ$. This makes it possible to set the derrick ballast down up to a ground slope of 2.5° .



DANGER

Danger of accident!

If the following notes are not observed, personnel can be severely injured or killed. In addition, this can result damage to the derrick ballast.

- ▶ Pay attention to the horizontal alignment of the derrick ballast when lifting and lowering the derrick ballast.
- ▶ When lifting and lowering the derrick ballast, check the forces in the D-guyings regularly on LICCON monitor 1. If the difference of forces between „derrick ballast guying A“ and „derrick ballast guying B“ is too large, an acoustic warning sounds and the values on the LICCON monitor 1 blink, see section „Differential force monitoring of Derrick ballast guying“.
- ▶ When adjusting manually (block pull cylinder A or pull cylinder B) the regulation is deactivated and the derrick ballast can be inclined within the limited angle range. This is exclusively permitted when setting down the derrick ballast on uneven ground and only by observing utmost caution.

**WARNING**

The crane can topple over!

If the suspended ballast is lifted off the ground past the **maximum permissible** 250 mm , then the crane can topple over to the rear if the load rips off.

Death, severe bodily injuries, property damage.

- ▶ Do not lift the suspended ballast by more than 250 mm off the ground.

During crane operation with derrick ballast the required maximum / minimum load can be actively influenced.

This is made possible by increasing or reducing the derrick ballast. Depending on the situation, this procedure is also possible under load.

**Note**

- ▶ The suspended ballast and the ballast trailer are generally referred to as the **derrick ballast**.
- ▶ The fixed compensation weight that is installed on the turntable is generally referred to as the **counterweight**.
- ▶ Additional personnel to carry out crane operation is generally referred to as **guide**.
- ▶ Operate the crane function to lift and lower the derrick ballast, see section „Carrying out crane movements“

Empty page!

LWE/LR 11000-001/23501-04-02/en

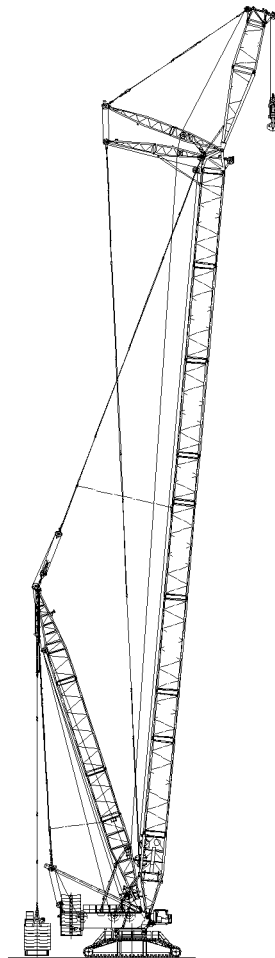
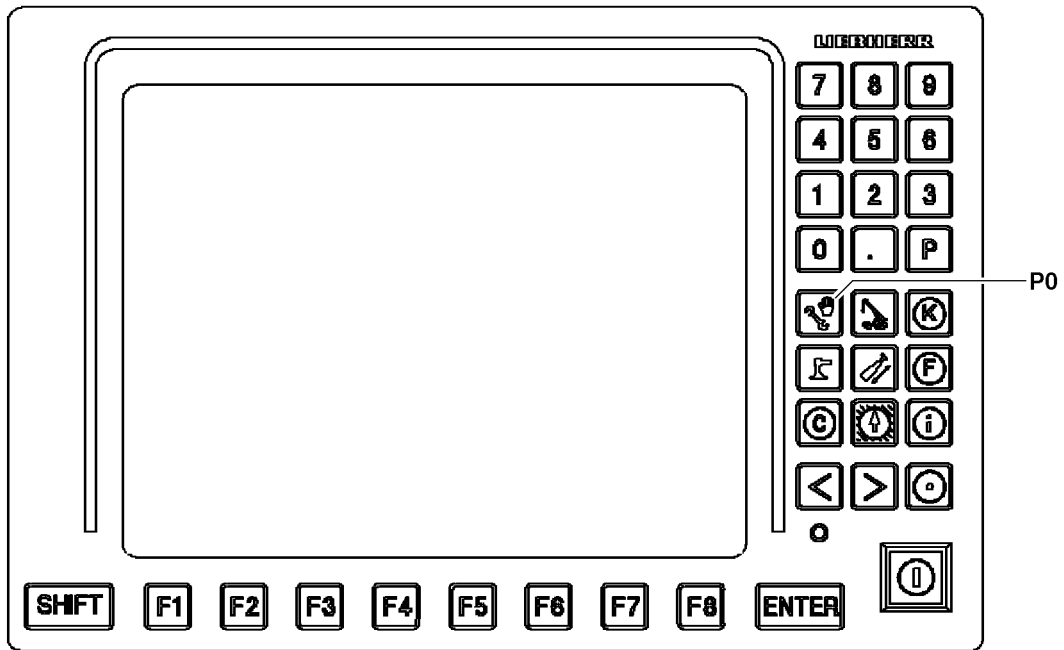

Fig.122800

LWE/LR 11000-001/23501-04-02/en

9.3 Checking the settings of the LICCON overload protection

Make sure that the following prerequisites are met:

- The derrick ballast is placed according to the load chart.
- The actual placed derrick ballast has been entered and confirmed in the Set up program, see Crane operating instructions, chapter 4.02.
- The derrick boom is in operating position.



WARNING

Incorrectly set overload protection!

If the actual set up configuration of the crane deviates from the entries and settings in the Set up program, then the overload protection is not correctly set.

An incorrectly set overload protection calculates the actual load incorrectly and transmits faulty display values.

The crane can be overloaded unnoticed and topple over.

This could result in serious accidents.

- ▶ The entries and settings in the set up program must match the actual set up configuration of the crane.
-



Note

- ▶ Set the LICCON overload protection in the set up program, see Crane operating instructions, chapter 4.02.
-

- ▶ Press the program key **P0**.

Result:

- The Set up program is called up.
- ▶ In the monitor display of the Set up program check if the LICCON overload protection is set according to the data in the load chart and the actual set up configuration of the crane, see example illustration.

LM

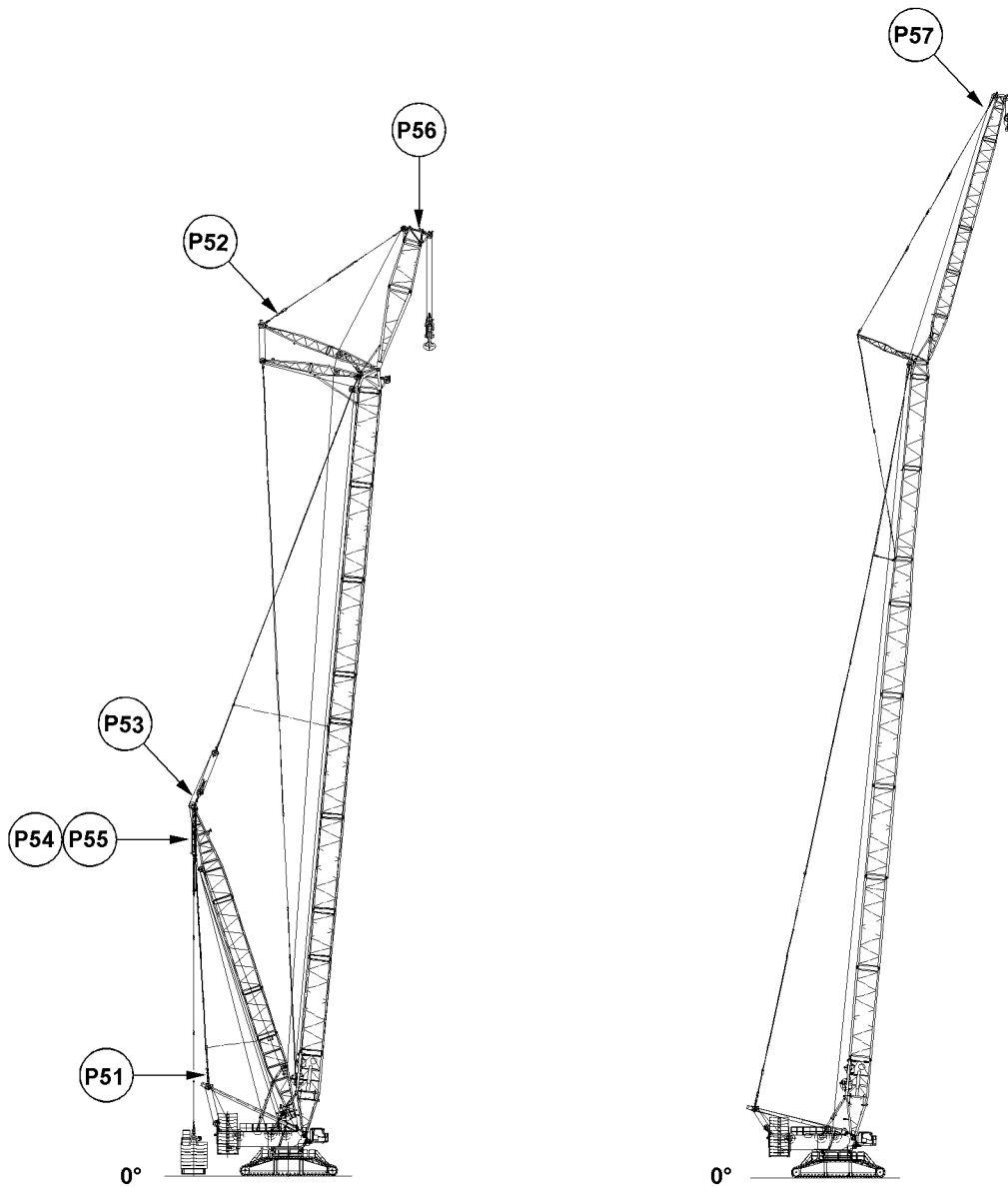
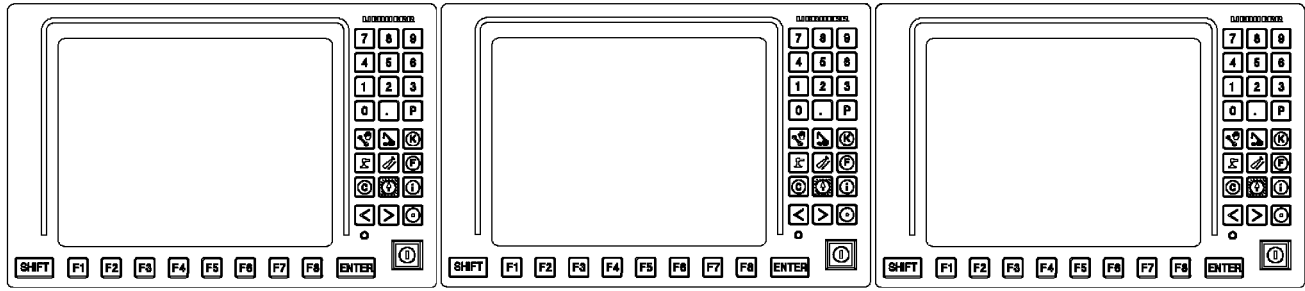

Fig.122806

LWE/LR 11000-001/23501-04-02/en

9.4 F-load display for operating modes with derrick ballast

Assignment of test points for operating modes with derrick ballast:

- Force in the guying between A-frame and derrick head:
 - Test point 1 on point **P51** = force F1
 - The display is made in the F-load display in the center LICCON monitor **LM**.
- Force in the guying between WA-frame and accessory head:
 - Test point 2 on point **P52** = force F2
 - The display is made in the F-load display in the center LICCON monitor **LM**.
Note: Only for the respective boom system.
- Force in the guying between the main boom head and the derrick head:
 - Test point 3 on point **P53** = force F3
 - The display is made in the F-load display in the center LICCON monitor **LM**.
- Force in the guying between derrick ballast and derrick head:
 - Test point 4/5 on point **P54/55** = force F4/5
 - The display is made in the display of the derrick ballast in the left LICCON monitor **LM**.
- Force on the pressure test bracket boom nose:
 - Test point 6 on point **P56** = force F6
 - The display is made in the actual load display in the right LICCON monitor **LM**.
Note: Only with existing boom nose.
- Force in the guying between the FA-frame and the accessory head:
 - Test point 11 on point **P57** = force 11
 - The display is made in the actual load display in the center LICCON monitor **LM**.
Note: Only for the respective boom system



Note

- ▶ For a detailed description of the displays for crane operation with derrick ballast, see the Crane operating instructions, chapter 4.02.



WARNING

Overloading / toppling of the crane!

If the permissible display values of the F-load display are exceeded / fallen below, then the crane can be overloaded.

This could result in serious accidents.

- ▶ Observe and adhere to the display values on the LICCON monitors.
- ▶ Observe and adhere to the specifications regarding the limit values on the assembly drawings.



Note

The values of the F-load display depend on the set up configuration of the crane and the crane geometry.

The values of the F-load display change continuously when the crane is moved.

- ▶ Monitor the F-load display continuously.

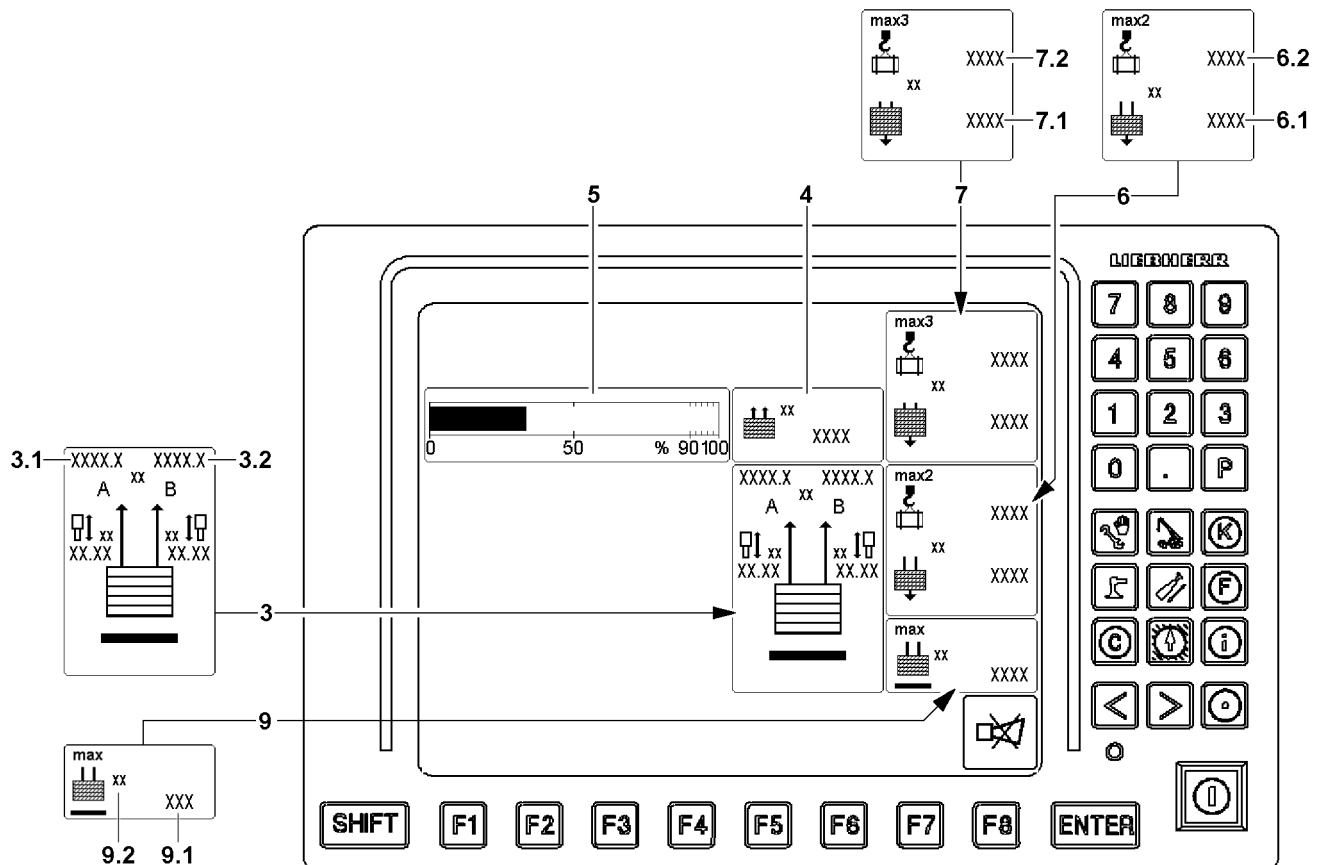
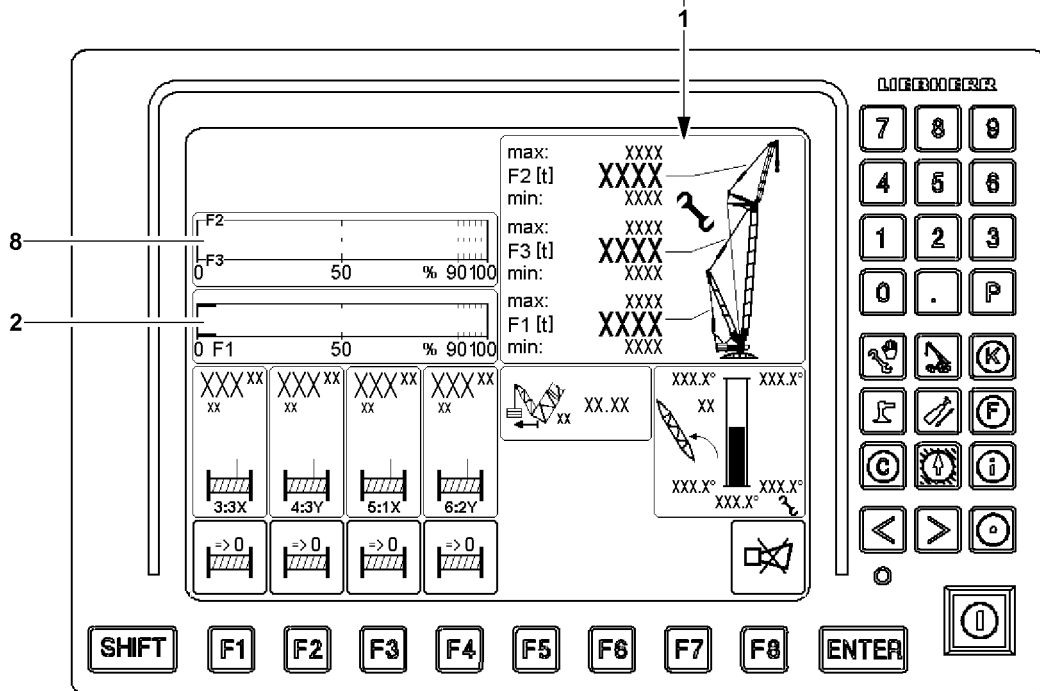
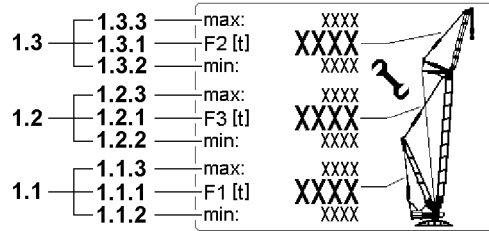

Fig.146968

LWE/LR 11000-001/23501-04-02/en

9.4.1 Force F1 (test point 1)

The force F1 (test point MS1) is determined in the guying between the A-frame and the derrick head and displayed in the LICCON monitor as operating force $F1_{\text{actual}}$.

Display values of force F1 (test point MS1) on the F-load display **1**:

- F1-maximum ($F1_{\text{max}}$) **1.1.3** = maximum value F1-force
- F1-actual value ($F1_{\text{actual}}$) **1.1.1** = actual value F1-force (operating force F1)
- F1-minimum ($F1_{\text{min}}$) **1.1.2** = minimum value F1-force

Structure of the F1-utilization bar **2**:

- Ratio of operating force $F1_{\text{actual}}$ to F1 maximum force

9.4.2 Force F2 (test point 2) and force F3 (test point 3)

The force F2 (test point 2) is determined between the WA-frame and the accessory head and displayed in the LICCON monitor as operating force $F2_{\text{actual}}$. A display is made only with the respective boom system.

The force F3 (test point 3) is determined between the main boom head and the derrick head and displayed in the LICCON monitor as operating force $F3_{\text{actual}}$.

Display values of force F2 (test point MS2) in the F-load display **1**:

- F2-maximum ($F2_{\text{max}}$) **1.3.3** = maximum value F2-force
- F2-actual value ($F2_{\text{actual}}$) **1.3.1** = actual value F2-force (operating force F2)
- F2-minimum ($F2_{\text{min}}$) **1.3.2** = minimum value F2-force

Display values of force F3 (test point MS3) in the F-load display **1**:

- F3-maximum ($F3_{\text{max}}$) **1.2.3** = maximum value F3-force
- F3-actual value ($F3_{\text{actual}}$) **1.2.1** = actual value F3-force (operating force F3)
- F3-minimum ($F3_{\text{min}}$) **1.2.2** = minimum value F3-force

Composition of the F2 / F3-utilization bar **8**:

- Ratio of operating force $F2_{\text{actual}}$ to F2 maximum force $F2_{\text{max}}$
- Ratio of operating force $F3_{\text{actual}}$ to F3 maximum force $F3_{\text{max}}$
- The F2/F3-utilization bars **8** appear only in assembly operation

In crane operation, the display values are displayed clearly for information. A special monitoring does not occur.

In assembly operation the display values are monitored. The limit values may not be exceeded.

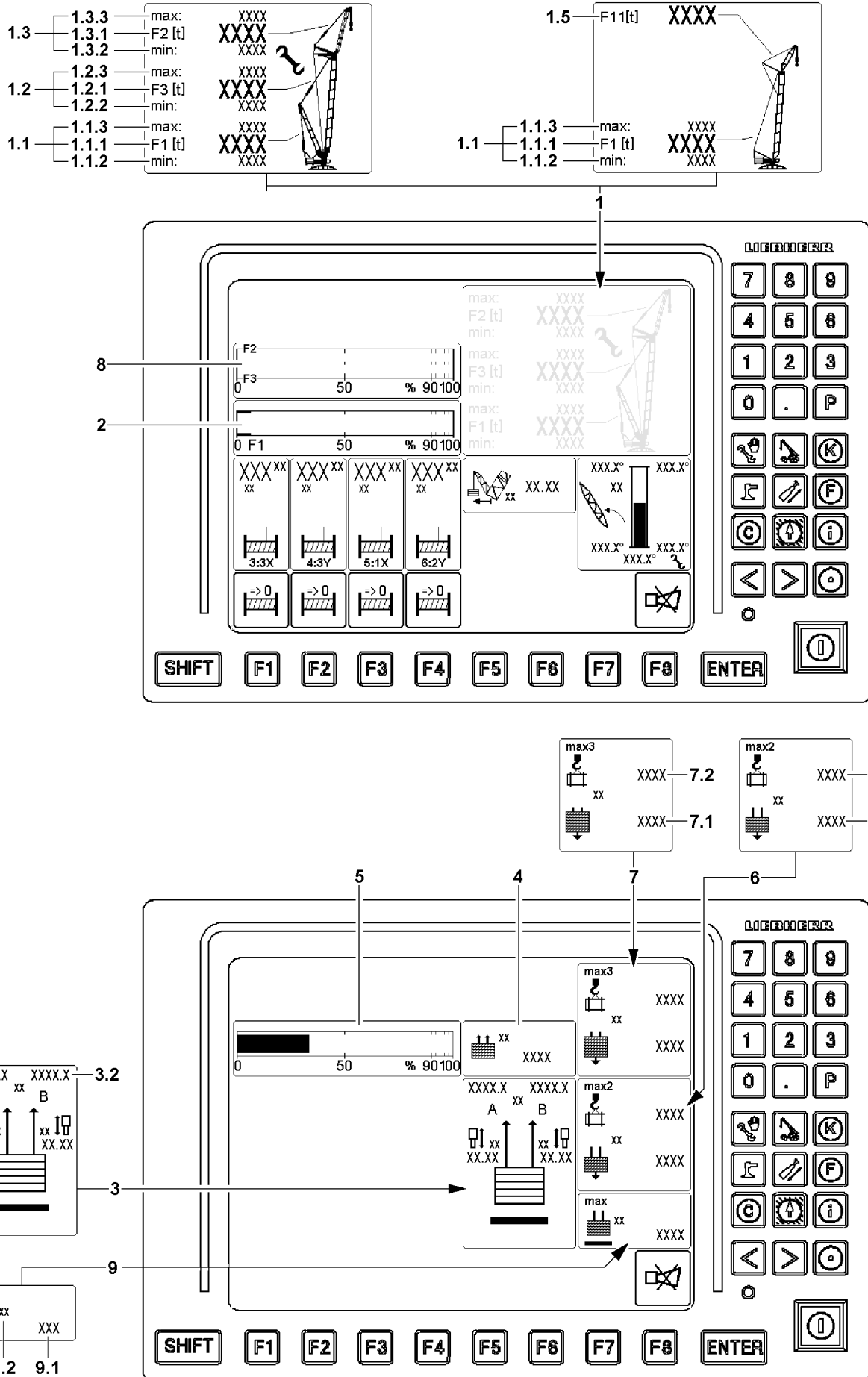

Fig.146967

LWE/LR 11000-001/23501-04-02/en

9.4.3 Force F4/5 (test point 4/5)

The forces F4/5 (test point 4/5) are effective in the guy rods from the derrick ballast to the derrick head.

The existing forces in the guy rods are calculated from four pressure sensors, which are installed on the pull cylinders.

Test points guying A (left) are:

- Test point 4A = pressure sensor ring surface left (force F4A)
- Test point 5A = pressure sensor piston surface left (force F5A)

Test points guying B (right) are:

- Test point 4B = pressure sensor ring surface right (force F4B)
- Test point 5B = pressure sensor piston surface right (force F5B)

Display values of force F4/5 (test point 4/5) in icon Guying derrick ballast **3**:

- Force in the derrick ballast guying A **3.1**
- Force in the derrick ballast guying B **3.2**

Display values derrick ballast:

- Currently pulled derrick ballast = BA_{pulled} **4**
- Current utilization of derrick ballast = Utilization bar derrick ballast **5**
- Currently placed derrick ballast = BA_{placed} **6.1**

From the sum of derrick ballast guying A **3.1** and derrick ballast guying B **3.2** is the pulled derrick ballast BA_{pulled} **4** calculated.

If the ballast still has ground contact, then only that part of the ballast is displayed which is pulled up by the D-guying. The remaining part is laying correspondingly on the ground.

Composition of utilization bar derrick ballast **5**:

- Ratio of pulled derrick ballast (BA_{pulled} **4**) to placed derrick ballast (BA_{placed} **6.1**)

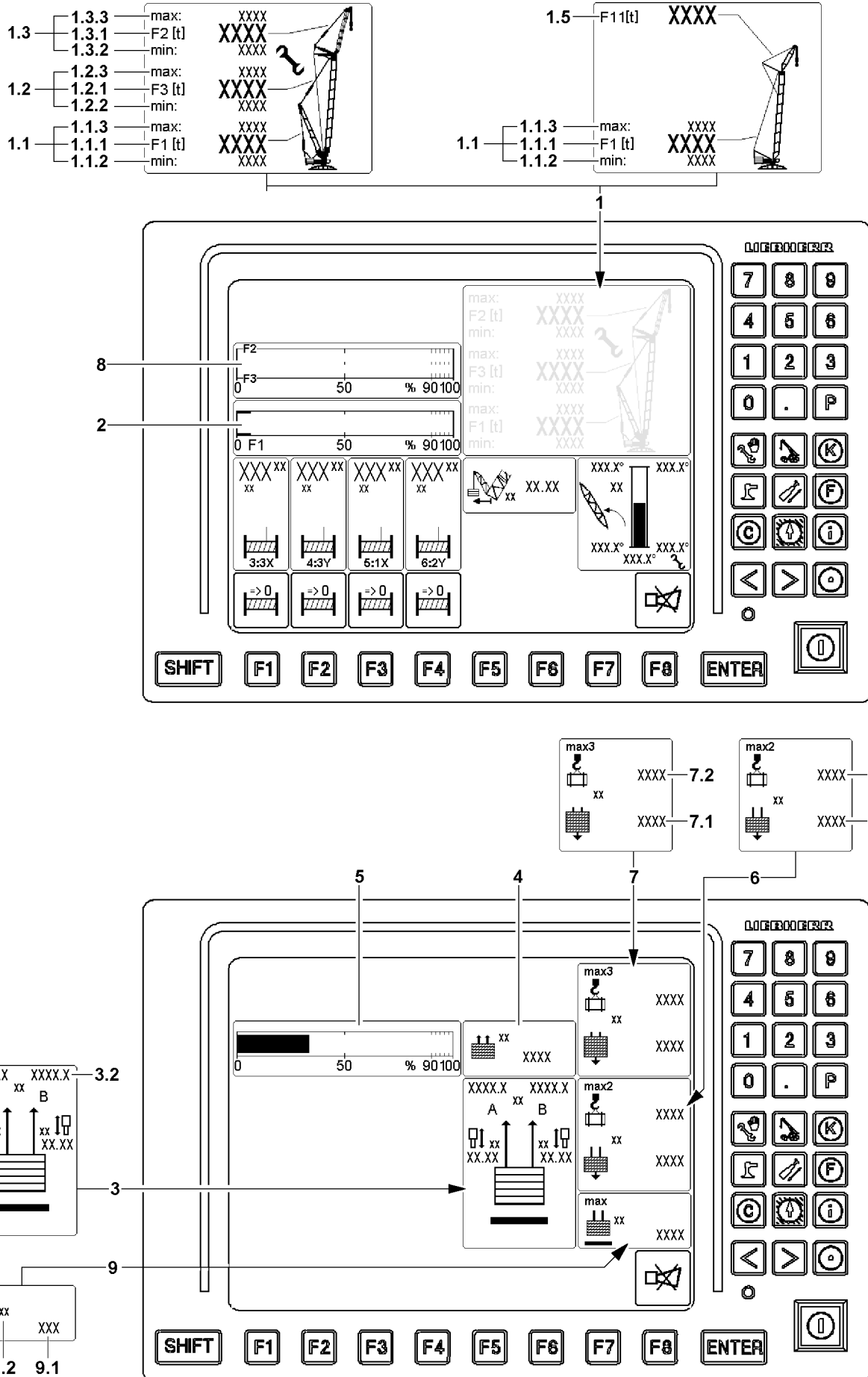

Fig.146967

LWE/LR 11000-001/23501-04-02/en

9.4.4 Maximum liftable derrick ballast

The *maximum liftable derrick ballast* **9** refers to the current crane condition and indicates the maximum derrick ballast that can be lifted off the ground with the pull cylinder or off the suspended ballast palette in case of the VarioTray without falling below the $F_{1_{\min}}$ force.

- **9** *Maximum liftable derrick ballast* icon
- **9.1** Maximum liftable derrick ballast
 - Maximum derrick ballast
- **9.2** Measuring unit
 - Measuring unit for display values in the *Pulled derrick ballast* icon **9**: [t] or [lb]

9.4.5 Force F11 (test point 11)

Force in the guying between the FA-frame and the accessory head:

Display values of force F11 (test point MS11) on the F-load display **1**:

- F11-actual value ($F_{11_{\text{actual}}}$) **1.5** = actual value F11-force (operating force F11)

9.4.6 Additional displays

- „Load max2“ icon **6** (see section „Utilization conditions“)
- Currently placed derrick ballast = BA_{placed} (Input value in set up program) **6.1**
- Possible load with currently placed derrick ballast = $Load_{\text{max2}}$ **6.2**
- „Load max3“ icon **7** (see section „Utilization conditions“)
- Maximum derrick ballast according to load chart = BA_{max} **7.1** (Highest value in Set up program)
- Possible load with maximum derrick ballast according to load chart = $Load_{\text{max3}}$ **7.2**

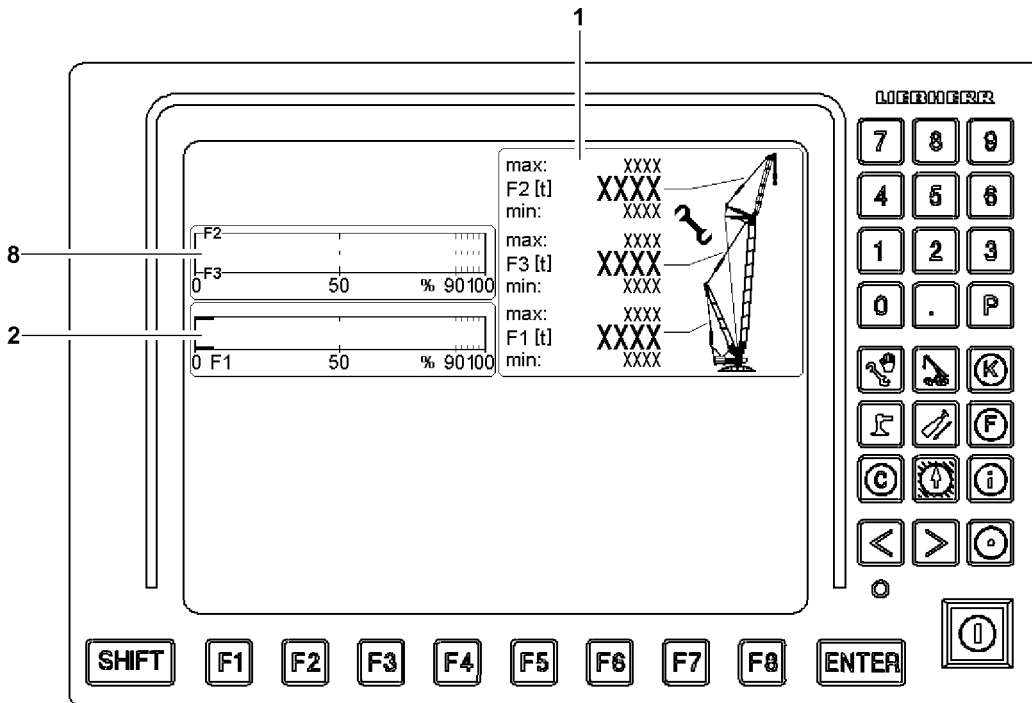
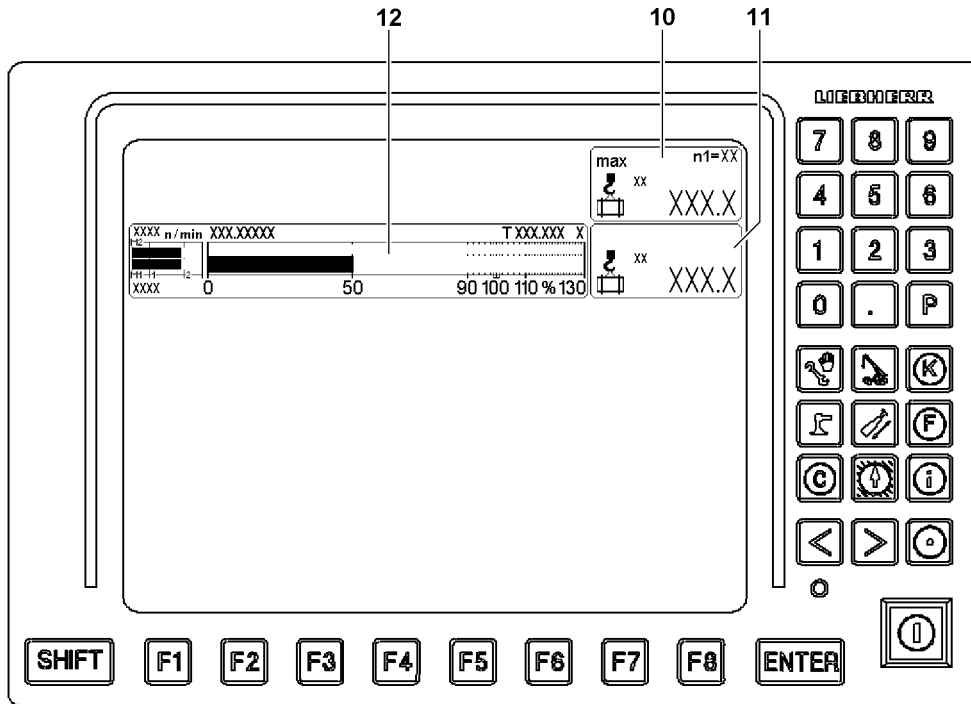

Fig.122808

9.5 Monitoring of crane utilization in operating modes with derrick ballast



Note

- ▶ The icon illustrations of the LICCON monitors are examples and may not match your crane.
- ▶ The icon illustrations of the LICCON monitors can deviate in number, arrangement and depiction of the icons on your crane.
- ▶ Observe the Crane operating instructions, chapter 4.02.



WARNING

Incorrect display values!

If the display values do not increase correspondingly when lifting known weights, an erroneous display value may be present.

If the crane is operated with erroneous display values, then the crane can be overloaded.

This could result in serious accidents.

- ▶ When lifting the hook block off the ground check if the display value for the actual load increases correspondingly.
- ▶ When lifting the derrick ballast off the ground check if the display value for the pulled derrick ballast (BA_{pulled}) increases correspondingly.
- ▶ When lifting the load off the ground check if the display value for the actual load increases correspondingly.

In operating modes with derrick ballast, the monitoring of the crane utilization includes, among others:

1. Monitoring of load torque
Via the „Maximum load“ icon **10**, „Actual load“ icon **11** and the „utilization bar diagram“ **12**.
2. Utilization conditions
Support the crane driver with additional display values.
3. Monitor the F-load display **1**.
Supported by the F1-utilization bar **2** and possibly the F2/F3-utilization bar **8**.

9.5.1 Monitoring of load torque

It monitors the „maximum load according to the load chart and reeving“.

In crane operation, the actual load is compared with the maximum load which may be lifted in the current crane configuration. The display of the values is made in the icon „Maximum load“ **10** and in icon „actual load“ **11**. The current percentage utilization is displayed as „bar diagram utilization“ **12** in the right LICCON monitor.

The color of the utilization bar in the „bar diagram utilization“ **12** also displays the crane utilization:

- Utilization bar blue / green (below 90 %): Utilization in permissible range
- Utilization bar yellow (90 % to 100 %): Advance warning. - Utilization just before impermissible range
- Utilization bar red (above 100 %): Warning. - Utilization in impermissible range



Note

- ▶ Procedure for optimum utilization of „maximum load according to load chart and reeving“, see section „Utilization conditions“.



Fig.122809

LWE/LR 11000-001/23501-04-02/en

**WARNING**

Access the functionality of the LICCON overload protection!

When accessing the functionality of the LICCON overload protection by activating assembly operation, the LICCON overload protection is totally deactivated, bypassed or limited.

It is possible to exceed several shut-off limits of the LICCON overload protection simultaneously or one after the other.

It is possible to carry out crane movements, which are not monitored by the LICCON overload protection.

Without the LICCON overload protection, no additional protection against overload of the crane via the crane control is present.

This could result in serious accidents.

- ▶ When accessing the functionality of the LICCON overload protection, take into account that the LICCON overload protection is deactivated totally or is limited.
- ▶ When accessing the functionality of the LICCON overload protection, the Crane operating instructions, chapter 4.02 must be observed.

**WARNING**

The crane can topple over!

In assembly operation the LICCON overload protection is deactivated.

In the event of deliberate improper use, the crane could collapse, the boom can break off or the crane can topple over.

Personnel can be killed.

This could result in high property damage.

- ▶ Activate the assembly operation only when the consequences are known.
- ▶ Enter the set up configuration correctly into the LICCON computer system.
- ▶ Observe the erection / take down charts.
- ▶ Crane operation with deactivated LICCON overload protection is prohibited.
- ▶ In assembly operation only load torque reducing crane movements may be carried out until a permissible operating and load range.
- ▶ The crane operator carries complete and sole responsibility for his actions if the LICCON overload protection is deactivated.

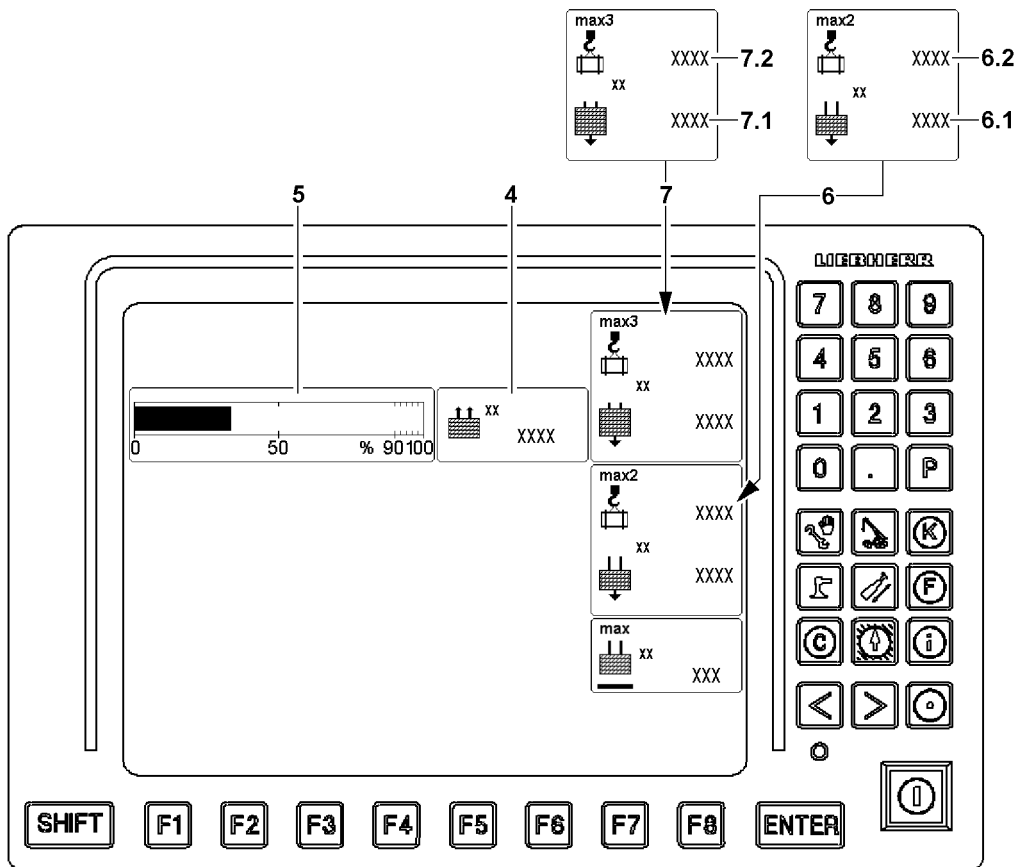
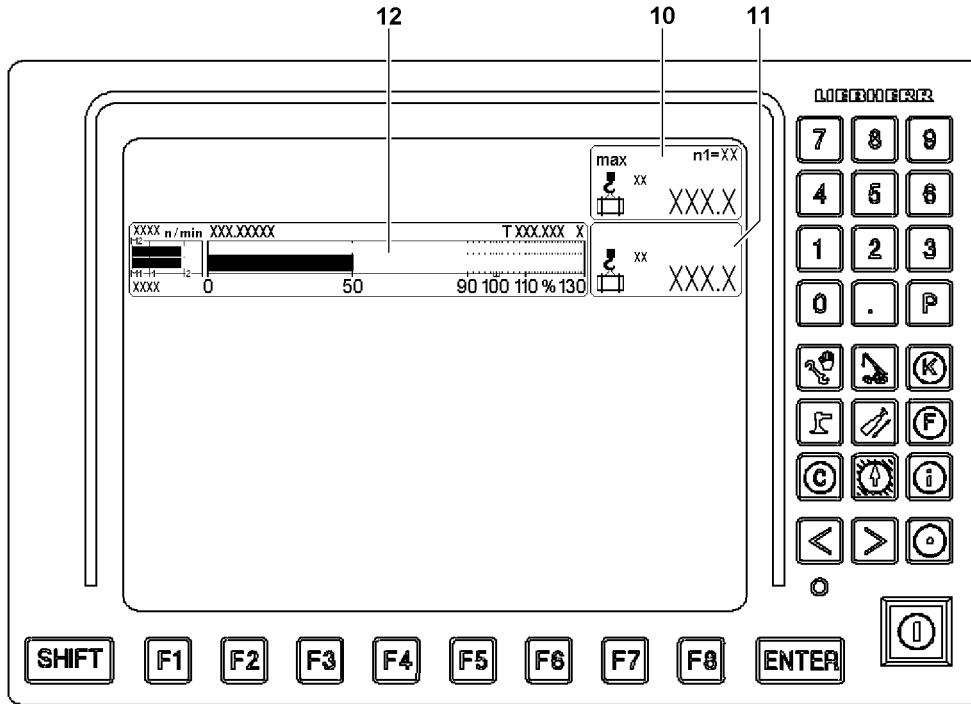

Fig.146966

LWE/LR 11000-001/23501-04-02/en

9.5.2 Utilization conditions

The current percentage utilization of the crane is displayed as „bar diagram utilization“ **10** in the right LICCON monitor.

Additional displays:

- **6** „Load max2“ icon
 - Currently placed derrick ballast = BA_{placed} (Input value in set up program) **6.1**
 - Possible load with currently placed derrick ballast = $\text{Load}_{\text{max2}}$ **6.2**
- **7** „Load max3“ icon
 - Maximum derrick ballast according to load chart = BA_{max} **7.1** (Highest value in Set up program)
 - Possible load with maximum derrick ballast according to load chart = $\text{Load}_{\text{max3}}$ **7.2**

Maximum load, right LICCON monitor:

- The maximum load in the current operating condition is reached when the utilization bar shows 100 % in the „bar diagram utilization“ **12**. This is the case when the „utilization of the crane according to the load chart and reeving“ reaches 100 % (Values in icon „Maximum load“ **10** and in icon „actual“ **11** are equal). When the „Maximum load“ **10** is smaller or the same as the load $\text{load}_{\text{max2}}$ **6.2**, then an increase might possibly be obtained:
 - By increasing the pulled derrick ballast BA_{pulled} **4**, if the utilization bar derrick ballast **5** is not yet at 100 % (derrick ballast not suspended).
 - By increasing the derrick ballast when the BA_{placed} **6.1** is smaller than BA_{max} **7.1**.
 - By changing the derrick ballast radius within the permissible range, see load chart manual or LICCON job planner.

max2-load, icon „load max2“ **6**:

- The highest possible load in current operating condition „**max2-load**“ is reached when in the „bar diagram utilization“ **12** 100 % is shown **and** the utilization bar derrick ballast **5** is at 100 % (Derrick ballast is completely lifted off the ground). This is the case when the value in icon „Actual load“ **11** is the same as the load $\text{load}_{\text{max2}}$ **6.2**. When the load $\text{load}_{\text{max2}}$ **6.2** is smaller or the same as the load $\text{load}_{\text{max3}}$ **7.2**, then an increase might possibly be obtained:
 - By increasing the derrick ballast by loading additional ballast plates (increase BA_{placed} **6.1** to BA_{max} **7.1**).

max3-load, icon „load max3“ **7**:

- The highest possible load at the maximum derrick ballast in current operating condition „**max3-load**“ is reached when the „bar diagram utilization“ **12** displays 100 % **and** the utilization bar derrick ballast **5** is at 100 % (Derrick ballast according to load chart is placed and is completely lifted off the ground). This is the case when the value in icon „Actual load“ **11** is the same as the load $\text{load}_{\text{max3}}$ **7.2**.
- The maximum derrick ballast according to the load chart is placed and completely pulled. Further increase of the derrick ballast is impermissible.



Fig.122809

LWE/LR 11000-001/23501-04-02/en

9.5.3 Monitoring of F1-maximum force

Display values of force F1 (test point MS1) on the F-load display 1:

- F1-maximum ($F1_{\max}$) **1.1.3** = maximum value F1-force
- F1-actual value ($F1_{\text{actual}}$) **1.1.1** = actual value F1-force (operating force F1)
- F1-minimum ($F1_{\min}$) **1.1.2** = minimum value F1-force

The display values of force F1 (test point 1) are displayed permanently in the LICCON monitor. At F1-actual value ($F1_{\text{actual}}$) **1.1.1** larger F1-maximum ($F1_{\max}$) **1.1.3** a shut off of all load moment increasing movements occurs.



WARNING

Access the functionality of the LICCON overload protection!

When accessing the functionality of the LICCON overload protection by activating assembly operation, the LICCON overload protection is totally deactivated, bypassed or limited.

It is possible to exceed several shut-off limits of the LICCON overload protection simultaneously or one after the other.

It is possible to carry out crane movements, which are not monitored by the LICCON overload protection.

Without the LICCON overload protection, no additional protection against overload of the crane via the crane control is present.

This could result in serious accidents.

- ▶ When accessing the functionality of the LICCON overload protection, take into account that the LICCON overload protection is deactivated totally or is limited.
- ▶ When accessing the functionality of the LICCON overload protection, the Crane operating instructions, chapter 4.02 must be observed.



Note

The limit value for the F1-maximum force depends not only on the set up configuration and the crane geometry, but also from the pulled derrick ballast.

- ▶ If the pulled derrick ballast is larger, then the limit value for the F1-minimum force is generally reduced.
- ▶ If the pulled derrick ballast is smaller, then the limit value for the F1-maximum force is generally increased.



Note

By engaging the assembly operation the limit value for the F1-maximum force can be exceeded by a few tons. This makes it possible to reset a crane movement, which has caused the shut off.

- ▶ Reset triggered shut off by reverse crane movement.



Fig.122809

LWE/LR 11000-001/23501-04-02/en

9.5.4 Monitoring of F1-minimum force

Display values of force F1 (test point MS1) on the F-load display 1:

- F1-maximum ($F1_{\max}$) **1.1.3** = maximum value F1-force
- F1-actual value ($F1_{\text{actual}}$) **1.1.1** = actual value F1-force (operating force F1)
- F1-minimum ($F1_{\min}$) **1.1.2** = minimum value F1-force



WARNING

Uncontrolled movements of the boom system!

If the guying between the A-frame and the derrick head (test point 1) becomes powerless, then this can lead to uncontrollable movements of the boom system.

This could result in serious accidents.

- ▶ The guying between the A-frame and the derrick head (test point 1) may never be without power.
- ▶ Relieve the D-guying between the derrick head and the derrick ballast to the point where the F1-actual value ($F1_{\text{actual}}$) **1.1.1** is larger than the F1-minimum ($F1_{\min}$) **1.1.2**.



WARNING

Access the functionality of the LICCON overload protection!

When accessing the functionality of the LICCON overload protection by activating assembly operation, the LICCON overload protection is totally deactivated, bypassed or limited.

It is possible to exceed several shut-off limits of the LICCON overload protection simultaneously or one after the other.

It is possible to carry out crane movements, which are not monitored by the LICCON overload protection.

Without the LICCON overload protection, no additional protection against overload of the crane via the crane control is present.

This could result in serious accidents.

- ▶ When accessing the functionality of the LICCON overload protection, take into account that the LICCON overload protection is deactivated totally or is limited.
- ▶ When accessing the functionality of the LICCON overload protection, the Crane operating instructions, chapter 4.02 must be observed.



Note

By engaging the assembly operation the limit value for the F1-minimum force can be fallen below by a few tons. This makes it possible to reset a crane movement, which has caused the shut off.

- ▶ Reset triggered shut off by reverse crane movement.



Fig.122809

**WARNING**

Autonomous movement of the boom system at increase of load torque!

If the F1-minimum force is fallen below, the guying between the A-frame and the derrick head can become powerless.

If the guying between the A-frame and the derrick head is powerless and the „Derrick ballast is on the ground“ at the same the derrick ballast can suddenly lift off the ground due to increase of the load torque.

As a result, the boom system can move forward suddenly. Strong oscillating movements of the derrick ballast and load can be the result.

The crane can be overloaded and severe accidents can be the result.

- ▶ Hold the F1-actual value ($F1_{\text{actual}}$) **1.1.1** above the F1-minimum ($F1_{\text{min}}$) **1.1.2**.
- ▶ It is prohibited to fall below the F1-minimum force.

**WARNING**

Autonomous movement of the boom system at decrease of load torque!

If the F1-minimum force is fallen below, the guying between the A-frame and the derrick head can become powerless.

If the guying between the A-frame and the derrick head is powerless and the „derrick ballast is suspended“ at the same time, the derrick ballast can suddenly set down on the ground due to decrease of the load torque.

As a result, the boom system can move suddenly backward. As a result, the relapse cylinders can be pressed on the block, be overloaded and damaged. Strong oscillating movements of the derrick ballast and load can be the result.

The crane can be overloaded and severe accidents can be the result.

- ▶ Hold the F1-actual value ($F1_{\text{actual}}$) **1.1.1** above the F1-minimum ($F1_{\text{min}}$) **1.1.2**.
- ▶ It is prohibited to fall below the F1-minimum force ($F1_{\text{min}}$).

The following applies:

- After a shut off due to falling below the F1-minimum ($F1_{\text{min}}$) **1.1.2** the F1-actual value ($F1_{\text{actual}}$) **1.1.1** must be increased by a crane movement. If the derrick ballast is suspended, this can be achieved by setting down the ballast.
- When picking up the load, the D-guying between the derrick ballast and the derrick head must be relieved to the point where the F1-actual value ($F1_{\text{actual}}$) **1.1.1** is greater than the F1-minimum ($F1_{\text{min}}$) **1.1.2**.
- When increasing the load torque, and the limit value F1-minimum ($F1_{\text{min}}$) **1.1.2** is fallen below, an already set down derrick ballast can lose contact with the ground and lift off.
- When decreasing the load torque, and the limit value F1-minimum ($F1_{\text{min}}$) **1.1.2** is fallen below, an already „suspended derrick ballast“ can set down on the ground.
- If the assembly operation is activated and the F1-force continues to drop below the minimum force $F1_{\text{min}}$, then the $F1_{\text{min}}$ shut off can no longer be bypassed.

Limitations from 50 % pulled derrick ballast

If more than 50 % of the set derrick ballast is being pulled (utilization bar derrick ballast **5** larger than 50 %) and the F1-minimum ($F1_{\text{min}}$) **1.1.2** is fallen below at the same time, all crane movements that increase load torque are turned off.

Limitations from 90 % pulled derrick ballast

If more than 90 % of the set derrick ballast is being pulled (utilization bar derrick ballast **5** larger than 90 %) and the F1-minimum ($F1_{\text{min}}$) **1.1.2** is fallen below at the same time, all crane movements that increase load torque and all crane movements that decrease load torque are turned off. This also turns off the „spooling out“ movement of the winch.

9.6 Monitoring of pull cylinders on block position

The pull cylinders (also called ballast lift cylinders) of the derrick ballast are equipped with length sensors and limit switches for monitoring.

In crane operation, the monitoring of the pull cylinders on block position is always active. If there is the danger of a block position, then only that direction of the pull cylinders can be moved which improves the condition. The other direction is unbyypassably blocked. As long as the length sensors and the limit switches function correctly, the pull cylinders cannot get into a block position.



WARNING

Problem at monitoring of pull cylinders!

If the length sensors or limit switches are defective or missing, then the monitoring of the pull cylinders is not active.

Without monitoring, the pull cylinders can be moved without restriction, as a result, a block position is possible.

At a block position, the pressure measurements of the pull cylinders become inexact and the values are incorrectly calculated.

The overload protection calculates the actual load incorrectly and transmits faulty display values.

The crane can be overloaded and topple over.

This could result in serious accidents.

- ▶ Observe the display values and possible error messages.
- ▶ If length sensors or limit switches are defective or missing, monitor the pull cylinders manually.

The following applies:

- The display values of the pull cylinders must function and be plausible.

9.7 Monitoring the lateral incline of the ballast pallet

The ballast pallet is equipped with an incline sensor for monitoring.

The monitoring to $\pm 2.5^\circ$ lateral incline of the ballast pallet is always active. If a lateral incline of $\pm 2.5^\circ$ is reached, then only those directions of the pull cylinders can be moved which improve the condition. The other directions are unbyypassably blocked. The ballast can be set down for that reason only to a maximum incline of the terrain of 2.5° .



WARNING

Defective incline sensor!

If an incline sensor is defective or missing, the monitoring of the lateral incline of the suspended ballast is not active.

The pull cylinders can be moved without restriction and the derrick ballast can be overturned as a result.

This could result in serious accidents.

- ▶ Observe the display values and possible error messages.
- ▶ If an incline sensor is defective, monitor the lateral incline of the derrick ballast manually.

The following applies:

- The display values of the lateral incline of the derrick ballast must function and be plausible.

9.8 Differential force monitoring for derrick ballast-guying

In operating modes with derrick ballast the forces of the derrick ballast guyings A and B are displayed in the LICCON monitor.



WARNING

Danger of accident!

If the forces in the derrick ballast guyings A and B are too high, then this can lead to an overload of the crane. Components can fail and severe accidents can be the result.

- ▶ Load the derrick ballast guyings A and B evenly.

After reaching the specified limit value of the difference force threshold, the displays of the pulled ballast of pull cylinder A and B blink and become red, the function ballast up / down is stopped. The difference force must be lowered again.

If the difference of the forces of the derrick ballast guying A and B exceeds the limit value, then this can have various causes:

- Flexing of the turntable.
- The ground under the derrick ballast is uneven.
- The crane is leaning to one side.
- The derrick ballast is loaded one-sided.
- The force measurement in one D-guying is incorrect.

The crane driver must recognize the correct cause and take countermeasures:

- The error, which caused the one-sided force, must be remedied.
- If the sensor values are implausible: Stop crane operation and find the cause and remedy it.

9.8.1 Bypassing the shut off of the function ballast up / down

- The following measures are permitted providing the ground is only slightly uneven: Control the individual pull cylinders in such a way that the difference between the forces becomes smaller. Ensure that the derrick ballast is not tilted at an inadmissible angle with respect to the crane, otherwise the derrick ballast guide and attachments will be damaged.
- ▶ Carry out the following: Activate assembly operation, see Crane operating instructions, chapter 4.02.

Result:

- The shut off of the function ballast up / down is bypassed.
- On the left LICCON monitor appears an assembly icon.
- ▶ Press the button Ballast „up“ or button Ballast „down“ **and** the stop button on the desired side at the same time, see section „Lifting / setting down / equalizing the derrick ballast“.

Problem remedy

The display of the entire pulled ballast is shown blinking red. An LMB-Stop was triggered. All crane functions were stopped.

The crane driver has moved the pull cylinders into the incorrect direction and further exceeded the limit value for the difference force threshold.

- ▶ Move the pull cylinders again into the correct (other) direction and align the ballast in such a way that the displays of the pulled ballast of pull cylinder A and B are again in the permissible range.

- ▶ Activate assembly operation again.

Result:

- The shut off of the function ballast up / down is bypassed again.
- All other crane functions are still suppressed.
- ▶ Move the pull cylinders into the correct direction.



DANGER

Overload of crane!

If the pull cylinders are moved into the incorrect direction after a new bypass of the function ballast up / down, the crane will be overloaded.

This could result in serious accidents.

- ▶ Monitor the display values and move the pull cylinders in the correct direction (values of pull cylinder A and B become closer).
 - ▶ If unsure: Contact Liebherr Service.
 - ▶ Find the error and remedy it which caused the shut off of the function „Ballast up / down“.
-

9.9 Carrying out crane movements



Note

- ▶ For an overview of the displays in the LICCON monitors, see Crane operating instructions, chapter 4.02.



WARNING

Incorrect display values!

If the display values do not increase correspondingly when lifting known weights, an erroneous display value may be present.

If the crane is operated with erroneous display values, then the crane can be overloaded.

This could result in serious accidents.

- ▶ When lifting the hook block off the ground check if the display value for the actual load increases correspondingly.
- ▶ When lifting the derrick ballast off the ground check if the display value for the pulled derrick ballast BA_{pulled} increases correspondingly.
- ▶ When lifting the load off the ground check if the display value for the actual load increases correspondingly.



WARNING

The crane can topple over!

The jerky execution or braking of turning maneuvers can cause the load and / or suspended ballast to swing.

If the load and / or the suspended ballast collides with obstacles then the crane can be damaged or impeded.

Oscillating movements, damage or impediments can cause the crane to topple over.

This could result in serious accidents.

- ▶ Initiate or slow down crane movements with load and / or suspended derrick ballast extremely sensitively.
- ▶ There may be no persons and / or objects within the working range / danger zone of the crane.
- ▶ During crane operation additional personnel (guide) must monitor and secure the working range / danger zone of the crane from a safe position.



WARNING

Danger of accident due to unsafe ground!

If the crane is operated on insufficient ground, there is a danger of accident.

- ▶ The ground in the entire working area of the crane must be level and of sufficient load carrying capacity, in order to be able to securely accept the encountered surface pressures.
- ▶ Before setting down the load or the derrick ballast, the crane operator must make sure that the intended placement surface is suitable. A safe set down of load and derrick ballast must be ensured.



WARNING

Uncontrolled movements of the boom system!

If the guying between the A-frame and the derrick head (test point 1) becomes powerless, then this can lead to uncontrolled movements of the boom system.

This could result in serious accidents.

- ▶ The guying between the A-frame and the derrick head (test point 1) may never be without power.

**WARNING**

Danger of accidents due to angular pull!

Due to angular pull of load or derrick ballast impermissible side forces are directed into the crane. Impermissible side forces can cause failure of the components or a dangerous change of the center of gravity of the crane and / or load, among others.

Crane and load can be severely damaged and topple over.

This could result in serious accidents.

- ▶ Before taking on a load or the derrick ballast, make sure that the derrick ballast, the center of rotation of the turntable and the load are on one line.

**WARNING**

The crane can topple over!

If the derrick ballast is lifted by more than 0.25 m above the ground, then the crane can fall over to the rear if the load rips off.

- ▶ Do not lift derrick ballast more than 0.25 m from the ground.

Make sure that the following prerequisites are met:

- The test points must be checked before crane operation for functionality.
- The weight of the load to be lifted must be known.
- The support surface / placement surface of the derrick ballast may be maximum 0.25 m above / below the support surface of the crane.
- The support surface / placement surface of the derrick ballast must be level, horizontal and of sufficient load bearing capacity.
- The support surface / placement surface of the derrick ballast must be able to safely absorb the surface pressure.
- There may not be any obstacles in the slewing range of the crane, derrick ballast and load.
- Additional personnel is instructed to monitor and secure the working range / danger zone of the crane from a safe distance.
- A permanent acoustic / visual connection between the crane operator and the additional personnel is available.
- A guide or the crane driver must monitor the lifting and setting down of the derrick ballast and the load.
- The lifted derrick ballast is monitored by a guide or the crane operator.

The following applies:

- When taking up the load, the D-guying between the derrick ballast and the derrick head must be relieved so that the operating force $F_{1_{actual}}$ is larger than the limit value for the F1-minimum force.
- Before taking up the load or the derrick ballast, make sure that the following components are on one line:
 - the load
 - the center of rotation of the turntable
 - the derrick ballast

9.9.1 Lifting / setting down the derrick ballast



WARNING

Danger of accident!

The placement surface for the ballast pallet must be level, horizontal and of sufficient load bearing capacity, otherwise the ballast pallet can tip over.

This could result in serious accidents.

- ▶ Check the incline of the crane during the set down procedure.
- ▶ Check the incline of the ballast pallet with the incline display **3.5**.
- ▶ Monitor the difference forces (derrick ballast guying A **3.1** to derrick ballast guying B **3.2**).
- ▶ It is strictly prohibited for anyone to stand under the ballast pallet or within the entire danger zone during the set down procedure.

The lifting and set down of the derrick ballast is monitored by the LICCON computer system. Normally the crane operator does not have to do anything. However, if corrective measures or preventative measures should be necessary, observe the following section „Equalizing the derrick ballast“.

Lifting the derrick ballast

- ▶ Lift the derrick ballast: Press the button **727**.
or
Deflect the master switch **MS1** in direction **Y-**.

Result:

- The piston rods of the pull cylinders retract together.
- The derrick ballast is raised.
- The ballast pallet loses all ground contact:
The ground contact switches are no longer actuated, the „Derrick ballast lifted off“ icon **3.4** appears.
The „turning the turntable“ and „driving the crawler“ crane movements are released.

Lowering the derrick ballast

- ▶ Lower the derrick ballast: Press the button **726**.
or
Deflect the master switch **MS1** in direction **Y+**.

Result:

- The piston rods of the pull cylinders extend together.
- The derrick ballast is countersunk
- When the ballast pallet touches the ground:
The ground contact switches are actuated, the „Derrick ballast has ground contact“ icon **3.3** appears.
The „turning the turntable“ and „driving the crawler“ crane movements are blocked.

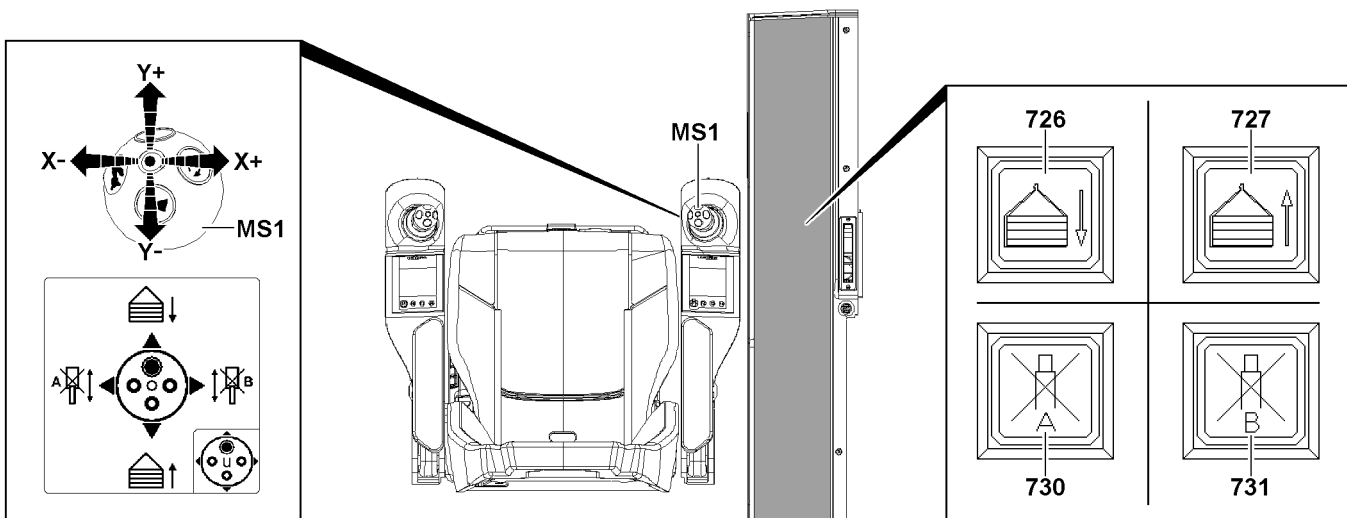
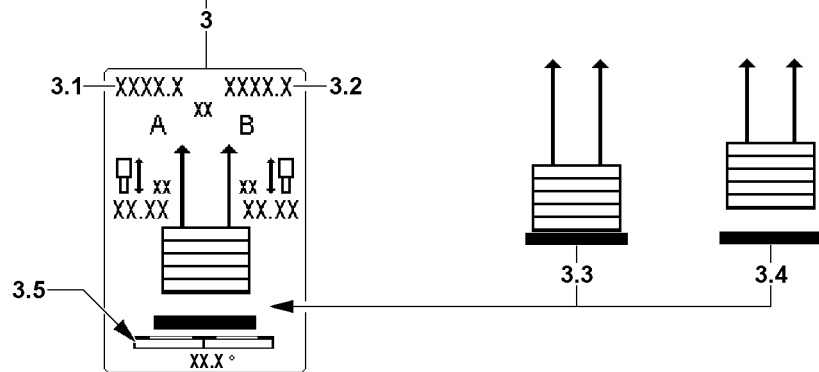
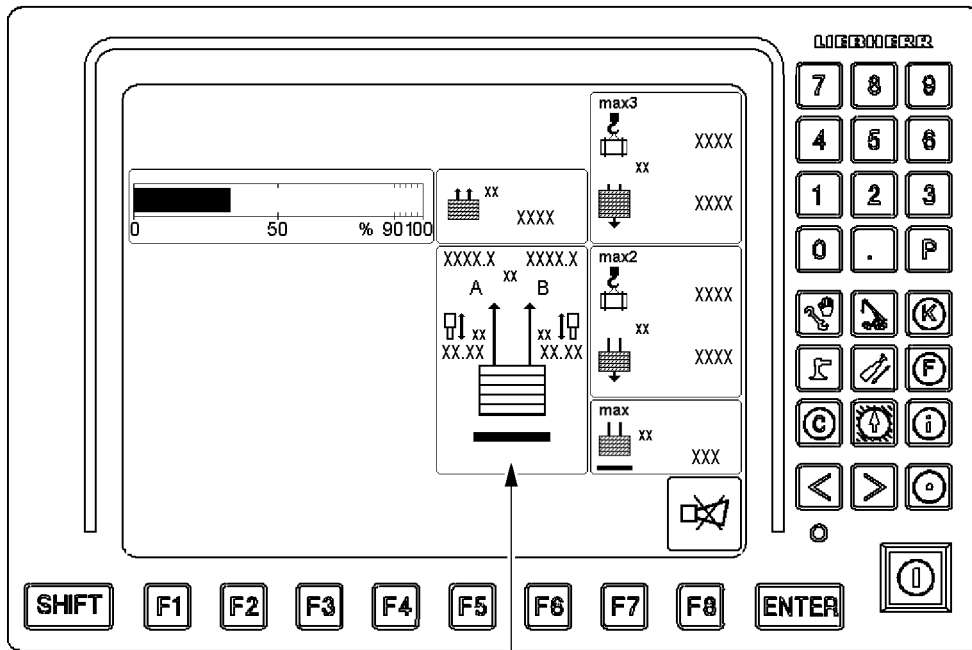

Fig.146965

LWE/LR 11000-001/23501-04-02/en

9.9.2 Equalizing the derrick ballast



WARNING

Danger of accident!

The placement surface for the ballast pallet must be level, horizontal and of sufficient load bearing capacity, otherwise the ballast pallet can tip over.

This could result in serious accidents.

- ▶ Check the incline of the crane during the set down procedure.
- ▶ Check the incline of the ballast pallet with the incline display **3.5**.
- ▶ Monitor the difference forces (derrick ballast guying A **3.1** to derrick ballast guying B **3.2**).
- ▶ It is strictly prohibited for anyone to stand under the ballast pallet or within the entire danger zone during the set down procedure.

If a limit value in the difference force monitoring (Ratio of derrick ballast guying A **3.1** to derrick ballast guying B **3.2**) or the incline display **3.5** is exceeded, the derrick ballast must be equalized.

Block the pull cylinder (A) when lifting:

- ▶ Press the button **727** and the button **730**.
- or
- Deflect the master switch **MS1** diagonally in direction **X-** and direction **Y-**.

Result:

- The piston rod of the pull cylinder (A) stops.
- The piston rod of pull cylinder (B) moves in.
- Side (B) of the derrick ballast lifts up.

Block the pull cylinder (B) when lifting:

- ▶ Press the button **727** and the button **731**.
- or
- Deflect the master switch **MS1** diagonally in direction **X+** and direction **Y-**.

Result:

- The piston rod of the pull cylinder (B) stops.
- The piston rod of pull cylinder (A) moves in.
- Side (A) of the derrick ballast lifts up.

Block the pull cylinder (A) when lowering:

- ▶ Press the button **726** and the button **730**.
- or
- Deflect the master switch **MS1** diagonally in direction **X-** and direction **Y+**.

Result:

- The piston rod of the pull cylinder (A) stops.
- The piston rod of pull cylinder (B) moves out.
- Side (B) of the derrick ballast lowers.

Block the pull cylinder (B) when lowering:

- ▶ Press the button **726** and the button **731**.
- or
- Deflect the master switch **MS1** diagonally in direction **X+** and direction **Y+**.

Result:

- The piston rod of the pull cylinder (B) stops.
- The piston rod of pull cylinder (A) moves out.
- Side (A) of the derrick ballast lowers.

10 Crawler operation with derrick ballast

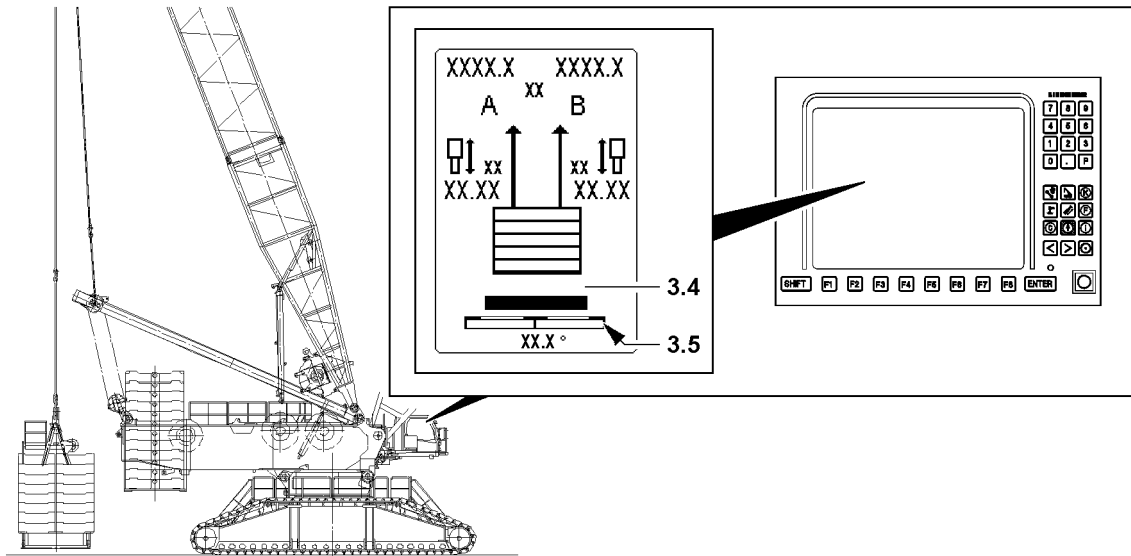

Fig.145934



Note

- ▶ Driving the crawler crane, see the Crane operating instructions, chapter 4.10.
- ▶ Release for driving the crawler takes place when all 4 ground contact rollers are no longer in contact with the ground.

10.1 Driving the crawler

Driving with suspended derrick ballast.



WARNING

Prerequisites for driving are not met, load or derrick ballast are oscillating too much!

If the specifications from the Crane operating instructions, chapter 4.10 are not observed, there is a danger of accident.

If the suspended load or the suspended derrick ballast starts to swing too much, then the crane operator can lose control over the crane.

If the following prerequisites are not observed, the crane can topple over.

This could result in serious accidents.

- ▶ Observe the specifications in the Crane operating instructions, chapter 4.10.
- ▶ Do not exceed the maximum permissible driving speed of the crawler.
- ▶ Avoid jerky driving movements.
- ▶ Avoid oscillation of the suspended load and the suspended derrick ballast. Turn and drive slowly.
- ▶ The attached load and suspended derrick ballast must be secured to prevent it from swinging. If oscillating movements should occur, set the load / derrick ballast as fast as possible down on the ground. Hereby pay attention to the limit values of the load moment display and the F-load display.
- ▶ Steering the crawler with a suspended load and / or installed derrick ballast is prohibited.
- ▶ Uphill and downhill inclines and lateral inclines may only be driven within the permissible angle range.

Make sure that the following prerequisites are met:

- Observe the specifications in the Crane operating instructions, chapter 4.10.
- Pay special attention to the limitations for crawler operation with derrick ballast.
- The ground is suitable for crawler operation with derrick ballast.
- The ground can safely take on the resulting surface pressure.
- The derrick ballast is lifted off the ground.
- The „Derrick ballast lifted off“ icon **3.4** appears on the LICCON monitor.
- The derrick ballast is horizontally aligned (observe the incline display **3.5**).

11 Disassembling the suspended ballast



WARNING

Danger of falling!

During assembly / disassembly, inspection and maintenance work, personnel must be secured with appropriate aids to prevent them from falling.

Death, severe bodily injuries, property damage.

- ▶ All work at a height, when there is a danger of falling, must be carried out with suitable aids.
- ▶ If aids are not available and work cannot be carried out from the ground, then assembly personnel must secure themselves with the supplied fall arrest system to prevent falling, see the Crane operating instructions, chapter 2.04.
- ▶ If fall protection equipment is available, then it must be used, see the Crane operating instructions, chapter 2.06.
- ▶ When lifting, lowering, swinging crane parts in and out, no persons may remain in the danger zone.
- ▶ If railings are present on the components, then they must be brought into the corresponding position and secured for assembly / disassembly work.
- ▶ Only step on the aids, ladders and catwalks with clean shoes.
- ▶ Keep aids, ladders and catwalks free of heavy dirt, snow and ice.
- ▶ During all assembly and disassembly work, maintenance work and inspections, travel or crane operation is prohibited.
- ▶ Remaining on a suspended load is prohibited.
- ▶ Stepping or walking on crane components and lattice sections, which have an incline of more than 20° is prohibited.
- ▶ For all assembly work, the crane operator of the main crane must be in voice contact with the crane operator / crane operators of the auxiliary crane / auxiliary cranes.
- ▶ For assembly / disassembly tasks, the crane operator may only initiate crane movements when the responsible guide has explicitly released the movement.



WARNING

Danger of impact / crushing!

When installing / removing crane components with the auxiliary crane, crane components can start to swing back and forth.

When lifting / lowering and positioning crane components, there is an increased danger of impacts / crushing.

Death, severe bodily injuries, property damage.

- ▶ Make sure that personnel cannot be caught by components.
- ▶ When working in danger zones: Use aids to protect limbs.
- ▶ Guide components with suitable aids to minimize oscillation.



DANGER

The components can fall down!

If the corresponding components are disengaged from the auxiliary crane before the corresponding component is pinned, the corresponding component can fall down and fatally injure personnel.

- ▶ Do not disengage the auxiliary crane until the respective component is pinned and secured.

Make sure that the following prerequisites are met:

- The crane is properly supported and horizontally aligned.
- An auxiliary crane is available.
- The counterweight has been installed on the turntable according to the load chart.
- The maximum ground unevenness for the placement surface of the derrick ballast is $\pm 1^\circ$.
- The LICCON overload protection has been set according to the data in the load chart.
- The LICCON overload protection settings have been compared with the actual set up configuration.

Empty page!

LWE/LR 11000-001/23501-04-02/en

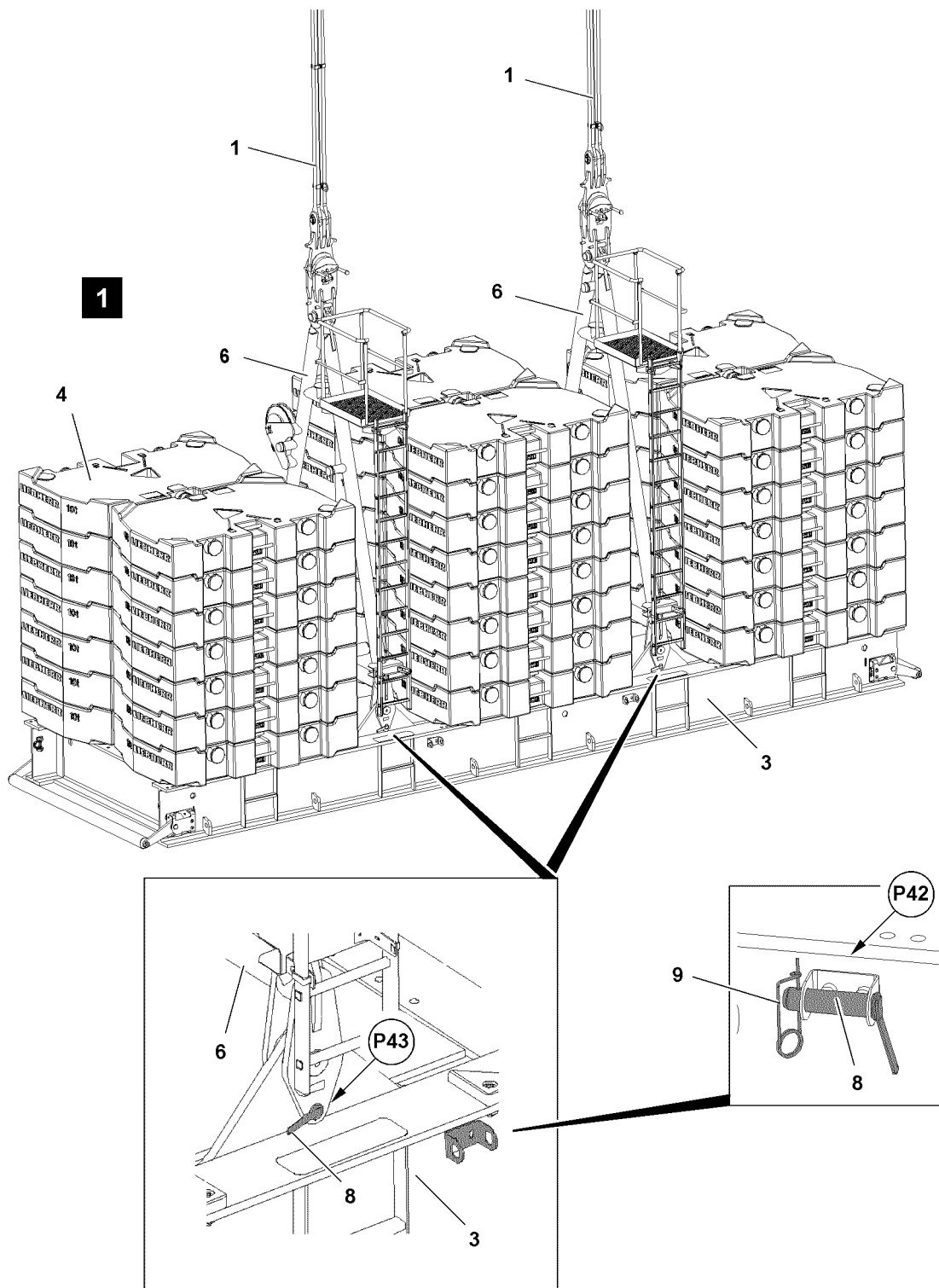

Fig.119010

11.1 Securing the erection racks to prevent them from folding down



DANGER

Falling erection racks!

If the erection racks are not secured with retaining pins, then they will fall down uncontrolled when unpinning the guy rods.

Death, severe bodily injuries, property damage.

- ▶ The two erection racks must be locked and secured in a vertical position with retaining pins **8**. Only then may the guy rods be removed.
- ▶ It is prohibited for anyone to remain under the erection racks as well as within the entire danger zone.

Make sure that the following prerequisite is met:

- The suspended ballast is positioned on the ground.
- ▶ Remove the spring retainer **9** at point **P42** and unpin the retaining pin **8** from the park position.
- ▶ Insert the retaining pin **8** at point **P43** and secure with spring retainer **9**.

Result:

- The erection racks **6** are secured, see illustration **1**.

11.2 Disconnecting the electrical connections



Note

- ▶ Disconnect the electrical connections from the suspended ballast to the turntable, see Electric wiring diagram.
- ▶ Disconnect the electrical connections.

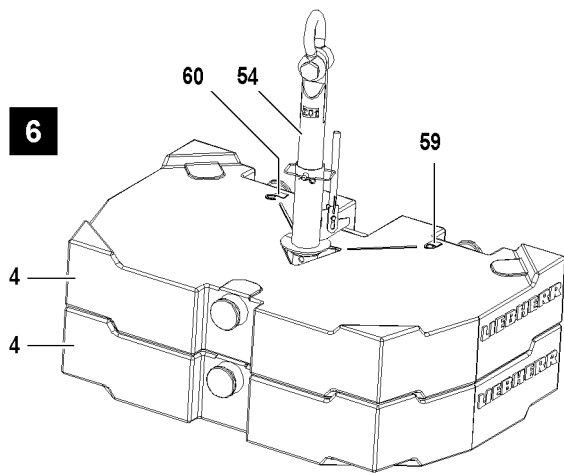
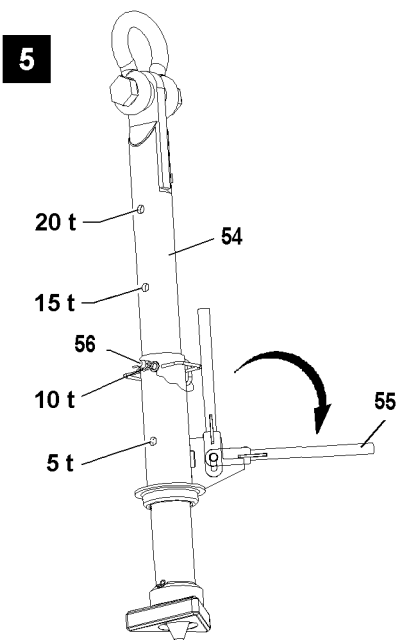
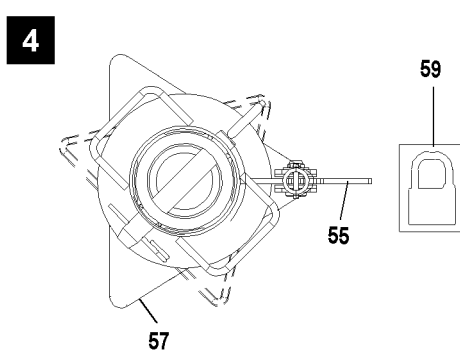
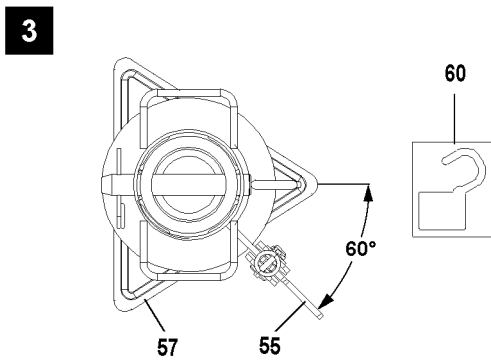
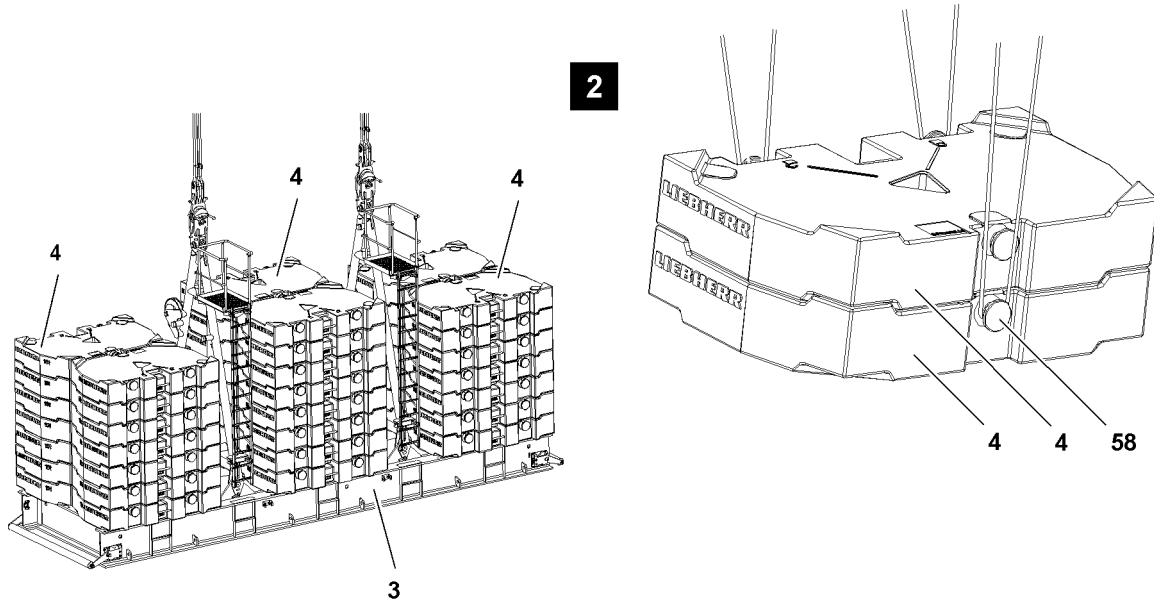

Fig.119011

LWE/LR 11000-001/23501-04-02/en

11.3 Ballasting the ballast pallet off

11.3.1 Removing the ballast plates, fastening system: „Twistlock“



WARNING

Danger of accident!

If more than the permissible two ballast plates are lifted with the receptacle stud, the receptacle stud will be overloaded and can be damaged.

Death, severe bodily injuries, property damage.

- ▶ Make sure that the ballast plates are placed correctly in the centerings.
- ▶ Replace damaged ballast plates.

To lift off the ballast plate(s) **4**, use the receptacle stud **54**.

Before the receptacle stud **54** is guided into the ballast plates, it must be ensured that the length of the receptacle stud **54** is set correctly. The length of the receptacle stud **54** can be adjusted with the pin **56**.

If the length of the receptacle stud **54** is to be adjusted:

- ▶ Release and unpin the pin **56**.
- ▶ Adjust the length of the receptacle stud by moving the receptacle stud **54**, see illustration **5**.
- ▶ Insert the pin **56** and secure with the spring retainer.
- ▶ Fasten the receptacle stud **54** to the auxiliary crane and guide it into the ballast plate(s).
- ▶ Pull the lever **54** up and fold it down.
- ▶ Turn the lever **55** by 60° until the lever **55** points to the icon **59**, see illustration **3** and illustration **4**.

Result:

- The receptacle stud **54** is locked with the ballast plate.
- ▶ Lift the ballast plate with the receptacle stud **54** and remove it carefully from the ballast stack or the ballast pallet.
- ▶ Turn the lever **55** by 60° until the lever **55** points to the icon **60**, see illustration **6**.

Result:

- The receptacle stud **54** is unlocked.
- ▶ Carefully pull the receptacle stud **54** from the ballast plate.
- ▶ Alternately remove the ballast plates on both sides.

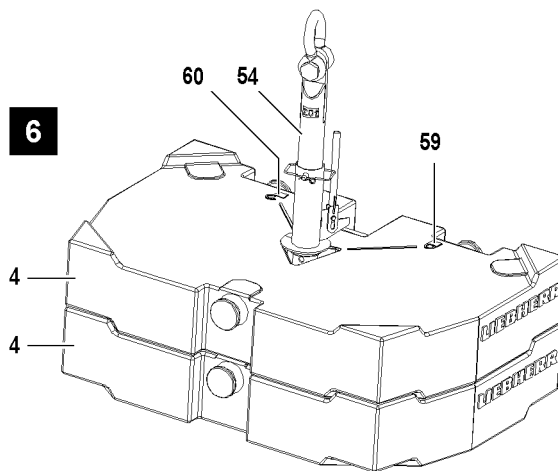
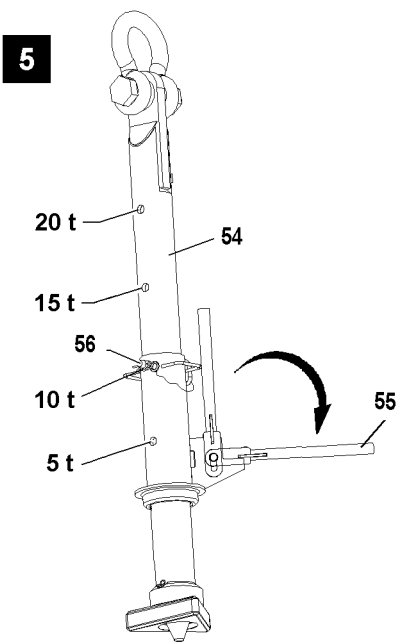
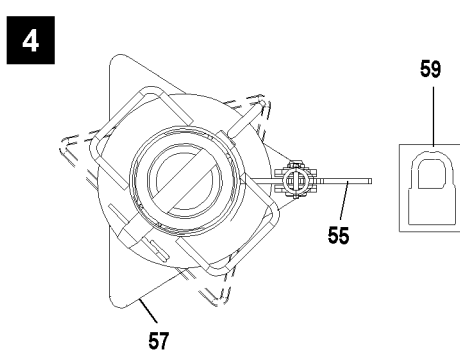
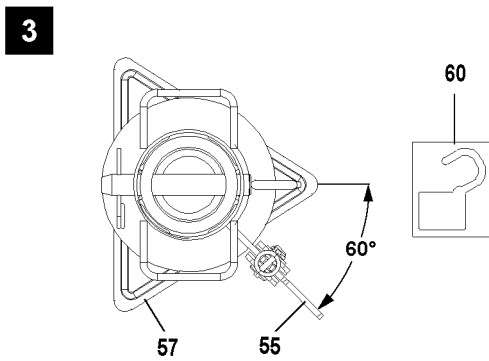
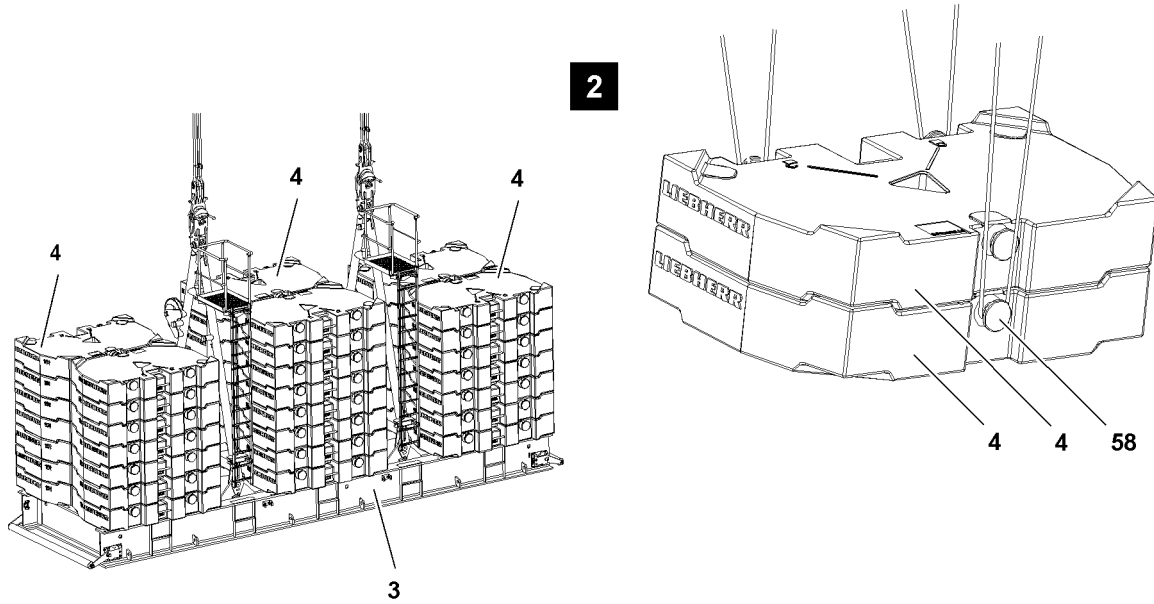

Fig.119011

LWE/LR 11000-001/23501-04-02/en

11.3.2 Removing the ballast plates, fastening system: „Bitt“

**WARNING**

Falling ballast plates!

If more than the permissible loads are lifted, then the bitts **58** are overloaded and the ballast plates can fall down.

Death, severe bodily injuries, property damage.

- ▶ Lift no more than maximum 20 t with the ropes, 3 fastening points.
- ▶ Replace damaged ballast plates immediately.

**WARNING**

Incorrect handling of the fastening equipment!

If the fastening equipment is not attached correctly and if it is not secured sufficiently to prevent it from loosening up, loads can fall down.

Death, severe bodily injuries, property damage.

- ▶ Make sure that the fastening equipment is correctly attached on the bitts **58** and that it is secured sufficiently to prevent it from loosening up.

**Note**

- ▶ Lift the ballast plates off individually or as an assembly, maximum 20 t.
 - ▶ 20 t ballast assembly, see illustration **2**.
-
- ▶ Lift the ballast plates **4** off individually or as an assembly of maximum two plates alternately on the left and right with the auxiliary crane.

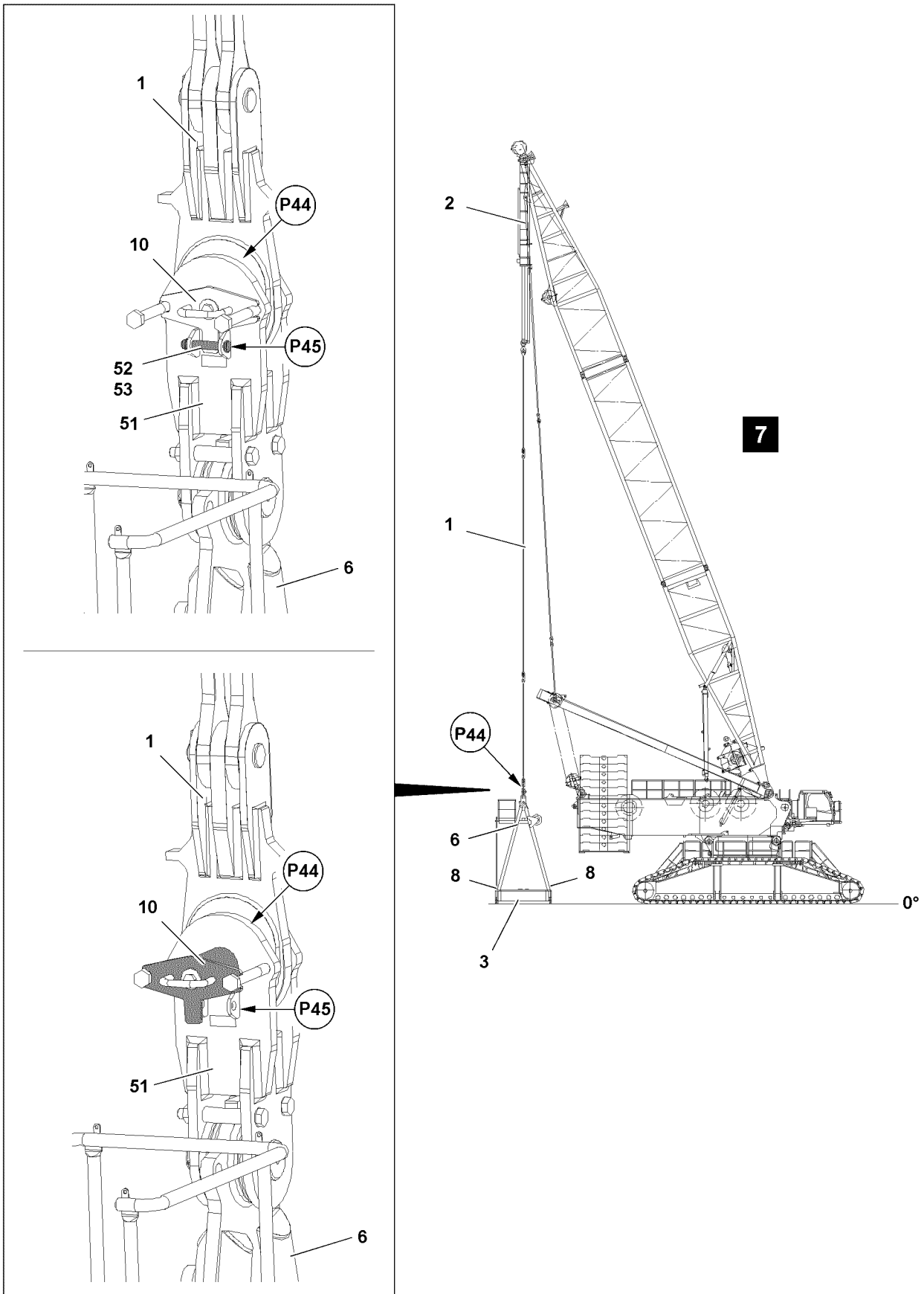

Fig.119012

11.4 Disassembling the guy rods from the erection racks



DANGER

Falling erection racks!

If the erection racks are not secured with retaining pins, then they will fall down uncontrolled when unpinning the guy rods.

Death, severe bodily injuries, property damage.

- ▶ The two erection racks must be locked and secured in a vertical position with retaining pins **8**. Only then may the guy rods be removed.
- ▶ It is prohibited for anyone to remain under the erection racks as well as within the entire danger zone.

Make sure that the following prerequisites are met:

- The erection racks are secured.
- The ballast plates are removed.

- ▶ Remove the safety locking pin **53** at point **P45** and unpin the retaining pin **52**.
- ▶ Unpin the connector pin **10** at point **P44**, see illustration **7**.
- ▶ Drive out the guy rods **1** out by retracting the piston rods on the pull cylinders **2** from the brackets **51** of the erection rack **6**.



Note

Retract / extend the pull cylinder **2**

- ▶ Control the pull cylinders **2** from the crane cab, see the section „Lifting and lowering the derrick ballast using the pull cylinders“.
- ▶ Operate the pull cylinder **2** with the radio remote control, see the „radio remote control operating instructions“.

- ▶ Insert the connector pin **10** again at point **P44**.
- ▶ Insert the retaining pin **52** at point **P45** and secure with the safety locking pin **53**, see illustration **7**.

Result:

- The connector pin **10** is secured.

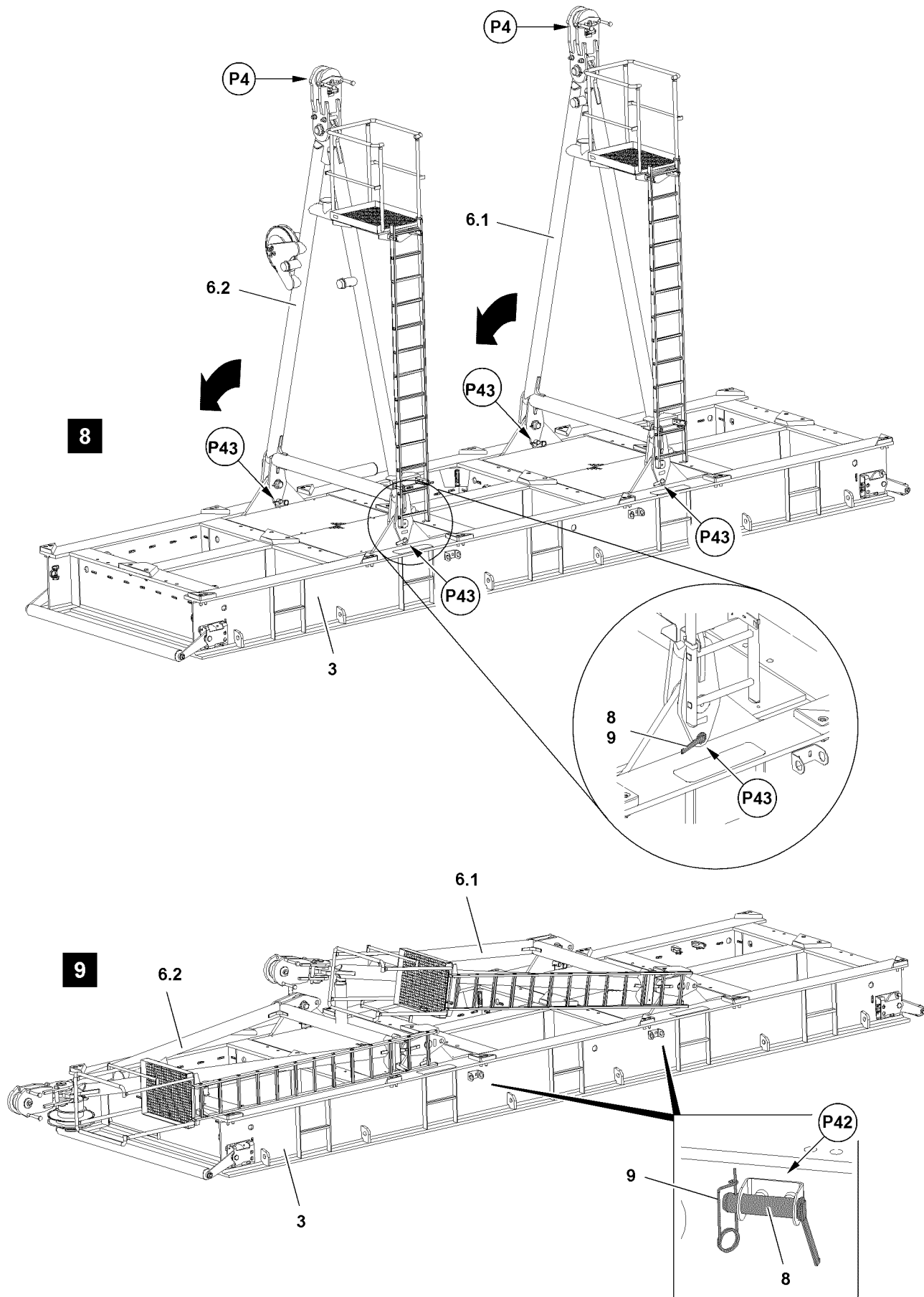

LWE/LR 11000-001/23501-04-02/en

Fig.119013

11.5 Removing the ballast pallet



Note

- ▶ The disassembly of the erection racks is described based on the example of one erection rack.

The erection rack is unpinned on two points. The unpinning procedure is described for one pin as an example.

- ▶ Hang the erection rack **6.2** on the auxiliary crane at point **P4**, see illustration **8**.



DANGER

Danger of accident during assembly / disassembly of the erection racks!

The erection racks must hang securely on the auxiliary crane, otherwise they could fall down and kill or severely injure personnel.

- ▶ Make sure that the erection rack hangs safely on the auxiliary crane.
- ▶ Never unpin the retaining pins of unsecured or unsupported erection racks.
- ▶ It is prohibited for anyone to remain under the erection racks or within the complete danger zone during the pinning and unpinning procedure.

When the erection rack is safely held by the auxiliary crane:

- ▶ Remove the spring retainer **9** on both sides at point **P43** and unpin the retaining pin **8**.
- ▶ Lower the erection rack **6.2** with the auxiliary crane until the rubber cushion touches the frame, see illustration **9**.
- ▶ Insert the retaining pin **8** at point **P42** on both sides and secure with spring retainer **9** in park position, see illustration **9**.
- ▶ Remove the auxiliary crane.
- ▶ Lower the second erection rack **6.1** with the auxiliary crane until the rubber cushion touches the erection rack **6.2**, see illustration **9**.

Fig.195219

LWE/LR 11000-001/23501-04-02/en

12 Disassembling the suspended ballast with the suspended ballast guide



WARNING

Danger of falling!

During assembly / disassembly, inspection and maintenance work, personnel must be secured with appropriate aids to prevent them from falling.

Death, severe bodily injuries, property damage.

- ▶ All work at a height, when there is a danger of falling, must be carried out with suitable aids.
- ▶ If aids are not available and work cannot be carried out from the ground, then assembly personnel must secure themselves with the supplied fall arrest system to prevent falling, see the Crane operating instructions, chapter 2.04.
- ▶ If fall protection equipment is available, then it must be used, see the Crane operating instructions, chapter 2.06.
- ▶ When lifting, lowering, swinging crane parts in and out, no persons may remain in the danger zone.
- ▶ If railings are present on the components, then they must be brought into the corresponding position and secured for assembly / disassembly work.
- ▶ Only step on the aids, ladders and catwalks with clean shoes.
- ▶ Keep aids, ladders and catwalks free of heavy dirt, snow and ice.
- ▶ During all assembly and disassembly work, maintenance work and inspections, travel or crane operation is prohibited.
- ▶ Remaining on a suspended load is prohibited.
- ▶ Stepping or walking on crane components and lattice sections, which have an incline of more than 20° is prohibited.
- ▶ For all assembly work, the crane operator of the main crane must be in voice contact with the crane operator / crane operators of the auxiliary crane / auxiliary cranes.
- ▶ For assembly / disassembly tasks, the crane operator may only initiate crane movements when the responsible guide has explicitly released the movement.



WARNING

Danger of impact / crushing!

When installing / removing crane components with the auxiliary crane, crane components can start to swing back and forth.

When lifting / lowering and positioning crane components, there is an increased danger of impacts / crushing.

Death, severe bodily injuries, property damage.

- ▶ Make sure that personnel cannot be caught by components.
- ▶ When working in danger zones: Use aids to protect limbs.
- ▶ Guide components with suitable aids to minimize oscillation.



DANGER

The components can fall down!

If the corresponding components are disengaged from the auxiliary crane before the corresponding component is pinned, the corresponding component can fall down and fatally injure personnel.

- ▶ Do not disengage the auxiliary crane until the respective component is pinned and secured.

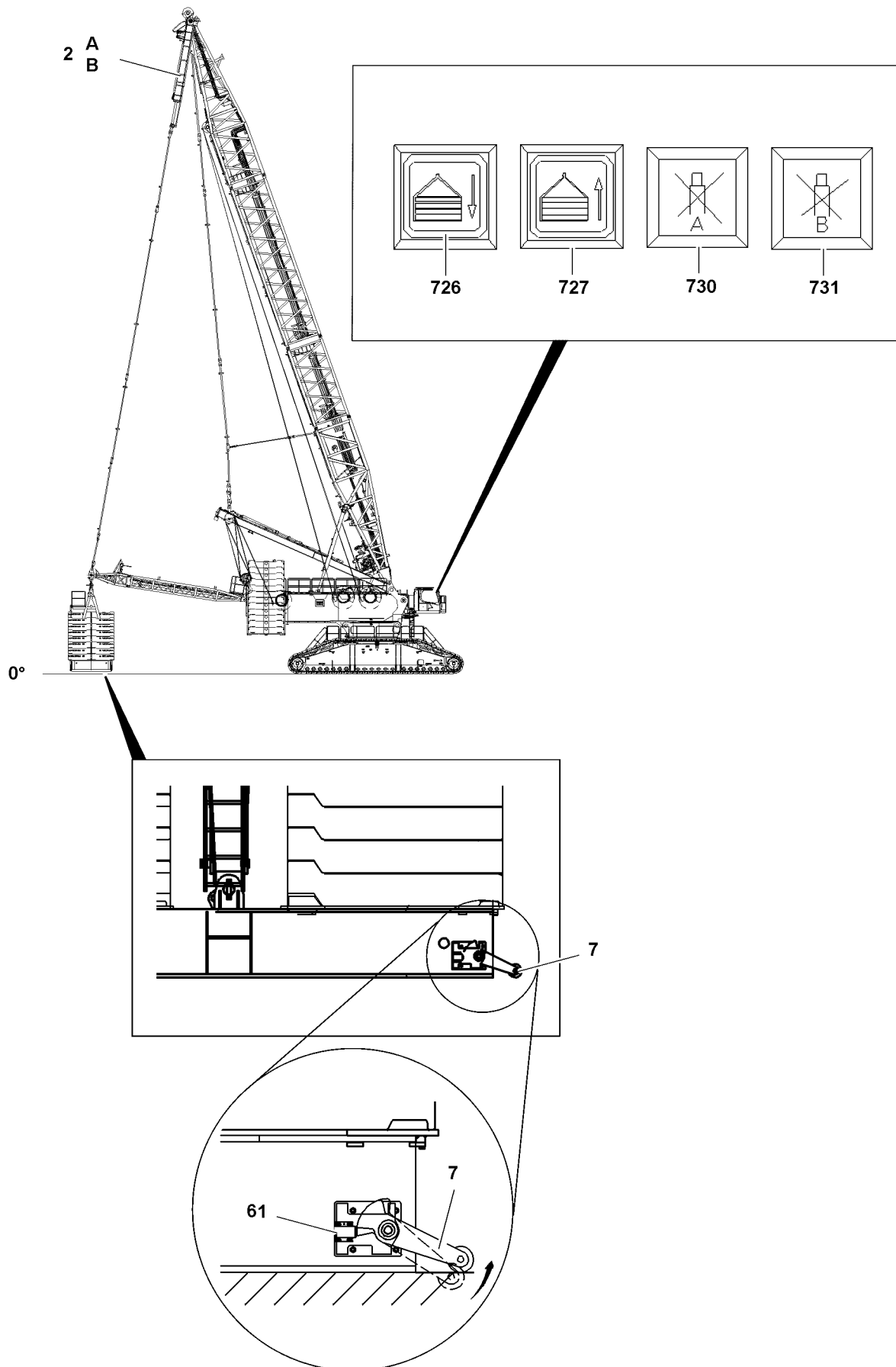

Fig.120210

LWE/LR 11000-001/23501-04-02/en

Make sure that the following prerequisites are met:

- The crane is properly supported and horizontally aligned.
- An auxiliary crane is available.
- The counterweight has been installed on the turntable according to the load chart.
- The maximum ground unevenness for the placement surface of the derrick ballast is $\pm 1^\circ$.
- The LICCON overload protection has been set according to the data in the load chart.
- The LICCON overload protection settings have been compared with the actual set up configuration.

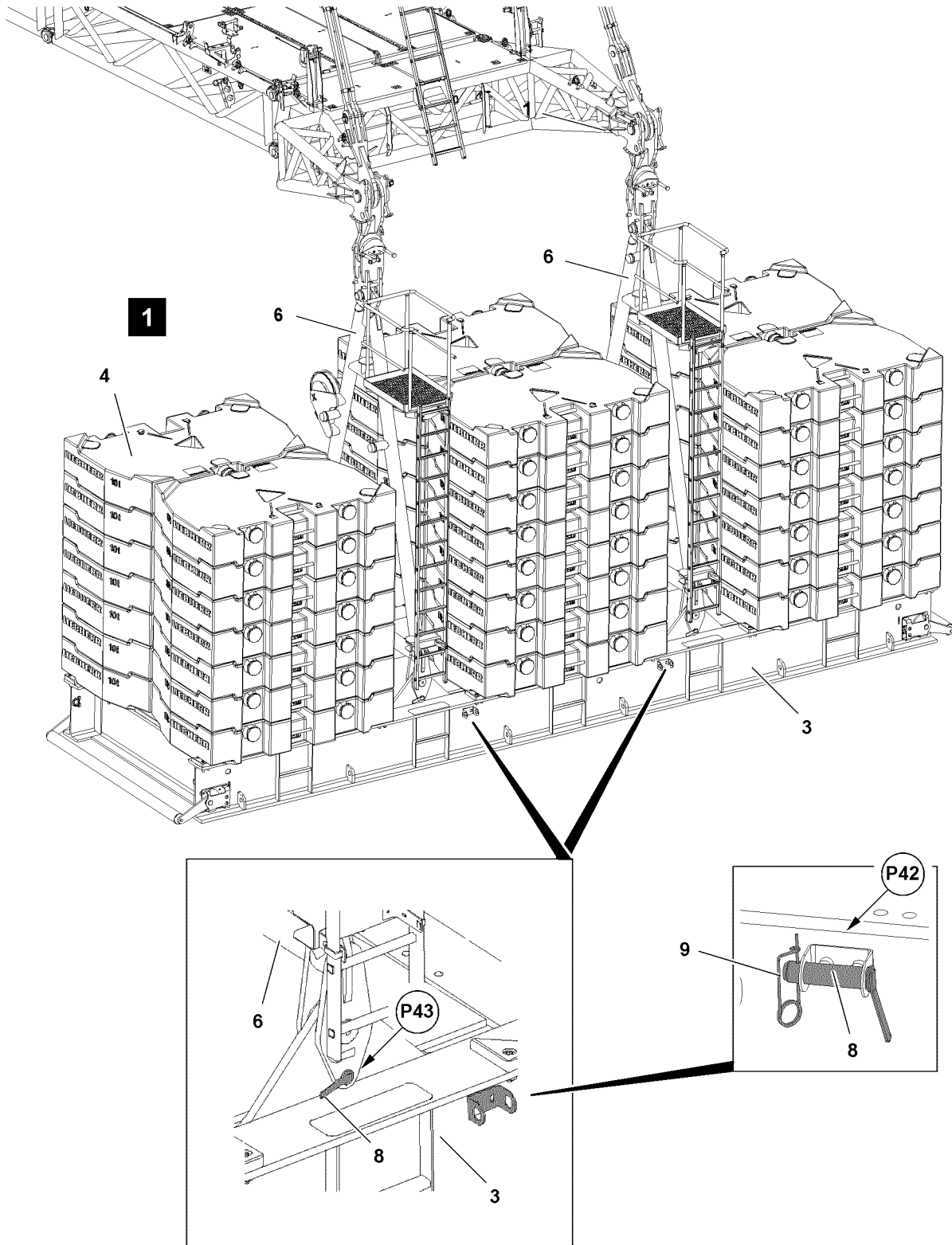

Fig.120211

12.1 Securing the erection racks to prevent them from folding down



DANGER

Falling erection racks!

If the erection racks are not secured with retaining pins, then they will fall down uncontrolled when unpinning the guy rods.

Death, severe bodily injuries, property damage.

- ▶ The two erection racks must be locked and secured in a vertical position with retaining pins **8**. Only then may the guy rods be removed.
- ▶ It is prohibited for anyone to remain under the erection racks as well as within the entire danger zone.

Make sure that the following prerequisite is met:

- The suspended ballast is positioned on the ground.
- ▶ Remove the spring retainer **9** at point **P42** and unpin the retaining pin **8** from the park position.
- ▶ Insert the retaining pin **8** at point **P43** and secure with spring retainer **9**.

Result:

- The erection racks **6** are secured, see illustration **1**.

12.2 Disconnecting the electrical connections



Note

- ▶ Disconnect the electrical connections from the suspended ballast to the turntable, see Electric wiring diagram.
- ▶ Disconnect the electrical connections.

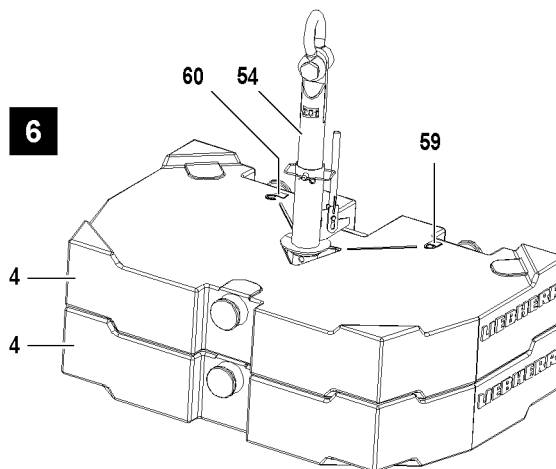
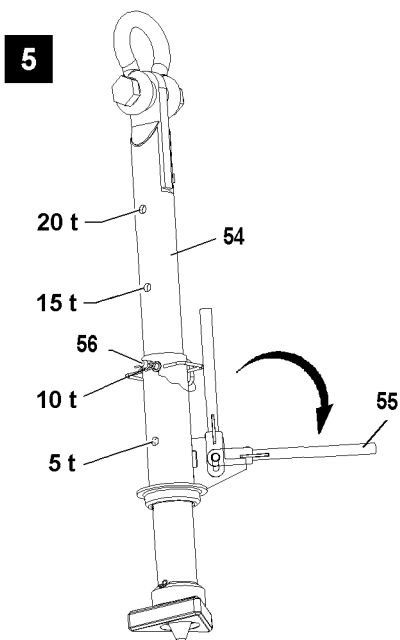
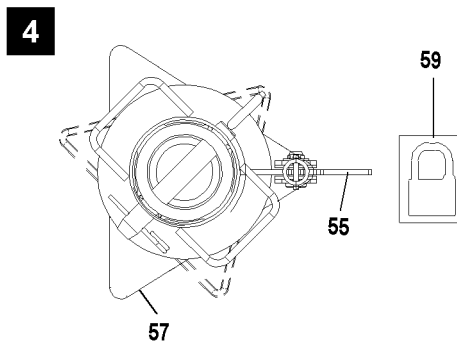
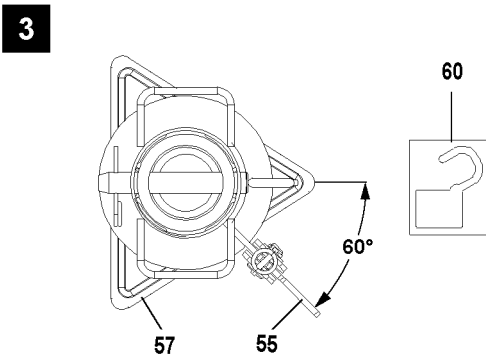
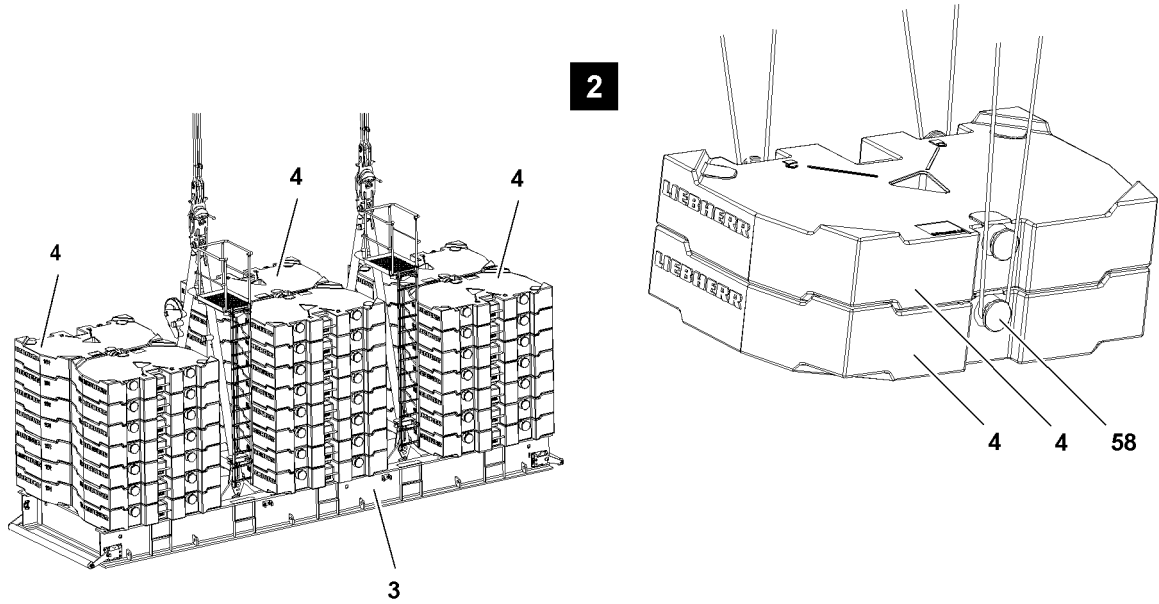

Fig.119011

LWE/LR 11000-001/23501-04-02/en

12.3 Ballasting the ballast pallet off

12.3.1 Removing the ballast plates, fastening system: „Twistlock“



WARNING

Danger of accident!

If more than the permissible two ballast plates are lifted with the receptacle stud, the receptacle stud will be overloaded and can be damaged.

Death, severe bodily injuries, property damage.

- ▶ Make sure that the ballast plates are placed correctly in the centerings.
- ▶ Replace damaged ballast plates.

To lift off the ballast plate(s) **4**, use the receptacle stud **54**.

Before the receptacle stud **54** is guided into the ballast plates, it must be ensured that the length of the receptacle stud **54** is set correctly. The length of the receptacle stud **54** can be adjusted with the pin **56**.

If the length of the receptacle stud **54** is to be adjusted:

- ▶ Release and unpin the pin **56**.
- ▶ Adjust the length of the receptacle stud by moving the receptacle stud **54**, see illustration **5**.
- ▶ Insert the pin **56** and secure with the spring retainer.
- ▶ Fasten the receptacle stud **54** to the auxiliary crane and guide it into the ballast plate(s).
- ▶ Pull the lever **54** up and fold it down.
- ▶ Turn the lever **55** by 60° until the lever **55** points to the icon **59**, see illustration **3** and illustration **4**.

Result:

- The receptacle stud **54** is locked with the ballast plate.
- ▶ Lift the ballast plate with the receptacle stud **54** and remove it carefully from the ballast stack or the ballast pallet.
- ▶ Turn the lever **55** by 60° until the lever **55** points to the icon **60**, see illustration **6**.

Result:

- The receptacle stud **54** is unlocked.
- ▶ Carefully pull the receptacle stud **54** from the ballast plate.
- ▶ Alternately remove the ballast plates on both sides.

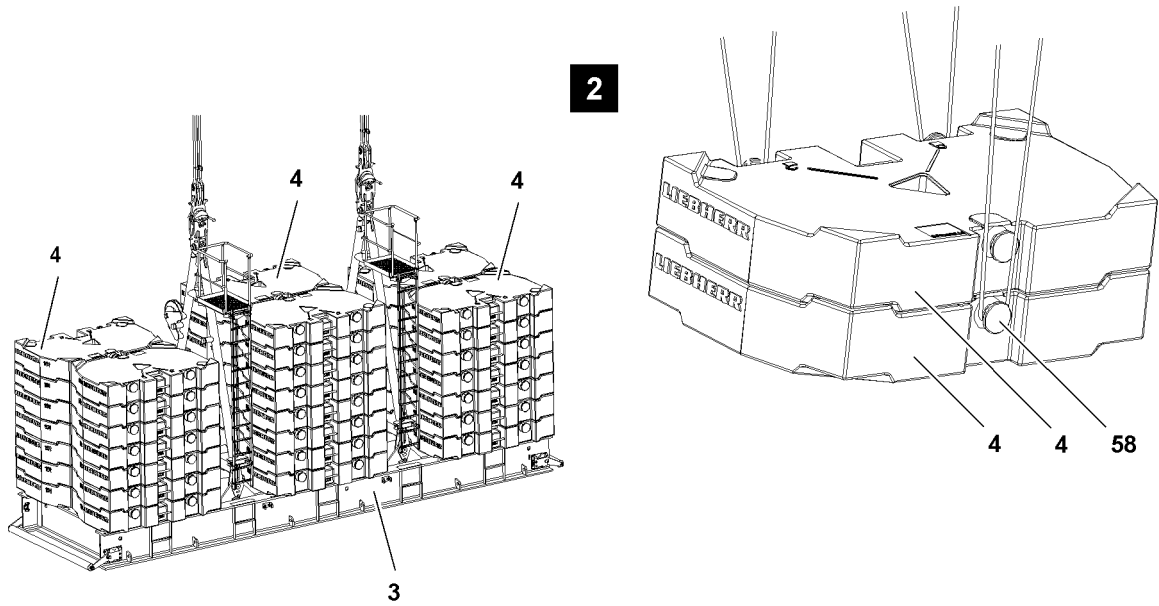

2

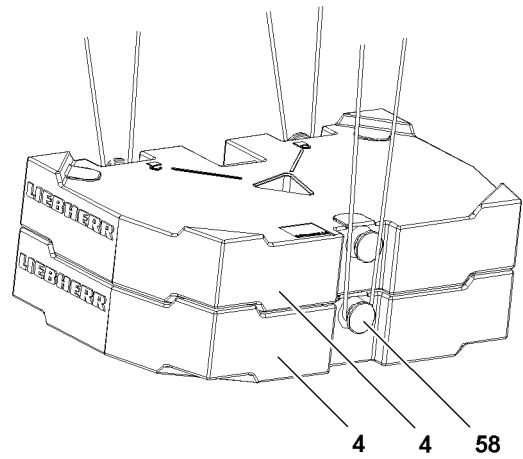

3

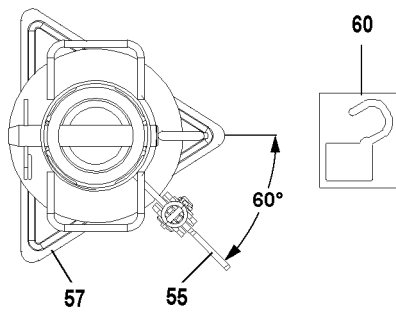

4

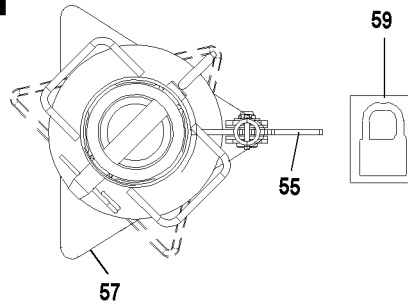

5

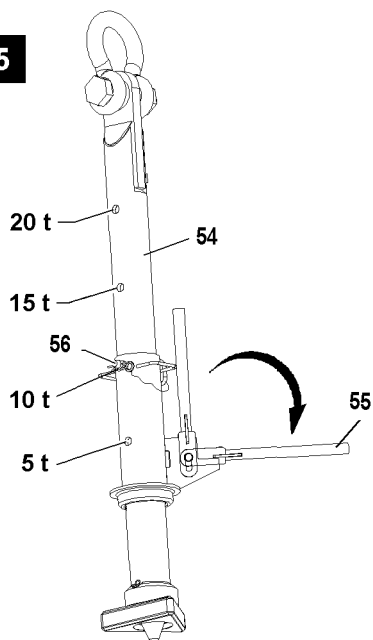

6

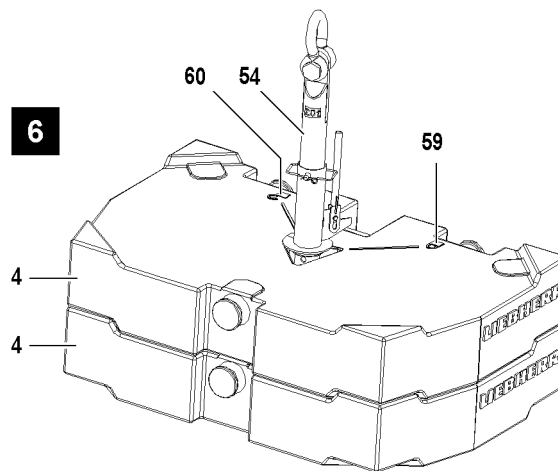

Fig.119011

LWE/LR 11000-001/23501-04-02/en

12.3.2 Removing the ballast plates, fastening system: „Bitt“

**WARNING**

Falling ballast plates!

If more than the permissible loads are lifted, then the bitts **58** are overloaded and the ballast plates can fall down.

Death, severe bodily injuries, property damage.

- ▶ Lift no more than maximum 20 t with the ropes, 3 fastening points.
- ▶ Replace damaged ballast plates immediately.

**WARNING**

Incorrect handling of the fastening equipment!

If the fastening equipment is not attached correctly and if it is not secured sufficiently to prevent it from loosening up, loads can fall down.

Death, severe bodily injuries, property damage.

- ▶ Make sure that the fastening equipment is correctly attached on the bitts **58** and that it is secured sufficiently to prevent it from loosening up.

**Note**

- ▶ Lift the ballast plates off individually or as an assembly, maximum 20 t.
- ▶ 20 t ballast assembly, see illustration **2**.

- ▶ Lift the ballast plates **4** off individually or as an assembly of maximum two plates alternately on the left and right with the auxiliary crane.

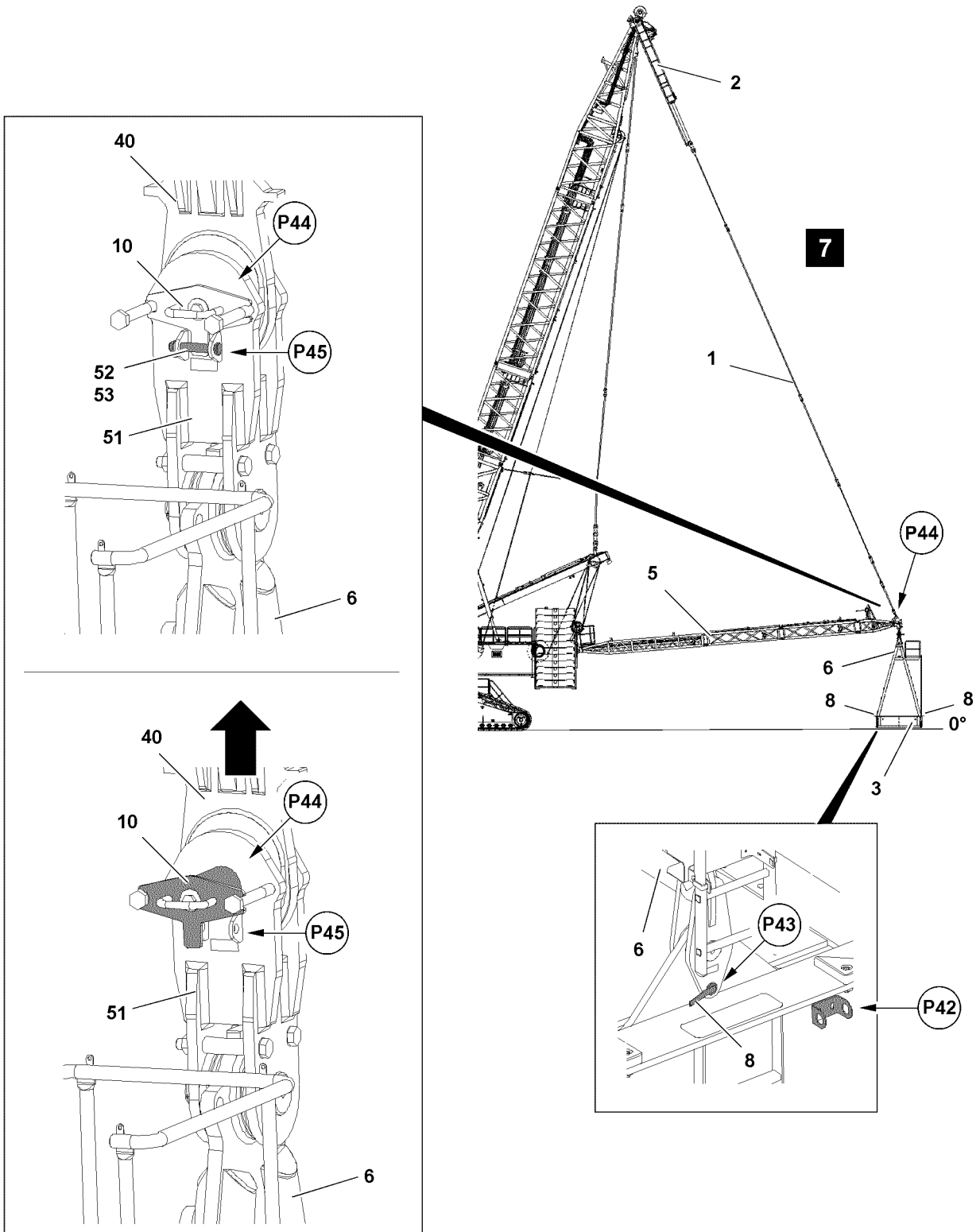

Fig.120212

LWE/LR 11000-001/23501-04-02/en

12.4 Disassembling the suspended ballast guide on the erection racks



DANGER

Falling erection racks!

If the erection racks are not secured with retaining pins, then they will fall down uncontrolled when unpinning the guy rods.

Death, severe bodily injuries, property damage.

- ▶ The two erection racks must be locked and secured in a vertical position with retaining pins. Only then may the guy rods be removed.
- ▶ It is prohibited for anyone to remain under the erection racks as well as within the entire danger zone.

Make sure that the following prerequisites are met:

- The erection racks are secured.
- The ballast plates are removed.

- ▶ Remove the safety locking pin **53** at point **P45** and unpin the retaining pin **52**.
- ▶ Unpin the connector pin **10** at point **P44**, see illustration **7**.
- ▶ Drive out the guy rods **1** out by retracting the piston rods on the pull cylinders **2** from the brackets **51** of the erection rack **6**.



Note

Retract / extend the pull cylinder **2**

- ▶ Control the pull cylinders **2** from the crane cab, see the section „Lifting and lowering the derrick ballast using the pull cylinders“.
- ▶ Operate the pull cylinder **2** with the radio remote control, see the „radio remote control operating instructions“.

- ▶ Insert the connector pin **10** again at point **P44**.
- ▶ Insert the retaining pin **52** at point **P45** and secure with the safety locking pin **53**, see illustration **7**.

Result:

- The connector pin **10** is secured.

10

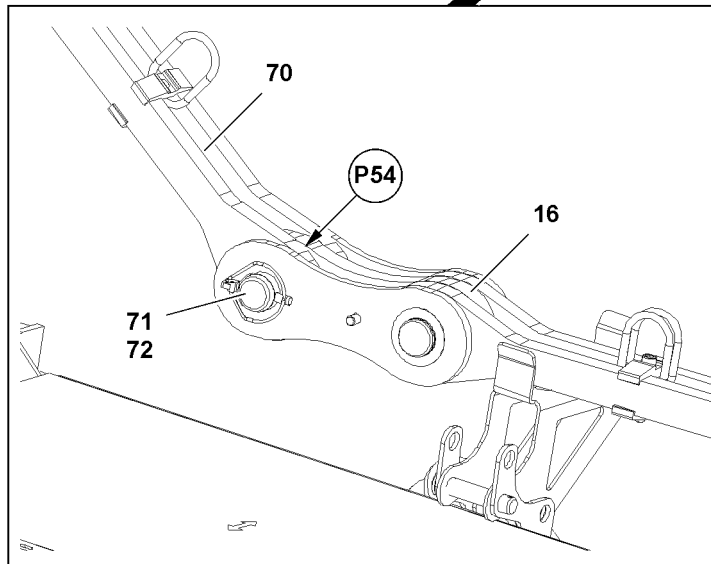
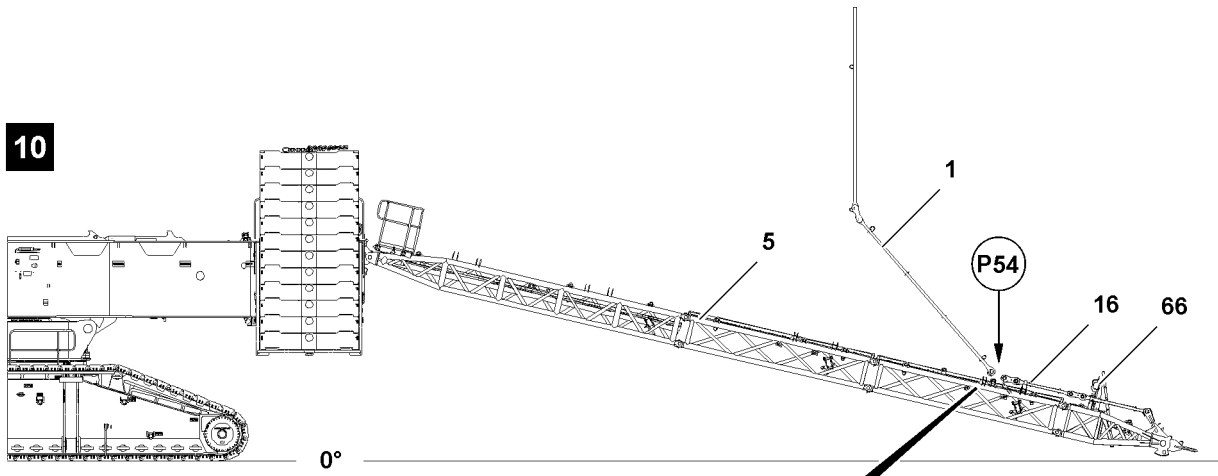

11

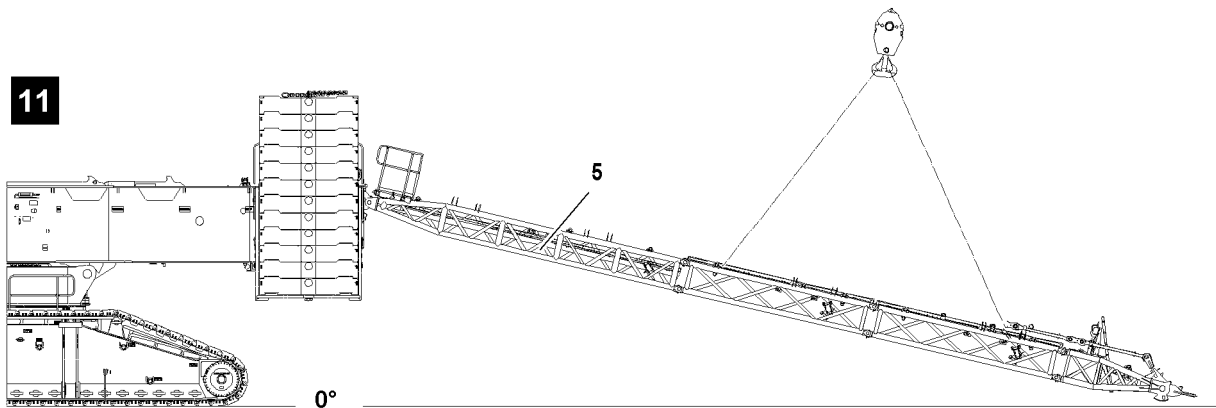

Fig.120215

LWE/LR 11000-001/23501-04-02/en

12.5 Disassembling the suspended ballast guide

Derrick ballast radius	Number of intermediate sections
20 m	0
25 m	1
30 m	2

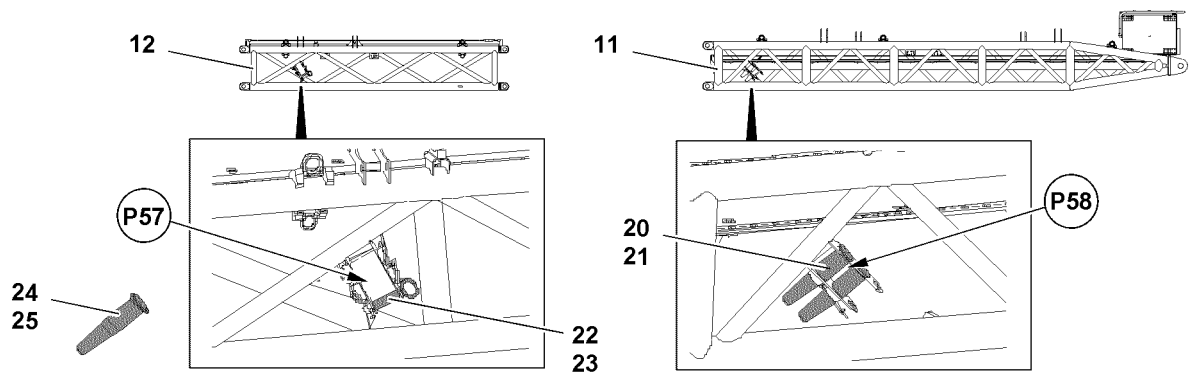

Fig.122802: Park position for pin



Note

- ▶ Park position **P57** for pin **24** and pin **22**.
- ▶ Park position **P58** for pin **20**.



WARNING

Falling pins!

Death, severe bodily injuries, property damage.

- ▶ Make sure that all pins are properly secured in the park positions with the respective retaining elements.

10

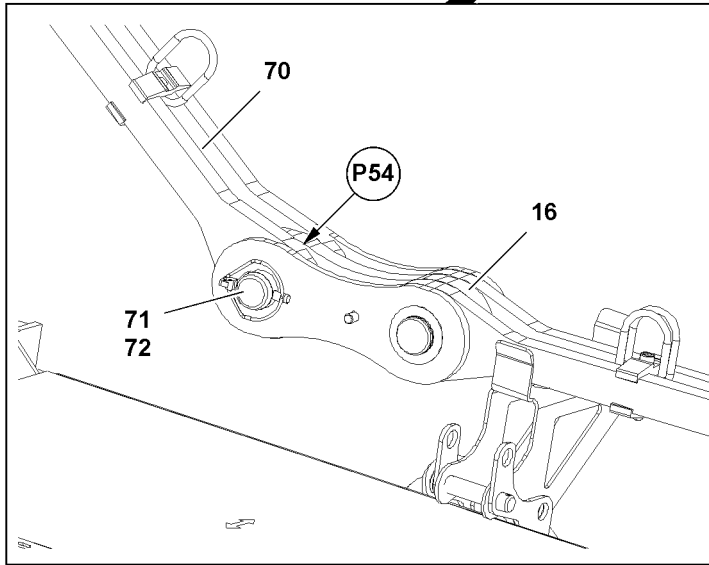
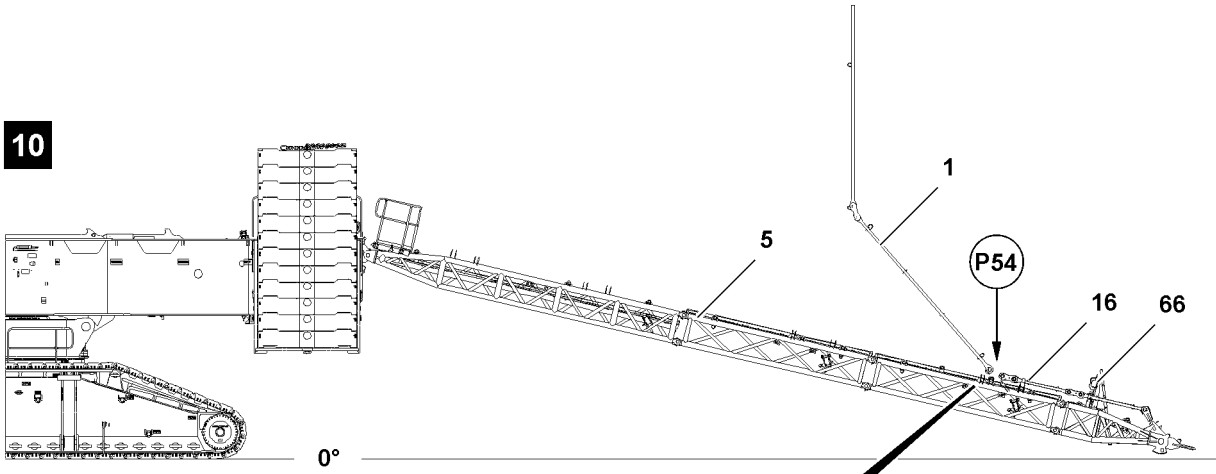

11

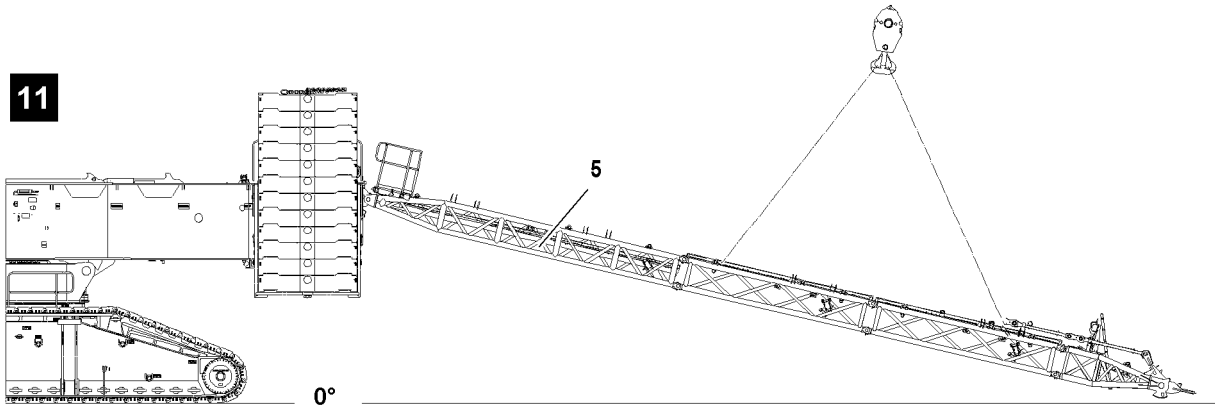

Fig.120215

LWE/LR 11000-001/23501-04-02/en

12.5.1 Unpinning the pull rods of the suspended ballast guide from the D-guy rods

Make sure that the following prerequisite is met:

- The suspended ballast guide is separated from the suspended ballast.

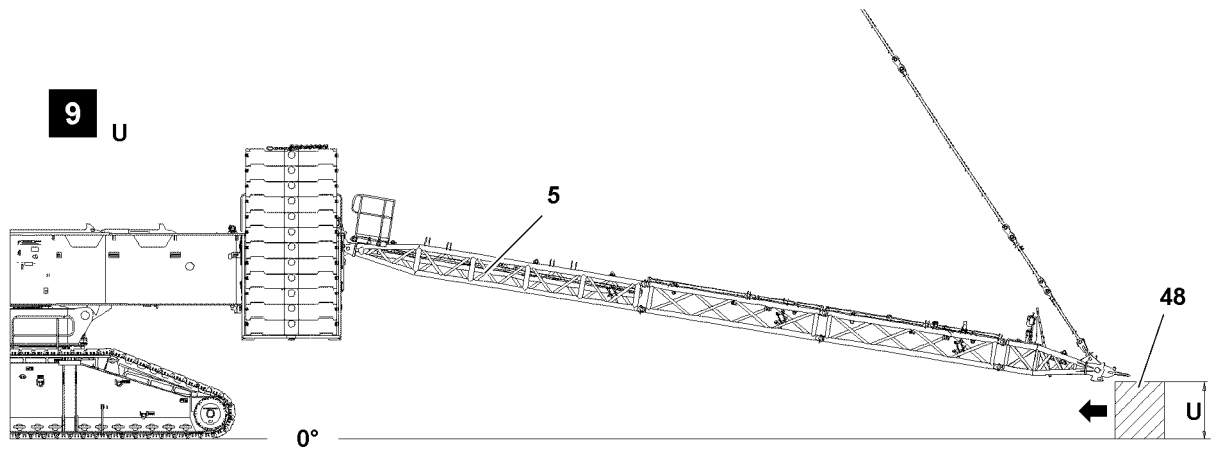

Fig.120214: Substructure

Suspended ballast guide	R30	R25	R20
Substructure height „U“	0 m	1.6 m	2.0 m

When the suspended ballast guide **5** is separated from the suspended ballast:

- ▶ Drive the crane away from the suspended ballast.
- ▶ Take the suspended ballast guide **5** down with the derrick onto the substructure **48**, see illustration **9** and chart.
- ▶ Connect the rope of the manual rope winch **66** with the D-guy rods **1**.

The D-guy rods **1** are pinned on both sides on the suspended ballast guide **5**. The unpinning procedure is described on the example for one D-guy rod.



WARNING

Swinging D-guy rods!

When unpinning the D-guy rods **1** at point **P54** they swing uncontrolled in the direction of the turntable. Death, severe bodily injuries, property damage.

- ▶ Make sure that the D-guy rods are secured with the manual rope winches before unpinning.
- ▶ Remove the safety locking pin **72** at point **P54** and unpin the pin **71**, see illustration **10**.
- ▶ Swing the D-guy rods **1** with the aid of the manual rope winch **66** and simultaneously luff up the derrick in direction of the turntable.

When the D-guy rods **1** hang vertically:

- ▶ Remove the rope of the manual rope winch **66** and spool it up.
- ▶ Fasten the suspended ballast guide **5** to the auxiliary crane, see illustration **11**.

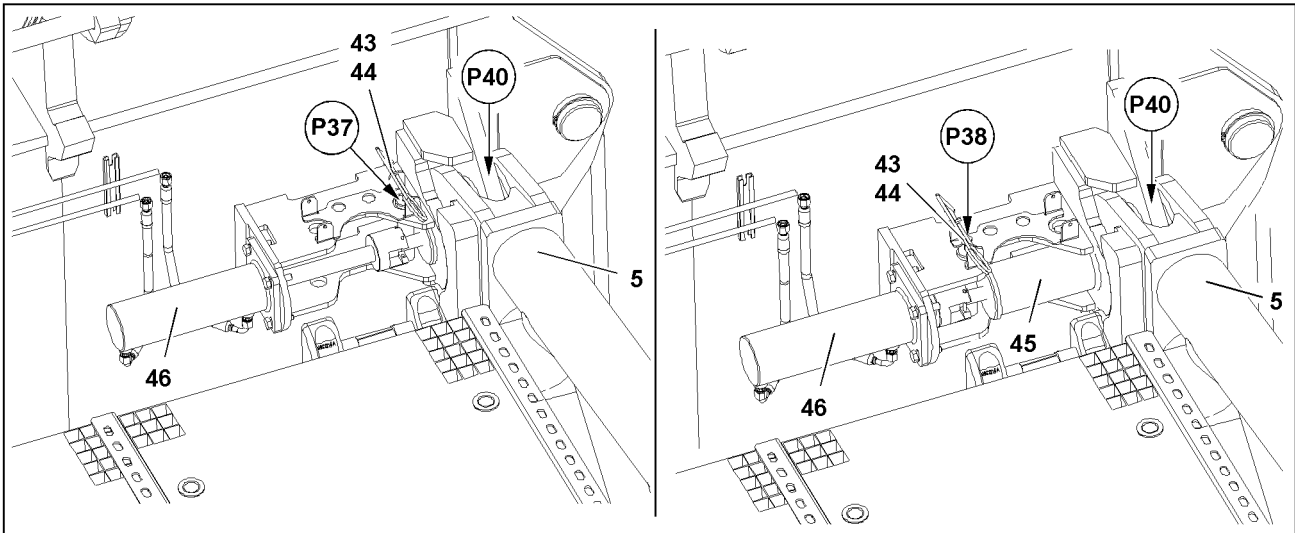

12

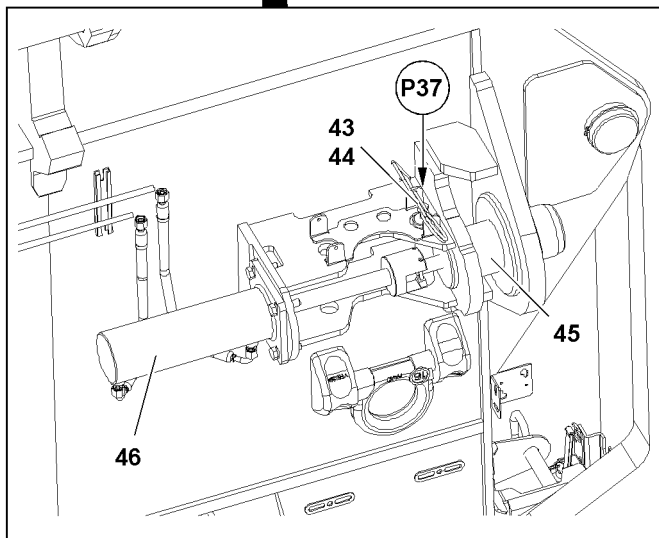
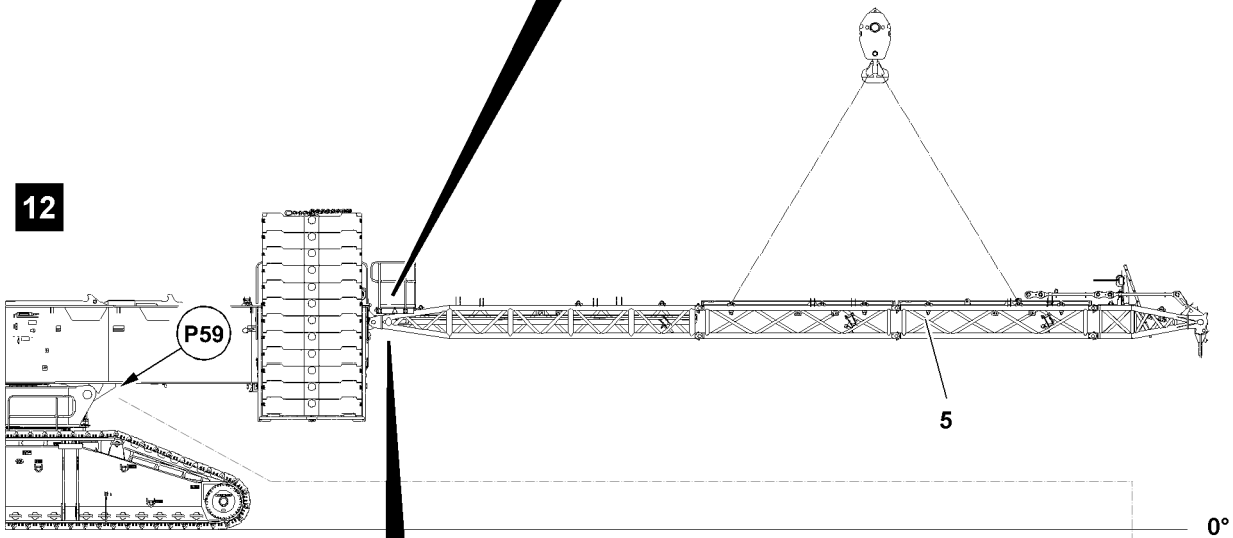

13

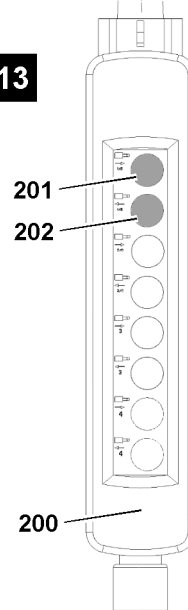

Fig.120216

12.5.2 Disassembling the suspended ballast guide on the turntable frame

Make sure that the following prerequisites are met:

- The suspended ballast guide is fastened to the auxiliary crane.
- The control panel is connected on the „turntable rear“ socket , point **P59**.

▶ Swing the suspended ballast guide **5** to the horizontal.

The suspended ballast guide **5** is pinned on two points **P40**. The unpinning procedure is described for one pin as an example:

- ▶ Release the pin **45**: Remove the spring retainer **44** at point **P37** and unpin the retaining pin **43**, see illustration **12**.
- ▶ Insert the retaining pin **43** at point **P38** and secure with spring retainer **44**.

When the suspended ballast guide **5** is safely held by the auxiliary crane:

- ▶ Unpin the pin **45**: Press button **202** on the control panel **200**, see illustration **13**.

Result:

- The pin **45** moves out.

When both pins **45** are unpinned:

- ▶ Remove the suspended ballast guide **5** from the pin points on the rear of the turntable and place it on the substructure.
- ▶ Insert the pins **45** again: Press button **201** on the control panel **200**, see illustration **13**.

Result:

- The pin **45** moves in.

- ▶ Secure the pin **45**: Insert the retaining pin **43** at point **P37** and secure with spring retainer **44** see illustration **12**.

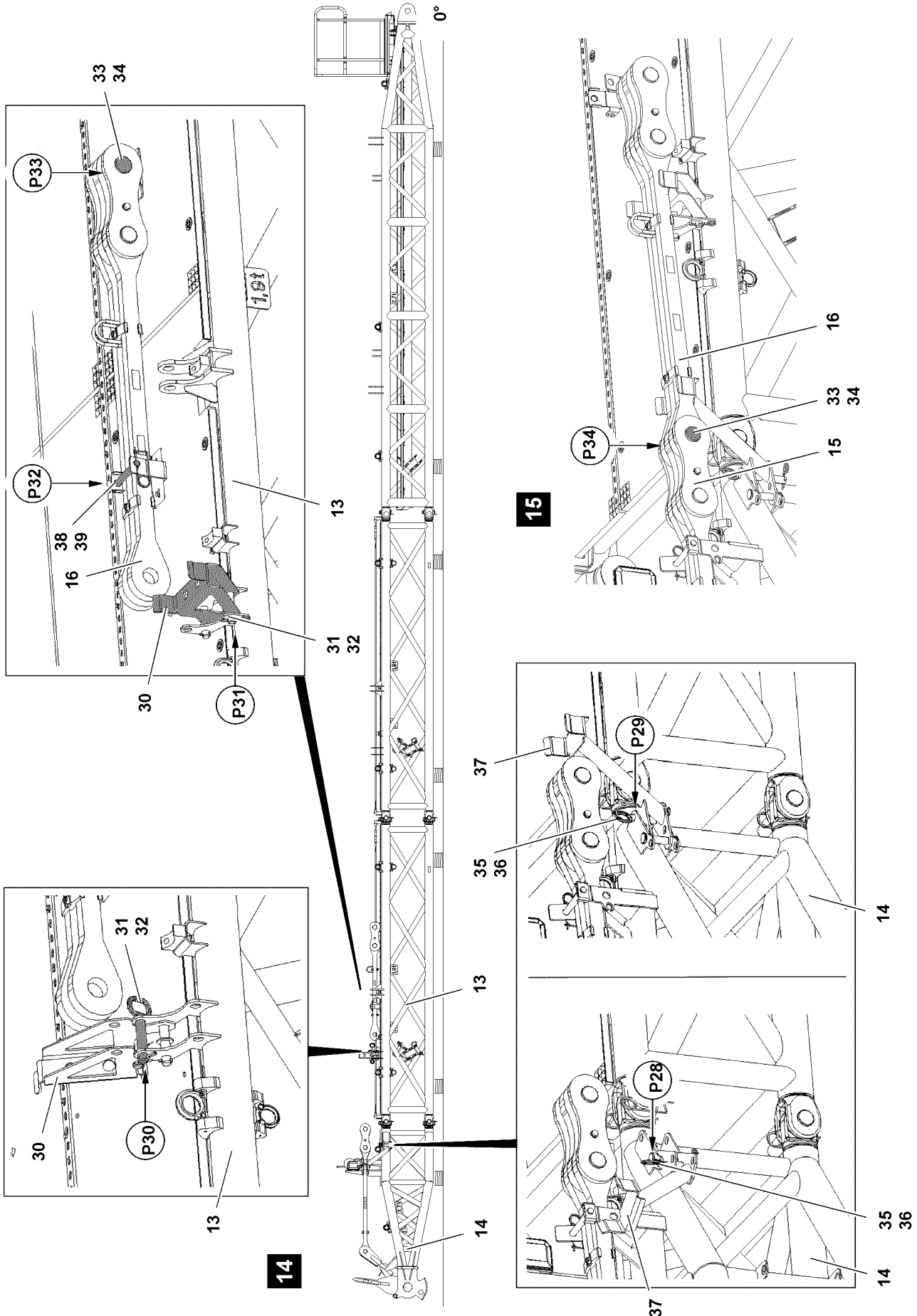

Fig.122951

LWE/LR 11000-001/23501-04-02/en

12.5.3 Disassembling the suspended ballast guide with 30 m suspended ballast radius



Note

- ▶ The disassembly of the suspended ballast guide is described based on the example of one suspended ballast guide with a 30 m suspended ballast radius.

Swinging the brackets

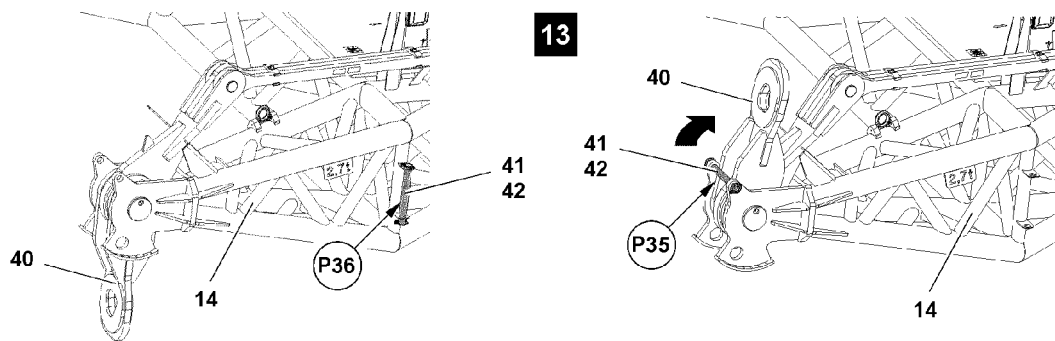

Fig.119029: Swinging the bracket

- ▶ Fasten the bracket **40** to the auxiliary crane.



WARNING

Bracket swinging down!

The bracket can swing down by itself due to its own weight when pinning it, see illustration. Death, severe bodily injuries, property damage. Fingers and hands can be crushed.

- ▶ Make sure that the platform is held by the auxiliary crane.
- ▶ Do not reach with your hands into the danger zone.
- ▶ Remove the safety locking pin **42** at point **P36** and unpin the pin **41**, see illustration **16**.
- ▶ Swing the bracket **40** upward with the auxiliary crane.
- ▶ Insert the pin **41** in park position at point **P35** and secure with safety locking pin **42**, see illustration **16**.

Disassembling the pull rods

- ▶ Fasten the auxiliary crane to the pull rod **16**.
- ▶ Unpin the pull rod **16** from the pull rod end section **15**: Remove the safety locking pin **34** at point **P34** and unpin the pin **33**, see illustration **15**.
- ▶ Lift the pull rod **16** with the auxiliary crane and take it down in transport position at point **P32** and point **P33**.
- ▶ Insert the pin **33** at point **P33** and secure with safety locking pin **34**.
- ▶ Insert the pin **38** on point **P32** and secure with spring retainer **39**.

Result:

- The pull rod **16** is secured in the transport position, see illustration **14**.

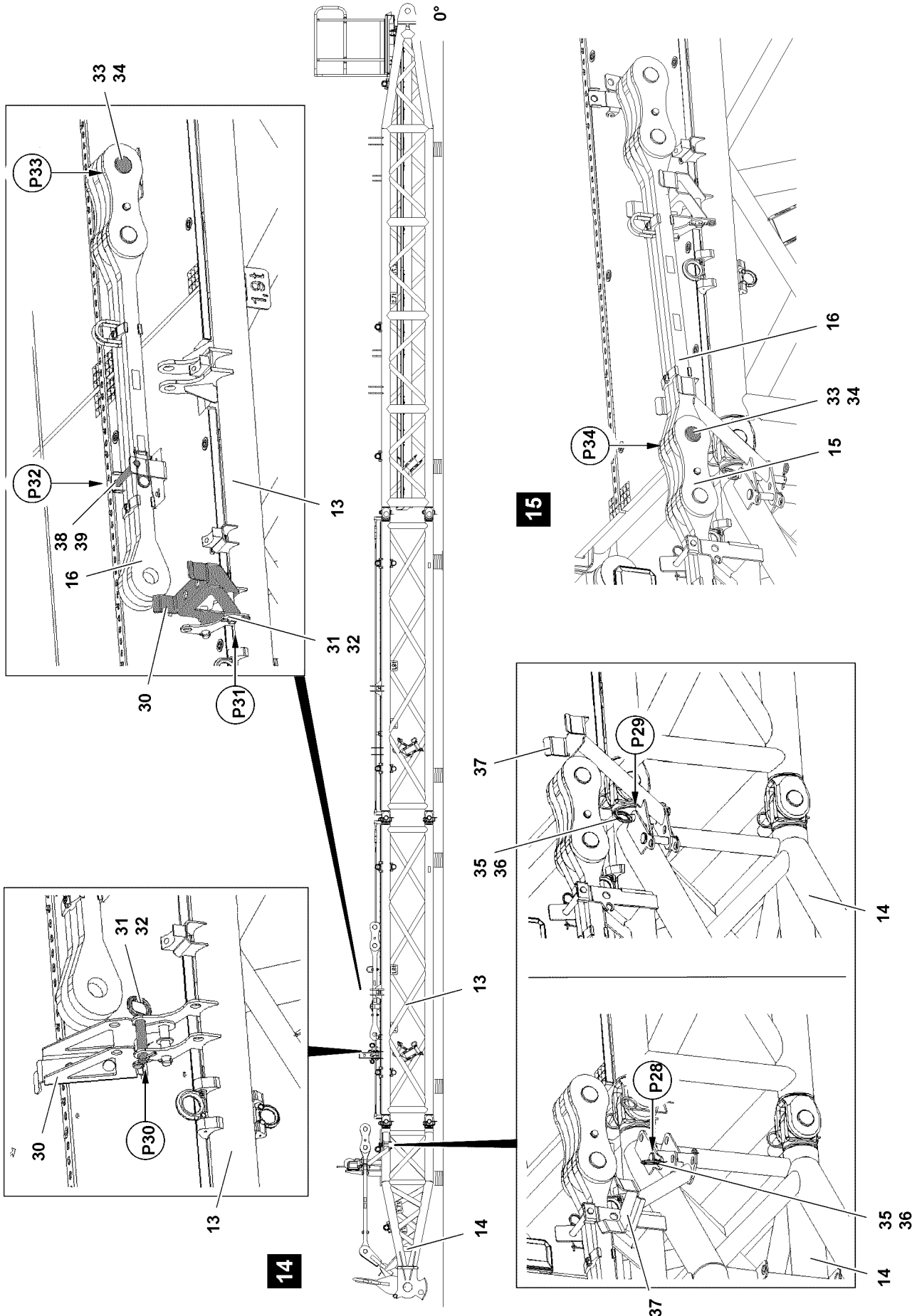

Fig.122951

LWE/LR 11000-001/23501-04-02/en

- ▶ Release the retainer **30** from operating position: Remove the spring retainer **32** at point **P31** and unpin the socket pin **31**, see illustration **14**.

**WARNING**

When swinging the retainer, fingers and hands can be crushed.

- ▶ Do not reach with your hands into the danger zone.
- ▶ Swing the retainer **30** until it can be pinned at point **P30**.
- ▶ Insert the socket pin **31** at point **P30** and secure with spring retainer **32**.

Result:

- The retainer **30** is secured in the transport position, see illustration **14**.
- ▶ Release the bracket **37** from operating position: Remove the spring retainer **36** at point **P29** and unpin the socket pin **35**, see illustration **14**.

**WARNING**

When swinging the bracket, fingers and hands can be crushed!

- ▶ Do not reach with your hands into the danger zone.
- ▶ Swing the bracket **37** until it can be pinned at point **P28**.
- ▶ Insert the socket pin **35** at point **P28** and secure with spring retainer **36**.

Result:

- The bracket **37** is secured in the transport position, see illustration **14**.
- ▶ Secure the pull rod **15** in transport position.

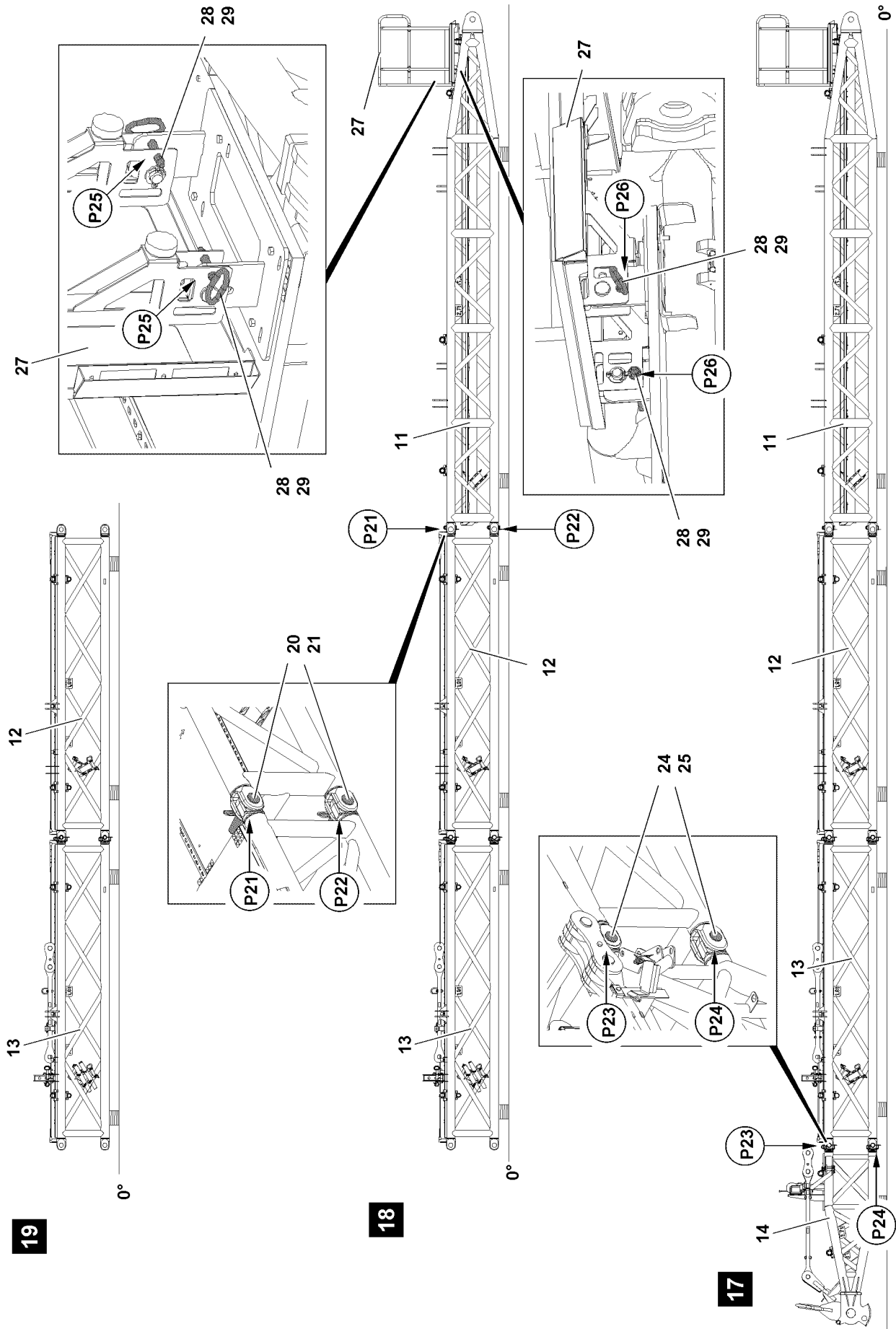

Fig.122952

LWE/LR 11000-001/23501-04-02/en

Disassembling the end section

- ▶ Fasten the end section **14** to the auxiliary crane.

The end section and the intermediate section are pinned together in four points. Every point is present on both sides of the component on one level, see illustration **17**.

- ▶ Unpin the end section **14** on both sides at point **P24**: Remove spring retainers **25** and unpin pins **24**.
- ▶ Unpin the end section **14** on both sides at point **P23**: Remove spring retainers **25** and unpin pins **24**.
- ▶ Remove the end section **14** with the auxiliary crane.
- ▶ Remove the fastening equipment.

Disassembling the pivot section

- ▶ Fasten the platform **27** to the auxiliary crane.
- ▶ Set the platform **27** in the transport position, see illustration **18**: Remove the safety locking pin **29** at points **P26** and unpin the grip pin **28**.



WARNING

Platform swinging down!

The platform can swing down by itself due to its own weight when pinning it, see illustration.

Death, severe bodily injuries, property damage.

Fingers and hands can be crushed.

- ▶ Make sure that the platform is held by the auxiliary crane.
- ▶ Do not reach with your hands into the danger zone.
- ▶ Use personal protective equipment.

-
- ▶ Swing the platform **27** with the auxiliary crane.
 - ▶ Insert the grip pin **28** at points **P25** and secure with safety locking pin **29**.
 - ▶ Remove the auxiliary crane.
 - ▶ Fasten the pivot section **11** to the auxiliary crane.

The pivot section and the intermediate section are pinned together in four points. Every point is present on both sides of the component on one level, see illustration **18**.

- ▶ Unpin the pivot section **11** on both sides at point **P22**: Remove spring retainers **21** and unpin pins **20**.
- ▶ Unpin the pivot section **11** on both sides at point **P21**: Remove spring retainers **21** and unpin pins **20**.
- ▶ Remove the pivot section **11** with the auxiliary crane.
- ▶ Remove the fastening equipment.

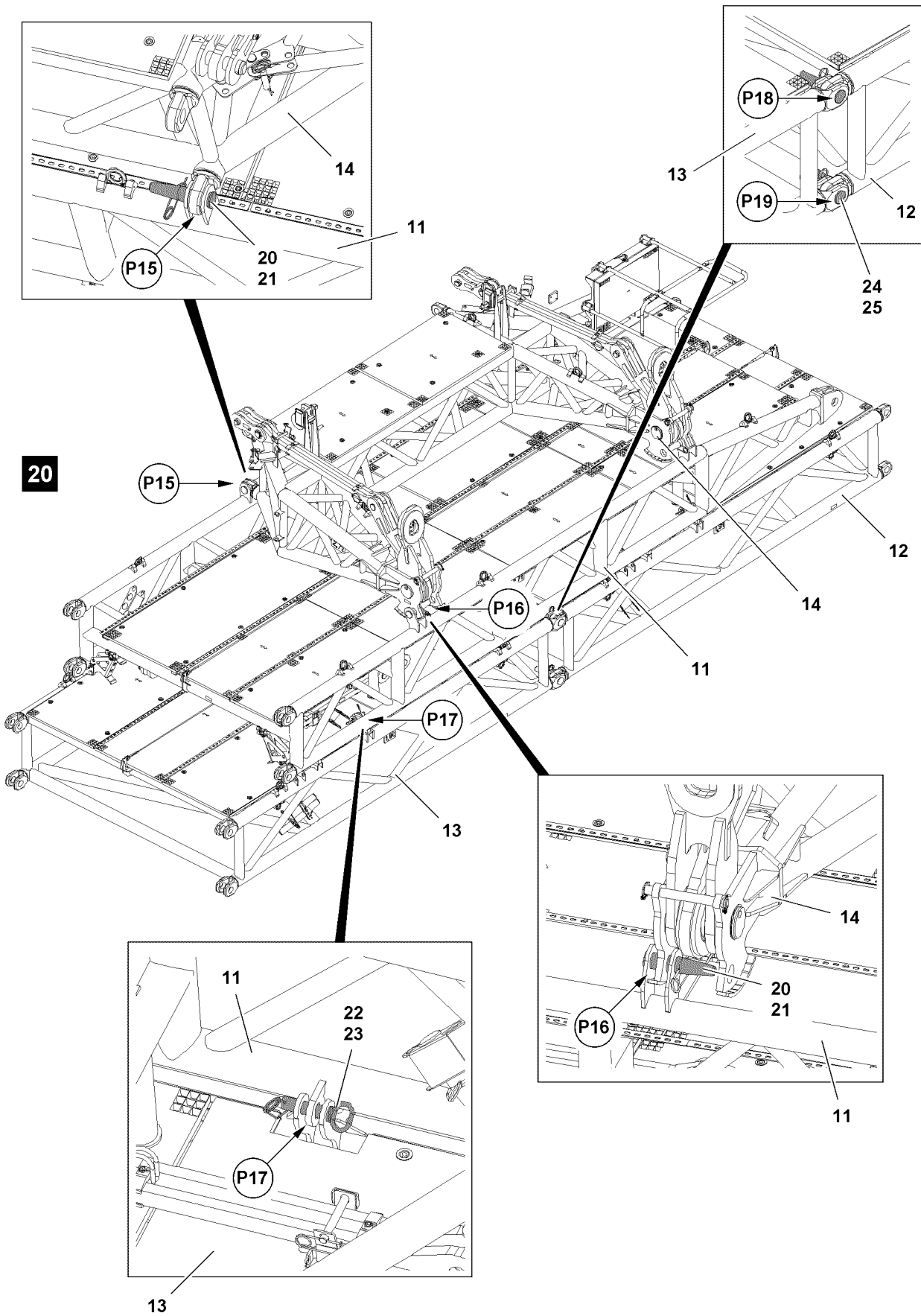

Fig.122953

LWE/LR 11000-001/23501-04-02/en

12.5.4 Installing the suspended ballast guide as a transport unit

Make sure that the following prerequisites are met:

- The pivot section has been removed.
- The end section has been removed.
- The platform has been placed down.
- The pull rods are placed down and secured.
- The retainer and the bracket are secured in transport position.

Assembling the intermediate sections

For the suspended ballast guide as a transport unit, only two intermediate sections are installed.

- ▶ Fasten the intermediate section **13** to the auxiliary crane.
- ▶ Position the intermediate section **13** with the auxiliary crane on the intermediate section **12** at point **P18** until the pin points align.

The intermediate section **13** and intermediate section **12** are pinned together on four points. Every point is present on both sides of the component on one level, see illustration **20**.

- ▶ Pin the intermediate section **13** on both sides at point **P18** with the intermediate section **12**: Insert the pins **24** and secure with the spring retainers **25**.
- ▶ Pin the intermediate section **13** on both sides at point **P19** with the intermediate section **12**: Insert the pins **24** and secure with the spring retainers **25**.
- ▶ Remove the fastening equipment.

Assembling the pivot section

The pivot section is pinned at four points. Every point is present on both sides of the component on one level.

- ▶ Fasten the auxiliary crane to the pivot section **11**.
- ▶ Position the pivot section **11** with the auxiliary crane on the intermediate section **12** and intermediate section **13** at point **P17** until the pin points align, see illustration.
- ▶ Pin the pivot section **11** at points **P17**: Insert the pins **22** and secure with spring retainers **23**, see illustration **20**.
- ▶ Remove the fastening equipment.

Assembling the end section

The end section is pinned at four points. Every point is present on both sides of the component on one level.

- ▶ Fasten the auxiliary crane to the end section **14**.
- ▶ Position the end section **14** with the auxiliary crane on the pivot section **11** at point **P15** and point **P16** until the pin points align, see illustration **20**.
- ▶ Pin the end section **14** at points **P15**: Insert the pins **20** and secure with spring retainers **21**, see illustration **20**.
- ▶ Pin the end section **14** at points **P16**: Insert the pins **20** and secure with spring retainers **21**, see illustration **20**.
- ▶ Remove the fastening equipment.

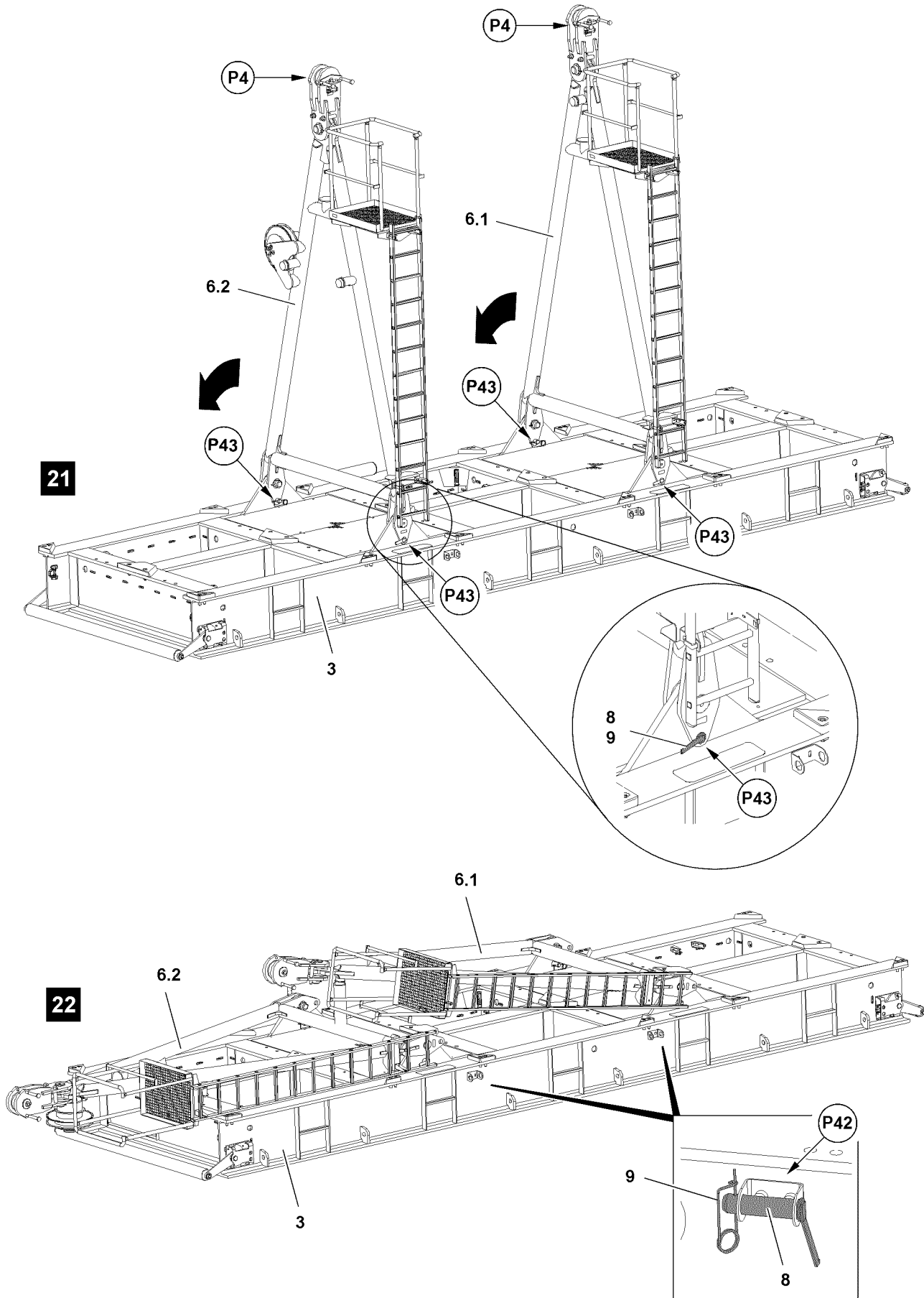

LWE/LR 11000-001/23501-04-02/en

Fig.120217

13 Removing the ballast pallet



Note

- ▶ The disassembly of the erection racks is described based on the example of one erection rack.

The erection rack is unpinned on two points. The unpinning procedure is described for one pin as an example.

- ▶ Hang the erection rack **6.2** on the auxiliary crane at point **P4**, see illustration **21**.



DANGER

Danger of accident during assembly / disassembly of the erection racks!

The erection racks must hang securely on the auxiliary crane, otherwise they could fall down and kill or severely injure personnel.

- ▶ Make sure that the erection rack hangs safely on the auxiliary crane.
- ▶ Never unpin the retaining pins of unsecured or unsupported erection racks.
- ▶ It is prohibited for anyone to remain under the erection racks or within the complete danger zone during the pinning and unpinning procedure.

When the erection rack is safely held by the auxiliary crane:

- ▶ Remove the spring retainer **9** on both sides at point **P43** and unpin the retaining pin **8**.
- ▶ Lower the erection rack **6.2** with the auxiliary crane until the rubber cushion touches the frame, see illustration **22**.
- ▶ Insert the retaining pin **8** at point **P42** on both sides and secure with spring retainer **9** in park position, see illustration **22**.
- ▶ Remove the auxiliary crane.
- ▶ Lower the second erection rack **6.1** with the auxiliary crane until the rubber cushion touches the erection rack **6.2**, see illustration **22**.

Empty page!

LWE/LR 11000-001/23501-04-02/en

5.36.20 Derrick ballast - suspended ballast - special design LTR

1	Product description	3
2	Usage	5
3	Component overview	6
4	Fastening points for suspended ballast components	10
5	Pull cylinder extension conditions	16
6	Derrick ballast radii	17
7	Assembling without suspended ballast guide	20
8	Assembly with suspended ballast guide*	26
9	Ballasting the ballast pallet	47
10	Crane operation with the derrick ballast	54
11	Crawler operation with derrick ballast	88
12	Disassembling, ballasted ballast pallet	89
13	Disassembling, complete	93

Fig.195219

LWE/LR 11000-001/23501-04-02/en

1 Product description

This chapter describes the following derrick ballast variations:

- Suspended ballast *special design*: Ballasting LTR crane and / or ballast plates
Ballasting consisting of an LTR crane and / or ballast plates on a ballast pallet

This crane type has additional derrick ballast variations, which will be described in other chapters of these operating instructions:

- Suspended ballast *special design*: Ballast Constant
Ballasting consisting of directly suspended ballast plates (without a ballast pallet)
- Ballast trailer
Ballasting consisting of ballast plates on a ballast trailer
- Suspended ballast
Ballasting consisting of ballast plates on a ballast pallet



Note

Designation of the ballast types

- ▶ The suspended ballast and the ballast trailer are generally described as derrick ballast.
- ▶ The ballast installed on the turntable is generally referred to as the counterweight.
- ▶ The ballast installed on the crawler travel gear is generally referred to as the central ballast.

1.1 Function

The D-guying contains two pull cylinders (pull cylinder A and pull cylinder B). These pull cylinders are used to pull, lift or lower the derrick ballast.

All relevant data regarding the derrick ballast is displayed on the LICCON monitors.

Ballast pallet for ballasting with LTR:

- It is a special ballast pallet for taking on an LTR crane as a suspended ballast
- Differs from the standard ballast pallet. The standard ballast pallet can only be ballasted with ballast plates.

The following crane types can be utilized as suspended ballast:

- LTR 1100
- LTR 1220

Variations for ballasting:

- LTR 1220 and ballast plates
- LTR 1100 and ballast plates
- Solely ballast plates

Permissible ballast plates:

- Ballast plates 10 t
- Ballast plates 12.5 t

1.2 Variations

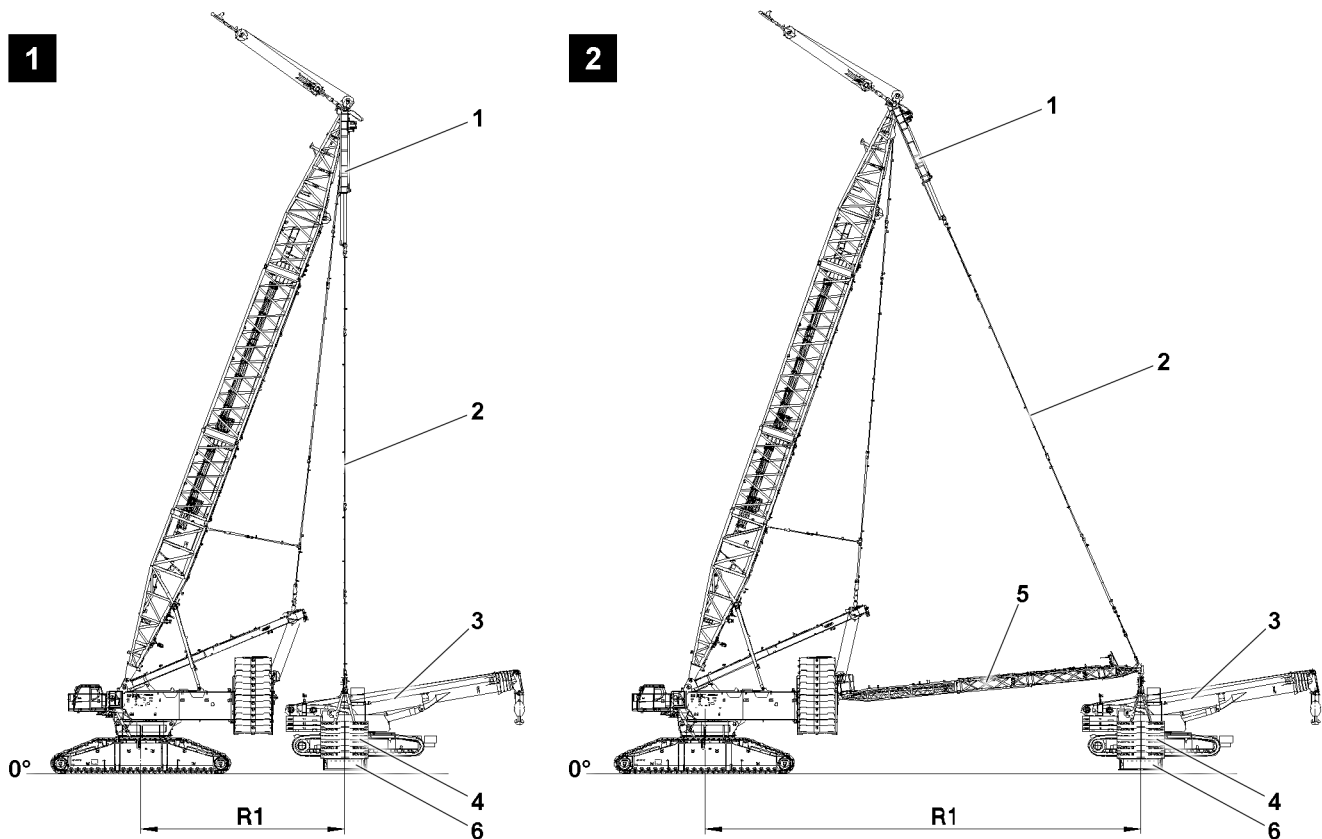

Fig.124995: Variations

The suspended ballast can be assembled with suspended ballast guide or without suspended ballast guide.

Derrick ballast variations:

- Derrick ballast **without** suspended ballast guide, see illustration 1
 - The derrick ballast radius **R1** can be set by adjusting the derrick boom.
- Derrick ballast **with** suspended ballast guide 5, illustration 2
 - The derrick ballast radius **R1** requires the conversion of the suspended ballast guide 5.

1.3 Maximum ballast

Set up configuration of LTR:

- Set up configuration (central ballast, counterweight) of the LTR can be variably adjusted.
- The following charts refer to the maximum set up configuration of the LTR on the ballast pallet.

1.3.1 Suspended ballast with LTR 1220

Position	Weight
Ballast pallet with cross beam	22 t
LTR 1220 with 70 t counterweight and 20 t central ballast	190 t
Ballast of ballast plates 10 t , maximum	240 t
Suspended ballast, total maximum	452 t

1.3.2 Suspended ballast with LTR 1100

Position	Weight
Ballast pallet with cross beam	22 t
LTR 1100 with 32 t counterweight and 15 t central ballast	108 t
Ballast of ballast plates 10 t , maximum	320 t
Suspended ballast, total maximum	450 t

2 Usage

2.1 Intended use

Use suspended ballast with LTR solely for:

- Erecting the boom system
- Taking down the boom system

2.2 Non-designated use

Do **not** use suspended ballast with LTR for:

- Erection / take-down of a luffing lattice jib (W-system)
- Crane operation with erected boom system
- Crane operation with a luffing lattice jib (W-system)
- Driving with a crawler

3 Component overview

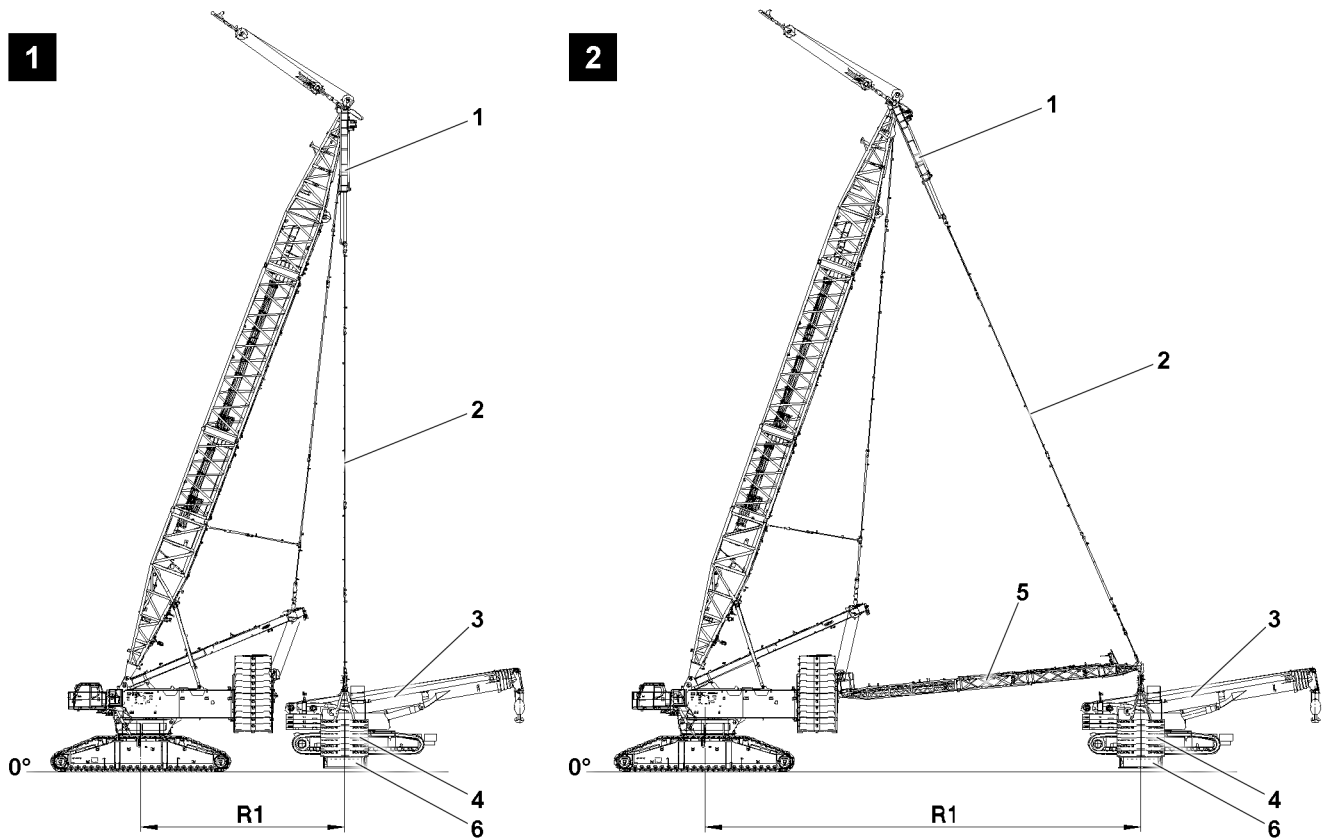

Fig.124995: Component overview Derrick ballast variations

- | | | | | | |
|---|---------------|---|----------------|---|----------------------------|
| 1 | Pull cylinder | 3 | LTR | 5 | Suspended ballast guide B2 |
| 2 | D-guying | 4 | Ballast plates | 6 | Ballast pallet |

3.1 Ballast pallet and ballast plates



Note

- ▶ The assembly sections are marked with their own weight.
- ▶ Dimensions and weights, see the Crane operating instructions, chapter 1.03.

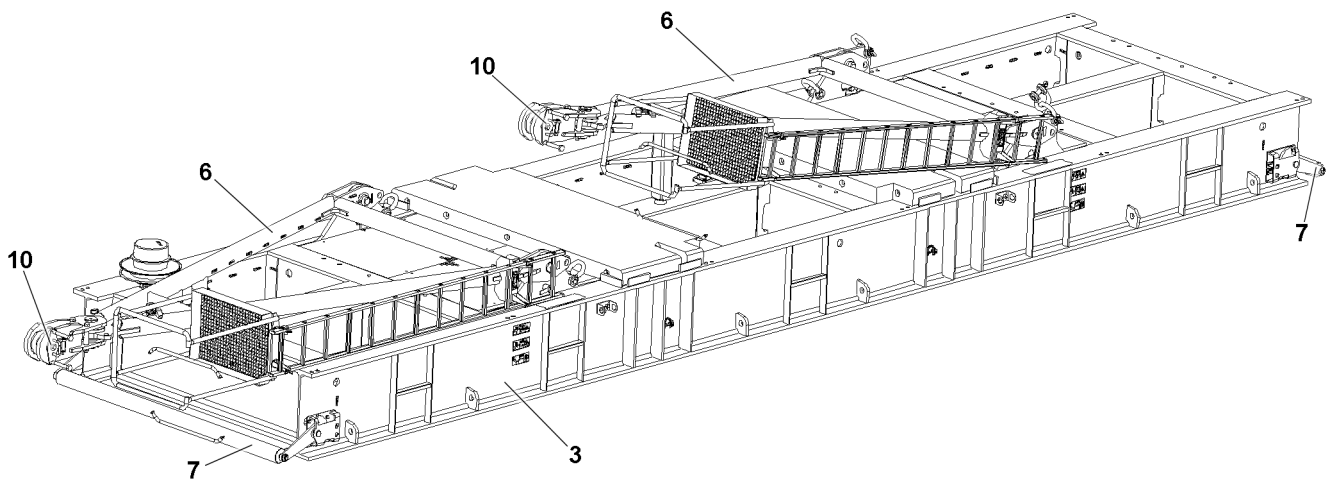

Fig. 124997: Ballast pallet, transport position

- | | | | |
|---|----------------|----|-----------------------|
| 3 | Ballast pallet | 7 | Ground contact roller |
| 6 | Erection rack | 10 | Connector pin |

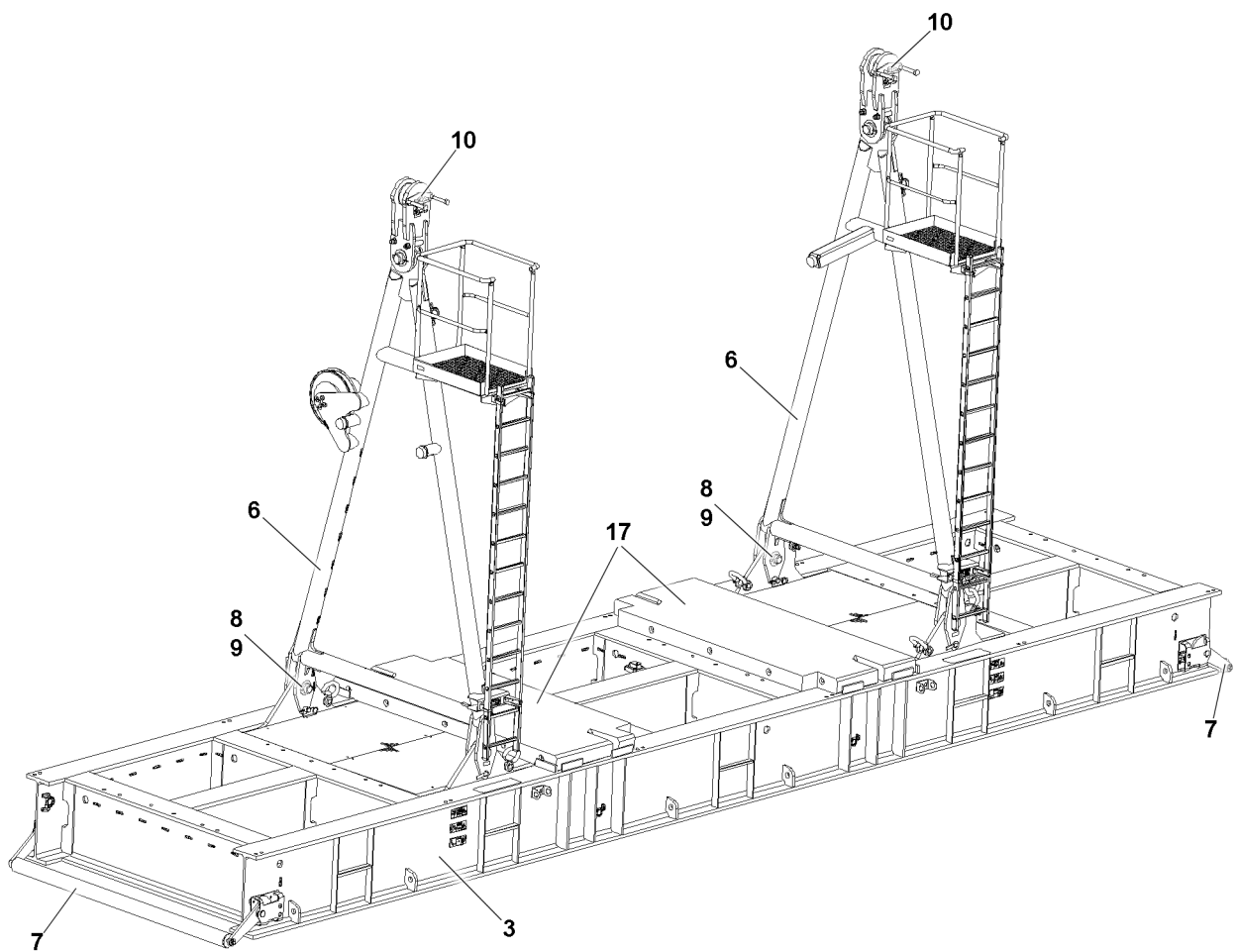

Fig. 124996: Ballast pallet, operating position

- | | | | | | |
|---|-----------------------|----|---------------|----|----------------|
| 3 | Ballast pallet | 8 | Retaining pin | 17 | Mat, removable |
| 6 | Erection rack | 9 | Safety spring | | |
| 7 | Ground contact roller | 10 | Connector pin | | |

LWE/LR 11000-001/23501-04-02/en

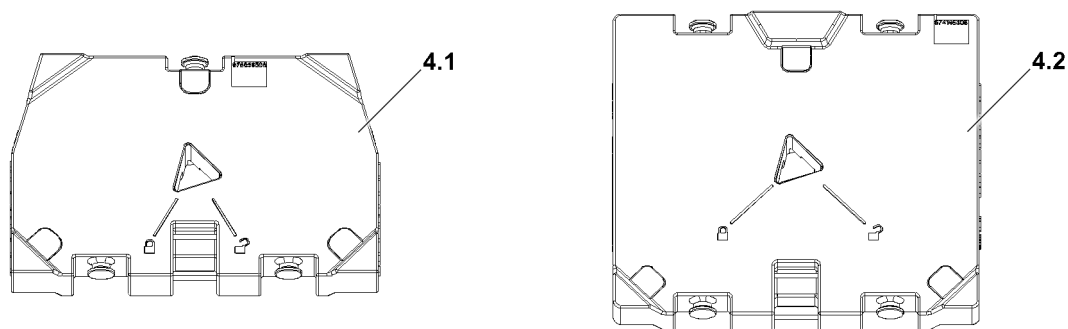

Fig.126480

4.1 10 t ballast plate

4.2 Ballast plate 12.5 t

3.2 Suspended ballast guide*



Note

- ▶ The assembly sections are marked with their own weight.
- ▶ Dimensions and weights, see the Crane operating instructions, chapter 1.03.

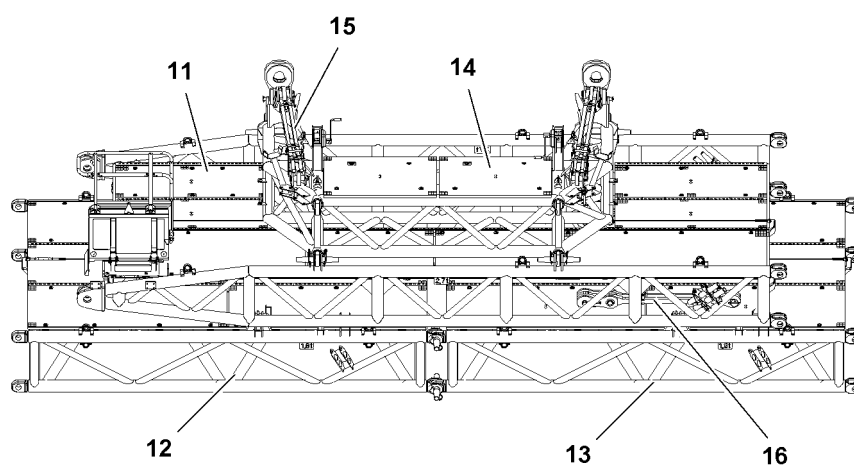

Fig.126059: Transport position

- | | | | |
|----|----------------------|----|-------------------------|
| 11 | Pivot section | 14 | End section |
| 12 | Intermediate section | 15 | Pull rods - end section |
| 13 | Intermediate section | 16 | Pull rods |

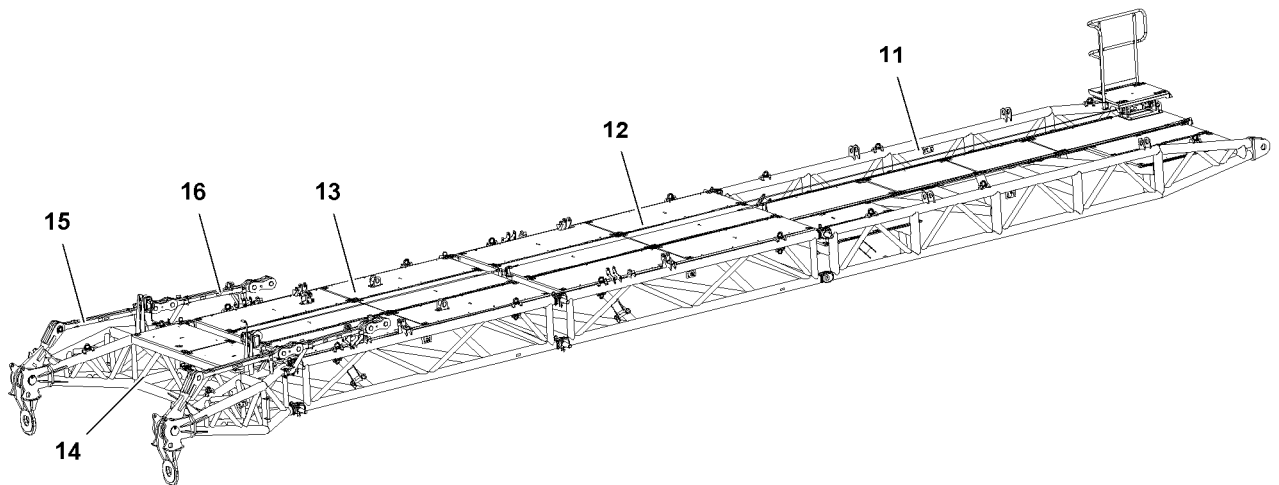

Fig. 124999: Operating position

- | | | | | | |
|----|----------------------|----|----------------------|----|-------------------------|
| 11 | Pivot section | 13 | Intermediate section | 15 | Pull rods - end section |
| 12 | Intermediate section | 14 | End section | 16 | Pull rods |

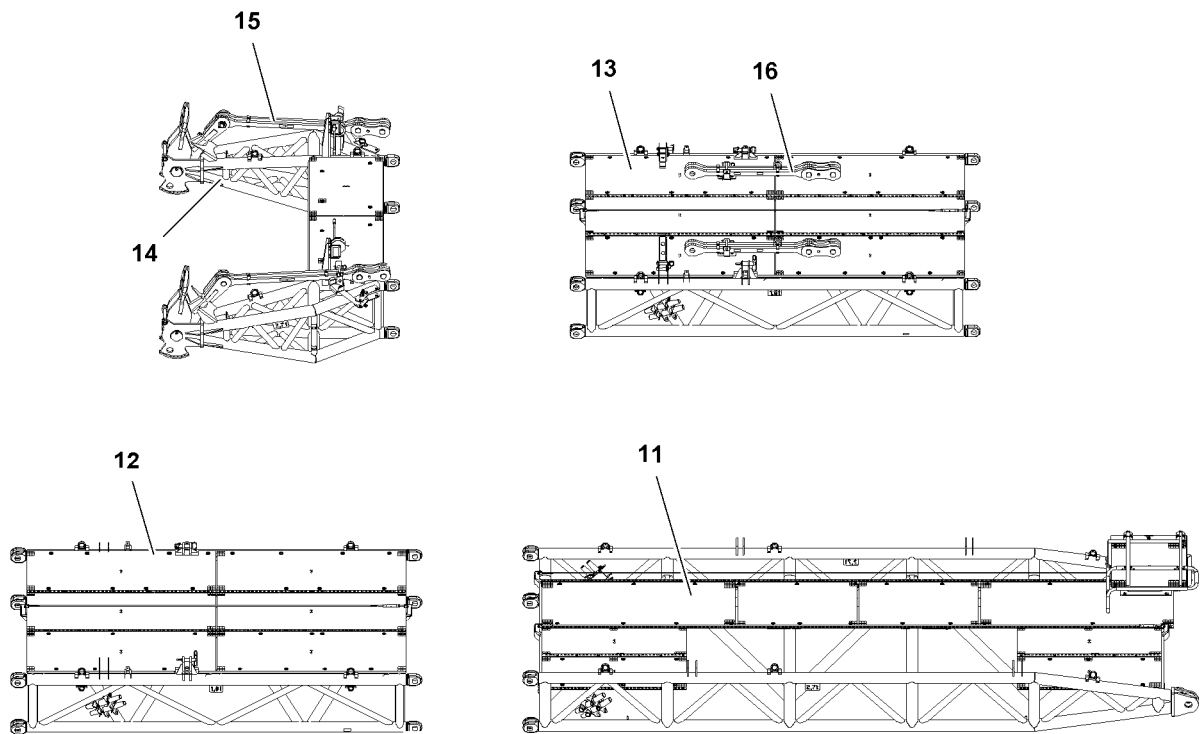

Fig. 124998: Component overview

- | | | | | | |
|----|----------------------|----|----------------------|----|-------------------------|
| 11 | Pivot section | 13 | Intermediate section | 15 | Pull rods - end section |
| 12 | Intermediate section | 14 | End section | 16 | Pull rods |

3.3 Auxiliary parts



Note

- ▶ The assembly sections are marked with their own weight.
- ▶ Dimensions and weights, see the Crane operating instructions, chapter 1.03.

LWE/LR 11000-001/23501-04-02/en

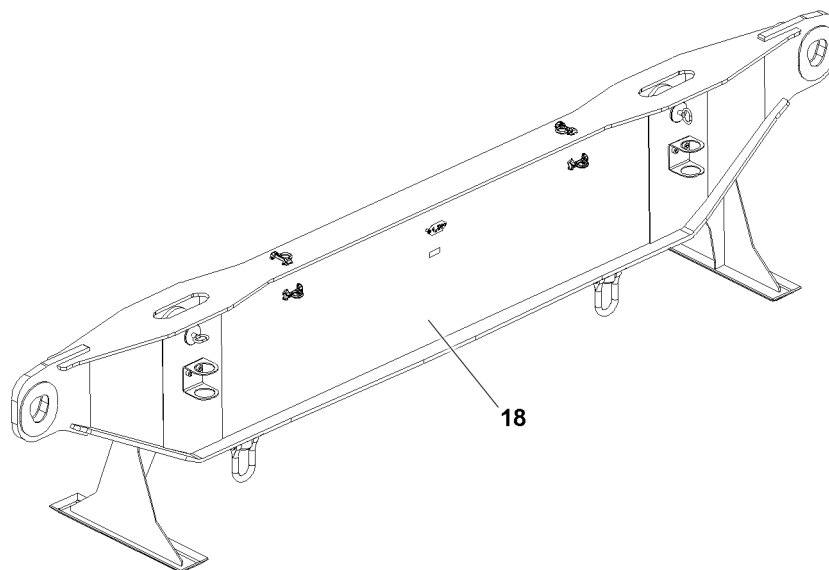

Fig.124993

18 Cross beam

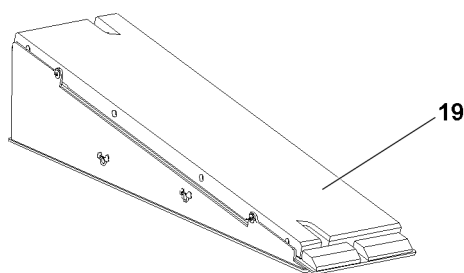

Fig.124994

19 Ramp

4 Fastening points for suspended ballast components

4.1 Ballast pallet and ballast plates



WARNING

Component incorrectly fastened!

Life-threatening situations can arise due to improper or incorrect attachment of the corresponding components.

Death, severe injury, property damage.

- ▶ Fasten the components only on the intended fastening points on both sides.
- ▶ Fastening of components and description of fastening points, see Crane operating instructions, chapter 5.01.

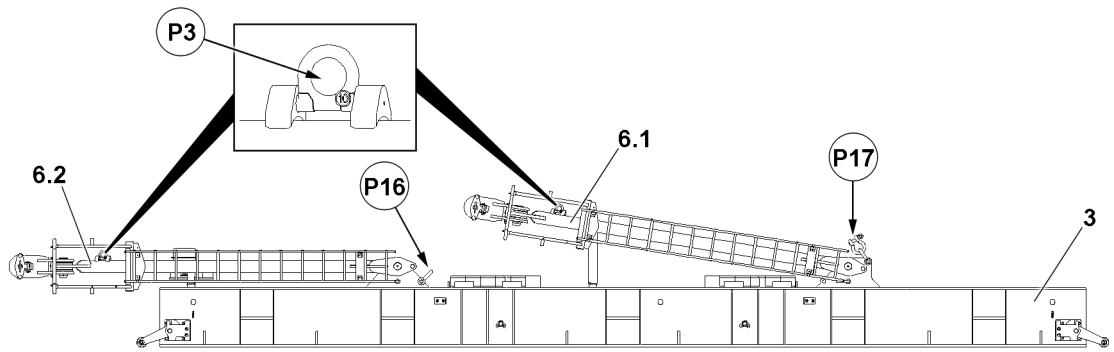

Fig.126065

3 Ballast pallet, transport position

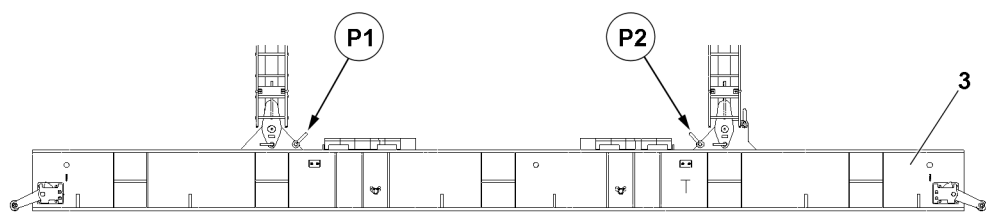

Fig.126066

3 Ballast pallet, operating position

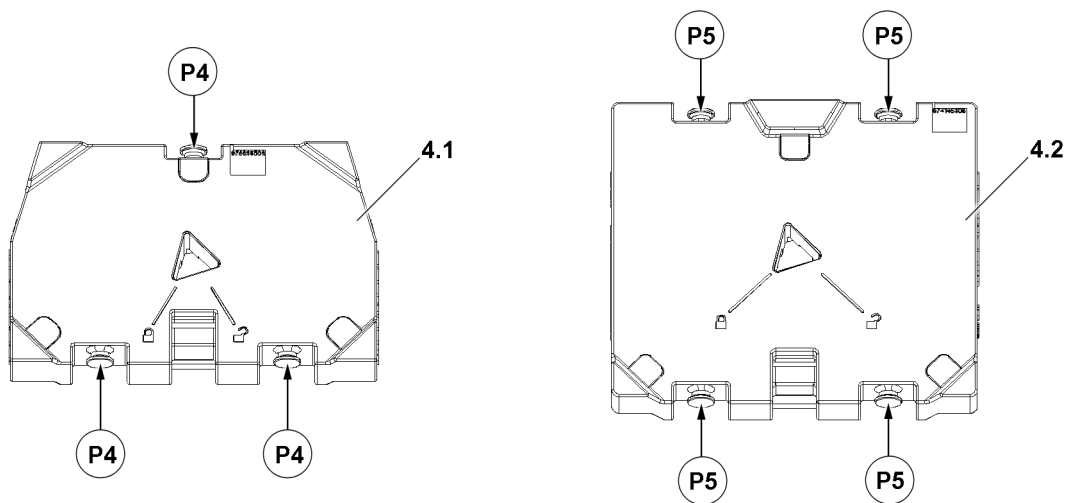

Fig.126067

4.1 10 t ballast plate

4.2 Ballast plate 12.5 t

Fastening points	
P16 and P17	Ballast pallet 3, transport position
P1 and P2	Ballast pallet 3, operating position
P3	Erection rack 6.1 and erection rack 6.2
P4	Ballast plate 4.1
P5	Ballast plate 4.2

LWE/LR 11000-001/23501-04-02/en

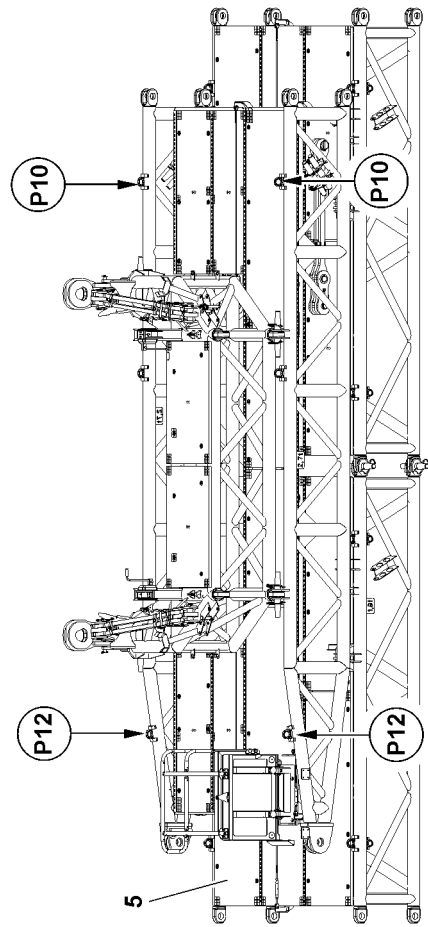
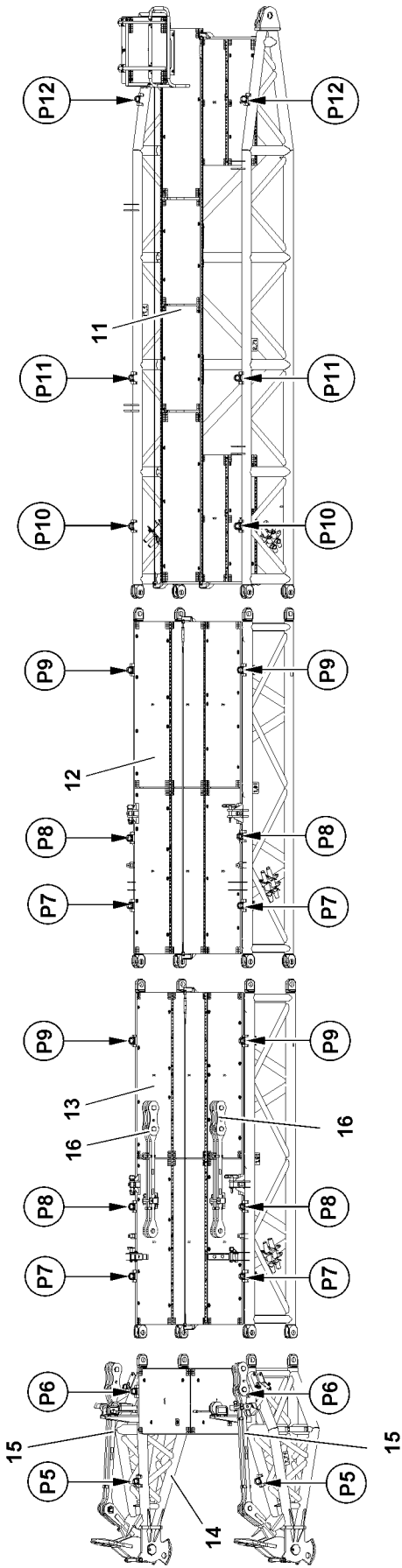

Fig.119023

LWE/LR 11000-001/23501-04-02/en

4.2 Suspended ballast guide*

4.2.1 Fastening points for lattice sections



WARNING

Component incorrectly fastened!

Life-threatening situations can arise due to improper or incorrect attachment of the corresponding components.

Death, severe injury, property damage.

- ▶ Fasten the components only on the intended fastening points on both sides.
- ▶ Fastening of components and description of fastening points, see Crane operating instructions, chapter 5.01.

Fastening points	
P5 and P6	End section 14
P7 and P9	Intermediate section 13
P7 and P9	Intermediate section 12
P10 and P12	Pivot section 11
P10 and P12	Suspended ballast guide (transport) 5

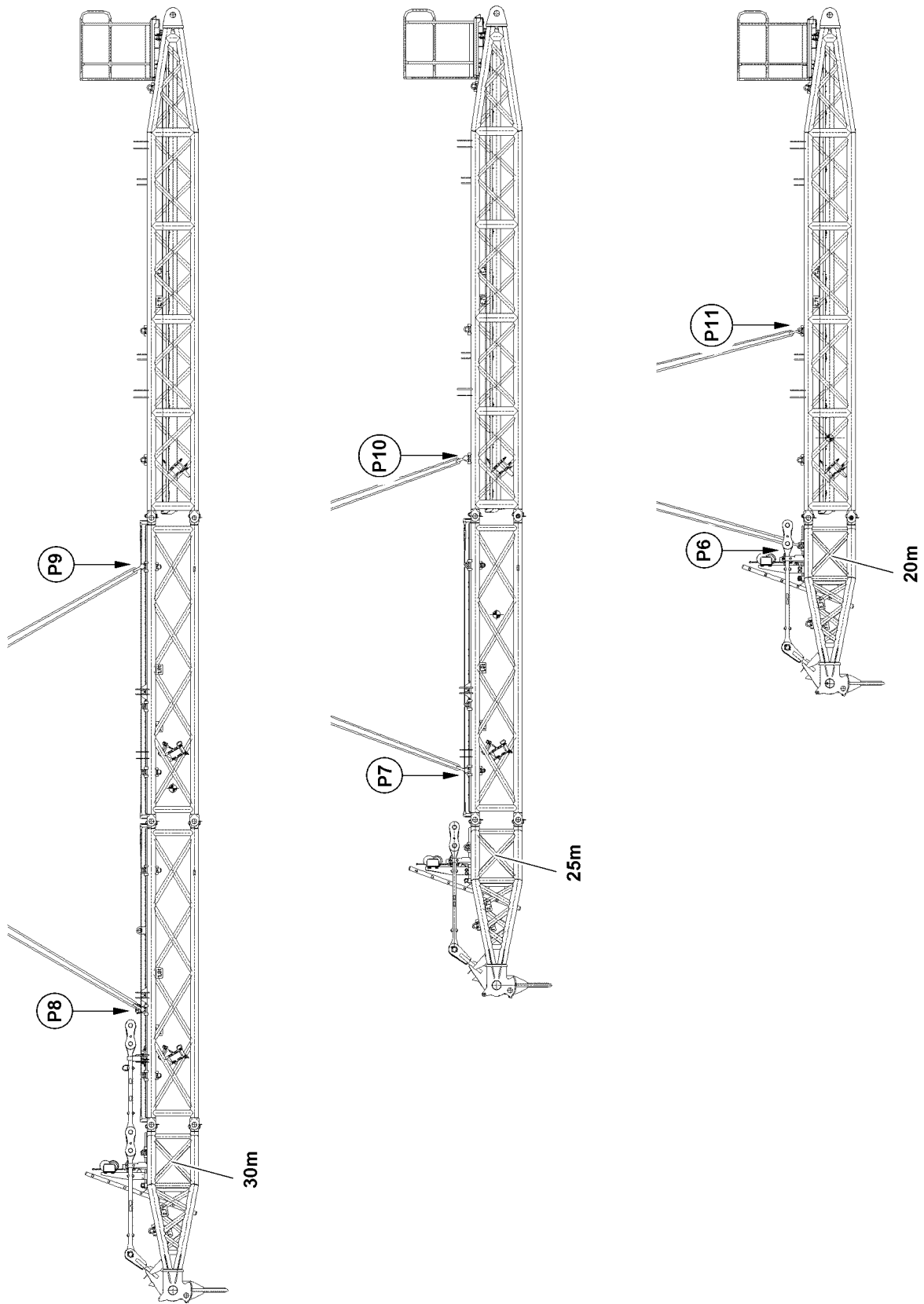

Fig.119084

4.2.2 Fastening points suspended ballast guide



WARNING

Component incorrectly fastened!

Life-threatening situations can arise due to improper or incorrect attachment of the corresponding components.

Death, severe injury, property damage.

- ▶ Fasten the components only on the intended fastening points on both sides.
- ▶ Fastening of components and description of fastening points, see Crane operating instructions, chapter 5.01.

Fastening points	
P8 and P9	Suspended ballast guide 30 m
P7 and P10	Suspended ballast guide 25 m
P6 and P11	Suspended ballast guide 20 m

4.3 Auxiliary parts

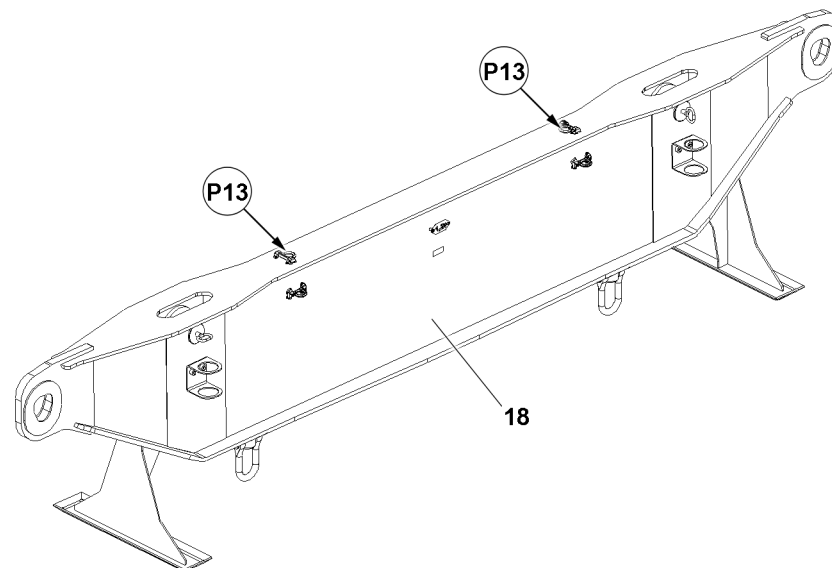

Fig.126060

18 Cross beam

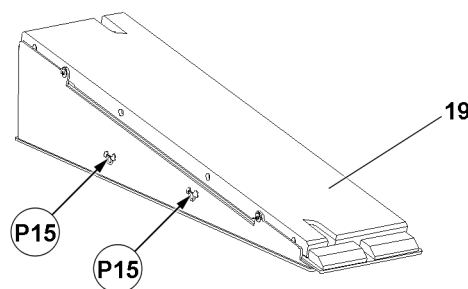

Fig.126061

19 Ramp

Fastening points	
P13	Cross beam
P15	Ramp

5 Pull cylinder extension conditions

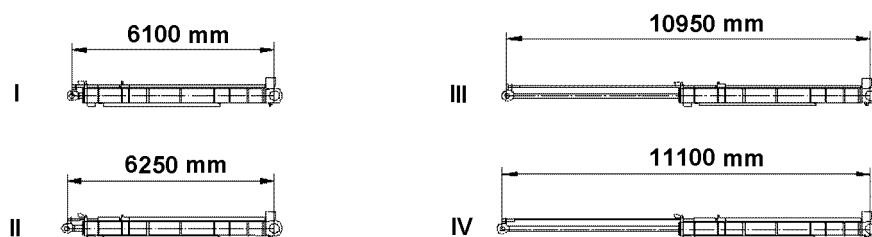

Fig.119003: Pull cylinder extension conditions

Extension conditions	
I	Block position „Retracted“
II	Switch position „Retracted“
III	Switch position „Extended“
IV	Block position „Extended“

6 Derrick ballast radii

6.1 Derrick ballast without suspended ballast guide

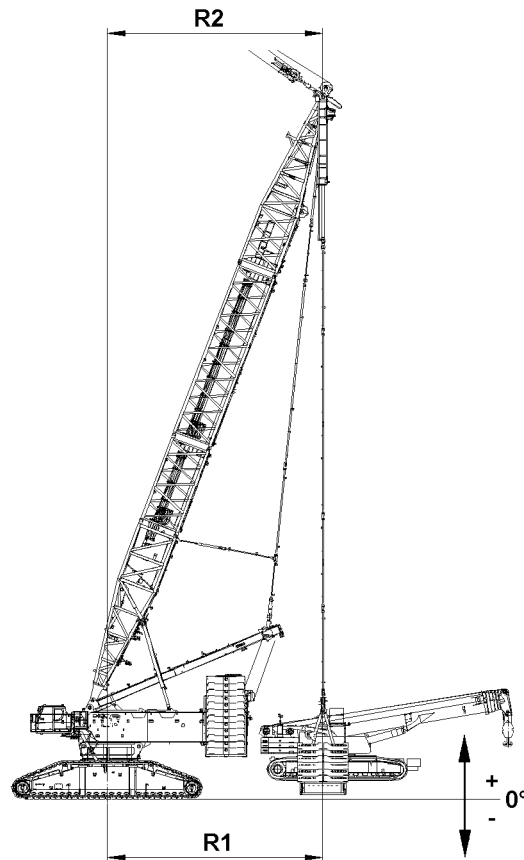

Fig.126477: Derrick ballast radii without suspended ballast guide



Note

- ▶ No suspended ballast guide is installed between the turntable and the ballast pallet.
- ▶ The derrick ballast radius **R1** and the derrick radius **R2** are identical.



Note

- ▶ Depending on the LRT in use, the minimum ballast radius of 12 m can **not** be set.

6.1.1 36 m derrick boom

With the 36 m derrick, the following derrick ballast radii are possible: R1= 12 m and R1 =18 m.

Radius R1 = 12 m	
Above base	+3696 mm
Below base	-1004 mm

Radius R1 = 18 m	
Above base	+719 mm
Below base	-3981 mm

6.1.2 Derrick boom 42 m

With the 42 m derrick, the following derrick ballast radii are possible: R1= 12 m and R1= 20 m.

Radius R1 = 12 m	
Above base	+4061 mm
Below base	-639 mm

Radius R1 = 20 m	
Above base	+509 mm
Below base	-4191 mm

6.2 Derrick ballast with suspended ballast guide

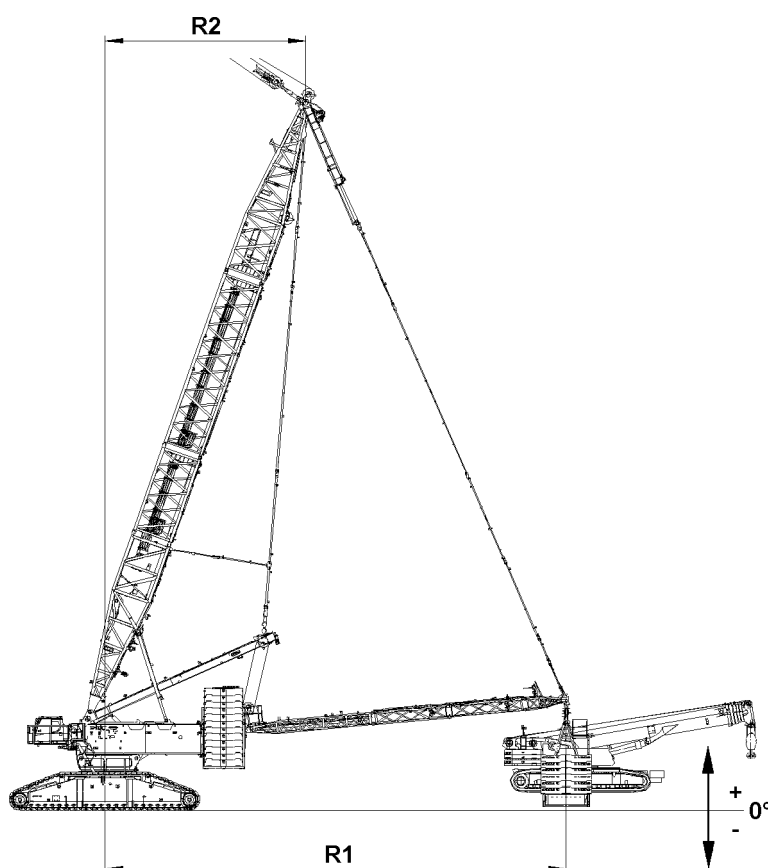

Fig.126478: Derrick ballast radii with suspended ballast guide



Note

- ▶ One suspended ballast guide is installed between the turntable and the ballast pallet.
- ▶ The derrick ballast radius **R1** and the derrick radius **R2** are **not** identical.

6.2.1 36 m derrick boom

Derrick radius with the 36 m derrick is $R_2 = 13$ m.

With the 36 m derrick, the following derrick ballast radii are possible: $R_1 = 20$ m and $R_1 = 25$ m.

Radius $R_1 = 20$ m	
Above base	+800 mm
Below base	-1200 mm

Radius $R_1 = 25$ m	
Above base	+800 mm
Below base	-1200 mm

6.2.2 Derrick boom 42 m

Derrick radius with the 42 m derrick is $R_2 = 13$ m.

With the 42 m derrick, the following derrick ballast radii are possible: $R_1 = 20$ m, $R_1 = 25$ m and $R_1 = 30$ m.

Radius $R_1 = 20$ m	
Above base	+800 mm
Below base	-1200 mm

Radius $R_1 = 25$ m	
Above base	+800 mm
Below base	-1200 mm

Radius $R_1 = 30$ m	
Above base	+800 mm
Below base	-1200 mm

7 Assembling without suspended ballast guide



WARNING

Danger of falling!

During assembly / disassembly, inspection and maintenance work, personnel must be secured with appropriate aids to prevent them from falling.

Death, severe injury, property damage.

- ▶ All work at a height, when there is a danger of falling, must be carried out with suitable aids.
- ▶ If aids are not available and work cannot be carried out from the ground, then assembly personnel must secure themselves with the supplied fall arrest system to prevent falling, see the Crane operating instructions, chapter 2.04.
- ▶ If fall protection equipment is available, then it must be used, see the Crane operating instructions, chapter 2.06.
- ▶ When lifting, lowering, swinging crane parts in and out, no persons may remain in the danger zone.
- ▶ If railings are present on the components, then they must be brought into the corresponding position and secured for assembly / disassembly work.
- ▶ Only step on the aids, ladders and catwalks with clean shoes.
- ▶ Keep aids, ladders and catwalks free of heavy dirt, snow and ice.
- ▶ During all assembly and disassembly work, maintenance work and inspections, travel or crane operation is prohibited.
- ▶ Remaining on a suspended load is prohibited.
- ▶ Stepping or walking on crane components and lattice sections, which have an incline of more than 20° is prohibited.
- ▶ For all assembly work, the crane operator of the main crane must be in voice contact with the crane operator / crane operators of the auxiliary crane / auxiliary cranes.
- ▶ For assembly / disassembly tasks, the crane operator may only initiate crane movements when the responsible guide has explicitly released the movement.

When the assembly personnel is within the danger zone of the crane:

- ▶ A guide and / or the crane operator must be able to see the entire danger zone.



WARNING

Danger of impact / crushing!

When installing / removing crane components with the auxiliary crane, crane components can start to swing back and forth.

When lifting / lowering and positioning crane components, there is an increased danger of impacts / crushing.

Personnel can be caught and severely injured or killed.

- ▶ Make sure that personnel cannot be caught by components.
- ▶ When working in danger zones: Use aids to protect limbs.
- ▶ Guide components with suitable aids to minimize oscillation.



DANGER

The components can fall down!

If the corresponding components are disengaged from the auxiliary crane before the corresponding component is pinned, the corresponding component can fall down and fatally injure personnel.

- ▶ Do not disengage the auxiliary crane until the respective component is pinned and secured.

Make sure that the following prerequisites are met:

- The crane is horizontally aligned.
- The ground is level and of sufficient load bearing capacity.
- An auxiliary crane is available.
- Main boom and derrick are installed on the turntable.
- The derrick is in the crane operating position.
- Main boom is assembled, guying is tensioned.
- The counterweight has been installed on the turntable according to the load charts and the erection charts.
- The LICCON overload protection has been set according to the data in the load charts and erection charts.
- The LICCON overload protection settings have been compared with the actual set up configuration.

7.1 Assembling the cross beam

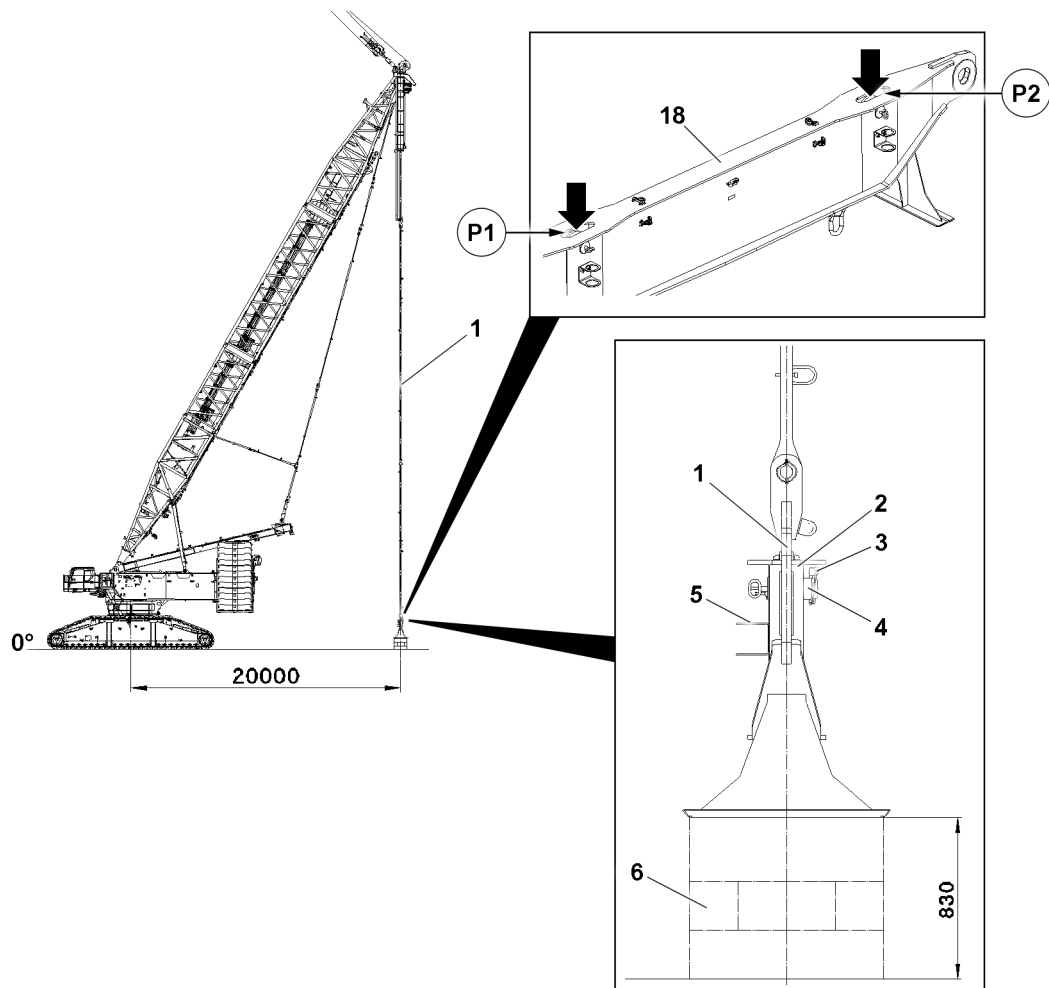

Fig.124981: Cross beam

- ▶ Set the derrick radius to 20 m.

The substructure **6** must be at least 830 mm above the crane placement surface.

- ▶ Position the substructure **6** under D-guy rods **1**.



Note

- ▶ Fastening points, see section „Fastening points for suspended ballast parts“.
- ▶ Fasten the cross beam **18** with fastening equipment to the auxiliary crane.
- ▶ Set the cross beam **18** on the substructure **6**.

- ▶ Release and unpin the pin **4** in transport retainer **5**.
- ▶ Extend the pull cylinder until the D-guy rods **1** can be pinned on point **P1** and on point **P2** with the cross beam.

**Note**

Retract / extend the pull cylinder

- ▶ Control the pull cylinders from the crane cab, see the section „Lifting and lowering the derrick ballast using the pull cylinders“.
- ▶ Operate the pull cylinder with the radio remote control, see the „radio remote control operating instructions“.

- ▶ Pin the D-guy rods **1** with the cross beam: Insert the pins **4** and secure with locking pins **3**.
- ▶ Lift the cross beam: Retract the pull cylinder.

7.2 Setting the ballast pallet in the assembly position

- ▶ Set the derrick to the required radius.

**Note**

- ▶ Fastening points, see section „Fastening points for suspended ballast parts“.

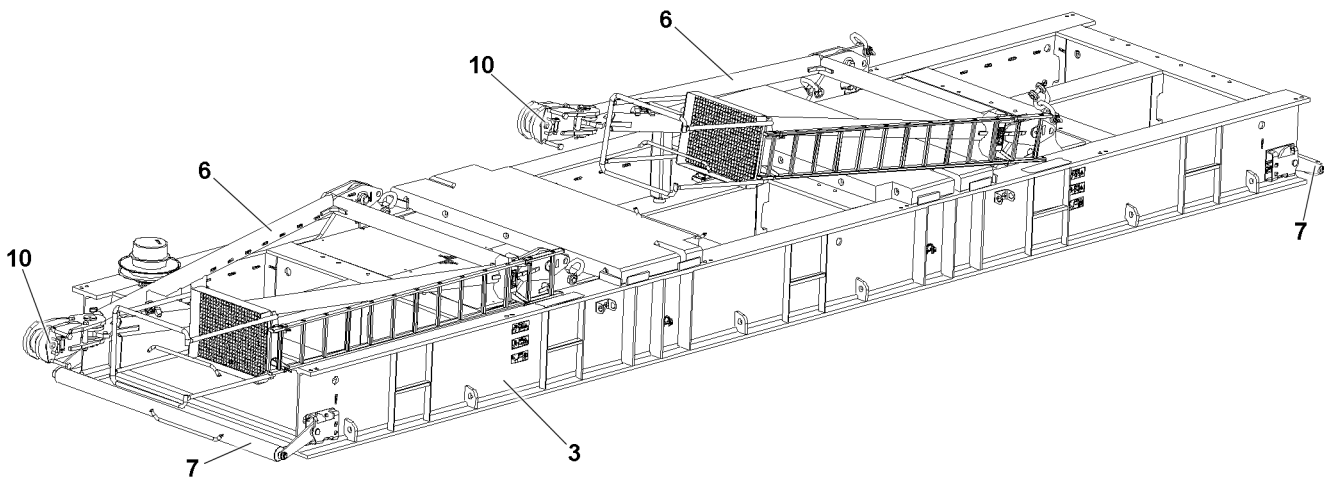

Fig.124997: Ballast pallet, transport position

- ▶ Fasten the ballast pallet **3** with fastening equipment to the auxiliary crane.
- ▶ Position the ballast pallet **3** in the slewing range of the crane under the guy rods on the derrick.

**Note**

- ▶ Set the ballast pallet **3** for easier assembly of the guy rods in lengthwise direction of the turntable.
- ▶ Align the ballast pallet **3** horizontally.

7.3 Erecting the erection racks

**Note**

- ▶ The assembly of the erection racks is described based on the example of one erection rack.

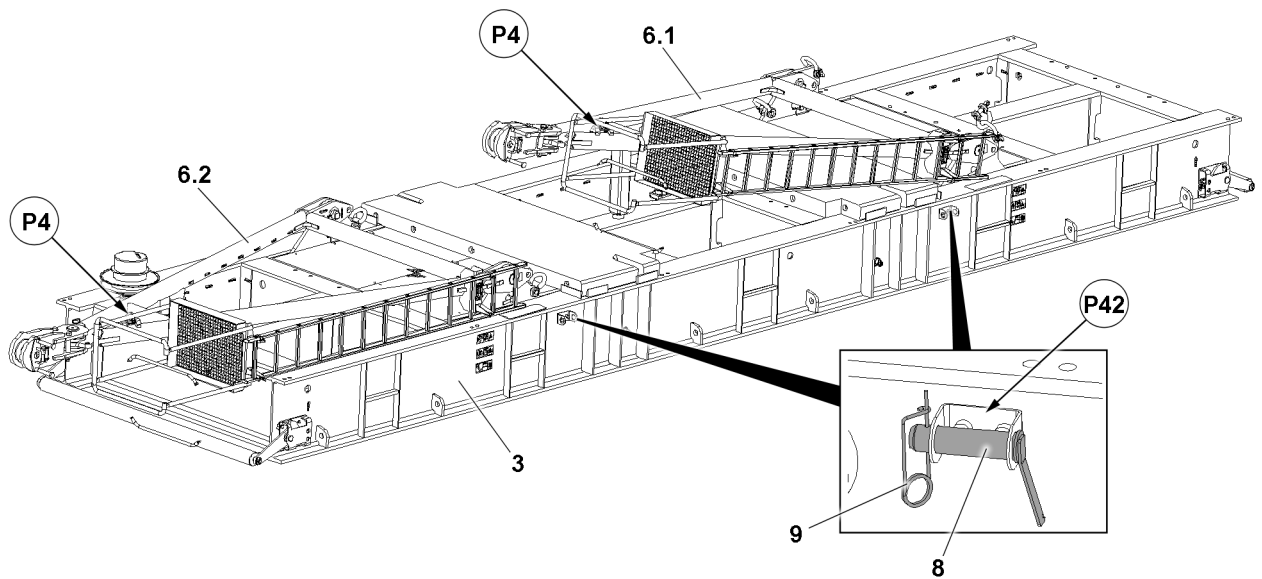

Fig.126063: Ballast pallet, transport position

The erection rack is pinned on two points. The pin procedure is described for one pin as an example.

- ▶ Fasten the erection rack **6.1** with fastening equipment to the auxiliary crane, point **P4**.
- ▶ Remove the spring retainer **9** on both sides on points **P42** and unpin the retaining pin **8** from the park position.

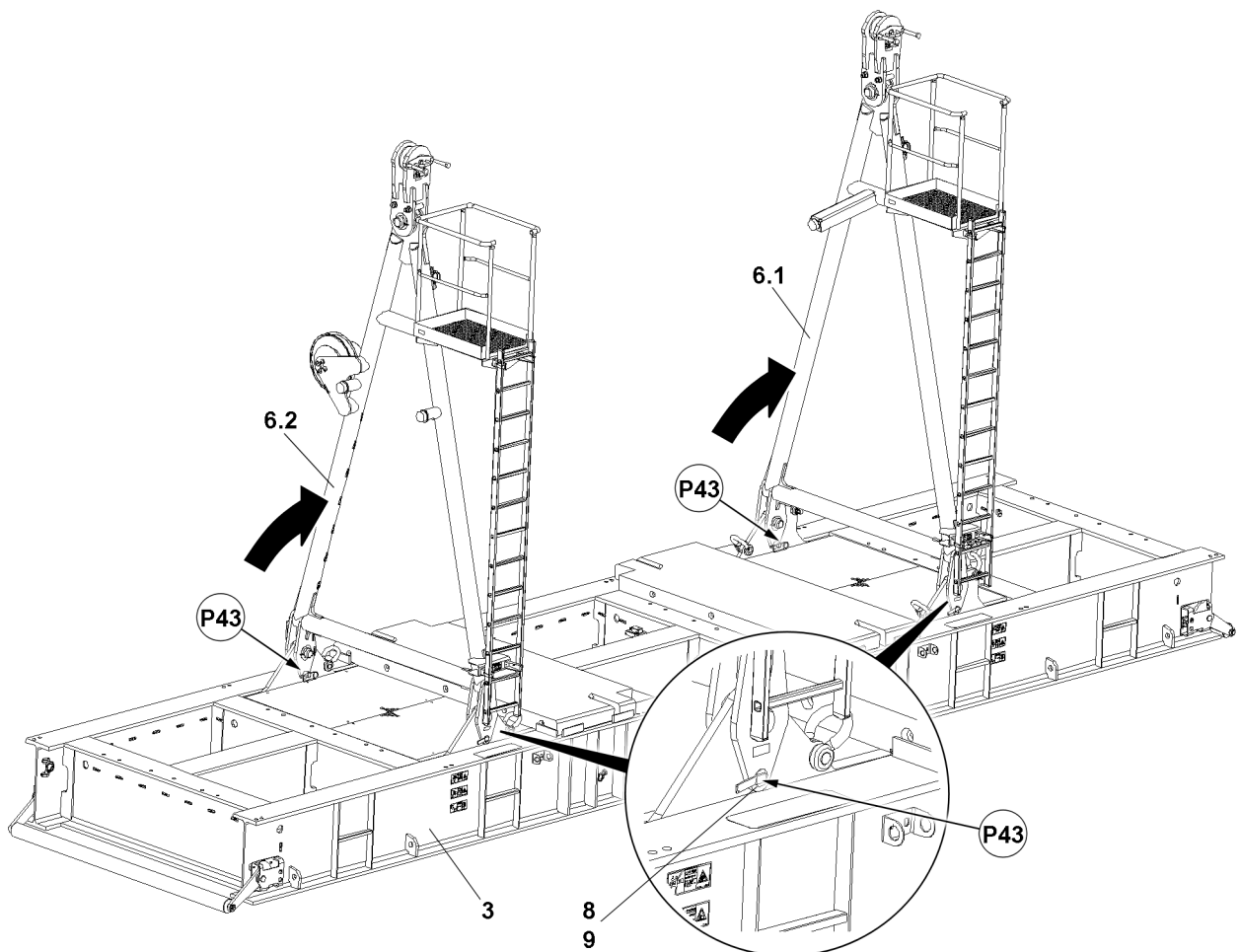

Fig.126064: Ballast pallet, operating position

**DANGER**

Unsecured erection racks!

Toppling erection racks. Death, severe bodily injuries, property damage.

- ▶ Secure the erection racks after erection with the auxiliary crane.
- ▶ When both erection racks are locked and secured in a vertical position with retaining pins **8**: Remove the auxiliary crane.
- ▶ Never unpin the retaining pins from unsecured erection racks.
- ▶ It is prohibited for anyone to remain under the erection racks or within the complete danger zone during the pinning and unpinning procedure.

- ▶ Set the erection rack **6.1** vertically with the auxiliary crane.
- ▶ Insert the retaining pin **8** at point **P43** on both sides and secure with spring retainer **9**.

When the erection rack is erected and secured:

- ▶ Remove the auxiliary crane.
- ▶ Erect the second erection rack **6.2** and secure with retaining pin **8**.

7.4 Pinning the ballast pallet with cross beam

Make sure that the following prerequisites are met:

- Ballast pallet is in assembly position.
- Erection racks are erected and secured to prevent them from folding down.

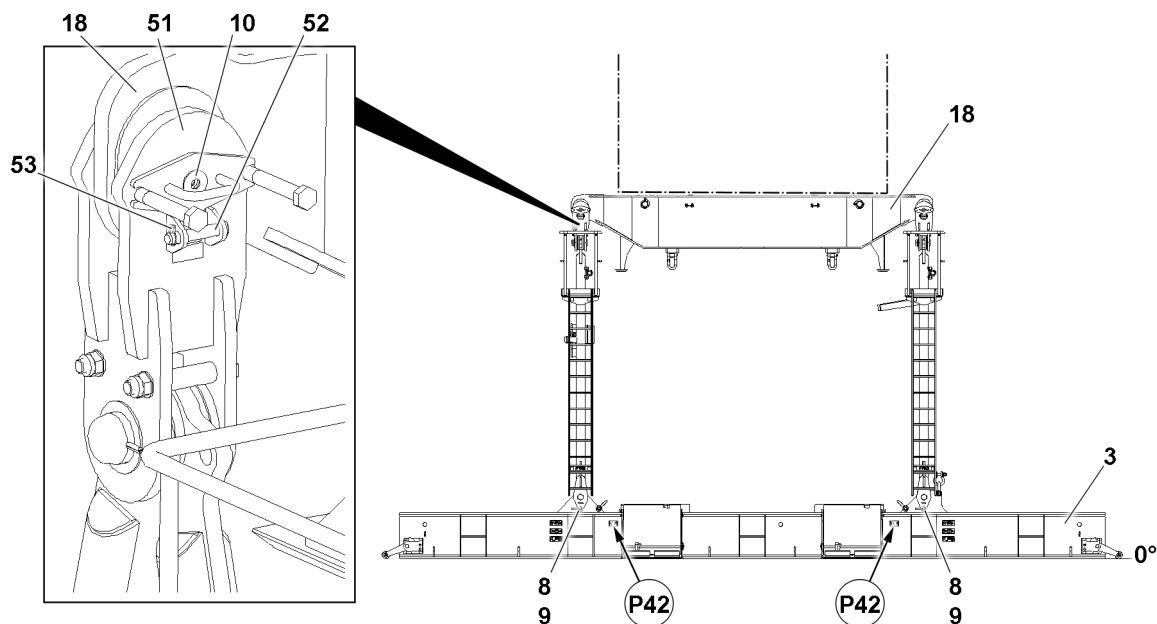

Fig.126062: Ballast pallet with cross beam

- ▶ Move the pull cylinder out until the pin bores align on bracket **51** and on cross beam **18**.

**Note**

Retract / extend the pull cylinder

- ▶ Control the pull cylinders from the crane cab, see the section „Lifting and lowering the derrick ballast using the pull cylinders“.
- ▶ Operate the pull cylinder with the radio remote control, see the „radio remote control operating instructions“.

Pins **10** must be pinned and secured on both erection racks.

When the pin bores align:

- ▶ Insert the pin **10**.
- ▶ Secure the pin **10**: Insert the pin **52** and secure with the locking pin **53**.

NOTICE

Retaining pins are inserted!
Damage to the retaining pins.

- ▶ Unpin the retaining pins **8** before lifting the ballast pallet.

When both erection racks are pinned and secured on the cross beam:

- ▶ Release the retaining pins **9** on both erection racks and unpin.
- ▶ Insert the retaining pins **9** on the both sides on points **P42** in park position and secure with spring retainer **9**.

**WARNING**

Uncontrolled oscillation of the ballast pallet!

When the ballast pallet **3** is raised, it can start to swing.

Death, severe injury, property damage.

- ▶ It is prohibited to remain in the danger zone.
- ▶ Secure the ballast pallet with auxiliary rope.

By lifting and balancing itself, the ballast pallet **3** is placed exactly vertically under the derrick head.

- ▶ Lift the ballast pallet **3** with the pull cylinders and let it balance itself.
- ▶ Set the ballast pallet **3** on the ground.
- ▶ Relieve the derrick guying completely.

7.5 Establishing the electrical connection from the suspended ballast to the turntable

**Note**

- ▶ Establish the electrical connections from the suspended ballast to the turntable, see Electric wiring diagram.

- ▶ Establish the electrical connections.

8 Assembly with suspended ballast guide*



WARNING

Danger of falling!

During assembly / disassembly, inspection and maintenance work, personnel must be secured with appropriate aids to prevent them from falling.

Death, severe injury, property damage.

- ▶ All work at a height, when there is a danger of falling, must be carried out with suitable aids.
- ▶ If aids are not available and work cannot be carried out from the ground, then assembly personnel must secure themselves with the supplied fall arrest system to prevent falling, see the Crane operating instructions, chapter 2.04.
- ▶ If fall protection equipment is available, then it must be used, see the Crane operating instructions, chapter 2.06.
- ▶ When lifting, lowering, swinging crane parts in and out, no persons may remain in the danger zone.
- ▶ If railings are present on the components, then they must be brought into the corresponding position and secured for assembly / disassembly work.
- ▶ Only step on the aids, ladders and catwalks with clean shoes.
- ▶ Keep aids, ladders and catwalks free of heavy dirt, snow and ice.
- ▶ During all assembly and disassembly work, maintenance work and inspections, travel or crane operation is prohibited.
- ▶ Remaining on a suspended load is prohibited.
- ▶ Stepping or walking on crane components and lattice sections, which have an incline of more than 20° is prohibited.
- ▶ For all assembly work, the crane operator of the main crane must be in voice contact with the crane operator / crane operators of the auxiliary crane / auxiliary cranes.
- ▶ For assembly / disassembly tasks, the crane operator may only initiate crane movements when the responsible guide has explicitly released the movement.

When the assembly personnel is within the danger zone of the crane:

- ▶ A guide and / or the crane operator must be able to see the entire danger zone.



WARNING

Danger of impact / crushing!

When installing / removing crane components with the auxiliary crane, crane components can start to swing back and forth.

When lifting / lowering and positioning crane components, there is an increased danger of impacts / crushing.

Personnel can be caught and severely injured or killed.

- ▶ Make sure that personnel cannot be caught by components.
- ▶ When working in danger zones: Use aids to protect limbs.
- ▶ Guide components with suitable aids to minimize oscillation.



DANGER

The components can fall down!

If the corresponding components are disengaged from the auxiliary crane before the corresponding component is pinned, the corresponding component can fall down and fatally injure personnel.

- ▶ Do not disengage the auxiliary crane until the respective component is pinned and secured.

Make sure that the following prerequisites are met:

- The crane is horizontally aligned.
- An auxiliary crane is available.
- The ground is level and of sufficient load bearing capacity.
- Main boom and derrick are installed on the turntable.
- The derrick is in the crane operating position.
- Main boom is assembled, guying is tensioned.
- The counterweight has been installed on the turntable according to the load chart.
- The LICCON overload protection has been set according to the data in the load charts and erection charts.
- The LICCON overload protection settings have been compared with the actual set up configuration.

8.1 Assembling the suspended ballast guide

The suspended ballast guide makes different derrick ballast radii possible.

The derrick ballast radius determines the number of intermediate section, which must be installed.

Derrick ballast radius	Number of intermediate sections
20 m	0
25 m	1
30 m	2

8.1.1 Removing the transport unit

Make sure that the following prerequisite is met:

- The transport unit is on the transport vehicle.

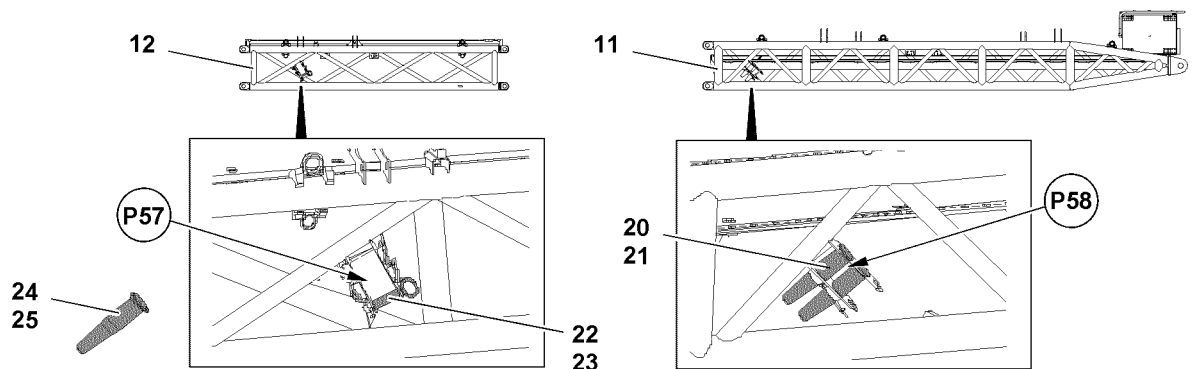

Fig.122802: Park position for pin



Note

- ▶ Park position **P57** for pin **24** and pin **22**.
- ▶ Park position **P58** for pin **20**.



WARNING

Falling pins!

Death, severe injury, property damage.

- ▶ Make sure that all pins are properly secured in the park positions with the respective retaining elements.

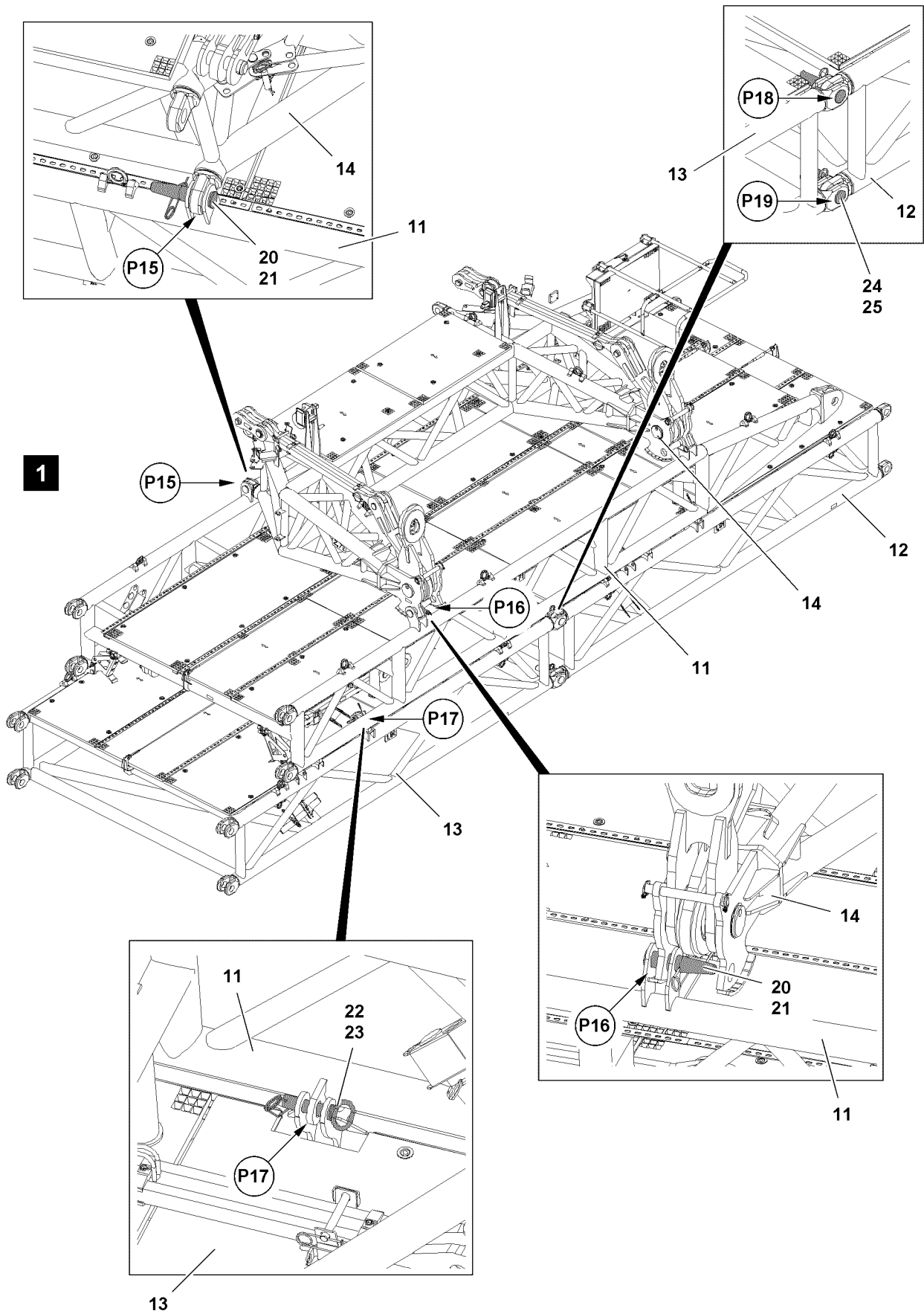

Fig.122801

LWE/LR 11000-001/23501-04-02/en

Disassembling the end section

- ▶ Release and remove the riggings on the transport vehicle.

The end section is unpinned at four points. Every point is present on both sides of the component on one level, see illustration 1.

- ▶ Fasten the auxiliary crane to the end section **14**.
- ▶ Unpin the end section **14** at points **P15**: Remove spring retainers **21** and unpin pins **20**.
- ▶ Unpin the end section **14** at points **P16**: Remove spring retainers **21** and unpin pins **20**.
- ▶ Place the end section **14** with the auxiliary crane on the ground.

Disassembling the pivot section

The pivot section is unpinned at four points. Every point is present on both sides of the component on one level, see illustration 1.

- ▶ Fasten the auxiliary crane to the pivot section **11**.
- ▶ Unpin the pivot section **11** at points **P17**: Remove spring retainers **23** and unpin pins **22**.
- ▶ Place the pivot section **11** with the auxiliary crane on the ground.

Disassembling the intermediate section

For a suspended ballast with a 25 m suspended ballast radius, the intermediate sections must be unpinned apart. The intermediate section is unpinned on four points. Every point is present on both sides of the component on one level, see illustration 1.

- ▶ Fasten the auxiliary crane on intermediate section **12**.
- ▶ Unpin the intermediate section **12** at points **P19**: Remove spring retainers **25** and unpin pins **24**.
- ▶ Unpin the intermediate section **12** at points **P18**: Remove spring retainers **25** and unpin pins **24**.
- ▶ Place the intermediate section **12** with the auxiliary crane on the ground.

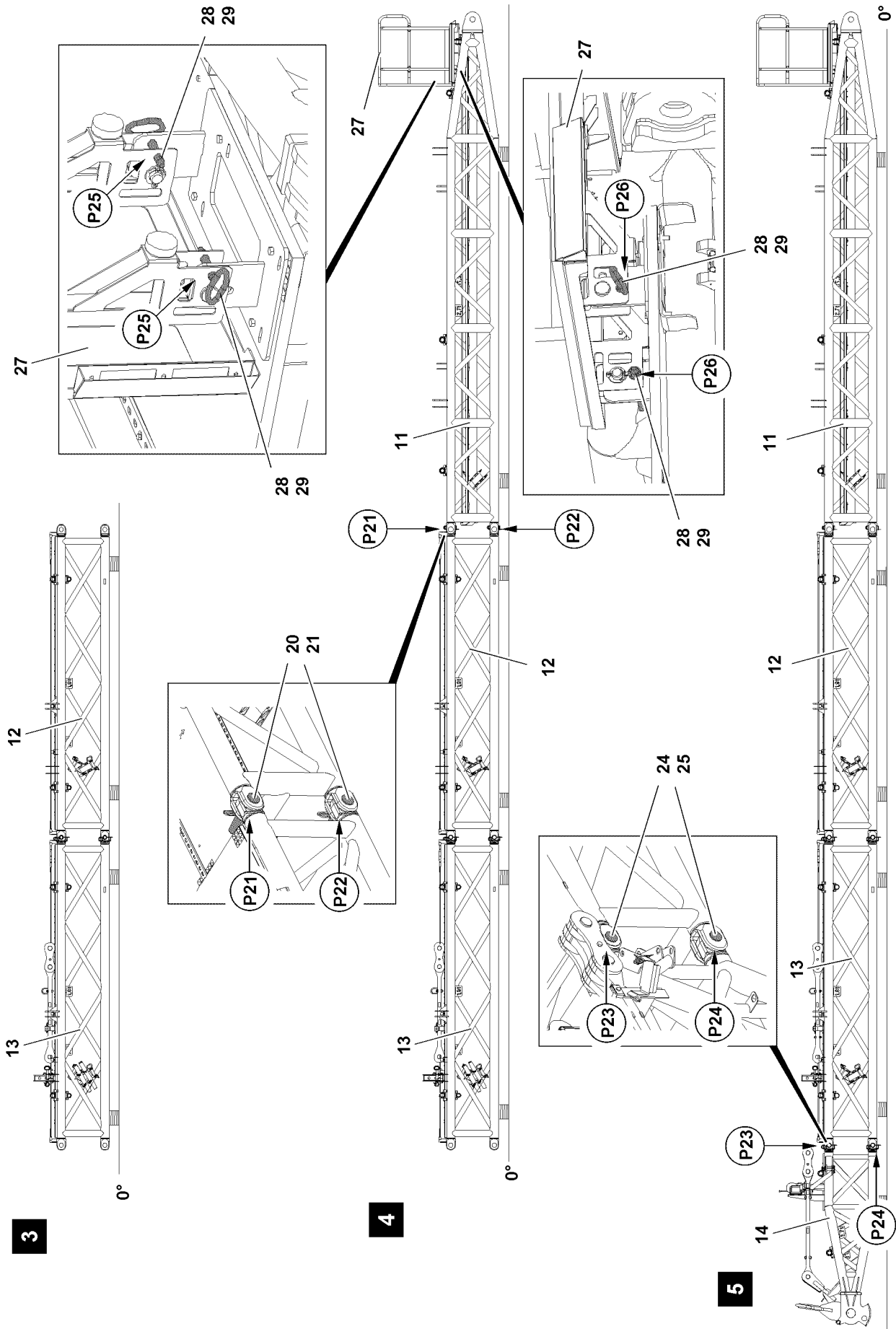

Fig.122803

LWE/LR 11000-001/23501-04-02/en

8.1.2 Assembling the suspended ballast guide



Note

- ▶ The assembly of the suspended ballast guide is described based on the example of a suspended ballast guide with a 30 m suspended ballast radius.

Make sure that the following prerequisites are met:

- The pivot section has been removed from the transport unit.
- The end section has been removed from the transport unit.

Assembling the intermediate sections

For the suspended ballast guide with a 30 m suspended ballast radius only two intermediate sections are installed.

- ▶ Support the ground in such a way that the intermediate sections can be placed down horizontally.
- ▶ Place the intermediate sections with the auxiliary crane on the substructure, see illustration 3.
- ▶ Remove the fastening equipment.

Assembling the pivot section

- ▶ Fasten the pivot section **11** to the auxiliary crane.
- ▶ Position the pivot section **11** with the auxiliary crane on the intermediate section **12** at point **P21** until the pin points align.
- ▶ Support the pivot section **11**.

The pivot section and the intermediate section are pinned together in four points. Every point is present on both sides of the component on one level, see illustration 4.

- ▶ Pin the pivot section **11** on both sides at point **P21** with the intermediate section **12**: Insert the pins **20** and secure with the spring retainers **21**.
- ▶ Pin the pivot section **11** on both sides at point **P22** with the intermediate section **12**: Insert the pins **20** and secure with the spring retainers **21**.
- ▶ Remove the fastening equipment.

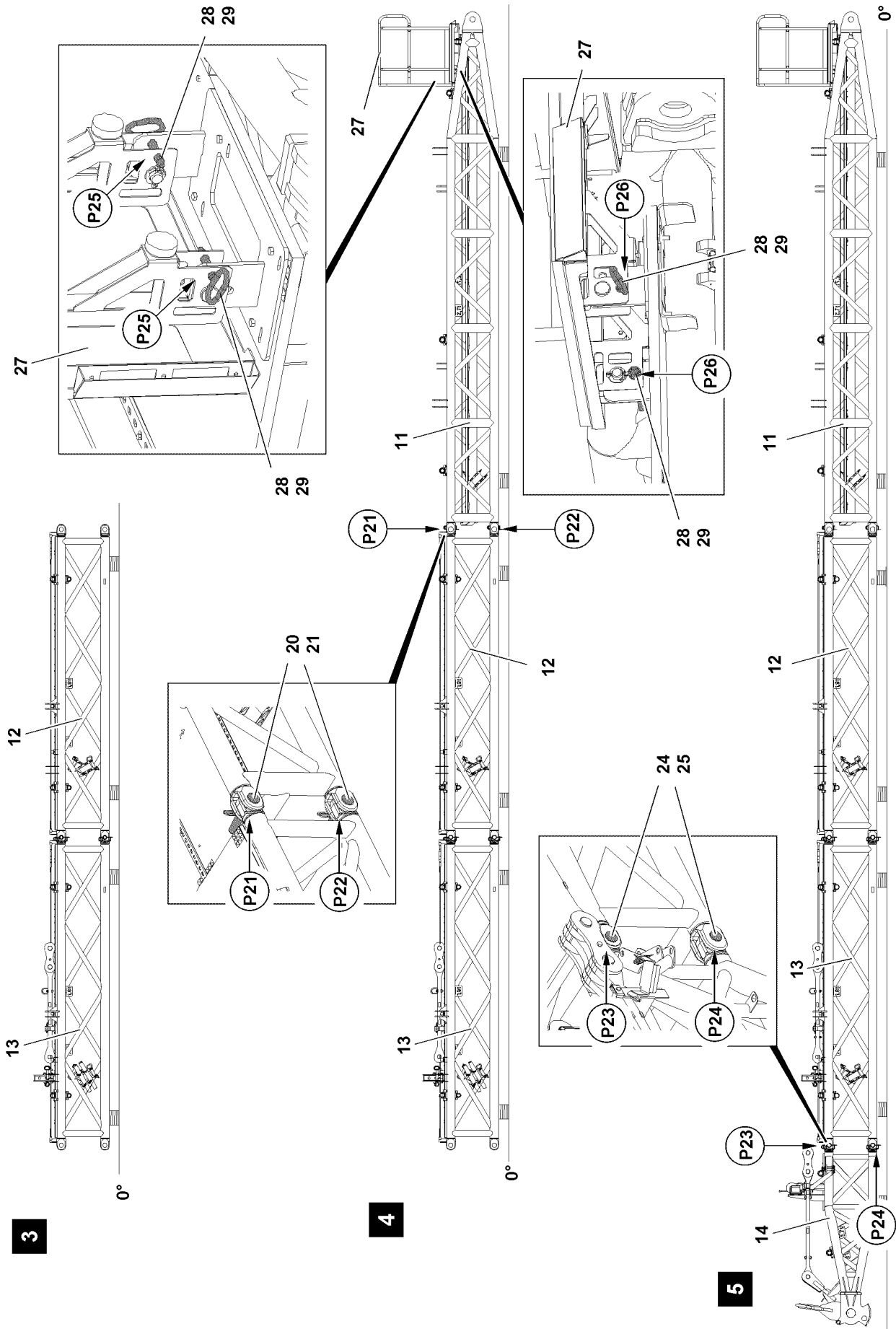

Fig.122803

LWE/LR 11000-001/23501-04-02/en

- ▶ Fasten the platform **27** to the auxiliary crane.



WARNING

Platform swinging down!

The platform can swing down by itself due to its own weight when unpinning it at points **P25**.

Death, severe injury, property damage.

Fingers and hands can be crushed.

- ▶ Make sure that the platform is safely held by the auxiliary crane.
- ▶ Do not reach with your hands into the danger zone.
- ▶ Use personal protective equipment.

-
- ▶ Set the platform **27** into operating position, see illustration 4: Remove the safety locking pin **29** at points **P25** and unpin the grip pin **28**.
 - ▶ Swing the platform **27** with the auxiliary crane.
 - ▶ Insert the grip pin **28** at points **P26** and secure with safety locking pin **29**.
 - ▶ Remove the auxiliary crane.

Assembling the end section

- ▶ Fasten the end section **14** to the auxiliary crane.
- ▶ Position the end section **14** with the auxiliary crane on the intermediate section **13** at point **P23** until the pin points align.
- ▶ Support the end section **14**.

The end section and the intermediate section are pinned together in four points. Every point is present on both sides of the component on one level, see illustration 5.

- ▶ Pin the end section **14** on both sides at point **P23** with the intermediate section **13**: Insert the pins **24** and secure with the spring retainers **25**.
- ▶ Pin the end section **14** on both sides at point **P24** with the intermediate section **13**: Insert the pins **24** and secure with the spring retainers **25**.
- ▶ Remove the fastening equipment.

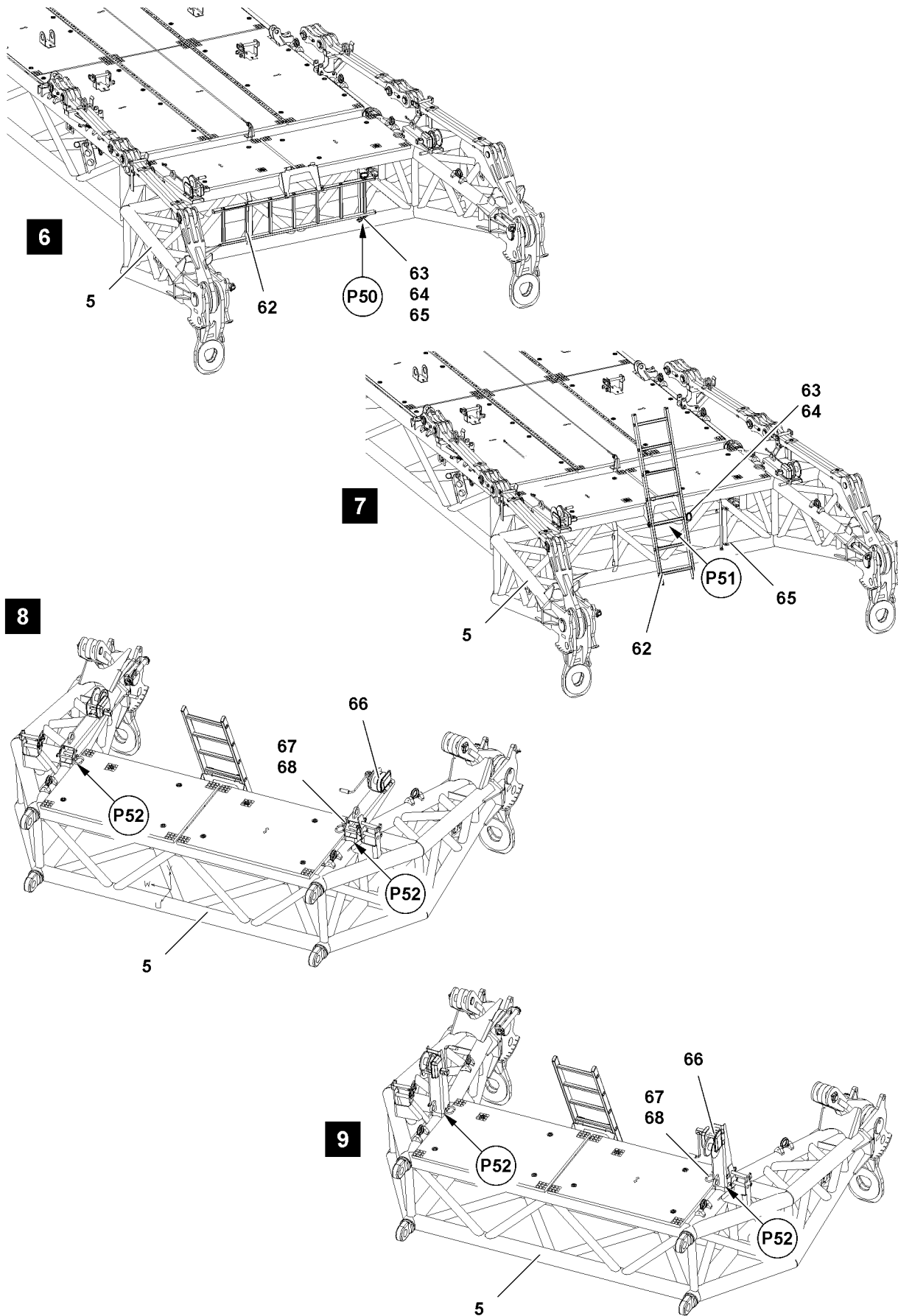

Fig.120205

LWE/LR 11000-001/23501-04-02/en

Assembling the ladder



WARNING

Falling ladder!

The ladder can fall down by itself due to its own weight when it is unpinned.

Death, severe injury, property damage.

Fingers and hands can be crushed.

- ▶ When unpinning the pin connection, hold the ladder.
- ▶ Do not reach with your hands into the danger zone.

- ▶ Release the ladder **62** from the transport retainer: Remove the lock **65** at point **P50** and unpin the grip pin **63**, see illustration **6**.
- ▶ Remove the safety locking pin **64** at point **P50** from park position, see illustration **6**.
- ▶ Attach the lock **65** at point **P50** in the park position, see illustration **6**.



WARNING

Danger of crushed limbs!

When hanging the ladder up, fingers and hands can be crushed.

- ▶ Do not reach with your hands into the danger zone.

- ▶ Get the ladder **62** from the transport retainer and hang it up at point **P51**, see illustration **7**.
- ▶ Secure the ladder **62** in operating position: Insert the grip pin **63** at point **P51** and secure with safety locking pin **64**, see illustration **7**.

Assembling the manual rope winch



WARNING

Danger of crushed limbs!

When setting up the manual rope winch, fingers and hands can be crushed.

- ▶ Do not reach with your hands into the danger zone.



WARNING

Falling manual rope winch!

The manual rope winch can fall down by itself due to its own weight when setting it up.

Death, severe injury, property damage.

Fingers and hands can be crushed.

- ▶ When unpinning the pin connection, hold the ladder.
- ▶ Do not reach with your hands into the danger zone.

- ▶ Set up the manual rope winch **66**, see illustration **9**.
- ▶ Secure the manual rope winch **66** in operating position: Insert the grip pin **67** at point **P52** and secure with safety locking pin **68**, see illustration **9**.

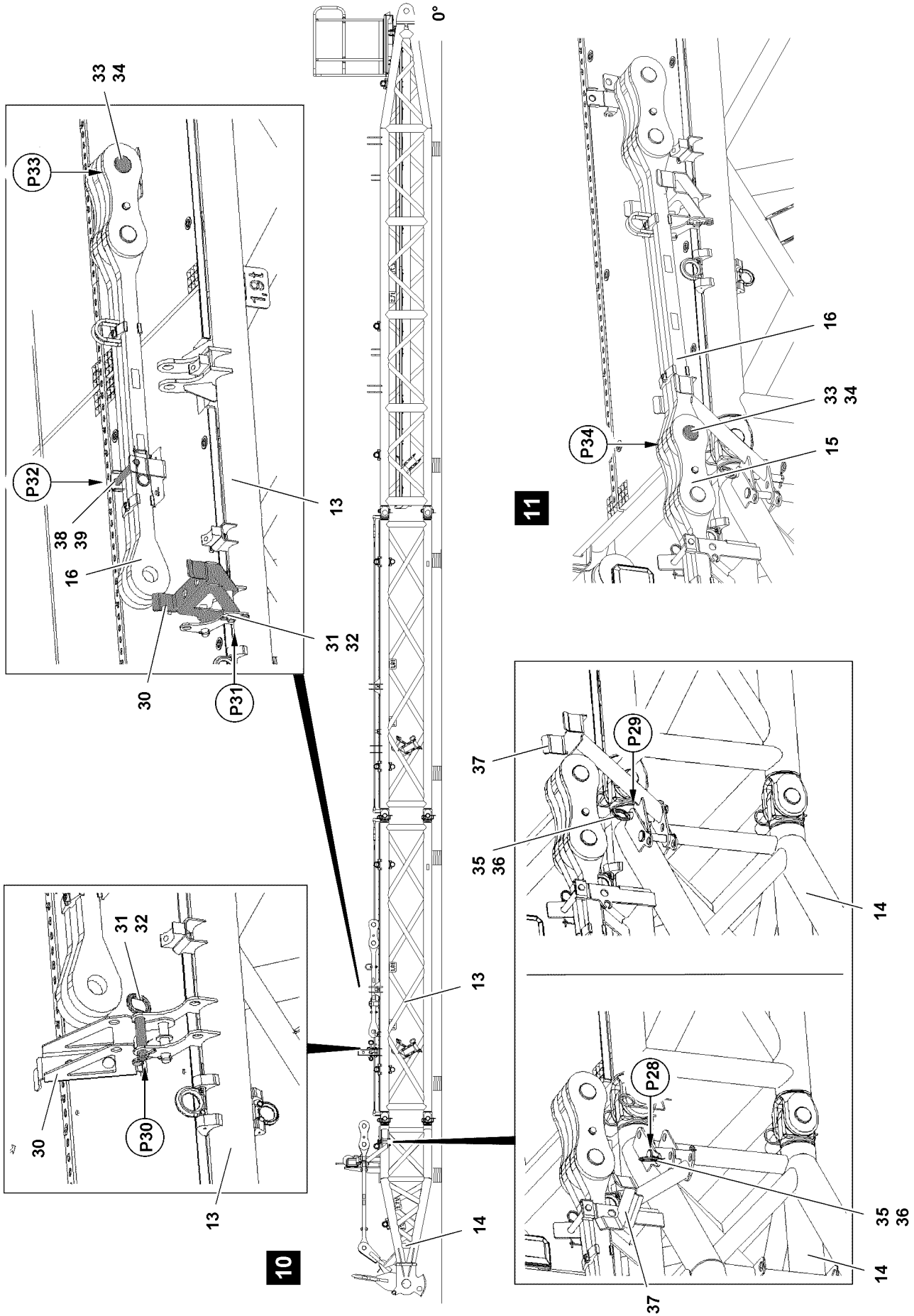

Fig.122804

LWE/LR 11000-001/23501-04-02/en

Assembling the pull rods

- ▶ Release the bracket **37** from the transport position: Remove the spring retainer **36** at point **P28** and unpin the socket pin **35**, see illustration **10**.

**WARNING**

When swinging the bracket, fingers and hands can be crushed.

- ▶ Do not reach with your hands into the danger zone.
- ▶ Swing the bracket **37** until it can be pinned at point **P29**.
- ▶ Insert the socket pins **35** at point **P29** and secure with spring retainer **36**, see illustration **10**.

Result:

- The bracket **37** is secured in the operating position.
- ▶ Release the retainer **30** from the transport position: Remove the spring retainer **32** at point **P30** and unpin the socket pin **31**, see illustration **10**.

**WARNING**

When swinging the retainer, fingers and hands can be crushed.

- ▶ Do not reach with your hands into the danger zone.
- ▶ Swing the retainer **30** until it can be pinned at point **P31**.
- ▶ Secure the retainer **30** in operating position: Insert the socket pins **31** at point **P31** and secure with spring retainer **32**, see illustration **10**.

Result:

- The retainer **30** is secured in the operating position.
- ▶ Release the pull rods **16** from the transport position: Remove the spring retainer **39** at point **P32** and unpin the pin **38**, see illustration **10**.
- ▶ Remove the safety locking pin **34** at point **P33** and unpin the pin **33**, see illustration **10**.
- ▶ Fasten the auxiliary crane to the pull rod **16**.
- ▶ Place the pull rod **16** down with the auxiliary crane in operating position on the retainer **30** and align at point **P34** on bores, see illustration **11**.
- ▶ Pin the pull rod **16** with the pull rod end section **15**: Insert the pin **33** at point **P34** and secure with the safety locking pin **34**, see illustration **11**.
- ▶ Remove the auxiliary crane.
- ▶ Insert the pin **38** in park position and secure with spring retainer **39**.
- ▶ Release the pull rod **15** from the transport position.

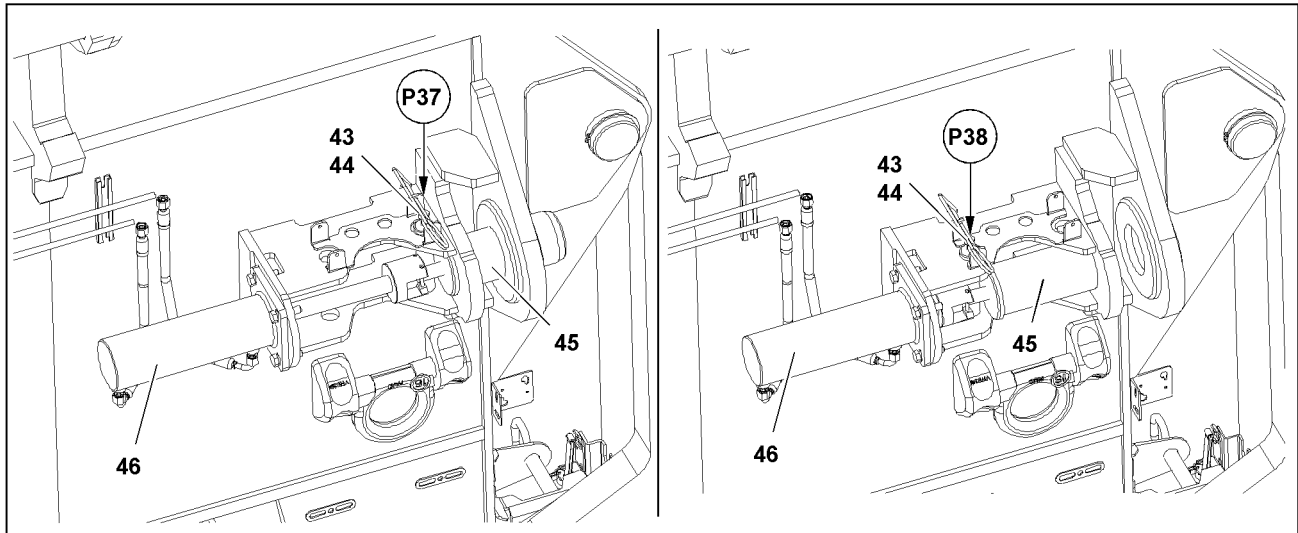

12

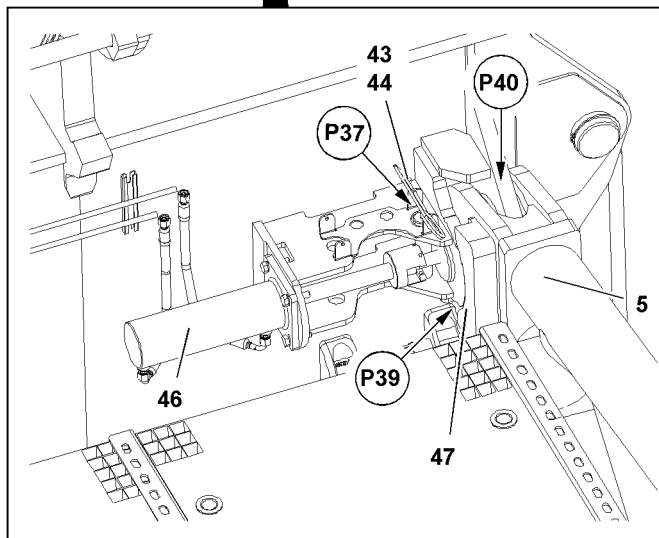
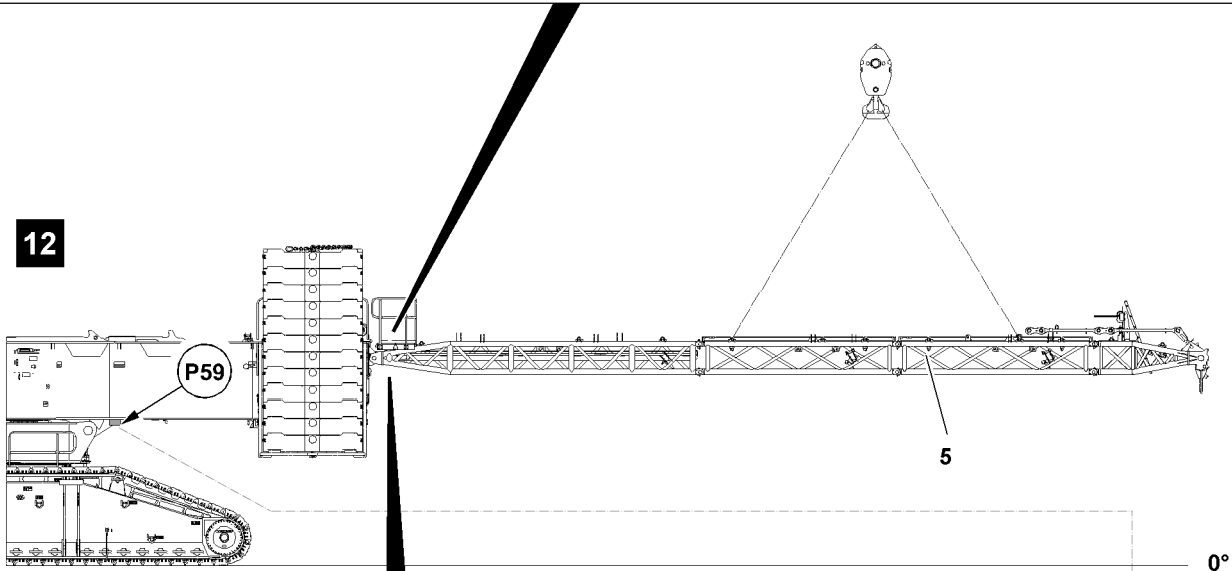

13

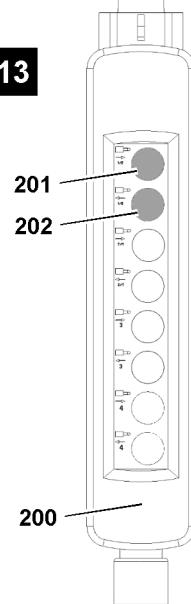

Fig.122805

LWE/LR 11000-001/23501-04-02/en

Swinging the brackets

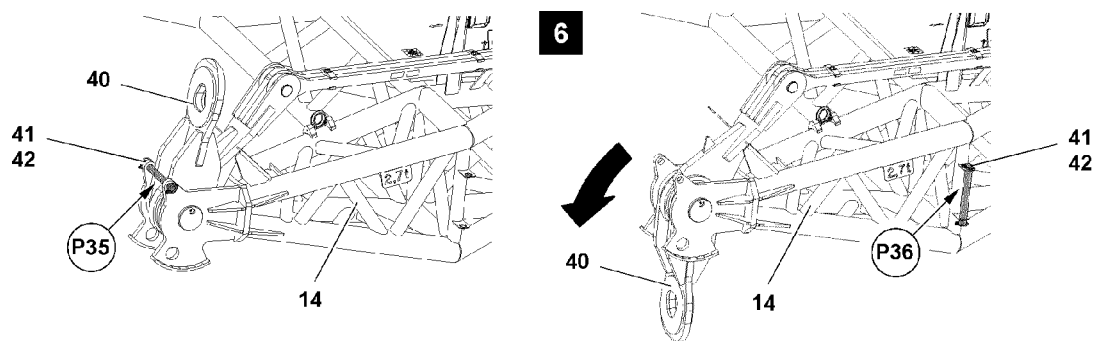

Fig.119028: Swinging the bracket

- ▶ Fasten the bracket **40** to the auxiliary crane.



WARNING

Bracket swinging down!

The bracket can swing down by itself due to its own weight when unpinning it at point **P25**, see illustration.

Death, severe injury, property damage.

Fingers and hands can be crushed.

- ▶ Make sure that the platform is held by the auxiliary crane.
- ▶ Do not reach with your hands into the danger zone.

- ▶ Remove the safety locking pin **42** at point **P35** and unpin the pin **41**, see illustration **6**.
- ▶ Swing the bracket **40** downward with the auxiliary crane.
- ▶ Insert the pin **41** in park position at point **P36** and secure with safety locking pin **42**, see illustration **6**.

8.1.3 Assembling the suspended ballast guide on the turntable frame

Make sure that the following prerequisites are met:

- A lifting platform or other aids are available.
- An auxiliary crane is available.
- The control panel is connected on the „turntable rear“ socket , point **P59**.

The suspended ballast guide **5** is pinned on two points. The pin procedure is described for one pin as an example:

- ▶ Release the pin **45**: Remove the spring retainer **44** at point **P37** and unpin the retaining pin **43**, see illustration **12**.
- ▶ Insert the retaining pin **43** at point **P38** and secure with spring retainer **44** see illustration **12**.
- ▶ Unpin the pin **45**: Press button **202** on the control panel **200**, see illustration **13**.

Result:

- The pin **45** moves out.

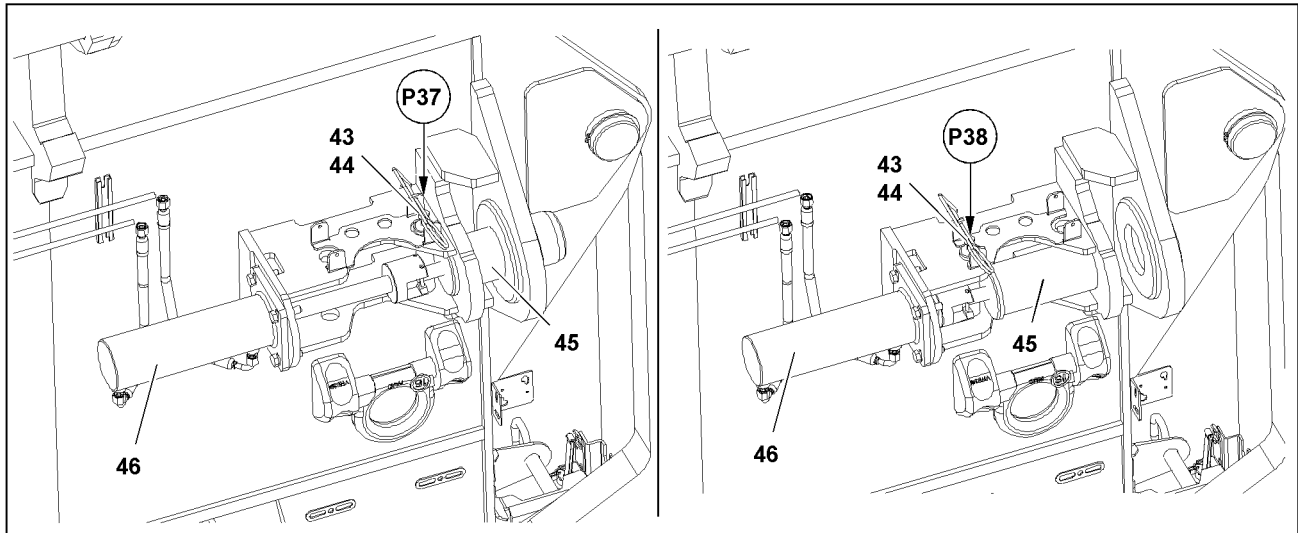

12

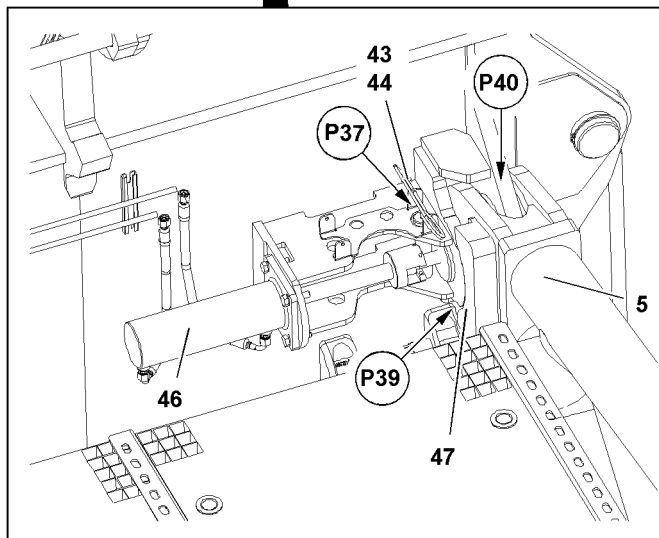
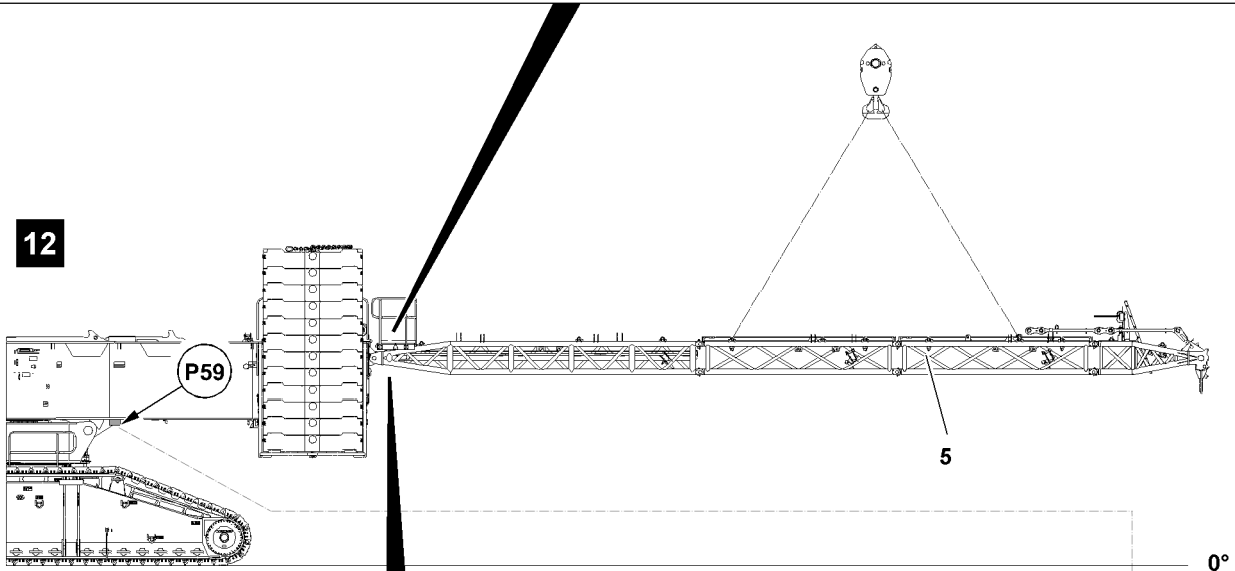

13

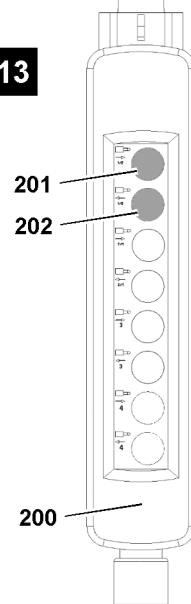

Fig.122805

- ▶ Attach the suspended ballast guide **5** on the auxiliary crane.
- ▶ Lift the suspended ballast guide **5** to the pin points **P40** on the rear of the turntable, see illustration **12**.
- ▶ Set the suspended ballast guide **5** on the centering **47** on points **P39** of the turntable, see illustration **12**.

Result:

- Align the pin bores.

- ▶ Insert the pin **45**: Press button **201** on the control panel **200**, see illustration **13**.

Result:

- The pin **45** moves in.

**WARNING**

Danger of accident!

If the pins are not secured with the retaining pin, then the connector pins can loosen up by themselves during crane operation.

This can cause the crane to topple over.

Death, severe injury, property damage.

- ▶ Make sure that the connector pins are secured.

- ▶ Secure the pin **45**: Insert the retaining pin **43** at point **P37** and secure with spring retainer **44** see illustration **12**.

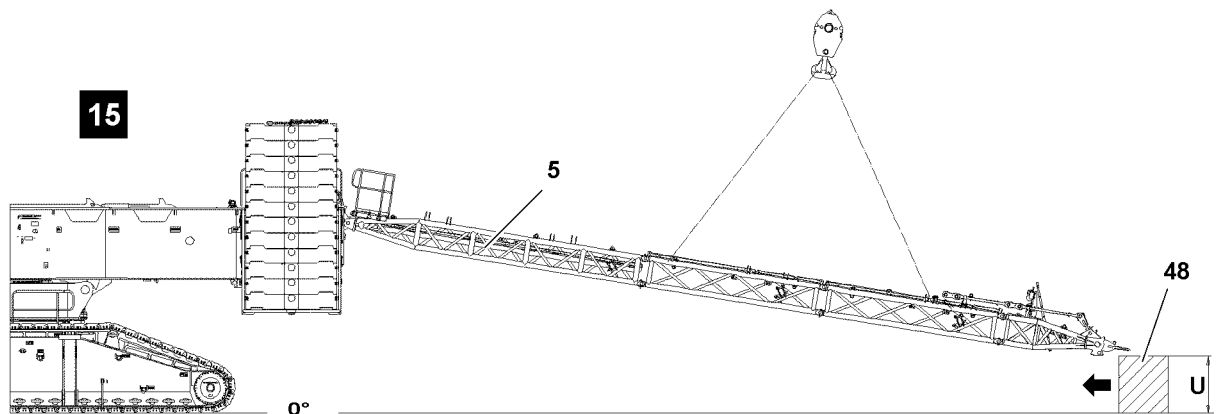

Fig.120203: Substructure, example

Suspended ballast guide	R30	R25	R20
Substructure height „U“	0 m	1.6 m	2.0 m

When R25 or R20 is installed:

- ▶ Establish a substructure and place the suspended ballast guide **5** with the auxiliary crane on the substructure, see illustration **15**.

When R30 is installed:

- ▶ Place the suspended ballast guide **5** with the auxiliary crane on the ground.

8.2 Pinning the D-guy rods with the pull rods of the suspended ballast guide

Make sure that the following prerequisites are met:

- The D-guy rods hang over the lugs of the suspended ballast guide.
- The manual rope winches are set up and secured.

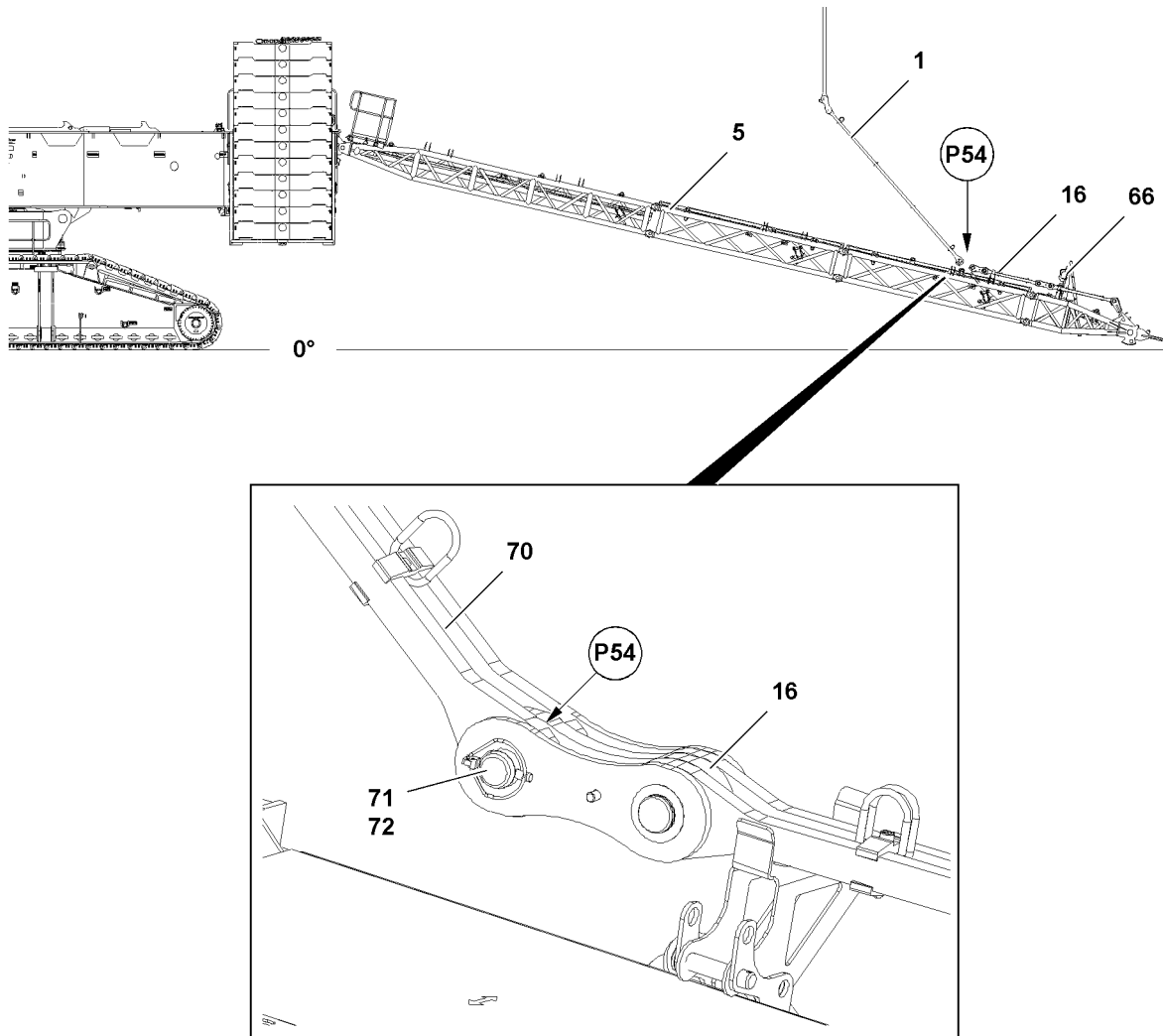

Fig. 126068

- ▶ Connect the rope of the manual rope winch **66** with the D-guy rods **1**.

The D-guy rods **1** are pinned on both sides on the suspended ballast guide **5**. The pin procedure is described on the example for one D-guy rod.

- ▶ Pull the D-guy rods **1** with the manual rope winch **66** to the pull rods **16** and luff the derrick down at the same time until it can be pinned on point **P54**.



WARNING

Danger of accident!

If the connector pins are not secured with the retaining pin, then they can loosen up by themselves during crane operation.

This can cause the crane to topple over.

Death, severe injury, property damage.

- ▶ Make sure that the connector pins are secured.

When the pin bores align:

- ▶ Insert the pin **71** at point **P54** and secure with safety locking pin **72**.
- ▶ Lift the suspended ballast guide **5** with the derrick.

8.3 Assembling the cross beam on the suspended ballast guide

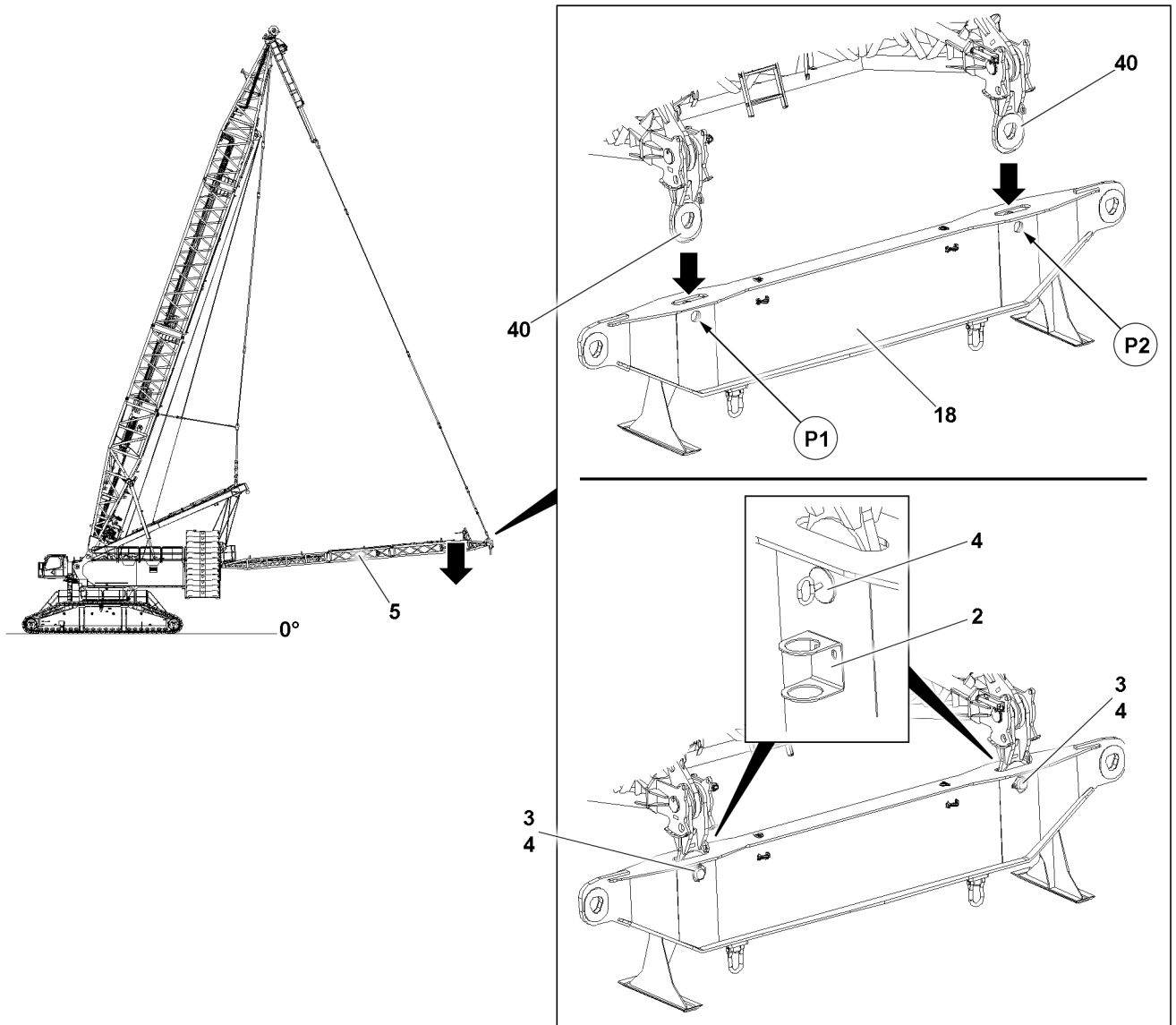

Fig.126069: Cross beam on suspended ballast guide

Make sure that the following prerequisites are met:

- The suspended ballast guide is completely installed and pinned with D-guy rods.
- ▶ Position the cross beam **18** under brackets **40** on the ground.

The suspended ballast guide is lowered by:

- Extending the pull cylinder to the switch position.
- Luffing the derrick boom down.

**Note**

Retract / extend the pull cylinder

- ▶ Control the pull cylinders from the crane cab, see the section „Lifting and lowering the derrick ballast using the pull cylinders“.
- ▶ Operate the pull cylinder with the radio remote control, see the „radio remote control operating instructions“.

- ▶ Lower the suspended ballast guide **5** until the brackets **40** can be pinned with the cross beam **18** on point **P1** and point **P2**.
- ▶ Release and unpin the pin **4** in transport retainer **2**.
- ▶ Pin the brackets **40** with the cross beam **18**: Insert the pins **4** and secure with locking pins **3**.
- ▶ Lift the cross beam **18**: Lift the suspended ballast guide.

8.4 Setting the ballast pallet in the assembly position

- ▶ Set the derrick to the required radius.

**Note**

- ▶ Fastening points, see section „Fastening points for suspended ballast parts“.

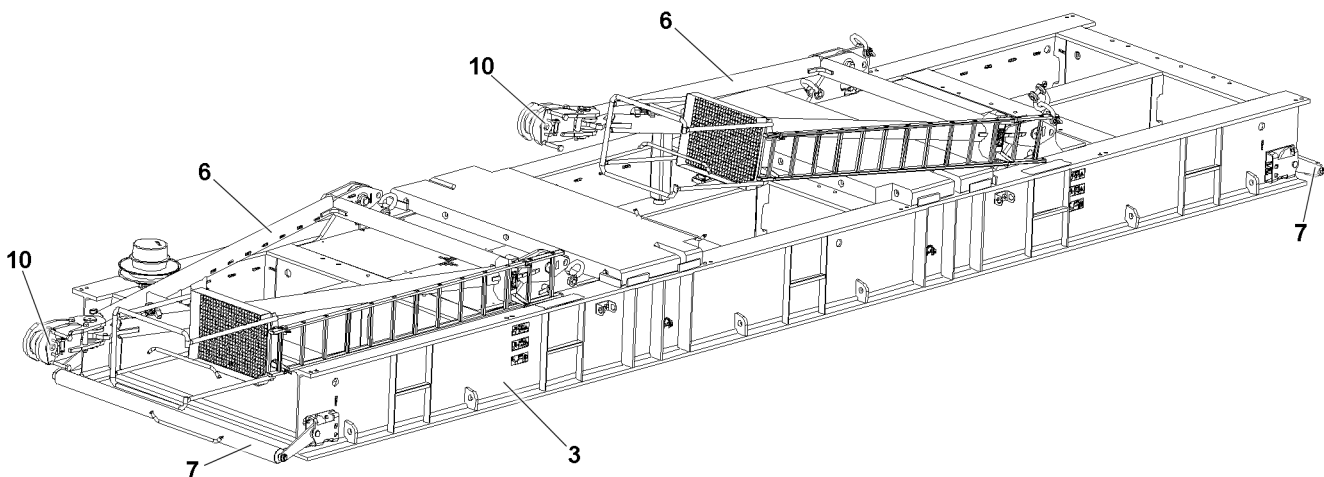

Fig.124997: Ballast pallet, transport position

- ▶ Fasten the ballast pallet **3** with fastening equipment to the auxiliary crane.
- ▶ Position the ballast pallet **3** in the slewing range of the crane under the guy rods on the derrick.

**Note**

- ▶ Set the ballast pallet **3** for easier assembly of the guy rods in lengthwise direction of the turntable.
- ▶ Align the ballast pallet **3** horizontally.

8.5 Erecting the erection racks

**Note**

- ▶ The assembly of the erection racks is described based on the example of one erection rack.

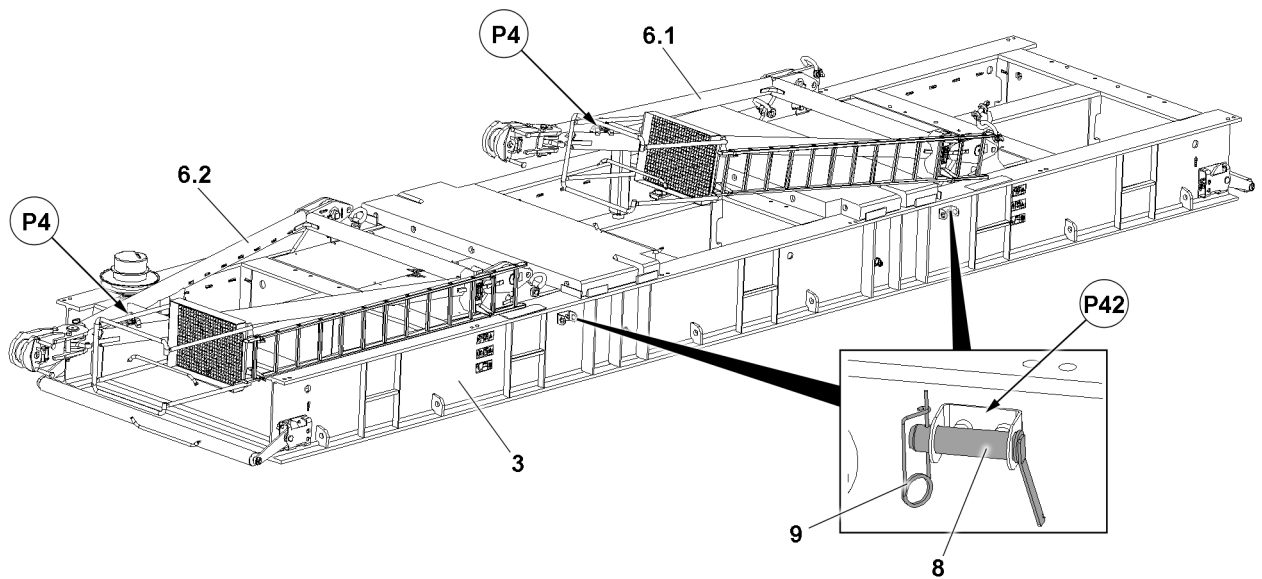

Fig.126063: Ballast pallet, transport position

The erection rack is pinned on two points. The pin procedure is described for one pin as an example.

- ▶ Fasten the erection rack **6.1** with fastening equipment to the auxiliary crane, point **P4**.
- ▶ Remove the spring retainer **9** on both sides on points **P42** and unpin the retaining pin **8** from the park position.

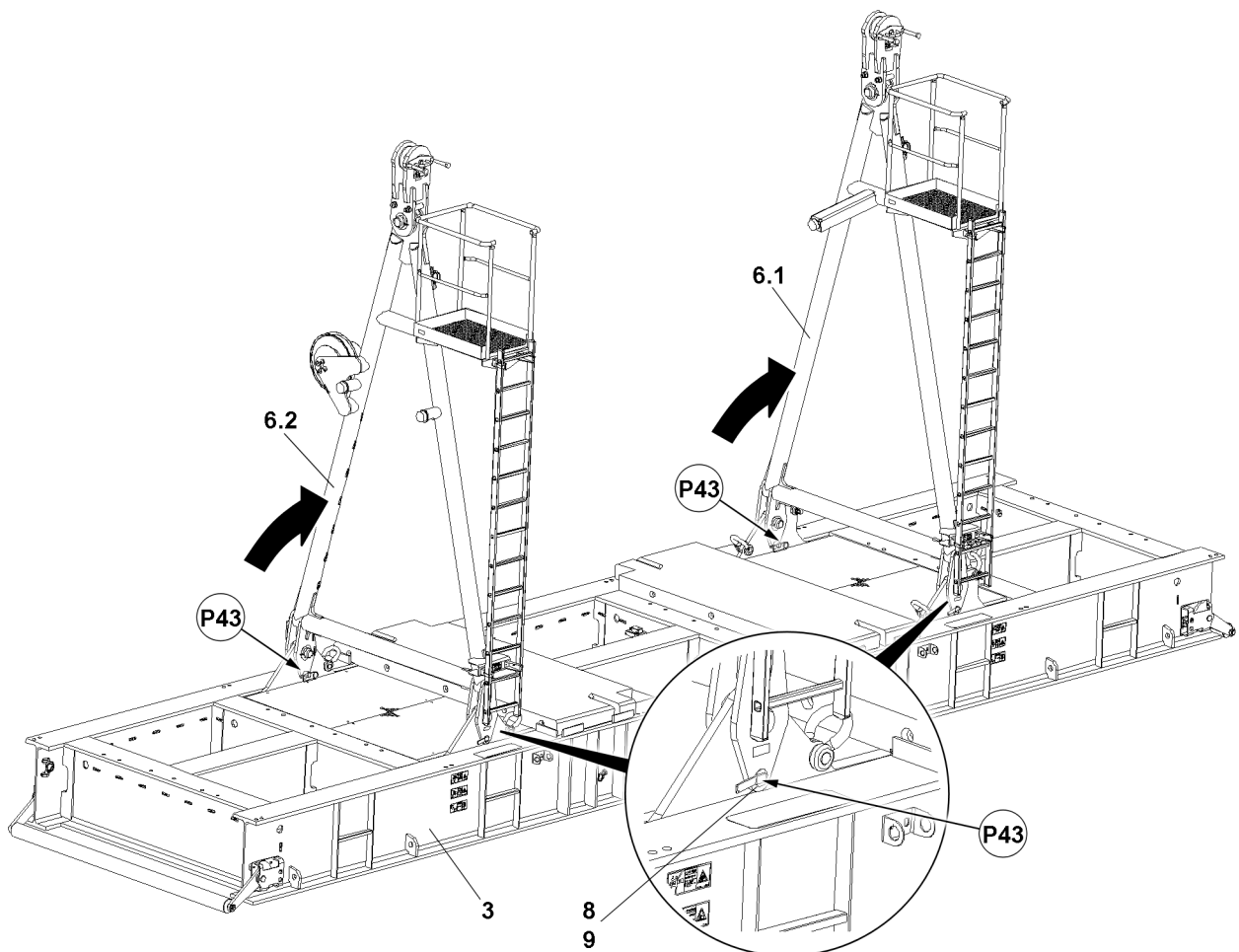

Fig.126064: Ballast pallet, operating position

**DANGER**

Unsecured erection racks!

Toppling erection racks. Death, severe bodily injuries, property damage.

- ▶ Secure the erection racks after erection with the auxiliary crane.
- ▶ When both erection racks are locked and secured in a vertical position with retaining pins **8**: Remove the auxiliary crane.
- ▶ Never unpin the retaining pins from unsecured erection racks.
- ▶ It is prohibited for anyone to remain under the erection racks or within the complete danger zone during the pinning and unpinning procedure.

- ▶ Set the erection rack **6.1** vertically with the auxiliary crane.
- ▶ Insert the retaining pin **8** at point **P43** on both sides and secure with spring retainer **9**.

When the erection rack is erected and secured:

- ▶ Remove the auxiliary crane.
- ▶ Erect the second erection rack **6.2** and secure with retaining pin **8**.

8.6 Pinning the ballast pallet with cross beam

Make sure that the following prerequisites are met:

- Ballast pallet is in assembly position.
- Erection racks are erected and secured to prevent them from folding down.

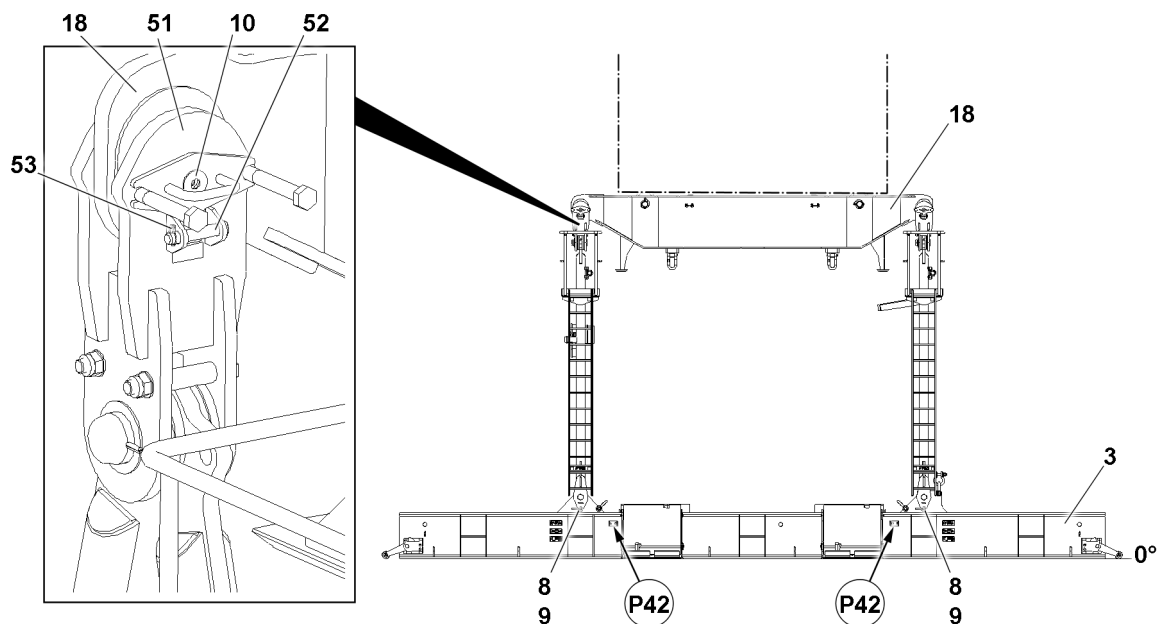

Fig.126062: Ballast pallet with cross beam

- ▶ Move the pull cylinder out until the pin bores align on bracket **51** and on cross beam **18**.
- Pins **10** must be pinned and secured on both erection racks.

**Note**

Retract / extend the pull cylinder

- ▶ Control the pull cylinders from the crane cab, see the section „Lifting and lowering the derrick ballast using the pull cylinders“.
- ▶ Operate the pull cylinder with the radio remote control, see the „radio remote control operating instructions“.

When the pin bores align:

- ▶ Insert the pin **10**.
- ▶ Secure the pin **10**: Insert the pin **52** and secure with the locking pin **53**.

NOTICE

Retaining pins are inserted!
Damage to the retaining pins.

- ▶ Unpin the retaining pins **8** before lifting the ballast pallet.

When both erection racks are pinned and secured on the cross beam:

- ▶ Release the retaining pins **9** on both erection racks and unpin.
- ▶ Insert the retaining pins **9** on the both sides on points **P42** in park position and secure with spring retainer **9**.

**WARNING**

Uncontrolled oscillation of the ballast pallet!

When the ballast pallet **3** is raised, it can start to swing.

Death, severe injury, property damage.

- ▶ It is prohibited to remain in the danger zone.
- ▶ Secure the ballast pallet with auxiliary rope.

By lifting and balancing itself, the ballast pallet **3** is placed exactly vertically under the derrick head.

- ▶ Lift the ballast pallet **3** with the pull cylinders and let it balance itself.
- ▶ Set the ballast pallet **3** on the ground.
- ▶ Relieve the derrick guying completely.

8.7 Establishing the electrical connection from the suspended ballast to the turntable

**Note**

- ▶ Establish the electrical connections from the suspended ballast to the turntable, see Electric wiring diagram.

- ▶ Establish the electrical connections.

9 Ballasting the ballast pallet

9.1 Ballast variation

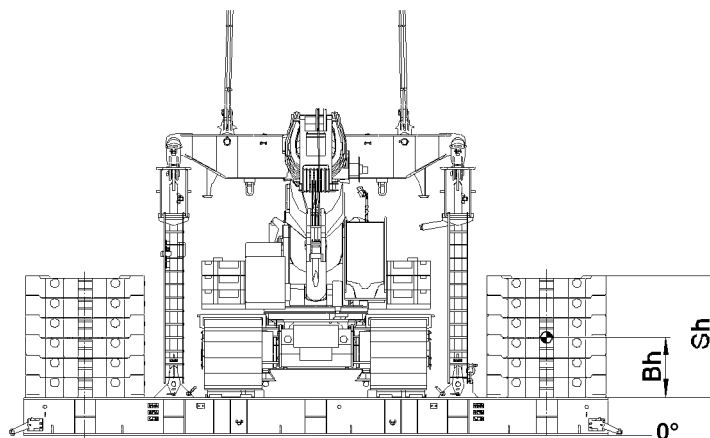

Fig.124988: Ballast pallet with LTR 1220

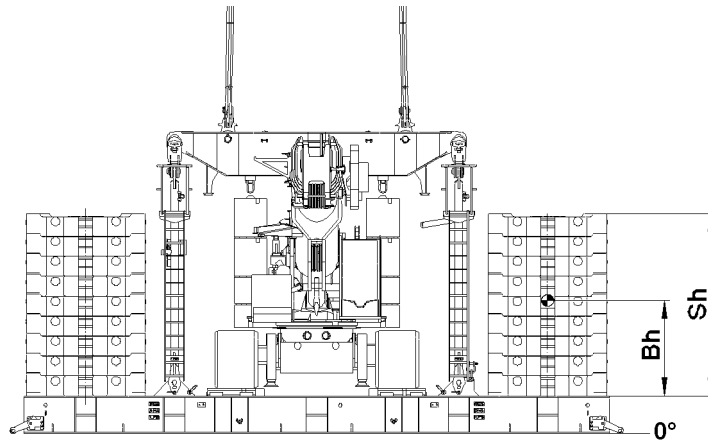

Fig.124987: Ballast pallet with LTR 1100

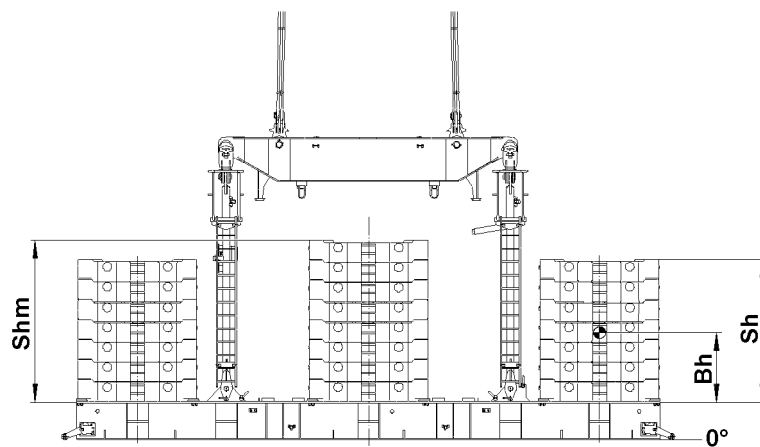

Fig.126073: Ballast pallet solely with ballast plates

9.2 Ballasting rules



WARNING

Impermissible ballasting, impermissible geometry of the ballast!
Slipping and falling ballast stacks.

The crane can topple over. Death, severe bodily injuries, property damage.

- ▶ The maximum permissible ballast center of gravity height **Bh** of 2000 mm above the upper belt may **not** be exceeded.

When ballasting in the center of the ballast pallet:

- ▶ Do **not** exceed the permissible stack height **Shm** of 4000 mm.

When the outer stacks are ballasted:

- ▶ Do **not** exceed the permissible stack height **Sh** of 4500 mm.
- ▶ Do **not** exceed the maximum permissible total weight of the suspended ballast of 455 t.
- ▶ Secure all ballast plates so they cannot move and fall down.
- ▶ Replace damaged ballast plates immediately with new ballast plates.
- ▶ Observe and comply with the rules for ballasting.

Rules for ballasting:

- Do **not** start with the two outer ballast stacks. Start ballasting in the center.
- Suspended ballast with LTR: First move LTR on ballast pallet.
- Always place the ballast plates symmetrically, in reference to the longitudinal axis.
- The outer ballast stacks must always weigh the same and always be the same height after ballasting.

- Ballasting with double stacks: The difference between front and rear may be no more than maximum 10 t for a double stack.
- First place only maximum 20 t ballast per stack.
- After the first ballast plates are placed, the difference between the stacks may be a maximum of 25 t.

Make sure that the following prerequisites are met:

- The ground on which the ballast pallet is ballasted is level and adequately load-bearing.
- The ballast pallet is properly assembled. The erection racks are secured.
- The ballast pallet is standing on the ground.
- An auxiliary crane is on hand.

9.3 Determining the position LTR on the ballast pallet

LTR 1220 and LTR 1100 must be in certain positions of the ballast pallet.

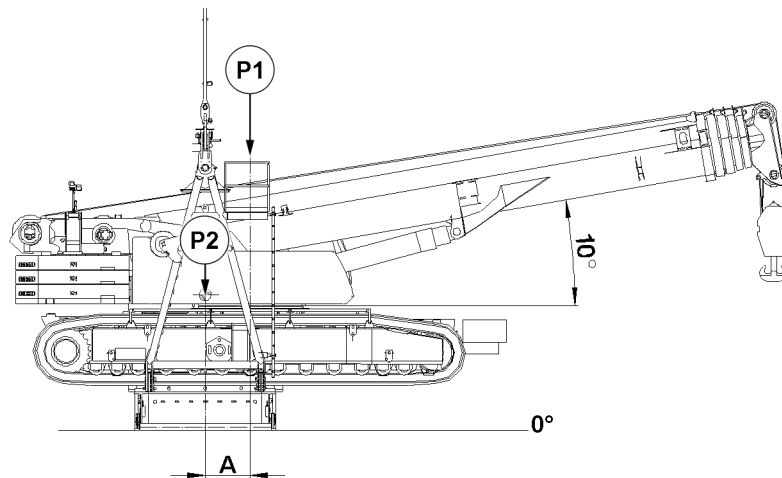

Fig.124990: Position LTR 1220 on ballast pallet

Distance **A** in the chart is valid solely for the following set up configurations, depending on the crane type:

- LTR 1220: 70 t ballast and 20 t central ballast.
- LTR 1100: 32 t ballast and 15 t central ballast.

A is the distance between the center of rotation LTR on point **P1** and the center of ballast pallet on point **P2**.

	LTR 1220	LTR 1100
Distance A	1000 mm ±150 mm	900 mm ±150 mm

Distance A depending on the crane type

When the set up configuration of the LTR deviates:

- ▶ Read the value for the center of gravity of the LTR from the LICCON display *Center of gravity* and adhere to it when positioning on the ballast pallet.

9.4 Moving the LTR on the ballast pallet

Make sure that the following prerequisites are met:

- The derrick guying is completely relieved.
- The telescopic boom is completely telescoped in and luffed to 10°.
- Position LTR on the ballast pallet is determined.

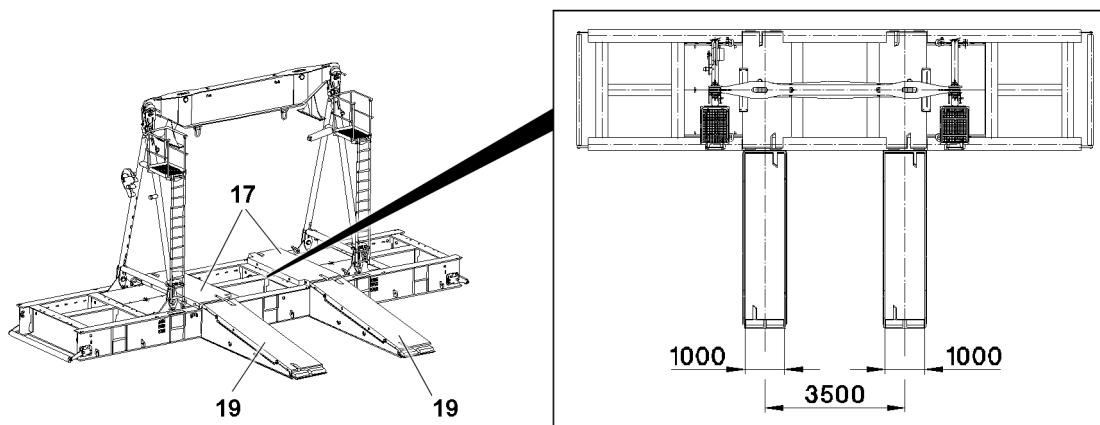

Fig.124986: Ramps on ballast pallet

- ▶ Make sure that mats **17** are positioned on the ballast pallet.
- ▶ Position ramps **19** on the ballast pallet.

	LTR 1220	LTR 1100
Track width	3500 mm	3400 mm

Track width depending on the crane type

- ▶ Set the track width LTR.

NOTICE

Camera support is in operating position!
Damage of camera support.

- ▶ Before moving on the ballast pallet: Fold the camera support in.

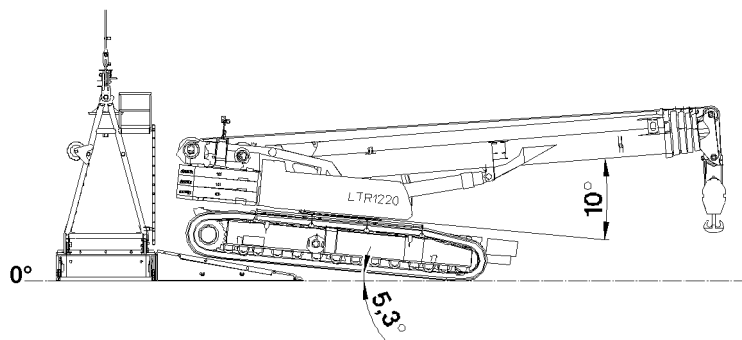

Fig.124983: LTR on ramp

- ▶ Move the LTR on the ramp

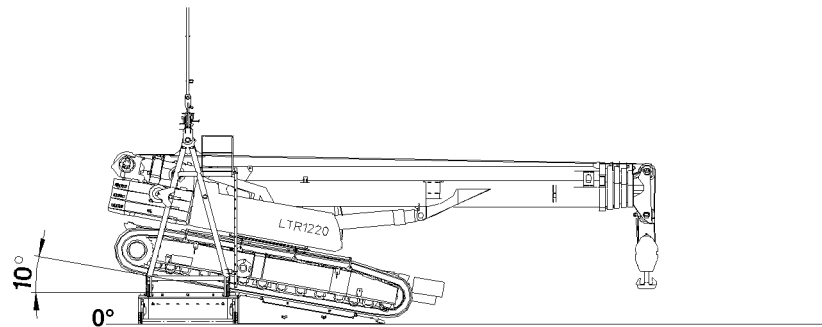

Fig.124984: LTR on tipping point

- ▶ Move LTR on tipping point.

LTR 1220 and LTR 1100 must be in certain positions of the ballast pallet.



WARNING

Position of LTR on ballast pallet is impermissible!

The crane can topple over. Death, severe bodily injuries, property damage.

- ▶ Make sure that the center of gravity of the LTR in travel direction is maximum ± 150 mm outside the center of the ballast pallet ($\pm 2.5^\circ$ incline): Adhere to the distance **A**. See section „Determining the position of the LTR on the ballast pallet“.

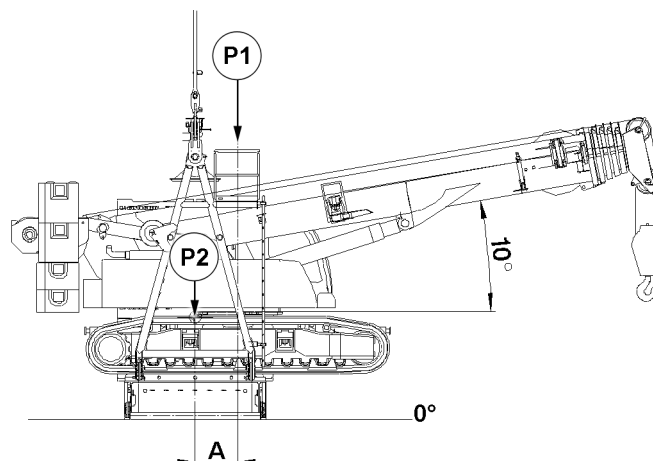

Fig.124989: Position LTR 1100 on ballast pallet

- ▶ Position the LTR on the ballast pallet: Establish distance **A**.

9.5 Placing the ballast plates, fastening system: „Twistlock“

Make sure that the following prerequisites are met:

- Ballasting **without** LTR: Mats on ballast pallet are removed.
- Centerings are installed on the ballast pallet depending on the ballast plates.
- Rules for ballasting are complied with.



WARNING

Receptacle stud **not** permissible for ballast plates!

Overload and damage of the receptacle stud. Death, severe injury, property damage.

- ▶ Use a permissible receptacle stud for ballast plates 10 t.
- ▶ Use a permissible receptacle stud for ballast plates 12.5 t.
- ▶ Replace damaged receptacle stud.

**WARNING**

More than two ballast plates lifted with the receptacle stud!
Overload and damage of the receptacle stud. Death, severe injury, property damage.

- ▶ Lift maximum two ballast plates with receptacle stud.
- ▶ Make sure that the ballast plates are placed correctly in the centerings of the receptacle stud.
- ▶ Replace damaged ballast plates.

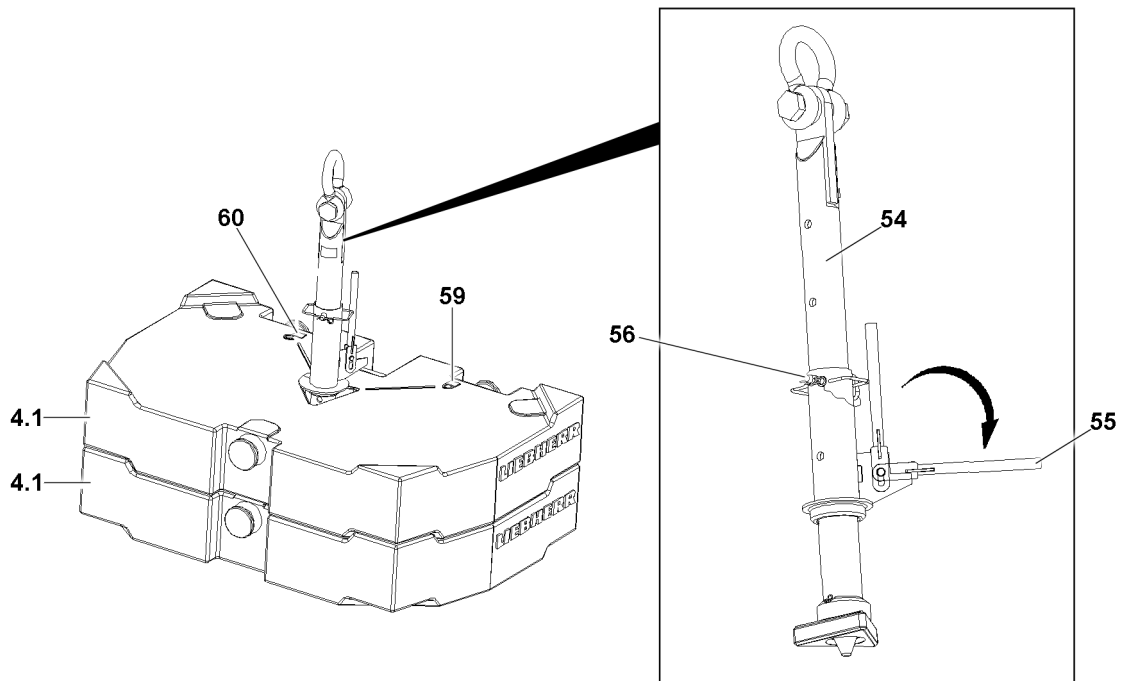

Fig.126074: Receptacle stud with two 10 t ballast plates 4.1

Ballast plates can be placed individually or as an assembly of maximum two ballast plates.

Before the receptacle stud **54** is guided into the ballast plates, it must be ensured that the length of the receptacle stud **54** is set correctly. The length of the receptacle stud **54** can be adjusted with the pin **56**.

- ▶ Release and unpin the pin **56**.
- ▶ Adjust the length of the receptacle stud by moving the receptacle stud **54**.
- ▶ Insert the pin **56** and secure with the spring retainer.
- ▶ Attach the receptacle stud **54** with fastening equipment on the auxiliary crane and guide it into the ballast plate(s).
- ▶ Pull the lever **55** up and fold it down.

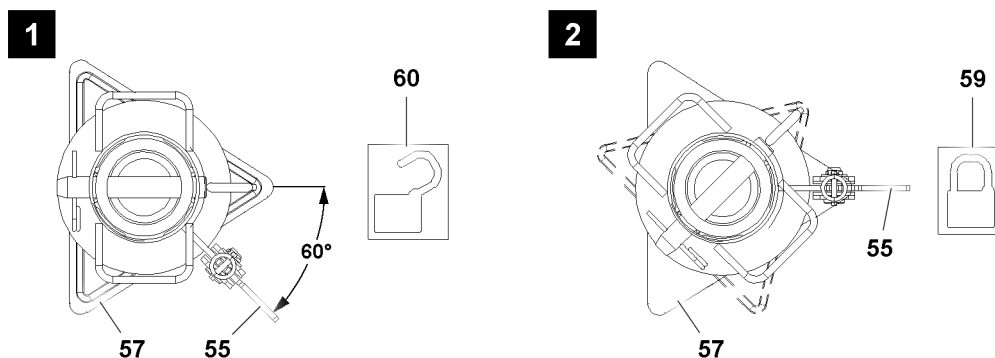

Fig.126075: Receptacle stud overhead view, positions lever **55**

- ▶ Turn the lever **55** by 60°, see illustration **1** until the lever **55** points on the icon **59**, illustration **2**.

Result:

- The receptacle stud **54** is locked with the ballast plate.
- ▶ Lift the ballast plate individually or as an assembly with the auxiliary crane and place it carefully on the centerings of the ballast pallet or on another ballast plate.

When the ballast plate is placed:

- ▶ Turn the lever **75** by 60° until the lever **75** points to the icon **60**, see illustration **1**.

Result:

- The receptacle stud is unlocked.
- ▶ Carefully pull the receptacle stud **54** from the ballast plate.
- ▶ Place the number of ballast plates according to the erection charts and the load charts.

9.6 Placing the ballast plates, fastening points: „Bitt“

Make sure that the following prerequisites are met:

- Ballasting **without** LTR: Mats on ballast pallet are removed.
- Centerings for ballast plates are installed on the ballast pallet.
- Rules for ballasting are complied with.

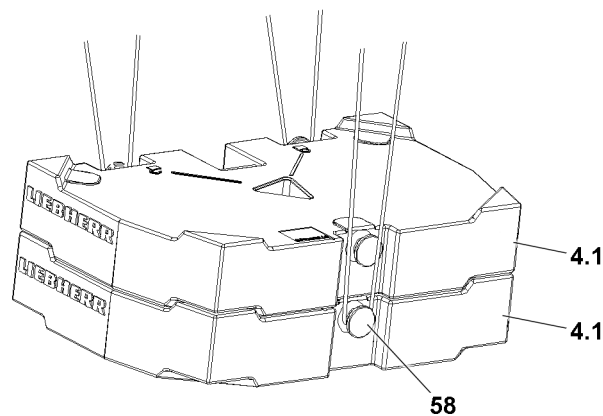

Fig.126076: Ballast assembly with two ballast plates 10 t **4.1**



WARNING

Exceeding permissible load!
Overload Bitt **58** Falling ballast plates.
Death, severe injury, property damage.

When 10 t ballast plates are used:

- ▶ Lift no more than maximum 20 t with ropes, three fastening points.

When 12.5 t ballast plates are used:

- ▶ Lift no more than maximum 25 t with ropes, four fastening points.
- ▶ Replace damaged ballast plates immediately.



WARNING

Fastening equipment is **not** properly fastened and **not** secured sufficiently to prevent it from releasing!
Falling ballast plates. Death, severe bodily injuries, property damage.

- ▶ Attach the fastening equipment properly on bitts **58** and secure it to prevent it from releasing.

Ballast plates can be placed individually or as an assembly of maximum two ballast plates.

- ▶ Lift the ballast plate individually or as an assembly with the auxiliary crane and place it carefully on the centerings of the ballast pallet or on another ballast plate.

- Place the number of ballast plates according to the erection charts and the load charts.

10 Crane operation with the derrick ballast

10.1 Function check of the ground contact switch

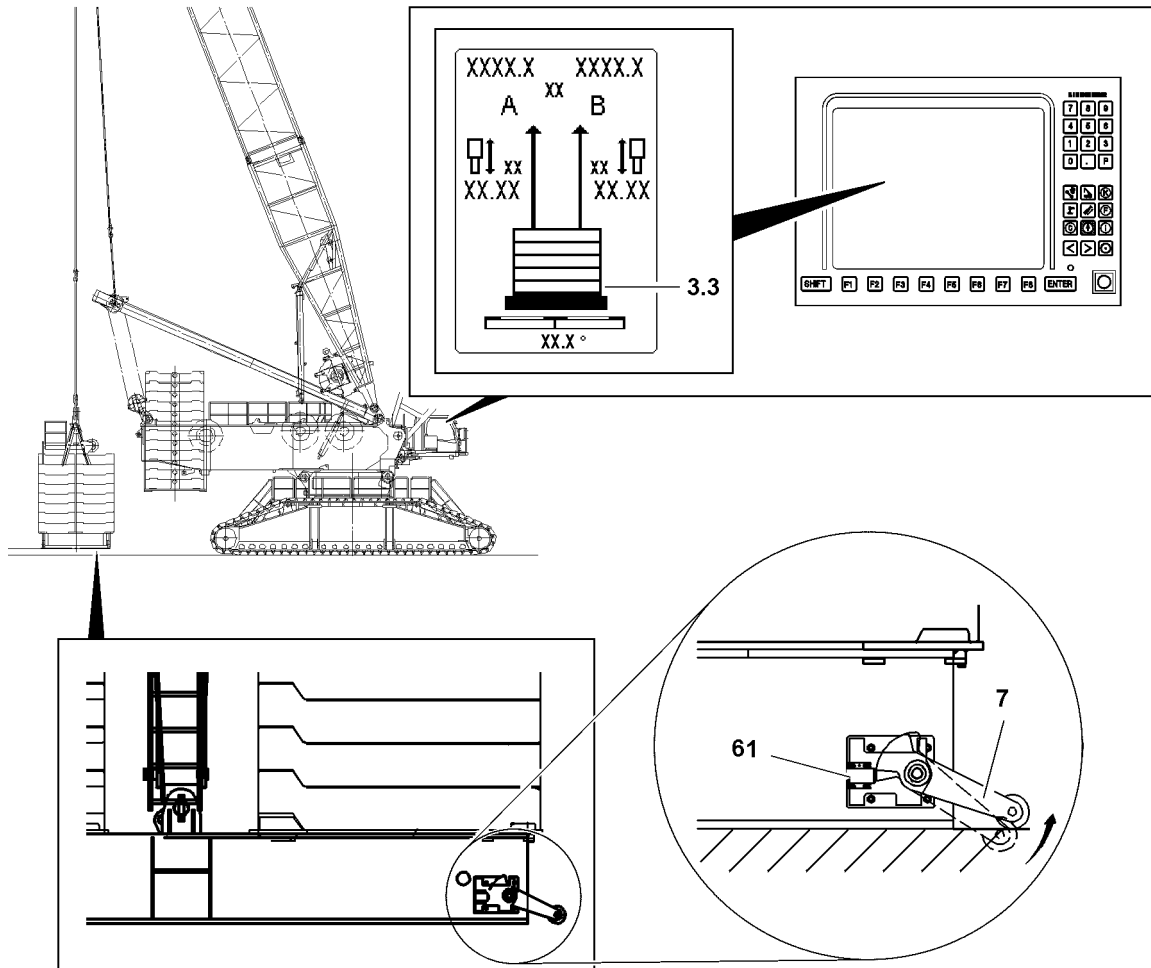

Fig.145935

Make sure that the following prerequisites are met:

- The electrical connection between the derrick ballast and the turntable has been established.
- The cable drum pull release is fastened to the turntable.



DANGER

Danger of accident if the derrick ballast touches the ground unintentionally!

If the terrain is very uneven, the danger exists that the derrick ballast rests on the ground even if a ground contact switch **61** was not actuated.

- If the ballast pallet touches the ground, **at least one** ground contact switch **61** must be actuated via the ground contact roller **7**.

- Check the ease of movement of the ground contact roller **7**.
- Manually operate the ground contact roller **7**.

Result:

- The ground contact switch **61** is actuated.
- The LICCON monitor displays derrick ballast has ground contact **3.3** - the „turning the turntable“ and „driving the crawler“ crane movements are deactivated.

10.2 Lifting and lowering the derrick ballast using the pull cylinders

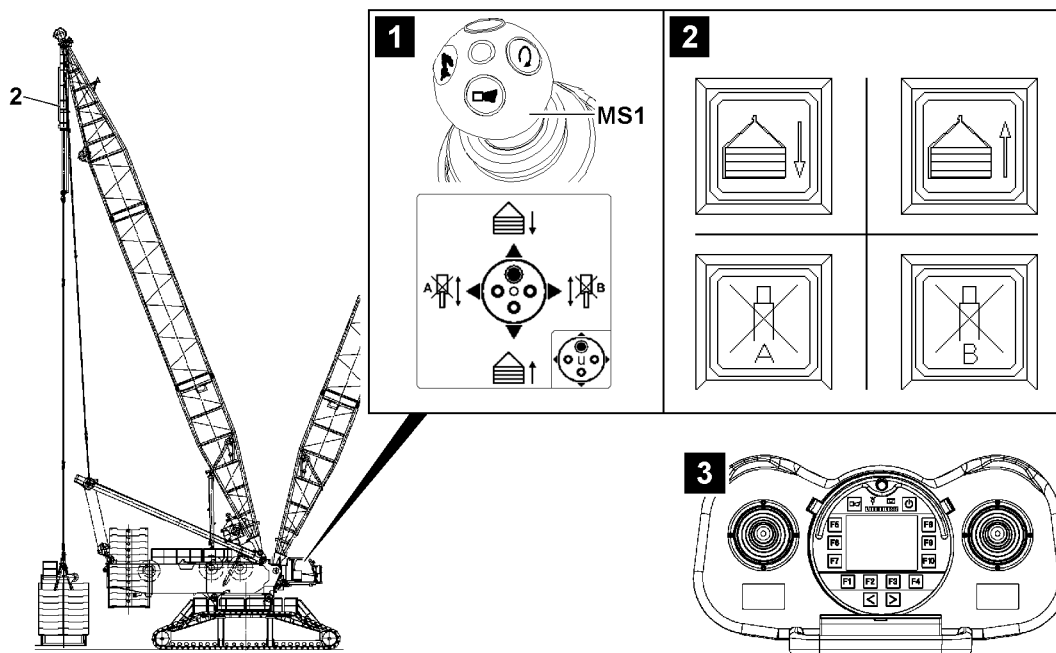

Fig.145937

The pull cylinders **2** in the derrick ballast guying can be operated in different ways:

- Operation with master switch **MS1** in the corresponding master switch assignment, see illustration 1
 - Select the master switch assignment for master switch MS1, see chapter 4.01.
- Operation with operating buttons on the instrument panel, see illustration 2

There is an additional operating option in assembly operation:

- Operation with the radio remote control (BTT-E), see illustration 3
 - Operation with the manual control lever in the corresponding assembly menu, see the radio remote control operating instructions.



Note

- ▶ If the derrick ballast is raised or lowered using the pull cylinder **2**, then the horizontal alignment of the derrick ballast is automatically regulated by both length sensors of the pull cylinder **2**.
- ▶ For a ballast utilization of **more than or equal to 90 percent**, the level sensor regulates the pull cylinder **2** to a difference of 1 cm.
- ▶ With a ballast utilization of **less than 90 percent**, the level sensor monitors the derrick ballast level to $\pm 2.5^\circ$. This makes it possible to set the derrick ballast down up to a ground slope of 2.5° .



DANGER

Danger of accident!

If the following notes are not observed, personnel can be severely injured or killed. In addition, this can result damage to the derrick ballast.

- ▶ Pay attention to the horizontal alignment of the derrick ballast when lifting and lowering the derrick ballast.
- ▶ When lifting and lowering the derrick ballast, check the forces in the D-guyings regularly on LICCON monitor 1. If the difference of forces between „derrick ballast guying A“ and „derrick ballast guying B“ is too large, an acoustic warning sounds and the values on the LICCON monitor 1 blink, see section „Differential force monitoring of Derrick ballast guying“.
- ▶ When adjusting manually (block pull cylinder A or pull cylinder B) the regulation is deactivated and the derrick ballast can be inclined within the limited angle range. This is exclusively permitted when setting down the derrick ballast on uneven ground and only by observing utmost caution.

During crane operation with derrick ballast the required maximum / minimum load can be actively influenced.

This is made possible by increasing or reducing the derrick ballast. Depending on the situation, this procedure is also possible under load.



Note

- ▶ The suspended ballast and the ballast trailer are generally referred to as the **derrick ballast**.
 - ▶ The fixed compensation weight that is installed on the turntable is generally referred to as the **counterweight**.
 - ▶ Additional personnel to carry out crane operation is generally referred to as **guide**.
-
- ▶ Operate the crane function to lift and lower the derrick ballast, see section „Carrying out crane movements“

Empty page!

LWE/LR 11000-001/23501-04-02/en

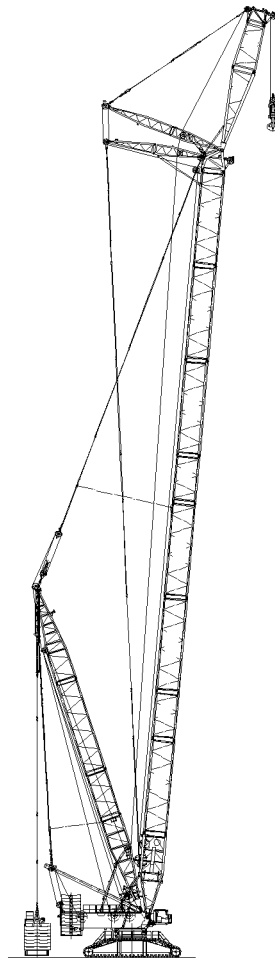
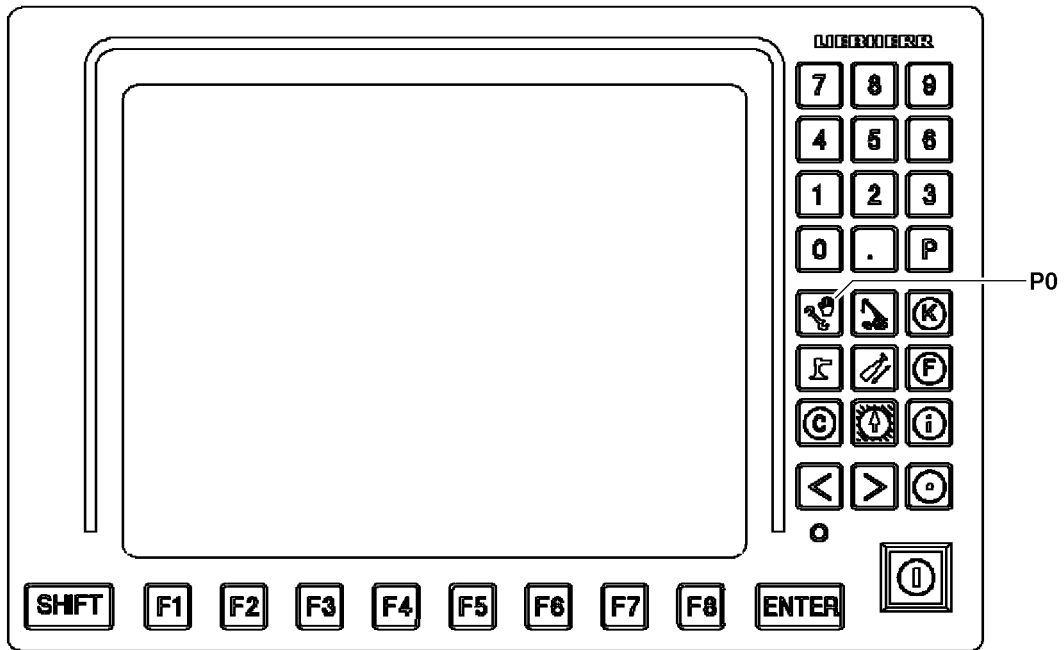

Fig.122800

LWE/LR 11000-001/23501-04-02/en

10.3 Checking the settings of the LICCON overload protection

Make sure that the following prerequisites are met:

- The derrick ballast is placed according to the load chart.
- The actual placed derrick ballast has been entered and confirmed in the Set up program, see Crane operating instructions, chapter 4.02.
- The derrick boom is in operating position.



WARNING

Incorrectly set overload protection!

If the actual set up configuration of the crane deviates from the entries and settings in the Set up program, then the overload protection is not correctly set.

An incorrectly set overload protection calculates the actual load incorrectly and transmits faulty display values.

The crane can be overloaded unnoticed and topple over.

This could result in serious accidents.

- ▶ The entries and settings in the set up program must match the actual set up configuration of the crane.
-



Note

- ▶ Set the LICCON overload protection in the set up program, see Crane operating instructions, chapter 4.02.
-

- ▶ Press the program key **P0**.

Result:

- The Set up program is called up.
- ▶ In the monitor display of the Set up program check if the LICCON overload protection is set according to the data in the load chart and the actual set up configuration of the crane, see example illustration.

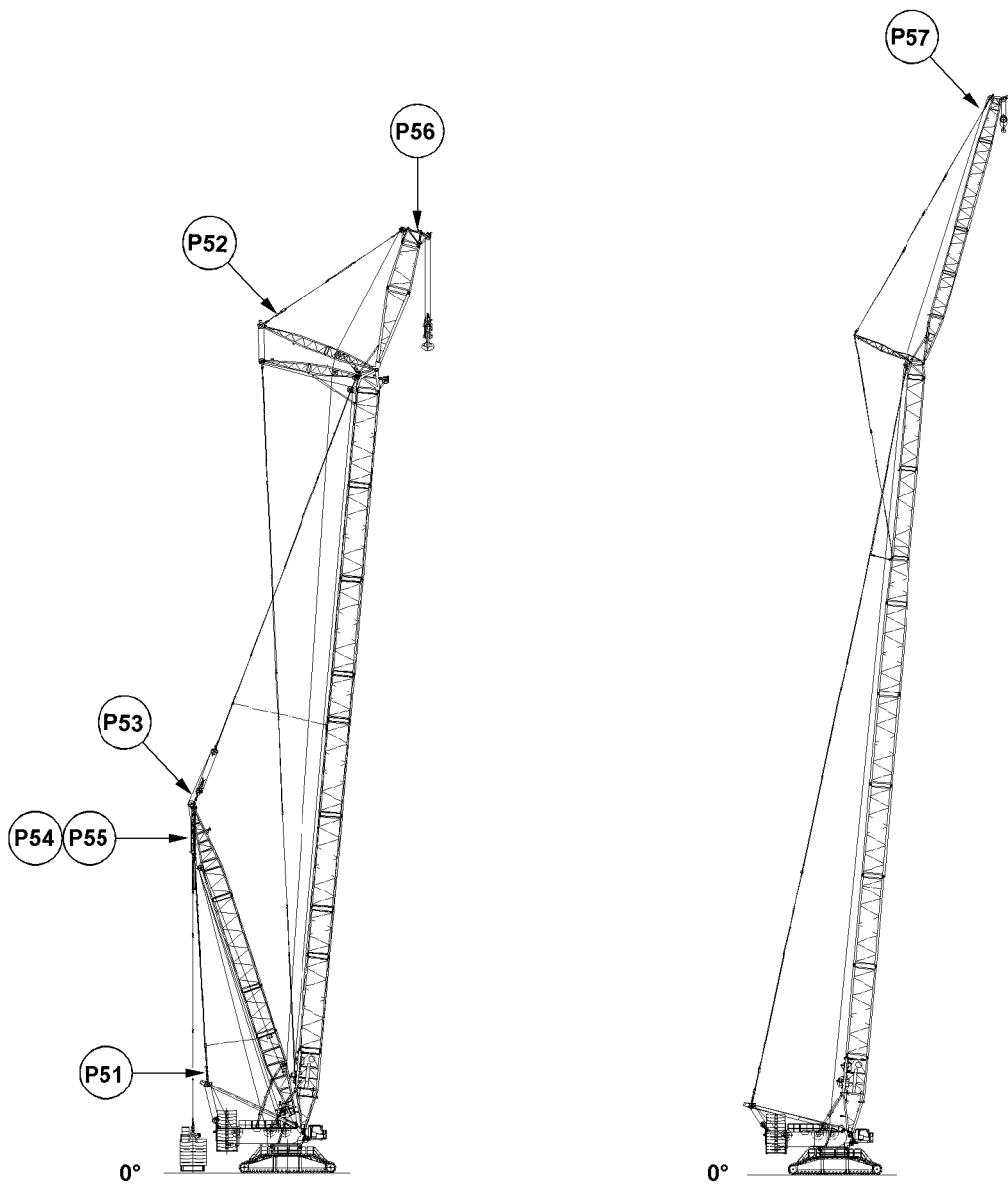
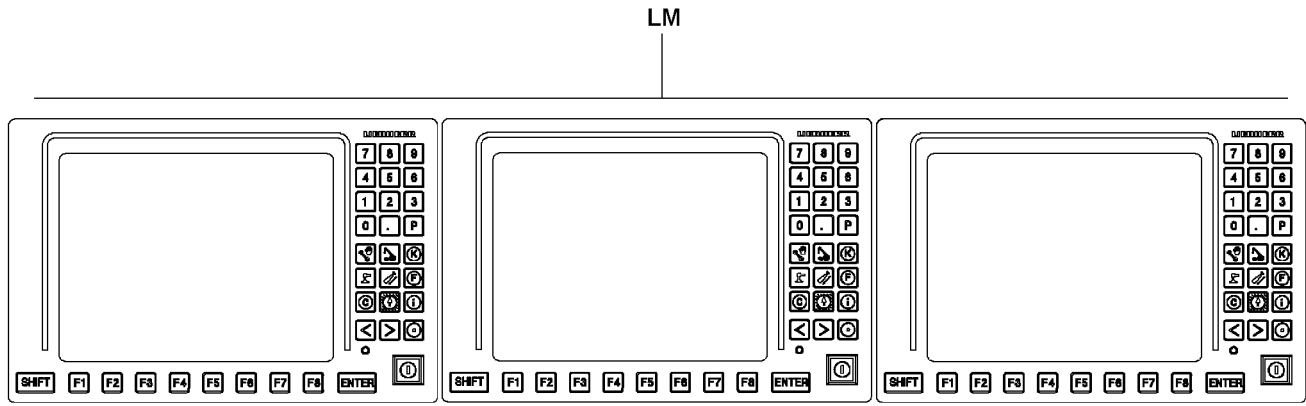

Fig.122806

LWE/LR 11000-001/23501-04-02/en

10.4 F-load display for operating modes with derrick ballast

Assignment of test points for operating modes with derrick ballast:

- Force in the guying between A-frame and derrick head:
 - Test point 1 on point **P51** = force F1
 - The display is made in the F-load display in the center LICCON monitor **LM**.
- Force in the guying between WA-frame and accessory head:
 - Test point 2 on point **P52** = force F2
 - The display is made in the F-load display in the center LICCON monitor **LM**.
Note: Only for the respective boom system.
- Force in the guying between the main boom head and the derrick head:
 - Test point 3 on point **P53** = force F3
 - The display is made in the F-load display in the center LICCON monitor **LM**.
- Force in the guying between derrick ballast and derrick head:
 - Test point 4/5 on point **P54/55** = force F4/5
 - The display is made in the display of the derrick ballast in the left LICCON monitor **LM**.
- Force on the pressure test bracket boom nose:
 - Test point 6 on point **P56** = force F6
 - The display is made in the actual load display in the right LICCON monitor **LM**.
Note: Only with existing boom nose.
- Force in the guying between the FA-frame and the accessory head:
 - Test point 11 on point **P57** = force 11
 - The display is made in the actual load display in the center LICCON monitor **LM**.
Note: Only for the respective boom system



Note

- ▶ For a detailed description of the displays for crane operation with derrick ballast, see the Crane operating instructions, chapter 4.02.



WARNING

Overloading / toppling of the crane!

If the permissible display values of the F-load display are exceeded / fallen below, then the crane can be overloaded.

This could result in serious accidents.

- ▶ Observe and adhere to the display values on the LICCON monitors.
- ▶ Observe and adhere to the specifications regarding the limit values on the assembly drawings.



Note

The values of the F-load display depend on the set up configuration of the crane and the crane geometry.

The values of the F-load display change continuously when the crane is moved.

- ▶ Monitor the F-load display continuously.

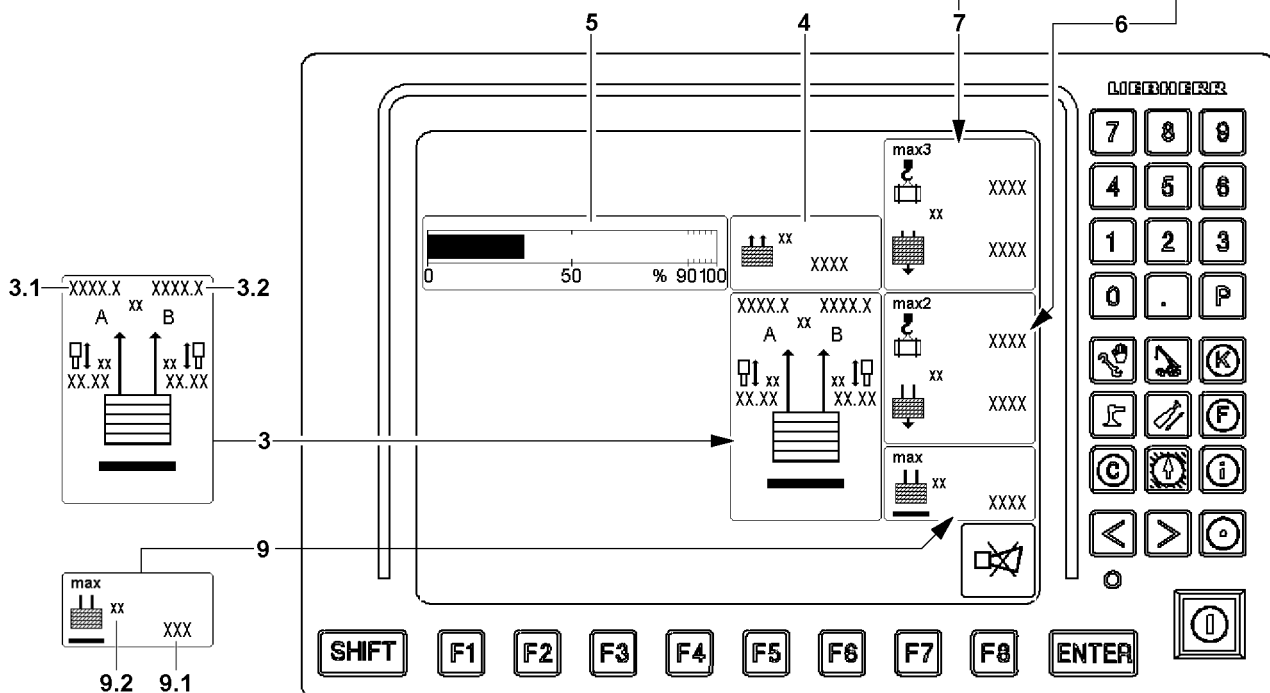
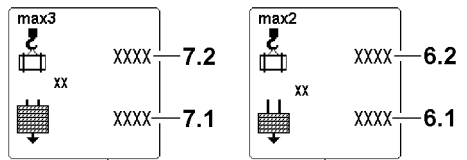
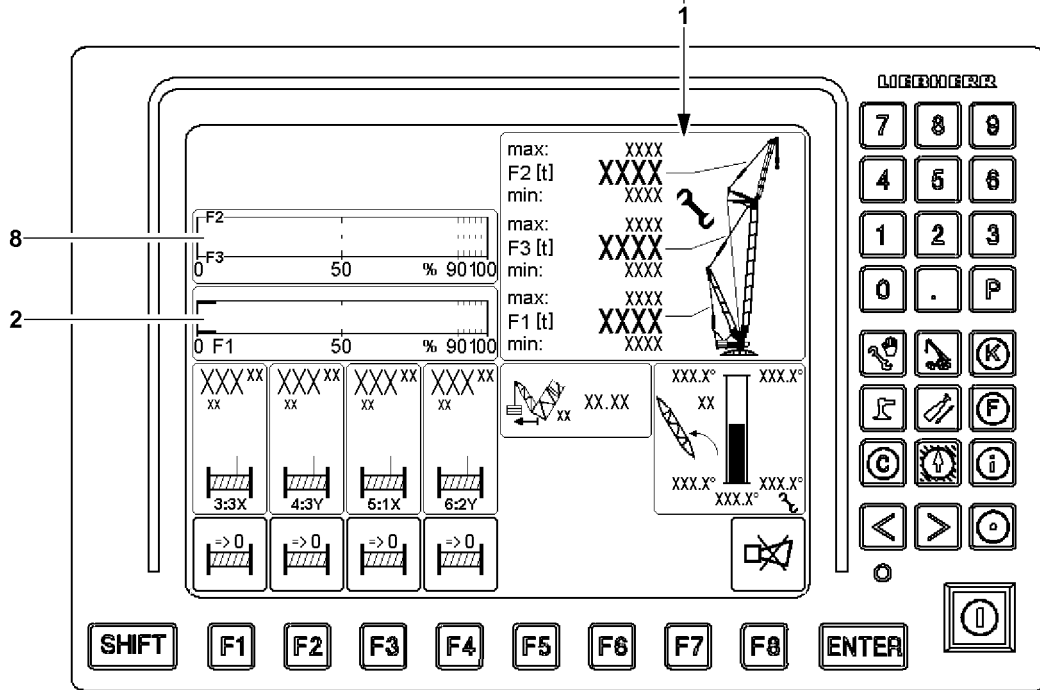
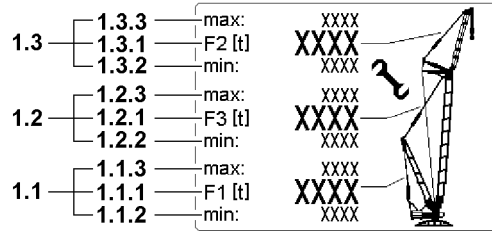

Fig.146968

LWE/LR 11000-001/23501-04-02/en

10.4.1 Force F1 (test point 1)

The force F1 (test point MS1) is determined in the guying between the A-frame and the derrick head and displayed in the LICCON monitor as operating force $F1_{\text{actual}}$.

Display values of force F1 (test point MS1) on the F-load display **1**:

- F1-maximum ($F1_{\text{max}}$) **1.1.3** = maximum value F1-force
- F1-actual value ($F1_{\text{actual}}$) **1.1.1** = actual value F1-force (operating force F1)
- F1-minimum ($F1_{\text{min}}$) **1.1.2** = minimum value F1-force

Structure of the F1-utilization bar **2**:

- Ratio of operating force $F1_{\text{actual}}$ to F1 maximum force

10.4.2 Force F2 (test point 2) and force F3 (test point 3)

The force F2 (test point 2) is determined between the WA-frame and the accessory head and displayed in the LICCON monitor as operating force $F2_{\text{actual}}$. A display is made only with the respective boom system.

The force F3 (test point 3) is determined between the main boom head and the derrick head and displayed in the LICCON monitor as operating force $F3_{\text{actual}}$.

Display values of force F2 (test point MS2) in the F-load display **1**:

- F2-maximum ($F2_{\text{max}}$) **1.3.3** = maximum value F2-force
- F2-actual value ($F2_{\text{actual}}$) **1.3.1** = actual value F2-force (operating force F2)
- F2-minimum ($F2_{\text{min}}$) **1.3.2** = minimum value F2-force

Display values of force F3 (test point MS3) in the F-load display **1**:

- F3-maximum ($F3_{\text{max}}$) **1.2.3** = maximum value F3-force
- F3-actual value ($F3_{\text{actual}}$) **1.2.1** = actual value F3-force (operating force F3)
- F3-minimum ($F3_{\text{min}}$) **1.2.2** = minimum value F3-force

Composition of the F2 / F3-utilization bar **8**:

- Ratio of operating force $F2_{\text{actual}}$ to F2 maximum force $F2_{\text{max}}$
- Ratio of operating force $F3_{\text{actual}}$ to F3 maximum force $F3_{\text{max}}$
- The F2/F3-utilization bars **8** appear only in assembly operation

In crane operation, the display values are displayed clearly for information. A special monitoring does not occur.

In assembly operation the display values are monitored. The limit values may not be exceeded.

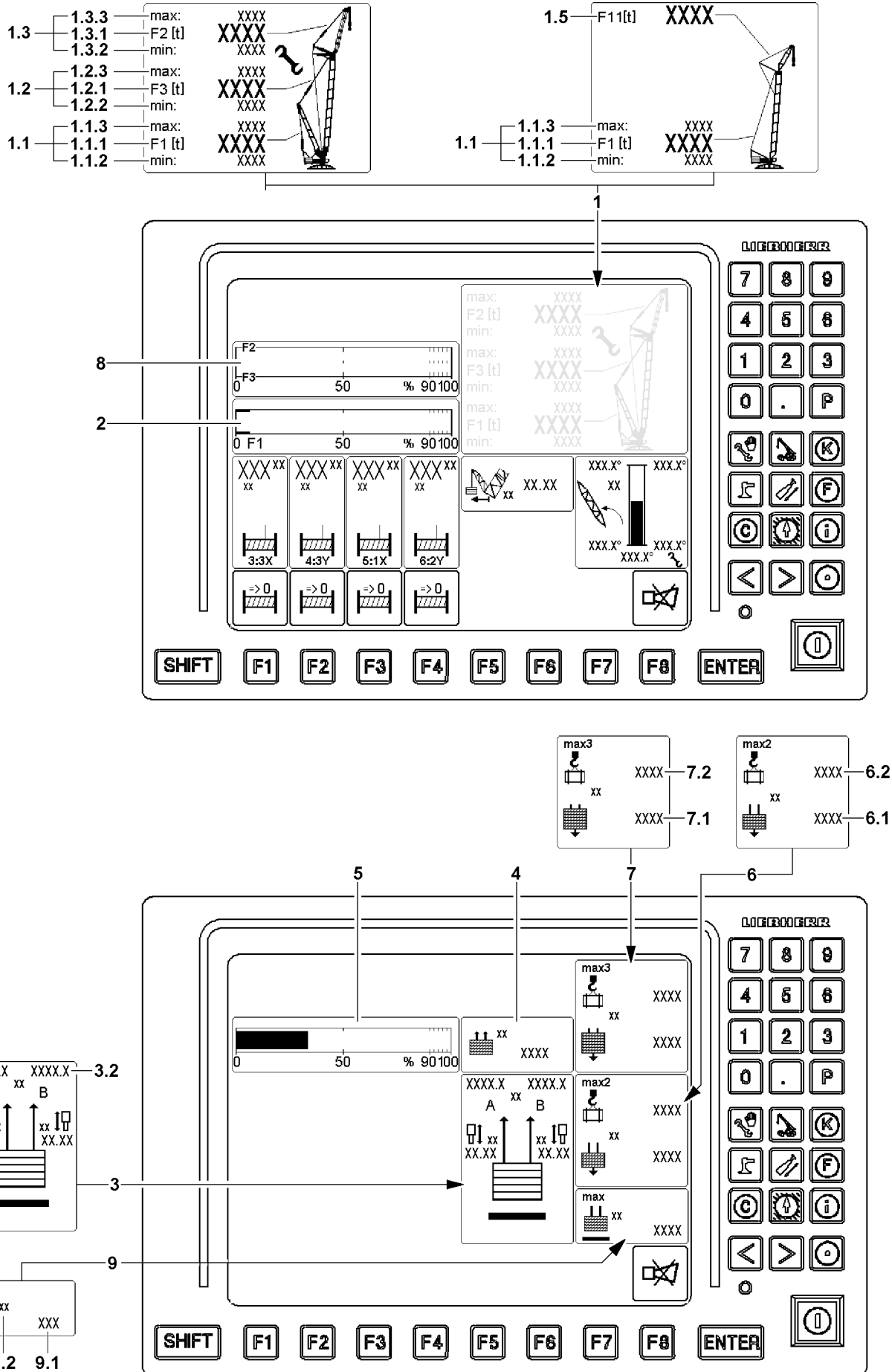

Fig.146967

LWE/LR 11000-001/23501-04-02/en

10.4.3 Force F4/5 (test point 4/5)

The forces F4/5 (test point 4/5) are effective in the guy rods from the derrick ballast to the derrick head.

The existing forces in the guy rods are calculated from four pressure sensors, which are installed on the pull cylinders.

Test points guying A (left) are:

- Test point 4A = pressure sensor ring surface left (force F4A)
- Test point 5A = pressure sensor piston surface left (force F5A)

Test points guying B (right) are:

- Test point 4B = pressure sensor ring surface right (force F4B)
- Test point 5B = pressure sensor piston surface right (force F5B)

Display values of force F4/5 (test point 4/5) in icon Guying derrick ballast **3**:

- Force in the derrick ballast guying A **3.1**
- Force in the derrick ballast guying B **3.2**

Display values derrick ballast:

- Currently pulled derrick ballast = BA_{pulled} **4**
- Current utilization of derrick ballast = Utilization bar derrick ballast **5**
- Currently placed derrick ballast = BA_{placed} **6.1**

From the sum of derrick ballast guying A **3.1** and derrick ballast guying B **3.2** is the pulled derrick ballast BA_{pulled} **4** calculated.

If the ballast still has ground contact, then only that part of the ballast is displayed which is pulled up by the D-guying. The remaining part is laying correspondingly on the ground.

Composition of utilization bar derrick ballast **5**:

- Ratio of pulled derrick ballast (BA_{pulled} **4**) to placed derrick ballast (BA_{placed} **6.1**)

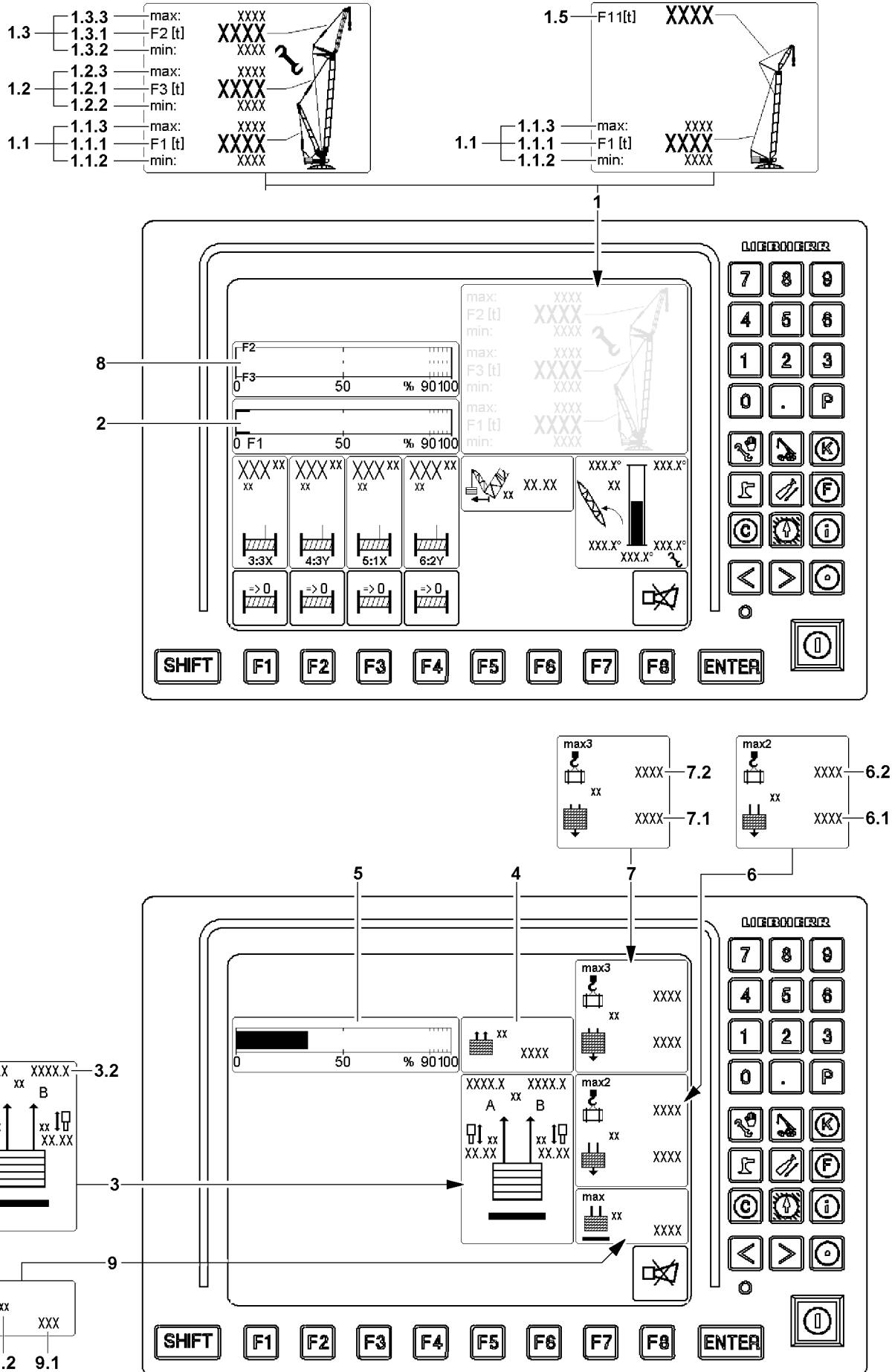

Fig.146967

LWE/LR 11000-001/23501-04-02/en

10.4.4 Maximum liftable derrick ballast

The *maximum liftable derrick ballast* **9** refers to the current crane condition and indicates the maximum derrick ballast that can be lifted off the ground with the pull cylinder or off the suspended ballast palette in case of the VarioTray without falling below the $F_{1_{min}}$ force.

- **9** *Maximum liftable derrick ballast* icon
- **9.1** Maximum liftable derrick ballast
 - Maximum derrick ballast
- **9.2** Measuring unit
 - Measuring unit for display values in the *Pulled derrick ballast* icon **9**: [t] or [lb]

10.4.5 Force F11 (test point 11)

Force in the guying between the FA-frame and the accessory head:

Display values of force F11 (test point MS11) on the F-load display **1**:

- F11-actual value ($F_{11_{actual}}$) **1.5** = actual value F11-force (operating force F11)

10.4.6 Additional displays

- „Load max2“ icon **6** (see section „Utilization conditions“)
- Currently placed derrick ballast = BA_{placed} (Input value in set up program) **6.1**
- Possible load with currently placed derrick ballast = $Load_{max2}$ **6.2**
- „Load max3“ icon **7** (see section „Utilization conditions“)
- Maximum derrick ballast according to load chart = BA_{max} **7.1** (Highest value in Set up program)
- Possible load with maximum derrick ballast according to load chart = $Load_{max3}$ **7.2**

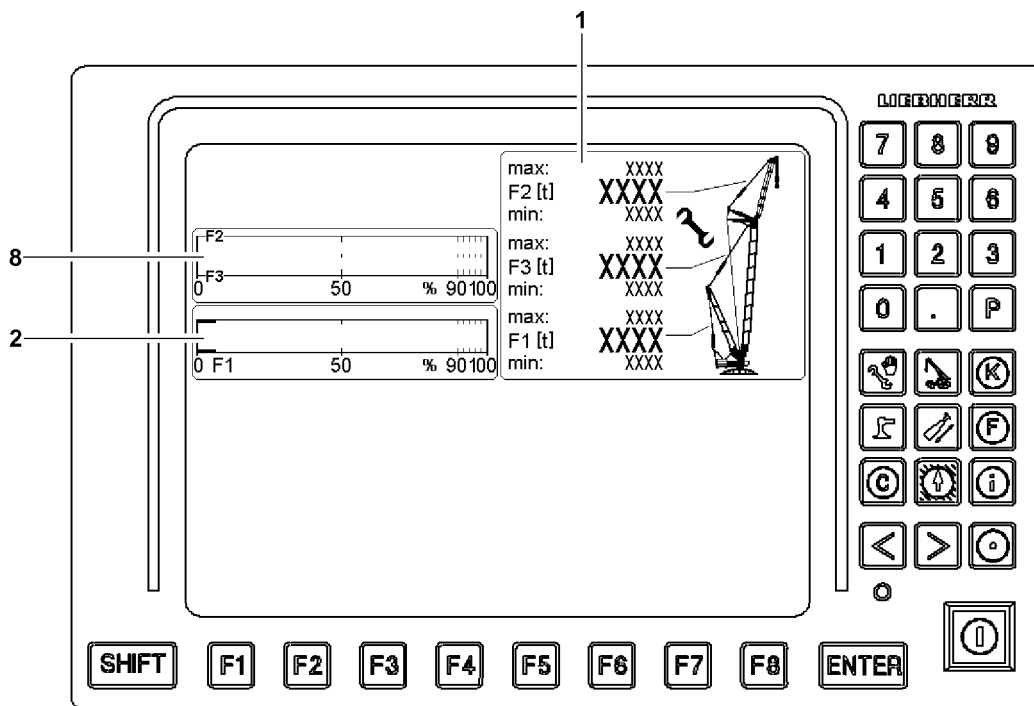
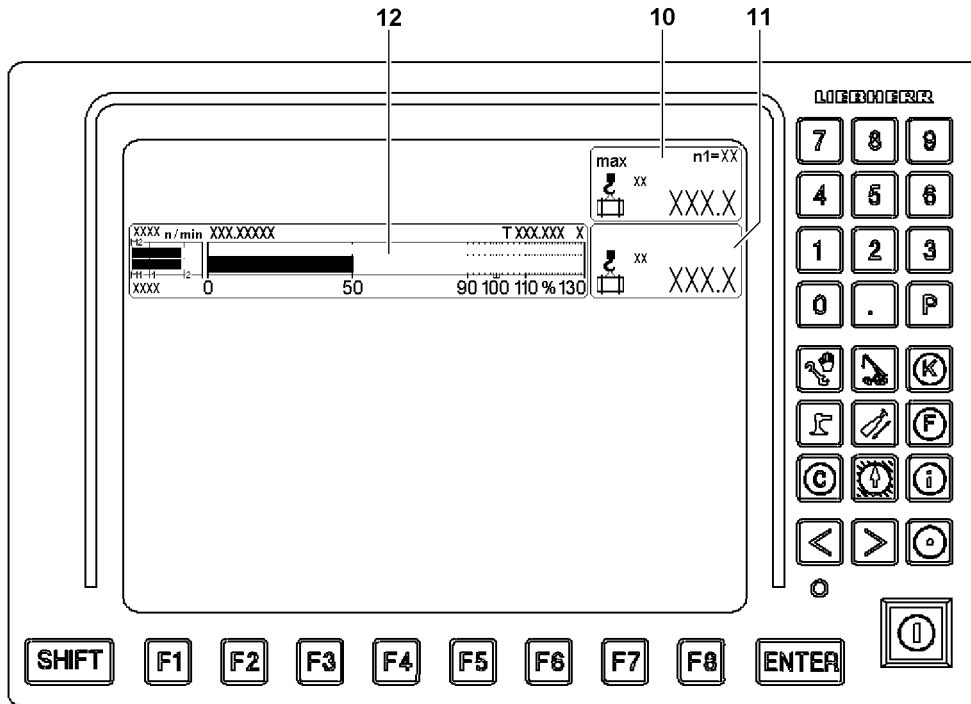

Fig.122808

LWE/LR 11000-001/23501-04-02/en

10.5 Monitoring of crane utilization in operating modes with derrick ballast



Note

- ▶ The icon illustrations of the LICCON monitors are examples and may not match your crane.
- ▶ The icon illustrations of the LICCON monitors can deviate in number, arrangement and depiction of the icons on your crane.
- ▶ Observe the Crane operating instructions, chapter 4.02.



WARNING

Incorrect display values!

If the display values do not increase correspondingly when lifting known weights, an erroneous display value may be present.

If the crane is operated with erroneous display values, then the crane can be overloaded.

This could result in serious accidents.

- ▶ When lifting the hook block off the ground check if the display value for the actual load increases correspondingly.
- ▶ When lifting the derrick ballast off the ground check if the display value for the pulled derrick ballast (BA_{pulled}) increases correspondingly.
- ▶ When lifting the load off the ground check if the display value for the actual load increases correspondingly.

In operating modes with derrick ballast, the monitoring of the crane utilization includes, among others:

1. Monitoring of load torque
Via the „Maximum load“ icon **10**, „Actual load“ icon **11** and the „utilization bar diagram“ **12**.
2. Utilization conditions
Support the crane driver with additional display values.
3. Monitor the F-load display **1**.
Supported by the F1-utilization bar **2** and possibly the F2/F3-utilization bar **8**.

10.5.1 Monitoring of load torque

It monitors the „maximum load according to the load chart and reeving“.

In crane operation, the actual load is compared with the maximum load which may be lifted in the current crane configuration. The display of the values is made in the icon „Maximum load“ **10** and in icon „actual load“ **11**. The current percentage utilization is displayed as „bar diagram utilization“ **12** in the right LICCON monitor.

The color of the utilization bar in the „bar diagram utilization“ **12** also displays the crane utilization:

- Utilization bar blue / green (below 90 %): Utilization in permissible range
- Utilization bar yellow (90 % to 100 %): Advance warning. - Utilization just before impermissible range
- Utilization bar red (above 100 %): Warning. - Utilization in impermissible range



Note

- ▶ Procedure for optimum utilization of „maximum load according to load chart and reeving“, see section „Utilization conditions“.



Fig.122809

LWE/LR 11000-001/23501-04-02/en

**WARNING**

Access the functionality of the LICCON overload protection!

When accessing the functionality of the LICCON overload protection by activating assembly operation, the LICCON overload protection is totally deactivated, bypassed or limited.

It is possible to exceed several shut-off limits of the LICCON overload protection simultaneously or one after the other.

It is possible to carry out crane movements, which are not monitored by the LICCON overload protection.

Without the LICCON overload protection, no additional protection against overload of the crane via the crane control is present.

This could result in serious accidents.

- ▶ When accessing the functionality of the LICCON overload protection, take into account that the LICCON overload protection is deactivated totally or is limited.
- ▶ When accessing the functionality of the LICCON overload protection, the Crane operating instructions, chapter 4.02 must be observed.

**WARNING**

The crane can topple over!

In assembly operation the LICCON overload protection is deactivated.

In the event of deliberate improper use, the crane could collapse, the boom can break off or the crane can topple over.

Personnel can be killed.

This could result in high property damage.

- ▶ Activate the assembly operation only when the consequences are known.
- ▶ Enter the set up configuration correctly into the LICCON computer system.
- ▶ Observe the erection / take down charts.
- ▶ Crane operation with deactivated LICCON overload protection is prohibited.
- ▶ In assembly operation only load torque reducing crane movements may be carried out until a permissible operating and load range.
- ▶ The crane operator carries complete and sole responsibility for his actions if the LICCON overload protection is deactivated.

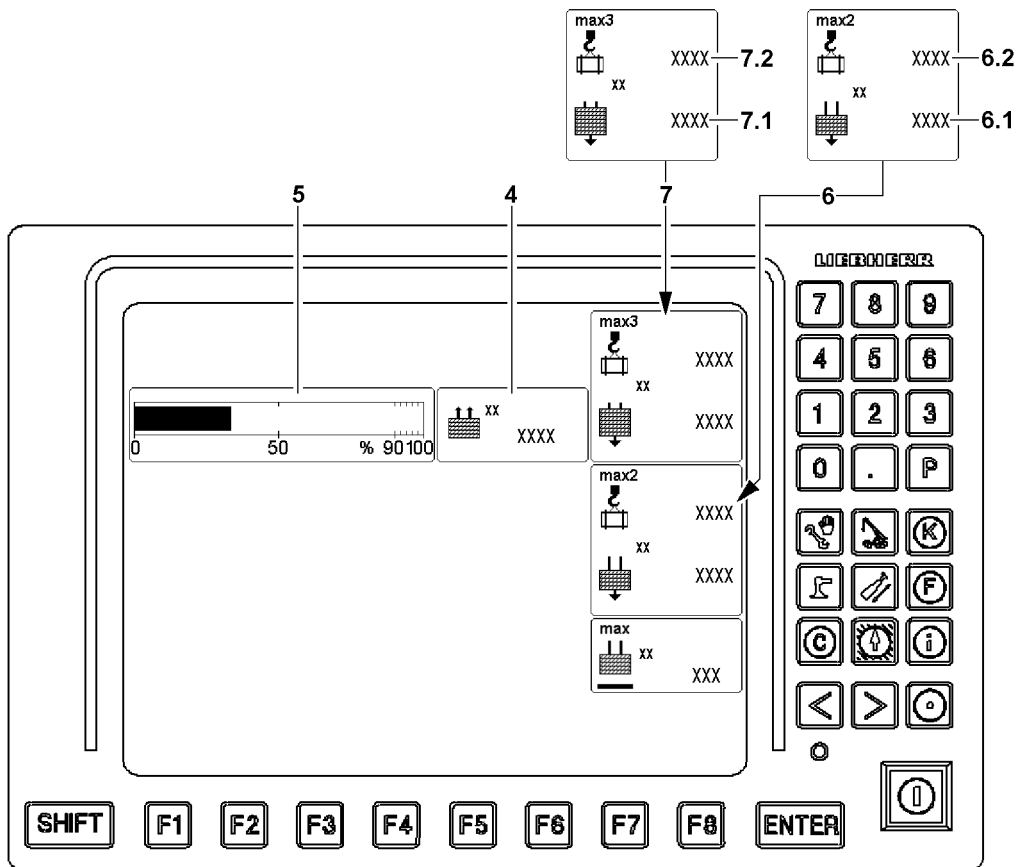
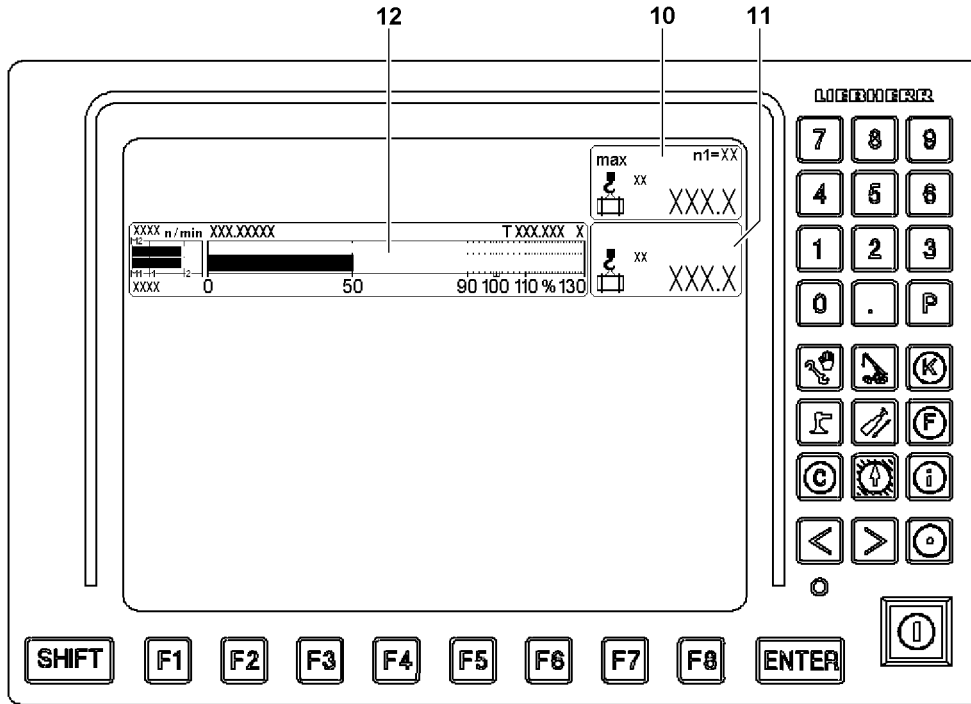

Fig.146966

LWE/LR 11000-001/23501-04-02/en

10.5.2 Utilization conditions

The current percentage utilization of the crane is displayed as „bar diagram utilization“ **10** in the right LICCON monitor.

Additional displays:

- **6** „Load max2“ icon
 - Currently placed derrick ballast = BA_{placed} (Input value in set up program) **6.1**
 - Possible load with currently placed derrick ballast = $\text{Load}_{\text{max2}}$ **6.2**
- **7** „Load max3“ icon
 - Maximum derrick ballast according to load chart = BA_{max} **7.1** (Highest value in Set up program)
 - Possible load with maximum derrick ballast according to load chart = $\text{Load}_{\text{max3}}$ **7.2**

Maximum load, right LICCON monitor:

- The maximum load in the current operating condition is reached when the utilization bar shows 100 % in the „bar diagram utilization“ **12**.
This is the case when the „utilization of the crane according to the load chart and reeving“ reaches 100 % (Values in icon „Maximum load“ **10** and in icon „actual“ **11** are equal).
When the „Maximum load“ **10** is smaller or the same as the $\text{load}_{\text{max2}}$ **6.2**, then an increase might possibly be obtained:
 - By increasing the pulled derrick ballast BA_{pulled} **4**, if the utilization bar derrick ballast **5** is not yet at 100 % (derrick ballast not suspended).
 - By increasing the derrick ballast when the BA_{placed} **6.1** is smaller than BA_{max} **7.1**.
 - By changing the derrick ballast radius within the permissible range, see load chart manual or LICCON job planner.

max2-load, icon „load max2“ **6**:

- The highest possible load in current operating condition „**max2-load**“ is reached when in the „bar diagram utilization“ **12** 100 % is shown **and** the utilization bar derrick ballast **5** is at 100 % (Derrick ballast is completely lifted off the ground).
This is the case when the value in icon „Actual load“ **11** is the same as the $\text{load}_{\text{max2}}$ **6.2**.
When the $\text{load}_{\text{max2}}$ **6.2** is smaller or the same as the $\text{load}_{\text{max3}}$ **7.2**, then an increase might possibly be obtained:
 - By increasing the derrick ballast by loading additional ballast plates (increase BA_{placed} **6.1** to BA_{max} **7.1**).

max3-load, icon „load max3“ **7**:

- The highest possible load at the maximum derrick ballast in current operating condition „**max3-load**“ is reached when the „bar diagram utilization“ **12** displays 100 % **and** the utilization bar derrick ballast **5** is at 100 % (Derrick ballast according to load chart is placed and is completely lifted off the ground).
This is the case when the value in icon „Actual load“ **11** is the same as the $\text{load}_{\text{max3}}$ **7.2**.
- The maximum derrick ballast according to the load chart is placed and completely pulled.
Further increase of the derrick ballast is impermissible.



Fig.122809

10.5.3 Monitoring of F1-maximum force

Display values of force F1 (test point MS1) on the F-load display 1:

- F1-maximum ($F1_{\max}$) **1.1.3** = maximum value F1-force
- F1-actual value ($F1_{\text{actual}}$) **1.1.1** = actual value F1-force (operating force F1)
- F1-minimum ($F1_{\min}$) **1.1.2** = minimum value F1-force

The display values of force F1 (test point 1) are displayed permanently in the LICCON monitor. At F1-actual value ($F1_{\text{actual}}$) **1.1.1** larger F1-maximum ($F1_{\max}$) **1.1.3** a shut off of all load moment increasing movements occurs.



WARNING

Access the functionality of the LICCON overload protection!

When accessing the functionality of the LICCON overload protection by activating assembly operation, the LICCON overload protection is totally deactivated, bypassed or limited.

It is possible to exceed several shut-off limits of the LICCON overload protection simultaneously or one after the other.

It is possible to carry out crane movements, which are not monitored by the LICCON overload protection.

Without the LICCON overload protection, no additional protection against overload of the crane via the crane control is present.

This could result in serious accidents.

- ▶ When accessing the functionality of the LICCON overload protection, take into account that the LICCON overload protection is deactivated totally or is limited.
- ▶ When accessing the functionality of the LICCON overload protection, the Crane operating instructions, chapter 4.02 must be observed.



Note

The limit value for the F1-maximum force depends not only on the set up configuration and the crane geometry, but also from the pulled derrick ballast.

- ▶ If the pulled derrick ballast is larger, then the limit value for the F1-minimum force is generally reduced.
- ▶ If the pulled derrick ballast is smaller, then the limit value for the F1-maximum force is generally increased.



Note

By engaging the assembly operation the limit value for the F1-maximum force can be exceeded by a few tons. This makes it possible to reset a crane movement, which has caused the shut off.

- ▶ Reset triggered shut off by reverse crane movement.



Fig.122809

LWE/LR 11000-001/23501-04-02/en

10.5.4 Monitoring of F1-minimum force

Display values of force F1 (test point MS1) on the F-load display 1:

- F1-maximum ($F1_{\max}$) **1.1.3** = maximum value F1-force
- F1-actual value ($F1_{\text{actual}}$) **1.1.1** = actual value F1-force (operating force F1)
- F1-minimum ($F1_{\min}$) **1.1.2** = minimum value F1-force



WARNING

Uncontrolled movements of the boom system!

If the guying between the A-frame and the derrick head (test point 1) becomes powerless, then this can lead to uncontrollable movements of the boom system.

This could result in serious accidents.

- ▶ The guying between the A-frame and the derrick head (test point 1) may never be without power.
- ▶ Relieve the D-guying between the derrick head and the derrick ballast to the point where the F1-actual value ($F1_{\text{actual}}$) **1.1.1** is larger than the F1-minimum ($F1_{\min}$) **1.1.2**.



WARNING

Access the functionality of the LICCON overload protection!

When accessing the functionality of the LICCON overload protection by activating assembly operation, the LICCON overload protection is totally deactivated, bypassed or limited.

It is possible to exceed several shut-off limits of the LICCON overload protection simultaneously or one after the other.

It is possible to carry out crane movements, which are not monitored by the LICCON overload protection.

Without the LICCON overload protection, no additional protection against overload of the crane via the crane control is present.

This could result in serious accidents.

- ▶ When accessing the functionality of the LICCON overload protection, take into account that the LICCON overload protection is deactivated totally or is limited.
- ▶ When accessing the functionality of the LICCON overload protection, the Crane operating instructions, chapter 4.02 must be observed.



Note

By engaging the assembly operation the limit value for the F1-minimum force can be fallen below by a few tons. This makes it possible to reset a crane movement, which has caused the shut off.

- ▶ Reset triggered shut off by reverse crane movement.



Fig.122809

LWE/LR 11000-001/23501-04-02/en

**WARNING**

Autonomous movement of the boom system at increase of load torque!

If the F1-minimum force is fallen below, the guying between the A-frame and the derrick head can become powerless.

If the guying between the A-frame and the derrick head is powerless and the „Derrick ballast is on the ground“ at the same the derrick ballast can suddenly lift off the ground due to increase of the load torque.

As a result, the boom system can move forward suddenly. Strong oscillating movements of the derrick ballast and load can be the result.

The crane can be overloaded and severe accidents can be the result.

- ▶ Hold the F1-actual value ($F1_{\text{actual}}$) **1.1.1** above the F1-minimum ($F1_{\text{min}}$) **1.1.2**.
- ▶ It is prohibited to fall below the F1-minimum force.

**WARNING**

Autonomous movement of the boom system at decrease of load torque!

If the F1-minimum force is fallen below, the guying between the A-frame and the derrick head can become powerless.

If the guying between the A-frame and the derrick head is powerless and the „derrick ballast is suspended“ at the same time, the derrick ballast can suddenly set down on the ground due to decrease of the load torque.

As a result, the boom system can move suddenly backward. As a result, the relapse cylinders can be pressed on the block, be overloaded and damaged. Strong oscillating movements of the derrick ballast and load can be the result.

The crane can be overloaded and severe accidents can be the result.

- ▶ Hold the F1-actual value ($F1_{\text{actual}}$) **1.1.1** above the F1-minimum ($F1_{\text{min}}$) **1.1.2**.
- ▶ It is prohibited to fall below the F1-minimum force ($F1_{\text{min}}$).

The following applies:

- After a shut off due to falling below the F1-minimum ($F1_{\text{min}}$) **1.1.2** the F1-actual value ($F1_{\text{actual}}$) **1.1.1** must be increased by a crane movement. If the derrick ballast is suspended, this can be achieved by setting down the ballast.
- When picking up the load, the D-guying between the derrick ballast and the derrick head must be relieved to the point where the F1-actual value ($F1_{\text{actual}}$) **1.1.1** is greater than the F1-minimum ($F1_{\text{min}}$) **1.1.2**.
- When increasing the load torque, and the limit value F1-minimum ($F1_{\text{min}}$) **1.1.2** is fallen below, an already set down derrick ballast can lose contact with the ground and lift off.
- When decreasing the load torque, and the limit value F1-minimum ($F1_{\text{min}}$) **1.1.2** is fallen below, an already „suspended derrick ballast“ can set down on the ground.
- If the assembly operation is activated and the F1-force continues to drop below the minimum force $F1_{\text{min}}$, then the $F1_{\text{min}}$ shut off can no longer be bypassed.

Limitations from 50 % pulled derrick ballast

If more than 50 % of the set derrick ballast is being pulled (utilization bar derrick ballast **5** larger than 50 %) and the F1-minimum ($F1_{\text{min}}$) **1.1.2** is fallen below at the same time, all crane movements that increase load torque are turned off.

Limitations from 90 % pulled derrick ballast

If more than 90 % of the set derrick ballast is being pulled (utilization bar derrick ballast **5** larger than 90 %) and the F1-minimum ($F1_{\text{min}}$) **1.1.2** is fallen below at the same time, all crane movements that increase load torque and all crane movements that decrease load torque are turned off. This also turns off the „spooling out“ movement of the winch.

10.6 Monitoring of pull cylinders on block position

The pull cylinders (also called ballast lift cylinders) of the derrick ballast are equipped with length sensors and limit switches for monitoring.

In crane operation, the monitoring of the pull cylinders on block position is always active. If there is the danger of a block position, then only that direction of the pull cylinders can be moved which improves the condition. The other direction is unbyypassably blocked. As long as the length sensors and the limit switches function correctly, the pull cylinders cannot get into a block position.



WARNING

Problem at monitoring of pull cylinders!

If the length sensors or limit switches are defective or missing, then the monitoring of the pull cylinders is not active.

Without monitoring, the pull cylinders can be moved without restriction, as a result, a block position is possible.

At a block position, the pressure measurements of the pull cylinders become inexact and the values are incorrectly calculated.

The overload protection calculates the actual load incorrectly and transmits faulty display values.

The crane can be overloaded and topple over.

This could result in serious accidents.

- ▶ Observe the display values and possible error messages.
- ▶ If length sensors or limit switches are defective or missing, monitor the pull cylinders manually.

The following applies:

- The display values of the pull cylinders must function and be plausible.

10.7 Monitoring the lateral incline of the ballast pallet

The ballast pallet is equipped with an incline sensor for monitoring.

The monitoring to $\pm 2.5^\circ$ lateral incline of the ballast pallet is always active. If a lateral incline of $\pm 2.5^\circ$ is reached, then only those directions of the pull cylinders can be moved which improve the condition. The other directions are unbyypassably blocked. The ballast can be set down for that reason only to a maximum incline of the terrain of 2.5° .



WARNING

Defective incline sensor!

If an incline sensor is defective or missing, the monitoring of the lateral incline of the suspended ballast is not active.

The pull cylinders can be moved without restriction and the derrick ballast can be overturned as a result.

This could result in serious accidents.

- ▶ Observe the display values and possible error messages.
- ▶ If an incline sensor is defective, monitor the lateral incline of the derrick ballast manually.

The following applies:

- The display values of the lateral incline of the derrick ballast must function and be plausible.

10.8 Differential force monitoring for derrick ballast-guying

In operating modes with derrick ballast the forces of the derrick ballast guyings A and B are displayed in the LICCON monitor.



WARNING

Danger of accident!

If the forces in the derrick ballast guyings A and B are too high, then this can lead to an overload of the crane. Components can fail and severe accidents can be the result.

- ▶ Load the derrick ballast guyings A and B evenly.

After reaching the specified limit value of the difference force threshold, the displays of the pulled ballast of pull cylinder A and B blink and become red, the function ballast up / down is stopped. The difference force must be lowered again.

If the difference of the forces of the derrick ballast guying A and B exceeds the limit value, then this can have various causes:

- Flexing of the turntable.
- The ground under the derrick ballast is uneven.
- The crane is leaning to one side.
- The derrick ballast is loaded one-sided.
- The force measurement in one D-guying is incorrect.

The crane driver must recognize the correct cause and take countermeasures:

- The error, which caused the one-sided force, must be remedied.
- If the sensor values are implausible: Stop crane operation and find the cause and remedy it.

10.8.1 Bypassing the shut off of the function ballast up / down

- The following measures are permitted providing the ground is only slightly uneven: Control the individual pull cylinders in such a way that the difference between the forces becomes smaller. Ensure that the derrick ballast is not tilted at an inadmissible angle with respect to the crane, otherwise the derrick ballast guide and attachments will be damaged.
- ▶ Carry out the following: Activate assembly operation, see Crane operating instructions, chapter 4.02.

Result:

- The shut off of the function ballast up / down is bypassed.
- On the left LICCON monitor appears an assembly icon.
- ▶ Press the button Ballast „up“ or button Ballast „down“ **and** the stop button on the desired side at the same time, see section „Carrying out crane movement“.

Problem remedy

The display of the entire pulled ballast is shown blinking red. An LMB-Stop was triggered. All crane functions were stopped.

The crane driver has moved the pull cylinders into the incorrect direction and further exceeded the limit value for the difference force threshold.

- ▶ Move the pull cylinders again into the correct (other) direction and align the ballast in such a way that the displays of the pulled ballast of pull cylinder A and B are again in the permissible range.

- ▶ Activate assembly operation again.

Result:

- The shut off of the function ballast up / down is bypassed again.
- All other crane functions are still suppressed.
- ▶ Move the pull cylinders into the correct direction.



DANGER

Overload of crane!

If the pull cylinders are moved into the incorrect direction after a new bypass of the function ballast up / down, the crane will be overloaded.

This could result in serious accidents.

- ▶ Monitor the display values and move the pull cylinders in the correct direction (values of pull cylinder A and B become closer).
 - ▶ If unsure: Contact Liebherr Service.
 - ▶ Find the error and remedy it which caused the shut off of the function „Ballast up / down“.
-

10.9 Carrying out crane movements



Note

- ▶ For an overview of the displays in the LICCON monitors, see Crane operating instructions, chapter 4.02.



WARNING

Incorrect display values!

If the display values do not increase correspondingly when lifting known weights, an erroneous display value may be present.

If the crane is operated with erroneous display values, then the crane can be overloaded.

This could result in serious accidents.

- ▶ When lifting the hook block off the ground check if the display value for the actual load increases correspondingly.
- ▶ When lifting the derrick ballast off the ground check if the display value for the pulled derrick ballast BA_{pulled} increases correspondingly.
- ▶ When lifting the load off the ground check if the display value for the actual load increases correspondingly.



WARNING

The crane can topple over!

The jerky execution or braking of turning maneuvers can cause the load and / or suspended ballast to swing.

If the load and / or the suspended ballast collides with obstacles then the crane can be damaged or impeded.

Oscillating movements, damage or impediments can cause the crane to topple over.

This could result in serious accidents.

- ▶ Initiate or slow down crane movements with load and / or suspended derrick ballast extremely sensitively.
- ▶ There may be no persons and / or objects within the working range / danger zone of the crane.
- ▶ During crane operation additional personnel (guide) must monitor and secure the working range / danger zone of the crane from a safe position.



WARNING

Danger of accident due to unsafe ground!

If the crane is operated on insufficient ground, there is a danger of accident.

- ▶ The ground in the entire working area of the crane must be level and of sufficient load carrying capacity, in order to be able to securely accept the encountered surface pressures.
- ▶ Before setting down the load or the derrick ballast, the crane operator must make sure that the intended placement surface is suitable. A safe set down of load and derrick ballast must be ensured.



WARNING

Uncontrolled movements of the boom system!

If the guying between the A-frame and the derrick head (test point 1) becomes powerless, then this can lead to uncontrolled movements of the boom system.

This could result in serious accidents.

- ▶ The guying between the A-frame and the derrick head (test point 1) may never be without power.

**WARNING**

Danger of accidents due to angular pull!

Due to angular pull of load or derrick ballast impermissible side forces are directed into the crane. Impermissible side forces can cause failure of the components or a dangerous change of the center of gravity of the crane and / or load, among others.

Crane and load can be severely damaged and topple over.

This could result in serious accidents.

- ▶ Before taking on a load or the derrick ballast, make sure that the derrick ballast, the center of rotation of the turntable and the load are on one line.

**WARNING**

The crane can topple over!

If the derrick ballast is lifted by more than 0.25 m above the ground, then the crane can fall over to the rear if the load rips off.

- ▶ Do not lift derrick ballast more than 0.25 m from the ground.

Make sure that the following prerequisites are met:

- The test points must be checked before crane operation for functionality.
- The weight of the load to be lifted must be known.
- The support surface / placement surface of the derrick ballast may be maximum 0.25 m above / below the support surface of the crane.
- The support surface / placement surface of the derrick ballast must be level, horizontal and of sufficient load bearing capacity.
- The support surface / placement surface of the derrick ballast must be able to safely absorb the surface pressure.
- There may not be any obstacles in the slewing range of the crane, derrick ballast and load.
- Additional personnel is instructed to monitor and secure the working range / danger zone of the crane from a safe distance.
- A permanent acoustic / visual connection between the crane operator and the additional personnel is available.
- A guide or the crane driver must monitor the lifting and setting down of the derrick ballast and the load.
- The lifted derrick ballast is monitored by a guide or the crane operator.

The following applies:

- When taking up the load, the D-guying between the derrick ballast and the derrick head must be relieved so that the operating force $F_{1_{actual}}$ is larger than the limit value for the F1-minimum force.
- Before taking up the load or the derrick ballast, make sure that the following components are on one line:
 - The load
 - The center of rotation of the turntable
 - The derrick ballast

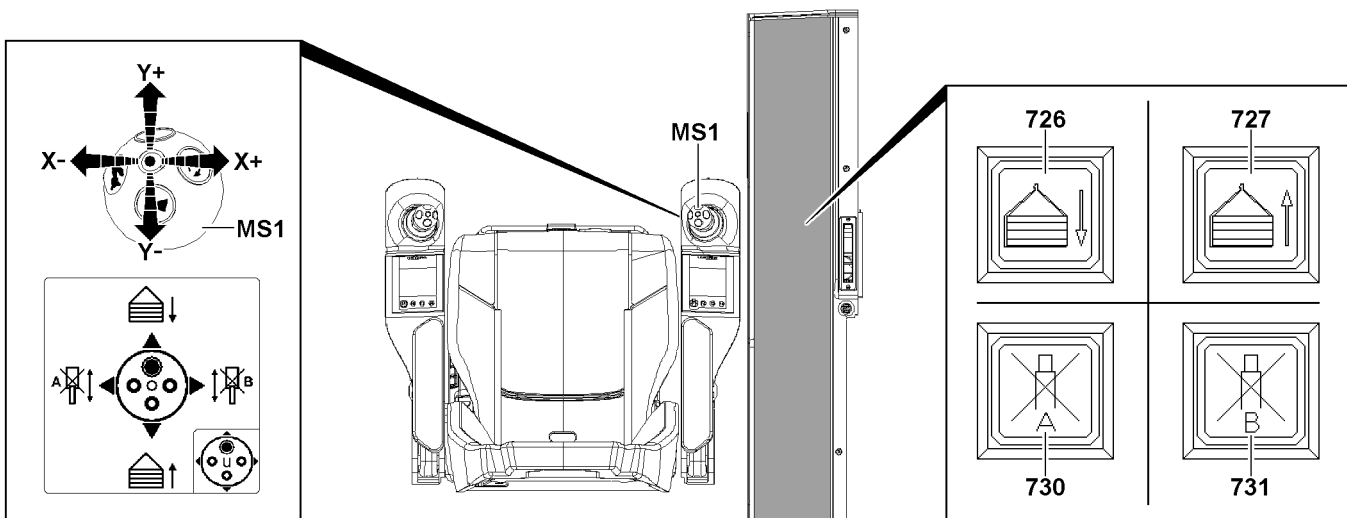
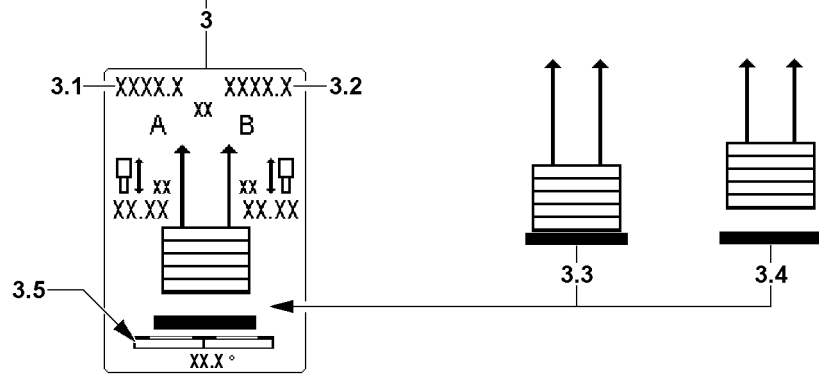
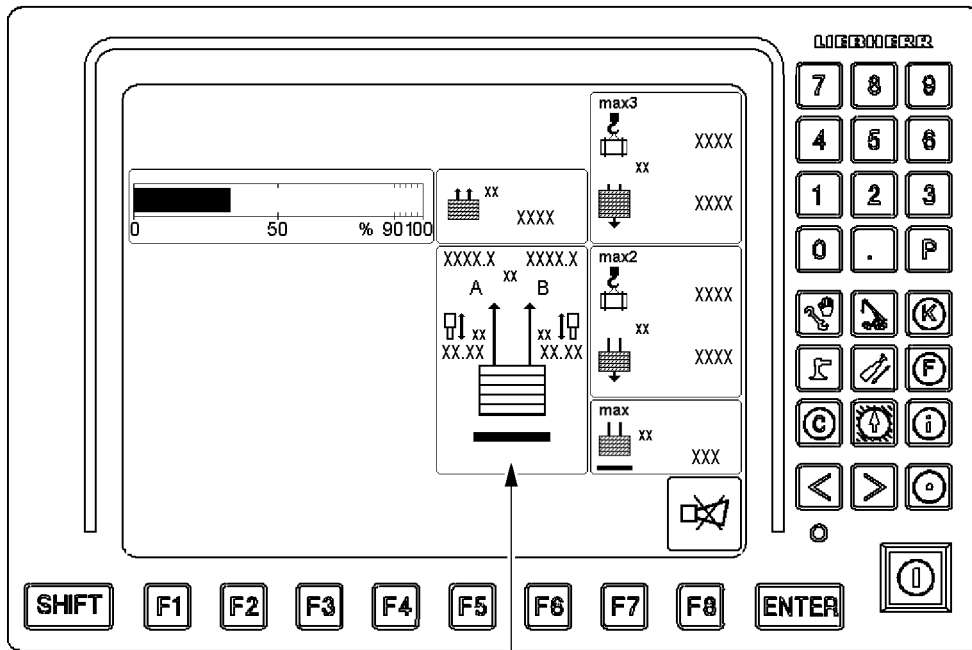

Fig.146965

LWE/LR 11000-001/23501-04-02/en

10.9.1 Lifting / setting down the derrick ballast



WARNING

Danger of accident!

The placement surface for the ballast pallet must be level, horizontal and of sufficient load bearing capacity, otherwise the ballast pallet can tip over.

This could result in serious accidents.

- ▶ Check the incline of the crane during the set down procedure.
- ▶ Check the incline of the ballast pallet with the incline display **3.5**.
- ▶ Monitor the difference forces (derrick ballast guying A **3.1** to derrick ballast guying B **3.2**).
- ▶ It is strictly prohibited for anyone to stand under the ballast pallet or within the entire danger zone during the set down procedure.

The lifting and set down of the derrick ballast is monitored by the LICCON computer system. Normally the crane operator does not have to do anything. However, if corrective measures or preventative measures should be necessary, observe the following section „Equalizing the derrick ballast“.

Lifting the derrick ballast

- ▶ Lift the derrick ballast: Press the button **727**.
or
Deflect the master switch **MS1** in direction **Y-**.

Result:

- The piston rods of the pull cylinders retract together.
- The derrick ballast is raised.
- The ballast pallet loses all ground contact:
The ground contact switches are no longer actuated, the „Derrick ballast lifted off“ icon **3.4** appears.
The „turning the turntable“ and „driving the crawler“ crane movements are released.

Lowering the derrick ballast

- ▶ Lower the derrick ballast: Press the button **726**.
or
Deflect the master switch **MS1** in direction **Y+**.

Result:

- The piston rods of the pull cylinders extend together.
- The derrick ballast is countersunk
- When the ballast pallet touches the ground:
The ground contact switches are actuated, the „Derrick ballast has ground contact“ icon **3.3** appears.
The „turning the turntable“ and „driving the crawler“ crane movements are blocked.

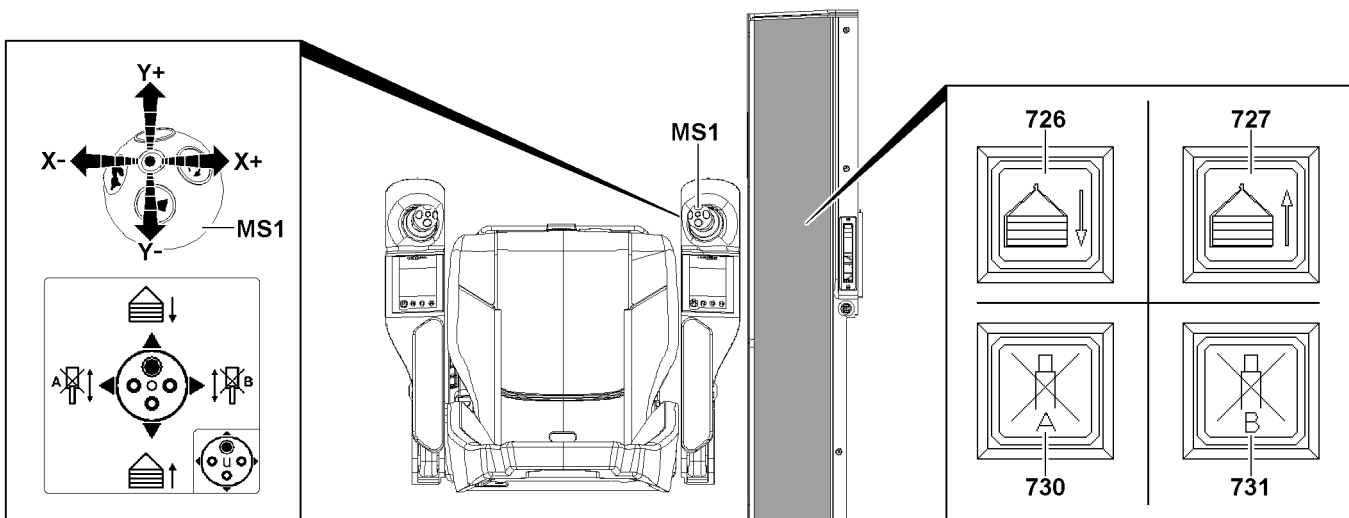
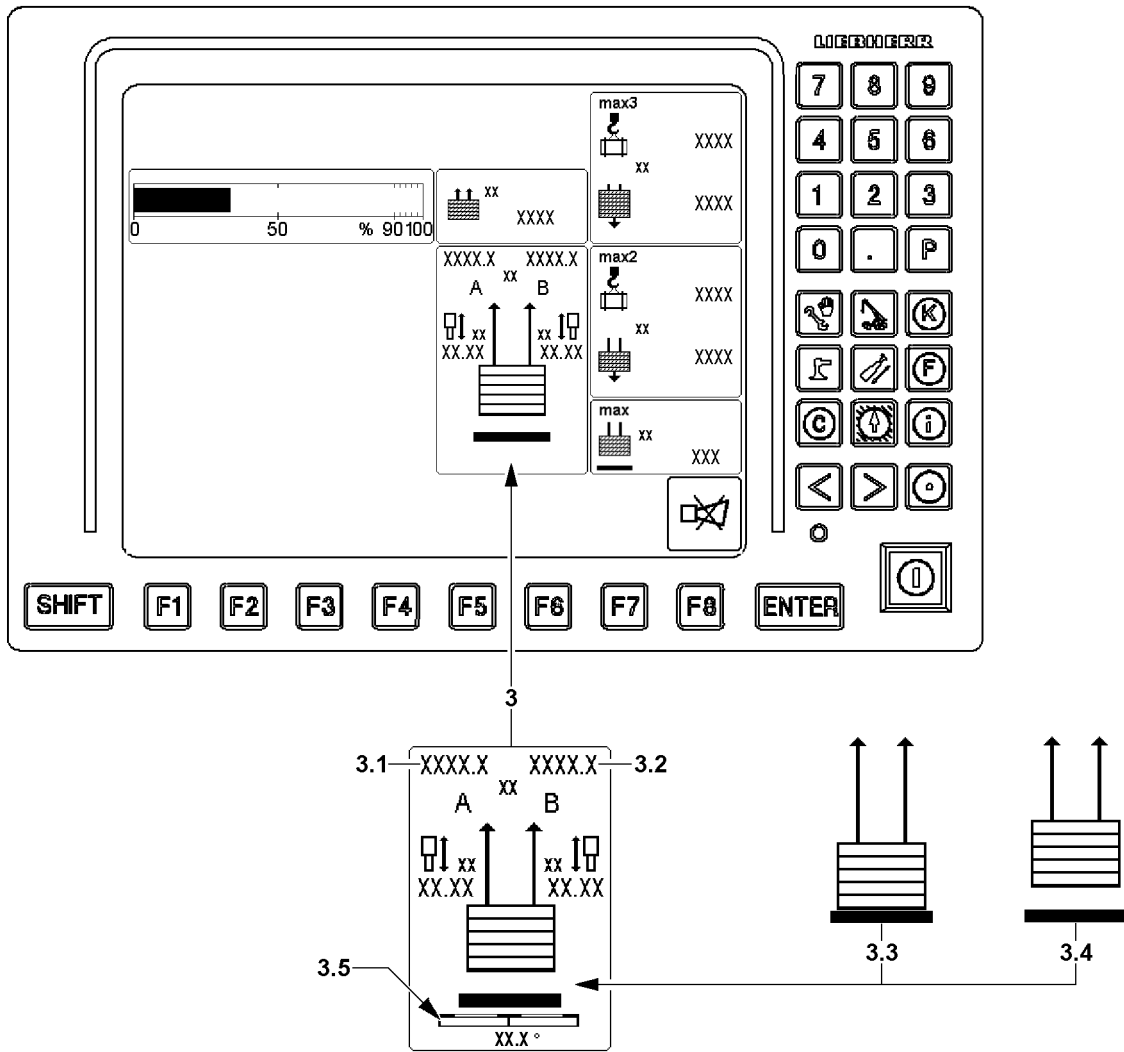

Fig.146965

LWE/LR 11000-001/23501-04-02/en

10.9.2 Equalizing the derrick ballast



WARNING

Danger of accident!

The placement surface for the ballast pallet must be level, horizontal and of sufficient load bearing capacity, otherwise the ballast pallet can tip over.

This could result in serious accidents.

- ▶ Check the incline of the crane during the set down procedure.
- ▶ Check the incline of the ballast pallet with the incline display **3.5**.
- ▶ Monitor the difference forces (derrick ballast guying A **3.1** to derrick ballast guying B **3.2**).
- ▶ It is strictly prohibited for anyone to stand under the ballast pallet or within the entire danger zone during the set down procedure.

If a limit value in the difference force monitoring (Ratio of derrick ballast guying A **3.1** to derrick ballast guying B **3.2**) or the incline display **3.5** is exceeded, the derrick ballast must be equalized.

Block the pull cylinder (A) when lifting:

- ▶ Press the button **727** and the button **730**.
- or
- Deflect the master switch **MS1** diagonally in direction **X-** and direction **Y-**.

Result:

- The piston rod of the pull cylinder (A) stops.
- The piston rod of pull cylinder (B) moves in.
- Side (B) of the derrick ballast lifts up.

Block the pull cylinder (B) when lifting:

- ▶ Press the button **727** and the button **731**.
- or
- Deflect the master switch **MS1** diagonally in direction **X+** and direction **Y-**.

Result:

- The piston rod of the pull cylinder (B) stops.
- The piston rod of pull cylinder (A) moves in.
- Side (A) of the derrick ballast lifts up.

Block the pull cylinder (A) when lowering:

- ▶ Press the button **726** and the button **730**.
- or
- Deflect the master switch **MS1** diagonally in direction **X-** and direction **Y+**.

Result:

- The piston rod of the pull cylinder (A) stops.
- The piston rod of pull cylinder (B) moves out.
- Side (B) of the derrick ballast lowers.

Block the pull cylinder (B) when lowering:

- ▶ Press the button **726** and the button **731**.
- or
- Deflect the master switch **MS1** diagonally in direction **X+** and direction **Y+**.

Result:

- The piston rod of the pull cylinder (B) stops.
- The piston rod of pull cylinder (A) moves out.
- Side (A) of the derrick ballast lowers.

11 Crawler operation with derrick ballast

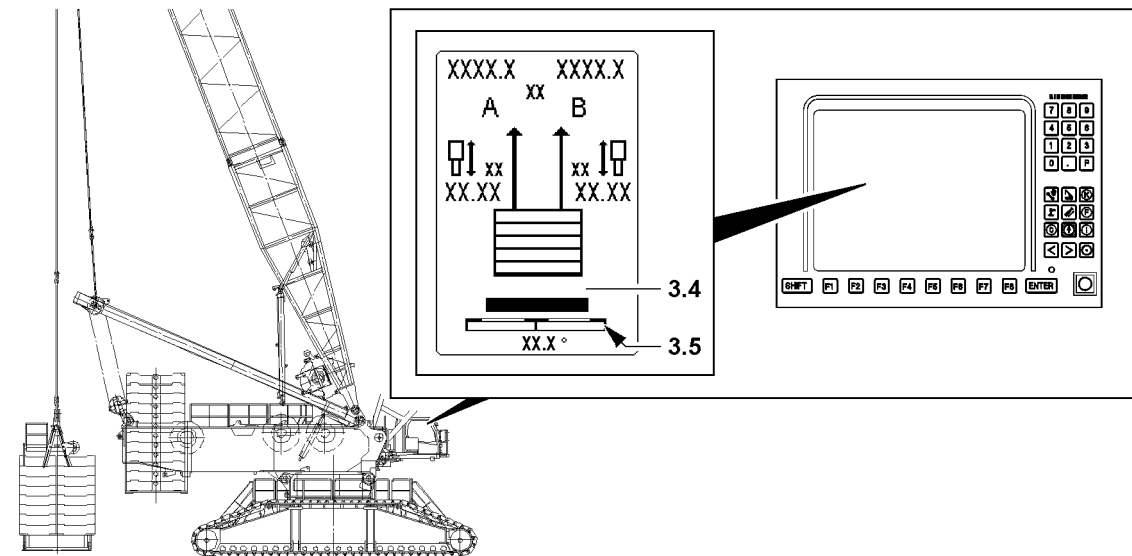

Fig.145934



Note

- ▶ Driving the crawler crane, see the Crane operating instructions, chapter 4.10.
- ▶ Release for driving the crawler takes place when all 4 ground contact rollers are no longer in contact with the ground.

11.1 Driving the crawler

Driving with suspended derrick ballast.



WARNING

Prerequisites for driving are not met, load or derrick ballast are oscillating too much!

If the specifications from the Crane operating instructions, chapter 4.10 are not observed, there is a danger of accident.

If the suspended load or the suspended derrick ballast starts to swing too much, then the crane operator can lose control over the crane.

If the following prerequisites are not observed, the crane can topple over.

This could result in serious accidents.

- ▶ Observe the specifications in the Crane operating instructions, chapter 4.10.
- ▶ Do not exceed the maximum permissible driving speed of the crawler.
- ▶ Avoid jerky driving movements.
- ▶ Avoid oscillation of the suspended load and the suspended derrick ballast. Turn and drive slowly.
- ▶ The attached load and suspended derrick ballast must be secured to prevent it from swinging. If oscillating movements should occur, set the load / derrick ballast as fast as possible down on the ground. Hereby pay attention to the limit values of the load moment display and the F-load display.
- ▶ Steering the crawler with a suspended load and / or installed derrick ballast is prohibited.
- ▶ Uphill and downhill inclines and lateral inclines may only be driven within the permissible angle range.

Make sure that the following prerequisites are met:

- Observe the specifications in the Crane operating instructions, chapter 4.10.
- Pay special attention to the limitations for crawler operation with derrick ballast.
- The ground is suitable for crawler operation with derrick ballast.
- The ground can safely take on the resulting surface pressure.
- The derrick ballast is lifted off the ground.
- The „Derrick ballast lifted off“ icon **3.4** appears on the LICCON monitor.
- The derrick ballast is horizontally aligned (observe the incline display **3.5**).

12 Disassembling, ballasted ballast pallet

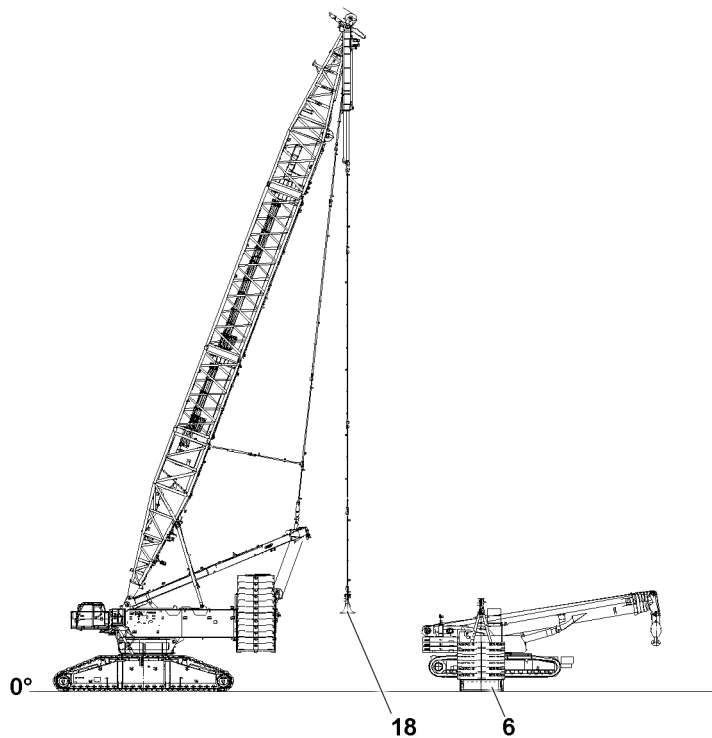

Fig.126488: Ballast pallet set down ballasted

The ballasted ballast pallet **6** can be unpinned and set down after erection or take down of the boom system on the cross beam **18**.

**WARNING**

Danger of falling!

During assembly / disassembly, inspection and maintenance work, personnel must be secured with appropriate aids to prevent them from falling.

Death, severe injury, property damage.

- ▶ All work at a height, when there is a danger of falling, must be carried out with suitable aids.
- ▶ If aids are not available and work cannot be carried out from the ground, then assembly personnel must secure themselves with the supplied fall arrest system to prevent falling, see the Crane operating instructions, chapter 2.04.
- ▶ If fall protection equipment is available, then it must be used, see the Crane operating instructions, chapter 2.06.
- ▶ When lifting, lowering, swinging crane parts in and out, no persons may remain in the danger zone.
- ▶ If railings are present on the components, then they must be brought into the corresponding position and secured for assembly / disassembly work.
- ▶ Only step on the aids, ladders and catwalks with clean shoes.
- ▶ Keep aids, ladders and catwalks free of heavy dirt, snow and ice.
- ▶ During all assembly and disassembly work, maintenance work and inspections, travel or crane operation is prohibited.
- ▶ Remaining on a suspended load is prohibited.
- ▶ Stepping or walking on crane components and lattice sections, which have an incline of more than 20° is prohibited.
- ▶ For all assembly work, the crane operator of the main crane must be in voice contact with the crane operator / crane operators of the auxiliary crane / auxiliary cranes.
- ▶ For assembly / disassembly tasks, the crane operator may only initiate crane movements when the responsible guide has explicitly released the movement.

**WARNING**

Danger of impact / crushing!

When installing / removing crane components with the auxiliary crane, crane components can start to swing back and forth.

When lifting / lowering and positioning crane components, there is an increased danger of impacts / crushing.

Personnel can be caught and severely injured or killed.

- ▶ Make sure that personnel cannot be caught by components.
- ▶ When working in danger zones: Use aids to protect limbs.
- ▶ Guide components with suitable aids to minimize oscillation.

**DANGER**

The components can fall down!

If the corresponding components are disengaged from the auxiliary crane before the corresponding component is pinned, the corresponding component can fall down and fatally injure personnel.

- ▶ Do not disengage the auxiliary crane until the respective component is pinned and secured.

Make sure that the following prerequisites are met:

- The crane is horizontally aligned.
- The ground is level and of sufficient load bearing capacity.
- The counterweight has been installed on the turntable according to the load charts and take down charts.
- The maximum ground unevenness for the placement surface of the derrick ballast is plus / minus 1°.
- The LICCON overload protection has been set according to the data in the load charts and take down charts.
- The LICCON overload protection settings have been compared with the actual set up configuration.
- An auxiliary crane is available.
- The ballast pallet is standing on the ground.
- D-guy rods are completely relieved.

12.1 Disconnecting the electrical connections



Note

- ▶ Disconnect the electrical connections from the suspended ballast to the turntable, see Electric wiring diagram.
-
- ▶ Disconnect the electrical connections.

12.2 Securing the erection racks to prevent them from folding over

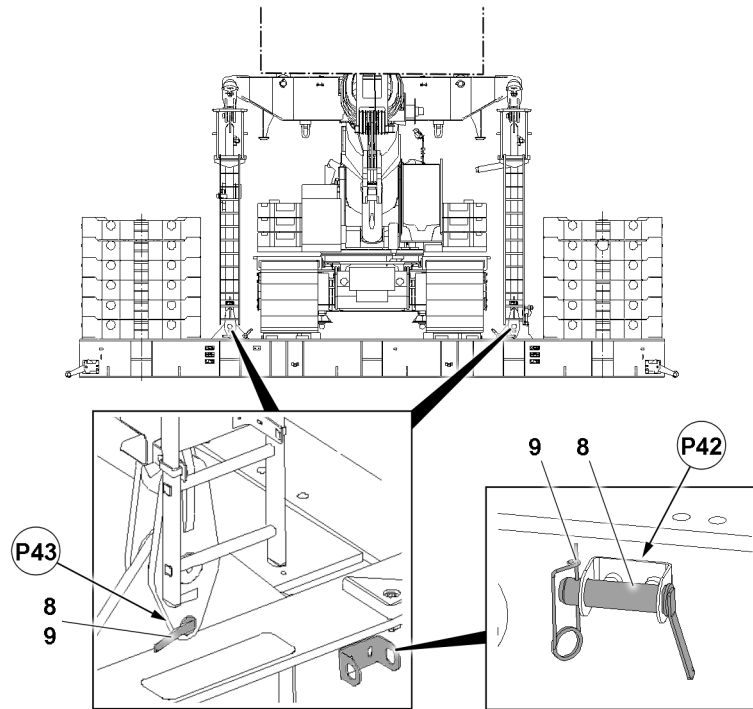

Fig.126072: Ballast pallet, retaining pins



DANGER

Unsecured erection racks!

Toppling erection racks. Death, severe bodily injuries, property damage.

- ▶ Secure both erection racks with retaining pins **8** to prevent them from tipping.
 - ▶ It is prohibited for anyone to remain under the erection racks or within the complete danger zone during the pinning and unpinning procedure.
-
- ▶ Remove the spring retainer **9** at point **P42** and unpin the retaining pin **8** from the park position.
 - ▶ Insert the retaining pin **8** at point **P43** and secure with spring retainer **9**.

12.3 Unpinning the ballast pallet on the cross beam



WARNING

Ballast pallet unpinned on impermissible position!

Death, severe bodily injuries, property damage.

- ▶ Do **not** unpin the ballasted ballast pallet on the guy rods.
- ▶ Unpin the ballasted ballast pallet solely on the cross beam.

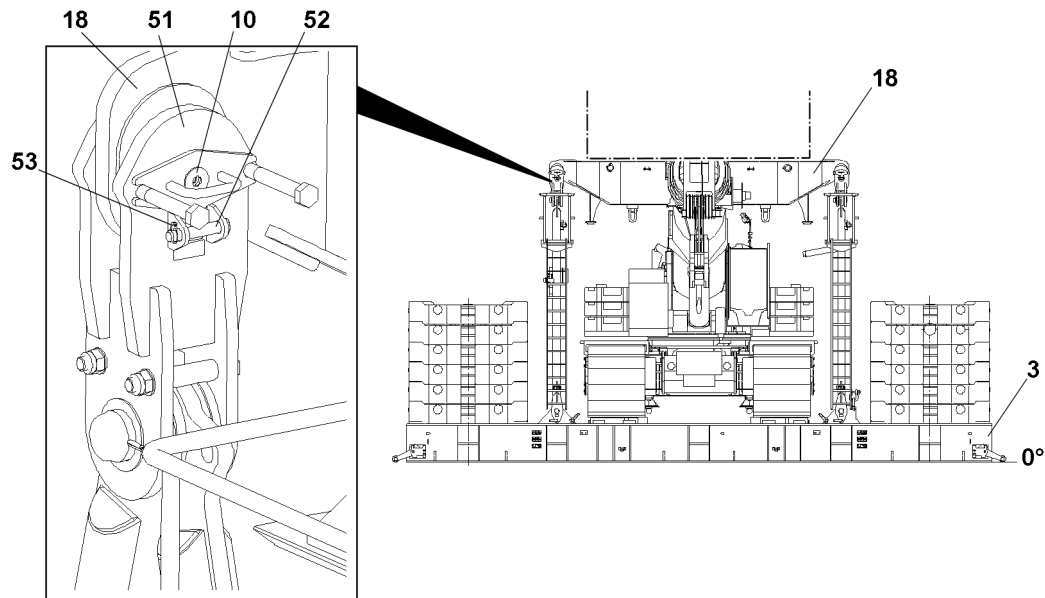

Fig.126487: Ballast pallet, cross beam

Pins **10** must be uninned und released on both erection racks.

- ▶ Release the pin **10**: Remove the spring retainer **53** and unpin the pin **52**.
- ▶ Unpin the pin **10**.
- ▶ Retract the pull cylinder: Lift the cross beam **18** until the ballast pallet is standing freely.



Note

Retract / extend the pull cylinder

- ▶ Control the pull cylinders from the crane cab, see the section „Lifting and lowering the derrick ballast using the pull cylinders“.
- ▶ Operate the pull cylinder with the radio remote control, see the „radio remote control operating instructions“.

13 Disassembling, complete



WARNING

Danger of falling!

During assembly / disassembly, inspection and maintenance work, personnel must be secured with appropriate aids to prevent them from falling.

Death, severe injury, property damage.

- ▶ All work at a height, when there is a danger of falling, must be carried out with suitable aids.
- ▶ If aids are not available and work cannot be carried out from the ground, then assembly personnel must secure themselves with the supplied fall arrest system to prevent falling, see the Crane operating instructions, chapter 2.04.
- ▶ If fall protection equipment is available, then it must be used, see the Crane operating instructions, chapter 2.06.
- ▶ When lifting, lowering, swinging crane parts in and out, no persons may remain in the danger zone.
- ▶ If railings are present on the components, then they must be brought into the corresponding position and secured for assembly / disassembly work.
- ▶ Only step on the aids, ladders and catwalks with clean shoes.
- ▶ Keep aids, ladders and catwalks free of heavy dirt, snow and ice.
- ▶ During all assembly and disassembly work, maintenance work and inspections, travel or crane operation is prohibited.
- ▶ Remaining on a suspended load is prohibited.
- ▶ Stepping or walking on crane components and lattice sections, which have an incline of more than 20° is prohibited.
- ▶ For all assembly work, the crane operator of the main crane must be in voice contact with the crane operator / crane operators of the auxiliary crane / auxiliary cranes.
- ▶ For assembly / disassembly tasks, the crane operator may only initiate crane movements when the responsible guide has explicitly released the movement.



WARNING

Danger of impact / crushing!

When installing / removing crane components with the auxiliary crane, crane components can start to swing back and forth.

When lifting / lowering and positioning crane components, there is an increased danger of impacts / crushing.

Personnel can be caught and severely injured or killed.

- ▶ Make sure that personnel cannot be caught by components.
- ▶ When working in danger zones: Use aids to protect limbs.
- ▶ Guide components with suitable aids to minimize oscillation.



DANGER

The components can fall down!

If the corresponding components are disengaged from the auxiliary crane before the corresponding component is pinned, the corresponding component can fall down and fatally injure personnel.

- ▶ Do not disengage the auxiliary crane until the respective component is pinned and secured.

Make sure that the following prerequisites are met:

- The crane is horizontally aligned.
- The ground is level and of sufficient load bearing capacity.
- The counterweight has been installed on the turntable according to the load charts and take down charts.
- The maximum ground unevenness for the placement surface of the derrick ballast is plus / minus 1°.
- The LICCON overload protection has been set according to the data in the load charts and take down charts.
- The LICCON overload protection settings have been compared with the actual set up configuration.
- An auxiliary crane is available.
- The ballast pallet is standing on the ground.
- D-guy rods are completely relieved.

13.1 Disconnecting the electrical connections



Note

► Disconnect the electrical connections from the suspended ballast to the turntable, see Electric wiring diagram.

► Disconnect the electrical connections.

13.2 Securing the erection racks to prevent them from folding over

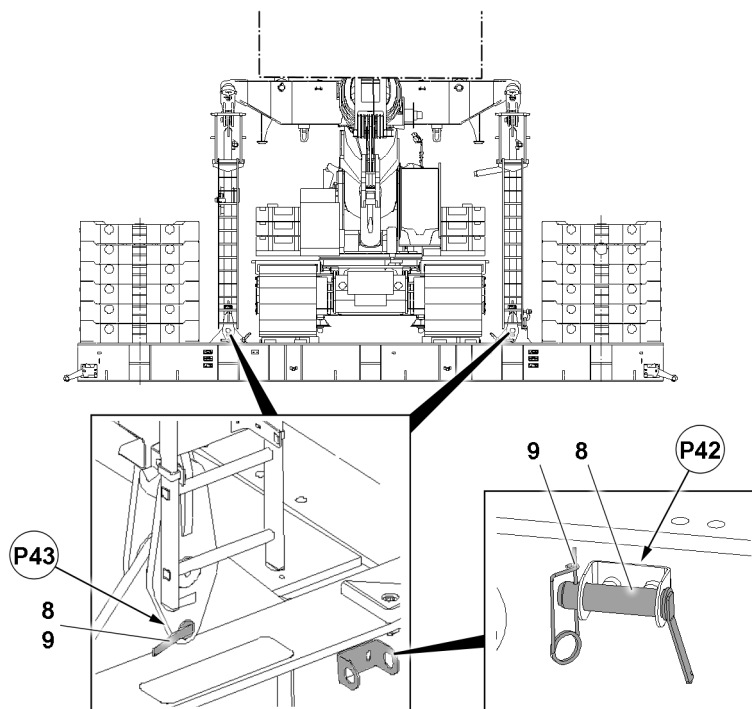

Fig.126072



DANGER

Unsecured erection racks!

Toppling erection racks. Death, severe bodily injuries, property damage.

- Secure both erection racks with retaining pins **8** to prevent them from tipping.
- It is prohibited for anyone to remain under the erection racks or within the complete danger zone during the pinning and unpinning procedure.

► Remove the spring retainer **9** at point **P42** and unpin the retaining pin **8** from the park position.

- ▶ Insert the retaining pin **8** at point **P43** and secure with spring retainer **9**.

13.3 Ballasting the ballast pallet off

13.3.1 Unballasting rules



WARNING

Impermissible ballasting, impermissible geometry of the ballast!

Slipping and falling ballast stacks.

The crane can topple over. Death, severe bodily injuries, property damage.

- ▶ Replace damaged ballast plates immediately with new ballast plates.
- ▶ Observe and comply with the rules for ballasting.

Rules for unballasting:

- Do **not** start in the center. Start unballasting on the outer ballast stacks.
- Suspended ballast with LTR: Unballast first the ballast plates.
- Remove the ballast plates always symmetrically, in reference to the longitudinal axis.
- The outer ballast stacks must always weigh the same and always be the same height after unballasting.
- Unballasting with double stacks: The difference between front and rear may be no more than maximum 10 t for a double stack.
- Remove the ballast until only a maximum of 20 t ballast are placed per stack.
- The difference between the stacks may be no more than maximum 25 t.

Make sure that the following prerequisites are met:

- The erection racks are secured to prevent them from folding over.

13.3.2 Removing the ballast plates, fastening system: „Twistlock“

Make sure that the following prerequisites are met:

- Rules for ballasting are complied with.



WARNING

Receptacle stud **not** permissible for ballast plates!

Overload and damage of the receptacle stud. Death, severe injury, property damage.

- ▶ Use a permissible receptacle stud for ballast plates 10 t.
- ▶ Use a permissible receptacle stud for ballast plates 12.5 t.
- ▶ Replace damaged receptacle stud.



WARNING

More than two ballast plates lifted with the receptacle stud!

Overload and damage of the receptacle stud. Death, severe injury, property damage.

- ▶ Lift maximum two ballast plates with receptacle stud.
- ▶ Make sure that the ballast plates are placed correctly in the centerings of the receptacle stud.
- ▶ Replace damaged ballast plates.

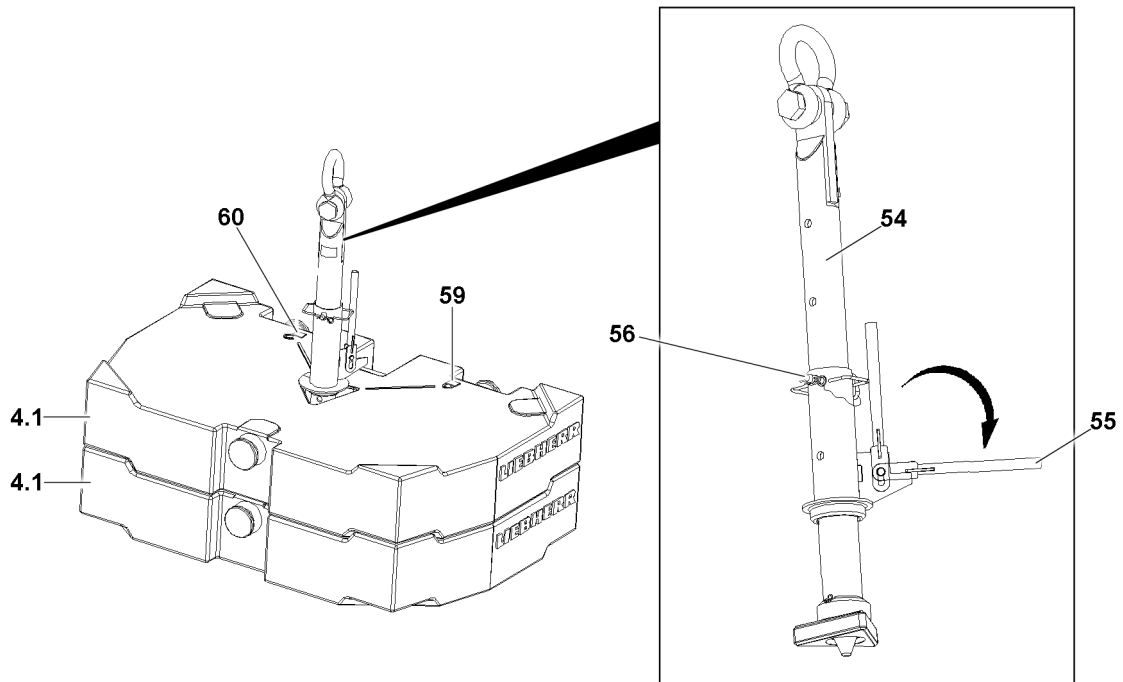

Fig. 126074: Receptacle stud with two 10 t ballast plates 4.1

Ballast plates can be removed individually or as an assembly of maximum two ballast plates.

Before the receptacle stud **54** is guided into the ballast plates, it must be ensured that the length of the receptacle stud **54** is set correctly. The length of the receptacle stud **54** can be adjusted with the pin **56**.

- ▶ Release and unpin the pin **56**.
- ▶ Adjust the length of the receptacle stud by moving the receptacle stud **54**.
- ▶ Insert the pin **56** and secure with the spring retainer.
- ▶ Attach the receptacle stud **54** with fastening equipment on the auxiliary crane and guide it into the ballast plates.
- ▶ Pull the lever **55** up and fold it down.

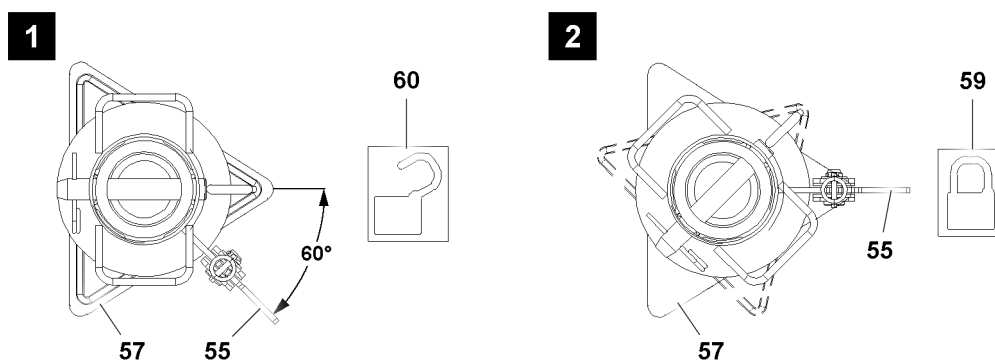

Fig. 126075: Receptacle stud overhead view, positions lever **55**

- ▶ Turn the lever **55** by 60°, see illustration 1 until the lever **55** points on the icon **59**, illustration 2.

Result:

- The receptacle stud **54** is locked with the ballast plate.
- ▶ Lift the ballast plate individually or as an assembly with the auxiliary crane and remove it carefully from the ballast stack or from the ballast pallet.

When the ballast plate is laying on the ground:

- ▶ Turn the lever **75** by 60° until the lever **75** points to the icon **60**, see illustration **1**.

Result:

- The receptacle stud is unlocked.
- ▶ Carefully pull the receptacle stud **54** from the ballast plate.
- ▶ Remove the ballast plates.

13.3.3 Removing the ballast plates, fastening points: „Bitt“

- Rules for unballasting are complied with.

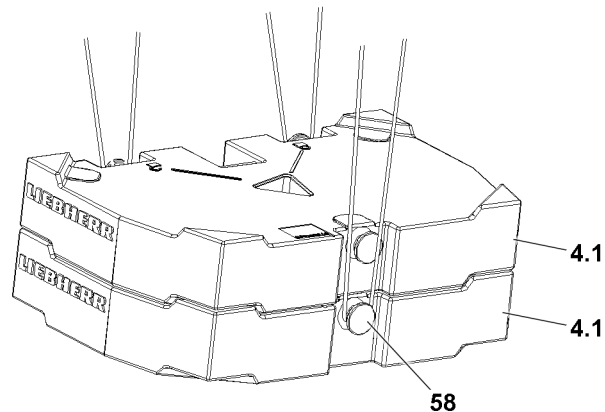

Fig.126076: Ballast assembly with two ballast plates 10 t **4.1**



WARNING

Exceeding permissible load!
Overload Bitt **58** Falling ballast plates.
Death, severe injury, property damage.

When 10 t ballast plates are used:

- ▶ Lift no more than maximum 20 t with ropes, three fastening points.

When 12.5 t ballast plates are used:

- ▶ Lift no more than maximum 25 t with ropes, four fastening points.
- ▶ Replace damaged ballast plates immediately.



WARNING

Fastening equipment is **not** properly fastened and **not** secured sufficiently to prevent it from releasing!
Falling ballast plates. Death, severe bodily injuries, property damage.

- ▶ Attach the fastening equipment properly on bits **58** and secure it to prevent it from releasing.

Ballast plates can be placed individually or as an assembly of maximum two ballast plates.

- ▶ Lift the ballast plate individually or as an assembly with the auxiliary crane and remove it carefully from the ballast stack or from the ballast pallet.

13.3.4 Moving the LTR from the ballast pallet

Make sure that the following prerequisites are met:

- The derrick guying is completely relieved.
- The telescopic boom is luffed up to 10° position.

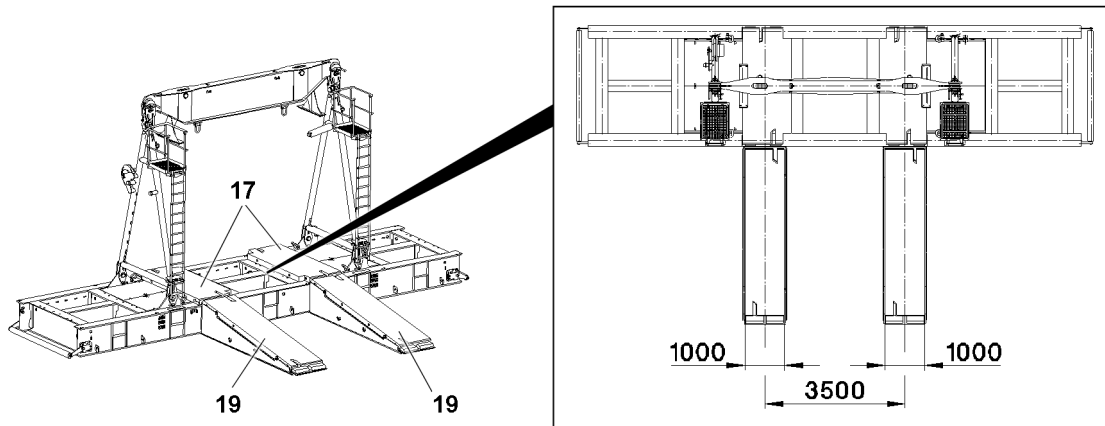

Fig.124986: Ramps on ballast pallet

- Position ramps 1 on the ballast pallet.

NOTICE

Camera support is in operating position!
Damage of camera support.

- Before moving off on the ballast pallet: Fold the camera support in.

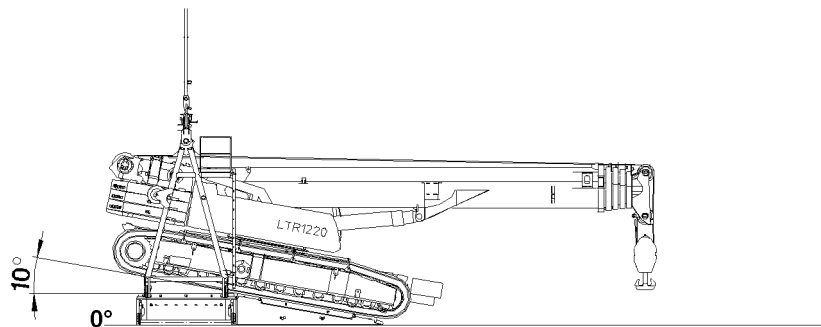

Fig.124984: LTR on tipping point

- Move LTR on tipping point.

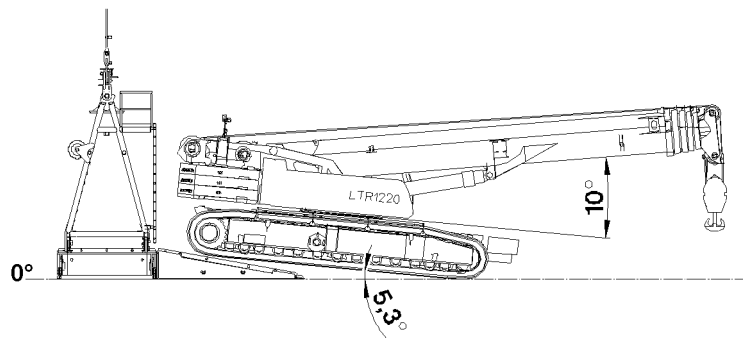

Fig.124983: LTR on ramp

- Move the LTR from the ramp.

13.4 Unpinning the ballast pallet on the cross beam

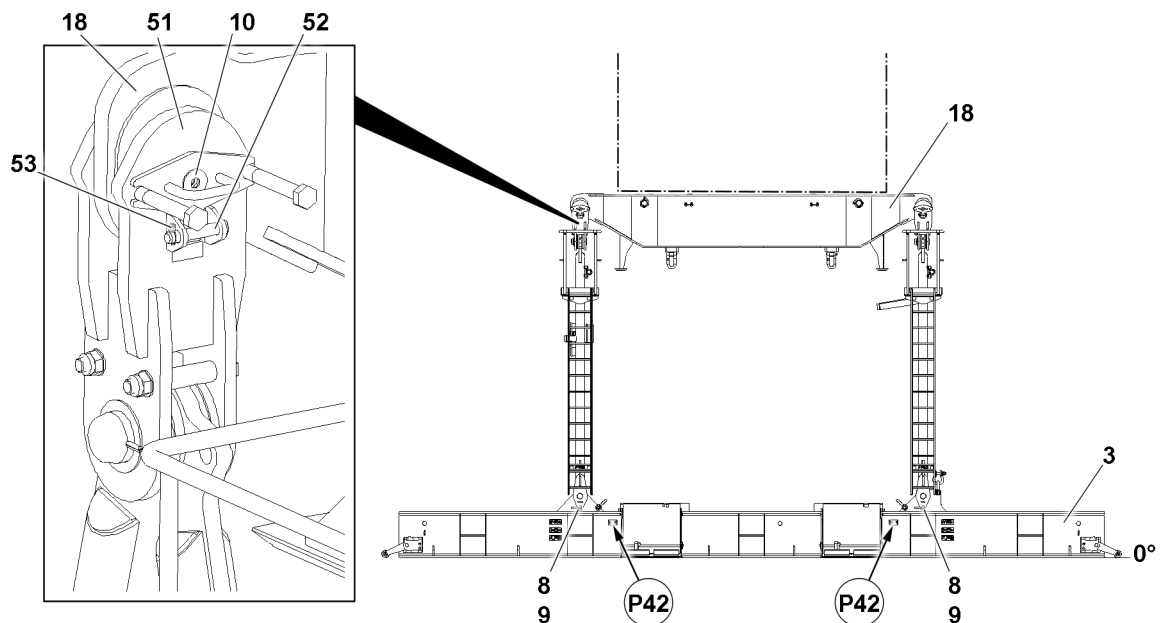

Fig. 126062: Ballast pallet with cross beam

Pins **10** must be unpinned and released on both erection racks.

- ▶ Release the pin **10**: Remove the spring retainer **53** and unpin the pin **52**.
- ▶ Unpin the pin **10**.
- ▶ Retract the pull cylinder: Lift the cross beam **18** until the ballast pallet is standing freely.



Note

Retract / extend the pull cylinder

- ▶ Control the pull cylinders from the crane cab, see the section „Lifting and lowering the derrick ballast using the pull cylinders“.
- ▶ Operate the pull cylinder with the radio remote control, see the „radio remote control operating instructions“.

13.5 Taking down the erection racks



Note

- ▶ The disassembly of the erection racks is described based on the example of one erection rack.

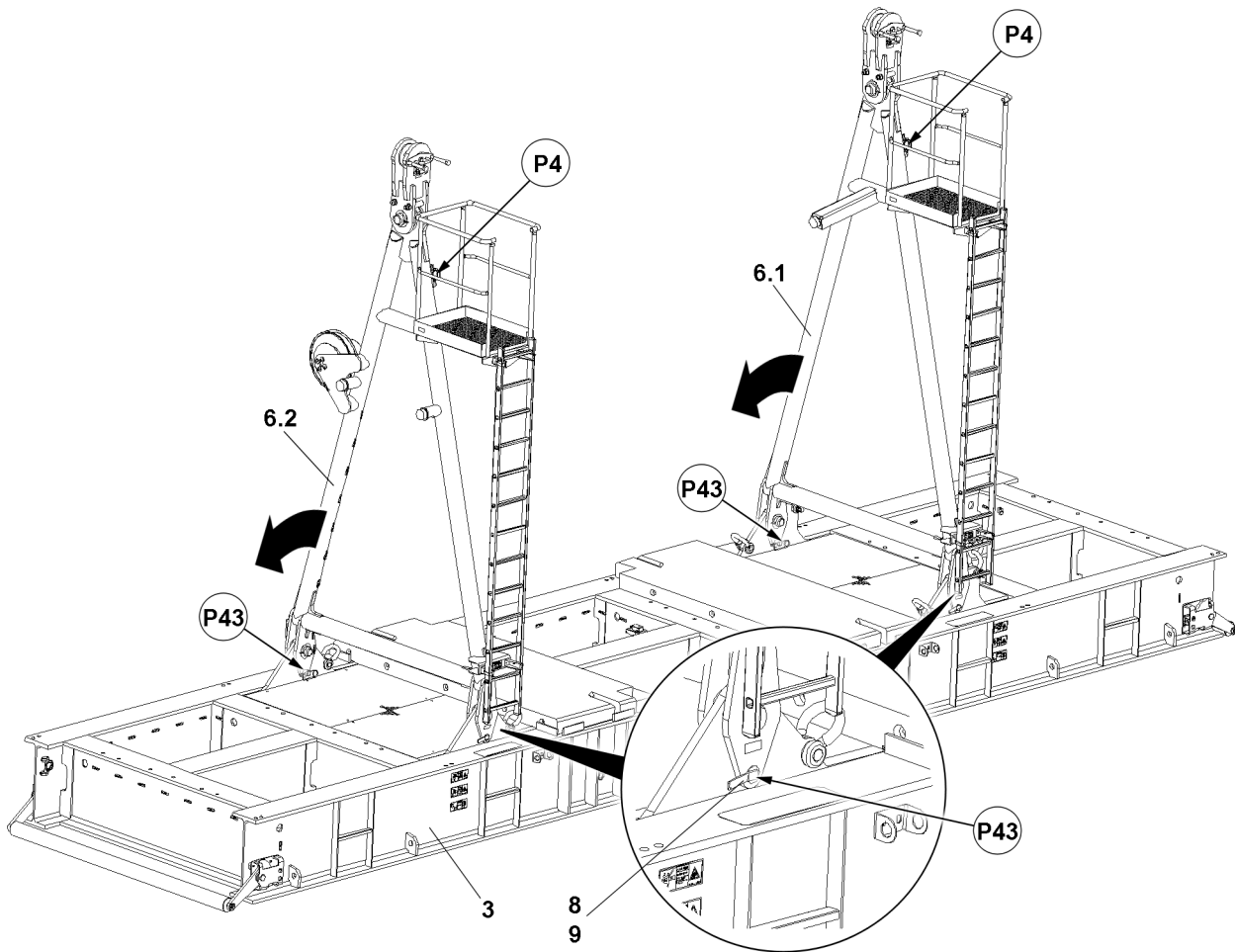

Fig.126078: Ballast pallet, transport position

The erection rack is unpinned on two points. The unpinning procedure is described for one pin as an example.

- ▶ Hang the erection rack **6.2** on the auxiliary crane at point **P4**.



DANGER

Danger of accident during assembly / disassembly of the erection racks!

The erection racks must hang securely on the auxiliary crane, otherwise they could fall down and kill or severely injure personnel.

- ▶ Make sure that the erection rack hangs safely on the auxiliary crane.
- ▶ Never unpin the retaining pins of unsecured or unsupported erection racks.
- ▶ It is prohibited for anyone to remain under the erection racks or within the complete danger zone during the pinning and unpinning procedure.

When the erection rack is safely held by the auxiliary crane:

- ▶ Remove the spring retainer **9** on both sides at point **P43** and unpin the retaining pin **8**.

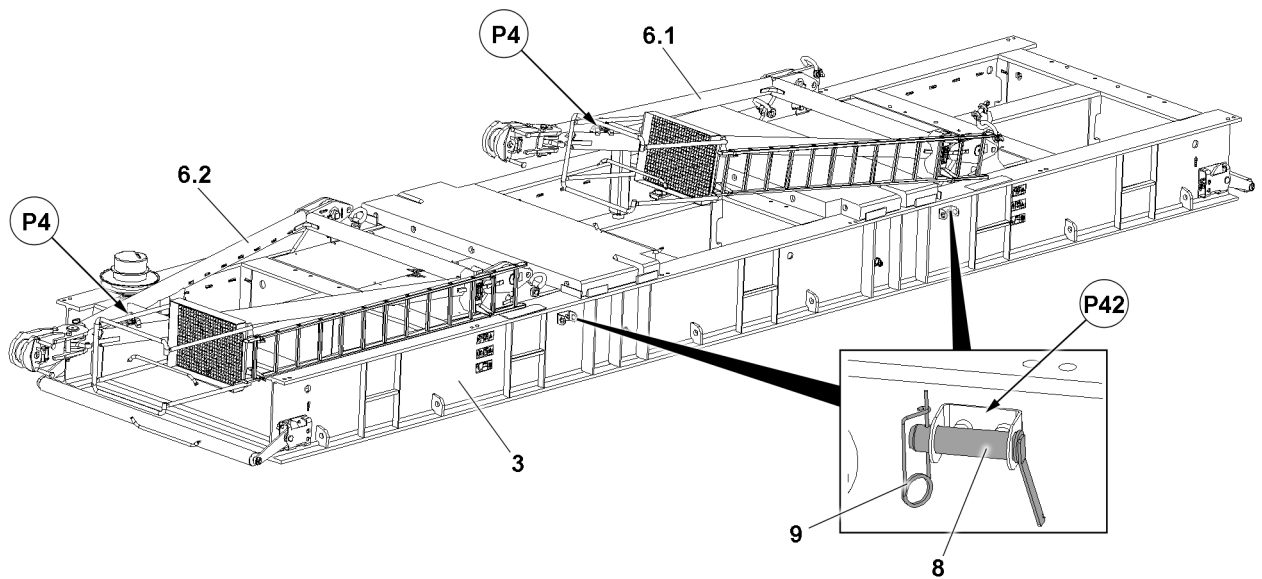

Fig.126063: Ballast pallet, transport position

- ▶ Lower the erection rack **6.2** with the auxiliary crane until the rubber cushions touch the frame.
- ▶ Insert the retaining pin **8** at point **P42** on both sides and secure with spring retainer **9** in park position.
- ▶ Remove the auxiliary crane.
- ▶ Lower the second erection rack **6.1** with the auxiliary crane until the rubber cushion touches the erection rack **6.2**.

13.6 Removing the ballast pallet



Note

- ▶ Fastening points, see section „Fastening points for suspended ballast parts“.

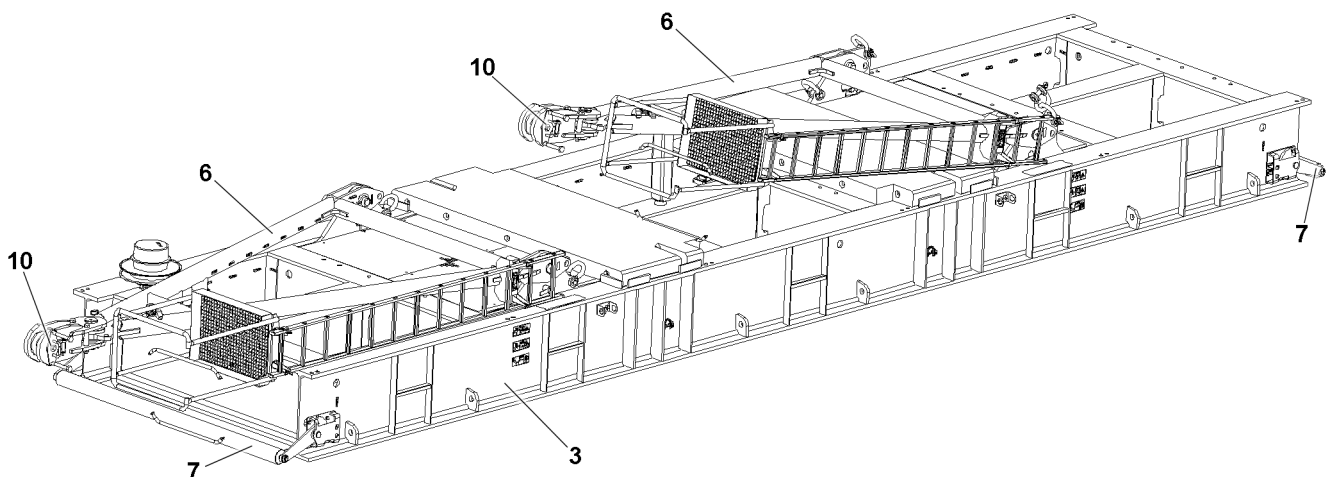

Fig.124997: Ballast pallet, transport position

- ▶ Fasten the ballast pallet **3** with fastening equipment to the auxiliary crane.
- ▶ Remove the ballast pallet **3** with the auxiliary crane.

13.7 Disassembling without suspended ballast guide

13.7.1 Disassembling the cross beam

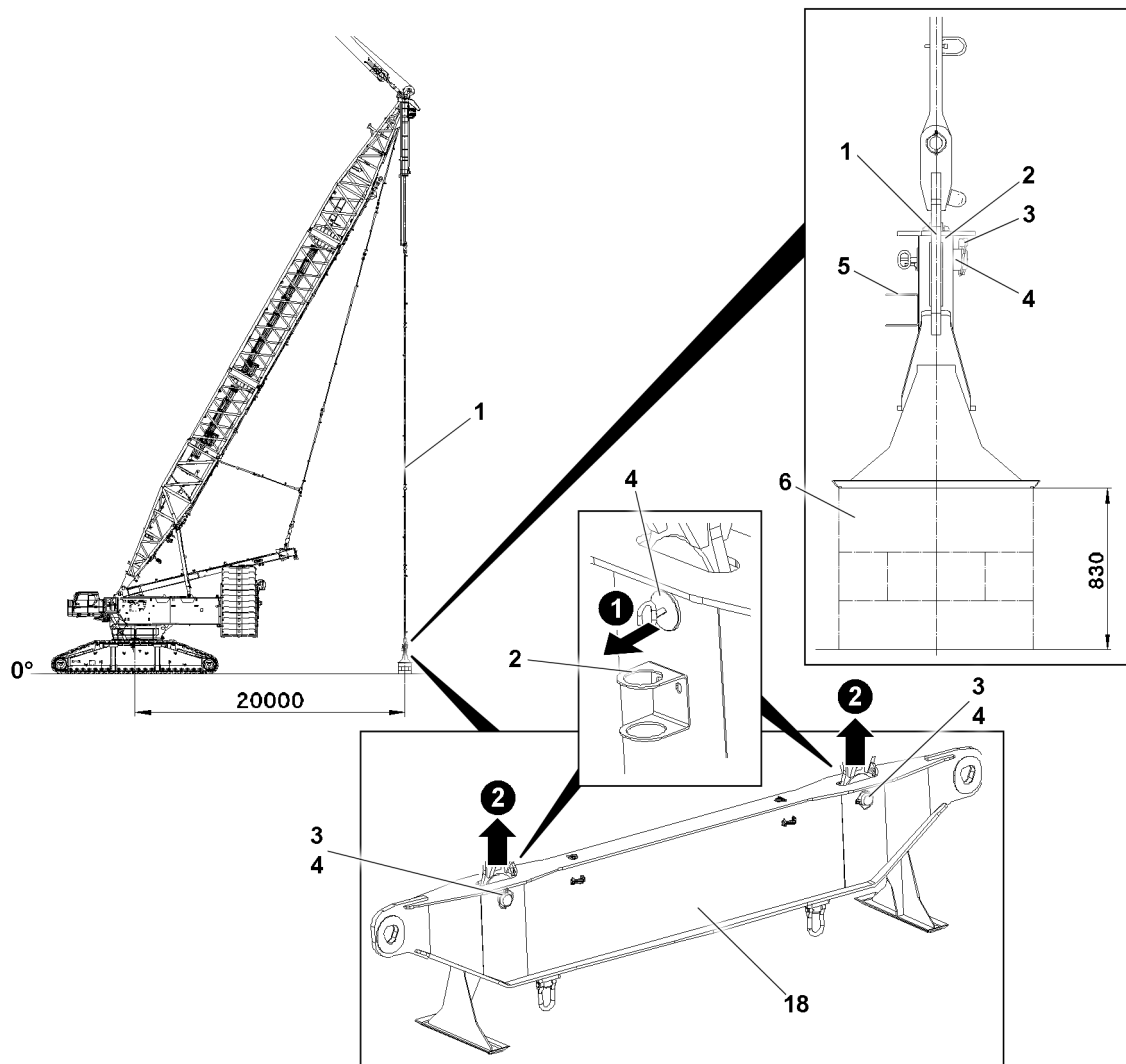

Fig.126481: Cross beam

- ▶ Set the derrick radius to 20 m.

The substructure **6** must be at least 830 mm above the crane placement surface.

- ▶ Position the substructure **6** under cross beam **18**.
- ▶ Set the cross beam **18** on the substructure **6**: Extend the pull cylinder.



Note

Retract / extend the pull cylinder

- ▶ Control the pull cylinders from the crane cab, see the section „Lifting and lowering the derrick ballast using the pull cylinders“.
- ▶ Operate the pull cylinder with the radio remote control, see the „radio remote control operating instructions“.

- ▶ Unpin the cross beam on the D-guy rods **1**: Remove the locking pin **3** and unpin the pin **4**.
- ▶ Insert the pin **4** in the transportation retainer **5** and secure.
- ▶ Lift the guy rods: Retract the pull cylinder.

**Note**

- ▶ Fastening points, see section „Fastening points for suspended ballast parts“.
- ▶ Fasten the cross beam **18** with fastening equipment to the auxiliary crane and remove.

13.8 Disassembling with suspended ballast guide*

13.8.1 Disassembling the suspended ballast with the suspended ballast guide

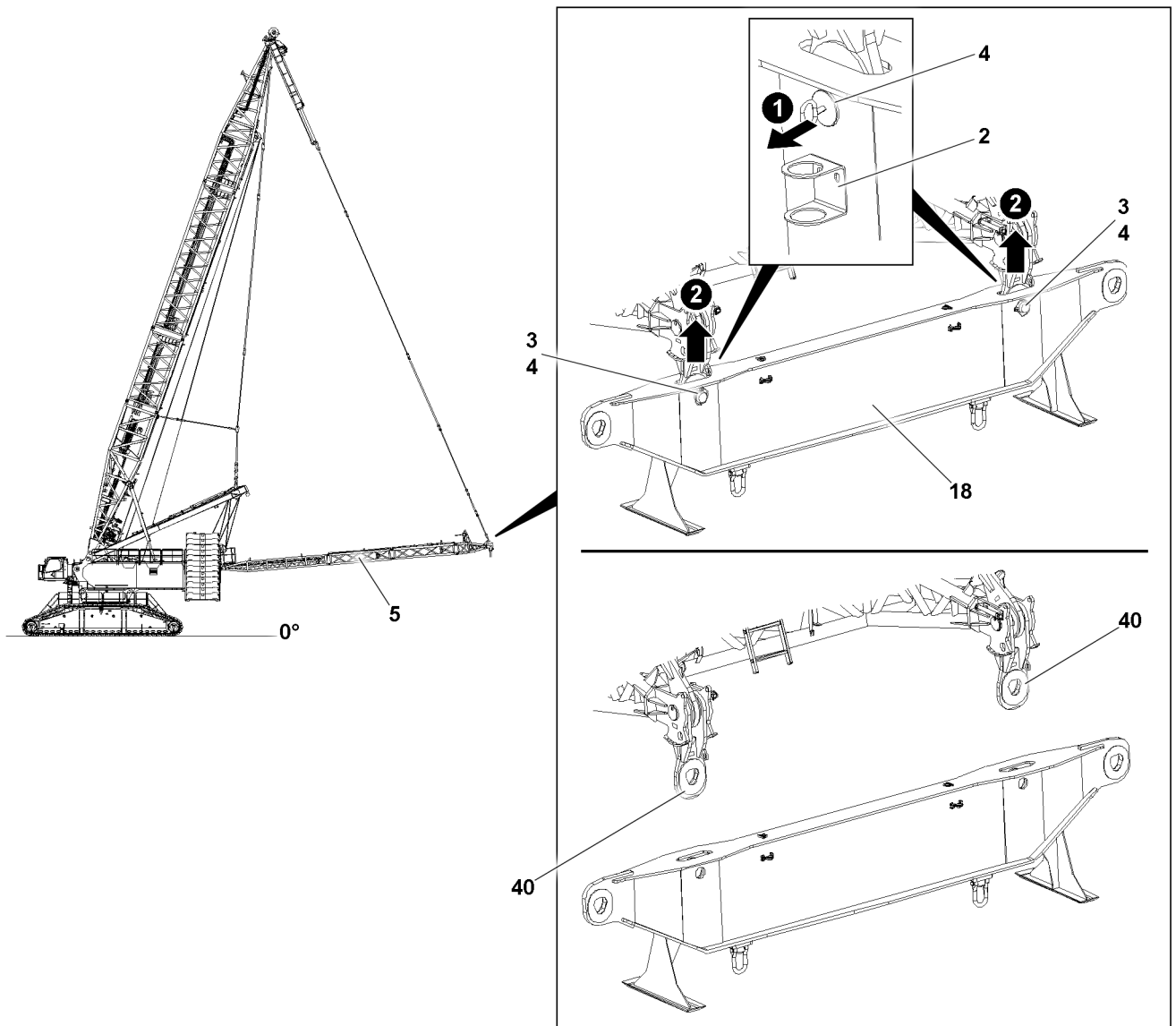

Fig.126479: Cross beam and suspended ballast guide

The suspended ballast guide **5** is lowered by:

- Extending the pull cylinder to the switch position.
- Luffing the derrick boom down.

**Note**

Retract / extend the pull cylinder

- ▶ Control the pull cylinders from the crane cab, see the section „Lifting and lowering the derrick ballast using the pull cylinders“.
- ▶ Operate the pull cylinder with the radio remote control, see the „radio remote control operating instructions“.

- ▶ Set the cross beam **18** on the ground: Lower the suspended ballast guide **5**.
- ▶ Remove the locking pin **3** and unpin the pin **4**.
- ▶ Insert the pin **4** in the transport retainer **2** and secure with locking pin **3**.
- ▶ Remove the brackets **40** from the cross beam: Lift the suspended ballast guide **5**.
- ▶ Remove the cross beam **18** with the auxiliary crane.

13.8.2 Disassembling the suspended ballast guide

Derrick ballast radius	Number of intermediate sections
20 m	0
25 m	1
30 m	2

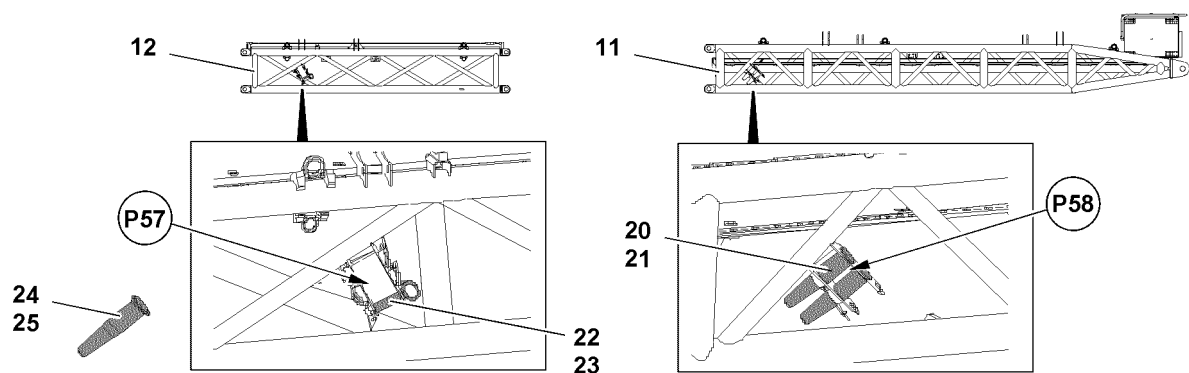

Fig.122802: Park position for pin

**Note**

- ▶ Park position **P57** for pin **24** and pin **22**.
- ▶ Park position **P58** for pin **20**.

**WARNING**

Falling pins!

Death, severe injury, property damage.

- ▶ Make sure that all pins are properly secured in the park positions with the respective retaining elements.

Unpinning the pull rods of the suspended ballast guide from the D-guy rods

Make sure that the following prerequisites are met:

- The cross beam is disassembled and removed.

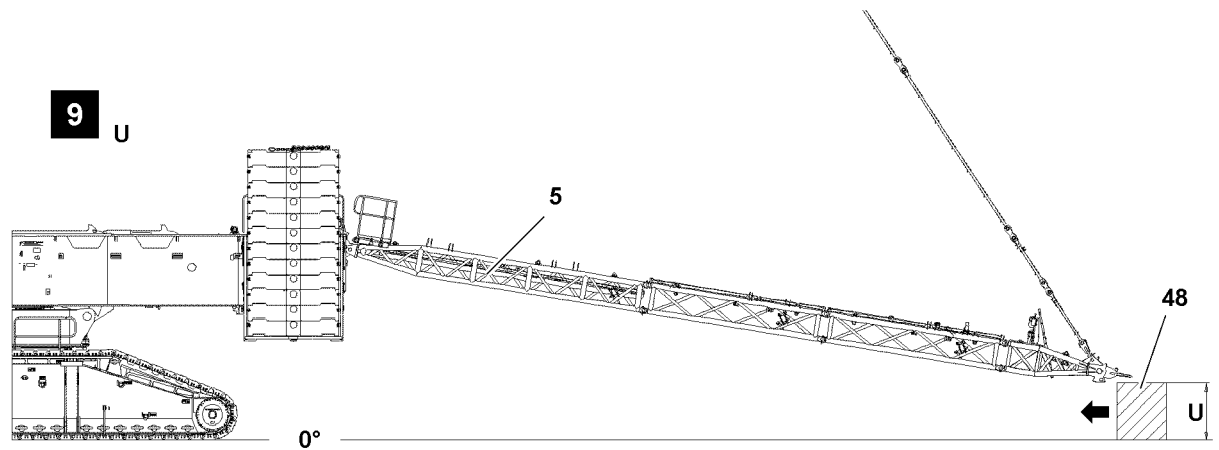

Fig.120214: Substructure, example

Suspended ballast guide	R30	R25	R20
Substructure height „U“	0 m	1.6 m	2.0 m

When R25 or R20 is removed:

- ▶ Establish a substructure and place the suspended ballast guide 5 with the auxiliary crane on the substructure, see illustration 9.

When R30 is removed:

- ▶ Place the suspended ballast guide 5 with the auxiliary crane on the ground.

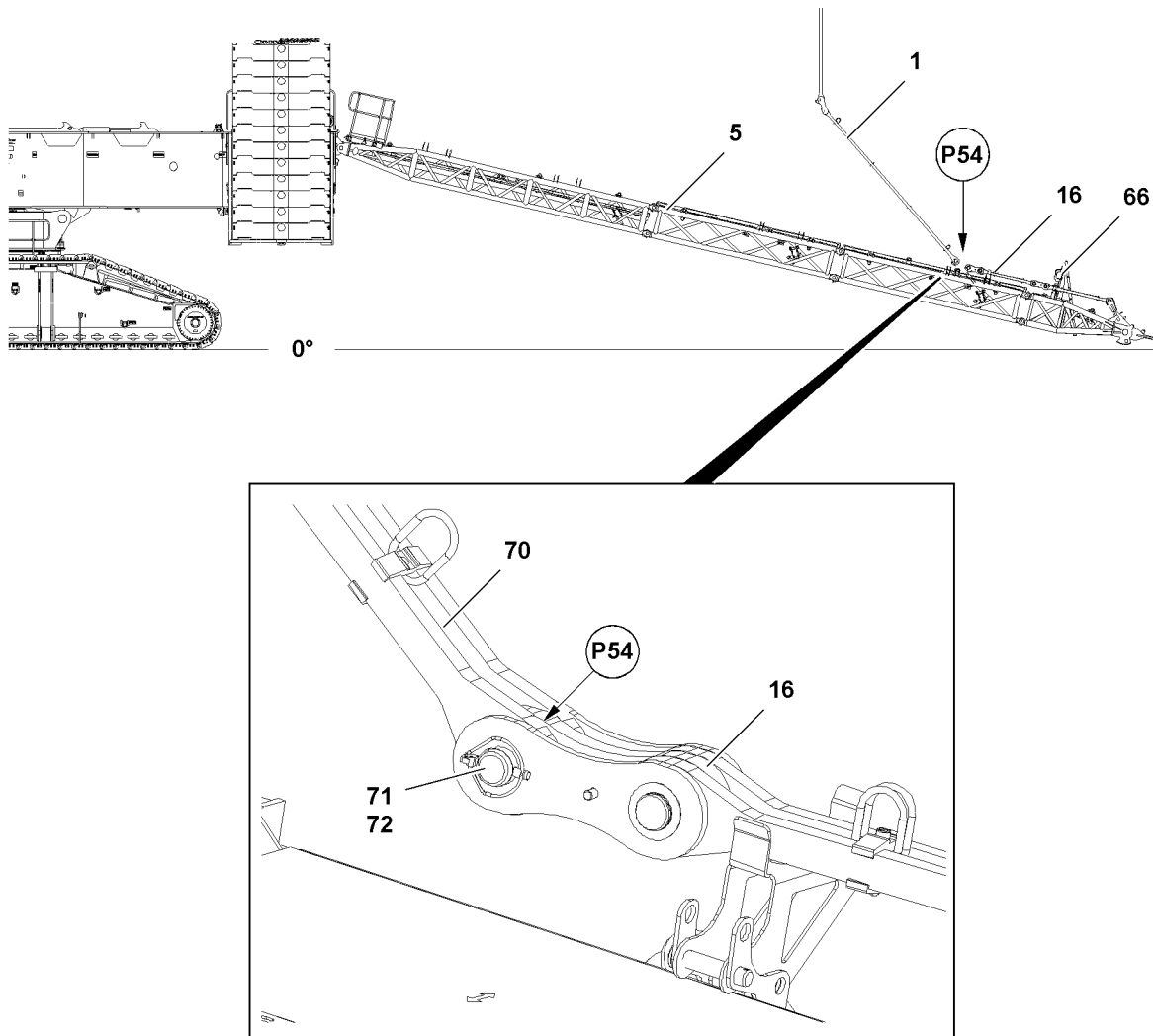

Fig.126068: D-guy rods

- ▶ Connect the rope of the manual rope winch **66** with the D-guy rods **1**.

The D-guy rods **1** are pinned on both sides on the suspended ballast guide **5**. The unpinning procedure is described on the example for one D-guy rod.



WARNING

Swinging D-guy rods!

When unpinning the D-guy rods **1** at point **P54** then they swing uncontrolled into direction of the turntable.

Personnel can be injured or killed.

- ▶ Make sure that the D-guy rods are secured with the manual rope winches before unpinning.

- ▶ Remove the safety locking pin **72** at point **P54** and unpin the pin **71**.
- ▶ Swing the D-guy rods **1** with the aid of the manual rope winch **66** and simultaneous luffing up the derrick boom in direction of the turntable.

When the D-guy rods **1** hang vertically:

- ▶ Remove the rope of the manual rope winch **66** and spool it up.
- ▶ Attach the suspended ballast guide **5** with fastening equipment on the auxiliary crane.

Empty page!

LWE/LR 11000-001/23501-04-02/en

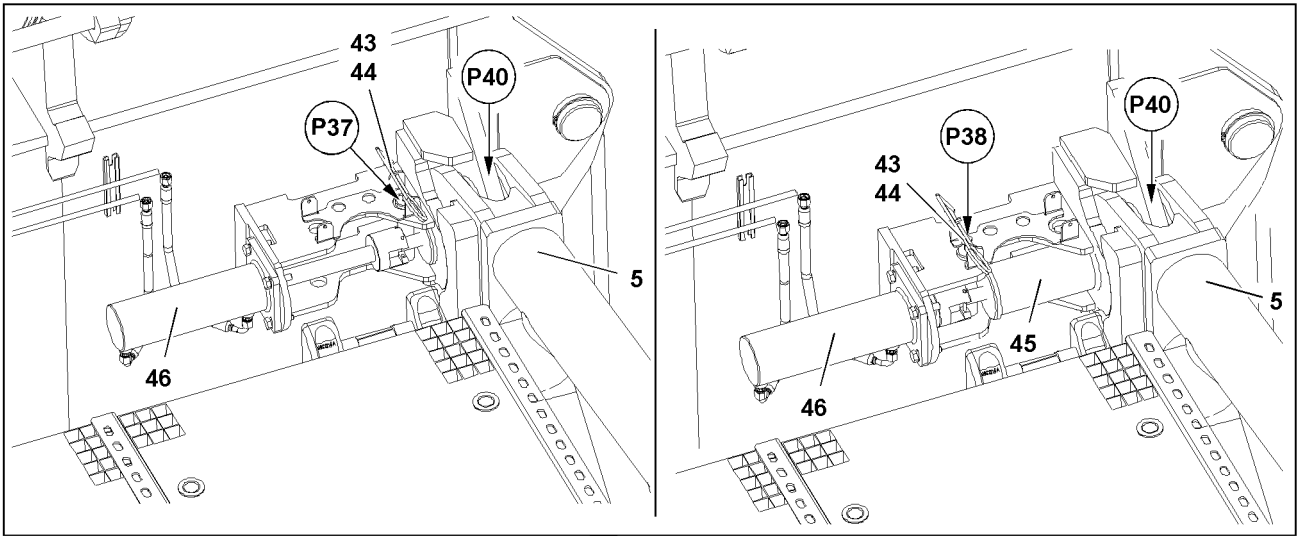

12

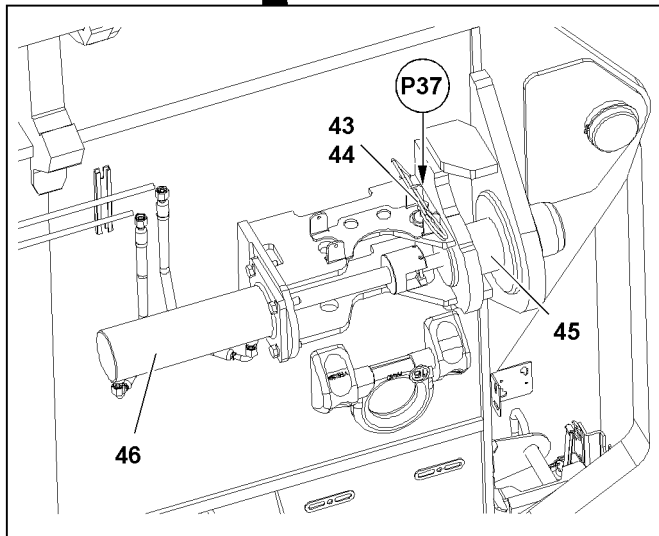
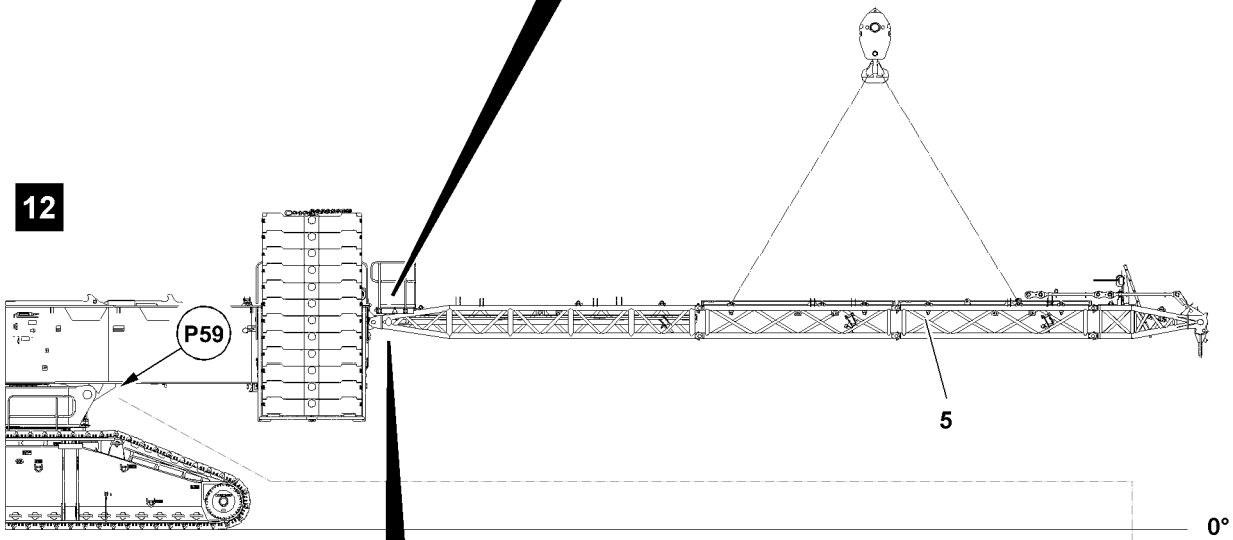

13

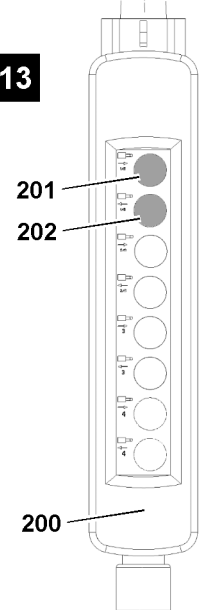

Fig.120216

Disassembling the suspended ballast guide on the turntable frame

Make sure that the following prerequisites are met:

- The suspended ballast guide is fastened on the auxiliary crane with fastening equipment.
- The control panel is connected on the socket „turntable rear“.

- ▶ Swing the suspended ballast guide **5** to the horizontal.

The suspended ballast guide **5** is pinned on two points **P40**. The unpinning procedure is described for one pin as an example:

- ▶ Release the pin **45**: Remove the spring retainer **44** at point **P37** and unpin the retaining pin **43**, see illustration **12**.
- ▶ Insert the retaining pin **43** at point **P38** and secure with spring retainer **44**.

When the suspended ballast guide **5** is safely held by the auxiliary crane:

- ▶ Unpin the pin **45**: Press button **202** on the control panel **200**, see illustration **13**.

Result:

- The pin **45** moves out.

When both pins **45** are unpinned:

- ▶ Remove the suspended ballast guide **5** from the pin points on the rear of the turntable and place it on the substructure.
- ▶ Insert the pins **45** again: Press button **201** on the control panel **200**, see illustration **13**.

Result:

- The pin **45** moves in.

- ▶ Secure the pin **45**: Insert the retaining pin **43** at point **P37** and secure with spring retainer **44** see illustration **12**.

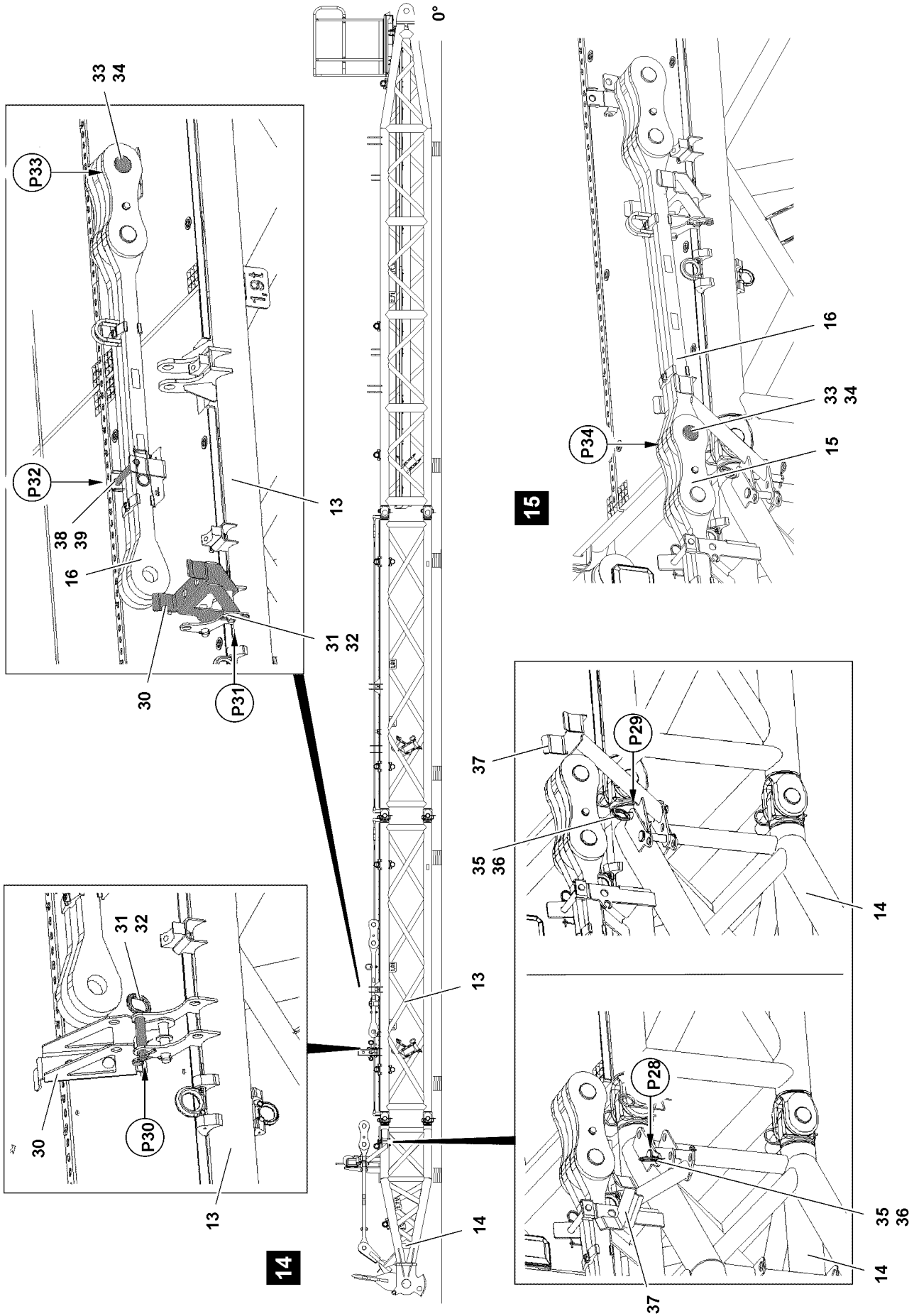

Fig.122951

LWE/LR 11000-001/23501-04-02/en

Disassembling the suspended ballast guide



Note

- ▶ The disassembly of the suspended ballast guide is described based on the example of one suspended ballast guide with a 30 m suspended ballast radius.

Swinging the brackets

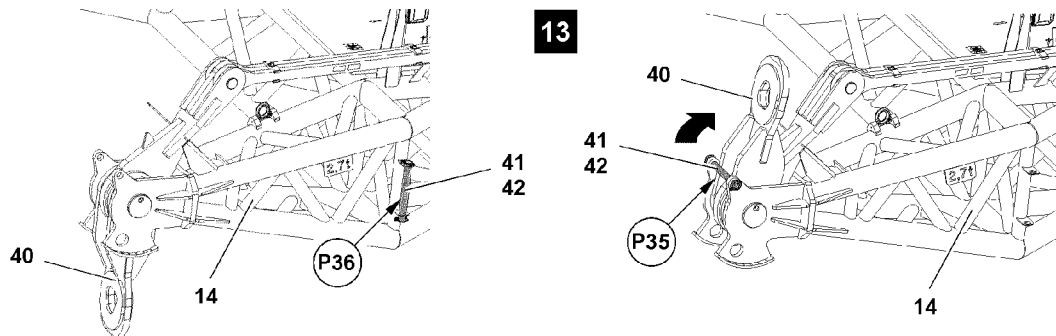

Fig.119029: Swinging the bracket

- ▶ Fasten the bracket **40** with fastening equipment to the auxiliary crane.



WARNING

Bracket swinging down!

The bracket can swing down by itself due to its own weight when pinning it, see illustration. Death, severe injury, property damage.

Fingers and hands can be crushed.

- ▶ Make sure that the platform is held by the auxiliary crane.
- ▶ Do not reach with your hands into the danger zone.
- ▶ Remove the safety locking pin **42** at point **P36** and unpin the pin **41**, see illustration **16**.
- ▶ Swing the bracket **40** upward with the auxiliary crane.
- ▶ Insert the pin **41** in park position at point **P35** and secure with safety locking pin **42**, see illustration **16**.

Disassembling the pull rods

- ▶ Fasten the pull rod **16** with fastening equipment to the auxiliary crane.
- ▶ Unpin the pull rod **16** from the pull rod end section **15**: Remove the safety locking pin **34** at point **P34** and unpin the pin **33**, see illustration **15**.
- ▶ Lift the pull rod **16** with the auxiliary crane and take it down in transport position at point **P32** and point **P33**.
- ▶ Insert the pin **33** at point **P33** and secure with safety locking pin **34**.
- ▶ Insert the pin **38** on point **P32** and secure with spring retainer **39**.

Result:

- The pull rod **16** is secured in the transport position, see illustration **14**.

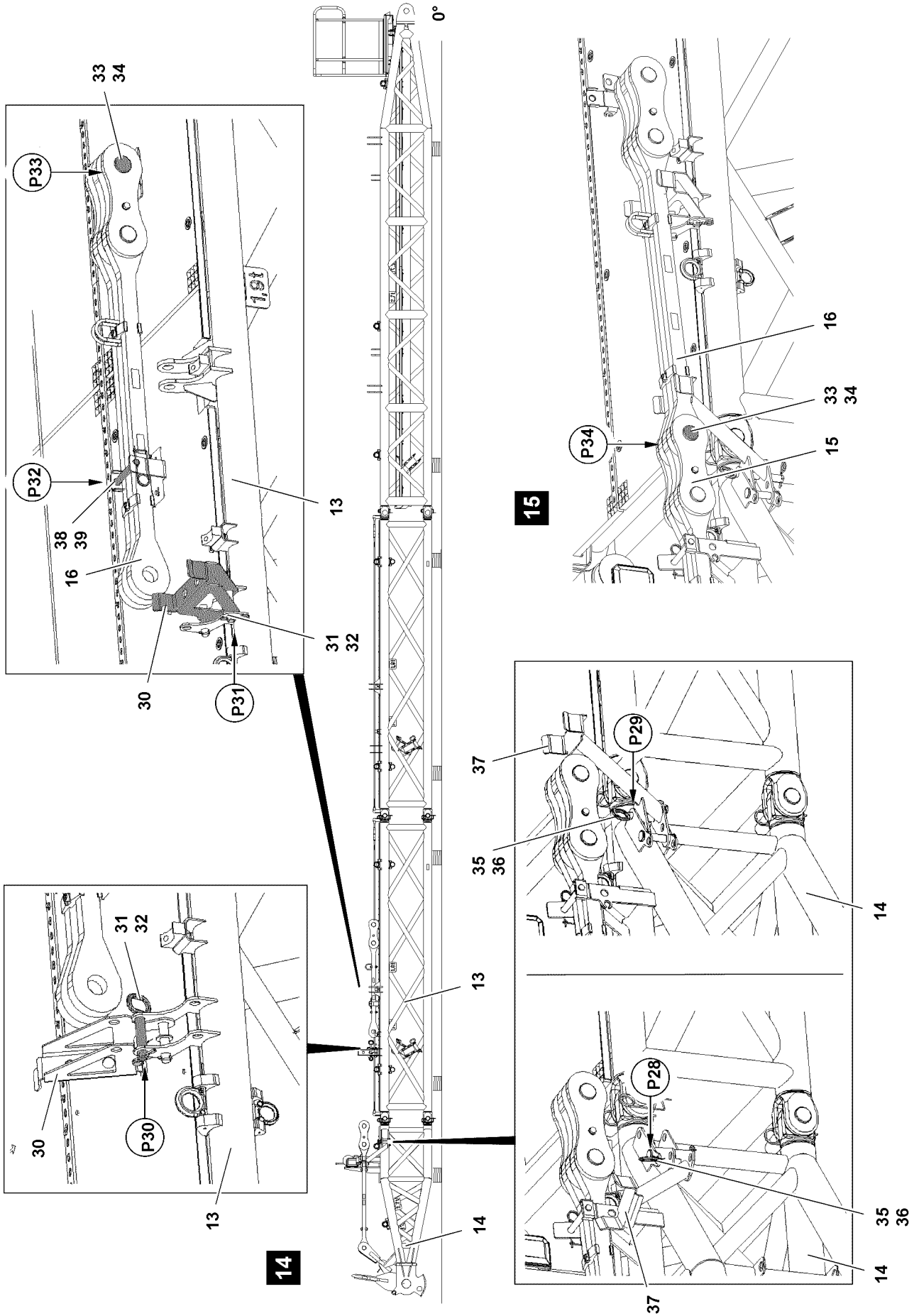

Fig.122951

LWE/LR 11000-001/23501-04-02/en

- ▶ Release the retainer **30** from operating position: Remove the spring retainer **32** at point **P31** and unpin the socket pin **31**, see illustration **14**.

**WARNING**

When swinging the retainer, fingers and hands can be crushed.

- ▶ Do not reach with your hands into the danger zone.
- ▶ Swing the retainer **30** until it can be pinned at point **P30**.
- ▶ Insert the socket pin **31** at point **P30** and secure with spring retainer **32**.

Result:

- The retainer **30** is secured in the transport position, see illustration **14**.
- ▶ Release the bracket **37** from operating position: Remove the spring retainer **36** at point **P29** and unpin the socket pin **35**, see illustration **14**.

**WARNING**

When swinging the bracket, fingers and hands can be crushed!

- ▶ Do not reach with your hands into the danger zone.
- ▶ Swing the bracket **37** until it can be pinned at point **P28**.
- ▶ Insert the socket pin **35** at point **P28** and secure with spring retainer **36**.

Result:

- The bracket **37** is secured in the transport position, see illustration **14**.
- ▶ Secure the pull rod **15** in transport position.

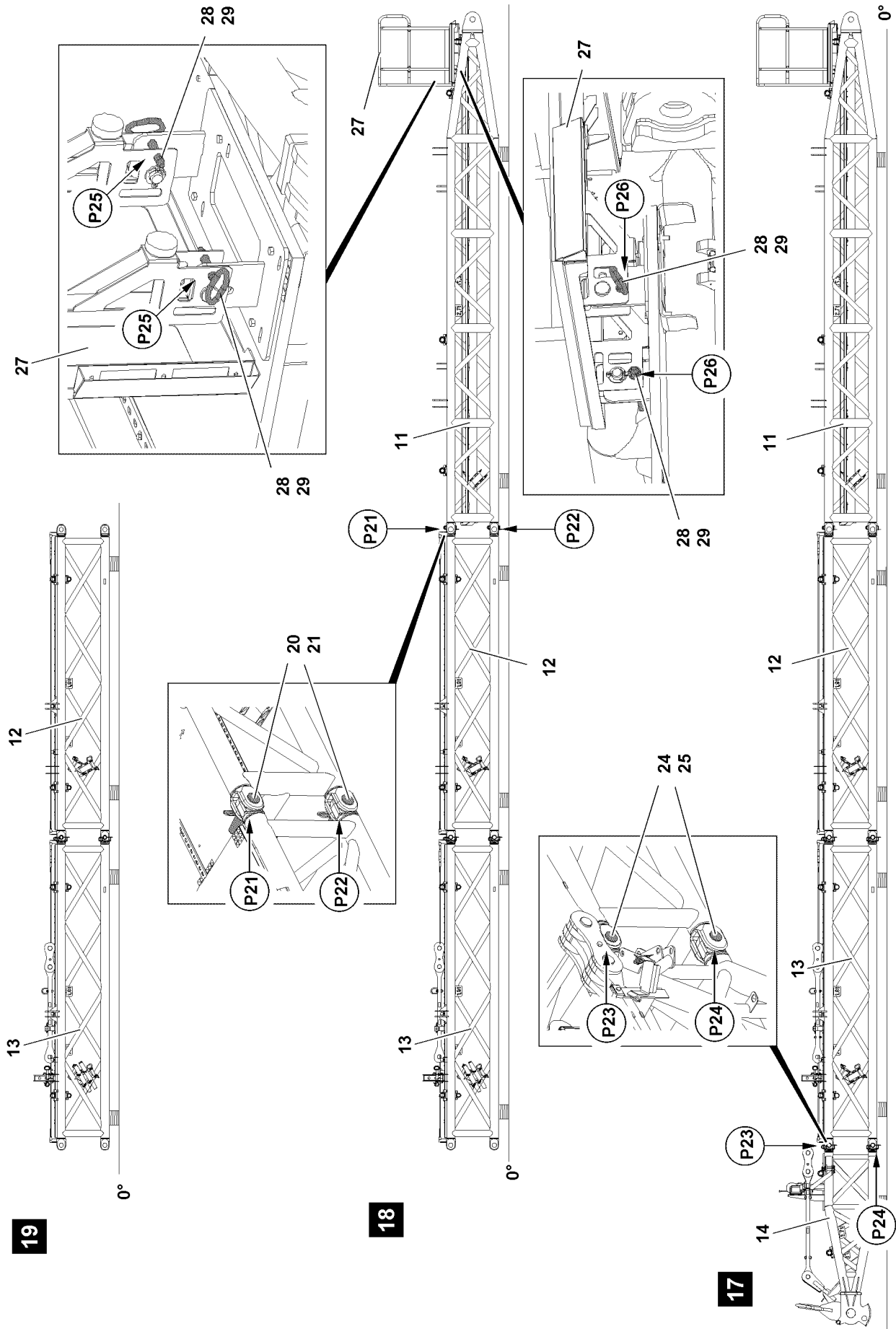

Fig.122952

LWE/LR 11000-001/23501-04-02/en

Disassembling the end section

- ▶ Fasten the end section **14** with fastening equipment to the auxiliary crane.

The end section and the intermediate section are pinned together in four points. Every point is present on both sides of the component on one level, see illustration **17**.

- ▶ Unpin the end section **14** on both sides at point **P24**: Remove spring retainers **25** and unpin pins **24**.
- ▶ Unpin the end section **14** on both sides at point **P23**: Remove spring retainers **25** and unpin pins **24**.
- ▶ Remove the end section **14** with the auxiliary crane.
- ▶ Remove the fastening equipment.

Disassembling the pivot section

- ▶ Fasten the platform **27** with fastening equipment to the auxiliary crane.
- ▶ Set the platform **27** in the transport position, see illustration **18**: Remove the safety locking pin **29** at points **P26** and unpin the grip pin **28**.

**WARNING**

Platform swinging down!

The platform can swing down by itself due to its own weight when pinning it, see illustration.

Death, severe injury, property damage.

Fingers and hands can be crushed.

- ▶ Make sure that the platform is held by the auxiliary crane.
- ▶ Do not reach with your hands into the danger zone.
- ▶ Use personal protective equipment.

- ▶ Swing the platform **27** with the auxiliary crane.
- ▶ Insert the grip pin **28** at points **P25** and secure with safety locking pin **29**.
- ▶ Remove the auxiliary crane.
- ▶ Fasten the pivot section **11** with fastening equipment to the auxiliary crane.

The pivot section and the intermediate section are pinned together in four points. Every point is present on both sides of the component on one level, see illustration **18**.

- ▶ Unpin the pivot section **11** on both sides at point **P22**: Remove spring retainers **21** and unpin pins **20**.
- ▶ Unpin the pivot section **11** on both sides at point **P21**: Remove spring retainers **21** and unpin pins **20**.
- ▶ Remove the pivot section **11** with the auxiliary crane.
- ▶ Remove the fastening equipment.

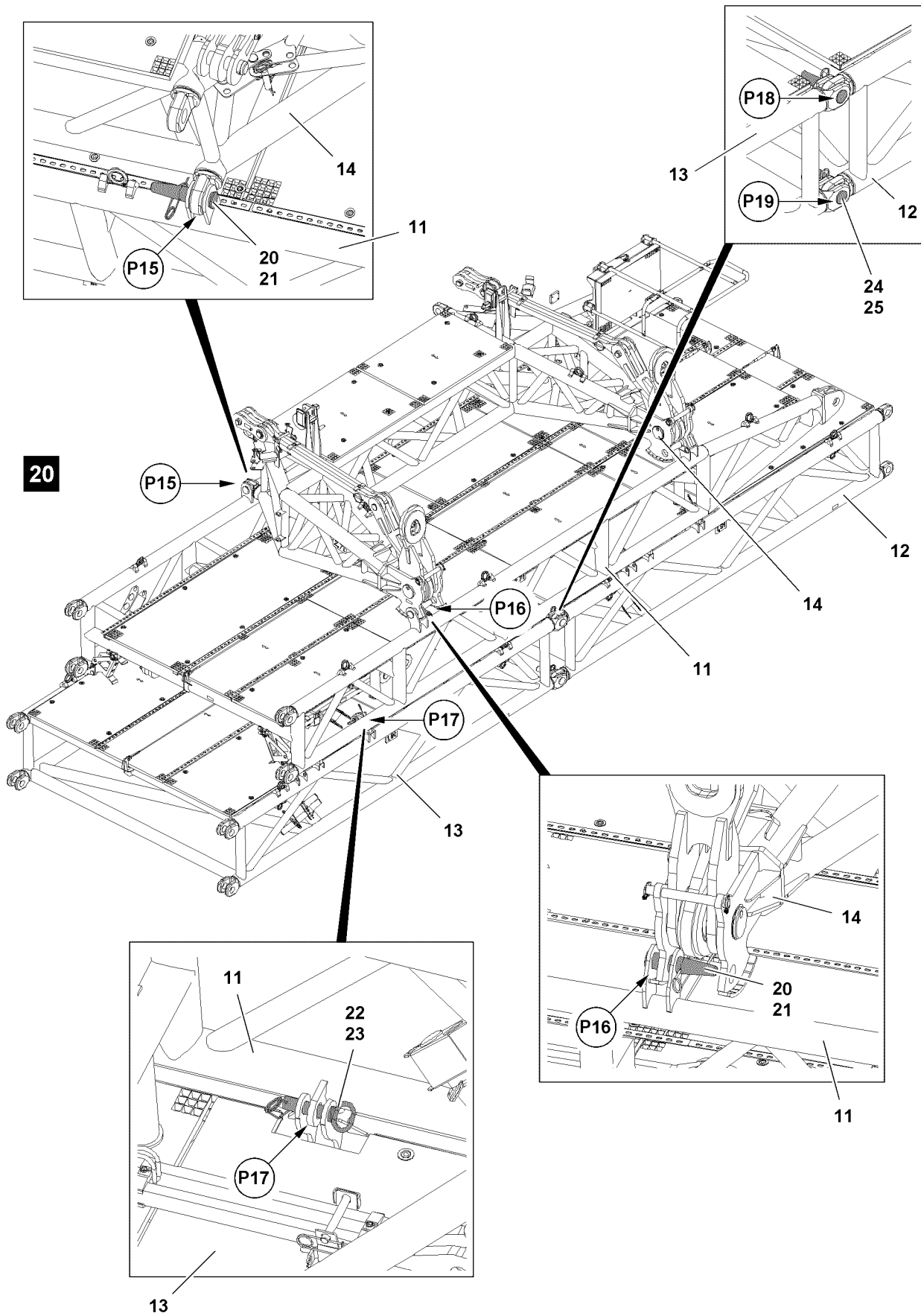

LWE/LR 11000-001/23501-04-02/en

Fig.122953

Installing the suspended ballast guide as a transport unit

Make sure that the following prerequisites are met:

- The pivot section has been removed.
- The end section has been removed.
- The platform has been placed down.
- The pull rods are placed down and secured.
- The retainer and the bracket are secured in transport position.

Assembling the intermediate sections

For the suspended ballast guide as a transport unit, only two intermediate sections are installed.

- ▶ Fasten the intermediate section **13** with fastening equipment to the auxiliary crane.
- ▶ Position the intermediate section **13** with the auxiliary crane on the intermediate section **12** at point **P18** until the pin points align.

The intermediate section **13** and intermediate section **12** are pinned together on four points. Every point is present on both sides of the component on one level, see illustration **20**.

- ▶ Pin the intermediate section **13** on both sides at point **P18** with the intermediate section **12**: Insert the pins **24** and secure with the spring retainers **25**.
- ▶ Pin the intermediate section **13** on both sides at point **P19** with the intermediate section **12**: Insert the pins **24** and secure with the spring retainers **25**.
- ▶ Remove the fastening equipment.

Assembling the pivot section

The pivot section is pinned at four points. Every point is present on both sides of the component on one level.

- ▶ Fasten the auxiliary crane to the pivot section **11**.
- ▶ Position the pivot section **11** with the auxiliary crane on the intermediate section **12** and intermediate section **13** at point **P17** until the pin points align, see illustration.
- ▶ Pin the pivot section **11** at points **P17**: Insert the pins **22** and secure with spring retainers **23**, see illustration **20**.
- ▶ Remove the fastening equipment.

Assembling the end section

The end section is pinned at four points. Every point is present on both sides of the component on one level.

- ▶ Fasten the end section **14** with fastening equipment to the auxiliary crane.
- ▶ Position the end section **14** with the auxiliary crane on the pivot section **11** at point **P15** and point **P16** until the pin points align, see illustration **20**.
- ▶ Pin the end section **14** at points **P15**: Insert the pins **20** and secure with spring retainers **21**, see illustration **20**.
- ▶ Pin the end section **14** at points **P16**: Insert the pins **20** and secure with spring retainers **21**, see illustration **20**.
- ▶ Remove the fastening equipment.

Empty page!

LWE/LR 11000-001/23501-04-02/en

5.36.30 Derrick ballast - suspended ballast - special design Ballast Constant (BC)

1	Product description	3
2	Component overview	5
3	Fastening points for suspended ballast components	6
4	Derrick ballast radii	7
5	Pull cylinder extension conditions	8
6	Assembly	9
7	Crane operation with the derrick ballast	15
8	Crawler operation with derrick ballast	48
9	Disassembling	49

Fig.195219

1 Product description

This chapter describes the following derrick ballast variations:

- Suspended ballast *special design*: Ballast Constant
Ballasting consisting of directly suspended ballast plates (with / without cross beam)

This crane type has additional derrick ballast variations, which will be described in other chapters of these operating instructions:

- Ballast trailer
Ballasting consisting of ballast plates on a ballast trailer
Permissible ballast plates: Ballast plates 10 t
Ballast Constant is assembled without a suspended ballast guide.
Ballast Constant is assembled without a ballast pallet.
- Suspended ballast
Ballasting consisting of ballast plates on a ballast pallet
- Suspended ballast *special design*: Ballasting LTR crane and / or ballast plates
Ballasting consisting of an LTR crane and / or ballast plates on a ballast pallet



Note

Designation of the ballast types

- ▶ The suspended ballast and the ballast trailer are generally described as derrick ballast.
- ▶ The ballast installed on the turntable is generally referred to as the counterweight.
- ▶ The ballast installed on the crawler travel gear is generally referred to as the central ballast.

1.1 Function

The D-guying contains two pull cylinders (pull cylinder A and pull cylinder B). After assembly on the ground, the derrick ballast is raised for crane operation with the pull cylinders

All relevant data regarding the derrick ballast is displayed on the LICCON monitors.

The required derrick ballast radius is set by adjusting the derrick boom.

1.2 Variations

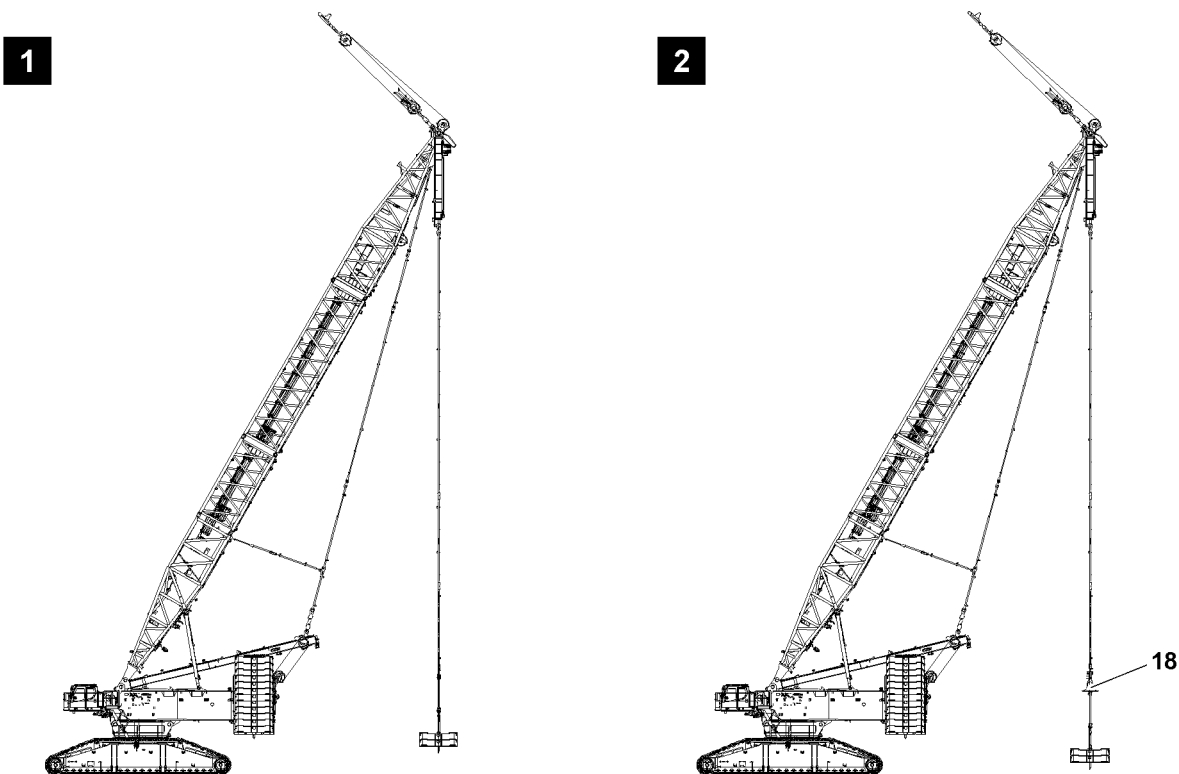

Fig. 145946: Ballast Constant, variations

Ballast Constant can be assembled without a cross beam **or** with a cross beam **18**.

Variations for Ballast Constant:

- **Without** cross beam, see illustration **1**
- **With** cross beam, illustration **2**

2 Component overview

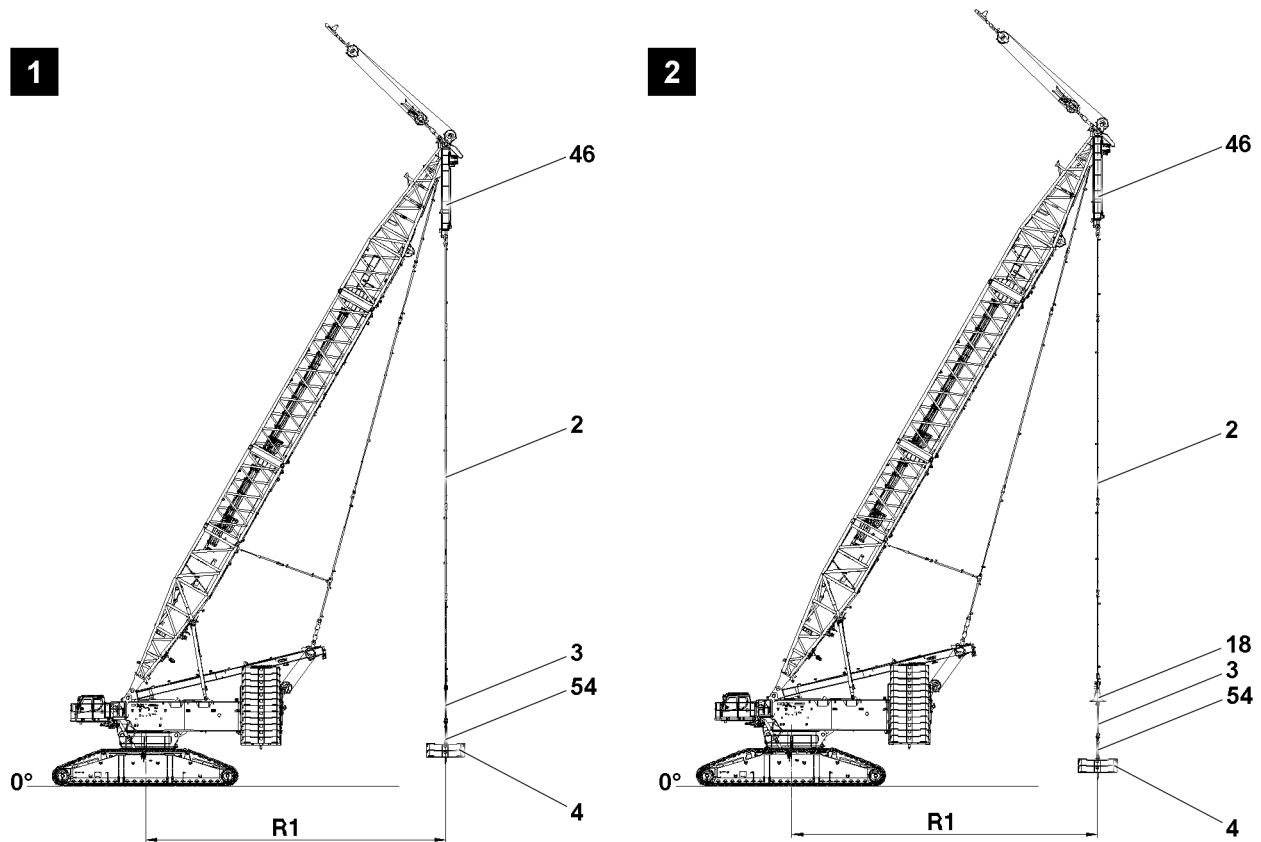

Fig.145949: Ballast Constant, component overview

46 Pull cylinder	18 Cross beam	54 Receptacle stud
2 D-guying	3 Supplied fastening equipment	4 Ballast plates

2.1 Fastening equipment

Supplied fastening equipment:

- Roundslings
- Shackle

2.2 Ballast plates



Note

- ▶ The assembly sections are marked with their own weight.
- ▶ Dimensions and weights, see the Crane operating instructions, chapter 1.03.

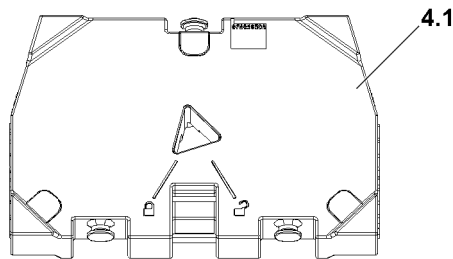

Fig.126484

4.1 10 t ballast plate

2.3 Cross beam*



Note

- ▶ The assembly sections are marked with their own weight.
- ▶ Dimensions and weights, see the Crane operating instructions, chapter 1.03.

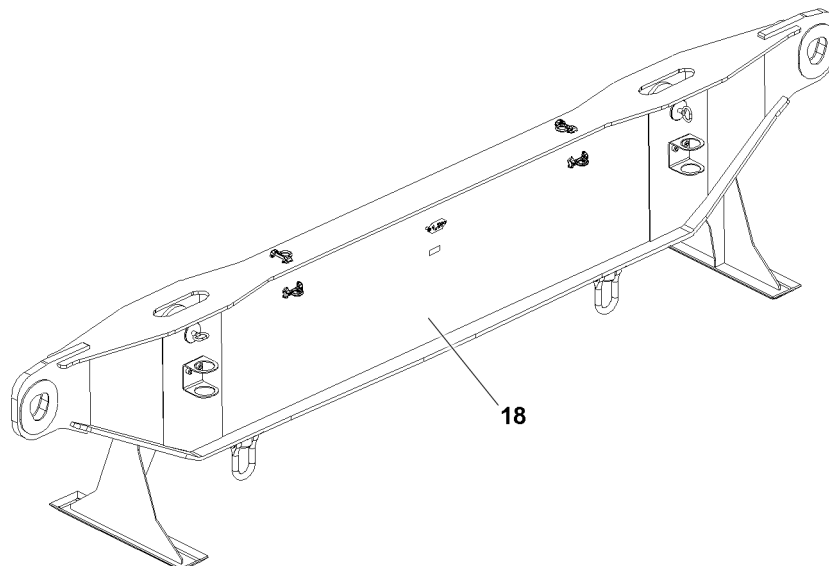

Fig.124993

18 Cross beam

3 Fastening points for suspended ballast components

3.1 Ballast plates



WARNING

Component incorrectly fastened!

Life-threatening situations can arise due to improper or incorrect attachment of the corresponding components.

Death, severe injury, property damage.

- ▶ Fasten the components only on the intended fastening points on both sides.
- ▶ Fastening of components and description of fastening points, see Crane operating instructions, chapter 5.01.

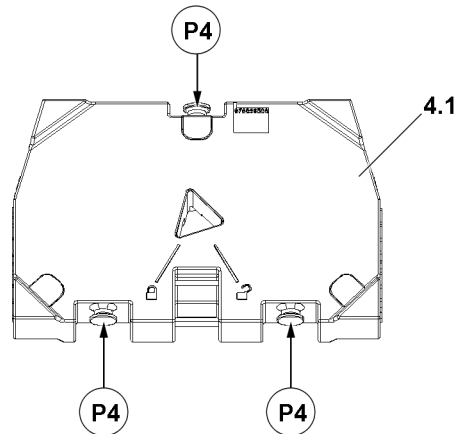

Fig.126483

Fastening points	
P4	10 t ballast plate 4.1

3.2 Cross beam*

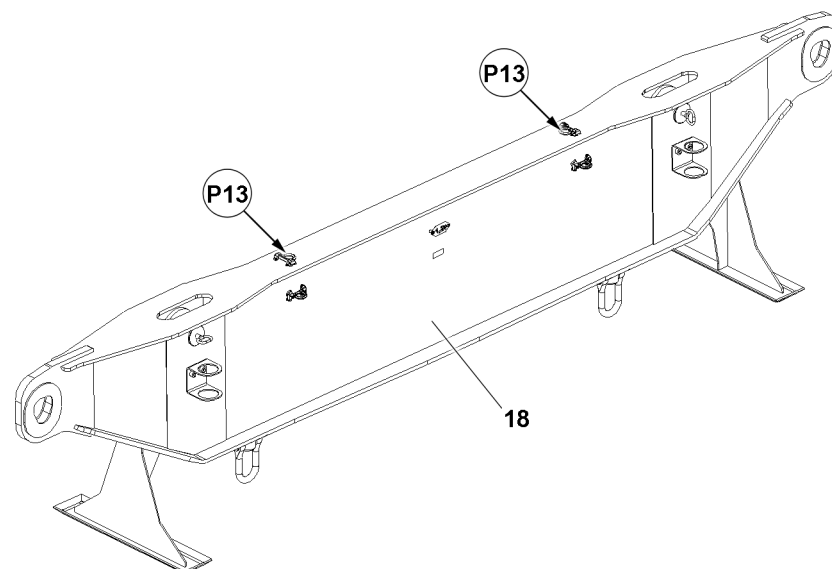

Fig.126060

Fastening points	
P13	Cross beam 18

4 Derrick ballast radii

4.1 36 m derrick boom

With the 36 m derrick, the following derrick ballast radii are possible: R1= 12 m and R1= 18 m.

4.2 Derrick boom 42 m

With the 42 m derrick, the following derrick ballast radii are possible: $R1 = 12\text{ m}$ and $R1 = 20\text{ m}$.

5 Pull cylinder extension conditions

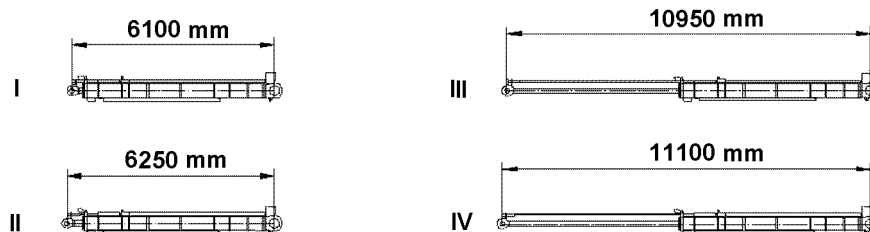

Fig.119003: Pull cylinder extension conditions

Extension conditions	
I	Block position „Retracted“
II	Switch position „Retracted“
III	Switch position „Extended“
IV	Block position „Extended“

6 Assembly



WARNING

Danger of falling!

During assembly / disassembly, inspection and maintenance work, personnel must be secured with appropriate aids to prevent them from falling.

Death, severe injury, property damage.

- ▶ All work at a height, when there is a danger of falling, must be carried out with suitable aids.
- ▶ If aids are not available and work cannot be carried out from the ground, then assembly personnel must secure themselves with the supplied fall arrest system to prevent falling, see the Crane operating instructions, chapter 2.04.
- ▶ If fall protection equipment is available, then it must be used, see the Crane operating instructions, chapter 2.06.
- ▶ When lifting, lowering, swinging crane parts in and out, no persons may remain in the danger zone.
- ▶ If railings are present on the components, then they must be brought into the corresponding position and secured for assembly / disassembly work.
- ▶ Only step on the aids, ladders and catwalks with clean shoes.
- ▶ Keep aids, ladders and catwalks free of heavy dirt, snow and ice.
- ▶ During all assembly and disassembly work, maintenance work and inspections, travel or crane operation is prohibited.
- ▶ Remaining on a suspended load is prohibited.
- ▶ Stepping or walking on crane components and lattice sections, which have an incline of more than 20° is prohibited.
- ▶ For all assembly work, the crane operator of the main crane must be in voice contact with the crane operator / crane operators of the auxiliary crane / auxiliary cranes.
- ▶ For assembly / disassembly tasks, the crane operator may only initiate crane movements when the responsible guide has explicitly released the movement.

When the assembly personnel is within the danger zone of the crane:

- ▶ A guide and / or the crane operator must be able to see the entire danger zone.



WARNING

Danger of impact / crushing!

When installing / removing crane components with the auxiliary crane, crane components can start to swing back and forth.

When lifting / lowering and positioning crane components, there is an increased danger of impacts / crushing.

Personnel can be caught and severely injured or killed.

- ▶ Make sure that personnel cannot be caught by components.
- ▶ When working in danger zones: Use aids to protect limbs.
- ▶ Guide components with suitable aids to minimize oscillation.



DANGER

The components can fall down!

If the corresponding components are disengaged from the auxiliary crane before the corresponding component is pinned, the corresponding component can fall down and fatally injure personnel.

- ▶ Do not disengage the auxiliary crane until the respective component is pinned and secured.

Make sure that the following prerequisites are met:

- The crane is horizontally aligned.
- An auxiliary crane is available.
- The derrick is in the crane operating position.
- The main boom is in the crane operating position.
- The counterweight has been installed on the turntable according to the load chart.
- The LICCON overload protection has been set according to the data in the load chart.
- The LICCON overload protection settings have been compared with the actual set up configuration.

6.1 Ballasting



WARNING

Impermissible geometry of the ballast!

Falling ballast plates.

Death, severe bodily injuries, property damage.

- ▶ Replace damaged ballast plates immediately with new ballast plates.
- ▶ Ballast the Ballast Constant symmetrically.

Make sure that the following prerequisites are met:

- An auxiliary crane is on hand.
- Receptacle studs are on hand.

6.1.1 Picking up the ballast plates with the receptacle stud



Note

There is a specific receptacle stud for each ballast plate version.

- ▶ Always use the appropriate receptacle stud.

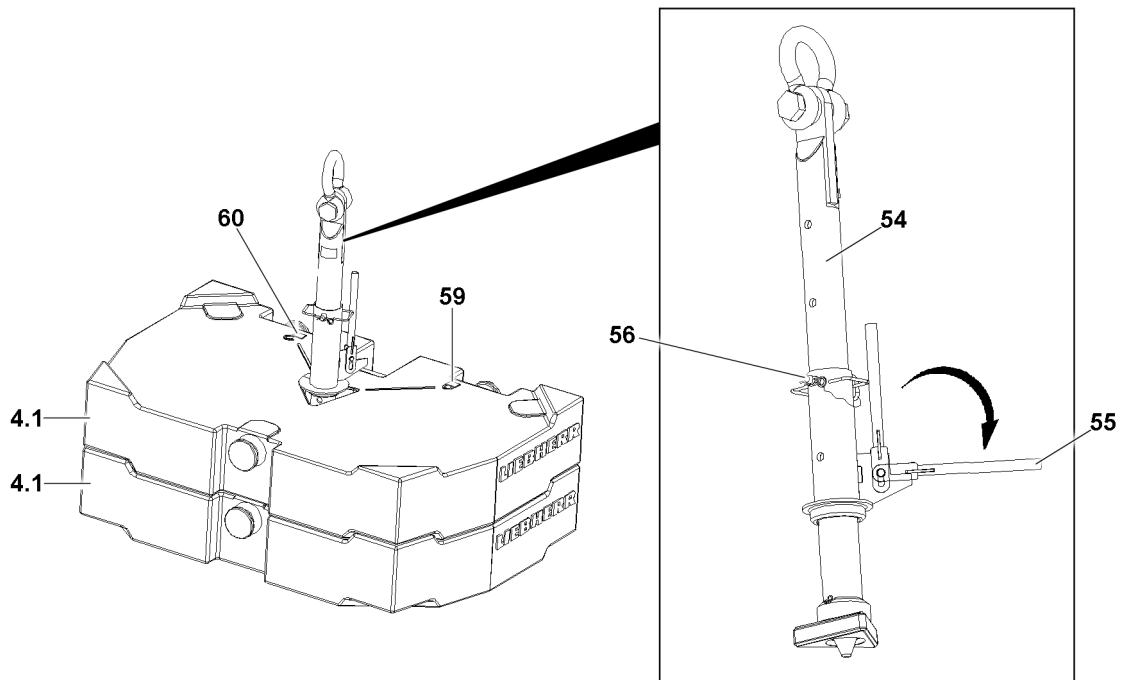

Fig.126074: Receptacle stud **54** with two 10 t ballast plates **4.1**



WARNING

Receptacle stud **not** permissible for provided ballast plates!

Overload and damage of the receptacle stud. Death, severe injury, property damage.

- ▶ Only use a receptacle stud **54** for ballast plates 10 t **4.1**.



WARNING

More than two ballast plates lifted with the receptacle stud!

Overload and damage of the receptacle stud. Death, severe injury, property damage.

- ▶ Lift a maximum of two 10 t ballast plates **4.1** with a receptacle stud **54**.
- ▶ Make sure that the ballast plates are placed correctly in the centerings of the receptacle stud.

**WARNING**

Danger of accident due to damaged components!

- ▶ Do not use a damaged receptacle stud **54**.
- ▶ Replace damaged ballast plates 10 t **4.1**.

Ballast plates for Ballast Constant are taken up with the receptacle stud, fastening system: „Twistlock“.

Ballast plates can be taken up individually or as an assembly of maximum two ballast plates.

Before the receptacle stud **54** is guided into the ballast plates, it must be ensured that the length of the receptacle stud **54** is set correctly. The length of the receptacle stud **54** can be adjusted with the pin **56**.

- ▶ Release and unpin the pin **56**.
- ▶ Adjust the length of the receptacle stud by moving the receptacle stud **54**.
- ▶ Insert the pin **56** and secure with the spring retainer.
- ▶ Attach the receptacle stud **54** with fastening equipment on the auxiliary crane and guide it into the ballast plate(s).
- ▶ Pull the lever **55** up and fold it down.

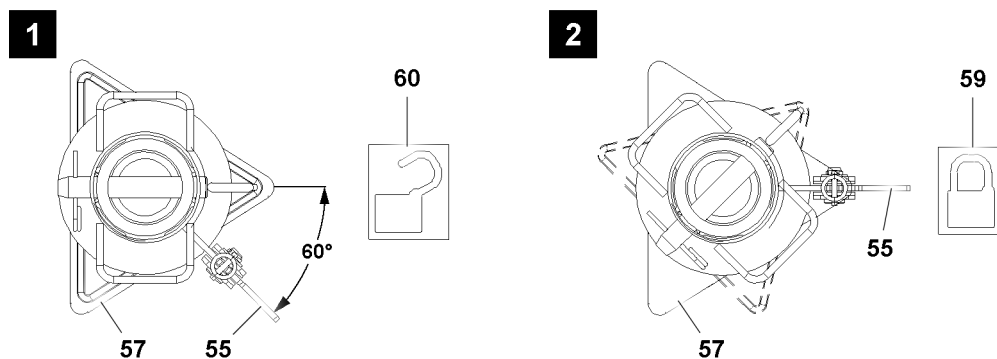

Fig.126075: Receptacle stud overhead view, positions lever **55**

- ▶ Turn the lever **55** by 60°, see illustration 1 until the lever **55** points on the icon **59**, illustration 2.

Result:

- The receptacle stud **54** is locked with the ballast plate.

6.2 Assembling without a cross beam

6.2.1 Fastening the ballast on the guy rods

Make sure that the following prerequisites are met:

- Ballast plates are on the receptacle stud.
- Supplied fastening equipment is on hand.

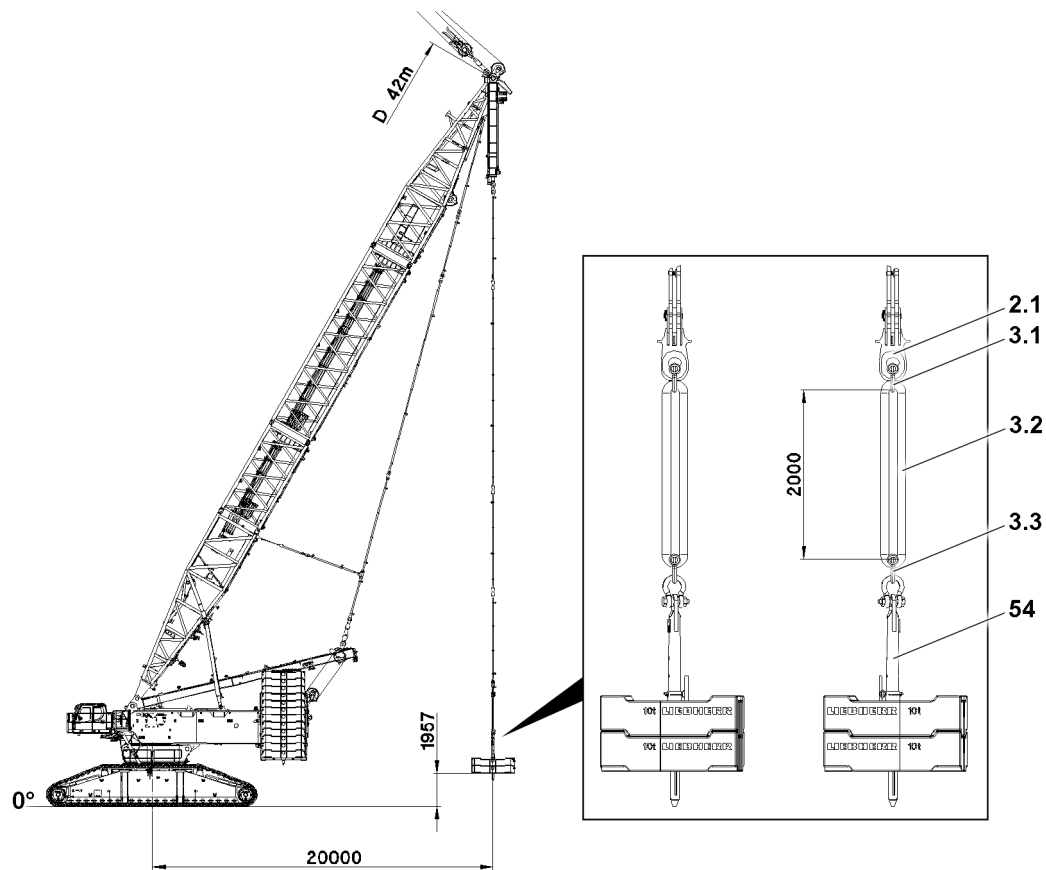

Fig.124979: Ballast Constant on the guy rods

When the derrick ballast radius is less than 15 m:

- ▶ Support the ballast plates before fastening.
- ▶ Position the ballast under the guy rods.
- ▶ Lower the guy rods until the ballast can be fastened.

The ballast must be fastened with the supplied fastening equipment.

- ▶ Fasten the receptacle stud **54** with the shackle **3.3**, roundsling **3.2** and shackle **3.1** on the bracket **2.1**.

6.3 Assembling with a cross beam*

6.3.1 Assembling the cross beam

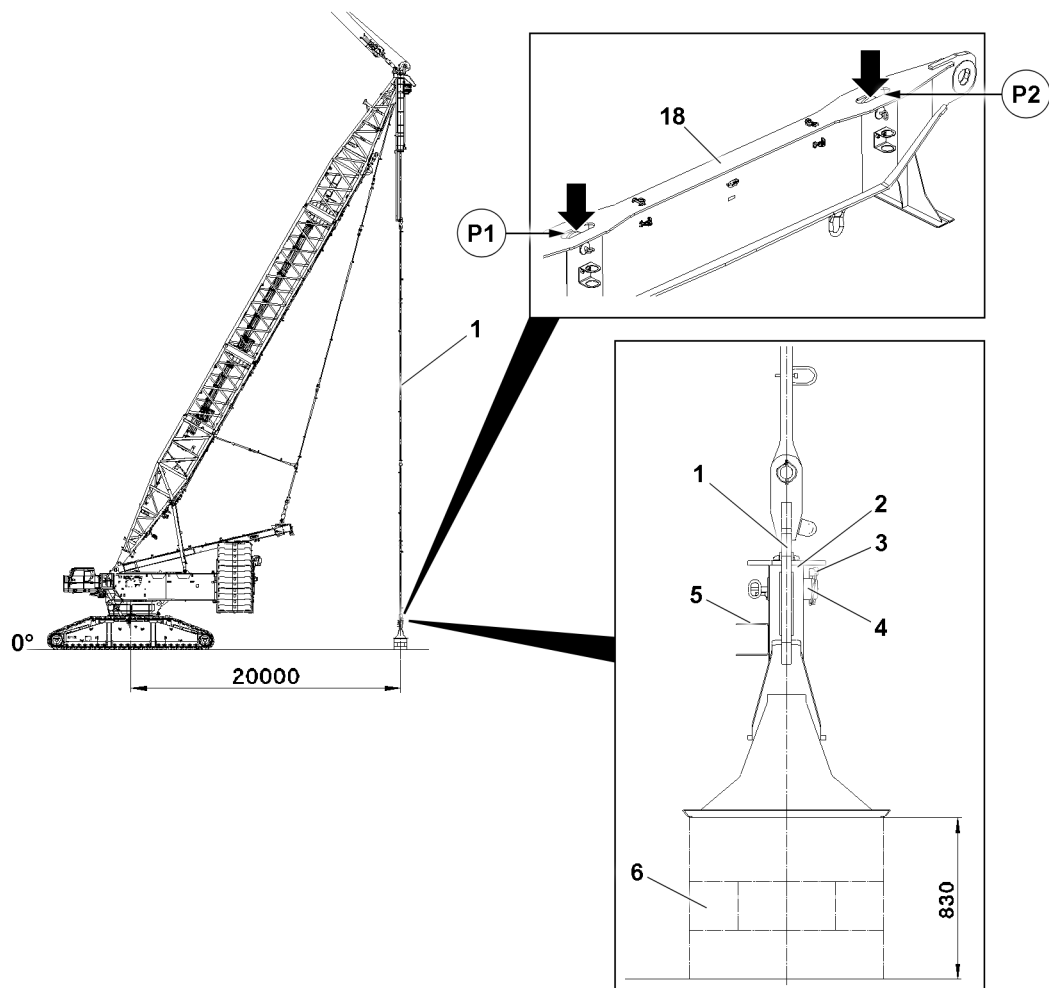

Fig.124981: Cross beam

Make sure that the following prerequisites are met:

- The ground is level and of sufficient load bearing capacity.

- ▶ Set the derrick radius to 20 m.

The substructure **6** must be at least 830 mm above the crane placement surface.

- ▶ Position the substructure **6** under D-guy rods **1**.



Note

- ▶ Fastening points, see section „Fastening points for suspended ballast parts“.

- ▶ Fasten the cross beam **18** with fastening equipment to the auxiliary crane.
- ▶ Set the cross beam **18** on the substructure **6**.
- ▶ Release and unpin the pin **4** in transport retainer **5**.
- ▶ Extend the pull cylinder until the D-guy rods **1** can be pinned on point **P1** and on point **P2** with the cross beam.

**Note**

Retract / extend the pull cylinder

- ▶ Control the pull cylinders from the crane cab or with the control panel, see section „lifting and lowering the derrick ballast with the pull cylinders“.
- ▶ Operate the pull cylinder with the radio remote control, see the „radio remote control operating instructions“.

- ▶ Pin the D-guy rods **1** with the cross beam: Insert the pins **4** and secure with locking pins **3**.
- ▶ Lift the cross beam: Retract the pull cylinder.

6.3.2 Fastening the ballast to the cross beam

Make sure that the following prerequisites are met:

- Ballast plates are on the receptacle stud.
- Supplied fastening equipment is on hand.

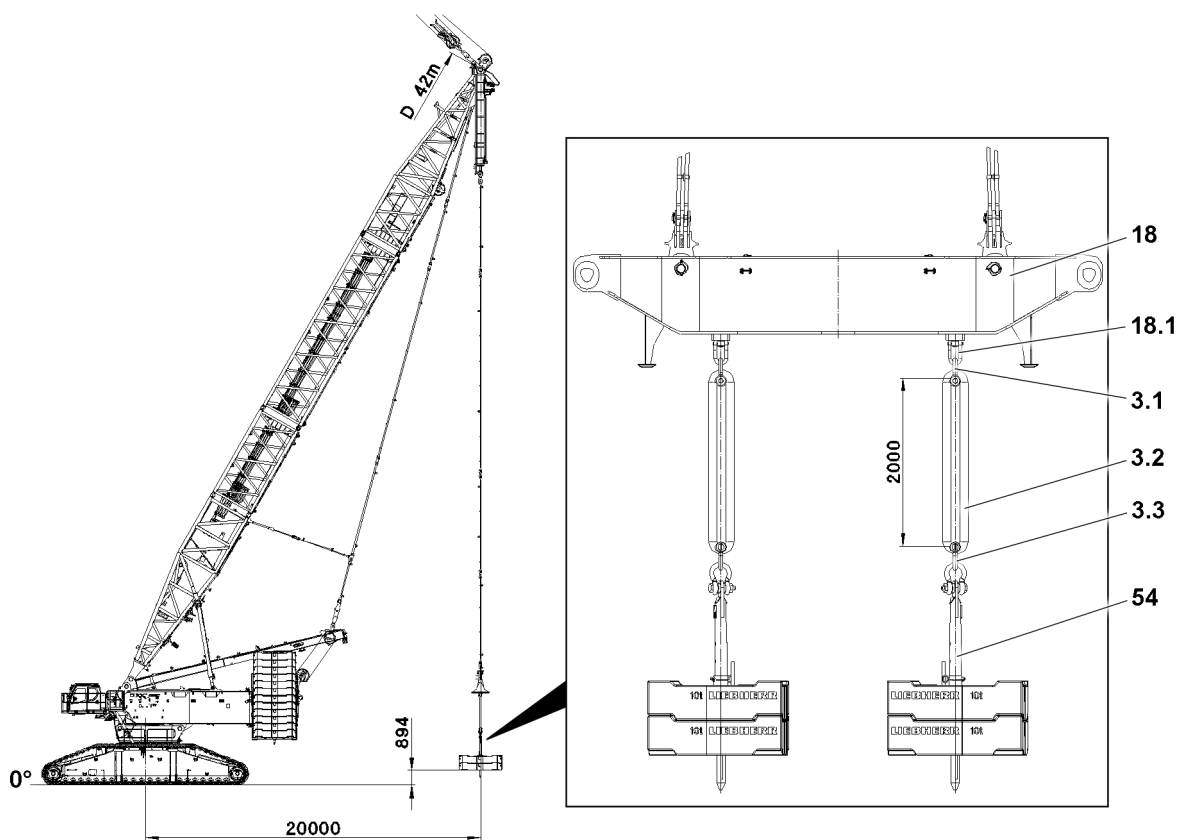

Fig.124980: Ballast Constant on the cross beam

- ▶ Position the ballast under the guy rods.
- ▶ Lower the cross beam **18** until the ballast can be fastened.

The ballast must be fastened with the supplied fastening equipment.

- ▶ Fasten the receptacle stud **54** with the shackle **3.3**, roundsling **3.2** and shackle **3.1** to the shackle **18.1**.

7 Crane operation with the derrick ballast

7.1 Lifting and lowering the derrick ballast using the pull cylinders

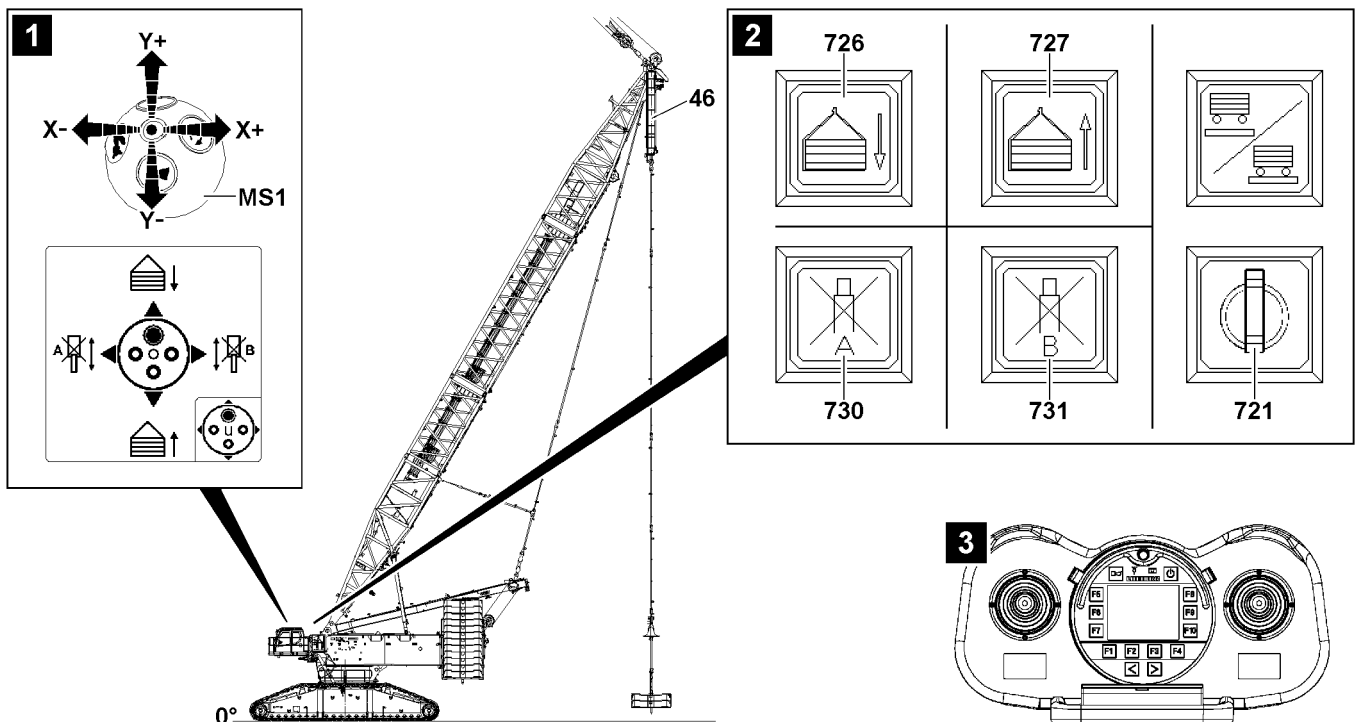

Fig.144126: Functions pull cylinder

The pull cylinders **46** in the derrick ballast guying can be operated in different ways:

- Operation with master switch **MS1** in the corresponding master switch assignment, see illustration 1
 - Select the master switch assignment for master switch MS1, see chapter 4.01.
- Operation with operating buttons on the instrument panel, see illustration 2

There is an additional operating option in assembly operation:

- Operation with the radio remote control (BTT-E), see illustration 3
 - Operation with the manual control lever in the corresponding assembly menu, see the radio remote control operating instructions.



Note

- ▶ If the derrick ballast (*Ballast Constant* function) is lifted via the button **727** or lowered via the button **726**, then the horizontal alignment of the derrick ballast is automatically regulated.
- ▶ Pressing one of the stop buttons (button **730** for pull cylinder A, button **731** for pull cylinder B) stops the corresponding pull cylinder. The cylinder that is not stopped can be moved only up to a maximum difference in length between the pull cylinders of 50 cm. Both pull cylinders are stopped when this limit is reached.
- ▶ Turning and driving the crawler travel is only permissible when the derrick ballast is completely lifted off the ground and hangs freely. If this is the case, turning on the “Derrick ballast lifted” function (key button **721**) releases the turning and driving functions.
- ▶ Driving is only possible with a reduced speed to prevent the derrick ballast from swinging up.

**DANGER**

Danger of accident!

If the following notes are not observed, personnel can be severely injured or killed.

In addition, this can result damage to the derrick ballast.

- ▶ Pay attention to the horizontal alignment of the derrick ballast when lifting and lowering the derrick ballast.
- ▶ When pressing the button **730** („Stop cylinder A on the derrick ballast“) or the button **731** („Stop cylinder B on the derrick ballast“), the automatic regulation is bypassed and the derrick ballast can be inclined within a limited difference in length (50 cm). This is exclusively permitted when setting down the derrick ballast on uneven ground and only by observing utmost caution.
- ▶ The lifting of the derrick ballast is not monitored by crane control. The crane driver is responsible for switching on the "derrick ballast lifted" function only when the derrick ballast is completely lifted off the ground and hanging freely.

During crane operation with derrick ballast the required maximum / minimum load can be actively influenced.

This is made possible by increasing or reducing the derrick ballast. Depending on the situation, this procedure is also possible under load.

**Note**

- ▶ The suspended ballast and the ballast trailer are generally referred to as the **derrick ballast**.
 - ▶ The fixed compensation weight that is installed on the turntable is generally referred to as the **counterweight**.
 - ▶ Additional personnel to carry out crane operation is generally referred to as **guide**.
- ▶ Operate the crane function to lift and lower the derrick ballast, see section „Carrying out crane movements“

Empty page!

LWE/LR 11000-001/23501-04-02/en

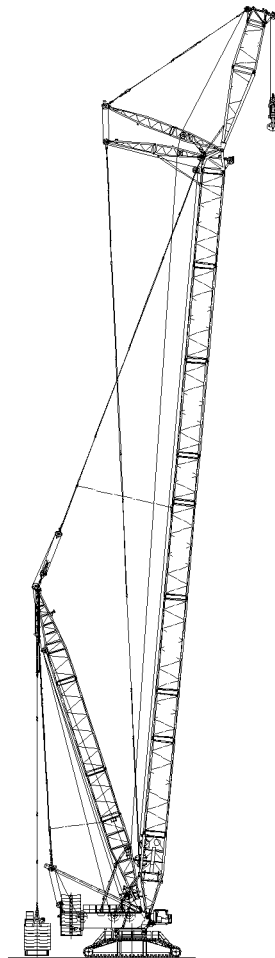
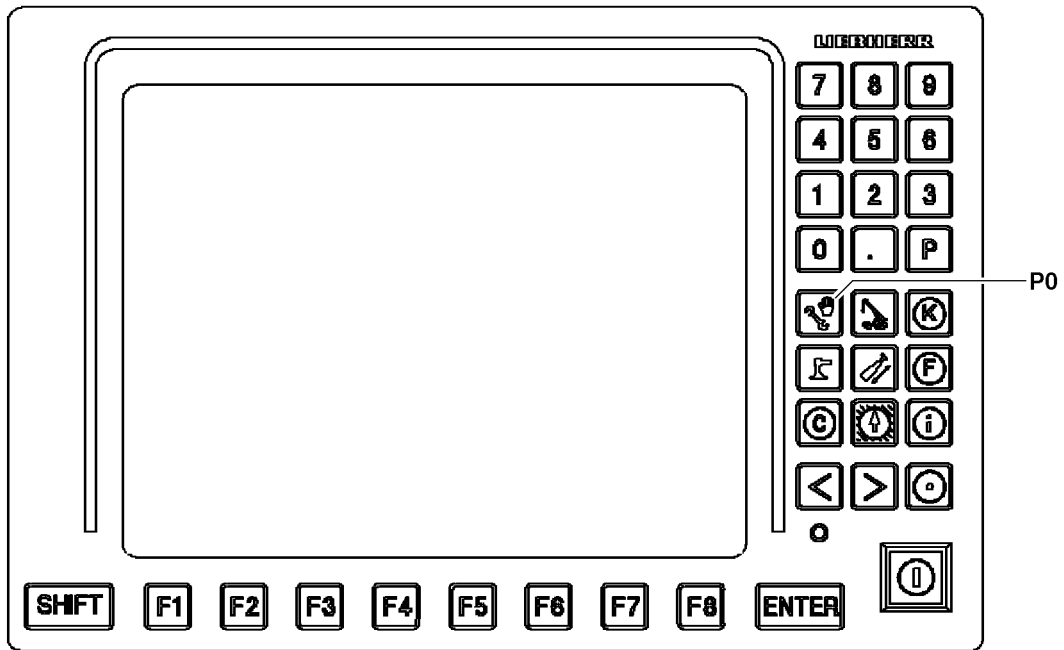

Fig.122800

LWE/LR 11000-001/23501-04-02/en

7.2 Checking the settings of the LICCON overload protection

Make sure that the following prerequisites are met:

- The derrick ballast is placed according to the load chart.
- The actual placed derrick ballast has been entered and confirmed in the Set up program, see Crane operating instructions, chapter 4.02.
- The derrick boom is in operating position.



WARNING

Incorrectly set overload protection!

If the actual set up configuration of the crane deviates from the entries and settings in the Set up program, then the overload protection is not correctly set.

An incorrectly set overload protection calculates the actual load incorrectly and transmits faulty display values.

The crane can be overloaded unnoticed and topple over.

This could result in serious accidents.

- ▶ The entries and settings in the set up program must match the actual set up configuration of the crane.
-



Note

- ▶ Set the LICCON overload protection in the set up program, see Crane operating instructions, chapter 4.02.
-

- ▶ Press the program key **P0**.

Result:

- The Set up program is called up.
- ▶ In the monitor display of the Set up program check if the LICCON overload protection is set according to the data in the load chart and the actual set up configuration of the crane, see example illustration.

LM

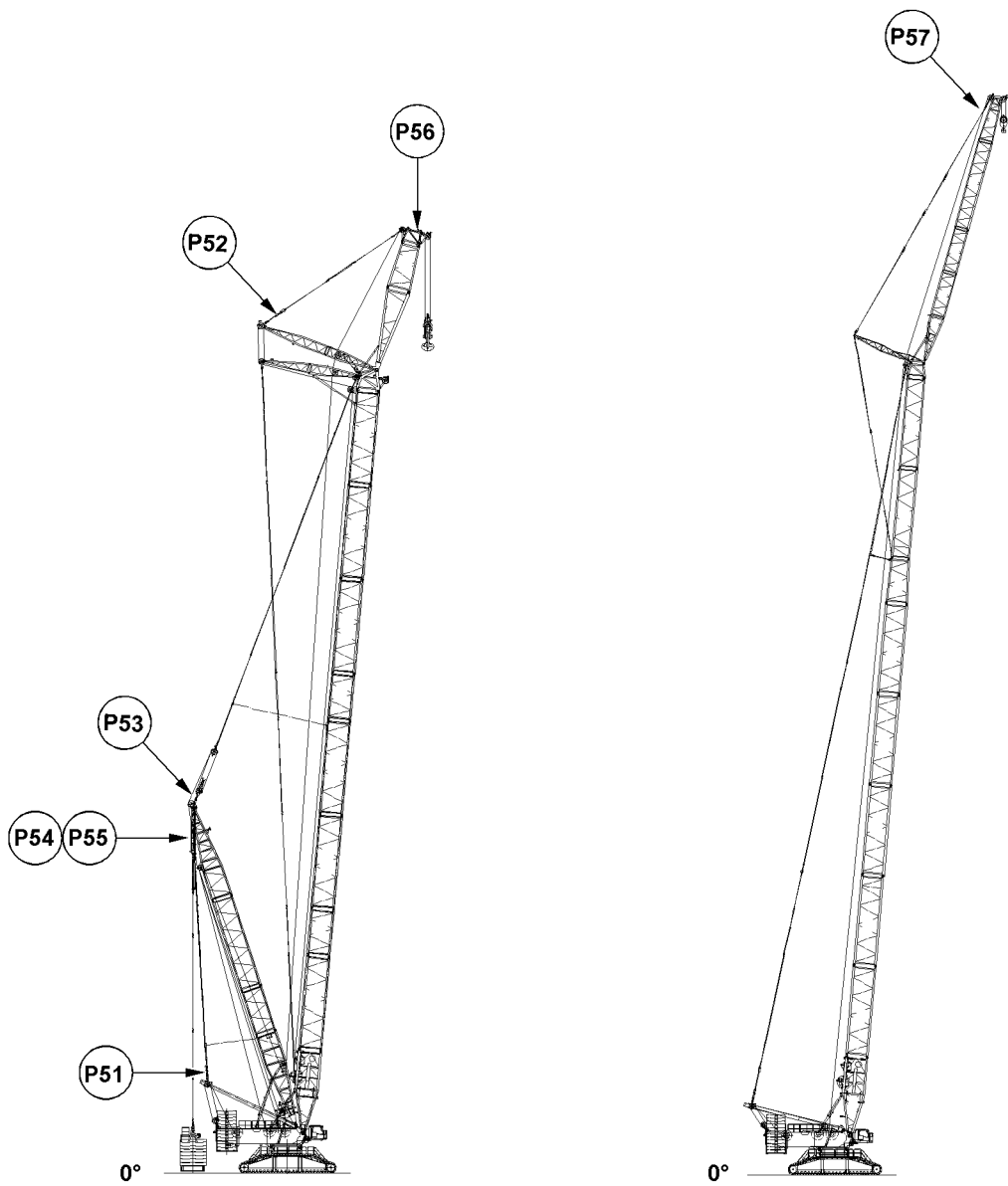
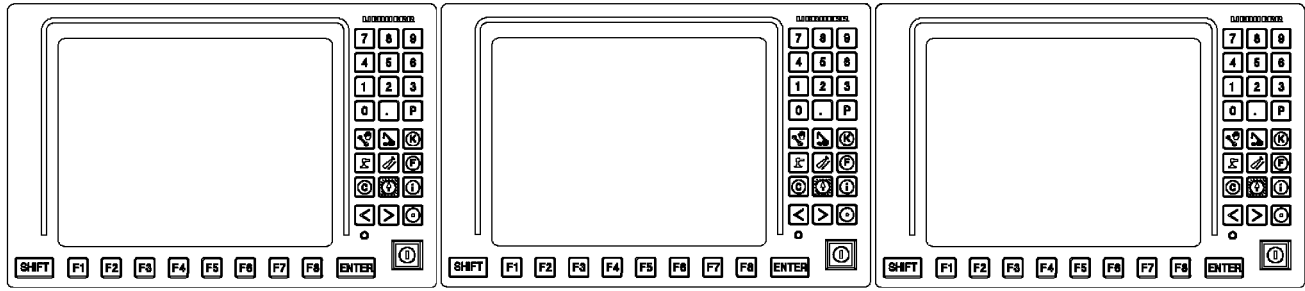

Fig.122806

LWE/LR 11000-001/23501-04-02/en

7.3 F-load display for operating modes with derrick ballast

Assignment of test points for operating modes with derrick ballast:

- Force in the guying between A-frame and derrick head:
 - Test point 1 on point **P51** = force F1
 - The display is made in the F-load display in the center LICCON monitor **LM**.
- Force in the guying between WA-frame and accessory head:
 - Test point 2 on point **P52** = force F2
 - The display is made in the F-load display in the center LICCON monitor **LM**.
Note: Only for the respective boom system.
- Force in the guying between the main boom head and the derrick head:
 - Test point 3 on point **P53** = force F3
 - The display is made in the F-load display in the center LICCON monitor **LM**.
- Force in the guying between derrick ballast and derrick head:
 - Test point 4/5 on point **P54/55** = force F4/5
 - The display is made in the display of the derrick ballast in the left LICCON monitor **LM**.
- Force on the pressure test bracket boom nose:
 - Test point 6 on point **P56** = force F6
 - The display is made in the actual load display in the right LICCON monitor **LM**.
Note: Only with existing boom nose.
- Force in the guying between the FA-frame and the accessory head:
 - Test point 11 on point **P57** = force 11
 - The display is made in the actual load display in the center LICCON monitor **LM**.
Note: Only for the respective boom system



Note

- ▶ For a detailed description of the displays for crane operation with derrick ballast, see the Crane operating instructions, chapter 4.02.



WARNING

Overloading / toppling of the crane!

If the permissible display values of the F-load display are exceeded / fallen below, then the crane can be overloaded.

This could result in serious accidents.

- ▶ Observe and adhere to the display values on the LICCON monitors.
- ▶ Observe and adhere to the specifications regarding the limit values on the assembly drawings.



Note

The values of the F-load display depend on the set up configuration of the crane and the crane geometry.

The values of the F-load display change continuously when the crane is moved.

- ▶ Monitor the F-load display continuously.

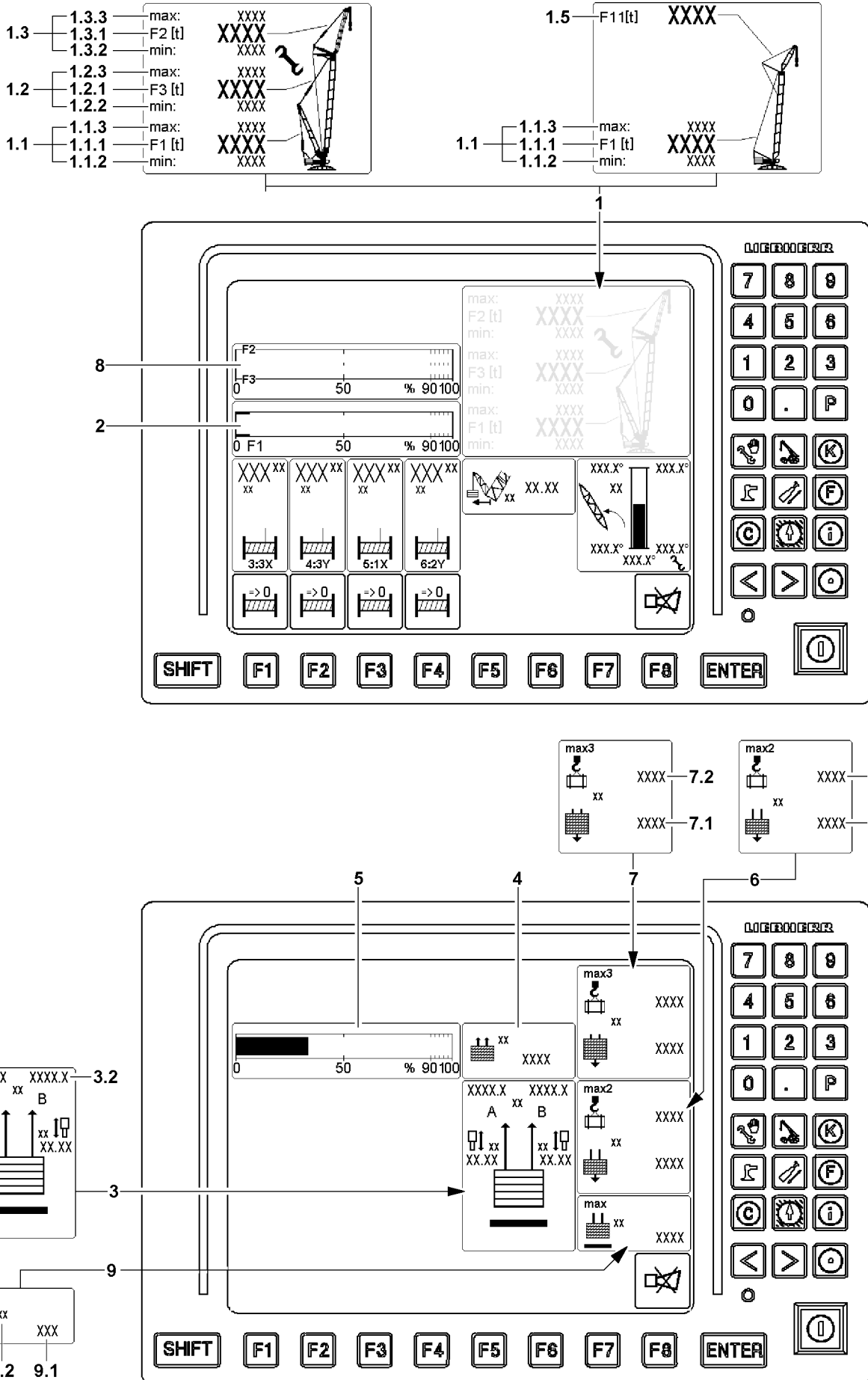

Fig.146967

LWE/LR 11000-001/23501-04-02/en

7.3.1 Force F1 (test point 1)

The force F1 (test point MS1) is determined in the guying between the A-frame and the derrick head and displayed in the LICCON monitor as operating force $F1_{\text{actual}}$.

Display values of force F1 (test point MS1) on the F-load display **1**:

- F1-maximum ($F1_{\text{max}}$) **1.1.3** = maximum value F1-force
- F1-actual value ($F1_{\text{actual}}$) **1.1.1** = actual value F1-force (operating force F1)
- F1-minimum ($F1_{\text{min}}$) **1.1.2** = minimum value F1-force

Structure of the F1-utilization bar **2**:

- Ratio of operating force $F1_{\text{actual}}$ to F1 maximum force

7.3.2 Force F2 (test point 2) and force F3 (test point 3)

The force F2 (test point 2) is determined between the WA-frame and the accessory head and displayed in the LICCON monitor as operating force $F2_{\text{actual}}$. A display is made only with the respective boom system.

The force F3 (test point 3) is determined between the main boom head and the derrick head and displayed in the LICCON monitor as operating force $F3_{\text{actual}}$.

Display values of force F2 (test point MS2) in the F-load display **1**:

- F2-maximum ($F2_{\text{max}}$) **1.3.3** = maximum value F2-force
- F2-actual value ($F2_{\text{actual}}$) **1.3.1** = actual value F2-force (operating force F2)
- F2-minimum ($F2_{\text{min}}$) **1.3.2** = minimum value F2-force

Display values of force F3 (test point MS3) in the F-load display **1**:

- F3-maximum ($F3_{\text{max}}$) **1.2.3** = maximum value F3-force
- F3-actual value ($F3_{\text{actual}}$) **1.2.1** = actual value F3-force (operating force F3)
- F3-minimum ($F3_{\text{min}}$) **1.2.2** = minimum value F3-force

Composition of the F2 / F3-utilization bar **8**:

- Ratio of operating force $F2_{\text{actual}}$ to F2 maximum force $F2_{\text{max}}$
- Ratio of operating force $F3_{\text{actual}}$ to F3 maximum force $F3_{\text{max}}$
- The F2/F3-utilization bars **8** appear only in assembly operation

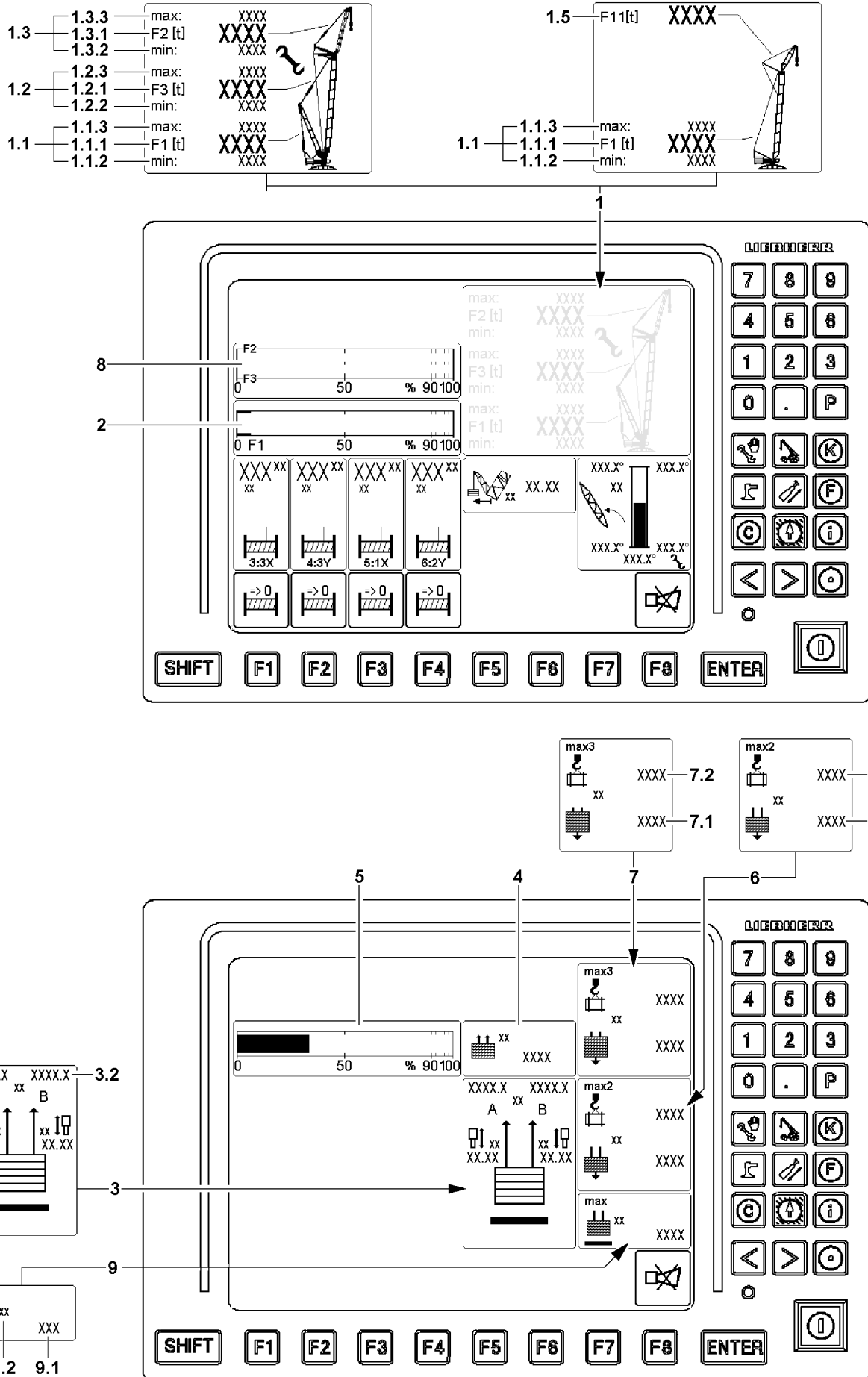

Fig.146967

LWE/LR 11000-001/23501-04-02/en

7.3.3 Force F4/5 (test point 4/5)

The forces F4/5 (test point 4/5) are effective in the guy rods from the derrick ballast to the derrick head.

The existing forces in the guy rods are calculated from four pressure sensors, which are installed on the pull cylinders.

Test points guying A (left) are:

- Test point 4A = pressure sensor ring surface left (force F4A)
- Test point 5A = pressure sensor piston surface left (force F5A)

Test points guying B (right) are:

- Test point 4B = pressure sensor ring surface right (force F4B)
- Test point 5B = pressure sensor piston surface right (force F5B)

Display values of force F4/5 (test point 4/5) in icon Guying derrick ballast **3**:

- Force in the derrick ballast guying A **3.1**
- Force in the derrick ballast guying B **3.2**

Display values derrick ballast:

- Currently pulled derrick ballast = BA_{pulled} **4**
- Current utilization of derrick ballast = Utilization bar derrick ballast **5**
- Currently placed derrick ballast = BA_{placed} **6.1**

From the sum of derrick ballast guying A **3.1** and derrick ballast guying B **3.2** is the pulled derrick ballast BA_{pulled} **4** calculated.

If the ballast still has ground contact, then only that part of the ballast is displayed which is pulled up by the D-guying. The remaining part is laying correspondingly on the ground.

Composition of utilization bar derrick ballast **5**:

- Ratio of pulled derrick ballast (BA_{pulled} **4**) to placed derrick ballast (BA_{placed} **6.1**)

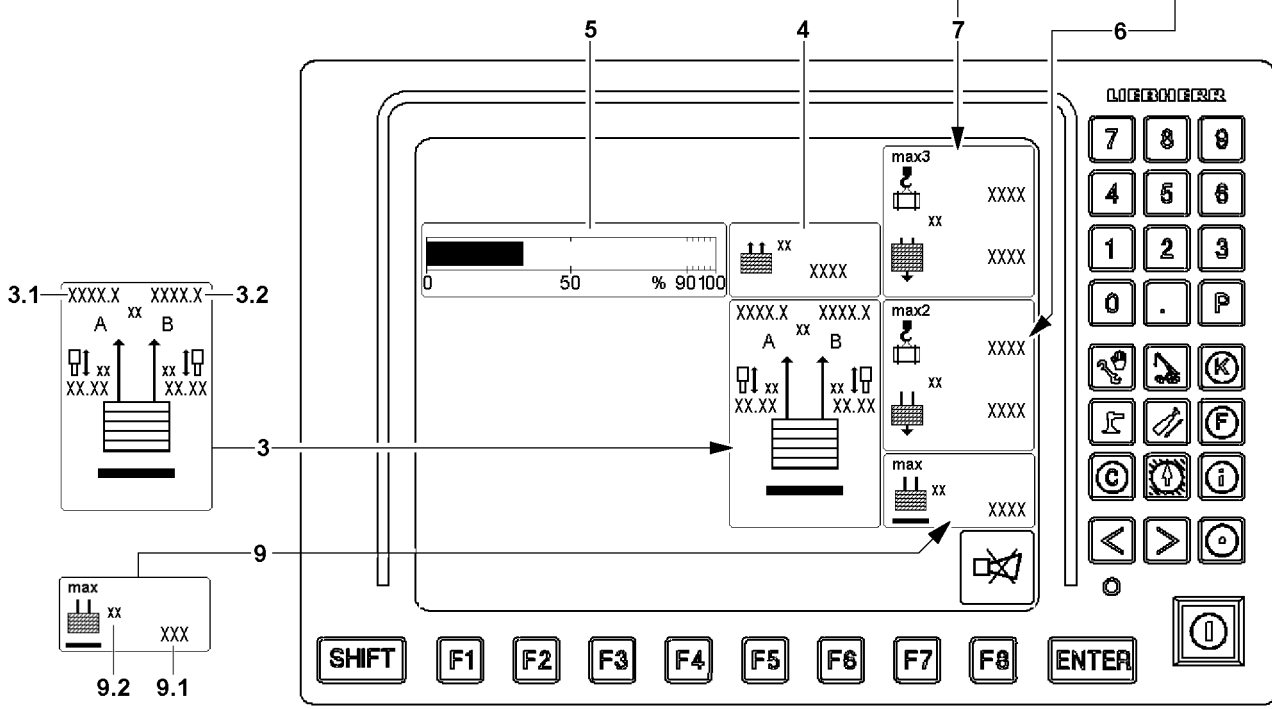
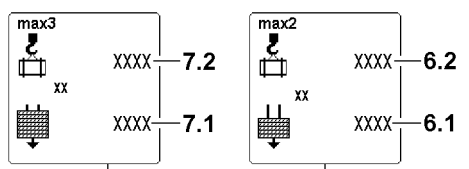
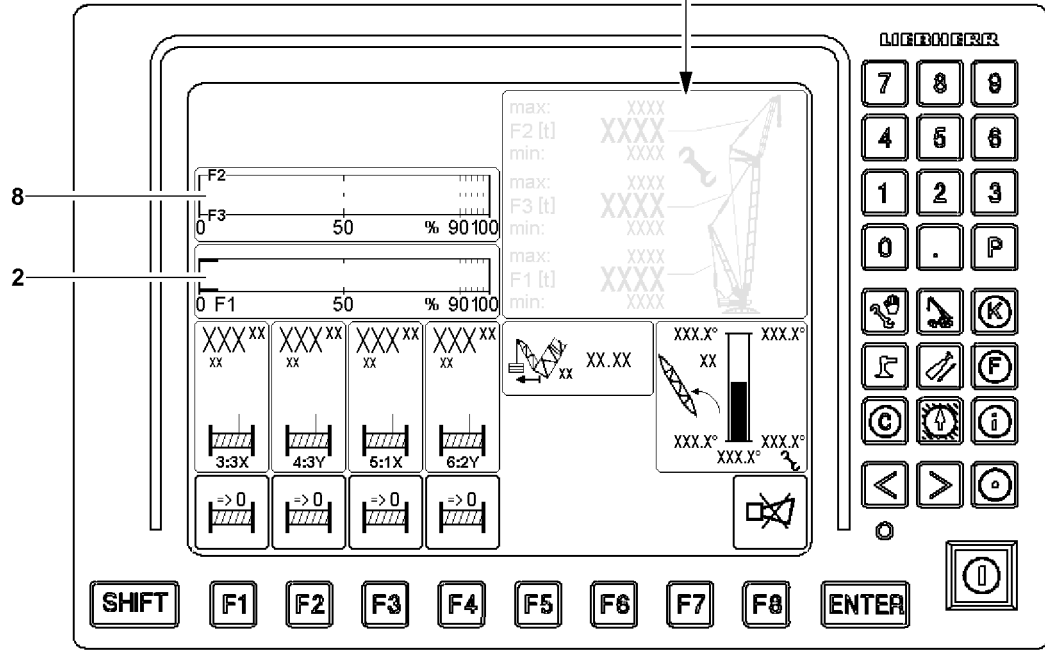
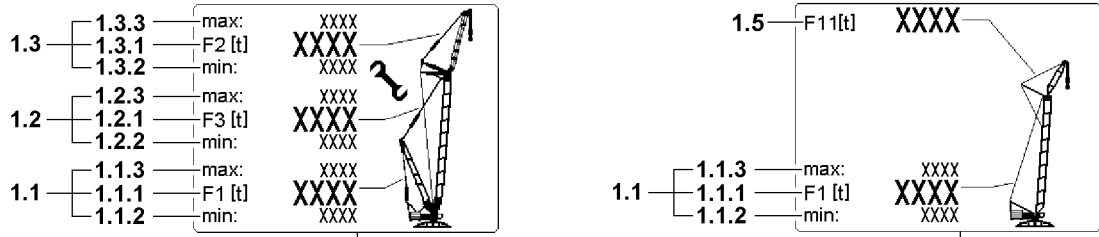

Fig.146967

LWE/LR 11000-001/23501-04-02/en

7.3.4 Maximum liftable derrick ballast

The *maximum liftable derrick ballast* **9** refers to the current crane condition and indicates the maximum derrick ballast that can be lifted off the ground with the pull cylinder or off the suspended ballast palette in case of the VarioTray without falling below the $F_{1_{\min}}$ force.

- **9** *Maximum liftable derrick ballast* icon
- **9.1** Maximum liftable derrick ballast
 - Maximum derrick ballast
- **9.2** Measuring unit
 - Measuring unit for display values in the *Pulled derrick ballast* icon **9**: [t] or [lb]

7.3.5 Force F11 (test point 11)

Force in the guying between the FA-frame and the accessory head:

Display values of force F11 (test point MS11) on the F-load display **1**:

- F11-actual value ($F_{11_{\text{actual}}}$) **1.5** = actual value F11-force (operating force F11)

7.3.6 Additional displays

- „Load max2“ icon **6** (see section „Utilization conditions“)
- Currently placed derrick ballast = BA_{placed} (Input value in set up program) **6.1**
- Possible load with currently placed derrick ballast = $Load_{\text{max2}}$ **6.2**
- „Load max3“ icon **7** (see section „Utilization conditions“)
- Maximum derrick ballast according to load chart = BA_{max} **7.1** (Highest value in Set up program)
- Possible load with maximum derrick ballast according to load chart = $Load_{\text{max3}}$ **7.2**

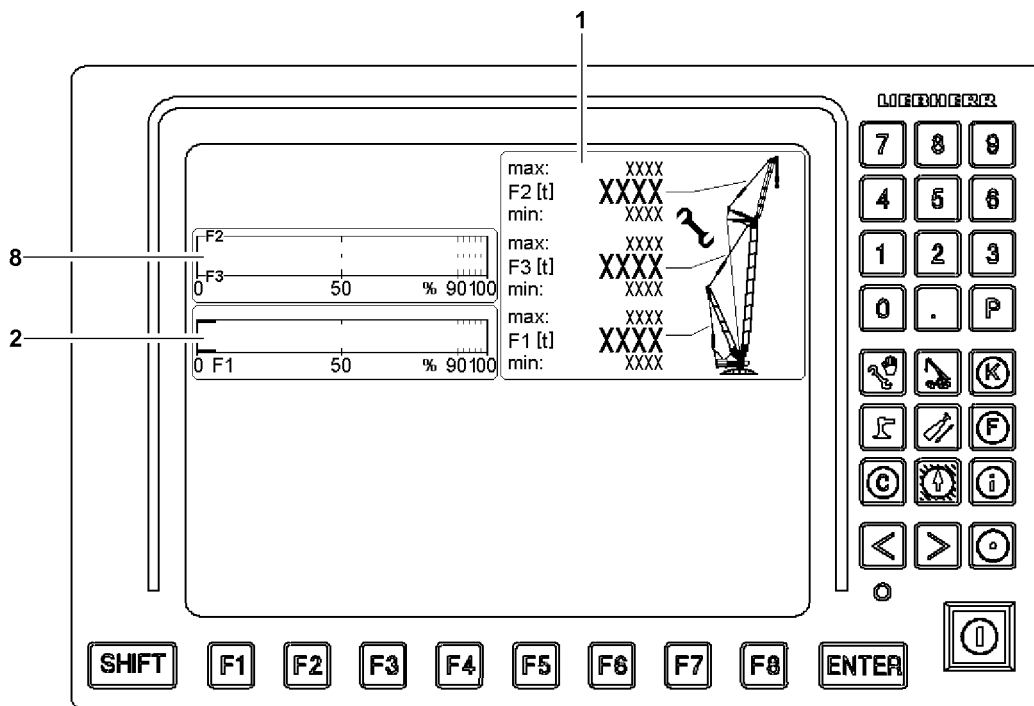
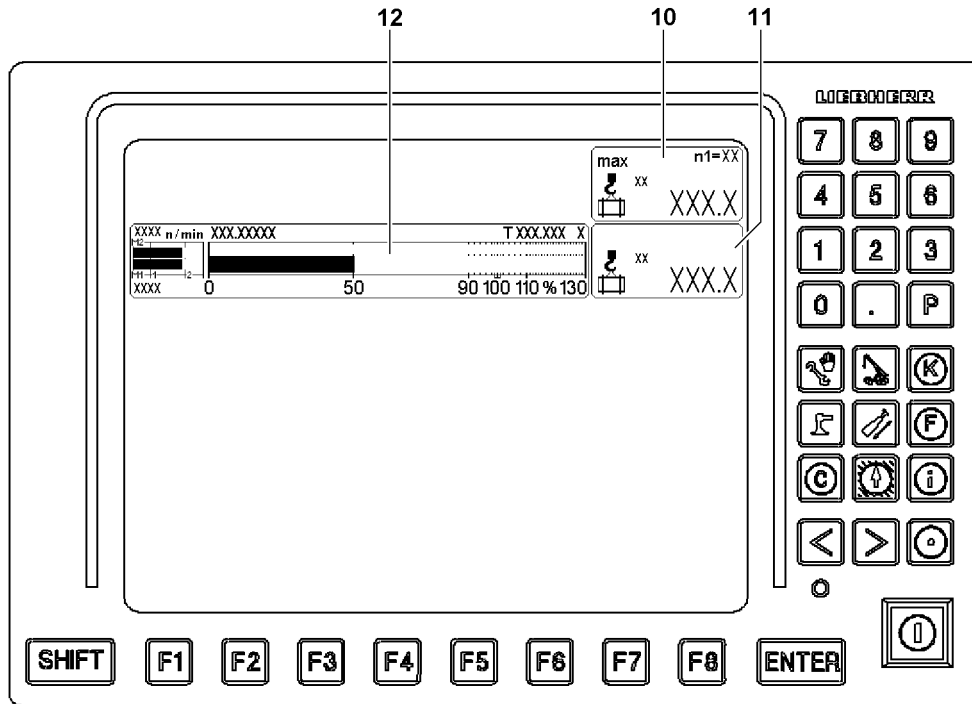

Fig.122808

LWE/LR 11000-001/23501-04-02/en

7.4 Monitoring of crane utilization in operating modes with derrick ballast



Note

- ▶ The icon illustrations of the LICCON monitors are examples and may not match your crane.
- ▶ The icon illustrations of the LICCON monitors can deviate in number, arrangement and depiction of the icons on your crane.
- ▶ Observe the Crane operating instructions, chapter 4.02.



WARNING

Incorrect display values!

If the display values do not increase correspondingly when lifting known weights, an erroneous display value may be present.

If the crane is operated with erroneous display values, then the crane can be overloaded.

This could result in serious accidents.

- ▶ When lifting the hook block off the ground check if the display value for the actual load increases correspondingly.
- ▶ When lifting the derrick ballast off the ground check if the display value for the pulled derrick ballast (BA_{pulled}) increases correspondingly.
- ▶ When lifting the load off the ground check if the display value for the actual load increases correspondingly.

In operating modes with derrick ballast, the monitoring of the crane utilization includes, among others:

1. Monitoring of load torque
Via the „Maximum load“ icon **10**, „Actual load“ icon **11** and the „utilization bar diagram“ **12**.
2. Utilization conditions
Support the crane driver with additional display values.
3. Monitor the F-load display **1**.
Supported by the F1-utilization bar **2** and possibly the F2/F3-utilization bar **8**.

7.4.1 Monitoring of load torque

It monitors the „maximum load according to the load chart and reeving“.

In crane operation, the actual load is compared with the maximum load which may be lifted in the current crane configuration. The display of the values is made in the icon „Maximum load“ **10** and in icon „actual load“ **11**. The current percentage utilization is displayed as „bar diagram utilization“ **12** in the right LICCON monitor.

The color of the utilization bar in the „bar diagram utilization“ **12** also displays the crane utilization:

- Utilization bar blue / green (below 90 %): Utilization in permissible range
- Utilization bar yellow (90 % to 100 %): Advance warning. - Utilization just before impermissible range
- Utilization bar red (above 100 %): Warning. - Utilization in impermissible range



Note

- ▶ Procedure for optimum utilization of „maximum load according to load chart and reeving“, see section „Utilization conditions“.



Fig.122809

**WARNING**

Access the functionality of the LICCON overload protection!

When accessing the functionality of the LICCON overload protection by activating assembly operation, the LICCON overload protection is totally deactivated, bypassed or limited.

It is possible to exceed several shut-off limits of the LICCON overload protection simultaneously or one after the other.

It is possible to carry out crane movements, which are not monitored by the LICCON overload protection.

Without the LICCON overload protection, no additional protection against overload of the crane via the crane control is present.

This could result in serious accidents.

- ▶ When accessing the functionality of the LICCON overload protection, take into account that the LICCON overload protection is deactivated totally or is limited.
- ▶ When accessing the functionality of the LICCON overload protection, the Crane operating instructions, chapter 4.02 must be observed.

**WARNING**

The crane can topple over!

In assembly operation the LICCON overload protection is deactivated.

In the event of deliberate improper use, the crane could collapse, the boom can break off or the crane can topple over.

Personnel can be killed.

This could result in high property damage.

- ▶ Activate the assembly operation only when the consequences are known.
- ▶ Enter the set up configuration correctly into the LICCON computer system.
- ▶ Observe the erection / take down charts.
- ▶ Crane operation with deactivated LICCON overload protection is prohibited.
- ▶ In assembly operation only load torque reducing crane movements may be carried out until a permissible operating and load range.
- ▶ The crane operator carries complete and sole responsibility for his actions if the LICCON overload protection is deactivated.

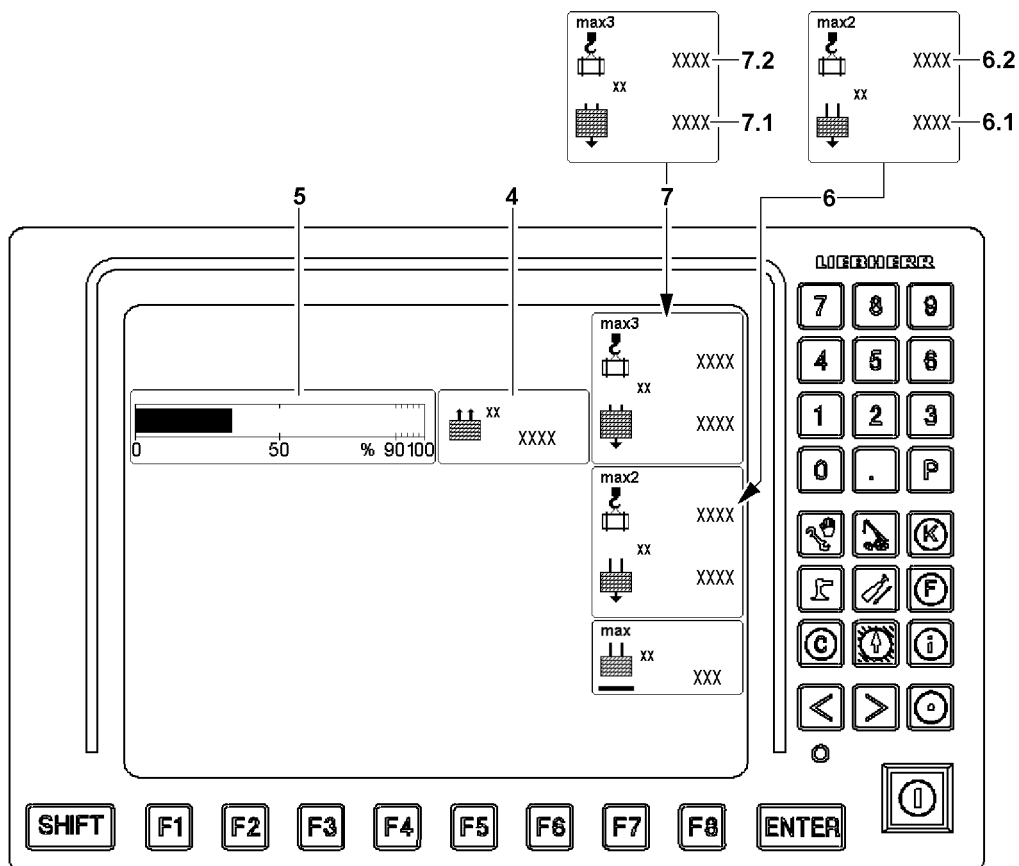
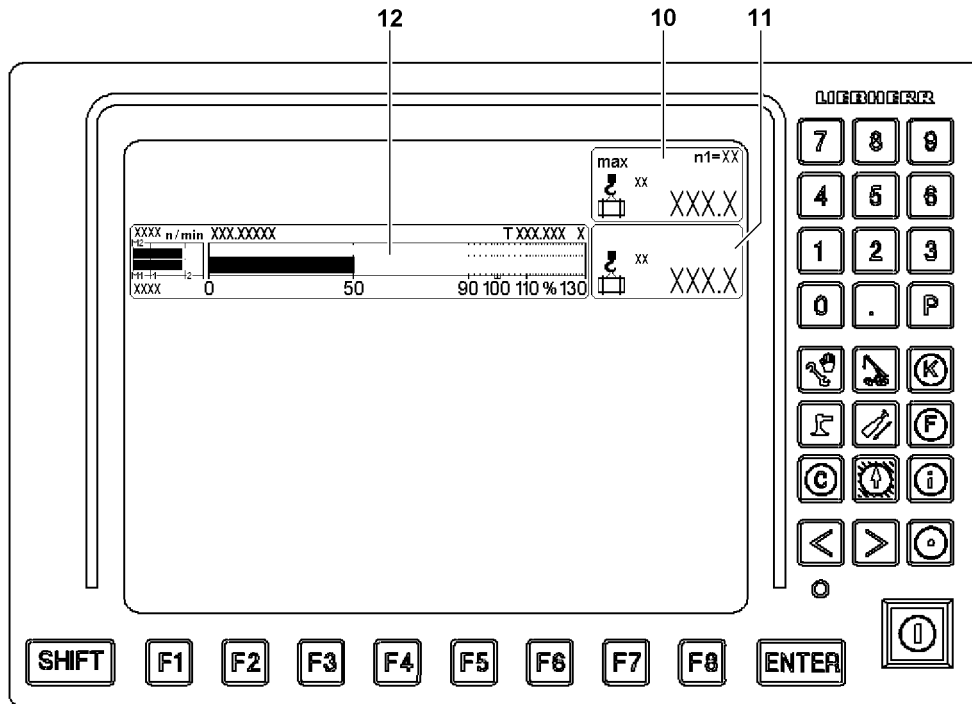

Fig.146966

LWE/LR 11000-001/23501-04-02/en

7.4.2 Utilization conditions

The current percentage utilization of the crane is displayed as „bar diagram utilization“ **10** in the right LICCON monitor.

Additional displays:

- **6** „Load max2“ icon
 - Currently placed derrick ballast = BA_{placed} (Input value in set up program) **6.1**
 - Possible load with currently placed derrick ballast = $\text{Load}_{\text{max2}}$ **6.2**
- **7** „Load max3“ icon
 - Maximum derrick ballast according to load chart = BA_{max} **7.1** (Highest value in Set up program)
 - Possible load with maximum derrick ballast according to load chart = $\text{Load}_{\text{max3}}$ **7.2**

Maximum load, right LICCON monitor:

- The maximum load in the current operating condition is reached when the utilization bar shows 100 % in the „bar diagram utilization“ **12**.
This is the case when the „utilization of the crane according to the load chart and reeving“ reaches 100 % (Values in icon „Maximum load“ **10** and in icon „actual“ **11** are equal).
When the „Maximum load“ **10** is smaller or the same as the $\text{load}_{\text{max2}}$ **6.2**, then an increase might possibly be obtained:
 - By increasing the pulled derrick ballast BA_{pulled} **4**, if the utilization bar derrick ballast **5** is not yet at 100 % (derrick ballast not suspended).
 - By increasing the derrick ballast when the BA_{placed} **6.1** is smaller than BA_{max} **7.1**.
 - By changing the derrick ballast radius within the permissible range, see load chart manual or LICCON job planner.

max2-load, icon „load max2“ **6**:

- The highest possible load in current operating condition „**max2-load**“ is reached when in the „bar diagram utilization“ **12** 100 % is shown **and** the utilization bar derrick ballast **5** is at 100 % (Derrick ballast is completely lifted off the ground).
This is the case when the value in icon „Actual load“ **11** is the same as the $\text{load}_{\text{max2}}$ **6.2**.
When the $\text{load}_{\text{max2}}$ **6.2** is smaller or the same as the $\text{load}_{\text{max3}}$ **7.2**, then an increase might possibly be obtained:
 - By increasing the derrick ballast by loading additional ballast plates (increase BA_{placed} **6.1** to BA_{max} **7.1**).

max3-load, icon „load max3“ **7**:

- The highest possible load at the maximum derrick ballast in current operating condition „**max3-load**“ is reached when the „bar diagram utilization“ **12** displays 100 % **and** the utilization bar derrick ballast **5** is at 100 % (Derrick ballast according to load chart is placed and is completely lifted off the ground).
This is the case when the value in icon „Actual load“ **11** is the same as the $\text{load}_{\text{max3}}$ **7.2**.
- The maximum derrick ballast according to the load chart is placed and completely pulled.
Further increase of the derrick ballast is impermissible.



Fig.122809

7.4.3 Monitoring of F1-maximum force

Display values of force F1 (test point MS1) on the F-load display 1:

- F1-maximum ($F1_{\max}$) **1.1.3** = maximum value F1-force
- F1-actual value ($F1_{\text{actual}}$) **1.1.1** = actual value F1-force (operating force F1)
- F1-minimum ($F1_{\min}$) **1.1.2** = minimum value F1-force

The display values of force F1 (test point 1) are displayed permanently in the LICCON monitor. At F1-actual value ($F1_{\text{actual}}$) **1.1.1** larger F1-maximum ($F1_{\max}$) **1.1.3** a shut off of all load moment increasing movements occurs.



WARNING

Access the functionality of the LICCON overload protection!

When accessing the functionality of the LICCON overload protection by activating assembly operation, the LICCON overload protection is totally deactivated, bypassed or limited.

It is possible to exceed several shut-off limits of the LICCON overload protection simultaneously or one after the other.

It is possible to carry out crane movements, which are not monitored by the LICCON overload protection.

Without the LICCON overload protection, no additional protection against overload of the crane via the crane control is present.

This could result in serious accidents.

- ▶ When accessing the functionality of the LICCON overload protection, take into account that the LICCON overload protection is deactivated totally or is limited.
- ▶ When accessing the functionality of the LICCON overload protection, the Crane operating instructions, chapter 4.02 must be observed.



Note

The limit value for the F1-maximum force depends not only on the set up configuration and the crane geometry, but also from the pulled derrick ballast.

- ▶ If the pulled derrick ballast is larger, then the limit value for the F1-minimum force is generally reduced.
- ▶ If the pulled derrick ballast is smaller, then the limit value for the F1-maximum force is generally increased.



Note

By engaging the assembly operation the limit value for the F1-maximum force can be exceeded by a few tons. This makes it possible to reset a crane movement, which has caused the shut off.

- ▶ Reset triggered shut off by reverse crane movement.



Fig.122809

7.4.4 Monitoring of F1-minimum force

Display values of force F1 (test point MS1) on the F-load display 1:

- F1-maximum ($F1_{\max}$) **1.1.3** = maximum value F1-force
- F1-actual value ($F1_{\text{actual}}$) **1.1.1** = actual value F1-force (operating force F1)
- F1-minimum ($F1_{\min}$) **1.1.2** = minimum value F1-force



WARNING

Uncontrolled movements of the boom system!

If the guying between the A-frame and the derrick head (test point 1) becomes powerless, then this can lead to uncontrollable movements of the boom system.

This could result in serious accidents.

- ▶ The guying between the A-frame and the derrick head (test point 1) may never be without power.
- ▶ Relieve the D-guying between the derrick head and the derrick ballast to the point where the F1-actual value ($F1_{\text{actual}}$) **1.1.1** is larger than the F1-minimum ($F1_{\min}$) **1.1.2**.



WARNING

Access the functionality of the LICCON overload protection!

When accessing the functionality of the LICCON overload protection by activating assembly operation, the LICCON overload protection is totally deactivated, bypassed or limited.

It is possible to exceed several shut-off limits of the LICCON overload protection simultaneously or one after the other.

It is possible to carry out crane movements, which are not monitored by the LICCON overload protection.

Without the LICCON overload protection, no additional protection against overload of the crane via the crane control is present.

This could result in serious accidents.

- ▶ When accessing the functionality of the LICCON overload protection, take into account that the LICCON overload protection is deactivated totally or is limited.
- ▶ When accessing the functionality of the LICCON overload protection, the Crane operating instructions, chapter 4.02 must be observed.



Note

By engaging the assembly operation the limit value for the F1-minimum force can be fallen below by a few tons. This makes it possible to reset a crane movement, which has caused the shut off.

- ▶ Reset triggered shut off by reverse crane movement.



Fig.122809

**WARNING**

Autonomous movement of the boom system at increase of load torque!

If the F1-minimum force is fallen below, the guying between the A-frame and the derrick head can become powerless.

If the guying between the A-frame and the derrick head is powerless and the „Derrick ballast is on the ground“ at the same the derrick ballast can suddenly lift off the ground due to increase of the load torque.

As a result, the boom system can move forward suddenly. Strong oscillating movements of the derrick ballast and load can be the result.

The crane can be overloaded and severe accidents can be the result.

- ▶ Hold the F1-actual value ($F1_{actual}$) **1.1.1** above the F1-minimum ($F1_{min}$) **1.1.2**.
- ▶ It is prohibited to fall below the F1-minimum force.

**WARNING**

Autonomous movement of the boom system at decrease of load torque!

If the F1-minimum force is fallen below, the guying between the A-frame and the derrick head can become powerless.

If the guying between the A-frame and the derrick head is powerless and the „derrick ballast is suspended“ at the same time, the derrick ballast can suddenly set down on the ground due to decrease of the load torque.

As a result, the boom system can move suddenly backward. As a result, the relapse cylinders can be pressed on the block, be overloaded and damaged. Strong oscillating movements of the derrick ballast and load can be the result.

The crane can be overloaded and severe accidents can be the result.

- ▶ Hold the F1-actual value ($F1_{actual}$) **1.1.1** above the F1-minimum ($F1_{min}$) **1.1.2**.
- ▶ It is prohibited to fall below the F1-minimum force ($F1_{min}$).

The following applies:

- After a shut off due to falling below the F1-minimum ($F1_{min}$) **1.1.2** the F1-actual value ($F1_{actual}$) **1.1.1** must be increased by a crane movement. If the derrick ballast is suspended, this can be achieved by setting down the ballast.
- When picking up the load, the D-guying between the derrick ballast and the derrick head must be relieved to the point where the F1-actual value ($F1_{actual}$) **1.1.1** is greater than the F1-minimum ($F1_{min}$) **1.1.2**.
- When increasing the load torque, and the limit value F1-minimum ($F1_{min}$) **1.1.2** is fallen below, an already set down derrick ballast can lose contact with the ground and lift off.
- When decreasing the load torque, and the limit value F1-minimum ($F1_{min}$) **1.1.2** is fallen below, an already „suspended derrick ballast“ can set down on the ground.
- If the assembly operation is activated and the F1-force continues to drop below the minimum force $F1_{min}$, then the $F1_{min}$ shut off can no longer be bypassed.

Limitations from 50 % pulled derrick ballast

If more than 50 % of the set derrick ballast is being pulled (utilization bar derrick ballast **5** larger than 50 %) and the F1-minimum ($F1_{min}$) **1.1.2** is fallen below at the same time, all crane movements that increase load torque are turned off.

Limitations from 90 % pulled derrick ballast

If more than 90 % of the set derrick ballast is being pulled (utilization bar derrick ballast **5** larger than 90 %) and the F1-minimum ($F1_{min}$) **1.1.2** is fallen below at the same time, all crane movements that increase load torque and all crane movements that decrease load torque are turned off. This also turns off the „spooling out“ movement of the winch.

7.5 Monitoring of pull cylinders on block position

The pull cylinders (also called ballast lift cylinders) of the derrick ballast are equipped with length sensors and limit switches for monitoring.

In crane operation, the monitoring of the pull cylinders on block position is always active. If there is the danger of a block position, then only that direction of the pull cylinders can be moved which improves the condition. The other direction is unbyypassably blocked. As long as the length sensors and the limit switches function correctly, the pull cylinders cannot get into a block position.



WARNING

Problem at monitoring of pull cylinders!

If the length sensors or limit switches are defective or missing, then the monitoring of the pull cylinders is not active.

Without monitoring, the pull cylinders can be moved without restriction, as a result, a block position is possible.

At a block position, the pressure measurements of the pull cylinders become inexact and the values are incorrectly calculated.

The overload protection calculates the actual load incorrectly and transmits faulty display values.

The crane can be overloaded and topple over.

This could result in serious accidents.

- ▶ Observe the display values and possible error messages.
- ▶ If length sensors or limit switches are defective or missing, monitor the pull cylinders manually.

The following applies:

- The display values of the pull cylinders must function and be plausible.

7.6 Monitoring the lateral incline of the ballast pallet

The ballast pallet is equipped with an incline sensor for monitoring.

The monitoring to $\pm 2.5^\circ$ lateral incline of the ballast pallet is always active. If a lateral incline of $\pm 2.5^\circ$ is reached, then only those directions of the pull cylinders can be moved which improve the condition. The other directions are unbyypassably blocked. The ballast can be set down for that reason only to a maximum incline of the terrain of 2.5° .



WARNING

Defective incline sensor!

If an incline sensor is defective or missing, the monitoring of the lateral incline of the suspended ballast is not active.

The pull cylinders can be moved without restriction and the derrick ballast can be overturned as a result.

This could result in serious accidents.

- ▶ Observe the display values and possible error messages.
- ▶ If an incline sensor is defective, monitor the lateral incline of the derrick ballast manually.

The following applies:

- The display values of the lateral incline of the derrick ballast must function and be plausible.

7.7 Differential force monitoring for derrick ballast-guying

In operating modes with derrick ballast the forces of the derrick ballast guyings A and B are displayed in the LICCON monitor.



WARNING

Danger of accident!

If the forces in the derrick ballast guyings A and B are too high, then this can lead to an overload of the crane. Components can fail and severe accidents can be the result.

- ▶ Load the derrick ballast guyings A and B evenly.

After reaching the specified limit value of the difference force threshold, the displays of the pulled ballast of pull cylinder A and B blink and become red, the function ballast up / down is stopped. The difference force must be lowered again.

If the difference of the forces of the derrick ballast guying A and B exceeds the limit value, then this can have various causes:

- Flexing of the turntable.
- The ground under the derrick ballast is uneven.
- The crane is leaning to one side.
- The derrick ballast is loaded one-sided.
- The force measurement in one D-guying is incorrect.

The crane driver must recognize the correct cause and take countermeasures:

- The error, which caused the one-sided force, must be remedied.
- If the sensor values are implausible: Stop crane operation and find the cause and remedy it.

7.7.1 Bypassing the shut off of the function ballast up / down

- The following measures are permitted providing the ground is only slightly uneven: Control the individual pull cylinders in such a way that the difference between the forces becomes smaller. Ensure that the derrick ballast is not tilted at an inadmissible angle with respect to the crane, otherwise the derrick ballast guide and attachments will be damaged.
- ▶ Carry out the following: Activate assembly operation, see Crane operating instructions, chapter 4.02.

Result:

- The shut off of the function ballast up / down is bypassed.
- On the left LICCON monitor appears an assembly icon.
- ▶ Press the button Ballast „up“ or button Ballast „down“ **and** the stop button on the desired side at the same time, see section „Lifting / setting down / equalizing the derrick ballast“.

Problem remedy

The display of the entire pulled ballast is shown blinking red. An LMB-Stop was triggered. All crane functions were stopped.

The crane driver has moved the pull cylinders into the incorrect direction and further exceeded the limit value for the difference force threshold.

- ▶ Move the pull cylinders again into the correct (other) direction and align the ballast in such a way that the displays of the pulled ballast of pull cylinder A and B are again in the permissible range.

- ▶ Activate assembly operation again.

Result:

- The shut off of the function ballast up / down is bypassed again.
- All other crane functions are still suppressed.
- ▶ Move the pull cylinders into the correct direction.



DANGER

Overload of crane!

If the pull cylinders are moved into the incorrect direction after a new bypass of the function ballast up / down, the crane will be overloaded.

This could result in serious accidents.

- ▶ Monitor the display values and move the pull cylinders in the correct direction (values of pull cylinder A and B become closer).
- ▶ If unsure: Contact Liebherr Service.
- ▶ Find the error and remedy it which caused the shut off of the function „Ballast up / down“.

7.8 Carrying out crane movements



Note

- ▶ For an overview of the displays in the LICCON monitors, see Crane operating instructions, chapter 4.02.



WARNING

Incorrect display values!

If the display values do not increase correspondingly when lifting known weights, an erroneous display value may be present.

If the crane is operated with erroneous display values, then the crane can be overloaded.

This could result in serious accidents.

- ▶ When lifting the hook block off the ground check if the display value for the actual load increases correspondingly.
- ▶ When lifting the derrick ballast off the ground check if the display value for the pulled derrick ballast BA_{pulled} increases correspondingly.
- ▶ When lifting the load off the ground check if the display value for the actual load increases correspondingly.



WARNING

The crane can topple over!

The jerky execution or braking of turning maneuvers can cause the load and / or suspended ballast to swing.

If the load and / or the suspended ballast collides with obstacles then the crane can be damaged or impeded.

Oscillating movements, damage or impediments can cause the crane to topple over.

This could result in serious accidents.

- ▶ Initiate or slow down crane movements with load and / or suspended derrick ballast extremely sensitively.
- ▶ There may be no persons and / or objects within the working range / danger zone of the crane.
- ▶ During crane operation additional personnel (guide) must monitor and secure the working range / danger zone of the crane from a safe position.



WARNING

Danger of accident due to unsafe ground!

If the crane is operated on insufficient ground, there is a danger of accident.

- ▶ The ground in the entire working area of the crane must be level and of sufficient load carrying capacity, in order to be able to securely accept the encountered surface pressures.
- ▶ Before setting down the load or the derrick ballast, the crane operator must make sure that the intended placement surface is suitable. A safe set down of load and derrick ballast must be ensured.



WARNING

Uncontrolled movements of the boom system!

If the guying between the A-frame and the derrick head (test point 1) becomes powerless, then this can lead to uncontrolled movements of the boom system.

This could result in serious accidents.

- ▶ The guying between the A-frame and the derrick head (test point 1) may never be without power.

**WARNING**

Danger of accidents due to angular pull!

Due to angular pull of load or derrick ballast impermissible side forces are directed into the crane. Impermissible side forces can cause failure of the components or a dangerous change of the center of gravity of the crane and / or load, among others.

Crane and load can be severely damaged and topple over.

This could result in serious accidents.

- ▶ Before taking on a load or the derrick ballast, make sure that the derrick ballast, the center of rotation of the turntable and the load are on one line.

**WARNING**

Ballast Constant **not** lifted off the ground!

Ballast Constant drags on the ground and can get caught.

- ▶ Before crane operation: Lift the ballast Constant off the ground.

**WARNING**

Danger of accident!

The placement surface for the ballast plates must be level, horizontal and of sufficient load carrying capacity.

This could result in serious accidents.

- ▶ Check the incline of the crane during the set down procedure.
- ▶ It is strictly prohibited for anyone to stand under the ballast plates or within the entire danger zone during the set down procedure.

Make sure that the following prerequisites are met:

- The test points must be checked before crane operation for functionality.
- The weight of the load to be lifted must be known.
- The support surface / placement surface of the derrick ballast may be maximum 0.25 m above / below the support surface of the crane.
- The support surface / placement surface of the derrick ballast must be level, horizontal and of sufficient load bearing capacity.
- The support surface / placement surface of the derrick ballast must be able to safely absorb the surface pressure.
- There may not be any obstacles in the slewing range of the crane, derrick ballast and load.
- Additional personnel is instructed to monitor and secure the working range / danger zone of the crane from a safe distance.
- A permanent acoustic / visual connection between the crane operator and the additional personnel is available.
- A guide or the crane driver must monitor the lifting and setting down of the derrick ballast and the load.
- The lifted derrick ballast is monitored by a guide or the crane operator.

The following applies:

- When taking up the load, the D-guying between the derrick ballast and the derrick head must be relieved so that the operating force $F_{1_{actual}}$ is larger than the limit value for the F1-minimum force.
- Before taking up the load or the derrick ballast, make sure that the following components are on one line:
 - The load
 - The center of rotation of the turntable
 - The derrick ballast

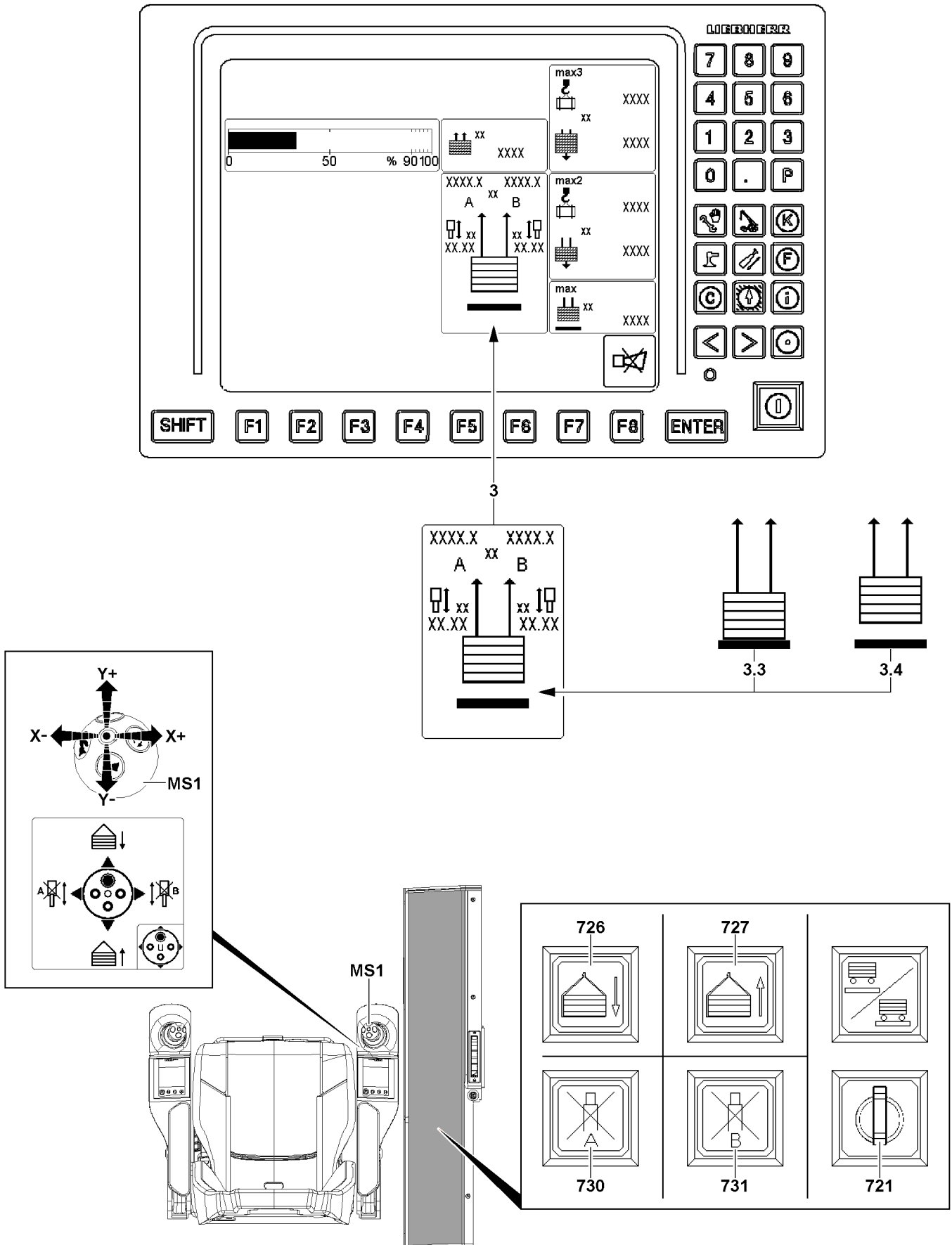

LWE/LR 11000-001/23501-04-02/en

Fig.146964

7.8.1 Lifting / setting down the derrick ballast

The even lifting and set down of the derrick ballast is monitored by the LICCON computer system. Normally the crane operator does not have to do anything. However, if corrective measures or preventative measures should be necessary, observe the following section „Equalizing the derrick ballast“.



WARNING

The crane can topple over!

- ▶ Only carry out the „turning the turntable“ and „driving the crawler“ crane movements when the derrick ballast is completely lifted and hangs free.

Only when the derrick ballast is completely lifted and hangs free:

- ▶ The „derrick ballast lifted“ **3.4** icon may be switched on using the *derrick ballast lifted* key button **721**.

Lifting the derrick ballast

- ▶ Press the button **727**.
or
Deflect the master switch **MS1** in direction **Y-**.

Result:

- The piston rods of the pull cylinders retract together.
- The derrick ballast is raised.

As soon as the derrick ballast is completely lifted and hangs free:

- ▶ Press the *derrick ballast lifted* key button **721**.

Result:

- The „Derrick ballast lifted off“ icon **3.4** appears.
- The „turning the turntable“ and „driving the crawler“ crane movements are released.

Setting down the derrick ballast

As long as the derrick ballast is not completely lifted and hanging free:

- ▶ Press the *derrick ballast lifted* key button **721**.

Result:

- The „Derrick ballast has ground contact“ icon **3.3** appears.
- The „turning the turntable“ and „driving the crawler“ crane movements are blocked.

- ▶ Press the button **726**.
or
Deflect the master switch **MS1** in direction **Y+**.

Result:

- The piston rods of the pull cylinders extend together.
- The derrick ballast is set down.

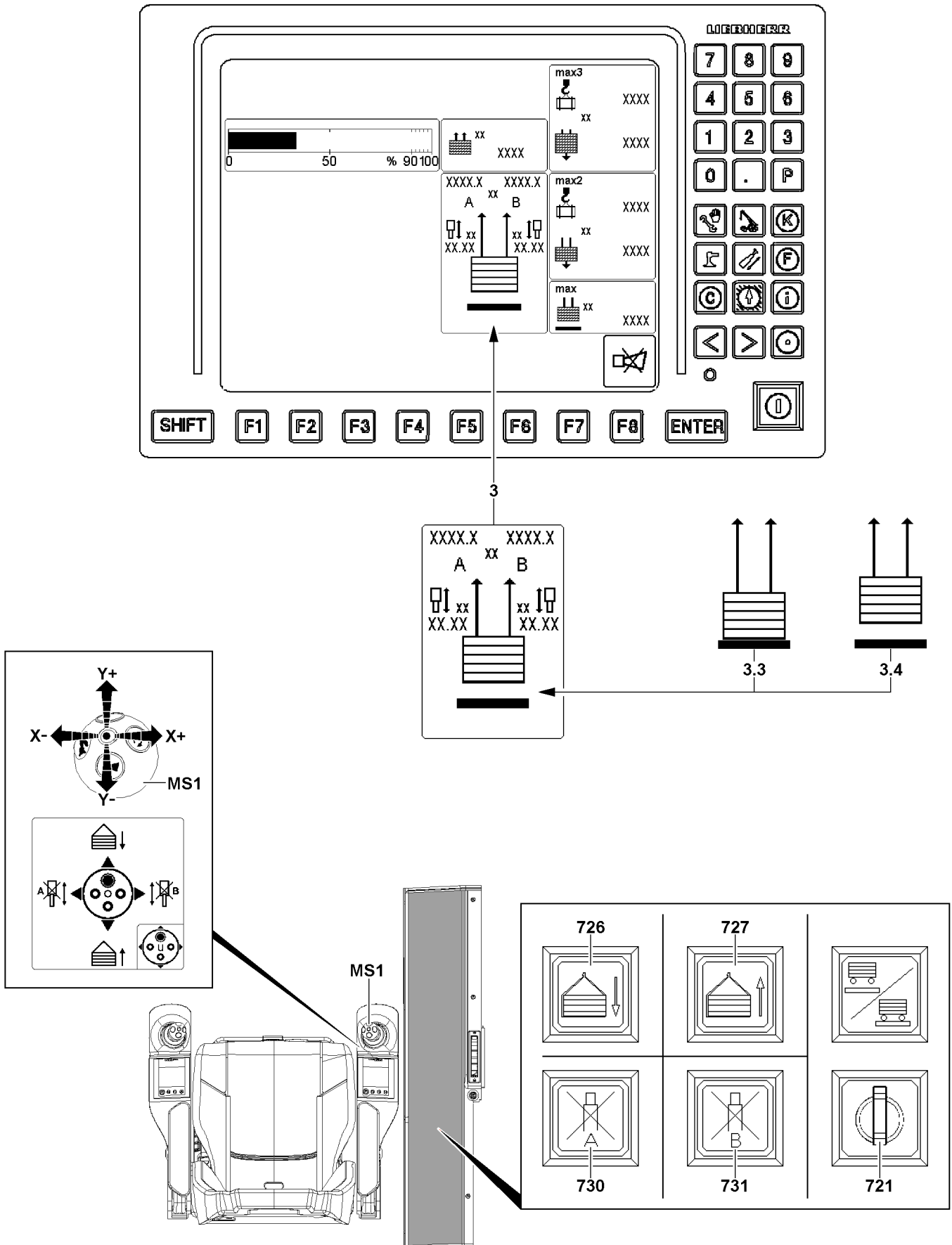

LWE/LR 11000-001/23501-04-02/en

Fig.146964

7.8.2 Equalizing the derrick ballast

The derrick ballast can be equalized with different extension lengths of the pull cylinders.

Block the pull cylinder (A) when lifting:

- ▶ Press the button **727** and the button **730**.

or

Deflect the master switch **MS1** diagonally in direction **X-** and direction **Y-**.

Result:

- The piston rod of the pull cylinder (A) stops.
- The piston rod of pull cylinder (B) moves in.
- Side (B) of the derrick ballast lifts up.

Block the pull cylinder (B) when lifting:

- ▶ Press the button **727** and the button **731**.

or

Deflect the master switch **MS1** diagonally in direction **X+** and direction **Y-**.

Result:

- The piston rod of the pull cylinder (B) stops.
- The piston rod of pull cylinder (A) moves in.
- Side (A) of the derrick ballast lifts up.

Block the pull cylinder (A) when lowering:

- ▶ Press the button **726** and the button **730**.

or

Deflect the master switch **MS1** diagonally in direction **X-** and direction **Y+**.

Result:

- The piston rod of the pull cylinder (A) stops.
- The piston rod of pull cylinder (B) moves out.
- Side (B) of the derrick ballast lowers.

Block the pull cylinder (B) when lowering:

- ▶ Press the button **726** and the button **731**.

or

Deflect the master switch **MS1** diagonally in direction **X+** and direction **Y+**.

Result:

- The piston rod of the pull cylinder (B) stops.
- The piston rod of pull cylinder (A) moves out.
- Side (A) of the derrick ballast lowers.

8 Crawler operation with derrick ballast

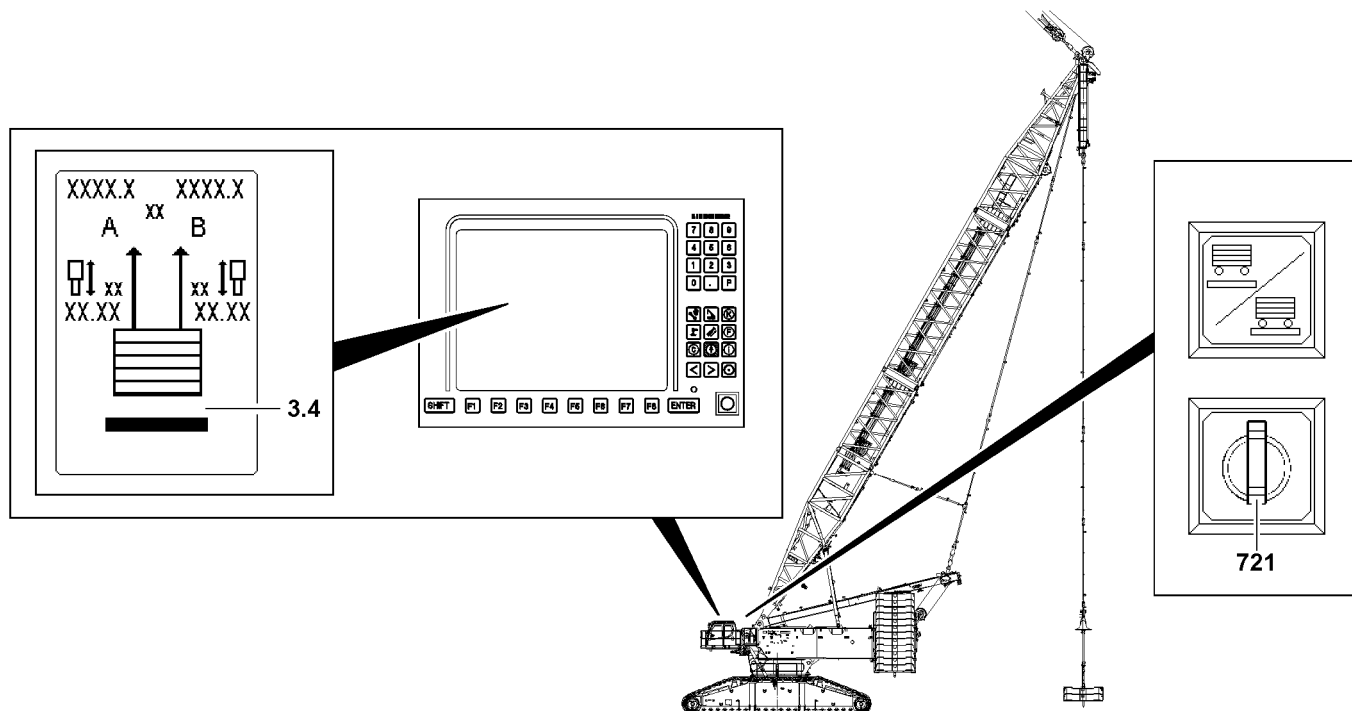

Fig.145933



WARNING

The crane can topple over!

- ▶ Only carry out the „turning the turntable“ and „driving the crawler“ crane movements when the derrick ballast is completely lifted and hangs free.

Only when the derrick ballast is completely lifted and hangs free:

- ▶ The „derrick ballast lifted“ 3.4 icon may be switched on using the *derrick ballast lifted* key button 721.



Note

- ▶ Driving the crawler crane, see the Crane operating instructions, chapter 4.10.

8.1 Driving the crawler

Driving with suspended derrick ballast.

**WARNING**

Suspended load or suspended derrick ballast oscillates too much! Specifications not observed! If the specifications from the Crane operating instructions, chapter 4.10 are **not** observed, there is a danger of accident.

Death, severe bodily injuries, property damage.

- ▶ Observe the specifications in the Crane operating instructions, chapter 4.10.
- ▶ Do **not** exceed the maximum permissible driving speed of the crawler.
- ▶ Avoid jerky driving movements.
- ▶ Avoid oscillation of load and suspended derrick ballast or keep it to a minimum: Drive and turn slowly.

When oscillation movements occur:

- ▶ Set the load / derrick ballast on the ground quickly. Pay attention to the limit values of the load torque display and the F-load display.
- ▶ Steering the crawler with suspended load and / or installed derrick ballast is prohibited.
- ▶ Always observe the permissible values for uphill and downhill inclines and lateral inclines.

Make sure that the following prerequisites are met:

- Observe the specifications in the Crane operating instructions, chapter 4.10.
- Pay special attention to the limitations for crawler operation with derrick ballast.
- The ground is suitable for crawler operation with derrick ballast.
- The ground can safely take on the resulting surface pressure.
- The derrick ballast is completely lifted off the ground and hangs free.
- The „Derrick ballast lifted off“ icon **3.4** appears on the LICCON monitor.

9 Disassembling

Make sure that the following prerequisites are met:

- The crane is horizontally aligned.
- The counterweight has been installed on the turntable according to the load charts.
- The LICCON overload protection has been set according to the data in the load charts.
- The LICCON overload protection settings have been compared with the actual set up configuration.
- An auxiliary crane is available.

9.1 Disassembling without a cross beam

9.1.1 Removing the ballast on the guy rods

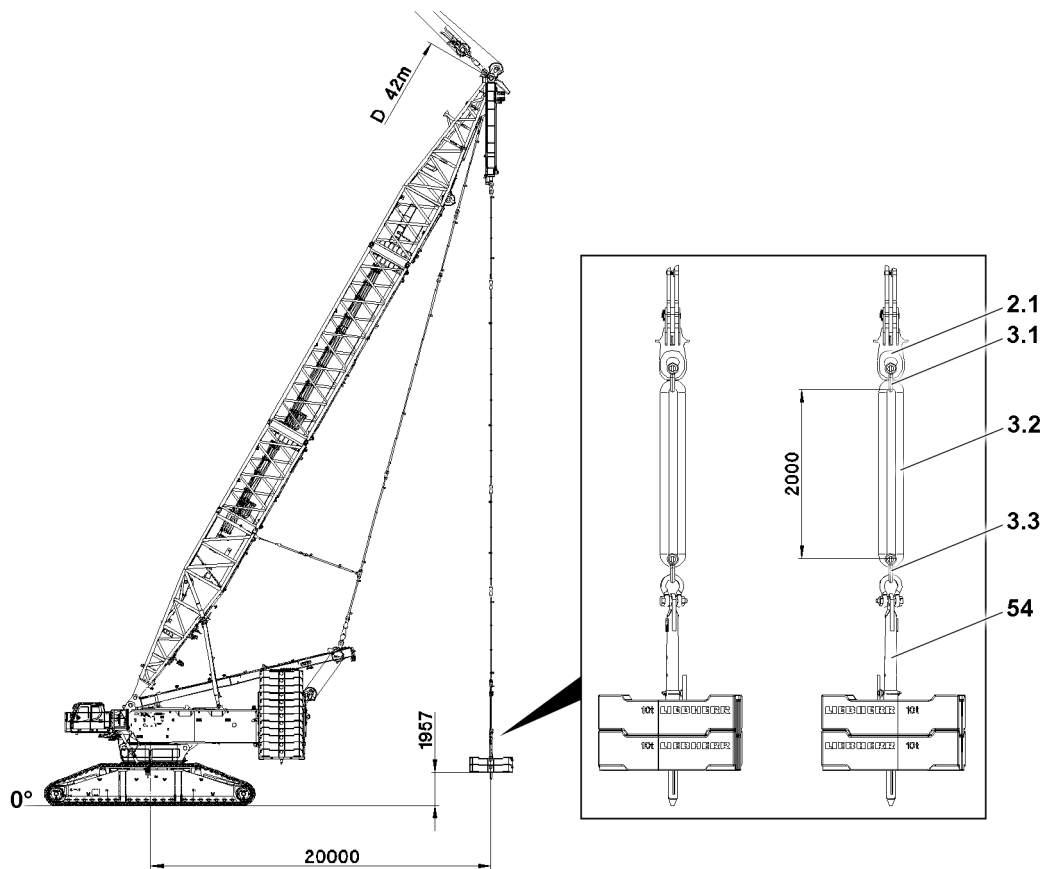

Fig.124979: Ballast Constant on the guy rods

When the derrick ballast radius is less than 15 m:

- ▶ Support the ballast plates.
- ▶ Set the ballast plate on the ground or on a substructure.
- ▶ Remove the shackle **3.3**, roundsling **3.2** and shackle **3.1**.
- ▶ Lift the guying until the ballast plates can be removed.

9.2 Disassembling with a cross beam*

9.2.1 Removing the ballast on the cross beam

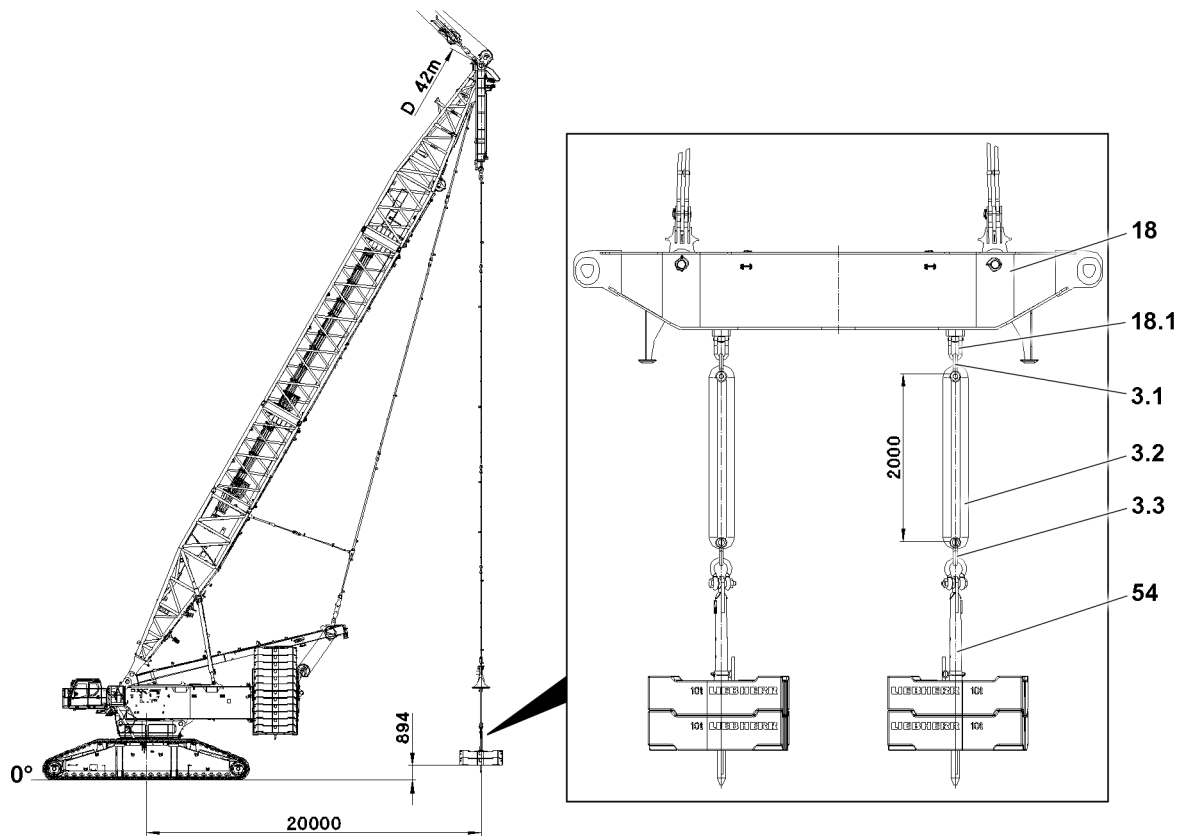

Fig.124980: Ballast Constant on the cross beam

- ▶ Set the ballast plate on the ground.
- ▶ Remove the shackle **3.3**, roundsling **3.2** and shackle **3.1**.
- ▶ Lift the guying until the ballast plates can be removed.

9.2.2 Disassembling the cross beam

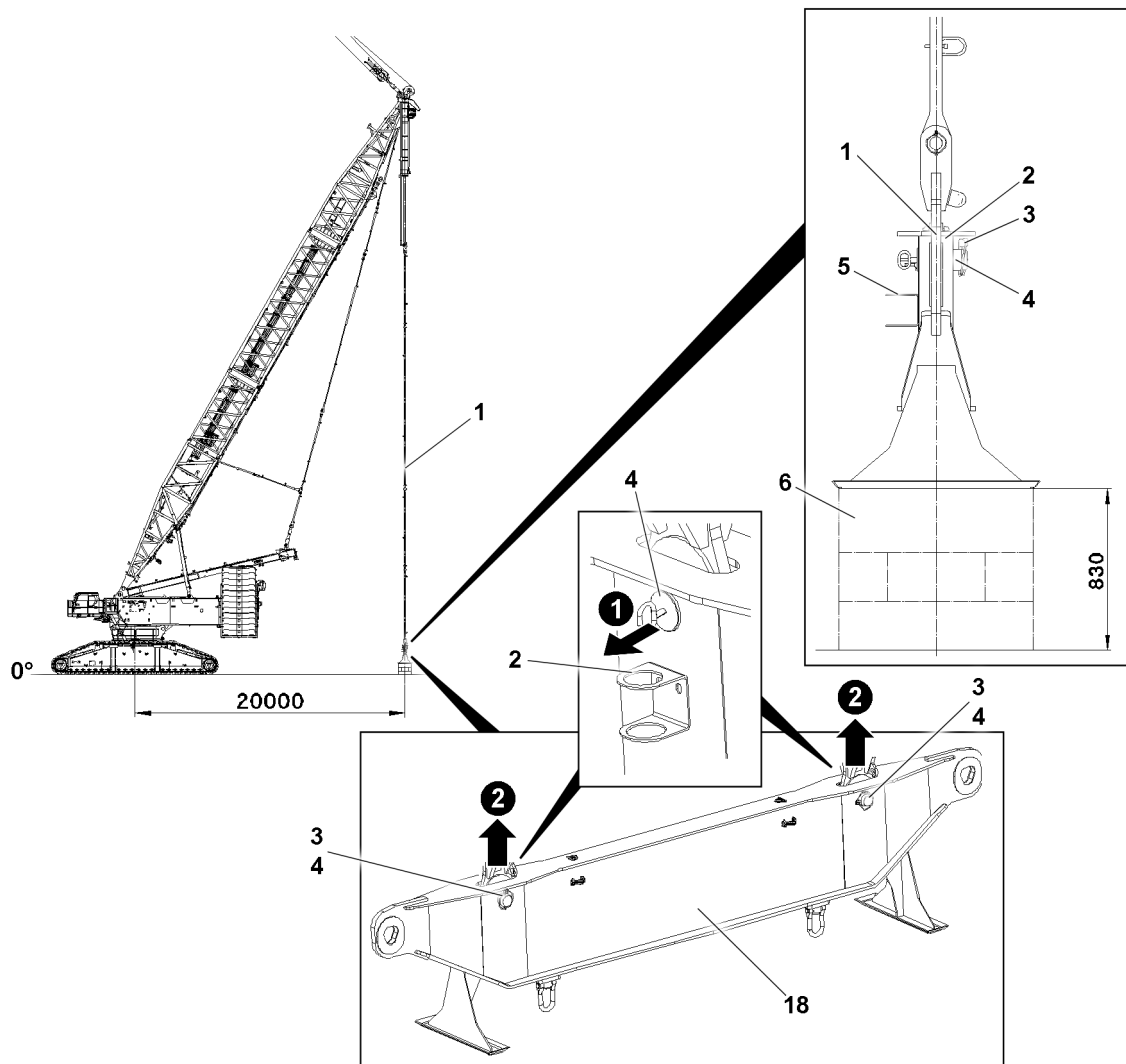

Fig.126481: Cross beam

Make sure that the following prerequisites are met:

- The ground is level and of sufficient load bearing capacity.

- ▶ Set the derrick radius to 20 m.

The substructure **6** must be at least 830 mm above the crane placement surface.

- ▶ Position the substructure **6** under cross beam **18**.
- ▶ Set the cross beam **18** on the substructure **6**: Extend the pull cylinder.



Note

Retract / extend the pull cylinder

- ▶ Control the pull cylinders from the crane cab or with the control panel, see section „lifting and lowering the derrick ballast with the pull cylinders“.
- ▶ Operate the pull cylinder with the radio remote control, see the „radio remote control operating instructions“.

- ▶ Unpin the cross beam on the D-guy rods **1**: Remove the locking pin **3** and unpin the pin **4**.
- ▶ Insert the pin **4** in the transportation retainer **5** and secure.
- ▶ Lift the guy rods: Retract the pull cylinder.

**Note**

- ▶ Fastening points, see section „Fastening points for suspended ballast parts“.
- ▶ Fasten the cross beam **18** with fastening equipment to the auxiliary crane and remove.

9.3 Removing the ballast

9.3.1 Removing the receptacle stud from the ballast plates

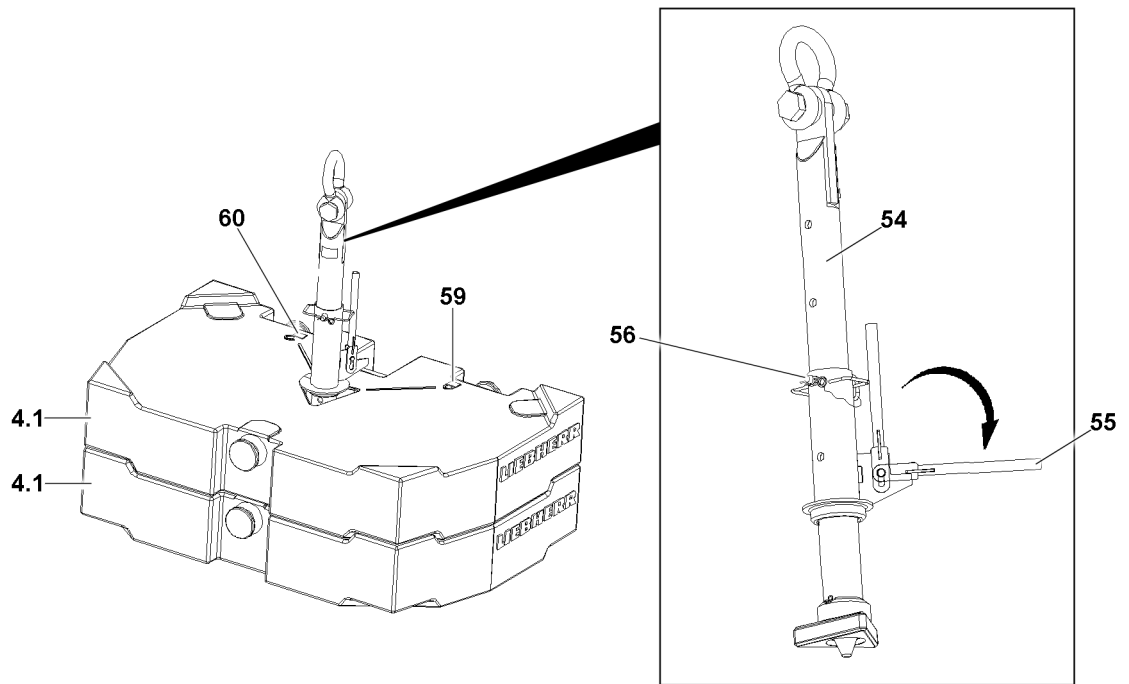

Fig.126074: Receptacle stud with two 10 t ballast plates 4.1

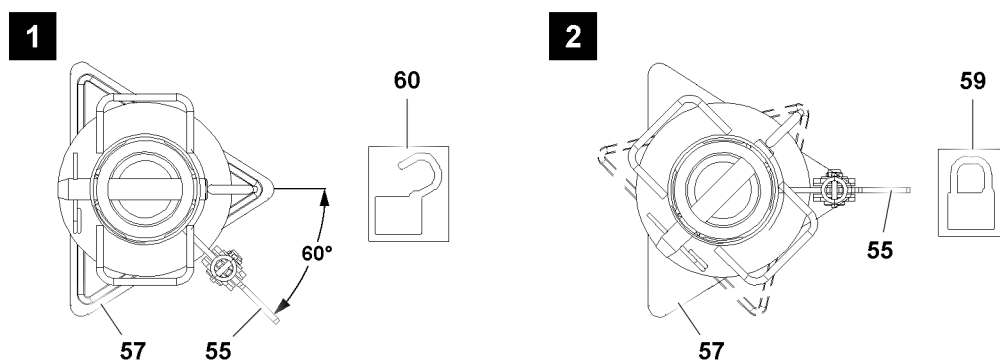

Fig.126075: Receptacle stud overhead view, positions lever 55

If the receptacle stud is to be removed:

- ▶ Turn the lever **75** by 60° until the lever **75** points to the icon **60**, see illustration 1.

Result:

- The receptacle stud is unlocked.
- ▶ Carefully pull the receptacle stud **54** with the auxiliary crane from the ballast plate.

Empty page!

LWE/LR 11000-001/23501-04-02/en

5.36.40 Derrick ballast - suspended ballast - special design VarioTray

1	Product description	3
2	Component overview	4
3	Fastening points	8
4	Pull cylinder extension conditions	11
5	Derrick ballast radii	13
6	Assembly	20
7	Installing the divisible ballast pallet „VarioTray“	20
8	Assembling the suspended ballast	23
9	Assembling the suspended ballast with suspended ballast guide	25
10	Ballasting the divisible ballast pallet „VarioTray“	45
11	Crane operation with small ballast pallet	48
12	Crane operation with the derrick ballast	54
13	Crawler operation with derrick ballast	88
14	Disassembling	89
15	Removing the ballast on the divisible ballast pallet „VarioTray“	90
16	Disassembling the suspended ballast	93
17	Disassembling the suspended ballast with the suspended ballast guide	95
18	Removing the divisible ballast pallet „VarioTray“	112

Fig.195219

LWE/LR 11000-001/23501-04-02/en

1 Product description

This chapter describes the following derrick ballast variations:

- Suspended ballast *special design*: Divisible ballast pallet „VarioTray“
Ballasting consisting of ballast plates on a divisible ballast pallet

This crane type has additional derrick ballast variations, which will be described in other chapters of these operating instructions:

- Suspended ballast
Ballasting consisting of ballast plates on a ballast pallet
- Suspended ballast *special design*: Ballast „Constant“
Ballasting consisting of directly suspended ballast plates (without a ballast pallet)
- Ballast trailer
Ballasting consisting of ballast plates on a ballast trailer
- Suspended ballast *special design*: Ballasting LTR crane and / or ballast plates
Ballasting consisting of an LTR crane and / or ballast plates on a ballast pallet



Note

Designation of the ballast types

- ▶ The suspended ballast and the ballast trailer are generally described as derrick ballast.
- ▶ The ballast installed on the turntable is generally referred to as the counterweight.
- ▶ The ballast installed on the crawler travel gear is generally referred to as the central ballast.

1.1 Function

The divisible ballast pallet is referred to as the „VarioTray“.

The divisible ballast pallet „VarioTray“ provides a system for erection with a high derrick ballast and crane operation with a small derrick ballast.

If the main boom is erected, the ballast that is not needed for the crane operation can simply be decoupled. Crane is then driven only with the derrick ballast that is actually needed.

The derrick boom angle, derrick ballast, weight and utilization are shown on LICCON monitor 1.

After assembly on the ground, the derrick ballast is raised for crane operation with the hydraulic cylinders in the D-guying.

The required derrick ballast radius is set by adjusting the derrick boom.

Crane operation with derrick ballast without suspended ballast guide* is referred to as „B operation“.

Crane operation with derrick ballast with suspended ballast guide* is referred to as „B 2 operation“.

For crane operation with derrick ballast, see the Crane operating instructions, chapter 4.02.

The D-guying contains two pull cylinders (pull cylinder A and pull cylinder B). These pull cylinders are used to pull, lift or lower the derrick ballast.

1.2 Variations

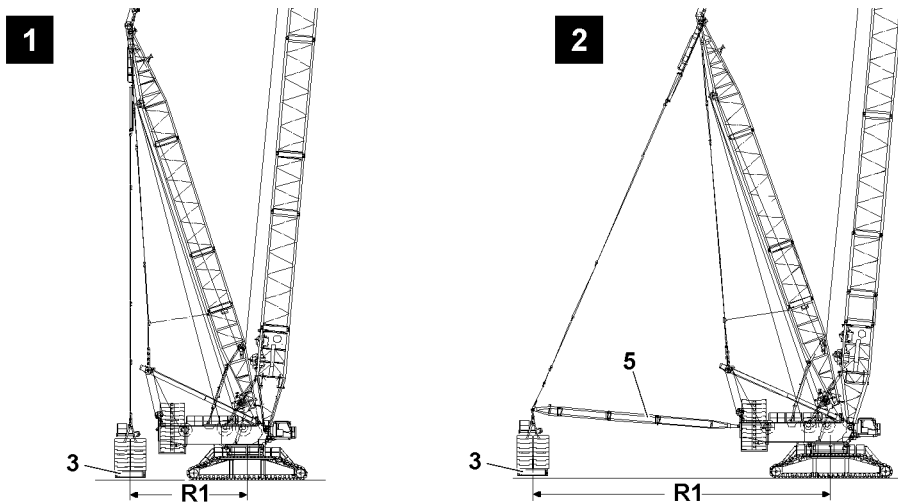

Fig.145947: Suspended ballast variations

LR 11000 has two suspended ballast variations:

- Divisible ballast pallet „VarioTray“ **3** **without** suspended ballast guide, see illustration **1**
 - The derrick ballast radius **R1** can be set by adjusting the derrick boom.
- Divisible ballast pallet „VarioTray“ **3** **with** suspended ballast guide **5**, see illustration **2**
 - The derrick ballast radius **R1** requires the conversion of the suspended ballast guide **5**.

2 Component overview



Note

- ▶ The assembly sections are marked with their own weight.
- ▶ Dimensions and weights, see the Crane operating instructions, chapter 1.03.

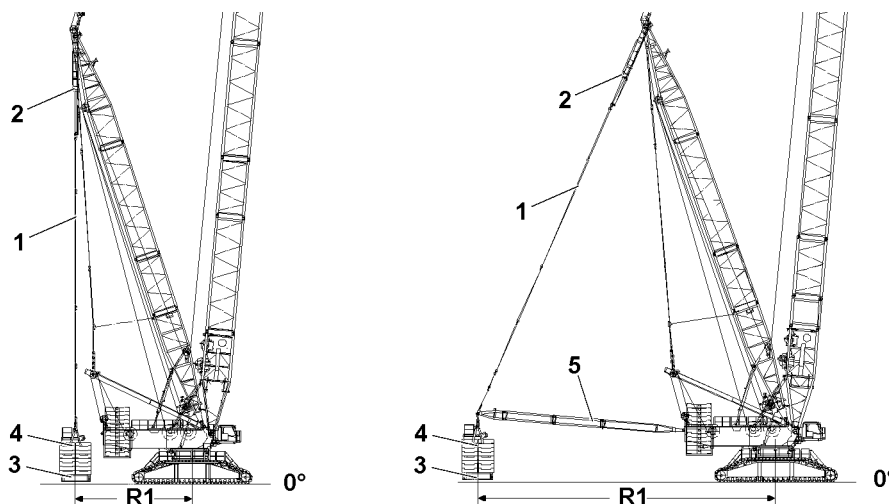

Fig.145263: Suspended ballast variations

Position	Component
1	D-guying
2	Pull cylinder
3	Divisible ballast pallet „VarioTray“
4	Ballast plates
5	Suspended ballast guide B2

2.1 Component overview for divisible ballast pallet „VarioTray“

2.1.1 Divisible ballast pallet „VarioTray“

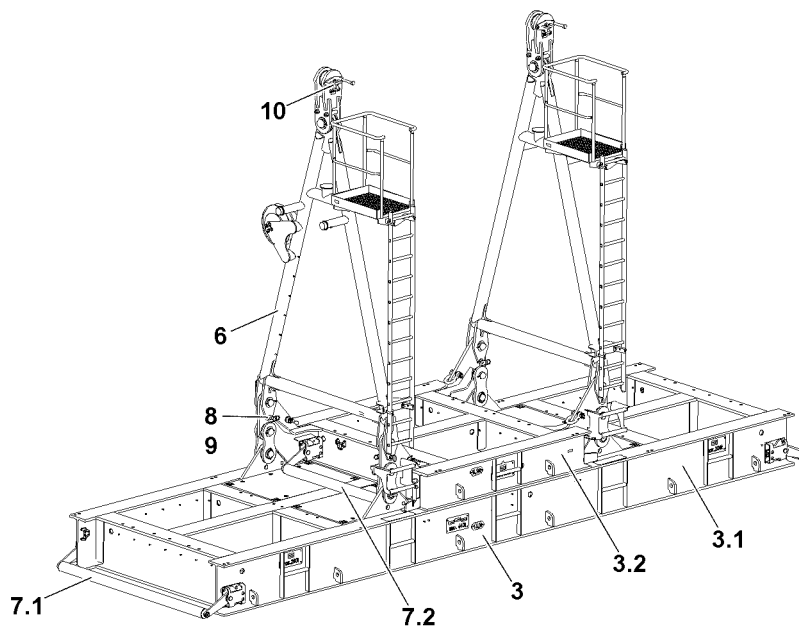

Fig.145262: Divisible ballast pallet „VarioTray“

Position	Component
3	Divisible ballast pallet „VarioTray“
3.1	Large ballast pallet
3.2	Small ballast pallet
6	Erection rack
7.1	Ground contact roller
7.2	Ground contact roller
8	Retaining pin
9	Retaining element
10	Connector pin

2.1.2 Lashing lugs

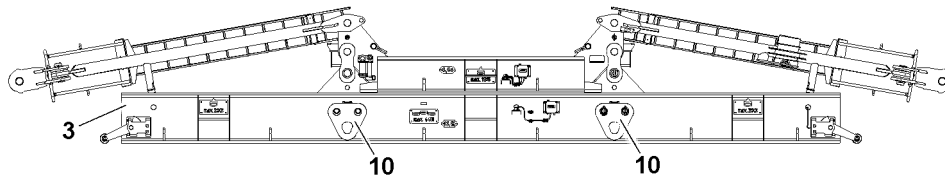

Fig.145264: Lashing lugs

Position	Component
10	Lashing lugs



Note

- Lashing lugs for fastening and transferring the divisible ballast pallet „VarioTray“ with the auxiliary crane.

2.2 Component overview Suspended ballast guide

2.2.1 Pivot section

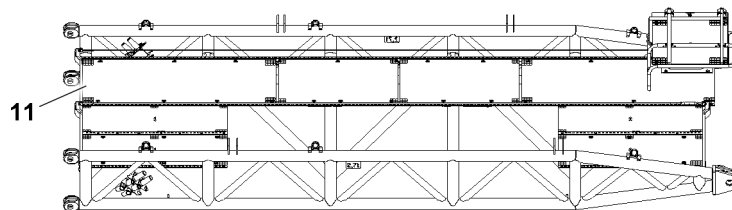

Fig.124480: Pivot section

Position	Component
11	Pivot section

2.2.2 Intermediate section

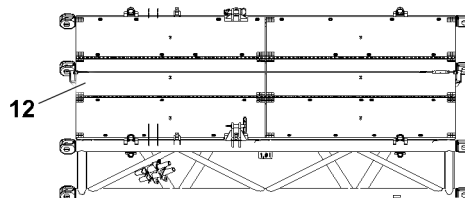

Fig.124481: Intermediate section

Position	Component
12	Intermediate section

2.2.3 Intermediate section

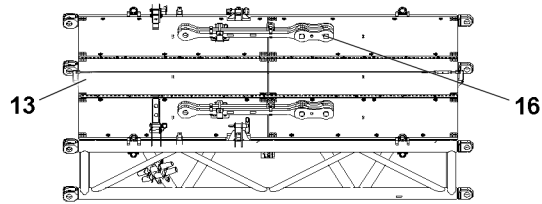

Fig.124482: Intermediate section

Position	Component
13	Intermediate section
16	Pull rods

2.2.4 End section

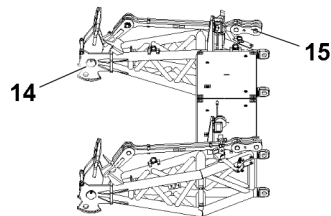

Fig.124483: End section

Position	Component
14	End section
15	Pull rods - end section

2.2.5 Suspended ballast guide „Transport position“

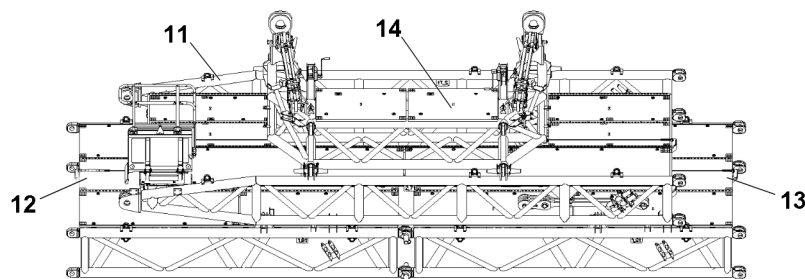

Fig.124484: Suspended ballast guide „Transport position“



Note

► Component, see section „Component overview Suspended ballast guide“.

3 Fastening points



WARNING

Falling lattice sections!

Death, severe bodily injuries, property damage.

- ▶ Make sure that the lattice sections are properly fastened on the respective fastening points.
- ▶ Make sure that the fastening equipment has the appropriate length and a sufficient load bearing capacity.
- ▶ Pay attention and adhere to the labels on the fastening points on the lattice sections and crane components.

3.1 Fastening points for suspended ballast components

3.1.1 Divisible ballast pallet „VarioTray“

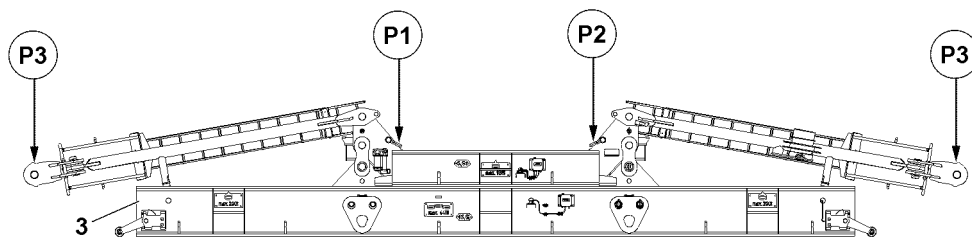

Fig.145265: Divisible ballast pallet „VarioTray“



Note

- ▶ Fastening points P1 and P2: Minimum rope length 6 m.

Fastening points	
P1 and P2	Divisible ballast pallet „VarioTray“
P3	Erection rack

3.1.2 Ballast plates

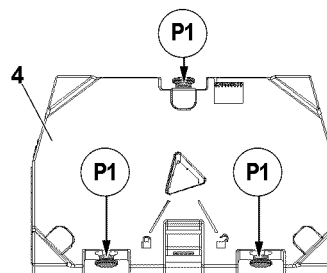

Fig.145266: Ballast plates

Fastening points	
P1	Ballast plates

3.2 Fastening points for suspended ballast guide components

3.2.1 End section

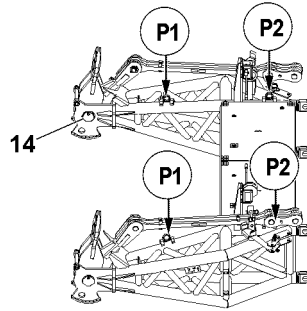

Fig.145269: End section

Fastening points	
P1 and P2	End section

3.2.2 Intermediate section

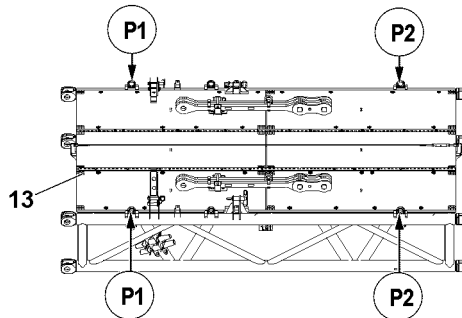

Fig.145268: Intermediate section

Fastening points	
P1 and P2	Intermediate section

3.2.3 Intermediate section

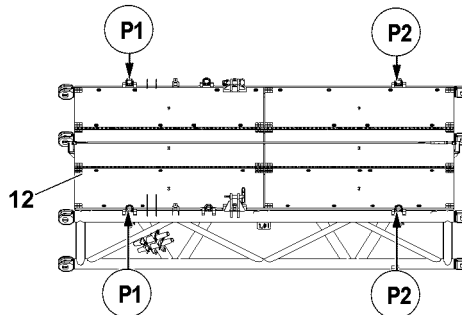

Fig.145270: Intermediate section

LWE/LR 11000-001/23501-04-02/en

Fastening points	
P1 and P2	Intermediate section

3.2.4 Pivot section

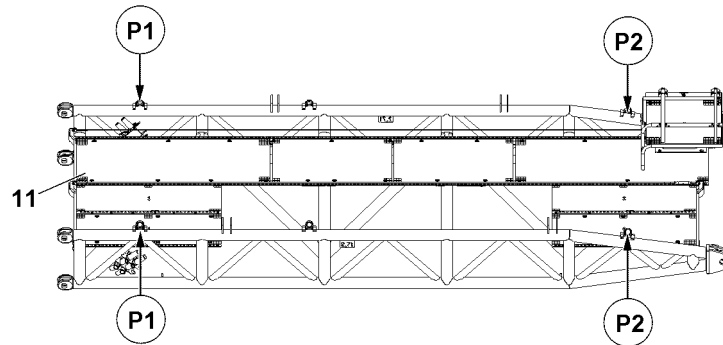

Fig.145271: Pivot section

Fastening points	
P1 and P2	Pivot section

3.3 Suspended ballast guide (transport)

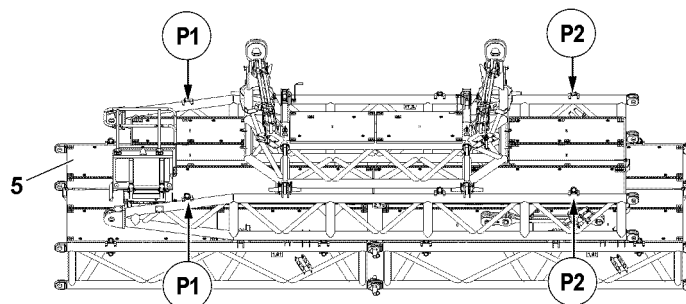

Fig.145272: Suspended ballast guide (transport)

Fastening points	
P1 and P2	Suspended ballast guide (transport)

LWE/LR 11000-001/23501-04-02/en

3.4 Suspended ballast guide (assembly)

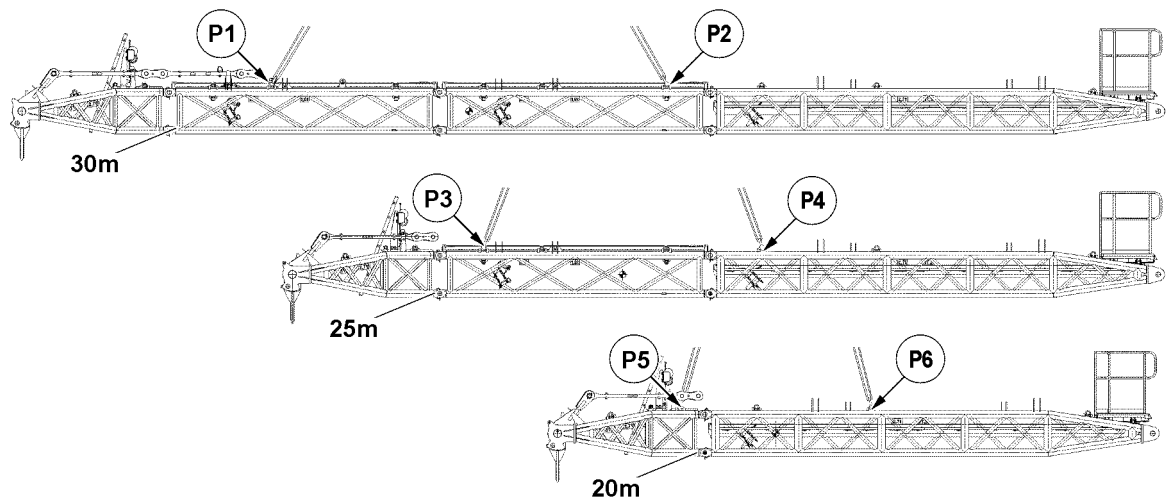

Fig.145267: Suspended ballast guide (assembly)

Fastening points	
P1 and P2	Suspended ballast guide 30 m
P3 and P4	Suspended ballast guide 25 m
P5 and P6	Suspended ballast guide 20 m

4 Pull cylinder extension conditions

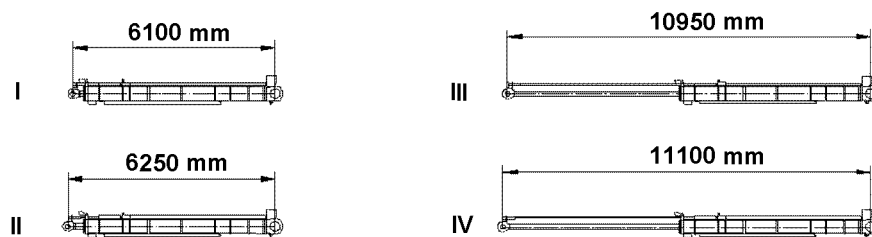

Fig.119003: Pull cylinder extension conditions

Extension conditions	
I	Block position „Retracted“
II	Switch position „Retracted“
III	Switch position „Extended“
IV	Block position „Extended“

LWE/LR 11000-001/23501-04-02/en

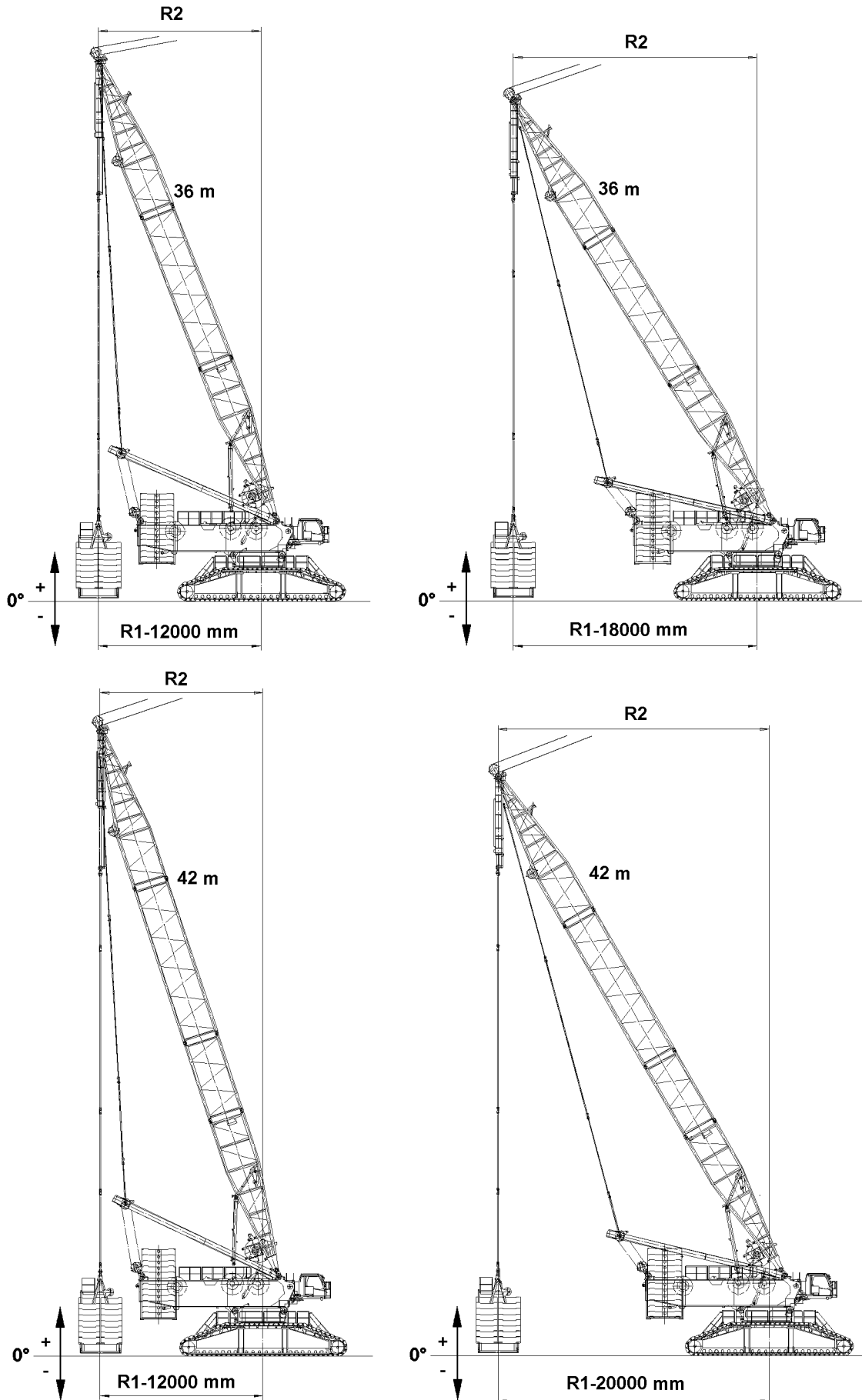

Fig.119004

LWE/LR 11000-001/23501-04-02/en

5 Derrick ballast radii

5.1 Derrick ballast without suspended ballast guide

5.1.1 36 m derrick boom



Note

- ▶ No suspended ballast guide is installed between the turntable and the divisible ballast pallet „VarioTray“.
- ▶ The derrick ballast radius **R1** and the derrick radius **R2** are identical, see illustration.

With the 36 m derrick, the following derrick ballast radii are possible: R1= 12 m and R1 =18 m.

Large ballast pallet (base pallet)

Radius R1 = 12 m	
Above base	+3545 mm
Below base	-1155 mm

Radius R1 = 18 m	
Above base	+569 mm
Below base	-4131 mm

Small ballast pallet (Vario-palette)

Radius R1 = 12 m	
Above base	+4245 mm
Below base	-455 mm

Radius R1 = 18 m	
Above base	+1269 mm
Below base	-3431 mm

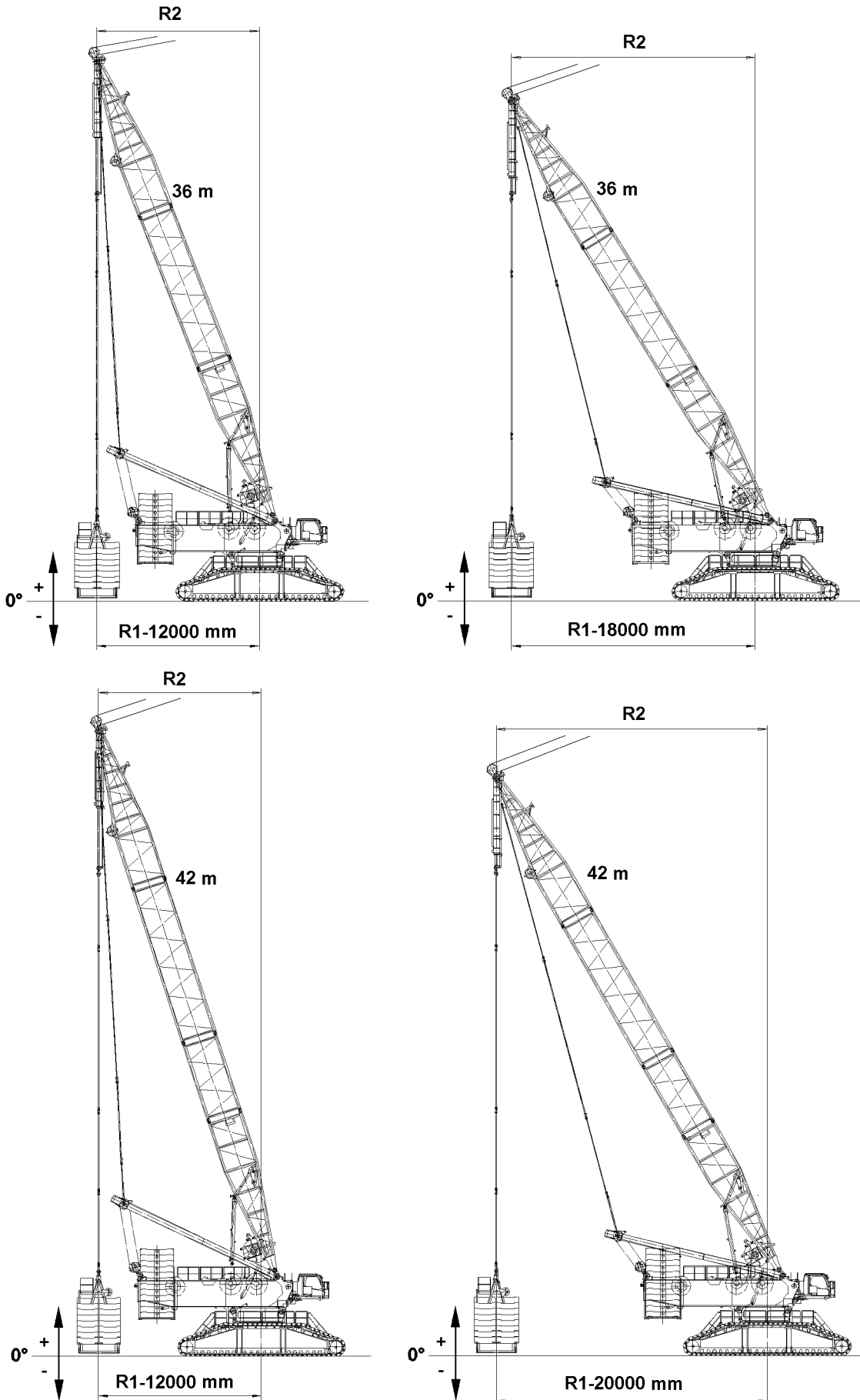

Fig.119004

LWE/LR 11000-001/23501-04-02/en

5.1.2 Derrick boom 42 m



Note

- ▶ No suspended ballast guide is installed between the turntable and the divisible ballast pallet „VarioTray“.
- ▶ The derrick ballast radius **R1** and the derrick radius **R2** are identical, see illustration.

With the 42 m derrick, the following derrick ballast radii are possible: R1= 12 m and R1= 20 m.

Large ballast pallet (base pallet)

Radius R1 = 12 m	
Above base	+3911 mm
Below base	-789 mm

Radius R1 = 20 m	
Above base	+539 mm
Below base	-4161 mm

Small ballast pallet (Vario-palette)

Radius R1 = 12 m	
Above base	+4611 mm
Below base	-89 mm

Radius R1 = 20 m	
Above base	+1059 mm
Below base	-3641 mm

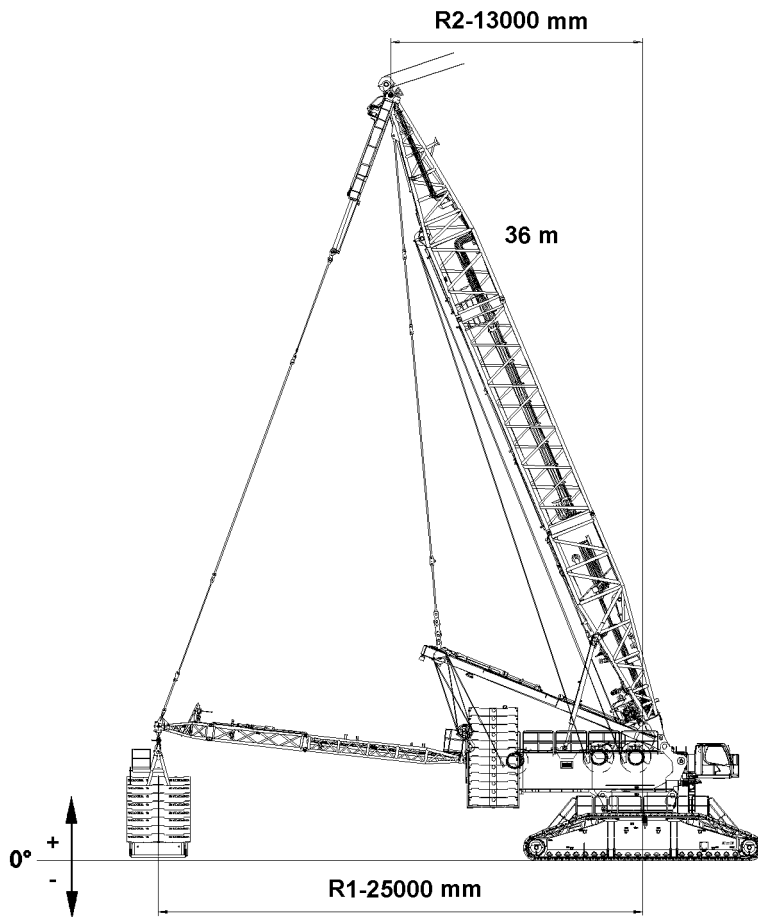
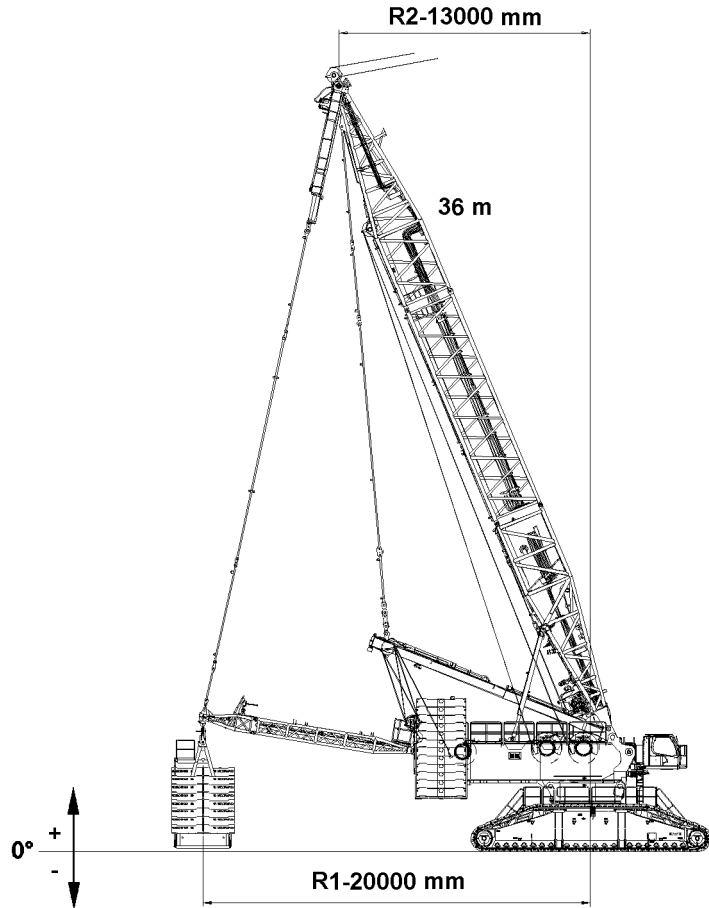

Fig.120208

LWE/LR 11000-001/23501-04-02/en

5.2 Derrick ballast with suspended ballast guide

5.2.1 36 m derrick boom



Note

- ▶ **One** suspended ballast guide is installed between the turntable and the divisible ballast pallet „VarioTray“.
- ▶ The derrick ballast radius **R1** and the derrick radius **R2** are **not** identical, see illustration.

Derrick radius with the 36 m derrick is $R_2 = 13$ m.

With the 36 m derrick, the following derrick ballast radii are possible: $R_1 = 20$ m and $R_1 = 25$ m.

Radius R1 = 20 m	
Above base	+1000 mm
Below base	-1000 mm

Radius R1 = 25 m	
Above base	+1000 mm
Below base	-1000 mm

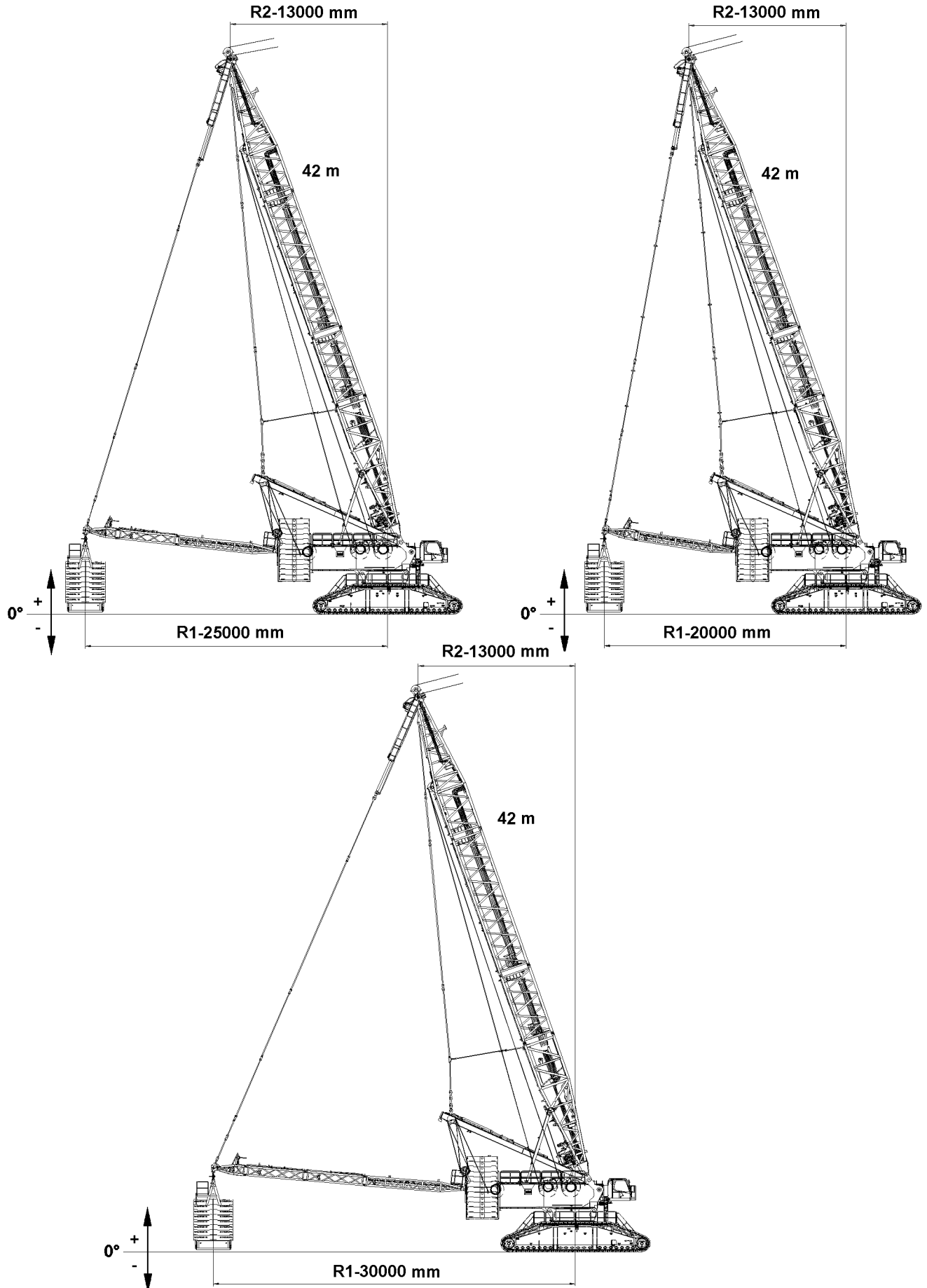

Fig.120209

LWE/LR 11000-001/23501-04-02/en

5.2.2 Derrick boom 42 m



Note

- ▶ **One** suspended ballast guide is installed between the turntable and the divisible ballast pallet „VarioTray“.
- ▶ The derrick ballast radius **R1** and the derrick radius **R2** are **not** identical, see illustration.

Derrick radius with the 42 m derrick is $R_2 = 13$ m.

With the 42 m derrick, the following derrick ballast radii are possible: $R_1 = 20$ m, $R_1 = 25$ m and $R_1 = 30$ m.

Radius $R_1 = 20$ m	
Above base	+1000 mm
Below base	-1000 mm

Radius $R_1 = 25$ m	
Above base	+1000 mm
Below base	-1000 mm

Radius $R_1 = 30$ m	
Above base	+1000 mm
Below base	-1000 mm

6 Assembly



WARNING

Danger of falling!

During assembly / disassembly, inspection and maintenance work, personnel must be secured with appropriate aids to prevent them from falling.

Death, severe bodily injuries, property damage.

- ▶ All work at a height, when there is a danger of falling, must be carried out with suitable aids.
- ▶ If aids are not available and work cannot be carried out from the ground, then assembly personnel must secure themselves with the supplied fall arrest system to prevent falling, see the Crane operating instructions, chapter 2.04.
- ▶ If fall protection equipment is available, then it must be used, see the Crane operating instructions, chapter 2.06.
- ▶ When lifting, lowering, swinging crane parts in and out, no persons may remain in the danger zone.
- ▶ If railings are present on the components, then they must be brought into the corresponding position and secured for assembly / disassembly work.
- ▶ Only step on the aids, ladders and catwalks with clean shoes.
- ▶ Keep aids, ladders and catwalks free of heavy dirt, snow and ice.
- ▶ During all assembly and disassembly work, maintenance work and inspections, travel or crane operation is prohibited.
- ▶ Remaining on a suspended load is prohibited.
- ▶ Stepping or walking on crane components and lattice sections, which have an incline of more than 20° is prohibited.
- ▶ For all assembly work, the crane operator of the main crane must be in voice contact with the crane operator / crane operators of the auxiliary crane / auxiliary cranes.
- ▶ For assembly / disassembly tasks, the crane operator may only initiate crane movements when the responsible guide has explicitly released the movement.



WARNING

Danger of impact / crushing!

When installing / removing crane components with the auxiliary crane, crane components can start to swing back and forth.

When lifting / lowering and positioning crane components, there is an increased danger of impacts / crushing.

Death, severe bodily injuries, property damage.

- ▶ Make sure that personnel cannot be caught by components.
- ▶ When working in danger zones: Use aids to protect limbs.
- ▶ Guide components with suitable aids to minimize oscillation.



DANGER

The components can fall down!

If the corresponding components are disengaged from the auxiliary crane before the corresponding component is pinned, the corresponding component can fall down and fatally injure personnel.

- ▶ Do not disengage the auxiliary crane until the respective component is pinned and secured.

7 Installing the divisible ballast pallet „VarioTray“



DANGER

Danger of accident during assembly / disassembly of the erection racks!

The disassembly of unsecured or unsupported erection racks can cause the erection racks to fall down and kill or severely injure personnel.

- ▶ Never unpin the retaining pins under unsecured or unsupported erection racks.
- ▶ It is prohibited for anyone to remain under the erection racks or within the complete danger zone during the pinning and unpinning procedure.

7.1 Setting the divisible ballast pallet „VarioTray“ into the assembly position

- ▶ Set the derrick to the required radius.



Note

- ▶ Fastening points, see section „Fastening points for suspended ballast parts“.

- ▶ Hang divisible ballast pallet „VarioTray“ on the auxiliary crane and position it within the slewing range of the crane under the guy rods on the derrick.



Note

- ▶ Set down the divisible ballast pallet „VarioTray“ in the lengthwise direction of the turntable for easier assembly to the guy rods.

- ▶ Align the divisible ballast pallet „VarioTray“ horizontally.

7.2 Erecting the erection racks

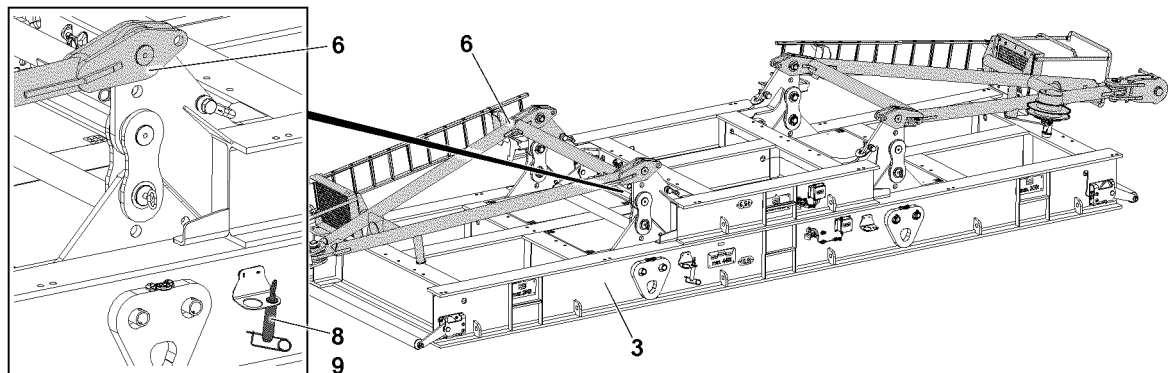

Fig.145273: Divisible ballast pallet „VarioTray“ in the transport position



Note

- ▶ The assembly of the erection racks is described based on the example of one erection rack.

The erection rack is pinned on two points. The pin procedure is described for one pin as an example.

- ▶ Hang the erection rack **6** on the auxiliary crane.
- ▶ Remove the retaining element **9** on both sides from the parking position and unpin the retaining pin **8**.

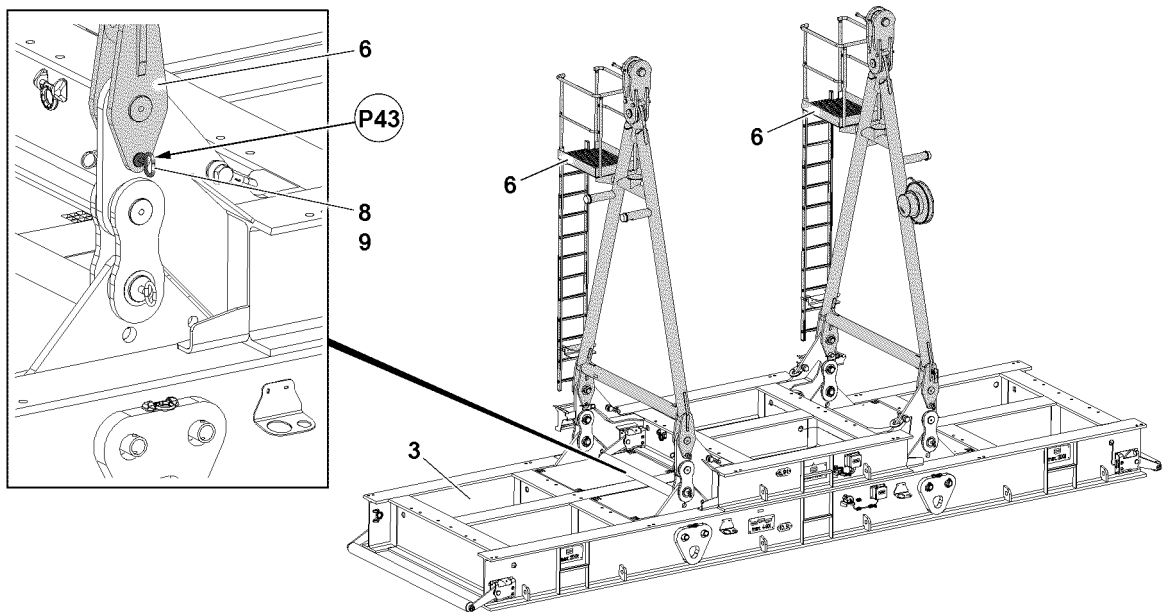

Fig.145274: Positioning the erection racks vertically



DANGER

Danger of accident during assembly / disassembly of the erection racks!

The erection racks must hang securely on the auxiliary crane, otherwise they could fall down and kill or severely injure personnel.

- ▶ The two erection racks must be locked and secured in a vertical position with retaining pins **8**. Only then may the auxiliary crane be removed.
- ▶ Never unpin the retaining pins of unsecured or unsupported erection racks.
- ▶ It is prohibited for anyone to remain under the erection racks or within the complete danger zone during the pinning and unpinning procedure.

- ▶ Set the erection rack **6** vertically with the auxiliary crane.
- ▶ Insert the retaining pin **8** at point **P43** on both sides and secure with the retaining element **9**.

When the erection rack is set up and secured:

- ▶ Remove the auxiliary crane.



WARNING

Danger of accident!

The two erection racks must be locked and secured in a vertical position during crane operation, as otherwise they could fall down.

Death, severe bodily injuries, property damage.

In the case of crane operation with a divisible ballast pallet „VarioTray“, the retaining pins **8** remain pinned in point **P43**.

- ▶ Make sure that the retaining pins **8** are pinned at point **P43**.

- ▶ Erect the second erection rack **6**.

8 Assembling the suspended ballast

Make sure that the following prerequisites are met:

- The crane is properly supported and horizontally aligned.
- An auxiliary crane is available.
- The derrick is properly assembled on the turntable.
- The boom is properly assembled on the turntable.
- The derrick is in the crane operating position.
- The boom is laying on the substructure on the ground.
- The central ballast has been installed on the turntable according to the load chart.
- The counterweight has been installed on the turntable according to the load chart.
- The LICCON overload protection has been set according to the data in the load chart.
- The LICCON overload protection settings have been compared with the actual set up configuration.

8.1 Assembling the D-guy rods on the erection racks

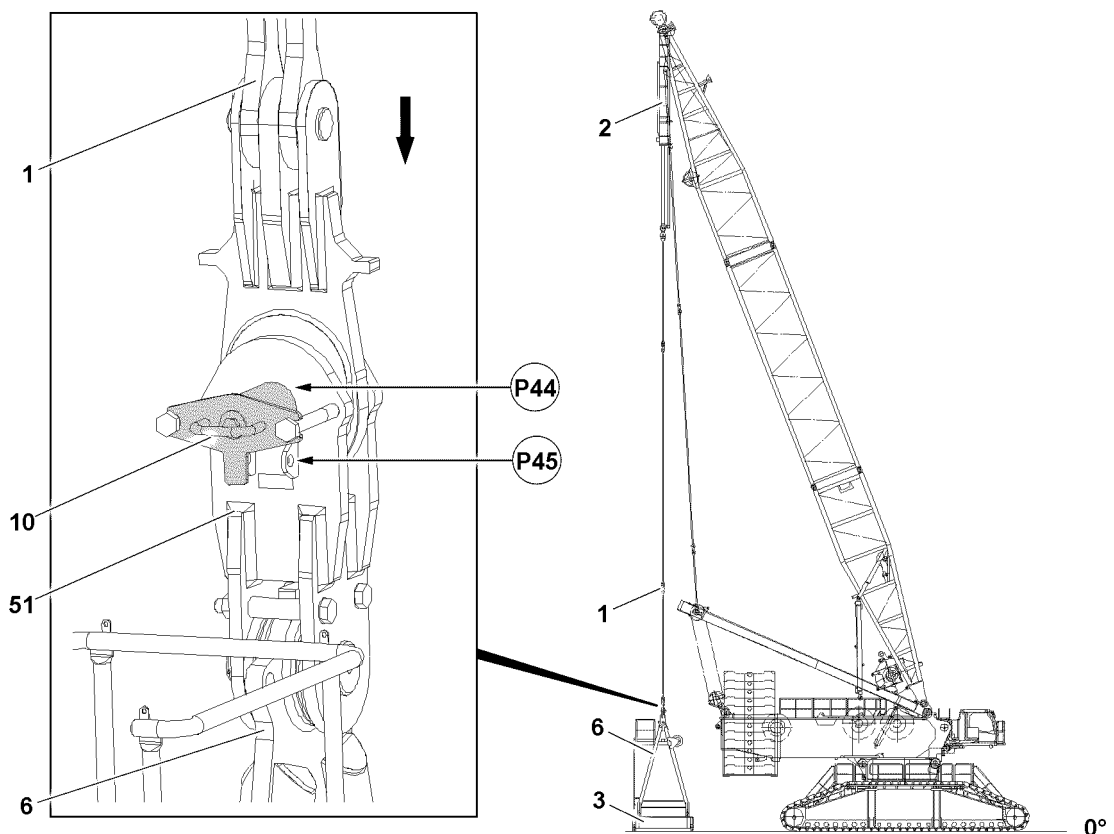

Fig.145275: Pinning procedure

Make sure that the following prerequisites are met:

- The guy rods hang over the brackets of the erection racks.
 - The erection racks are erected and secured with retaining pins.
 - The derrick is set to the required radius.
- ▶ Remove the retaining element **53** at point **P45** and unpin the retaining pin **52**.
 - ▶ Unpin the connector pin **10** at point **P44**.
 - ▶ Position the guy rods **1**, by extending the piston rods on the pull cylinders **2**, between the brackets **51** of the erection rack **6**.

**Note**

Retract / extend the pull cylinder **2**

- ▶ Control the pull cylinders **2** from the crane cab, see the section „Lifting and lowering the derrick ballast using the pull cylinders“.
- ▶ Operate the pull cylinder **2** with the radio remote control, see the „radio remote control operating instructions“.

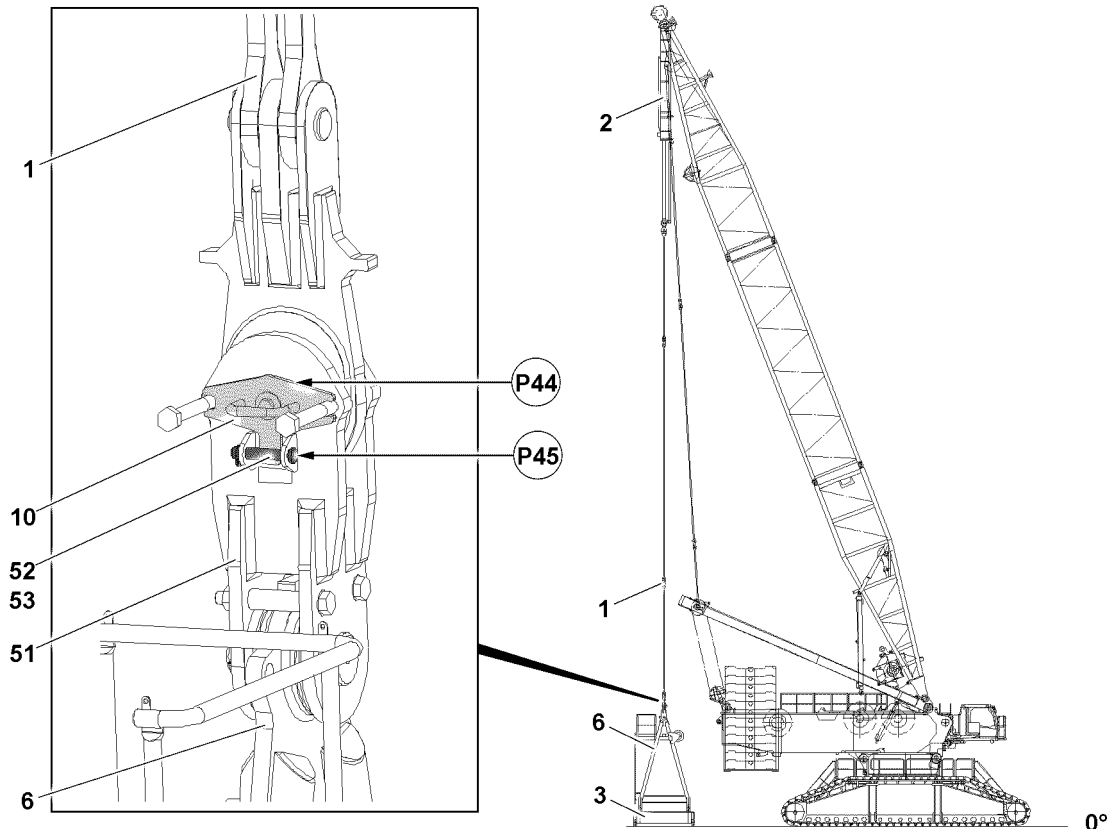

Fig.145276: Pinning procedure

- ▶ Pin the guy rods **1** on the brackets **51** and secure.
- ▶ Insert the connector pin **10** at point **P44**.

**WARNING**

Danger of accident!

If the connector pins are not secured with the retaining pin, then they can loosen up by themselves during crane operation.

This can cause the crane to topple over.

Death, severe bodily injuries, property damage.

- ▶ Make sure that the connector pins are secured.

- ▶ Insert the retaining pin **52** at point **P45** and secure with the retaining element **53**.
- ▶ Pin the second erection rack on the D-guy rod **1**.

**WARNING**

Uncontrolled swinging of the divisible ballast pallet „VarioTray“!

If the divisible ballast pallet „VarioTray“ **3** is lifted, it can start swinging.

Death, severe bodily injuries, property damage.

- ▶ It is prohibited to remain in the danger zone.
- ▶ Secure the divisible ballast pallet „VarioTray“ with an auxiliary rope.

- ▶ Lift the empty divisible ballast pallet „VarioTray“ **3** with the pull cylinders **2** and then set it down again.

Result:

- The divisible ballast pallet „VarioTray“ 3 is thereby precisely placed vertically under the derrick head.
- ▶ Align the divisible ballast pallet „VarioTray“ 3 horizontally.

8.2 Establishing the electrical connection from the suspended ballast to the turntable

**Note**

- ▶ Establish the electrical connections from the suspended ballast to the turntable, see Electric wiring diagram.
- ▶ Establish the electrical connections.

9 Assembling the suspended ballast with suspended ballast guide

Make sure that the following prerequisites are met:

- The crane is properly supported and horizontally aligned.
- An auxiliary crane is available.
- The derrick is properly assembled on the turntable.
- The boom is properly assembled on the turntable.
- The derrick is in the crane operating position.
- The boom is laying on the substructure on the ground.
- The central ballast has been installed on the turntable according to the load chart.
- The counterweight has been installed on the turntable according to the load chart.
- The LICCON overload protection has been set according to the data in the load chart.
- The LICCON overload protection settings have been compared with the actual set up configuration.

9.1 Assembling the suspended ballast guide

The suspended ballast guide makes different derrick ballast radii possible.

The derrick ballast radius determines the number of intermediate section, which must be installed.

Derrick ballast radius	Number of intermediate sections
20 m	0
25 m	1
30 m	2

9.1.1 Removing the transport unit

Make sure that the following prerequisite is met:

- The transport unit is on the transport vehicle.

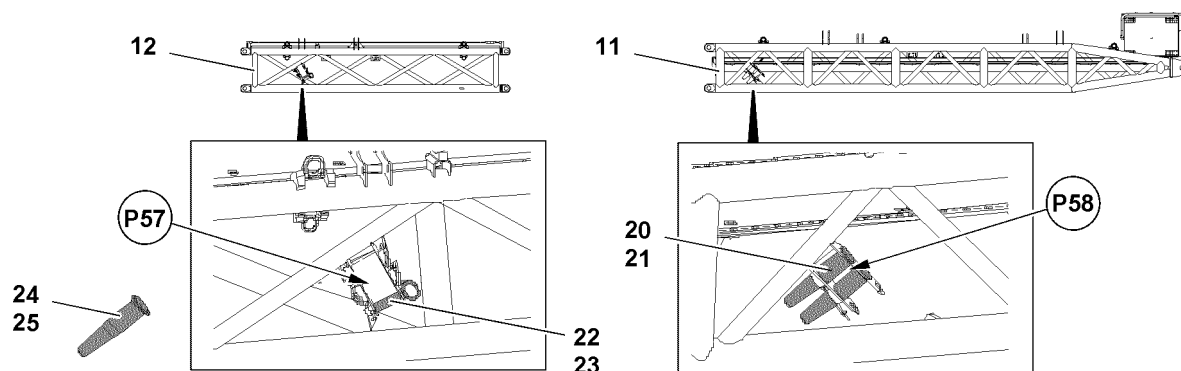

Fig.122802: Park position for pin



Note

- ▶ Park position **P57** for pin **24** and pin **22**.
- ▶ Park position **P58** for pin **20**.



WARNING

Falling pins!
Death, severe bodily injuries, property damage.

- ▶ Make sure that all pins are properly secured in the park positions with the respective retaining elements.

Empty page!

LWE/LR 11000-001/23501-04-02/en

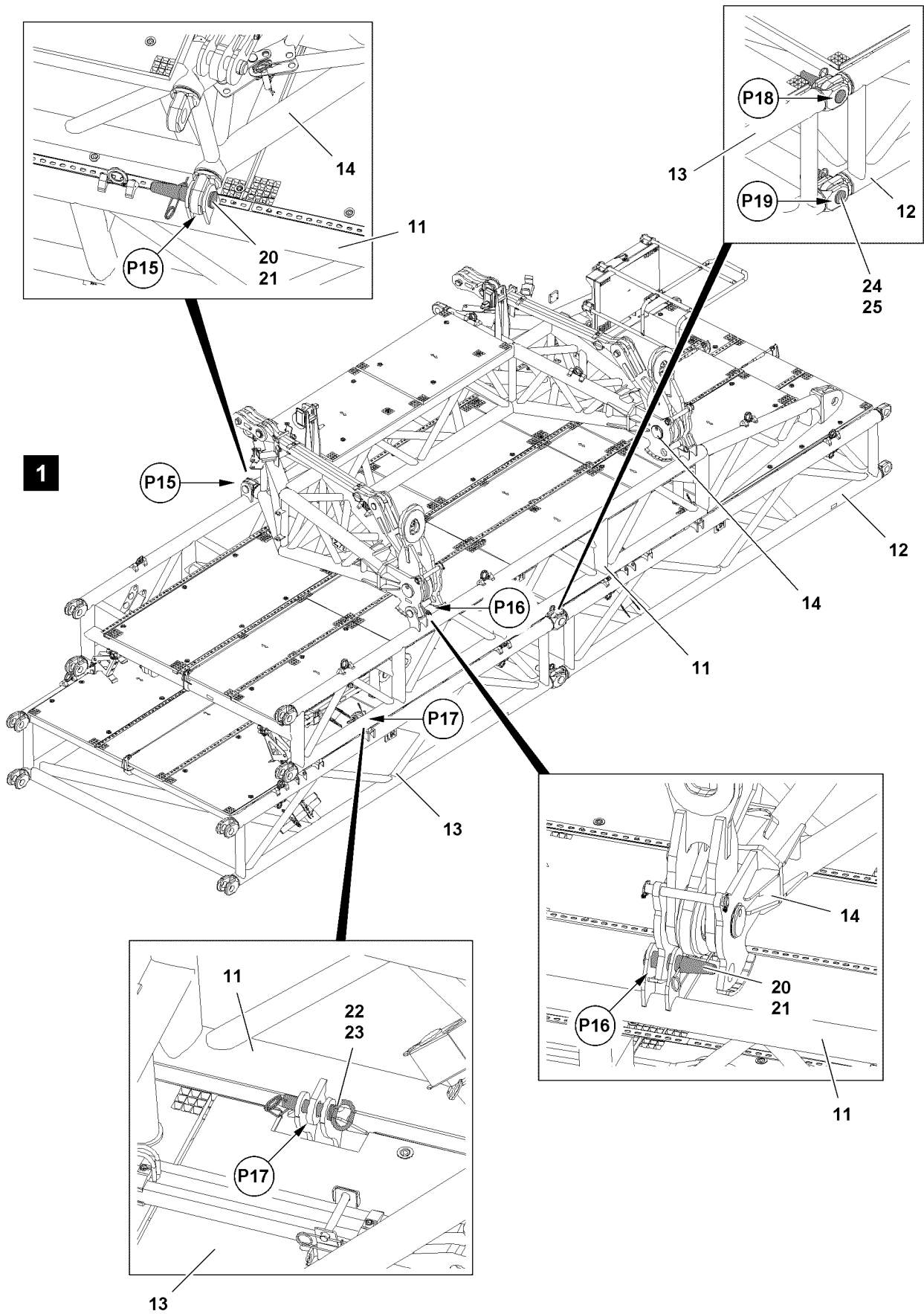

Fig.122801

LWE/LR 11000-001/23501-04-02/en

Disassembling the end section

- ▶ Release and remove the riggings on the transport vehicle.

The end section is unpinned at four points. Every point is present on both sides of the component on one level, see illustration 1.

- ▶ Fasten the auxiliary crane to the end section **14**.
- ▶ Unpin the end section **14** at points **P15**: Remove the retaining element **21** and unpin the pin **20**.
- ▶ Unpin the end section **14** at points **P16**: Remove the retaining element **21** and unpin the pin **20**.
- ▶ Take the end section **14** down on the ground with the auxiliary crane.

Disassembling the pivot section

The pivot section is unpinned at four points. Every point is present on both sides of the component on one level, see illustration 1.

- ▶ Fasten the auxiliary crane to the pivot section **11**.
- ▶ Unpin the pivot section **11** at points **P17**: Remove the retaining element **23** and unpin the pin **22**.
- ▶ Take the pivot section **11** down on the ground with the auxiliary crane.

Disassembling the intermediate section

For a suspended ballast with a 25 m suspended ballast radius, the intermediate sections must be unpinned apart. The intermediate section is unpinned on four points. Every point is present on both sides of the component on one level, see illustration 1.

- ▶ Fasten the auxiliary crane on intermediate section **12**.
- ▶ Unpin the intermediate section **12** at points **P19**: Remove the retaining element **25** and unpin the pin **24**.
- ▶ Unpin the intermediate section **12** at points **P18**: Remove the retaining element **25** and unpin the pin **24**.
- ▶ Take the intermediate section **12** down on the ground with the auxiliary.

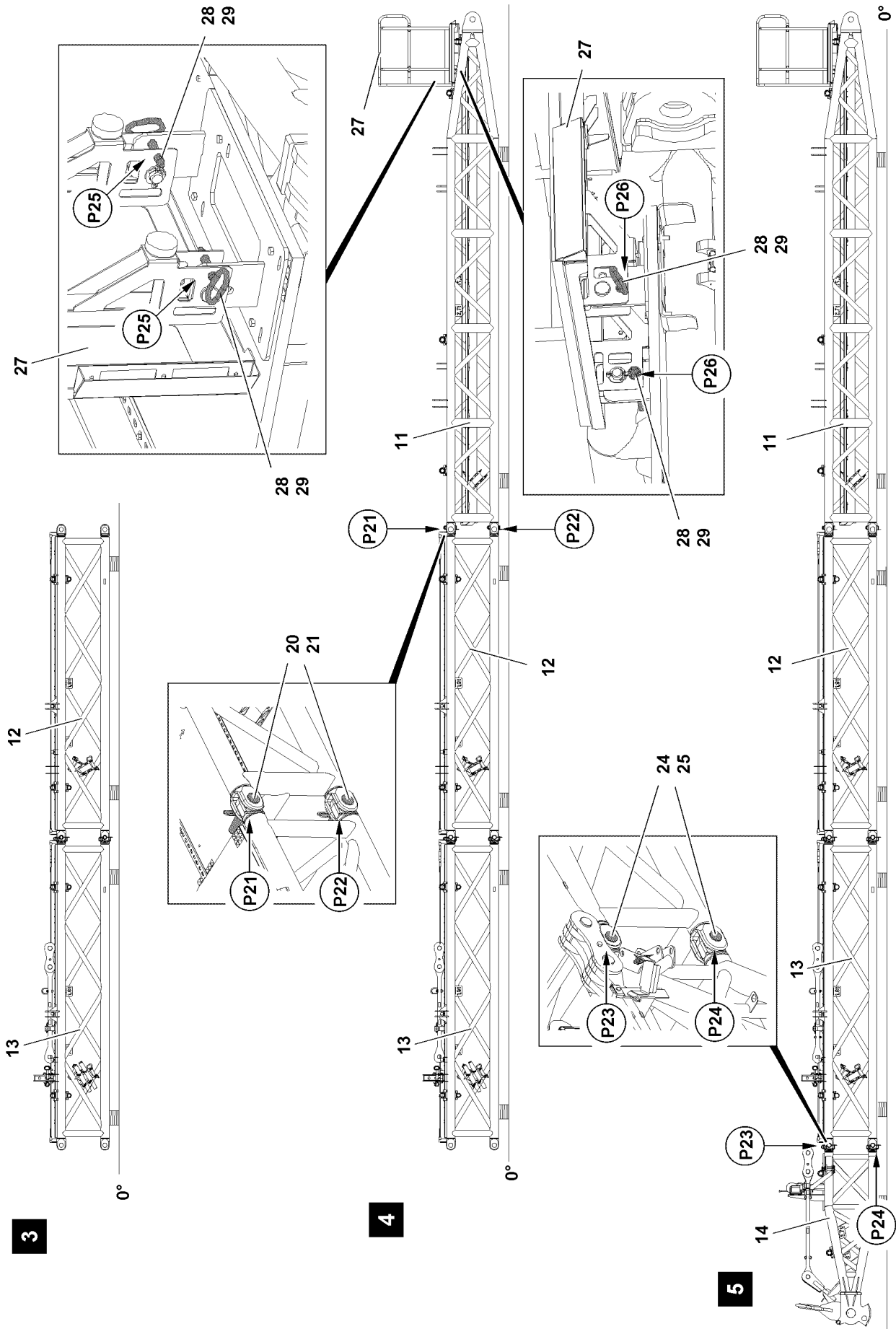

Fig.122803

LWE/LR 11000-001/23501-04-02/en

9.1.2 Assembling the suspended ballast guide with a suspended ballast radius of 30 m



Note

- ▶ The assembly of the suspended ballast guide is described based on the example of a suspended ballast guide with a 30 m suspended ballast radius.

Make sure that the following prerequisites are met:

- The pivot section has been removed from the transport unit.
- The end section has been removed from the transport unit.

Assembling the intermediate sections

For the suspended ballast guide with a 30 m suspended ballast radius only two intermediate sections are installed.

- ▶ Support the ground in such a way that the intermediate sections can be placed down horizontally.
- ▶ Place the intermediate sections with the auxiliary crane on the substructure, see illustration 3.
- ▶ Remove the fastening equipment.

Assembling the pivot section

- ▶ Fasten the pivot section **11** to the auxiliary crane.
- ▶ Position the pivot section **11** with the auxiliary crane on the intermediate section **12** at point **P21** until the pin points align.
- ▶ Support the pivot section **11**.

The pivot section and the intermediate section are pinned together in four points. Every point is present on both sides of the component on one level, see illustration 4.

- ▶ Pin the pivot section **11** on both sides at point **P21** with the intermediate section **12**: Insert the pin **20** and secure it with the retaining element **21**.
- ▶ Pin the pivot section **11** on both sides at point **P22** with the intermediate section **12**: Insert the pin **20** and secure it with the retaining element **21**.
- ▶ Remove the fastening equipment.

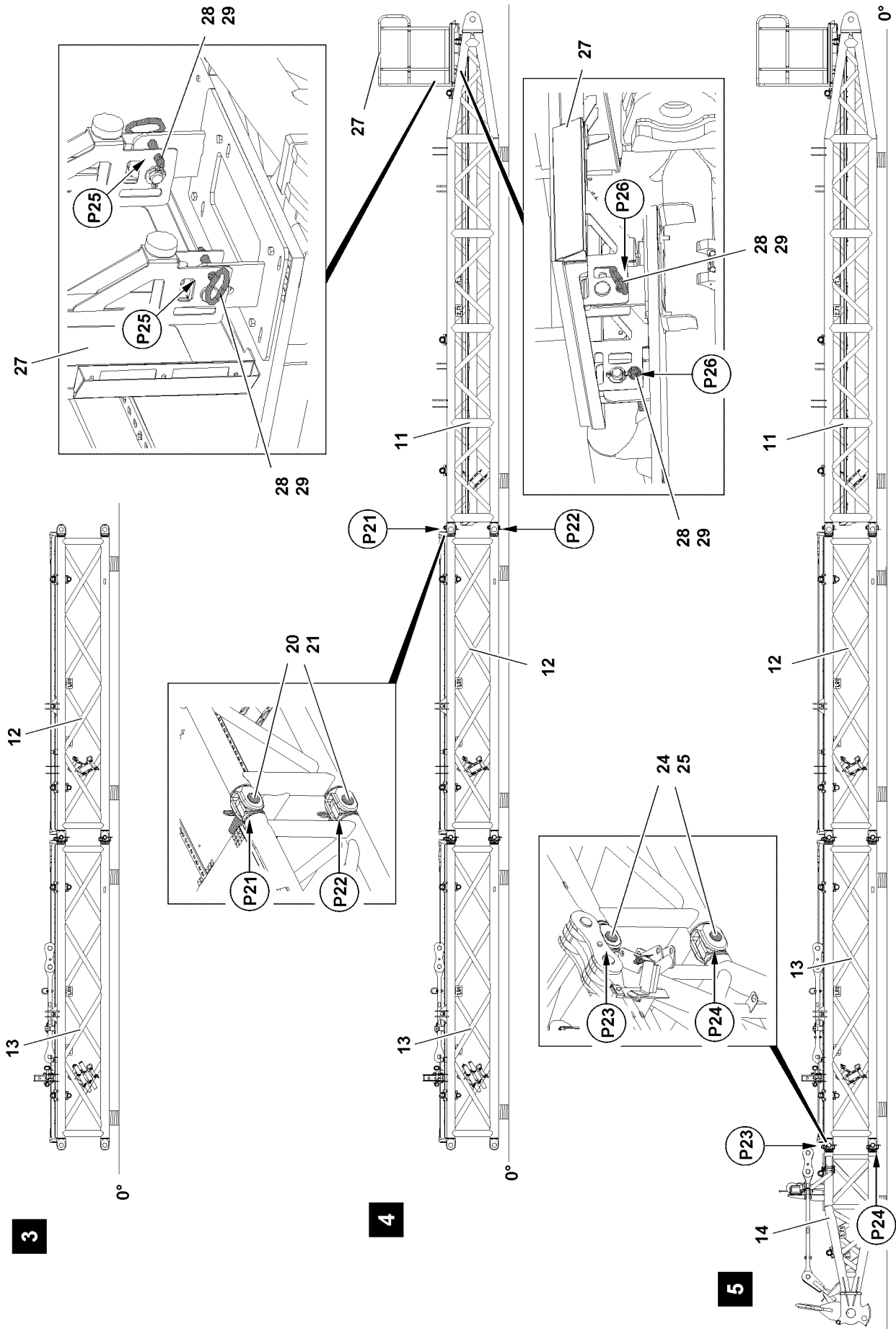

Fig.122803

LWE/LR 11000-001/23501-04-02/en

- ▶ Fasten the platform **27** to the auxiliary crane.



WARNING

Platform swinging down!

The platform can swing down by itself due to its own weight when unpinning it at points **P25**.

Death, severe bodily injuries, property damage.

Fingers and hands can be crushed.

- ▶ Make sure that the platform is safely held by the auxiliary crane.
- ▶ Do not reach with your hands into the danger zone.
- ▶ Use personal protective equipment.

-
- ▶ Set the platform **27** into operating position, see illustration 4: Remove the retaining element **29** at points **P25** and unpin the grip pins **28**.
 - ▶ Swing the platform **27** with the auxiliary crane.
 - ▶ Insert the grip pins **28** at points **P26** and secure with the retaining element **29**.
 - ▶ Remove the auxiliary crane.

Assembling the end section

- ▶ Fasten the end section **14** to the auxiliary crane.
- ▶ Position the end section **14** with the auxiliary crane on the intermediate section **13** at point **P23** until the pin points align.
- ▶ Support the end section **14**.

The end section and the intermediate section are pinned together in four points. Every point is present on both sides of the component on one level, see illustration 5.

- ▶ Pin the end section **14** on both sides at point **P23** with the intermediate section **13**: Insert the pin **24** and secure it with the retaining element **25**.
- ▶ Pin the end section **14** on both sides at point **P24** with the intermediate section **13**: Insert the pin **24** and secure it with the retaining element **25**.
- ▶ Remove the fastening equipment.

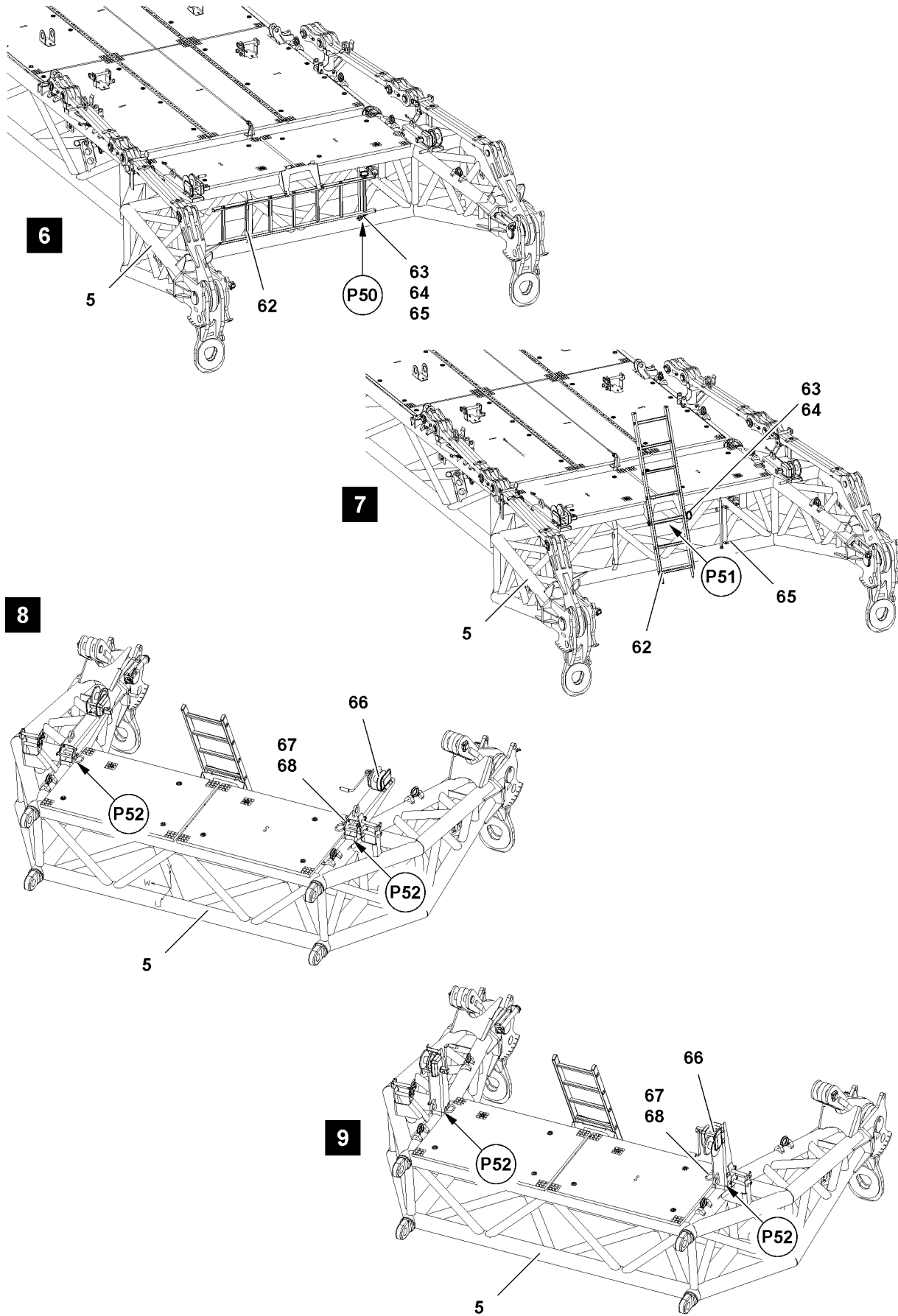

Fig.120205

LWE/LR 11000-001/23501-04-02/en

Assembling the ladder



WARNING

Falling ladder!

The ladder can fall down by itself due to its own weight when it is unpinned.

Death, severe bodily injuries, property damage.

Fingers and hands can be crushed.

- ▶ When unpinning the pin connection, hold the ladder.
 - ▶ Do not reach with your hands into the danger zone.
-
- ▶ Release the ladder **62** from the transport retainer: Remove the lock **65** at point **P50** and unpin the grip pin **63**, see illustration **6**.
 - ▶ Remove the retaining element **64** at point **P50** from the park position, see illustration **6**.
 - ▶ Attach the lock **65** at point **P50** in the park position, see illustration **6**.



WARNING

Danger of crushed limbs!

When hanging the ladder up, fingers and hands can be crushed.

- ▶ Do not reach with your hands into the danger zone.
-
- ▶ Get the ladder **62** from the transport retainer and hang it up at point **P51**, see illustration **7**.
 - ▶ Secure the ladder **62** in operating position: Insert the grip pin **63** at point **P51** and secure with the retaining element **64**, see illustration **7**.

Assembling the manual rope winch



WARNING

Danger of crushed limbs!

When setting up the manual rope winch, fingers and hands can be crushed.

- ▶ Do not reach with your hands into the danger zone.



WARNING

Falling manual rope winch!

The manual rope winch can fall down by itself due to its own weight when setting it up.

Death, severe bodily injuries, property damage.

Fingers and hands can be crushed.

- ▶ When unpinning the pin connection, hold the ladder.
 - ▶ Do not reach with your hands into the danger zone.
-
- ▶ Set up the manual rope winch **66**, see illustration **9**.
 - ▶ Secure the manual rope winch **66** in operating position: Insert the grip pin **67** at point **P52** and secure with the retaining element **68**, see illustration **9**.

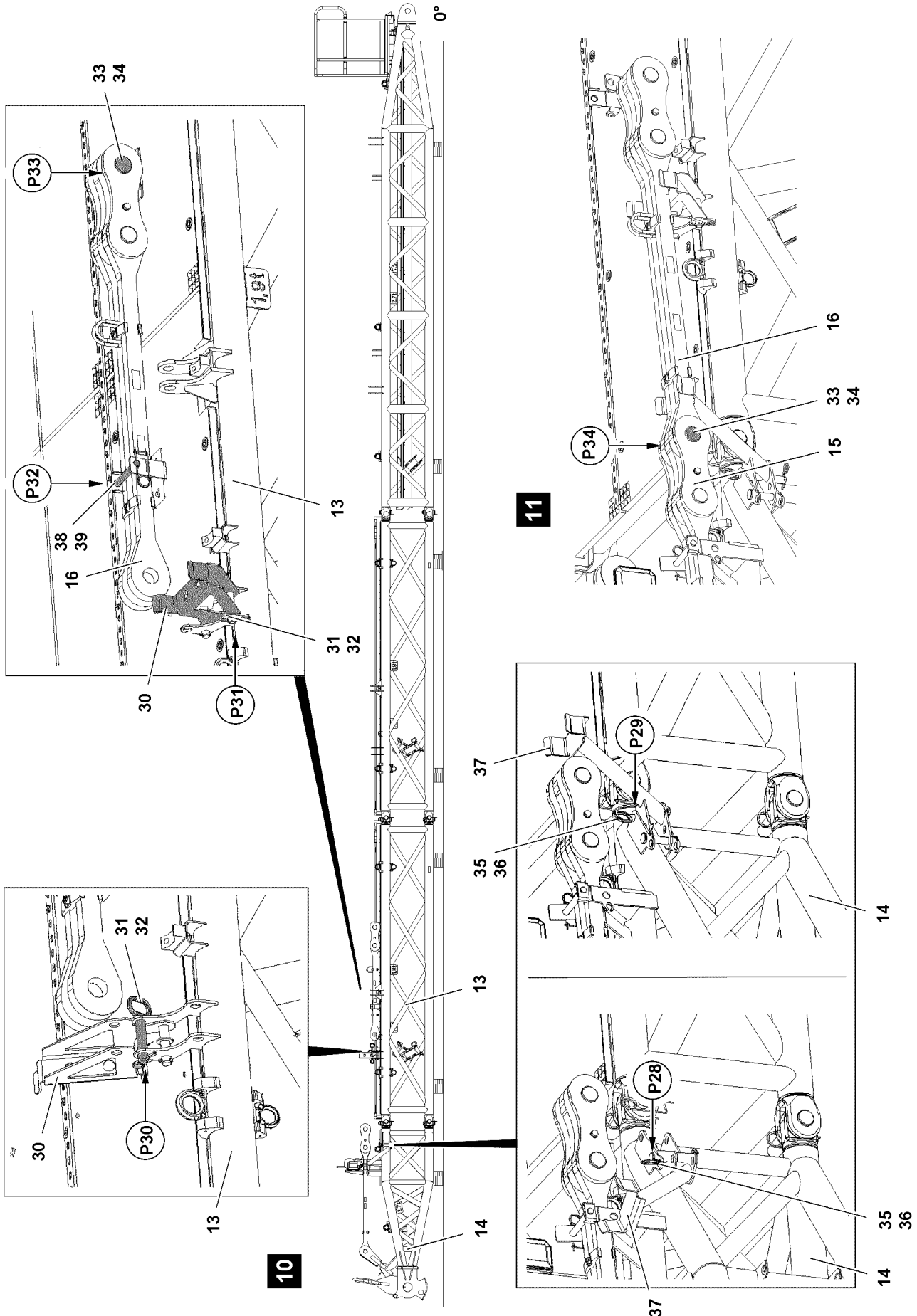

Fig.122804

LWE/LR 11000-001/23501-04-02/en

Assembling the pull rods

- ▶ Release the bracket **37** from the transport position: Remove the retaining element **36** at point **P28** and unpin the socket pin **35**, see illustration **10**.

**WARNING**

Danger of crushed limbs!

When swinging the bracket, fingers and hands can be crushed.

- ▶ Do not reach with your hands into the danger zone.

- ▶ Swing the bracket **37** until it can be pinned at point **P29**.
- ▶ Insert the socket pin **35** at point **P29** and secure with the retaining element **36**, see illustration **10**.

Result:

- The bracket **37** is secured in the operating position.

- ▶ Release the retainer **30** from the transport position: Remove the retaining element **32** at point **P30** and unpin the socket pin **31**, see illustration **10**.

**WARNING**

Danger of crushed limbs!

When swinging the retainer, fingers and hands can be crushed.

- ▶ Do not reach with your hands into the danger zone.

- ▶ Swing the retainer **30** until it can be pinned at point **P31**.
- ▶ Secure the retainer **30** in operating position: Insert the socket pin **31** at point **P31** and secure with the retaining element **32**, see illustration **10**.

Result:

- The retainer **30** is secured in the operating position.

- ▶ Release the pull rods **16** from the transport position: Remove the retaining element **39** at point **P32** and unpin the pin **38**, see illustration **10**.
- ▶ Remove the retaining element **34** at point **P33** and unpin the pin **33**, see illustration **10**.
- ▶ Fasten the auxiliary crane to the pull rod **16**.
- ▶ Place the pull rod **16** down with the auxiliary crane in operating position on the retainer **30** and align at point **P34** on bores, see illustration **11**.
- ▶ Pin the pull rod **16** with the pull rod end section **15**: Insert the pin **33** at point **P34** and secure with the retaining element **34**, see illustration **11**.
- ▶ Remove the auxiliary crane.
- ▶ Insert the pin **38** in the park position and secure with the retaining element **39**.
- ▶ Release the pull rod **15** from the transport position.

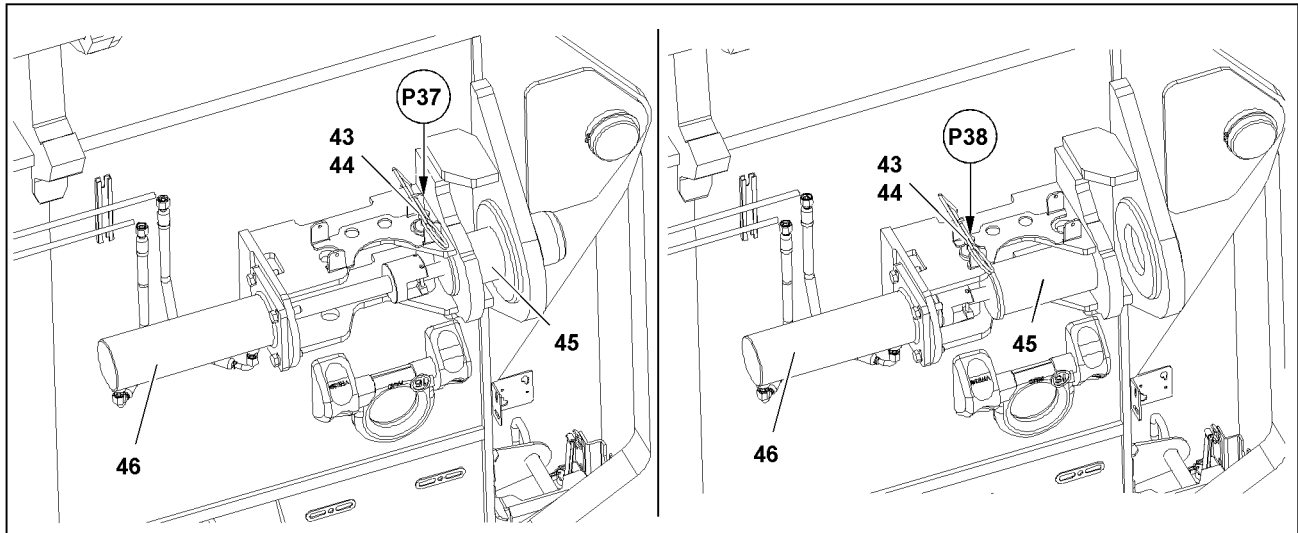

12

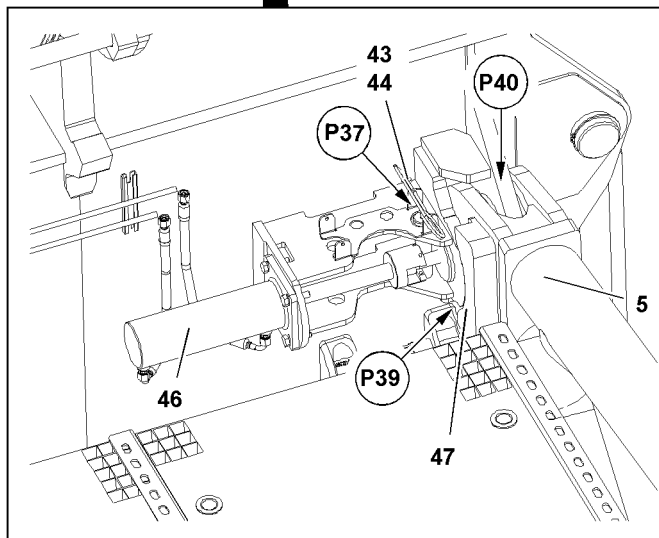
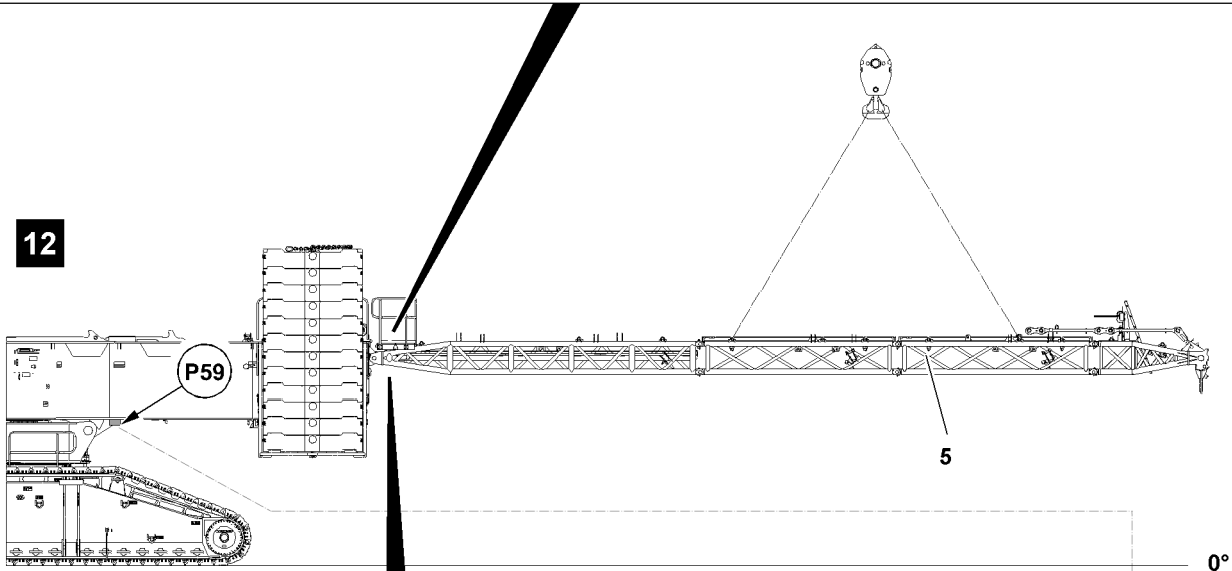

13

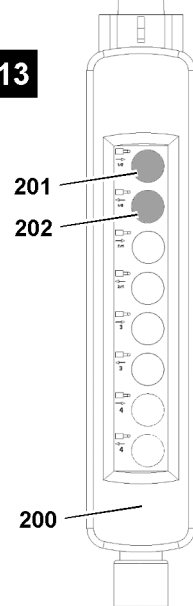

Fig.122805

LWE/LR 11000-001/23501-04-02/en

Swinging the brackets

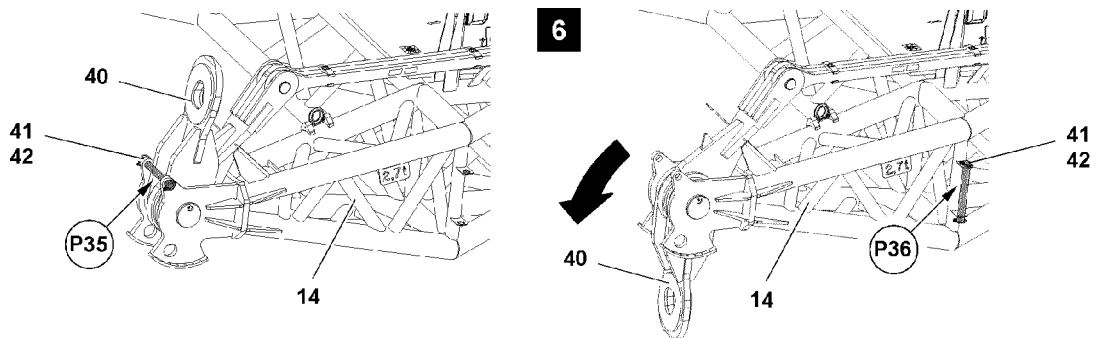

Fig.119028: Swinging the bracket

- ▶ Fasten the bracket 40 to the auxiliary crane.



WARNING

Bracket swinging down!

The bracket can swing down by itself due to its own weight when unpinning it at point P25, see illustration.

Death, severe bodily injuries, property damage.

Fingers and hands can be crushed.

- ▶ Make sure that the platform is held by the auxiliary crane.
- ▶ Do not reach with your hands into the danger zone.

- ▶ Remove the retaining element 42 at point P35 and unpin the pin 41, see illustration 14.
- ▶ Swing the bracket 40 downward with the auxiliary crane.
- ▶ Insert the pin 41 in the park position at point P36 and secure with the retaining element 42, see illustration 14.

9.1.3 Assembling the suspended ballast guide on the turntable frame

Make sure that the following prerequisites are met:

- A lifting platform or other aids are available.
- An auxiliary crane is available.
- The control panel is connected on the „rear turntable“ socket, point P59.

The suspended ballast guide 5 is pinned on two points. The pin procedure is described for one pin as an example:

- ▶ Release the pin 45: Remove the retaining element 44 at point P37 and unpin the retaining pin 43, see illustration 12.
- ▶ Insert the retaining pin 43 at point P38 and secure with the retaining element 44, see illustration 12.
- ▶ Plug the control panel on the turntable in on the rear, see illustration 13.
- ▶ Unpin the pin 45: Press button 202 on the control panel 200, see illustration 13.

Result:

- The pin 45 moves out.

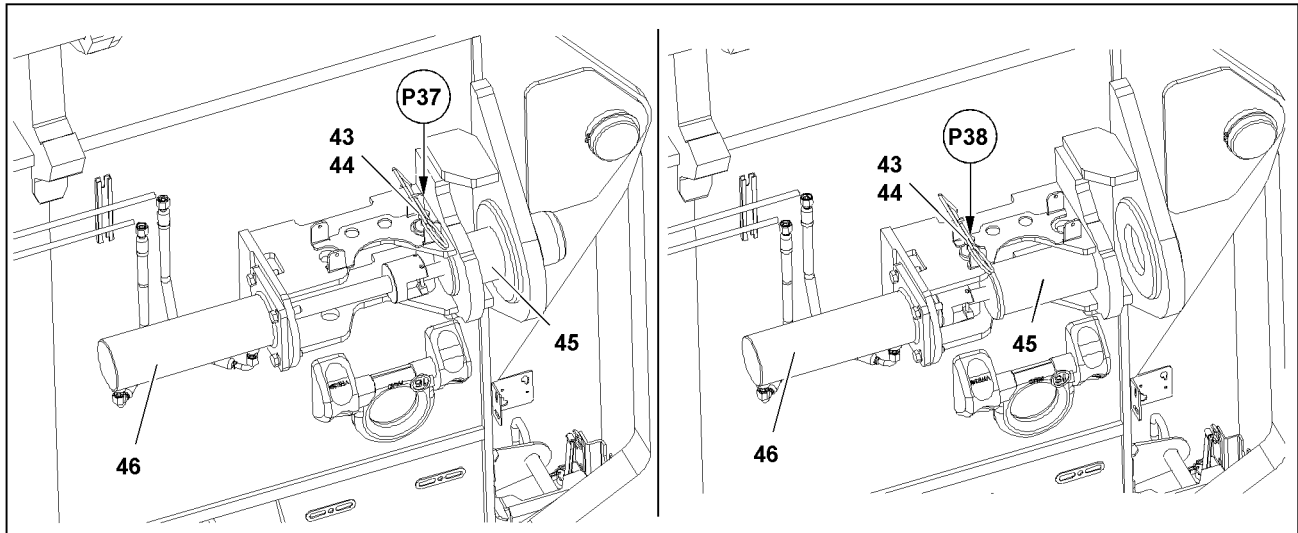

12

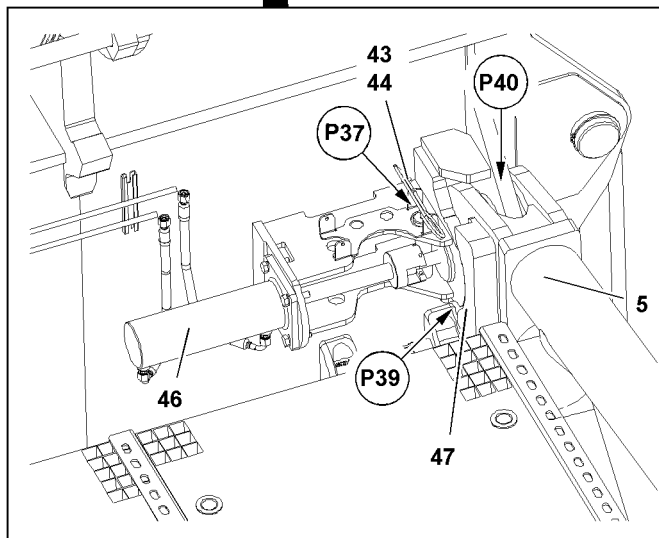
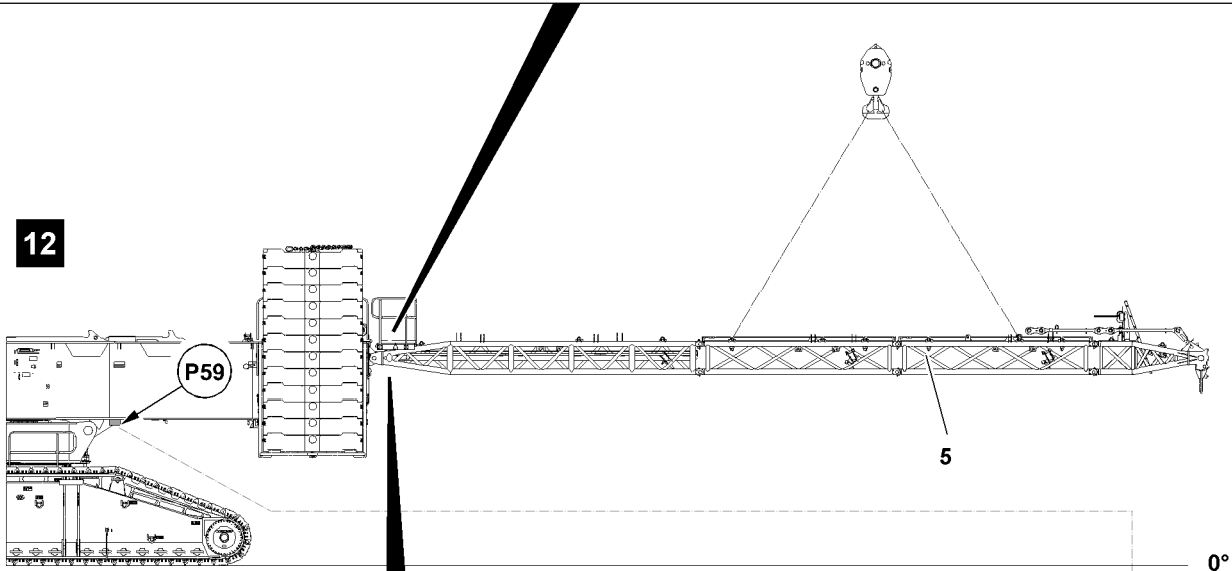

13

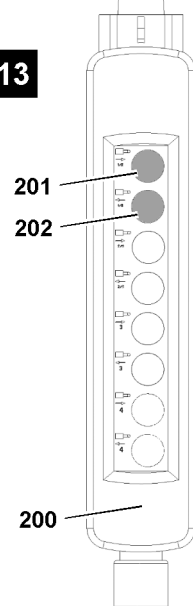

Fig.122805

- ▶ Attach the suspended ballast guide **5** on the auxiliary crane.
- ▶ Lift the suspended ballast guide **5** to the pin points **P40** on the rear of the turntable, see illustration **12**.
- ▶ Set the suspended ballast guide **5** on the centering **47** on points **P39** of the turntable, see illustration **12**.

Result:

- Align the pin bores.

- ▶ Insert the pin **45**: Press button **201** on the control panel **200**, see illustration **13**.

Result:

- The pin **45** moves in.

**WARNING**

Danger of accident!

If the pins are not secured with the retaining pin, then the connector pins can loosen up by themselves during crane operation.

This can cause the crane to topple over.

Death, severe bodily injuries, property damage.

- ▶ Make sure that the connector pins are secured.

- ▶ Secure the pin **45**: Insert the retaining pin **43** at point **P37** and secure with the retaining element **44**, see illustration **12**.

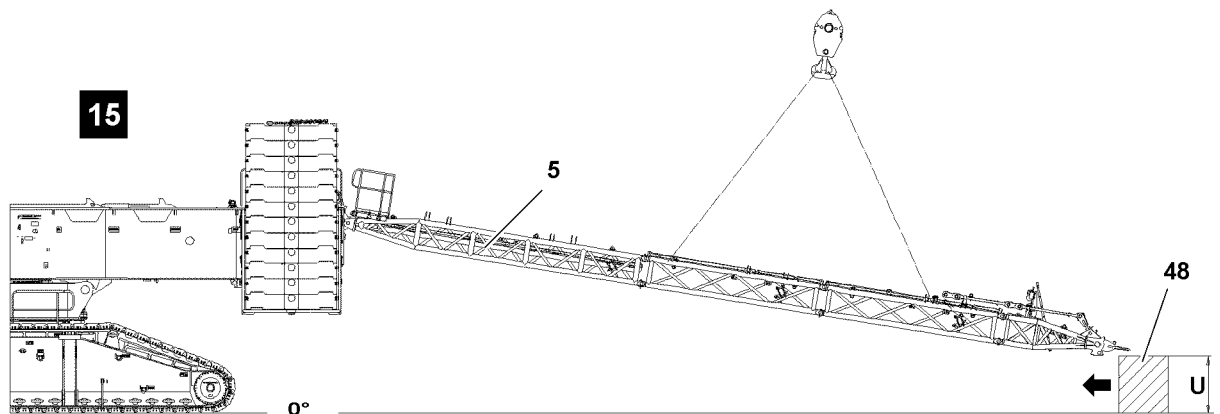

Fig.120203: Substructure

Suspended ballast guide	R30	R25	R20
Substructure height „U“	0 m	1.6 m	2.0 m

- ▶ Take the suspended ballast guide **5** down on the substructure with the auxiliary crane, see illustration **15** and chart.

9.2 Pinning the suspended ballast guide with the divisible ballast pallet „VarioTray“

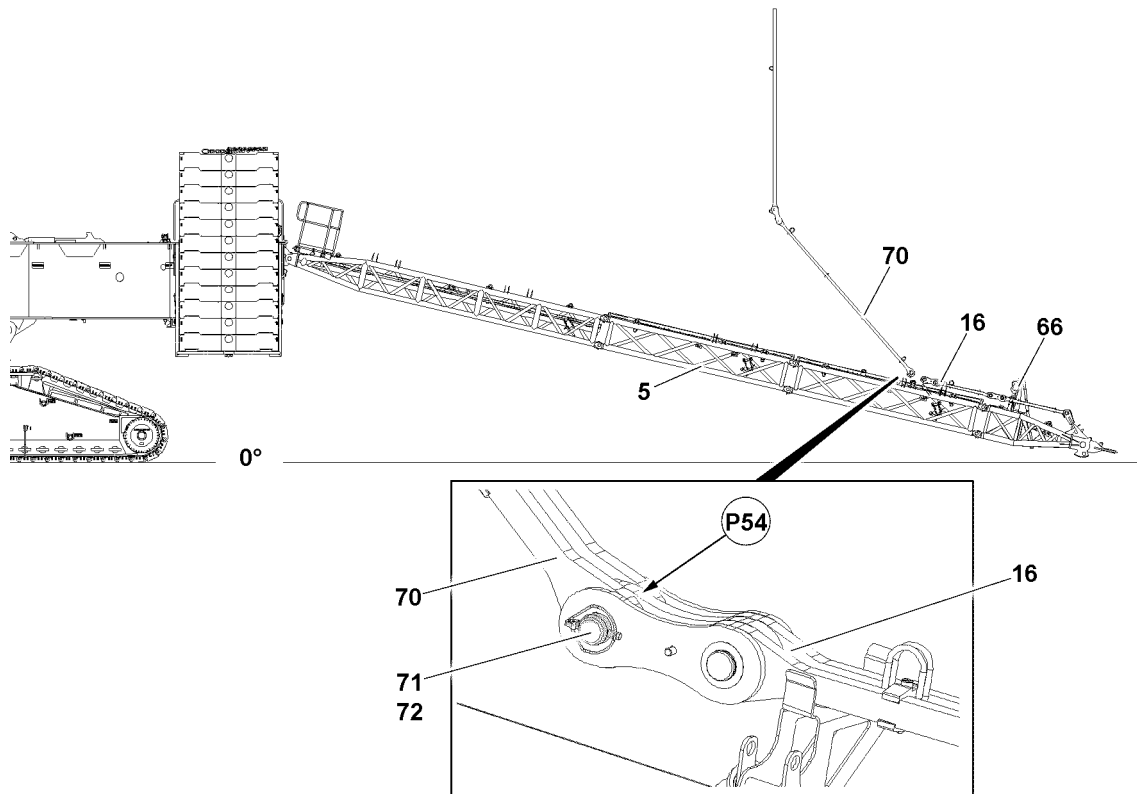

Fig.145280: Pinning the D-guy rods

Make sure that the following prerequisites are met:

- The D-guy rods hang over the brackets of the suspended ballast guide.
- The manual rope winches are set up and secured.
- The erection racks are erected and secured with retaining pins.

9.2.1 Pinning the D-guy rods with the pull rods of the suspended ballast guide

- ▶ Connect the rope of the manual rope winch **66** with the D-guy rods **1**.

The D-guy rods **1** are pinned on both sides on the suspended ballast guide **5**. The pin procedure is described on the example for one D-guy rod.

- ▶ Pull the D-guy rods **1** with the manual rope winch **66** to the pull rods **16** and luff the derrick down at the same time until it can be pinned on point **P54**.



WARNING

Danger of accident!

If the connector pins are not secured with the retaining pin, then they can loosen up by themselves during crane operation.

This can cause the crane to topple over.

Death, severe bodily injuries, property damage.

- ▶ Make sure that the connector pins are secured.

When the pin bores align:

- ▶ Pin the pin **71** in point **P54** and secure with the retaining element **72**.

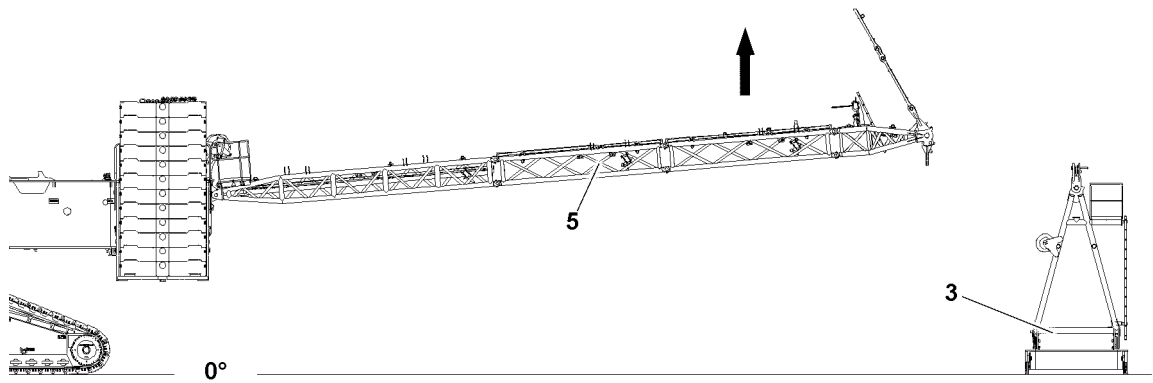

Fig. 145281: Lifting the suspended ballast guide

- ▶ Lift the suspended ballast guide **5** with the derrick.

9.2.2 Pinning the suspended ballast guide on the divisible ballast pallet „VarioTray“

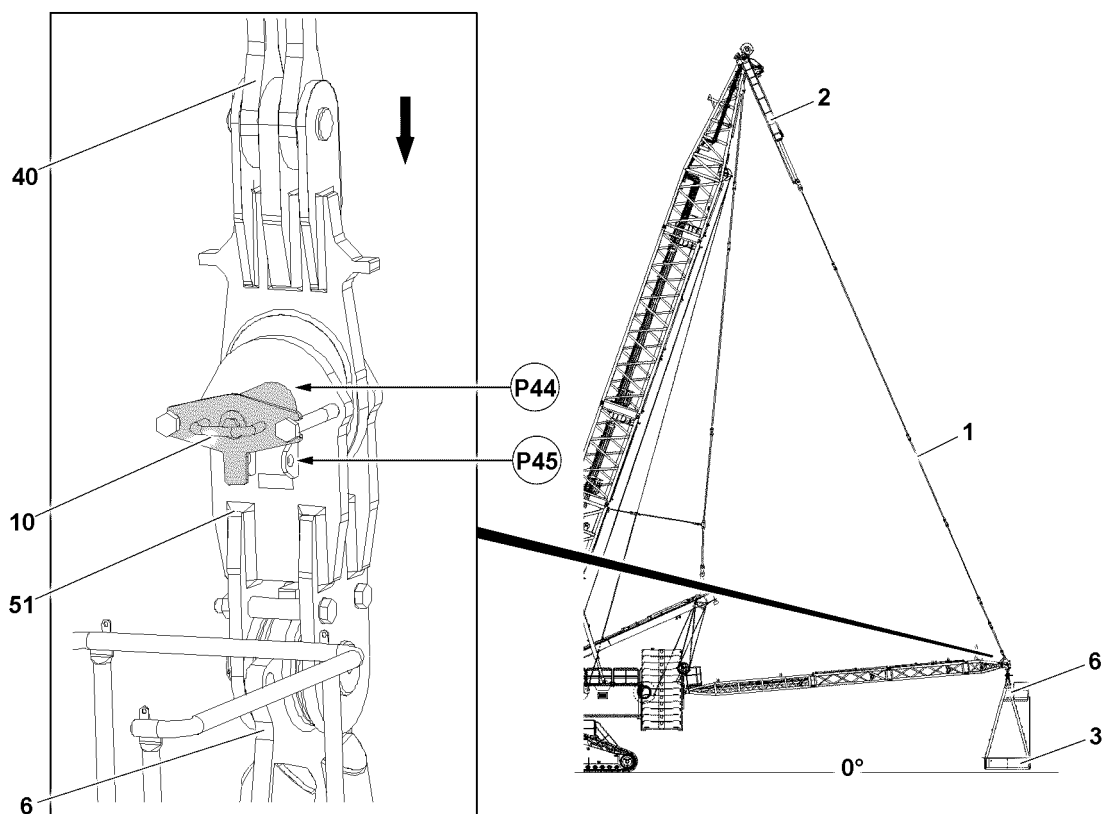

Fig. 145278: Pinning procedure

Make sure that the following prerequisite is met:

- The derrick is set to the required radius.

The divisible ballast pallet „VarioTray“ **3** is pinned at two points. The pin procedure is described for one pin as an example.

- ▶ Position the suspended ballast guide **5** over the divisible ballast pallet „VarioTray“ **3**.
- ▶ Remove the retaining element **53** at point **P45** and unpin the retaining pin **52**.
- ▶ Unpin the connector pin **10** at point **P44**.
- ▶ Lower the brackets **40** of the suspended ballast guide by extending the piston rods on the pull cylinders **2** into the brackets **51** until the pin bores align.

**Note**

Retract / extend the pull cylinder **2**:

- ▶ Control the pull cylinders **2** from the crane cab, see the section „Lifting and lowering the derrick ballast using the pull cylinders“.
- ▶ Operate the pull cylinder **2** with the radio remote control, see the „radio remote control operating instructions“.

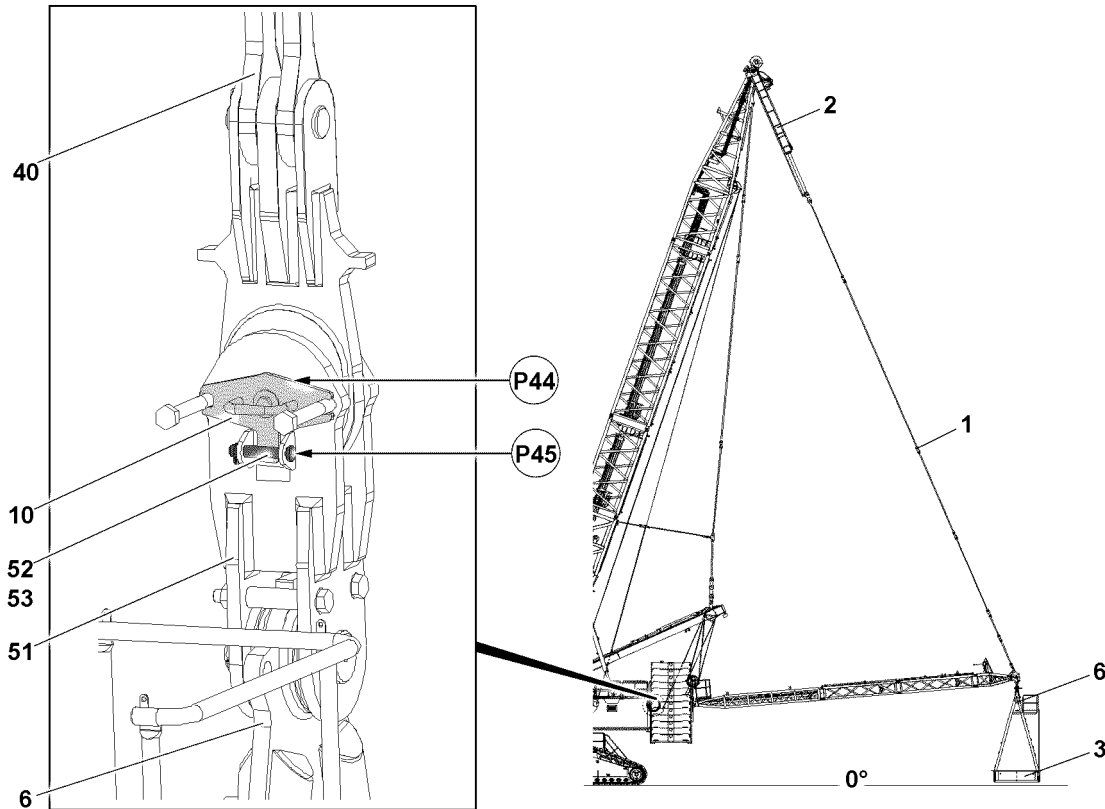

Fig.145279: Pinning procedure

Pin the brackets **40** on the brackets **51** and secure.

- ▶ Insert the connector pin **10** at point **P44**.

**WARNING**

Danger of accident!

If the connector pins are not secured with the retaining pin, then they can loosen up by themselves during crane operation.

This can cause the crane to topple over.

Death, severe bodily injuries, property damage.

- ▶ Make sure that the connector pins are secured.

- ▶ Insert the retaining pin **52** at point **P45** and secure with the retaining element **53**.

- ▶ Pin the second erection rack **7** on the suspended ballast guide **5**.

**WARNING**

Uncontrolled swinging of the divisible ballast pallet „VarioTray“!

When the ballast plate **3** is raised, it can start to swing.

Death, severe bodily injuries, property damage.

- ▶ It is prohibited to remain in the danger zone.
- ▶ Secure the divisible ballast pallet „VarioTray“ with an auxiliary rope.

- ▶ Lift the empty divisible ballast pallet „VarioTray“ **3** with the pull cylinders **2** and then set it down again.

Result:

- The divisible ballast pallet „VarioTray“ **3** is vertically aligned.
- ▶ Align the divisible ballast pallet „VarioTray“ **3** horizontally.

9.3 Establishing the electrical connection from the suspended ballast to the turntable



Note

- ▶ Establish the electrical connections from the suspended ballast to the turntable, see Electric wiring diagram.



WARNING

Malfunction if dummy plugs are not installed!

If the dummy plugs on the non-required electrical connections are not installed, then malfunctions or functional limitations can occur on the crane.

- ▶ Make sure that all non-required electrical connections, which have a dummy plug are closed off with dummy plugs.
- ▶ Pay attention to the Electrical wiring diagram.
- ▶ As a rule, close off on-required electrical connections (for example for accessories which cannot be installed) with the respective dummy plugs.
- ▶ Establish the electrical connections.

10 Ballasting the divisible ballast pallet „VarioTray“

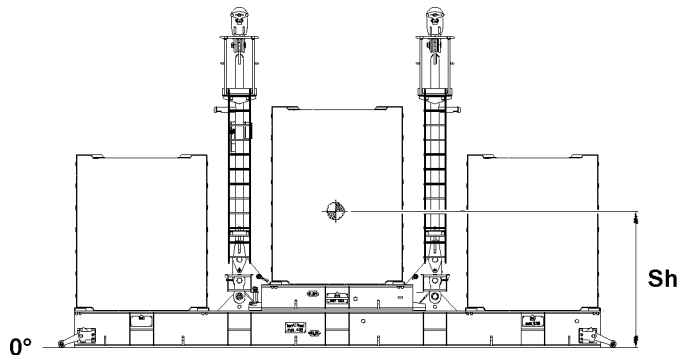

Fig.145286: Maximum permissible ballast center of gravity height

**WARNING**

The crane can topple over!

If the following danger notes are not observed, the ballast plates or the ballast stack can slip on the divisible ballast pallet „VarioTray“ and fall down.

Death, severe bodily injuries, property damage.

- ▶ The ground on which the divisible ballast pallet „VarioTray“ is ballasted must be level and have adequate load bearing capacity.
- ▶ Always place the ballast plates symmetrically, in reference to the longitudinal axis.
- ▶ It is necessary to start with the two center ballast stacks.
- ▶ The difference for the center ballast stack may not be more than a maximum of one ballast plate during ballasting.
- ▶ When ballasting the two outer ballast stacks, only one ballast plate may be placed at the start of each ballast stack.
- ▶ The two outer ballast stacks may be ballasted with ballast assemblies of two ballast plates after the first ballast plate has been placed on each stack.
- ▶ The difference between both outer ballast stacks may not be more than maximum 25 t when ballasting.
- ▶ The outer ballast stacks must always weigh the same and be the same height after ballasting.
- ▶ The two center ballast stacks can have a maximum difference of 10 t after ballasting.
- ▶ The outer ballast stacks can differ in stack height from the inner ballast stacks.
- ▶ The maximum permissible ballast center of gravity height **Sh** of 2800 mm may not be exceeded.
- ▶ Secure all ballast plates so they cannot move and fall down.
- ▶ Replace damaged ballast plates immediately with new ballast plates.

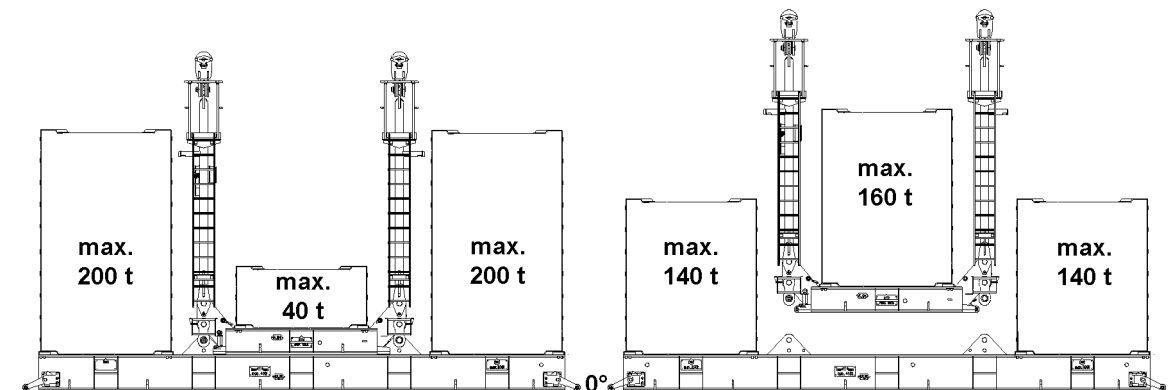

Fig.145285: Maximum permissible total weight

**WARNING**

The crane can topple over!

If the following danger notes are not observed, the crane can topple over.

Death, severe bodily injuries, property damage.

- ▶ The maximum permissible total weight of the entire derrick ballast may not exceed 440 t.
- ▶ The maximum permissible total weight of the entire derrick ballast may not exceed 160 t during crane operation with ballast pallet.
- ▶ Observe the weight signs on the ballast pallets.

Make sure that the following prerequisites are met:

- The divisible ballast pallet „VarioTray“ is properly installed and secured.
- An auxiliary crane is available.
- The consoles for the ballast centering are properly installed and secured in operating position.

10.1 Placing the ballast plates, fastening system: „Twistlock“

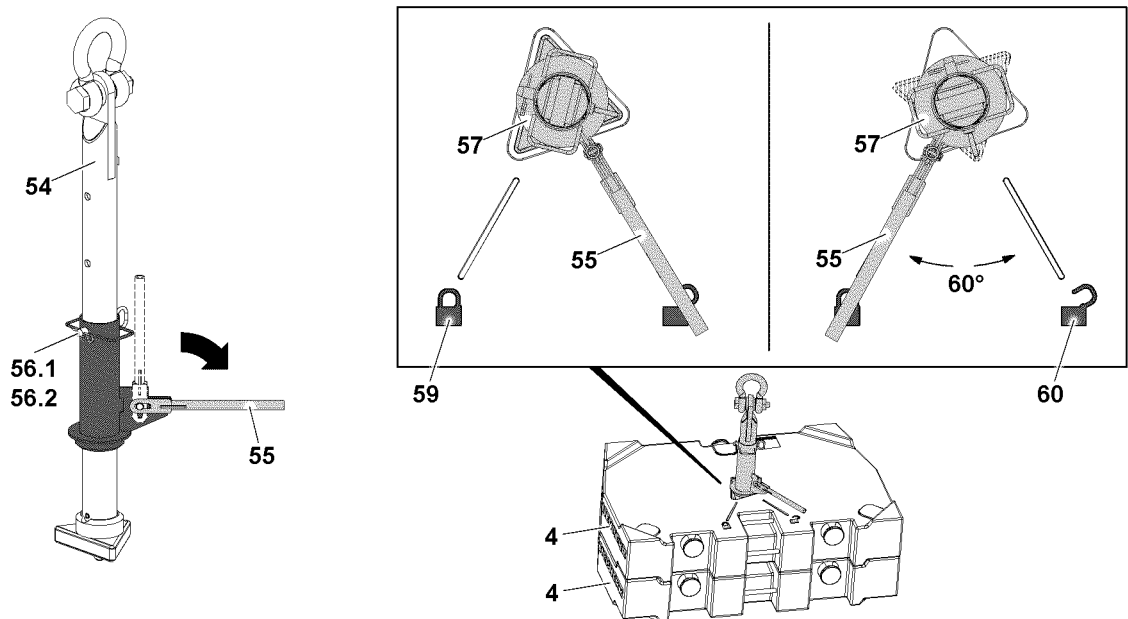

Fig.145282: Ballast plates, fastening system: „Twistlock“



WARNING

Danger of accident!

If more than the permissible two ballast plates are lifted with the receptacle stud, the receptacle stud will be overloaded and can be damaged.

Death, severe bodily injuries, property damage.

- ▶ Make sure that the ballast plates are placed correctly in the centerings.
- ▶ Replace damaged ballast plates.

To stack the ballast plate(s) **4**, use the receptacle stud **54**.

Before the receptacle stud **54** is guided into the ballast plates, it must be ensured that the length of the receptacle stud **54** is set correctly. The length of the receptacle stud **54** can be adjusted with the pin **56**.

If the length of the receptacle stud **54** is to be adjusted:

- ▶ Release and unpin the pin **56.1**.
- ▶ Adjust the length of the receptacle stud by moving the receptacle stud **54**.
- ▶ Insert the pin **56.1** and secure it with the retaining element **56.2**.
- ▶ Fasten the receptacle stud **54** to the auxiliary crane and guide it into the ballast plate(s).
- ▶ Pull the lever **55** up and fold it down.
- ▶ Turn the lever **55** by 60° until the lever **55** points to the icon **59**.

Result:

- The receptacle stud **54** is locked with the ballast plate.
- ▶ Lift always one ballast plate with the receptacle stud **54** and take it down carefully on the outer centerings of the divisible ballast pallet „VarioTray“ **3**.

When the ballast plate has been taken down on the outer centerings of the divisible ballast pallet „VarioTray“ **4**:

- ▶ Turn the lever **55** by 60° until the lever **55** points to the icon **60**.

Result:

- The receptacle stud **54** is unlocked.
- ▶ Carefully pull the receptacle stud **54** from the ballast plate.

- ▶ Stack the ballast plates according to the load chart, observe the danger notes.

10.2 Placing the ballast plates, fastening points: „Bitt“

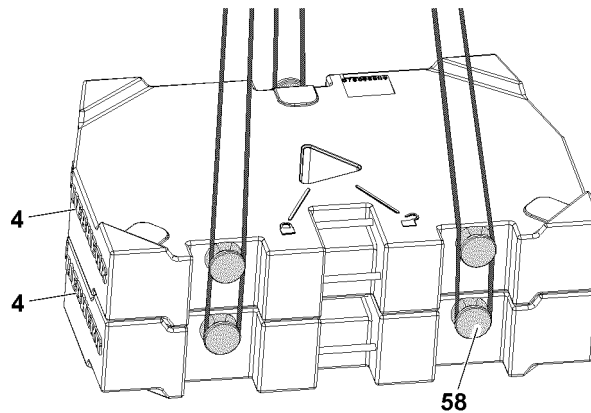

Fig.145283: Ballast plates, fastening points: „Bitt“



WARNING

Falling ballast plates!

If more than the permissible loads are lifted, then the bits **58** are overloaded and the ballast plates can fall down.

Death, severe bodily injuries, property damage.

- ▶ Place the ballast plates individually or as a package, maximum 20 t , 3 fastening points.
- ▶ Replace damaged ballast plates immediately.



WARNING

Incorrect handling of the fastening equipment!

If fastening equipment is not attached correctly and if it is not secured sufficiently to prevent it from loosening up, loads can fall down.

Death, severe bodily injuries, property damage.

- ▶ Make sure that the fastening equipment is correctly attached on the bits **58** and that it is secured sufficiently to prevent it from loosening up.

- ▶ Always place only one ballast plate on the outer centerings on the divisible ballast pallet „VarioTray“.

When a ballast plate has been placed on each of the outer centerings of the divisible ballast pallet „VarioTray“:

- ▶ Place the ballast plates individually or as an assembly of maximum two plates alternately on the left and right with the auxiliary crane.
- ▶ Stack the ballast plates according to the load chart, observe the danger notes.

11 Crane operation with small ballast pallet



WARNING

The crane can topple over!

If the derrick ballast is lifted past the maximum permissible 250 mm off the ground, then the crane can be topple over to the rear if the load rips off.

Death, severe bodily injuries, property damage.

- ▶ Make sure that the derrick ballast is not lifted more than 250 mm off the ground.

**WARNING**

The crane can topple over!

During the attaching /setting down procedure, the small ballast pallet swings out past the maximum permissible 250 mm , up to 1000 mm over the ground.

If the small ballast pallet is lifted past the maximum permissible 250 mm off the ground, then the crane can be topple over to the rear if the load rips off.

Death, severe bodily injuries, property damage.

- ▶ Make sure that the small ballast pallet is lifted or attached from the ballast pallet **without** a load on the hook.

11.1 Setting up crane operation with the small ballast pallet

11.1.1 Disconnecting the divisible ballast pallet „VarioTray“

Make sure that the following prerequisites are met:

- The divisible ballast pallet „VarioTray“ is properly installed and secured on the derrick ballast guying or on the suspended ballast guide*.
- The electrical connection from the derrick ballast to the turntable has been established.
- The cable drum cable is plugged in on the turntable.
- The ground contact rollers must move easily.
- Ballast plates are installed on the large ballast pallet according to the load chart or the erection and take-down charts.
- Ballast plates are installed on the small ballast pallet according to the load chart or the erection and take-down charts.

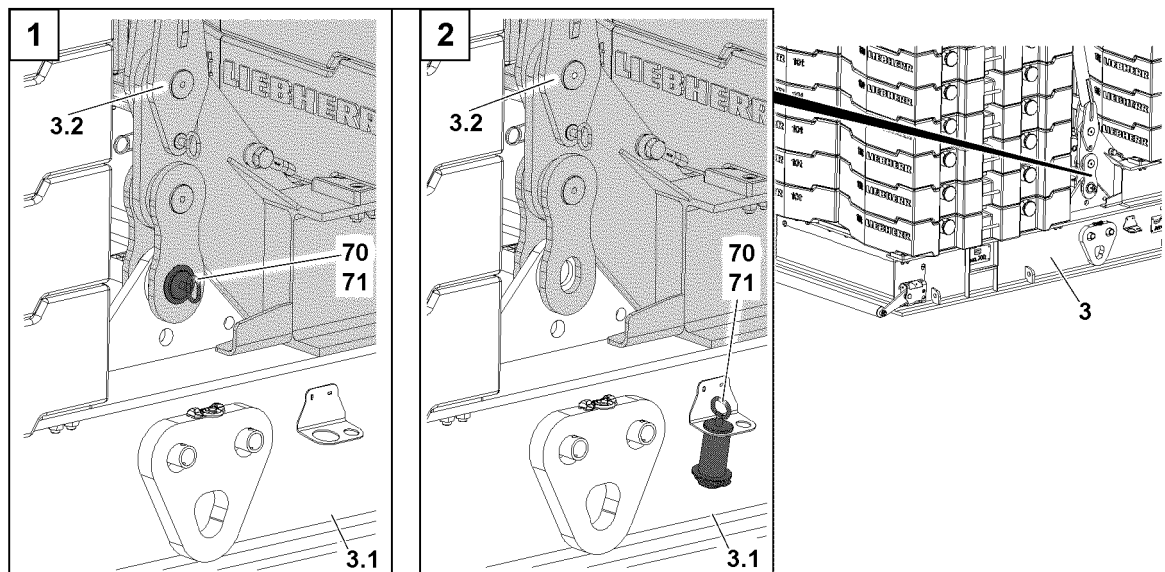

Fig.145287: Disconnecting the divisible ballast pallet „VarioTray“

- ▶ Disconnect electrical connections from the large ballast pallet 1.1 to the small ballast pallet 1.2, see electric wiring diagram.
- ▶ Close the electrical connections off properly with dummy plugs or protective caps.

The small ballast pallet 3.2 is pinned at four points. The unpinning procedure is described for one pin as an example.

- ▶ Remove the retaining element 71 and unpin the connector pin 70.

Result:

- The small ballast pallet 3.2 is disconnected from the large ballast pallet 3.1.
- ▶ Pin the connector pin 70 in the parking position and secure with a retaining element 71.

If the erection racks must be released:

- ▶ Remove the retaining element and unpin the retaining pin, see section „Pinning the suspended ballast guide on the divisible ballast pallet „VarioTray““.

11.1.2 Function check before lifting the derrick ballast

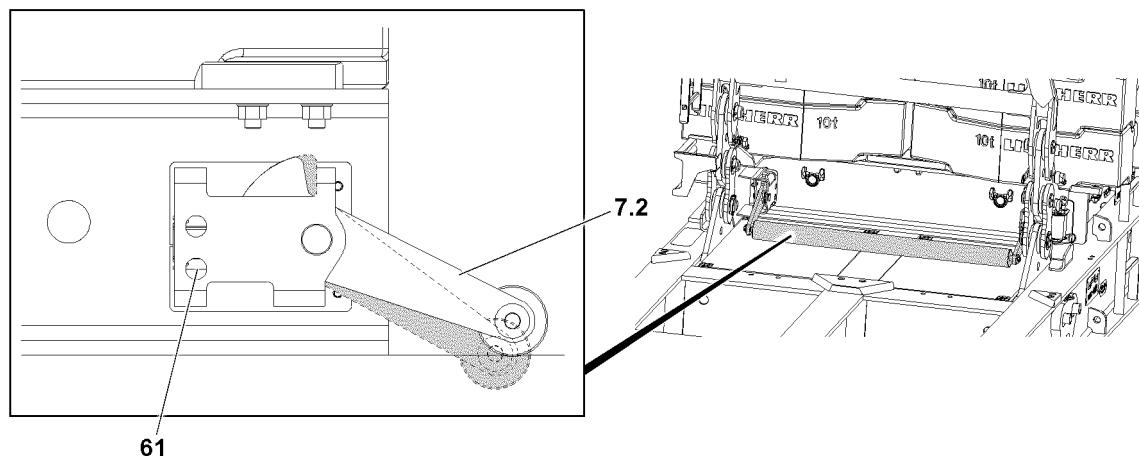

Fig.145288: Ground contact roller

Make sure that the following prerequisite is met:

- The ground contact rollers must move easily.



DANGER

Danger of accident if the derrick ballast touches the ground!

- ▶ If the small ballast pallet touches the ground, **at least one** ground contact switch **61** must be actuated via the ground contact roller **7.2**.
- ▶ The **turning the turntable** and **driving the crawler** crane movements turn off.
- ▶ Manually lift the ground contact roller **7.2**.

Result:

- The ground contact switch **61** is actuated.
- The **turning the turntable** and **driving the crawler** crane movements turn off.

11.1.3 Lifting the small ballast pallet

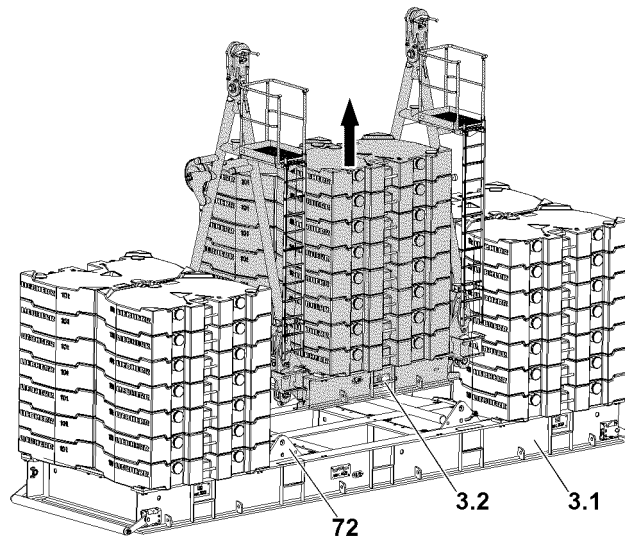

Fig.145289: Small ballast pallet

Make sure that the following prerequisite is met:

- The small ballast pallet **3.2** is disconnected from the large ballast pallet **3.1**.



WARNING

Danger of fatal injury due to tipping ballast plates!

If the crane is turned after the small ballast pallet **3.2** is lifted, the small ballast pallet **3.2** will tip over the ballast plates of the large ballast pallet **3.1**.

Death, severe bodily injuries, property damage.

- ▶ Make sure that the crane is never turned directly after lifting the small ballast pallet **3.2**.
 - ▶ The large ballast pallet **3.1** must always be put down outside of the slewing range of the crane.
-
- ▶ Lift the small ballast pallet **3.2** until it is hovering over the plates **72** of the large ballast pallet **3.1**: Actuate the pull cylinder, see section „Carrying out crane movements“.

11.2 Removing the crane operation with the small ballast pallet

11.2.1 Setting down the small ballast pallet

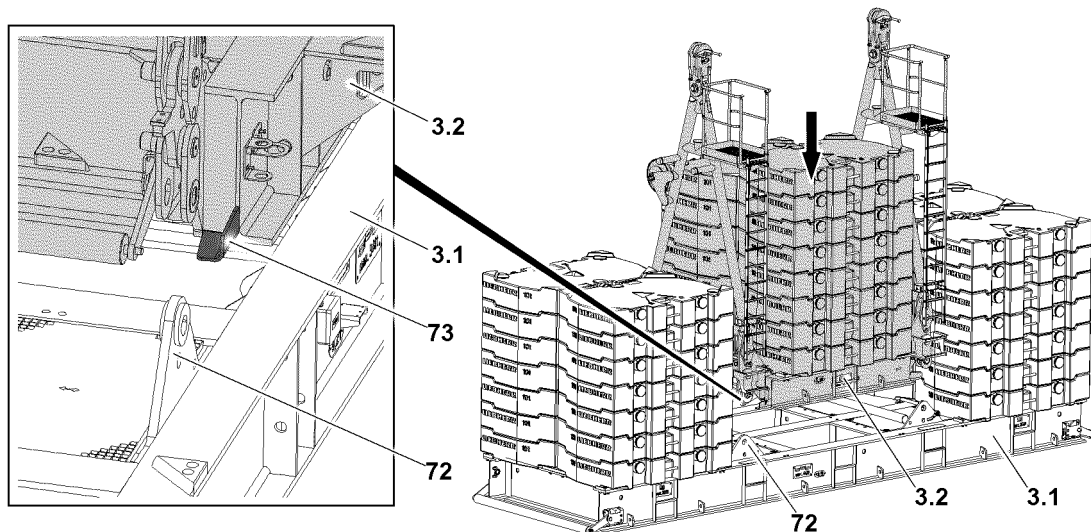

Fig.145290: Setting down the small ballast pallet

Make sure that the following prerequisites are met:

- The small ballast pallet **3.2** is located over the pin locations of the large ballast pallet **3.1**.
- The ground contact rollers must move easily.
- Ballast plates are installed on the large ballast pallet **3.1** according to the load chart or the erection and take-down charts.



WARNING

Danger of fatal injury due to tipping ballast plates!

If the crane is turned when the small ballast pallet **3.2** is being set down, the small ballast pallet **3.2** will tip over the ballast plates of the large ballast pallet **3.1**.

Death, severe bodily injuries, property damage.

- ▶ Make sure that the crane is never turned while the small ballast pallet **3.2** is being set down.



Note

- ▶ When setting down the small ballast pallet **3.2**, use the centerings **93** on the small ballast pallet **3.2** as a guide.
- ▶ Set down the small ballast pallet **3.2** on the large ballast pallet **3.1**: Actuate the pull cylinder, see section „Carrying out crane movements“.

11.2.2 Connecting the divisible ballast pallet „VarioTray“

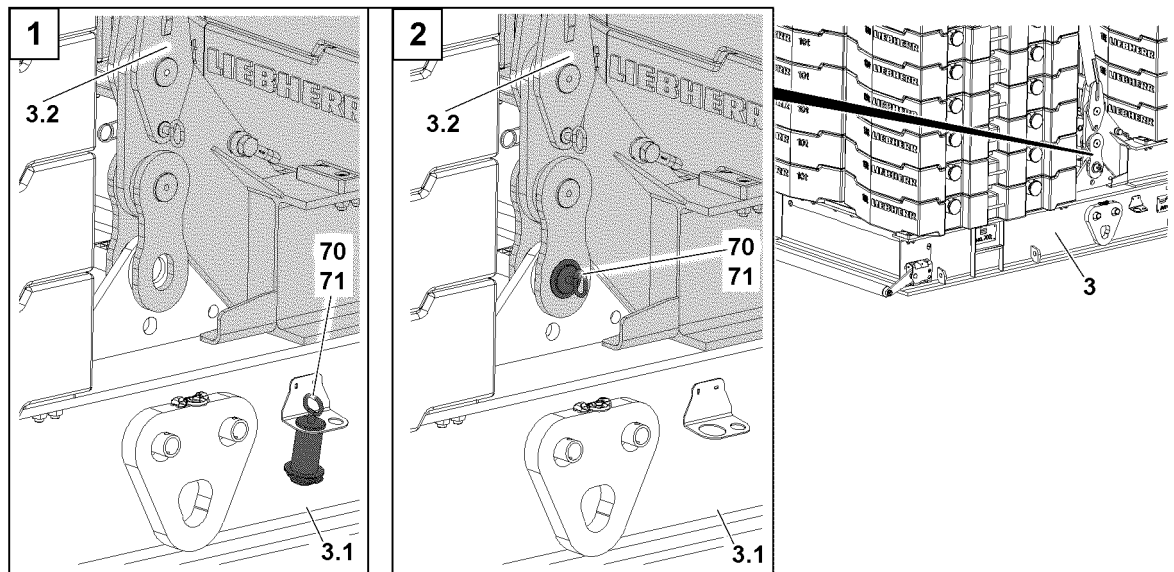

Fig.145291: Connecting the divisible ballast pallet „VarioTray“

Make sure that the following prerequisites are met:

- The small ballast pallet **3.2** is resting completely on the large ballast pallet **3.1**.
- The pin bores on the small ballast pallet **3.2** and on the large ballast pallet **3.1** align.

The small ballast pallet **3.2** is pinned at four points. The pin procedure is described for one pin as an example.

- ▶ Remove the retaining element **71** from the parking position and unpin the connecting pin **70**.
- ▶ Insert the connector pin **70** and secure it with a retaining element **71**.

Result:

- The small ballast pallet **3.2** is pinned to the large ballast pallet **3.1**.

If the erection racks must be secured:

- ▶ Remove the retaining element from the parking position and unpin the retaining pin, see section „Pinning the suspended ballast guide on the divisible ballast pallet „VarioTray““.
- ▶ Pin the retaining pin and secure with the retaining element, see section „Pinning the suspended ballast guide on the divisible ballast pallet „VarioTray““.
- ▶ Establish electrical connections from the large ballast pallet **3.1** to the small ballast pallet **3.2**, see the electric wiring diagram.

12 Crane operation with the derrick ballast

12.1 Function check of the ground contact switch

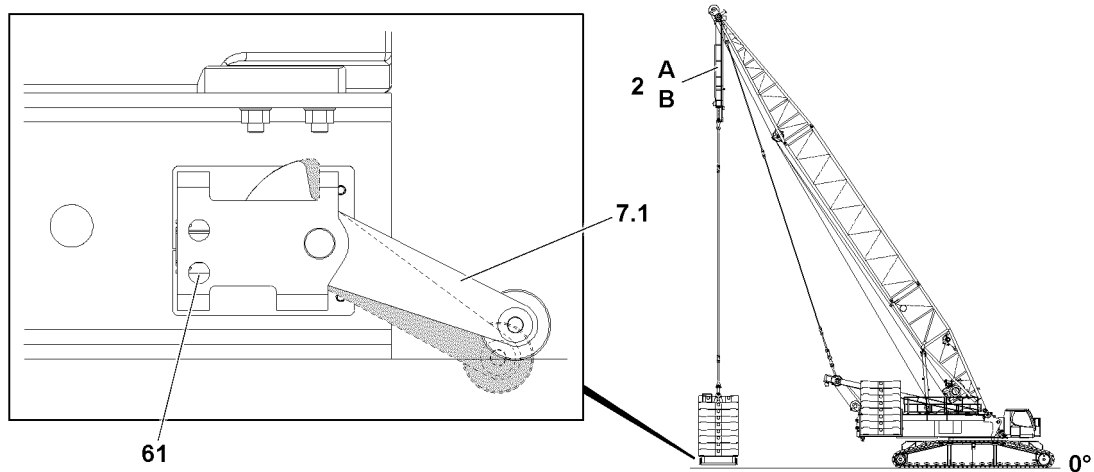

Fig.145284: Ground contact roller

Make sure that the following prerequisites are met:

- The electrical connection from the derrick ballast to the turntable has been established.
- The cable drum pull release is fastened to the turntable.
- The ground contact rollers must move easily.



DANGER

Danger of accident if the derrick ballast touches the ground!

If the terrain is very uneven, the danger exists that the derrick ballast rests on the ground even if a ground contact switch **61** was not actuated.

- ▶ If the divisible ballast pallet „VarioTray“ touches the ground, **at least one** ground contact switch **61** must be actuated via the ground contact roller **7.1**.

- ▶ Check the ease of movement of the ground contact roller **7.1**.
- ▶ Manually operate the ground contact roller **7.1**.

Result:

- The ground contact switch **61** is actuated.
- The LICCON monitor displays derrick ballast has ground contact - the „turning the turntable“ and „driving the crawler“ crane movements are deactivated.

12.2 Lifting and lowering the derrick ballast using the pull cylinders

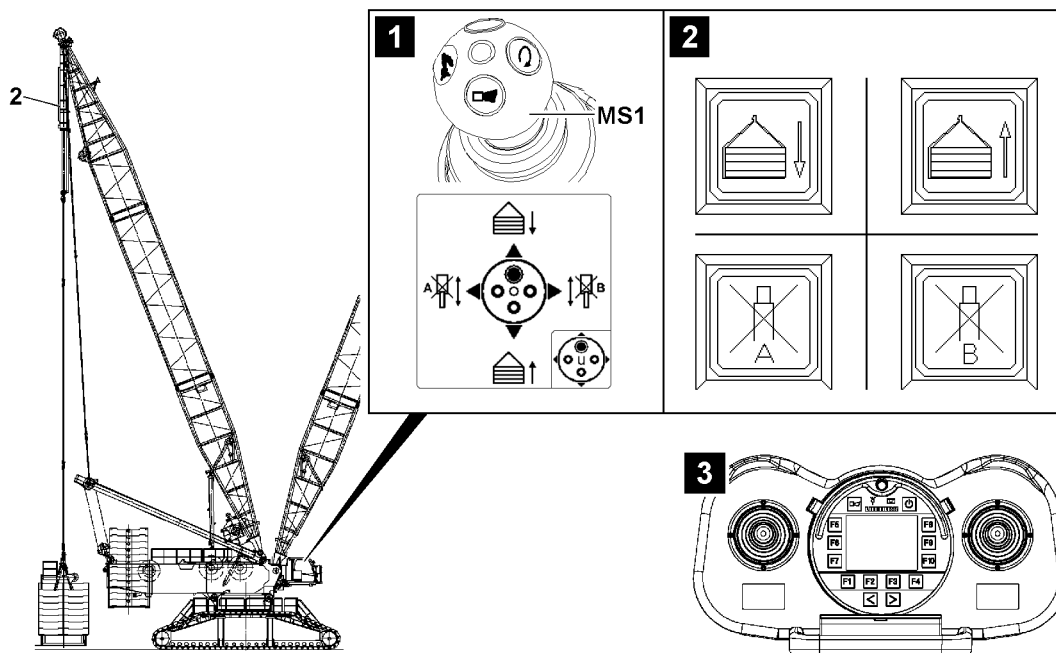

Fig.145937

The pull cylinders **2** in the derrick ballast guying can be operated in different ways:

- Operation with master switch **MS1** in the corresponding master switch assignment, see illustration 1
 - Select the master switch assignment for master switch MS1, see chapter 4.01.
- Operation with operating buttons on the instrument panel, see illustration 2

There is an additional operating option in assembly operation:

- Operation with the radio remote control (BTT-E), see illustration 3
 - Operation with the manual control lever in the corresponding assembly menu, see the radio remote control operating instructions.



Note

- ▶ If the derrick ballast is raised or lowered using the pull cylinder **2**, then the horizontal alignment of the derrick ballast is automatically regulated by both length sensors of the pull cylinder **2**.
- ▶ For a ballast utilization of **more than or equal to 90 percent**, the level sensor regulates the pull cylinder **2** to a difference of 1 cm.
- ▶ With a ballast utilization of **less than 90 percent**, the level sensor monitors the derrick ballast level to $\pm 2.5^\circ$. This makes it possible to set the derrick ballast down up to a ground slope of 2.5° .



DANGER

Danger of accident!

If the following notes are not observed, personnel can be severely injured or killed. In addition, this can result damage to the derrick ballast.

- ▶ Pay attention to the horizontal alignment of the derrick ballast when lifting and lowering the derrick ballast.
- ▶ When lifting and lowering the derrick ballast, check the forces in the D-guyings regularly on LICCON monitor 1. If the difference of forces between „derrick ballast guying A“ and „derrick ballast guying B“ is too large, an acoustic warning sounds and the values on the LICCON monitor 1 blink, see section „Differential force monitoring of Derrick ballast guying“.
- ▶ When adjusting manually (block pull cylinder A or pull cylinder B) the regulation is deactivated and the derrick ballast can be inclined within the limited angle range. This is exclusively permitted when setting down the derrick ballast on uneven ground and only by observing utmost caution.

During crane operation with derrick ballast the required maximum / minimum load can be actively influenced.

This is made possible by increasing or reducing the derrick ballast. Depending on the situation, this procedure is also possible under load.



Note

- ▶ The suspended ballast and the ballast trailer are generally referred to as the **derrick ballast**.
 - ▶ The fixed compensation weight that is installed on the turntable is generally referred to as the **counterweight**.
 - ▶ Additional personnel to carry out crane operation is generally referred to as **guide**.
-
- ▶ Operate the crane function to lift and lower the derrick ballast, see section „Carrying out crane movements“

Empty page!

LWE/LR 11000-001/23501-04-02/en

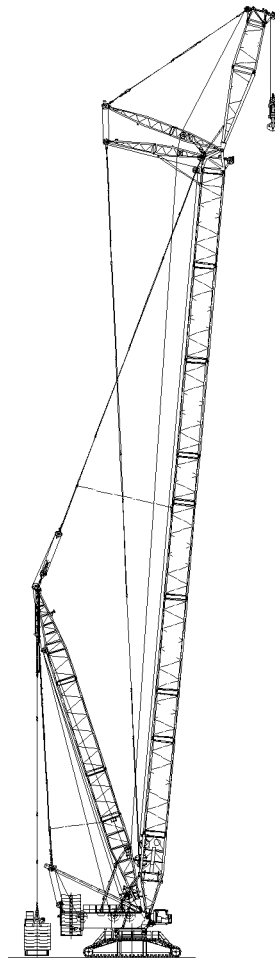
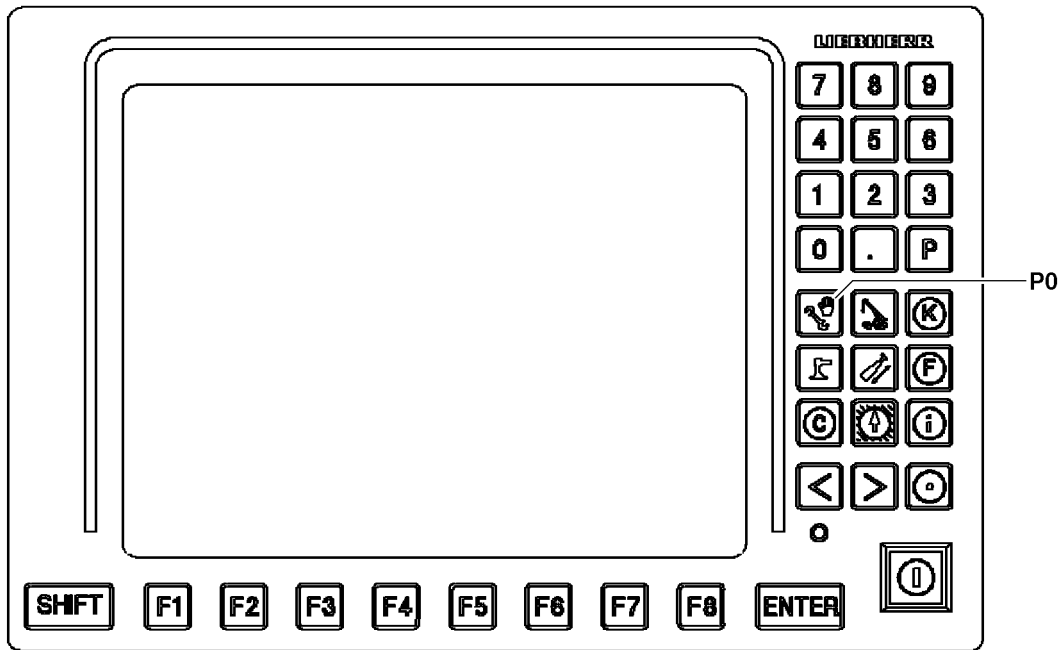

Fig.122800

LWE/LR 11000-001/23501-04-02/en

12.3 Checking the settings of the LICCON overload protection

Make sure that the following prerequisites are met:

- The derrick ballast is placed according to the load chart.
- The actual placed derrick ballast has been entered and confirmed in the Set up program, see Crane operating instructions, chapter 4.02.
- The derrick boom is in operating position.



WARNING

Incorrectly set overload protection!

If the actual set up configuration of the crane deviates from the entries and settings in the Set up program, then the overload protection is not correctly set.

An incorrectly set overload protection calculates the actual load incorrectly and transmits faulty display values.

The crane can be overloaded unnoticed and topple over.

This could result in serious accidents.

- ▶ The entries and settings in the set up program must match the actual set up configuration of the crane.



Note

- ▶ Set the LICCON overload protection in the set up program, see Crane operating instructions, chapter 4.02.

-
- ▶ Press the program key **P0**.

Result:

- The Set up program is called up.
- ▶ In the monitor display of the Set up program check if the LICCON overload protection is set according to the data in the load chart and the actual set up configuration of the crane, see example illustration.

LM

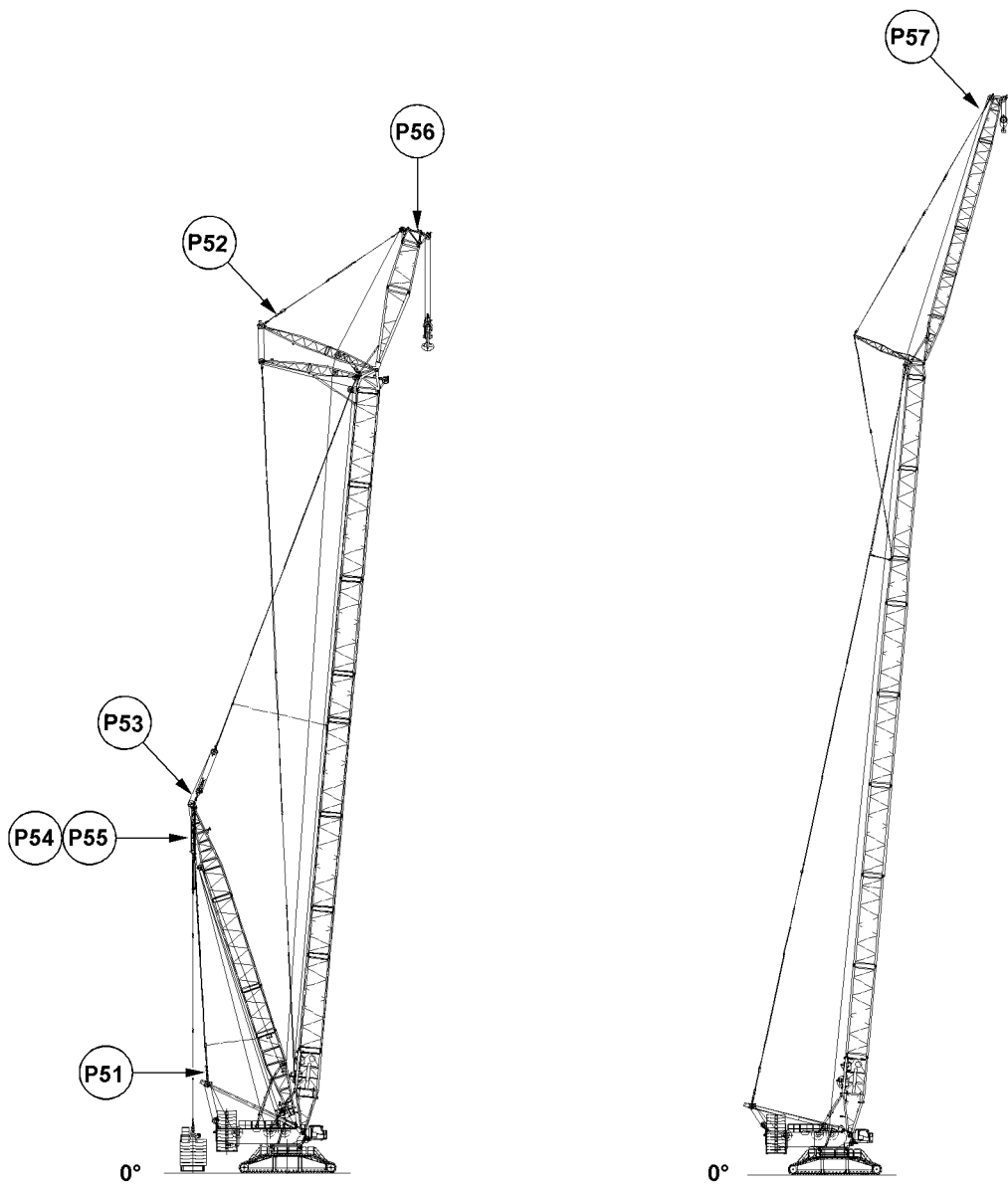
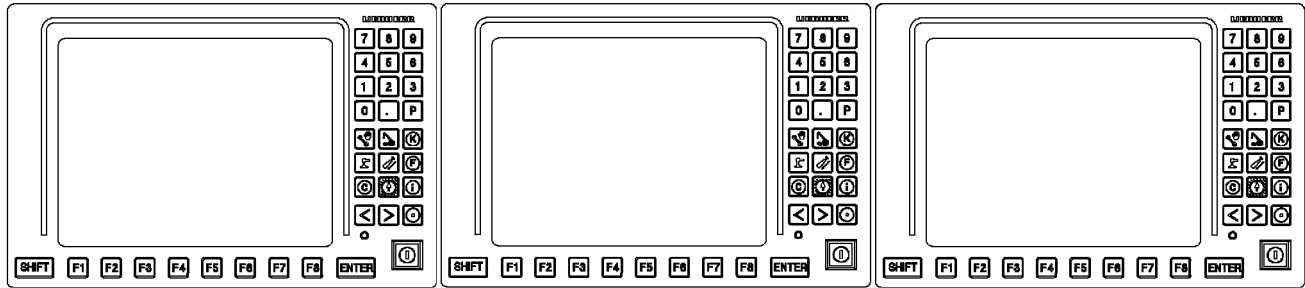

Fig.122806

LWE/LR 11000-001/23501-04-02/en

12.4 F-load display for operating modes with derrick ballast

Assignment of test points for operating modes with derrick ballast:

- Force in the guying between A-frame and derrick head:
 - Test point 1 on point **P51** = force F1
 - The display is made in the F-load display in the center LICCON monitor **LM**.
- Force in the guying between WA-frame and accessory head:
 - Test point 2 on point **P52** = force F2
 - The display is made in the F-load display in the center LICCON monitor **LM**.
Note: Only for the respective boom system.
- Force in the guying between the main boom head and the derrick head:
 - Test point 3 on point **P53** = force F3
 - The display is made in the F-load display in the center LICCON monitor **LM**.
- Force in the guying between derrick ballast and derrick head:
 - Test point 4/5 on point **P54/55** = force F4/5
 - The display is made in the display of the derrick ballast in the left LICCON monitor **LM**.
- Force on the pressure test bracket boom nose:
 - Test point 6 on point **P56** = force F6
 - The display is made in the actual load display in the right LICCON monitor **LM**.
Note: Only with existing boom nose.
- Force in the guying between the FA-frame and the accessory head:
 - Test point 11 on point **P57** = force 11
 - The display is made in the actual load display in the center LICCON monitor **LM**.
Note: Only for the respective boom system



Note

- ▶ For a detailed description of the displays for crane operation with derrick ballast, see the Crane operating instructions, chapter 4.02.



WARNING

Overloading / toppling of the crane!

If the permissible display values of the F-load display are exceeded / fallen below, then the crane can be overloaded.

This could result in serious accidents.

- ▶ Observe and adhere to the display values on the LICCON monitors.
- ▶ Observe and adhere to the specifications regarding the limit values on the assembly drawings.



Note

The values of the F-load display depend on the set up configuration of the crane and the crane geometry.

The values of the F-load display change continuously when the crane is moved.

- ▶ Monitor the F-load display continuously.

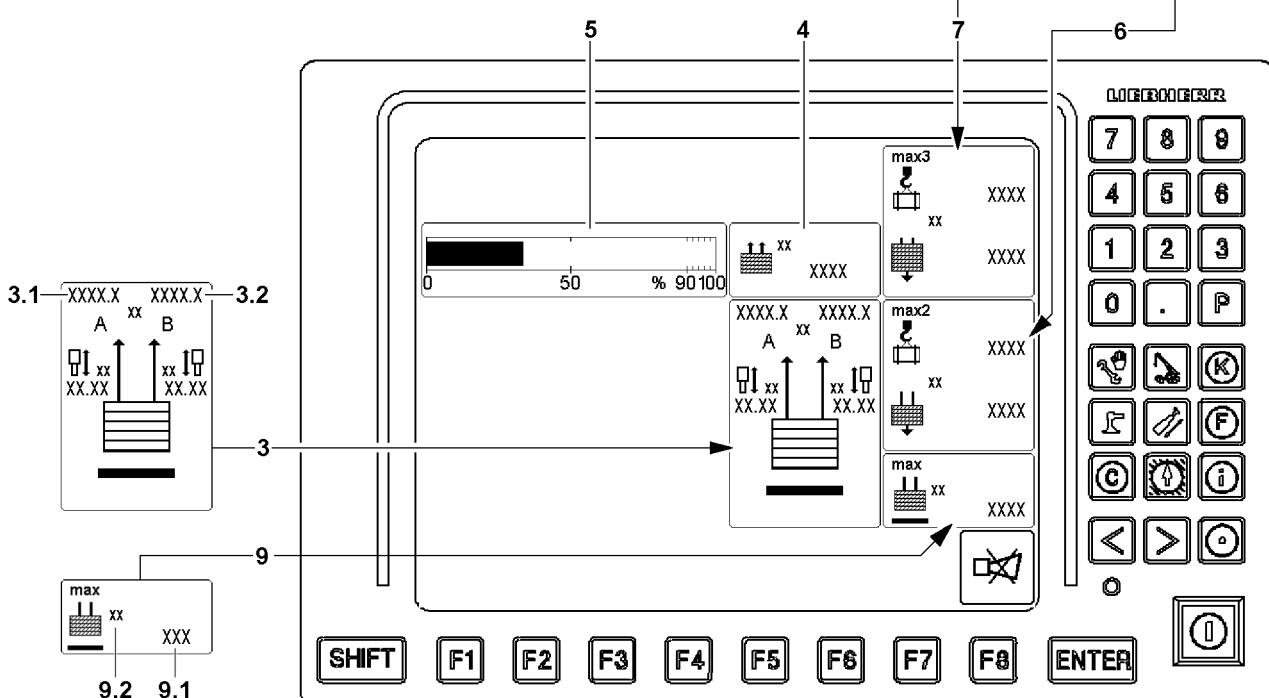
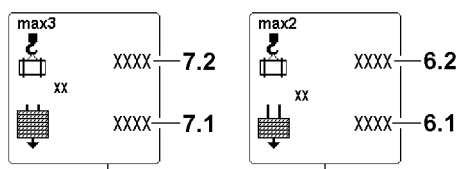
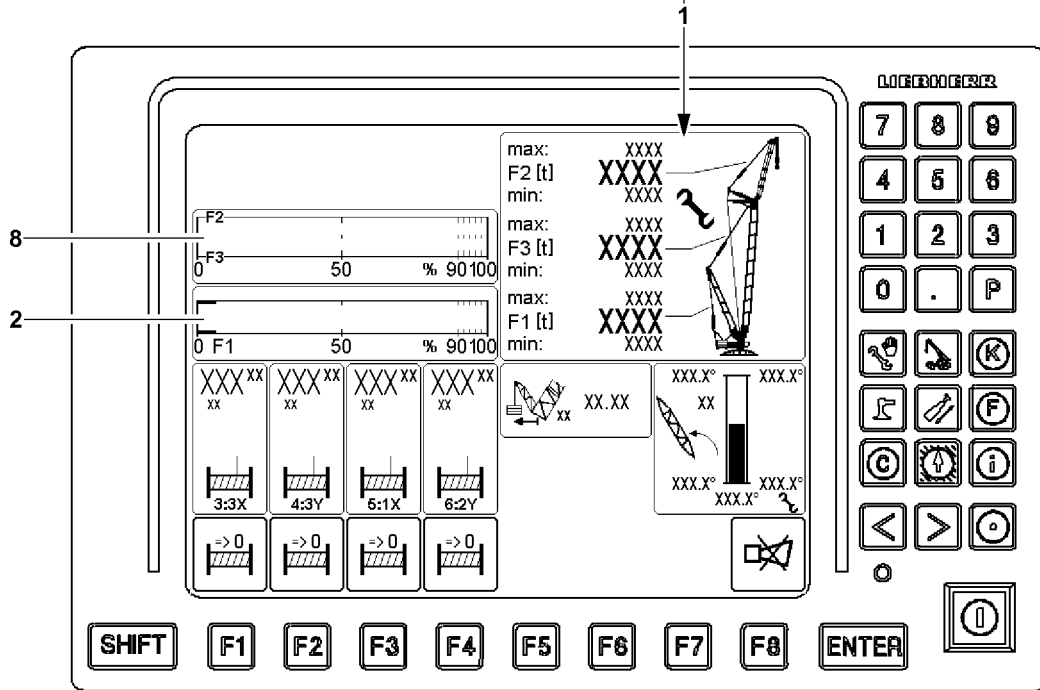
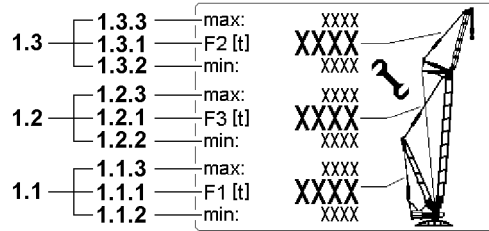

Fig.146968

LWE/LR 11000-001/23501-04-02/en

12.4.1 Force F1 (test point 1)

The force F1 (test point MS1) is determined in the guying between the A-frame and the derrick head and displayed in the LICCON monitor as operating force $F1_{\text{actual}}$.

Display values of force F1 (test point MS1) on the F-load display **1**:

- F1-maximum ($F1_{\text{max}}$) **1.1.3** = maximum value F1-force
- F1-actual value ($F1_{\text{actual}}$) **1.1.1** = actual value F1-force (operating force F1)
- F1-minimum ($F1_{\text{min}}$) **1.1.2** = minimum value F1-force

Structure of the F1-utilization bar **2**:

- Ratio of operating force $F1_{\text{actual}}$ to F1 maximum force

12.4.2 Force F2 (test point 2) and force F3 (test point 3)

The force F2 (test point 2) is determined between the WA-frame and the accessory head and displayed in the LICCON monitor as operating force $F2_{\text{actual}}$. A display is made only with the respective boom system.

The force F3 (test point 3) is determined between the main boom head and the derrick head and displayed in the LICCON monitor as operating force $F3_{\text{actual}}$.

Display values of force F2 (test point MS2) in the F-load display **1**:

- F2-maximum ($F2_{\text{max}}$) **1.3.3** = maximum value F2-force
- F2-actual value ($F2_{\text{actual}}$) **1.3.1** = actual value F2-force (operating force F2)
- F2-minimum ($F2_{\text{min}}$) **1.3.2** = minimum value F2-force

Display values of force F3 (test point MS3) in the F-load display **1**:

- F3-maximum ($F3_{\text{max}}$) **1.2.3** = maximum value F3-force
- F3-actual value ($F3_{\text{actual}}$) **1.2.1** = actual value F3-force (operating force F3)
- F3-minimum ($F3_{\text{min}}$) **1.2.2** = minimum value F3-force

Composition of the F2 / F3-utilization bar **8**:

- Ratio of operating force $F2_{\text{actual}}$ to F2 maximum force $F2_{\text{max}}$
- Ratio of operating force $F3_{\text{actual}}$ to F3 maximum force $F3_{\text{max}}$
- The F2/F3-utilization bars **8** appear only in assembly operation

In crane operation, the display values are displayed clearly for information. A special monitoring does not occur.

In assembly operation the display values are monitored. The limit values may not be exceeded.

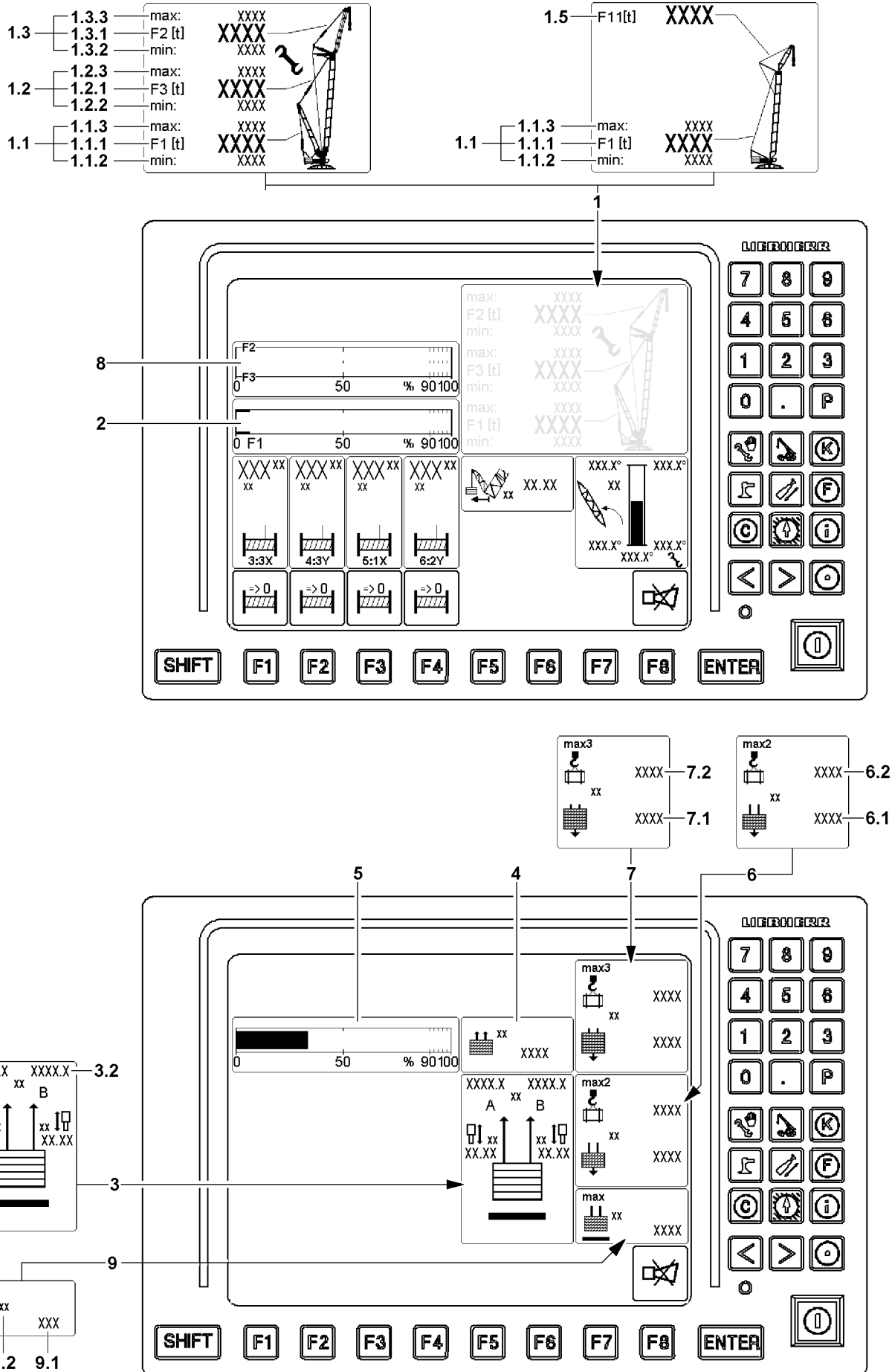

Fig.146967

LWE/LR 11000-001/23501-04-02/en

12.4.3 Force F4/5 (test point 4/5)

The forces F4/5 (test point 4/5) are effective in the guy rods from the derrick ballast to the derrick head.

The existing forces in the guy rods are calculated from four pressure sensors, which are installed on the pull cylinders.

Test points guying A (left) are:

- Test point 4A = pressure sensor ring surface left (force F4A)
- Test point 5A = pressure sensor piston surface left (force F5A)

Test points guying B (right) are:

- Test point 4B = pressure sensor ring surface right (force F4B)
- Test point 5B = pressure sensor piston surface right (force F5B)

Display values of force F4/5 (test point 4/5) in icon Guying derrick ballast **3**:

- Force in the derrick ballast guying A **3.1**
- Force in the derrick ballast guying B **3.2**

Display values derrick ballast:

- Currently pulled derrick ballast = BA_{pulled} **4**
- Current utilization of derrick ballast = Utilization bar derrick ballast **5**
- Currently placed derrick ballast = BA_{placed} **6.1**

From the sum of derrick ballast guying A **3.1** and derrick ballast guying B **3.2** is the pulled derrick ballast BA_{pulled} **4** calculated.

If the ballast still has ground contact, then only that part of the ballast is displayed which is pulled up by the D-guying. The remaining part is laying correspondingly on the ground.

Composition of utilization bar derrick ballast **5**:

- Ratio of pulled derrick ballast (BA_{pulled} **4**) to placed derrick ballast (BA_{placed} **6.1**)

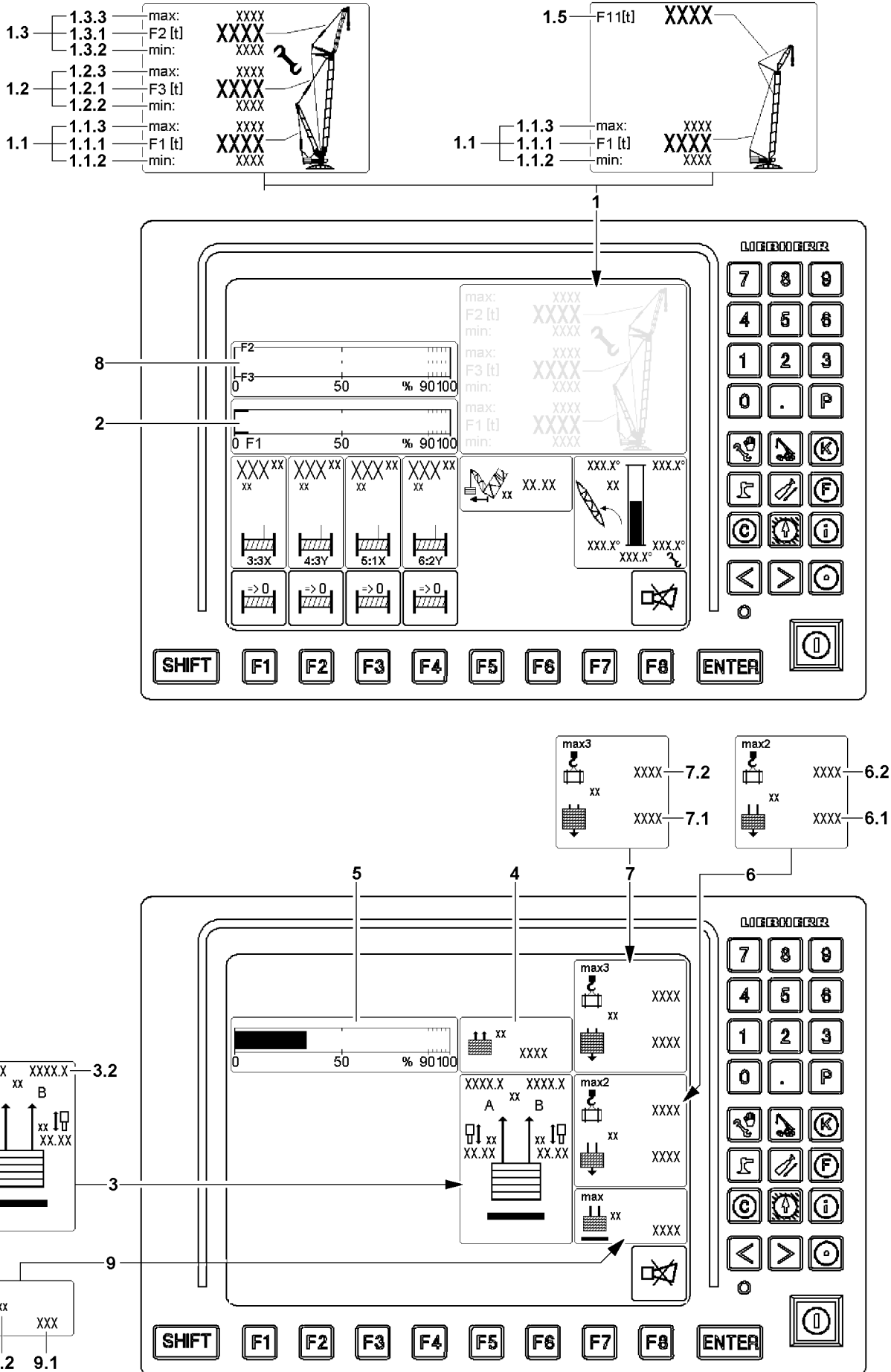

Fig.146967

LWE/LR 11000-001/23501-04-02/en

12.4.4 Maximum liftable derrick ballast

The *maximum liftable derrick ballast* **9** refers to the current crane condition and indicates the maximum derrick ballast that can be lifted off the ground with the pull cylinder or off the suspended ballast palette in case of the VarioTray without falling below the $F_{1_{\min}}$ force.

- **9** *Maximum liftable derrick ballast* icon
- **9.1** Maximum liftable derrick ballast
 - Maximum derrick ballast
- **9.2** Measuring unit
 - Measuring unit for display values in the *Pulled derrick ballast* icon **9**: [t] or [lb]

12.4.5 Force F11 (test point 11)

Force in the guying between the FA-frame and the accessory head:

Display values of force F11 (test point MS11) on the F-load display **1**:

- F11-actual value ($F_{11_{\text{actual}}}$) **1.5** = actual value F11-force (operating force F11)

12.4.6 Additional displays

- „Load max2“ icon **6** (see section „Utilization conditions“)
- Currently placed derrick ballast = BA_{placed} (Input value in set up program) **6.1**
- Possible load with currently placed derrick ballast = $Load_{\text{max2}}$ **6.2**
- „Load max3“ icon **7** (see section „Utilization conditions“)
- Maximum derrick ballast according to load chart = BA_{max} **7.1** (Highest value in Set up program)
- Possible load with maximum derrick ballast according to load chart = $Load_{\text{max3}}$ **7.2**

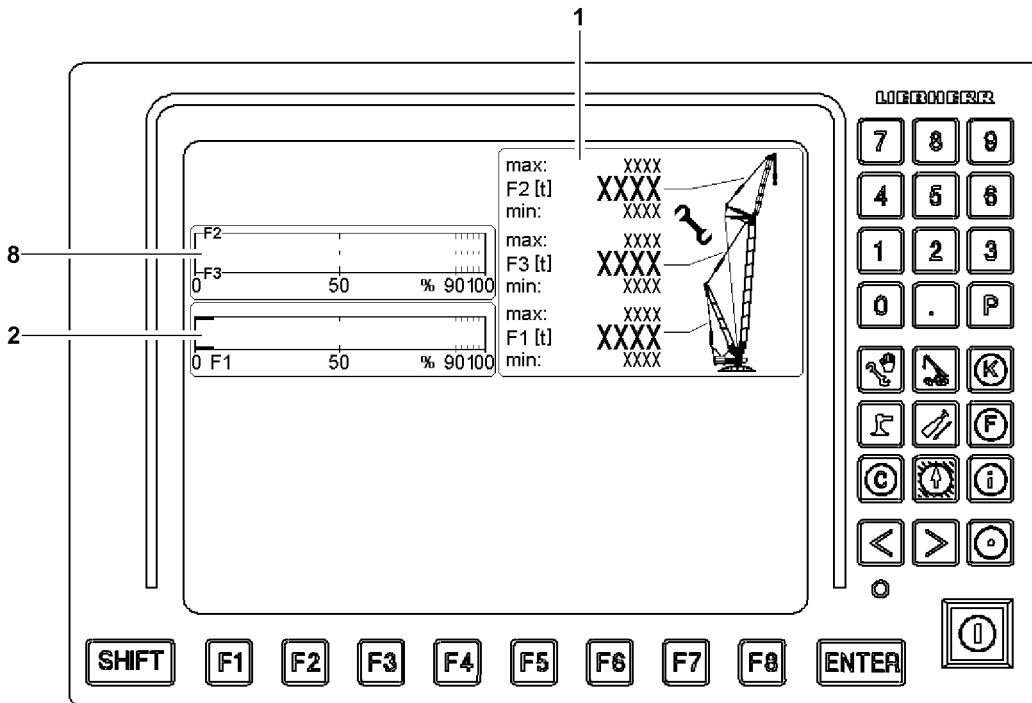
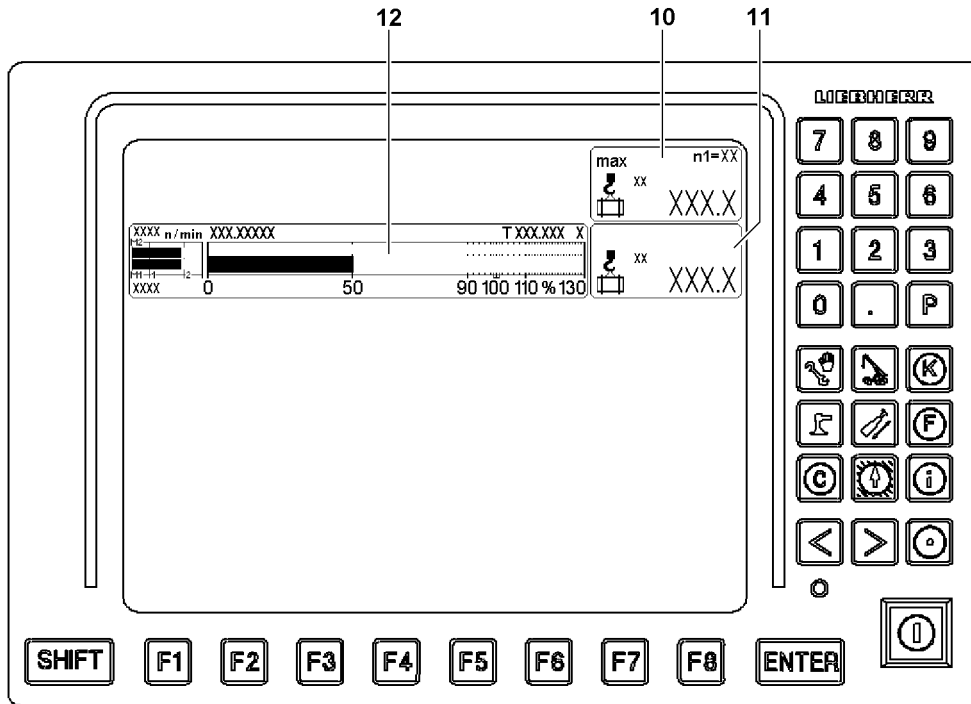

Fig.122808

LWE/LR 11000-001/23501-04-02/en

12.5 Monitoring of crane utilization in operating modes with derrick ballast



Note

- ▶ The icon illustrations of the LICCON monitors are examples and may not match your crane.
- ▶ The icon illustrations of the LICCON monitors can deviate in number, arrangement and depiction of the icons on your crane.
- ▶ Observe the Crane operating instructions, chapter 4.02.



WARNING

Incorrect display values!

If the display values do not increase correspondingly when lifting known weights, an erroneous display value may be present.

If the crane is operated with erroneous display values, then the crane can be overloaded.

This could result in serious accidents.

- ▶ When lifting the hook block off the ground check if the display value for the actual load increases correspondingly.
- ▶ When lifting the derrick ballast off the ground check if the display value for the pulled derrick ballast (BA_{pulled}) increases correspondingly.
- ▶ When lifting the load off the ground check if the display value for the actual load increases correspondingly.

In operating modes with derrick ballast, the monitoring of the crane utilization includes, among others:

1. Monitoring of load torque
Via the „Maximum load“ icon **10**, „Actual load“ icon **11** and the „utilization bar diagram“ **12**.
2. Utilization conditions
Support the crane driver with additional display values.
3. Monitor the F-load display **1**.
Supported by the F1-utilization bar **2** and possibly the F2/F3-utilization bar **8**.

12.5.1 Monitoring of load torque

It monitors the „maximum load according to the load chart and reeving“.

In crane operation, the actual load is compared with the maximum load which may be lifted in the current crane configuration. The display of the values is made in the icon „Maximum load“ **10** and in icon „actual load“ **11**. The current percentage utilization is displayed as „bar diagram utilization“ **12** in the right LICCON monitor.

The color of the utilization bar in the „bar diagram utilization“ **12** also displays the crane utilization:

- Utilization bar blue / green (below 90 %): Utilization in permissible range
- Utilization bar yellow (90 % to 100 %): Advance warning. - Utilization just before impermissible range
- Utilization bar red (above 100 %): Warning. - Utilization in impermissible range



Note

- ▶ Procedure for optimum utilization of „maximum load according to load chart and reeving“, see section „Utilization conditions“.



Fig.122809

LWE/LR 11000-001/23501-04-02/en

**WARNING**

Access the functionality of the LICCON overload protection!

When accessing the functionality of the LICCON overload protection by activating assembly operation, the LICCON overload protection is totally deactivated, bypassed or limited.

It is possible to exceed several shut-off limits of the LICCON overload protection simultaneously or one after the other.

It is possible to carry out crane movements, which are not monitored by the LICCON overload protection.

Without the LICCON overload protection, no additional protection against overload of the crane via the crane control is present.

This could result in serious accidents.

- ▶ When accessing the functionality of the LICCON overload protection, take into account that the LICCON overload protection is deactivated totally or is limited.
- ▶ When accessing the functionality of the LICCON overload protection, the Crane operating instructions, chapter 4.02 must be observed.

**WARNING**

The crane can topple over!

In assembly operation the LICCON overload protection is deactivated.

In the event of deliberate improper use, the crane could collapse, the boom can break off or the crane can topple over.

Personnel can be killed.

This could result in high property damage.

- ▶ Activate the assembly operation only when the consequences are known.
- ▶ Enter the set up configuration correctly into the LICCON computer system.
- ▶ Observe the erection / take down charts.
- ▶ Crane operation with deactivated LICCON overload protection is prohibited.
- ▶ In assembly operation only load torque reducing crane movements may be carried out until a permissible operating and load range.
- ▶ The crane operator carries complete and sole responsibility for his actions if the LICCON overload protection is deactivated.

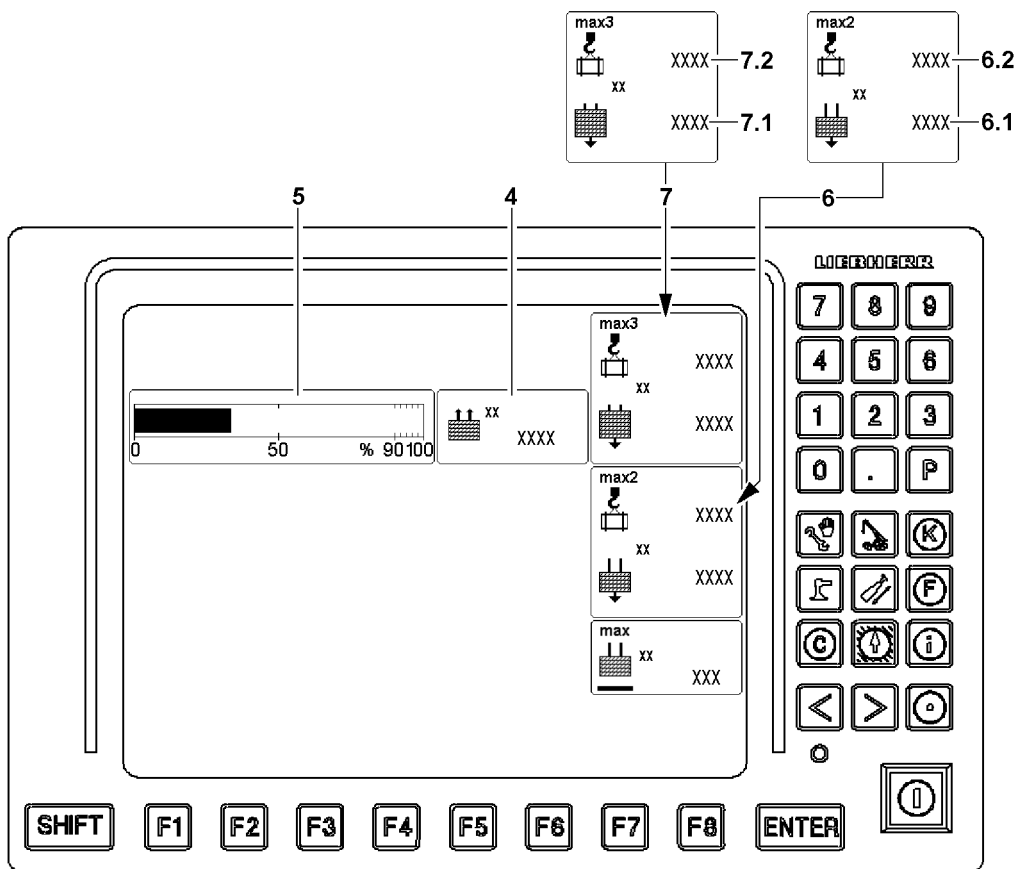
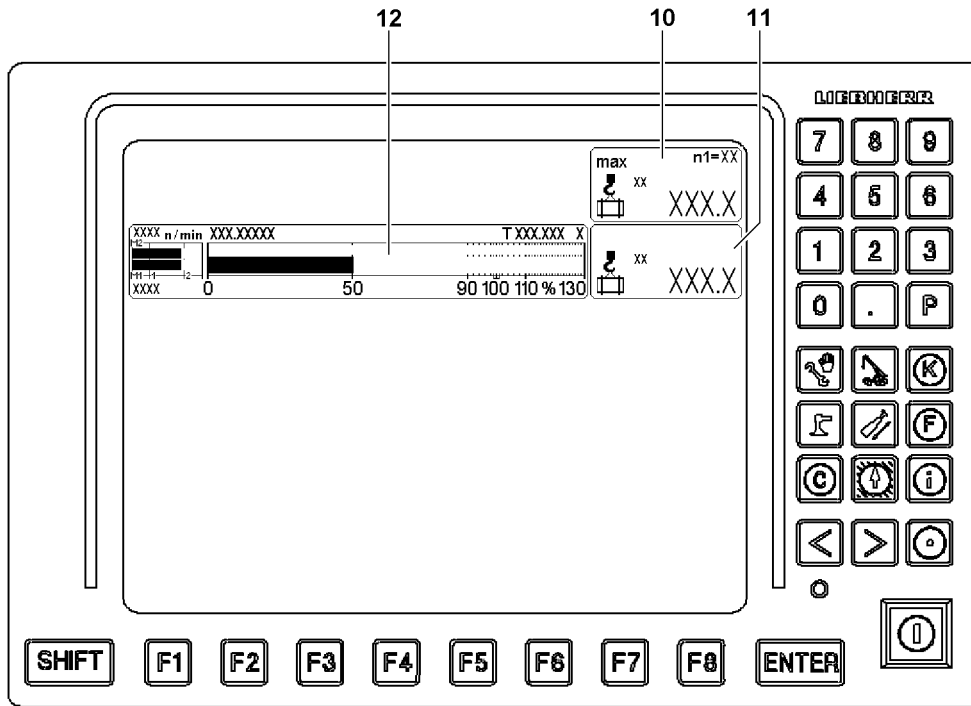

Fig.146966

LWE/LR 11000-001/23501-04-02/en

12.5.2 Utilization conditions

The current percentage utilization of the crane is displayed as „bar diagram utilization“ **10** in the right LICCON monitor.

Additional displays:

- **6** „Load max2“ icon
 - Currently placed derrick ballast = BA_{placed} (Input value in set up program) **6.1**
 - Possible load with currently placed derrick ballast = $\text{Load}_{\text{max2}}$ **6.2**
- **7** „Load max3“ icon
 - Maximum derrick ballast according to load chart = BA_{max} **7.1** (Highest value in Set up program)
 - Possible load with maximum derrick ballast according to load chart = $\text{Load}_{\text{max3}}$ **7.2**

Maximum load, right LICCON monitor:

- The maximum load in the current operating condition is reached when the utilization bar shows 100 % in the „bar diagram utilization“ **12**.
This is the case when the „utilization of the crane according to the load chart and reeving“ reaches 100 % (Values in icon „Maximum load“ **10** and in icon „actual“ **11** are equal).
When the „Maximum load“ **10** is smaller or the same as the $\text{load}_{\text{max2}}$ **6.2**, then an increase might possibly be obtained:
 - By increasing the pulled derrick ballast BA_{pulled} **4**, if the utilization bar derrick ballast **5** is not yet at 100 % (derrick ballast not suspended).
 - By increasing the derrick ballast when the BA_{placed} **6.1** is smaller than BA_{max} **7.1**.
 - By changing the derrick ballast radius within the permissible range, see load chart manual or LICCON job planner.

max2-load, icon „load max2“ **6**:

- The highest possible load in current operating condition „**max2-load**“ is reached when in the „bar diagram utilization“ **12** 100 % is shown **and** the utilization bar derrick ballast **5** is at 100 % (Derrick ballast is completely lifted off the ground).
This is the case when the value in icon „Actual load“ **11** is the same as the $\text{load}_{\text{max2}}$ **6.2**.
When the $\text{load}_{\text{max2}}$ **6.2** is smaller or the same as the $\text{load}_{\text{max3}}$ **7.2**, then an increase might possibly be obtained:
 - By increasing the derrick ballast by loading additional ballast plates (increase BA_{placed} **6.1** to BA_{max} **7.1**).

max3-load, icon „load max3“ **7**:

- The highest possible load at the maximum derrick ballast in current operating condition „**max3-load**“ is reached when the „bar diagram utilization“ **12** displays 100 % **and** the utilization bar derrick ballast **5** is at 100 % (Derrick ballast according to load chart is placed and is completely lifted off the ground).
This is the case when the value in icon „Actual load“ **11** is the same as the $\text{load}_{\text{max3}}$ **7.2**.
- The maximum derrick ballast according to the load chart is placed and completely pulled.
Further increase of the derrick ballast is impermissible.

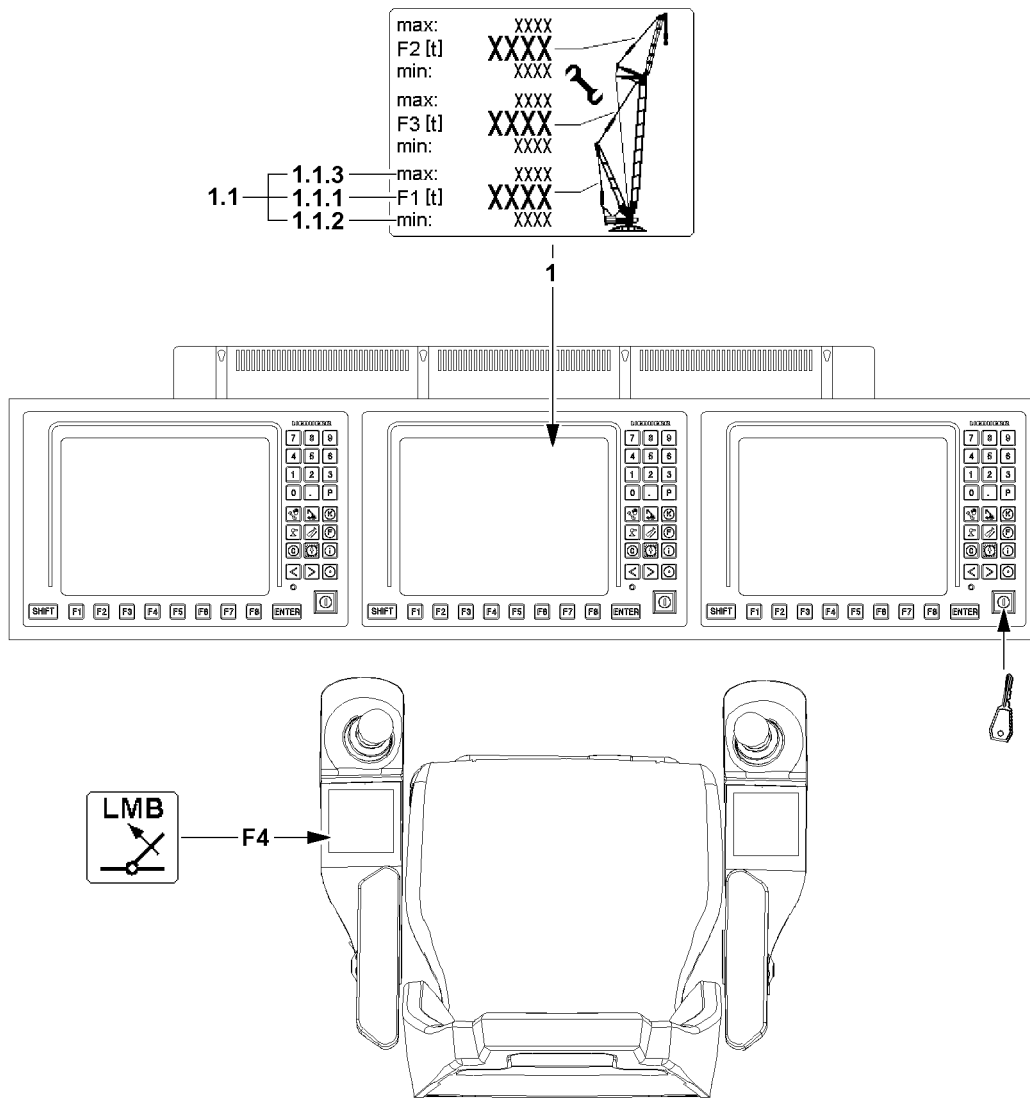

Fig.122809

12.5.3 Monitoring of F1-maximum force

Display values of force F1 (test point MS1) on the F-load display 1:

- F1-maximum ($F1_{max}$) **1.1.3** = maximum value F1-force
- F1-actual value ($F1_{actual}$) **1.1.1** = actual value F1-force (operating force F1)
- F1-minimum ($F1_{min}$) **1.1.2** = minimum value F1-force

The display values of force F1 (test point 1) are displayed permanently in the LICCON monitor. At F1-actual value ($F1_{actual}$) **1.1.1** larger F1-maximum ($F1_{max}$) **1.1.3** a shut off of all load moment increasing movements occurs.



WARNING

Access the functionality of the LICCON overload protection!

When accessing the functionality of the LICCON overload protection by activating assembly operation, the LICCON overload protection is totally deactivated, bypassed or limited.

It is possible to exceed several shut-off limits of the LICCON overload protection simultaneously or one after the other.

It is possible to carry out crane movements, which are not monitored by the LICCON overload protection.

Without the LICCON overload protection, no additional protection against overload of the crane via the crane control is present.

This could result in serious accidents.

- ▶ When accessing the functionality of the LICCON overload protection, take into account that the LICCON overload protection is deactivated totally or is limited.
- ▶ When accessing the functionality of the LICCON overload protection, the Crane operating instructions, chapter 4.02 must be observed.



Note

The limit value for the F1-maximum force depends not only on the set up configuration and the crane geometry, but also from the pulled derrick ballast.

- ▶ If the pulled derrick ballast is larger, then the limit value for the F1-minimum force is generally reduced.
- ▶ If the pulled derrick ballast is smaller, then the limit value for the F1-maximum force is generally increased.



Note

By engaging the assembly operation the limit value for the F1-maximum force can be exceeded by a few tons. This makes it possible to reset a crane movement, which has caused the shut off.

- ▶ Reset triggered shut off by reverse crane movement.



Fig.122809

12.5.4 Monitoring of F1-minimum force

Display values of force F1 (test point MS1) on the F-load display 1:

- F1-maximum ($F1_{\max}$) **1.1.3** = maximum value F1-force
- F1-actual value ($F1_{\text{actual}}$) **1.1.1** = actual value F1-force (operating force F1)
- F1-minimum ($F1_{\min}$) **1.1.2** = minimum value F1-force



WARNING

Uncontrolled movements of the boom system!

If the guying between the A-frame and the derrick head (test point 1) becomes powerless, then this can lead to uncontrollable movements of the boom system.

This could result in serious accidents.

- ▶ The guying between the A-frame and the derrick head (test point 1) may never be without power.
- ▶ Relieve the D-guying between the derrick head and the derrick ballast to the point where the F1-actual value ($F1_{\text{actual}}$) **1.1.1** is larger than the F1-minimum ($F1_{\min}$) **1.1.2**.



WARNING

Access the functionality of the LICCON overload protection!

When accessing the functionality of the LICCON overload protection by activating assembly operation, the LICCON overload protection is totally deactivated, bypassed or limited.

It is possible to exceed several shut-off limits of the LICCON overload protection simultaneously or one after the other.

It is possible to carry out crane movements, which are not monitored by the LICCON overload protection.

Without the LICCON overload protection, no additional protection against overload of the crane via the crane control is present.

This could result in serious accidents.

- ▶ When accessing the functionality of the LICCON overload protection, take into account that the LICCON overload protection is deactivated totally or is limited.
- ▶ When accessing the functionality of the LICCON overload protection, the Crane operating instructions, chapter 4.02 must be observed.



Note

By engaging the assembly operation the limit value for the F1-minimum force can be fallen below by a few tons. This makes it possible to reset a crane movement, which has caused the shut off.

- ▶ Reset triggered shut off by reverse crane movement.



Fig.122809

LWE/LR 11000-001/23501-04-02/en

**WARNING**

Autonomous movement of the boom system at increase of load torque!

If the F1-minimum force is fallen below, the guying between the A-frame and the derrick head can become powerless.

If the guying between the A-frame and the derrick head is powerless and the „Derrick ballast is on the ground“ at the same the derrick ballast can suddenly lift off the ground due to increase of the load torque.

As a result, the boom system can move forward suddenly. Strong oscillating movements of the derrick ballast and load can be the result.

The crane can be overloaded and severe accidents can be the result.

- ▶ Hold the F1-actual value ($F1_{\text{actual}}$) **1.1.1** above the F1-minimum ($F1_{\text{min}}$) **1.1.2**.
- ▶ It is prohibited to fall below the F1-minimum force.

**WARNING**

Autonomous movement of the boom system at decrease of load torque!

If the F1-minimum force is fallen below, the guying between the A-frame and the derrick head can become powerless.

If the guying between the A-frame and the derrick head is powerless and the „derrick ballast is suspended“ at the same time, the derrick ballast can suddenly set down on the ground due to decrease of the load torque.

As a result, the boom system can move suddenly backward. As a result, the relapse cylinders can be pressed on block, be overloaded and damaged. Strong oscillating movements of the derrick ballast and load can be the result.

The crane can be overloaded and severe accidents can be the result.

- ▶ Hold the F1-actual value ($F1_{\text{actual}}$) **1.1.1** above the F1-minimum ($F1_{\text{min}}$) **1.1.2**.
- ▶ It is prohibited to fall below the F1-minimum force ($F1_{\text{min}}$).

The following applies:

- After a shut off due to falling below the F1-minimum ($F1_{\text{min}}$) **1.1.2** the F1-actual value ($F1_{\text{actual}}$) **1.1.1** must be increased by a crane movement. If the derrick ballast is suspended, this can be achieved by setting down the ballast.
- When picking up the load, the D-guying between the derrick ballast and the derrick head must be relieved to the point where the F1-actual value ($F1_{\text{actual}}$) **1.1.1** is greater than the F1-minimum ($F1_{\text{min}}$) **1.1.2**.
- When increasing the load torque, the limit value F1-minimum ($F1_{\text{min}}$) **1.1.2** is fallen below, an already set down derrick ballast can lose contact with the ground and lift off.
- When decreasing the load torque, and the limit value F1-minimum ($F1_{\text{min}}$) **1.1.2** is fallen below, an already „suspended derrick ballast“ can set down on the ground.
- If the assembly operation is activated and the F1-force continues to drop below the minimum force $F1_{\text{min}}$, then the $F1_{\text{min}}$ shut off can no longer be bypassed.

Limitations from 50 % pulled derrick ballast

If more than 50 % of the set derrick ballast is being pulled (utilization bar derrick ballast **5** larger than 50 %) and the F1-minimum ($F1_{\text{min}}$) **1.1.2** is fallen below at the same time, all crane movements that increase load torque are turned off.

Limitations from 90 % pulled derrick ballast

If more than 90 % of the set derrick ballast is being pulled (utilization bar derrick ballast **5** larger than 90 %) and the F1-minimum ($F1_{\text{min}}$) **1.1.2** is fallen below at the same time, all crane movements that increase load torque and all crane movements that decrease load torque are turned off. This also turns off the „spooling out“ movement of the winch.

12.6 Monitoring of pull cylinders on block position

The pull cylinders (also called ballast lift cylinders) of the derrick ballast are equipped with length sensors and limit switches for monitoring.

In crane operation, the monitoring of the pull cylinders on block position is always active. If there is the danger of a block position, then only that direction of the pull cylinders can be moved which improves the condition. The other direction is unbyypassably blocked. As long as the length sensors and the limit switches function correctly, the pull cylinders cannot get into a block position.



WARNING

Problem at monitoring of pull cylinders!

If the length sensors or limit switches are defective or missing, then the monitoring of the pull cylinders is not active.

Without monitoring, the pull cylinders can be moved without restriction, as a result, a block position is possible.

At a block position, the pressure measurements of the pull cylinders become inexact and the values are incorrectly calculated.

The overload protection calculates the actual load incorrectly and transmits faulty display values.

The crane can be overloaded and topple over.

This could result in serious accidents.

► Observe the display values and possible error messages.

► If length sensors or limit switches are defective or missing, monitor the pull cylinders manually.

The following applies:

- The display values of the pull cylinders must function and be plausible.

12.7 Monitoring the lateral incline of the divisible ballast pallet „VarioTray“

The divisible ballast pallet „VarioTray“ is equipped with an incline sensor for monitoring.

The monitoring to $\pm 2.5^\circ$ lateral incline of the divisible ballast pallet „VarioTray“ is always active. If a lateral incline of $\pm 2.5^\circ$ is reached, then only those directions of the pull cylinders can be moved which improve the condition. The other directions are unbyypassably blocked. The ballast can be set down for that reason only to a maximum incline of the terrain of 2.5° .



WARNING

Defective incline sensor!

If an incline sensor is defective or missing, the monitoring of the lateral incline of the suspended ballast is not active.

The pull cylinders can be moved without restriction and the derrick ballast can be overturned as a result.

This could result in serious accidents.

► Observe the display values and possible error messages.

► If an incline sensor is defective, monitor the lateral incline of the derrick ballast manually.

The following applies:

- The display values of the lateral incline of the derrick ballast must function and be plausible.

12.8 Differential force monitoring for derrick ballast-guying

In operating modes with derrick ballast the forces of the derrick ballast guyings A and B are displayed in the LICCON monitor.



WARNING

Danger of accident!

If the forces in the derrick ballast guyings A and B are too high, then this can lead to an overload of the crane. Components can fail and severe accidents can be the result.

► Load the derrick ballast guyings A and B evenly.

After reaching the specified limit value of the difference force threshold, the displays of the pulled ballast of pull cylinder A and B blink and become red, the function ballast up / down is stopped. The difference force must be lowered again.

If the difference of the forces of the derrick ballast guying A and B exceeds the limit value, then this can have various causes:

- Flexing of the turntable.
- The ground under the derrick ballast is uneven.
- The crane is leaning to one side.
- The derrick ballast is loaded one-sided.
- The force measurement in one D-guying is incorrect.

The crane driver must recognize the correct cause and take countermeasures:

- The error, which caused the one-sided force, must be remedied.
- If the sensor values are implausible: Stop crane operation and find the cause and remedy it.

12.8.1 Bypassing the shut off of the function ballast up / down

- The following measures are permitted providing the ground is only slightly uneven: Control the individual pull cylinders in such a way that the difference between the forces becomes smaller. Ensure that the derrick ballast is not tilted at an inadmissible angle with respect to the crane, otherwise the derrick ballast guide and attachments will be damaged.
- ▶ Carry out the following: Activate assembly operation, see Crane operating instructions, chapter 4.02.

Result:

- The shut off of the function ballast up / down is bypassed.
- On the left LICCON monitor appears an assembly icon.
- ▶ Press the button Ballast „up“ or button Ballast „down“ **and** the stop button on the desired side at the same time, see section „Lifting / setting down / equalizing the derrick ballast“.

Problem remedy

The display of the entire pulled ballast is shown blinking red. An LMB-Stop was triggered. All crane functions were stopped.

The crane driver has moved the pull cylinders into the incorrect direction and further exceeded the limit value for the difference force threshold.

- ▶ Move the pull cylinders again into the correct (other) direction and align the ballast in such a way that the displays of the pulled ballast of pull cylinder A and B are again in the permissible range.

- ▶ Activate assembly operation again.

Result:

- The shut off of the function ballast up / down is bypassed again.
- All other crane functions are still suppressed.
- ▶ Move the pull cylinders into the correct direction.



DANGER

Overload of crane!

If the pull cylinders are moved into the incorrect direction after a new bypass of the function ballast up / down, the crane will be overloaded.

This could result in serious accidents.

- ▶ Monitor the display values and move the pull cylinders in the correct direction (values of pull cylinder A and B become closer).
 - ▶ If unsure: Contact Liebherr Service.
 - ▶ Find the error and remedy it which caused the shut off of the function „Ballast up / down“.
-

12.9 Carrying out crane movements



Note

- ▶ For an overview of the displays in the LICCON monitors, see Crane operating instructions, chapter 4.02.



WARNING

Incorrect display values!

If the display values do not increase correspondingly when lifting known weights, an erroneous display value may be present.

If the crane is operated with erroneous display values, then the crane can be overloaded.

This could result in serious accidents.

- ▶ When lifting the hook block off the ground check if the display value for the actual load increases correspondingly.
- ▶ When lifting the derrick ballast off the ground check if the display value for the pulled derrick ballast BA_{pulled} increases correspondingly.
- ▶ When lifting the load off the ground check if the display value for the actual load increases correspondingly.



WARNING

The crane can topple over!

The jerky execution or braking of turning maneuvers can cause the load and / or suspended ballast to swing.

If the load and / or the suspended ballast collides with obstacles then the crane can be damaged or impeded.

Oscillating movements, damage or impediments can cause the crane to topple over.

This could result in serious accidents.

- ▶ Initiate or slow down crane movements with load and / or suspended derrick ballast extremely sensitively.
- ▶ There may be no persons and / or objects within the working range / danger zone of the crane.
- ▶ During crane operation additional personnel (guide) must monitor and secure the working range / danger zone of the crane from a safe position.



WARNING

Danger of accident due to unsafe ground!

If the crane is operated on insufficient ground, there is a danger of accident.

- ▶ The ground in the entire working area of the crane must be level and of sufficient load carrying capacity, in order to be able to securely accept the encountered surface pressures.
- ▶ Before setting down the load or the derrick ballast, the crane operator must make sure that the intended placement surface is suitable. A safe set down of load and derrick ballast must be ensured.



WARNING

Uncontrolled movements of the boom system!

If the guying between the A-frame and the derrick head (test point 1) becomes powerless, then this can lead to uncontrolled movements of the boom system.

This could result in serious accidents.

- ▶ The guying between the A-frame and the derrick head (test point 1) may never be without power.

**WARNING**

Danger of accidents due to angular pull!

Due to angular pull of load or derrick ballast impermissible side forces are directed into the crane. Impermissible side forces can cause failure of the components or a dangerous change of the center of gravity of the crane and / or load, among others.

Crane and load can be severely damaged and topple over.

This could result in serious accidents.

- ▶ Before taking on a load or the derrick ballast, make sure that the derrick ballast, the center of rotation of the turntable and the load are on one line.

**WARNING**

The crane can topple over!

If the derrick ballast is lifted by more than 0.25 m above the ground, then the crane can fall over to the rear if the load rips off.

- ▶ Do not lift derrick ballast more than 0.25 m from the ground.

Make sure that the following prerequisites are met:

- The test points must be checked for function before crane operation.
- The weight of the load to be lifted must be known.
- The support surface / placement surface of the derrick ballast may be maximum 0.25 m above / below the support surface of the crane.
- The support surface / placement surface of the derrick ballast must be level, horizontal and of sufficient load bearing capacity.
- The support surface / placement surface of the derrick ballast must be able to safely absorb the surface pressure.
- There may not be any obstacles in the slewing range of the crane, derrick ballast and load.
- Additional personnel is instructed to monitor and secure the working range / danger zone of the crane from a safe distance.
- A permanent acoustic / visual connection between the crane operator and the additional personnel is available.
- A guide or the crane driver must monitor the lifting and setting down of the derrick ballast and the load.
- The lifted derrick ballast is monitored by a guide or the crane operator.

The following applies:

- When taking up the load, the D-guying between the derrick ballast and the derrick head must be relieved so that the operating force $F_{1_{actual}}$ is larger than the limit value for the F1-minimum force.
- Before taking up the load or the derrick ballast, make sure that the following components are on one line:
 - The load
 - The center of rotation of the turntable
 - The derrick ballast

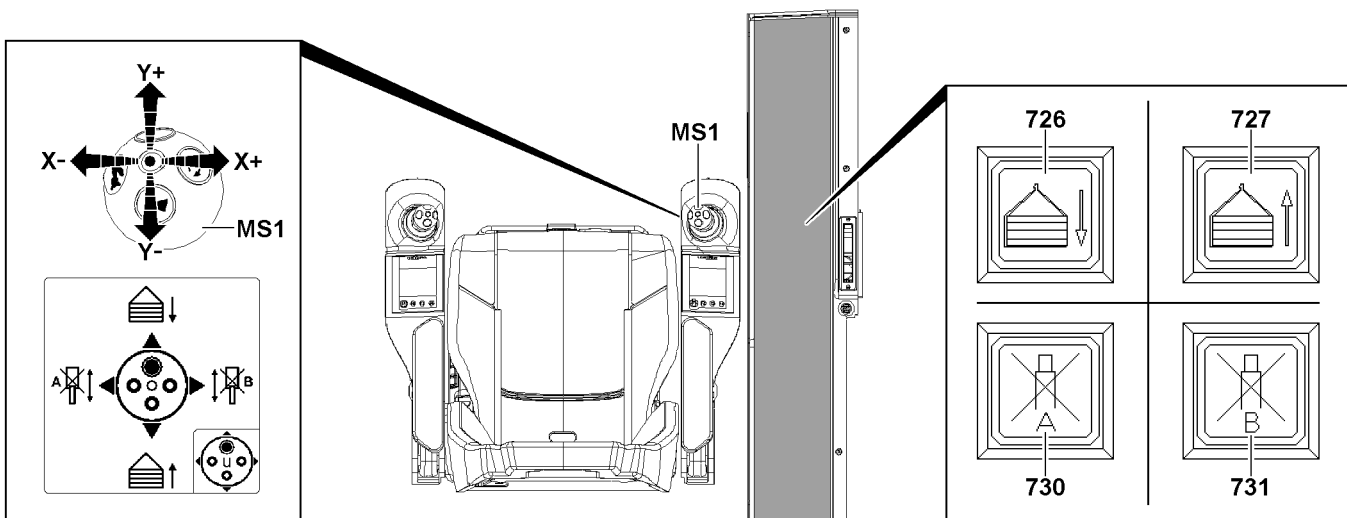
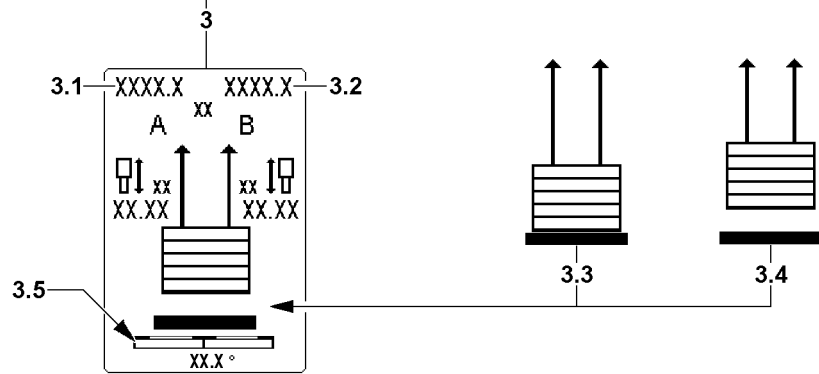
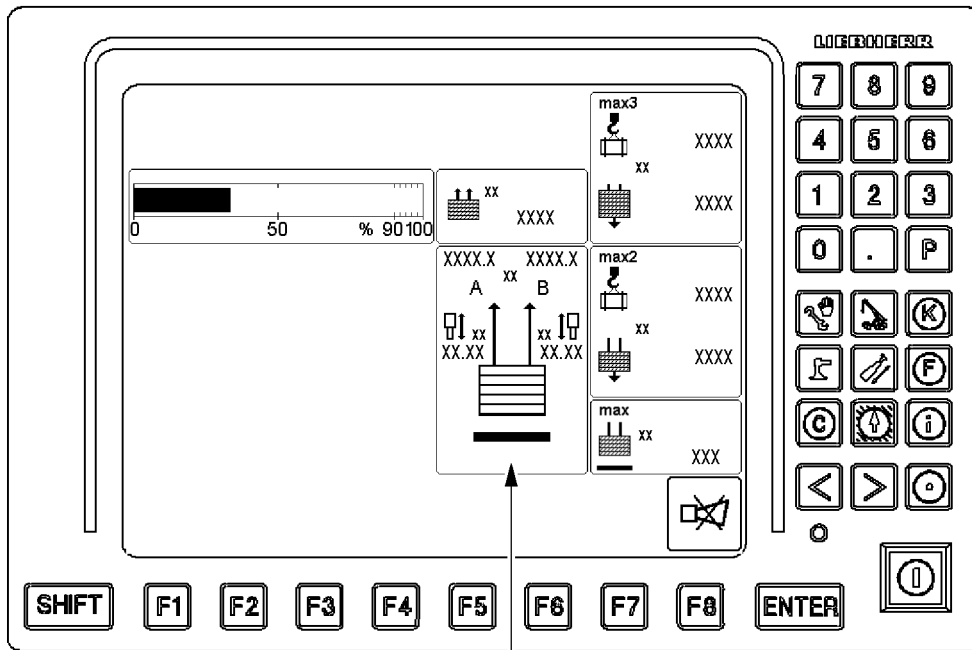

Fig.146965

LWE/LR 11000-001/23501-04-02/en

12.9.1 Lifting / setting down the derrick ballast



WARNING

Danger of accident!

The placement surface for the divisible ballast pallet „VarioTray“ must be level, horizontal and of sufficient load bearing capacity, otherwise the divisible ballast pallet „VarioTray“ can tip over.

This could result in serious accidents.

- ▶ Check the incline of the crane during the set down procedure.
- ▶ Check the incline of the divisible ballast pallet „VarioTray“ with the incline display **3.5**.
- ▶ Monitor the difference forces (derrick ballast guying A **3.1** to derrick ballast guying B **3.2**).
- ▶ It is strictly prohibited for anyone to stand under the divisible ballast pallet „VarioTray“ or within the entire danger zone during the set down procedure.

The lifting and set down of the derrick ballast is monitored by the LICCON computer system. Normally the crane operator does not have to do anything. However, if corrective measures or preventative measures should be necessary, observe the following section „Equalizing the derrick ballast“.

Lifting the derrick ballast

- ▶ Lift the derrick ballast: Press the button **727**.
or
Deflect the master switch **MS1** in direction **Y-**.

Result:

- The piston rods of the pull cylinders retract together.
- The derrick ballast is raised.
- The divisible ballast pallet „VarioTray“ loses all ground contact:
The ground contact switches are no longer actuated, the „Derrick ballast lifted off“ icon **3.4** appears.
The „turning the turntable“ and „driving the crawler“ crane movements are released.

Lowering the derrick ballast

- ▶ Lower the derrick ballast: Press the button **726**.
or
Deflect the master switch **MS1** in direction **Y+**.

Result:

- The piston rods of the pull cylinders extend together.
- The derrick ballast is countersunk
- When the divisible ballast pallet „VarioTray“ touches the ground:
The ground contact switches are actuated, the „Derrick ballast has ground contact“ icon **3.3** appears.
The „turning the turntable“ and „driving the crawler“ crane movements are blocked.

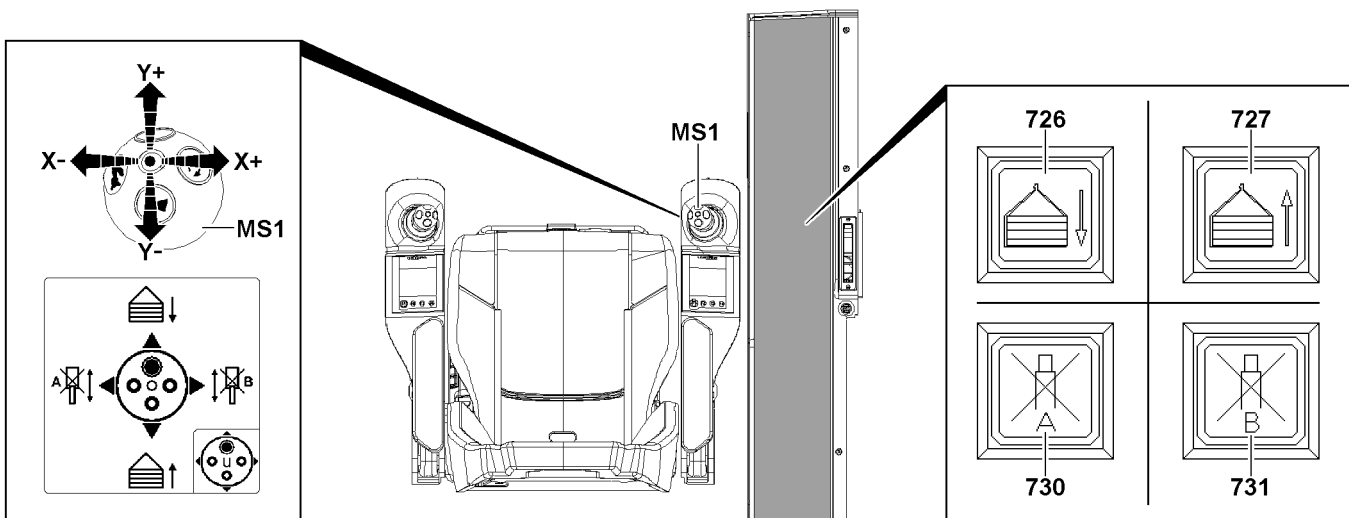
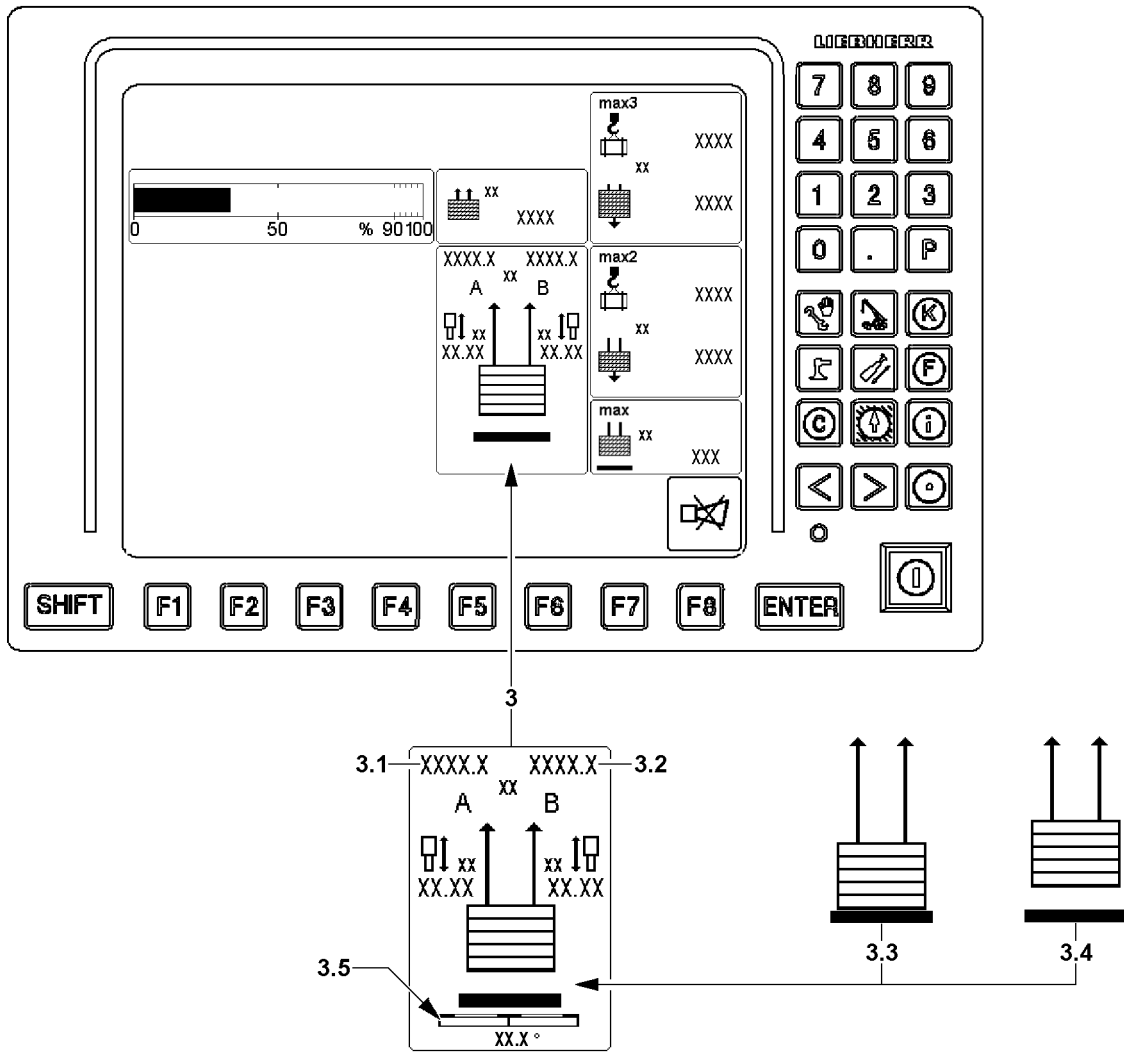

Fig.146965

LWE/LR 11000-001/23501-04-02/en

12.9.2 Equalizing the derrick ballast



WARNING

Danger of accident!

The placement surface for the divisible ballast pallet „VarioTray“ must be level, horizontal and of sufficient load bearing capacity, otherwise the divisible ballast pallet „VarioTray“ can tip over.

This could result in serious accidents.

- ▶ Check the incline of the crane during the set down procedure.
- ▶ Check the incline of the divisible ballast pallet „VarioTray“ with the incline display **3.5**.
- ▶ Monitor the difference forces (derrick ballast guying A **3.1** to derrick ballast guying B **3.2**).
- ▶ It is strictly prohibited for anyone to stand under the divisible ballast pallet „VarioTray“ or within the entire danger zone during the set down procedure.

If a limit value in the difference force monitoring (Ratio of derrick ballast guying A **3.1** to derrick ballast guying B **3.2**) or the incline display **3.5** is exceeded, the derrick ballast must be equalized.

Block the pull cylinder (A) when lifting:

- ▶ Press the button **727** and the button **730**.
- or
- Deflect the master switch **MS1** diagonally in direction **X-** and direction **Y-**.

Result:

- The piston rod of the pull cylinder (A) stops.
- The piston rod of pull cylinder (B) moves in.
- Side (B) of the derrick ballast lifts up.

Block the pull cylinder (B) when lifting:

- ▶ Press the button **727** and the button **731**.
- or
- Deflect the master switch **MS1** diagonally in direction **X+** and direction **Y-**.

Result:

- The piston rod of the pull cylinder (B) stops.
- The piston rod of pull cylinder (A) moves in.
- Side (A) of the derrick ballast lifts up.

Block the pull cylinder (A) when lowering:

- ▶ Press the button **726** and the button **730**.
- or
- Deflect the master switch **MS1** diagonally in direction **X-** and direction **Y+**.

Result:

- The piston rod of the pull cylinder (A) stops.
- The piston rod of pull cylinder (B) moves out.
- Side (B) of the derrick ballast lowers.

Block the pull cylinder (B) when lowering:

- ▶ Press the button **726** and the button **731**.
- or
- Deflect the master switch **MS1** diagonally in direction **X+** and direction **Y+**.

Result:

- The piston rod of the pull cylinder (B) stops.
- The piston rod of pull cylinder (A) moves out.
- Side (A) of the derrick ballast lowers.

13 Crawler operation with derrick ballast

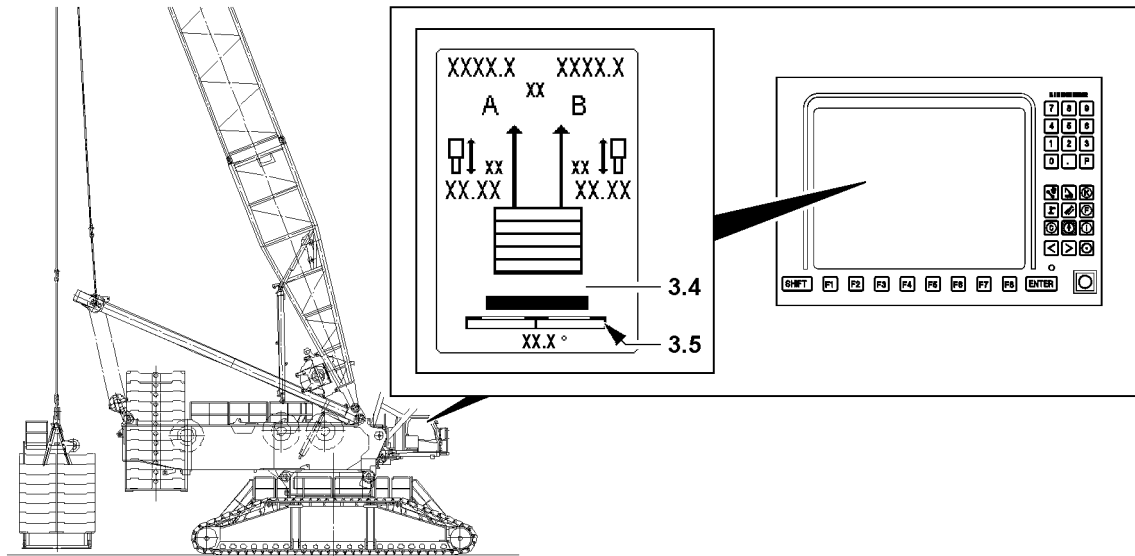

Fig.145934



Note

- ▶ Driving the crawler crane, see the Crane operating instructions, chapter 4.10.
- ▶ Release for driving the crawler takes place when all 4 ground contact rollers are no longer in contact with the ground.

13.1 Driving the crawler

Driving with suspended derrick ballast.



WARNING

Prerequisites for driving are not met, load or derrick ballast are oscillating too much!

If the specifications from the Crane operating instructions, chapter 4.10 are not observed, there is a danger of accident.

If the suspended load or the suspended derrick ballast starts to swing too much, then the crane operator can lose control over the crane.

If the following prerequisites are not observed, the crane can topple over.

This could result in serious accidents.

- ▶ Observe the specifications in the Crane operating instructions, chapter 4.10.
- ▶ Do not exceed the maximum permissible driving speed of the crawler.
- ▶ Avoid jerky driving movements.
- ▶ Avoid oscillation of the suspended load and the suspended derrick ballast. Turn and drive slowly.
- ▶ The attached load and suspended derrick ballast must be secured to prevent it from swinging. If oscillating movements should occur, set the load / derrick ballast as fast as possible down on the ground. Hereby pay attention to the limit values of the load moment display and the F-load display.
- ▶ Steering the crawler with a suspended load and / or installed derrick ballast is prohibited.
- ▶ Uphill and downhill inclines and lateral inclines may only be driven within the permissible angle range.

Make sure that the following prerequisites are met:

- Observe the specifications in the Crane operating instructions, chapter 4.10.
- Pay special attention to the limitations for crawler operation with derrick ballast.
- The ground is suitable for crawler operation with derrick ballast.
- The ground can safely take on the resulting surface pressure.
- The derrick ballast is lifted off the ground.
- The „Derrick ballast lifted off“ icon **3.4** appears on the LICCON monitor.
- The derrick ballast is horizontally aligned (observe the incline display **3.5**).

14 Disassembling



WARNING

Danger of falling!

During assembly / disassembly, inspection and maintenance work, personnel must be secured with appropriate aids to prevent them from falling.

Death, severe bodily injuries, property damage.

- ▶ All work at a height, when there is a danger of falling, must be carried out with suitable aids.
- ▶ If aids are not available and work cannot be carried out from the ground, then assembly personnel must secure themselves with the supplied fall arrest system to prevent falling, see the Crane operating instructions, chapter 2.04.
- ▶ If fall protection equipment is available, then it must be used, see the Crane operating instructions, chapter 2.06.
- ▶ When lifting, lowering, swinging crane parts in and out, no persons may remain in the danger zone.
- ▶ If railings are present on the components, then they must be brought into the corresponding position and secured for assembly / disassembly work.
- ▶ Only step on the aids, ladders and catwalks with clean shoes.
- ▶ Keep aids, ladders and catwalks free of heavy dirt, snow and ice.
- ▶ During all assembly and disassembly work, maintenance work and inspections, travel or crane operation is prohibited.
- ▶ Remaining on a suspended load is prohibited.
- ▶ Stepping or walking on crane components and lattice sections, which have an incline of more than 20° is prohibited.
- ▶ For all assembly work, the crane operator of the main crane must be in voice contact with the crane operator / crane operators of the auxiliary crane / auxiliary cranes.
- ▶ For assembly / disassembly tasks, the crane operator may only initiate crane movements when the responsible guide has explicitly released the movement.



WARNING

Danger of impact / crushing!

When installing / removing crane components with the auxiliary crane, crane components can start to swing back and forth.

When lifting / lowering and positioning crane components, there is an increased danger of impacts / crushing.

Death, severe bodily injuries, property damage.

- ▶ Make sure that personnel cannot be caught by components.
- ▶ When working in danger zones: Use aids to protect limbs.
- ▶ Guide components with suitable aids to minimize oscillation.



DANGER

The components can fall down!

If the corresponding components are disengaged from the auxiliary crane before the corresponding component is pinned, the corresponding component can fall down and fatally injure personnel.

- ▶ Do not disengage the auxiliary crane until the respective component is pinned and secured.

**DANGER**

Falling erection racks!

If the erection racks are not secured with retaining pins, then they will fall down uncontrolled when unpinning the guy rods.

Death, severe bodily injuries, property damage.

- ▶ The two erection racks must be locked and secured in a vertical position with retaining pins. Only then may the guy rods be removed.
- ▶ It is prohibited for anyone to remain under the erection racks as well as within the entire danger zone.

15 Removing the ballast on the divisible ballast pallet „VarioTray“

Make sure that the following prerequisites are met:

- The crane is properly supported and horizontally aligned.
- An auxiliary crane is available.
- The counterweight has been installed on the turntable according to the load chart.
- The maximum ground unevenness for the placement surface of the derrick ballast is plus / minus 1°.
- The LICCON overload protection has been set according to the data in the load chart.
- The LICCON overload protection settings have been compared with the actual set up configuration.
- The two erection racks are be locked and secured in a vertical position with retaining pins.

15.1 Setting down the derrick ballast

**WARNING**

Danger of toppling the ballast stack!

The placement surface for the derrick ballast must be level, horizontal and of sufficient load bearing capacity, otherwise the ballast stacks can tip over.

Death, severe bodily injuries, property damage.

- ▶ Check the horizontal position of the crane during the set down procedure.
- ▶ Check the horizontal position of the derrick ballast during the set down procedure.
- ▶ Constantly check the differential forces in the guying on LICCON monitor 1.
- ▶ It is strictly prohibited for anyone to stand under the derrick ballast or in any part of the danger zone during the set down procedure.

Make sure that the following prerequisites are met:

- The placement surface for the derrick ballast must be level, horizontal and of sufficient load bearing capacity.
- A guide or crane driver monitor the setting down of the derrick ballast and the load.
- ▶ Extend the piston rods, see section „Carrying out crane movements“.

Result:

- The derrick ballast is lowered.
- ▶ When the ballast pallet touches the ground, the ground contact switches are actuated.

Result:

- The **turning the turntable** and **driving the crawler** crane movements turn off.

15.2 Disconnecting the electrical connections



Note

- ▶ Disconnect the electrical connections from the suspended ballast to the turntable, see Electric wiring diagram.

- ▶ Disconnect the electrical connections.
- ▶ Close the electrical connections off properly with dummy plugs or protective caps.

15.3 Removing the ballast on the divisible ballast pallet „VarioTray“



WARNING

The crane can topple over!

If the following danger notes are not observed, the ballast plates or the ballast stack can slip on the divisible ballast pallet „VarioTray“ and fall down.

Death, severe bodily injuries, property damage.

- ▶ The ground on which the ballast is removed from the divisible ballast pallet „VarioTray“ must be level and have adequate load bearing capacity.
- ▶ Always take down the ballast plates symmetrically, in reference to the longitudinal axis.
- ▶ It is necessary to start with the two outer ballast stacks.
- ▶ The difference for the center ballast stack may not be more than a maximum of one ballast plate while removing the ballast.
- ▶ The ballast on both outer ballast stacks can be removed with ballast assemblies of two ballast plates each.
- ▶ The difference between both outer ballast stacks may not be more than maximum 25 t when removing the ballast.
- ▶ Replace damaged ballast plates immediately with new ballast plates.
- ▶ Observe the weight signs on the ballast pallets.

15.3.1 Removing the ballast plates, fastening system: „Twistlock“

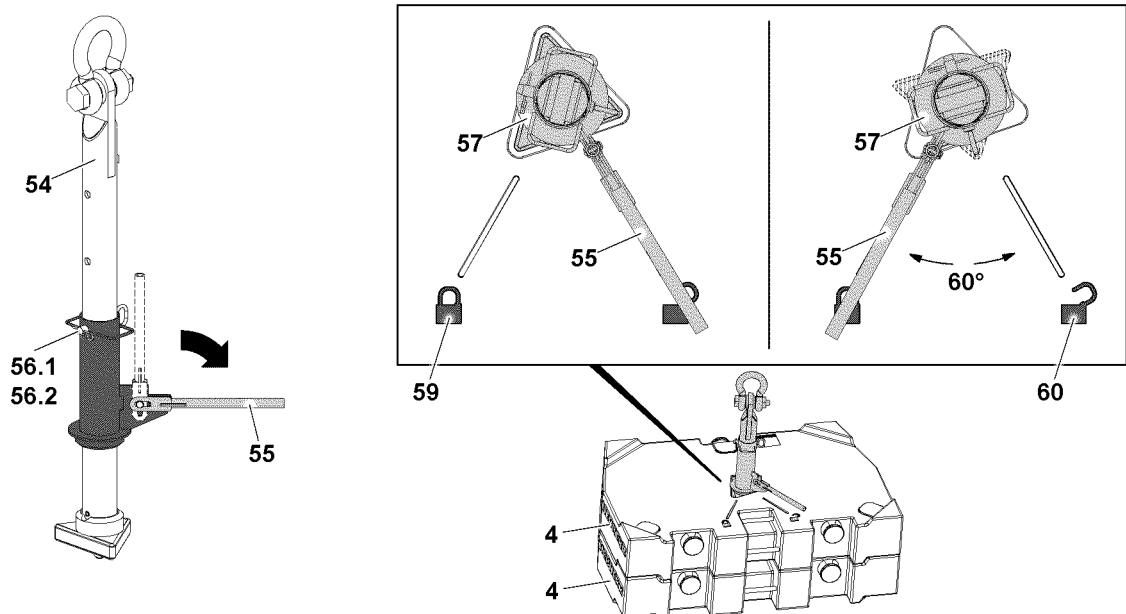

Fig.145282: Ballast plates, fastening system: „Twistlock“

**WARNING**

Danger of accident!

If more than the permissible two ballast plates are lifted with the receptacle stud, the receptacle stud will be overloaded and can be damaged.

Death, severe bodily injuries, property damage.

- ▶ Make sure that the ballast plates are placed correctly in the centerings.
- ▶ Replace damaged ballast plates.

To lift off the ballast plate(s) **4**, use the receptacle stud **54**.

Before the receptacle stud **54** is guided into the ballast plates, it must be ensured that the length of the receptacle stud **54** is set correctly. The length of the receptacle stud **54** can be adjusted with the pin **56**.

If the length of the receptacle stud **54** is to be adjusted:

- ▶ Release and unpin the pin **56.1**.
- ▶ Adjust the length of the receptacle stud by moving the receptacle stud **54**.
- ▶ Insert the pin **56** and secure it with the retaining element **56.2**.
- ▶ Fasten the receptacle stud **54** to the auxiliary crane and guide it into the ballast plate(s).
- ▶ Pull the lever **54** up and fold it down.
- ▶ Turn the lever **55** by 60° until the lever **55** points to the icon **59**.

Result:

– The receptacle stud **54** is locked with the ballast plate.

- ▶ Lift the ballast plate with the receptacle stud **54** and remove it carefully from the ballast stack or the divisible ballast pallet „VarioTray“.
- ▶ Turn the lever **55** by 60° until the lever **55** points to the icon **60**.

Result:

– The receptacle stud **54** is unlocked.

- ▶ Carefully pull the receptacle stud **54** from the ballast plate.
- ▶ Alternately remove the ballast plates on both sides.

15.3.2 Removing the ballast plates, fastening system: „Bitt“

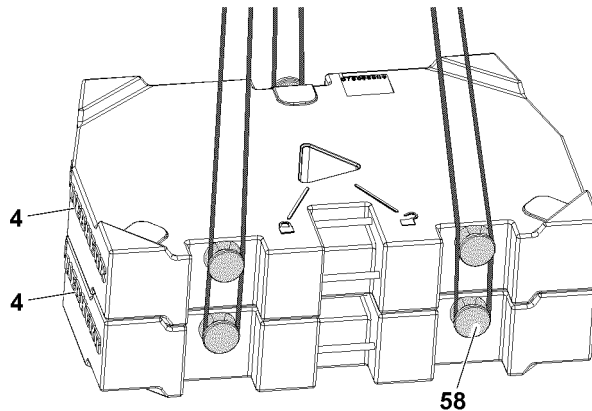

Fig.145283: Ballast plates, fastening system: „Bitt“

**WARNING**

Falling ballast plates!

If more than the permissible loads are lifted, then the bits **58** are overloaded and the ballast plates can fall down.

Death, severe bodily injuries, property damage.

- ▶ Lift the ballast plates individually or as a package, maximum 20 t , 3 fastening points.
- ▶ Replace damaged ballast plates immediately.

**WARNING**

Incorrect handling of the fastening equipment!

If the fastening equipment is not attached correctly and if it is not secured sufficiently to prevent it from loosening up, loads can fall down.

Death, severe bodily injuries, property damage.

- ▶ Make sure that the fastening equipment is correctly attached on the bits **58** and that it is secured sufficiently to prevent it from loosening up.

- ▶ Lift the ballast plates **4** off individually or as an assembly of maximum two plates alternately on the left and right with the auxiliary crane.

16 Disassembling the suspended ballast

16.1 Disassembling the guy rods from the erection racks

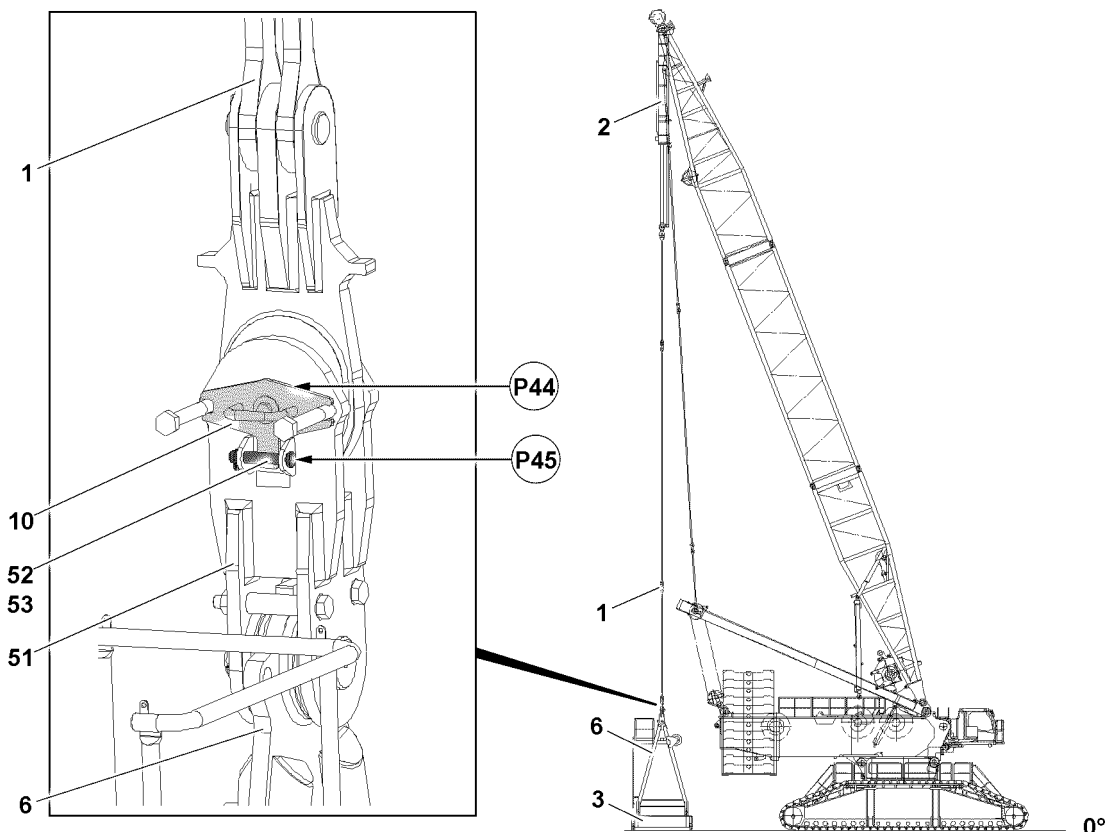

Fig.145276: Unpinning procedure

**DANGER**

Falling erection racks!

If the erection racks are not secured with retaining pins, then they will fall down uncontrolled when unpinning the guy rods.

Death, severe bodily injuries, property damage.

- ▶ The two erection racks must be locked and secured in a vertical position with retaining pins **8**. Only then may the guy rods be removed.
- ▶ It is prohibited for anyone to remain under the erection racks as well as within the entire danger zone.

Make sure that the following prerequisites are met:

- The erection racks are secured.
- The ballast plates are removed.
- ▶ Remove the retaining element **53** at point **P45** and unpin the retaining pin **52**.
- ▶ Unpin the connector pin **10** at point **P44**.

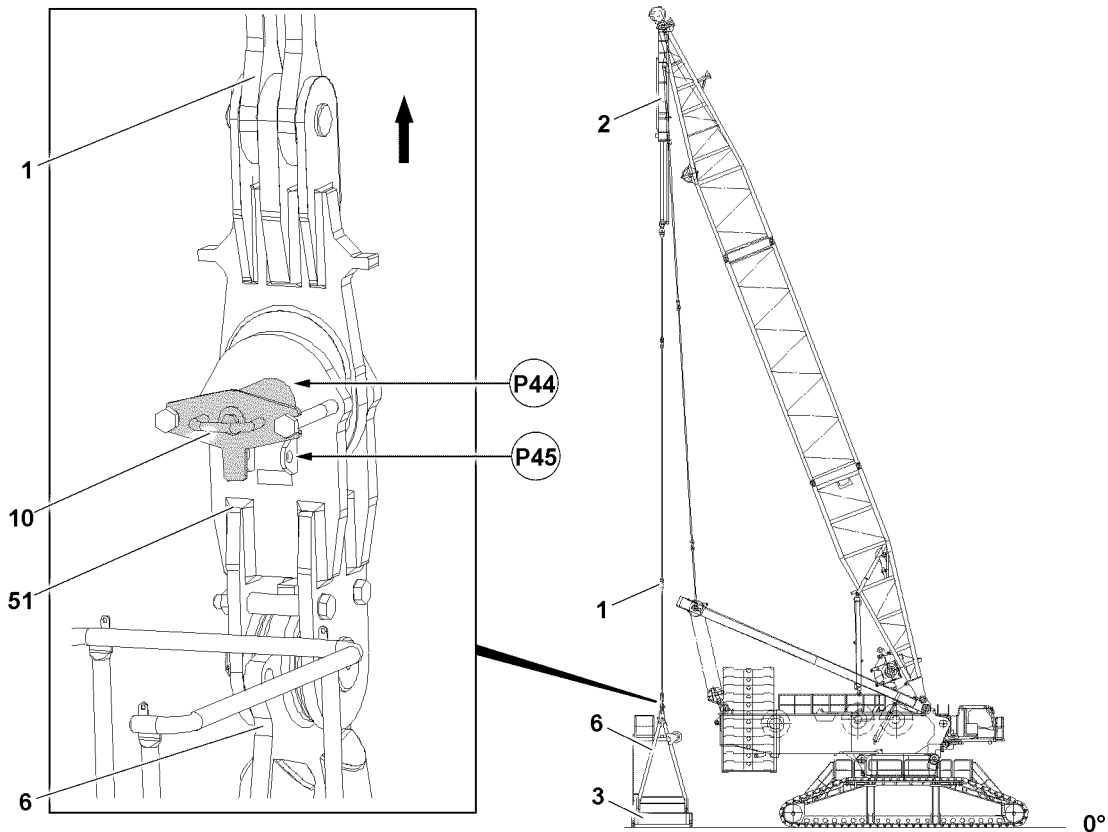

Fig.145293: Unpinning procedure

- ▶ Drive out the guy rods **1** out by retracting the piston rods on the pull cylinders **2** from the brackets **51** of the erection rack **6**.



Note

Retract / extend the pull cylinder **2**

- ▶ Control the pull cylinders **2** from the crane cab, see the section „Lifting and lowering the derrick ballast using the pull cylinders“.
- ▶ Operate the pull cylinder **2** with the radio remote control, see the „radio remote control operating instructions“.

- ▶ Insert the connector pin **10** again at point **P44**.
- ▶ Insert the retaining pin **52** at point **P45** and secure with the retaining element **53**.

Result:

- The connector pin **10** is secured.

17 Disassembling the suspended ballast with the suspended ballast guide

17.1 Disassembling the suspended ballast guide on the erection racks

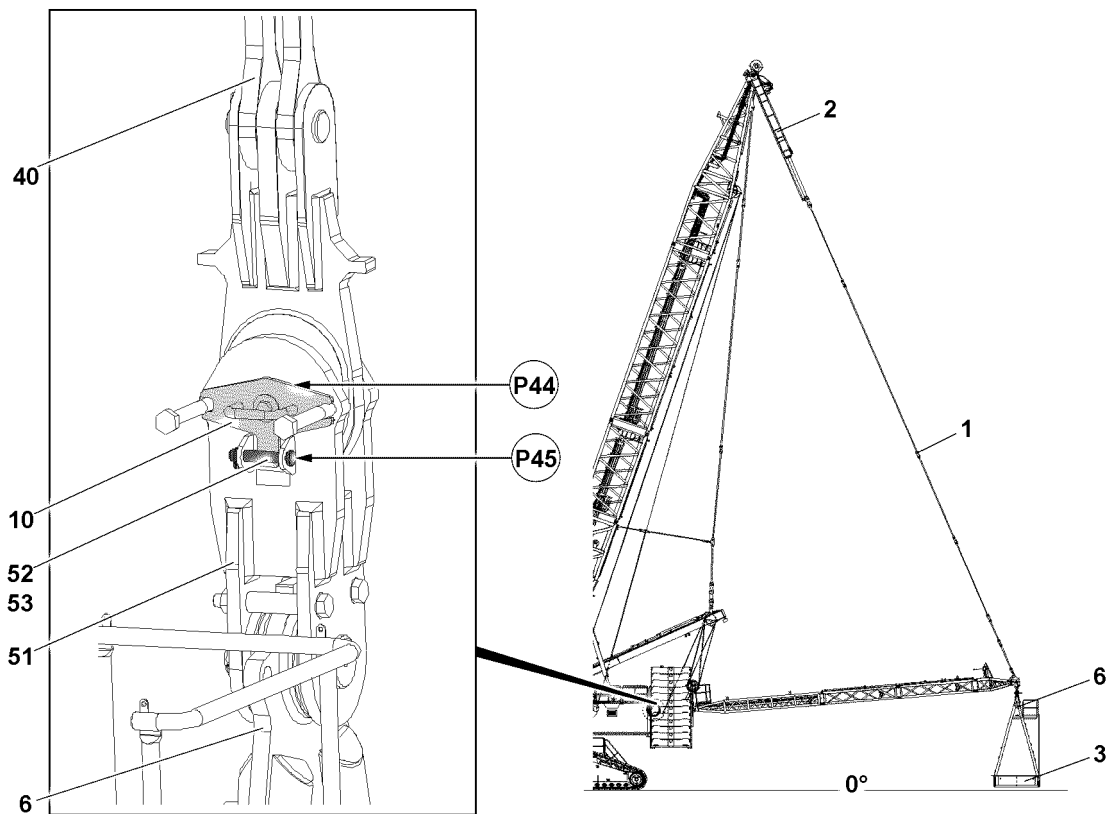

Fig.145279: Unpinning procedure



DANGER

Falling erection racks!

If the erection racks are not secured with retaining pins, then they will fall down uncontrolled when unpinning the guy rods.

Death, severe bodily injuries, property damage.

- ▶ The two erection racks must be locked and secured in a vertical position with retaining pins. Only then may the guy rods be removed.
- ▶ It is prohibited for anyone to remain under the erection racks as well as within the entire danger zone.

Make sure that the following prerequisites are met:

- The erection racks are secured.
- The ballast plates are removed.

- ▶ Remove the retaining element **53** at point **P45** and unpin the retaining pin **52**.
- ▶ Unpin the connector pin **10** at point **P44**.

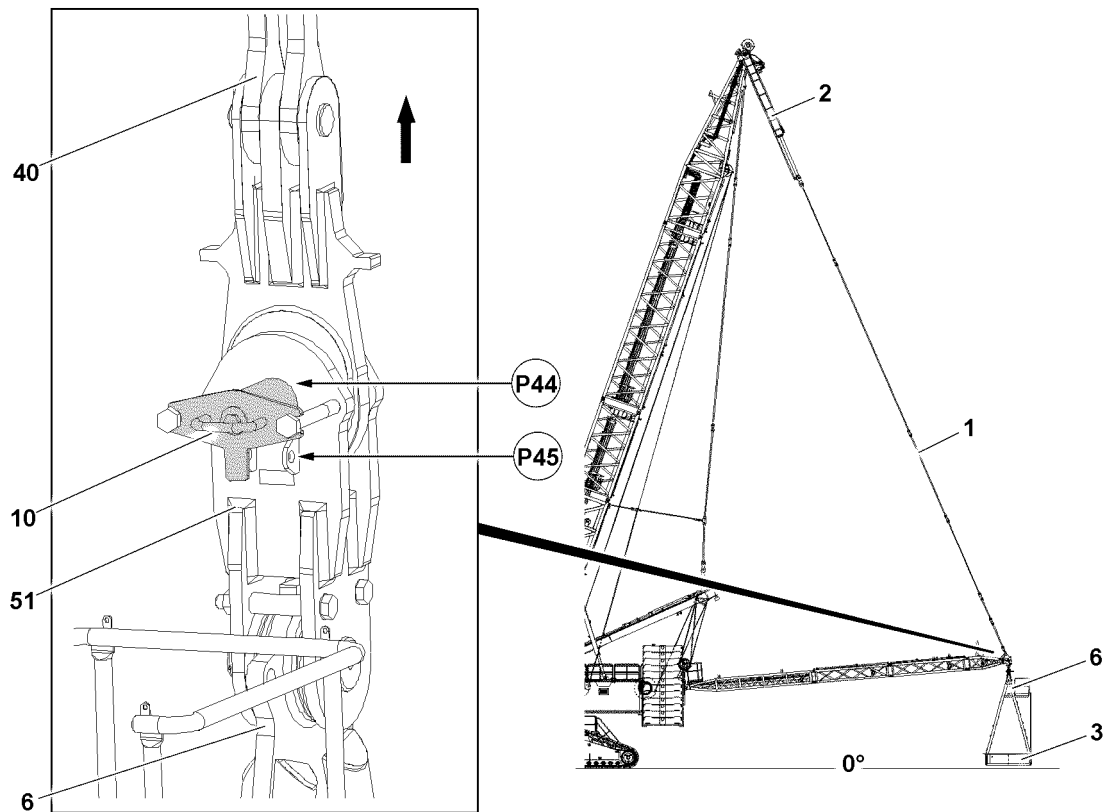

Fig.145294: Unpinning procedure

- ▶ Drive out the guy rods **1** out by retracting the piston rods on the pull cylinders **2** from the brackets **51** of the erection rack **6**.



Note

Retract / extend the pull cylinder **2**

- ▶ Control the pull cylinders **2** from the crane cab, see the section „Lifting and lowering the derrick ballast using the pull cylinders“.
- ▶ Operate the pull cylinder **2** with the radio remote control, see the „radio remote control operating instructions“.

- ▶ Insert the connector pin **10** again at point **P44**.
- ▶ Insert the retaining pin **52** at point **P45** and secure with the retaining element **53**.

Result:

- The connector pin **10** is secured.

Empty page!

LWE/LR 11000-001/23501-04-02/en

10

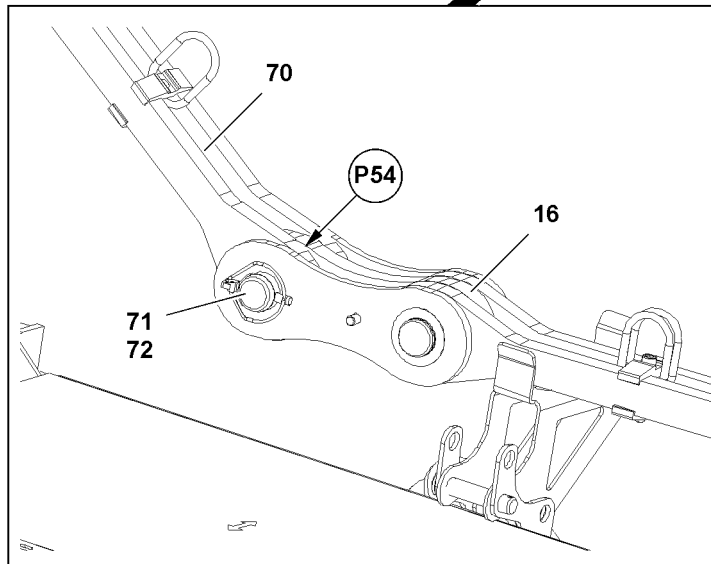
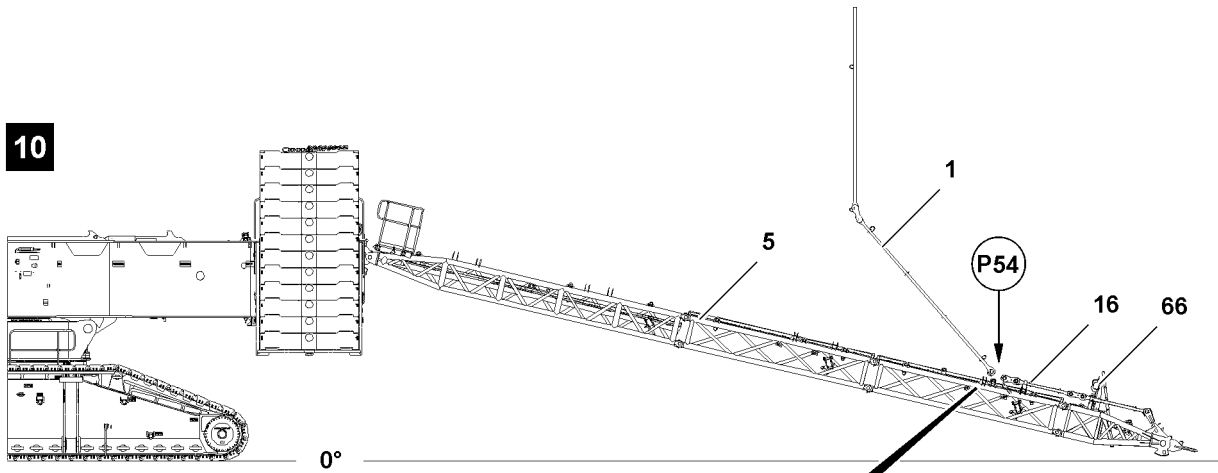

11

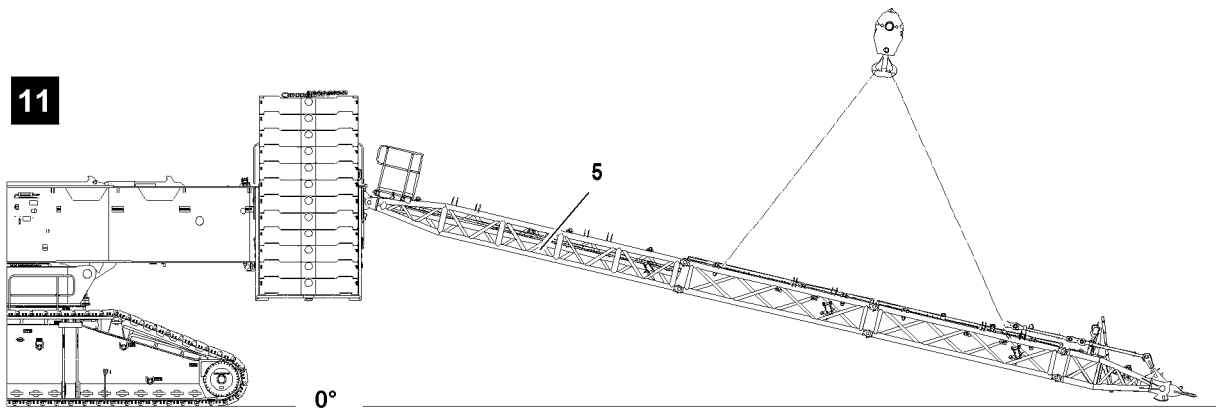

Fig.120215

LWE/LR 11000-001/23501-04-02/en

17.2 Disassembling the suspended ballast guide

Derrick ballast radius	Number of intermediate sections
20 m	0
25 m	1
30 m	2

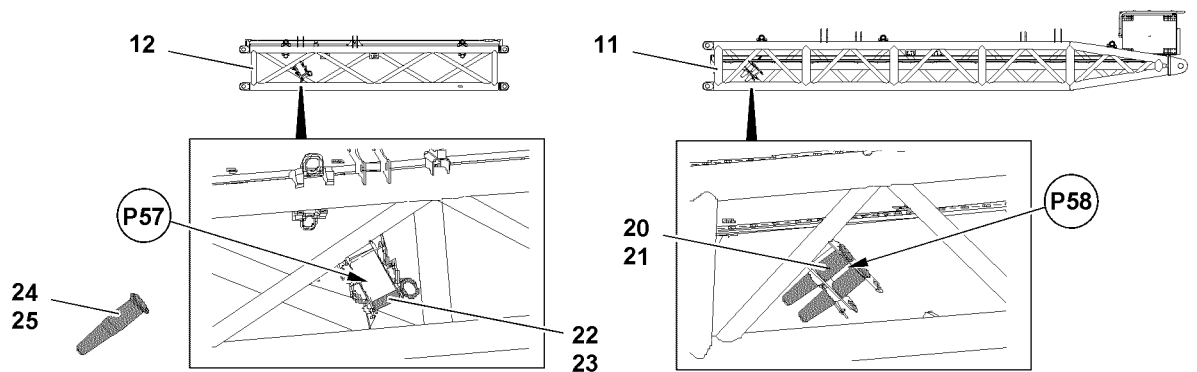

Fig.122802: Park position for pin



Note

- ▶ Park position **P57** for pin **24** and pin **22**.
- ▶ Park position **P58** for pin **20**.



WARNING

Falling pins!

Death, severe bodily injuries, property damage.

- ▶ Make sure that all pins are properly secured in the park positions with the respective retaining elements.

10

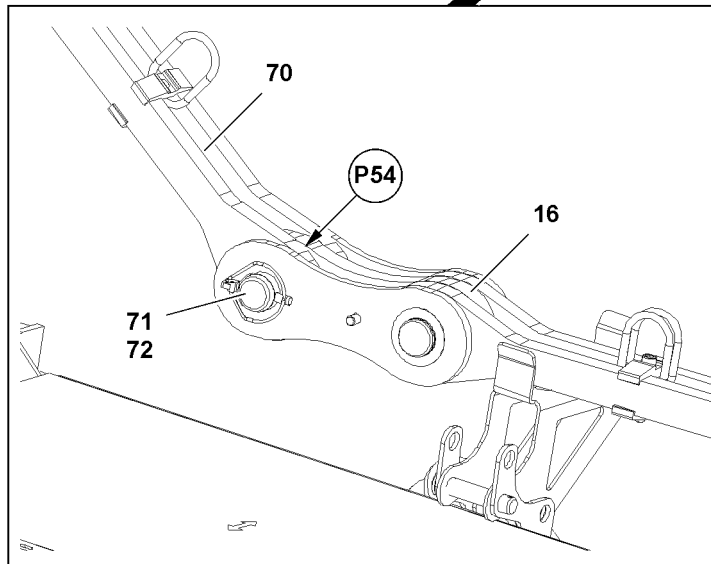
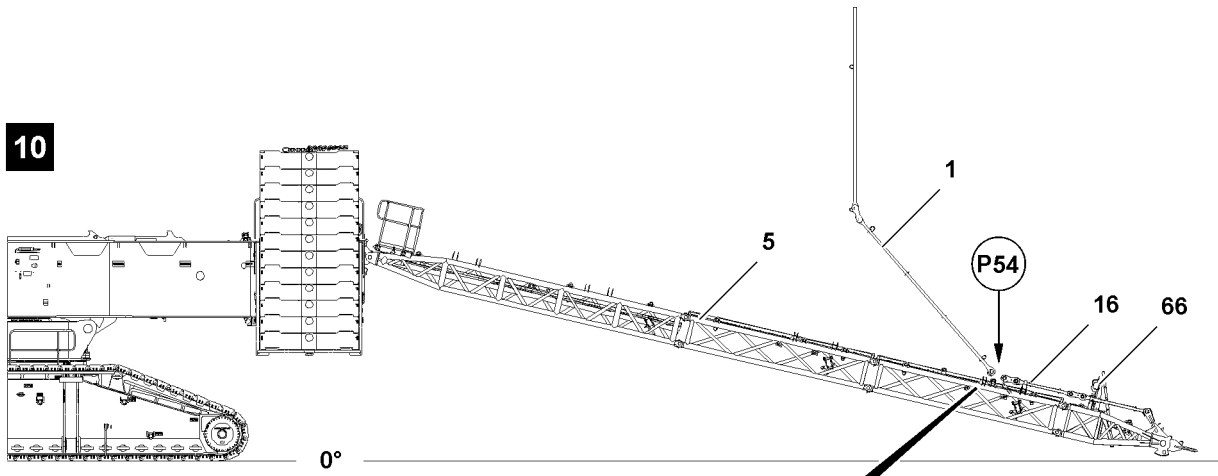

11

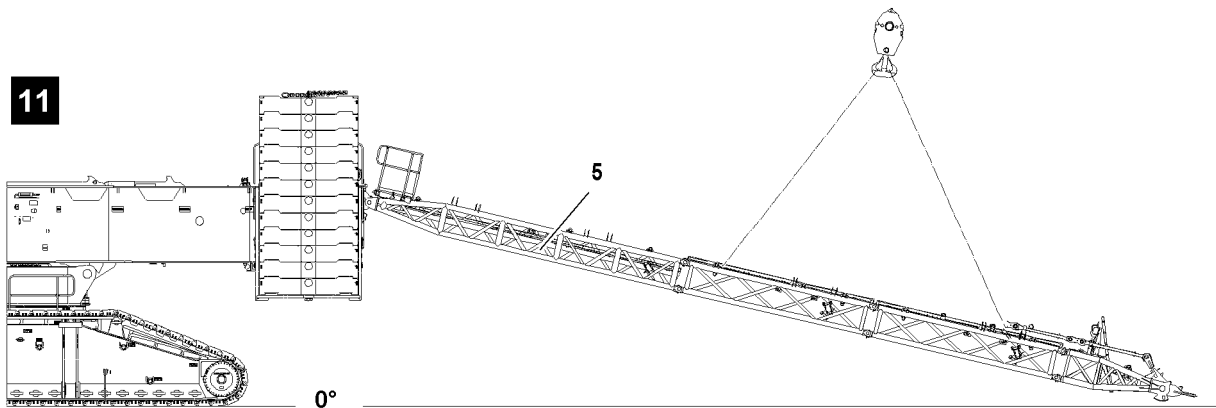

Fig.120215

LWE/LR 11000-001/23501-04-02/en

17.2.1 Unpinning the pull rods of the suspended ballast guide from the D-guy rods

Make sure that the following prerequisite is met:

- The suspended ballast guide is separated from the suspended ballast.

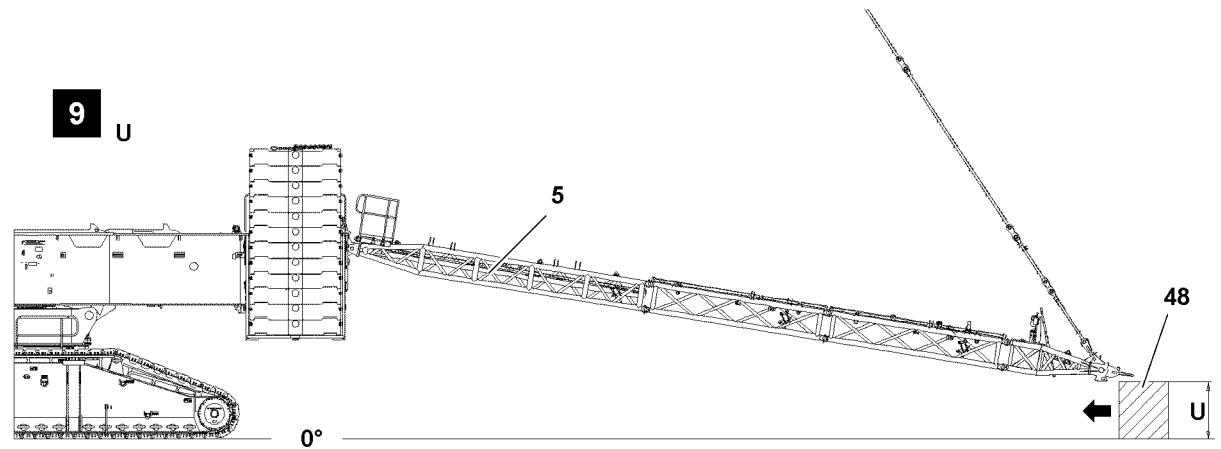

Fig.120214: Substructure

Suspended ballast guide	R30	R25	R20
Substructure height „U“	0 m	1.6 m	2.0 m

When the suspended ballast guide **5** is separated from the suspended ballast:

- ▶ Drive the crane away from the suspended ballast.
- ▶ Take the suspended ballast guide **5** down with the derrick onto the substructure **48**, see illustration **9** and chart.
- ▶ Connect the rope of the manual rope winch **66** with the D-guy rods **1**.

The D-guy rods **1** are pinned on both sides on the suspended ballast guide **5**. The unpinning procedure is described on the example for one D-guy rod.



WARNING

Swinging D-guy rods!

When unpinning the D-guy rods **1** at point **P54** they swing uncontrolled in the direction of the turntable. Death, severe bodily injuries, property damage.

- ▶ Make sure that the D-guy rods are secured with the manual rope winches before unpinning.
- ▶ Remove the retaining element **72** at point **P54** and unpin the pin **71**, see illustration **10**.
- ▶ Swing the D-guy rods **1** with the aid of the manual rope winch **66** and simultaneously luff up the derrick in direction of the turntable.

When the D-guy rods **1** hang vertically:

- ▶ Remove the rope of the manual rope winch **66** and spool it up.
- ▶ Fasten the suspended ballast guide **5** to the auxiliary crane, see illustration **11**.

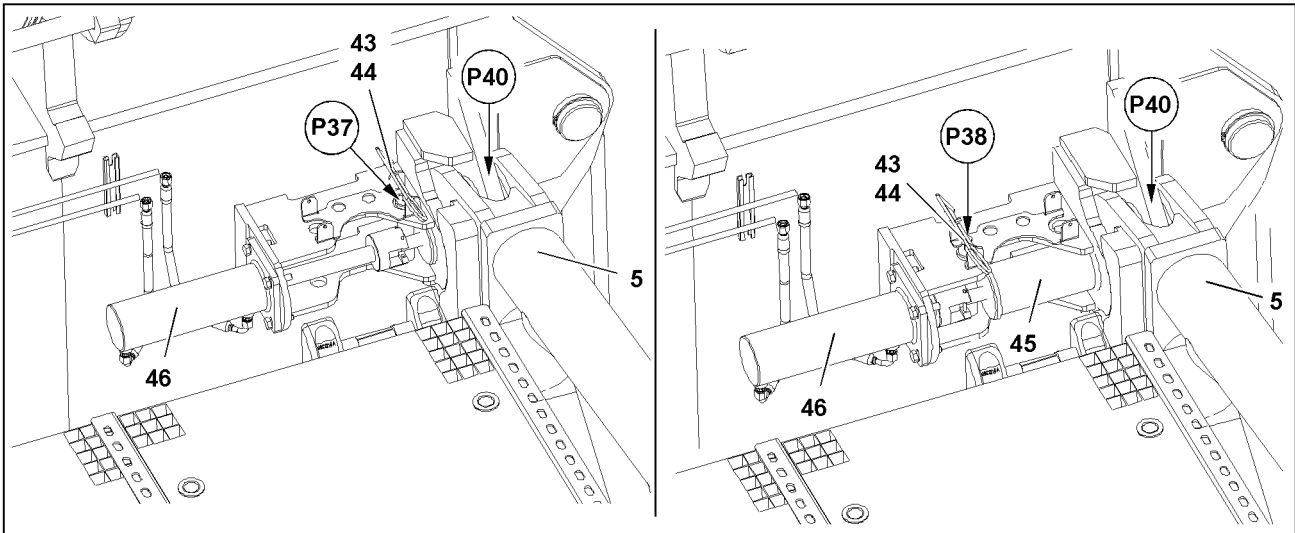

12

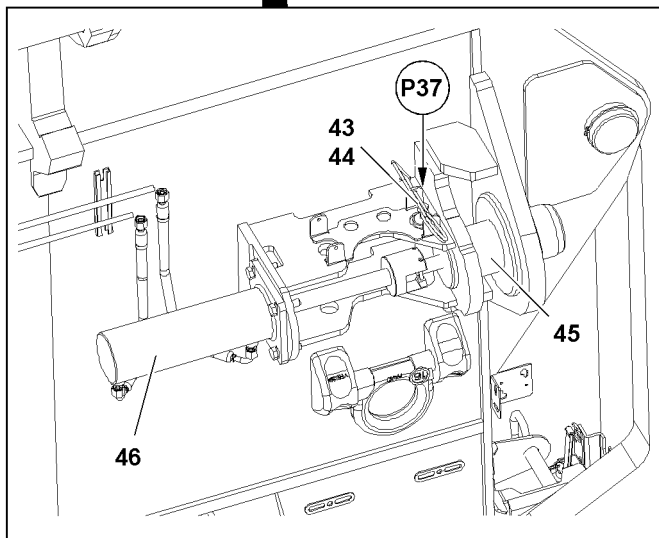
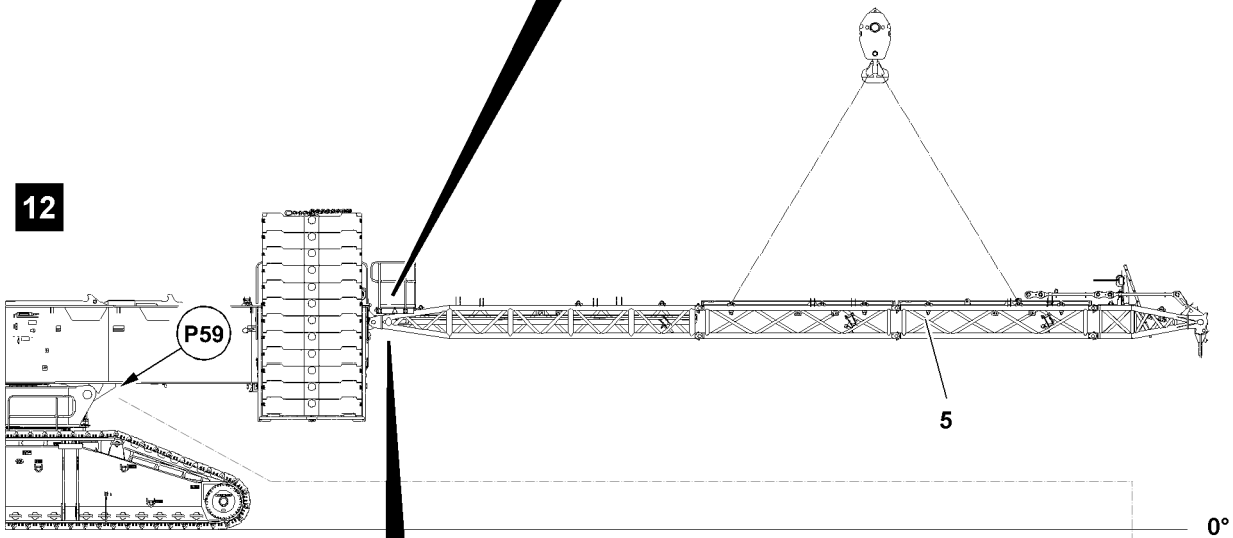

13

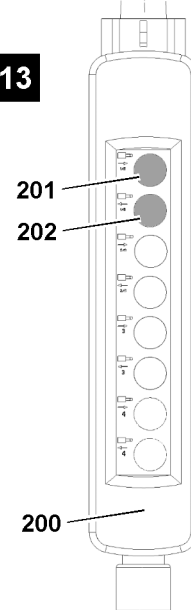

Fig.120216

17.2.2 Disassembling the suspended ballast guide on the turntable frame

Make sure that the following prerequisites are met:

- The suspended ballast guide is fastened to the auxiliary crane.
- The control panel is connected on the „rear turntable“ socket, point **P59**.

▶ Swing the suspended ballast guide **5** to the horizontal.

The suspended ballast guide **5** is pinned on two points **P40**. The unpinning procedure is described for one pin as an example:

- ▶ Release the pin **45**: Remove the retaining element **44** at point **P37** and unpin the retaining pin **43**, see illustration **12**.
- ▶ Insert the retaining pin **43** at point **P38** and secure with the retaining element **44**.

When the suspended ballast guide **5** is safely held by the auxiliary crane:

- ▶ Unpin the pin **45**: Press button **202** on the control panel **200**, see illustration **13**.

Result:

- The pin **45** moves out.

When both pins **45** are unpinned:

- ▶ Remove the suspended ballast guide **5** from the pin points on the rear of the turntable and place it on the substructure.
- ▶ Insert the pins **45** again: Press button **201** on the control panel **200**, see illustration **13**.

Result:

- The pin **45** moves in.
- ▶ Secure the pin **45**: Insert the retaining pin **43** at point **P37** and secure with the retaining element **44**, see illustration **12**.

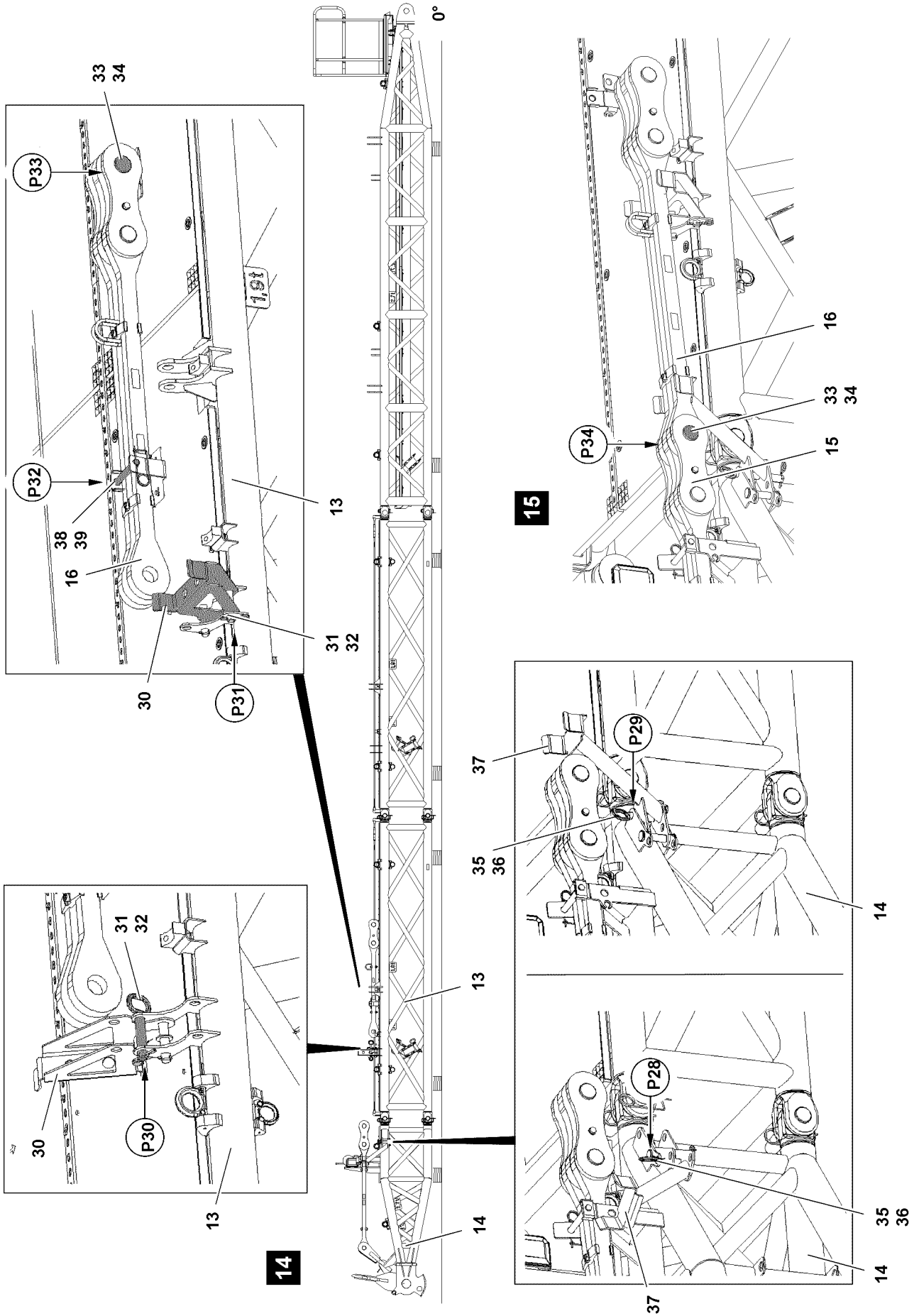

Fig.122951

LWE/LR 11000-001/23501-04-02/en

17.2.3 Disassembling the suspended ballast guide with 30 m suspended ballast radius



Note

- ▶ The disassembly of the suspended ballast guide is described based on the example of one suspended ballast guide with a 30 m suspended ballast radius.

Swinging the brackets

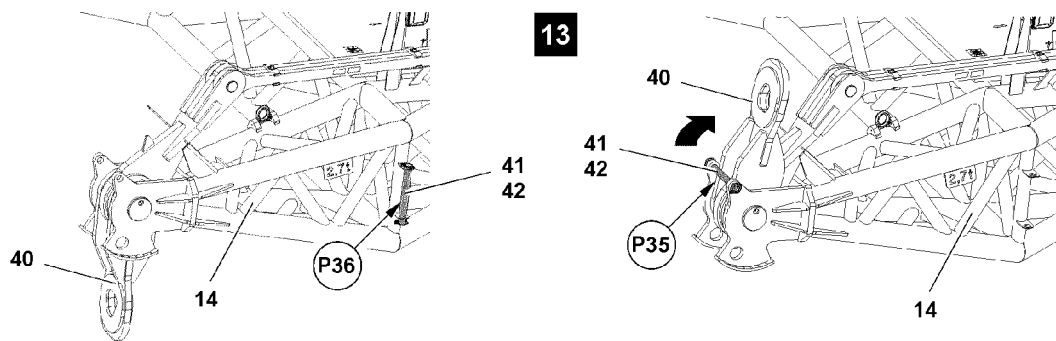

Fig.119029: Swinging the bracket

- ▶ Fasten the bracket **40** to the auxiliary crane.



WARNING

Bracket swinging down!

The bracket can swing down by itself due to its own weight when pinning it, see illustration. Death, severe bodily injuries, property damage. Fingers and hands can be crushed.

- ▶ Make sure that the platform is held by the auxiliary crane.
- ▶ Do not reach with your hands into the danger zone.
- ▶ Remove the retaining element **42** at point **P36** and unpin the pin **41**, see illustration **16**.
- ▶ Swing the bracket **40** upward with the auxiliary crane.
- ▶ Insert the pin **41** in the park position at point **P35** and secure with the retaining element **42**, see illustration **16**.

Disassembling the pull rods

- ▶ Fasten the auxiliary crane to the pull rod **16**.
- ▶ Unpin the pull rod **16** from the pull rod end section **15**: Remove the retaining element **34** at point **P34** and unpin the pin **33**, see illustration **15**.
- ▶ Lift the pull rod **16** with the auxiliary crane and take it down in transport position at point **P32** and point **P33**.
- ▶ Pin the pin **33** in point **P33** and secure with the retaining element **34**.
- ▶ Pin the pin **38** in point **P32** and secure with the retaining element **39**.

Result:

- The pull rod **16** is secured in the transport position, see illustration **14**.

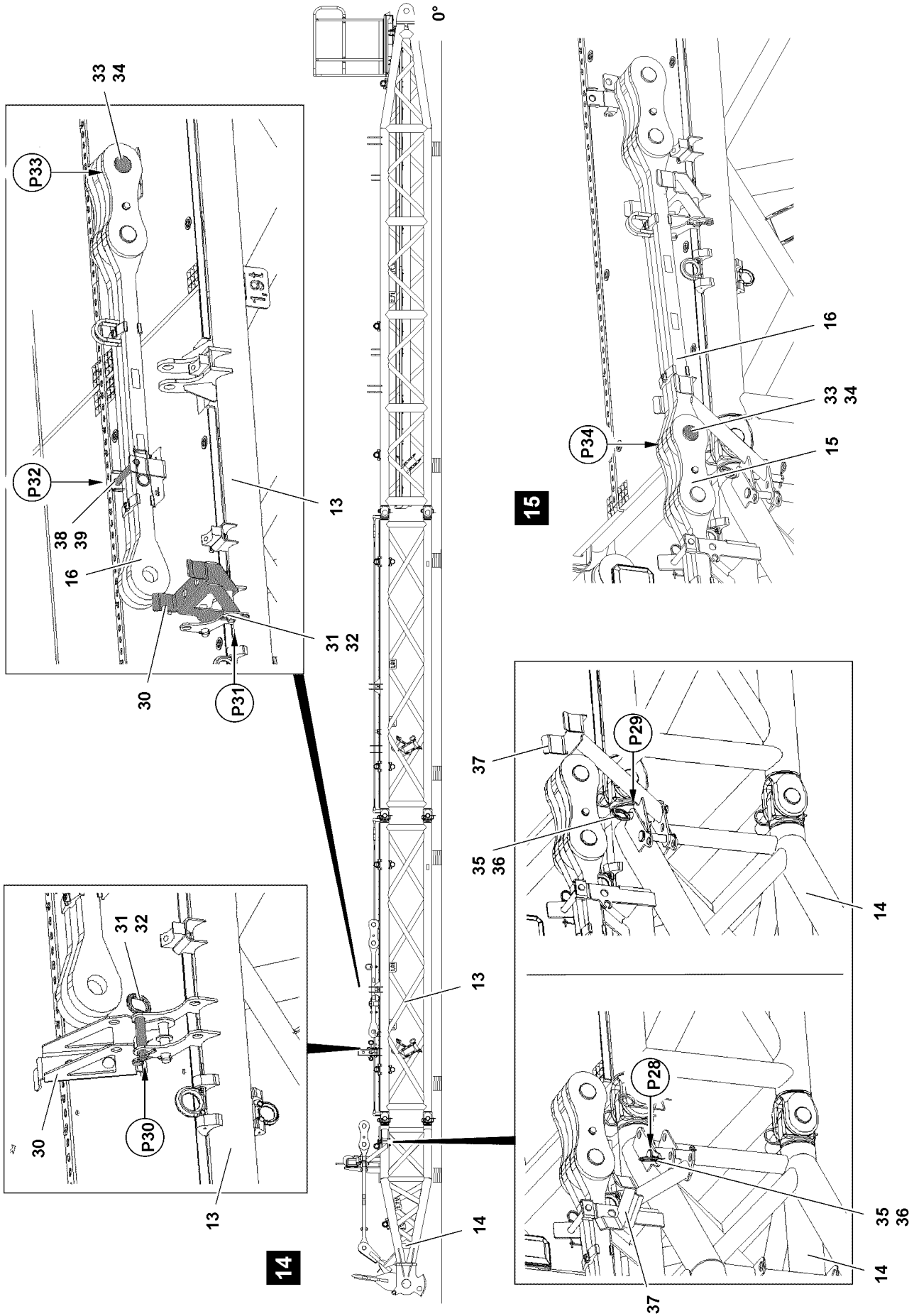

Fig.122951

LWE/LR 11000-001/23501-04-02/en

- ▶ Release the retainer **30** from operating position: Remove the retaining element **32** at point **P31** and unpin the socket pin **31**, see illustration **14**.

**WARNING**

Danger of crushed limbs!

When swinging the retainer, fingers and hands can be crushed.

- ▶ Do not reach with your hands into the danger zone.

- ▶ Swing the retainer **30** until it can be pinned at point **P30**.
- ▶ Pin the socket pin **31** in point **P30** and secure with the retaining element **32**.

Result:

- The retainer **30** is secured in the transport position, see illustration **14**.
- ▶ Release the bracket **37** from operating position: Remove the retaining element **36** at point **P29** and unpin the socket pin **35**, see illustration **14**.

**WARNING**

Danger of crushed limbs!

When swinging the bracket, fingers and hands can be crushed!

- ▶ Do not reach with your hands into the danger zone.

- ▶ Swing the bracket **37** until it can be pinned at point **P28**.
- ▶ Pin the socket pin **35** in point **P28** and secure with the retaining element **36**.

Result:

- The bracket **37** is secured in the transport position, see illustration **14**.
- ▶ Secure the pull rod **15** in transport position.

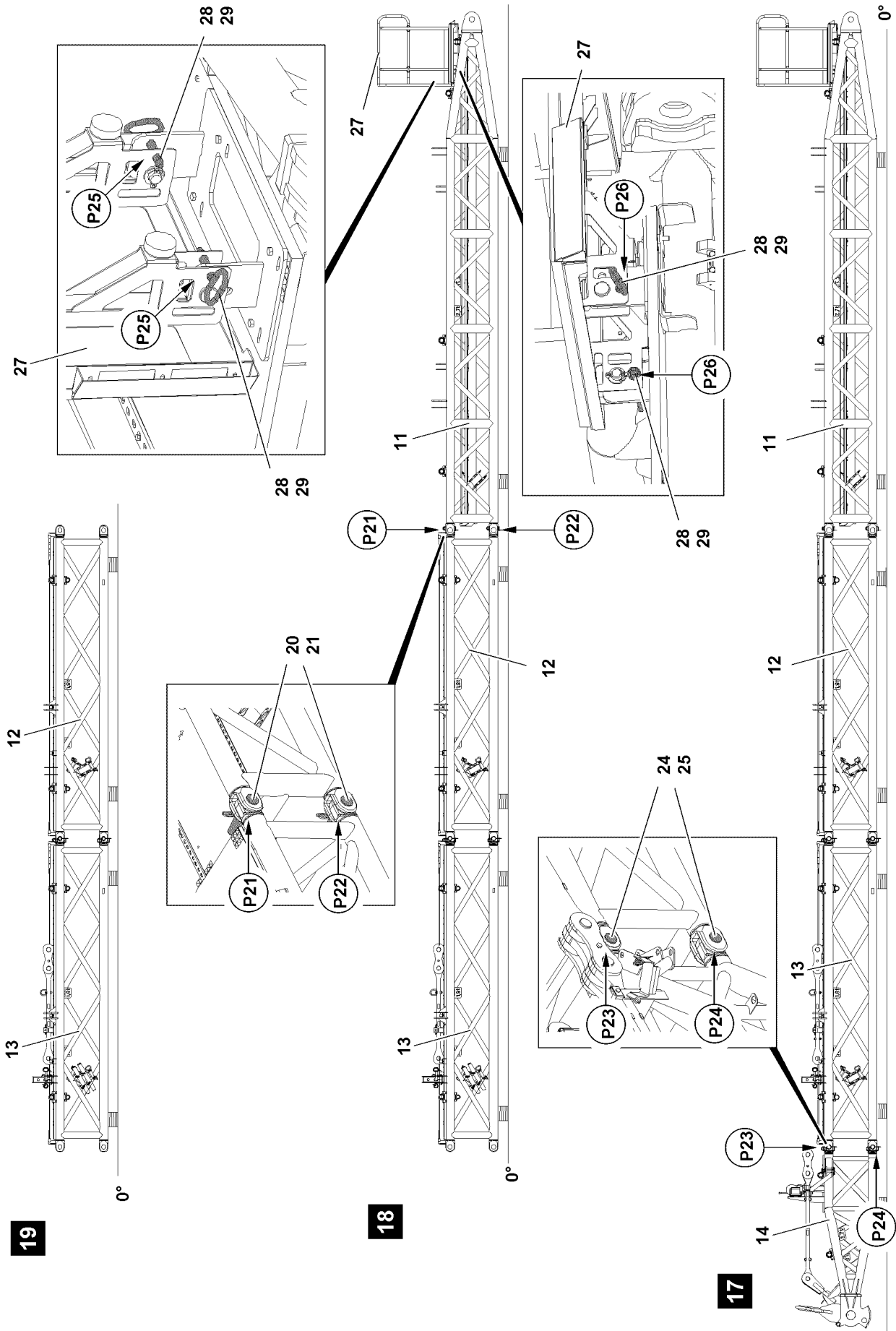

Fig.122952

LWE/LR 11000-001/23501-04-02/en

Disassembling the end section

- ▶ Fasten the end section **14** to the auxiliary crane.

The end section and the intermediate section are pinned together in four points. Every point is present on both sides of the component on one level, see illustration **17**.

- ▶ Unpin the end section **14** on both sides at point **P24**: Remove the retaining element **25** and unpin the pin **24**.
- ▶ Unpin the end section **14** on both sides at point **P23**: Remove the retaining element **25** and unpin the pin **24**.
- ▶ Remove the end section **14** with the auxiliary crane.
- ▶ Remove the fastening equipment.

Disassembling the pivot section

- ▶ Fasten the platform **27** to the auxiliary crane.
- ▶ Set the platform **27** in the transport position, see illustration **18**: Remove the retaining element **29** at points **P26** and unpin the grip pins **28**.

**WARNING**

Platform swinging down!

The platform can swing down by itself due to its own weight when pinning it, see illustration.

Death, severe bodily injuries, property damage.

Fingers and hands can be crushed.

- ▶ Make sure that the platform is held by the auxiliary crane.
- ▶ Do not reach with your hands into the danger zone.
- ▶ Use personal protective equipment.

-
- ▶ Swing the platform **27** with the auxiliary crane.
 - ▶ Insert the grip pins **28** at points **P25** and secure with the retaining element **29**.
 - ▶ Remove the auxiliary crane.
 - ▶ Fasten the pivot section **11** to the auxiliary crane.

The pivot section and the intermediate section are pinned together in four points. Every point is present on both sides of the component on one level, see illustration **18**.

- ▶ Unpin the pivot section **11** on both sides at point **P22**: Remove the retaining element **21** and unpin the pin **20**.
- ▶ Unpin the pivot section **11** on both sides at point **P21**: Remove the retaining element **21** and unpin the pin **20**.
- ▶ Remove the pivot section **11** with the auxiliary crane.
- ▶ Remove the fastening equipment.

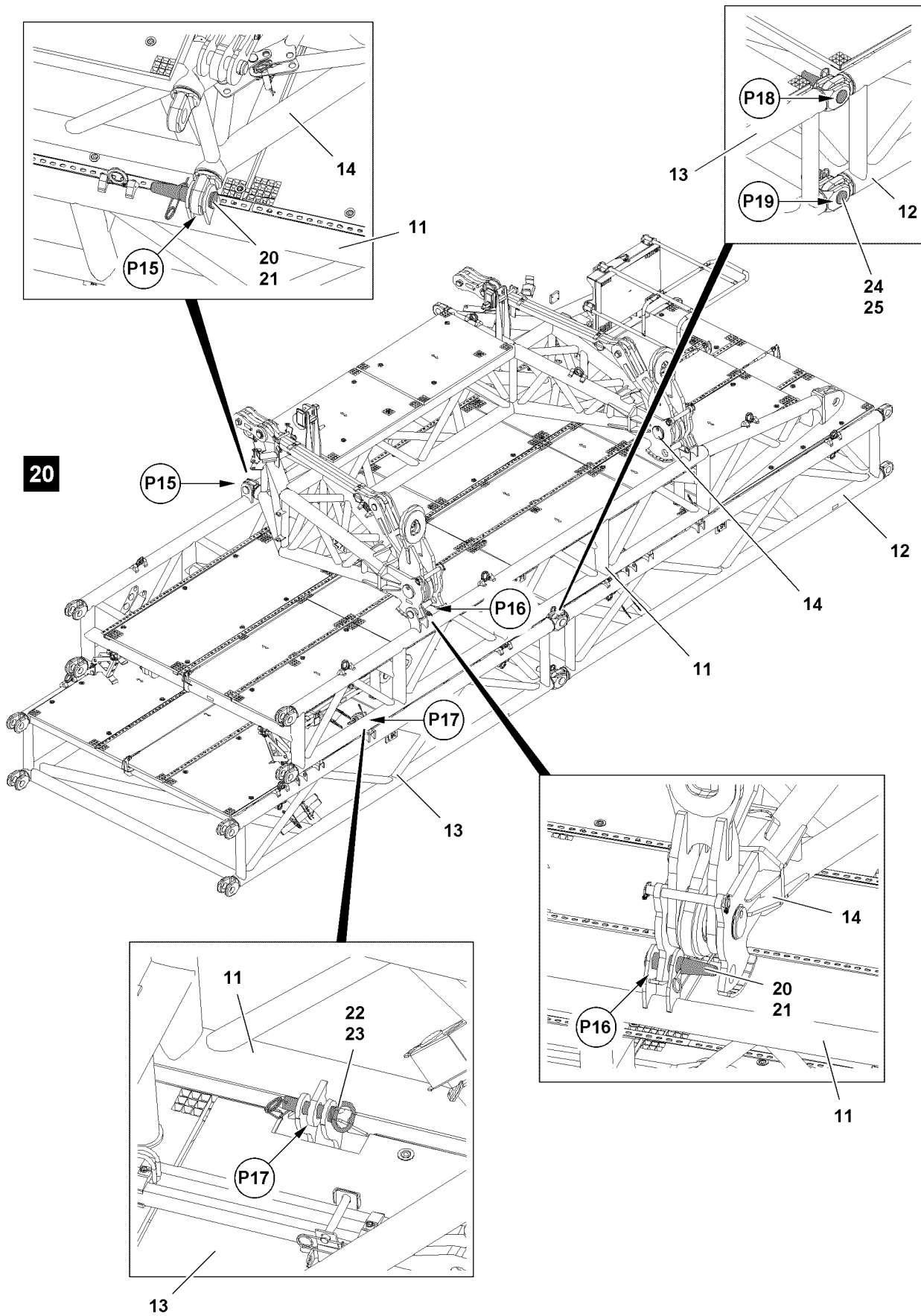

Fig.122953

LWE/LR 11000-001/23501-04-02/en

17.2.4 Installing the suspended ballast guide as a transport unit

Make sure that the following prerequisites are met:

- The pivot section is disassembled.
- The end section is disassembled.
- The platform is taken down.
- The pull rods are taken down and secured.
- The retainer and the bracket are secured in the transport position.

Assembling the intermediate sections

For the suspended ballast guide as a transport unit, only two intermediate sections are installed.

- ▶ Fasten the intermediate section **13** to the auxiliary crane.
- ▶ Position the intermediate section **13** with the auxiliary crane on the intermediate section **12** at point **P18** until the pin points align.

The intermediate section **13** and intermediate section **12** are pinned together on four points. Every point is present on both sides of the component on one level, see illustration **20**.

- ▶ Pin the intermediate section **13** on both sides at point **P18** with the intermediate section **12**: Insert the pins **24** and secure with the retaining elements **25**.
- ▶ Pin the intermediate section **13** on both sides at point **P19** with the intermediate section **12**: Insert the pins **24** and secure with the retaining elements **25**.
- ▶ Remove the fastening equipment.

Assembling the pivot section

The pivot section is pinned at four points. Every point is present on both sides of the component on one level.

- ▶ Fasten the auxiliary crane to the pivot section **11**.
- ▶ Position the pivot section **11** with the auxiliary crane on the intermediate section **12** and intermediate section **13** at point **P17** until the pin points align, see illustration.
- ▶ Pin the pivot section **11** at points **P17**: Insert the pin **22** and secure with the retaining elements **23**, see illustration **20**.
- ▶ Remove the fastening equipment.

Assembling the end section

The end section is pinned at four points. Every point is present on both sides of the component on one level.

- ▶ Fasten the auxiliary crane to the end section **14**.
- ▶ Position the end section **14** with the auxiliary crane on the pivot section **11** at point **P15** and point **P16** until the pin points align, see illustration **20**.
- ▶ Pin the end section **14** at points **P15**: Insert the pin **20** and secure with the retaining elements **21**, see illustration **20**.
- ▶ Pin the end section **14** at points **P16**: Insert the pin **20** and secure with the retaining elements **21**, see illustration **20**.
- ▶ Remove the fastening equipment.

18 Removing the divisible ballast pallet „VarioTray“

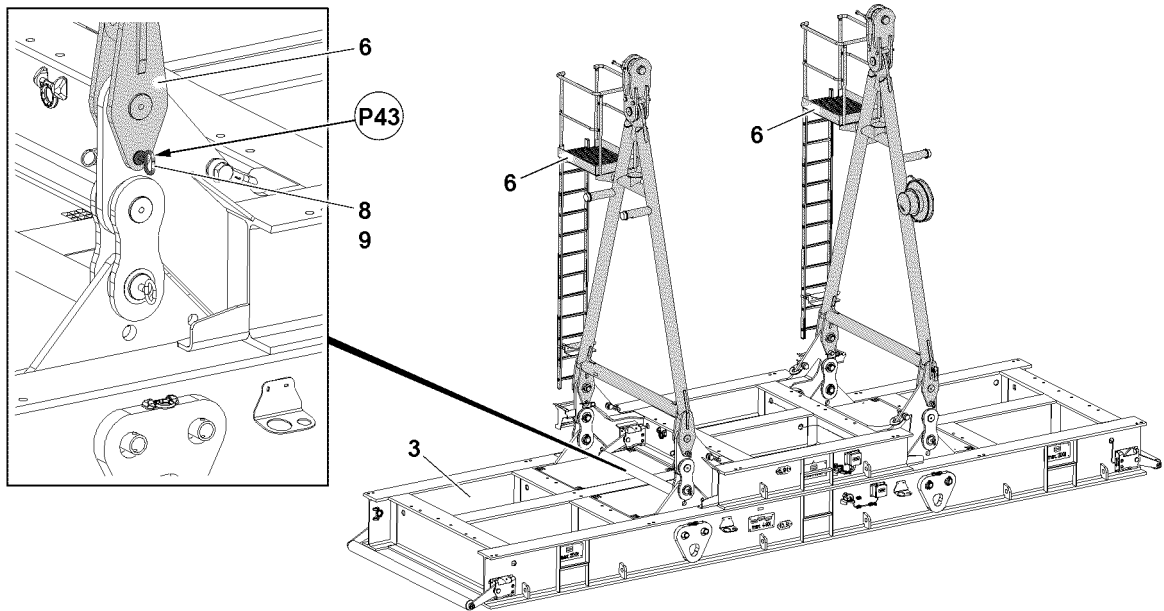

Fig.145274: Divisible ballast pallet „VarioTray“, operating position



Note

- The disassembly of the erection racks is described based on the example of one erection rack.

The erection rack is unpinned on two points. The unpinning procedure is described for one pin as an example.

- Hang the erection rack **6** on the auxiliary crane.



DANGER

Danger of accident during assembly / disassembly of the erection racks!

The erection racks must hang securely on the auxiliary crane, otherwise they could fall down and kill or severely injure personnel.

- Make sure that the erection rack hangs safely on the auxiliary crane.
- Never unpin the retaining pins of unsecured or unsupported erection racks.
- It is prohibited for anyone to remain under the erection racks or within the complete danger zone during the pinning and unpinning procedure.

When the erection rack is safely held by the auxiliary crane:

- Remove the retaining element **9** on both sides at point **P43** and unpin the retaining pin **8**.

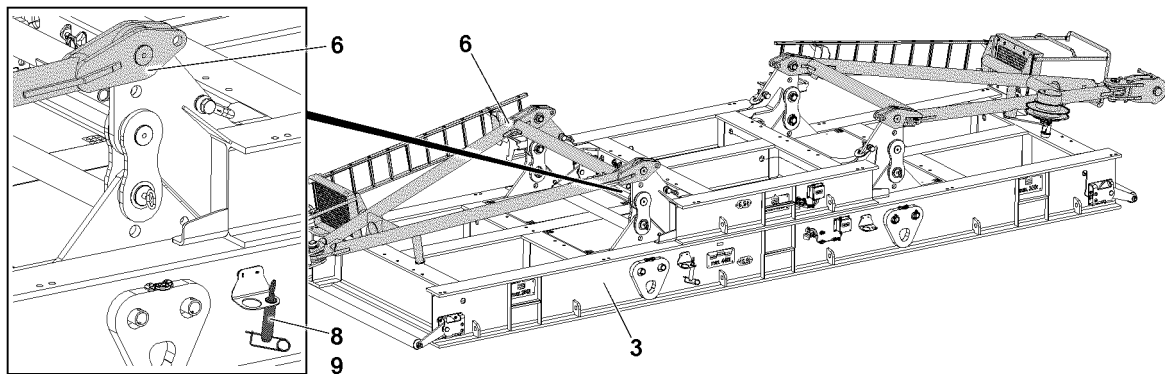

Fig.145273: Divisible ballast pallet „VarioTray“, transport position

- ▶ Lower the erection rack **6** with the auxiliary crane until the rubber cushions touch the frame.
- ▶ Insert the retaining pin **8** on both sides in the park position and secure with the retaining element **9**.
- ▶ Remove the auxiliary crane.
- ▶ Lower the second erection rack **6** with the auxiliary crane.

Empty page!

LWE/LR 11000-001/23501-04-02/en

5.38 S/SL-boom

1	Component overview S-pivot section	3
2	Fastening points	3
3	Assembly S2/SL/SL3-boom	11
4	Assembling the boom system in flying mode	27
5	Assembling the boom combinations with substructure	37
6	Assembling the S-guy rods	38
7	Assembling the roller sets on the boom head	40
8	Performing the function checks	41
9	Erecting the boom	42
10	Operating the crane	45
11	Disassembly S2/SL/SL3-boom	49

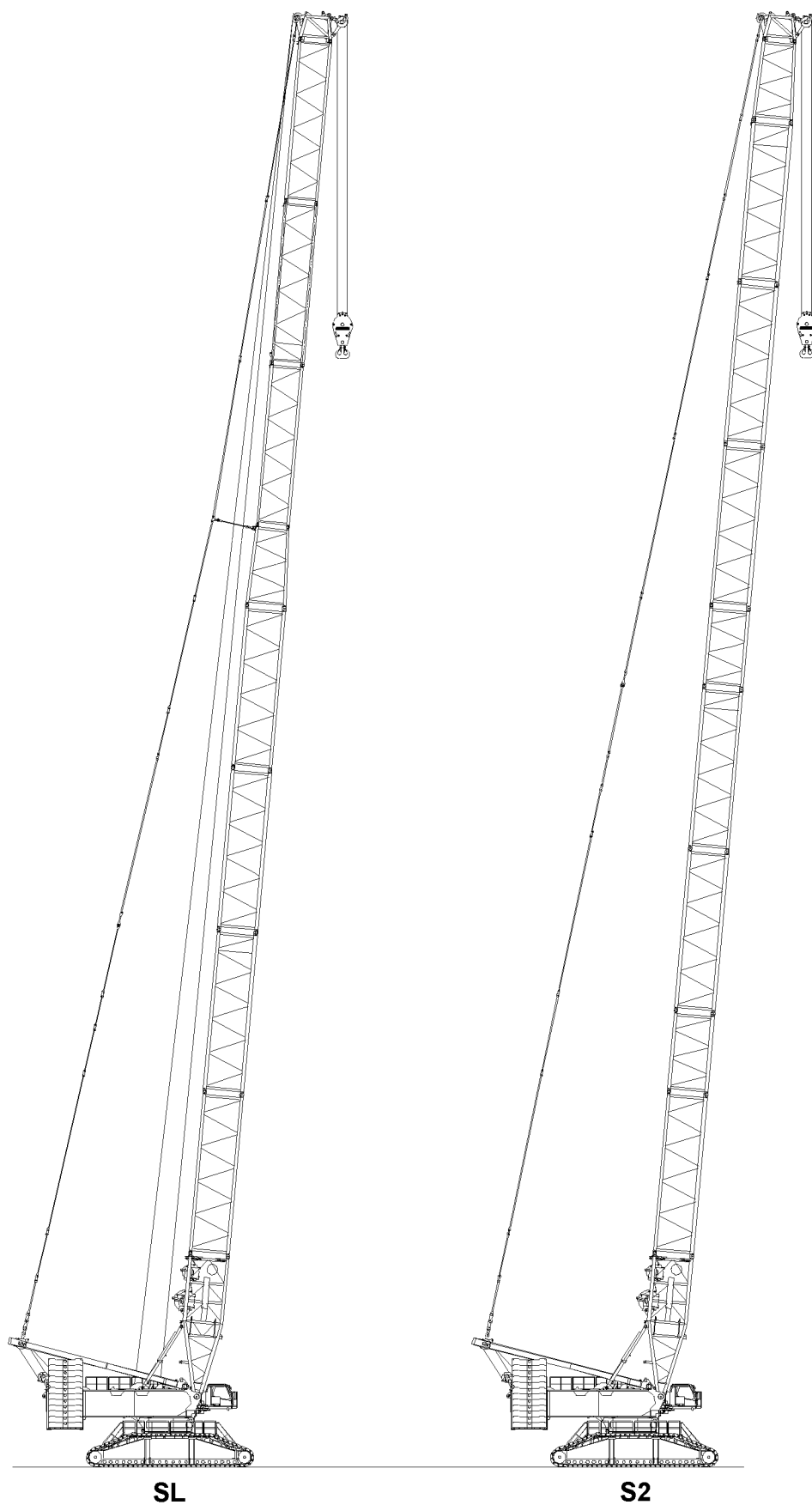

Fig.119108: S2/SL/SL3

LWE/LR 11000-001/23501-04-02/en

1 Component overview S-pivot section



Note

- ▶ The boom components (boom - lattice sections) such as S/L-intermediate sections, S-Adapter, SL-reducer section and the S/L-end sections, as well as dimensions and weights are described in the Crane operating instructions, chapter 1.03.
- ▶ For the combination of the various boom systems, refer to the Rod plan and the Crane operating instructions, chapter 5.03.

2 Fastening points



WARNING

Falling lattice sections!

Death, severe bodily injuries, property damage.

- ▶ Make sure that the lattice sections are properly fastened on the respective fastening points.
- ▶ Make sure that the fastening equipment has the appropriate length and a sufficient load bearing capacity.
- ▶ Pay attention and adhere to the labels on the fastening points on the lattice sections and crane components.

2.1 Fastening points S-pivot section

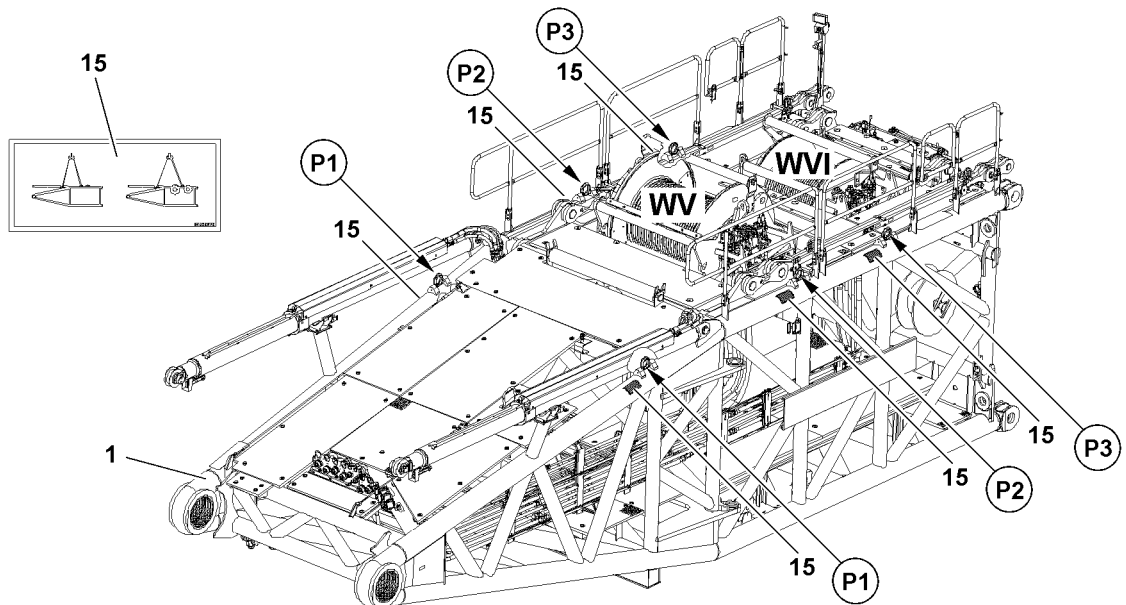

Fig.119100: Fastening points S-pivot section

Fastening points	
P1 + P2	S-pivot section without winch 5, without winch 6
P1 + P3	S-pivot section with winch 5, without winch 6
P1 + P3	S-pivot section without winch 5, with winch 6
P1 + P3	S-pivot section with winch 5, with winch 6

2.2 Fastening points S-intermediate sections 6 m

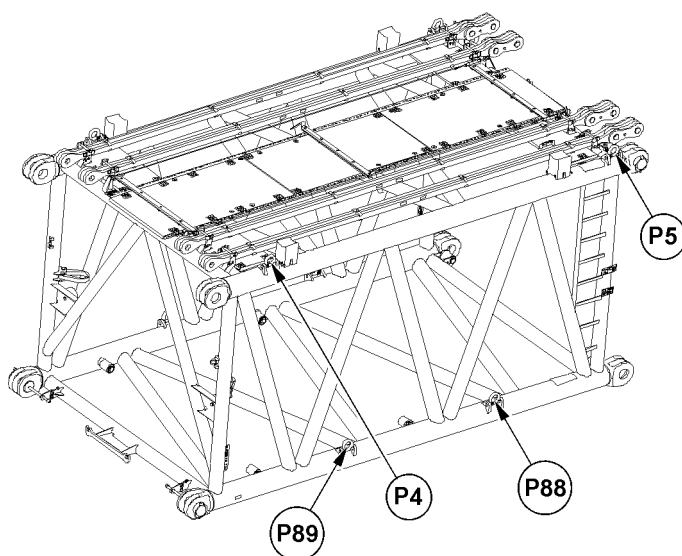

Fig.121930: Fastening points S-intermediate section 6 m



Note

- ▶ The S-intermediate sections are available in various system dimensions.
- ▶ The distance between the fastening pints can vary, depending on the respective S-intermediate section.
- ▶ The lattice section must be fastened on both sides on the fastening points.

Fastening points	
P4 + P5 or P88 + P89	S-intermediate section 6 m

2.3 Fastening points S-intermediate sections 12 m / S-adapter 12 m

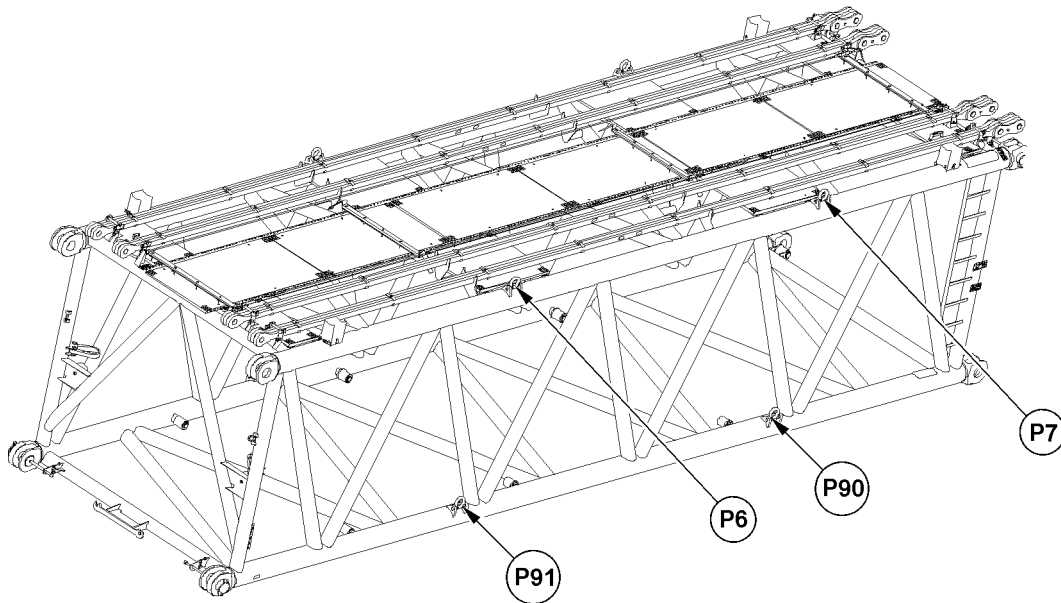

Fig.121931: Fastening points S-intermediate section 12 m / S-adapter 12 m



Note

- ▶ The S-intermediate sections are available in various system dimensions.
- ▶ The distance between the fastening pints can vary, depending on the respective S-intermediate section.
- ▶ The lattice section must be fastened on both sides on the fastening points.

Fastening points	
P6 + P7 or P90 + P91	Assembly S-intermediate section 12 m / S-adapter 12 m

2.4 Fastening points SL-reducer section 6 m

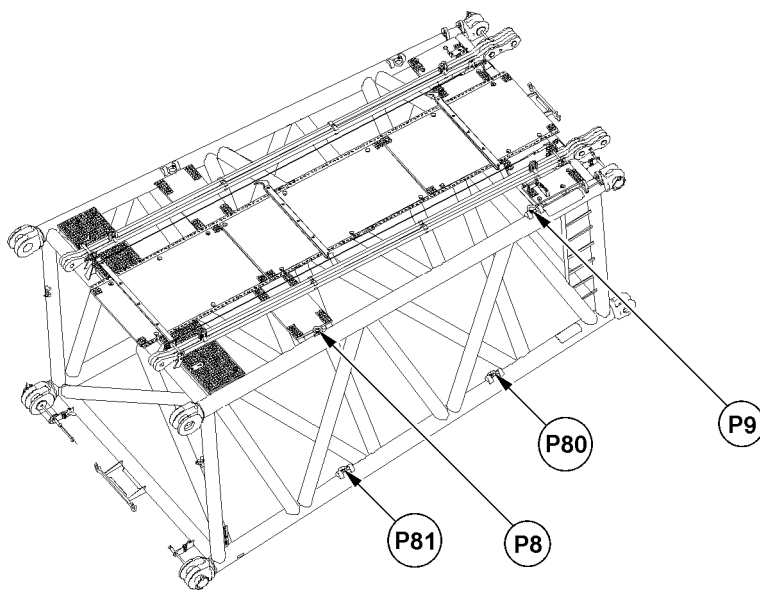

Fig.121932: Fastening points SL-reducer section 6 m



Note

► The lattice section must be fastened on both sides on the fastening points.

Fastening points	
P8 + P9 or P80 + P81	SL-reducer 6 m

2.5 Fastening points S-end section

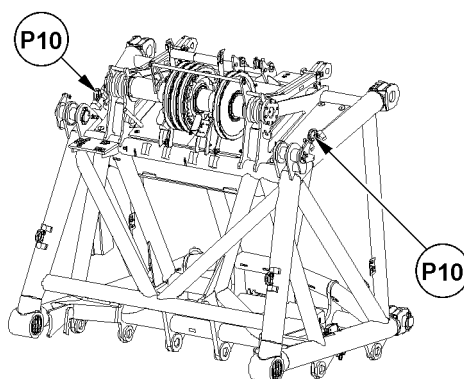

Fig.119104: Fastening points S-end section

Fastening points	
P10	Assembly S-end section

LWE/LR 11000-001/23501-04-02/en

2.6 Fastening points L-end section

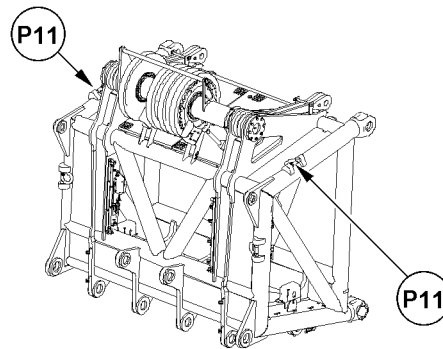

Fig.119105: Fastening points L-end section

Fastening points	
P11	Assembly L-end section

2.7 Fastening points L-intermediate sections 6 m

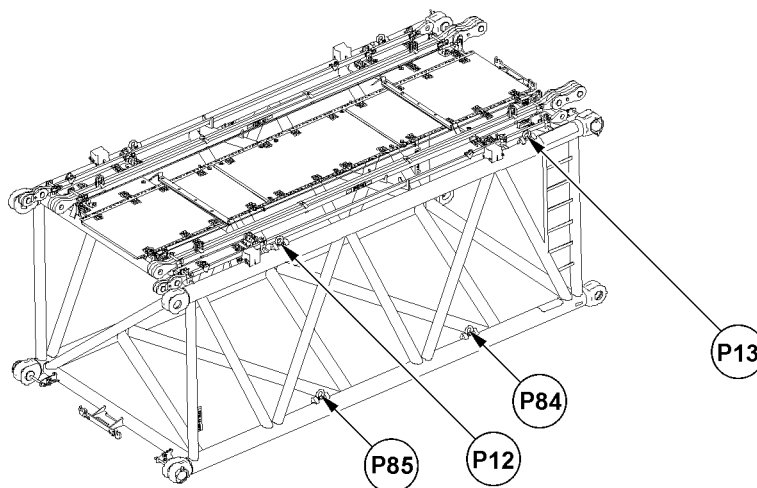

Fig.121933: Fastening points L-intermediate section 6 m



Note

- ▶ The L-intermediate sections are available in various system dimensions.
- ▶ The distance between the fastening points can vary, depending on the respective L-intermediate section.
- ▶ The lattice section must be fastened on both sides on the fastening points.

Fastening points	
P12 + P13 or P84 + P85	L-intermediate section 6 m

2.8 Fastening points L-intermediate sections 12 m

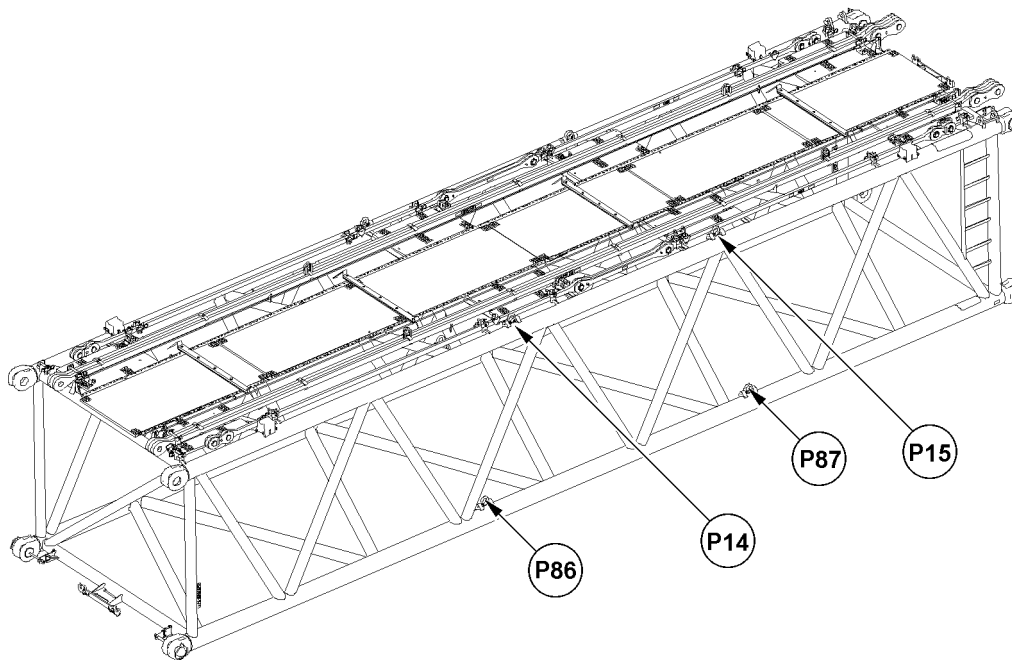

Fig.121934: Fastening points L-intermediate section 12 m



Note

- ▶ The L-intermediate sections are available in various system dimensions.
- ▶ The distance between the fastening points can vary, depending on the respective L-intermediate section.
- ▶ The lattice section must be fastened on both sides on the fastening points.

Fastening points	
P14 + P15 or P86 + P87	Assembly L-intermediate section 12 m

Empty page!

LWE/LR 11000-001/23501-04-02/en

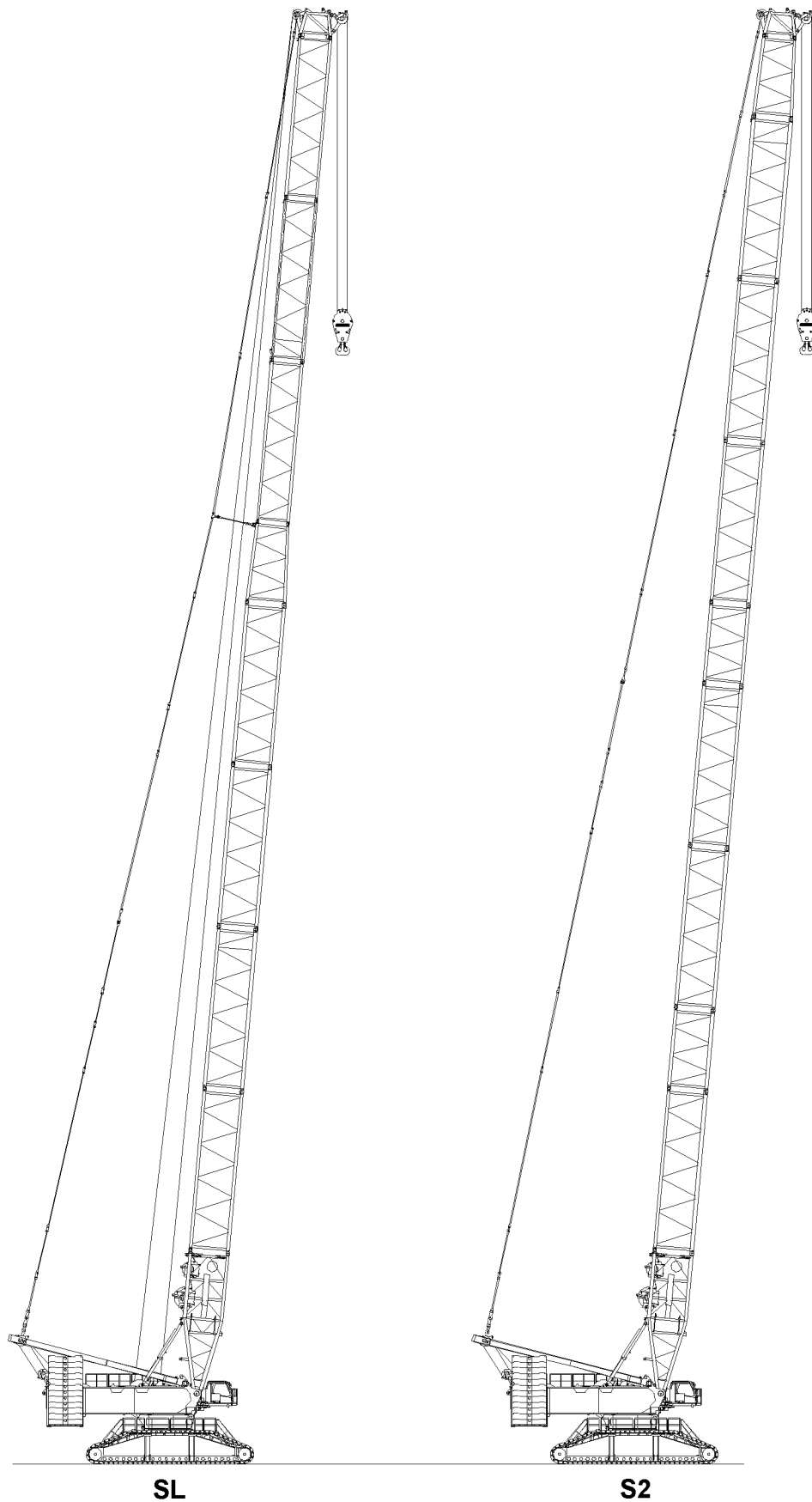

Fig.119108: S2/SL/SL3

LWE/LR 11000-001/23501-04-02/en

3 Assembly S2/SL/SL3-boom



Note

- ▶ The assembly is described on the example of the S-boom.
- ▶ For the combination of the boom lattice sections, observe and adhere to the Rod plan and the Crane operating instructions, chapter 5.03.



WARNING

Danger of falling!

During assembly / disassembly, inspection and maintenance work, assembly personnel must be secured with appropriate aids to prevent them from falling.

Death, severe bodily injuries, property damage.

- ▶ All work at a height, when there is a danger of falling, must be carried out with suitable aids.
- ▶ If aids are not available and work cannot be carried out from the ground, then assembly personnel must secure themselves with the supplied fall arrest system to prevent falling, see the Crane operating instructions, chapter 2.04.
- ▶ If fall protection equipment is available, then it must be used, see the Crane operating instructions, chapter 2.06.
- ▶ When lifting, lowering, swinging crane parts in and out, no persons may remain in the danger zone.
- ▶ When closing or opening boom systems during boom assembly or boom disassembly, no persons may remain on the boom system or in the danger zone.
- ▶ If railings are present on the components, then they must be brought into the corresponding position and secured for assembly / disassembly work.
- ▶ Only step on the aids, ladders and catwalks with clean shoes.
- ▶ Keep aids, ladders and catwalks free of heavy dirt, snow and ice.
- ▶ During all assembly and disassembly work, maintenance work and inspections, travel or crane operation is prohibited.
- ▶ Remaining on a suspended load is prohibited.
- ▶ Stepping or walking on crane components and lattice sections, which have an incline of more than 20° is prohibited.
- ▶ For all assembly work, the crane driver of the main crane must be in voice contact with the crane driver / crane drivers of the auxiliary crane / auxiliary cranes.
- ▶ For assembly tasks, the crane driver may only initiate crane movements when the responsible guide has explicitly released the movement.



WARNING

The lattice sections can fall down!

If the lattice sections are not pinned and secured correctly, then they can fall down.

Death, severe bodily injuries, property damage.

- ▶ Pin or unpin both pins at the same horizontal level, i.e. **left and right**.
- ▶ Do not stand under the lattice sections or within the entire danger zone during the pinning and unpinning procedure of the boom.
- ▶ Safely secure the pins in the storage locations as well as in the receptacles.
- ▶ It is prohibited to lean the auxiliary ladder against the component being disassembled.



WARNING

Danger of impact / crushing!

When installing / removing crane components with the auxiliary crane, crane components can start to swing back and forth.

When lifting / lowering and positioning crane components, there is an increased danger of impacts / crushing.

Death, severe bodily injuries, property damage.

- ▶ Make sure that personnel cannot be caught by components.
- ▶ Make sure that the crane is horizontally aligned.
- ▶ When working in danger zones: Use aids to protect limbs.
- ▶ Guide components with suitable aids to minimize oscillation.

**DANGER**

The components can fall down!

If the corresponding component is disengaged from the auxiliary crane before the corresponding component is pinned, then the corresponding component can fall down.

Death, severe bodily injuries, property damage.

- ▶ Do not disengage the auxiliary crane until the respective component is pinned and secured.

Make sure that the following prerequisites are met:

- The ground is able to safely take on the entire operating weight of the crane including the load to be lifted.
- The crane is horizontally aligned.
- An auxiliary crane with sufficient load bearing capacity if available.
- An assembly scaffolding or a work platform is available.
- Winch 1 and winch 2 are properly installed and secured on the turntable.
- The SA-frame properly installed and secured on the turntable.
- The transport retainers for the guy rods on the SA-frame are removed.
- The central ballast has been installed on the crawler travel gear according to the load chart or the erection and take down charts.
- The counterweight has been installed on the turntable according to the load chart or the erection and take down charts.
- The LICCON overload protection has been set according to the data in the load chart.

3.1 Turning the turntable into the assembly position

**WARNING**

The crane can topple over!

If the following conditions are not met before turning the turntable - **without** assembled S-boom, the crane can topple over.

Death, severe bodily injuries, property damage.

- ▶ Observe the assembly conditions, see the Crane operating instructions, chapter 3.06.
- ▶ Observe the specifications in the erection and take-down charts.
- ▶ Observe the specifications in the load charts.

- ▶ Turn the turntable in lengthwise direction of the crawler travel gear.

3.2 Swinging the railing on the S-pivot section into operating position

**WARNING**

Danger of falling!

Death, severe bodily injuries, property damage.

- ▶ Assembly personnel must secure themselves for the assembly / disassembly of the railings and protective devices with an approved fall arrest system to prevent them from falling.
- ▶ For assembly and disassembly work, maintenance and inspection work on the S-pivot section, all railings and protective devices must be properly assembled and secured.

Make sure that the following prerequisites are met:

- The ground is able to safely take on the weight of the S-pivot section.
- The S-pivot section is laying completely on the ground.
- ▶ For assembly / disassembly of railings and protective devices, see Crane operating instructions, chapter 2.06.

3.3 Exceeding the shut off limits of the LICCON overload protection for assembly operation

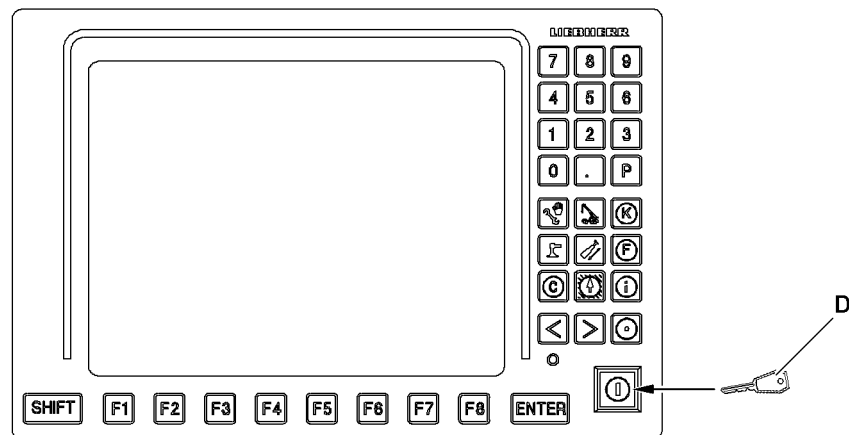

Fig.119109: LICCON monitor with assembly icon



WARNING

Danger of accident due to function „Exceedance of shut-off limits of the LICCON overload protection“! If the shut off limits of the LICCON overload protection are exceeded, there is no additional protection against crane overload.

Due to erroneous operation or deliberate misuse, the crane could collapse, the boom can break off or the crane can topple over.

Death, severe bodily injuries, property damage.

- ▶ The function „Exceedance of shut off limits of the LICCON overload protection“ is only permissible in emergencies and for assembly purposes.
- ▶ The function „Exceeding the shut off limits of the LICCON overload protection“ may only be actuated by persons who know the effects of their actions regarding the function „Exceeding the shut off limits of the LICCON overload protection“.
- ▶ The function „Exceedance of shut off limits of the LICCON overload protection“ requires the presence of an authorized person and must be performed with utmost caution.
- ▶ Crane operation with activated function „Exceedance of shut off limits of the LICCON overload protection“ is prohibited.

- ▶ Exceeding the shut off limits of the LICCON overload protection: Engage assembly operation.

Result:

- The shut off limits of the LICCON overload protection are exceeded.
- The assembly icon appears on the LICCON monitor.



Note

- ▶ See the Crane operating instructions, chapter 4.02 and chapter 4.20.

3.4 Unpinning the S-connector pins on the turntable

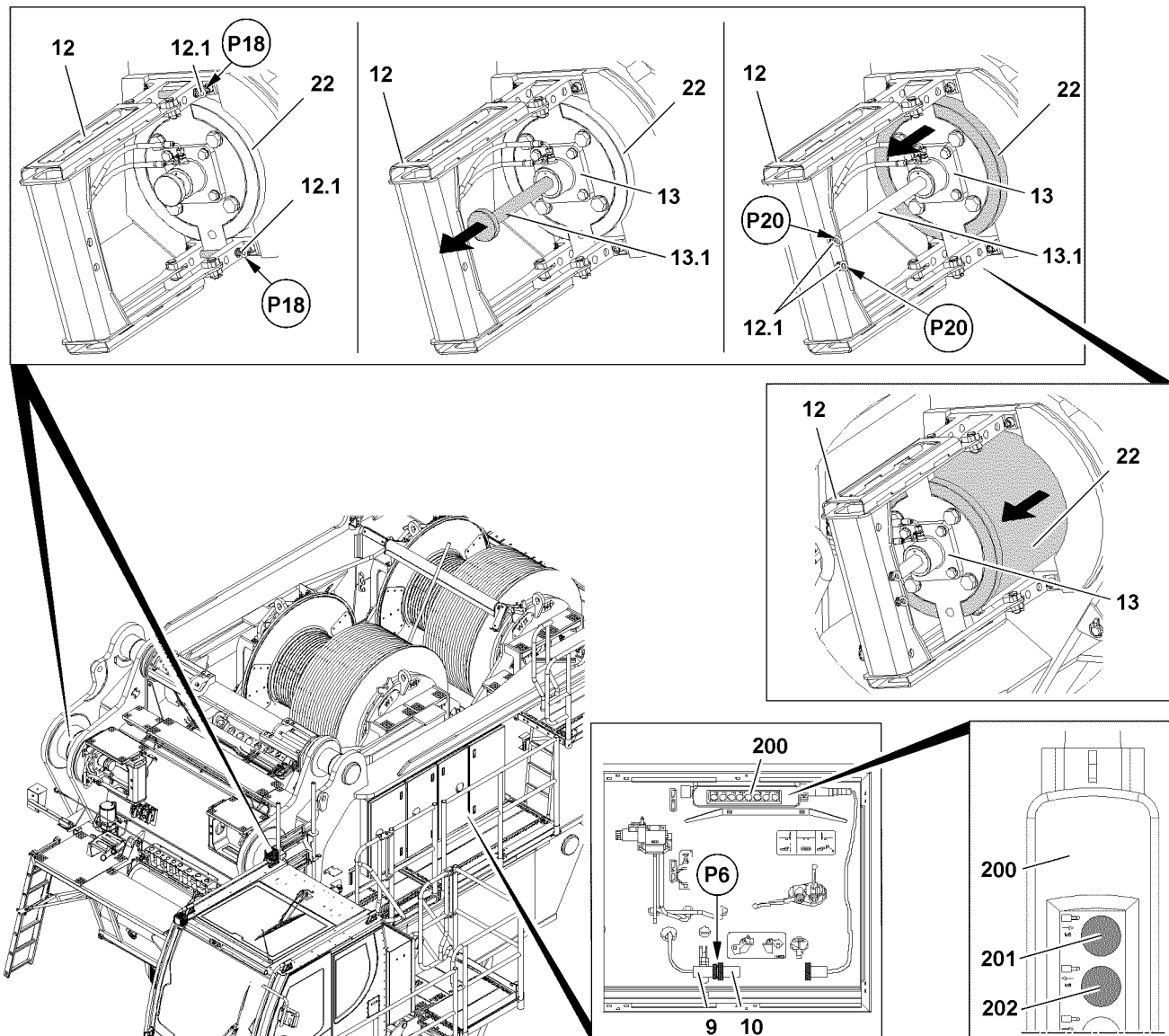

Fig.119111: Unpinning the connector pins 22 on the turntable



Note

- ▶ The pin pulling cylinders 13 are integrated on this crane in the S-connector pins 22.
- ▶ Unpinning and pinning of the S-connector pins 22 can be done only in connection with the pin pulling device installed on the crane.

Make sure that the following prerequisites are met:

- The pin pulling devices 12 are installed on the pin points.
- The SA-frame is standing vertically.
- The crane engine is running.

3.4.1 Unpinning the S-connector pins

In transport condition, the S-connector pins 22 are pinned on the turntable and secured with the retaining pins 12.1.

**WARNING**

Danger of crushing!

When unpinning or pinning the S-connector pins **22**, there is a danger of crushing. Limbs can be crushed or severed.

- ▶ During the unpinning or pinning procedure, make sure that no persons are within the danger zone.
- ▶ Do not reach into the danger zone of the pin pulling device and the connector pins.

- ▶ Release and unpin the retaining pins **12.1** on the points **P18** of the pin pulling device.
- ▶ Connect the control panel **200** at point **P6**.
- ▶ Extend the piston rod **13.1** of the pin pulling cylinder: Press the button **201** on the control panel **200** until the piston rods **13.1** are completely moved out on the pin pulling cylinders **13**.

When the piston rods **13.1** for the pin pulling cylinders are completely extended on both sides:

- ▶ Insert the retaining pin **12.1** on both sides at point **P20** and secure.

Result:

- The piston rods **13.1** of the pin pulling cylinders **13** are locked with the pressure / pull plate in the pin pulling device.
- ▶ Press the button **202** on the control panel **200** until the S-connector pins **22** are completely unpinned.

3.5 Assembling the S-pivot section on the turntable

NOTICE

Danger of property damage!

When swinging the S-pivot section in to the pin points on the turntable, the S-connector pins **22** or the S-pivot section can be damaged.

- ▶ Make sure that the S-connector pins **22** are completely unpinned before assembly of the S-pivot section.

**Note**

- ▶ Assemble the boom combinations according to the supplied Rod plans.

**WARNING**

The crane can topple over!

If the specifications listed below are not observed, the crane can collapse, the boom can break off or the crane can topple over.

Death, severe bodily injuries, property damage.

- ▶ The instructions in the Crane operating instructions, chapter 5.01 and chapter 5.03 must be observed and adhered to.
- ▶ All pins are to be secured after assembly with the intended retaining elements.
- ▶ The guy rods must be inspected regularly, see the Crane operating instructions, chapter 8.15.

Make sure that the following prerequisites are met:

- The S-connector pins **22** are completely unpinned.
- The crane engine is running.

**Note**

- ▶ Select the fastening points on the S-pivot section **1** in such a way that the S-pivot section **1** hangs horizontally on the auxiliary crane at assembly. See section „Fastening points“.
- ▶ Fasten the S-pivot section **1** to the auxiliary crane.

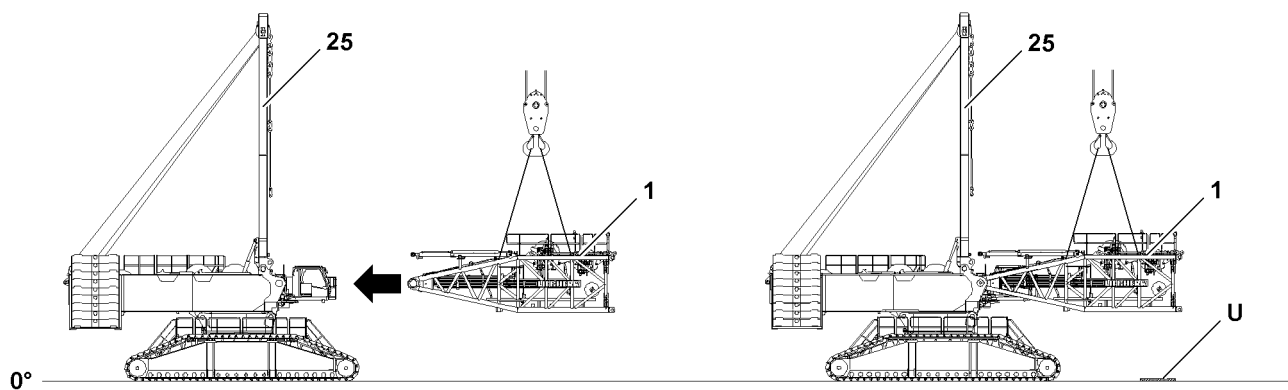

Fig.119116: Swinging the S-pivot section in on the turntable and pin

- ▶ Swing the S-pivot section 1 in with the auxiliary crane to the pin points on the turntable.



DANGER

Falling S-pivot section!

Death, severe bodily injuries, property damage.

- ▶ Secure the S-connector pins 22 between the S-pivot section 1 and the turntable after the pinning procedure immediately with the retaining pins 12.1.

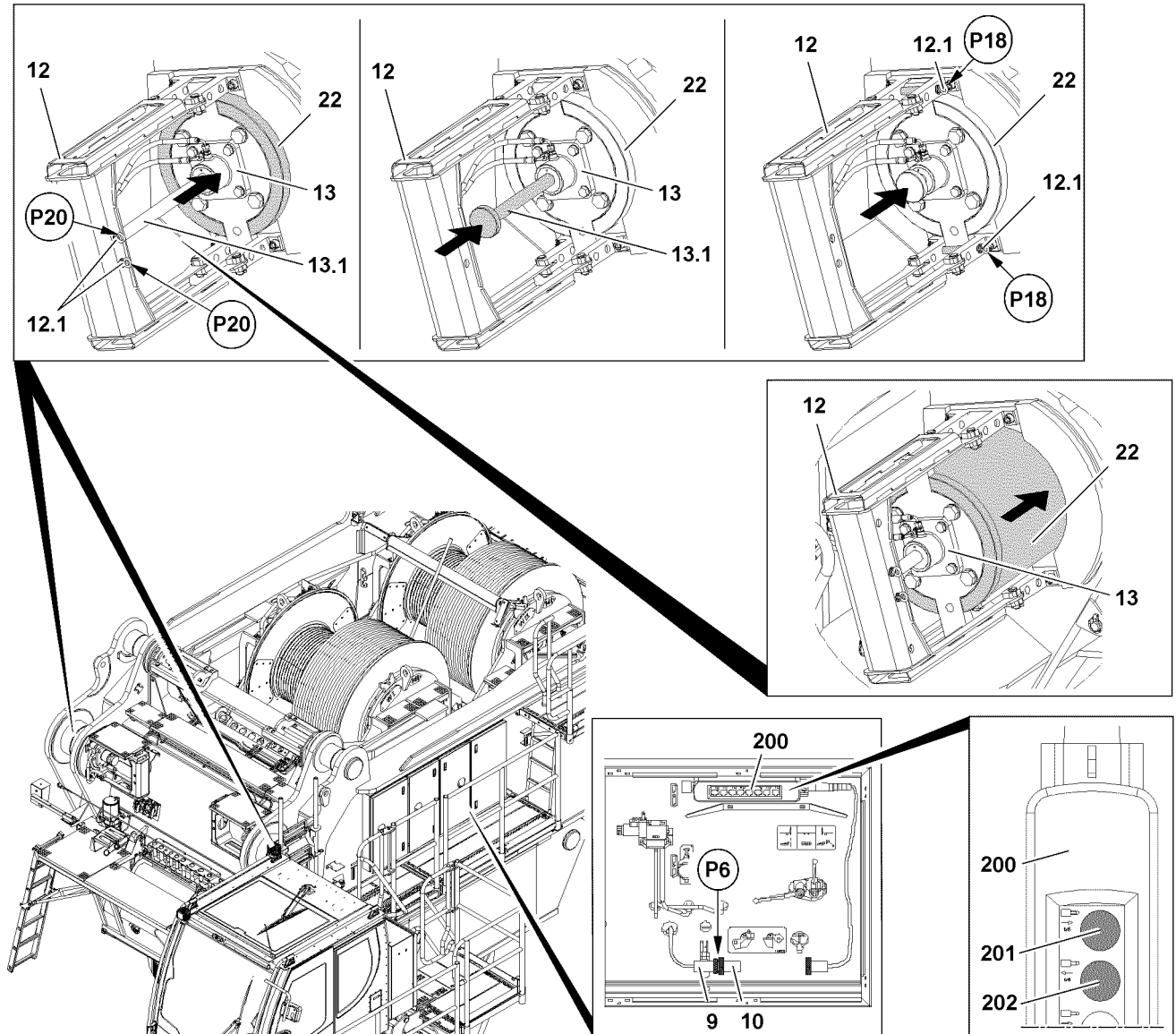

Fig.119115: Pinning the S-pivot section on the turntable / insert connector pin 22

When the S-pivot section is positioned in pin position:

- ▶ Insert the S-connector pins 22 on both sides with the pin pulling cylinder 13: Press the button 201 on the control panel 200 until the S-connector pins 22 are completely pinned on both sides.

When the S-connector pins 22 are completely pinned on both sides:

- ▶ Secure the S-connector pins 22: Unpin the retaining pins 12.1 on the pin pulling device 12 on points P20 and insert on points P18 and secure.

Result:

- The S-pivot section 1 is pinned and secured on the turntable.
- ▶ Retract the piston rods 13.1 of the pin pulling cylinders 13: Press the button 202 on the control panel 200 until the piston rods are completely retracted on both sides.

NOTICE

Danger of property damage!

When taking down the assembled S-pivot section, the S-pivot section or the turntable can be damaged.

- ▶ Lower the S-pivot section 1 after assembly on the turntable carefully on the substructure U on the ground.

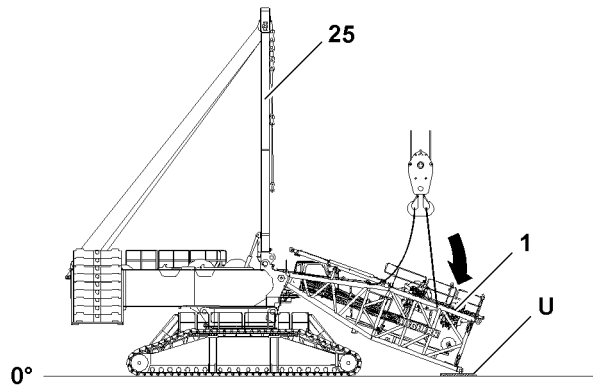

Fig.119118: Placing the S-pivot section on the substructure on the ground

- ▶ Lower the S-pivot section **1** carefully and at slow speed on the substructure **U** on the ground.

When the S-pivot section **1** is placed on the substructure on the ground:

- ▶ Remove the auxiliary crane.

3.6 Establishing the electric and hydraulic connections on the S-pivot section

3.6.1 Establishing the electrical connections

NOTICE

Danger of damage to the electrical connections!

If the electrical connection between the terminal box and the S-pivot section and the cable drum in the S-pivot section is established before the boom end section is installed and electrically connected, then the electric connection can be damaged.

- ▶ Make sure that the electric connection between the terminal box in the S-pivot section and the cable drum in the S-pivot section is only established **after** assembly and the connection of the electric wiring for the boom end section.



Note

- ▶ To establish the electrical connections on the S-pivot section: Use the Electrical wiring diagram.

Make sure that the following prerequisites are met:

- The S-pivot section is completely assembled and placed on the substructure.
- ▶ Establish the electrical connections.
- ▶ Make sure that all electrical connections to the S-pivot section have been established.



WARNING

Malfunction if dummy plugs are not installed!

If the dummy plugs on the non-required electrical connections are not installed, then malfunctions or functional limitations can occur on the crane.

- ▶ Make sure that all non-required electrical connections that have a dummy plug are closed off with dummy plugs.
- ▶ Pay attention to the Electrical wiring diagram.
- ▶ As a rule, close off on-required electrical connections (for example for accessories which cannot be installed) with the respective dummy plugs.

NOTICE

Property damage due to dirt and / or corrosion!

If non-required electrical connections are not closed off with the respective protective caps, then dirt and / or corrosion can damage the electrical connections.

This could result in malfunctions.

- ▶ Make sure that all non-required electrical connections are always closed off properly.
- ▶ Pay attention to the Electrical wiring diagram.

- ▶ Close electrical connections, which have no dummy plugs, properly off with the corresponding protective caps.

3.6.2 Establishing the hydraulic connections

When connecting and releasing hydraulic lines with quick couplings, make sure that the coupling procedure is carried out correctly.

**DANGER**

Danger of accident due to loss of pressure or leakage!

Incorrectly coupled or self-loosening quick couplings (particularly return lines) can result in serious accidents due to component failure.

- ▶ Check that the quick couplings have been properly connected before using the crane.

**Note**

- ▶ To connect or release the hydraulic lines with quick couplings, see Crane operating instructions, chapter 5.01.

- ▶ Release the pressure in the hydraulic system before connecting or disconnecting. Turn the engine off and wait for short time.
- ▶ Assembling coupling components (sleeve and connector) by using knurled nut.
- ▶ Connect coupling components.

3.7 Assembly of winch 5 (WV) on the S-pivot section**Note**

- ▶ The assembly of winch 5 is described in detail in the Crane operating instructions, chapter 3.07.50.

3.8 Assembly of winch 6 (WVI) on the S-pivot section**Note**

- ▶ The assembly of winch 6 is described in detail in the Crane operating instructions, chapter 3.07.60.

3.9 Assembling the boom system on the ground**Note**

- ▶ Liebherr-Werk Ehingen GmbH recommends supporting the intermediate sections for assembly with assembly shoes, see the Crane operating instructions, chapter 5.62.

3.9.1 Assembling the S-intermediate section on the S-pivot section

Make sure that the following prerequisites are met:

- The S-pivot section **1** is properly pinned and secured on the turntable.
- The S-pivot section **1** is placed properly on the substructure on the ground.
- Winch **5 WV** is properly installed on the S-pivot section **1** (if only winch **5 WV** is required for the upcoming crane operation).
- Winch **6 WVI** is properly installed on the S-pivot section **1** (if only winch **6 WV** is required for the upcoming crane operation).
- The connector pins **1.1** on the S-pivot section **1** are fully unpinned.



Note

- ▶ The S-intermediate sections **2** are pinned with the pin pulling cylinders, see Crane operating instructions, chapter 5.30.



WARNING

General danger notes!

- ▶ All connector pins **1.1** are to be secured after assembly with the intended locking pins **1.2**.



Note

- ▶ For fastening of boom sections, observe and adhere to section „Fastening points“.

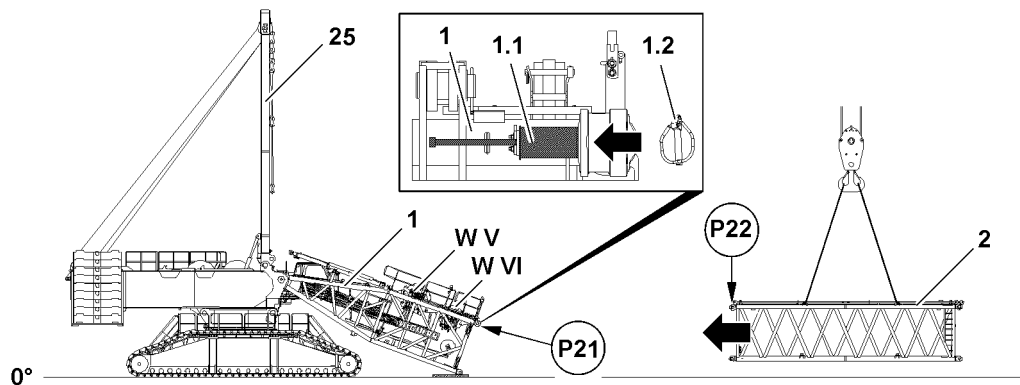

Fig.119120: Positioning the S-intermediate section on the S-pivot section

- ▶ Fasten the first S-intermediate section **2** to the auxiliary crane and align on the S-pivot section **1**. When the pin bores on the S-pivot section **1** (point **P21**) and on the S-intermediate section **2** „on top“ (point **P22**) align.
- ▶ Insert the connector pins **1.1** with the pin pulling cylinders on both sides to the stop.

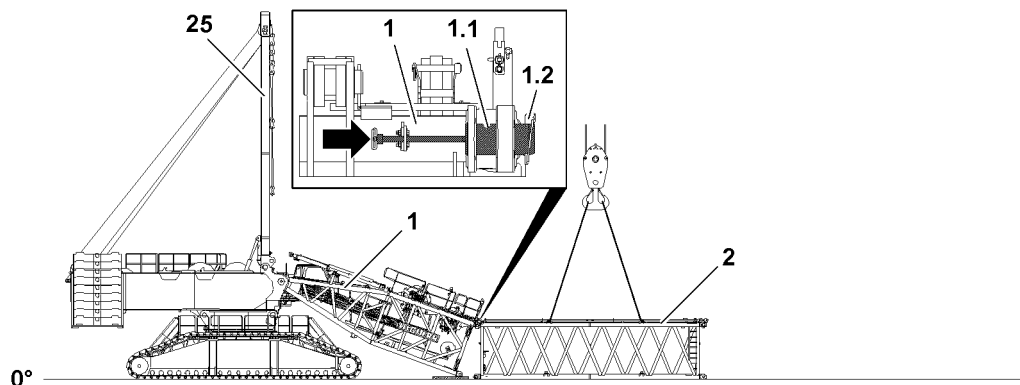

Fig.119121: Pinning the S-intermediate section on the S-pivot section

- ▶ Secure the connector pin **1.1** with the locking pin **1.2**.

When the first S-intermediate section **2** is pinned and secured on the S-pivot section **1** „on top“:

- ▶ Lower the S-intermediate section **2** on the substructure on the ground.
- ▶ Remove the auxiliary crane.

3.9.2 Continuing boom assembly

Make sure that the following prerequisites are met:

- The connector pins on the S-intermediate sections **2** - in direction of the expansion of the boom system - are completely unpinned.
- The first S-intermediate section **2** is laying properly on the ground or on the substructure.

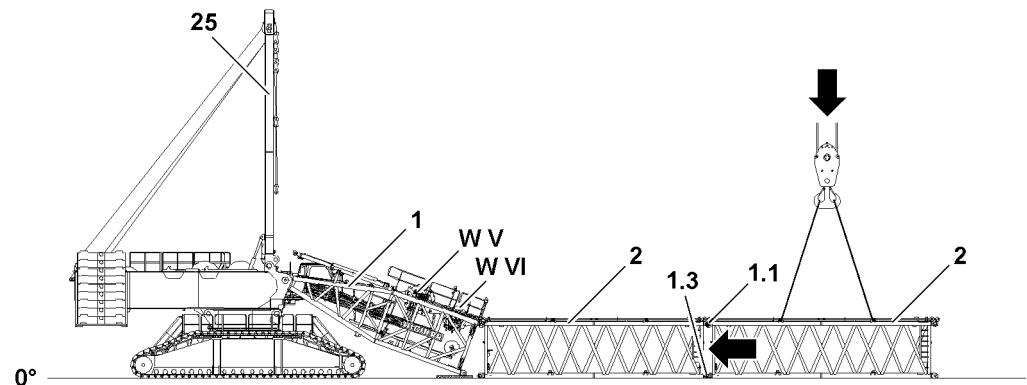

Fig.119122



WARNING

The crane can topple over!

Death, severe bodily injuries, property damage.

- ▶ The combination of the various boom systems must be taken from the Rod plan and it must be adhered to.
- ▶ The instructions in the Crane operating instructions, chapter 5.01 and chapter 5.03 must be observed.
- ▶ Make sure that all pin connections are secured after assembly.
- ▶ Support the boom during assembly and disassembly with assembly shoes.

When the connector pins **1.1** on the first S-intermediate section **2** are fully unpinned:

- ▶ Fasten the second S-intermediate section **2** to the auxiliary crane and swing in to the pin points on the first S-intermediate section **2**.

When the pin bores between the first and the second S-intermediate section **2** align „on top“ and „on the bottom“:

- ▶ Insert the connector pins **1.1** „on top“ with the pin pulling cylinders on both sides to the stop and secure.

When the connector pins **1.1** „on top“ are fully pinned to the stop and secured on both sides:

- ▶ Insert the connector pins **1.3** „on the bottom“ with the pin pulling cylinders on both sides to the stop and secure.
- ▶ Continue boom assembly to the required system length.

3.9.3 Assembling the S-end section / L-end section



Note

- ▶ The following description is an example and will be described by means of the L-end section.
- ▶ The process for the S-end section is identical.

Lifting the end section from the flatbed trailer

Make sure that the following prerequisites are met:

- The transport retainers are removed on the respective end section.
- No roller sets are installed on the end section.
- The ground is able to safely take on the weight of the respective end section.



WARNING

Danger of falling!

Death, severe bodily injuries, property damage.

- ▶ To fasten the end sections, use an assembly platform.

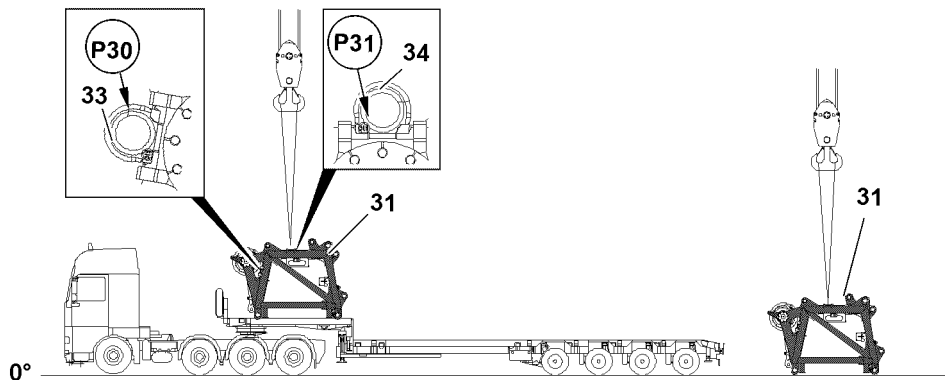

Fig.119112: Lifting the end section from the flatbed trailer

- ▶ Fasten the end section 31 on both sides on the eyes 34 of the fastening points P31 on the auxiliary crane.

When the end section is properly fastened on the auxiliary crane:

- ▶ Carefully lift the end section with the auxiliary crane from the transport vehicle and remove the transport vehicle.
- ▶ Lower the end section to the ground.

Turning the end section into assembly position

The end section must be turned before assembly on the boom with two auxiliary cranes from the transport position into the assembly position.

Make sure that the following prerequisite is met:

- **No** roller sets are installed on the end section.
- The ground on which the end section is placed is sufficiently load bearing.

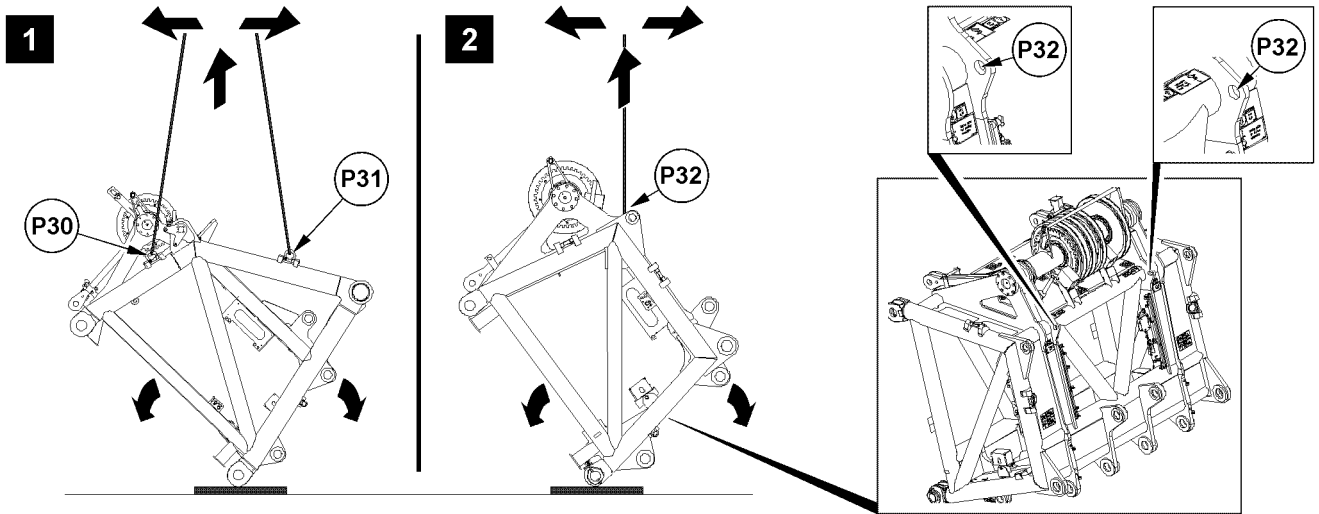

Fig.122035: Turning the end sections

Illustration 1: S-end section

Illustration 2: L-end section

- ▶ Fasten the end section on the respective fastening points on both sides.

NOTICE

Danger of property damage!

- ▶ To avoid damage to the end sections: Make sure that the end sections are supported for the turning procedure.



WARNING

Tipping end section!

Death, severe bodily injuries, property damage.

- ▶ Make sure that there are no persons within the danger zone.
- ▶ Make sure that solely fastening equipment with the corresponding load bearing capacity is used.
- ▶ Select the fastening points to turn the end sections according to the signs on the end sections.

When the end section is properly fastened on the auxiliary crane:

- ▶ Lift the end section with the auxiliary crane and turn into assembly position.

When the end section is turned in assembly position:

- ▶ Carefully and at slow speed at the end section on the ground.

When the end section is seated completely on the ground:

- ▶ Remove the auxiliary crane.

Assembling the end section on the boom



Note

- ▶ The following description is an example and will be described by means of the L-end section.
- ▶ The process for the S-end section is identical.

Make sure that the following prerequisites are met:

- The boom system is assembled to the required system length.
- The connector pins on the last assembled lattice section are unpinned.
- The connector pins on the end section are unpinned.
- The fastening equipment on the end section **31** is tensioned.

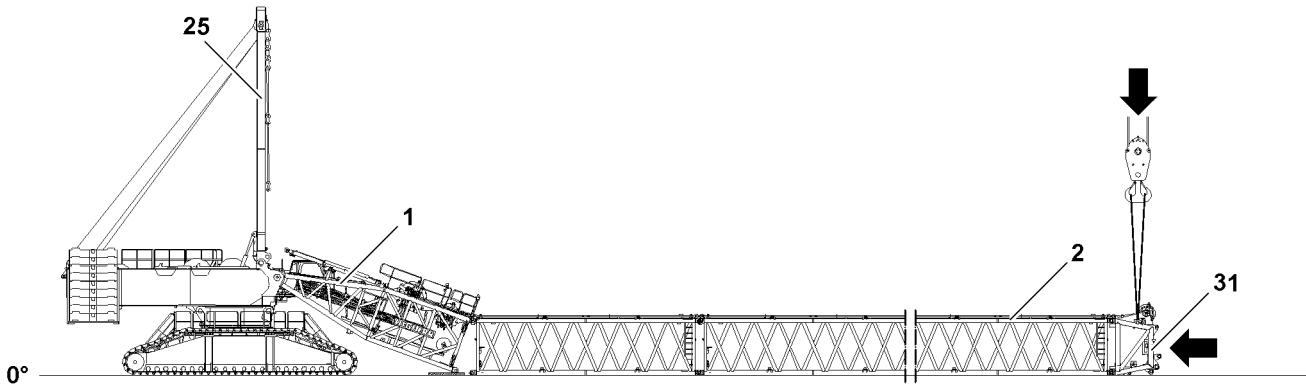

Fig.119123: Installing the end section on the boom

- ▶ Swing the end section **31** in with the auxiliary crane to the pin points.

When the pin bores between the end section **31** and the last installed lattice section **2** align „on top“ and „bottom“:

- ▶ Insert the connector pins „on top“ with the pin pulling cylinders on both sides to the stop and secure.

When the connector pins „on top“ are fully pinned to the stop and secured on both sides:

- ▶ Insert the connector pins „on the bottom“ with the pin pulling cylinders on both sides to the stop and secure.

When the connector pins „on top“ and „on the bottom“ are properly pinned:

- ▶ Secure the connector pin with the locking pin.
- ▶ Remove the auxiliary crane.

3.9.4 Establishing the electrical connections to the boom end section

Make sure that the following prerequisites are met:

- The S-intermediate sections are properly assembled and secured on the ground.
- The boom end section is properly assembled and secured.

NOTICE

Danger of damage to the electrical connections!

If the electrical connection from the cable drum in the S-pivot section to the terminal box on the S-pivot section is established first before the connection to the terminal box on the boom end section, then the electrical connection will be damaged when spooling out the cable drum.

- ▶ Establish first the electrical connection from the cable drum in the S-pivot section to the terminal box on the boom end section and then the electrical connection from the terminal box in the S-pivot section to the cable drum in the S-pivot section.



Note

- ▶ To establish the electrical connections on the S-boom: Use the Electrical wiring diagram.
- ▶ Establish the electrical connections.
- ▶ Make sure that all electrical connections on the boom are established.



WARNING

Malfunction if dummy plugs are not installed!

If the dummy plugs on the non-required electrical connections are not installed, then malfunctions or functional limitations can occur on the crane.

- ▶ Make sure that all non-required electrical connections that have a dummy plug are closed off with dummy plugs.
- ▶ Pay attention to the Electrical wiring diagram.

- ▶ As a rule, close off on-required electrical connections (for example for accessories which cannot be installed) with the respective dummy plugs.

NOTICE

Property damage due to dirt and / or corrosion!

If non-required electrical connections are not closed off with the respective protective caps, then dirt and / or corrosion can damage the electrical connections.

This could result in malfunctions.

- ▶ Make sure that all non-required electrical connections are always closed off properly.

- ▶ Pay attention to the Electrical wiring diagram.

- ▶ Close electrical connections, which have no dummy plugs, properly off with the corresponding protective caps.

3.9.5 Closing the boom system

Make sure that the following prerequisites are met:

- The boom system is completely assembled.
- All lattice sections are properly pinned with each other.
- All pin connections are properly pinned and secured.



Note

- ▶ The actual forces on test point 1 **MS1** - which are used during the closing procedure of the boom system - are shown on LICCON monitor 1.
- ▶ Note the actual forces of test point 1 **MS1** and keep it ready for the disassembly of the boom system.

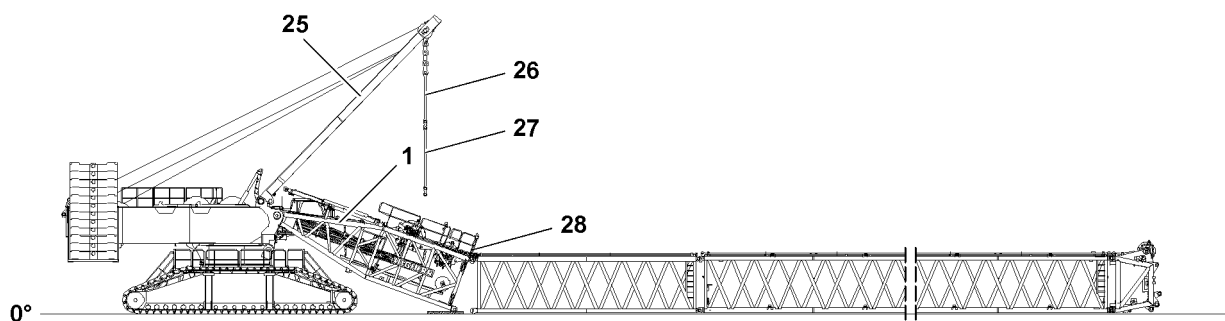

Fig.119114: Lowering the SA-frame to the front

- ▶ Lower the SA-frame **25** to the front until the guy rods **27** hang freely over the brackets **28** of the S-pivot section **1**.



WARNING

Neglected guy rod inspection and maintenance!
Death, severe bodily injuries, property damage.

- ▶ The guy rods must be checked before every assembly, see Crane operating instructions, chapter 8.15.

- ▶ Pin the guy rods **27** of the SA-frame with the brackets **28** of the S-pivot section: Insert the pin **27.1** on both sides and secure with locking pin **27.2**.

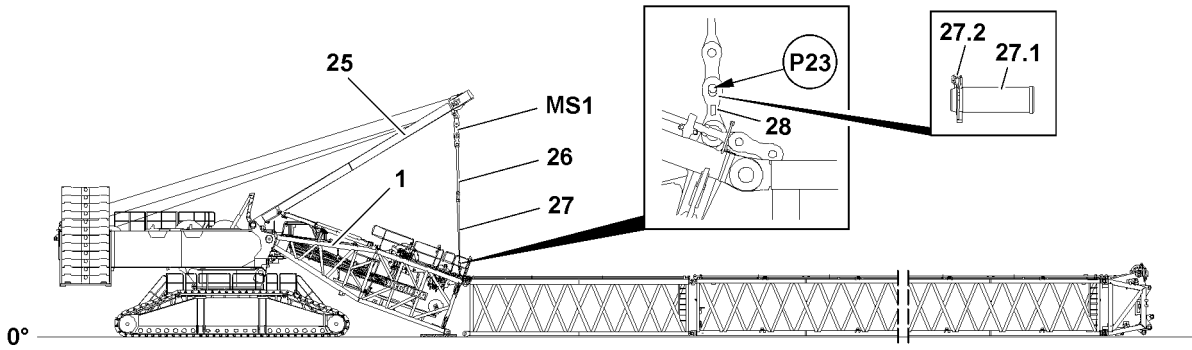

Fig. 119113: Pinning the SA-frame guying on the S-pivot section

- ▶ Erect the SA-frame 25 until the guy rods between the SA-frame and the S-pivot section are completely tensioned.



DANGER

Overload of crane!
Death, severe bodily injuries, property damage.

- ▶ During the „closing procedure“ of the boom system, the maximum permissible F1-total force ($F_{1_{max}}$) of **109 t** on test point 1 MS1 may **not** be exceeded.
- ▶ The closing of different boom systems with the SA-frame 25 is only permissible up to certain maximum boom lengths, see the following chart overview.
- ▶ The end section may **not** lift off the ground during closing procedure of the boom system, it must be laying on the ground.
- ▶ Make sure that there are no persons on the boom system as well as in the danger zone during the closing procedure.

Counterweight and central ballast, see the Erection chart, depending on the boom length

Boom system	Maximum system length	MS1	Equipment
S2	Maximum	109 t	- with S-guy rods
SL	Maximum	109 t	- with S-guy rods
SL3	Maximum	109 t	- with S-guy rods

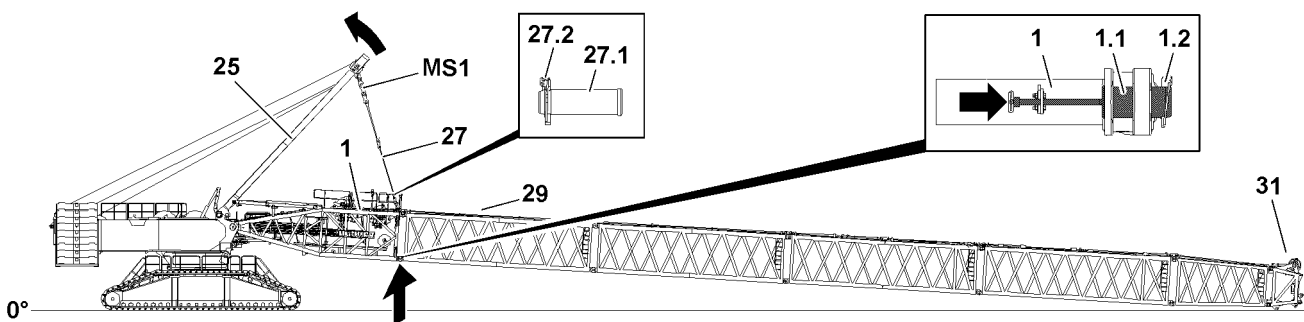

Fig. 119125: Closing the boom system with the SA-frame

- ▶ Pull the S-pivot section 1 up with the SA-frame 25 and pin on both sides **on the bottom**: Insert the pin 1.1 and secure with the locking pin 1.2.

LWE/LR 11000-001/23501-04-02/en

**Note**

- ▶ The ACTUAL force on test point **MS1** is shown on LICCON monitor 1. Note the displayed ACTUAL force.
- ▶ When **unpinning** with the same ACTUAL force on test point **MS1**, tension the guying on the SA-frame **25**.

When the boom system is closed and the pins on the S-pivot section are properly pinned and secured on the bottom:

- ▶ Relieve the guy rods between the SA-frame and S-pivot section by lowering the SA-frame **25**.

**DANGER**

The boom can suddenly fold down!

If the guy rods are unpinned on the S-pivot section before the lower pins **1.1** are pinned, the boom can fold down.

Death, severe bodily injuries, property damage.

- ▶ Do not unpin pins **27.1** until the lower pins **1.1** have been pinned and secured.
- ▶ Unpin the guy rods: Release and unpin the pin **27.1**.
- ▶ Pin the guy rods **27** with the guy rods **29**: Insert the pin **27.1** and secure with the locking pin **27.2**.

Pin the subsequent guy rods with each other and secure them properly.

**Note**

- ▶ For the combination of the various boom lattice sections refer to the Rod plan.

When the guy rods are properly pinned and secured with each other:

- ▶ Tension the boom guying.

**WARNING**

Unutilized guy rods on boom!

Death, severe bodily injuries, property damage.

- ▶ Non-required guy rods must be removed from the lattice sections, see Crane operating instructions, chapter 5.01.
- ▶ Remove non-required guy rods from the lattice sections.

4 Assembling the boom system in flying mode

If spatial prerequisites on the job site are limited for the assembly of the boom system, or if they are limited by buildings or similar, then the S-SL-boom can be installed in „flying mode“.

**WARNING**

General danger notes!

Death, severe bodily injuries, property damage.

- ▶ All pins are to be secured after assembly with the intended retaining elements.
- ▶ The guy rods must be inspected regularly, see the Crane operating instructions, chapter 8.15.
- ▶ Secure the boom with substructure or auxiliary crane, see Crane operating instructions, chapter 5.01.
- ▶ It is prohibited for anyone to remain under the booms or within the complete danger zone during the pinning and unpinning procedure of the lattice section.

**WARNING**

Impermissible boom lengths guyed!

Death, severe bodily injuries, property damage.

- ▶ The maximum permissible boom lengths for the „flying“ assembly may not be exceeded.
- ▶ Pin the SA-frame guy rods with the brackets on the S-pivot section.

When the boom system is longer than the permissible flying assembly length:

- ▶ Support the boom on the end of the permissible flying assembly length or secure with an auxiliary crane, see Operating instructions, chapter 5.01.
- ▶ Observe the assembly conditions, see the Crane operating instructions, chapter 3.06.
- ▶ The data in the erection and take-down charts as well as the load charts must be adhered to.

NOTICE

Property damage!

If the pins of the guy rods are not pinned from the „inside“ to the „outside“, the hoist rope can scrape on the pins and be damaged.

- ▶ Always insert the pins of the guy rods from the „inside“ to the „outside“, see the Rod plan.

**WARNING**

The crane can topple over!

Death, severe bodily injuries, property damage.

- ▶ For the „flying“ boom assembly, the maximum permissible total force ($F_{1_{max}}$) on test point **MS1** may **not** be exceeded.
- ▶ The „flying“ boom assembly is only permissible up to a maximum flying assembly length.
- ▶ Make sure that the maximum permissible flying assembly lengths are not exceeded, even when $F_{1_{max}}$ (MS1) is not yet reached.
- ▶ The „actual force“ on test point 1 **MS1** is shown on LICCON monitor 1.
- ▶ Observe the assembly conditions, see the Crane operating instructions, chapter 3.06.
- ▶ The specifications in the erection and take-down charts as well as the load charts must be observed.
- ▶ For the itemization of the lattice sections refer to the Rod plan.

4.1 Assembling the S-lattice section in „flying mode“ on the S-pivot section

For the flying assembly of the boom system, the S-pivot section must be guyed with the SA-frame.

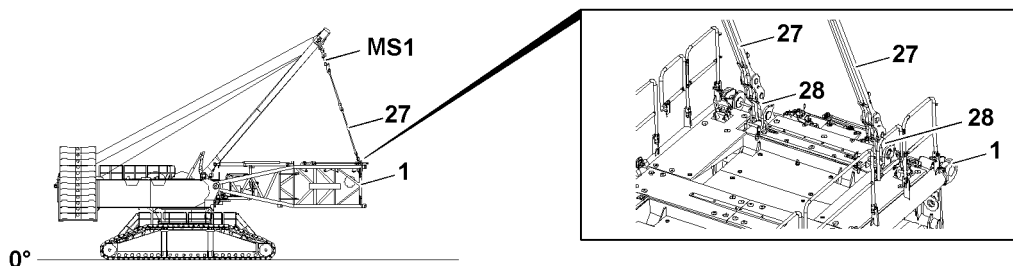

Fig.119466: Pinning the SA-frame guying on the assembly brackets on the S-pivot section

Make sure that the following prerequisites are met:

- The electrical and hydraulic connections to the S-pivot section have been established.
- The S-pivot section is horizontally tensioned.
- An auxiliary crane with sufficient load bearing capacity if available.



WARNING

Falling components!

Death, severe bodily injuries, property damage.

- ▶ During pinning and unpinning of the intermediate sections, it is prohibited for anyone to remain **under** or **on** the components as well as within the entire danger zone.
- ▶ Before unpinning: Support the components and boom.
- ▶ Secure the pins in the storage locations and in the receptacles.
- ▶ It is prohibited to lean a ladder against the crane section that is being disassembled.

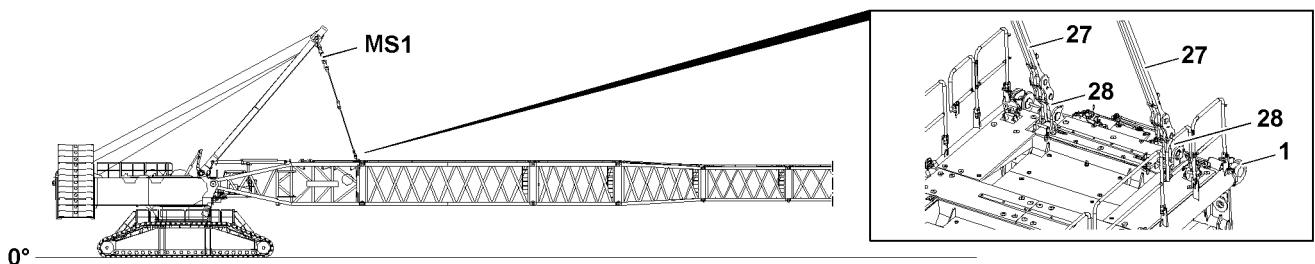

Fig.119464: Flying assembly up to maximum permissible flying assembly length

For „flying“ assembly of the intermediate sections, they can be installed individually or as preassembled boom unit on the S-pivot section 1.



WARNING

The crane can topple over!

Death, severe bodily injuries, property damage.

- ▶ Make sure that the maximum permissible flying assembly lengths are **not** exceeded.
- ▶ The crane operator bears the sole and full responsibility for the observation of the maximum permissible flying assembly lengths.
- ▶ Fasten the S-intermediate section 4 or preassembled boom unit to the auxiliary crane.
- ▶ Lift the S-intermediate section 4 or preassembled boom unit with the auxiliary crane and position on the S-pivot section 1 until the pin points align.

When the pin points between the S-pivot section 1 and S-intermediate section 4 or the preassembled boom unit align „on top“ and „bottom“:

- ▶ Pin the S-intermediate section 4 or preassembled boom unit „on top“: Insert the pin 1.1 on both sides and secure with locking pin 1.2.
- ▶ Pin the S-intermediate section 4 or preassembled boom unit „on the bottom“: Insert the pin 1.1 on both sides and secure with locking pin 1.2.

When the pins are properly pinned and secured on both sides on „top“ and „bottom“ between the S-pivot section 1 and the S-intermediate section 4 or the preassembled boom unit:

- ▶ Remove the auxiliary crane.

If additional lattice sections are assembled:

- ▶ Assemble the lattice sections the same way as described in this section.

4.1.1 Assembling SL-/SL3-/S2-boom systems in flying mode - without end section



WARNING

The crane can topple over!
Death, severe bodily injuries, property damage.

- ▶ Make sure that $F1_{max}$ (MS1) is **not** exceeded at flying assembly.
- ▶ Make sure that the maximum permissible flying assembly lengths are not exceeded, even when $F1_{max}$ (MS1) is not yet reached.
- ▶ Make sure that no hook block is reeved at flying assembly.
- ▶ Make sure that all guy rods which are not required have been removed from the lattice sections.
- ▶ Make sure that at least the required counterweight is installed on the turntable, see the following chart.
- ▶ For the ballasting of central ballast, in as far as a central ballast is required for the respective operating mode, refer to the Erection and take down charts.



Note

- ▶ $F1_{max}$ (MS1) = see the following chart

Operating mode	$F1_{max}$	Counterweight	Central ballast
SL	170 t	150 t	0 t
S2	200 t	190 t	0 t
SL3	200 t	190 t	0 t

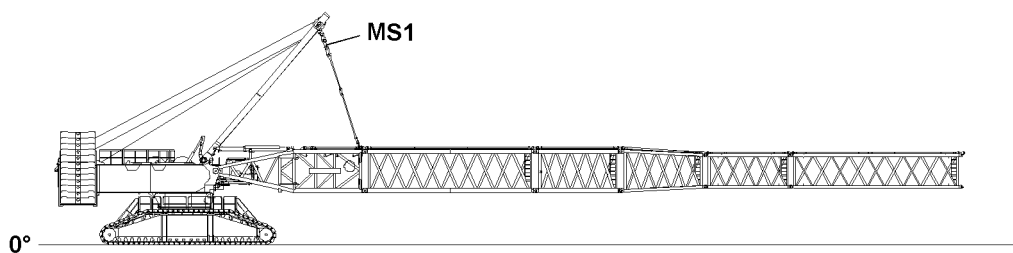

Fig.119467: SL/SL3/S2-boom system - Flying assembly length to **maximum** 52.5 m

- without end section

- with S-guy rods

- with WA-frame II guy rods

4.1.2 Assembling SL-/S2-boom systems in flying mode - with end section



WARNING

The crane can topple over!
Death, severe bodily injuries, property damage.

- ▶ Make sure that $F1_{max}$ (MS1) is **not** exceeded at flying assembly.
- ▶ Make sure that the maximum permissible flying assembly lengths are not exceeded, even when $F1_{max}$ (MS1) is not yet reached.
- ▶ Make sure that no hook block is reeved at flying assembly.
- ▶ Make sure that all guy rods which are not required have been removed from the lattice sections.
- ▶ Make sure that at least the required counterweight is installed on the turntable, see the following chart.



Note

- ▶ $F1_{max}$ (MS1) = see the following chart

Operating mode	F1 _{max}	Counterweight	Central ballast
SL	170 t	150 t	0 t
S2	200 t	190 t	0 t

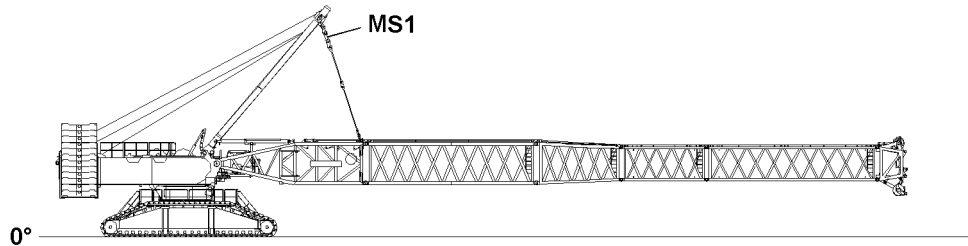

Fig.119465: SL/S2-boom system - Flying assembly length to **maximum 48.0 m**

- with end section

- with S-guy rods

- with WA-frame II guy rods

4.2 Assembling the S-lattice section in „flying mode“ on the S-intermediate section 12 m 3228.25 FLM

For the flying assembly of the boom system, preassemble the boom system up to the S-intermediate section 3228.25 FLM on the ground, close the boom system and change the pinning on the guy rods accordingly.

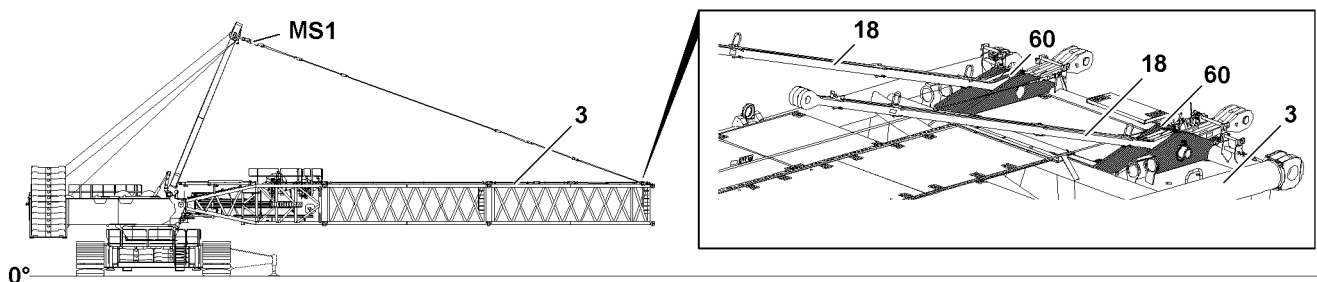

Fig.119135: Guying on assembly brackets on S-intermediate section (Flying assembly - intermediate section) pinned



WARNING

General danger notes!

- ▶ All pins are to be secured after assembly with the intended retaining elements.
- ▶ The guy rods must be inspected regularly, see the Crane operating instructions, chapter 8.15.
- ▶ Secure the boom with substructure or auxiliary crane, see Crane operating instructions, chapter 5.01.
- ▶ It is prohibited for anyone to remain under the booms or within the complete danger zone during the pinning and unpinning procedure of the lattice section.

**WARNING**

Impermissible boom lengths guyed!

Death, severe bodily injuries, property damage.

- ▶ The maximum permissible boom lengths for the „flying“ assembly may not be exceeded.
- ▶ Pin the guy rods of the lattice sections, coming from the direction of the crane, with the guy rods **18** of the S-intermediate section 3228.25 FLM **3** for flying assembly.

When the boom system is longer than the permissible flying assembly length:

- ▶ Support the boom on the end of the permissible flying assembly length or secure with an auxiliary crane, see Operating instructions, chapter 5.01.
- ▶ Observe the assembly conditions, see the Crane operating instructions, chapter 3.06.
- ▶ The data in the erection and take-down charts as well as the load charts must be adhered to.

Make sure that the following prerequisites are met:

- The electrical and hydraulic connections to the S-pivot section have been established.
- The boom system is horizontally guyed on the S-intermediate section 3228.25 FLM **3**.
- An auxiliary crane with sufficient load bearing capacity if available.

**WARNING**

Falling components!

Death, severe bodily injuries, property damage.

- ▶ During pinning and unpinning of the intermediate sections, it is prohibited for anyone to remain **under** or **on** the components as well as within the entire danger zone.
- ▶ Before unpinning: Support the components and boom.
- ▶ Secure the pins in the storage locations and in the receptacles.
- ▶ It is prohibited to lean a ladder against the crane section that is being disassembled.

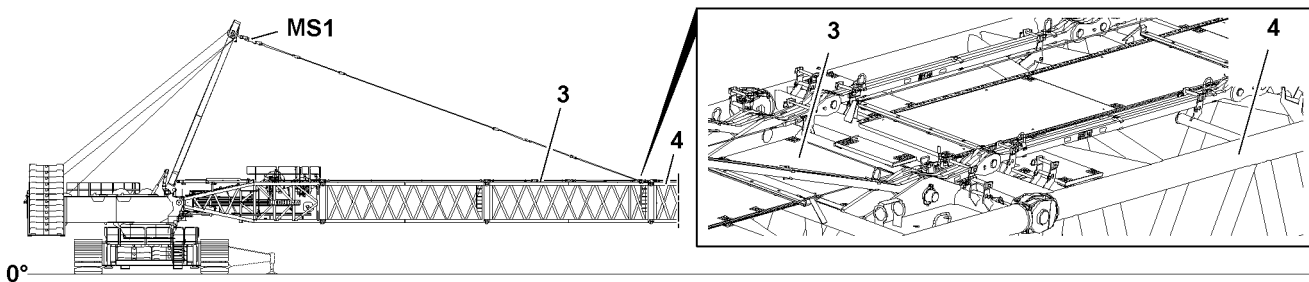

Fig.119136: Flying assembly up to maximum permissible flying assembly length

For „flying“ assembly of the intermediate sections, they can be installed individually or as preassembled boom unit on the S-intermediate section 3228.25 FLM **3**.

**WARNING**

The crane can topple over!

Death, severe bodily injuries, property damage.

- ▶ Make sure that the maximum permissible flying assembly lengths are **not** exceeded.
- ▶ The crane operator bears the sole and full responsibility for the observation of the maximum permissible flying assembly lengths.
- ▶ Fasten the S-intermediate section **4** or preassembled boom unit to the auxiliary crane.
- ▶ Lift the S-intermediate section **4** or preassembled boom unit with the auxiliary crane and position on the S-intermediate section 3228.25 FLM **3** until the pin points align.

When the pin points between the S-intermediate section 3228.25 FLM **3** and the S-intermediate section **4** on preassembled boom unit align „on top“ and „bottom“:

- ▶ Pin the S-intermediate section **4** or preassembled boom unit „on top“: Insert the pin **1.1** on both sides and secure with locking pin **1.2**.
- ▶ Pin the S-intermediate section **4** or preassembled boom unit „on the bottom“: Insert the pin **1.1** on both sides and secure with locking pin **1.2**.

When the pins are properly pinned and secured on „top“ and „bottom“ between the S-intermediate section 3228.25 FLM 3 and the S-intermediate section 4 or the preassembled boom unit:

- ▶ Remove the auxiliary crane.

If additional lattice sections are assembled:

- ▶ Assemble the lattice sections the same way as described in this section.

4.2.1 Assembling the S2-boom system in flying mode



WARNING

The crane can topple over!

Death, severe bodily injuries, property damage.

- ▶ Make sure that $F1_{max}$ (MS1) is **not** exceeded at flying assembly.
- ▶ Make sure that the maximum permissible flying assembly lengths are not exceeded, even when $F1_{max}$ (MS1) is not yet reached.
- ▶ Make sure that no hook block is reeved at flying assembly.
- ▶ Make sure that all guy rods which are not required have been removed from the lattice sections.
- ▶ Make sure that a minimum of 190 t counterweight is assembled on the turntable.
- ▶ For the ballasting of the central ballast, refer to the erection and take down charts.
- ▶ To determine the required ballasting, assume a hook block weight of a minimum of 4 t in the erection and take-down charts.



Note

- ▶ $F1_{max}$ (MS1) = 300 t.

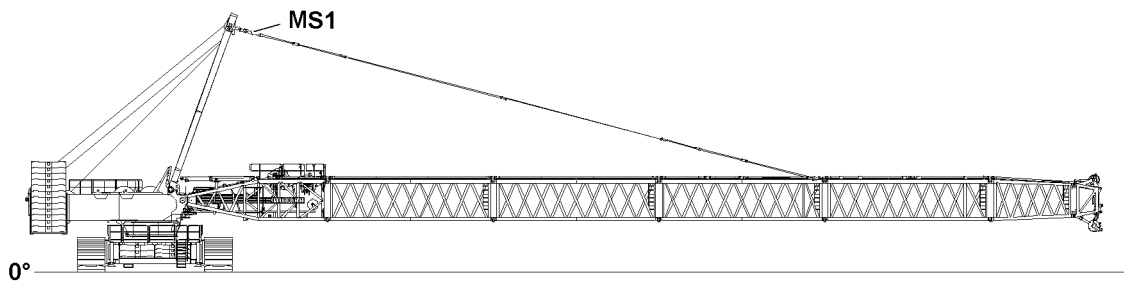

Fig.119127: S2-boom system - Flying assembly length to **maximum** S2 66 m

- with L-end section
- with S-guy rods
- with roller sets
- without WA-frame II guy rods

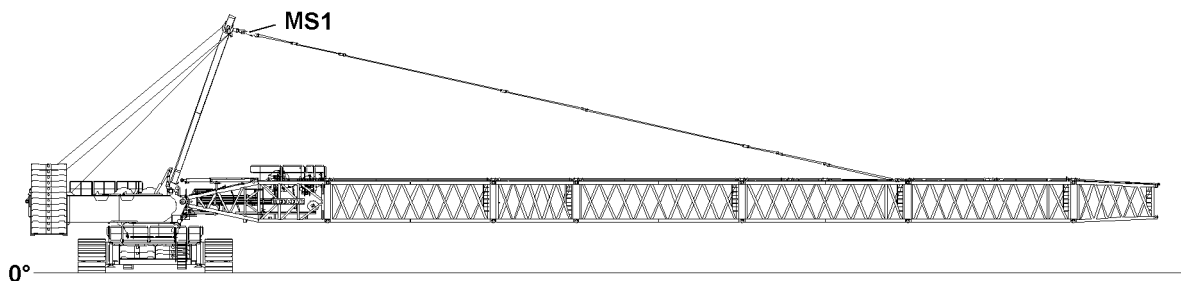

Fig.119128: S2-boom system - Flying assembly length to **maximum** S2 72 m

- without end section
- with S-guy rods
- without WA-frame II guy rods

4.2.2 Assembling the SL-boom system in flying mode



WARNING

The crane can topple over!

Death, severe bodily injuries, property damage.

- ▶ Make sure that $F1_{max}$ (MS1) is **not** exceeded at flying assembly.
- ▶ Make sure that the maximum permissible flying assembly lengths are not exceeded, even when $F1_{max}$ (MS1) is not yet reached.
- ▶ Make sure that no hook block is reeved at flying assembly.
- ▶ Make sure that all guy rods which are not required have been removed from the lattice sections.
- ▶ Make sure that a minimum of 150 t counterweight is assembled on the turntable.
- ▶ For the ballasting of the central ballast, refer to the erection and take down charts.
- ▶ To determine the required ballasting, assume a hook block weight of a minimum of 5 t in the erection and take-down charts. When using the mechanical auxiliary support, assume a hook block weight of 7 t.



Note

- ▶ $F1_{max}$ (MS1) = 300 t.

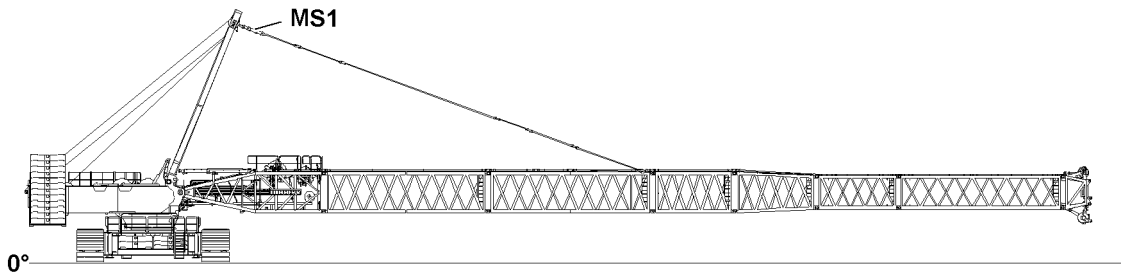

Fig.119129: SL-boom system - Flying assembly length to **maximum** SL 66 m

- with L-end section
- with roller sets
- with S-guy rods
- without WA-frame II guy rods

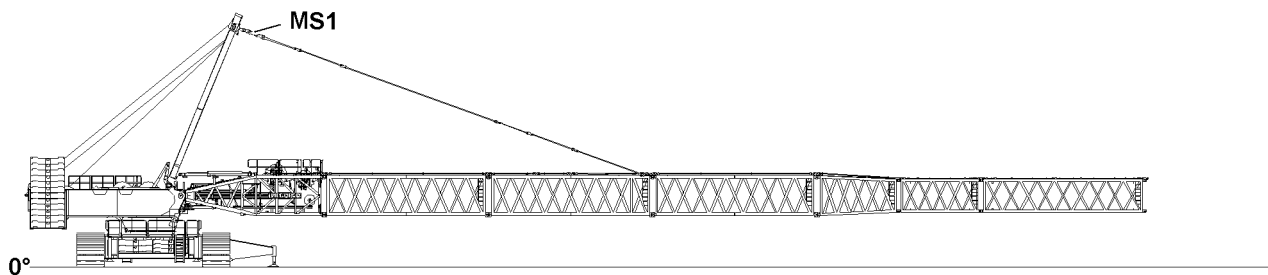

Fig.119130: SL-boom system - Flying assembly length to **maximum** SL 72 m

- without end section
- with S-guy rods
- without WA-frame II guy rods

4.2.3 Assembling the SL3-boom system in flying mode



WARNING

The crane can topple over!

Death, severe bodily injuries, property damage.

- ▶ Make sure that $F1_{max}$ (MS1) is **not** exceeded at flying assembly.
- ▶ Make sure that the maximum permissible flying assembly lengths are not exceeded, even when $F1_{max}$ (MS1) is not yet reached.
- ▶ Make sure that no hook block is reeved at flying assembly.
- ▶ Make sure that all guy rods which are not required have been removed from the lattice sections.
- ▶ Make sure that a minimum of 210 t counterweight is assembled on the turntable.
- ▶ For ballasting of the central ballast, refer to the erection and take down charts.



Note

- ▶ $F1_{max}$ (MS1) = 300 t.

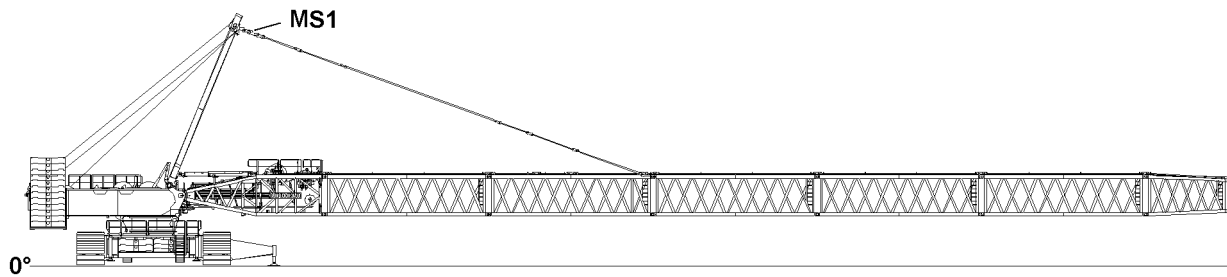

Fig.119131: SL3- 102 m - boom system / Flying assembly length to **maximum** SL3 76.5 m

- without end section

- with S-guy rods

- without WA-frame II guy rods

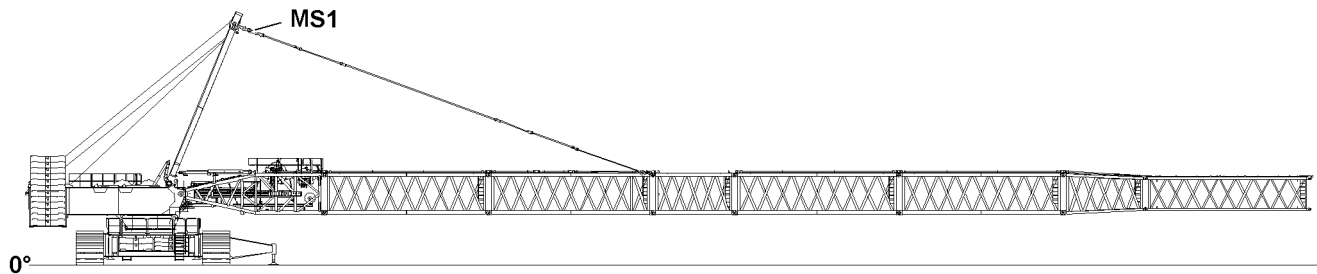

Fig.119132: SL3- 108 m - boom system / Flying assembly length to **maximum** SL3 82.5 m

- without end section

- with S-guy rods

- without WA-frame II guy rods

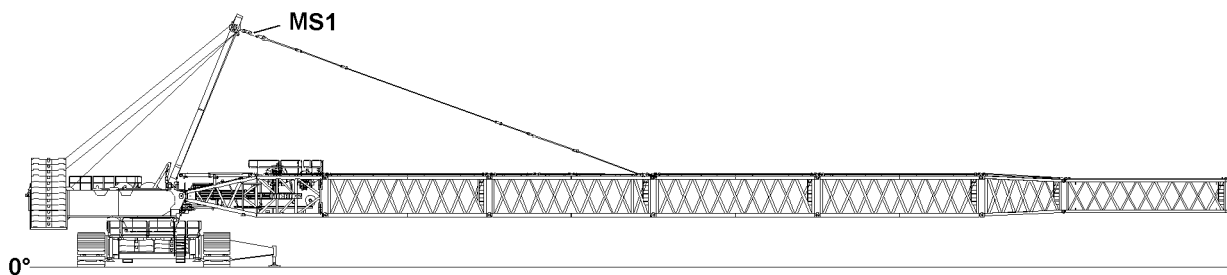

Fig.119133: SL3- 114 m - boom system / Flying assembly length to **maximum** SL3 76.5 m

- without end section

- with S-guy rods

- without WA-frame II guy rods

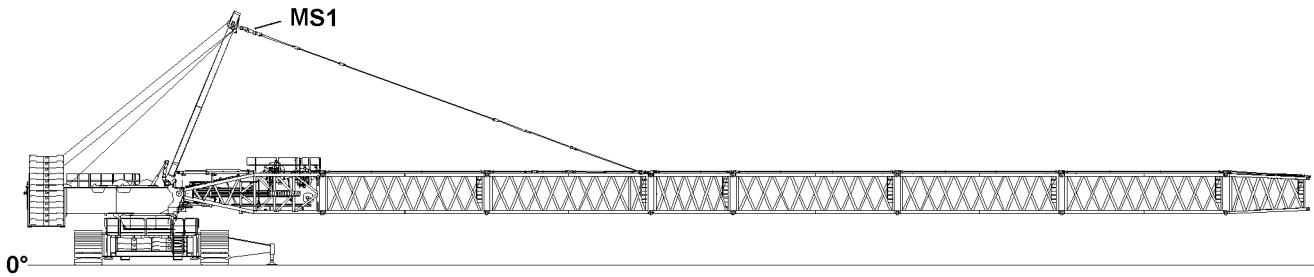

Fig. 119134: SL3- 120 m - boom system / Flying assembly length to **maximum** SL3 82.5 m

- without end section

- with S-guy rods

- without WA-frame II guy rods

4.3 Completing the flying assembly

If the maximum permissible flying assembly length is installed and tensioned on the S-intermediate section 3228.25 FLM, the boom system must be taken down on the ground or a load bearing sub-structure.

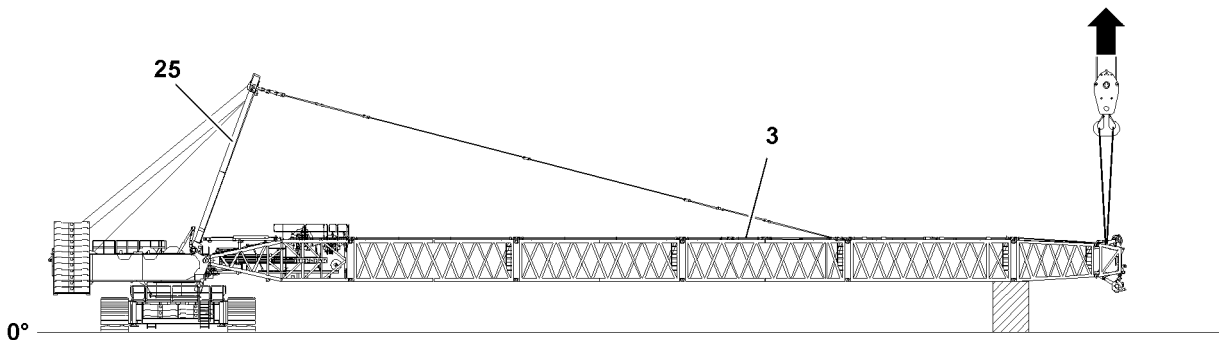

Fig. 119138: Example: Boom system installed and supported up to the maximum permissible flying assembly length

Make sure that the following prerequisite is met:

- An auxiliary crane with sufficient load bearing capacity if available.

When the permissible flying assembly length is reached:

- ▶ Take the boom system down on the ground or on a load bearing substructure.
- ▶ Install the boom end section properly on the boom system.

Problem remedy

The maximum permissible flying assembly length does not correspond to the operating length?

- ▶ Take the boom system down on the ground.
- ▶ Expand the boom system on the ground to the required operating length.
- ▶ Close the boom system after reaching the required operating length with the auxiliary crane.



WARNING

The boom can suddenly fold down!

Death, severe bodily injuries, property damage.

- ▶ Before unpinning the guy rods: Support the boom system properly or take it down on the ground.
- ▶ Observe and adhere to the Rod plan.

When the boom system is properly taken down on the ground or supported:

- ▶ Relieve the guying between the SA-frame and S-intermediate section 3228.25 FLM by lowering the SA-frame.

5 Assembling the boom combinations with substructure

If the assembly conditions for the assembly of the boom system are restricted due to the terrain on the jobsite, then it is possible to install the S-/SL-boom with a substructure.



WARNING

General danger notes!

- ▶ All pins are to be secured after assembly with the intended retaining elements.
- ▶ The guy rods must be inspected regularly, see the Crane operating instructions, chapter 8.15.
- ▶ Secure the boom with substructure or auxiliary crane, see Crane operating instructions, chapter 5.01.
- ▶ It is prohibited for anyone to remain under the booms or within the complete danger zone during the pinning and unpinning procedure of the lattice section.

NOTICE

Property damage!

If the pins of the guy rods are not pinned from the „inside“ to the „outside“, the hoist rope can scrape on the pins and be damaged.

- ▶ Always insert the pins of the guy rods from the „inside“ to the „outside“, see the Rod plan.



WARNING

The crane can topple over!

Death, severe bodily injuries, property damage.

- ▶ For boom assembly / disassembly with the substructure, observe chapter 5.01.
- ▶ The „actual force“ on test point 1 **MS1** is shown on LICCON monitor 1.
- ▶ Observe the assembly conditions, see the Crane operating instructions, chapter 3.06.
- ▶ The specifications in the erection and take-down charts as well as the load charts must be observed.
- ▶ For the itemization of the lattice sections refer to the Rod plan.

NOTICE

Overload of boom!

If the boom system is not properly supported at assembly, then the boom system can be overloaded. The boom system will be damaged.

- ▶ Support boom systems from a length of more than 114 m properly within the marked area: use suitable materials with sufficient load carrying capacity.
- ▶ Make sure that the dimension **X** for the maximum permissible deflection of the boom system is never exceeded.

Make sure that the following prerequisites are met:

- Observe the danger notes and the prerequisites in section „Assembling S2/SL/SL3 boom“.

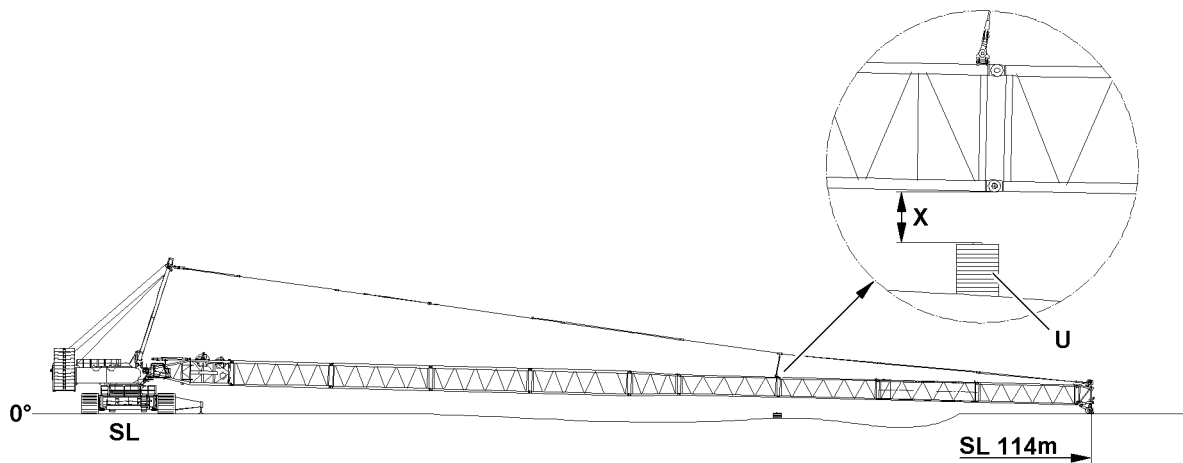

Fig.119450: Assembling the boom combination with substructure

The boom combinations must be preassembled at a suitable location.

Swing the preassembled boom combination with the auxiliary crane(s) in to the turntable, pin and secure.

- ▶ Preassemble the boom combination.



WARNING

Danger of accident due to boom system!

Death, severe bodily injuries, property damage.

- ▶ Make sure that no persons are within the danger zone of the crane and the boom system to be assembled.

- ▶ Swing the preassembled boom combination with the auxiliary crane (s) to the turntable.
- ▶ Pin and secure the boom combination with the S-pivot section on the turntable, see section „Assembling the S-pivot section on the turntable“.

When the boom system is properly installed with the S-pivot section on the turntable:

- ▶ Support the boom system properly before taking it down on the ground.

Operating mode	Support from length	Dimension ¹⁾ X
SL	114 m	1.1 m

¹⁾ X = maximum permissible flexation of the boom system

- ▶ Lower the boom combination on the ground.

6 Assembling the S-guy rods



WARNING

Neglected guy rod inspection and maintenance!

Death, severe bodily injuries, property damage.

- ▶ Check the guy rods before every assembly, see Crane operating instructions, chapter 8.15.
- ▶ The S-guy rods must be assembled and secured, see Rod plan. The numbering in the rod plan must be identical to the numbering on the guy rods.
- ▶ Make sure that the inspection and maintenance intervals are adhered to.

**WARNING**

Falling components!

Death, severe bodily injuries, property damage.

- ▶ Make sure that the intermediate sections or preassembled boom unit are properly pinned and secured on the S-pivot section.
- ▶ Make sure that the intermediate sections or preassembled boom unit is supported with suitable materials, secured with the auxiliary crane or the boom is placed on the ground.

Make sure that the following prerequisites are met:

- The boom system is closed.
- The boom is supported
- **or** the boom is held in position by the auxiliary crane
- **or** the boom is laying on the ground.
- The guying is relieved.

The guy rods are placed and secured for transport on the S-intermediate sections. Before assembly of the guy rods, release the transport retainers.

- ▶ Release and unpin transport retainers for the guy rods.

NOTICE

Property damage!

If the pins of the guy rods are not pinned from the „inside“ to the „outside“, the hoist rope can scrape on the pins and be damaged.

- ▶ Always insert the pins of the guy rods from the „inside“ to the „outside“, see the Rod plan.
- ▶ Pin the guy rods of all intermediate sections: Insert the pin from the „inside“ to the „outside“ and secure with locking pin.
- ▶ Assemble the guying according to the Rod plan, pin and secure it properly.
- ▶ Make sure that all guy rods of the boom system are pinned and secured.
- ▶ If it is required according to the Rod plan: Assemble the auxiliary guying, see Crane operating instructions, chapter 5.01 and 5.03.

**WARNING**

Unutilized guy rods on boom!

Death, severe bodily injuries, property damage.

- ▶ Non-required guy rods must be removed from the lattice sections, see Crane operating instructions, chapter 5.01.
- ▶ Remove non-required guy rods from the lattice sections.

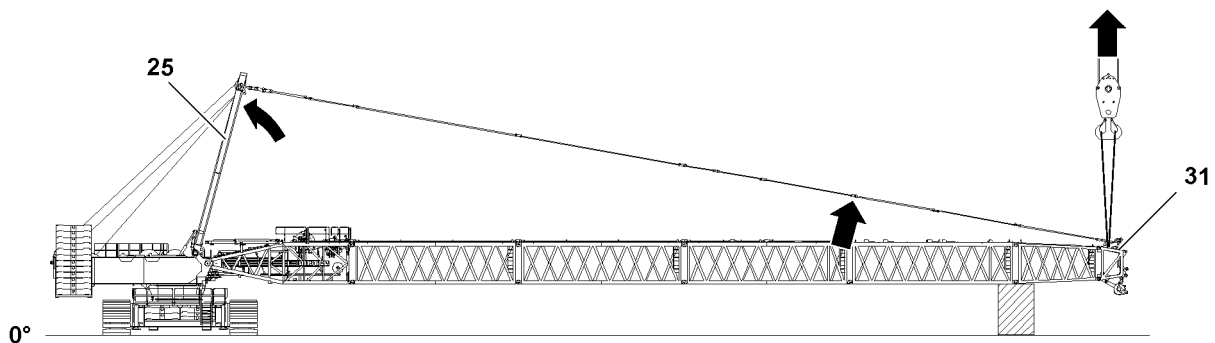

Fig.119139: Luffing the SA-frame up and tensioning the guying

- ▶ Erect the SA-frame 25 until the guy rods between the SA-frame 25 and end section 31 tension.

7 Assembling the roller sets on the boom head

7.1 Assembling the roller sets



Note

- ▶ The assembly of the roller sets is described in the Crane operating instructions, chapter 5.14.

When the roller set / the roller sets are properly installed on the end section:

- ▶ Route the hoist limit switch from the end section forward on the roller set / the roller sets, pay attention and adhere to the Electrical wiring diagram.

7.2 Establishing the electrical connections on the boom end section

Make sure that the following prerequisites are met:

- The S-intermediate sections are properly assembled and secured on the ground.
- The boom end section is properly assembled and secured.
- The electrical connections to the boom end section have been established.
- The airplane warning light, wind speed sensor and all sensors are properly installed and secured on the boom end section.
- The hoist limit switches are properly installed and secured on the pulley head / pulley heads.

NOTICE

Danger of damage to the electrical connections!

If the electrical connection from the cable drum on the S-pivot section to the terminal box on the S-pivot section is established first before the connection to the terminal box on the boom end section, the electrical connection can be damaged when spooling out the cable drum.

- ▶ Establish first the electrical connection from the cable drum in the S-pivot section to the terminal box on the boom end section and then the electrical connection from the terminal box in the S-pivot section to the cable drum.



Note

- ▶ To establish the electrical connections on the S-boom: Use the Electrical wiring diagram.

- ▶ Establish the electrical connections.
- ▶ Make sure that all electrical connections on the boom are established.



WARNING

Malfunction if dummy plugs are not installed!

If the dummy plugs on the non-required electrical connections are not installed, then malfunctions or functional limitations can occur on the crane.

- ▶ Make sure that all non-required electrical connections that have a dummy plug are closed off with dummy plugs.
- ▶ Pay attention to the Electrical wiring diagram.
- ▶ As a rule, close off on-required electrical connections (for example for accessories which cannot be installed) with the respective dummy plugs.

NOTICE

Property damage due to dirt and / or corrosion!

If non-required electrical connections are not closed off with the respective protective caps, then dirt and / or corrosion can damage the electrical connections.

This could result in malfunctions.

- ▶ Make sure that all non-required electrical connections are always closed off properly.
- ▶ Pay attention to the Electrical wiring diagram.
- ▶ Close electrical connections, which have no dummy plugs, properly off with the corresponding protective caps.

8 Performing the function checks



WARNING

Malfunctioning safety equipment!
Death, severe bodily injuries, property damage.

- ▶ Crane operation with non-functioning safety equipment is **prohibited**.
- ▶ Start crane operation only after all safety equipment have been checked and are functioning correctly.



Note

- ▶ The function of the individual limit switches must be checked before erection of the boom system.
- ▶ The function of the limit switch initiators must be checked in the test system, see the Diagnostics manual.



Note

- ▶ If a function check on the limit switches or on the safety equipment does not lead to the desired shut-offs, then the plug connections on the connector boxes or the components themselves must be checked.
- ▶ If no visible connection errors or component defects can be found, contact Liebherr Service.

Make sure that the following prerequisites are met:

- All electrical connections have been made.
- The crane engine is running.
- The corresponding operating mode is set on the LICCON monitor.
- The actuator levers of the limit switches have been checked for easy movement and are lubricated.

8.1 Wind speed sensor

- ▶ Check the movement and the function of the wind speed sensor.

8.2 Airplane warning light

- ▶ Turn the airplane warning light on, see Crane operating instructions, chapter 4.01.
- ▶ Check the function visually.

8.3 Hoist limit switch

- ▶ Actuate the hoist limit switch manually on the pulley head.

Result:

- The hoist winch turns off in upward movement.
- The hoist top icon on the LICCON monitor 0 blinks.
- The hoist limit switch is functioning.

8.4 Checking the limit switch main boom „steepest position“



Note

- ▶ The limit switch functions have to be checked individually before erection.
- ▶ Cover the limit switch initiators on the relapse cylinders of the main boom individually with a metal plate.

Result:

- The limit switch is actuated manually.
- The spool up function of winch 4 turns off.
- The icon „Boom limitation“ appears on the LICCON monitor 0.

9 Erecting the boom

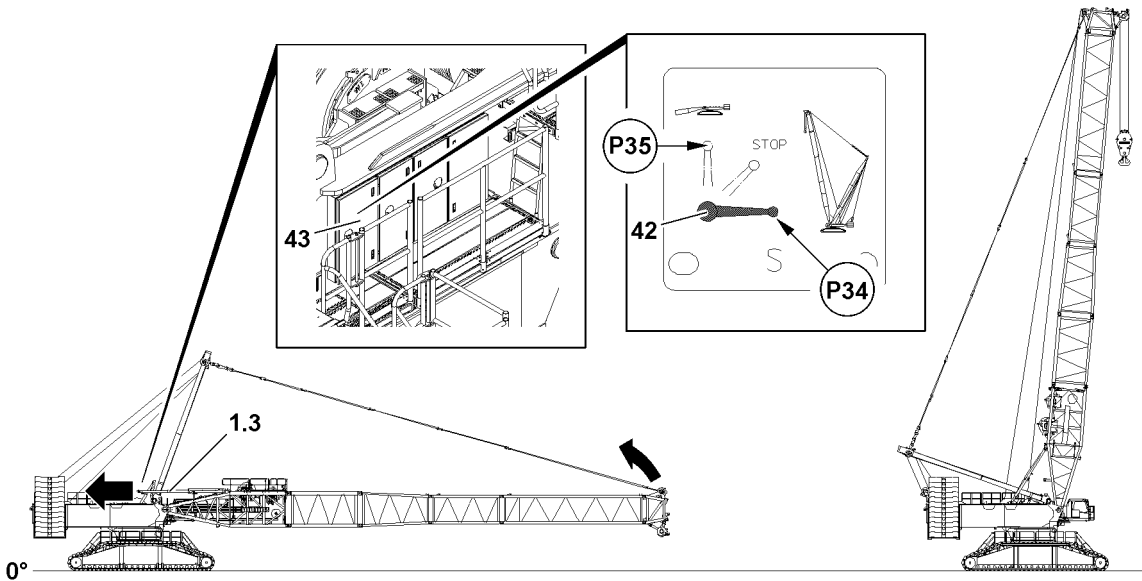

Fig.119137: Extending the relapse cylinder / erecting the boom system



WARNING

The crane can topple over!

In crane operation with bypassed LICCON overload protection, the crane can topple over.
Death, severe bodily injuries, property damage.

- ▶ The radii listed in the load chart may not be exceeded or fallen below, even if there is no load on the hook.

If required in the erection and take down chart:

- ▶ Carry the hook block along with the auxiliary crane.



WARNING

The crane can topple over!

Death, severe bodily injuries, property damage.

- ▶ Observe the technical safety instructions, see the Crane operating instructions, chapter 5.01.
- ▶ Make sure that the relapse cylinders of the main boom are completely extended before erection of the boom combination.
- ▶ Do not allow slack rope to build up on the winch 4.



WARNING

Falling hoist rope!

Death, severe bodily injuries, property damage.

- ▶ Reeve the hoist rope before the erection procedure with a sufficient length on the roller set / the roller sets of the end section.
- ▶ The hoist rope must be constantly monitored during the erection procedure.
- ▶ Make sure that there are no persons within the danger zone.

Make sure that the following prerequisites are met:

- The crane is horizontally aligned.
- The guy rods are properly assembled.
- The guy rods which are not required have been removed from the lattice sections.
- All electrical connections have been made.
- All hydraulic connections have been made.
- The function checks were carried out properly.
- All limit switches and warning devices are functioning.
- Crane ballasting (counterweight, central ballast, derrick ballast and / or auxiliary ballast) is carried out according to the load charts and / or the erection and take-down charts
- The crane has been set up according to the load charts and / or the erection and take-down charts.
- The LICCON overload protection has been set according to the data in the load charts and / or the erection and take-down charts.
- The LICCON overload protection settings have been checked for completeness and correctness.
- Assembly operation of the crane control is activated: the assembly icon is visible on the LICCON monitor.
- All pin connections have been secured.
- The hoist rope has been correctly placed in the rope pulleys and is prevented from jumping out with the rope retaining pins.
- There are no loose parts on the boom system.
- The boom system and the safety equipment are free from snow, frost and ice.
- No personnel or obstacles are within the danger zone.

9.1 Moving the S-relapse cylinders out



WARNING

The crane can topple over!

Death, severe bodily injuries, property damage.

- ▶ Move the S-relapse cylinders **1.3** out completely before erecting the S-boom.
- ▶ Secure the ball valve **42** during crane operation to prevent inadvertent actuation.

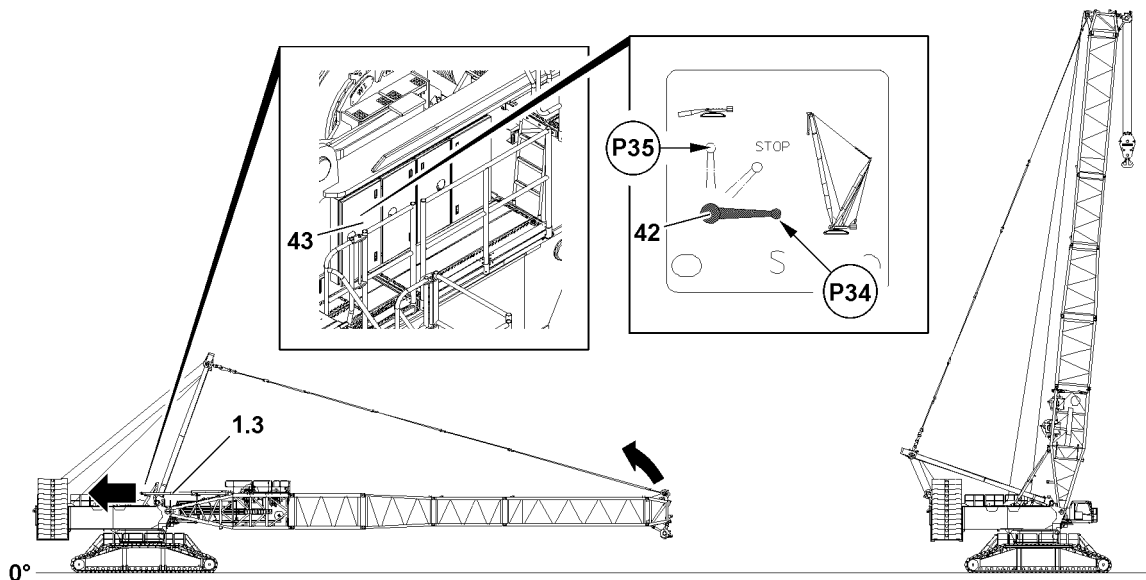

Fig.119137: Extending the relapse cylinder / erecting the boom system

Ball valve positions	
Position (P)	Function
34	Crane operation, extend the piston rod
35	Assembly, retract the piston rod
STOP	The piston rod cannot be retracted / extended

The piston rods on the S-relapse cylinders **1.3** can be moved out with the ball valve **42**.

- ▶ Set the ball valve **42** to position **P34**.

Result:

- The piston rods of the S-relapse cylinders **1.3** move out.



Note

- ▶ The ball valve **42** is secured by closing the cabinet door **43** and removing the key.

- ▶ Close the cabinet door **43** and pull out the key.
- ▶ Hand the key to an authorized person.

9.2 Erection procedure



DANGER

The crane can topple over!

- ▶ It is prohibited to turn the crane superstructure while erecting the boom.
- ▶ Adhere to the specifications in the erection and take down charts.

Make sure that the following prerequisite is met:

- The correct hook block weight is entered on the LICCON monitor, see the Crane operating instructions, chapter 4.02.

9.2.1 Reeving in the hook block

Make sure that the following prerequisites are met:

- The crane is horizontally aligned.
- The slewing gear brake is applied.



WARNING

Danger of accident due to side wind!

If the slewing gear brake is released after reeving in / reeving out the hook block / load hook, then the crane can turn uncontrolled if there is a strong side wind.

The crane can collide with close-by structures or objects.

Death, severe bodily injuries, property damage.

- ▶ Make sure that the current wind speed does not exceed the values from the wind speed chart when releasing the slewing gear brake.

- ▶ Erect the boom until the end section lifts off the ground.

NOTICE

Danger of slack rope formation!

By spooling the hoist winch out too fast during the reeving procedure, slack rope can form.

- ▶ Make sure that the hoist rope is tensioned during the entire reeving procedure.

**WARNING**

Falling hoist rope!

Death, severe bodily injuries, property damage.

- ▶ Reeve in the hoist rope with sufficient length on the S-boom before the erection process.
- ▶ The hoist rope must be constantly monitored during erection.
- ▶ Do not step into the danger zone.

- ▶ Reeve the hoist rope properly and secure it on the rope fixed point: Reeving, see Reeving plan.
- ▶ Pin and secure the rope retainers on the rope pulleys.
- ▶ Attach the hoist limit switch weight, see the Crane operating instructions, chapter 4.06.

9.2.2 Erecting the boom

**WARNING**

The crane can topple over!

In crane operation with bypassed LICCON overload protection, the crane can topple over.

There is then no additional protection against crane overload.

Death, severe bodily injuries, property damage.

- ▶ The radii listed in the load chart may not be exceeded or fallen below, even if there is no load on the hook.
- ▶ Crane operation with bypassed LICCON overload protection is prohibited.

**Note**

- ▶ When the lowest operating position of the boom is reached, the set load chart of the LICCON overload protection is activated.
- ▶ In the maximum load icon appears a load number in „t“ instead of the display „???“.

- ▶ Luff the S-boom up to the lowest operating position.

When the S-boom has reached the lowest operating position:

- ▶ Make sure that the assembly icon on the LICCON monitor turns off.

Result:

- The LICCON overload protection is active.

10 Operating the crane

10.1 Preparing for crane operation

**Note**

- ▶ Observe the notes, see Crane operating instructions, chapter 4.02, chapter 4.04, chapter 4.05, chapter 4.08 and chapter 5.01.

Make sure that the following prerequisites are met:

- The LICCON overload protection is active.
- The LICCON overload protection has been set according to the data in the load chart.

**WARNING**

The crane can topple over!

- ▶ Check the horizontal position of the crane before and during operation.
- ▶ If the crane operator leaves the cab, even for a short time, the operating mode setting must be checked and reset if necessary before resuming crane operation.

10.1.1 Checking the settings

- ▶ Check the function of the overload protection by running against the operating positions „on top“ and „bottom“.
- ▶ Check the hoist limit switch by running against the hoist limit switch weight.

Empty page!

LWE/LR 11000-001/23501-04-02/en

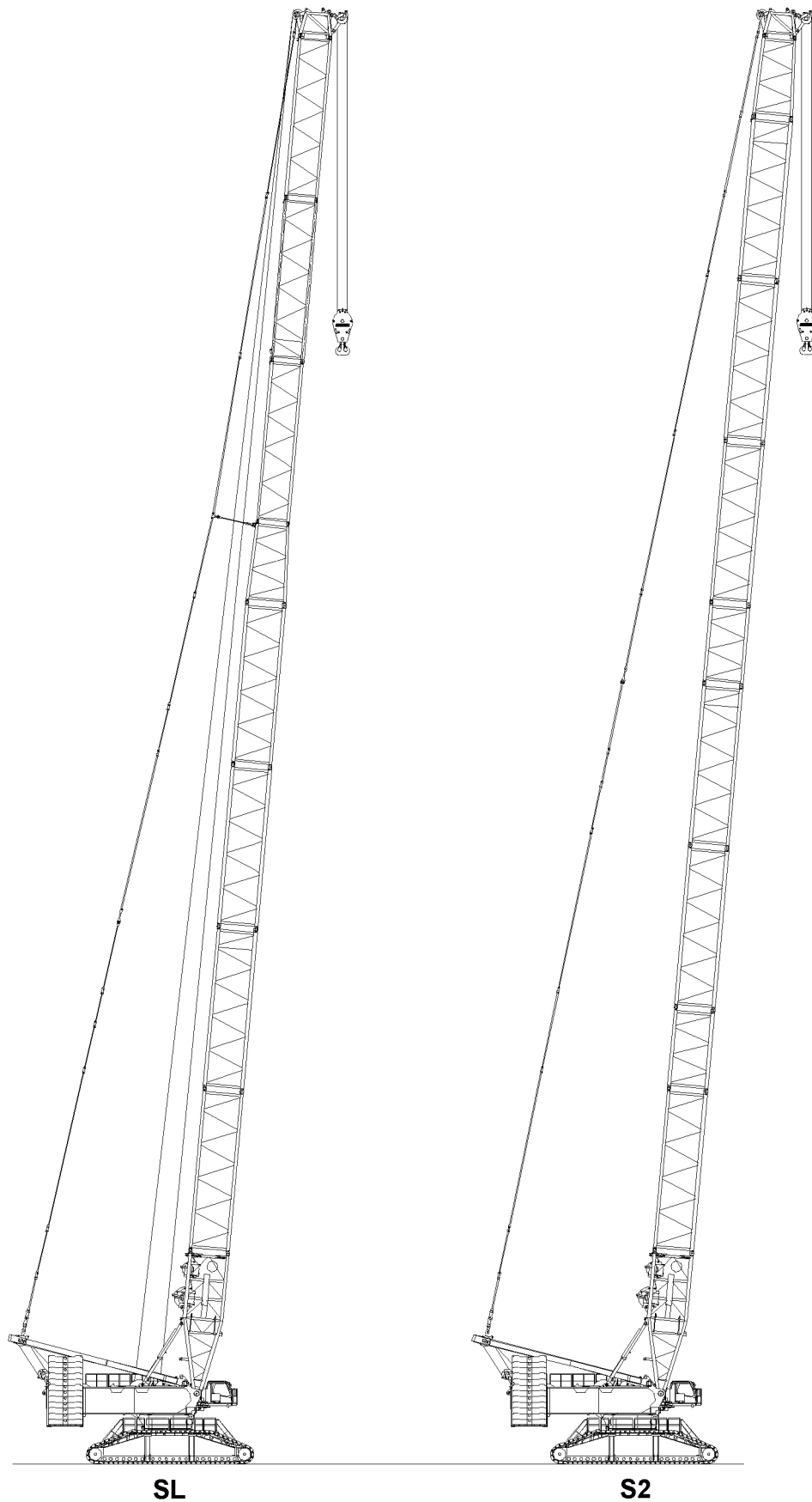

Fig.119108: S2/SL/SL3

LWE/LR 11000-001/23501-04-02/en

11 Disassembly S2/SL/SL3-boom



Note

- ▶ The disassembly is described on the example of the S-boom.
- ▶ For the combination of the boom lattice sections, observe and adhere to the Rod plan and the Crane operating instructions, chapter 5.03.



WARNING

Danger of falling!

During assembly / disassembly, inspection and maintenance work, assembly personnel must be secured with appropriate aids to prevent them from falling.

If this is not observed, assembly personnel could fall and be killed or seriously injured.

- ▶ All work at a height, when there is a danger of falling, must be carried out with suitable aids.
- ▶ If aids are not available and work cannot be carried out from the ground, then assembly personnel must secure themselves with the supplied fall arrest system to prevent falling, see the Crane operating instructions, chapter 2.04.
- ▶ If fall protection equipment is available, then it must be used, see the Crane operating instructions, chapter 2.06.
- ▶ When lifting, lowering, swinging crane parts in and out, no persons may remain in the danger zone.
- ▶ When closing or opening boom systems during boom assembly or boom disassembly, no persons may remain on the boom system or in the danger zone.
- ▶ If railings are present on the components, then they must be brought into the corresponding position and secured for assembly / disassembly work.
- ▶ Only step on the aids, ladders and catwalks with clean shoes.
- ▶ Keep aids, ladders and catwalks free of heavy dirt, snow and ice.
- ▶ During all assembly and disassembly work, maintenance work and inspections, travel or crane operation is prohibited.
- ▶ Remaining on a suspended load is prohibited.
- ▶ Stepping or walking on crane components and lattice sections, which have an incline of more than 20° is prohibited.
- ▶ For all assembly work, the crane driver of the main crane must be in voice contact with the crane driver / crane drivers of the auxiliary crane / auxiliary cranes.
- ▶ For assembly tasks, the crane driver may only initiate crane movements when the responsible guide has explicitly released the movement.



WARNING

The lattice sections can fall down!

Death, severe bodily injuries, property damage.

- ▶ Pin or unpin both pins at the same horizontal level, i.e. **left and right**.
- ▶ Do not stand under the lattice sections or within the entire danger zone during the pinning and unpinning procedure of the boom.
- ▶ Safely secure the pins in the storage locations as well as in the receptacles.
- ▶ It is prohibited to lean the auxiliary ladder against the component being disassembled.



WARNING

Danger of impact / crushing!

When installing / removing crane components with the auxiliary crane, crane components can start to swing back and forth.

When lifting / lowering and positioning crane components, there is an increased danger of impacts / crushing.

Death, severe bodily injuries, property damage.

- ▶ Make sure that personnel cannot be caught by components.
- ▶ Make sure that the crane is horizontally aligned.
- ▶ When working in danger zones: Use aids to protect limbs.
- ▶ Guide components with suitable aids to minimize oscillation.

**DANGER**

The components can fall down!

Death, severe bodily injuries, property damage.

- ▶ Do not disengage the auxiliary crane until the respective component is pinned and secured.

Make sure that the following prerequisites are met:

- The ground is able to safely take on the total operating weight of the crane.
- The crane is horizontally aligned.
- An auxiliary crane with sufficient load bearing capacity if available.
- An assembly scaffolding or a work platform is available.
- The central ballast has been installed on the crawler travel gear according to the load chart or the erection and take down charts.
- The counterweight has been installed on the turntable according to the load chart or the erection and take down charts.
- The LICCON overload protection has been set according to the data in the load chart.

11.1 Disassembling the central ballast

**WARNING**

The crane can topple over!

Death, severe bodily injuries, property damage.

- ▶ Observe the Erection and take down charts.
- ▶ If a central ballast is required for taking down the boom system, then leave the central ballast on the crane.

When no central ballast is required for taking down the boom system:

- ▶ Remove the central ballast, see Crane operating instructions, chapter 3.03.

11.2 Turning the turntable to the disassembly position

**WARNING**

The crane can topple over!

Death, severe bodily injuries, property damage.

- ▶ Observe the specifications in the erection and take-down charts.
- ▶ Observe the data in the load charts.

- ▶ Turn the turntable into disassembly position according to the erection and take down charts.

11.3 Luffing the boom system down and reeving the hoist rope out

**WARNING**

The crane can topple over!

Death, severe bodily injuries, property damage.

- ▶ Observe the technical safety instructions, see the Crane operating instructions, chapter 5.01.
- ▶ Observe the specifications in the erection and take-down charts.

NOTICE

Damage of boom components!

Taking down the boom system can lead to a collision between the hook block and the pulley head.

Boom components can be severely damaged.

- ▶ Luff the boom system down and at the same time spool the hoist winch out.
- ▶ When luffing the boom system down, the SA-frame must remain in operating position until the S-end section is laying on the ground or on a substructure or it is safely held by an auxiliary crane.

**Note**

- ▶ The luff down movement is turned off as soon as the lowest operating position of the S-boom is reached.
- ▶ When the lowest operating position of the S-boom is reached, the load display in the maximum load icon turns off and instead of the load display appears the display „???“.
- ▶ In the crane operating screen appear alarm functions.

- ▶ Luff the S-boom down to the **lowest** operating position.

Result:

- The luff down movement is turned off.
- The „STOP“ icon appears on the LICCON monitor.
- The horn icon appears on the LICCON monitor.

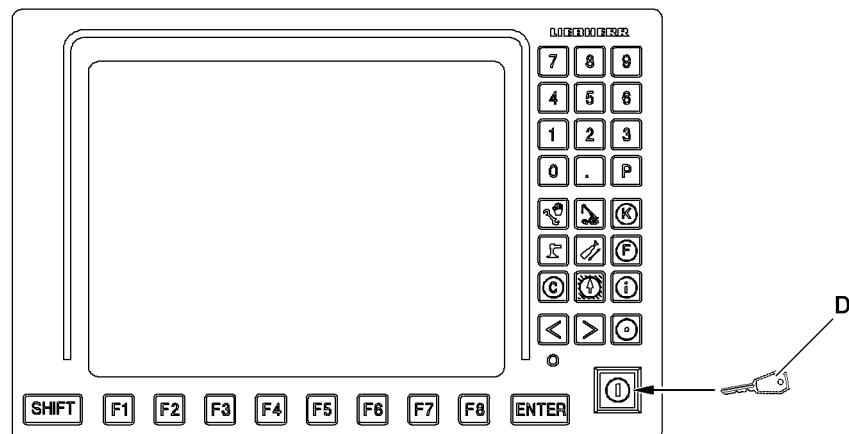

Fig.119109

**WARNING**

Danger of accident due to function „Exceedance of shut-off limits of the LICCON overload protection“! If the shut off limits of the LICCON overload protection are exceeded, there is no additional protection against crane overload.

Due to erroneous operation or deliberate misuse, the crane could collapse, the boom can break off or the crane can topple over.

Death, severe bodily injuries, property damage.

- ▶ The function „Exceedance of shut off limits of the LICCON overload protection“ is only permissible in emergencies and for assembly purposes.
- ▶ The function „Exceeding the shut off limits of the LICCON overload protection“ may only be actuated by persons who know the effects of their actions regarding the function „Exceeding the shut off limits of the LICCON overload protection“.
- ▶ The function „Exceedance of shut off limits of the LICCON overload protection“ requires the presence of an authorized person and must be performed with utmost caution.
- ▶ Crane operation with activated function „Exceedance of shut off limits of the LICCON overload protection“ is prohibited.

- ▶ Exceeding the shut off limits of the LICCON overload protection: Engage assembly operation.

Result:

- The shut off limits of the LICCON overload protection are exceeded.
- The assembly icon appears on the LICCON monitor.

**Note**

- ▶ See the Crane operating instructions, chapter 4.02 and chapter 4.20.

- ▶ At the same time, spool the hoist winch out and luff the boom down until the hook block touches the ground.
- ▶ Remove the hoist limit switch weight and reeve the hook block out.
- ▶ Remove the hook block with the auxiliary crane.

When the hook block is removed under the boom head:

- ▶ Continue to luff the boom system down until the roller set / roller sets of the boom head are just above the ground.



WARNING

Spooling up of hoist rope!

Death, severe bodily injuries, property damage.

- ▶ All rope retaining pins / pipes on the S-boom are removed.
- ▶ Slowly spool up the hoist rope over the rope pulleys back to the winch.
- ▶ No one may be present in the danger zone.

NOTICE

Overspooled winch!

If the hoist rope is pulled under the winch when spooling up, then the adjustment of the winch speed sensor can change.

A new adjustment by **Liebherr Service** is required.

- ▶ Stop the winch in time, with sufficient rope reserve.
- ▶ Do not overspool the winch.

- ▶ Spool the hoist rope up.

11.4 Moving the S-relapse cylinder in

Make sure that the following prerequisite is met:

- The crane engine is running.

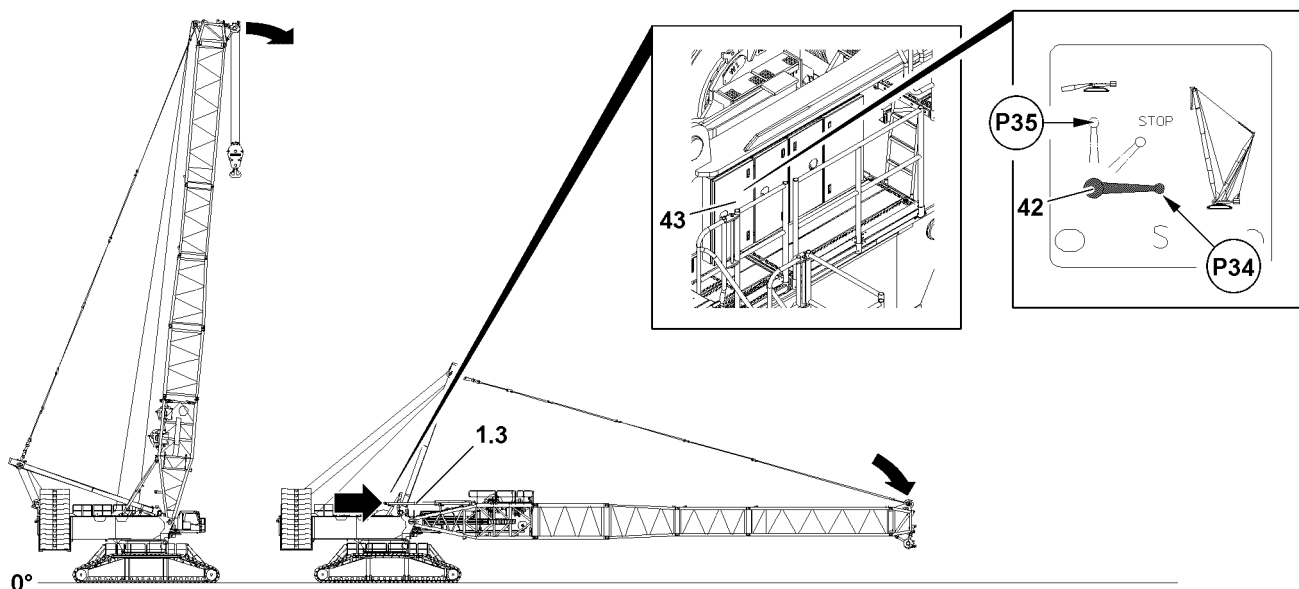

Fig.119140: Luffing the boom system down / retracting the relapse cylinder

Ball valve positions	
Position (P)	Function
34	Crane operation, extend the piston rod
35	Assembly, retract the piston rod
STOP	The piston rod cannot be retracted / extended

The piston rods on the S-relapse cylinders **1.3** can be moved in with the ball valve **42**.

- ▶ Set the ball valve **42** to position **P35**.

Result:

- The piston rods of the S-relapse cylinders **1.3** move out.



Note

- ▶ The ball valve **42** is secured by closing the cabinet door **43** and removing the key.

- ▶ Close the cabinet door **43** and pull out the key.
- ▶ Hand the key to an authorized person.

11.5 Disassembly of the roller sets on the boom head

NOTICE

Danger of property damage!

During the disassembly of the roller sets the electrical connections to the hoist limit switches can be damaged.

- ▶ Remove the hoist limit switches on the roller sets.
- ▶ Before disassembly of the roller sets, route the hoist limit switches from the roller sets back to the end section.



Note

- ▶ The disassembly of the roller sets is described in the Crane operating instructions, chapter 5.14.

11.6 Placing the boom on the substructure

Make sure that the following prerequisites are met:

- The hook block is properly unreeved and removed.
- The hoist limit switch is on the end section.
- The roller set / the roller sets are removed.

NOTICE

Overload of boom!

If the boom system is not properly supported at disassembly, then the boom system can be overloaded.

The boom system will be damaged.

- ▶ Support boom systems from a length of more than 114 m properly within the marked area: use suitable materials with sufficient load carrying capacity, see section „Assembling the boom combinations with substructure“.
- ▶ Make sure that the dimension **X** for the maximum permissible deflection of the boom system is never exceeded.

- ▶ Take the boom system down on the substructure.
- or
- Secure the boom system with the auxiliary crane in the horizontal position.
- or
- Take the boom system down on the ground.

11.7 Disconnecting the electrical connections on the boom end section

Make sure that the following prerequisite is met:

- The main boom is placed on the ground or is safely held by the auxiliary crane.

NOTICE

Damage to cable drum or cable!

If the cable of the cable drum is not properly spooled up on the cable drum after unplugging the S-end section, then the cable drum or the cable can be significantly damaged.

- ▶ Spool the cable drum up after unplugging.
- ▶ Spool the cable drum up and secure it to prevent inadvertent spooling out.
- ▶ Disconnect the electrical connections and store the plugs and cables properly.

11.8 Disassembling the guy rods

Make sure that the following prerequisites are met:

- The boom is laying on the substructure on the ground.
- The guying is relieved.
- The auxiliary guying is removed (only if present).
- ▶ Luff the SA-frame **25** down until the guy rods **29** are placed in the transport receptacles of the intermediate sections.
- ▶ Secure guy rods **29** in the transport receptacles: Insert and secure the pin.
- ▶ Disconnect the guy rods **27** of the SA-frame **25** from the guy rods **29** of the intermediate sections.
- ▶ Pin and secure the SA-frame guy rods **27** with the brackets **28** on the S-pivot section **1** at point **P23**: Use pin **27.1** and locking pin **27.2**.

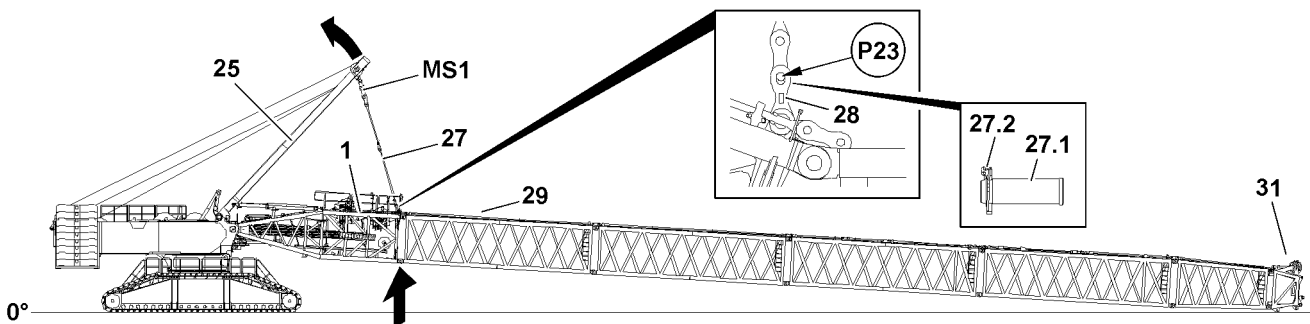

Fig.119143: Pinning the SA-frame guy rods on the S-pivot section



WARNING

The crane can topple over!

- ▶ Make sure that the end section of the boom system does **not** lift off the ground when tensioning the SA-frame guying.

When the SA-frame guy rods **27** are pinned with the brackets **28**:

- ▶ Luff the SA-frame **25** up until the SA-frame guy rods **27** are tensioned.

11.9 Opening the boom system

Make sure that the following prerequisites are met:

- The boom system is safely held by the SA-frame.
- No personnel or obstacles are within the danger zone.

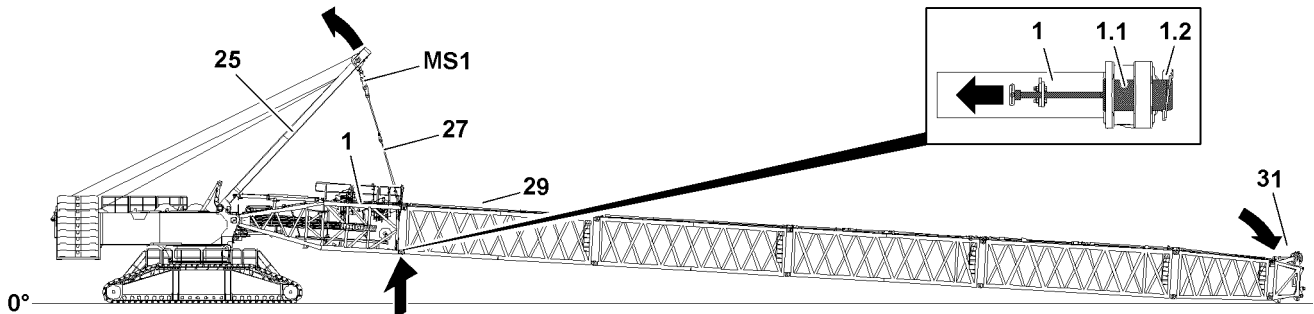

Fig.119142: Tensioning the SA-frame guying



WARNING

The crane can topple over!
Death, severe bodily injuries, property damage.

- ▶ Do **not** exceed the maximum permissible total force on test point 1 (MS1).
- ▶ Lifting and opening the respective boom is only permissible by observing the maximum permissible boom lengths and total forces.
- ▶ The end section may **not** lift off the ground during „opening procedure“ of the boom system.
- ▶ Make sure that there are no persons on the boom system as well as in the danger zone during the opening procedure.



Note

- ▶ The actual forces on test point 1 **MS1** - which are used during the opening - closing procedure of the boom system - are shown on LICCON monitor 1.
- ▶ Tension the guying on the test points at disassembly with the same forces as for assembly.
- ▶ For this, set the **ACTUAL** force at the test point 1 (MS1) measured and recorded during the assembly.
- ▶ The pins can be pulled easier and the pins and lugs are therefore not damaged.

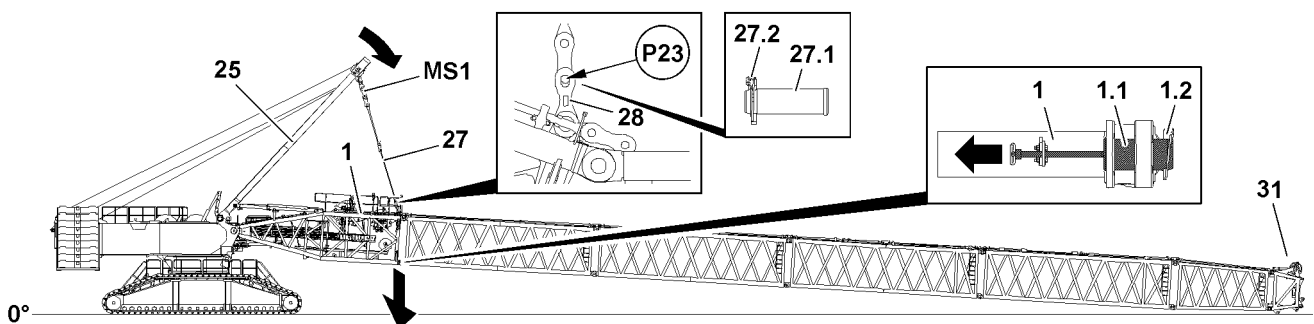

Fig.119144: Opening the boom system / lowering the SA-frame to the front

- ▶ Open the boom system: Unpin the connector pins **1.1** on both sides: Release and unpin the connector pins **1.1**.

NOTICE

Danger of property damage!

When lowering the boom system, crane components can be damaged.

- ▶ Make sure that the S-pivot section **1** is not lowered directly on the ground.
- ▶ Lower the S-pivot section **1** on the substructure when opening the boom system.

When the connector pins 1.1 are completely unpinned:

- ▶ Lower the boom system carefully on the substructure on the ground.

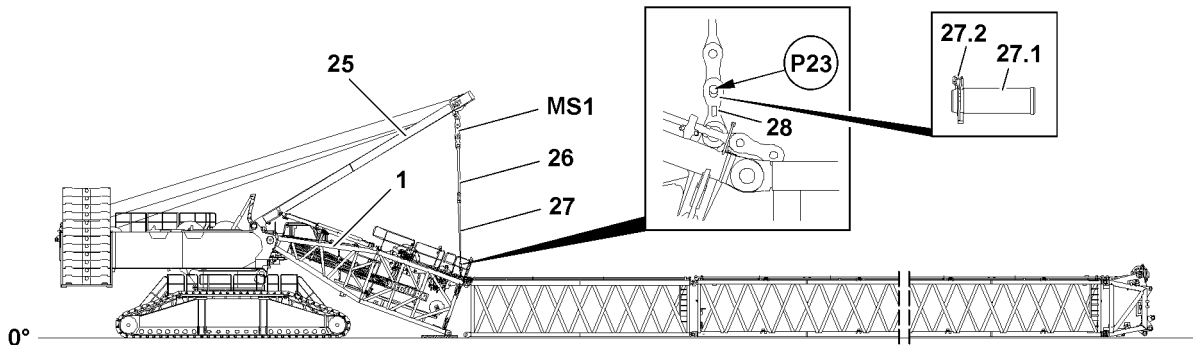

Fig.119113: Unpinning the SA-frame guying on the S-pivot section

When the S-pivot section is laying on the substructure on the ground:

- ▶ Unpin the guy rods 27 of the SA-frame 1 on the brackets 28: Release and unpin the pin 27.1.



Note

- ▶ Install and secure the guy rods which are not required and which have been removed at the assembly of the lattice section properly in the transport retainers of the lattice sections.
- ▶ Place the guy rods which are not required on the lattice sections, pin and secure.
- ▶ Disassemble the boom system properly.

11.10 Disassembling winch 5 (WV) on the S-pivot section



Note

- ▶ The disassembly of winch 5 is described in detail in the Crane operating instructions, chapter 3.07.50.

11.11 Disassembling winch 6 (WVI) on the S-pivot section



Note

- ▶ The disassembly of winch 6 is described in detail in the Crane operating instructions, chapter 3.07.60.

11.12 Disconnecting the electric and hydraulic connections on the S-pivot section

11.12.1 Disconnecting the electrical connections

Make sure that the following prerequisites are met:

- The boom system is opened.
- The S-pivot section is laying on the ground on the substructure.

NOTICE

Damage to cable drum or cable!

If the cable of the cable drum is not properly spooled up on the cable drum after unplugging the S-end section, then the cable drum or the cable can be significantly damaged.

- ▶ Spool the cable drum up after unplugging.
- ▶ Spool the cable drum up and secure it to prevent inadvertent spooling out.
- ▶ Disconnect the electrical connections and store the plugs and cables properly.

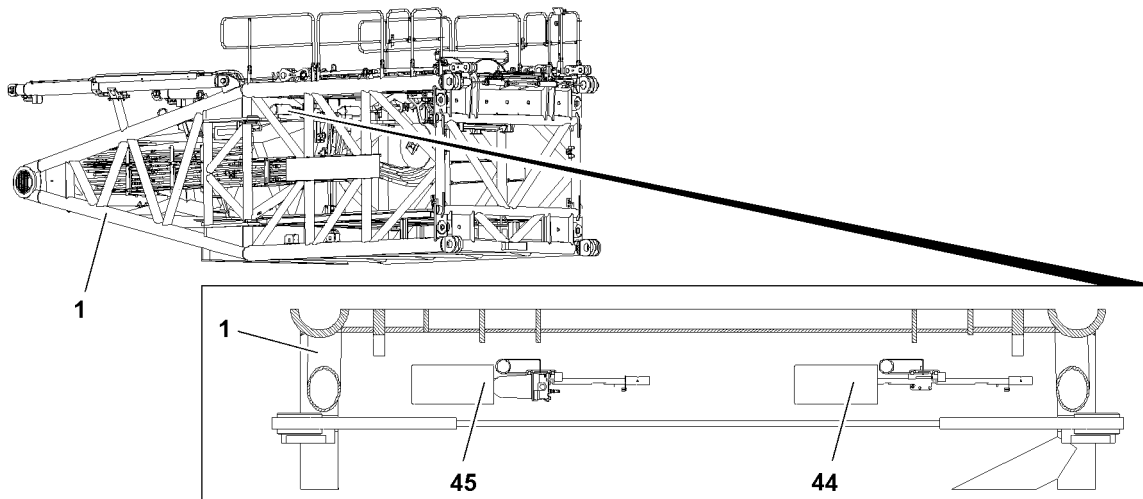

Fig.122057: Park position Wind speed sensor and airplane warning light

- ▶ Remove the wind speed sensor **44** and / or airplane warning light with wind speed sensor **45** on the boom end section and store it on the S-pivot section **1** properly in park position.

11.12.2 Disconnecting the hydraulic connections

When connecting and releasing hydraulic lines with quick couplings, make sure that the coupling procedure is carried out correctly.



DANGER

Danger of accident due to loss of pressure or leakage!

Incorrectly coupled or self-loosening quick couplings (particularly return lines) can result in serious accidents due to component failure.

Death, severe bodily injuries, property damage.

- ▶ Check that the quick couplings have been properly connected before using the crane.



Note

- ▶ To connect or release the hydraulic lines with quick couplings, see Crane operating instructions, chapter 5.01.

- ▶ Release the pressure in the hydraulic system before connecting or disconnecting. Turn the engine off and wait for short time.
- ▶ Assembling coupling components (sleeve and connector) by using knurled nut.
- ▶ Connect coupling components.

11.13 Disassembling the S-pivot section on the turntable



WARNING

General danger notes!

- ▶ Insert and secure all pins after disassembly in the intended transport receptacles.

Make sure that the following prerequisites are met:

- The hydraulic connections to the S-pivot section are properly disconnected.
- The hydraulic connections on the S-pivot sections are properly closed off with caps.
- The electrical connections to the S-pivot section are properly disconnected.
- The electrical connections are properly closed off with dummy plugs (see Electrical wiring diagram).
- The crane engine is running.
- An auxiliary crane with sufficient load bearing capacity if available.

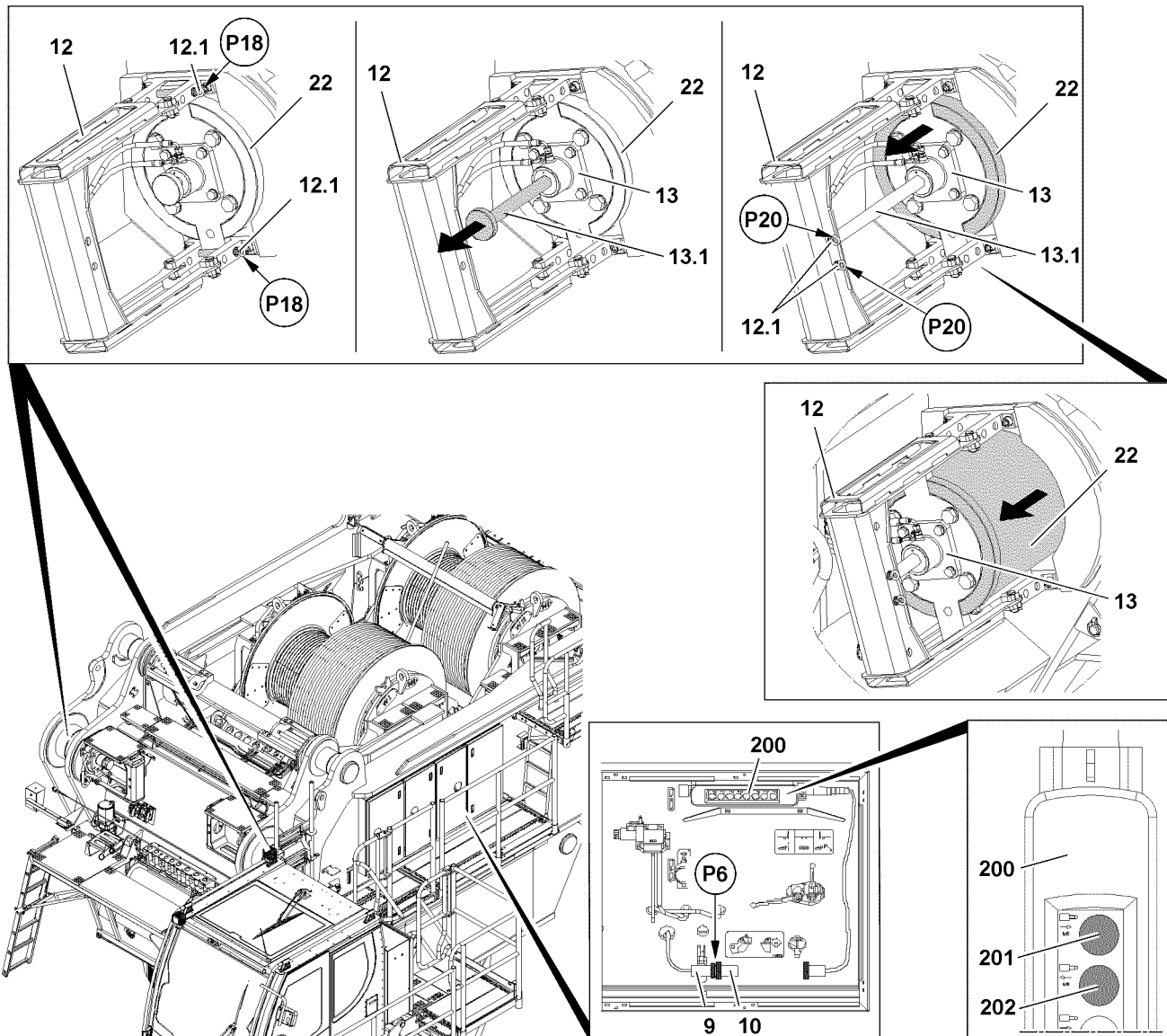

Fig.119111



Note

- ▶ Select the fastening points on the S-pivot section 1 in such a way that the S-pivot section 1 hangs horizontally on the auxiliary crane at disassembly. See section „Fastening points“.
- ▶ Attach the S-pivot section 1 properly on the auxiliary crane.

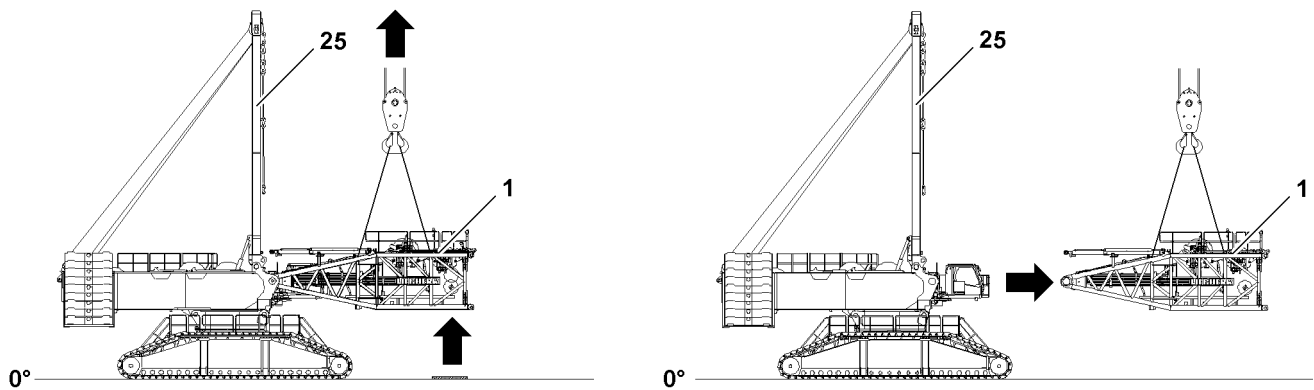

Fig.119145: Lifting the S-pivot section with the auxiliary crane horizontally / swinging the S-pivot section out from the turntable

- ▶ Lift the S-pivot section 1 with the auxiliary crane to the horizontal.



WARNING

Falling S-pivot section!
Death, severe bodily injuries, property damage.

- ▶ Make sure that the S-pivot section 1 is safely held by the auxiliary crane before unpinning the S-connector pins 22.



Note

- ▶ The unpinning of the S-pivot section 1 on the turntable is described in detail in section: „Unpinning the S-connector pins on the turntable“.

When the S-pivot section is horizontally aligned and safely held by the auxiliary crane:

- ▶ Unpin the S-connector pins 22 on the turntable.

NOTICE

Damage of the turntable and the S-pivot section 1!

- ▶ Slowly swing the S-pivot section 1 out with the auxiliary crane and at low speed on the turntable.
- ▶ Before placing it on the ground, support the S-pivot section 1.

When the S-connector pins 22 on the S-pivot section 1 are fully unpinned on both sides:

- ▶ Swing the S-pivot section 1 out on the turntable with the auxiliary crane and place it down.
- ▶ Remove the auxiliary crane.

When the S-pivot section 1 is removed on the turntable:

- ▶ Fully insert and secure the S-connector pins 22 again.

11.14 Swinging the railing on the S-pivot section into transport position



WARNING

Danger of falling!
Death, severe bodily injuries, property damage.

- ▶ Assembly personnel must secure themselves for the assembly / disassembly of the railings and protective devices with an approved fall arrest system to prevent them from falling.
- ▶ For assembly and disassembly work, maintenance and inspection work on the S-pivot section, all railings and protective devices must be properly assembled and secured.

Make sure that the following prerequisite is met:

- The ground is able to safely take on the weight of the S-pivot section.
- The S-pivot section is laying completely on the ground.

- ▶ For assembly / disassembly of railings and protective devices, see Crane operating instructions, chapter 2.06.

Empty page!

LWE/LR 11000-001/23501-04-02/en

5.39.10 LD/SLD/SD boom combination

1	Component overview LD/SLD/SD boom	3
2	Fastening points	3
3	Assembly SD/S2D/SL2D-boom	11
4	Installing the derrick ballast	30
5	Assembling the boom system in flying mode (guying on the flying assembly intermediate section)	30
6	Assembling the boom system in flying mode (guying on S-pivot section)	41
7	Assembling the boom combinations with substructure	50
8	Assembling the S-guy rods	52
9	Assembling the roller sets on the boom head	53
10	Performing the function checks	54
11	Erecting the boom	56
12	Operating the crane	59
13	Disassembly SD/S2D/SL2D-boom	63

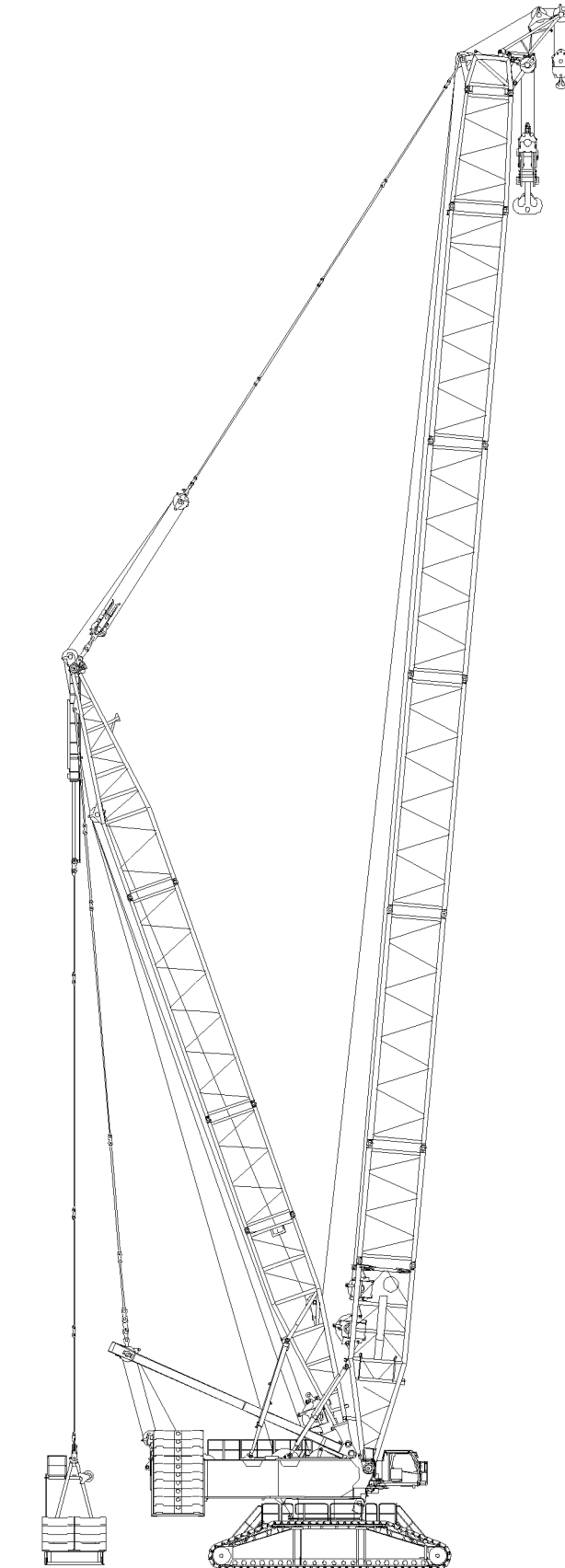

Fig.119146: SD/S2D/SL2D

LWE/LR 11000-001/23501-04-02/en

1 Component overview LD/SLD/SD boom



Note

- ▶ The boom components (boom - lattice sections) such as S/L-intermediate sections, S-Adapter, SL-reducer section and the S/L-end sections, as well as dimensions and weights are described in the Crane operating instructions, chapter 1.03.
- ▶ For the combination of the various boom systems, refer to the Rod plan and the Crane operating instructions, chapter 5.03.

2 Fastening points



WARNING

Falling lattice sections!

Death, severe bodily injuries, property damage.

- ▶ Make sure that the lattice sections are properly fastened on the respective fastening points.
- ▶ Make sure that the fastening equipment has the appropriate length and a sufficient load bearing capacity.
- ▶ Pay attention and adhere to the labels on the fastening points on the lattice sections and crane components.

2.1 Fastening points S-pivot section

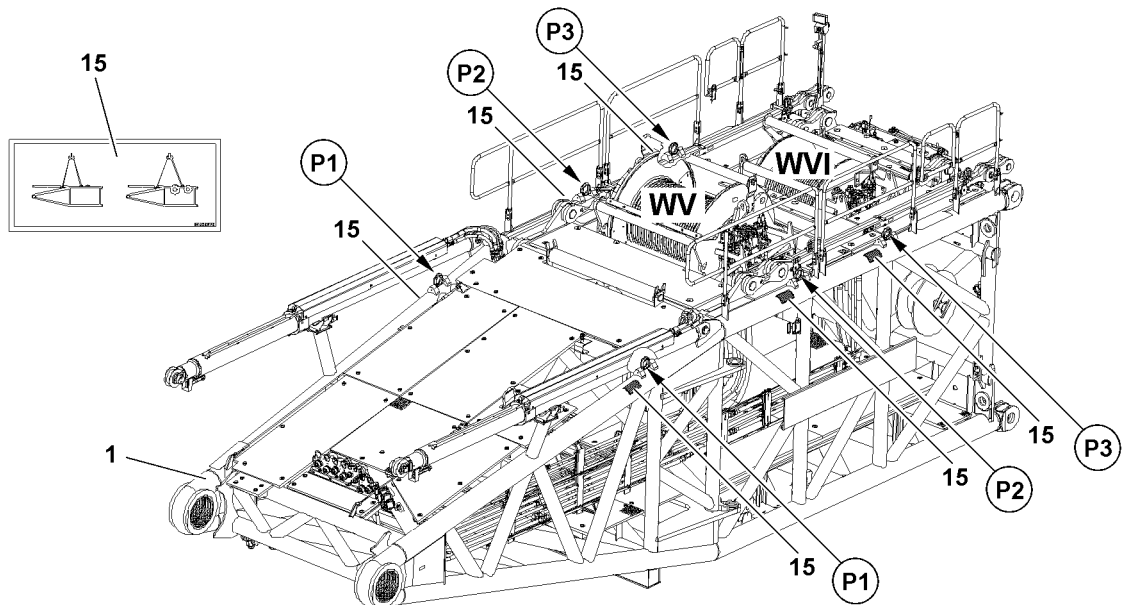

Fig.119100: Fastening points S-pivot section

Fastening points	
P1 + P2	S-pivot section without winch 5, without winch 6
P1 + P3	S-pivot section with winch 5, without winch 6
P1 + P3	S-pivot section without winch 5, with winch 6
P1 + P3	S-pivot section with winch 5, with winch 6

2.2 Fastening points S-intermediate sections 6 m

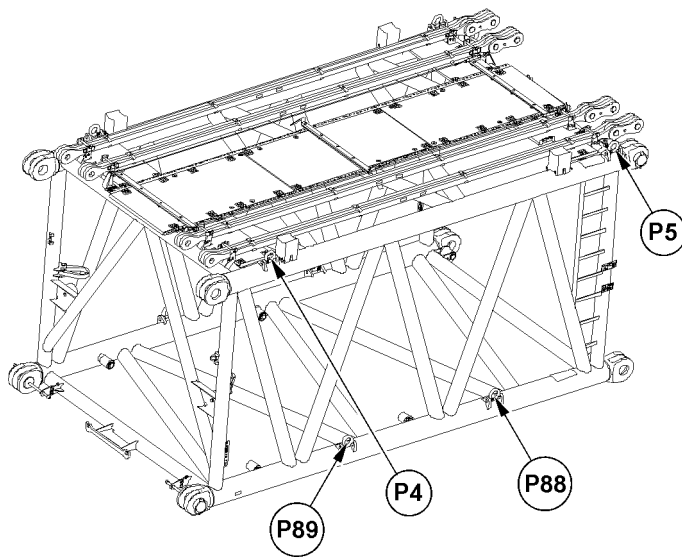

Fig.121930: Fastening points S-intermediate section 6 m



Note

- ▶ The S-intermediate sections are available in various system dimensions.
- ▶ The distance between the fastening pints can vary, depending on the respective S-intermediate section.
- ▶ The lattice section must be fastened on both sides on the fastening points.

Fastening points	
P4 + P5 or P88 + P89	S-intermediate section 6 m

2.3 Fastening points S-intermediate sections 12 m / S-adapter 12 m

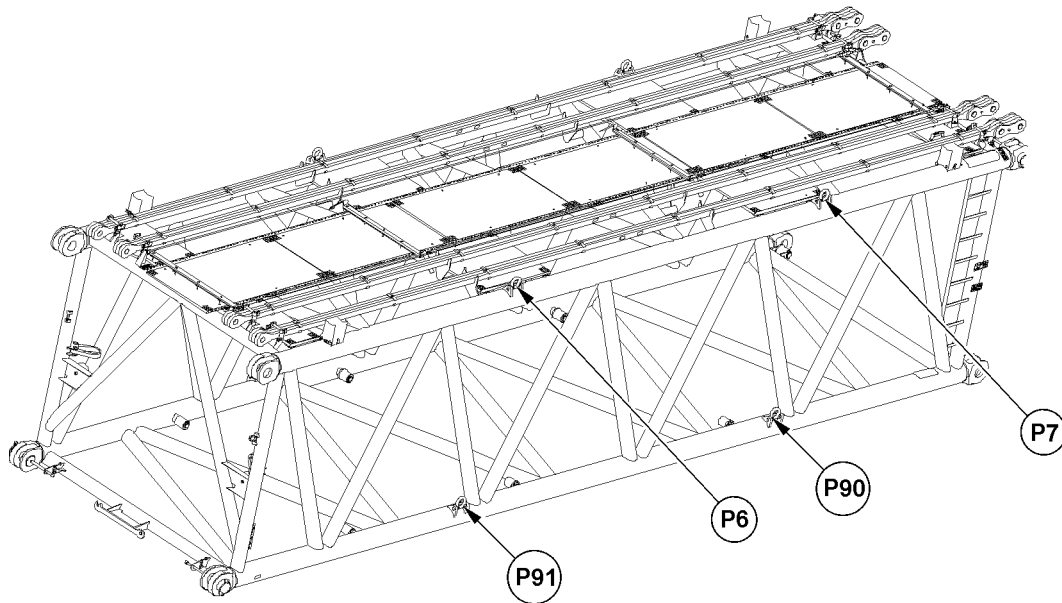

Fig.121931: Fastening points S-intermediate section 12 m / S-adapter 12 m



Note

- ▶ The S-intermediate sections are available in various system dimensions.
- ▶ The distance between the fastening pints can vary, depending on the respective S-intermediate section.
- ▶ The lattice section must be fastened on both sides on the fastening points.

Fastening points	
P6 + P7 or P90 + P91	Assembly S-intermediate section 12 m / S-adapter 12 m

2.4 Fastening points SL-reducer section 6 m

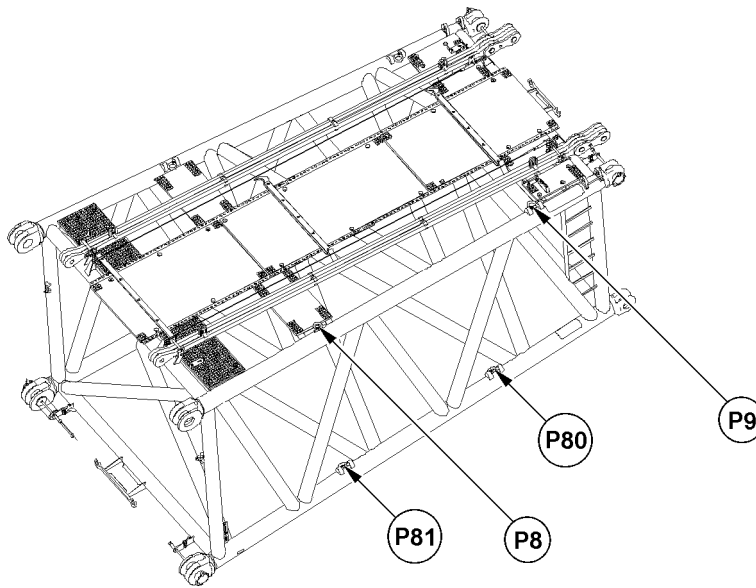

Fig.121932: Fastening points SL-reducer section 6 m



Note

► The lattice section must be fastened on both sides on the fastening points.

Fastening points	
P8 + P9 or P80 + P81	SL-reducer 6 m

2.5 Fastening points S-end section

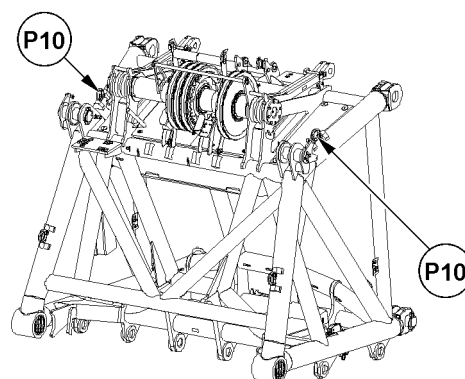

Fig.119104: Fastening points S-end section

Fastening points	
P10	Assembly S-end section

2.6 Fastening points L-end section

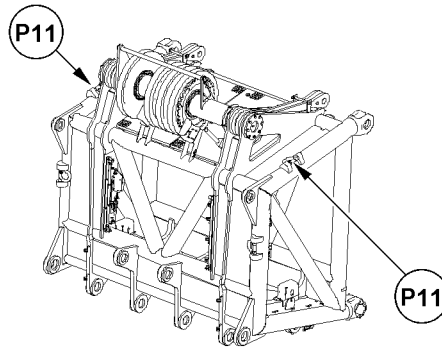

Fig.119105: Fastening points L-end section

Fastening points	
P11	Assembly L-end section

2.7 Fastening points L-intermediate sections 6 m

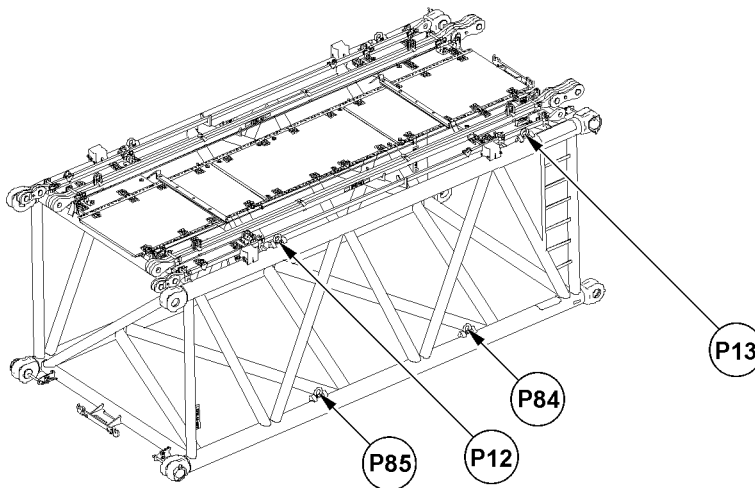

Fig.121933: Fastening points L-intermediate section 6 m



Note

- ▶ The L-intermediate sections are available in various system dimensions.
- ▶ The distance between the fastening points can vary, depending on the respective L-intermediate section.
- ▶ The lattice section must be fastened on both sides on the fastening points.

Fastening points	
P12 + P13 or P84 + P85	L-intermediate section 6 m

LWE/LR 11000-001/23501-04-02/en

2.8 Fastening points L-intermediate sections 12 m

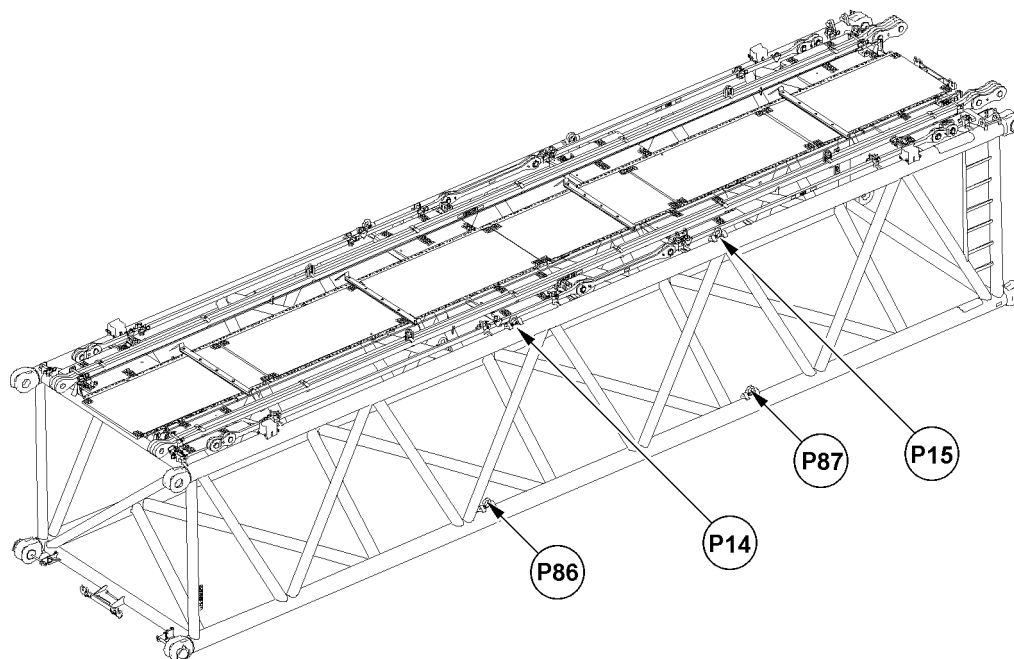

Fig.121934: Fastening points L-intermediate section 12 m



Note

- ▶ The L-intermediate sections are available in various system dimensions.
- ▶ The distance between the fastening points can vary, depending on the respective L-intermediate section.
- ▶ The lattice section must be fastened on both sides on the fastening points.

Fastening points	
P14 + P15 or P86 + P87	Assembly L-intermediate section 12 m

Empty page!

LWE/LR 11000-001/23501-04-02/en

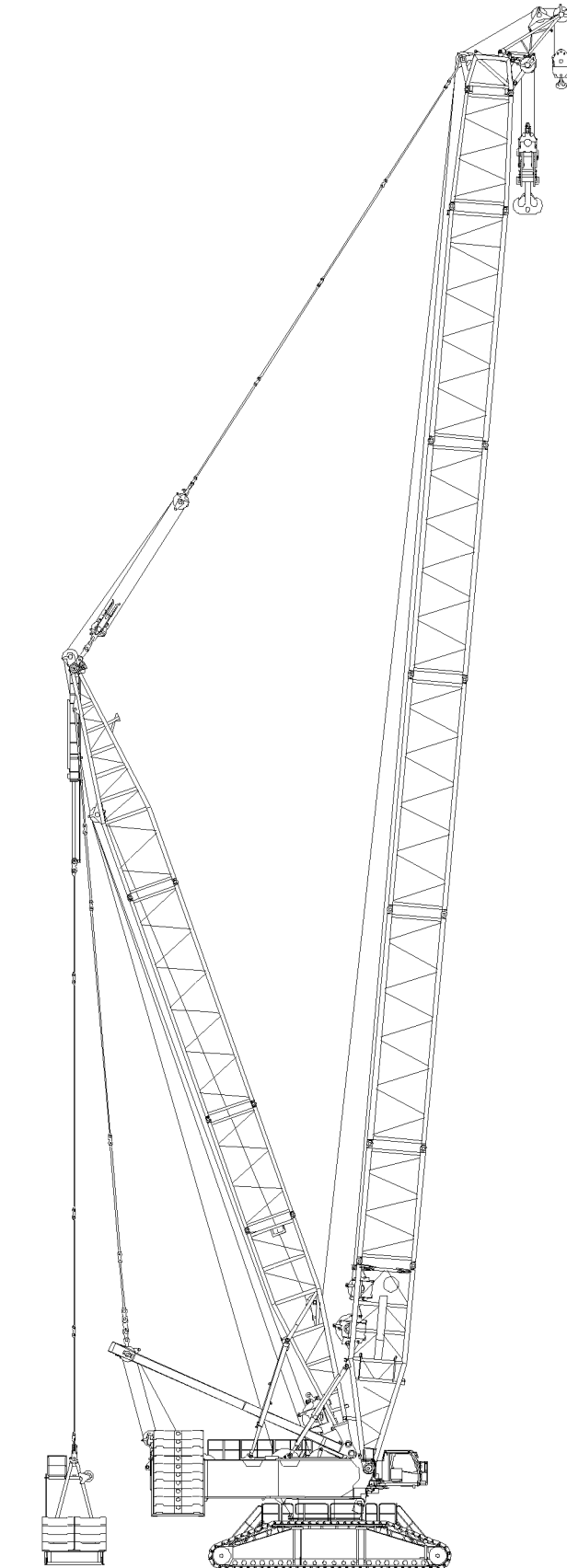

Fig.119146: SD/S2D/SL2D

LWE/LR 11000-001/23501-04-02/en

3 Assembly SD/S2D/SL2D-boom



Note

- ▶ The assembly is described on the example of the S-boom.
- ▶ For the combination of the boom lattice sections, observe and adhere to the Rod plan and the Crane operating instructions, chapter 5.03.



WARNING

Danger of falling!

During assembly / disassembly, inspection and maintenance work, assembly personnel must be secured with appropriate aids to prevent them from falling.

Death, severe bodily injuries, property damage.

- ▶ All work at a height, when there is a danger of falling, must be carried out with suitable aids.
- ▶ If aids are not available and work cannot be carried out from the ground, then assembly personnel must secure themselves with the supplied fall arrest system to prevent falling, see the Crane operating instructions, chapter 2.04.
- ▶ If fall protection equipment is available, then it must be used, see the Crane operating instructions, chapter 2.06.
- ▶ When lifting, lowering, swinging crane parts in and out, no persons may remain in the danger zone.
- ▶ When closing or opening boom systems during boom assembly or boom disassembly, no persons may remain on the boom system or in the danger zone.
- ▶ If railings are present on the components, then they must be brought into the corresponding position and secured for assembly / disassembly work.
- ▶ Only step on the aids, ladders and catwalks with clean shoes.
- ▶ Keep aids, ladders and catwalks free of heavy dirt, snow and ice.
- ▶ During all assembly and disassembly work, maintenance work and inspections, travel or crane operation is prohibited.
- ▶ Remaining on a suspended load is prohibited.
- ▶ Stepping or walking on crane components and lattice sections, which have an incline of more than 20° is prohibited.
- ▶ For all assembly work, the crane driver of the main crane must be in voice contact with the crane driver / crane drivers of the auxiliary crane / auxiliary cranes.
- ▶ For assembly tasks, the crane driver may only initiate crane movements when the responsible guide has explicitly released the movement.



WARNING

The lattice sections can fall down!

If the lattice sections are not pinned and secured correctly, then they can fall down.

Death, severe bodily injuries, property damage.

- ▶ Pin or unpin both pins at the same horizontal level, i.e. **left and right**.
- ▶ Do not stand under the lattice sections or within the entire danger zone during the pinning and unpinning procedure of the boom.
- ▶ Safely secure the pins in the storage locations as well as in the receptacles.
- ▶ It is prohibited to lean the auxiliary ladder against the component being disassembled.



WARNING

Danger of impact / crushing!

When installing / removing crane components with the auxiliary crane, crane components can start to swing back and forth.

When lifting / lowering and positioning crane components, there is an increased danger of impacts / crushing.

Death, severe bodily injuries, property damage.

- ▶ Make sure that personnel cannot be caught by components.
- ▶ Make sure that the crane is horizontally aligned.
- ▶ When working in danger zones: Use aids to protect limbs.
- ▶ Guide components with suitable aids to minimize oscillation.

**DANGER**

The components can fall down!

If the corresponding component is disengaged from the auxiliary crane before the corresponding component is pinned, then the corresponding component can fall down.

Death, severe bodily injuries, property damage.

- ▶ Do not disengage the auxiliary crane until the respective component is pinned and secured.

Make sure that the following prerequisites are met:

- The ground is able to safely take on the entire operating weight of the crane including the load to be lifted.
- The crane is horizontally aligned.
- The SA-frame properly installed and secured on the turntable.
- Winch 1 and winch 2 are properly installed and secured on the turntable.
- The D-boom is properly assembled and secured.
- The D-boom is erected to 85°.
- An auxiliary crane with sufficient load bearing capacity if available.
- An assembly scaffolding or a work platform is available.
- The central ballast has been installed on the crawler travel gear according to the load chart or the erection and take down charts.
- The counterweight has been installed on the turntable according to the load chart or the erection and take down charts.
- The LICCON overload protection has been set according to the data in the load chart.

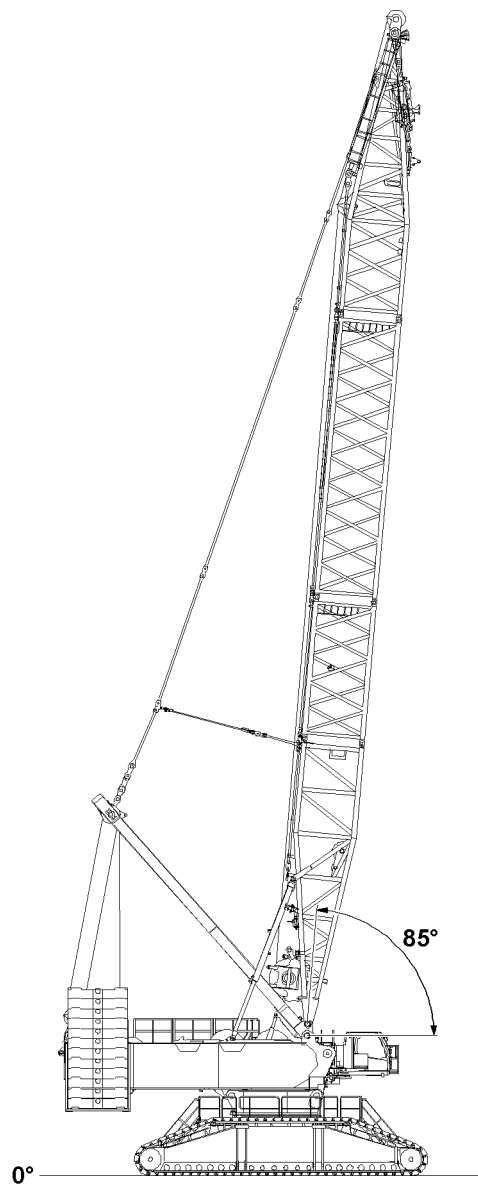

Fig.119147: Derrick boom in assembly position (85°) for S-pivot section

3.1 Turning the turntable into the assembly position



WARNING

The crane can topple over!

If the following conditions are not met before turning the turntable - **without** assembled S-boom, the crane can topple over.

Death, severe bodily injuries, property damage.

- ▶ Observe the assembly conditions, see the Crane operating instructions, chapter 3.06.
- ▶ Observe the specifications in the erection and take-down charts.
- ▶ Observe the specifications in the load charts.

- ▶ Turn the turntable in lengthwise direction of the crawler travel gear.

3.2 Swinging the railing on the S-pivot section into operating position



WARNING

Danger of falling!

Death, severe bodily injuries, property damage.

- ▶ Assembly personnel must secure themselves for the assembly / disassembly of the railings and protective devices with an approved fall arrest system to prevent them from falling.
- ▶ For assembly and disassembly work, maintenance and inspection work on the S-pivot section, all railings and protective devices must be properly assembled and secured.

Make sure that the following prerequisites are met:

- The ground is able to safely take on the weight of the S-pivot section.
- The S-pivot section is laying completely on the ground.
- ▶ For assembly / disassembly of railings and protective devices, see Crane operating instructions, chapter 2.06.

3.3 Exceeding the shut off limits of the LICCON overload protection for assembly operation

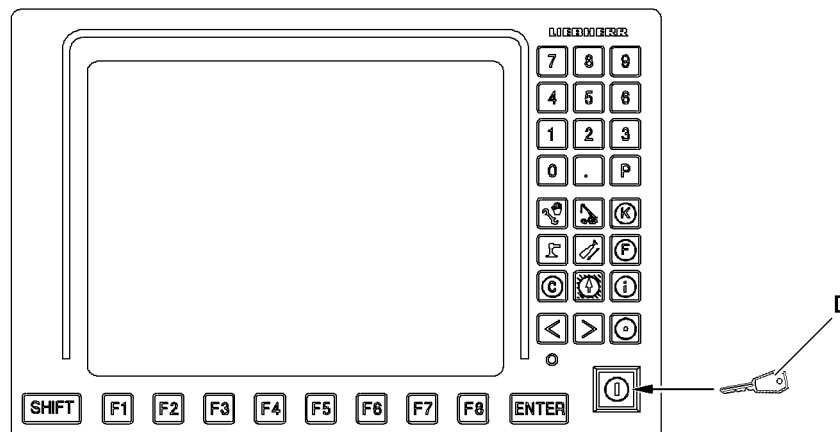

Fig.119109: LICCON monitor with assembly icon

**WARNING**

Danger of accident due to function „Exceedance of shut-off limits of the LICCON overload protection“! If the shut off limits of the LICCON overload protection are exceeded, there is no additional protection against crane overload.

Due to erroneous operation or deliberate misuse, the crane could collapse, the boom can break off or the crane can topple over.

Death, severe bodily injuries, property damage.

- ▶ The function „Exceedance of shut off limits of the LICCON overload protection“ is only permissible in emergencies and for assembly purposes.
- ▶ The function „Exceeding the shut off limits of the LICCON overload protection“ may only be actuated by persons who know the effects of their actions regarding the function „Exceeding the shut off limits of the LICCON overload protection“.
- ▶ The function „Exceedance of shut off limits of the LICCON overload protection“ requires the presence of an authorized person and must be performed with utmost caution.
- ▶ Crane operation with activated function „Exceedance of shut off limits of the LICCON overload protection“ is prohibited.

- ▶ Exceeding the shut off limits of the LICCON overload protection: Engage assembly operation.

Result:

- The shut off limits of the LICCON overload protection are exceeded.
- The assembly icon appears on the LICCON monitor.

**Note**

- ▶ See the Crane operating instructions, chapter 4.02 and chapter 4.20.

3.4 Unpinning the S-connector pins on the turntable

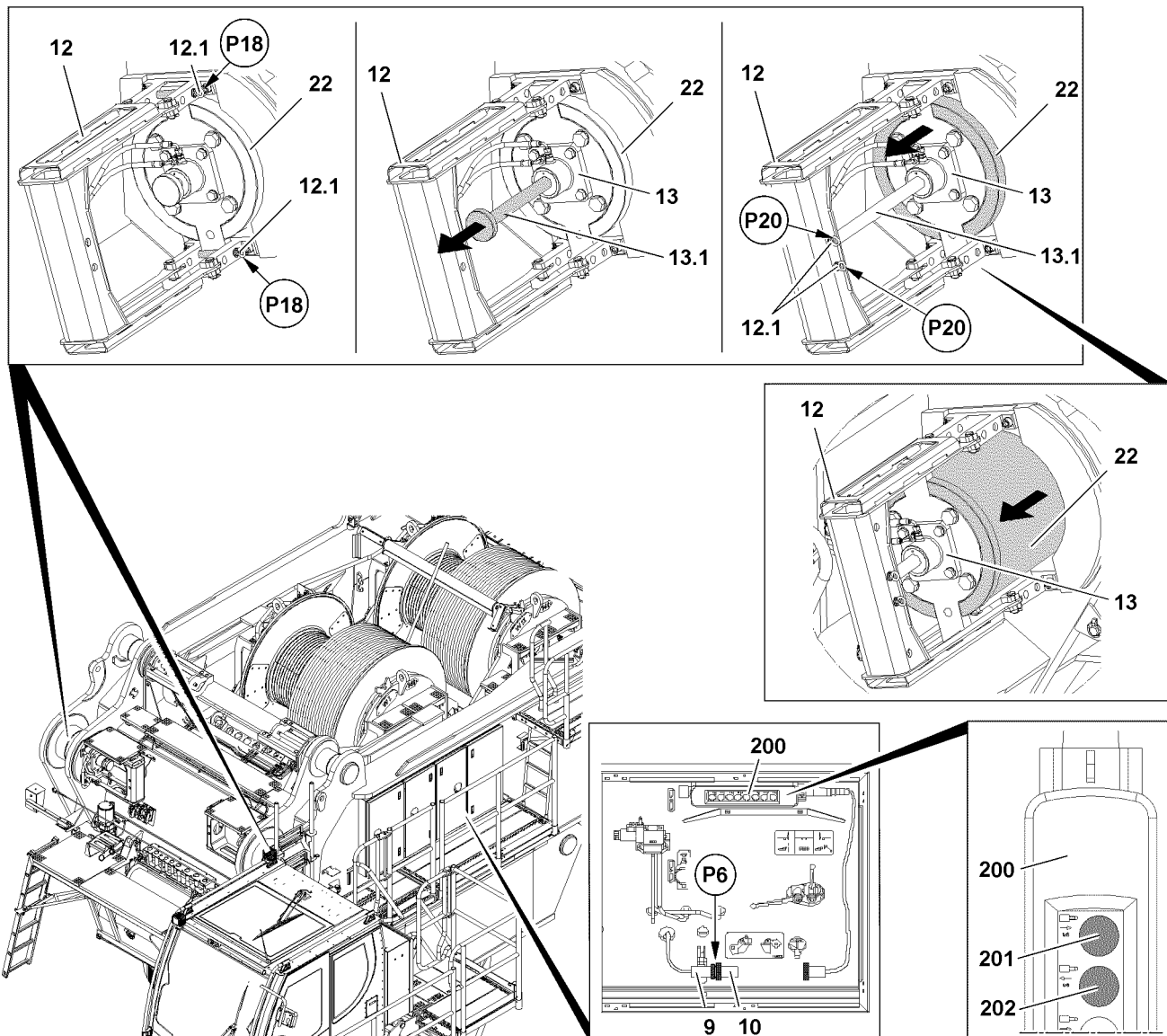

Fig.119111: Unpinning the connector pins 22 on the turntable



Note

- ▶ The pin pulling cylinders 13 are integrated on this crane in the S-connector pins 22.
- ▶ Unpinning and pinning of the S-connector pins 22 can be done only in connection with the pin pulling device installed on the crane.

Make sure that the following prerequisites are met:

- The derrick boom is properly pinned and secured to the turntable.
- The derrick boom is erected to 85°.
- The pin pulling devices 12 are installed on the pin points.
- The crane engine is running.

3.4.1 Unpinning the S-connector pins

In transport condition, the S-connector pins 22 are pinned on the turntable and secured with the retaining pins 12.1.

**WARNING**

Danger of crushing!

When unpinning or pinning the S-connector pins **22**, there is a danger of crushing. Limbs can be crushed or severed.

- ▶ During the unpinning or pinning procedure, make sure that no persons are within the danger zone.
 - ▶ Do not reach into the danger zone of the pin pulling device and the connector pins.
-
- ▶ Release and unpin the retaining pins **12.1** on the points **P18** of the pin pulling device.
 - ▶ Connect the control panel **200** at point **P6**.
 - ▶ Extend the piston rod **13.1** of the pin pulling cylinder: Press the button **201** on the control panel **200** until the piston rods **13.1** are completely moved out on the pin pulling cylinders **13**.

When the piston rods **13.1** for the pin pulling cylinders are completely extended on both sides:

- ▶ Insert the retaining pin **12.1** on both sides at point **P20** and secure.

Result:

- The piston rods **13.1** of the pin pulling cylinders **13** are locked with the pressure / pull plate in the pin pulling device.
- ▶ Press the button **202** on the control panel **200** until the S-connector pins **22** are completely unpinned.

3.5 Assembling the S-pivot section on the turntable

NOTICE

Danger of property damage!

When swinging the S-pivot section in to the pin points on the turntable, the S-connector pins **22** or the S-pivot section can be damaged.

- ▶ Make sure that the S-connector pins **22** are completely unpinned before assembly of the S-pivot section.

**Note**

- ▶ Assemble the boom combinations according to the supplied Rod plans.

**WARNING**

The crane can topple over!

If the specifications listed below are not observed, the crane can collapse, the boom can break off or the crane can topple over.

Death, severe bodily injuries, property damage.

- ▶ The instructions in the Crane operating instructions, chapter 5.01 and chapter 5.03 must be observed and adhered to.
- ▶ All pins are to be secured after assembly with the intended retaining elements.
- ▶ The guy rods must be inspected regularly, see the Crane operating instructions, chapter 8.15.

Make sure that the following prerequisites are met:

- The S-connector pins **22** are completely unpinned.
- The crane engine is running.

**Note**

- ▶ Select the fastening points on the S-pivot section **1** in such a way that the S-pivot section **1** hangs horizontally on the auxiliary crane at assembly. See section „Fastening points“.
- ▶ Fasten the S-pivot section **1** to the auxiliary crane.

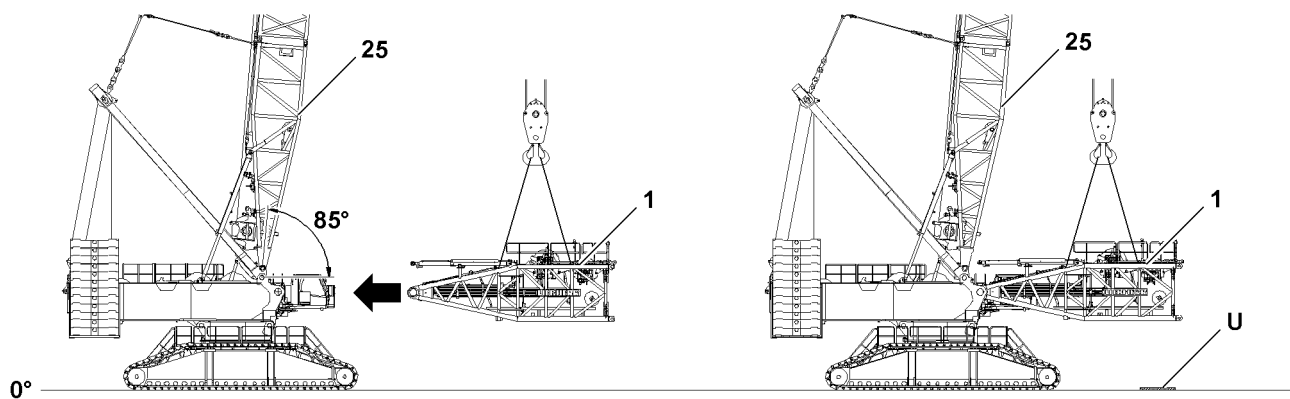

Fig.119148: Swinging the S-pivot section in with the auxiliary crane on the turntable and pin

- ▶ Swing the S-pivot section 1 in with the auxiliary crane to the pin points on the turntable.



DANGER

Falling S-pivot section!

Death, severe bodily injuries, property damage.

- ▶ Secure the S-connector pins 22 between the S-pivot section 1 and the turntable after the pinning procedure immediately with the retaining pins 12.1.

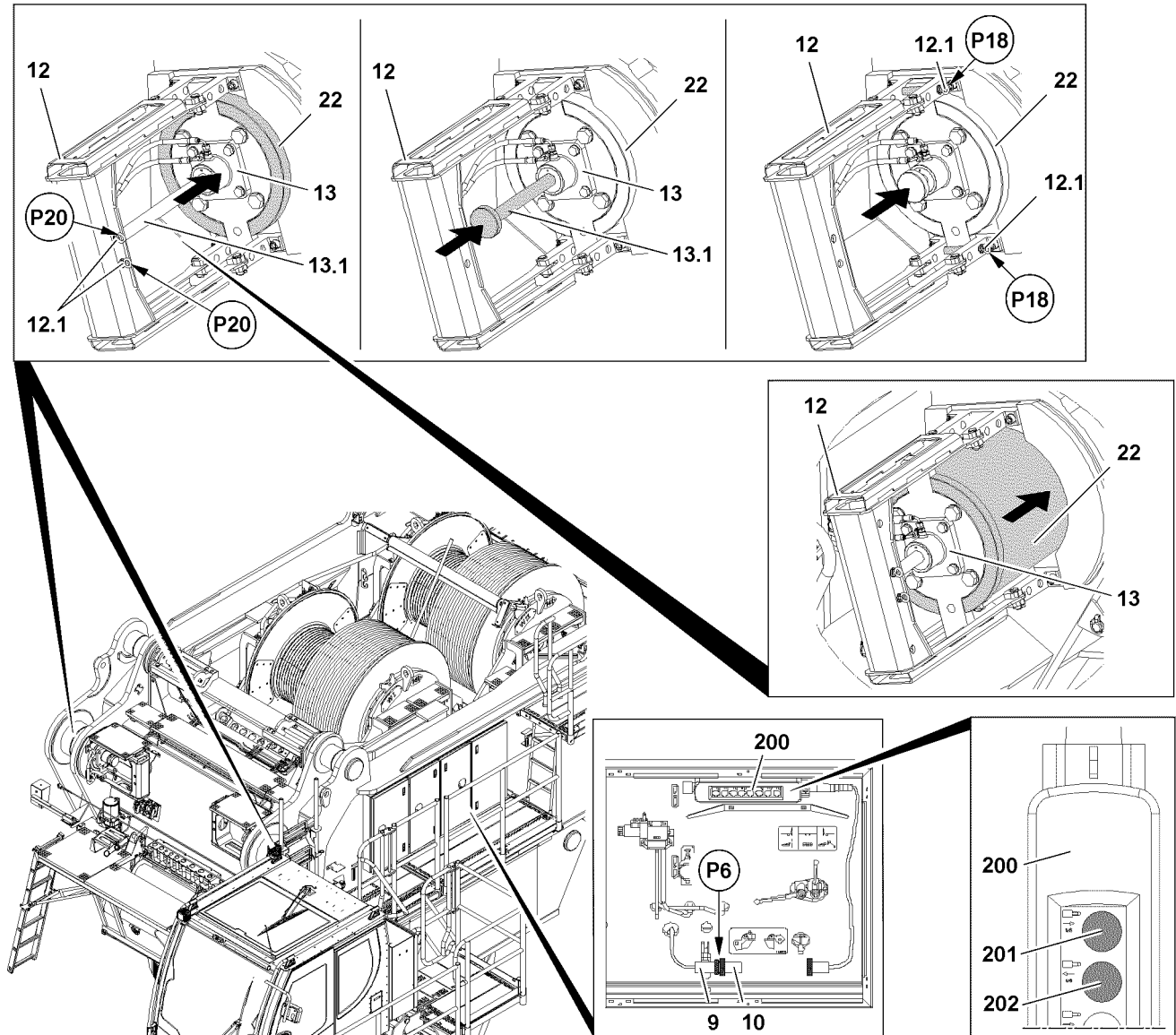

Fig.119115: Pinning the S-pivot section on the turntable / insert connector pin 22

When the S-pivot section is positioned in pin position:

- ▶ Insert the S-connector pins 22 on both sides with the pin pulling cylinder 13: Press the button 201 on the control panel 200 until the S-connector pins 22 are completely pinned on both sides.

When the S-connector pins 22 are completely pinned on both sides:

- ▶ Secure the S-connector pins 22: Unpin the retaining pins 12.1 on the pin pulling device 12 on points P20 and insert on points P18 and secure.

Result:

- The S-pivot section 1 is pinned and secured on the turntable.
- ▶ Retract the piston rods 13.1 of the pin pulling cylinders 13: Press the button 202 on the control panel 200 until the piston rods are completely retracted on both sides.

NOTICE

Danger of property damage!

When taking down the assembled S-pivot section, the S-pivot section or the turntable can be damaged.

- ▶ Lower the S-pivot section 1 after assembly on the turntable carefully on the substructure U on the ground.

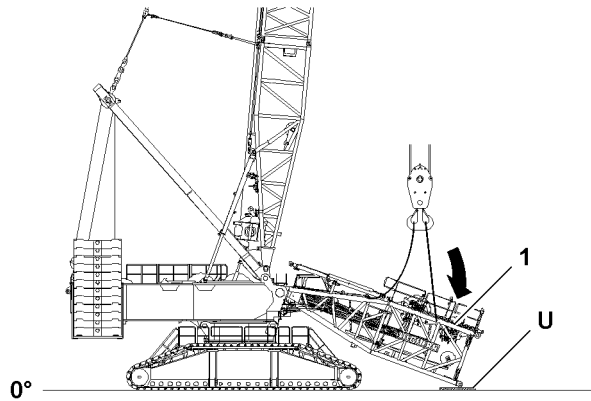

Fig.119149: Placing the S-pivot section with the auxiliary crane on the substructure on the ground

- ▶ Lower the S-pivot section **1** carefully and at slow speed on the substructure **U** on the ground.

When the S-pivot section **1** is placed on the substructure on the ground:

- ▶ Remove the auxiliary crane.

3.6 Establishing the electric and hydraulic connections on the S-pivot section

3.6.1 Establishing the electrical connections

NOTICE

Danger of damage to the electrical connections!

If the electrical connection between the terminal box and the S-pivot section and the cable drum in the S-pivot section is established before the boom end section is installed and electrically connected, then the electric connection can be damaged.

- ▶ Make sure that the electric connection between the terminal box in the S-pivot section and the cable drum in the S-pivot section is only established **after** assembly and the connection of the electric wiring for the boom end section.



Note

- ▶ To establish the electrical connections on the S-pivot section: Use the Electrical wiring diagram.

Make sure that the following prerequisites are met:

- The S-pivot section is completely assembled and placed on the substructure.

- ▶ Establish the electrical connections.
- ▶ Make sure that all electrical connections to the S-pivot section have been established.



WARNING

Malfunction if dummy plugs are not installed!

If the dummy plugs on the non-required electrical connections are not installed, then malfunctions or functional limitations can occur on the crane.

- ▶ Make sure that all non-required electrical connections that have a dummy plug are closed off with dummy plugs.
- ▶ Pay attention to the Electrical wiring diagram.
- ▶ As a rule, close off on-required electrical connections (for example for accessories which cannot be installed) with the respective dummy plugs.

NOTICE

Property damage due to dirt and / or corrosion!

If non-required electrical connections are not closed off with the respective protective caps, then dirt and / or corrosion can damage the electrical connections.

This could result in malfunctions.

- ▶ Make sure that all non-required electrical connections are always closed off properly.
- ▶ Pay attention to the Electrical wiring diagram.

- ▶ Close electrical connections, which have no dummy plugs, properly off with the corresponding protective caps.

3.6.2 Establishing the hydraulic connections

When connecting and releasing hydraulic lines with quick couplings, make sure that the coupling procedure is carried out correctly.

**DANGER**

Danger of accident due to loss of pressure or leakage!

Incorrectly coupled or self-loosening quick couplings (particularly return lines) can result in serious accidents due to component failure.

- ▶ Check that the quick couplings have been properly connected before using the crane.

**Note**

- ▶ To connect or release the hydraulic lines with quick couplings, see Crane operating instructions, chapter 5.01.

- ▶ Release the pressure in the hydraulic system before connecting or disconnecting. Turn the engine off and wait for short time.
- ▶ Assembling coupling components (sleeve and connector) by using knurled nut.
- ▶ Connect coupling components.

3.7 Assembly of winch 5 (WV) on the S-pivot section**Note**

- ▶ The assembly of winch 5 is described in detail in the Crane operating instructions, chapter 3.07.50.

3.8 Assembly of winch 6 (WVI) on the S-pivot section**Note**

- ▶ The assembly of winch 6 is described in detail in the Crane operating instructions, chapter 3.07.60.

3.9 Assembling the boom system on the ground**Note**

- ▶ Liebherr-Werk Ehingen GmbH recommends supporting the intermediate sections for assembly with assembly shoes, see the Crane operating instructions, chapter 5.62.

3.9.1 Assembling the S-intermediate section on the S-pivot section

Make sure that the following prerequisites are met:

- The S-pivot section **1** is properly pinned and secured on the turntable.
- The S-pivot section **1** is placed properly on the substructure on the ground.
- Winch **5 WV** is properly installed on the S-pivot section **1** (if only winch **5 WV** is required for the upcoming crane operation).
- Winch **6 WVI** is properly installed on the S-pivot section **1** (if only winch **6 WV** is required for the upcoming crane operation).
- The connector pins **1.1** on the S-pivot section **1** are fully unpinned.



Note

- ▶ The S-intermediate sections **2** are pinned with the pin pulling cylinders, see Crane operating instructions, chapter 5.30.



WARNING

General danger notes!

- ▶ All connector pins **1.1** are to be secured after assembly with the intended locking pins **1.2**.



Note

- ▶ For fastening of boom sections, observe and adhere to section „Fastening points“.

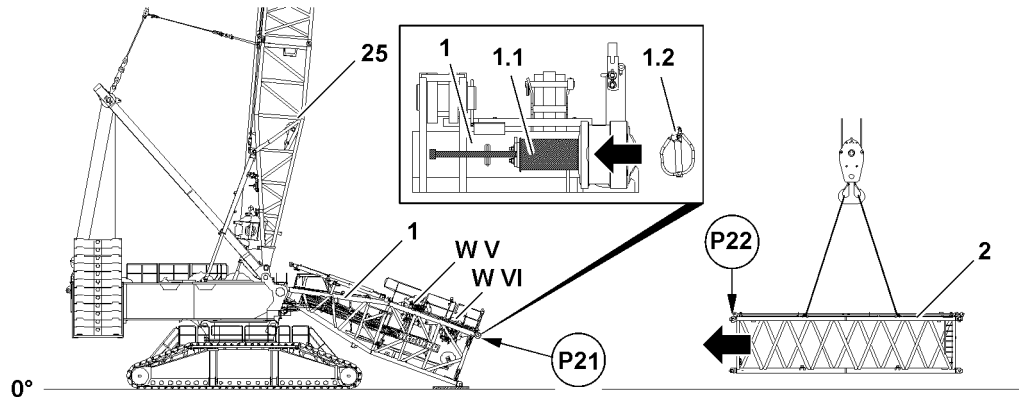

Fig.119150: Positioning the S-intermediate section on the S-pivot section

- ▶ Fasten the first S-intermediate section **2** to the auxiliary crane and align on the S-pivot section **1**.

When the pin bores on the S-pivot section **1** (point **P21**) and on the S-intermediate section **2** „on top“ (point **P22**) align.

- ▶ Insert the connector pins **1.1** with the pin pulling cylinders on both sides to the stop.

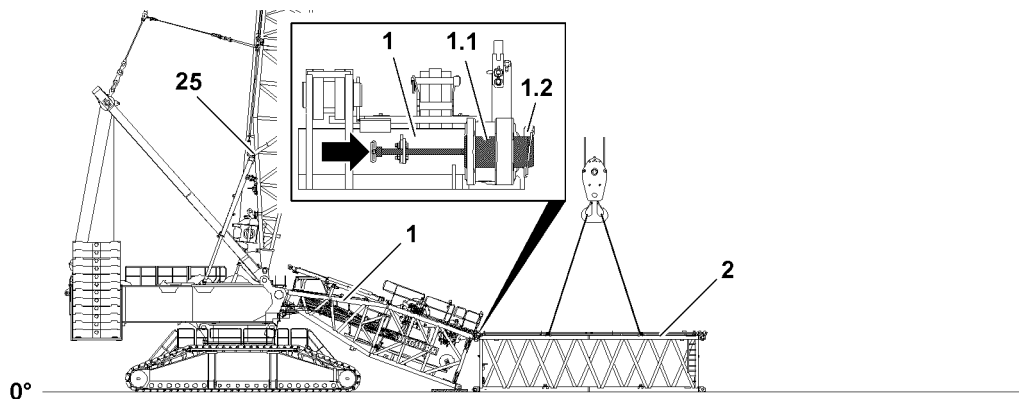

Fig.119421: Pinning the S-intermediate section on the S-pivot section

- ▶ Secure the connector pin **1.1** with the locking pin **1.2**.

When the first S-intermediate section **2** is pinned and secured on the S-pivot section **1** „on top“:

- ▶ Lower the S-intermediate section **2** on the substructure on the ground.
- ▶ Remove the auxiliary crane.

3.9.2 Continuing boom assembly

Make sure that the following prerequisites are met:

- The connector pins on the S-intermediate sections **2** - in direction of the expansion of the boom system - are completely unpinned.
- The first S-intermediate section **2** is laying properly on the ground or on the substructure.

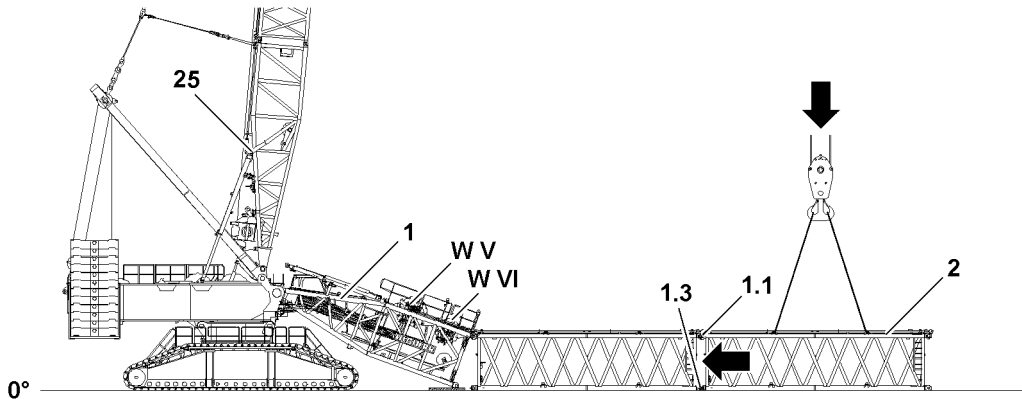

Fig.119443



WARNING

The crane can topple over!

Death, severe bodily injuries, property damage.

- ▶ The combination of the various boom systems must be taken from the Rod plan and it must be adhered to.
- ▶ The instructions in the Crane operating instructions, chapter 5.01 and chapter 5.03 must be observed and adhered to.
- ▶ Make sure that all pin connections are secured after assembly.
- ▶ Support the boom during assembly and disassembly with assembly shoes.

When the connector pins **1.1** on the first S-intermediate section **2** are fully unpinned:

- ▶ Fasten the second S-intermediate section **2** to the auxiliary crane and swing in to the pin points on the first S-intermediate section **2**.

When the pin bores between the first and the second S-intermediate section **2** align „on top“ and „on the bottom“:

- ▶ Insert the connector pins **1.1** „on top“ with the pin pulling cylinders on both sides to the stop and secure.

When the connector pins **1.1** „on top“ are fully pinned to the stop and secured on both sides:

- ▶ Insert the connector pins **1.3** „on the bottom“ with the pin pulling cylinders on both sides to the stop and secure.
- ▶ Continue boom assembly to the required system length.

3.9.3 Assembling the S-end section / L-end section



Note

- ▶ The following description is an example and will be described by means of the L-end section.
- ▶ The process for the S-end section is identical.

Lifting the end section from the flatbed trailer

Make sure that the following prerequisites are met:

- The transport retainers are removed on the respective end section.
- No roller sets are installed on the end section.
- The ground is able to safely take on the weight of the respective end section.



WARNING

Danger of falling!

Death, severe bodily injuries, property damage.

- ▶ To fasten the end sections, use an assembly platform.

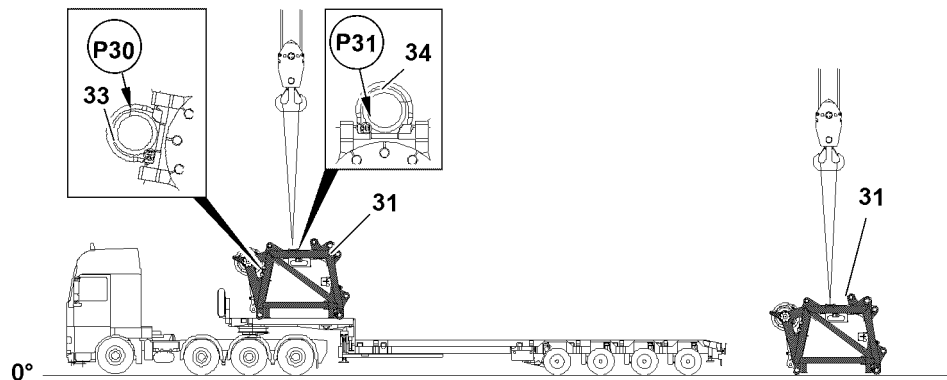

Fig.119112: Lifting the end section from the flatbed trailer

- ▶ Fasten the end section 31 on both sides on the eyes 34 of the fastening points P31 on the auxiliary crane.

When the end section is properly fastened on the auxiliary crane:

- ▶ Carefully lift the end section with the auxiliary crane from the transport vehicle and remove the transport vehicle.
- ▶ Lower the end section to the ground.

Turning the end section into assembly position

The end section must be turned before assembly on the boom with two auxiliary cranes from the transport position into the assembly position.

Make sure that the following prerequisite is met:

- **No** roller sets are installed on the end section.
- The ground on which the end section is placed is sufficiently load bearing.

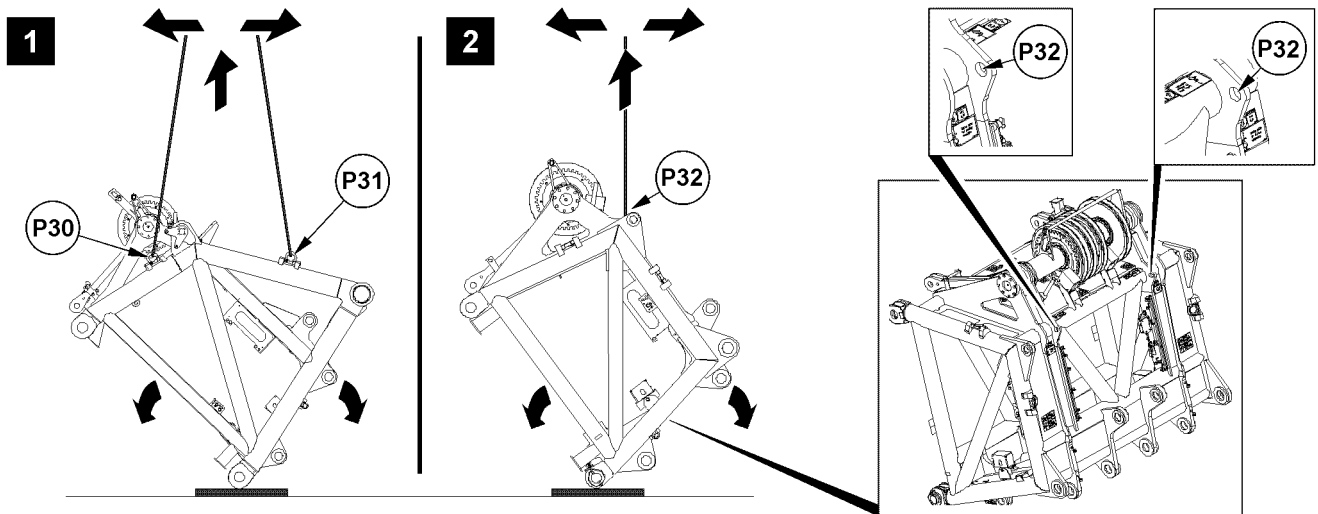

Fig.122035: Turning the end sections

Illustration 1: S-end section

Illustration 2: L-end section

- ▶ Fasten the end section on the respective fastening points on both sides.

NOTICE

Danger of property damage!

- ▶ To avoid damage to the end sections: Make sure that the end sections are supported for the turning procedure.



WARNING

Tipping end section!

Death, severe bodily injuries, property damage.

- ▶ Make sure that there are no persons within the danger zone.
- ▶ Make sure that solely fastening equipment with the corresponding load bearing capacity is used.
- ▶ Select the fastening points to turn the end sections according to the signs on the end sections.

When the end section is properly fastened on the auxiliary crane:

- ▶ Lift the end section with the auxiliary crane and turn into assembly position.

When the end section is turned in assembly position:

- ▶ Carefully and at slow speed at the end section on the ground.

When the end section is seated completely on the ground:

- ▶ Remove the auxiliary crane.

Assembling the end section on the boom



Note

- ▶ The following description is an example and will be described by means of the L-end section.
- ▶ The process for the S-end section is identical.

Make sure that the following prerequisites are met:

- The boom system is assembled to the required system length.
- The connector pins on the last assembled lattice section are unpinned.
- The connector pins on the end section are unpinned.
- The fastening equipment on the end section **31** is tensioned.

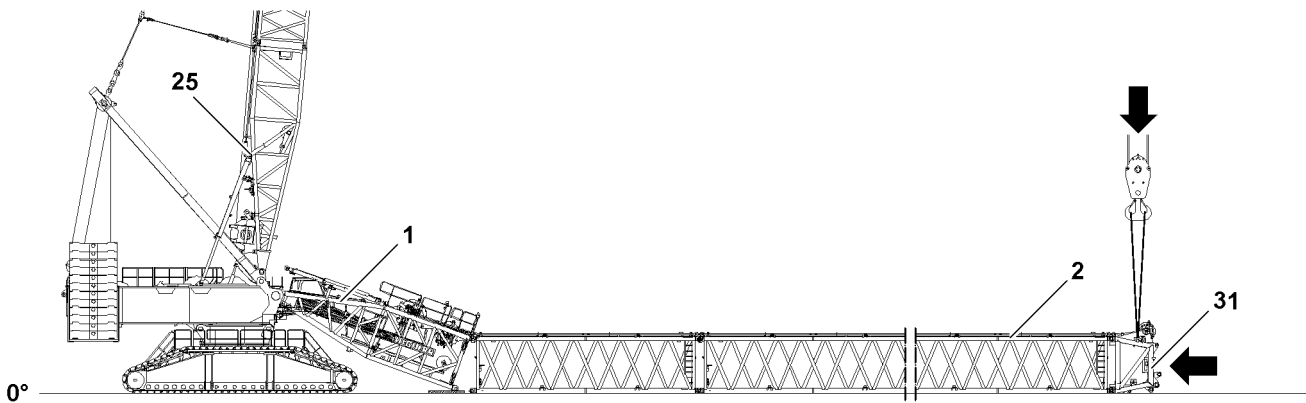

Fig.119422: Installing the end section on the boom

- ▶ Swing the end section 31 in with the auxiliary crane to the pin points.

When the pin bores between the end section 31 and the last installed lattice section 2 align „on top“ and „bottom“:

- ▶ Insert the connector pins „on top“ with the pin pulling cylinders on both sides to the stop and secure.

When the connector pins „on top“ are fully pinned to the stop and secured on both sides:

- ▶ Insert the connector pins „on the bottom“ with the pin pulling cylinders on both sides to the stop and secure.

When the connector pins „on top“ and „on the bottom“ are properly pinned:

- ▶ Secure the connector pin with the locking pin.
- ▶ Remove the auxiliary crane.

3.9.4 Establishing the electrical connections to the boom end section

Make sure that the following prerequisites are met:

- The S-intermediate sections are properly assembled and secured on the ground.
- The boom end section is properly assembled and secured.

NOTICE

Danger of damage to the electrical connections!

If the electrical connection from the cable drum in the S-pivot section to the terminal box on the S-pivot section is established first before the connection to the terminal box on the boom end section, then the electrical connection will be damaged when spooling out the cable drum.

- ▶ Establish first the electrical connection from the cable drum in the S-pivot section to the terminal box on the boom end section and then the electrical connection from the terminal box in the S-pivot section to the cable drum in the S-pivot section.



Note

- ▶ To establish the electrical connections on the S-boom: Use the Electrical wiring diagram.
- ▶ Establish the electrical connections.
- ▶ Make sure that all electrical connections on the boom are established.



WARNING

Malfunction if dummy plugs are not installed!

If the dummy plugs on the non-required electrical connections are not installed, then malfunctions or functional limitations can occur on the crane.

- ▶ Make sure that all non-required electrical connections that have a dummy plug are closed off with dummy plugs.
- ▶ Pay attention to the Electrical wiring diagram.

- ▶ As a rule, close off on-required electrical connections (for example for accessories which cannot be installed) with the respective dummy plugs.

NOTICE

Property damage due to dirt and / or corrosion!

If non-required electrical connections are not closed off with the respective protective caps, then dirt and / or corrosion can damage the electrical connections.

This could result in malfunctions.

- ▶ Make sure that all non-required electrical connections are always closed off properly.

- ▶ Pay attention to the Electrical wiring diagram.

-
- ▶ Close electrical connections, which have no dummy plugs, properly off with the corresponding protective caps.

3.9.5 Pinning the upper pulley block on the S-pivot section

**Note**

Shut off Winch 3!

If the D-boom is at an angle of more than / equal to 76° , then the luffing pulley block is laying on the D-end section.

The luffing pulley block may therefore not be moved, winch 3 turns off.

- ▶ The upper pulley block **37** can no longer be lowered or raised.

To be able to „close“ the S-boom combination after assembly of the lattice sections, the D-boom must be positioned at an angle of less than 76° .

Lower the upper pulley block **37** until it can be pinned with the brackets **37.2** of the assembly weight **37.1** on the S-pivot section **1**.

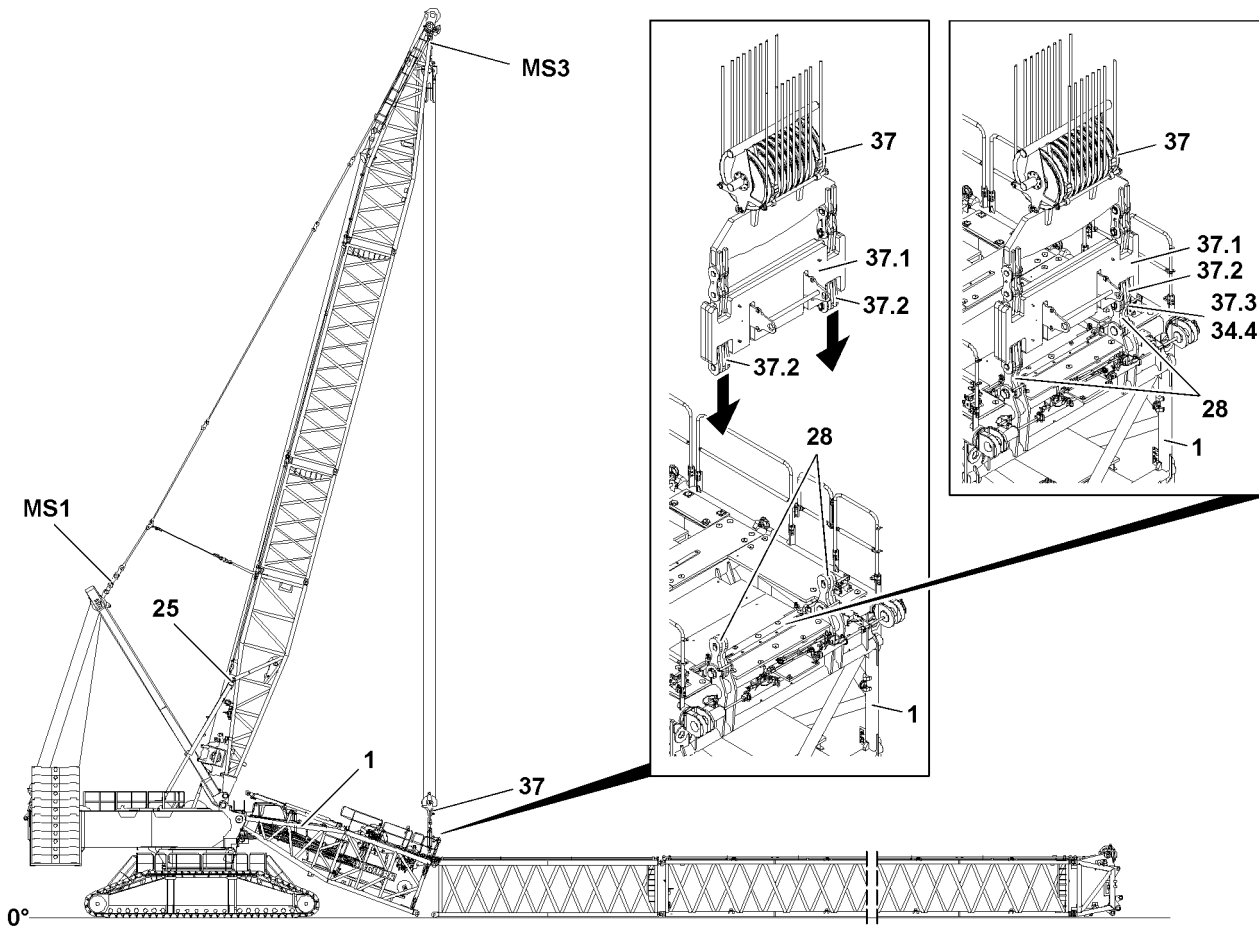

Fig.119444: Lowering the upper pulley block and pinning it on the S-pivot section



Note

- ▶ Luff the D-boom forward to the point where the upper pulley block 37 „stands“ vertically above the pin points 28 on the S-pivot section 1.

Make sure that the following prerequisites are met:

- The S-pivot section 1 is laying on the ground on the substructure.
- The boom system is properly assembled and secured.
- The boom end section is properly assembled and secured.
- The assembly weight is properly installed and secured on the upper pulley block.
- The auxiliary crane is removed.

- ▶ Luff the D-boom down until the upper pulley block stands vertically over the brackets 28 on the S-pivot section.
- ▶ Lower the upper pulley block 37 until the brackets 37.2 of the assembly weight 37.1 hang over the pin points of the brackets 28.
- ▶ Remove the safety locking pin 37.4 on the brackets 28 and unpin the pin 37.3.

When the pins 37.3 are fully unpinned on both sides:

- ▶ Continue to lower the upper pulley block 37 until the pin bores of the brackets 37.2 align with the pin points of the brackets 28.

When the pin bores align:

- ▶ Insert the pin 37.3 on both sides completely and secure with safety locking pin 37.4.

3.9.6 Closing the boom system

Make sure that the following prerequisites are met:

- The boom system is completely assembled.
- All lattice sections are properly pinned with each other.
- All pin connections are properly pinned and secured.
- The upper pulley block **37** is properly pinned and secured with the brackets **28** on the S-pivot section **1**.



WARNING

The crane can topple over!

Death, severe bodily injuries, property damage.

- ▶ During the „closing procedure“ of the boom system, the maximum permissible F3-total force of **136 t** on test point 3 **MS3** may not be exceeded.
- ▶ The end section of the corresponding S/SL-boom combination may **not** lift off the ground during the „closing procedure“.
- ▶ Make sure that there are no persons on the boom system as well as in the danger zone during the closing procedure.
- ▶ Non-required guy rods must be removed from the lattice sections, see Crane operating instructions, chapter 5.01.



Note

- ▶ The actual forces on test point 3 **MS3** - which are used during the opening - closing procedure of the S-boom system - are shown on LICCON monitor 1.
- ▶ Note the actual forces of test point 3 **MS3** and keep it ready for the disassembly of the S-boom system.
- ▶ At boom disassembly, pretension the control rope of winch 3 until the noted (assembly) actual forces of test point 3 **MS3** on the LICCON monitor are reached, so that the connector pins between the S-pivot section and the S-intermediate section can be unpinned.

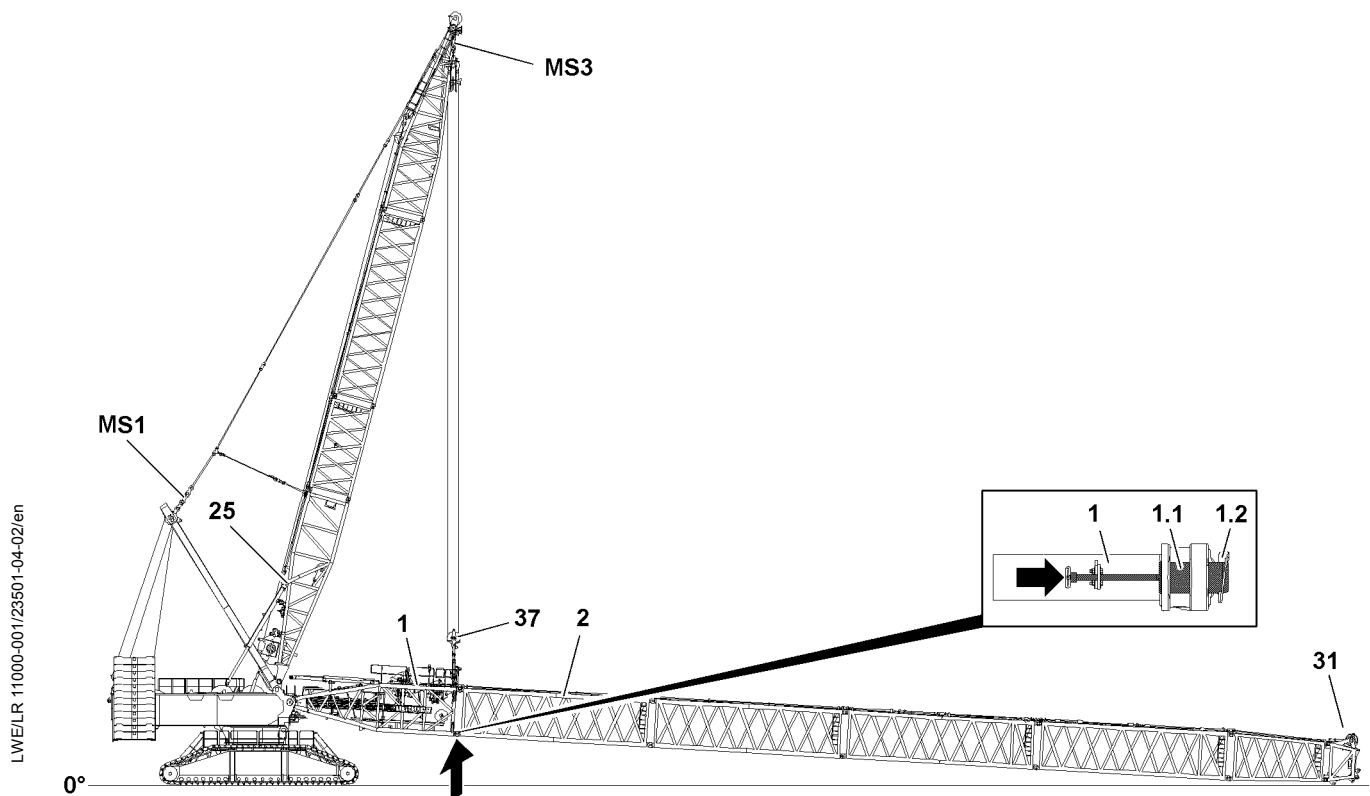

Fig.119425: Closing the boom system and pinning on both sides „on the bottom“

Close the SL-/S-boom combination with the upper pulley block:

- ▶ Lift the S-boom system with the upper pulley block **37** until the pin bores „on the bottom“ align.
- ▶ Insert the connector pin **1.1** „on the bottom“ and secure with the retaining pin **1.2**.



WARNING

Danger of fatal injury due to folding down of boom!

By unpinning the upper pulley block **37** on the S-pivot section **1**, the boom can suddenly fold down if the boom is not properly pinned and secured „on the bottom“.

Death, severe bodily injuries, property damage.

- ▶ It is prohibited for anyone to remain under the raised boom combination during the pinning / unpinning procedure.
- ▶ Unpin the upper pulley block **37** on the S-pivot section **1** only when it is ensured that the S-pivot section **1** is properly pinned and secured „on top“ and „bottom“ with the S-intermediate section.

When the S-boom is „closed“:

- ▶ Unpin the bracket **37.2** of the assembly weight **37.1** on bracket **28**: Release and unpin the pins **37.3** on both sides.

4 Installing the derrick ballast

If a derrick ballast is required for the flying assembly of the boom system, for erection and take down of the boom system as well as for the entire planned crane operation, install a derrick ballast according to the Crane operating instructions, chapter 5.35 or chapter 5.36.



WARNING

The crane can topple over!

Death, severe bodily injuries, property damage.

- ▶ Make sure that the derrick ballast is installed according to the erection and take down charts.
- ▶ Make sure that the derrick ballast according to the load charts is installed for the planned crane operation.

- ▶ Assemble the derrick ballast properly.
- ▶ Ballast the derrick ballast as specified.

5 Assembling the boom system in flying mode (guying on the flying assembly intermediate section)

If spatial prerequisites on the job site are limited for the assembly of the boom system, or if they are limited by buildings or similar, then the SD/S2D/SL2D-boom can be installed in „flying mode“.



WARNING

General danger notes!

Death, severe bodily injuries, property damage.

- ▶ All pins are to be secured after assembly with the intended retaining elements.
- ▶ The guy rods must be inspected regularly, see the Crane operating instructions, chapter 8.15.
- ▶ Secure the boom with substructure or auxiliary crane, see Crane operating instructions, chapter 5.01.
- ▶ It is prohibited for anyone to remain under the booms or within the complete danger zone during the pinning and unpinning procedure of the lattice section.

**WARNING**

Impermissible boom lengths guyed!

Death, severe bodily injuries, property damage.

- ▶ The maximum permissible boom lengths for the „flying“ assembly may not be exceeded.

When the boom system to be installed is longer than the permissible flying assembly length:

- ▶ Support the boom on the end of the permissible flying assembly length or secure with an auxiliary crane, see Operating instructions, chapter 5.01.
- ▶ Observe the assembly conditions, see the Crane operating instructions, chapter 3.06.
- ▶ The data in the erection and take-down charts as well as the load charts must be adhered to.

NOTICE

Property damage!

If the pins of the guy rods are not pinned from the „inside“ to the „outside“, the hoist rope can scrape on the pins and be damaged.

- ▶ Always insert the pins of the guy rods from the „inside“ to the „outside“, see the Rod plan.

**WARNING**

The crane can topple over!

Death, severe bodily injuries, property damage.

- ▶ For the „flying“ boom assembly, the maximum permissible total force at test point **MS3** may **not** be exceeded.
- ▶ The „flying“ boom assembly is only permissible up to a maximum flying assembly length.
- ▶ Make sure that the maximum permissible flying assembly length is not exceeded.
- ▶ The „actual force“ on test point 3 **MS3** is shown on LICCON monitor 1.
- ▶ Observe the assembly conditions, see the Crane operating instructions, chapter 3.06.
- ▶ The specifications in the erection and take-down charts as well as the load charts must be observed.
- ▶ For the itemization of the lattice sections refer to the Rod plan.

5.1 Installing the upper pulley block on the S-intermediate section for flying assembly

Make sure that the following prerequisites are met:

- The derrick ballast is properly installed and secured.
- The derrick ballast is properly ballasted.
- The boom system is properly assembled up to the S-intermediate section 3228.25 FLM 3.
- The boom system is closed.
- The S-intermediate section 3228.25 FLM 3 is laying on the ground on the substructure.

NOTICE

Danger of property damage!

When luffing the D-boom down, the upper pulley block **37** can run with the assembly weight **37.1** into the S-boom system and damage the boom.

This could result in high property damage.

- ▶ Make sure that the assembly weight **37.1** does not run on the S-boom when luffing down the D-boom.
- ▶ Make sure, when luffing down the D-boom, that there is always sufficient distance between the S-boom and the assembly weight **37.1**.

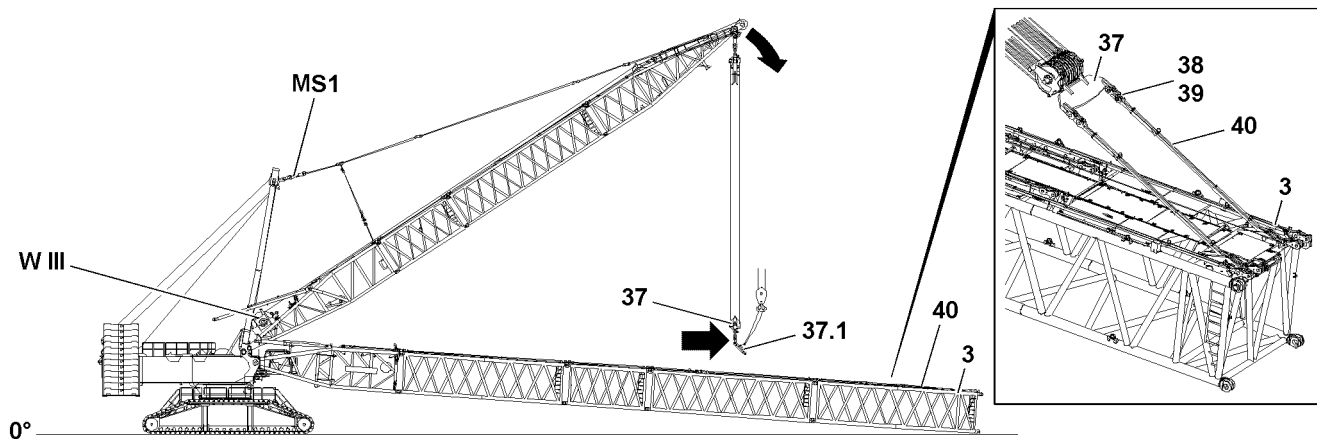

Fig.119446: Lowering the D-boom to the front and pin the upper pulley block on the S-intermediate section 3228.25 FLM

- ▶ Luff the D-boom down carefully to the front.

When the D-boom is in position:

- ▶ Lower the upper pulley block **37** until the brackets between the upper pulley block and the assembly weight **37.1** are easily accessible.
- ▶ Fasten the assembly weight **37.1** properly to the auxiliary crane.
- ▶ Lift the assembly weight **37.1** with the auxiliary crane to the horizontal.

When the assembly weight **37.1** hangs horizontally on the auxiliary crane:

- ▶ Release and unpin the pin between the assembly weight **37.1** and the upper pulley block **37**.
- ▶ Swing the assembly weight **37.1** out with the auxiliary crane and place it on a suitable substructure.
- ▶ Continue to luff the D-boom down until the upper pulley block **37** is positioned over the boom system.

Problem remedy

The D-boom cannot be luffed down further?

You luffed the D-boom down to the mandatory system shut off.

- ▶ Move the D-boom into the opposite direction from the shut off.

- ▶ Luff the D-boom slightly up.



Note

- ▶ Pull the upper pulley block **37** with the auxiliary crane in direction of the S-intermediate section 3228.25 FLM **3** and position it over the guy rods **40** in such a way that the guy rods can be safely pinned on the upper pulley block **37**.

When the upper pulley block is positioned over the guy rods:

- ▶ Pin and secure the guy rods **40** with the upper pulley block **37**: Insert the pin from the inside to the outside and secure with safety locking pin.



Note

- ▶ The S-boom must remain on the ground when erecting the D-boom and may **not** be pulled up along.



WARNING

D-boom falling to the rear!

If the relapse cylinders of the D-boom are not completely moved out before erection, then the D-boom can fall backward when erecting it into operating position.

Death, severe bodily injuries, property damage.

- ▶ Make sure that the relapse cylinders of the D-boom are completely moved out.

When the guy rods **40** are properly pinned and secured with the upper pulley block **37**:

- ▶ Erect the D-boom to operating position and at the same time, spool out winch **3 WIII**.

**Note**

- ▶ When erecting the D-boom, pay attention to the minimum force **F1** on test point 1 **MS1**.
- ▶ To avoid a shut-off of the LMB during the erection procedure on the D-boom, do not fall below the minimum force **F1** on test point 1 **MS1**.

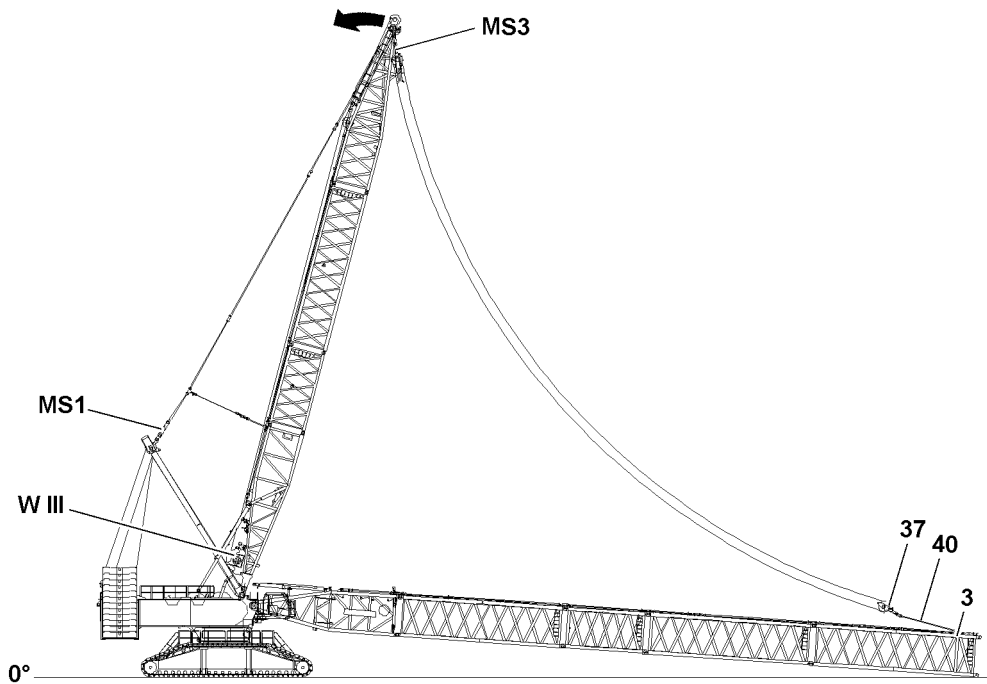

Fig.119447: Bringing the D-boom into operating position

When the D-boom has reached the operating position:

- ▶ Tension the guying carefully between the D-boom and the S-intermediate section 3228.25 FLM 3.

When the guying is tensioned:

- ▶ Lift the boom system off the ground carefully and at a slow speed.
- ▶ Luff the boom system up to the horizontal so that the boom expansion can be installed on the S-intermediate section 3228.25 FLM 3.

5.2 Assembling the S-lattice section in „flying mode“ on the S-intermediate section 12 m 3228.25 FLM

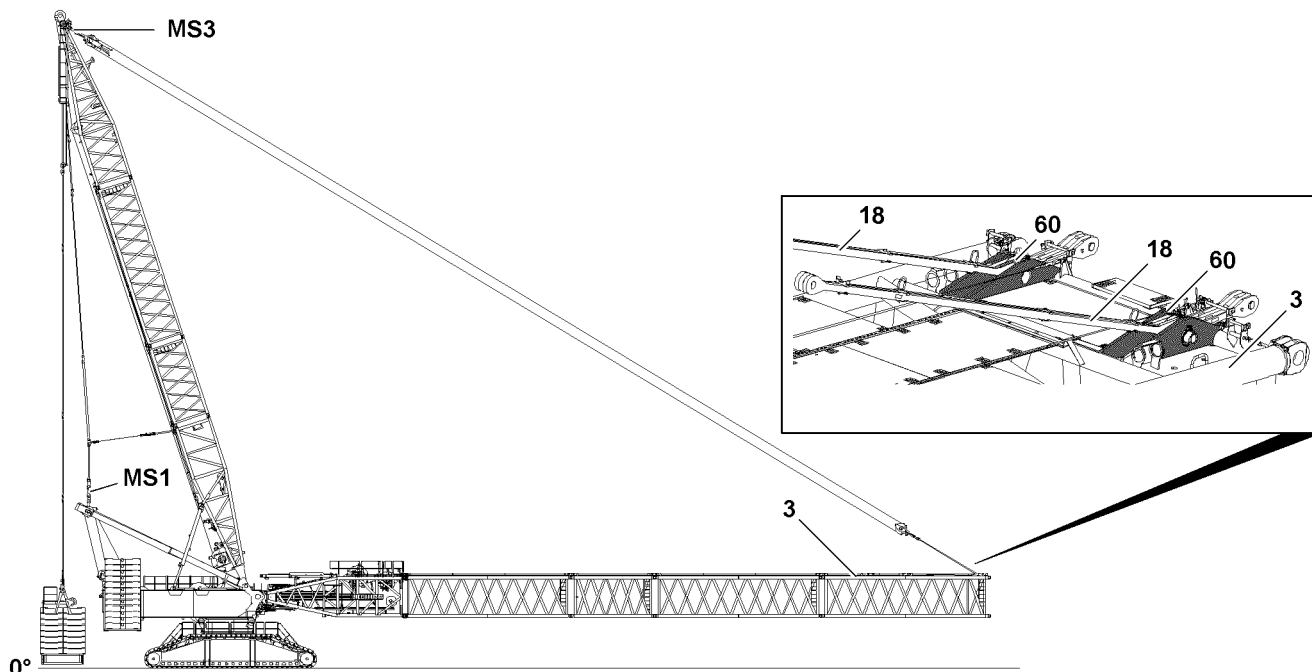

Fig.119426: Boom system on flying assembly intermediate section guyed

Make sure that the following prerequisites are met:

- The electrical and hydraulic connections to the S-pivot section have been established.
- The boom system is horizontally guyed on the S-intermediate section 12 m 3228.25 3.
- An auxiliary crane with sufficient load bearing capacity if available.



WARNING

Falling components!

If unsecured or non-supported components are assembled or disassembled, they can fall down. Death, severe bodily injuries, property damage.

- ▶ During pinning and unpinning of the intermediate sections, it is prohibited for anyone to remain **under** or **on** the components as well as within the entire danger zone.
- ▶ Before unpinning: Support the components and boom.
- ▶ Secure the pins in the storage locations and in the receptacles.
- ▶ It is prohibited to lean a ladder against the crane section that is being disassembled.

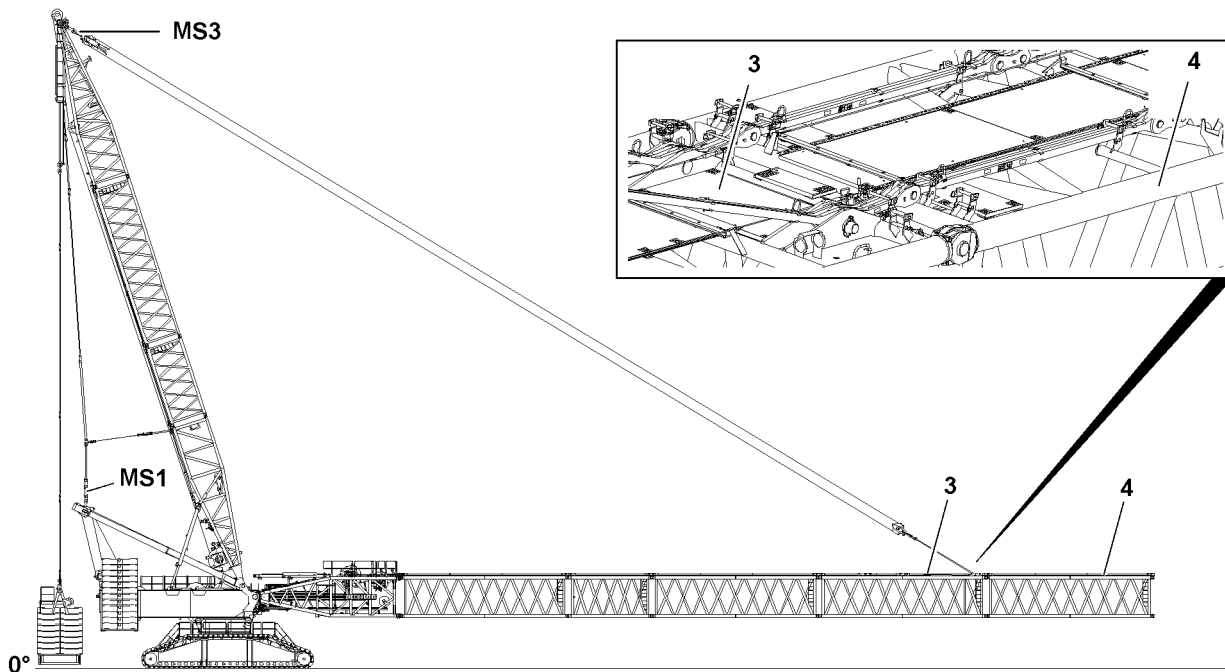

Fig.119427: Flying assembly up to maximum permissible flying assembly length

For „flying“ assembly of the intermediate sections, they can be installed individually or as preassembled boom unit on the S-intermediate section 3228.25 FLM 3.



WARNING

The crane can topple over!

Death, severe bodily injuries, property damage.

- ▶ Make sure that the maximum permissible flying assembly lengths are **not** exceeded.
- ▶ The crane operator bears the sole and full responsibility for the observation of the maximum permissible flying assembly lengths.

- ▶ Fasten the S-intermediate section 4 or preassembled boom unit to the auxiliary crane.
- ▶ Lift the S-intermediate section 4 or preassembled boom unit with the auxiliary crane and position on the S-intermediate section 3228.25 FLM 3 until the pin points align.

When the pin points between the S-intermediate section 3228.25 FLM 3 and the S-intermediate section 4 on preassembled boom unit align „on top“ and „bottom“:

- ▶ Pin the S-intermediate section 4 or preassembled boom unit „on top“: Insert the pin 1.1 on both sides and secure with locking pin 1.2.
- ▶ Pin the S-intermediate section 4 or preassembled boom unit „on the bottom“: Insert the pin 1.1 on both sides and secure with locking pin 1.2.

When the pins are properly pinned and secured on „top“ and „bottom“ between the S-intermediate section 3228.25 FLM 3 and the S-intermediate section 4 or the preassembled boom unit:

- ▶ Remove the auxiliary crane.

If additional lattice sections are assembled:

- ▶ Assemble the lattice sections the same way as described in this section.

5.2.1 Assembling the SDB-boom system in flying mode



WARNING

The crane can topple over!
Death, severe bodily injuries, property damage.

- ▶ Make sure that $F3_{\max}$ (MS3) is **not** exceeded at flying assembly.
- ▶ Make sure that the maximum permissible flying assembly lengths are not exceeded, even when $F3_{\max}$ (MS3) is not yet reached.
- ▶ Make sure that no hook block is reeved at flying assembly.
- ▶ Make sure that all guy rods which are not required have been removed from the lattice sections.
- ▶ For counterweight, central ballast and derrick ballast refer to the erection and take down charts. If the end section is not present, the respective boom length with the end section is to be taken into account.
- ▶ To determine the required derrick ballast, assume a hook block weight of a minimum of 13 t in the erection and take-down charts.



Note

- ▶ $F3_{\max}$ (MS3) = 260 t.

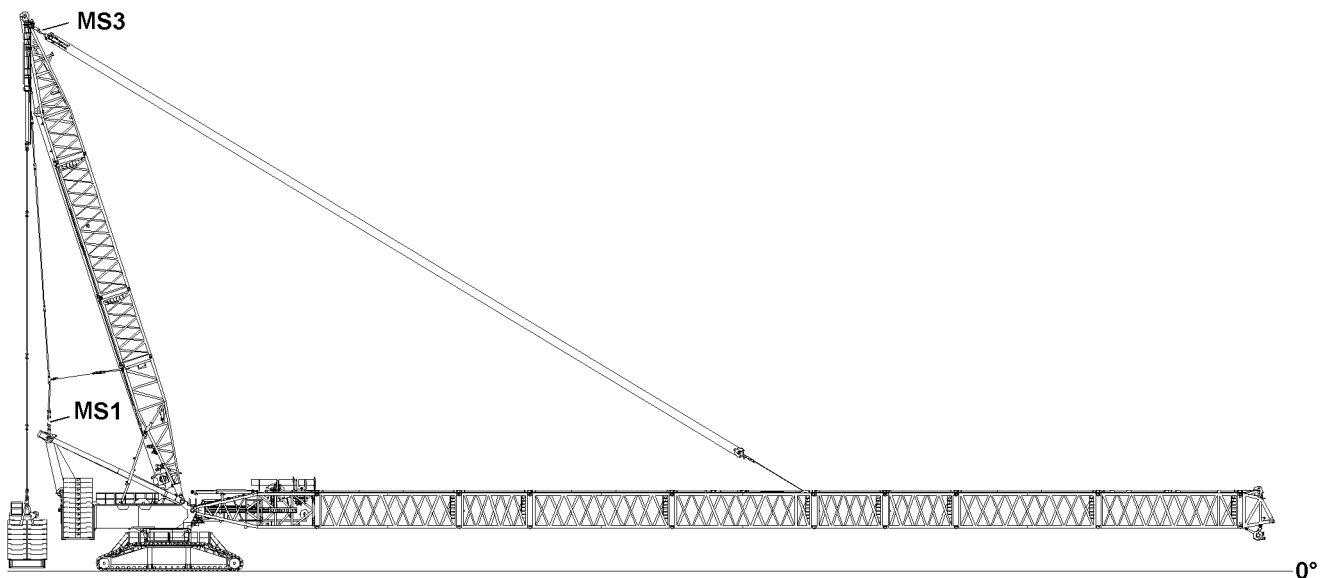

Fig.119428: SDB-boom system - Flying assembly length to **maximum** S 90 m

- with L-end section
- with S-guy rods
- with roller sets
- without WA-frame II guy rods

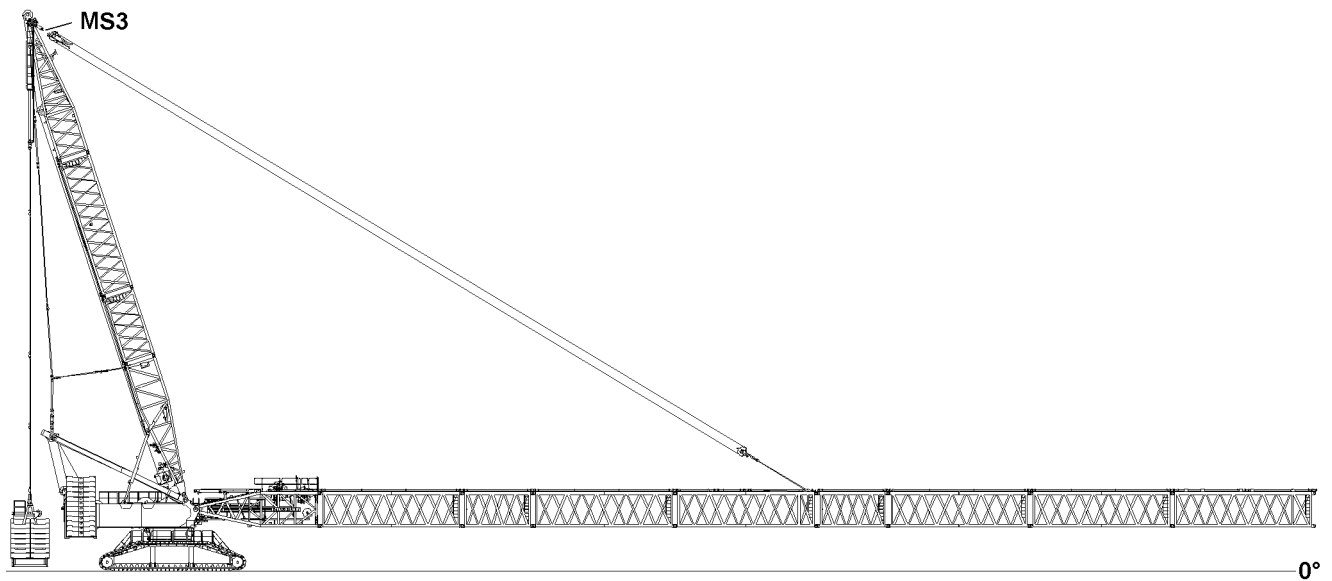

Fig.119429: SDB-boom system - Flying assembly length to **maximum** S 96 m

- without end section

- with S-guy rods

- without WA-frame II guy rods

5.2.2 Assembling the S2DB-boom system in flying mode



WARNING

The crane can topple over!

Death, severe bodily injuries, property damage.

- ▶ Make sure that $F3_{max}$ (MS3) is **not** exceeded at flying assembly.
- ▶ Make sure that the maximum permissible flying assembly lengths are not exceeded, even when $F3_{max}$ (MS3) is not yet reached.
- ▶ Make sure that no hook block is reeved at flying assembly.
- ▶ Make sure that all guy rods which are not required have been removed from the lattice sections.
- ▶ For counterweight, central ballast and derrick ballast refer to the erection and take down charts. If the end section is not present, the respective boom length with the end section is to be taken into account.
- ▶ To determine the required derrick ballast, assume a hook block weight of a minimum of 7 t in the erection and take-down charts.



Note

- ▶ $F3_{max}$ (MS3) = 260 t.

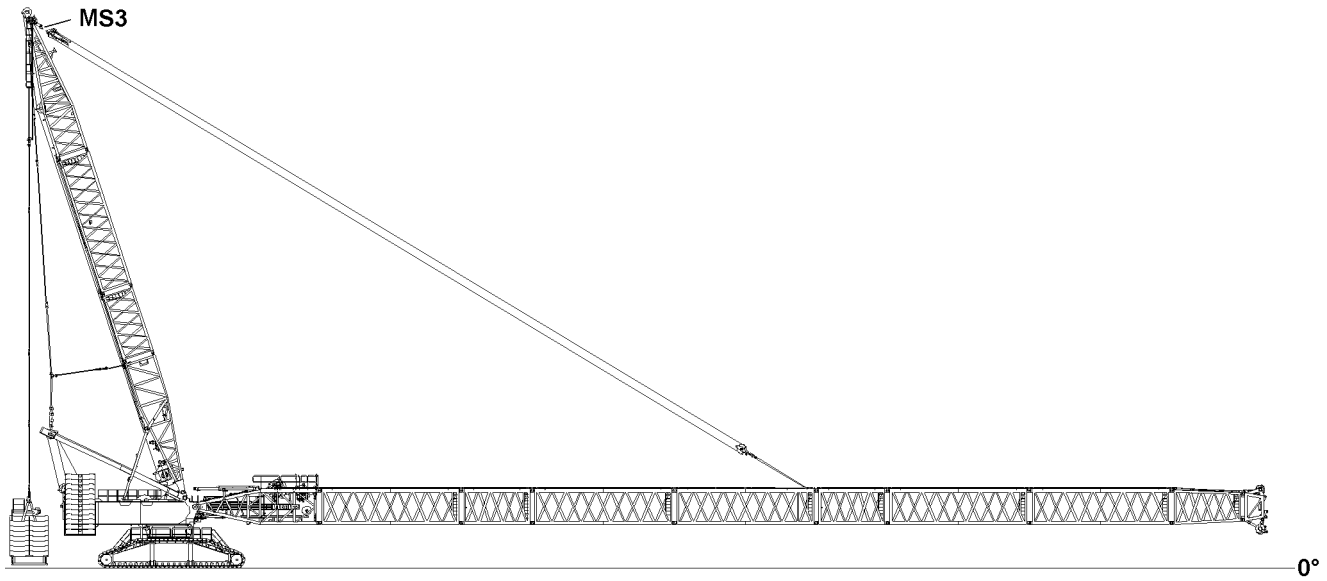

Fig.119430: S2DB-boom system - Flying assembly length to **maximum** S2 90 m

- with L-end section
- with S-guy rods
- with roller sets
- without WA-frame II guy rods

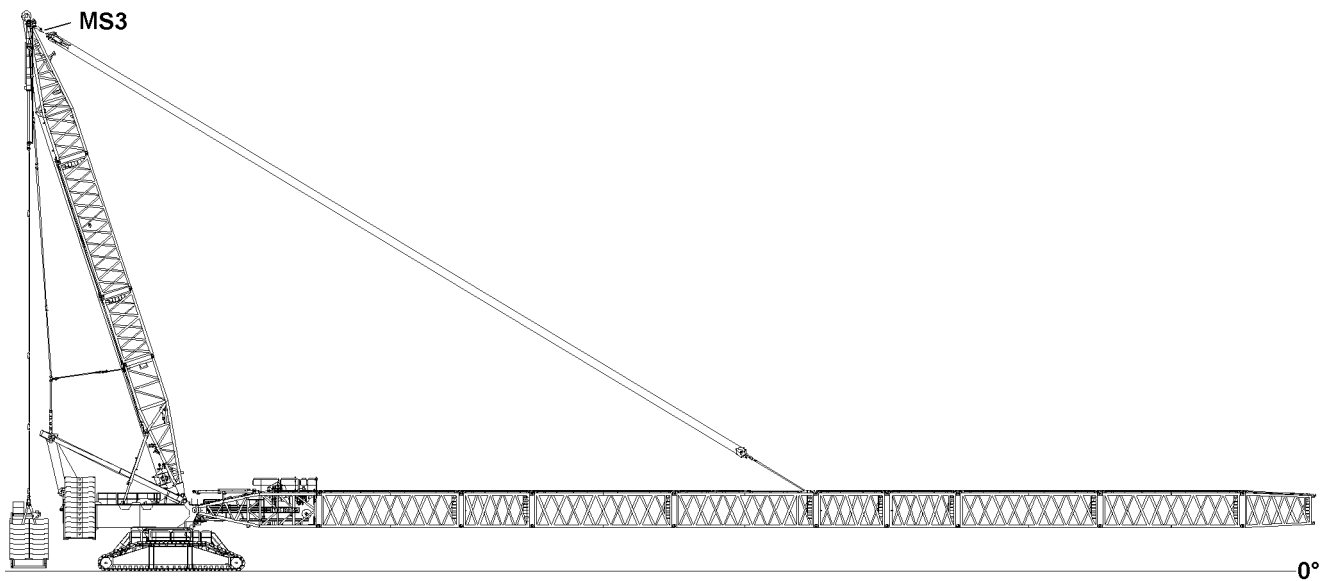

Fig.119431: S2DB-boom system - Flying assembly length to **maximum** S2 96 m

- without end section
- with S-guy rods
- without WA-frame II guy rods

5.2.3 Assembling the SL2DB-boom system in flying mode



WARNING

The crane can topple over!

Death, severe bodily injuries, property damage.

- ▶ Make sure that $F_{3_{max}}$ (MS3) is **not** exceeded at flying assembly.
- ▶ Make sure that the maximum permissible flying assembly lengths are not exceeded, even when $F_{3_{max}}$ (MS3) is not yet reached.
- ▶ Make sure that no hook block is reeved at flying assembly.
- ▶ Make sure that all guy rods which are not required have been removed from the lattice sections.
- ▶ For counterweight, central ballast and derrick ballast refer to the erection and take down charts. If the end section is not present, the respective boom length with the end section is to be taken into account.
- ▶ To determine the required derrick ballast, assume a hook block weight of a minimum of 7 t in the erection and take-down charts.



Note

- ▶ $F_{3_{max}}$ (MS3) = 260 t.

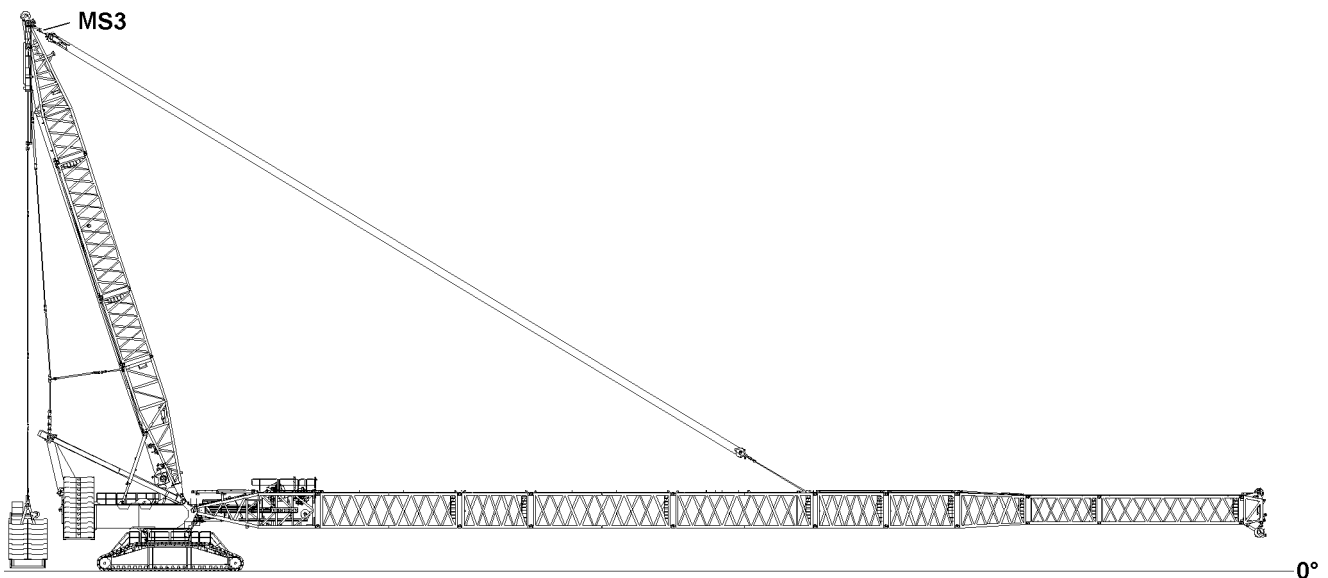

Fig.119432: SL2DB-boom system - Flying assembly length to **maximum** SL2 90 m

- without end section

- with S-guy rods

- without WA-frame II guy rods

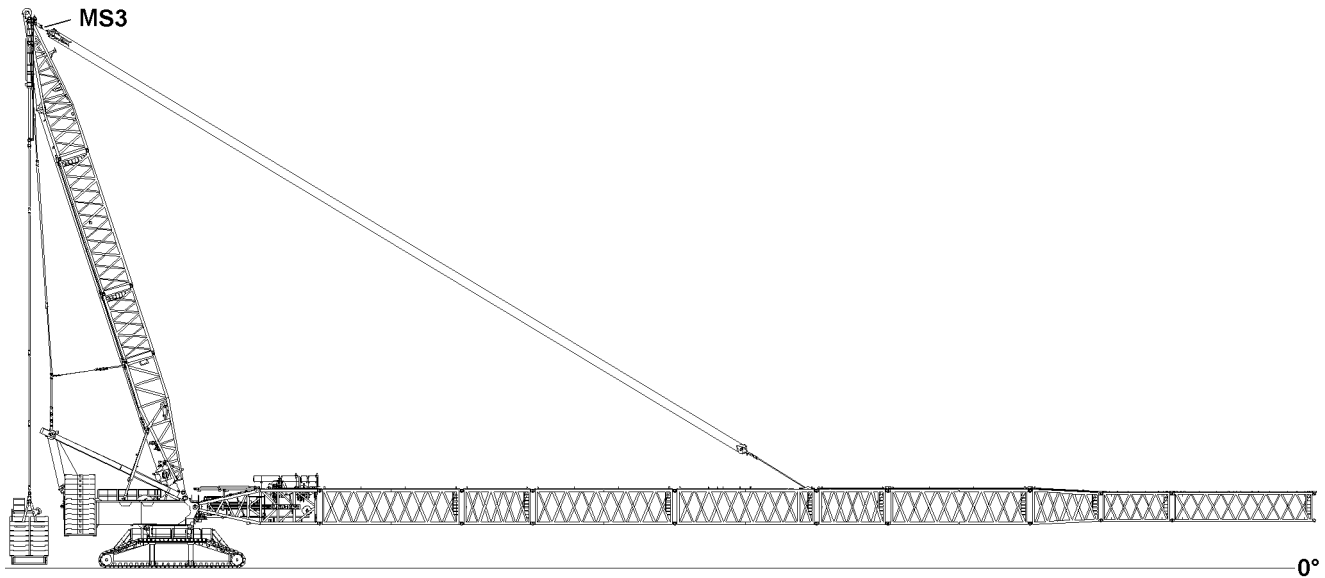

Fig.119433: SL2DB-boom system - Flying assembly length to **maximum** SL2 96 m

- without end section

- with S-guy rods

- without WA-frame II guy rods

5.2.4 Completing the flying assembly

If the maximum permissible flying assembly length is installed and tensioned on the S-intermediate section 3228.25 FLM, the boom system must be taken down on the ground or a load bearing sub-structure.

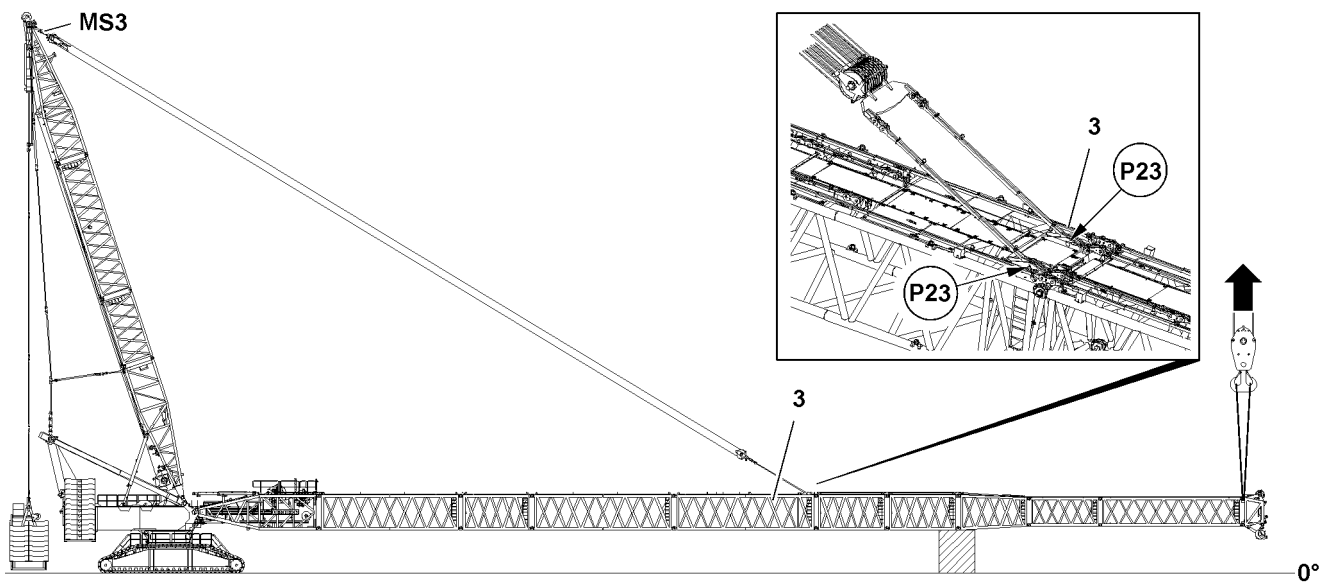

Fig.119434: Boom system supported **or** held by an auxiliary crane

Make sure that the following prerequisite is met:

- An auxiliary crane with sufficient load bearing capacity if available.

When the permissible flying assembly length is reached:

- ▶ Take the boom system down on the ground or on a load bearing substructure.
- ▶ Install the boom end section properly on the boom system.

Problem remedy

The maximum permissible flying assembly length does not correspond to the operating length?

- ▶ Take the boom system down on the ground.
- ▶ Expand the boom system on the ground to the required operating length.
- ▶ Close the boom system after reaching the required operating length with the auxiliary crane.

**WARNING**

The boom can suddenly fold down!

Death, severe bodily injuries, property damage.

- ▶ Before unpinning the guy rods: Support the boom system properly or take it down on the ground.
- ▶ Observe and adhere to the Rod plan.

When the boom system is properly taken down on the ground or supported:

- ▶ Relieve the guying between the D-end section and the S-intermediate section 3228.25 FLM 3.

6 Assembling the boom system in flying mode (guying on S-pivot section)

If spatial prerequisites on the job site are limited for the assembly of the boom system, or if they are limited by buildings or similar, then the SD/S2D/SL2D-boom can be installed in „flying mode“.

**WARNING**

General danger notes!

Death, severe bodily injuries, property damage.

- ▶ All pins are to be secured after assembly with the intended retaining elements.
- ▶ The guy rods must be inspected regularly, see the Crane operating instructions, chapter 8.15.
- ▶ Secure the boom with substructure or auxiliary crane, see Crane operating instructions, chapter 5.01.
- ▶ It is prohibited for anyone to remain under the booms or within the complete danger zone during the pinning and unpinning procedure of the lattice section.

**WARNING**

Impermissible boom lengths guyed!

Death, severe bodily injuries, property damage.

- ▶ The maximum permissible boom lengths for the „flying“ assembly may not be exceeded.

When the boom system to be installed is longer than the permissible flying assembly length:

- ▶ Support the boom on the end of the permissible flying assembly length or secure with an auxiliary crane, see Operating instructions, chapter 5.01.
- ▶ Observe the assembly conditions, see the Crane operating instructions, chapter 3.06.
- ▶ The data in the erection and take-down charts as well as the load charts must be adhered to.

NOTICE

Property damage!

If the pins of the guy rods are not pinned from the „inside“ to the „outside“, the hoist rope can scrape on the pins and be damaged.

- ▶ Always insert the pins of the guy rods from the „inside“ to the „outside“, see the Rod plan.

**WARNING**

The crane can topple over!

Death, severe bodily injuries, property damage.

- ▶ For the „flying“ boom assembly, the maximum permissible total force at test point **MS3** may **not** be exceeded.
- ▶ The „flying“ boom assembly is only permissible up to a maximum flying assembly length.
- ▶ Make sure that the maximum permissible flying assembly length is not exceeded.
- ▶ The „actual force“ on test point 3 **MS3** is shown on LICCON monitor 1.
- ▶ Observe the assembly conditions, see the Crane operating instructions, chapter 3.06.
- ▶ The specifications in the erection and take-down charts as well as the load charts must be observed.
- ▶ For the itemization of the lattice sections refer to the Rod plan.

6.1 Assembling the upper pulley block on the S-pivot section

Make sure that the following prerequisites are met:

- The derrick ballast is properly installed and secured.
- The derrick ballast is properly ballasted.
- The S-pivot section **1** is properly installed.
- The S-pivot section **1** is laying on the ground on the substructure.

NOTICE

Danger of property damage!

When luffing the D-boom down, the upper pulley block **37** can run with the assembly weight **37.1** on the S-pivot section **1** and damage the boom.

This could result in high property damage.

- ▶ Make sure that the assembly weight **37.1** does not run on the S-pivot section **1** when luffing down the D-boom.
- ▶ Make sure, when luffing down the D-boom, that there is always sufficient distance between the S-pivot section **1** and the assembly weight **37.1**.

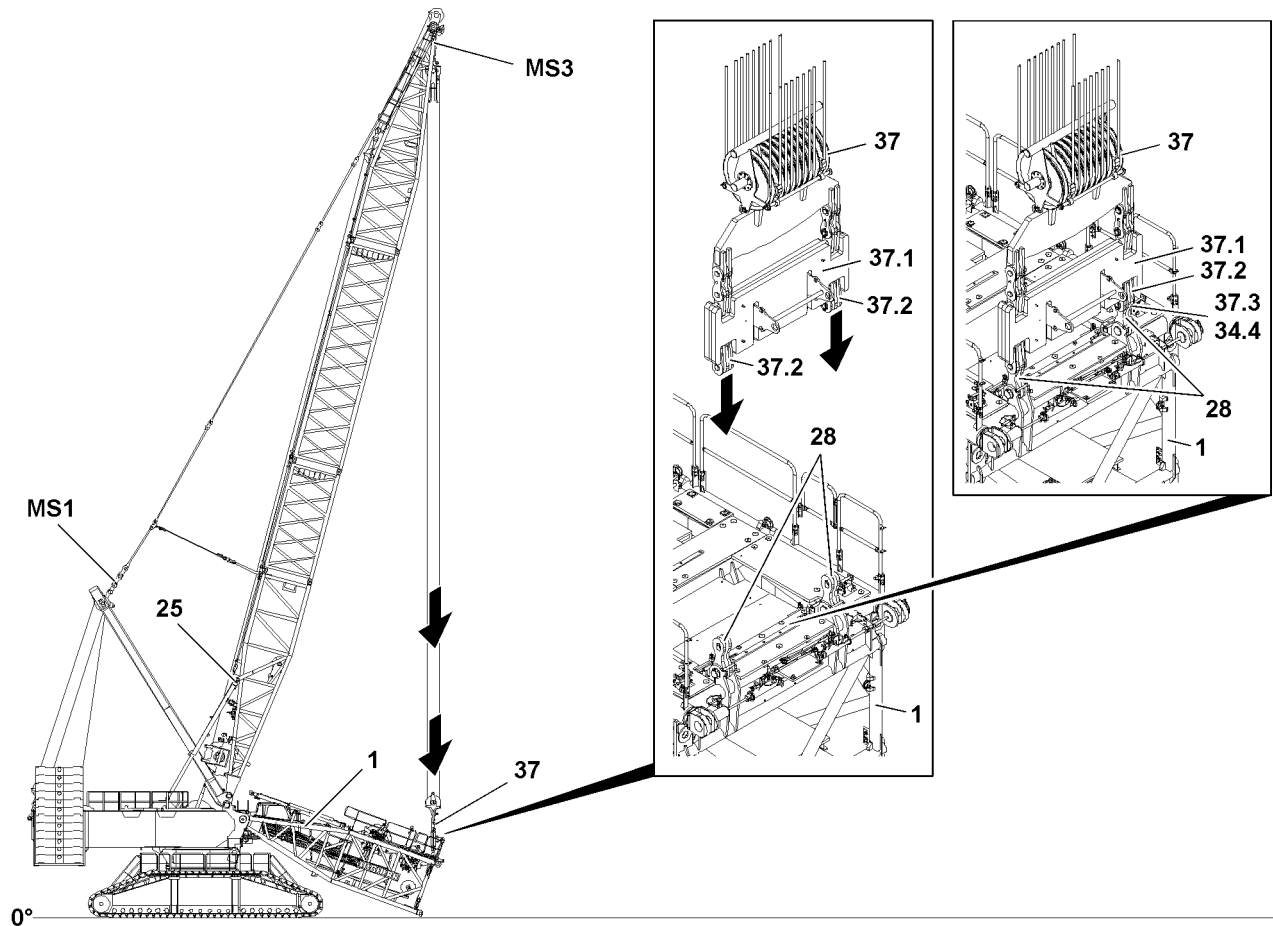

Fig.122705: Pinning the upper pulley block on the S-pivot section

- ▶ Lower the upper pulley block **37** until the brackets of the assembly weight are above the tension brackets of the S-pivot section **1**.
- ▶ Pin the brackets of the assembly weight **37.1** with the brackets of the S-pivot section **1**: Insert the pin from the inside to the outside and secure with safety locking pin.



WARNING

D-boom falling to the rear!

If the relapse cylinders of the D-boom are not completely moved out before erection, then the D-boom can fall backward when erecting it into operating position.

Death, severe bodily injuries, property damage.

- ▶ Make sure that the relapse cylinders of the D-boom are completely moved out.

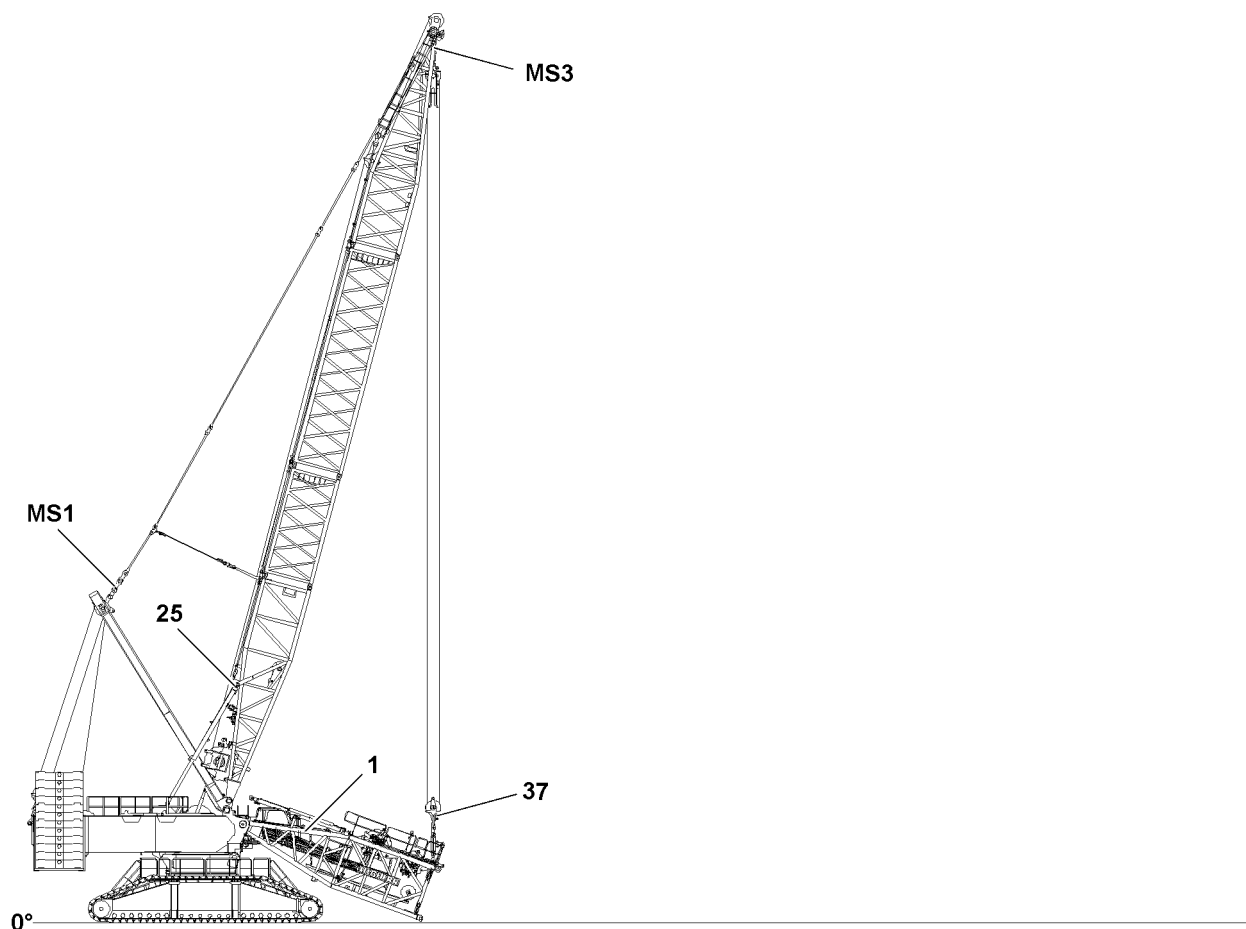

Fig.122706: S-pivot section 1 in assembly position

When the brackets of the assembly weight are properly pinned and secured with the brackets on the S-pivot section 1:

- ▶ Tension the guying carefully between the D-boom and the S-pivot section 1.

When the guying is tensioned:

- ▶ Carefully and at slow speed lift the S-pivot section 1 off the ground.
- ▶ Lift the S-pivot section 1 to the horizontal so that the boom expansion can be assembled on the S-pivot section 1 in flying mode.

6.2 Assembling the S-lattice sections in „flying mode“ on the S-pivot section

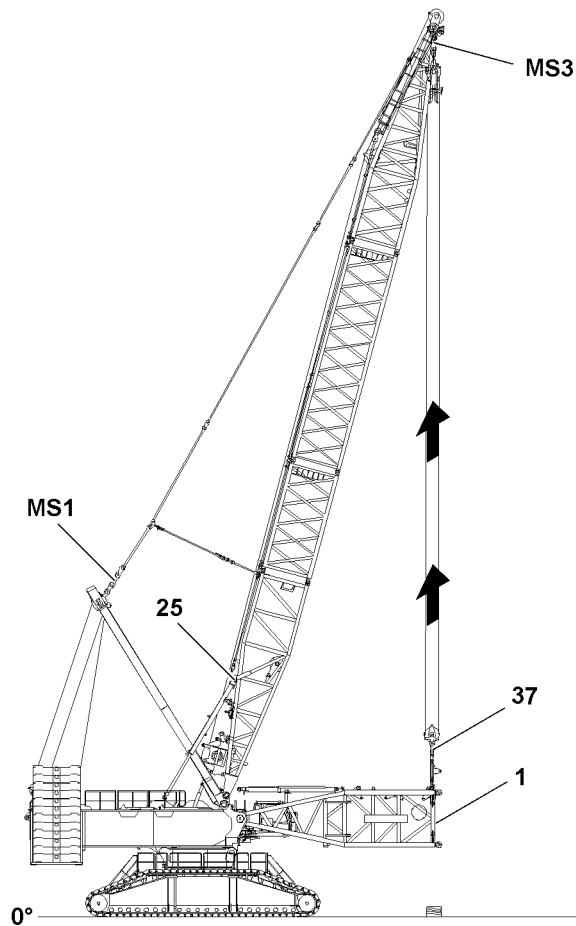

Fig.122707: S-pivot section tensioned with winch 3

Make sure that the following prerequisites are met:

- The electrical and hydraulic connections to the S-pivot section have been established.
- The S-pivot section is horizontally tensioned.
- An auxiliary crane with sufficient load bearing capacity if available.



WARNING

Falling components!

If unsecured or non-supported components are assembled or disassembled, they can fall down. Death, severe bodily injuries, property damage.

- ▶ During pinning and unpinning of the intermediate sections, it is prohibited for anyone to remain **under** or **on** the components as well as within the entire danger zone.
- ▶ Before unpinning: Support the components and boom.
- ▶ Secure the pins in the storage locations and in the receptacles.
- ▶ It is prohibited to lean a ladder against the crane section that is being disassembled.

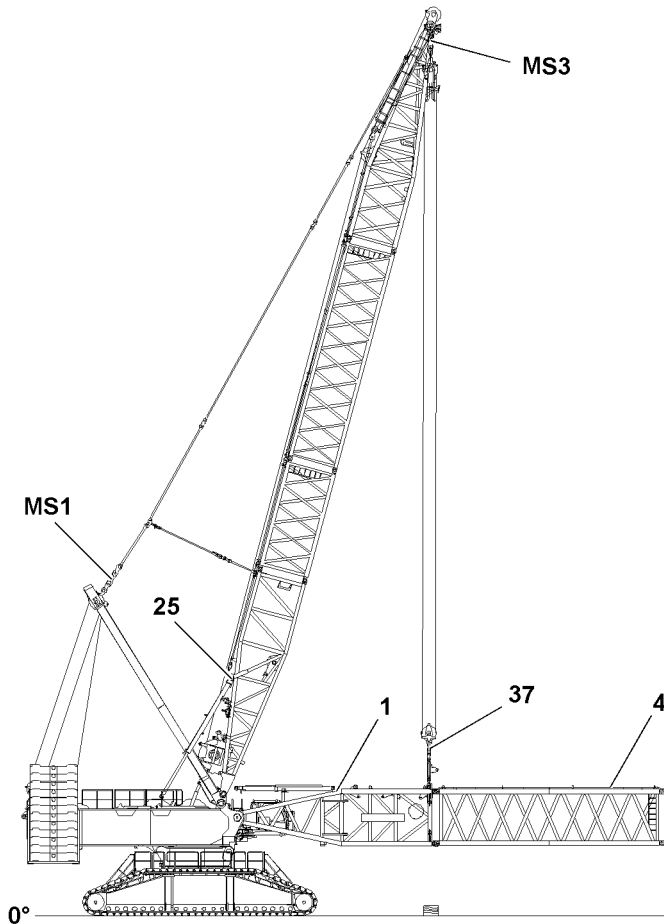

Fig.122708: Flying assembly up to maximum permissible flying assembly length

For „flying“ assembly of the intermediate sections, they can be installed individually or as preassembled boom unit on the S-pivot section.



WARNING

The crane can topple over!
Death, severe bodily injuries, property damage.

- ▶ Make sure that the maximum permissible flying assembly lengths are **not** exceeded.
- ▶ The crane operator bears the sole and full responsibility for the observation of the maximum permissible flying assembly lengths.

- ▶ Fasten the S-intermediate section **4** or preassembled boom unit to the auxiliary crane.
- ▶ Lift the S-intermediate section **4** or preassembled boom unit with the auxiliary crane and position on the S-pivot section until the pin points align.

When the pin points between the S-pivot section and S-intermediate section **4** or the preassembled boom unit align „on top“ and „bottom“:

- ▶ Pin the S-intermediate section **4** or preassembled boom unit „on top“: Insert the pin **1.1** on both sides and secure with locking pin **1.2**.
- ▶ Pin the S-intermediate section **4** or preassembled boom unit „on the bottom“: Insert the pin **1.1** on both sides and secure with locking pin **1.2**.

When the pins are properly pinned and secured on both sides on „top“ and „bottom“ between the S-pivot section and the S-intermediate section **4** or the preassembled boom unit:

- ▶ Remove the auxiliary crane.

If additional lattice sections are assembled:

- ▶ Assemble the lattice sections the same way as described in this section.

6.2.1 Assembling the SD // S2D // SL2D boom system in flying mode with the end section



WARNING

The crane can topple over!

Death, severe bodily injuries, property damage.

- ▶ Make sure that $F_{3_{max}}$ (MS3) is **not** exceeded at flying assembly.
- ▶ Make sure that the maximum permissible flying assembly lengths are not exceeded, even when $F_{3_{max}}$ (MS3) is not yet reached.
- ▶ Make sure that no hook block is reeved at flying assembly.
- ▶ Make sure that all guy rods which are not required have been removed from the lattice sections.
- ▶ For counterweight and central ballast refer to the erection and take down charts.
- ▶ Observe the system configurations, see the following chart.



Note

- ▶ $F_{3_{max}}$ (MS3) = 210 t.

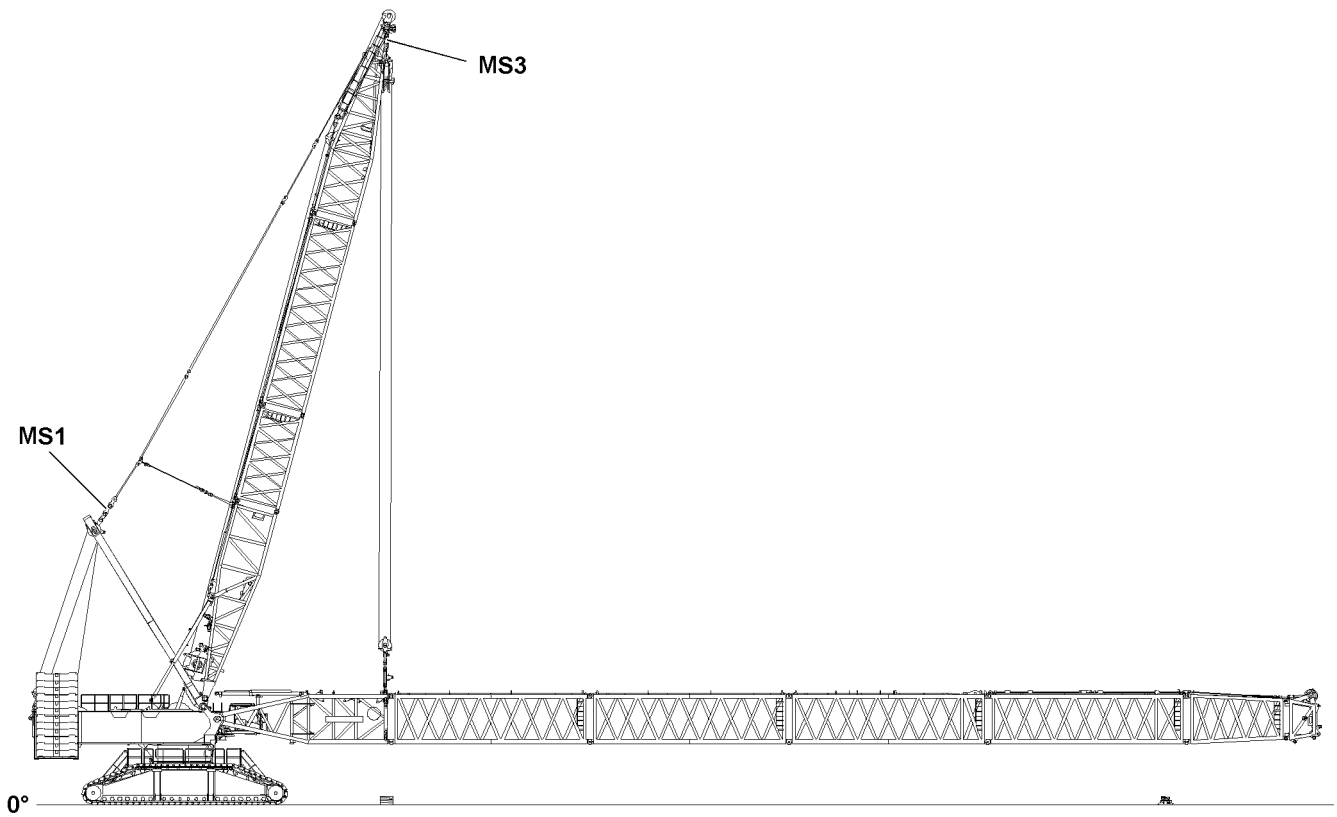

Fig.122709: SD // S2D // SL2D boom system - flying mode with end section

	System configuration for flying assembly		
	SD	S2D	SL2D
L-end section	—	X	X
S-end section	X	—	—
Roller set R8	2	—	—
Roller set R12	—	1	1
S-guying	X	X	X

LWE/LR 11000-001/23501-04-02/en

	System configuration for flying assembly		
	SD	S2D	SL2D
WAB 2-guying	—	—	—
Counterweight	210 t	170 t	170 t
Central ballast	50 t	10 t	10 t
Maximum permissible flying assembly length	48 m	48 m	54 m

6.2.2 Assembling the SD // S2D // SL2D boom system in flying mode without the end section



WARNING

The crane can topple over!
Death, severe bodily injuries, property damage.

- ▶ Make sure that $F3_{max}$ (MS3) is **not** exceeded at flying assembly.
- ▶ Make sure that the maximum permissible flying assembly lengths are not exceeded, even when $F3_{max}$ (MS3) is not yet reached.
- ▶ Make sure that no hook block is reeved at flying assembly.
- ▶ Make sure that all guy rods which are not required have been removed from the lattice sections.
- ▶ For counterweight and central ballast refer to the erection and take down charts. If the end section is not present, the respective boom length with the end section is to be taken into account.
- ▶ Observe the system configurations, see the following chart.



Note

- ▶ $F3_{max}$ (MS3) = 210 t.

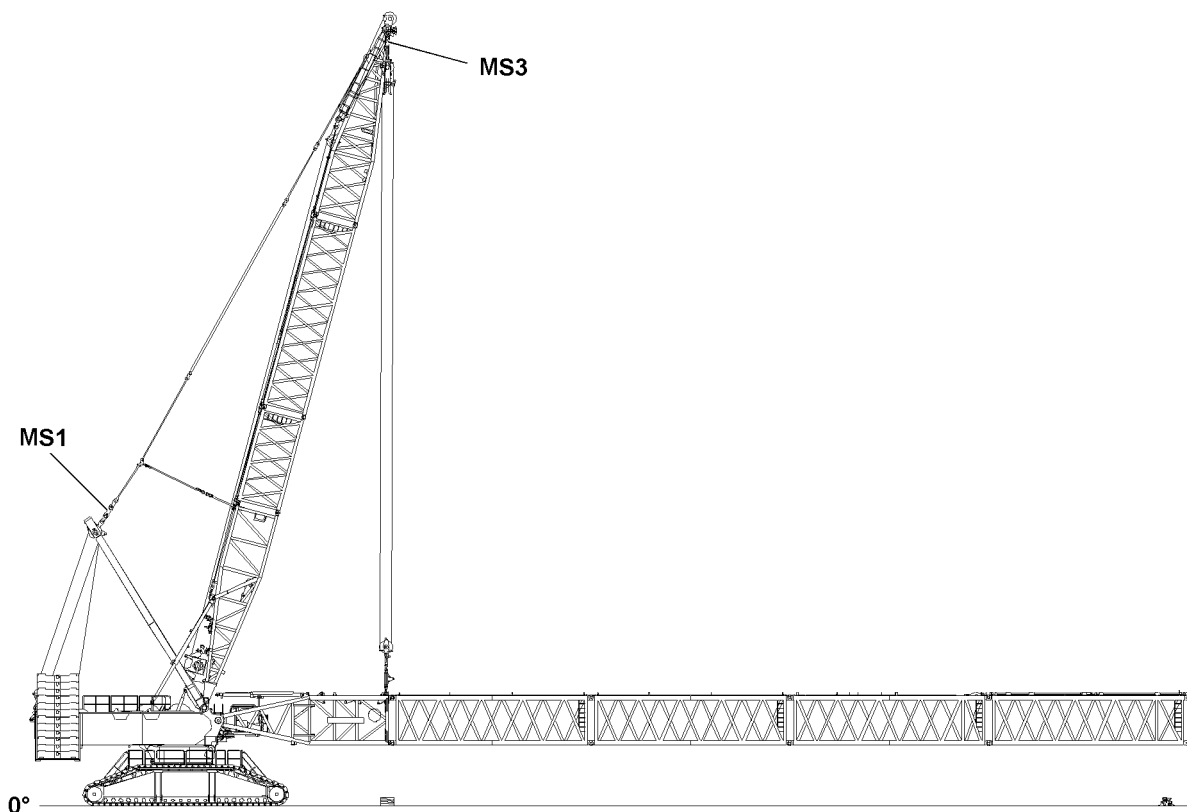

Fig.122710: SD // S2D // SL2D boom system - flying mode without end section

	System configuration for flying assembly		
	SD	S2D	SL2D
S-guying	X	X	X
WAB 2-guying	—	—	—
Counterweight	210 t	170 t	170 t
Central ballast	50 t	10 t	10 t
Maximum permissible flying assembly length	54 m	54 m	60 m

6.2.3 Completing the flying assembly

If the maximum permissible flying assembly length is installed and tensioned on the S-pivot section 1, the boom system must be taken down on the ground or a load bearing substructure.

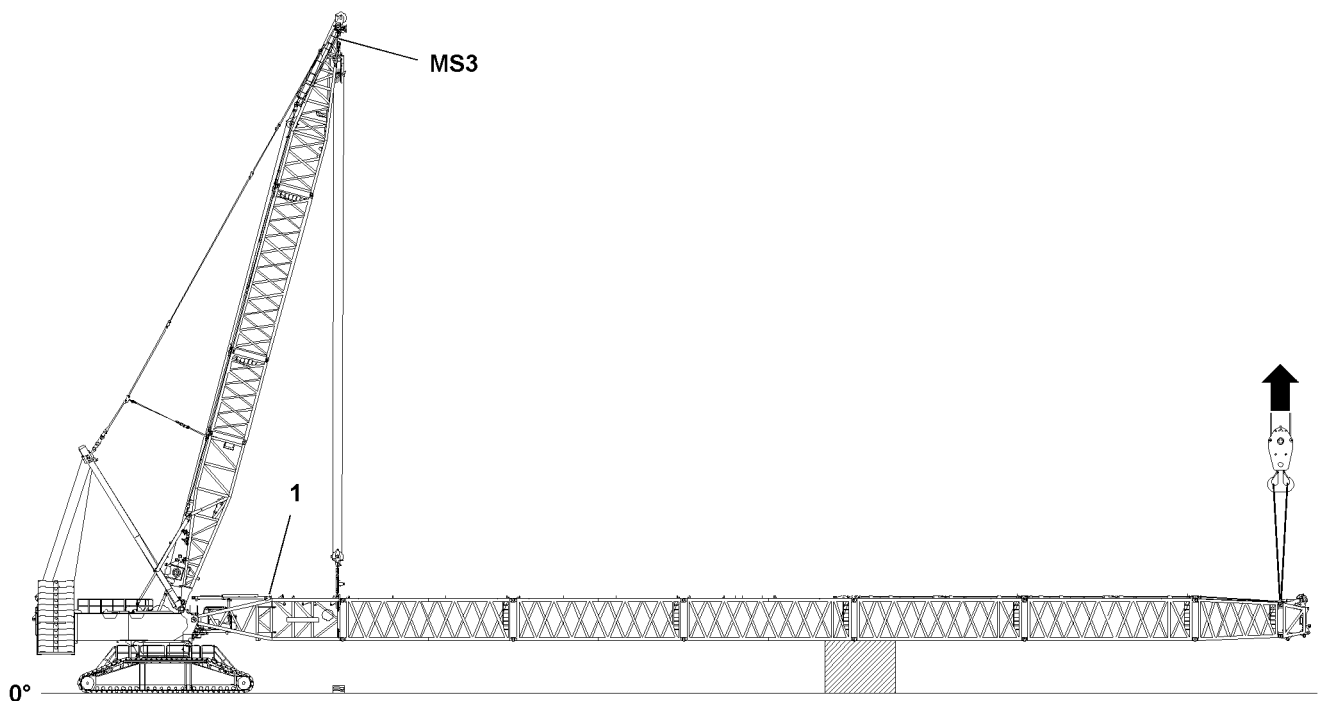

Fig.122711: Boom system supported **or** held by an auxiliary crane

Make sure that the following prerequisite is met:

- An auxiliary crane with sufficient load bearing capacity if available.

When the permissible flying assembly length is reached:

- ▶ Take the boom system down on the ground or on a load bearing substructure.
- ▶ Install the boom end section properly on the boom system.

Problem remedy

The maximum permissible flying assembly length does not correspond to the operating length?

- ▶ Take the boom system down on the ground.
- ▶ Expand the boom system on the ground to the required operating length.
- ▶ Close the boom system after reaching the required operating length with the auxiliary crane.

**WARNING**

The boom can suddenly fold down!
Death, severe bodily injuries, property damage.

- ▶ Before unpinning the brackets on the upper pulley block: Support the boom system properly or take it down on the ground.

When the boom system is properly taken down on the ground or supported:

- ▶ Relieve the guying between the D-end section and the S-pivot section.

7 Assembling the boom combinations with substructure

If the assembly conditions for the assembly of the boom system are restricted due to the terrain on the jobsite, then it is possible to install the SD-/S2D-/SL2D-boom with a substructure.

**WARNING**

General danger notes!

- ▶ All pins are to be secured after assembly with the intended retaining elements.
- ▶ The guy rods must be inspected regularly, see the Crane operating instructions, chapter 8.15.
- ▶ Secure the boom with substructure or auxiliary crane, see Crane operating instructions, chapter 5.01.
- ▶ It is prohibited for anyone to remain under the booms or within the complete danger zone during the pinning and unpinning procedure of the lattice section.

NOTICE

Property damage!

If the pins of the guy rods are not pinned from the „inside“ to the „outside“, the hoist rope can scrape on the pins and be damaged.

- ▶ Always insert the pins of the guy rods from the „inside“ to the „outside“, see the Rod plan.

**WARNING**

The crane can topple over!
Death, severe bodily injuries, property damage.

- ▶ For boom assembly / disassembly with the substructure, observe chapter 5.01.
- ▶ The „actual force“ on test point 3 **MS3** is shown on LICCON monitor 1.
- ▶ Observe the assembly conditions, see the Crane operating instructions, chapter 3.06.
- ▶ The specifications in the erection and take-down charts as well as the load charts must be observed.
- ▶ For the itemization of the lattice sections refer to the Rod plan.

NOTICE

Overload of boom!

If the boom is not supported before the erection procedure, then the boom will be overloaded during the erection procedure.

The boom system will be damaged.

- ▶ Support the SL2-boom from a length of more than 120 m.
- ▶ Support the S2-boom from a length of more than 138 m.
- ▶ Make sure that the dimension **X** for the maximum permissible deflection of the boom system is never exceeded.
- ▶ Support the boom with suitable materials with sufficient load carrying capacity in the marked area, see illustration.

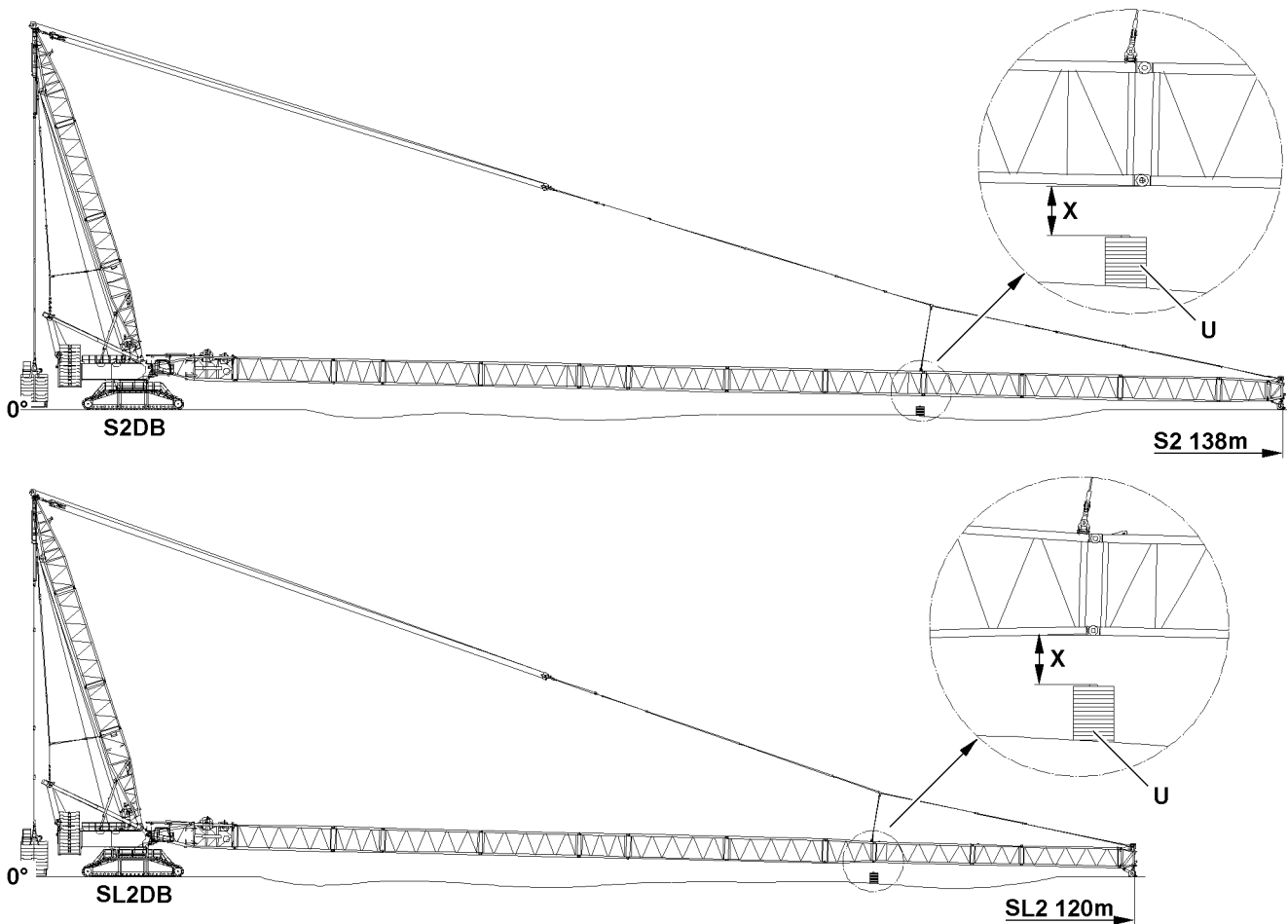

Fig.119449: Assembling the boom combinations with substructure

The boom combinations must be preassembled at a suitable location.

Swing the preassembled boom combination with the auxiliary crane(s) in to the turntable, pin and secure.

- ▶ Preassemble the boom combination.



WARNING

Danger of accident due to boom system!
Death, severe bodily injuries, property damage.

- ▶ Make sure that no persons are within the danger zone of the crane and the boom system to be assembled.
- ▶ Swing the preassembled boom combination with the auxiliary crane (s) to the turntable.
- ▶ Pin and secure the boom combination with the S-pivot section on the turntable, see section „Assembling the S-pivot section on the turntable“.

When the boom system is properly installed with the S-pivot section on the turntable:

- ▶ Support the boom system properly before taking it down on the ground.

Operating mode	Support from length	Dimension ¹⁾ X
SL2	120 m	0.9 m
S2	138 m	1.2 m

¹⁾ X = maximum permissible flexation of the boom system

- ▶ Lower the boom combination on the ground.

8 Assembling the S-guy rods



WARNING

Neglected guy rod inspection and maintenance!
Death, severe bodily injuries, property damage.

- ▶ Check the guy rods before every assembly, see Crane operating instructions, chapter 8.15.
- ▶ The S-guy rods must be assembled and secured, see Rod plan. The numbering in the rod plan must be identical to the numbering on the guy rods.
- ▶ Make sure that the inspection and maintenance intervals are adhered to.



WARNING

Falling components!
Death, severe bodily injuries, property damage.

- ▶ Make sure that the intermediate sections or preassembled boom unit are pinned and secured on the S-pivot section.
- ▶ Make sure that the intermediate sections or preassembled boom unit is supported with suitable materials, secured with the auxiliary crane or the boom is placed on the ground.

Make sure that the following prerequisites are met:

- The boom system is closed.
- The boom is supported
- **or** the boom is held in position by the auxiliary crane
- **or** the boom is laying on the ground.
- The D-boom is luffed down to the front.



Note

- ▶ The assembly of the upper pulley block on the guy rods for crane operation is according to the assembly „Assembling the upper pulley block on S-intermediate section for flying assembly“.

The guy rods are placed and secured for transport on the S-intermediate sections. Before assembly of the guy rods, release the transport retainers.

- ▶ Release and unpin transport retainers for the guy rods.

NOTICE

Property damage!

If the pins of the guy rods are not pinned from the „inside“ to the „outside“, the hoist rope can scrape on the pins and be damaged.

- ▶ Always insert the pins of the guy rods from the „inside“ to the „outside“, see the Rod plan.
- ▶ Pin the required guy rods with each other: Insert the pin from the „inside“ to the „outside“ and secure with locking pin.
- ▶ Assemble the guying according to the Rod plan, pin and secure it properly.
- ▶ Make sure that all required guy rods of the boom system are pinned and secured.
- ▶ If it is required according to the Rod plan: Assemble the auxiliary guying, see Crane operating instructions, chapter 5.01 and 5.03.



WARNING

Unutilized guy rods on boom!

If guy rods are on the lattice sections which are not required for crane operation, then there is a danger of accidents.

Death, severe bodily injuries, property damage.

- ▶ Non-required guy rods must be removed from the lattice sections, see Crane operating instructions, chapter 5.01.
- ▶ Remove non-required guy rods from the lattice sections.

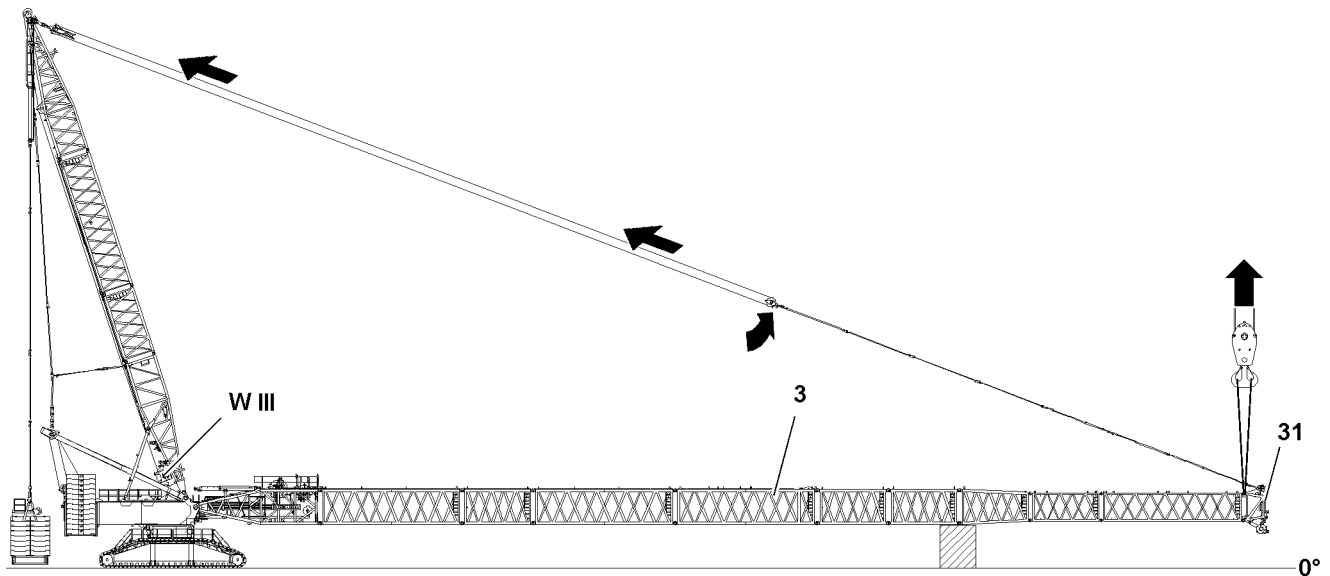

Fig.119435: Tension the boom guying with winch 3 (W III)

NOTICE

Danger of slack rope formation!

If winch 3 **W III** is spooled out too quickly during the erection procedure of the D-boom, slack rope can form.

- ▶ Make sure that the rope of winch 3 **W III** is tensioned during the entire erection procedure of the D-boom.



WARNING

Danger of accident due to boom system!

Death, severe bodily injuries, property damage.

- ▶ The boom system may not be raised during the erection of the D-boom in the operating position, and must remain in the initial position.

- ▶ Erect the D-boom in operating position and spool out winch 3 **W III** at the same time.

When the D-boom is in operating position:

- ▶ Tension the main boom guying between the D-boom and the boom end section.

9 Assembling the roller sets on the boom head

9.1 Assembling the roller sets



Note

- ▶ The assembly of the roller sets is described in the Crane operating instructions, chapter 5.14.

When the roller set / the roller sets are properly installed on the end section:

- ▶ Route the hoist limit switch from the end section forward on the roller set / the roller sets, pay attention and adhere to the Electrical wiring diagram.

9.2 Establishing the electrical connections on the boom end section

Make sure that the following prerequisites are met:

- The S-intermediate sections are properly assembled and secured on the ground.
- The boom end section is properly assembled and secured.
- The electrical connections to the boom end section have been established.
- The airplane warning light, wind speed sensor and all sensors are properly installed and secured on the boom end section.
- The hoist limit switches are properly installed and secured on the pulley head / pulley heads.

NOTICE

Danger of damage to the electrical connections!

If the electrical connection from the cable drum on the S-pivot section to the terminal box on the S-pivot section is established first before the connection to the terminal box on the boom end section, the electrical connection can be damaged when spooling out the cable drum.

- ▶ Establish first the electrical connection from the cable drum in the S-pivot section to the terminal box on the boom end section and then the electrical connection from the terminal box in the S-pivot section to the cable drum.
-



Note

- ▶ To establish the electrical connections on the S-boom: Use the Electrical wiring diagram.
-

- ▶ Establish the electrical connections.
 - ▶ Make sure that all electrical connections on the boom are established.
-



WARNING

Malfunction if dummy plugs are not installed!

If the dummy plugs on the non-required electrical connections are not installed, then malfunctions or functional limitations can occur on the crane.

- ▶ Make sure that all non-required electrical connections that have a dummy plug are closed off with dummy plugs.
 - ▶ Pay attention to the Electrical wiring diagram.
-
- ▶ As a rule, close off on-required electrical connections (for example for accessories which cannot be installed) with the respective dummy plugs.
-

NOTICE

Property damage due to dirt and / or corrosion!

If non-required electrical connections are not closed off with the respective protective caps, then dirt and / or corrosion can damage the electrical connections.

This could result in malfunctions.

- ▶ Make sure that all non-required electrical connections are always closed off properly.
 - ▶ Pay attention to the Electrical wiring diagram.
-
- ▶ Close electrical connections, which have no dummy plugs, properly off with the corresponding protective caps.
-

10 Performing the function checks



WARNING

Malfunctioning safety equipment!

Death, severe bodily injuries, property damage.

- ▶ Crane operation with non-functioning safety equipment is **prohibited**.
 - ▶ Start crane operation only after all safety equipment have been checked and are functioning correctly.
-

**Note**

- ▶ The function of the individual limit switches must be checked before erection of the boom system.
- ▶ The function of the limit switch initiators must be checked in the test system, see the Diagnostics manual.

**Note**

- ▶ If a function check on the limit switches or on the safety equipment does not lead to the desired shut-offs, then the plug connections on the connector boxes or the components themselves must be checked.
- ▶ If no visible connection errors or component defects can be found, contact Liebherr Service.

Make sure that the following prerequisites are met:

- All electrical connections have been made.
- The crane engine is running.
- The corresponding operating mode is set on the LICCON monitor.
- The actuator levers of the limit switches have been checked for easy movement and are lubricated.

10.1 Wind speed sensor

- ▶ Check the movement and the function of the wind speed sensor.

10.2 Airplane warning light

- ▶ Turn the airplane warning light on, see Crane operating instructions, chapter 4.01.
- ▶ Check the function visually.

10.3 Hoist limit switch

- ▶ Actuate the hoist limit switch manually on the pulley head.

Result:

- The hoist winch turns off in upward movement.
- The hoist top icon on the LICCON monitor 0 blinks.
- The hoist limit switch is functioning.

10.4 Checking the limit switch main boom „steepest position“

**Note**

- ▶ The limit switch functions have to be checked individually before erection.
- ▶ Cover the limit switch initiators on the relapse cylinders of the main boom individually with a metal plate.

Result:

- The limit switch is actuated manually.
- The spool up function of winch 4 turns off.
- The icon „Boom limitation“ appears on the LICCON monitor 0.

11 Erecting the boom

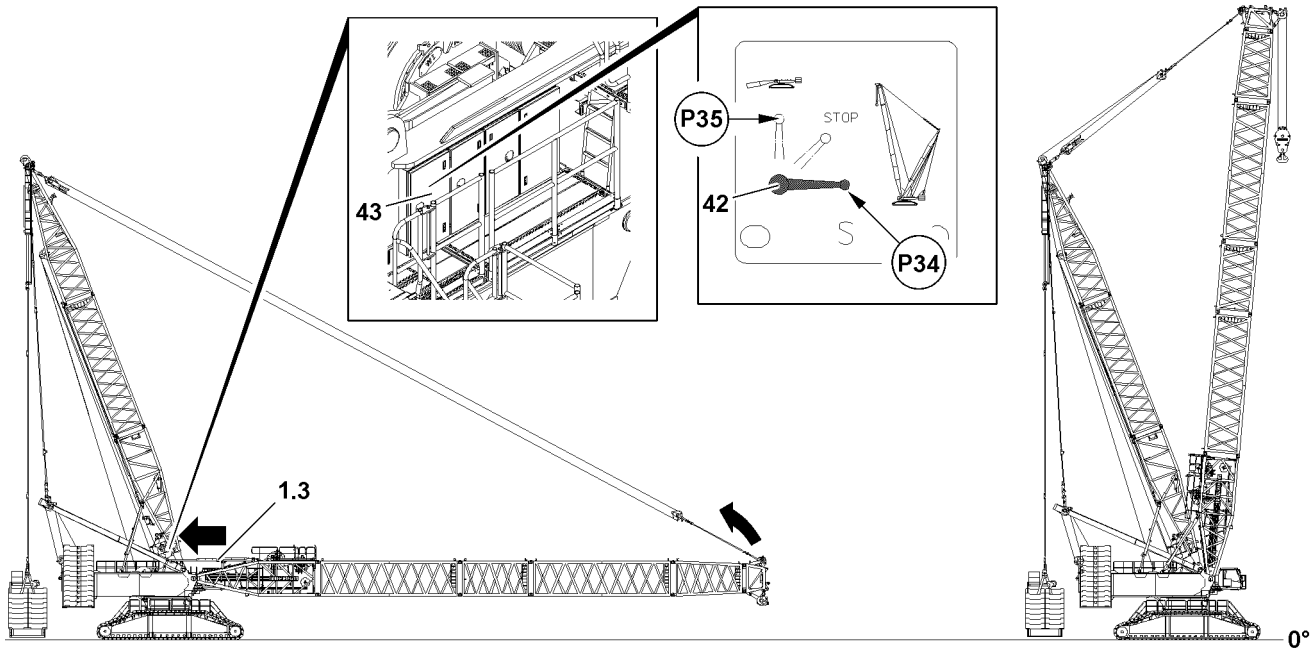

Fig.119436: Extending the relapse cylinder / erecting the boom system



WARNING

The crane can topple over!

In crane operation with bypassed LICCON overload protection, the crane can topple over. Death, severe bodily injuries, property damage.

- ▶ The radii listed in the load chart may not be exceeded or fallen below, even if there is no load on the hook.

If required in the erection and take down chart:

- ▶ Carry the hook block along with the auxiliary crane.



WARNING

The crane can topple over!

Death, severe bodily injuries, property damage.

- ▶ Observe the technical safety instructions, see the Crane operating instructions, chapter 5.01.
- ▶ Make sure that the relapse cylinders of the main boom are completely extended before erection of the boom combination.
- ▶ Do not allow slack rope to build up on the winch 4.



WARNING

Falling hoist rope!

Death, severe bodily injuries, property damage.

- ▶ Reeve the hoist rope before the erection procedure with a sufficient length on the roller set / the roller sets of the end section.
- ▶ The hoist rope must be constantly monitored during the erection procedure.
- ▶ Make sure that there are no persons within the danger zone.

Make sure that the following prerequisites are met:

- The crane is horizontally aligned.
- The guy rods are properly assembled.
- The guy rods which are not required have been removed from the lattice sections.
- All electrical connections have been made.
- All hydraulic connections have been made.
- The function checks were carried out properly.
- All limit switches and warning devices are functioning.
- Crane ballasting (counterweight, central ballast, derrick ballast and / or auxiliary ballast) is carried out according to the load charts and / or the erection and take-down charts
- The crane has been set up according to the load charts and / or the erection and take-down charts.
- The LICCON overload protection has been set according to the data in the load charts and / or the erection and take-down charts.
- The LICCON overload protection settings have been checked for completeness and correctness.
- Assembly operation of the crane control is activated: the assembly icon is visible on the LICCON monitor.
- All pin connections have been secured.
- The hoist rope has been correctly placed in the rope pulleys and is prevented from jumping out with the rope retaining pins.
- There are no loose parts on the boom system.
- The boom system and the safety equipment are free from snow, frost and ice.
- No personnel or obstacles are within the danger zone.

11.1 Moving the S-relapse cylinders out



WARNING

The crane can topple over!

Death, severe bodily injuries, property damage.

- ▶ Move the S-relapse cylinders **1.3** out completely before erecting the S-boom.
- ▶ Secure the ball valve **42** during crane operation to prevent inadvertent actuation.

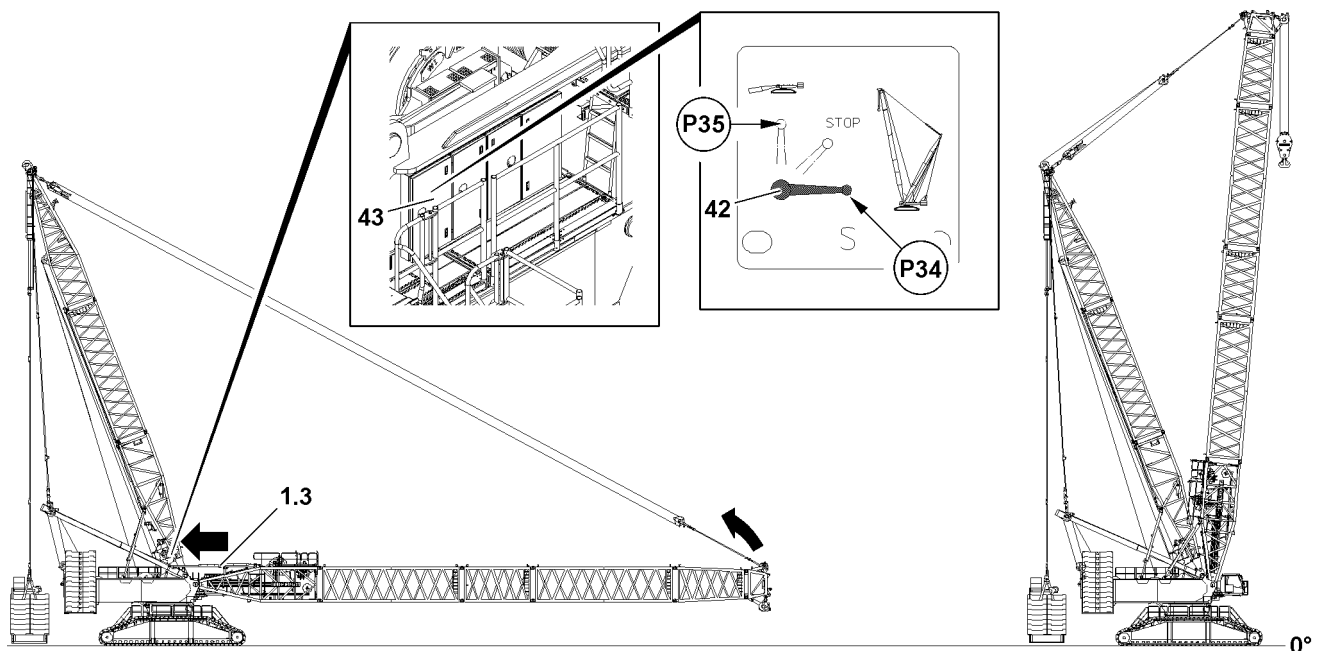

Fig.119436: Extending the relapse cylinder / erecting the boom system

Ball valve positions	
Position (P)	Function
34	Crane operation, extend the piston rod
35	Assembly, retract the piston rod
STOP	The piston rod cannot be retracted / extended

The piston rods on the S-relapse cylinders **1.3** can be moved out with the ball valve **42**.

- ▶ Set the ball valve **42** to position **P34**.

Result:

- The piston rods of the S-relapse cylinders **1.3** move out.



Note

- ▶ The ball valve **42** is secured by closing the cabinet door **43** and removing the key.

- ▶ Close the cabinet door **43** and pull out the key.
- ▶ Hand the key to an authorized person.

11.2 Erection procedure



DANGER

The crane can topple over!

- ▶ It is prohibited to turn the crane superstructure while erecting the boom.
- ▶ Adhere to the specifications in the erection and take down charts.

Make sure that the following prerequisite is met:

- The correct hook block weight is entered on the LICCON monitor, see the Crane operating instructions, chapter 4.02.

11.2.1 Reeving in the hook block

Make sure that the following prerequisites are met:

- The crane is horizontally aligned.
- The slewing gear brake is applied.



WARNING

Danger of accident due to side wind!

If the slewing gear brake is released after reeving in / reeving out the hook block / load hook, then the crane can turn uncontrolled if there is a strong side wind.

The crane can collide with close-by structures or objects.

Death, severe bodily injuries, property damage.

- ▶ Make sure that the current wind speed does not exceed the values from the wind speed chart when releasing the slewing gear brake.

- ▶ Erect the boom until the end section lifts off the ground.

NOTICE

Danger of slack rope formation!

By spooling the hoist winch out too fast during the reeving procedure, slack rope can form.

- ▶ Make sure that the hoist rope is tensioned during the entire reeving procedure.

**WARNING**

Falling hoist rope!

Death, severe bodily injuries, property damage.

- ▶ Reeve in the hoist rope with sufficient length on the S-boom before the erection process.
- ▶ The hoist rope must be constantly monitored during erection.
- ▶ Do not step into the danger zone.

- ▶ Reeve the hoist rope properly and secure it on the rope fixed point: Reeving, see Reeving plan.
- ▶ Pin and secure the rope retainers on the rope pulleys.
- ▶ Attach the hoist limit switch weight, see the Crane operating instructions, chapter 4.06.

11.2.2 Erecting the boom**WARNING**

The crane can topple over!

In crane operation with bypassed LICCON overload protection, the crane can topple over.

There is then no additional protection against crane overload.

Death, severe bodily injuries, property damage.

- ▶ The radii listed in the load chart may not be exceeded or fallen below, even if there is no load on the hook.
- ▶ Crane operation with bypassed LICCON overload protection is prohibited.

**Note**

- ▶ When the lowest operating position of the boom is reached, the set load chart of the LICCON overload protection is activated.
- ▶ In the maximum load icon appears a load number in „t“ instead of the display „???“.
- ▶ Luff the S-boom up to the lowest operating position.

Problem remedy

The erection procedure was turned off as a result of falling below the value $F3_{min}$?

- ▶ See the Crane operating instructions, chapter 4.02 and chapter 4.20.

When the S-boom has reached the lowest operating position:

- ▶ Make sure that the assembly icon on the LICCON monitor turns off.

Result:

- The LICCON overload protection is active.

12 Operating the crane**12.1 Preparing for crane operation****Note**

- ▶ Observe the notes, see Crane operating instructions, chapter 4.02, chapter 4.04, chapter 4.05, chapter 4.08 and chapter 5.01.

Make sure that the following prerequisites are met:

- The LICCON overload protection is active.
- The LICCON overload protection has been set according to the data in the load chart.



WARNING

The crane can topple over!

- ▶ Check the horizontal position of the crane before and during operation.
 - ▶ If the crane operator leaves the cab, even for a short time, the operating mode setting must be checked and reset if necessary before resuming crane operation.
-

12.1.1 Checking the settings

- ▶ Check the function of the overload protection by running against the operating positions „on top“ and „bottom“.
- ▶ Check the hoist limit switch by running against the hoist limit switch weight.

Empty page!

LWE/LR 11000-001/23501-04-02/en

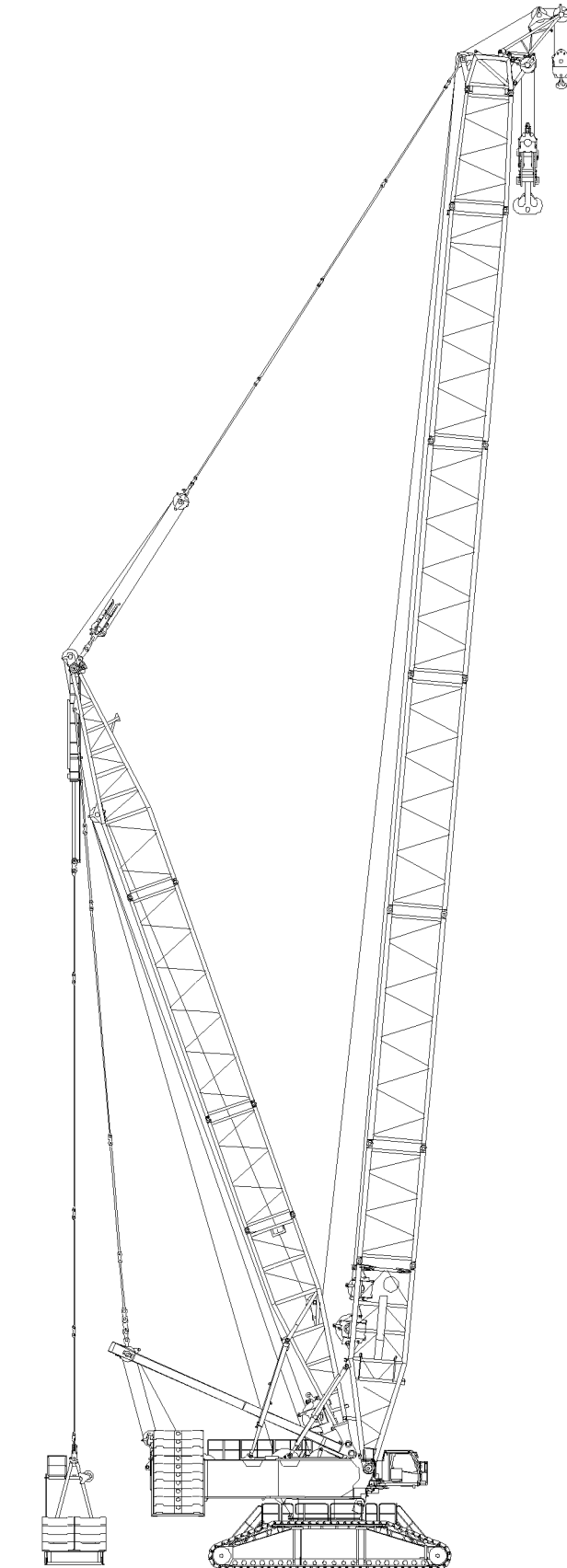

Fig.119146: SD/S2D/SL2D

LWE/LR 11000-001/23501-04-02/en

13 Disassembly SD/S2D/SL2D-boom



Note

- ▶ The disassembly is described on the example of the S-boom.
- ▶ For the combination of the boom lattice sections, observe and adhere to the Rod plan and the Crane operating instructions, chapter 5.03.



WARNING

Danger of falling!

During assembly / disassembly, inspection and maintenance work, assembly personnel must be secured with appropriate aids to prevent them from falling.

If this is not observed, assembly personnel could fall and be killed or seriously injured.

- ▶ All work at a height, when there is a danger of falling, must be carried out with suitable aids.
- ▶ If aids are not available and work cannot be carried out from the ground, then assembly personnel must secure themselves with the supplied fall arrest system to prevent falling, see the Crane operating instructions, chapter 2.04.
- ▶ If fall protection equipment is available, then it must be used, see the Crane operating instructions, chapter 2.06.
- ▶ When lifting, lowering, swinging crane parts in and out, no persons may remain in the danger zone.
- ▶ When closing or opening boom systems during boom assembly or boom disassembly, no persons may remain on the boom system or in the danger zone.
- ▶ If railings are present on the components, then they must be brought into the corresponding position and secured for assembly / disassembly work.
- ▶ Only step on the aids, ladders and catwalks with clean shoes.
- ▶ Keep aids, ladders and catwalks free of heavy dirt, snow and ice.
- ▶ During all assembly and disassembly work, maintenance work and inspections, travel or crane operation is prohibited.
- ▶ Remaining on a suspended load is prohibited.
- ▶ Stepping or walking on crane components and lattice sections, which have an incline of more than 20° is prohibited.
- ▶ For all assembly work, the crane driver of the main crane must be in voice contact with the crane driver / crane drivers of the auxiliary crane / auxiliary cranes.
- ▶ For assembly tasks, the crane driver may only initiate crane movements when the responsible guide has explicitly released the movement.



WARNING

The lattice sections can fall down!

Death, severe bodily injuries, property damage.

- ▶ Pin or unpin both pins at the same horizontal level, i.e. **left and right**.
- ▶ Do not stand under the lattice sections or within the entire danger zone during the pinning and unpinning procedure of the boom.
- ▶ Safely secure the pins in the storage locations as well as in the receptacles.
- ▶ It is prohibited to lean the auxiliary ladder against the component being disassembled.



WARNING

Danger of impact / crushing!

When installing / removing crane components with the auxiliary crane, crane components can start to swing back and forth.

When lifting / lowering and positioning crane components, there is an increased danger of impacts / crushing.

Death, severe bodily injuries, property damage.

- ▶ Make sure that personnel cannot be caught by components.
- ▶ Make sure that the crane is horizontally aligned.
- ▶ When working in danger zones: Use aids to protect limbs.
- ▶ Guide components with suitable aids to minimize oscillation.

**DANGER**

The components can fall down!

Death, severe bodily injuries, property damage.

- ▶ Do not disengage the auxiliary crane until the respective component is pinned and secured.

Make sure that the following prerequisites are met:

- The ground is able to safely take on the total operating weight of the crane.
- The crane is horizontally aligned.
- An auxiliary crane with sufficient load bearing capacity if available.
- An assembly scaffolding or a work platform is available.
- The central ballast has been installed on the crawler travel gear according to the load chart or the erection and take down charts.
- The counterweight has been installed on the turntable according to the load chart or the erection and take down charts.
- The LICCON overload protection has been set according to the data in the load chart.

13.1 Disassembling the derrick ballast

**WARNING**

The crane can topple over!

Death, severe bodily injuries, property damage.

- ▶ Observe the Erection and take down charts.
- ▶ If a derrick ballast is required for taking down the boom system, then leave the derrick ballast on the crane.

When no derrick ballast is required for taking down the boom system:

- ▶ Disassemble the derrick ballast, see Crane operating instructions, chapter 5.36.

13.2 Disassembling the central ballast

**WARNING**

The crane can topple over!

Death, severe bodily injuries, property damage.

- ▶ Observe the Erection and take down charts.
- ▶ If a central ballast is required for taking down the boom system, then leave the central ballast on the crane.

When no central ballast is required for taking down the boom system:

- ▶ Remove the central ballast, see Crane operating instructions, chapter 3.03.

13.3 Turning the turntable to the disassembly position

**WARNING**

The crane can topple over!

Death, severe bodily injuries, property damage.

- ▶ Observe the specifications in the erection and take-down charts.
 - ▶ Observe the data in the load charts.
-
- ▶ Turn the turntable into disassembly position according to the erection and take down charts.

13.4 Luffing the boom system down and reeving the hoist rope out



WARNING

The crane can topple over!

Death, severe bodily injuries, property damage.

- ▶ Observe the technical safety instructions, see the Crane operating instructions, chapter 5.01.
- ▶ Observe the specifications in the erection and take-down charts.

NOTICE

Damage of boom components!

Taking down the boom system can lead to a collision between the hook block and the pulley head.

Boom components can be severely damaged.

- ▶ Luff the boom system down and at the same time spool the hoist winch out.
- ▶ When luffing the boom system down, the D-boom must remain in operating position until the boom is laying on the substructure or until the boom end section is laying on the ground or is safely held by an auxiliary crane.



Note

- ▶ The luff down movement is turned off as soon as the lowest operating position of the main boom is reached.
 - ▶ When the lowest operating position of the main boom is reached, the load display in the maximum load icon turns off and instead of the load display appears the display „???“.
 - ▶ In the crane operating screen appear alarm functions.
- ▶ Luff the S-boom down to the **lowest** operating position.

Result:

- The luff down movement is turned off.
- The „STOP“ icon appears on the LICCON monitor.
- The horn icon appears on the LICCON monitor.

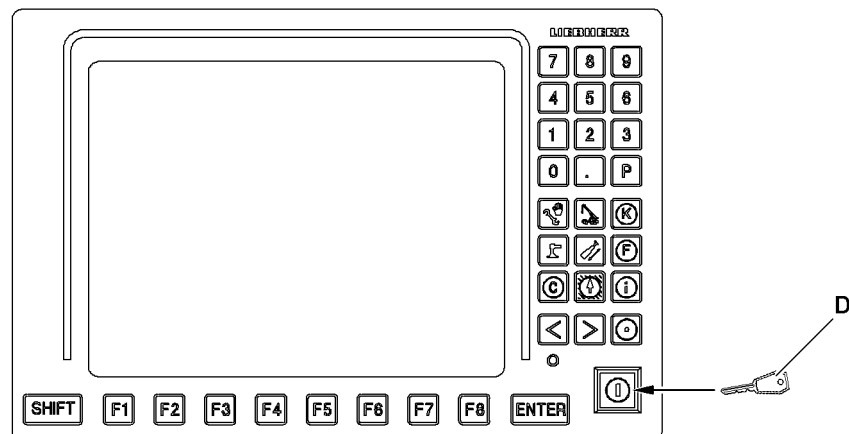

Fig.119109

**WARNING**

Danger of accident due to function „Exceedance of shut-off limits of the LICCON overload protection“! If the shut off limits of the LICCON overload protection are exceeded, there is no additional protection against crane overload.

Due to erroneous operation or deliberate misuse, the crane could collapse, the boom can break off or the crane can topple over.

Death, severe bodily injuries, property damage.

- ▶ The function „Exceedance of shut off limits of the LICCON overload protection“ is only permissible in emergencies and for assembly purposes.
- ▶ The function „Exceeding the shut off limits of the LICCON overload protection“ may only be actuated by persons who know the effects of their actions regarding the function „Exceeding the shut off limits of the LICCON overload protection“.
- ▶ The function „Exceedance of shut off limits of the LICCON overload protection“ requires the presence of an authorized person and must be performed with utmost caution.
- ▶ Crane operation with activated function „Exceedance of shut off limits of the LICCON overload protection“ is prohibited.

- ▶ Exceeding the shut off limits of the LICCON overload protection: Engage assembly operation.

Result:

- The shut off limits of the LICCON overload protection are exceeded.
- The assembly icon appears on the LICCON monitor.

**Note**

- ▶ See the Crane operating instructions, chapter 4.02 and 4.20.

- ▶ At the same time, spool the hoist winch out and luff the boom system down until the hook block touches the ground.
- ▶ Remove the hoist limit switch weight and reeve the hook block out.
- ▶ Remove the hook block with the auxiliary crane.

When the hook block is removed under the boom head:

- ▶ Continue to luff the boom system down until the roller set / roller sets are just above the ground.

**WARNING**

Spooling up of hoist rope!

Death, severe bodily injuries, property damage.

- ▶ All rope retaining pins / pipes on the boom system are removed.
- ▶ Slowly spool up the hoist rope over the rope pulleys back to the winch.
- ▶ No one may be present in the danger zone.

NOTICE

Overspoiled winch!

If the hoist rope is pulled under the winch when spooling up, then the adjustment of the cam limit switch can change.

A new adjustment by **Liebherr Service** is required.

- ▶ Stop the winch in time, with sufficient rope reserve.
 - ▶ Do not overspool the winch.
- ▶ Spool the hoist rope up.

13.5 Moving the S-relapse cylinder in

Make sure that the following prerequisite is met:

- The crane engine is running.

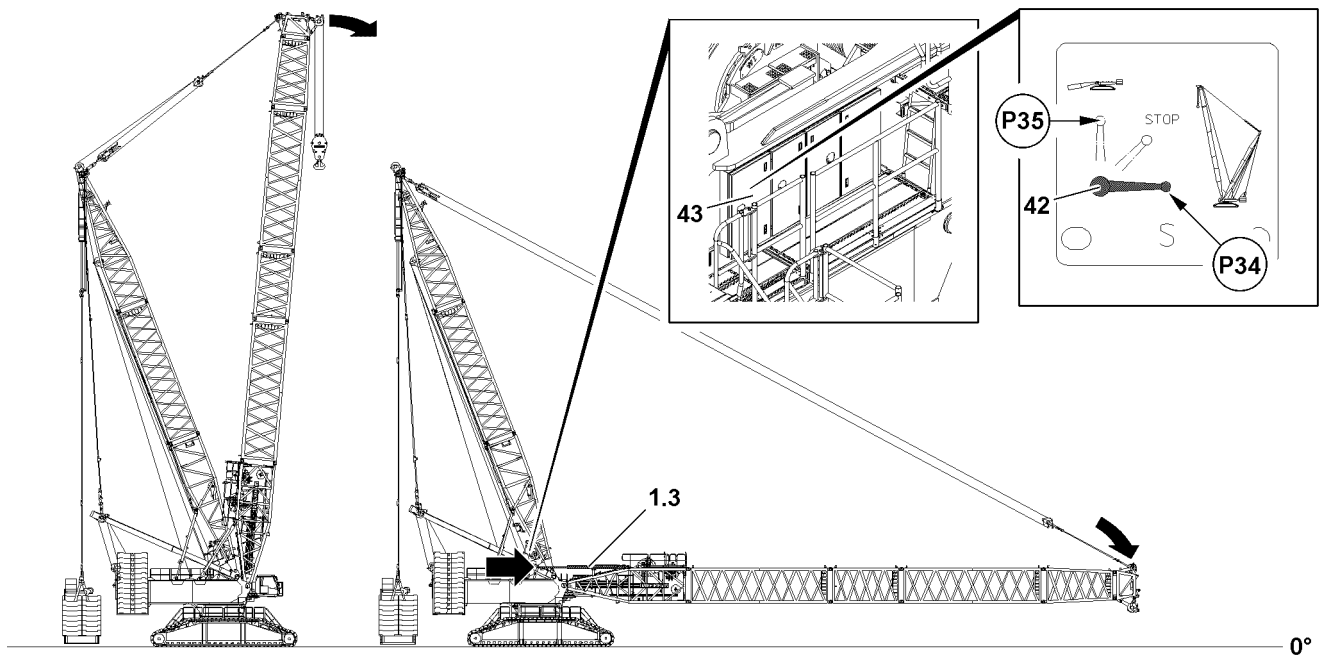

Fig.119437: Luffing the boom system down / retracting the relapse cylinder

Ball valve positions	
Position (P)	Function
34	Crane operation, extend the piston rod
35	Assembly, retract the piston rod
STOP	The piston rod cannot be retracted / extended

- ▶ Move the S-relapse cylinder **1.3** in: Actuate the ball valve **42** in position **P35**.

Result:

- The piston rods of the S-relapse cylinders **1.3** move in.



Note

- ▶ The ball valve **42** is secured by closing the cabinet door and removing the key.
- ▶ Close the cabinet door **43** and pull the key.
- ▶ Hand the key to an authorized person.

13.6 Disassembly of the roller sets on the boom head

NOTICE

Danger of property damage!

During the disassembly of the roller sets the electrical connections to the hoist limit switches can be damaged.

- ▶ Remove the hoist limit switches on the roller sets.
- ▶ Before disassembly of the roller sets, route the hoist limit switches from the roller sets back to the end section.

**Note**

- ▶ The disassembly of the roller sets is described in the Crane operating instructions, chapter 5.14.

13.7 Placing the boom on the substructure

Make sure that the following prerequisites are met:

- The hook block is properly unreeved and removed.
- The hoist limit switch is on the end section.
- The roller set / the roller sets are removed.

NOTICE

Overload of boom!

If the boom is not supported before the take down procedure, then the boom can be overloaded during the take down procedure.

The boom system will be damaged.

- ▶ Support the SL2-boom from a length of more than 120 m.
 - ▶ Support the S2-boom from a length of more than 138 m.
 - ▶ Make sure that the dimension **X** for the maximum permissible deflection of the boom system is never exceeded.
 - ▶ Support the boom with suitable materials with sufficient load carrying capacity in the marked area, see section „Assembling the boom combinations with the substructure“.
-
- ▶ Take the boom system down on the substructure.
or
Secure the boom system with the auxiliary crane in the horizontal position.
or
Take the boom system down on the ground.

13.8 Disconnecting the electrical connections on the boom end section

Make sure that the following prerequisite is met:

- The main boom is placed on the ground or is safely held by the auxiliary crane.

NOTICE

Damage to cable drum or cable!

If the cable of the cable drum is not properly spooled up on the cable drum after unplugging the S-end section, then the cable drum or the cable can be significantly damaged.

- ▶ Spool the cable drum up after unplugging.
-
- ▶ Spool the cable drum up and secure it to prevent inadvertent spooling out.
 - ▶ Disconnect the electrical connections and store the plugs and cables properly.

13.9 Disassembling the guy rods

Make sure that the following prerequisites are met:

- The boom is laying on the substructure on the ground.
- The guying is relieved.
- The auxiliary guying is removed (only if present).

NOTICE

Danger of slack rope formation!

If the D-boom is luffed down too quickly at disassembly of the guy rods, then slack rope formation can occur.

- ▶ Make sure that the rope of winch 3 is tensioned during the entire luff down procedure of the D-boom.
-
- ▶ Luff the D-boom down to the front and spool up winch 3 simultaneously until the guy rods are placed in the transport receptacles of the intermediate sections.

- ▶ Fasten the upper pulley block to the auxiliary crane and hold it in position with the auxiliary crane.

When the upper pulley block is safely held by the auxiliary crane:

- ▶ Unpin the guy rods **29** on the upper pulley block.
- ▶ Secure guy rods **29** in the transport receptacles of the intermediate sections: Insert and secure the pin.
- ▶ Spool winch 3 up carefully and guide the upper pulley block with the auxiliary crane to the D-end section.
- ▶ Erect the D-boom until the D-end section stands vertically over the brackets on the S-pivot section.
- ▶ Install the assembly weight on the upper pulley block.
- ▶ Pin and secure the upper pulley block properly with the brackets of the assembly weight on the bracket on the S-pivot section.

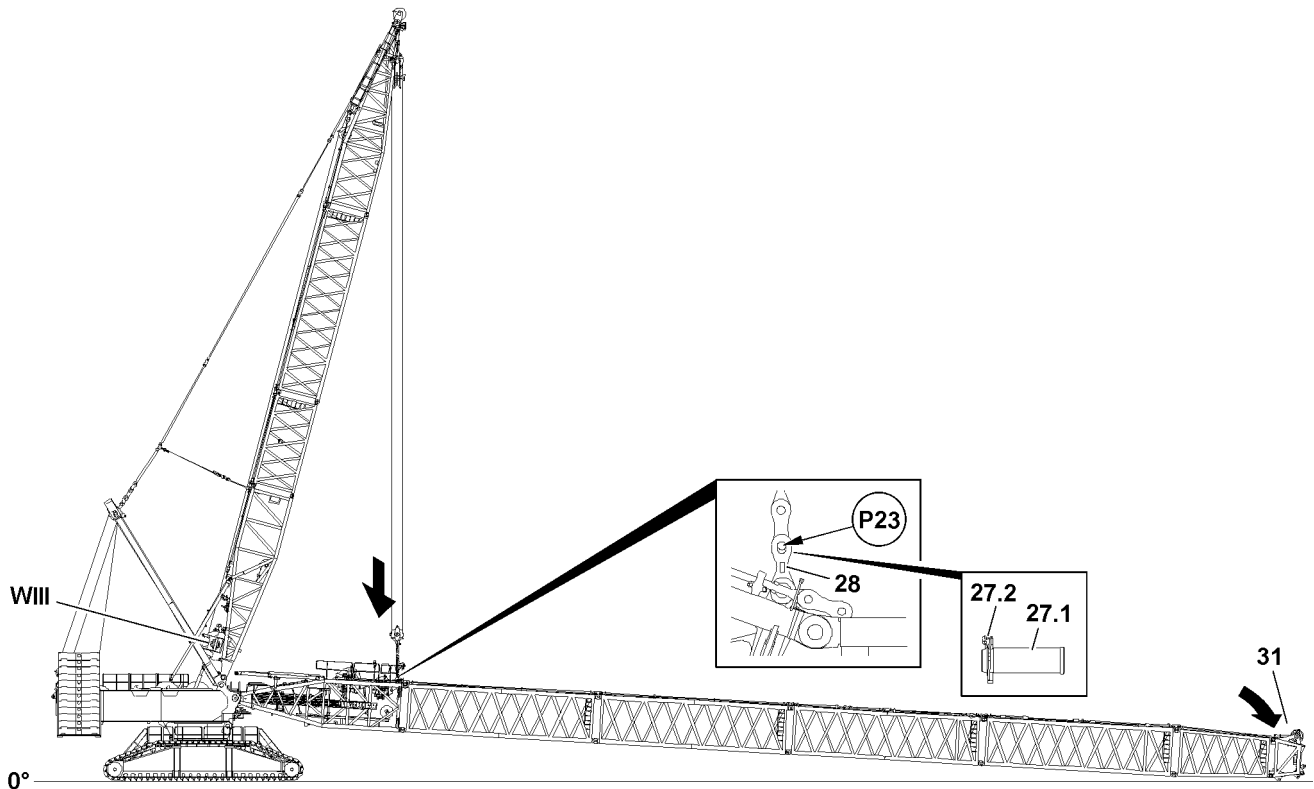

Fig.119438: Pinning the upper pulley block on the S-pivot section

- ▶ Tension the main boom by spooling up winch 3.



WARNING

The crane can topple over!

- ▶ Make sure that the end section of the boom system does **not** lift off the ground when opening the boom system.

When the brackets of the assembly weight are pinned with the brackets **28** on the S-pivot section:

- ▶ Spool winch 3 up until the guying is tensioned.

13.10 Opening the boom system

Make sure that the following prerequisites are met:

- The boom system is held safely by the upper pulley block.
- No personnel or obstacles are within the danger zone.

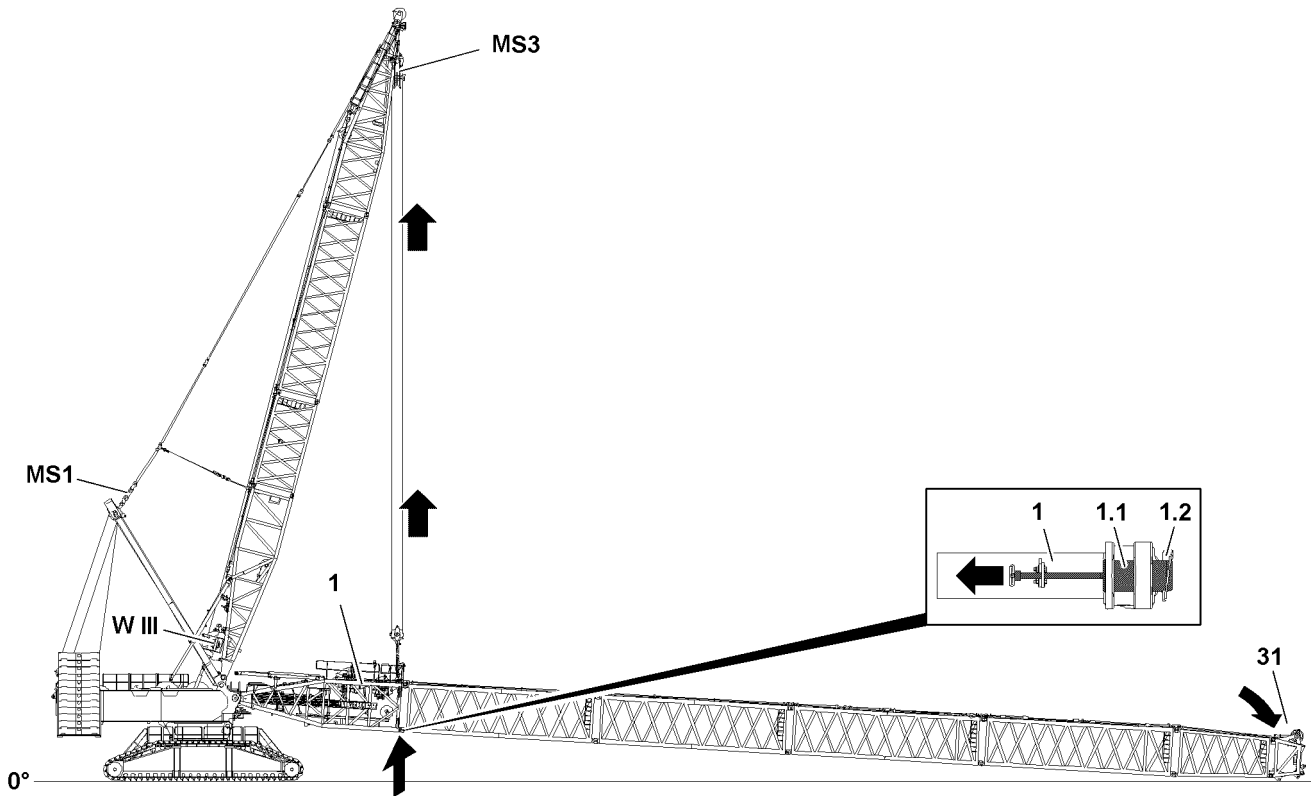

Fig.119439: Tension the guying



WARNING

The crane can topple over!
Death, severe bodily injuries, property damage.

- ▶ Do **not** exceed the maximum permissible total forces on test point 1 (MS1) and test point 3 (MS3).
- ▶ Lifting and opening the respective boom is only permissible by observing the maximum permissible boom lengths and total forces.
- ▶ The end section may **not** lift off the ground during „opening procedure“ of the boom system.
- ▶ Make sure that there are no persons on the boom system as well as in the danger zone during the opening procedure.



Note

- ▶ The actual forces on test point 1 **MS1** and test point 3 **MS3** - which are used during the closing procedure of the boom system - are shown on LICCON monitor 1.
- ▶ Tension the guying on the test points at disassembly with the same forces as for assembly.
- ▶ For this, refer to the **ACTUAL** forces on the test point 1 (MS1) and test point 3 (MS3) measured and recorded during the assembly.
- ▶ The pins can be pulled easier and the pins and lugs are therefore not damaged.

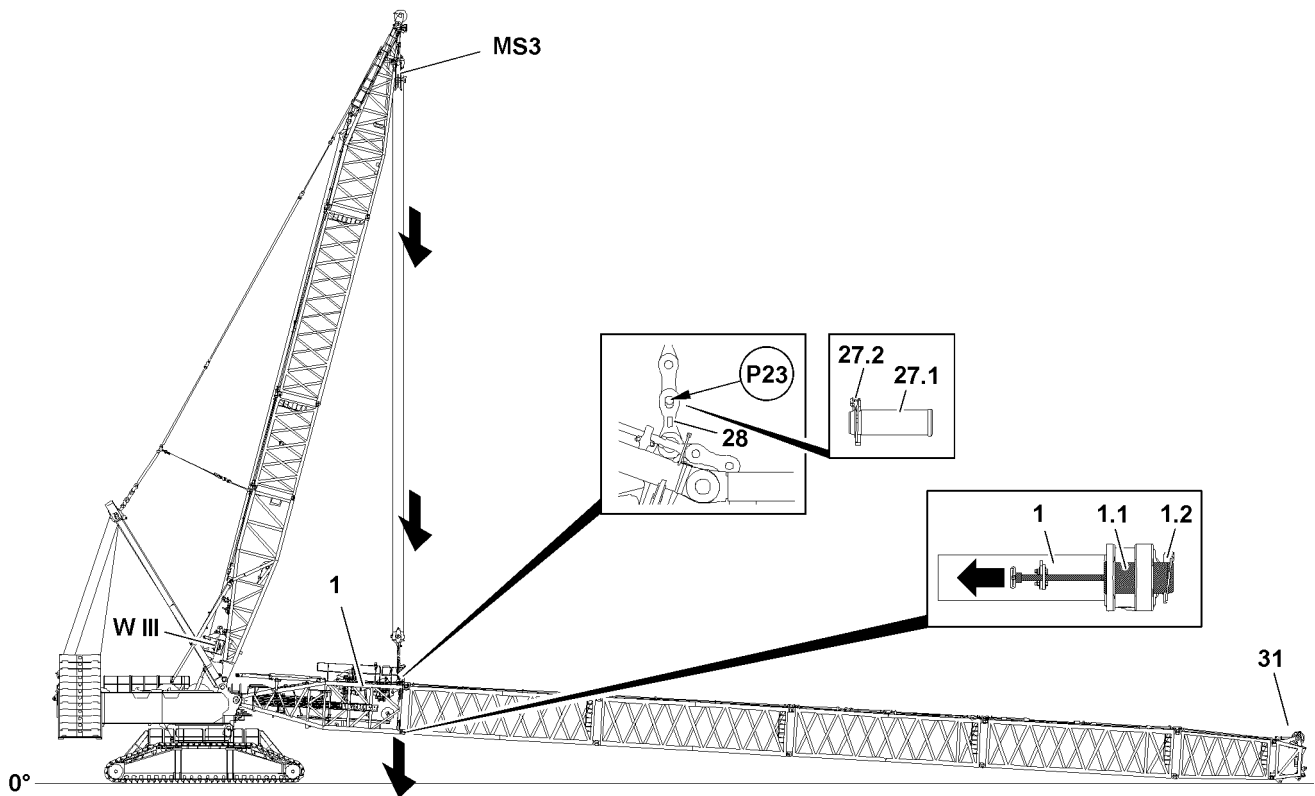

Fig.119440: Opening the boom system

- ▶ Open the boom system: Unpin the connector pins 1.1 on both sides „on the bottom“: Release and unpin the connector pins 1.1.

NOTICE

Danger of property damage!

When lowering the boom system, crane components can be damaged.

- ▶ Make sure that the S-pivot section 1 is not lowered directly on the ground.
- ▶ Lower the S-pivot section 1 on the substructure when opening the boom system.

When the connector pins 1.1 are completely unpinned:

- ▶ Lower the boom system carefully on the substructure on the ground.

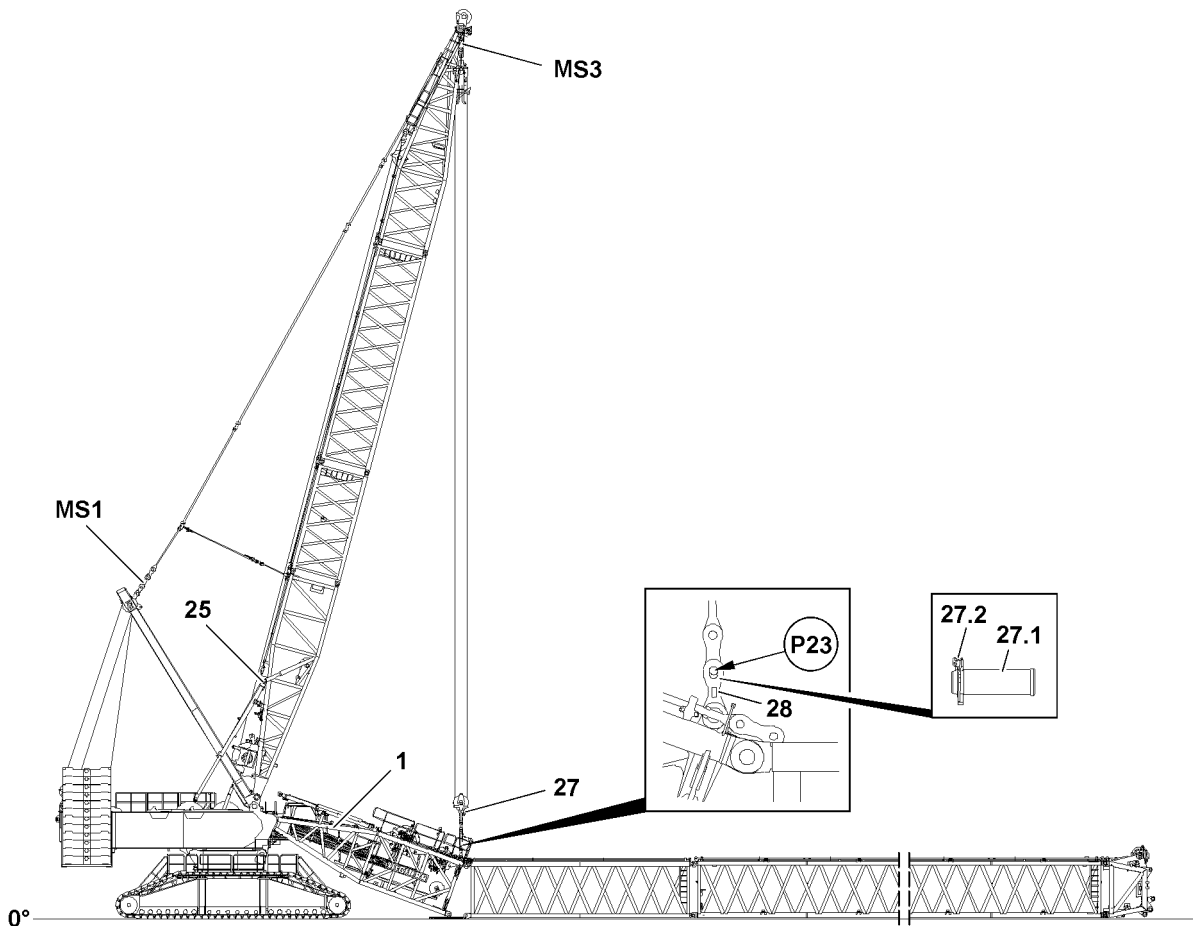

Fig.119424: Unpinning the upper pulley block on the S-pivot section

When the S-pivot section is laying on the substructure on the ground:

- ▶ Unpin the assembly weight of the upper pulley block on the brackets **28**: Release and unpin the pin **27.1**.
- ▶ Disconnect the electrical connections between the boom end section and the S-pivot section properly.



Note

- ▶ Install and secure the guy rods which are not required and which have been removed at the assembly of the lattice section properly in the transport retainers of the lattice sections.

- ▶ Place the guy rods which are not required on the lattice sections, pin and secure.
- ▶ Disassemble the boom system properly.

13.11 Disassembling winch 5 on the S-pivot section



Note

- ▶ The disassembly of winch 5 is described in the Crane operating instructions, chapter 3.07.50.

13.12 Disassembling winch 6 on the S-pivot section



Note

- ▶ The disassembly of winch 6 is described in the Crane operating instructions, chapter 3.07.60.

13.13 Disconnecting the electric and hydraulic connections on the S-pivot section

13.13.1 Disconnecting the electrical connections

Make sure that the following prerequisites are met:

- The boom system is opened.
- The S-pivot section is laying on the ground on the substructure.

NOTICE

Damage to cable drum or cable!

If the cable of the cable drum is not properly spooled up on the cable drum after unplugging the S-end section, then the cable drum or the cable can be significantly damaged.

- ▶ Spool the cable drum up after unplugging.
- ▶ Spool the cable drum up and secure it to prevent inadvertent spooling out.
- ▶ Disconnect the electrical connections and store the plugs and cables properly.

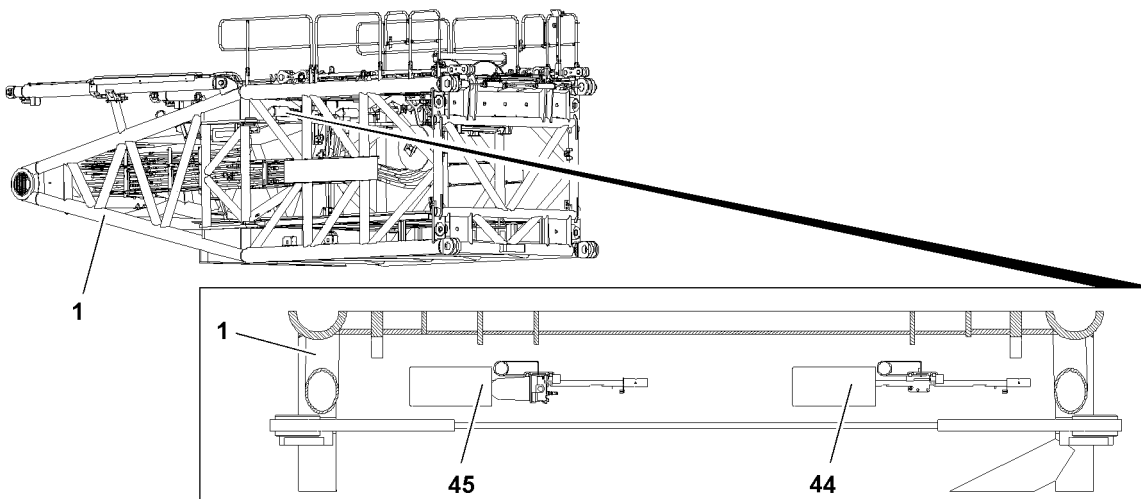

Fig.122057: Park position Wind speed sensor and airplane warning light

- ▶ Remove the wind speed sensor **44** and / or airplane warning light with wind speed sensor **45** on the boom end section and store it on the S-pivot section **1** properly in park position.

13.13.2 Disconnecting the hydraulic connections

When connecting and releasing hydraulic lines with quick couplings, make sure that the coupling procedure is carried out correctly.



DANGER

Danger of accident due to loss of pressure or leakage!

Incorrectly coupled or self-loosening quick couplings (particularly return lines) can result in serious accidents due to component failure.

Death, severe bodily injuries, property damage.

- ▶ Check that the quick couplings have been properly connected before using the crane.



Note

- ▶ To connect or release the hydraulic lines with quick couplings, see Crane operating instructions, chapter 5.01.

- ▶ Release the pressure in the hydraulic system before connecting or disconnecting. Turn the engine off and wait for short time.
- ▶ Assembling coupling components (sleeve and connector) by using knurled nut.

- ▶ Connect coupling components.

13.14 Disassembling the S-pivot section on the turntable



WARNING

General danger note!

- ▶ Insert and secure all pins after disassembly in the intended transport receptacles.

Make sure that the following prerequisites are met:

- The hydraulic connections to the S-pivot section are properly disconnected.
- The hydraulic connections on the S-pivot sections are properly closed off with caps.
- The electrical connections to the S-pivot section are properly disconnected.
- The electrical connections are properly closed off with dummy plugs (see Electrical wiring diagram).
- The crane engine is running.
- An auxiliary crane with sufficient load bearing capacity is available.

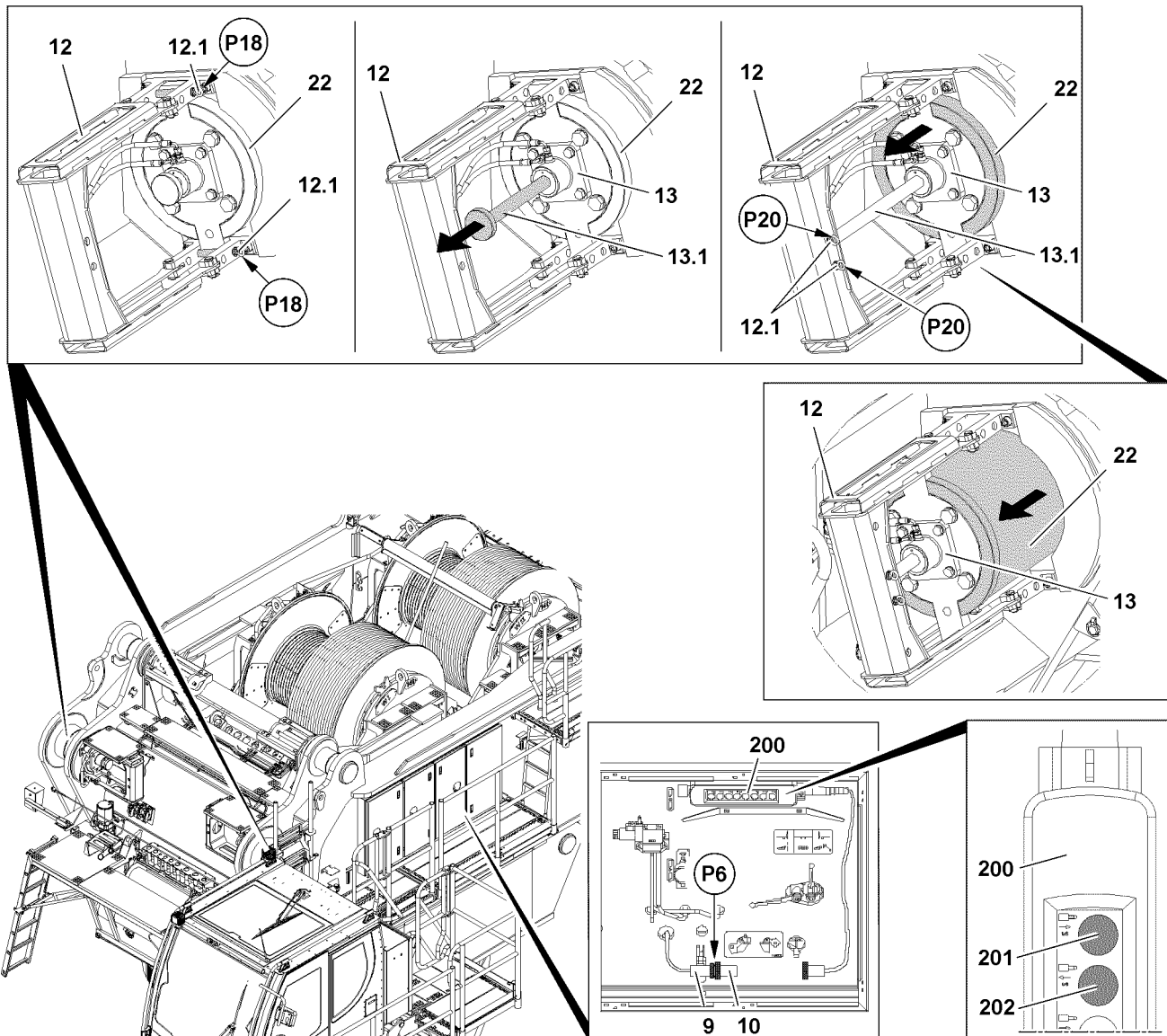

Fig.119111

**Note**

- ▶ Select the fastening points on the S-pivot section **1** in such a way that the S-pivot section **1** hangs horizontally on the auxiliary crane at disassembly. See section „Fastening points“.
- ▶ Attach the S-pivot section **1** properly on the auxiliary crane.

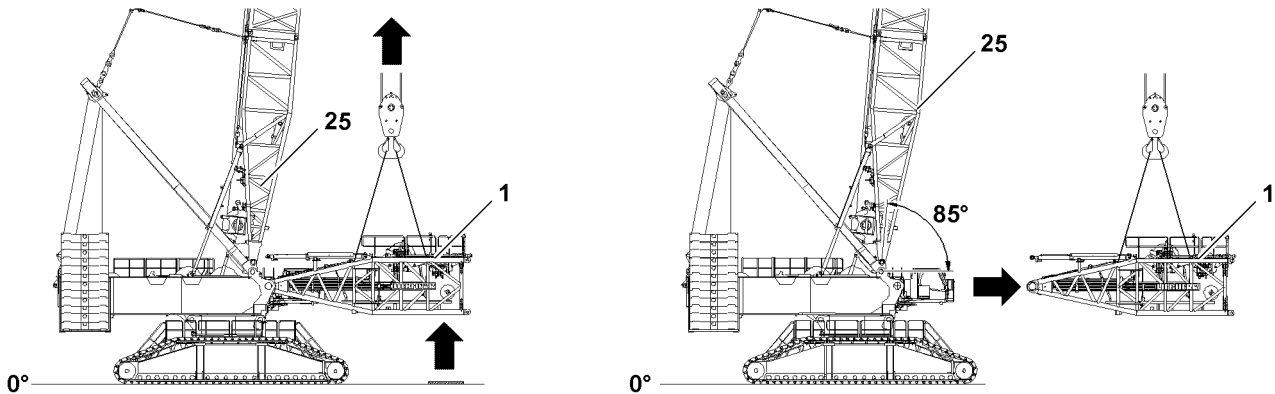

Fig.119442: Lifting the S-pivot section with the auxiliary crane horizontally / swinging the S-pivot section out from the turntable

- ▶ Lift the S-pivot section **1** with the auxiliary crane to the horizontal.

**WARNING**

Falling S-pivot section!
Death, severe bodily injuries, property damage.

- ▶ Make sure that the S-pivot section **1** is safely held by the auxiliary crane before unpinning the S-connector pins **22**.

**Note**

- ▶ The unpinning of the S-pivot section **1** on the turntable is described in detail in section: „Unpinning the S-connector pins on the turntable“.

When the S-pivot section is horizontally aligned and safely held by the auxiliary crane:

- ▶ Unpin the S-connector pins **22** on the turntable.

NOTICE

Damage of the turntable and the S-pivot section **1**!

- ▶ Slowly swing the S-pivot section **1** out with the auxiliary crane and at low speed on the turntable.
- ▶ Before placing it on the ground, support the S-pivot section **1**.

When the S-connector pins **22** on the S-pivot section **1** are fully unpinned on both sides:

- ▶ Swing the S-pivot section **1** out on the turntable with the auxiliary crane and place it down.
- ▶ Remove the auxiliary crane.

When the S-pivot section **1** is removed on the turntable:

- ▶ Fully insert and secure the S-connector pins **22** again.

13.15 Swinging the railing on the S-pivot section into transport position

**WARNING**

Danger of falling!
Death, severe bodily injuries, property damage.

- ▶ Assembly personnel must secure themselves for the assembly / disassembly of the railings and protective devices with an approved fall arrest system to prevent them from falling.
- ▶ For assembly and disassembly work, maintenance and inspection work on the S-pivot section, all railings and protective devices must be properly assembled and secured.

Make sure that the following prerequisites are met:

- The ground is able to safely take on the weight of the S-pivot section.
 - The S-pivot section is laying completely on the ground.
- For assembly / disassembly of railings and protective devices, see Crane operating instructions, chapter 2.06.

5.44 PD - boom combination

1	Component overview P-boom	3
2	Fastening points	3
3	Installing the central ballast	11
4	Assembly PD-boom	13
5	Assembling the boom combinations with substructure	42
6	Assembling the guy rods	44
7	Assembling the roller sets on the boom head	47
8	Performing the function checks	49
9	Erecting the boom	50
10	Operating the crane	53
11	Disassembly PD-boom	56

Fig.195219: PD-boom

LWE/LR 11000-001/23501-04-02/en

1 Component overview P-boom



Note

- ▶ The boom components (boom - lattice sections) such as S/L-intermediate sections, lower / upper P-adapter, cross carrier, S-adapter and the S-end section, as well as dimensions and weights are described in the Crane operating instructions, chapter 1.03.
- ▶ For the combination of the various boom systems, refer to the Rod plan and the Crane operating instructions, chapter 5.03.

2 Fastening points



WARNING

Falling lattice sections!

If the lattice sections are not properly fastened on the respective fastening points, then the lattice sections can tip over or fall down.

Death, severe bodily injuries, property damage.

- ▶ Make sure that the lattice sections are properly fastened on the respective fastening points.
- ▶ Make sure that the fastening equipment has the appropriate length and a sufficient load bearing capacity.
- ▶ Pay attention and adhere to the labels on the fastening points on the lattice sections and crane components.

2.1 Fastening points S-pivot section

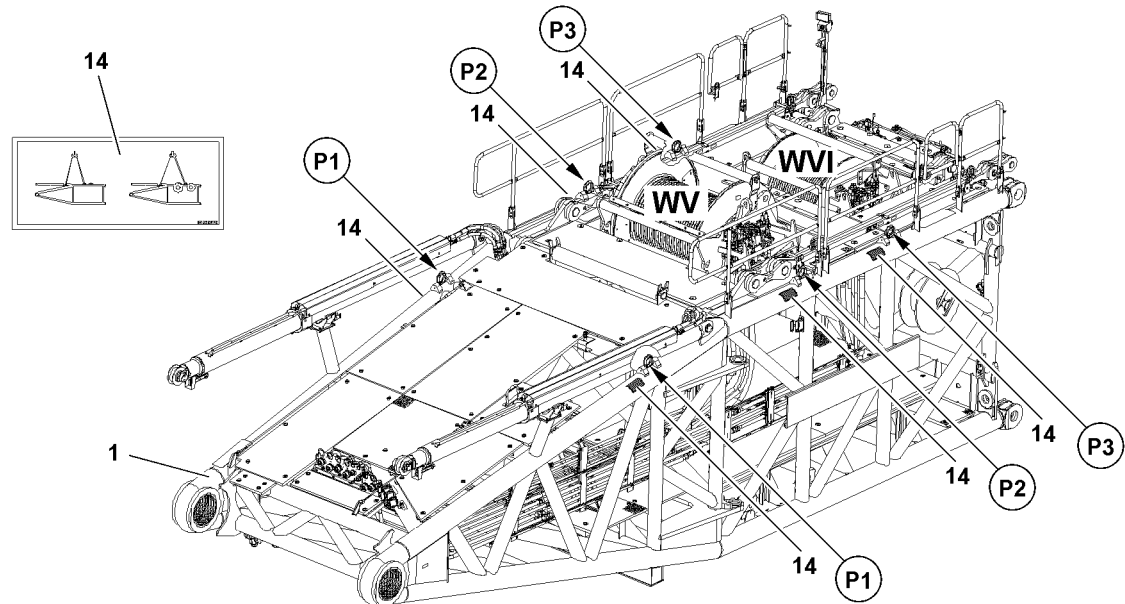

Fig.120275: Fastening points S-pivot section

Fastening points	
P1 + P2	S-pivot section without winch 5, without winch 6
P1 + P3	S-pivot section with winch 5, without winch 6
P1 + P3	S-pivot section without winch 5, with winch 6
P1 + P3	S-pivot section with winch 5, with winch 6

2.2 Fastening points lower P-adapters

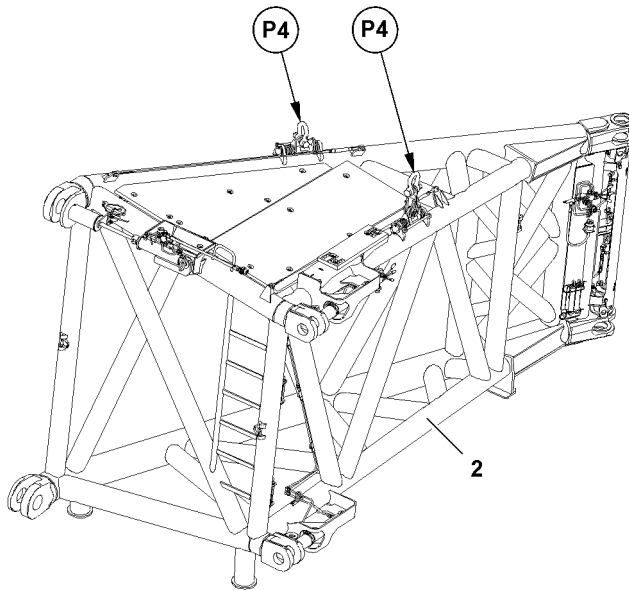

Fig.120276: Fastening points lower P-adapters

Fastening points	
P4	Lower P-adapter

2.3 Fastening points cross carrier

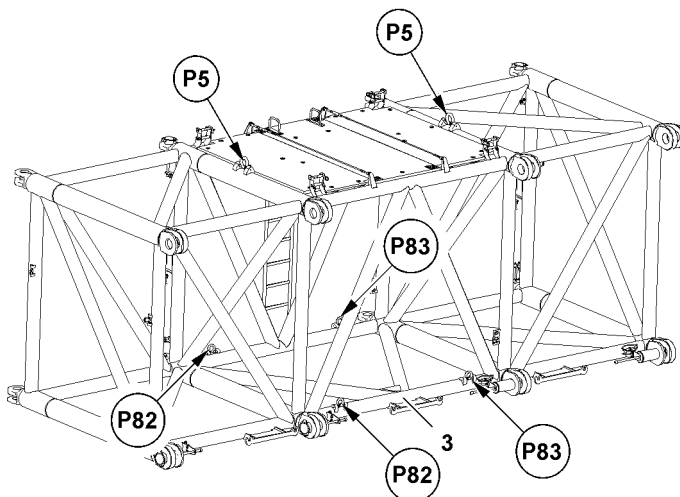

Fig.120277: Fastening points cross carrier

Fastening points	
P5 or P82 + P83	Cross carrier

2.4 Fastening points L-intermediate section 6 m

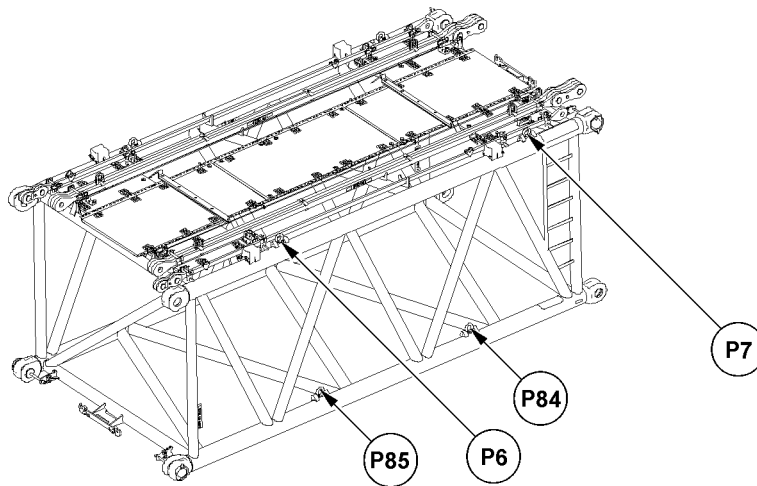

Fig.120278: Fastening points L-intermediate section 6 m



Note

- ▶ The L-intermediate sections are available in various system dimensions.
- ▶ The distance between the fastening points can vary, depending on the respective L-intermediate section.
- ▶ The lattice section must be fastened on both sides on the fastening points.

Fastening points	
P6 + P7 or P84 + P85	L-intermediate section 6 m

2.5 Fastening points L-intermediate section 12 m

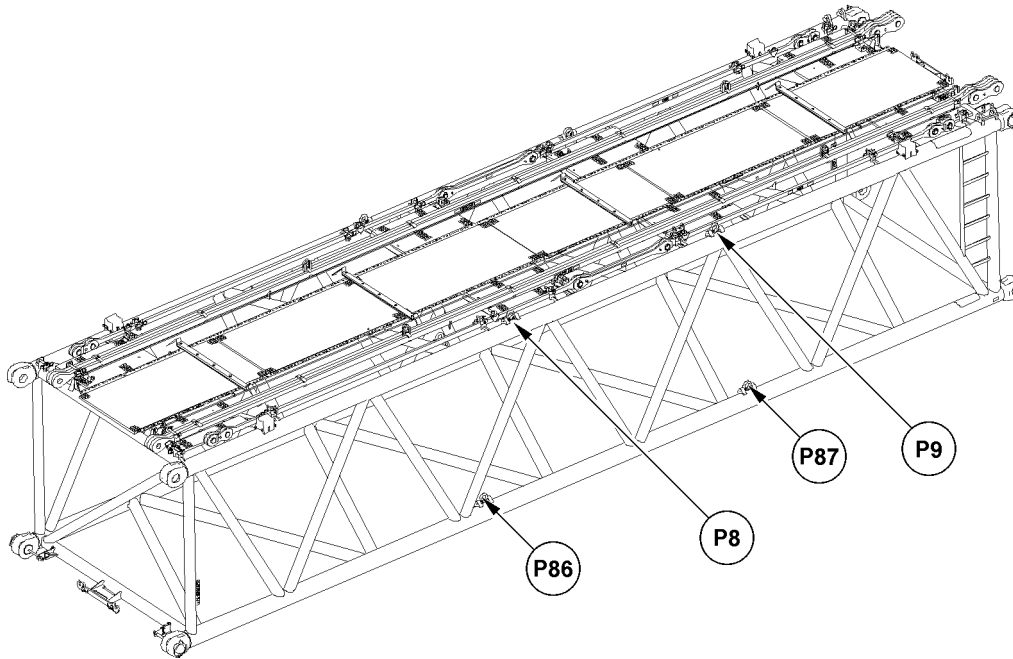

Fig.120279: Fastening points L-intermediate section 12 m



Note

- ▶ The L-intermediate sections are available in various system dimensions.
- ▶ The distance between the fastening points can vary, depending on the respective L-intermediate section.
- ▶ The lattice section must be fastened on both sides on the fastening points.

Fastening points	
P8 + P9 or P86 + P87	L-intermediate section 12 m

2.6 Fastening points turned L-intermediate section 6 m / L-intermediate section 12 m

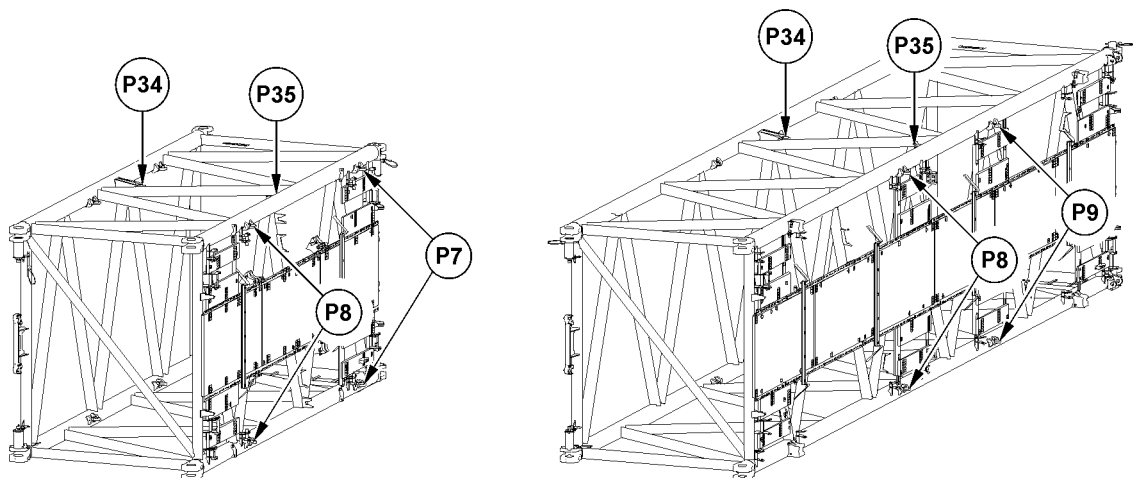

Fig.120297: Fastening points turned L-intermediate section 6 m / L-intermediate section 12 m



Note

- ▶ The L-intermediate sections are available in various system dimensions.
- ▶ The distance between the fastening points can vary, depending on the respective L-intermediate section.

Fastening points	
P6 + P7	L-intermediate section 6 m (normal location)
P8 + P9	L-intermediate section 12 m (normal location)
P34 + P35	L-intermediate section (turned)

2.7 Fastening points upper P-adapter

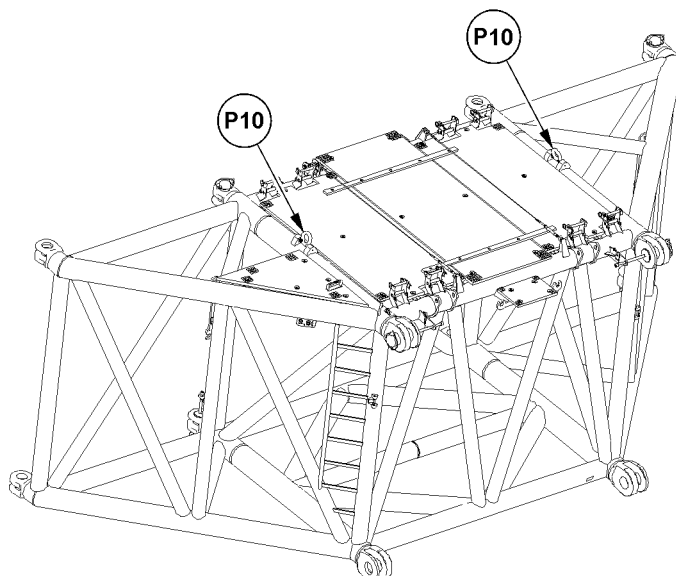

Fig.120280: Fastening points upper P-adapters

Fastening points	
P10	Upper P-adapter

2.8 Fastening points S-intermediate section 6 m

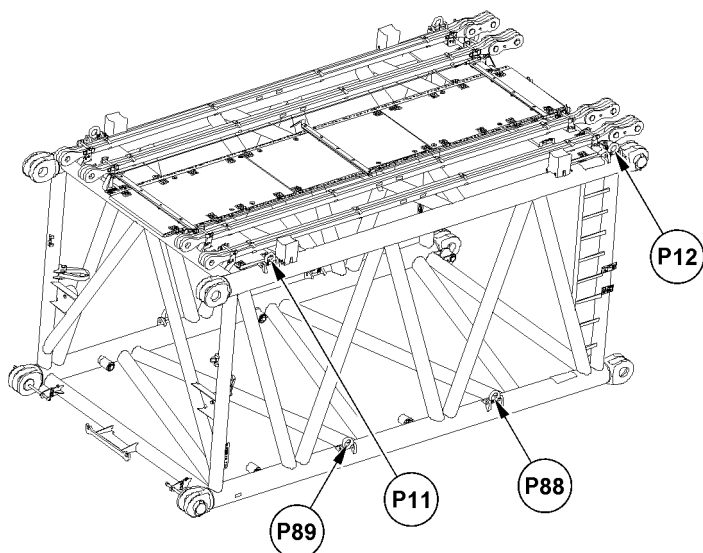

Fig.120281: Fastening points S-intermediate section 6 m



Note

- ▶ The S-intermediate sections are available in various system dimensions.
- ▶ The distance between the fastening pints can vary, depending on the respective S-intermediate section.
- ▶ The lattice section must be fastened on both sides on the fastening points.

Fastening points	
P11 + P12 or P88 + P89	S-intermediate section 6 m

2.9 Fastening points S-intermediate section 12 m / S-adapter 12 m

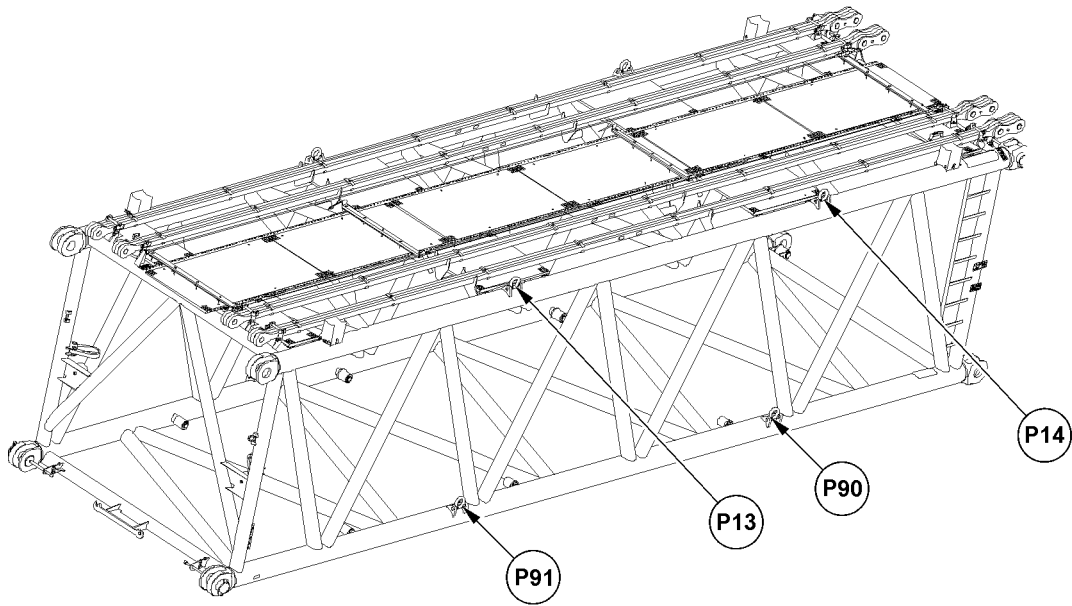

Fig.120282: Fastening points S-intermediate section 12 m / S-adapter 12 m



Note

- ▶ The S-intermediate sections are available in various system dimensions.
- ▶ The distance between the fastening pints can vary, depending on the respective S-intermediate section.
- ▶ The lattice section must be fastened on both sides on the fastening points.

Fastening points	
P13 + P14 or P90 + P91	S-intermediate section 12 m / S-adapter 12 m

2.10 Fastening points S-end section

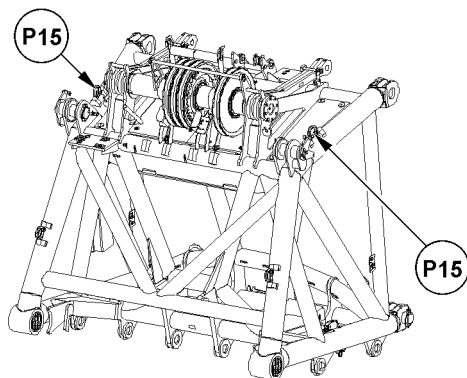

Fig.120283: Fastening points S-end section

LWE/LR 11000-001/23501-04-02/en

Fastening points	
P15	S-end section

2.11 Fastening points Transport unit Bridges

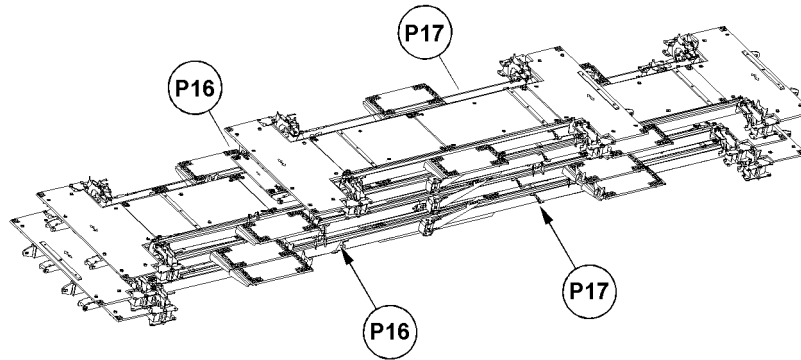

Fig.124513: Fastening points Transport unit Bridges



WARNING

Missing rigging!

Death, severe bodily injuries, property damage.

► Rig the transport unit bridges properly before lifting.

Fastening points	
P16 + P17	Transport unit Bridges

2.12 Fastening points Bridges 6 m

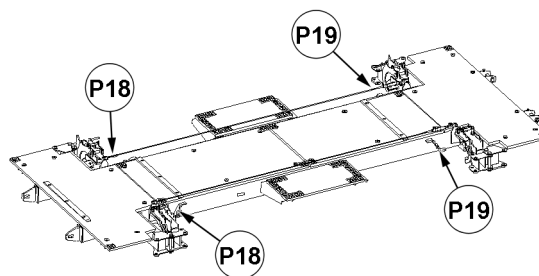

Fig.124514: Fastening points Bridges 6 m

Fastening points	
P18 + P19	Bridge 6 m

2.13 Fastening points Bridges 12 m

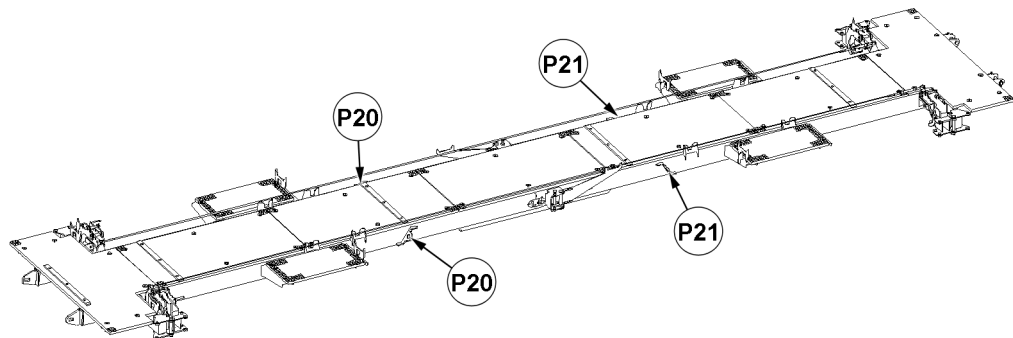

Fig.124515: Fastening points Bridges 12 m

Fastening points	
P20 + P21	Bridge 12 m

3 Installing the central ballast

If a central ballast according to the load chart is required for the planned crane operation, then install the central ballast, see Crane operating instructions, chapter 3.03.



WARNING

The crane can topple over!

If no central ballast is installed on the crane, the crane can topple over.

Death, severe bodily injuries, property damage.

- ▶ Make sure that the central ballast according to the load chart is installed for the planned crane operation.
- ▶ Observe the assembly conditions in the Crane operating instructions, chapter 3.06.

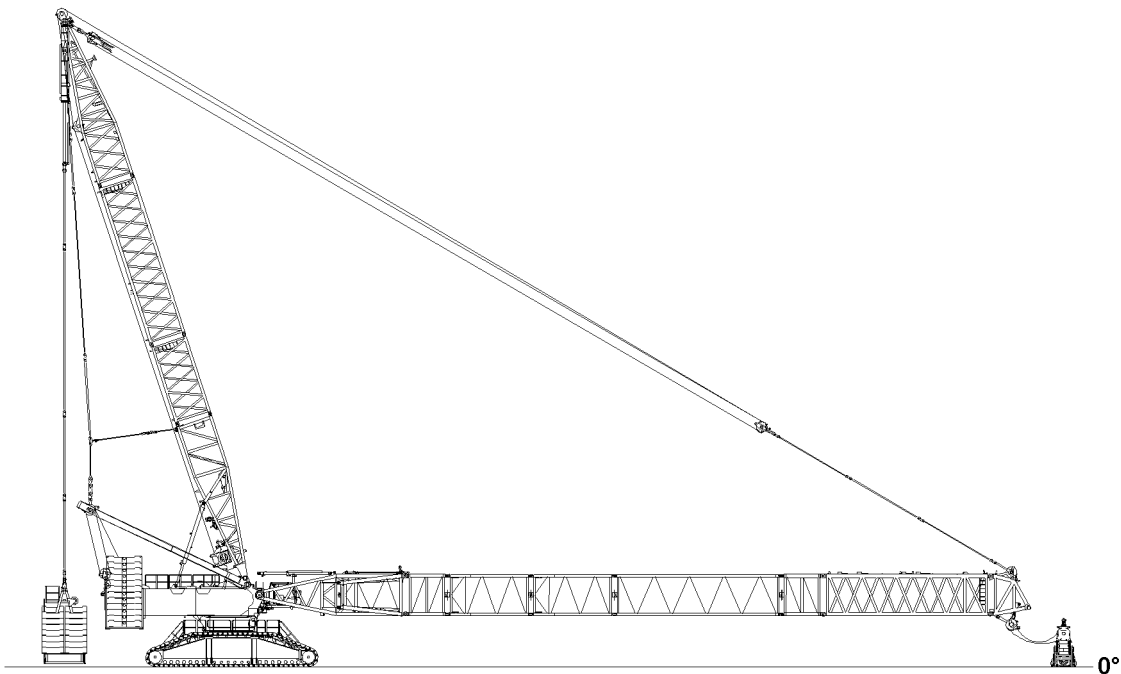
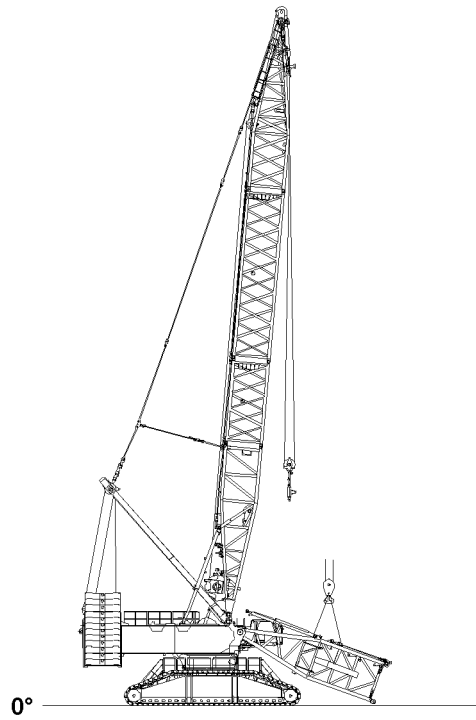

LWE/LR 11000-001/23501-04-02/en

Fig.122961: Assembly PD-boom

4 Assembly PD-boom



WARNING

Danger of falling!

During assembly / disassembly, inspection and maintenance work, assembly personnel must be secured with appropriate aids to prevent them from falling.

Death, severe bodily injuries, property damage.

- ▶ All work at a height, when there is a danger of falling, must be carried out with suitable aids.
- ▶ If aids are not available and work cannot be carried out from the ground, then assembly personnel must secure themselves with the supplied fall arrest system to prevent falling, see the Crane operating instructions, chapter 2.04.
- ▶ If fall protection equipment is available, then it must be used, see the Crane operating instructions, chapter 2.06.
- ▶ When lifting, lowering, swinging crane parts in and out, no persons may remain in the danger zone.
- ▶ When closing or opening boom systems during boom assembly or boom disassembly, no persons may remain on the boom system or in the danger zone.
- ▶ If railings are present on the components, then they must be brought into the corresponding position and secured for assembly / disassembly work.
- ▶ Only step on the aids, ladders and catwalks with clean shoes.
- ▶ Keep aids, ladders and catwalks free of heavy dirt, snow and ice.
- ▶ During all assembly and disassembly work, maintenance work and inspections, travel or crane operation is prohibited.
- ▶ Remaining on a suspended load is prohibited.
- ▶ Stepping or walking on crane components and lattice sections, which have an incline of more than 20° is prohibited.
- ▶ For all assembly work, the crane driver of the main crane must be in voice contact with the crane driver / crane drivers of the auxiliary crane / auxiliary cranes.
- ▶ For assembly tasks, the crane driver may only initiate crane movements when the responsible guide has explicitly released the movement.



WARNING

The lattice sections can fall down!

If the lattice sections are not pinned and secured correctly, then they can fall down.

Death, severe bodily injuries, property damage.

- ▶ Pin or unpin both pins at the same horizontal level, i.e. **left and right**.
- ▶ Do not stand under the lattice sections or within the entire danger zone during the pinning and unpinning procedure of the boom.
- ▶ Safely secure the pins in the storage locations as well as in the receptacles.
- ▶ It is prohibited to lean the auxiliary ladder against the component being disassembled.



WARNING

Danger of impact / crushing!

When installing / removing crane components with the auxiliary crane, crane components can start to swing back and forth.

When lifting / lowering and positioning crane components, there is an increased danger of impacts / crushing.

Death, severe bodily injuries, property damage.

- ▶ Make sure that personnel cannot be caught by components.
- ▶ Make sure that the crane is horizontally aligned.
- ▶ When working in danger zones: Use aids to protect limbs.
- ▶ Guide components with suitable aids to minimize oscillation.

**WARNING**

Danger of accident!

If no guide is present during assembly work who has voice connection to the crane operator as well as to the drivers of the auxiliary units, then there is a great danger of accidents.

Crane movements, which are carried out without the approval of the guide, can cause accidents. Death, severe bodily injuries, property damage.

- ▶ For all assembly work, observe the instructions of the guide.
- ▶ Make sure that the danger zone can be seen completely by the crane operator and / or the guide.

**DANGER**

The components can fall down!

If the corresponding components are disengaged from the auxiliary crane before the corresponding component is pinned, the corresponding component can fall down and fatally injure personnel.

- ▶ Do not disengage the auxiliary crane until the respective component is pinned and secured.

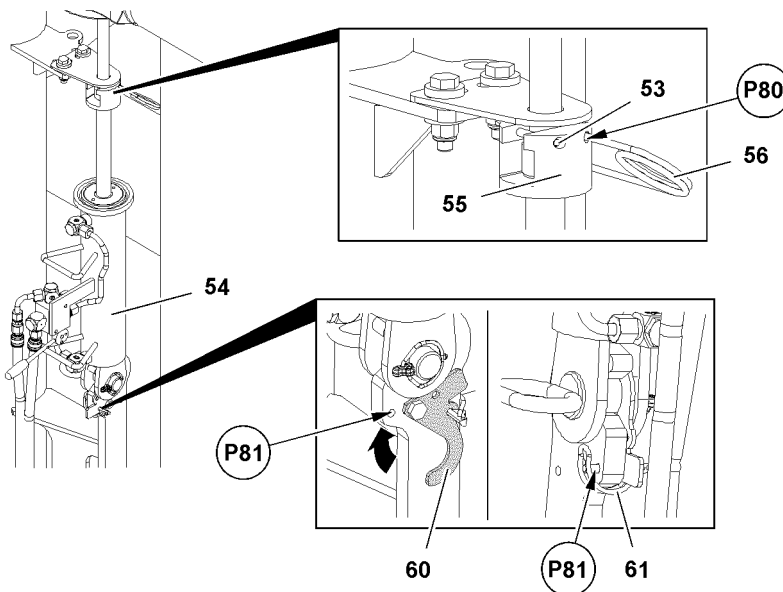

Fig.120317: Securing the pin pulling cylinder

**WARNING**

Unsecured pin pulling cylinder **54**!

When the claw **55** of the pin pulling cylinder **54** is not secured by a split pin **53** and a spring retainer **56**, then the pin pulling cylinder **54** can fall down.

Death, severe bodily injuries, property damage.

- ▶ Make sure that the claw **55** of the pin pulling cylinder **54** is secured on point **P80** by a spring retainer **56**.
- ▶ Make sure that the retaining plate **60** on point **P81** is pinned in operating position and secured with safety locking pin **61**.

Make sure that the following prerequisites are met:

- The ground is able to safely take on the entire operating weight of the crane including the load to be lifted.
- The crane is horizontally aligned.
- The SA-frame properly installed and secured on the turntable.
- Winch 1 and winch 2 are properly installed and secured on the turntable.
- The D-boom is properly assembled and secured.
- The D-boom is erected to 85°.
- An auxiliary crane with sufficient load bearing capacity if available.
- An assembly scaffolding or a work platform is available.
- The central ballast has been installed on the crawler travel gear according to the load chart or the erection and take down charts.
- The counterweight has been installed on the turntable according to the load chart or the erection and take down charts.
- The LICCON overload protection has been set according to the data in the load chart.

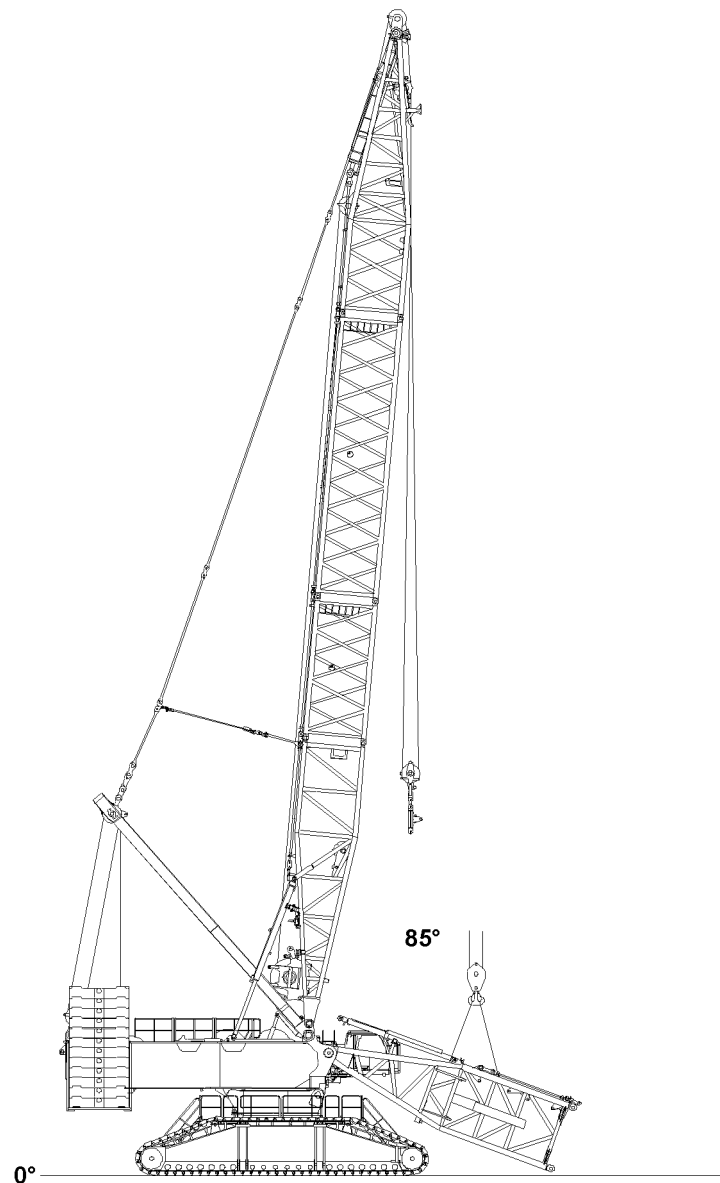

Fig.122962: Derrick boom in assembly position (85°) for S-pivot section

4.1 Turning the turntable into the assembly position



WARNING

The crane can topple over!

If the following conditions are not met before turning the turntable - **without** assembled S-boom, the crane can topple over.

Death, severe bodily injuries, property damage.

- ▶ Observe the assembly conditions, see the Crane operating instructions, chapter 3.06.
- ▶ Observe the specifications in the erection and take down charts.
- ▶ Observe the specifications in the load charts.

- ▶ Turn the turntable in lengthwise direction of the crawler travel gear.

4.2 Preparatory tasks on the S-pivot section

4.2.1 Assembling the railing on the S-pivot section in operating position

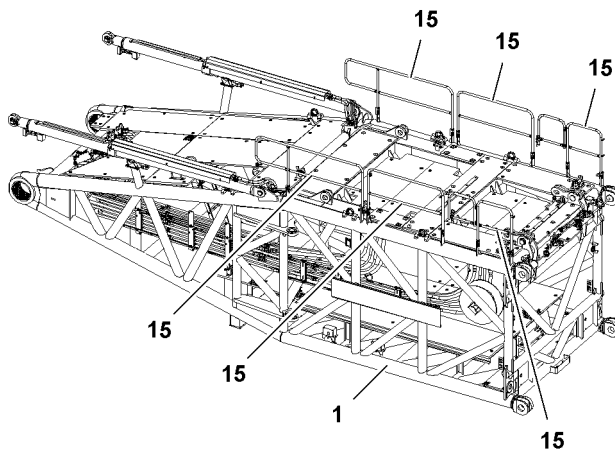

Fig.120288: Assembling the railing on the S-pivot section in operating position



WARNING

Danger of falling!

Death, severe bodily injuries, property damage.

- ▶ Assembly personnel must secure themselves for the assembly / disassembly of the railings **15** and protective devices with an approved fall arrest system to prevent them from falling.
- ▶ For assembly and disassembly work, maintenance and inspection work on the S-pivot section **1**, all railings **15** and protective devices must be properly assembled and secured.

Make sure that the following prerequisites are met:

- The ground is able to safely take on the weight of the S-pivot section **1**.
- The S-pivot section **1** is laying completely on the ground.
- ▶ For assembly / disassembly of railings **15** and protective devices, see Crane operating instructions, chapter 2.06.

4.2.2 Assembling the catwalk grating



WARNING

Disassembled or incompletely assembled catwalk!

Death, severe bodily injuries, property damage.

- ▶ For non-assembled winch 5 on the S-pivot section: Assemble the catwalk.
- ▶ The catwalk may only be accessed when it is pinned and secured in operating position, check visually.

**WARNING**

Catwalks swung down!

Death, severe bodily injuries, property damage.

- ▶ For safety reasons, assemble the catwalks always with two persons.

**Note**

- ▶ If winch 5 is installed in operating position on the S-pivot section, then the removed catwalk must be pinned and secured in transport position.

Make sure that the following prerequisites are met:

- The railings are pinned in operating position and secured.
- The assembly personnel is secured to prevent them from falling.

Installing the catwalk grating in operating position

Make sure that the following prerequisite is met:

- The catwalk is in transport position.

**Note**

- ▶ For assembly of the catwalk / assembly platform, see Crane operating instructions, chapter 3.07.50.

Installing the grating in transport position

Make sure that the following prerequisite is met:

- The catwalk is in operating position.

**Note**

- ▶ For disassembly of the catwalk / assembly platform, see Crane operating instructions, chapter 3.07.50.

4.2.3 Assembly of winch 5 (WV) on the S-pivot section**Note**

- ▶ The assembly of winch 5 is described in detail in the Crane operating instructions, chapter 3.07.50.

4.2.4 Assembly of winch 6 (WVI) on the S-pivot section**Note**

- ▶ The assembly of winch 6 is described in detail in the Crane operating instructions, chapter 3.07.60.

4.3 Exceeding the shut off limits of the LICCON overload protection for assembly operation

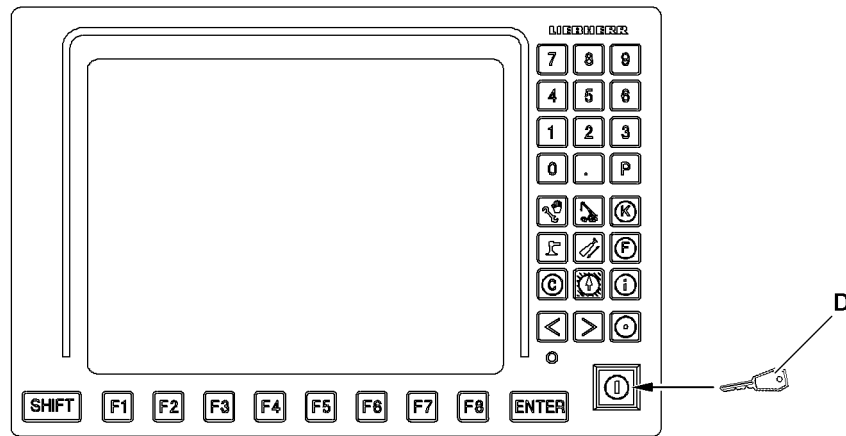

Fig.119109: Exceeding the shut off limits of the LICCON overload protection for assembly operation



WARNING

Danger of accident due to function „Exceedance of shut-off limits of the LICCON overload protection“! If the shut off limits of the LICCON overload protection are exceeded, there is no additional protection against crane overload.

Due to erroneous operation or deliberate misuse, the crane could collapse, the boom can break off or the crane can topple over.

Death, severe bodily injuries, property damage.

- ▶ The function „Exceedance of shut off limits of the LICCON overload protection“ is only permissible in emergencies and for assembly purposes.
- ▶ The function „Exceeding the shut off limits of the LICCON overload protection“ may only be actuated by persons who know the effects of their actions regarding the function „Exceeding the shut off limits of the LICCON overload protection“.
- ▶ The function „Exceedance of shut off limits of the LICCON overload protection“ requires the presence of an authorized person and must be performed with utmost caution.
- ▶ Crane operation with activated function „Exceedance of shut off limits of the LICCON overload protection“ is prohibited.

- ▶ Exceeding the shut off limits of the LICCON overload protection: Engage assembly operation.

Result:

- The shut off limits of the LICCON overload protection are exceeded.
- The assembly icon appears on the LICCON monitor.



Note

- ▶ See the Crane operating instructions, chapter 4.02 and chapter 4.20.

4.4 Unpinning the S-connector pins on the turntable

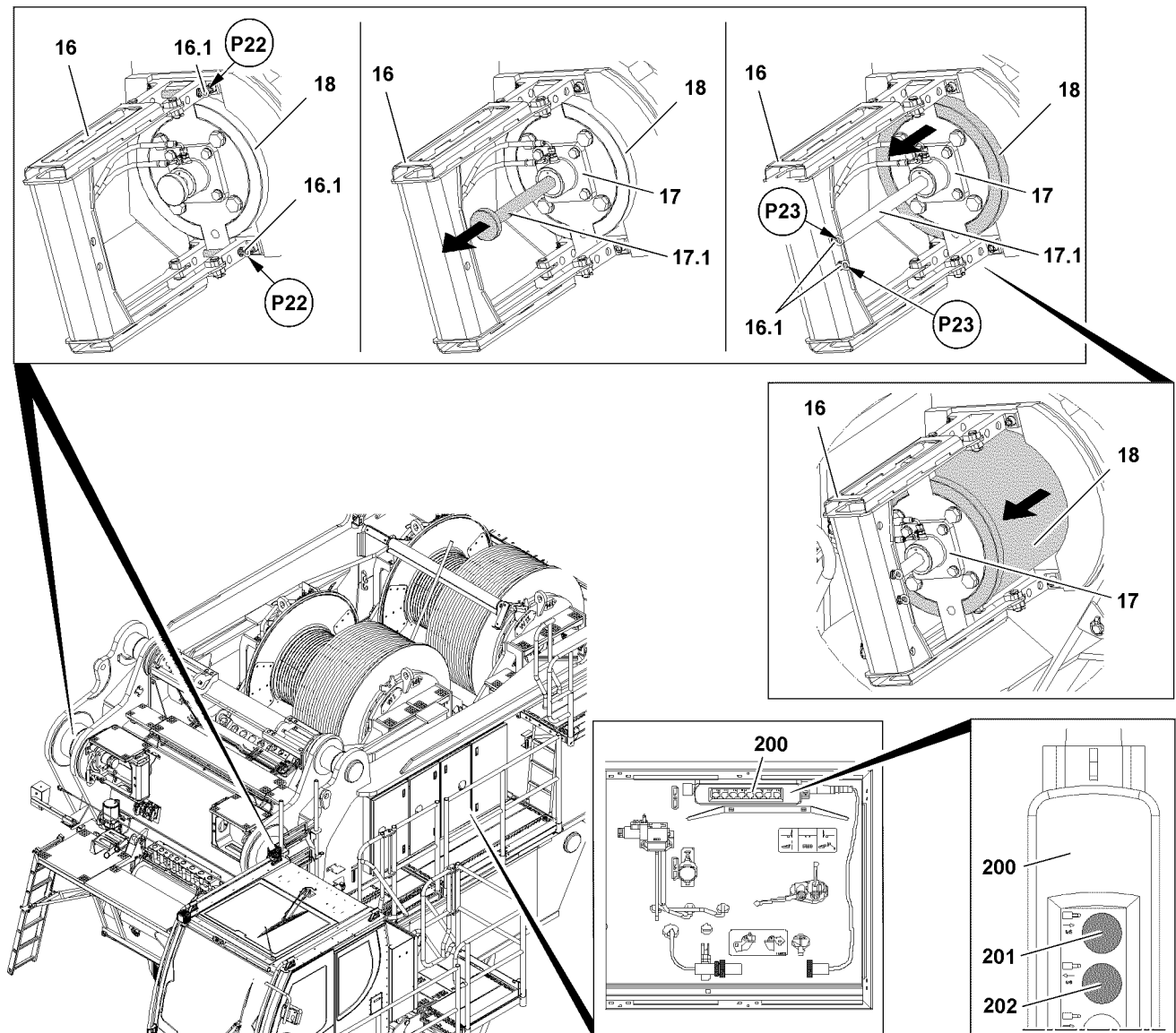

Fig.120289: Unpinning the S-connector pins on the turntable



Note

- ▶ The pin pulling cylinders **17** are integrated on this crane in the S-connector pins **18**.
- ▶ Unpinning and pinning of the S-connector pins **18** can be done only in connection with the pin pulling device installed on the crane.

Make sure that the following prerequisites are met:

- The derrick boom is properly pinned and secured to the turntable.
- The derrick boom is erected to 85°.
- The pin pulling devices **16** are installed on the pin points.
- The crane engine is running.

In transport condition, the S-connector pins **18** are pinned on the turntable and secured with the retaining pins **16.1**.

**WARNING**

Danger of crushing!

When unpinning or pinning the S-connector pins **18**, there is a danger of crushing.

Limbs can be crushed or severed.

- ▶ During the unpinning or pinning procedure, make sure that no persons are within the danger zone.
- ▶ Do not reach into the danger zone of the pin pulling device and the connector pins.

- ▶ Release and unpin the retaining pins **16.1** on the points **P22** of the pin pulling device.
- ▶ Extend the piston rod **17.1** of the pin pulling cylinder **17**: Press the button **201** on the control panel **200** until the piston rods **17.1** are completely moved out on the pin pulling cylinders **17**.

When the piston rods **17.1** for the pin pulling cylinders **17** are completely extended on both sides:

- ▶ Insert the retaining pin **16.1** on both sides at point **P23** and secure.

Result:

- The piston rods **17.1** of the pin pulling cylinders **17** are locked with the pressure / pull plate in the pin pulling device.
- ▶ Press the button **202** on the control panel **200** until the S-connector pins **18** are completely unpin-
ned.

4.5 Assembling the S-pivot section on the turntable

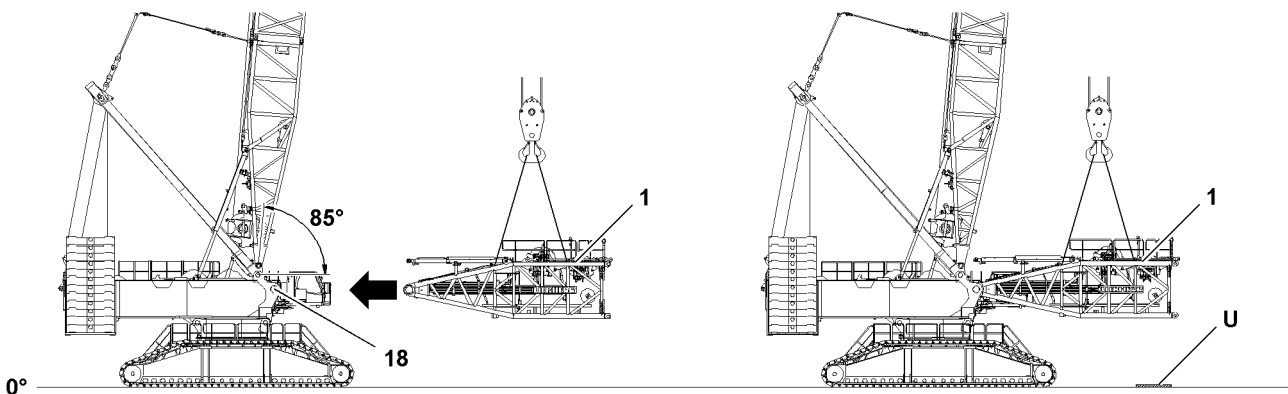

Fig.120290: Assembling the S-pivot section on the turntable - swinging the S-pivot section in

NOTICE

Danger of property damage!

When swinging the S-pivot section **1** in to the pin points on the turntable, the S-connector pins **18** or the S-pivot section **1** can be damaged.

- ▶ Make sure that the S-connector pins **18** are completely unpin-
ned before assembly of the S-pivot
section **1**.

**Note**

- ▶ Assemble the boom combinations according to the supplied Rod plans.

**WARNING**

The crane can topple over!

If the specifications listed below are not observed, the crane can collapse, the boom can break off or the crane can topple over.

Death, severe bodily injuries, property damage.

- ▶ The instructions in the Crane operating instructions, chapter 5.01 and chapter 5.03 must be observed and adhered to.
- ▶ All pins are to be secured after assembly with the intended retaining elements.
- ▶ The guy rods must be inspected regularly, see the Crane operating instructions, chapter 8.15.

Make sure that the following prerequisites are met:

- The S-connector pins **18** are completely unpinned.
- The derrick boom is erected to 85°.
- The crane engine is running.



Note

- ▶ Select the fastening points on the S-pivot section **1** in such a way that the S-pivot section **1** hangs horizontally on the auxiliary crane at assembly. See section „Fastening points“.
- ▶ Fasten the S-pivot section **1** to the auxiliary crane.
- ▶ Swing the S-pivot section **1** in with the auxiliary crane to the pin points on the turntable.

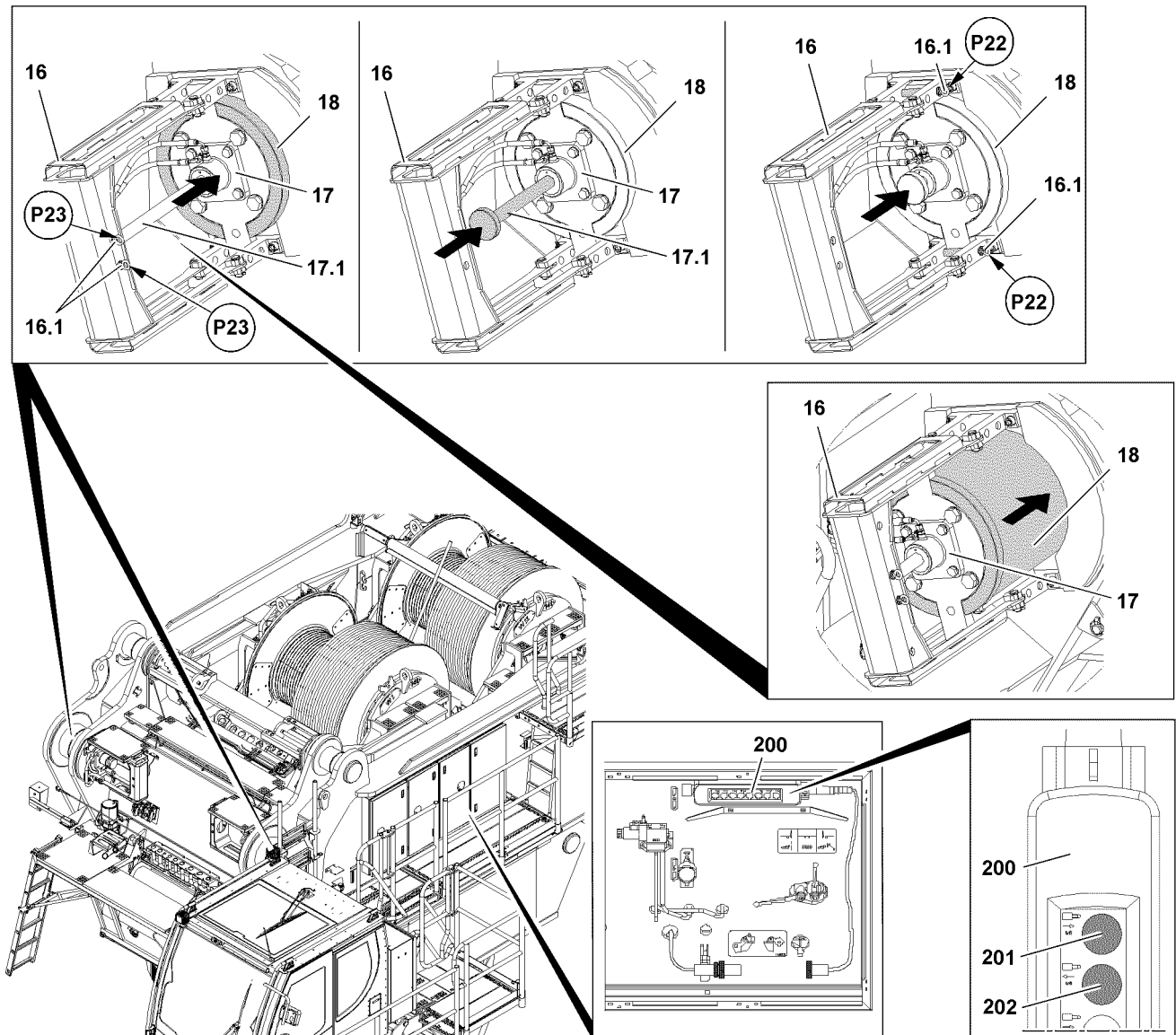

Fig.120291: Assembling the S-pivot section on the turntable - Pinning procedure



DANGER

Falling S-pivot section **1**!

Due to non-secured or insufficiently secured S-connector pins **18**, the S-pivot section **1** can fall down. Death, severe bodily injuries, property damage.

- ▶ Secure the S-connector pins **18** between the S-pivot section **1** and the turntable after the pinning procedure immediately with the retaining pins **16.1**.

When the S-pivot section is positioned in pin position:

- ▶ Insert the S-connector pins **18** on both sides with the pin pulling cylinder **17**: Press the button **201** on the control panel **200** until the S-connector pins **18** are completely pinned on both sides.

When the S-connector pins **18** are completely pinned on both sides:

- ▶ Secure the S-connector pins **18**: **16.1** Unpin the retaining pins **16.1** on the pin pulling device **16** on points **P23** and insert on points **P22** and secure.

Result:

- The S-pivot section **1** is pinned and secured on the turntable.
- ▶ Retract the piston rods **17.1** of the pin pulling cylinders **17**: Press the button **202** on the control panel **200** until the piston rod **17.1** is completely retracted on both sides.

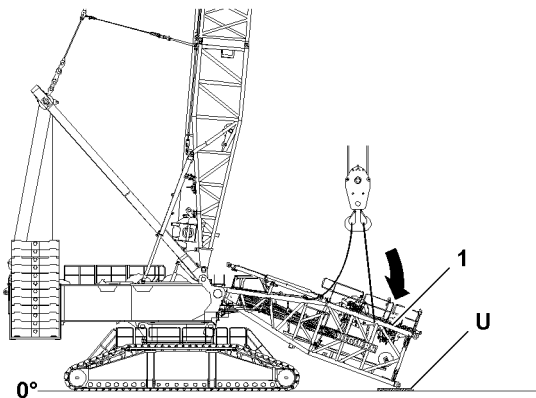

Fig.120292: Assembling the S-pivot section on the turntable - taking down the S-pivot section

NOTICE

Danger of property damage!

When taking down the assembled S-pivot section **1**, the S-pivot section **1** or the turntable can be damaged.

- ▶ Lower the S-pivot section **1** after assembly on the turntable carefully on the substructure **U** on the ground.
- ▶ Lower the S-pivot section **1** carefully and at slow speed on the substructure **U** on the ground.

When the S-pivot section **1** is placed on the substructure on the ground:

- ▶ Remove the auxiliary crane.

4.6 Establishing the electric and hydraulic connections on the S-pivot section

4.6.1 Establishing the electrical connections

NOTICE

Danger of damage to the electrical connections!

If the electrical connection between the terminal box and the S-pivot section and the cable drum in the S-pivot section is established before the boom end section is installed and electrically connected, then the electric connection can be damaged.

- ▶ Make sure that the electric connection between the terminal box in the S-pivot section and the cable drum in the S-pivot section is only established **after** assembly and the connection of the electric wiring for the boom end section.



Note

- ▶ To establish the electrical connections on the S-pivot section: Use the Electrical wiring diagram.

Make sure that the following prerequisite is met:

- The S-pivot section is completely assembled and placed on the substructure.
- ▶ Establish the electrical connections.
- ▶ Make sure that all electrical connections to the S-pivot section have been established.



WARNING

Malfunction if dummy plugs are not installed!

If the dummy plugs on the non-required electrical connections are not installed, then malfunctions or functional limitations can occur on the crane.

- ▶ Make sure that all non-required electrical connections that have a dummy plug are closed off with dummy plugs.
- ▶ Pay attention to the Electrical wiring diagram.

- ▶ As a rule, close off on-required electrical connections (for example for accessories which cannot be installed) with the respective dummy plugs.

NOTICE

Property damage due to dirt and / or corrosion!

If non-required electrical connections are not closed off with the respective protective caps, then dirt and / or corrosion can damage the electrical connections.

This could result in malfunctions.

- ▶ Make sure that all non-required electrical connections are always closed off properly.
- ▶ Pay attention to the Electrical wiring diagram.

- ▶ Close electrical connections, which have no dummy plugs, properly off with the corresponding protective caps.

4.6.2 Establishing the hydraulic connections

When connecting and releasing hydraulic lines with quick couplings, make sure that the coupling procedure is carried out correctly.



DANGER

Danger of accident due to loss of pressure or leakage!

Incorrectly coupled or self-loosening quick couplings (particularly return lines) can result in serious accidents due to component failure.

- ▶ Check that the quick couplings have been properly connected before using the crane.



Note

- ▶ To connect or release the hydraulic lines with quick couplings, see Crane operating instructions, chapter 5.01.

- ▶ Release the pressure in the hydraulic system before connecting or disconnecting. Turn the engine off and wait for short time.
- ▶ Assembling coupling components (sleeve and connector) by using knurled nut.
- ▶ Connect coupling components.

4.7 Installing the lattice sections of the PD-boom



Note

- ▶ Observe the arrangement of the intermediate sections of the boom system, see Crane operating instructions, chapter 5.03!



WARNING

The crane can topple over!

Death, severe bodily injuries, property damage.

- ▶ The turntable may not be turned during the assembly of the boom.

**WARNING**

Danger of accident!

Death, severe bodily injuries, property damage.

- ▶ For assembly of the boom combinations, the rod plan must be observed and adhered to.
- ▶ Depending on the condition of the ground, the boom and the lattice sections must be supported from below for the assembly of the boom.
- ▶ Observe the technical safety instructions, see Crane operating instructions, chapter 5.01.

**WARNING**

General danger notes!

Death, severe bodily injuries, property damage.

- ▶ Support the main boom during assembly / disassembly with suitable materials.
- ▶ All pins must be secured after assembly with the intended retaining elements.
- ▶ The guy rods must be checked regularly, see the Crane operating instructions, chapter 8.15.
- ▶ The boom must be secured with the substructure or auxiliary crane, see Crane operating instructions, chapter 5.01.
- ▶ It is prohibited for anyone to remain under the booms or within the complete danger zone during the pinning and unpinning procedure of the lattice section.

**Note**

- ▶ For weights of lattice sections with placed guy rods, see Crane operating instructions, chapter 1.03.
- ▶ The lattice sections are pinned with the pin pulling device, see Crane operating instructions, chapter 5.30.

Make sure that the following prerequisites are met:

- The crane is horizontally aligned.
- An auxiliary crane with an adequate load bearing capacity is available.
- An assembly scaffolding / work platform is available.
- The counterweight has been installed on the turntable according to the load chart.
- The D-boom is completely assembled and erected on the turntable, see Crane operating instructions, chapter 5.05.
- The LICCON overload protection has been set according to the data in the load chart.
- In the area of the parallel lattice section legs, the terrain may not slope upward.

4.7.1 Pinning the upper pulley block on the S-pivot section

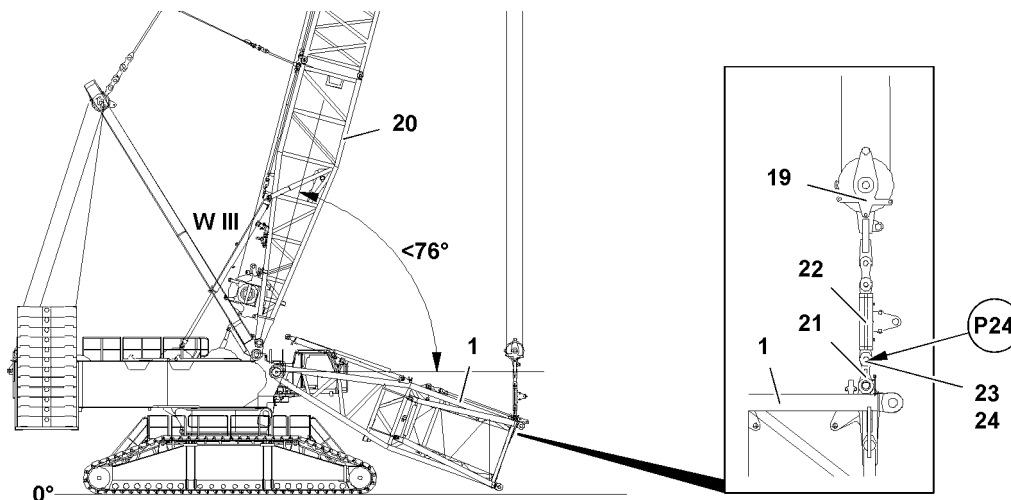

Fig.120293: Pinning the upper pulley block on the S-pivot section

Make sure that the following prerequisites are met:

- The S-pivot section **1** is pinned and secured on the turntable.
- The S-pivot section **1** is placed on the ground on the substructure.
- The angle between the D-boom and the horizontal is less than 76°.
- The auxiliary weight is installed on the upper pulley block, see Crane operating instructions, chapter 5.05
- An auxiliary crane is available.
- The railings on the S-pivot section **1** are in operating position, see Crane operating instructions, chapter 3.07.50.
- The winch 5, if present, is installed in operating position.
- The catwalk is in operating position (only if winch 5 is not present), see Crane operating instructions, chapter 3.07.50.

To be able to lift the S-pivot section **1** to install the two lower P-adapters on the S-pivot section **1** it is necessary to connect the upper pulley block **19** with the S-pivot section **1**. To do so, the D-boom **20** is luffed forward until the upper pulley block **19** can be pinned on the brackets **21** on the S-pivot section **1**.

- ▶ Luff the D-boom **20** down to the front until the upper pulley block **19** hangs freely with the assembly weight **22** over the bracket **21** on the S-pivot section **1**.

Problem remedy

The control rope (winch 3 **WIII**) cannot be spooled up or out?

You are in an angle range, where the winch movement is deactivated.

- ▶ Luff the D-boom down forward until the angle is less than 76°.
 - ▶ Spool the control rope out until the upper pulley block **19** hangs freely with the assembly weight **22** over the bracket **21** on the S-pivot section **1**.
-
- ▶ Pin the assembly weight **22** with the brackets **21**: Insert the pin **23** on both sides at point **P24** and secure with spring retainer **24**.
 - ▶ Spool winch 3 **W III** up carefully until the S-pivot section **1** is aligned horizontally.

4.7.2 Installing the lower P-adapters

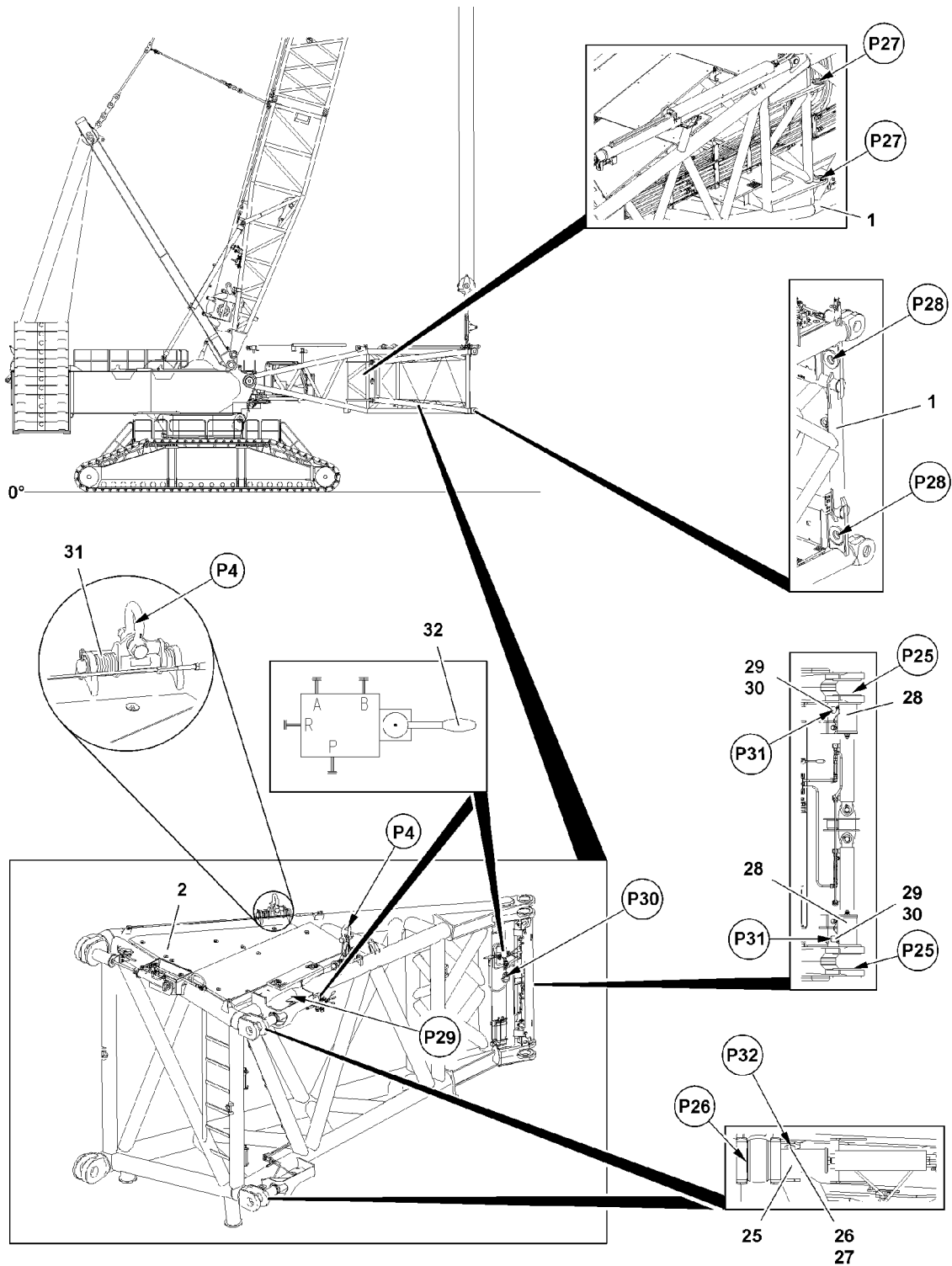

Fig.120294: Installing the lower P-adapters

LWE/LR 11000-001/23501-04-02/en

**Note**

- ▶ The hydraulic supply for the assembly of the lower P-adapters **2** is made via the external hydraulic aggregate.

**WARNING**

Pressure in the hydraulic lines!

If the pressure supply is not interrupted before connecting / releasing the hydraulic lines, the hydraulic oil can escape with high pressure.

Death, severe bodily injuries, property damage.

- ▶ Release the pressure in the hydraulic system before connecting / disconnecting: Interrupt the pressure supply and wait for a short time.

Make sure that the following prerequisites are met:

- The S-pivot section **1** is horizontally aligned.
- The two pins **25** are completely unpinned on the points **P26**.
- The two pins **28** are completely unpinned on the points **P25**.
- A hydraulic aggregate is available.

The assembly is described on the example of the right, lower P-adapter **2**.

- ▶ Fasten the lower P-adapter **2** on both sides on the points **P4** and lift.
- ▶ Check if the lower P-adapter **2** hangs horizontally on the auxiliary crane.

Problem remedy

The lower P-adapter **2** does not hang horizontally on the auxiliary crane:

- ▶ Place the lower P-adapter **2** down.
 - ▶ With the disks **31** adjust the center of gravity so that the lower P-adapter **2** hangs horizontally during the lifting procedure.
 - ▶ Lift the lower P-adapter **2**.
-
- ▶ Position the lower P-adapter **2** so that the pins **28** can be pinned on points **P27**.
 - ▶ Establish the hydraulic connection on point **P30**: Connect the coupling parts (sleeve and plug) and screw together by hand until the knurled nut is turned to a noticeable, fixed stop.
 - ▶ Actuate the hand lever **32** until the pins **28** are completely pinned.
 - ▶ Take both retaining pins **29** from the retainer.
 - ▶ Insert the retaining pins **29** on points **P31** and secure with safety locking pins **30**.
 - ▶ Disconnect the hydraulic connection on point **P30**: Install the coupling components (sleeve and connector) with the knurled nut.
 - ▶ Install dust caps on the quick couplings.
 - ▶ Fold the lower P-adapter **2** on the S-pivot section **1** so that the pins **25** can be pinned on points **P28**.
 - ▶ Establish the hydraulic connection on point **P29**: Connect the coupling parts (sleeve and plug) and screw together by hand until the knurled nut is turned to a noticeable, fixed stop.
 - ▶ Actuate the hand lever **32** until the pins **25** are completely pinned.
 - ▶ Take both retaining pins **26** from the retainer.
 - ▶ Insert the retaining pins **26** on points **P32** and secure with locking pins **27**.
 - ▶ Disconnect the hydraulic connection on point **P29**: Install the coupling components (sleeve and connector) with the knurled nut.
 - ▶ Install dust caps on the quick couplings.
 - ▶ Remove the auxiliary crane.
 - ▶ Install the left, lower P-adapter **2** the same way as described before.
 - ▶ Place the S-pivot section **1** with the installed lower P-adapters **2** on the substructure.

4.7.3 Installing the cross carrier

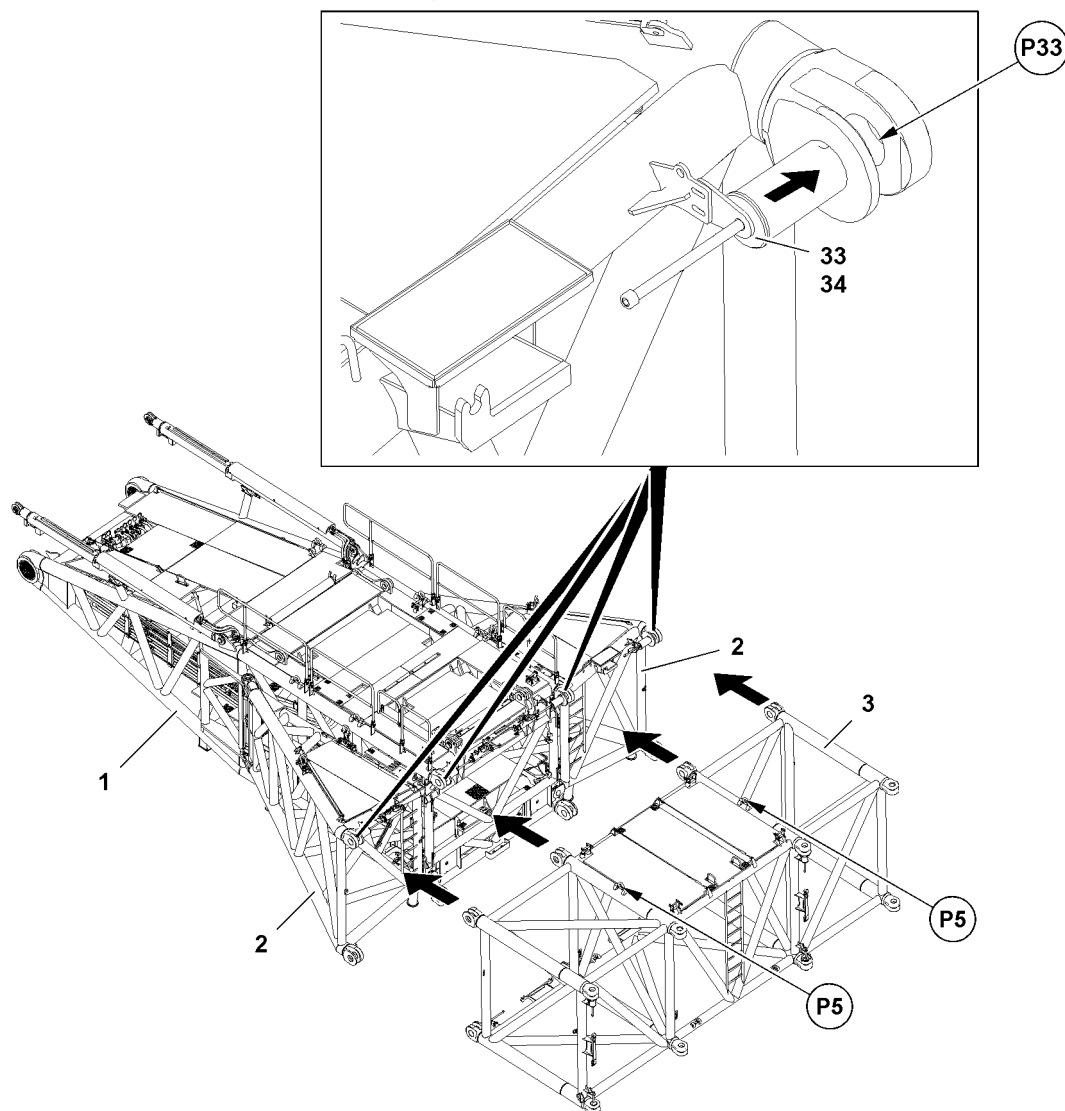

Fig.120295: Installing the cross carrier

Make sure that the following prerequisites are met:

- Both lower P-adapters **2** are properly installed on the S-pivot section **1**.
- The S-pivot section is completely installed.
- The S-pivot section **1** is placed on the ground and supported according to the assembly drawing.
- The four pins **33** are completely unpinning on position **P33**.
- A hydraulic aggregate is available.
- The upper pulley block (including assembly weight) is unpinning from the S-pivot section **1** and pulled up to approx. 4 m.

- ▶ Fasten the cross carrier **3** on both sides on the points **P5** and lift, see section „Fastening points“.
- ▶ Position the cross carrier **3** so that the pins **33** can be pinned in points **P33**.



Note

- ▶ The pinning or unpinning is carried out with the pin pulling device, see Crane operating instructions, chapter 5.30.
- ▶ Pin the cross carrier **3** with the lower P-adapters **2** and with the S-pivot section **1**: Insert all four pins **33** on points **P33** and secure each with safety folding pins **34**.

**Note**

- ▶ If no assembly shoes are placed under the cross carrier **3** then it is not possible to install the L-intermediate sections.
-
- ▶ Place the cross carrier **3** on the ground.
 - ▶ Remove the auxiliary crane.

4.7.4 Changing the boom: Turning the L-intermediate sections

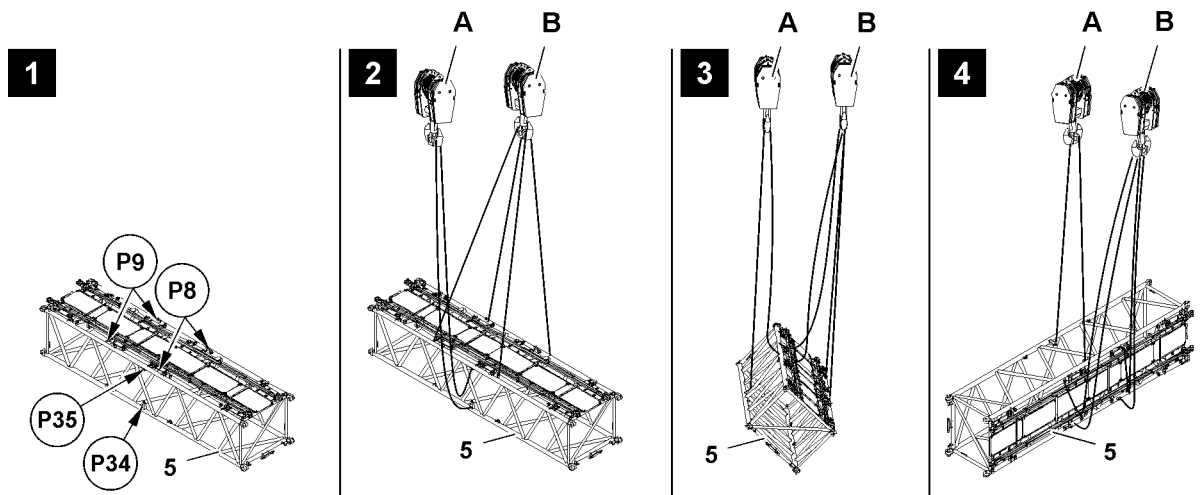

Fig.120296: Changing the boom: Turning the L-intermediate sections

**Note**

- ▶ The illustrations in this section are an example. The L-intermediate sections can look differently.
- ▶ For the correct fastening points, see section „Fastening points“.

This section applies only if the L-intermediate sections **5** were used previously in another boom system.

The L-intermediate sections **5** must be turned for use in the P-boom system.

Make sure that the following prerequisites are met:

- Two auxiliary cranes with sufficient load carrying capacity are available.
- No guy rods are on the L-intermediate sections **5**.

**WARNING**

Selection of incorrect fastening points!

Death, severe bodily injuries, property damage.

- ▶ It is prohibited to use the lower positioned fastening points for the turning procedure.
- ▶ For fastening of crane / boom sections, observe and adhere to section „Fastening points“.

**WARNING**

Turning in excessive height!

Death, severe bodily injuries, property damage.

- ▶ Make sure that there are no persons within the danger zone.
- ▶ Turn the L-intermediate sections **5** as close as possible near the ground without them touching the ground.

**WARNING**

Placed guy rods!

Death, severe bodily injuries, property damage.

- ▶ Make sure that no guy rods are laying on the L-intermediate sections which are to be turned.

- ▶ Fasten the first L-intermediate section **5** on both auxiliary cranes: Fasten the auxiliary crane **A** on point **P34** and point **P35** and fasten the auxiliary crane **B** on points **P8** and points **P9**, see illustration 1.
- ▶ Relieve the fastening equipment completely from the auxiliary crane **A**, see illustration 2.

When the fastening equipment is completely relieved from the auxiliary crane **A**:

- ▶ Lift the L-intermediate section **5** with the auxiliary crane **B**, see illustration 2.
- ▶ Turn the L-intermediate section **5** by 90°: Lift the L-intermediate section **5** slowly with the auxiliary crane **A** and lower simultaneously with the auxiliary crane **B** until the L-intermediate section **5** is lifted completely by the auxiliary crane **A**, see illustration 3 and illustration 4.
- ▶ Relieve the fastening equipment completely on auxiliary crane **B**.

When the fastening equipment is completely relieved on the auxiliary crane **B**:

- ▶ Place the L-intermediate section **5** with the auxiliary crane **A** on the ground.
- ▶ Remove the fastening equipment from auxiliary crane **B** and on points **P8** and points **P9**.
- ▶ Remove the fastening equipment from auxiliary crane **A** and on point **P34** and point **P35**.
- ▶ Carry out the procedure the same way as was described before for all required L-intermediate sections **5**.

4.7.5 Assembling the L-intermediate sections on the cross carrier

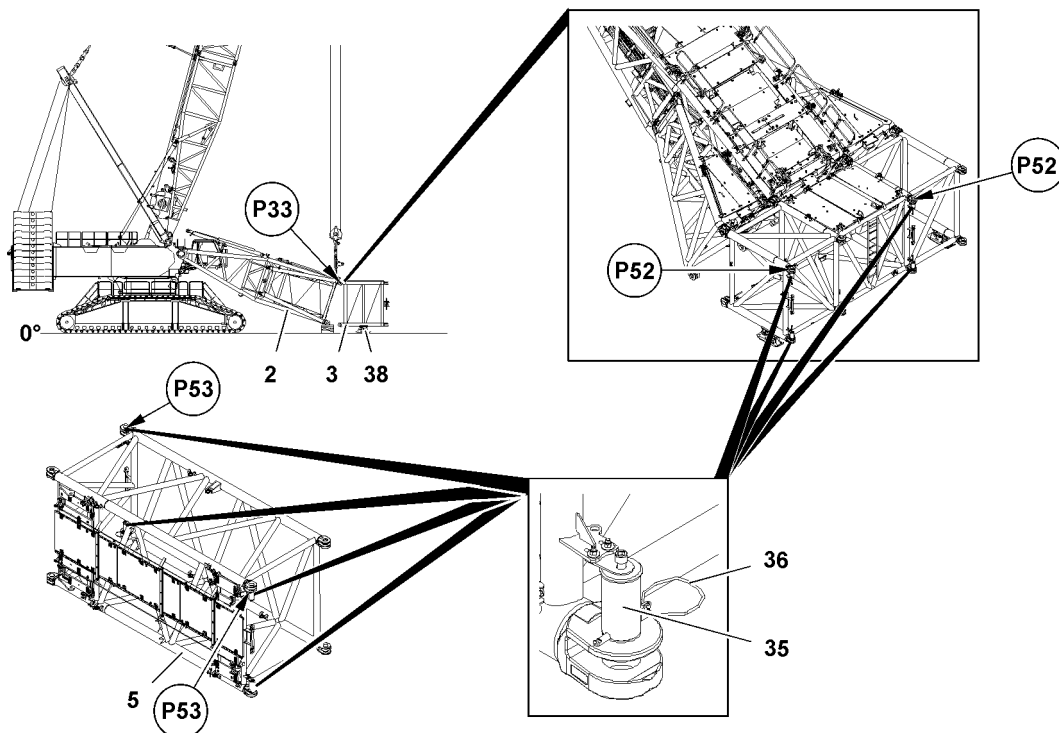

Fig.120306: Assembling the L-intermediate sections on the cross carrier - Pin points

Make sure that the following prerequisites are met:

- The cross carrier **3** is properly pinned and secured on points **P33** of the lower P-adapter **2**.
- The cross carrier **3** is properly placed on the assembly shoes **38**.
- On the cross carrier **3** the pins **35** are completely unpinned on top and bottom on points **P52**.
- On all required L-intermediate sections **5** the pins **35** are completely unpinned on top and bottom on points **P53**.
- On the cross carrier and on the L-intermediate sections the pins are secured on the lower pin points with safety locking pins to prevent them from falling down.
- The fastening equipment is removed on the cross carrier **3**.
- The L-intermediate sections **5** are placed down in such a way that it can be pinned without further turning.
- Two auxiliary cranes are provided.

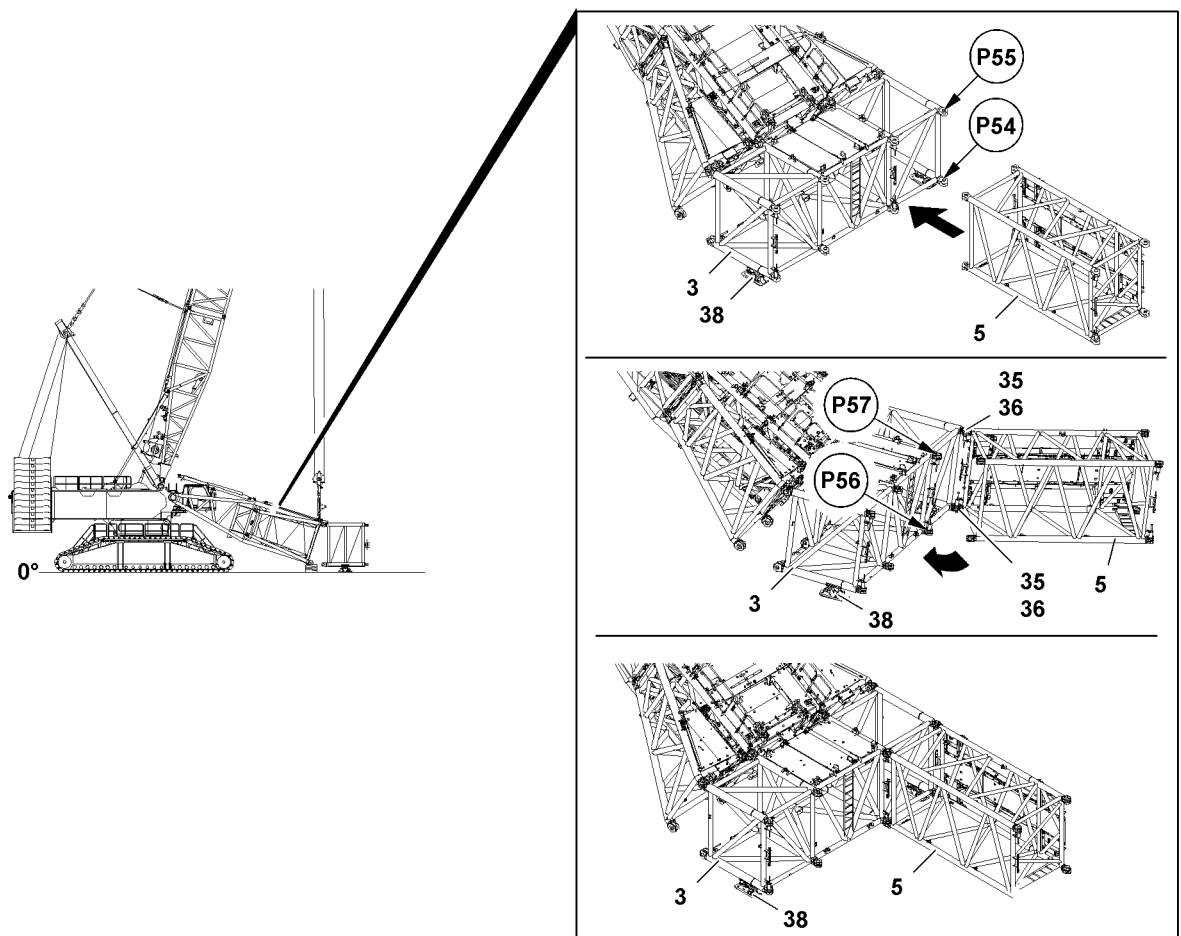

Fig.120307: Assembling the L-intermediate sections on the cross carrier - Assembly procedure



Note

- ▶ The assembly is described for the left lattice section leg.
- ▶ The combination of the various boom systems must be taken from the Rod plan and it must be adhered to.

**Note**

- ▶ The L-intermediate sections **5** are pinned with the pin pulling device on the cross carrier **3** and the subsequent L-intermediate sections **5**, see Crane operating instructions, chapter 5.30.
- ▶ For easier assembly / disassembly of the L-intermediate sections **5**, the last installed L-intermediate section **5** must always be supported with the supplied assembly shoes **38**, see Crane operating instructions, chapter 5.62.
- ▶ On all L-intermediate sections **5** which are installed, the gratings are on the outside of the P-boom.

The L-intermediate sections **5** have to be pinned and secured on both sides each of the cross carrier **3**.

- ▶ Lift the L-intermediate section **5** with the auxiliary crane.
- ▶ Position the L-intermediate section **5** on the cross carrier **3** in such a way that it can be pinned on point **P54** and point **P55**.

When the pin bores on the cross carrier **3** and on the L-intermediate section **5** align on point **P54** and point **P55**:

- ▶ Pin the cross carrier **3** with the L-intermediate section **5**: Insert the pins **35** with the pin pulling device on point **P54** and point **P55** to the stop and secure with safety locking pin **36**.
- ▶ Fold the L-intermediate section **5** in so that it can be pinned on point **P56** and point **P57**.
- ▶ Repeat the pinning procedure on point **P56** and point **P57** the same way as described before.
- ▶ Remove the auxiliary crane.
- ▶ Place the assembly shoes **38** properly under the L-intermediate section **5**, see Crane operating instructions, chapter 5.62.

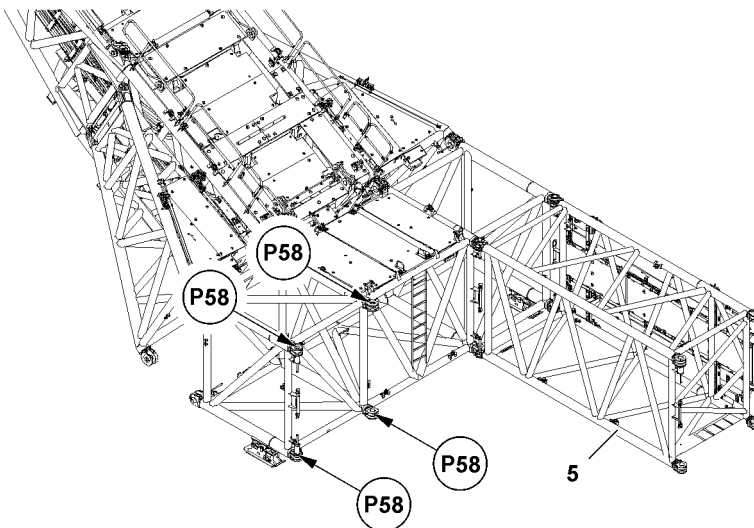

Fig. 120308: Assembling the L-intermediate sections on the cross carrier - Pin points for the second strand

**WARNING**

The crane can topple over!

If the rod plans and the data in the Crane operating instructions, chapter 5.03 are not observed, this can cause the crane to collapse, the boom to break off or the crane to topple over.

Death, severe bodily injuries, property damage.

- ▶ The combination of the various boom systems must be taken from the Rod plan and it must be adhered to.
 - ▶ Observe and adhere to the instructions in the Crane operating instructions, chapter 5.03.
-
- ▶ Assemble the L-intermediate section **5** on points **P58** of the cross carrier the same way as described before.

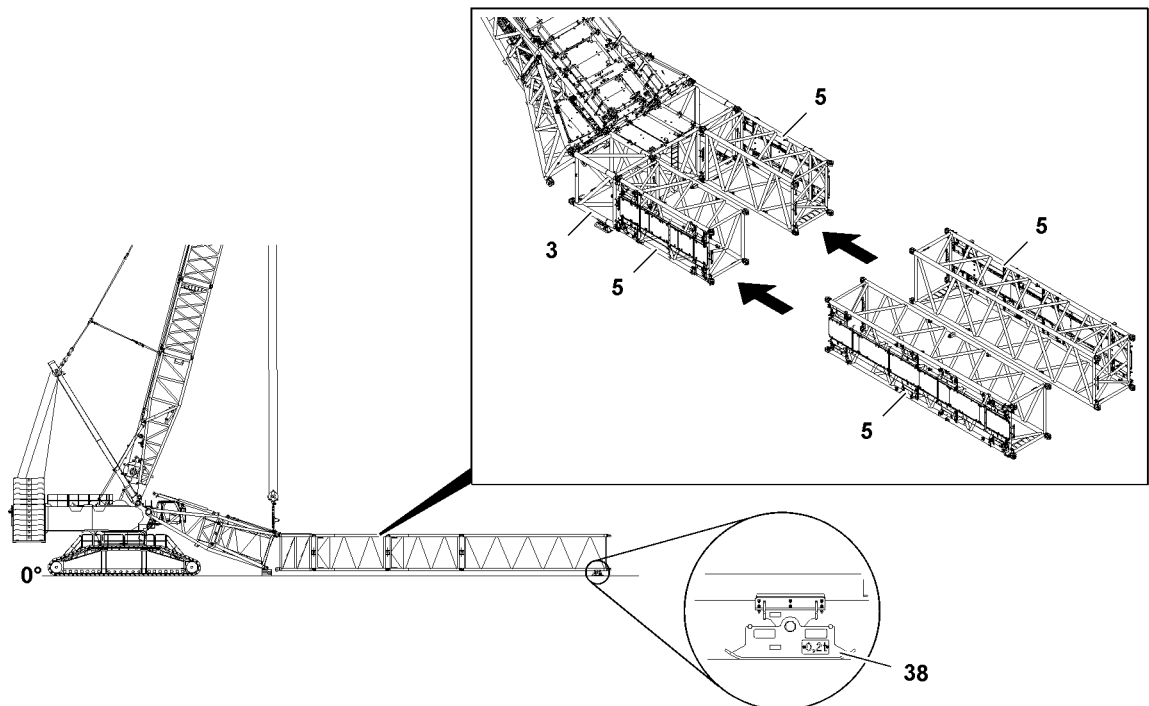

Fig.120309: Assembling the L-intermediate sections on the cross carrier - Assembly of additional L-intermediate sections

Depending on the system length, a different number of L-intermediate sections **5** is used.

Refer to the rod plan for the number and sequence of the L-intermediate sections **5**.

The assembly between the L-intermediate sections **5** is identical with the previously described assembly between the cross carrier **3** and an L-intermediate section **5**.



WARNING

Changing the assembly shoes **38**!

If the assembly shoes **38** are not changed over under the last assembled L-intermediate section **5**, the L-intermediate sections **5** can be overloaded and damaged.

An accident can occur during crane operation due to a damaged or previously overloaded lattice section.

Death, severe bodily injuries, property damage.

► Place the assembly shoes **38** properly under the last installed L-intermediate section **5**, see Crane operating instructions, chapter 5.62.

► Assemble the parallel section of the boom system to the required length.

4.7.6 Assembling the upper P-adapter on the L-intermediate sections

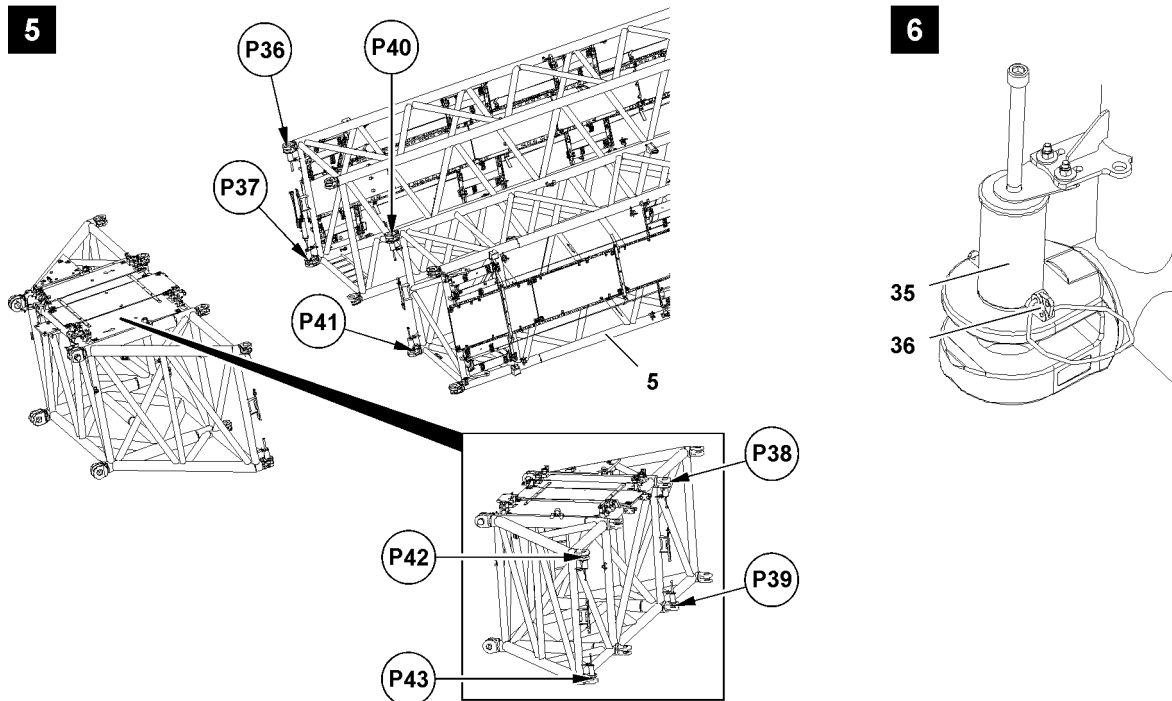

Fig.120298: Assembling the upper P-adapter on the L-intermediate sections - Pin points

Make sure that the following prerequisites are met:

- The parallel section of the P-boom is assembled to the desired length.
- The assembly shoes are properly supported under the L-intermediate sections 5.
- The connector pins 35 are completely unpinned on point P36, point P37, point P38, point P39, point P40, point P41, point P42, point P43 of the L-intermediate sections 5, see illustration 5.
- The connector pins 35 on point P37, point P39, point P41 and point P43 are secured in unpinned position with safety locking pins 36, see illustration 6
- The pin pulling device is installed on point P37.
- A second auxiliary crane with sufficient load carrying capacity is available.

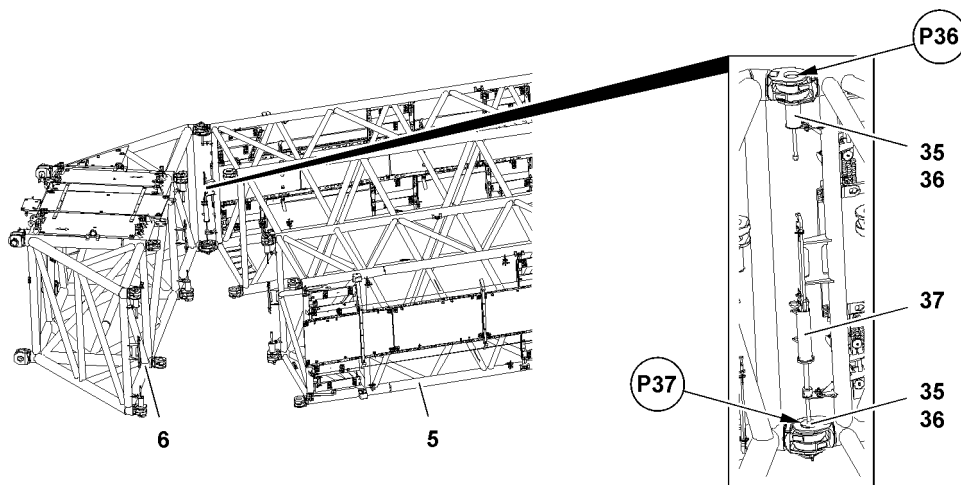

Fig.120299: Assembling the upper P-adapter on the L-intermediate sections - Positioning procedure

**Note**

- ▶ The pinning or unpinning is carried out with the pin pulling device **10**, see the Crane operating instructions, chapter 5.30.

The upper P-adapter **6** must be pinned and secured on both L-intermediate sections **5**.

The upper P-adapter **6** must be pinned and secured on both sides on the respective L-intermediate section **5**.

- ▶ Fasten the upper P-adapter **6** to the auxiliary crane, see section „Fastening points“.
- ▶ Lift and position the upper P-adapter **6** in such a way that it can be pinned on point **P36** and point **P37**.

When the pin bores on the upper P-Adapter **6** and on the L-intermediate section **5** align on point **P36** and point **P37**:

- ▶ Pin the upper P-adapter **6** with the L-intermediate section **5**: Insert the pins **35** with the pin pulling device **37** on point **P37** to the stop and secure with safety locking pin **36**.
- ▶ Install the pin pulling device **37** on the upper pin point.
- ▶ Pin the upper P-adapter **6** with the L-intermediate section **5**: Insert the pins **35** with the pin pulling device **37** on point **P36** to the stop and secure with safety locking pin **36**.

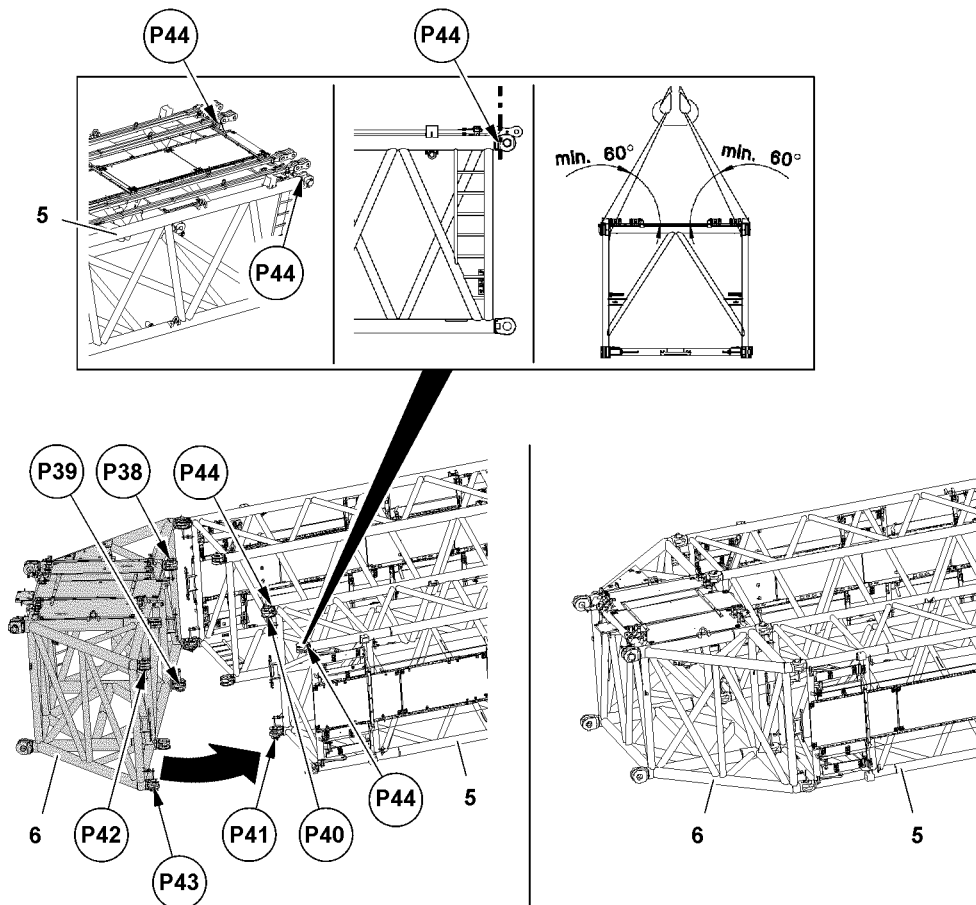

Fig.120300: Assembling the upper P-adapter on the L-intermediate sections - Assembling the upper P-adapter completely

To be able to fold the upper P-adapter **6** in, the free L-strand is fastened on points **P44** and lifted and positioned with the second auxiliary crane.

- ▶ Fold the upper P-adapter **6** in and position the free lattice section leg with the auxiliary crane in such a way that it can be pinned on point **P38**, point **P39**, point **P40**, point **P41**, point **P42** and point **P43**.
- ▶ Repeat the pinning procedure on point **P38**, point **P39**, point **P40**, point **P41**, point **P42** and point **P43** the same way as was described before.

- ▶ Remove the auxiliary crane.

4.7.7 Assembling the S-intermediate sections / S-adapter / S-end section on the upper P-adapter

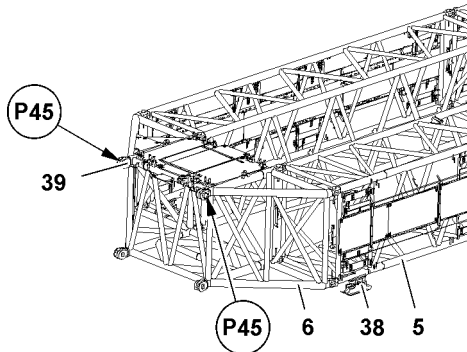

Fig. 120301: Assembling the S-intermediate sections / S-adapter / S-end section on the upper P-adapter — Pin points

Make sure that the following prerequisites are met:

- The upper P-adapter **6** is completely installed on the L-intermediate sections **5**.
- The pins **39** on the points **P45** are completely unpinned.
- The L-intermediate sections **5** are laying properly on the assembly shoes **38**.

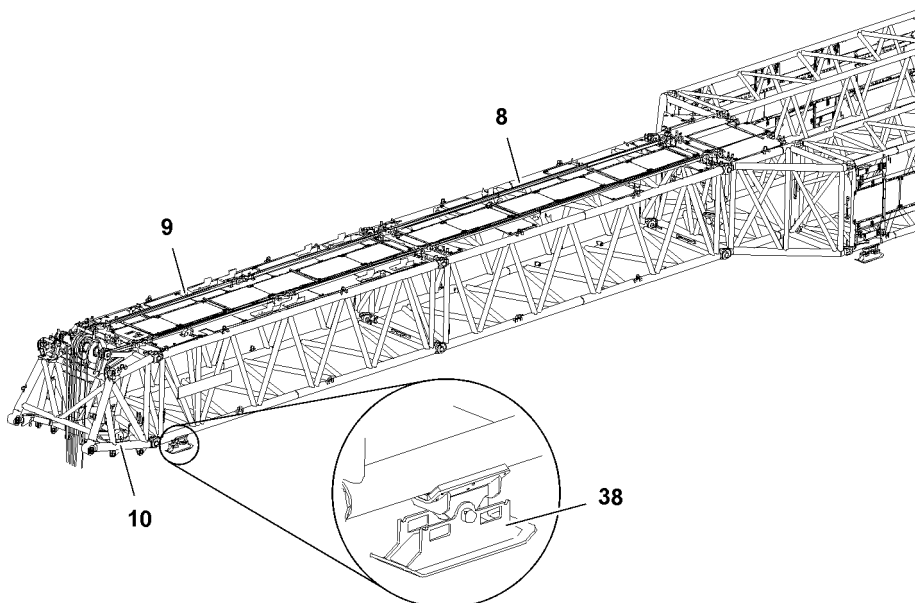

Fig. 120302: Assembling the S-intermediate sections / S-adapter / S-end section on the upper P-adapter — Changing the assembly shoes



WARNING

The crane can topple over!

If the rod plans and the data in the Crane operating instructions, chapter 5.03 are not observed, this can cause the crane to collapse, the boom to break off or the crane to topple over.

Death, severe bodily injuries, property damage.

- ▶ The combination of the various boom systems must be taken from the Rod plan and it must be adhered to.
- ▶ Observe and adhere to the instructions in the Crane operating instructions, chapter 5.03.

**WARNING**

Changing the assembly shoes **38**!

If the assembly shoes **38** are not changed over under the last assembled S-intermediate section, the S-intermediate sections can be overloaded and damaged.

An accident can occur during crane operation due to a damaged or previously overloaded lattice section.

Death, severe bodily injuries, property damage.

- ▶ Place the assembly shoes **38** properly under the last assembled S-intermediate section, see section „Changing the assembly shoes at assembly“.

**Note**

- ▶ The assembly of the S-intermediate section **8**, the S-adapter **9** and the S-end section **10** is described in detail in the Crane operating instructions, chapter 5.39. The assembly described there is an example from the S-pivot section on. Carry out the assembly of the S-boom section leg the same way, starting from the upper P-adapter.

- ▶ Assembling the S-boom section leg, see Crane operating instructions, chapter 5.39.

4.7.8 Installing the bridges

**Note**

- ▶ The P-boom system is shown in the following illustration solely for the purpose of providing a clearer illustration, in the „closed“ condition.

- ▶ The illustration of the P-boom with installed bridges, the platform as well as the rod receptacles in the operating position should make the installation situation and the arrangement of the components in the P-boom system clearer.

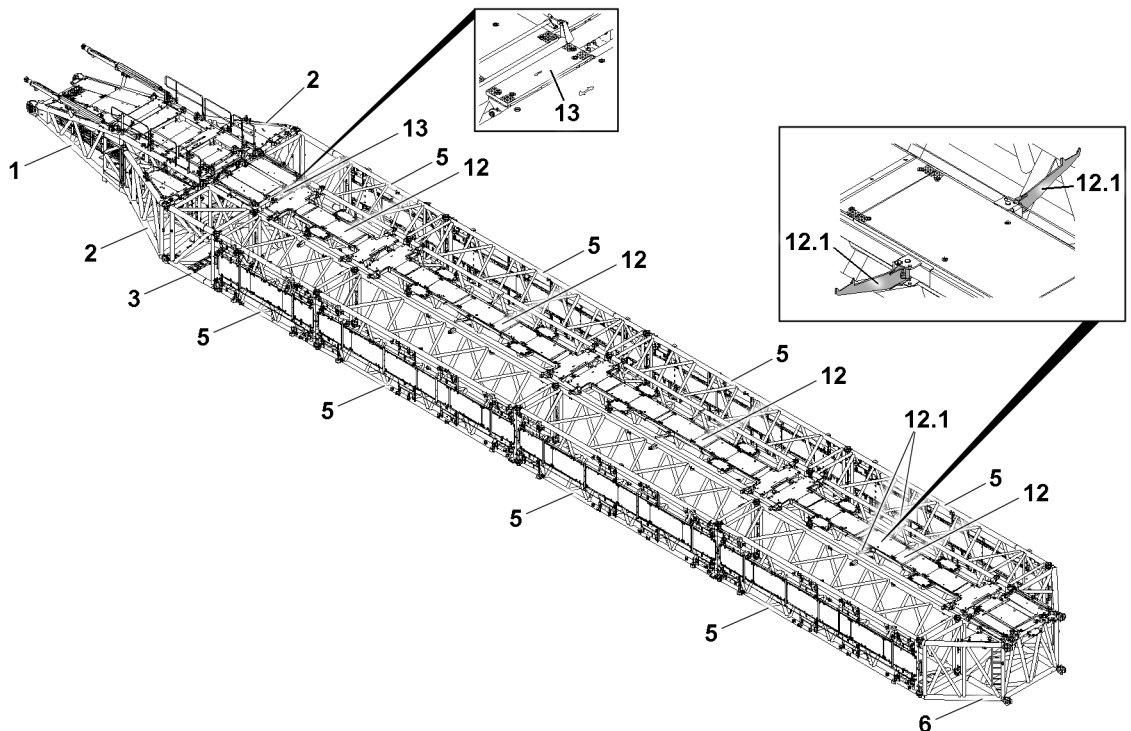

Fig.124517: P-boom system

- | | | | |
|----------|------------------------|-------------|----------------|
| 1 | S-pivot section | 6 | P-adapter top |
| 2 | P-adapter bottom | 12 | Bridge |
| 3 | Cross carrier | 12.1 | Rod receptacle |
| 5 | L-intermediate section | 13 | Platform |

**Note**

- ▶ The following descriptions are an example for the installation of all bridges **12**.
- ▶ The number of bridges **12** used varies, depending on the main boom length, check the rod plan.

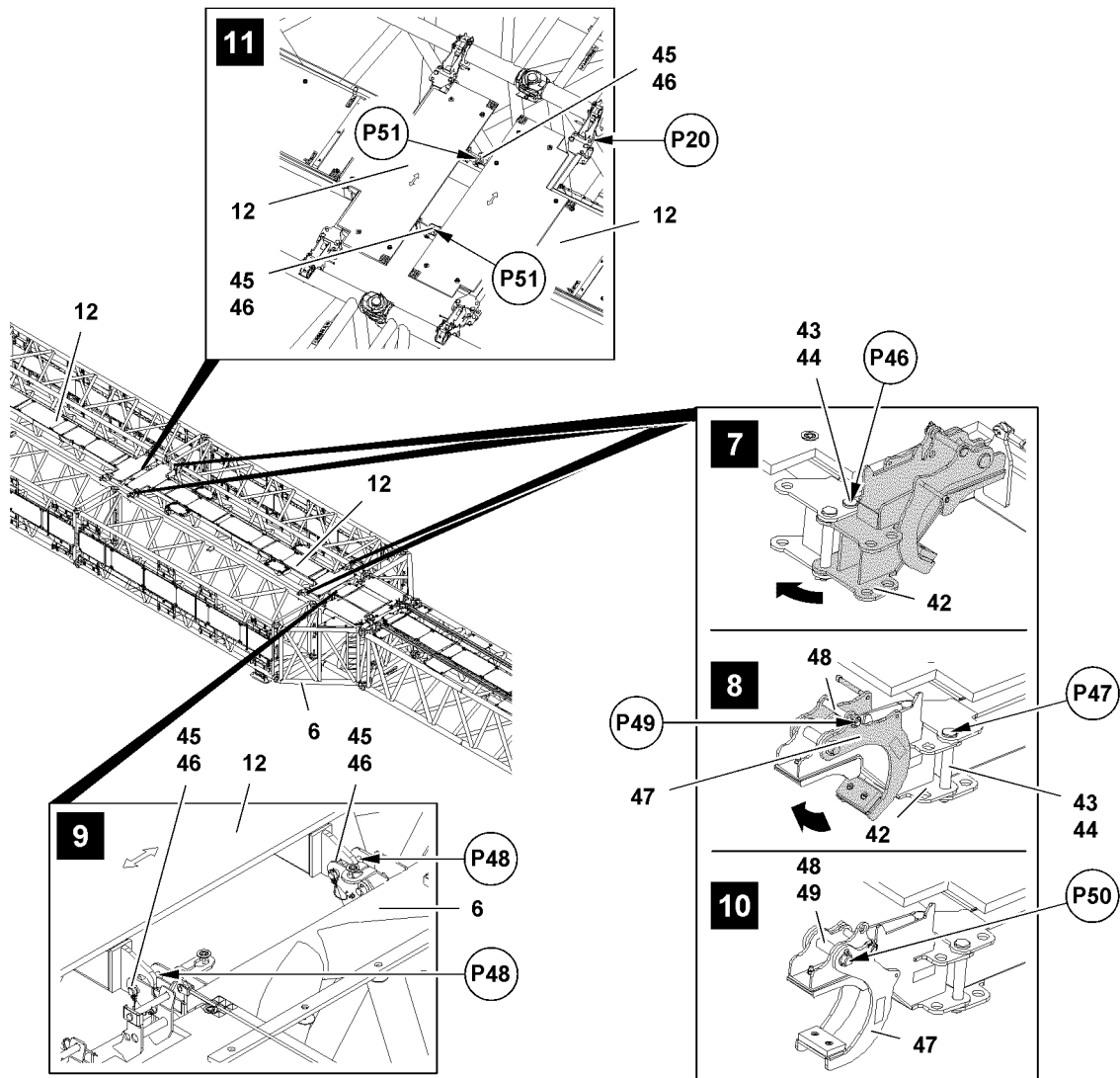

Fig.120303: Installing the bridges - Assembling the bridges on the P-boom

**WARNING**

Danger of falling!

- ▶ Make sure that the assembly personnel is secured with the supplied fall arrest system to prevent them from falling when installing the bridges.

Make sure that the following prerequisite is met:

- The P-boom system is completely assembled.

- ▶ Unpin the folding brackets **42** on the four points **P46** in transport position: Release and unpin the pin **43**, see illustration **7**.
- ▶ Swing the folding brackets **42** from transport position into operating position.
- ▶ Pin the folding brackets **42** on the four points **P47** in operating position: Insert the pin **43** and secure with the safety locking pin **44**, see illustration **8**.

**WARNING**

Falling bridge!

If not all four folding brackets **42** are installed before placing in operating position, then the bridge can fall down later.

Death, severe bodily injuries, property damage.

► Make sure that all four folding brackets **42** are pinned and secured in operating position before placing.

► Fasten the bridge **12** to the auxiliary crane, see section „Fastening points“.

► Lift the bridge **12** with the auxiliary crane and position it in such a way that it can be pinned on points **P48** with the upper P-adapter **6**, see illustration **9**.

► Pin the bridge **12** with the upper P-adapter **6**: Insert the pins **45** on both sides on points **P48** and secure with safety locking pin **46**, see illustration **9**.

► Unpin the retaining brackets **47** on the four points **P49** in transport position: Release and unpin the pin **48**, see illustration **8**.

► Fold the retaining plates **47** down and secure on points **P50** in operating position: Insert the pin **48** and secure with the safety locking pin **49**, see illustration **10**.

► Remove the auxiliary crane.

Subsequent bridges **12** are installed the same way as described before.

► Pin the bridge **12** with the bridge **12**: Insert the pins **45** on both sides on points **P51** and secure with safety locking pin **46**, see illustration **11**.

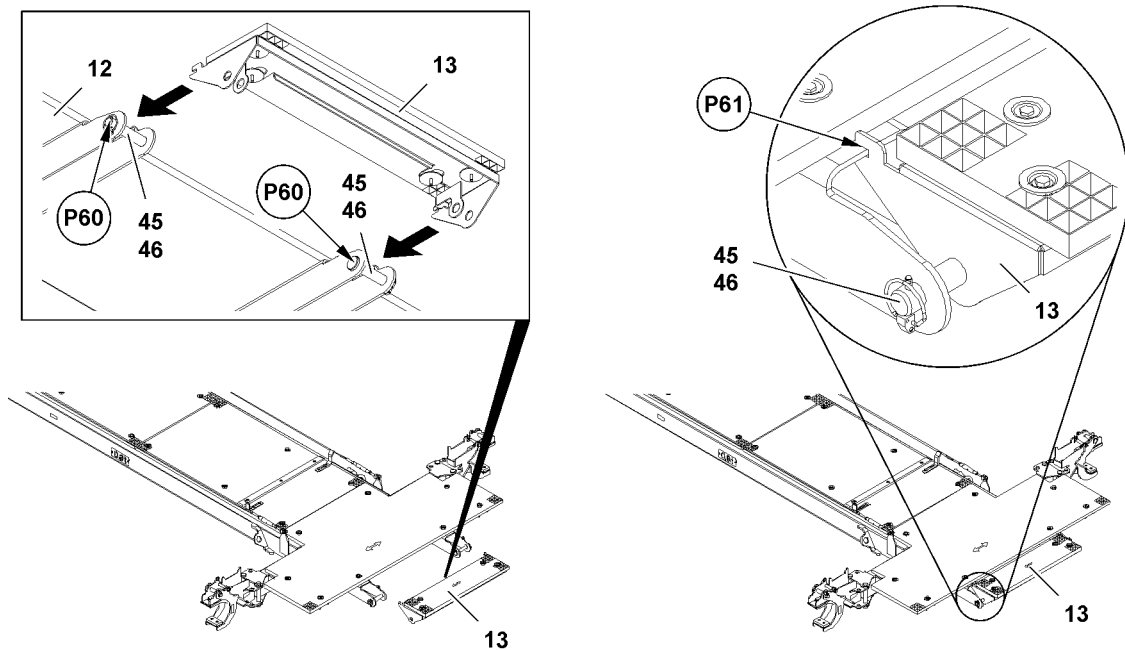

Fig.120311: Assembling the platform on the bridge

**Note**

► On the last bridge **12** which ends on the cross carrier **3**, install the platform **13** before fastening on the auxiliary crane.

► Release pins **45** on points **P60** and unpin.

► Position the platform **13** in such a way that it is affixed on both sides on points **P61** and can be pinned on points **P60**.

► Pin the platform **13** with the bridge **12**: Insert the pins **45** on both sides on points **P60** and secure with safety locking pins **46**.

4.7.9 Bringing the rod receptacle into operating position

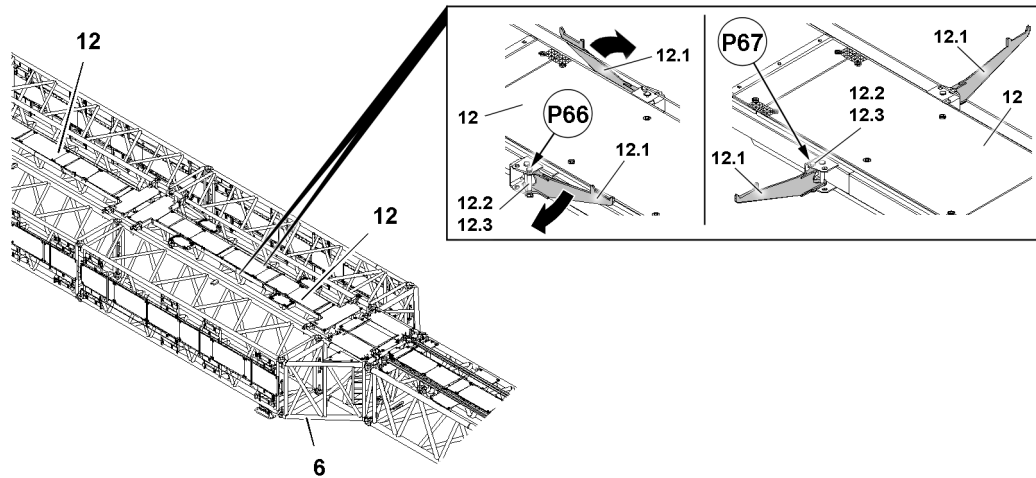

Fig.124516: Bringing the rod receptacle into operating position

The 12 m bridges **12** are equipped with a swingable rod receptacle **12.1**. The rod receptacle **12.1** is required for the assembly of the S-guy rods, but only on the last bridge before the P-adapter on top **6**.

Make sure that the following prerequisites are met:

- The bridges **12** are properly assembled.
- The bridge **12** with the installed platform **13** is properly assembled.



Note

- ▶ The description of the procedure „Bringing the rod receptacle into operating position“ is an example and is described via one rod receptacle **12.1**.
- ▶ The procedure for the rod receptacle on the opposite side is identical.

- ▶ Unpin the rod receptacle **12.1** at point **P66**: Remove the locking pin **12.3** and unpin the pin **12.2**.
- ▶ Swing the rod receptacle **12.1** outward.

When the rod receptacle **12.1** is in operating position:

- ▶ Pin the rod receptacle **12.1** in operating position: Insert the pin **12.2** at point **P67** and secure with the locking pin **12.3**.

4.7.10 Closing the boom system

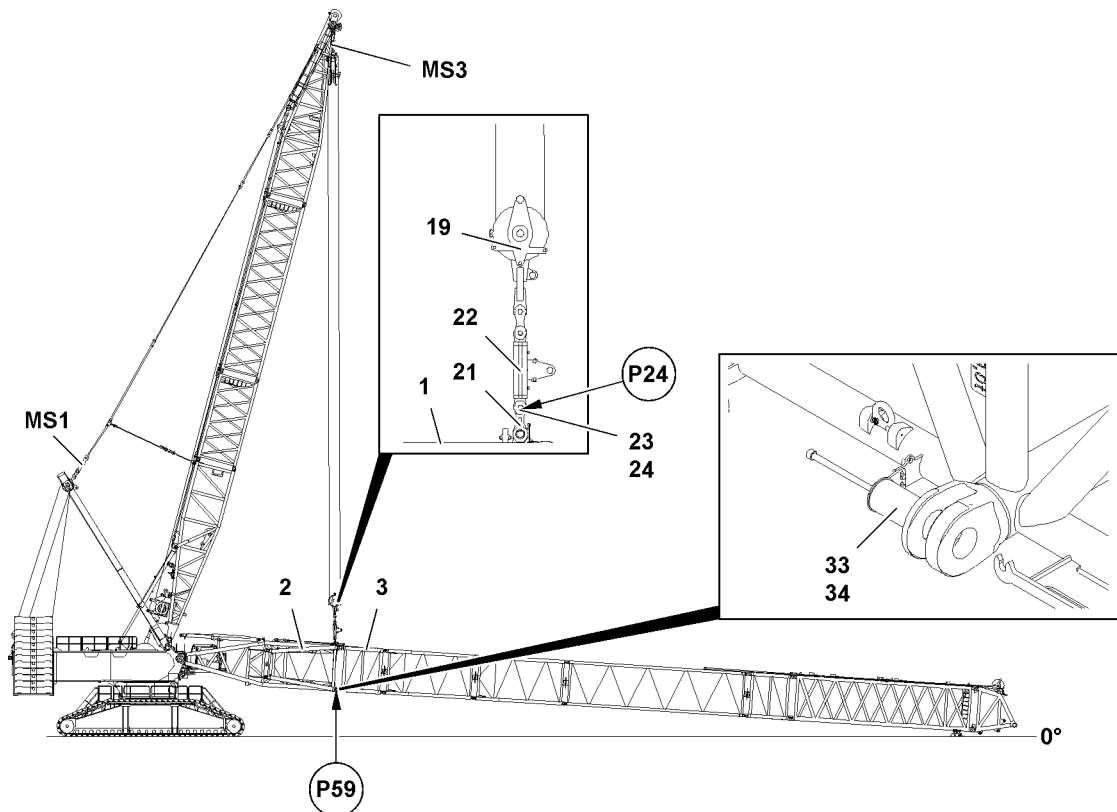

Fig.120310: Closing the boom system

Make sure that the following prerequisites are met:

- The boom system is completely assembled.
- The boom system is supported, if necessary.
- All lattice sections are properly pinned with each other.
- All pin connections are properly pinned and secured.
- All required guy rods are laying on the boom according to the rod plan and are secured to prevent them from falling down.
- The upper pulley block **19** (including assembly weight **22**) is completely pinned and secured with the brackets **21** on the S-pivot section **1**.



WARNING

The crane can topple over!

If the following conditions are not met, the crane can topple over or be significantly damaged. Death, severe bodily injuries, property damage.

- ▶ During the „closing procedure“ of the boom system, the maximum permissible F3-total force of **136 t** on test point 3 **MS3** may not be exceeded.
- ▶ During the „closing procedure“ of the boom system observe the values in the erection chart.
- ▶ The end section of the corresponding PD-boom combination may **not** lift off the ground during the „Closing procedure“.
- ▶ Make sure that there are no persons on the boom system as well as in the danger zone during the closing procedure.
- ▶ Non-required guy rods must be removed from the lattice sections, see Crane operating instructions, chapter 5.01.

**Note**

- ▶ The actual forces on test point 3 **MS3** - which are used during the closing procedure of the PD-boom system - are shown on LICCON monitor 1.
- ▶ Note the actual forces of test point 3 **MS3** and keep it ready for the disassembly of the PD-boom system.
- ▶ At boom disassembly, pretension the control rope of winch 3 until the noted (assembly) actual forces of test point 3 **MS3** on the LICCON monitor are reached, so that the connector pins between the lower P-adapters and the cross carriers can be uninned.

Close the PD-boom combination with the upper pulley block **19**:

- ▶ Lift the PD-boom system with the upper pulley block **19** until the four pin bores align at points **P59**.
- ▶ Pin the cross carrier **3** with the P-adapter: Insert the four connector pins **33** and secure with the safety locking pins **34**.

**WARNING**

Mortal danger if upper pulley block is uninned to soon!

By unpinning the upper pulley block **19** on the S-pivot section **1**, the boom can suddenly fold down if the boom is not properly pinned and secured „on the bottom“.

Death, severe bodily injuries, property damage.

- ▶ It is prohibited for anyone to remain under the raised boom combination during the pinning / unpinning procedure.
- ▶ Unpin the upper pulley block **19** on the S-pivot section **1** only when it is ensured that the lower P-adapters are properly pinned and secured „on top“ and „bottom“ with the cross carrier.

When the S-boom is „closed“:

- ▶ Unpin the bracket of the assembly weight **22** on bracket **21**: Release and unpin the pins **23** on both sides.

4.7.11 Installing the suspended ballast

If a derrick ballast according to the load chart is required for the planned crane operation, then install the derrick ballast, see Crane operating instructions, chapter 5.36.

**WARNING**

The crane can topple over!

If no derrick ballast is installed on the crane, the crane can topple over.

Death, severe bodily injuries, property damage.

- ▶ Make sure that the derrick ballast according to the load chart is installed for the planned crane operation.

5 Assembling the boom combinations with substructure

If the assembly conditions for the assembly of the boom system are restricted due to the terrain on the jobsite, then it is possible to install the PD-boom with a substructure.

**WARNING**

General danger notes!

- ▶ All pins are to be secured after assembly with the intended retaining elements.
- ▶ The guy rods must be inspected regularly, see the Crane operating instructions, chapter 8.15.
- ▶ Secure the boom with substructure or auxiliary crane, see Crane operating instructions, chapter 5.01.
- ▶ It is prohibited for anyone to remain under the booms or within the complete danger zone during the pinning and unpinning procedure of the lattice section.

NOTICE

Property damage!

If the pins of the guy rods are not pinned from the „inside“ to the „outside“, the hoist rope can scrape on the pins and be damaged.

- ▶ Always insert the pins of the guy rods from the „inside“ to the „outside“, see the Rod plan.

**WARNING**

The crane can topple over!

Death, severe bodily injuries, property damage.

- ▶ For boom assembly / disassembly with the substructure, observe chapter 5.01.
- ▶ The „actual force“ on test point 3 **MS3** is shown on LICCON monitor 1.
- ▶ Observe the assembly conditions, see the Crane operating instructions, chapter 3.06.
- ▶ The specifications in the erection and take-down charts as well as the load charts must be observed.
- ▶ For the itemization of the lattice sections refer to the Rod plan.

NOTICE

Overload of boom!

If the boom is not supported before the erection procedure, then the boom will be overloaded during the erection procedure.

The boom system will be damaged.

- ▶ Support the PD-boom from a length of more than 120 m.
- ▶ Make sure that the dimension **X** for the maximum permissible flexation of the boom system is never exceeded.
- ▶ Support the boom with suitable materials with sufficient load carrying capacity in the marked area, see illustration.

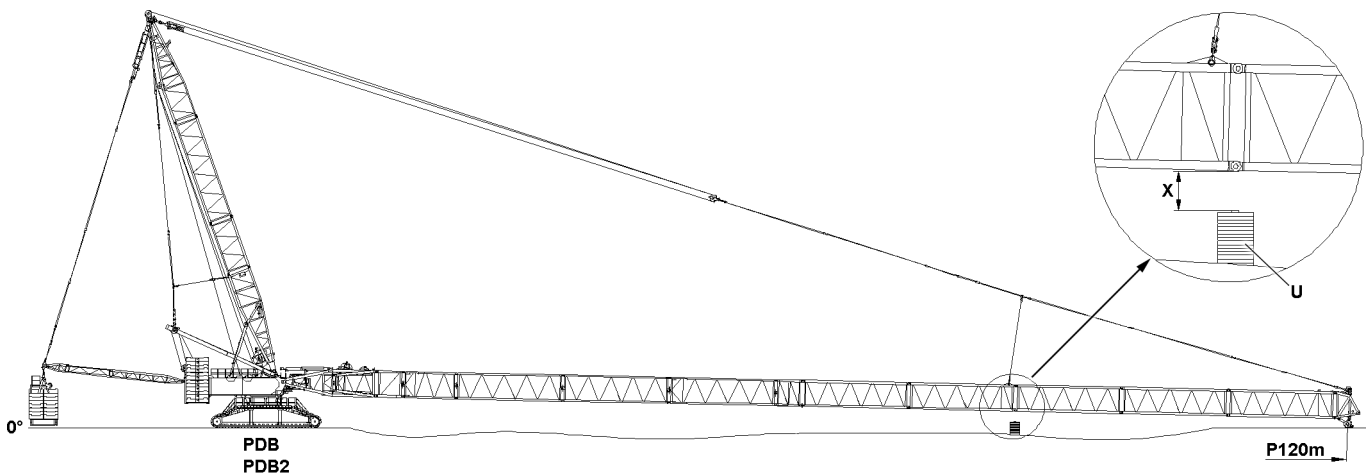

Fig.124521: Assembling the PD-boom with substructure

The PD-boom combination must be preassembled at a suitable location.

Swing the preassembled boom combination with the auxiliary crane(s) in to the turntable, pin and secure.

- ▶ Preassemble the boom combination.

**WARNING**

Danger of accident due to boom system!

Death, severe bodily injuries, property damage.

- ▶ Make sure that no persons are within the danger zone of the crane and the boom system to be assembled.
- ▶ Swing the preassembled boom combination with the auxiliary crane (s) to the turntable.

- ▶ Pin and secure the boom combination with the S-pivot section on the turntable, see section „Assembling the S-pivot section on the turntable“.

When the boom system is properly installed with the S-pivot section on the turntable:

- ▶ Support the boom system properly before taking it down on the ground.

Operating mode	Support from length	Dimension ¹⁾ X
PD	120 m	1.1 m

¹⁾ X = maximum permissible flexation of the boom system

- ▶ Lower the boom combination on the ground.

6 Assembling the guy rods



WARNING

Neglected guy rod inspection and maintenance!

If the regular inspection and maintenance of the guy rods is not carried out or is carried out only at irregular intervals, then severe accidents can occur due to existing and unrecognized damage to the guy rods.

Death, severe bodily injuries, property damage.

- ▶ Check the guy rods before every assembly, see Crane operating instructions, chapter 8.15.
- ▶ The guy rods must be installed and secured, see Rod plan. The numbering in the rod plan must be identical to the numbering on the guy rods.

Make sure that the following prerequisites are met:

- The boom is laying with the S-end section on the ground
- **or** the boom (from a length of 120 m) is laying on the substructure
- **or** the boom (from a length of 120 m) is held in position by an auxiliary crane.
- The D-boom is luffed down to the front.

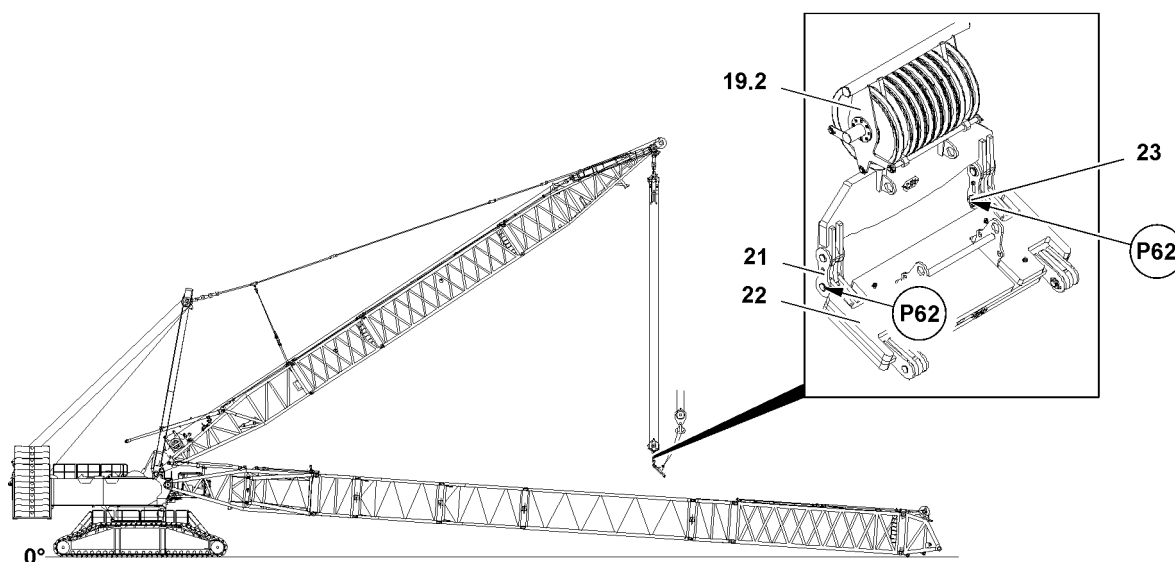

Fig.120312: Assembling the guy rods - Lowering the D-boom to the front and removing the assembly weight

- ▶ Luff the D-boom down carefully to the front.

When the D-boom is in position:

- ▶ Lower the upper pulley block **19** until the brackets **21** between the upper pulley block **19** and the assembly weight **22** are easily accessible.
- ▶ Fasten the assembly weight **22** properly to the auxiliary crane.
- ▶ Lift the assembly weight **22** with the auxiliary crane to the horizontal.

When the assembly weight **22** hangs horizontally on the auxiliary crane:

- ▶ Unpin the assembly weight **22** on the upper pulley block **19**: Release the pins **23** on both sides on points **P62** and unpin.
- ▶ Swing the assembly weight **22** out with the auxiliary crane and place it on a suitable substructure.
- ▶ Continue to luff the D-boom down until the upper pulley block **19** is positioned over the boom system.

Problem remedy

The D-boom cannot be luffed down further?

You luffed the D-boom down to the mandatory system shut off.

- ▶ Move the D-boom into the opposite direction from the shut off.
-
- ▶ Luff the D-boom slightly up.

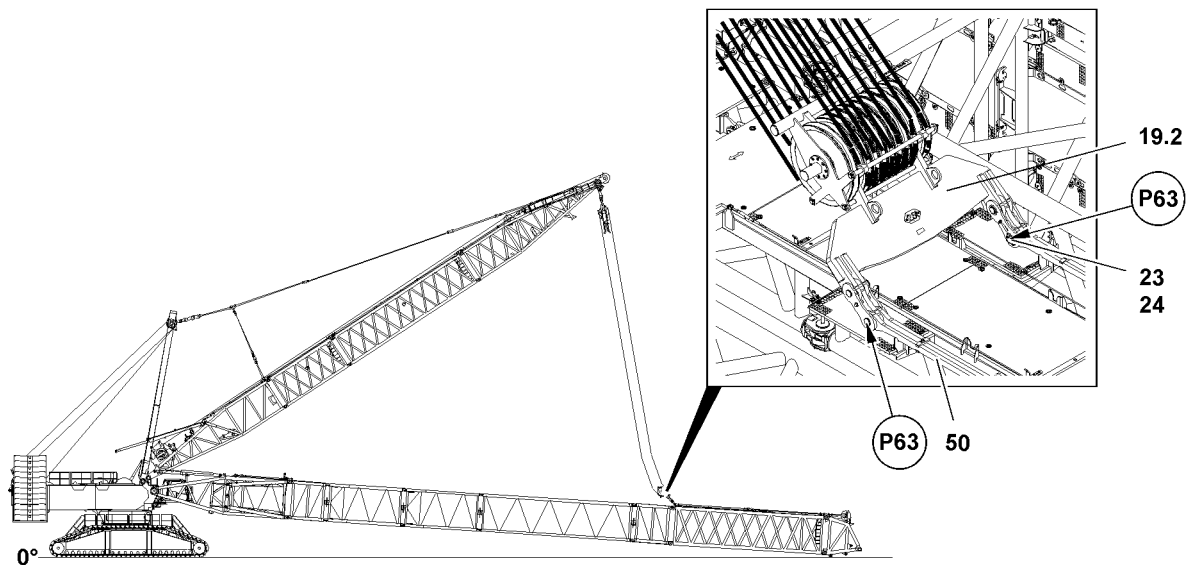

Fig.120313: Assembling the guy rods - Pinning the upper pulley block on the guy rods



Note

- ▶ Pull the upper pulley block **19** with the auxiliary crane to the pin points (points **P63**) of the guy rods **50** and position it in such a way that the guy rods **50** can be safely pinned on the upper pulley block **19**.

When the upper pulley block **19** is positioned over the guy rods **50**:

- ▶ Pin and secure the guy rods **50** with the upper pulley block **19**: Insert the pin **23** from the inside to the outside and secure with safety locking pin **24**.

12

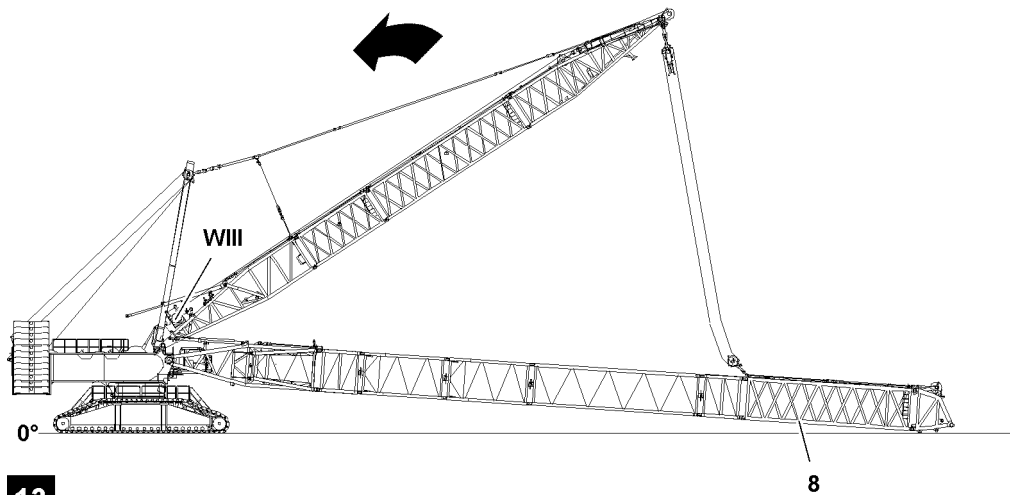

13

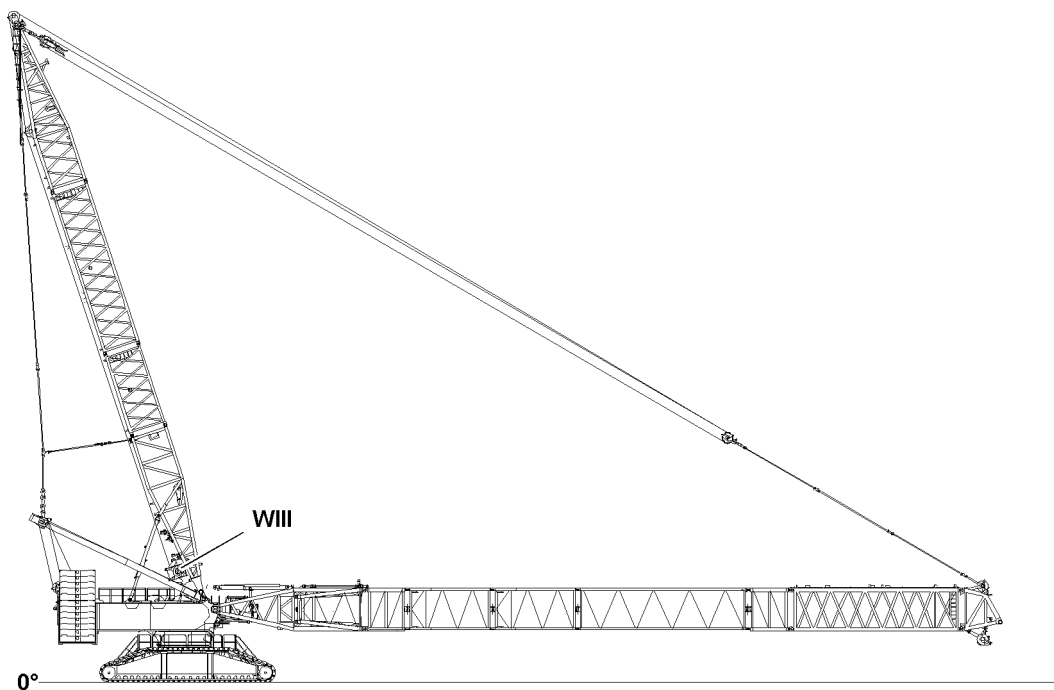

Fig.120314: Assembling the guy rods - Tensioning the guying



Note

- ▶ The P-boom must remain on the ground when erecting the D-boom and may **not** be pulled up along.

The guy rods **50** are placed and secured for transport on the S-intermediate sections **8**. Before assembly of the guy rods **50**, the transport retainers must be released.

When the guy rods **50** are properly pinned and secured with the upper pulley block **19**:

- ▶ Release and unpin transport retainers for the guy rods **50**.

NOTICE

Property damage!

If the pins of the guy rods **50** are not pinned from the „inside“ to the „outside“, the hoist rope can scrape on the pins and be damaged.

- ▶ Always insert the pins of the guy rods **50** from the „inside“ to the „outside“, see Rod plan.
- ▶ Pin the required guy rods **50** with each other: Insert the pin from the „inside“ to the „outside“ and secure with locking pin.
- ▶ Assemble the guying according to the Rod plan, pin and secure it properly.
- ▶ Make sure that all required guy rods **50** of the boom system are pinned and secured.
- ▶ If it is required according to the Rod plan: Assemble the auxiliary guying, see Crane operating instructions, chapter 5.01 and 5.03.

**WARNING**

Unutilized guy rods on boom!

If guy rods are on the lattice sections which are not required for crane operation, then there is a danger of accidents.

Death, severe bodily injuries, property damage.

- ▶ Non-required guy rods must be removed from the lattice sections, see Crane operating instructions, chapter 5.01.
- ▶ Remove non-required guy rods from the lattice sections.

**WARNING**

D-boom falling to the rear!

If the relapse cylinders of the D-boom are not completely moved out before erection, then the D-boom can fall backward when erecting it into operating position.

Death, severe bodily injuries, property damage.

- ▶ Make sure that the relapse cylinders of the D-boom are completely moved out.

NOTICE

Danger of slack rope formation!

If winch 3 **WIII** is spooled out too quickly during the erection procedure of the D-boom, slack rope can form.

- ▶ Make sure that the rope of winch 3 **WIII** is tensioned during the entire erection procedure of the D-boom.

**WARNING**

Danger of accident due to lifting of the P-boom system!

Death, severe bodily injuries, property damage.

- ▶ The P-boom system may not be raised during the erection of the D-boom in the operating position and must remain in the initial position.
- ▶ Erect the D-boom in operating position and spool out winch 3 **WIII** at the same time, see illustration 12.

When the D-boom is in operating position:

- ▶ Tension the guying between the D-end section and the boom end section, see illustration 13.

7 Assembling the roller sets on the boom head

7.1 Assembling the roller sets

**Note**

- ▶ The assembly of the roller sets is described in the Crane operating instructions, chapter 5.14.

When the roller set / the roller sets are properly installed on the end section:

- ▶ Route the hoist limit switch from the end section forward on the roller set / the roller sets, pay attention and adhere to the Electrical wiring diagram.

7.2 Establishing the electrical connections on the boom end section

Make sure that the following prerequisites are met:

- The S-intermediate sections are properly assembled and secured on the ground.
- The boom end section is properly assembled and secured.
- The electrical connections to the boom end section have been established.
- The airplane warning light, wind speed sensor and all sensors are properly installed and secured on the boom end section.
- The hoist limit switches are properly installed and secured on the pulley head / pulley heads.

NOTICE

Danger of damage to the electrical connections!

If the electrical connection from the cable drum on the S-pivot section to the terminal box on the S-pivot section is established first before the connection to the terminal box on the boom end section, the electrical connection can be damaged when spooling out the cable drum.

- ▶ Establish first the electrical connection from the cable drum in the S-pivot section to the terminal box on the boom end section and then the electrical connection from the terminal box in the S-pivot section to the cable drum.
-



Note

- ▶ To establish the electrical connections on the S-boom: Use the Electrical wiring diagram.
-

- ▶ Establish the electrical connections.
 - ▶ Make sure that all electrical connections on the boom are established.
-



WARNING

Malfunction if dummy plugs are not installed!

If the dummy plugs on the non-required electrical connections are not installed, then malfunctions or functional limitations can occur on the crane.

- ▶ Make sure that all non-required electrical connections that have a dummy plug are closed off with dummy plugs.
 - ▶ Pay attention to the Electrical wiring diagram.
-
- ▶ As a rule, close off on-required electrical connections (for example for accessories which cannot be installed) with the respective dummy plugs.
-

NOTICE

Property damage due to dirt and / or corrosion!

If non-required electrical connections are not closed off with the respective protective caps, then dirt and / or corrosion can damage the electrical connections.

This could result in malfunctions.

- ▶ Make sure that all non-required electrical connections are always closed off properly.
 - ▶ Pay attention to the Electrical wiring diagram.
-
- ▶ Close electrical connections, which have no dummy plugs, properly off with the corresponding protective caps.
-

8 Performing the function checks



WARNING

Malfunctioning safety equipment!
Death, severe bodily injuries, property damage.

- ▶ Crane operation with non-functioning safety equipment is **prohibited**.
- ▶ Start crane operation only after all safety equipment have been checked and are functioning correctly.



Note

- ▶ The function of the individual limit switches must be checked before erection of the boom system.
- ▶ The function of the limit switch initiators must be checked in the test system, see the Diagnostics manual.



Note

- ▶ If a function check on the limit switches or on the safety equipment does not lead to the desired shut-offs, then the plug connections on the connector boxes or the components themselves must be checked.
- ▶ If no visible connection errors or component defects can be found, contact Liebherr Service.

Make sure that the following prerequisites are met:

- All electrical connections have been made.
- The crane engine is running.
- The corresponding operating mode is set on the LICCON monitor.
- The actuator levers of the limit switches have been checked for easy movement and are lubricated.

8.1 Wind speed sensor

- ▶ Check the movement and the function of the wind speed sensor.

8.2 Airplane warning light

- ▶ Turn the airplane warning light on, see Crane operating instructions, chapter 4.01.
- ▶ Check the function visually.

8.3 Hoist limit switch

- ▶ Actuate the hoist limit switch manually on the pulley head.

Result:

- The hoist winch turns off in upward movement.
- The hoist top icon blinks on the LICCON monitor 0.
- The hoist limit switch is functioning.

8.4 Checking the limit switch main boom „steepest position“



Note

- ▶ The limit switch functions have to be checked individually before erection.
- ▶ Cover the limit switch initiators on the relapse cylinders of the main boom individually with a metal plate.

Result:

- The limit switch is actuated manually.
- The spool up function of winch 4 turns off.
- The „Boom limitation“ icon appears on the LICCON monitor 0.

9 Erecting the boom

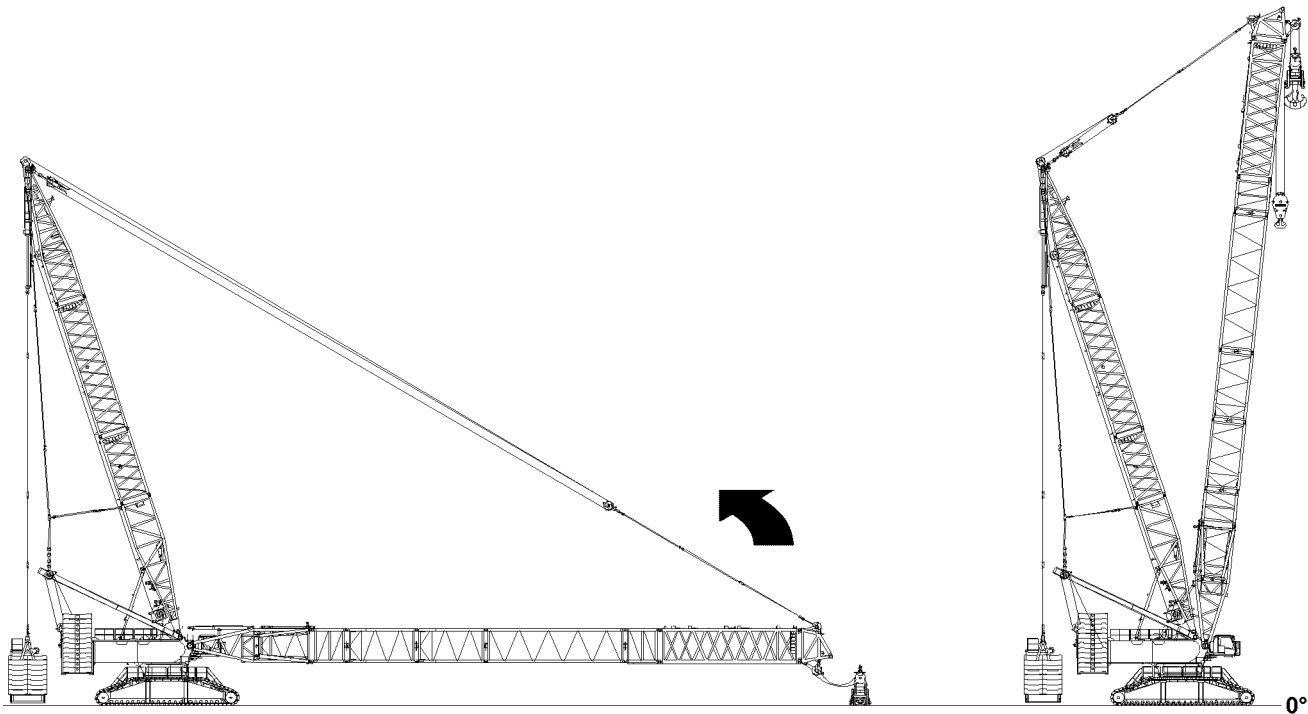

Fig.120316: Erecting the boom



WARNING

The crane can topple over!

In crane operation with deactivated LICCON overload protection, the crane can topple over. Death, severe bodily injuries, property damage.

- ▶ The radii listed in the load chart may not be exceeded or fallen below, even if there is no load on the hook.

If required in the erection and take down chart:

- ▶ Carry the hook block along with the auxiliary crane.



WARNING

The crane can topple over!

If the following conditions are not met before erecting the boom, the crane can topple over. Death, severe bodily injuries, property damage.

- ▶ Observe the technical safety instructions, see Crane operating instructions, chapter 5.01.
- ▶ Make sure that the relapse cylinders of the main boom are completely extended before erection of the boom combination.
- ▶ Do not allow slack rope to build up on the winch 4.



WARNING

Falling hoist rope!

If the hoist rope is not reeved with the respective length on the roller set / the roller sets of the end section before the erection procedure, then it can fall down backward due to its own weight. Death, severe bodily injuries, property damage.

- ▶ Reeve the hoist rope before the erection procedure with a sufficient length on the roller set / the roller sets of the end section.
- ▶ The hoist rope must be constantly monitored during the erection procedure.
- ▶ Make sure that there are no persons within the danger zone.

Make sure that the following prerequisites are met:

- The crane is horizontally aligned.
- The guy rods are properly assembled.
- The guy rods which are not required have been removed from the lattice sections.
- All electrical connections have been made.
- All hydraulic connections have been made.
- The function checks were carried out properly.
- All limit switches and warning devices are functioning.
- Crane ballasting (counterweight, central ballast, derrick ballast and / or auxiliary ballast) is carried out according to the load charts and / or the erection and take-down charts
- The crane has been set up according to the load charts and / or the erection and take-down charts.
- The LICCON overload protection has been set according to the data in the load charts and / or the erection and take-down charts.
- The LICCON overload protection settings have been checked for completeness and correctness.
- Assembly operation of the crane control is activated: the assembly icon is visible on the LICCON monitor.
- All pin connections have been secured.
- The hoist rope has been correctly placed in the rope pulleys and is prevented from jumping out with the rope retaining pins.
- There are no loose parts on the boom system.
- The boom system and the safety equipment are free from snow, frost and ice.
- No personnel or obstacles are within the danger zone.

9.1 Moving the S-relapse cylinders out

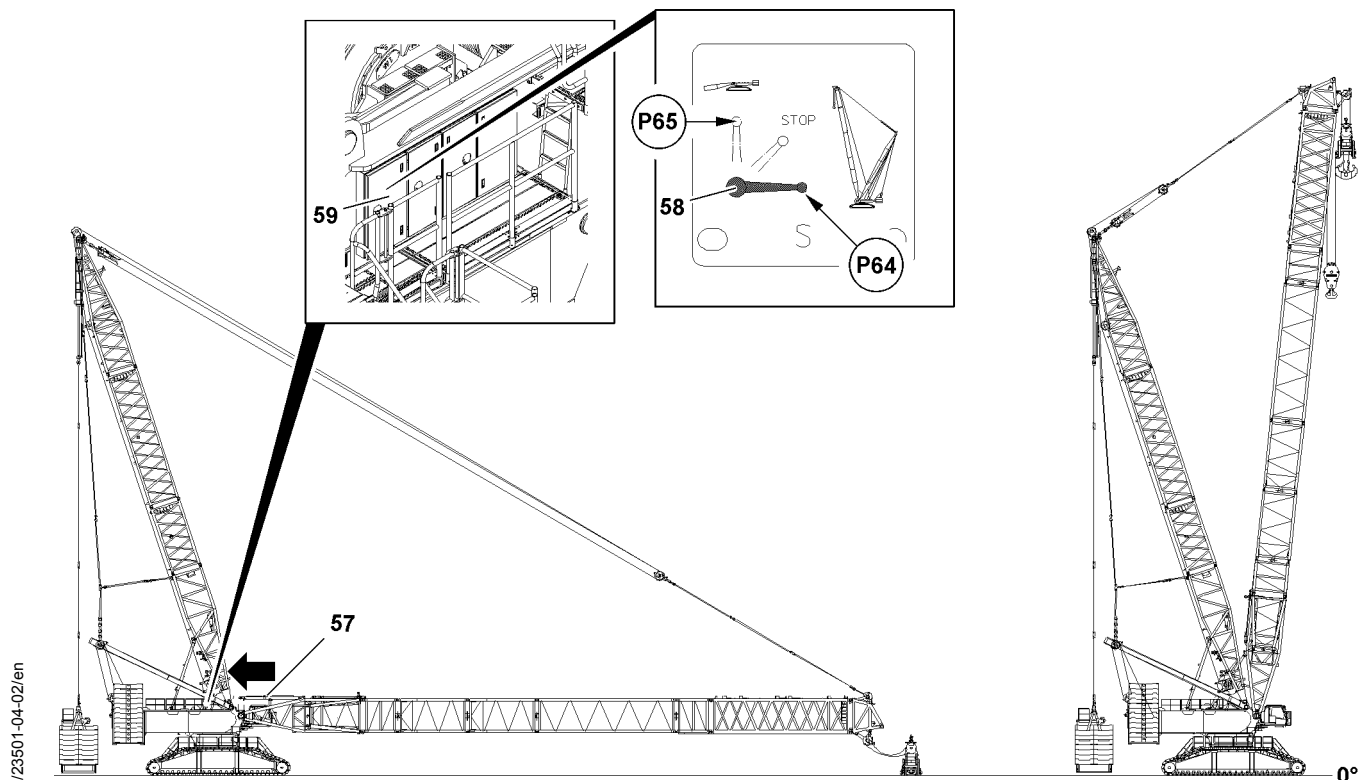

Fig.120315: Extending the relapse cylinder

**WARNING**

The crane can topple over!

If the S-relapse cylinders **57** are not moved out before erecting the P-boom, then the P-boom can fall to the rear in crane operation and the crane can topple over.

Death, severe bodily injuries, property damage.

- ▶ Move the S-relapse cylinders **57** out completely before erecting the P-boom.
- ▶ Secure the ball valve **58** during crane operation to prevent inadvertent actuation.

Ball valve positions	
Position (P)	Function
64	Crane operation, extend the piston rod
65	Assembly, retract the piston rod
STOP	The piston rod cannot be retracted / extended

The piston rods on the S-relapse cylinders **57** can be moved out with the ball valve **58**.

- ▶ Set the ball valve **58** to position **P64**.

Result:

- The piston rods of the S-relapse cylinders **57** move out.

**Note**

- ▶ The ball valve **58** is secured by closing the cabinet door **59** and removing the key.

- ▶ Close the cabinet door **59** and pull out the key.
- ▶ Hand the key to an authorized person.

9.2 Erection procedure

**DANGER**

The crane can topple over!

- ▶ It is prohibited to turn the crane superstructure while erecting the boom.
- ▶ Adhere to the specifications in the erection and take down charts.

Make sure that the following prerequisite is met:

- The load weighing was carried out on the boom and the hook block weight has been entered on the LICCON monitor, see Crane operating instructions, chapter 4.02.

9.2.1 Reeving in the hook block

Make sure that the following prerequisites are met:

- The crane is horizontally aligned.
- The slewing gear brake is applied.

**WARNING**

Danger of accident due to side wind!

If the slewing gear brake is released after reeving in / reeving out the hook block / load hook, then the crane can turn uncontrolled if there is a strong side wind.

Death, severe bodily injuries, property damage.

The crane can collide with close-by structures or objects.

- ▶ Make sure that the current wind speed does not exceed the values from the wind speed chart when releasing the slewing gear brake.

- ▶ Erect the boom until the end section lifts off the ground.

NOTICE

Danger of slack rope formation!

By spooling the hoist winch out too fast during the reeving procedure, slack rope can form.

- ▶ Make sure that the hoist rope is tensioned during the entire reeving procedure.

**WARNING**

Falling hoist rope!

If the hoist rope is not reeved with the respective length over the S-boom before the erection procedure, then it can fall backward due to its own weight.

Death, severe bodily injuries, property damage.

- ▶ Reeve in the hoist rope with sufficient length on the S-boom before the erection process.
- ▶ The hoist rope must be constantly monitored during erection.
- ▶ Do not step into the danger zone.

- ▶ Reeve in the hoist rope properly and secure on the rope fixed point, see Crane operating instructions, chapter 4.06.

**Note**

- ▶ Reeving, see Reeving plan.

- ▶ Pin and secure the rope retainers on the rope pulleys.
- ▶ Attach the hoist limit switch weight, see section Crane operating instructions, chapter 4.06.

9.2.2 Erecting the boom

**WARNING**

The crane can topple over!

In crane operation with deactivated LICCON overload protection, the crane can topple over. There is then no additional protection against crane overload.

Death, severe bodily injuries, property damage.

- ▶ The radii listed in the load chart may not be exceeded or fallen below, even if there is no load on the hook.
- ▶ Crane operation with deactivated LICCON overload protection is prohibited.

**Note**

- ▶ When the lowest operating position of the boom is reached, the LICCON overload protection is activated.
- ▶ In the maximum load icon appears a load number in „t“ instead of the display „???“.

- ▶ Luff the S-boom up to the lowest operating position.

When the S-boom has reached the lowest operating position:

- ▶ Make sure that the assembly icon on the LICCON monitor turns off.

Result:

- The LICCON overload protection is active.

10 Operating the crane

10.1 Preparing for crane operation

**Note**

- ▶ Observe the notes, see Crane operating instructions, chapter 4.02, chapter 4.04, chapter 4.05, chapter 4.08 and chapter 5.01.

Make sure that the following prerequisites are met:

- The LICCON overload protection is active.
- The LICCON overload protection has been set according to the data in the load chart.



WARNING

The crane can topple over!

- ▶ Check the horizontal position of the crane before and during operation.
 - ▶ If the crane operator leaves the cab, even for a short time, the operating mode setting must be checked and reset if necessary before resuming crane operation.
-

10.1.1 Checking the settings

- ▶ Check the function of the overload protection by running against the operating positions „on top“ and „bottom“.
- ▶ Check the hoist limit switch by running against the hoist limit switch weight.
- ▶ Check the function of the limit switches „Boom steep“ on the relapse cylinders.

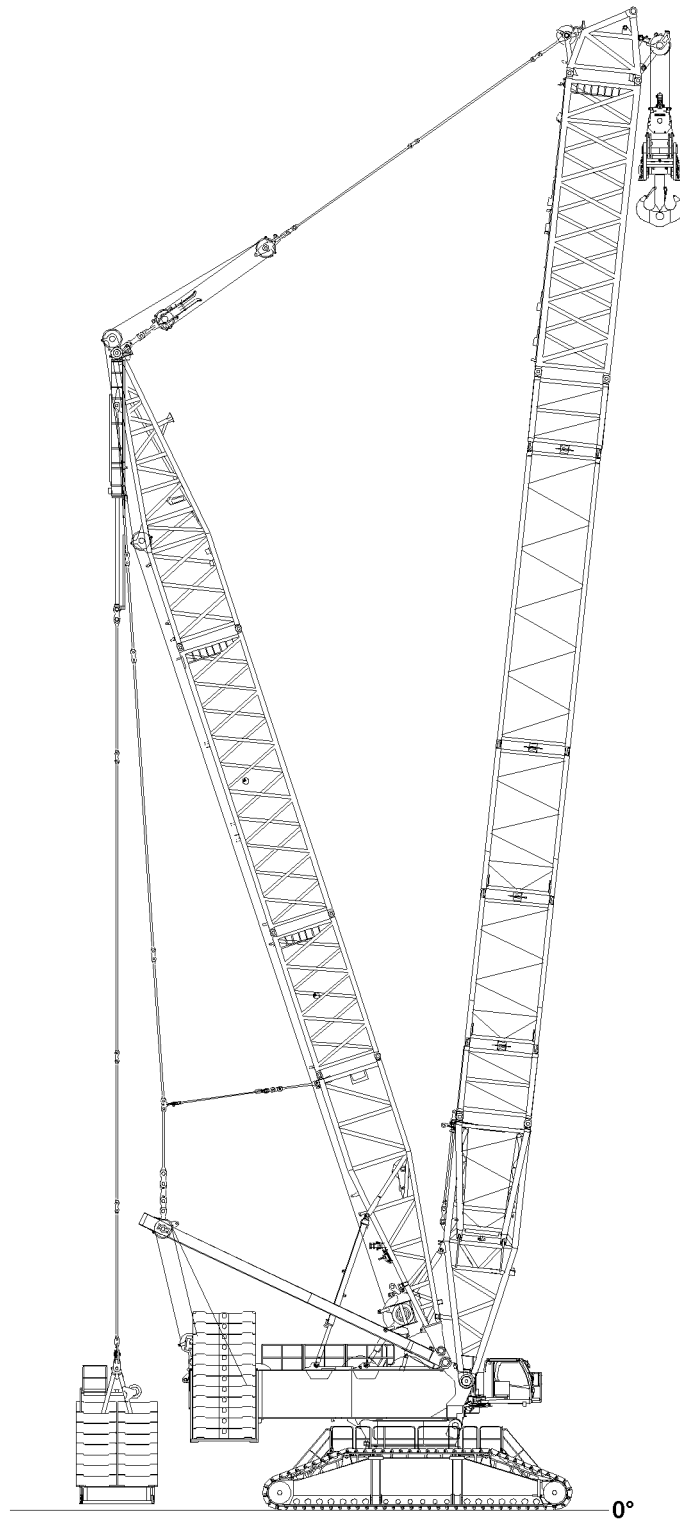

Fig.120326: Disassembly PD-boom

LWE/LR 11000-001/23501-04-02/en

11 Disassembly PD-boom



WARNING

Danger of falling!

During assembly / disassembly, inspection and maintenance work, assembly personnel must be secured with appropriate aids to prevent them from falling.

Death, severe bodily injuries, property damage.

- ▶ All work at a height, when there is a danger of falling, must be carried out with suitable aids.
- ▶ If aids are not available and work cannot be carried out from the ground, then assembly personnel must secure themselves with the supplied fall arrest system to prevent falling, see the Crane operating instructions, chapter 2.04.
- ▶ If fall protection equipment is available, then it must be used, see the Crane operating instructions, chapter 2.06.
- ▶ When lifting, lowering, swinging crane parts in and out, no persons may remain in the danger zone.
- ▶ When closing or opening boom systems during boom assembly or boom disassembly, no persons may remain on the boom system or in the danger zone.
- ▶ If railings are present on the components, then they must be brought into the corresponding position and secured for assembly / disassembly work.
- ▶ Only step on the aids, ladders and catwalks with clean shoes.
- ▶ Keep aids, ladders and catwalks free of heavy dirt, snow and ice.
- ▶ During all assembly and disassembly work, maintenance work and inspections, travel or crane operation is prohibited.
- ▶ Remaining on a suspended load is prohibited.
- ▶ Stepping or walking on crane components and lattice sections, which have an incline of more than 20° is prohibited.
- ▶ For all assembly work, the crane driver of the main crane must be in voice contact with the crane driver / crane drivers of the auxiliary crane / auxiliary cranes.
- ▶ For assembly tasks, the crane driver may only initiate crane movements when the responsible guide has explicitly released the movement.



WARNING

The lattice sections can fall down!

If the lattice sections are not pinned and secured correctly, then they can fall down.

Death, severe bodily injuries, property damage.

- ▶ Pin or unpin both pins at the same horizontal level, i.e. **left and right**.
- ▶ Do not stand under the lattice sections or within the entire danger zone during the pinning and unpinning procedure of the boom.
- ▶ Safely secure the pins in the storage locations as well as in the receptacles.
- ▶ It is prohibited to lean the auxiliary ladder against the component being disassembled.



WARNING

Danger of impact / crushing!

When installing / removing crane components with the auxiliary crane, crane components can start to swing back and forth.

When lifting / lowering and positioning crane components, there is an increased danger of impacts / crushing.

Death, severe bodily injuries, property damage.

- ▶ Make sure that personnel cannot be caught by components.
- ▶ Make sure that the crane is horizontally aligned.
- ▶ When working in danger zones: Use aids to protect limbs.
- ▶ Guide components with suitable aids to minimize oscillation.

**DANGER**

The components can fall down!

If the corresponding components are disengaged from the auxiliary crane before the corresponding component is pinned, the corresponding component can fall down and fatally injure personnel.

- ▶ Do not disengage the auxiliary crane until the respective component is pinned and secured.

Make sure that the following prerequisites are met:

- The ground is able to safely take on the total operating weight of the crane.
- The crane is horizontally aligned.
- A substructure is standing on the correct location, if needed, see Crane operating instructions, chapter 5.01.
- An auxiliary crane with sufficient load bearing capacity if available.
- An assembly scaffolding or a work platform is available.
- The counterweight has been installed on the turntable according to the load chart or the erection and take down charts.
- The LICCON overload protection has been set according to the data in the load chart.

11.1 Disassembling the derrick ballast

**WARNING**

The crane can topple over!

If no derrick ballast is installed on the crane, the crane can topple over.

Death, severe bodily injuries, property damage.

- ▶ Observe the Erection and take down charts.
- ▶ If a derrick ballast is required for taking down the boom system, then leave the derrick ballast on the crane.

When no derrick ballast is required for taking down the boom system:

- ▶ Disassemble the derrick ballast, see Crane operating instructions, chapter 5.36.

11.2 Disassembling the central ballast

**WARNING**

The crane can topple over!

If no central ballast is installed on the crane, the crane can topple over.

Death, severe bodily injuries, property damage.

- ▶ Observe the Erection and take down charts.
- ▶ If a central ballast is required for taking down the boom system, then leave the central ballast on the crane.

When no central ballast is required for taking down the boom system:

- ▶ Remove the central ballast, see Crane operating instructions, chapter 3.03.

11.3 Turning the turntable to the disassembly position

**WARNING**

The crane can topple over!

If the following conditions are not met before turning the turntable, then the crane can topple over.

Death, severe bodily injuries, property damage.

- ▶ Observe the specifications in the erection and take-down charts.
- ▶ Observe the data in the load charts.

- ▶ Turn the turntable into disassembly position according to the erection and take down charts.

11.4 Luffing the boom system down and reeving the hoist rope out



WARNING

The crane can topple over!

If the following conditions are not met before taking down the main boom, the crane can topple over. Death, severe bodily injuries, property damage.

- ▶ Observe the technical safety instructions, see Crane operating instructions, chapter 5.01.
- ▶ Observe the specifications in the erection and take-down charts.

NOTICE

Damage of boom components!

Taking down the boom system can lead to a collision between the hook block and the pulley head.

Boom components can be severely damaged.

- ▶ Luff the boom system down and at the same time spool the hoist winch out.
- ▶ When luffing the boom system down, the D-boom must remain in operating position until the boom is laying on the substructure or until the boom end section is laying on the ground or is safely held by an auxiliary crane.



Note

- ▶ The luff down movement is turned off as soon as the lowest operating position of the main boom is reached.
 - ▶ When the lowest operating position of the main boom is reached, the load display in the maximum load icon turns off and instead of the load display appears the display „???“.
 - ▶ In the crane operating screen appear alarm functions.
- ▶ Luff the boom down to the **lowest** operating position.

Result:

- The luff down movement is turned off.
- The „STOP“ icon appears on the LICCON monitor.
- The horn icon appears on the LICCON monitor.

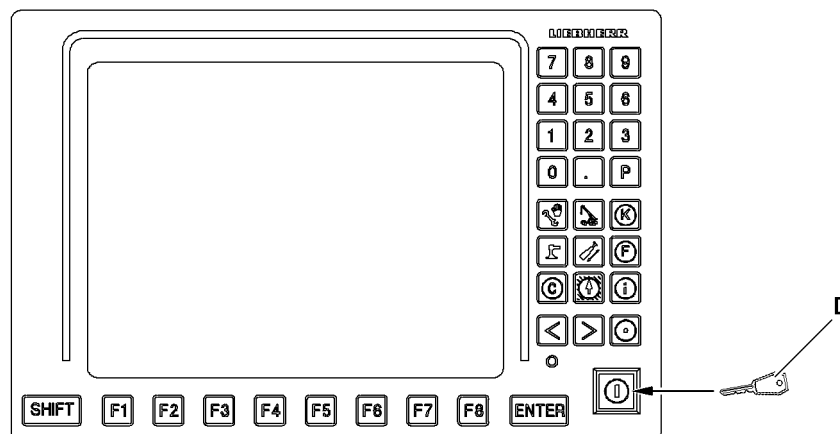

Fig.119109: Exceeding the shut off limits of the LICCON overload protection: Engage assembly operation

**WARNING**

Danger of accident due to function „Exceedance of shut-off limits of the LICCON overload protection“! If the shut off limits of the LICCON overload protection are exceeded, there is no additional protection against crane overload.

Due to erroneous operation or deliberate misuse, the crane could collapse, the boom can break off or the crane can topple over.

Death, severe bodily injuries, property damage.

- ▶ The function „Exceedance of shut off limits of the LICCON overload protection“ is only permissible in emergencies and for assembly purposes.
- ▶ The function „Exceeding the shut off limits of the LICCON overload protection“ may only be actuated by persons who know the effects of their actions regarding the function „Exceeding the shut off limits of the LICCON overload protection“.
- ▶ The function „Exceedance of shut off limits of the LICCON overload protection“ requires the presence of an authorized person and must be performed with utmost caution.
- ▶ Crane operation with activated function „Exceedance of shut off limits of the LICCON overload protection“ is prohibited.

- ▶ Exceeding the shut off limits of the LICCON overload protection: Engage assembly operation.

Result:

- The shut off limits of the LICCON overload protection are exceeded.
- The assembly icon appears on the LICCON monitor.

**Note**

- ▶ See the Crane operating instructions, chapter 4.02 and chapter 4.20.

- ▶ At the same time, spool the hoist winch out and luff the boom system down until the hook block touches the ground.

**WARNING**

Danger of accident due to side wind!

If the slewing gear brake is released after reeving in / reeving out the hook block / load hook, then the crane can turn uncontrolled if there is a strong side wind.

Death, severe bodily injuries, property damage.

The crane can collide with close-by structures or objects.

- ▶ Make sure that the current wind speed does not exceed the values from the wind speed chart when releasing the slewing gear brake.

- ▶ Remove the hoist limit switch weight and reeve out the hook block, see Crane operating instructions, chapter 4.06.
- ▶ Remove the hook block with the auxiliary crane.

When the hook block is removed under the boom head:

- ▶ Continue to luff the boom system down until the roller set / roller sets are just above the ground.

**WARNING**

Spooling up of hoist rope!

Death, severe bodily injuries, property damage.

- ▶ All rope retaining pins / pipes on the boom system are removed.
- ▶ Slowly spool up the hoist rope over the rope pulleys back to the winch.
- ▶ No one may be present in the danger zone.

NOTICE

Overspooled winch!

If the hoist rope is pulled under the winch when spooling up, then the adjustment of the cam limit switch can change.

A new adjustment by **Liebherr Service** is required.

- ▶ Stop the winch in time, with sufficient rope reserve.
- ▶ Do not overspool the winch.

- ▶ Spool the hoist rope up.

11.5 Moving the S-relapse cylinder in

Make sure that the following prerequisite is met:

- The crane engine is running.

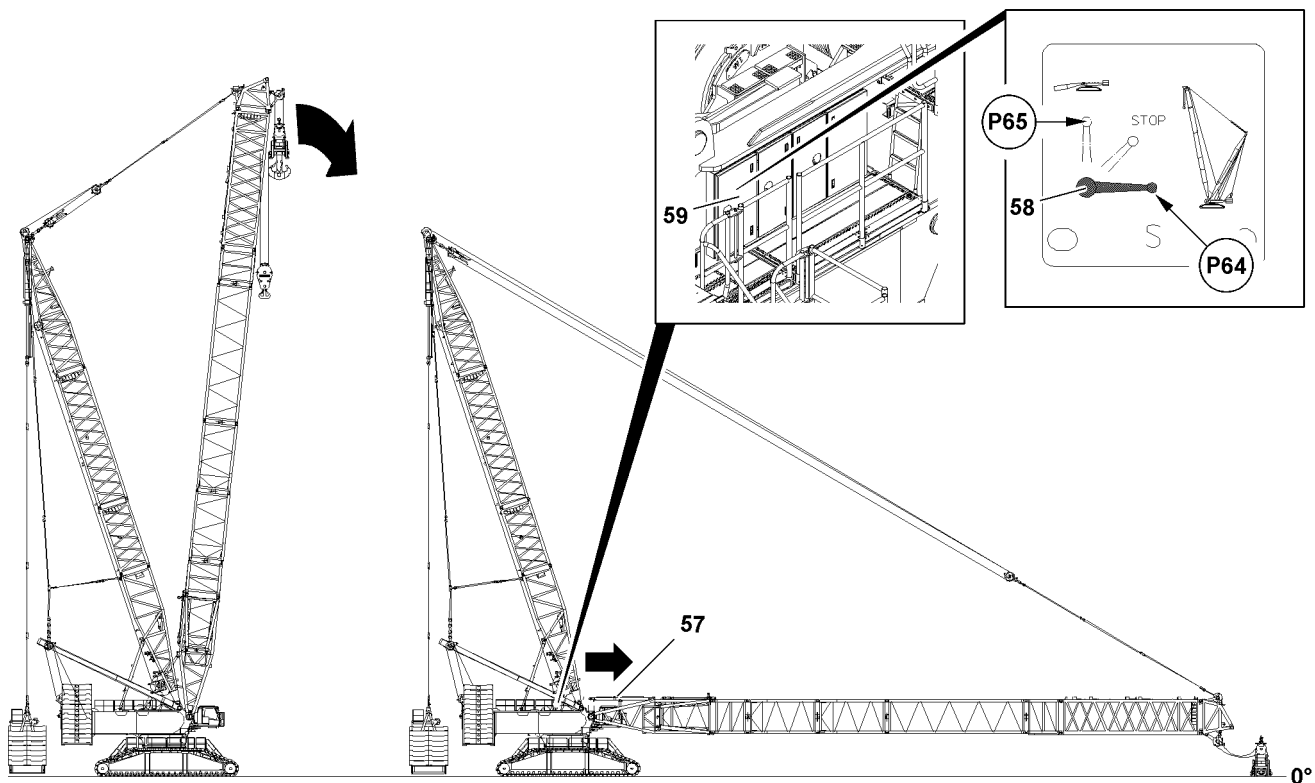

Fig.120327: Luffing the boom system down / retracting the relapse cylinder

Ball valve positions	
Position (P)	Function
64	Crane operation, extend the piston rod
65	Assembly, retract the piston rod
STOP	The piston rod cannot be retracted / extended

- ▶ Move the S-relapse cylinder **57** in: Actuate the ball valve **58** in position **P65**.

Result:

- The piston rods of the S-relapse cylinders **57** move in.

**Note**

- ▶ The ball valve **58** is secured by closing the cabinet door **59** and removing the key.
- ▶ Close the cabinet door **59** and pull the key.
- ▶ Hand the key to an authorized person.

11.6 Disassembly of the roller sets on the boom head

NOTICE

Danger of property damage!

During the disassembly of the roller sets the electrical connections to the hoist limit switches can be damaged.

- ▶ Remove the hoist limit switches on the roller sets.
- ▶ Before disassembly of the roller sets, route the hoist limit switches from the roller sets back to the end section.

**Note**

- ▶ The disassembly of the roller sets is described in the Crane operating instructions, chapter 5.14.

11.7 Placing the boom on the substructure

Make sure that the following prerequisites are met:

- The hook block is properly unreeved and removed.
- The hoist limit switch is on the end section.
- The roller set / the roller sets are removed.

NOTICE

Overload of boom!

If the boom is not supported before the take down procedure, then the boom can be overloaded during the take down procedure.

The boom system will be damaged.

- ▶ Support the PD-boom from a length of more than 120 m.
- ▶ Make sure that the dimension **X** for the maximum permissible flexation of the boom system is never exceeded.
- ▶ Support the boom with suitable materials with sufficient load carrying capacity in the marked area, see section „Assembling the boom combinations with the substructure“.
- ▶ Take the boom system down on the substructure.
 - or**
 - Secure the boom system with the auxiliary crane in the horizontal position.
 - or**
 - Take the boom system down on the ground.

11.8 Disconnecting the electrical connections on the boom end section

Make sure that the following prerequisite is met:

- The main boom is placed on the ground or is safely held by the auxiliary crane.

NOTICE

Damage to cable drum or cable!

If the cable of the cable drum is not properly spooled up on the cable drum after unplugging the S-end section, then the cable drum or the cable can be significantly damaged.

- ▶ Spool the cable drum up after unplugging.
- ▶ Spool the cable drum up and secure it to prevent inadvertent spooling out.
- ▶ Disconnect the electrical connections and store the plugs and cables properly.

11.9 Placing the guy rods down

Make sure that the following prerequisites are met:

- The boom is laying on the substructure on the ground.
- The guying is relieved.
- The auxiliary guying is removed (only if present).

NOTICE

Danger of slack rope formation!

If the D-boom is luffed down too quickly at disassembly of the guy rods, then slack rope formation can occur.

- ▶ Make sure that the rope of winch 3 is tensioned during the entire luff down procedure of the D-boom.

- ▶ Luff the D-boom down to the front and spool up winch 3 simultaneously until the guy rods are placed in the transport receptacles of the intermediate sections and in the transport receptacles of the bridge.
- ▶ Fasten the upper pulley block **19** to the auxiliary crane and hold it in position with the auxiliary crane.

When the upper pulley block **19** is safely held by the auxiliary crane:

- ▶ Unpin the guy rods on the upper pulley block **19**.
- ▶ Secure guy rods in the transport retainers of the S-intermediate sections: Insert and secure the pin.
- ▶ Guy rods, which are taken down on the rod receptacles of the bridges must be lifted off the boom system with the auxiliary crane and properly removed.

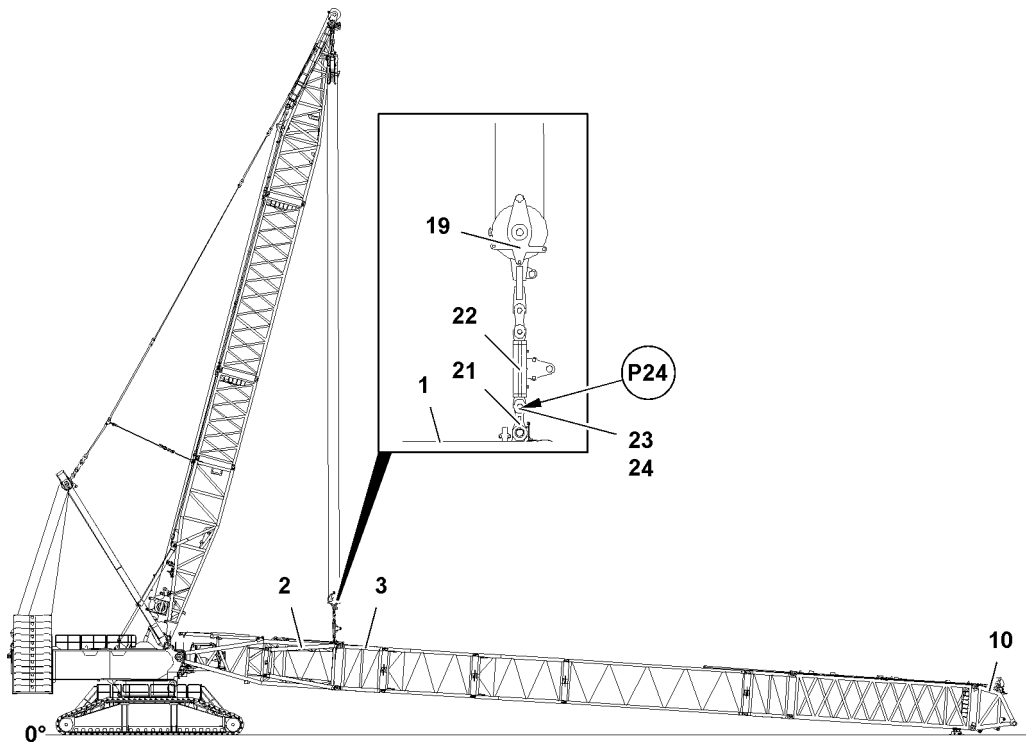

Fig. 120328: Taking the guy rods down - Pinning the upper pulley block on the S-pivot section

- ▶ Install the assembly weight **22** on the upper pulley block **19**.
- ▶ Properly pin and secure the upper pulley block **19** (including assembly weight **22**) on the brackets **21** on the S-pivot section **1**.
- ▶ Spool winch 3 up carefully and guide the upper pulley block **19** with the auxiliary crane to the D-end section.
- ▶ Erect the D-boom until the D-end section stands vertically over the brackets **21** on the S-pivot section **1**.

- ▶ Tension the main boom by spooling up winch 3.

**WARNING**

The crane can topple over!

- ▶ Make sure that the end section **10** of the boom system does **not** lift off the ground when opening the boom system.

When the upper pulley block **19** including the assembly weight **22** are pinned with the brackets **21** on the S-pivot section **1**:

- ▶ Spool winch 3 up until the boom system is held.

11.10 Opening the boom system

Make sure that the following prerequisites are met:

- The boom system is held safely by the upper pulley block.
- No personnel or obstacles are within the danger zone.

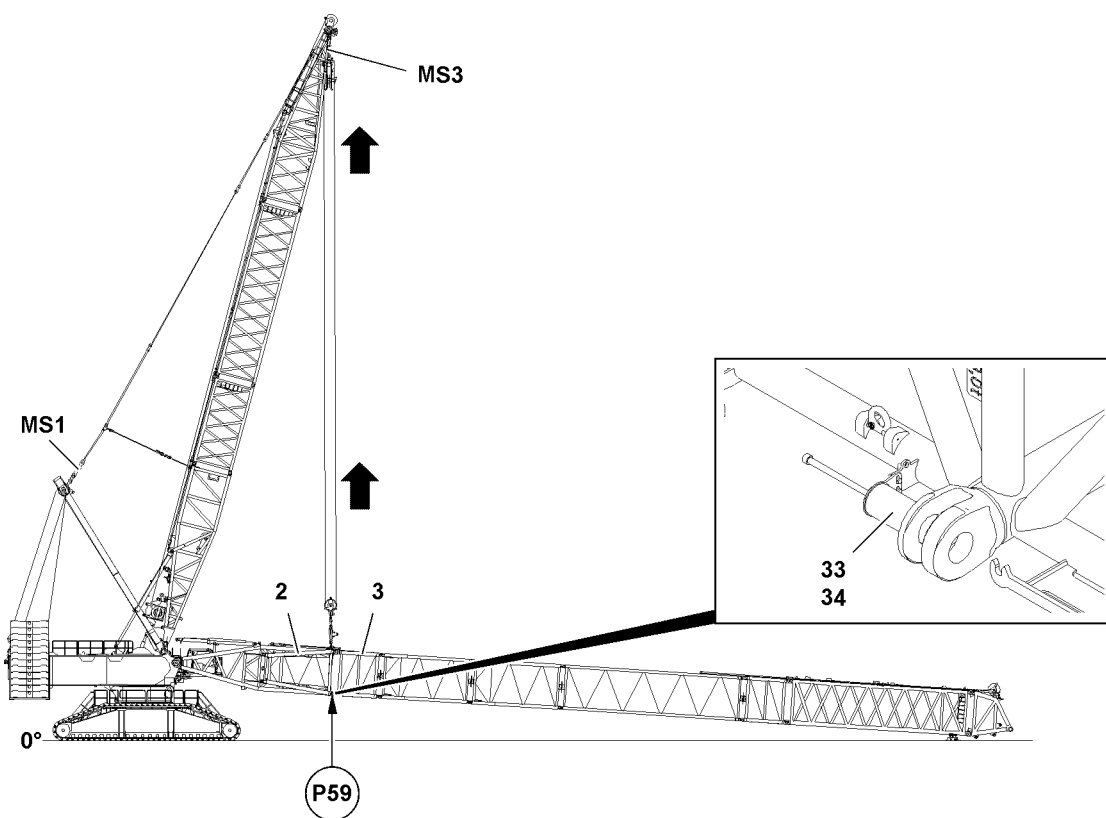

Fig.120329: Opening the boom system - tensioning the guying

**WARNING**

The crane can topple over!

If the following conditions are not met, the crane can topple over or be significantly damaged. Death, severe bodily injuries, property damage.

- ▶ Do **not** exceed the maximum permissible total forces on test point 1 **MS1** and test point 3 **MS3**.
- ▶ Lifting and opening the respective boom is only permissible by observing the maximum permissible boom lengths and total forces.
- ▶ The end section may **not** lift off the ground during „opening procedure“ of the boom system.
- ▶ Make sure that there are no persons on the boom system as well as in the danger zone during the opening procedure.

**Note**

- ▶ The actual forces on test point 1 **MS1** and test point 3 **MS3** - which are used during the closing procedure of the boom system - are shown on LICCON monitor 1.
- ▶ Tension the guying on the test points at disassembly with the same forces as for assembly.
- ▶ For this, use the ACTUAL forces on the test point 1 (MS1) and test point 3 (MS3) measured and recorded during the assembly.
- ▶ The pins can be pulled easier and the pins and lugs are therefore not damaged.

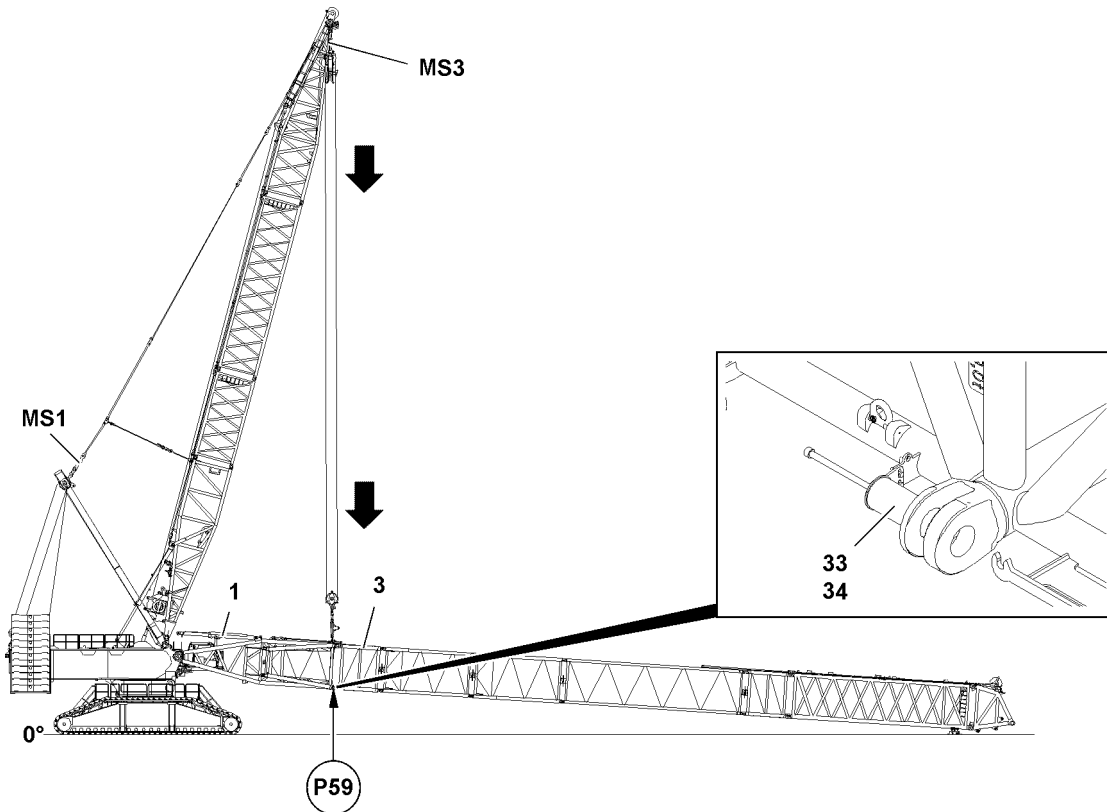

Fig.120330: Opening the boom system - unpinning the cross carrier on the bottom

- ▶ Open the boom system: Release and unpin the pins **33** on the „bottom“ on the four points **P59**.

NOTICE

Danger of property damage!

When lowering the boom system, crane components can be damaged.

- ▶ Make sure that the S-pivot section **1** is not lowered directly on the ground.
- ▶ Lower the S-pivot section **1** in the substructure when opening the boom system.

When the pins **33** are completely unpinned:

- ▶ Lower the boom system carefully on the substructure on the ground.

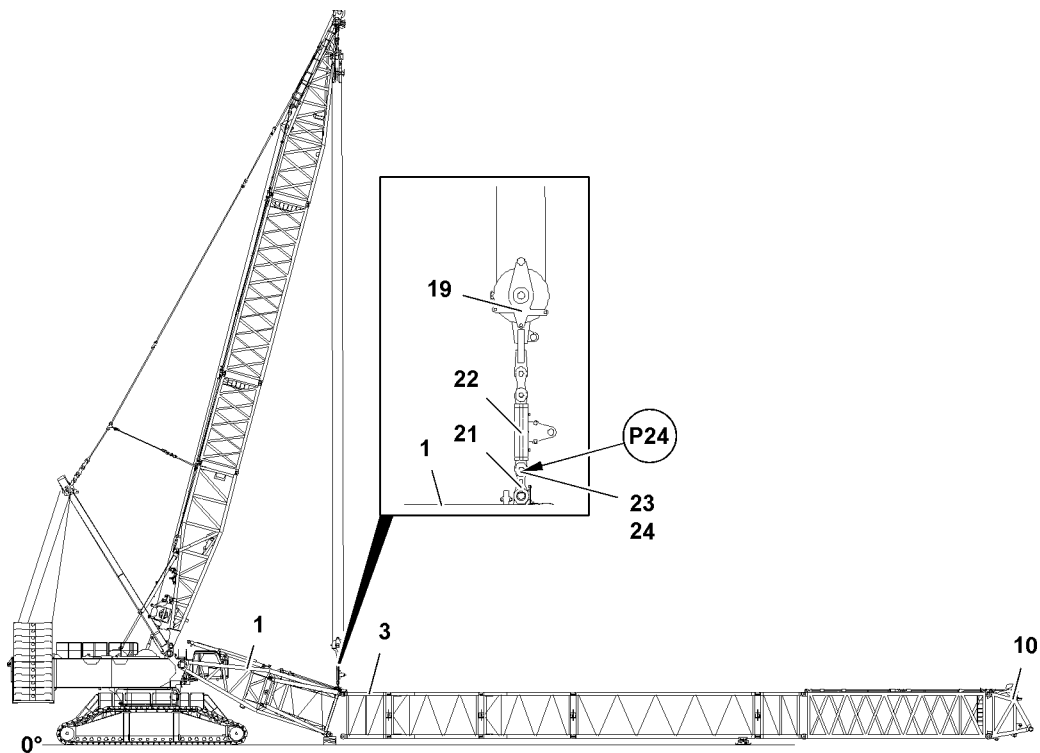

Fig.120331: Opening the boom system - Unpinning the upper pulley block on the S-pivot section

When the S-pivot section 1 is laying on the substructure on the ground:

- ▶ Unpin the assembly weight 22 on the brackets 21: Release the pin 23 on point P24 and unpin.
- ▶ Disconnect the electrical connections between the boom end section 10 and the S-pivot section 1 properly.
- ▶ Place the previously removed guy rods, which were not required, on the lattice sections, pin and secure.

11.11 Removing the lattice sections of the PD-boom



WARNING

The crane can topple over!

Death, severe bodily injuries, property damage.

- ▶ The turntable may not be turned during the disassembly of the boom



WARNING

Danger of accident!

Death, severe bodily injuries, property damage.

- ▶ Depending on the condition of the ground, the boom and the lattice sections must be supported from below for the assembly of the boom.
- ▶ Observe the technical safety instructions, see Crane operating instructions, chapter 5.01.



WARNING

General danger notes!

Death, severe bodily injuries, property damage.

- ▶ Support the main boom during assembly / disassembly with suitable materials.
- ▶ It is prohibited for anyone to remain under the booms or within the complete danger zone during the pinning and unpinning procedure of the lattice section.

**Note**

- ▶ The lattice sections are unpinned with the pin pulling device, see Crane operating instructions, chapter 5.30.

Make sure that the following prerequisites are met:

- The crane is horizontally aligned.
- An auxiliary crane with an adequate load bearing capacity is available.
- An assembly scaffolding / work platform is available.
- The counterweight has been installed on the turntable according to the load chart.
- The LICCON overload protection has been set according to the data in the load chart.
- The guy rods are properly removed from the rod receptacles of the bridges **12**.

11.11.1 Bringing the rod receptacle in transport position

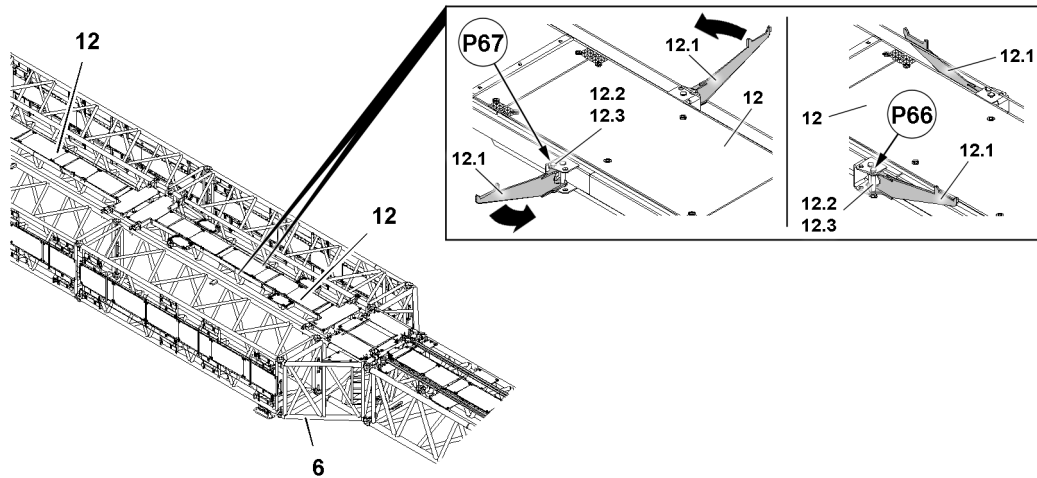

Fig.124518: Bringing the rod receptacle in transport position

**Note**

- ▶ The description of the procedure „Bringing the rod receptacle in transport position“ is an example and is described via one rod receptacle **12.1**.
- ▶ The procedure for the rod receptacle on the opposite side is identical.

- ▶ Remove the locking pin **12.1** at point **P67** and unpin the pin **12.2**.
- ▶ Swing the rod receptacle **12.1** all the way in.

When the rod receptacle **12.1** is in transport position:

- ▶ Insert the pin **12.2** at point and secure properly with the locking pin **12.1**.

11.11.2 Removing the bridges

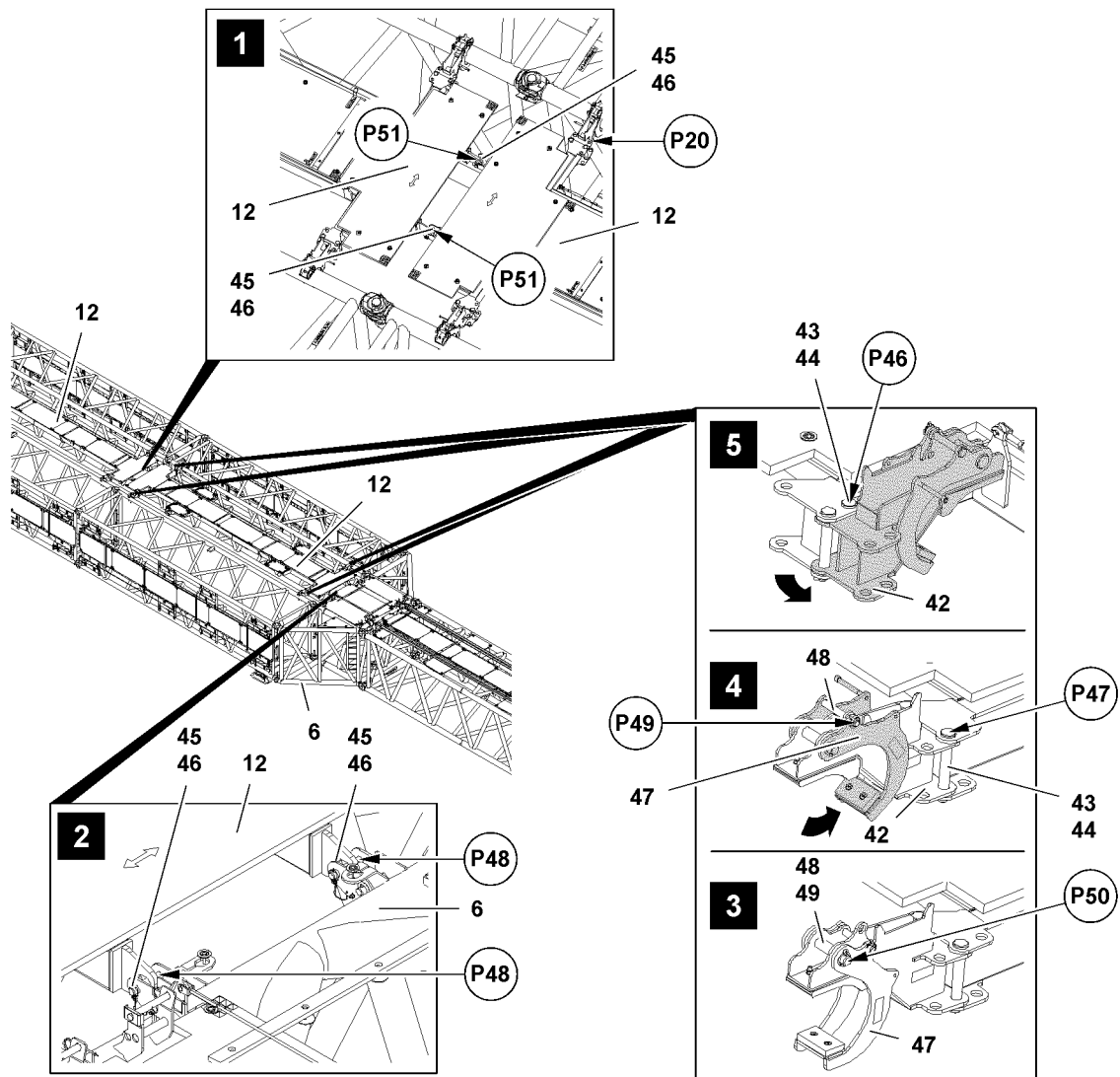

Fig.120325: Removing the bridges

NOTICE

Danger of property damage!

At disassembly, the rod receptacles 12.1 can be severely damaged.

- ▶ Make sure that the rod receptacles 12.1 on the bridges 12 are in transport position.



Note

- ▶ The following descriptions are an example for the removal of all bridges 12.



WARNING

Danger of falling!

- ▶ Make sure that the assembly personnel is secured with the supplied fall arrest system to prevent them from falling when removing the bridges.

Make sure that the following prerequisites are met:

- The P-boom system is taken down on the ground.
- No guy rods are on the bridges 12.
- The rod receptacles 12.1 on the bridges 12 are in transport position.

- ▶ Fasten the bridge **12** to the auxiliary crane, see section „Fastening points“.

When one bridge **12** is removed from another bridge **12**:

- ▶ Unpin the bridge **12** on bridge **12**: Release the pins **45** on both sides on points **P51** and unpin, see illustration 1.

When a bridge **12** is removed from the upper P-adapter **6**:

- ▶ Unpin the bridge **12** on the upper P-adapter **6**: Release the pins **45** on both sides on points **P48** and unpin, see illustration 2.

Securing the retaining plates **47** in transport position is made for all four retaining plates **47** of the bridge **12**.

- ▶ Release the retaining plate **47** in operating position: Release the pin **48** on point **P50** and unpin, see illustration 3.
- ▶ Fold the retaining plate **47** up and secure in transport position: Insert the pin **48** on point **P49** and secure with safety locking pin **49**, see illustration 4.
- ▶ Repeat the procedure for all retaining plates **47** on the bridge **12**.
- ▶ Lift the bridge **12** with the auxiliary crane.
- ▶ Take the bridge **12** down in a suitable storage location.
- ▶ Remove the auxiliary crane.

Securing the folding brackets **42** in transport position is made for all four folding brackets **42** of the bridge **12**.

- ▶ Unpin the folding bracket **42** in operating position: Release the pin **43** on point **P47** and unpin, see illustration 4.
- ▶ Swing the folding bracket **42** from operating position into transport position.
- ▶ Pin the folding bracket **42** in the transport position: Insert the pin **43** on point **P46** and secure with safety locking pin **44**, see illustration 5.
- ▶ Repeat the procedure for all folding bracket **42** on the bridge **12**.



Note

- ▶ Subsequent bridges **12** are removed the same way as described before.
-
- ▶ Remove all bridges **12**.

11.11.3 Disassembling the S-intermediate sections / S-adapter / S-end section on the upper P-adapter

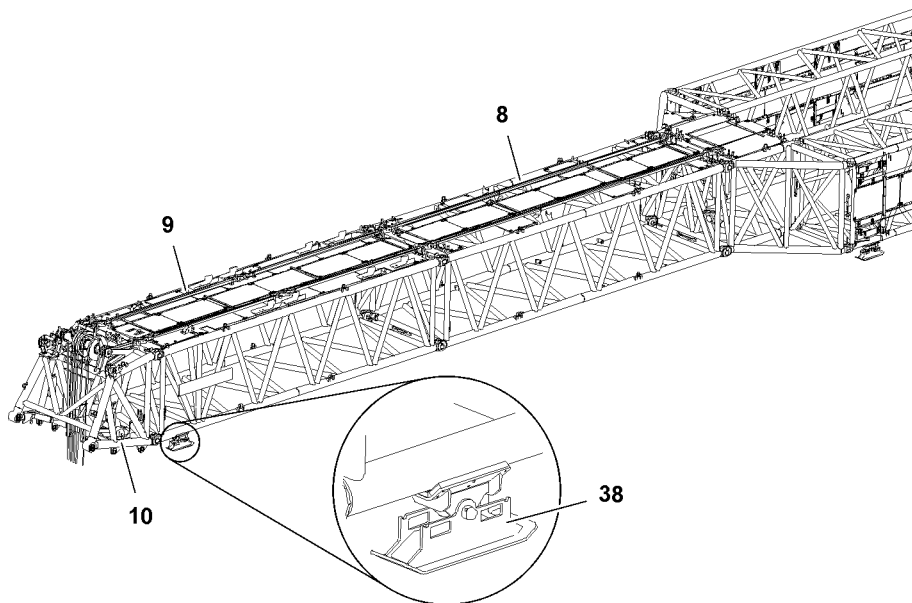

Fig.120318: Disassembling the S-intermediate sections / S-adapter / S-end section on the upper P-adapter

Make sure that the following prerequisites are met:

- The PD-boom system is open and properly taken down on the assembly shoes.
- The upper pulley block is disassembled and lifted on the lower P-adapter.
- The guy rods on the S-intermediate sections **8**, the S-adapter **9** and the S-end section **10** are unpinned from each other.
- The guy rods on the S-intermediate sections **8**, the S-adapter **9** and the S-end section **10** are secured in the transport receptacles.
- An auxiliary crane with sufficient load carrying capacity is available.



Note

- ▶ The technical safety instructions during assembly and disassembly must be observed, see Crane operating instructions, chapter 5.01.



WARNING

Neglected change of the assembly shoes **38**!
Death, severe bodily injuries, property damage.

- ▶ Place the assembly shoes **38** properly under the lattice section, which is laying in front of the one to be removed, see Crane operating instructions, chapter 5.62.
 - ▶ Place the assembly shoes in the marked area underneath, see Crane operating instructions, chapter 5.62.
-
- ▶ Disassemble the S-boom section leg properly.

11.11.4 Disassembling the upper P-adapter on the L-intermediate sections

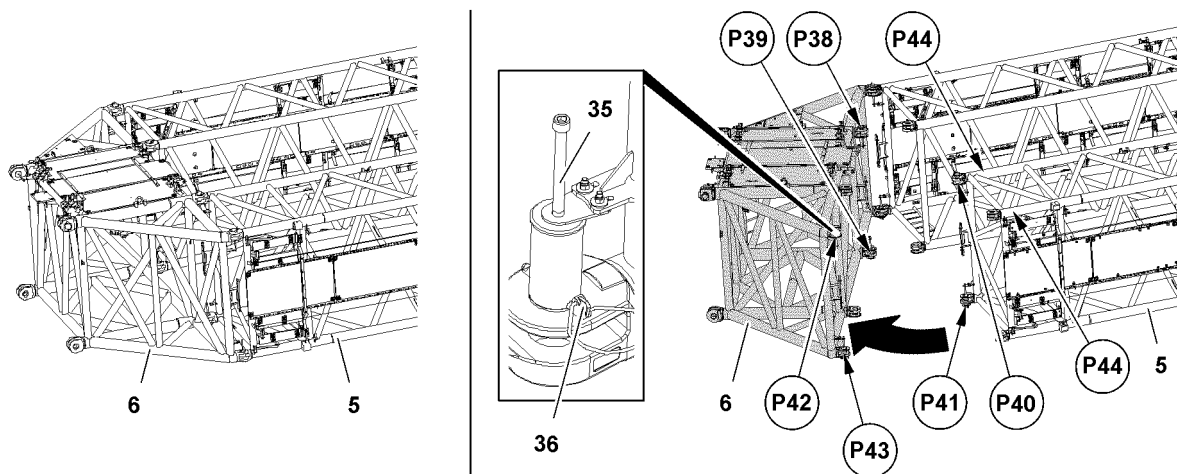

Fig.120319: Disassembling the upper P-adapter on the L-intermediate sections - Unpinning procedure

Make sure that the following prerequisites are met:

- The bridges are completely disassembled.
- The two strands between the L-intermediate sections **5** are each laying properly on the assembly shoes.
- ▶ Fasten the auxiliary crane on the upper P-adapter **6**, see section „Fastening points of the lattice sections“.

The pins **35** on the bottom, while they are still held by the pin pulling device, must be secured with the safety locking pins **36** to prevent them from falling down.

- ▶ Unpin the upper P-adapter **6** on the L-intermediate section **5**: Remove the safety locking pin **36** and unpin the pins **35** with the pin pulling device on point **P43**, point **P42**, point **P41**, point **P40**, point **P39** and point **P38**.
- ▶ Swing the upper P-adapter **6** up with the auxiliary crane.

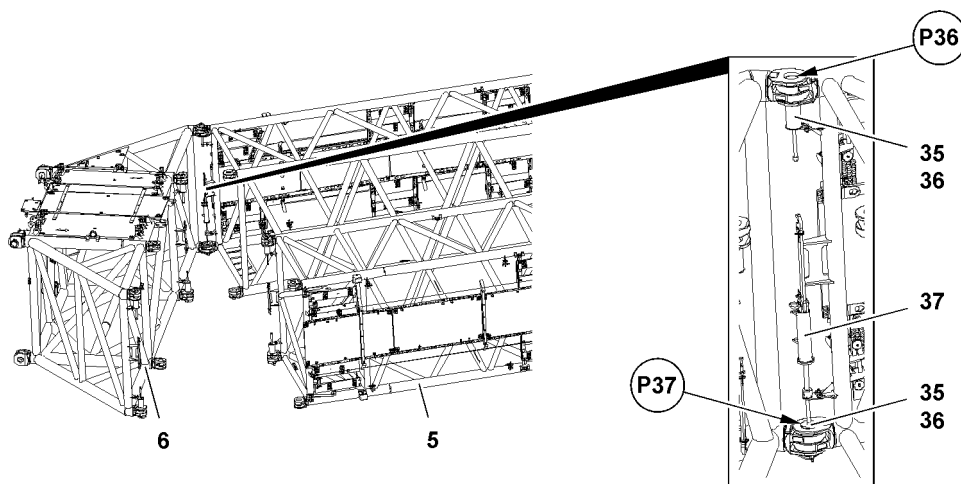

Fig.120320: Disassembling the upper P-adapter on the L-intermediate sections - Removing the upper P-adapter

The pin **35** on the bottom must be secured with the safety locking pin **36** while it is still held by the pin pulling device **37** to prevent it from falling down.

- ▶ Unpin the upper P-adapter **6** on the L-intermediate section **5**: Remove the safety locking pins **36** and unpin the pins **35** with the pin pulling device on point **P37** and point **P36**.

- ▶ Remove the upper P-adapter **5** with the auxiliary crane and take it down in a suitable storage location.

11.11.5 Disassembling the L-intermediate sections

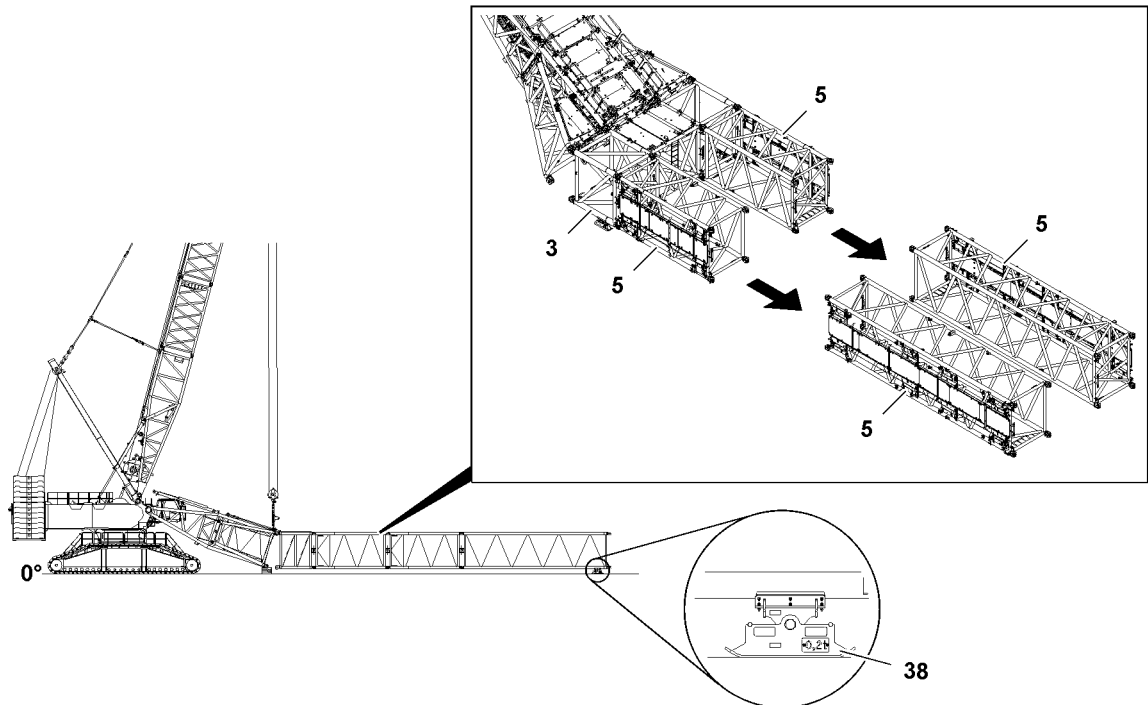

Fig.120321: Disassembling the L-intermediate sections

Make sure that the following prerequisites are met:

- The upper P-adapter is completely disassembled.
- The respective L-intermediate section **5** is placed on the assembly shoes **38**.
- An auxiliary crane is available.



Note

- ▶ The disassembly of the L-intermediate sections **5** is identical for each L-intermediate section **5**. The disassembly procedure is described as an example for one L-intermediate section **5**.

- ▶ Fasten the L-intermediate section **5** to the auxiliary crane.
- ▶ Move the assembly shoes **38**, see Crane operating instructions, chapter 5.62.
- ▶ Unpin the L-intermediate section **5** on L-intermediate section **5**, see unpinning procedure in section „Disassembling the upper P-adapter on the L-intermediate sections“.
- ▶ Remove the L-intermediate section **5** with the auxiliary crane.
- ▶ Turn the L-intermediate section **5** 90° in the transport position, see section „Changing the boom“: „Turn the L-intermediate sections“.
- ▶ Take the L-intermediate section **5** down in a suitable storage location.



Note

- ▶ The guy rods which are not required and which have been removed at the assembly of the boom system from the lattice sections must be installed in the transport retainers of the lattice sections and properly secured.
- ▶ Install the guy rods belonging to the L-intermediate section **5** in the transport retainers of the lattice sections and secure properly.
- ▶ Repeat the procedure for all L-intermediate sections **5** the same way.

11.11.6 Removing the cross carrier

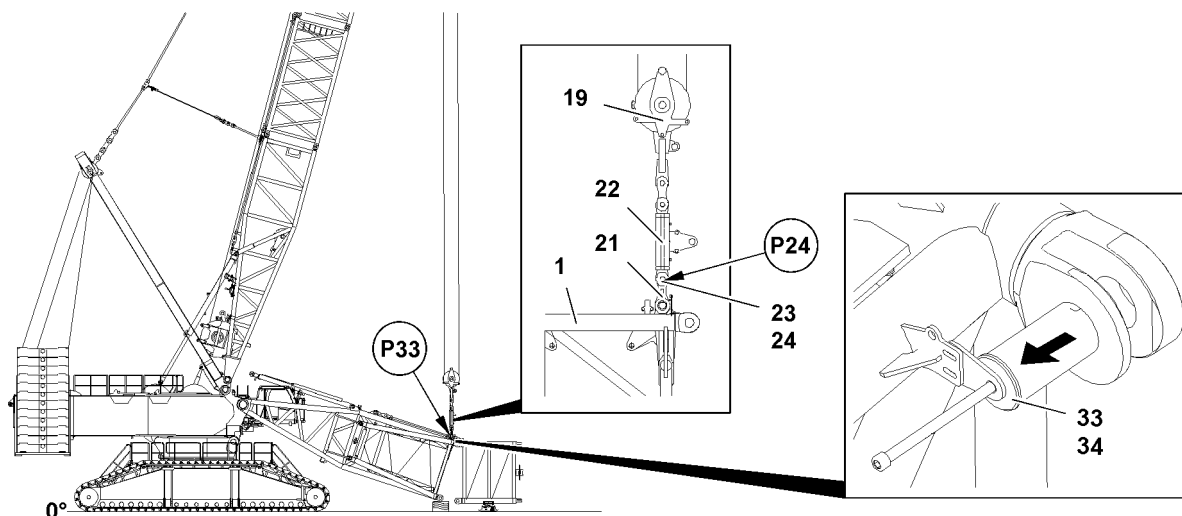

Fig.120322: Removing the cross carrier

The upper pulley block **19** must be removed for the disassembly from the working range, otherwise it is not possible to unpin the cross carrier due to space restrictions.

- ▶ Unpin the assembly weight **22** on the brackets **21**: Release the pins **23** on both sides on points **P24** and unpin.
- ▶ Lift the upper pulley block **19** including the auxiliary weight **22** from the assembly area.
- ▶ Fasten the cross carrier **3** to the auxiliary crane, see section „Fastening points of the lattice sections“.



Note

- ▶ The pinning or unpinning is carried out with the pin pulling device, see Crane operating instructions, chapter 5.30.
- ▶ Unpin the cross carrier **3** on the lower P-adapters **2**: Release and unpin all four pins **29** on points **P33** with the pin pulling device.
- ▶ Lift the cross carrier **3** with the auxiliary crane and remove.
- ▶ Pin the assembly weight **22** with the brackets **21**: Insert the pin **23** on both sides at point **P24** and secure with spring retainer **24**.

**Note**

- ▶ The hydraulic supply for the disassembly of the lower P-adapters **2** is made via the external hydraulic aggregate.

**WARNING**

Pressure in the hydraulic lines!

If the pressure supply is not interrupted before connecting / releasing the hydraulic lines, the hydraulic oil can escape with high pressure.

Death, severe bodily injuries, property damage.

- ▶ Release the pressure in the hydraulic system before connecting / disconnecting: Interrupt the pressure supply and wait for a short time.

Make sure that the following prerequisites are met:

- The S-pivot section **1** is horizontally aligned.
- An auxiliary crane is available.
- A hydraulic aggregate is available.

The disassembly is described on the example of the right, lower P-adapter **2**.

- ▶ Fasten the lower P-adapter **2** on both sides to the auxiliary crane, see section „Fastening points“.
- ▶ Establish the hydraulic connection on point **P29**: Connect the coupling parts (sleeve and plug) and screw together by hand until the knurled nut is turned to a noticeable, fixed stop.
- ▶ Release retaining pins **26** on points **P32** and unpin.
- ▶ Insert the retaining pins **26** into the transport retainer and secure with safety locking pins **27**.
- ▶ Unpin the lower P-adapter **2** on the S-pivot section **1**: **32** Actuate the hand lever **32** until the pins **25** on points **P28** are completely unpinned.
- ▶ Disconnect the hydraulic connection on point **P29**: Install the coupling components (sleeve and connector) with the knurled nut.
- ▶ Install dust caps on the quick couplings.
- ▶ Establish the hydraulic connection on point **P30**: Connect the coupling parts (sleeve and plug) and screw together by hand until the knurled nut is turned to a noticeable, fixed stop.
- ▶ Release retaining pins **29** on points **P32** and unpin.
- ▶ Insert the retaining pins **29** into the transport retainer and secure with safety locking pins **30**.
- ▶ Unpin the lower P-adapter **2** on the S-pivot section **1**: **32** Actuate the hand lever **32** until the pins **28** on points **P27** are completely unpinned.
- ▶ Disconnect the hydraulic connection on point **P30**: Install the coupling components (sleeve and connector) with the knurled nut.
- ▶ Install dust caps on the quick couplings.
- ▶ Take the lower P-adapter down with the auxiliary crane in a suitable storage location.
- ▶ Remove the auxiliary crane.
- ▶ Remove the left, lower P-adapter **2** the same way as described before.

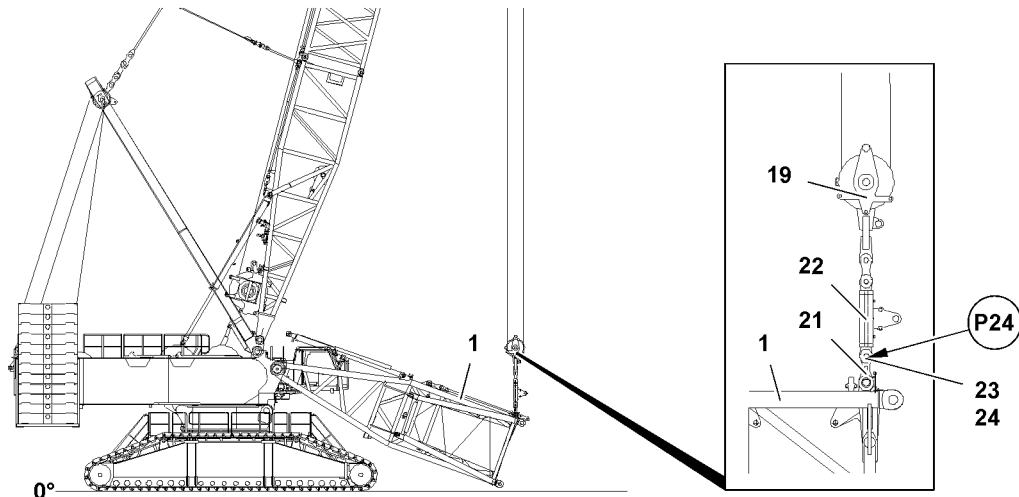

Fig.120324: Disassembling the lower P-adapter - Unpinning the upper pulley block on the S-pivot section

- ▶ Take the S-pivot section 1 down on the substructure.
- ▶ Unpin the assembly weight 22 on the brackets 21: Release the pins 23 on both sides on points P24 and unpin.
- ▶ Lift the upper pulley block 19 including the auxiliary weight 22 from the assembly area.

11.12 Disconnecting the electric and hydraulic connections on the S-pivot section

11.12.1 Disconnecting the electrical connections

Make sure that the following prerequisites are met:

- The boom system is opened.
- The S-pivot section is laying on the ground on the substructure.

NOTICE

Damage to cable drum or cable!

If the cable of the cable drum is not properly spooled up on the cable drum after unplugging the S-end section, then the cable drum or the cable can be significantly damaged.

- ▶ Spool the cable drum up after unplugging.
- ▶ Spool the cable drum up and secure it to prevent inadvertent spooling out.
- ▶ Disconnect the electrical connections and store the plugs and cables properly.

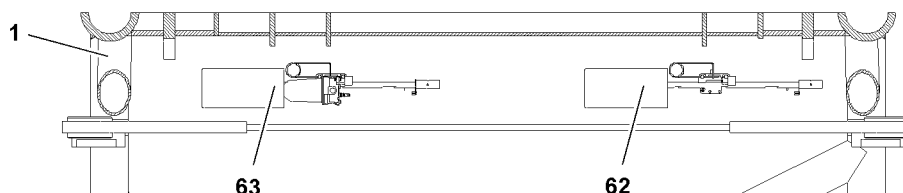

Fig.120332: Park position Wind speed sensor and airplane warning light

- ▶ Remove the wind speed sensor 62 and / or airplane warning light with wind speed sensor 63 on the boom end section and store it on the S-pivot section 1 properly in park position.

11.12.2 Disconnecting the hydraulic connections

When connecting and releasing hydraulic lines with quick couplings, make sure that the coupling procedure is carried out correctly.



DANGER

Danger of accident due to loss of pressure or leakage!

Incorrectly coupled or self-loosening quick couplings (particularly return lines) can result in serious accidents due to component failure.

- ▶ Check that the quick couplings have been properly connected before using the crane.



Note

- ▶ To connect or release the hydraulic lines with quick couplings, see Crane operating instructions, chapter 5.01.

- ▶ Release the pressure in the hydraulic system before connecting or disconnecting. Turn the engine off and wait for short time.
- ▶ Assembling coupling components (sleeve and connector) by using knurled nut.
- ▶ Connect coupling components.

11.13 Disassembling the S-pivot section on the turntable

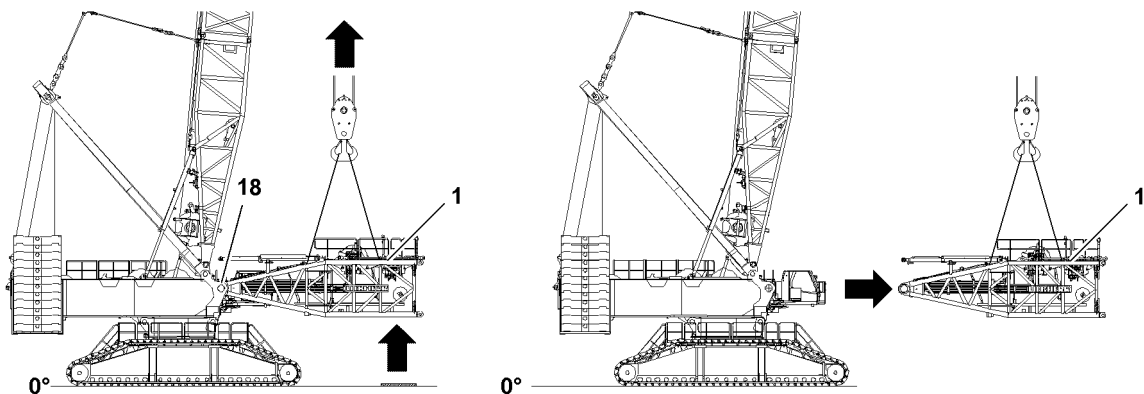

Fig.120333: Disassembling the S-pivot section on the turntable



WARNING

General danger note!

- ▶ Insert and secure all pins after disassembly in the intended transport receptacles.

Make sure that the following prerequisites are met:

- The hydraulic connections to the S-pivot section are properly disconnected.
- The hydraulic connections on the S-pivot sections are properly closed off with caps.
- The electrical connections to the S-pivot section are properly disconnected.
- The electrical connections are properly closed off with dummy plugs (see Electrical wiring diagram).
- The crane engine is running.
- An auxiliary crane with sufficient load bearing capacity if available.



Note

- ▶ Select the fastening points on the S-pivot section **1** in such a way that the S-pivot section **1** hangs horizontally on the auxiliary crane at disassembly. See section „Fastening points“.

- ▶ Attach the S-pivot section **1** properly on the auxiliary crane.
- ▶ Lift the S-pivot section **1** with the auxiliary crane to the horizontal.



WARNING

Falling S-pivot section!

- ▶ Make sure that the S-pivot section 1 is safely held by the auxiliary crane before unpinning the S-connector pins 18.



Note

- ▶ The unpinning of the S-pivot section 1 on the turntable is described in detail in section: „Unpinning the S-connector pins on the turntable“.

When the S-pivot section is horizontally aligned and safely held by the auxiliary crane:

- ▶ Unpin the S-connector pins 18 on the turntable.

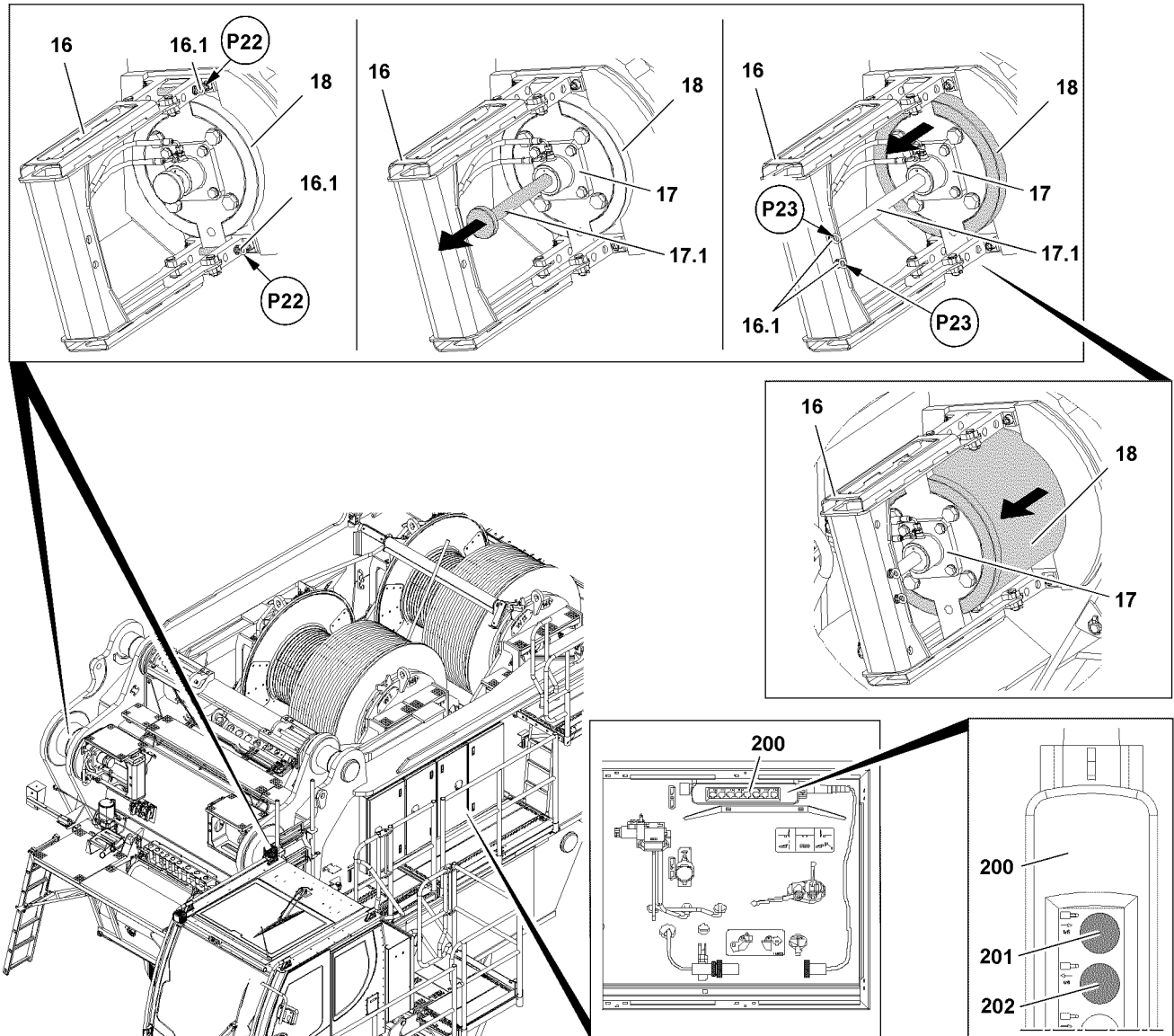

Fig.120289: Disassembling the S-pivot section on the turntable - Unpinning procedure

NOTICE

Damage of the turntable and the S-pivot section 1!

- ▶ Slowly swing the S-pivot section 1 out with the auxiliary crane and at low speed on the turntable.
- ▶ Before placing it on the ground, support the S-pivot section 1.

When the S-connector pins 18 on the S-pivot section 1 are fully uninned on both sides:

- ▶ Swing the S-pivot section 1 out on the turntable with the auxiliary crane and place it down.

LWE/LR 11000-001/23501-04-02/en

- ▶ Remove the auxiliary crane.

When the S-pivot section 1 is removed on the turntable:

- ▶ Fully insert and secure the S-connector pins 18 again.

11.14 Disassembling winch 5 on the S-pivot section



Note

- ▶ The disassembly of winch 5 is described in the Crane operating instructions, chapter 3.07.50.

11.15 Disassembling winch 6 on the S-pivot section



Note

- ▶ The disassembly of winch 6 is described in the Crane operating instructions, chapter 3.07.60.

11.16 Swinging the railing on the S-pivot section into transport position



WARNING

Danger of falling!

Death, severe bodily injuries, property damage.

- ▶ Assembly personnel must secure themselves for the assembly / disassembly of the railings and protective devices with an approved fall arrest system to prevent them from falling.
- ▶ For assembly and disassembly work, maintenance and inspection work on the S-pivot section, all railings and protective devices must be properly assembled and secured.

Make sure that the following prerequisites are met:

- The ground is able to safely take on the weight of the S-pivot section.
- The S-pivot section is laying completely on the ground.
- ▶ For assembly / disassembly of railings and protective devices, see Crane operating instructions, chapter 2.06.

5.61 Pulley cart

1	Component overview	3
2	Fastening points for pulley cart	3
3	Assembly	5
4	Disassembly	7

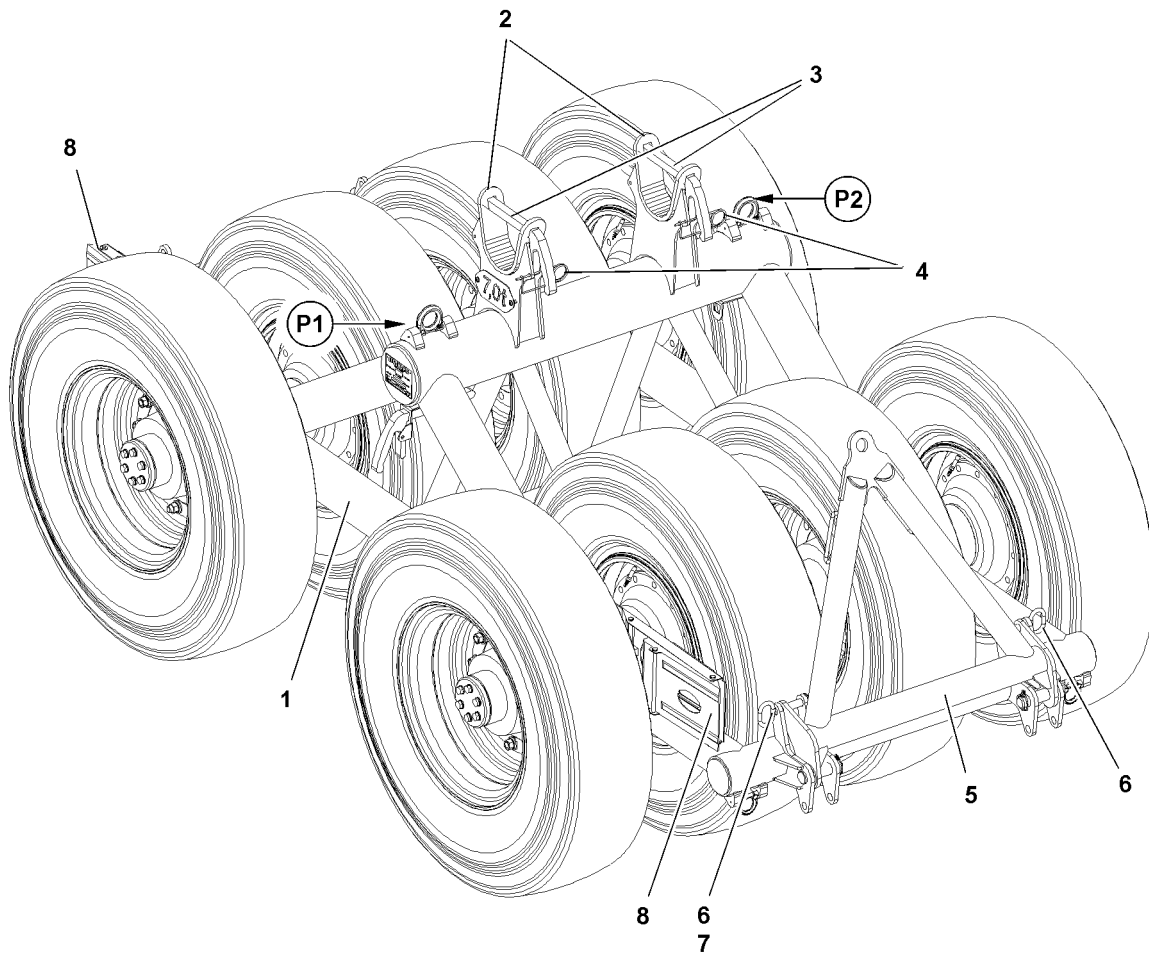

Fig.119034

1 Component overview



Note

- ▶ The pulley cart is marked with its own weight.

Position	Component
1	Pulley cart
2	Receptacle
3	Retainer
4	Spring retainer
5	Drawbar
6	Socket pin
7	Safety locking pin
8	Wedge

2 Fastening points for pulley cart



WARNING

Component incorrectly fastened!

Life-threatening situations can arise due to improper or incorrect attachment of the corresponding components.

Death, severe injury, property damage.

- ▶ Fasten the components only on the intended fastening points on both sides.
- ▶ Fastening of components and description of fastening points, see Crane operating instructions, chapter 5.01.

Fastening points	
P1 and P2	Pulley cart

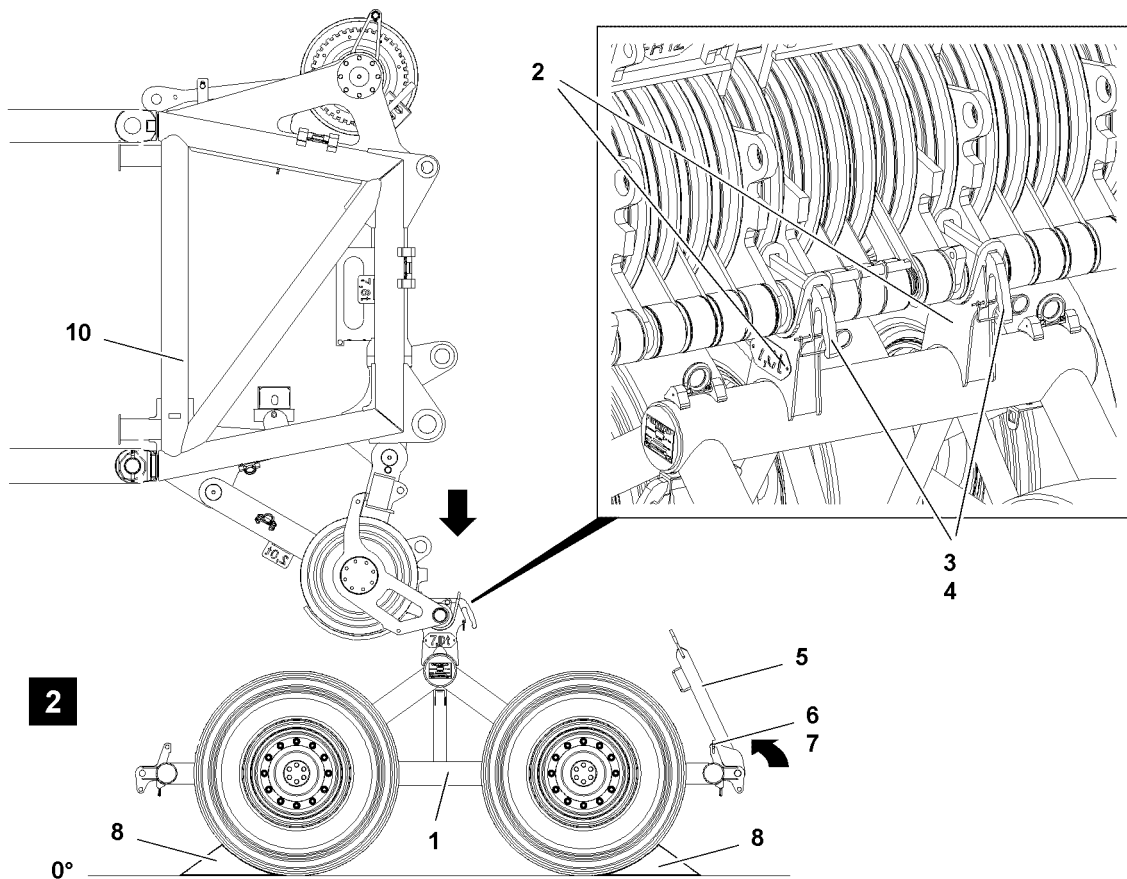
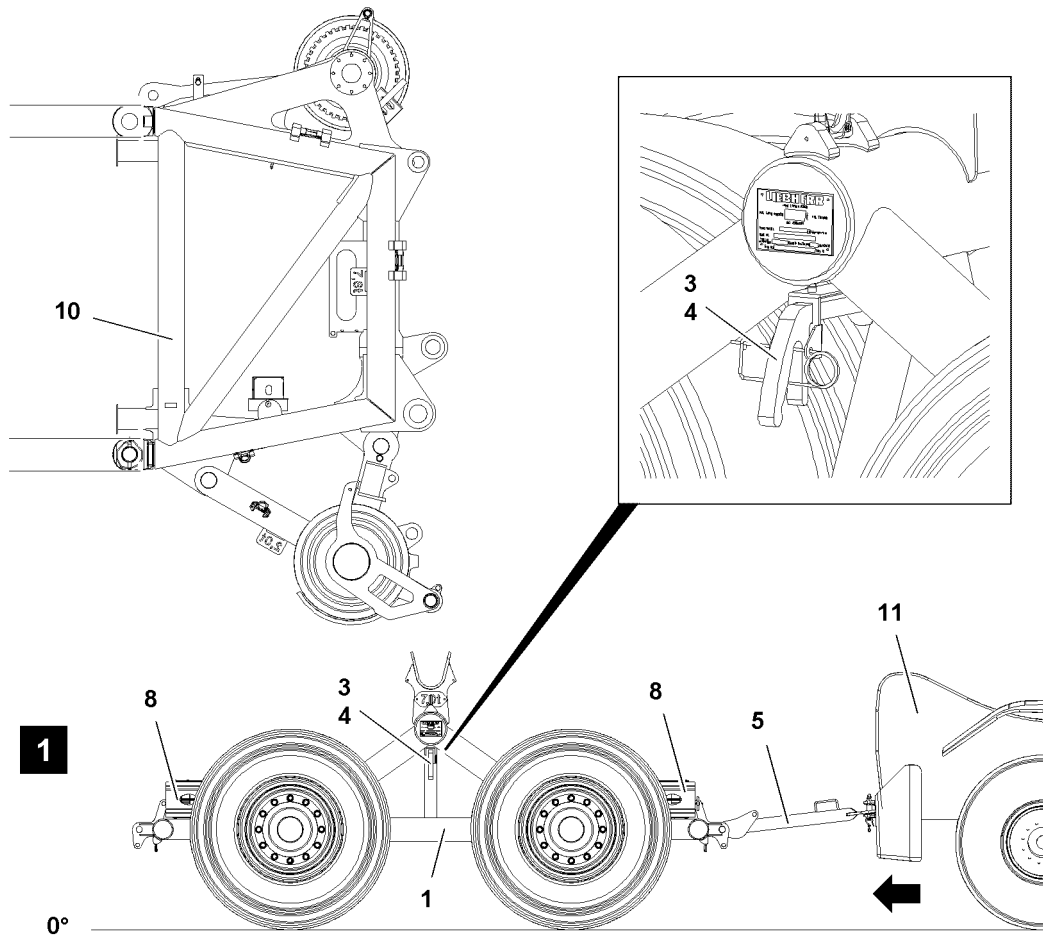

Fig.119033

LWE/LR 11000-001/23501-04-02/en

3 Assembly

3.1 Installing the pulley cart

Make sure that the following prerequisites are met:

- The retainer **3** is in park position, see illustration **1**
- An auxiliary crane with sufficient load carrying capacity is available.
- The W-boom is properly fastened on the auxiliary crane, see Crane operating instructions, chapter 5.01.
- The W-boom is lifted off the ground with the auxiliary crane.
- ▶ Position the pulley cart **1** below the pulley set of the boom end section **10**, see illustration **1**.
- ▶ Remove the wedges **8** from the transport retainer on the pulley cart **1**.
- ▶ Secure the pulley cart **1** with wedges **8** to prevent it from rolling off: Push the wedges **8** on the left and right hand side tightly under the wheels, see illustration **2**.
- ▶ Unpin the drawbar **5** from the auxiliary vehicle **11**.
- ▶ Remove the auxiliary vehicle.



WARNING

Danger of crushed limbs!

When swinging the drawbar **5**, fingers and hands can be crushed.
Death, severe injury, property damage.

- ▶ Do not reach with your hands into the danger zone.
- ▶ Swing the drawbar **5** in park position up, see illustration **2**.
- ▶ Pin the drawbar **5** in park position with socket pin **6** and secure with safety locking pin **7**, see illustration **2**.



WARNING

Danger of accident when placing the boom system in the pulley cart!
Death, severe injury, property damage.

- ▶ Make sure that the boom system is properly positioned under the pulley set / the pulley sets.
- ▶ Make sure, when placing the boom system in the pulley cart, that no personnel is within the danger zone.
- ▶ Slowly lower the boom **10** with the auxiliary crane until the carrier rollers of the pulley set are laying in the receptacles **2** of the pulley cart **1**, see illustration **2**.
- ▶ Take the retainer **3** from the park position: Remove the spring retainer **4** and pull out the retainer **3**, see illustration **1**.
- ▶ Secure the pulley cart **1**: Insert the retainer **3** on the receptacles **2** and secure with spring retainer **4**, see illustration **2**.
- ▶ Remove the wedges **8** on the wheels.
- ▶ Secure the wedges **8** again in the transport retainers on the pulley cart.

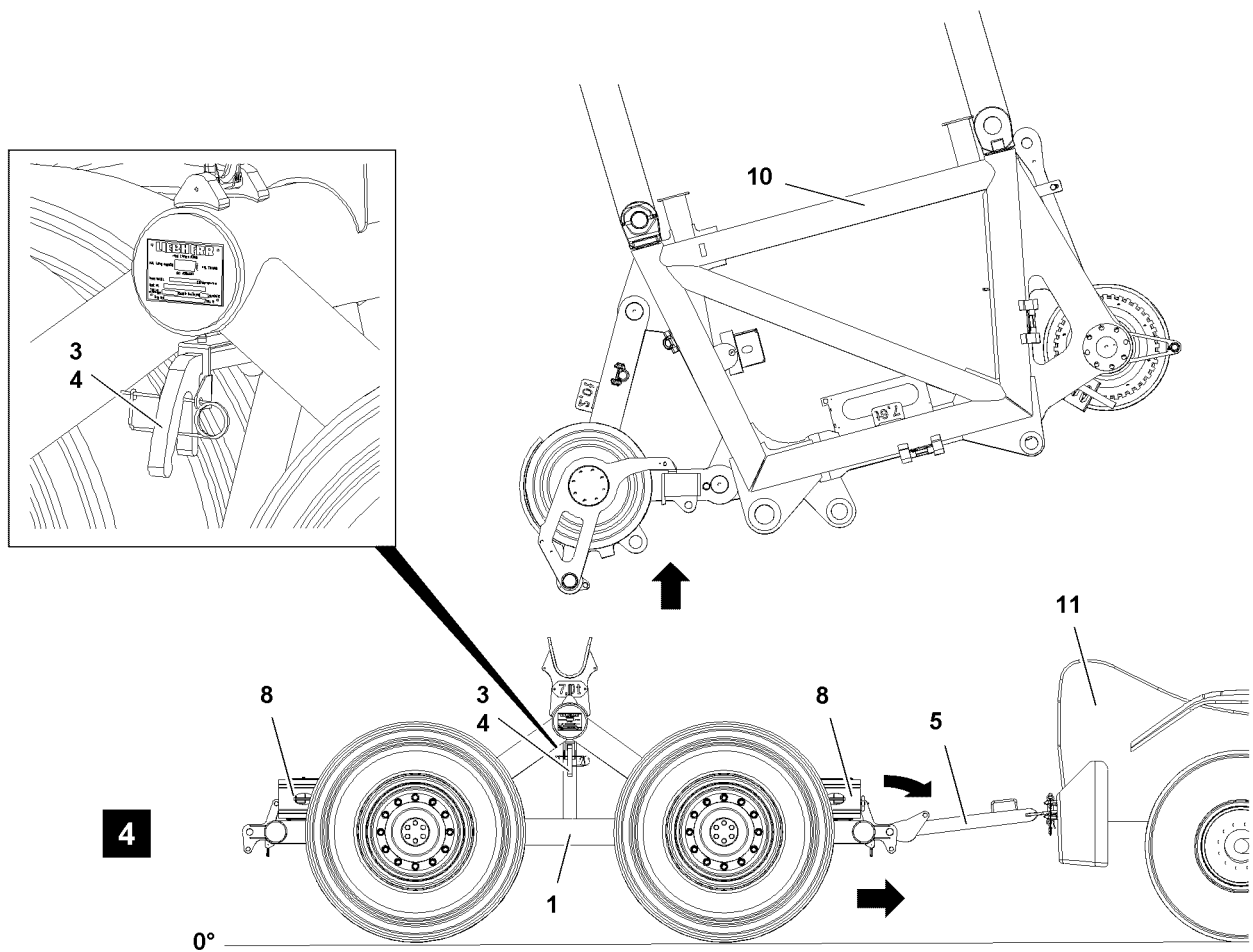
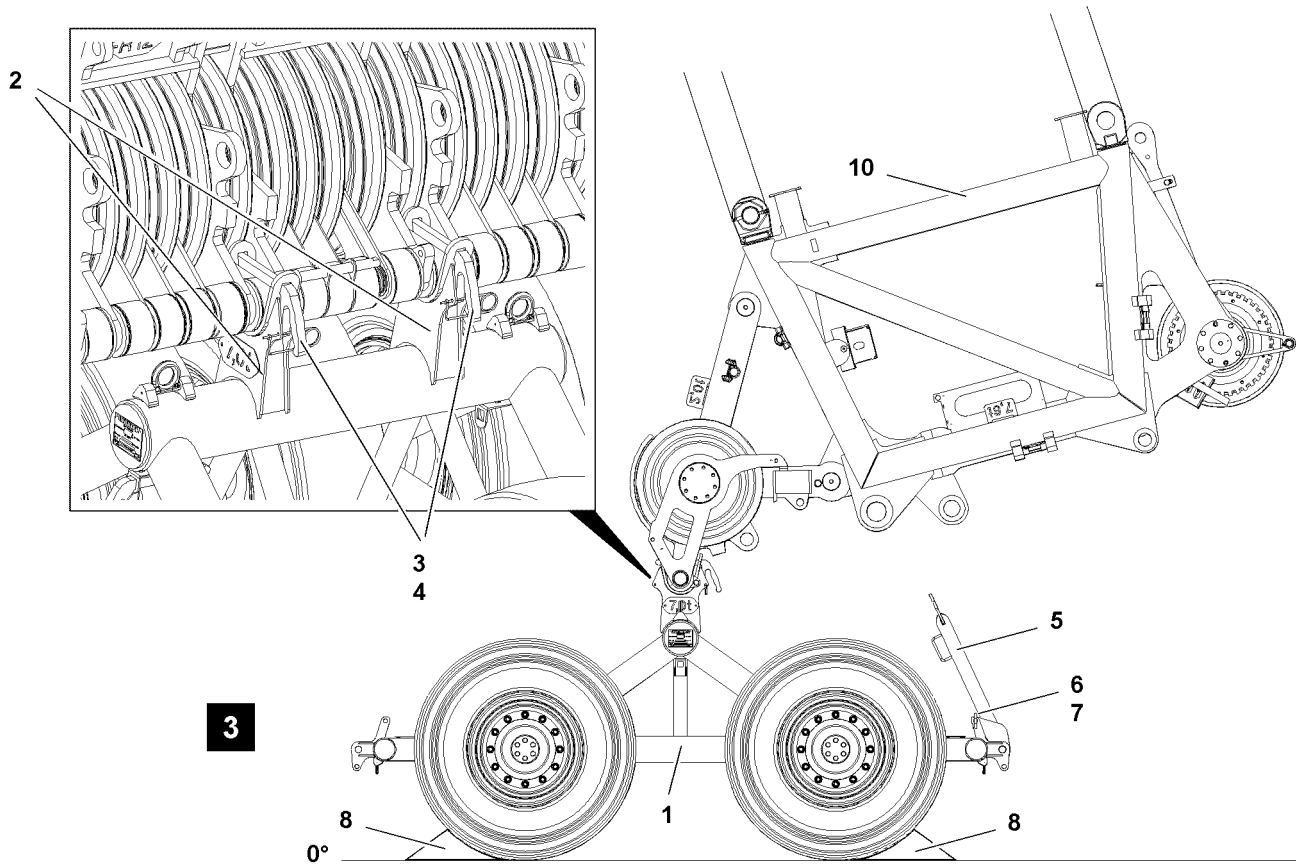

Fig.119035

LWE/LR 11000-001/23501-04-02/en

4 Disassembly

4.1 Removing the pulley cart

When the boom system has reached a certain angle, the pulley cart **1** is no longer required. Before lifting the W-boom system off, remove the pulley cart **1**.



WARNING

Overload of crane!

If the pulley cart **1** is not removed before erecting the boom system all the way, the crane can be overloaded and topple over.

Death, severe injury, property damage.

- ▶ Make sure that the pulley cart **1** is removed before the W-boom lifts off the ground.

Make sure that the following prerequisite is met:

- The boom system has reached a certain angle.

- ▶ Remove the wedges **8** from the transport retainer on the pulley cart **1**.
- ▶ Secure the pulley cart with wedges **8** to prevent it from rolling off: Push the wedges **8** on the left and right hand side tightly under the wheels, see illustration **3**.
- ▶ Remove the spring retainer **4** and pull out the retainer **3**, see illustration **3**.

Result:

- The boom system can be luffed up.
- ▶ Insert the retainer **3** in park position and secure with spring retainer **4**, see illustration **4**.
- ▶ Luff the boom system up.



WARNING

Drawbar swinging down!

The drawbar can swing down by itself due to its own weight when it is uninned.

Death, severe injury, property damage.

- ▶ Make sure that the position of the drawbar is always changed by **two** persons.
- ▶ When unpinning the drawbar, hold the drawbar.
- ▶ Do not reach with your hands into the danger zone.

- ▶ Unpin the drawbar **5** in park position: Remove the safety locking pin **7** and unpin the socket pin **6**, see illustration **3**.
- ▶ Swing the drawbar **5** downward into operating position.
- ▶ Pin the drawbar **5** on the auxiliary vehicle **11**, see illustration **4**.

When the boom system is luffed up:

- ▶ Remove the wedges **8** on the pulley cart.
- ▶ Secure the wedges **8** on the transport receptacle on the pulley cart **1**, see illustration **4**.
- ▶ Remove the pulley cart **1**.

Empty page!

LWE/LR 11000-001/23501-04-02/en

5.62 Assembly shoes

1 Assembly shoes

3

LWE/LR 11000-001/23501-04-02/en

Fig.195219

LWE/LR 11000-001/23501-04-02/en

1 Assembly shoes

**Note**

- ▶ During assembly / disassembly of the S-boom system, the W-boom system and the P-boom system the assembly shoes **1** must be offset to avoid overload of the intermediate sections **3**.
- ▶ The change of the assembly shoes **1** is described on the example of the S-boom and is made the same way for boom assembly / disassembly of the P-boom system and the W-boom system.

**WARNING**

Incorrect position of the assembly shoes **1**!

If the assembly shoes **1** are not placed underneath in the permitted area of the intermediate sections **3**, then the intermediate sections **3** can be overloaded and damaged.

An accident can occur during crane operation due to a damaged or previously overloaded intermediate sections **3**.

Personnel can be severely injured or killed.

- ▶ Make sure that the assembly shoes **1** are placed underneath between the arrow marks **2**.
- ▶ The crane operator is responsible for the proper support of the assembly shoes **1** on the intermediate sections **3**.

1.1 Changing the assembly shoes at assembly

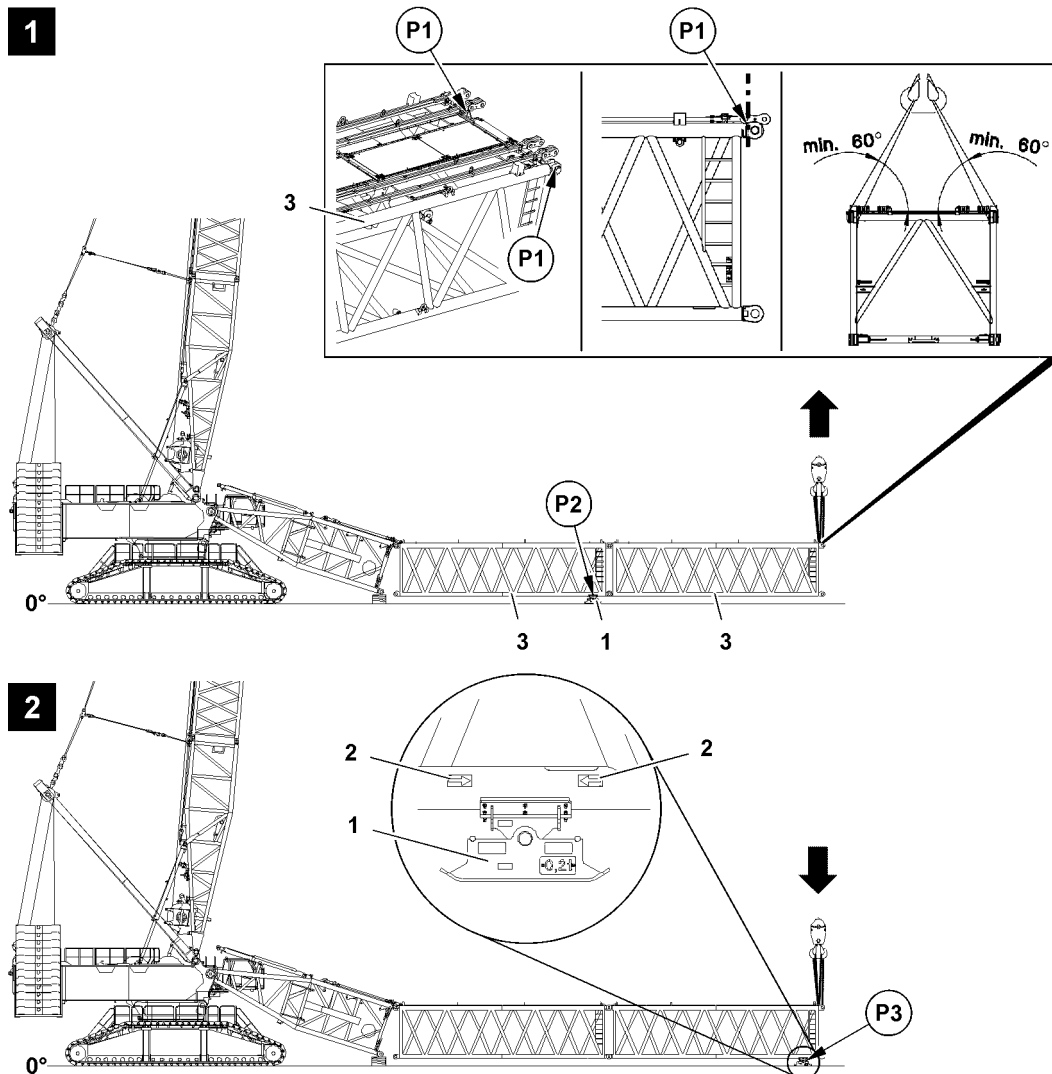

Fig.120304: Change the assembly shoes at assembly

Make sure that the following prerequisites are met:

- The respective intermediate section 3 is completely assembled.
- The fastening equipment has been removed.
- An auxiliary crane is available.



Note

- Changing the assembly shoes 1 is identical for each intermediate section 3. The change procedure is described as an example for one intermediate section 3.

- Fasten the intermediate section 3 on the points P1.



WARNING

Overload of lattice sections!

Personnel can be severely injured or killed.

Significant property damage can result.

If the lattice section leg is lifted higher than necessary, the lattice sections can be overloaded.

At a later point in time an accident can occur.

- Lift the lattice section leg only as high until the assembly shoes can be moved freely.
- Lift the lattice section leg with the auxiliary crane, see illustration 1.

Result:

- The assembly shoes 1 on point P2 are not subjected to a load and can be changed over.
- ▶ Remove the assembly shoes 1 on point P2, see illustration 1.
- ▶ Support the assembly shoes 1 on point P3 so that they are between the arrow marks 2, see illustration 2.
- ▶ Lower the lattice section leg with the auxiliary crane until the intermediate section 3 is properly laying on the assembly shoes 1, see illustration 2.
- ▶ Repeat the procedure the same way for additional intermediate sections 3.

1.2 Changing the assembly shoes at disassembly

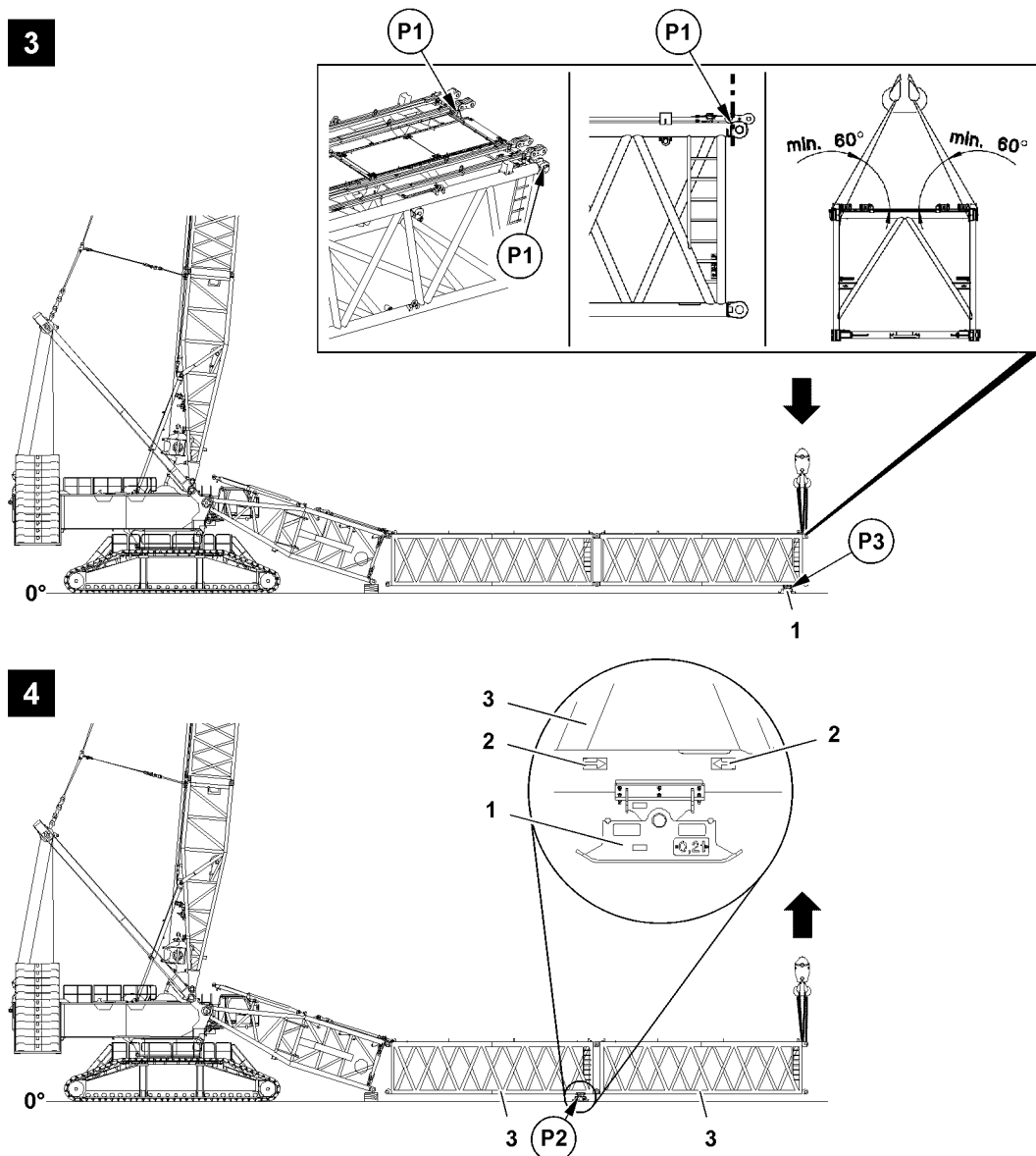

Fig.120305

Make sure that the following prerequisites are met:

- The respective intermediate section is laying on the assembly shoes.
- An auxiliary crane is available.

LWE/LR 11000-001/23501-04-02/en

**Note**

- ▶ Changing the assembly shoes **1** is identical for each intermediate section **3**. The change procedure is described as an example for one intermediate section **3**.

- ▶ Fasten the intermediate section **3** on the points **P1**.

**WARNING**

Overload of lattice sections!

Personnel can be severely injured or killed.

Significant property damage can result.

If the lattice section leg is lifted higher than necessary, the lattice sections can be overloaded.

At a later point in time an accident can occur.

- ▶ Lift the lattice section leg only as high until the assembly shoes can be moved freely.

- ▶ Lift the lattice section leg with the auxiliary crane, see illustration **3**.

Result:

- The assembly shoes **1** on point **P3** are not subjected to a load and can be changed over.

- ▶ Remove the assembly shoes **1** on point **P3**, see illustration **3**.
- ▶ Support the assembly shoes **1** on point **P2** so that they are between the arrow marks **2**, see illustration **4**.
- ▶ Lower the lattice section leg with the auxiliary crane.
- ▶ Remove the front intermediate section **3**.
- ▶ Repeat the procedure the same way for additional intermediate sections **3**.

6 Additional equipment

LWE/LR 11000-001/23501-04-02/en

LWE/LR 11000-001/23501-04-02/en

6.02 Heater / engine preheating / Air conditioning system Crane operator's cab

1	Climate control systems	3
2	Safety guidelines	3
3	Climate control	4
4	Adjusting the air supply	9
5	Air distribution	10
6	Defrosting the window	12
7	Climate control system*	13
8	Auxiliary heater	14
9	Maintenance Heater	26
10	Maintenance Auxiliary heater	27

Fig.195219

LWE/LR 11000-001/23501-04-02/en

1 Climate control systems

Depending on the crane type, the climate control system consists of up to three components (partially optional equipment*):

- Heater, coupled with the coolant circuit of the crane engine (only for crane types with engine in crane superstructure).
- Auxiliary heater with engine preheating (optional equipment* for crane types with engine in crane superstructure).
- Climate control system*.

1.1 Operating instructions

The heater and the climate control system* are only operational when the crane engine is running.

The auxiliary heater* is operational when the crane engine is turned on and off.

If the outside temperatures are very low, heating the crane cab without an auxiliary heater* can be limited.

If the outside temperatures are very high, cooling the crane cab without a climate control system* can be limited.

Keep the air intake and the air filter of the climate control system free of:

- Ice
- Snow
- Contaminants
- Objects

For efficient climate control, close the windows and door of the crane cab.

2 Safety guidelines

Observe the country specific regulations for the operation of climate control systems.



WARNING

Danger of accident due to bad visibility!

A window that is fogged up, icy or dirty impedes the view of the crane operator.

- ▶ Only drive / operate the crane with good visibility through the windows.



Note

Fogged up or icy window

- ▶ Observe the section „Defrosting the window“.

NOTICE

Damage of climate control systems!

- ▶ Adjust the operating fluids in time to the ambient temperatures.
- ▶ Operate the auxiliary heater and climate control system* at least once a month for 15 minutes.
- ▶ Regularly burn-off the burner of the auxiliary heater. See section „Auxiliary heater maintenance“.

NOTICE

Total discharge of battery!

When the engine is turned off, operating the auxiliary heater can discharge the batteries.

A long-term programmed turn on time for the auxiliary heater can discharge the batteries.

- ▶ Make sure that the battery charge is sufficient.

NOTICE

Damage of climate control systems!

Repair work on the climate control systems:

- ▶ Contact Service at Liebherr-Werk Ehingen and coordinate the procedure.

3 Climate control

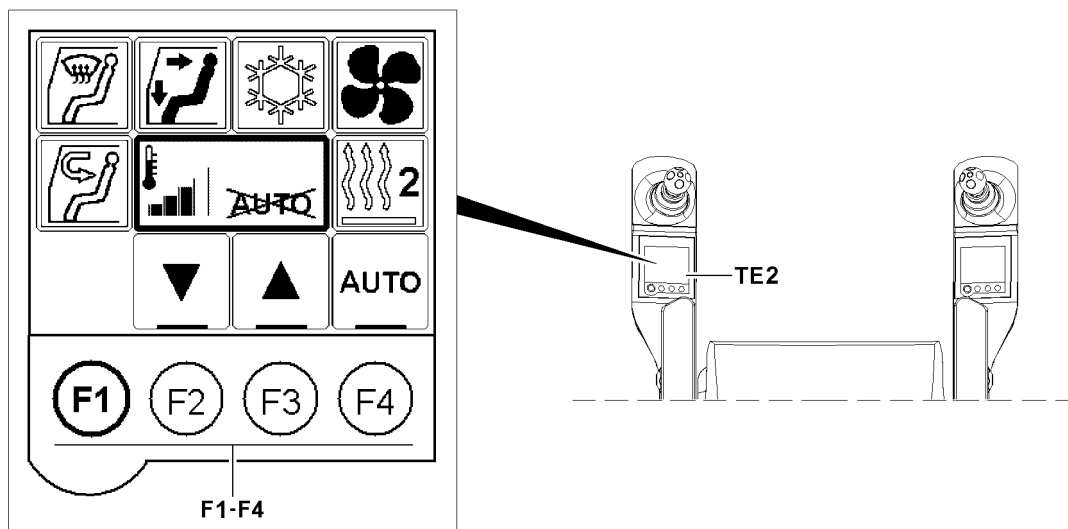

Fig.144224: Exemplary view of the Climate control menu

The *Climate control* menu is displayed on the touch display **TE2** and can be displayed / hidden by pressing the function key **F1**.

The climate control in the crane cab can:

- Be automatically regulated in automatic operation.
- Be manually regulated in manual operation.

In the *Climate control* menu, the climate control functions are selected by tapping the respective icons on the display.

- By pressing the function keys **F1-F4**, the settings can be changed.
- If nothing is selected / changed after a certain period of time, the *Climate control* menu is blanked out and the master switch assignment appears again on the touch display **TE2**.

**Note**

At low temperatures, the touch display can react delayed initially.

- ▶ Wait a few minutes when the ignition is turned on until the touch display reacts.

3.1 Switching between automatic and manual operation

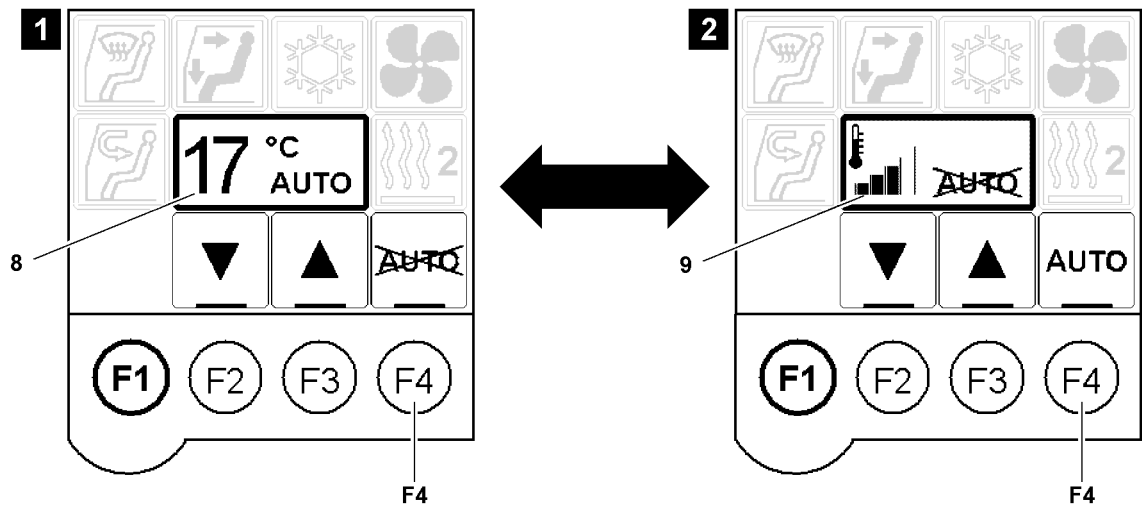

Fig.144089: Switching between automatic and manual operation

To switch from automatic operation (sample illustration 1) to manual operation (sample illustration 2):

- ▶ Press the function key **F4**.

Result:

- The *manual operation* icon **9** is shown.
- Manual operation is turned on.

To switch from manual operation (illustration 2) to automatic operation (illustration 1):

- ▶ Press the function key **F4**.

Result:

- The *Automatic operation* icon **8** is shown.
- Automatic operation is turned on.



Note

In automatic operation:

- ▶ If the fan stage is changed manually, the climate control switches to manual operation.

3.2 Automatic operation

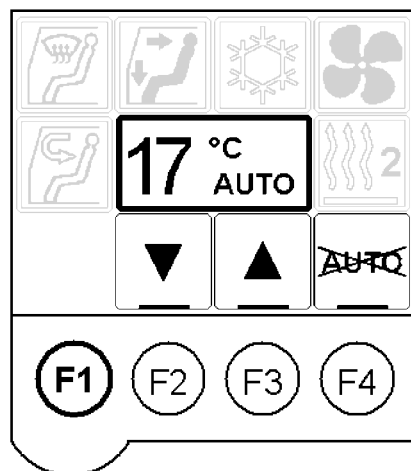

Fig.144090: Automatic operation

Automatic operation automatically regulates the climate control to reach the set temperature and keep it constant.

The following settings are automatically adjusted:

- Warm air supply
- Fan stage
- Air supply

If the engine is running, the auxiliary heater* is automatically engaged if needed.

If the engine is running, the climate control system* is automatically engaged if needed.

3.2.1 Adjusting the temperature

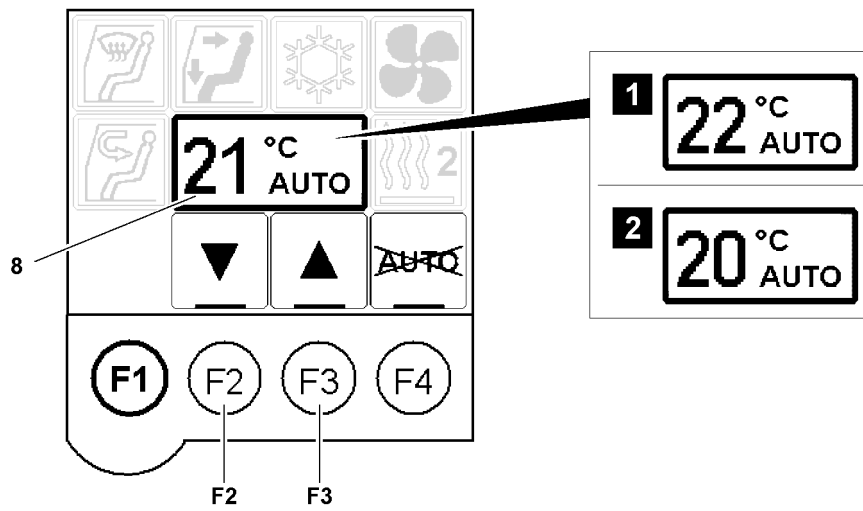

Fig.144091: Adjusting the temperature in automatic operation

The temperature setting can be changed directly in automatic operation.

To increase the temperature setting:

- ▶ Press the function key **F3**.

Result:

- The temperature setting is increased, see example illustration 1.
- The warm air supply and fan stage are automatically regulated.

To decrease the temperature setting:

- ▶ Press the function key **F2**.

Result:

- The temperature setting is decreased, see example illustration 2.
- The warm air supply and fan stage are automatically regulated.

Problem remedy

Does the **AUTO** text blink on the display?

The temperature setting can momentarily not be reached.

Observe the information in section „Climate control system“.

Speed up the heating of the cab:

- ▶ Adjust the air supply to recirculating air.

Speed up the cooling of the cab:

- ▶ Ventilate the crane cab for a short time.

3.3 Manual operation

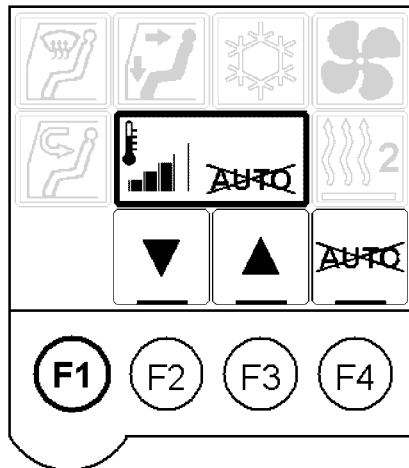

Fig.144092: Manual operation

In manual operation all settings must be carried out manually.

3.3.1 Adjusting the warm air supply

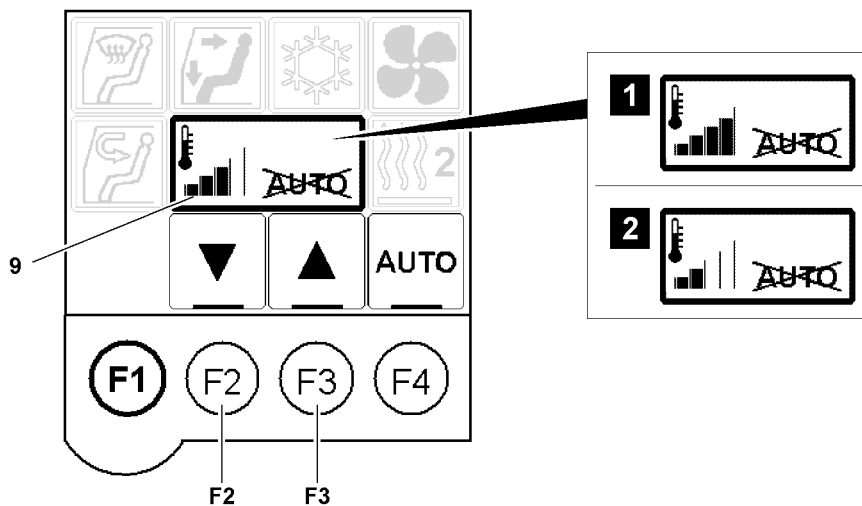

Fig.144093: Adjusting the warm air supply in manual operation

The warm air supply can be set directly in manual operation.

To increase the warm air supply:

- ▶ Press the function key **F3**.

Result:

- The bar display is increased, see example illustration **1**.

To decrease the warm air supply:

- ▶ Press the function key **F2**.

Result:

- The bar display is decreased, see example illustration **2**.

Problem remedy

Does the temperature in the crane cab not change accordingly?
Observe the information in section „Climate control system“.

Speed up the heating of the cab:

- ▶ Adjust the air supply to recirculating air.

Speed up the cooling of the cab:

- ▶ Ventilate the crane cab for a short time.

3.3.2 Adjusting the fan stage

Fig.144094: Selecting the Fan stage menu

The fan stages can be set to different stages.

- ▶ Tap the *fan stage* icon 5.

Result:

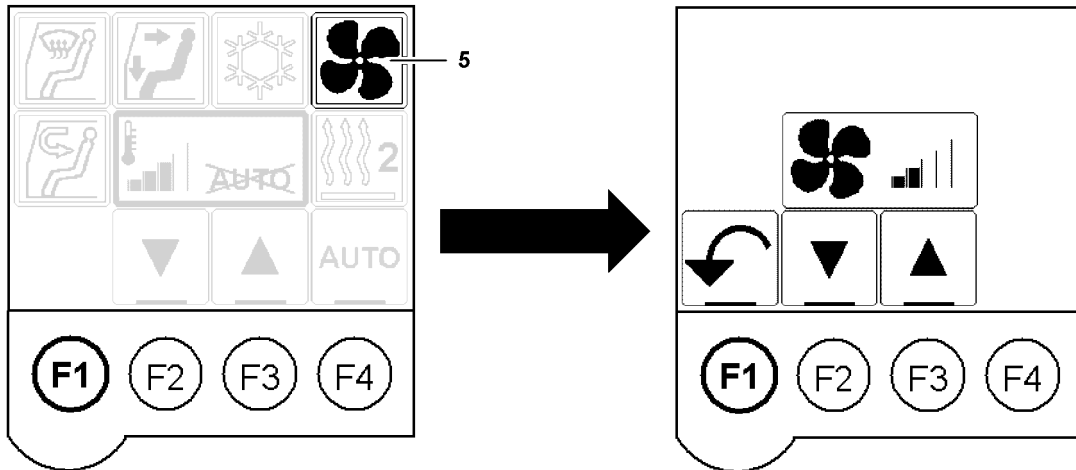
- The *Fan stage* menu is selected.

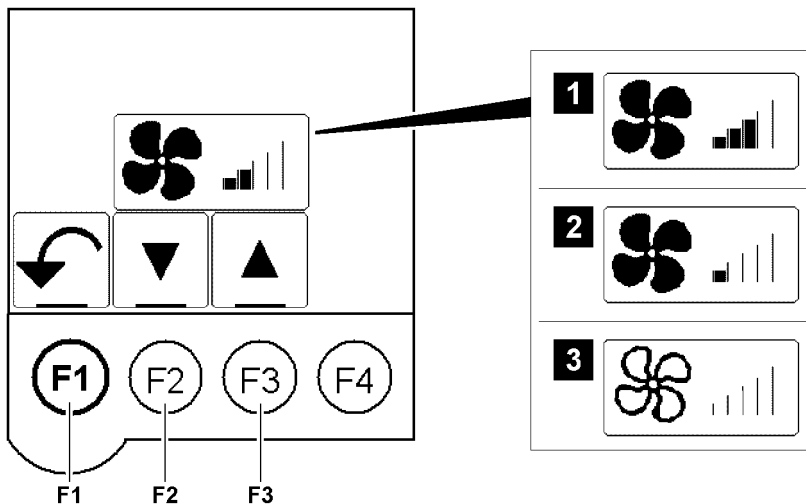

Fig.144060: Adjusting the fan stage

To increase the fan stage:

- ▶ Press the function key **F3**.

Result:

- The bar display is increased, see example illustration 1.

- The fan stage is increased.

To decrease the fan stage:

- ▶ Press the function key **F2**.

Result:

- The bar display is decreased, see example illustration 2.
- Fan stage is decreased.



Note

- ▶ When the fan is switched off, the fan icon is displayed not filled out, see illustration 3.

To return to the *Climate control* menu:

- ▶ Press the function key **F1**.

4 Adjusting the air supply

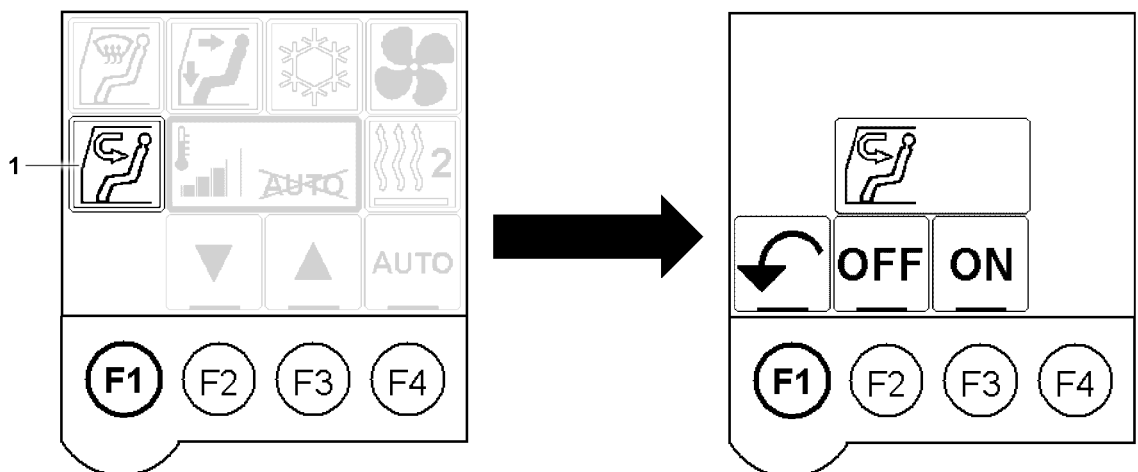

Fig.144095: Climate control menu

Use the recirculating air function to regulate the air supply between recirculating air and fresh air.

- ▶ Tap the *recirculating air* icon 1.

Result:

- The *Recirculating air* menu is selected.

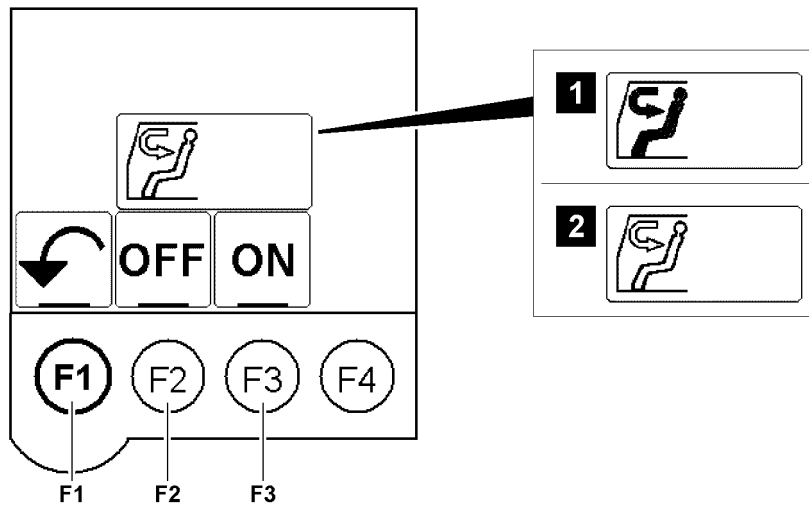

Fig.144230: Recirculating air menu

To turn the *recirculating air* function on:

- ▶ Press the function key **F3**.

Result:

- The *recirculating air* icon is highlighted in black, see illustration 1.
- The air supply is switched to recirculating air.

To turn the *recirculating air* function off:

- ▶ Press the function key **F2**.

Result:

- The *recirculating air* icon is highlighted in white, see illustration 2.
- The air supply is switched to fresh air.

To return to the *Climate control* menu:

- ▶ Press the function key **F1**.

5 Air distribution

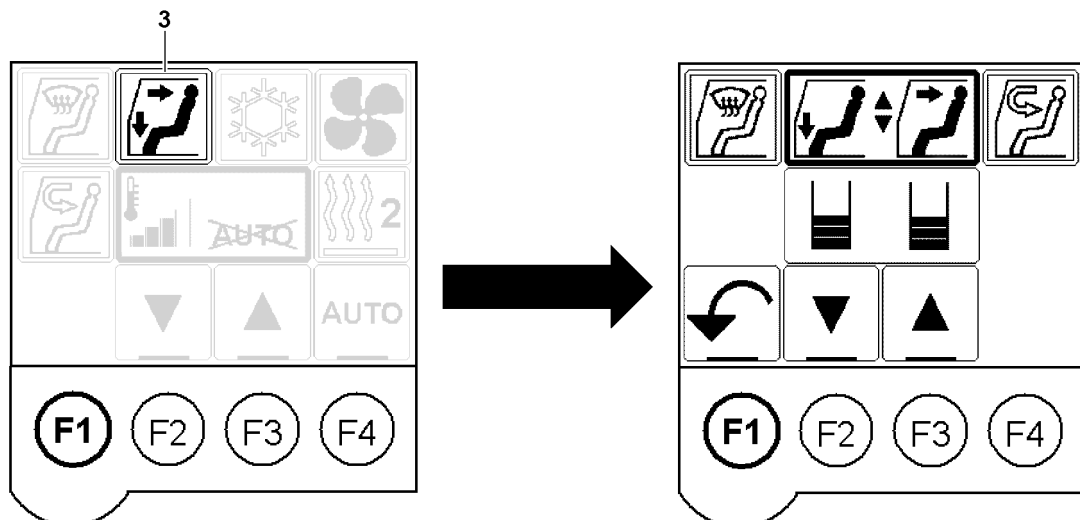

Fig.144096: Climate control menu

Use the air distribution function to regulate the air distribution between floorboard area and the head area.

- ▶ Tap the *air distribution* icon 3.

Result:

- The *air distribution* menu is selected.

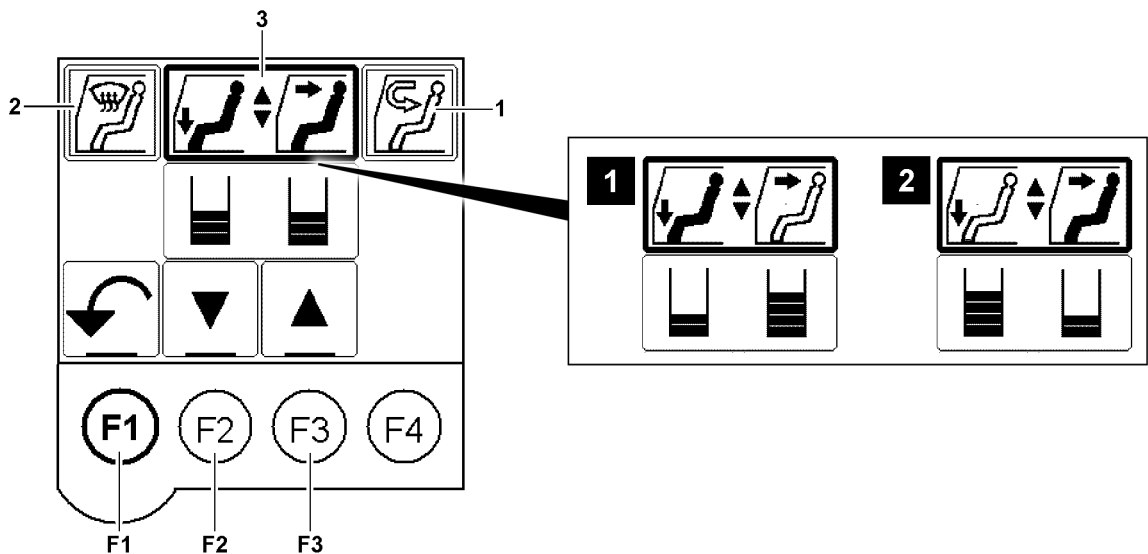

Fig.144097: Air distribution menu

By tapping the *recirculating air* icon 1, the *air supply* function is preselected.

By tapping the *defrost window* icon 2 the *defrost window* function is preselected.

By tapping the *air distribution* icon 3, the *air distribution* function is preselected.



Note

To regulate the air supply:

- ▶ Observe and adhere to the description in section *Air supply*.

To defrost the window:

- ▶ Observe and adhere to the description in section *Defrost window*.

When the *air distribution* icon is 3 **not** selected:

- ▶ Tap the *air distribution* icon 3.

To increase *air distribution* to the head area:

- ▶ Press the function key F3.

Result:

- The bar display on the right side is increased.
- At maximum *air distribution* to the head area, the *floorboard area* icon is highlighted in white, see illustration 1.

To increase *air distribution* to the floorboard area:

- ▶ Press the function key F2.

Result:

- The bar display on the left side is increased.
- At maximum *air distribution* to the floorboard area, the *head area* icon is highlighted in white, see illustration 2.

To return to the *Climate control* menu:

- ▶ Press the function key F1.

6 Defrosting the window

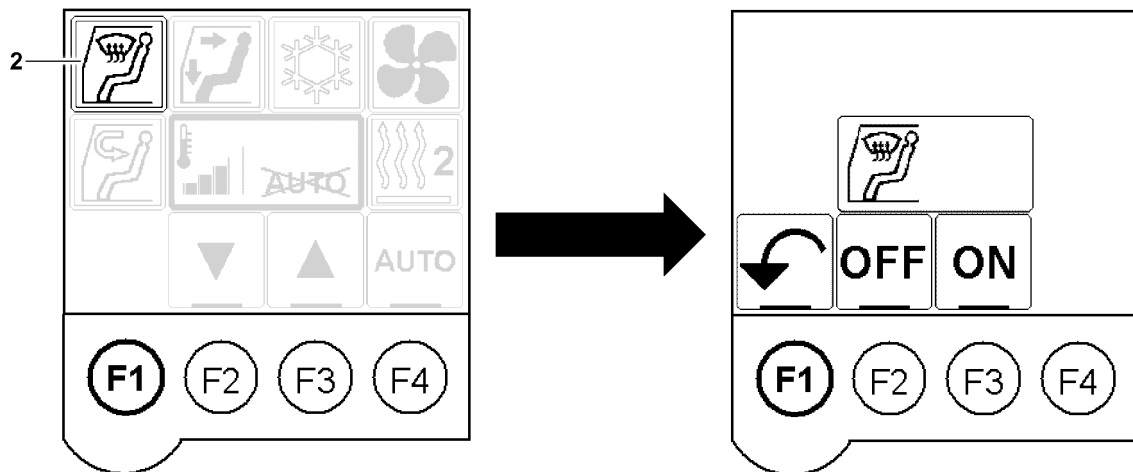

Fig.144098: Climate control menu

Use the *defrost window* function to quickly defrost the window to remove condensation on the inside of the window.



Note

When the window is defrosted:

► Turn the function *defrost window* off.

► Tap the *defrost window* icon 2.

Result:

– The *defrost window* menu is selected.

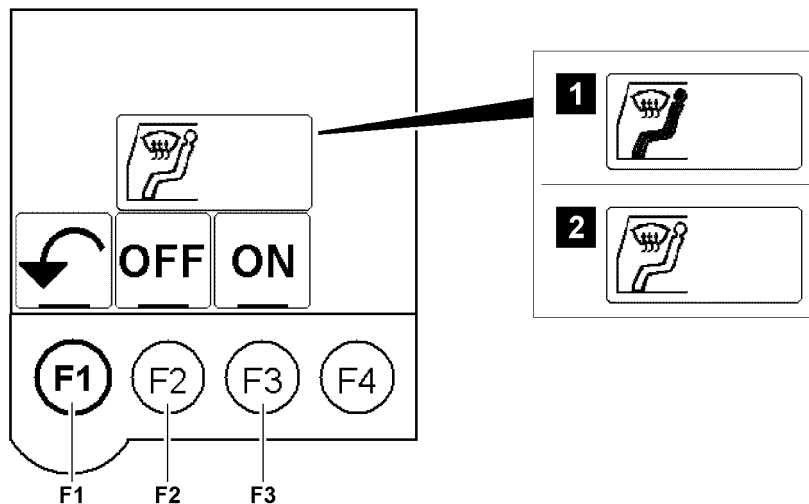

Fig.144232: Defrost window menu

To turn the function *defrost window* on:

► Press the function key **F3**.

Result:

- The *defrost window* icon is highlighted in black, see illustration 1.
- The fan stage is increased.
- Air is directed to the window.
- The air supply is switched to recirculating air.

- The Climate control system* switches on, as needed.

To turn the *defrost window* function off:

- ▶ Press the function key **F2**.

Result:

- The *defrost window* icon is highlighted in white, see illustration 2.

To return to the *Climate control* menu:

- ▶ Press the function key **F1**.

7 Climate control system*



Note

Protection against condenser freezing

- ▶ The climate control system cannot be operated if the outside temperature is too low. This prevents the condenser from freezing.

7.1 Turning the climate control system* on / off

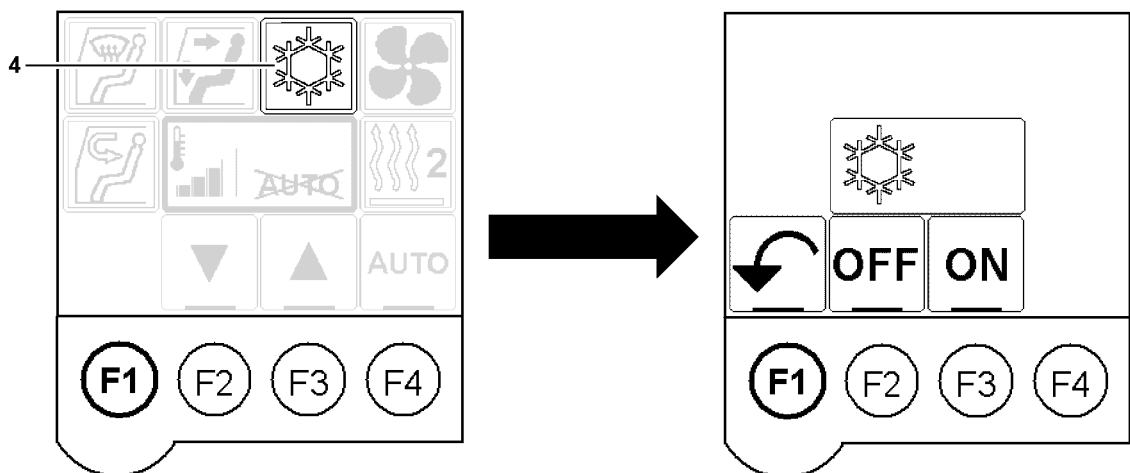

Fig.144099: Selecting the Climate control system menu

The climate control system* is responsible for cooling and the dehumidification of the air in the crane cab.

The humidity is reduced considerably when the climate control system* is switched on. This counteracts the fogging up of the windows.

The maximum cooling output is reached when:

- The air supply is switched to recirculating air.
- The fan stage is set to maximum output.
- The temperature stage is set to the lowest value.
- All air vents are open.
- The door and windows are closed.

Make sure that the following prerequisites are met:

- The engine is running.
- The *Climate control* menu is selected.
- ▶ Tap the *climate control system* icon 4.

Result:

- The *Climate control system* menu is selected.

**Note**

- ▶ In automatic operation (*climate control* menu), the climate control system* is switched on automatically if needed.

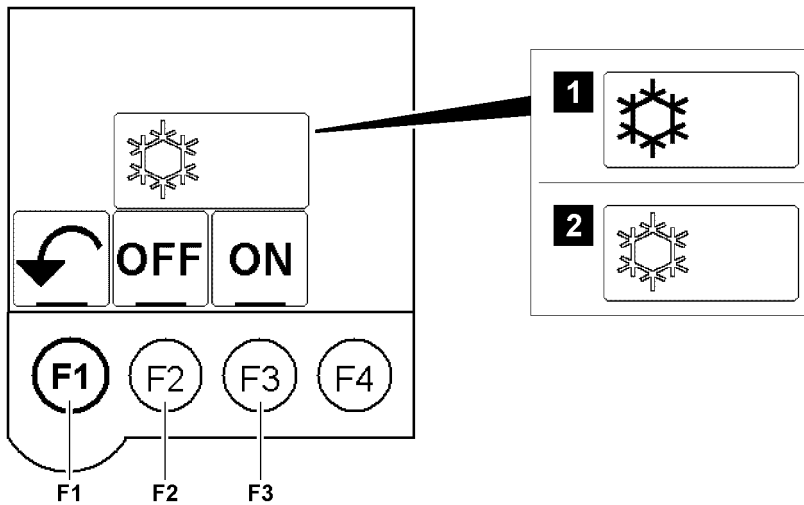

Fig.144063: Turning the climate control system on / off

Turn the climate control system on:

- ▶ Press the function key **F3**.

Result:

- The *climate control system* icon is highlighted in black, see illustration 1.
- The climate control system is turned on.

Problem remedy

The temperature from the air vents is not below the ambient temperature?

The air circulation filter, fresh air filter or condenser could be dirty.

- ▶ Check the filter for impurities. If necessary, clean or replace.
- ▶ Check the evaporator for impurities and clean, if necessary.

When all these measures do not help:

- ▶ Contact the Service Dept. at Liebherr-Werk Ehingen.

Turn the climate control system off:

- ▶ Press the function key **F2**.

Result:

- The *climate control system* icon is highlighted in white, see illustration 2.
- The climate control system is turned off.

To return to the *Climate control* menu:

- ▶ Press the function key **F1**.

8 Auxiliary heater

The auxiliary heater can be used as:

- Auxiliary heater crane cab
- Engine preheating
 - **Note:** Only for crane types with a crane engine in the crane superstructure.
- Auxiliary heater crane cab / engine preheating
 - **Note:** Only for crane types with a crane engine in the crane superstructure.

**WARNING**

Danger of poisoning and suffocation in enclosed areas!

- ▶ Do **not** operate the auxiliary heater in closed rooms.

There is a danger of explosion and fires on the following locations:

- Gas stations and refueling facilities.
- Locations where vapors, gases or dust can form.
- Locations with easily flammable materials or fluids.

**WARNING**

Danger of explosion and fires!

- ▶ Do **not** operate the auxiliary heater if there is a danger of explosion or fires.

**WARNING**

Danger of poisoning and suffocation!

After turning it off, a shut off delay occurs.

During the shut off delay, exhaust gases are still emitted.

- ▶ Ensure sufficient ventilation.

Signs of a defective auxiliary heater:

- Significant smoke development.
- Unusual combustion noise.
- Fuel odor.

NOTICE

Auxiliary heater* defective!

- ▶ Turn the auxiliary heater* off.
- ▶ Take the auxiliary heater* out of service: Shut off the power supply to the auxiliary heater.
- ▶ Before turning it on again: Have the auxiliary heater* inspected by authorized and trained expert personnel.

NOTICE

Damage of auxiliary heater*!

- ▶ Operate the auxiliary heater* at least once a month for 15 minutes.
- ▶ Regularly burn-off the burner of the auxiliary heater*. See section „Auxiliary heater maintenance“.

8.1 Auxiliary heater icons

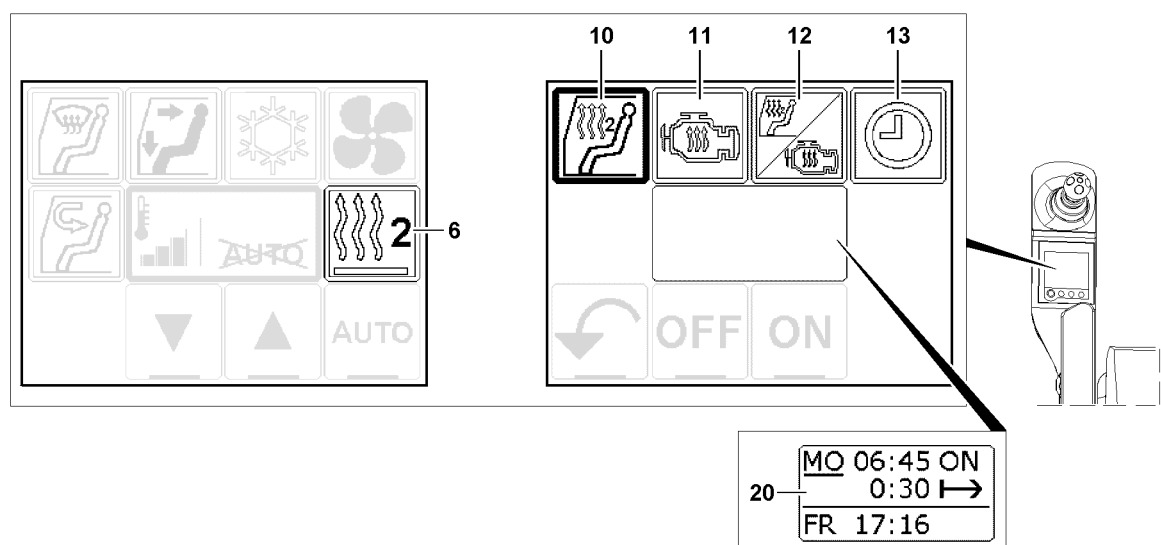

Fig.144100: Auxiliary heater icons

**Note**





- The field in the middle of the *Auxiliary heater* menu displays, depending on the situation, the selected icon or the timer program dialog **20**.

Climate control menu: Auxiliary heater icon 6	
Icon	Function
	Auxiliary heater crane cab turned off
	Auxiliary heater crane cab turned off, timer activated
	Auxiliary heater crane cab turned on, timer activated



Auxiliary heater menu: Auxiliary heater crane cab icon 10	
Icon	Function
	Auxiliary heater crane cab turned off
	Auxiliary heater crane cab turned on
	Auxiliary heater crane cab turned off, timer activated
	Auxiliary heater crane cab turned on, timer activated



Auxiliary heater menu: Engine preheating icon 11¹⁾	
Icon	Function
	Engine preheating turned off
	Engine preheating turned on
	Engine preheating turned off, timer activated
	Engine preheating turned on, timer activated

1) Only for crane types with a crane engine in the crane superstructure

Auxiliary heater menu: Auxiliary heater crane cab / engine preheating icon 12¹⁾	
Icon	Function
	Auxiliary heater crane cab / engine preheating turned off
	Auxiliary heater crane cab / engine preheating turned on
	Auxiliary heater crane cab / engine preheating turned off, timer activated
	Auxiliary heater crane cab / engine preheating turned on, timer activated

1) Only for crane types with a crane engine in the crane superstructure

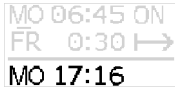
Auxiliary heater menu: Timer icon 13	
Icon	Function
	Timer turned off
	Timer turned on

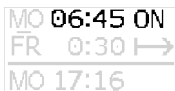
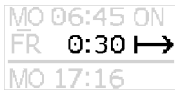
Auxiliary heater menu: Timer program dialog 20	
Icon	Function
	System time The day of the week and time of day is transferred from the system time of the LICCON computer system
	Turn on day The following can be set as the turn on day: - single day of the week - five days in a row from Monday to Friday - seven days in a row from Monday to Sunday
	Turn on time Current programmed start time / turn on time of auxiliary heater
	Turn on duration Current programmed turn on duration of the auxiliary heater from the turn on time

1) Only for crane types with a crane engine in the crane superstructure

LWE/LR 11000-001/23501-04-02/en

8.2 Operating the auxiliary heater with the ignition on

Make sure that the following prerequisites are met:

- The crane superstructure ignition is turned on.
- Sufficient fuel for the auxiliary heater has been added.
- The *Climate control* menu is selected.

8.2.1 Selecting the *Auxiliary heater* menu

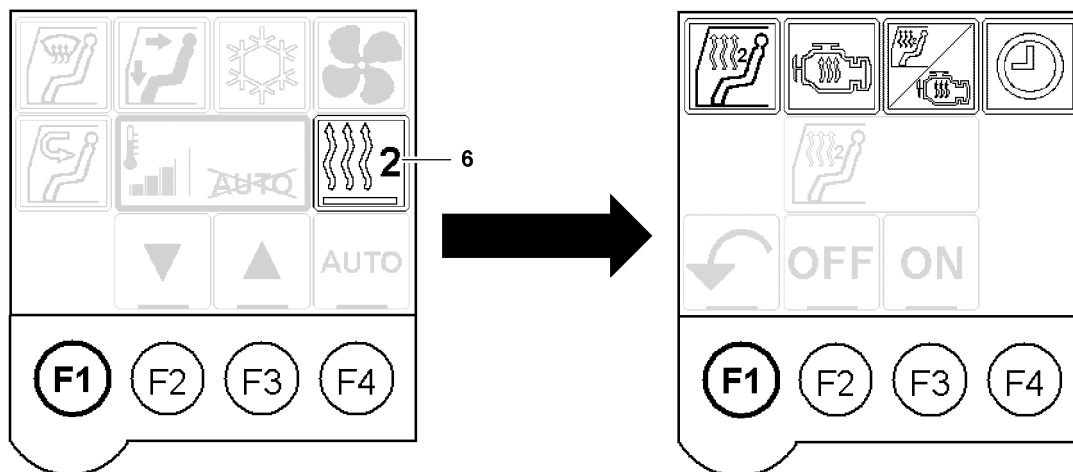

Fig.144101: Selecting the *Auxiliary heater* menu

- ▶ Tap the *auxiliary heater* icon 6.

Result:

- The *auxiliary heater* menu is selected.



Note

- ▶ If a selection is made in the *auxiliary heater* menu, it is displayed again.

8.2.2 Turning the auxiliary heater on

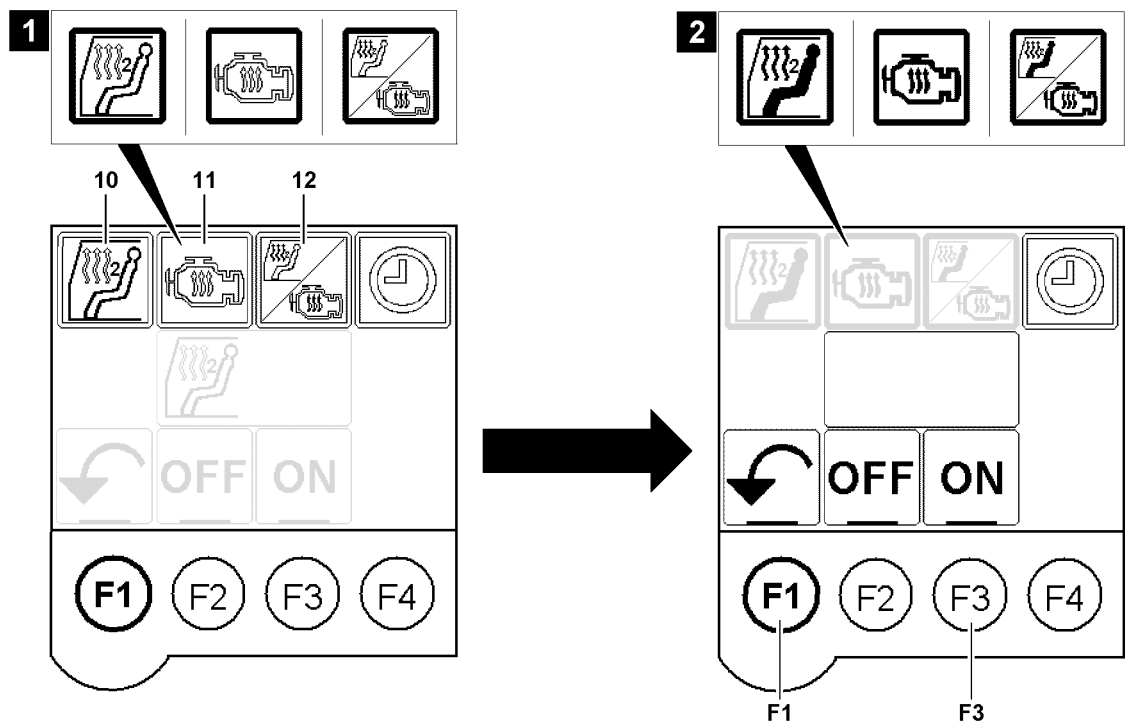

Fig.144084: Turning the auxiliary heater on

The auxiliary heater functions are selected by tapping the respective icon on the display:

- Auxiliary heater crane cab
 - Tap the *auxiliary heater crane cab* icon 10
- Engine preheating
 - Tap the *engine preheating* icon 11
 - **Note:** Only for crane types with a crane engine in the crane superstructure.
- Auxiliary heater crane cab / engine preheating
 - Tap the *auxiliary heater crane cab / engine preheating* icon 12
 - **Note:** Only for crane types with a crane engine in the crane superstructure.

A selected function is bordered in black, see illustration 1. By tapping another function, the previous selection is discarded.

- ▶ Tap the *auxiliary heater crane cab* icon 10.
or
Tap the *engine preheating* icon 11.
or
Tap the *auxiliary heater crane cab / engine preheating* icon 12.

Result:

- The selected icon is bordered in black, see illustration 1.
- The function is selected and is displayed in the field in the middle of the *auxiliary heater* menu.

To turn on the auxiliary heater for the selected function:

- ▶ Press the function key **F3**.

Result:

- The selected icon is filled out in black, see illustration 2.
- The auxiliary heater is turned on.

To return to the *Climate control* menu:

- ▶ Press the function key **F1**.

8.2.3 Turning the auxiliary heater off

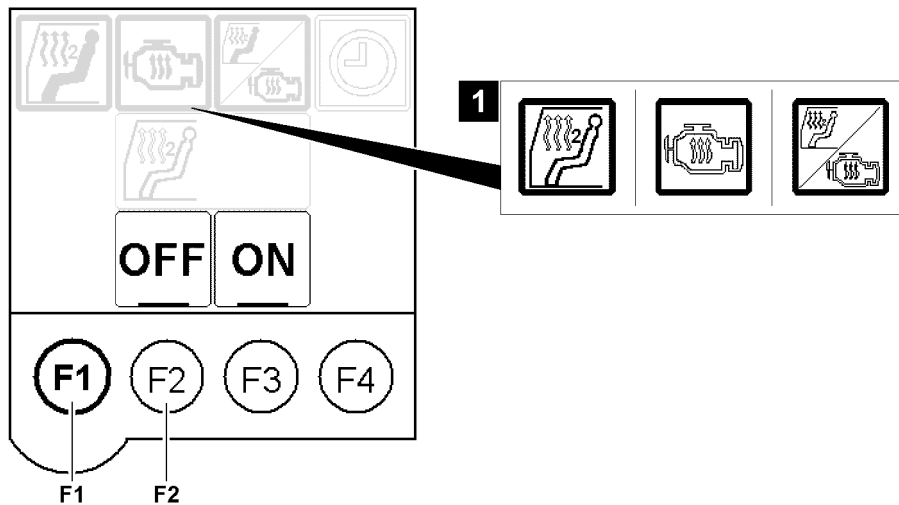

Fig.144085: Turning the auxiliary heater off

When the *auxiliary heater* menu is not displayed:

- ▶ Select the *auxiliary heater* menu.

To turn the auxiliary heater off:

- ▶ Press the function key **F2**.

Result:

- The selected auxiliary heater function is no longer displayed filled out in black, see illustration 1.
- The auxiliary heater is turned off.

To return to the *Climate control* menu:

- ▶ Press the function key **F1**.

8.2.4 Operating the timer

The auxiliary heater can be turned on at any time using the timer.



WARNING

Danger of suffocation and explosion!

Only when the auxiliary heater is turned on if sufficient ventilation is ensured and no danger of explosion exists:

- ▶ Activate the timer.



Note

- ▶ Pay attention to a sufficient fuel reserve for the auxiliary heater.

Programming the timer

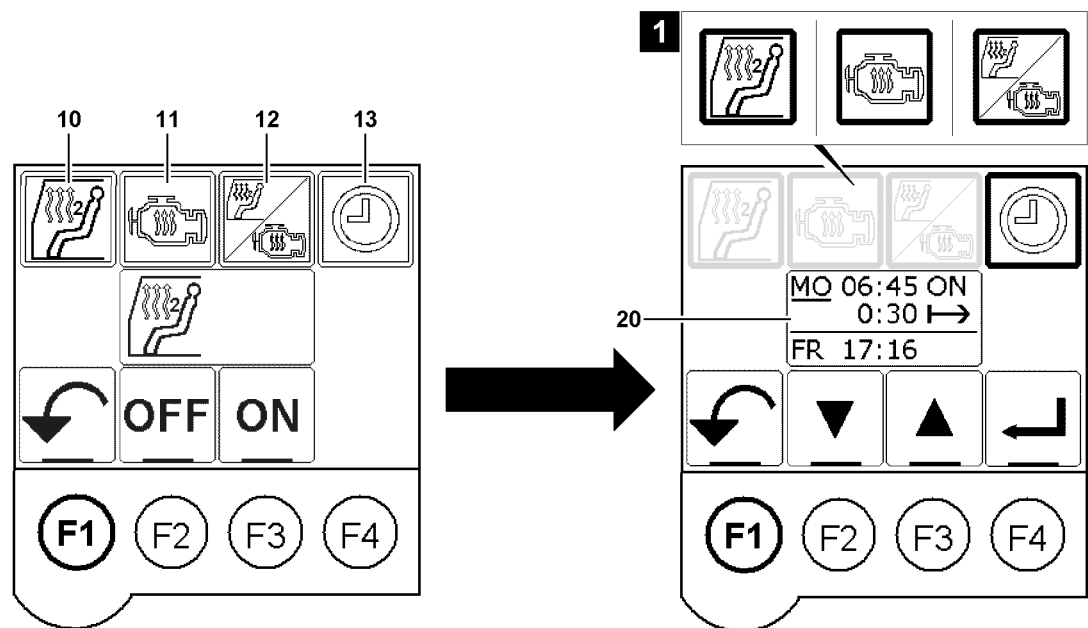

Fig.144087: Auxiliary heater menu: Programming the timer

The previously set function, air supply and air distribution is taken over.

The fan stage is set to 30 %.

The program ends after the set time and does not repeat.

The timer is only activated when all program steps are completed.

Make sure that the following prerequisites are met:

- The *auxiliary heater* menu is selected.
- At the programmer start time for the timer, the ignition is turned off.

- ▶ Tap the *auxiliary heater crane cab* icon 10.
or
Tap the *engine preheating* icon 11.
or
Tap the *auxiliary heater crane cab / engine preheating* icon 12.

Result:

- The selected icon is bordered in black, see illustration 1.

- ▶ Tap the *timer* icon 13.

Result:

- The *timer* icon 13 is bordered in black.
- The timer program dialog 20 is shown on the display.
- The cursor is on the turn on day - the turn on day is underlined.

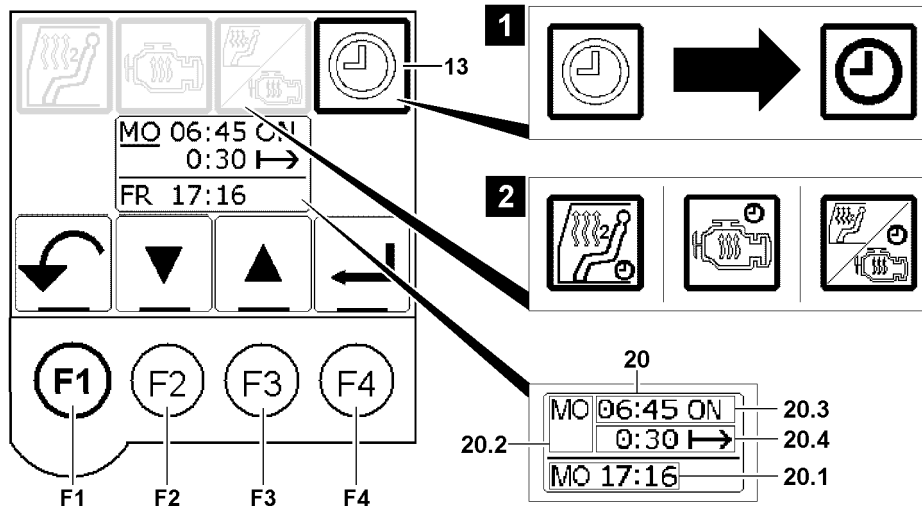

Fig.144088: Auxiliary heater menu: Programming the timer

The timer program dialog **20** displays the current system time **20.1**. The system time **20.1** is the determining factor for the timer.

The following can be set as the turn on day **20.2**:

- Single day of the week
- Daily from Monday to Friday
- Daily from Monday to Sunday
- ▶ Select the turn on day **20.2** with function key **F2** and function key **F3**.
- ▶ Confirm the turn on day **20.2** with function key **F4**.

Result:

- The cursor is on turn on time **20.3** (hour). The turn on time **20.3** (hour) is underlined.

Set the turn on time **20.3** (hour).

- ▶ Select the turn on time **20.3** (hour) with function key **F2** and function key **F3**.
- ▶ Confirm the turn on time **20.3** (hour) with function key **F4**.

Result:

- The cursor is on turn on time **20.3** (minute). The turn on time **20.3** (minute) is underlined.

Set the turn on time **20.3** (minute).

- ▶ Select the turn on time **20.3** (minute) with function key **F2** and function key **F3**.
- ▶ Confirm the turn on time **20.3** (minute) with function key **F4**.

Result:

- The cursor is on the turn on duration **20.4**. The turn on duration **20.4** is underlined.

Set the turn on duration **20.4** between 5 minutes and 55 minutes.

- ▶ Select the turn on duration **20.4** with function key **F2** and function key **F3**.
- ▶ Confirm the turn on duration **20.4** with function key **F4**.

Result:

- The *timer* icon **13** is filled out, see illustration **1**.
- The selected *auxiliary heater* icon has a clock symbol, see illustration **2**.
- The timer is programmed and activated.

**Note**

- ▶ As soon as the timer is activated, the current turn on time is displayed also when the ignition is turned off.
- ▶ At the programmer start time for the timer, the ignition must be turned off so that the auxiliary heater turns on.

To return to the *Climate control* menu:

- ▶ Press the function key **F1**.

Turning the timer off

Fig.144086: Auxiliary heater menu: turning off the timer

Make sure that the following prerequisite is met:

- The *timer* icon **13** is not filled out in black.

- ▶ Press the function key **F4**.

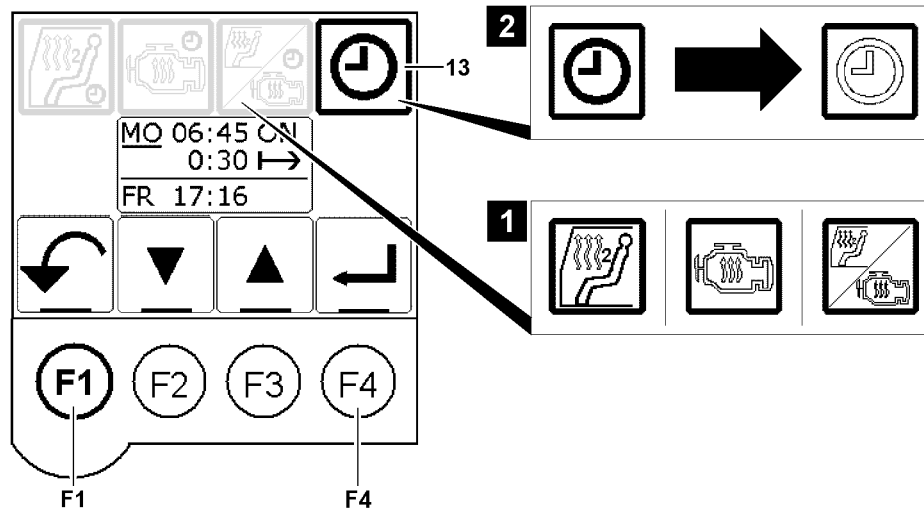
Result:

- The clock on the selected *auxiliary heater* icon is deleted, see illustration **1**.
- The *timer* icon **13** is not filled out, see illustration **2**.
- The timer is turned off.

To return to the *Climate control* menu:

- ▶ Press the function key **F1**.

8.3 Operating the auxiliary heater with the ignition off

Make sure that the following prerequisites are met:

- The crane superstructure ignition is turned off.
- Sufficient fuel for the auxiliary heater has been added.

8.3.1 Turning the auxiliary heater on / off (ignition off)

If the ignition is turned off during operation of the auxiliary heater, the auxiliary heater continues to run for up to 30 minutes due to the shut off delay. In the *auxiliary heater* menu, the auxiliary heater can be turned off immediately, ending the shut off delay.

Turning the auxiliary heater on

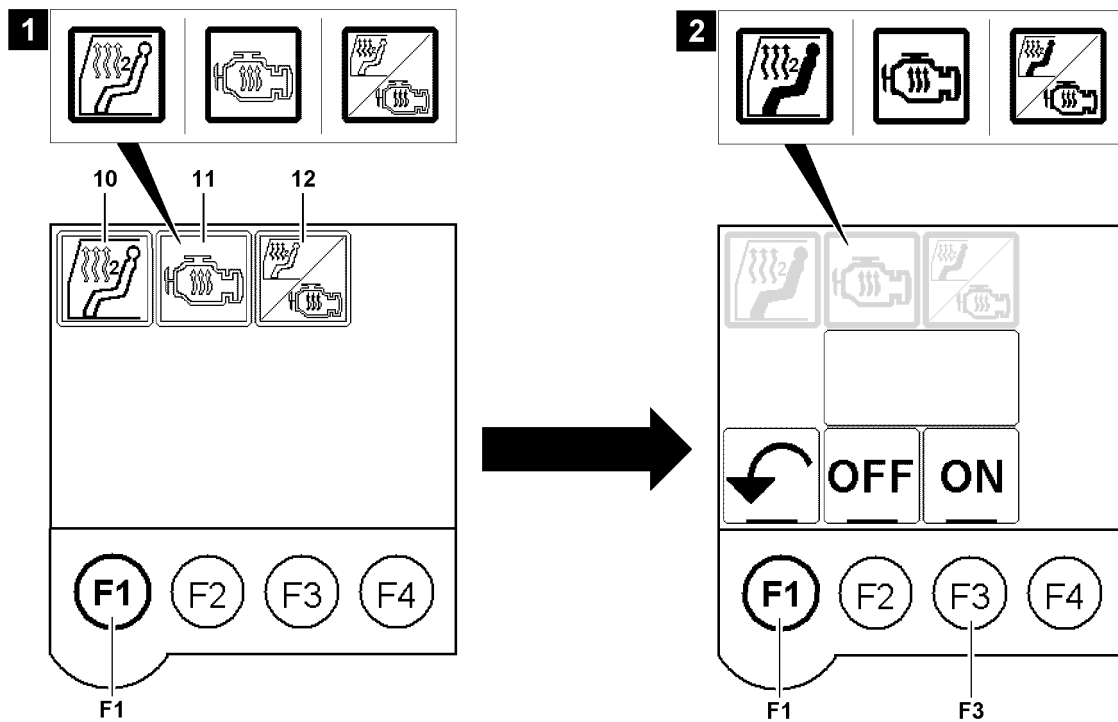

Fig.144073: Auxiliary heater menu: Turning the auxiliary heater on

When the *auxiliary heater* menu is not displayed:

- ▶ Hold down the function key **F1** until the *auxiliary heater* menu appears.

**Note**

- ▶ If no entry is made within a certain time, then the touch display is automatically turned off.
- ▶ The *engine preheating* icon **11** and *auxiliary heater crane cab / engine preheating* icon **12** are only available for crane types with a crane engine in the crane superstructure.

Select the settings:

- ▶ Tap the *auxiliary heater crane cab* icon **10**.
or
Tap the *engine preheating* icon **11**.
or
Tap the *auxiliary heater crane cab / engine preheating* icon **12**.
- ▶ Press the function key **F3**.

Result:

- The icon for the selected function is filled out in black, see illustration **1**.
- The auxiliary heater is turned on.

**Note**

- ▶ After the auxiliary heater is turned on, pressing the function key **F1** calls up the *Climate control* menu. Description of setting possibilities, see section „Climate control“

Turning the auxiliary heater off

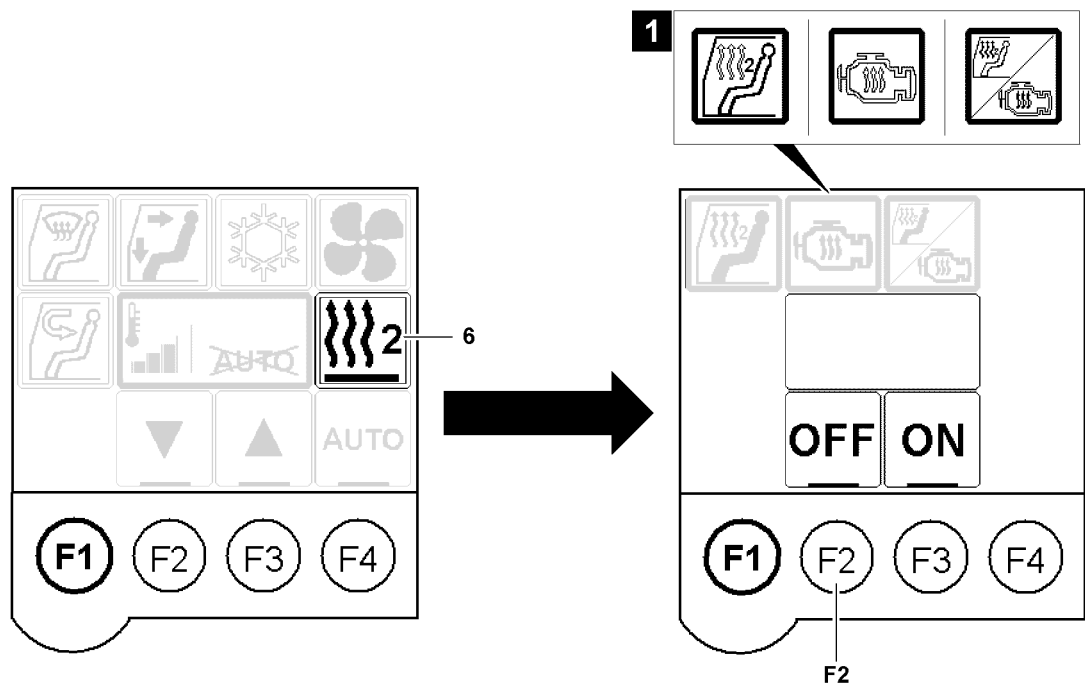

Fig.144102: Auxiliary heater menu: Turning the auxiliary heater off

When the auxiliary heater menu is not displayed:

- ▶ Tap the auxiliary heater icon 6.

The programmed auxiliary heater function is displayed bordered in black

To turn the auxiliary heater off:

- ▶ Press the function key F2.

Result:

- The icon for the selected function is no longer filled out in black, see illustration 1.
- The auxiliary heater is turned off.

8.3.2 Turning the timer off (ignition off)

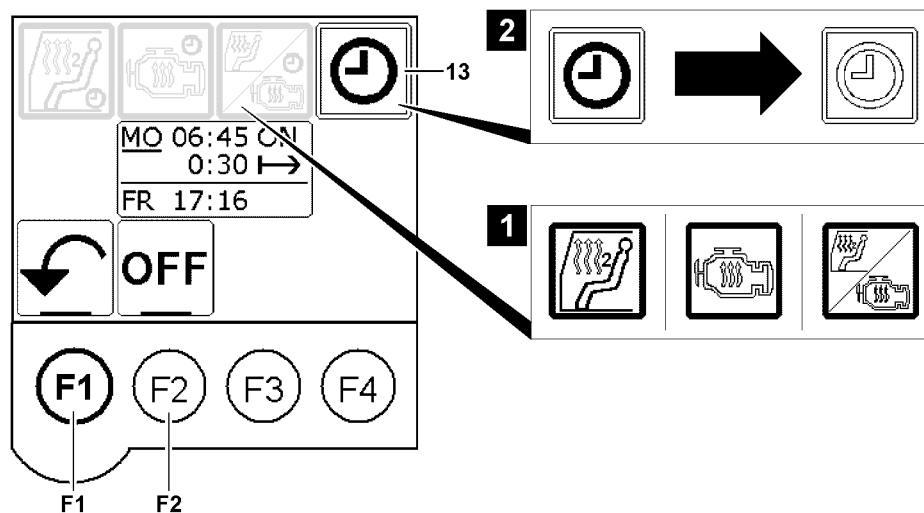

Fig.144075: Turning the timer off (ignition off)

- ▶ Press the function key F2.

LWE/LR 11000-001/23501-04-02/en

Result:

- The clock on the selected *auxiliary heater* icon is deleted, see illustration 1.
- The *timer* icon 13 is no longer filled out, see illustration 2.
- The timer is turned off.

9 Maintenance Heater

**WARNING**

Danger of injury due to scalding!

- ▶ Never open the cap on the coolant reservoir as long as the engine is warm! Hot, pressurized fluid can escape!
-

Crane types with the heater coupled with the coolant circuit of the crane engine use the engine coolant as the heat carrier.

When the heater is coupled with the coolant circuit of the crane engine:

- Bleed the cooling circuit every time the engine coolant is topped up or refilled.

9.1 Bleeding the coolant circuit

**WARNING**

Severe burns!

- ▶ Let the cooling circuit and all additional crane components cool off.
 - ▶ Carry out maintenance solely when components and cooling circuit are cold.
 - ▶ Take into account that the temperature of the engine coolant and the component increase when the crane engine is running - allow for cooling pauses in time with the crane engine turned off.
-

Make sure that the following prerequisites are met:

- The components and cooling circuit are cooled off.
- Sufficient engine coolant has been added.

- ▶ Start the crane engine.
-

**Note**

- ▶ Operate the crane engine idling.
-

- ▶ In manual operation, set the heater to maximum warm air supply, see section „Climate control“.

As soon as no more air bubbles rise in the expansion tank and the fill level remains constant, continue with the next step.

When no more air bubbles rise:

- ▶ In manual operation, set the heater to the minimum temperature.

As soon as no more air bubbles rise in the expansion tank and the fill level remains constant, the coolant circuit is bled.

- ▶ Wait until no more air bubbles rise in the expansion tank.

10 Maintenance Auxiliary heater



WARNING

Danger of injury due to scalding!

- ▶ Never open the cap on the coolant reservoir as long as the engine is warm! Hot, pressurized fluid can escape!
- ▶ Never open the cap on the expansion tank for the auxiliary heater as long as the heating circuit is warm! Hot, pressurized fluid can escape!



WARNING

Severe burns!

- ▶ Let the cooling circuit and all additional crane components cool off.
- ▶ Carry out maintenance solely when components and cooling circuit are cold.
- ▶ Take into account that the temperature of the engine coolant and the component increase when the crane engine is running - allow for cooling pauses in time with the crane engine turned off.

The maintenance of the auxiliary heater* includes:

- Function test (monthly).
- Inspections and maintenance work (before and after every heating period).
- Burn-off the burner (1x week during the heating period).
- Replacing parts.
- Bleeding the fuel line.

10.1 Function test

Operate the auxiliary heater* at least once a month for 15 minutes.

Make sure that the following prerequisites are met:

- Air filters are clear.
 - Combustion air infiltration and exhaust emission of the heater are free of foreign particles.
 - If present: Pollen filter / dust filter of the heater are not blocked.
 - Heating circuit is bled.
 - Fuel line is bled.
 - Heating circuit is cold.
 - Error stack of the LICCON computer system contains no error messages regarding the auxiliary heater*.
 - The engine is **turned off**.
- ▶ Turn the auxiliary heater* on.

Wait a few minutes:

- ▶ Check the heat effect on the air vents of the vehicle.

When engine preheating* is active:

- ▶ Check the increase of the engine temperature.

10.2 Inspections and maintenance work

Carry out the following inspections and maintenance work before and after every heating period.

Make sure that the following prerequisites are met:

- The heater and the heating circuit are cold.

When cleaning the heater, avoid water penetration.

- ▶ Clean the heater externally.
- ▶ Check the electrical connections for corrosion and tight seating.
- ▶ Check the exhaust and combustion air line for damage and free passage.
- ▶ Check the hoses for leaks and cracks.
- ▶ Check the circulation pump for leaks.
- ▶ Check the heating circuit for leaks and cracks.

- ▶ Check the fuel line for leaks and cracks.

When separately installed:

- ▶ Check the fuel filter for free passage.

When the fuel filter is dirty:

- ▶ Replace the fuel filter.

The ratio of corrosion inhibitor - antifreeze in the heating circuit must be 50 %.

- ▶ Check the ratio of corrosion inhibitor / antifreeze in the heating circuit.

10.3 Burning-off the burner

To prevent soot deposits in the burner of the auxiliary heater*, free-burn the burner during the heating period once per week. Free-burning is used for the self-cleaning of the burner of the auxiliary heater*.

Make sure that the following prerequisites are met:

- All outlet nozzles in the crane cab are open.
 - The crane cab door is open.
 - The interior temperature is set to the highest level.
 - The fan stage is set to the highest level.
 - The air supply is set to fresh air.
 - The heater is in manual operation.
- ▶ Operate the auxiliary heater* at full load for 15 minutes.

10.4 Replacing parts

The heater manufacturer specifies time frames, after which the components of the heater must be replaced.

No later than after 3000 operating hours:

- ▶ Replace the burner of the heating unit.

No later than after 10 years:

- ▶ Replace the heat exchanger of the heating unit.

10.5 Bleeding the fuel line

If the fuel ran out, then the fuel line may have to be bled.



Note

- ▶ Contact Service at Liebherr-Werk Ehingen and coordinate the procedure.
-

6.05 Emergency take-down

1	Emergency control	2
2	Emergency control with assembly plate Variation 1 (V1)	9
3	Emergency control of slewing gear(s) with assembly plate Variation 1 (V1)	15
4	Emergency control with assembly plate(s) Variation 2 (V2)	19
5	Emergency control slewing gear(s) with assembly plate(s) Variation 2 (V2)	31
6	Completing emergency control	31

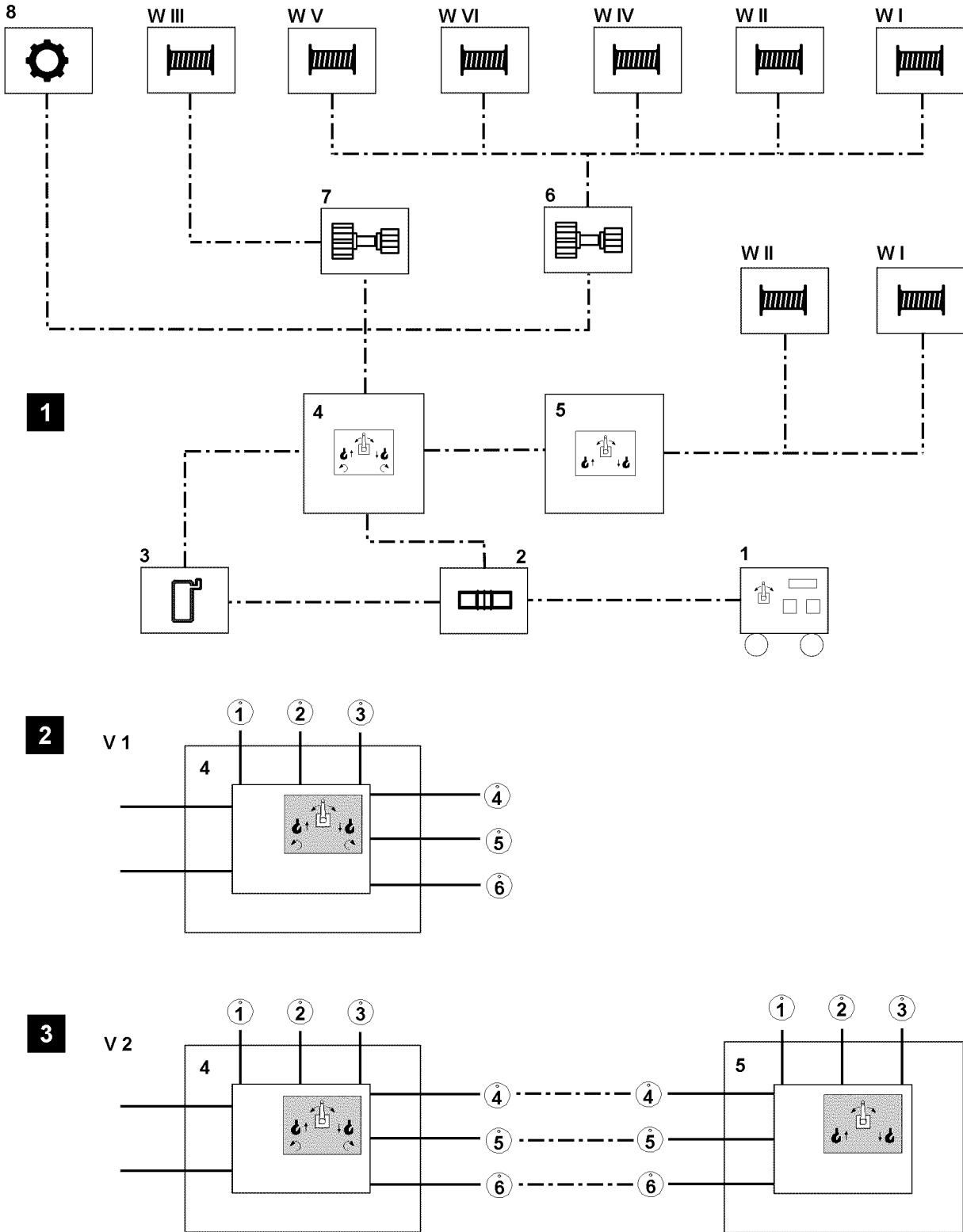

Fig.121033: Piping plan Emergency operation

1 Emergency control



Note

► The illustrations in this chapter are examples and may not apply exactly to your crane.

LWE/LR 11000-001/23501-04-02/en

**Note**

- Before you start with preparations for emergency operation, check which of the following assembly plates you have available to carry out the emergency operation.

There are two **different** variations of assembly plates.

With variation 1 **V1**, all winches, which are equipped with the respective auxiliary hydraulic for emergency control and the slewing gear can be actuated, each individually, see illustration 1 and illustration 2.

With variation 2 **V2**, which consists of two assembly plates, all winches, which are equipped with the respective auxiliary hydraulic for emergency control can be actuated, each individually, **or** winch 1 **WI** and winch 2 **WII** can be actuated in parallel operation or the slewing gear can be actuated individually, see illustration 1 and illustration 3.

Position	Component
1	Emergency operation aggregate
2	Hydraulic transformer
3	Oil container
4	Assembly plate emergency operation
5	Assembly plate parallel operation
6	Adapter 1
7	Adapter 2
8	Slewing gear
W I - W VI	Winch 1 WI to winch 6 WVI

Component overview

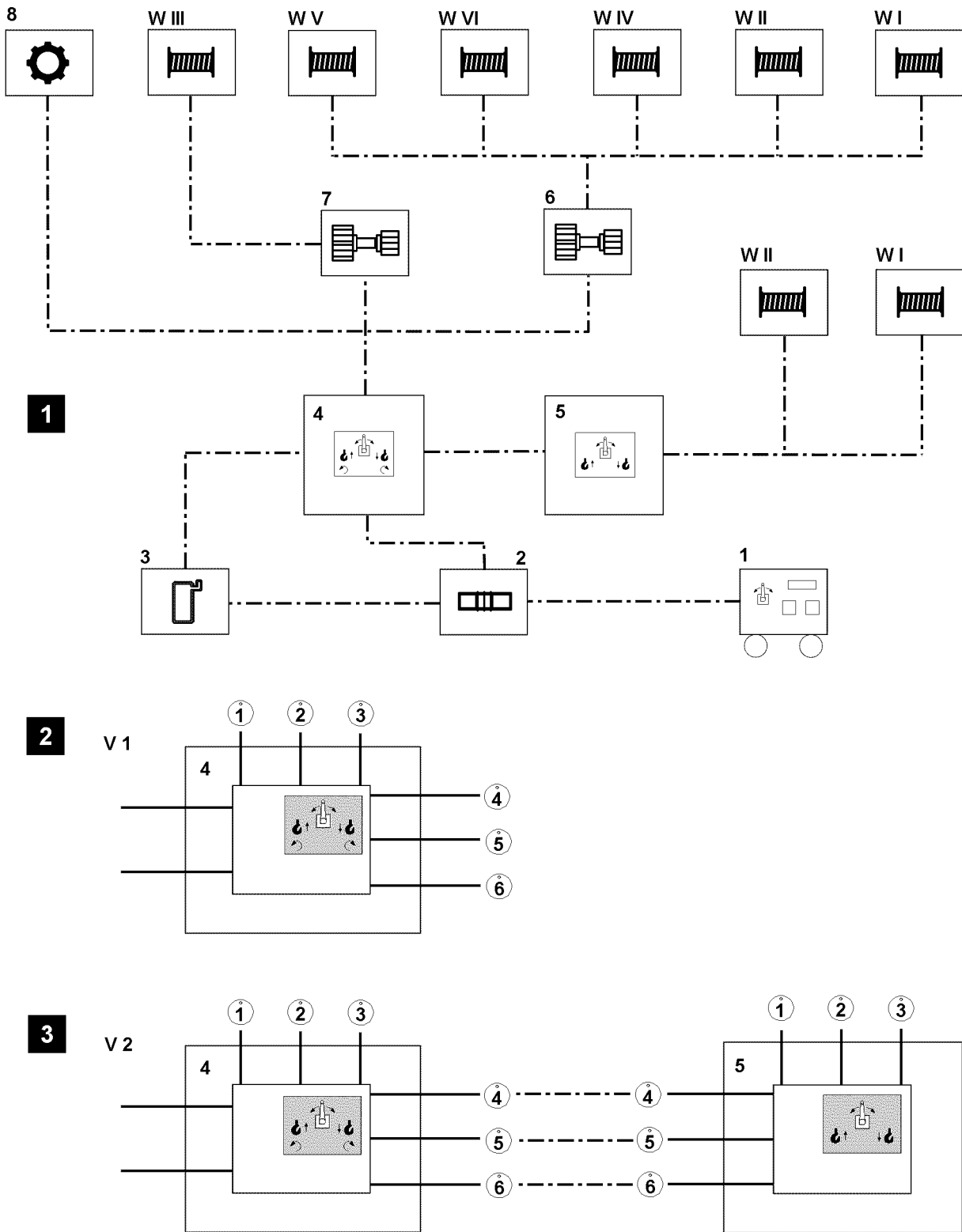

Fig.121033: Piping plan Emergency operation

LWE/LR 11000-001/23501-04-02/en

1.1 General danger notes



DANGER

Significant danger of accident during emergency control!

During an emergency control, crane movements are no longer monitored by the LICCON computer system.

In the event of improper operation or deliberate misuse, the crane can topple over.

There is an increased risk of accident if the following danger notes are not observed.

Personnel can be severely injured or killed.

This could result in high property damage.

► All danger notes are to be observed and maintained.

General danger notes!

1. **Emergency control of the crane superstructure may only be carried out:**

- To remove a dangerous situation.
- After consultation with customer service at LIEBHERR-Werk Ehingen GmbH.
- By authorized personnel who are knowledgeable of the hydraulic circuit diagram, the connection diagram and carrying out emergency control.
- By authorized personnel who are aware of the risks of emergency control.
- To carry out load reducing movements.

2. The danger zone must be blocked off.

3. No persons or objects may remain in the danger zone.

4. If a load is on the hook, then it must first be set down to relieve the boom.

5. During emergency control, all safety equipment, with the exception of „winch spooled out“ are automatically bypassed.

6. In the event of a problem or failure of the LICCON computer system, each step must be carried out and checked with extreme caution and care, since a visual check on the LICCON monitor is no longer possible. Visual check.

7. All crane movements must be carried out with extreme caution and at the lowest speed.

8. The crane operator must be in visual contact with auxiliary personnel or guides.



Note

Please note!

► The hydraulic supply for the crane can, to the extent that the crane has been equipped, take place through an emergency unit*. If this is not the case, the crane must be taken down by using auxiliary cranes.



WARNING

The crane can topple over!

► The boom may only be luffed down if the stability of the crane permits this action, observe and adhere to the data in the load charts.

► When taking down the boom, the information in the erection and take down charts must be observed and adhered to.

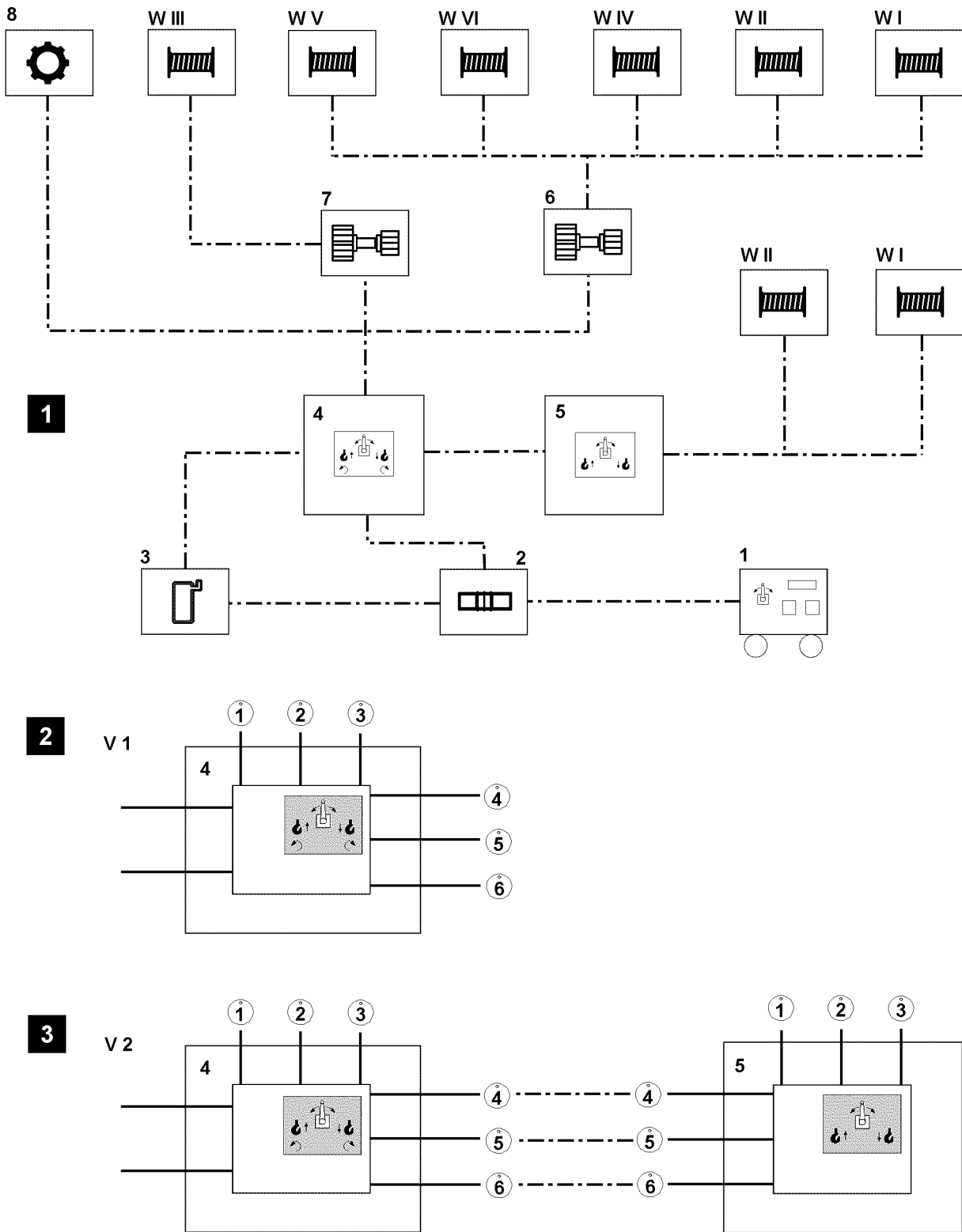

Fig.121033: Piping plan Emergency operation

LWE/LR 11000-001/23501-04-02/en

1.2 Handling of assembly plates



WARNING

Falling assembly plates!

Non-secured assembly plates can fall down when carrying out the emergency control.

Personnel can be severely injured or killed.

- ▶ For emergency control, secure the assembly plates with the chains to prevent them from falling down.
- ▶ Do not secure the assembly plates near movable crane components.

1.3 Prerequisites for emergency control



Note

- ▶ Due to different line diameters on the hydraulic lines, they cannot be connected incorrectly, in addition, the hydraulic connections are identified with numbers.

Make sure that the following prerequisites are met:

- The hydraulic schematic is available.
- The hydraulic system is functional.
- An emergency operation aggregate **1** is available.
- A „hydraulic transformer **2**“ is available.
- The assembly plate(s) are available.
- Adapter **6** and adapter **7** are available.
- The dust caps for the hydraulic connections are removed.
- The pressure in the hydraulic system has been relieved.

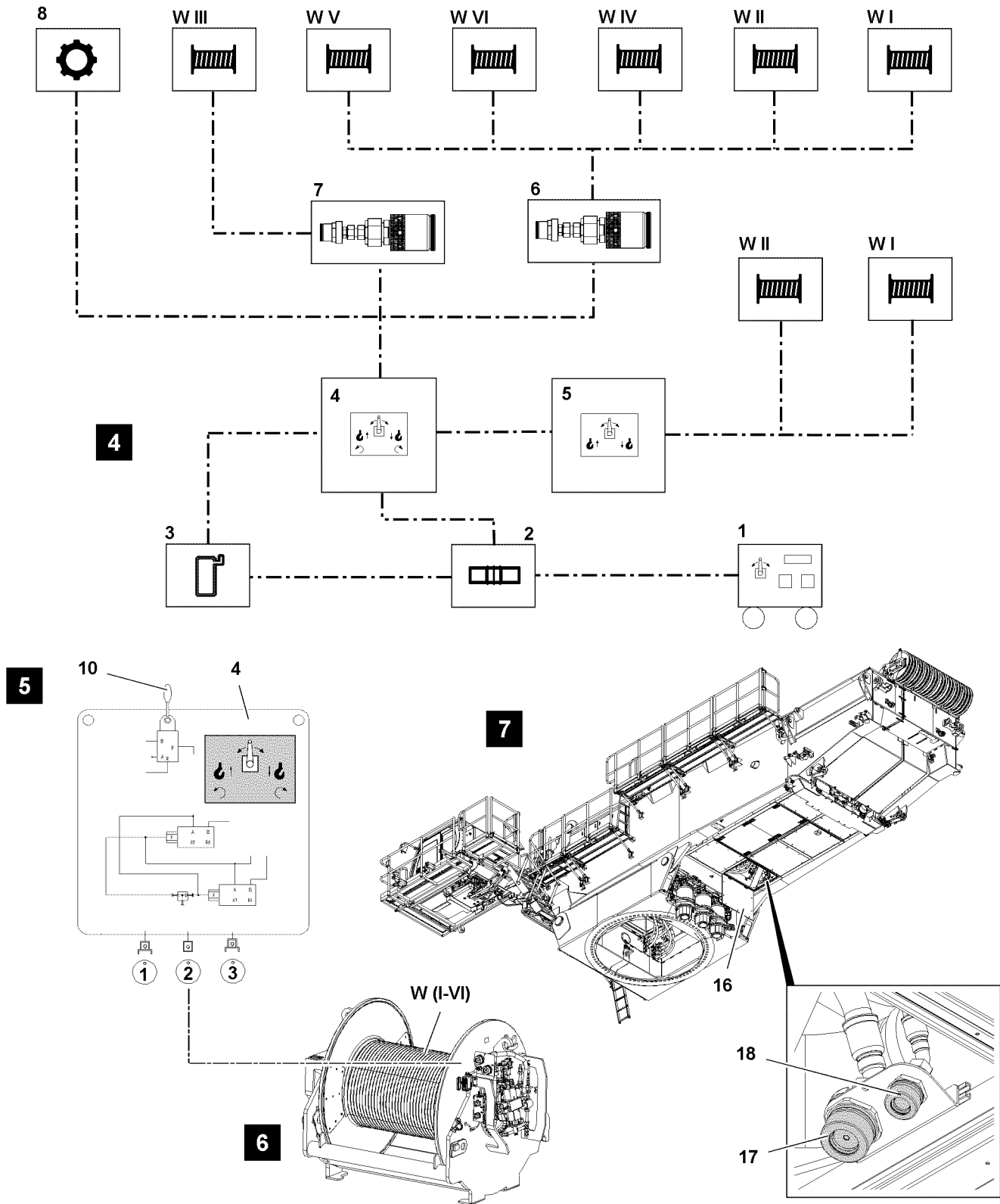

Fig.121034: Emergency control with assembly plate Variation 1 (V1)

LWE/LR 11000-001/23501-04-02/en

2 Emergency control with assembly plate Variation 1 (V1)



Note

- Carrying out emergency control is identical for all winches and is described on the example of one winch.

Numbering						
	Connections of assembly plate					
	Connection 1 „lift“		Connection 2 „lower“		Connection 3 „brake“	
Winch 1 WI	1 ¹⁾	1 ²⁾	2 ¹⁾	2 ²⁾	5 ¹⁾	5 ²⁾
Winch 2 WII	1 ¹⁾	1 ²⁾	2 ¹⁾	2 ²⁾	5 ¹⁾	5 ²⁾
Winch 3 WIII	1 ¹⁾	5 ²⁾	2 ¹⁾	6 ²⁾	5 ¹⁾	W3 ²⁾
Winch 4 WIV	1 ¹⁾	1 ²⁾	2 ¹⁾	2 ²⁾	5 or 6 ¹⁾	5/6 ²⁾
Winch 5 WV	1 ¹⁾	7 ²⁾	2 ¹⁾	6 ²⁾	5 ¹⁾	W5 ²⁾
Winch 6 WVI	1 ¹⁾	9 ²⁾	2 ¹⁾	8 ²⁾	5 ¹⁾	W6 ²⁾

Numbering of hydraulic connections

¹⁾ - Identification (numbering) on winches

²⁾ - Identification (numbering) on piping plan

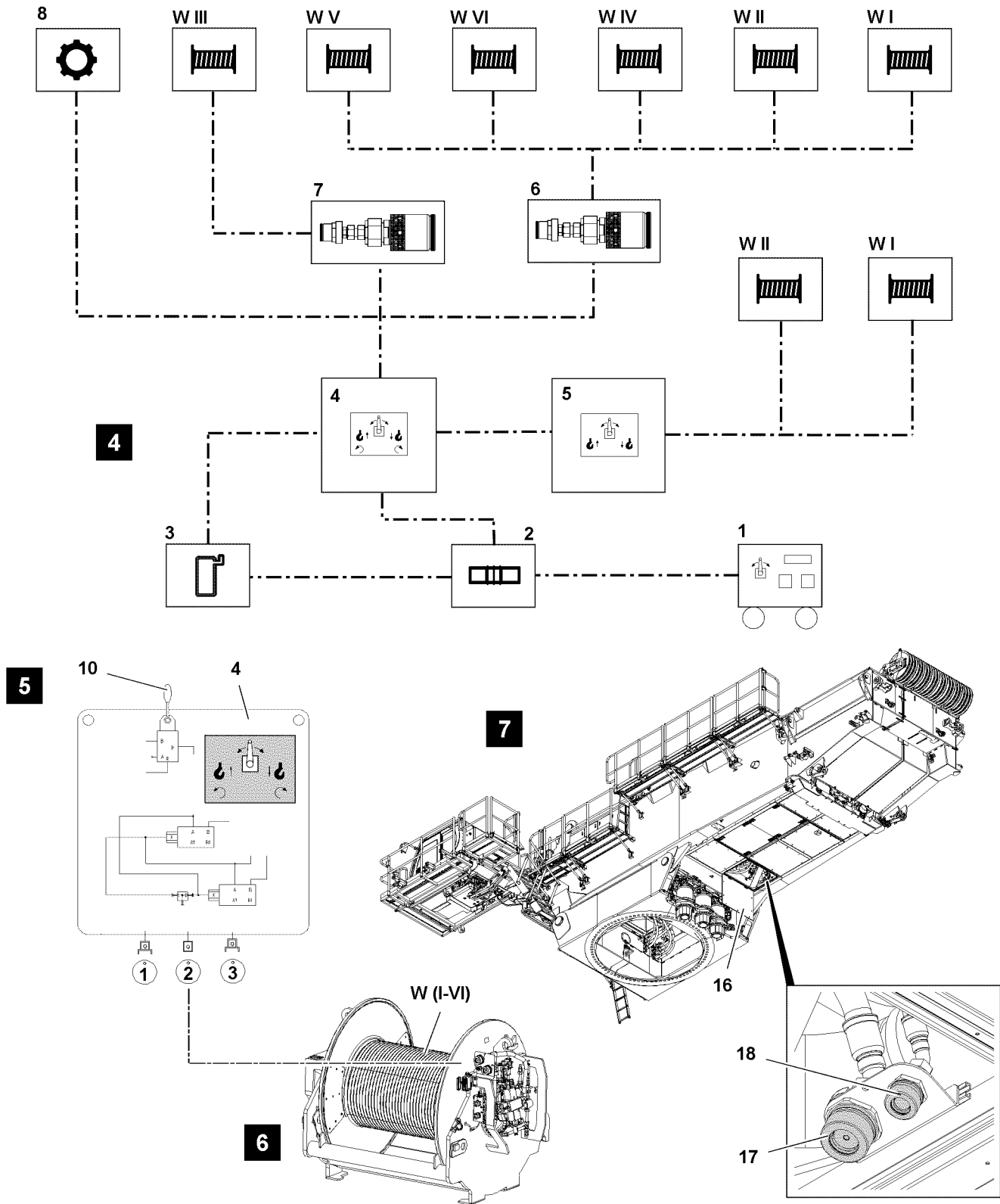

Fig.121034: Emergency control with assembly plate Variation 1 (V1)

LWE/LR 11000-001/23501-04-02/en

2.1 Establishing the hydraulic connections



WARNING

Danger due to hydraulic pressure!

If the hydraulic lines are under pressure when releasing the connections, assembly personnel can be severely injured.

- ▶ Relieve the pressure in the hydraulic lines before releasing.
- ▶ Make sure that the engine is turned off.

- ▶ Establish the hydraulic connections from the emergency operation aggregate* 1 to the transformer 2, see illustration 4.



WARNING

Cover swinging down!

The cover 16 can swing down by itself due to its own weight when releasing the connections, see illustration 7.

Personnel can be injured.

- ▶ When releasing the connections, hold the cover 16.

- ▶ Open the cover 16, see illustration 7.
- ▶ Establish the hydraulic connection from the hydraulic transformer 2 to the suction line 17 of the oil tank 3 on the turntable of the crane, see illustration 4 and illustration 7.
- ▶ Establish the hydraulic connection from the turntable of the crane (oil tank 3, return line 18) to the Assembly plate emergency operation 4, see illustration 4 and illustration 7.
- ▶ Establish the hydraulic connection (pressure line) from the hydraulic transformer 2 to the assembly plate emergency operation 4, see illustration 4.
- ▶ Release the hydraulic connections on the corresponding winch.



Note

- ▶ Pay attention to the numbering of the hydraulic lines, see chart.

- ▶ Establish the hydraulic connection from the assembly plate emergency operation 4 to the winch through adapter 6 or adapter 7, see illustration 4, illustration 5 and illustration 6.

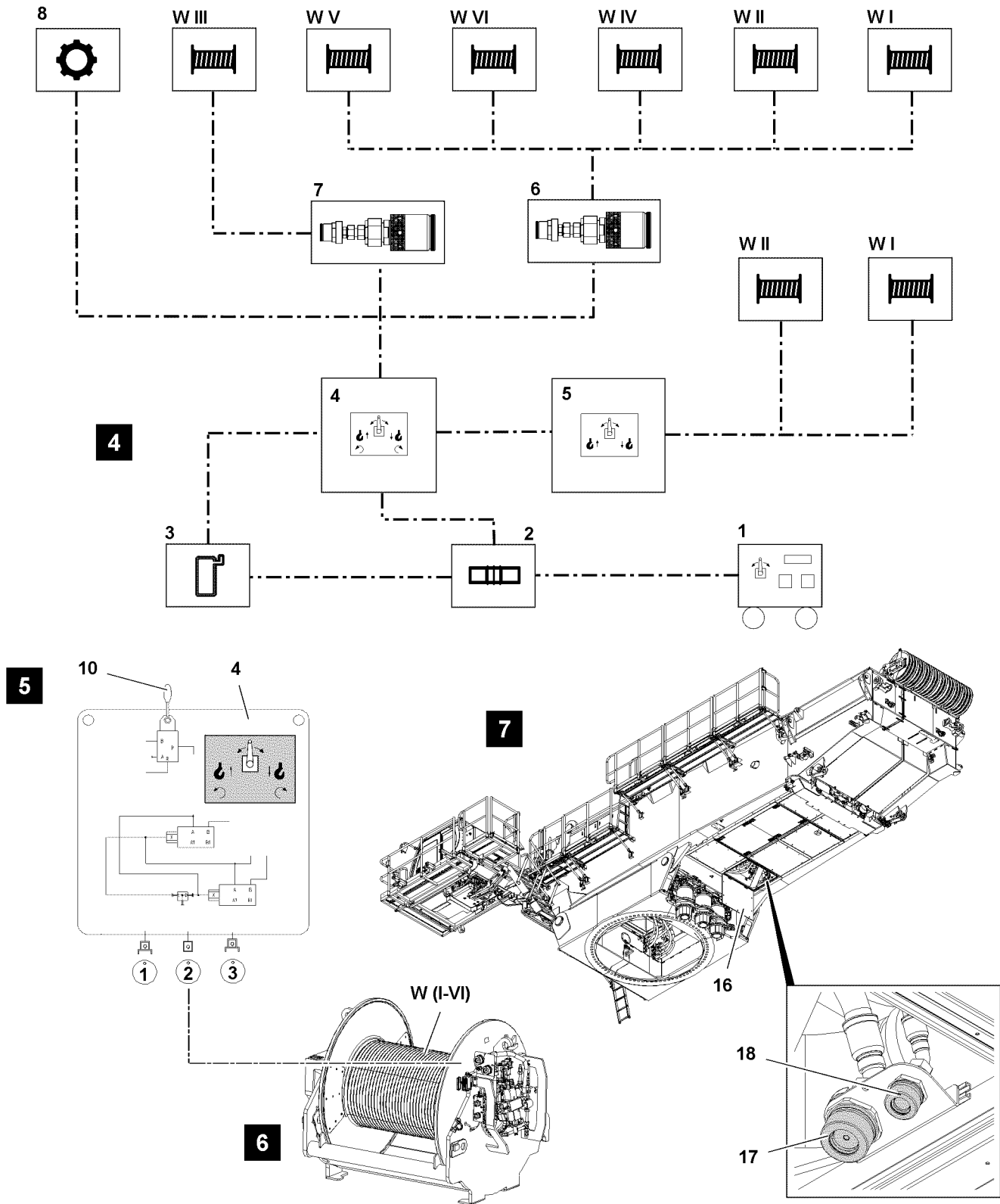

Fig.121034: Emergency control with assembly plate Variation 1 (V1)

LWE/LR 11000-001/23501-04-02/en

2.2 Starting the emergency operation aggregate



Note

- ▶ Start the emergency operation aggregate, see Operating instructions for emergency operation aggregate.
- ▶ The engine rpm on the emergency operation aggregate can be set via a separate speed regulation.

2.3 Emergency control winches

2.3.1 Function selection on the assembly plate emergency operation



Note

- ▶ The crane movements are actuated and the speed of the respective crane movement is determined via the ball valve **10**.

With the ball valve **10** on the assembly plate emergency operation **4** the following movements for the winches are preselected:

- Lift or lower

- ▶ Preselect crane movement: Set the ball valve **10** in the respective direction and carry out the respective crane movement carefully, see illustration **5**.

2.3.2 Spooling the winch out

- ▶ Spool the winch out: Set the ball valve **10** for the assembly plate emergency operation **4** in „lower“ direction.

Result:

- The winch spools out.

2.3.3 Spooling the winch up

- ▶ Spool the winch up: Set the ball valve **10** for the assembly plate emergency operation **4** in „lift“ direction.

Result:

- The winch spools up.

2.4 Disconnecting the hydraulic connections

Make sure that the following prerequisites are met:

- The emergency control is completed.
- The pressure in the hydraulic system has been relieved.
- ▶ Disconnect the hydraulic connections from the winch to the assembly plate emergency operation **4**.
- ▶ Disassemble adapter **6** or adapter **7**.
- ▶ Close off the hydraulic connections of the winch with dust caps.
- or**
- Reconnect the winch to the hydraulic system of the crane.

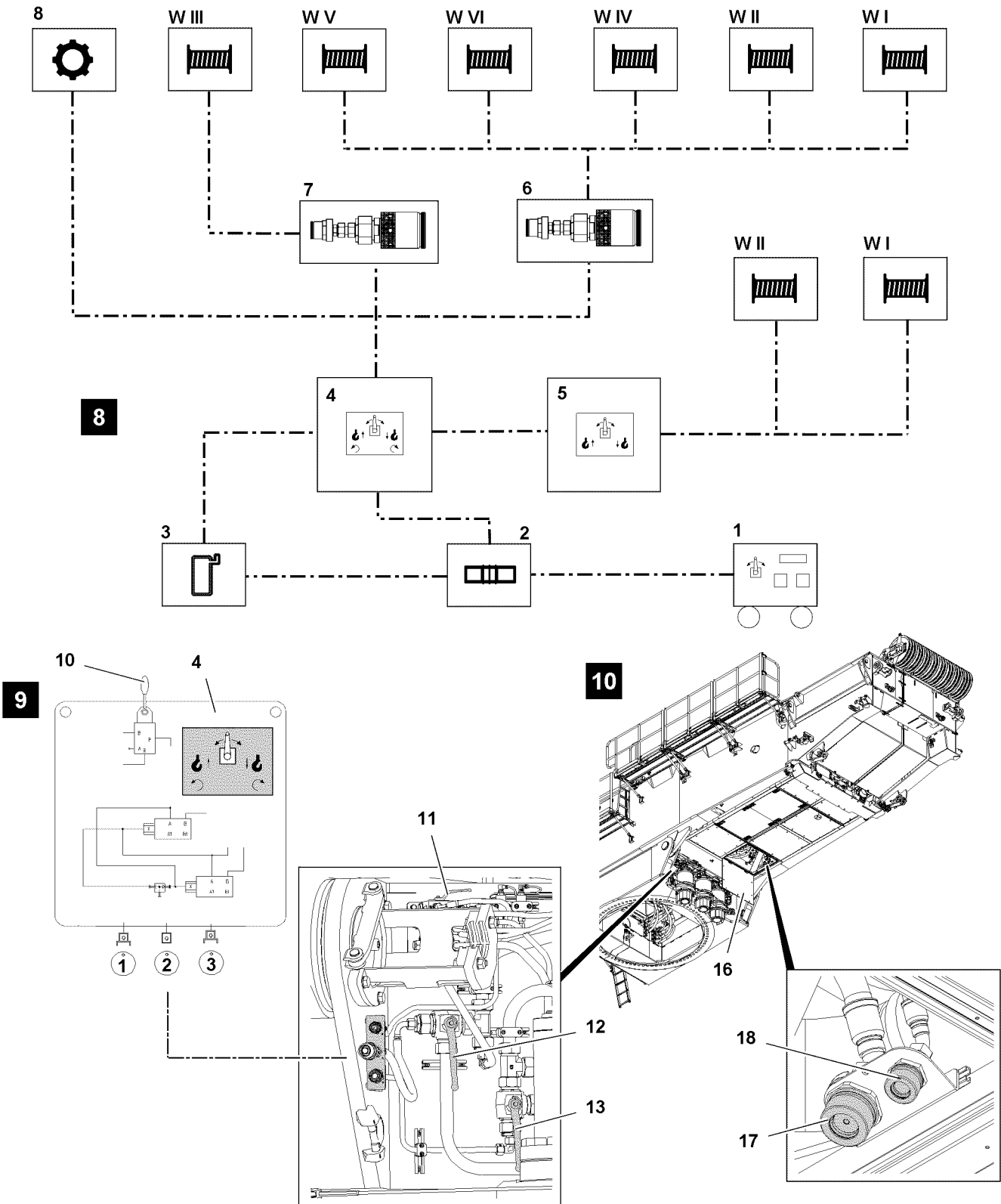

Fig.121035: Emergency control of slewing gear(s) with assembly plate Variation 1 (V1)

LWE/LR 11000-001/23501-04-02/en

3 Emergency control of slewing gear(s) with assembly plate Variation 1 (V1)



WARNING

Danger due to hydraulic pressure!

If the hydraulic lines are under pressure when releasing the connections, assembly personnel can be severely injured.

- ▶ Relieve the pressure in the hydraulic lines before releasing.



Note

- ▶ The crane movements are actuated and the speed of the respective crane movement is determined via the ball valve **10**.

With the ball valve **10** on the assembly plate emergency operation **4** the following movements are pre-selected:

- turn left
- turn right

3.1 Establishing the hydraulic connection to the slewing gears



WARNING

Danger due to hydraulic pressure!

If the hydraulic lines are under pressure when releasing the connections, assembly personnel can be severely injured.

- ▶ Relieve the pressure in the hydraulic lines before releasing.
- ▶ Make sure that the engine is turned off.

- ▶ Establish the hydraulic connections from the emergency operation aggregate* **1** to the transformer **2**, see illustration **8**.



WARNING

Cover swinging down!

The cover **16** can swing down by itself due to its own weight when releasing the connections, see illustration **10**.

Personnel can be injured.

- ▶ When releasing the connections, hold the cover **16**.

- ▶ Open the cover **16**, see illustration **10**.
- ▶ Establish the hydraulic connection from the hydraulic transformer **2** to the suction line **17** of the oil tank **3** on the turntable of the crane, see illustration **8** and illustration **10**.
- ▶ Establish the hydraulic connection from the turntable of the crane (oil tank **3**, return line **18**) to the Assembly plate emergency operation **4**, see illustration **8** and illustration **10**.
- ▶ Establish the hydraulic connection (pressure line) from the hydraulic transformer **2** to the assembly plate emergency operation **8**, see illustration **8**.



Note

- ▶ Pay attention to the numbering of the hydraulic lines.

- ▶ Establish the hydraulic connections for the Assembly plate emergency operation **4** to the slewing gear **8** on the turntable „ball valves for emergency control“, see illustration **8**, illustration **9** and illustration **10**.

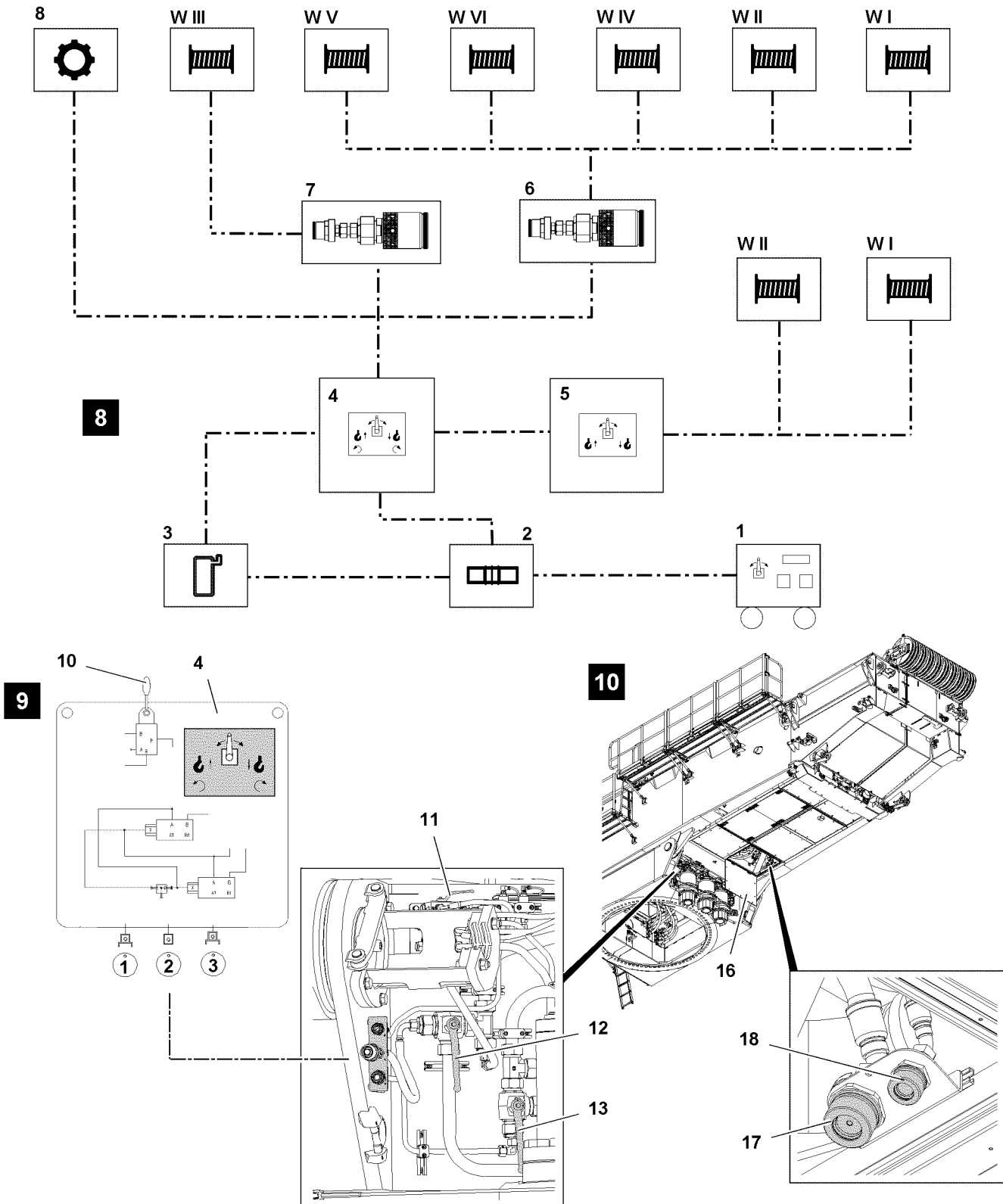

Fig.121035: Emergency control of slewing gear(s) with assembly plate Variation 1 (V1)

3.2 Turning the turntable to the left

- ▶ Set the ball valve 11 into emergency control position.
- ▶ Set the ball valve 12 into emergency control position.
- ▶ Set the ball valve 13 into emergency control position.

- ▶ Turn the turntable to the left: Carefully set the ball valve **10** for the assembly plate emergency operation **4** in „turn left“ direction, see illustration **9**.

Result:

- The turntable turns to the left.

3.3 Turning the turntable to the right

- ▶ Set the ball valve **11** into emergency control position.
- ▶ Set the ball valve **12** into emergency control position.
- ▶ Set the ball valve **13** into emergency control position.
- ▶ Turn the turntable to the right: Carefully set the ball valve **10** for the assembly plate emergency operation **4** in „turn right“ direction, see illustration **9**.

Result:

- The turntable turns to the right.

3.4 Disconnecting the hydraulic connections

Make sure that the following prerequisites are met:

- The emergency control is completed.
- The pressure in the hydraulic system has been relieved.

Disconnect the hydraulic connections to the assembly plate emergency operation **4**.

- ▶ Change the ball valve **11** in crane operation position.
- ▶ Change the ball valve **12** in crane operation position.
- ▶ Change the ball valve **13** in crane operation position.

When the ball valve **11**, ball valve **12** and ball valve **13** are changed to crane operation position:

- ▶ Disconnect the hydraulic connections from the slewing gear **8** on the turntable „ball valves for emergency control“ to the assembly plate emergency operation **4**.
- ▶ Close off the hydraulic connections with dust caps.

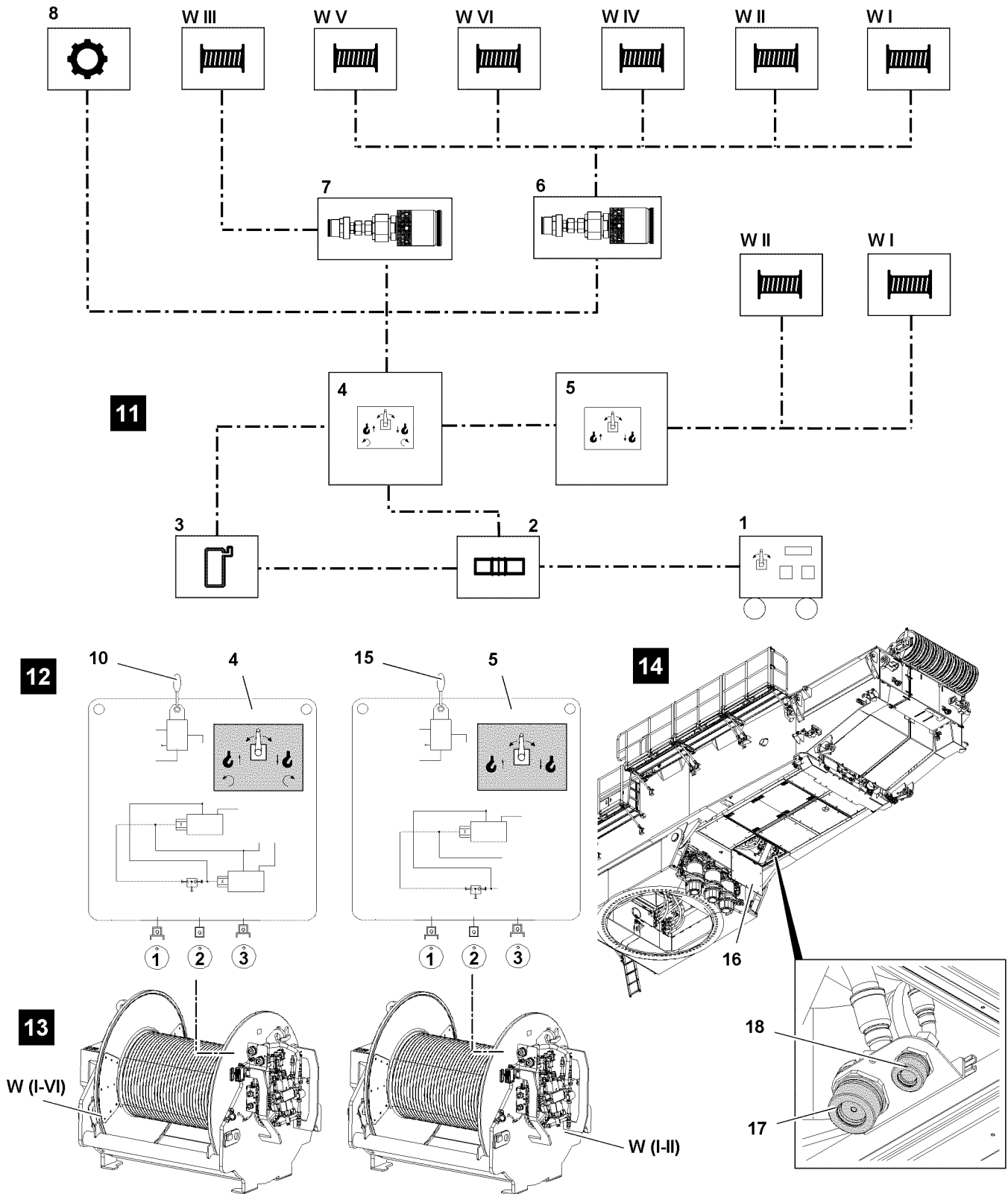

Fig.121036: Emergency control with assembly plate(s) Variation 2 (V2)

LWE/LR 11000-001/23501-04-02/en

4 Emergency control with assembly plate(s) Variation 2 (V2)



Note

- Carrying out emergency control is identical for all winches and is described on the example of one winch.

Numbering						
	Connections of assembly plate					
	Connection 1 „lift“		Connection 2 „lower“		Connection 3 „brake“	
Winch 1 WI	1¹⁾	1²⁾	2¹⁾	2²⁾	5¹⁾	5²⁾
Winch 2 WII	1¹⁾	1²⁾	2¹⁾	2²⁾	5¹⁾	5²⁾
Winch 3 WIII	1¹⁾	5²⁾	2¹⁾	6²⁾	5¹⁾	W3²⁾
Winch 4 WIV	1¹⁾	1²⁾	2¹⁾	2²⁾	5 or 6¹⁾	5/6²⁾
Winch 5 WV	1¹⁾	7²⁾	2¹⁾	6²⁾	5¹⁾	W5²⁾
Winch 6 WVI	1¹⁾	9²⁾	2¹⁾	8²⁾	5¹⁾	W6²⁾

Numbering of hydraulic connections

¹⁾ - Identification (numbering) on winches

²⁾ - Identification (numbering) on piping plan

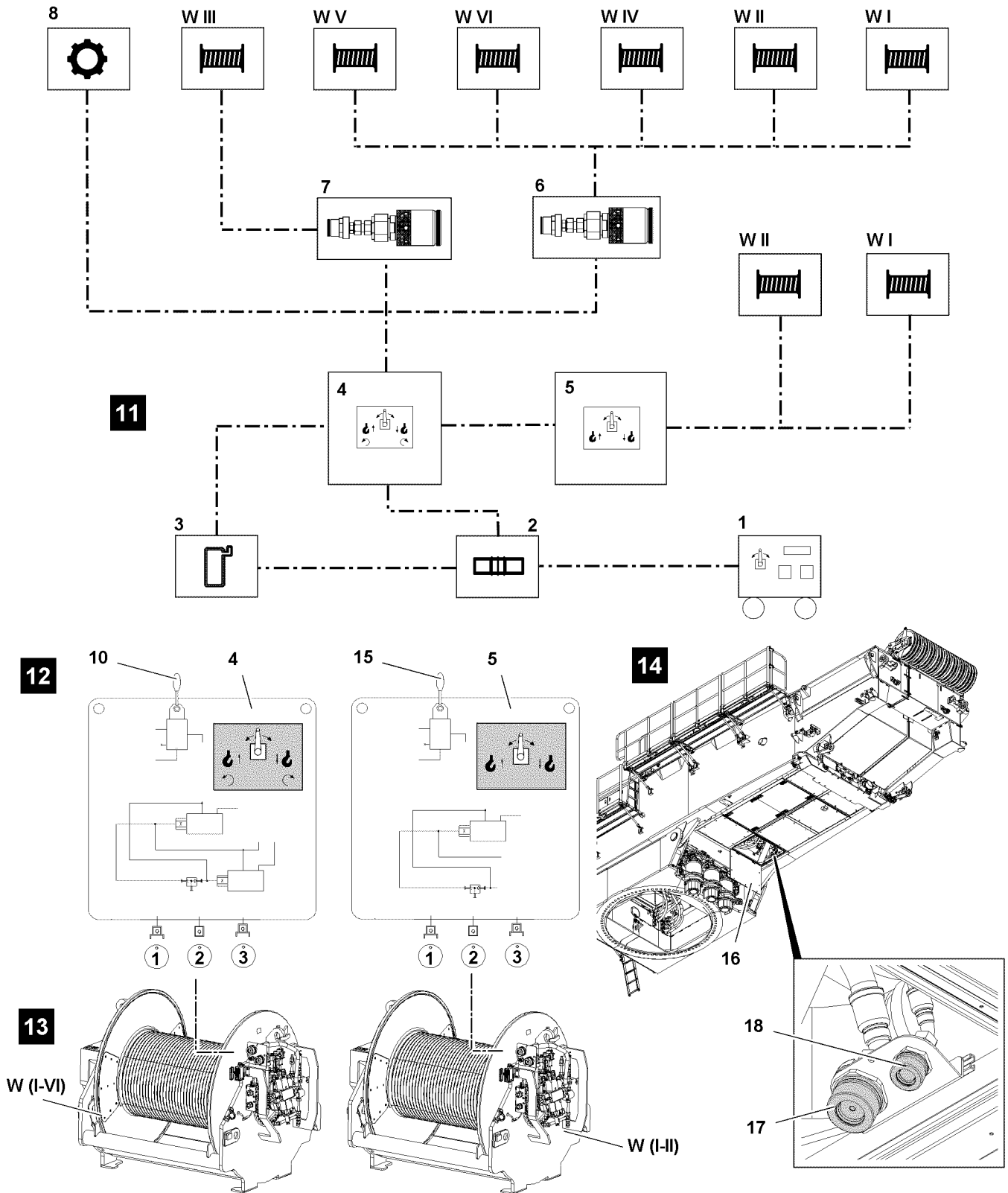

Fig.121036: Emergency control with assembly plate(s) Variation 2 (V2)

LWE/LR 11000-001/23501-04-02/en

4.1 Establishing the hydraulic connections



WARNING

Danger due to hydraulic pressure!

If the hydraulic lines are under pressure when releasing the connections, assembly personnel can be severely injured.

- ▶ Relieve the pressure in the hydraulic lines before releasing.
- ▶ Make sure that the engine is turned off.

- ▶ Establish the hydraulic connections from the emergency operation aggregate* 1 to the transformer 2, see illustration 11.



WARNING

Cover swinging down!

The cover 16 can swing down by itself due to its own weight when releasing the connections, see illustration 14.

Personnel can be injured.

- ▶ When releasing the connections, hold the cover 16.

- ▶ Open the cover 16, see illustration 14.
- ▶ Establish the hydraulic connection from the hydraulic transformer 2 to the suction line of the oil tank 3 on the turntable of the crane, see illustration 11 and illustration 14.
- ▶ Establish the hydraulic connection from the turntable of the crane (oil tank 3, return line) to the assembly plate emergency operation 4, see illustration 11 and illustration 14.
- ▶ Establish the hydraulic connection (pressure line) from the hydraulic transformer 2 to the assembly plate emergency operation 4, see illustration 11.
- ▶ Establish the hydraulic connection from the assembly plate emergency operation 4 to the assembly plate parallel operation 5, see illustration 11 and illustration 12.
- ▶ Release the hydraulic connections on the corresponding winch.



Note

- ▶ Pay attention to the numbering of the hydraulic lines, see chart.

- ▶ Establish the hydraulic connection from the assembly plate emergency operation 4 to the winch through adapter 6 or adapter 7, see illustration 11 and illustration 13.
- ▶ Establish the hydraulic connection from the assembly plate parallel operation 5 to the winch 1 WI, see illustration 11 and illustration 13.

or

Establish the hydraulic connection from the assembly plate parallel operation 5 to the winch 2 WII, see illustration 11 and illustration 13.

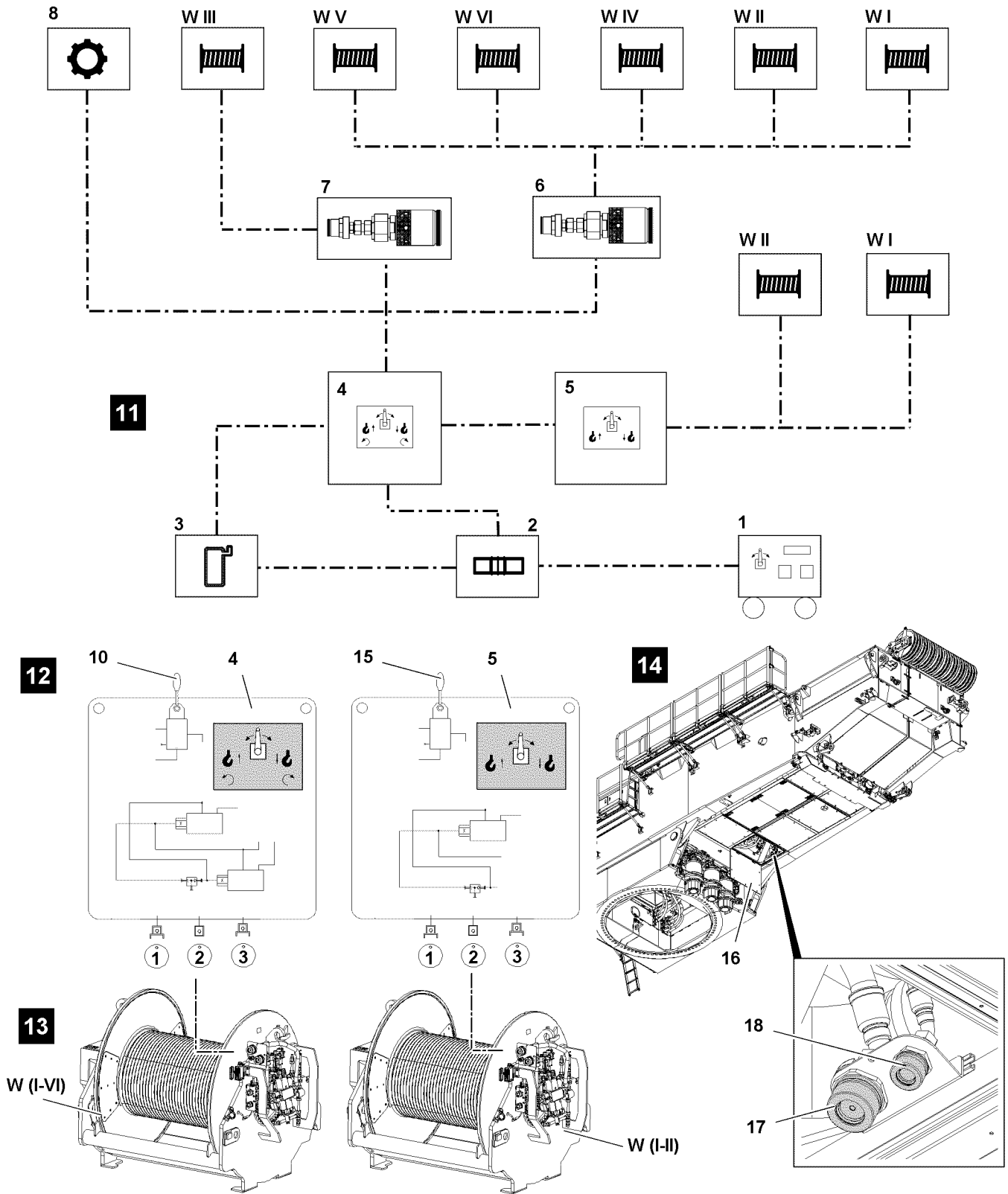

Fig.121036: Emergency control with assembly plate(s) Variation 2 (V2)

LWE/LR 11000-001/23501-04-02/en

4.2 Starting the emergency operation aggregate

**Note**

- ▶ Start the emergency operation aggregate, see Operating instructions for emergency operation aggregate.
- ▶ The engine rpm on the emergency operation aggregate can be set via a separate speed regulation.

4.3 Emergency control of winches, individual operation

**Note**

- ▶ The crane movements are actuated and the speed of the respective crane movement is determined via the ball valve **10** and ball valve **15**.

4.3.1 Function selection on the assembly plate emergency operation

With the ball valve **10** on the assembly plate emergency operation **4** the following movements for the winches are preselected:

- Lift or lower

- ▶ Preselect crane movement: Set the ball valve **10** in the respective direction and carry out the respective crane movement carefully.

4.3.2 Function selection on the assembly plate parallel operation

With the ball valve **15** on the assembly plate parallel operation **5** the following movements for winch 1 **WI** or winch 2 **WII** are preselected:

- Lift or lower

- ▶ Preselect crane movement: Set the ball valve **15** in the respective direction and carry out the respective crane movement carefully.

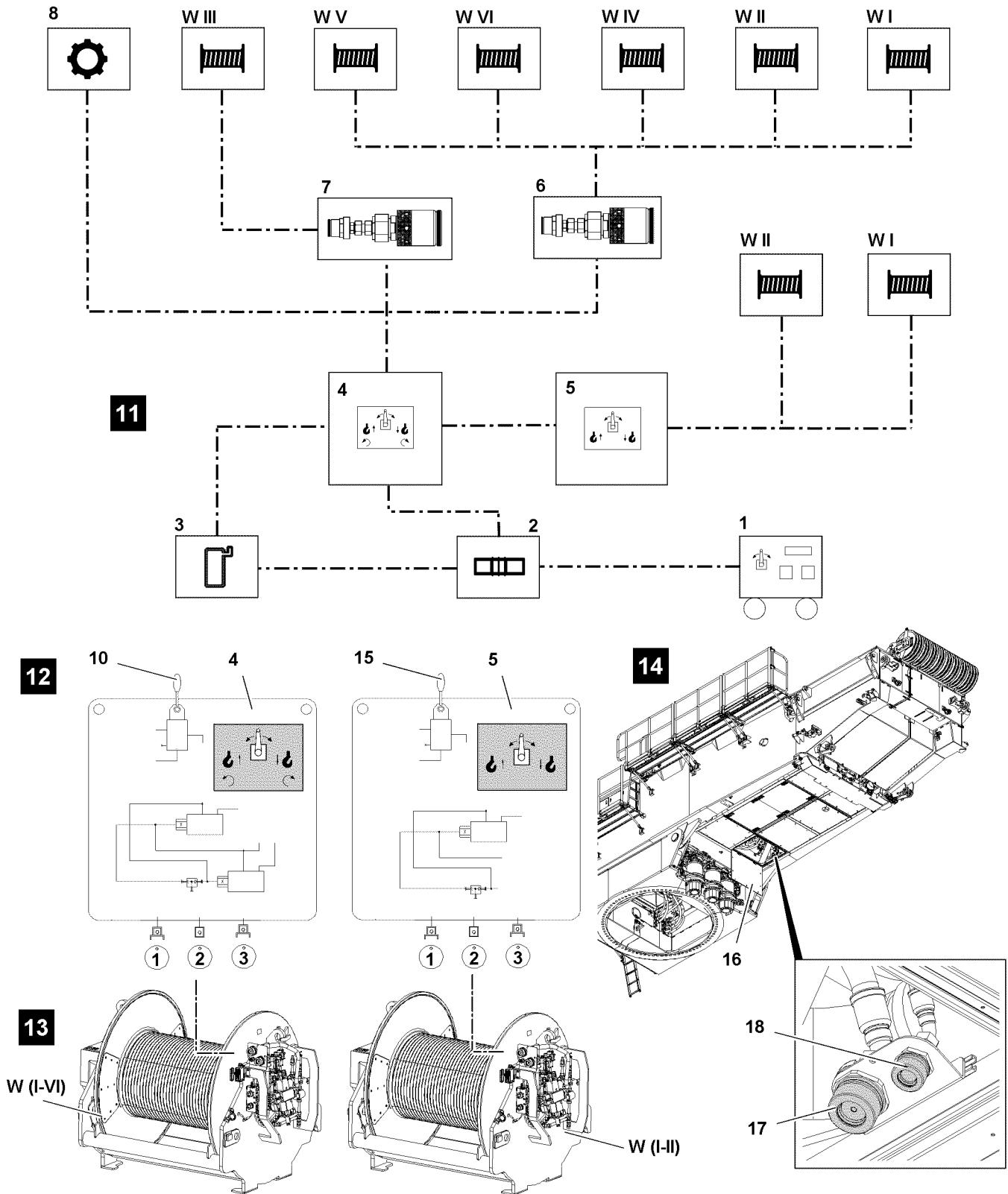

Fig.121036: Emergency control with assembly plate(s) Variation 2 (V2)

4.3.3 Spooling the winch out

- Spool the winch out: Set the ball valve **10** for the assembly plate emergency operation **4** in „lower“ direction.
or
Set the ball valve **15** on the assembly plate parallel operation **5** in „lower“ direction.

LWE/LR 11000-001/23501-04-02/en

Result:

- The winch spools out.

4.3.4 Spooling the winch up

- ▶ Spool the winch up: Set the ball valve **10** for the assembly plate emergency operation **4** in „lift“ direction.

or

Carefully set the ball valve **15** on the assembly plate parallel operation **5** in „lift“ direction.

Result:

- The winch spools up.

4.3.5 Disconnecting the hydraulic connections

Make sure that the following prerequisites are met:

- The emergency control is completed.
- The pressure in the hydraulic system has been relieved.
- ▶ Disconnect the hydraulic connections from the respective winch to the respective assembly plates.
- ▶ Close off the hydraulic connections of the winch with dust caps.

or

Reconnect the winch to the hydraulic system of the crane.

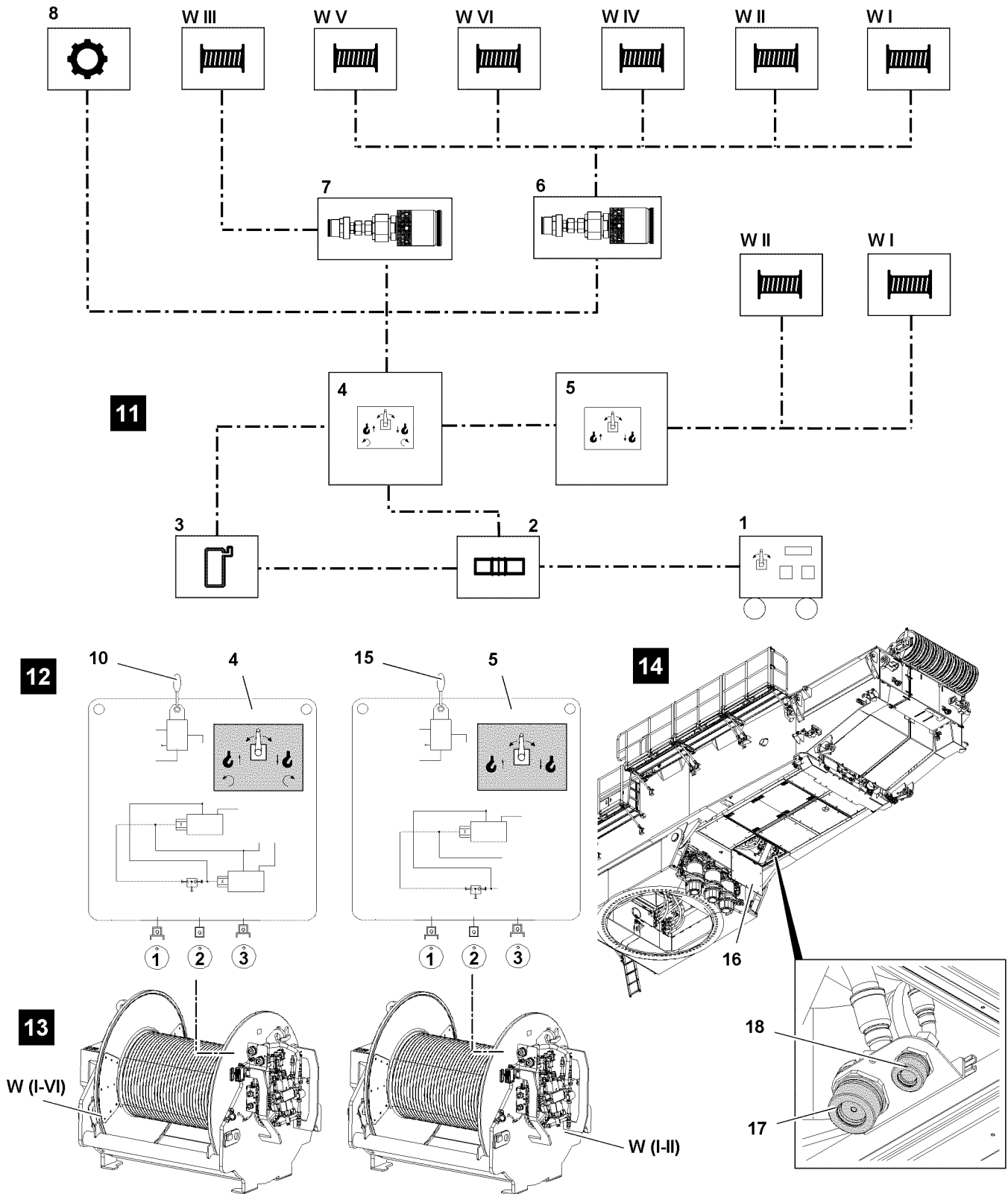

Fig.121036: Emergency control of winches, parallel operation winch 11I2

4.4 Emergency control of winches, parallel operation winch 11I2



Note

► The crane movements are actuated and the speed of the respective crane movement is determined via the ball valve 10 and ball valve 15.

LWE/LR 11000-001/23501-04-02/en

**WARNING**

Danger of accident!

If the following notes are not observed, dangerous situations can arise.

Personnel can be severely injured or killed.

- ▶ If winch 1 **WI** and winch 2 **WII** are actuated in emergency control in parallel operation, then it must be ensured that the hook blocks are horizontally aligned.
- ▶ Always actuate winch 1 **WI** and winch 2 **WII** simultaneously.

4.4.1 Establishing the hydraulic connections to the winches

Make sure that the following prerequisite is met:

- The pressure in the hydraulic system has been relieved.
- ▶ Release the hydraulic connections on winch 1 **WI** and winch 2 **WII**.

**Note**

- ▶ Pay attention to the numbering of the hydraulic lines.
- ▶ Establish the hydraulic connection from the assembly plate emergency operation **4** to winch 1 **WI** through adapter **6**.
or
Establish the hydraulic connections of assembly plate parallel operation **5** to winch 2 **WII**.
- ▶ Establish the hydraulic connections of the assembly plate emergency operation **4** to winch 2 **WII** through adapter **6**.
or
Establish the hydraulic connections of assembly plate parallel operation **5** to winch 1 **WI**.

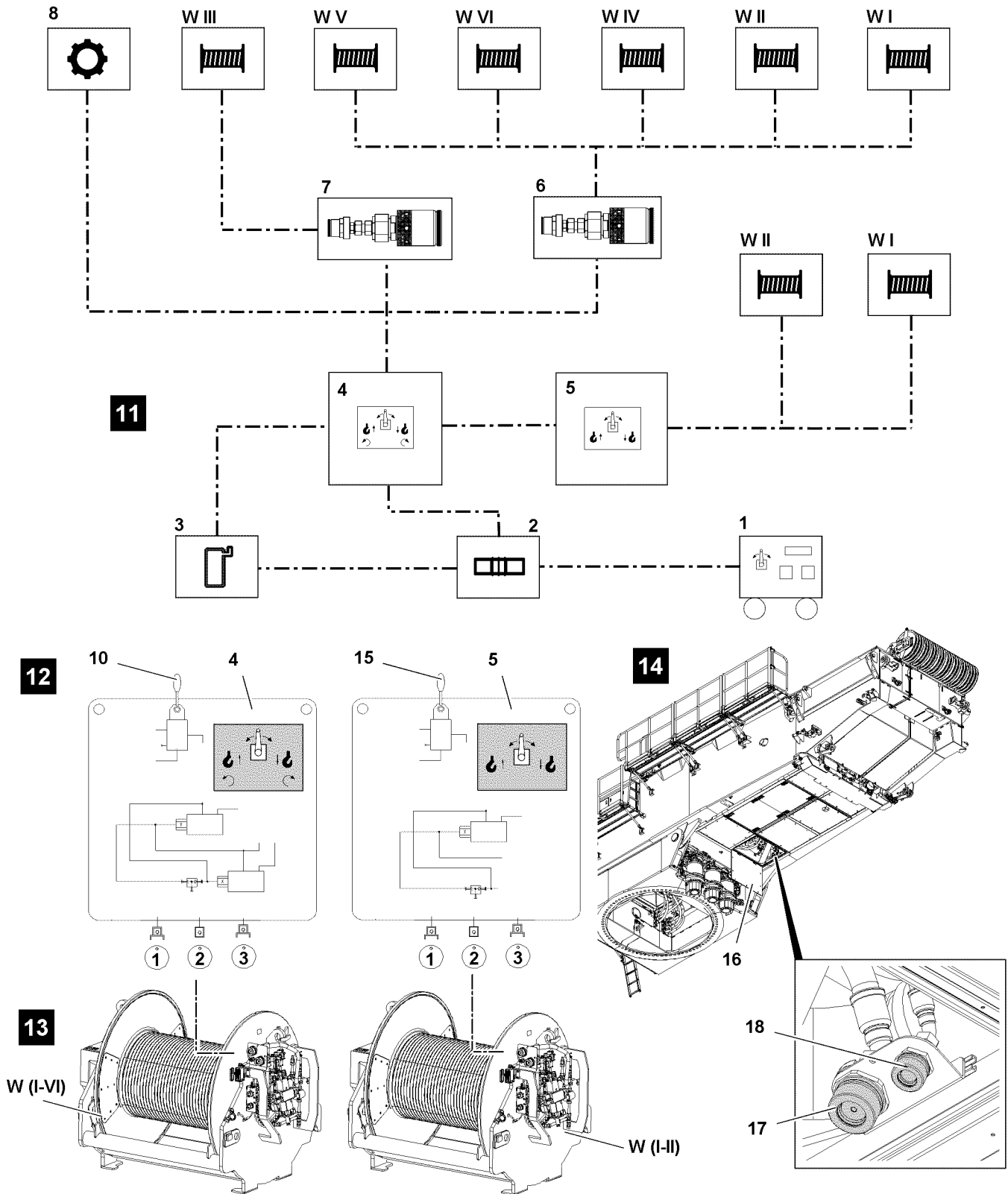

Fig.121036: Emergency control of winches, parallel operation winch 11I2

4.4.2 Spooling the winches out



Note

► Check which winch you have connected to which assembly plate.

LWE/LR 11000-001/23501-04-02/en

- ▶ Spool out winch 1 **WI** or winch 2 **WII**: Set the ball valve **10** for the assembly plate emergency operation **4** in „lower“ direction.
- or**
- Set the ball valve **15** on the assembly plate parallel operation **5** in „lower“ direction.

Result:

- Winch 1 **WI** or winch 2 **WII** spools out.

4.4.3 Spooling the winches up**Note**

- ▶ Check which winch you have connected to which assembly plate.

- ▶ Spool up winch 1 **WI** or winch 2 **WII**: Set the ball valve **10** for the assembly plate emergency operation **4** in „lift“ direction.
- or**
- Carefully set the ball valve **15** on the assembly plate parallel operation **5** in „lift“ direction.

Result:

- Winch 1 **WI** or winch 2 **WII** spools up.

4.4.4 Disconnecting the hydraulic connections

Make sure that the following prerequisites are met:

- The emergency control is completed.
- The pressure in the hydraulic system has been relieved.
- ▶ Disconnect the hydraulic connections of winch 1 **WI** and winch 2 **WII** to the respective assembly plates.
- ▶ Close off the hydraulic connections of the winch with dust caps.
- or**
- Reconnect the winch to the hydraulic system of the crane.

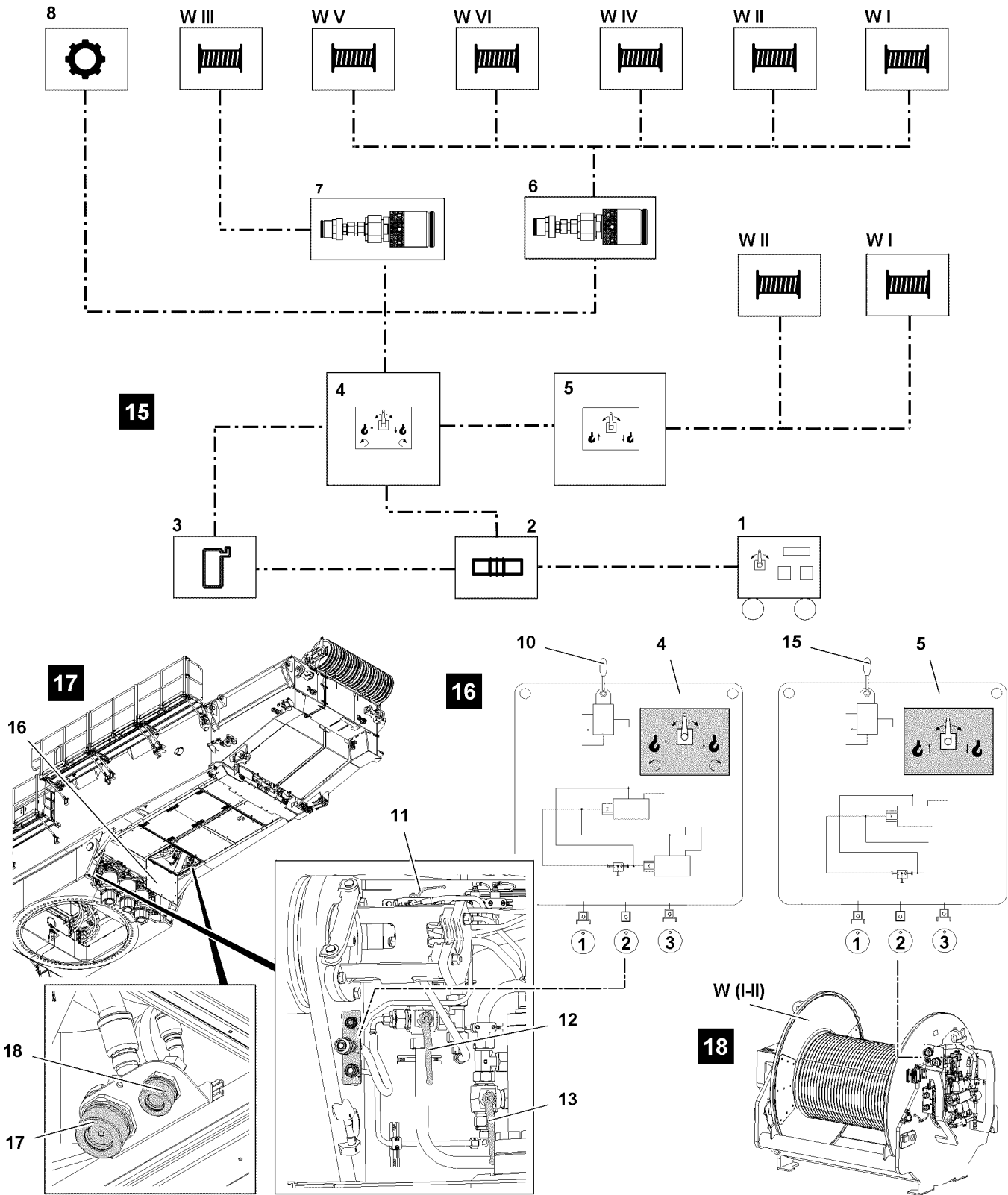

Fig.121037: Emergency control slewing gear(s) with assembly plate(s) Variation 2 (V2)

LWE/LR 11000-001/23501-04-02/en

5 Emergency control slewing gear(s) with assembly plate(s) Variation 2 (V2)



WARNING

Danger due to hydraulic pressure!

If the hydraulic lines are under pressure when releasing the connections, assembly personnel can be severely injured.

- ▶ Relieve the pressure in the hydraulic lines before releasing.



Note

- ▶ The slewing movement is actuated and the speed of the slewing movement is determined via the ball valve **10** on the assembly plate emergency operation **4**.



Note

- ▶ Pay attention to the numbering of the hydraulic lines.



Note

- ▶ „Emergency control slewing gear(s) with assembly plate(s) Variation 2 **VII**“ is identical with „Emergency control slewing gear(s) with assembly plate Variation 1 **VI**“ except that for Variation 2 **VII** the assembly plate parallel operation **5** is additionally connected.
- ▶ Connection of hydraulic lines and turning the turntable, see section „Emergency control slewing gear(s) with assembly plate Variation 1 **VI**“.

6 Completing emergency control

6.1 Procedure



Note

- ▶ Turn the emergency operation aggregate off, see Operating instructions for emergency operation aggregate.

- ▶ Turn the emergency operation aggregate* **1** off.
- ▶ Disconnect the hydraulic connections and close them off with dust caps.

Empty page!

LWE/LR 11000-001/23501-04-02/en

7 Service and maintenance

LWE/LR 11000-001/23501-04-02/en

LWE/LR 11000-001/23501-04-02/en

7.01 Maintenance and service - General

1	Technical safety instructions	3
2	Warranty and coverage	7
3	Liebherr Service	8
4	Taking an oil sample	8
5	Cleaning	9
6	Disposal	10

Fig.195219

LWE/LR 11000-001/23501-04-02/en

1 Technical safety instructions



WARNING

Maintenance instructions **not** adhered to!

Death, severe injury, increased wear and failure of components.

- ▶ Observe the following listed safety notes and the generally applicable safety rules!
- ▶ Adhere to the maintenance intervals.
- ▶ Carry out only applicable maintenance tasks.
- ▶ Repair and maintenance tasks are to be carried out carefully.
- ▶ For aggregates and components: Follow the operating instructions of the manufacturer.

1.1 Description of intervals and tasks



Note

- ▶ Fill quantities and descriptions of service items and lubricants are specified in the Service fill.

The maintenance intervals and scope of maintenance are described in several chapters.

For crane maintenance, observe the following chapters:

- Crane operating instructions, chapter 7.02: Maintenance intervals - Crane chassis ¹⁾
- Crane operating instructions, chapter 7.02.50: Maintenance intervals Ballast trailer*¹⁾
- Crane operating instructions, chapter 7.03: Maintenance intervals - Crane superstructure ¹⁾
- Crane operating instructions, chapter 7.03.50: Maintenance intervals - Crane boom ¹⁾
- Crane operating instructions, chapter 7.04: Maintenance instructions - Crane chassis ²⁾
- Crane operating instructions, chapter 7.04.50: Ballast trailer maintenance instructions ²⁾
- Crane operating instructions, chapter 7.05: Maintenance instructions - Crane superstructure ²⁾
- Crane operating instructions, chapter 7.05.50: Crane boom maintenance instructions ²⁾
- Crane operating instructions, chapter 7.06: Fill quantities, lubrication chart
- Crane operating instructions, chapter 7.07: Operating fluids and lubricants

¹⁾ These chapters contain a list of maintenance intervals for all maintenance tasks.

²⁾ For aggregates, observe and adhere to additionally to the instructions of the manufacturer.

1.2 Definition of „Checking“

The action of „Checking“ includes all required task in connection with the maintenance, for example:

- Determining a specified value
- Cleaning
- Adjusting
- Refilling
- Replacing

1.3 Maintenance intervals

Use the following rules for interval determination:

- Carry out maintenance and inspection tasks on the crane chassis after reaching the specified driven mileage, operating hours or calendar intervals. The interval which occurs first is the deciding factor.
- Carry out maintenance and inspection tasks on the crane superstructure after reaching the specified operating hours or calendar intervals. The interval which occurs first is the deciding factor.
- The maintenance intervals complement each other. If a higher interval is coming up, then carry out the tasks according to the lower interval also.

1.4 Securing against operation



WARNING

Impermissible travel or crane operation during maintenance or repair tasks!
Death, severe injury, severe property damage.

- ▶ Make sure that travel and crane operation is not possible during maintenance and repair tasks.
- ▶ Show clearly with signs that maintenance or repair tasks are being carried out on the mobile crane.
- ▶ Use signs which show without a doubt that it is prohibited to drive and operate the crane.
- ▶ Adhere to the national regulations regarding tagging on mobile crane and signs.
- ▶ Turn the engine on the crane superstructure and the crane chassis off!
- ▶ Apply the „parking brake crane chassis“.

If possible:

- ▶ Lock the driver's cab and the crane cab.
- ▶ Hand the ignition key from the crane superstructure and the crane chassis to an authorized person.

1.5 Personnel



WARNING

Unauthorized and untrained expert personnel!

Improper maintenance, personal injury, property damage.

- ▶ Observe and follow the personnel requirements for the respective maintenance task.

If there are no personnel requirements:

- ▶ The crane operator can perform the maintenance task.
- ▶ Have the repair tasks performed exclusively by authorized and trained expert personnel.
- ▶ Make sure that only authorized persons are within the danger zone.

Maintenance tasks may only be carried out by expert, authorized and trained employees.

An expert is someone who possesses the required expert knowledge for performing a certain task. Requirements regarding the technical qualification depends on the type of task.

Requirements regarding the technical qualification of a person:

- Corresponding professional training.
- Professional experience or a currently performed corresponding professional activity.
- Participation in training to keep the expert knowledge up to date.

1.6 Securing against falls



WARNING

Personnel is **not** secured against falls!

During maintenance tasks on the crane superstructure or boom, personnel must be secured with appropriate safety measures to prevent them from falling. If this is **not** observed, working personnel can fall and be killed or severely injured.

- ▶ For all tasks on the crane where there is a danger of falling, take suitable safety measures.
- ▶ The crane superstructure or the boom may **not** be accessed without suitable aids.
- ▶ Suitable aids are, for example: Lifting platforms, scaffoldings, ladders, assembly platforms, auxiliary crane.
- ▶ If railings are present on the crane superstructure, then they must be swung into operating position and secured for all tasks. See the Crane operating instructions, chapter 2.06.
- ▶ Only step on such aids with clean shoes.
- ▶ Keep aids clean, free of snow and ice.
- ▶ If tasks cannot be carried out using these aids or from the ground, then the maintenance personnel must be protected from falling using approved fall arrest systems. See the Crane operating instructions, chapter 2.04.
- ▶ It is prohibited to step on the driver's cab or cab roof and specially marked surfaces. See the Crane operating instructions, chapter 2.05.

**WARNING**

Dirty slip-resistant mats!

Fall

- ▶ Keep slip-resistant mats clean and free of snow and ice!
- ▶ Only step on slip-resistant mats with clean shoes!
- ▶ Replace or renew missing or damaged slip-resistant mats!

1.7 Preventing fires

**WARNING**

Excess fuel, excess oil in engine compartment during operation!

Death, severe injury, fire damage.

- ▶ Check the diesel engine after repairs and Service tasks but also in regular intervals for leaking oil and fuel.
- ▶ Make sure that the V-area of the Diesel engine is free of oil and fuel.
- ▶ Do **not** spill any service fluids over the hot components.

**WARNING**

Disregard of general safety regulations during tasks on the fuel system or on the electrical system!

Severe burns, fire damage.

- ▶ Disconnect the battery from the power supply.
- ▶ Do **not** smoke.
- ▶ Do **not** work near open flames.
- ▶ Keep a functioning fire extinguisher ready.

**WARNING**

Sound insulation mats are contaminated with fuel, engine oil, gear oil, hydraulic oil or solvents!

The sound insulation mats can ignite. Severe burns, fire damage.

- ▶ Remove any polluted sound insulation mats **immediately** and **replace immediately** with **Original Liebherr spare parts**.
- ▶ Do **not** replace the sound insulation mats near the starter.

1.8 Protecting from burns

**WARNING**

Hot surfaces!

Severe burns.

- ▶ Let any components to be maintained or inspected cool off.
- ▶ Let hot components cool off.
- ▶ Avoid contact with hands and skin.
- ▶ Wear personal protective equipment and suitable protective gloves.

**WARNING**

Hot Service fluids!

Severe burns.

- ▶ Let hot service fluids cool off.
- ▶ Avoid contact with hands, skin and eyes.
- ▶ Wear safety glasses.
- ▶ Wear personal protective equipment and suitable protective gloves.

**WARNING**

Electric short circuit!

Severe burns.

- ▶ Prevent short circuits in the electrical system, especially on the battery.
- ▶ Replace or change missing or defective protective insulation.

1.9 Protecting from scalding

**WARNING**

Cooling system is pressurized!

When the coolant reservoir is opened, hot coolant can escape explosively.
Severe scalding.

When the engine is warm:

- ▶ Do **not** open the cover of the coolant reservoir.
- ▶ To protect face, hands and arms from hot steam of hot coolant, cover the cap with a large rag when opening.

1.10 Rotating parts

**WARNING**

Rotating parts, ignition system on running engine!

The cooler fan can turn on suddenly.

Death, severe injury.

- ▶ Proceed especially careful.
- ▶ Do **not** reach into rotating parts.
- ▶ Never reach into the cooler fan when the engine is warm.

1.11 Protecting from aggressive environmental conditions

NOTICE

Aggressive environmental conditions!

When using cranes under aggressive environmental conditions, for example at places with maritime climates and particularly salty air, hydraulic cylinders can corrode and thereby be destroyed or severely damaged.

Elaborate and expensive repairs.

If the crane is taken out of operation for an extended period of time:

- ▶ Take down the crane.
- ▶ Fully retract all crane hydraulic cylinders.

When hydraulic cylinders can **not** be retracted completely:

- ▶ Protect exposed areas of the piston rod from corrosion, for example with grease.
- ▶ Grease any exposed areas on the piston rods, for example on luffing cylinders and ballasting cylinders, especially carefully.

1.12 Use of suitable operating fluids

**WARNING**

Operating fluids **not** suitable for ambient temperature!

Death, severe injuries, property damage.

- ▶ Adjust the operating fluids in time to the ambient temperatures.

1.13 Replacing damaged crane components



WARNING

Damaged crane components **not** replaced!
Death, severe injury, failure of components.

- ▶ Maintain crane components according to the data in the maintenance intervals, the maintenance guidelines and the chart for service items and lubricants.
- ▶ Replace damaged crane components immediately.

1.14 After replacement of components

Type of oil, see data tag and supplied „Service fill“.

The following instructions must be observed when replacing components such as engine, gear or axle:



WARNING

Maintenance of a replaced component **not** carried out!

- ▶ Before start up, be sure to refill with the correct type of oil to the center of the minimum / maximum mark.
- ▶ Carry out first maintenance. See chapter „Maintenance intervals“.
- ▶ Adhere to regular maintenance intervals.
- ▶ Follow the break-in instructions. See the Crane operating instructions, chapter 2.02.

1.15 Tire size

When changing certain tire sizes, the mobile crane must be modified.

Contact Liebherr customer service to change the following tire sizes:

- From 385/95 R 25 to 445/95 R 25
- From 385/95 R 25 to 525/80 R 25
- From 445/95 R 25 to 385/95 R 25
- From 525/80 R 25 to 385/95 R 25

2 Warranty and coverage

NOTICE

Maintenance intervals and maintenance guidelines **not** adhered to, impermissible lubricants used!
Damage, failure of crane components.

The warranty for the respective crane component is voided.

- ▶ Maintain crane components according to the data in the maintenance intervals, the maintenance guidelines and the chart for service items and lubricants.

NOTICE

Not using Original Liebherr spare parts and **not** using Original Liebherr Service items!

In the event that replacement parts are used that are **not** Original Liebherr replacement parts and **not** Original Liebherr service items and lubricants, Liebherr-Werk Echingen GmbH disclaims all liability for system functionality as well as for the parts.

- ▶ Use exclusively Original Liebherr spare parts.



Note

- ▶ Original Liebherr replacement parts have been tested for crane operation and may be used without risking safety.

The buyer is entitled to warranty or coverage only:

- when exclusively Original Liebherr spare parts are used.

- when Liebherr Service items and Liebherr lubricants are used for the Liebherr crane.

3 Liebherr Service

Liebherr mobile cranes, whether truck-mounted, mobile or crawler cranes - are technically advanced products, which prove their worth daily even under tough conditions.

The high technical standards of these cranes provide functional security, resistance to failure and ease of maintenance.

Liebherr is continuously developing the drive and control components. The combination of well proven units and modern manufacturing methods produces cranes that are safe to operate and easy to maintain.

Several hundred cranes are built every year for the international market, supported by international service.

Liebherr's „After Sales Service“ plays an important role at Liebherr in ensuring operational readiness and high crane availability.

With Liebherr, Service begins when the crane is handed over. Your crane operators will be professionally trained in line with their level of knowledge and we devote much time to this.

We also train your workshop staff in all crane-specific matters, because we know that they can deal with more than just minor repairs themselves. Often there are specialists who can quickly and reliably carry out crane repairs.

We have special service advisers available who will solve any problems you may have. This phone contact saves time and money. You should take advantage of it as soon as possible.

Our service technicians are specialists with years of experience, who can be deployed from local support points. Naturally these experts have specialized knowledge and special tools.

But before you call these specialists, it is worth making use of the facilities for getting advice mentioned above.

4 Taking an oil sample



Note

- ▶ Liebherr recommends taking oil samples for the gears, engines and hydraulic system in regular intervals.
- ▶ Based on the trend analysis of the oil analysis results, changes can be determined in the lubricity of the oil and increased component wear.



WARNING

Tasks on components and operating fluids at operating temperature!
Burns.

- ▶ Carry out all tasks with utmost caution.
- ▶ Wear protective clothing.

Make sure that the following prerequisites are met:

- Oil has a normal operating temperature
- ▶ Always take oil in the same location.
- ▶ Take oil always according to the same method.
- ▶ Do **not** take oil right after an oil change.
- ▶ Do **not** take oil immediately after larger amounts of oil have been added.

**Note**

Recommendation:

- ▶ Fill oil into original laboratory sample containers.
- ▶ Fill oil exclusively in a clean and dry sample container.

5 Cleaning

5.1 Exhaust system

NOTICE

Ingress of water, steam or cleaning substances into the SCR-module!

Sensors for exhaust aftertreatment can be destroyed, the coating of the SCR catalytic converter can be washed off.

- ▶ Before cleaning, let the SCR system cool off (surface temperature 50 °C).
- ▶ Before cleaning, cover all openings.
- ▶ Make sure that **no** fluids and **no** dirt gets into the tailpipe opening of the SCR module.
- ▶ During cleaning, keep sufficient distance to the tailpipe opening.

5.2 Sound insulation mats

NOTICE

Improper cleaning (tools or cleaning methods)!

Sound insulation mats can be destroyed or damaged.

- ▶ Remove severe contamination with suitable tools, for example with soft plastic scrapers.
- ▶ Do **not** use tools with sharp edges.
- ▶ Use steam cleaners **exclusively** with extreme caution and with a sufficient distance to the sound insulation mats and with low water pressure.
- ▶ Do **not** use solvents for cleaning.

5.3 Slip-resistant mats

- ▶ Before every access: Check the slip-resistant mats for slip resistance and cleanliness.
- ▶ If dirty: Clean the slip-resistant mats with a brush with hard plastic bristles.
- ▶ For cleaning the surfaces, use commercially available cleaners.
- ▶ Flush with water.

5.4 Driver's cab and crane cab

**Note**

- ▶ The steering wheel, center console, instrument panel cover, floor covering and dirty upholstery in the driver's cab and the crane cab should only be cleaned with warm water mixed with dishwashing detergent!
- ▶ Do not use any scouring agents!

5.5 Ladders

- ▶ Remove any dirt on the ladders.
- ▶ Make sure that the grooves on the rungs are free of dirt.

6 Disposal

6.1 Operating fluids and lubricants



WARNING

Operating items and lubricants are dangerous waste products!

- ▶ Dispose of operating fluids and lubricants separately.
- ▶ Service items and lubricants may **not** be disposed of in the ground, bodies of waters, wastewater systems, sewers or in the groundwater.
- ▶ Dispose of operating items and lubricants in an environmentally safe manner.
- ▶ When disposing operating items and lubricants observe and follow the valid regulations of the relevant authorities.

Service items and lubricants are:

- Fuels
- Coolant
- Urea
- Engine oils, gear oils
- Hydraulic fluids
- Brake fluids
- Window washer concentrate
- Greases

6.2 Batteries



WARNING

Batteries contain harmful substances!

- ▶ Do **not** dispose of batteries in regular household trash.
- ▶ Collect batteries separately and send them for environmentally safe disposal.
- ▶ Leave batteries at a qualified workshop or at a collection points for used batteries.

7.02 Maintenance intervals Crawler chassis

1 Maintenance and inspection schedule

3

Fig.195219

LWE/LR 11000-001/23501-04-02/en

1 Maintenance and inspection schedule



Note

- ▶ Carry out maintenance work after reaching the specified operating hours or calendar intervals. The interval which occurs first is the deciding factor.
- ▶ The maintenance intervals complement each other. If a higher interval is coming up, then carry out the work according to the lower interval also.
- ▶ The operating hour meter of the crawler travel gear is the determining factor for the operator hour intervals.
- ▶ The „crawler travel gear“ operating hour meter* is located in the control cabinet.

First maintenance after	Operating hour intervals			Calendar intervals			Work to be carried out	O.K.
	10 h	100 h	1000 h	Daily	Weekly	Annually		
Safety systems								
						X	Personal protective equipment Follow the instructions of the manufacturer	□
						X	Height rescue system Follow the instructions of the manufacturer	
Fall protection equipment								
						X	Check protection points	□
						X	Check safety ropes	
						X	Check the ladders for technically immaculate condition	
						X	Check railings, steps and pedestals for safe function	
						X	Check catwalks and open mesh flooring for safe function	
Crane surface								
					X		Check accessible surfaces for cleanliness	□
						X	Check accessible surfaces for completeness and slip resistance	
						X	Check labels for completeness and legibility	
Rigging and fastening points								
				X ²⁾			Check condition and mounting	□
						X	Check for continued suitability by expert	

LWE/LR 11000-001/23501-04-02/en

First maintenance after	Operating hour intervals			Calendar intervals			Work to be carried out	O.K.
	10 h	100 h	1000 h	Daily	Weekly	Annually		
Travel gear								□
		X					Check for leaks	
	X						Grease the sprocket bearing if it is not lubricated via the central lubrication system	
		X					Check the mounting screws for tight seating	
		500 h					Check the gear oil via oil analysis	
200 h			1000 h			Every 4 years	Changing the gear oil	
Crawler carrier								□
		X					Check track rollers, carrier rollers with oil lubrication for leaks	
	X						Grease the track rollers, carrier rollers if it is not lubricated via the central lubrication system	
	X				Every 4 weeks		Check the wear on the roll off surfaces of the track rollers / carrier rollers, replace the track rollers / carrier rollers if necessary	
	X				Every 4 weeks		Check for wear on the glide rails	
						X	Grease guide rails on sliding section	
						X	Lubricate the consoles	
					Every 4 weeks		Lubricate the connector pins between crawler carrier and crawler center section or crawler carrier and cross carriers	

First maintenance after	Operating hour intervals			Calendar intervals			Work to be carried out	O.K.
	10 h	100 h	1000 h	Daily	Weekly	Annually		
Crawler chain								<input type="checkbox"/>
		X					Check the connector pin retainer	
		X					Check for damage	
	X				Every 4 weeks		Check the chain tension, retension the track chain if necessary	
	X						Check the wear on the bores of the track pads, replace track pads if necessary	
	X						Check the wear on the connector pins of the track pads, replace pins if necessary	
	X				Every 4 weeks		Check the wear on the roll off surfaces of the track pads / track rollers, replace track pads if necessary	
					Every 4 weeks		Check the wear on the sprocket wheels and the transport cams of the track pads	
Assembly support								<input type="checkbox"/>
					X		Check the hydraulic cylinder for leaks	
						X	Check support beam for ease of movement, grease	
						X	Lubricate the bearing points of the support beams	
						X	Check sight gauge, adjust if necessary	
Crane support								<input type="checkbox"/>
					X		Check the hydraulic cylinder for leaks	
						X	Check support beams for ease of movement, grease	
						X	Lubricate the struts	
						X	Lubricate the mounting pins on the struts	
						X	Lubricate the support pad bearing	
Concrete ballast plates / concrete catwalks (central ballast) (only LR1500)								
				X			Check for damage	
						X ⁴⁾	Have an authorized inspector check that the fastening points are fit tightly and for continued suitability	

LWE/LR 11000-001/23501-04-02/en

First maintenance after	Operating hour intervals			Calendar intervals			Work to be carried out	O.K.
	10 h	100 h	1000 h	Daily	Weekly	Annually		
Pin connections								
						Every 2 months ³⁾	Check the retainer of the pin connections	□
						Every 2 months ³⁾	Check the pins and / or connector elements for damage, visual inspection	
						Every 2 months ³⁾	Check the retaining elements for damage, visual inspection	
Rotary connection								
			X				Lubricate	□
Hydraulic cylinder								
					X		Check for leaks	□
Hydraulic hose lines								
				X			Check for leaks and damage	□
						X	Have safe working condition checked by expert	
Central lubrication system								
					Every 6 months ¹⁾		Carry out intermediate lubrication (with central lubrication system with control unit).	□
		X					Check for correct function	
				X			Check the lubricant level	

¹⁾ if the crane is not moved: every 3 months

²⁾ before every start up: checking visually

³⁾ for cranes used for a long period of time

⁴⁾ and at each assembly / disassembly

7.02.50 Maintenance intervals ballast trailer

1 Maintenance and inspection schedule

3

Fig.195219

LWE/LR 11000-001/23501-04-02/en

1 Maintenance and inspection schedule



Note

- ▶ Carry out maintenance work after reaching the specified operating hours or calendar intervals. The interval which occurs first is the deciding factor!
- ▶ The maintenance intervals complement each other. If a higher interval is coming up, then carry out the work according to the lower interval also!

First maintenance after	Operating hour intervals			Calendar intervals			Work to be carried out	O.K.
	10 h	100 h	1000 h	Daily	Weekly	Annually		
Fall protection equipment								
						X	Check protection points	
						X	Check safety ropes	
						X	Check the ladders for technically immaculate condition	
						X	Check railings, steps and pedestals for safe function	
						X	Check catwalks and open mesh flooring for safe function	
Ballast trailer surface								
					X		Check accessible surfaces for cleanliness	
						X	Check accessible surfaces for completeness and slip resistance	
						X	Check labels for completeness and legibility	
Rigging and fastening points								
				X ²⁾			Check condition and mounting	
						X	Check for continued suitability by an authorized inspector, inspection expert	
Tires								
					X		Check for external damage and distortion	
					X		Check the tire pressure	
	X						Check lug nuts for tight seating, retighten if necessary	
						Every 5 years	Replace tires; have further service life confirmed by a tire manufacturer expert	
Axle link								
						X	Lubricate	
Hydraulic cylinder								
					X		Check for leaks	

First maintenance after	Operating hour intervals			Calendar intervals			Work to be carried out	O.K.
	10 h	100 h	1000 h	Daily	Weekly	Annually		
Hydraulic hose lines								
				X			Check for leaks and damage	
						X	Check for a safe condition by an authorized inspector, inspection expert	
Travel drive								
						X	Check the mounting screws for tight seating	
					X		Check for leaks	
						X	Checking the oil level	
						Every 5 years	Change the gear oil if necessary	
Slewing gear								
						X	Check the mounting screws for tight seating	
					X		Check for leaks	
						X	Checking the oil level	
						Every 5 years	Change the gear oil if necessary	
Central lubrication system								
				X			Check grease supply of central lubrication system. Fill the reservoir if the grease supply has dropped below 1/4 of the reservoir content.	
						X	Check for correct function	
Pin connections								
						Every 2 months ³⁾	Check the retainer of the pin connections	
						Every 2 months ³⁾	Check the pins and / or connector elements for damage, visual inspection	
						Every 2 months ³⁾	Check the retaining elements for damage, visual inspection	
Emergency control								
						X	Check for correct function	

²⁾ before every start-up: Checking visually

³⁾ for cranes used for a long period of time

7.03 Maintenance intervals - Crane superstructure

1 Maintenance and inspection schedule

3

LWE/LR 11000-001/23501-04-02/en

Fig.195219

LWE/LR 11000-001/23501-04-02/en

1 Maintenance and inspection schedule



Note

- ▶ Carry out maintenance work after reaching the specified operating hours or calendar intervals. The interval which occurs first is the deciding factor!
- ▶ The maintenance intervals complement each other. If a higher interval is coming up, then carry out the work according to the lower interval also!

First maintenance after	Operating hour intervals			Calendar intervals			Work to be carried out	O.K.
	250 h	500 h	1000 h	Daily	Weekly	Annually		
Safety systems								
						X	Personal protective equipment Follow the instructions of the manufacturer	□
						X	Height rescue system Follow the instructions of the manufacturer	
Fall protection equipment								
						X	Check protection points	□
						X	Check safety ropes	
						X	Check the ladders for technically immaculate condition	
						X	Check railings, steps and pedestals for safe function	
						X	Check catwalks and open mesh flooring for safe function	
Crane surface								
					X		Check accessible surfaces for cleanliness	□
						X	Check accessible surfaces for completeness and slip resistance	
						X	Check labels for completeness and legibility	
Rigging and fastening points								
				X ²⁾			Check condition and mounting	□
						X	Check for continued suitability by an authorized inspector, inspection expert	
Load handling equipment and assembly aids								
				X ²⁾			Check for cracks, damage, wear and distortion	□
						X	Check for continued suitability by an authorized inspector, inspection expert	

LWE/LR 11000-001/23501-04-02/en

First maintenance after	Operating hour intervals			Calendar intervals			Work to be carried out	O.K.
	250 h	500 h	1000 h	Daily	Weekly	Annually		
Fastening equipment and load securing devices								<input type="checkbox"/>
				X ²⁾			Observe and adhere to the manufacturer's instructions	
Fire extinguishing system								<input type="checkbox"/>
						X	Carry out a visual inspection of the system For all other maintenance tasks, observe the instructions of the fire extinguisher manufacturer.	
						Every 5 years	Replace trigger elements and extinguisher tank.	
Diesel engine								<input type="checkbox"/>
				X			Check the oil level For all other maintenance tasks, observe the instructions of the engine manufacturer	
Cooling system								<input type="checkbox"/>
				X			Check the coolant level in the expansion tank	
			6000 h			Every 4 years	Replace the coolant if filled with Liebherr Antifreeze OS Mix	
			3000 h			Every 2 years	Replacing the coolant	
SCR Exhaust aftertreatment								<input type="checkbox"/>
			4500 h			Every 2 years	Replace foam and filter element of urea pump	
Engine independent heater (auxiliary heater)								<input type="checkbox"/>
				X			Check the fluid level in the expansion tank	
						Every 4 weeks ⁸⁾	Operate and check the function for 10 minutes with the engine cold and the highest fan stage	
						X ⁹⁾	Operate and burn-free for 15 minutes with the engine cold and the highest fan stage	
						X	Carry out maintenance work before and after every heating period	
						Every 2 years	Replace the fluid for the heating system	
				X			Check the fill level of the fuel container	

First maintenance after	Operating hour intervals			Calendar intervals			Work to be carried out	O.K.
	250 h	500 h	1000 h	Daily	Weekly	Annually		
Air filter								
					X		Check monitoring device	□
						X	Clean, change the filter insert Observe the instructions of the engine manufacturer	
Slewing ring connection								
	X						Lubricate the gears	□
						X ¹⁾	Lubricating the slewing ring connection	
					Every 6 months ¹⁾		Drain water on the water drain bores of the slewing ring connection (only LTM 11200-9.1, LTR 11200)	
250 h			1500 h			X	Check the mounting screws for tight seating	
						X	Checking the tilt play	
Winches								
250 h			X			X	Check the mounting screws for tight seating	□
				X			Check for leaks	
					X ⁶⁾		Check the oil level	
250 h			3000 h			Every 4 years	Replacing the gear oil	
			1500 h ⁴⁾			X ⁴⁾	Lubricate the space between V-ring / winch bearing (only for winches with a winch bearing that is lubricated with a grease fitting)	
			200 h			X	Check the condition of the tooth flanks; determining factor are the operating hours of the winch (only for winches with gear ring drive)	
						X	Check the remaining theoretical service life by an authorized inspector	
						Every 4 years	Check the remaining theoretical utilization life by an inspection expert	
Winch brakes								
				X			Check for leaks	□
						X	Check for correct function	

LWE/LR 11000-001/23501-04-02/en

First maintenance after	Operating hour intervals			Calendar intervals			Work to be carried out	O.K.
	250 h	500 h	1000 h	Daily	Weekly	Annually		
Relapse supports								
					Every 3 months ^{5), 6)}		Lubricating the bearings	□
X ^{2), 6)}							Check the oscillation guard for easy movement	
Relapse cylinder								
X ^{2), 6)}					X		Check for leaks	□
					Every 3 months ^{5), 6)}		Lubricating the bearings	
X ^{2), 6)}		X				X	Check pretension pressure (nitrogen)	
X ^{2), 6)}		X				X	Check the oil quantity	
Pneumatic springs								
X ^{2), 5), 6)}		X				X	Check for correct function	□
A-frame								
		X					Lubricate the bearing	□
X ^{2), 6)}						X	Check the lever for the limit switch on the A-frame 3 for easy movement and reset of spring	
X ^{2), 6)}						X	Check the rods with guide rail on the A-frame 2 and A-frame 3 for easy movement and distortion	
Counterweight								
1000 km		or 10,000 km				X	Check tightening torque of mounting screws	□
Concrete ballast plates (ballast container) (only LR 13000)								
				X			Check for damage	□
						Every 5 years	Check by licensing agency	
Ballasting								
	X					X	Lubricating the bearings	□
						X	Check the swing play (only LTM 11200-9.1)	
						X	Check the braid ropes (only LTM 11200-9.1)	
Press on pulleys of rope winches								
	X					X	Grease guides	□

First maintenance after	Operating hour intervals			Calendar intervals			Work to be carried out	O.K.
	250 h	500 h	1000 h	Daily	Weekly	Annually		
Rope pulleys								
					X ^{5), 6)}		Check groove base for cleanliness	□
			X			X	Check for wear, damage, cracks and easy movement	
			3000 h			Every 3 years	Lubricate the bearings	
Carrier rollers								
				X ²⁾			Check for damage and distortion	□
			X			X	Check for wear, damage and easy movement	
			X			X	Check the mounting screws for tight seating	
Crane cab								
				X			Check instruments for function	□
				X			Check indicator lights for function	
						X	Replace the filter insert for switch cabinet ventilation	
						X	Replace filter insert in water heater	
				X			Check fluid level in expansion tank of engine regulation	
		X				X	Check the sliding or incline device for function	
		X				X	Lubricate the bearings of the sliding or incline device	
		X				X ⁷⁾	Check the lift device (telescope arm) for function	
		X				X ⁷⁾	Lubricate the bearings of the lift device and telescope arm	
Window washing bays, camera washing bays								
				X			Check the fluid level in the reservoir for the washing bays	□
Overload protection								
				X			Check for correct function	□
		X				X	Check length sensor for function	
		X				X	Check length sensor rope for damage	
Remote diagnostics device								
						X	Check for correct function	□
						X	Check the validity of the SIM card	

LWE/LR 11000-001/23501-04-02/en

First maintenance after	Operating hour intervals			Calendar intervals			Work to be carried out	O.K.
	250 h	500 h	1000 h	Daily	Weekly	Annually		
Electrical system								
						X	Cable connections	□
					Every 6 months ³⁾		Service the batteries	
					Every 6 months ³⁾		Empty the acid container	
						X ⁵⁾	Replace the interior compartment filter of the switch cabinet ventilation	
Fuel system								
				X			Check for leaks	□
						X	Check condition and mounting	
						X	Drain off water and sediments	
						X	Clean preliminary filter for auxiliary fuel pump	
	Every 50 h						Check fuel preliminary filter, drain off water if necessary	
		Every 1000 h					Replace preliminary fuel filter	
Slewing gear								
250 h			X			X	Check the mounting screws for tight seating	□
				X			Check for leaks	
					X		Check the oil level	
250 h			3000 h			Every 4 years	Replacing the gear oil	
Slewing gear brakes								
				X			Check for leaks	□
						X	Check for correct function	
Turntable lock								
		X				X	Grease	□
		X				X	Check for correct function	
Bearings								
						X	Checking the retaining elements	□

First maintenance after	Operating hour intervals			Calendar intervals			Work to be carried out	O.K.
	250 h	500 h	1000 h	Daily	Weekly	Annually		
Pin connections								
						Every 2 months ¹⁰⁾	Check the retainer of the pin connections	<input type="checkbox"/>
						Every 2 months ¹⁰⁾	Check the pins and / or connector elements for damage, visual inspection	
						Every 2 months ¹⁰⁾	Check the retaining elements for damage, visual inspection	
Pump distributor gear								
				X			Check for leaks	<input type="checkbox"/>
					X		Check the oil level	
500 h			1500 h			X	Replacing the gear oil	
Hydraulic hose lines								
				X			Check for leaks and damage	<input type="checkbox"/>
						X	Check for a safe condition by an authorized inspector, inspection expert	
Hydraulic system								
				X			Check the oil level	<input type="checkbox"/>
					X		Check for leaks	
250 h		X				X	Replace the servo pressure and replenishing pressure filter inserts	
250 h		X				X	Replace return filter inserts (only for cranes with open hydraulic circuit)	
250 h		X				X	Replace bleeder filter of hydraulic tank	
500 h			X			X	Check hydraulic oil, required degree of purity: 20/18/15 Take oil sample and have it tested by oil supplier	
Hydraulic cylinder								
					X		Check for leaks	<input type="checkbox"/>
					Every 3 months ^{5), 6)}		Lubricating the bearings	
Hydraulic pressure accumulator (nitrogen)								
		X ⁴⁾				X ⁴⁾	Check pretension pressures	<input type="checkbox"/>
Hydraulic coupling system LIKUFIX								
				X ^{2) 6)}			Check for leaks, dirt and lubricate the guides	<input type="checkbox"/>

LWE/LR 11000-001/23501-04-02/en

First maintenance after	Operating hour intervals			Calendar intervals			Work to be carried out	O.K.
	250 h	500 h	1000 h	Daily	Weekly	Annually		
Compressed air system								<input type="checkbox"/>
					X		Check for leaks	
					X		Check operating pressure	
					X		Check shut off pressure	
					X		Check operation of automatic drain valve	
						X	Replace air dryer granular cartridges	
						X	Clean air dryer preliminary filter	
Central lubrication system								<input type="checkbox"/>
					Every 6 months ¹⁾		Carrying out an intermediate lubrication	
		X					Check for correct function	
					X		Check the grease container fill level	
Emergency control								<input type="checkbox"/>
						X	Check for correct function	
Suspended ballast								<input type="checkbox"/>
						X	Check the fall protection equipment	
						X	Check frame, suspension and guide section for distortion and cracks	

- ¹⁾ if the crane is not moved: every 3 months
²⁾ before every start up: checking visually
³⁾ in hot climate zones: every 3 months
⁴⁾ observe maintenance instructions - crane superstructure, chapter 7.05
⁵⁾ and as necessary
⁶⁾ and during assembly
⁷⁾ in Great Britain: every 6 months
⁸⁾ outside of the heating period
⁹⁾ during the heating period
¹⁰⁾ for cranes used for a long period of time

7.03.50 Maintenance intervals - Crane boom

1 Maintenance and inspection schedule

3

LWE/LR 11000-001/23501-04-02/en

Fig.195219

LWE/LR 11000-001/23501-04-02/en

1 Maintenance and inspection schedule



Note

- ▶ Carry out maintenance work after reaching the specified operating hours or calendar intervals. The interval which occurs first is the deciding factor!
- ▶ The maintenance intervals complement each other. If a higher interval is coming up, then carry out the work according to the lower interval also!

First maintenance after	Operating hour intervals			Calendar intervals			Work to be carried out	O.K.
	250 h	500 h	1000 h	Daily	Weekly	Annually		
Safety systems								
						X	Personal protective equipment Follow the instructions of the manufacturer	□
						X	Height rescue system Follow the instructions of the manufacturer	
Fall protection equipment								
						X	Check protection points	□
						X	Check safety ropes	
						X	Check the ladders for technically immaculate condition	
						X	Check railings, steps and pedestals for safe function	
						X	Check catwalks and open mesh flooring for safe function	
Surface of crane boom								
					X		Check accessible surfaces for cleanliness	□
						X	Check accessible surfaces for completeness and slip resistance	
						X	Check labels for completeness and legibility	
Rigging and fastening points								
				X ²⁾			Check condition and mounting	□
						X	Check for continued suitability by an authorized inspector, inspection expert	
Load handling equipment and assembly aids								
				X ²⁾			Check for cracks, damage, wear and distortion	□
						X	Check for continued suitability by an authorized inspector, inspection expert	

LWE/LR 11000-001/23501-04-02/en

First maintenance after	Operating hour intervals			Calendar intervals			Work to be carried out	O.K.
	250 h	500 h	1000 h	Daily	Weekly	Annually		
Fastening equipment and load securing devices								<input type="checkbox"/>
				X ²⁾			Observe and adhere to the manufacturer's instructions	
Lattice sections								<input type="checkbox"/>
						X	Check cracks, damage and distortion	
						X	Check protection points	
						X	Check safety ropes	
						X	Check railings and pedestals for safe function	
						X	Check catwalks and open mesh flooring for safe function	
X ⁶⁾						X	Grease the lube points of lattice sections	
Guy rods								<input type="checkbox"/>
						X	Check for cracks, damage and distortion by an authorized person	
						Every 4 years	Check cracks, damage and distortion by an authorized inspector	
						X	Checking the retaining elements	
						X	Check labels for completeness and legibility	
X ⁶⁾						X	Grease the lube points of guy rods	
Fiber guy ropes								<input type="checkbox"/>
					Every 3 months ⁷⁾		Check braid and intermediate layers for damage and distortion	
					Every 3 months ⁷⁾		Check rope end connections for cracks, damage and distortion	
					Every 3 months ⁷⁾		Check rope grommet transitions for damage and distortion	
Relapse supports								<input type="checkbox"/>
					Every 3 months ^{5), 6)}		Lubricating the bearings	
X ^{2), 6)}							Check the oscillation guard for easy movement	

First maintenance after	Operating hour intervals			Calendar intervals			Work to be carried out	O.K.
	250 h	500 h	1000 h	Daily	Weekly	Annually		
Relapse cylinder								<input type="checkbox"/>
X ^{2), 6)}					X		Check for leaks	
					Every 3 months ^{5), 6)}		Lubricating the bearings	
X ^{2), 6)}		X				X	Check pretension pressure (nitrogen)	
X ^{2), 6)}		X				X	Check the oil quantity	
Hydraulic hose lines								<input type="checkbox"/>
				X			Check for leaks and damage	
						X	Check for a safe condition by an authorized inspector, inspection expert	
Hydraulic cylinder								<input type="checkbox"/>
					X		Check for leaks	
					Every 3 months ^{5), 6)}		Lubricating the bearings	
Hydraulic pressure accumulator (nitrogen)								<input type="checkbox"/>
		X ⁴⁾				X ⁴⁾	Check pretension pressures	
Rope pulleys								<input type="checkbox"/>
					X ^{5), 6)}		Check groove base for cleanliness	
			X			X	Check for wear, damage, cracks and easy movement	
			3000 h			Every 3 years	Lubricate the bearings	
Carrier rollers								<input type="checkbox"/>
				X ²⁾			Check for damage and distortion	
			X			X	Check for wear, damage and easy movement	
			X			X	Check the mounting screws for tight seating	
Auxiliary guying								<input type="checkbox"/>
						X ⁶⁾	Check the rope connection between the guy point and the lattice section	
						X ⁶⁾	Check cracks, damage and distortion	

LWE/LR 11000-001/23501-04-02/en

First maintenance after	Operating hour intervals			Calendar intervals			Work to be carried out	O.K.
	250 h	500 h	1000 h	Daily	Weekly	Annually		
Pin connections								
						Every 2 months ⁸⁾	Check the retainer of the pin connections	□
						Every 2 months ⁸⁾	Check the pins and / or connector elements for damage, visual inspection	
						Every 2 months ⁸⁾	Check the retaining elements for damage, visual inspection	
Crane ropes								
				X			Check for damage and distortion	□
					Monthly ⁵⁾		Check, grease by expert personnel	
						X	Check by an authorized inspector	
						Every 4 years	Check by an inspection expert	
Hook blocks								
			X			X	Check rope pulleys for distortion, wear, damage and cracks	□
			3000 h			Every 3 years	Lubricate rope pulley bearings	
	100 h				Every 3 months ⁵⁾		Lubricate pressure bearings	
	100 h				Every 3 months ⁵⁾		Lubricate radial bushing	
	100 h				Every 3 months ⁵⁾		Lubricate suspension of hook beam	
					Every 6 months ⁵⁾		Replace batteries on incline sensor	
						X	Check distance dimension (y)	
						X	Check for distortion, wear, damage and cracks by an authorized person	
						Every 4 years	Check for distortion, wear, damage and cracks by an inspection expert	

²⁾ before every start-up: Checking visually

⁴⁾ observe maintenance instructions - crane superstructure, chapter 7.05

⁵⁾ and as necessary

⁶⁾ and during assembly

LWELR 11000-001/23501-04-02/en

- 7) by authorized and trained expert personnel with boom placed down and before every erection procedure
- 8) for cranes used for a long period of time

Empty page!

LWE/LR 11000-001/23501-04-02/en

7.04 Maintenance guidelines - Crane chassis

1	Travel gear	3
2	Central lubrication system	7
3	Servicing the track chain	16
4	Ladders	27

Fig.195219

LWE/LR 11000-001/23501-04-02/en

1 Travel gear

NOTICE

Dirt inside the gear!
Transmission damage.

- ▶ Maintain extreme cleanliness during all tasks.
 - ▶ Make sure that **no** dirt gets into the inside of the gear.
-



Note

- ▶ The planetary gear and the miter gear have separate, different sized oil chambers: Check the oil levels of the gear independent of each other.
 - ▶ Control bores for checking the oil level on the planetary gear and on the miter gear can differ in design.
 - ▶ On the planetary gear is **no** separate fill bore. Fill gear oil on the control bore.
-

The travel gear consists of the following components:

- Planetary gear
- Miter gear with brake

1.1 Checking for leaks

NOTICE

Gear damage due to leaky gear!

- ▶ Check the travel gear for leaks according to the maintenance schedule.
-

- ▶ Check the travel gear for leaks: Perform a visual inspection.

When the travel gear leaks:

- ▶ Have the travel gear sealed by authorized and trained expert personnel.

1.2 Planetary gear

1.2.1 Checking the oil level

NOTICE

Transmission damage due to lack of oil!

- ▶ Check the oil level and add gear oil if necessary.
-

Make sure that the following prerequisite is met:

- Authorized and trained expert personnel checks the oil level.
- The crane is in horizontal position.
- The travel gear has been at a standstill for two minutes before checking the oil: The gear oil has drained back completely.

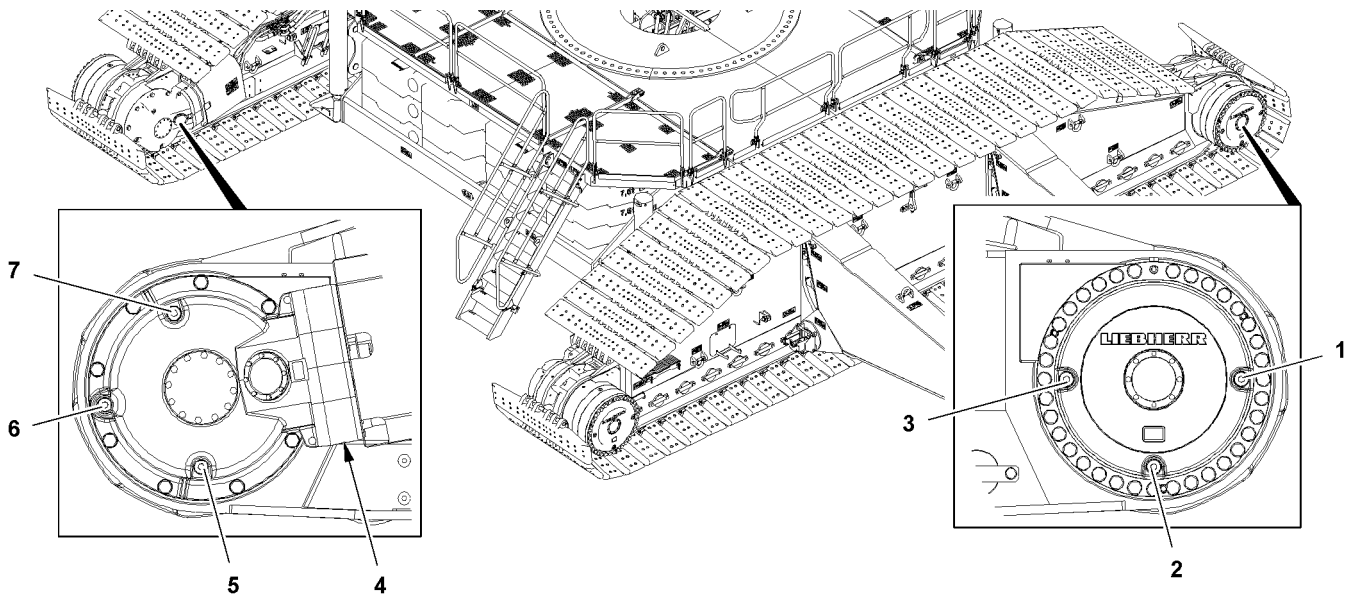

Fig.120158

- ▶ Unscrew the control plug 1 or control plug 3.

The oil level must be on the lower edge of the control bore.

- ▶ Perform a visual inspection.
- ▶ Screw in the control plug with new seal and tighten.

Problem remedy

When opening the control plug, oil emerges?

Depending on the position of the gears in the planetary gear, the oil level can be higher than the control bore.

- ▶ Replace any emerged gear oil in the same amount.

Problem remedy

The oil level is **not** on the lower edge of the control bore?

- ▶ Unscrew the second control plug.
- ▶ Add gear oil on one control bore until gear oil starts to run over on the second control bore.
- ▶ Install the control plugs with a new seal and tighten.

Problem remedy

Oil consumption or loss of oil too high?

- ▶ Find the cause and remedy it.

If the cause cannot be remedied:

- ▶ Contact Liebherr Service.
-

1.2.2 Replacing the gear oil

Make sure that the following prerequisite is met:

- Authorized and trained expert personnel checks the oil level.
- The crane is in horizontal position.
- The travel gear is at operating temperature.
- Container for the used oil is on hand.

To be able to hold the entire old oil, the container must be sufficiently sized.

For fill quantity of miter gear, see Service fill.

**WARNING**

Components and gear oil at operating temperature!
Burns.

- ▶ Avoid direct body contact with travel gears and gear oil.

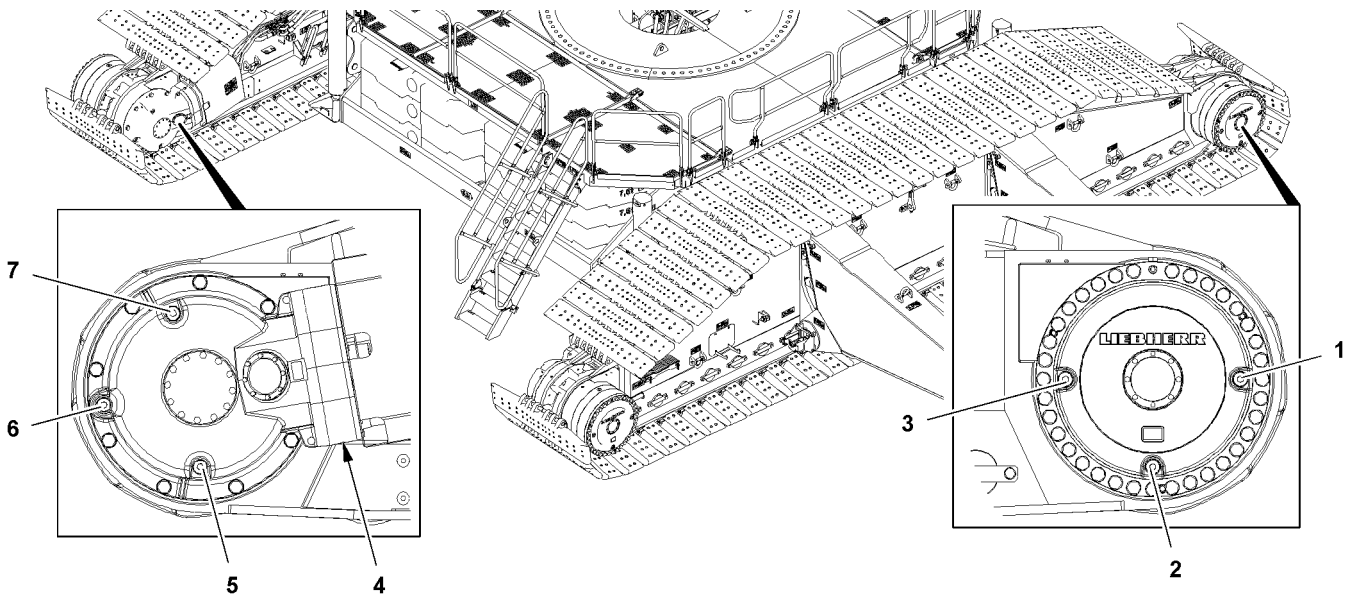

Fig.120158

- ▶ Unscrew the control plug 1 and control plug 3.
- ▶ Catch the gear oil: Position a container under the drain plug 2.
- ▶ Drain the gear oil: Unscrew the drain plug 2.

When gear oil is completely drained:

- ▶ Install the drain plug 2 with new seal and tighten.
- ▶ Add gear oil on one control bore until gear oil starts to run over on the second control bore.
- ▶ Install the control plugs with a new seal and tighten.

1.3 Miter gear

1.3.1 Checking the oil level

NOTICE

Transmission damage due to lack of oil!

- ▶ Check the oil level and add gear oil if necessary.

Make sure that the following prerequisite is met:

- Authorized and trained expert personnel checks the oil level.
- The crane is in horizontal position.
- The travel gear has been at a standstill for two minutes before checking the oil: The gear oil has drained back completely.

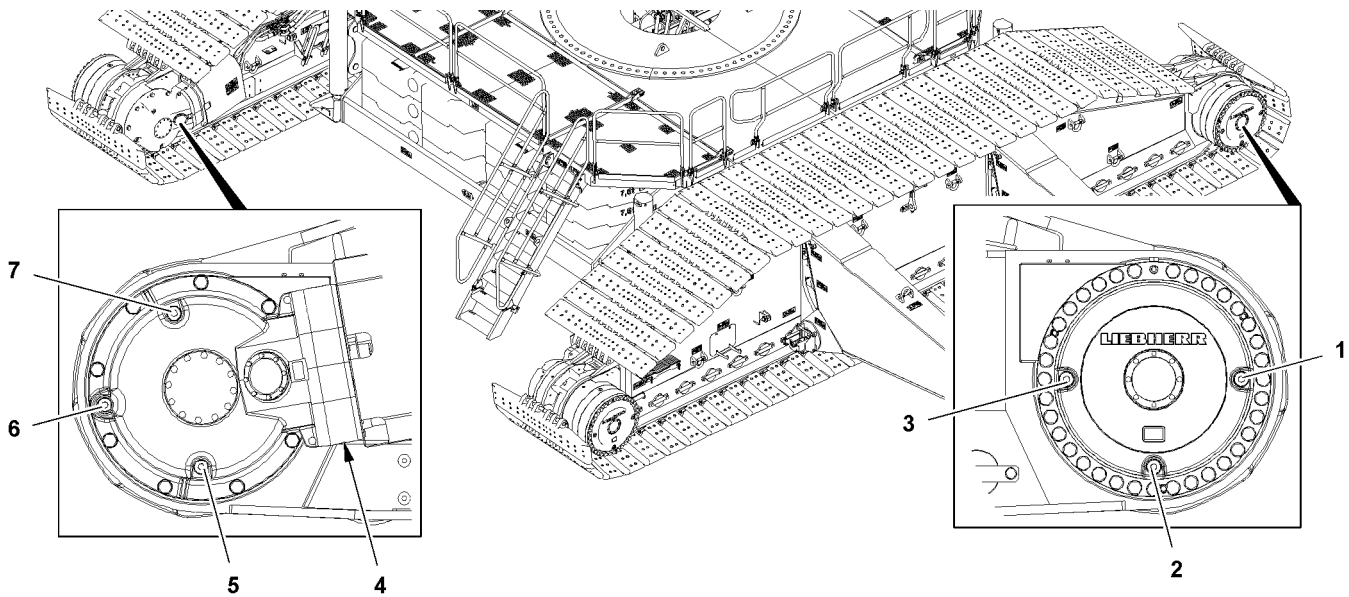

Fig.120158

- ▶ Unscrew the control plug **6**.

The oil level must be on the lower edge of the control bore.

- ▶ Perform a visual inspection.
- ▶ Screw in the control plug **6** with new seal and tighten.

Problem remedy

The oil level is **not** on the lower edge of the control bore?

- ▶ Unscrew the filler plug **7**.
- ▶ Add gear oil on the filler bore until gear oil starts to run over on the control bore.
- ▶ Install the filler plug **7** with a new seal and tighten.

Problem remedy

Oil consumption or loss of oil too high?

- ▶ Find the cause and remedy it.

If the cause cannot be remedied:

- ▶ Contact Liebherr Service.

1.3.2 Replacing the gear oil

Make sure that the following prerequisite is met:

- Authorized and trained expert personnel checks the oil level.
- The crane is in horizontal position.
- The travel gear is at operating temperature.
- Container for the used oil is on hand.

To be able to hold the entire old oil, the container must be sufficiently sized.

For fill quantity of miter gear, see Service fill.



WARNING

Components and gear oil at operating temperature!
Burns.

- ▶ Avoid direct body contact with travel gears and gear oil.
- ▶ Wear suitable protective gloves.

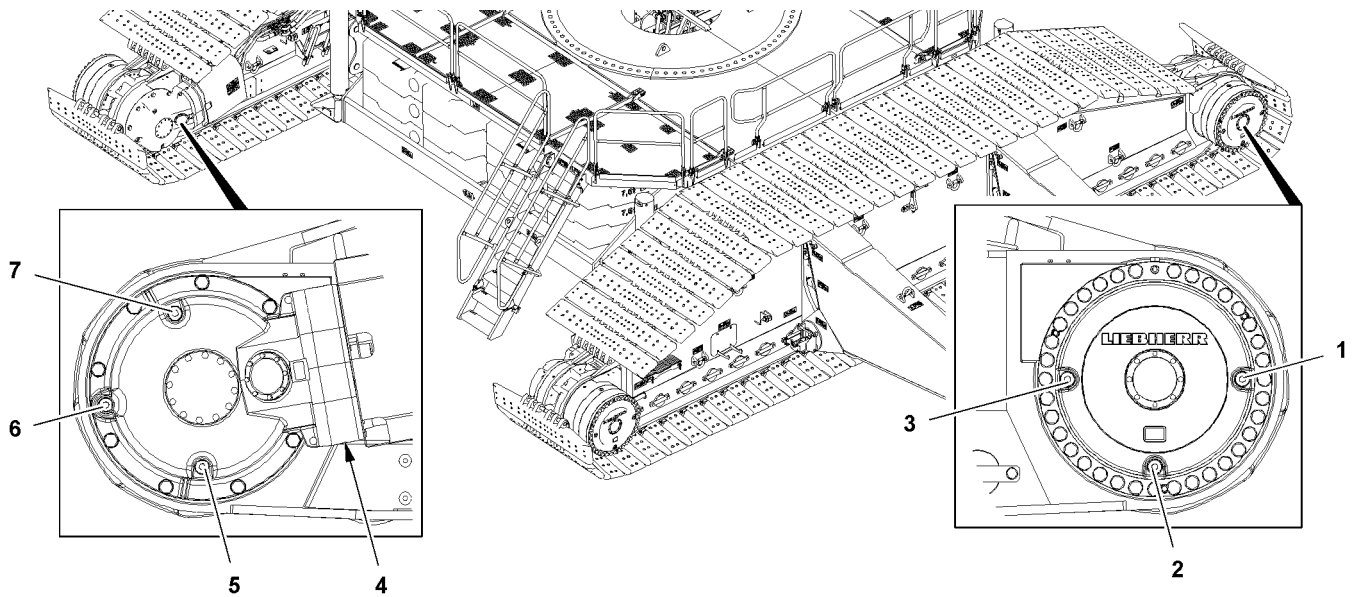

Fig.120158

- ▶ Unscrew the filler plug 7.
- ▶ Catch the gear oil: Place a container under the drain plug 5 and under the drain plug 4.
- ▶ Drain the gear oil: Unscrew the drain plug 5 and drain plug 4.

When gear oil is completely drained:

- ▶ Install the drain plug 5 with new seal and tighten.
- ▶ Install the drain plug 4 with new seal and tighten.
- ▶ Add gear oil on the filler bore until gear oil starts to run over on the control bore.
- ▶ Screw in the control plug 6 with new seal and tighten.
- ▶ Screw in the filler plug 7 and tighten.

2 Central lubrication system

Differentiation between central lubrication systems:

- Central lubrication system **with** integrated control unit
- Central lubrication system **without** integrated control unit

2.1 Technical safety instructions



WARNING

Non-observance of safety instructions!

Personnel can be harmed due to electrical, mechanical and chemical exposure.

Dangerous substances can be discharged and endanger the environment.

Death, severe injury, property damage.

- ▶ Have maintenance and repair work carried out exclusively by authorized and trained expert personnel.
- ▶ Use exclusively Original Liebherr spare parts.

If defects affect the safety:

- ▶ Remedy the defect immediately.

NOTICE

Dirt in lubrication system!

Failure of lubrication, property damage. Damage to central lubrication system.

- ▶ Maintain extreme cleanliness during all work.

NOTICE

Crane is not being moved for longer than three months!

Insufficient lubrication, property damage.

- ▶ Check central lubrication system for correct function.
 - ▶ Carry out intermediate lubrication until lubricant emerges on all lube points.
 - ▶ Repeat the respective crane movement several times.
 - ▶ Carry out intermediate lubrications again.
-

NOTICE

Property damage due to crane cleaning procedure!

- ▶ Carry out the cleaning procedure with a steam cleaner or high pressure cleaner at a minimum distance of 0.4 m.

When the crane is cleaned:

- ▶ Carry out intermediate lubrication until lubricant emerges on all lube points.
-

**Note**

- ▶ Cleaning is only permitted in washing bays.
-

2.2 Central lubrication system with control unit

Types of central lubrication systems with integrated control unit, see illustration.

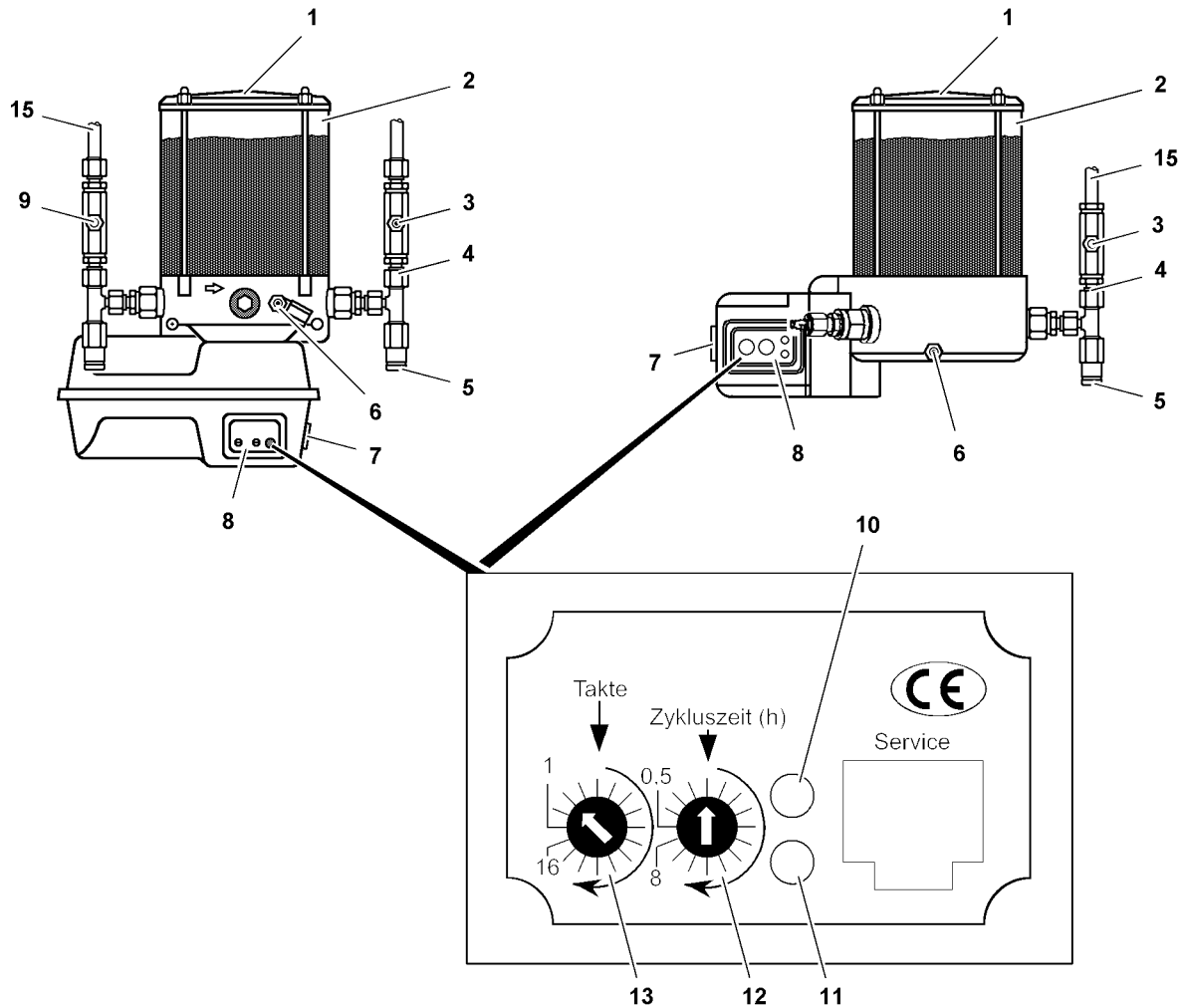

Fig.120487: Central lubrication system with control unit

- | | | |
|-----------------------------------|--|--------------------------------------|
| 1 Cover Grease container | 6 Grease fitting Grease container | 11 LED green |
| 2 Grease container | 7 Button | 12 Latched switch cycle time |
| 3 Grease fitting Lube line | 8 Control element | 13 Latched switch lube cycles |
| 4 Pump outlet | 9 Grease fitting Lube line | 15 Main line |
| 5 Pressure relief valve | 10 LED red | |

2.2.1 Description of function

Displays on control element



Note

- ▶ In the crane operator's cab, operating conditions and problems of the central lubrication system are shown on indicator lights.
- ▶ Indicator lights on operating and control unit, see Crane operating instructions, chapter 4.01.

LWE/LR 11000-001/23501-04-02/en

LED red 11	LED green 10	Operating condition
Lights up for 1.5 seconds	Lights up for 1.5 seconds	Operational readiness after ignition on
Off	Lights up	Lubrication is active (during lube cycles)

Status of LEDs on control element 8

Lube cycle



Note

The lubrication time and the cycle time are set in the factory!

► Do **not** change the settings.

Cycle time: Time from start of one lubrication to the start of another lubrication.

The cycle time is set with the latched switch **12**.

Lube cycles: Number of strokes, during which lubricant is supplied by the pump cylinder.

The number of lube pulses for a lube cycle is set with the latched switch **13**.

2.2.2 Carrying out an intermediate lubrication

Manual intermediate lubrication is carried out, for example:

- If the crane has not been moved for longer than three months.
- After washing the crane.



Note

► When an intermediate lubrication is carried out, the pump starts the lube cycle again. The lube cycle is reset.

Several lube pulses may be required until lubricant emerges on all lube points.

► Press the button **7** until lubricant emerges on all lube points.

or



381

Fig. 124495

In the crane operator's cab: Press the button **381** until lubricant emerges on all lube points.

2.2.3 Checking the function

Make sure that the following prerequisite is met:

- The ignition is turned on.



Note

► Problems, see section „Diagnostics and troubleshooting“

When lubricant emerges on all lube points, then the central lubrication system functions error-free.

- Check the function: Trigger several lube pulses.
- Carry out intermediate lubrication until lubricant emerges on all lube points.

2.2.4 Filling the grease container

NOTICE

Insufficient lubrication!
Lube points run dry, property damage.

- ▶ Make sure that the grease container **2** is filled.
- ▶ Fill the grease container **2** before it is completely empty.
- ▶ Make sure that all grease fittings are clean.

When the grease container is completely empty:

- ▶ Bleed the central lubrication system.
- ▶ Fill the grease container **2** with a grease pump on the grease fitting **6**.

2.2.5 Bleeding the central lubrication system

NOTICE

Insufficient lubrication!
Air in the grease pump, lube points running dry.

- ▶ Bleed the central lubrication system carefully.

When the grease container **2** is completely empty, the central lubrication system must be bled.



Note

- ▶ Carry out the bleeding procedure individually for each main line **15**.
- ▶ Every crawler carrier has a separate grease pump.
- ▶ Fill the grease container **2** with a grease pump via the grease fitting **6**.
- ▶ Fill the main lines **15** with an external grease pump via the grease fittings **3** until grease free of air bubbles emerges on all grease points.
- ▶ Unscrew main line **15** on the pump outlet **4**.
- ▶ Carry out intermediate lubrication until lubricant emerges without air bubbles on the pump outlet **4**.
- ▶ Install the main line **15**.
- ▶ Carry out intermediate lubrication until lubricant emerges on all lube points.

2.2.6 Filling repaired lube lines

NOTICE

Components running dry due to insufficient lubrication!

- ▶ After every repair on lubricated components fill the lube lines completely with lubricant.
- ▶ Make sure that all grease fittings are clean.

- ▶ Fill lube lines completely with lubricant before installation.

or

- ▶ Carry out intermediate lubrication until lubricant emerges on all lube points.
- ▶ Check repaired lube lines for function and leaks.

2.2.7 Diagnostics and problem remedy

Problem signals on control element



Note

- ▶ In the crane operator's cab, operating conditions and problems of the central lubrication system are shown on indicator lights.
- ▶ Indicator lights on operating and control unit, see Crane operating instructions, chapter 4.01.

Status LEDs		Cause	Remedy
LED red 10	LED green 11		
Blinks once in two seconds	Blinks once in two seconds	Cycle error	Fix the system; contact Liebherr Service.
Blinks once a second	Off	CPU error, memory error	Fix the system; contact Liebherr Service.
Lights up	Off	Lubricant level too low (depending on system type)	Fill the grease container.

Problem signals on the control element 8 with diagnostics

Problems on central lubrication system

Status lubrication system	Cause	Remedy
The grease pump does not work.	Electrical line interrupted, grease pump defective	Fix the system or contact Liebherr Service.
Grease pump works but lubricant is not supplied.	Air cushion in delivery piston, minimum fill level fallen below, grease pump element defective.	Bleed the central lubrication system, fill the grease container, fix the system or contact Liebherr Service.
No lubricant emerges on all lube points.	Grease pump is defective, system is blocked or grease container is empty.	See „Grease pump does not work“ or „Lubricant emerges on the pressure relief valve 5“.
No lubricant emerges on several lube points or on one lube point.	Supply lines to auxiliary distributor broken or leaky, associated lube line broken or leaky, fittings leak.	Retighten fittings, fix the system or contact Liebherr Service.
Grease pump speed reduced	High system pressure, low ambient temperature	Check system / bearing points, if no damage can be found: Carry out one or two intermediate lubrications.
Lubricant emerges via pressure relief valve 5	System pressure too high, distributor blocked, system blocked, defective valve spring on pressure relief valve	Check the system, fix the system or contact Liebherr Service.

Problems and diagnostics on the central lubrication system

Resetting a problem

- ▶ Press the button 7.

Result:

- Problem signal on control element turns off.

When a problem signal occurs again:

- ▶ Contact Liebherr Service.

2.3 Central lubrication system without control unit

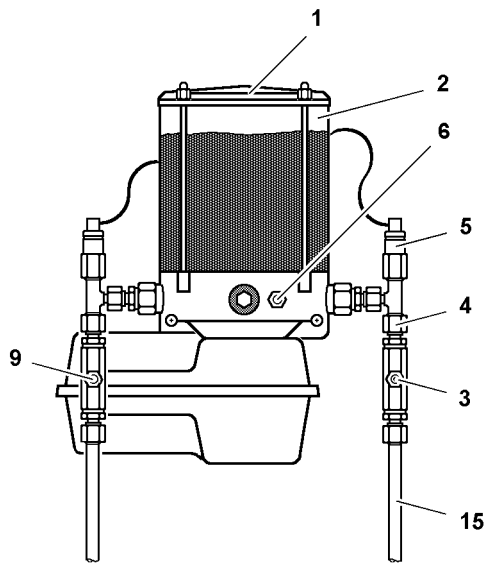

Fig.120489: Central lubrication system without control unit

1	Cover Grease container	4	Pump outlet	9	Grease fitting Lube line
2	Grease container	5	Pressure relief valve	15	Main line
3	Grease fitting Lube line	6	Grease fitting Grease container		

2.3.1 Description of function

If the crawler crane is driven via the crawler travel gear, then the central lubrication systems turn on automatically. The central lubrication systems supply all connected lube points with the correct amount of lubricant.

2.3.2 Carrying out an intermediate lubrication

Manual intermediate lubrication is carried out, for example:

- If the crane has not been moved for longer than three months.
- After washing the crane.

Several lube pulses may be required until lubricant emerges on all lube points.

- ▶ Fill the main line **15** with an external grease pump via the grease fitting **3** until lubricant free of air bubbles emerges on all lube points.



WARNING

Crane can start to drive unintentionally!

If the foot rocker in the crane operator's cab or the manual control lever on the radio remote control panel* is moved too far while bleeding the grease pump, then the track chain can start to move. Death, severe injury, property damage.

- ▶ Actuate the foot rocker carefully to bleed the grease pump.
- ▶ Watch the emergence of lubricant from the grease pump from a safe distance.



Note

- ▶ For assignment of foot rockers to the crawler carriers, see Crane operating instructions, chapter 4.01.

- ▶ Make sure that the track chain does **not** start to move when actuating the foot rocker.
- ▶ Move the foot rocker or the manual control lever to the point where the grease pump supplies.
- ▶ Actuate the foot rocker or the manual control lever until lubricant emerges on all lube points.

2.3.3 Checking the function

Make sure that the following prerequisite is met:

- The ignition is turned on.



Note

- ▶ Problems, see section „Diagnostics and troubleshooting“

When lubricant emerges on all lube points, then the central lubrication system functions error-free.



WARNING

Crane can start to drive unintentionally!

If the foot rocker in the crane operator's cab or the manual control lever on the radio remote control panel* is moved too far while bleeding the grease pump, then the track chain can start to move.

Death, severe injury, property damage.

- ▶ Actuate the foot rocker carefully while bleeding the grease pump.
- ▶ Watch the emergence of lubricant from the grease pump from a safe distance.

- ▶ Carry out intermediate lubrication until lubricant emerges on all lube points.

2.3.4 Filling the grease container

NOTICE

Insufficient lubrication!

Lube points run dry, property damage.

- ▶ Make sure that the grease container **2** is filled.
- ▶ Fill the grease container **2** before it is completely empty.
- ▶ Make sure that all grease fittings are clean.

When the grease container is completely empty:

- ▶ Bleed the central lubrication system.
- ▶ Fill the grease container **2** with a grease pump on the grease fitting **6**.

2.3.5 Bleeding the central lubrication system

NOTICE

Insufficient lubrication!

Air in the grease pump, lube points running dry.

- ▶ Bleed the central lubrication system carefully.

The central lubrication system of the crawler travel gear can be bled two ways:

- By actuation of the grease pump by simulating the crawler operation.
- By separate actuation of the grease pump with the aid of the electric wiring diagram.

Bleeding by simulating crawler operation

- ▶ Fill the grease container **2** with an external grease pump via the grease fitting **6**.
- ▶ Fill the main lines **15** with an external grease pump via the grease fittings **3** until grease free of air bubbles emerges on all grease points.



Note

- ▶ Carry out the bleeding procedure individually for each pump outlet **4**.
- ▶ Every crawler carrier has a separate grease pump.

- ▶ Unscrew main line **15** on the pump outlet **4**.
- ▶ Start the crane engine.
- ▶ Select crawler operation.

**WARNING**

Crane can start to drive unintentionally!

If the foot rocker in the crane operator's cab or the manual control lever on the radio remote control panel* is moved too far while bleeding the grease pump, then the track chain can start to move.

Death, severe injury, property damage.

- ▶ Actuate the foot rocker carefully to bleed the grease pump.
- ▶ Watch the emergence of lubricant from the grease pump from a safe distance.

**Note**

- ▶ For assignment of foot rockers to the crawler carriers, see Crane operating instructions, chapter 4.01.

- ▶ Make sure that the track chain does **not** start to move when actuating the foot rocker.
- ▶ Move the foot rocker or the manual control lever to the point where the grease pump supplies.

Result:

- The acoustic signal crawler operation sounds.
- ▶ Actuate the foot rocker or the manual control lever until lubricant free of air bubbles emerges on the pump outlet **4**.
- ▶ Install the main line **15**.
- ▶ Actuate the foot rocker / manual control lever until lubricant emerges on at least one of the lube points in the bled lubrication circuit.

Bleeding by separate actuation of the grease pump

Make sure that the following prerequisites are met:

- Authorized and trained expert personnel works on the electrical system.
- The separate electric wiring diagram of the crane is available.
- ▶ Fill the grease container **2** with an external grease pump via the grease fitting **6**.
- ▶ Fill the main lines **15** with an external grease pump via the grease fittings **3** until grease free of air bubbles emerges on all grease points.

**Note**

- ▶ Carry out the bleeding procedure individually for each main line **15**.
- ▶ Every crawler carrier has a separate grease pump.

- ▶ Unscrew main line **15** on the pump outlet **4**.
- ▶ Actuate the grease pump separately, see crane electric wiring plan.

Result:

- The grease pump starts to supply.
- ▶ Actuate the lube pump until lubricant emerges without air bubbles on the pump outlet **4**.
- ▶ Install the main line **15**.
- ▶ Actuate the grease pump again until lubricant emerges again on at least one of the lube points in the bled lubrication circuit.

2.3.6 Filling repaired lube lines**NOTICE**

Components running dry due to insufficient lubrication!

- ▶ After every repair on lubricated components fill the lube lines completely with lubricant.
- ▶ Make sure that all grease fittings are clean.

- ▶ Fill lube lines completely with lubricant before installation.

or

- ▶ Carry out intermediate lubrication until lubricant emerges on all lube points.
- ▶ Check repaired lube lines for function and leaks.

2.3.7 Diagnostics and problem remedy

Status lubrication system	Cause	Remedy
The grease pump does not work.	Electrical line interrupted, grease pump defective	Fix the system or contact Liebherr Service.
Grease pump works but lubricant is not supplied.	Air cushion in delivery piston, minimum fill level fallen below, grease pump element defective.	Bleed the central lubrication system, fill the grease container, fix the system or contact Liebherr Service.
No lubricant emerges on all lube points.	Grease pump is defective, system is blocked or grease container is empty.	See „Grease pump does not work“ or „Lubricant emerges on the pressure relief valve 5“.
No lubricant emerges on several lube points or on one lube point.	Supply lines to auxiliary distributor broken or leaky, associated lube line broken or leaky, fittings leak.	Retighten fittings, fix the system or contact Liebherr Service.
Grease pump speed reduced	High system pressure, low ambient temperature	Check system / bearing points, if no damage can be found: Carry out one or two intermediate lubrications.
Lubricant emerges via pressure relief valve 5	System pressure too high, distributor blocked, system blocked, defective valve spring on pressure relief valve	Check the system, fix the system or contact Liebherr Service.

Problems and diagnostics on the central lubrication system

3 Servicing the track chain



Note

► The illustrations in this chapter are examples and may not apply exactly to your crane.

In crawler operation, the components of the crawler travel gear are subject to wear caused by operation.

In order to continuously guarantee safe and effective crane operation, components must be checked at the specified maintenance intervals and replaced if necessary, see the Crane operating instructions, chapter 7.02.



WARNING

Maintenance interval exceeded!

Failure to observe the specified maintenance intervals can lead to increased crane failure time as well as to damage on the crawler travel gear.

Death, severe bodily injuries, property damage.

- Make sure that the maintenance intervals in the Crane operating instructions chapter 7.02 are observed.
- The crane operator is responsible for complying with the maintenance intervals, properly performing the specified maintenance tasks as well as initiating the corresponding measures as a result of the inspection results.

3.1 Tensioning the track chain

The track chain must be retensioned at the latest when three track pads **2** at point **P2** are laying flat on the glide rails **1.1** on the crawler carrier **1**.

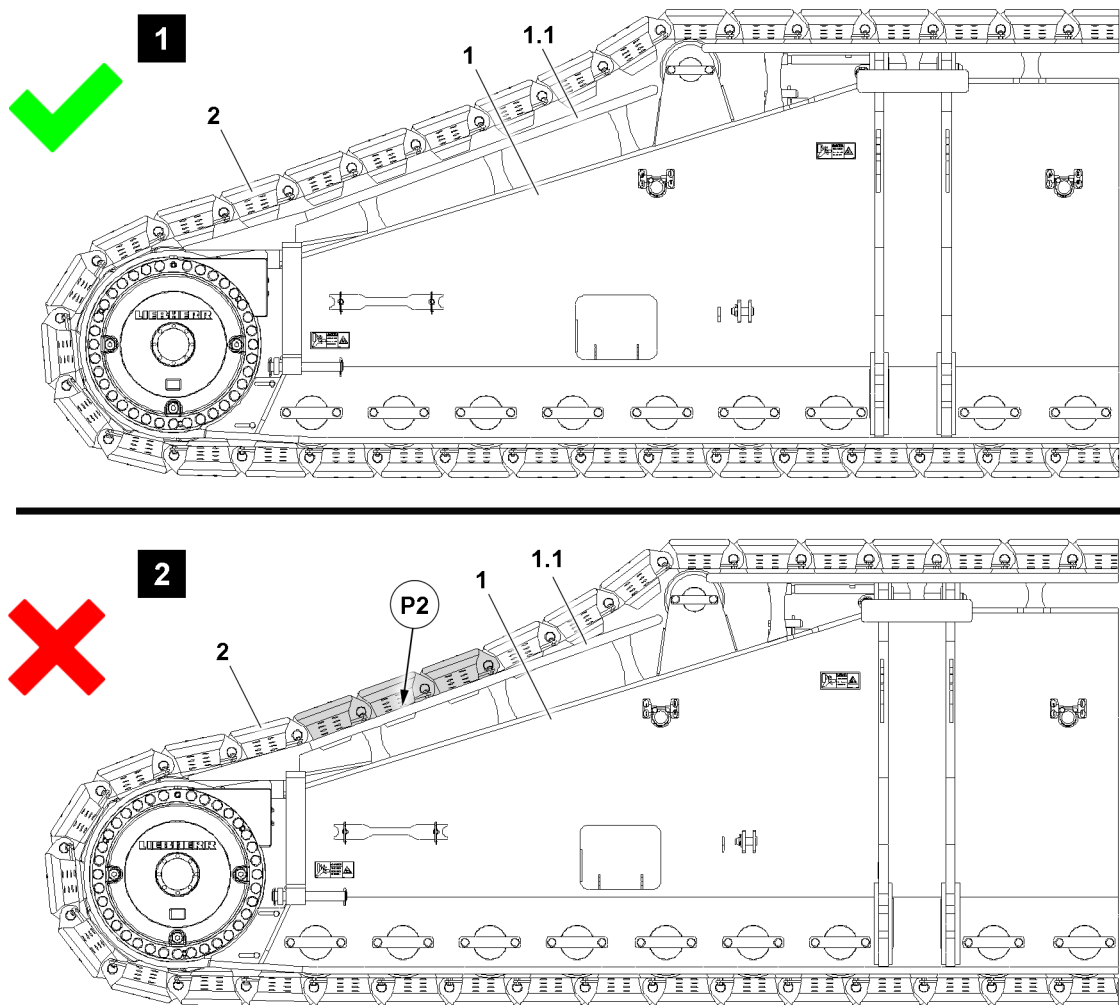

Fig.128241: Chain tension OK, illustration 1 // Track chain too slack, illustration 2

NOTICE

Damage to the track chain!

If the chain tension is not checked within the specified maintenance intervals, the track chain or the steel structure of the crawler carrier can be damaged.

- ▶ Observe and adhere to the maintenance intervals, see the Crane operating instructions, chapter 7.02.
- ▶ If **three** of the track pads **2** of the track chain lie flat on the glide rails **1.1** on the crawler carrier **1** (see point **P2**), then the track chain must be retensioned **immediately**.

The following applies in the case of crawler carriers **1** without glide rails **1.1** or with worn glide rails **1.1**:

- ▶ Make sure that the track pad cams never come into contact with the base steel structure of the crawler carrier. Always retension the track chain early on.

The following applies:

- ▶ The crane driver bears full responsibility for damage resulting from a non-tensioned track chain.

NOTICE

Glide rails worn!

If the glide rails on the crawler carriers are worn to the extent that the remaining material can be deformed or could break under the weight of the track chain, this could result in capital property damage to the crawler travel gear.

- ▶ Retension the track chain early on.
- ▶ Make sure that worn glide rails are replaced early on, please contact Customer Service at LIEBHERR-Werk Ehingen GmbH.

**Note**

- ▶ The chain tension is held by spacer plates **16**.

NOTICE

Foreign matter in track chains!

Foreign matter in the track chains and on the travel drive can cause damage.

- ▶ Before tensioning the track chains, check the track chains and the travel drives for foreign particles, such as rocks, and clean them, if necessary.

Make sure that the following prerequisite is met:

- The crane is horizontal.

3.1.1 Placing the tension cylinder in crawler carrier opening

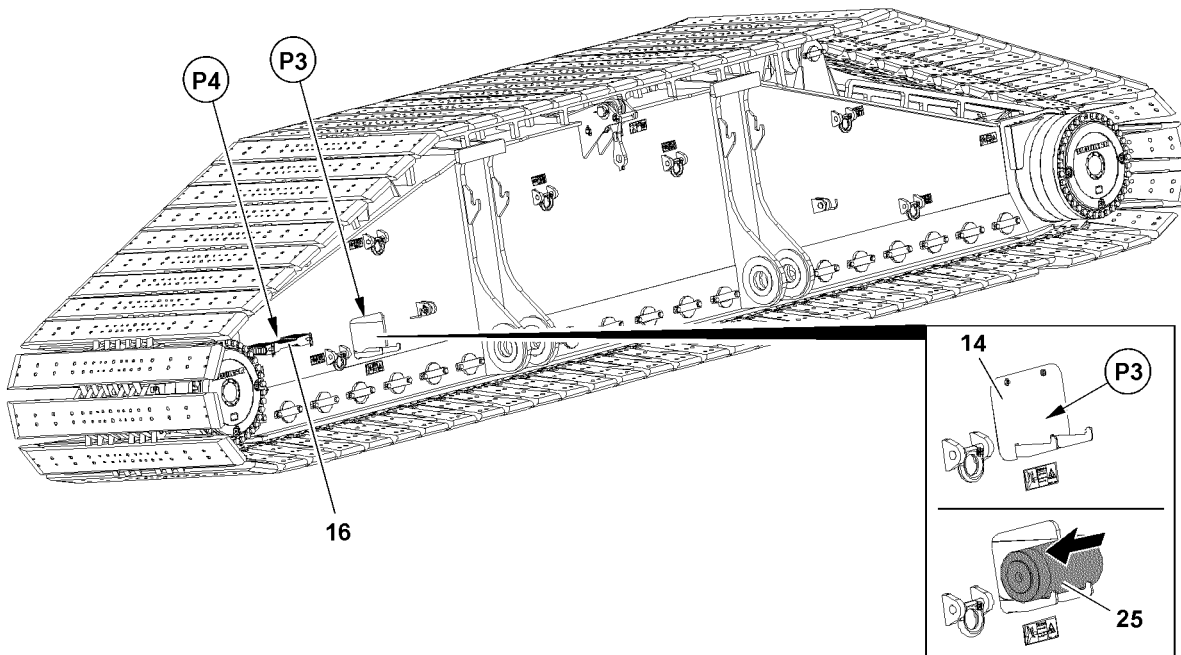

Fig.123567: Placing the tension cylinder in crawler carrier opening

- ▶ Remove maintenance flap **14** at point **P3**.

NOTICE

Damage to hydraulic connections!

When sliding the tension cylinder **25** in the crawler carrier opening, the hydraulic connections can be damaged.

- ▶ Make sure that the hydraulic connections of the tension cylinder point forward to the crawler carrier opening when sliding it in.
- ▶ Place the tension cylinder **25** on the cylinder receptacle.
- ▶ Slide the tension cylinder in the crawler carrier opening until it is centered in „working position“.

3.1.2 Carrying out the tension procedure

Make sure that the following prerequisites are met:

- The tension cylinder **25** is properly placed in the crawler carrier opening.
- The hydraulic lines **15.1** between the tension cylinder **25** and hand lever pump **15** are properly installed.

**Note**

- ▶ By extending the tension cylinder **25**, the sliding section of the crawler carrier is moved in direction of the arrow.

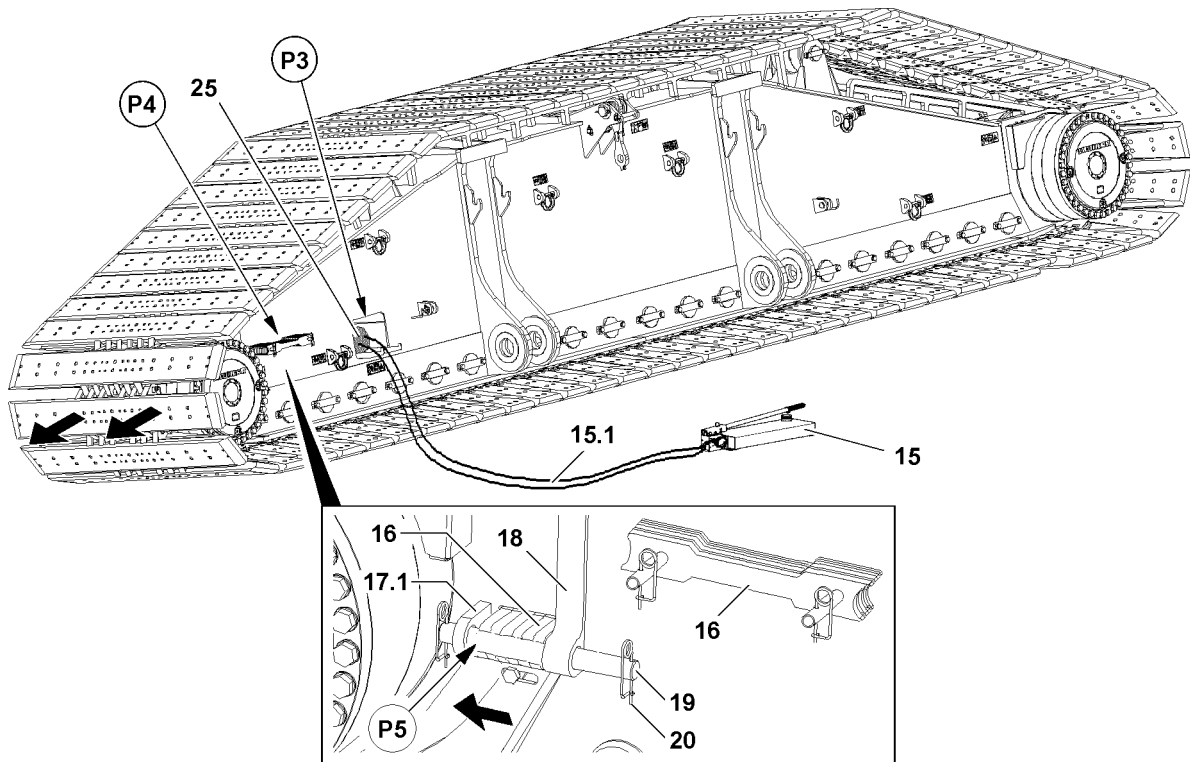

Fig.123568: Tension the track chain with the tension cylinder and the hand lever pump

- ▶ Actuate the hand lever pump **15**.

Result:

- The tension cylinder **25** extends.
- The crawler chain is tensioned.
- ▶ Remove the spacer plates **16** from the transport receptacle at point **P4**.
- ▶ At point **P5**, insert as many spacer plates **16** as fit into the gap between the stop sliding section **17.1** and the stop crawler carrier **18**.
- ▶ Secure the spacer plates **16** with pin **19** and spring retainer **20**.

**WARNING**

Moving in tension cylinder!

Crushing and shearing off body parts, such as: fingers, hands and arms.

Death, severe injury, property damage.

When the tension cylinder is moved in:

- ▶ Make sure that personnel keeps away from the crawler carrier.
- ▶ Stop work on the crawler carrier.

- ▶ Move the tension cylinder **25** in with the hand lever pump **15**.
- ▶ After the tension procedure, drive the crawler back and forth by one crawler length in operating mode „Straight forward travel“.

Result:

- The tension of the track chain is reduced.
- ▶ Check the distance of the crawler chain to the steel structure of the crawler carrier at point **P2**.

If necessary:

- ▶ Repeat the tension procedure of the track chain and insert additional spacer plates **16**.

Problem remedy

Crawler chain can **not** be tensioned?

The stroke on the tension cylinder is **not** sufficient.

- ▶ Have one track pad removed by authorized and trained expert personnel.

3.1.3 Removing the tension cylinder on the crawler carrier

Make sure that the following prerequisites are met:

- The track chain is tensioned.
- The spacer plates are properly placed in the gap between the stop sliding section **17.1** and stop crawler carrier **18**.
- The spacer plates **16** are properly secured with pins.
- The tension cylinder **25** is retracted in all the way.

NOTICE

Damage to hydraulic connections!

When removing the tension cylinder **25** on the crawler carrier, the hydraulic connections can be damaged.

- ▶ Pull the tension cylinder carefully from the crawler carrier opening on the cylinder receptacle.

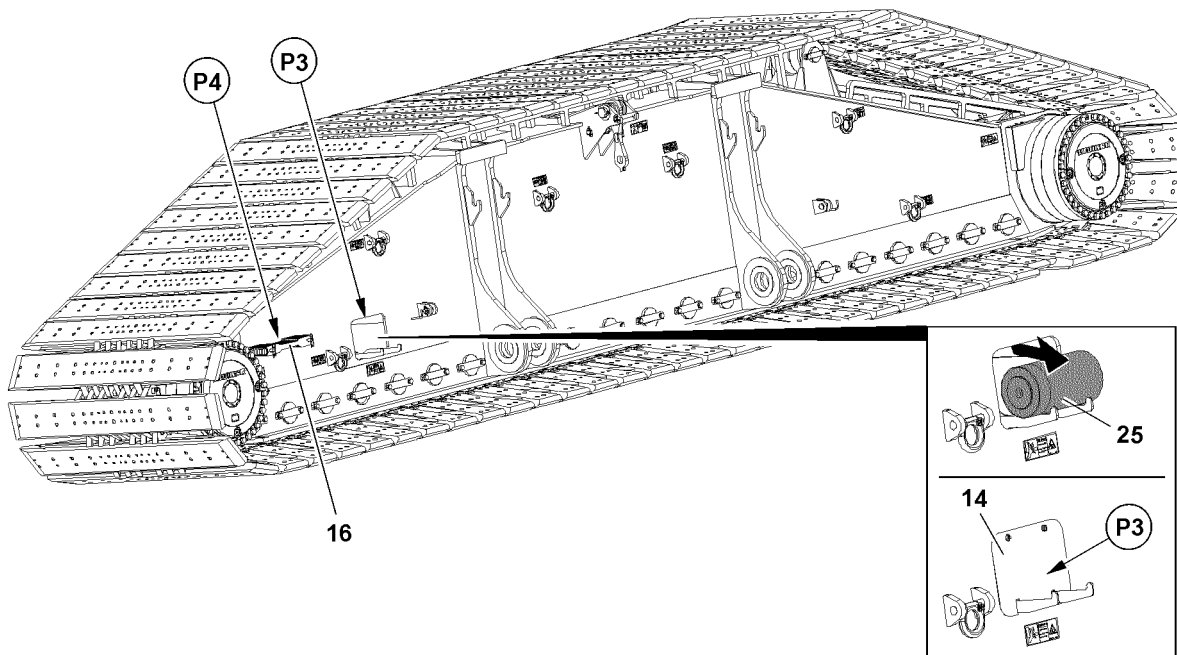
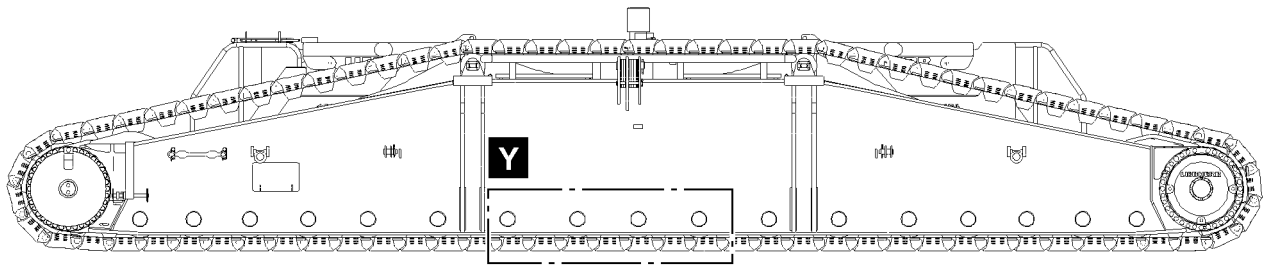
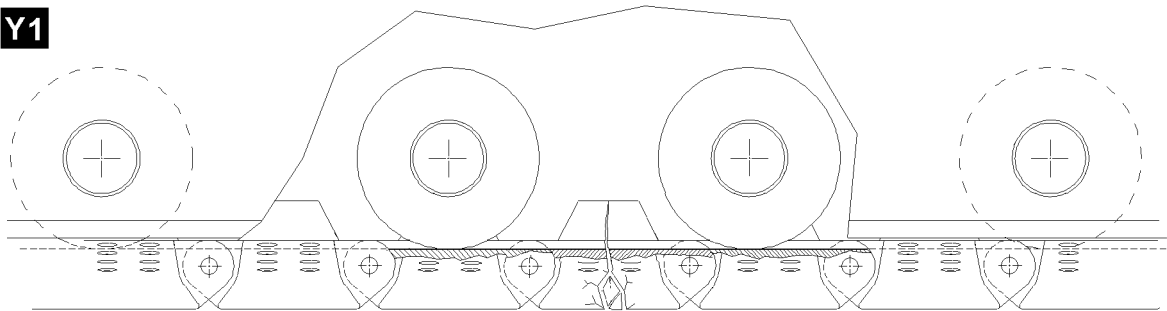

Fig.123570: Removing the tension cylinder on the crawler carrier

- ▶ Slide the tension cylinder **25** from the crawler carrier opening at point **P3** on the cylinder receptacle.
- ▶ Lift the tension cylinder **25** from the cylinder receptacle.
- ▶ Install the maintenance flap **14** properly at point **P3**.



Y1



Y2

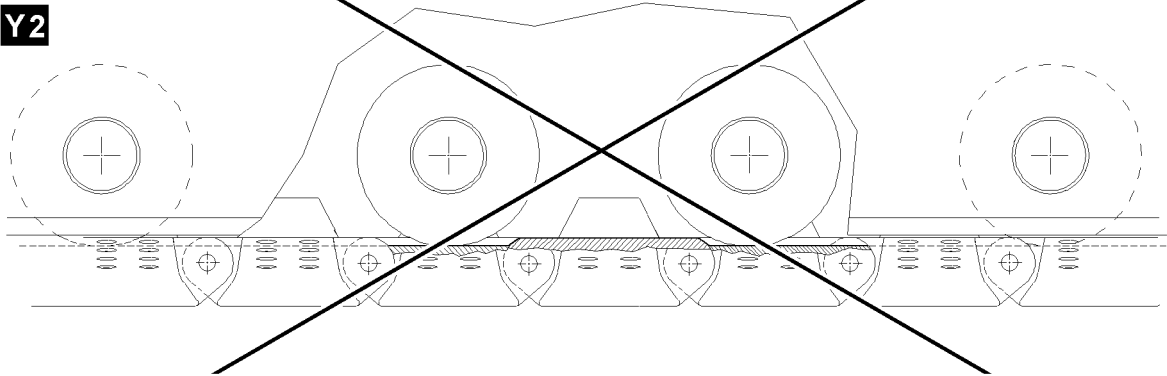

Y3

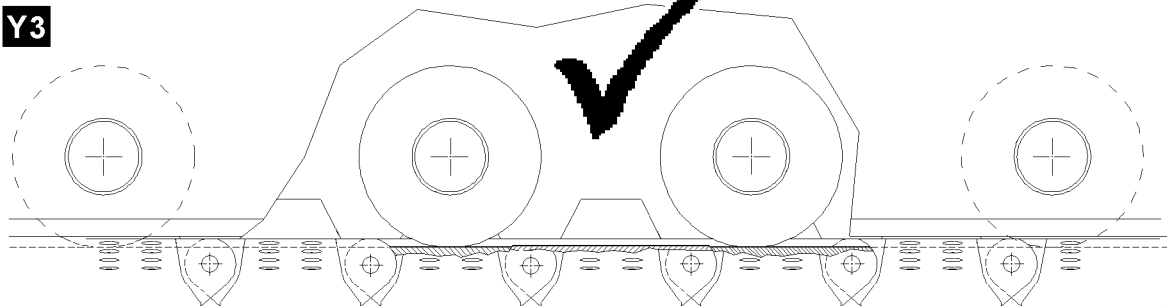

LWE/LR 11000-001/23501-04-02/en

Fig.109917

3.2 Checking wear on the track chain



WARNING

Exceeding the wear limits on track pads **21**, pins **22** or track rollers **23**!
Track chain can be ripped off. Toppling crane. Death, severe injuries.

- ▶ Make sure that random checks of the track pads **21**, pins **22** and track rollers **23** are carried out within the specified intervals.
- ▶ During the random inspection of the track rollers, always check the first and the last track roller on the crawler carrier.

When a wear limit on the component is reached:

- ▶ Replace the component or have it reworked by authorized and trained expert personnel.

NOTICE

Significant height differences between the individual track pads, see illustration **Y2**!
Increased mechanical stress on the track pads **21** and the track rollers **23**. Property damage.

If one individual track pad **21** must be replaced:

- ▶ Make sure that the track pad is **not** replaced by a track pad **21** with a much lower degree of wear.
- ▶ Replace a defective track pad **21** with a track pad **21** which shows a similar degree of wear, see illustration **Y3**.



Note

- ▶ New crawler track: As the components break in toward each other, the track chain lengthens initially more.

If necessary:

- ▶ To be able to tension the track chain correctly, remove a track pad **21** early on.

The wear of the track pad **21**, pin **22** and track rollers **23** depends a various factors:

- Length of travel route
- Frequency of driving in curves
- Friction ratios between track pad **21** and ground
- Evenness of the ground
- Type of ground
- Load bearing capacity of the ground / base
- Position of the total center of gravity
- Load on the hook
- Placed ballast on the crane

3.2.1 Checking the wear on the connections of the track pads

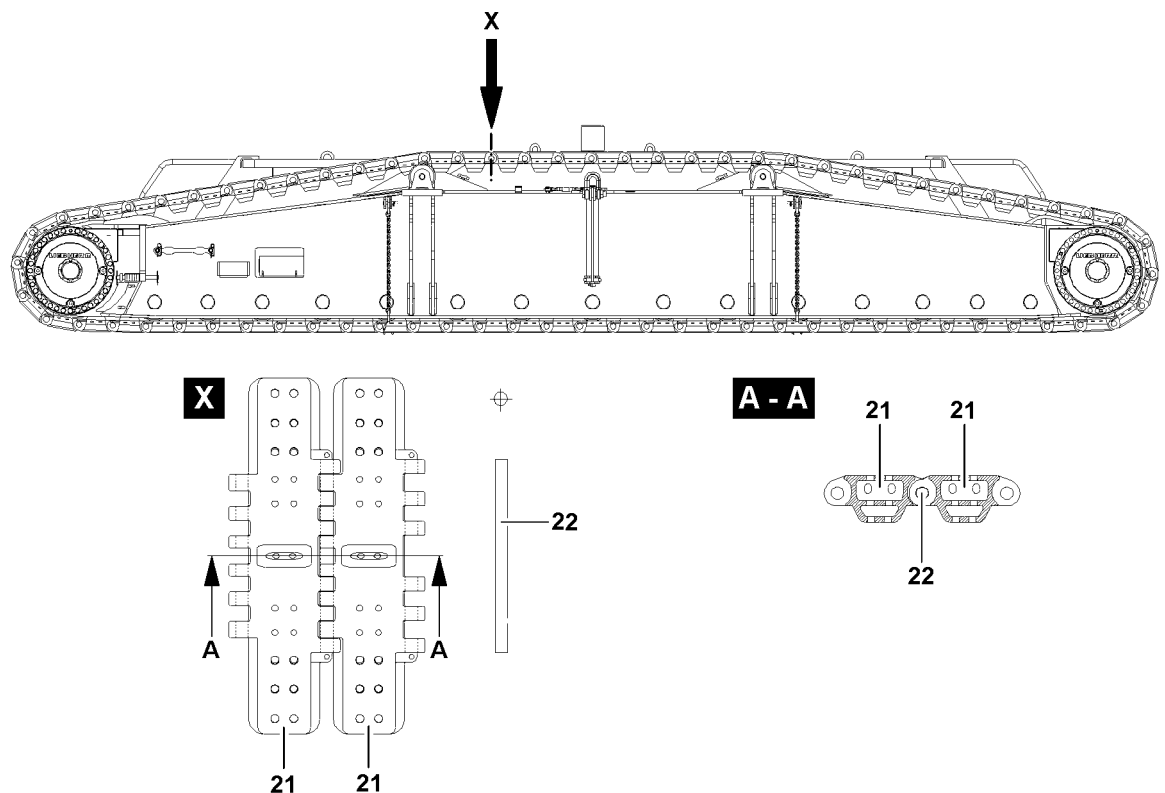

Fig.108536: Checking the wear on the connections of the track pads

NOTICE

Wear limits at the connections to the track pads is reached!

Damage of sprocket, chain lengthening too much, increased wear on sprocket and on transport cams of track pads.

Expensive and extensive repairs.

- ▶ Make sure, that the random inspection of the bolt diameter is made within the specified intervals.

When one pin **22** falls below the minimum dimension:

- ▶ Replace the pin **22**.
- ▶ Make sure, that the random inspection of the bore diameter is made within the specified intervals.

If a bore diameter exceeds the maximum permissible highest dimension:

- ▶ Replace the track pad **21**.

NOTICE

Dimension and association of wear on pins, bore and run in depth on track pads!

On the sprocket and on the transport cams increased wear can occur, before wear limits of pins, bore and run in depth of the track pad are reached.

Expensive and extensive repairs.

- ▶ Check the sprocket and transport cams of the track pads for wear.
- ▶ Check the run in depth of the track pads.

If increased wear is found:

- ▶ Stop crawler operation and contact Liebherr Service.

The track pads **21** of the crawler track are connected by pins **22**.

Wear limit bore for the track pad	
Initial diameter	53 mm
Maximum permissible upper limit	56 mm

Pin wear limit	
Initial diameter	50 mm
Maximum permissible minimum dimension	47 mm

3.2.2 Checking the wear on the roll off surfaces of the track pads / track rollers

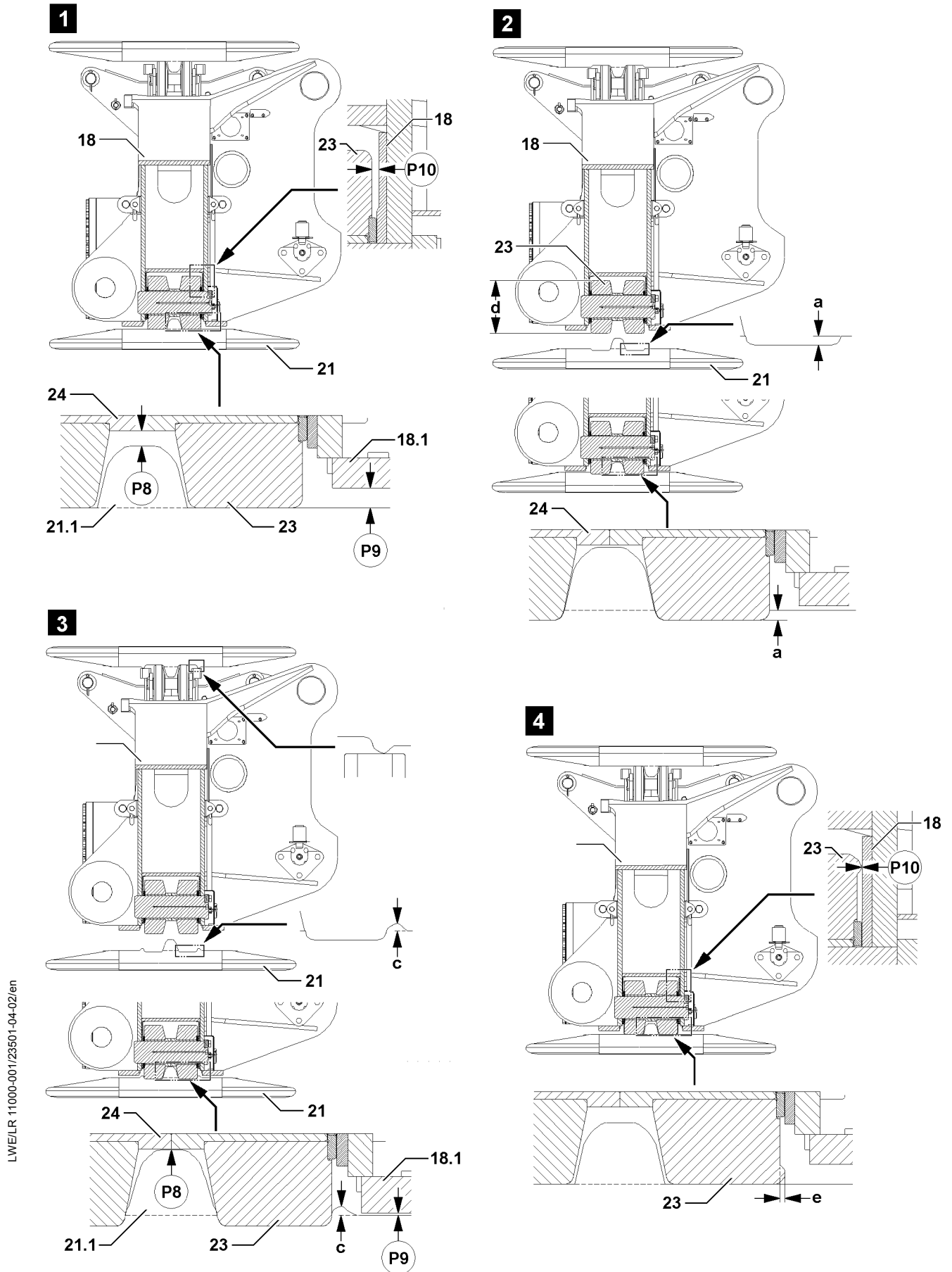

LWE/LR 11000-001/23501-04-02/en

NOTICE

Destruction of track pad!

If a track pad **21** is not fixed or replaced after reaching the wear limit, then the track pad **21** will be destroyed and can cause damage to the crawler carrier **18**.

This could result in high property damage.

- ▶ Fix or replace the track pad **21** after reaching the wear limit.

NOTICE

Failure of track rollers!

If the track rollers **23** are not replaced after reaching the wear limit, then they can fail and cause damage to the crawler carrier **18** and track pad **21**.

This could result in high property damage.

- ▶ Replace track rollers **23** after reaching the wear limit.

NOTICE

Bulges on track pads **21** and track rollers **23** are too large, see illustration **3** and illustration **4**!

Increased wear on the crawler travel gear!

This could result in high property damage.

- ▶ Grind off or remove bulges in time.

When the wear limits are exceeded, the minimum distances are fallen below on the following points:

- On point **P8** between the transport cams **21.1** and track roller body **24**
- On point **P9** between the track pad **21** and base belt **18.1**
- On point **P10** between the track rollers **23** and crawler carrier **18**

Wear limit track pad	
Maximum permissible run in depth a	8 mm
Maximum permissible bulge c	¹⁾

Wear limit track roller	
Initial diameter	370 mm
Permissible minimum diameter d (measured in the center of the running surface)	366 mm
Maximum permissible bulge e	3 mm ²⁾

1) As soon as the bulge scrapes on the base belt of the crawler carrier, **grind the bulge off**.

2) Valid for all track systems: If the bulge is larger than 3 mm, **grind the bulge off**.

**WARNING**

Danger of injury due to improper procedure!

- ▶ Have all work on the track chains carried out by authorized and trained expert personnel.

**Note**

When the maximum run in depth is reached or the running surfaces are significantly worn:

- ▶ Track pads can be repaired by repair welds according to welding guidelines or repair instructions from Liebherr-Werk Ehingen GmbH.

When sprocket and track pad are worn or damaged due to operation:

- ▶ Damage can be repaired by repair welds according to welding guidelines or repair instructions from Liebherr-Werk Ehingen GmbH.
- ▶ Contact Liebherr Service.
- ▶ Replace worn track rollers **23**.

- ▶ Grind off excessive bulges, see illustration 3 and illustration 4.

4 Ladders



Note

- ▶ The following listed ladders are examples and may not match your crane exactly.



WARNING

Danger of falling!

If the following safety notes are **not** observed, personnel can fall down.
Death, severe bodily injuries, property damage.

- ▶ Observe and adhere to the installation and safety guidelines for ladders.
- ▶ Observe and adhere to the safety signs on the ladders.
- ▶ Install and secure the ladders properly.
- ▶ Do **not** use damaged ladders and replace them immediately.
- ▶ Repair the ladder exclusively through authorized service facilities.

4.1 Lubricating ladders

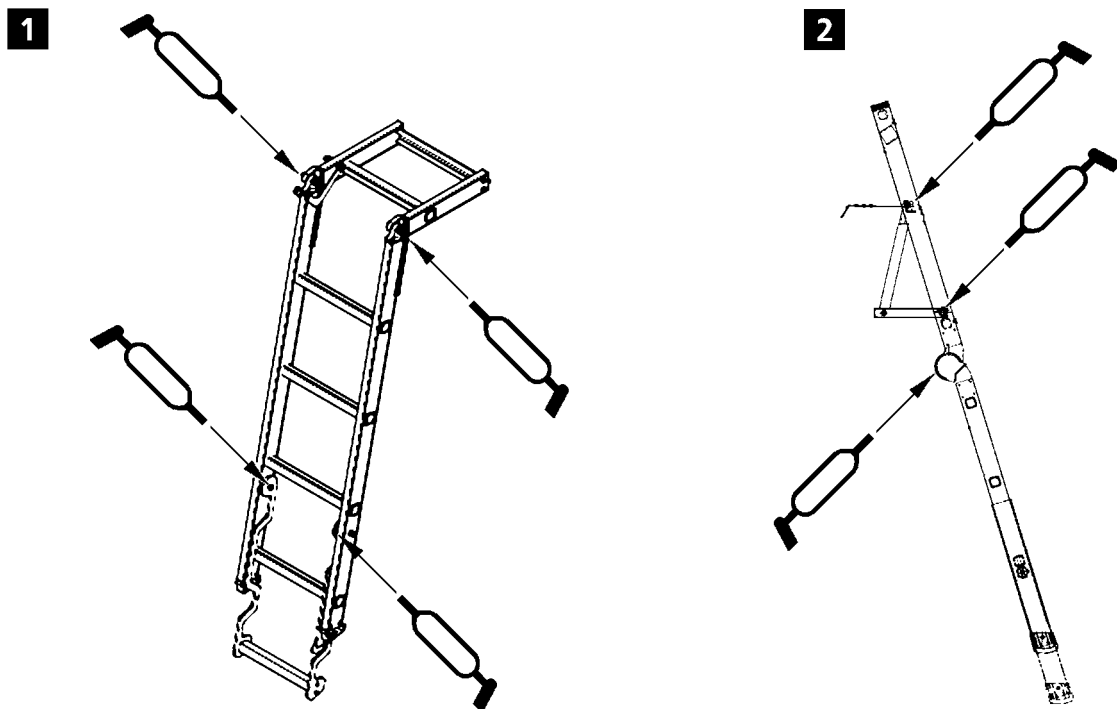

Fig.109766

- ▶ Grease joints and pivot points on the ladders regularly and check them for easy movement, see illustration 1 and illustration 2.
- ▶ Repairs and maintenance work on the ladder must be made by expert personnel.

Empty page!

LWE/LR 11000-001/23501-04-02/en

7.04.50 Ballast trailer maintenance instructions

1	Maintenance	3
2	Ballast trailer tires	3
3	Hydraulic hose lines	3
4	Slewing gear	4
5	Wheel set drive	7
6	Central lubrication system	9

Fig.195219

LWE/LR 11000-001/23501-04-02/en

1 Maintenance

**Note**

- ▶ For all maintenance work, use service items and lubricants according to the service fill list.
- ▶ Observe the ballast trailer maintenance intervals, see the chapter 7.02.50.

2 Ballast trailer tires

2.1 Ballast trailer tires

**Note**

- ▶ See chapter 2.15.

2.2 Ballast trailer tires and disk wheels

**Note**

- ▶ See chapter 8.01.

3 Hydraulic hose lines

**Note**

- ▶ See chapter 7.05.

4 Slewing gear

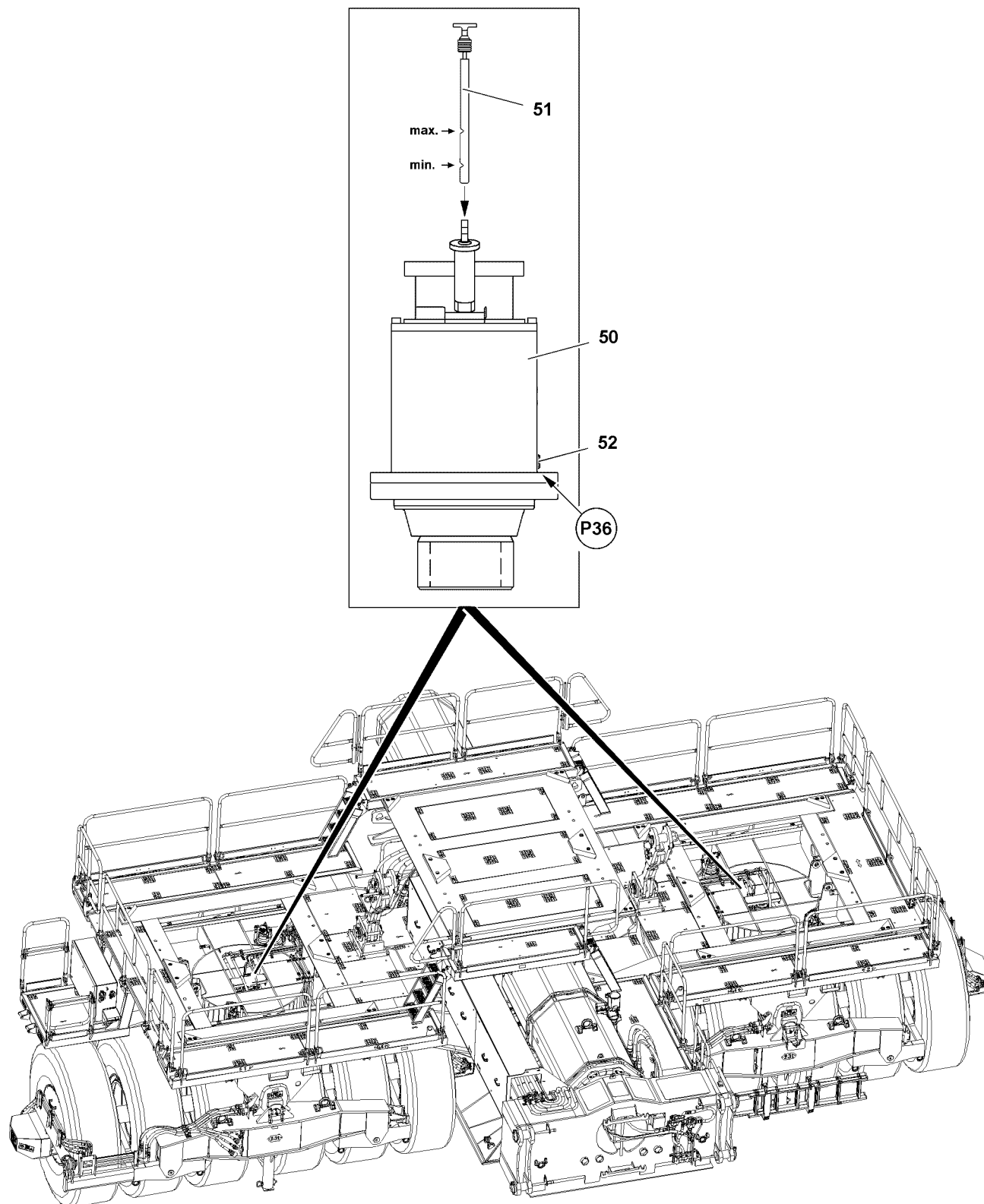

Fig.120246: Slewing gear

Maintain utmost cleanliness during all work to prevent dirt from entering the interior of the slewing gear.

**WARNING**

Danger of burns during maintenance and inspection work!

Severe burns can result due to the crane components and service fluids at operating temperatures.

- ▶ Avoid direct body contact to heated crane components and service fluids.

NOTICE

Dirt in the slewing gear!

If any dirt gets inside the slewing gear it can be damaged.

- ▶ Make sure that no dirt gets inside the slewing gear during maintenance work.

NOTICE

Danger of property damage.

- ▶ Do not mix synthetic oils with mineral oils.

The specified fill quantities (change quantities) are orientation values. The markings on the dipsticks, inspection ports or sight gauges are decisive for filling.

Position	Components	Fill quantity
50	Slewing gear	4.4 l

4.1 Checking for leaks

NOTICE

Leaky slewing gear!

If a leak is found during the visual inspection of the slewing gear, it can result in failure of the slewing gear.

The slewing gears can be damaged, resulting in high property damage.

- ▶ Repair the leaky slewing gear and replace the slewing gear, if in doubt.

- ▶ Check visually to ensure that the slewing gears do not leak.

4.2 Checking the oil level

**Note**

- ▶ To ensure a reliable oil level check, it must be ensured that the slewing gears have been at a standstill for at least two minutes. This ensures that the gear oil has returned to the oil chamber completely.

Make sure that the following prerequisite is met:

- Ballast trailer is in horizontal position.

- ▶ Remove and wipe off the dipstick **51**.
- ▶ Insert and pull out the dipstick **51**.

The gear oil must be visible between both marks on the dipstick **51**.

- ▶ Check the oil level.

NOTICE

Transmission damage due to impermissible oil level!

Too little gear oil causes lubricating problems and reduces the service life of the gear.

Too much gear oil causes more displacement work and overheats the gear.

- ▶ Check the oil level.

If necessary:

- ▶ Add or drain gear oil.

- ▶ Add or drain gear oil.
- ▶ Reinsert the dipstick **51**.

4.3 Changing the oil

NOTICE

Damage to the slewing gear!

If seal rings are used repeatedly, it can result in loss of oil.

Due to loss of oil, the slewing gears can wear significantly and / or be damaged.

- ▶ Use the seal rings on the maintenance ports only once.
-

Make sure that the following prerequisites are met:

– Ballast trailer is in horizontal position.

– The slewing gear is warm.

- ▶ Open the oil filler port by unscrewing the dipstick **51**.
- ▶ Catch the gear oil: Position a container under the oil drain plug **52** at point **P36**.
- ▶ Drain the gear oil: Unscrew the oil drain plug **52** with seal ring at point **P36**.
- ▶ Clean the oil drain plug **52** and sealing surface on the housing.

When gear oil is drained:

- ▶ Install the oil drain plug **52** with new a seal ring and tighten.
- ▶ Add oil as specified in the Service schedule on the oil filler port until the oil level is visible between the two marks on the dipstick **51**.
- ▶ Close the oil filler port by screwing in the dipstick **51**.
- ▶ Check the oil level, see section „Checking the oil level“.

5 Wheel set drive

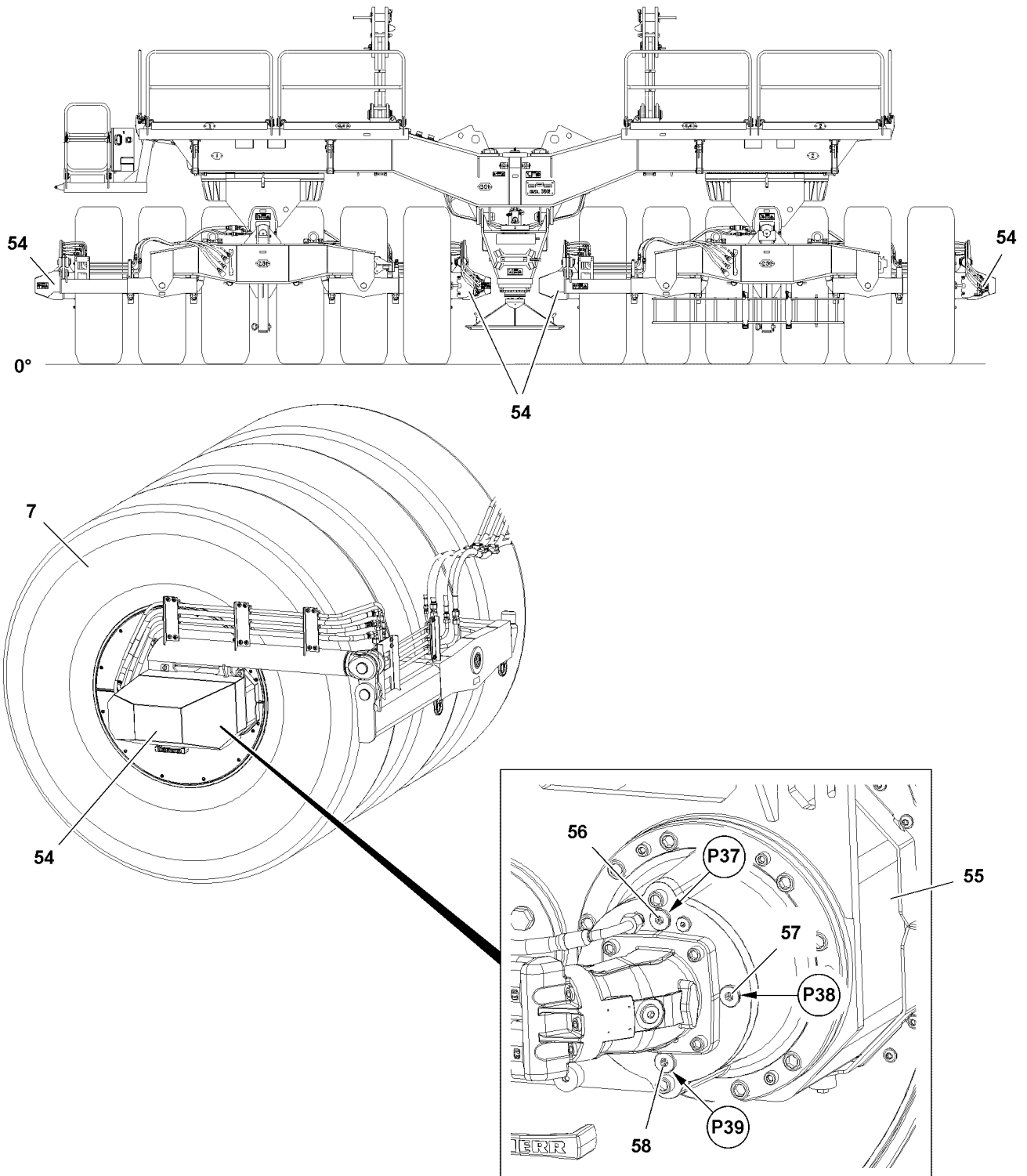

Fig.120248: Wheel set drive

Maintain utmost cleanliness during all work to prevent dirt from entering the interior of the slewing gear.

LWE/LR 11000-001/23501-04-02/en

**WARNING**

Danger of burns during maintenance and inspection work!
Severe burns can result due to the crane components and service fluids at operating temperatures.

- ▶ Avoid direct body contact to heated crane components and service fluids.

NOTICE

Dirt in the wheel set drive!
If any dirt gets inside the wheel set drive it can be damaged.

- ▶ Make sure that no dirt gets inside the wheel set drive during maintenance work.

NOTICE

Danger of property damage.

- ▶ Do not mix synthetic oils with mineral oils.

The specified fill quantities (change quantities) are orientation values. The markings on the dipsticks, inspection ports or sight gauges are decisive for filling.

Position	Components	Fill quantity
55	Wheel set drive	0.33 l

5.1 Checking for leaks

NOTICE

Leaky wheel set drive!
If a leak is found during the visual inspection of the wheel set drives, it can result in failure of the wheel set drive.
The wheel set drives can be damaged, resulting in considerable property damage.

- ▶ Repair the leaky wheel set drive and replace the wheel set drive, if in doubt.

- ▶ Check visually to ensure that the wheel set drives do not leak.

5.2 Checking the oil level

NOTICE

Damage to wheel set drives!
If seal rings are used repeatedly, it can result in loss of oil.
Due to loss of oil, the wheel set drives can wear significantly and / or be damaged.

- ▶ Use the seal rings on the maintenance ports only once.

**Note**

- ▶ To ensure a reliable oil level check, it must be ensured that the wheel set drives have been at a standstill for at least two minutes. This ensures that the gear oil has returned to the oil chamber completely.

Make sure that the following prerequisite is met:

- Ballast trailer is in horizontal position.
- ▶ Remove the hoods **54** on the wheel set drives **7**.
- ▶ Unscrew the oil level plug **57** with seal ring at point **P38**.

The gear oil must be visible at the fill height on the oil level plug **57**.

- ▶ Check the oil level.

NOTICE

Transmission damage due to impermissible oil level!

Too little gear oil causes lubricating problems and reduces the service life of the gear.

Too much gear oil causes more displacement work and overheats the gear.

- ▶ Check the oil level.

If necessary:

- ▶ Add or drain gear oil.

- ▶ Add or drain gear oil.

If gear oil must be added:

- ▶ Open the oil filler port by unscrewing the oil filler plug **56** at point **P37**.
- ▶ Add gear oil to the fill height on the oil level plug **57**.
- ▶ Close the maintenance ports tightly.
- ▶ Reinstall the hoods **54** on the wheel set drives **7** again properly.

5.3 Changing the gear oil

Make sure that the following prerequisites are met:

- Ballast trailer is in horizontal position.
- The wheel set drive is warm.

- ▶ Remove the hoods **54** on the wheel set drives **7**.

If gear oil must be replaced:

- ▶ Open the oil filler port by unscrewing the oil filler plug **56** at point **P37**.
- ▶ Catch the gear oil: Position a container under the oil drain plug **58** at point **P39**.
- ▶ Drain the gear oil: Unscrew the oil drain plug **58** with seal ring at point **P39**.
- ▶ Clean the oil drain plug **58** and sealing surface on the housing.

When gear oil is drained:

- ▶ Install the oil drain plug **58** with new a seal ring and tighten.
- ▶ Add gear oil to the fill height on the oil level plug **57**.
- ▶ Install the oil level plug **57** with new a seal and tighten.
- ▶ Install the oil filler plug **56** with new a seal and tighten.
- ▶ Install the hoods **54** on the wheel set drives **7**.

6 Central lubrication system

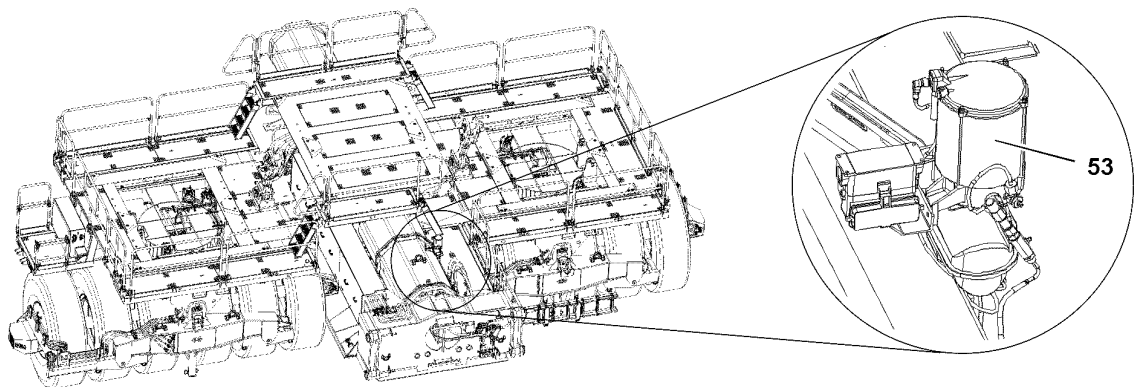

Fig.120249: Position of central lubrication system

**Note**

▶ See chapter 7.05.

The specified fill quantities (change quantities) are orientation values. The markings on the dipsticks, inspection ports or sight gauges are decisive for filling.

Position	Components	Fill quantity
53	Central lubrication system	2.5 kg

7.05 Maintenance guidelines - Crane superstructure

1	Safety guidelines	3
2	Engine	3
3	Cooling system	5
4	Air filter system	7
5	Fuel system	8
6	Urea system*	14
7	Exhaust system	15
8	Pump distributor gear	15
9	Central lubrication system	17
10	Slewing ring connection	23
11	Slewing gear	24
12	Hoist gears	26
13	Assembly winch	28
14	Auxiliary heater*	29
15	Hydraulic system	31
16	Hydraulic hose lines	34
17	Air dryer	35
18	Electrical system	36
19	Ballast trailer*	39
20	Ladders	43
21	Window cleaning system	45

Fig.195219

LWE/LR 11000-001/23501-04-02/en

1 Safety guidelines

Observe and adhere to the Crane operating instructions, chapter 2.04 and chapter 2.06.

Observe and adhere to the Crane operating instructions, chapter 7.01.

2 Engine



Note

Recommendation!

► Check the oil level before starting to travel or before starting to work.

2.1 Checking the oil level on the LICCON monitor

Make sure that the following prerequisites are met:

- The crane is in a horizontal position.
- The engine has been turned off for at least 30 minutes.
- The ignition is turned on.

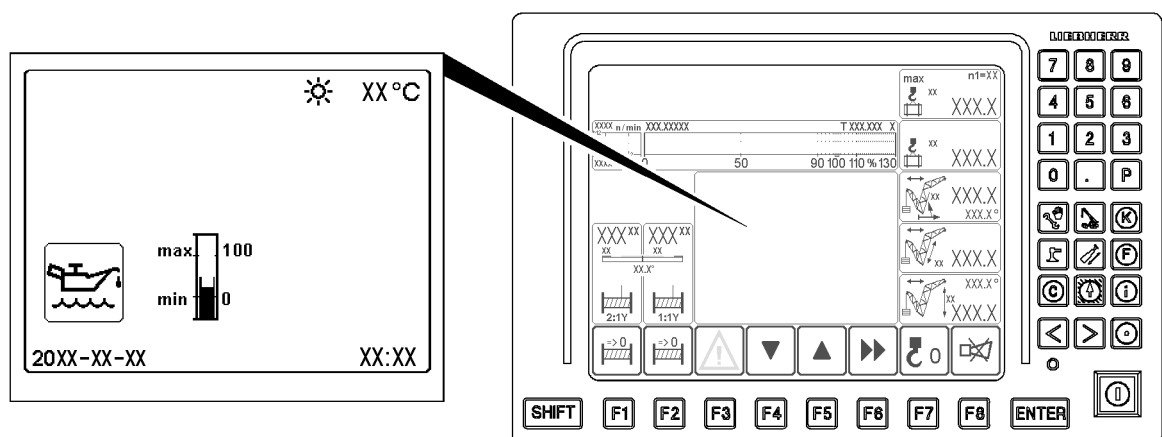

Fig.126500: Individual control display for Engine oil level

In the LICCON monitor the oil level is shown in the form of a bargraph in percentages [%].

Explanation of bargraph:

- Under *min*: Oil level too low.
- Between *min* and *max*: Oil level OK.
- Over *max*: Oil level overfilled.

The selection of the individual control display is described in the Crane operating instructions, chapter 4.02.

► Select Individual control display *Engine oil level*

NOTICE

Engine damage due to insufficient engine oil!

If too little engine oil is shown:

- Add engine oil.
- Check the oil level.

Problem remedy

Oil consumption or loss of oil too high?

- ▶ Find the cause and remedy it.

If the cause cannot be remedied:

- ▶ Contact Liebherr Service.

2.2 Checking the oil level with the dipstick

**Note**

Recommendation!

- ▶ Check the oil level before starting to travel or before starting to work.

NOTICE

Engine damage due to lack of oil!

- ▶ Check the oil level and establish the permissible oil level, if necessary.

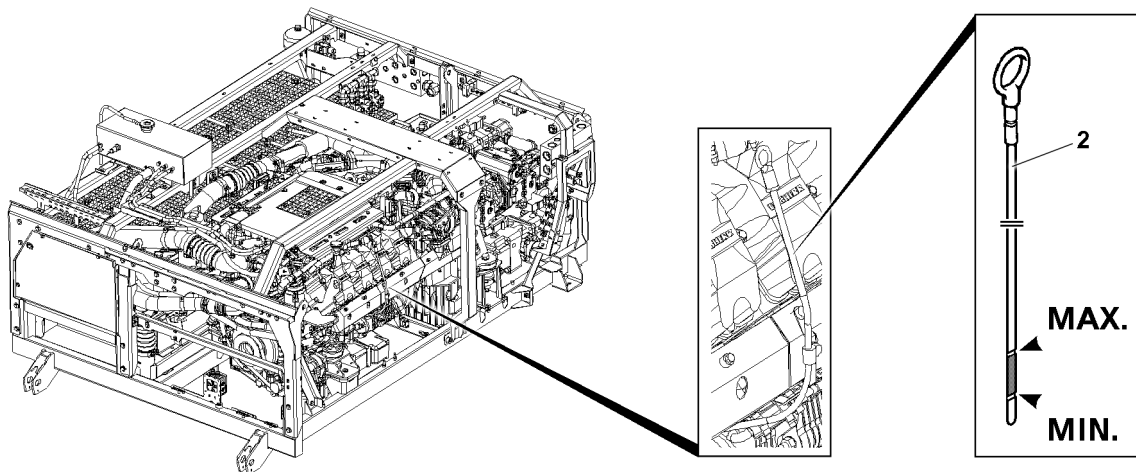

Fig.126501: Engine dipstick

Make sure that the following prerequisites are met:

- The crane is in a horizontal position.
- The engine has been turned off for at least 30 minutes.

- ▶ Pull out the dipstick **2** and wipe it off.
- ▶ Insert the dipstick **2** and pull it out.

The engine oil must be visible between both marks on the dipstick **2**.

- ▶ Check the oil level.

Problem remedy

The oil level is too low?

- ▶ Add engine oil until the oil level is visible between both marks on the dipstick **2**. See Engine operating instructions.

- ▶ Insert the dipstick **2**.

Problem remedy

Oil consumption or loss of oil too high?

- ▶ Find the cause and remedy it.

If the cause cannot be remedied:

- ▶ Contact Liebherr Service.

2.3 Servicing the engine according to the information from the manufacturer

Service the engine according to the information from the manufacturer.

3 Cooling system



WARNING

Swallowing coolant, contact with coolant!

Poisoning when ingesting, eye damage and skin irritation at contact.

- ▶ Make sure that eyes, skin and clothing do **not** come in contact with coolant.

If coolant was swallowed:

- ▶ Contact a physician immediately.

When eyes came in contact with coolant:

- ▶ Flush the eyes out with a lot of clear water and go to a physician, if necessary.

When skin and clothing came in contact with coolant:

- ▶ Clean the skin and clothing immediately with water and soap.

NOTICE

Property damage due to impermissible coolant!

- ▶ Do **not** mix different coolant products.
- ▶ Do **not** thin Liebherr-Fertig-Mix (Liebherr Ready Made Mix).

When adding coolant:

- ▶ Use only the same coolant with the same color.

Different coolants are differentiated by different colors.

Coolants contain corrosion inhibitor - antifreeze fluid.

3.1 Checking the coolant level

Make sure that the following prerequisites are met:

- The crane is in a horizontal position.
- The engine is cold.

The coolant level is monitored by the LICCON computer system.

- ▶ Call up the monitoring functions. See the Crane operating instructions, chapter 4.02.



11

Fig.122792

When the *coolant level* icon **11** is yellow, then the coolant level is too low.

- ▶ Call up the individual control display.



12

Fig.122795

When the *coolant temperature* icon **12** is red:

- ▶ Wait until the coolant is cooled off.

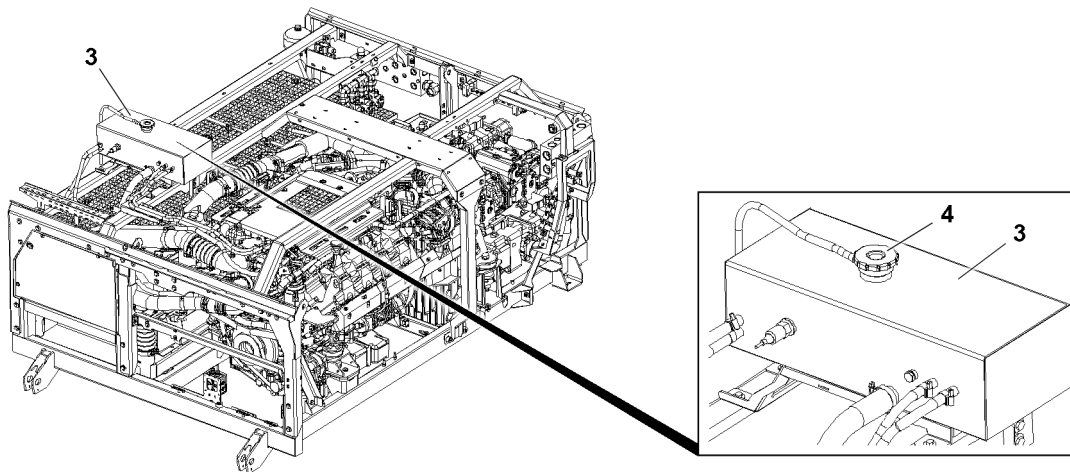

Fig.126502: Water cooler expansion tank

**DANGER**

Scalding due to hot coolant vapor!

- ▶ Check the coolant level only when the engine is cold.
- ▶ Wear protective gloves and safety glasses.

- ▶ Release excess pressure: Turn the cap **4** on the filler neck of water cooler expansion tank to the first notch.
- ▶ Remove the cap **4**.
- ▶ Check the coolant level.

Problem remedy

Coolant level is too low?

When the coolant level is too low:

- ▶ Add coolant until the lower edge of the riser tube.
- ▶ Add coolant only at the filler neck.

3.2 Replacing the coolant

**Note**

When the coolant is changed:

- ▶ Empty the cooling system completely and flush it.

Make sure that the following prerequisites are met:

- Coolant is replaced by authorized and trained expert personnel.

When the cooling system is completely emptied:

- ▶ Add coolant until the lower edge of the riser tube.

3.3 Servicing the cooling system according to the information from the manufacturer

Service the cooling system according to the information from the manufacturer.

4 Air filter system

4.1 Replacing the air filter

The air filters are monitored by the LICCON computer system.

► Call up the monitoring functions. See the Crane operating instructions, chapter 4.02.

Depending on the crane, different icons appear for the air filter.

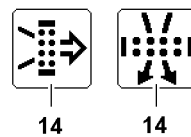

Fig.122794

When the *air filter* icon **14** is yellow, then the air filter is dirty.

► Call up the individual control display.

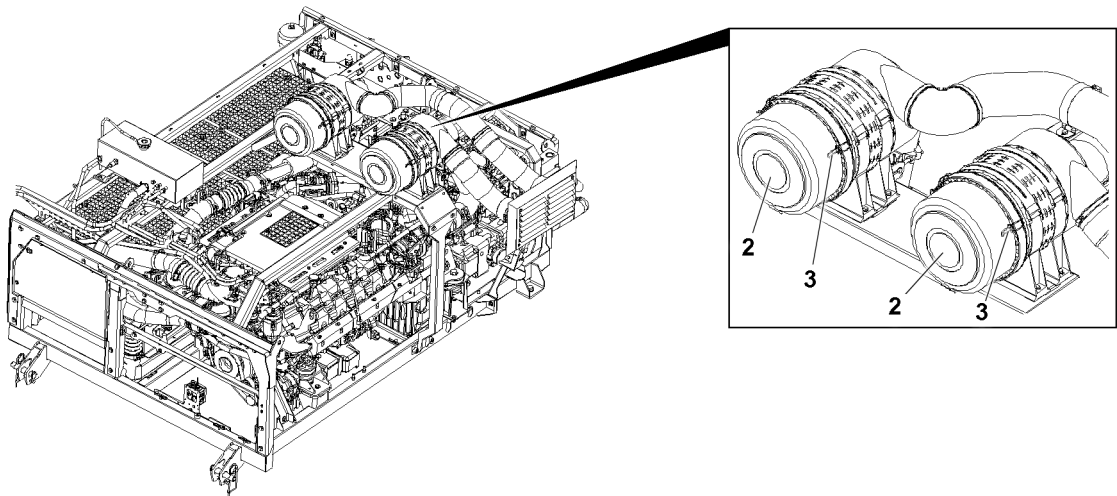

Fig.126503: Air filter system

When the *air filter* icon **14** is yellow:

- Remove the cover **2**.
- Open the locks **3** and open the cover **2**.
- Replace the filter insert.
- Close the cover **2** and fasten with locks **3**.

5 Fuel system



DANGER

Danger of fire and explosion!

- ▶ Do **not** smoke.
- ▶ Avoid open flames and light.
- ▶ Work only when the engine is turned off.
- ▶ Maintain extreme cleanliness during all work.



Note

Recommendation!

- ▶ Before releasing the fuel filter, place cleaning rags underneath.

5.1 Bleeding the fuel preliminary filter

Bleeding the preliminary fuel filter and the fuel low pressure system becomes necessary after:

- Draining the fuel preliminary filter.
- Changing the fuel preliminary filter.
- Emptying the fuel tank.
- Operating the engine for the first time.



WARNING

Manual opening of the fuel system!

Death, severe injuries, destruction of the Common Rail System.

- ▶ Do **not** release or open the fuel lines and injection lines.
- ▶ Bleed only through actuation of the hand pump.
- ▶ Maintain extreme cleanliness during all work.

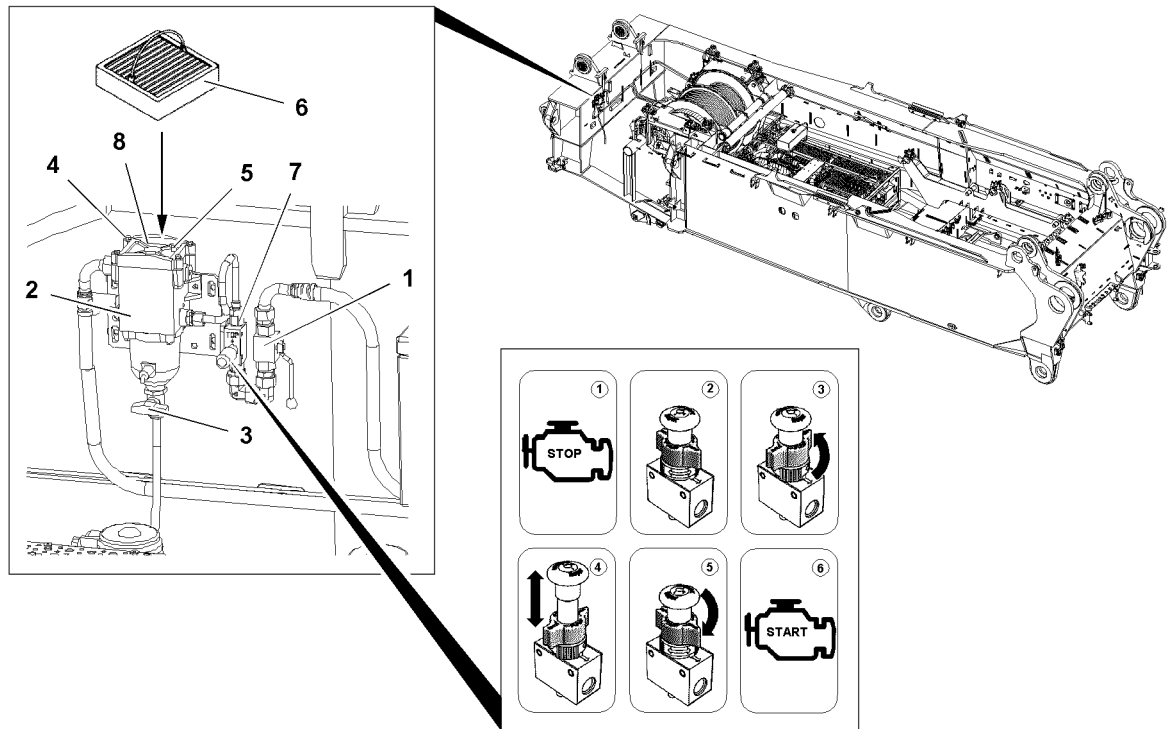

Fig.126504: Fuel preliminary filter

NOTICE

Breather screw is open!
Emerging fuel.

- ▶ Screw in the breather screw **5** on the fuel preliminary filter and tighten.

Make sure that the following prerequisites are met:

- The breather screw **5** on the fuel preliminary filter is screwed in and tightened.
- The ball valve is open.

- ▶ Turn the flow indicator on the manual supply pump to the pump position (PUMP).

The hand pump **7** is actuated by pulling.

- ▶ Actuate the hand pump **7** until a stronger resistance can be felt.
- ▶ Turn the mark of the flow indicator into operating position (RUN).

Result:

- The red arrow of the flow indicator points in the same direction as the connections of the fuel lines on the pump housing.
- ▶ Start the engine.

Problem remedy

Starting procedure remains unsuccessful after approx. 20 seconds?

Mark of flow indicator is in incorrect position.

- ▶ Wait for 1 minute.
- ▶ Check if the red arrow of the flow indicator points in the same direction as the connections of the fuel lines on the pump housing.

When the procedure has been repeated three times:

- ▶ Repeat the bleeding procedure.

5.2 Replacing the fuel preliminary filter insert

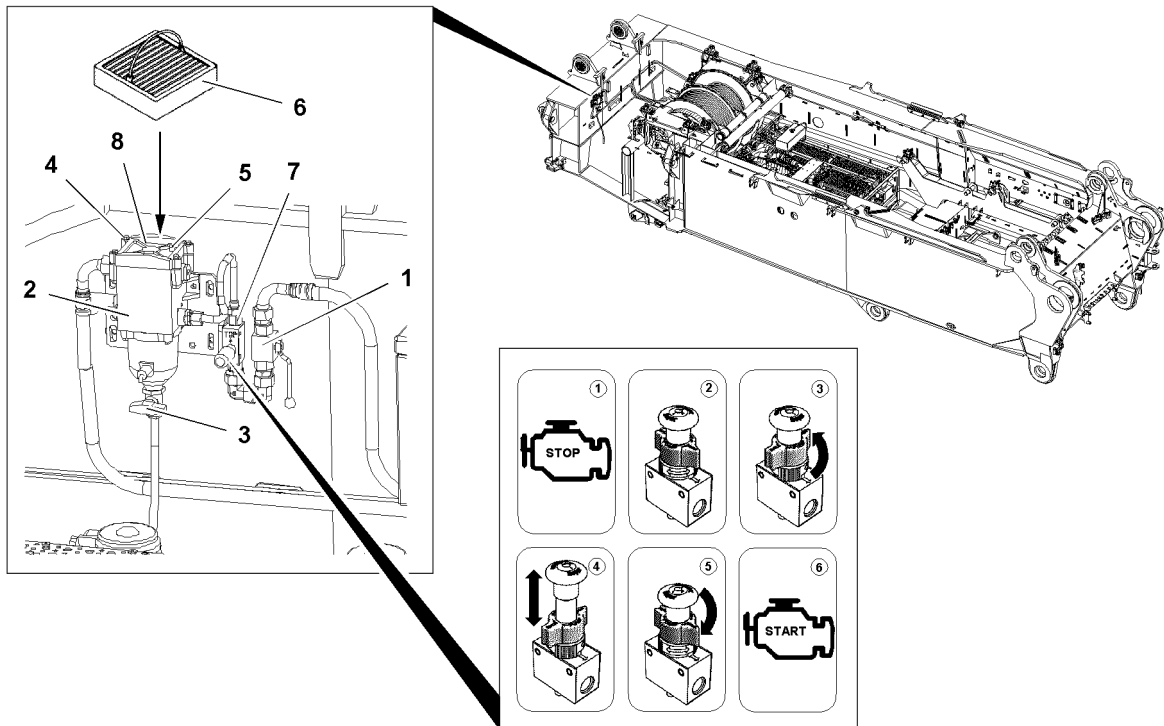

Fig.126504: Fuel preliminary filter

The filter strainer **6** on the fuel preliminary filter is changed:

- According to the maintenance intervals,
- **or** when an error message is shown.

Make sure that the following prerequisites are met:

- A container with the required capacity is on hand.
- New fuel preliminary filter insert is available.

- ▶ Turn the engine off.
- ▶ Catch the diesel fuel: Position a container under the fuel preliminary filter.
- ▶ Close the ball valve **1**.
- ▶ Turn the flow indicator on the hand pump to the pump position (PUMP).
- ▶ Release the breather screw **5**.
- ▶ Drain diesel fuel: Open the drain valve **3** until diesel fuel is visible on the water separator **2**.
- ▶ Close the drain valve **3**.
- ▶ Screw in the breather screw **5** on the fuel preliminary filter and tighten.

NOTICE

Dirt!

Destruction of Common Rail System.

- ▶ Make sure that **no** dirt gets into the inside of the filter.
- ▶ Do not reuse a used filter.

- ▶ Back out the screws **4** and remove the cover **8**.
- ▶ Take out the filter strainer **6**.
- ▶ Insert a new filter strainer **6** properly.
- ▶ Check the seal for damage.

When the seal is damaged:

- ▶ Replace the seal.
- ▶ Install the cover **8** with seals properly.
- ▶ Properly install and tighten the screws **4**.
- ▶ Open the ball valve **1**.

The hand pump 7 is actuated by pulling.

- ▶ Actuate the hand pump 7 until a stronger resistance can be felt.
- ▶ Turn the mark of the flow indicator into operating position (RUN).

Result:

- The red arrow of the flow indicator points in the same direction as the connections of the fuel lines on the pump housing.
- ▶ Remove the container and dispose of the fluid.
- ▶ Start the engine.

Problem remedy

Starting procedure remains unsuccessful after approx. 20 seconds?

Mark of flow indicator is in incorrect position.

- ▶ Wait for 1 minute.
- ▶ Check if the red arrow of the flow indicator points in the same direction as the connections of the fuel lines on the pump housing.

When the procedure has been repeated three times:

- ▶ Repeat the bleeding procedure.

5.3 Draining the fuel preliminary filter

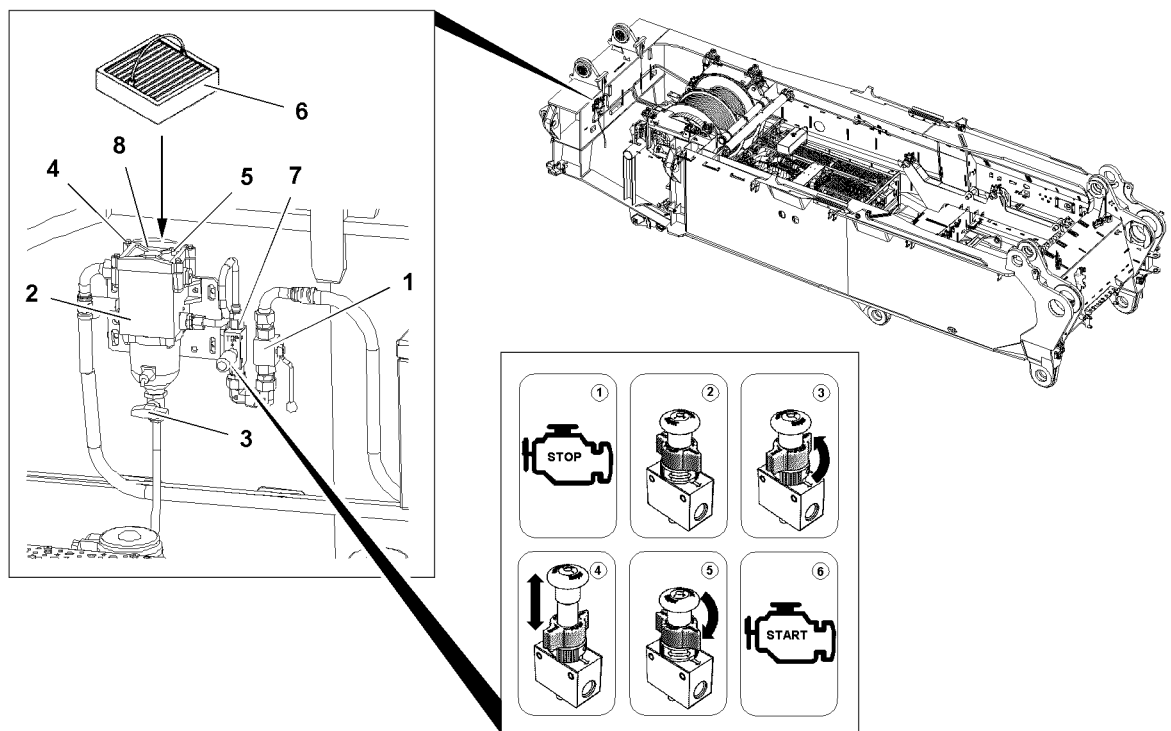

Fig.126504: Fuel preliminary filter

The water separator 2 on the fuel preliminary filter is drained:

- When an error message is shown.
- When a diesel - water mix is found in the water separator.

Make sure that the following prerequisites are met:

- The engine is turned off, the ignition is turned off.
- A container with the required capacity is on hand.
- New fuel preliminary filter insert is available.
- ▶ Catch the diesel fuel: Position a container under the fuel preliminary filter.
- ▶ Close the ball valve 1.

- ▶ Turn the flow indicator on the hand pump to the pump position (PUMP).
- ▶ Release the breather screw **5**.
- ▶ Drain the diesel - water mix: Open the drain valve **3** until diesel fuel is visible on the water separator **2**.
- ▶ Close the drain valve **3**.
- ▶ Screw in the breather screw **5** on the fuel preliminary filter and tighten.
- ▶ Open the ball valve **1**.

The hand pump **7** is actuated by pulling.

- ▶ Actuate the hand pump **7** until a stronger resistance can be felt.
- ▶ Turn the mark of the flow indicator into operating position (RUN).

Result:

- The red arrow of the flow indicator points in the same direction as the connections of the fuel lines on the pump housing.
- ▶ Remove the container and dispose of the fluid.
- ▶ Start the engine.

Problem remedy

Starting procedure remains unsuccessful after approx. 20 seconds?

Mark of flow indicator is in incorrect position.

- ▶ Wait for 1 minute.
- ▶ Check if the red arrow of the flow indicator points in the same direction as the connections of the fuel lines on the pump housing.

When the procedure has been repeated three times:

- ▶ Repeat the bleeding procedure.
-

5.4 Servicing the fuel system according to the information from the manufacturer

- ▶ Service the fuel system according to the information from the manufacturer.

5.5 Adding diesel fuel



WARNING

Danger of fire!

Diesel fuel is easily flammable and can cause fatal accidents in case of fire or open flames.

High property damage.

- ▶ Before the refueling procedure, turn the heating systems off, for example the auxiliary heater, flame start system.
 - ▶ During refueling, preclude fire, open light and smoking.
-



DANGER

Danger of fires due to spilled fuel!

- ▶ Keep the engine area free of fuel.
 - ▶ Absorb fuel with rags.
 - ▶ Dry up spilled fuel.
-

**WARNING**

Poisoning due to fuel!

Fuel is poisonous and hazardous to health.

- ▶ Do **not** allow for fuel to come in contact with skin, eyes or clothing.
- ▶ Do **not** breathe in fuel vapors.
- ▶ Keep children away from fuel.

If persons did come in contact with fuel:

- ▶ In case of eye contact, flush out the eyes immediately and consult a physician if necessary.
- ▶ Clean affected skin areas with clear water.

If fuel was swallowed:

- ▶ Contact a physician immediately.

NOTICE

Engine damage due to impermissible fuel!

When using incorrect fuel, the engine and the fuel system can be severely damaged.

- ▶ Do **not** add gasoline.
- ▶ Do **not** mix diesel fuel with gasoline.

When impermissible fuel was added:

- ▶ Do **not** turn the ignition on.
- ▶ Have the fuel tank and fuel lines completely drained by authorized and trained expert personnel.

Make sure that the following prerequisites are met:

- The crane vehicle is horizontal.
- The parking brake is applied.
- The engine is turned off.
- The ignition is turned off.
- The heating systems are turned off, for example auxiliary heater, flame start system.

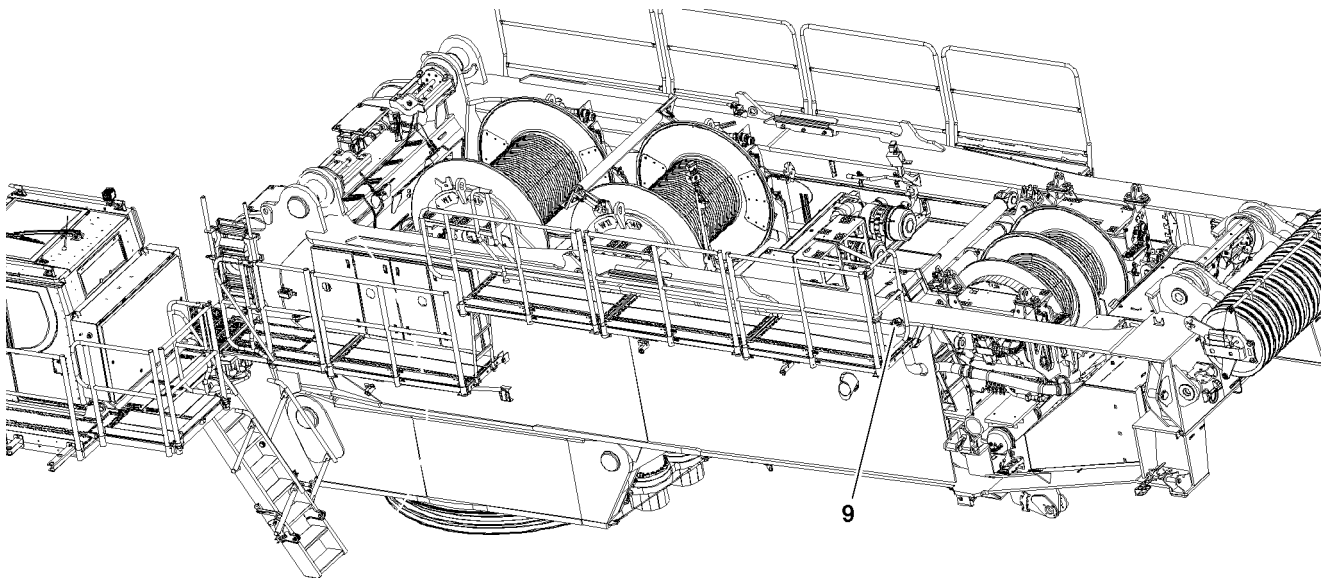

Fig.119065: Fuel tank

- ▶ Hang the fuel nozzle in the retainer.

Climb up and down on the crane vehicle.

- ▶ Open the tank cover **9**.
- ▶ Insert the fuel nozzle in the filler neck.
- ▶ Add diesel fuel.

When the refueling procedure is done:

- ▶ Remove the fuel nozzle from the filler neck.

- ▶ Close the tank cover **9**.

6 Urea system*



Note

- ▶ Applies only if an engine with exhaust aftertreatment, system SCR is installed.



WARNING

Skin irritation and eye injuries due to contact with urea!
Urea can cause skin irritation and eye injuries at contact.

- ▶ Do **not** allow for urea to come in contact with skin, eyes or clothing.

If persons did come in contact with urea:

- ▶ In case of eye contact, flush out the eyes immediately and consult a physician if necessary.
- ▶ Clean affected skin areas with clear water.

If urea was swallowed:

- ▶ Flush the mouth immediately with a lot of water. Then drink a lot of water and consult a physician, if necessary.



WARNING

Irritation of eyes and mucous membranes due to ammonia vapors!

If the urea tank cover is opened at high temperatures, ammonia vapors can emerge.

Burning eyes, nose, throat. Urge to cough.

- ▶ Keep the urea tank **1** closed at high temperatures.
- ▶ Do **not** breathe in ammonia vapors.

6.1 Adding urea solution

Make sure that the following prerequisites are met:

- The crane vehicle is horizontal.
- The engine is turned off, the ignition is turned off.
- The heating systems are turned off, for example auxiliary heater, flame start system.

NOTICE

Corrosion due to spilled urea!

If urea is spilled during refueling, affected surfaces can corrode.

- ▶ Flush affected surfaces immediately with lots of water.
- ▶ Do **not** overfill the urea tank.

If present:

- ▶ Refuel on a fuel pump with nozzle.

In this section, the refueling procedure with a fuel nozzle is described.

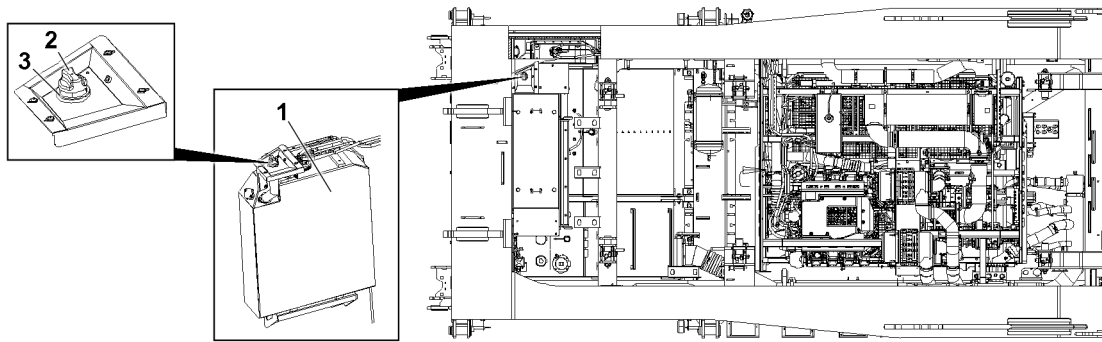

Fig.126505: Urea system

- ▶ Remove the cover **2**.
- ▶ Insert the fuel nozzle in the filler neck **3**.

NOTICE

Urea tank overfilled!

Urea solution expands at temperature fluctuations: Crack formation in the urea tank.

When the fuel nozzle turns off:

- ▶ End the refueling procedure.
- ▶ Do **not** overfill the urea tank.

- ▶ Refill Urea.

When the refueling procedure is done:

- ▶ Remove the fuel nozzle and close urea tank **1** with the cover **2**.

7 Exhaust system

7.1 Diesel particle filter*



DANGER

Danger of igniting the diesel particle filter*!

- ▶ Regenerate the diesel particle filter* only under supervision of the operating personnel.



Note

- ▶ Diesel particle filter **not** possible on Diesel engines with exhaust aftertreatment system SCR (Selective Catalytic Reduction).
- ▶ Maintain and operate the diesel particle filter*, see Operating instructions of the manufacturer.

8 Pump distributor gear

NOTICE

Transmission damage due to lack of oil!

When the oil level has dropped below the minimum mark:

- ▶ Add gear oil on the filler bore until the oil level is visible between the minimum and maximum mark on the dipstick **1**.

Maintain utmost cleanliness during all work to prevent any dirt from entering the inside of the gear.

Make sure that the following prerequisites are met:

- The crane is in a horizontal position.
- The gear has warmed up.

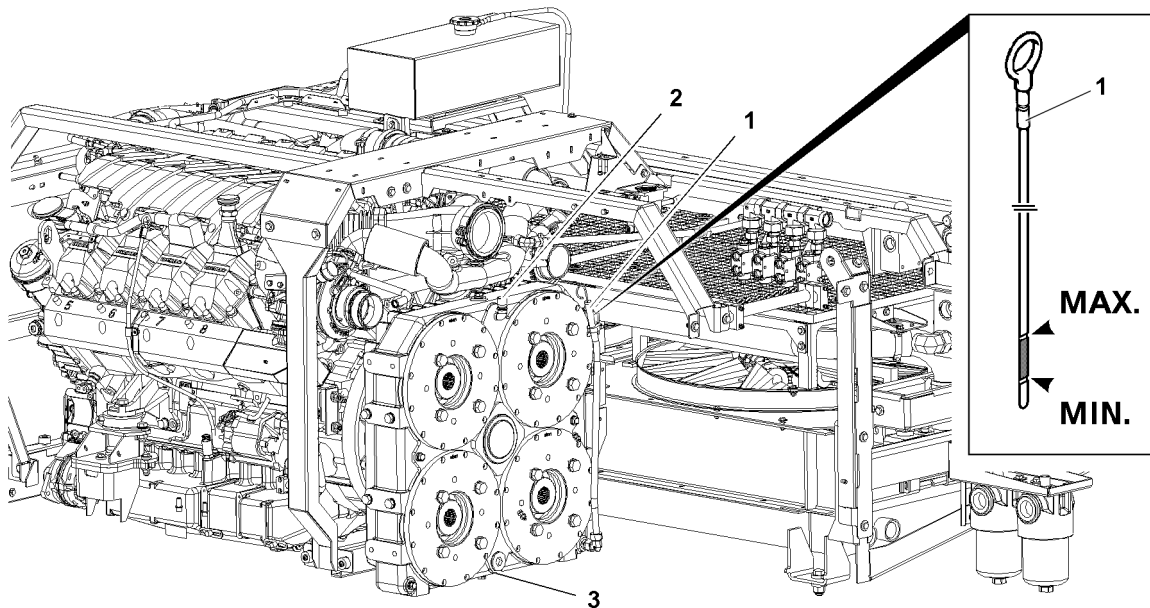

Fig.126506: Pump distributor gear

8.1 Checking the oil level

- ▶ Pull out the dipstick 1 and wipe it off.
- ▶ Insert the dipstick 1 and pull it out.

The oil level must be visible between the minimum and maximum mark on the dipstick 1.

- ▶ Check the oil level.
- ▶ Insert the dipstick 1.

Problem remedy

Oil consumption or loss of oil too high?

- ▶ Find the cause and remedy it.

If the cause cannot be remedied:

- ▶ Contact Liebherr Service.

8.2 Changing the gear oil

Make sure that the following prerequisites are met:

- The gear oil is changed by authorized and trained expert personnel.

- ▶ Unscrew the filler plug 2.
- ▶ Catch the gear oil: Position a container under the drain plug.
- ▶ Drain the gear oil: Unscrew the drain plug 3.

When gear oil is drained:

- ▶ Clean the drain plug 3 and sealing surface on the housing.
- ▶ Install the drain plug 3 with a new seal and tighten.
- ▶ Add gear oil on the filler bore until gear oil is visible between the minimum and maximum mark on the dipstick 1.
- ▶ Install the filler plug 2 with new seal.
- ▶ Check the oil level.

9 Central lubrication system

9.1 Technical safety instructions



WARNING

Non-observance of safety instructions!

Personnel can be harmed due to electrical, mechanical and chemical exposure.

Dangerous substances can be discharged and endanger the environment.

Property damage on the system can occur.

- ▶ Have maintenance and repair work carried out exclusively by authorized and trained expert personnel.
 - ▶ Use exclusively original Liebherr spare parts.
 - ▶ Remedy any problems, which affect safety immediately.
 - ▶ Avoid direct body contact to heated components.
 - ▶ Maintain cleanliness during all work.
-

NOTICE

Property damage if the crane has not been moved for longer than three months!

- ▶ Actuate the central lubrication system until lubricant emerges on all lube points.
 - ▶ Repeat the respective crane movement several times.
 - ▶ Carry out intermediate lubrications again.
-

NOTICE

Property damage due to crane cleaning procedure!

- ▶ Cleaning is only permitted in washing bays.
- ▶ Carry out the cleaning procedure with a steam cleaner or high pressure cleaner at a minimum distance of 0.4 m.

When the crane is cleaned:

- ▶ Carry out intermediate lubrication processes manually, see section „Carrying out intermediate lubrication“.
-

9.2 Description of function

The crane superstructure is equipped with three central lubrication systems.

The lube points in the bearings of the components are automatically supplied with lubricant.

9.2.1 Central lubrication system Superstructure

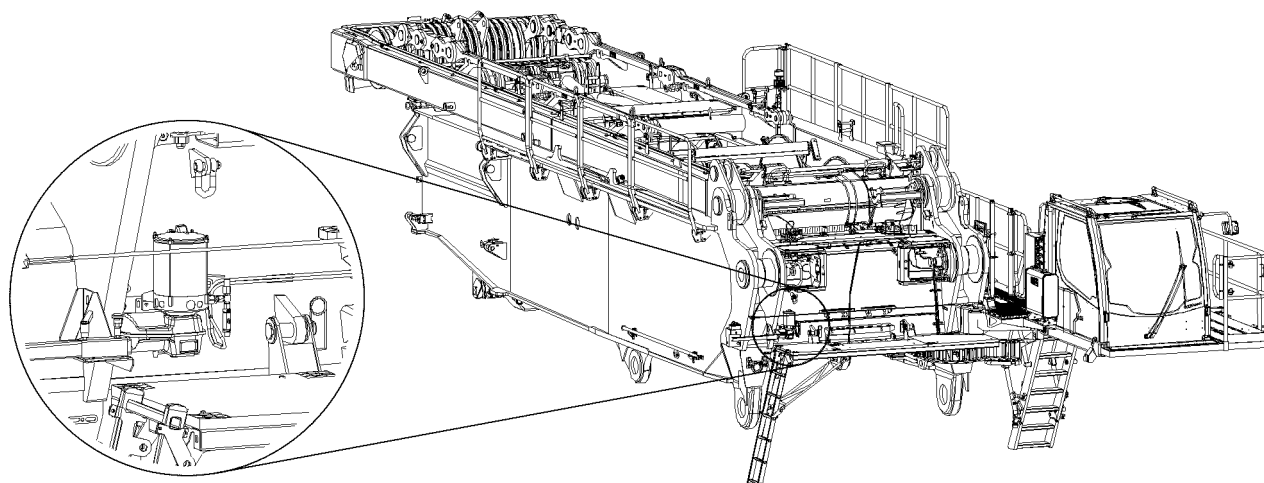

Fig.119078: Position of central lubrication system

The lube points in the bearings of the following components are supplied with lubricant:

- Pin SA-frame
- Pin S-pivot section
- Pin D-pivot section
- Winch 1
- Winch 2
- Cab
- Assembly winch
- Pin roller set

9.2.2 Central lubrication system Roller ring connection

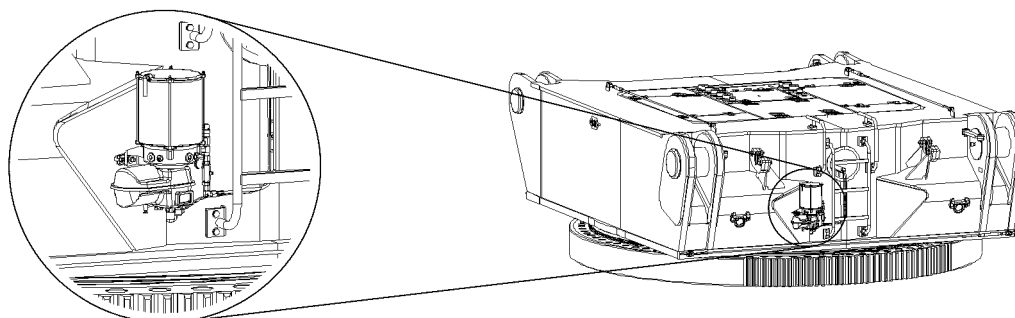

Fig.119079: Position of central lubrication system

The lube points in the bearing of the following component are supplied with lubricant:

- Roller ring connection

9.2.3 Central lubrication system Ballast trailer*

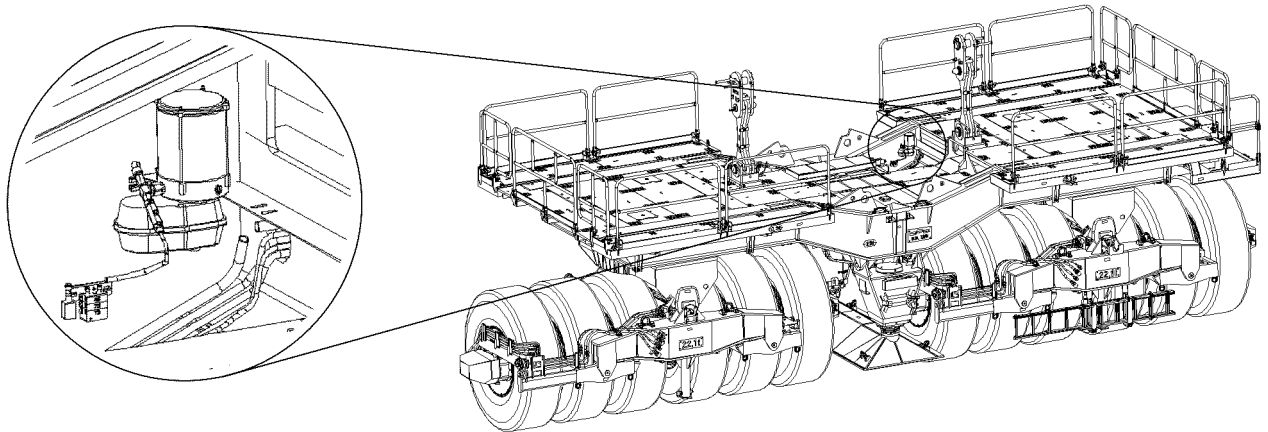

Fig.119080: Position of central lubrication system

The lube points in the bearings of the following components are supplied with lubricant:

- Drive shaft
- Roller ring connection
- Rotary connection

9.3 Operating and maintaining the central lubrication system

9.3.1 Displays on the control element

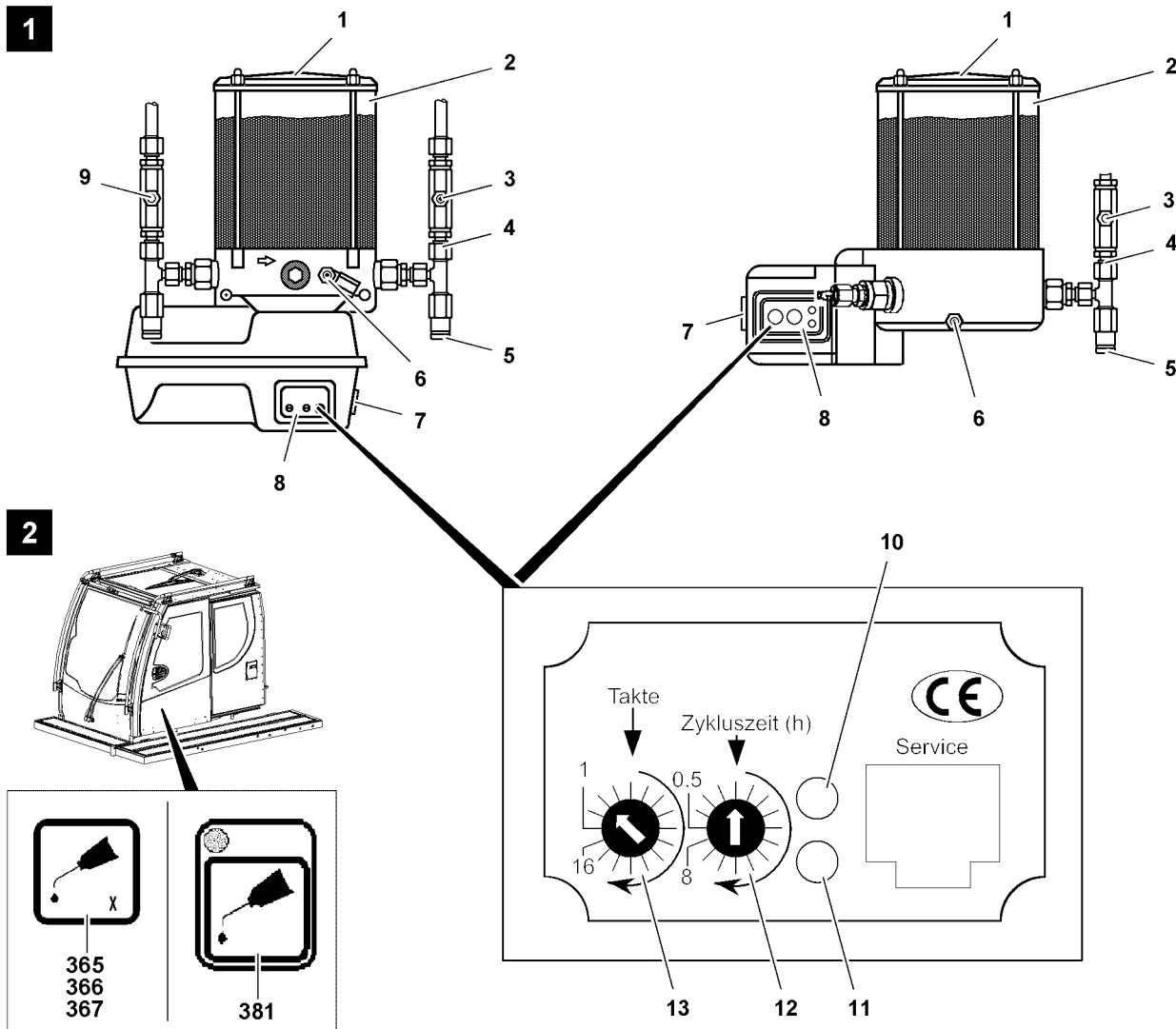

Fig.145952: Operation - Central lubrication system

- | | | | | | |
|---|---------------------------------|----|---------------------------------|-----|---------------------------------------|
| 1 | Cover Grease container | 7 | Intermediate lubrication button | 13 | Latched switch lube cycles |
| 2 | Grease container | 8 | Control element | 365 | Indicator light lubrication circuit 1 |
| 3 | Grease fitting Lube line | 9 | Grease fitting Lube line | 366 | Indicator light lubrication circuit 2 |
| 4 | Pump outlet | 10 | LED red | 367 | Indicator light lubrication circuit 3 |
| 5 | Pressure relief valve | 11 | LED green | 381 | Intermediate lubrication button |
| 6 | Grease fitting Grease container | 12 | Latched switch cycle time | | |

LWE/LR 11000-001/23501-04-02/en

**Note**

- ▶ In the crane operator's cab, operating conditions and problems of the central lubrication system are shown on indicator light **365**, indicator light **366** and indicator light **365**, see illustration **2**.
- ▶ For an overview of the indicator lights on the crane operator's cab, see the Crane operating instructions, chapter 4.01.
- ▶ Warning messages red LED **10** and green LED **11**, see section „Diagnostics and troubleshooting“

LED red 11	LED green 10	Operating condition
Lights up for 1.5 seconds	Lights up for 1.5 seconds	Operational readiness after ignition on
Off	Lights up	Lubrication is active (during lube cycles)
Lights up / blinks continuously	See section „Diagnostics and troubleshooting“	

Status of LEDs on the control element 8

9.3.2 Lube cycle

**Note**

- The lubrication time and the cycle time are set in the factory.
- ▶ Do **not** change the settings.

Cycle time: Time from start of one lubrication to the start of another lubrication.

The cycle time is set with the latched switch **12**.

Lube cycles: Number of strokes, during which lubricant is supplied by the pump cylinder.

The number of lube pulses for a lube cycle is set with the latched switch **13**.

9.3.3 Checking the function

Make sure that the following prerequisites are met:

- The ignition is turned on.

**Note**

- ▶ When lubricant emerges on all lube points, then the central lubrication system functions error-free.
 - ▶ Problems, see section „Diagnostics“.
-
- ▶ To check the function, trigger several lube pulses.
 - ▶ Trigger a lube pulse: Press the button **7** until lubricant emerges on all lube points.

9.3.4 Carrying out an intermediate lubrication

Manual intermediate lubrication is carried out, for example:

- If the crane has not been moved for longer than three months.
- After washing the crane.

**Note**

- ▶ When intermediate lubrication is carried out, the pump starts the lube cycle again. The lube cycle is reset.

Several lube pulses may be required until lubricant emerges on all lube points.

- ▶ Press the button **7** until lubricant emerges on all lube points.

or

Press the button **381** (in the crane operator's cab) until lubricant emerges on all lube points.

9.3.5 Filling the grease container

NOTICE

Property damage due to insufficient lubrication!

- ▶ Make sure that the grease container **2** is filled.
- ▶ Make sure that all grease fittings are clean.

- ▶ Fill the grease container **2** with a grease pump on the grease fitting **6**.

9.3.6 Bleeding the central lubrication system

If the grease container **2** is emptied, it may be necessary to bleed the central lubrication system.

- ▶ Fill the grease container **2** with a grease pump via the grease fitting **6**.
- ▶ Unscrew the main line from the pump outlet **4**.
- ▶ Trigger additional lubricating pulses until there are no more air bubbles in the emerging grease at the pump outlet **4**.
- ▶ Reconnect the main line.
- ▶ Carry out intermediate lubrication until lubricant emerges on all lube points.

9.3.7 Filling the lubrication lines

NOTICE

Components running dry due to insufficient lubrication!

- ▶ After every repair on greased components, fill the lube lines with grease.
- ▶ Make sure that all grease fittings are clean.

- ▶ Fill lube lines with a grease pump on grease fitting **3** (and grease fitting **9**).
or
Carry out intermediate lubrication until lubricant emerges on all lube points.

9.4 Diagnostics and problem remedy

9.4.1 Problem signals on control element



Note

- ▶ In the crane operator's cab, operating conditions and problems of the central lubrication system are shown on button **662**, see illustration **2**.
- ▶ For an overview of the indicator lights on the crane operator's cab, see the Crane operating instructions, chapter 4.01.

Status LEDs		Cause	Remedy
LED red 10	LED green 11		
Blinks once in two seconds	Blinks once in two seconds	Cycle error	Fix the system; contact Liebherr Service
Blinks once a second	Off	CPU error, memory error	Fix the system; contact Liebherr Service
Lights up	Off	Grease level too low (depending on system type)	Filling the grease container

Diagnostics for problem signals on control element 8

9.4.2 Problems on central lubrication system

Lubrication system status	Cause	Remedy
Lubricant emerges via pressure relief valve 5	The lubrication system is blocked	Fix the system; contact Liebherr Service
No lubricant emerges from the system	Grease container is empty or electric pump is defective	Fill grease container or fix system; contact Liebherr Service

Diagnostics for problems on the central lubrication system

9.4.3 Resetting a problem

- ▶ Press the button 7.

Result:

- Problem signal on control element turns off.

When a problem signal occurs again:

- ▶ Contact Liebherr Service.

10 Slewing ring connection



WARNING

Impermissible set up configuration when turning the crane superstructure!
Toppling crane. Death, severe bodily injuries, property damage.

- ▶ Enter and activate the load chart for crane operation *Turning 360°* in the LICCON overload protection.
- ▶ Set up the crane according to the set up configuration for load chart *Turning 360°*.



WARNING

Danger of crushing due to turning of crane superstructure!

- ▶ Work only when the crane superstructure is at a standstill.
- ▶ Do not crush your fingers during lubrication.

Make sure that the following prerequisites are met:

- The crane is supported and horizontally aligned.
- The load chart for crane operation *Turning 360°* is entered in the LICCON overload protection and active.
- The crane is equipped according to the set up configuration for load chart *Turning 360°*.

10.1 Lubricating the slewing ring connection



WARNING

Persons in the slewing range!
Crushing danger, death, severe bodily injuries.

- ▶ Monitor the slewing range.
- ▶ Make sure that there are **no** persons within the slewing range.
- ▶ Before initiating the turning movement, give a warning signal (horn).

**WARNING**

Obstacle in the slewing range!

Danger of collision, property damage.

- ▶ Make sure that there is **no** obstacle within the slewing range of the crane and the crane components.
-
- ▶ Trigger and intermediate lubrication manually on the central lubrication system.
or
Lubricate with external grease pump.
 - ▶ Turn the crane superstructure slowly.
 - ▶ Carry out lubrication until lubricant emerges on the sealing lips.
 - ▶ Stop the slewing movement of the crane superstructure.

10.2 Lubricating the gear ring and the slewing gear pinion

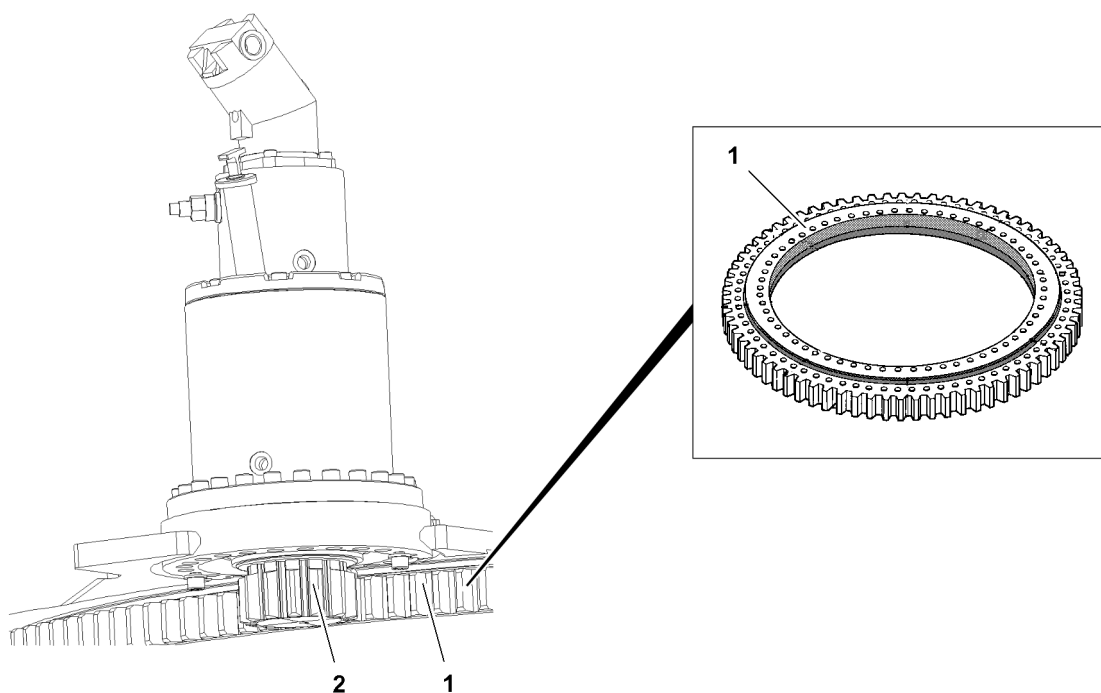

Fig.126815: Slewing gear

Before and after extended breaks in service, grease the gear ring **1** and the slewing gear pinion **2** to ensure the best possible protection from corrosion.

- ▶ Grease the gear ring **1** and the slewing gear pinion **2** externally.

11 Slewing gear

Maintain utmost cleanliness during all work to prevent any dirt from entering the inside of the gear.

Make sure that the following prerequisites are met:

- The crane is in a horizontal position.
- The gear has warmed up.

11.1 Checking the oil level with the dipstick

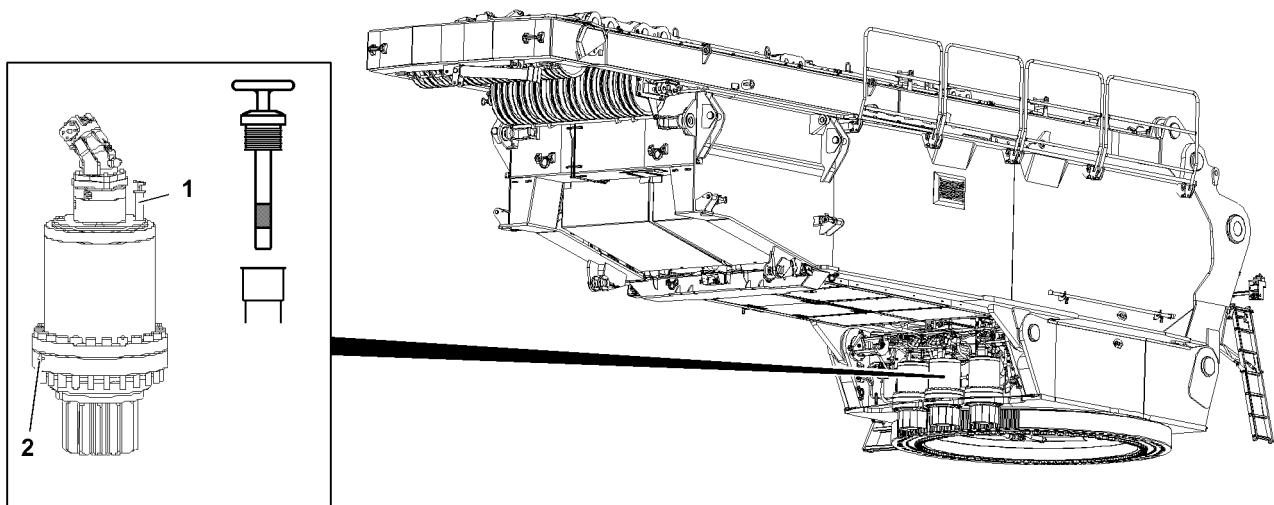

Fig.119070: Slewing gear

- ▶ Pull out the dipstick 1 and wipe it off.
- ▶ Insert the dipstick 1 and pull it out.

NOTICE

Danger of gear damage!

If the oil level has dropped below the minimum mark, add gear oil until the oil level is between the minimum and maximum mark on the dipstick 1.

- ▶ Add gear oil and check again.

The oil level must be visible between the minimum and maximum mark on the dipstick 1.

- ▶ Check the oil level.
- ▶ Insert the dipstick 1.

Problem remedy

Oil consumption or loss of oil too high?

- ▶ Find the cause and remedy it.

If the cause cannot be remedied:

- ▶ Contact Liebherr Service.

11.2 Changing the gear oil

Make sure that the following prerequisites are met:

- The gear oil is changed by authorized and trained expert personnel.

- ▶ Pull out the dipstick 1.
- ▶ Catch the gear oil: Position a container under the drain plug.
- ▶ Drain the gear oil: 2Unscrew the drain plug 2.

When gear oil is drained:

- ▶ Clean the drain plug 2 and sealing surface on the housing.
- ▶ Install the drain plug 2 with a new seal and tighten.
- ▶ Add gear oil on the filler bore until gear oil is visible between the minimum and maximum mark on the dipstick 1.
- ▶ Insert the dipstick 1.
- ▶ Check the oil level.

12 Hoist gears

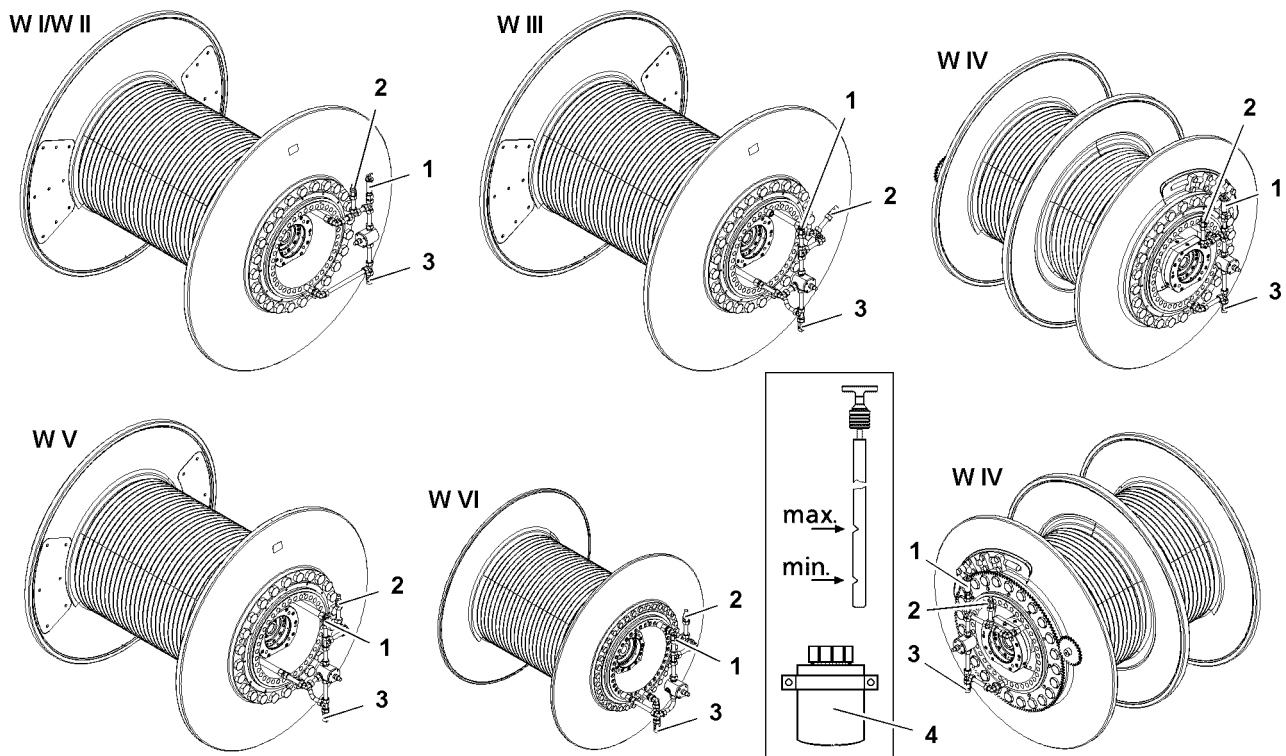

Fig.119077: Winches 1 to 6

Maintain utmost cleanliness during all work to prevent any dirt from entering the inside of the gear.

Make sure that the following prerequisites are met:

- The hoist gears are at a standstill.
- The crane is in a horizontal position.

12.1 Checking the oil level

- ▶ Remove and wipe off the dipstick 1.
- ▶ Reinsert the dipstick 1 and pull it out again.

NOTICE

Transmission damage due to lack of oil!

When the oil level has dropped below the minimum mark:

- ▶ Add gear oil at the oil filler port until the oil level is between the minimum and maximum mark on the dipstick 1.

The oil level must be between the min. and max. marks on the dipstick 1.

- ▶ Check the oil level.
- ▶ Insert the dipstick 1.

Problem remedy

Unusual oil consumption or loss of oil!

- ▶ Find the cause and remedy it.

If the cause cannot be remedied:

- ▶ Contact Liebherr Service.

12.2 Changing the gear oil

- ▶ Unscrew the breather screw **2**.
- ▶ Drain the gear oil into a suitable container: Remove the oil drain plug **3**.
- ▶ Clean the oil drain plug **3** and sealing surface on the housing.
- ▶ Install the oil drain plug **3** with a new seal and tighten.
- ▶ Pull out the dipstick **1**.
- ▶ Add gear oil on the oil filler port until the gear oil is between the minimum and maximum mark on the dipstick **1**.
- ▶ Screw in the breather screw **2** and tighten.
- ▶ Insert the dipstick **1**.
- ▶ Check the oil level.

12.3 Overflow container

When the oil heats up in the winch hydraulic motor, the oil can enter the overflow container **4** via a check valve, but cannot flow back into the hydraulic system after cooling off.

- ▶ Dispose of the oil in the overflow container **4** properly.

12.4 Lubricating the bearing at winch 1 and winch 2



Note

- ▶ Winch 1 and winch 2 are identical, for that reason the lubrication of the bearing is described on the example of one winch.

NOTICE

Insufficient lubrication!

In case of insufficient lubrication, the lubrication points can run dry.

This could result in high property damage.

- ▶ Adhere to the maintenance intervals: Lubricate the bearing at winch 1 and winch 2.



Note

- ▶ The amount of grease for the entire lubrication procedure is 200 g.
- ▶ Lubricate the winch bearing in 45° steps with 25 g each of grease.

Make sure that the following prerequisites are met:

- The hoist gears are at a standstill.
- The crane engine is running.

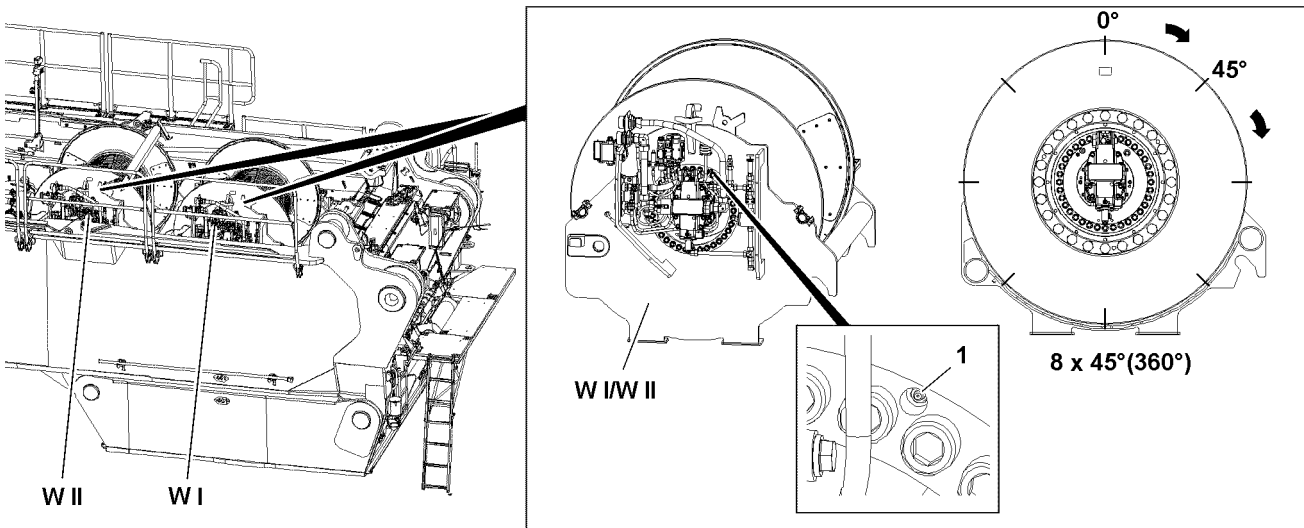

Fig.119083: Position of the grease fitting

- ▶ Lubricate the bearing of winch 1 with an external grease gun via the grease fitting 1, amount of grease approx. 25 g.



WARNING

Danger of accident due to running winch!

If the following instructions are not observed, dangerous situations can arise. Death, severe bodily injuries, property damage.

- ▶ Make sure that winch 1 is at a standstill during the lubrication procedure.
- ▶ Make sure that there are no persons within the danger zone.

When no persons are present in the danger zone:

- ▶ Turn winch 1 by 45° (spool up / out).
- ▶ Lubricate the bearing of winch 1 again with an external grease gun via the grease fitting 1, amount of grease approx. 25 g.

When no persons are present in the danger zone:

- ▶ Turn winch 1 again by 45° in the same direction.
- ▶ Lubricate the bearing of winch 1 again with an external grease gun via the grease fitting 1, amount of grease approx. 25 g.
- ▶ Carry out the lubrication procedure until winch 1 has completed a full turn (8 x 45°).



Note

- ▶ The lubrication of the bearing of winch 2 is identical with the lubrication procedure of the bearing of winch 1.
- ▶ Lubricate the bearing of winch 2.

13 Assembly winch

13.1 Changing the gear oil

Make sure that the following prerequisites are met:

- The assembly winch is spooled out.
- The winch mark is on top.

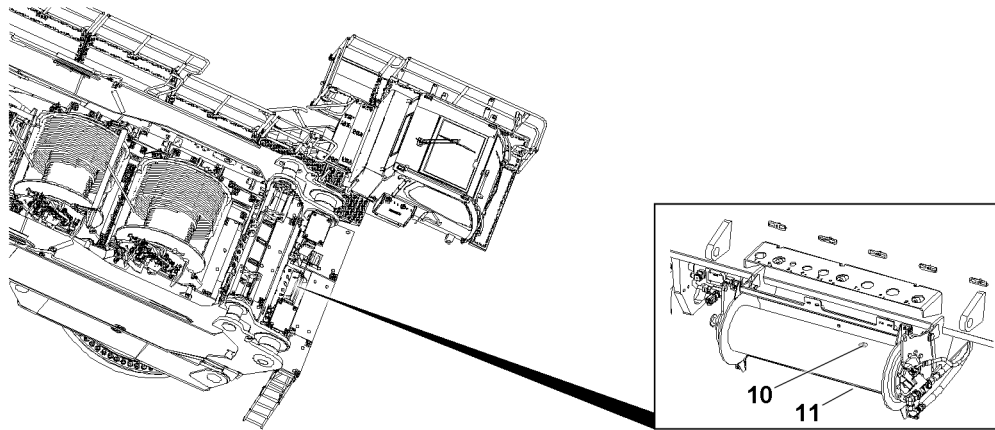

Fig.126507: Assembly winch

- ▶ Unscrew the filler plug **10**.
- ▶ Catch the gear oil: Position a container under the drain plug.
- ▶ Drain the gear oil: Unscrew the drain plug **11**.

When gear oil is drained:

- ▶ Install the drain plug **11** with a new seal and tighten.
- ▶ Add gear oil on the filler bore.
- ▶ Install the filler plug **10** with a new seal and tighten.

14 Auxiliary heater*

14.1 Replacing the filter insert

The crane operator's cab can be tilted upward for maintenance work.



WARNING

Danger of accident!

Death, severe bodily injuries, property damage.

- ▶ While the crane operator's cab is tilted, it is prohibited for any persons or objects to remain within the danger zone of the crane operator's cab.
- ▶ Make sure that the crane operator's cab is horizontally aligned.

14.1.1 Replacing the filter insert



Note

- ▶ Maintenance interval, see the Crane operating instructions, chapter 7.03.
- ▶ The maintenance interval can change depending on the area of operation.

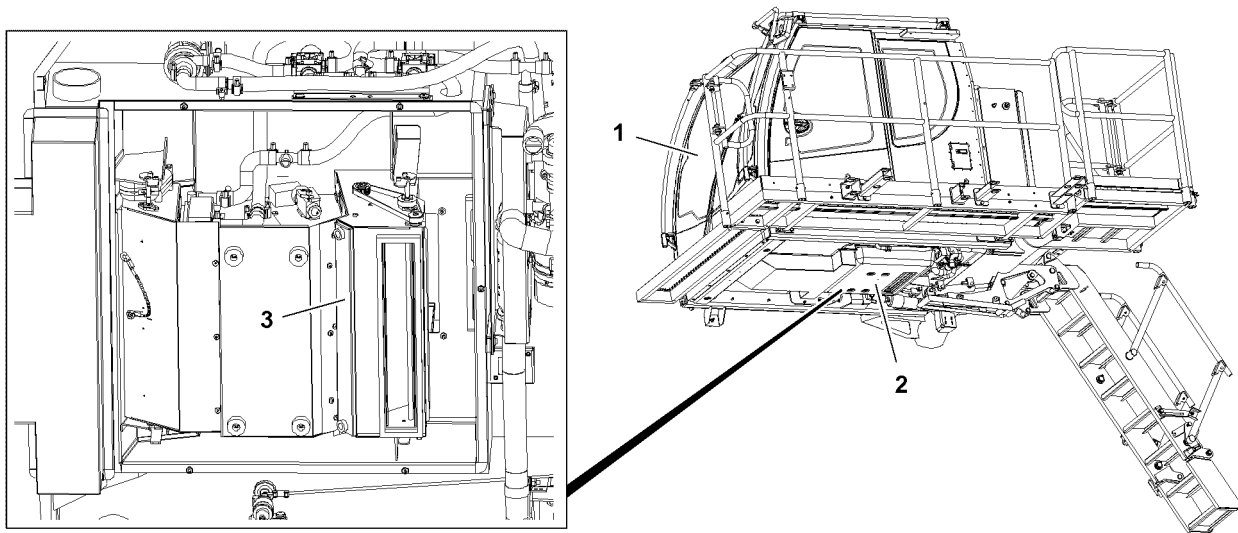

Fig.119075: Filter insert, auxiliary heater

- ▶ Remove the housing and cover 2.
- ▶ Remove the filter insert 4 and replace it.
- ▶ Install the cover 2 and housing.

14.2 Refueling fuel

Make sure that the following prerequisites are met:

- The crane is in a horizontal position.
- The auxiliary heater is turned off.
- The engine and the ignition are turned off.
- All railings and steps are swung into assembly position, see Crane operating instructions, chapter 2.06.

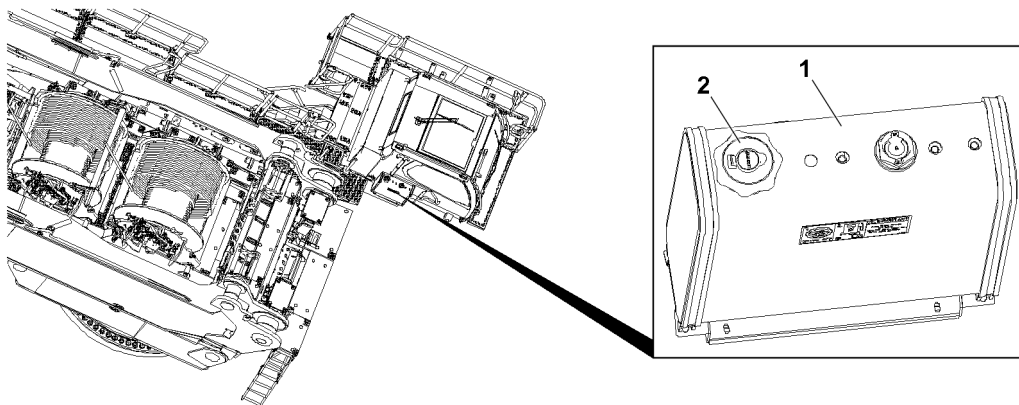

Fig.126508: Fuel container, auxiliary heater

- ▶ Open the cover 2.
- ▶ Insert the fuel nozzle in the filler neck.
- ▶ Refuel fuel.

After the refueling procedure:

- ▶ Remove the fuel nozzle from the filler neck.
- ▶ Close the fuel container 1 with the cover 2.

15 Hydraulic system

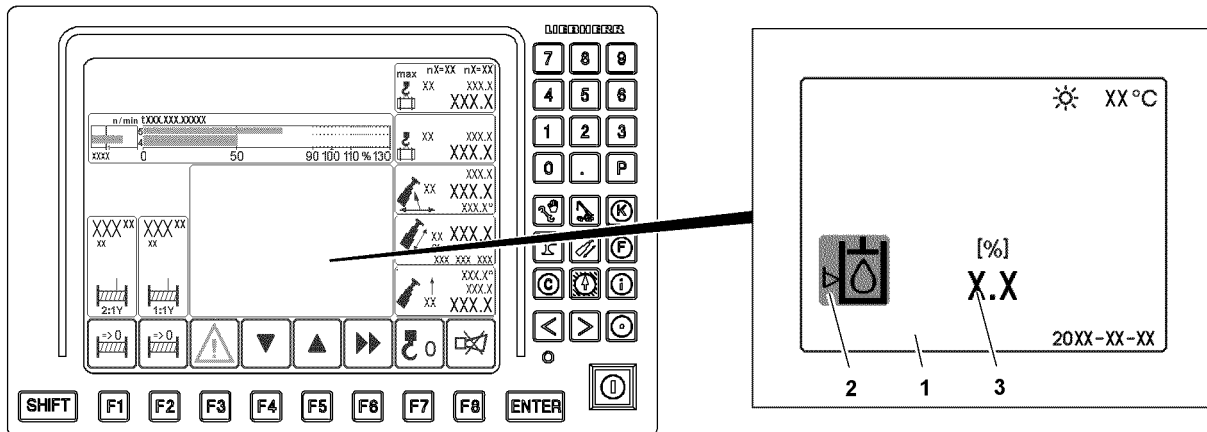

Fig.119071: Hydraulic oil level display

Extreme cleanliness must be maintained when adding hydraulic oil.

15.1 Checking the hydraulic oil level

Make sure that the following prerequisites are met:

- The crane is in a horizontal position.
- The luffing cylinder and the telescoping cylinder are fully retracted.
- The engine is turned off.
- The ignition is turned on.



Note

Recommendation!

- ▶ Check the oil level before starting to work.



Note

- ▶ The current oil level is shown in percentages.

All hydraulic cylinders are retracted:

- Display 2 is „green“ and display 3 shows a value between 95 % and 100 %, the oil level is ok.

Crane operation relevant hydraulic cylinders are extended or are in intermediate position:

- Display 2 is „green“, the oil level is ok.
- Display 2 is „yellow“ and display 3 shows a value under 10 %. Hydraulic oil must be added.
- Display 2 is „red“ and display 3 shows a value under 5 %. Hydraulic oil must be added.

When the hydraulic temperature is lower than 20 °C:

- ▶ Warm up the hydraulic oil.

When the hydraulic temperature is higher than 20 °C:

- ▶ Let the hydraulic oil cool off.
- ▶ Select display 1 of oil level. See the Crane operating instructions, chapter 4.02.
- ▶ Check the oil level on the display 3.

Problem remedy

Display 3 shows low oil level:

- ▶ Add hydraulic oil.
- ▶ Filter hydraulic oil when adding it through a fine mesh strainer.

Problem remedy

Unusual high hydraulic oil usage or loss of hydraulic oil!

- ▶ Find the cause and remedy it.

If the cause cannot be remedied:

- ▶ Contact Liebherr Service.

15.2 Checking the vent filter / breather filter

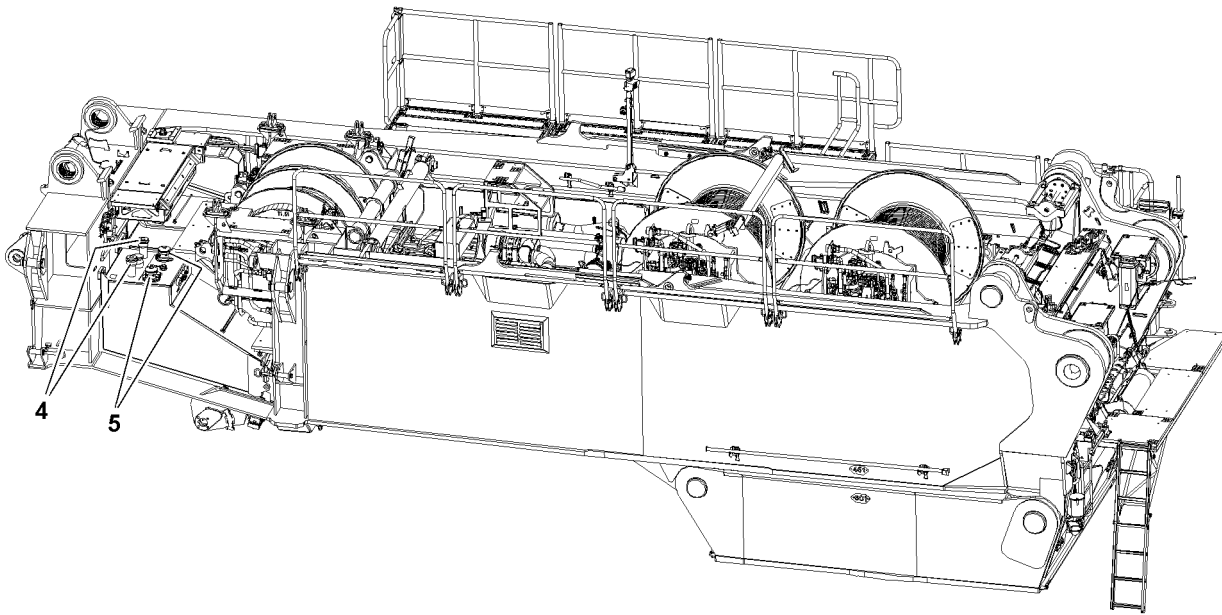

Fig.119072: Position of hydraulic system

- ▶ Turn the diesel engine off.
- ▶ Open the cover with the turn lock.
- ▶ Check the filter 4 for impurities (visual inspection).

In the event of heavy contamination:

- ▶ Replace the filter.
- ▶ Close the cover with the turn lock again.
- ▶ Start the diesel engine.
- ▶ Slowly go through all crane movements, this will bleed the hydraulic system.

Result:

- This bleeds the hydraulic system.
- ▶ Check the oil level again and add oil if necessary.

15.3 Checking the return filter

The return filter 5 is equipped with a maintenance indicator.

If the indicator moves into the red zone when the oil is warmed up ready for operation, then the filter must be changed.

- ▶ Turn the diesel engine off.
- ▶ Open the cover with the turn lock.
- ▶ Remove the filter insert.
- ▶ Rinse out the filter housing.
- ▶ Clean sealing surface on the cover and filter bracket.
- ▶ Insert a new filter insert.
- ▶ Lubricate the rubber seal ring on the new oil filter cartridge with oil.

- ▶ Close the cover with the turn lock again.
- ▶ Start the diesel engine.
- ▶ Slowly go through all crane movements, this will bleed the hydraulic system.

Result:

- This bleeds the hydraulic system.
- ▶ Check the oil level again and add oil if necessary.

15.4 Replacing the pressure filter

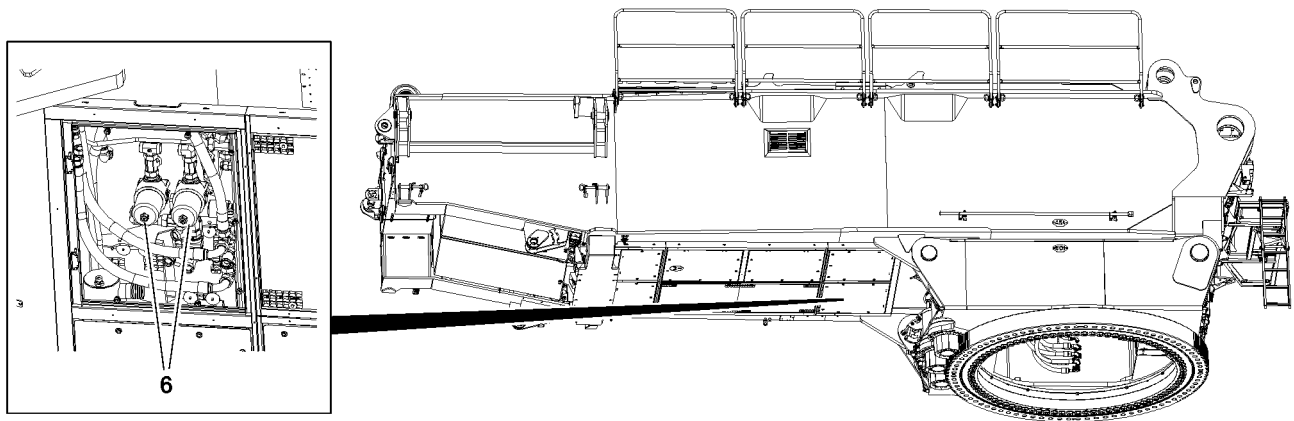

Fig.119074: Position of the pressure filter

The pressure filters **6** are equipped with a maintenance indicator. If the red bar is visible when the hydraulic oil is at the operating temperature, then the filter cartridge must be replaced.

- ▶ Turn the diesel engine off.
- ▶ Release the filter cartridge and collect escaping oil in a container.
- ▶ Remove and dispose of the filter cartridge.
- ▶ Clean the sealing surface on the filter bracket.
- ▶ Lubricate the rubber seal ring on the new oil filter cartridge with oil.
- ▶ Install a new filter cartridge and tighten.
- ▶ Start the diesel engine and check for leaks.
- ▶ Slowly run through all crane movements.

Result:

- The hydraulic system is bled.
- ▶ Check the oil level again and add oil if necessary.

15.5 Checking pretension pressure for the diaphragm reservoir

Various diaphragm reservoirs are installed in the hydraulic system. The pretension pressures are specified in the hydraulic circuit diagram as well as on the individual diaphragm reservoirs. The pretension pressure must be measured separately in each diaphragm reservoir.

**CAUTION**

Damage to the hydraulic system due to significantly fluctuating ambient temperatures!
If the outside temperature fluctuates considerably, e.g. after transport to extremely hot or cold countries or in countries with considerable differences between the summer and winter temperatures, the gas accumulator pressures may change.

- ▶ Check the gas accumulator pressures and correct if necessary.

Make sure that the following prerequisites are met:

- The diesel engine is turned off (diaphragm reservoir is relieved on the fluid side).



DANGER

Explosion due to exceedance of the maximum permissible operating pressure!

The pressure in the nitrogen cylinder must be less than the maximum permissible operating pressure of the accumulator or the pressure gauge. Otherwise install a pressure reducer between the cylinder and the filling device.

- ▶ Make sure that the pressure in the nitrogen cylinder is below the maximum permissible operating pressure of the reservoir or the pressure gauge.

When

- ▶ Switch the pressure reducing device between the bottle and the fill device.
 - ▶ Do not use air or oxygen to fill the diaphragm reservoir.
 - ▶ Make sure that the pretension pressure in the hydraulic reservoirs is only checked by expert personnel with appropriate training and equipment.
 - ▶ Adhere to the national regulations regarding the inspection of pressurized containers.
-
- ▶ Check the pretension pressure with a testing and filling device and correct, if necessary.

16 Hydraulic hose lines



WARNING

Damaged and leaky hydraulic hose lines!

Fire. Accident. Death, severe injury, property damage.

If leaky areas are found during the visual inspection:

- ▶ Have these leaky areas inspected immediately by authorized and trained expert personnel and remedied.

If damage is found during the visual inspection:

- ▶ Have the hydraulic hose lines checked by an **expert person for hydraulic hose lines**.



Note

- ▶ For annual inspection of hydraulic hose lines and for definition of **expert person for hydraulic hose lines**, see the Crane operating instructions, chapter 8.06.

Hydraulic hose lines must be inspected **once a year** by an **expert person for hydraulic hose lines**.

The system must be visually inspected **before starting to work**.

16.1 Inspecting the hydraulic hose lines for damage

Hydraulic hose lines must be inspected by an **expert person for hydraulic hose lines** when one of the following defects is found:

- Damage on outer surface, such as chafe marks, cuts and cracks.
- Brittleness due to aging of outer layer (cracks).
- Distortion, such as splitting of hose layers, bubbles, crushed areas, kinks, twists.
- Damage or distortion of hose fixtures or hose fitting (seal is endangered).

- ▶ Inspect the hydraulic hose lines for damage.

If one of the listed defects is found:

- ▶ Have the hydraulic hose lines checked by an **expert person for hydraulic hose lines**.
- ▶ Document conspicuous findings, decisions and replacements comprehensibly, see the Crane operating instructions, chapter 8.06.

16.2 Checking the hydraulic hose lines for leaks

- ▶ Check the crane for escaped hydraulic oil.
- ▶ Check the ground under the crane for leaks.

When the hydraulic system leaks:

- ▶ Have these leaky areas inspected by authorized and trained expert personnel and remedied.

If one of the listed defects is found:

- ▶ Have the hydraulic hose lines checked by an **expert person for hydraulic hose lines.**
or

Contact Liebherr Service.

- ▶ Document conspicuous findings, decisions and replacements comprehensibly, see the Crane operating instructions, chapter 8.06.

17 Air dryer

17.1 Replacing the granular cartridge of the air dryer

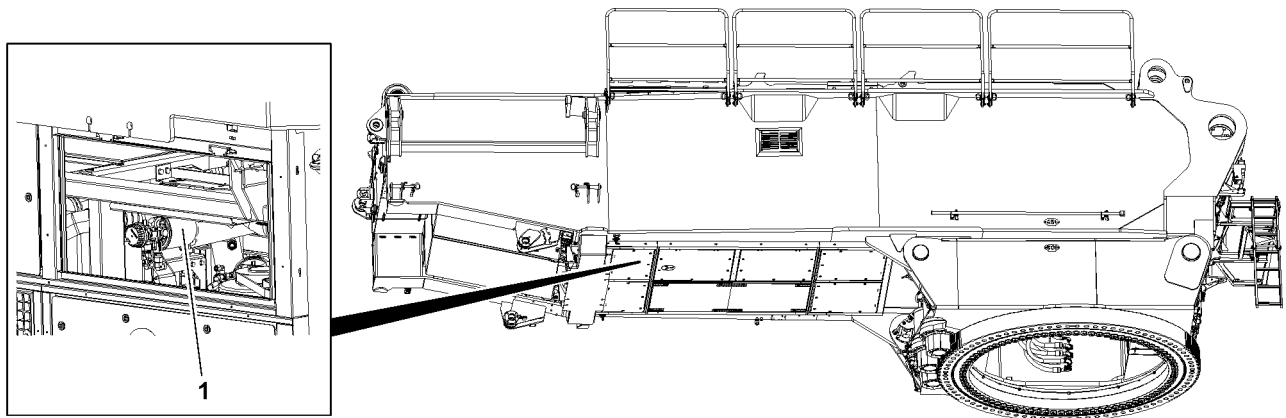

Fig.119076: Air dryer granular cartridge

NOTICE

Erroneous function of compressed air system and exhaust aftertreatment!

If the maintenance interval is exceeded, the drying and filter performance of the granular cartridge is reduced.

Condensation and dirt can accumulate in the compressed air system, which can cause erroneous functions of the compressed air system and the exhaust aftertreatment.

- ▶ Replace the granular cartridge **1** according to maintenance intervals.

The granular cartridge **1** of the air dryer is under spring tension.



WARNING

Uncontrolled release of the granular cartridge!

Severe injury, property damage.

- ▶ Release the granular cartridge carefully.
- ▶ Replace the granular cartridge **1** according to maintenance intervals.

18 Electrical system

18.1 Bulbs and fuses

NOTICE

Property damage on the electrical system!

- ▶ Defective fuses may **not** be bypassed with wire or the like.
- ▶ Always replace defective fuses with fuses for the same current strength.
- ▶ Always replace defective bulbs with bulbs that have the same output.

When the same fuse or bulb becomes defective repeatedly:

- ▶ Check the electrical system.

18.2 Lines

- ▶ Make sure that all electrical lines are properly routed and fastened in their retainers.
- ▶ Fix any chafes or brittle areas in the insulation and coverings immediately.
- ▶ Any installation lines that are **not** in perfect condition must be immediately and professionally replaced.

18.3 Batteries

18.3.1 Safety guidelines



WARNING



Danger of accidents due to discharged batteries!







- ▶ Plug in the cable of the external power supply on the Liebherr charger.
- ▶ Make sure that the batteries are charged while the crane is not in operation.



Note

- ▶ All safety signs on the batteries must be complete and always legible.
- ▶ Observe and adhere to the manufacturer's operating instructions.

Sign	Explanation
	Follow the guidelines on the battery, in the instruction manual and in the Crane operating instructions.
	Wear eye protection.
	Keep children away from acid and batteries.

Sign	Explanation
	Danger of explosion! A highly explosive acoustic mixture is created when charging batteries.
	Warning! Fire, sparks, open light and smoking is prohibited. Avoid spark formation when handling cables and electrical devices. Avoid short circuits.
	Danger of chemical burns! Battery acid is very caustic, for that reason: Wear protective gloves and eye protection. Do not tilt the battery, acid can emerge from the vent openings.
	First aid: Flush splashed acid in the eye immediately for several minutes with clear water and consult a physician immediately. Neutralize splashed acid on skin or clothing immediately with an antacid or soap and flush with lots of water. When acid was ingested, contact a physician immediately.
	Warning! Do not expose batteries unprotected to direct daylight. Discharged batteries can freeze. Store batteries frost free.
	Disposal! Dispose old batteries at a collection point. During transport, observe the guidelines of the manufacturer. Never dispose of old batteries in general trash.
	Back to the manufacturer! Used batteries with this sign are reusable assets. Send batteries for recycling. Old batteries, which are not recycled must be disposed of as hazardous waste under observation of all regulations.

18.3.2 Checking the batteries



DANGER

Mortal danger due to electric shock!

- ▶ When working on the electrical system of the crane, disconnect batteries from the electric circuits.
- ▶ Avoid spark formation caused by electrostatic charge.

When working on batteries:

- ▶ Wear a ground strap.
- ▶ Do **not** bring oil, grease, fuel or solvents into contact with the battery casting compound.

- ▶ Keep batteries dry and clean.
- ▶ Release dirty terminals, clean and grease them with an acid-free and acid-resistant grease.
- ▶ Charge batteries in time.
- ▶ Make sure that batteries are charged in the cold season.

18.3.3 Charging batteries with the Liebherr charger*

The Liebherr charger is integrated in the crane electrical system.

Make sure that the following prerequisites are met:

- The ignition is turned off.
- ▶ Turn the battery master switch off.

A socket for external power supply for the Liebherr charger is located on the crane.

- ▶ Plug in the cable of the external power supply on the socket.

18.3.4 Charging the battery with an external charger



WARNING

Danger of injuries!

- ▶ Do **not** place tools on batteries and keep out of open light.
- ▶ Eliminate spark formation caused by electrostatic charge.
- ▶ Work only in well ventilated rooms.
- ▶ Before working on batteries, wear a ground strap.
- ▶ Do **not** tilt or shake the batteries.

NOTICE

Property damage if charge voltage is more than 14.4 V !

- ▶ Make sure that the external charger delivers a charge voltage of maximum 14.4 V.

NOTICE

Loss of data due to disconnected battery!

When the battery is disconnected:

- ▶ Make sure that the temporary data memory is **not** needed.

Make sure that the following prerequisites are met:

- The ignition is turned off.

Charging the battery while installed

- ▶ Turn the battery master switch off.
- ▶ Use an external charger with a charge voltage of maximum 14.4 V.
- ▶ Charge the battery professionally with an external charger.

Charging the battery while removed

NOTICE

Damage to alternator!

- ▶ Do not disconnect batteries unless the diesel engine has been turned off.

Removing the batteries

- ▶ Turn the battery master switch off.
- ▶ Use an external charger with a charge voltage of maximum 14.4 V.
- ▶ Disconnect the negative terminal first (ground cable), then the positive terminal.
- ▶ Disconnect the vent hose from the vent channels of the batteries.
- ▶ Remove the batteries.

Charging the batteries externally

NOTICE

Damage to batteries!

- ▶ Charge only with direct current: Maximum current: 1/10 of the battery capacity.
-

Example for charging: To charge a battery with 70 Ah , the maximum charge current is 7 A.

- ▶ Thaw frozen batteries before charging.
- ▶ Make sure that the battery is ventilated during the charging procedure (danger of oxyhydrogen explosion).
- ▶ Connect the battery to a charger (positive to positive and negative to negative).
- ▶ Turn on the battery charger after connecting the battery.

Stop charging immediately if:

- The acid temperature exceeds 55 °C (casing more than warm to the touch).
 - The battery starts to give off gas.
 - The charging voltage has **not** changed for 2 hours.
- ▶ Turn the battery charger off after charging, then remove the connector cables individually from the battery and battery charger.

Installing the batteries

- ▶ Reinstall the batteries tightly in the vehicle.
- ▶ Connect the vent hose on the vent channels of the batteries.
- ▶ First connect positive terminal to battery, then negative terminal (ground lead).
- ▶ Check that the terminals are tightly seated (low transfer resistance).
- ▶ Grease the terminals and terminal posts with acid-free and acid-resistant grease (use corrosion protection even for modern maintenance-free batteries).

19 Ballast trailer*

19.1 Ballast trailer tires

19.1.1 Ballast trailer tires



Note

- ▶ See the Crane operating instructions, chapter 2.15.
-

19.1.2 Ballast trailer tires and disk wheels



Note

- ▶ See Crane operating instructions, chapter 8.01!
-

19.2 Slewing gear

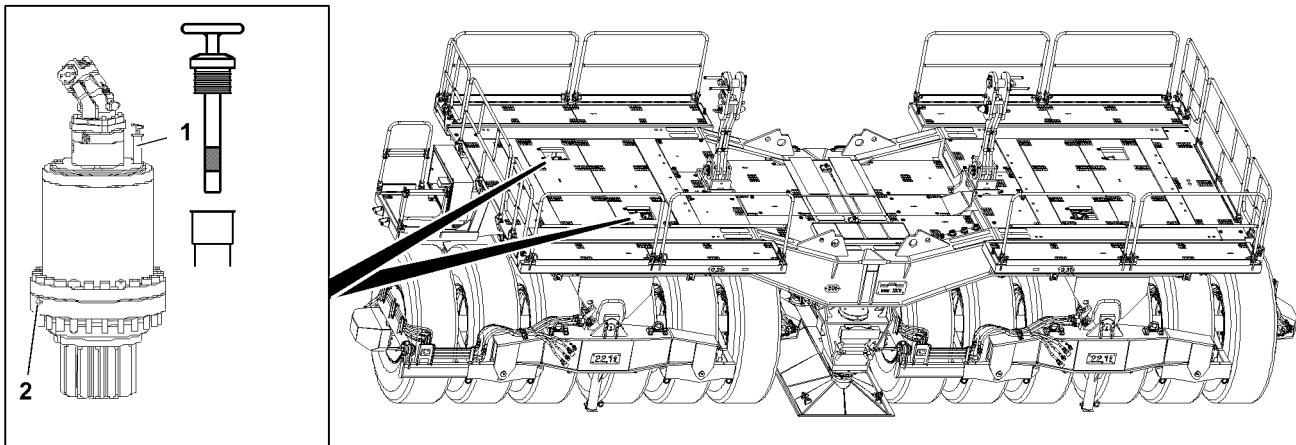

Fig.119081: Position of the slewing gear

NOTICE

Transmission damage due to lack of oil!

When the oil level has dropped below the minimum mark:

- ▶ Add gear oil at the oil filler port until the oil level is between the minimum and maximum mark on the dipstick 1.

Maintain utmost cleanliness during all work to prevent any dirt from entering the inside of the gear.

Make sure that the following prerequisites are met:

- Ballast trailer is in horizontal position.
- The gear has warmed up.

19.2.1 Checking for leaks

NOTICE

Leaky slewing gear!

If a leak was found on one or several slewing gears during the visual inspection, it can result in a failure of the affected slewing gear / slewing gears.

The slewing gears can be damaged, resulting in high property damage.

- ▶ Take the crane out of service, repair the leaky slewing gear / slewing gears and replace the slewing gear(s) if in doubt.

- ▶ Check visually to ensure that the slewing gears do not leak.

19.2.2 Checking the gear oil level

- ▶ Remove and wipe off the dipstick 1.
- ▶ Reinsert the dipstick 1 and pull it out again.

The oil level must be between the min. and max. marks on the dipstick 1.

- ▶ Check the oil level.
- ▶ Insert the dipstick 1.

Problem remedy

Unusual oil consumption or loss of oil!

- ▶ Find the cause and remedy it.

If the cause cannot be remedied:

- ▶ Contact Liebherr Service.

19.2.3 Changing the gear oil

- ▶ Pull out the dipstick 1.
- ▶ Drain the gear oil into a suitable container: Remove the oil drain plug 2.
- ▶ Clean the oil drain plug 2 and sealing surface on the housing.
- ▶ Install the oil drain plug 2 with a new seal and tighten.
- ▶ Add gear oil on the oil filler port until the gear oil is between the minimum and maximum mark on the dipstick 1.
- ▶ Insert the dipstick 1.
- ▶ Check the oil level.

19.3 Wheel drive



WARNING

Danger of burns during maintenance and inspection work!

Severe burns can result due to the crane components and service fluids at operating temperatures.

- ▶ Avoid direct body contact to heated crane components and service fluids.

Maintain utmost cleanliness during all work to prevent any dirt from entering the inside of the gear.

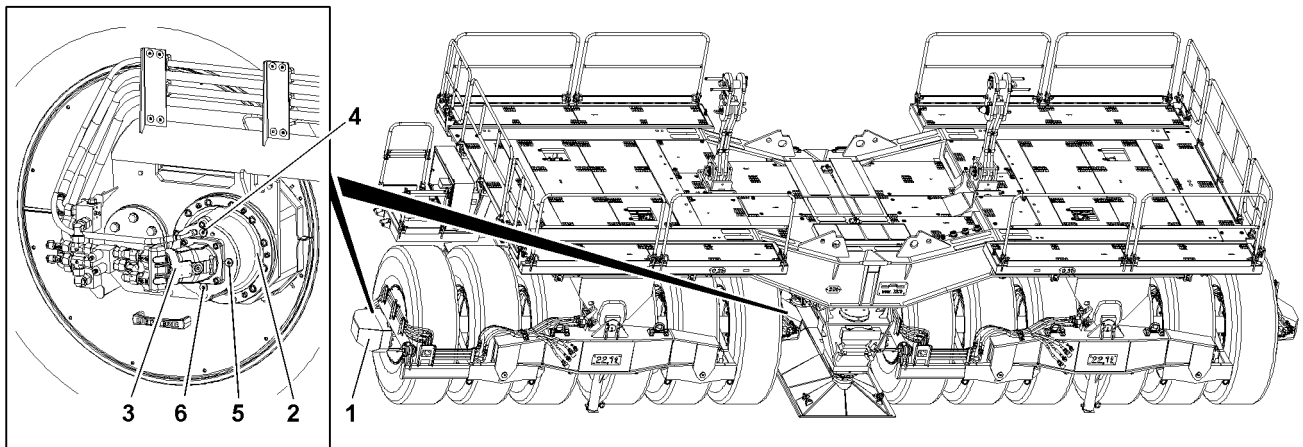

Fig.119082: Position of the wheel drive

The following maintenance ports are on the wheel drive 2:

- 4 Oil filler plug, oil filler port
- 5 Oil level plug, oil level port
- 6 Oil drain plug, oil drain port

Make sure that the following prerequisites are met:

- Ballast trailer is in horizontal position.
- The gear has warmed up.

19.3.1 Checking for leaks

NOTICE

Leaky swing drive!

If a leakage is found during the visual inspection of the swing drive, it can result in failure of the swing drive!

The swing drive can be damaged, resulting in high property damage.

- ▶ Repair the leaky swing drive and replace the swing drive, if in doubt.

- ▶ Check visually to ensure that the swing drives do not leak.

19.3.2 Checking the oil level

NOTICE

Damage to swing drives!

If seals are used repeatedly, it can result in loss of oil!

Due to loss of oil, the swing drives can wear significantly and / or be damaged.

- ▶ Use the seals on the maintenance ports only once.



Note

- ▶ To ensure a reliable oil level check, it must be ensured that the swing drives have been at a standstill for at least two minutes. This ensures that the oil has returned to the oil chamber completely.

- ▶ Remove the hoods **1** on the swing drives **2**.
- ▶ Carefully unscrew the oil level plug **5**.

NOTICE

Insufficient oil fill quantity!

If the oil level drops below the fill level on the oil level plug **5**, the swing drives can be damaged.

- ▶ Add gear oil until the oil level is again on the fill level on the oil level plug **5**.

If oil must be added:

- ▶ Add oil in the oil filler port **4**.
- ▶ If the oil level is on the fill level on the oil level plug **5**, then the oil level on the swing drive is OK.
- ▶ Close the maintenance ports tightly.
- ▶ Reinstall the hoods **1** on the swing drives **2** again properly.

19.3.3 Changing the oil

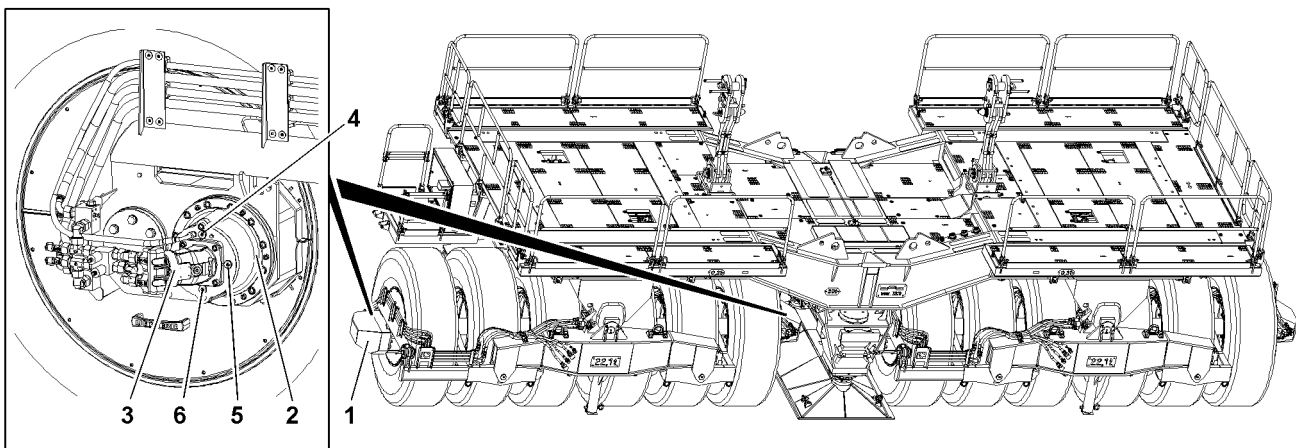

Fig.119082: Position of the wheel drive



Note

- ▶ Drain the gear oil on the oil drain plug **6**.

Make sure that the following prerequisites are met:

- The ballast trailer is in a horizontal position.
- The swing drive **2** must be at a standstill.
- The swing drive is warm.
- A suitable container to catch the used oil is available.



Note

- ▶ When selecting the container to catch the used oil, make sure that the container is sufficiently sized to be able to catch all the used oil.
- ▶ Pay attention to the fill quantity of the swing drive.



WARNING

Risk of burns during maintenance or inspection work!

While carrying out maintenance or inspection work, maintenance personnel can get severe burns on hot crane components.

When opening the oil drain plug, hot oil can cause burns on arms, hands, face or eyes.

Death, severe bodily injuries, property damage.

- ▶ Let any crane components to be maintained or inspected cool off until „hand warm“.
- ▶ Wear protective equipment.

- ▶ Remove the hoods **1** on the swing drives **2**.
- ▶ Remove the oil filler plug **4**.
- ▶ Unscrew the oil drain plug **6** with seal ring and drain oil into a suitable container.



Note

- ▶ Allow the swing drive **2** to empty completely.
- ▶ Clean the oil drain plug **6** and sealing surface on the housing.
- ▶ Screw in the oil drain plug **6** with a new seal ring and tighten.
- ▶ Open the oil level port **5**.
- ▶ Add oil on the oil filler port **4** until it is at the fill level on the oil level port **5** or until it starts to run over.
- ▶ Clean the sealing surface on the oil level port **5**.
- ▶ Close off the oil level port **5** tightly.
- ▶ Close off the oil fill port **4** tightly.
- ▶ Reinstall the hoods **1** on the swing drives **2** again properly.

20 Ladders



WARNING

Danger of falling!

If the following safety notes are **not** observed, personnel can fall down.

Death, severe bodily injuries, property damage.

- ▶ Observe and adhere to the assembly and safety guidelines for ladders.
- ▶ Observe and adhere to the safety signs on the ladders.
- ▶ Install and secure the ladders properly.
- ▶ Do **not** use damaged ladders and replace them immediately.
- ▶ Have ladders repaired only at authorized expert repair shops.

20.1 Lubricating ladders

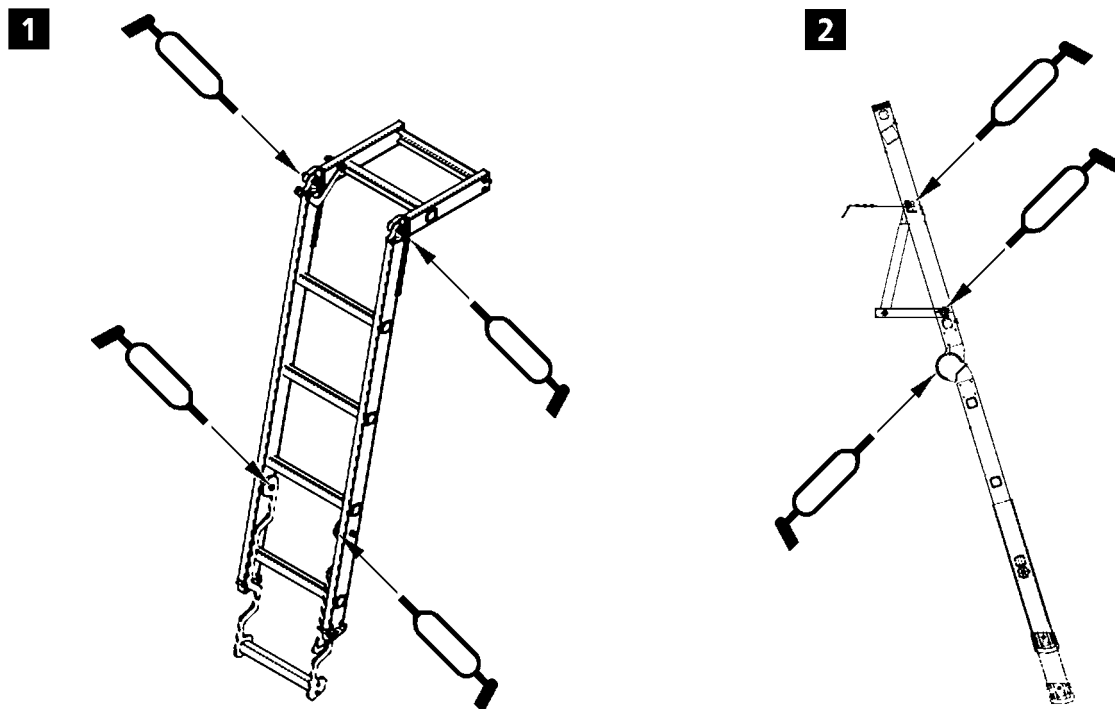

Fig.109766

Make sure that the following prerequisites are met:

- Repairs and maintenance work are carried out by expert personnel.
- ▶ Grease joints and pivot points on the ladders according to maintenance interval and check them for easy movement, see illustration 1 and illustration 2.

21 Window cleaning system

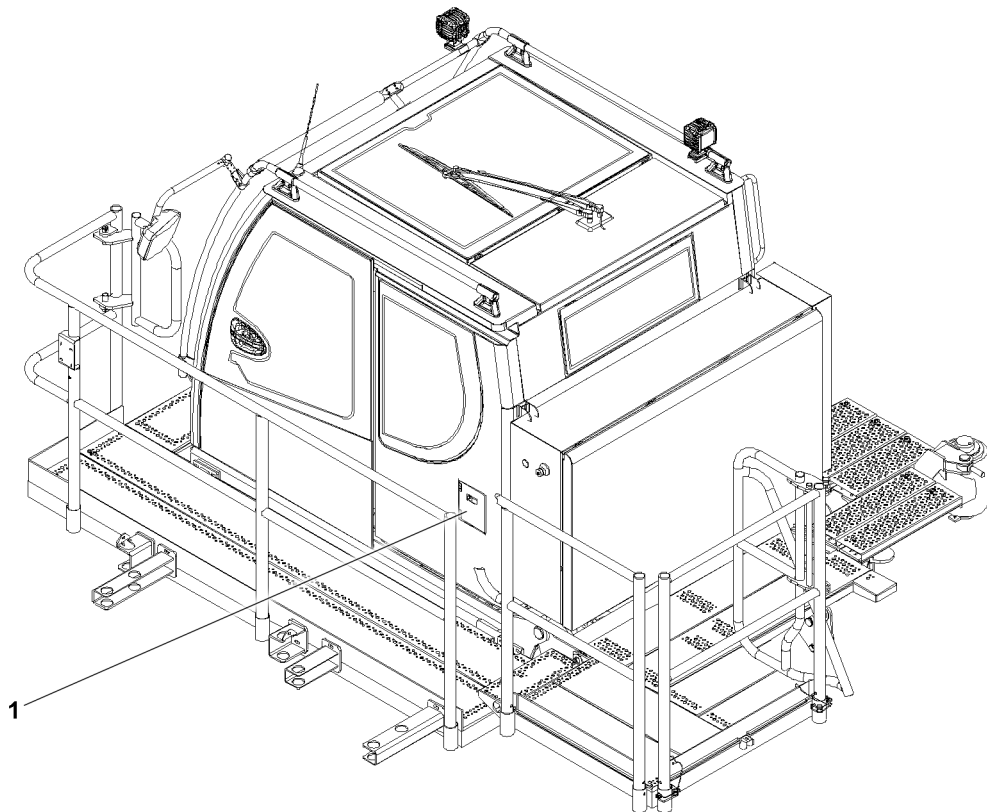

Fig.126509: Container Window cleaning system

21.1 Checking the cleaning fluid level

- ▶ Open the container 1.
- ▶ Check the cleaning fluid level.

When the cleaning fluid level is low:

- ▶ Add cleaning fluid.
- ▶ Close the container 1.

21.2 Replacing the cleaning fluid

The cleaning fluid must be replaced before the cold season.

- ▶ Open the container 1.
- ▶ Empty the container 1.
- ▶ Fill the container with a commercially available, frost resistant window cleaning fluid.
- ▶ Close the container 1.

Empty page!

LWE/LR 11000-001/23501-04-02/en

7.05.50 Maintenance guidelines - Crane boom

1	Lattice mast boom	3
2	Rope pulleys and guide pulleys	4
3	Crane ropes	4

Fig.195219

LWE/LR 11000-001/23501-04-02/en

1 Lattice mast boom



WARNING

Danger of falling!
Death, severe injuries.

- ▶ For all work on the crane where there is a danger of falling, suitable safety measures must be taken, see Crane operating instructions, chapter 2.06.



Note

- ▶ The following illustration is an example and may not exactly match to your crane.

1.1 Lubricating the pin bores on the lattice sections and guy rods

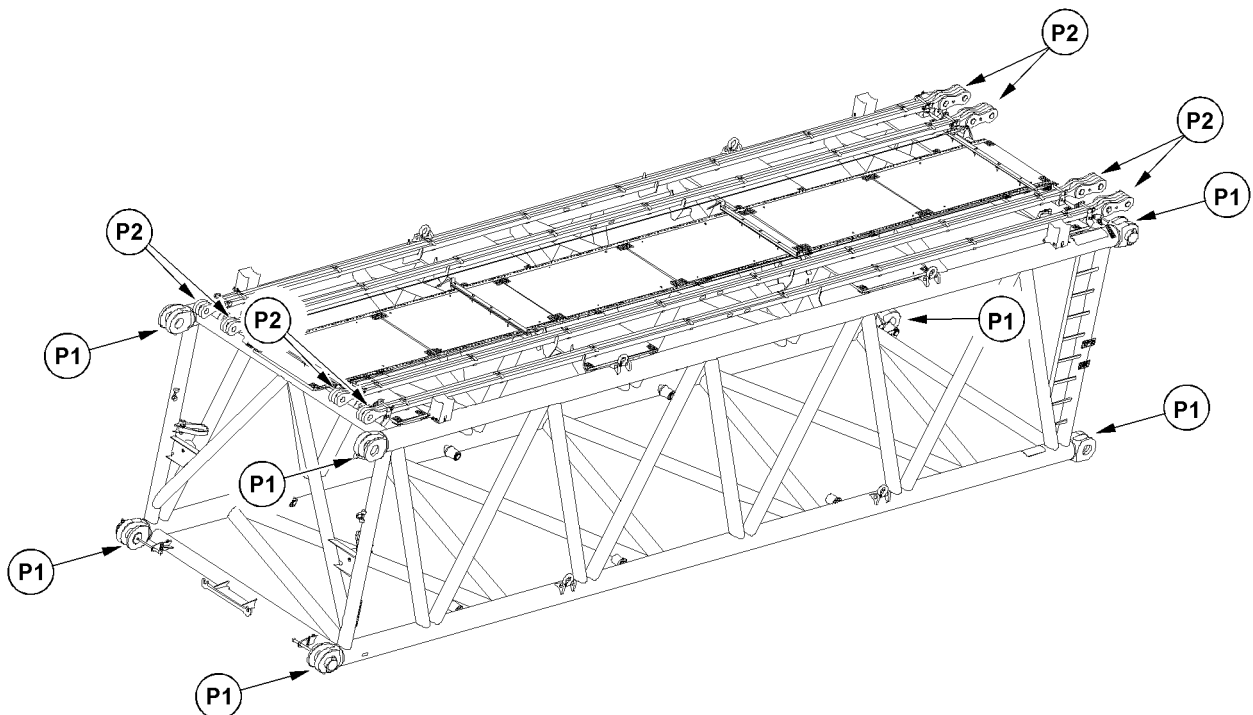

Fig.123861: Lube points on boom lattice sections and guy rods



Note

- ▶ For the pin bores on the lattice sections (points **P1**) and the guy rods (points **P2**), use special grease as lubricant. See Service fill and Crane operating instructions, chapter 7.07.
- ▶ Apply the grease on the pin bores over the entire circumference.
- ▶ The lubrication of the pin bores on the boom lattice sections and the guy rods is made before assembly or after disassembly.

Make sure that the following prerequisites are met:

- The lattice sections are not installed on the crane.
- The lattice sections are playing on a load bearing support on the ground.
- ▶ Grease the pin bores on the boom lattice sections and the guy rods.

2 Rope pulleys and guide pulleys

2.1 Check bearings for easy movement

Stiff or blocked rope pulleys or compensation pulleys wear rapidly and unevenly and cause serious rope abrasion.

Ineffective compensation pulleys can lead to irregular rope tension.

- ▶ Check the rope pulleys for proper movement in their bearings.

When rope pulleys are **not** easily moveable in their bearings:

- ▶ Fix the bearings.

2.2 Checking for mechanical damage

Ropes can cause mechanical damage, such as stress marks.

- ▶ Check guide pulleys and rope pulleys for mechanical damage.

3 Crane ropes

3.1 Personal protective equipment



WARNING

Injury due to wires and skin irritation due to lubricant!

- ▶ When working with ropes, always wear work gloves.



WARNING

Injuries if protective equipment is **not** worn!

- ▶ Wear hard hat, safety shoes and safety glasses.

3.2 Safe and problem-free operation



WARNING

Wear, overload, incorrect use, damage, improper maintenance!

Failure of ropes. Death, severe injuries, property damage.

- ▶ Prevent failure of ropes: Observe and adhere to the following notes.

Carry out the following measures to ensure safe and problem-free rope operation.

- Service ropes and rope end connections regularly according to the maintenance intervals.
- Check ropes and rope end connections regularly according to the inspection intervals.
- When it is determined that the ropes should be withdrawn from service, do **not** continue to use them further.
- Exclude contact of rope with components except rope drive elements.
- Exclude contact of rope with structural parts, power lines or other objects within the surrounding area.
- Avoid corrosive and chemical surroundings.
- Avoid excessive soiling.
- Avoid excessive heat influence.
- Ensure proper condition of all elements of rope drive.
- Ensure proper spooling formation on the rope drum.
- Use the entire rope length of hoist ropes.
- Avoid slack rope formation on the drum.
- Do **not** bring outer twists into the rope.
- Avoid shock relief of the rope, such as sudden set down of the load.

- Avoid **non-permissible** angular pull, for example by pulling the load at an angle.

3.3 Temperature operating limits

Adhere the temperature operating limits for steel ropes. The determining factors are wire material, lubricant, rope end connections. See Manufacturer's specifications.

3.4 Qualification Maintenance personnel

Make sure that the following prerequisites are met:

- The maintenance personnel is trained and instructed in maintenance tasks.
- The maintenance personnel is assigned (authorized) for the maintenance by the crane operator.

3.5 Damage on rope

Rope removal criteria: If severe damage reduces the operational safety, then the rope can reach the removal criteria.

This section provides an overview for possible damage on the rope. For clearer illustration, the distortions on the illustrations are exaggerated.

The displayed ropes show a condition, which is far above the removal criteria.

Damage on the rope causes uneven load distribution in the affected areas.

Damage on the rope is most often localized.

Typical examples for damage, which can be recognized during maintenance work:

- Broken strands
- Wire breaks
- Reduction of rope diameter
- Localized increase of rope diameter
- Corrosion
- Flattenings
- Corkscrew-like distortion
- Basket formation
- Protruding, distorted inlay or braiding
- Loop formation
- Kinking, rope loops (grommets) pulled closed
- Buckles
- Influence of heat or electrical voltage, such as arcing

3.5.1 Broken strands

A strand consists of several individual wires.

When a complete braid is broken, then the rope must be taken down.

3.5.2 Broken wire

Externally visible broken wires are the result of wear caused by operation.

Additional types of broken wires:

- Broken wire in the inside of the rope
- Broken wire in the strand valleys
- Broken wire on a rope connection

A broken wire does not endanger the safety of the rope.

3.5.3 Reduction of rope diameter

The rope diameter changes due to abrasion, settling and external influences.

Abrasion of cover wires of outer strands of rope due to frictional contact. Especially in those areas where ropes are in contact with the rope pulleys during start up or slow down of the load.

Wear is increased by lack of or incorrect lubrication and the effect of dust.

Abrasion reduces the tensile strength of steel ropes because the cross section of the steel is reduced.

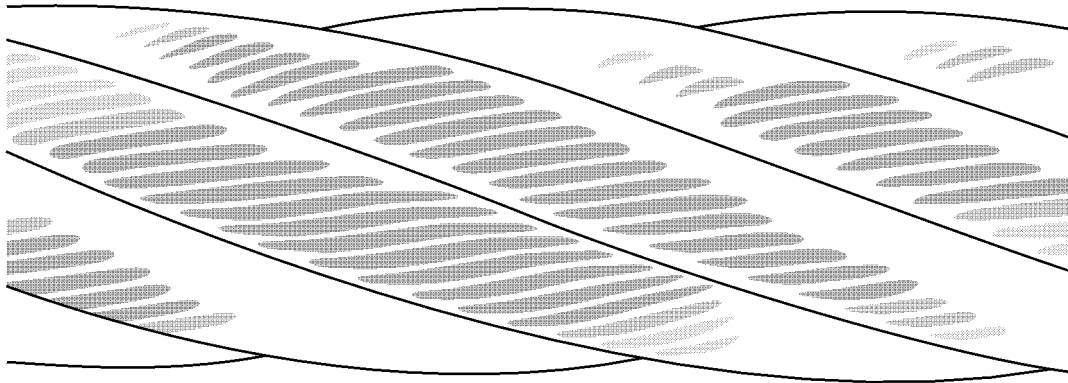

Fig.121001: External abrasion on the rope

When the rope diameter is reduced, the rope must be checked by **expert personnel for crane rope inspection**.

3.5.4 Localized increase of rope diameter

An increase, which occurs over a longer area of the rope can be caused by absorption of moisture in the fiber insert or due to corrosion in the inside of the rope.

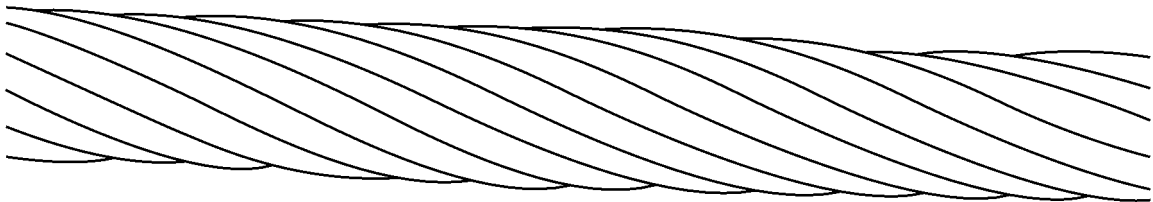

Fig.120992: Increase of rope diameter

When a localized increase of the rope diameter is present, then the rope must be checked by **expert personnel for crane rope inspection**.

3.5.5 Corrosion

Corrosion occurs due to insufficient lubrication, in maritime climates and in an atmosphere polluted by industrial fumes.

External corrosion is indicated by a rough wire surface. A superficial rust film can be wiped off.

Significant corrosion reduces the strength and elasticity of the rope due to the reduction of the rope diameter.

Inner corrosion is hard to detect.

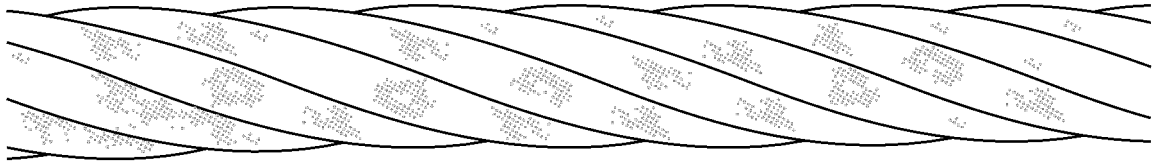

Fig.120994: External corrosion

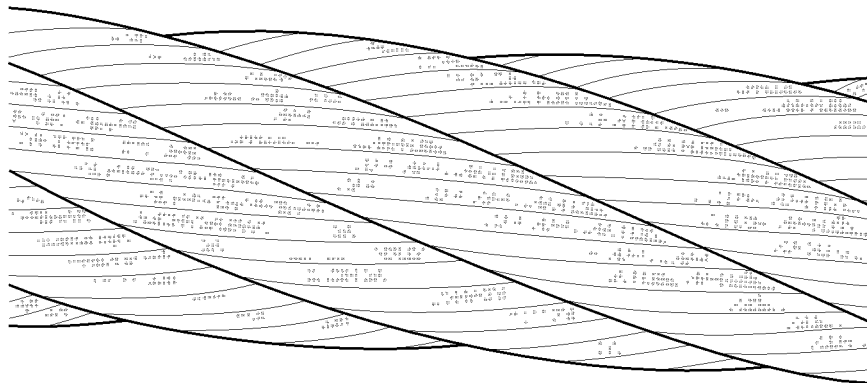

Fig.120995: Magnification of external corrosion for better depiction

When significant corrosion is present, the rope must be checked by **expert personnel for crane rope inspection**.

3.5.6 Flattening

Flattening occurs when the rope runs through the rope pulleys. In this area the rope wears quicker. Corrosion occurs faster on retaining ropes and guy ropes.

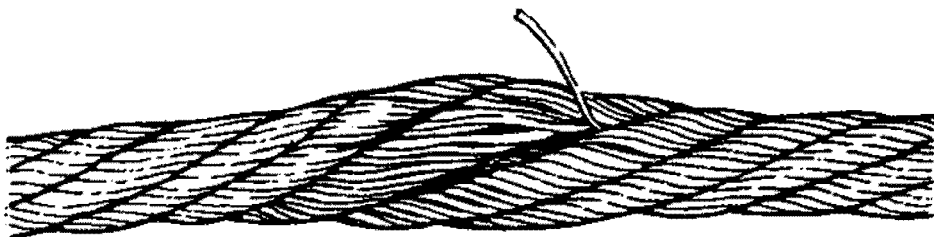

Fig.120997: Localized limited flattening, which leads to broken wires (single layer rope)

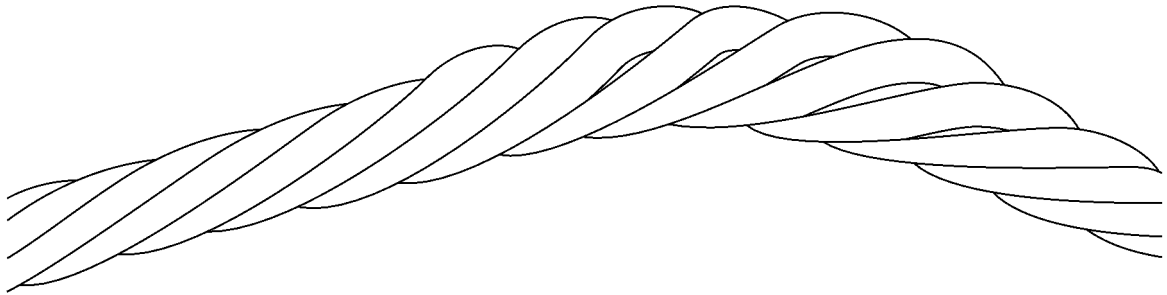

Fig.120996: Flattenings on multi layer spoolings

When flattening is present, the rope must be checked by **expert personnel for crane rope inspection**.

3.5.7 Corkscrew-like distortion

Distortion where the rope is in the form of a corkscrew along its longitudinal axis.

Corkscrew-like distortion causes rope wear, broken wires and bearing damage on rope pulleys.



Fig.120988: Corkscrew-like distortion

When corkscrew-like distortion is present, the rope must be checked by **expert personnel for crane rope inspection**.

3.5.8 Basket formation

This distortion occurs due to different layers between the outer strand layers and the inside of the rope.

Causes for basket formation are high angular pull angles during the run over the rope pulleys and run-in rope pulleys. Even load distribution over the entire cross section is not possible.

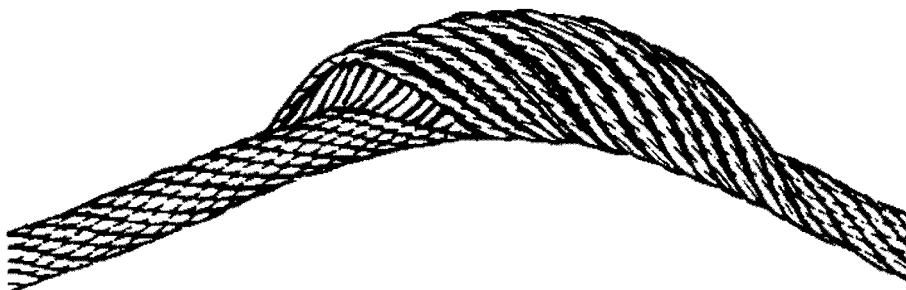

Fig.120989: Basket formation

When basket formation is present, then the rope must be taken down.

3.5.9 Protruding, distorted inlay, braiding

This distortion is a special form of basket formation: The insert or the core of the rope protrudes between the external braids or an external braid protrudes from the rope banding.

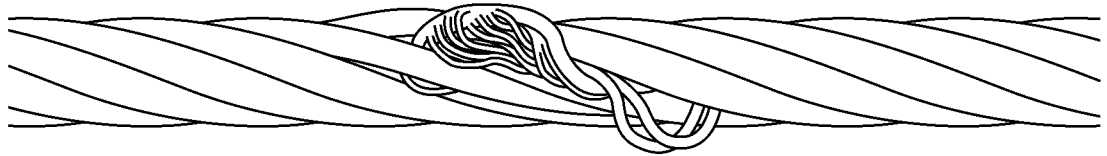

Fig.120990: Protrusion of an insert (rope single layer)



Fig.120991: Distorted or protruding strand

When the insert or a strand protrudes or is distorted, place the rope down. Have **expert personnel for crane rope inspection** check if the rope area with the distortion can be removed.

3.5.10 Loop formation

At loop formation individual wires protrude from the rope banding, when no broken wire ends can be seen.

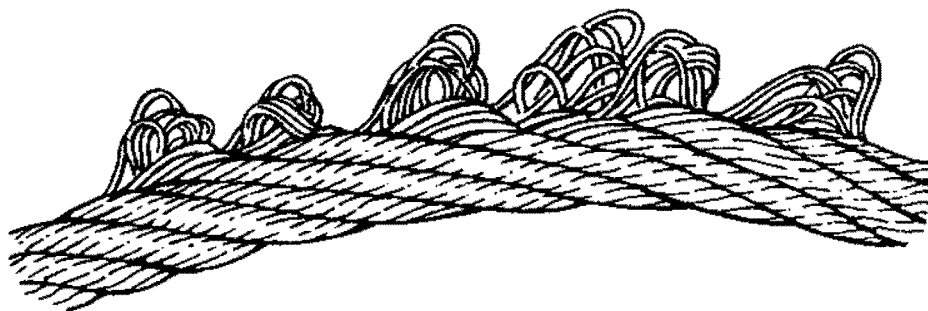

Fig.120993: Emergence of individual wires

When loop formation is present, take the rope down.

3.5.11 Kinking, rope loops (grommets) pulled closed

Deformation, where a loop has formed in the rope, without the possibility to rotate around its own axis during a load. The rope is subjected to more wear.

The rope is deformed. The strength remains only in part.

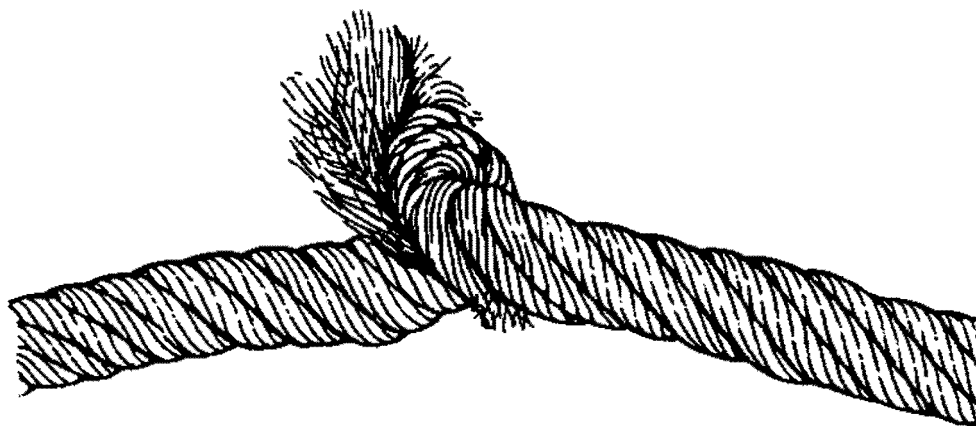

Fig.120998: Severe kinking or knots

When kinking or rope loops are present, place the rope down.

3.5.12 Buckles

Buckles are angular deformations. The rope was damaged due to external influences. Strong deformations of the rope cause stronger wear.

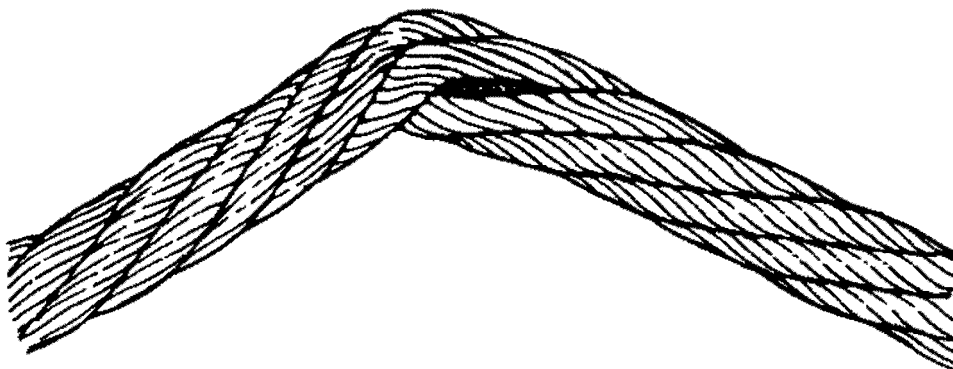

Fig.120999: Severe buckle

When buckles are present, take the rope down.

3.5.13 Effects of heat, arcs

Damage caused to the rope by welding work, for example.

Unusual heat impact is visible by tempering colors and loss of lubricant.

When heat impact has occurred on the rope, then the rope must be taken down.

3.6 Checking the ropes



WARNING

Operation with damaged rope!
Failure of rope. Death, severe injury, property damage.

When damage, wear and deformations are present:

- ▶ Have **expert personnel for crane rope inspection** determine if the rope has to be taken down.

The following sections describe the tasks for **daily visual inspection**.

The crane operator can carry out a daily visual inspection if he is sufficiently trained in the tasks and considered to be able to do so.

3.6.1 Intervals

Intervals and situations where the daily visual inspection must be made:

- Daily, before starting to work
- In case of change of the reeving of the crane rope due to
 - Transport
 - New reeving
 - Removal and installation

3.6.2 Areas

The rope must be checked over the entire length.

The following areas must be checked with special diligence:

- Rope end connections
- Safety coils and fixed point on the winch
- Areas of the rope which run through the hook block
- Areas of the rope which run over the rope pulleys or laying on the rope pulleys
- Areas of the rope which are spooled on the winch, especially cross over areas
- Areas of the rope which are laying above the compensation pulleys
- Areas of the rope which are subjected to abrasion due to external components
- All areas of the rope which are subjected to temperatures above 60°C

3.6.3 Documentation of rope condition

Every visible change of the wire rope must be documented in the crane records.

3.6.4 Checking the lubrication



WARNING

Missing lubrication!

Functional problems. Inner and outer corrosion.

- ▶ Lubricate the rope regularly.
- ▶ Make sure that the rope is lubricated all around.
- ▶ Select manual or automatic lubrication procedures.

The lubrication must be checked at least once a **month**.

When the rope shows signs of drying out:

- ▶ Lubricate the rope, see section „Lubricating the rope“.

3.6.5 Check for wear and distortion

- ▶ Check all visible parts of the rope for wear and distortion.
- ▶ Check the rope end connections and fixed points especially carefully for wear, damage, cracks and distortion.
- ▶ Check pressed together rope end connection for slipping and traces on the rope.



Note

- ▶ The maximum permissible number for broken wires over a certain rope length may not be exceeded.
- ▶ Determine the maximum permissible number of broken wires, see Crane operating instructions, chapter 8.04.
- ▶ Check the rope end connection and rope area near the rope end connection for broken wires.

When broken wires are present on the rope:

- ▶ Remove the broken wire, see section „Removing broken wires“.

When broken wires or damage is present on the rope end connection:

- ▶ Document visible changes of the rope condition.
- ▶ Have the rope checked by **expert personnel for crane rope inspection**.

When the rope can be shortened without reducing the operational safety:

- ▶ Shorten the rope, see section „Shortening the rope“.

3.6.6 Checking the rope drive for spooling problems

Lacking pretension of the rope on the winch can cause spooling problems in multi layer spooling.

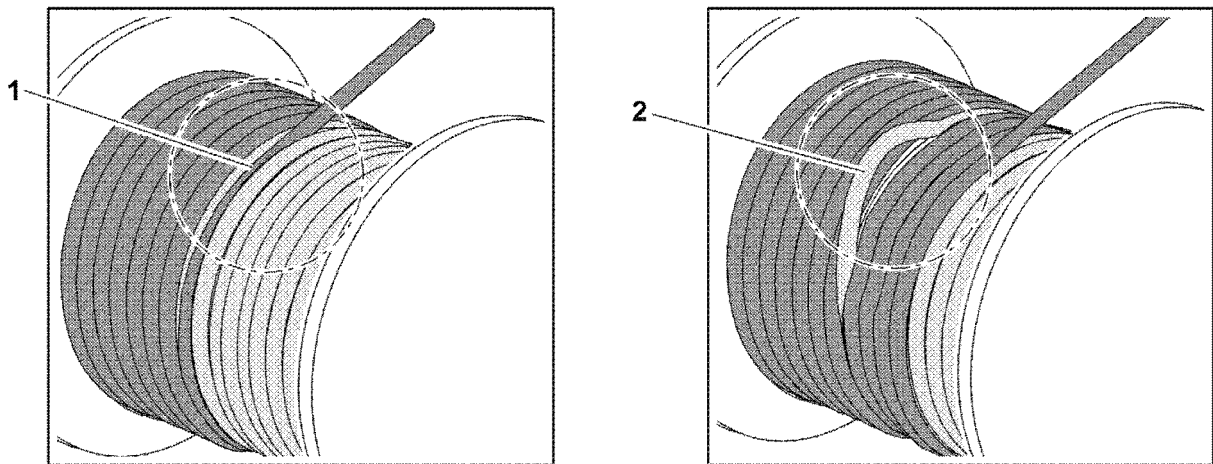

Fig.120967: Possible spooling problems on the rope winch

- 1** Cutting into the lower rope layers **2** Loop formation in the lower rope layers

- ▶ Check the spooling behavior of rope on the rope winch for cutting into the lower rope layers **1**.
- ▶ Check the spooling behavior of rope on the rope winch for loop formation in the lower rope layers **2**.

When spooling defects are found:

- ▶ Renew the pretension, see section „Renewing the pretension of hoist ropes“.
- ▶ Document visible changes of the rope condition.
- ▶ Have the rope checked by **expert personnel for crane rope inspection**.

3.6.7 Checking the position

- ▶ Check the correct position of the rope on the rope pulleys.

When the rope is **not** correctly laying on the rope pulley:

- ▶ Have the rope and rope pulley checked by **expert personnel for crane rope inspection**.

3.6.8 Checking for corrosion

A superficial „rust film“ can be wiped off.

- ▶ Do **not** clean the rope with solvents or cleaners.
- ▶ Clean the rope solely with a wire hand brush.
- ▶ Check rope for corrosion.

When the rope shows a rough surface:

- ▶ Document visible changes of the rope condition and have the rope checked by **expert personnel for crane rope inspection**.

If there is any uncertainty regarding the condition of the rope:

- ▶ Place the rope down or contact Liebherr Service.

3.6.9 Checking for flattenings

In the cross over area of the spooled up rope layers on the winch the rope is stressed more. The rope can be flattened as a result.

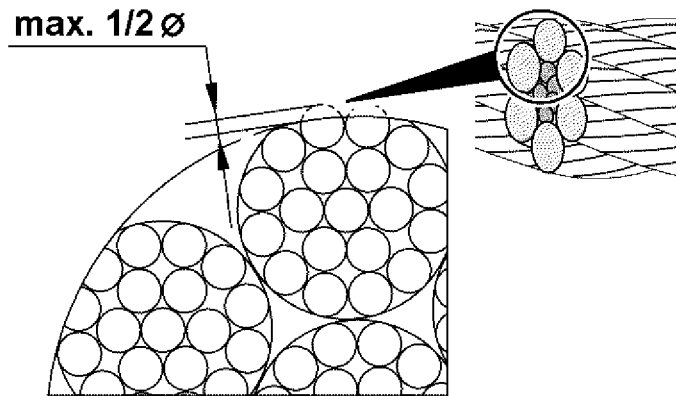

Fig.120966: Maximum flattening of wires on the outer strands

- ▶ Check the rope in the ascent zones of the rope spooling on the winch for flattenings.

When the outer braids are flattened more than half of the wire diameter:

- ▶ Document visible changes of the rope condition.
- ▶ Have the rope inspected by **expert personnel for crane rope inspection** or place the rope down.

When the rope can be shortened without reducing the operational safety:

- ▶ Shorten the rope on the rope drum fixed point, see section „Shortening the rope“.

3.7 Checking the control rope for distortions

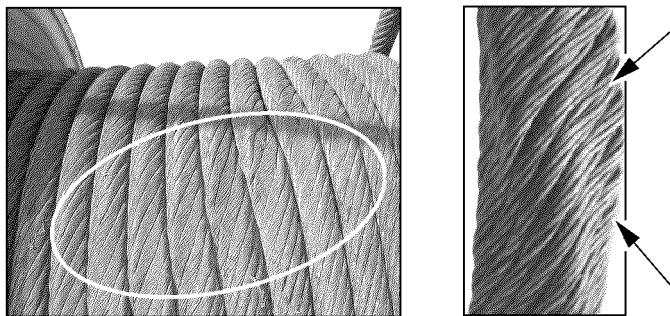

Fig.114002: Distortion on control ropes

- ▶ Check the first rope layer of the control rope for crushed areas and distortions.

When distortions are present:

- ▶ Have the rope checked by **expert personnel for crane rope inspection**.

3.8 Lubricating the rope



WARNING

Missing lubrication!

Functional problems. Inner and outer corrosion.

- ▶ Lubricate the rope regularly.
- ▶ Make sure that the rope is lubricated all around.
- ▶ Select manual or automatic lubrication procedures.

NOTICE

Too much or incorrect lubricant!

Excessive soiling. Wear on rope, on rope pulley and on winch. Recognition of take down criteria is impeded.

- ▶ Use lubricant, which is compatible with the rope and the original lubricant.
- ▶ Do **not** clean the rope with solvents or cleaners.
- ▶ Clean the rope solely with a wire hand brush.

Areas, which must be lubricated especially well are bending zones on winch and rope pulleys.

- ▶ Lubricate the rope.

3.9 Removing broken wires

NOTICE

Broken wires!

Damage of other components in crane operation, for example rope pulleys and compensation pulleys.

- ▶ Remove broken wires.

Make sure that the following prerequisite is met:

- Suitable pliers are on hand.

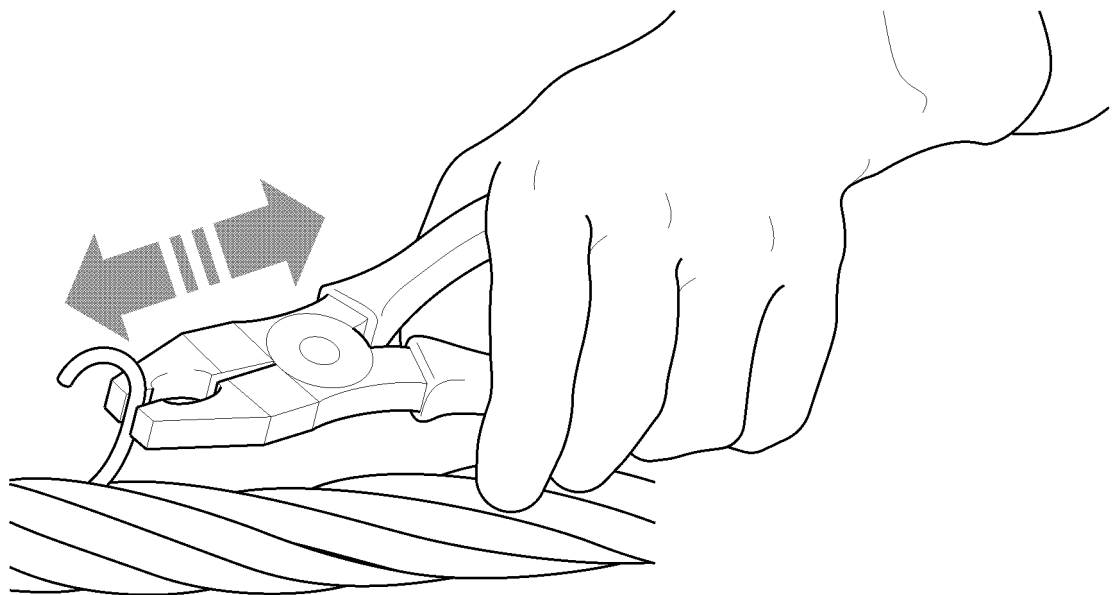

Fig.120979: Remove broken wire

- ▶ Grasp the wire on the upper end with pliers. Bend the wire back and forth until the wire breaks off in the braid valley.

The position of a broken wire is important for subsequent inspection. Individual broken wires are counted and are recorded later in the evaluation for withdrawal from service.

- ▶ Document the position of the broken wires in the crane record. Inspection checklist, see chapter 8.04.

3.10 Turning an extremely rotation-resistant hoist rope out



WARNING

Damage of rope due to incorrect procedure!

- ▶ Use extreme caution for the following procedures.
- ▶ Observe the following instructions exactly.

The cause for the turn-in of the hook block can have various reasons.

Check the crane for the following peculiarities:

- Scrub marks: Are hoist rope scrub marks present on the crane components? If scrub marks are present, check the hoist rope run and correct it.
- Rope pulleys: Did the groove diameter become too small?
 - Groove diameter dimensional stability must be present.
 - If this is not the case, the rope pulley must be replaced.
- Rope lubrication: Has the hoist rope been sufficiently lubricated? If the rope surface is dry, the hoist rope must be re-lubricated.

If the crane does not display other peculiarities, the hoist rope must be spun out.

The following sections describe two methods of how to spin out the hoist rope. The methods must be applied in the described sequence.

3.10.1 Spinning out with single strand reeving

- ▶ Reeve in the single strand hoist rope.
- ▶ Extend the boom to the maximal boom length and hook height.
- ▶ Lower hooks to approximately 1 m above the ground and allow the hoist rope to spin out.
- ▶ With an empty hook block, carry out one complete hoist cycle.
- ▶ Lower the hook again to approximately 1 m above the ground and allow the hoist rope to spin out again.
- ▶ Reeve the number of strands of hoist rope carefully and spin free where the twisting of the hook block is largest.
- ▶ Distribute the spin out to the entire rope length: Run at least two entire hoist cycles at maximum boom length and hook height.



Note

When the hook block continues to turn in:

- ▶ Spin the rope out, see section „Spinning out by turning the hook block out“.

3.10.2 Spinning out by turning out the hook block

Make sure that the following prerequisite is met:

- The hook block is reeved with the number of strands where the twisting is the largest.
- ▶ Extend the boom completely and lower the hook block.
- ▶ Attach a load of approximately 10 % of the nominal rope pull on the hook block.

Before lifting the load, a helper must rotate the twisted hook block to a straight position by hand until the rope strands no longer touch each other.

- ▶ Continue to turn the hook block by one entire turn.

Result:

- The rope strands touch again.

NOTICE

The hook block turns back under load in a straight position!

When the hook block turns back in a straight position:

- ▶ Release the hook block.
-
- ▶ Hold the hook block in the prescribed position until the load lifts off the ground.
 - ▶ Move the load until approximately 15 m before the uppermost hook position of the completely extended boom.
 - ▶ Lower load and set it down.

3.11 Renewing the pretension of hoist ropes

**WARNING**

Lacking pretension of the rope on the winch!

Excessive rope wear in the lower spooling layers, gap formation, rope cutting in.

When the lower rope layers on the winch are hardly used or **not**:

- ▶ Renew the pretension in the entire rope regularly.

Make sure that the following prerequisites are met:

- A reeving is selected where the entire rope length can be spooled.
- Clean spooling pattern on the drum at spooling.

**Note**

Recommendation!

- ▶ The rope application is the most economical when the entire rope length is utilized.

When only a part of the rope length is used for a longer period of time:

- ▶ Use a proportionally shorter rope.
-
- ▶ Spool the rope out until three safety coils.
 - ▶ Spool the rope up with a rope tensile force of 10 % of the maximum rope tensile force.

3.12 Shortening the rope

**WARNING**

Distortions and mechanical damage!

Operational safety significantly disturbed, uneven load distribution within the rope.

- ▶ Have the manufacturer check if the distorted and damaged area can be severed.

Visible form changes often occur localized or in short rope sections.

When a safe operation of the rope is ensured, a distorted and damaged area can be severed.

To shorten the rope there are different prerequisites:

- Rope shows flattenings
- Broken wires occur solely within the area of the rope end connection, the remaining rope is undamaged

**DANGER**

Minimum number of remaining coils on the winch fallen below!

Rope releases or rips off, falling load. Death, severe injury, property damage.

- ▶ Make sure, after shortening the rope that **at least three remaining coils** remain on the winch in all working positions of the crane.

Make sure that the following prerequisite is met:

- The rope was shortened by authorized and trained expert personnel.

Multi layer spooling: When the rope on the fixed point on the winch is shortened by half the winch diameter, then the service life of the rope increases significantly.

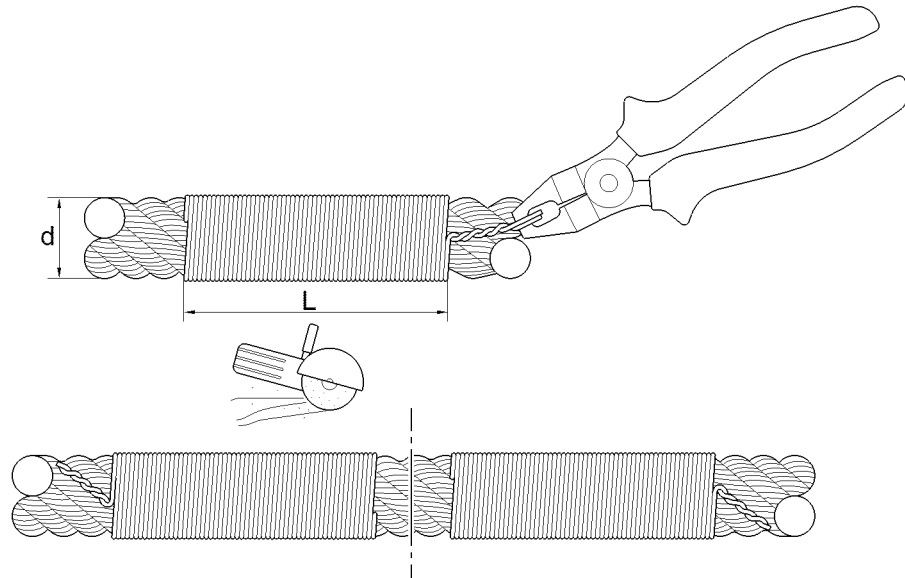

Fig.120972: Tie the rope before shortening it

d Rope nominal diameter

L Length of tie, at least $2d$

The length of the tie **L** must be at least 2 times the rope nominal diameter ($2d$).

The shortening of the rope in this section applies to a single layer rope. On rotation-resistance, parallel roped ropes it may be necessary to tie several times to prevent the rope from jumping open when it is cut.

- ▶ Tie the rope on both sides with wire.
- ▶ Twist the end of the wire with the pliers to prevent them from releasing.



WARNING

Danger of injury due to flying sparks!

- ▶ Wear safety glasses and safety gloves.
- ▶ Separate the rope vertically to the rope axis.
- ▶ Fasten the end connections on the rope according to the manufacturer's instructions.
- ▶ Remove the tie on both ends of the separation from the rope.

Empty page!

LWE/LR 11000-001/23501-04-02/en

7.06 Fill quantities, lubrication schedule

1	Fill quantities	3
2	Lubrication schedule	4

Fig.195219

LWE/LR 11000-001/23501-04-02/en

1 Fill quantities



WARNING

Handling poisonous operating fluids and lubricants!
Poisoning, severe health damage.

When operating fluids are to be used, stored and disposed of:

- ▶ Observe and follow the printed instructions on the original containers.
- ▶ Store operating fluids exclusively in the closed original container.
- ▶ Keep children away from operating fluids. Keep operating fluids away from children.
- ▶ Dispose of operating items and lubricants in an environmentally safe manner.

NOTICE

Damage on aggregates due to impermissible additives!

- ▶ Make sure that **no** impermissible additives are added to the operating fluids.



Note

- ▶ Fill quantities and descriptions of service items and lubricants are specified in the Service fill.
- ▶ Fill the crane chassis, crane superstructure and equipment with the respective operating fluids.
- ▶ The specified fill quantities (change quantities) are orientation values. The marks on the dipsticks, inspection ports and sight gauges are decisive for filling.
- ▶ The equipment depends on the purchased scope of delivery.

On mobile cranes with truck chassis:

- ▶ Observe the maintenance intervals and maintenance notes of the truck chassis manufacturer.

NOTICE

Danger of property damage!

- ▶ Do **not** mix different oil products!
- ▶ Do **not** mix synthetic oils with mineral oils!
- ▶ Adhere to the data in the Service fill!

1.1 Diesel engine

- ▶ Check the engine oil. See Maintenance intervals and maintenance instructions.
- ▶ Adhere to the operating instructions of the engine manufacturer.

1.2 Coolant system

NOTICE

Property damage due to impermissible coolant!

- ▶ Do **not** mix different coolant products.
- ▶ Do **not** thin Liebherr-Fertig-Mix (Liebherr Ready Made Mix).

When adding coolant:

- ▶ Use exclusively the same coolant.

Coolants contain corrosion inhibitor - antifreeze fluid.

Add coolant only on the filler neck. See Service fill.



Note

If the coolant is changed:

- ▶ Contact the Service Dept. at Liebherr-Werk Ehingen GmbH for procedure.
- ▶ Empty the cooling system completely and flush.

In exceptional cases, the coolant can be supplemented with different coolants.

**Note**

Supplementing the coolant with different coolants:

- ▶ Contact the Service Dept. at Liebherr-Werk Ehingen GmbH for procedure.

- ▶ Check the coolant level. See Maintenance intervals and maintenance instructions.

1.3 Transmission

- ▶ Check the gear oil. See Maintenance intervals and maintenance instructions.

1.4 Hydraulic system

**Note**

- ▶ The oil level must be in the center of the hydraulic oil level sight gauge at 20 °C oil temperature.

At lower hydraulic oil temperature:

- ▶ Warm up the hydraulic oil.

At higher hydraulic oil temperature:

- ▶ Cool off the hydraulic oil.
- ▶ Retract all hydraulic cylinders completely, for example luffing cylinder, telescoping cylinder.

On vehicles with level regulation:

- ▶ Lower the vehicle completely with the level regulation.

- ▶ Check the hydraulic oil. See Maintenance intervals and maintenance instructions.

2 Lubrication schedule

**Note**

- ▶ Grease the crane chassis, crane superstructure and equipment with the respective lubricants. See Service fill.
- ▶ The equipment depends on the purchased scope of delivery.

On mobile cranes with truck chassis:

- ▶ Observe the maintenance intervals and maintenance notes of the truck chassis manufacturer.

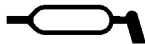

Fig.107729

**Note**

- ▶ Lube points are marked with a symbol.

7.07 Service fluids and lubricants

1	Specified service fluids and lubricants for Liebherr cranes	3
---	---	---

3

Fig.195219

LWE/LR 11000-001/23501-04-02/en

1 Specified service fluids and lubricants for Liebherr cranes

No.	Crane components	Ambient temperature for driving and crane operation	
		-20 °C to +50 °C	-40 °C to +30 °C
1.1	Diesel engine with Exhaust aftertreatment US Tier 4, EU-Stage IV LMB D936 A7-04, D944 A7-04, D946 A7-04, D9508 A7-04 MTU 6R 1000 Euro V ECE R.49, K LMB D936 A7-50, D946 A7-50, D9508 A7-50	LWE Id. No.: 10871536 Liebherr Motoroil 5W-30 SAE 5W-30 and ACEA E6 or: SAE 10W-40 and ACEA E6 Observe the instructions of the engine manufacturer	LWE Id. No.: 10871536 Liebherr Motoroil 5W-30 SAE 5W-30 and ACEA E6 or: SAE 10W-40 and ACEA E6 Observe the instructions of the engine manufacturer Below -20 °C with pre-heating
		Note: To improve the cold start ability of the diesel engine at an ambient temperature below -10 °C , we recommend the use of Liebherr Motoroil 5W-30, LWE-Id no.: 10871536	
1.2	Diesel engine with Exhaust aftertreatment US Tier 4 interim, EU-Stage III B LMB D936 A7 SCR, D934 A7 SCR, D856 A7 SCR, D9508 A7 SCR MTU/Mercedes Benz OM 906, OM 926	LWE Id. No.: 10663796 Liebherr Motoroil 10W-40 low ash SAE 10W-40 low ash and ACEA E6 Observe the instructions of the engine manufacturer	LWE Id. No.: 11100934 Liebherr Motoroil 5W-30 low ash SAE 5W-30 low ash and ACEA E6 Observe the instructions of the engine manufacturer Below -20 °C with pre-heating
		Note: To improve the cold start ability of the diesel engine at an ambient temperature below -10 °C , we recommend the use of Liebherr Motoroil 5W-30 low ash, LWE-Id no.: 11100934	
1.3	Diesel engine without Exhaust aftertreatment US Tier 3, EU-Stage IIIA such as 1.2 or optionally also LMB D936 A6, D934 A6, D846 A7, D9508 A7 MTU/Mercedes Benz OM 906	LWE Id. No.: 861005308 Liebherr Motoroil 10W-40 SAE 10W-40 and ACEA E4 Observe the instructions of the engine manufacturer	LWE Id. No.: 10871536 Liebherr Motoroil 5W-30 SAE 5W-30 and ACEA E4 Observe the instructions of the engine manufacturer Below -20 °C with pre-heating
		Note: To improve the cold start ability of the diesel engine at an ambient temperature below -10 °C , we recommend the use of Liebherr Motoroil 5W-30, LWE-Id no.: 10871536	

LWE/LR 11000-001/23501-04-02/en

No.	Crane components	Ambient temperature for driving and crane operation	
		-20 °C to +50 °C	-40 °C to +30 °C
1.4	Diesel engine without Exhaust aftertreatment Power band H and I ECE R.96 LMB D936 A7-03, D944 A7-03, D946 A7-03, D9508 A7-03	LWE Id. No.: 10871536 Liebherr Motoroil 5W-30 SAE 5W-30 and ACEA E4 or: SAE 10W-40 and ACEA E4 Observe the instructions of the engine manufacturer	LWE Id. No.: 10871536 Liebherr Motoroil 5W-30 SAE 5W-30 and ACEA E4 or: SAE 10W-40 and ACEA E4 Observe the instructions of the engine manufacturer Below -20 °C with pre-heating
		Note: To improve the cold start ability of the diesel engine at an ambient temperature below -10 °C , we recommend the use of Liebherr Motoroil 5W-30, LWE-Id no.: 10871536	
1.5	Diesel engine without Exhaust aftertreatment US Tier 2, EU-Stage II Cummins QSK 23	LWE Id. No.: 861005308 Liebherr Motoroil 10W-40 SAE 10W-40 and Cummins Engineering Standard CES 20078, 20077, 20076, 20075, 20071 SAE 10W-40 and API CI-4, CH-4, CF-4 SAE 10W-40 and ACEA E7, E5, E3, E2 Observe the instructions of the engine manufacturer	LWE Id. No.: 10871536 Liebherr Motoroil 5W-30 SAE 5W-30 and Cummins Engineering Standard CES 20078, 20077, 20076, 20075, 20071 SAE 5W-30 and API CI-4, CH-4, CF-4 SAE 5W-30 and ACEA E7, E5, E3, E2 Observe the instructions of the engine manufacturer Below -20 °C with pre-heating
		Note: To improve the cold start ability of the diesel engine at an ambient temperature below -10 °C , we recommend the use of Liebherr Motoroil 5W-30, LWE-Id no.: 10871536	
2	Drive axle with differentials, planetary gear and installed distributor gear	LWE Id. No.: 861901008 Liebherr Gear Hypoid 90 EP SAE 90 and API GL 5	LWE Id. No.: 10425142 Liebherr Syntogear Plus 75W-90 SAE 75W-90 and API GL 5
3	Axle drive ZF DK-7	LWE Id. No.: 861901008 Liebherr Gear Hypoid 90 EP ZF TE-ML 05	LWE Id. No.: 10425142 Liebherr Syntogear Plus 75W-90 ZF TE-ML 05
4.1	Vehicle distributor gear KESSLER VG 1800, VG 2400, VG 2550, VG 2600, VG 2700, VG 3750, VG 3751 W 3750, W 3751	LWE Id. No.: 861901008 Liebherr Gear Hypoid 90 EP SAE 90 and API GL 5	LWE Id. No.: 10425142 Liebherr Syntogear Plus 75W-90 SAE 75W-90 and API GL 5

No.	Crane components	Ambient temperature for driving and crane operation	
		-20 °C to +50 °C	-40 °C to +30 °C
4.2	Vehicle distributor gear with PTO for crane drive KESSLER VG 2700 with PTO VG 3751 with PTO	LWE Id. No.: 10425142 Liebherr Syntogear Plus 75W-90 SAE 75W-90 and API GL 5	LWE Id. No.: 10425142 Liebherr Syntogear Plus 75W-90 SAE 75W-90 and API GL 5
4.3	Vehicle distributor gear ZF Passau, STEYR PUCH VG 1200, VG 1600, VG 2000, VG 3800	LWE Id. No.: 861901008 Liebherr Gear Hypoid 90 EP ZF TE-ML 19	LWE Id. No.: 10425142 Liebherr Syntogear Plus 75W-90 ZF TE-ML 19
5	Miter gear for crane drive	LWE Id. No.: 10425142 Liebherr Syntogear Plus 75W-90 SAE 75W-90 and API GL 5	LWE Id. No.: 10425142 Liebherr Syntogear Plus 75W-90 SAE 75W-90 and API GL 5
6	Offset gear (drop box) ZF Passau, STEYR PUCH	LWE Id. No.: 861901008 Liebherr Gear Hypoid 90 EP ZF TE-ML 19	LWE Id. No.: 10425142 Liebherr Syntogear Plus 75W-90 ZF TE-ML 19
7.1	Pump distributor gear filled with mineral gear oil	LWE Id. No.: 861901008 Liebherr Gear Hypoid 90 EP SAE 90 and API GL 5	LWE Id. No.: 10425142 Liebherr Syntogear Plus 75W-90 SAE 75W-90 and API GL 5
7.2	Pump distributor gear filled with synthetic gear oil	LWE Id. No.: 861901208 Liebherr Gear PG 220 CLP PG 220, DIN 51517-3 WARNING: May not be mixed with other oils!	LWE Id. No.: 10664125 Liebherr Gear PG 150 CLP PG 150, DIN 51517-3 WARNING: May not be mixed with other oils!
7.3	Pump distributor gear LTC 1055-3.1	LWE Id. No.: 10425142 Liebherr Syntogear Plus 75W-90 SAE 75W-90 and API GL 5	LWE Id. No.: 10425142 Liebherr Syntogear Plus 75W-90 SAE 75W-90 and API GL 5
8.1	Powershift transmission ZF torque converter WG 120, WG 150, WG 180, WG 181, WG 200, WG 201	LWE Id. No.: 861005308 Liebherr Motoroil 10W-40 ZF TE-ML 03	LWE Id. No.: 861900608 Liebherr Hydraulic-Gear ATF ZF TE-ML 03 Below -20 °C run until warm according to operating instructions

LWE/LR 11000-001/23501-04-02/en

No.	Crane components	Ambient temperature for driving and crane operation	
		-20 °C to +50 °C	-40 °C to +30 °C
8.2	Powershift transmission ZF torque converter WG 251* ZF ERGOPOWER WG 210, WG 260, WG 310 * also for ambient temperatures above -10 °C	LWE Id. No.: 861900608 Liebherr Hydraulic-Gear ATF ZF TE-ML 03	LWE Id. No.: 861900608 Liebherr Hydraulic-Gear ATF ZF TE-ML 03 Below -20 °C run until warm according to operating instructi- ons
9	Powershift transmission CLARK	LWE Id. No.: 861005308 Liebherr Motoroil 10W-40 SAE 10W-40 and ACEA E4	LWE Id. No.: 861900608 Liebherr Hydraulic-Gear ATF ATF Dexron II D and ALLI- SON C4 Below -20 °C run until warm according to operating instructi- ons
10	Offset gear (drop box) ALLISON	LWE Id. No.: 861005308 Liebherr Motoroil 10W-40 SAE 10W-40 and API CF, ACEA E4	LWE Id. No.: 861900608 Liebherr Hydraulic-Gear ATF ATF Dexron II D or ALLI- SON C4 Below -20 °C run until warm according to operating instructi- ons
11.1	Automatic transmission ALLISON CLBT 740, CLBT 750, CLBT 754, CLBT 755 HT 755, HD 4560	LWE Id. No.: 861900608 Liebherr Hydraulic-Gear ATF ATF Dexron III or ALLISON C4	LWE Id. No.: 861903708 CASTROL Transynd ATF Dexron III or ALLISON C4 Below -20 °C run until warm according to operating instructi- ons
11.2	Automatic transmission ZF	LWE Id. No.: 861900608 Liebherr Hydraulic-Gear ATF ZF TE-ML 14	LWE Id. No.: 861900608 Liebherr Hydraulic-Gear ATF ZF TE-ML 14 Below -20 °C run until warm according to operating instructi- ons
12	Automatic transmission ZF AS-Tronic ZF TC-Tronic (basic gear) ZF TC-Tronic HD (basic gear)	LWE Id. No.: 10218305 ZF-Ecofluid M ZF TE-ML 02	LWE Id. No.: 10218305 ZF-Ecofluid M ZF TE-ML 02 below -20 °C preheat gear ac- cording to operating instructi- ons

No.	Crane components	Ambient temperature for driving and crane operation	
		-20 °C to +50 °C	-40 °C to +30 °C
13.1	Torque converter coupling ZF TC HD	LWE Id. No.: 10218305 ZF-Ecofluid M ZF TE-ML 02	LWE Id. No.: 10218305 ZF-Ecofluid M ZF TE-ML 02 below -20 °C preheat gear according to operating instructions
13.2	Torque converter coupling ZF TC 2	LWE Id. No.: 861900608 Liebherr Hydraulic-Gear ATF ZF TE-ML 14	LWE Id. No.: 861900608 Liebherr Hydraulic-Gear ATF ZF TE-ML 14
14	Transmission ZF ECO-Split	LWE Id. No.: 10218305 ZF-Ecofluid M ZF TE-ML 02	LWE Id. No.: 10218305 ZF-Ecofluid M ZF TE-ML 02
15	Slewing gear	LWE Id. No.: 861901208 Liebherr Gear PG 220 CLP PG 220, DIN 51517-3 WARNING: May not be mixed with other oils!	LWE Id. No.: 861901208 Liebherr Gear PG 220 CLP PG 220, DIN 51517-3 WARNING: May not be mixed with other oils!
16.1	Rope winch	LWE Id. No.: 861901208 Liebherr Gear PG 220 CLP PG 220, DIN 51517-3 WARNING: May not be mixed with other oils!	LWE Id. No.: 861901208 Liebherr Gear PG 220 CLP PG 220, DIN 51517-3 WARNING: May not be mixed with other oils!
16.2	Rope winch LR 13000	LWE Id. No.: 11000948 Liebherr Universal grease 9900 KPF2N-25, DIN 51502	LWE Id. No.: 11000948 Liebherr Universal grease 9900 KPF2N-25, DIN 51502
17	Winch of Telescopic boom guying	LWE Id. No.: 861901208 Liebherr Gear PG 220 CLP PG 220, DIN 51517-3 WARNING: May not be mixed with other oils!	LWE Id. No.: 861901208 Liebherr Gear PG 220 CLP PG 220, DIN 51517-3 WARNING: May not be mixed with other oils!
18.1	Crane hydraulics Crane chassis and crane superstructure Observe exceptions, see 18.2	LWE Id. No.: 861903508 Liebherr Hydraulic 37 HVLP, DIN 51524-3	LWE Id. No.: 10293807 Liebherr Hydraulic Plus Arctic HVLPD HC, DIN 51524-3

LWE/LR 11000-001/23501-04-02/en

No.	Crane components	Ambient temperature for driving and crane operation	
		-20 °C to +50 °C	-40 °C to +30 °C
18.2	Crane hydraulics Crane chassis and crane superstructure LTM 11200-9.1 LTR 11200 LR 13000, LR 11000, LR 1600/2, LR 1600/2-W LTC 1055-3.1	LWE Id. No.: 10293807 Liebherr Hydraulic Plus Arctic HVLPD HC, DIN 51524-3	LWE Id. No.: 10293807 Liebherr Hydraulic Plus Arctic HVLPD HC, DIN 51524-3
19	Brake system if hydraulically actuated	LWE Id. No.: 861000108 DOT 4 SAE J 1703e	LWE Id. No.: 861000108 DOT 4 SAE J 1703e
20	Clutch actuator	LWE Id. No.: 861000108 DOT 4 SAE J 1703e	LWE Id. No.: 861000108 DOT 4 SAE J 1703e
21	King pin bearing Gear shaft if not maintenance-free	LWE Id. No.: 861301308 Liebherr Special grease 9610 Plus KP2K-20, DIN 51502	LWE Id. No.: 10296825 Liebherr Universal grease Arctic KPFHC1N-60, DIN 51502
22.1	Glide and roller bearing roller bearing joint	LWE Id. No.: 861301308 Liebherr Special grease 9610 Plus KP2K-20, DIN 51502	LWE Id. No.: 10296825 Liebherr Universal grease Arctic KPFHC1N-60, DIN 51502
22.2	Rope pulley bearing	LWE Id. No.: 10296825 Liebherr Universal grease Arctic KPFHC1N-60, DIN 51502	LWE Id. No.: 10296825 Liebherr Universal grease Arctic KPFHC1N-60, DIN 51502
23	Central lubrication system	LWE Id. No.: 861301308 Liebherr Special grease 9610 Plus KP2K-20, DIN 51502	LWE Id. No.: 10296825 Liebherr Universal grease Arctic KPFHC1N-60, DIN 51502
24.1	Slewing ring connection Roller bearing	LWE Id. No.: 861301308 Liebherr Special grease 9610 Plus KP2K-20, DIN 51502	LWE Id. No.: 10296825 Liebherr Universal grease Arctic KPFHC1N-60, DIN 51502
24.2	Slewing ring connection LR 13000	LWE Id. No.: 11000948 Liebherr Universal grease 9900 KPF2N-25, DIN 51502	LWE Id. No.: 10296825 Liebherr Universal grease Arctic KPFHC1N-60, DIN 51502

No.	Crane components	Ambient temperature for driving and crane operation	
		-20 °C to +50 °C	-40 °C to +30 °C
25.1	Support plate with equalization	LWE Id. No.: 10877698 Loctite LB 8104 Silicone oil base WARNING: Do not use oils with another base!	LWE Id. No.: 10877698 Loctite LB 8104 Silicone oil base WARNING: Do not use oils with another base!
25.2	Glide shoes for cab guidance on vehicle frame LTC 1045-3.1 LTC 1050-3.1	LWE Id. No.: 861303608 Liebherr Telescope grease 9613 Plus KP2K-30, DIN 51502	LWE Id. No.: 861303608 Liebherr Telescope grease 9613 Plus KP2K-30, DIN 51502
26	Sliding beam Plastic glide bearing Beam for track adjustment	LWE Id. No.: 861303608 Liebherr Telescope grease 9613 Plus KP2K-30, DIN 51502	LWE Id. No.: 861303608 Liebherr Telescope grease 9613 Plus KP2K-30, DIN 51502
27.1	Telescopic boom Plastic glide bearing Corner guide top	LWE Id. No.: 861303608 Liebherr Telescope grease 9613 Plus KP2K-30, DIN 51502	LWE Id. No.: 861303608 Liebherr Telescope grease 9613 Plus KP2K-30, DIN 51502
27.2	Telescopic boom Outer glide bearing Lower shell Inner glide bearing (only during assembly)	LWE Id. No.: 861303308 Liebherr Special grease 1336 KP2K-30, DIN 51502 Spray grease	LWE Id. No.: 861303308 Liebherr Special grease 1336 KP2K-30, DIN 51502 Spray grease
27.3	Telescopic boom LTC 1045-3.1 LTM 1050-3.1	LWE Id. No.: 11651459 Bechem Berulub TCG 1 V	LWE Id. No.: 11651459 Bechem Berulub TCG 1 V
28	Boom lock	LWE Id. No.: 861301308 Liebherr Special grease 9610 Plus KP2K-20, DIN 51502	LWE Id. No.: 10296825 Liebherr Universal grease Arctic KPFHC1N-60, DIN 51502
29	Guide rail on Telescoping cylinder	LWE Id. No.: 861303308 Liebherr Special grease 1336 KP2K-30, DIN 51502 Spray grease	LWE Id. No.: 861303308 Liebherr Special grease 1336 KP2K-30, DIN 51502 Spray grease
30	Gear ring rotary connection Slewing gear drive pinion	LWE Id. No.: 861007708 RHS-Fluid OGPFOS-20, DIN 51502	LWE Id. No.: 861007708 RHS-Fluid OGPFOS-20, DIN 51502
31	Running rope	LWE Id. No.: 10173371 Liebherr WR-Lube SC Adhesive grease	LWE Id. No.: 10173371 Liebherr WR-Lube SC Adhesive grease

LWE/LR 11000-001/23501-04-02/en

No.	Crane components	Ambient temperature for driving and crane operation	
		-20 °C to +50 °C	-40 °C to +30 °C
32	Radiator fluid Diesel engine and heating system	LWE Id. No.: 10871121 Liebherr Antifreeze OS Mix Pre-mixed corrosion inhibitor / antifreeze WARNING: May not be diluted and / or mixed with other corrosion inhibitors / anti-freeze!	LWE Id. No.: 10871121 Liebherr Antifreeze OS Mix Pre-mixed corrosion inhibitor / antifreeze WARNING: May not be diluted and / or mixed with other corrosion inhibitors / anti-freeze!
33.1	Travel gears Crawler crane	see data tag	see data tag
33.2	Travel gears telescope crawler crane	see data tag	see data tag
34	Recovery winch	See the data tag and manufacturer's specifications	See the data tag and manufacturer's specifications
35	Recovery winch rope	See the manufacturer's specifications	See the manufacturer's specifications
36	Steering uncoupling LTC 1045-3.1 LTC 1050-3.1	LWE Id. No.: 10800345 Teflon Spray	LWE Id. No.: 10800345 Teflon Spray

8 Inspections of cranes

LWE/LR 11000-001/23501-04-02/en

LWE/LR 11000-001/23501-04-02/en

8.01 Periodic crane inspections

1	General information	3
2	Inspection of carrying crane structures, especially steel structures	4
3	Inspection of locking system of telescopic boom	79
4	Inspection of safety ropes and anchor points	81
5	Inspection of load handling equipment and assembly aids	83
6	Inspection of fastening equipment	84
7	Inspection of diaphragm reservoir	84
8	Inspection of relapse cylinders	84
9	Inspection of rope pulleys	85
10	Inspection of carrier rollers	85
11	Inspection of extension conditions of sliding beams	87
12	Inspection of the function of the overload protection	87
13	Inspecting the pin connections	87
14	Inspection of slewing ring connection	87
15	Inspection of the mounting of the load bearing equipment	88
16	Inspection of the tele extension with eccentric, illustration 1	89
17	Inspection of change over pulleys, illustration 2	90
18	Inspection of the oil and fuel tanks	90

Fig.195219

LWE/LR 11000-001/23501-04-02/en

1 General information

This crane was tested at the manufacturer's facilities prior to shipment in accordance with the valid ISO, FEM and DIN Standards and DGUV 52 (DGUV 309-001).

The safety level achieved during initial start up may not be attainable during operation.

Examples of the root cause of such deviations include; e.g., wear and tear, corrosion, effects of external forces, changes in the environment and changes to the mode of operation.

The operator is responsible for taking the necessary steps to ensure that the level of safety is maintained.

Periodic inspections are regulated nationally in the BetrSichV.

The crane operator is therefore obligated to have the crane inspected by an **authorized inspector**, at intervals depending on the operational conditions but at least once per year, from the first day of vehicle registration.

Every 4 operating years, in the 13th operating year and thereafter at least annually, from the first day of vehicle registration, the crane must be inspected by an **inspection expert**.

Periodic inspection are principally a visual inspection, where the inspector (either type) appraises the condition of the crane and its components.



WARNING

There is a risk of weakening the supporting components when major changes or repairs are made to the crane!

- ▶ In this case, the operator must have the crane reinspected by an inspection expert before placing it back into service!

In addition, all respective local and national regulations also apply.

Authorized inspector

Authorized inspectors are those persons who through their professional training, their professional experience and their recent professional activity have the necessary knowledge for the inspection of work equipment.

Authorized inspector for pressure tanks

Authorized inspector for pressure tanks are authorized inspectors who additionally:

- Have relevant technical professional training.
- Have at least one year of experience with the manufacture, assembly, operation or maintenance of the equipment or components to be inspected in accordance with BetrSichV.
- Keep their knowledge about pressure-related hazards up to date by participating in training or instruction, in particular with regard to the following topics:
 - Design and manufacturing processes
 - Equipment and safeguarding concepts
 - Assembly, installation and operation / use
 - Destined use
 - Risk assessment
 - Inspections, inspection periods, inspection procedures including assessment of the results
 - Relevant influences and damage symptoms found in practice

Inspection expert

Inspection experts are authorized inspectors who also:

- Have completed training as an engineer or have equivalent knowledge and experience in the subject area with which their activities are involved.
- Have at least three years of experience in the design, construction, maintenance or inspection of cranes, of which at least half a year were involved in the inspection activities of an inspection expert.
- Possess sufficient knowledge of the relevant regulations and rules.
- Have the necessary facilities for inspection and documentation.
- Keep their professional knowledge up to date.

To ensure the high safety standard of the crane, it is recommended, no later than the 12th year, in the 20th year, in the 26th year and then every 4 years, to have the crane undergo a **general inspection** by an **inspection expert**. At that time, in addition to the usual scope of inspection, all load carrying parts of the crane - the complete steel structure with all welding seams as well as all components and connecting devices - are to be subjected to a complete visual inspection. The following procedural notes for repeat inspections are to be observed for that.

The purpose of the inspections is to avoid accidents by detecting deficiencies early on. Any deficiencies found by the inspector must be documented, corrected and subsequently reinspected.

A number of important examples of items that are particularly important during the periodic crane inspections are listed in the following. We wish to advise that the **authorized inspectors** or **inspection experts** take sole responsibility for the crane inspections that they carry out.



Note

- ▶ The inspection may not be solely limited to the following positions shown in the sample construction illustrations. Rather the **entire** crane structure must be subjected to a careful inspection!

In the Crane operating instructions, chapter 8.90 is a checklist to assist the inspector during the periodic inspections of Liebherr mobile and crawler cranes.

If the inspector has any questions they should be directed through the Service Department of Liebherr-Werk Ehingen GmbH to the technical departments.



WARNING

Danger of accident!

- ▶ Adhere to the following inspection guidelines and intervals.

2 Inspection of carrying crane structures, especially steel structures

2.1 Basic principles and procedure



DANGER

Danger of fatal injury!

The crane structures, particularly steel constructions, have to be checked by an **authorized inspector** or **inspection expert** at least once a year. If this is not the case, they could fail and cause fatal injury or seriously damage the crane!

- ▶ Crane structures, particularly steel constructions must be checked by an **authorized inspector** or an **inspection expert** at least once a year!
- ▶ Shorten the inspection intervals when the crane is subjected to above-average load spectrums, for example when handling large material quantities or frequently erecting long boom systems.
- ▶ When the crane was subjected to excessive operating loads; e.g., due to an unusual impact, the crane structure, especially the steel structures must be inspected immediately!

Crane structures, especially steel structures, such as booms, turntables, chassis, support equipment (e.g., sliding beams or folding outriggers) must be carefully inspected, at the very least during the annual recommended crane inspections. Inspect welding seams especially through an intensive visual inspection.

If paint damage with corrosion (rust) is found on load carrying parts of the crane structure, especially on telescopic booms, lattice booms, lattice jibs, pull rods etc., then the rust must be removed, primed and painted.

During an electrolyte process, such as corrosion in combination with water, an atomic hydrogen is created, which causes to hydrogen induced corrosion with resulting cracks on high tensile fine grain construction steel.

If disassembly and assembly work on the crane is required to carry out the inspections, then they must be carried out by taking the manufacturer's data into account or in coordination with the crane manufacturer.

We would like to point out that the framework of mobile cranes is designed for a limited number of stress work cycles. This also determines the utilization or service life of the framework. The service life is not determined solely by the number of stress cycles. It also depends on the loads (load spectrum) applied during the time in operation.

Liebherr mobile and crawler cranes are designed for specific characteristics and movements, such as constant deployment of drive forces, only occasional operation and load conditions according to EN 13000.

Liebherr mobile and crawler cranes are designed for assembly operation and, according to grouping in class A1 according to ISO 4301-1, they can only take on a limited number of work cycles ($N = 63000$) with a collective class Q1 = light ($k_p = 0.125$).

Example of a load collective according to grouping in collective class Q₁ = light ($k_p = 0.125$).

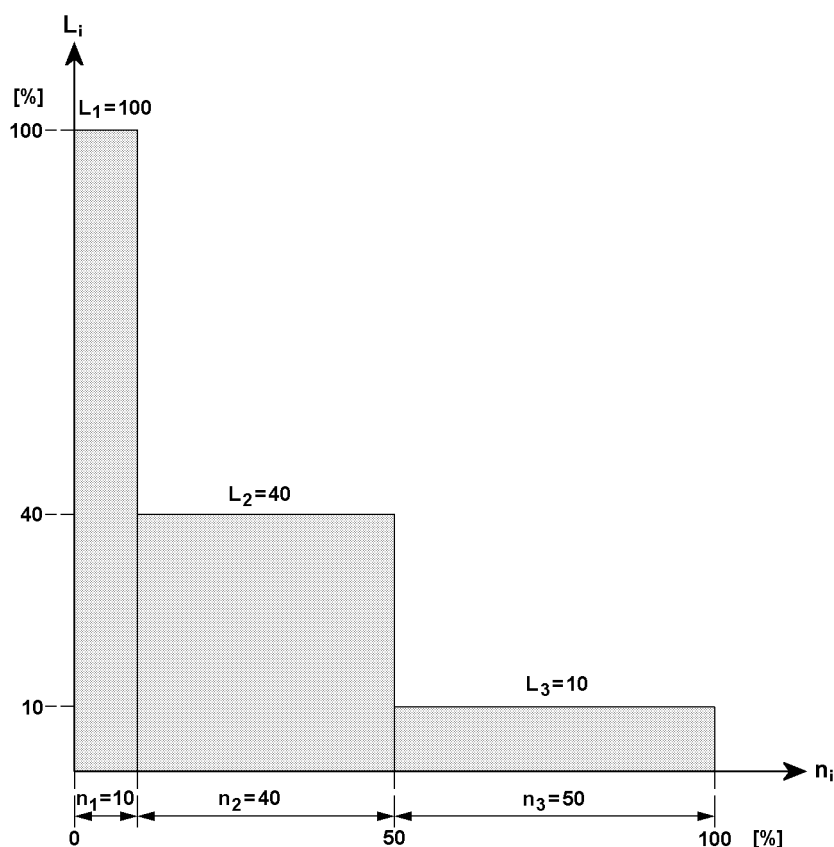

Fig. 104716

L_i: Load proportion in relation to maximum load [%]

n_i: Load cycles in relation to maximum number [%]



Note

- ▶ The service life of Liebherr mobile and crawler cranes can be drastically reduced, for example when used in magnet, grapple or material handling applications!
- ▶ Repeated inspection of crane structure, especially the steel structure and the welding seams must then be carried out in shorter intervals than specified.

For that reason, the steel structures and the welding joints must be subjected to a visual intensive inspection by the **authorized inspector** or **inspection expert** during the specified periodic inspections.

If any damage (such as cracks or suspicion of cracks) are apparent on any part of the steel structure, the total extent of the damage must be determined by qualified specialists using appropriate material

testing methods, such as magnetic crack detection, ultrasound or x-rays. Thereafter, the qualified personnel must determine whether or not the damaged area can be repaired by welding or by other means.

The following diagrams are samples of the load-bearing welding structures. The welding joints or seams or steel structural zones that require inspection may be present more than once and in various forms. The joints or zones must be inspected all around at the locations identified by arrows.



Note

- ▶ The scope and extent of all inspections remain the sole responsibility of the inspectors!
- ▶ The scope and results of tests should be documented to permit reproducibility. This documentation forms part of the crane records and should be safely stored during the entire service life of the crane!
- ▶ The following diagrams are provided to assist the inspector. The illustrations are only examples and are not necessarily 100 % complete!

2.2 Repair welding

Defects such as cracks or permanent deformation on load-bearing steel components must be immediately reported to the Service Department at **Liebherr-Werk Ebingen GmbH**.

The defect must immediately be appraised by an inspection expert according to standard welding technology rules. The inspection expert must immediately ascertain if the crane can continue to be safely operated due to danger of accident until a repair welding is performed.

Repair welding may solely be made in consultation and under the instructions of the Customer Service at **Liebherr-Werk Ebingen GmbH** by authorized and trained expert personnel.



WARNING

Repair welding **not** according to regulations!
Death, severe bodily injuries, property damage.

- ▶ Contact Customer Service at **Liebherr-Werk Ebingen GmbH**.
- ▶ Coordinate the procedure for repair welding with **Liebherr-Werk Ebingen GmbH**.



Note

Exclusion of liability!

For repair welding, which were not carried out by personnel from **Liebherr-Werk Ebingen GmbH** or by authorized personnel from **Liebherr-Werk Ebingen GmbH**, **Liebherr-Werk Ebingen GmbH** excludes any liability, for system functionality as well as for the parts.

- ▶ Have repair welding made solely by personnel of **Liebherr-Werk Ebingen GmbH** or by personnel authorized by **Liebherr-Werk Ebingen GmbH**.

2.3 Example for test points

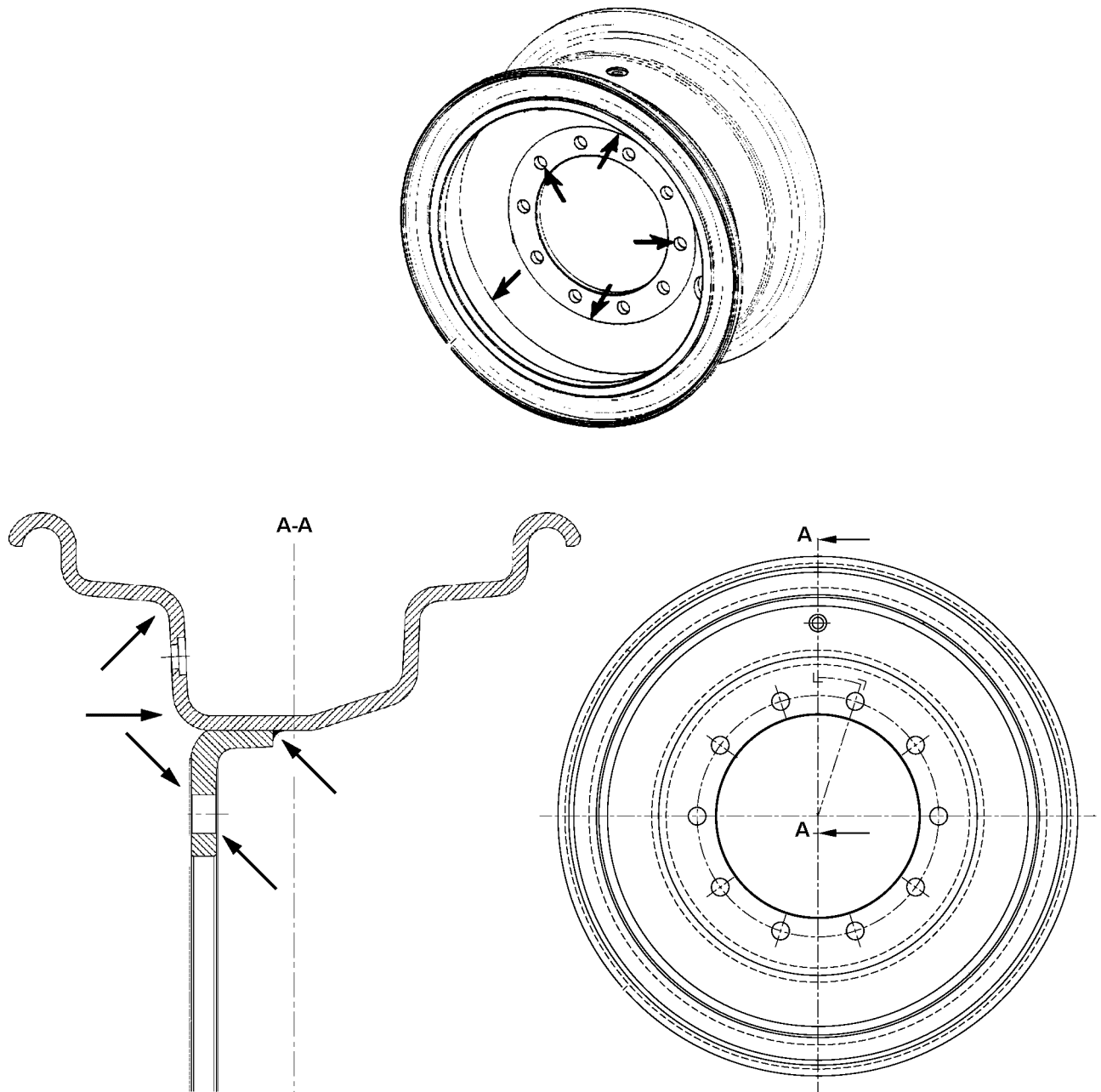

Fig.118052: Example for 1-part disk wheel

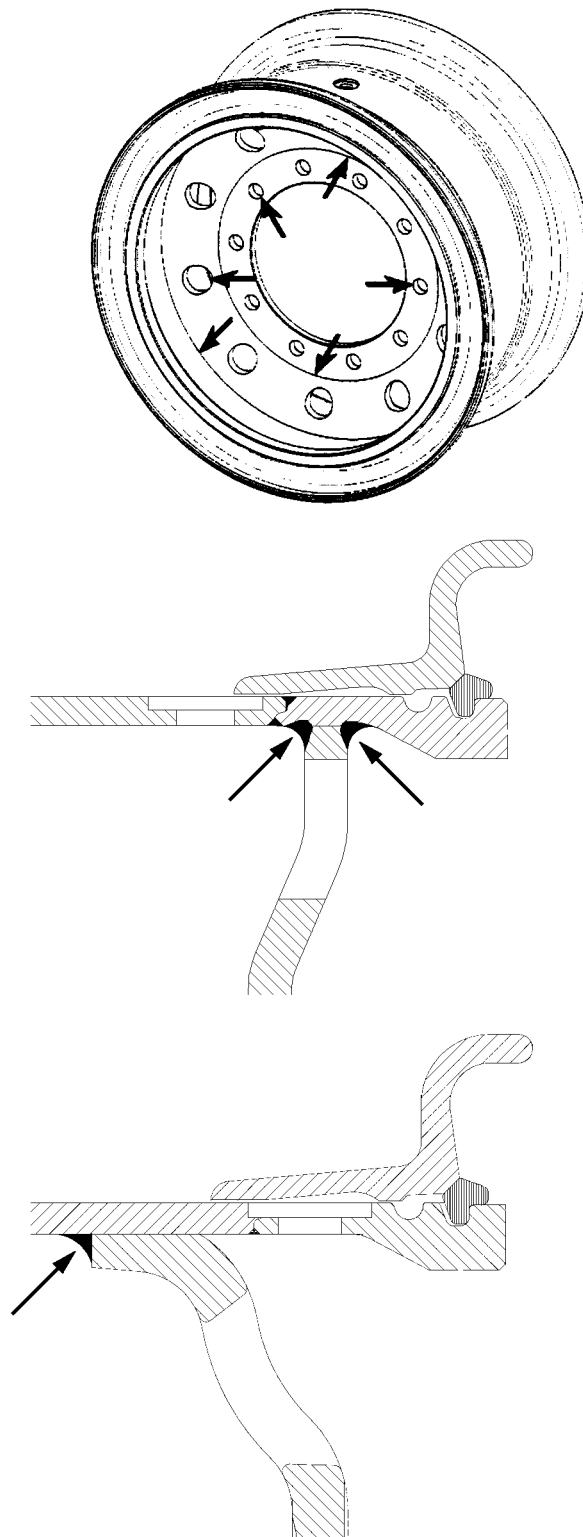
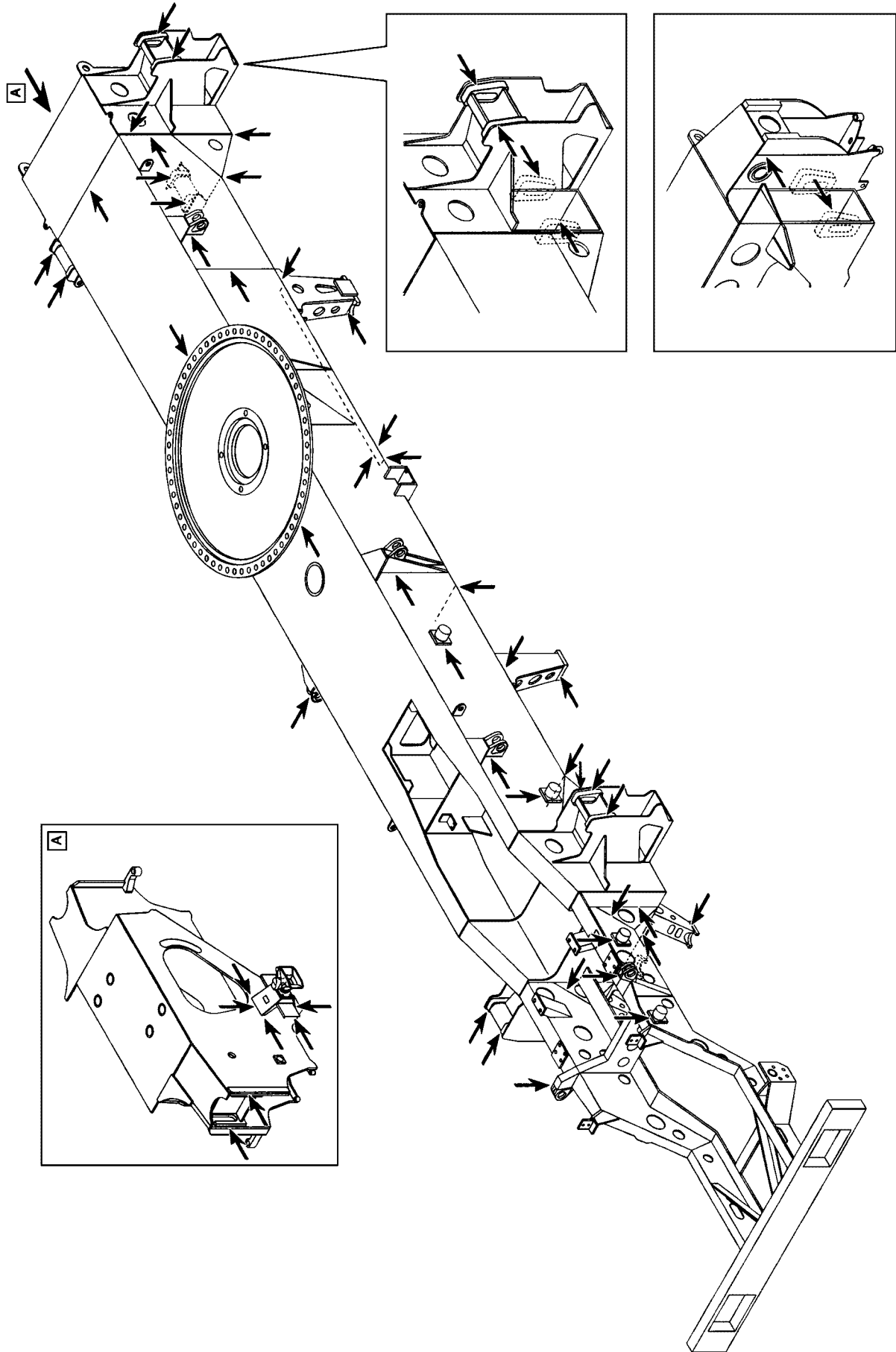

Fig.118053: Example for 3-part disk wheel



LWE/LR 11000-001/23501-04-02/en

Fig.185046: Example for vehicle frames

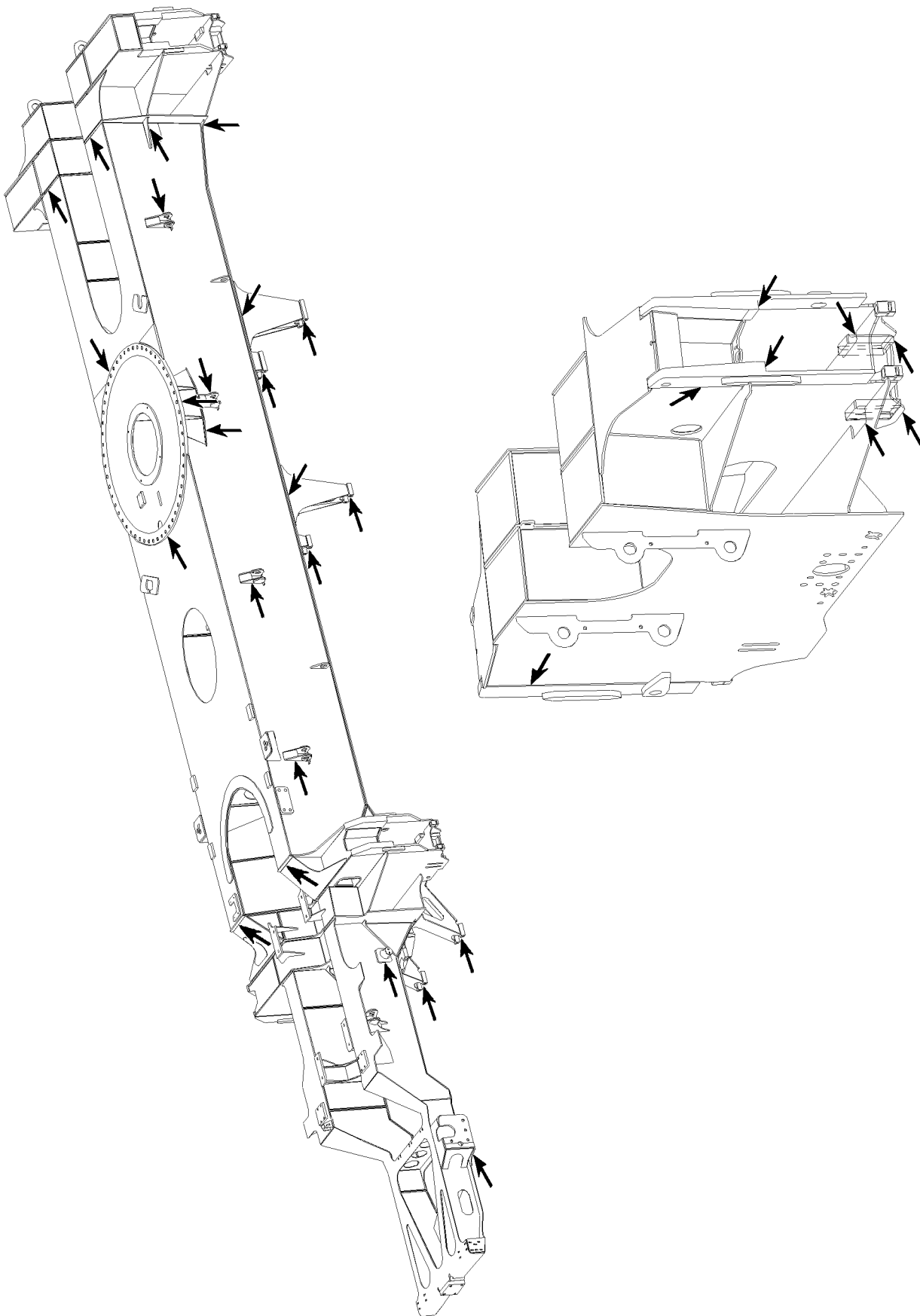
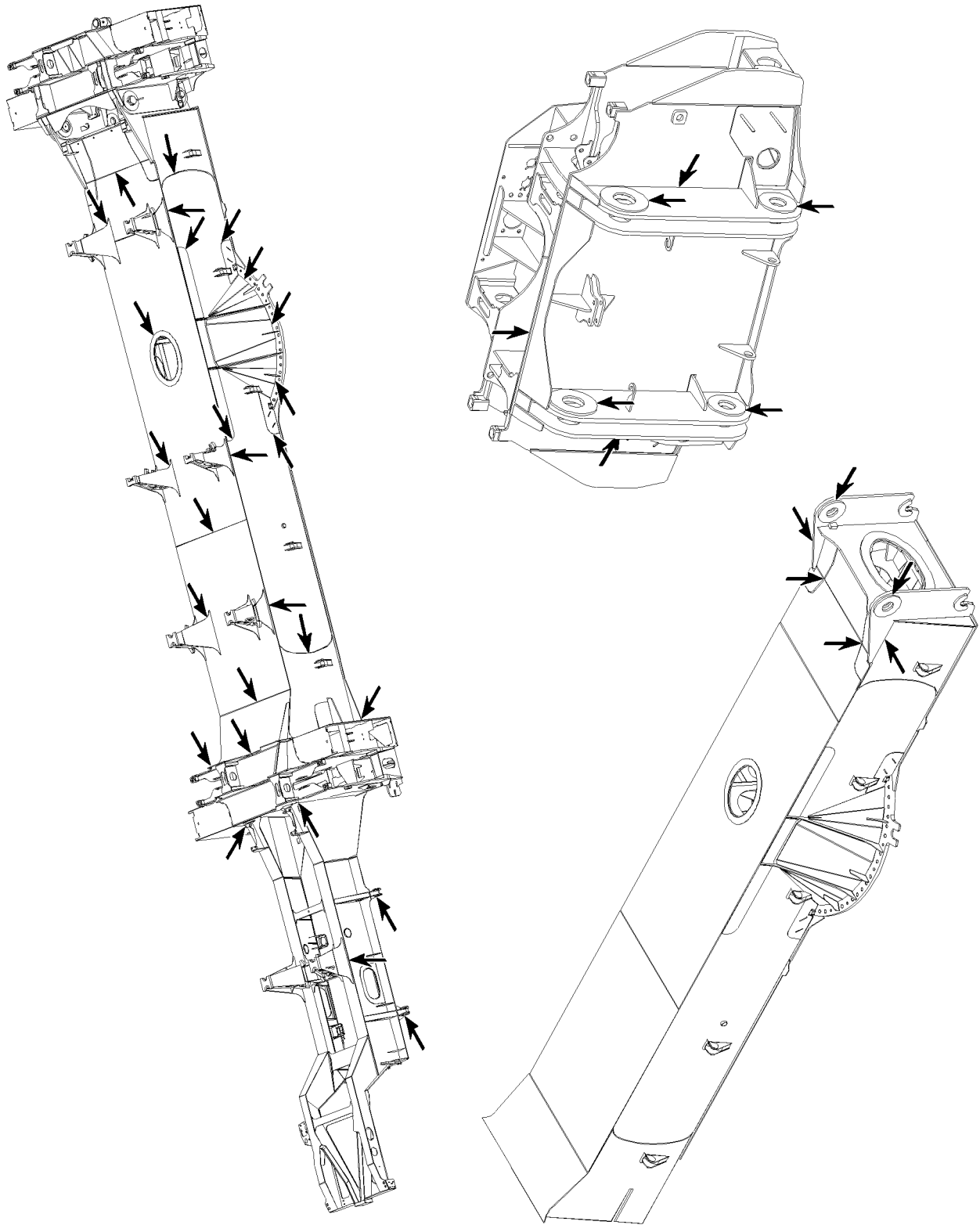

Fig.105702: Example for vehicle frames



LWE/LR 11000-001/23501-04-02/en

Fig.105719: Example for vehicle frames

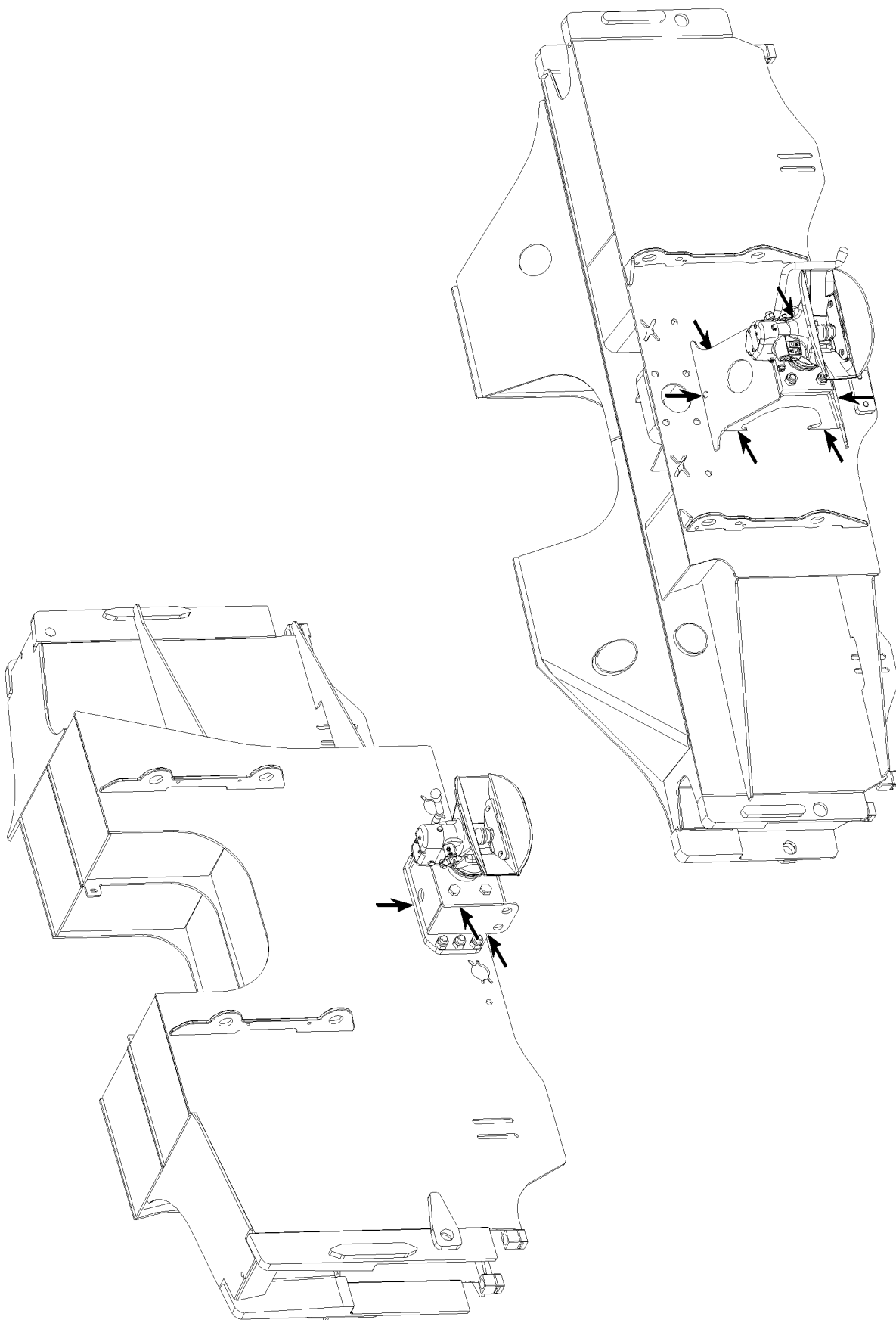
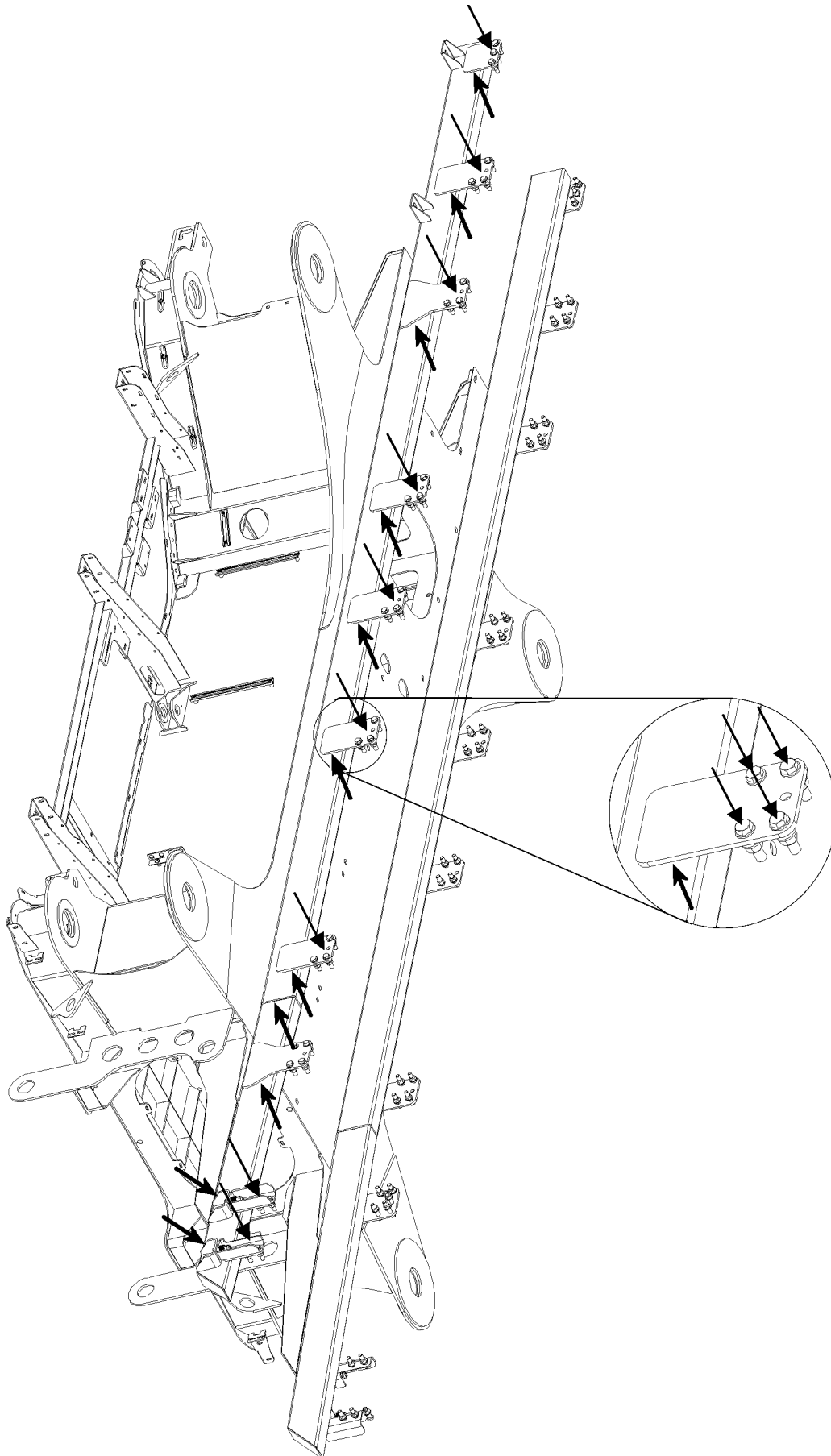

Fig.105687: Example for tow coupling



LWE/LR 11000-001/23501-04-02/en

Fig.113940: Example for intermediate frame

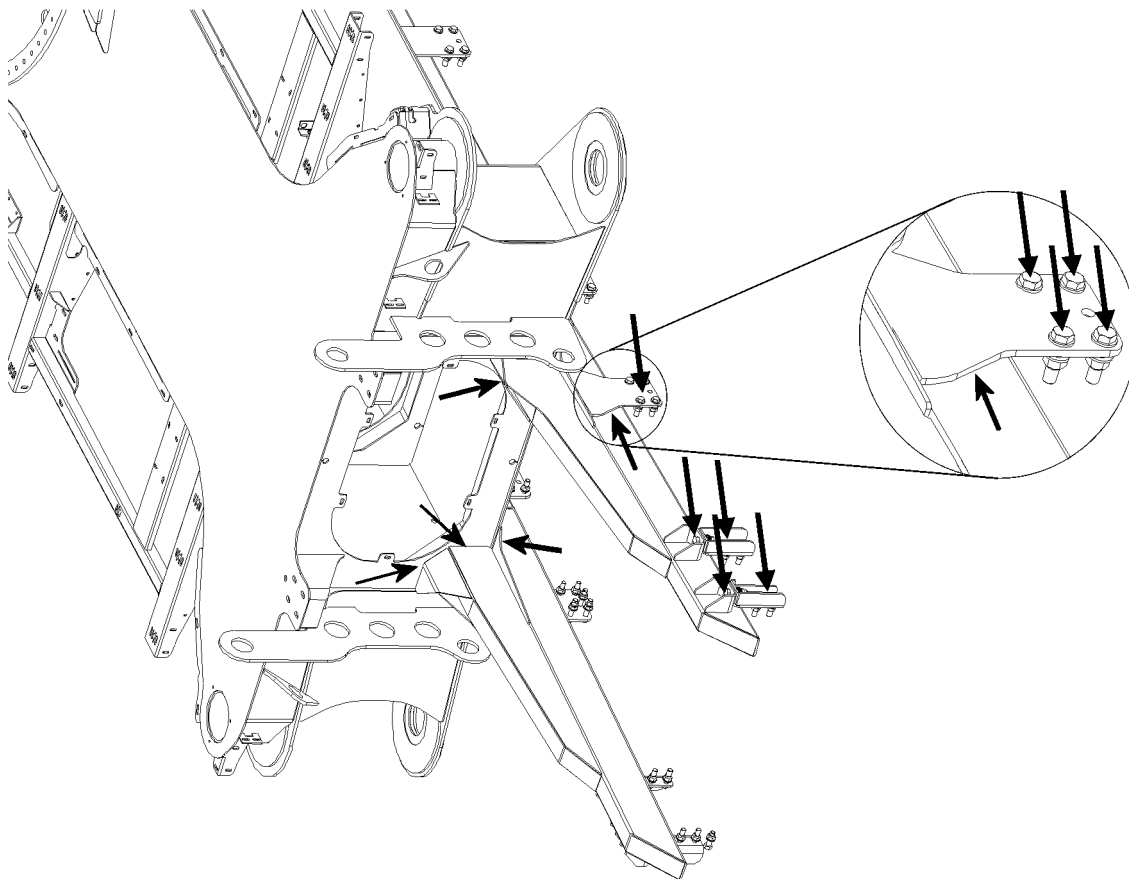
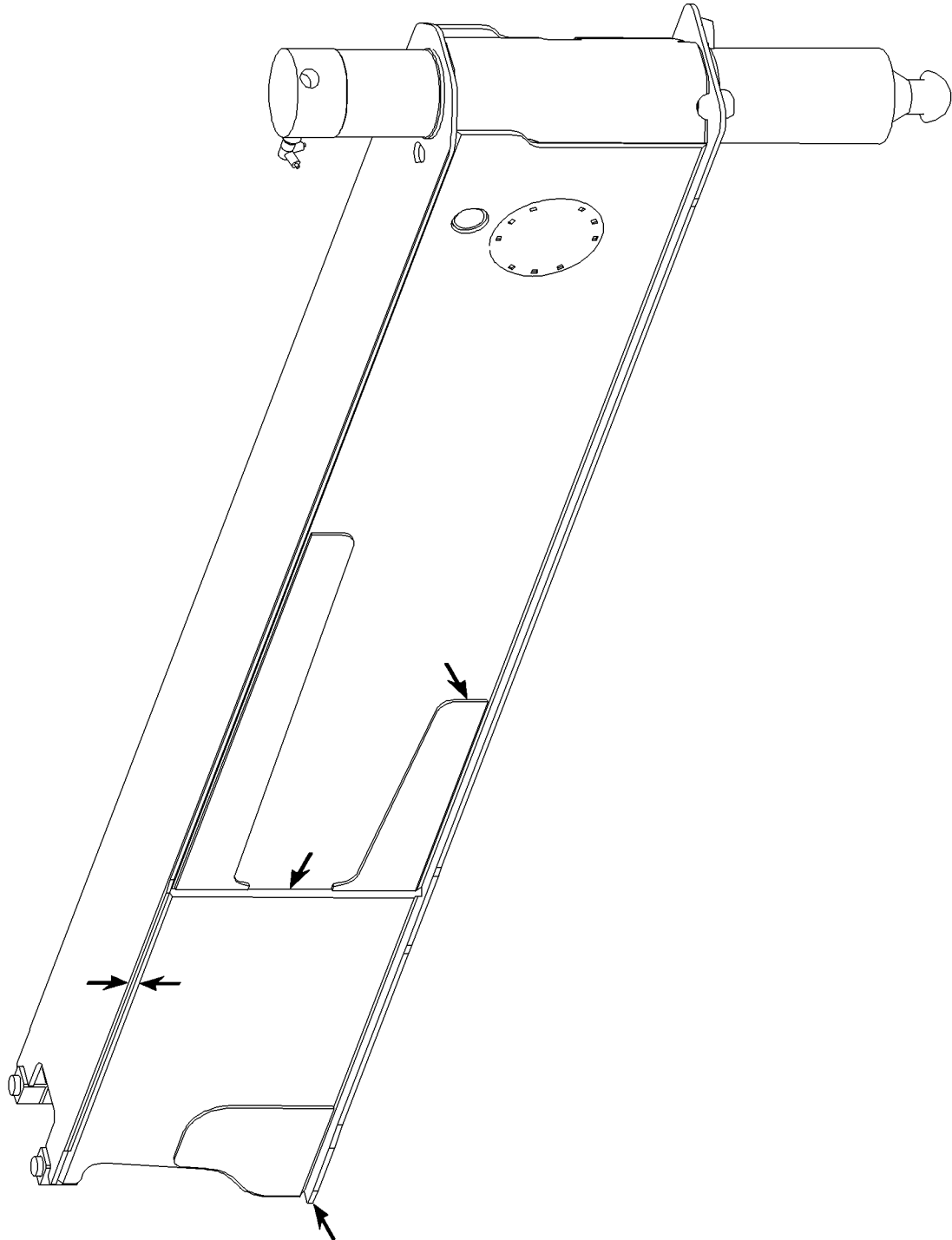

Fig.114000: Example for intermediate frame



LWE/LR 11000-001/23501-04-02/en

Fig.105698: Example for sliding beam

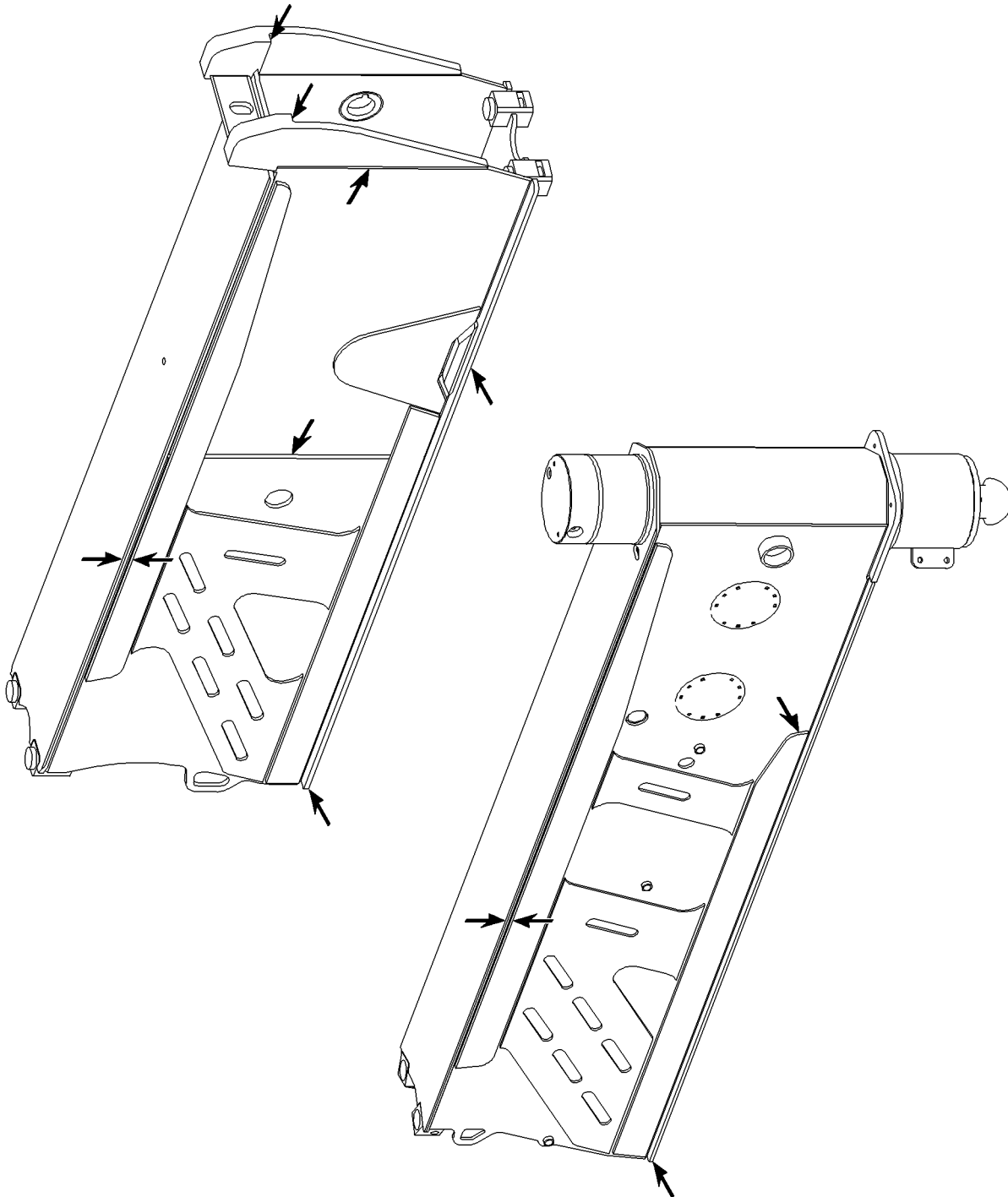
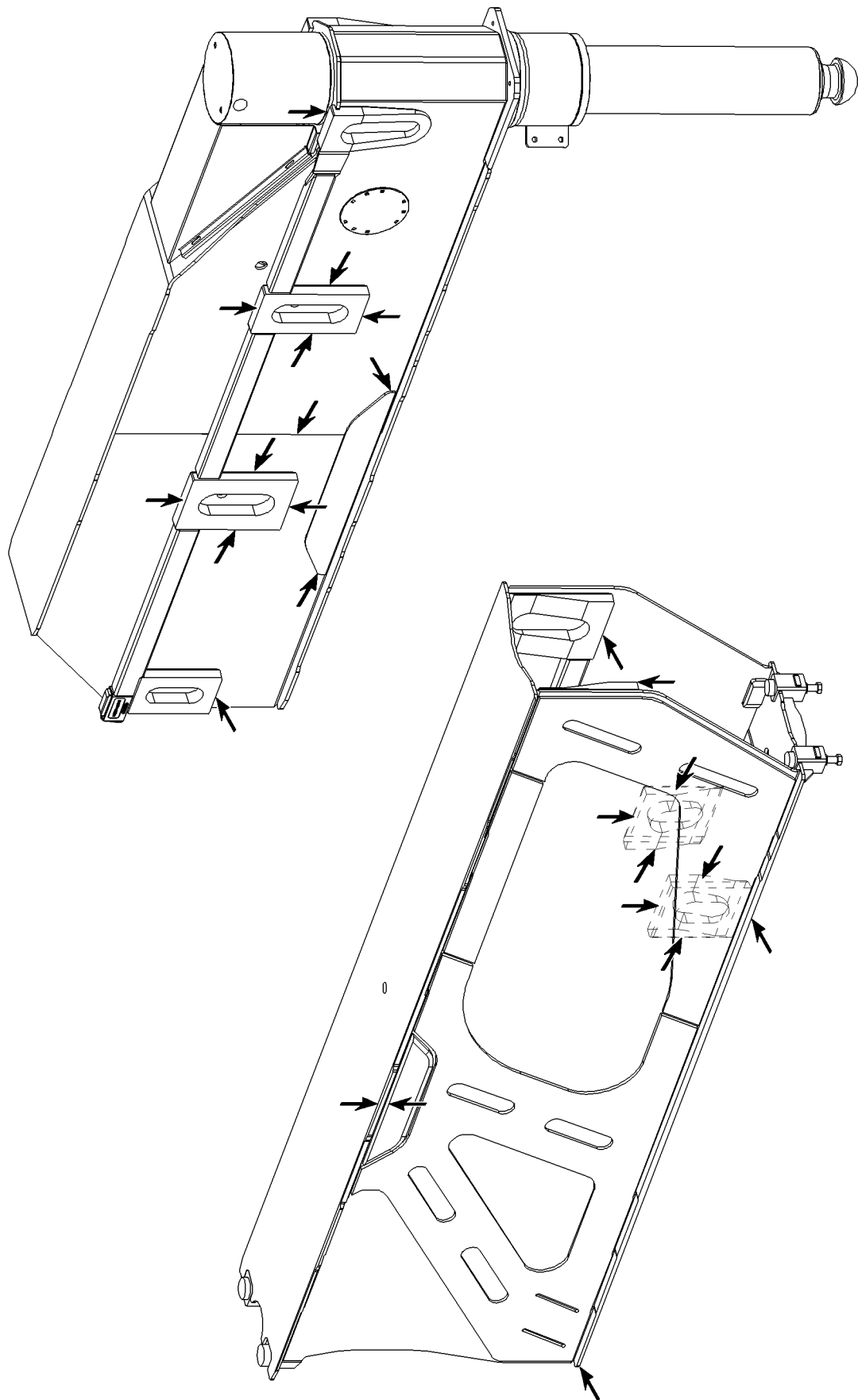

Fig.105717: Example for sliding beam



LWE/LR 11000-001/23501-04-02/en

Fig.105718: Example for sliding beam

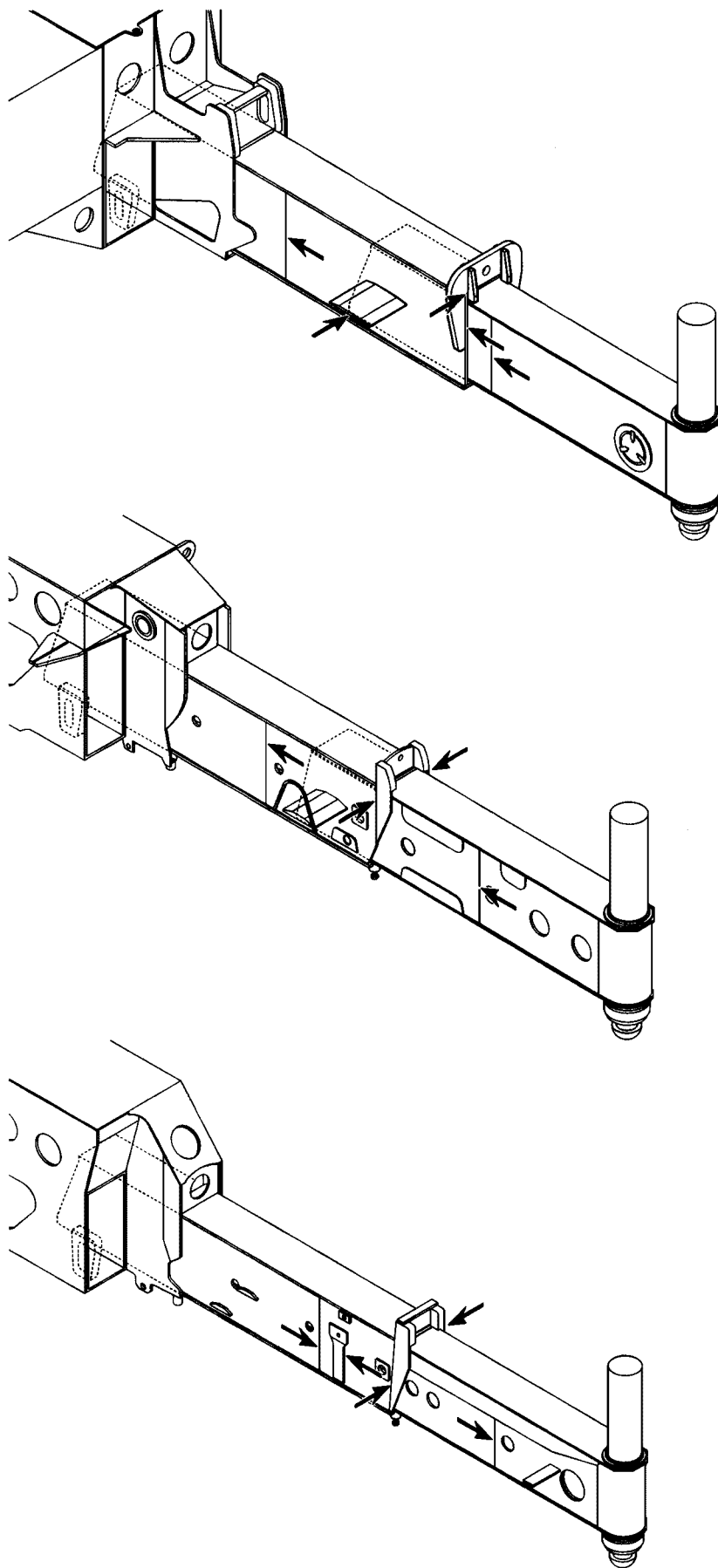
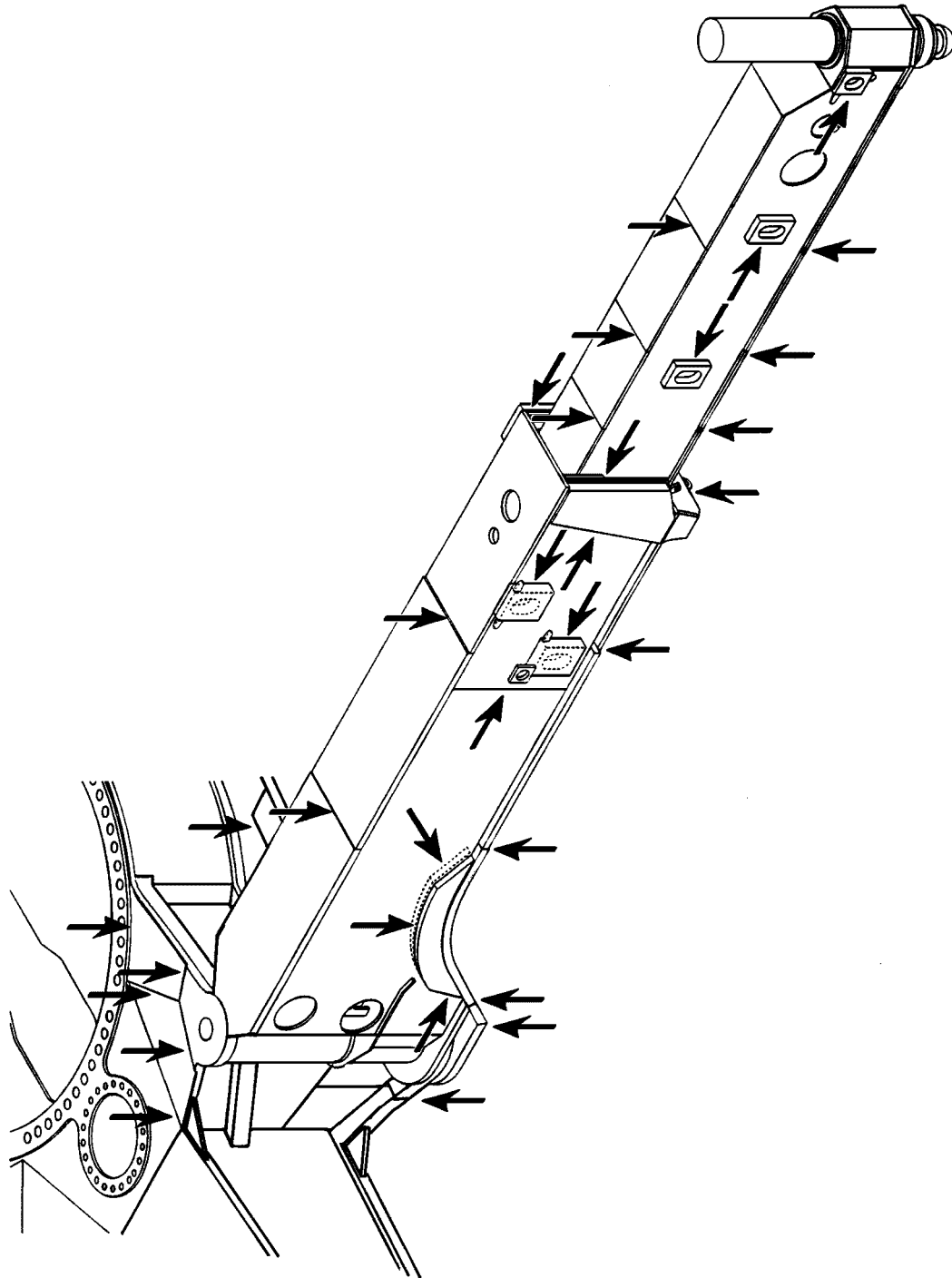

Fig.185047: Example for sliding beam

LWE/LR 11000-001/23501-04-02/en



LWE/LR 11000-001/23501-04-02/en

Fig.185060: Example for swingable sliding beam

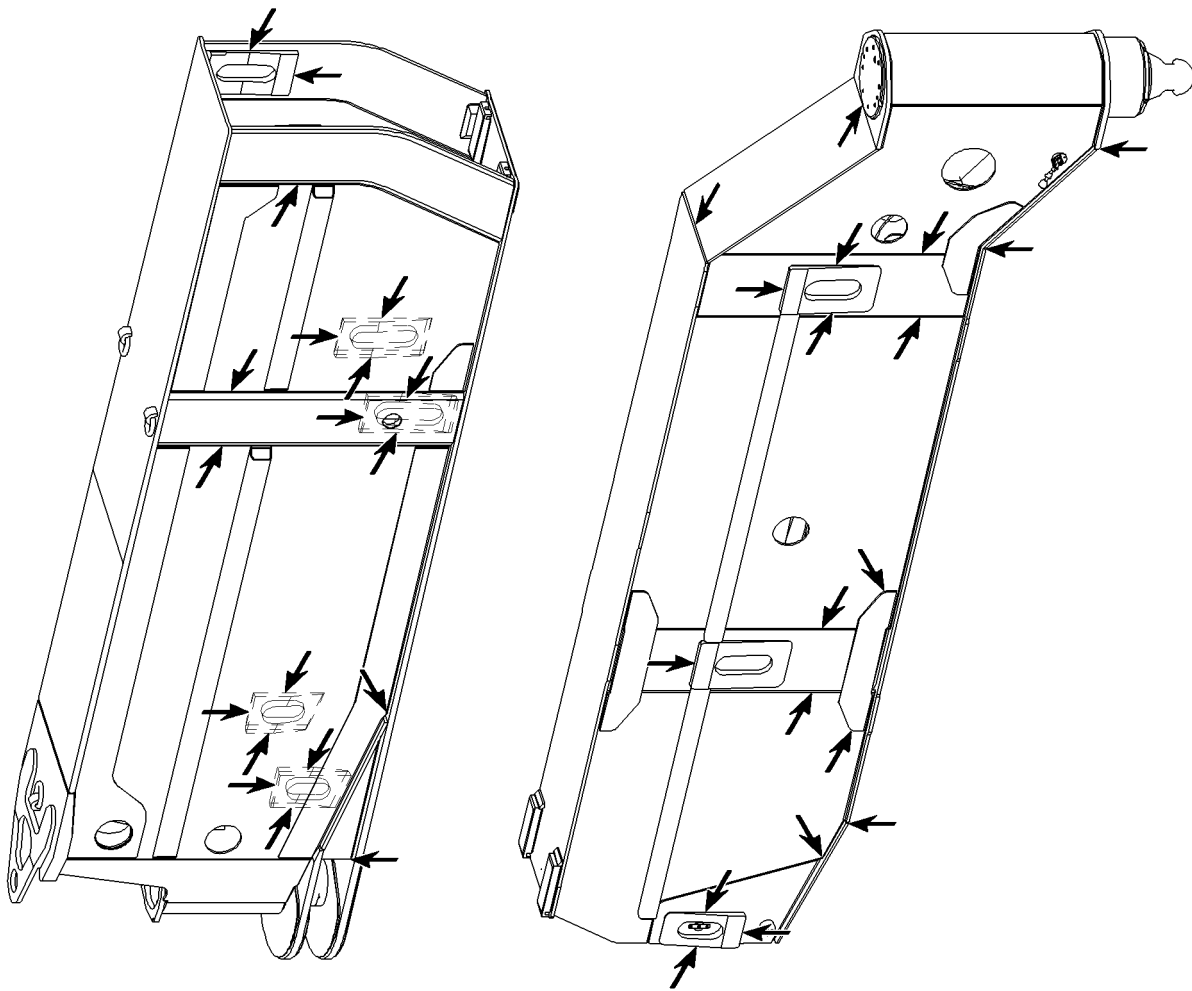
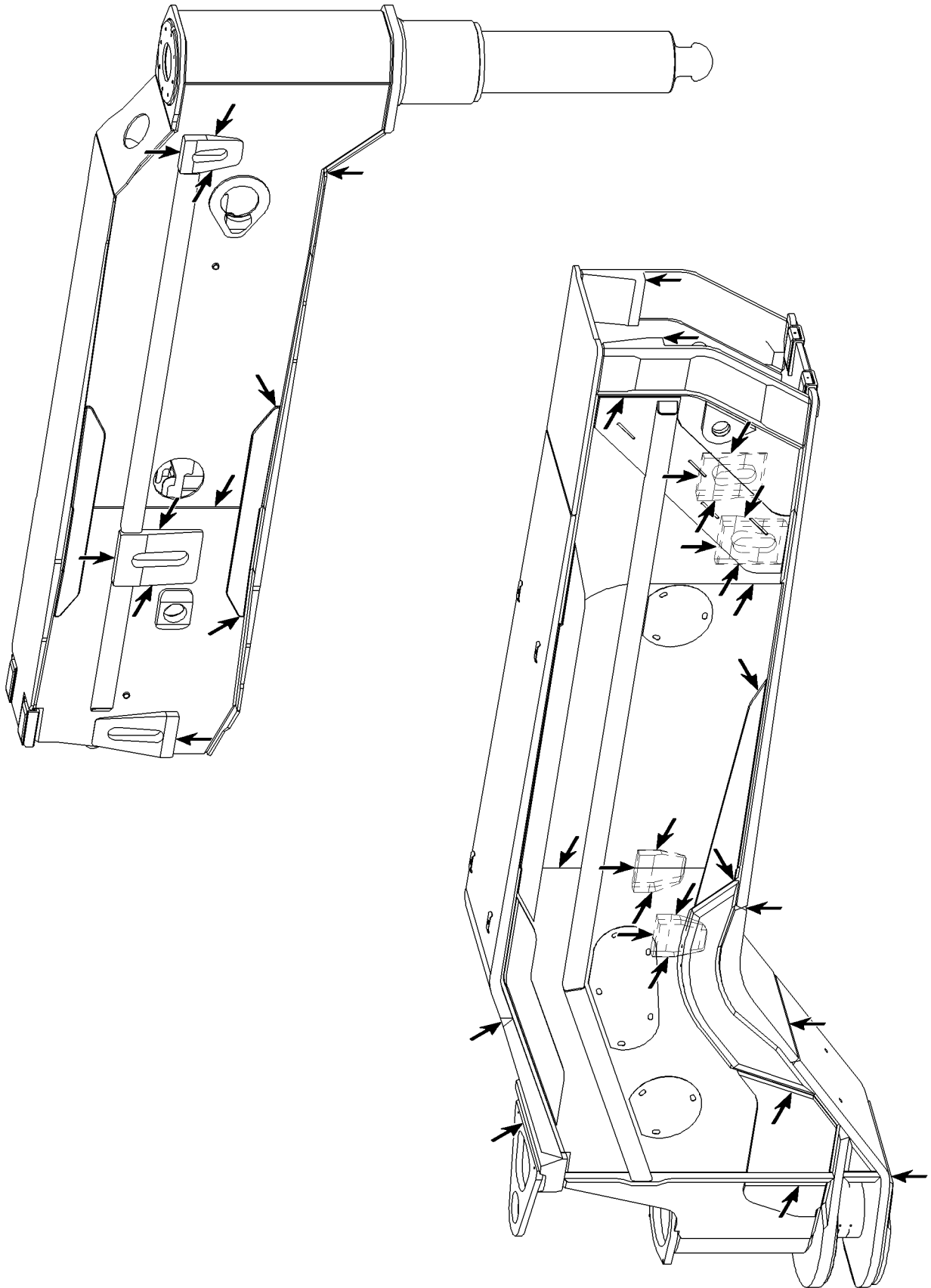

Fig.105690: Example for swingable sliding beam



LWE/LR 11000-001/23501-04-02/en

Fig.105704: Example for swingable sliding beam

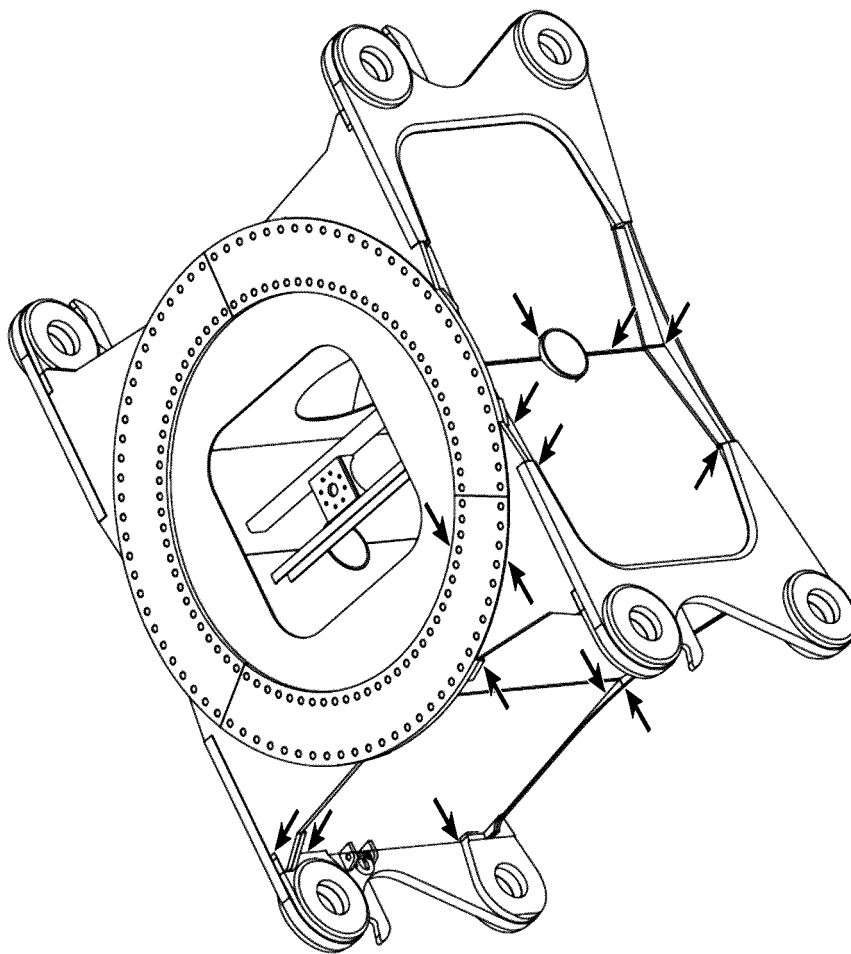
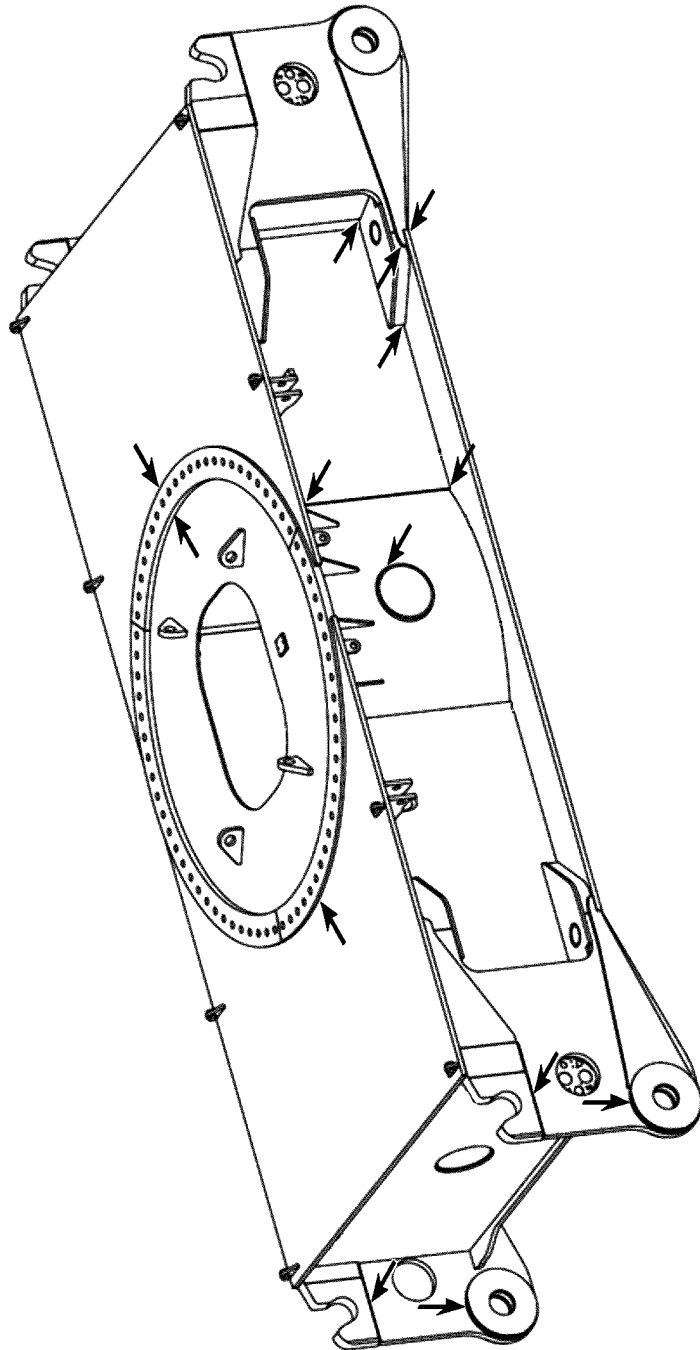

Fig.105725: Example for crawler center section

LWE/LR 11000-001/23501-04-02/en



LWE/LR 11000-001/23501-04-02/en

Fig.105726: Example for crawler center section

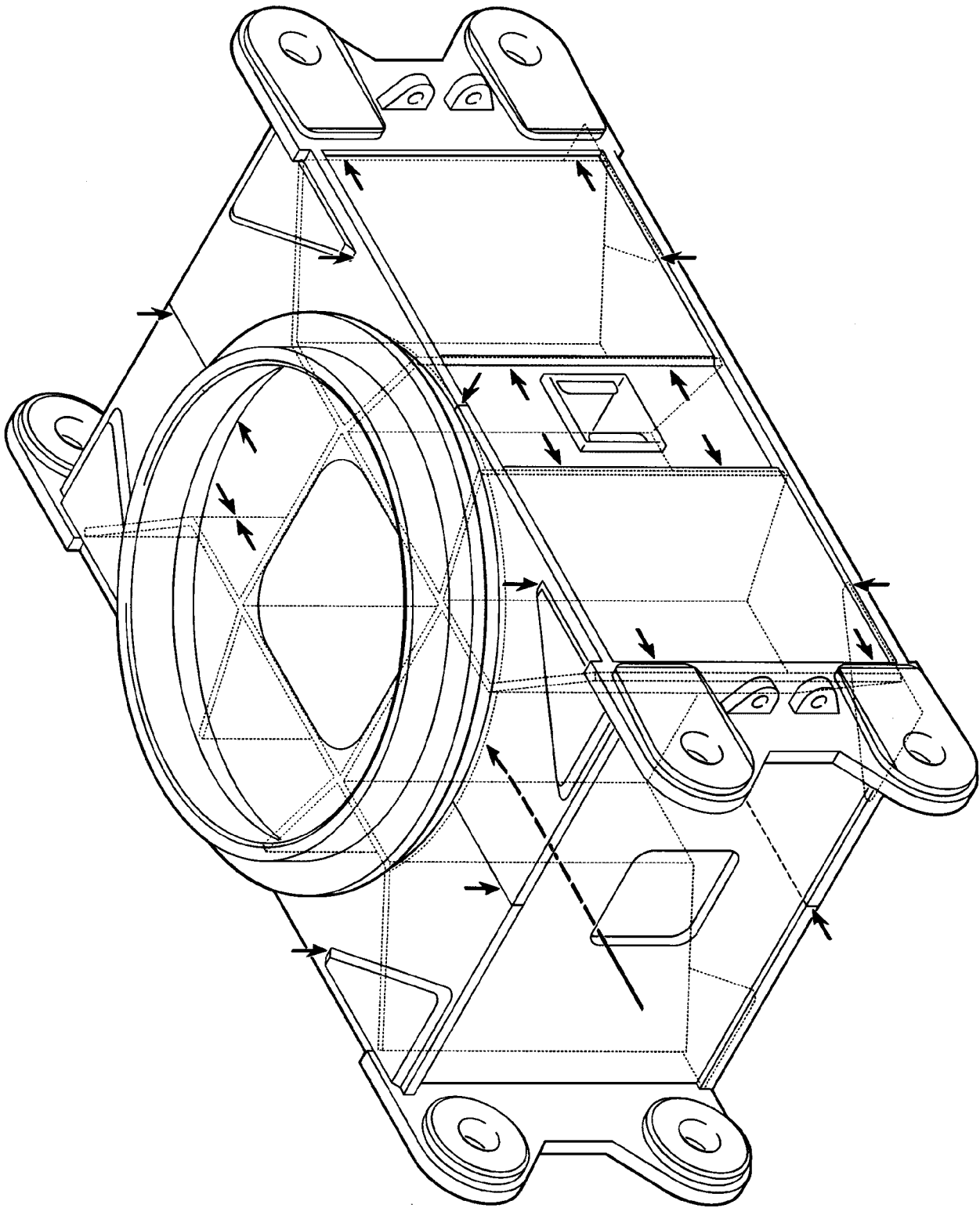
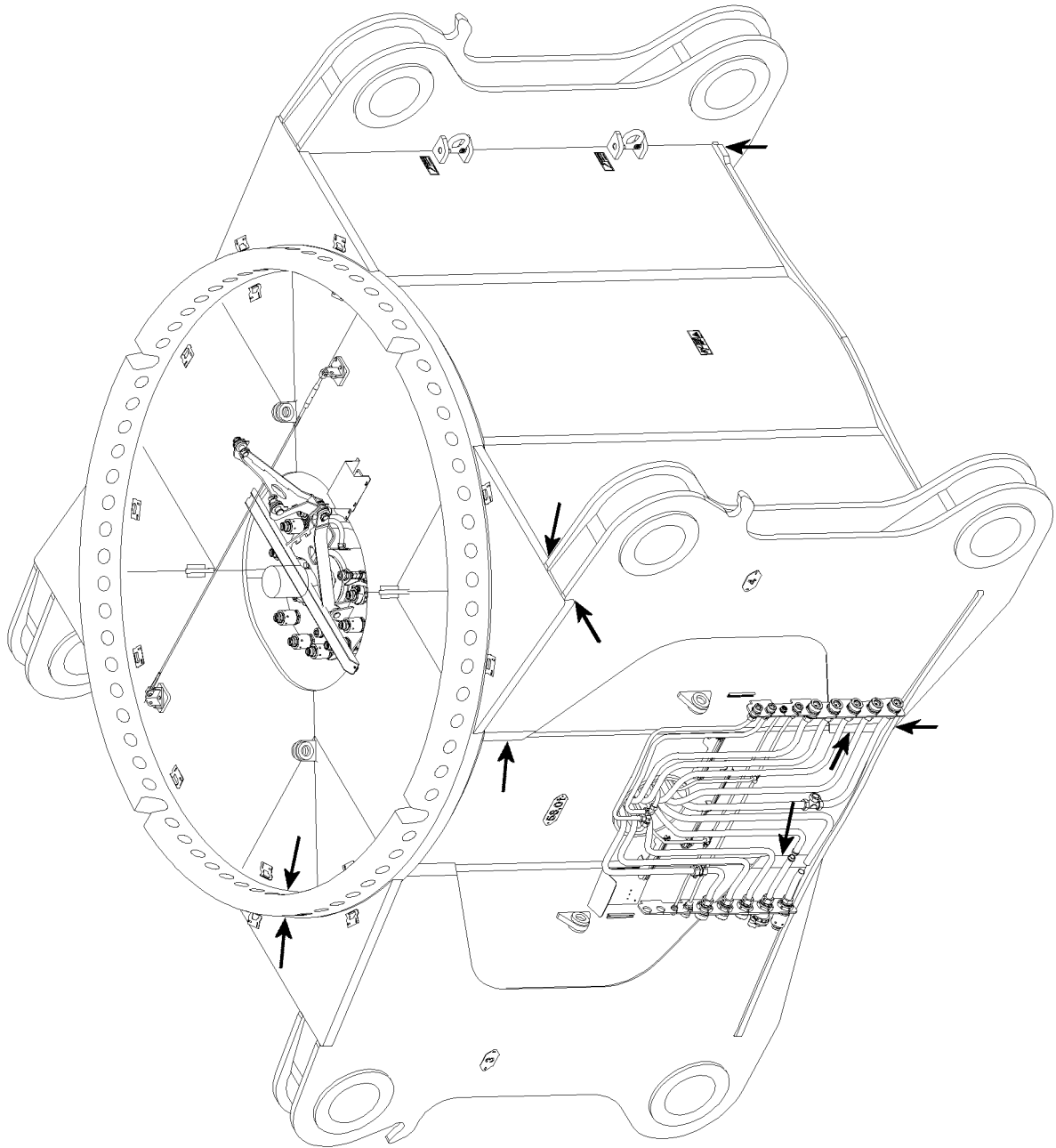

Fig.187347: Example for crawler center section

LWE/LR 11000-001/23501-04-02/en



LWE/LR 11000-001/23501-04-02/en

Fig.115920: Example for crawler center section

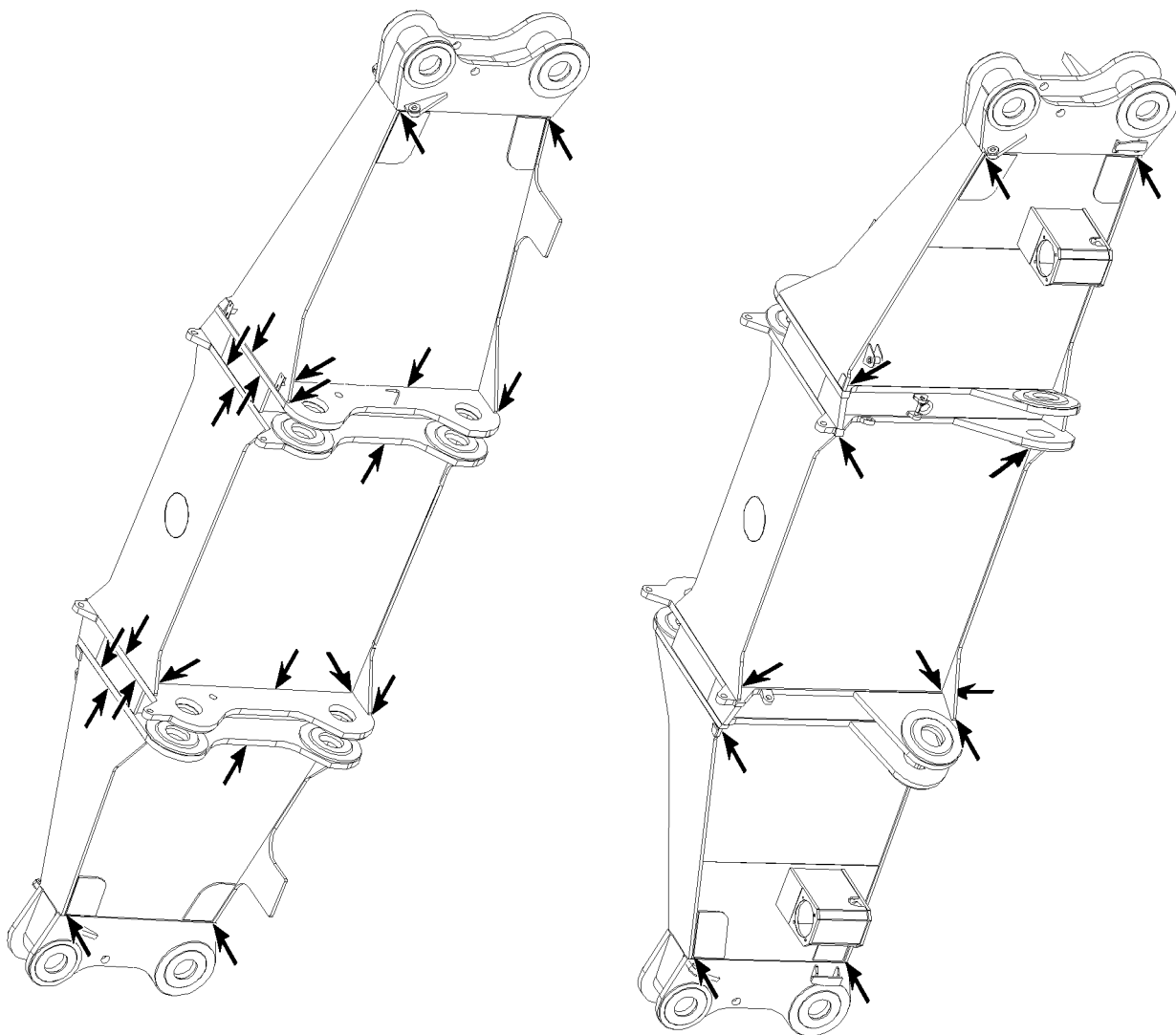
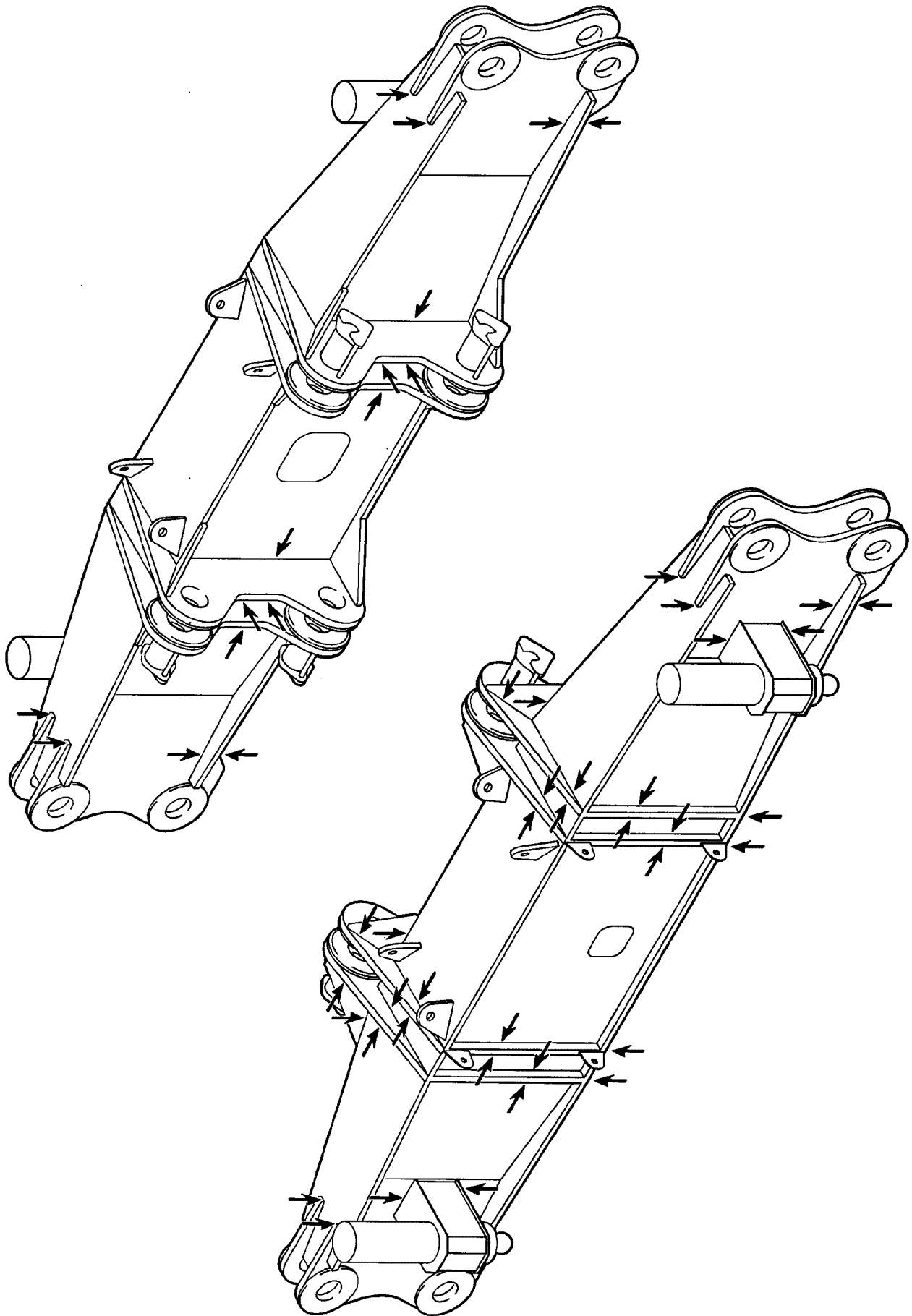

Fig.105727: Example for cross carrier

LWE/LR 11000-001/23501-04-02/en



LWE/LR 11000-001/23501-04-02/en

Fig.187348: Example for cross carrier

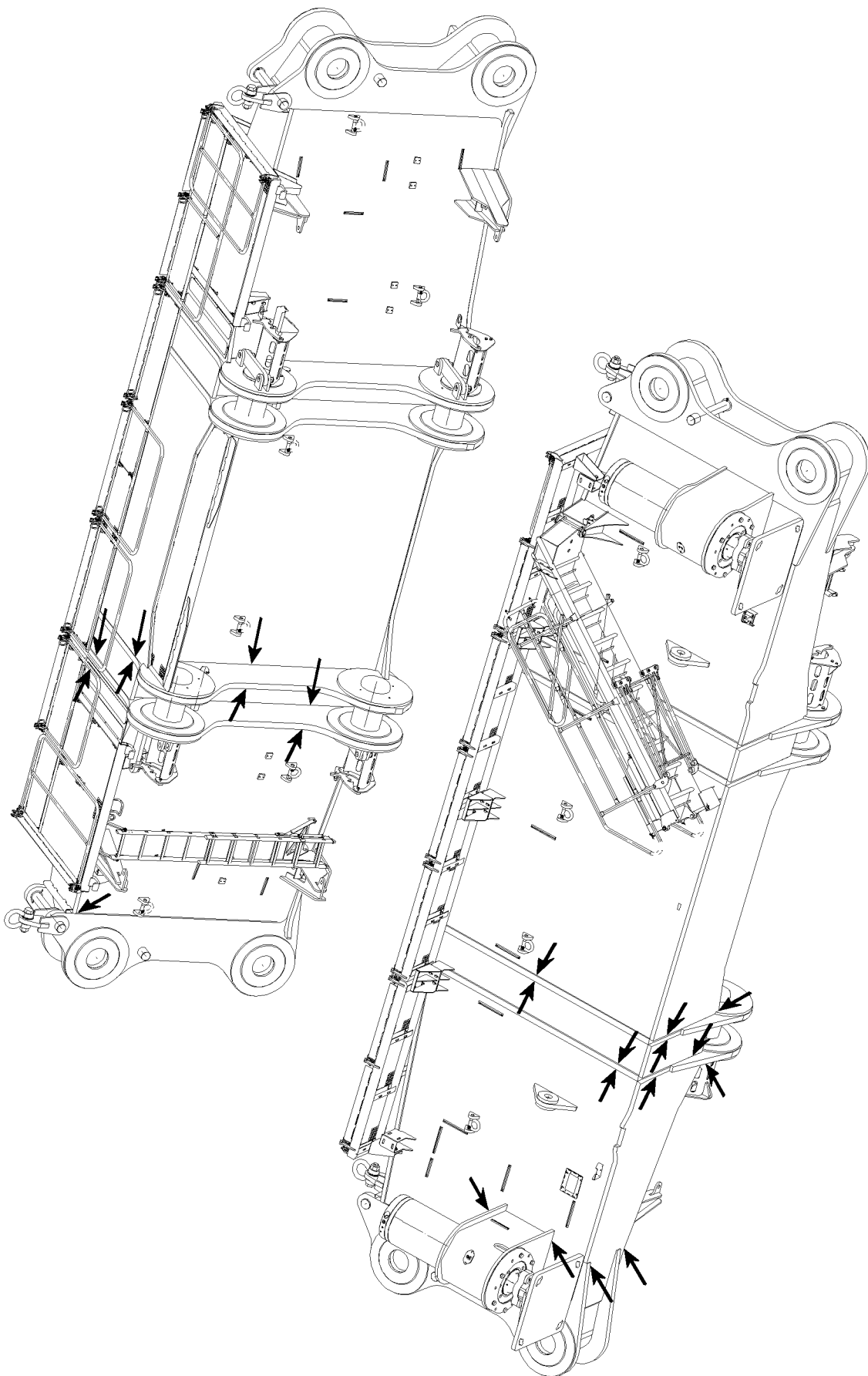
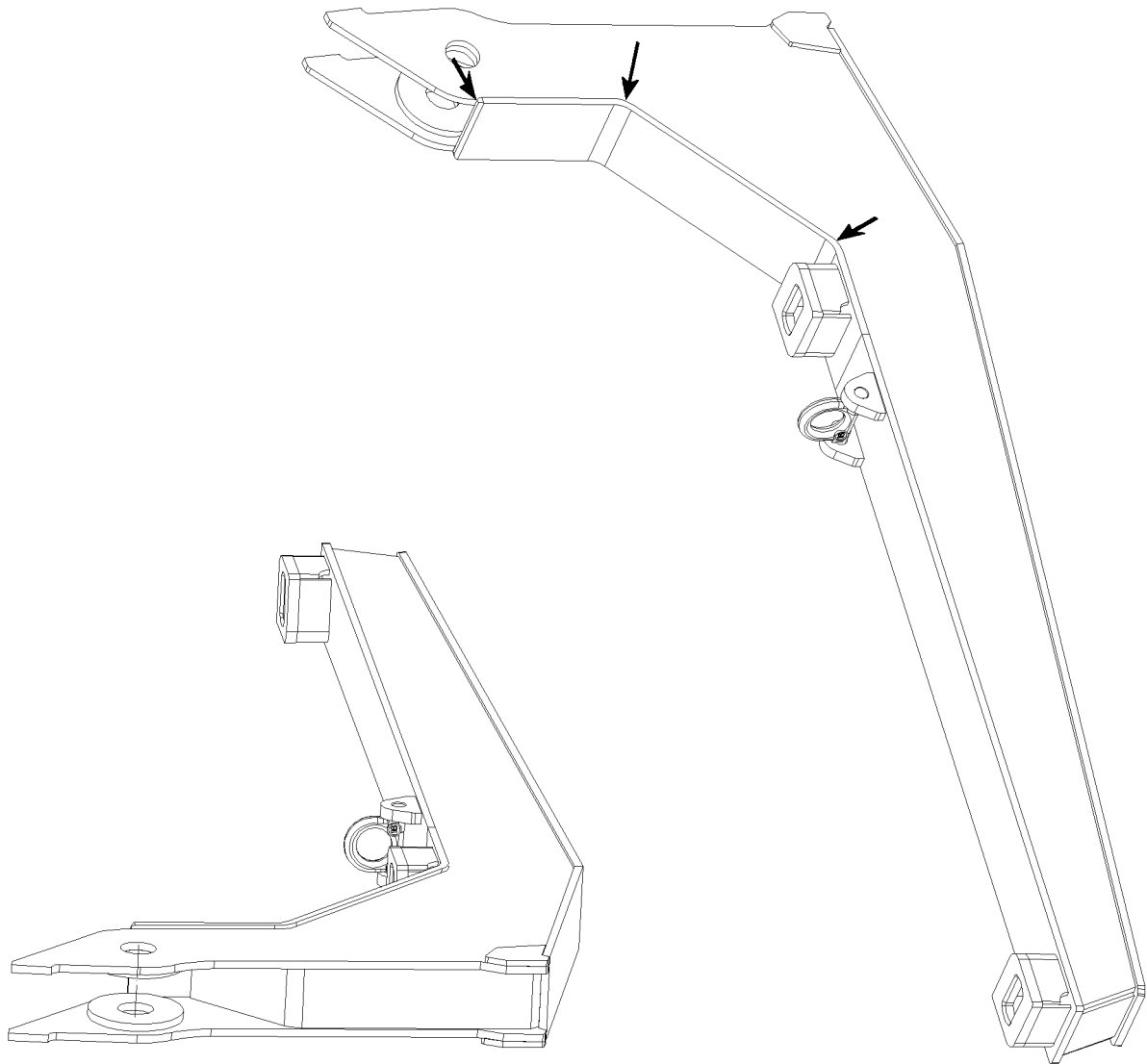

Fig.115921: Example for cross carrier

LWE/LR 11000-001/23501-04-02/en



LWE/LR 11000-001/23501-04-02/en

Fig.115919: Example for carrier for central ballast

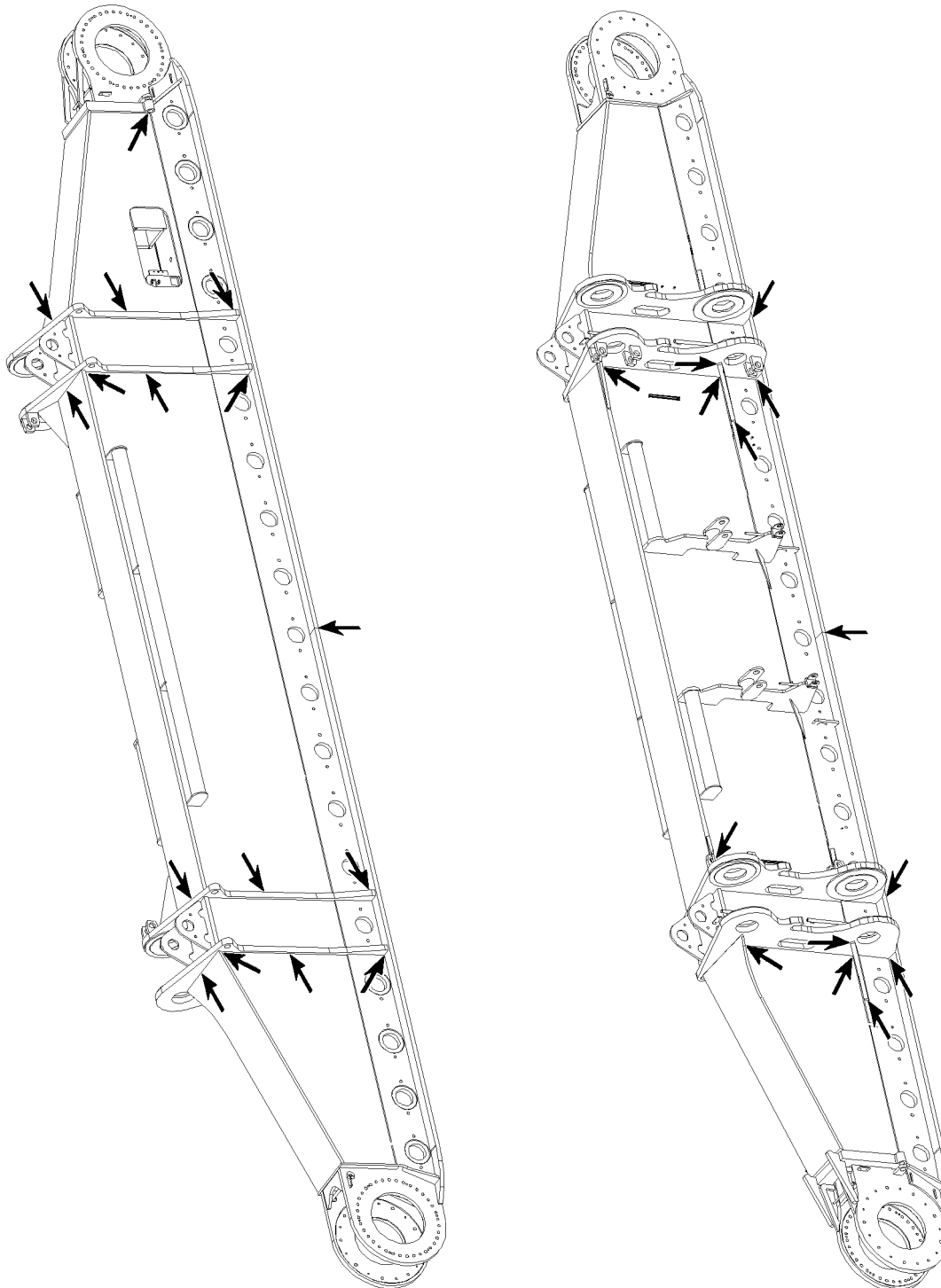
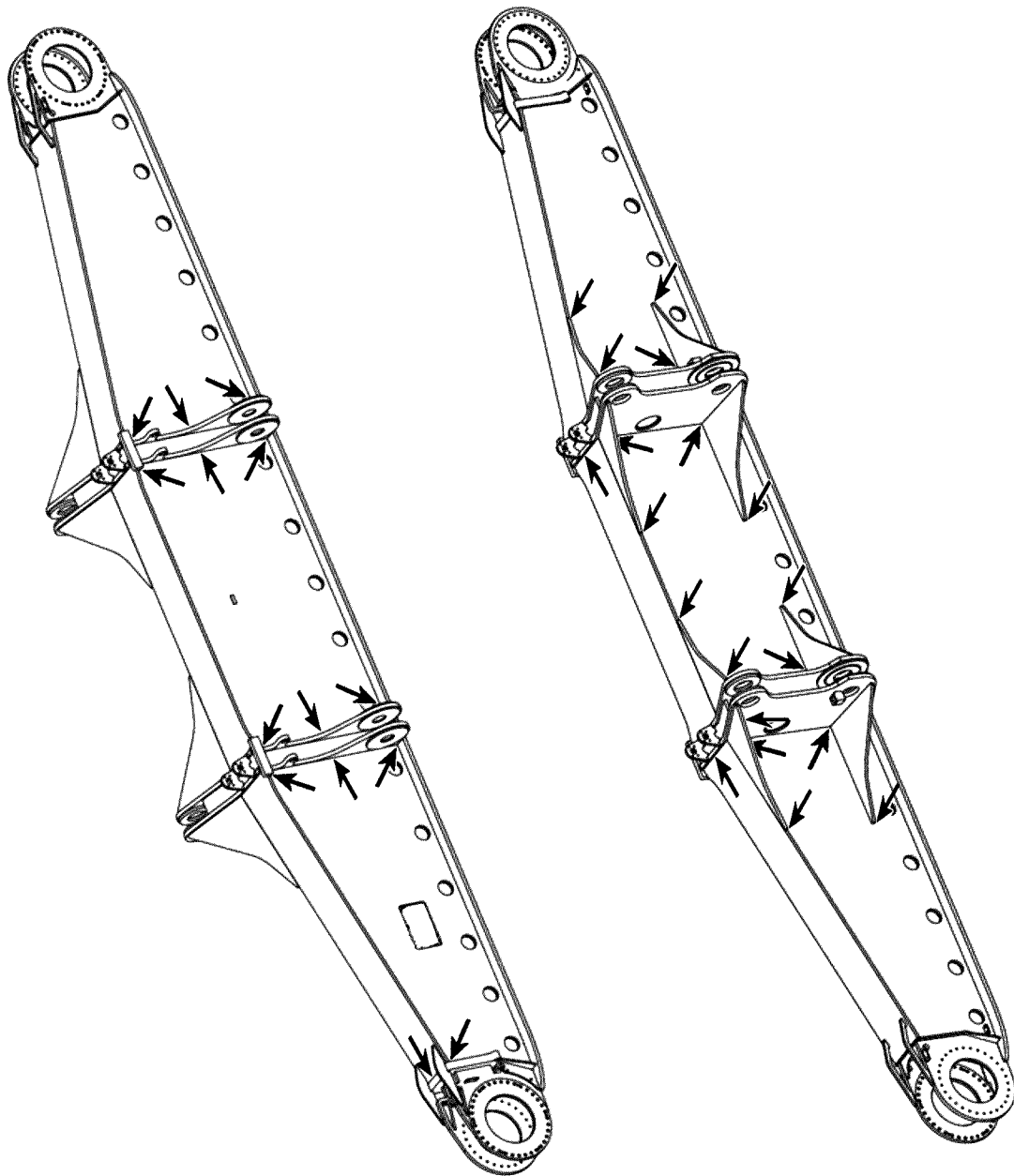

Fig.105728: Example for crawler carrier



LWE/LR 11000-001/23501-04-02/en

Fig.105729: Example for crawler carrier

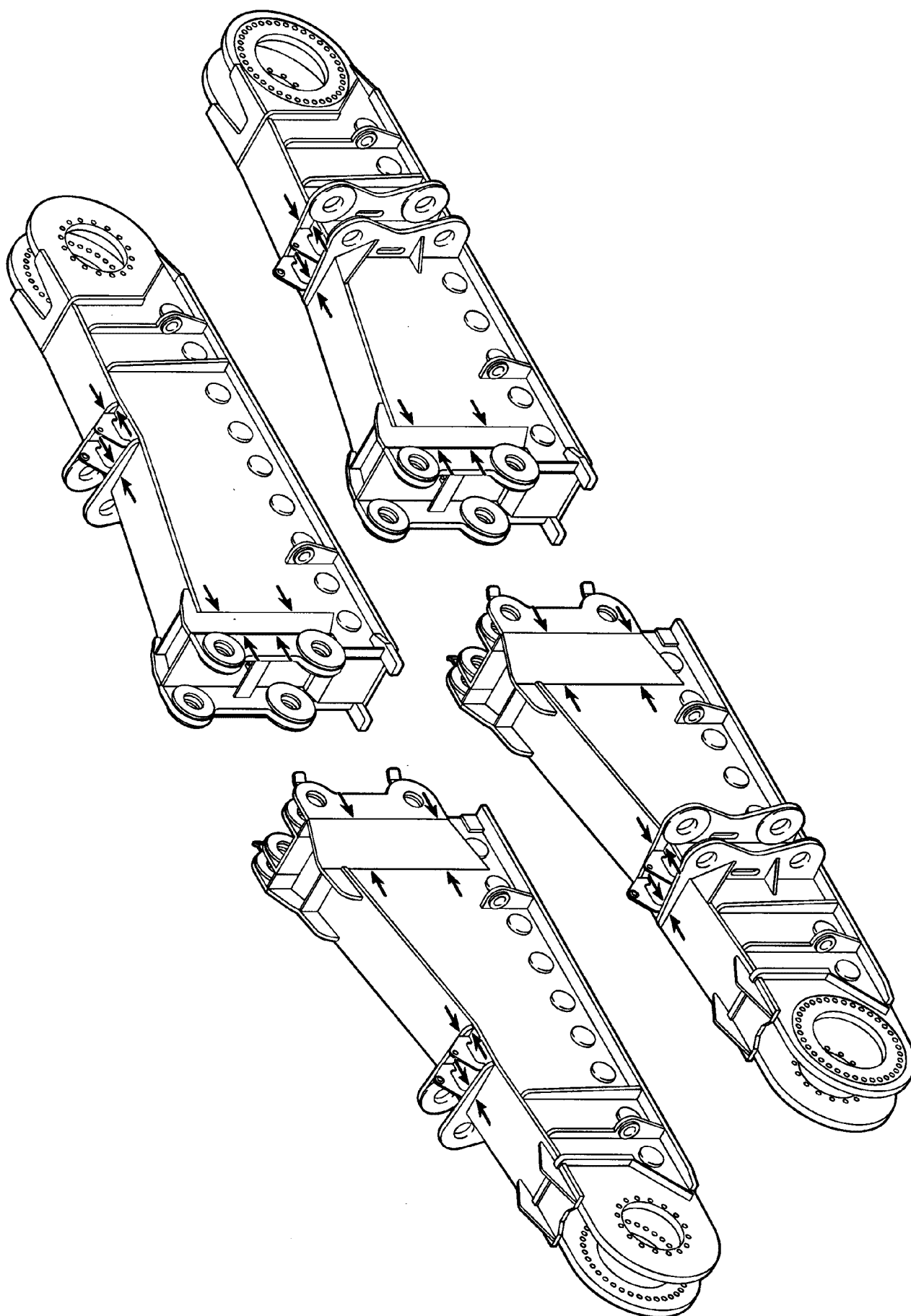
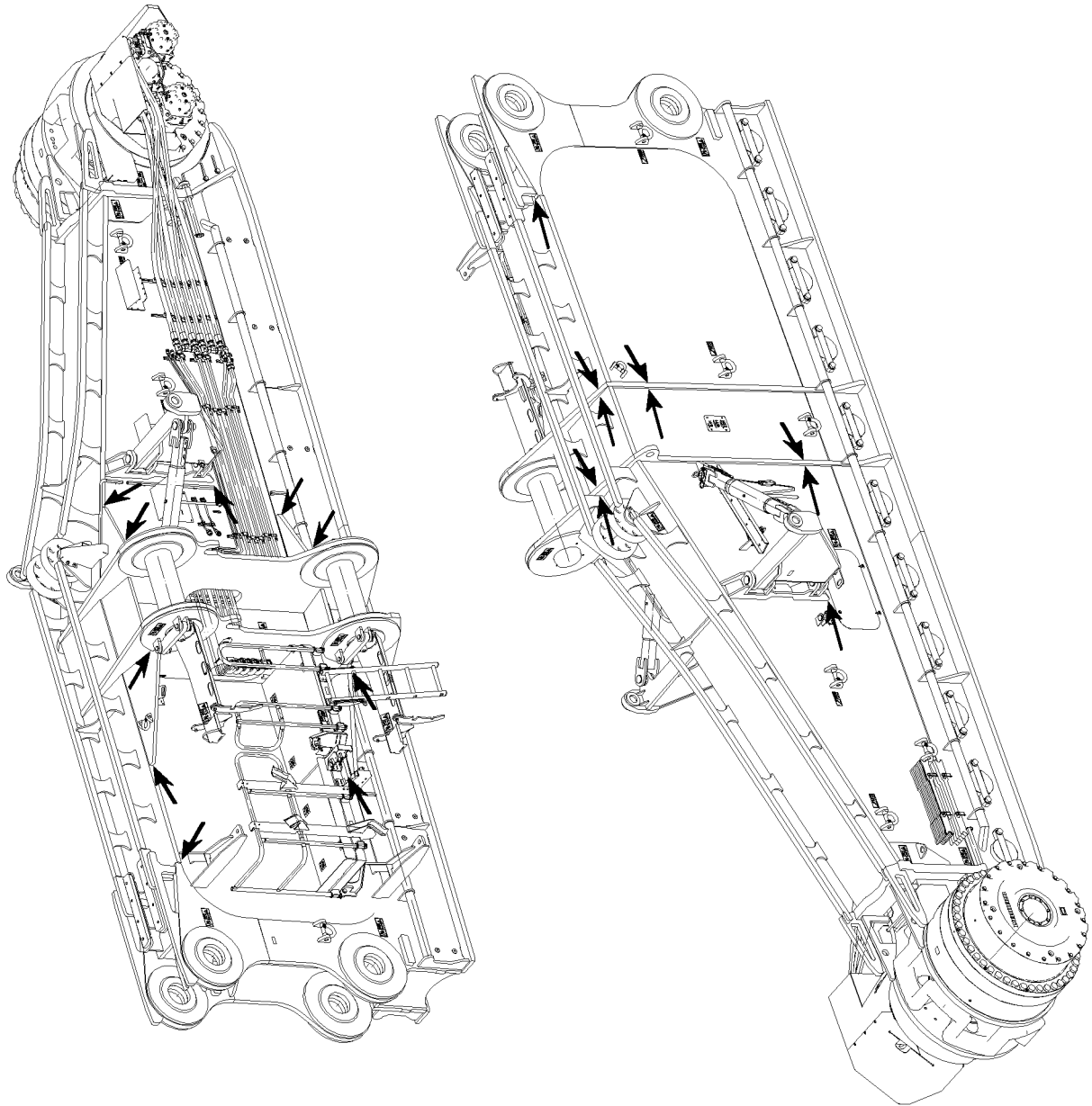

Fig.187349: Example for crawler carrier



LWE/LR 11000-001/23501-04-02/en

Fig.115917: Example for crawler carrier

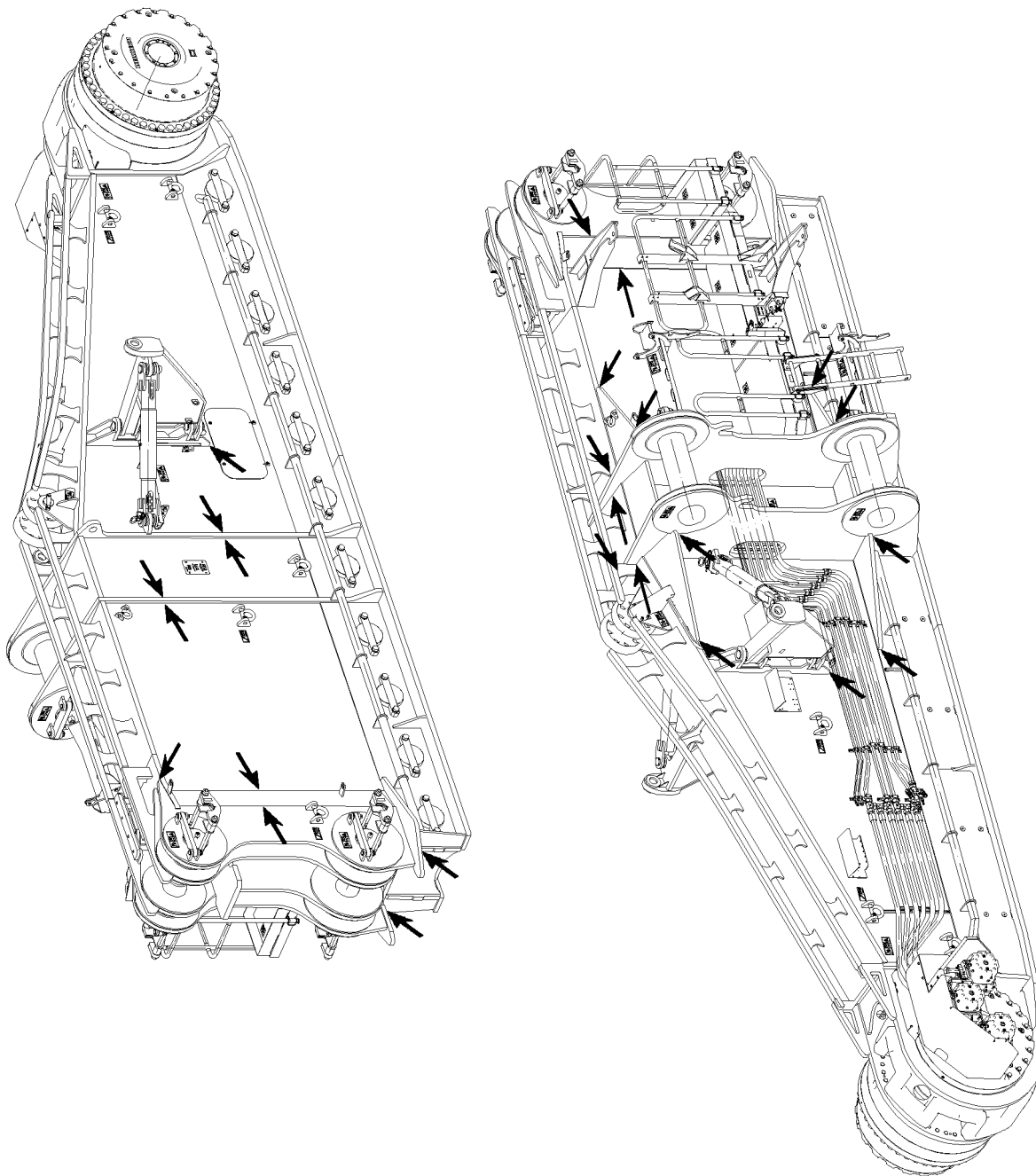
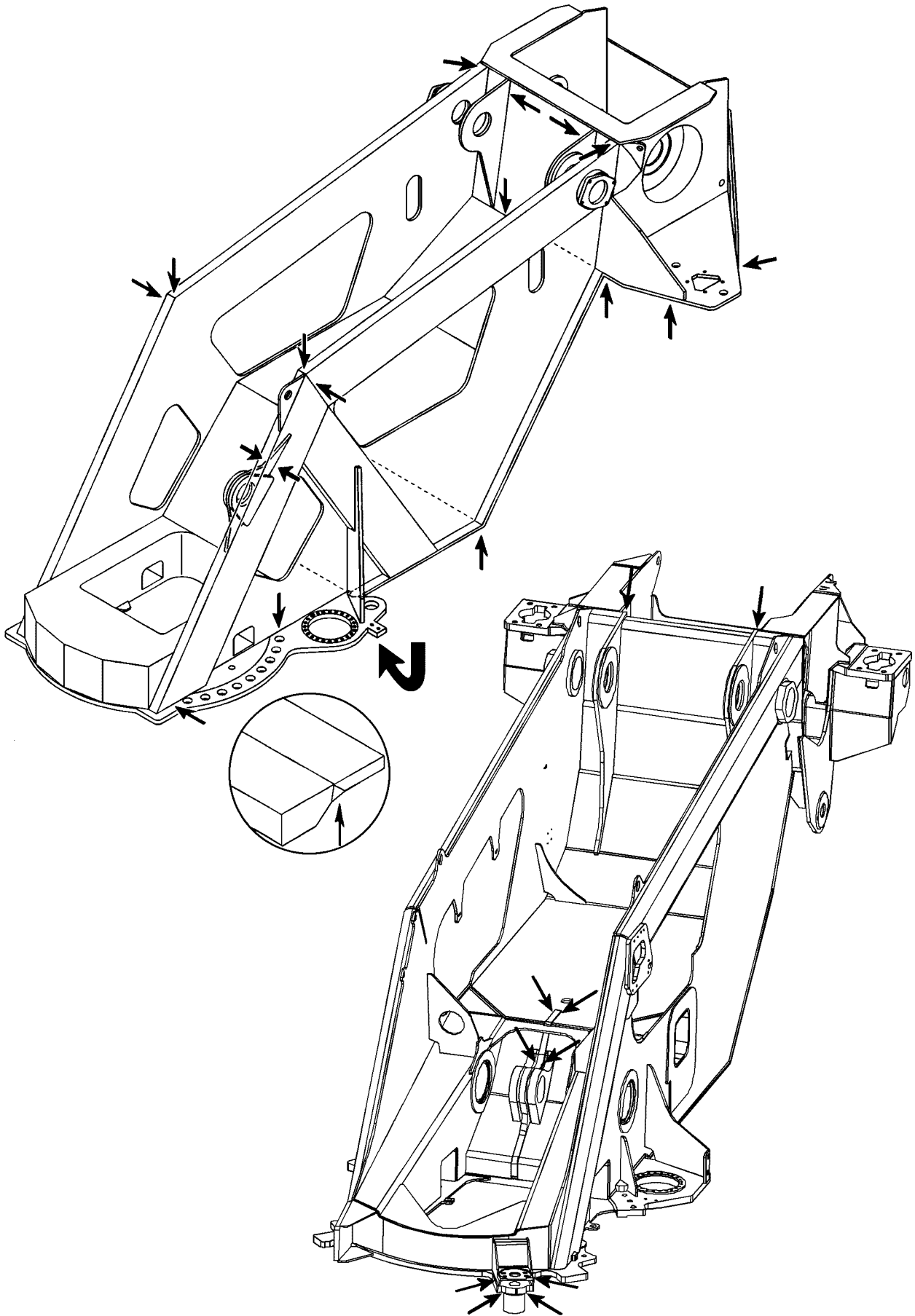

Fig.115918: Example for crawler carrier



LWE/LR 11000-001/23501-04-02/en

Fig.185048: Example for turntable frame

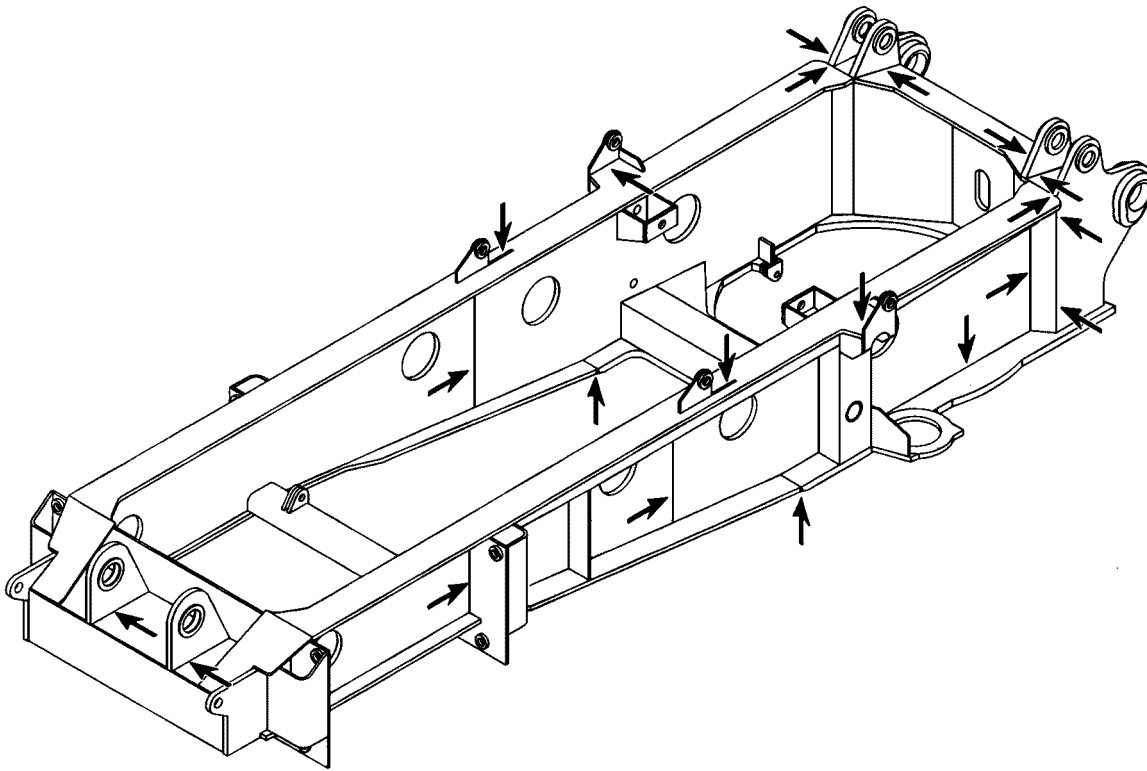

Fig.185049: Example for turntable frame

LWE/LR 11000-001/23501-04-02/en

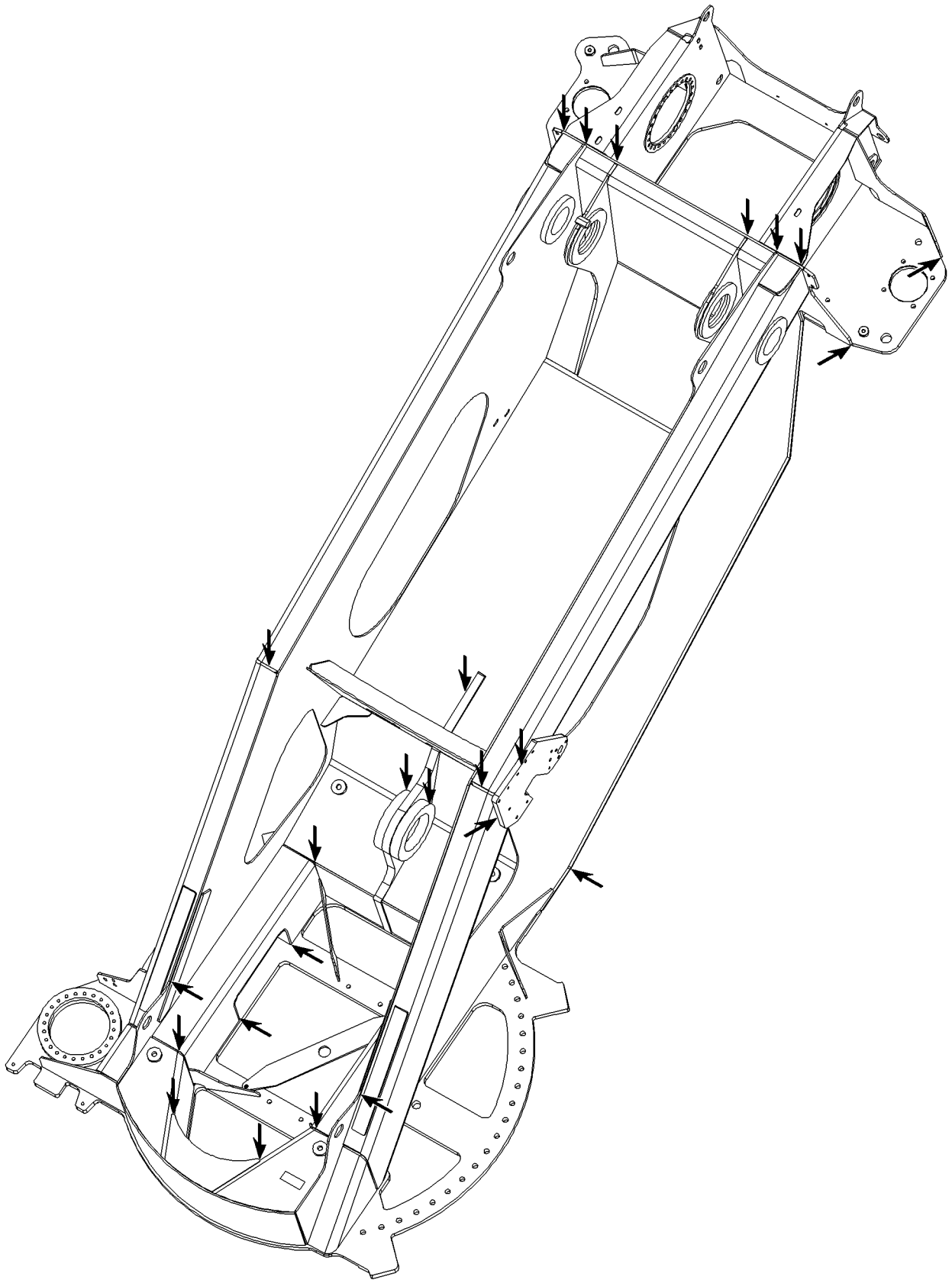

Fig.105700: Example for turntable frame

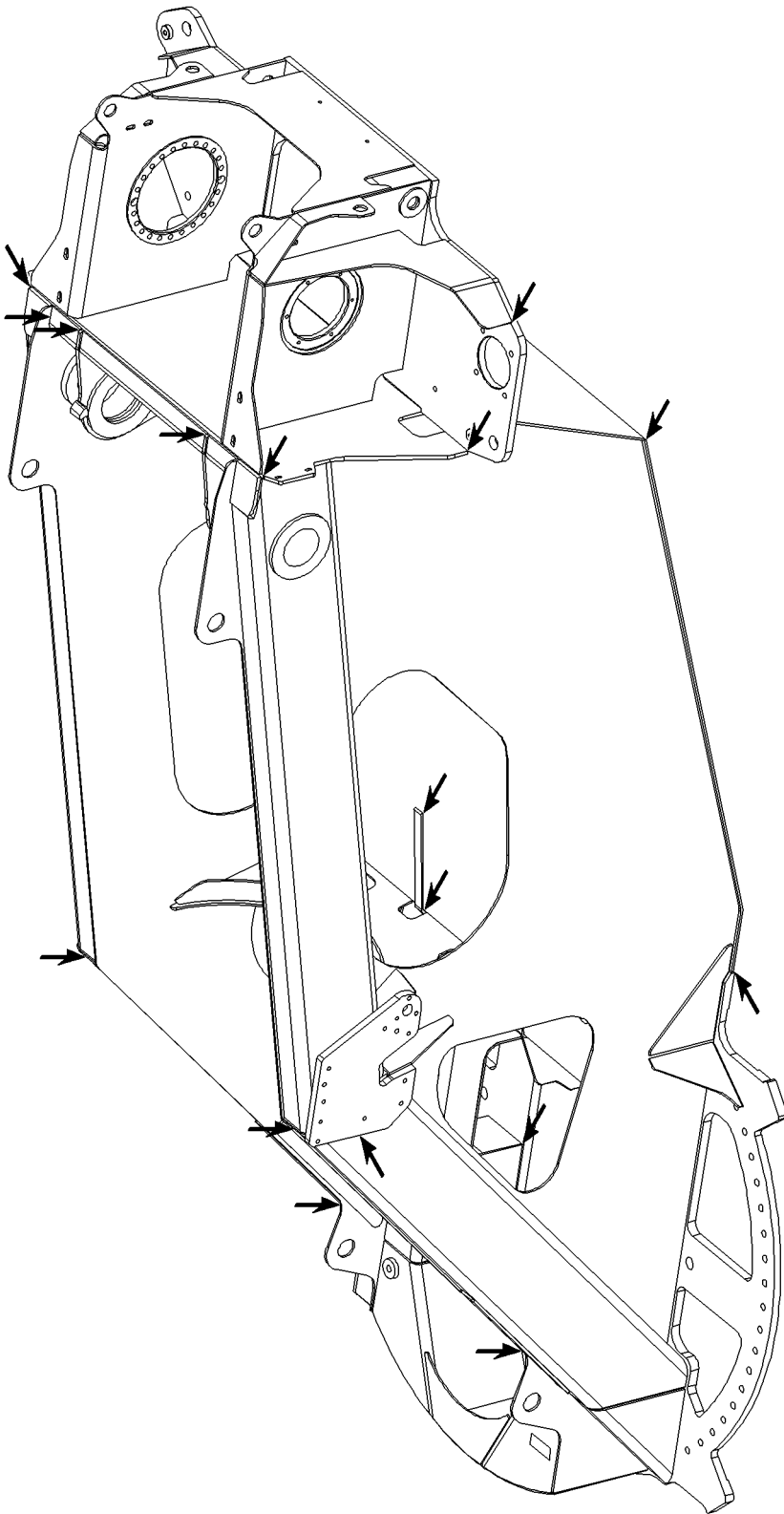
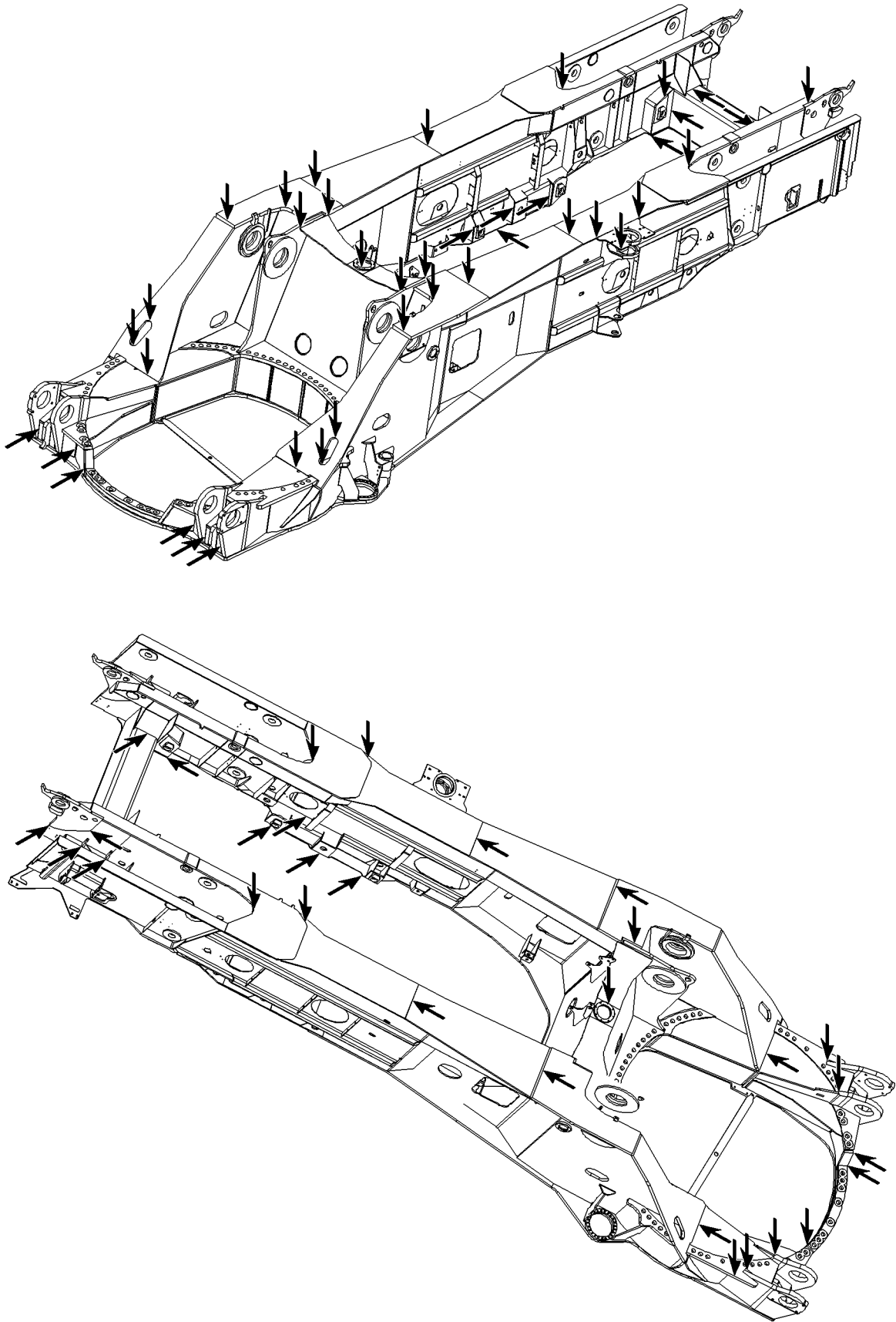
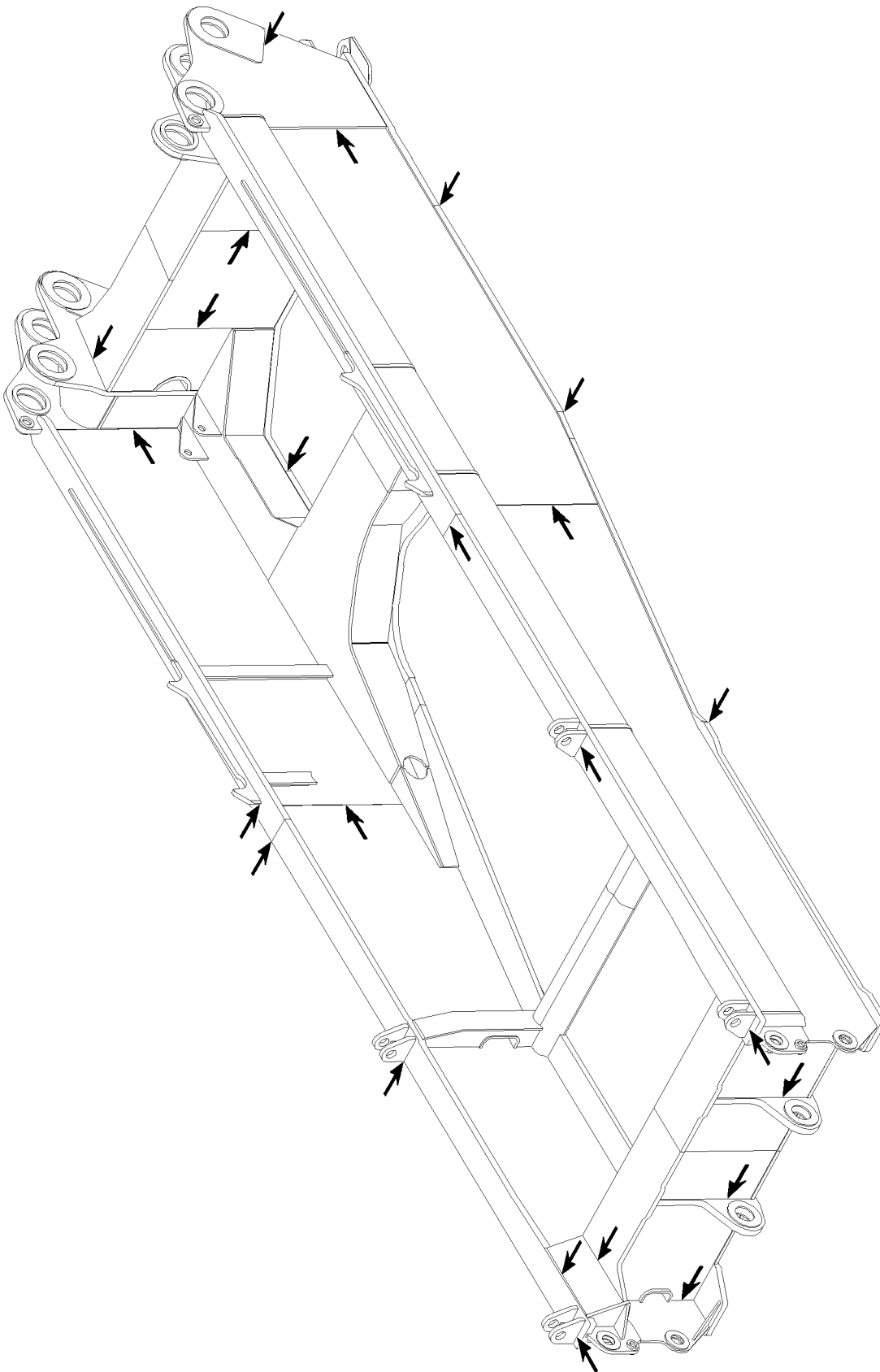

Fig.105701: Example for turntable frame



LWE/LR 11000-001/23501-04-02/en

Fig.105706: Example for turntable frame



LWE/LR 11000-001/23501-04-02/en

Fig.105694: Example for turntable frame

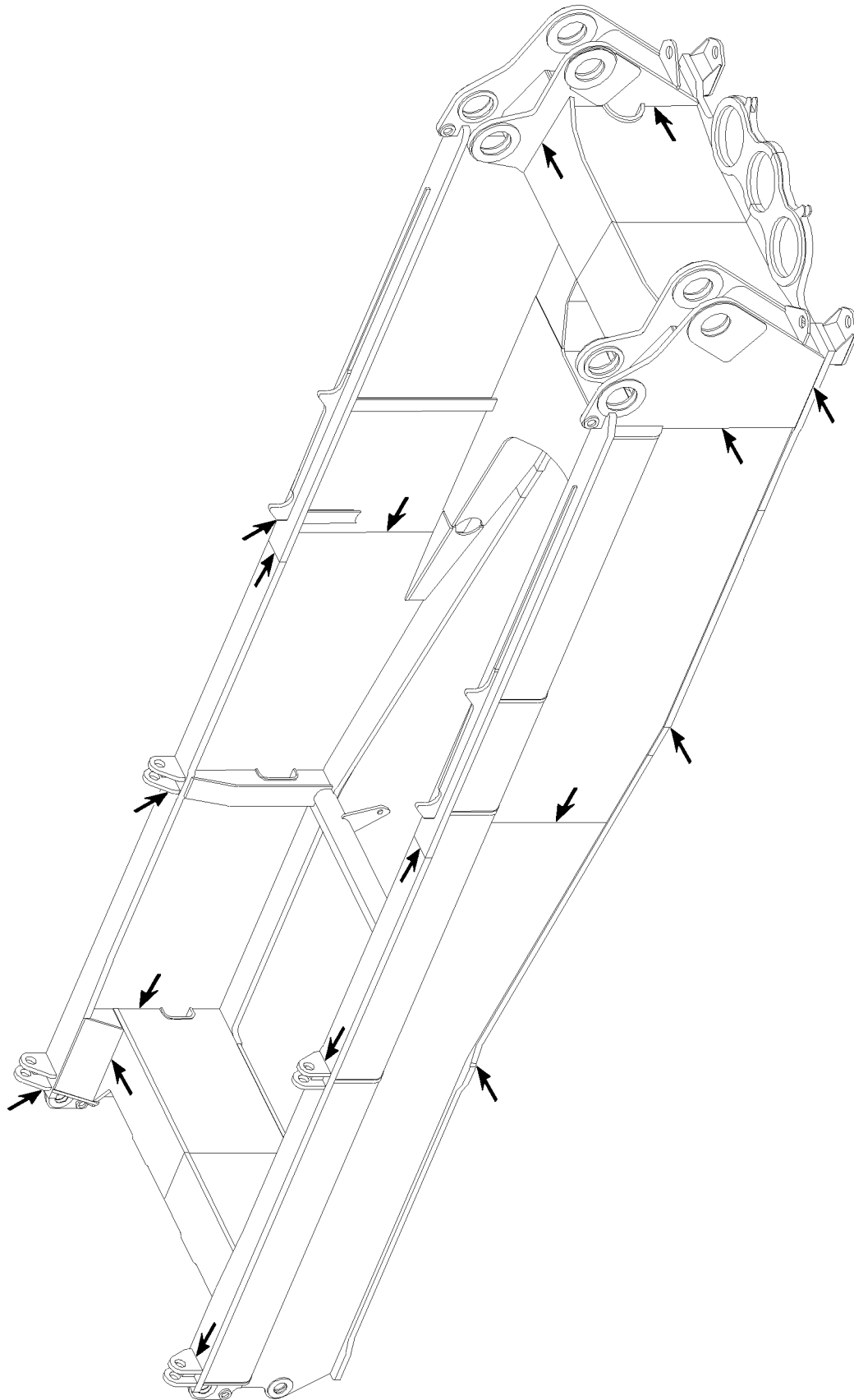

LWE/LR 11000-001/23501-04-02/en

Fig.105695: Example for turntable frame

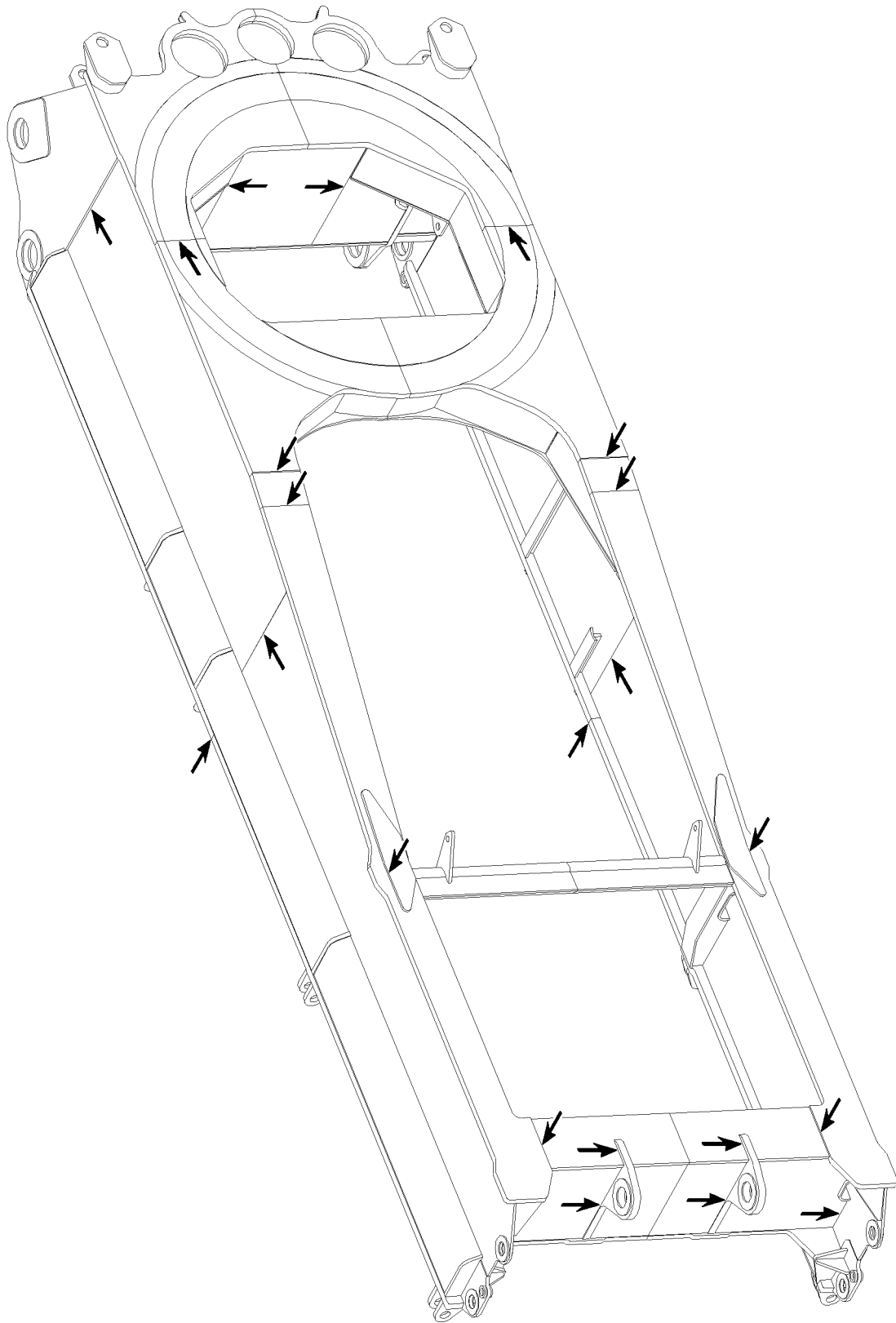
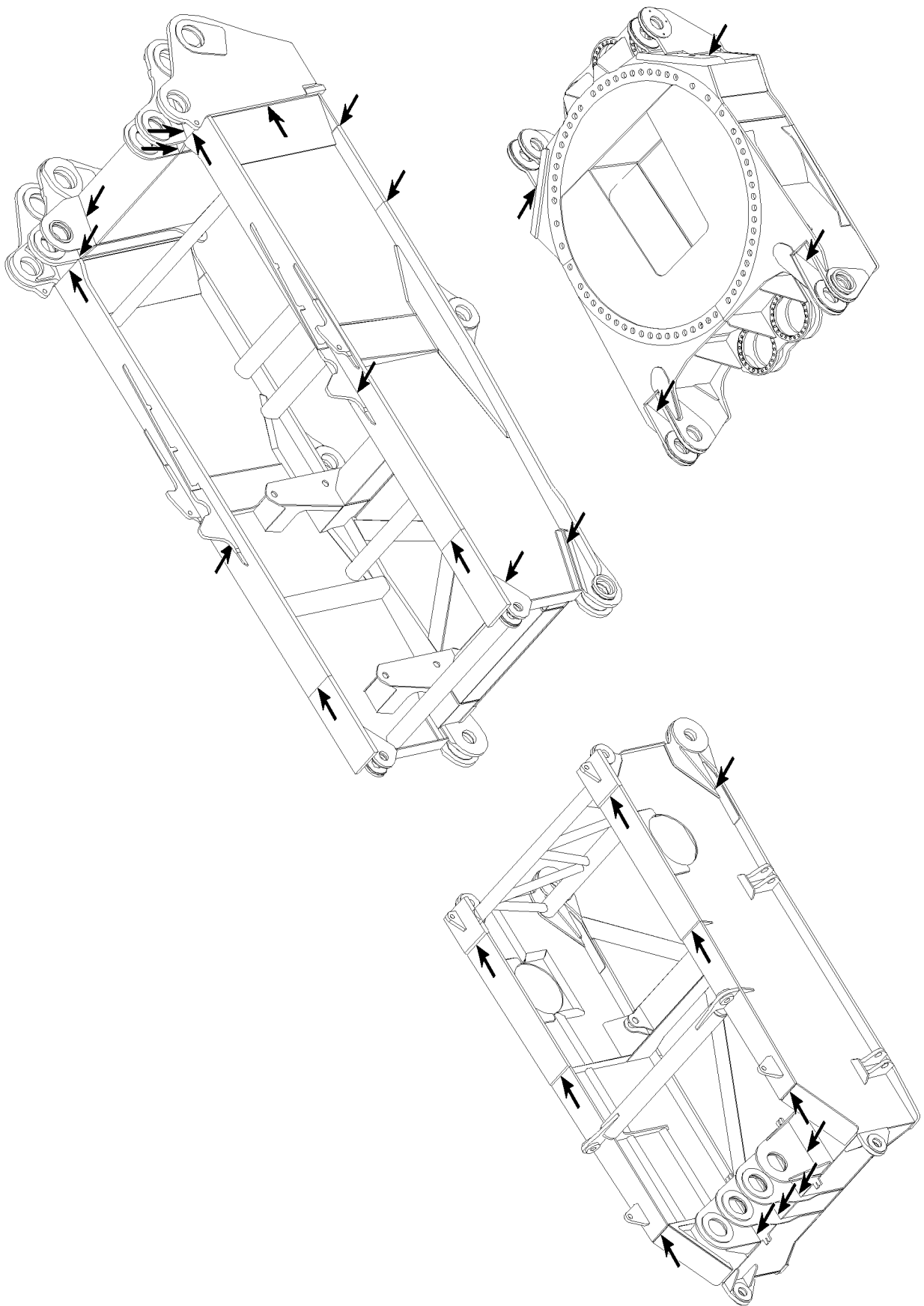

Fig.105696: Example for turntable frame

LWE/LR 11000-001/23501-04-02/en



LWE/LR 11000-001/23501-04-02/en

Fig.105691: Example for turntable frame

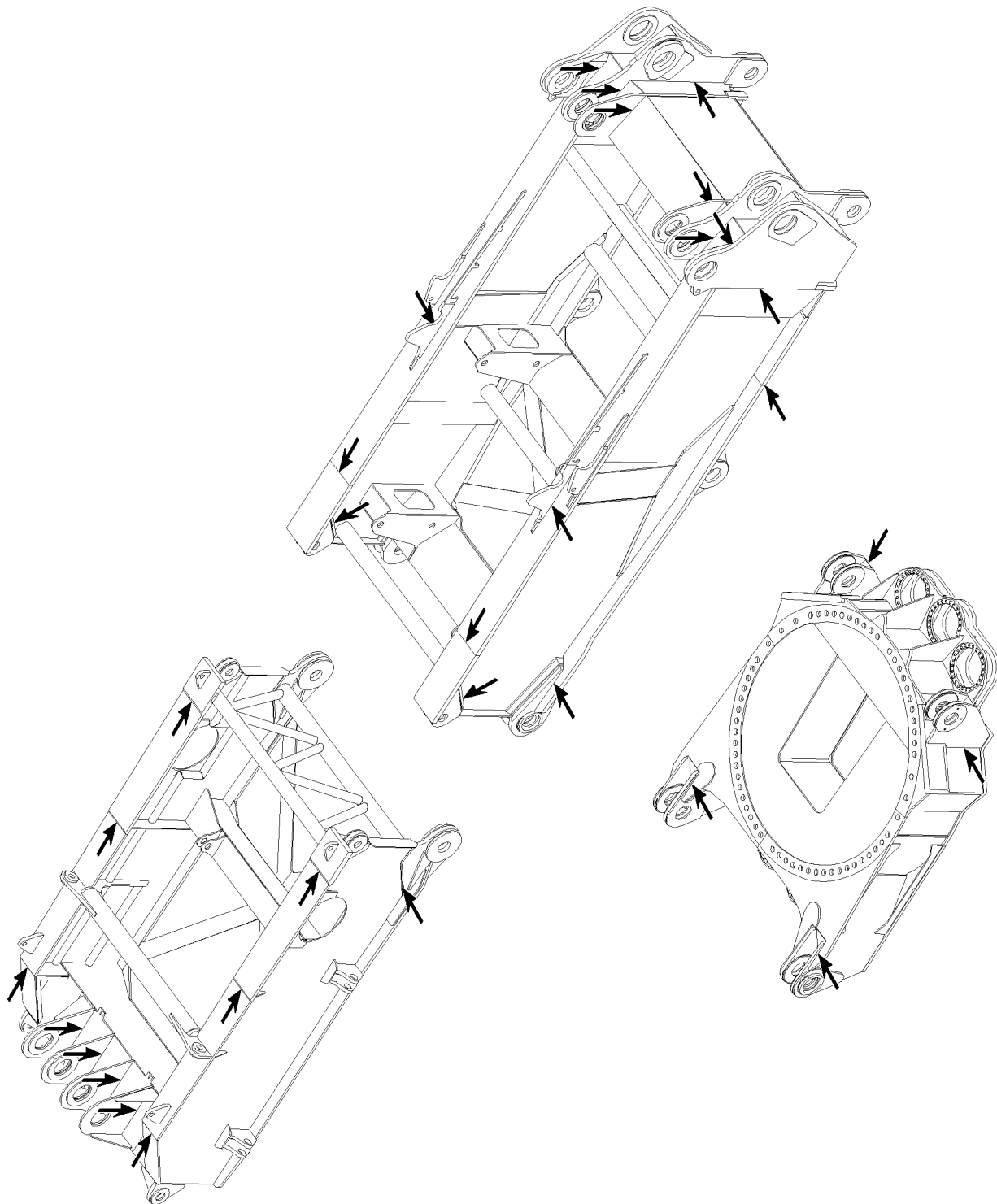
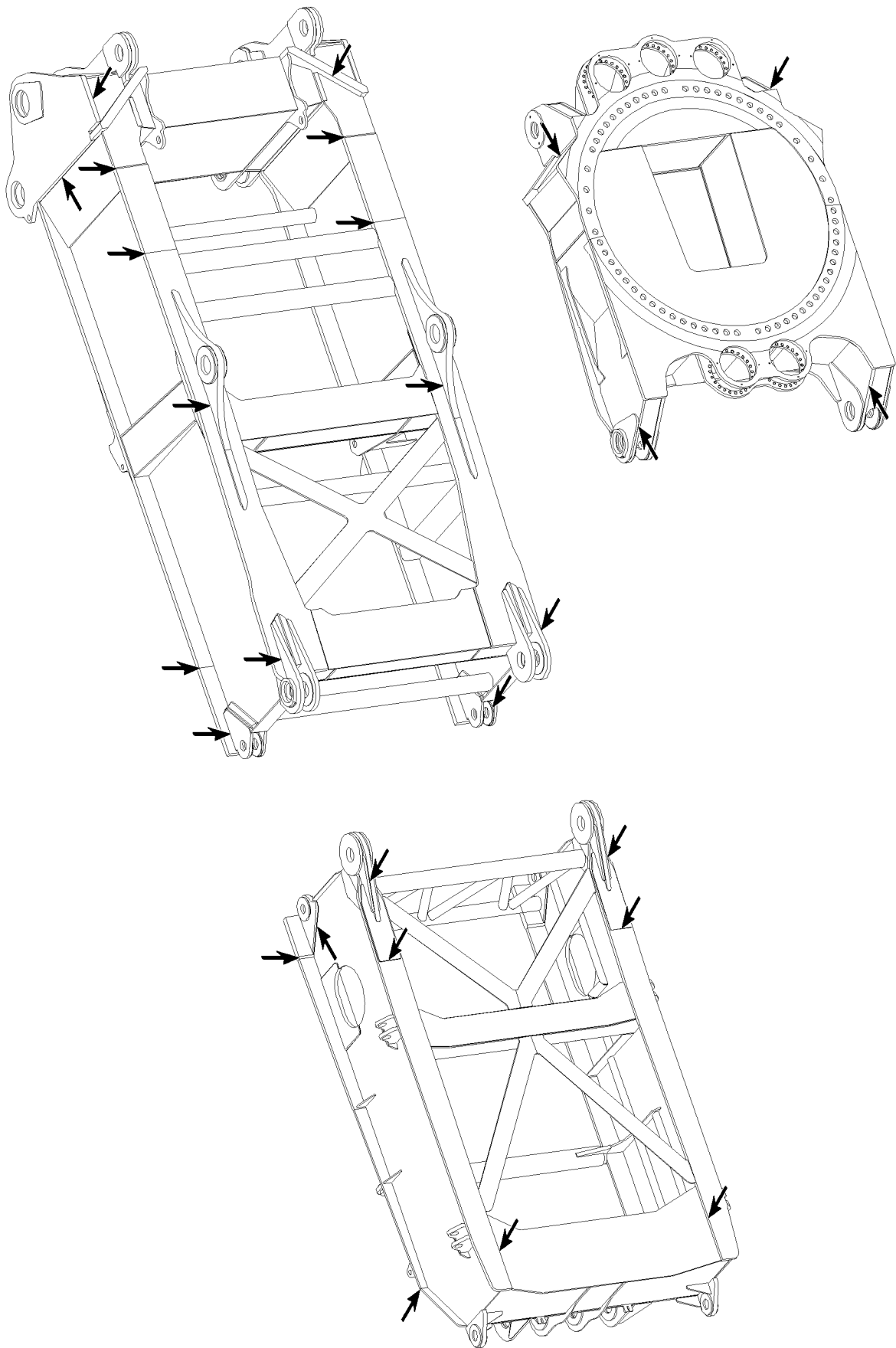

Fig.105692: Example for turntable frame



LWE/LR 11000-001/23501-04-02/en

Fig.105693: Example for turntable frame

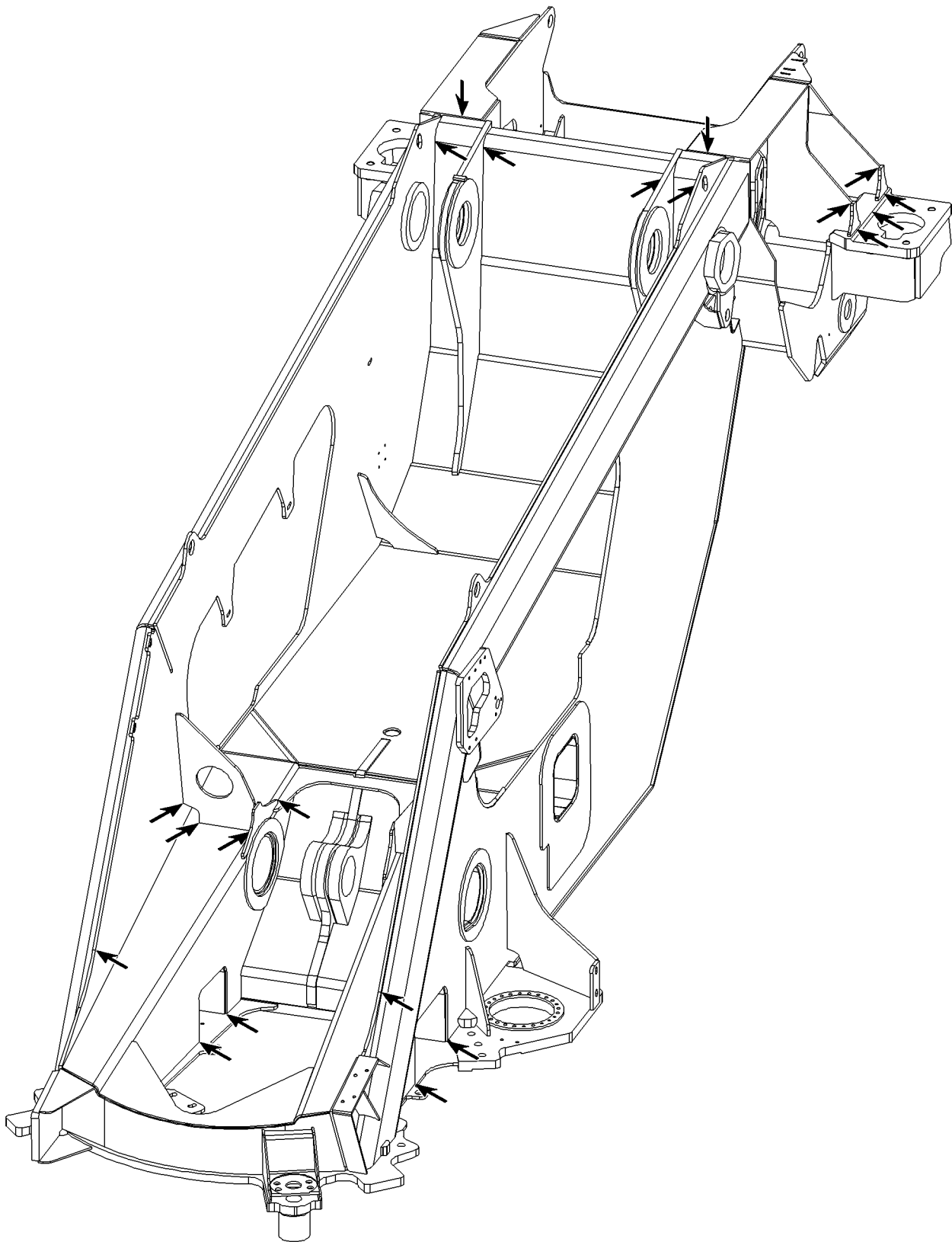
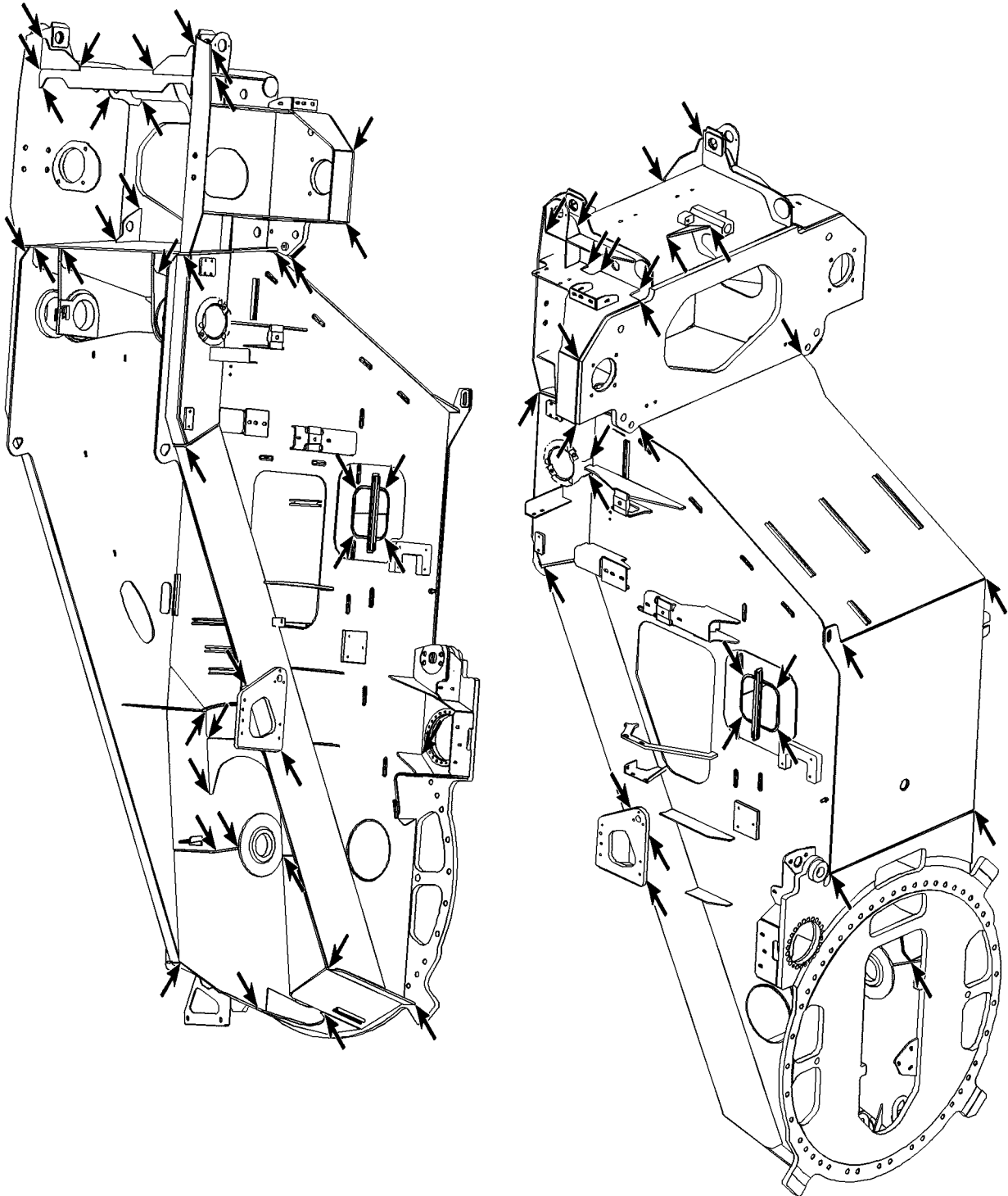

Fig.105722: Example for turntable frame

LWE/LR 11000-001/23501-04-02/en



LWE/LR 11000-001/23501-04-02/en

Fig.105932: Example for turntable frame

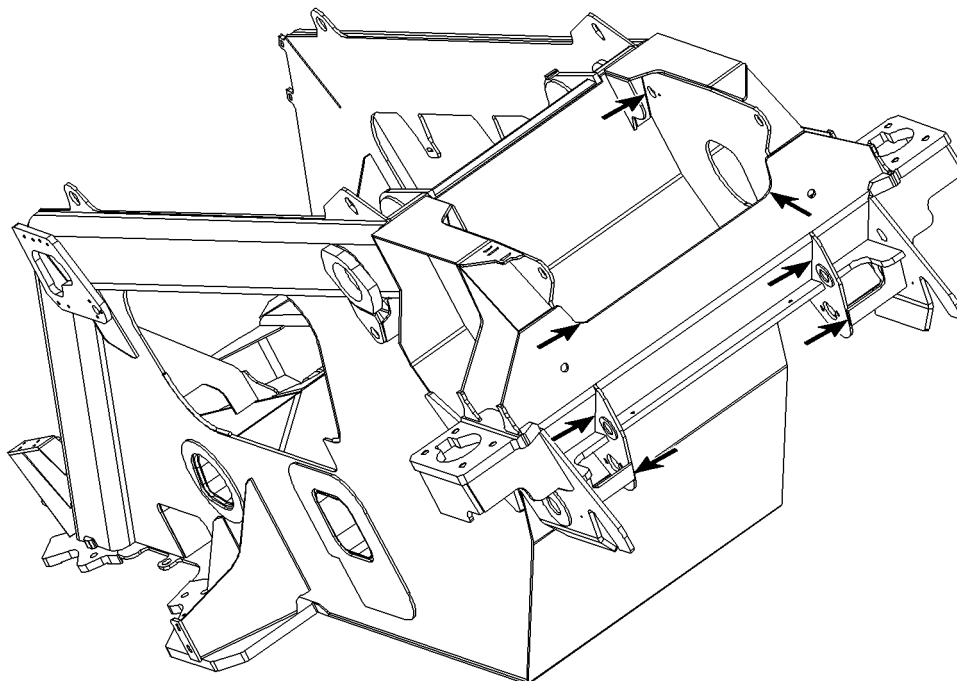
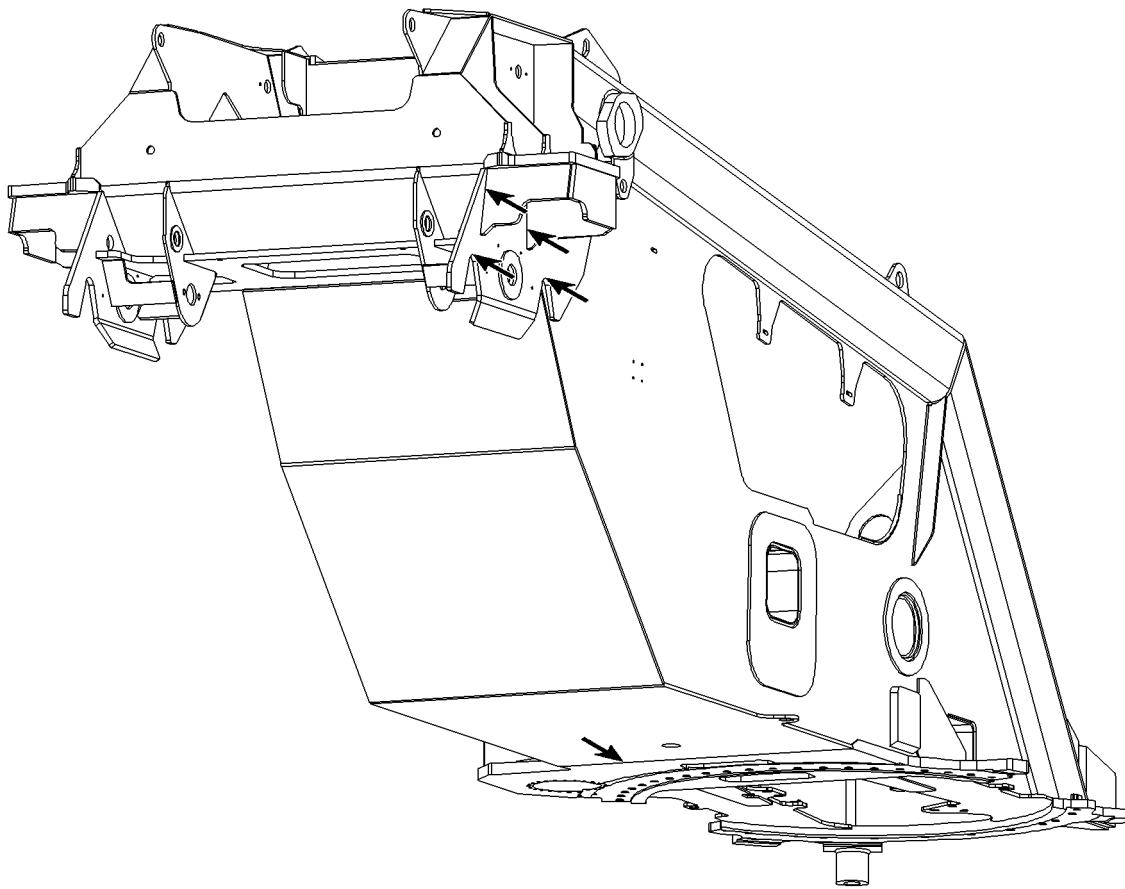
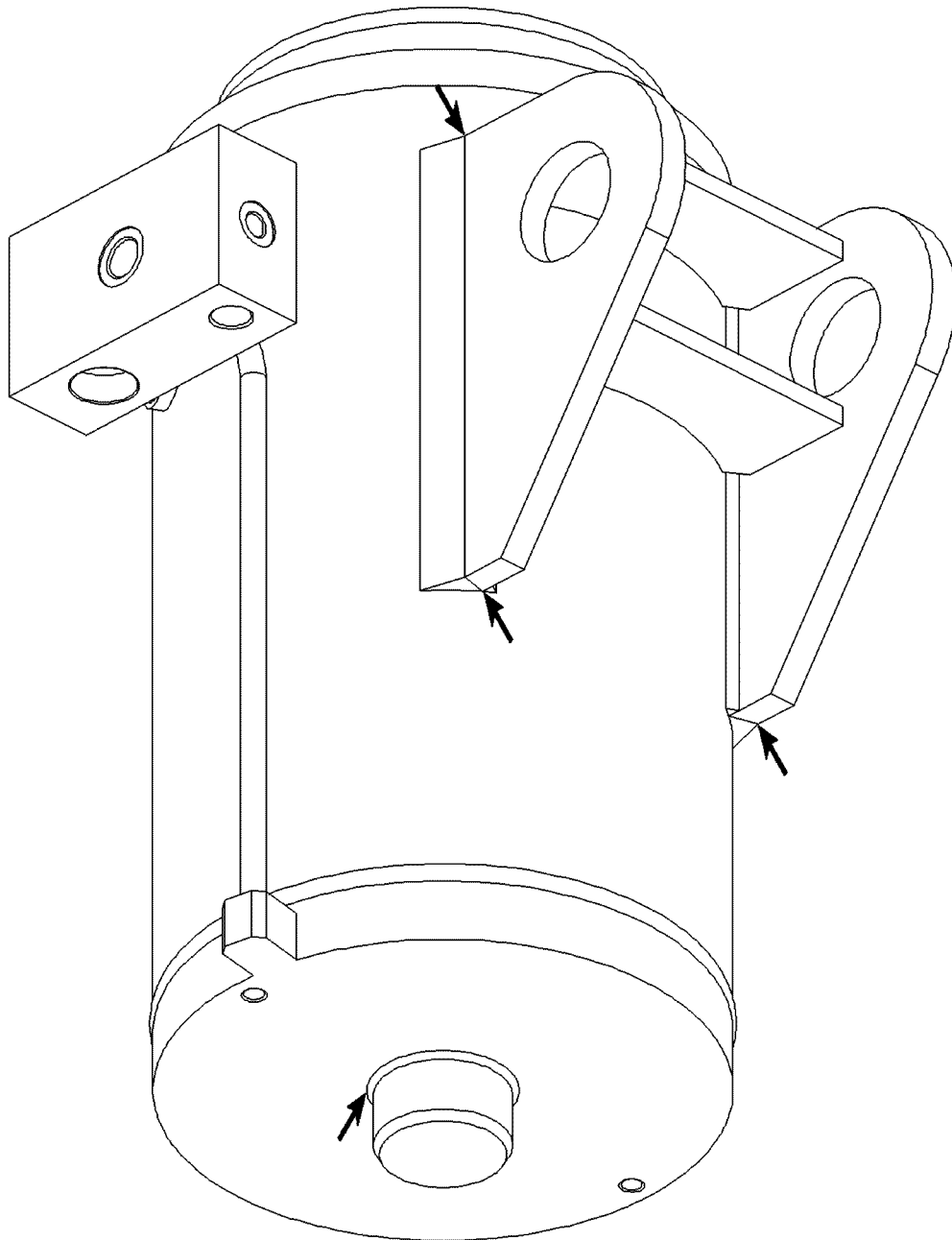

Fig.105723: Example for turntable frame



LWE/LR 11000-001/23501-04-02/en

Fig.105801: Example for ballast cylinder

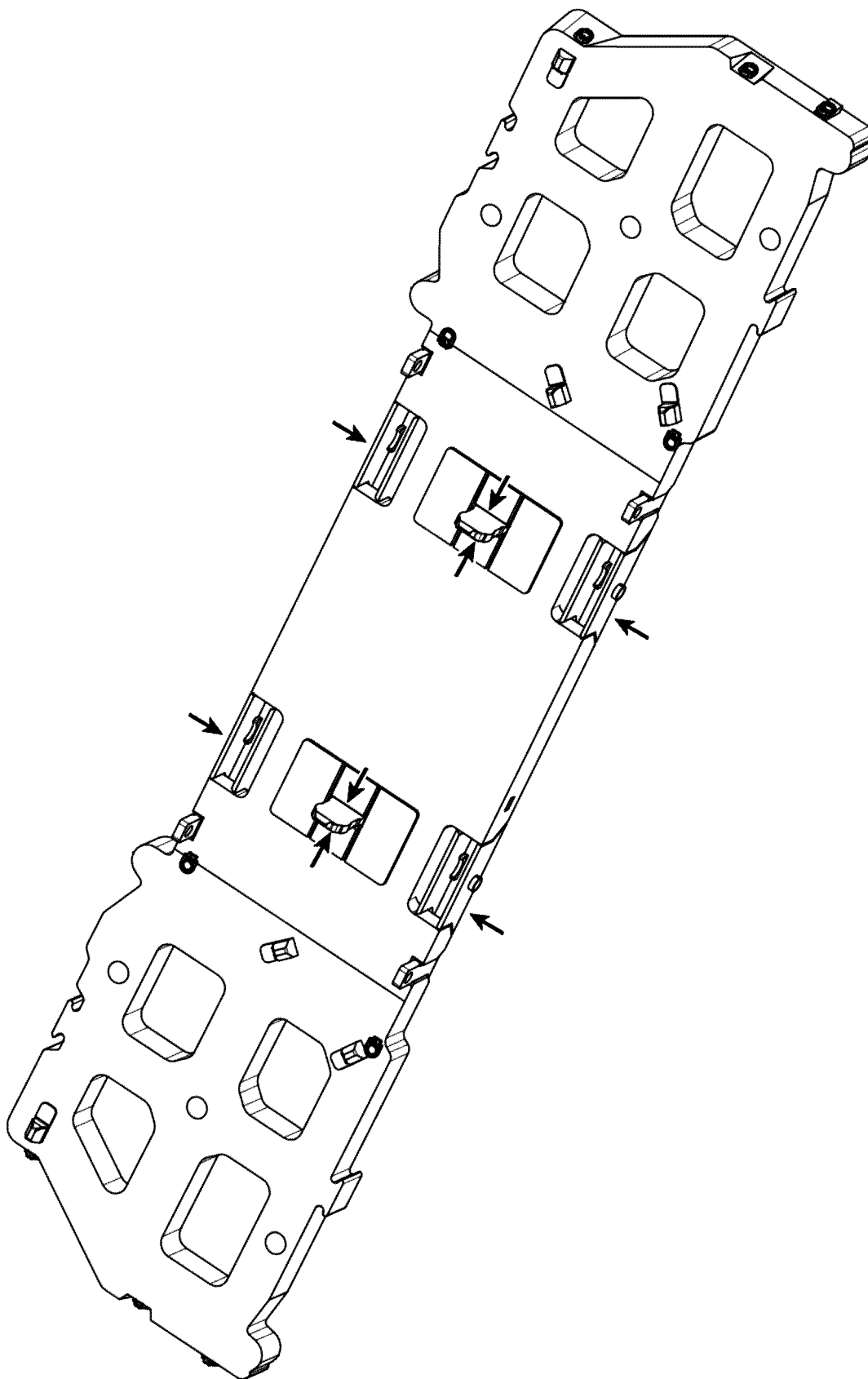
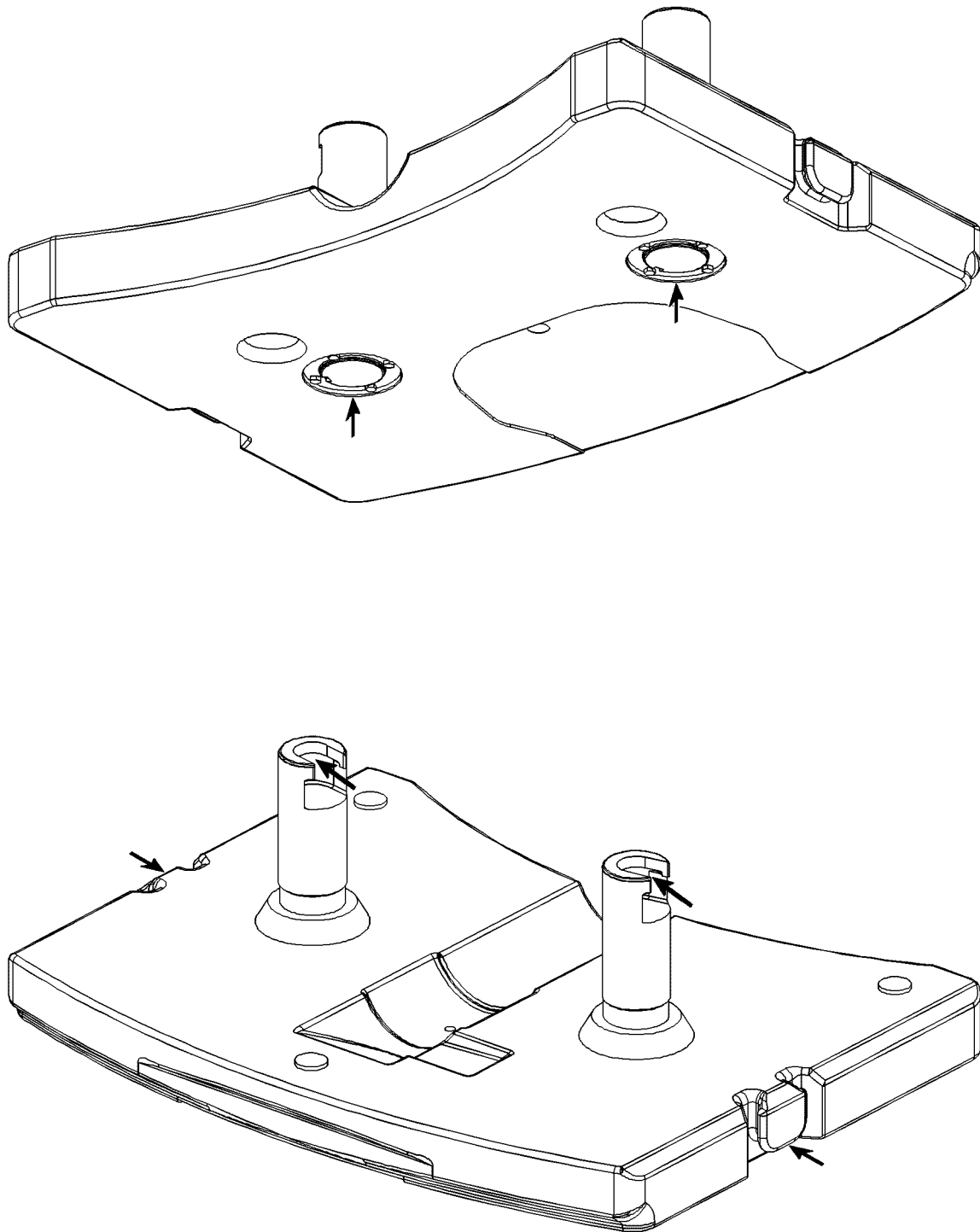

Fig.105705: Example for mounting plate

LWE/LR 11000-001/23501-04-02/en



LWE/LR 11000-001/23501-04-02/en

Fig.105807: Example for base plate

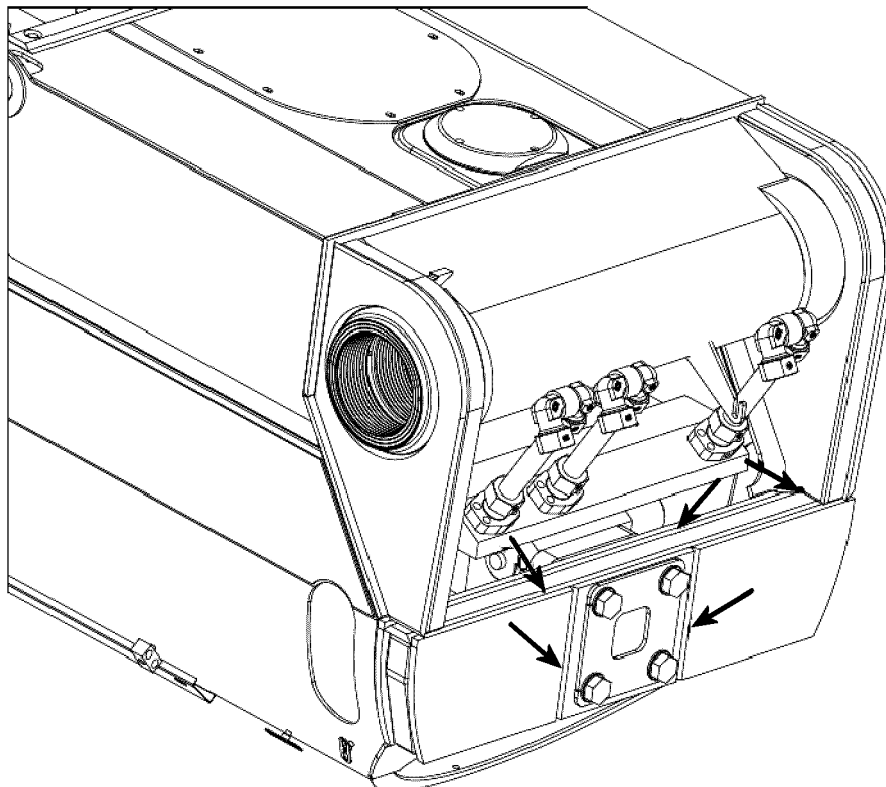
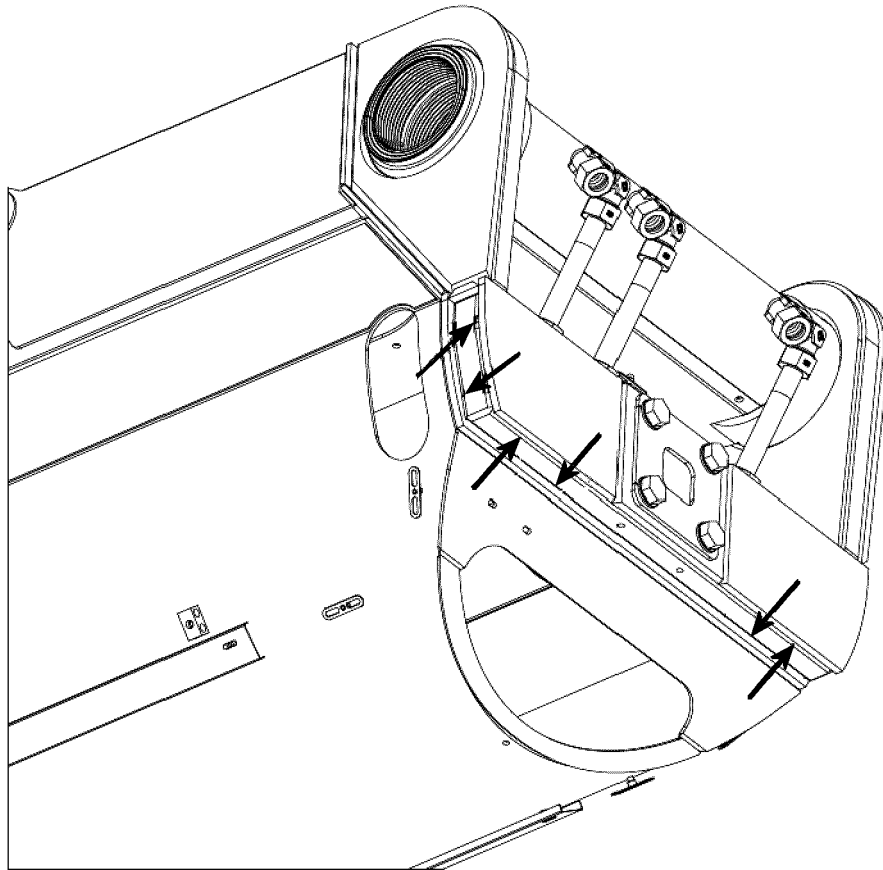
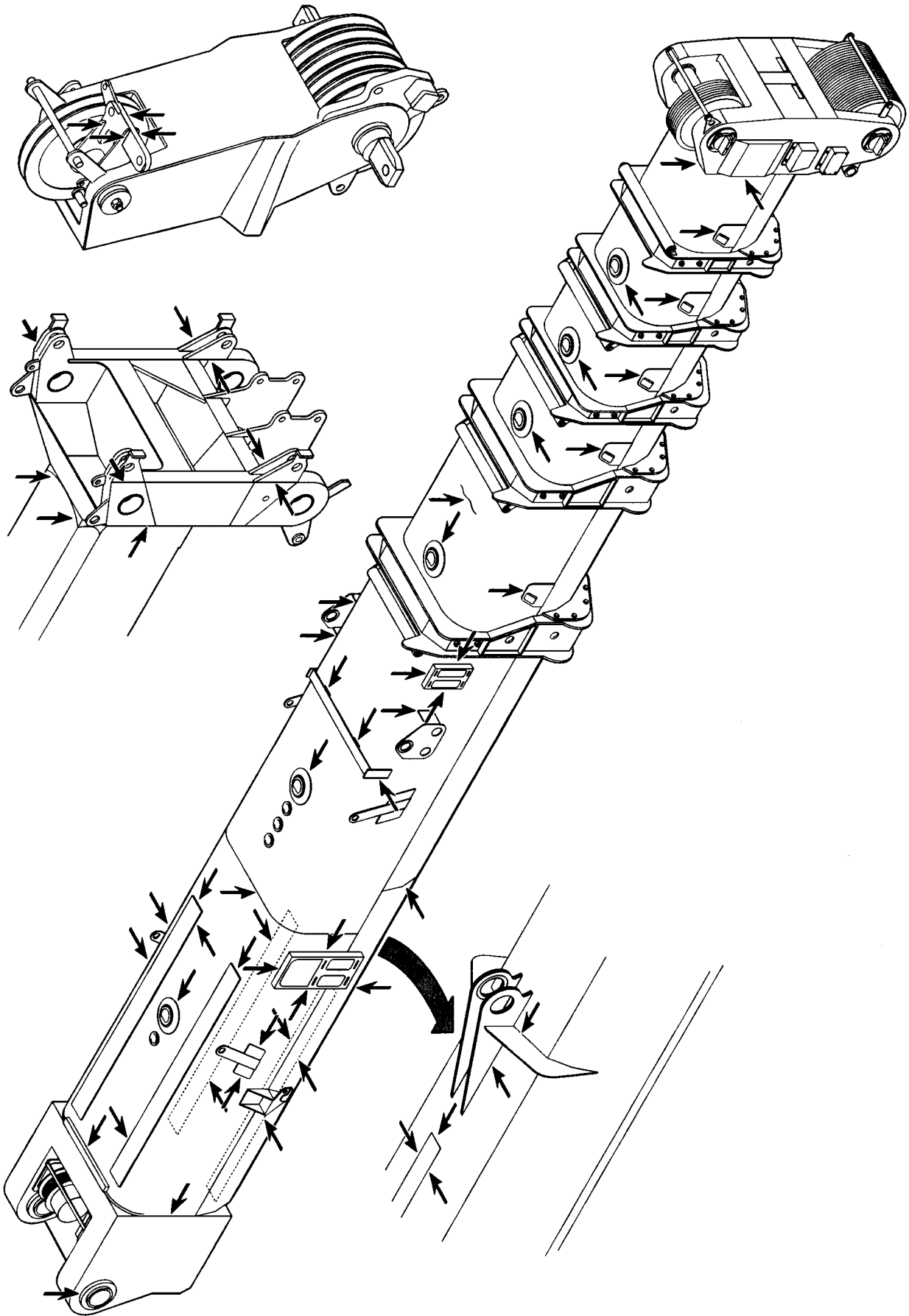

Fig.120273: Example for pivot section

LWE/LR 11000-001/23501-04-02/en



LWE/LR 11000-001/23501-04-02/en

Fig.185050: Example for telescopic boom

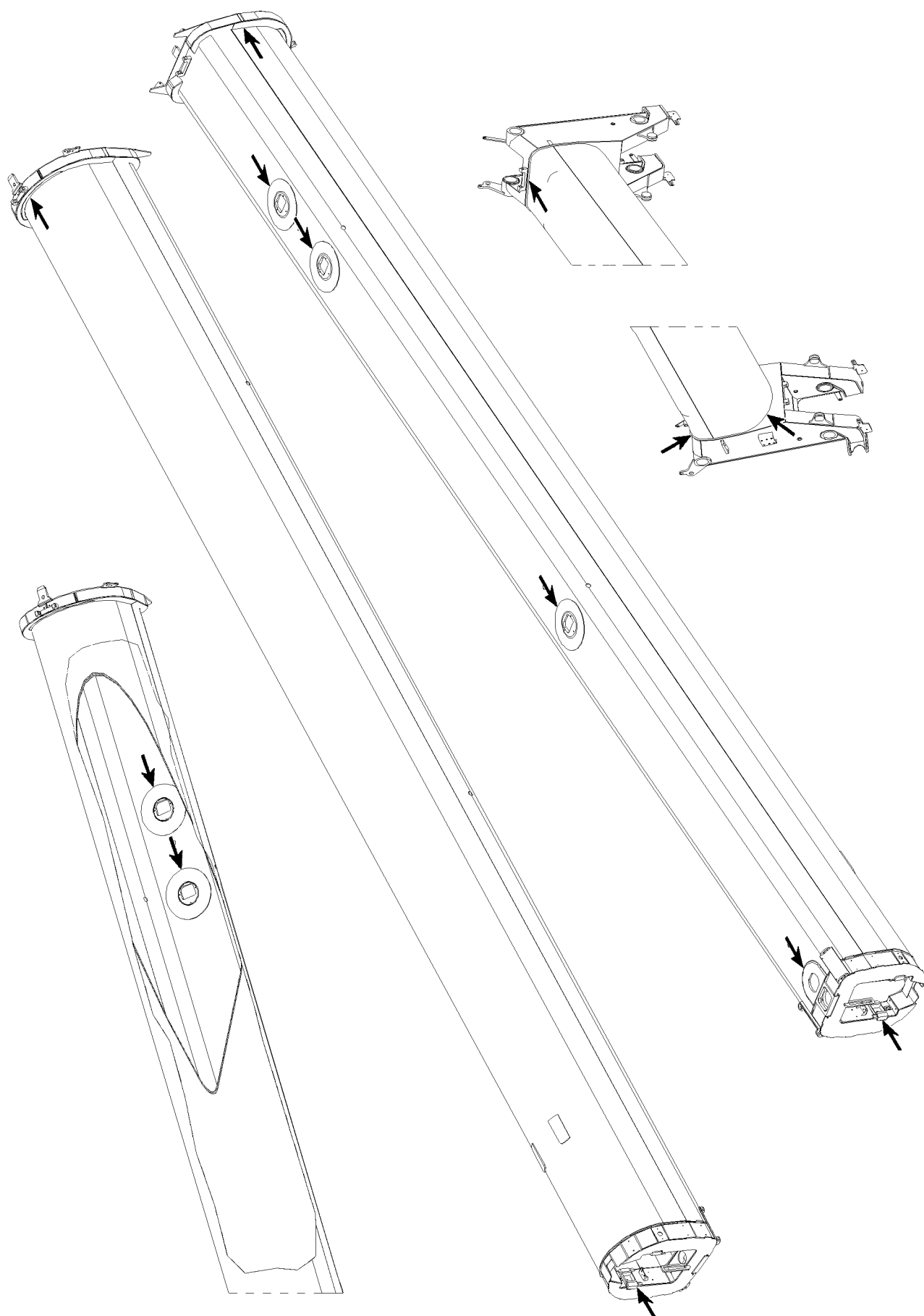
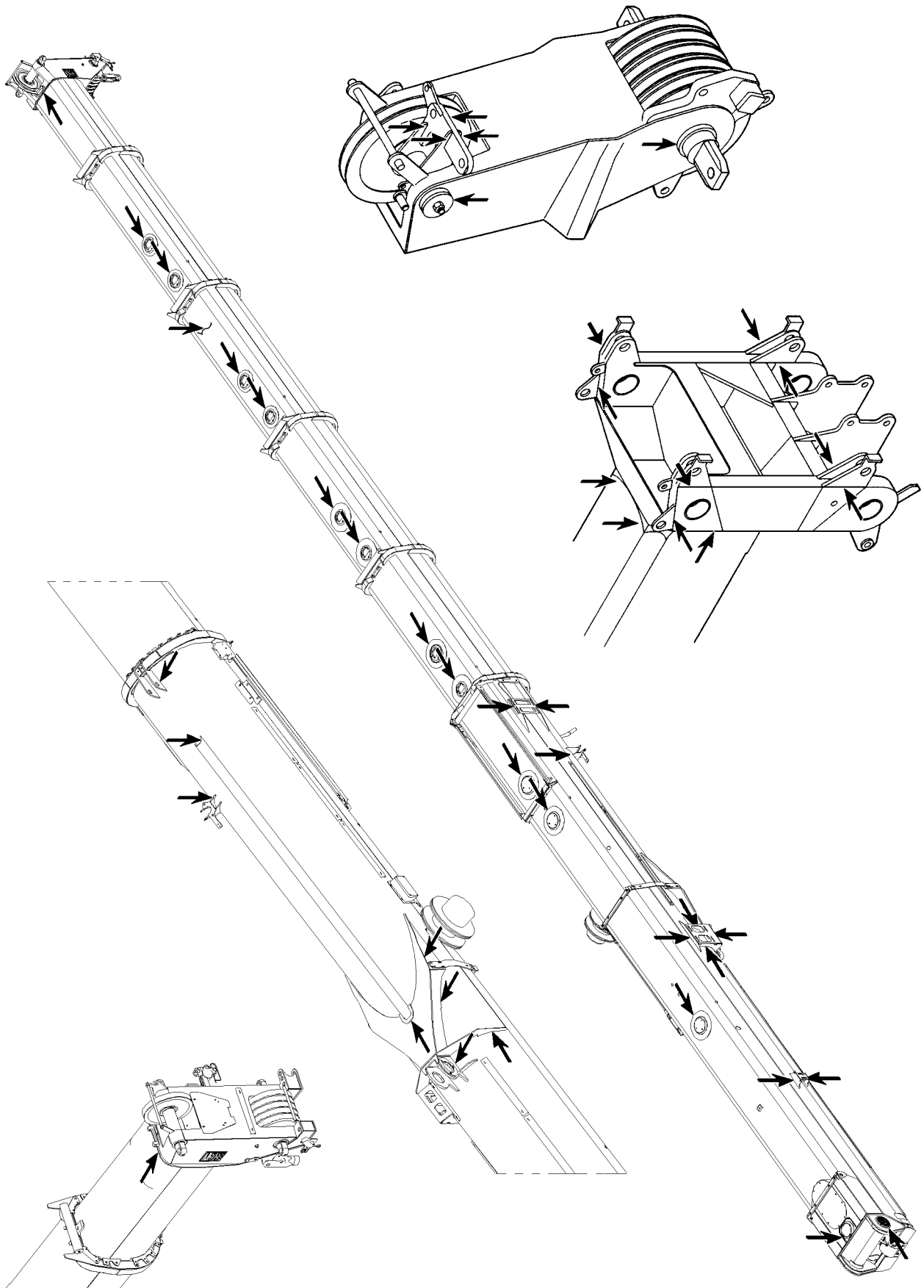

Fig.105710: Example for telescopic boom

LWE/LR 11000-001/23501-04-02/en



LWE/LR 11000-001/23501-04-02/en

Fig.105711: Example for telescopic boom

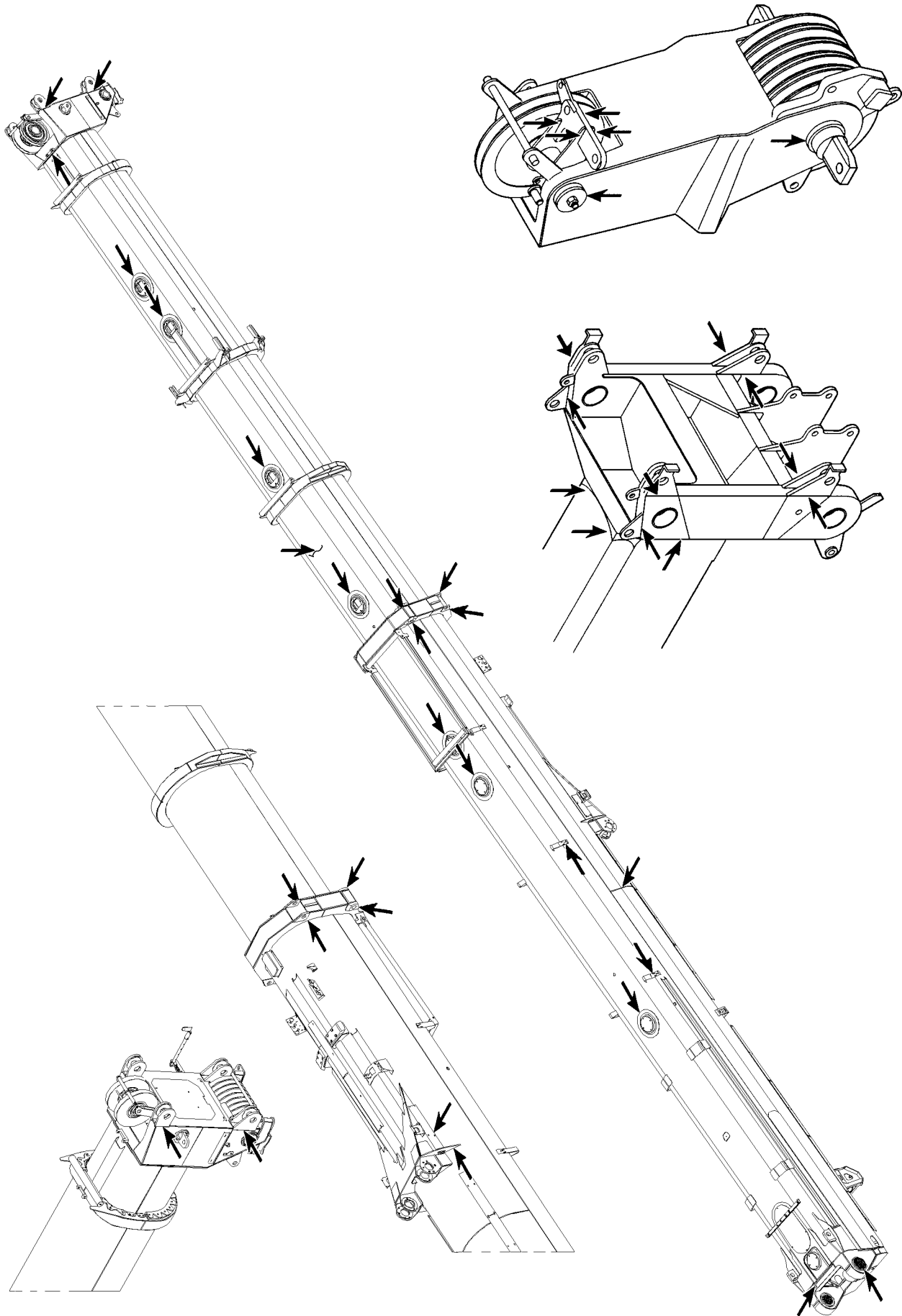
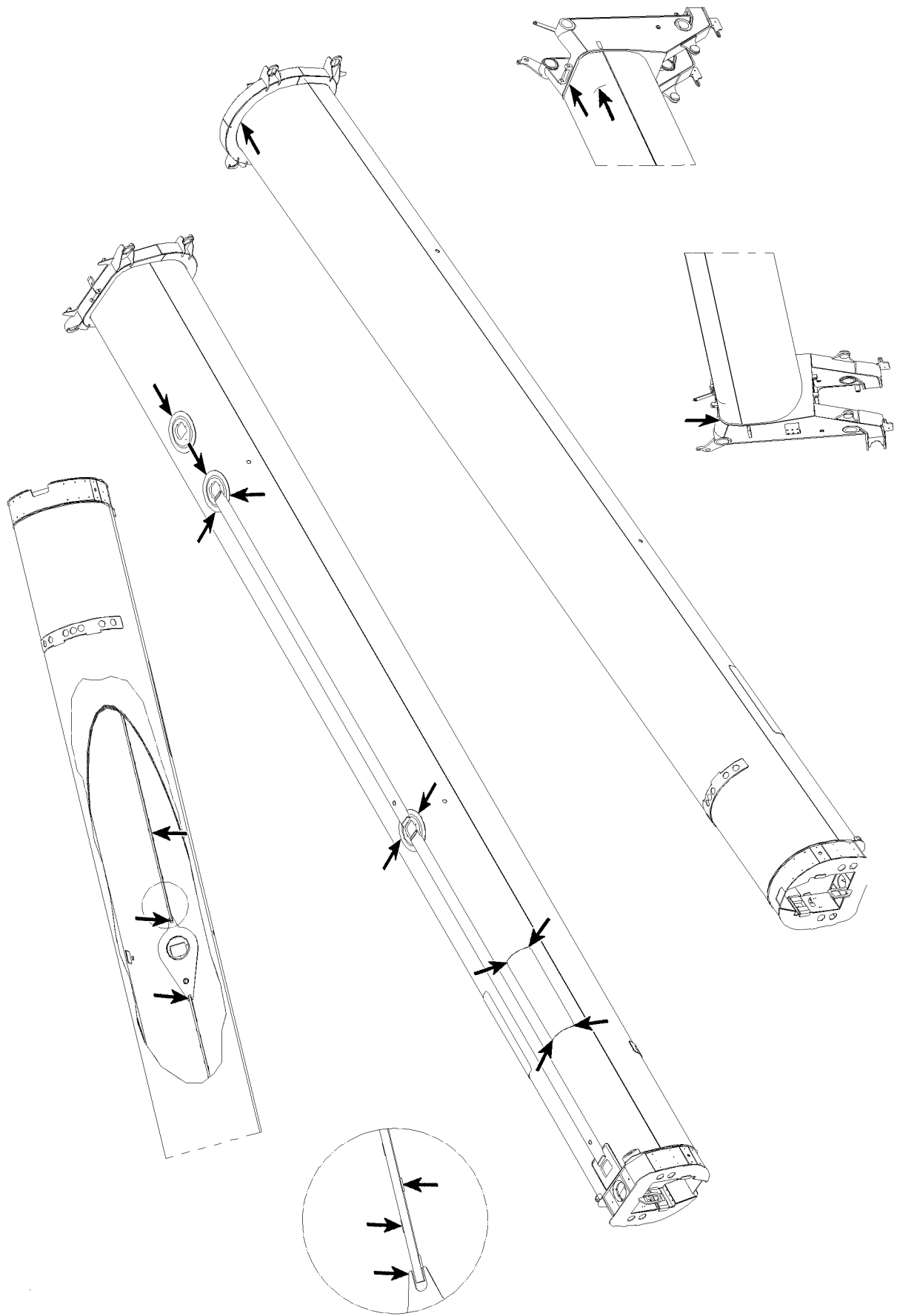

Fig.105720: Example for telescopic boom

LWE/LR 11000-001/23501-04-02/en



LWE/LR 11000-001/23501-04-02/en

Fig.105721: Example for telescopic boom

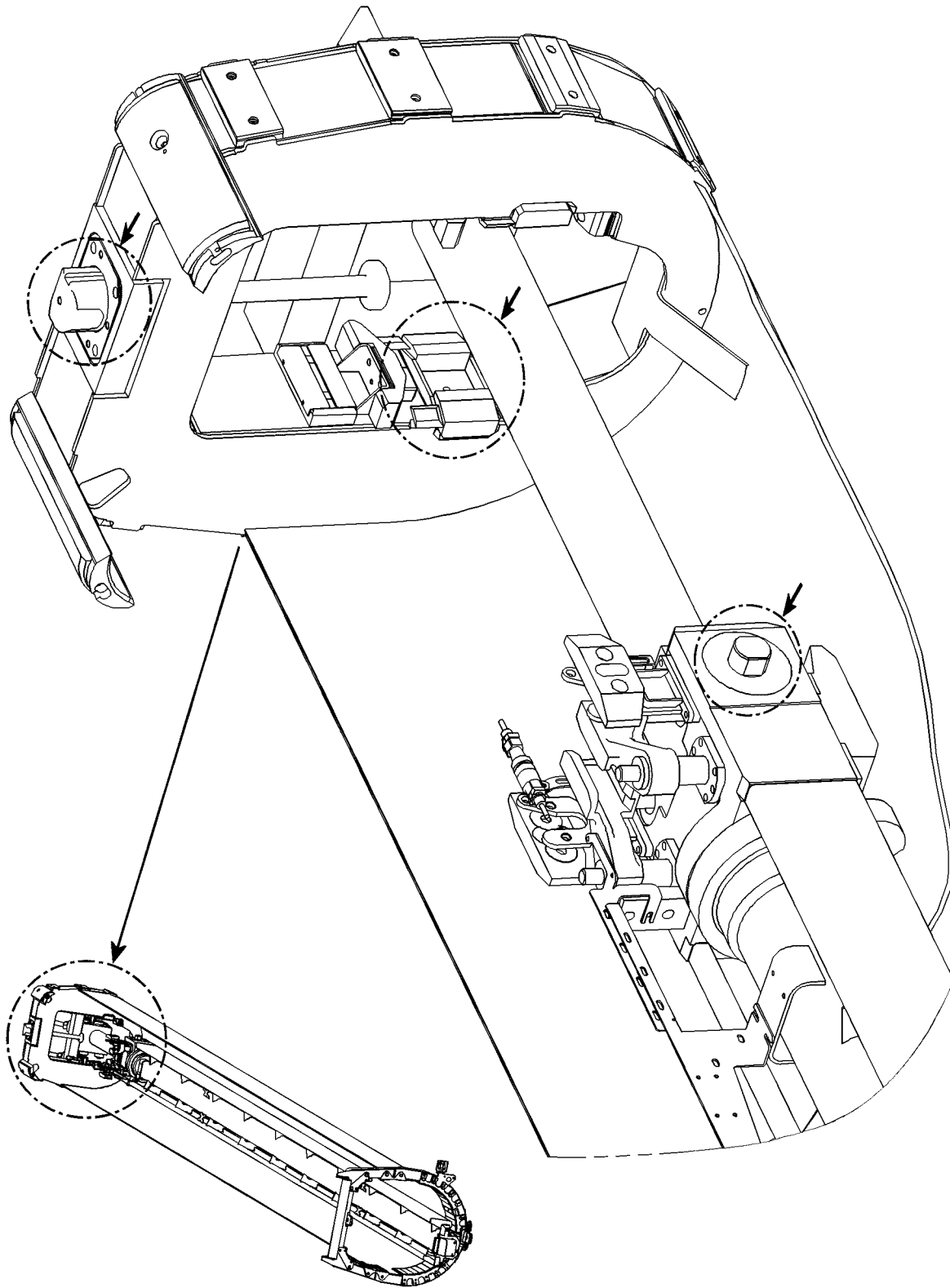

LWE/LR 11000-001/23501-04-02/en

Fig.105891: Example for push out mechanics telescopic boom

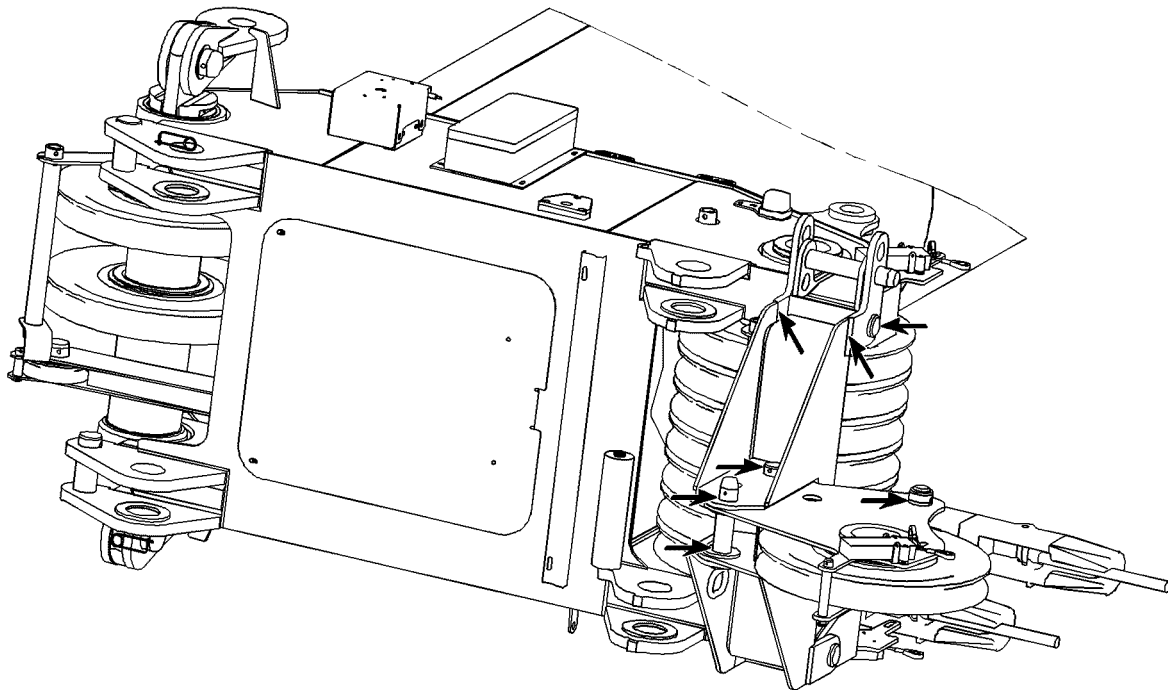
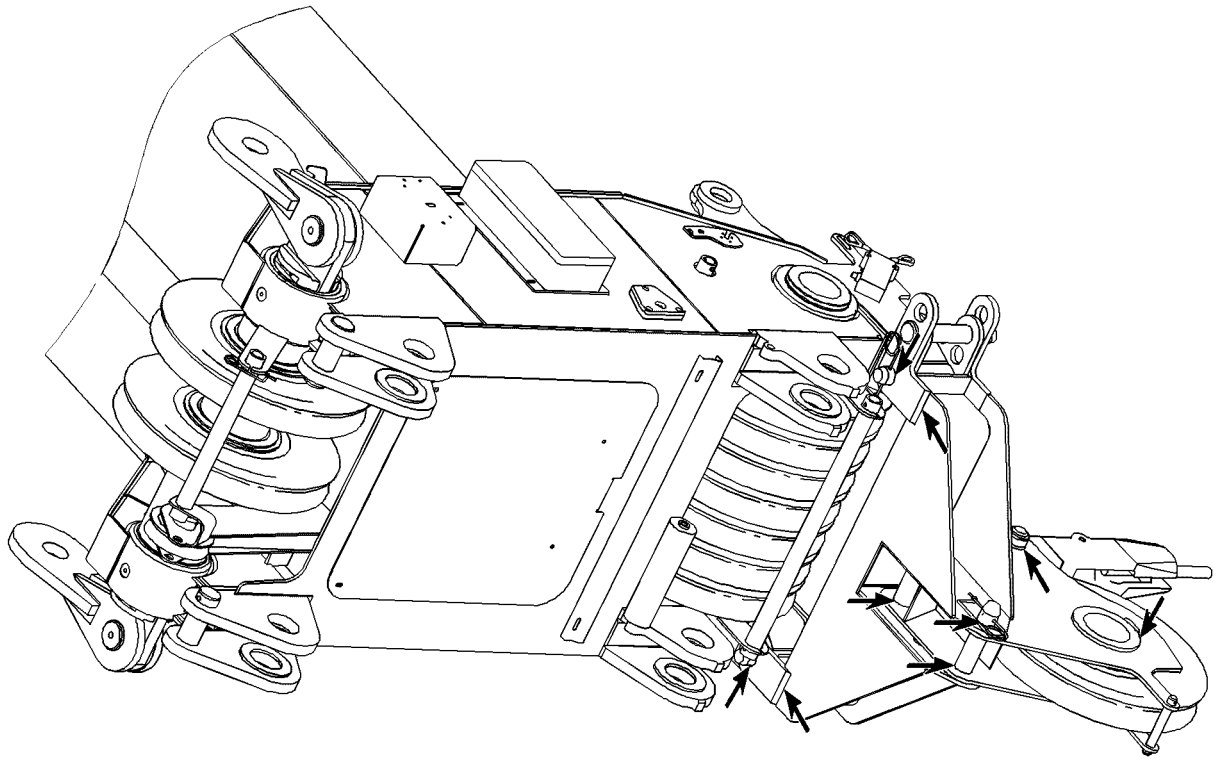

LWE/LR 11000-001/23501-04-02/en

Fig.105892: Example for boom nose

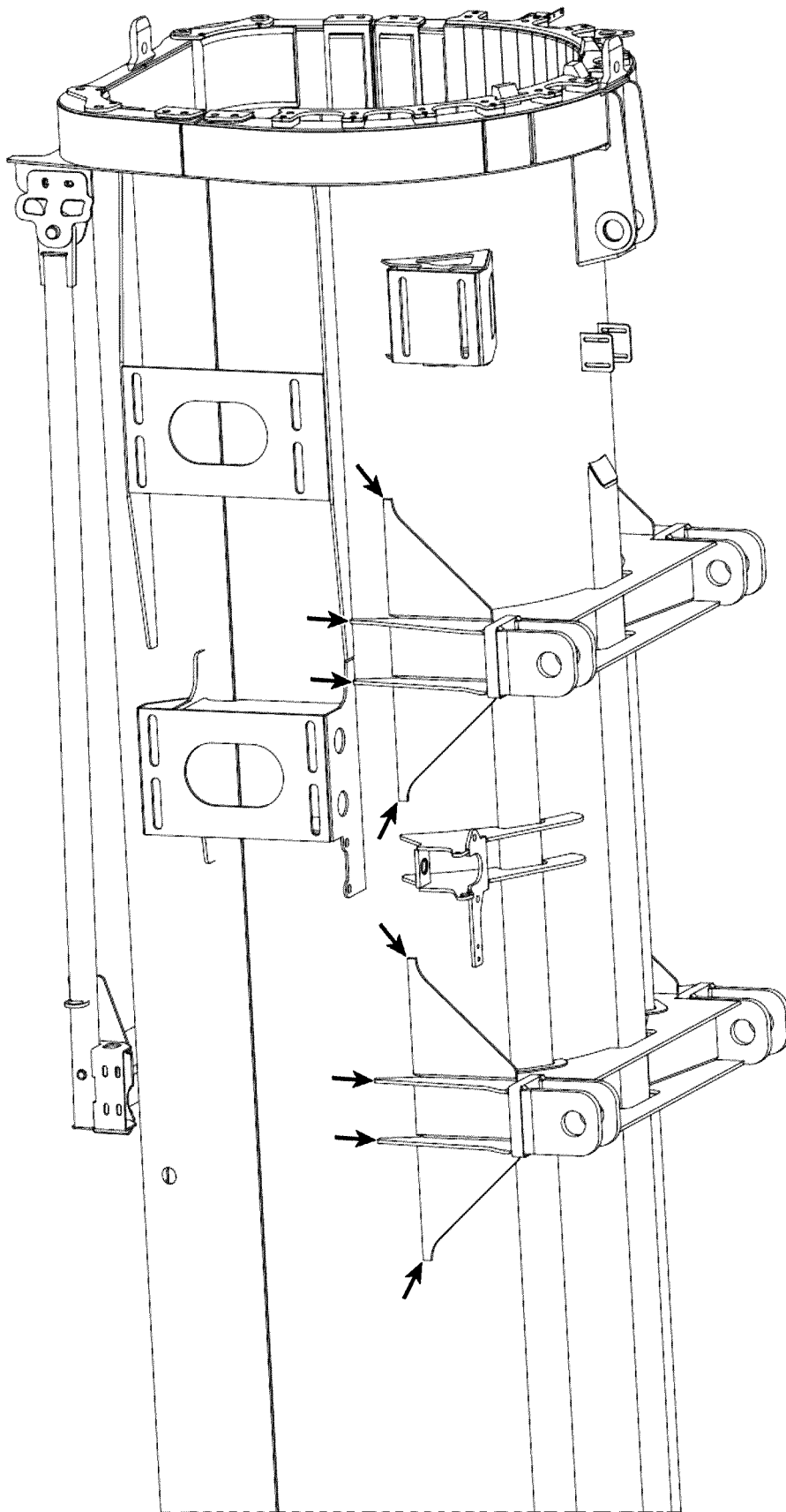
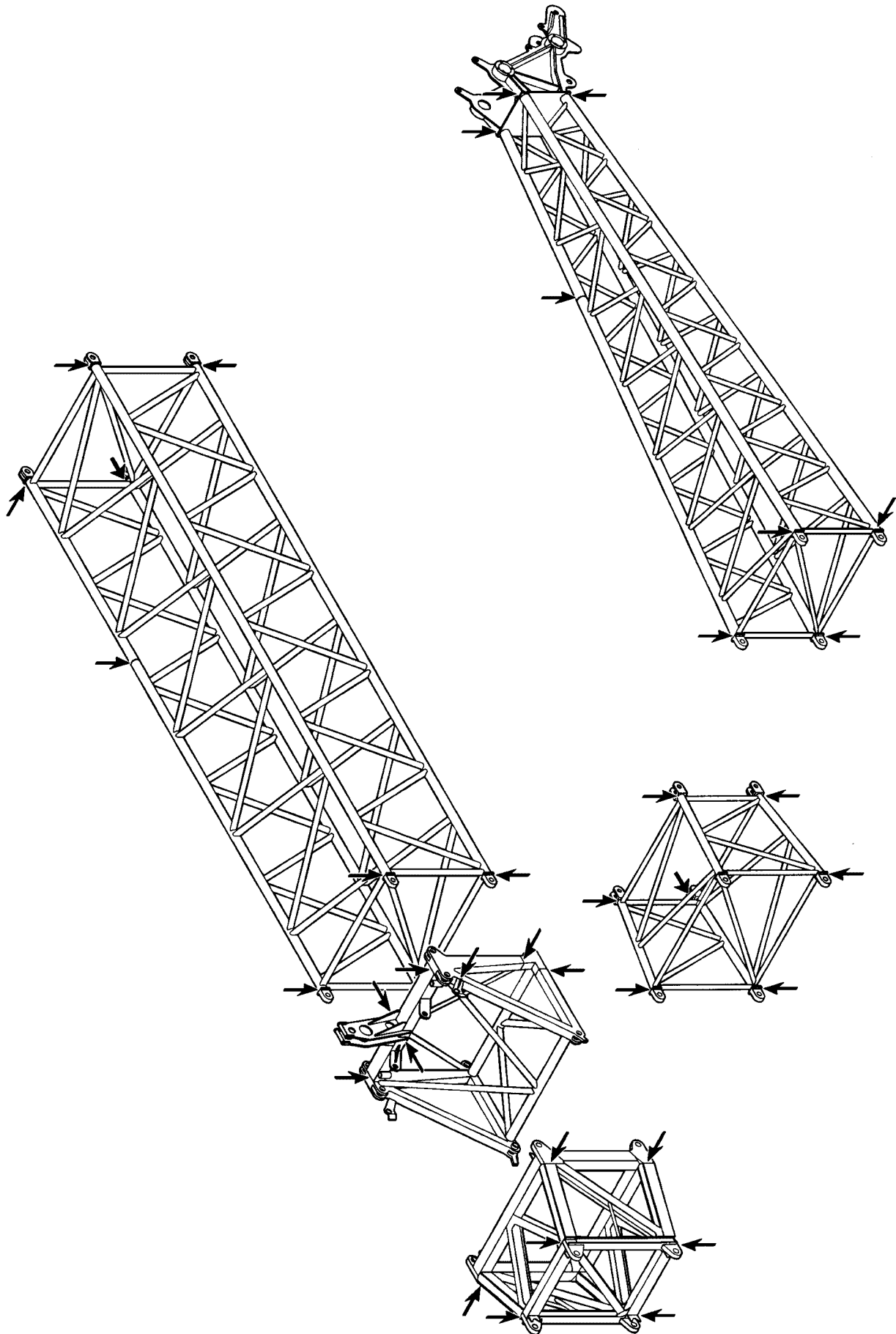

Fig.105689: Example for dolly console

LWE/LR 11000-001/23501-04-02/en



LWE/LR 11000-001/23501-04-02/en

Fig.185051: Example for lattice jib

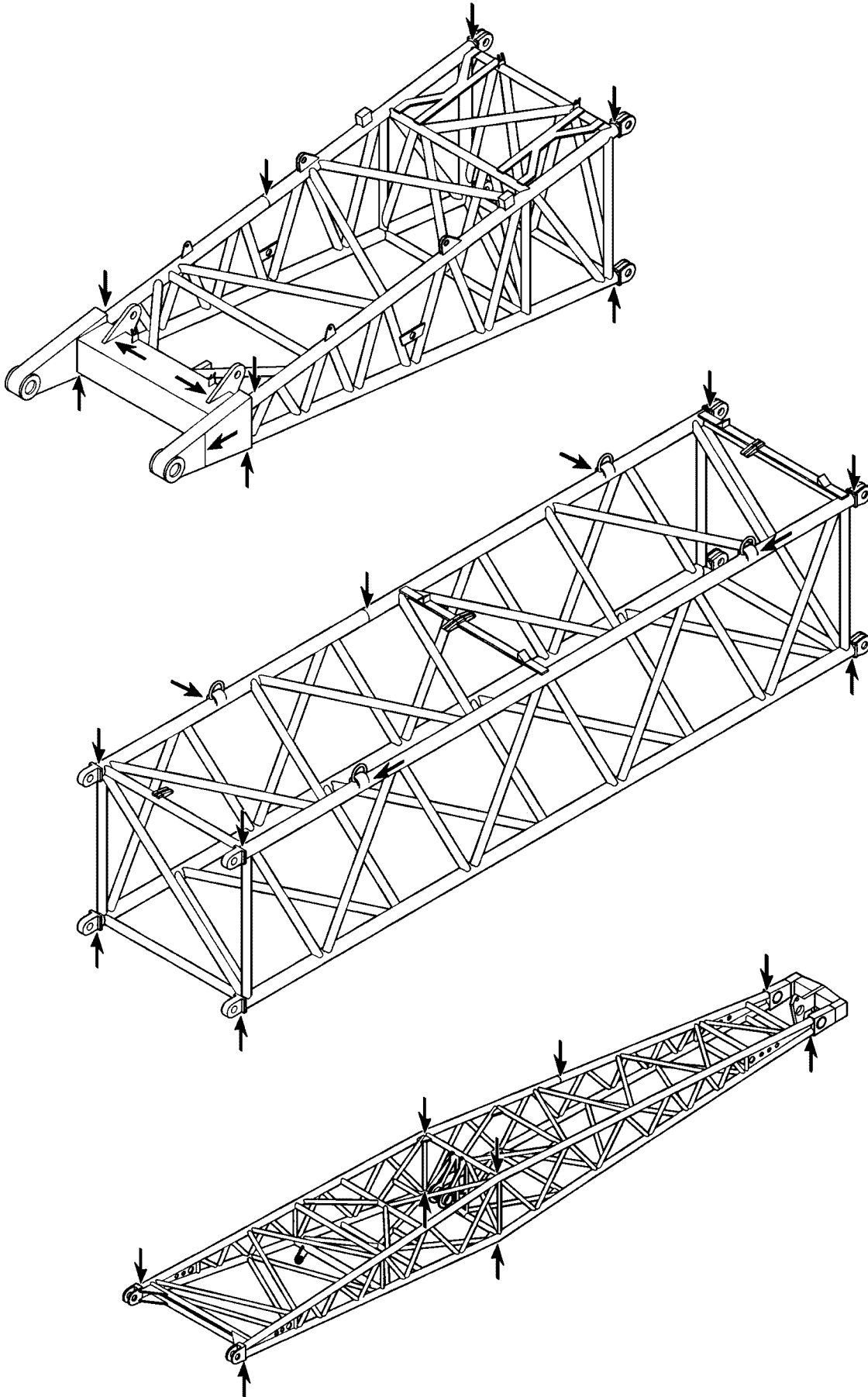
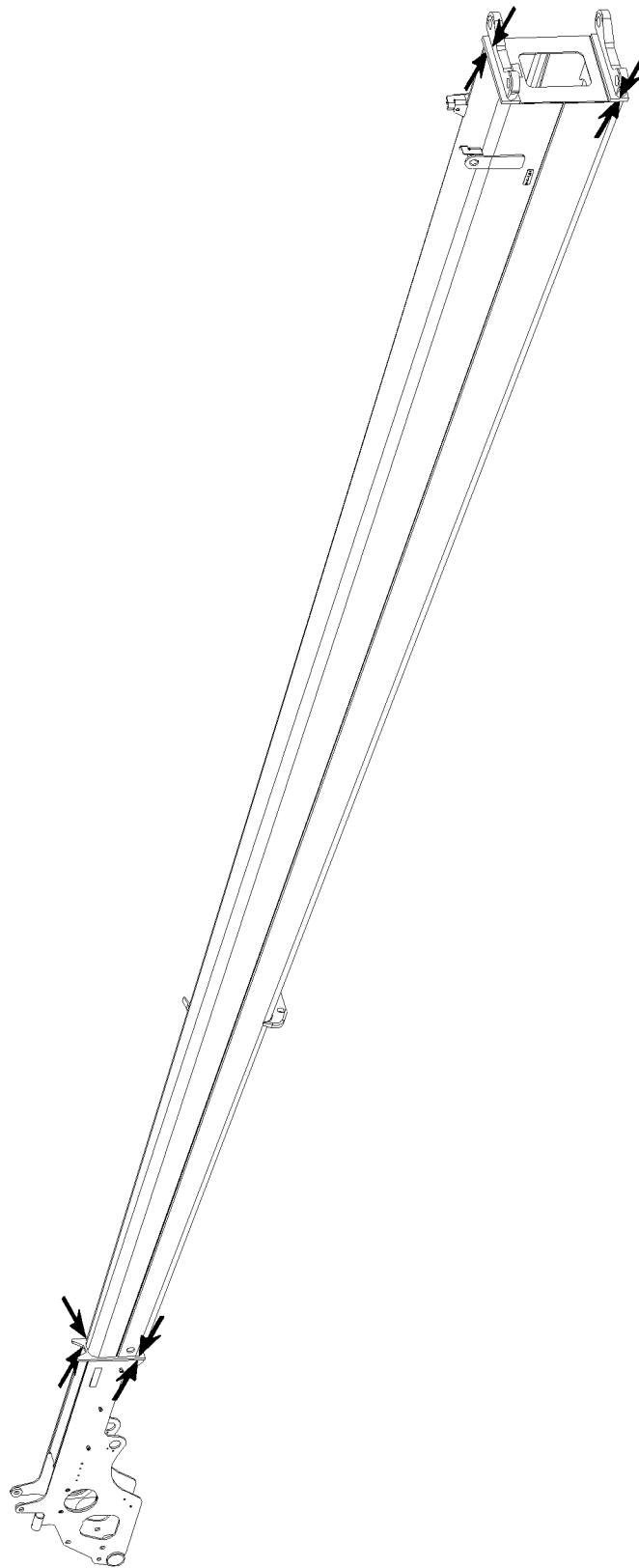

Fig.185052: Example for NA / WA-frame

LWE/LR 11000-001/23501-04-02/en



LWE/LR 11000-001/23501-04-02/en

Fig.105713: Example for end section

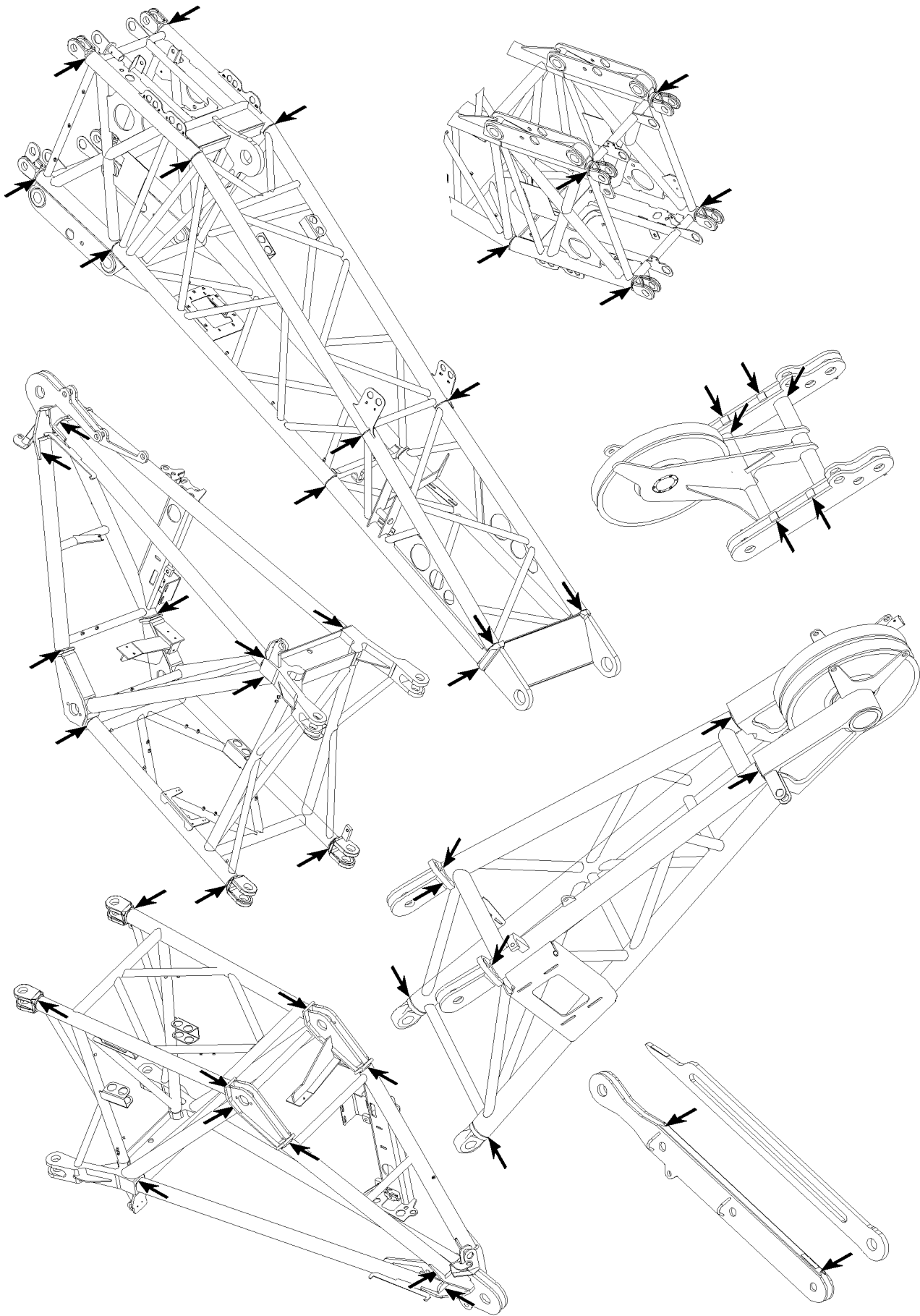
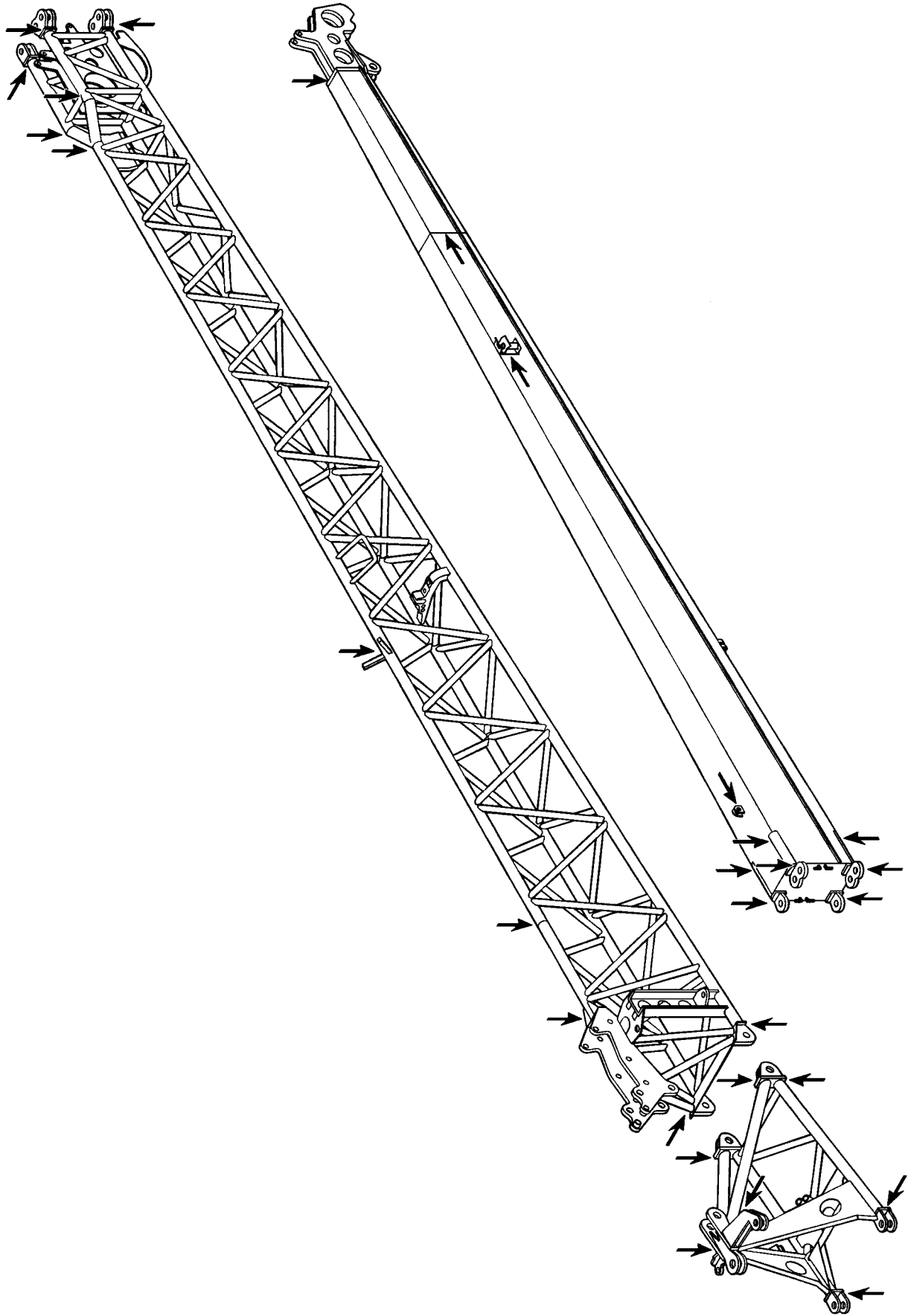

Fig.105836: Example for pivot section, adapter and boom nose

LWE/LR 11000-001/23501-04-02/en



LWE/LR 11000-001/23501-04-02/en

Fig.185058: Example for folding jib

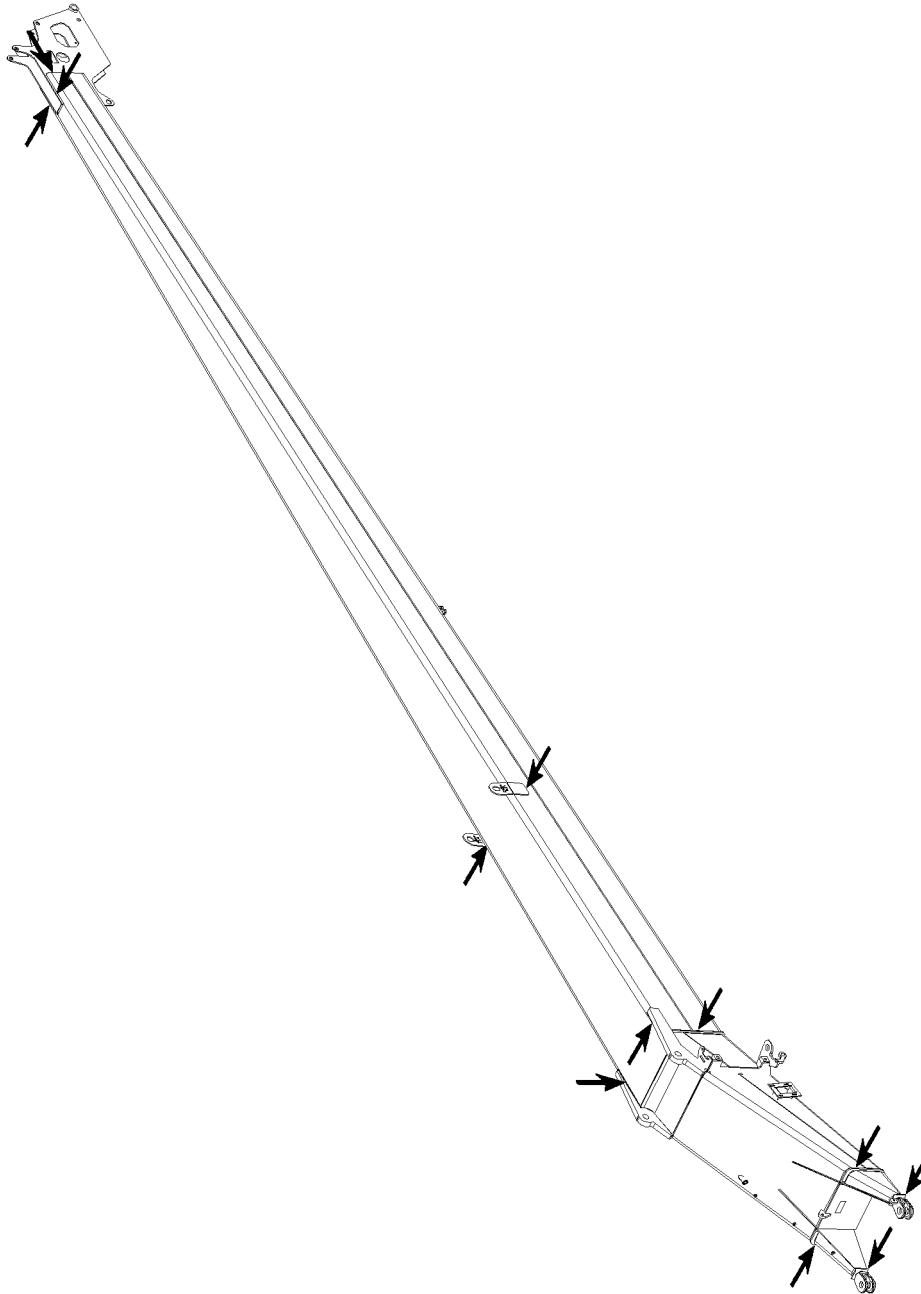
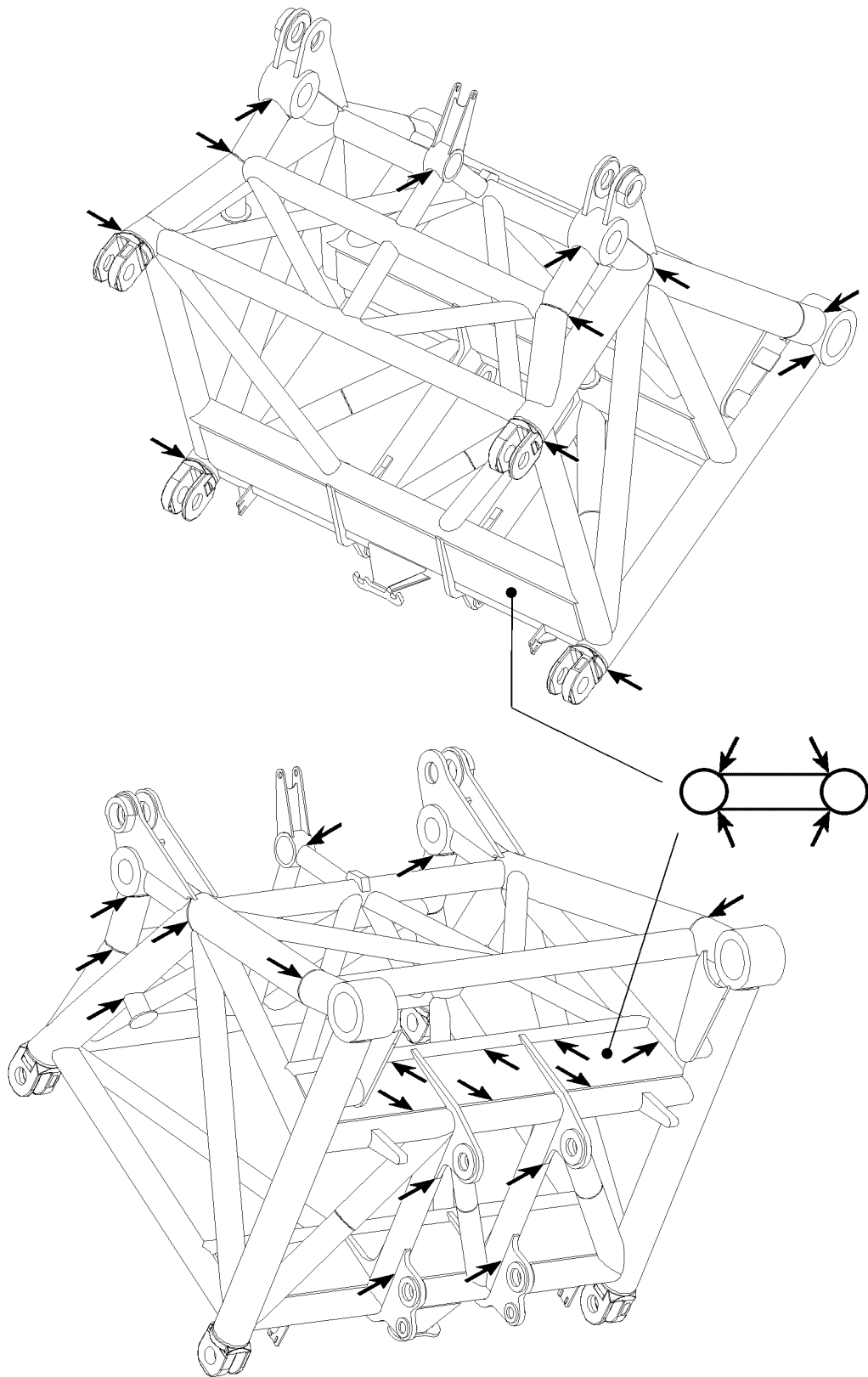

Fig.105697: Example for folding jib

LWE/LR 11000-001/23501-04-02/en



LWE/LR 11000-001/23501-04-02/en

Fig.105732: Example for W-connector head

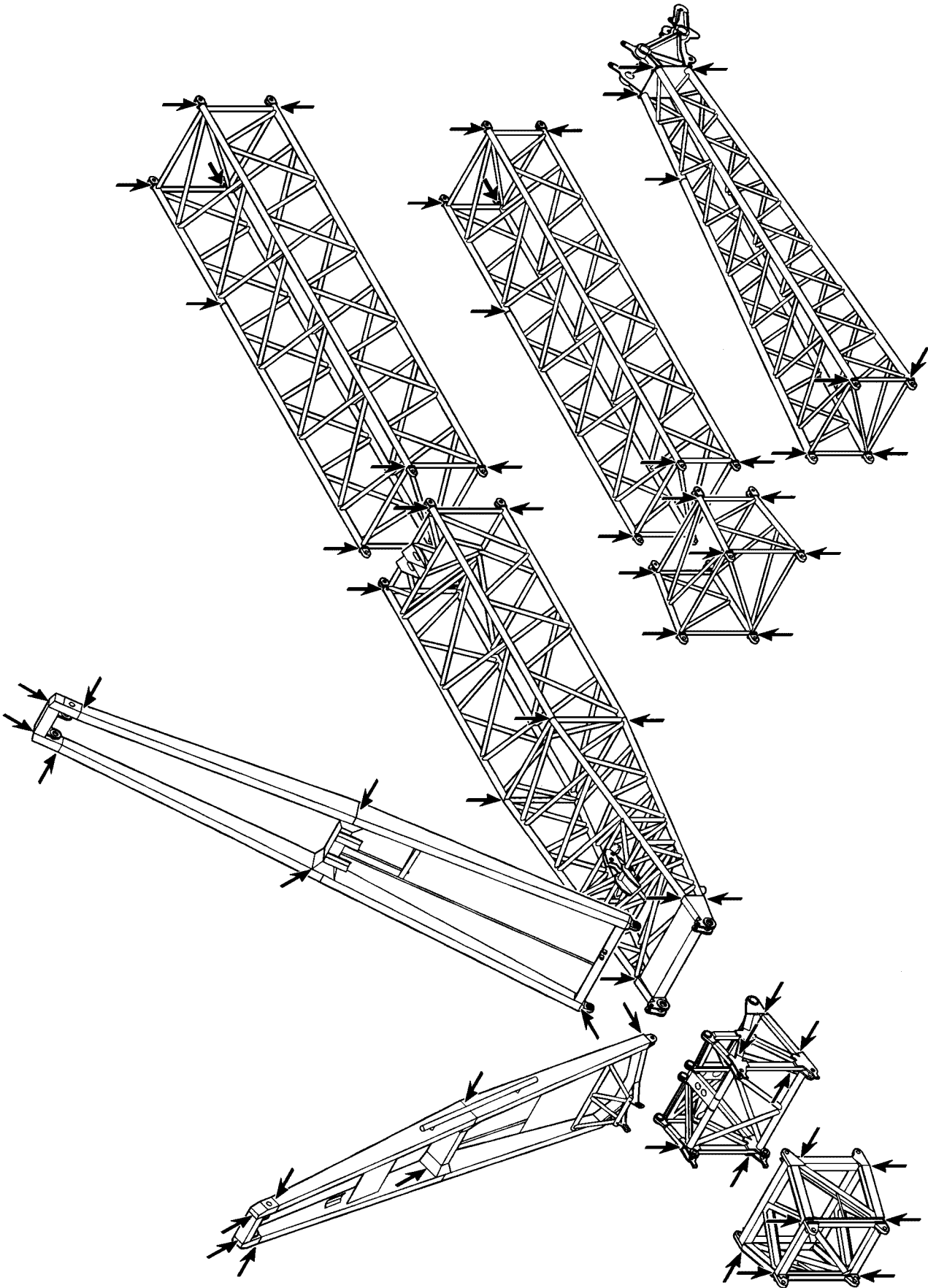
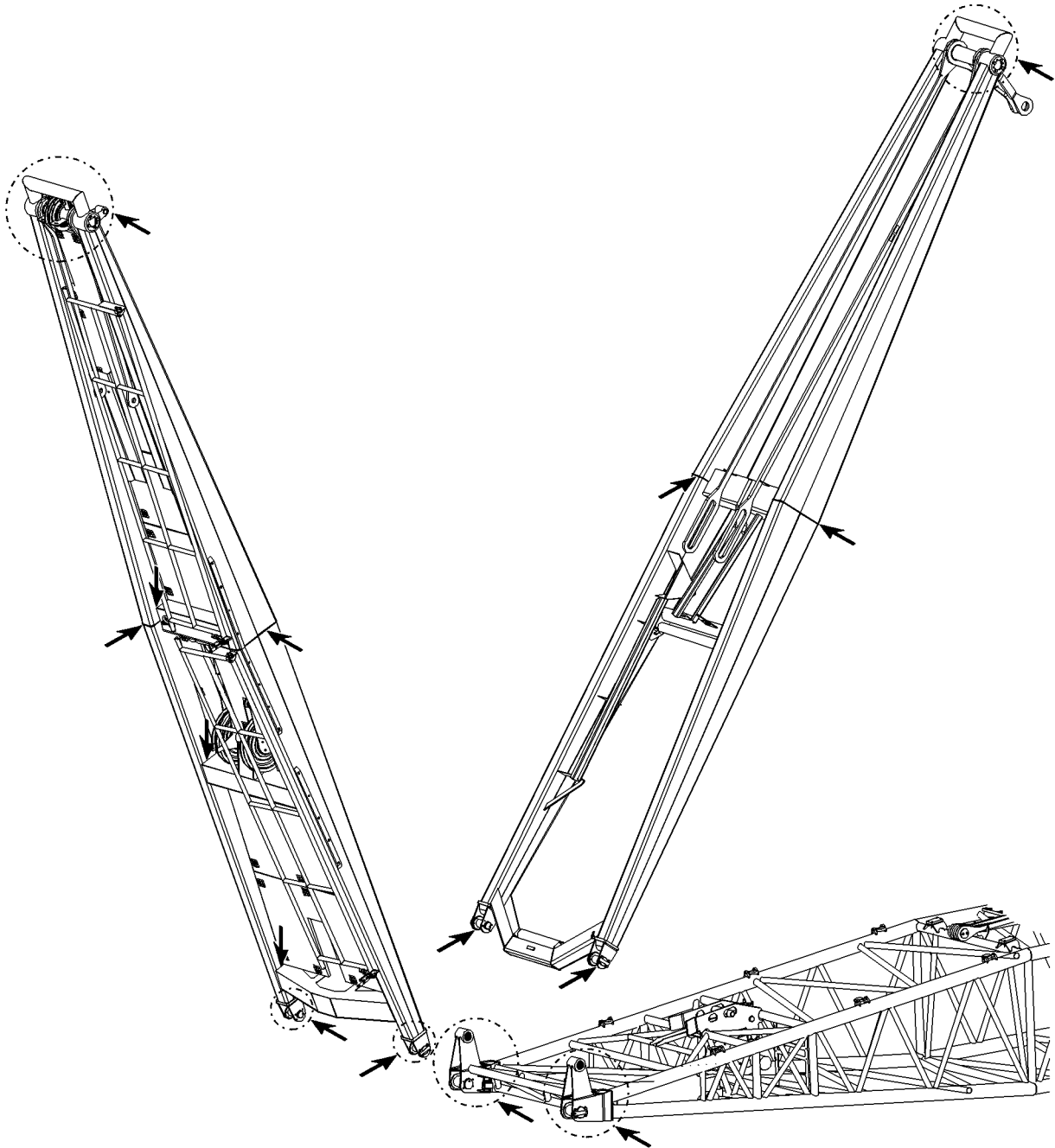

Fig.185053: Example for assembly unit with lattice jib

LWE/LR 11000-001/23501-04-02/en



LWE/LR 11000-001/23501-04-02/en

Fig.105838: Example for NA frames

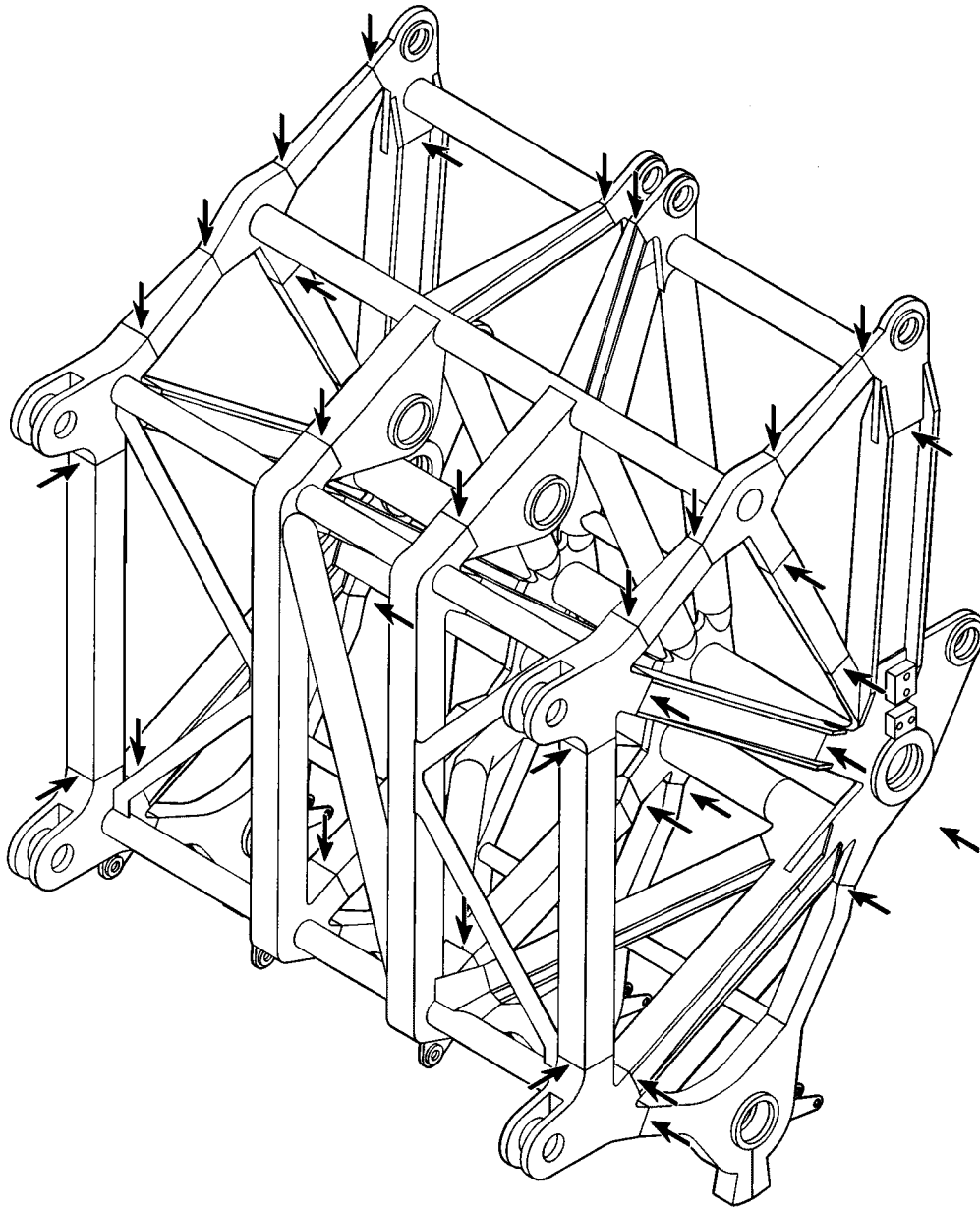
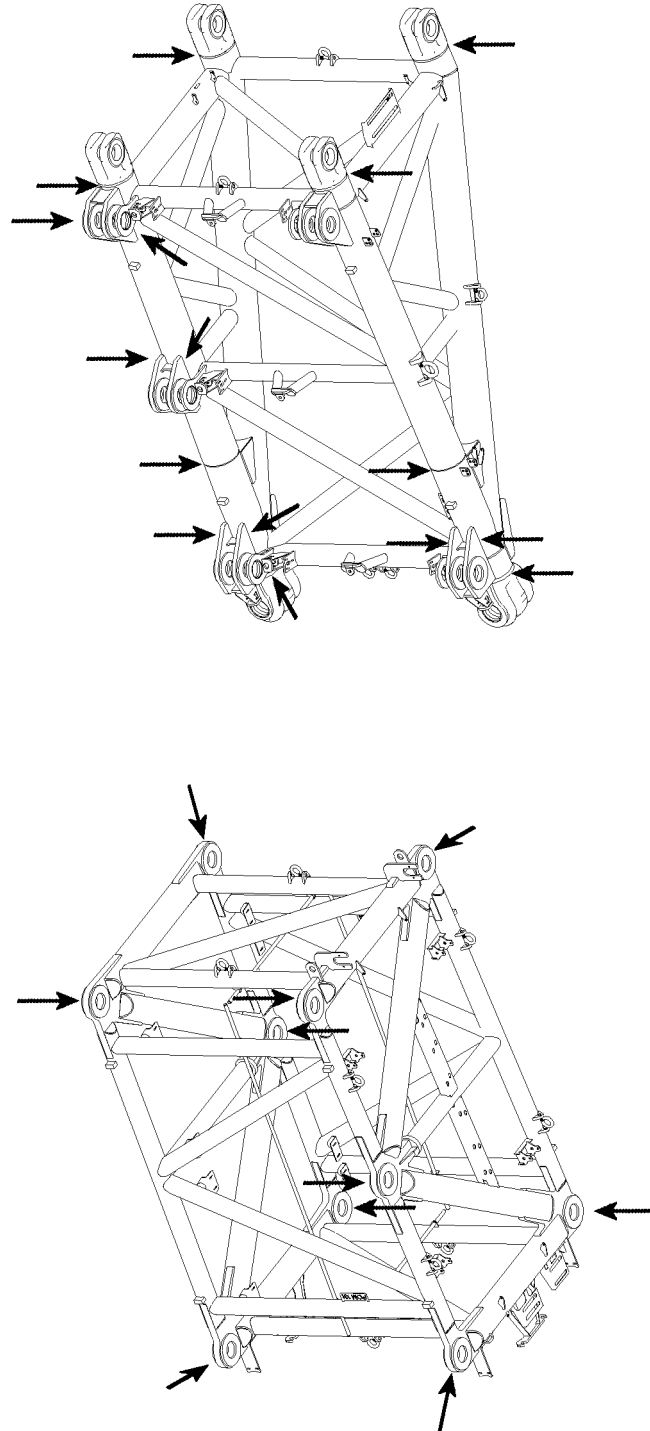

Fig.185054: Example for pulley head

LWE/LR 11000-001/23501-04-02/en



LWE/LR 11000-001/23501-04-02/en

Fig.116609: Example for P-adapter

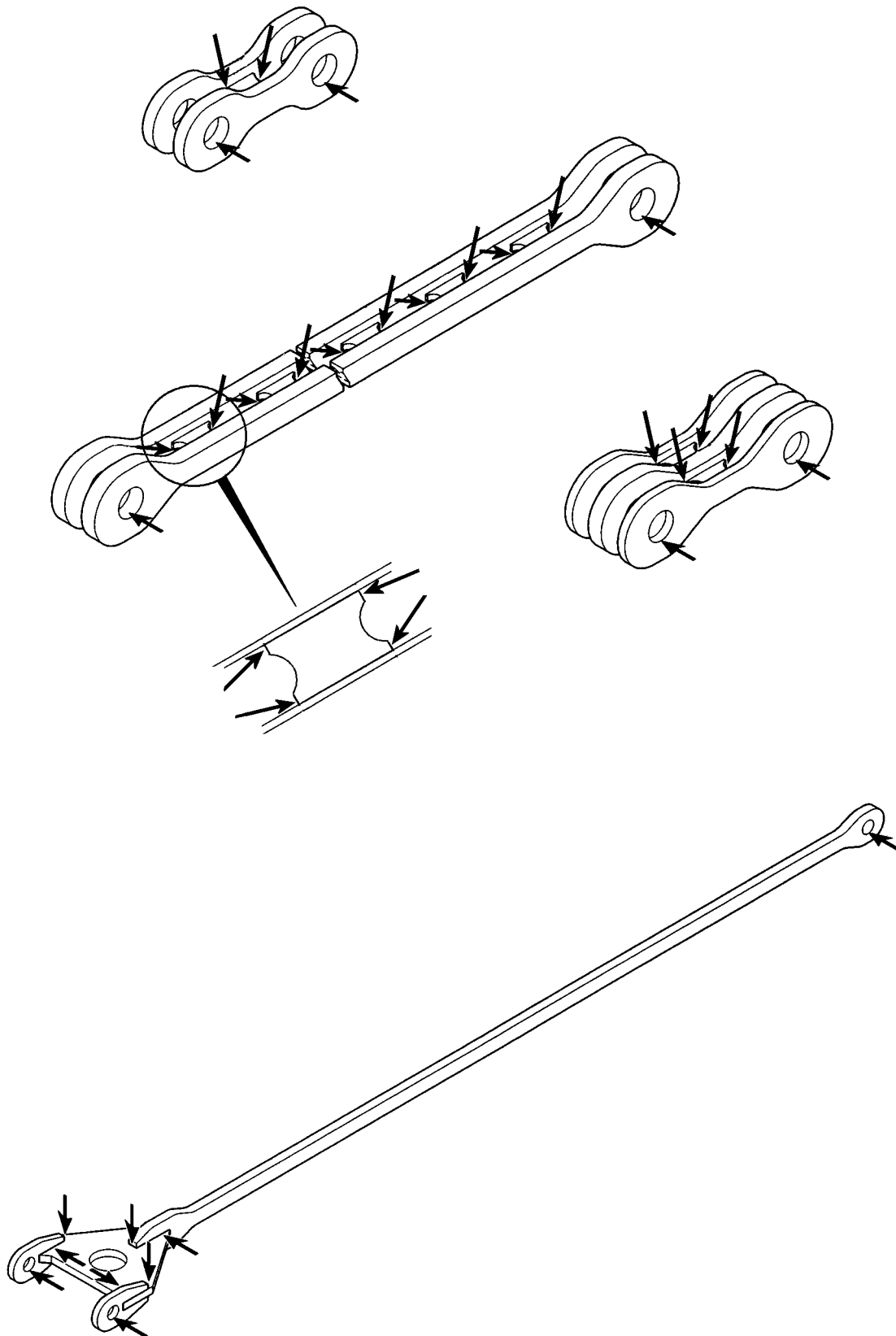
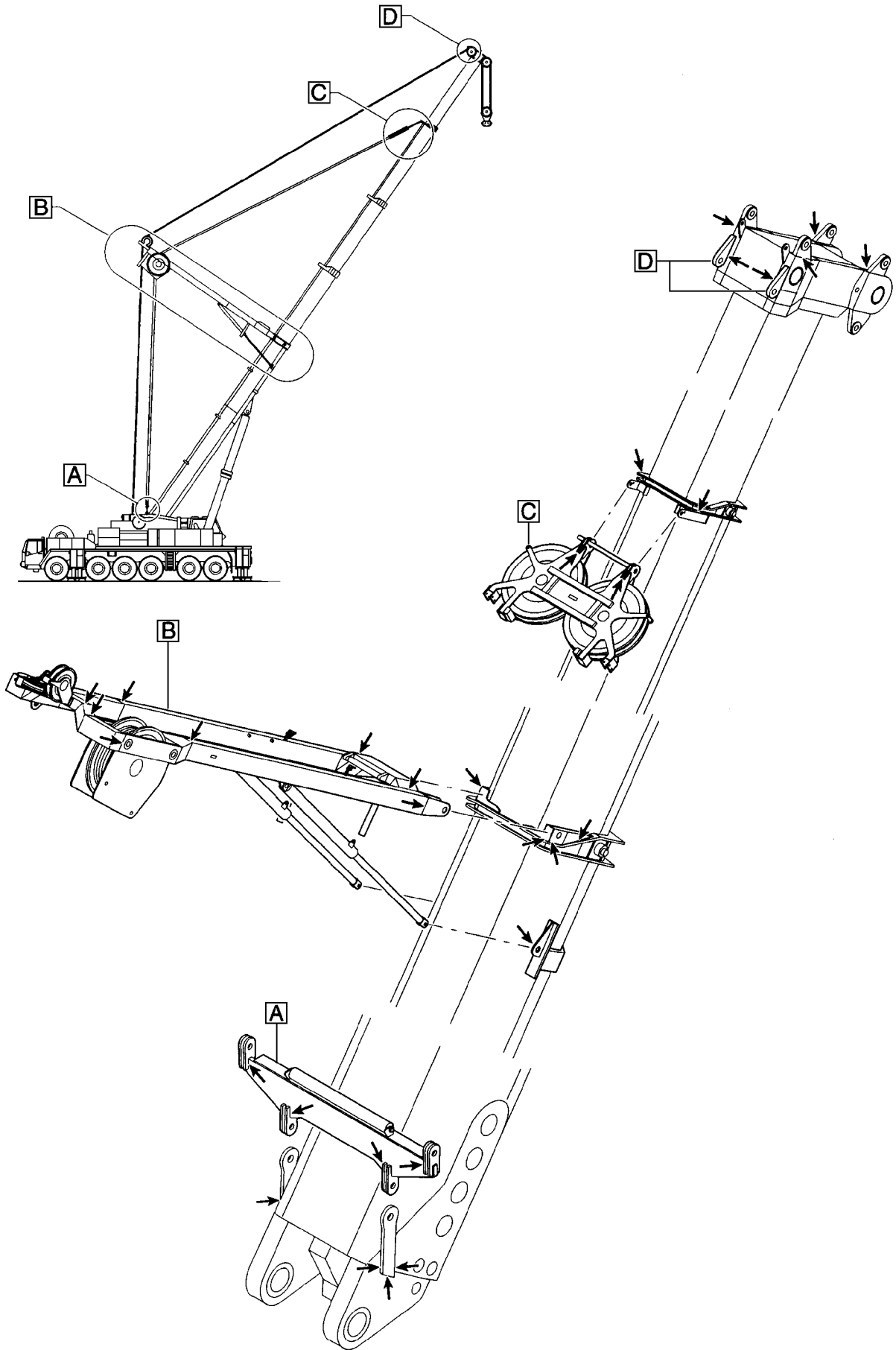

Fig.185055: Example for guy rod



LWE/LR 11000-001/23501-04-02/en

Fig.185059: Example for TA-guying

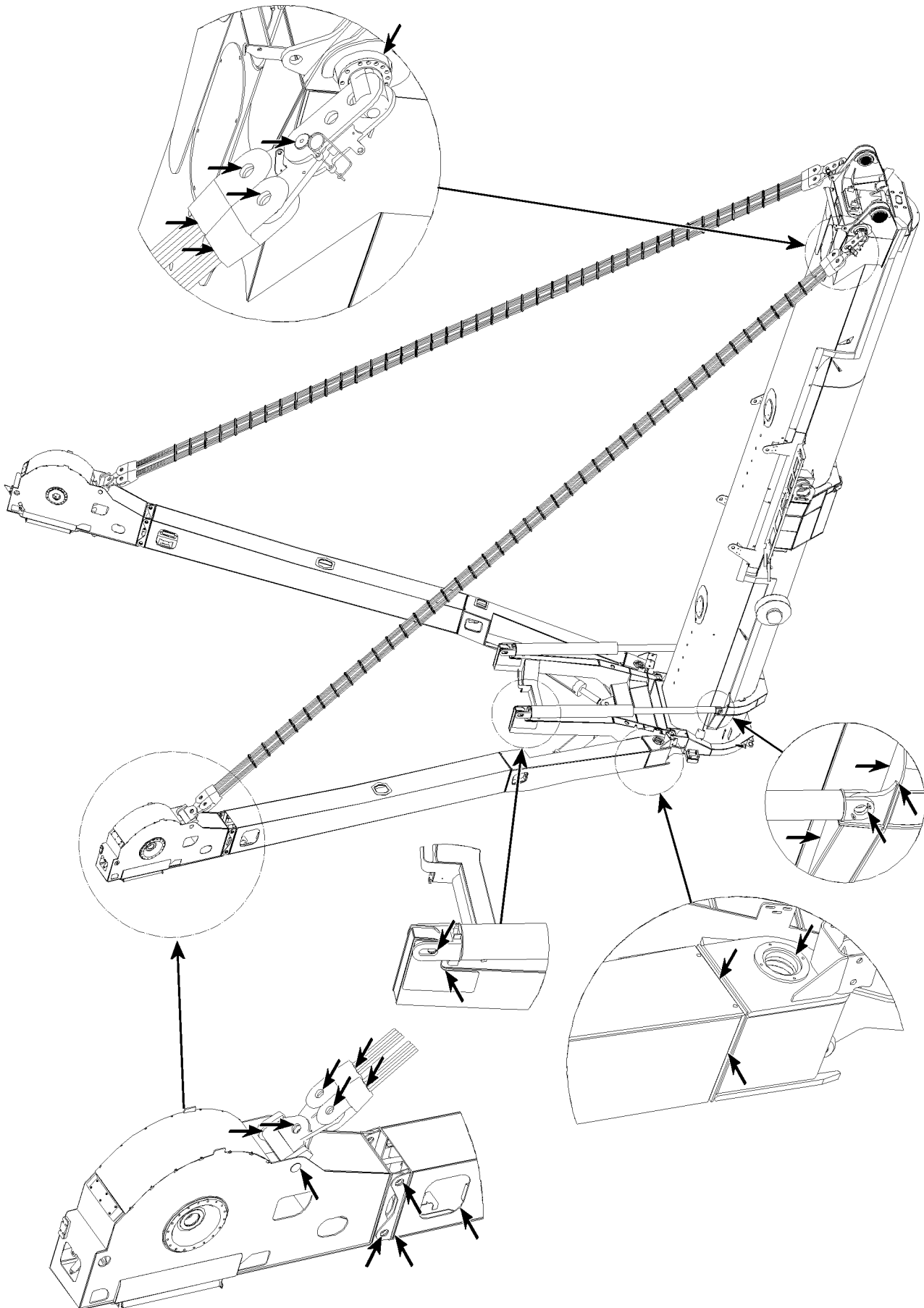
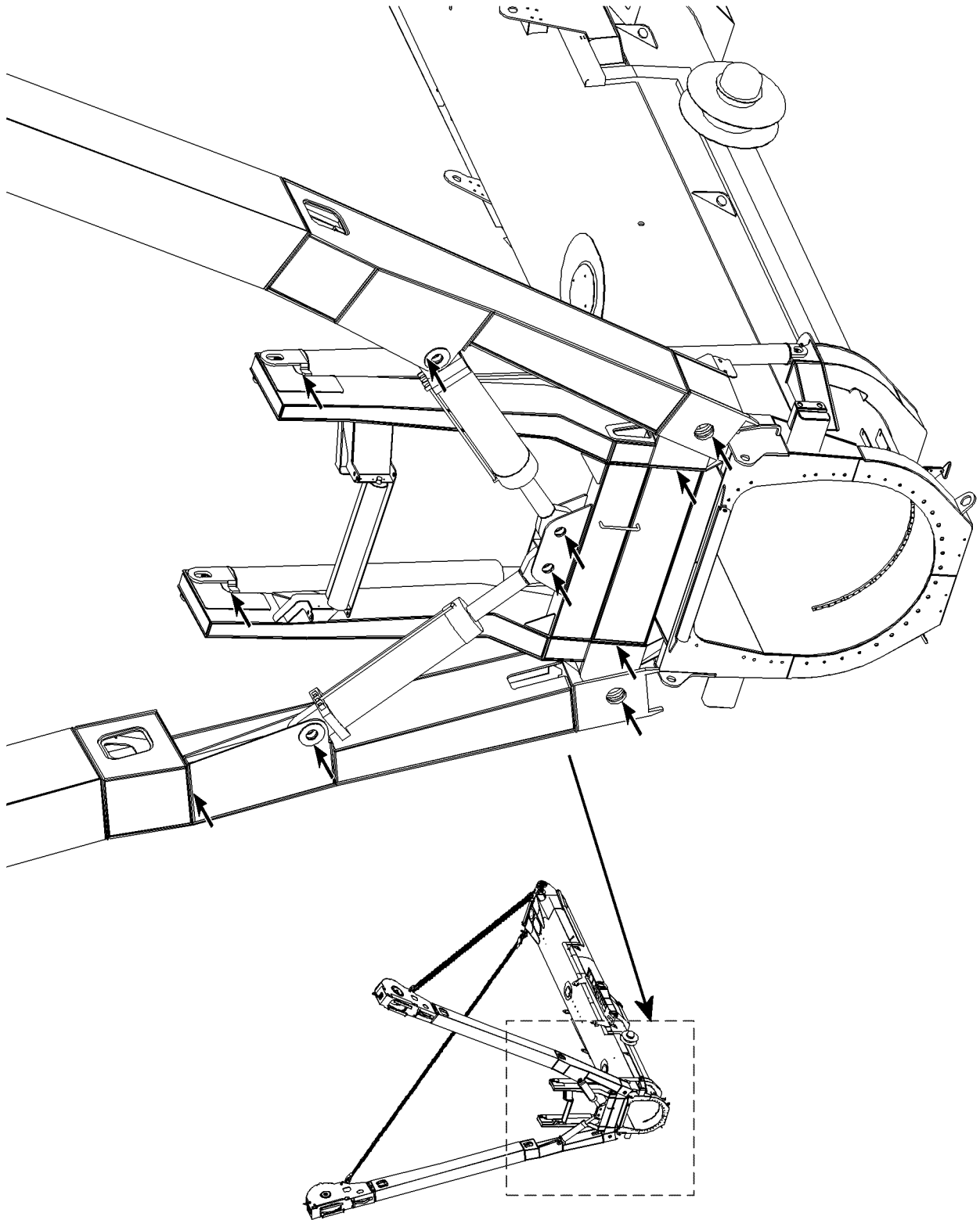

Fig.105707: Example for TY-guying

LWE/LR 11000-001/23501-04-02/en



LWE/LR 11000-001/23501-04-02/en

Fig.105708: Example for TY-guying

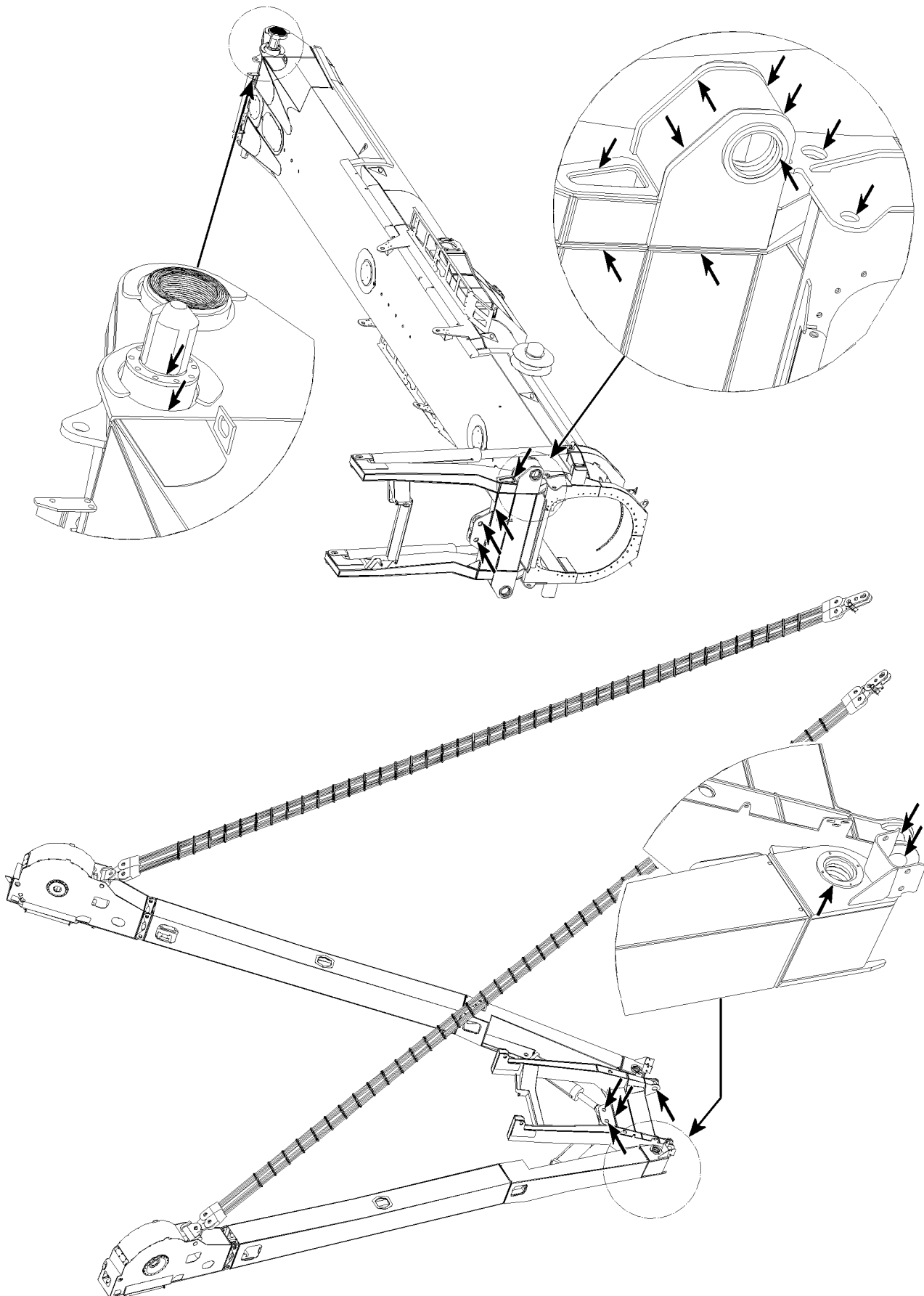
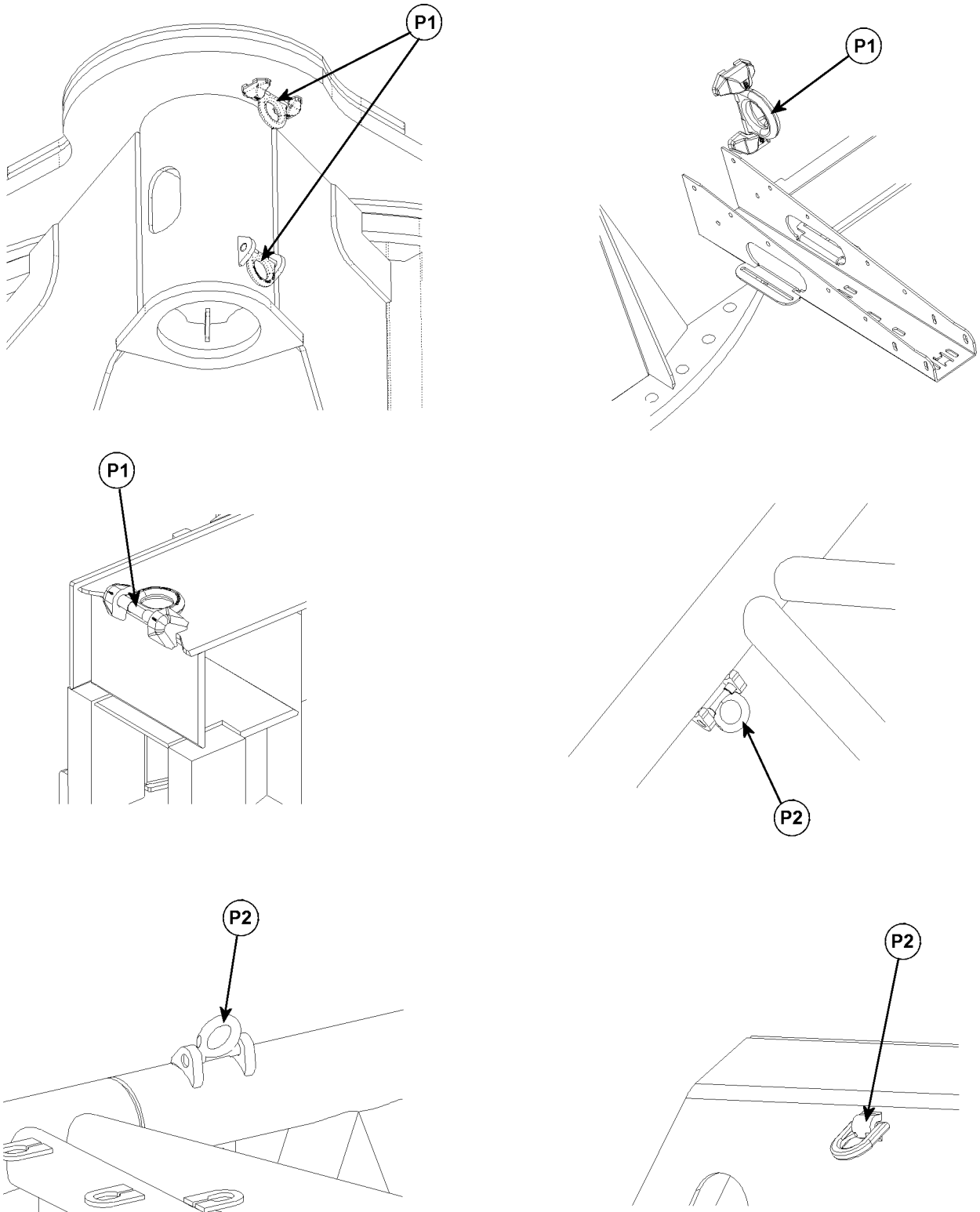

Fig.105709: Example for TY-guying

LWE/LR 11000-001/23501-04-02/en

2.4 Rigging and fastening points



LWE/LR 11000-001/23501-04-02/en

Fig.121160: Examples for rigging and fastening points

P1 Rigging points

P2 Fastening points

**WARNING**

Unsafe rigging point or fastening point!

The mobile crane or component can rip free and fall down!

When a rigging point or fastening point is not safe for operation:

- ▶ Have the rigging point or fastening point replaced by authorized and trained expert personnel.
- ▶ Avoid damage on the rigging device due to sharp-edged exposure.

Make sure that the following damage does **not** occur:

- Crushing points
- Shearing points
- Catch points
- Impact points

Inspection criteria:

- Completeness of rigging point.
- Distortion of carrying parts.
- Mechanical damage such as severe nicks.
- Changes in diameter due to wear.
- Significant corrosion (pitting)
- Cracks on carrying parts.
- Cracks or other damage on the welding seam.

Check the rigging points **P1** and fastening points **P2** before every start up and at regular intervals.

2.5 Inspecting the lattice sections

**Note**

- ▶ The illustration is only an example and is valid for all lattice sections!
- ▶ Check all diagonal and frame pipe connections!
- ▶ Check all bores of the fork - finger connections!

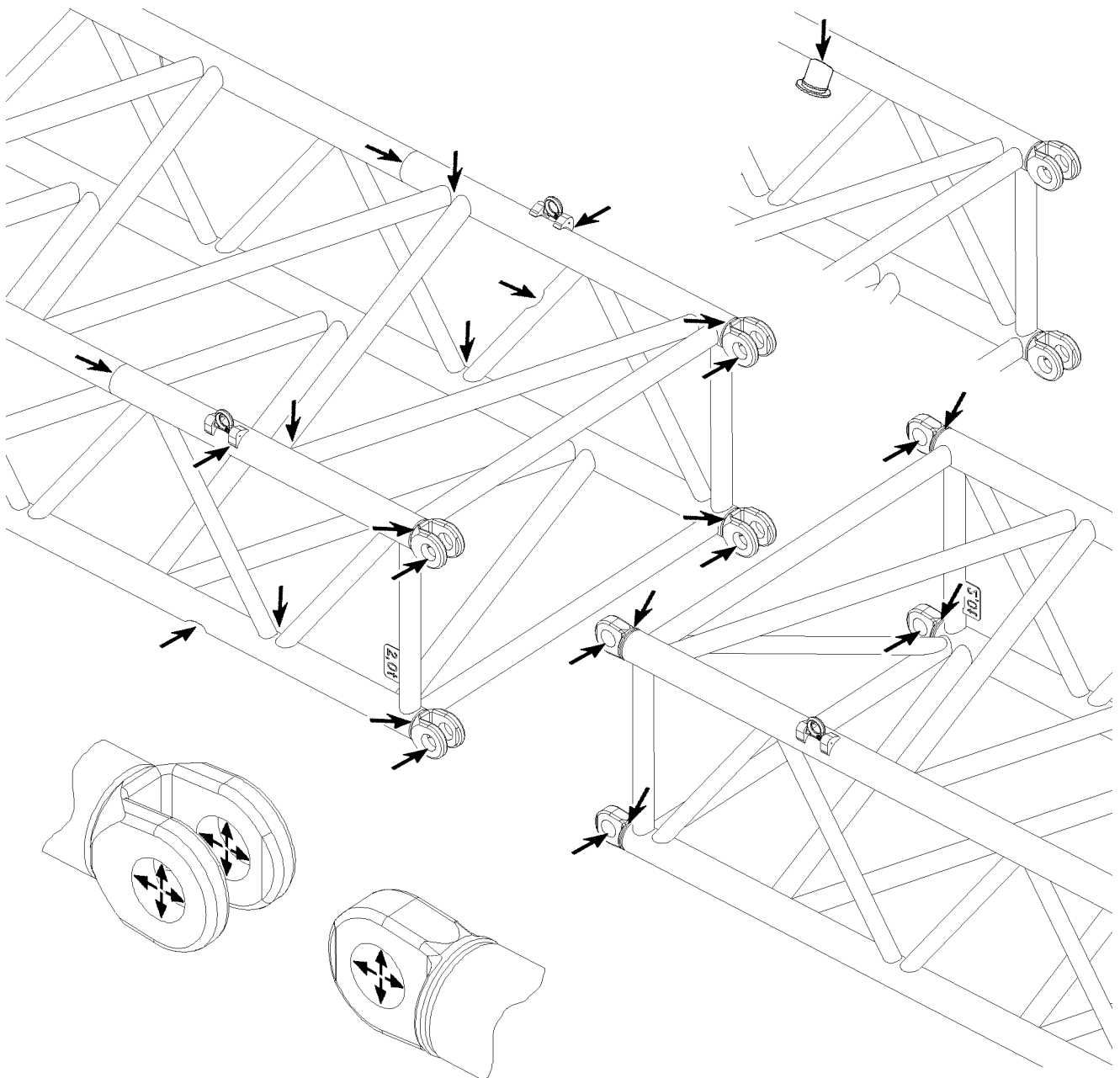

Fig.121023: Example for lattice sections

3 Inspection of locking system of telescopic boom

3.1 For cranes with pneumatic boom locking system

- For inspection of function, see chapter 8.11.
- For inspection of pin wear pattern, see chapter 8.11.
- For inspection of wear, see chapter 8.11.
- For inspection of safety control, see chapter 8.11.

3.2 For cranes with telescopic boom system Telematik

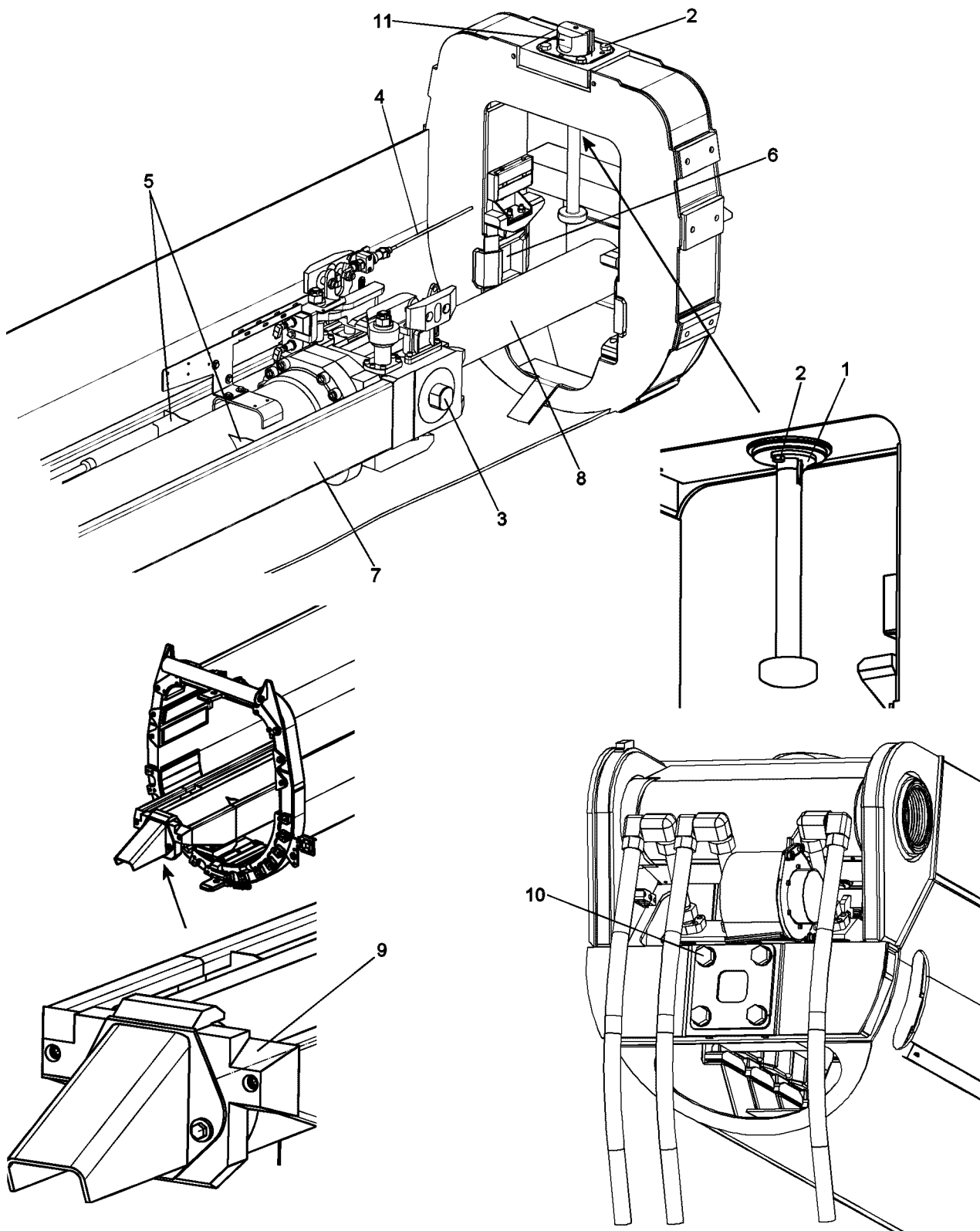

Fig.109286

- Inspection of the pull knob safety **1** and all mounting screws **2** for tight seating
- Inspection of twist guards of cylinder pinning **3** and the telescopic boom pinning **11**
- Inspection of the length sensor rope **4** for damage
- Inspection of the cylinder barrel in the area of all welding seams **5** for crack formation
- Inspection of the locking pockets **6** for damage

- Grease the guide rail **7**
- In case of leakage: Inspection of the piston rod **8** for grooves
- Inspection of the wear pattern on the cylinder pinning **3** and the telescopic boom pinning **11**
- Inspection of guide rail **7** for distortion of contour
- Inspection of plastic guide **9** on cylinder bottom for damage
- Inspection of all mounting screws **10** on the push out cylinder for tight seating

4 Inspection of safety ropes and anchor points

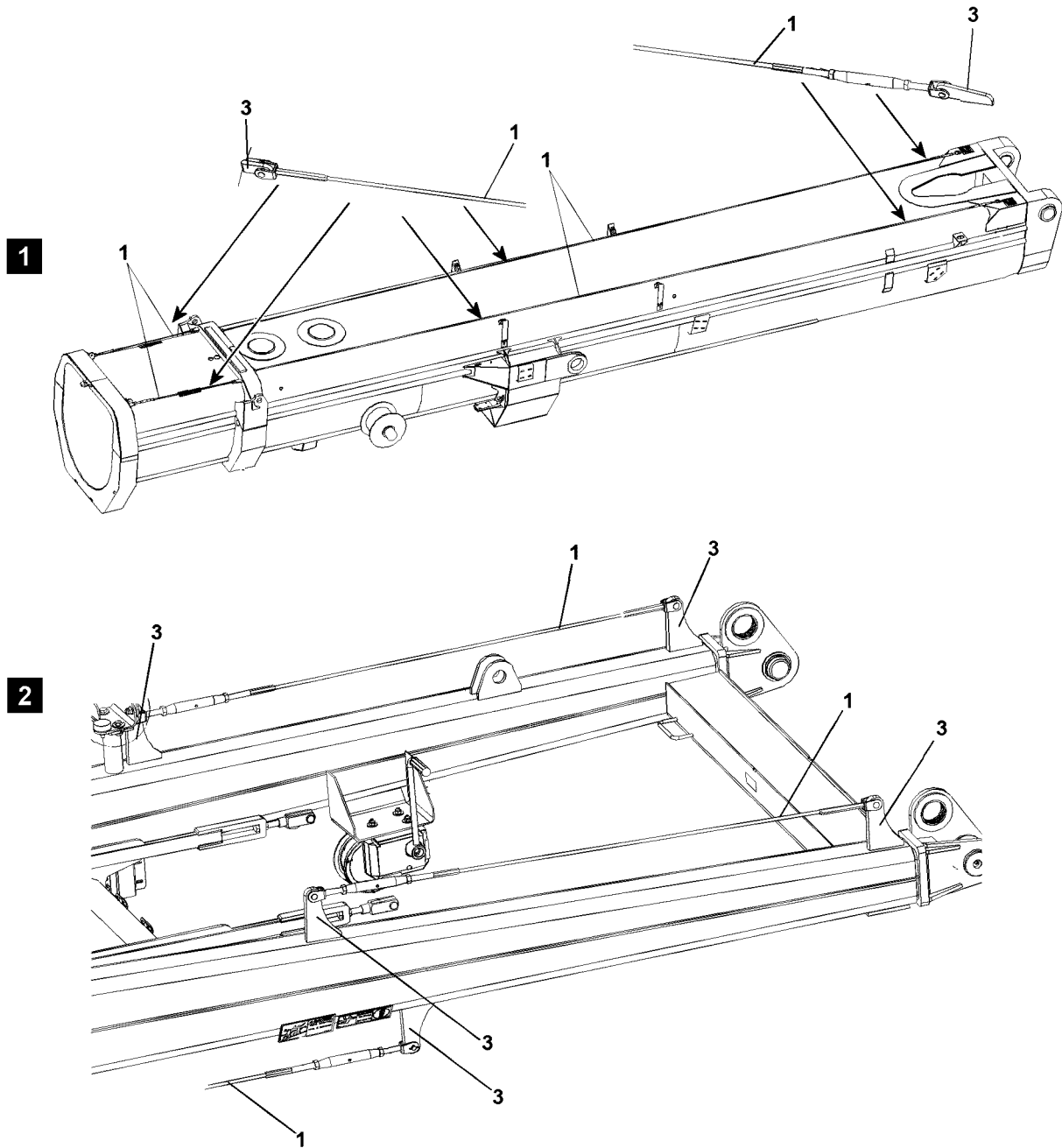

Fig.127130

**WARNING**

Danger of falls due to damaged safety ropes or anchor points!

The safety ropes **1** and anchor points **3** must be checked **at least once a year** by **authorized inspectors** for safety and damage!

If any defects are found on the safety ropes **1** or anchor points **3** during the inspections, then the safety ropes **1** or anchor points **3** must be replaced immediately by authorized and trained specialists! If this is not observed, assembly personnel could be killed or fatally injured in a fall!

- ▶ The rope pretension on the safety ropes must be 800 N !
- ▶ Have damaged safety ropes **1** or anchor points **3** replaced immediately by trained expert personnel!

**Note**

Document the inspections in writing!

- ▶ The scope and results of tests should be documented to permit reproducibility. This documentation forms part of the crane records and should be safely stored during the entire service life of the crane.

4.1 Checking of rope pretension on telescopic booms, illustration 1

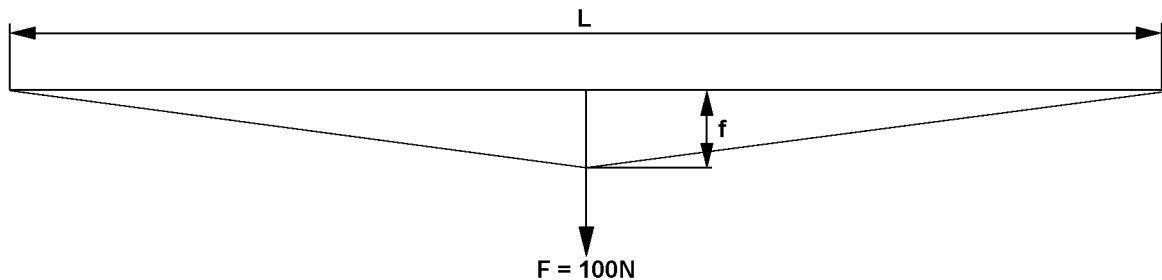

Fig.112738

The rope pretension must be 800 N. This can be checked with the aid of a spring balance, which is pulled centered on the safety rope. If the specified deflection (f) depending on the rope length (L) according to the following charts results for the raised load $F = 100\text{ N}$ then the rope pretension of 800 N is set correctly.

Rope pretension is 800 N if:					
Rope length (L)	1.0 m	1.5 m	2.0 m	2.5 m	3.5 m
Deflection (f)	15 mm	25 mm	30 mm	40 mm	55 mm

Rope pretension is 800 N if:					
Rope length (L)	5.5 m	7.5 m	9.5 m	11.5 m	13.5 m
Deflection (f)	85 mm	115 mm	145 mm	180 mm	215 mm

4.2 Inspection of rope pretension on lattice sections, illustration 2

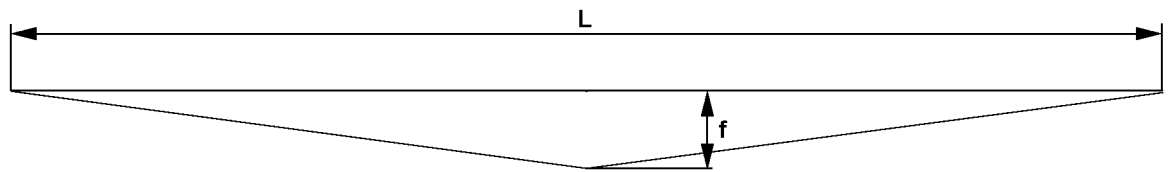

Fig.117747

The rope pretension is 800 N, if a sag (f) according to the chart is present on the safety rope according to the rope length (L).

Rope pretension is 800 N if:					
Rope length (L)	1.0 m	1.5 m	2.0 m	2.5 m	3.5 m
Deflection (f)	0	1 mm	2 mm	3 mm	6 mm

Rope pretension is 800 N if:					
Rope length (L)	5.5 m	7.5 m	9.5 m	11.5 m	13.5 m
Deflection (f)	15 mm	28 mm	45 mm	66 mm	90 mm

5 Inspection of load handling equipment and assembly aids



WARNING

Load handling equipment and / or assembly aids **not** inspected!
Death, severe bodily injuries, property damage.

► Inspect load handling equipment and / or assembly aids at least once a year.

The recurring inspection of the load handling equipment and / or assembly aids must be carried out once a year.

The inspections of load handling equipment and / or assembly aids must be recorded.

The welding seams must be subjected to a visual inspection.

Inspect load handling equipment and assembly aids for:

- Damage
- Wear
- Cracks

Replace damaged, worn or ripped load handling equipment and assembly aids immediately.

Repairs on load handling equipment and assembly aids may solely be made in consultation and under the instructions of the Customer Service at **Liebherr-Werk Ehingen GmbH** by authorized and trained expert personnel.



Note

- Document the scope of the inspection and the results in writing and comprehensibly.
- Save the documentation as a part of the crane records for the entire service life of the crane.

6 Inspection of fastening equipment



WARNING

Fastening equipment **not** inspected!
Death, severe bodily injuries, property damage.

- ▶ Inspect the fastening equipment at least once a year.

The recurring inspection of the fastening equipment must be carried out once a year.

The inspections of the fastening equipment must be recorded.

The welding seams must be subjected to a visual inspection.

Inspect the fastening equipment according to the specifications of the corresponding regulations and standards.

Replace damaged, worn or ripped fastening equipment immediately.



Note

- ▶ Document the scope of the inspection and the results in writing and comprehensibly.
- ▶ Save the documentation as a part of the crane records for the entire service life of the crane.

7 Inspection of diaphragm reservoir



Note

- ▶ The national regulations for pressurized container inspection must be observed!

The inspection of the diaphragm reservoir for specified gas pressure must be carried out by an **authorized inspector**, see chapter 7.04 and chapter 7.05.

8 Inspection of relapse cylinders



WARNING

Fatal accidents due to defective relapse cylinders!
Loss of oil or corrosion can damage the relapse cylinders!
Safe crane operation is no longer ensured!

- ▶ Crane operation with defective relapse cylinders is prohibited!

8.1 Pressure test of relapse cylinders

The relapse cylinders must be inspected annually by an **authorized inspector**. The purpose of the inspections is to avoid accidents by detecting deficiencies early on.

8.2 Checking the gas pressure and oil fill before operation



WARNING

Fatal accidents due to defective relapse cylinders!
Loss of oil or corrosion can damage the relapse cylinders!
Safe crane operation is no longer ensured!

- ▶ Before every start-up: Carry out a visual inspection for leaks, damage and corrosion on the relapse cylinders.
- ▶ If any defects are found, the relapse cylinders must be inspected by the cylinder manufacturer!

The gas pressure and the oil fill must be checked by an **authorized inspector** for pressure tanks.

8.3 Inspection of the safety controls on the relapse cylinders

Inspecting the interlocking system or limit switches on the relapse cylinders and the boom A-frames, see Chapter 8.12.

9 Inspection of rope pulleys

9.1 Checking for damage and cracks



DANGER

Danger of accident in case of damage or cracks!

- ▶ Replace rope pulley immediately!

Check the entire rope pulley assemblies for damage and cracks once a year.

If rope pulleys are subjected to any impacts (e.g., with buildings) or are otherwise overloaded, they must be visually inspected for damage or cracks immediately.

9.2 Checking the groove diameter

NOTICE

Worn rope pulleys!

The functionality and service life of the rope is reduced. Damage on rope.

- ▶ Before placing the rope, check the groove diameter of rope pulleys.

Visible wear on rope pulleys:

- Reduced groove diameter
- Negative impressions of the rope profile in the groove

Make sure that the following tools are available:

- Groove caliber

Make sure that the following prerequisites are met:

- All components to be inspected are cleaned.
- The rope does **not** obstruct the inspection of the components



Note

- ▶ The actual groove diameter **must** be larger than the actual diameter of the rope!

The groove diameter of rope pulleys and winches must be at least 6 % larger than the nominal rope diameter.

Check the rope pulleys with a groove caliber for wear. When wear exists on the rope grooves: Fix the rope pulleys or replace.

10 Inspection of carrier rollers

10.1 Checking visually



DANGER

Damaged carrier rollers!

Breakage and falling components. Death, severe bodily injuries, property damage.

- ▶ Carry out a visual inspection according to the maintenance intervals.
- ▶ Replace the carrier roller immediately.

The visual inspection must be carried out according to the following criteria:

- Wear
- Damage
- Cracks

Visible wear on carrier rollers:

- Negative imprints of the rope profile on the circumference of the carrier rollers
- Lead-in tracks

10.2 Checking the depth of the lead-in tracks



DANGER

Worn carrier rollers!

Breakage and falling components. Damage to ropes. Death, severe bodily injuries, property damage.

- ▶ Check the depth of the lead-in tracks.
- ▶ Replace worn carrier rollers immediately.

Make sure that the following prerequisites are met:

- All components to be inspected are cleaned.
- The rope does **not** obstruct the inspection of the components.

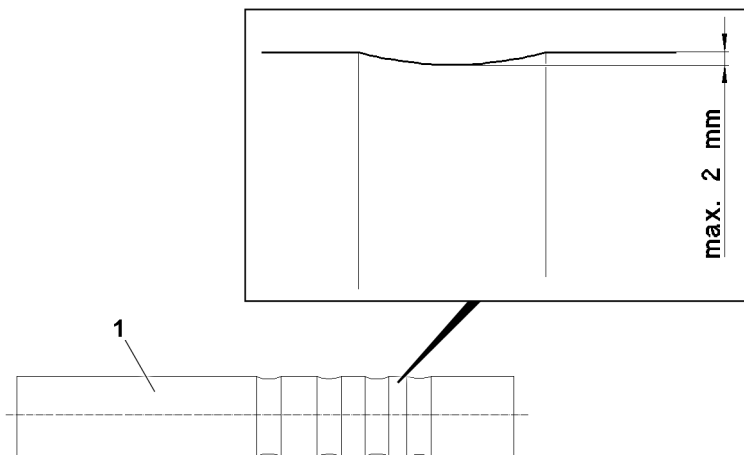

Fig.124864: Permissible depth of the lead-in tracks

1 Carrier roller

The depth of the lead-in tracks may be maximum 2 mm.

10.3 Checking bearings for easy movement

Stiff or blocked carrier rollers wear unevenly and cause serious rope abrasion.

Ineffective carrier rollers can lead to irregular rope tension.

Tasks to check the carrier rollers:

- Check the carrier rollers for proper movement in their bearings.
- When carrier rollers are **not** easily moveable in their bearings: Fix the bearings.

10.4 Checking the tightening torque

The tightening torque of screws must be checked according to maintenance interval.

11 Inspection of extension conditions of sliding beams

The extension conditions of the sliding beams must be inspected annually by an **authorized inspector**.

Check the extension conditions on every sliding beam:

- Check if the position 0 % of the LICCON display matches the actual condition of the sliding beam.
- Check if the position 100 % of the LICCON display matches the actual condition of the sliding beam.

12 Inspection of the function of the overload protection

Position the longest boom at minimum and maximum radius: Check the load indicator, using the hook block as a test load.

The display reading may not deviate by more than 10 % off the true load value at these two extreme positions.

Measure the indicated radius for the longest boom at its minimum radius and at a boom angle of 45°.

The indicator readings may not deviate more than 10 % off the measured boom radius.

13 Inspecting the pin connections



WARNING

Pin connections **not** inspected!

Death, severe bodily injuries, property damage.

- ▶ Inspect the pin connections at least once a year.

The recurring inspection of all pin connections must be carried out once a year.

The inspections of the pin connection must be recorded.

Check the pin connections for:

- Properly secured pin connections
- Damage to the pins and / or connector elements
- Damage to the retaining elements

Replace damaged pins immediately.

Immediately replace damaged, bent or broken retaining elements.

Only replace damaged pins with identical pins.

Only replace damaged retaining elements with identical retaining elements.



Note

- ▶ Document the scope of the inspection and the results in writing and comprehensibly.
- ▶ Save the documentation as a part of the crane records for the entire service life of the crane.

14 Inspection of slewing ring connection

14.1 Checking the tilt play

The wear of the slewing ring connection is determined by measuring the tilt play with the ring installed.

The permissible tilt play depends on the type of slewing ring connection.

**WARNING**

The tilt play of the slewing ring connection is too large!
If the permissible tilt play is exceeded, then safe crane operation is **no** longer possible.
Death, severe bodily injuries, property damage.

When the permissible tilt play is exceeded:

- ▶ Replace the slewing ring connection.

The determination of the tilt play must be carried out according to the **test instructions** of **Liebherr-Werk Ehingen GmbH**.

Request the test instructions and permissible tilt play: Contact Liebherr Service.

15 Inspection of the mounting of the load bearing equipment

15.1 Check the mounting screws for tight seating

The mounting screws must be checked for a tight fit during the annual crane inspection.

The mounting screws are pre-stressed at the factory, so that no loosening of the screw connections will occur during normal crane operation.

The screw connection may become overloaded and the mounting screws may be permanently stretched if the crane is overloaded or if the load is pulled free. The mounting screws must be checked immediately for a tight fit after an overload.

Check the tightening torque of the mounting screws of load bearing equipment for a tight fit:

- Slewing ring connection
- Winches
- Slewing gears
- Transmission
- Trailer coupling

If a mounting screw can be tightened, then the mounting screw is loose. Follow the instructions in section „Checking the mounting screws for damage“.

15.2 Checking the mounting screws for damage

Completely unscrew the loose mounting screws and check in detail for damage.

Completely unscrew the adjacent mounting screws and check in detail for damage.

Replace the mounting screw if any of the following damage is present:

- The mounting screw is stretched by more than 2 % (in relation to its original length).
- Cracks, permanent deformation or other damage is visible on the mounting screw.
- The mounting screw is uneven.
- There is pitting.
- The thread is hard to move.

If there is **no** damage, reuse the checked mounting screws (expansion screws) a maximum of two times.

16 Inspection of the tele extension with eccentric, illustration 1

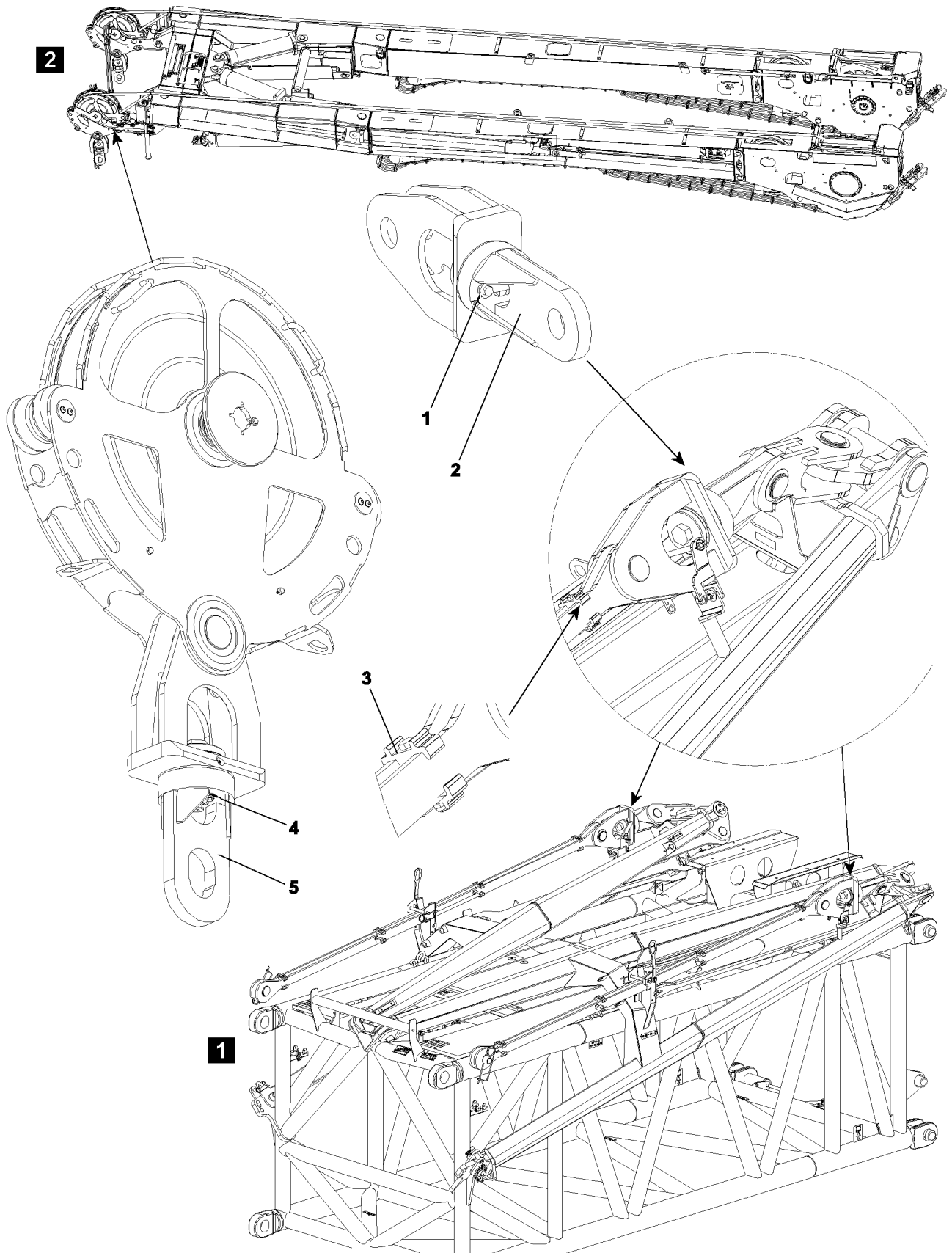

LWE/LR 11000-001/23501-04-02/en

Fig. 109096

- Inspection of twist guard **1** for damage and loose screw connection.
- Inspection of swivel **2** for easy turnability.
- Inspection of all clamps **3** for damage and function.

17 Inspection of change over pulleys, illustration 2

- Inspection of twist guard **4** for damage and loose screw connection.
- Inspection of swivel **5** for easy turnability.

18 Inspection of the oil and fuel tanks

Visually check the oil and fuel tanks at least once a year for leaks and safe mounting.

Repairs may only be carried out by authorized and trained specialists.

Improper repairs; e.g., welding, hard or soft soldering is not permitted, particularly if the Service department at Liebherr-Werk Ehingen GmbH has not been consulted!

8.03 Inspection of winches

1	Inspecting the hoist and retracting winches	3
2	Inspection of the auxiliary reeving winch, recovery winch and spare wheel winch	4
3	Monitoring the winches	5

Fig.195219

LWE/LR 11000-001/23501-04-02/en

1 Inspecting the hoist and retracting winches

The hoist and retracting winches are designed in sealed planetary gear version. These gears are sized for long service life and the drive shafts and gears are rated for endurance.

Even though the hoist and retracting winches are designed for long life, an external visual inspection is not adequate, since their life can be significantly affected by bad maintenance (insufficient oil), using oil that does not meet specification requirements, defective seals, improper operation or overloading.

The annual inspection must therefore be carried out by an **expert** in accordance with the following requirements.

The winches must be inspected by an **authorized inspector** every four years after the initial license.

Within the territorial validity of the BGV D6, after the 10th year in operation, counted from the first day of initial license, when the theoretical utilization time is not over, the winches must be checked annually by an **authorized inspector**.

1.1 Checking the groove diameter



WARNING

Worn winches!

Damage of flanged disks, high rope wear, operational problems. Broken rope, falling load.

► Before placing the rope, check the groove diameter of winches.

Visible wear on winches:

- Reduced groove diameter
- Mechanical damage, for example scrub marks or scouring on flanged disks

Make sure that the following tools are available:

- Groove caliber

Make sure that the following prerequisites are met:

- All components to be inspected are cleaned
- The rope does **not** obstruct the inspection of the components



Note

► The groove radius may **not** be smaller than the actual diameter of the rope.

The groove diameter of rope pulleys and winches must be at least 6 % larger than the nominal rope diameter.

Check winches with a groove caliber for wear. When wear is present: Fix the winch or replace.

1.2 Inspection intervals

At least once a year, see Crane operating instructions, chapter 7.03.

1.3 Checking the oil level

Check the oil level with the dipstick.

For hoist and retracting winches **without** a dipstick, we recommend that the oil is drained and the amount compared to the specified oil quantity.

1.4 Evaluating oil color

Assume that the oil has been overheated if it is black and / or a burnt oil smell is detected. Change the oil.

1.5 Checking for solid foreign substances

In general, the oil must be analyzed by a qualified laboratory.

For simple testing, the following procedure can be used:

- Drip the used oil on a specified filter fleece.
- Visual inspection with a magnifying glass may reveal coarse particles.
- If coarse particles are found: Have the components of the oil analyzed by a qualified laboratory.

NOTICE

Danger of property damage!

- ▶ Repairs may only be carried out by authorized and especially trained personnel.
 - ▶ Replace damaged parts and change the gear oil.
-

1.6 Visual inspection for leaks

The gears must be checked for leaks, since oil losses - in addition to polluting the environment - can lead to gear failure.

1.7 Inspecting the gear brakes

Check the brakes each time the gears are inspected.

In order to do so, proceed as follows:

- Attach a load, which creates 40 % of the maximum rope pull in the uppermost layer of the coil and raise it just off the ground.
- Remove the plug on the brake vent magnet.
This means the brake remains applied when activated.
- Activate the winch in the lowering direction.



Note

- ▶ The brake may not slip, in other words, the winch may not turn. If the brake slips, contact the Service department at Liebherr-Werk Ehingen GmbH!
 - ▶ Only operate the crane after it has been checked and approved for use by the Service department at Liebherr Werk Ehingen GmbH!
-

NOTICE

Danger of property damage!

- ▶ Only qualified personnel with specialized knowledge may be used to evaluate gears and brakes!
-

1.8 Documenting the completed inspection

The results of the annual inspections and maintenance work, including the steps taken, must be documented by the competent or authorized inspector, including attachments from the inspection labs and qualified service companies if applicable.

This documentation must be filed in the crane inspection log under the heading "Periodic inspections".

2 Inspection of the auxiliary reeving winch, recovery winch and spare wheel winch

The inspection of the auxiliary reeving winch, recovery winch and spare wheel winch regarding scope and content is made according to the manufacturer's instructions.

- Inspect the auxiliary reeving winch, recovery winch and spare wheel winch according to the manufacturer's instructions.

- Request data about the service life of the auxiliary reeving winch, recovery winch and spare wheel winch from the respective manufacturer.

3 Monitoring the winches

3.1 Theoretical service life

The designer of your crane used a theoretical total operating time when designing and sizing the winches. This resulted in the theoretical service life of the equipment.

The winches of your crane are classified according to ISO 4301/1 as follows:

Winches	Classification
Power train group:	M3
Load spectrum:	L1
Load spectrum factor Km:	0.125
Theoretical service life D:	3200 h



Note

- ▶ The „theoretic service life“ is not equal to the real (true) service life of a winch!

The actual life of the winch is affected by many additional outside factors; for example:

- Overloads caused by unapproved use of the crane.
- Inadequate maintenance: Oil is not changed in a timely manner
- Improper operation:
 - Extreme acceleration or deceleration of the load
 - Load falling into the ropes
- Maintenance errors:
 - Using the wrong type of oil
 - Too much or too little oil
 - Contamination during oil change
- Assembly errors during repair and maintenance
- Undetected leakage
- Incorrectly set safety equipment
- Hidden damage from accidents
- Extreme environmental conditions:
 - Extreme low or high temperatures
 - Corrosive atmosphere
 - Dust and dirt

3.2 Used proportion of the theoretical service life

The crane operator is obligated to carry out an inspection of the crane at least once a year.

At this time, the actually used part of the theoretical service life must also be calculated. If necessary, the crane operator must contract an authorized inspector.

For the determination of the used part of the theoretical service life, the actual operating conditions (load spectrum) and the hoist gear operating hours for each inspection interval are to be determined. The operator is responsible for the documentation in the crane inspection log.

3.2.1 Determining the operating conditions (load spectrum)

The load spectrum of the crane is divided into groups, please refer to ISO 4301/1.

Select one of the following load spectrums and record it in the crane inspection log for the respective inspection interval based on the actual operating conditions. A more precise determination of the load spectrum is permissible.

Load spectrum class: Light L1

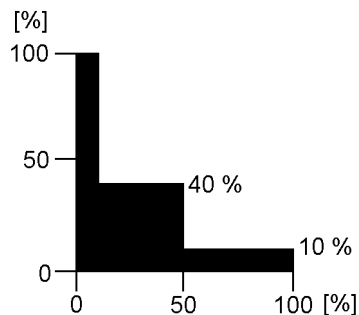

Fig.195234: Graphic illustration Load spectrum L1

Definition:

Power train or parts thereof are subjected to maximum stress only in exceptional cases, but normally only operate at very light loads.

Operating time rates:

- 10 % of the time at maximum load (dead load and 1/1 working load)
- 40 % of the time with dead load and 1/3 working load
- 50 % of the time only with dead load

Factor of load spectrum:

$K_m = 0.125$



Note

- Load spectrum L1 with load spectrum factor $K_m = 0.125$ is normally applied to cranes used for assembly operations!

Load spectrum class: Medium L2

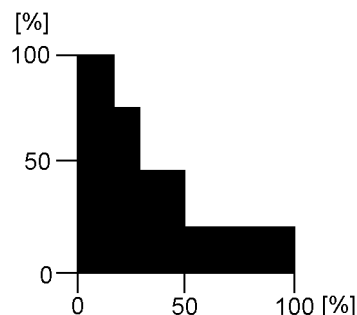

Fig.195235: Graphic illustration Load spectrum L2

Definition:

Power train or parts thereof are subjected to maximum load relatively often, but normally only operate at light load.

Operating time rates:

- 1/6 of the time at maximum load (dead load and 1/1 working load)
- 1/6 of the time with dead load and 2/3 working load

1/6 of the time with dead load and 1/3 working load
 50 % of the time only with dead load

Factor of load spectrum:
 $K_m = 0.25$

Load spectrum class: Heavy L3

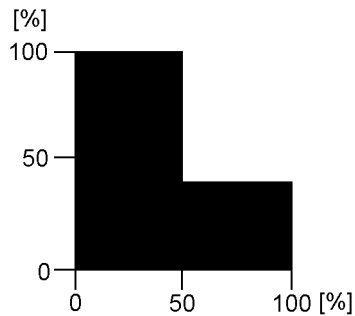

Fig.195236: Graphic illustration Load spectrum L3

Definition:

Power train or parts thereof are frequently subjected to maximum load and normally operate at medium load.

Operating time rates:

50 % of the time at maximum load (dead load and 1/1 working load)
 50 % of the time only with dead load

Factor of load spectrum:
 $K_m = 0.5$

Load spectrum class: Very heavy L4

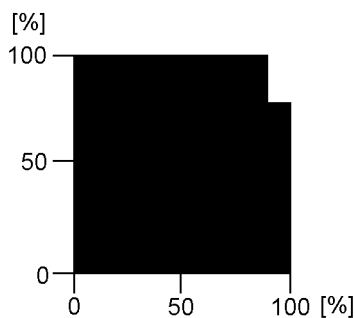

Fig.195237: Graphic illustration Load spectrum L4

Definition:

Power train or parts thereof are regularly subjected to near maximum loads.

Operating time rates:

90 % of the time at maximum load (dead load and 1/1 working load)
 10 % of the time only with dead load

Factor of load spectrum:
 $K_m = 1$

3.2.2 Determining the effective operating hours T_i

The effective operating hours calculated as follows must be entered into the crane inspection log for the respective inspection interval.

There are four different scenarios:

1. Operating hour meter installed on every winch.
If an operating hour meter is installed on every winch, the effective operating hours T_i can be read directly during each inspection.
2. Operating hour meter installed for the overall crane drive.
The winch proportion of the total superstructure operating hours must be estimated.
For cranes used in assembly operations, the operating time for the hoist winches can be estimated generally at 20 % of the total operating hours of the superstructure.
3. One operating hour meter is used for both the crane engine and the crane drive
The winch proportion of the total crane operating hours must be estimated.
For cranes used in assembly operations, the operating time for the superstructure can be estimated at 60 % of the total operating hours of the crane. If the hoist winch proportion is estimated at 20 % of the superstructure operating hours (see previous item), then the result in relation to the **total** operating hours of the crane is: 12 %.
4. No operating hour meter installed.
In this case, the operator must estimate and document the actual operating hours of the winch.
The approximate percentages stated above normally apply to main hoist winches. For auxiliary hoist winches or boom control winches, the proportion of the total operating hours can be significantly less and should therefore be estimated by the operator.

3.2.3 Determining the used proportion of the theoretical service life

For an inspection interval i (max. 1 year), the actually used proportion S_i of the theoretical Service life is derived from the formula:

$$S_i = \frac{K_{m_i}}{K_m} \times T_i$$

Fig.195230

Abbreviation	Explanation
S_i	Used proportion of the theoretical service life.
K_m	Load spectrum factor that was used to calculate the winch rates. This factor is provided in the Operating instructions.
K_{m_i}	Load spectrum factor for inspection interval i according to section „Determining the operating conditions“.
T_i	Effective operating hours for inspection interval i according to section „Determining the effective operating hours T_i “.

The actually used proportion is subtracted from the remaining theoretical service life D_i after each inspection interval (see example).

If the remaining theoretical service life is not long enough to cover the next projected operating period, a general overhaul of the winch is required.

If the theoretical service life D has been reached (see chapter on „Theoretical service life“), then the winch may only be operated after conducting a general overhaul.

A general overhaul of the winch is required not later than 10 years after commissioning.

The general overhaul must be arranged by the operator and carried out by the manufacturer or the manufacturer's authorized representatives and must be documented in the inspection log. After the

general overhaul, the manufacturer or the manufacturer's authorized representative will define a new theoretical service life D.

When the design life has not been reached after 10 years, continued operation of the winch without a general overhaul is acceptable, when the crane's authorized inspector has confirmed the accuracy of the actual usage calculation by signing the crane inspection log at each authorized inspection interval.

In such a case, the authorized crane inspector must thoroughly inspect the winch. This comprises at least:

- External visual inspection (leakage, damage, deformation, etc.).
- Oil check, especially for metal residues.
- Load test at minimum and maximum rope tension and at maximum possible speed in both cases. At least one layer must be spooled up. Pay particular attention to any unusual noises during this load test.

The authorized crane inspector must confirm this inspection in the crane inspection log and must make a statement regarding suitability of the winch for continued operation. The next inspection must take place at the end of the 12th operating year and annually thereafter.

3.3 Example

According to the manufacturer's operating manual, a mobile crane with a separate operating hour meter for the crane engine and the crane drives is classified as follows:

- Power train group: M3
- Load spectrum class: Light L1
- Factor of load spectrum: $K_m = 0.125$
- Theoretical service life: $D = 3200$ h

Actual usage proportion S of the theoretical service life is calculated using the individual inspection intervals as follows:

3.3.1 First inspection (first year)

The crane was used for assembly work during the past year:

Load spectrum L1, in other words $K_{m1} = 0.125$.

The superstructure operating hour meter indicates 800 h. The winch was operated about 20 % of the time; i.e. $T_1 = 160$ h.

The actual usage proportion S of the theoretical service life at the time of the first inspection is therefore:

$$S_1 = \frac{0,125}{0,125} \times 160 \text{ h} = 160 \text{ h}$$

Fig.195231

Remaining theoretical service life:

$$D_1 = 3200 \text{ h} - 160 \text{ h} = 3040 \text{ h}$$

The above values are recorded in the crane inspection log.

3.3.2 Second inspection (second year)

The crane was used at a harbor for unloading work:

Load spectrum L3, in other words $K_{m2} = 0.5$.

The superstructure operating hour meter indicates 2000 h ; i.e., during this period:

2000 h – 800 h = 1200 h (800 h were used in the first year of operation)

The winch was operated about 40 % of the time; i.e. $T_2 = 480$ h.

The actual usage proportion S_2 of the theoretical service life at the time of the second inspection is therefore:

$$S_2 = \frac{0,5}{0,125} \times 480 \text{ h} = 1920 \text{ h}$$

Fig.195232

Remaining theoretical service life:

$$D_2 = 3040 \text{ h} - 1920 \text{ h} = 1120 \text{ h}$$

3.3.3 Third inspection (third year)

The crane was used for assembly work and occasionally at a harbor for unloading work:

Load spectrum L2, in other words $Km_3 = 0.25$.

The superstructure operating hour meter indicates 3000 h ; i.e., during this period:

$$3000 \text{ h} - 2000 \text{ h} = 1000 \text{ h} \text{ (2000 h were used in the first two years of operation)}$$

The winch was operated about 30 % of the time; i.e. $T_3 = 300 \text{ h}$.

The actual usage proportion S_3 of the theoretical service life at the time of the third inspection is therefore:

$$S_3 = \frac{0,25}{0,125} \times 300 \text{ h} = 600 \text{ h}$$

Fig.195233

Remaining theoretical service life:

$$D_3 = 1120 \text{ h} - 600 \text{ h} = 520 \text{ h}$$

3.4 Chart for determining the theoretically remaining service life

Chart 1 includes an example.

The remaining theoretical service life is to be documented in chart 2.

LWE/LR 11000-001/23501-04-02/en

Chart to determine the remaining theoretical service life of winch No. 1 (Main hoist winch)

Crane type: LTM 1050
 Fabrication No.: 0010 540 08
 Put in service: 12345
 Serial number of winch according to data tag: 0815
 Last general overhaul performed on:
 Configuration data of winch (see Operating Manual):
 Drive gear group: M 3
 Load collective: L 1
 Factor of load collective Km: 0.125
 Theoretical service life D: 3200 hrs.

S_i = Used part of theoretical service life since last inspection
 D_i = Remaining theoretical service life
 D_{i-1} = Remaining theoretical service life after previous inspection
 Km = Factor of load collective, which was taken for calculation of winch.
 This factor is to be taken from the Operating Manual
 Km_i = Factor of load collective in inspection interval i
 T_i = Effective operating hours in inspection interval i

(*) In the following pages, carry over the last line from the previous page.

Inspection interval No. (max. annually)	Date of initial service data of inspection	Operating conditions since last inspection (load collective)	Factor of load collective	Total crane operating hours	Operating hours of super-structure	Operating hours of super-structure since last inspection	Operating hours of winch	Operating hours of winch since last inspection T_i	Used part of theoretical service life D_i : $S_i \times \frac{Km_i}{Km} \times T_i$	Remaining theoretical service life $D_i = D_{i-1} - S_i$	Name of inspector	Signature	Remarks	Name of expert	Signature
(*) 0	10.06.90	-	-	-	0	-	-	-	0	3200					
1	05.06.91	L1	0,125	-	800	800	-	160 (20% of 800)	160	3040	Müller				
2	20.05.92	L3	0,5	-	2000	1200	-	480 (40% of 1200)	1920	1120	Huber				
3	18.05.93	L2	0,25	-	3000	1000	-	300 (30% of 1000)	600	520	Mater				
4															

CAUTION: Perform general overhaul at least once every 10 years! In case of deviation, see guidelines in this chapter.

General overhaul last performed on :

Fig.121551-en: Chart 1

Chart to determine the remaining theoretical service life of winch No.

- Crane type:
 - Fabrication No.:
 - Put in service:
 - Serial number of winch according to data tag:
 - Last general overhaul performed on:
 - Configuration data of winch (see Operating Manual):
 - Drive gear group: M.....
 - Load collective: L.....
 - Factor of load collective Km:
 - Theoretical service life D:
-
- S_i = Used part of theoretical service life since last inspection
 - D_i = Remaining theoretical service life
 - D_{i-1} = Remaining theoretical service life after previous inspection
 - Km = Factor of load collective, which was taken for calculation of winch.
 - This factor is to be taken from the Operating Manual
 - Km_i = Factor of load collective in inspection interval i
 - T_i = Effective operating hours in inspection interval i
- *) In the following pages, carry over the last line from the previous page.

Inspection interval No. (max. annually)	Date of initial service data of inspection	Operating conditions since last inspection (load collective)	Factor of load collective	Total crane operating hours	Operating hours of super-structure	Operating hours of super-structure since last inspection	Operating hours of winch	Operating hours of winch since last inspection T_i	Used part of theoretical service life $D: \frac{S_i}{Km_i} \times T_i$	Remaining theoretical service life $D_i = D_{i-1} - S_i$	Name of inspector	Signature	Remarks	Name of expert	Signature
i			Km_i	[h]	[h]	[h]	[h]	[h]	[h]	[h]					
(*)															

CAUTION: Perform general overhaul at least once every 10 years! In case of deviation, see guidelines in this chapter.

General overhaul last performed on :

LWE/LR 11000-001/23501-04-02/en

Empty page!

LWE/LR 11000-001/23501-04-02/en

8.04 Inspection of crane wire ropes

1	Crane ropes	3
2	Importance of inspection	3
3	Personal protective equipment	3
4	Qualification Inspection personnel	3
5	Unscheduled inspection	3
6	Intervals	4
7	Areas	4
8	Documenting inspection results	5
9	Wire ropes and rope end connections	5
10	Degree of severity	7
11	Abbreviations Rope diameter	7
12	Distortions and mechanical damage	8
13	Removal criteria Overview	8
14	Checking for broken strands	9
15	Determining the number of broken wires	9
16	Checking the rope end connection	14
17	Checking of rope diameter	14
18	Corrosion	17
19	Corkscrew-like distortion	19
20	Basket formation	20
21	Protruding, distorted insert or strand	21
22	Loop formation	22
23	Kinking or rope loops pulled closed	23
24	Buckles	24
25	Effects of heat, arcs	25
26	Combined degree of severity	25
27	Flattenings	25
28	Current checklist	28

Fig.195219

LWE/LR 11000-001/23501-04-02/en

1 Crane ropes

This chapter applies, for example, for the following crane ropes:

- Hoist ropes
- Control ropes for the boom system
- Control ropes of the telescopic boom with rope mechanism: Pull-out ropes and return ropes
- Guy ropes for boom system

2 Importance of inspection

Rope removal criteria: If severe damage reduces the operational safety, then the rope has reached the removal criteria.

The importance of regular inspections is demonstrated by:

- Evaluation of operational safety of ropes
- Determination of rope removal criteria
- Determination of next inspection

3 Personal protective equipment



WARNING

Wires and lubricant!

Severe injury and skin irritation.

- ▶ When working with ropes, always wear work gloves.



WARNING

Protective equipment **not** worn!

Severe injuries.

- ▶ Wear hard hat, safety shoes and safety glasses.

4 Qualification Inspection personnel

Make sure that the following prerequisites are met:

- Inspection personnel are **expert personnel for crane rope inspection**.
- **Expert personnel for crane rope inspection:**
 - Are trained in the inspection of crane ropes according to **DIN ISO 4309** and have practical experience in the evaluation of rope removal criteria.
 - Have practical experience in the evaluation of rope removal criteria according to **DIN ISO 4309**.
- The inspection personnel is assigned (authorized) for the maintenance by the crane operator.

5 Unscheduled inspection

In the following situations the rope must be inspected:

- After unusual strain
- If non-visible damage is suspected
- when a rope or the rope end connection is damaged
- when the rope has been placed again after removal
- when the rope has been out of service for longer than three months

6 Intervals

Intervals for crane inspection:

- according to determination by **expert personnel for crane rope inspection**
- or **at least once a year**



Note

- ▶ Shortening the inspection interval: The older a rope is the more frequently will wire breaks occur.

Determining factors for determination of inspection intervals are:

- Legal regulations in the country where the crane is operated
- Climate conditions under which the rope drive is utilized
- Power train group
- Results of previous inspections on current or comparable machine and under comparable operating conditions
- Frequency and type of use of a rope
- Service life of rope

7 Areas



WARNING

Broken wires and distortions on ropes in cross over areas!

Rope performance can be greatly reduced. Rope breakage. Death, severe injuries, property damage.

- ▶ Inspection rope cross over areas especially diligently.

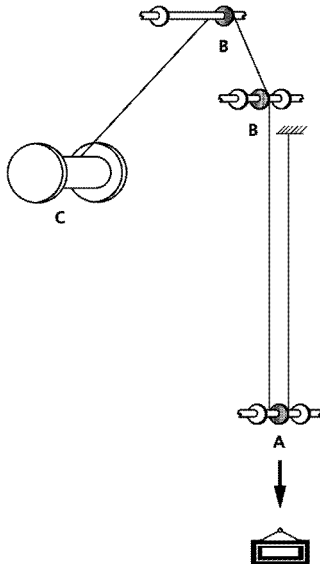

Fig.120969: Important inspection areas for multi layer spooled up ropes

- | | |
|---|---|
| <p>A Rope sections, which run in the area of the load rise into the lower rope pulleys (the load is raised here).</p> <p>B Rope intake on the first rope pulley in the area of the load rise.</p> | <p>C Rope sections, which are subjected in the cross over areas to the strongest effects (maximum deflection angle).</p> |
|---|---|

The rope must be checked over the entire length.

The following areas must be checked with special diligence:

- Rope end connections
- Safety coils and fixed point on the winch
- Areas of the rope which run through the hook block.
- Areas of the rope that run over the rope pulleys or lay on the rope pulleys.
- Areas of the rope that are spooled on the winch, especially cross over areas.
- Areas of the rope which are laying above the compensation pulleys.
- Areas of the rope which are subjected to abrasion due to external components.
- All areas of the rope that are subjected to temperatures above 60 °C.

8 Documenting inspection results



Note

- ▶ Document the results of the inspections in an inspection checklist.
- ▶ Form for an inspection checklist, see section „Current checklist“.

9 Wire ropes and rope end connections



WARNING

Wire rope with impermissible rope end connection!

The wire rope can fail. The load can fall down.

Death, severe bodily injuries, property damage.

- ▶ Select the permissible rope type for the respective application.
- ▶ Select the permissible rope end connection for the respective rope type.
- ▶ Observe and adhere to the warning display on the lock.

Wire rope application	Rope type
Hoist rope	Rotation-resistant rope
Guy rope or control rope	Non-rotation resistant rope
Auxiliary rope or assembly rope	Non-rotation resistant rope

Rope type depending on the application

The type of rope that is selected determines the corresponding rope end connections.

9.1 Rotation-resistant ropes with rope end connections

Use rotation-resistant ropes as **hoist ropes**.

Rotation-resistant ropes are special ropes that produce extremely little torque and twisting at the rope end connection when they are under strain.

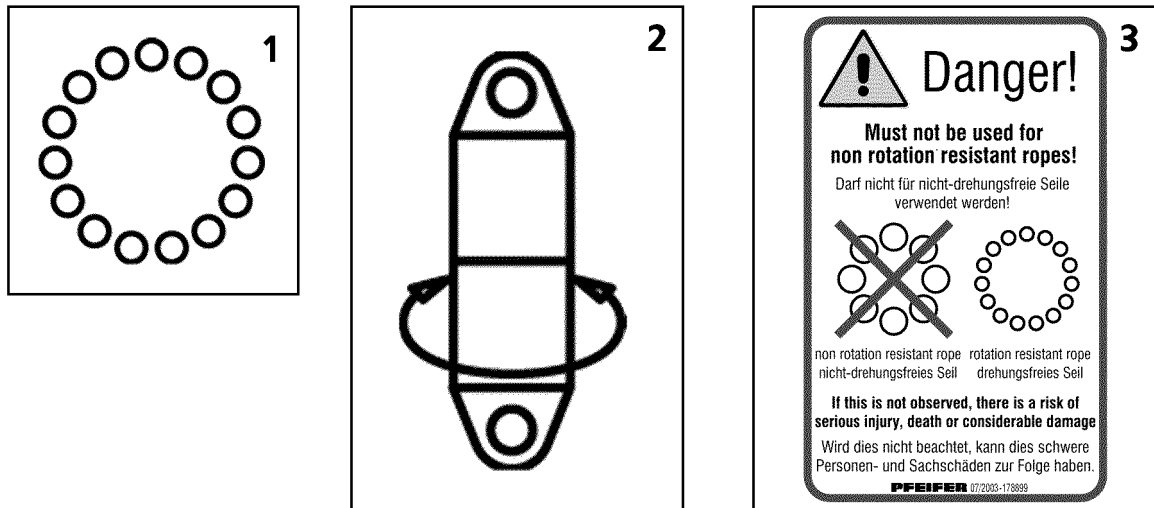

Fig.195653: Symbols for rotation-resistant ropes with rope end connections

- 1 Rotation-resistant rope symbol 3 Warning display on the PFEIFER lock
 2 Rotating rope end connection symbol

Typical rotation-resistant rope structures are wire ropes with 15 to 18 outer strands. Rotation-resistant ropes are symbolically depicted with 15 outer strands (circles), see illustration 1.

9.1.1 Non-rotating rope end connection



Note

- In the case of a rotation-resistant ropes, Liebherr recommends the use of a lock **without** a swivel or a wedge lock. This can reduce the stress on the hoist ropes.

9.1.2 Rotating rope end connection



Note

- In the case of rotation-resistant ropes, Liebherr recommends **not** using a lock **with** a swivel and **not** to use a twist compensator / swivel.

To reduce a problematic turning behavior, the following rope end connections can be used in an individual case and after consultation with Liebherr customer service:

- Lock **with** swivel
- Twist compensator / swivel

9.2 Non-twisting ropes with rope end connections



WARNING

Wire rope with impermissible rope end connection!

The wire rope can fail. The load call fall down.

Death, severe bodily injuries, property damage.

- Use a lock **without** a swivel or a wedge lock.
- **Never** use a lock **with** a swivel with non-twisting rope.
- **Never** use a twist compensator / swivel with a non-twisting rope.

Use non-twisting ropes as **guy ropes** or **control ropes**, **auxiliary ropes** or **assembly ropes**.

Non-twisting ropes generate high torque levels on the rope end connection under strain. For this reason, the rope ends must be protected from twisting using an appropriate rope end connection to prevent the wire rope from unscrewing under strain.

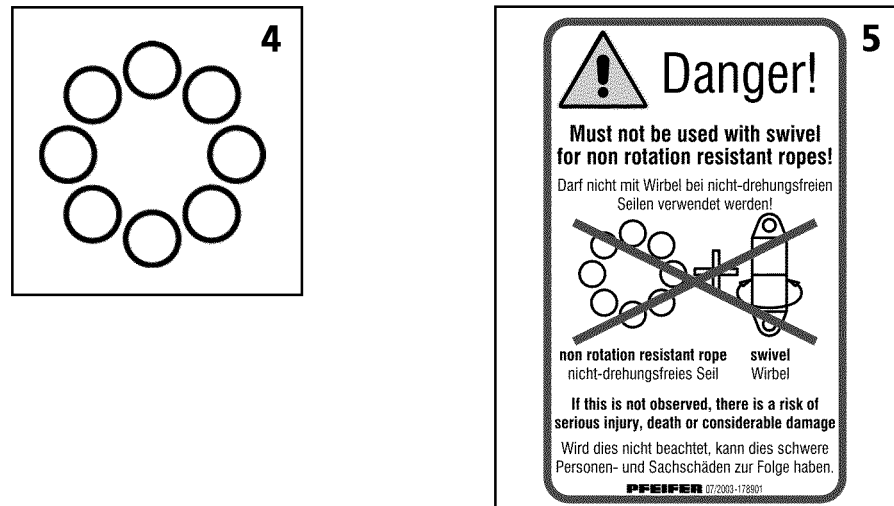

Fig.195654: Symbols for non-twisting ropes with rope end connections

4 Non-twisting rope symbol

5 Warning display on the PFEIFER lock / wedge lock

Typical non-twisting rope structures are wire ropes with eight or ten outer strands. Non-twisting ropes are symbolically depicted with eight outer strands (circles), see illustration 4.

Only use non-twisting ropes with the following **non-twisting** rope end connections:

- Lock **without** swivel
- Wedge lock

A non-rotating rope end connection is also the mounting of the rope on the fixed point of the winch drum.

10 Degree of severity

The deciding factor for the removal criteria is which removal criteria are present and to which degree they occur.

When various removal criteria are **not** present to a full degree, then the removal criteria must be evaluated as a total entity. For every individual removal criteria a degree of severity must be determined (percentage value).

For a certain rope section the sum of individual degrees of severity results in a **combined degree of severity**, see section „Combined degree of severity“.

When the combined degree of severity is more than 100 %, then the rope must be taken down.

11 Abbreviations Rope diameter

Abbreviations	Description
Rope nominal diameter d	Rope diameter, identification of rope
Reference diameter d_{ref}	Measured rope diameter of a straight rope section, directly after placing the rope
6d	Length of 6-fold rope nominal diameter
30d	Length of 30-fold rope nominal diameter

Abbreviations Rope diameter

12 Distortions and mechanical damage



WARNING

Distortions and mechanical damage!

Operational safety significantly disturbed, uneven load distribution within the rope.

- ▶ Have the manufacturer check if the distorted and damaged area can be severed.

Visible form changes often occur localized or in short rope sections.

When a safe operation of the rope is ensured, a distorted and damaged area can be severed.

13 Removal criteria Overview

The following chart provides an overview between removal criteria and the respective method for inspection. The degree is described, when the removal criteria is reached.

The removal criteria is described in detail in the subsequent sections.



Note

When the rope for parallel operation has reached the removal criteria:

- ▶ Often, both ropes must be replaced. The new rope has a larger diameter and other elongation characteristics.

Removal criteria	Degree for removal criteria	Inspection method
Broken strands	One strand is broken	Visual check
Broken wires on ropes, which run over rope pulleys and are spooled in multiple layers	Maximum number of broken wires reached, see Section Determining the number of broken wires	Count
Broken wire in the strand valleys	Two or more broken wires in strand valleys, on the contact points of two neighboring strands within an angular length (corresponds approx. to 6d)	Count
Broken wires in the area of the rope end connection	Two or more broken wires, according to decision of expert personnel for crane rope inspection	Visual inspection, test with marlin spike
Broken wire nests	On occurrence	Visual check
Reduction rope diameter at even diameter reduction	Maximum reduction of rope diameter reached	Measurement, calculation
Localized increase of rope diameter	Maximum increase of rope diameter reached	Measurement
Significant corrosion	Surface of rope is significantly affected or rust film emerges, according to decision of expert personnel for crane rope inspection	Visual check
Corkscrew-like distortion	Maximum permissible distortion reached	Measurement, calculation
Basket formation	On occurrence	Visual check
Wires or bunches of wires protruding from the rope	On occurrence, if more than one wire protrudes from the rope	Visual check

Removal criteria	Degree for removal criteria	Inspection method
Flattenings	Larger than half of the diameter of the outer strand, according to decision of expert personnel for crane rope inspection	Visual check
Loop formation	Loops on several wires	Visual check
Kinking or remaining distortion	On occurrence	Visual check
Buckles or contusions	On occurrence, according to decision of expert personnel for crane rope inspection	Visual check
Heat influence, electric voltage	Bluish discoloration, broken or melted wires	Visual check
Damage on rope end connections: Material cracks, deformation, wear, corrosion, traces of slipping between the locking clamp and rope	According to decision of expert personnel for crane rope inspection	Visual inspection
Combined degree of severity	Degree of severity 100 % or above, according to decision of expert personnel for crane rope inspection	Calculation of individual degrees of severity

Removal criteria Overview

14 Checking for broken strands

A strand consists of several individual wires.

If a complete strand is broken:

- ▶ Take the rope down.

15 Determining the number of broken wires

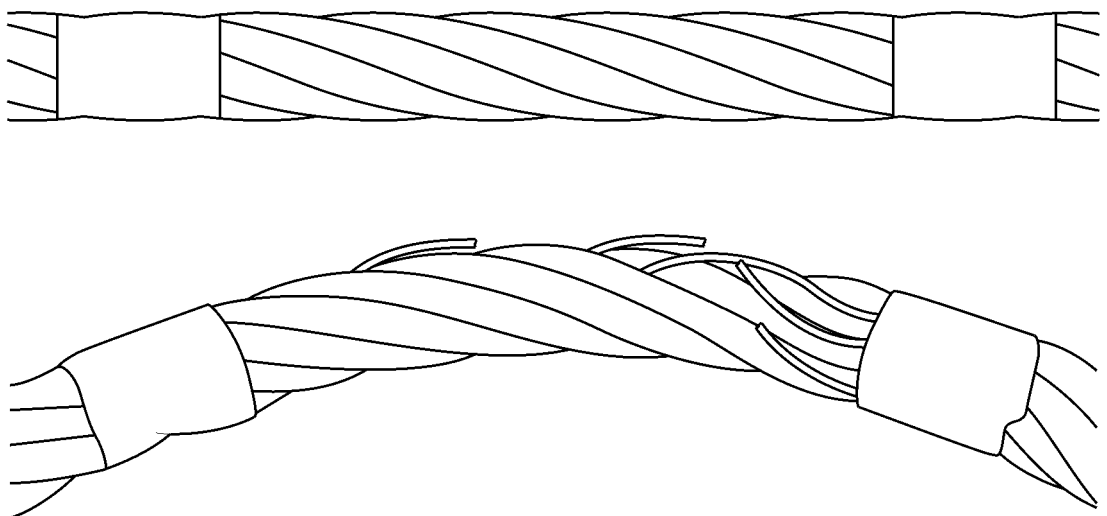

Fig.120980: Determine broken wires by bending

By bending the rope, broken wires can be recognized better.

Make sure that the following prerequisites are met:

- The rope is clean.
- Inspection checklist is on hand.

15.1 Scattered occurring broken wires

The following different rope types each have their own chart for the permissible number of broken wires:

- Single layer and parallel roped ropes
- Rotation resistant ropes

The charts in this section are valid exclusively for **scattered occurring broken wires**.

15.1.1 Wire break increase rate

The wire break increase rate is an increase of broken wires, which can skyrocket with increasing use of the rope.

- Include the inspection checklists for the previous inspection and use it to draw a conclusion for the wire break rate increase.

15.1.2 Single layer and parallel roped ropes

Rope category number RCN	Total number of load carrying wires in the outer strand layer of rope ¹ n	Number of visible outer wire breaks ²					
		Rope sections, which run over steel pulleys and / or spool up on a single layer spooling drum (coincidental distribution of broken wires)				Rope sections, which spool up on a multi layer drum ³	
		Class M1 to M4, or class unknown ⁴				All classes	
		Lang lay		Even lay		Lang lay and even lay	
		Over a length of 6d ⁵	Over a length of 30d ⁵	Over a length of 6d ⁵	Over a length of 30d ⁵	Over a length of 6d ⁵	Over a length of 30d ⁵
01	$n \leq 50$	2	4	1	2	4	8
02	$51 \leq n \leq 75$	3	6	2	3	6	12
03	$76 \leq n \leq 100$	4	8	2	4	8	16
04	$101 \leq n \leq 120$	5	10	2	5	10	20
05	$121 \leq n \leq 140$	6	11	3	6	12	22
06	$141 \leq n \leq 160$	6	13	3	6	12	26
07	$161 \leq n \leq 180$	7	14	4	7	14	28
08	$181 \leq n \leq 200$	8	16	4	8	16	32
09	$201 \leq n \leq 220$	9	18	4	9	18	36
10	$221 \leq n \leq 240$	10	19	5	10	20	38
11	$241 \leq n \leq 260$	10	21	5	10	20	42
12	$261 \leq n \leq 280$	11	22	6	11	22	44

LWELR 11000-001/23501-04-02/en

Rope category number RCN	Total number of load carrying wires in the outer strand layer of rope ¹ n	Number of visible outer wire breaks ²					
		Rope sections, which run over steel pulleys and / or spool up on a single layer spooling drum (coincidental distribution of broken wires)				Rope sections, which spool up on a multi layer drum ³	
		Class M1 to M4, or class unknown ⁴				All classes	
		Lang lay		Even lay		Lang lay and even lay	
		Over a length of 6d ⁵	Over a length of 30d ⁵	Over a length of 6d ⁵	Over a length of 30d ⁵	Over a length of 6d ⁵	Over a length of 30d ⁵
13	281 ≤ n ≤ 300	12	24	6	12	24	48
	n > 300	0.04 x n	0.08 x n	0.02 x n	0.04 x n	0.08 x n	0.16 x n

Note: Ropes with outer strands in the Seale type, number of wires per strand 19 or less (for example 6 × 19 Seale), are classified in this chart as two lines over the line, which would be defined due to the number of load carrying wires in the outer strands.

Number of visible broken wires (reached or exceeded) for removal criteria is reached, for **single-layer** and **parallel roped ropes** according to **DIN ISO 4309**

- 1) For the purpose of this international standard, fill wires are not considered to be load carrying wires and are not included in the value for n.
- 2) A broken wire has two ends (counted as one wire).
- 3) The values apply for damage in the cross over areas and the layers of coils due to deflection angles (not for rope sections, which run only over rope pulleys and do not spool up on the winch).
- 4) For ropes on drive gears of groups M5 to M8 twice the number of broken wires listed can be used.
- 5) d = Rope nominal diameter

- ▶ Check the rope over the entire length for visible broken wires.

When visible broken wires are scattered present:

- ▶ On the point of a broken wire, mark the rope sections on a length of 30d in both directions.
- ▶ Count visible broken wires in the marked rope sections and record them.
- ▶ Take the RCN (Rope category number) from the manufacturer's documentation of the rope.

When the make for single layer and parallel roped ropes is **not** listed in the chart:

- ▶ Determine the total number of load carrying wires in the rope: Add all wires in the strands of the outer layer, do **not** count fill wires.
- ▶ Compare the number of broken wires of each marked rope section 30d with the number of broken wires in the chart.

When the number of visible broken wires is smaller than listed in the chart:

- ▶ Within the rope section with the most broken wires: Mark the rope section with the most broken wires on a length of 6d.
- ▶ Count visible broken wires in the marked rope sections 6d and record them.
- ▶ Compare the number of broken wires of the marked rope section with the number of broken wires in the chart.

When the number of visible broken wires is equal to or larger than that listed in the chart:

- ▶ Take the rope down.
- ▶ Enter the results in the inspection checklist.

15.1.3 Rotation resistant ropes

Rope category number RCN	Total number of load carrying wires in the outer strands of rope ¹ n	Number of visible outer wire breaks ²			
		Rope sections, which run over steel pulleys and / or spool up on a single layer spooling drum (coincidental distribution of broken wires)		Rope sections, which spool up on a multi layer drum ³	
		Over a length of 6d ⁴	Over a length of 30d ⁴	Over a length of 6d ⁴	Over a length of 30d ⁴
21	4 strands $n \leq 100$	2	4	2	4
22	3 or 4 strands $n \geq 100$	2	4	4	8
	At least 11 strands in the outer layer				
23-1	$71 \leq n \leq 100$	2	4	4	8
23-2	$101 \leq n \leq 120$	3	5	5	10
23-3	$121 \leq n \leq 140$	3	5	6	11
24	$141 \leq n \leq 160$	3	6	6	13
25	$161 \leq n \leq 180$	4	7	7	14
26	$181 \leq n \leq 200$	4	8	8	16
27	$201 \leq n \leq 220$	4	9	9	18
28	$221 \leq n \leq 240$	5	10	10	19
29	$241 \leq n \leq 260$	5	10	10	21
30	$261 \leq n \leq 280$	6	11	11	22
31	$281 \leq n \leq 300$	6	12	12	24
	$n > 300$	6	12	12	24

Note: Ropes with outer strands in Seale type, number of wires in each strand 19 or less (for example 18 × 19 Seale - WSC), are classified in this chart as two lines over the line, which would be defined due to the number of load carrying wires in the outer strands.

Number of visible broken wires (reached or exceeded) is achieved in the rope removal criteria, for **rotation-resistant** ropes according to **DIN ISO 4309**

1) For the purpose of this international standard, fill wires are not considered to be load carrying wires and are not included in the value for n.

2) A broken wire has two ends (counted as one wire).

3) The values apply for damage in the cross over areas and the layers of coils due to deflection angles (not for rope sections, which run only over rope pulleys and do not spool up on the drum).

4) d = Rope nominal diameter

- ▶ Check the rope over the entire length for visible broken wires.

When visible broken wires are scattered present:

- ▶ On the point of a broken wire, mark the rope sections on a length of 30d in both directions.
- ▶ Count visible broken wires in the marked rope sections and record them.
- ▶ Take the RCN (Rope category number) from the manufacturer's documentation of the rope.

When the make for rotation-resistant ropes is **not** listed in the chart:

- ▶ Determine the total number of load carrying wires in the rope: Add all wires in the strands of the outer layer, do **not** count fill wires.

- ▶ Compare the number of broken wires of each marked rope section 30d with the number of broken wires in the chart.

When the number of visible broken wires is smaller than listed in the chart:

- ▶ Within the rope section with the most broken wires: Mark the rope section with the most broken wires on a length of 6d.
- ▶ Count visible broken wires in the marked rope sections 6d and record them.
- ▶ Compare the number of broken wires of the marked rope section with the number of broken wires in the chart.

When the number of visible broken wires is equal to or larger than that listed in the chart:

- ▶ Take the rope down.
- ▶ Enter the results in the inspection checklist.

15.2 Broken wire in the strand valleys

The broken wires in these areas point to the fact that the condition in the inside of the rope is deteriorating.

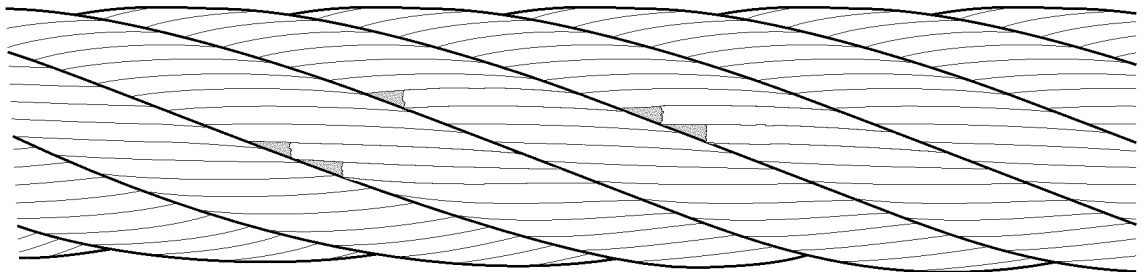

Fig.121005: Broken wire in the strand valleys

When two or more broken wires occur within a 6d long rope section:

- ▶ Take the rope down.

15.3 Broken wires on rope end connections

- ▶ Check the area near the rope end connections and carefully check for broken wires.

Loose wires are a sign of broken wires in the rope end connection.

- ▶ Use a marlin spike to check for loose wires.

When broken wires are near a rope end connection and two or more wires are affected:

- ▶ Take the rope down.

or

When the remaining rope lengths fulfil the minimum number of remaining coils in all operating positions:

- ▶ Shorten the rope, see chapter 7.05.50.
- ▶ Attach the rope end connection.

15.4 Broken wires in rope sections, which are not spooled up on the winch

When the broken wires are concentrated on one or two strands, the removal criteria can be present at fewer broken wires as noted in the chart (rope section in the length of 6d).

- ▶ Have the rope removal criteria determined by **expert personnel for crane rope inspection**.

15.5 Broken wire nests

When broken wires are very close to each other or when the broken wires are concentrated on one strand, then the rope must be taken down, even at fewer broken wires than noted in the chart (rope section 6d).

- ▶ Have the rope removal criteria determined by **expert personnel for crane rope inspection**.

16 Checking the rope end connection

The removal criteria are evaluated by the **expert personnel for crane rope inspection**.

Check for broken wires, see section „Broken wires on rope end connections“.

16.1 Pressed rope end connection

Example of a pressed rope end connection: Locking clamp.

- ▶ Check the rope end connections for signs of possible slipping between the locking clamp and the wire rope.
- ▶ Check the rope end connections for material cracks.
- ▶ Check rope end connections for corrosion, deformation and wear.

16.2 Enlarged rope end connection

Example of an enlarged rope end connection: Locking cast sleeve.

- ▶ If present: Remove the beam.
- ▶ Check rope end connections for corrosion, deformation and wear.

If the rope connection is on a flat rope:

- ▶ Check the cone setting, see chapter 8.04.10.

16.3 Detachable rope end connection

Example of a detachable rope end connection: Wedge lock.

- ▶ Check that the rope end connections are fit tightly and correctly installed.
- ▶ Check the wire rope inside and at the outlet of the rope end connection. Check the rope according to the removal criteria in this chapter.

17 Checking of rope diameter

17.1 Even reduction of rope diameter



WARNING

Spooling problems due to reduced rope diameter!

- ▶ Take the rope down even when the removal criteria according to **DIN ISO 4309** has not yet been reached.

The values in this section do **not** apply for rope sections, which were damaged in cross over areas due to multi layer spooling on a winch.

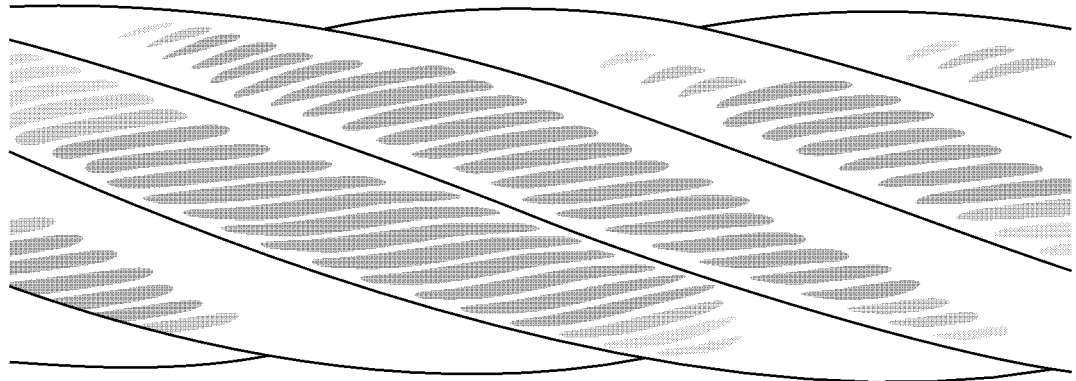

Fig.121001: External abrasion on the rope

The rope diameter changes due to abrasion, settling and external influences.

Abrasion of cover wires of outer strands of rope due to frictional contact. Especially in those areas where ropes are in contact with the rope pulleys during start up or slow down of the load.

Wear is increased by lack of or incorrect lubrication and the effect of dust.

Abrasion reduces the tensile strength of steel ropes because the cross section of the steel is reduced.

Additional possible causes for reduction of rope diameter:

- Wear in the inside of the rope
- Wear of fiber insert
- Breakage of a steel insert
- Broken inner strands

This section is valid solely for the following ropes:

- Ropes, which spool up on single layer winches
- Ropes, which run through a steel rope pulley

$$d_v = \frac{d_{ref} - d_m}{d} \times 100 \%$$

Fig.121372: Formula Reduction of rope diameter

d_v = even reduction of rope diameter

d_{ref} = rope diameter, which was determined before placement

d_m = measured rope diameter

d = rope nominal diameter: Take value from inspection checklist

The following chart applies exclusively for ropes, which spool up on single layer winches and / or run through a steel rope pulley.

Rope type	Even reduction of diameter d_v (in percentages of rope nominal diameter d)	Classification of degree of severity	
		Description	%
	Less than 6 %	—	0
Single layer rope with fiber insert	6 % and above, but less than 7 %	Light	20
	7 % and above, but less than 8 %	Medium	40
	8 % and above, but less than 9 %	High	60
	9 % and above, but less than 10 %	Very high	80
	10 % and above	Rope removal criteria	100

Rope type	Even reduction of diameter d_v (in percentages of rope nominal diameter d)	Classification of degree of severity	
		Description	%
Single layer rope with steel insert or parallel roped rope	Less than 3.5 %	—	0
	3.5 % and above, but less than 4.5 %	Light	20
	4.5 % and above, but less than 5.5 %	Medium	40
	5.5 % and above, but less than 6.5 %	High	60
	6.5 % and above, but less than 7.5 %	Very high	80
	7.5 % and above	Rope removal criteria	100
Rotation-resistant rope	Less than 1 %	—	0
	1 % and above, but less than 2 %	Light	20
	2 % and above, but less than 3 %	Medium	40
	3 % and above, but less than 4 %	High	60
	4 % and above, but less than 5 %	Very high	80
	5 % and above	Rope removal criteria	100

Degree of severity and removal criteria depending on rope type and even diameter reduction according to DIN ISO 4309

The medium value from the smallest and the largest measured diameter results in the value for d_m .

- ▶ Measure rope diameter on several locations and calculate measured diameter d_m .
- ▶ Calculate even reduction d_v of rope diameter with formula.
- ▶ Read the degree of severity in the chart, depending on the rope type.
- ▶ Document the degree of severity in the inspection checklist.

When the degree of severity has reached 100 %:

- ▶ Take the rope down.

17.2 Localized reduction of rope diameter

Localized reductions of rope diameter point to the fact that a rope insert may have failed, for example.

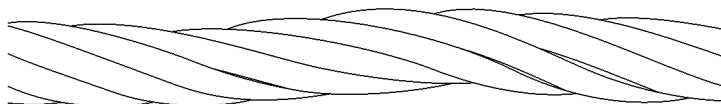

Fig. 120983: Localized reduction of rope diameter

- ▶ Check the rope for localized reduction of rope diameter.

When a localized reduction of the rope diameter is found:

- ▶ Take the rope down.

17.3 Localized increases of rope diameter

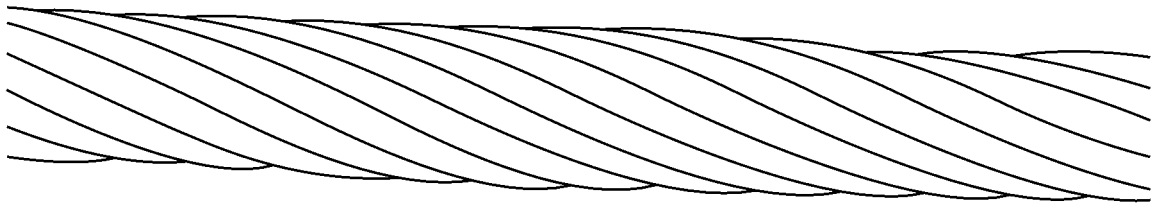

Fig.120992: Localized increase of rope diameter

An increase over a longer area of the rope can be caused by absorption of moisture in the fiber insert or due to corrosion in the inside of the rope.

Rope insert	Maximum increase of rope diameter during operation
Steel	5 %
Fiber	10 %

► Check the rope for increases in rope diameter.

When the increases exceed the maximum values:

► Take the rope down.

18 Corrosion

Corrosion occurs due to insufficient lubrication, in maritime climates and in an atmosphere polluted by industrial fumes.

External corrosion is indicated by a rough wire surface. A superficial rust film can be wiped off.

Significant corrosion reduces the strength and elasticity of the rope due to the reduction of the rope diameter.

Inner corrosion is hard to detect.

Do **not** use solvents to clean the rope.

Make sure that the following prerequisite is met:

- Rope is cleaned (wiped and brushed).

18.1 External corrosion

The various types of corrosion are classified and noted with the classification for removal criteria in percentages:

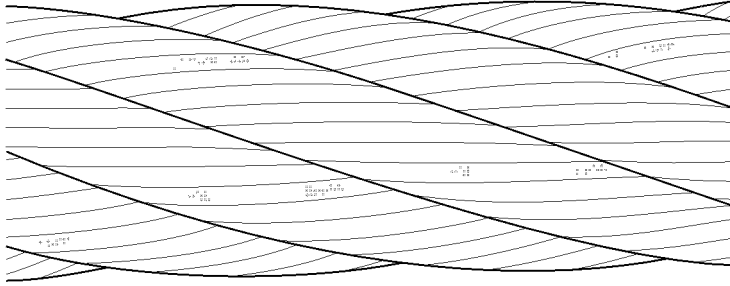

Fig.120984: Surface light corrosion: Classification 0 % of removal criteria

Superficial light corrosion (rust film) can be wiped off.

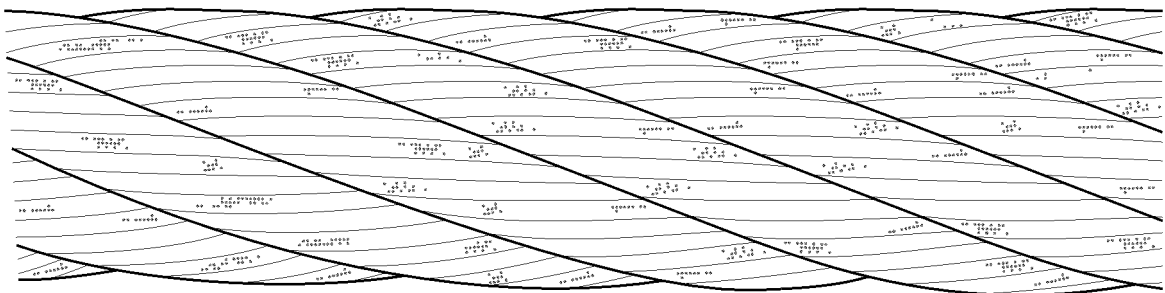

Fig.120985: Surface feels rough: Classification 20 % of removal criteria

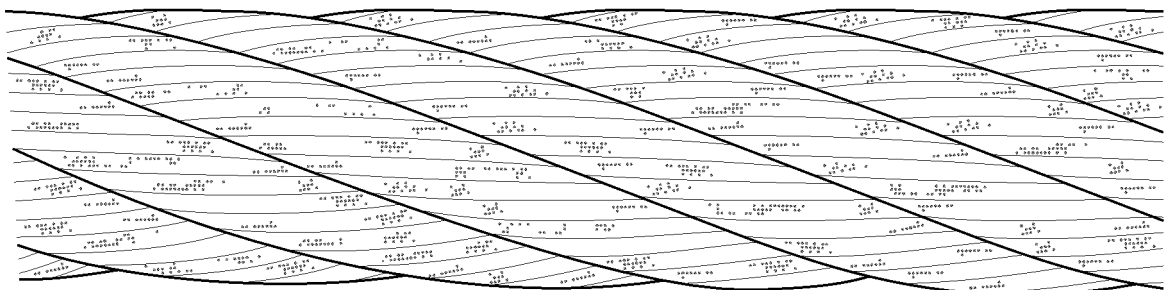

Fig.120986: Surface feels very rough: Classification 60 % of removal criteria

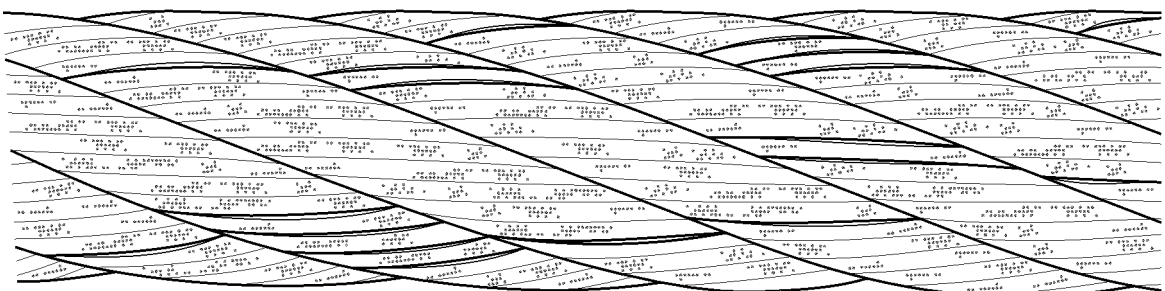

Fig.120987: Surface very decayed, spaces between individual wires can be easily recognized: Classification 100 % of removal criteria

When 100 % of removal criteria is reached:

- ▶ Take the rope down.

18.2 Internal corrosion

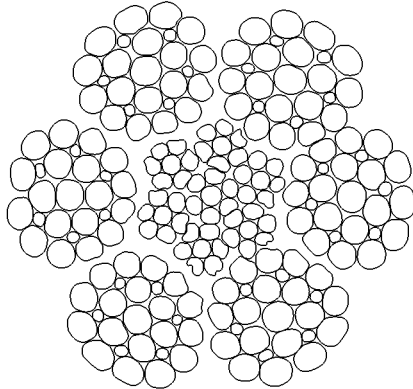

Fig.120982: Corrosion in the inside of the rope

Internal corrosion is present when clearly visible corrosion particles migrate between the valleys of the outer strands: Classification 100 % removal criteria.

When internal corrosion is found:

- ▶ Have the rope removal criteria evaluated by **expert personnel for crane rope inspection** or place the rope down.

18.3 Friction corrosion

Friction corrosion occurs as a type of brown powder, which migrates from the inside of the rope to the outside: Classification 100 % of removal criteria.

- ▶ Check the rope diligently for friction corrosion.

If friction corrosion is found:

- ▶ Have the rope removal criteria evaluated by **expert personnel for crane rope inspection** or place the rope down.

19 Corkscrew-like distortion



Fig.120988: Corkscrew-like distortion

Distortion where the rope is in the form of a corkscrew along its longitudinal axis.

Effects of corkscrew-like distortion:

- Irregular rope drive
- Rope wear
- Broken wire
- Bearing damage on rope pulleys

If the distortion is very pronounced, then other components can be affected in their function when the affected rope section runs through in crane operation.

- ▶ Check the entire rope for corkscrew-like distortion.

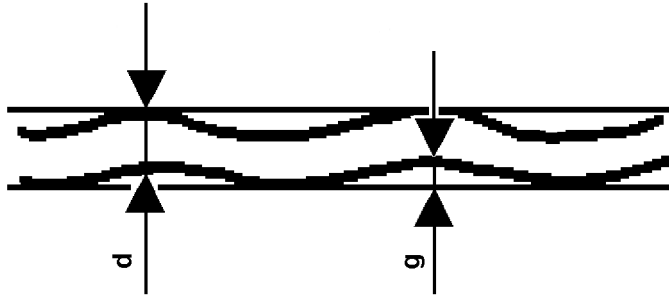

Fig.123988: Example for corkscrew-type distortion

d Rope nominal diameter **g** Distance

Rope section	Conditions for removal criteria, formula
Straight rope section, which does not run through or around a rope pulley or spool up on a winch	$g \geq \frac{1}{3} \times d$
Straight rope section, which runs through or around a rope pulley or spools up on a winch	$g \geq \frac{1}{10} \times d$

When corkscrew-like distortion is present:

- ▶ Determine the rope nominal diameter **d** and distance **g** on the rope.
- ▶ Check the removal criteria with the formula.

When the removal criteria is reached:

- ▶ Take the rope down.

20 Basket formation

This distortion occurs due to different layers between the outer strand layers and the inside of the rope.

Causes for basket formation are high angular pull angles during the run over the rope pulleys and run-in rope pulleys. Even load distribution over the entire cross section is not possible.

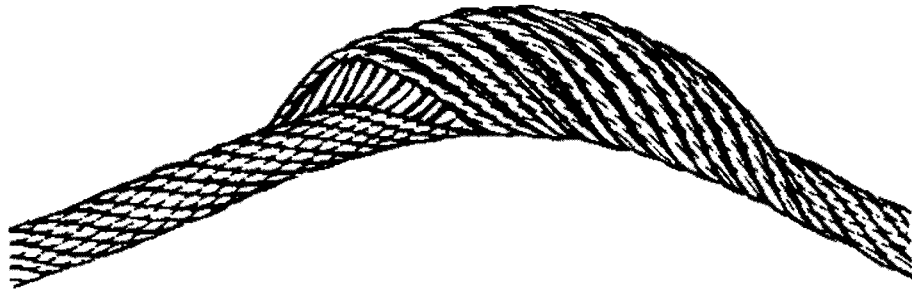

Fig.120989: Basket formation

► Check the entire rope for basket formation.

When basket formation is present:

► Take the rope down.

21 Protruding, distorted insert or strand

This distortion is a special form of basket formation. The insert or the core of the rope protrudes between the outer strands or an outer strand protrudes from the rope banding.

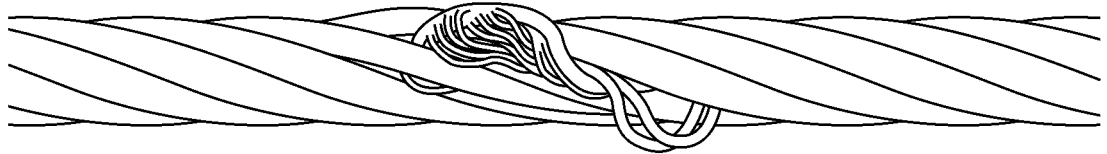

Fig.120990: Protrusion of an insert (rope single layer)



Fig.120991: Distorted or protruding strand

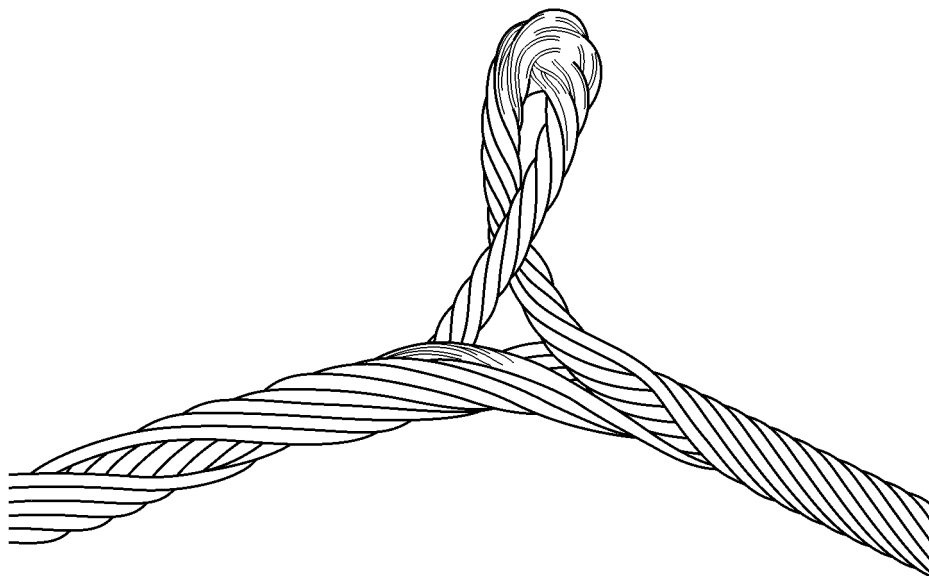

Fig.121373: Protrusion of rope insert on rotation-resistant rope

When the insert or a strand protrudes or is distorted, place the rope down. Have authorized inspector for crane rope inspection check if the rope area with the distortion can be removed.

- ▶ Check the entire rope for protruding, distorted insert or strand.

When protruding, distorted insert or braid is present:

- ▶ Take the rope down.
- ▶ Have **expert personnel for crane rope inspection** check if the rope area with the distortion can be removed.

22 Loop formation

At loop formation individual or several wires protrude from the rope and bulge upward (bird-caging).

These areas are most often on the opposite side of the rope pulley groove.

Make sure that the following prerequisite is met:

- There are **no** broken wire ends present.

If only a core wire of the rope insert protrudes through the outer strands, then the rope does not have to be taken down when:

- The wire can be removed.
- The wire does not disturb other elements of the rope drive.

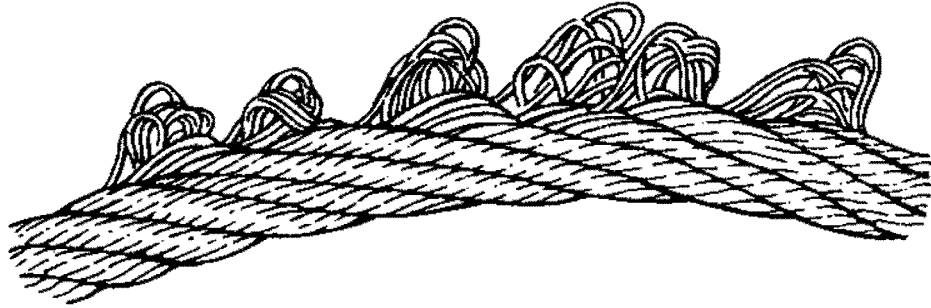

Fig.120993: Emergence of individual wires

▶ Check rope for loop formation.

When solely a core wire protrudes:

▶ Remove the core wire.

When several wires are affected from the loop formation:

▶ Take the rope down.

23 Kinking or rope loops pulled closed

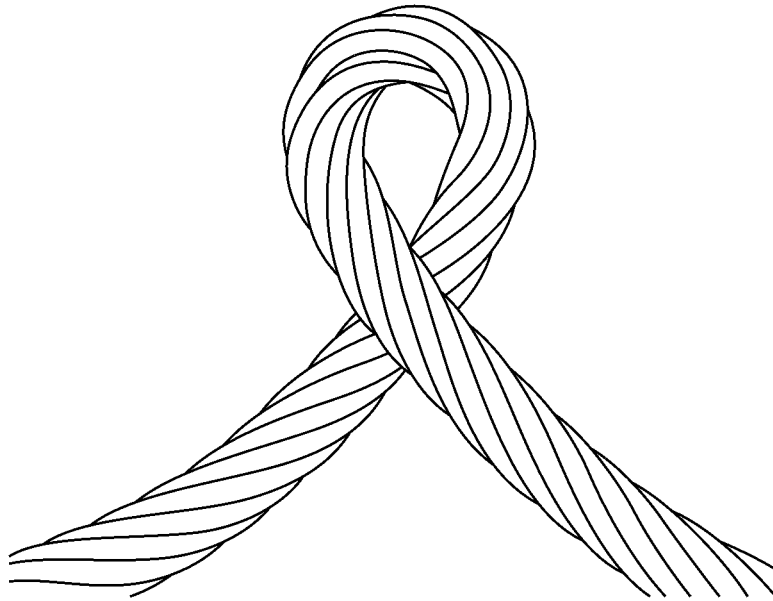

Fig.121007: Kinking or rope loop pulled closed

At this deformation a loop has formed in the rope, without the possibility to rotate around its own axis during a load. The rope is subjected to more wear.

The rope is significantly distorted. The strength remains only in part.

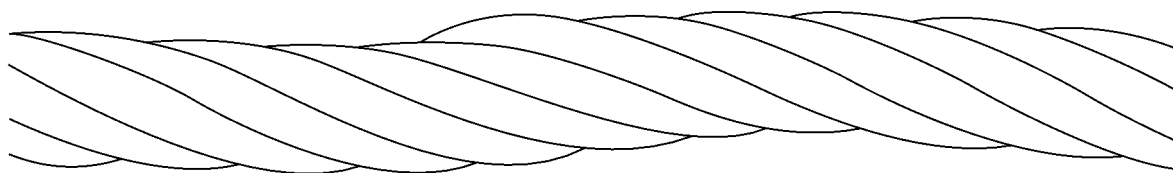

Fig.121002: Positive Kinking

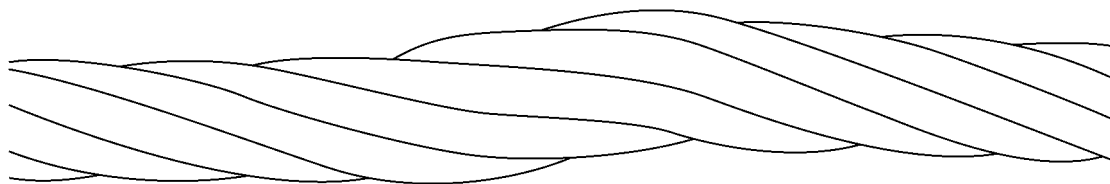

Fig.121003: Negative Kinking

- ▶ Check the rope for kinking or rope loops pulled closed.

When kinking or rope loops pulled closed occur:

- ▶ Take the rope down.

24 Buckles

Buckles are angular deformations. The rope was damaged due to external influences. Strong deformations of the rope cause stronger wear.

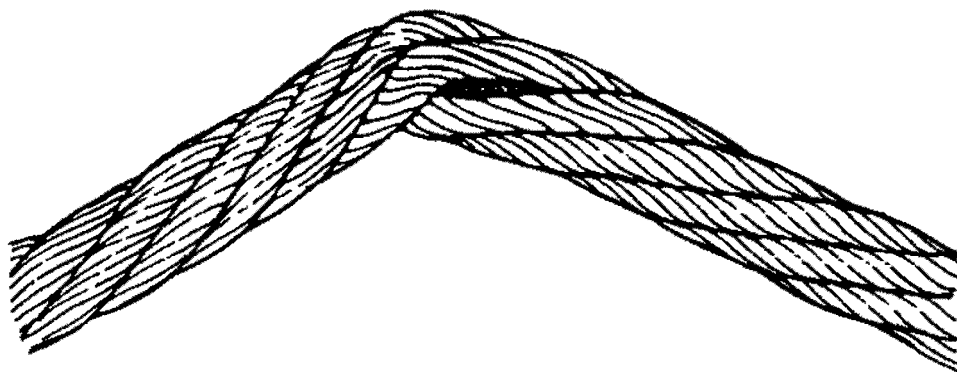

Fig.120999: Severe buckle

A buckle is a serious matter if a fold is visible on the underside of the rope.

When buckles are present:

- ▶ Have the rope inspected by **expert personnel for crane rope inspection**.

When a distortion and degree of severity permits further operation:

- ▶ Shorten the inspection interval.

When the removal criteria is reached:

- ▶ Take the rope down.

25 Effects of heat, arcs

Damage caused to the rope by welding work, for example.

Exceptional thermal effect is visible through tempering colors, the loss of lubricant and by localized melting of wires.

When thermal effect has occurred on the rope:

- ▶ Take the rope down.

26 Combined degree of severity



Note

- ▶ For a method to determine the effect of a combined degree of severity and damage on the rope, see **DIN ISO 4309**.

When the condition of the rope deteriorates, then often a combination of various causes occurs.

To determine the degree of severity, the **expert personnel for crane rope inspection** must:

- take different damage within a rope section into account
- evaluate the entire effect of the damage and the distortions
- decide about the operational safety of the rope
- evaluate if inspection intervals must be adjusted
- decide if the rope must be taken down

When the combined degree of severity is more than 100 %, then the rope must be taken down.

27 Flattenings

Effects of flattenings on the rope:

- Rope sections with flattenings, which move **over the rope pulleys** tend to higher wear and a higher number of broken wires.
- Rope pulleys can be damaged.
- Flattenings on **stationary ropes** (guy ropes boom) promote quicker corrosion, especially in the areas where the outer strands have opened.

Flattened rope sections must be checked in shorter intervals for broken wires and corrosion.

27.1 Shorting the intervals

- ▶ Check the entire rope for flattenings.

When flattenings are present on stationary ropes:

- ▶ Shorten the intervals for rope inspection.

When it is **not** possible to shorten the intervals for the rope inspection:

- ▶ Take the rope down.

27.2 Improper mechanical damage

An improper mechanical damage occurs, for example, when the rope is trapped.

- ▶ Take the rope down immediately or shorten it, see chapter 7.05.50.

27.3 Operational transverse pressure

Operational transverse pressure causes flattenings, for example in the incline range of multi layer spooling.

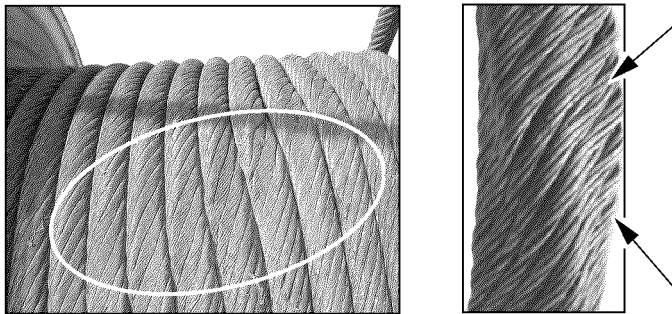

Fig.114002: Flattenings

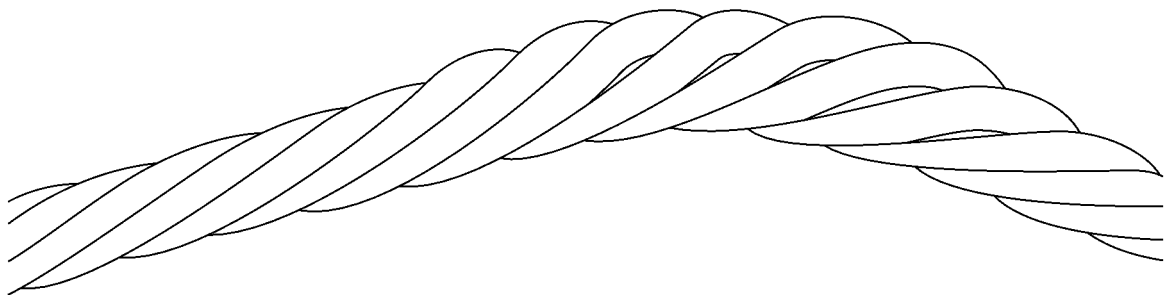

Fig.120996: Flattenings on multi layer spoolings

- ▶ Check the first rope layer of the winches for crushed areas and distortions.

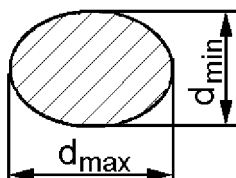

Fig.121006: Largest and smallest diameter on the distortion area

$$V = \frac{d_{\max} - d_{\min}}{d} \times 100 \%$$

Fig.121374: Formula to calculate the distortion

V Rope distortion in percentages

d_{max} Largest diameter of distortion area

d Rope nominal diameter

x

d_{min} Smallest diameter of distortion area

n

When distortions are present:

- ▶ Determine the number of broken wires See section „Determining the number of broken wires“.

When the number of permissible broken wires is exceeded:

- ▶ Take the rope down.
- ▶ Calculate the distortion V with the formula and document it in the inspection checklist.

When distortion V is larger than 5 %:

- ▶ Check the rope before every assembly and erection procedure.

When distortion V is larger than 10 %:

- ▶ Document the degree of severity of 50 % in the inspection checklist.

When distortion V is larger than 20 %:

- ▶ The degree of severity of 100 % is reached: Take the rope down.

28 Current checklist

Crane and use:		RCN ³⁾ :		Installation date:																				
Rope application:		Nominal diameter:		Take-down date:																				
Brand name:		<input type="radio"/> Right hand <input type="radio"/> Lang's lay <input type="radio"/> IWRC <input type="radio"/> Bare		Minimum tensile strength																				
Make ¹⁾ :		<input type="radio"/> Left hand <input type="radio"/> Ordinary lay <input type="radio"/> FC <input type="radio"/> WSC		Permissible number of visible external broken wires																				
Direction of lay ¹⁾ :		<input type="radio"/> IWRC <input type="radio"/> Bare		Datum diameter																				
Intermediate layer ¹⁾ :		<input type="radio"/> FC <input type="radio"/> Galvanized		Permissible diameter reduction: 6d: 30d:																				
Wire surface ¹⁾ :		Rope end connections:																						
Date	JJ/MM/TT	6d	30d	Number in length of	6d	30d	Position in the rope	6d	30d	Actual reduction to datum diameter	Position in the rope	Severity level ²⁾	Diameter	Position in the rope	Severity level ²⁾	Corrosion	Position in the rope	Severity level ²⁾	Damage, deformation	Position in the rope	Severity level ²⁾	Combined severity level ²⁾	Name of expert for the wire rope inspection	Signature

1) Check where applicable.
 2) State extent of damage; slight or 20%; medium or 40%; high or 60%; very high or 80%; take-down or 100%
 3) RCN = Rope Category Number

Fig.121370-en: Form for current checklist

LWE/LR 11000-001/23501-04-02/en

Empty page!

LWE/LR 11000-001/23501-04-02/en

8.05 Inspection of load hooks

1	Safety guidelines	3
2	Inspection intervals	3
3	Inspecting and monitoring the load hook	3

Fig.195219

LWE/LR 11000-001/23501-04-02/en

1 Safety guidelines



DANGER

Death, severe injury, property damage due to welding on load hooks!

- ▶ Do **not** weld load hooks to repair wear.
- ▶ Replace the load hook in case of impermissible wear.
- ▶ Contact Liebherr Service.

Make sure that the following regulation is followed:

- Do **not** carry out any welding work on load hooks, for example to repair wear.

2 Inspection intervals

By recognizing defects in time, accidents are prevented.

An inspection must be made before operation.

Load hooks must be inspected as needed, but at least once a year by an expert.

The load hook must be inspected every 4 years by an expert.

3 Inspecting and monitoring the load hook

Any defects found must be remedied and documented.

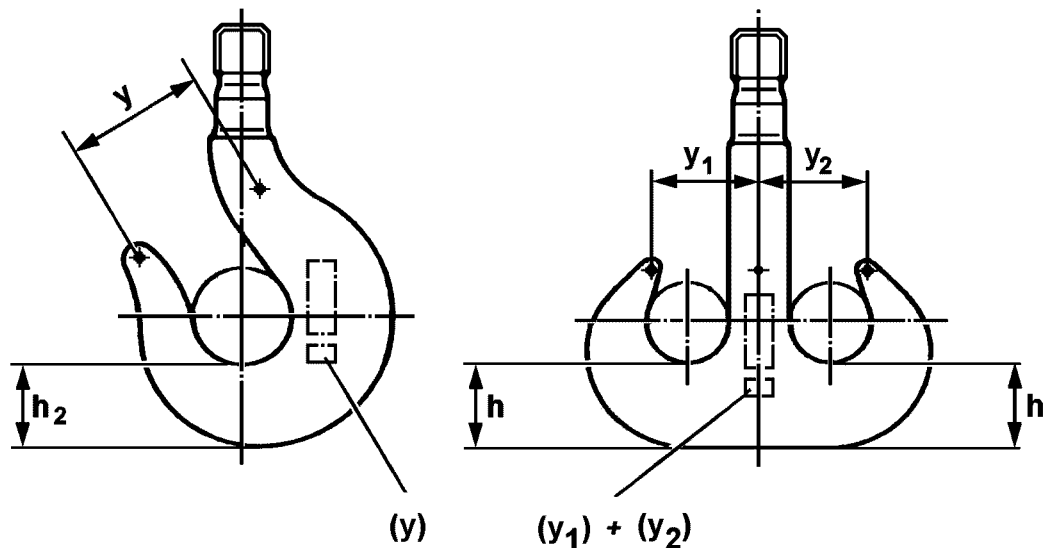

Fig.121531: Description of measured distances of load hooks

3.1 Checking the load hook for distortion



DANGER

Death, severe injury, property damage due to expansion of hook jaw!

- ▶ Replace the load hook in case of impermissible expansion.
- ▶ Contact Liebherr Service.

The initial dimension (**y**) for the single hook is marked on the load hook.

The initial dimension (**y₁**) and the initial dimension (**y₂**) for the double hook is marked on the load hook.

The expansion of the hook jaw may not exceed more than 10 % in reference to the initial dimension (**y**) or the initial dimension (**y₁**) and the initial dimension (**y₂**).

- ▶ Measure dimension **y** or dimension **y₁** and dimension **y₂** from center punch to center punch.
- ▶ Check for dimensional accuracy within the permissible tolerance.

3.2 Checking the load hook for surface cracks



DANGER

Death, severe injury, property damage due to surface cracks and damage on the load hook!

- ▶ Replace the load hook in case of surface cracks and damage.
- ▶ Contact Liebherr Service.

When distortions are found on the hook jaw:

- ▶ Check the load hook for surface cracks with a suitable procedure.
- ▶ Check the load hook for damage

3.3 Checking the load hook for wear



DANGER

Death, severe injury, property damage due to wear on the hook base!

- ▶ Replace the load hook in case of impermissible wear.
- ▶ Contact Liebherr Service.

The wear on the hook base may be no more than 5 % of the initial nominal dimension **h₂** for single hooks or initial nominal dimension **h** for double hooks.

The initial nominal dimensions **h₂** for single hooks and **h** for double hooks are listed in the chart.

Hook Number	Single hook h ₂ [mm]	Double hook h [mm]
4	67	—
5	75	—
6	85	75
8	95	85
10	106	95
12	118	106
16	132	118
20	150	132
25	170	150
32	—	170

Hook Number	Single hook h_2 [mm]	Double hook h [mm]
40	—	190
50	—	212
63	—	236
80	—	265
100	—	300
125	—	335
160	—	375
200	—	425
250	—	475
320	—	545

Initial nominal dimensions h_2 for single hooks and h for double hooks

- ▶ Measure dimension h_2 for single hooks or dimension h for double hooks.
- ▶ Check for dimensional accuracy within the permissible tolerance.

3.4 Checking load hooks for corrosion and wear



DANGER

Death, severe injury, property damage due to corrosion and wear on the thread!

- ▶ Replace load hooks which are **not** dimensionally accurate.

When wear or impermissible axial play on the hook nut is present:

- ▶ Replace the hook nut.
- ▶ Contact Liebherr Service.

To check the threads regarding corrosion and wear, the hook nut must be unscrewed from the hook shaft.

- ▶ Check the load hook thread and hook nut for corrosion and wear.

When reconditioning work is required to remove corrosion notches:

- ▶ Carry out a test for dimensional accuracy.

Empty page!

LWE/LR 11000-001/23501-04-02/en

8.06 Inspection of hydraulic hose lines

1	Safety guidelines	3
2	Inspection intervals	3
3	Checking the end of the service life	3
4	Inspecting the hydraulic hose lines for damage	4
5	Inspecting the hydraulic hose lines for leaks	5
6	Documenting the inspection	5
7	Replacing hydraulic hose lines	5

Fig.195219

LWE/LR 11000-001/23501-04-02/en

1 Safety guidelines



WARNING

Damaged and leaky hydraulic hose lines!
Fire, accidents, death, severe injury, property damage.

If leaky areas are found:

- ▶ Have these leaky areas inspected immediately by authorized and trained expert personnel and remedied.

If damage is found:

- ▶ Have the hydraulic hose lines replaced exclusively by authorized and trained expert personnel.

If it is determined that the service life is over:

- ▶ Have the hydraulic hose lines replaced exclusively by authorized and trained expert personnel.

Make sure that the following prerequisite is met:

- A **competent person for hydraulic hose lines** inspects the hydraulic hose lines.

A **competent person for hydraulic hose lines** has the following knowledge:

- Knowledge and experience in hydraulic and mechanics
- Knowledge of all requirements regarding valid standards:
 - ISO 8331
 - ISO 2230
 - ISO 1402
 - ISO/TR
 - EN 853 to EN 857
 - National regulations
- **or:** Knowledge of all requirements regarding the valid German standards, for example:
 - DIN 20066:202-10
 - BGR 237 Feb 2008, BG-Regulation

2 Inspection intervals

The inspection of hydraulic hose lines must be carried out in the following intervals:

- when the crane is **up to 10 years** old, at least one inspection every twelve months
- when the crane is **older than 10 years**, at least one inspection every six months

3 Checking the end of the service life

Hydraulic hose lines have a limited service life.

When hydraulic hose lines are properly stored, installed and used, then the manufacturer guarantees a service life of at least 10 years.

The life expectancy of hydraulic hose lines can deviate significantly from the noted service life of hydraulic hose lines.



Note

Special case: Active rear axle steering!

- ▶ The life expectancy of hydraulic hose lines is six years, including a storage period of maximum two years.

The life expectancy of a hydraulic hose line depends on various factors:

- Environmental influences, for example: Temperature, humidity, corrosive air
- Use

- Working cycles
- Number of bending cycles
- Friction
- Fluid

The following factors reduce the life expectancy significantly:

- Heat
- Repeated bending under pressure

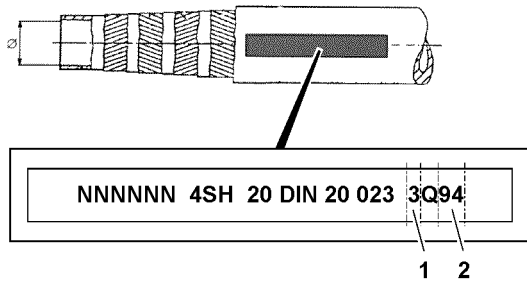

Fig.120159: Example for identification of hydraulic hose lines

The manufacturing date is marked on the fixtures or fittings.

- ▶ Read the quarter **1** of manufacture.
- ▶ Read the year **2** of manufacture.

When the life expectancy of a hydraulic hose line has been exceeded, then a **competent person** can decide **not** to replace the hydraulic hose line. Document the decisions, see section „Documenting the inspection“.

When the end of the service life is determined:

- ▶ Have the hydraulic hose lines replaced exclusively by authorized and trained expert personnel.

4 Inspecting the hydraulic hose lines for damage

Hydraulic hose lines must be replaced when one of the following damage is present:

- Damage on outer surface, such as chafe marks, cuts and cracks
- Brittleness due to aging of outer layer (cracks)
- Distortion, such as splitting of hose layers, bubbles, crushed areas, kinks, rotational stress
- Leakages
- Damage or distortion of hose fixtures or hose fitting (seal is endangered)
- Movement between hose and hose line, hose working itself loose from the fixture or the fitting
- Requirements for installation **not** observed
- Corrosion of fixture or fitting (solidness or function of fitting is endangered)

When the hydraulic hose line is **not** completely accessible:

- ▶ Remove the hydraulic hose line.

When the hydraulic hose line is protected with a protective hose:

- ▶ Check the hose protection for abrasion. Abrasion on a hose protective hose can indicate abrasion on the hydraulic hose line.
- ▶ Check hydraulic hose lines for distortion in pressureless and pressurized status and during bending.

When the hydraulic hose line is slightly damaged, then a **competent person** can decide **not** to replace the hydraulic hose line. Document the decisions, see section „Documenting the inspection“.

If damage is found:

- ▶ Have the hydraulic hose lines replaced exclusively by authorized and trained expert personnel.

5 Inspecting the hydraulic hose lines for leaks

- ▶ Check the crane for escaped hydraulic oil.
- ▶ Check the crane for leaks by visually checking the ground under the crane.

When the hydraulic system leaks:

- ▶ Have these leaks inspected immediately by authorized and trained expert personnel and remedied.
or
Contact Liebherr Service.

6 Documenting the inspection

Make sure that the following prerequisite is met:

- A **competent person for hydraulic hose lines** documents noticeable observations.

The following data about hydraulic hose lines is documented:

- Installation location
- Condition
- Date
- Time
- ▶ Document noticeable observations comprehensibly.

When the life expectancy of a hydraulic hose line has been exceeded or if the hydraulic hose line is slightly damaged, then a **competent person** can decide **not** to replace the hydraulic hose line.

When the hydraulic hose line is **not** replaced:

- ▶ Document decisions and replacements comprehensibly.
- ▶ Document the date for the next inspection comprehensibly.

7 Replacing hydraulic hose lines

To ensure maximum safety, sealing and service life, the following guidelines apply for replacement of hydraulic hose lines.



WARNING

Impermissible spare parts!

Death, severe injury, property damage.

- ▶ Do **not** use repaired or used hydraulic hose lines.
- ▶ Use exclusively Original Liebherr spare parts.
- ▶ Use exclusively hydraulic hose lines according to manufacturer's specification (including fixtures, rubber piece goods and manufacturing process).

NOTICE

Routing of hydraulic hose lines changed!

Abrasion. Incorrect bending radius. Stress. Shortened service life.

- ▶ Keep the routing of hydraulic hose lines.
- ▶ Inspect the hydraulic hose lines according to intervals.

- ▶ Adhere to the hose bending radii according to the manufacturer's specifications.
- ▶ Ensure the routing of hydraulic hose lines according to manufacturer's specifications (pressureless and pressurized condition).
- ▶ Ensure the distance between lines and structures.

If necessary:

- ▶ Check moving parts in the area of hydraulic hose lines.

When the hydraulic hose line is installed in straight direction:

- ▶ Ensure a sag of the hose.
- ▶ Avoid mechanical tension and twisting of the hose during installation.
- ▶ Fasten the hydraulic hose line according to manufacturer's specification.
- ▶ Do not cross hydraulic hose lines for high pressure and low pressure.
- ▶ Keep hydraulic hose lines away from hot components.

When hydraulic hose lines are in a surrounding with high temperatures:

- ▶ Install protective insulation according to manufacturer's specifications.

8.12 Inspection of safety switching on the relapse supports

1	S-boom relapse retainer	3
4	F-lattice jib relapse retainer	17

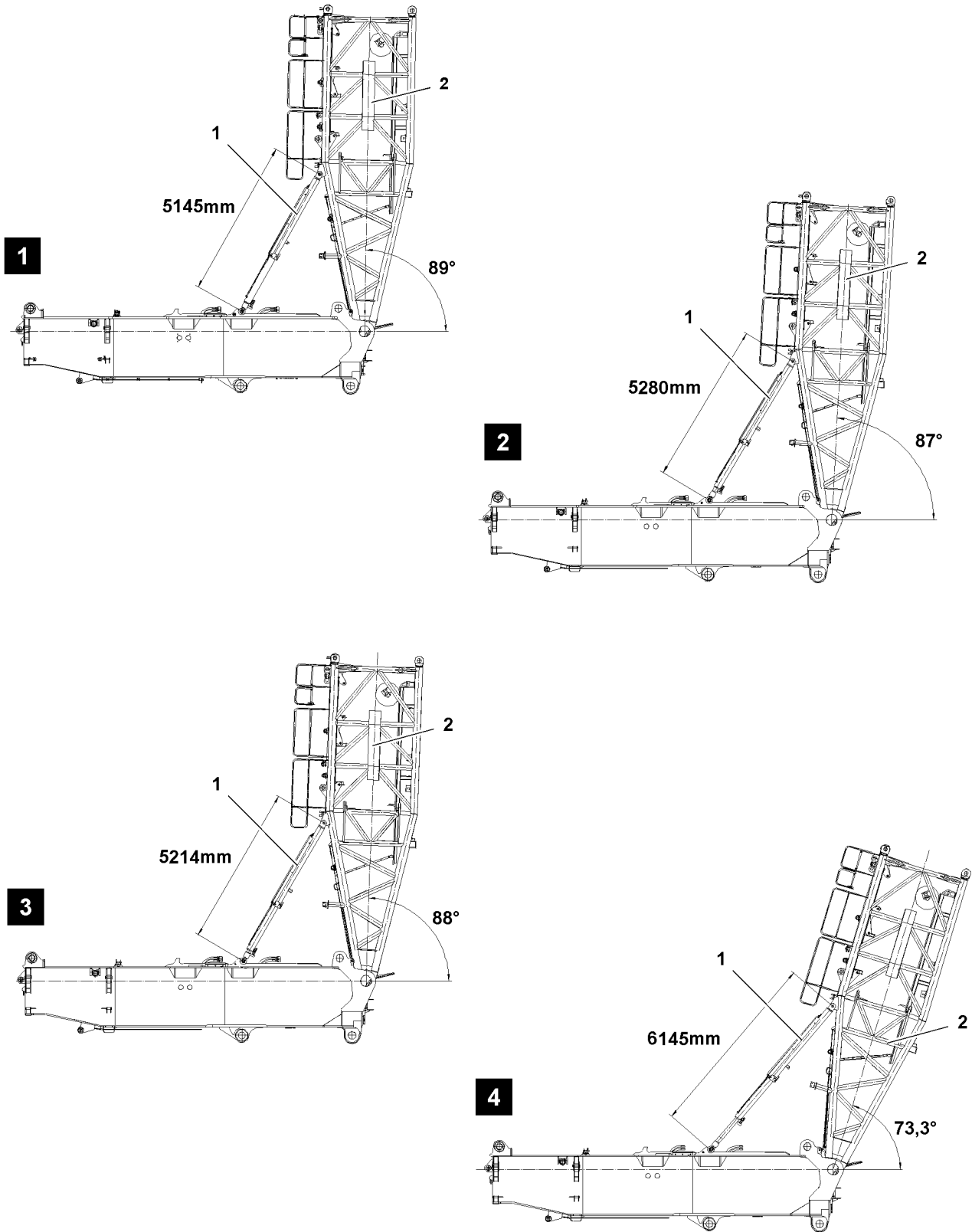

Fig.119048

LWE/LR 11000-001/23501-04-02/en

1 S-boom relapse retainer

Two S-relapse cylinders **1** prevent the S-boom **2** from falling backward.

1.1 Checking the limit switch actuators for function before erection

Before erecting the S-boom **2**, check the function of the limit switch actuators.

Cover limit switch actuators on the S-relapse cylinder **1** individually with a metal plate.

- The „luffing up“ movement of the S-boom **2** is turned off.
- Icon appears on the LICCON monitor.

1.2 Checking the limit switch actuators for function

In the steepest boom position, the luffing up movement is turned off by the activated limit switch actuators on the cylinder.

- When the limit switches are actuated on the two S-relapse cylinders **1** the „luffing up“ movement of the S-boom **2** is turned off.
- Icon appears on the LICCON monitor.

	Angle	S-relapse cylinder length	Illustration
Block position	89°	5145 mm	1
Steepest position	87°	5280 mm	2
Electric switch position	88°	5214 mm	3
S-relapse cylinders moved out	73.3°	6145 mm	4

Switch positions of the S-relapse cylinders

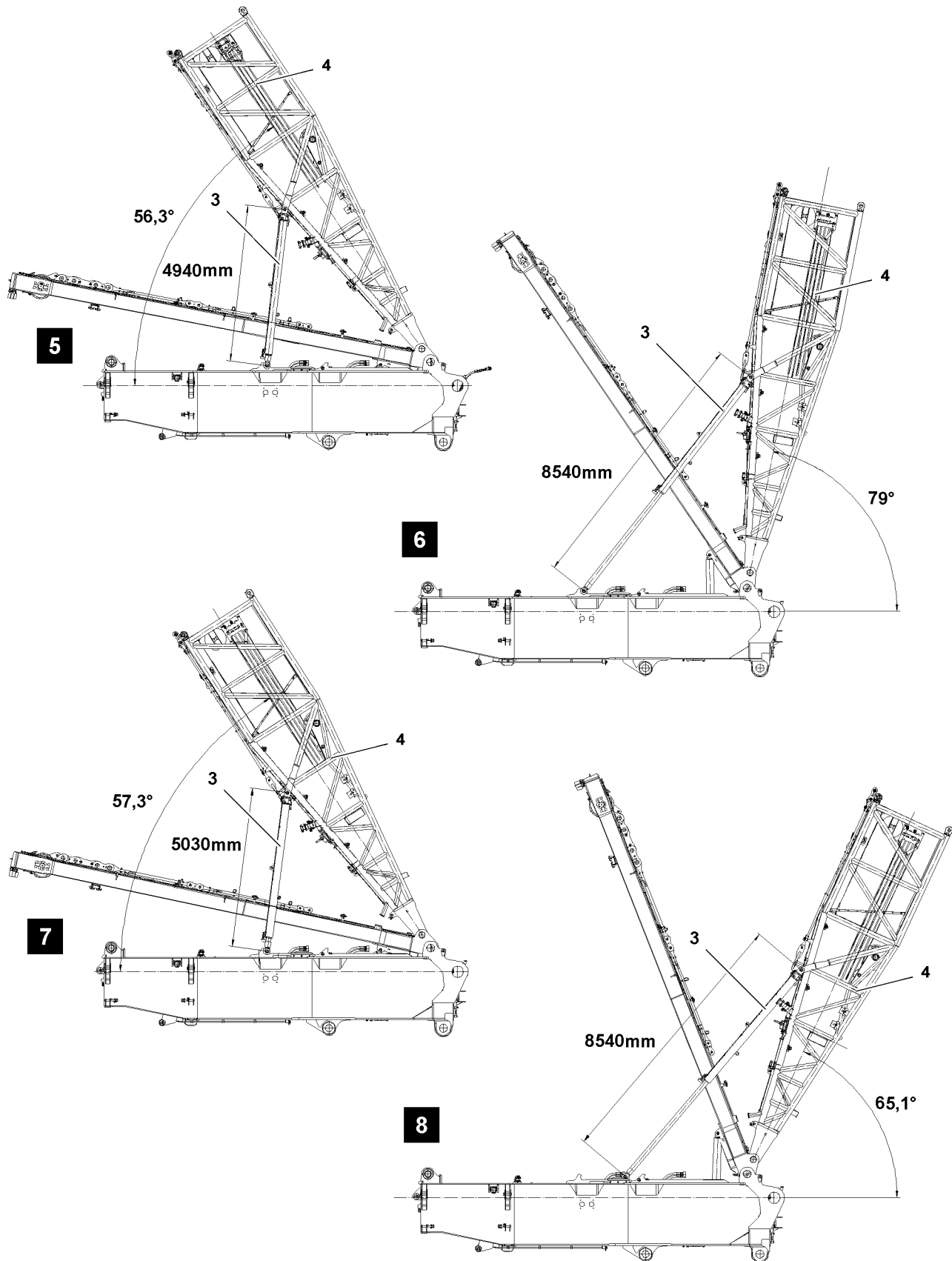

Fig.119049

LWE/LR 11000-001/23501-04-02/en

2 D-boom relapse retainer

Two D-relapse cylinders **3** prevent the D-boom **4** from falling backward.

2.1 Checking the limit switch actuators for function before erection

Before erecting the D-boom **4**, check the function of the limit switch actuators.

Cover limit switch actuators individually on the D-relapse cylinder **3** with a metal plate.

- „Spooling up“ winch **4** is blocked.
- Icon appears on the LICCON monitor.

2.2 Checking the limit switch actuators for function

When the limit switches are actuated on the two S-relapse cylinders **3** the movement of the D-boom **4** is turned off.

- „Spooling up“ winch **4** is blocked.
- Icon appears on the LICCON monitor.

	Angle	D-relapse cylinder length	Illustration
Block position	56.3°	4940 mm	5
D-relapse cylinders moved out	79°	8540 mm	6
Electric switch position	57.3°	5030 mm	7
Contact D-relapse cylinder turntable	65.1°	8540 mm	8

Switch positions of the D-relapse cylinders

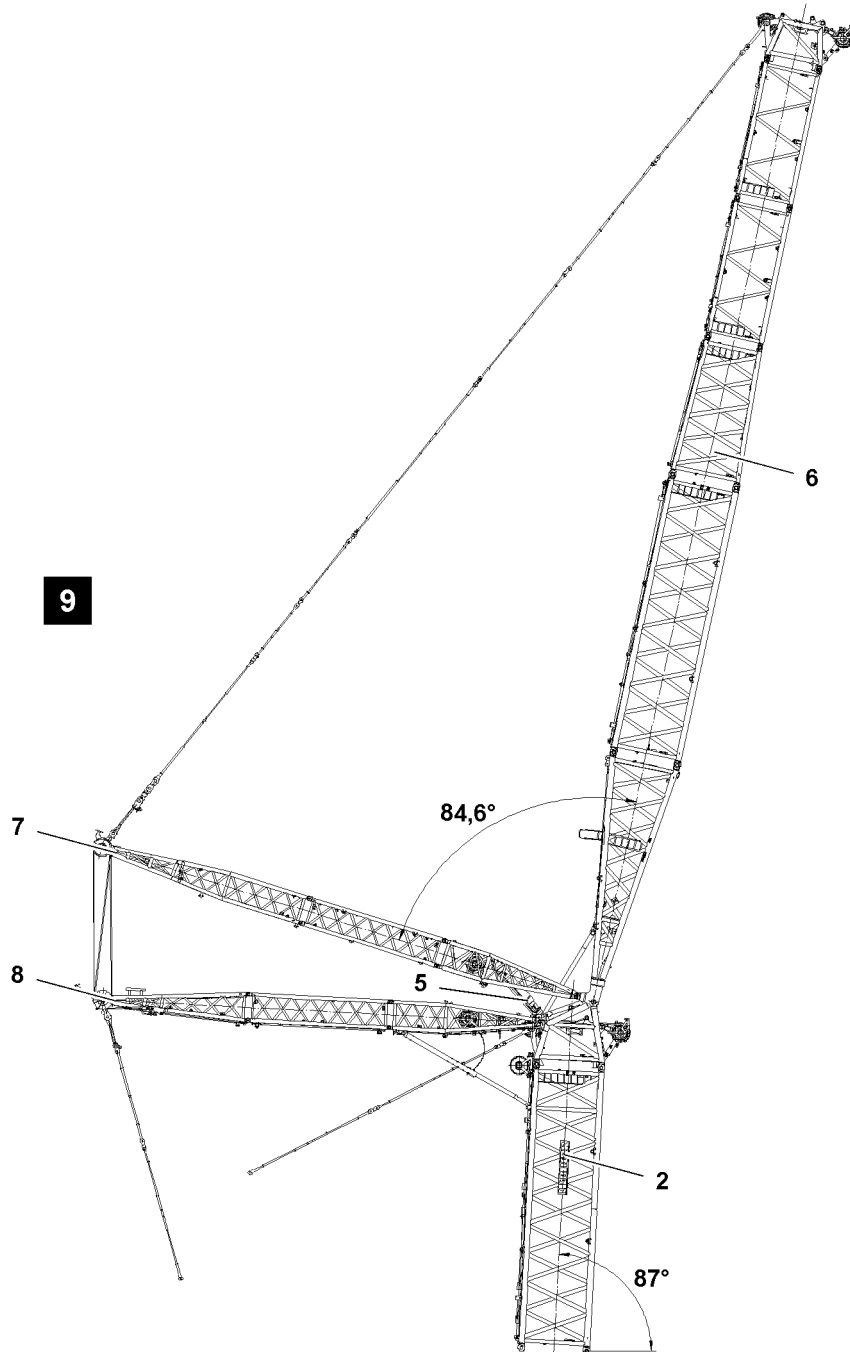

Fig.119050

LWE/LR 11000-001/23501-04-02/en

3 W-lattice jib relapse retainer

3.1 Checking the limit switch actuators for function before erection

Before erecting the W-lattice jib **6**, check the function of the limit switch actuators.

Cover the limit switch actuators on the W-relapse cylinder **5** individually with a metal plate.

- The W-control winch „spooling up“ movement is turned off.
- Icon appears on the LICCON monitor.

3.2 Checking the limit switch actuators on switch point „steepest position“

In steepest boom position the luffing up movement is turned off by the actuators.

Pull the WA-frame **7** and WA-frame **8** together to the specified angle dimension, see illustration **9**, until the limit switch actuators are activated.

- The W-control winch „spooling up“ movement is turned off.
- Icon appears on the LICCON monitor.



Note

- ▶ Angle 84.6° is independent of the W-boom length and the guy length.
-

After successful test, reset the WA-frames to set up configuration, see Crane operating instructions, chapter 5.07.

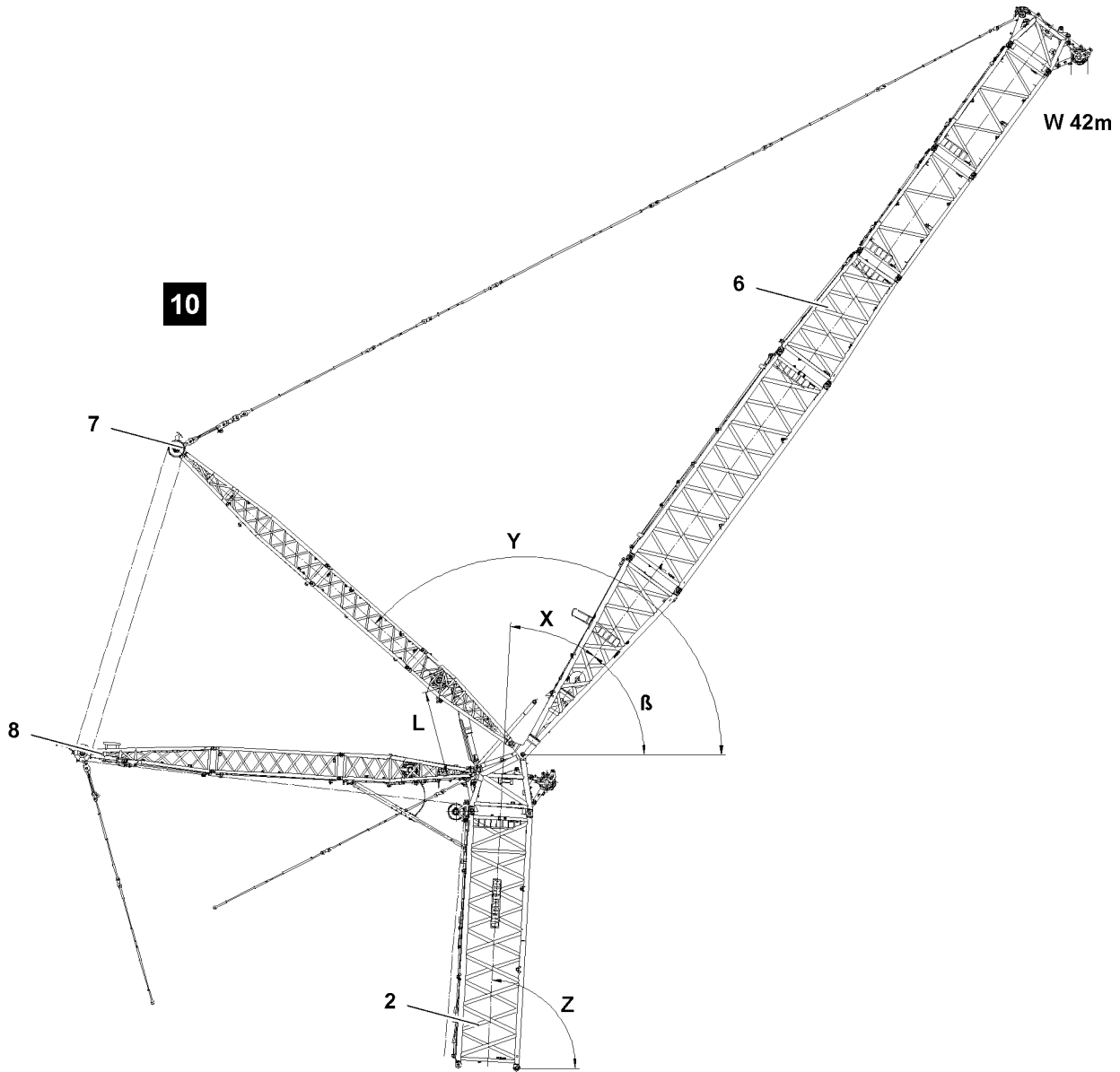

Fig.119054

LWE/LR 11000-001/23501-04-02/en

3.3 W-lattice jib Test position

In test position, the W-control winch movement is turned off by the activated limit switch actuators on the cylinders.

- The W-control winch movement is turned off.
- Icon appears on the LICCON monitor.



Note

- ▶ Specified angles are valid for W-lattice jib 42 m.

	Angle				Cylinder length L
	X ¹⁾	Y ²⁾	Z ³⁾	β ⁴⁾	
End position specified by the control	10°	161.6° ⁵⁾	87°	77°	3158.1 mm
Switch position „Relapse support in flap“	9°	162.6°	87°	78°	3123 mm
Block position „Relapse support in flap on block“	7.7°	163.9° ⁵⁾	87°	79,3°	3078.2 mm
W-relapse cylinder moved out all the way to stop on S-end section	45.2° ⁵⁾	126.4°	87°	41.8° ⁵⁾	4500 mm

W-lattice jib test positions, see also illustration 10

¹⁾ X-angle between S-boom and W-lattice jib

²⁾ Y- angle between horizontal and WA-frame 7

³⁾ Z- angle between horizontal and S-boom

⁴⁾ β- angle between horizontal and W-lattice jib

⁵⁾ Angle dependent on the length of the W-lattice jib

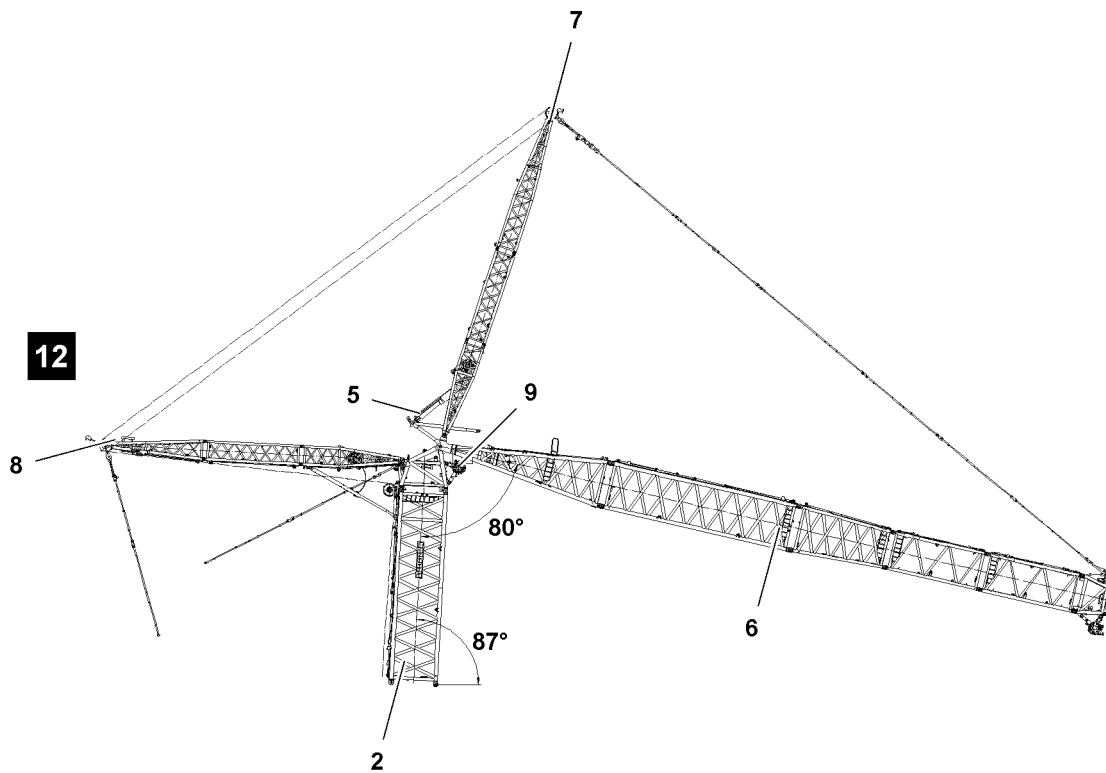
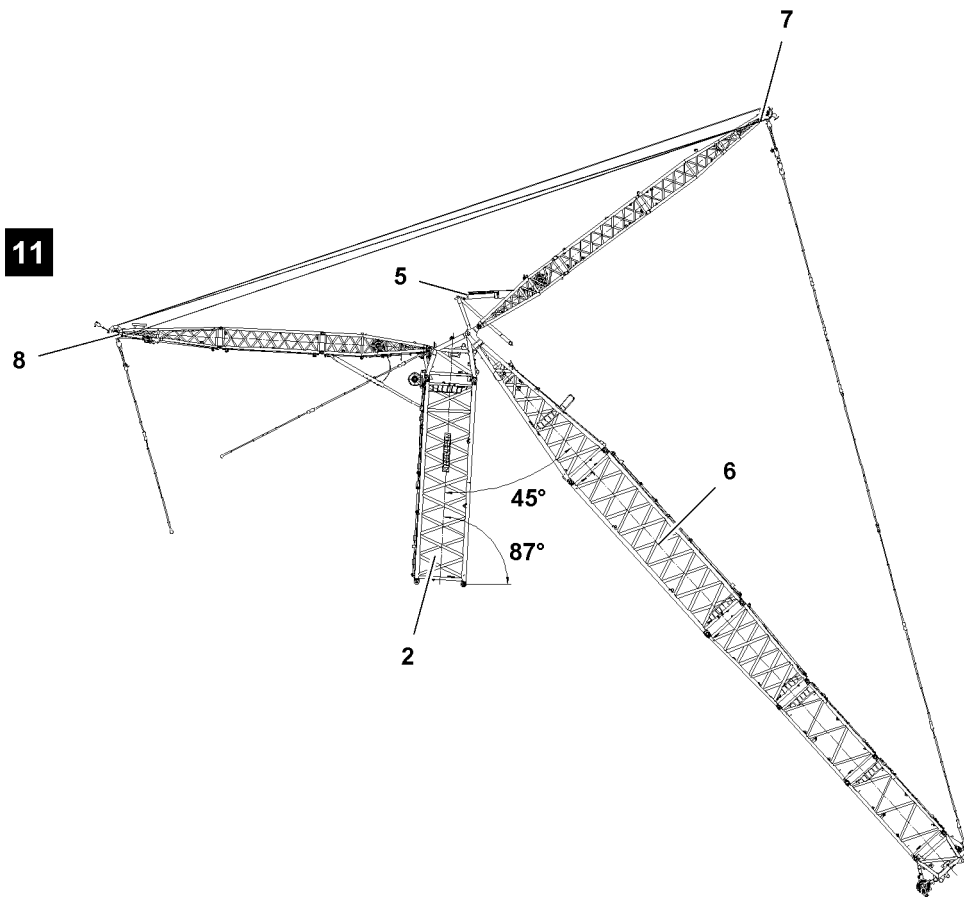

Fig.119051

LWE/LR 11000-001/23501-04-02/en

3.4 W-lattice jib „bottom“

Two switch positions W-lattice jib „bottom“: S-end section without pulley set and S-end section with pulley set 9.

3.4.1 Checking the limit switch actuators for function (S-end section without pulley set)

Swing the WA-frame 7 to the specified angle dimension, see illustration 11, until the limit switch actuators are activated.

- The W-control winch „spooling out“ movement is turned off.
- Icon appears on the LICCON monitor.

3.4.2 Checking the limit switch actuators for function (S-end section with pulley set)

Swing the WA-frame 7 to the specified angle dimension, see illustration 12, until the limit switch actuators are activated.

- The W-control winch „spooling out“ movement is turned off.
- Icon appears on the LICCON monitor.

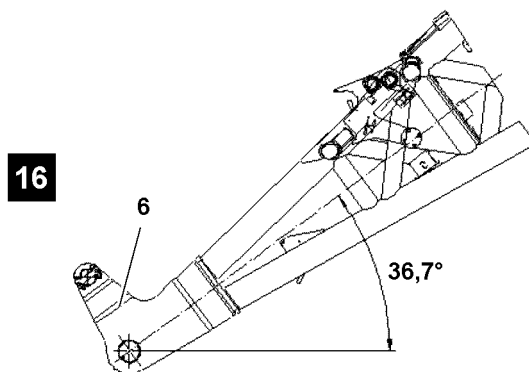
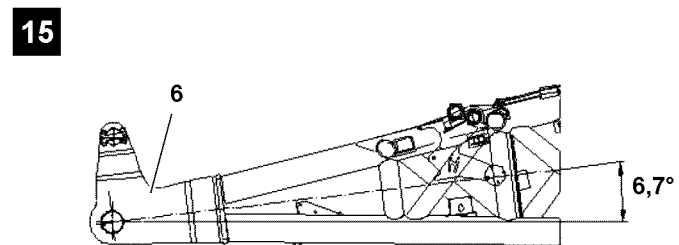
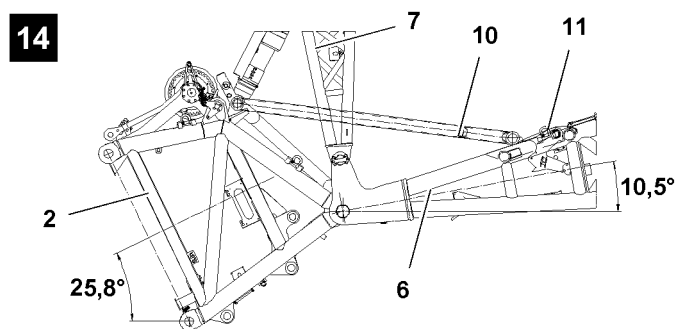
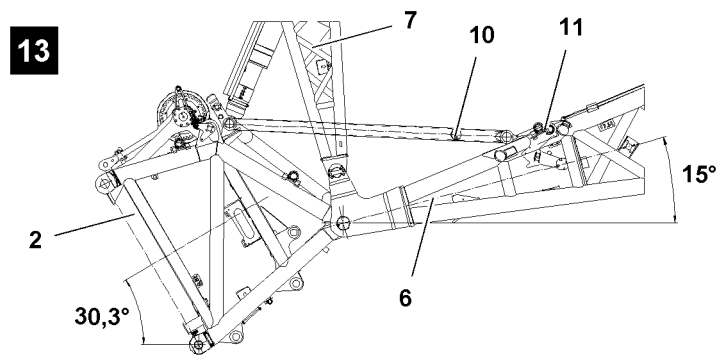

Fig.119052

3.5 Function check of limit switch actuators on the mechanical relapse support - flap

- **10** Mechanical relapse support
- Flap **11** (oscillation guard for mechanical relapse support)

In addition to the W-relapse cylinders, the W-lattice jib is also secured by a mechanical relapse support **10**, which engages in steepest lattice jib position into the flap **11** of the oscillation guard. The luffing up movement of the W-lattice jib is turned off by the actuated limit switches on the oscillation guard.



DANGER

Danger of tipping over if the oscillation guard is hard to move!

If the flap **11** is hard to move, the mechanical relapse retainer will no longer function!

The W-lattice jib can tip backwards uncontrolled and cause the crane to topple over!

Personnel can be severely injured or killed!

- ▶ Before erecting the boom system, the flap **11** must be checked for easy movement over the entire swing range.
- ▶ Make sure that the easy movement of the flap **11** is ensured before every crane application.
- ▶ Crane operation with hard to move flap **11** is prohibited.



Note

- ▶ Depending on the angle of the W-lattice jib, the position of the flap changes due to the pendulum weight.

3.5.1 Flap can be pushed open

Flap can be pushed open, see illustration **13**.

3.5.2 Flap can be pushed closed

Flap can be pushed closed, see illustration **14**.

3.5.3 Flap swings in at stop

Flap swung in at stop, see illustration **15**.

3.5.4 Flap swings out to stop

Flap swung in to stop, see illustration **16**.

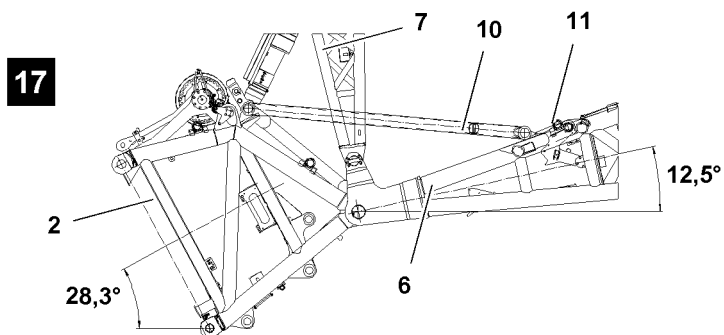
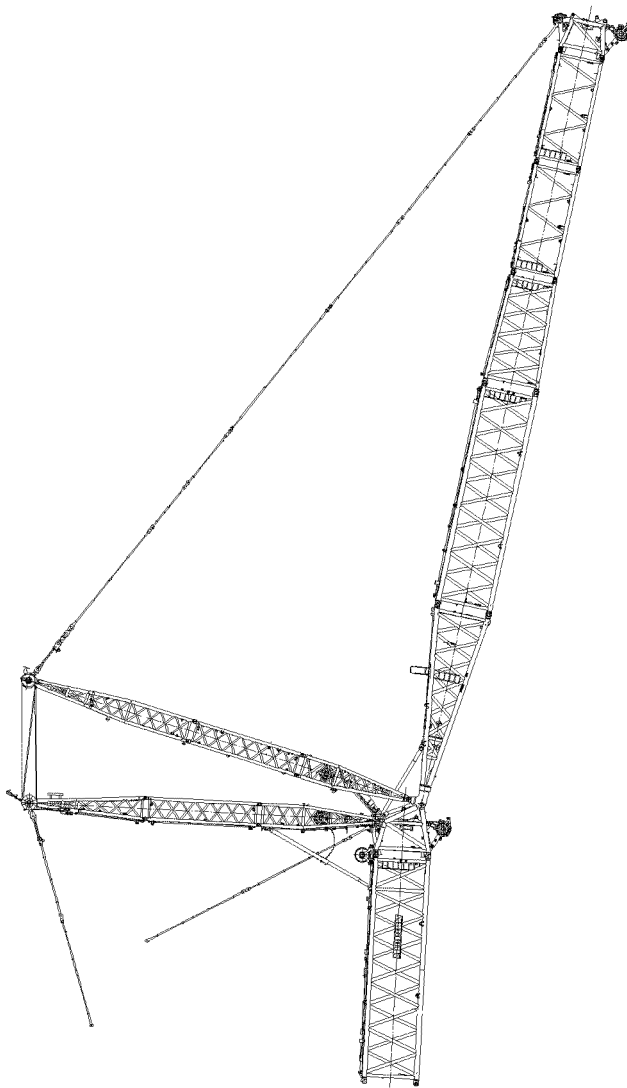

Fig.119053

LWE/LR 11000-001/23501-04-02/en

3.6 Collision of mechanical relapse support with flap

**DANGER**

Danger of collision!

At an angle between the main boom and the W-lattice jib of 20.7° , the mechanical relapse support collides with the flap **11**.

The W-lattice jib can tip backwards uncontrolled and cause the crane to topple over!

Personnel can be severely injured or killed!

- ▶ Make sure that no collision will occur between the relapse support and the flap.
 - ▶ Perform a visual inspection.
-

Collision of mechanical relapse support with flap, see illustration **17**.

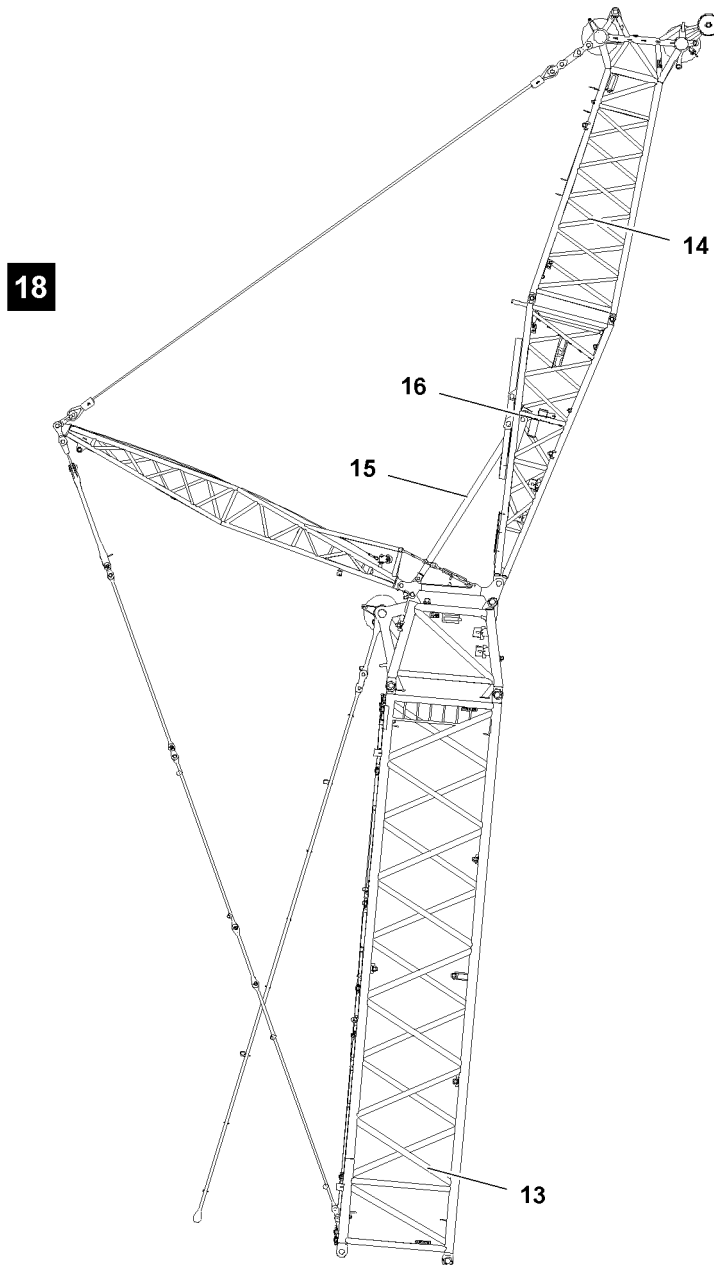

Fig.119055

LWE/LR 11000-001/23501-04-02/en

4 F-lattice jib relapse retainer

4.1 Checking the limit switch actuators for function before erection

Before erecting the F-lattice jib **14**, check the function of the limit switch actuators.

Cover the limit switch actuators individually with a metal plate.

- The movement is turned off.
- Icon appears on the LICCON monitor.

4.2 Relapse support flap

F-lattice jib **14** secured by a mechanical relapse support **15**, which engages in the steepest lattice jib position in the flap **16** of the oscillation guard, see illustration **18**.

The movement of the F-lattice jib **14** is turned off by the actuated limit switches on the oscillation guard.



DANGER

Danger of tipping over if the oscillation guard is hard to move!

If the flap **16** is hard to move, the mechanical relapse retainer will no longer function!

The F-lattice jib can tip backwards uncontrolled and cause the crane to topple over!

Personnel can be severely injured or killed!

- ▶ Before erecting the boom system, the flap **16** must be checked for easy movement over the entire swing range.
 - ▶ Make sure that the easy movement of the flap **16** is ensured before every crane application.
 - ▶ Crane operation with hard to move flap **16** is prohibited.
-

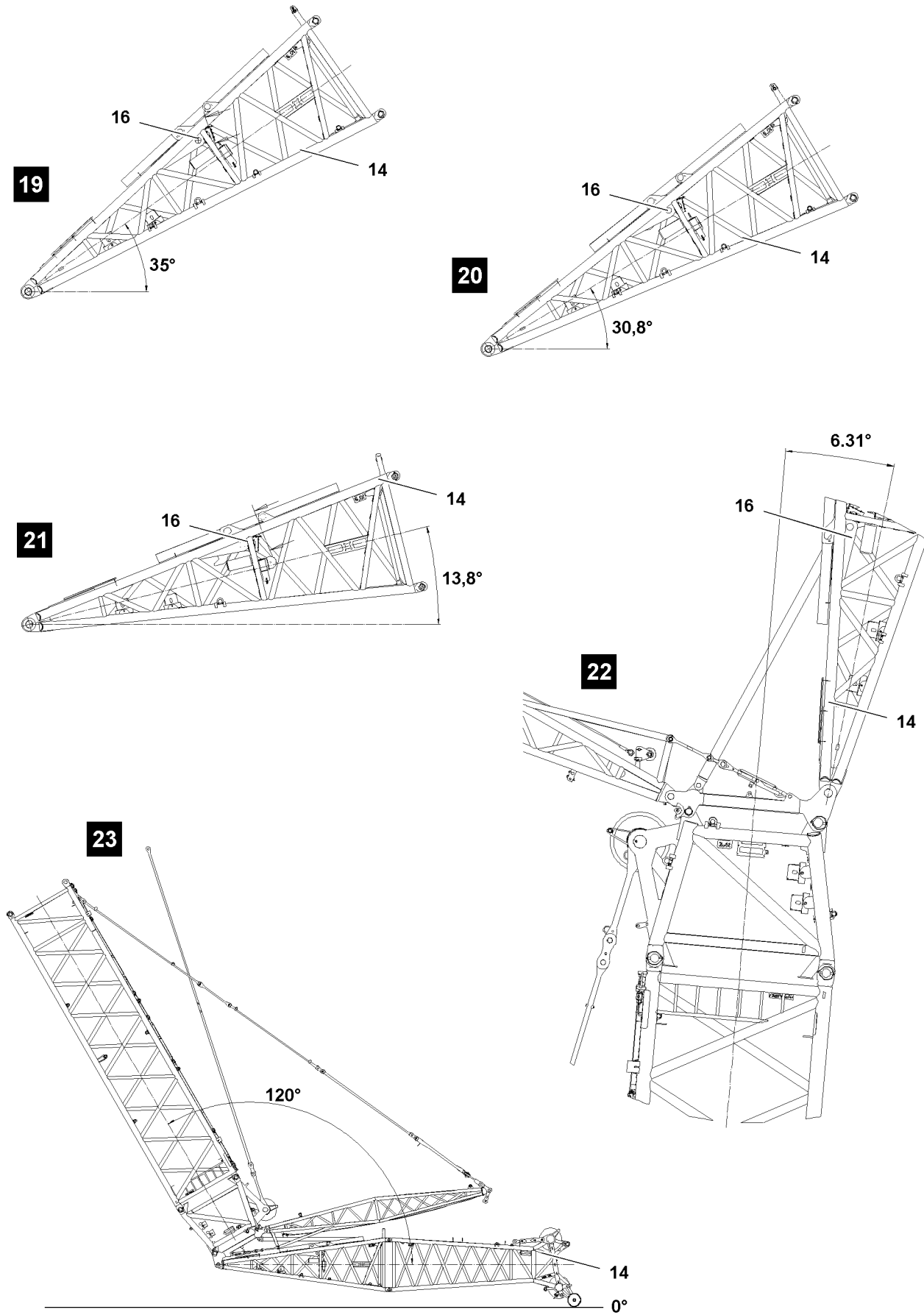

Fig.119056

LWE/LR 11000-001/23501-04-02/en

4.3 Function check of limit switch actuators on the mechanical relapse support - flap

4.3.1 Flap in operating position

Flap **16** in operating position (flap touches on the stop) from approx. 35° between the F-lattice jib and the horizontal.

Flap in operating position, see illustration **19**.

4.3.2 Switch position „Flap top“

Switch position „Flap **16** top“ at approx. 30.8° between F-lattice jib and horizontal.

Switch position „Flap top“, see illustration **20**.

4.3.3 Switch position „Flap bottom“

Switch position „Flap **16** bottom“ at approx. 13.8° between F-lattice jib and horizontal.

Switch position „Flap bottom“, see illustration **21**.

4.3.4 Block position „Relapse support in flap on block“

Flap **16** on block, see illustration **22**.

4.4 Monitoring at SWF-erection procedure

With the aid of the angle sensor the angle between the luffing boom and the F-lattice jib **14** is monitored during the erection procedure.

NOTICE

Danger of property damage!

During the SWF-erection procedure the angle between the luffing boom and the F-lattice jib may not fall below the value of 120°!

► Make sure that the angle between the luffing boom and the F-lattice jib does not fall below 120°.

Erection procedure, see illustration **23**.

Empty page!

LWE/LR 11000-001/23501-04-02/en

8.14 Inspection of accumulator pressure in anti-tilt cylinder

1 Checking the accumulator pressure in the W-relapse cylinder

3

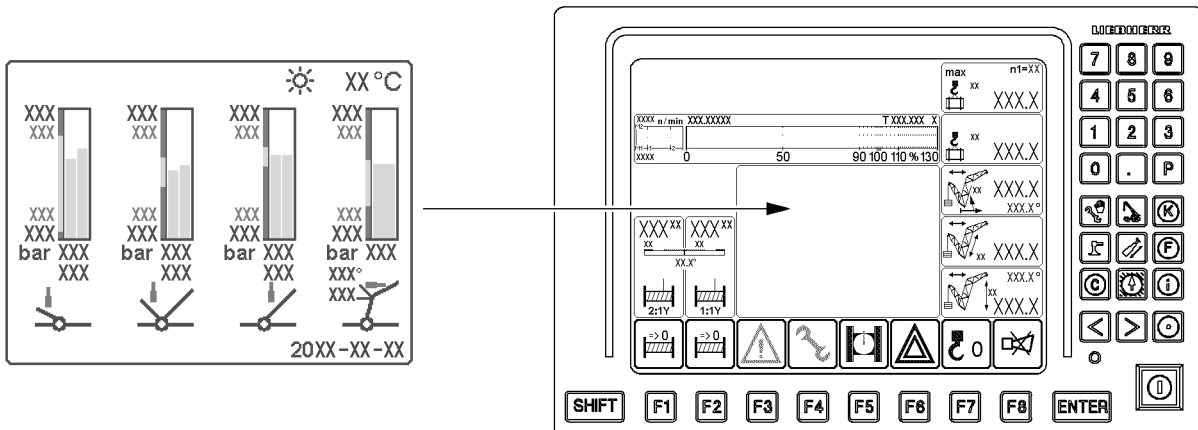
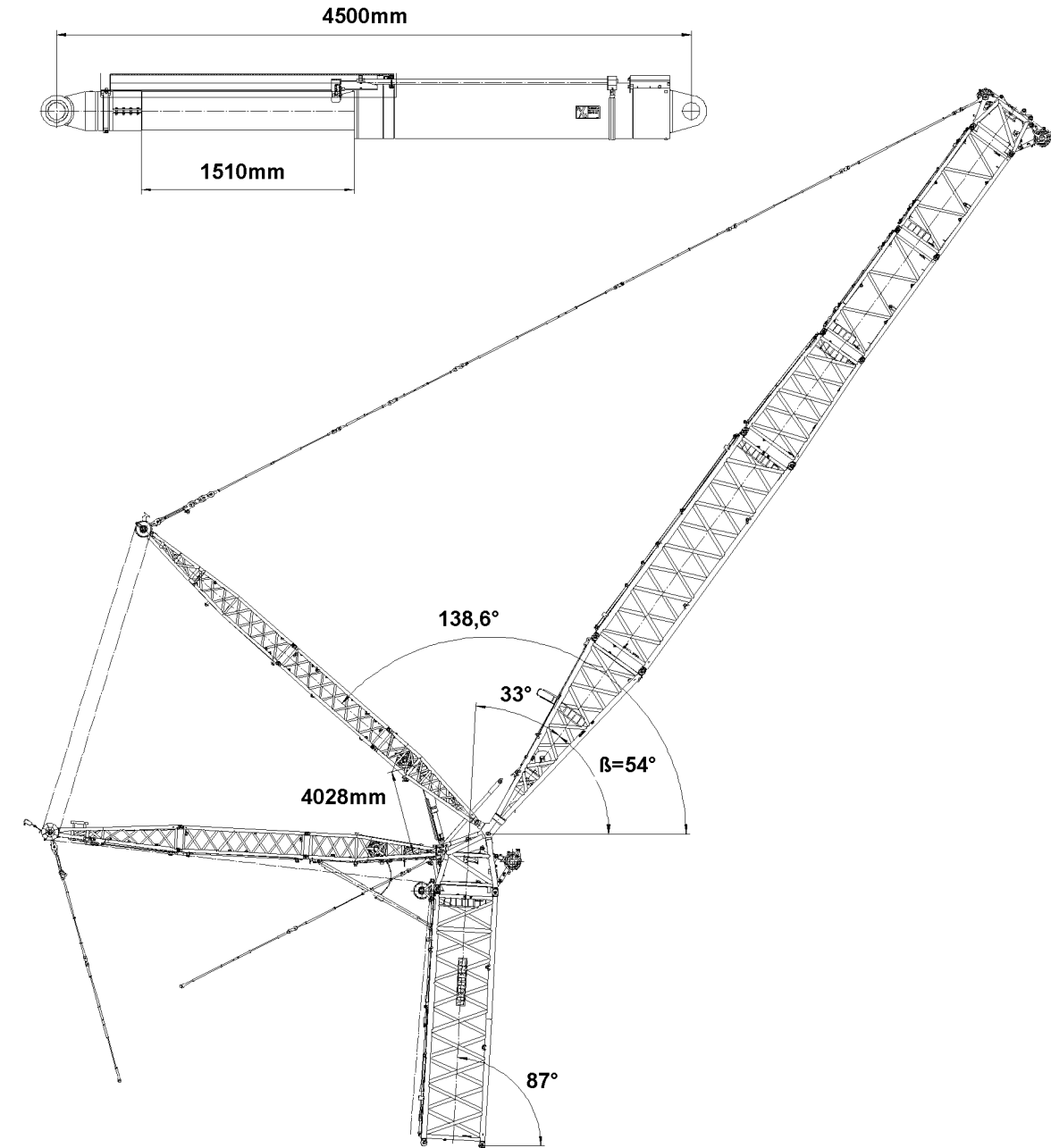

Fig.124294

LWE/LR 11000-001/23501-04-02/en

1 Checking the accumulator pressure in the W-relapse cylinder

Before and during crane operation, the accumulator pressure in the W-relapse cylinder must be checked in the crane operating screen of the LICCON monitor, see Crane operating instructions, chapter 4.02.

The actual pressure shown must match the nominal pressure in the chart.



Note

- ▶ The specified nominal pressure depends on the ambient temperature.
- ▶ The maximum permissible difference between the actual and the nominal pressure is maximum ± 10 bar.

1.1 Checking the accumulator pressure with the „W-relapse cylinder in test position“

- Set the main boom and the lattice jib to the angle specified in the chart, see illustration.
- Compare the actual pressure on the LICCON monitor with the nominal pressure in the chart.

				Pressure / bar				
	$\beta^3)$	Cylinder length	Stroke	- 40 °C	- 20 °C	0 °C	+ 20 °C	+ 40 °C
I ¹⁾	54 ^{0+2°}	4028 mm	1028 mm	136,0	147,8	159,5	172,2	184,2
II ²⁾	41,7°	4500 mm	1500 mm	106,6	115,7	124,9	134,0	143,1

Relapse cylinder in test position

- ¹⁾ I- test position W-relapse cylinder
²⁾ II- W-relapse cylinder moved out all the way
³⁾ At a main boom position of 87°

Empty page!

LWE/LR 11000-001/23501-04-02/en

8.15 Inspection of guy rods

1	Safety guidelines	3
2	Inspection intervals	3
3	Checking the guy rods	3

Fig.195219

LWE/LR 11000-001/23501-04-02/en

1 Safety guidelines



WARNING

Damaged guy rods!

Accident. Death, severe injury, property damage.

- ▶ Crane operation with damaged guy rods **1** is prohibited.
- ▶ Replace damaged guy rods **1**.

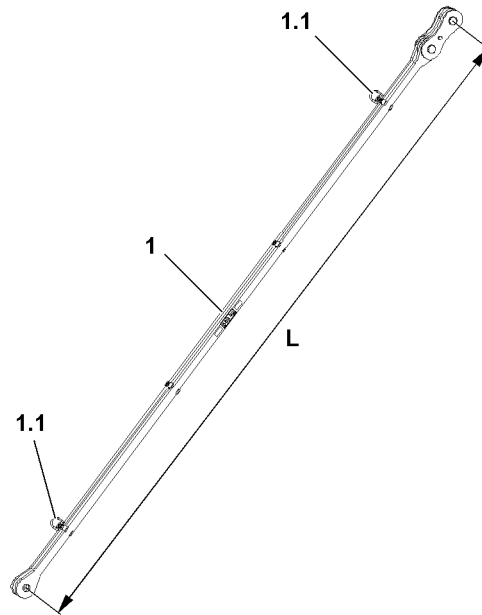

Fig.123845: Guy rod

Make sure that the following prerequisites are met:

- **Authorized and trained expert personnel** checks the guy rods **1**.
- A checklist for documentation of the inspection is on hand

2 Inspection intervals

The inspection of the guy rods **1** must be carried out in the following intervals:

- One inspection of the guy rods every 12 months by an expert.
- One inspection of the guy rods every four years by an authorized inspector.

After a load rip-off or overload of the crane:

- immediate inspection of guy rods by an expert

3 Checking the guy rods

3.1 Inspection



Note

- ▶ All inspections of the guy rods **1** must be documented.

The guy rods must be inspected in removed condition.

**WARNING**

The guy rods **1** can be ripped off!

If a damaged guy rod **1** is used further, it can rip off in crane operation.

Death, severe injury, property damage.

- ▶ Crane operation with damaged guy rods is prohibited.
- ▶ Repairs on guy rods **1** (for example: through welding) are prohibited.
- ▶ Replace damaged guy rods immediately.
- ▶ If one of the following stated damage is found, then the guy rods **1** may no longer be used.

3.2 Cracks and dents

- ▶ Check the guy rods **1** thoroughly through a visual inspection for cracks and dents.

Problem remedy

Damage to guy rods is not clearly evidenced through a visual inspection?

- ▶ Check the respective areas of the guy rods thoroughly, for example with a magnetic particle test.
- ▶ If damage is found: Replace the guy rods **1** immediately.

3.3 Elongation

**Note**

- ▶ The initial dimension **L** of the guy rods **1** refers to the bore spacing of the pin bores.
- ▶ The initial dimension **L** of the guy rods **1** is listed in the separate rod plan.
- ▶ Check the elongation of the guy rods **1** by measuring the guy rods.

**WARNING**

The guy rods can be ripped off!

The permissible elongation of the guy rods **1** may be a maximum of 0.2 %, for example 14 mm , at an initial dimension **L** of 7000 mm.

Death, severe injury, property damage.

- ▶ If the maximum permissible elongation is reached or exceeded: Replace the guy rods **1** immediately.
- ▶ If an elongation of the guy rods of more / equal to 0.2 % of the initial dimension **L** is proven: Replace the guy rods **1** immediately.

3.4 Wear

- ▶ Check the bores, pins and pin retainers for signs of wear.
- ▶ If respective wear is present in the stated areas: Replace the guy rods **1** immediately.

3.5 Ductile deformation

- ▶ If a guy rod **1** shows any ductile deformation: Replace the guy rod **1** immediately.

3.6 Paint / coating

- ▶ The guy rods **1** must be checked for paint damage or corrosion.
- ▶ If damage is present on the paint finish / coating: Repair the paint / coating of the guy rods **1** expertly.

NOTICE

Danger of property damage!

- ▶ Never store guy rods **1** in or near aggressive media, for example: Seawater.
- ▶ Always store the guy rods **1** properly and outside of aggressive media.

3.7 Fastening points

- ▶ Check the fastening points **1.1** of the guy rods **1** for damage.
- ▶ Replace damaged fastening points **1.1**.

Empty page!

LWE/LR 11000-001/23501-04-02/en

8.16 Inspection of fiber guy ropes

1	Safety guidelines	3
2	Inspection intervals	4
3	Inspecting the fiber guy ropes	4

Fig.195219

LWE/LR 11000-001/23501-04-02/en

1 Safety guidelines



WARNING

Damaged fiber guy rope!
Accident. Death, severe injury, property damage.

If damage is found:

- ▶ Have fiber guy rope **1** inspected by authorized and trained expert personnel.

When no final evaluation of the damage can be made:

- ▶ Send the fiber guy rope **1** to the rope manufacturer for inspection and damage evaluation.

If it is found that a fiber guy rope **1** cannot be used any longer or cannot be repaired:

- ▶ Replace the fiber guy rope **1**.

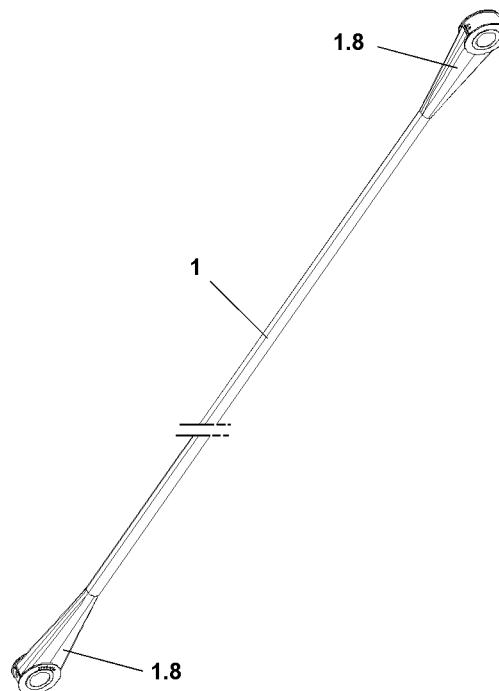

Fig.123614: Fiber guy rope

Make sure that the following prerequisites are met:

- **Authorized and trained expert personnel** inspects the fiber guy rope **1**.
- **In case of doubt:** Rope manufacturer inspects the fiber guy rope **1**

The authorized and trained expert personnel has the following expertise:

- Knowledge about technical design and the condition of fiber guy ropes **1**
- Knowledge about relevant inspection criteria for fiber guy ropes **1**
- Knowledge and experience in the use of various test procedures to determine the scope of the damage
- Knowledge and experience in the evaluation of rope damage on fiber guy ropes **1**
- Has the knowledge about inspection intervals for the required inspections, as specified by the manufacturer
- Knowledge and experience in the evaluation of further use of the fiber guy ropes **1** is permissible
- Knowledge about the required prerequisites for the inspection of fiber guy ropes **1**, as specified by the manufacturer

2 Inspection intervals

Inspection intervals for fiber guy ropes, see Crane operating instructions, chapter 7.03.50.

After a load rip-off or overload of the crane:

- Immediate inspection of fiber guy ropes by an expert

3 Inspecting the fiber guy ropes

3.1 Composition

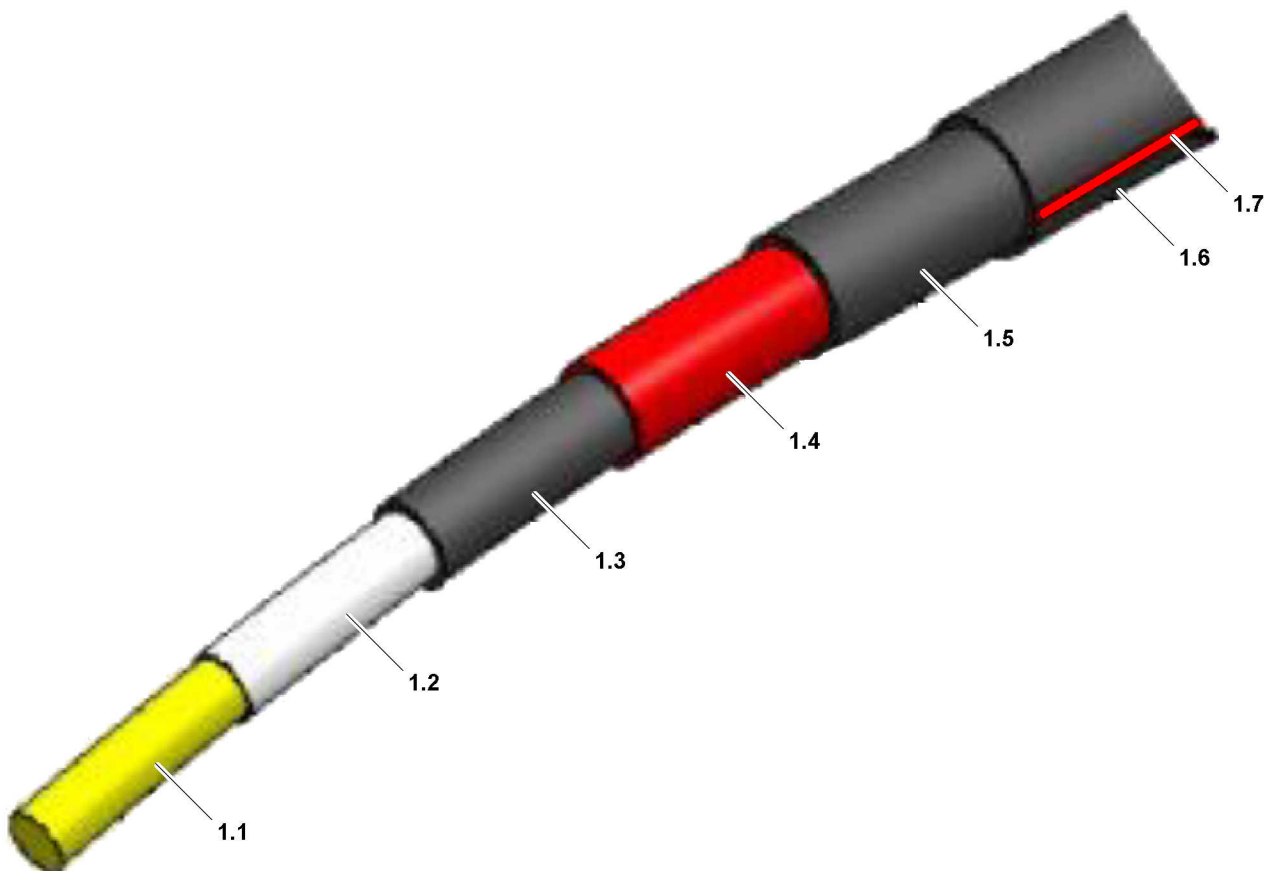

Fig.123619: Composition of a fiber guy rope

1.1 Aramid suspension rope (yellow)	1.4 Inner braiding (red)	1.7 Twist display
1.2 Compression band	1.5 Intermediate layer	
1.3 Sealing band	1.6 Outer braiding	

3.2 Inspection



Note

- All inspections of the fiber guy ropes **1** must be documented.

The inspection of the fiber guy ropes can be made via a visual inspection.

The fiber guy ropes must be inspected in removed condition.

The degree of severity of possible damage and further use of the fiber guy ropes depends mainly on which layers of the rope structure were damaged where and how.

In case of obvious severe rope damage, a safe crane operation should always be the priority and the respective fiber guy rope should be replaced.

If there is any doubt regarding the rope damage, only a detailed inspection of the fiber guy rope by the rope manufacturer can provide information if further use is possible or permissible.



WARNING

The fiber guy ropes can rip off!

Depending on the degree of severity, a damaged fiber guy rope can rip off in crane operation.

- ▶ To ensure a safe crane operation: Continue to use damaged fiber guy ropes only after and extensive inspection and release by the rope manufacturer.



Note

- ▶ If one or several fiber guy rope(s) must be replaced, inform Liebherr Service.

To determine the degree of severity of a damaged fiber guy rope, have the fiber guy rope inspected by the rope manufacturer.

The rope manufacturer decides after intensive inspection of the damage:

- if a repair of the fiber guy rope is possible
- if further use of the fiber guy rope is possible or useful

Only use the fiber guy rope again if the rope manufacturer declares that the damage is harmless and releases the fiber guy rope for further use.



Note

- ▶ The following listed fiber guy rope damage is an example.

3.3 Grommets and rope end connections

The grommets 1.8 and the rope end connections must be thoroughly inspected visually for cracks and dents.



Note

- ▶ If there is any doubt, have the respective areas of the grommet 1.8 thoroughly tested, for example with a magnetic particle test.

Check the pin bores for expansion, elongation and diameter changes.

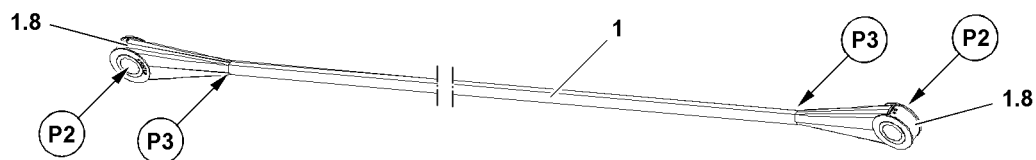

Fig.123700: Grommets and rope end connections on fiber guy rope

- ▶ Remove the fiber guy rope 1.
- ▶ Inspect the fiber guy rope.

**DANGER**

Damaged fiber guy ropes can rip off!

If a fiber guy rope **1** is damaged in the area of the grommet **1.8** or the rope end connection, then the load capacity is significantly reduced.

The grommet **1.8** or the rope end connection can rip off if used further under load in crane operation. Death, severe injury, property damage.

- ▶ Crane operation with damaged rope end connection is prohibited.
- ▶ Replace fiber guy ropes **1** with damaged grommet **1.8** or rope end connection.

- ▶ Check grommets **1.8** on the pin bores **P2** and the rope - grommet transitions **P3**.

When cracks or other severe damage are present:

- ▶ Replace the fiber guy rope **1**.

3.4 Damage symptoms of fiber guy rope

3.4.1 Damaged outer braiding

The fiber guy rope is damaged on the outer braiding **1.6**.

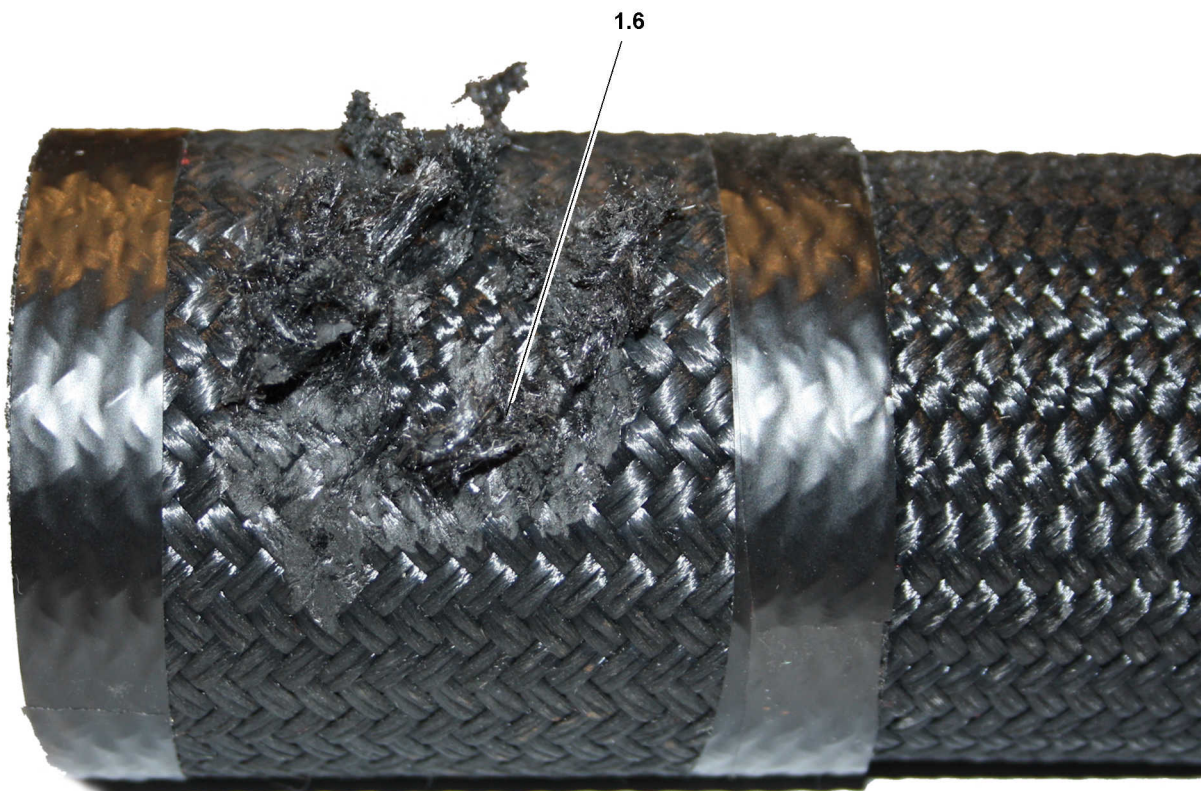

Fig.123615: Damage on outer braiding 1.6

- ▶ Remove the fiber guy rope.
- ▶ Inspect the fiber guy rope.

**WARNING**

Fiber guy rope ripping off!

If the outer braiding **1.6** is not properly repaired, then the outer braiding **1.6** can unravel widely if further used and the braiding underneath can be damaged.

Death, severe injury, property damage.

- ▶ Seal fibers of the outer braiding **1.6** with approved repair agents to prevent further unraveling of the outer braiding **1.6**.

If solely the outer braiding **1.6** is damaged:

- ▶ Carefully remove protruding fibers with a sharp knife or scissors.
- ▶ Repair the outer braiding **1.6** properly with approved repair agents to prevent it from unraveling further.

Result:

- The fiber guy rope can be further used for crane operation.

3.4.2 Damaged rope braiding

The fiber guy rope is damaged on the outer braiding **1.6** and the intermediate layer **1.5**.

The inner braiding (red) **1.4** is visible.

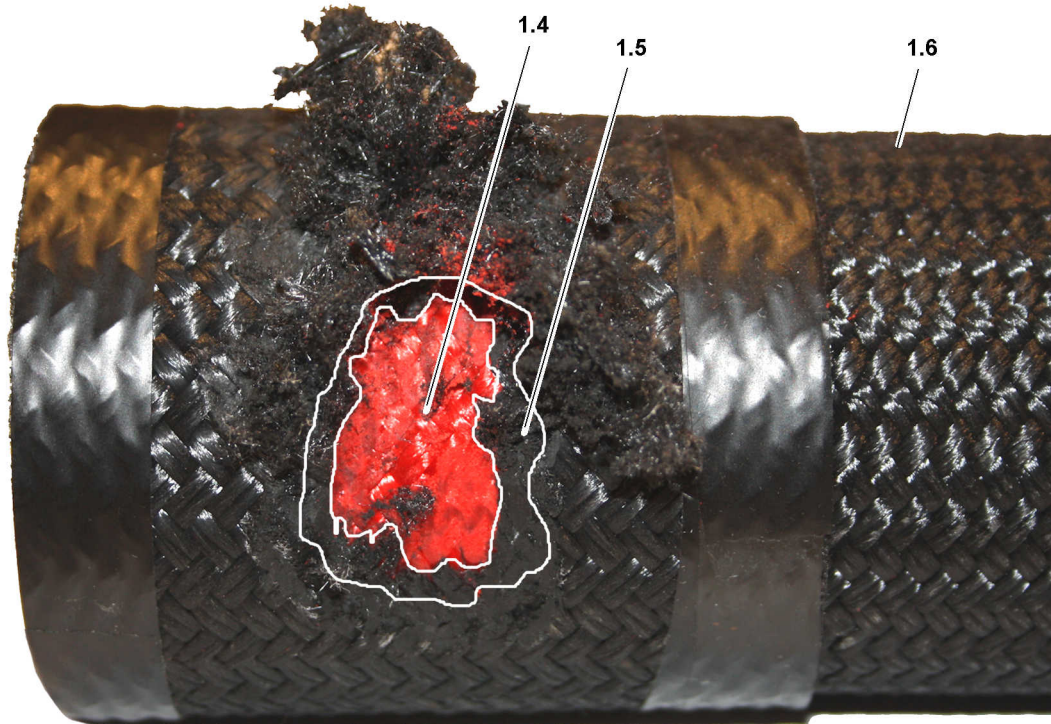

Fig.123616: Damage of outer two rope braidings, inner braiding (red) is undamaged

- ▶ Remove the fiber guy rope.
- ▶ Inspect the fiber guy rope.

**WARNING**

Damaged fiber guy ropes can rip off!

If a fiber guy rope is damaged, then it can rip off if used further under load in crane operation.

Death, severe injury, property damage.

- ▶ Crane operation with damaged fiber guy rope is prohibited.
- ▶ Replace the damaged fiber guy rope.

When the outer braiding **1.6** and the intermediate layer **1.5** are damaged:

- ▶ Replace the fiber guy rope.

3.4.3 Damaged intermediate layers

The fiber guy rope shows grave damage.

The Aramid suspension rope **1.1** is visible and / or damaged.

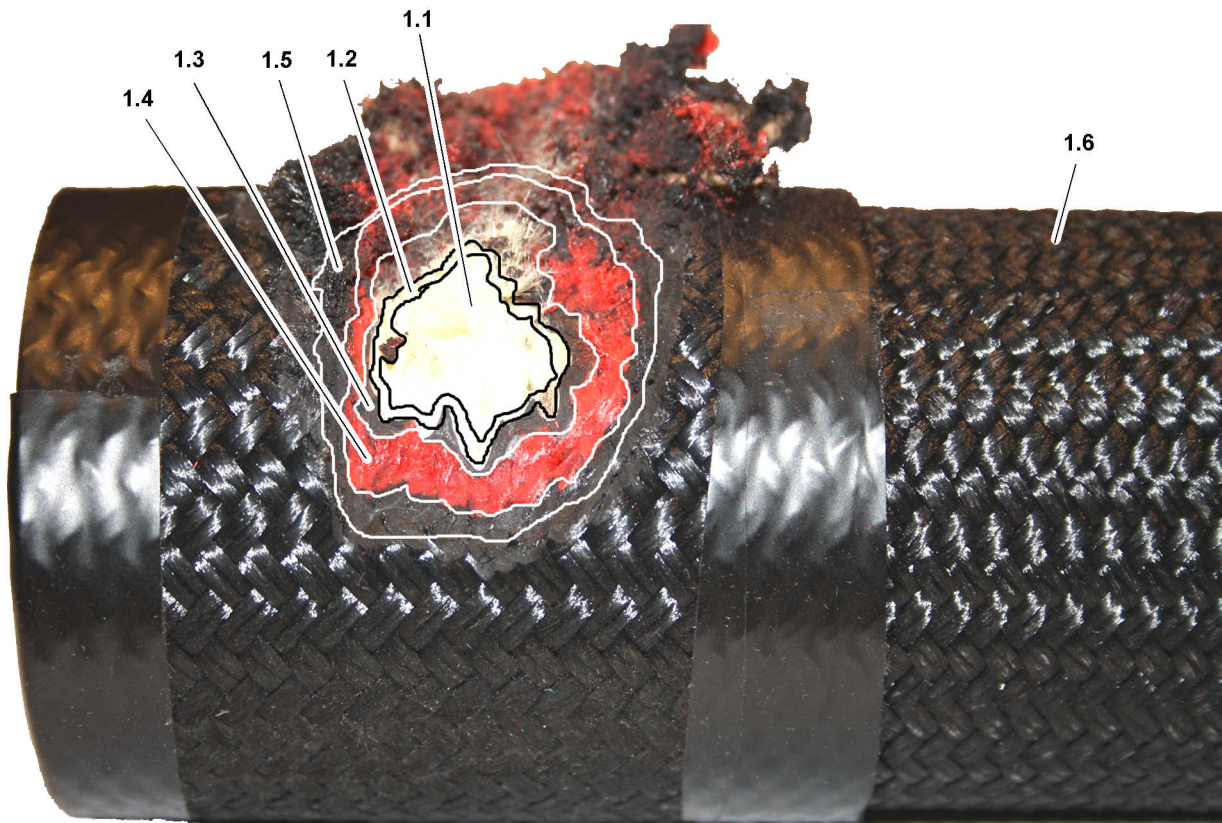

Fig.123617: Damage of outer braiding and all intermediate layers

- ▶ Remove the fiber guy rope.
- ▶ Inspect the fiber guy rope.



DANGER

Damaged fiber guy ropes can rip off!

If a fiber guy rope is damaged into the carrying structure of the Aramid suspension rope (yellow) **1.1** then the fiber guy rope will rip off if used further under load in crane operation.

Death, severe injury, property damage.

- ▶ Crane operation with damaged fiber guy rope is prohibited.
- ▶ Replace the damaged fiber guy rope.

When the outer braiding **1.6** and all intermediate layers are damaged up to the Aramid suspension rope (yellow) **1.1**:

- ▶ Replace the fiber guy rope.

3.4.4 Buckles

Buckles are angular deformations.

The rope was damaged due to external influences.

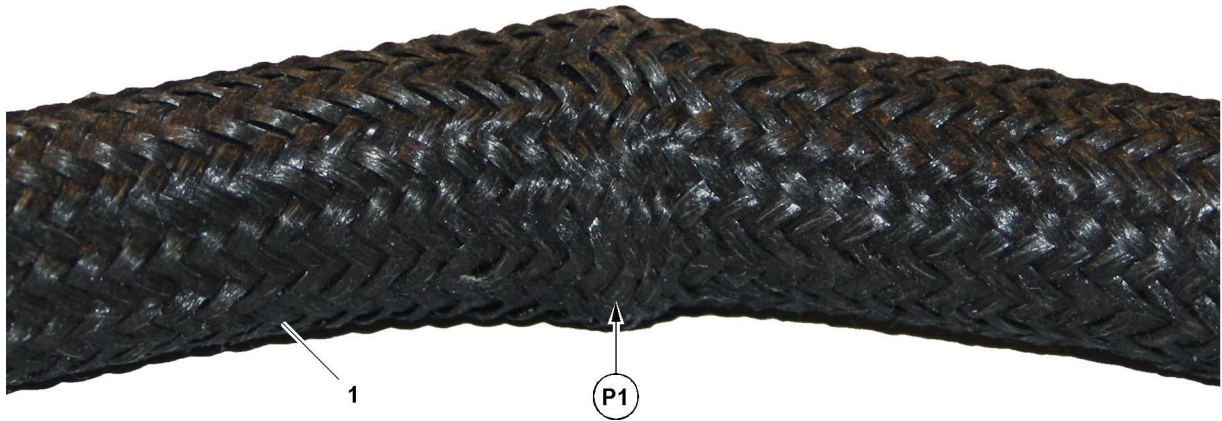

Fig.123618: Fiber guy rope buckled at point **P1**

- ▶ Remove the fiber guy rope.
- ▶ Inspect the fiber guy rope.



DANGER

Damaged fiber guy ropes can rip off!

If a fiber guy rope is buckled, then the load capacity is significantly reduced.

The fiber guy rope can rip off if further used under load in crane operation.

Death, severe injury, property damage.

- ▶ Crane operation with buckled fiber guy rope is prohibited.
- ▶ Replace the damaged fiber guy rope.

A buckle is severe if a fold / compression well as a clear buckle is visible on one side of the fiber guy rope (for example at point **P1**).

When a buckle is present:

- ▶ Replace the fiber guy rope.
- ▶ Have the fiber guy rope inspected by the rope manufacturer.

Empty page!

LWE/LR 11000-001/23501-04-02/en

8.17 Inspection of ladders

1	Safety guidelines	3
2	Inspection intervals	3
3	Inspecting ladders	3
4	Inspection sheet and check list	3

Fig.195219

LWE/LR 11000-001/23501-04-02/en

1 Safety guidelines



WARNING

Damaged ladders!
Accident. Death, severe injury, property damage.

If damage is found:

- ▶ Have ladders repaired by authorized and trained expert personnel.

If it is determined that the ladder cannot be repaired:

- ▶ Scrap the ladder immediately.

Make sure that the following prerequisite is met:

- **Authorized and trained expert personnel** checks the ladders.

The authorized and trained expert personnel has the following expertise:

- Knowledge, experience and abilities in repairing ladders
- Is familiar with the necessary prerequisites as determined by the contractor for the inspection of ladders
- Has the knowledge about the type, scope and intervals for the required inspections as determined by the contractor

2 Inspection intervals

The inspection of ladders must be carried out in the following intervals:

- The contractor determines the **required** intervals
- But there must be at least one inspection every **12 months**

Intervals depend on:

- Operating conditions
- Frequency of use
- Operational demands during use
- Frequency and severity of defects found during previous inspections

3 Inspecting ladders

Make sure that the following prerequisites are met:

- Ladder inspection sheets are on hand. For blank form, see section „Inspection form for the inspection of ladders and steps“
- Check lists are on hand. For blank form, see section „Check list for the inspection of ladders and steps“
- ▶ For every ladder and every step: Enter the data in the ladder inspection form.
or
Get the ladder inspection form for ladders or steps.
- ▶ Check the ladders and steps according to the check list and document the results.
- ▶ Collect the ladder inspection forms and check lists in the crane documentation.

4 Inspection sheet and check list

The following is shown, as an example: Inspection form and check list for the inspection of ladders and steps.

4.1 Inspection form for the inspection of ladders and steps

Ladder control sheet	
Stock no. of the ladder/steps	
Location/installation location	
Ladder type	Stepladder
	Leaning ladder
	Leaning ladder with overshoot
	Vertical ladder
	Vertical ladder with overshoot aid
	Platform ladder
	Steps
Material of the ladder	Aluminium
	Plastic
	Steel
	Stainless steel
Number of rungs/stairs	
Ladder length/ladder shortened to	
Manufacturer/dealer	
Article/type number	
Date of purchase	
Date of discard	
Name of representative	
Next inspection	

Control sheet for inspecting ladders and steps

Fig.121361-en

4.2 Check list for the inspection of ladders and steps

Inspection criteria	1st Inspection	2nd Inspection	3rd Inspection	4th Inspection	5th Inspection
1. Beams					
Deformation					
Damage (for example cracks)					
Sharp edges, splinters, burrs					
Wear					
Protective treatment					
2. Rungs/stairs/platform					
Deformation					
Damage					
Sharp edges, splinters, burrs					
Connection to the beam (for example, flanging, screw/rivet connections, welding seam)					
Wear (for example, stepping surfaces, platform overlay)					
3. Spreader safety					
Completeness/fastening					
Functionality					
Damage					
4. Fitting parts					
Damage/corrosion					
Completeness/fastening					
Functionality					
Wear					
Lubrication (mechanical parts)					

Fig.121362-en

Inspection criteria	1st Inspection	2nd Inspection	3rd Inspection	4th Inspection	5th Inspection
5. Ladder/stands/pulleys					
Completeness/fastening					
Wear/damage					
Functionality					
6. Accessories (for example, beam extension, base expansion, wall support)					
Completeness/fastening					
7. Identification					
Operating instructions (for example, pictogram)					
8. Inspection result					
Ladder OK and usable					
Repair necessary					
Discard ladder immediately					
Comments					
Next inspection (month/year)					
Ladder inspected					
Date					
Signature					

Check list for inspecting ladders and steps

Fig.121363-en

8.90 Inspection chart for cranes

1 Inspection chart for recurring inspections of Liebherr cranes

3

LWE/LR 11000-001/23501-04-02/en

Fig.195219

LWE/LR 11000-001/23501-04-02/en

1 Inspection chart for recurring inspections of Liebherr cranes

The following is a checklist to assist the inspector during the periodic inspections of Liebherr mobile and crawler cranes.

Company:	Inspector:
Crane manufacturer: Liebherr	Crane type:
Serial number:	Stock number:
Year of construction:	Date:
Inspector's signature for No. 1 to 22:	

1. inspection category: Crane document						
Component to be inspected	A	B	C	D	E	Comments
Crane inspection log						
Operating and installation instructions						
Crane control log						
Load chart manual						
Job planner						

2. inspection category: Signs / identification						
Component to be inspected	A	B	C	D	E	Comments
Factory tag						
Load data						
Operating instruction label						
Prohibition and command signs						
Other safety signs						

3. inspection category: Travel gear ¹						
Component to be inspected	A	B	C	D	E	Comments
Frame ²						
Supports ³						
Axles						
Wheels						
Tires						
Bearings						
Transmission						
Universal drive shaft						
Leaf springs / springs						
Shock absorbers						

LWE/LR 11000-001/23501-04-02/en

3. inspection category: Travel gear ¹						
Component to be inspected	A	B	C	D	E	Comments
Steering						
Brakes						
Hydraulic axle suspension						

4. inspection category: Chassis ¹						
Component to be inspected	A	B	C	D	E	Comments
Coverings						
Accessible surfaces						
Counterweight holders ²						
Towing devices						
Accesses, ladders						
Holding devices, handles						
Platforms, railings						
Retainer for hook block ²						
Boom support ²						

5. inspection category: Chassis - driver's cab ¹						
Component to be inspected	A	B	C	D	E	Comments
Doors						
Windows / windshields						
Window wipers						
Mirrors						
Seat						
Heater						
Ventilation						
Sound absorber						
Trip recorder						
First aid kit						
Spare bulbs						
Hazard warning triangle						
Safety vest						

6. inspection category: Chassis - drive ¹						
Component to be inspected	A	B	C	D	E	Comments
Combustion engine						
Exhaust system						
Fuel tank						

6. inspection category: Chassis - drive ¹						
Component to be inspected	A	B	C	D	E	Comments
Urea container						
Fuel container						
Filters						
Sound absorber						
Engine mount						
Oil levels						
Fuel lines						
Urea lines						
Fuel lines						

7. inspection category: Chassis - hydraulics ¹						
Component to be inspected	A	B	C	D	E	Comments
Oil container						
Filter with maintenance indicator						
Pumps						
Motors						
Valves						
Lines						
Hoses						
Cylinder						
Pressure limiting valves						

8. inspection category: Chassis - compressed air system ¹						
Component to be inspected	A	B	C	D	E	Comments
Compressor						
Filters						
Air tanks						
Valves						
Lines						
Hoses						
Cylinder						

9th inspection category: Chassis - electrical system ¹						
Component to be inspected	A	B	C	D	E	Comments
Motors						
Generators						
Battery						

LWE/LR 11000-001/23501-04-02/en

9th inspection category: Chassis - electrical system ¹						
Component to be inspected	A	B	C	D	E	Comments
Switches / buttons						
Lines						
Fuses						
Resistors						
Lighting						
Brake lights						
Blinkers						
Tail lights						
Working lights						
Signaling systems						
Indicator lights						
Battery switch						
Limit switches: Transmission, steering, drive train						
Support pressure indicator ²						

10th inspection category: Chassis - control systems ¹						
Component to be inspected	A	B	C	D	E	Comments
Engine regulation						
Transmission						
Couplings						
Circuits						
Brakes						
Steering						
Control displays						
Engine shut off line						
Control of supports ²						
Axle suspension						
Crane leveling						
Rear axle steering						

11th inspection category: Superstructure						
Component to be inspected	A	B	C	D	E	Comments
Frame						
Coverings						
Treads						
Bearings						

11th inspection category: Superstructure						
Component to be inspected	A	B	C	D	E	Comments
Counterweights						
Relapse retainer						
Slewing ring connection: Tilt play						
Slewing ring connection: Mounting screws						
Slewing ring connection: Gears						
Slewing gear: Mounting screws						
Slewing gear: Gears						

12th inspection category: Superstructure - crane operator's cab						
Component to be inspected	A	B	C	D	E	Comments
Doors						
Windows / windshields						
Window wipers						
Mirrors						
Seat						
Heater						
Ventilation						
Muffler						
Joystick for working functions						
Gear shifts						
Safety: Crushing / shear locations						

13th inspection category: Superstructure - Retaining and protection devices						
Component to be inspected	A	B	C	D	E	Comments
Accesses, ladders						
Handles						
Coverings						
Covers						
Hatches						
Treads						

14th inspection category: Superstructure - drive train						
Component to be inspected	A	B	C	D	E	Comments
Combustion engine						
Exhaust system						
Fuel tank						
Urea container						

LWE/LR 11000-001/23501-04-02/en

14th inspection category: Superstructure - drive train						
Component to be inspected	A	B	C	D	E	Comments
Fuel container						
Filters						
Sound absorber						
Engine mount						
Fuel lines						
Urea lines						
Fuel lines						

15. inspection category: Superstructure - hydraulic system						
Component to be inspected	A	B	C	D	E	Comments
Oil container						
Filters						
Pumps						
Motors						
Valves						
Lines						
Hoses						
Cylinder						
Pressure limiting valves						
Lowering brake valves						
Brake control: Hoist gear						
Brake control: Slewing gear						

16th inspection category: Superstructure - electrical system						
Component to be inspected	A	B	C	D	E	Comments
Motors						
Generators						
Batteries						
Switches / buttons						
Lines						
Fuses						
Resistors						
Lighting						
Signal lights						

17. inspection category: Superstructure - control systems						
Component to be inspected	A	B	C	D	E	Comments
Engine regulation						
Transmission						
Flexible couplings						
Circuits						
Engine shut off line						
Control displays						

18. inspection category: Superstructure - rope drives						
Component to be inspected	A	B	C	D	E	Comments
Winch 1 ³						
Winch 2 ³						
Winch 3 ³						
Winch 4 ³						
Winch 5 ³						
Winch 6 ³						
Assembly winches ³						
Rope pulleys						
Rope end connection						
Rope for winch 1						
Rope for winch 2						
Rope for winch 3						
Rope for winch 4						
Rope for winch 5						
Rope for winch 6						
Rope for assembly winches						
Guy ropes						

19th inspection category: Superstructure - hook						
Component to be inspected	A	B	C	D	E	Comments
Pulleys						
Rope guards on pulleys						
Axle support						
Load hook						
Load hook mounting						
Hook retention						

LWE/LR 11000-001/23501-04-02/en

20th inspection category: Superstructure - safety and switch systems						
Component to be inspected	A	B	C	D	E	Comments
Hoist emergency limit switch I						
Hoist emergency limit switch II						
Lowering emergency limit switch I						
Lowering emergency limit switch II						
Boom emergency limit switch I						
Boom emergency limit switch II						
Luffing jib: Boom limit switch I						
Luffing jib: Boom limit switch II						
Load torque limiter						
Angle display: Boom						
Angle display: Luffing jib						
Angle display: Slewing gear						
Safety devices: Control						
Working range limitation						
Pressure sensors						
Speed sensor						
Wind sensor						
Sliding beam monitoring						
Support pressure indicator						
Incline display						
Length indicator: Radius, boom length						
Emergency off system						
Engine stop						

21th inspection category: Boom						
Component to be inspected	A	B	C	D	E	Comments
Weld structure						
Rope pulleys						
Change over pulleys feed mechanism						
Luffing cylinder						
Telescoping cylinder						
Boom extension ropes						
Boom retraction ropes						
Boom bearings						
Boom pinning						
Guy rods						
Guy ropes						

21th inspection category: Boom						
Component to be inspected	A	B	C	D	E	Comments
Control ropes						
Guide ropes						
Safety ropes						
Relapse cylinders						
Pin connections						

22. inspection category: Equipment						
Component to be inspected	A	B	C	D	E	Comments
Weld structure						
Rope pulleys						
Relapse cylinder						
Relapse support						
Oscillation guard						
A-frame bearings						
Pinning of components						
Guy rods with pinning						
Rods with guide rail on A-frame 2 and A-frame 3						
All limit switches with switch mechanism						
Pin connections						

Inspection chart for periodic inspections of Liebherr mobile and crawler cranes

Inspection criteria:

- A = Present / complete
- B = Condition / maintenance
- C = Function
- D = Repair / replace
- E = Re-inspection required

Evaluation:

- Satisfactory = x
- Unsatisfactory = -
- Not required = 0

Comments:

- ¹ Inspection of the crane carrier vehicle road worthiness is also fulfilled if it has already been certified by the road traffic department certification authority. For cranes that are not certified for use on public roads, an expert or authorized inspector must conduct the required tests to validate the vehicle's road worthiness.
- ² These inspections must be carried out by an authorized inspector even if it has passed the road traffic department test and is certified.
- ³ Inspection of the winches with respect to the actually used proportion of their design life.

Empty page!

LWE/LR 11000-001/23501-04-02/en

90 Attachment

LWE/LR 11000-001/23501-04-02/en

LWE/LR 11000-001/23501-04-02/en

90.01 Foreword to attachment

1 Foreword

3

LWE/LR 11000-001/23501-04-02/en

Fig.195219

LWE/LR 11000-001/23501-04-02/en

1 Foreword

This crane may only be used in a flawless technical condition and according to its mission as well as with constant awareness of safety and dangers. Any problems, which could affect safety, must be fixed immediately.



Note

- ▶ Modifications on the crane may only be made with written approval by Liebherr-Werk Ehingen GmbH.

1.1 Change to the operating instructions

Changes to the operating instructions are received in the form of chapters. The chapter to be replaced must be removed from the operating instructions and replaced with the new chapter in the same location.

When you receive a change to the operating instructions:

- ▶ Remove the chapter to be replaced from the operating instructions.
- ▶ File the new chapter in the same location in the operating instructions.
- ▶ Destroy the replaced chapter.
- ▶ Fill out the change confirmation form in chapter 90.05 of the operating instructions.

1.2 Update to the operating instructions

Updates to the operating instructions, which you receive in the circular as Customer information, must be filed in the operating instructions in chapter 90.05.



Fig.113870: Customer information decal

When you receive an update to the operating instructions:

- ▶ Attach the decals **1**, which are enclosed in the customer information to the footer of the respective chapter. See the following example.



Note

Example: Update to the operating instructions!

If there is an update that concerns the operating instructions, chapter 2.04:

- ▶ Attach the decal **1** in the footer of chapter 2.04.
- ▶ File the update in chapter 90.05 of the operating instructions.
- ▶ Fill out the update confirmation form in chapter 90.05 of the operating instructions.

Empty page!

LWE/LR 11000-001/23501-04-02/en

90.05 Update confirmation

1	Change confirmation form	3
2	Update confirmation	3
3	Customer information	4

Fig.195219

LWE/LR 11000-001/23501-04-02/en

3 Customer information

Index

3

3-point support **2.04.10 - 9**

7

7725039 – Warning of high voltage **2.05 - 3**
772564008 – Slewing range **2.05 - 3**
772580408 – Limitation of maximum travel speed **2.05 - 4**

9

9402377 – Fastening point / lifting point **2.05 - 10**
9412158 – Reading the operating instructions **2.05 - 5**
97001802 – Falling platform **2.05 - 33**
97003109 – Accessing of step ladder **2.05 - 14**
97003110 – Folding the step ladder in and out **2.05 - 15**
97003112 – Maximum suspended load **2.05 - 21**
97004046 – Safety harness, maximum two persons **2.05 - 6**
97006167 – Identification of the support base **2.05 - 15, 2.05 - 15**
97008514 – Warning of head injuries **2.05 - 16**
97009799 – Data logger **2.05 - 16**
97011336 – Transport weights of the components **2.05 - 34**
97011689 – Danger of crushing **2.05 - 18**
97011690 – Overload of cab is prohibited **2.05 - 19**
97012095 – Maximum load **2.05 - 17**
97012737 – Danger of accident **2.05 - 20**
97012949 – Maximum load **2.05 - 17**
97016304 – Refueling **2.05 - 19**
97016392 – Crushing danger for feet **2.05 - 20**
97016911 – Danger of collision **2.05 - 28**
97017585 – Falling telescopic boom during disassembly / assembly **2.05 - 6**
97018351 – Falling telescopic boom during transport! **2.05 - 7**
97018564 – Falling telescopic boom during transport! **2.05 - 7**
97023034 – Disassembling **2.05 - 20**
97027147 – Overloading of combi box is prohibited **2.05 - 7**
97033982 – Mounting / demounting the Derrick pivot section **2.05 - 25**
97036732 – Access via 3-point support **2.05 - 21**
97036733 – Fastening point **2.05 - 8**
97036734 – Rigging point **2.05 - 31**
97036735 – Fastening point for lattice section **2.05 - 11**
97036736 – Fastening point for lattice sections **2.05 - 11**

97036917 – Maximum suspended load **2.05 - 22**
97037383 – Urea **2.05 - 22**
97037625 – Suspended load Fastening points / rigging points **2.05 - 10**
97037871 – Fastening points for lattice sections **2.05 - 12**
97037952 – Warning of fatal electric shock **2.05 - 22**
97038442 – Fastening point for lattice section **2.05 - 11**
97038452 – Fastening point for lattice sections **2.05 - 12**
97038454 – Fastening point for lattice sections **2.05 - 12**
97039035 – Suspended load Assembly unit **2.05 - 14**
97039753 – Danger of stumbling **2.05 - 28**
97041305 – Overload of components **2.05 - 24**
97042730 – Falling luffing cylinder **2.05 - 23**
97042797 – Overload of components **2.05 - 23**
97046488 – Corrosion inhibitor - antifreeze fluids **2.05 - 19**
97047566 – Center of gravity Counterweight **2.05 - 37, 2.05 - 38, 2.05 - 38, 2.05 - 38, 2.05 - 39, 2.05 - 39**
97047810 – Pin brackets **2.05 - 23**
97053409 – Entanglement hazard during winch operation **2.05 - 18**
97057097 – Fastening point to turn the component **2.05 - 13**
97057524 – Fastening point for assembly of lattice sections **2.05 - 13**
97057767 – Fastening points for lattice sections **2.05 - 13**
97059339 – Suspended load Derrick pivot section **2.05 - 14**
97068370 – Closing the cab door **2.05 - 18**
97068839 – Transport weights of the components / fastening length of the fastening equipment **2.05 - 34**
97069053 – Storage boxes open **2.05 - 17**
97070905 – Removing the auxiliary jib (boom nose) **2.05 - 24**
97094940 – Spark catcher **2.05 - 32**
97096132 – Fastening points N-assembly unit **2.05 - 10**
971494208 – Limitation of maximum travel speed **2.05 - 26**
971539808 – Warning notice for unpinning the auxiliary boom on the pulley head **2.05 - 26**
971539908 – Warning notice for unlocking the auxiliary boom **2.05 - 27**
973974408 – Transport weights of the components **2.05 - 33**
973974608 – Transport weights of the components **2.05 - 34**
976624808 – Fastening the load **2.05 - 36**
977055908 – Fastening point for swingable sliding beam **2.05 - 25**
978673908 – Warning of suspended load **2.05 - 27**
978674008 – Access for unauthorized personnel prohibited **2.05 - 27**

978674108 – Warning of crushing danger **2.05 - 28**
978674308 – Radio remote control **2.05 - 29**
978674408 – Danger of burning hands **2.05 - 29**
978674508 – Warning of rotating parts **2.05 - 29**
978674608 – Crushing danger for hands **2.05 - 30**
978674808 – Personal protective equipment **2.05 - 30**
978674908 – Walking on the area is prohibited **2.05 - 30**
978675008 – Access prohibited **2.05 - 31**
978687408 – Rigging point **2.05 - 31**
978867108 – Warning of fatal electric shock **2.05 - 32**
979383308 – Oil change **2.05 - 32**
979561108 – Counterweight **2.05 - 33**

A

Abbreviations Rope diameter **8.04 - 7**
Accelerating, changing the load **2.04 - 19**
Accepting the entries and settings **4.02 - 57**
Accepting the entries and settings of the lifting category **4.02 - 68**
Accepting the entries and settings of the operating mode category **4.02 - 35**
Access to lattice sections or booms **2.04 - 13**
Acoustic / visual warnings outside the crane operator's cab **4.20 - 15**
Acoustic / visual warnings within the crane operator's cab **4.20 - 13**
Acoustic and optical warning devices **4.04 - 11**
Acoustic and optical warning signals **4.02 - 4**
Acoustic warning on LICCON monitor 0 **4.02 - 107**
Acoustic warning on LICCON monitor 1 **4.02 - 177**
Acoustic warning on LICCON monitor 2 **4.02 - 191**
Activating the bypass at assembly and disassembly **5.01 - 27**
Activating the bypass at crawler assembly and crawler disassembly **5.01 - 26**
Actual load **4.02 - 4**
Actual load (current load) / net load **4.02 - 77**
Actuating the slewing gear brake with the pedal **4.05 - 51**
Actuation of winch and / or crane movements during assembly / disassembly **5.01 - 28**
Adapting the consoles to the crane operator **4.03 - 27**
Adapting to the wind speed **4.05 - 21**
Adding diesel fuel **7.05 - 12**
Adding the vibration sensor for the slewing gear **4.05 - 15**
Adding the vibration sensor winch 1 **4.05 - 13**
Adding urea solution **7.05 - 14**
Additional controls for certain crawler cranes **5.01 - 6**
Additional controls for cranes on tires on the front and supported on the rear **5.01 - 5**
Additional controls for cranes supported on the front and on tires on the rear **5.01 - 5**

Additional controls for cranes with a derrick boom **5.01 - 6**
Additional controls for cranes with crane support **5.01 - 5**
Additional controls for cranes with luffing auxiliary boom / accessories **5.01 - 6**
Additional controls for freestanding crane operation (on tires) **5.01 - 6**
Additional displays **5.36.10 - 75, 5.36.20 - 67, 5.36.30 - 27, 5.36.40 - 67**
Additional emergency operating modes **4.02 - 110**
Additional notes **0.01 - 2**
Additional risks **2.04 - 69**
Adjusting the air supply **6.02 - 9**
Adjusting the consoles **4.03 - 25**
Adjusting the crane operator's seat **4.03 - 23**
Adjusting the fan stage **6.02 - 8**
Adjusting the mechanical auxiliary support **3.04 - 7**
Adjusting the temperature **6.02 - 6**
Adjusting the warm air supply **6.02 - 7**
Adjusting winch 1 and winch 2 **4.05 - 25**
Adjustment of reeving **4.03 - 51**
Advance settings for curve display of any desired set up configuration **4.02 - 227**
Advance settings for curve display of load charts **4.02 - 226**
Advance settings for curve display of the current set up configuration **4.02 - 226**
After replacement of components **7.01 - 7**
Air distribution **6.02 - 10**
Air dryer **7.05 - 35**
Air filter system **7.05 - 7**
Airplane warning light **5.38 - 41, 5.39.10 - 55, 5.44 - 49**
Airplane warning light * **5.07 - 55**
Alarm functions **4.02 - 91**
Alarm functions of LICCON monitor 1 **4.02 - 175**
Aligning the assembly unit I on the S-end section **5.07 - 21**
Aligning the crane **2.04 - 35**
Aligning the crawler center section horizontally **3.01 - 21**
Aligning the wheel sets in the circular travel position **5.35.10 - 64, 5.35.10 - 137**
Aligning the wheel sets in the parallel travel position **5.35.10 - 65**
Aligning the wheel sets in the towing position **5.35.10 - 62, 5.35.10 - 135**
Ambient temperature **0.01 - 6**
Ambient temperatures below -20°C **2.08 - 3**
Angle adjustment on the fixed lattice jib with mechanical adjustment **5.01 - 36**
Angle display Derrick boom **4.02 - 165**
Angle sensors **4.04 - 18**
Angular pulling **4.08 - 11**
Antifall guards on the crane **2.06 - 1**
Applying the parking brake **4.05 - 49**
Areas **7.05.50 - 11, 8.04 - 4**

- Armrests **4.03 - 27**
- Arrangement of intermediate sections **5.03 - 5**
- Arrangement of intermediate sections on the boom **5.03 - 3**
- Assemble railing 23 on catwalk 3 **2.06 - 59**
- Assemble railing 24 on catwalk 4 **2.06 - 59**
- Assemble railing 25 and railing 26 on catwalk 5 **2.06 - 59**
- Assemble railing 27 on catwalk 7 **2.06 - 61**
- Assemble railing 28 on catwalk 7 **2.06 - 61**
- Assembling **5.07 - 13**
- Assembling / disassembling of hydraulic lines **5.01 - 25**
- Assembling / disassembling the ballast trailer with the BTT-E **5.35.10 - 15**
- Assembling / disassembling the crane component **2.08 - 6**
- Assembling / disassembling the lattice sections on telescopic cranes with a luffing lattice jib **5.01 - 39**
- Assembling / disassembling the lattice sections on telescopic cranes with an auxiliary boom, with an auxiliary crane **5.01 - 43**
- Assembling / disassembling the lattice sections on telescopic cranes with an auxiliary boom, without an auxiliary crane **5.01 - 47**
- Assembling / disassembling the wedge lock **4.06 - 21**
- Assembling assembly unit I on the S-end section **5.07 - 20**
- Assembling catwalk 3 in operating position **2.06 - 53**
- Assembling catwalk 4 in operating position **2.06 - 55**
- Assembling catwalk 5 in operating position **2.06 - 55**
- Assembling catwalk 7 in operating position **2.06 - 57**
- Assembling catwalks on crawler center section **2.06 - 31**
- Assembling SA-frame **3.05 - 5**
- Assembling SL-/S2-boom systems in flying mode - with end section **5.38 - 30**
- Assembling SL-/SL3-/S2-boom systems in flying mode - without end section **5.38 - 30**
- Assembling the 12m guy rod **5.07 - 48**
- Assembling the 9m guy rod and 3m guy rod **5.07 - 47**
- Assembling the auxiliary weight on the upper pulley block **5.05 - 39**
- Assembling the ballast trailer guide **5.35.10 - 25**
- Assembling the ballast trailer guide on the ballast trailer **5.35.10 - 31**
- Assembling the ballast trailer guide with ballast trailer radius 13-19m **5.35.10 - 26**
- Assembling the ballast trailer guide with ballast trailer radius 13-19m on the ballast trailer **5.35.10 - 32**
- Assembling the ballast trailer guide with ballast trailer radius 19-25m **5.35.10 - 27**
- Assembling the ballast trailer guide with ballast trailer radius 19-25m or with ballast trailer radius 24-30m on the ballast trailer **5.35.10 - 34**
- Assembling the ballast trailer guide with ballast trailer radius 24-30m **5.35.10 - 29**
- Assembling the ballast trailer guying **5.35.10 - 43**
- Assembling the ballast trailer on the turntable **5.35.10 - 35**
- Assembling the boom combinations with substructure **5.38 - 37, 5.39.10 - 50, 5.44 - 42**
- Assembling the boom system in flying mode **5.38 - 27**
- Assembling the boom system in flying mode (guying on S-pivot section) **5.39.10 - 41**
- Assembling the boom system in flying mode (guying on the flying assembly intermediate section) **5.39.10 - 30**
- Assembling the boom system on the ground **5.38 - 19, 5.39.10 - 21**
- Assembling the catwalk grating **5.44 - 16**
- Assembling the catwalks on the left turntable frame main section in operating position **2.06 - 53**
- Assembling the central ballast brackets **3.03 - 9**
- Assembling the central ballast brackets with placed ballast plates (turntable is assembled on the crawler center section) **3.03 - 15**
- Assembling the central ballast brackets with placed ballast plates (turntable is not assembled on the crawler center section) **3.03 - 15**
- Assembling the change over pulley **5.07 - 15**
- Assembling the counterweight brackets on the turntable **4.07 - 9**
- Assembling the crawler center section **3.01 - 11**
- Assembling the cross beam **5.36.20 - 21, 5.36.30 - 13**
- Assembling the cross beam on the suspended ballast guide **5.36.20 - 43**
- Assembling the D-boom on the D-pivot section **5.05 - 46**
- Assembling the D-boom on the SA-frame **5.05 - 44**
- Assembling the D-guy rods **5.05 - 32**
- Assembling the D-guy rods on the erection racks **5.36.10 - 27, 5.36.40 - 23**
- Assembling the D-lattice sections **5.05 - 21**
- Assembling the double cone pins horizontally **5.01 - 13**
- Assembling the double cone pins vertically **5.01 - 13**
- Assembling the D-pivot section on the SA-frame **5.05 - 45**
- Assembling the drawbars on the rotary connection on the turntable frame lower section **3.01 - 10**
- Assembling the end section **5.36.10 - 37, 5.36.10 - 135, 5.36.20 - 33, 5.36.20 - 117, 5.36.40 - 33, 5.36.40 - 111**
- Assembling the end section on the boom **5.38 - 23, 5.39.10 - 25**
- Assembling the erection ropes **5.07 - 36**
- Assembling the F-assembly unit **5.13 - 11**
- Assembling the F-assembly unit with F-end section **5.13 - 23, 5.13 - 33, 5.13 - 43**
- Assembling the F-guy ropes **5.13 - 13, 5.13 - 23, 5.13 - 43**
- Assembling the first catwalk **2.06 - 31**
- Assembling the first central ballast bracket (turntable is assembled on the crawler center section) **3.03 - 10**

Assembling the first central ballast bracket (turntable is not assembled on the crawler center section) **3.03 - 13**
Assembling the first wheel set **5.35.10 - 18**
Assembling the fixed lattice jib on the TF-adapter **5.01 - 33**
Assembling the F-jib **5.13 - 8**
Assembling the F-jib — assembly variants **5.13 - 9**
Assembling the frame on the wheel sets **5.35.10 - 17**
Assembling the guy rods **5.44 - 44**
Assembling the intermediate sections **5.36.10 - 35, 5.36.10 - 135, 5.36.20 - 31, 5.36.20 - 117, 5.36.40 - 31, 5.36.40 - 111**
Assembling the ladder **5.36.10 - 39, 5.36.20 - 35, 5.36.40 - 35**
Assembling the lattice sections **5.13 - 19**
Assembling the lattice sections on a luffing lattice jib **5.01 - 39**
Assembling the lattice sections on an auxiliary boom with an auxiliary crane **5.01 - 43**
Assembling the lattice sections on an auxiliary boom without an auxiliary crane **5.01 - 47**
Assembling the L-intermediate sections on the cross carrier **5.44 - 30**
Assembling the load hook * **4.06 - 16**
Assembling the manual rope winch **5.36.10 - 39, 5.36.20 - 35, 5.36.40 - 35**
Assembling the mechanical auxiliary support **3.04 - 3**
Assembling the pivot section **5.36.10 - 35, 5.36.10 - 135, 5.36.20 - 31, 5.36.20 - 117, 5.36.40 - 31, 5.36.40 - 111**
Assembling the platforms **5.35.10 - 22**
Assembling the pull rods **5.36.10 - 41, 5.36.20 - 37, 5.36.40 - 37**
Assembling the radio receiver **5.19.10 - 4**
Assembling the radio sending unit on the hook block **5.19.10 - 7**
Assembling the railing on the S-pivot section in operating position **5.44 - 16**
Assembling the railings on the cab platform **4.03 - 7**
Assembling the railings on the left turntable frame main section in operating position **2.06 - 59**
Assembling the railings on the left turntable frame main section in transport position **2.06 - 63**
Assembling the railings on the right turntable frame main section in operating position **2.06 - 69**
Assembling the receiver-incline sensor * **5.19.10 - 3**
Assembling the roller cart on the W-lattice jib **5.07 - 51**
Assembling the roller set / roller sets **5.14 - 8**
Assembling the roller sets **5.38 - 40, 5.39.10 - 53, 5.44 - 47**
Assembling the roller sets on the boom head **5.38 - 40, 5.39.10 - 53, 5.44 - 47**
Assembling the roller sets R8/R12 on the L- or S-end section **5.14 - 10**
Assembling the S2-boom system in flying mode **5.38 - 33**

Assembling the S2DB-boom system in flying mode **5.39.10 - 37**
Assembling the SD // S2D // SL2D boom system in flying mode without the end section **5.39.10 - 48**
Assembling the SD // S2D // SL2D boom system in flying mode with the end section **5.39.10 - 47**
Assembling the SDB-boom system in flying mode **5.39.10 - 36**
Assembling the second catwalk **2.06 - 31**
Assembling the second central ballast bracket (turntable is assembled on the crawler center section) **3.03 - 12**
Assembling the second central ballast bracket (turntable is not assembled on the crawler center section) **3.03 - 14**
Assembling the second wheel set **5.35.10 - 19**
Assembling the sending unit-incline sensor * on the hook block **5.19.10 - 6**
Assembling the S-end section / L-end section **5.38 - 21, 5.39.10 - 23**
Assembling the S-guy rods **5.38 - 38, 5.39.10 - 52**
Assembling the S-intermediate section on the S-pivot section **5.38 - 20, 5.39.10 - 22**
Assembling the S-intermediate sections / S-adapter / S-end section on the upper P-adapter **5.44 - 36**
Assembling the SL2DB-boom system in flying mode **5.39.10 - 39**
Assembling the SL3-boom system in flying mode **5.38 - 35**
Assembling the S-lattice section in „flying mode“ on the S-intermediate section 12m 3228.25 FLM **5.38 - 31, 5.39.10 - 34**
Assembling the S-lattice section in „flying mode“ on the S-pivot section **5.38 - 28**
Assembling the S-lattice sections in „flying mode“ on the S-pivot section **5.39.10 - 45**
Assembling the SL-boom system in flying mode **5.38 - 34**
Assembling the S-pivot section on the turntable **5.38 - 15, 5.39.10 - 17, 5.44 - 20**
Assembling the stairs **2.06 - 35**
Assembling the stairs on the catwalk **2.06 - 35**
Assembling the support **2.06 - 35**
Assembling the suspended ballast **5.36.10 - 21, 5.36.40 - 23**
Assembling the suspended ballast guide **5.36.10 - 31, 5.36.20 - 27, 5.36.20 - 31, 5.36.40 - 25**
Assembling the suspended ballast guide on the turntable frame **5.36.10 - 43, 5.36.20 - 39, 5.36.40 - 39**
Assembling the suspended ballast guide with a suspended ballast radius of 30m **5.36.10 - 35, 5.36.40 - 31**
Assembling the suspended ballast with suspended ballast guide **5.36.10 - 28, 5.36.40 - 25**
Assembling the upper P-adapter on the L-intermediate sections **5.44 - 34**
Assembling the upper pulley block on the S-pivot section **5.39.10 - 42**

Assembling the WA-frame 1 guy rods **5.07 - 45, 5.07 - 47**
 Assembling the WA-frame intermediate sections with the WA-frame end sections **5.07 - 18**
 Assembling the WA-frames **5.07 - 15, 5.07 - 23**
 Assembling the W-lattice jib on the W-pivot section **5.07 - 46**
 Assembling turntable frame lower section with Quick Connection (QC) on crawler center section with QC **3.01 - 6**
 Assembling with a cross beam * **5.36.30 - 13**
 Assembling without a cross beam **5.36.30 - 11**
 Assembling without suspended ballast guide **5.36.20 - 20**
 Assembly **5.36.30 - 9, 5.36.40 - 20, 5.61 - 5**
 Assembly / disassembly **5.01 - 22**
 Assembly / disassembly of booms **5.01 - 29**
 Assembly / disassembly of boom systems for supporting on ascending terrain (assembly / disassembly schematic) **5.01 - 61**
 Assembly / disassembly of boom systems for supporting on descending terrain (assembly / disassembly schematic) **5.01 - 64**
 Assembly / disassembly of electrical lines **5.01 - 24**
 Assembly / disassembly of lattice sections for lattice mast cranes **5.01 - 51**
 Assembly / disassembly procedures **4.20 - 5**
 Assembly conditions **3.06 - 1**
 Assembly conditions for operation on crawlers **3.06 - 3**
 Assembly drawings **5.01 - 24**
 Assembly of boom systems on ascending terrain **5.01 - 61**
 Assembly of boom systems on descending terrain **5.01 - 64**
 Assembly of crawler carrier with the auxiliary crane **3.01 - 22**
 Assembly of lattice sections **5.01 - 51**
 Assembly of railing on crawler center section **2.06 - 19**
 Assembly of SA bracket **3.05 - 1**
 Assembly of the crawler carrier with SA-frame **3.01 - 46, 3.01 - 47**
 Assembly of winch 5 (WV) on the S-pivot section **5.38 - 19, 5.39.10 - 21, 5.44 - 17**
 Assembly of winch 6 (WVI) on the S-pivot section **5.38 - 19, 5.39.10 - 21, 5.44 - 17**
 Assembly PD-boom **5.44 - 13**
 Assembly procedure **5.10 - 11**
 Assembly rack for roller set **5.14 - 4**
 Assembly rope **1.03 - 9**
 Assembly S2/SL/SL3-boom **5.38 - 11**
 Assembly SD/S2D/SL2D-boom **5.39.10 - 11**
 Assembly shoes **5.62 - 1, 5.62 - 3**
 Assembly Turntable frame main section **3.02 - 11**
 Assembly unit I **5.07 - 3**
 Assembly unit II **5.07 - 3**
 Assembly unit III **5.07 - 4**
 Assembly unit IV **5.07 - 4**

Assembly variant V1 **5.13 - 9**
 Assembly variant V2 **5.13 - 9**
 Assembly variant V2 — Assembling the complete F-jib (maximum length of 12m) on the ground **5.13 - 23**
 Assembly variant V3 **5.13 - 9**
 Assembly variant V3 — Assembling the complete F-jib (maximum length of 12m) in flying mode **5.13 - 33**
 Assembly variant V4 **5.13 - 9**
 Assembly variant V4 — Assembling the complete F-jib (maximum length of 12m) in flying mode **5.13 - 43**
 Assembly variation V1 — Assembling the F-jib in parts **5.13 - 11**
 Assembly winch **1.02 - 4, 7.05 - 28**
 Assembly winch 1 **3.07.10 - 1, 3.07.10 - 5**
 Assembly winch 2 **3.07.20 - 1, 3.07.20 - 5**
 Assembly winch 3 **3.07.30 - 1**
 Assembly winch 5 **3.07.50 - 1, 3.07.50 - 11**
 Assembly winch 6 **3.07.60 - 1, 3.07.60 - 11**
 Assembly with suspended ballast guide * **5.36.20 - 26**
 Assigning a color **4.02 - 232**
 Assigning fixed accessory **4.02 - 65**
 Assigning reeving **4.02 - 61**
 Assigning the hoist winch **4.02 - 59**
 Assignment of the crane superstructure to the travel direction **4.10 - 33**
 Attaching / removing the hoist limit switch weight **4.06 - 19**
 Attaching and removing the load hook * **4.06 - 16**
 Attaching the hoist limit switch weight **4.06 - 19**
 Attachment points SA-frame **3.05 - 3**
 Automatic operation **6.02 - 5**
 Auxiliary equipment **1.02 - 5, 2.08 - 3**
 Auxiliary guying **5.01 - 8, 5.03 - 7**
 Auxiliary heater **6.02 - 14**
 Auxiliary heater * **7.05 - 29**
 Auxiliary heater icons **6.02 - 15**
 Auxiliary parts **5.36.20 - 9, 5.36.20 - 15**

B

Ballast automatic * **4.02 - 165**
 Ballasting **5.36.30 - 10**
 Ballasting rules **5.36.20 - 48**
 Ballasting the ballast pallet **5.36.10 - 57, 5.36.20 - 47**
 Ballasting the ballast pallet off **5.36.10 - 103, 5.36.10 - 117, 5.36.20 - 95**
 Ballasting the ballast trailer **5.35.10 - 48**
 Ballasting the ballast trailer down **5.35.10 - 101**
 Ballasting the divisible ballast pallet „VarioT-ray“ **5.36.40 - 45**
 Ballast pallet **1.03 - 25, 5.36.10 - 6, 5.36.10 - 8**
 Ballast pallet and ballast plates **5.36.20 - 6, 5.36.20 - 10**
 Ballast pallet special design (LTR as ballast) **1.03 - 25**
 Ballast plate for central ballast / counterweight / derrick ballast **1.03 - 14**

Ballast plates **5.36.10 - 9, 5.36.30 - 5, 5.36.30 - 6, 5.36.40 - 8**
Ballast trailer **1.03 - 26**
Ballast trailer * **4.02 - 184, 7.05 - 39**
Ballast trailer drive **5.35.10 - 78**
Ballast trailer guide extension **1.03 - 27**
Ballast trailer guide with adapter for ballast trailer **1.03 - 27**
Ballast trailer lifted off **5.35.10 - 82, 5.35.10 - 82**
Ballast trailer maintenance instructions **7.04.50 - 1**
Ballast trailer on the ground **5.35.10 - 82, 5.35.10 - 82**
Ballast trailer radii **5.35.10 - 7**
Ballast trailer tires **7.04.50 - 3, 7.04.50 - 3, 7.05 - 39, 7.05 - 39**
Ballast trailer tires and disk wheels **7.04.50 - 3, 7.05 - 39**
Ballast variation **5.36.20 - 47**
Ball locking pin **5.01 - 20**
Bar diagram Utilization **4.02 - 79**
Basic principles and procedure **8.01 - 4**
Basket formation **7.05.50 - 8, 8.04 - 20**
Batteries **7.01 - 10, 7.05 - 36**
Before starting to work **2.04 - 60**
Bleeding by separate actuation of the grease pump **7.04 - 15**
Bleeding by simulating crawler operation **7.04 - 14**
Bleeding the central lubrication system **7.04 - 11, 7.04 - 14, 7.05 - 22**
Bleeding the coolant circuit **6.02 - 26**
Bleeding the fuel line **6.02 - 28**
Bleeding the fuel preliminary filter **7.05 - 8**
Block position of the relapse cylinders when setting down the load **5.01 - 6**
Block position relapse cylinders **5.35.10 - 77**
Block position „Relapse support in flap on block“ **8.12 - 19**
Bluetooth Terminal (BTT) **5.31 - 1**
Boom components **5.03 - 3**
Boom configurations **5.14 - 5**
Boom length **4.02 - 83**
Boom limitation **4.02 - 91**
Boom nose 32t **1.03 - 27**
Boom nose lattice boom **5.10 - 1**
Boom on the ground function **4.02 - 175**
Boom radius **4.02 - 81**
Boom systems **1.02 - 5, 5.03 - 1**
Boom systems / boom combinations **1.02 - 5**
Breaking away fixed loads **4.08 - 13**
Bridges **1.03 - 18**
Brief description **4.08 - 16**
Bringing catwalk 3 into transport position **2.06 - 67**
Bringing catwalk 4 into transport position **2.06 - 67**
Bringing catwalk 5 into transport position **2.06 - 67**
Bringing catwalks 7 into transport position **2.06 - 65**
Bringing the access stairs / cab platform into operating position **4.03 - 7**
Bringing the access stairs into transport position **4.03 - 57**

Bringing the catwalks on the left turntable frame main section in transport position **2.06 - 65**
Bringing the crane operator's cab into operating position **4.03 - 3**
Bringing the crane operator's cab into transport position **4.03 - 55, 4.03 - 62**
Bringing the extension ladder into operating position **2.06 - 19**
Bringing the extension ladder into transport position **2.06 - 27**
Bringing the handrails into operating position **4.03 - 9**
Bringing the hand rails into transport position **4.03 - 57**
Bringing the ladder into assembly position **2.06 - 81**
Bringing the ladder into park position **2.06 - 81**
Bringing the ladder on the main boom assembly platform into operating position **2.06 - 73**
Bringing the ladder on the main boom assembly platform into transport position **2.06 - 75**
Bringing the pulley retainer on the D-end section into transport position **5.05 - 56**
Bringing the pulley retainers into the operating position **5.05 - 29**
Bringing the pull test brackets into operating position **5.05 - 27**
Bringing the pull test brackets into transport position **5.05 - 56**
Bringing the radio receiver to the operating position from the transport position **5.19.10 - 5**
Bringing the radio receiver to the transport position from the operating position **5.19.10 - 5**
Bringing the railing on the cab platform into operating position **2.06 - 77**
Bringing the railing on the cab platform into transport position **2.06 - 79**
Bringing the railings into transport position **2.06 - 85**
Bringing the railings on the counterweight bracket into operating position **2.06 - 87**
Bringing the railings on the counterweight bracket into transport position **2.06 - 89**
Bringing the railings on the counterweight brackets into operating position **4.07 - 9**
Bringing the railings on the counterweight brackets into transport position **4.07 - 21**
Bringing the railings on the right turntable frame main section in transport position **2.06 - 71**
Bringing the removable ladder into assembly position **2.06 - 51**
Bringing the removable ladder into park position **2.06 - 51**
Bringing the rod receptacle into operating position **5.44 - 40**
Bringing the rod receptacle in transport position **5.44 - 66**
Bringing the stairs into assembly position **2.06 - 83**
Bringing the stairs into operating position **2.06 - 83**
Bringing winch 5 from operating position into transport position **3.07.50 - 9**

Bringing winch 5 from transport position into operating position **3.07.50 - 7**
 Bringing winch 6 from operating position into transport position **3.07.60 - 9**
 Bringing winch 6 from transport position into operating position. **3.07.60 - 7**
 Broken strands **7.05.50 - 5**
 Broken wire **7.05.50 - 5**
 Broken wire in the strand valleys **8.04 - 13**
 Broken wire nests **8.04 - 14**
 Broken wires in rope sections, which are not spooled up on the winch **8.04 - 13**
 Broken wires on rope end connections **8.04 - 13**
 Buckles **7.05.50 - 10, 8.04 - 24, 8.16 - 8**
 Bulbs and fuses **7.05 - 36**
 Burning-off the burner **6.02 - 28**
 Bypass at assembly / disassembly **5.01 - 27**
 Bypass at assembly / disassembly Crawler **5.01 - 26**
 Bypass at assembly and disassembly **5.01 - 28**
 Bypassing the difference force monitoring for derrick ballast guying **4.02 - 110**
 Bypassing the hoist top shut off **5.01 - 11**
 Bypassing the hoist top shut-off **4.20 - 49**
 Bypassing the LICCON overload protection **5.01 - 10**
 Bypassing the overload protection **5.01 - 9**
 Bypassing the PAT overload protection **5.01 - 10**
 Bypassing the radio connection **5.31 - 41**
 Bypassing the shut off of the function ballast up / down **5.36.10 - 89, 5.36.20 - 81, 5.36.30 - 41, 5.36.40 - 81**
 Bypass of hoist limit switch **4.02 - 110**
 Bypass of overload protection **4.04 - 5**
 Bypass of overload protection: Emergency situation (according to EN 13000:2010) **4.04 - 6**
 Bypass of overload protection: Failure of overload protection (according to EN 13000:2010) **4.04 - 6**
 Bypass of overload protection: Failure of the overload protection **4.04 - 5**

C

Cab platform rear **2.06 - 77**
 Calculation example **4.10 - 6**
 Calculation examples **2.04 - 30**
 Calculation of required length of transfers in uphill / downhill slopes **4.10 - 5**
 Calling up / closing the system screen **5.31 - 15**
 Calling up and checking the individual control displays **4.03 - 45**
 Calling up and checking the monitoring functions of the LICCON computer system **4.03 - 14**
 Calling up the filter category **4.02 - 228**
 Calling up the monitoring functions **4.02 - 113**
 Camera monitoring **4.01 - 23**
 Carrying out an intermediate lubrication **7.04 - 10, 7.04 - 13, 7.05 - 21**
 Carrying out crane movements **5.36.10 - 90, 5.36.20 - 82, 5.36.30 - 42, 5.36.40 - 82**

Carrying out erection procedures **4.20 - 57**
 Carrying out take down procedures **4.20 - 59**
 Carrying out the assembly procedures **4.20 - 61**
 Carrying out the erection / take down procedures **4.20 - 53**
 Carrying out the parameter settings **4.02 - 228**
 Carrying out the tension procedure **7.04 - 18**
 Case 1: The boom system is pulled to the rear **5.35.10 - 72**
 Case 2: The ballast trailer guying is relieved **5.35.10 - 73**
 Case 3: The load torque is increased **5.35.10 - 75**
 Case 4: The load torque is decreased **5.35.10 - 76**
 Catwalk / stairs crawler travel gear **2.06 - 29**
 Catwalk crawler **1.03 - 11**
 Catwalks and railing on the turntable frame main section **2.06 - 53**
 CE marking **0.01 - 5**
 Central ballast **1.02 - 3, 3.03 - 1**
 Central ballast combinations **3.03 - 6**
 Central ballast platform **1.03 - 10**
 Central lubrication system **7.04 - 7, 7.04.50 - 9, 7.05 - 17**
 Central lubrication system Ballast trailer * **7.05 - 19**
 Central lubrication system Roller ring connection **7.05 - 18**
 Central lubrication system Superstructure **7.05 - 18**
 Central lubrication system with control unit **7.04 - 8**
 Central lubrication system without control unit **7.04 - 13**
 Change confirmation form **90.05 - 3**
 Change to the operating instructions **90.01 - 3**
 Changing over regulation Parallel operation winch 1 and winch 2 **4.02 - 188, 4.05 - 31**
 Changing the assembly shoes at assembly **5.62 - 4**
 Changing the assembly shoes at disassembly **5.62 - 5**
 Changing the boom: Turning the L-intermediate sections **5.44 - 29**
 Changing the gear oil **7.04.50 - 9, 7.05 - 16, 7.05 - 25, 7.05 - 27, 7.05 - 28, 7.05 - 41**
 Changing the oil **7.04.50 - 6, 7.05 - 42**
 Changing the set up configuration **4.03 - 39**
 Charging batteries with the Liebherr charger * **7.05 - 38**
 Charging the batteries externally **7.05 - 39**
 Charging the battery while installed **7.05 - 38**
 Charging the battery while removed **7.05 - 38**
 Charging the battery with an external charger **7.05 - 38**
 Chart for determining the theoretically remaining service life **8.03 - 10**
 Chart view program: Curve illustration of load charts **4.02 - 216**
 Check bearings for easy movement **7.05.50 - 4**
 Check for wear and distortion **7.05.50 - 11**
 Checking bearings for easy movement **8.01 - 86**
 Checking for broken strands **8.04 - 9**

Checking for corrosion **7.05.50 - 12**
Checking for damage and cracks **8.01 - 85**
Checking for flattenings **7.05.50 - 13**
Checking for le-
aks **7.04 - 3, 7.04.50 - 5, 7.04.50 - 8, 7.05 - 40, 7.05 - 41**
Checking for mechanical damage **7.05.50 - 4**
Checking for solid foreign substances **8.03 - 4**
Checking load hooks for corrosion and wear **8.05 - 5**
Checking of rope diameter **8.04 - 14**
Checking of rope pretension on telescopic booms, illustration 1 **8.01 - 82**
Checking pretension pressure for the diaphragm reservoir **7.05 - 33**
Checking the accumulator pressure in the W-relapse cylinder **8.14 - 3**
Checking the accumulator pressure with the „W-relapse cylinder in test position“ **8.14 - 3**
Checking the airplane warning light **5.10 - 17, 5.13 - 45**
Checking the batteries **7.05 - 37**
Checking the battery voltage **4.03 - 16**
Checking the battery voltage on LICCON monitor **4.03 - 17**
Checking the battery voltage on the batteries **4.03 - 17**
Checking the central lubrication systems **4.03 - 14**
Checking the cleaning fluid level **7.05 - 45**
Checking the connection type **5.31 - 15**
Checking the control rope for distortions **7.05.50 - 13**
Checking the coolant level **4.03 - 13, 7.05 - 5**
Checking the depth of the lead-in tracks **8.01 - 86**
Checking the display for the center of gravity on the LICCON monitor **4.03 - 17**
Checking the display for the incline in the LICCON monitor **4.03 - 20**
Checking the display for the surface pressure in the LICCON monitor **4.03 - 18**
Checking the end of the service life **8.06 - 3**
Checking the engine oil level **4.03 - 12, 4.03 - 16**
Checking the filter for the hydraulic tank **4.03 - 13**
Checking the fuel level **4.03 - 15**
Checking the function **7.04 - 10, 7.04 - 14, 7.05 - 21**
Checking the function of the safety equipment **5.05 - 40, 5.07 - 55, 5.13 - 45**
Checking the gas pressure and oil fill before operation **8.01 - 84**
Checking the gear oil level **7.05 - 40**
Checking the general condition of the crane **4.03 - 12**
Checking the groove diameter **8.01 - 85, 8.03 - 3**
Checking the guy rods **8.15 - 3**
Checking the hoist limit switch on the pulley head **5.10 - 17, 5.13 - 46**
Checking the horn **4.03 - 31**
Checking the hydraulic hose lines for leaks **7.05 - 35**
Checking the hydraulic oil level **7.05 - 31**
Checking the hydraulic tank **4.03 - 13**
Checking the length sensor value on the ballast trailer **5.35.10 - 97**

Checking the limit switch actuators for function **8.12 - 3, 8.12 - 5**
Checking the limit switch actuators for function (S-end section without pulley set) **8.12 - 11**
Checking the limit switch actuators for function (S-end section with pulley set) **8.12 - 11**
Checking the limit switch actuators for function before erection **8.12 - 3, 8.12 - 5, 8.12 - 7, 8.12 - 17**
Checking the limit switch actuators on switch point „steepest position“ **8.12 - 7**
Checking the limit switches for the relapse cylinder for function **5.07 - 35**
Checking the limit switches in general **5.10 - 17, 5.13 - 46**
Checking the limit switch main boom „steepest position“ **5.38 - 41, 5.39.10 - 55, 5.44 - 49**
Checking the load hook for distortion **8.05 - 4**
Checking the load hook for surface cracks **8.05 - 4**
Checking the load hook for wear **8.05 - 4**
Checking the lubrication **7.05.50 - 11**
Checking the monitoring functions on the LICCON monitor **4.03 - 43**
Checking the mounting screws for damage **8.01 - 88**
Checking the oil level in the hydraulic tank **4.03 - 13**
Checking the oil level on the LICCON monitor **7.05 - 3**
Checking the oil level with the dipstick **7.05 - 4, 7.05 - 25**
Checking the operating and control instruments after start **4.03 - 43**
Checking the position **7.05.50 - 12**
Checking the retaining elements **5.01 - 14**
Checking the return filter **7.05 - 32**
Checking the rope drive for spooling problems **7.05.50 - 12**
Checking the rope end connection **8.04 - 14**
Checking the ropes **7.05.50 - 10**
Checking the safety measures **2.04 - 36**
Checking the set-
tings **5.07 - 66, 5.10 - 21, 5.13 - 48, 5.38 - 46, 5.39.10 - 60, 5.44 - 54**
Checking the settings of the LICCON overload protection **5.36.10 - 67, 5.36.20 - 59, 5.36.30 - 19, 5.36.40 - 59**
Checking the tightening torque **8.01 - 86**
Checking the tilt play **8.01 - 87**
Checking the urea reserve **4.03 - 15**
Checking the vent filter / breather filter **7.05 - 32**
Checking the wear on the connections of the track pads **7.04 - 23**
Checking the wear on the roll off surfaces of the track pads / track rollers **7.04 - 25**
Checking the winch oil level **4.03 - 12**
Checking the window cleaning fluid **4.03 - 14**
Checking the wind speed sensor **5.10 - 17, 5.13 - 45**
Checking visually **8.01 - 85**
Checking wear on the track chain **7.04 - 22**

- Check list for the inspection of ladders and steps **8.17 - 5**
- Checks before starting to work with the crane **4.08 - 4**
- Checks before start up **4.03 - 11**
- Check the hydraulic oil level **4.03 - 16**
- Check the mounting screws for tight seating **8.01 - 88**
- Circular travel **5.35.10 - 64, 5.35.10 - 137**
- Circular travel steering program **5.35.10 - 59**
- Cleaning **7.01 - 9**
- Climate control **6.02 - 4**
- Climate control system * **6.02 - 13**
- Climate control systems **6.02 - 3**
- Closing the assembly opening winch 5 **3.07.50 - 26**
- Closing the assembly opening winch 6 **3.07.60 - 28**
- Closing the boom system **5.38 - 25, 5.39.10 - 29, 5.44 - 41**
- Closing the end section **5.01 - 30**
- Closing the fixed lattice jib **5.01 - 35**
- Closing the roof window **4.03 - 33**
- Closing the side window pane **2.04 - 18**
- Closing the transport retainer of the cross beam **5.07 - 90**
- Closing the transport retainers of the guy rods **5.07 - 88**
- Code calibration **5.31 - 7**
- Collision of mechanical relapse support with flap **8.12 - 15**
- Column category **4.02 - 220**
- Combinations End section - Roller set **5.14 - 7**
- Combined degree of severity **8.04 - 25**
- Comparing the load columns **4.02 - 233**
- Comparison **4.02 - 4**
- Compensating for ground unevenness **5.35.10 - 78**
- Completing emergency control **6.05 - 31**
- Completing the D-boom assembly **5.05 - 44, 5.05 - 46**
- Completing the flying assembly **5.38 - 36, 5.39.10 - 40, 5.39.10 - 49**
- Component overview - Ballast pallet **5.36.10 - 5**
- Component overview crawler travel gear **1.01 - 3**
- Component overview derrick ballast **1.01 - 5**
- Component overview for divisible ballast pallet „Variotray“ **5.36.40 - 5**
- Component overview LD/SLD/SD boom **5.39.10 - 3**
- Component overview P-boom **5.44 - 3**
- Component overview S-pivot section **5.38 - 3**
- Component overview Suspended ballast guide **5.36.10 - 6, 5.36.40 - 6**
- Component overview turntable **1.01 - 3**
- Component overview winches **1.01 - 5**
- Components **3.03 - 3**
- Composition **8.16 - 4**
- Connecting the BTB and the BTT **5.31 - 7**
- Connecting the divisible ballast pallet „Variotray“ **5.36.40 - 53**
- Connecting the hydraulic aggregate **3.01 - 17, 3.01 - 35**
- Continuing boom assembly **5.38 - 21, 5.39.10 - 23**
- Continuing the erection procedure **5.07 - 63**
- Control cabinet **4.01 - 9**
- Control elements in the set up program **4.02 - 14**
- Control measures **5.01 - 4**
- Control platform **4.01 - 11**
- Control release **4.04 - 17**
- Control ropes **1.03 - 8**
- Conversion chart **0.01 - 8**
- Conversion chart for wind force **2.04 - 43**
- Coolant system **7.06 - 3**
- Cooling system **7.05 - 5**
- Corkscrew-like distortion **7.05.50 - 8, 8.04 - 19**
- Corrective steering **5.35.10 - 66**
- Corrective steering of the wheel sets **5.35.10 - 63**
- Corrective steering steering program **5.35.10 - 59**
- Corrosion **7.05.50 - 6, 8.04 - 17**
- Cotter pin **5.01 - 15**
- Counterrotation to the left (counterclockwise direction) **4.10 - 45**
- Counterrotation to the right (clockwise direction) **4.10 - 45**
- Counterweight **1.02 - 4, 4.07 - 1**
- Counterweight and / or ballast **2.04 - 62**
- Counterweight platform **1.03 - 14**
- Cracks and dents **8.15 - 4**
- Crane **2.04 - 69**
- Crane and crane components **2.04 - 18**
- Crane cab **1.02 - 4**
- Crane cab inside and control cabinet **4.01 - 6**
- Crane cab outside and turntable **4.01 - 3**
- Crane cab with incline adjustment **2.04 - 16**
- Crane commissioning **4.03 - 3**
- Crane control **1.02 - 4**
- Crane documentation **0.01 - 2**
- Crane geometry and load information **4.02 - 73**
- Crane incline **4.02 - 135**
- Crane in operation **2.04 - 3**
- Crane movement - Telescoping **4.08 - 5**
- Crane on floating device **2.25 - 1**
- Crane operation in case of thunderstorms **2.04 - 40**
- Crane operation with a load **2.04 - 60**
- Crane operation with small ballast pallet **5.36.40 - 48**
- Crane operation with the derrick ballast **5.35.10 - 84, 5.36.10 - 62, 5.36.20 - 54, 5.36.30 - 15, 5.36.40 - 54**
- Crane operator's cab with retractable / extendable step **2.04 - 15**
- Crane operator responsibilities **2.04 - 20**
- Crane out of service **2.04 - 3**
- Crane rope pretension **4.08 - 15**
- Crane ropes **7.05.50 - 4, 8.04 - 3**
- Crane speeds **1.03 - 7**
- Crane start up and taking the crane out of service **4.03 - 1**
- Crane superstructure **1.02 - 3**
- Crane surface pressure **1.03 - 8**
- Cranes with cam limit switch **5.01 - 3**
- Cranes with lattice mast boom **2.08 - 5, 2.08 - 7**

Cranes with telescopic boom **2.08 - 6, 2.08 - 7**
Cranes with winch speed sensor **5.01 - 4**
Crane transport on floating devices **2.25 - 4**
Crawler carrier assembly **3.01 - 1**
Crawler center section with Quick-Connection (QC) **1.03 - 10**
Crawler center section with turntable frame lower section **1.03 - 9**
Crawler operation with derrick ballast **5.36.10 - 96, 5.36.20 - 88, 5.36.30 - 48, 5.36.40 - 88**
Crawler travel gear **1.02 - 3, 1.02 - 3**
Creeper gear or very slow movement **2.04 - 51**
Cross beam **1.03 - 26**
Cross beam * **5.36.30 - 6, 5.36.30 - 7**
Cross carrier 3m, P-adapter bottom **1.03 - 17**
Current checklist **8.04 - 28**
Curve display **4.02 - 222**
Customer information **90.05 - 4**

D

Damaged intermediate layers **8.16 - 8**
Damaged outer braiding **8.16 - 6**
Damaged rope braiding **8.16 - 7**
Damage on rope **7.05.50 - 5**
Damage symptoms of fiber guy rope **8.16 - 6**
Danger of crushing **4.08 - 14**
Danger of falling **4.08 - 14**
Danger zone of crane **2.04 - 3**
Data logger **0.01 - 1**
D-boom **5.05 - 1**
D-boom assembly on the crane **5.05 - 7**
D-boom assembly on the ground **5.05 - 42**
D-boom disassembly on the ground **5.05 - 75**
D-boom relapse retainer **8.12 - 5**
Deactivating steering programs for assembly / disassembly purposes **5.35.10 - 68**
Deactivating the bypass at crawler assembly and crawler disassembly **5.01 - 26**
Deactivating the circular travel steering program **5.35.10 - 70**
Deactivating the parallel travel steering program **5.35.10 - 70**
Deactivating the towing steering program **5.35.10 - 70**
Decrease crane utilization **2.08 - 7**
Defined ballast trailer operation **5.35.10 - 81**
Definition of assembly conditions **3.06 - 3**
Definition of directional data for crawler cranes **0.01 - 7**
Definition of directional data for mobile cranes **0.01 - 7**
Definition of „Checking“ **7.01 - 3**
Defrosting the window **6.02 - 12**
Degree of severity **8.04 - 7**
D-end section **1.03 - 23**
Derrick ballast **4.02 - 181**
Derrick ballast - ballast trailer **5.35.10 - 1**

Derrick ballast lifted off key button **5.35.10 - 80**
Derrick ballast ra-
dii **5.36.10 - 15, 5.36.20 - 17, 5.36.30 - 7, 5.36.40 - 13**
Derrick ballast - suspended ballast **5.36.10 - 1**
Derrick ballast - suspended ballast - special design Ballast Constant (BC) **5.36.30 - 1**
Derrick ballast - suspended ballast - special design LTR **5.36.20 - 1**
Derrick ballast - suspended ballast - special design VarioTray **5.36.40 - 1**
Derrick ballast without suspended ballast guide **5.36.10 - 15, 5.36.20 - 17, 5.36.40 - 13**
Derrick ballast with suspended ballast guide **5.36.10 - 17, 5.36.20 - 18, 5.36.40 - 17**
Descending from lattice sections or booms **2.04 - 13**
Description of acoustic / visual warnings **4.20 - 11**
Description of function **7.04 - 9, 7.04 - 13, 7.05 - 17**
Description of intervals and tasks **7.01 - 3**
Description using the example LR 1600-2, SL3F **4.08 - 16**
Destined use **0.01 - 5, 2.04 - 66, 2.04 - 67, 2.25 - 3**
Detachable rope end connection **8.04 - 14**
Detaching the hoist rope **4.06 - 11, 4.06 - 15, 4.06 - 18**
Detent pin **5.01 - 18**
Determination of forces in operating mode with derrick ballast **5.35.10 - 87**
Determining main boom variation **4.02 - 22**
Determining the effective operating hours Ti **8.03 - 8**
Determining the exact charge condition of the rechargeable battery **5.31 - 15**
Determining the number of broken wires **8.04 - 9**
Determining the operating conditions (load spectrum) **8.03 - 5**
Determining the position LTR on the ballast pallet **5.36.20 - 49**
Determining the used proportion of the theoretical service life **8.03 - 8**
Determining variation auxiliary boom / accessory **4.02 - 29**
Diagnostics and problem remedy **7.04 - 11, 7.04 - 16, 7.05 - 22**
Did an error message occur? **5.31 - 39**
Diesel engine **1.02 - 3, 7.06 - 3**
Diesel particle filter * **7.05 - 15**
Difference force monitoring of ballast guying **5.35.10 - 98**
Differential force monitoring for derrick ballast-guying **5.36.10 - 88, 5.36.20 - 80, 5.36.30 - 40, 5.36.40 - 80**
Dimensions and weights Crane components **1.03 - 5**
Dimensions of the crane basic unit **1.03 - 5**
D-intermediate section 12m **1.03 - 22**
D-intermediate section 6m **1.03 - 22**
Disassemble railing 23 on catwalk 3 **2.06 - 63**
Disassemble railing 24 on catwalk 4 **2.06 - 63**
Disassemble railing 25 and railing 26 on catwalk 5 **2.06 - 63**

Disassemble railing 27 on catwalk 7 **2.06 - 63**
 Disassemble railing 28 on catwalk 7 **2.06 - 63**
 Disassemb-
 ling **5.05 - 49, 5.07 - 67, 5.36.30 - 49, 5.36.40 - 89**
 Disassembling, ballasted ballast pallet **5.36.20 - 89**
 Disassembling, complete **5.36.20 - 93**
 Disassembling catwalks on crawler center sec-
 tion **2.06 - 47**
 Disassembling the 12m guy rod **5.07 - 77**
 Disassembling the 32 t boom nose **5.10 - 23**
 Disassembling the 9m guy rod **5.07 - 76**
 Disassembling the assembly sup-
 port **3.01 - 45, 3.01 - 72**
 Disassembling the assembly supports **3.01 - 82**
 Disassembling the assembly unit I on the S-end sec-
 tion **5.07 - 101**
 Disassembling the assembly unit V **5.07 - 98**
 Disassembling the ballast trailer **5.35.10 - 99**
 Disassembling the ballast trailer guide **5.35.10 - 124**
 Disassembling the ballast trailer guide with ballast
 trailer radius 13-19m **5.35.10 - 124**
 Disassembling the ballast trailer guide with ballast
 trailer radius 13-19m on the ballast trai-
 ler **5.35.10 - 117**
 Disassembling the ballast trailer guide with ballast
 trailer radius 19-25m **5.35.10 - 127**
 Disassembling the ballast trailer guide with ballast
 trailer radius 19–25m or with ballast trailer radius 24–
 30m on the ballast trailer **5.35.10 - 118**
 Disassembling the ballast trailer guide with ballast
 trailer radius 24-30m **5.35.10 - 128**
 Disassembling the ballast trailer guying **5.35.10 - 106**
 Disassembling the central bal-
 last **3.03 - 21, 5.38 - 50, 5.39.10 - 64, 5.44 - 57**
 Disassembling the central ballast brackets with
 placed ballast plates (turntable is not assembled on
 the crawler center section) **3.03 - 29**
 Disassembling the crawler center section **3.01 - 73**
 Disassembling the cross
 beam **5.36.20 - 102, 5.36.30 - 52**
 Disassembling the D-boom on the ground **5.05 - 75**
 Disassembling the derrick bal-
 last **5.39.10 - 64, 5.44 - 57**
 Disassembling the D-guy rods **5.05 - 61**
 Disassembling the D-lattice sections **5.05 - 71**
 Disassembling the drawbars of the rotary connection
 on the turntable frame lower section **3.01 - 43**
 Disassembling the end sec-
 tion **5.36.10 - 33, 5.36.10 - 133, 5.36.20 - 29,**
5.36.20 - 115, 5.36.40 - 29, 5.36.40 - 109
 Disassembling the F-assembly unit **5.13 - 60**
 Disassembling the F-assembly unit with F-end sec-
 tion **5.13 - 67**
 Disassembling the first catwalk **2.06 - 47**
 Disassembling the first central ballast bracket (turn-
 table is assembled on the crawler center sec-
 tion) **3.03 - 27**
 Disassembling the first crawler carrier with SA-
 frame **3.01 - 64**

Disassembling the first wheel set **5.35.10 - 130**
 Disassembling the F-jib **5.13 - 49**
 Disassembling the F-jib completely as the F-as-
 sembly unit with the F-end section (maximum length
 12m) **5.13 - 62**
 Disassembling the F-jib in parts **5.13 - 52**
 Disassembling the frame **5.35.10 - 130**
 Disassembling the guy rods **5.38 - 54, 5.39.10 - 68**
 Disassembling the guy rods from the erection
 racks **5.36.10 - 107, 5.36.40 - 93**
 Disassembling the intermediate sec-
 tion **5.36.10 - 33, 5.36.20 - 29, 5.36.40 - 29**
 Disassembling the lattice sections **5.13 - 53**
 Disassembling the lattice sections on a luffing lattice
 jib **5.01 - 41**
 Disassembling the lattice sections on an auxiliary
 boom with an auxiliary crane **5.01 - 45**
 Disassembling the lattice sections on an auxiliary
 boom without an auxiliary crane **5.01 - 49**
 Disassembling the L-intermediate sections **5.44 - 71**
 Disassembling the mechanical auxiliary sup-
 port **3.04 - 9**
 Disassembling the pivot sec-
 tion **5.36.10 - 33, 5.36.10 - 133, 5.36.20 - 29,**
5.36.20 - 115, 5.36.40 - 29, 5.36.40 - 109
 Disassembling the platforms **5.35.10 - 122**
 Disassembling the pull
 rods **5.36.10 - 129, 5.36.20 - 111, 5.36.40 - 105**
 Disassembling the radio receiver **5.19.10 - 5**
 Disassembling the radio sending unit on the hook
 block **5.19.10 - 8**
 Disassembling the roller cart **5.07 - 79**
 Disassembling the roller cart on the W-lattice
 jib **5.07 - 79**
 Disassembling the roller set **5.07 - 80**
 Disassembling the roller sets R8/R12 on the L- or S-
 end section **5.14 - 17**
 Disassembling the SA-frame **3.05 - 29**
 Disassembling the second catwalk **2.06 - 47**
 Disassembling the second crawler carrier with SA-
 frame **3.01 - 68**
 Disassembling the second wheel set **5.35.10 - 133**
 Disassembling the S-intermediate sections / S-adap-
 ter / S-end section on the upper P-adapter **5.44 - 69**
 Disassembling the S-pivot section on the turn-
 table **5.38 - 57, 5.39.10 - 74, 5.44 - 76**
 Disassembling the stairs **2.06 - 43**
 Disassembling the stairs on the catwalk **2.06 - 39**
 Disassembling the suspended bal-
 last **5.36.10 - 97, 5.36.40 - 93**
 Disassembling the suspended ballast
 guide **5.36.10 - 123, 5.36.20 - 104, 5.36.20 - 111,**
5.36.40 - 99
 Disassembling the suspended ballast guide on the
 erection racks **5.36.10 - 121, 5.36.40 - 95**
 Disassembling the suspended ballast guide on the
 turntable
 frame **5.36.10 - 127, 5.36.20 - 109, 5.36.40 - 103**

Disassembling the suspended ballast guide with 30 m suspended ballast radius **5.36.10 - 129, 5.36.40 - 105**
Disassembling the suspended ballast with the suspended ballast guide **5.36.10 - 111, 5.36.20 - 103, 5.36.40 - 95**
Disassembling the turntable frame lower section with the QC on the crawler center section with QC **3.01 - 43**
Disassembling the upper P-adapter on the L-intermediate sections **5.44 - 70**
Disassembling the WA-frame 1 guy rods **5.07 - 82**
Disassembling the WA-frame 2 pivot section **5.07 - 100**
Disassembling the WA-frame end sections on the WA-frame intermediate sections **5.07 - 102**
Disassembling the WA-frames **5.07 - 91**
Disassembling the W-lattice jib **5.07 - 79**
Disassembling the W-lattice jib to the W-pivot section **5.07 - 81**
Disassembling winch 5 (WV) on the S-pivot section **5.38 - 56**
Disassembling winch 5 on the S-pivot section **5.39.10 - 72, 5.44 - 78**
Disassembling winch 6 (WVI) on the S-pivot section **5.38 - 56**
Disassembling winch 6 on the S-pivot section **5.39.10 - 72, 5.44 - 78**
Disassembling with a cross beam * **5.36.30 - 51**
Disassembling without a cross beam **5.36.30 - 50**
Disassembling without suspended ballast guide **5.36.20 - 102**
Disassembling with suspended ballast guide * **5.36.20 - 103**
Disassembly **5.61 - 7**
Disassembly Catwalk / stairs crawler travel gear **2.06 - 39**
Disassembly of boom systems on ascending terrain **5.01 - 62**
Disassembly of boom systems on descending terrain **5.01 - 65**
Disassembly of crawler carrier with the auxiliary crane **3.01 - 31**
Disassembly of lattice sections **5.01 - 53**
Disassembly of the crawler carrier with SA-frame **3.01 - 59**
Disassembly of the roller sets on the boom head **5.38 - 53, 5.39.10 - 67, 5.44 - 61**
Disassembly of turntable **3.02 - 15**
Disassembly PD-boom **5.44 - 56**
Disassembly procedure **5.10 - 29**
Disassembly S2/SL/SL3-boom **5.38 - 49**
Disassembly SD/S2D/SL2D-boom **5.39.10 - 63**
Disassembly Turntable frame main section **3.02 - 19**
Disassembly winch 1 **3.07.10 - 15**
Disassembly winch 2 **3.07.20 - 15**
Disassembly winch 5 **3.07.50 - 21**
Disassembly winch 6 **3.07.60 - 23**
Disconnecting the connections **5.35.10 - 126**

Disconnecting the connections of the central lubrication system to the winch **3.07.10 - 17, 3.07.20 - 17, 3.07.50 - 23, 3.07.60 - 25**
Disconnecting the connections to the crawler carriers **3.01 - 32, 3.01 - 59**
Disconnecting the connections to the SA-frame **3.05 - 35**
Disconnecting the connections to winch 1 **3.07.10 - 17**
Disconnecting the connections to winch 2 **3.07.20 - 17**
Disconnecting the connections to winch 5 **3.07.50 - 23**
Disconnecting the connections to winch 6 **3.07.60 - 25**
Disconnecting the connection to the central lubrication system **3.01 - 32, 3.01 - 60, 3.05 - 35, 5.35.10 - 127**
Disconnecting the divisible ballast pallet „VarioT-ray“ **5.36.40 - 49**
Disconnecting the electrical connections on the boom end section **5.38 - 54, 5.39.10 - 68, 5.44 - 61**
Disconnecting the electrical connections on the D-boom **5.05 - 61**
Disconnecting the electrical connections to the D-pivot section **5.05 - 71**
Disconnecting the electrical connections to the luffing pulley block **5.05 - 54**
Disconnecting the electrical connections to the winch **3.07.10 - 17, 3.07.20 - 17, 3.07.50 - 23, 3.07.60 - 25**
Disconnecting the electric and hydraulic connections on the S-pivot section **5.38 - 56, 5.39.10 - 73, 5.44 - 75**
Disconnecting the hydraulic aggregate **3.01 - 80**
Disconnecting the hydraulic connections on the D-boom **5.05 - 61**
Disconnecting the hydraulic connections to the D-pivot section **5.05 - 71**
Disconnecting the hydraulic connections to the winch **3.07.10 - 17, 3.07.20 - 17, 3.07.50 - 23, 3.07.60 - 25**
Display / operating element BTT **5.31 - 3**
Display for surface pressure in the LICCON monitor **4.10 - 9**
Display for the center of gravity in the LICCON monitor **4.10 - 8**
Display for the incline in the LICCON monitor **4.10 - 10**
Displaying the settings windows **4.02 - 197**
Display of auxiliary functions **4.02 - 133**
Displays in LICCON monitor **4.10 - 7**
Displays on control element **7.04 - 9**
Displays on the control element **7.05 - 20**
Disposal **7.01 - 10**
Distortions and mechanical damage **8.04 - 8**
Distribution of surface pressure **4.10 - 13**

Divisible ballast pallet „VarioT-ray“ **5.36.40 - 5, 5.36.40 - 8**
 Documentation Fall arrest systems and Height rescue system **2.04 - 12**
 Documentation of rope condition **7.05.50 - 11**
 Documenting inspection results **8.04 - 5**
 Documenting the completed inspection **8.03 - 4**
 Documenting the inspection **8.06 - 5**
 D-pivot section with winch 3 **1.03 - 22**
 Draining the fuel preliminary filter **7.05 - 11**
 Drive **1.02 - 3**
 Driver's cab and crane cab **7.01 - 9**
 Driving at side inclines **4.10 - 20**
 Driving forward **4.10 - 39, 4.10 - 47**
 Driving from the crane operator's cab **4.10 - 1**
 Driving in curves forward to the left **4.10 - 41, 4.10 - 49**
 Driving in curves forward to the right **4.10 - 41, 4.10 - 49**
 Driving in curves reverse to the left **4.10 - 41, 4.10 - 51**
 Driving in curves reverse to the right **4.10 - 41, 4.10 - 51**
 Driving in reverse **4.10 - 39, 4.10 - 47**
 Driving the ballast trailer **5.35.10 - 71**
 Driving the crane: Ballast trailer installed **4.10 - 21**
 Driving the crane: Load chart available **4.10 - 16**
 Driving the crane: No load chart is available **4.10 - 17**
 Driving the crawler **5.36.10 - 96, 5.36.20 - 88, 5.36.30 - 48, 5.36.40 - 88**
 Driving the crawler crane **4.10 - 22**
 Driving the crawler crane in normal travel **4.10 - 39**
 Driving the crawler crane in parallel travel **4.10 - 47**
 Driving uphill / downhill **4.10 - 18**
 Driving uphill / downhill by changing the angle of the boom system **4.10 - 19**
 Driving with a load on the hook and / or derrick ballast **4.10 - 16**
 Driving without a load on the hook and without derrick ballast **4.10 - 17**
 Ductile deformation **8.15 - 4**

E

Editing and selection area **4.02 - 221**
 Effects of heat, arcs **7.05.50 - 10, 8.04 - 25**
 Electrical system **1.02 - 5, 7.05 - 36**
 Elongation **8.15 - 4**
 Emergency control **6.05 - 2**
 Emergency control of slewing gear(s) with assembly plate Variation 1 (V1) **6.05 - 15**
 Emergency control of winches, individual operation **6.05 - 23**
 Emergency control of winches, parallel operation winch 11I2 **6.05 - 26**
 Emergency control slewing gear(s) with assembly plate(s) Variation 2 (V2) **6.05 - 31**
 Emergency control winches **6.05 - 13**

Emergency control with assembly plate(s) Variation 2 (V2) **6.05 - 19**
 Emergency control with assembly plate Variation 1 (V1) **6.05 - 9**
 Emergency equipment Crane cab inside **4.01 - 7**
 Emergency equipment Crane cab outside **4.01 - 5**
 Emergency exist crane cab **2.04 - 5**
 Emergency exit **2.04 - 5**
 Emergency exit - driver's cab **2.04 - 5**
 Emergency exit through front window **2.04 - 6**
 Emergency exit through the roof window **2.04 - 6**
 Emergency exit with EMERGENCY hammer * **2.04 - 6**
 Emergency operation ballast trailer **4.02 - 189**
 Emergency operation - circular travel **5.35.10 - 136**
 Emergency operation in case of a defective control module of the ballast trailer control **5.35.10 - 134**
 Emergency operation LICCON overload protection (according to EN 13000:2010) **4.02 - 110**
 Emergency operation of ballast trailer **5.35.10 - 135**
 Emergency operation - towing **5.35.10 - 135**
 Emergency situations **4.20 - 6**
 Emergency stop (quick stop) **2.04 - 51**
 EMERGENCY STOP switch / EMERGENCY OFF switch **4.04 - 17**
 Emergency take-down **6.05 - 1**
 Endangering air traffic **2.04 - 3**
 Ending crane operation **2.04 - 65**
 End operation, no longer follow my instructions **2.04 - 51**
 End section **5.36.10 - 7, 5.36.10 - 9, 5.36.40 - 7, 5.36.40 - 9**
 Engine **7.05 - 3**
 Engine monitoring functions **5.31 - 19**
 Engine oil level Bar diagram **4.02 - 120**
 Engine oil level Number value **4.02 - 120**
 Engine operation menu **5.31 - 17**
 Engine preheating **2.08 - 4**
 Engine regulation **4.10 - 29**
 Engine rpm **4.05 - 7**
 Engine type D 9508 A7-03 without exhaust aftertreatment system **1.02 - 4**
 Engine type D 9508 A7-04 with exhaust aftertreatment system SCR **1.02 - 4**
 Enlarged rope end connection **8.04 - 14**
 Entering / changing the maximum permissible surface pressure **4.03 - 19**
 Entering / exiting a swung crane superstructure **2.04 - 16**
 Entering / exiting of crane superstructure alignment length axis crane chassis **2.04 - 16**
 Entering the hook block weight **4.02 - 63**
 Entering the maximum permissible surface pressure **4.10 - 10**
 Equalizing the ballast trailer position **5.35.10 - 53**
 Equalizing the derrick ballast **5.36.10 - 95, 5.36.20 - 87, 5.36.30 - 47, 5.36.40 - 87**
 Equipment and spare parts **0.01 - 7**

Erecting the boom system with a roller set on the S-end section **5.07 - 62**
Erecting the boom system without a roller set on the S-end section **5.07 - 61**
Erecting the boom system without a roller set on the S-end section and long W-lattice jib **5.07 - 62**
Erecting the D-boom **5.05 - 35**
Erecting the D-boom to maximum 85° **5.05 - 42**
Erecting the D-boom to the horizontal **5.05 - 37**
Erecting the D-relapse cylinder **5.05 - 13**
Erecting the erection racks **5.36.10 - 25, 5.36.10 - 49, 5.36.20 - 22, 5.36.20 - 44, 5.36.40 - 21**
Erecting the FA-frame **5.13 - 14, 5.13 - 25, 5.13 - 36, 5.13 - 44**
Erecting the pull brackets **5.35.10 - 23**
Erecting the SA-frame **5.02 - 5**
Erecting the WA-frame 1 **5.07 - 50**
Erecting the WA-frame 2 **5.07 - 38**
Erection / take down **5.01 - 67**
Erection / take down for crawler cranes **5.01 - 68**
Erection / take down for mobile cranes **5.01 - 67**
Error messages **4.02 - 4**
Error messages by the LICCON computer system **4.04 - 11**
Establishing the connections **5.35.10 - 22, 5.35.10 - 28, 5.35.10 - 30**
Establishing the connections of the central lubrication system to the winch **3.07.10 - 13, 3.07.20 - 13, 3.07.50 - 19, 3.07.60 - 21**
Establishing the connections to the central lubrication system **3.01 - 31, 3.01 - 58, 3.05 - 21**
Establishing the connections to the crawler carriers **3.01 - 30, 3.01 - 58**
Establishing the connections to the SA-frame **3.05 - 21**
Establishing the electrical connection **5.35.10 - 22, 5.35.10 - 28**
Establishing the electrical connection from the ballast trailer to the turntable **5.35.10 - 44**
Establishing the electrical connection from the suspended ballast to the turntable **5.36.10 - 28, 5.36.10 - 54, 5.36.20 - 25, 5.36.20 - 47, 5.36.40 - 25, 5.36.40 - 45**
Establishing the electrical connections on the boom end section **5.38 - 40, 5.39.10 - 54, 5.44 - 48**
Establishing the electrical connections on the D-boom **5.05 - 22**
Establishing the electrical connections on the end section of the W-boom **5.07 - 54**
Establishing the electrical connections to the assembly unit I **5.07 - 22**
Establishing the electrical connections to the boom end section **5.38 - 24, 5.39.10 - 26**
Establishing the electrical connections to the D-pivot section **5.05 - 17**
Establishing the electrical connections to the luffing pulley block **5.05 - 39**

Establishing the electrical connections to the winch **3.07.10 - 13, 3.07.20 - 13, 3.07.50 - 19, 3.07.60 - 21**
Establishing the electric and hydraulic connections on the S-pivot section **5.38 - 18, 5.39.10 - 20, 5.44 - 22**
Establishing the hydraulic connection **5.35.10 - 22, 5.35.10 - 28**
Establishing the hydraulic connection from the ballast trailer to the turntable **5.35.10 - 45**
Establishing the hydraulic connections on the D-boom **5.05 - 21**
Establishing the hydraulic connections to the D-pivot section **5.05 - 16**
Establishing the hydraulic connections to the winch **3.07.10 - 13, 3.07.20 - 13, 3.07.50 - 19, 3.07.60 - 21**
Establishing the hydraulic connections to the winches **6.05 - 27**
Establishing the hydraulic connections to winch 1 **3.07.10 - 13**
Establishing the hydraulic connections to winch 2 **3.07.20 - 13**
Establishing the hydraulic connections to winch 5 **3.07.50 - 19**
Establishing the hydraulic connections to winch 6 **3.07.60 - 21**
Establishing the hydraulic connection to the slewing gears **6.05 - 15**
Evaluating oil color **8.03 - 3**
Even reduction of rope diameter **8.04 - 14**
Example **8.03 - 9**
Example for crane on crawler with derrick boom, suspended ballast and long (main) boom system **2.04 - 32**
Example for crane on crawler with derrick boom, suspended ballast and short (main) boom system **2.04 - 32**
Example for crane on supports **2.04 - 33**
Example for test points **8.01 - 7**
Examples for the distribution of surface pressure **4.10 - 13**
Examples for the load bearing capacity of the ground **2.04 - 30**
Exceeding the LICCON overload protection for assembly **5.07 - 15**
Exceeding the shut off limits of the LICCON overload protection **4.02 - 109**
Exceeding the shut off limits of the LICCON overload protection for assembly operation **5.05 - 10, 5.05 - 50, 5.38 - 13, 5.39.10 - 14, 5.44 - 18**
Exhaust system **7.01 - 9, 7.05 - 15**
Extending the boom **2.04 - 57**
Extending the D-relapse cylinder **5.05 - 36**
Extending the front support cylinder **5.35.10 - 61**
Extending the pull cylinder **5.05 - 25**
Extending the rear support cylinder **5.35.10 - 62**
Extending the supply lines between the turntable and the ballast trailer **5.35.10 - 105**

Extending the support cylinders **5.35.10 - 105**
Extension ladder on ballast trailer **2.06 - 97, 2.06 - 99**
Extension ladder on ballast trailer guide **2.06 - 103**
Extension ladder on control cabinet pedestal **2.06 - 101**
External corrosion **8.04 - 17**

F

F1-display bar **4.02 - 163**
F2/F3-display bar **4.02 - 163**
Failure of components **4.20 - 6**
Failure of sensor / limit switch! **4.02 - 99**
Failure of the overload protection **4.04 - 5**
Falling below the minimum value of the F-load display in crane operation **4.20 - 45**
Fall protection equipment on counterweights **2.06 - 91**
Fall protection equipment on the counterweight bracket **2.06 - 87**
F-assembly unit **1.03 - 23, 5.13 - 4, 5.13 - 7**
F-assembly unit with F-end section **1.03 - 23, 5.13 - 5, 5.13 - 7**
Fastening and hook points on the counterweights **2.06 - 91**
Fastening device **2.04 - 69**
Fastening equipment **5.36.30 - 5**
Fastening points and weights **3.03 - 3**
Fastening points Assembly unit I **5.07 - 6**
Fastening points Assembly unit II **5.07 - 6**
Fastening points Assembly unit III **5.07 - 7**
Fastening points Assembly unit IV **5.07 - 7**
Fastening points Assembly unit V **5.07 - 7**
Fastening points Auxiliary weight **5.05 - 5**
Fastening points Bridges 12m **5.44 - 11**
Fastening points Bridges 6m **5.44 - 10**
Fastening points catwalk / stairs **2.06 - 29**
Fastening points central ballast bracket **3.03 - 4**
Fastening points central ballast bracket with ballast plates **3.03 - 4**
Fastening points Change over pulley **5.07 - 10**
Fastening points Counterweight bracket **4.07 - 4**
Fastening points counterweight bracket with counterweight plates **4.07 - 4**
Fastening points crawler center section (turntable frame lower section fixed assembled) **3.01 - 4**
Fastening points crawler center section with QC (turntable frame lower section not assembled) **3.01 - 5**
Fastening points Crawler center section with turntable frame lower section **3.02 - 3**
Fastening points cross carrier **5.44 - 4**
Fastening points D-end section **5.05 - 5**
Fastening points D-intermediate section 2825.20 12m **5.05 - 4**
Fastening points D-intermediate section 2825.25 6m **5.05 - 4**
Fastening points D-pivot section **5.05 - 4**
Fastening points for boom nose 32 t **5.10 - 4**
Fastening points for derrick components **5.05 - 3**
Fastening points for lattice sections **5.36.20 - 13**
Fastening points for pulley cart **5.61 - 3**
Fastening points for roller set **5.14 - 4**
Fastening points for suspended ballast components **5.36.10 - 8, 5.36.20 - 10, 5.36.30 - 6, 5.36.40 - 8**
Fastening points for suspended ballast guide components **5.36.10 - 9, 5.36.40 - 9**
Fastening points for the F-jib **5.13 - 5**
Fastening points L-end section **5.07 - 9, 5.38 - 7, 5.39.10 - 7**
Fastening points L-intermediate section 12m **5.07 - 9, 5.44 - 6**
Fastening points L-intermediate section 6m **5.44 - 5**
Fastening points L-intermediate sections 12m **5.38 - 8, 5.39.10 - 8**
Fastening points L-intermediate sections 6m **5.38 - 7, 5.39.10 - 7**
Fastening points lower P-adapters **5.44 - 4**
Fastening points on crawler center section with QC **3.01 - 5**
Fastening points on the crawler carrier **3.01 - 6**
Fastening points on turntable frame lower section with QC **3.01 - 5**
Fastening points on turntable frame main section **3.02 - 4**
Fastening points S-end section **5.38 - 6, 5.39.10 - 6, 5.44 - 9**
Fastening points S-intermediate section 12m **5.07 - 8**
Fastening points S-intermediate section 12m / S-adapter 12m **5.44 - 9**
Fastening points S-intermediate section 6m **5.44 - 8**
Fastening points S-intermediate sections 12m / S-adapter 12m **5.38 - 5, 5.39.10 - 5**
Fastening points S-intermediate sections 6m **5.38 - 4, 5.39.10 - 4**
Fastening points SL-reducer section **5.07 - 8**
Fastening points SL-reducer section 6m **5.38 - 6, 5.39.10 - 6**
Fastening points S-luffing pulley block **5.05 - 5**
Fastening points S-pivot section **5.38 - 3, 5.39.10 - 3, 5.44 - 3**
Fastening points suspended ballast guide **5.36.20 - 15**
Fastening points Transport unit Bridges **5.44 - 10**
Fastening points turned L-intermediate section 6m / L-intermediate section 12m **5.44 - 7**
Fastening points upper P-adapter **5.44 - 7**
Fastening points winch 1 **3.07.10 - 3**
Fastening points winch 2 **3.07.20 - 3**
Fastening points winch 5 **3.07.50 - 3**
Fastening points winch 6 **3.07.60 - 3**
Fastening positions for assembly / disassembly of the lattice jib **5.01 - 30**
Fastening the ballast on the guy rods **5.36.30 - 11**
Fastening the ballast to the cross beam **5.36.30 - 14**
Fastening the hoist rope **4.06 - 17**
Fastening the load **4.08 - 7**

Fastening the load hook * **4.06 - 16**
Fastening the SA-frame on the auxiliary crane **3.05 - 11, 3.05 - 39**
Fastening the transport unit „Turntable with SA-frame and winch 4“ with two auxiliary cranes **3.02 - 6**
Fastening the transport unit „Turntable with winches“ with two auxiliary cranes **3.02 - 5**
Fastening the transport unit „Turntable“ with an auxiliary crane **3.02 - 4**
Fast settings * Speed reduction master switch / pedal sensor **4.02 - 197**
F-connector head **1.03 - 20**
F-end section **1.03 - 24, 5.13 - 3, 5.13 - 6**
Filling repaired lube lines **7.04 - 11, 7.04 - 15**
Filling the grease container **7.04 - 11, 7.04 - 14, 7.05 - 22**
Filling the lubrication lines **7.05 - 22**
Filling the windshield washer system **4.03 - 31**
Fill quantities **7.06 - 3**
Fill quantities, lubrication schedule **7.06 - 1**
Filter category **4.02 - 218**
Final tasks **5.07 - 102**
F-intermediate section
12m **1.03 - 24, 5.13 - 4, 5.13 - 6**
F-intermediate section
6m **1.03 - 24, 5.13 - 4, 5.13 - 6**
First aid measures after rescue **2.04 - 14**
First inspection (first year) **8.03 - 9**
Fitting the hoist rope on the rope lock, L-shaped rope end connection **4.06 - 14**
Fixed ladder **2.06 - 49**
Flap can be pushed closed **8.12 - 13**
Flap can be pushed open **8.12 - 13**
Flap in operating position **8.12 - 19**
Flap swings in at stop **8.12 - 13**
Flap swings out to stop **8.12 - 13**
Flattening **7.05.50 - 7**
Flattenings **8.04 - 25**
F-lattice jib relapse retainer **8.12 - 17**
F-load display **4.02 - 159**
F-load display for operating modes with derrick ballast **5.36.10 - 69, 5.36.20 - 61, 5.36.30 - 21, 5.36.40 - 61**
Floating device **2.25 - 3**
Floating device, non-supported/non-jacked up **2.25 - 4**
Floating device, supported/jacked up **2.25 - 4**
Flying assembly / disassembly of lattice sections **5.01 - 55**
Flying assembly of lattice sections **5.01 - 55**
Flying D-boom assembly **5.05 - 44**
Flying D-boom disassembly **5.05 - 77**
Flying disassembly of lattice sections **5.01 - 57**
Flying disassembly of the D-boom **5.05 - 77**
Folding the platform down from transport position into operating position **2.06 - 15**
Folding the platform from operating position into transport position **2.06 - 17**

Force distribution when driving on pressure distributor plates **4.10 - 27**
Force F1 (test point 1) **5.36.10 - 71, 5.36.20 - 63, 5.36.30 - 23, 5.36.40 - 63**
Force F1 (test point 1) between guying SA-frame - derrick end section **5.35.10 - 88**
Force F11 (test point 11) **5.36.10 - 75, 5.36.20 - 67, 5.36.30 - 27, 5.36.40 - 67**
Force F2 (test point 2) and force F3 (test point 3) **5.36.10 - 71, 5.36.20 - 63, 5.36.30 - 23, 5.36.40 - 63**
Force F4/5 (test point 4/5) **5.36.10 - 73, 5.36.20 - 65, 5.36.30 - 25, 5.36.40 - 65**
Force F4/F5 (test point 4/5) guying derrick ballast - derrick end section **5.35.10 - 88**
For cranes with pneumatic boom locking system **8.01 - 79**
For cranes with telescopic boom system Telematik **8.01 - 80**
Foreword **90.01 - 3**
Foreword to attachment **90.01 - 1**
F-pivot section **5.13 - 3, 5.13 - 5**
Frame **1.02 - 3**
F-relapse support **5.13 - 33**
Friction corrosion **8.04 - 19**
Fuel system **7.05 - 8**
Function **5.35.10 - 3, 5.36.10 - 3, 5.36.20 - 3, 5.36.30 - 3, 5.36.40 - 3**
Function check **5.10 - 15**
Function check before lifting the derrick ballast **5.36.40 - 50**
Function check of limit switch actuators on the mechanical relapse support - flap **8.12 - 13, 8.12 - 19**
Function check of the ground contact switch **5.36.10 - 62, 5.36.20 - 54, 5.36.40 - 54**
Function key assignment TE3 **4.01 - 53**
Function key line in the Working range limitation program **4.02 - 215**
Function keys **4.02 - 224**
Function keys in Crane cab / stepladder menu **5.31 - 29**
Function keys in the Engine monitoring functions **5.31 - 20**
Function keys in the Test system menu **5.31 - 35**
Function selection on the assembly plate emergency operation **6.05 - 13, 6.05 - 23**
Function selection on the assembly plate parallel operation **6.05 - 23**
Functions master switch MS2 **4.01 - 39**
Function test **6.02 - 27**

G

Gene-
ral **0.01 - 1, 2.04 - 20, 4.02 - 3, 4.04 - 3, 4.08 - 13, 4.20 - 3**
General controls before crane operation **5.01 - 5**
General danger notes **6.05 - 5**
General information **8.01 - 3**
General information regarding the BTT **5.31 - 9**
General notes regarding the acoustic / optical warn-
ings to the crane surrounding area **4.20 - 9**
General operating elements on LICCON Moni-
tor 0 **4.02 - 8**
General operating elements on LICCON Moni-
tor 1 **4.02 - 10**
General operating elements on LICCON Moni-
tor 2 **4.02 - 11**
General safety technical guidelines **2.04 - 1**
General safety technical notes for operation with bal-
last trailer **2.15 - 1**
Giving a warning signal **4.05 - 5**
Gravity actuated relapse retainer **4.04 - 18**
Grommets and rope end connections **8.16 - 5**
Grounding **2.04 - 37**
Grounding the crane **2.04 - 37**
Grounding the load **2.04 - 38**
Guiding crane structures, lattice sections or crane
components **5.01 - 24**
Guiding the load **4.08 - 13**
Guying and erecting the WA-frame 2 **5.07 - 36**
Guying the pivot section in flying mode with the der-
rick boom **5.01 - 59**
Guying the pivot section in flying mode with the SA-
frame **5.01 - 57**
Guy rods **5.01 - 8**
Guy rope **1.03 - 8**

H

Handling of assembly plates **6.05 - 7**
Hand signals **2.04 - 50**
Hand signals for guidance **2.04 - 50**
Hanging the extension ladder in operating posi-
tion **2.06 - 99, 2.06 - 101, 2.06 - 103**
Head weights W1-lattice jib **5.07 - 52**
Head weights W2-lattice jib **5.07 - 52**
Head weights W3-lattice jib **5.07 - 52**
Head weights W-lattice jib **5.07 - 51**
Heated crane components **2.04 - 19**
Heater / engine preheating / Air conditioning system
Crane operator's cab **6.02 - 1**
Height dependant wind speed **2.04 - 44**
Highlighting the load column in color **4.02 - 231**
Hoist gear, hoist rope **2.04 - 62**
Hoist gears **7.05 - 26**
Hoist limit
switch **4.02 - 101, 5.07 - 56, 5.38 - 41, 5.39.10 - 55, 5.44 - 49**
Hoist limit switch „Hoist top“ **4.04 - 11**

Hoist ropes **1.03 - 8**
Holding the luffing lattice jib **5.01 - 33**
Hook block incline sensors **5.19.10 - 1**
Hook blocks **5.19 - 1, 5.19 - 3**
Hooking the hoist rope on the rope lock **4.06 - 10**
Horizontally aligning the hook block **4.05 - 23**
Horizontal movements **2.04 - 53**
Hydraulic assembly cylinder **1.02 - 5**
Hydraulic assembly support **1.02 - 5**
Hydraulic hose lines **7.04.50 - 3, 7.05 - 34**
Hydraulic oil level **5.30 - 5**
Hydraulic safety valves **4.04 - 18**
Hydraulic system **7.05 - 31, 7.06 - 4**

I

Icon explanation in Engine operation menu **5.31 - 17**
Icon explanation Start screen BTT **5.31 - 11**
Icons Crawler operating modes in touch dis-
play 3 **4.10 - 30**
Icons in the Engine monitoring functions **5.31 - 23**
Identification of protective equipment **2.04 - 9**
Identification of sliding beam **2.05 - 35**
Identifications on auxiliary weights **2.05.10 - 5**
Identifications on auxiliary weights at deli-
very **2.05.10 - 6**
Identifications on auxiliary weights for reor-
der **2.05.10 - 6**
Identifications on single hook or double
hook **2.05.10 - 4**
Identifications on the hook block or load
hooks **2.05.10 - 3**
Identification Track width retracted **2.05 - 36**
If winch 5 is installed **3.07.60 - 13**
If winch 5 is not installed **3.07.60 - 15**
Importance of inspection **8.04 - 3**
Important information about the BTT **5.31 - 5**
Improper mechanical damage **8.04 - 25**
Improvement of force ratio in the guying of the boom
system **4.20 - 63**
Increased corrosion **2.25 - 5**
Increase the hook block weight **2.08 - 6**
Increasing the hook block weight **4.08 - 18**
Increasing the reeving number **4.08 - 18**
Indicator lights on the BKE **4.01 - 17**
Individual control display Battery voltage **4.02 - 119**
Individual control display Charge air tempera-
ture **4.02 - 118**
Individual control display Coolant temperature Single
motor / Double motor **4.02 - 117**
Individual control display Engine oil level **4.02 - 119**
Individual control display Engine oil press-
ure **4.02 - 118**
Individual control display Fuel reserve **4.02 - 117**
Individual control display Hydraulic oil le-
vel **4.02 - 120**
Individual control display Hydraulic oil tempera-
ture **4.02 - 119**
Individual control display Urea reserve **4.02 - 118**

Information about crane geometry and load in the SA-operating mode **4.02 - 87**
Inserting the pins for transport **3.07.50 - 26, 3.07.60 - 28**
Inspecting and monitoring the load hook **8.05 - 3**
Inspecting ladders **8.17 - 3**
Inspecting the fiber guy ropes **8.16 - 4**
Inspecting the gear brakes **8.03 - 4**
Inspecting the hoist and retracting winches **8.03 - 3**
Inspecting the hydraulic hose lines for damage **7.05 - 34, 8.06 - 4**
Inspecting the hydraulic hose lines for leaks **8.06 - 5**
Inspecting the lattice sections **8.01 - 78**
Inspecting the pin connections **8.01 - 87**
Inspection **8.15 - 3, 8.16 - 4**
Inspection before operation **2.04 - 67**
Inspection chart for cranes **8.90 - 1**
Inspection chart for recurring inspections of Liebherr cranes **8.90 - 3**
Inspection form for the inspection of ladders and steps **8.17 - 4**
Inspection intervals **8.03 - 3, 8.05 - 3, 8.06 - 3, 8.15 - 3, 8.16 - 4, 8.17 - 3**
Inspection of accumulator pressure in anti-tilt cylinder **8.14 - 1**
Inspection of carrier rollers **8.01 - 85**
Inspection of carrying crane structures, especially steel structures **8.01 - 4**
Inspection of change over pulleys, illustration 2 **8.01 - 90**
Inspection of crane wire ropes **8.04 - 1**
Inspection of diaphragm reservoir **8.01 - 84**
Inspection of extension conditions of sliding beams **8.01 - 87**
Inspection of fastening equipment **8.01 - 84**
Inspection of fiber guy ropes **8.16 - 1**
Inspection of guy rods **8.15 - 1**
Inspection of hydraulic hose lines **8.06 - 1**
Inspection of ladders **8.17 - 1**
Inspection of load handling equipment and assembly aids **8.01 - 83**
Inspection of load hooks **8.05 - 1**
Inspection of locking system of telescopic boom **8.01 - 79**
Inspection of relapse cylinders **8.01 - 84**
Inspection of rope pretension on lattice sections, illustration 2 **8.01 - 83**
Inspection of rope pulleys **8.01 - 85**
Inspection of safety ropes and anchor points **2.06 - 13, 8.01 - 81**
Inspection of safety switching on the relapse supports **8.12 - 1**
Inspection of slewing ring connection **8.01 - 87**
Inspection of the auxiliary reeving winch, recovery winch and spare wheel winch **8.03 - 4**
Inspection of the function of the overload protection **8.01 - 87**

Inspection of the mounting of the load bearing equipment **8.01 - 88**
Inspection of the oil and fuel tanks **8.01 - 90**
Inspection of the safety controls on the relapse cylinders **8.01 - 85**
Inspection of the tele extension with eccentric, illustration 1 **8.01 - 89**
Inspection of tires and disk wheels **2.15 - 4**
Inspection of winches **8.03 - 1**
Inspections and maintenance work **6.02 - 27**
Inspection sheet and check list **8.17 - 3**
Installation parts Crane cab / control cabinet outside **4.01 - 3**
Installation parts Crane cab bottom **4.01 - 5**
Installation parts turntable **4.01 - 5**
Installation winch 5 from transport into operating position **3.07.50 - 5**
Installation winch 6 from transport into operating position **3.07.60 - 5**
Installing roller set R8 with the forklift and assembly rack **5.14 - 11**
Installing the assembly supports **3.01 - 15**
Installing the auxiliary guying **5.03 - 7, 5.07 - 49**
Installing the ballast pallet **5.36.10 - 23, 5.36.10 - 47**
Installing the ballast trailer on the turntable **5.35.10 - 37**
Installing the batteries **7.05 - 39**
Installing the boom nose 32 t **5.10 - 7**
Installing the bridges **5.44 - 37**
Installing the catwalk grating in operating position **5.44 - 17**
Installing the central ballast **3.03 - 8, 5.44 - 11**
Installing the central ballast brackets with placed ballast plates **3.03 - 14**
Installing the change over pulley in the transport position **5.07 - 104**
Installing the counterweight **4.07 - 6**
Installing the counterweight brackets **4.07 - 9**
Installing the cross carrier **5.44 - 28**
Installing the D-boom in sections **5.05 - 13**
Installing the derrick ballast **5.39.10 - 30**
Installing the divisible ballast pallet „VarioT-ray“ **5.36.40 - 20**
Installing the extension ladder on the ballast trailer **5.35.10 - 21, 5.35.10 - 121**
Installing the extension ladder on the ballast trailer guide **5.35.10 - 32, 5.35.10 - 100, 5.35.10 - 117**
Installing the first crawler carrier with SA-frame **3.01 - 48**
Installing the first crawler carrier with the auxiliary crane **3.01 - 25**
Installing the grating in transport position **5.44 - 17**
Installing the hoist rope on the erection ropes **5.07 - 83**
Installing the ladder and railing on the ballast trailer guide **5.35.10 - 26**
Installing the lattice sections of the PD-boom **5.44 - 23**
Installing the lower P-adapters **5.44 - 26**

Installing the mechanical auxiliary support on the crawler travel gear **3.04 - 5**
 Installing the pin pulling device on the support beam **3.04 - 5**
 Installing the pulley cart **5.61 - 5**
 Installing the railing on the ballast trailer **5.35.10 - 22**
 Installing the relapse supports in operating position **5.07 - 40, 5.07 - 43**
 Installing the roller cart **5.07 - 53**
 Installing the roller set **5.07 - 50**
 Installing the roller set R8 with the auxiliary crane **5.14 - 12**
 Installing the rope guide pulley on the roller set / roller sets **5.14 - 13**
 Installing the second crawler carrier with SA-frame **3.01 - 55**
 Installing the second crawler carrier with the auxiliary crane **3.01 - 28**
 Installing the suspended ballast **5.44 - 42**
 Installing the suspended ballast guide as a transport unit **5.36.10 - 135, 5.36.20 - 117, 5.36.40 - 111**
 Installing the upper pulley block on the S-intermediate section for flying assembly **5.39.10 - 31**
 Installing the wedge lock **4.06 - 22**
 Installing the wind speed sensor **5.07 - 18**
 Installing winch 1 **3.07.10 - 7**
 Installing winch 2 **3.07.20 - 7**
 Installing winch 5 **3.07.50 - 15**
 Installing winch 6 **3.07.60 - 17**
 Instructions for resuming crane movement **4.20 - 17**
 Instrument panel **4.01 - 12**
 Intended use **5.36.20 - 5**
 Interfaces crane cab **4.01 - 8**
 Interior equipment crane cab **4.01 - 6**
 Internal corrosion **8.04 - 19**
 Interrupting crane operation **2.04 - 63**
 Intervals **7.05.50 - 11, 8.04 - 4**
 Invalid chart name **4.02 - 26**
 Is the radio connection faulty? **5.31 - 40**

J

Job planning **2.03 - 1**

K

Key button Boom on the ground **4.20 - 61**
 Key button with associated indicator lights / operating buttons / signs **4.01 - 12**
 Kinking, rope loops (grommets) pulled closed **7.05.50 - 9**
 Kinking or rope loops pulled closed **8.04 - 23**

L

Labeling of load lifting equipment **2.05.10 - 1**
 Ladder access **2.04.10 - 9**
 Ladder inspection **2.04.10 - 8**
 Ladders **2.04.10 - 1, 7.01 - 9, 7.04 - 27, 7.05 - 43**

Ladder safeguards **2.04.10 - 9**
 Ladders on ballast trailer guide **2.06 - 95**
 Ladder Turntable frame lower section **2.06 - 49**
 Ladder turntable frame main section **2.06 - 81**
 Large ballast pallet (base pallet) **5.36.40 - 13, 5.36.40 - 15**
 Lashing lugs **5.36.10 - 6, 5.36.40 - 6**
 Latch **5.01 - 19**
 Lattice mast boom **7.05.50 - 3**
 Lattice sections **2.04 - 18**
 LD/SLD/SD boom combination **5.39.10 - 1**
 Leaning (extension) ladder **2.04.10 - 13**
 Leaning (extension) ladder with transition **2.04.10 - 15**
 Legal prerequisites **2.04 - 66**
 L-end section **1.03 - 19, 5.07 - 5**
 Leveling instrument in the Bluetooth™ Terminal (BTT) **4.04 - 9**
 Leveling instruments **4.04 - 9**
 Leveling instruments in the LICCON monitor **4.04 - 9**
 LICCON computer system **4.02 - 1, 4.04 - 3, 4.05 - 3**
 LICCON computer system monitors **4.01 - 22**
 LICCON job planner **2.04 - 31**
 LICCON monitor 0 **4.02 - 6**
 LICCON Monitor 0 special functions **4.02 - 109**
 LICCON monitor 1 **4.02 - 6**
 LICCON monitor 2 **4.02 - 7**
 LICCON Monitor 2 special functions **4.02 - 188**
 LICCON overload protection **5.35.10 - 85**
 LICCON overload safety device **4.04 - 3**
 Liebherr Service **7.01 - 8**
 Lifting, illustration 1 **4.03 - 53**
 Lifting / lowering a load with even speed **2.04 - 52**
 Lifting / setting down the derrick ballast **5.36.10 - 93, 5.36.20 - 85, 5.36.30 - 45, 5.36.40 - 85**
 Lifting above ground level, illustration 2A **4.03 - 53**
 Lifting a load with two cranes **2.04 - 47**
 Lifting and lowering **4.05 - 17**
 Lifting and lowering the ballast trailer with the pull cylinders **5.35.10 - 52**
 Lifting and lowering the derrick ballast using the pull cylinders **5.36.10 - 63, 5.36.20 - 55, 5.36.30 - 15, 5.36.40 - 55**
 Lifting below ground, illustration 3 **4.03 - 53**
 Lifting category **4.02 - 57**
 Lifting of personnel **2.04 - 66**
 Lifting slowly **2.04 - 52**
 Lifting the ballast trailer **5.35.10 - 52**
 Lifting the ballast trailer with the support cylinders **5.35.10 - 61, 5.35.10 - 135, 5.35.10 - 136**
 Lifting the boom **2.04 - 56**
 Lifting the boom and lower the load at the same time **2.04 - 58**
 Lifting the crawler center section over the assembly support **3.01 - 18**
 Lifting the crawler center section with the control panel **3.01 - 19**

Lifting the crawler center section with the crawler carriers **3.01 - 37**
Lifting the crawler center section with the hydraulic hand levers **3.01 - 19**
Lifting the derrick bal-
last **5.36.10 - 93, 5.36.20 - 85, 5.36.30 - 45, 5.36.40 - 85**
Lifting the end section from the flatbed trailer **5.38 - 22, 5.39.10 - 24**
Lifting the load **4.08 - 11**
Lifting the small ballast pallet **5.36.40 - 51**
Lifting winch 1 from the flatbed trailer **3.07.10 - 7**
Lifting winch 1 from the turntable **3.07.10 - 21**
Lifting winch 2 from the flatbed trailer **3.07.20 - 7**
Lifting winch 2 from the turntable **3.07.20 - 21**
Lifting winch 5 from the flatbed trailer **3.07.50 - 15**
Lifting winch 5 from the S-pivot section **3.07.50 - 25**
Lifting winch 6 from the flatbed trailer **3.07.60 - 17**
Lifting winch 6 from the S-pivot section **3.07.60 - 27**
Lifting with auxiliary winch **2.04 - 56**
Lifting with main winch **2.04 - 56**
Light and / or heavy work **2.04.10 - 10**
Limitations from 50 % pulled derrick bal-
last **5.36.10 - 87, 5.36.20 - 79, 5.36.30 - 39, 5.36.40 - 79**
Limitations from 90 % pulled derrick bal-
last **5.36.10 - 87, 5.36.20 - 79, 5.36.30 - 39, 5.36.40 - 79**
Limit sign auxiliary boom / accessory **4.02 - 95**
Limit signs main boom **4.02 - 91**
Limit switch, general **5.07 - 56**
Limit switch Boom system **4.04 - 19**
Limit switch D-boom, relapse cylinder **5.05 - 40**
Limit switch on flap, position „W-lattice jib in steepest position“, mechanical relapse support in flap **5.07 - 57**
Limit switch on relapse cylinder, „W-lattice jib steepest position“ **5.07 - 56**
Limit switch on W-pivot section **5.07 - 57**
Limit switch on W-pivot section, position „flap in position“ **5.07 - 57**
Limit switch on W-pivot section, position „W-lattice jib on bottom 45°“, S-boom without roller set **5.07 - 57**
Limit switch on W-pivot section, position „W-lattice jib on bottom 80°“, S-boom with roller set **5.07 - 57**
Limit switch winch spooled out **4.04 - 13**
Linch pin **5.01 - 17**
Lines **7.05 - 36**
L-intermediate section 12m **1.03 - 19, 5.07 - 5**
L-intermediate section 6m **1.03 - 18**
Load bearing crane structures **2.08 - 7**
Load burdens on the ground due to crane operation **2.04 - 29**
Load burdens on the ground on cranes on crawlers **2.04 - 29**
Load burdens on the ground on cranes on supports **2.04 - 29**
Load display **4.03 - 53**
Load handling equipment **1.03 - 8**

Loading the preassembled lattice jib **5.01 - 36**
Load max **4.02 - 181**
Load max2 **4.02 - 181**
Load max3 **4.02 - 181**
Load reduction **4.03 - 49**
Load spectrum class: Heavy L3 **8.03 - 7**
Load spectrum class: Light L1 **8.03 - 6**
Load spectrum class: Medium L2 **8.03 - 6**
Load spectrum class: Very heavy L4 **8.03 - 7**
Load take up on high rise, illustration 2B **4.03 - 53**
Load weighing **4.03 - 51**
Load weighing and load display **4.03 - 49**
Localized increase of rope diameter **7.05.50 - 6**
Localized increases of rope diameter **8.04 - 17**
Localized reduction of rope diameter **8.04 - 16**
Locking the engine rpm **4.05 - 7**
Long WA-frames: Installing the relapse supports in transport position and removing the guy rods **5.07 - 84**
Long WA-frames: Pining the guy rods with each other and installing the relapse supports in operating position **5.07 - 39**
Long WA-frames: Pinning the guy rods with each other **5.07 - 47**
Long WA-frames: Unpinning the guy rods **5.07 - 76**
Loop formation **7.05.50 - 9, 8.04 - 22**
Lowering slowly **2.04 - 53**
Lowering the ballast trailer **5.35.10 - 53**
Lowering the ballast trailer with the support cylinders **5.35.10 - 62, 5.35.10 - 136, 5.35.10 - 137**
Lowering the boom **2.04 - 57**
Lowering the boom and lift the load at the same time **2.04 - 58**
Lowering the crane **3.01 - 57**
Lowering the crane on the supporting base **3.01 - 71**
Lowering the crawler center section on the supporting base **3.01 - 42, 3.01 - 75**
Lowering the crawler center section with the hydraulic hand levers **3.01 - 75**
Lowering the crawler track **3.01 - 29**
Lowering the derrick bal-
last **5.36.10 - 93, 5.36.20 - 85, 5.36.40 - 85**
Lowering the hook block **4.06 - 11, 4.06 - 15, 5.19 - 3**
Lowering the load hook **4.06 - 18**
Lowering the load while stationary **2.04 - 53**
Lowering the SA-frame **5.05 - 17**
Lower the crawler center section with the control panel **3.01 - 78**
Lube cycle **7.04 - 10, 7.05 - 21**
Lubricating ladders **7.04 - 27, 7.05 - 44**
Lubricating the bearing at winch 1 and winch 2 **7.05 - 27**
Lubricating the gear ring and the slewing gear pinion **7.05 - 24**
Lubricating the pin bores on the lattice sections and guy rods **7.05.50 - 3**
Lubricating the rope **7.05.50 - 14**
Lubricating the slewing ring connection **7.05 - 23**
Lubrication schedule **7.06 - 4**

Luffing **4.05 - 39**
 Luffing pulley block limit switch **5.05 - 41**
 Luffing the boom down **5.19 - 3**
 Luffing the boom system down and reeving the hoist rope out **5.38 - 50, 5.39.10 - 65, 5.44 - 58**
 Luffing the D-boom down **5.05 - 51**
 Luffing the derrick boom **4.05 - 43**
 Luffing the derrick boom down **4.05 - 43**
 Luffing the derrick boom up **4.05 - 43**
 Luffing the luffing jib **4.05 - 45**
 Luffing the luffing jib down **4.05 - 45**
 Luffing the luffing jib up **4.05 - 45**
 Luffing the main boom **4.05 - 41**
 Luffing the main boom down **4.05 - 41**
 Luffing the main boom up **4.05 - 41**
 Luffing the S-boom down **5.13 - 50**
 Luff in with suspended load **4.20 - 35**

M

Machine related movements **2.04 - 56**
 Main boom assembly platform on turntable **2.06 - 73**
 Maintenance intervals - Crane superstructure **7.03 - 1**
 Maintenance **2.08 - 7, 7.04.50 - 3**
 Maintenance and inspection schedule **7.02 - 3, 7.02.50 - 3, 7.03 - 3, 7.03.50 - 3**
 Maintenance and service - General **7.01 - 1**
 Maintenance Auxiliary heater **6.02 - 27**
 Maintenance guidelines - Crane boom **7.05.50 - 1**
 Maintenance guidelines - Crane chassis **7.04 - 1**
 Maintenance guidelines - Crane superstructure **7.05 - 1**
 Maintenance Heater **6.02 - 26**
 Maintenance intervals **7.01 - 3**
 Maintenance intervals / maintenance instructions for the ballast trailer **5.35.10 - 137**
 Maintenance intervals ballast trailer **7.02.50 - 1**
 Maintenance intervals - Crane boom **7.03.50 - 1**
 Maintenance intervals Crawler chassis **7.02 - 1**
 Manual operation **6.02 - 7**
 Manual rope winches **5.01 - 7**
 Manufacturer **0.01 - 1**
 Master switch assignment MS1 **4.01 - 31**
 Master switch assignment MS2 **4.01 - 39**
 Master switch assignment MS3 **4.01 - 53**
 Master switch functions **4.05 - 5**
 Maximum ballast **5.36.20 - 4**
 Maximum climbing ability **4.10 - 19**
 Maximum liftable derrick ballast **4.02 - 187, 5.35.10 - 88, 5.36.10 - 75, 5.36.20 - 67, 5.36.30 - 27, 5.36.40 - 67**
 Maximum load **4.02 - 75**
 Maximum load according to load chart and reeving **4.02 - 4**
 Maximum permissible ground unevenness **5.35.10 - 78**
 Maximum sound power level **2.05 - 25**
 Measurement of wind speed **2.04 - 42**
 Measures in case of problems **5.31 - 39**
 Mechanical auxiliary support **1.02 - 5, 1.03 - 11, 3.04 - 1**
 Menu Crane cab / stepladder **5.31 - 29**
 Minimum rope coils **5.01 - 3**
 Minimum rope reeving / minimum hook block weight **2.05 - 40**
 Minimum value F3-load display during erection of the derrick boom fallen below **4.20 - 63**
 Minimum values or maximum values of F-load display reached **4.20 - 63**
 Miter gear **7.04 - 5**
 Mobile cranes **2.04 - 18**
 Monitored auxiliary functions **4.02 - 133**
 Monitoring at SWF-erection procedure **8.12 - 19**
 Monitoring functions during crane operation **4.02 - 113**
 Monitoring of crane utilization in operating modes with derrick ballast **5.36.10 - 77, 5.36.20 - 69, 5.36.30 - 29, 5.36.40 - 69**
 Monitoring of F1-maximum force **5.36.10 - 83, 5.36.20 - 75, 5.36.30 - 35, 5.36.40 - 75**
 Monitoring of F1-minimum force **5.36.10 - 85, 5.36.20 - 77, 5.36.30 - 37, 5.36.40 - 77**
 Monitoring of load torque **5.36.10 - 77, 5.36.20 - 69, 5.36.30 - 29, 5.36.40 - 69**
 Monitoring of maximum load on the LICCON monitor **0 5.35.10 - 91**
 Monitoring of minimum force F1 **5.35.10 - 88**
 Monitoring of pull cylinders on block position **5.36.10 - 87, 5.36.20 - 79, 5.36.30 - 39, 5.36.40 - 79**
 Monitoring of surface pressure and center of gravity **4.02 - 127**
 Monitoring of test point 1-operational maximum force (= F1max operation) **5.35.10 - 91**
 Monitoring Relapse cylinder / erection cylinder **4.02 - 123**
 Monitoring the lateral incline of the ballast pallet **5.36.10 - 88, 5.36.20 - 80, 5.36.30 - 40**
 Monitoring the lateral incline of the divisible ballast pallet „VarioTray“ **5.36.40 - 80**
 Monitoring the winches **8.03 - 5**
 Movement on the crane **2.04 - 4**
 Moving / swinging in specified direction **2.04 - 53**
 Moving away from me **2.04 - 54**
 Moving both track chains **2.04 - 54**
 Moving one track chain **2.04 - 55**
 Moving the LTR from the ballast pallet **5.36.20 - 97**
 Moving the LTR on the ballast pallet **5.36.20 - 49**
 Moving the S-relapse cylinder in **5.38 - 52, 5.39.10 - 67, 5.44 - 60**
 Moving the S-relapse cylinders out **5.38 - 43, 5.39.10 - 57, 5.44 - 51**
 Moving toward me **2.04 - 54**

N

Negative longitudinal incline **4.10 - 20**
Noise emission **1.03 - 6**
No load chart is available **4.02 - 109**
Non-designated use **5.36.20 - 5**
Non-destined use **0.01 - 5, 2.25 - 3**
Non-rotating rope end connection **8.04 - 6**
Non-twisting ropes with rope end connections **8.04 - 6**
Note for assembly aid **2.05 - 5**
Note Weight sliding beams **2.05 - 37**
Numeric display **4.02 - 223**
Numeric F-load display **4.02 - 159**

O

Obligations of the crane operator **2.04 - 21**
Occurrence of an advance warning **4.02 - 103, 4.02 - 175**
Occurrence of a shut off in the working range limitation **4.02 - 215**
Opening / closing cab doors and cab windows **4.03 - 32**
Opening / closing the roof window **4.03 - 32**
Opening and closing the parking brake slewing gear **4.05 - 49**
Opening the boom system **5.38 - 55, 5.39.10 - 69, 5.44 - 63**
Opening the end section **5.01 - 32**
Opening the roof window **4.03 - 32**
Opening the transport retainers of the guy rods **5.07 - 37**
Operating and control instruments on the crane superstructure **4.01 - 1**
Operating and control unit (BKE) **4.01 - 16**
Operating and maintaining the central lubrication system **7.05 - 20**
Operating and monitoring instruments **4.01 - 3**
Operating buttons BKE for release operations **4.01 - 21**
Operating condition of crane **4.20 - 7**
Operating conditions **2.25 - 3**
Operating elements at speed reduction of master switch / pedal sensor **4.02 - 193**
Operating elements for curve display of load charts **4.02 - 225**
Operating elements for special cases at operation of the LICCON overload protection **4.20 - 3**
Operating elements for the crawler operation **4.10 - 29**
Operating elements on the control panels **5.35.10 - 13**
Operating fluids and lubricants **7.01 - 10**
Operating instructions **6.02 - 3**
Operating interface **4.02 - 209**
Operating keys on the BKE, Standard assignment **4.01 - 18**

Operating switch / operating button / indicator lights **4.01 - 13**
Operating the auxiliary heater with the ignition off **6.02 - 23**
Operating the auxiliary heater with the ignition on **6.02 - 18**
Operating the crane **5.13 - 48, 5.38 - 45, 5.39.10 - 59, 5.44 - 53**
Operating the support cylinders individually **5.35.10 - 61**
Operating the test system **5.31 - 35**
Operating the timer **6.02 - 20**
Operating the windshield washer system **4.03 - 30**
Operating the windshield wiper **4.03 - 30**
Operating touch functions **4.01 - 28**
Operating unit HATZ Diesel aggregate * **4.01 - 16**
Operational transverse pressure **8.04 - 26**
Operation BTT **5.31 - 37**
Optimizing measures for travel route **4.10 - 5**
Optional equipment and functions **0.01 - 7**
Optional winches * **1.02 - 5**
Oscillation guard **5.07 - 55**
Other operating elements **4.02 - 154**
Overflow container **7.05 - 27**
Overload monitoring in operating mode with derrick ballast **5.35.10 - 90**
Overload protection **4.02 - 3**
Overview Control units crane cab **4.01 - 10**
Overview Load chart **4.20 - 18**
Overview of acoustic / optical warnings **4.20 - 9**
Overview of function key assignment **4.02 - 121**
Overview of general operating elements on the LICCON monitors **4.02 - 7**
Overview of icons for monitoring functions **4.02 - 114**
Overview of individual control displays **4.02 - 117**
Overview of the retaining elements **5.01 - 14**
Overview of the steering programs **5.35.10 - 58**
Overview Operating console **4.01 - 17**
Overview rods **1.03 - 28**

P

P-adapter bottom left / P-adapter bottom right **1.03 - 17**
P-adapter top, 3m **1.03 - 18**
Page counter **4.02 - 223**
Paint / coating **8.15 - 4**
Pairing process **5.31 - 7**
Parallel operation: Spooling the hoist winches up **4.05 - 29**
Parallel operation: Spooling the hoist winches up and out **4.05 - 27**
Parallel operation: Spool the hoist winches out. **4.05 - 31**
Parallel travel **5.35.10 - 65**
Parallel travel steering program **5.35.10 - 59**
PDB/B2/BW boom combination **1.01 - 16, 1.01 - 17**
PD - boom combination **5.44 - 1**

PDW3B/B2/BW boom combination **1.01 - 18, 1.01 - 19**
 Pedal carrier **4.01 - 24, 4.10 - 29**
 Performing a visual inspection **4.03 - 12**
 Performing the function checks **5.38 - 41, 5.39.10 - 54, 5.44 - 49**
 Periodic crane inspections **8.01 - 1**
 Permissible counterweight assemblies **3.03 - 7, 4.07 - 5**
 Permissible turntable ballast / ballast combinations **3.06 - 5**
 Personal protective equipment **2.04 - 7, 2.06 - 3, 7.05.50 - 4, 8.04 - 3**
 Personnel **7.01 - 4**
 Personnel and qualification **2.04 - 68**
 Picking up and lowering overhead loads **4.08 - 18**
 Picking up the ballast plates with the receptacle stud **5.36.30 - 10**
 Picking up the fastening equipment **4.08 - 15**
 Pin and unpin the pin with the pin pulling cylinder 2. **5.30 - 5**
 Pin and unpin the pin with the pin pulling cylinder 3. **5.30 - 7**
 Pin connections **5.01 - 11**
 Pinning **3.01 - 9**
 Pinning and unpinning with pin pulling device **5.30 - 3**
 Pinning or unpinning pins **5.30 - 5, 5.30 - 7**
 Pinning the ballast pallet with cross beam **5.36.20 - 24, 5.36.20 - 46**
 Pinning the ballast trailer on the turntable **5.35.10 - 38**
 Pinning the ballast trailer with ballast trailer radius 13–19m on the turntable **5.35.10 - 38**
 Pinning the ballast trailer with ballast trailer radius 19–25m on the turntable or pin the ballast trailer with ballast trailer radius 24–30m on the turntable **5.35.10 - 42**
 Pinning the collar pin **5.01 - 12**
 Pinning the D-guy rods with the pull rods of the suspended ballast guide **5.36.10 - 51, 5.36.20 - 42, 5.36.40 - 42**
 Pinning the D-pivot section on the SA-frame **5.05 - 15**
 Pinning the guy rods with each other **5.07 - 40, 5.07 - 42**
 Pinning the luffing pulley block on the pull test brackets **5.05 - 37**
 Pinning the pulley support with the turntable **3.05 - 23**
 Pinning the pull rods **3.05 - 25**
 Pinning the Quick Connection **3.01 - 9**
 Pinning the relapse supports on the S-adapter **5.07 - 42**
 Pinning the SA-frame **3.05 - 13**
 Pinning the SA-frame on the turntable **3.05 - 11**
 Pinning the strut on the ballast trailer **5.35.10 - 105**
 Pinning the suspended ballast guide on the ballast pallet **5.36.10 - 53**

Pinning the suspended ballast guide on the divisible ballast pallet „VarioTray“ **5.36.40 - 43**
 Pinning the suspended ballast guide with the ballast pallet **5.36.10 - 51**
 Pinning the suspended ballast guide with the divisible ballast pallet „VarioTray“ **5.36.40 - 42**
 Pinning the swing from the WA-frame 1 in transport position **5.07 - 97**
 Pinning the turntable frame main section on the front **3.02 - 11**
 Pinning the turntable frame main section on the rear **3.02 - 11**
 Pinning the upper pulley block on the S-pivot section **5.39.10 - 27, 5.44 - 24**
 Pinning the upper pulley block with the lower pulley block **5.05 - 53**
 Pinning winch 1 **3.07.10 - 11**
 Pinning winch 2 **3.07.20 - 11**
 Pinning winch 4 on the turntable **3.05 - 19**
 Pinning winch 5 **3.07.50 - 17**
 Pinning winch 6 **3.07.60 - 19**
 Pin pulling device **1.02 - 6, 5.30 - 1**
 Pivot section **5.36.10 - 6, 5.36.10 - 10, 5.36.40 - 6, 5.36.40 - 10**
 Place the ballast plates **3.03 - 16**
 Placing additional guy rods **5.07 - 16**
 Placing a shorter crane rope **4.08 - 15**
 Placing the ballast plates, fastening points: Bitt **3.03 - 19**
 Placing the ballast plates, fastening points: „Bitt“ **5.36.10 - 61, 5.36.20 - 53, 5.36.40 - 48**
 Placing the ballast plates, fastening system: „Twistlock“ **3.03 - 17, 5.36.10 - 59, 5.36.20 - 51, 5.36.40 - 47**
 Placing the boom down **5.10 - 27**
 Placing the boom on the substructure **5.38 - 53, 5.39.10 - 68, 5.44 - 61**
 Placing the counterweight plates **4.07 - 10**
 Placing the counterweight plates, fastening points: Bitt **4.07 - 13**
 Placing the counterweight plates, fastening system: „Twistlock“ **4.07 - 12**
 Placing the extension ladder down in park position for assembly **2.06 - 23**
 Placing the FA-frame in the operating position **5.13 - 17, 5.13 - 28, 5.13 - 38, 5.13 - 44**
 Placing the guy rods down **5.44 - 62**
 Placing the hoist rope or the control rope **5.01 - 3**
 Placing the lattice jib into the roller cart **5.01 - 30**
 Placing the pull brackets down **5.35.10 - 120, 5.35.10 - 121**
 Placing the SA-frame down **3.01 - 72**
 Placing the SA-frame onto the turntable **5.02 - 11**
 Placing the tension cylinder in crawler carrier opening **7.04 - 18**
 Placing the turntable frame lower section on the crawler center section **3.01 - 7**
 Placing the WA-frame 2 down **5.07 - 83**

Placing the WA-frame 2 on WA-frame 1 **5.07 - 86**
Planetary gear **7.04 - 3**
Planning Crane operation **2.03 - 3**
Platform ladder **2.04.10 - 17**
Platforms on the crawler carriers **2.06 - 15**
Pneumatic springs **5.01 - 7**
Positioning the railings into operating position **2.06 - 85**
Positioning the stepladder **5.31 - 33**
Positioning winch 1 **3.07.10 - 9**
Positioning winch 2 **3.07.20 - 9**
Positioning winch 5 **3.07.50 - 17**
Positioning winch 6 **3.07.60 - 19**
Positive longitudinal incline **4.10 - 20**
Possible weighing errors **4.03 - 51**
Power-Save mode and Stand-by mode in the LIC-CON computer system **4.02 - 201**
Pre-assembling the ballast trailer **5.35.10 - 15**
Preassembling the D-boom on the ground **5.05 - 43, 5.05 - 45**
Preface **0.01 - 1**
Preheating the hydraulic oil **2.08 - 4**
Preheating the hydraulic oil with the Hydraulic oil preheating * **4.03 - 37**
Preheating time **2.08 - 4**
Preparatory tasks on the S-pivot section **5.44 - 16**
Preparatory work **5.07 - 15, 5.30 - 5, 5.30 - 7**
Preparing for crane operation **5.13 - 48, 5.38 - 45, 5.39.10 - 59, 5.44 - 53**
Preparing for driving the crane **4.10 - 13**
Preparing installation of winch 5 **3.07.50 - 13**
Preparing installation of winch 6 **3.07.60 - 13**
Preparing the assembly of the roller cart **5.07 - 51**
Preparing the crawler carrier for assembly **3.01 - 23, 3.01 - 47**
Preparing the crawler carrier for disassembly **3.01 - 33, 3.01 - 61**
Preparing the disassembly of the roll cart **5.07 - 79**
Preparing the hook block **4.06 - 9, 4.06 - 13**
Preparing the pin locations on the turntable **3.05 - 7**
Preparing the rope pulley retainer for the assembly of the F-jib **5.13 - 13, 5.13 - 35**
Prerequisites **2.04 - 68**
Prerequisites for crane equipment and accessories **2.04 - 67**
Prerequisites for driving the crane (crawler operation) **4.10 - 3**
Prerequisites for driving uphill / downhill without changing the angle of the boom system **4.10 - 20**
Prerequisites for emergency control **6.05 - 7**
Prerequisites for lifting of personnel **2.04 - 66**
Prerequisites for operation with lifting cage (cherry picker) **2.04 - 67**
Preselection of slewing speed **4.05 - 55**
Presettings **5.35.10 - 85**
Pressed rope end connection **8.04 - 14**
Pressure monitoring in the relapse cylinders **4.04 - 15**
Pressure test of relapse cylinders **8.01 - 84**

Pretensioning the hoist rope with pretensioning ballast with two hook operation **4.08 - 18**
Preventing fires **7.01 - 5**
Priority acoustic warning **4.02 - 107, 4.02 - 177, 4.02 - 191**
Problem signals on control element **7.04 - 11, 7.05 - 22**
Problems on central lubrication system **7.04 - 12, 7.05 - 23**
Procedure **4.02 - 197, 6.05 - 31**
Procedure for shut off of crane movements **4.20 - 1**
Procedure for special cases at operation of the LIC-CON overload protection **4.20 - 31**
Procedure in case of slack rope **5.19 - 3**
Processing the speed reduction **4.02 - 195**
Product description **1.02 - 1, 5.35.10 - 3, 5.36.10 - 3, 5.36.20 - 3, 5.36.30 - 3, 5.36.40 - 3**
Programming fast settings **4.02 - 197**
Programming the timer **6.02 - 21**
Protecting from aggressive environmental conditions **7.01 - 6**
Protecting from burns **7.01 - 5**
Protecting from scalding **7.01 - 6**
Protective roller on winch 2 **3.07.20 - 11**
Protruding, distorted inlay, braiding **7.05.50 - 9**
Protruding, distorted insert or strand **8.04 - 21**
PSAgA, rescue equipment and tools **2.04 - 68**
Pull cylinder extension conditions **5.36.10 - 12, 5.36.20 - 16, 5.36.30 - 8, 5.36.40 - 11**
Pull cylinder limit switch **5.05 - 41**
Pull cylinder on block **5.35.10 - 88**
Pulley cart **5.61 - 1**
Pulley head height **4.02 - 85**
Pulling the hoist ropes forward to the W-pivot section **5.07 - 44**
Pulling the hoist ropes in **5.07 - 53**
Pulling the luffing pulley block to the D-end section and taking it down on the ground **5.05 - 31**
Pump distributor gear **7.05 - 15**

Q

Qualification Inspection personnel **8.04 - 3**
Qualification Maintenance personnel **7.05.50 - 5**
Quick test Crane geometry **4.04 - 3**
Quick test EMERGENCY STOP switch / EMERGENCY OFF switch **4.04 - 17**
Quick test Hoist limit switch **4.04 - 11**
Quick test Leveling instrument **4.04 - 9**
Quick test Limit switch winch **4.04 - 15**
Quick test Overload protection **4.04 - 3**
Quick test Wind speed sensor **4.04 - 13**

R

Radio sending unit for the incline display hook block **5.19 - 3**

- Radius display Derrick ballast **4.02 - 165**
- Railing on ballast trailer **2.06 - 105, 2.06 - 107**
- Railing on ballast trailer guide **2.06 - 93**
- Railing on platforms **2.06 - 105**
- Railing on the control cabinet platform **2.06 - 109**
- Railings on the S-pivot section **2.06 - 85**
- Ramp **1.03 - 26**
- Ram work or pulling sheet piles **4.08 - 14**
- Ranges of curve display of load charts **4.02 - 217**
- Rapid gear **4.02 - 111**
- Reduce rope pull **2.08 - 6**
- Reducing rope unwinding **4.08 - 15**
- Reducing the maximum permissible wind speed
* **4.02 - 139**
- Reduction of rope diameter **7.05.50 - 5**
- Reeving in / reeving out the hook block, L-shaped rope end connection (LR 11000 only) **4.06 - 11**
- Reeving in the hoist rope **4.06 - 5**
- Reeving in the hoist rope with the assembly winch **4.06 - 6**
- Reeving in the hook block **4.06 - 9, 4.06 - 13, 5.13 - 47, 5.38 - 44, 5.39.10 - 58, 5.44 - 52**
- Reeving out the hoist rope / removing the rope guide pulley **5.14 - 16**
- Reeving the hoist rope / installing the rope guide pulley **5.14 - 14**
- Reeving the hoist rope out **5.05 - 61**
- Reeving the hook block in and out **4.06 - 8**
- Reeving the W-control rope in and pulling the hoist ropes forward to the S-end section **5.07 - 31**
- Refueling fuel **7.05 - 30**
- Relapse cylinder **5.01 - 6, 5.35.10 - 77**
- Relapse support flap **8.12 - 17**
- Releasing the button block on the BTT **5.31 - 5**
- Releasing the counterweight **4.07 - 16**
- Releasing the electrical connection from the ballast trailer to the turntable **5.35.10 - 113**
- Releasing the engine rpm lock **4.05 - 7**
- Releasing the F-relapse support **5.13 - 11, 5.13 - 23, 5.13 - 43**
- Releasing the hydraulic connections from the ballast trailer to the turntable **5.35.10 - 113**
- Releasing the parking brake **4.05 - 49**
- Releasing the pull cylinder **5.05 - 25**
- Releasing the tension belt from the crane operator's cab **4.03 - 3**
- Releasing the upper pulley block on the lower pulley block **5.05 - 32**
- Releasing the WA-frame 1 guy rods **5.07 - 75**
- Removable ladder **2.06 - 51**
- Removable ladder QC **2.06 - 51**
- Removal criteria Overview **8.04 - 8**
- Remove the end section on the leaning ladder **2.04.10 - 10**
- Removing additional guy rods **5.07 - 103**
- Removing broken wires **7.05.50 - 14**
- Removing roller set R8 with the forklift and assembly rack **5.14 - 18**
- Removing the auxiliary guying **5.07 - 75**
- Removing the ballast **5.36.30 - 53**
- Removing the ballast on the cross beam **5.36.30 - 51**
- Removing the ballast on the divisible ballast pallet „VarioTray“ **5.36.40 - 90, 5.36.40 - 91**
- Removing the ballast on the guy rods **5.36.30 - 50**
- Removing the ballast pallet **5.36.10 - 109, 5.36.10 - 137, 5.36.20 - 101**
- Removing the ballast plates **3.03 - 22**
- Removing the ballast plates, fastening points: Bitt **3.03 - 26, 5.35.10 - 103**
- Removing the ballast plates, fastening points: „Bitt“ **5.36.20 - 97**
- Removing the ballast plates, fastening system: „Bitt“ **5.36.10 - 105, 5.36.10 - 119, 5.36.40 - 92**
- Removing the ballast plates, fastening system: „Twistlock“ **3.03 - 24, 5.35.10 - 102, 5.36.10 - 103, 5.36.10 - 117, 5.36.20 - 95, 5.36.40 - 91**
- Removing the ballast trailer **5.35.10 - 114**
- Removing the ballast trailer guide on the ballast trailer **5.35.10 - 116**
- Removing the ballast trailer on the turntable **5.35.10 - 105**
- Removing the batteries **7.05 - 38**
- Removing the bridges **5.44 - 67**
- Removing the central ballast brackets **3.03 - 26**
- Removing the counterweight **4.07 - 15**
- Removing the counterweight brackets on the turntable **4.07 - 21**
- Removing the counterweight plates **4.07 - 16**
- Removing the counterweight plates, fastening points: Bitt **4.07 - 18**
- Removing the counterweight plates, fastening system: „Twistlock“ **4.07 - 17**
- Removing the crane operation with the small ballast pallet **5.36.40 - 52**
- Removing the cross carrier **5.44 - 72**
- Removing the D-boom in sections **5.05 - 51**
- Removing the divisible ballast pallet „VarioTray“ **5.36.40 - 112**
- Removing the erection ropes **5.07 - 91**
- Removing the extension ladder on the ballast trailer **5.35.10 - 24**
- Removing the fastening equipment **3.01 - 70**
- Removing the first crawler carrier with the auxiliary crane **3.01 - 39**
- Removing the hoist limit switch weight **4.06 - 20**
- Removing the hoist ropes **5.07 - 74**
- Removing the hydraulic aggregate **3.01 - 45, 3.01 - 72**
- Removing the lattice sections of the PD-boom **5.44 - 65**
- Removing the load hook * **4.06 - 18**
- Removing the lower P-adapters **5.44 - 73**
- Removing the mechanical auxiliary support on the crawler travel gear **3.04 - 9**
- Removing the pulley cart **5.61 - 7**

Removing the railing on the ballast trailer **5.35.10 - 121**
Removing the railings on the cab platform **4.03 - 59**
Removing the receptacle stud from the ballast plates **5.36.30 - 53**
Removing the roller set / roller sets **5.14 - 15**
Removing the roller set R8 with the auxiliary crane **5.14 - 18**
Removing the rope guide pulley on the roller set / roller sets **5.14 - 16**
Removing the second crawler carrier with the auxiliary crane **3.01 - 41**
Removing the support **2.06 - 41**
Removing the tension cylinder on the crawler carrier **7.04 - 20**
Removing the transport retainer on the assembly cylinder **3.05 - 27**
Removing the transport unit **5.36.10 - 31, 5.36.20 - 27, 5.36.40 - 26**
Removing the WA-frame 1 guying **5.07 - 76**
Removing the W-control rope and hoist ropes **5.07 - 91**
Removing the wedge lock **4.06 - 22**
Removing the wind speed sensor **5.07 - 102**
Removing winch 1 **3.07.10 - 19**
Removing winch 2 **3.07.20 - 19**
Removing winch 5 **3.07.50 - 25**
Removing winch 6 **3.07.60 - 27**
Renewing the pretension of hoist ropes **7.05.50 - 16**
Repair welding **8.01 - 6**
Replacing damaged crane components **7.01 - 7**
Replacing hydraulic hose lines **8.06 - 5**
Replacing parts **6.02 - 28**
Replacing safety ropes subjected by a fall **2.06 - 13**
Replacing the air filter **7.05 - 7**
Replacing the cleaning fluid **7.05 - 45**
Replacing the coolant **7.05 - 6**
Replacing the filter insert **7.05 - 29, 7.05 - 29**
Replacing the fuel preliminary filter insert **7.05 - 10**
Replacing the gear oil **7.04 - 4, 7.04 - 6**
Replacing the granular cartridge of the air dryer **7.05 - 35**
Replacing the pressure filter **7.05 - 33**
Rescue **2.04 - 69**
Rescuing the assembly personnel **2.04 - 14**
Resetting a problem **7.04 - 12, 7.05 - 23**
Restoring hoist rope pretension **4.08 - 16**
Resuming crane operation **2.04 - 65**
Retaining clips **5.01 - 21**
Retaining elements **5.01 - 14**
Retracting and securing the pull cylinder **5.05 - 59**
Retracting the boom **2.04 - 57**
Retracting the D-relapse cylinder **5.05 - 65**
Retracting the front support cylinder **5.35.10 - 61**
Retracting the rear support cylinder **5.35.10 - 61**
Retracting the support cylinders **5.35.10 - 46**
Rigging and fastening points **8.01 - 77**
Rigging plans **3.80 - 3**

Rigging the guy rods on lattice booms on placed down boom system **5.01 - 68**
Roller cart **1.03 - 28**
Roller set **1.03 - 20, 5.14 - 1**
Roller sets overview **5.14 - 3**
Rope end connections **4.06 - 3**
Rope end connections with locking clamp or locking cast sleeve **4.06 - 3**
Rope end connection without locking clamp or locking cast sleeve **4.06 - 4**
Rope pulleys **5.01 - 3**
Rope pulleys and guide pulleys **7.05.50 - 4**
Rope pulleys and hydraulic cylinders **2.08 - 8**
Rope reeving **4.06 - 1, 4.06 - 22**
Ropes **5.01 - 3**
Rotating parts **7.01 - 6**
Rotating rope end connection **8.04 - 6**
Rotation resistant ropes **8.04 - 12**
Rotation-resistant ropes with rope end connections **8.04 - 5**

S

S/SL-boom **5.38 - 1**
S2 // SL // SLF // SL3F-boom **1.01 - 6**
S2 boom combination **1.01 - 7**
S2DB/B2/BW boom combination **1.01 - 11**
S-adapter **1.03 - 16**
Safe and problem-free operation **7.05.50 - 4**
Safety **3.80 - 3**
Safety and warning display **0.01 - 1**
Safety equipment **0.01 - 6, 1.02 - 5, 4.04 - 1**
Safety guidelines in case of external power supply **2.04 - 37**
Safety locking pin **5.01 - 16**
Safety ropes as fall protection equipment **2.06 - 5**
Safety ropes on lattice sections **2.06 - 5**
Safety ropes turntable frame lower section **2.06 - 5**
Safety signs **2.04.10 - 3**
Safety systems on the crane **4.04 - 9**
Safety technical notes for assembly and disassembly **5.01 - 1**
SA-frame **5.02 - 1, 5.02 - 3**
SA-frame with winch 4 **1.03 - 12**
S-boom relapse retainer **8.12 - 3**
Scattered occurring broken wires **8.04 - 10**
Screen display in the Set up program **4.02 - 13**
SDB/B2/BW // S2DB/B2/BW // SL2DB/B2/BW boom combination **1.01 - 10**
SDB/B2/BW-boom combination **1.01 - 11**
SDWB/B2/BW boom combination **1.01 - 14, 1.01 - 15**
Second inspection (second year) **8.03 - 9**
Securing against falls **7.01 - 4**
Securing against operation **7.01 - 4**
Securing bracket **2.04 - 17**
Securing catwalk 3 and catwalk 4 in transport position **2.06 - 67**

- Securing catwalks 7 and catwalks 5 in transport position **2.06 - 67**
- Securing personnel on shut off crane **2.04 - 67**
- Securing persons to prevent them from falling **2.04 - 12**
- Securing the counterweight **4.07 - 14**
- Securing the crane operator's cab with the tension belt in transport position **4.03 - 65**
- Securing the erection racks to prevent them from folding down **5.36.10 - 101, 5.36.10 - 115**
- Securing the erection racks to prevent them from folding over **5.36.20 - 91, 5.36.20 - 94**
- Securing the relapse supports on the WA-frame 2 **5.07 - 88**
- Securing the ropes in park position **5.07 - 43**
- Selecting and deselecting touch functions **4.01 - 27**
- Selecting auxiliary boom / accessory **4.02 - 28**
- Selecting auxiliary boom / accessory for the first variation (V1) **4.02 - 30**
- Selecting auxiliary boom / accessory for the second variation (V2) **4.02 - 33**
- Selecting derrick ballast settings **4.02 - 34**
- Selecting main boom for the first variation (V1) **4.02 - 23**
- Selecting the abbreviation for the boom system **4.02 - 21**
- Selecting the Auxiliary heater menu **6.02 - 18**
- Selecting the crane operating location **2.04 - 22**
- Selecting the derrick boom **4.02 - 26**
- Selecting the environmental / mechanical influence category **4.02 - 38**
- Selecting the function in the touch display **4.10 - 35**
- Selecting the lifting category **4.02 - 58**
- Selecting the main boom for the second variation (V2) **4.02 - 25**
- Selecting the operating mode category **4.02 - 20**
- Selecting the parameter setting from a list **4.02 - 230**
- Selecting the program category **4.02 - 38**
- Selecting the set up completion category **4.02 - 38**
- Selecting the steering program **5.35.10 - 59**
- S-end section **1.03 - 16**
- Separating the FA-frame relapse retainers **5.13 - 12, 5.13 - 24, 5.13 - 34, 5.13 - 44**
- Service fluids and lubricants **7.07 - 1**
- Servicing the cooling system according to the information from the manufacturer **7.05 - 7**
- Servicing the engine according to the information from the manufacturer **7.05 - 5**
- Servicing the fuel system according to the information from the manufacturer **7.05 - 12**
- Servicing the track chain **7.04 - 16**
- Servo oil pressure monitoring in the winches **4.04 - 15**
- Setting down the derrick ballast **5.36.30 - 45, 5.36.40 - 90**
- Setting down the small ballast pallet **5.36.40 - 52**
- Setting parameters via number entry **4.02 - 229**
- Settings and status displays on the BTT **5.31 - 15**
- Setting the ballast pallet in the assembly position **5.36.10 - 23, 5.36.10 - 47, 5.36.20 - 22, 5.36.20 - 44**
- Setting the ballast trailer radii **5.35.10 - 55**
- Setting the ball valve on the pull cylinder to the „crane operation“ position **5.05 - 22**
- Setting the ball valve on the pull cylinder to the „transport and storage“ position **5.05 - 59**
- Setting the brightness on the BTT display **5.31 - 15**
- Setting the cab to horizontal position **4.03 - 29**
- Setting the central ballast **4.02 - 42**
- Setting the central ballast: Specified settings distances **4.02 - 42**
- Setting the central ballast: Stepless settings distances **4.02 - 43**
- Setting the contrast on the BTT display **5.31 - 15**
- Setting the counterweight **4.02 - 53**
- Setting the counterweight: Specified settings distances **4.02 - 53**
- Setting the counterweight: Stepless settings distances **4.02 - 54**
- Setting the crane chassis **4.02 - 39**
- Setting the derrick ballast radius **4.02 - 41**
- Setting the derrick ballast weight **4.02 - 51**
- Setting the divisible ballast pallet „VarioTray“ into the assembly position **5.36.40 - 21**
- Setting the extension ladder in transport position **2.06 - 99, 2.06 - 101, 2.06 - 103**
- Setting the incline range **4.02 - 46**
- Setting the incline range: Specified settings distances **4.02 - 46**
- Setting the incline range: Stepless settings distances **4.02 - 47**
- Setting the load position **4.02 - 49**
- Setting the operating mode via chart name (chart number) **4.02 - 18**
- Setting the operating mode via the function keys **4.02 - 20**
- Setting the set up configuration in general **4.02 - 16**
- Setting the set up functions **4.02 - 36**
- Setting the slewing range **4.02 - 45**
- Setting the speed reduction master switch **4.03 - 39**
- Setting the wind speed **4.02 - 56**
- Setting up crane operation with the small ballast pallet **5.36.40 - 49**
- Setting up parallel operation **4.05 - 21**
- Set up program **4.02 - 12**
- Shortening the rope **7.05.50 - 16**
- Shorting the intervals **8.04 - 25**
- Short WA-frames: Assembling the relapse supports in operating position and pinning the guy rods with each other **5.07 - 41**
- Short WA-frames: Disassembling the guy rods **5.07 - 78**
- Short WA-frames: Pinning the guy rods with each other **5.07 - 49**
- Short WA-frames: Removing the guy rods and installing the relapse supports in the transport position **5.07 - 85**

Showing the horizontal distance **2.04 - 55**
 Showing the vertical distance **2.04 - 52**
 Shut off difference force monitoring derrick ballast guying **4.02 - 188**
 Shut-off difference force monitoring of derrick ballast guying **4.20 - 28**
 Shut-off due to error message **4.20 - 28**
 Shut off hoist top **4.20 - 26**
 Shut-off luffing the auxiliary boom / accessory up / down **4.20 - 21**
 Shut-off luffing the derrick boom up / down **4.20 - 26**
 Shut-off luffing the main boom up / down **4.20 - 20**
 Shut off maximum / minimum value F-load display **4.20 - 23**
 Shut off maximum value F1 in crane operation **4.20 - 23**
 Shut off minimum value F1 in crane operation **4.20 - 24**
 Shut off of crane movement **4.02 - 105, 4.02 - 175**
 Shut-off of crane movement **4.20 - 18**
 Shut-off overload **4.20 - 19**
 Shut-off parallel operation winch 1 and winch 2 **4.20 - 27**
 Shut-off spooling the winch up / out **4.20 - 25**
 Signs **2.05 - 3**
 Signs on the crane **2.05 - 1**
 Single layer and parallel roped ropes **8.04 - 10**
 S-intermediate section 12m **1.03 - 15, 5.07 - 4**
 S-intermediate section 6m **1.03 - 15**
 SL2DB/B2/BW boom combination **1.01 - 11**
 SL2DFB/BC/B2/BW // SL4DFB/BC/B2 boom combination **1.01 - 12**
 SL2DFB/BC/B2/BW boom combination **1.01 - 13**
 SL3F boom combination **1.01 - 7**
 SL4DFB/BC/B2 boom combination **1.01 - 13**
 SL boom combination **1.01 - 7**
 Slewing
 gear **1.02 - 4, 7.04.50 - 4, 7.05 - 24, 7.05 - 40**
 Slewing gear brake **4.10 - 29**
 Slewing range **4.02 - 141**
 Slewing ring connection **7.05 - 23**
 SLF boom combination **1.01 - 7**
 SLF-boom combination **5.13 - 1**
 Slip-resistant mats **7.01 - 9**
 Slopes and excavations **2.04 - 26**
 SL-reducer **1.03 - 17**
 SL-reducer section **5.07 - 5**
 Small ballast pallet (Vario-palette) **5.36.40 - 13, 5.36.40 - 15**
 Sound insulation mats **7.01 - 9**
 Special cases at operation of the LICCON overload protection **4.20 - 5**
 Special operating conditions **4.20 - 5**
 Specified service fluids and lubricants for Liebherr cranes **7.07 - 3**
 Speed reduction master switch / pedal sensor **4.02 - 193**
 Spinning out by turning out the hook block **7.05.50 - 15**
 Spinning out with single strand reeving **7.05.50 - 15**
 S-pivot section **1.03 - 14**
 Split pin **5.01 - 15**
 Spooling the assembly winch up and out **4.05 - 33**
 Spooling the assembly winch up constantly **4.05 - 37**
 Spooling the hoist winches up and out **4.05 - 19**
 Spooling the hoist winch out **4.05 - 19**
 Spooling the hoist winch up **4.05 - 21**
 Spooling the winches out **6.05 - 28**
 Spooling the winches up **6.05 - 29**
 Spooling the winch out **6.05 - 13, 6.05 - 24**
 Spooling the winch up **6.05 - 13, 6.05 - 25**
 Spooling up loose hoist rope **5.19 - 3**
 Spool the assembly winch out **4.05 - 33**
 Spool the assembly winch up **4.05 - 35**
 Spring retainer **5.01 - 17**
 Stability and tipping safety **5.35.10 - 9**
 Stacking the ballast plates on the ballast trailer, fastening points: Bitt **5.35.10 - 50**
 Stacking the ballast plates on the ballast trailer, fastening system „Twistlock“ **5.35.10 - 49**
 Stairs turntable frame main section **2.06 - 83**
 Stand-by mode **4.02 - 205**
 Starting and stopping the engine **4.03 - 41**
 Starting out with a strong side wind **4.05 - 51**
 Starting the emergency operation aggregate **6.05 - 13, 6.05 - 23**
 Starting the engine **4.03 - 41**
 Starting the LICCON computer system (before engine start) **4.03 - 38**
 Starting the LICCON computer system parallel to the engine **4.03 - 47**
 Starting the program **4.02 - 209**
 Starting to drive **2.04 - 58**
 Starting up the LICCON Computer system and the touch displays **4.01 - 28**
 Start menu of the BTT **5.31 - 12**
 Start operation, follow my instructions **2.04 - 50**
 Start screen BTT **5.31 - 11**
 Steering ability **4.10 - 15**
 Steering and corrective steering of the wheel sets **5.35.10 - 67**
 Steering programs **5.35.10 - 58**
 Stepladder **2.04.10 - 12**
 Stop (normal stop) **2.04 - 50**
 Stopping the ballast trailer **5.35.10 - 11**
 Stopping the mobile crane **2.04 - 59**
 Stopping the slewing movement with a strong side wind **4.05 - 51**
 Stops **2.04 - 19**
 Structure of the operating mode category **4.02 - 17**
 Suitable distribution of surface pressure **4.10 - 15**
 Supplied fall arrest system (safety harness and height safety equipment) **2.04 - 10**
 Supply via external feed / power aggregate **4.03 - 35**
 Support **2.04 - 33**
 Supporting support plates **3.01 - 62**
 Supporting the ballast trailer **5.35.10 - 104**

Supporting the ballast trailer to align the wheel sets with the support cylinders **5.35.10 - 60**
 Supporting the crane **2.04 - 34, 2.08 - 5**
 Supporting the crane with variable support **2.04 - 34**
 Supporting the crawler center section **3.01 - 13, 3.01 - 42, 3.01 - 70, 3.01 - 74**
 Support left front **3.01 - 21, 3.01 - 80**
 Support left rear **3.01 - 21, 3.01 - 80**
 Support plates **2.04 - 33**
 Support right front **3.01 - 20, 3.01 - 79**
 Support right rear **3.01 - 20, 3.01 - 79**
 Support the crawler center section without turntable frame lower section **3.01 - 14**
 Support the crawler center section with turntable frame lower section **3.01 - 13**
 Surface pressures and force distribution when driving the crane **4.10 - 25**
 Surface pressures in case of wind load on boom **4.10 - 25**
 Suspended ballast * **4.02 - 183**
 Suspended ballast guide (assembly) **5.36.10 - 11, 5.36.40 - 11**
 Suspended ballast guide (transport) **5.36.10 - 11, 5.36.40 - 10**
 Suspended ballast guide * **5.36.20 - 8, 5.36.20 - 13**
 Suspended ballast guide B2 **1.03 - 25**
 Suspended ballast guide „Transport position“ **5.36.10 - 8, 5.36.40 - 7**
 Suspended ballast with LTR 1100 **5.36.20 - 5**
 Suspended ballast with LTR 1220 **5.36.20 - 4**
 Suspended load fastening point **2.05 - 8, 2.05 - 9, 2.05 - 9**
 SW/SDW boom combination **5.07 - 1**
 SW1 boom combination **1.01 - 8, 1.01 - 9**
 Swinging the access stairs into operating position **4.03 - 7**
 Swinging the access stairs into transport position **4.03 - 61**
 Swinging the brackets **5.36.10 - 43, 5.36.10 - 129, 5.36.20 - 39, 5.36.20 - 111, 5.36.40 - 39, 5.36.40 - 105**
 Swinging the crane cab **5.31 - 31**
 Swinging the crane operator's cab into operating position **4.03 - 5**
 Swinging the ladder into operating position **2.06 - 95**
 Swinging the ladder into transport position **2.06 - 95**
 Swinging the railing into operating position **2.06 - 93**
 Swinging the railing on the ballast trailer into operating position **2.06 - 107**
 Swinging the railing on the ballast trailer into transport position **2.06 - 107**
 Swinging the railing on the catwalk into operating position **2.06 - 33**
 Swinging the railing on the catwalk into transport position **2.06 - 45**
 Swinging the railing on the control cabinet platform into operating position **2.06 - 109**
 Swinging the railing on the control cabinet platform into transport position **2.06 - 109**

Swinging the railing on the crawler center section into operating position **2.06 - 21**
 Swinging the railing on the crawler center section into transport position **2.06 - 25**
 Swinging the railing on the S-pivot section into operating position **5.38 - 12, 5.39.10 - 14**
 Swinging the railing on the S-pivot section into transport position **5.38 - 59, 5.39.10 - 75, 5.44 - 78**
 Swinging the railings into transport position **2.06 - 93**
 Swinging the railings on the platforms in operating position **2.06 - 105**
 Swinging the railings on the platforms in transport position **2.06 - 105**
 Swinging the stair folding section into operating position **2.06 - 37, 4.03 - 9**
 Swinging the stair folding section into transport position **2.06 - 39, 4.03 - 59**
 Swinging the support into operating position **3.05 - 11**
 Swinging the support into the transport position **3.05 - 43**
 Switching between automatic and manual operation **6.02 - 5**
 Switching the slewing gear to freewheeling **4.05 - 53**
 Switch position „Flap bottom“ **8.12 - 19**
 Switch position „Flap top“ **8.12 - 19**
 System start of the LICCON computer system **4.02 - 5, 4.03 - 38**

T

Take down procedure **5.02 - 11**
 Taking an oil sample **7.01 - 8**
 Taking down the boom **5.07 - 69**
 Taking down the erection racks **5.36.20 - 99**
 Taking on a load **4.08 - 7**
 Taking on a load with cross beam **4.08 - 9**
 Taking over the entries and settings from the Set up program **4.02 - 68**
 Taking over the previously set set up configuration **4.03 - 39**
 Taking the D-relapse cylinder down and securing it **5.05 - 67**
 Taking the FA-frame down **5.13 - 58, 5.13 - 64**
 Taking the luffing pulley block down into the transport receptacle on the D-pivot section **5.05 - 69**
 Taking the S-boom down **5.13 - 50**
 TE1 Assignment boom and equipment **4.01 - 33**
 TE1 Assignment winches **4.01 - 32**
 TE1 Function key assignment **4.01 - 31**
 TE1 main menu: Functions and assignment **4.01 - 32**
 TE1 Touch functions **4.01 - 32**
 TE2 Assignment slewing gear and equipment **4.01 - 41**
 TE2 Assignment winches **4.01 - 40**
 TE2 Function key assignment **4.01 - 39**
 TE2 main menu: Functions and assignment **4.01 - 40**
 TE2 Menu: „Climate control settings“ (Left touch display) **4.01 - 43**

TE2 Menu: „Hydraulic oil preheating“ (Left touch display) **4.01 - 51**
TE2 Menu „Working floodlight“ (left touch display) **4.01 - 47**
TE2 Touch functions **4.01 - 40**
TE3 Assignment boom and equipment **4.01 - 55**
TE3 Assignment support ballast trailer **4.01 - 56**
TE3 Assignment winches **4.01 - 54**
TE3 main menu: Functions and assignment **4.01 - 54**
TE3 Touch functions **4.01 - 54**
Technical data **1.03 - 1**
Technical safety instructions **7.01 - 3, 7.04 - 7, 7.05 - 17**
Telescopic boom **4.08 - 15**
Telescopic boom distortion because of sunshine on one side **4.08 - 4**
Telescoping the ballast trailer guide in **5.35.10 - 57**
Telescoping the ballast trailer guide in manually (master switch MS2) **5.35.10 - 58**
Telescoping the ballast trailer guide in manually (operating buttons in the instrument panel) **5.35.10 - 58**
Telescoping the ballast trailer guide in with the ballast automatic **5.35.10 - 57**
Telescoping the ballast trailer guide out **5.35.10 - 56**
Telescoping the ballast trailer guide out manually (master switch MS2) **5.35.10 - 57**
Telescoping the ballast trailer guide out manually (operating buttons in the instrument panel) **5.35.10 - 57**
Telescoping the ballast trailer guide out with the ballast automatic **5.35.10 - 56**
TE Menu „Block winch“ (right touch display) **4.01 - 36**
TE Menu „Block winch“ assignment **4.01 - 37**
TE Menu „Block winch“ function key assignment **4.01 - 37**
TE Menu „Block winch“ touch functions **4.01 - 37**
TE Menu „Climate control settings“ assignment **4.01 - 44**
TE Menu „Climate control settings“ function key assignment **4.01 - 43**
TE Menu „Climate control settings“ touch functions **4.01 - 43**
TE Menu „Hydraulic oil preheating“ assignment **4.01 - 51**
TE Menu „Hydraulic oil preheating“ touch functions **4.01 - 51**
TE Menu „Working floodlight“ function key assignment **4.01 - 47**
TE Menu „Working floodlight“ touch functions **4.01 - 48**
Temperature operating limits **7.05.50 - 5**
Tensioning the track chain **7.04 - 16**
Terminology **1.01 - 1**
Terms and abbreviations **2.04 - 67**
Test brackets (force test boxes) **4.04 - 18**
Test point 1 (F1-Load display) **5.35.10 - 77**
Test system menu **5.31 - 35**
The BTT display remains dark? **5.31 - 40**

The Crane operation program on LICCON monitor 0 **4.02 - 71**
The Crane operation program on LICCON monitor 1 **4.02 - 157**
The Crane operation program on LICCON monitor 2 **4.02 - 179**
The function key line in the set up program **4.02 - 15**
The function key line of LICCON monitor 0 **4.02 - 151**
The function key line of LICCON monitor 1 **4.02 - 173**
The function keys **5.31 - 19**
The LICCON monitors at system start **4.02 - 5**
The L-shaped rope end connection with locking clamp or locking cast sleeve (LR 11000 only) **4.06 - 4**
Theoretical service life **8.03 - 5**
The Power-Save mode **4.02 - 201**
The Working range limitation program **4.02 - 209**
Third inspection (third year) **8.03 - 10**
Tilting the cab upward **4.03 - 29**
Tilting the crane operator's cab * **4.03 - 29**
Tires foamed with special foam **2.15 - 5**
Tire size **7.01 - 7**
Tires with air inflation **2.15 - 4**
To exceed the maximum permissible load moment. **4.20 - 37**
To exceed the maximum value of the F-load display in crane operation. **4.20 - 41**
Touch displays **4.01 - 27**
Touch functions **4.01 - 27**
Towing **5.35.10 - 62, 5.35.10 - 136**
Towing steering program **5.35.10 - 58**
Traffic endangerment and environmental damage **2.04 - 3**
Transfer (between two cranes or two hooks) **2.04 - 55**
Transmission **7.06 - 4**
Transport **2.04 - 18**
Transporting the hook block **4.08 - 9**
Transport of crane and crane components **3.80 - 1**
Travel gear **7.04 - 3**
Travel gears / hydraulic motors / track rollers **4.10 - 7**
Travel operation **2.04 - 58**
Travel power **1.02 - 3**
Travel route **4.10 - 4**
Turning **4.05 - 47**
Turning / driving in reverse **2.04 - 59**
Turning an extremely rotation-resistant hoist rope out **7.05.50 - 15**
Turning backward to the left **4.10 - 43, 4.10 - 53**
Turning backward to the right **4.10 - 43, 4.10 - 53**
Turning crane superstructure to the right **4.05 - 57**
Turning crawler operating modes on / off **4.10 - 35**
Turning forward to the left **4.10 - 43, 4.10 - 53**
Turning forward to the right **4.10 - 43, 4.10 - 53**
Turning normal travel crawler operation on / off **4.10 - 35**
Turning off „Power Plus“ rapid gear **4.05 - 11**

Turning on „Power Plus“ rapid gear **4.05 - 9**
 Turning parallel travel crawler operation on / off **4.10 - 36**
 Turning rapid gear crawler operation on / off **4.10 - 36**
 Turning the auxiliary heater off **6.02 - 20, 6.02 - 25**
 Turning the auxiliary heater on **6.02 - 19, 6.02 - 24**
 Turning the auxiliary heater on / off (ignition off) **6.02 - 23**
 Turning the BTT on using the ignition switch **5.31 - 37**
 Turning the BTT on using the ON / OFF button **5.31 - 37**
 Turning the climate control system * on / off **6.02 - 13**
 Turning the crane superstructure **4.05 - 55, 4.05 - 55**
 Turning the crane superstructure to the left **4.05 - 57**
 Turning the end section into assembly position **5.38 - 22, 5.39.10 - 24**
 Turning the engine off **4.03 - 47, 4.03 - 47**
 Turning the engine off in the event of danger **4.03 - 47**
 Turning the Hydraulic oil preheating * on **4.03 - 37**
 Turning the hydraulic oil preheating on **2.08 - 4**
 Turning the timer off **6.02 - 23**
 Turning the timer off (ignition off) **6.02 - 25**
 Turning the turntable into the assembly position **5.05 - 10, 5.38 - 12, 5.39.10 - 14, 5.44 - 16**
 Turning the turntable to the disassembly position **5.05 - 50, 5.38 - 50, 5.39.10 - 64, 5.44 - 57**
 Turning the turntable to the left **6.05 - 16**
 Turning the turntable to the right **6.05 - 17**
 Turning the vibration sensor for the slewing gear off **4.05 - 15**
 Turning the vibration sensor winch 1 off **4.05 - 15**
 Turning the wheel sets individually **5.35.10 - 68**
 Turntable assembly **3.02 - 1, 3.02 - 9**
 Turntable frame **1.02 - 3**
 Turntable frame lower section with Quick-Connection (QC) **1.03 - 10**
 Turntable with crawler center section with SA-frame **1.03 - 9**
 Turntable without SA-frame **1.03 - 11**
 Turntable with SA-frame **1.03 - 12**
 Types of ladders **2.04.10 - 12**

U

Unballasting rules **5.36.20 - 95**
 Undefined ballast trailer operation **5.35.10 - 82**
 Uneven ground **5.35.10 - 10**
 Unpinning the ballast pallet on the cross beam **5.36.20 - 91, 5.36.20 - 99**
 Unpinning the ballast trailer on the turntable **5.35.10 - 109**
 Unpinning the ballast trailer with ballast trailer radius 13–19m on the turntable **5.35.10 - 110**
 Unpinning the ballast trailer with ballast trailer radius 19–25m on the turntable or unpinning the ballast trailer

with ballast trailer radius 24–30m on the turntable **5.35.10 - 111**
 Unpinning the D-pivot section on the SA-frame **5.05 - 73**
 Unpinning the FAB-guy rods **5.13 - 62**
 Unpinning the guy rods **5.13 - 54, 5.35.10 - 106**
 Unpinning the lattice components **5.01 - 61**
 Unpinning the luffing pulley block and taking it down on the ground **5.05 - 54**
 Unpinning the pulley support on the turntable **3.05 - 33**
 Unpinning the pull rods **3.05 - 31**
 Unpinning the pull rods of the suspended ballast guide from the D-guy rods **5.36.10 - 125, 5.36.20 - 104, 5.36.40 - 101**
 Unpinning the Quick Connection **3.01 - 44**
 Unpinning the SA-frame **3.05 - 39**
 Unpinning the SA-frame on the turntable **3.05 - 39**
 Unpinning the S-connector pins **5.38 - 14, 5.39.10 - 16**
 Unpinning the S-connector pins on the turntable **5.38 - 14, 5.39.10 - 16, 5.44 - 19**
 Unpinning the turntable frame main section on the front **3.02 - 21**
 Unpinning the turntable frame main section on the rear **3.02 - 19**
 Unpinning winch 1 **3.07.10 - 19**
 Unpinning winch 2 **3.07.20 - 19**
 Unpinning winch 4 on the turntable **3.05 - 37**
 Unpinning winch 5 **3.07.50 - 25**
 Unpinning winch 6 **3.07.60 - 27**
 Unreeving the hook block **4.06 - 10, 4.06 - 14**
 Unscheduled inspection **8.04 - 3**
 Update confirmation **90.05 - 1, 90.05 - 3**
 Update to the operating instructions **90.01 - 3**
 Urea system * **7.05 - 14**
 Usage **5.36.20 - 5**
 Used proportion of the theoretical service life **8.03 - 5**
 Use of double strand height safety equipment **2.04 - 12**
 Use of single strand height safety equipment **2.04 - 11**
 Use of suitable operating fluids **7.01 - 6**
 User guidelines **2.04.10 - 8**
 User platform in settings window for speed reduction of master switch / pedal sensor **4.02 - 195**
 Utilization conditions **5.35.10 - 95, 5.36.10 - 81, 5.36.20 - 73, 5.36.30 - 33, 5.36.40 - 73**
 Utilization display Derrick ballast **4.02 - 182**

V

Variation 1: Installing / removing the radio receiver on the boom end section / lattice section **5.19.10 - 4**
 Variation 2: Installing the radio receiver on the boom end section **5.19.10 - 6**
 Variations **5.36.10 - 3, 5.36.20 - 4, 5.36.30 - 4, 5.36.40 - 4**

Vehicle height **2.05 - 4**
Vertical ladder with transition aid **2.04.10 - 16**
Vertical movements **2.04 - 52**
Vibrations **1.03 - 7**
Vibration sensor **4.05 - 13**
Vibration sensor slewing gear **4.05 - 15**
Vibration sensor winches **4.05 - 13**
Visual check for damage **4.08 - 4**
Visual inspection for leaks **8.03 - 4**

W

WA-frame 2 - pivot section **1.03 - 21**
WA-frame - end section 1 and 2 **1.03 - 21**
WA-frame - intermediate section 1 and 2 **1.03 - 21**
Walking on lattice sections or booms **2.04 - 13**
Walking on the telescopic boom **2.04 - 13**
W- and WA-frame 1 - pivot section **1.03 - 20**
Warning sound
Horn **4.02 - 107, 4.02 - 177, 4.02 - 191**
Warning sound Short
horn **4.02 - 107, 4.02 - 177, 4.02 - 191**
Warranty and coverage **7.01 - 7**
Wear **8.15 - 4**
Weight ballast plate **3.03 - 5**
Weight central ballast bracket **3.03 - 5**
Weight central ballast bracket with ballast plates **3.03 - 5**
Weights **5.01 - 7**
Welding work on the load **2.04 - 69**
Wheel drive **7.05 - 41**
Wheel set adjustment procedure for the steering programs **5.35.10 - 60**
Wheel set drive **7.04.50 - 7**
Wheel set manual operation for assembly / emergency operation **5.35.10 - 68**
While working with the crane **2.04 - 60**
Winch 1 **1.02 - 4, 1.03 - 12**
Winch 2 **1.03 - 13**
Winch 4 **1.02 - 4**
Winch 5 **1.03 - 13**
Winch 6 **1.03 - 13**
Winch display **4.02 - 145, 4.02 - 167**
Wind influences **2.04 - 41**
Wind influences during erection and take down **2.04 - 45**
Wind influences for „Crane out of operation“ **2.04 - 47**
Wind influences in crane operation **2.04 - 46**
Window cleaning system **7.05 - 45**
Windshield wiper / windshield washer system **4.03 - 30**
Wind speed **4.02 - 137**
Wind speed, wind gust speed and wind direction **2.04 - 42**
Wind speed charts for variable support **2.04 - 42**
Wind speed sensor **4.04 - 13, 5.38 - 41, 5.39.10 - 55, 5.44 - 49**
Wind speed sensor * **5.07 - 55**

Winter operation **2.08 - 3**
Wire break increase rate **8.04 - 10**
Wire ropes **4.06 - 3**
Wire ropes and rope end connections **4.06 - 3, 8.04 - 5**
W-lattice jib relapse retainer **8.12 - 7**
W-lattice jib Test position **8.12 - 9**
W-lattice jib „bottom“ **8.12 - 11**
Working in low temperatures **2.08 - 1**
Working in the vicinity of electricity transmission lines **4.08 - 14**
Working in the vicinity of transmitters **2.04 - 39**
Working on lattice sections or booms **2.04 - 13**
Working on the crane superstructure or boom **2.04 - 21**
Working on the telescopic boom head and / or auxiliary boom **2.04 - 12**
Working ranges of several cranes overlap **2.04 - 49**
Working with a high rope pull **4.08 - 15**
Working with a load **4.08 - 1**
Working with the ballast trailer **5.35.10 - 51**
Work station - Crane operator's cab **4.03 - 23**

”

„Closing“ the D-boom **5.05 - 21**
„Floodlight“ TE menu assignment **4.01 - 47**
„Hydraulic oil preheating“ TE menu function key assignment **4.01 - 51**
„Opening“ the D-boom and taking it down **5.05 - 61**
„Power Plus“ rapid gear **4.05 - 9**

LWE/LR 11000-001/23501-04-02/en