

LIEBHERR

Crawler crane with lattice mast

LR 13000

LR 13000-001

Operating instructions

BAL No.: 19503-01-33

Serial No.	
Date	

ORIGINAL OPERATING INSTRUCTIONS

The operating instructions are part of the crane and must be followed!

The operating instructions must always be available within reach!

All local regulations for crane operation must be observed!

Liebherr-Werk Ebingen GmbH

Postfach 1361

D-89582 Ebingen / Donau

+49 (0) 7391 502-0

+49 (0) 7391 502-3399

info.lwe@liebherr.com

www.liebherr.com

Preface

Manufacturer

Liebherr - Werk Ehingen GmbH
 P.O. Box 1361
 D-89582 Ehingen / Donau
 +49 (0) 7391 502-0
 +49 (0) 7391 502-3399
 info.lwe@liebherr.com
 www.liebherr.com

California Proposition 65

Proposition 65 of the US State of California warns against chemicals that are known to cause cancer and birth defects or other reproductive harm.

For additional information, see the website: www.P65Warnings.ca.gov.

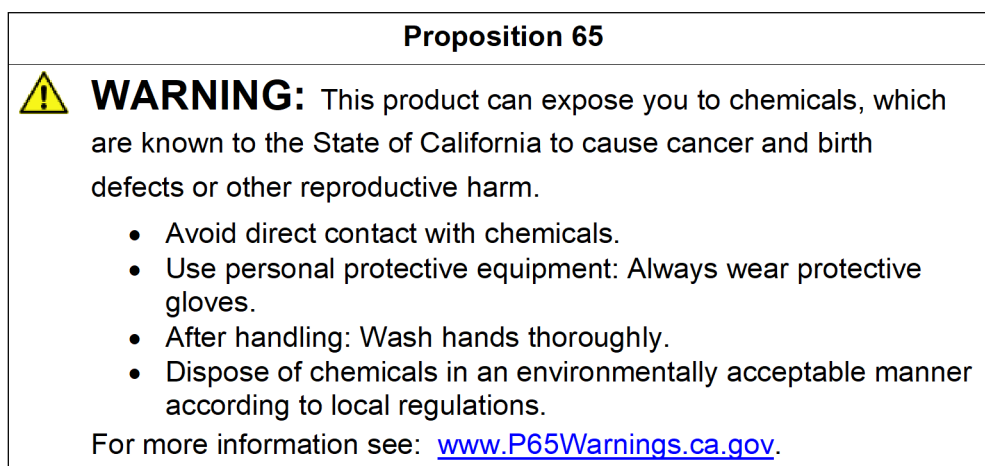

Fig.154660: Example of a Proposition 65 sign for USA: Chemicals

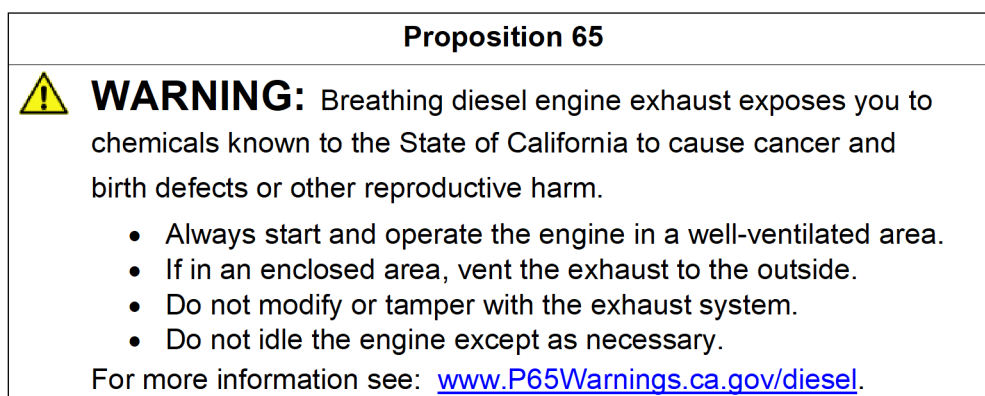

Fig.154661: Example of a Proposition 65 sign for USA: Diesel engine exhaust

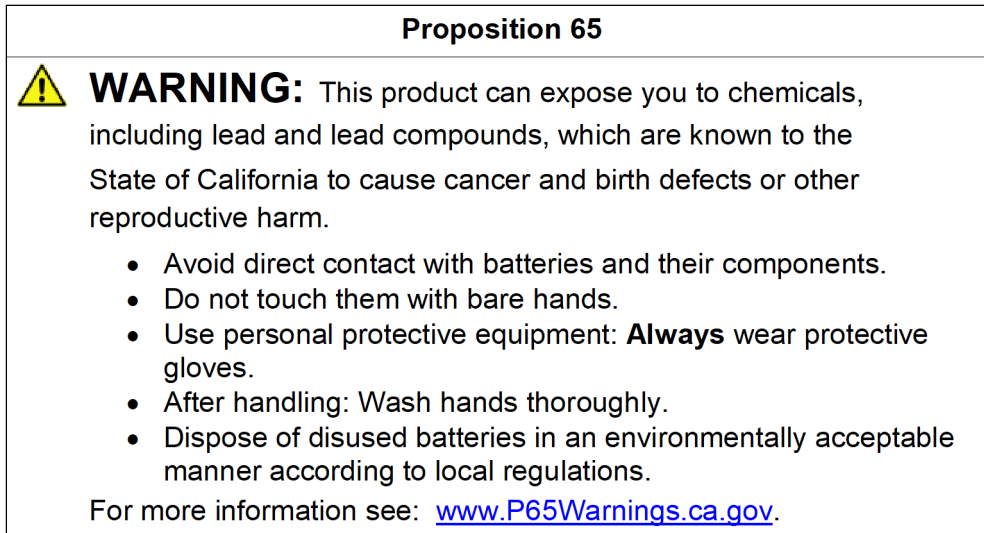

Fig.154662: Example of a Proposition 65 sign for USA: Lead and lead compounds

General

This crane was built according to the state of technology and recognized safety technical regulations. Despite that, danger to body and life for the user and / or third persons or damage to the crane and / or other material assets is still possible.

This crane may only be used:

- when in a perfect technical condition.
- for intended use.
- by trained personnel, who work in a safety and danger conscious way.
- when no safety relevant problems are present.
- when no modifications were made on the crane.

Any problems that could affect safety must be fixed immediately.

Modifications to the crane may only be made with written approval by Liebherr-Werk Ehingen GmbH.

Data logger

This crane is equipped with a data recording device. Among others, the following data is recorded:



- Date and time of day
- Entered set up configuration of the crane
- Actual load
- Percentage of crane utilization
- Boom radius (working radius)
- Main boom angle, luffing jib angle
- Total telescopic boom length, length of each telescopic section
- Every actuation of bypass devices

The recorded data can be read with a respective software.

Safety and warning display

The safety and warning display is directed to all persons who work with the crane or are located nearby. Failure to observe the safety and warning display can lead to accidents.

The terms **DANGER**, **WARNING**, **CAUTION** and **NOTICE** used in the crane documentation are intended to point out certain rules of conduct to all persons working with the crane or are located nearby.

Warning signs	Signal word	Explanation
	DANGER	Designates a dangerous situation which will lead to death or serious injury if it is not prevented. ¹⁾
	WARNING	Designates a dangerous situation which could lead to death or serious injury if it is not prevented. ¹⁾
	CAUTION	Designates a dangerous situation which could lead to slight or medium injury if it is not prevented. ¹⁾
	NOTICE	Designates a dangerous situation, which can lead to property damage if it is not prevented.

¹⁾ This could also result in property damage.

Additional notes

The term **Note** is used in the crane documentation to make all persons working with the crane or are located nearby aware of useful information and tips.

Sign	Signal word	Explanation
	Note	Designates useful information and tips.

Crane documentation

The crane documentation is comprised of:

- all supplied documents on paper and in digital form.
- all supplied programs and applications.
- all subsequently supplied information, updates and addenda for the crane documentation.

The crane documentation:

- indicates how to use the crane safely
- supports the operators in using the permissible application possibilities of the crane
- provides information about the functionality of important components and systems



Note

Terminology in the crane documentation

Certain expressions are used in the crane documentation.

- ▶ In order to avoid misunderstandings, the same expressions should always be used.

If you find any errors or if any misunderstandings arise when reading the crane documentation, please contact Liebherr-Werk Ehingen GmbH immediately.



WARNING

Danger of accident due to incorrect operation of the crane!

Incorrect operation of the crane can lead to accidents.

Death, severe bodily injuries, property damage.

- ▶ Only authorized and trained expert personnel are permitted to work on the crane or have access to it.
- ▶ The crane documentation is part of the crane and must be accessible on the crane.
- ▶ The crane documentation and on-site regulations and specifications (such as accident prevention regulations) must be observed.

Using the crane documentation:

- **makes it easier** to become familiar with the crane.
- **avoids** problems due to improper operation.

Observing the crane documentation:

- **increases** reliability in use.
- **extends** the service life of the crane.
- **minimizes** repair costs and downtime.

The crane documentation must be accessible in the driver's cab or in the crane cab.



WARNING

Outdated version of crane documentation!

If subsequently supplied information, updates and addenda to the crane documentation are not observed and added, there is a danger of accident.

Death, severe bodily injuries, property damage.

- ▶ Add and observe all subsequently supplied information, updates and supplements for the crane documentation.
- ▶ Make sure that all involved persons always know of and understand the latest version of the crane documentation.

If there is any doubt regarding if the crane documentation is **not** up-to-date:

- ▶ Do **not** operate the crane. Contact Liebherr-Werk Ehingen GmbH.



WARNING

Crane documentation is not understood!

If parts of the crane documentation are not understood and the tasks are carried out on or with the crane, then there is a danger of accident.

Death, severe bodily injuries, property damage.

- ▶ Have any open questions clarified by Customer Service at Liebherr-Werk Ehingen GmbH before carrying out the respective task.

This documentation may not be reproduced or duplicated, distributed or used for purposes of competition, neither in part nor in excerpts. All rights are expressly reserved in accordance with copyright laws.

All accident prevention regulations, operating instructions, load charts etc. are based on the destined use of the crane.

Data tag

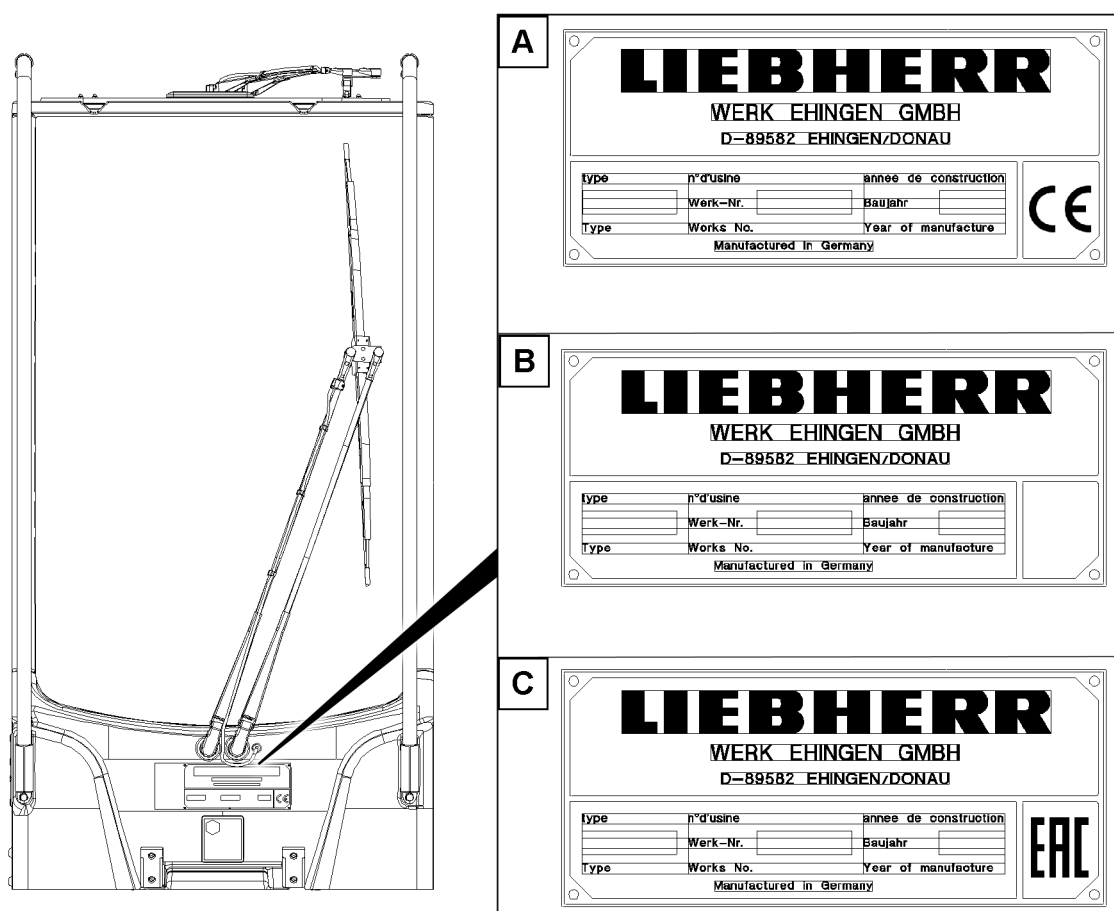

Fig.154689: Data tag shown as an example

- A** Data tag with CE mark
B Data tag without mark

- C** Data tag with EAC mark

CE marking

The CE marking is a mark according to EU laws:

- Cranes with CE marking are compliant with the European Directives applicable at the moment of placing the cranes on the market, and in particular European Machinery Directive 2006/42/EC and product standard EN 13000! Data tag Crane with CE-marking, see illustration **A**.
- Cranes that are operated outside the respective area of application of the European Machinery Directive do not require a CE marking. Crane data tag without CE marking, see illustration **B** and illustration **C**.
- It is prohibited to market and operate cranes without a CE marking, and which do not meet the product-specific regulations valid in Europe, when a CE marking is specified for the country, especially in the single European market.
- European Union Directives prohibit operating cranes with a tipping load utilization of 85 % or a bypass device that does not comply with EN 13000 within the European Union or in countries that only permit a lower tipping load utilization! The local regulations apply. Cranes that do not comply with EN 13000 may not have the CE marking and therefore may not be operated in the European Union.

EU Declaration of Conformity

Upon delivery of the equipment with a CE marking, the EU Declaration of Conformity according to Directive 2006/42/EC is provided directly after the cover sheet. The EU Declaration of Conformity is valid

in the following form and language in all countries of the European Union, as well as in countries that recognize the Directives of the European Union. Keep the EU Declaration of Conformity in a safe place.



Note

- ▶ This declaration of conformity is only valid when this mobile crane meets the directives and standards stated in this EU Declaration of Conformity. This applies especially for the programming and function of the safety-relevant overload protection. The CE sign must be removed if changes were made on the crane, which do not conform to the stated directives and standards. These include in particular a tipping load utilization (85 % load charts) that are not permissible in Europe and a changed version of the bypass device for the overload protection.
- ▶ If this modified mobile crane is re-imported later into a country which is within the validity range of the EC machine directive, then the importer is responsible for the verification and the written confirmation, that the condition of the mobile crane at importation into the EC meets the directives and standards, which are stated in this declaration of conformity.
- ▶ The complete crane documentation must be complete and present in the official language of the community of the member state, in which the machine is placed into service and / or where it is operated.
- ▶ For the verification and confirmation we recommend that the importer contacts the crane manufacturer or a person authorized by him.
- ▶ After written confirmation of the importer and the mobile crane manufacturer, the mobile crane may be labelled again with a CE marking and the EU Declaration of Conformity becomes valid again. Therefore for this crane, the directives and standards valid at initial delivery continue to apply.

Intended use

The crane is designed and intended for assembly operation.

The intended use of the crane consists solely in the vertical lifting and lowering of free and unfixed loads, whose weight and center of gravity are known as well as the moving of these loads, using slewing gear, luffing gear, telescoping gear as well as travel gear within the permissible moving speeds and deceleration speeds.

To do so, a load hook or hook block approved by Liebherr must be reeved on the hoist rope and it may only be operated within the set up configurations according to the operating instructions or the set up conditions that can be selected in the crane control.

The crane may only be used in a flawless technical condition and according to its mission as well as with constant awareness of safety and dangers. Any problems that could affect safety must be fixed immediately.

Driving with the crane, with or without an attached load is only permissible if corresponding driving charts or load charts are available. The set up configurations intended for it and the safety conditions must be observed according to the corresponding crane documentation.

For cranes approved for on-road driving: Intended use also includes on-road driving in a permissible travel condition according to the national regulations applicable in the respective country.

Part of destined use is also the observance of the crane documentation as well as the safety regulations, conditions, prerequisites, set up configurations and working steps required in the crane documentation (for example: operating instructions, load chart, erection and take-down charts, job planner).

Any other use or any use that exceeds what is indicated is not destined use.

Non-intended use

The manufacturer is **not** liable for damage caused by non-destined use or improper use of the crane. Any associated risk it is carried solely by the owner, the operator and the user of the crane.

Non-destined use is:

- Working outside the permissible boom radii and slewing ranges according to the load charts.

- When the set up key is activated, not operating the crane in compliance with the operating instruction
- Operating the crane outside of the limit values approved by the manufacturer, such as:
 - Ambient temperature range
 - Load chart (load / boom radius / slewing range)
 - Moving speeds
 - Deceleration speeds
 - Wind speed
- Moving the crane superstructure at a slewing speed higher than permitted in the operating instructions
- Moving the crane without taking the actual operating conditions into account
- Operating the suspended ballast or the ballast trailer at a distance greater than 250 mm from the ground
- Approaching shut-off limits at an excessive speed without prior braking in accordance with the situation (for example when turning with a load, not carrying out the turning movement or braking in a very careful manner or approaching the hoist limit switch too quickly)
- Selecting load charts that do not correspond to the actual set up configuration.
- Operating the crane when the entries and settings in the set up program do not comply with the actual crane set up configuration (for example incorrect reeving of the hoist rope, incorrect specification of the hook block, incorrect specification of the counterweight)
- Crane ballasting (counterweight, central ballast, derrick ballast and / or auxiliary ballast) is not carried out according to the load charts and / or the erection and take-down charts.
- Working with bypassed / deactivated safety equipment, for example bypassed load torque limiter or with bypassed hoist limit switch.
- Increasing the boom radius of the lifted load after a load torque limiter shut-off, for example by diagonally pulling the load.
- Using the support pressure display as information in order to utilize the crane up to the tipping limit.
- Using the crane in emergency operation without an emergency situation.
- Operating the crane in an area exposed to explosion hazards.
- Start up or attempted start up or use of the crane or crane parts or equipment that is not assembled according to the operating instructions or the corresponding rod plan.
- Installation of non-original or unapproved equipment or replacement parts.
- Operating the crane with non-original or unapproved equipment or replacement parts.
- Using counterweights that are not approved by Liebherr.
- Using external ballast that is not slip-resistant (for example, on the suspended ballast pallet)
- Using service items that are not approved in the operating instructions
- Repairs without considering the operating instructions.
- The maintenance work and repair work required in the maintenance schedule and inspection plan in the operating instructions were not carried out by authorized and trained service personnel or Liebherr service personnel.
- Changing the pressure accumulator for the W-relapse press by unauthorized service personnel
- Using the crane at sports events or recreational events, especially use for:
 - „Bungee jumps“
 - „Dinner in the sky®“ or „suspended restaurants“
 - Lifting equipment on which persons are located.
 - Lifting persons for entertainment purposes.
- Driving in an impermissible travel condition.
- Driving the crane with the equipment in place with or without a load in an impermissible travel condition.
- Driving a crawler crane outside of the limit conditions specified in the operating instructions, such as, for example:
 - Ground incline.
 - Position of the superstructure and boom.
 - Travel speed too high.
- Using the crane on ground that is not suitable for the applied loads.
- Driving the crane without a suitable view or without a guide.
- Pushing, pulling or lifting loads with the level control, the sliding beams or the support cylinders.
- Pushing, pulling or lifting loads by actuating the slewing gear or the telescoping gear.

- Rubbing or pulling the load on the ground.
- Ripping stuck objects loose with the crane.
- Use of the crane for dynamic uses, for example soil compaction, demolition balls.
- Handling operation without consideration of the work cycle in the load spectrum, or without observing the information for the handling operation in the operating instructions.
- Lifting loads that are fastened to multiple cranes without observing the operating instructions.
- Releasing the crane suddenly (for example operating the grab or dumping operation).
- Utilizing the crane when the weight of the load suspended on the crane is changed, for example by filling a container suspended on the load hook, except when saving and salvaging persons and in consideration of the chapter „Lifting of personnel“ in the operating instruction.
- Use, start up, assembly, operation or maintenance of the crane without consideration of the operating instructions.
- Operating the crane with incomplete or a non-current version of the operating instructions.
- Erecting and taking down the crane when the mechanical auxiliary support is required, without supporting the mechanical auxiliary support on load bearing ground.
- Closing or opening the crane boom using a method other than what is specified in the operating instructions (for example, closing it on another intermediate section, etc.).
- Substructure not in compliance with the operating instructions, for example during the assembly or disassembly of boom systems.
- Interrupting crane operation or ending crane operation without considering the operating instructions.
- Operating the crane without an emergency plan (for example how the crane is brought into a safe condition if an unforeseen event occurs).
- Operation of the crane and access to the crane by unauthorized and untrained expert personnel who do not work in a safety and danger conscious manner.
- Start up or operation of the crane without complying with the periodic inspections required by national **and** international directives and standards and as described in the operating instructions.
- Start up or operation of the crane without observing the national regulations concerning safety distances when working with the crane or the information in the operating instructions.
- Start up or operation of the crane with safety equipment not applied properly or defective.
- Working on the crane with defective protective equipment (such as defective height safety equipment).
- Using a fall arrest system (for example height safety equipment) that was not obtained from Liebherr-Werk Ehingen.

The crane may **not** be used for:

- Fastening a stuck load for which the weight and center of gravity are not known and which is released only by flame cutting, for example.
- Transporting persons outside the driver's cab during travel operation.
- Transporting persons outside the crane cab during crane operation.
- Start up or operation of the crane when there are persons in addition to the crane operator outside of the cab or on the crane, except for the procedures approved in the operating instructions.
- Transporting personnel in the crane cab.
- Transporting personnel with the carrying equipment or the load handling equipment or on the load.
- Transporting personnel with work baskets (cherry pickers), if national regulations (for example the responsible work safety organization) are not observed.
- Using cranes for protecting persons against falling without considering the operating instructions.
- Transporting loads and objects on the crane chassis except for in the specified points, storage boxes, storage compartments.
- Transporting loads and objects on the crane superstructure.
- Transporting loads and objects on the ballast trailer.
- Transporting loads and objects on the suspended ballast.
- Transporting loads and objects on the boom lattice sections and / or the crane boom.
- Two hook operation without auxiliary equipment.
- Extended material handling operation.
- Crane operation on a floating device if the conditions in chapter „Crane on a floating device“ are not fulfilled and the written release by **Liebherr Werk Ehingen GmbH** is not present.

The crane documentation must be read and used by all persons who are involved in use, operation, assembly and maintenance of the crane.

Ambient temperature

The crane is designed for an ambient temperature of -20 °C to +50 °C.

If the ambient temperature is lower than -20 °C the crane must be modified with „auxiliary equipment for working at low temperatures“.



WARNING

Working at low temperatures without the corresponding auxiliary equipment!
The crane components can be damaged and fail. The load can rip off.
Death, severe bodily injuries, property damage.

If the crane is operated at an ambient temperature lower than -20 °C:

- ▶ Make sure that the crane is equipped with the corresponding „auxiliary equipment for working at low temperatures“. Observe and comply with chapter 2.08.
- ▶ Use the operating fluids for the corresponding ambient temperature in time. Observe and comply with chapter 7.07.

Safety equipment

Special attention must be paid to the safety equipment built into the crane. The safety equipment must constantly be checked for functionality. The crane may not be operated if the safety equipment are not working or not working correctly.



Note

Your motto must always be:

- ▶ **Safety first!**

The crane has been built in accordance with the European regulations for crane operation and travel operation and has been approved by the relevant authorities.

Responsibility when using or reselling the crane

If the crane is to be operated or sold in an area where other laws or regulations apply, the operator is responsible for ensuring that the crane complies with the requirements of the laws and regulations of the operating location.

For example, this may apply to:

- Labelling
- Emission regulations
- Lighting
- Underride protection

The operator must obtain information in advance about any modification that may be required. Contact Customer Service at Liebherr-Werk Ehingen GmbH.

Equipment and spare parts



WARNING

Danger of fatal injury if original equipment parts are **not** used!

If the crane is operated with **non**-original equipment parts, the crane can fail.

Death, severe bodily injuries, property damage.

- ▶ Operate the crane only with original equipment parts!
- ▶ Crane operation with equipment parts, which do **not** belong to the crane is prohibited!
- ▶ If there is any doubt about the origin of equipment parts, contact Customer Service at Liebherr-Werk Ehingen GmbH.



WARNING

The crane permit and the manufacturer's warranty will become void!

If any original installed parts are modified, manipulated or replaced (e.g. removal of parts, installation of non-original Liebherr parts), both the crane permit and the manufacturer's warranty will become void.

- ▶ Leave installed original parts unchanged.
- ▶ Do not remove installed original parts.
- ▶ Use only Original Liebherr spare parts.
- ▶ If there is any doubt about the origin of spare parts, contact Customer Service at Liebherr-Werk Ehingen GmbH.

For ordering equipment parts and spare parts, always keep the crane number handy and provide it.

Definition of directional data for mobile cranes

Driving forward: Driving with the driver's cab forward.

Driving in reverse: Driving with the taillights of the crane chassis forward.

Front, rear, right, left in the **driver's cab** refer to the crane chassis. The driver's cab is always in the front.

Front, rear, right, left in the **crane cab** refer to the crane superstructure. The front is always in the direction of the taken-down boom.

0° crane superstructure slewing angle: The boom points in the longitudinal direction to the rear over the rear of the vehicle.

180° crane superstructure slewing angle: The boom points in the longitudinal direction to the front over the driver's cab.

Definition of directional data for crawler cranes

Driving forward driving forward from the view of the crane operator seated in the crane cab. Turntable in the 0° or 180° position.

Driving reverse driving backward from the view of the crane operator seated in the crane cab. Turntable in the 0° or 180° position.

Front, rear, right, left always orient themselves on the **crawler travel gear** from the position of the chain tension devices. The chain tension devices on the crawler travel gear are always on the front.

Front, rear, right, left refer to the direction of view of the crane operator seated in the **crane cab**. The front is always in the direction of the taken-down boom.

Optional equipment and functions

The equipment marked with * and the functions are optionally available and are **not** part of the standard crane (optional equipment).

Conversion chart

	Initial unit	Multiplication factor	Target unit
Length	mm	0.03937	in
	in	25.4000	mm
	mm	0.00328	ft
	ft	304.8	mm
	cm	0.39370	in
	in	2.5400	cm
	cm	0.0328	ft
	ft	30.48	cm
	m	39.37	in
	in	0.0254	m
	m	3.281	ft
	ft	0.3048	m
	km	0.62137	mile
	mile	1.6093	km
Area	cm ²	0.155	in ²
	in ²	6.4516	cm ²
	m²	10.764	ft²
	ft²	0.0929	m²
Volume	cm ³	0.06102	in ³
	in ³	16.387	cm ³
	m ³	35.3147	ft ³
	ft ³	0.0283	m ³
	l	0.001	m ³
	m ³	1000	l
	l	61.024	in ³
	in ³	0.016387	l
	l	0.0353	ft ³
	ft ³	28.32	l
	l	0.264178	US. liq. gal
	US. liq. gal	3.7853265	l

LWE/LR 13000-001/19503-01-02/en

	Initial unit	Multiplication factor	Target unit
Mass (weight)	kg	2.20462	lb
	lb	0.45359	kg
	t	2204.62	lb
	lb	0.0004536	t
	t	1.1023	short ton US (tn. sh.)
	short ton US (tn. sh.)	0.90718	t
	t	0.45359	kip
	kip	2.20462	t
Mass / length	kg/m	0.055998	lb/in
	lb/in	17.857781	kg/m
	kg/m	0.67197	lb/ft
	lb/ft	1.48816	kg/m
Force	N	0.2248	lbf
	lbf	4.4483986	N
	kN	224.809	lbf
	lbf	0.0044483986	kN
Turning moment	Nm	8.85075	lbf·in
	lbf·in	0.112984	Nm
	Nm	0.73756	lbf·ft
	lbf·ft	1.3559	Nm
Performance	HP (DIN HP)	0.7355	kW
	kW	1.3596	HP (DIN HP)
Speed	m/s	39.37	in/s
	in/s	0.0254	m/s
	m/s	3.28084	ft/s
	ft/s	0.3048	m/s
	km/h	0.62137	mph (mi/h)
	mph (mi/h)	1.60935	km/h
	m/s	2.2369	mph (mi/h)
	mph (mi/h)	0.44704	m/s

	Initial unit	Multiplication factor	Target unit
Pressure	kPa (kN/m ²)	0.01	bar
	bar	100	kPa (kN/m ²)
	bar	14.5038	psi
	psi	0.06895	bar
	kPa (kN/m²)	0.145038	psi
	psi	6.894759	kPa (kN/m²)
	N/cm ²	1.450377	psi
	psi	0.6894759	N/cm ²
	N/m ²	0.000145038	psi
	psi	6894.759	N/m ²
	t/m ²	204.81	lbs/ft ²
	lbs/ft ²	0.0048828	t/m ²
Load-related area	m ² /t	0.004882	ft ² /lbs
	ft ² /lb	204.81	m ² /t
Temperature	°C	$([^{\circ}\text{C}] \cdot 1.8) + 32$	°F
	°F	$([^{\circ}\text{F}] - 32) / 1.8$	°C

Conversion chart

Empty page!

LWE/LR 13000-001/19503-01-02/en

Contents

1 Description of crane

1.01 Terminology	1
1 Component overview	3
2 Boom system component overview	4
1.02 Product description	1
1 Crawler travel gear	2
2 Crane superstructure	2
3 Winches	4
4 Boom systems / boom combinations	5
5 Auxiliary equipment	5
1.03 Technical data	1
1 Dimensions and weights	3
2 Load handling equipment	33
3 Crane surface pressure	33
4 Noise emission	33
5 Vibrations	34
6 Crane speeds	34
7 Ropes	34
1.03.10 Outrigger pads	1
1 Description	2
2 Safety	2
3 Fastening the outrigger pad	5
4 Technical track pad data for cranes with a telescopic boom	8
5 Technical outrigger pad data for cranes with a lattice mast boom	23

2 Safety

2.03 Job planning	1
1 Planning Crane operation	3
2.04 Technical safety instructions	1
1 Dangers on the crane	3
2 Danger zone of crane	5
3 Traffic endangerment and environmental damage	6
4 Endangering air traffic	6
5 Movement on the crane	7
6 Emergency exit - driver's cab	8
7 Emergency crane cab exit	8
8 Personal protective equipment	12
9 Supplied fire extinguisher	19
10 Securing persons to prevent them from falling	19
11 Rescuing the assembly personnel	21
12 Crane cab	21
13 Side window	29
14 Emergency hammer*	29

15	Transport	30
16	Fastening	33
17	Crane operator responsibilities	33
18	Selecting the location	35
19	Slopes and excavations	39
20	Loads on the ground due to crane operation	42
21	Support	46
22	Aligning the crane	48
23	Checking the safety measures	49
24	Safety instructions in case of an external power supply	50
25	Grounding for potential equalization	50
26	Working in the vicinity of transmitters	52
27	Crane operation in case of thunderstorms	53
28	Winch influences	54
29	Lifting a load with two cranes	61
30	Overlapping of working ranges of several cranes	63
31	Hand signals for guidance	64
32	Travel operation	72
33	Crane operation	74
34	Lifting of personnel	82
35	Securing personnel on shut off crane	84
36	Welding work on the load	86
2.04.10 Ladders		1
1	Intended use	2
2	Safety instructions	2
3	Safety signs	3
4	Ladder inspection	12
5	User guidelines	12
6	Assembling the ladder	14
7	Ladder access	25
2.05 Signs on the crane		1
1	Signs	2
2.05.10 Labeling of the load carriers		1
1	Identifications on the hook block or load hook	3
2	Identifications on single hook or double hook	4
3	Identifications on auxiliary weights	5
2.06 Fall protection equipment on the crane		1
1	Personal protective equipment	3
2	Safety ropes as fall protection equipment	5
3	Fall protection equipment and ladders on the crane chassis	9
4	Fall protection equipment and ladders on the crane superstructure	43
5	Fall protection equipment and ladders on the D-boom	83
6	Fall protection equipment and ladders on the S-boom	131
2.08 Working in low temperatures		1
1	Auxiliary equipment	2
2	Safety	2
3	Environmental / component temperature below -20 °C	3

4	Maintenance	7
<hr/>		
2.25	Crane on floating body	1
1	Non-intended use	2
2	Intended use	2
3	Floating device	2
4	Operating conditions	2
5	Crane transport on floating devices	3
6	Increased corrosion	4

3 Crane assembly

<hr/>		
3.01.10	Assembling crawler carrier halves and track chain	1
1	Components of the crawler carrier	3
2	Crawler carrier fastening points	5
3	Assembling the crawler carrier	7
4	Installing the crawler carrier on the preassembled crawler center section	47
5	Disassembling the crawler carriers	47
<hr/>		
3.01.20	Assembling the cross carrier on the crawler center section	1
1	Component overview	3
2	Component fastening points	3
3	Assembling the cross carrier on the crawler center section	5
4	Disassembling the cross carrier on the crawler center section	29
<hr/>		
3.01.30	Assembling the crawler carrier on the preassembled crawler center section	1
1	Assembling the crawler carrier on the cross carrier	3
2	Assembling the roller ring connection	23
3	Disassembling the roller ring connection	33
4	Disassembling the crawler carrier on the cross carrier	39
<hr/>		
3.02	Turntable assembly	1
1	Turntable components	3
2	Fastening points	5
3	Assembling the turntable	11
4	Assembling the carrier for the counterweight on the turntable	75
5	Assembling the A-frame on the turntable	75
6	Assembling the counterweight on the turntable	75
7	Disassembling the counterweight on the turntable	77
8	Disassembling the A-frame on the turntable	77
9	Disassembling the carriers for the counterweight on the turntable	77
10	Disassembling the turntable	79
<hr/>		
3.03	Central ballast	1
1	Component overview	3
2	Installing the central ballast	5
3	Removing the central ballast	15
<hr/>		
3.05	A-frame assembly	1
1	Component overview	3
2	Fastening points A-frame - assembly	3
3	Fastening points A-frame - assembly	5
4	Assembling the A-frame	7

5	Disassembling the A-frame	33
3.06	Assembly conditions	1
1	Assembly configurations on the crawler carrier	3
3.07.10	Winch 1 assembly	1
1	Component overview	3
2	Fastening points for winch 1	3
3	Installing the winch	5
4	Removing the winch	15
3.07.20	Winch 2 assembly	1
1	Component overview	3
2	Fastening points for winch 2	3
3	Installing the winch	5
4	Removing the winch	15
3.07.30	Winch 3 assembly	1
1	Component overview	3
2	Fastening points for winch 3	3
3	Installing the winch	5
4	Removing the winch	15
3.07.50	Winch 5 assembly	1
1	Component overview	3
2	Fastening points for winch 5	3
3	Assembling the winch	5
4	Disassembling the winch	17
3.07.60	Winch 6 assembly	1
1	Component overview	3
2	Fastening points for winch 6	3
3	Installing the winch	5
4	Removing the winch	15
3.80	Crane and crane component transport	1
1	Safety	3
2	Rigging plans	3

4 Operation of crane superstructure

4.01	Operating and monitoring instruments on the crane superstructure	1
1	Cab equipment	3
2	Equipment in engine house	7
3	Cab operating units overview	9
4	Instrument panel	11
5	Operating and control unit (BKE)	15
6	LICCON computer system monitors	21
7	Camera monitoring	21
8	Pedal carrier	25
9	Touch displays	27
10	Master switch assignment MS1	29
11	Master switch assignment MS2	39

12	Master switch assignment MS3	53
4.01.10	Touch display menu operation	1
1	Touch display	2
2	Operating variations	2
4.02	LICCON computer system	1
1	General	2
2	System start of the LICCON computer system	4
3	Operating elements on the LICCON monitors	6
4	<i>Set up</i> program	11
5	The <i>Crane operation</i> program on LICCON monitor 0	77
6	The <i>Crane operation</i> program on LICCON monitor 1	163
7	The <i>Crane operation</i> program on LICCON monitor 2	185
8	<i>Curve illustration</i> program	197
9	<i>Working range limitation</i> program	201
10	Master switch / pedal sensor speed reduction	209
11	Power-save mode and Stand-by mode in the LICCON computer system	219
4.03	Start up and shut down of crane	1
1	Checking before start up	2
2	Diesel particle filter (DPF)*	13
3	<i>Exhaust system cleaning procedure</i>	18
4	Crane operator's cab work station	21
5	Supply via external feed / power aggregate	33
6	Preheating the hydraulic oil with Hydraulic oil preheating*	37
7	Starting the LICCON computer system (before engine start)	38
8	Starting and turning off the engine	41
9	Starting the LICCON computer system parallel to the engine	48
4.04	Safety equipment	1
1	General	3
2	Quick test Crane geometry	3
3	Quick test Overload protection	3
4	LICCON computer system	3
5	Safety systems on the crane	9
4.05	Crane operation	1
1	LICCON computer system	3
2	Master switch functions	5
3	Lifting and lowering	17
4	Luffing	43
5	Turning	51
4.06	Rope reeving	1
1	Wire ropes and rope end connections	2
2	Reeving in the hoist rope	5
3	Reeving in / reeving out the hook block, rope end connection in the standard version	8
4	Reeving in / reeving out the hook block, rope end connection with L-shaped rope lock	11
5	Attaching and removing the load hook*	15
6	Two-part hoist limit switch weight	18
7	One-part hoist limit switch weight	21
8	Assembling / disassembling the wedge lock	23

9	Rope reeving	35
4.07	Counterweight	1
1	Components of counterweight	3
2	Fastening points	5
3	Assembling the counterweight frame	7
4	Assembly of A-frame	17
5	Installing the counterweight	19
6	Removing the counterweight	31
7	Removal of A-frame	39
8	Disassembling the counterweight frame	41
9	Disassembling the brackets on the carriers	49
4.08	Working with a load	1
1	Safety instructions	3
2	Checks before starting to work with the crane	4
3	Telescoping crane movement	5
4	Taking on a load	7
5	Load weighing and load display	13
6	Crane operation	18
7	Ram work or pulling sheet piles	19
8	Crane rope pretension	20
4.10	Driving from the crane cab	1
1	Prerequisites for driving the crane (crawler operation)	2
2	Displays on the LICCON monitor	6
3	Preparing for crane driving	11
4	Driving the crane: Load chart available	13
5	Driving the crane: No load chart is available	15
6	Driving the crawler crane	19
4.15	Reeving plans	1
1	Reeving plans	3
4.20	Procedure for shut-off of crane movement	1
1	General	3
2	Instructions for resuming crane movement	17

5 Equipment

5.01	Technical safety instructions for assembly and disassembly	1
1	Equipment	2
2	Rope pulleys	2
3	Ropes	2
4	Fiber guy ropes	4
5	Control measures before crane operation	8
6	Relapse cylinders	11
7	Pneumatic springs	11
8	Manual rope winches	11
9	Weights	12
10	Guy rods	12
11	Auxiliary guying	13
12	Bypassing the overload protection	13

13	Bypassing the hoist top shut-off	15
14	Pin connections	16
15	Retaining elements	21
16	Assembling / disassembling	29
17	Erecting / taking-down	91
18	Walking on a boom component	95
5.03 Boom systems		1
1	Boom components	2
2	Arrangement of intermediate sections and guy rods on the booms / boom systems	2
3	Wire rope auxiliary guying	5
4	Fiber guy rope auxiliary guying	15
5.05 D-boom		1
1	Component overview	3
2	Fastening points for derrick components	5
3	Assembling the D-boom	6
4	Disassembling the D-boom	113
5	Preparing the lattice sections for transport	183
5.07 W/WV-lattice jib		1
1	Component overview	3
2	Fastening points	6
3	Assembling	13
4	Crane operation	65
5	Disassembling	67
5.07.50 Erecting / taking down the boom system with luffing jib		1
1	Information about use and the illustrations	2
2	Determining the steepest main boom operating position	2
3	Erecting the boom system with luffing jib	8
4	Taking down the boom system with the luffing jib	15
5.10 Boom nose lattice boom		1
1	Boom nose 120 t	3
2	Assembly	6
3	Erecting the boom	15
4	Operating the crane	15
5	Disassembly	16
5.14 Roller set		1
1	Fastening points	3
2	Boom configuration	5
3	Installing pulley set / pulley sets	7
4	Heavy load device*	25
5	Removing the pulley set / pulley sets	33
5.19 Hook blocks		1
1	Hook blocks	3
2	Radio sending unit for the incline display hook block	3
3	Procedure in case of slack rope	3
5.19.10 Hook block incline sensors		1

1	General	2
2	Assembling the radio receiving unit	2
3	Assembling the radio sender unit on the hook block	5
4	Batteries in the radio sender unit	9
5	Radio sender unit and radio receiving unit park position	11
5.30 Pin pulling device		1
1	Pin pulling device	2
2	Hydraulic oil level, hydraulic oil, hydraulic oil pressure	6
3	Pinning and unpinning with the pin pulling device	7
5.31 Bluetooth Terminal (BTT)		1
1	Technical safety instructions	2
2	Description of the function	3
3	BTT operating elements	3
4	BTT system start	6
5	BTT button block	8
6	BTT EMERGENCY OFF switch	9
7	Settings and status displays on the BTT	10
8	Turning the BTT on / off	11
9	Charging the BTT rechargeable battery	13
10	Start menu of the BTT	14
11	<i>Engine operation</i> menu	15
12	<i>Assembly winch</i> menu	22
13	<i>Test system</i> menu	25
14	Measures in case of problems	27
15	Inspection and maintenance	30
5.36 Derrick ballast - suspended ballast		1
1	Description of suspended ballast	3
2	Component overview - Derrick ballast	5
3	Component overview Derrick ballast pallet	7
4	Lifting heights of derrick ballast	9
5	Installing the suspended ballast	13
6	Crane operation with derrick ballast	67
7	Crawler operation with derrick ballast	97
8	Disassembling the derrick ballast	99
5.39 LD/SLD/SD-boom combination		1
1	Component overview S-pivot section	3
2	Fastening points	5
3	Assembling the SD/SLD-boom	12
4	Assembling the SD/SLD-boom in „flying“ mode	61
5	Preassembling the SD/SLD-boom on the ground and installing it on the crane	67
6	Assembling the boom with the substructure	67
7	Assembling the roller sets on the boom head	71
8	Performing the function checks	71
9	Erecting the boom	75
10	Installing the central ballast	85
11	Installing the derrick ballast	85
12	Operating the crane	87
13	Disassembling the SD/SLD-boom	87

5.44 PD-boom combination	1
1 Components	3
2 Fastening points	4
3 Assembling the PD-boom	11
4 Erecting the boom	59
5 Operating the crane	67
6 Disassembling the PD-boom	69
5.61 Roller cart	1
1 Pulley cart	3
5.62 Assembly shoes	1
1 Assembly shoes	3

6 Auxiliary equipment

6.02 Crane operator's cab heater / engine preheating / air conditioning system	1
1 Heating the crane cab	3
2 The „Air conditioning settings“ menu	3
6.50 Customer-specific special equipment	1
1 Load handling equipment LMZ- 1250 t	3

7 Maintenance and service

7.01 Maintenance and service - General	1
1 Safety	2
2 Warranty and coverage	7
3 Liebherr Customer Service	7
4 Taking an oil sample	8
5 Taking care of the crane	8
6 Storage	14
7 Recommendation for safe disposal	15
7.01.10 Service system	1
1 Description	2
2 Safety instructions	2
3 Calling up the service system	2
4 <i>Service system</i> operating interface	3
5 <i>Service system</i> function key line	6
6 Checking the maintenance status	6
7 Resetting the maintenance status	7
7.02 Maintenance intervals - Crawler chassis	1
1 Maintenance and inspection schedule	2
7.03 Maintenance intervals - Crane superstructure	1
1 Maintenance and inspection schedule	2
7.03.50 Maintenance intervals - Crane boom	1
1 Maintenance and inspection schedule	3
7.04 Maintenance instructions - Crane chassis	1
1 Servicing the travel gear	3

2	Servicing the central lubrication system of the crawler carrier	11
3	Servicing the track chain	19
4	Ladders	33
7.05 Maintenance instructions - Crane superstructure		1
1	Crane engine	3
2	Pump distributor gear	9
3	Hydraulic system	11
4	Fuel system	17
5	Slewing ring connection	21
6	Central lubrication system	25
7	Winches 1, 2, 3, 4, 5	41
8	Winch 6	47
9	Air dryer of the pressurized air system	49
10	Electrical system - Lighting	49
7.05.50 Maintenance instructions - Crane boom		1
1	Lattice mast boom	3
2	Rope pulleys and guide pulleys	4
3	Crane ropes	4
7.06 Fill quantities, lubrication chart		1
1	Fill quantities	3
2	Lubrication schedule	4
7.07 Operating fluids and lubricants		1
1	Specified service fluids and lubricants for Liebherr cranes	3

8 Inspections of cranes

8.01 Periodic crane inspections		1
1	General information	2
2	Inspecting load bearing crane structures, especially steel structures	4
3	Inspecting the locking system of the telescopic boom	79
4	Inspection of the screws in the adjustment plates	81
5	Checking the safety ropes and anchor points	82
6	Inspecting the load handling equipment and assembly aids	84
7	Inspecting of fastening equipment	84
8	Inspecting the diaphragm reservoir	85
9	Inspecting the relapse cylinders	85
10	Inspecting the rope pulleys	86
11	Inspecting the carrier rollers	87
12	Inspecting the extension conditions of sliding beams	88
13	Inspecting the function of the overload protection	88
14	Inspecting the pin connections	89
15	Inspecting the slewing ring connection	89
16	Inspecting the mounting of the load bearing equipment	90
17	Inspecting the tele extension with eccentric, illustration 1	91
18	Inspecting the change over pulleys, illustration 2	92
19	Inspecting the oil and fuel tanks	92
8.03 Inspecting of winches		1
1	Inspecting the hoist and retracting winches	3

2	Inspection of the auxiliary reeving winch, recovery winch and spare wheel winch	5
3	Monitoring the winches	5

8.04 Inspection of crane wire ropes 1

1	Crane ropes	3
2	Importance of inspection	3
3	Personal protective equipment	3
4	Qualification Inspection personnel	3
5	Unscheduled inspection	3
6	Intervals	4
7	Areas	4
8	Documenting inspection results	5
9	Wire ropes and rope end connections	5
10	Degree of severity	8
11	Abbreviations Rope diameter	8
12	Distortions and mechanical damage	8
13	Removal criteria Overview	8
14	Checking for broken strands	10
15	Determining the number of broken wires	10
16	Checking the rope end connection	15
17	Checking of rope diameter	15
18	Corrosion	18
19	Corkscrew-like distortion	20
20	Basket formation	21
21	Protruding, distorted insert or strand	22
22	Loop formation	23
23	Kinking or rope loops pulled closed	24
24	Buckles	25
25	Effects of heat, arcs	26
26	Combined degree of severity	26
27	Flattenings	26
28	Current checklist	29

8.05 Inspection of load hooks 1

1	Safety instructions	2
2	Inspection intervals	2
3	Checking the load hook	2

8.06 Inspection of hydraulic hose lines 1

1	Safety guidelines	3
2	Inspection intervals	3
3	Checking the end of the service life	3
4	Inspecting the hydraulic hose lines for damage	4
5	Inspecting the hydraulic hose lines for leaks	5
6	Documenting the inspection	5
7	Replacing hydraulic hose lines	5

8.12 Inspection of safety controls on the relapse supports 1

1	S-boom relapse retainer	3
2	Derrick relapse retainer	5
3	W-lattice jib	7

8.14 Inspection of accumulator pressure in relapse cylinder	1
1 Checking the accumulator pressure in the relapse cylinder	2
2 Checking the accumulator pressure in the W-relapse cylinder, W-boom on the ground	3
3 Checking the accumulator pressure in the W-relapse cylinder, W-boom luffed up	4
8.15 Inspection of guy rods	1
1 Safety guidelines	3
2 Inspection intervals	3
3 Checking the guy rods	3
8.17 Inspection of ladders	1
1 Safety instructions	3
2 Inspection intervals	3
3 Inspecting the ladders	3
4 Inspection sheet and check list	3
8.20 Country-specific content	1
1 Country-specific content	2
8.90 Inspection chart for cranes	1
1 Inspection chart for recurring inspections of Liebherr cranes	3

90 Appendix

90.01 Preface to the appendix	1
1 Foreword	3
90.05 Update confirmation	1
1 Change confirmation form	3
2 Update confirmation	3
3 Customer information	4

1 Description of crane

LWE/LR 13000-001/19503-01-02/en

LWE/LR 13000-001/19503-01-02/en

1.01 Terminology

1	Component overview	3
2	Boom system component overview	4

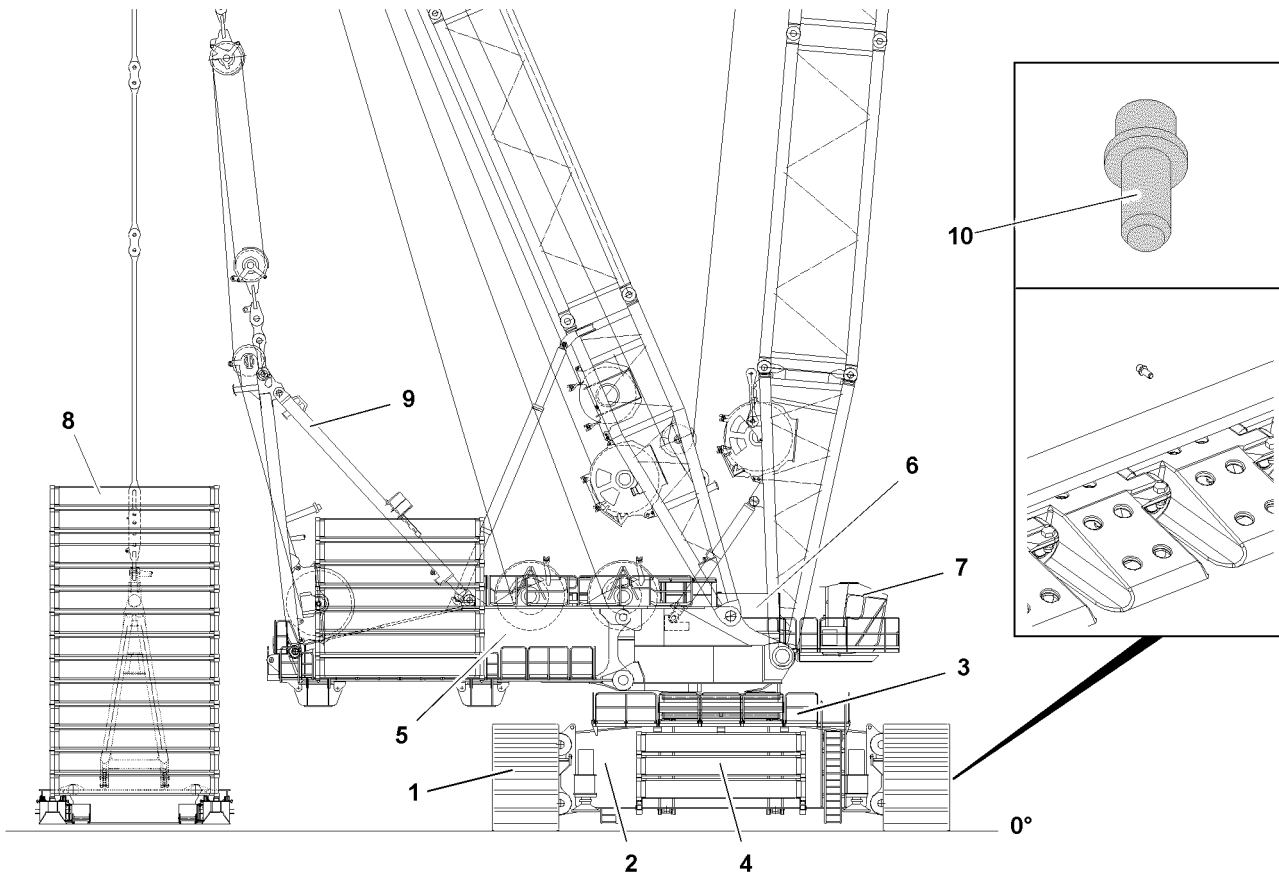
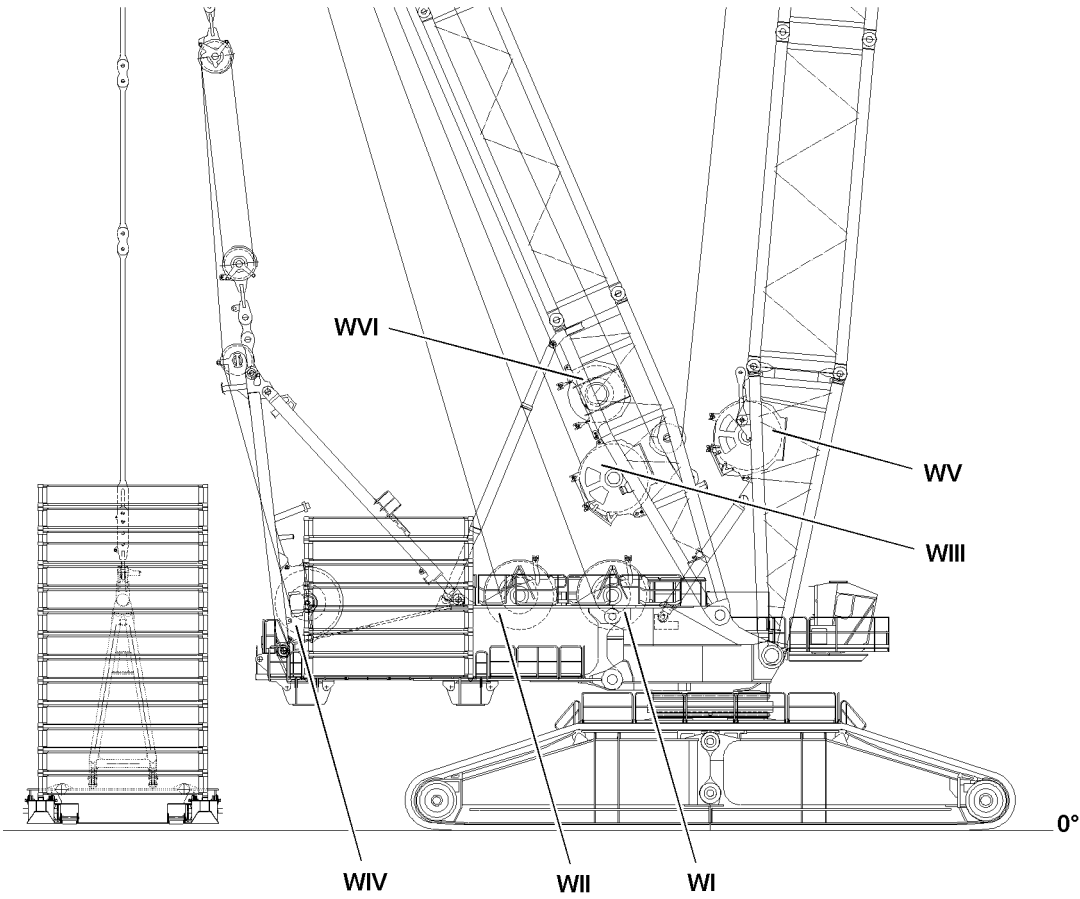

Fig.147681

LWE/LR 13000-001/19503-01-02/en

1 Component overview

1.1 Crawler travel gear

- 1 Crawler carrier
- 2 Cross carrier
- 3 Center section
- 4 Central ballast
- 10 Ground connection



Note

Ground the crane:

- ▶ Observe and adhere to the instructions in chapter 2.04.
-

1.2 Turntable

- 5 Turntable
- 6 Engine house
- 7 Cab
- 8 Counterweight
- 9 A-frame
- WI** Winch 1
- WII** Winch 2
- WIII** Winch 3
- WIV** Winch 4
- WV** Winch 5
- WVI** Winch 6

2 Boom system component overview

2.1 SD/SDB0- boom

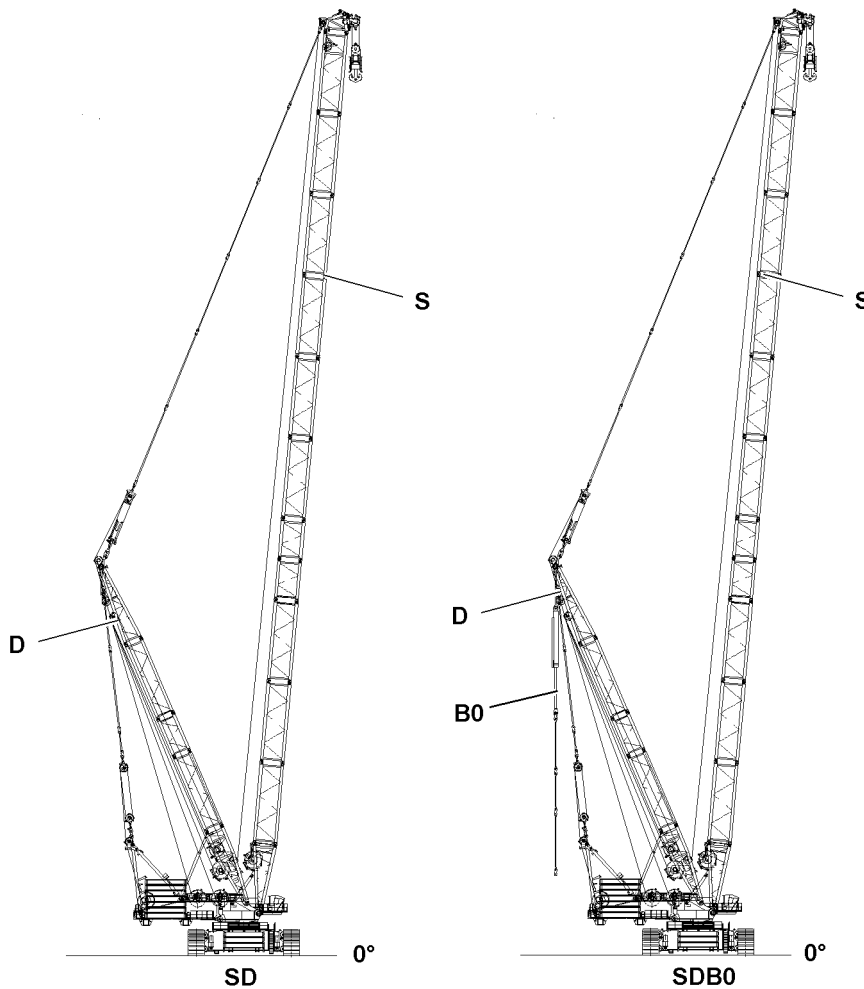

Fig.164545

LWE/LR 13000-001/19503-01-02/en

**WARNING**

The crane can topple over!

- ▶ Make sure that all boom systems are installed only according to the respective assembly chapters and the associated rod plans.
- ▶ Make sure that danger notes for assembly and for crane operation are observed and adhered to.
- ▶ The use of the following boom illustrations for assembly purposes is prohibited.

S Main boom

- Heavy-duty version
- With roller set / roller sets on the S-end section

D Derrick boom

- Derrick-boom length 54 m
- Alone as an assembly device or in connection with **SD**

B0 Derrick ballast

- Suspended ballast, without ballast pallet

2.2 SDB/SDWB- boom

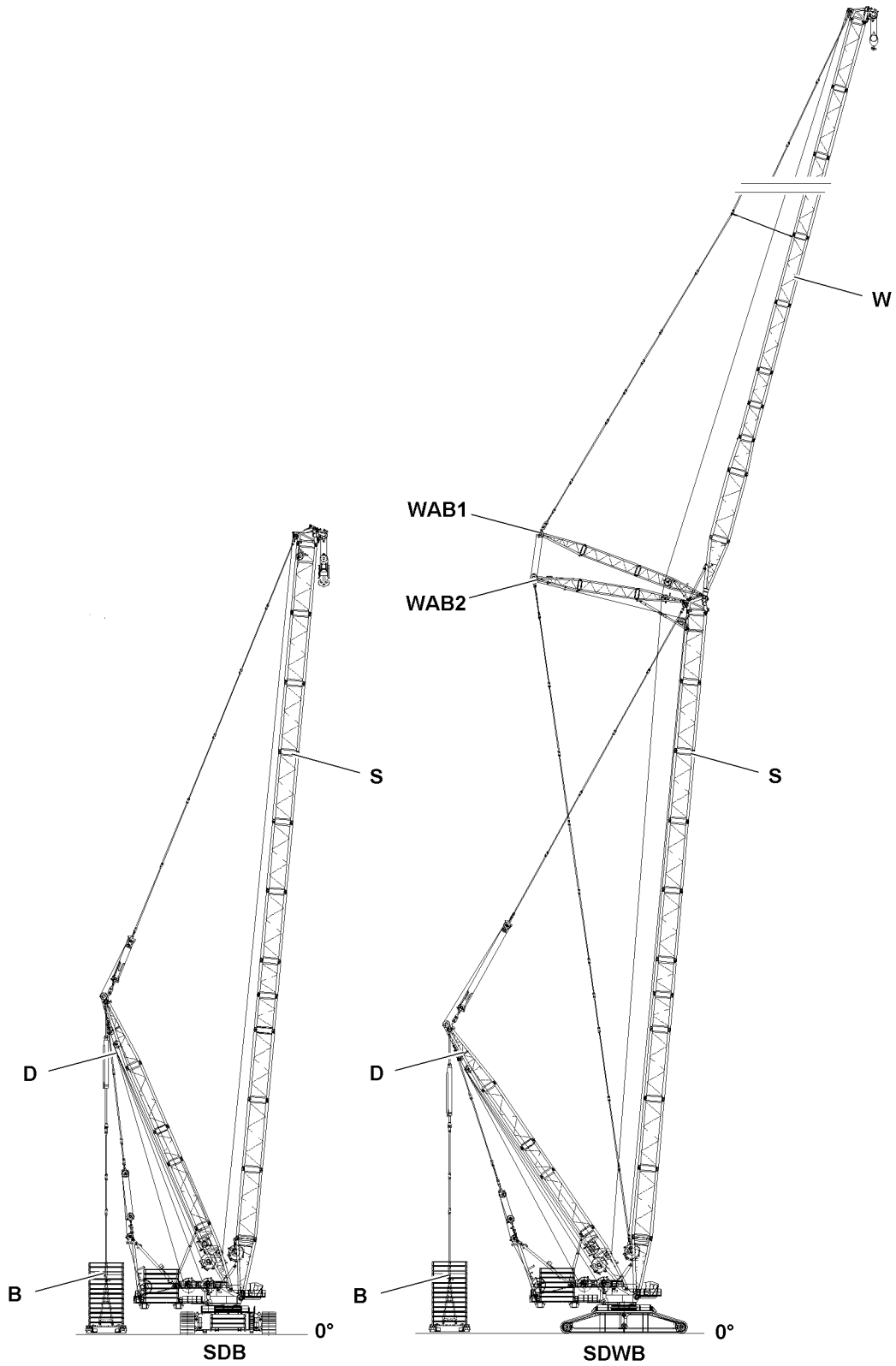

Fig.164546

LWE/LR 13000-001/19503-01-02/en

**WARNING**

The crane can topple over!

- ▶ Make sure that all boom systems are installed only according to the respective assembly chapters and the associated rod plans.
- ▶ Make sure that danger notes for assembly and for crane operation are observed and adhered to.
- ▶ The use of the following boom illustrations for assembly purposes is prohibited.

S Main boom

- Heavy-duty version
- With roller set / roller sets on the S-end section

W Luffing lattice jib**D** Derrick boom

- Derrick-boom length 54 m
- Alone as an assembly device or in connection with **SD**

B Derrick ballast

- Suspended ballast

WAB1 WA-frame 1

WAB2 WA-frame 2

2.3 SDW2B/SLDB- boom

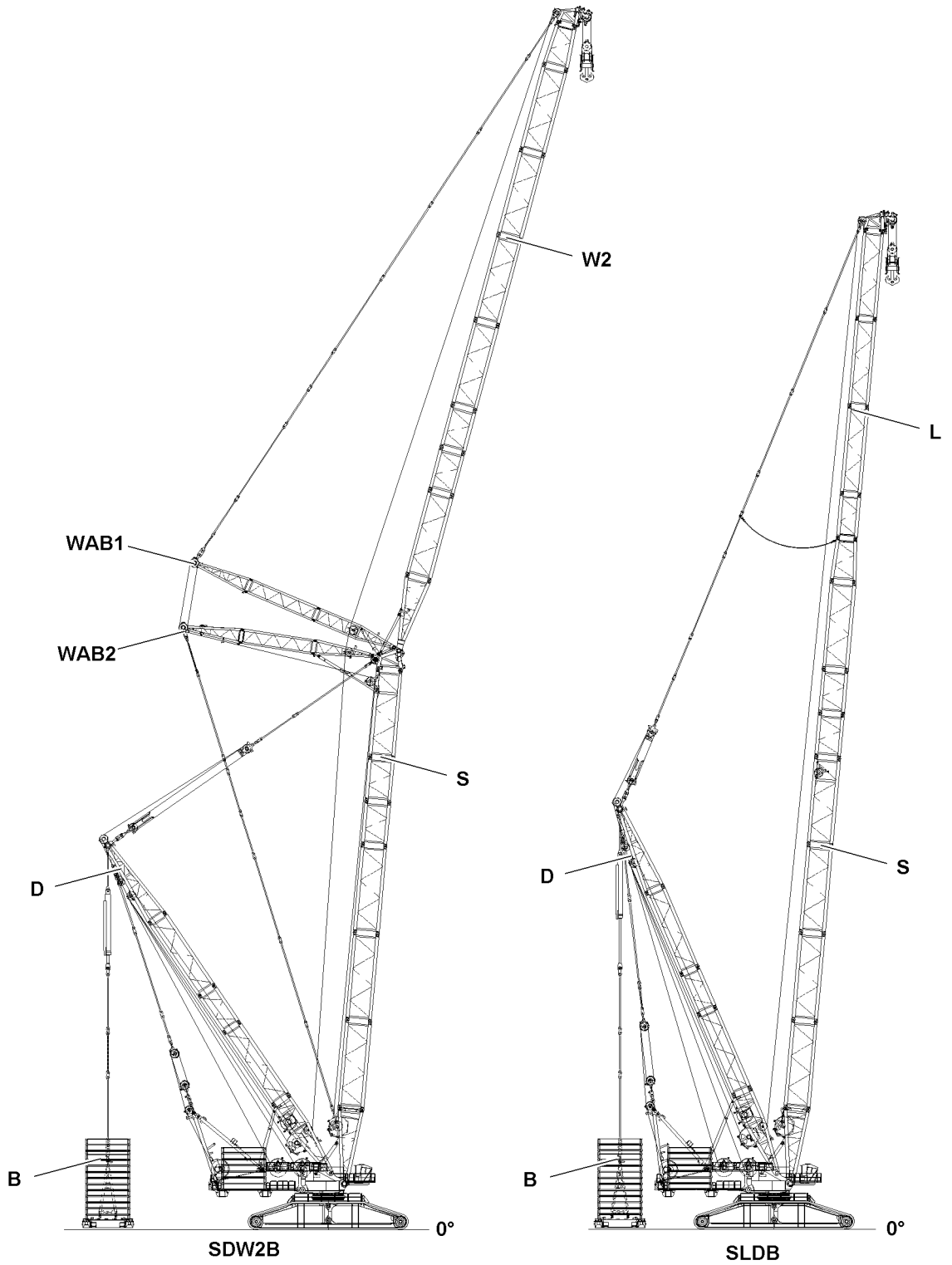

Fig.115659

LWE/LR 13000-001/19503-01-02/en

**WARNING**

The crane can topple over!

- ▶ Make sure that all boom systems are installed only according to the respective assembly chapters and the associated rod plans.
- ▶ Make sure that danger notes for assembly and for crane operation are observed and adhered to.
- ▶ The use of the following boom illustrations for assembly purposes is prohibited.

S Main boom

- Heavy-duty version
- With roller set / roller sets on the S-end section

SL Main boom

- Heavy-duty version, supplemented on top with light lattice sections **L**
- With roller set / roller sets on the L-end section

W2 Luffing lattice jib

- Lift the lattice jib with the S-lattice sections on the S-main boom.

D Derrick boom

- Derrick-boom length 54 m
- Alone as an assembly device or in connection with **SD/SLD**

B Derrick ballast

- Suspended ballast

WAB1 WA-frame 1

WAB2 WA-frame 2

2.4 PDW3B/PDB- boom

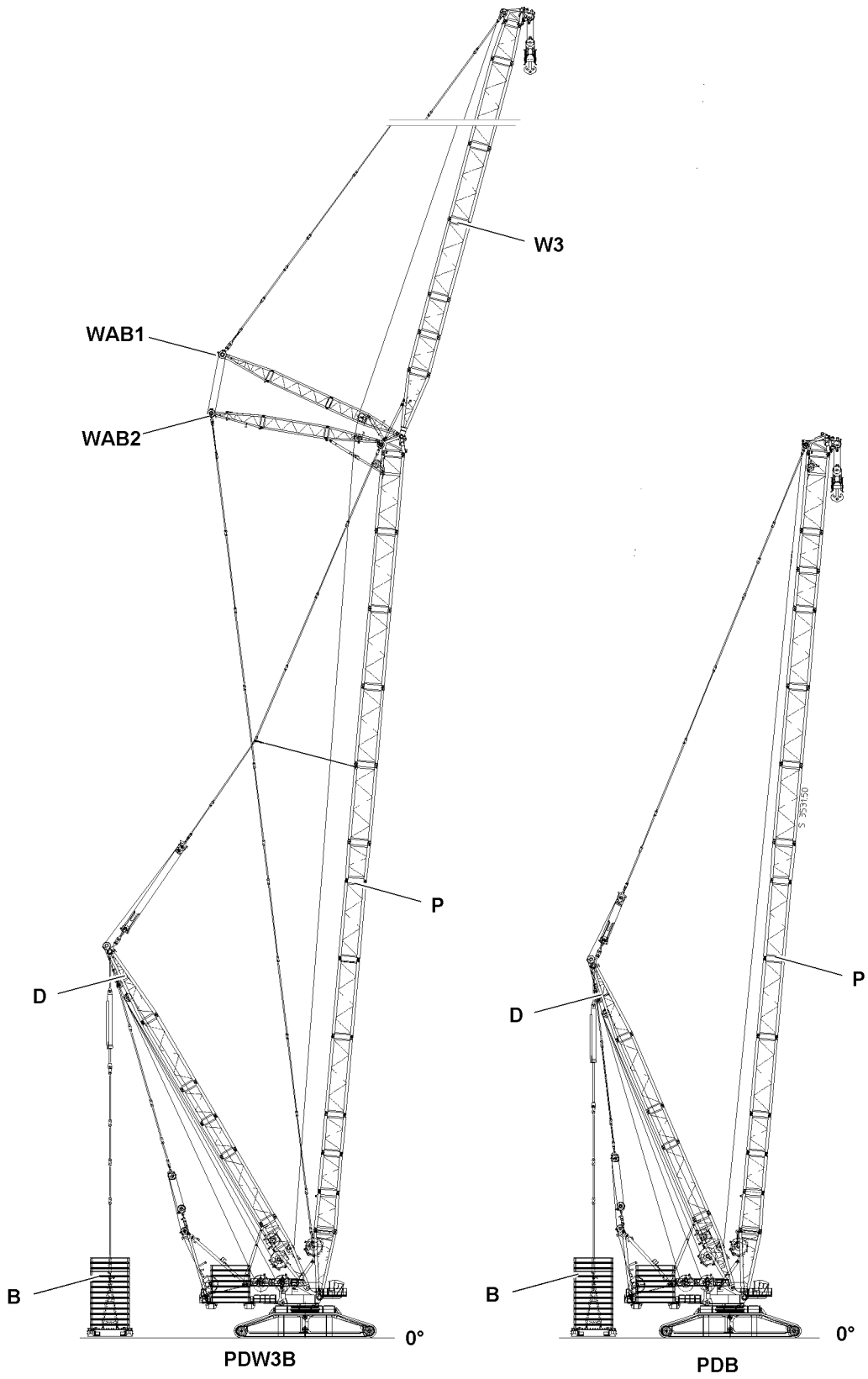

Fig.115660

LWE/LR 13000-001/19503-01-02/en

**WARNING**

The crane can topple over!

- ▶ Make sure that all boom systems are installed only according to the respective assembly chapters and the associated rod plans.
- ▶ Make sure that danger notes for assembly and for crane operation are observed and adhered to.
- ▶ The use of the following boom illustrations for assembly purposes is prohibited.

P Main boom

- Heavy-duty version, double
- With roller set / roller sets on the S-end section

W3 Luffing lattice jib

- Lift the lattice jib with the S-lattice sections on the P-main boom.

D Derrick boom

- Derrick boom length 54 m or 60 m
- Alone as an assembly device or in connection with **PD**

B Derrick ballast

- Suspended ballast

WAB1 WA-frame 1

WAB2 WA-frame 2

2.5 SDWVB– boom

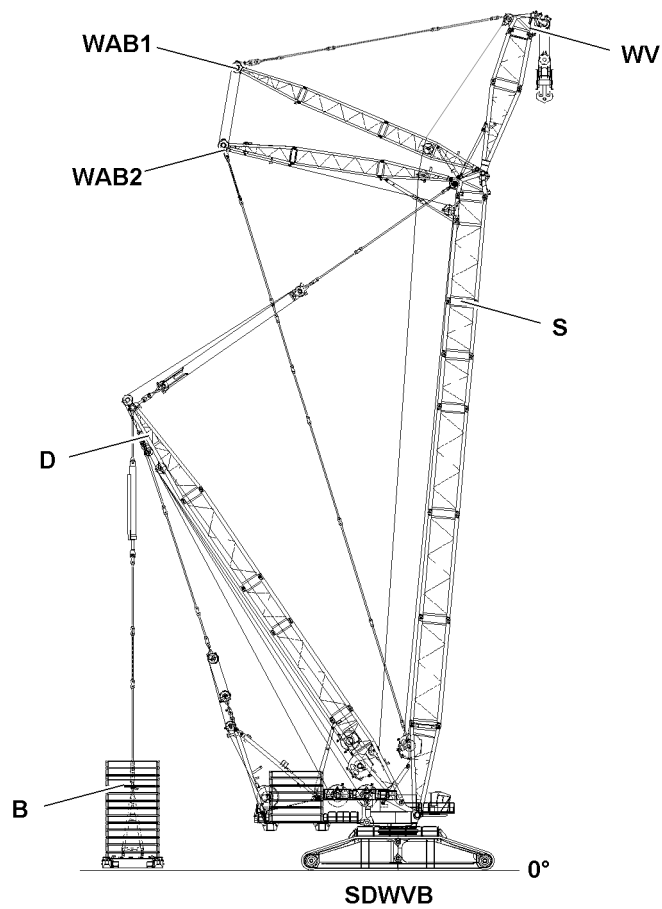

Fig.164547

LWE/LR 13000-001/19503-01-02/en

**WARNING**

The crane can topple over!

- ▶ Make sure that all boom systems are installed only according to the respective assembly chapters and the associated rod plans.
- ▶ Make sure that danger notes for assembly and for crane operation are observed and adhered to.
- ▶ The use of the following boom illustrations for assembly purposes is prohibited.

S Main boom

- Heavy-duty version

D Derrick boom

- Derrick-boom length 54 m
- Alone as an assembly device or in connection with **SD**

WV Luffing lattice jib

- Lift the lattice jib with the S-lattice sections on the S-main boom, at a fixed angle to the main boom.

B Derrick ballast

- Suspended ballast

Empty page!

LWE/LR 13000-001/19503-01-02/en

1.02 Product description

1	Crawler travel gear	2
2	Crane superstructure	2
3	Winches	4
4	Boom systems / boom combinations	5
5	Auxiliary equipment	5

1 Crawler travel gear

1.1 Frame

- In-house manufactured, distortion-resistant welded structure made from high-strength, close-grained structural steel

1.2 Crawler travel gear

- Dirt protected crawler travel gear with flat outrigger pads
- Pad width: 2.4 m
- Track width: 14.0 m

1.3 Drive

- Hydraulic travel drives with planetary gears
- The crawler chains can be controlled independently and in the opposite direction

1.4 Travel power

- Stepless speed

1.5 Central ballast

- 4 central ballast brackets each 0.75 t
- 6 central ballast plates each 25.0 t
- Total central ballast 153.0 t

2 Crane superstructure

2.1 Turntable frame

- In-house manufactured, distortion-resistant welded structure made from high-strength, close-grained structural steel
- Connection to crawler travel gear via roller ring connection
- Turntable frame swingable by 360°

2.2 Engine

Diesel engine D 9508 A7 is installed for this crane.

8-cylinder diesel, manufactured by Liebherr, water cooled.

The devices can be equipped with different exhaust aftertreatment systems.

Refer to the diesel engine operating instructions to see which engine exhaust aftertreatment system is installed in your crane.

2.2.1 Engine type D 9508 A7-05

Engine exhaust emissions Stage V according to Regulation (EU) 2016/1628 and engine exhaust emissions Tier 4 according to EPA CARB

Power: 505 KW at 1900 rpm
Maximum torque: 3075 Nm at 1350 rpm

2.2.2 Engine type D 9508 A7-05

Engine exhaust emissions Stage V according to Regulation (EU) 2016/1628

Power: 505 KW at 1900 rpm
Maximum torque: 3075 Nm at 1350 rpm

2.2.3 Engine type D 9508 A7-04

Engine exhaust emissions Tier 4 according to ECE-R.96 performance range Q (previously Stage IV according to Directive 97/68/EC)

Power: 505 KW at 1900 rpm
Maximum torque: 3075 Nm at 1350 rpm

2.2.4 Engine type D 9508 A7-03

Engine exhaust emissions according to ECE-R.96 H

Power: 505 KW at 1900 rpm
Maximum torque: 3075 Nm at 1350 rpm

2.3 Crane cab

- Air conditioned crane cab, tiltable to the rear with safety glass
- Roof window with bullet-proof pane
- Standardized control units ergonomically located
- Thermostatically regulated warm water auxiliary heater

2.4 Crane control

- All crane movements are controlled by three 4-way master switches as well as two 2-way hand / foot levers
- All working movements can be actuated independently from each other

2.5 Assembly winch

- To reeve the ropes in

2.6 Slewing gear

- 6 slewing gears: hydraulically driven via axial piston adjusting pumps and integrated planetary gear
- Spring loaded and hydraulically vented multiple disk brakes
- Slewing speed can be steplessly regulated

2.7 Counterweight

- 2 counterweight consoles each 25.0 t
- 28 counterweight plates each 25.0 t
- Total counterweight 750.0 t

2.8 Safety equipment

- Hoist limit switch for hoist limitation
- Rope drum limit switch with 3 safety coils
- Safety valves against hose and pipe bursts
- Wind warning system
- Electronic incline display
- Airplane warning light

2.9 Electrical system

- Modern data bus technology
- 24 V DC
- 12 batteries, each 12 V / 70 Ah

3 Winches

- Winches hydraulically driven via axial piston variable displacement pumps and integrated planetary gear
- Spring loaded and hydraulically vented multiple disk brakes

3.1 Winch 1

- Hoist winch

3.2 Winch 2

- Hoist winch

3.3 Winch 3

- Control winch for main boom for derrick operation

3.4 Winch 4

- Intake gear

3.5 Winch 5

- Adjustment luffing lattice jib

3.6 Winch 6

- Auxiliary hoist winch (boom nose)

4 Boom systems / boom combinations

4.1 Boom systems

**Note**

- ▶ See the Crane operating instructions, chapter 1.01.

5 Auxiliary equipment

5.1 Hydraulic assembly support

- Lifting of basic machine for assembly / removal
- Consisting of 4 support cylinders, including support plates

5.2 Pin pulling device

- Including mobile hydraulic aggregate
- For assembly / disassembly of the boom intermediate sections

Empty page!

LWE/LR 13000-001/19503-01-02/en

1.03 Technical data

1	Dimensions and weights	3
2	Load handling equipment	33
3	Crane surface pressure	33
4	Noise emission	33
5	Vibrations	34
6	Crane speeds	34
7	Ropes	34

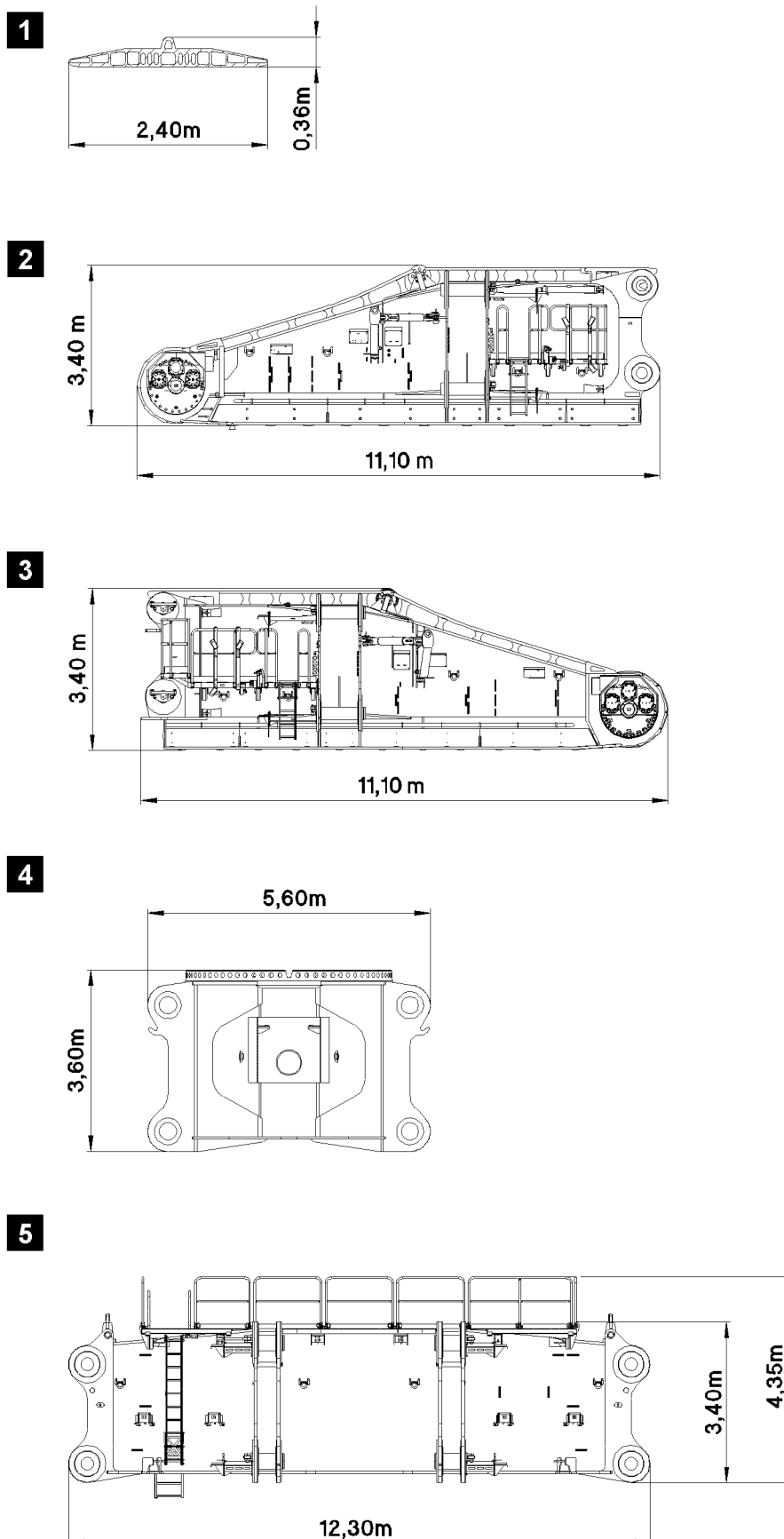

Fig.113009

LWE/LR 13000-001/19503-01-02/en

1 Dimensions and weights

1.1 Dimensions and weights crawler crane chassis

1.1.1 Crawler chain

See illustration 1

Component	Weight	Width
Individual outrigger pad	1.0 t	0.7 m

Component	Weight	Outrigger pad width
Track chain for a crawler carrier	86.0 t	2.4 m
4 belts (2 x 20 pieces and 2 x 21 pieces)		
Belt with 20 pieces (11.4 m long)	21.0 t	2.4 m
Belt with 21 pieces (12.0 m long)	22.0 t	2.4 m

1.1.2 Crawler carrier halves, front

See illustration 2

Component	Weight	Width
Crawler carrier half, left front, fastening brackets folded out	64.0 t	3.3 m
Crawler carrier half, left front, fastening brackets folded in	64.0 t	2.9 m
Crawler carrier half, right front, fastening brackets folded out	64.0 t	3.3 m
Crawler carrier half, right front, fastening brackets folded in	64.0 t	2.9 m

1.1.3 Crawler carrier halves, rear

See illustration 3

Component	Weight	Width
Crawler carrier half, left rear, fastening brackets folded out	63.0 t	3.3 m
Crawler carrier half, left rear, fastening brackets folded in	63.0 t	2.9 m
Crawler carrier half, right rear, fastening brackets folded out	63.0 t	3.3 m
Crawler carrier half, right rear, fastening brackets folded in	63.0 t	2.9 m

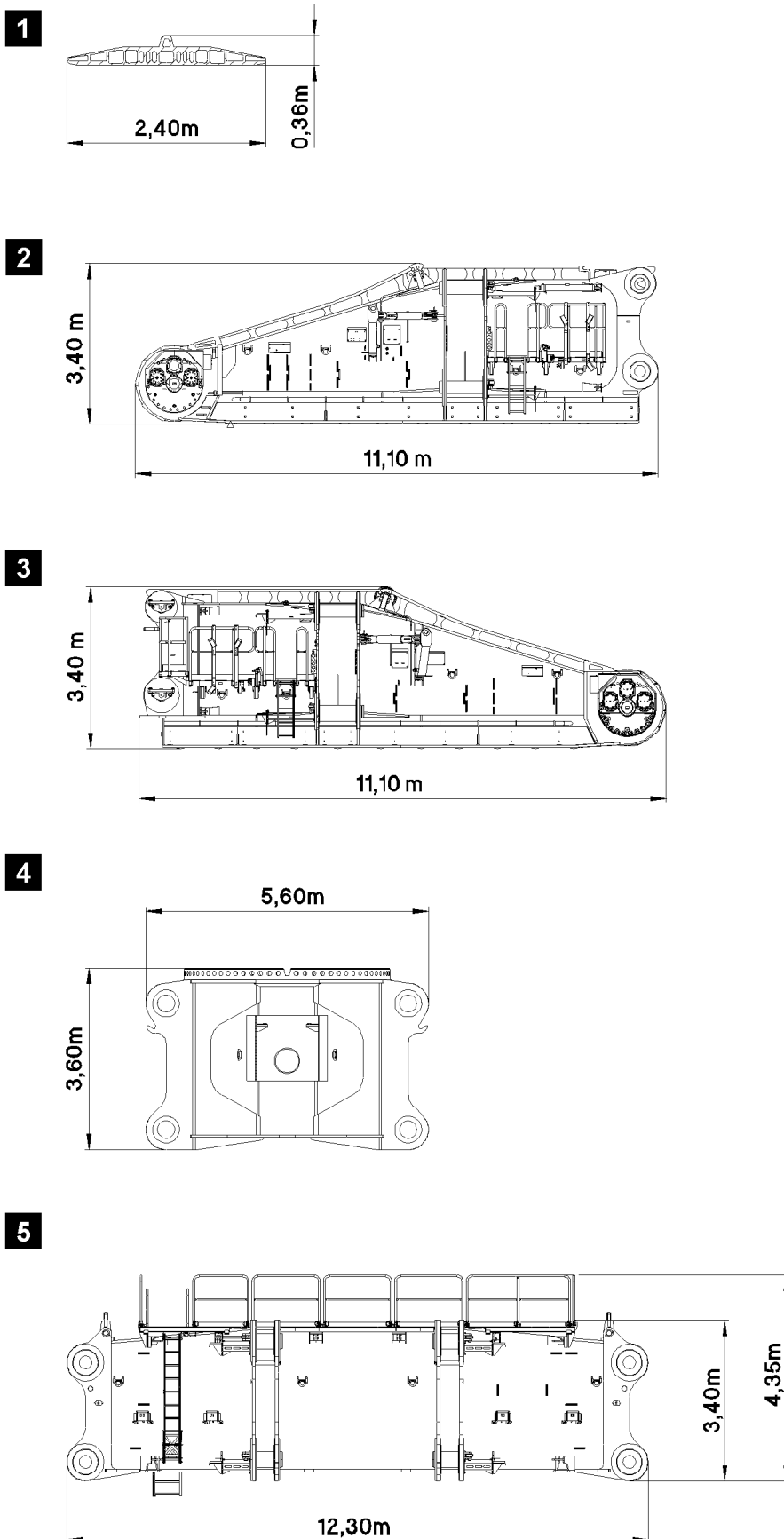

Fig.113009

LWE/LR 13000-001/19503-01-02/en

1.1.4 Crawler carrier halves installed

Component	Weight	Width
Crawler carrier without outrigger pads, fastening brackets folded out	127.0 t	3.3 m
Crawler carrier without outrigger pads, fastening brackets folded in	127.0 t	2.9 m

1.1.5 Complete crawler carrier

Component	Weight	Width
Crawler carrier complete, fastening brackets folded out	213.0 t	3.3 m
Crawler carrier complete, fastening brackets folded in	213.0 t	2.9 m

1.1.6 Crawler center section

See illustration 4

Component	Weight	Width
Crawler center section	58.0 t	4.3 m

1.1.7 Cross carrier, front

See illustration 5

Component	Weight	Width
Cross carrier front with assembly support, access ladder and railing in the transport position	58.0 t	3.4 m

1.1.8 Cross carrier, rear

See illustration 5

Component	Weight	Width
Cross carrier rear with assembly support, access ladder and railing in the transport position	58.0 t	3.4 m

6**7****8****9**

Fig.164524

1.1.9 Roller ring connection with quick connection (QC)

See illustration 6

Component	Weight	Height
Roller ring connection with QC and six slewing gears	35.0 t	1.9 m

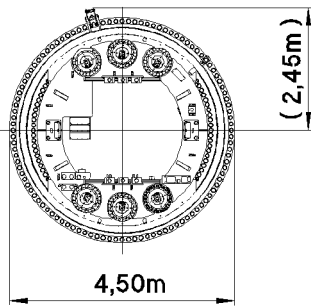
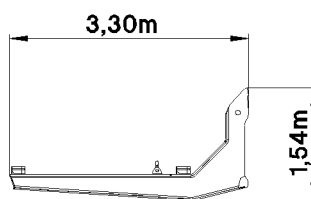
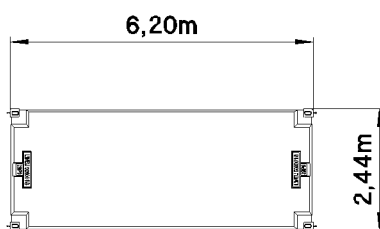
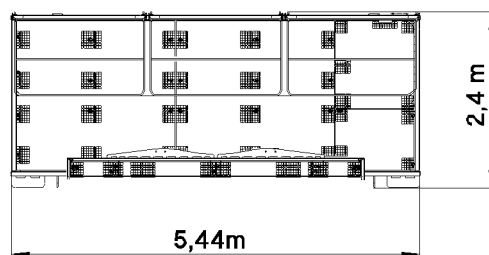
1.1.10 Carrier central ballast

See illustration 7

Component	Weight	Width
Carrier	0.7 t	0.3 m

1.1.11 Central ballast plate



Note

- For each of the central ballast, turntable counterweight and derrick ballast the same 25 t ballast plates are used.

See illustration 8

Component	Weight	Height
Ballast plate	25.0 t	0.8 m

1.1.12 Catwalk crawler travel gear

See illustration 9

Component	Weight	Height
Catwalk crawler travel gear, railing in the transport position	0.9 t	0.4 m

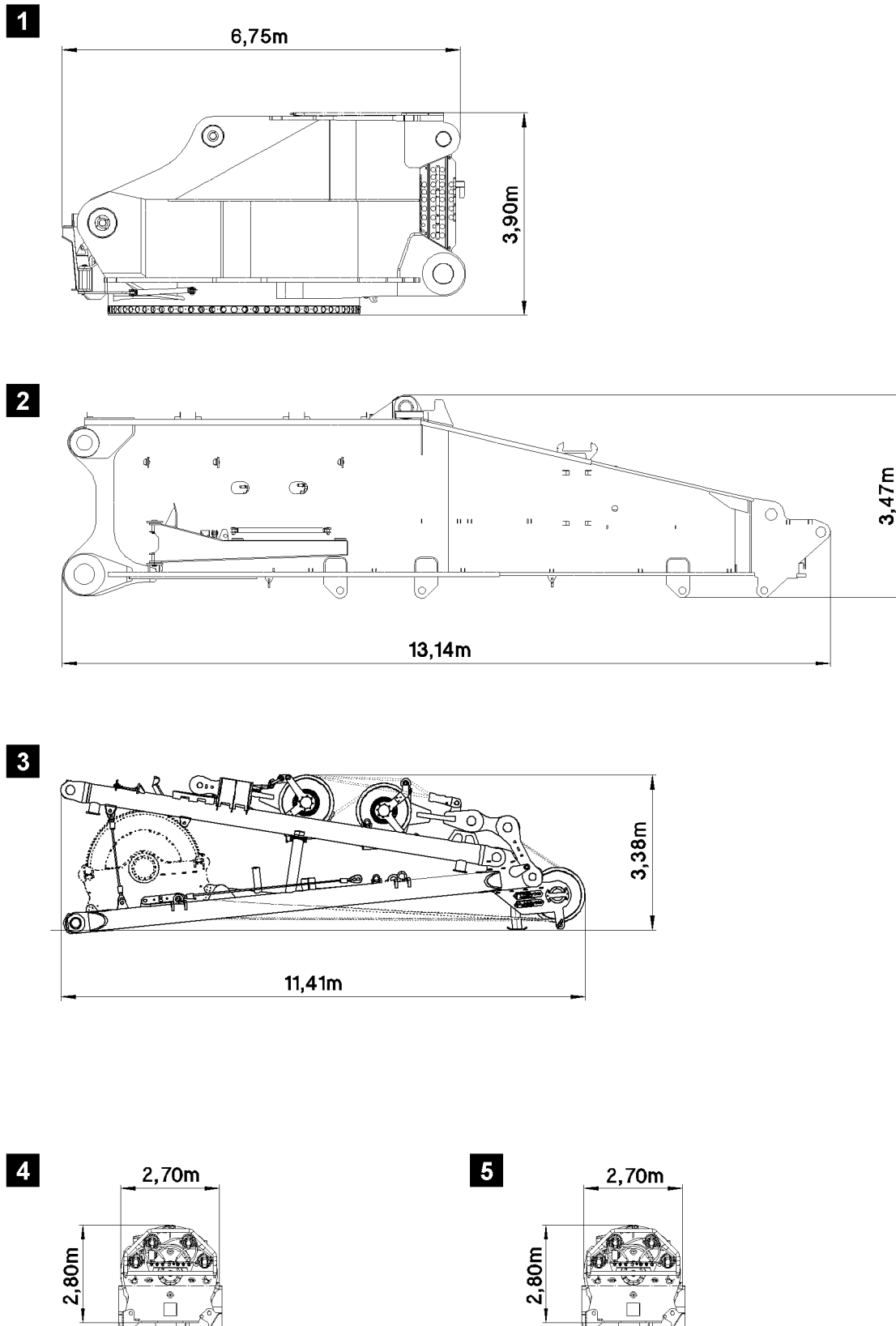

Fig.164525

1.2 Turntable dimensions and weights

1.2.1 Turntable frame front

See illustration 1

Component	Weight	Width
Turntable frame front	68.0 t	4.4 m

1.2.2 Turntable frame rear

See illustration 2

Component	Weight	Width
Turntable frame rear	55.0 t	4.0 m

1.2.3 A-frame

See illustration 3

Component	Weight	Width
A-frame complete with winch 4	70.0 t	3.9 m
A-frame with winch 4, without support	60.0 t	3.9 m

1.2.4 Winch 1

See illustration 4

Component	Weight	Width
Winch 1 with rope	53.0 t	4.11 m

1.2.5 Winch 2

See illustration 5

Component	Weight	Width
Winch 2 with rope	53.0 t	4.11 m

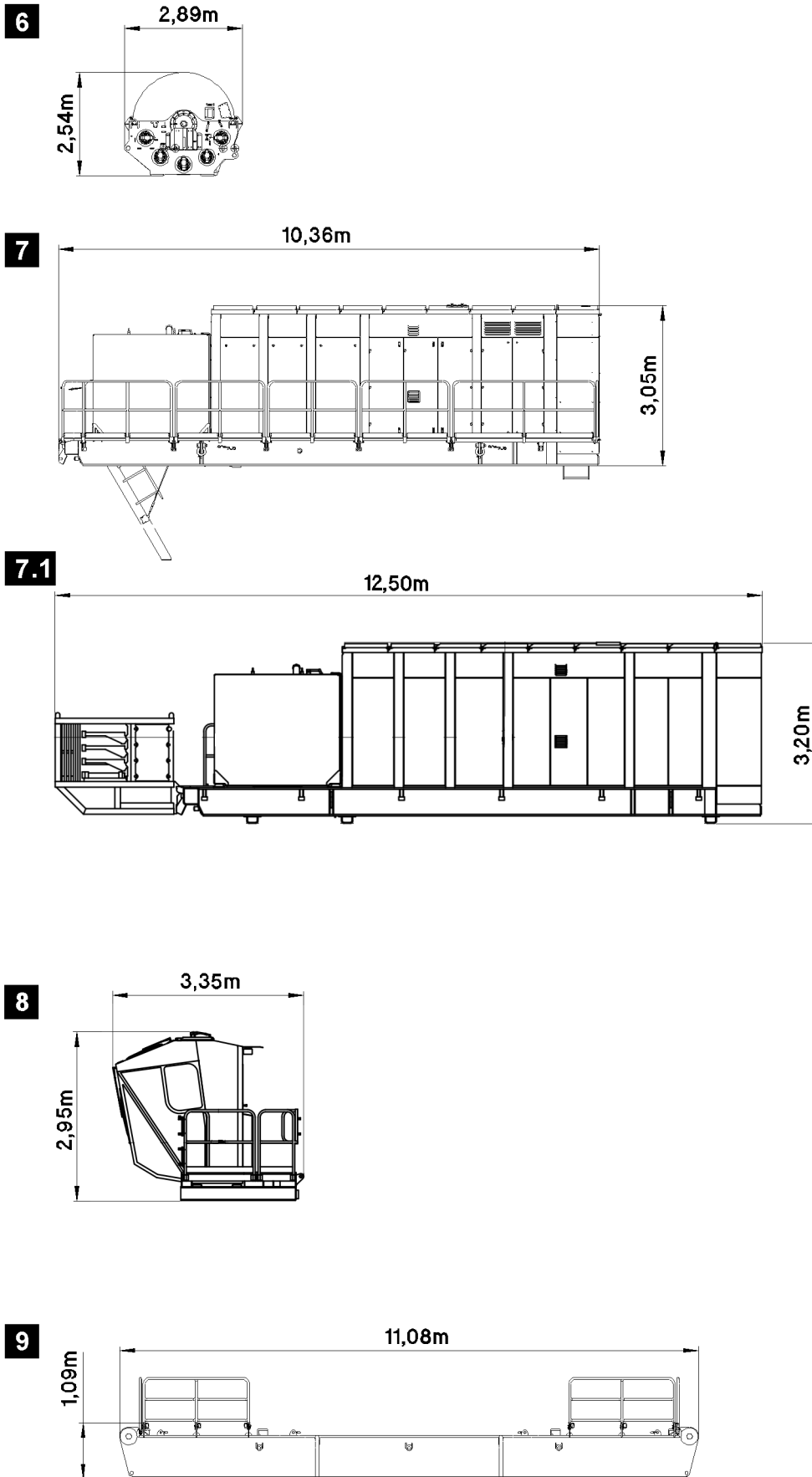

Fig.164526

LWE/LR 13000-001/19503-01-02/en

1.2.6 Assembly winch

See illustration 6

Component	Weight	Width
Assembly winch with rope	0.3 t	4.3 m

1.2.7 Engine house

See illustration 7

Component	Weight	Width
Machine house with catwalk	31.5 t	3.8 t

1.2.8 Engine house

See illustration 7.1

Component	Weight	Width
Engine house with catwalk and platform	33.0 t	3.8 t

1.2.9 Crane cab

See illustration 8

Component	Weight	Width
Crane cab	2.9 t	3.0 m

1.2.10 Counterweight frame

See illustration 9

Component	Weight	Width
Counterweight frame	25.0 t	1.7 m

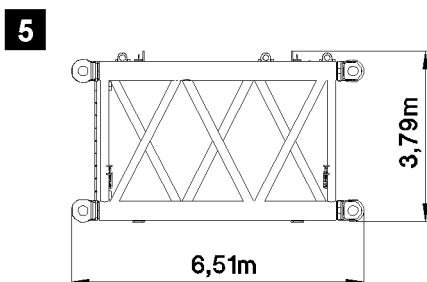
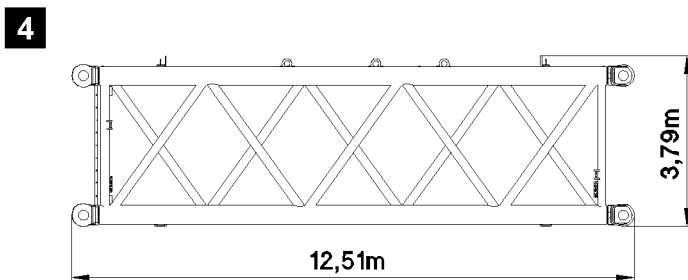
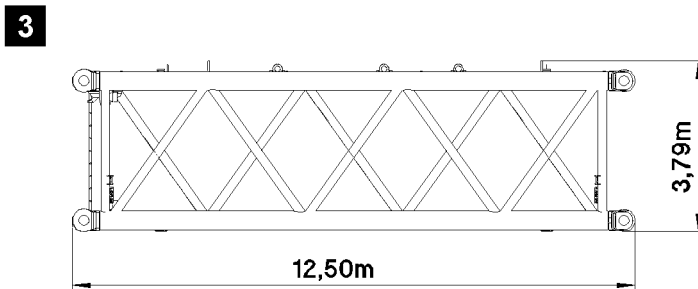
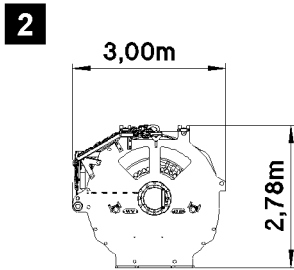
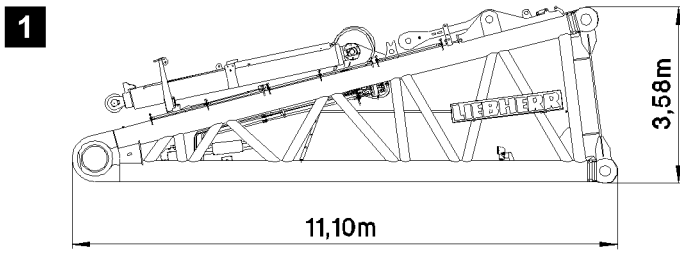

Fig.113013

LWE/LR 13000-001/19503-01-02/en

1.3 Boom system dimensions and weights

1.3.1 S-pivot section 10.25 m

See illustration 1

Component	Weight	Width
S-pivot section with WA-frame I relapse retainer and rods	49.0 t	4.0 m

1.3.2 Winch 5

See illustration 2

Component	Weight	Width
Winch 5 including rope	42.5 t	3.4 m

1.3.3 S-intermediate section 12.0 m

System dimension: 3531.50

See illustration 3

Component	Weight	Width
S-intermediate section 3531.50	32.9 t	4.0 m

1.3.4 S-intermediate section 12.0 m

System dimension: 3531.45

See illustration 4

Component	Weight	Width
S-intermediate section 3531.45	30.4 t	4.0 m

1.3.5 S-intermediate section 6.0 m

System dimension: 3531.36

See illustration 5

Component	Weight	Width
S-intermediate section 3531.36	16.0 t	4.0 m

6

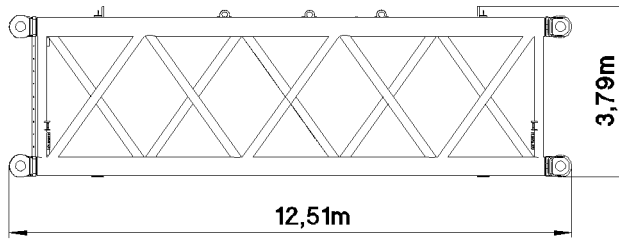

7

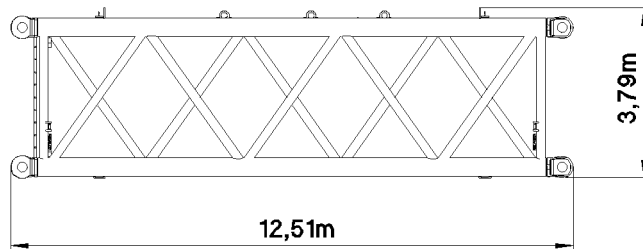

8

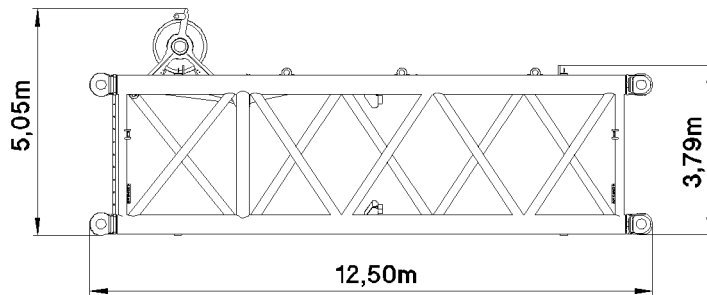

9

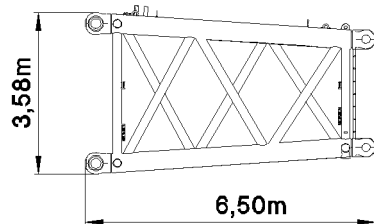

10

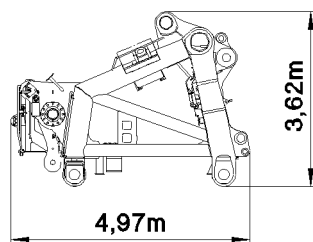

11

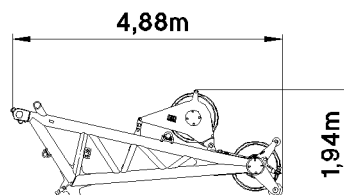

Fig.113014

LWE/LR 13000-001/19503-01-02/en

1.3.6 S-intermediate section 12.0 m

System dimension: 3531.36

See illustration 6

Component	Weight	Width
S-intermediate section 3531.36	26.1 t	4.0 m

1.3.7 S-intermediate section 12.0 m

System dimension: 3531.25

See illustration 7

Component	Weight	Width
S-intermediate section 3531.25	21.8 t	4.0 m

1.3.8 S-adapter 12.0 m

System dimension: 3531.45

See illustration 8

Component	Weight	Width
S-adapter	30.9 t	4.0 m

1.3.9 SL-reducer 6.0 m

See illustration 9

Component	Weight	Width
SL-reducer	15.1 t	4.0 m

1.3.10 S-end section

See illustration 10

Component	Weight	Width
S-end section	27.2 t	3.9 m

1.3.11 Boom nose

See illustration 11

Component	Weight	Width
Boom nose	3.3 t	1.4 m

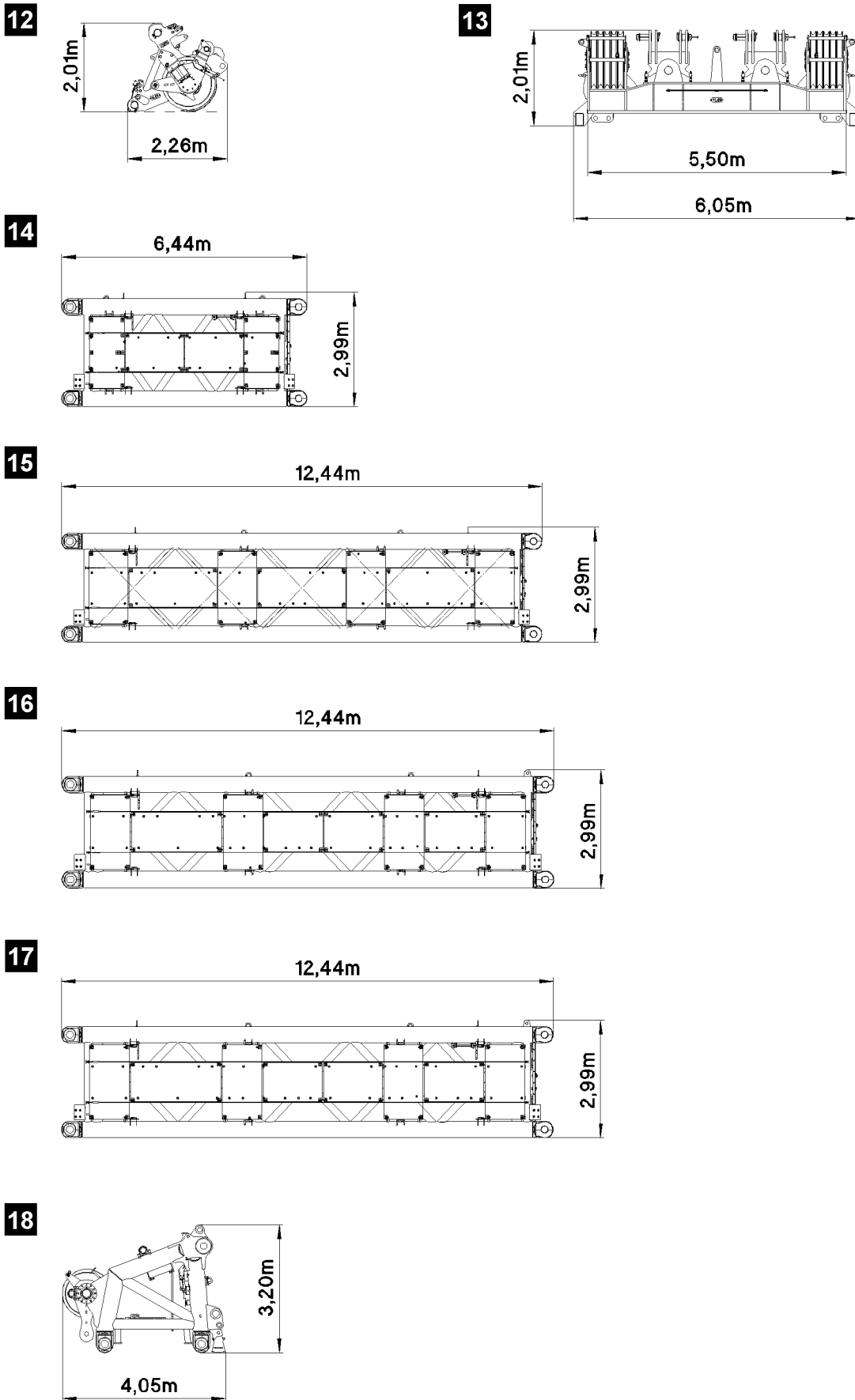

Fig.113015

LWE/LR 13000-001/19503-01-02/en

1.3.12 Roller set

See illustration 12

Component	Weight	Width
Left roller set	9.6 t	2.3 m
Right roller set	9.6 t	2.3 m

1.3.13 Heavy load system for the roller set

See illustration 13

Component	Weight	Width
Heavy load system for the roller set	11.4 t	6.1 m

1.3.14 LI-intermediate section 6.0 m

System dimension: 2824.36

See illustration 14

Component	Weight	Width
LI-intermediate section 2824.36	13.1 t	3.3 m

1.3.15 LI-intermediate section 12.0 m

System dimension: 2824.36

See illustration 15

Component	Weight	Width
LI-intermediate section 2824.36	23.2 t	3.3 m

1.3.16 LI-intermediate section 12.0 m

System dimension: 2824.25

See illustration 16

Component	Weight	Width
LI-intermediate section 2824.25	18.6 t	3.3 m

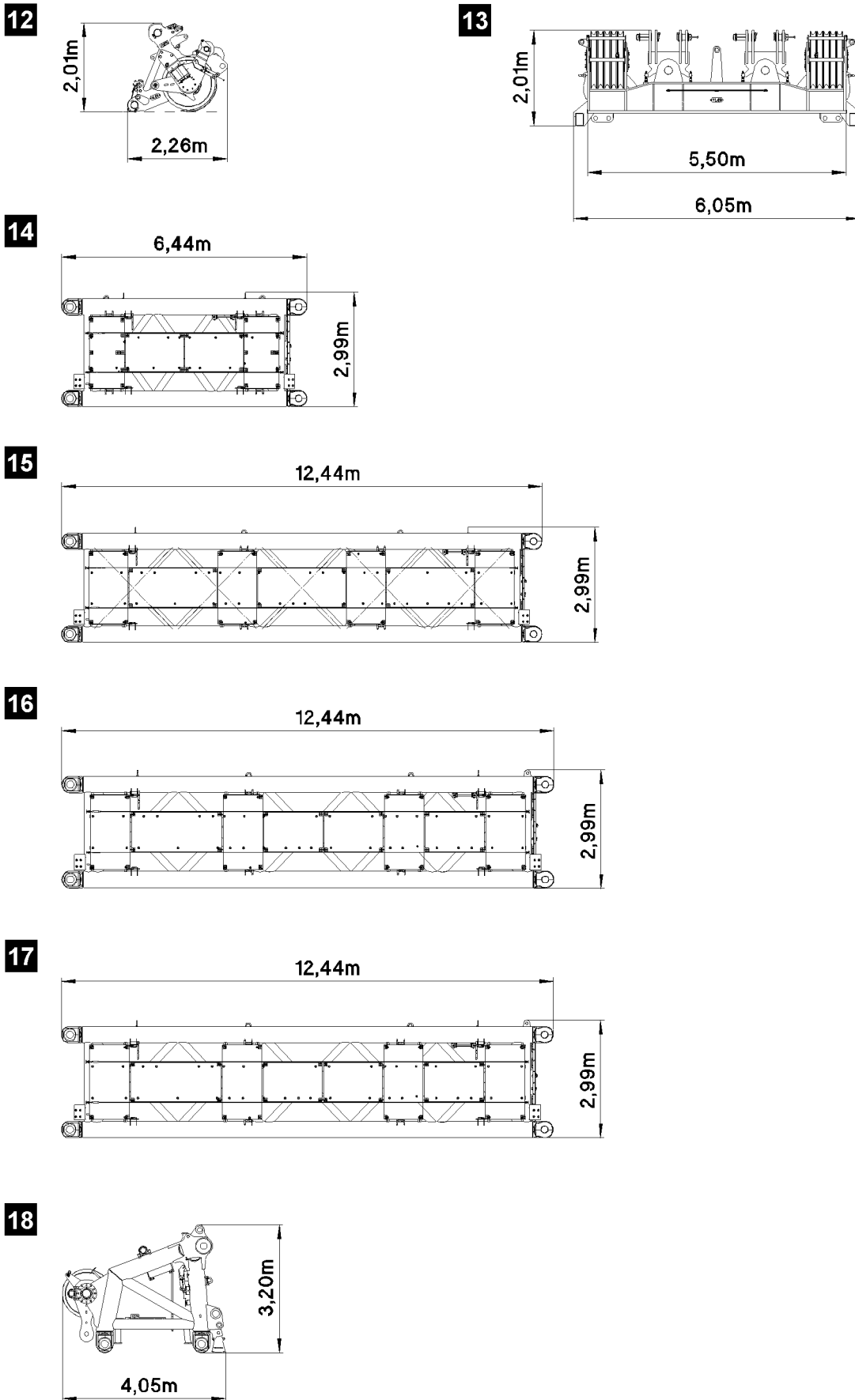

Fig.113015

LWE/LR 13000-001/19503-01-02/en

1.3.17 LI-intermediate section 12.0 m

System dimension: 2824.25 Z

See illustration 17

Component	Weight	Width
LI-intermediate section 2824.25 Z	18.9 t	3.3 m

1.3.18 L-end section

See illustration 18

Component	Weight	Width
L-end section	17.7 t	3.3 m

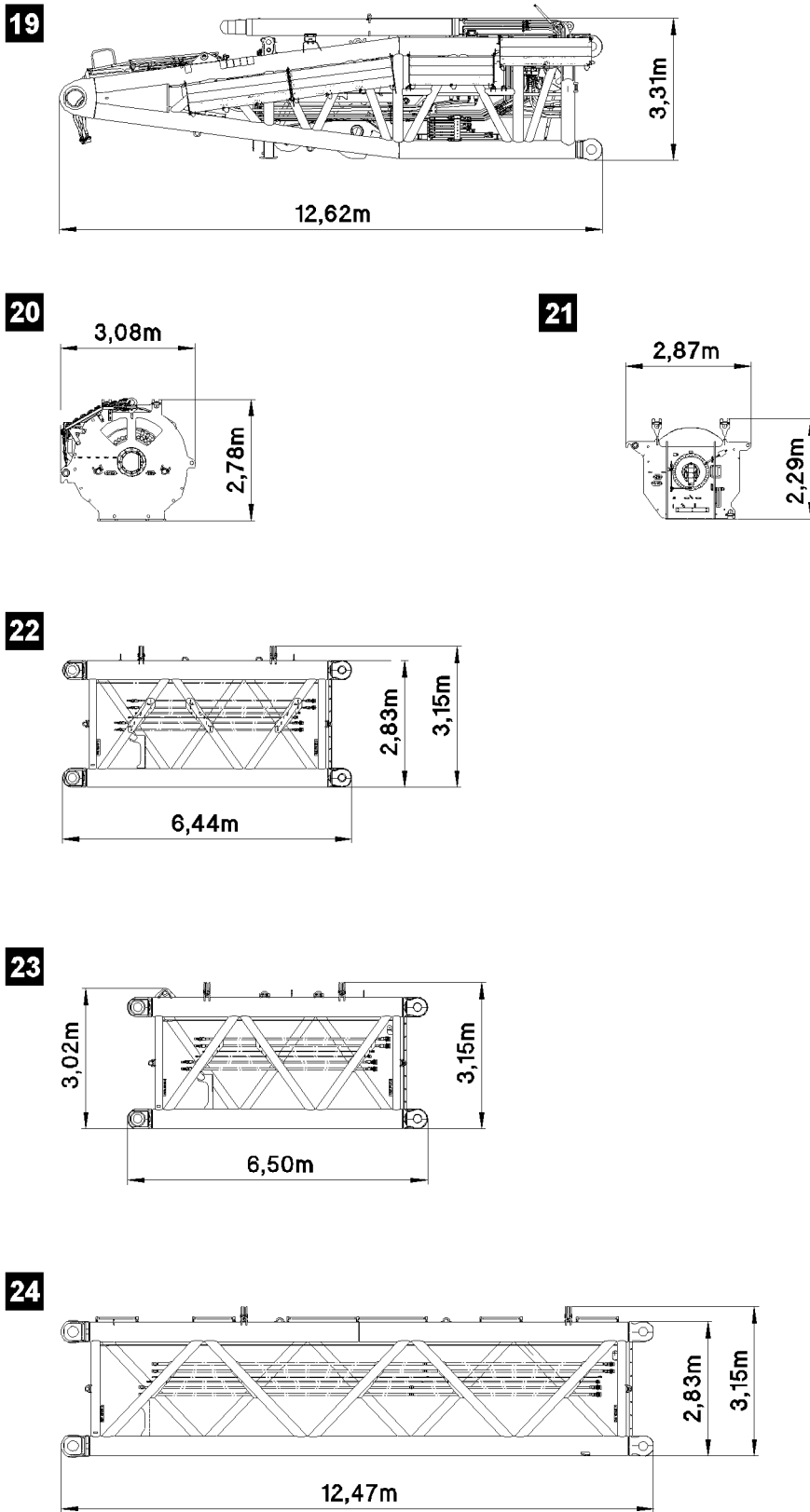

Fig.113016

LWE/LR 13000-001/19503-01-02/en

1.3.19 D-pivot section complete 12.0 m

See illustration 19

Component	Weight	Width
D-pivot section without winches, with relapse retainer	55.5 t	4.7 m

1.3.20 Winch 3

See illustration 20

Component	Weight	Width
Winch 3 including rope	59.0 t	4.3 m

1.3.21 Winch 6

See illustration 21

Component	Weight	Width
Winch 6 including rope	21.0 t	2.4 m

1.3.22 D-intermediate section 6.0 m

System dimension: 2824.36

See illustration 22

Component	Weight	Width
D-intermediate section 2824.36	13.4 t	3.5 m

1.3.23 D-intermediate section 6.0 m

System dimension: 2824.36 A

See illustration 23

Component	Weight	Width
D-intermediate section 2824.36 A	13.9 t	3.5 m

1.3.24 D-intermediate section 12.0 m

System dimension: 2824.36

See illustration 24

Component	Weight	Width
D-intermediate section 2824.36	25.0 t	3.5 m

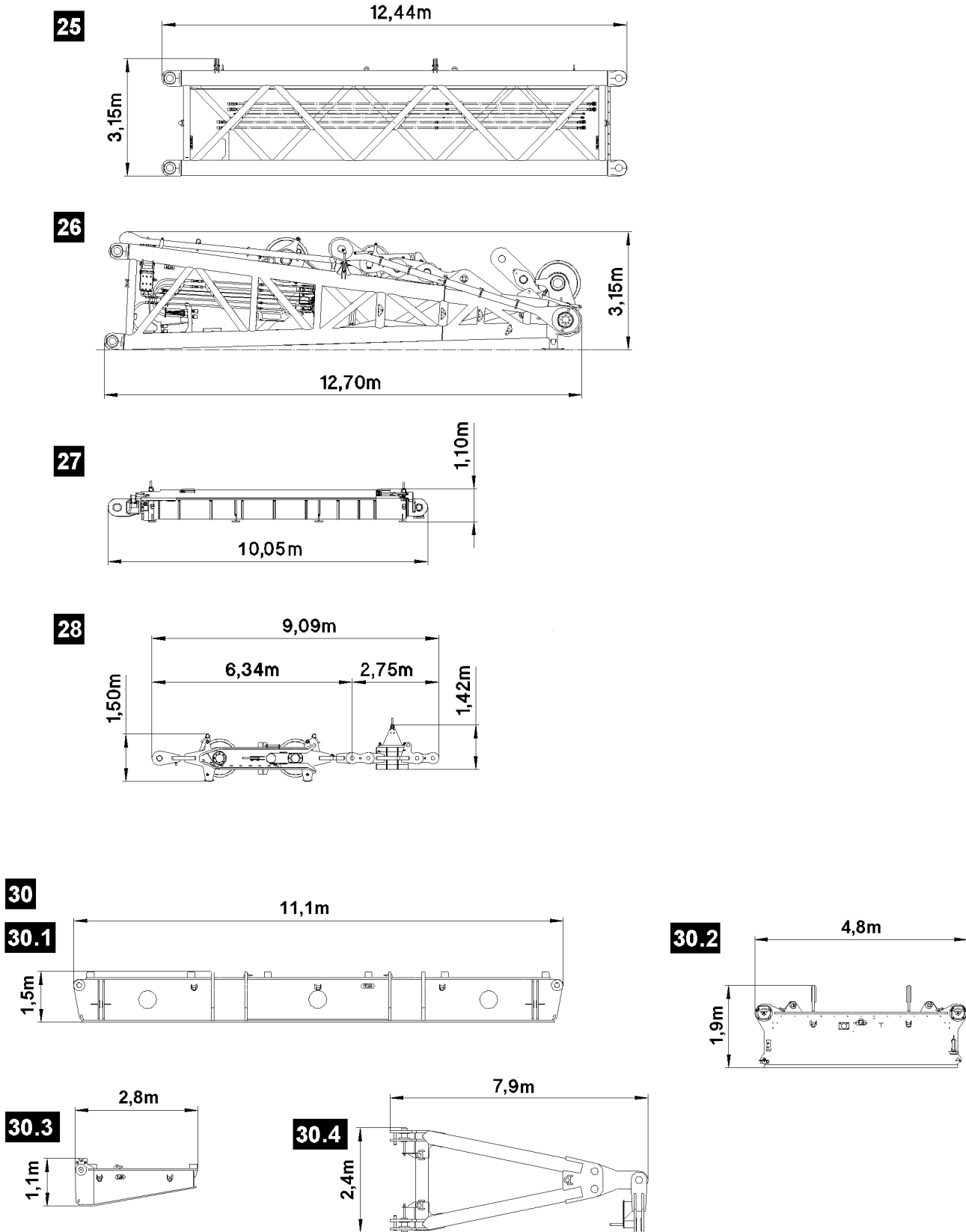

Fig.164527

LWE/LR 13000-001/19503-01-02/en

1.3.25 D-intermediate section 12.0 m

System dimension: 2824.25

See illustration 25

Component	Weight	Width
D-intermediate section 2824.25	18.8 t	3.5 m

1.3.26 D-end section 12.0 m

See illustration 26

Component	Weight	Width
D-end section without pull cylinder	45.5 t	3.4 m

1.3.27 Pull cylinder

See illustration 27

Component	Weight	Width
Pull cylinder	17.5 t	1.0 m

1.3.28 S-luffing pulley block

See illustration 28

Component	Weight	Width
S-luffing pulley block, without weight	15.9 t	2.5 m
Weight for S-luffing pulley block	14.0 t	3.9 m
S-luffing pulley block, with weight	30.0 t	3.9 m

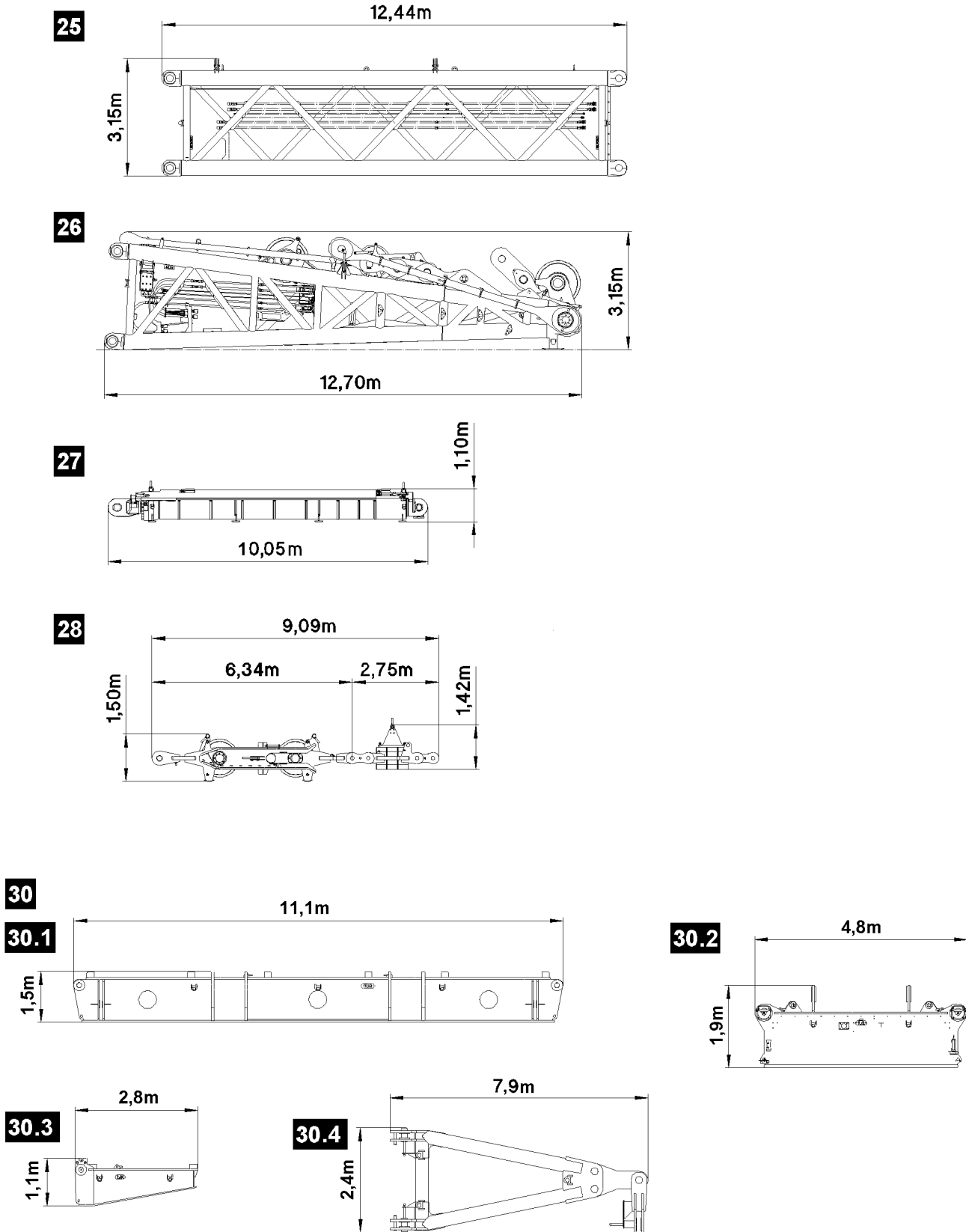

Fig.164527

LWE/LR 13000-001/19503-01-02/en

1.3.29 Suspended ballast pallet

See illustration 30

Cross carrier

See illustration 30.1

Component	Weight	Width
Cross carrier	18.0 t	1.4 m

Connector carrier

See illustration 30.2

Component	Weight	Width
Connector carrier	11.4 t	1.7 m

Bracket

See illustration 30.3

Component	Weight	Width
Bracket	2.2 t	1.3 m

Frame

See illustration 30.4

Component	Weight	Width
Frame	3.8 t	0.5 m

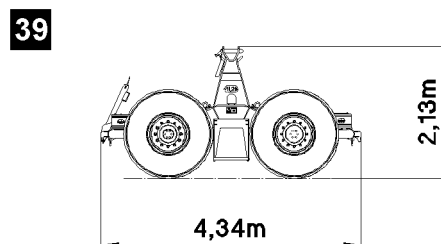
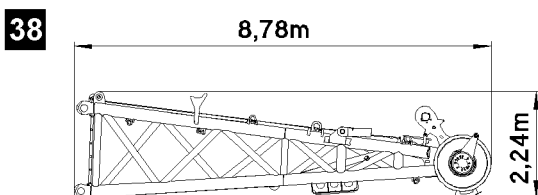
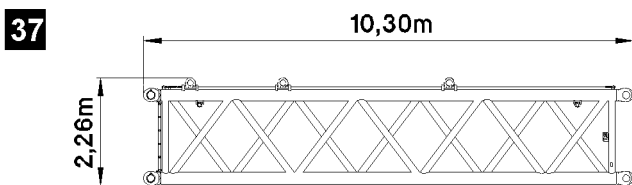
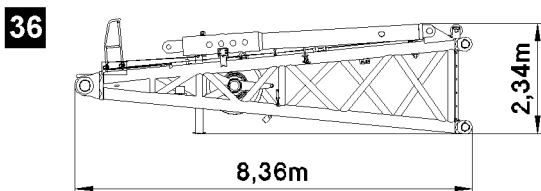
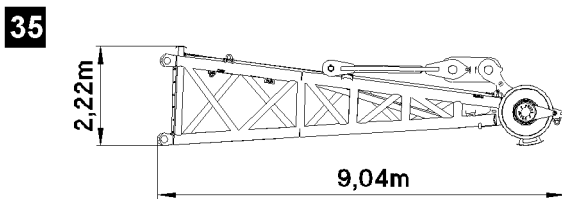
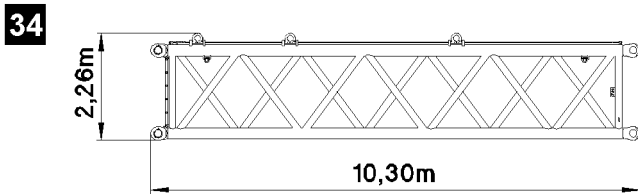
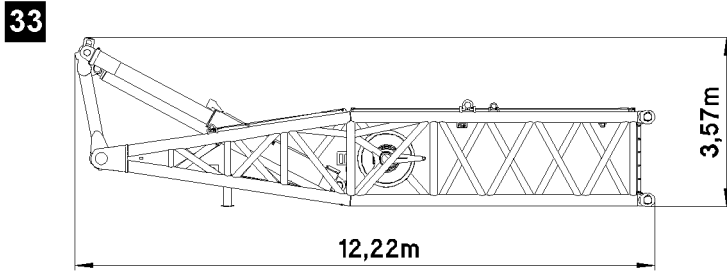
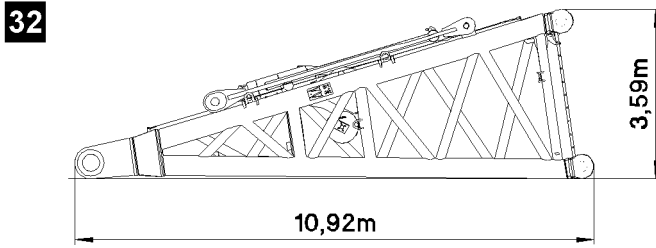

Fig.113017

LWE/LR 13000-001/19503-01-02/en

1.3.30 W-pivot section 10.25 m

See illustration 32

Component	Weight	Width
W-pivot section	34.0 t	4.1 m

1.3.31 WA-frame I pivot section

See illustration 33

Component	Weight	Width
WA-frame I pivot section	21.8 t	3.7 m

1.3.32 Intermediate section WA-frame I

See illustration 34

Component	Weight	Width
Intermediate section WA-frame I	7.9 t	3.0 m

1.3.33 WA-frame I end section

See illustration 35

Component	Weight	Width
WA-frame I end section	16.9 t	2.9 m

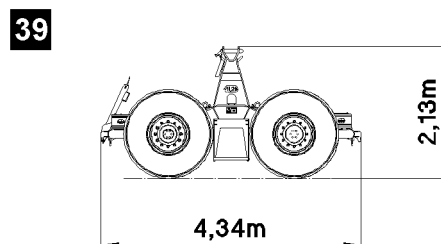
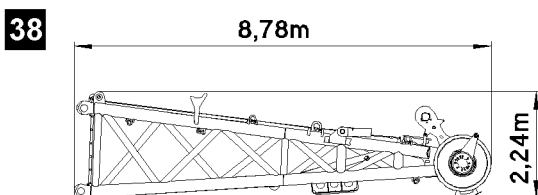
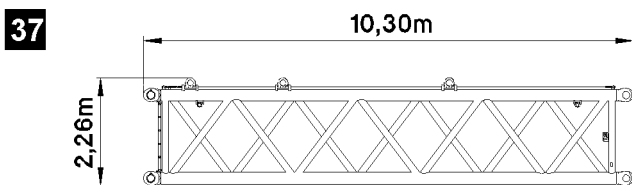
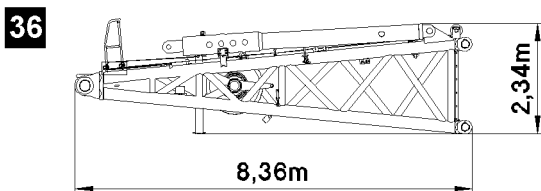
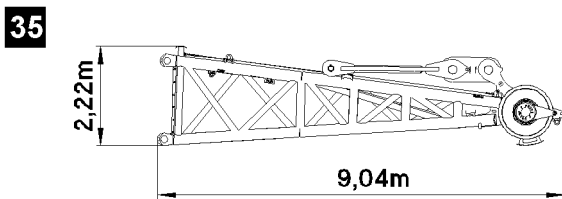
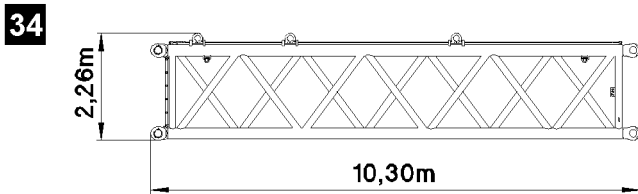
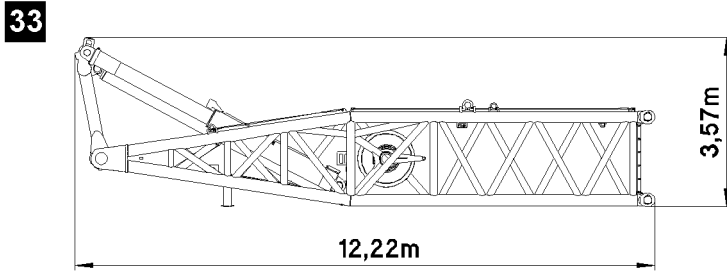
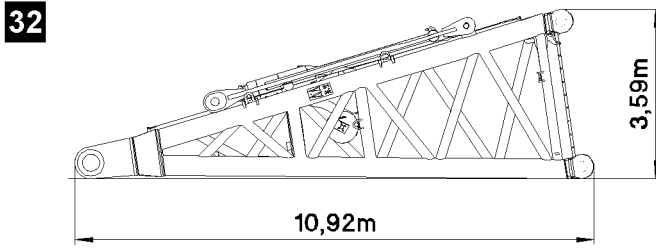

Fig.113017

LWE/LR 13000-001/19503-01-02/en

1.3.34 WA-frame II pivot section

See illustration 36

Component	Weight	Width
WA-frame II pivot section	14.2 t	3.2 m

1.3.35 Intermediate section WA-frame II

See illustration 37

Component	Weight	Width
Intermediate section WA-frame II	8.2 t	3.0 m

1.3.36 WA-frame II end section

See illustration 38

Component	Weight	Width
WA-frame II end section	14.0 t	2.9 m

1.3.37 Roller cart W

See illustration 39

Component	Weight	Width
Roller cart W	11.2 t	3.0 m

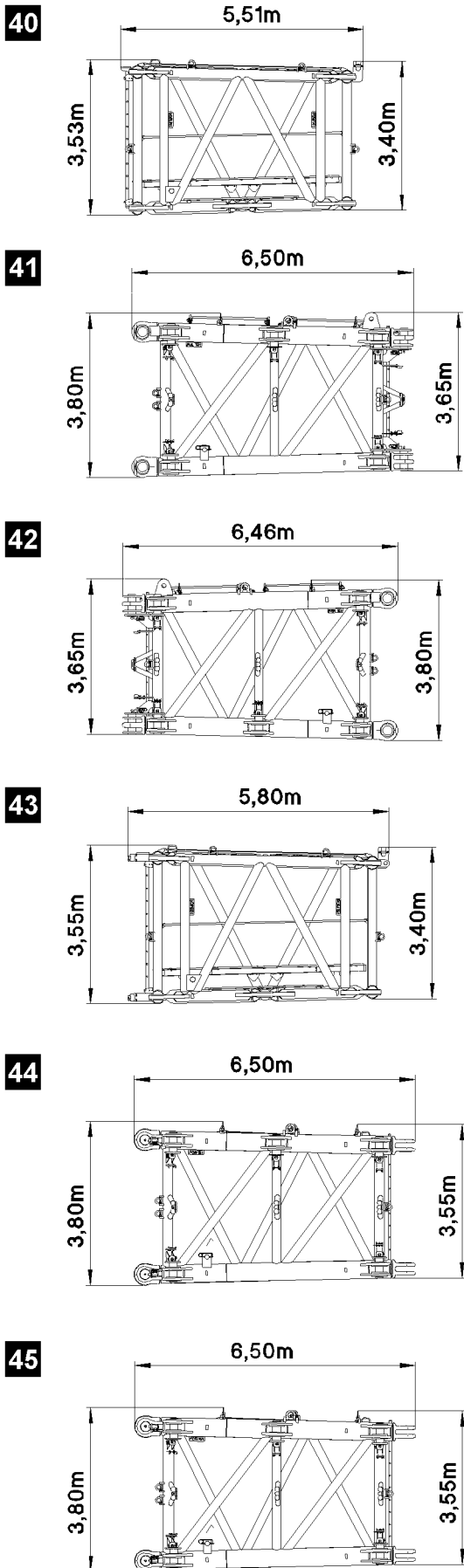

Fig.113019

LWE/LR 13000-001/19503-01-02/en

1.3.38 P-adapter bottom center

See illustration 40

Component	Weight	Width
P-adapter bottom center	14.0 t	3.1 m

1.3.39 P-adapter bottom left

See illustration 41

Component	Weight	Width
P-adapter bottom left	19.0 t	3.3 m

1.3.40 P-adapter bottom right

See illustration 42

Component	Weight	Width
P-adapter bottom right	19.0 t	3.3 m

1.3.41 P-adapter top center

See illustration 43

Component	Weight	Width
P-adapter top center	13.0 t	3.1 m

1.3.42 P-adapter top left

See illustration 44

Component	Weight	Width
P-adapter top left	18.0 t	3.3 m

1.3.43 P-adapter top right

See illustration 45

Component	Weight	Width
P-adapter top right	18.0 t	3.3 m

46

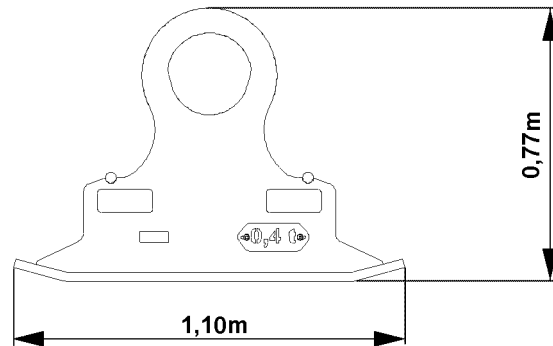

47

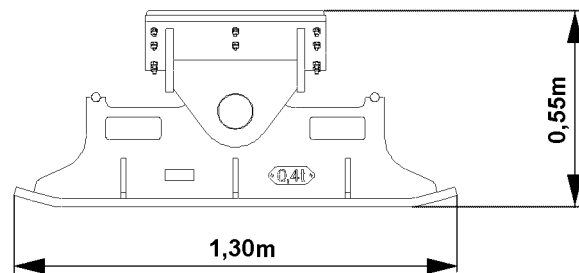

48

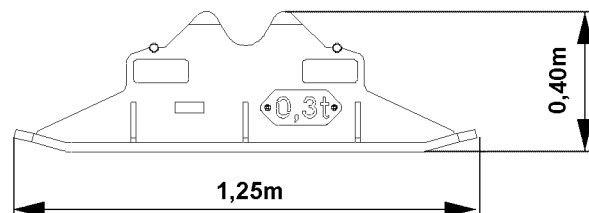

Fig.115238

1.3.44 Assembly shoe for S-pivot section

See illustration 46

Component	Weight	Width
Assembly shoe for S-pivot section	0.4 t	0.3 m

1.3.45 Assembly shoe for boom

See illustration 47

Component	Weight	Width
Assembly shoe for boom	0.4 t	0.5 m

1.3.46 Assembly shoe for the roller set, end section

See illustration 48

Component	Weight	Width
Assembly shoe for the roller set, end section	0.3 t	0.5 m

1.3.47 Rods



Note

- ▶ Use of rods, see Rod plan.
- ▶ Rod weight, see load charts.

2 Load handling equipment



Note

- ▶ For load handling equipment, see the load chart manual.

3 Crane surface pressure



Note

- ▶ Determination of the crane's surface pressure, see the LICCON job planner operating instructions.

4 Noise emission

Control platform Crane cab	
Sound pressure level $[L_{pA}]$, according to EN13000	70 db(A)

5 Vibrations

Vibrations transferred to the operator	Value
Total vibration value to which the upper body limbs are exposed	Not more than 2.5 m/s ²
Effective value of weighted acceleration to which the entire body is exposed.	Not more than 0.5 m/s ²

6 Crane speeds



Note

- The crane speeds refer to an engine rpm of 1900 rpm.

Drives	Speed
Winch 1	0 m/min to 120 m/min for a single strand
Winch 2	0 m/min to 120 m/min for a single strand
Winch 3	0 m/min to 140 m/min for a single strand
Winch 5	0 m/min to 107 m/min for a single strand
Winch 6	0 m/min to 120 m/min for a single strand
Winch 4	1 x 49 m/min for single strand

Drives	RPM
Slewing gear	0 rpm to 0.31 rpm

7 Ropes

7.1 Hoist ropes

	Rope diameter	Rope category number RCN
Winch 1	52 mm	See the rope certificate
Winch 2	52 mm	See the rope certificate
Winch 6	38 mm	See the rope certificate

7.2 Control ropes

	Rope diameter	Rope category number RCN
Winch 3	52 mm	See the rope certificate
Winch 4	52 mm	See the rope certificate
Winch 5	52 mm	See the rope certificate

7.3 Guy ropes

	Rope diameter	Rope category number RCN
Auxiliary guying	60 mm	See the rope certificate

7.4 Assembly rope

	Rope diameter	Rope category number RCN
Assembly winch	8 mm	See the rope certificate

Empty page!

LWE/LR 13000-001/19503-01-02/en

1.03.10 Outrigger pads

1	Description	2
2	Safety	2
3	Fastening the outrigger pad	5
4	Technical track pad data for cranes with a telescopic boom	8
5	Technical outrigger pad data for cranes with a lattice mast boom	23

1 Description

By using the outrigger pads, the support load is distributed over a large area of the ground. Liebherr-Werk Ehingen GmbH offers different versions of outrigger pads. The outrigger pads suitable for the respective crane type can be taken via the corresponding LWE ID number from the following table „Track pads for support load distribution“.

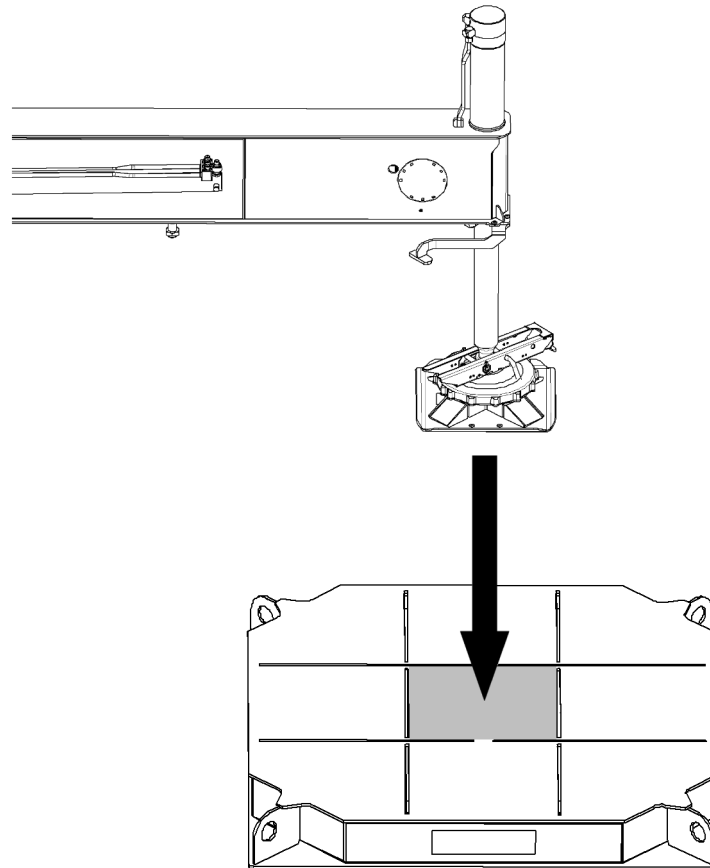

Fig.154813: Sample illustration of a outrigger pad for a crane with a telescopic boom

2 Safety

Before working with the outrigger pads, observe the safety instructions:

- General safety instructions, see chapter 2.04.
- Supporting the crane, see chapter 3.05.
- Installing and driving the outrigger pad (not for all crane types), see chapter 3.05.
- Assembling the outrigger pad (not for all crane types), see chapter 3.10.



WARNING

Impermissible support plate substructure!

The crane can topple over.

Death, bodily injury, property damage.

- ▶ The ground must be able to safely absorb the occurring forces.
- ▶ Position a maximum of **one** support plate on **one** outrigger pad.
- ▶ Place the outrigger pads **centrally** below the support plates.
- ▶ The outrigger pad must be able to safely absorb the support force.

2.1 Placement width

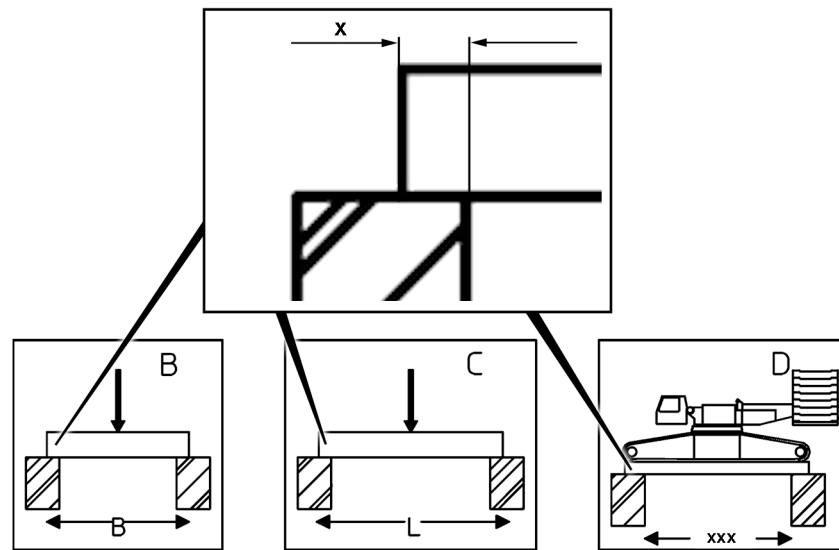

Fig.154918: Placement width x



WARNING

Placement width x **not** adhered to!
The crane can topple over.
Death, bodily injury, property damage.
► Adhere to the placement width x .

2.2 Loads on the ground

When the crane is supported, significant forces (support forces) are transferred by the support cylinders via the support plates to the ground, see chapter 2.04. The same applies for crane operation on crawler. In this case, the forces (support forces) are transferred via the crawler plates to the ground.

- The ground must be able to safely withstand the resulting pressure. If the surface area of the crawler plates or support plates is inadequate, a substructure is required according to the load bearing capacity of the ground. Outrigger pads can be used for this.
- The support plate must be placed in the **center** on the outrigger pad. If off-center positioning is permitted, this is indicated for the corresponding outrigger pad with permissible support area.
- The required substructure for outrigger pads can be calculated from the load bearing capacity of the ground and the crawler pressures of the crane, see chapter 2.04. For the calculation examples, an even pressure distribution over the substructure surface is assumed.



Note

► An even pressure distribution over the substructure surface can be obtained by centrally positioning the crawler or the support plates on the outrigger pad.

2.2.1 Permissible load configurations

Pressure forces distribute themselves differently on the ground depending on the support type and the support condition. The permissible load configurations are shown in the following illustration.

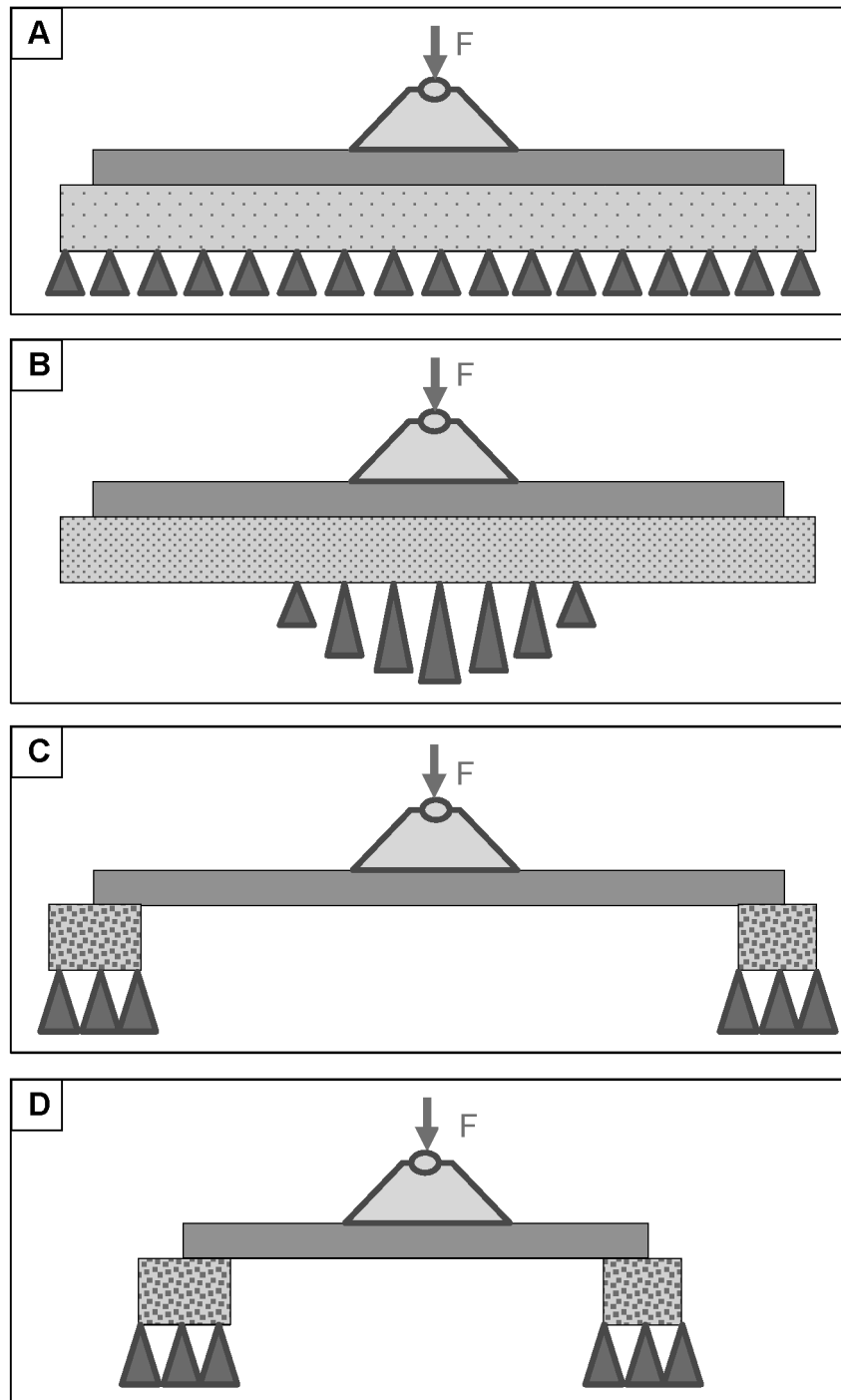

Fig.154921: Permissible load configurations

- | | |
|---|---|
| A Soft ground — even pressure distribution | C Bridge a cavity (longitudinal direction) — concentrated pressure distribution on the support surface |
| B Hard ground — concentrated pressure distribution in the middle | D Bridge a cavity (cross direction) — concentrated pressure distribution on the support surface |

3 Fastening the outrigger pad



WARNING

Incorrectly fastened outrigger pad!

Death, severe bodily injury, property damage.

- ▶ Fasten the outrigger pad in **all** fastening points.
- ▶ Use only approved and suitable fastening equipment.
- ▶ Always maintain a sufficient distance from the suspended load.
- ▶ Carry out all crane movements with a suspended load precisely and with caution.

Depending on the version, the outrigger pad can be fastened individually or in multiples in a stack. The number of outrigger pads permitted when fastening is specified in the chapter for the respective outrigger pads.

3.1 Fastening the individual outrigger pad

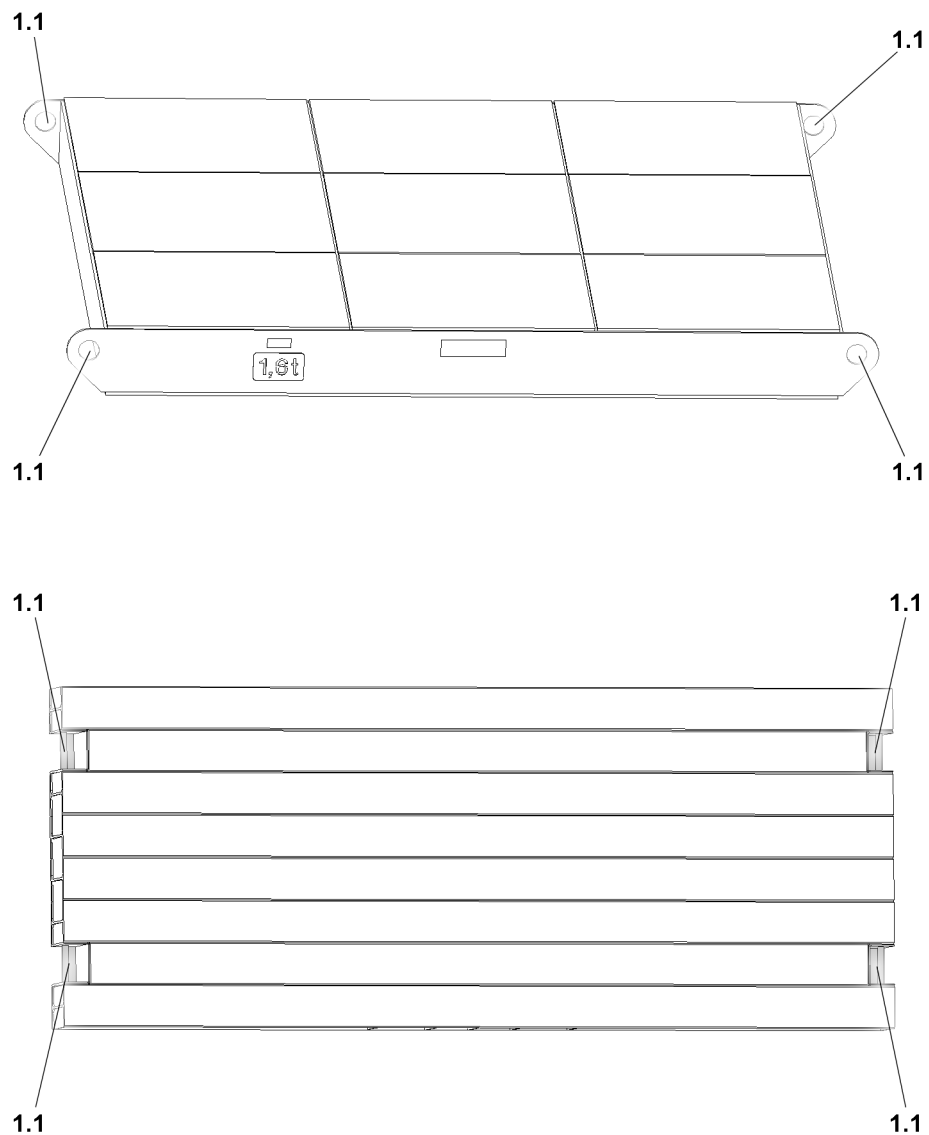

Fig. 154993: Fastening points on the outrigger pads are shown as an example

Fasten the outrigger pad in the fastening points 1.1.

3.2 Fastening the multiple outrigger pads

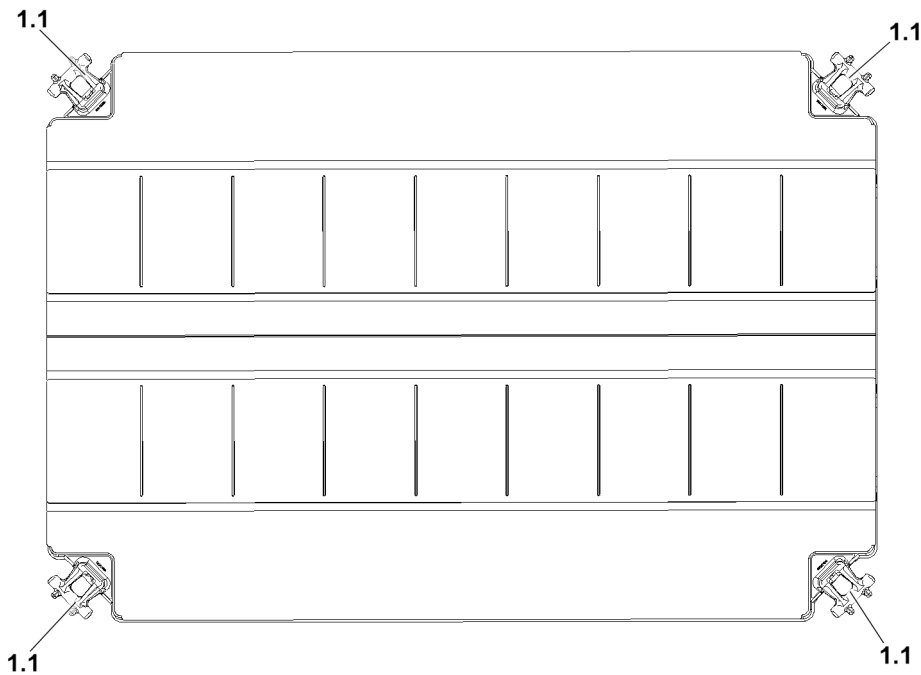

Fig.162745: Fastening points on the outrigger pads are shown as an example
Fasten the outrigger pad in the fastening points 1.1.

3.2.1 Fastening multiple outrigger pads with a round sling

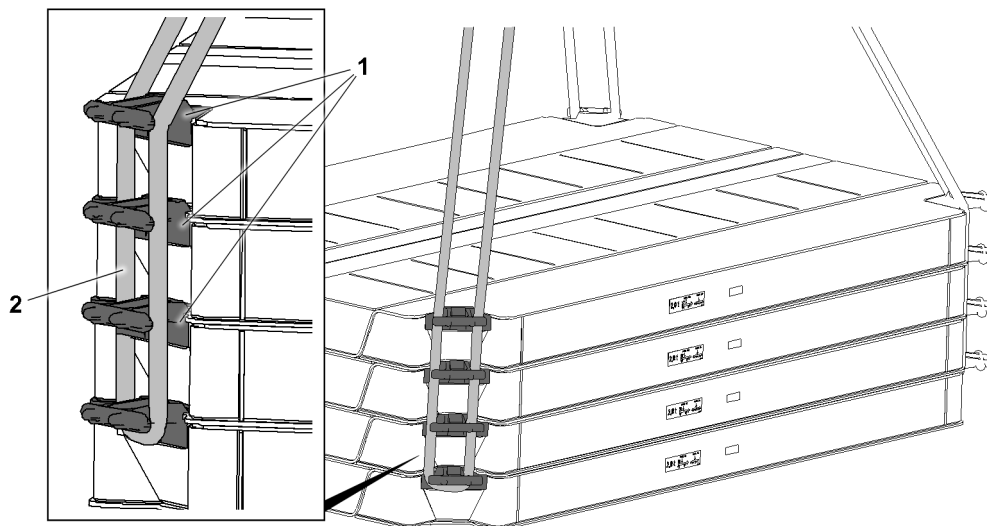

Fig.162740: Fastening multiple outrigger pads with a round sling

Fasten only the lowest outrigger pad.

When fastening with a round sling **2** make sure that the round sling **2** is located to the **side** on the fastening panel **1**.

3.2.2 Fastening multiple outrigger pads with a chain

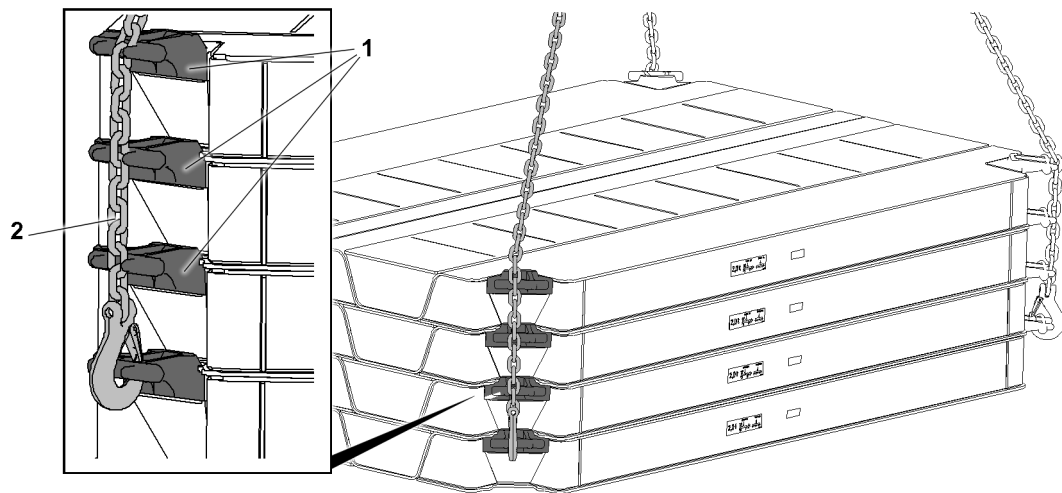

Fig.162742: Fastening multiple outrigger pads with a chain

Fasten only the lowest outrigger pad.

When fastening with a chain **2** make sure that the chain **2** is located to the **front** on the fastening panel **1**.

3.2.3 Stacking the outrigger pads

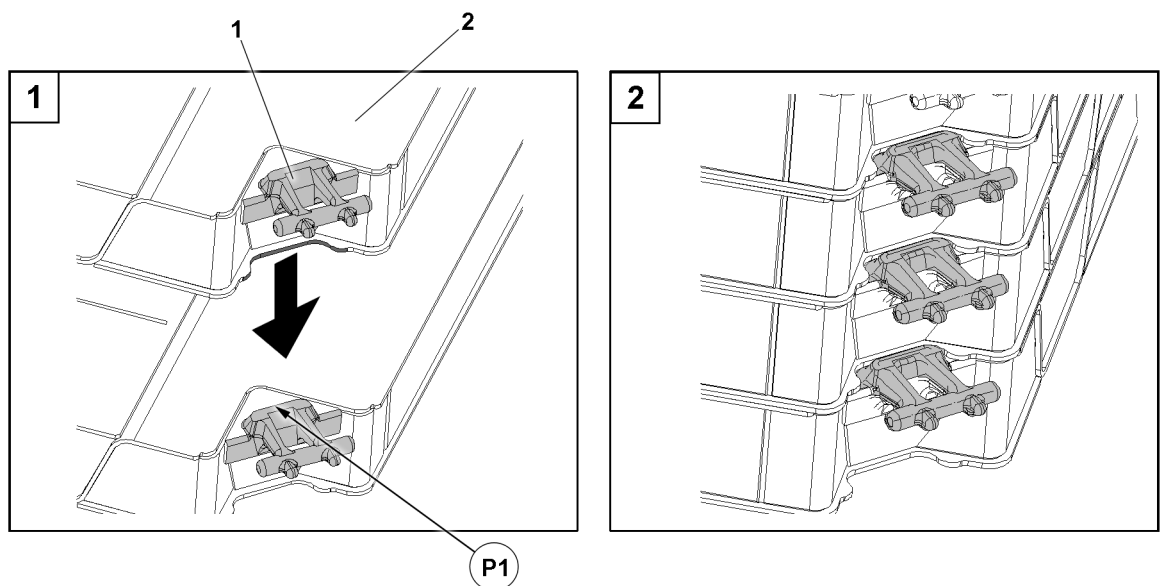

Fig.162744: Stacking the interlocking outrigger pads

Until the outrigger pads align on top of each other:

Position the upper outrigger pad **2** and lower carefully.

The fastening panels **1** are used when stacking the outrigger pads to establish an interlocking connection in position **P1**.

4 Technical track pad data for cranes with a telescopic boom

The following description of the outrigger pads only applies for supported crane operation.

The following outrigger pads are designed for all LWE support plates.

4.1 Outrigger pad LWE ID number 914786508

Observe the additional information:

- see section “Fastening the outrigger pads”.



WARNING

Incorrectly fastened outrigger pad!
Death, severe bodily injury, property damage.
► Fasten a maximum of **one** outrigger pad.

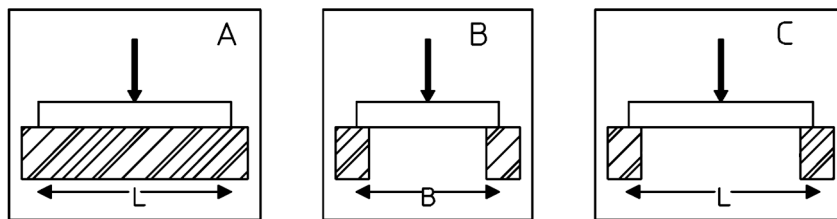

Fig.154815: Permissible support pressures

- A** The outrigger pad is placed completely on the surface
- B** The outrigger pad is positioned in the cross direction over a cavity
- C** The outrigger pad is placed in the longitudinal direction over a cavity

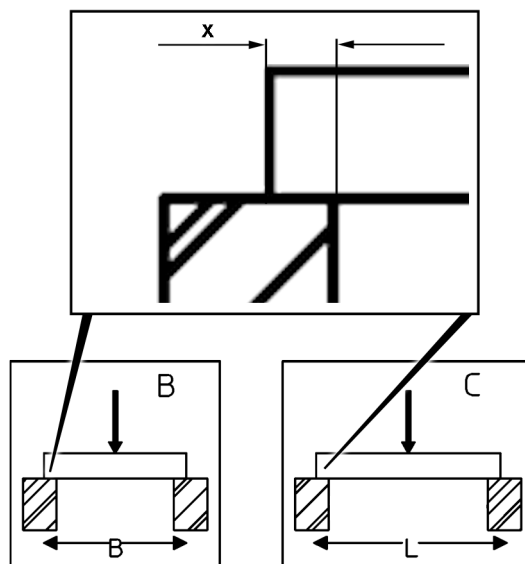

Fig.154911: Placement width x

The placement width x must be at least 1.5 x height of the outrigger pad.

LWE ID number	Dimensions L x W x H ¹⁾	Surface	Mass	Permissible support pressures		
				A ²⁾	B ³⁾	C ⁴⁾
914786508	1.0 x 1.0 x 0.12 m	1 m ²	130 kg	100 t	100 t	100 t

Outrigger pads for support load distribution

- ¹⁾ Dimensions in Length x Width x Height
- ²⁾ The outrigger pad is placed completely on the surface
- ³⁾ The outrigger pad is positioned in the cross direction over a cavity
- ⁴⁾ The outrigger pad is placed in the longitudinal direction over a cavity

4.2 Outrigger pad LWE ID number 914861908

Observe the additional information:
 – see section “Fastening the outrigger pads”.



WARNING

Incorrectly fastened outrigger pad!
 Death, severe bodily injury, property damage.
 ► Fasten a maximum of **one** outrigger pad.

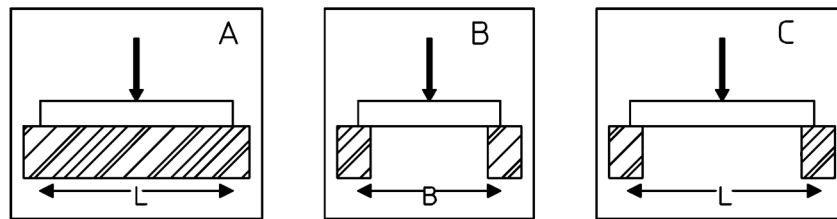

Fig.154815: Permissible support pressures

- A** The outrigger pad is placed completely on the surface
- B** The outrigger pad is positioned in the cross direction over a cavity
- C** The outrigger pad is placed in the longitudinal direction over a cavity

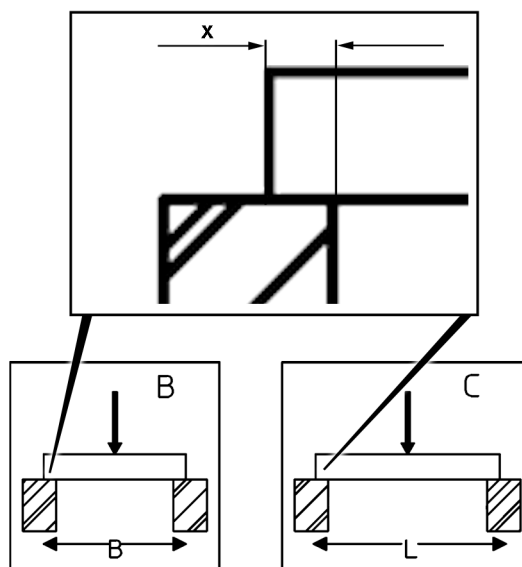

Fig.154911: Placement width x

The placement width x must be at least 1.5 x height of the outrigger pad.

LWE/LR 13000-001/19503-01-02/en

LWE ID number	Dimensions L x W x H ¹⁾	Surface	Mass	Permissible support pressures		
				A ²⁾	B ³⁾	C ⁴⁾
914861908	1.4 x 1.2 x 0.122 m	1.68 m ²	232 kg	130 t	130 t	130 t

Outrigger pads for support load distribution

¹⁾ Dimensions in Length x Width x Height

²⁾ The outrigger pad is placed completely on the surface

³⁾ The outrigger pad is positioned in the cross direction over a cavity

⁴⁾ The outrigger pad is placed in the longitudinal direction over a cavity

4.3 Outrigger pad LWE ID number 914786808

Observe the additional information:

- see section “Fastening the outrigger pads”.



WARNING

Incorrectly fastened outrigger pad!
Death, severe bodily injury, property damage.

- Fasten a maximum of **one** outrigger pad.

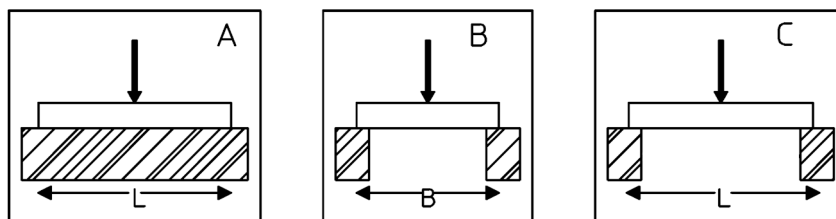

Fig.154815: Permissible support pressures

- A** The outrigger pad is placed completely on the surface
- B** The outrigger pad is positioned in the cross direction over a cavity
- C** The outrigger pad is placed in the longitudinal direction over a cavity

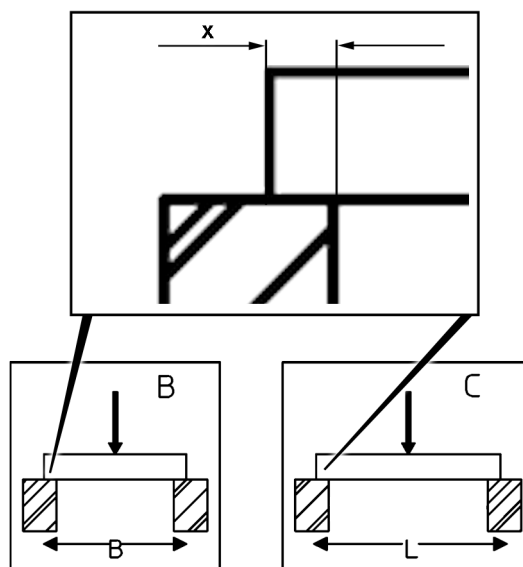

Fig.154911: Placement width x

The placement width x must be at least 1.5 x height of the outrigger pad.

LWE ID number	Dimensions L x W x H ¹⁾	Surface	Mass	Permissible support pressures		
				A ²⁾	B ³⁾	C ⁴⁾
914786808	2.0 x 1.8 x 0.2 m	3.6 m ²	555 kg	210 t	210 t	210 t

Outrigger pads for support load distribution

- ¹⁾ Dimensions in Length x Width x Height
- ²⁾ The outrigger pad is placed completely on the surface
- ³⁾ The outrigger pad is positioned in the cross direction over a cavity
- ⁴⁾ The outrigger pad is placed in the longitudinal direction over a cavity

4.4 Outrigger pad LWE ID number 915236308

Observe the additional information:
 – see section “Fastening the outrigger pads”.



WARNING

Incorrectly fastened outrigger pad!
 Death, severe bodily injury, property damage.
 ► Fasten a maximum of **one** outrigger pad.

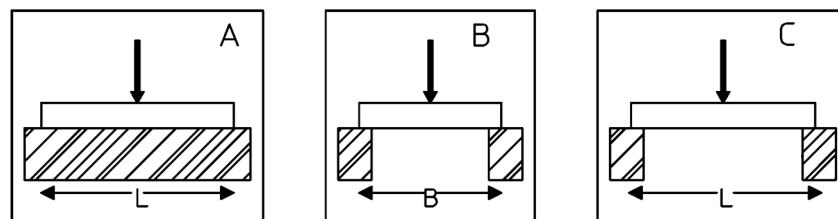

Fig.154815: Permissible support pressures

- A** The outrigger pad is placed completely on the surface
- B** The outrigger pad is positioned in the cross direction over a cavity
- C** The outrigger pad is placed in the longitudinal direction over a cavity

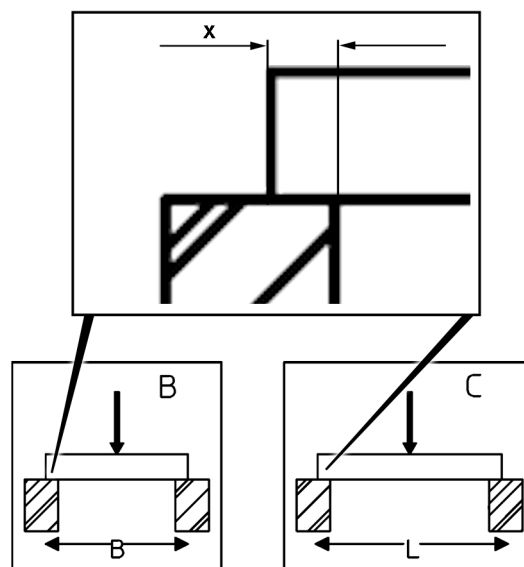

Fig.154911: Placement width x

The placement width x must be at least 1.5 x height of the outrigger pad.

LWE/LR 13000-001/19503-01-02/en

LWE ID number	Dimensions L x W x H ¹⁾	Surface	Mass	Permissible support pressures		
				A ²⁾	B ³⁾	C ⁴⁾
915236308	2.5 x 2.4 x 0.25 m	6 m ²	1600 kg	320 t	320 t	320 t

Outrigger pads for support load distribution

- 1) Dimensions in Length x Width x Height
 2) The outrigger pad is placed completely on the surface
 3) The outrigger pad is positioned in the cross direction over a cavity
 4) The outrigger pad is placed in the longitudinal direction over a cavity

4.4.1 Positioning the support plate off-center on the outrigger pad

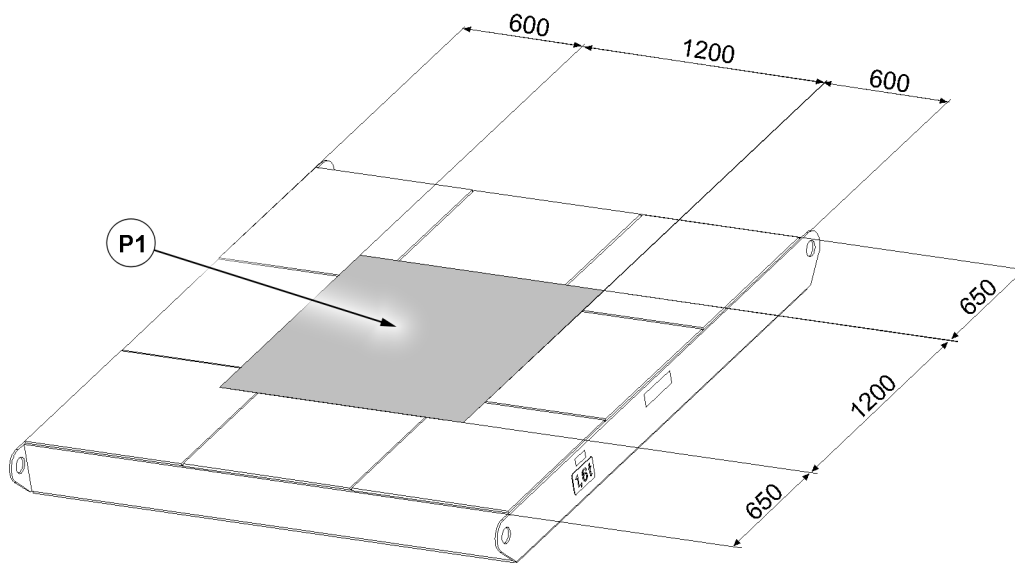

Fig.154923: Permissible placement surface for support plates

P1 Support surface for support plates with permissible support pressure 320 t

An even pressure distribution over the substructure surface can be obtained by centrally positioning the support plates on the outrigger pad.



WARNING

Impermissible support plate substructure!
 The crane can topple over.
 Death, bodily injury, property damage.

- Place the outrigger pads **centrally** or according to the description under the support plates.

4.5 Outrigger pad LWE ID number 915236408/915464608

Observe the additional information:

- see section “Fastening the outrigger pads”.



WARNING

Incorrectly fastened outrigger pad!
 Death, severe bodily injury, property damage.

- Fasten a maximum of **one** outrigger pad.

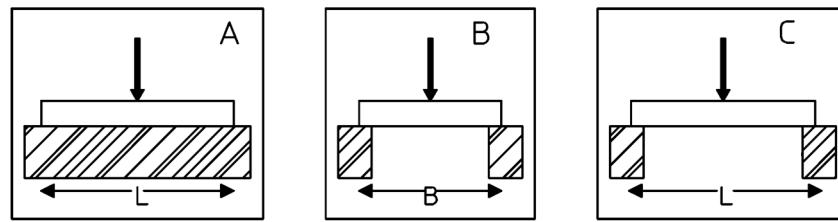

Fig.154815: Permissible support pressures

- A** The outrigger pad is placed completely on the surface
- B** The outrigger pad is positioned in the cross direction over a cavity
- C** The outrigger pad is placed in the longitudinal direction over a cavity

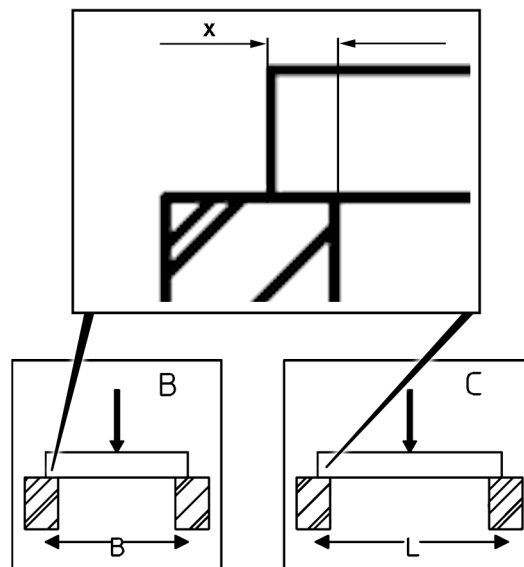

Fig.154911: Placement width x

The placement width x must be at least 1.5 x height of the outrigger pad.

LWE ID number	Dimensions L x W x H ¹⁾	Surface	Mass	Permissible support pressures		
				A ²⁾	B ³⁾	C ⁴⁾
915236408/9154646 08	3.5 x 2.4 x 0.25 m	8.4 m ²	2350 kg	320 t	320 t	320 t

Outrigger pads for support load distribution

- ¹⁾ Dimensions in Length x Width x Height
- ²⁾ The outrigger pad is placed completely on the surface
- ³⁾ The outrigger pad is positioned in the cross direction over a cavity
- ⁴⁾ The outrigger pad is placed in the longitudinal direction over a cavity

LWE/LR 13000-001/19503-01-02/en

4.5.1 Positioning the support plate off-center on the outrigger pad

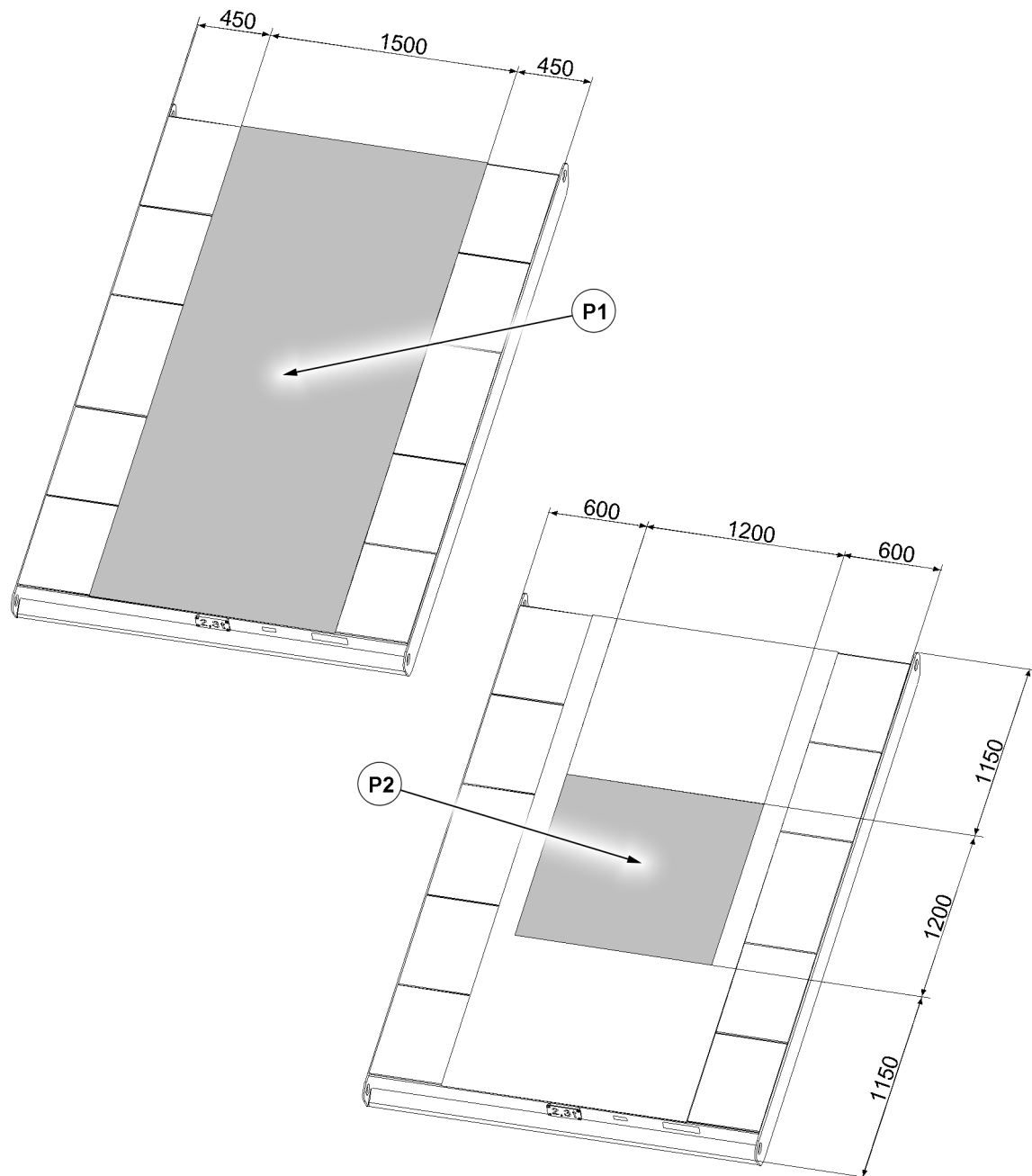

Fig. 154924: Permissible placement surface for support plates

P1 Support surface for support plates with permissible support pressure up to 210 t

P2 Support surface for support plates with permissible support pressure greater than 210 t up to 320 t

An even pressure distribution over the substructure surface can be obtained by centrally positioning the support plates on the outrigger pad.



WARNING

Impermissible support plate substructure!

The crane can topple over.

Death, bodily injury, property damage.

► Place the outrigger pads **centrally** or according to the description under the support plates.

4.6 Outrigger pad LWE ID number 919663108

Observe the additional information:
 – see section “Fastening the outrigger pads”.



WARNING

- Incorrectly fastened outrigger pad!
 Death, severe bodily injury, property damage.
- ▶ Fasten a maximum of **four** outrigger pads.
 - ▶ Fasten the fastening equipment only on the lowest outrigger pad.

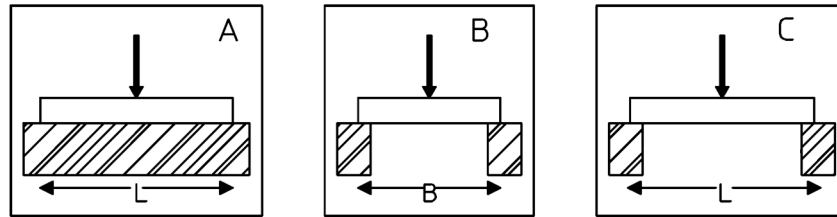

Fig.154815: Permissible support pressures

- A** The outrigger pad is placed completely on the surface
- B** The outrigger pad is positioned in the cross direction over a cavity
- C** The outrigger pad is placed in the longitudinal direction over a cavity

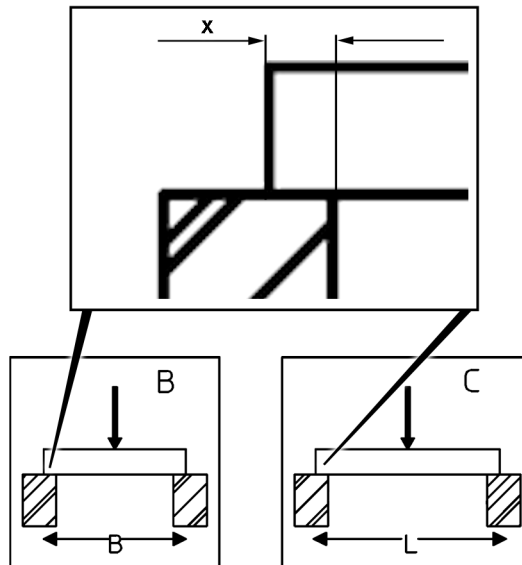

Fig.154911: Placement width x

The placement width **x** must be at least 2.5 x height of the outrigger pad.

LWE ID number	Dimensions L x W x H ¹⁾	Surface	Mass	Permissible support pressures		
				A ²⁾	B ³⁾	C ⁴⁾
919663108	1.2 x 1.5 x 0.12 m	1.7 m ²	270 kg	112 t	112 t	112 t

Outrigger pads for support load distribution

¹⁾ Dimensions in Length x Width x Height
²⁾ The outrigger pad is placed completely on the surface
³⁾ The outrigger pad is positioned in the cross direction over a cavity
⁴⁾ The outrigger pad is placed in the longitudinal direction over a cavity

LWE/LR_13000-001/19503-01-02/en

4.6.1 Positioning the support plate off-center on the outrigger pad

Depending on the support surfaces of the outrigger pad, the support plates can be placed off-center on the outrigger pad.

Positioning the support plate off-center on the outrigger pad lying on the complete surface

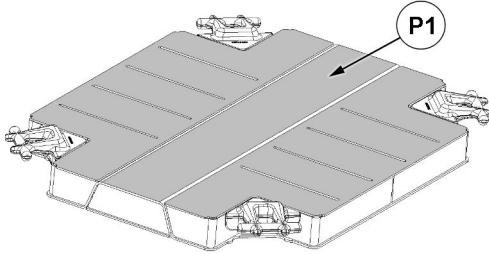

Fig. 162737: Permissible placement surface for support plates

P1 Support surface for support plates with permissible support pressure 112 t

An even pressure distribution below the support surface can be obtained by centrally positioning the support plates on the outrigger pad.

Positioning the support plate off-center on the outrigger pad over a cavity

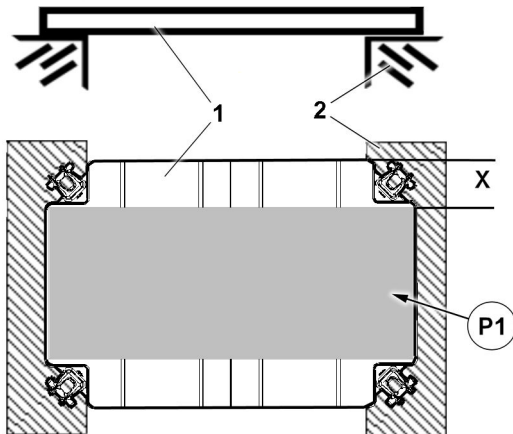

Fig. 162738: Exemplary illustration of a permissible placement surface for support plates

1 Outrigger pad

P1 Support surface for support plates with permissible support pressure 112 t

2 Substructure

The distance **X** between the support plates and freely standing outrigger pad edge must be at least 2.5 x the height of the outrigger pad.

An even pressure distribution on the substructure surface can be obtained by centrally positioning the support plates on the outrigger pad.



WARNING

Impermissible support plate substructure!

The crane can topple over.

Death, bodily injury, property damage.

► Place the outrigger pads **centrally** or according to the description under the support plates.

4.7 Outrigger pad LWE ID number 919663508

Observe the additional information:
 – see section “Fastening the outrigger pads”.



WARNING

- Incorrectly fastened outrigger pad!
 Death, severe bodily injury, property damage.
- ▶ Fasten a maximum of **four** outrigger pads.
 - ▶ Fasten the fastening equipment only on the lowest outrigger pad.

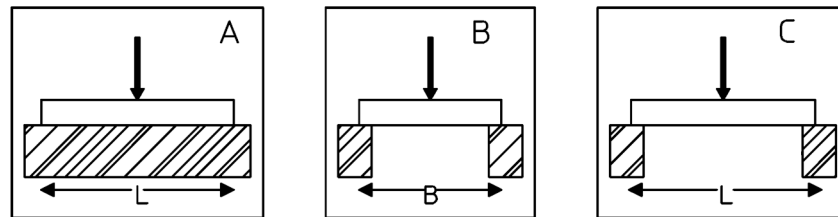

Fig.154815: Permissible support pressures

- A** The outrigger pad is placed completely on the surface
- B** The outrigger pad is positioned in the cross direction over a cavity
- C** The outrigger pad is placed in the longitudinal direction over a cavity

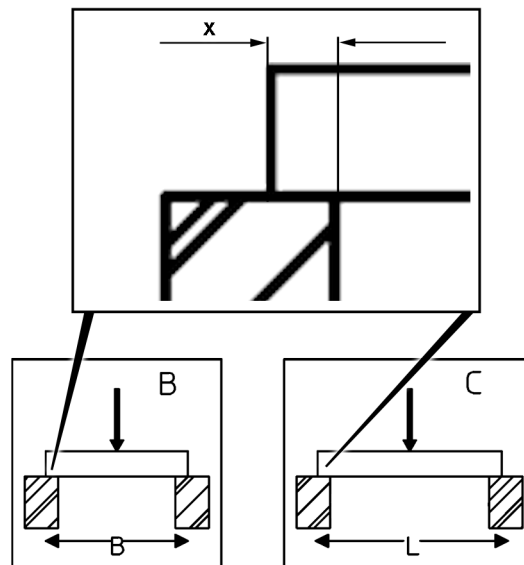

Fig.154911: Placement width x

The placement width **x** must be at least 1.5 x height of the outrigger pad.

LWE ID number	Dimensions L x W x H ¹⁾	Surface	Mass	Permissible support pressures		
				A ²⁾	B ³⁾	C ⁴⁾
919663508	2.4 x 1.6 x 0.19 m	3.8 m ²	720 kg	183 t	183 t	183 t

Outrigger pads for support load distribution

¹⁾ Dimensions in Length x Width x Height
²⁾ The outrigger pad is placed completely on the surface
³⁾ The outrigger pad is positioned in the cross direction over a cavity
⁴⁾ The outrigger pad is placed in the longitudinal direction over a cavity

LWE/LR_13000-001/19503-01-02/en

4.7.1 Positioning the support plate off-center on the outrigger pad

Depending on the support surfaces of the outrigger pad, the support plates can be placed off-center on the outrigger pad.

Positioning the support plate off-center on the outrigger pad lying on the complete surface

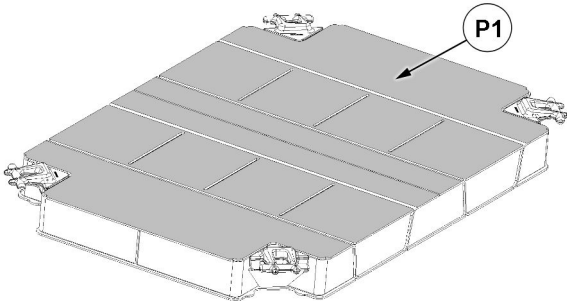

Fig.162739: Permissible placement surface for support plates

P1 Support surface for support plates with permissible support pressure 183 t

An even pressure distribution below the support surface can be obtained by centrally positioning the support plates on the outrigger pad.

Positioning the support plate off-center on the outrigger pad over a cavity

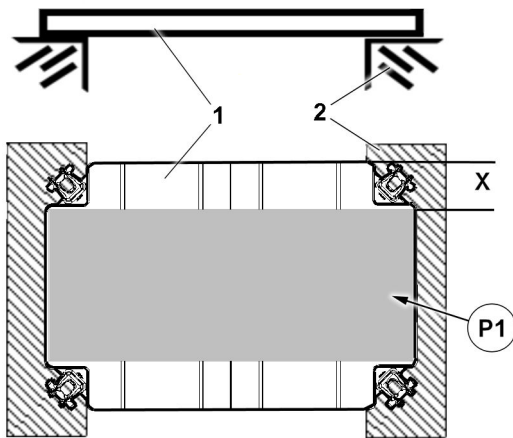

Fig.162738: Exemplary illustration of a permissible placement surface for support plates

1 Outrigger pad

P1 Support surface for support plates with permissible support pressure 183 t

2 Substructure

The distance **X** between the support plates and freely standing outrigger pad edge must be at least 1.5 x the height of the outrigger pad.

An even pressure distribution on the substructure surface can be obtained by centrally positioning the support plates on the outrigger pad.



WARNING

Impermissible support plate substructure!

The crane can topple over.

Death, bodily injury, property damage.

► Place the outrigger pads **centrally** or according to the description under the support plates.

4.8 Outrigger pad LWE ID number 919663608

Observe the additional information:
 – see section “Fastening the outrigger pads”.



WARNING

- Incorrectly fastened outrigger pad!
 Death, severe bodily injury, property damage.
- ▶ Fasten a maximum of **four** outrigger pads.
 - ▶ Fasten the fastening equipment only on the lowest outrigger pad.

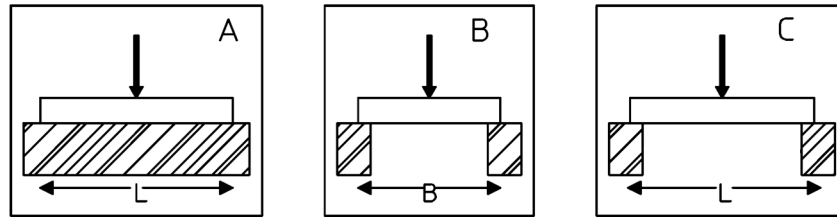

Fig.154815: Permissible support pressures

- A** The outrigger pad is placed completely on the surface
- B** The outrigger pad is positioned in the cross direction over a cavity
- C** The outrigger pad is placed in the longitudinal direction over a cavity

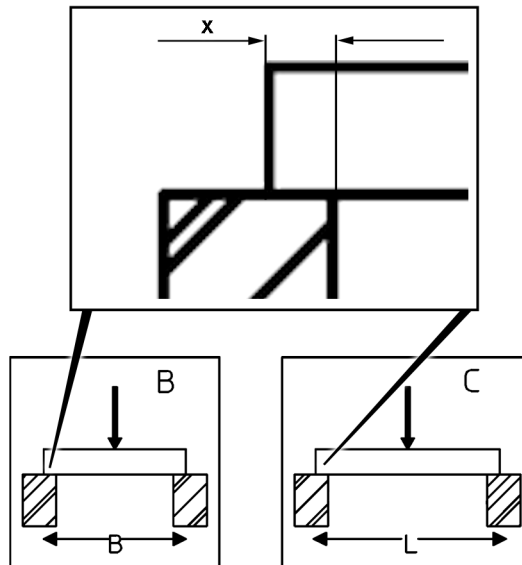

Fig.154911: Placement width x

The placement width **x** must be at least 1.5 x height of the outrigger pad.

LWE ID number	Dimensions L x W x H ¹⁾	Surface	Mass	Permissible support pressures		
				A ²⁾	B ³⁾	C ⁴⁾
919663608	2.4 x 2.4 x 0.21 m	5.7 m ²	1200 kg	214 t	214 t	214 t

Outrigger pads for support load distribution

¹⁾ Dimensions in Length x Width x Height
²⁾ The outrigger pad is placed completely on the surface
³⁾ The outrigger pad is positioned in the cross direction over a cavity
⁴⁾ The outrigger pad is placed in the longitudinal direction over a cavity

LWE/LR_13000-001/19503-01-02/en

4.8.1 Positioning the support plate off-center on the outrigger pad

Depending on the support surfaces of the outrigger pad, the support plates can be placed off-center on the outrigger pad.

Positioning the support plate off-center on the outrigger pad lying on the complete surface

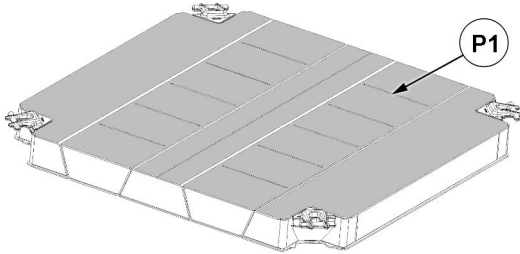

Fig.162741: Permissible placement surface for support plates

P1 Support surface for support plates with permissible support pressure 214 t

An even pressure distribution below the support surface can be obtained by centrally positioning the support plates on the outrigger pad.

Positioning the support plate off-center on the outrigger pad over a cavity

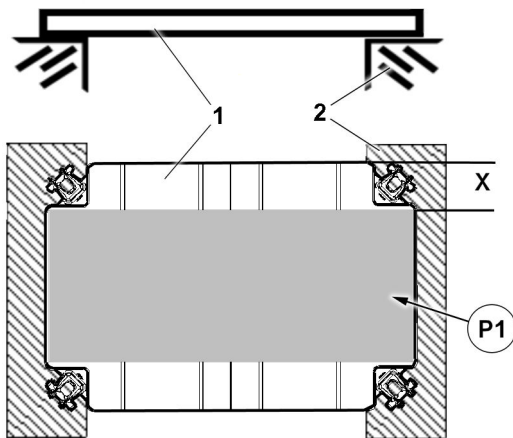

Fig.162738: Exemplary illustration of a permissible placement surface for support plates

1 Outrigger pad

P1 Support surface for support plates with permissible support pressure 214 t

2 Substructure

The distance **X** between the support plates and freely standing outrigger pad edge must be at least 1.5 x the height of the outrigger pad.

An even pressure distribution on the substructure surface can be obtained by centrally positioning the support plates on the outrigger pad.



WARNING

Impermissible support plate substructure!

The crane can topple over.

Death, bodily injury, property damage.

► Place the outrigger pads **centrally** or according to the description under the support plates.

4.9 Outrigger pad LWE ID number 919663708

Observe the additional information:

- see section "Fastening the outrigger pads".



WARNING

Incorrectly fastened outrigger pad!

Death, severe bodily injury, property damage.

- ▶ Fasten a maximum of **four** outrigger pads.
- ▶ Fasten the fastening equipment only on the lowest outrigger pad.

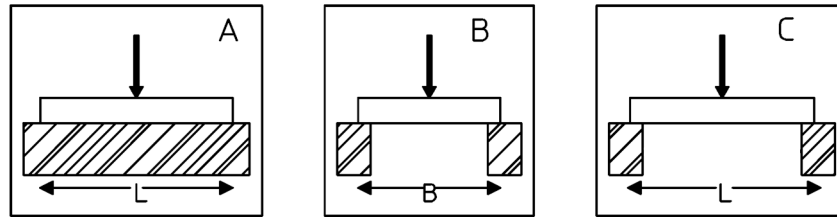

Fig.154815: Permissible support pressures

- A** The outrigger pad is placed completely on the surface
- B** The outrigger pad is positioned in the cross direction over a cavity

- C** The outrigger pad is placed in the longitudinal direction over a cavity

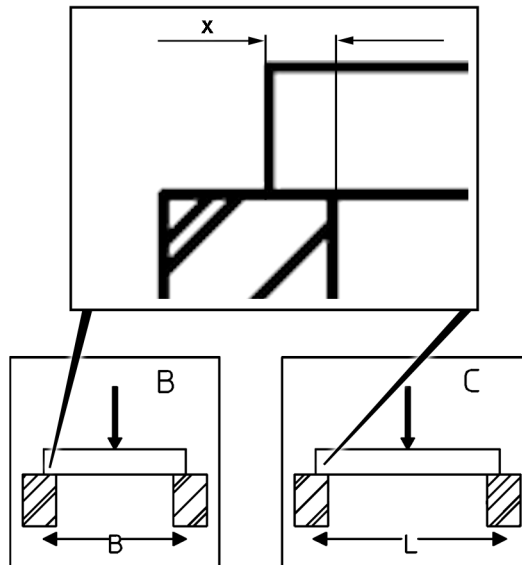

Fig.154911: Placement width x

The placement width x must be at least 1.5 x height of the outrigger pad.

LWE ID number	Dimensions L x W x H ¹⁾	Surface	Mass	Permissible support pressures		
				A ²⁾	B ³⁾	C ⁴⁾
919663708	3.5 x 2.4 x 0.23 m	8.3 m ²	2000 kg	326 t	326 t	326 t

Outrigger pads for support load distribution

- ¹⁾ Dimensions in Length x Width x Height
- ²⁾ The outrigger pad is placed completely on the surface
- ³⁾ The outrigger pad is positioned in the cross direction over a cavity
- ⁴⁾ The outrigger pad is placed in the longitudinal direction over a cavity

LWE/LR 13000-001/19503-01-02/en

4.9.1 Positioning the support plate off-center on the outrigger pad

Depending on the support surfaces of the outrigger pad, the support plates can be placed off-center on the outrigger pad.

Positioning the support plate off-center on the outrigger pad lying on the complete surface

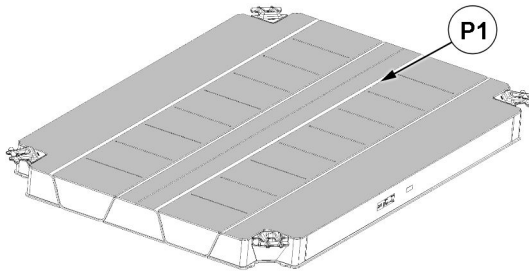

Fig.162743: Permissible placement surface for support plates

P1 Support surface for support plates with permissible support pressure 326 t

An even pressure distribution below the support surface can be obtained by centrally positioning the support plates on the outrigger pad.

Positioning the support plate off-center on the outrigger pad over a cavity

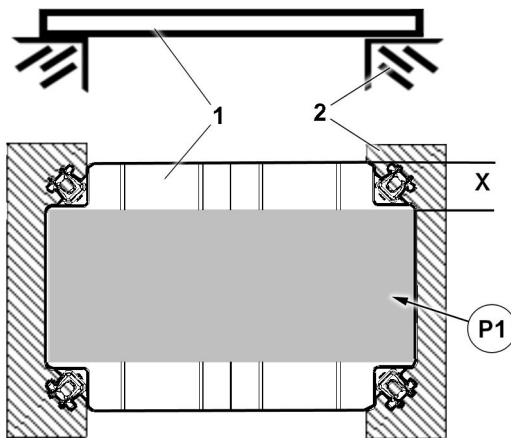

Fig.162738: Exemplary illustration of a permissible placement surface for support plates

1 Outrigger pad

P1 Support surface for support plates with permissible support pressure 326 t

2 Substructure

The distance **X** between the support plates and freely standing outrigger pad edge must be at least 1.5 x the height of the outrigger pad.

An even pressure distribution on the substructure surface can be obtained by centrally positioning the support plates on the outrigger pad.



WARNING

Impermissible support plate substructure!

The crane can topple over.

Death, bodily injury, property damage.

► Place the outrigger pads **centrally** or according to the description under the support plates.

5 Technical outrigger pad data for cranes with a lattice mast boom

The following description of the outrigger pads only applies for supported crane operation and in crane operation on crawler.

5.1 Outrigger pad LWE ID number 914618608

Observe the additional information:

- Installing and driving the outrigger pad, see chapter 3.05.

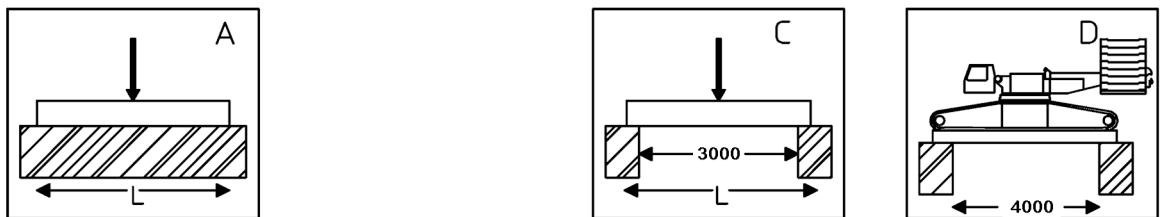

Fig.154942: Permissible support pressures

- A** The outrigger pad is placed completely on the surface
- C** The outrigger pad is placed in the longitudinal direction over a cavity
- D** The outrigger pad is placed in the longitudinal direction over a cavity and driven with the crawler crane



Note

- Driving the outrigger pads over a cavity is only permissible with the own weight of the crane (without a hoist load).

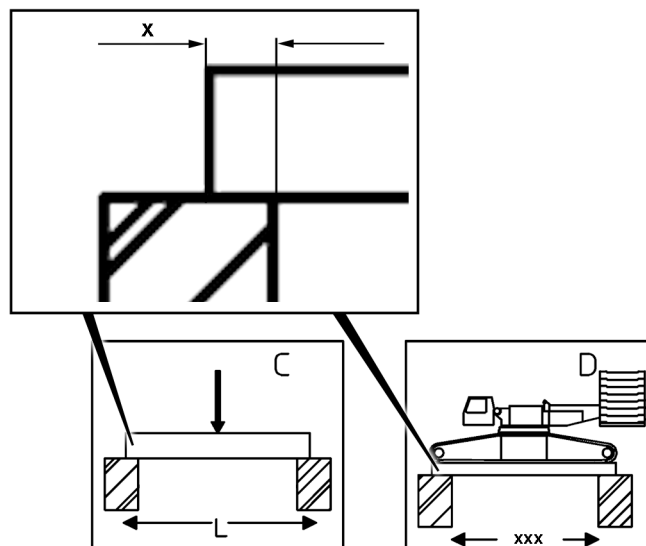

Fig.154941: Placement widths x

- C** The placement width must be at least 1.5 m.
- D** The placement width must be at least 1.0 m.

LWE/LR 13000-001/19503-01-02/en

LWE ID number	Dimensions L x W x H ¹⁾	Surface	Mass	Permissible support pressures			
				A ²⁾	B ³⁾	C ⁴⁾	D ⁵⁾
914618608	6.0 x 2.4 x 0.3 m	14.4 m ²	7800 kg	450 t		450 t	

Outrigger pads for support load distribution

1) Dimensions in Length x Width x Height

2) The outrigger pad is placed completely on the surface

3) The outrigger pad is positioned in the cross direction over a cavity

4) The outrigger pad is placed in the longitudinal direction over a cavity

5) The outrigger pad is placed in the longitudinal direction over a cavity and driven with the crawler crane

5.1.1 Positioning the support plate off-center on the outrigger pad

Off-center positioning is only permitted if the outrigger pad lies across the entire circumference (not only on two sides) on ground that is at least 100 mm wide.

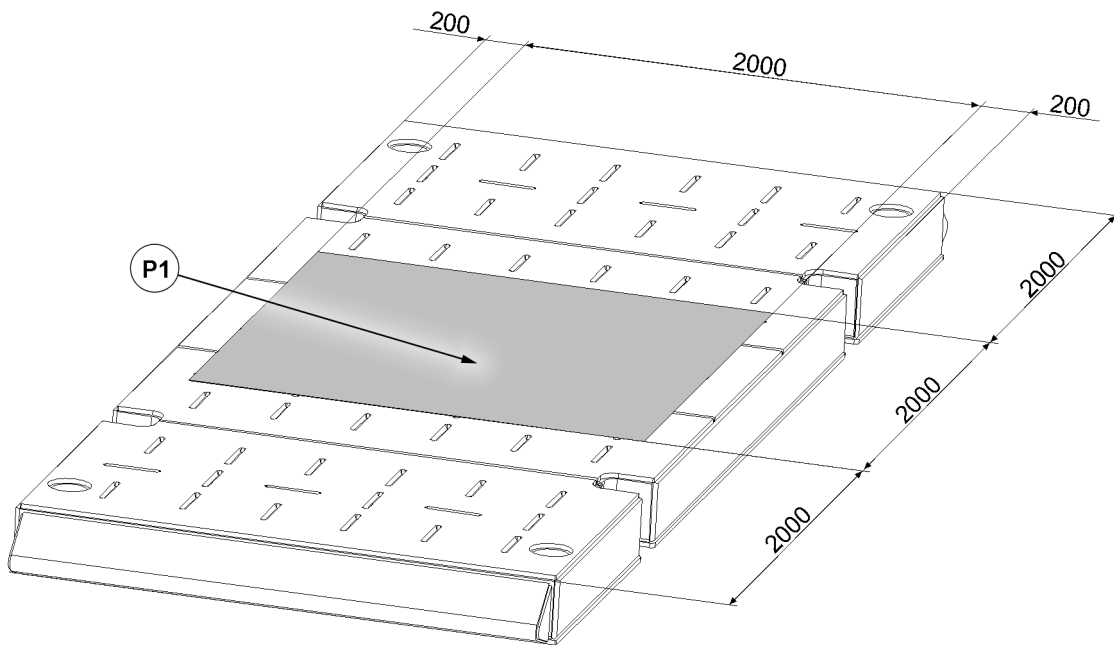

Fig.154926: Permissible placement surface for support plates

P1 Support surface for support plates with permissible support pressure 450 t

An even pressure distribution over the substructure surface can be obtained by centrally positioning the support plates on the outrigger pad.



WARNING

Impermissible support plate substructure!

The crane can topple over.

Death, bodily injury, property damage.

► Place the outrigger pads **centrally** or according to the description under the support plates.

5.2 Outrigger pad LWE ID number 915696408

Observe the additional information:

- Outrigger pad assembly, see chapter 3.10.

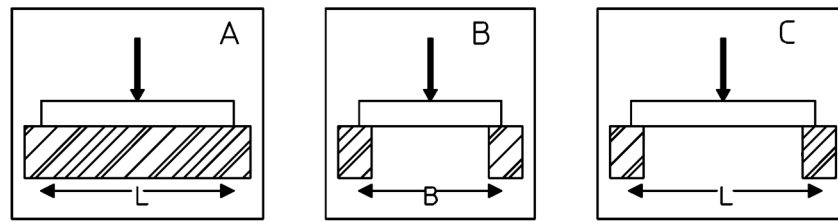

Fig.154815: Permissible support pressures

- A** The outrigger pad is placed completely on the surface
- B** The outrigger pad is positioned in the cross direction over a cavity
- C** The outrigger pad is placed in the longitudinal direction over a cavity

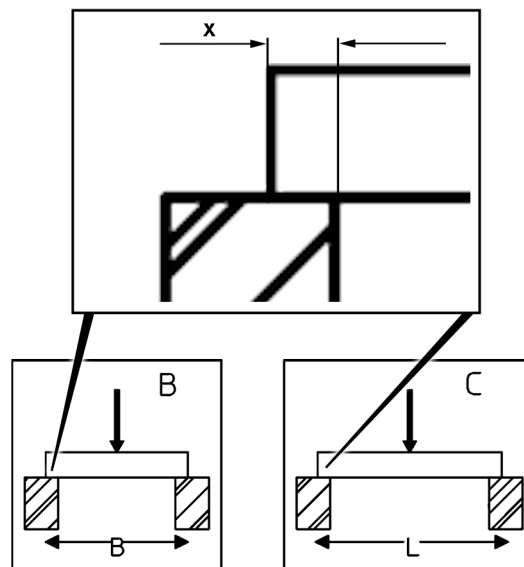

Fig.154911: Placement width *x*

The placement width *x* must be at least 2.5 x height of the outrigger pad.

LWE ID number	Dimensions L x W x H ¹⁾	Surface	Mass	Permissible support pressures		
				A ²⁾	B ³⁾	C ⁴⁾
915696408	4.0 x 2.4 x 0.25 m	9.6 m ²	3300 kg	450 t	450 t	450 t

Outrigger pads for support load distribution

- ¹⁾ Dimensions in Length x Width x Height
- ²⁾ The outrigger pad is placed completely on the surface
- ³⁾ The outrigger pad is positioned in the cross direction over a cavity
- ⁴⁾ The outrigger pad is placed according to the longitudinal direction over a cavity

LWE/LR 13000-001/19503-01-02/en

5.3 Outrigger pad **LWE ID number 918339808**

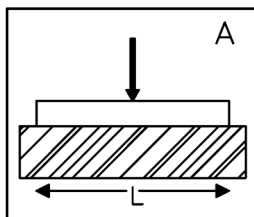

Fig.154917: Permissible support pressures

- A** The outrigger pad is placed completely on the surface

LWE ID number	Dimensions L x W x H ¹⁾	Surface	Mass	Permissible support pressures
				A²⁾
918339808	6.0 x 2.4 x 0.4 m	14.4 m ²	7900 kg	265 t

Outrigger pads for support load distribution

¹⁾ Dimensions in Length x Width x Height

²⁾ The outrigger pad is placed completely on the surface

5.3.1 Positioning the support plate off-center on the outrigger pad

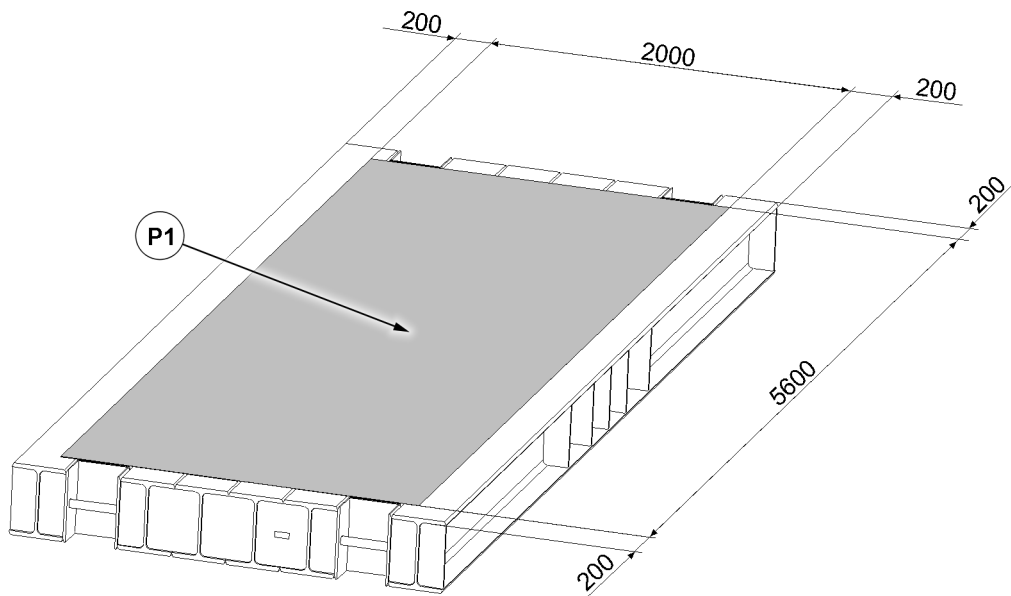

Fig.154925: Permissible placement surface for support plates

P1 Support surface for support plates with permissible support pressure 265 t

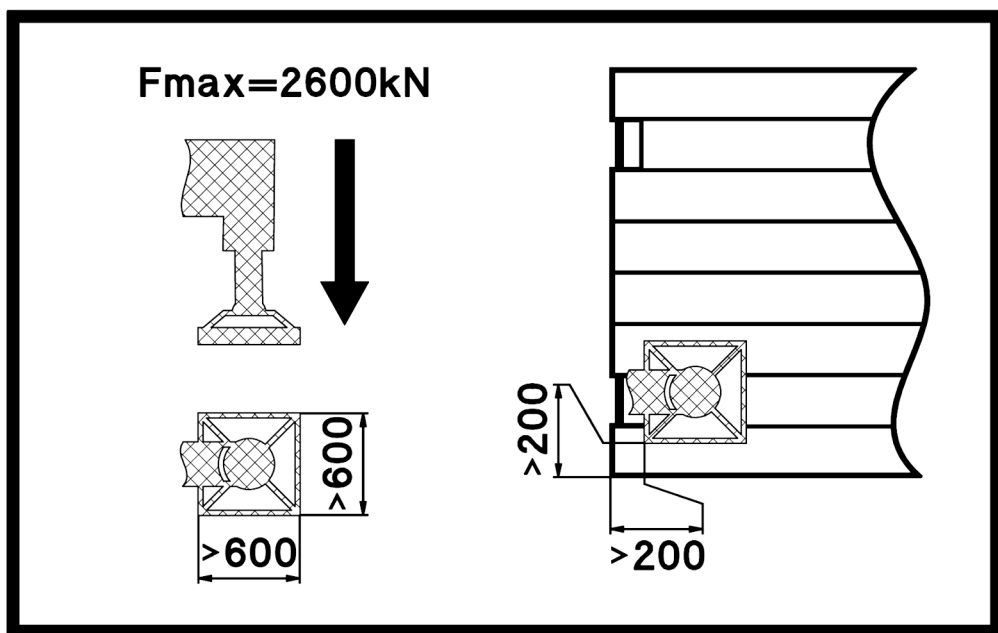

Fig.154913: The support plate is positioned off-center on the outrigger pad

LWE/LR 13000-001/19503-01-02/en

An even pressure distribution over the substructure surface can be obtained by centrally positioning the support plates on the outrigger pad.



WARNING

Impermissible support plate substructure!

The crane can topple over.

Death, bodily injury, property damage.

► Place the outrigger pads **centrally** or according to the description under the support plates.

A support plate can be placed off-center on this outrigger pad. The minimum distance is 200 mm from the side edge of the outrigger pad. The side length of the support plate must be at least 600 mm.

5.3.2 Driving the outrigger pad in the cross direction with a crawler crane

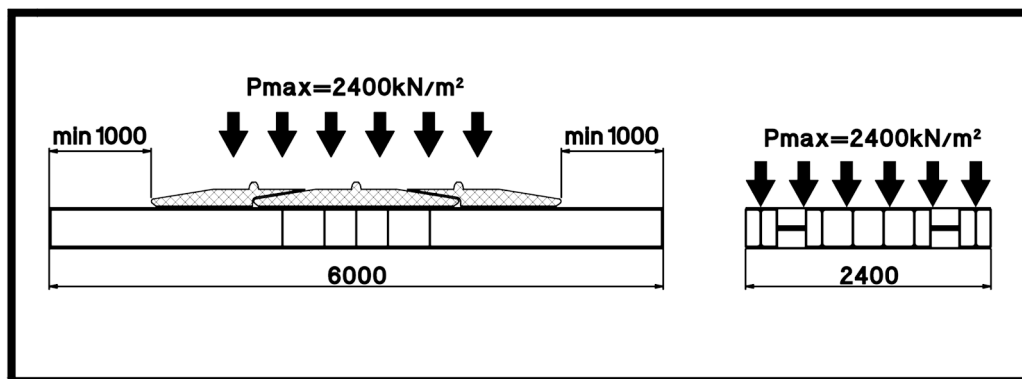

Fig.154912: Driving the outrigger pad in the cross direction with a crawler crane

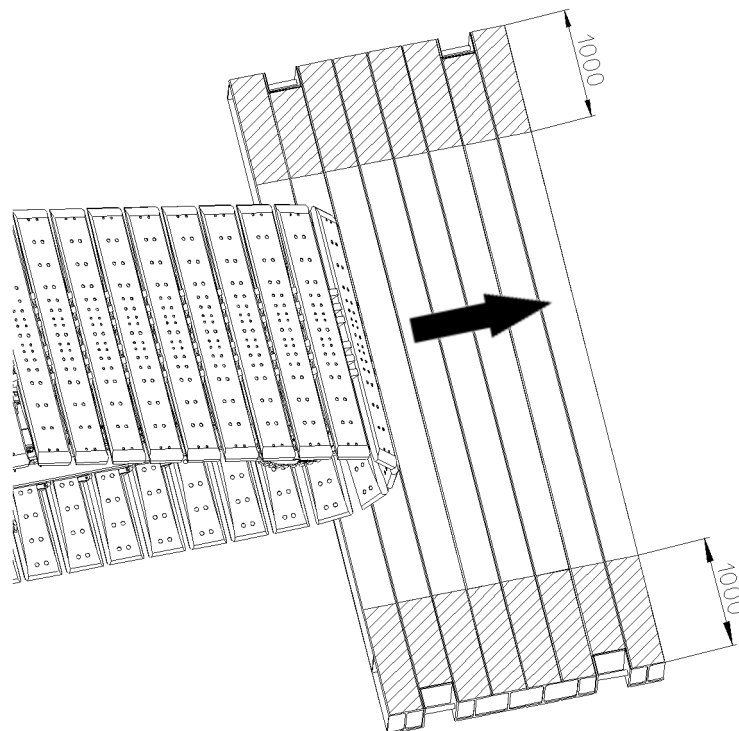

Fig.154922: Permissible driving range with the crawler crane

This outrigger pad can be driven in the cross direction with an approved crawler crane. The distance of at least 1000 mm to the side edges (longitudinal side) of the outrigger pad must be observed.

5.4 Outrigger pad LWE ID number 919427108

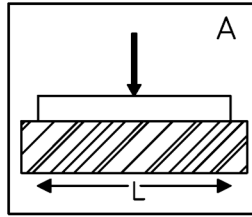

Fig.154917: Permissible support pressures

- A** The outrigger pad is placed completely on the surface



Note

- Driving the outrigger pads over a cavity is only permissible with the own weight of the crane (without a hoist load).

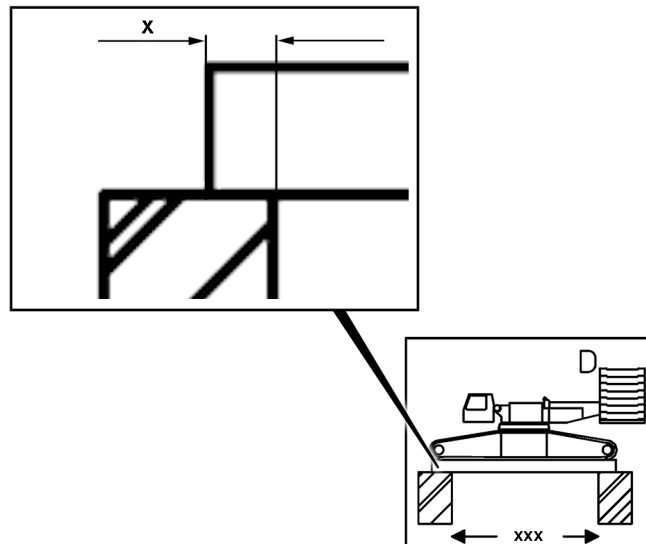

Fig.156550: Placement widths x

- D** The placement width must be at least 0.5 m .
- D** The cavity may be maximum 1.0 m .

LWE ID number	Dimensions L x W x H ¹⁾	Surface	Mass	Permissible support pressures	
				A ²⁾	D ³⁾
919427108	4.0 x 2.4 x 0.2 m	9.6 m ²	3200 kg	200 t for support plates with a placement surface of 0.6 x 0.6 m	
				310 t for support plates with a placement surface of 0.7 x 0.7 m	

Outrigger pads for support load distribution

¹⁾ Dimensions in Length x Width x Height

²⁾ The outrigger pad is placed completely on the surface

³⁾ The outrigger pad is placed in the longitudinal direction over a cavity and driven with the crawler crane

5.4.1 Positioning the support plate off-center on the outrigger pad

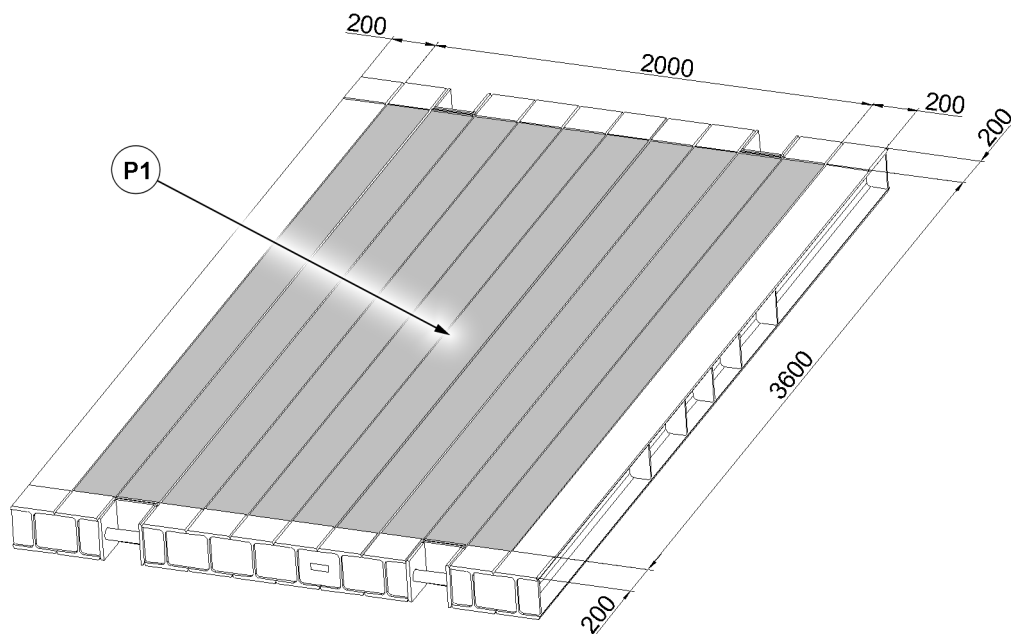

Fig.156546: Permissible placement surface for support plates

- P1** Support surface for support plates with placement surface of 600 x 600 mm with permissible support pressure of 265 t
- P1** Support surface for support plates with placement surface of 700 x 700 mm with permissible support pressure of 310 t

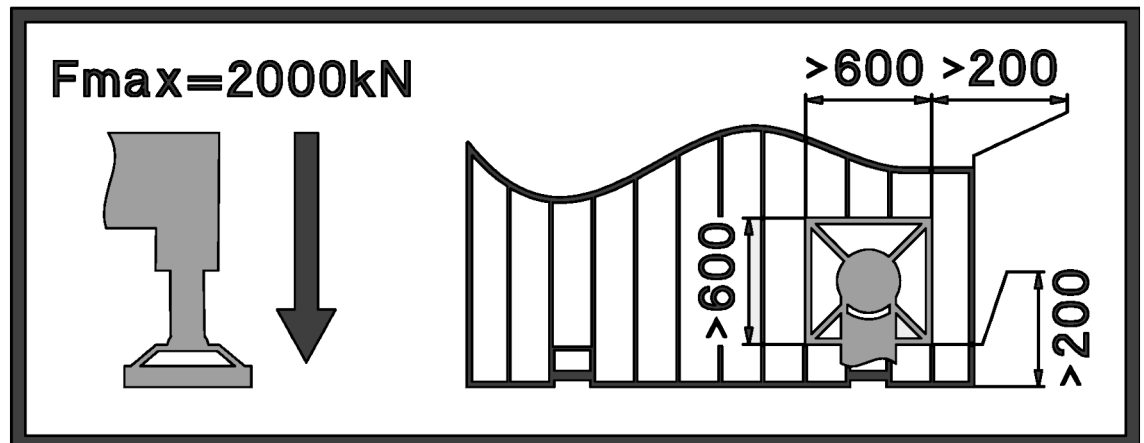

Fig.156549: The support plate is positioned off-center on the outrigger pad

An even pressure distribution over the substructure surface can be obtained by centrally positioning the support plates on the outrigger pad.



WARNING

Impermissible support plate substructure!
The crane can topple over.
Death, bodily injury, property damage.

- ▶ Place the outrigger pads **centrally** or according to the description under the support plates.

A support plate can be placed off-center on this outrigger pad. The minimum distance is 200 mm from the side edge of the outrigger pad. The side length of the support plate must be at least 600 mm.

5.4.2 Driving the outrigger pad in the cross direction with a crawler crane

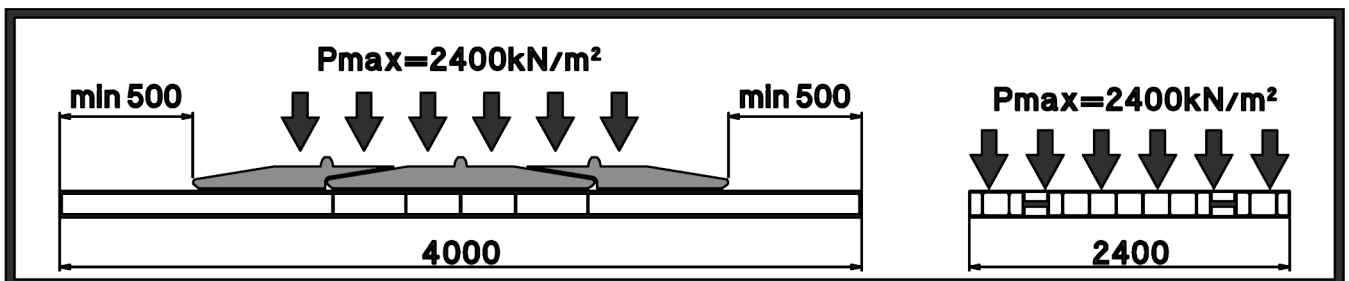

Fig.156548: Driving the outrigger pad in the cross direction with a crawler crane

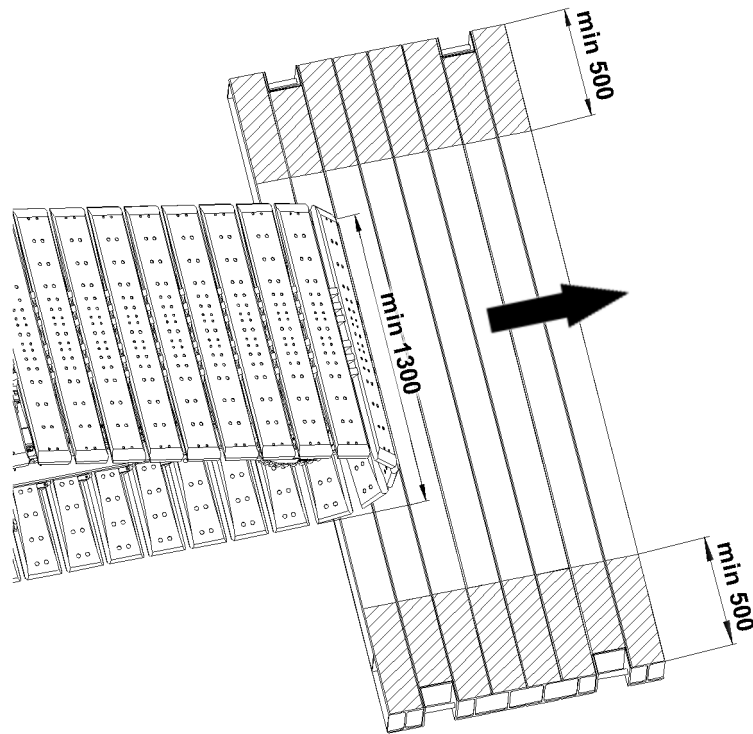

Fig.156547: Permissible driving range with the crawler crane

This outrigger pad can be driven in the cross direction with an approved crawler crane. The distance of at least 500 mm to the side edges (longitudinal side) of the outrigger pad must be observed. The support width of the crawler chain must be at least 1300 mm.

5.4.3 Driving the outrigger pad in the cross direction over a cavity with a crawler crane

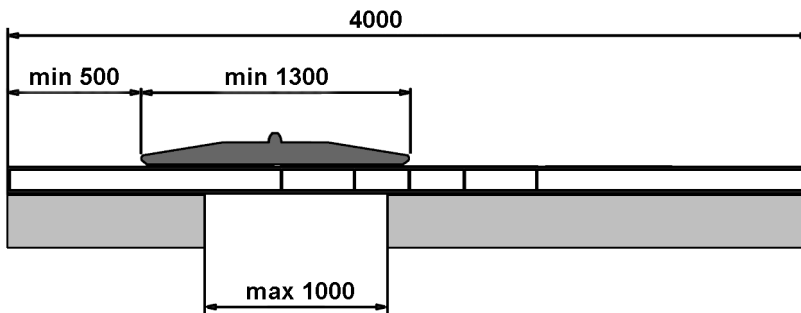

Fig.156551: Permissible driving range with the crawler crane

This outrigger pad can be driven in the cross direction over a cavity with an approved crawler crane. The distance of at least 500 mm to the side edges (longitudinal side) of the outrigger pad must be observed. The support width of the crawler chain must be at least 1300 mm. The cavity can have a maximum width of 1000 mm.

2 Safety

LWE/LR 13000-001/19503-01-02/en

LWE/LR 13000-001/19503-01-02/en

2.03 Job planning

1 Planning Crane operation

3

LWE/LR 13000-001/19503-01-02/en

Fig.195219

LWE/LR 13000-001/19503-01-02/en

1 Planning Crane operation

In addition to a perfectly working crane and a well-trained crew, the **planning for crane operation** is an important principle for safe crane operation.



WARNING

Missing information!

Death, severe bodily injuries, property damage.

- ▶ Obtain the required information and adhere to it.
-

Obtain the following information before crane operation and adhere to it:

- Type of crane operation
- National laws and regulations
- Height and width clearance measurements
- When mobile crane: Job site, distance and travel route
- Space prerequisites at the job site
- Electrical transmission lines with voltage data
- Movement restrictions caused by buildings
- Weight and dimensions of the load(s) to be lifted
- Geometric form and air resistance coefficient of the load(s) to be lifted
- Required lifting height and boom projection
- Ground bearing capacity at the job site
- Required space for the assembly and disassembly of the crane
- Weather data and weather forecasts

Assemble the equipment for crane operation:

- Hook block / load hook
- Auxiliary boom
- Fastening equipment
- Counterweight
- Base materials for support plates

Empty page!

LWE/LR 13000-001/19503-01-02/en

2.04 Technical safety instructions

1	Dangers on the crane	3
2	Danger zone of crane	5
3	Traffic endangerment and environmental damage	6
4	Endangering air traffic	6
5	Movement on the crane	7
6	Emergency exit - driver's cab	8
7	Emergency crane cab exit	8
8	Personal protective equipment	12
9	Supplied fire extinguisher	19
10	Securing persons to prevent them from falling	19
11	Rescuing the assembly personnel	21
12	Crane cab	21
13	Side window	29
14	Emergency hammer*	29
15	Transport	30
16	Fastening	33
17	Crane operator responsibilities	33
18	Selecting the location	35
19	Slopes and excavations	39
20	Loads on the ground due to crane operation	42
21	Support	46
22	Aligning the crane	48
23	Checking the safety measures	49
24	Safety instructions in case of an external power supply	50
25	Grounding for potential equalization	50
26	Working in the vicinity of transmitters	52
27	Crane operation in case of thunderstorms	53
28	Winch influences	54
29	Lifting a load with two cranes	61
30	Overlapping of working ranges of several cranes	63
31	Hand signals for guidance	64
32	Travel operation	72
33	Crane operation	74
34	Lifting of personnel	82
35	Securing personnel on shut off crane	84
36	Welding work on the load	86

Fig.195219

LWE/LR 13000-001/19503-01-02/en

**Note**

- ▶ The illustrations in this chapter are only examples. The illustrations may differ depending on the crane model.

1 Dangers on the crane

1.1 Chemicals

Proposition 65 of the US State of California warns against chemicals that are known to cause cancer and birth defects or other reproductive harm. For additional information, see the website: www.P65Warnings.ca.gov

Proposition 65	
	<p>WARNING: This product can expose you to chemicals, which are known to the State of California to cause cancer and birth defects or other reproductive harm.</p> <ul style="list-style-type: none"> • Avoid direct contact with chemicals. • Use personal protective equipment: Always wear protective gloves. • After handling: Wash hands thoroughly. • Dispose of chemicals in an environmentally acceptable manner according to local regulations. <p>For more information see: www.P65Warnings.ca.gov.</p>

Fig.154660: Example of a Proposition 65 sign for USA: Chemicals

**WARNING**

Chemicals!

Damage to health such as cancer and birth defects or other reproductive harm.

- ▶ Avoid direct contact with chemicals.
- ▶ Use personal protective equipment: **Always** wear protective gloves.
- ▶ After handling: Wash hands thoroughly.
- ▶ Dispose of chemicals in an environmentally acceptable manner according to local regulations.

1.2 Diesel engine exhaust emissions

Proposition 65 of the US State of California warns against diesel engine exhaust emissions that are known to cause cancer and birth defects or other reproductive harm. For additional information, see the website: www.P65Warnings.ca.gov/diesel

Proposition 65	
	<p>WARNING: Breathing diesel engine exhaust exposes you to chemicals known to the State of California to cause cancer and birth defects or other reproductive harm.</p> <ul style="list-style-type: none"> • Always start and operate the engine in a well-ventilated area. • If in an enclosed area, vent the exhaust to the outside. • Do not modify or tamper with the exhaust system. • Do not idle the engine except as necessary. <p>For more information see: www.P65Warnings.ca.gov/diesel.</p>

Fig.154661: Example of a Proposition 65 sign for USA: Diesel engine exhaust emissions



WARNING

Diesel engine exhaust emissions!

Damage to health such as cancer and birth defects or other reproductive harm.

- ▶ Always start and operate the diesel engine in properly ventilated spaces.
- ▶ If in enclosed areas: Direct the exhaust gas to the outside.
- ▶ Do not convert the exhaust system or make any other changes.
- ▶ Do not run the engine at idle speed for longer than necessary.

1.3 Lead and lead compounds

Proposition 65 of the US State of California warns against lead and lead compounds that are known to cause cancer and birth defects or other reproductive harm. For additional information, see the website: www.P65Warnings.ca.gov

Proposition 65	
	<p>WARNING: This product can expose you to chemicals, including lead and lead compounds, which are known to the State of California to cause cancer and birth defects or other reproductive harm.</p> <ul style="list-style-type: none"> • Avoid direct contact with batteries and their components. • Do not touch them with bare hands. • Use personal protective equipment: Always wear protective gloves. • After handling: Wash hands thoroughly. • Dispose of disused batteries in an environmentally acceptable manner according to local regulations. <p>For more information see: www.P65Warnings.ca.gov.</p>

Fig.154662: Example of a Proposition 65 sign for USA: Lead and lead compounds

**WARNING**

Batteries, battery poles, battery terminals and other battery components contain lead and lead compounds!

Damage to health such as birth defects and other reproductive harm.

- ▶ Avoid direct contact with batteries and their components.
- ▶ Do not touch them with bare hands.
- ▶ Use personal protective equipment: **Always** wear protective gloves.
- ▶ After handling: Wash hands thoroughly.
- ▶ Dispose of disused batteries in an environmentally acceptable manner according to local regulations.

1.4 Hydraulic oil, diesel fuel, operating fluids

**WARNING**

Due to technical defects or open tank covers, hydraulic oil, diesel fuel or service fluids spill out!

Dirt from the road and ground.

Traffic endangerment: Danger of skidding, death, severe bodily injuries.

Environmental pollution: Death, severe damage to health.

- ▶ Remedy the technical defect immediately.
- ▶ Securely close the tank cover after refueling.
- ▶ Immediately and thoroughly remove traces of hydraulic oil, diesel fuel, operating fluids.
- ▶ Avoid skin contact with hydraulic oil, diesel fuel and operating fluids.
- ▶ Wear personal protective equipment.

**WARNING**

Hot hydraulic oil! Hot service fluids!

Severe burns, severe scalds and severe bodily injuries.

- ▶ Before all work: Let hot hydraulic oil and hot operating fluids cool off.
- ▶ Avoid contact with hot hydraulic oil and hot operating fluids.
- ▶ Wear personal protective equipment.

1.5 Heated crane components

**WARNING**

Heated crane components! Hot surfaces!

Severe burns.

This applies in particular to exhaust systems, engines and transmissions.

- ▶ Let the components cool down before touching them.
- ▶ Proceed with special caution near heated crane components.
- ▶ Avoid skin contact with hot surfaces.
- ▶ Use personal protective equipment, such as protective gloves.

2 Danger zone of crane

2.1 Crane in operation

The danger zone of the crane is made up of the areas which are accessed during crane operation by the load or by movements of the crane or the crane components.

**WARNING**

Do not stay in danger zone!

Personnel within the danger zone can be hit by falling loads or components.

Personnel in the danger zone can be caught by moving crane components or loads.

Fatal or severe injuries can be the result.

- ▶ Warn any personnel within the danger zone with the warning device of the crane.
- ▶ After the warning is issued, wait and ensure that no personnel remains within the danger zone.
- ▶ If required, block off the danger zone at a safety distance.

2.2 Crane out of service

Take the crane out of service, failure to comply with the regulations represents considerable danger for the entire area around the crane.

**WARNING**

Actual wind speed higher than the wind speed permitted for the crane set up configuration!

Personnel within the danger zone can be hit by a toppling crane or crane components.

- ▶ Make sure that the condition of the crane complies with the regulations and the wind speed charts.
- ▶ If required, block off the danger zone at a safety distance.

**WARNING**

Icing on the boom!

Personnel within the danger zone can be hit by a falling ice.

- ▶ Make sure that there is no personnel in the danger zone.
- ▶ If required, block off the danger zone at a safety distance.

3 Traffic endangerment and environmental damage

**WARNING**

Danger of slipping and skidding!

If the road becomes contaminated due to technical defects, open tank covers or leaking hydraulic oil, then this would pose a severe traffic endangerment.

Fatal accidents can result.

- ▶ Remove oil immediately and thoroughly.

4 Endangering air traffic

When working with crane, heights are reached which could endanger air traffic. This applies especially to areas near airports.

**WARNING**

Endangering air traffic!

If no protective measures are taken, this can result in endangerment to air traffic.

- ▶ Get the approval from agency responsible for air traffic.
- ▶ Comply with national and international regulations and laws. For example, in order to identify aviation obstructions.
- ▶ Carry out identification if required according to the regulations and laws (for example with flags or warning signs).
- ▶ Install the airplane warning light on the boom head and turn it on.
- ▶ If the airplane warning lights is operated for a longer period of time, with the engine turned off, then the battery can be discharged and as the result the airplane warning light turns off. To prevent the battery from discharging, an external electrical power supply must be established.

5 Movement on the crane

To ensure that people can move safely on the crane, the crane has accessible surfaces.

Flat accessible surfaces have an anti-slip coating.

Accessible surfaces are, for example:

- Walking surfaces and stepping surfaces
- Stairs
- Ladders
- Gratings
- Platforms



WARNING

Danger of slipping and falling!

The traction of accessible surfaces and hand rails changes due to effects of the weather, such as wetness, snow, ice, frost and dirt.

People can slip and fall down from the crane. Death, severe bodily injuries are possible.

The crane can be damaged.

- ▶ Step on the accessible surfaces only by taking the present conditions into account, such as icing in winter or dirt.
- ▶ Step or place a load only on the approved accessible surfaces.
- ▶ Observe the signage.
- ▶ Replace damaged safety signs (warning signs) immediately.



WARNING

Slippery surfaces, lack of stability!

Personnel can fall down. Death, severe bodily injuries.

- ▶ Keep accessible surfaces free of objects and obstacles.
- ▶ Only step on accessible surfaces with a sufficiently clear height.
- ▶ Step on accessible surfaces only with clean shoes.
- ▶ Keep accessible surfaces free of heavy dirt, snow and ice!
- ▶ Stepping on accessible surfaces by persons, including tools and equipment, weighing more than 150 kg is prohibited.
- ▶ Do **not** step on damaged accessible surfaces and replace them immediately.
- ▶ Do **not** trip over attachment parts.
- ▶ Personnel must wear an approved fall arrest system and protective equipment before performing any work on the crane superstructure.

When fall protection equipment is **not** in the assembly / disassembly position or personnel is on **non-accessible** surfaces:

- ▶ Personnel must hook themselves to the hook points and safety ropes with an approved fall arrest system to prevent falling.



WARNING

Danger of tripping and falling!

When walking on a lattice boom / lattice section, there is a danger of tripping due to attachment parts. Personnel can fall down. Death, severe bodily injuries.

- ▶ Personnel must hook themselves to the hook points and safety ropes with an approved fall arrest system to prevent falling.
- ▶ A grating is approved for a maximum of two people with a total weight of 150 kg including tools and equipment.
- ▶ No objects, such as boom components or a pin pulling aggregate may be placed or moved on the grating.

6 Emergency exit - driver's cab



WARNING

The driver's cab **can** not be left using the normal path!

Danger of falling when exiting.

Crane damaged, inclined or tipped over: Increased danger of falling when exiting.

- ▶ Exit carefully in an emergency.

If the crane is damaged, inclined or tipped over:

- ▶ Accept help from others if possible.

The driver's cab can be exited through the driver's door or the passenger door.

6.1 Emergency exit through an open door

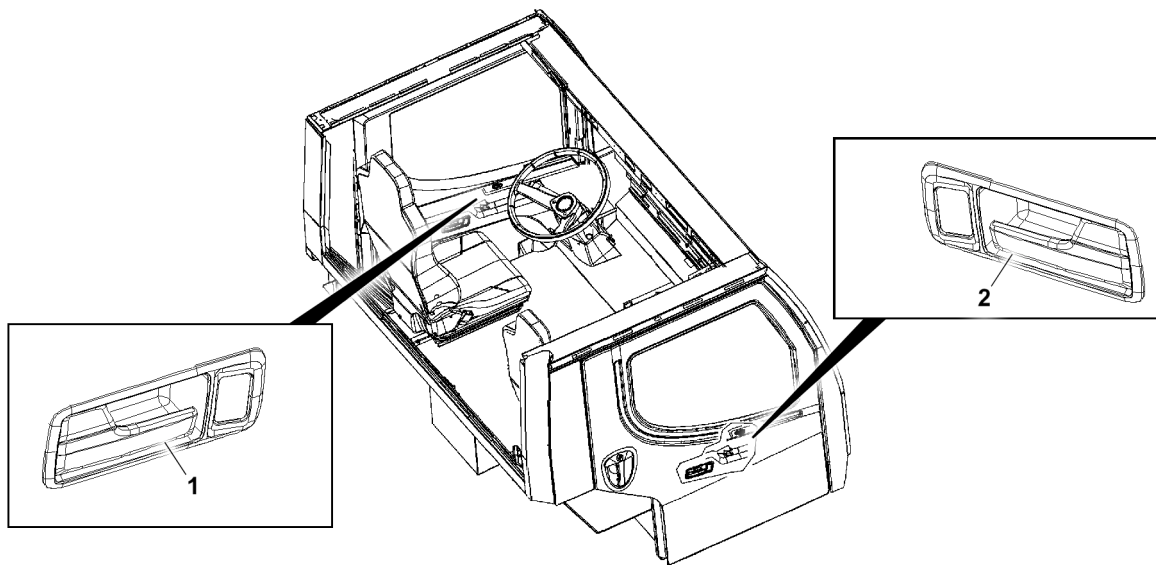

Fig.160365: Example of an emergency exit through an open door

Emergency exit through the open driver's door:

- Pull the door handle *to the left* 1 and open the driver's door.
- Leave the driver's cab through the driver's door.

Emergency exit through the open passenger door:

- Pull the door handle *to the right* 2 and open the passenger door.
- Leave the driver's cab through the passenger door.

7 Emergency crane cab exit



WARNING

The crane cab **can** not be left using the normal path!

Danger of falling when exiting.

Crane damaged, inclined or tipped over: Increased danger of falling when exiting.

- ▶ Exit carefully in an emergency.

If the crane is damaged, inclined or tipped over:

- ▶ Accept help from others if possible.

The crane cab can be left in different ways depending on the type of crane:

- Emergency exit through the open cab door

- Emergency exit through the open front window
- Emergency exit through the roof window with emergency release
- Emergency exit through the side window with emergency release

**Note**

Each crane cab has at least a suitable window for an emergency exit.

- ▶ Windows with sufficiently large openings can be used as an emergency exit depending on the emergency situation.
- ▶ Some windows require an emergency release in order to create an opening large enough to climb through.

Not all windows can be used for an emergency exit:

- ▶ Some windows are kept small for safety reasons or secured, for example with a securing bracket.

7.1 Emergency exit through the open cab door

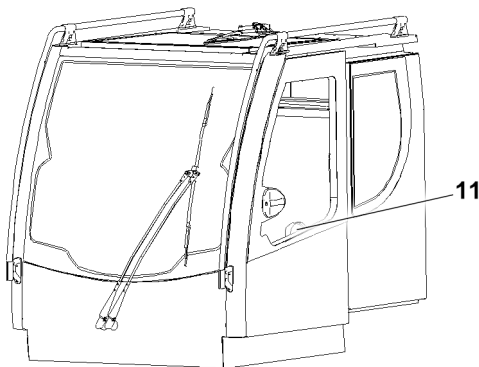

Fig.160389: Emergency exit through the open cab door

Emergency exit through the open cab door:

- Turn the inner door handle **11** and open the cab door.
- Leave the crane cab through the cab door.

7.2 Emergency exit through the open front window

For crane types with a tipping front window

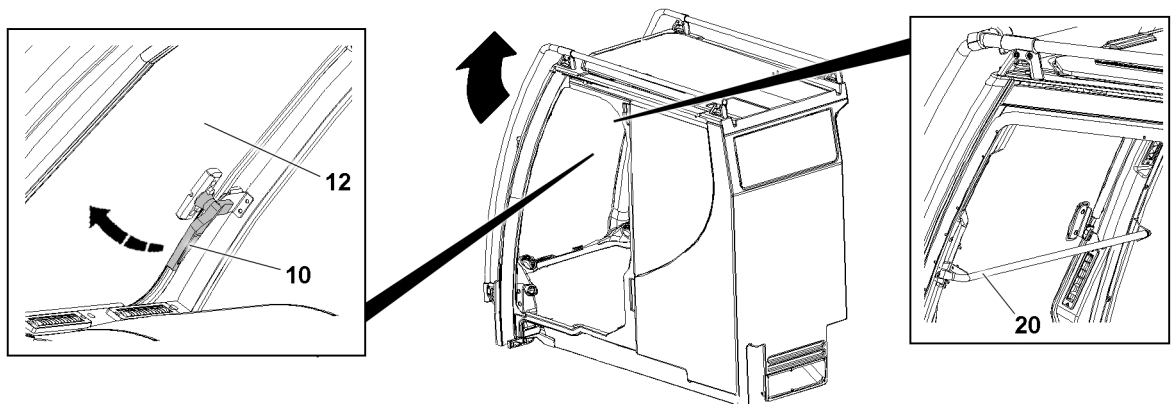

Fig.157680: Emergency exit through the open front window

**Note**

- ▶ The front windows **12** with a securing bracket **20** are not designed as an emergency exit.

- Release all turn handles **10** on the front window **12**.
- Open the front window **12**.
- Leave the crane cab through the front window **12**.

7.3 Emergency exit through the roof window with emergency release



Note

When the roof window is closed, the emergency release is difficult to operate.

- ▶ First open the roof window.

There are two variations of the emergency release:

- Window handle emergency release
- Gas pressure spring emergency release

7.3.1 Emergency release on the window handle

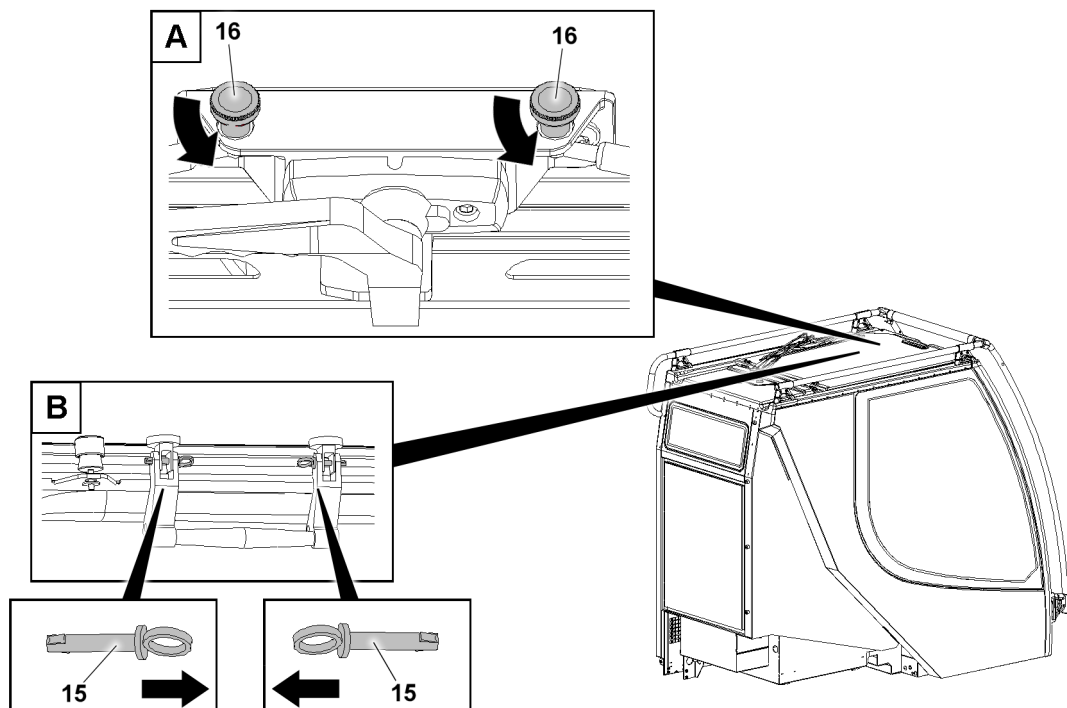

Fig.160655: Emergency release on the window handle

For crane types with an emergency release on the roof window:

- Open the roof window with the window handle.
- Operate the emergency release for the roof window, see variation A or variation B.

Variation A:

- Turn both thumbscrews **16** counterclockwise and release.

Variation B:

- Unpin both pins **15** by pulling them.
- Leave the crane cab through the roof window.

7.3.2 Gas pressure spring emergency release

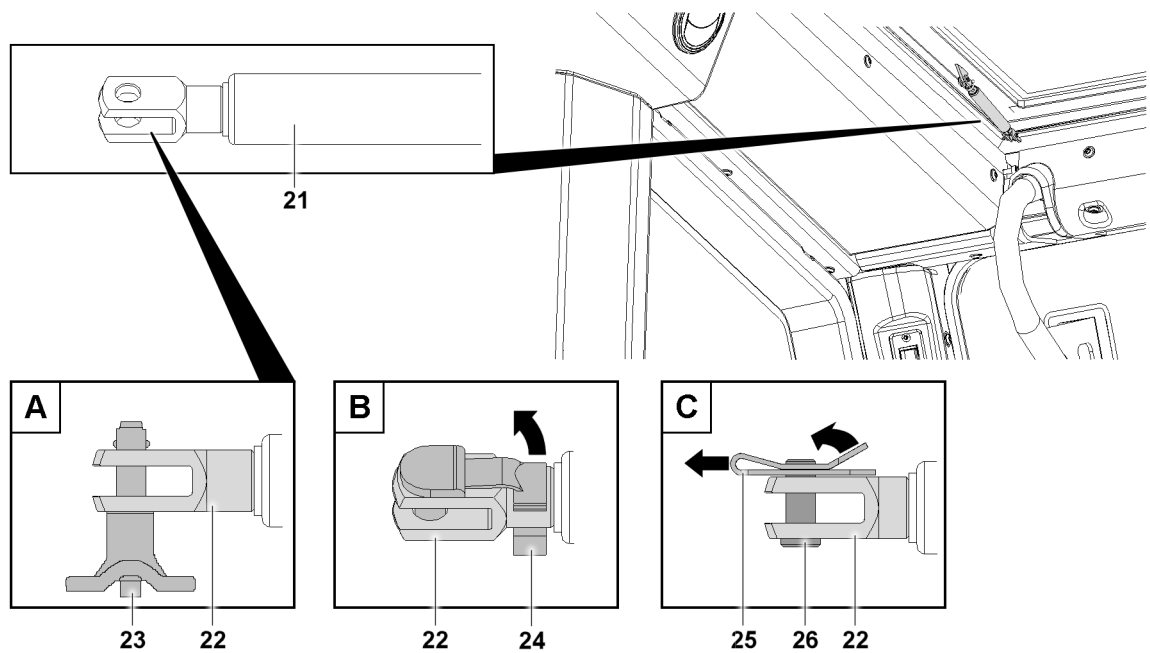

Fig.160604: Gas pressure spring emergency release

For crane types with an emergency release on the roof window:

- Open the roof window with the window handle.
- Operate the gas pressure spring **21** for the roof window, see variation A, variation B or variation C:

Variation A:

- Release the ball locking pin **23** by pressing and holding the press button on the side of the handle.
- Unpin the ball locking pin **23** by pulling it out of the fork head **22**.

Variation B:

- Release the pin **24** on the fork head **22** by swinging it.
- Unpin the released pin **24** by pulling it out of the fork head **22**.

Variation C:

- Lift the retaining element **25** on the protruding part and push it away at the same time.
- Unpin the released pin **26** by pulling it out of the fork head **22**.
- Leave the crane cab through the roof window.

7.4 Emergency exit through the side window with emergency release

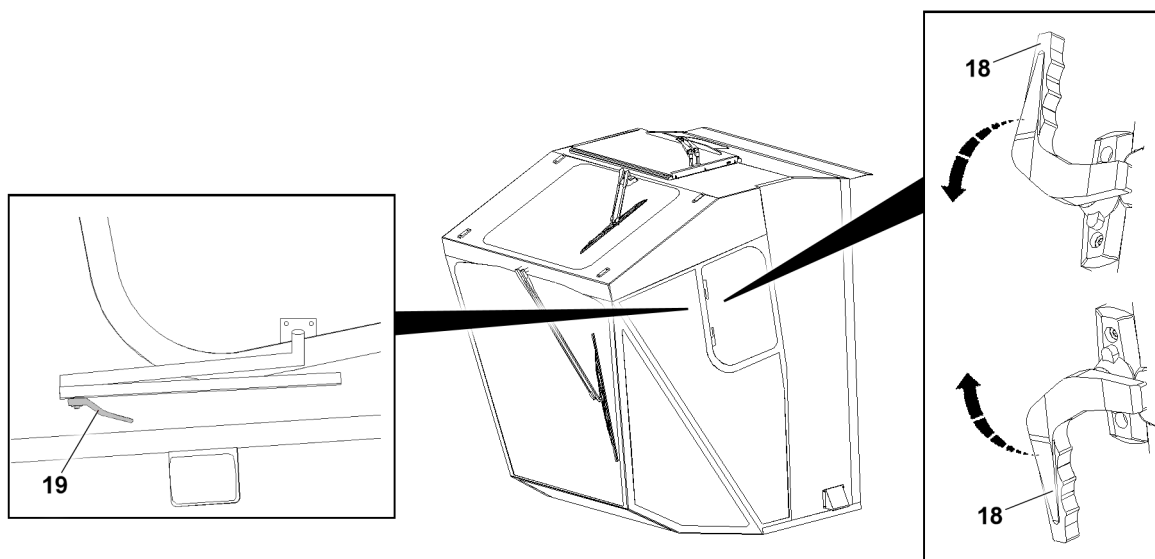

Fig.158755: Emergency exit through the side window with emergency release

For crane types with an emergency release on the side window:

- Release all turn handles **18** on the side window.
- Disassemble the clamping lever **19** on the side window.
- Open the side window completely.
- Leave the crane cab through the side window.

8 Personal protective equipment

When working on the crane, the required personal protective equipment according to national regulations and accident prevention regulations must be provided and used.

Personal protective equipment includes the following:

- Supplied fall arrest system (safety harness and height safety equipment)
- Supplied height rescue system
- Head protection with chin strap
- Safety shoes
- Protective gloves
- Safety goggles
- Warning apparel
- Hearing protection
- Respiratory protection

**WARNING**

Personal protective equipment when working on the crane not used!
Death, severe bodily injuries.

The crane operator must ensure the following:

- ▶ The personal protective equipment is made available.
- ▶ The provided personal protective equipment is taken along and used.
- ▶ The operating instructions and maintenance instructions of the manufacturer for the personal protective equipment are observed and complied with.
- ▶ The product identifications are regularly checked for damage.
- ▶ Personal protective equipment with damaged product identification is replaced immediately.
- ▶ Damaged fall arrest systems with height rescue systems will be replaced immediately and handed over to an authorized inspector.
- ▶ Personal protective equipment is checked for damage and completeness before use.
- ▶ Defective or damaged personal protective equipment is replaced immediately with functioning protective equipment.

8.1 Supplied fall arrest system

When no other safety measures are possible for working in the presence of a fall hazard, the supplied fall arrest system must be used.

A fall with a fall arrest system cannot exclude an injury. The fall arrest system reduces however the severity of the injuries.

**WARNING**

Persons not secured!
Personnel can fall down. Death, severe bodily injuries.

- ▶ Use the supplied fall arrest system.

**WARNING**

Fall arrest system damaged!
Personnel can fall down. Death, severe bodily injuries.

- ▶ Do **not** use a damaged fall arrest system.
- ▶ Replace a damaged fall arrest system immediately with a new fall arrest system.
- ▶ Do **not** use the fall arrest system as fastening equipment for loads.
- ▶ Protect the fall arrest system from external influences.

The fall arrest system must be protected against the following external influences:

- Extreme temperatures
- Guiding the connecting devices over or around sharp edges
- Chemical influences
- Electrical influences
- Cuts, wear
- Climatic effects

**Note**

If the fall arrest system (safety harness and height safety equipment) is not available or is damaged:
▶ Order is from Liebherr-Werk Ehingen GmbH.

Identification and operating instructions

- The supplied fall arrest system must be clearly and permanently identified.
- If the identification is no longer legible, then the supplied fall arrest system must be immediately replaced and handed over to an authorized inspector.
- The operating instructions must be available in the language of the user country.
- If the crane and the relative personal protective equipment is sold to another country, then the purchaser must make sure that the complete documentation, such as the operating instructions, the

manufacturer's operating instructions, inspection log and maintenance documents, are available in the language of the user country.

8.1.1 Safety harness with height safety equipment

The fall arrest system consists of the following components:

- Safety harness **1** approved according to **EN 361**
- Single strand height safety equipment **2** approved according to **EN 360** (for horizontal use and sharp edges)
- or two strand height safety equipment **3** approved according to **EN 360** (for horizontal use and sharp edges)

Fall arrest systems that are not obtained from Liebherr-Werk Ehingen GmbH are **not** designed for the crane structure.



WARNING

Impermissible fall arrest system!

Personnel can fall down. Death, severe bodily injuries.

- ▶ Utilize exclusively a fall arrest system from Liebherr-Werk Ehingen GmbH.

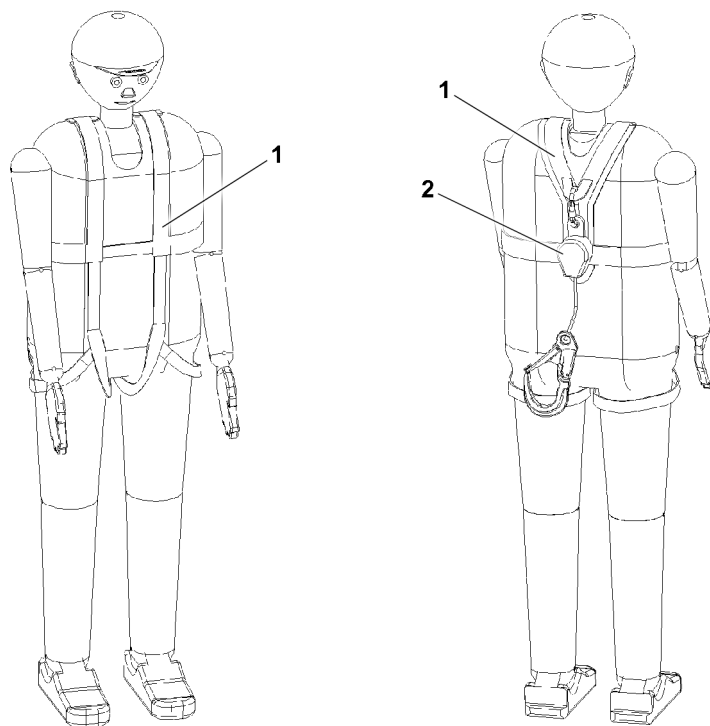

Fig.146453: Example of a safety harness **1** with single strand height safety equipment **2**

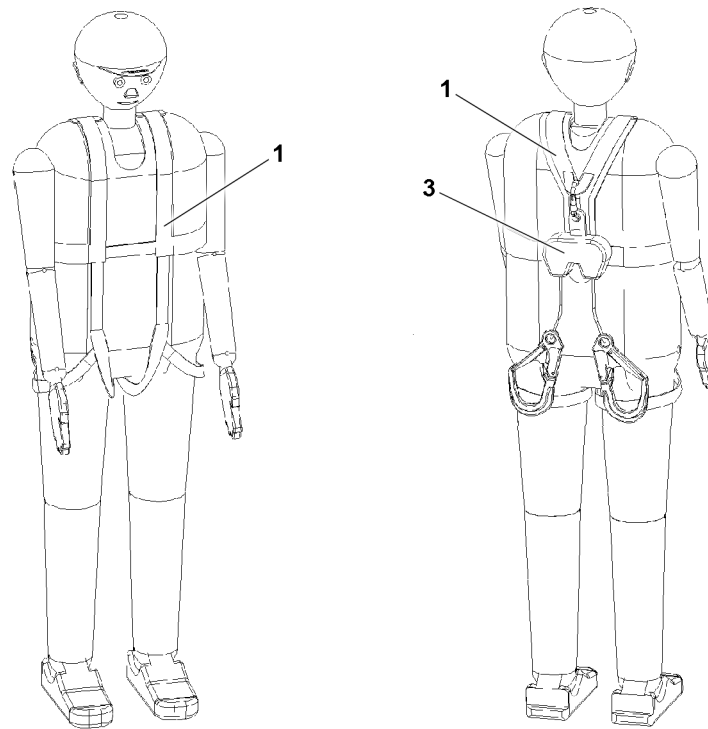

Fig.146454: Example of a safety harness 1 with two strand height safety equipment 3

Prior to crane operation:

- Make sure that the fall arrest system is completely available and functional.
- Check the fall arrest system before use for visible defects. In the case of visible defects: Replace the fall arrest system immediately.

Handling the supplied fall arrest system:

- Observe and comply with the operating instructions of the fall arrest system.
- Check the fall arrest system before use for visible defects.
- The fall arrest system must be worn where no other fall protection equipment, such as railings, can be installed for technical reasons.
- The fall arrest system is effective from a height of 2.5 m. The fall space must be free of obstacles.
- Do **not** change the configuration of the fall arrest system.
- Do **not** lengthen or shorten the fall arrest rope.
- A fall absorber is integrated in the height safety equipment. Do **not** use an additional fall absorber.
- Fasten the fall arrest system only to the hook points, safety ropes and fastening points designed for this purpose. See chapter 2.06.

Behavior in the case of a fall, damage or impairment of the functionality:

- In the case of damage or impairment of the functionality: Replace the fall arrest systems immediately and hand them over to an authorized inspector.
- After every fall: Take down the fall arrest system immediately and hand it over to an authorized inspector. The results must be documented in the fall arrest system inspection log book.
- Only after a written approval may the fall arrest system be reused. The approval must be provided in writing and documented.
- Fall arrest systems that are no longer approved must **not** be used. Unapproved fall arrest systems must be disposed of and replaced with new fall arrest systems.

Storage of the fall arrest system:

- Store the fall arrest system dry and without the effect of UV radiation in the corresponding transport bag.

The operator must ensure the following:

- Personnel must be instructed at least once a year on how to use the supplied fall arrest system (safety harness and height safety equipment) with practical exercises. Performance of the instruction and exercises must be documented.

- The safety harness and height safety equipment must be checked at least once a year by an authorized inspector. The results must be documented in the fall arrest system inspection log book.

Single strand height safety equipment

The single strand height safety equipment is equipped with a belt strap. Single strand height safety equipment is provided for all cranes that do not have walking surfaces with safety ropes.

Use the supplied height safety equipment with extendable belt strap and snap hook with swivel according to **EN 362 Class A**.

Two strand height safety equipment

The two strand height safety equipment is equipped with two belt straps. Height safety equipment with two belt straps are provided for cranes with walking surfaces and two ropes as fastening device on the left and right hand side of the walking surface, for example lattice sections, lattice booms, possibly telescopic booms or assembly units.

Use the supplied height safety equipment with two extendable belt straps and snap hooks with swivel according to **EN 362 Class A**.



WARNING

Height safety equipment incorrectly used!
Personnel can fall down. Death, severe bodily injuries.

When two safety ropes are present on the booms, lattice sections or other components:

- ▶ Only use the height safety equipment with two belt straps.
- ▶ Connect one belt strap with snap hook for the fall arrest system per safety rope.
- ▶ When transferring to new safety equipment, a snap hook for the fall arrest system must **always** be hooked.

8.2 Height rescue system

The height rescue system is only supplied on certain crane types.

The height rescue system is an evacuation and rescue device. It is used to lift the fallen person to be able to unhook him from the height safety equipment and to lower him by rope.

The height rescue system consists of the following components:

- Rappelling rescue device
- Telescopic rod for hooking the snap hook on the safety harness



WARNING

Height rescue system not present!
Fallen person cannot be saved. Suspension trauma, death, severe bodily injuries.

- ▶ Always have the height rescue system ready.



WARNING

Height rescue system damaged!
Personnel cannot be saved.

- ▶ Do **not** use a damaged height rescue system.
- ▶ Replace a damaged height rescue system immediately with a new height rescue system.
- ▶ Protect the height rescue system from external influences.

The height rescue system must be protected against the following external influences:

- Extreme temperatures
- Chemical influences
- Electrical influences
- Cuts, wear
- Climatic effects

Prior to crane operation:

- Make sure that the height rescue system is completely available and functional.
- Check the height rescue system before use for visible defects. In the case of visible defects: Replace the height rescue system immediately.

Handling the height rescue system:

- Observe and comply with the operating instructions of the height rescue system.
- Do **not** change the configuration of the height rescue system.

Behavior in the case of a fall, damage or impairment of the functionality:

- In the case of damage or impairment of the functionality: Replace the height rescue system immediately and hand it over to an authorized inspector.
- After every use: Hand the height rescue system over to authorized inspector. The results must be documented in the height rescue system inspection log book.
- Only after a written approval may the height rescue system be reused. The approval must be provided in writing and documented.
- Height rescue systems that are no longer approved must **not** be used. Unapproved height rescue systems must be disposed of and replaced with new height rescue systems.

Storage of the height rescue system:

- Store the height rescue system dry and without the effect of UV radiation in the corresponding transport bag.

The operator must ensure the following:

- Personnel must be instructed at least once a year on how to use the height rescue system with practical exercises. Performance of the instruction and exercises must be documented.
- The height rescue system must be checked at least once a year by an authorized inspector. The results must be documented in the height rescue system inspection log book.

8.3 Hard hat

Wear a hard hat with a chin strap, if head injuries are possible. For example, due to:

- Striking
- Falling, tipping or flying objects
- Oscillating objects

Replace the hard hat immediately, if:

- If is struck with force
- It has visible defects
- The maximum service life specified by the manufacture has been reached

An industrial hard hat can protect against striking fixed objects and falling or oscillating objects, but **not** against falling loads.



WARNING

Suspended and falling loads!
Death, severe bodily injuries.

- ▶ Do **not** remain under suspended loads.

8.4 Protective gloves

Wear protective gloves, if hand injuries are possible. For example, due to:

- Pointy or sharp objects
- Hot surfaces

When working with ropes: Protective gloves must be puncture proof.

8.5 Safety shoes

Wear safety shoes, if foot injuries are possible. For example, due to:

- Oscillating or falling parts
- Pointy or sharp objects

- Impact or trapping
- Slipping on slippery ground or surfaces

8.6 Warning apparel

Avoid accidents: Wear reflecting, signal color warning clothing, when personnel must be visible and recognizable.

The „warning clothing“ category includes, for example:

- Safety vest
- Safety jacket
- Safety pants

8.7 Safety goggles

Wear safety goggles when eye injuries are possible. For example, due to:

- Corrosive fluids
- Pressurized fluids
- Flying parts

8.8 Hearing protection

Wear hearing protection when there is danger of hearing damage due to noise.

8.9 Respiratory protection

Wear respiratory protection when there is danger of damage due to polluted air.

8.10 Aids for work at a height

All work at a height, when there is a danger of falling, must be carried out with suitable aids.

Part of the category „Aids for working at a height“ are, for example:

- Work platforms
- Scaffolding
- Assembly platform
- Catwalks
- Ladders

When working at a height, working on a work platform, scaffolding, assembly platform, catwalk or similar is preferential to working on a ladder.



WARNING

Persons not secured when working at a height!
Personnel can fall down. Death, severe bodily injuries.

When work platforms, scaffolding, catwalks or similar are not available and the work cannot be carried out from the ground:

- ▶ Secure personnel with the supplied fall arrest system to prevent falling.

When fall protection equipment such as hook points, safety ropes and fastening points are available on the crane:

- ▶ Secure personnel with the fall arrest system to the fall protection equipment. See chapter 2.06.

When stepping on a ladder:

- ▶ Do not hold any objects in your hands.
- ▶ Adhere to the 3-point support. See chapter 2.04.10.

Rules when using the aids:

- Step on the ladder only with clean shoes.
- Keep it free from heavy dirt deposits.
- Keep it free of snow and ice.

9 Supplied fire extinguisher

Storage of the fire extinguisher:

- To protect against damage, store the fire extinguisher in its designated location.

Before crane operation and travel operation:

- Make sure that the fire extinguisher is always freely accessible and functional.

After use:

- Have the fire extinguisher refilled immediately or replaced.

Replace the fire extinguisher immediately, if:

- It has visible defects.
- The fire extinguisher does not function.
- The inspection term specified by the manufacturer has been exceeded.
- The maximum service life specified by the manufacture has been reached.

The operator must ensure the following:

- Personnel must be instructed at least once a year on how to use the fire extinguisher with practical exercises. Performance of the instruction and exercises must be documented.
- The fire extinguisher must be checked by an authorized inspector according to the manufacturer's specifications and national regulations. The results must be documented.
- Non-functional and used fire extinguishers must be immediately repaired or replaced.

10 Securing persons to prevent them from falling



WARNING

Danger of falling!

- ▶ Wear the supplied fall arrest systems (safety harnesses and height safety equipment) correctly.
- ▶ When accessing a ladder, do not hold any objects in your hands.
- ▶ When accessing a ladder, adhere to the 3-point support. See the Crane operating instructions, chapter 2.04.10.

10.1 Working on the telescopic boom head and / or auxiliary boom

When performing assembly or disassembly work on a ladder, people can fall down:

- A second person must be present to hand the necessary items to the person on the ladder.

Reeve the hoist rope in or out on the pulley head:

- For ladder work, use the supplied ladder: For fastening and hook points, see the Crane operating instructions, chapter 2.06.
- For cranes that carry a ladder along **with** a hook device:
Use the hook device to secure the ladder.
- For cranes, which carry a ladder along **without** hook device:
Use the rigging belt to secure the ladder.
- When ascending, assembly personnel must ensure a 3-point support.
- If there is a danger of falling, the assembly personnel must hook themselves with the snap hooks of the fall arrest system on the fastening points and secure themselves against falling.

10.2 Walking on the telescopic boom



WARNING

Danger of falling!

The assembly personnel can fall down by slipping on the telescopic boom and be killed or severely injured!

- ▶ The telescopic boom may only be accessed if assembly personnel is protected with suitable safety measures to prevent them from falling.
- ▶ If safety ropes are present on the telescopic boom, then assembly personnel must hook themselves with the supplied fall arrest system to the safety ropes of the telescopic boom on the left and right with both snap hooks and secure themselves against falling.
- ▶ Without safety measures, it is **strictly** prohibited to step on the telescopic boom.

Assembly of the hoist rope or the TY-guying:

- During assembly, the assembly personnel must hook themselves on the fastening devices on the left and right with both snap hooks of the fall arrest system and secure themselves against falling.

10.3 Accessing the lattice sections or booms

Climbing the ladder:

- When ascending, assembly personnel must ensure a 3-point support.

Changing from a ladder to a catwalk **without** a transition aid:

- From a transition height above 1.8 m: **Before** transitioning, assembly personnel must hook at least one snap hook of the fall arrest system to a safety rope and secure themselves against falling.

Changing from a ladder to a catwalk **with** a transition aid:

- **After** transitioning, assembly personnel must hook at least one snap hook of the fall arrest system to a safety rope and secure themselves against falling.

10.4 Walking on lattice sections or booms

Walking on catwalks:

- When walking on catwalks, the assembly personnel must hook themselves on the safety ropes on the left and right with both snap hooks of the fall arrest system and secure themselves against falling.
- When changing the fall arrest system over to a new lattice section, the assembly personnel must be hooked with at least one snap hook of the fall arrest system to one item of safety equipment.

10.5 Working on lattice sections or booms

Pinning, unpinning the lattice sections of pull rods:

- During pinning, unpinning of lattice sections or pull rods, the assembly personnel must hook themselves on the safety ropes on the left and right with both snap hooks of the fall arrest system and secure themselves against falling.

Fastening the lattice sections:

- When fastening the lattice sections, the assembly personnel must hook themselves on the safety ropes on the left and right with both snap hooks of the fall arrest system and secure themselves against falling.

10.6 Descending from lattice sections or booms

Accessing the ladder **without** a transition aid:

- From a transition height above 1.8 m: **Before** stepping on the ladder, assembly personnel must hook at least one snap hook of the fall arrest system to a safety rope and secure themselves against falling.
- When stepping on the ladder, assembly personnel must ensure a 3-point support.
- The snap hook of the fall arrest system may only be unhooked after standing safely on the ladder (3-point support).

Accessing the ladder **with** transition aid:

- When stepping on the ladder, assembly personnel must ensure a 3-point support.

Climbing down the ladder:

- When descending, the assembly personnel must ensure a 3-point support.

11 Rescuing the assembly personnel

The height rescue system is only supplied on certain crane types.

The height rescue system, consisting of the rappelling rescue device, is an evacuation and rescue device. It is used to lift the fallen person to be able to unhook him from the height safety equipment and to lower him by rope.



WARNING

Danger of falling!

- ▶ The assembly personnel must be instructed and trained properly in the correct handling of the height rescue system. Annual practice instructions and drills must be carried out.
- ▶ The supplied height rescue system must be kept available.
- ▶ The operating instructions of the manufacturer for the height rescue system must be observed and adhered to.
- ▶ The height rescue system must be checked annually by authorized and trained expert personnel and documented in the inspection log book.

11.1 First aid measures after rescue



WARNING

Danger of fatal injury!

- ▶ After the rescue, the patient must be positioned with the upper body raised (in seated or squatting position).
- ▶ Immediate flat position or even shock position can be fatal.

12 Crane cab

The roof of the crane cab is not designed as a support surface.



WARNING

Standing on the roof of the crane cab!

Persons on the roof of the crane cab can fall down, break through the roof or slide off.

- ▶ Do not access the roof of the crane cab.



WARNING

The superstructure is in a position in which it is **no** longer safe to climb up to it and it is **no** longer possible to change the position of the superstructure to a safe ascent position!

People can fall down while ascending. Death, severe bodily injuries.

- ▶ Guarantee safe ascent / descent: Set up suitable climbing aids, such as a platform or ladder.

12.1 Extendible step* for cranes on tires

An extendible step allows comfortable entry into the crane cab as well as safe exit from the crane cab to the crane chassis and safe access to the turntable.

The description for an „extendible step for cranes on tires“ only applies for cranes that drive on tires.

Ascending and descending takes place via the ladder on the crane chassis. See chapter 2.07 „Accesses to the crane“.



WARNING

Extendible step in the incorrect position!
Personnel can fall down. Death, severe bodily injuries.

- ▶ Make sure that the extendible step is in the correct position.

The extendible step must be **retracted** for:

- **Access to the crane cab below the cab door**
Access to the crane cab via the ladder from the ground or when directly descending from the crane cab via the ladder to the ground
- **Access to the crane cab in front of the crane cab**
Access to the crane cab via the ladder from the ground or when directly descending from the crane cab via the ladder to the ground

The extendible step must be **extended** for:

- **Access via an extendible step from the rear**
Access to the crane cab via the crane chassis or the crane superstructure
- **Accessing via the front step**
Access to the crane cab via the crane chassis or the crane superstructure

12.1.1 Access to the crane cab below the cab door

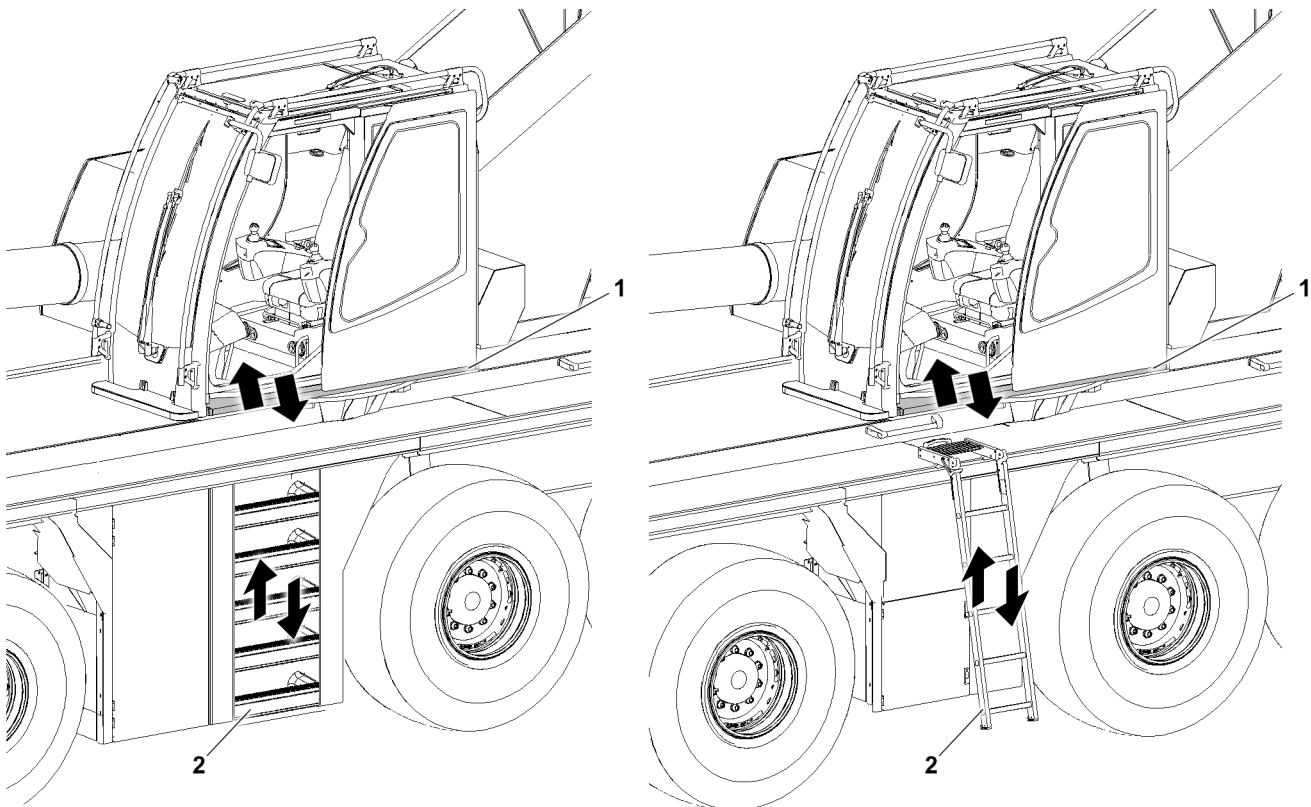

Fig.160754: Crane superstructure in the 180° position: Step retracted

- 1 Extendible step 2 Ladder / folding ladder

Prior to climbing up to the crane cab via the ladder **2** from the ground or before descending from the crane cab via the ladder **2** to the ground, the following prerequisites must be met:

- The crane superstructure is in the 180° position.
- In the case of a crane cab with incline adjustment: The crane cab is in the horizontal position.
- The extendible step **1** under the crane cab is **retracted**.
- The folding ladders **2** are in the ascent and descent position.

**WARNING**

Extendible step **1** in the incorrect position!
 Personnel can fall down. Death, severe bodily injuries.
 ► Make sure that the extendible step **1** is fully retracted.

**WARNING**

The step **1** **cannot** be retracted!
 People can fall during ascent and descent via the ladder **2**.
 Death, severe bodily injuries.
 ► Guarantee safe ascent / descent: Set up suitable climbing aids, such as a platform or ladder.

12.1.2 Access to the crane cab in front of the crane cab

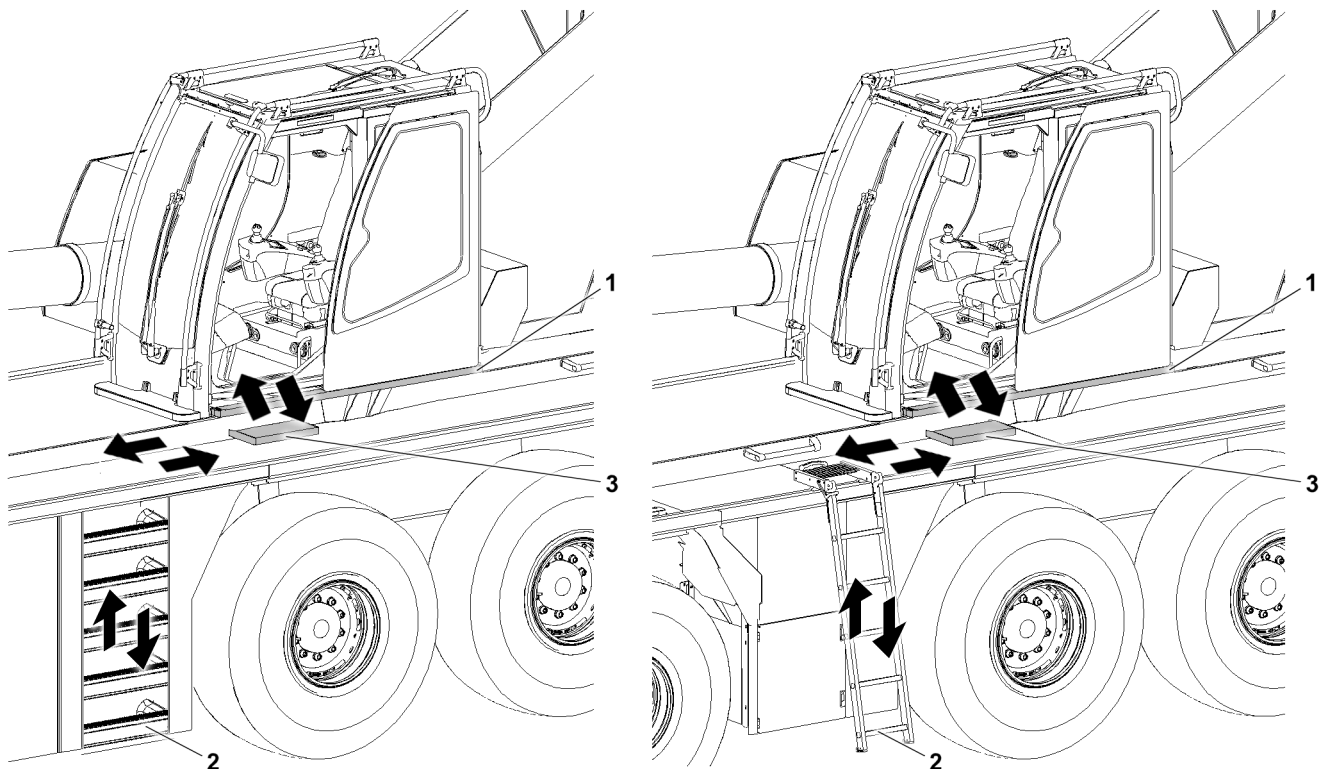

Fig.160768: Crane superstructure in the 180° position: Step **retracted**

- 1** Extendible step **2** Ladder / folding ladder **3** Intermediate step

The intermediate step **3** is installed only for certain crane types.

When accessing the crane cab in front of the crane cab, the following prerequisites must be met:

- The crane superstructure is in the 180° position.
- In the case of a crane cab with incline adjustment: The crane cab is in the horizontal position.
- The extendible step **1** is **retracted**.
- The folding ladders **2** are in the ascent and descent position.

**WARNING**

Extendible step **1** in the incorrect position!
 Personnel can fall down. Death, severe bodily injuries.
 ► Make sure that the extendible step **1** is fully retracted.

12.1.3 Access via an extendable step from the rear

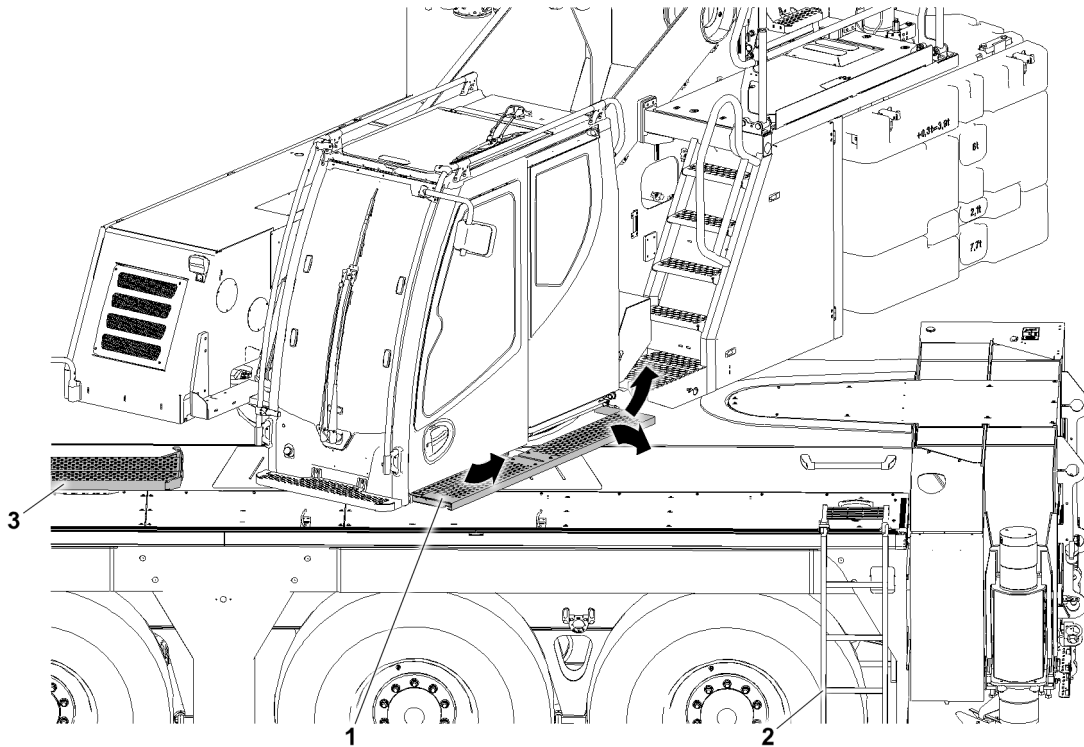

Fig.160756: Access via an extendable step from the rear

- | | | | |
|---|-----------------|---|-------------------|
| 1 | Extendible step | 3 | Intermediate step |
| 2 | Folding ladder | | |

The intermediate step **3** is installed only for certain crane types.

When accessing via an extendable step **1** from the rear, the following prerequisites must be met:

- Access to walkable surfaces of the crane chassis is ensured.
- The extendible step **1** **must** be extended.
- The **cab door** must be closed.
- In the case of a crane cab with incline adjustment: The crane cab is in the horizontal position.
- The folding ladders **2** are in the ascent and descent position.



WARNING

Extendible step **1** in the incorrect position!
Personnel can fall down. Death, severe bodily injuries.
▶ Make sure that the extendible step **1** is fully extended.



WARNING

Cab door opened!
The step depth of the extendible step **1** is too shallow.
Personnel can fall down. Death, severe bodily injuries.
▶ Make sure that the cab door is closed completely.

12.1.4 Accessing via the front step

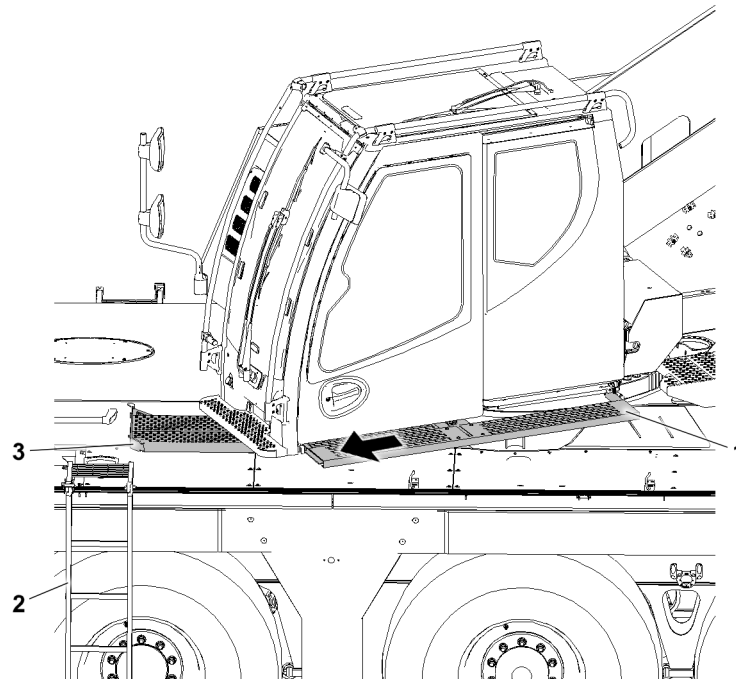

Fig.160757: Accessing via the front step

- | | | | |
|---|-----------------|---|-------------------|
| 1 | Extendible step | 3 | Intermediate step |
| 2 | Folding ladder | | |

The intermediate step **3** is installed only for certain crane types.

When accessing via the front step, the following prerequisites must be met:

- Access to walkable surfaces of the crane chassis is ensured.
- The extendible step **1** **must** be extended.
- In the case of a crane cab with incline adjustment: The crane cab is in the horizontal position.
- The folding ladders **2** are in the ascent and descent position.



WARNING

Extendible step **1** in the incorrect position!

Personnel can fall down. Death, severe bodily injuries.

- ▶ Make sure that the extendible step **1** is fully extended.

12.2 Access for LTR cranes

An extendible step allows comfortable entry into the crane cab as well as exit from the crane cab during crane operation.

The description for an „extendible step for LTR cranes“ only applies for LTR cranes.

12.2.1 Access for LTR 1060 and LTR 1100

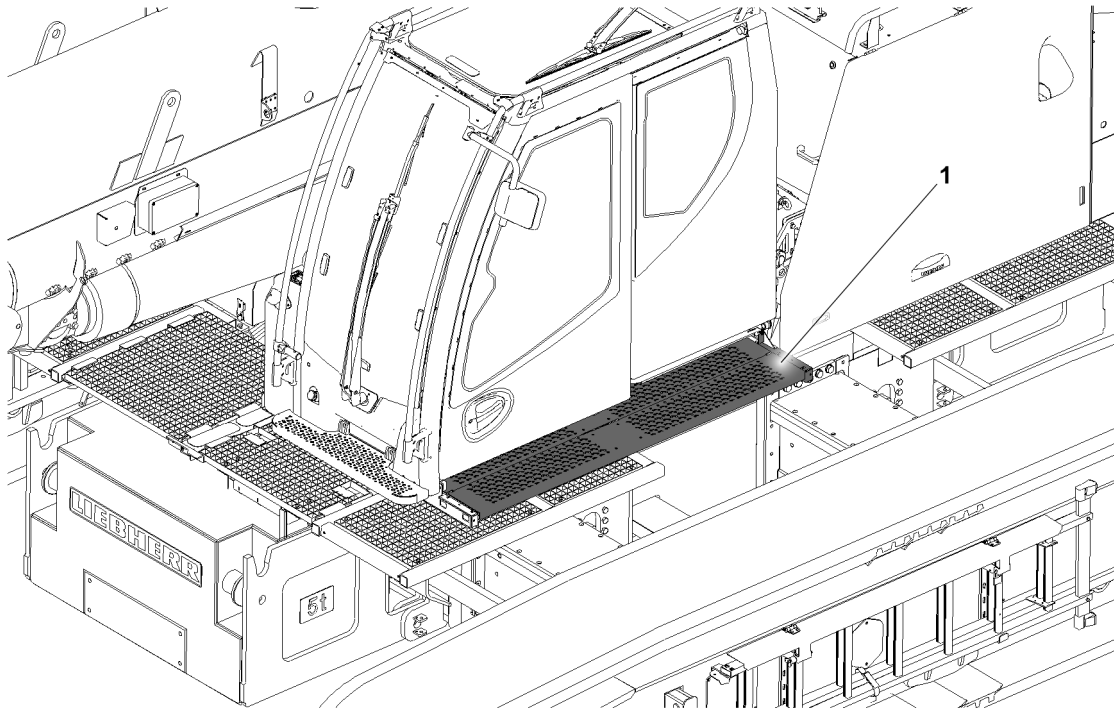

Fig.161886: Access for LTR 1060 and LTR 1100

1 Extendible step

Ascending and descending takes place on the walking surfaces of the crawler chain. See chapter 2.07 „Accesses to the crane“.

Before entering or exiting the crane cab, the following prerequisites must be met:

- The crane superstructure is in the 0° position (driving position).
- The crane is horizontally aligned.
- The crane cab is in the horizontal position.



WARNING

The superstructure is in a position in which it is **no** longer safe to climb up to it and it is **no** longer possible to change the position of the superstructure to a safe ascent position!
People can fall down while ascending. Death, severe bodily injuries.

- ▶ Guarantee safe ascent / descent: Set up suitable climbing aids, such as a platform or ladder.



WARNING

The rise from the walking surface and cab floor is more than 300 mm !
Personnel can fall down. Death, severe bodily injuries.

- ▶ Guarantee safe ascent and descent: Set up suitable climbing aids, such as a safety step.

12.2.2 Access for LTR 1220

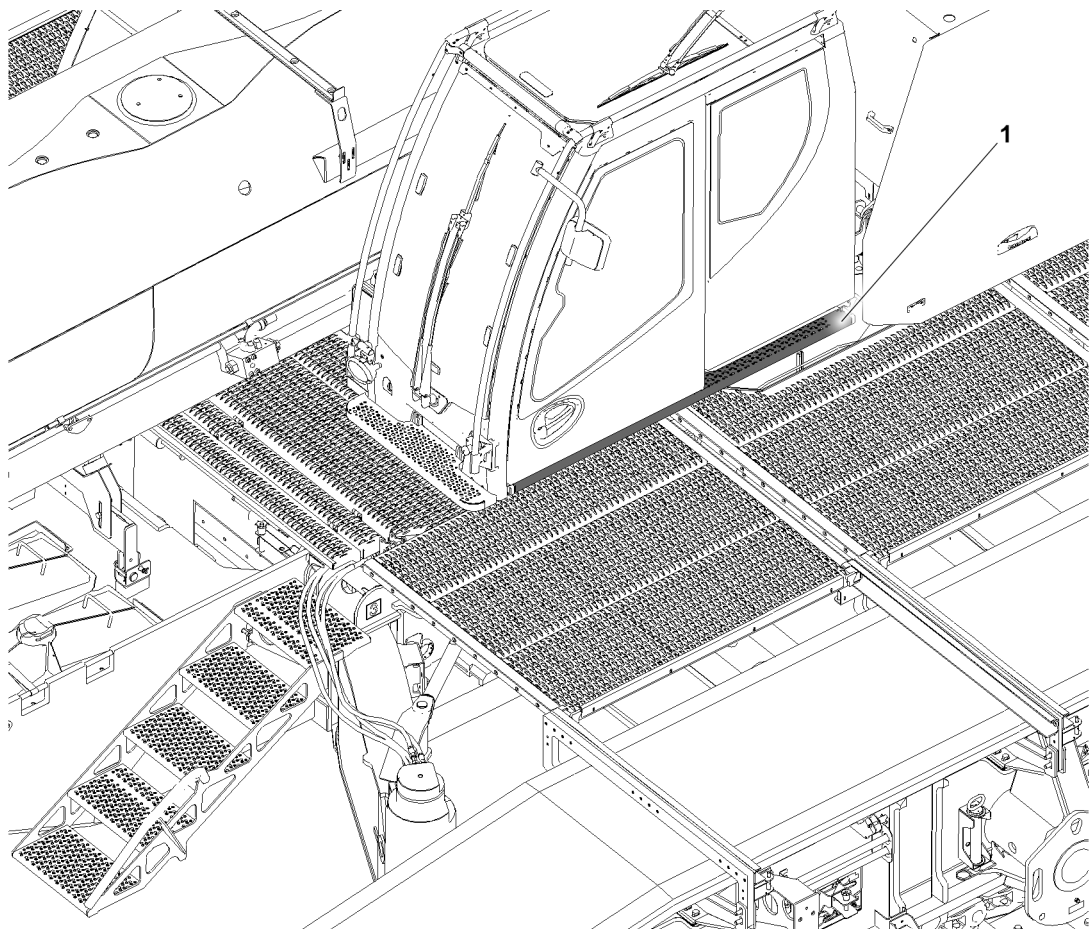

Fig.161887: Access for LTR 1220

1 Extendible step

Ascending and descending takes place on the walking surfaces of the crawler chain. See chapter 2.07 „Accesses to the crane“.

Before entering or exiting the crane cab, the following prerequisites must be met:

- The crane superstructure is turned to the point where a safe access to walkable surfaces of the crane chassis is ensured.
- The crane is horizontally aligned.
- The crane cab is in the horizontal position.



WARNING

The superstructure is in a position in which it is **no** longer safe to climb up to it and it is **no** longer possible to change the position of the superstructure to a safe ascent position!
People can fall down while ascending. Death, severe bodily injuries.

- ▶ Guarantee safe ascent / descent: Set up suitable climbing aids, such as a platform or ladder.



WARNING

The rise from the walking surface and cab floor is more than 300 mm !
Personnel can fall down. Death, severe bodily injuries.

- ▶ Guarantee safe ascent and descent: Set up suitable climbing aids, such as a safety step.

12.3 Crane cab with incline adjustment



WARNING

Danger of falling!

If the crane cab cannot be swung from an inclined position (for example 20° position) to the horizontal position, for example due to a problem, then utmost caution must be used when entering and exiting. Personnel can fall, death, severe bodily injuries.

- ▶ For safety reasons, we recommend making use of outside help.
- ▶ If necessary, have platforms or other suitable entry aids set up to ensure safe exit from the crane cab.



WARNING

Danger of accident!

If the door of the crane cab is opened in inclined position, then the door can move back suddenly. Hands can be crushed or injured.

- ▶ When the crane cab is in an inclined position, open the door carefully.

12.4 Crane cab with securing bracket

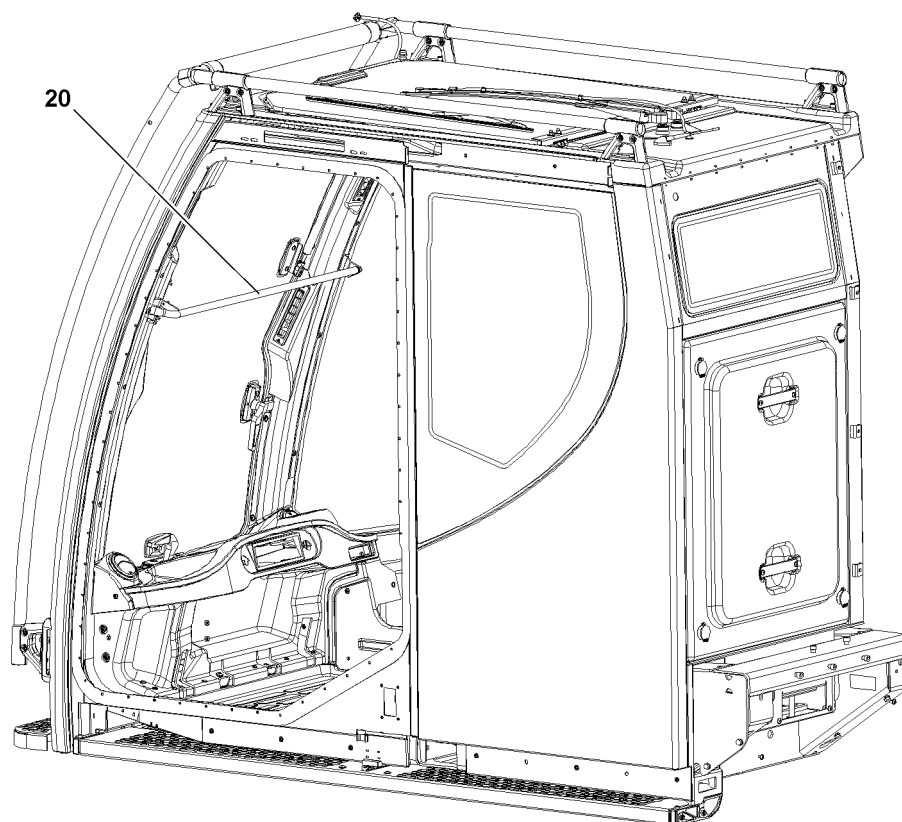

Fig.121158: Example of crane cab with securing bracket



Note

- ▶ The securing bracket **20** is installed to protect the crane operator from a danger of falling when the front window is open.

13 Side window



WARNING

Close side window inadvertently!

Personnel can be crushed. Objects can be damaged!

- ▶ During closing, watch the side window pane as it moves up.
- ▶ Make sure that no persons are crushed or objects damaged.

14 Emergency hammer*

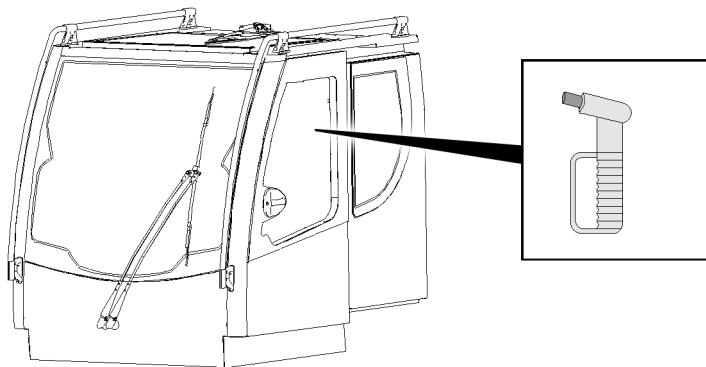

Fig.157682: The emergency hammer* is shown as an example



WARNING

Glass splinters and sharp broken edges!

If personnel is not suitably protected against glass splinters and sharp broken edges, serious bodily injury can result.

- ▶ Protect personnel when possible against glass splinters and sharp broken edges.
- ▶ When removing the destroyed glass pane, take the falling direction of the glass splinter into account.
- ▶ To climb through a destroyed glass pane, cover the broken edges or keep a distance.

14.1 Destruction of a glass pane

When an object suitable for destroying a glass panel is carried along, for example an emergency hammer* (as shown in the example)



WARNING

Glass splinters and sharp broken edges!

If personnel is not suitably protected against glass splinters when destroying a glass pane, serious bodily injury can result.

When a glass panel is destroyed:

- ▶ Cover your eyes and protect against glass splinters.

**Note**

- ▶ Glass panes breaker easier when the outer edge of the glass pane is struck.
- ▶ Cover your eyes when striking a pane.
- ▶ When striking a pane, go to a position if possible that offers protection from the falling glass splinters.
- ▶ When removing the destroyed glass splinters, use an object if possible and protect people against the glass splinters.
- ▶ When removing the destroyed glass pane, proceed from the top to the bottom and take the falling direction of the glass splinter into account.
- ▶ In the case of a glass pane made out of laminated safety glass, the incorporated film makes it is harder to create a large opening for climbing through. Select another pane if possible.

With suitable self-protection:

- Knock out the glass pane using a suitable object, such as an emergency hammer*.
- Create a large enough opening.
- Climb through the opening carefully.

15 Transport

**WARNING**

Error during transport!

Death, severe bodily injuries, property damage.

- ▶ To avoid accidents, observe and follow the notes provided in the following sections.
- ▶ Observe the legal as well as country-specific regulations for load securing.

**WARNING**

Falling of crane components!

If rigging devices are released and removed from crane components after transport, the crane components can slip or fall over.

Death, severe bodily injuries, property damage.

- ▶ Make sure that the crane components are fastened to the auxiliary crane after releasing the rigging devices.
- ▶ Make sure that the fastening equipment is tensioned before releasing the rigging devices on the crane components.

15.1 Crane and crane components

Follow the notes provided below to safely transport the crane and crane components:

- Close the crane cab and all cover doors.
- Use suitable transport vehicles.
- Use rigging devices with sufficient load capacity.
- Regularly check the rigging points and fastening points. See chapter 8.01.
- Properly support and secure the components on the transport vehicle.
- Use special transport devices. See chapter 3.80.
- Transporting a complete luffing lattice jib is prohibited.

15.2 Lattice sections

Follow the notes provided below to safely transport the telescoped lattice sections:

- Securely rig the lattice sections on the transport vehicle and secure them together in at least two independent points.
- When there are rigging points on the lattice sections: Secure each lattice section individually to the provided rigging points using suitable rigging elements and clamping elements on the transport vehicle.
- If there are no rigging points on the lattice sections: Secure each lattice section individually with suitable rigging devices and clamping elements to the transport vehicle.

15.3 Fiber guy ropes

The prerequisites for transporting the fiber guy ropes are closely connected with the prerequisites for storage.



WARNING

Incorrect storage or transport of the fiber guy ropes!

Damage. The fiber guy ropes can rip.

Death, severe bodily injuries, property damage.

- ▶ Comply with the instructions and conditions for storage and transport in this section.
- ▶ Inspect the fiber guy ropes regularly, see chapter 8.16.
- ▶ Comply with the maintenance intervals, see chapter 7.03.50.

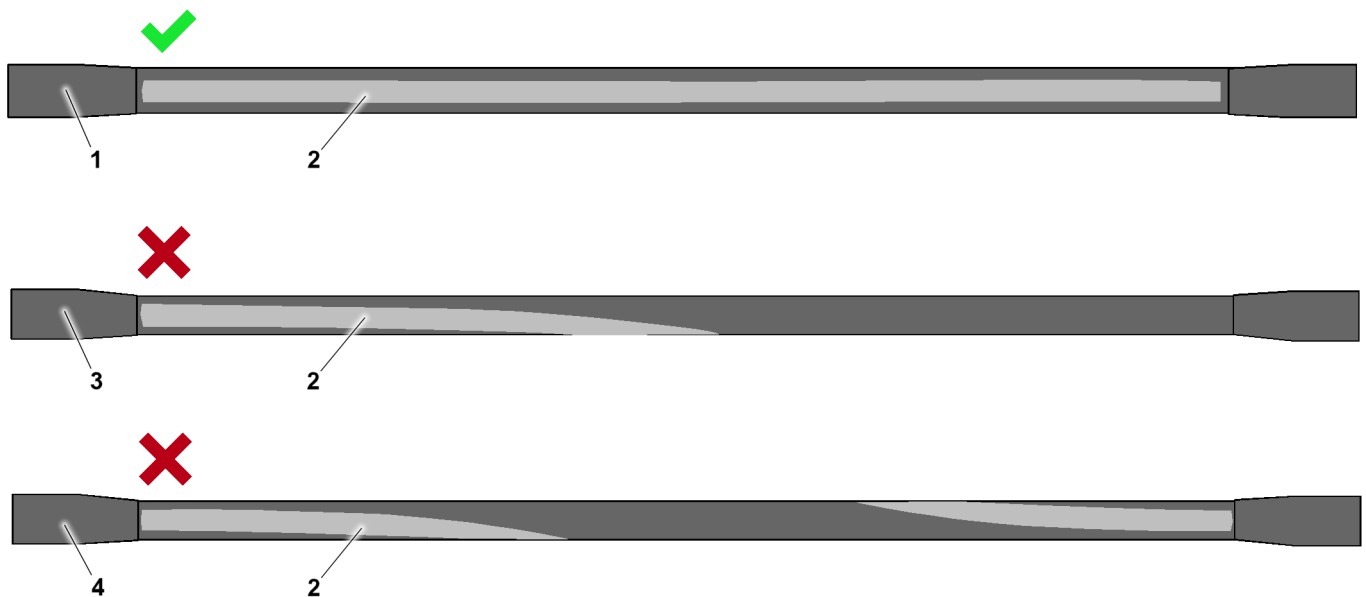
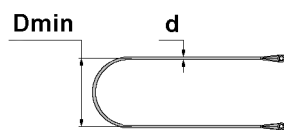

Fig.160904: Twisting marking for a straight fiber guy rope, example of a twisted fiber guy rope!

- | | | | |
|---|-------------------------|---|-----------------------------|
| 1 | Straight fiber guy rope | 3 | Fiber guy rope twisted 180° |
| 2 | Twisting marking | 4 | Fiber guy rope twisted 360° |



$$D_{min} = 20 \times d$$

Fig.160908: Fiber guy rope: Calculation of minimum permissible bending diameter

Formula element	Meaning
Dmin	Minimum permissible bending diameter
d	Rope diameter

Minimum permissible bending diameter: Definition of the formula elements

Make sure that the following instructions for storage and transport of fiber guy ropes are observed:

- Do **not** bend, knot, twist or sever the fiber guy ropes.
- The twist marking **2** is aligned straight along the entire rope length.
- Never fall below the minimum permissible bending diameter **Dmin** of **20 x** rope diameter **d**.
- Do **not** drag the fiber guy ropes over the ground, rough surfaces or sharp edges.

LWE/LR_13000-001/19503-01-02/en

- Do **not** let the fiber guy ropes ball onto the ground or components.
- Do not place heavy loads on the rope.
- Do **not** allow heavy or sharp-edged objects fall onto the rope.
- Do **not** place the fiber guy ropes on sharp edges or pull them over sharp edges.
- Keep the fiber guy ropes away from hot surfaces, flames, lamps or other objects that radiate heat.
- Keep fiber guy ropes away from environments where grinding or welding takes place.
- Keep the fiber guy ropes free of ice and snow.
- Prevent contact with chemicals.
- Only fasten the fiber guy ropes in the permissible range with belt loops, see chapter 5.01.

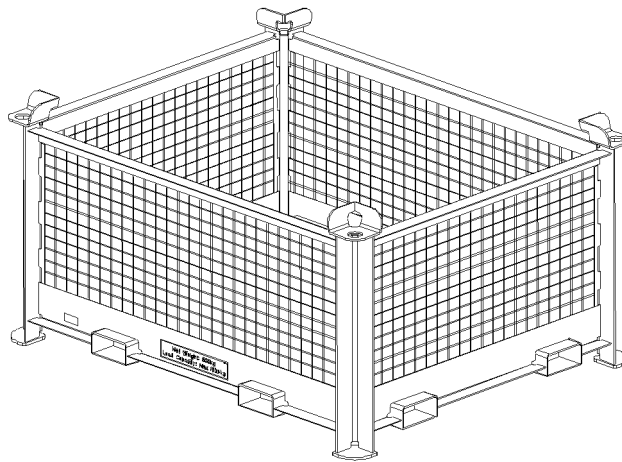

Fig.149503: Transport box for fiber guy ropes

Moist and wet environments lead to damage of the fiber guy ropes.

Make sure that the following conditions for storage and transport are observed:

- Let wet fiber guy ropes dry in the air at approx. 20 °C prior to storage.
- Store and transport the fiber guy ropes only in the provided transport box.
- Do **not** store or transport fiber guy ropes together with other components.
- Store the fiber guy ropes in a dry and well-ventilated area.

When assembled fiber guy ropes are transported and stored as part of an assembly unit:

- All instructions for storage and transport of fiber guy ropes apply to the same extent.
- Make sure that the assembly unit is stored in a dry and well-ventilated area.
- If the assembly unit **cannot** be stored in a well-ventilated and dry area until the next assembly: Disassemble the fiber guy ropes.

15.4 Mobile cranes

Follow the notes provided below for the safe transport of mobile cranes:

- To ensure the largest possible frictional coefficient to the transport surface, clean the wheels before transport.
- When driving on the transport vehicle, check the easy movement of the vehicle with the aid of a guide to avoid hitting too hard.
- Apply the parking brake. See the Crane operating instructions, chapter 3.04.
- Lower the crane with the level control to obtain a center of gravity as low as possible. Level control, see Crane operating instructions, chapter 3.03
- Stopping the mobile crane: Place wedges under the wheels. See the Crane operating instructions, chapter 2.04.
- Close the driver's cab.

15.5 Accelerating, changing the load

NOTICE

Permissible acceleration exceeded!

Damage to the crane.

- ▶ Observe the maximum permissible longitudinal acceleration of 1.0 g.
- ▶ Observe the maximum permissible lateral acceleration of 0.8 g.
- ▶ Offloading and running is prohibited during rail transport.

If higher accelerations are expected (sea transport, rail transport, maneuvering operation):

- ▶ Carry out the special measures to secure the crane and crane components.

NOTICE

Frequent dynamic load change!

Premature fatigue of load bearing crane components.

- ▶ Demount and properly secure components with large masses.
- ▶ Prior to transport: Have the rigging points and crane structures checked for damage by an authorized inspector. See chapter 8.01.

16 Fastening



WARNING

Defective fastening equipment or fastening points!

The load can fall down.

- ▶ Make sure that the fastening points and fastening equipment are in a perfect condition.
- ▶ Regularly check the rigging points and fastening points. See the Crane operating instructions, chapter 8.01.
- ▶ Check the fastening equipment regularly. See the Crane operating instructions, chapter 8.01.



WARNING

Load bearing capacity of the fastening equipment is **not** sufficient!

The load can fall down.

- ▶ Determine the weight of the crane component to be fastened.
- ▶ Fasten the components solely with approved and sufficiently load bearing fastening equipment.



WARNING

Component incorrectly fastened!

The load can fall down.

- ▶ Attach the components only on the intended fastening points.

17 Crane operator responsibilities

17.1 General

The crane operator's primary responsibility is to use and operate the crane in a manner that is safe for both himself and others.

The following important safety instructions will help you achieve this.

Many crane accidents are caused by crane control errors.

**WARNING**

Danger due to operating error!

- ▶ In your interest and in the interest of others, make sure that you know your crane. Also learn to recognize all dangers connected with the work to be carried out.

Operating errors, which are made again and again during travel operation or crane operation are especially careless while working, in particular:

- Swinging too quickly
- Stopping the load too quickly
- Pulling the load at an angle
- Allowing slack rope formation
- Overloading the crane
- Driving too fast with a load and / or equipment on an uneven road
- Error when fastening the load
- Unsuitable operation; especially angular pulling, breaking away stuck loads
- Wind action on suspended loads
- Errors during on-road driving, for example:
 - Overspeeding the engine when driving downhill
 - Driving with turned on differential lock
- Crashing into bridges, roofs or high voltage wires due to insufficient overhead clearance
- Inadequate support; support base, substructure under the support plates
- Errors during assembly or removal of booms
- Incorrect positioning of the crane when it is taken out of service
- Exceeding the permissible wind speeds in operation and when out of service

In many cases, crane damage is caused by improper maintenance:

- Insufficient oil, grease or antifreeze
- Contamination
- Broken cable wires, defective tires, worn components
- Emergency limit switch or load torque limiter (LMB) not operating properly
- Brake and clutch failure
- Hydraulic defects; for example cracked hoses
- Loose bolts

17.2 Working on the crane superstructure or boom

**WARNING**

Danger of falling!

When working on the crane superstructure or boom, personnel must be secured with appropriate safety measures to prevent them from falling. If this is not observed, working personnel can fall and be killed or severely injured.

- ▶ For all work on the crane where there is a danger of falling, suitable safety measures must be taken.
- ▶ The crane superstructure or the boom may not be accessed without suitable aids.
- ▶ Suitable aids are, for example: Lifting platforms, scaffoldings, ladders, assembly platforms, auxiliary crane.
- ▶ If railing are present on the crane superstructure, then they must be swung into operating position and secured for all work, see Crane operating instructions, chapter 2.06.
- ▶ Step on aids and stepping surfaces on the crane only with clean shoes.
- ▶ Keep aids and stepping surfaces on the crane clean and free from snow and ice.
- ▶ If the work cannot be carried out with such aids nor from the ground, then the assembly personnel must secure themselves with supplied fall arrest systems to avoid falling, see section „Personal protective equipment“.
- ▶ It is prohibited to step on the driver's cab or crane cab roof and specially marked surfaces, see Crane operating instructions, chapter 2.05.

17.3 Obligations of the crane operator

1. Before starting to work, the crane operator must check the brake function and the emergency shut off devices. He must monitor the condition of the crane for obvious defects. On wireless controlled cranes, he must check the assignment of control unit and crane.
2. The crane operator must cease crane operation in case of problems endangering the safety.
3. The crane operator must report all defects on the crane to the appropriate supervisor, also to his replacement in case of crane change.
4. The crane operator must make sure that:
 - All control systems are set to neutral or idle position before release of the energy supply to the drive components.
 - The control systems are set to neutral or idle position and the energy supply is shut off before leaving the control platform.
 - When taking down the control unit for wireless control, the control unit is secured to prevent unauthorized persons from turning it on.
5. The crane operator must ensure that cranes subjected to wind are not operated past the limits which were set by the crane manufacturer, and that the boom is taken down at least when the critical wind speeds for the crane are reached and at the end of the work.
6. The crane operator must monitor the load for all crane movements or the load lifting devices when moving the crane without a load, if they could cause a dangerous situation. If observation is not possible, then the crane operator may move the crane only with the aid of a guide.
7. The crane operator must give warning signs when necessary.
8. The crane operator may not move loads over personnel.
9. Any loads attached by hand may only be moved by the crane operator after he received a clear sign from the person who attached the load, the guide or any other responsible party which was assigned to that task by the contractor. If signals must be used to communicate with the crane operator, then these signals must be agreed upon before use between the responsible party and the crane operator. If the crane operator determines that the loads are not properly attached, then he may not move these loads.
10. As long as a load is suspended on the crane, the crane operator must keep the control systems within reach. This does not apply for the towing of vehicles with towing cranes.
11. The crane operator may not run up operationally to end positions that are only limited by the emergency limit switches.
12. After a load torque limiter was triggered, the crane operator may not pick up an overload by pulling in / raising the boom.
13. The crane operator may **not** bypass the overload protection to increase the hoisting power of the crane.

18 Selecting the location

In the following illustrations 1 to 3 the possible situations are shown as an example.

It is very important to choose an appropriate location in order to prevent the danger of accident.

It must always be possible to take down the crane in order to take it down in a timely manner in the case of unexpected weather conditions.

It must always be possible to position the crane in a safe out of service position.

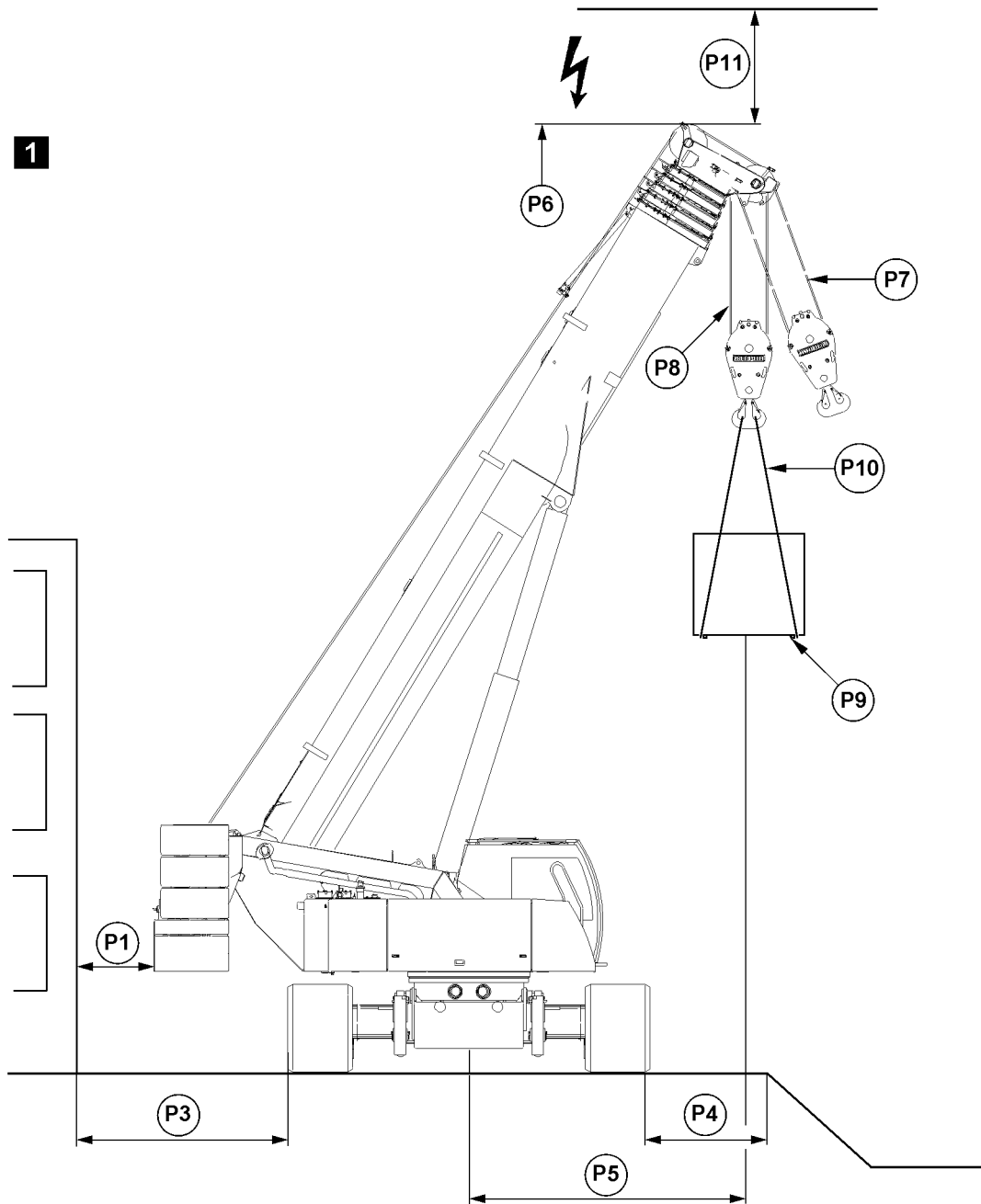

Fig.121166: Example of crawler crane with telescopic boom

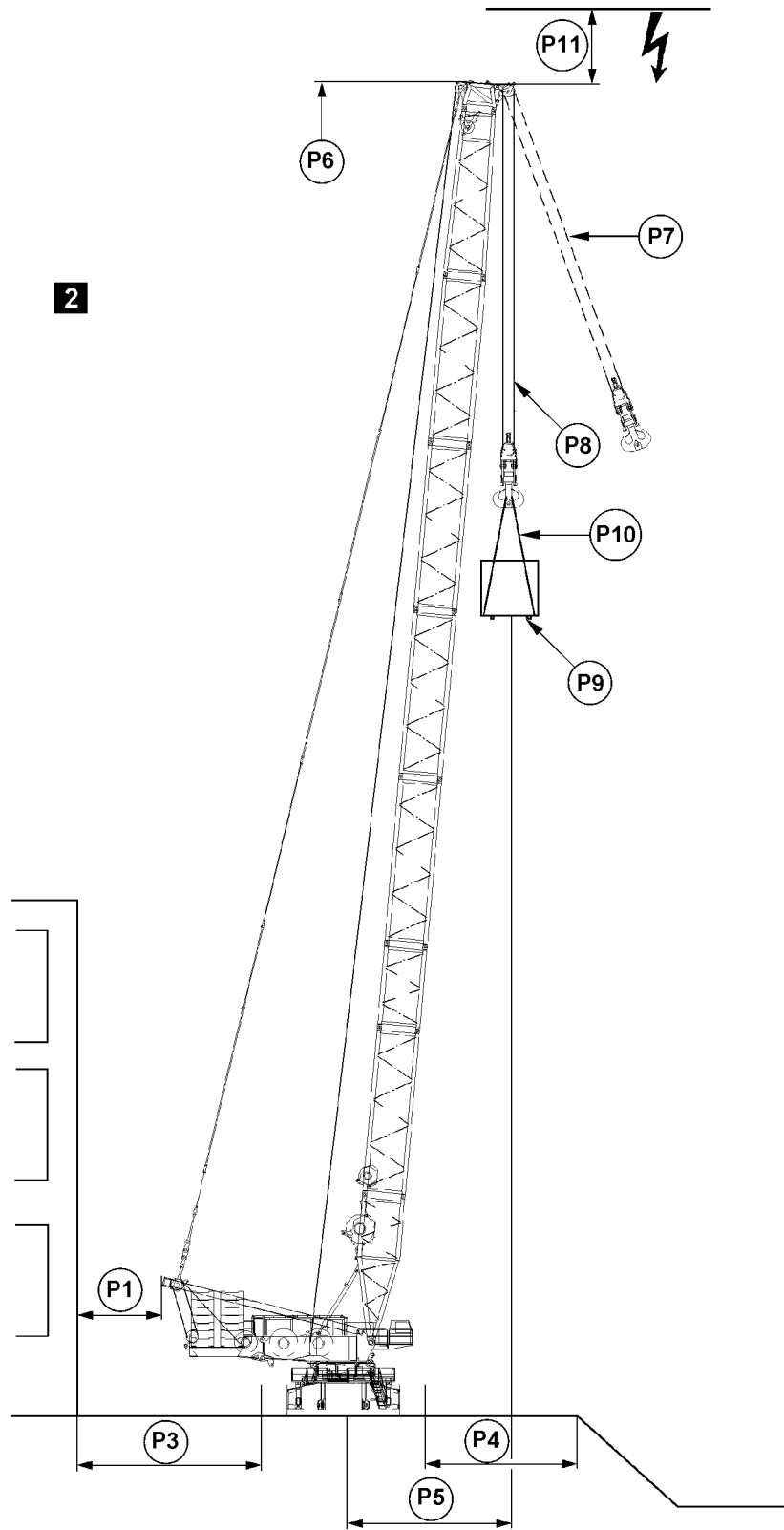

Fig.121167: Example of crawler crane with lattice mast boom

LWE/LR 13000-001/19503-01-02/en

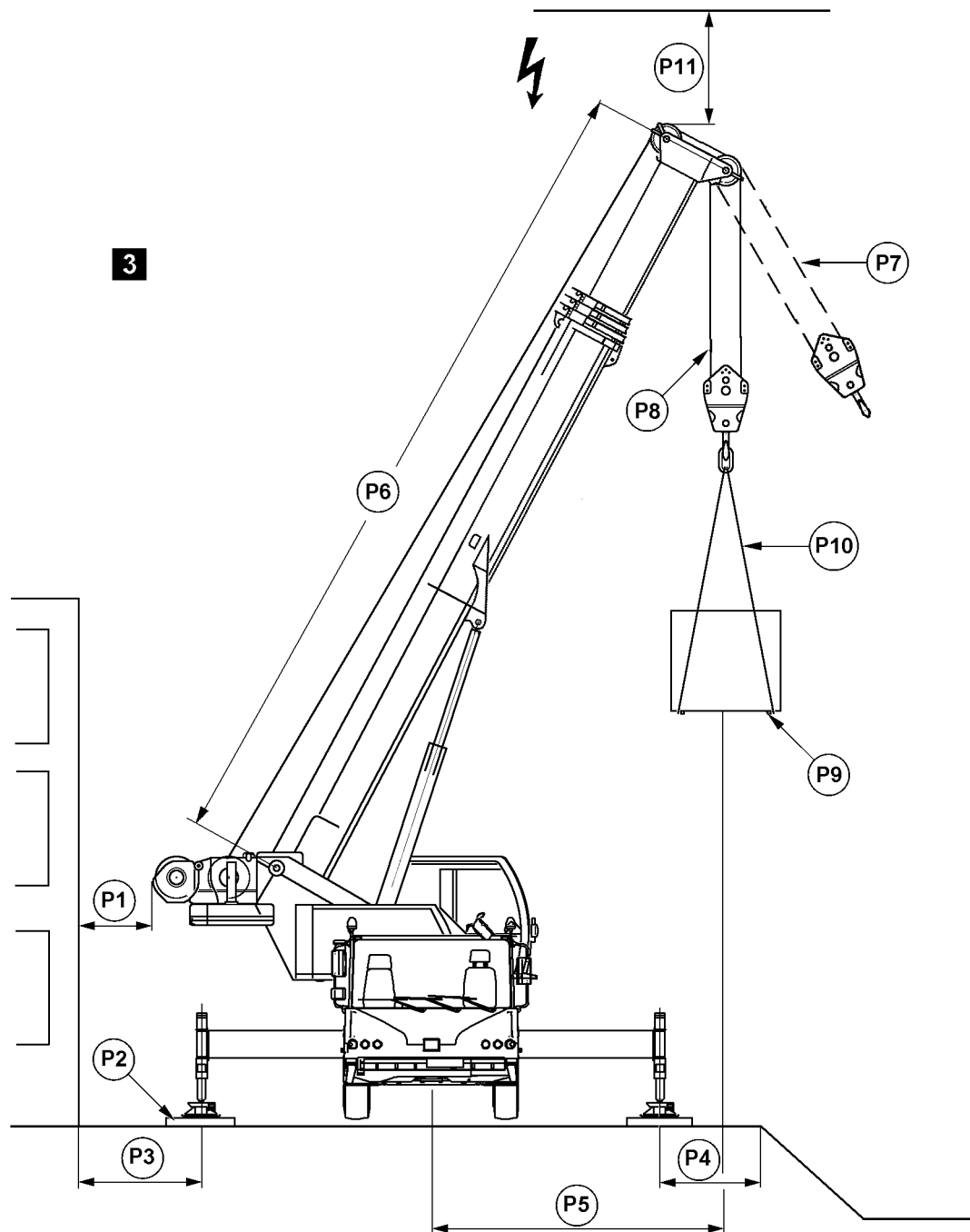

Fig.121168: Example of mobile cranes



DANGER

Danger of accidents due to ground with **insufficient** load bearing capacity!

If the crane is supported or driven on ground with an **insufficient** load bearing capacity, then the crane can topple over and kill personnel.

- ▶ Only support or drive the crane on ground with a sufficient load bearing capacity.
- ▶ Act responsibly when planning and selecting the crane location and route.
- ▶ Observe the following points.

Sign	When selecting the placement location for the crane, observe and adhere to the following:
P1	Select the placement location in such a way that crane movements can be carried out without collision and that the supports can be extended to the support base specified in the load charts Make sure that no personnel is injured or killed Always keep a safety distance of 0.5 m. If this is not possible, block the danger zone off
P2	When crane support is required: Support the crane correctly and support the support plates large enough according to the load bearing capacity of the ground and the placement location
P3	Maintain a safety distance from basements or similar
P4	Maintain a safety distance from slopes or similar
P5	Select a boom radius as low as possible
P6	Select the correct boom length for the load case
P7	Angular pull is prohibited
P8	Select the correct reeving of the hoist rope for the load case
P9	Keep in mind the weight and the wind-exposed surface of the load
P10	Select fastening equipment according to the weight of the load, the type of attachment and the incline angle
P11	Maintain sufficient distance from electrical overhead lines

19 Slopes and excavations

In the following illustrations 4 and 5 the possible situations are shown as an example.

The crane may not be set up too close to slopes or excavations. Maintain adequate safety distance **A** and safety distance **B** in accordance with the type of soil.

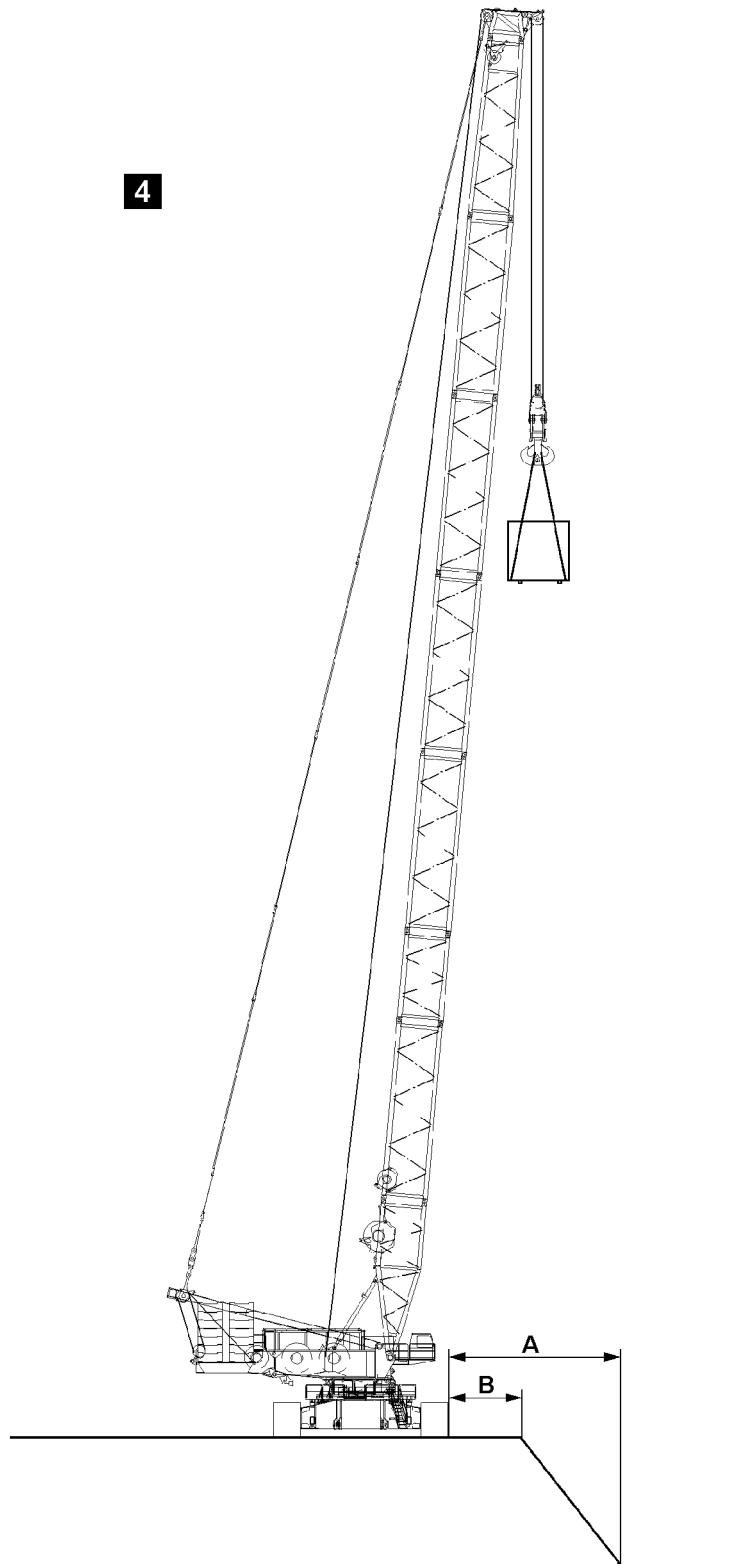

Fig.121162: Example of crawler cranes

- A** Distance from the bottom of excavation
- B** Distance from the excavation

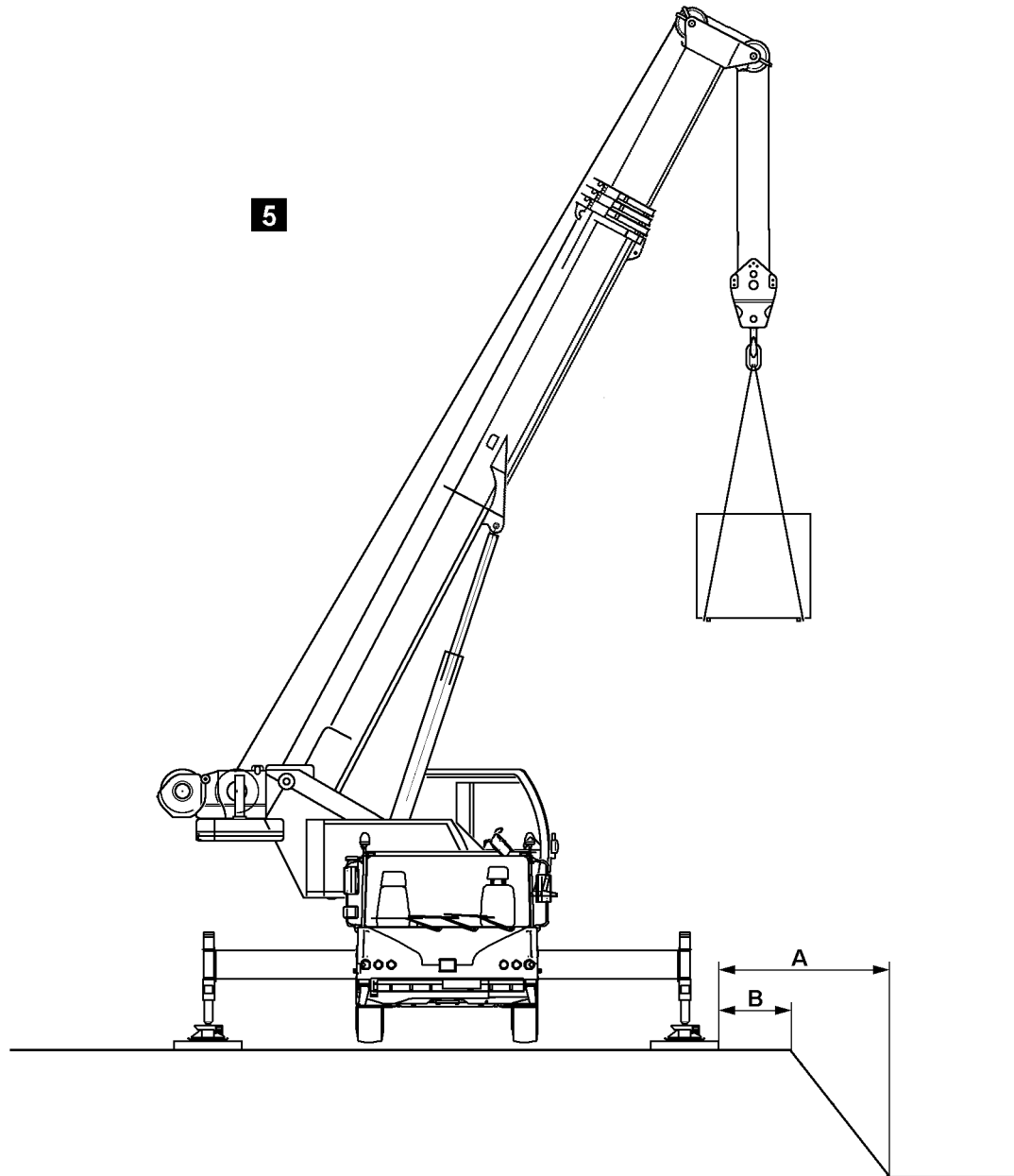

Fig.121163: Example of mobile cranes

- A** Distance from the bottom of excavation
- B** Distance from the excavation



WARNING

Safety distance **A** or safety distance **B** is too small!
 The edge of the slope or the edge of the excavation can cave in.
 The crane can topple over. Death, severe bodily injuries, property damage.
 ► Maintain the safety distance **A** and safety distance **B**.

Have the safety distance **A** and safety distance **B** calculated by a soil expert or geologist.

20 Loads on the ground due to crane operation



Note

- ▶ Take into account that on a crane with high counterweight the crawler pressures or support forces at low load can be higher than at high load.

20.1 Load burdens on the ground on cranes on crawlers

For cranes on crawlers significant forces are transferred via the outrigger pads of the crawlers into the ground (crawler pressures).

- The ground must be able to safely withstand the resulting pressure.
- If the area of the outrigger pads is inadequate, then the crawlers must be supported from below according to the load bearing capacity of the ground.
- The required substructure can be calculated from the load bearing capacity of the ground and the crawler pressures of the crane.



WARNING

Load bearing capacity of the ground insufficient!
The ground can give, the crane can topple over.
Death or severe bodily injuries.

- ▶ Support large enough, according to the load bearing capacity of the ground with suitable materials, such as wooden beams or steel plates.

To obtain an even pressure distribution over the substructure surface:

- ▶ Set the crawlers centered on the substructure.



Note

- ▶ The respective ideal crawler pressure can be determined with the job planner program.

20.2 Load burdens on the ground on cranes on supports

When the crane is supported, significant forces (support forces) are transferred by the support cylinders via the support plates to the ground.

The ground must be able to safely withstand the resulting pressure.

If the support plate surface area is inadequate, then the support plates must be supported from below according to the load bearing capacity of the ground.

The required support surface areas can be calculated from the load bearing capacity of the ground and the support forces of the crane.



WARNING

Load bearing capacity of the ground insufficient!
The ground can give, the crane can topple over.
Death or severe bodily injuries.

- ▶ Support large enough, according to the load bearing capacity of the ground with suitable materials, such as wooden beams or steel plates.

To obtain an even pressure distribution over the substructure surface:

- ▶ Set the support plates centered on the substructure.

20.3 Examples of the load bearing capacity of the ground

Soil type		Permissible ground pressure [kN/m ²]
1.	Organic ground: Peat, sludge, muck	0
2.	Uncompacted fill: Construction debris	0 to 100
3.	Non-cohesive ground: Sand, gravel, rocks and mix	200
4.	Cohesive soil: a) Clayed silt, mixed with topsoil b) Silt, consisting of poor clay and coarse clay c) Plastic clay, consisting of potter's clay and fill Stiff Semi-solid Solid d) Mixed granular ground, clay to sand, gravel and rocky areas Stiff Semi-solid Solid	120 130 90 140 200 150 220 330
5.	Rock in evenly solid condition: a) Brittle, with traces of decomposition b) Not brittle	1500 4000

Examples: Permissible ground pressure of the ground

If there is any doubt about the load bearing capacity of the ground at the placement location, soil tests must be carried out by an authorized inspector, for example with a ram penetrometer.

20.4 Calculation examples

The following are general calculation examples. The values are used only to explain the calculation steps. The crane specific values are in chapter 1.03 of the crane operating instructions.

Example: Calculation of ground pressure of support plates for cranes on supports		□
Support force according to Crane operating instructions, chapter 1.03 for example: 720 kN	720 kN	
Surface of square support plate with 550 mm side length according to the crane operating instructions, chapter 1.03, for example: 0.55 m x 0.55 m = 0.3 m ²	0.3 m ²	
80 % as the load bearing surface of the support plate: 0.3 m ² x 0.8 = 0.24 m ²	0.24 m ²	
Ground pressure = Support force / load bearing surface support plate	720 kN / 0.24 m ² = 3000 kN/m ²	
Ground pressure per support:	3000 kN/m²	

Example: Calculation of ground pressure

- The value of the ground pressure is far higher than the permissible ground pressure for all types of granular soil.
- If this crane is utilized on bedrock, gravel type of ground, permissible ground pressure 200 kN/m², then the support surface must be increased.

Example: Calculation of required support surface for cranes on supports		□
Support force according to Crane operating instructions, chapter 1.03 for example: 720 kN	720 kN	
Ground pressure from chart <i>Permissible ground pressures</i> for example: 200 kN/m ²	200 kN/m ²	
Required support surface = Support force / permissible ground pressure	720 kN / 200 kN/m ² = 3.6 m ²	
Required support surface per support:	3.6 m²	

Example: Calculation of the support surface

- The surface of the substructure for each support plate must be at least **3.6 m²**.
- The height of the substructure must be selected depending on the load distribution angle.



Note

- ▶ The corresponding ideal support forces can be determined with the Job planner.

20.5 LICCON job planner

The calculation of support forces and crawler pressures with the LICCON job planner are based on idealized assumptions: level and homogenous ground, rigid crane structure, no consideration in regard to wind.

Side deformations of the boom system due to wind, incline position and elastic compliance of the steel structure can lead to increase of support forces or to increase of crawler pressures.

The determination of the values, taking wind load on the crane and the load into account, as well as the elastic deformation of the crane can only be carried out by the crane manufacturer or a qualified authorized inspector.

20.5.1 Example of crane on crawler with derrick boom, suspended ballast and short (main) boom system

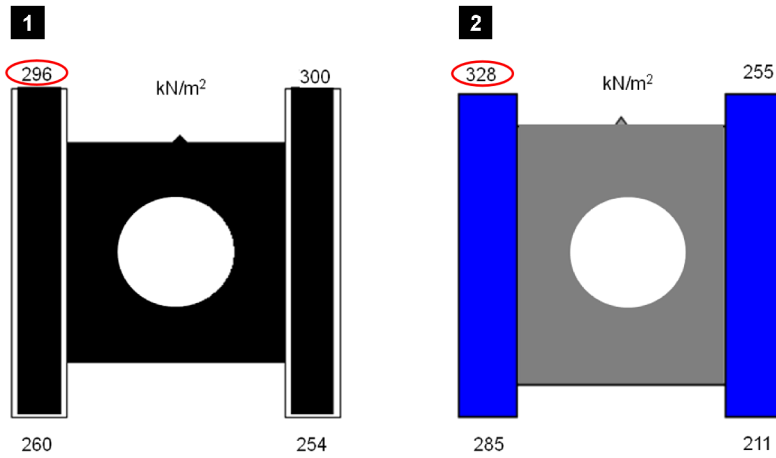

Fig.125052: Example of crane on crawler with derrick boom, suspended ballast and short (main) boom system

Illustration 1: Idealized crawler pressures from Job planner calculated with the aid of a rigid body system and without considering the wind

Illustration 2: Idealized crawler pressures with consideration of elastic deformation and wind on crane and load

20.5.2 Example of crane on crawler with derrick boom, suspended ballast and long (main) boom system

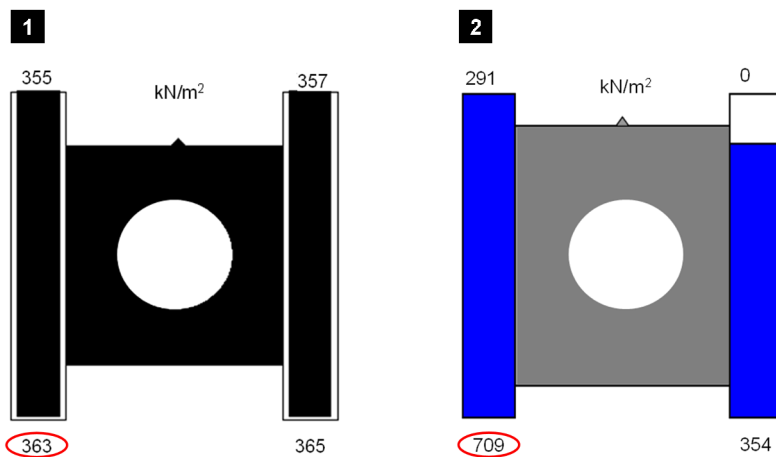

Fig.125053: Example of crane on crawler with derrick boom, suspended ballast and long (main) boom system

Illustration 1: Idealized crawler pressures from Job planner calculated with the aid of a rigid body system and without considering the wind

Illustration 2: Idealized crawler pressures with consideration of elastic deformation and wind on crane and load

LWE/LR_13000-001/19503-01-02/en

20.5.3 Example of crane on supports

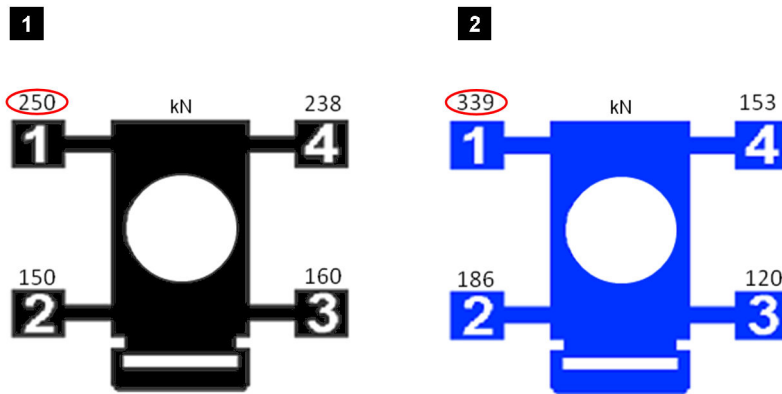

Fig.125054: Example of crane on supports

Illustration 1: Support forces from Job planner calculated with the aid of a rigid body system and without considering the wind

Illustration 2: Support forces with consideration of elastic deformation and wind on crane and load

21 Support

21.1 Support plates

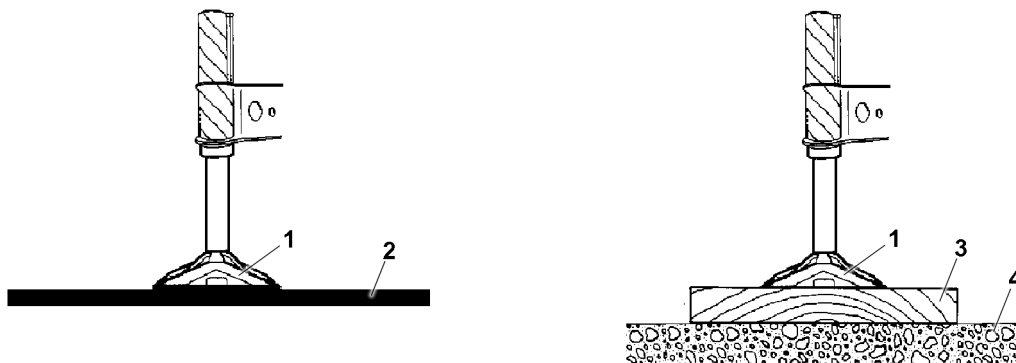

Fig.144244: Support plates

- | | | | |
|---|--|---|---------------------------------|
| 1 | Support plate | 3 | Substructure |
| 2 | Ground (no substructure necessary) | 4 | Ground (substructure necessary) |

When supporting the crane, the support plates must lie horizontally on the ground or on the substructure.



WARNING

The support plates are **not** laying horizontally!
The crane can topple over, death, property damage.

- ▶ Before supporting the crane, align the support plates horizontally.

21.2 Supporting the crane



WARNING

The crane is **not** horizontally aligned!

The crane can topple over, death, property damage.

- ▶ Align the crane horizontally to 0.0° during the support procedure.



DANGER

The crane can topple over!

When actuating the supports with attached load and / or at loaded derrick ballast guying, the incline and the force conditions of the entire boom system change.

There is **no** shut-off by the LICCON overload protection.

The crane can topple over.

Personnel can be severely injured or killed.

- ▶ When a load is suspended it is prohibited to actuate the support.
- ▶ When the derrick ballast guying is loaded it is prohibited to actuate the support.

It is absolutely essential that the crane be supported with the support base exactly in accordance with the load chart to ensure safe crane operation.

The correspondence of the sliding beams placement surfaces must be observed to ensure proper force transfer between the sliding beams.

The crane may only be supported in these extension conditions.



WARNING

The crane can topple over!

If only the sliding beams on the load side are extended, then the crane can topple over and kill personnel.

- ▶ Push all four sliding beams and support cylinders out according to the data in the load chart and pin.
- ▶ Do **not** support in intermediate positions between the support bases.
- ▶ Pin the sliding beams to the support base according to the load chart.
- ▶ Fully insert and secure the pins.



WARNING

Risk of toppling the crane due to incorrect extension of the sliding beams!

The load suspended on the hook causes tension and deformation of the hoist rope and telescopic boom. The same applies for operation with lattice jib and guy ropes. If the load falls from the fastening ropes or if the fastening or hoist rope breaks in this situation, a sudden relief occurs. The boom snaps back quickly. This can cause the crane to topple over.

Despite previous assumption, it might become necessary to swing the load to the opposite side. This can cause the crane to topple over.

The boom and / or counterweight momentum may cause the crane to topple when turning from the longitudinal vehicle direction.

- ▶ Extend all four sliding beams and support cylinders according to the data in the load chart.

21.3 Supporting the crane with a *variable support*

When supporting the crane with a *variable support* special measures are required. These measures are described in detail in the Crane operating instructions, chapter 6.26.

22 Aligning the crane

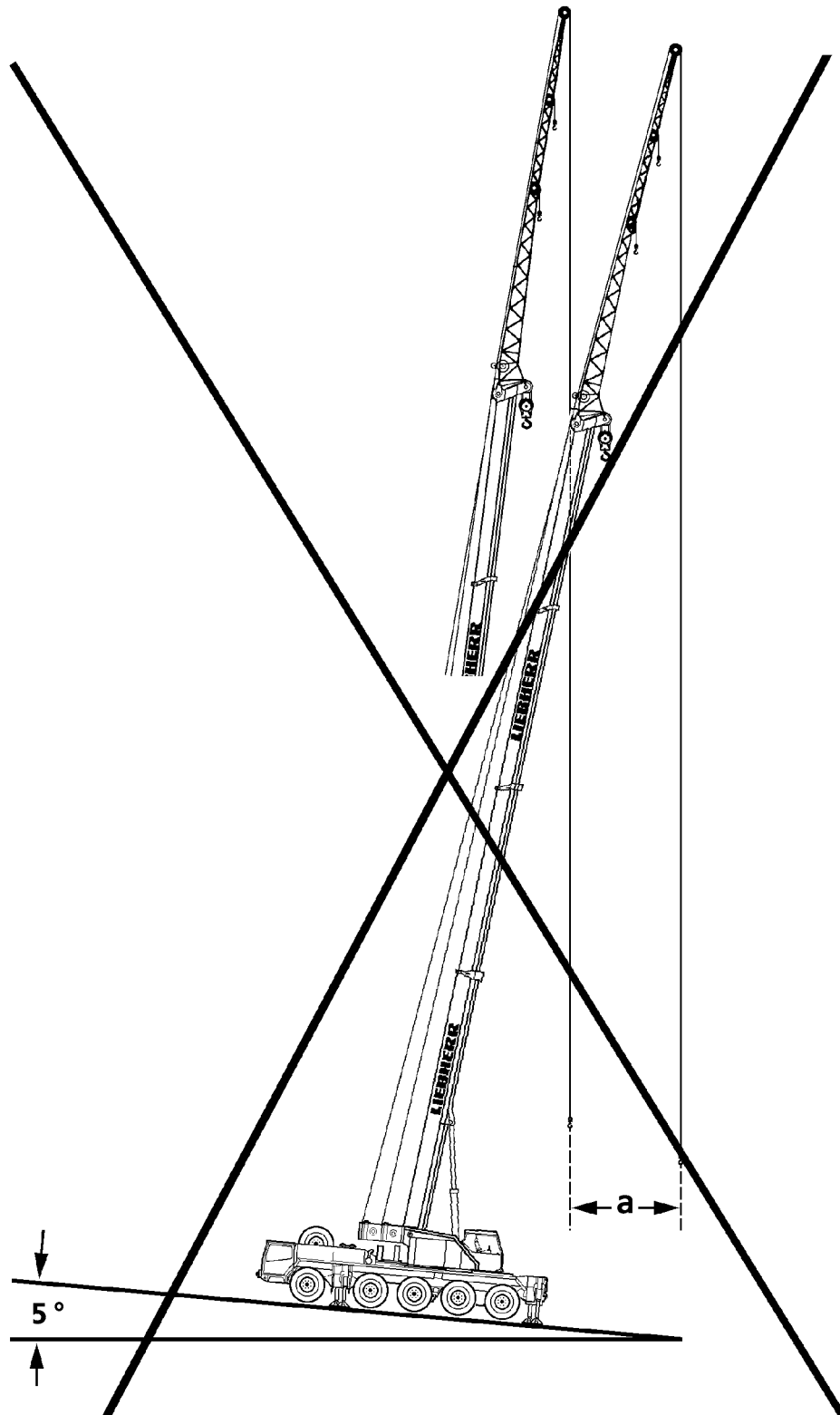

Fig.121164: Example of **non-permissible** incline position

In addition to the proper substructure for the supports, the horizontal alignment of the crane is of utmost importance for safe crane operation.

**DANGER**

The crane can topple over due to the incline position!

If the crane is positioned at an incline, and if the boom is turned towards the slope, then the boom radius is increased as a result.

It is possible that the slewing gear can no longer hold the crane superstructure and, in extreme cases, the crane can topple over.

Personnel can be severely injured or killed.

- ▶ Align the crane horizontally before starting crane operation.

If the horizontal alignment of the crane has to be readjusted:

- ▶ Set the load down on the ground before readjusting the crane.

For cranes on crawlers, readjustment is **not** possible:

- ▶ If possible, use load charts for limited terrain incline.

Example: At a boom length of 50 m, an incline position of the crane by only 5° at a boom radius of 10 m causes an increase of the radius of $a = 4$ m.

23 Checking the safety measures

- The placement location has been selected so that all planned lifts included in the load chart for the erected set up configuration can be lifted.
- The load bearing capacity of the ground is adequate.
- There is safety distance to excavations and slopes.
- There are no live transmission wires within the working range of the crane.
- There are no obstacles that will hinder required crane movements.
- The crane is horizontally aligned.
- When crane support is required:
 - All four sliding beams and support cylinders have been extended according to the support base given in the load chart.
 - The sliding beams have been secured with pins to prevent them from moving.
 - The support plates are pinned and secured in the operating position.
- On mobile cranes:
 - The axle suspension is blocked.
 - The axles are relieved, which means the tires do not touch the ground.

24 Safety instructions in case of an external power supply



Fig.197720

A potential danger exists when supplying a crane with an external power supply from a low voltage distribution system (100 V AC to 400 V AC).

A special electrical hazard is present when a protective conductor is interrupted (caused by the mechanical stress on flexible supply lines or the service connection), loose terminal connections, high wire or contact resistance, mixed up conductors, defective or missing protective equipment (FI / fault interrupters) in combination with a body contact on the crane.



WARNING

Danger of fatal injury if the body conducts current!

Water and / or defective devices can cause hazardous stray voltages when touched. The person touching the crane is subject to lethal currents.

- ▶ The external supply cable must be in good working order.

Make sure that the external flexible supply cable is in good working order.

Where applicable, we recommend the use of a power isolating transformer.

25 Grounding for potential equalization

Have tasks regarding grounding performed by authorized and trained expert personnel.

- Crane grounding is done to establish the defined potential equalization between the crane that is electrically charged for any reason and the ground.
- Potential equalization protects people who are located near the crane. Potential equalization prevents currents from flowing through people who possibly touch a charged crane while standing on the ground.
- Potential equalization serves the purpose of protecting electronic components to prevent electrostatic charge.

- Grounding for potential equalization is not designed to protect crane protections against extreme external influences (such as lightning).

25.1 Grounding the crane

For crane types with a ground connection*:

- Location of the ground connection*, see chapter 1.01 or chapter 3.01.

For crane types without a ground connection for grounding the crane:

- Properly connect the grounding with the crane.



WARNING

Danger of fatal injury due to electric shock!

There is a danger of electrical shock, if the crane is not properly grounded.

- ▶ Properly ground the crane.
- ▶ Make sure that there is a potential equalization between the crane and the ground.

The crane must be grounded before start up.

Examples of extremely strong electromagnetic fields:

- Near transmitters (transmission equipment, radio and TV transmitters, radio stations, etc.)
- Near high frequency switching stations and high voltage lines.
- In case of severe possibility of thunderstorms or potential thunderstorms.

Note: As regards protecting a crane against lightning, grounding must be considered separately.

The crane can become electrostatically charged, especially if the crane is equipped with synthetic support mats or if the support mats are placed on insulating materials (such as wooden planks).

25.2 Grounding the load



WARNING

Danger of fatal injury due to electric shock!

There is a danger of electrical shock, if the load is not properly grounded.

- ▶ Properly ground the load.
- ▶ Make sure that there is a potential equalization between the load and the ground.

The load must be grounded before start up:

- Near transmitters (radio and TV transmitters, radio stations, etc.).
- Near high frequency switching stations and high voltage lines.
- In case of severe possibility of thunderstorms or potential thunderstorms.

Note: As regards protecting the load against lightning, grounding must be considered separately.

The load can become electrostatically charged, even if the crane is grounded. This applies in particular if a hook block with pulleys made of synthetic material and non-conductive fastening equipment (for example plastic or manila ropes) are used.

26 Working in the vicinity of transmitters

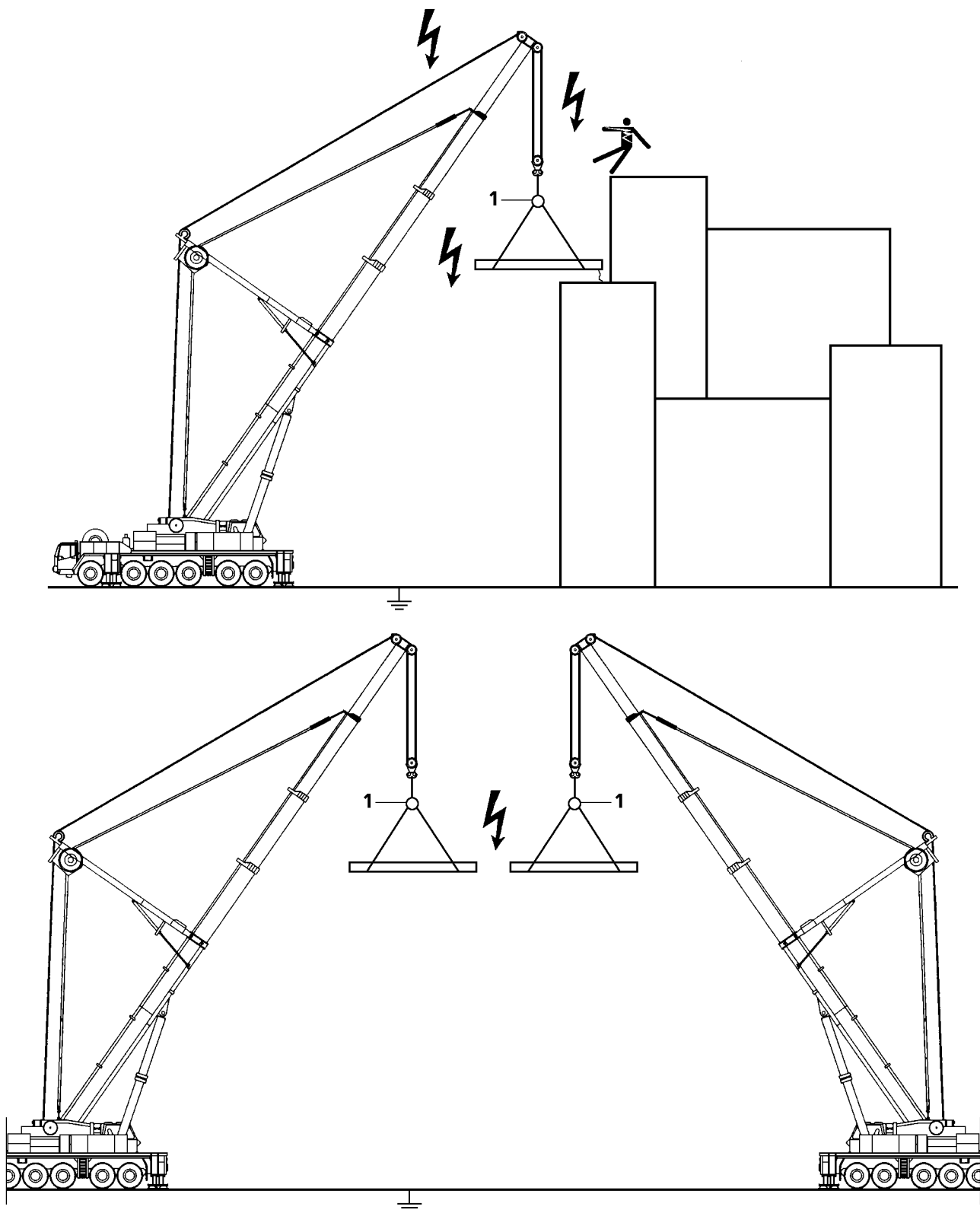

Fig.121165: Example of electrostatic charge

Strong electromagnetic fields are likely to be present if the construction site is close to a transmitter.

These electromagnetic fields can pose direct or indirect danger to persons or objects, for example:

- Effect on human organs due to temperature increase

- Danger of burns or inflammation due to temperature increase
- Spark or electric arc formation

**DANGER**

Danger due to electromagnetic fields!

- ▶ Before operating a crane in the vicinity of transmitters, be sure to consult with Liebherr-Werk Ehingen GmbH.
- ▶ Also consult a high frequency specialist.

High frequency (HF) radiation from a transmitter requires extended work safety protection and special environmental specifications for crane operators and slingers:

1. Each crane must be „fully“ grounded. Check visually or use a simple continuity tester to ensure that the ladder, crane cab and rope pulleys are grounded.
2. All personnel working on the crane or with large metal objects must protect themselves from burns by wearing non-conductive synthetic gloves and suitable clothing while working.
3. There is no need to panic if you feel your hand warm up. Always work under the assumption that the respective workpiece, structural steel member or carrier is „hot“.
4. The temperature of objects affected by high frequency radiation depends on their „size“. Cranes, carriers and coverings, for example, are „hotter“.
5. Contact with other crane loads is not permitted when operating the crane (arcing). Since defects caused by burns considerably reduce rope's load bearing capacity, any such occurrences must be reported immediately to the customer service of Liebherr-Werk Ehingen GmbH so that the ropes can be inspected.
6. An insulator **1** is required at all times between the crane load hook and fastening equipment. It is strictly prohibited to remove this insulator **1**.
7. Do not touch the ropes above the insulator **1**.
8. Loads that are attached to the crane may not be touched by any unprotected parts of the body after the load has been lifted or set down.
9. Do not work with a bare upper torso or in short pants, this is prohibited.
10. To minimize absorption of high-frequency radiation, larger loads should be transported horizontally if possible.
11. Loads must be grounded, or additional insulation used (rubber material between the object and gloves) when manual work is required.
12. Use a suitable measuring instrument to check the „temperature“ of the workpiece.
For example, if 500 V can be measured on a workpiece at a distance of 1 cm to 2 cm , then the workpiece may not be touched with bare hands.
The greater the distance, the higher the voltage is on the object:
At 10 cm distance, approx. 600 V are present, at 30 cm distance approx. 2000 V are present.
13. When refueling the crane, it must be ensured that no sparks are created within a radius of 6 m , neither by handling larger metallic parts nor by other work.
14. To avoid secondary accidents, use personal protective equipment when working on components that are high off the ground.
15. Any accidents and unexpected events must immediately be reported to the local construction supervisor and the safety engineer.

27 Crane operation in case of thunderstorms

**WARNING**

Danger of accident due to lightning!

Direct or indirect high current flow through the body.

Danger of falling when working above ground.

Death or severe bodily injuries.

- ▶ Make sure that there are no persons in the immediate area of the crane.
- ▶ Get the weather forecast for the entire period during which the will be used.
- ▶ Introduce safety measures in time.

In the case of weather where there may be lightning, observe the following specifications:

- Work on the crane is stopped.
- The load is set down.
- In the case of cranes with derrick ballast: The derrick ballast is set down, if possible.
- The boom is, if possible, telescoped in and / or taken down.
- The crane is in a safe condition.

Make sure that no persons are seeking protection in the immediate area of the crane.

Make sure that the danger zone of crane is blocked off.

27.1 After a possible lightening strike to the crane

Lightening can cause many types of damage. For example, damage to casings, scorched cable or melding of metal components.

27.1.1 Checking the crane



WARNING

Damaged crane!

When crane damage is found:

- ▶ Crane operation with damaged components is prohibited.
- ▶ Repair the crane.



WARNING

Possible damage to the crane!

When crane damage cannot be excluded:

- ▶ Do not restart crane operation.
- ▶ Contact Liebherr Customer Service.

Step 1: Inspect the crane in detail, in particular perform a visual inspection for:

- Damage to the fiber guy ropes and plastic ropes.
- Damage to the hoist ropes and control ropes.
- Damage to cables, lines and hoses.
- Damage to hydraulic cylinders.

Step 2: If no damage is found during the visual inspection:

- Check the operation of the crane control, evaluate the error memory.

Step 3: If no damage was found in step 1 or step 2:

- Perform a function check for unusual behavior, vibrations and noise - control the slewing gear and winches slowly and pay attention to functionality and the generation of noise.
- Monitor the hydraulic cylinder for a long period of time for leakage.

27.2 Lightning: Protective measures for the crane and load

Protective measures regarding lightning / lightning protection for the crane and load, including optional grounding.

- Have the protective measures implemented by authorized and trained expert personnel with suitable knowledge about lightning protection.

28 Winch influences



Note

- ▶ The wind speeds are valid for a 360° wind direction for a 3-second wind gust at the highest point of the crane.

**WARNING**

Disregard of permissible wind speeds!

If the permissible wind speeds are disregarded, the crane can topple over. Personnel can be severely injured or killed.

- ▶ It is prohibited to erect the crane to measure the wind speed.
- ▶ Observe the permissible wind speeds depending on the assembly / crane conditions and act accordingly, see following chart.

Assembly / crane conditions	Reference for permissible wind speed
Erection and take-down of various boom configurations	Wind speed charts and / or erection and take-down charts
Crane operation	Load chart manual
When the permissible wind speed according to the load charts is exceeded during crane operation, then crane operation is prohibited .	Wind speed charts
Interruption of crane operation when crane remains equipped	Wind speed charts
Crane out of operation, when crane remains equipped	Wind speed charts

**Note**

No wind speed charts available!

For a set up configuration for which no wind speed charts are available:

- ▶ Observe and adhere the maximum wind speeds of the load charts.

The wind load on the crane boom has **not** been taken into account for the planning of crane operation with the LICCON job planner.

- As a result, the actual values of the support force and / or the crawler pressure can be significantly higher than the values determined with the LICCON Job planner.
- The wind affecting the crane and the load, the elastic distortion of the crane structure, incline position as well as wind-exposed surface (A_w) per ton of hoist load larger than 1.2 m²/t can significantly increase the support force and / or the crawler pressure.

**WARNING**

Increase of support force and / or the crawler pressure!

The resulting pressure on the ground becomes larger.

The permissible ground pressure can be exceeded.

- ▶ Do not exceed the permissible ground pressure.

**Note**

- ▶ The determining factor for all crane work in the actual wind speed at the job site of the crane.
- ▶ The current wind speed can be checked at the nearest weather bureau.
- ▶ Be aware that the wind speed on the boom jib is higher than near the ground.
- ▶ Always observe the national valid regulations.

28.1 Wind speed charts for a *variable support*

For a *variable support*: Observe and adhere to the wind speed charts according to the support base for the smallest extension length of the sliding beams.

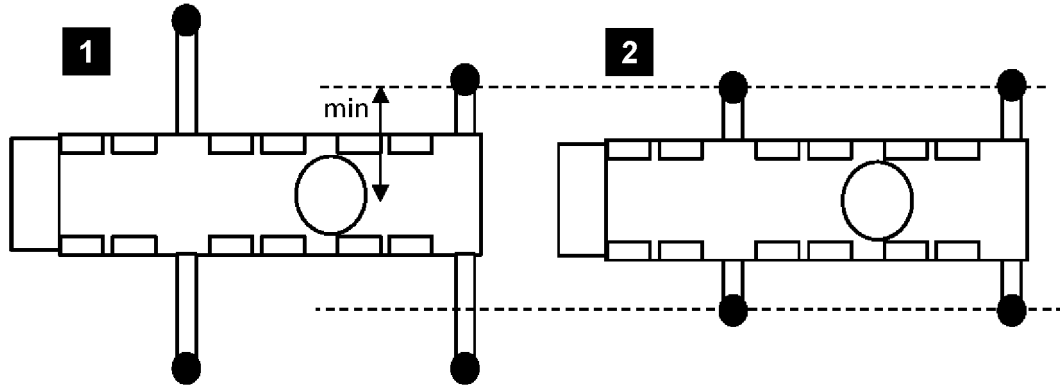

Fig.121577: Example of the selection of wind speed charts for a variable support

Example of the selection of wind speed charts for a *variable support*:

- The crane is supported with a *variable support* according to illustration 1.
- Select wind speed charts according to the support base in illustration 2.



Note

No wind speed charts available!

If the smallest extension length of a sliding beam is less than those of the wind speed charts on hand:

- ▶ Observe and adhere the maximum wind speeds of the load charts.

28.2 Wind speed, wind gust speed and wind direction

The depiction of the wind is made by statement of wind speed (wind force), wind gust speed and wind direction.

High above the ground, the wind is less influenced by the surface condition of the ground. In the lower layers of the atmosphere, the wind speed is reduced by the ground friction. One differentiates between roughness of terrain, influence of obstacles and influence of terrain contours. Vegetation, buildings etc. have great influence on the wind speed, wind gust speed and wind direction.

The site selection is thus especially important for wind measurement.

The wind speed, wind gust speed and wind direction are subject to significant time and local fluctuations. For that reason it is important to have reliable information regarding the expected wind speed, wind gust speed and wind direction during a load lift and to carry out exact wind measurements.

For mobile cranes, always assume a wind load of 360°. The determining factor is the „3 second gust speed“ on the highest point of the boom.

28.3 Measurement of wind speed

The anemometer installed on the crane boom measures the wind speed on the boom jib and shows the current wind speed in the crane cab.

The function of the anemometer must be checked every time before erection of the boom by manually actuating the shell start for easy movement and proper function.

Before lifting a load, especially with large wind-exposed surface, the wind speed and the wind direction expected during the lift must be known. Information can be obtained for example from the local weather bureau. The determining factor is the „3 second gust speed“ on the highest point of the boom.

**WARNING**

Overload of crane!

The acoustic wind warning is only issued if the wind speed specified for the standard wind exposure surface in the load chart is exceeded (wind surface per ton load: 1 m², drag coefficient: 1.2).

If the permissible wind speed must be reduced for loads due to large wind-exposed surfaces, no acoustic wind warning is issued.

There is no shut-off of crane movement.

- ▶ The wind-exposed surface and the wind resistance coefficient for the load to be lifted must be known.
- ▶ The maximum permissible wind speed specified in the load chart must be reduced for large wind exposure surfaces as described in the load chart manual chapter "Wind influences during crane operation".

To safely determination the wind speed, the crane must be turned 360° before use. The highest measured value while doing so must be compared with the „maximum permissible wind speed“ for the load according to the load chart. Therefore the possibility that the result of the measurement is distorted due to nearby buildings, cranes or components is eliminated.

In gusty wind conditions, the probability of sudden high wind speed increases. In gusty wind conditions no loads with a large surface may be lifted.

**Note**

- ▶ If in doubt and in case of questions for further information and / or training in the area of „Wind influences in crane operation“ contact the Customer Service at Liebherr-Werk Ehingen GmbH.

28.4 Conversion chart for wind force

**Note**

- ▶ The influence of the wind on the surrounding is described clearly in the Beaufort scale to provide an orientation for the crane driver.
- ▶ The wind force of the Beaufort scale refers to the wind speed determined over 10 minutes at a height of 10 m.

Wind force		Wind speed		Effect of the wind Inland
Beaufort number	Designation	[m/s]	[km/h]	
0	Calm	0 to 0.2	1	Calm, smoke rises vertically
1	Slight air movement (draft)	0.3 to 1.5	1 to 5	Wind direction is shown only by observing the trail of smoke, not by the wind sock
2	Light breeze	1.6 to 3.3	6 to 11	Wind can be felt on the face, the leaves rustle, wind sock moves slightly
3	Gentle breeze	3.4 to 5.4	12 to 19	Leaves and small twigs in constant motion. Wind extends a flag
4	Moderate breeze	5.5 to 7.9	20 to 28	Swirls up dust and loose paper, moves twigs and thin branches
5	Fresh breeze	8.0 to 10.7	29 to 38	Small deciduous trees begin to sway, whitecaps form at sea
6	Strong breeze	10.8 to 13.8	39 to 49	Thicker branches move; telephone lines begin to whistle, umbrellas are difficult to use
7	Near gale	13.9 to 17.1	50 to 61	Entire trees swaying; difficult to walk into wind

Wind force		Wind speed		Effect of the wind Inland
Beaufort number	Designation	[m/s]	[km/h]	
8	Gale force wind	17.2 to 20.7	62 to 74	Breaks branches off trees, impedes walking in open areas considerably
9	Gale	20.8 to 24.4	75 to 88	Minor damage to property (chimney caps and roofing tile are blown off)
10	Severe storm	24.5 to 28.4	89 to 102	Trees are uprooted, significant damage to property
11	Violent storm	28.5 to 32.6	103 to 117	Extensive, widespread storm damage
12	Hurricane	32.7 and more	118 and more	Major destruction

Beaufort scale

28.5 Height-dependent wind speed



Note

- ▶ The maximum permissible wind speed (v_{max}) and the maximum permissible wind speed according to the load chart (v_{max_TAB}) always refer to the 3 second wind gust speed, which is present at the maximum height of the crane.
- ▶ Instead of the 3 second wind gust speed, weather information services often report a wind speed (v_m), which is averaged within a time period of 10 minutes (so-called 10 minute average). It refers to the wind force on the Beaufort scale, normally to the medium value of the wind speed, which is determined within a time from of 10 minutes at a height of 10 m above ground or above sea level.
- ▶ The 3 second wind gust speed at the maximum height of the crane that is the determining factor for the calculation is significantly higher than the average value of the wind speed, which is determined over a time of 10 minutes at a height of 10 m above ground.



Note

- ▶ The following chart shows the 3-second wind gust speed depending on the height and the Beaufort number and / or the wind speed determined over a period of 10 minutes at a height of 10 m.
- ▶ With the aid of this chart, the 3-second wind gust speed can be determined for a certain height.

Beaufort number	3	4	5 ^a	5	6	7 ^a	7	8	9	10
v_m [m/s ^b]	5.4	7.9	10.1	10.7	13.8	14.3	17.1	20.7	24.4	28.4
z [m]	$v(z)$ [m/s]									
10	7.6	11.1	14.1	15.0	19.3	20.0	23.9	29.0	34.2	39.8
20	8.1	11.9	15.2	16.1	20.7	21.5	25.7	31.1	36.6	42.7
30	8.5	12.4	15.8	16.8	21.6	22.4	26.8	32.4	38.2	44.5
40	8.7	12.8	16.3	17.3	22.3	23.1	27.6	33.4	39.4	45.8
50	8.9	13.1	16.7	17.7	22.8	23.6	28.3	34.2	40.3	46.9
60	9.1	13.3	17.0	18.0	23.3	24.1	28.8	34.9	41.1	47.9
70	9.3	13.5	17.3	18.3	23.6	24.5	29.3	35.5	41.8	48.7
80	9.4	13.7	17.6	18.6	24.0	24.8	29.7	36.0	42.4	49.4
90	9.5	13.9	17.8	18.8	24.3	25.1	30.1	36.4	42.9	50.0
100	9.6	14.1	18.0	19.1	24.6	25.4	30.4	36.9	43.4	50.6

Beaufort number	3	4	5 ^a	5	6	7 ^a	7	8	9	10
110	9.7	14.2	18.2	19.2	24.8	25.7	30.8	37.2	43.9	51.1
120	9.8	14.3	18.3	19.4	25.1	25.9	31.1	37.6	44.3	51.6
130	9.9	14.5	18.5	19.6	25.3	26.2	31.3	37.9	44.7	52.0
140	10.0	14.6	18.7	19.8	25.5	26.4	31.6	38.2	45.1	52.5
150	10.0	14.7	18.8	19.9	25.7	26.6	31.8	38.5	45.4	52.9
160	10.1	14.8	18.9	20.1	25.9	26.8	32.1	38.8	45.7	53.2
170	10.2	14.9	19.1	20.2	26.0	27.0	32.3	39.1	46.0	53.6
180	10.3	15.0	19.2	20.3	26.2	27.1	32.5	39.3	46.3	53.9
190	10.3	15.1	19.3	20.4	26.4	27.3	32.7	39.5	46.6	54.2
200	10.4	15.2	19.4	20.6	26.5	27.4	32.8	39.8	46.9	54.6
^a Wind stages for the crane in operation: 1 light $v_m = 10.1 \text{ m/s}$ at $z = 10 \text{ m}$ $v(z) = 14.1 \text{ m/s}$ $q(z) = 125 \text{ N/m}^2$ 2 normal $v_m = 14.3 \text{ m/s}$ at $z = 10 \text{ m}$ $v(z) = 20.0 \text{ m/s}$ $q(z) = 250 \text{ N/m}^2$										
^b Upper limit of the Beaufort scale										

3-second wind gust speed depending on the height and the Beaufort number and / or the wind speed determined over a time of 10 minutes at a height of 10 m

Sign	Unit	Definition
v_m	[m/s]	Wind speed determined over a time of 10 minutes at a height of 10 m
z	[m]	Height above level ground
$v(z)$	[m/s]	Speed effective at height z , decisive for the calculation of a 3 second gust
$q(z)$	[N/m ²]	At a height z effective quasi-static dynamic pressure, determined from $v(z)$

Symbol

28.6 Wind influences during erection and take-down



WARNING

The crane can topple over!

If a boom or a boom system is erected or taken down and the expected wind speeds are larger than the maximum permissible wind speeds according to the wind speed chart, then the crane can topple over and fatally injure personnel.

- ▶ If wind speeds are expected which are larger than the maximum permissible wind speeds for erection, then erection of the boom or erection of the boom system is prohibited.
- ▶ If wind speeds are expected, which are larger than the maximum permissible wind speeds for take-down, then the boom or the boom system must be taken down immediately.

**WARNING**

Wind speed higher than permissible!

When the permissible wind speed for „Crane out of operation“ is higher than the permissible wind speed for take-down: Take-down of the boom is not permissible in case of an unexpected increase in wind speed.

The crane can topple over. Death, severe injury, property damage.

- ▶ If wind speeds are expected that are higher than the maximum permissible wind speeds for "Crane out of operation", then take the equipment and the boom down.
- ▶ Always take the boom down for safety reasons if weather conditions are unclear, see the Erection and take-down charts.
- ▶ Observe the permissible wind speeds for take-down.

28.7 Wind influences during crane operation

**WARNING**

The crane can topple over!

Unforeseeable factors, such as sudden wind gusts on the crane and the load cannot be exactly predicted in advance.

- ▶ The size and shape of the load has a significant influence on the permissible wind speed during crane operation.
- ▶ Carry out a professional job planning with authorized and trained expert personnel. All environmental conditions, such as weather forecast and wind speeds, must be taken into account.
- ▶ The authorized and trained expert personnel must have sufficient knowledge in the area of „Wind influences in crane operation“.

**Note**

- ▶ Calculation examples are included in the load charts. If you need further information, contact Liebherr-Werk Ehingen GmbH.

Depending on crane application, for example:

1. Lifting of large surfaced loads.
2. Working with long boom combinations.
3. Erection and take-down of boom combinations.

The crane operator must check with appropriate information sources about the expected wind speeds, at:

1. The start of crane operation.
2. Interruption of crane operation.
3. Resumption of crane operation.

**WARNING**

The crane can topple over!

If the crane is operated at wind speeds which are larger than the maximum permissible wind speeds according to the load chart, then the crane can topple over and kill personnel.

- ▶ If wind speeds are expected that are larger than the maximum permissible wind speeds for the equipped crane, then the equipment and the boom must be taken down.
- ▶ If wind speeds are expected that are higher than the maximum permissible winds speeds for crane operation, then it is prohibited to lift the load.

28.8 Wind influences for „Crane out of operation“



WARNING

The crane can topple over. Death, severe injury, property damage!

If the crane is taken out of operation in the set up condition and the expected wind speeds are higher than the maximum permissible wind speeds according to the wind chart, then the crane can topple over and fatally injure personnel.

- ▶ If wind speeds are expected that are higher than the maximum permissible wind speeds for „Crane out of operation“, then take the equipment and the boom down.
- ▶ Always take the boom down for safety reasons if weather conditions are unclear, see the Erection and take-down charts.
- ▶ Observe the permissible wind speeds for take-down.

29 Lifting a load with two cranes

Before lifting a load with two cranes, the crane operator or a representative of the operator must determine the work sequence and assign a responsible supervisory person for the operation. The responsible supervisor must monitor the operation and remain in constant contact with the crane operators.



WARNING

Overload and toppling of the cranes!

If the load is not lifted or lowered exactly evenly by both cranes, then the center of gravity changes. The cranes can be overloaded and topple over.

Personnel can be killed or seriously injured.

- ▶ Make sure that the cranes are horizontally aligned.
- ▶ Observe the national valid standards, regulations and accident prevention regulations.
- ▶ Determine the utilization degree of the cranes in operation, depending on the complexity of the load lift.
- ▶ Plan for sufficient safety reserves.
- ▶ Avoid side load on the boom.
- ▶ Carry out crane movements synchronously and slowly.



Note

- ▶ The total weight and the center of gravity of the load must be known exactly.
- ▶ Carry out the job planning in detail and with care.
- ▶ Avoid fastening points below the center of gravity of the load.

When the operational conditions or the work to be carried out require:

- ▶ Set up an assembly plan and operating instructions for the operation.

In the drawing is shown how the center of gravity for the load changes if the load is lifted or lowered unevenly. Even a slight incline of the load can cause the crane to be overloaded.

If the load on crane 2 (F_2) is lowered, the load on crane 1 (F_1) increases. Crane 1 can thereby be overloaded.

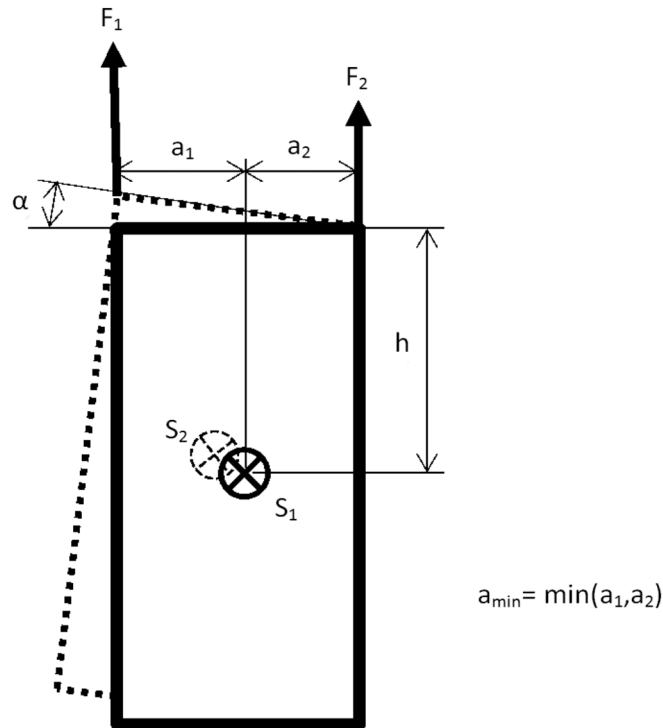

Fig.124126: Geometric conditions

F_1	Load on crane 1	F_2	Load on crane 2
S_1	Center of gravity of load	S_2	Center of gravity of load at incline position
h	Vertical distance between center of gravity of the load and the fastening points	α	Angle of load at incline position
a_1	Horizontal distance between center of gravity of load and fastening point crane 1	a_2	Horizontal distance between center of gravity of load and fastening point crane 2
a_{\min}	Smallest horizontal distance between the center of gravity of the load and the fastening point (minimum from a_1 and a_2)		

The following diagram shows the dependence of the ratio of h/a_{\min} at a maximum permissible incline position of the load of 3° in reference to the permissible load utilization of cranes as a percentage.

31 Hand signals for guidance

For all crane movements, the crane operator must always keep the load as well as the crane hook or load handling equipment when the crane is not loaded, in his field of vision.



WARNING

Danger of accident if standing under suspended loads!

- ▶ Always keep loads in sight.
- ▶ Standing under suspended loads is prohibited.

If this is not possible, the crane operator may only operate the crane if he is signed by an assigned guide.

The operator may be guided by hand signals or a two-way radio. It must be ensured that there are no misunderstandings.



WARNING

Danger of accident caused by misunderstood hand signals!

- ▶ Hand signals must be mutually agreed upon and clearly executed.
- ▶ In any case, the **national regulations** must be observed.

31.1 Hand signals

31.1.1 Starting operation, follow my instructions

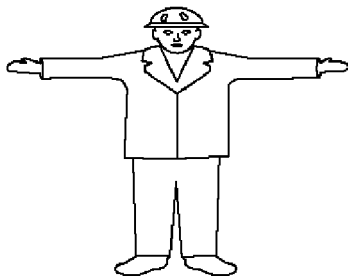

Fig.111700: Starting operation, follow my instructions

Both arms stretched out horizontally with hands open and palms directed to the front.

31.1.2 Stop (normal stop)



Fig.144245: Stop (normal stop)

Arm stretched out, palm of hand facing down, move the arm horizontally backward and forward.

31.1.3 Emergency stop (quick stop)

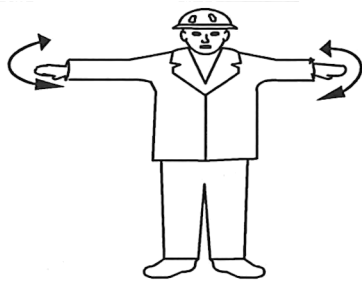

Fig.144246: Emergency stop (quick stop)

Both arms stretched out, both hand palms facing down, move arms horizontally backward and forward.

31.1.4 Ending operation, no longer follow my instructions

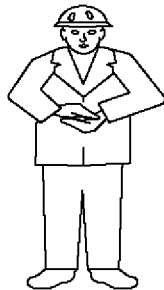

Fig.111703: Ending operation, no longer follow my instructions

Fold hands together at chest height in front of body.

31.1.5 Creeper gear or very slow movement

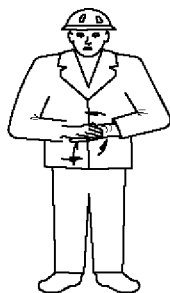

Fig.111704: Creeper gear or very slow movement

Rub palms together in circular motion. After this sign, all other applicable hand signals apply.

31.2 Vertical movements

31.2.1 Showing the vertical distance

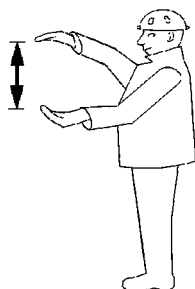

Fig.121364: Showing the vertical distance

Both arms stretched out in front of the body one on top of the other, with opposing palms.

31.2.2 Lifting / lowering a load with even speed



Fig.111706: Lifting / lowering a load with even speed

Lift one arm overhead with closed hand and index finger pointing upward, with small horizontal circular movements with forearm.

31.2.3 Lifting slowly



Fig.121365: Lifting slowly

Give lift signal with one hand, the other palm is not moving and positioned over the hand, which gives the signal.

31.2.4 Lowering the load while stationary

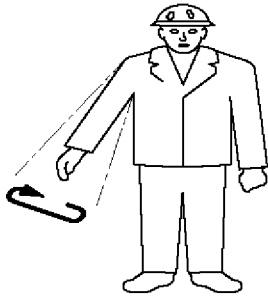

Fig.111708: Lowering the load while stationary

Point one arm away from the body, downward, with hand closed and index finger pointing down. Make small circular movements with forearm.

31.2.5 Lowering slowly



Fig.121366: Lowering slowly

Give lowering signal with one hand, do not move the other palm and hold it under the hand, pointing to the hand which gives the signal.

31.3 Horizontal movements

31.3.1 Driving / swinging in the specified direction

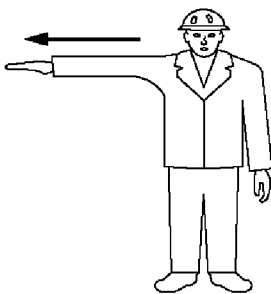

Fig.111710: Driving / swinging in the specified direction

Hold stretched out arm horizontally into the desired direction, with the hand open and the palm pointing down.

31.3.2 Moving away from me



Fig.111711: Moving away from me

Stretch out both arms simultaneously with forearms in front, with both hands open and the palms pointing down. Move the forearms repeatedly between the horizontal and vertical position up and down.

31.3.3 Moving toward me

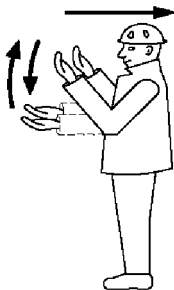

Fig.111712: Moving toward me

Stretch out both arms simultaneously with forearms vertically, with both hands open and the palms pointing to the rear. Move the forearms repeatedly up and down.

31.3.4 Moving both track chains

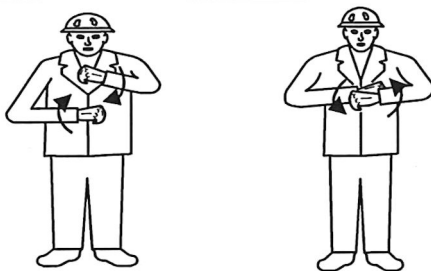

Fig.144247: Moving both track chains

Turn both fists around each other in front of the body in direction of the movement (forward or reverse).

31.3.5 Moving one crawler chain



Fig.144248: Moving one crawler chain

Lift one fist to show blockage of chain on one side. Turn the other fist vertically in front of the body to signal movement of the opposite chain.

31.3.6 Showing the horizontal distance

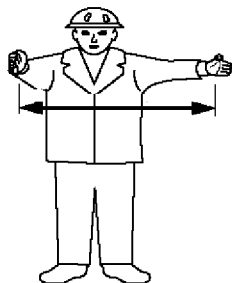

Fig.121380: Showing the horizontal distance

Keep both arms stretched out horizontally in front of the body with the palms opposite each other.

31.3.7 Transfer (between two cranes or two hooks)

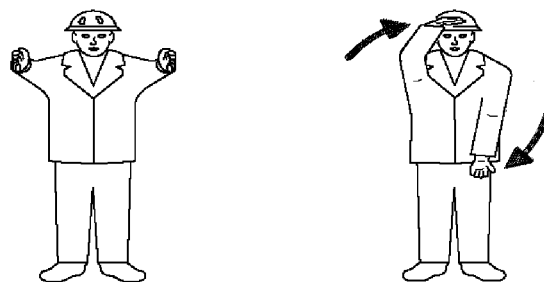

Fig.121368: Transfer (between two cranes or two hooks)

Hold both arms stretched out to the front, parallel and horizontally and turn by 90° in direction of the transfer.



WARNING

Load bearing capacity is **not** sufficient!

The crane can topple over, death, property damage.

- ▶ Make sure that the load bearing capacity of the individual crane and hook is sufficient even if the transfer of the load is suddenly asymmetric.

31.4 Machine related movements

31.4.1 Lifting with main winch

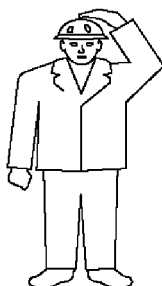

Fig.111719: Lifting with main winch

Place one hand on your head and hold the other arm on the side of the body.

After this signal all other hand signals apply only for the main winch.



Note

- ▶ If two or more main winches are present, then the signaller can show the number of the crane by pointing to it or signal with one finger.

31.4.2 Lifting with auxiliary winch

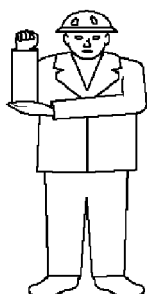

Fig.111720: Lifting with auxiliary winch

Hold one forearm vertically with closed hand and touch the elbow of this arm with the other hand.

After this signal all other hand signals apply only for the auxiliary winch.

31.4.3 Lifting the boom

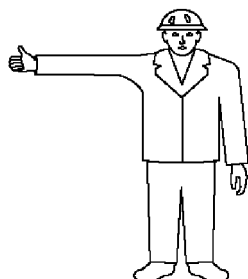

Fig.111721: Lifting the boom

Hold one arm horizontally with thumb directed upward.

31.4.4 Lowering the boom

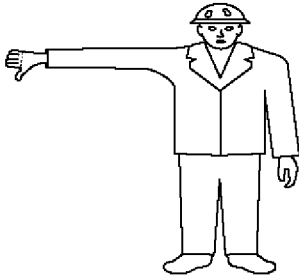

Fig.111722: Lowering the boom

Hold one arm horizontally with thumb directed downward.

31.4.5 Extending the boom



Fig.144249: Extending the boom

Hold both hands (with closed fists) stretched out to the front, with both thumbs directed away from each other.

31.4.6 Retracting the boom



Fig.144250: Retracting the boom

Hold both hands (with closed fists) stretched out to the front, with both thumbs directed toward each other.

31.4.7 Lifting the boom and lower the load at the same time

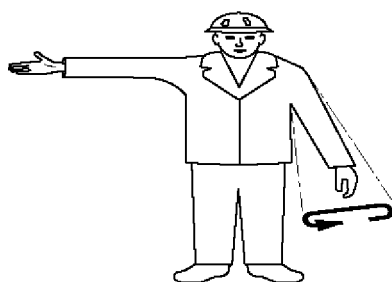

Fig.111725: Lifting the boom and lower the load at the same time

Hold one arm stretched out horizontally with thumb directed upward and stretch the other arm downward and away from the body, make small flat circles with the forearm.

31.4.8 Lowering the boom and lift the load at the same time

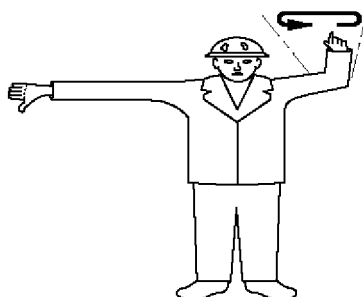

Fig.111726: Lowering the boom and lift the load at the same time

Hold one arm stretched out with thumb pointing down, stretch the other forearm upward and make small flat circles.

32 Travel operation

32.1 Starting to drive

Before starting to drive the crane

- Close all doors.
- Keep the doors closed during the travel operation.

32.2 Turning / driving in reverse



WARNING

Danger of accidents when turning or driving in reverse!

When turning or driving in reverse, personnel can be overlooked and killed.

Objects can be severely damaged.

- ▶ When turning or driving in reverse, the driver must act in such a way that he does not endanger other traffic participants.
- ▶ The driver may only drive in reverse or back up when persons or devices are **not** endangered. If this can **not** be ensured, then he must use a guide.
- ▶ An acoustical back up warning device will never replace the guide.
- ▶ Make sure that there are no persons or objects behind the vehicle when driving in reverse.
- ▶ Make sure that no personnel is injured or even killed.
- ▶ Make sure that no objects are damaged.
- ▶ Driving in reverse is only permissible at slow driving speed (maneuvering speed).
- ▶ Adhere to the national regulations.

32.3 Driving with a trailer

Driving with a trailer depends on the weight of the mobile crane. The minimum weight of the mobile crane in trailer mode is 70 percent of the permissible total weight.

Number of axles	Permissible total weight of the mobile crane	Minimum weight of the mobile crane in trailer mode
4	48000 kg	Approx. 33000 kg
5	60000 kg	Approx. 42000 kg
6	72000 kg	Approx. 50000 kg

32.3.1 Driving with a reduced load

The load of the vehicle crane has been reduced to a range between the permissible total weight and the minimum weight for trailer mode. The load of the vehicle crane can be reduced by disassembling equipment.

The vehicle crane has a different, strong braking behavior. The vehicle crane can reeve out.

32.3.2 Driving with an extremely reduced load

The load of the vehicle crane has been reduced to the minimum weight for trailer mode or less. The load of the vehicle crane can be reduced extremely for example by disassembling the telescopic boom and by disassembling other equipment.



WARNING

Driving with a trailer with an extremely reduced load!

The mobile crane has a different, strong braking behavior. The mobile crane can reeve out. Danger of accident, death, property damage.

- ▶ In the case of an extremely reduced load, do **not** drive the crane vehicle with a trailer.

32.4 Stopping the mobile crane

Make sure that the following prerequisites are met:

- The mobile crane is standing on load bearing, level and tractive ground.
- The parking brake is applied.

**WARNING**

Parking brake is **not** applied!

The mobile crane can roll off, death, property damage.

- ▶ Park the mobile crane exclusively with applied parking brake.

- Turn off the ignition and pull out the ignition key.

When a battery master switch is present:

- Wait 10 seconds, turn off the battery master switch and pull out the switch cam.

**WARNING**

Downhill or uphill slope is too steep!

The mobile crane can roll off, death, property damage.

- ▶ Park the mobile crane at an downhill or uphill slope of no more than maximum 18 %.

Under the following conditions the mobile crane must be additionally secured with wheel chocks to prevent it from rolling off:

- The mobile crane is parked on a slope or an incline.
- The mobile crane is defective, particularly when the brake system is defective.

**WARNING**

Wedges incorrectly placed!

The mobile crane can roll off, death, property damage.

- ▶ So that the wedges have an immediate braking action and hold the mobile crane in park position: Place all wedges tightly directly under the wheel.
- ▶ Place all specified wedges.
- ▶ All wedges must counteract the downhill slope force.

If necessary:

- Place the wedges.

33 Crane operation

33.1 Before starting to work

Before starting to work with the crane:

- Make sure that the cylinders are free of ice.
- Close all doors.
- Keep the doors closed during crane operation.

33.2 While working with the crane

**WARNING**

Defective crane!

Death, severe bodily injuries, property damage.

If an erroneous function of a crane movement is recognized during crane operation:

- ▶ Telescope the boom in all the way and take it down, find the source of the problem and remedy it.

**WARNING**

Relapse cylinder pressure loss!

The luffing lattice jib can luff uncontrollably.

If the luffing lattice jib is assembled

- ▶ Make sure that no persons or obstacles are in the luffing range or are located below the lattice jib.

**WARNING**

Relapse cylinder pressure loss!

The luffing lattice jib can luff uncontrollably due to slack rope on the luffing pulley block.

If an actuated luff down movement does not take place as expected:

- ▶ Immediately stop the luff down movement.
- ▶ Make sure that no slack rope has formed.

If slack rope has formed:

- ▶ Remedy the slack rope.

NOTICE

Freezing rain!

Property damage to the cylinder seals.

If freezing rain starts when working with the crane:

- ▶ Working with the crane is prohibited.
- ▶ Make sure that all cylinders are free of ice.

33.3 Crane operation with a load

**WARNING**

The crane can topple over!

If the crane is in condition which is **not** operationally safe, the crane can topple over or crane components can fall down.

Personnel can be severely injured or killed.

- ▶ Before starting to work, the crane operator must ensure that the crane is in operationally safe condition.
- ▶ If safe crane operation cannot be ensured by the crane operator, then crane operation is prohibited until an operationally safe condition for the crane is established.
- ▶ Safety equipment, for example: Load torque limiter, hoist limit switch, brakes must be fully functioning, otherwise crane operation is prohibited.

Make sure that the following prerequisites are met:

- The load torque limiter must be adjusted according to the current set up configuration of the crane.
- The loads given in the load chart may not be exceeded.
- The crane may never be subjected to a load that exceeds what is specified in the load charts.
- The weight, center of gravity and dimensions of the load to be lifted must be known.
- Load carriers, load handling and fastening equipment must be in accordance with specified requirements.

**Note**

- ▶ Make sure that the weight of the hook block and the weight of the fastening equipment is subtracted from the load given in the load chart, see the following chart.

Example:		
Maximum permissible load according to the chart		30.000 t
Weight of the hook block	350 kg	- 0.350 t
Weight of the fastening rope	50 kg	- 0.050 t
Actual load capacity of the crane		= 29.600 t

The weight of the load to be lifted, in this example, may not exceed **29.6 t**.

**DANGER**

There is a high danger of accident if the following points are not observed!

- ▶ Observe the following points.

There is a great danger of accident if:

- The load torque limiter is not set in accordance with the current crane set up configuration and is therefore not able to provide proper protection.
- The load torque limiter is defective or taken out of operation.
- The hoist limit switches are defective or not functioning.
- For crawler cranes and mobile cranes with luffing lattice jib:
The angle sensor and the force test brackets are not functioning.
- For mobile cranes and crawler cranes with support:
The sliding beams of the hydraulic support are not extended to the dimensions specified in the load chart.
- On crawler cranes:
The crawlers are not supported with stable base material sufficiently large for the ground conditions.
- For mobile cranes and crawler cranes with support:
The support plates are not supported with stable materials large enough for the ground conditions.
- Angular pulling is performed.
Angular pull to the side is particularly dangerous, because the boom has only minimal lateral resistance momentum.

Angular pull is prohibited.

- Load that is too heavy is attached during disassembly and hangs freely on the crane after release.
- The load hook is used to break away stuck loads.
Even if the weight of a stuck load does not exceed the permissible load capacity, the crane can topple over backwards if the load is suddenly released due to the tension of the boom, which can cause it to tip backwards.
- Working when the wind is excessively strong.
Comply with the load chart specifications.
- The crane is not levelled and the load is slewed in the direction of the slope.
- If improper control of crane movements cause the suspended load to swing like a pendulum.
- The loads and boom radii specified in the load charts are exceeded.
- When working in the vicinity of electricity transmission lines:
 - The electricity transmission lines were not turned off by expert electricians.
 - The danger zone was not covered or blocked off.

**WARNING**

Danger of current transfer!

If electricity transmission lines are not shut off nor covered nor blocked off, then there is an increased danger of accident due to current transfer.

- ▶ Adhere to the safety distance according to the following chart.

If the crane becomes electrified despite having taken all necessary precautions, proceed as follows:

- ▶ Remain calm.
- ▶ Do not leave the crane cab.
- ▶ Warn people outside: Stay in place and do not touch the crane.
- ▶ Move the crane away from the danger zone.

Nominal voltage	Safety distance	
	m	ft
Up to 50 kV	4 m	10 ft
Above 50 kV to 200 kV	5 m	15 ft
Above 200 kV to 350 kV	7 m	20 ft
Above 350 kV to 500 kV	8 m	25 ft

Nominal voltage	Safety distance	
Above 500 kV to 750 kV	11 m	35 ft
Above 750 kV to 1000 kV	14 m	45 ft
Above 1000 kV	Determination by power supplier or authorized electrician	Determination by power supplier or authorized electrician

Safety distance to electrical power lines depending on the nominal voltage

33.3.1 Counterweight and / or ballast

The type of counterweight and / or ballast required depends on the weight of the load to be lifted and the boom radius required for crane operation. The deciding factor for the selection of the counterweight and / or ballast is the data in the corresponding load chart.



WARNING

The crane can topple over!

If the counterweight and / or ballast is not installed according to the load chart, then the crane can topple over and fatally injure personnel.

- ▶ Install the counterweight and / or ballast according to the load chart.

33.3.2 Derrick ballast - suspended ballast

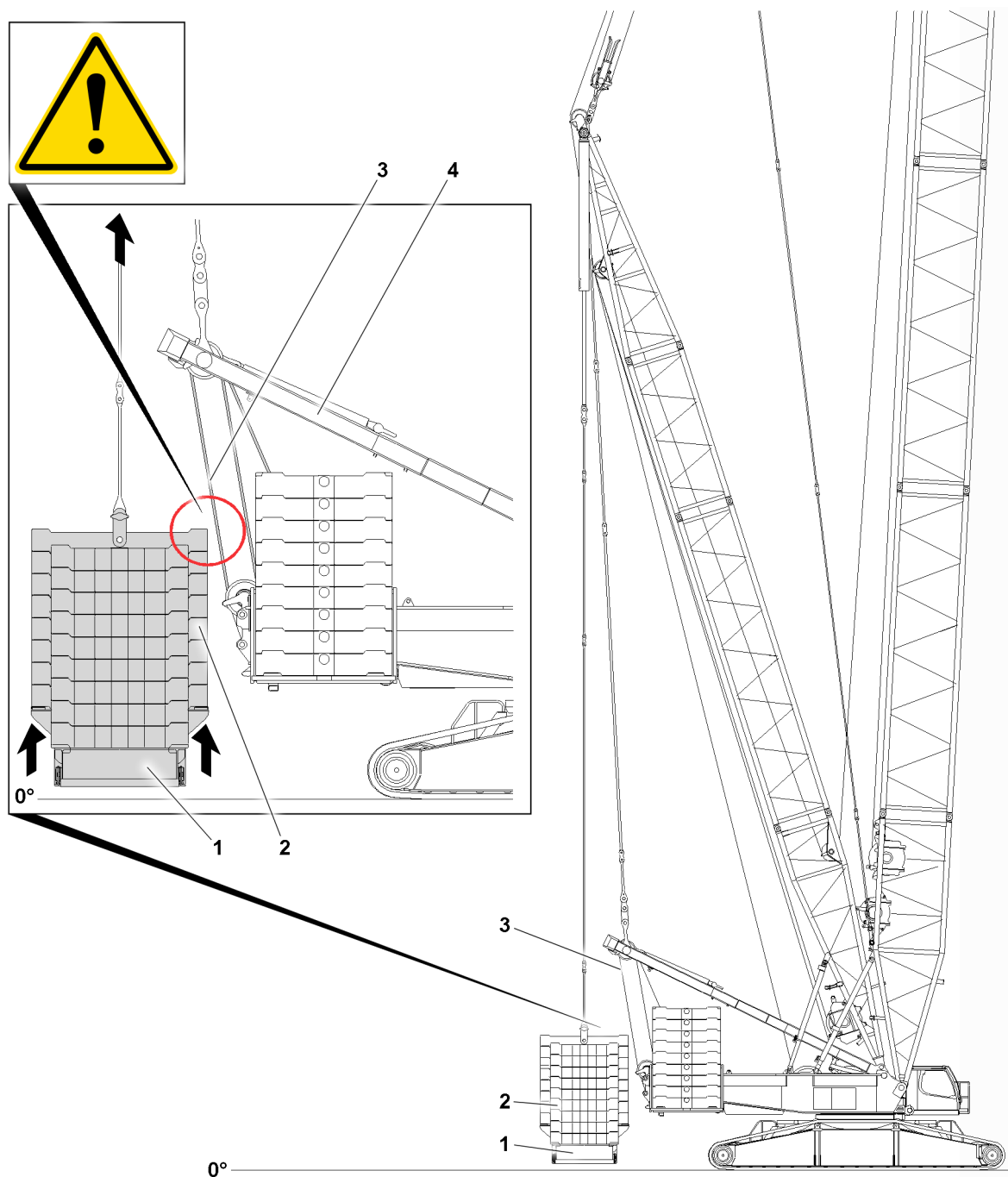

Fig.154801: Danger of collision when lifting the derrick ballast with small derrick ballast radii

- 1 Suspended ballast pallet
- 2 Derrick ballast plate
- 3 Winch 4 control rope
- 4 SA-frame

**WARNING**

Danger of collision!

With small derrick ballast radii, the derrick ballast plates **2** can collide with the winch **4** control rope **3** when lifting the derrick ballast up off the ground.

Death, severe bodily injuries, property damage.

- ▶ Make sure that a guide monitors the lifting of the derrick ballast up off the ground.
- ▶ Adjust the lifting height of the derrick ballast.

33.3.3 Hoist gear, hoist rope

The lifting capability of the crane depends on the pull force of the hoist gear and the number of possible hoist rope reevings. When using a single strand, the crane can only lift a load that is pulled by the hoist gear.

If the load to be lifted is heavier than the pull force of the hoist gear, then the hoist rope must be reeved as needed according to the principle of a pulley between the pulley head on the boom and the hook block.

When reeving, carefully observe the load chart specifications and the operating instructions.

**WARNING**

Hoist rope failure!

If the maximum pull force of the hoist gear is exceeded, the hoist rope can break or the hoist gear can be damaged.

The load can fall and kill personnel.

- ▶ Observe the maximum pull force of the hoist gear.

33.3.4 Hydraulically adjustable auxiliary boom

**WARNING**

Impermissible luffing of the auxiliary boom!

Damage to the auxiliary boom due to collision with the ground or other objects. Component failure.

Death, severe bodily injuries, property damage.

- ▶ Do **not** luff the auxiliary boom down onto the ground or other objects by means of hydraulic adjustment.
- ▶ Do **not** luff the auxiliary boom down onto the ground or other objects by luffing the main boom down.

33.4 Interrupting crane operation

**WARNING**

Impermissible weather conditions!

If the crane is exposed to impermissible weather conditions during interruption of crane operation, situations can occur which could bring the crane into an unsafe condition.

Toppling crane, death, severe bodily injuries, property damage.

- ▶ Get the weather forecast for the entire period during which the crane is set up.

If the predicted wind speeds are above the permissible values according to the load chart and / or the wind speed chart:

- ▶ Take the boom and equipment down in time before impermissible wind speeds occur. See Crane operating instructions, wind speed charts and Erection and take down charts.

When wind conditions are present, which are above the permissible values of the wind speed chart and the boom can no longer be taken down:

- ▶ Make sure that there is no danger for persons, crane and surrounding area. Secure the crane and surrounding area of the crane far enough against access. Warn persons in the surrounding area and bring them in safety.

A weather forecast includes information about:

- Changing weather conditions
- Wind
- Ice
- Precipitation
- Flooding
- Lightning



WARNING

Defective crane!

Death, severe bodily injuries, property damage.

If a crane movement occurs during the interruption of crane operation:

- ▶ Make sure, when an unintentional crane movement occurs, for example as a result of leak, no danger for persons, crane and surrounding is created.

Leaks can occur all on pressurized hydraulic cylinders, for example on the following cylinders:

- Support cylinder
- Luffing cylinder
- Telescoping cylinder
- Control cylinder
- Relapse cylinders



Note

- ▶ Movements can occur on hydraulic cylinders also as a result of changing oil temperature.



WARNING

Set up crane is not supervised!

Situations during interruption of crane operation may occur which could cause the crane to become unsafe if left unsupervised.

Toppling crane, death, severe bodily injuries, property damage.

- ▶ Always watch the crane and keep it under control.

If the crane is in set up condition:

- ▶ Do **not** leave the crane.

If the crane can **not** be constantly kept under control:

- ▶ Take the equipment down and telescope the boom in and take it down.
- ▶ The boom on the crane may only be placed down if the predicted wind speeds according to the wind speed charts are less than the maximum permissible wind speeds during assembly and disassembly.
- ▶ Before the crane is unsupervised: Establish an emergency plan.
- ▶ Carry out the measures listed below.



Note

- ▶ An emergency plan includes information how the crane is brought into a safe condition if an unforeseen event occurs.

If possible:

- Take down and secure the equipment, see the erection and take-down charts.
- Telescope the boom in and secure it. The crane boom may only be telescoped when the prevalent wind speed is lower than the wind speed indicated in the load chart for the boom.
- Take the boom down and secure it. The crane boom may only be placed down if the wind speeds are lower than the maximum permitted wind speeds according to the wind speed charts or does not exceed them according to the assembly / disassembly instructions.

On mobile cranes:

- Lift the axles to the maximum position and block the hydraulic suspension.

On lattice mast cranes:

- Set the Derrick ballast, if present, down on the ground.

- Place the load completely on the ground and unhook it from the crane hook.
- Remove the fastening ropes from the hook.
- Place the load completely on the ground and unhook it from the crane hook.
- Remove the fastening ropes from the hook.

When the hook block remains installed:

- Lift the hook block into the highest position.
- Make sure that the hook block does not touch other crane parts or obstacles.
- Make sure that all measures were taken to keep the crane in a safe condition if something happens.
- If possible, turn the engines off.
- Set all control levers into neutral position or into a locked position.
- Turn all secondary systems off, except systems that are required for restart.
- Establish the energy supply and functionality of safety equipment.
- Close off all control devices, which are not in use.
- Disconnect all control devices, which are connected with cables, if possible, and secure them to prevent unauthorized use.
- Secure control devices without cables to prevent unauthorized use.
- Make sure that the batteries in control devices without cables are charged.
- Make sure that access to the crane and operation for unauthorized personnel is excluded: Lock the driver's cab and the crane cab.
- Secure all keys to prevent unauthorized access.

If the construction site has limited space:

- The decision not to take the boom down while the crane is unsupervised can only be made by an authorized and qualified crane operator, who is familiar with the construction site.
- Make sure that no danger can occur for persons, the crane and its surroundings if something unforeseen happens.
- Make sure for the duration of the interruption of crane operation, that the predicted wind speeds do not exceed the permissible values for the respective set up configuration, see wind speed chart.
- If the wind speed charts do not provide values for the set up condition, the permissible wind speed in the load chart shall be observed.

If crane operation with a set up crane is interrupted:

- Make sure measures are initiated in time by trained, qualified personnel to bring the crane into a safe condition if anything happens.
- Make sure that no danger can occur for persons, the crane and its surroundings if something unforeseen happens.

If the predicted wind speeds are above the permissible values:

- Bring the boom and equipment in time into a permissible condition before impermissible wind speeds occur, depending on the predicted wind speed, or take it down completely on the ground. See Crane operating instructions, wind speed charts and Erection and take down charts.
- Telescope the telescopic boom in and luff down to 0°. Position the boom and auxiliary boom, see the Crane operating instructions, wind speed charts and erection and take-down charts.

Situations are for example:

- Vandalism
- The ground giving way due to severe rain
- Melting ice under the supports
- Storm and thunderstorm
- Storm and wind
- Lightning
- Flooding
- Earthquakes
- Landslides
- Washouts
- For mobile cranes and crawler cranes with support:
Yielding of support cylinders (leak, temperature changes)
- For cranes with a telescopic boom:
Yielding of luffing cylinders (leak, temperature changes)

- Yielding of luffing lattice jib relapse cylinders (leak, temperature changes)

33.5 Resuming crane operation

Before resuming crane operation, the crane operator is obligated, among others, but not exclusively, to check the crane condition, the safety equipment, as well as the environmental conditions.



WARNING

Danger of accident!

When the crane operator leaves the crane cab:

- ▶ Before resuming work, check the operating mode setting and reset, if necessary.

33.6 Ending crane operation

Before the crane operator may leave the crane, the following prerequisites must be met:

- Place the load fully on the ground and unhook from the crane hook.
- On crane with telescopic boom: Telescope the telescopic boom in all the way and take the boom down in the boom receptacle.
- For a crane with a lattice mast boom: Take the lattice mast boom down and disassemble if necessary.
- Bring the control lever (master switch) to the 0-position.
- Apply the parking brake on the crane chassis.
- Turn the engine off and pull out the ignition key.
- When a battery master switch is present: Wait ten minutes after removing the ignition key. After these ten seconds have passed, turn off the battery master switch and pull off the switch cam.
- Lock the crane cab.
- Secure the crane to prevent unauthorized use.
- For a mobile crane: Make sure that the driver's cab is **not** occupied. Lock the driver's cab. Secure the crane to prevent it from rolling off unintentionally, see section „Parking the vehicle“.
- Make sure that no danger can occur for persons, the crane and its surroundings if something unforeseen happens.

34 Lifting of personnel

34.1 Intended use

- The intended use of the crane is **lifting loads**.
- **Lifting personnel** is **not** part of the intended use of the crane.



Note

- ▶ These instructions do **not** apply for work platforms, which are attached on the crane boom and are used to lift personnel. This situation is governed by international standards for mobile aerial work platforms.

**WARNING**

Non-designated use of the crane!

Personnel can be severely injured or killed.

- ▶ The crane is **not** intended to lift personnel.
- ▶ Lifting persons on the variable support is prohibited.
- ▶ The crane may **not** be used for recreational purposes and exhibitions, such as lifting personnel for shows, bungee jumping or Dinner in the sky.
- ▶ The crane may **not** be used for lifting of devices with personnel on them or under the device, such as lifting of tents.
- ▶ Exception: If lifting of personnel for special work situations is the least dangerous possibility to carry out the work, then personnel may be lifted or brought into a suspended position when using lifting cages (cherry pickers).

34.2 Prerequisites for lifting of personnel

Make sure that the following prerequisites are met:

- Lifting personnel with cranes is permissible by national and local laws in the country where this crane application is carried out.

**DANGER**

Lifting of personnel!

Accidents which occur when lifting personnel often result in severe injuries or even death.

- ▶ This exceptional application is within the scope of responsibility of the user and is only permitted if the requirements and instructions in the next sections are observed and adhered to.
- ▶ The company, the supervisor, the crane operator and auxiliary personnel must proceed especially carefully and safety conscious.
- ▶ Before the lifting procedure, a meeting must be held with all associated personnel.
- ▶ The following warning notes and safety regulations must be strictly observed.

34.2.1 Legal prerequisites

Make sure that the following prerequisites are met:

- Special arrangements were made for the use of the lifting cage (cherry picker) according to the requirements of national laws.
- If required by national laws: The use of the crane to lift personnel is reported to the state agency for occupational health and safety. The lifting procedure may possibly require a special permit.
- Before the implementation of the lifting procedure with the aid of a work-specific risk analysis for the possibility of rescuing personnel in emergencies was defined.
- To rescue personnel in emergencies, precautionary measures must be present on the crane, if they are required by national laws.
- The measures for safe operation near power lines, depending on the conditions on the job site and the national laws / national regulations were observed and adhered to.

34.2.2 Prerequisites for crane equipment and accessories

Make sure that the following prerequisites are met:

- The hoist gear to lift personnel must also be able to be moved in emergency operation.
- Before lifting personnel, the crane was inspected. No damage was found.
- The lifting cage (cherry picker) is utilized according to national laws and / or standards and according to intended purpose.
- Before lifting personnel, the lifting cage (cherry picker) was carefully inspected. No damage was found.
- Every emergency rescue device was inspected and its operational readiness was determined, if required by national laws.
- Any hooks in use must be equipped with a latch, which prevents the hook mouth to open. According to national laws, the latch must be manually closable or lockable or must automatically close via a spring.

34.2.3 Inspecting before start up

Make sure that the following inspections are made before starting up the lifting cage (cherry picker):

- On every new construction site and after every modification or repair: To ensure the operating safety of the lifting cage (cherry picker) and the lifting equipment, a test with 125 % of the nominal load carrying capacity of the lifting cage (cherry picker) without personnel must be carried out. During the test, the lifting cage (cherry picker) may only be lifted just above the ground.
- A test lift with loaded lifting cage (cherry picker) without personnel must be carried out. The weight in the lifting cage (cherry picker) for the test lift must be at least as large as the weight of the personnel and the weight with the work equipment carried along. For this test lift, the course of all planned movements of the lifting procedure must be simulated.
- This test lift must be carried out for every location on a construction site, where personnel must be carried.

34.2.4 Prerequisites for operation with lifting cage (cherry picker)

Make sure that the following prerequisites are met for operation with lifting cage (cherry picker):

- The personnel and technical prerequisites for safe use and operation of the emergency control of the crane are present.
- The emergency control for emergency rescue of the person in the lifting cage is functioning.
- The rope pull is limited to 50 % of the maximum rope pull.
- The crane is utilized only to 50 % of its maximum load bearing capacity of the valid load chart.
- Only the hoist gear lifting / lowering, turning and luffing crane movements may be performed.



WARNING

Superimposed crane movements with hydraulic auxiliary users!

Superimposed crane movements by actuating hydraulic auxiliary users can lead to the unwanted acceleration or deceleration of the safety cage movement.

- ▶ It is prohibited to superimpose crane movements with hydraulic auxiliary users to tilt the cab, for example.

35 Securing personnel on shut off crane

35.1 Terms and abbreviations

- PSAgA: Personal protective equipment to prevent falling
- HSG: Height safety device

35.2 Intended use

Cranes are **not** designed to protect personnel against falling.

When the following prerequisites are met, personnel protection may be permissible:

- A justified individual case is present.
- A project-specific written risk assessment and work procedure for the precise case by the employer is on hand.
- The specific safety measures are strictly adhered to.

Limitations for transport and operation:

- Transporting the secured person on the crane **from** job site and **to** job site is impermissible.
- Transporting the secured person on the crane **from** job site and **to** job site is permissible only in case of a rescue operation.
- Operation of the crane by the secured person is impermissible.
- The crane is stopped off and secured against any movement.

35.3 Prerequisites



WARNING

Prerequisites for personnel protection are **not** met!
Danger of accident. Death, severe bodily injuries.

- ▶ Carry out the personnel protection on the shut off crane only when **all** prerequisites in this section have been met.

Make sure that the following prerequisites are met:

- The country-specific, legal regulations are being observed.
- The written risk assessment shows:
 - Technical protective measures with at least the same protective effect are **not** available.
 - The normal fastening devices can **not** be used.
 - Personnel protection on the shut off crane is the safest and most useful method to carry out this work.
- Load transport and personnel protection occur independently of each other:
 - Do **not** carry out personnel protection at the same time as load transport. Simultaneous personnel transport is impermissible.
 - Riding along on the load is impermissible.
- Determination of fastening points and rescue plan for the precise case is on hand from the employer.

35.3.1 Personnel and qualification

Make sure that the following prerequisites for personnel and qualification are met:

- The crane operator is suited and competent to operate the crane.
- Person, which is secured, must be trained in handling the PSAgA.
- The following persons are present on the job site and separately instructed:
 - A supervisor
 - The crane operator
 - The required number of rescue staff according to the rescue plan
- Access protection, fall protection on the shut off crane is made in accordance with the project-specific risk assessment on hand and the measures to be taken.
- The supervisor monitors the safe execution of work. He may **not** take part in the work.
- An effective communication must be ensured between crane operator and the secured person.

35.3.2 PSAgA, rescue equipment and tools

Make sure that the following prerequisites and measures are met:

- Use only HSG (height safety device) according to EN 360 in connection with a safety harness according to EN 361 to secure the person.
- Connecting device is suited for the occurring stress on the edges, see Manufacturer's documentation or device identification.
- Recurring inspections have been made. There are **no** visible defects present.
- At least 1 m connecting device of the maximum possible extension length of the HSG (height safety device) must remain in the housing.
- Fasten the HSG (height safety device) with two separate connecting devices (for example securing on the crane hook and on the crane pulley block).
- Position the crane in such a way that the HSG (height safety device) is at least 5 m and plumb **over** the person being secured.
- Do **not** exceed the maximum permissible deflection of the HSG (height safety device)
- Keep the required clearance **below** the person being secured.
- All required objects (tools, building material) for the work are secured to prevent them from falling.

35.3.3 Crane

Make sure that the following prerequisites are met:

- The maintenance intervals and periodic crane inspections have been adhered to. There are **no** visible defects present.
- The load on the crane hook in any possible position is at least 600 kg , see the Load chart (take the crane pulley block into account).
- Ensure sufficient load bearing capacity: For the load cases catching, pendular fall and possible angular pull adhere to the manufacturer's instructions.
- The crane is secured against movements and inadvertent movement (remote control is deactivated, crane control is activated).
- The overload protection is active.

35.4 Fastening device

Make sure that the following prerequisites are met:

- The crane hook is equipped with the hook safety.
- On the carrying device two connecting devices separated from each other can be fastened.
- HSG (height safety device) is redundantly fastened.
- Suitable fastening devices according to EN 795 Type B are on hand:
 - Round sling or fastening rope with steel core
 - Belt loop
- Textile components must be protected against greases, oils and other aggressive substances.
- Use only steel carabiners according to EN 362 with Tri-Lock function.

35.5 Rescue

A person in an accident must be lifted or lowered with the aid of the crane.

Carry out the following measures to ensure a safe rescue operation:

- Determine the rescue plan and rescue chain at the preparation of the mission.
- Ensure the rescue of a person involved in an accident immediately with locally available means and trained personnel.
- Have the rescue mission coordinated by another person, with visual and voice contact to the crane operator, ground personnel as well as to the person, which is rescued.

35.6 Additional risks

Make sure that the following risks are taken into account:

- Wind effect and environmental influences.
- Crushing and shearing points.
- Endangerment by additional cranes, for example material transport.

36 Welding work on the load



Note

- ▶ The load must also be grounded.

In case of welding work on the load, the screw clamp of the welding unit must be attached on the work piece to avoid current flow via hoist rope, crane superstructure or crane chassis.

2.04.10 Ladders

1	Intended use	2
2	Safety instructions	2
3	Safety signs	3
4	Ladder inspection	12
5	User guidelines	12
6	Assembling the ladder	14
7	Ladder access	25

1 Intended use

Ladders are mobile work equipment that can be used in different locations. Ladders can be used to perform minor work at heights in cases where the use of other equipment would not be appropriate.

Ladders are designated for the ascent and descent of personnel.

Ladders may only be used as described. Any other use is considered unintended use and is therefore forbidden.

The manufacturer is **not** liable for damage caused by unintended use or improper usage.

2 Safety instructions

The ladders are built according to the present level of technology and recognized safety technical regulations. Despite that, during their use dangers to life and physical condition of the user and / or third parties can occur.

Ladders may exclusively be used in a flawless technical condition and according to their missions as well as with constant awareness of safety and dangers.

Changes to the structure may exclusively be made with written approval of the manufacturer.

The ladders that are illustrated are an example. Ladders with the same functional principle may appear differently.



WARNING

Safety instructions not observed!

Personnel can fall, death, severe bodily injuries.

- ▶ Observe and adhere to the assembly and safety instructions for ladders.
- ▶ Observe and adhere to the safety signs on the ladders.
- ▶ Install and secure the ladders properly.
- ▶ Use ladders exclusively if you are healthy enough to do this.
- ▶ Climb up / down with the 3-point support.
- ▶ Use the rungs as handles.
- ▶ Step into the rungs deep enough.
- ▶ Never bring the ladder to a new position during use.
- ▶ Do not use damaged ladders and replace them immediately.
- ▶ Repair the ladder exclusively through authorized service facilities.

2.1 Ladder categories

Ladders are divided into two categories according to the most up-to-date specifications:

- Ladders for industrial use
- Ladders for private use

Ladders for industrial use are tested according to the strictest criteria. Only use ladders for industrial use.

Ladders are marked according to their category allocation by a corresponding pictogram. See section „Safety signs“.

2.2 Stationary stability

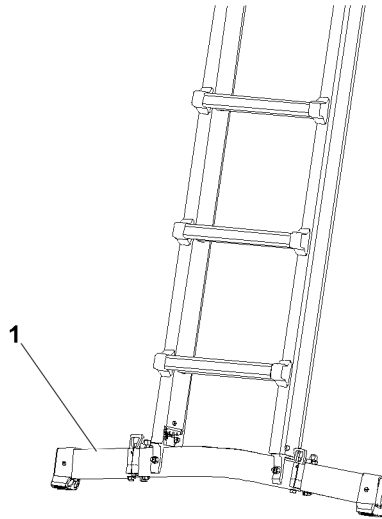

Fig.149993: Ladder with cross beam

According to the most up-to-date regulations, ladders with a length of more than 3 m must have a larger standing width. These ladders are equipped with a cross beam 1.

2.3 Retrofitting old ladders

It is not mandatory to retrofit old ladders. It is the responsibility of the industrial user to ensure, in accordance with the operational safety regulation by means of a risk assessment, that the safety of the work equipment is ensured for all work tasks.

Older ladders that no longer corresponds with the state of technology according to current regulations, can continue to be used, **if** their safety has been checked **and** guaranteed.





3 Safety signs







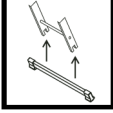
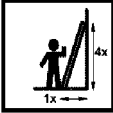
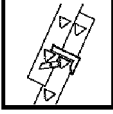
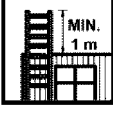

Note

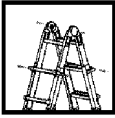
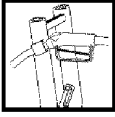
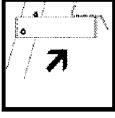





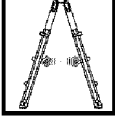
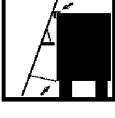

- ▶ The safety signs and instructions on the ladders must be complete and always legible.
- ▶ Observe and adhere to the manufacturer's operating instructions.

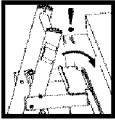
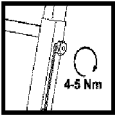





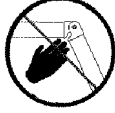

3.1 Symbols until the end of 2017

Sign	Explanation
	Read the operating instructions
	Maximum number of users on one ladder
	Maximum load
	In the case of ladders that have a cross beam, the cross beam must be assembled before the first use
	Correct set up angle 65° to 75°
	Before use: Engage the lift out safety
	Ladder overhang above the exit level
	Secure the upper / lower end of the ladder
	Before use: Tension the safety struts on stepladders



Sign	Explanation
	<p>Before use: Engage the locking pin joints and pull pin locks</p>
	<p>To open / close the tank cover and to ascent / descent: Insert the fuel nozzle into the retainer.</p>
	<p>Before setting up the ladder: Fold out the platform.</p>
	<p>Before use: Check the ladder for damage</p>
	<p>Check the legs of the ladder</p>
	<p>Do not use the three uppermost rungs of an extension ladders as rungs to stand on</p>
	<p>Do not use the four uppermost rungs / steps of a stepladder without a platform to stand on</p>
	<p>Do not use the two uppermost rungs of a stepladder with integrated extension ladder as rungs to stand on</p>
	<p>If hinged ladders are used as stepladders: Spread the ladder legs to the stop</p>
	<p>Place the upper placement angle flat. Hold the belt on tension</p>

LWE/LR 13000-001/19503-01-02/en







Sign	Explanation
	Hook the hook on the platform of the refueling ladder on the vehicle
	Tightening the star knob on the beam extension tightly
	Do not use a damaged ladder
	Preclude any contaminants on the ground
	Make sure the upper end of the ladder is placed correctly. Place the ladder only on safe surfaces
	Only one person may climb up / down on any accessible leg of the ladder
	Avoid leaning out to the side. Keep the body's center of gravity between the ladder beams
	Face the ladder when climbing up / down the ladder
	Use the ladder only with suitable shoes
	Do not use a stepladder as a leaning ladder









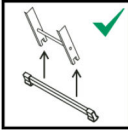

Sign	Explanation
	Do not use the inner section of multi-part hinged ladders without outer sections as a stepladder
	Crushing danger
	Set the ladder up on horizontal and solid ground
	Set the ladder up on solid ground
	Use the ladder in the correct set up direction
	Do not carry along bulky objects or objects over 10 kg on the ladder
	It is not permitted to step off the ladder to the side
	During transport, pay attention to danger due to power lines
	Do not use the ladder as a walkway
	Do not transport snow and ice shovels over the ladder Use hooks!











Sign	Explanation
	Danger due to shearing point
	Do not use the ladder with the cross beam folded in
	Do not use a ladder under the influence of drugs or alcohol
	Do not use a ladder to climb up to another lever
	Make sure that both ladder sections are opened completely and secured. Avoid an incorrect ladder position
	Only use the platform ladder with a locked spreader lock
	Only permissible ladder rungs / platforms may be used as standing and stepping surfaces. Other surfaces such as placement surfaces for cable clips or attachment hooks may not be used as standing and stepping surfaces
	If a crossbars is part of the delivery scope of the mobile platform ladder: Only use a mobile platform ladder with the crossbar assembled
	If auxiliary weights are part of the delivery scope of the mobile platform ladder: Only use the platform ladder with the auxiliary weights assembled

Sign	Explanation
	If a foot brake is installed on the mobile platform ladder: Use the foot brake
	Make sure that the joint is locked
	In unfavorable weather conditions, do not use the ladder in the open





3.2 Symbols from 2018

Sign	Explanation
	Danger of falling!
	Read the operating instructions
	Maximum load
	Ladder for professional use
	Ladder for private use
	Maximum number of users on one ladder

Sign	Explanation
	In the case of ladders that have a cross beam, the cross beam must be assembled before the first use
	Correct set up angle 65° to 75°
	Always keep a firm grip: When ascending and descending and when working on the ladder
	Ladder overhang above the exit level
	Before use: Engage the lift guards
	Do not use a damaged ladder
	Only use the ladder with the cross beam folded out
	Prior to use: The hinges and locks must be engaged
	Use the ladder in the correct set up direction
	Only use the ladder with appropriate footwear

Sign	Explanation
	<p>Do not use the ladder if physically impaired or under the influence of drugs or alcohol.</p>
	<p>Do not use the ladder on uneven or unsteady surface</p>
	<p>Do not use the ladder on a slippery or contaminated surface</p>
	<p>Do not place the ladder on unsuitable surfaces</p>
	<p>Do not carry along bulky objects or objects over 10 kg on the ladder</p>
	<p>Do not use the top three rungs as rungs to stand on</p>
	<p>Avoid leaning out to the side. Keep the body's center of gravity between the ladder beams</p>
	<p>Avoid working with a side load</p>
	<p>Climb up and down the ladder while facing it</p>
	<p>Do not use a stepladder as a leaning ladder</p>

LWE/LR 13000-001/19503-01-02/en

Sign	Explanation
	Prior to use: Tension the safety struts on stepladders
	For stepladders without a platform: Do not use the top two rungs as rungs to stand on
	It is not permitted to step off to the side from the ladder
	When transporting or using the ladder, be aware of any danger due to overhead wires
	Do not use the ladder as a walkway

4 Ladder inspection

Make sure that the following conditions are met:

- All ladders are inspected at least every 12 months. See chapter 8.17.
- The inspection may be made exclusively by authorized and trained expert personnel.
- The results of the inspection are documented.

5 User guidelines

Make sure that the following prerequisites are met before using the ladder:

- A risk evaluation had been made.
The national legal regulations have been taken into account.
- People are physically able to use a ladder.
- The ladder is suited for the respective application.
- The ladder is complete and not damaged (visual inspection).
- The ladder is free of contaminants, such as:
 - Ice
 - Snow
 - Frost
 - Wet paint
 - Lubricants
- The legs of the ladders are not worn.
- Screws and connections have been checked for tight seating.
- The base is:

- Level
- Horizontal
- Slip-resistant
- Unmoveable

When climbing up the ladder:

- Set the ladder up in the correct set up angle.
- Secure the locking devices of the ladder.
- Tension the spreaders of the stepladder.
- Do **not** set up the ladder from above.
- Do **not** set the ladder on braces or steps.
- Avoid the risk of a collision with pedestrians, vehicles or doors.
- Place the leaning ladder only suitably stable contact surfaces with both rails.

When using the ladder:

- Make sure that no children are playing on the ladders.
- Subject the ladder to no more than maximum 150 kg.
- Use the ladder exclusively as described in section „Ladder access“.
- Do **not** use the ladder outside in strong wind.
- Do **not** subject the ladder horizontally to excessive loads in side assembly work.
- Face the ladder when climbing up or down the ladder.
- Step on the ladder with suitable shoes.
- Do not use the ladder as a walkway.
- Secure the ladder to prevent it from being knocked over inadvertently.
- For leaning ladders, do not step on the uppermost three steps / rungs, in reference to the ladder placement point.
- For stepladders, do not step on the uppermost two steps / rungs.
- Do not work too long on the ladder without pauses. Tiredness is a safety risk.
- When working on a ladder, hold on tightly with one hand.

If this is not possible: Take additional safety measures, such as: use the WORK POSITIONING SYSTEM (WPS).

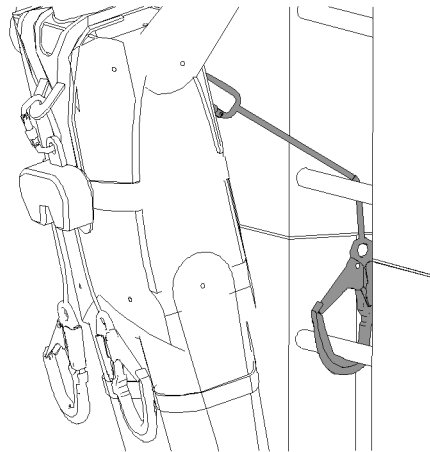

Fig.126746: Example of how to use the WPS

For repair, maintenance and storage of a ladder:

- Have repairs and maintenance made by expert personnel according to the manufacturer's instructions.
- Store the ladders according to the manufacturer's instructions.

Before transporting the ladders:

- Lock and secure the ladders in their provided transport retainers.

6 Assembling the ladder

6.1 Supplied cross beam

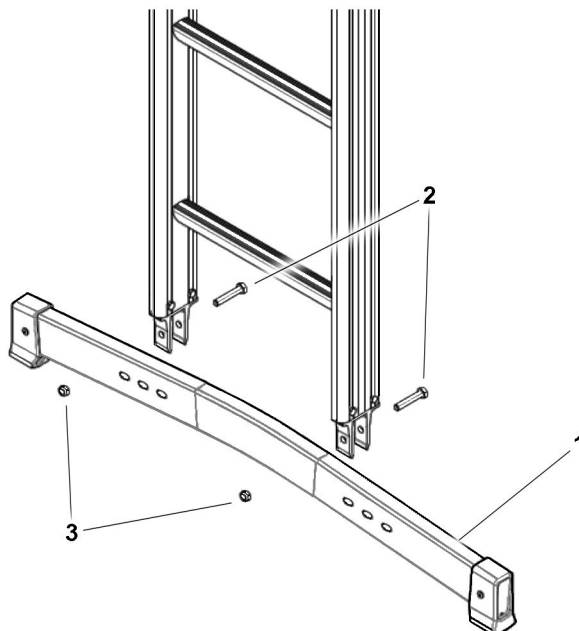

Fig.149565: Assembling the cross beam

Depending on the type of ladder and the delivery condition, the cross beam must be assembled prior to use.

Required tools:

- 2 x 13 mm wrenches
- The screws and nuts are included in the delivery scope.

Tightening torque:

- Approx. 8 Nm

- ▶ Position the cross beam **1** centrally between the cross beam fasteners.
- ▶ Secure the cross beam **1** with screws **2** and nuts **3**.
- ▶ Before using the ladder: Make sure that the screws **2** and nuts **3** are tightened correctly.

6.2 Folding cross beam

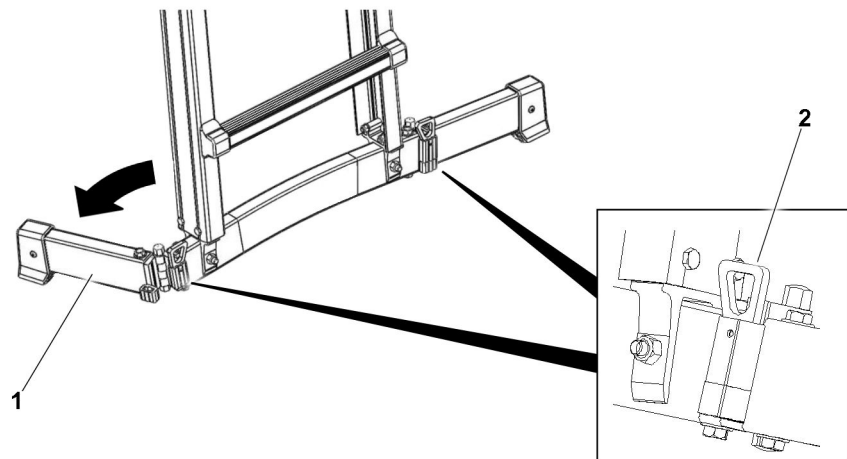

Fig.149566: Use the folding cross beam

Depending on the type of ladder, the folding cross beam must be brought into the operating position prior to use and brought to the transport position after use.

6.2.1 Bringing the cross beam into the operating position

- ▶ Swing the folding cross beam **1** on both sides into the operating position.
- ▶ Make sure that the retaining element **2** is engaged.
- ▶ Before using the ladder: Make sure that both retaining elements **2** have engaged.

6.2.2 Bringing the cross beam into the transport position

- ▶ Unlock the retaining element **2**.
- ▶ Swing the folding cross beam **1** on both sides into the transport position.
- ▶ Before storing the ladder: Make sure that both retaining elements **2** have engaged.

6.3 Cross beams for platform ladder

For platform ladders, the supplied cross beams must be assembled prior to use.

Required tools:

- 2 x 13 mm wrenches
- The screws and nuts are included in the delivery scope.

6.3.1 Assembling the cross beam without wheels

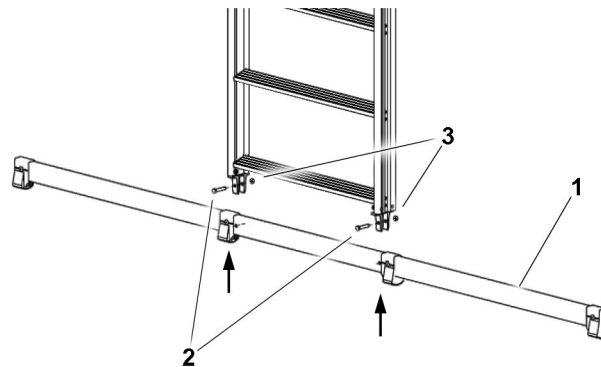

Fig.149595: Assembling the cross beam

- ▶ Position the cross beam 1 centrally between the cross beam fasteners.
- ▶ Secure the cross beam 1 with two screws 2 and two nuts 3.
- ▶ Tighten the screws 2 by hand.

6.3.2 Assembling the cross beam with wheels

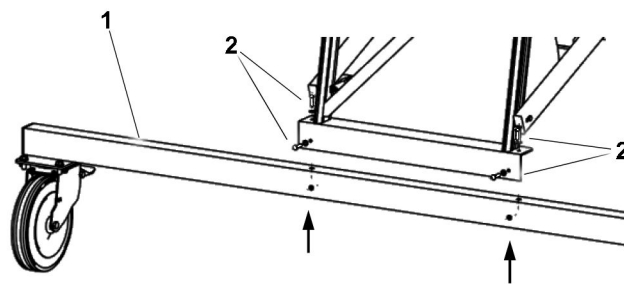

Fig.149596: Assembling the cross beam

- ▶ Position the cross beam 1 centrally between the cross beam fasteners.
- ▶ Secure the cross beam 1 with four screws 2 and four nuts.
- ▶ Tighten the screws 2 by hand.
- ▶ Before using the ladder: Make sure that all screws and nuts are correctly tightened.

6.4 Platform ladder

At least two people are required for ladder assembly and removal.

6.4.1 Assembling the platform ladder



WARNING

Platform ladder not correctly assembled!
Personnel can fall down. Death, severe bodily injuries.

- ▶ Before the platform ladder is correctly assembled: Do **not** step on or load the platform ladder.

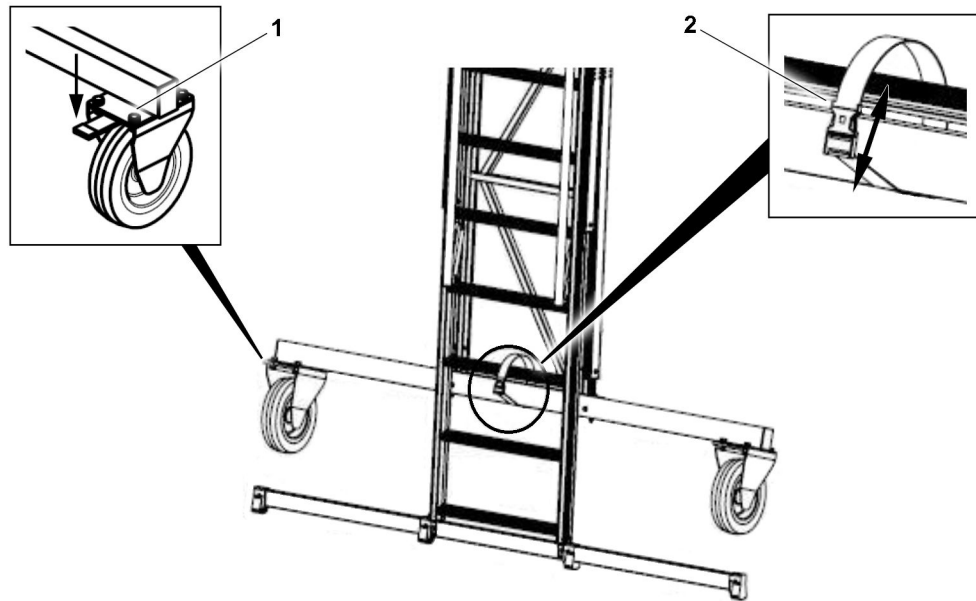

Fig.149597: Preparing the ladder

- ▶ Secure both pulleys 1.
- ▶ Erect the ladder with two people.
- ▶ Release the rigging belt 2.

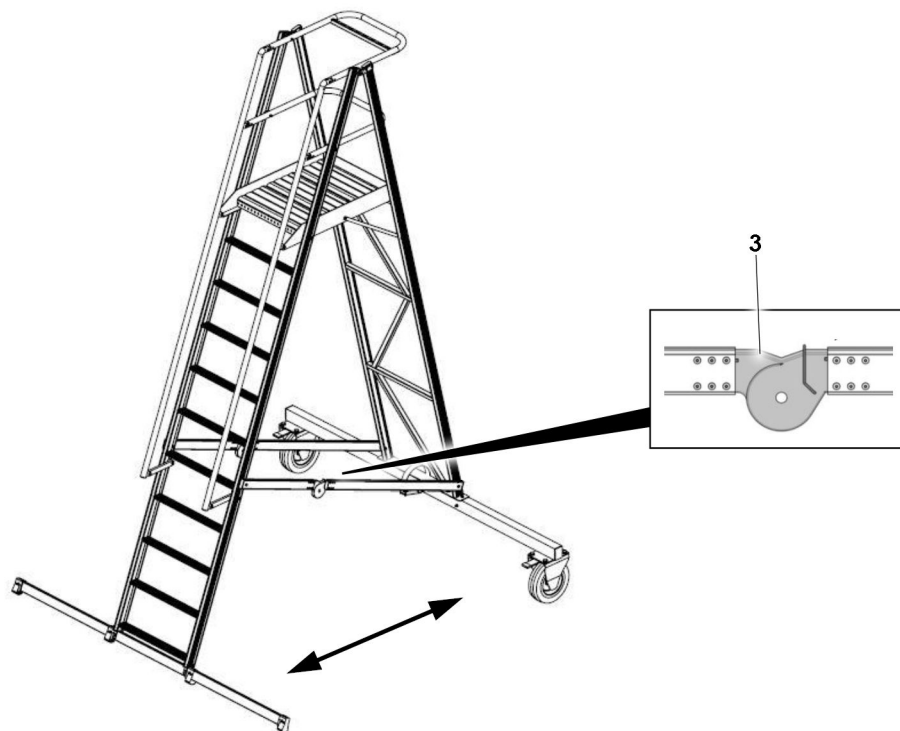

Fig.149598: Setting up the ladder

- ▶ Each half of the ladder is held by a person.
- ▶ Until both hinges 3 engage audibly: Carefully guide the ladder halves away from each other. When doing so, the platform surface will fold out automatically.

Result:

- The ladder is now assembled.

6.4.2 Dismantling the platform ladder

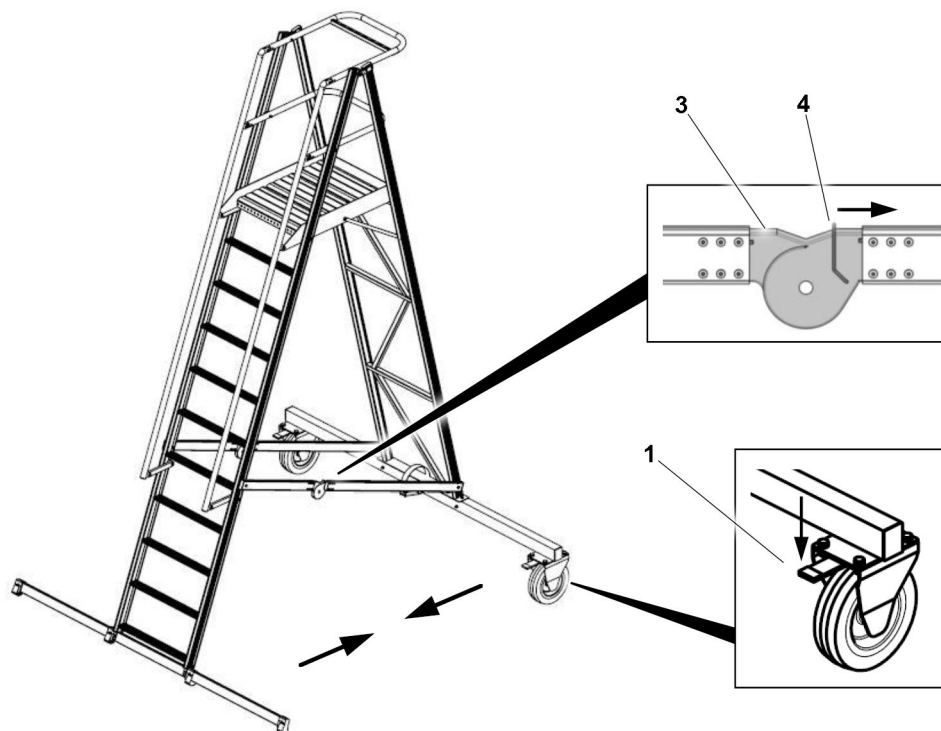

Fig.149599: Releasing the hinges

- ▶ Secure both pulleys 1.
- ▶ Unlock the locking bracket 4 in the hinge 3 on both sides.
- ▶ Each half of the ladder is held by a person.
- ▶ Carefully guide the ladder halves toward each other. When doing so, the platform surface will fold together automatically.

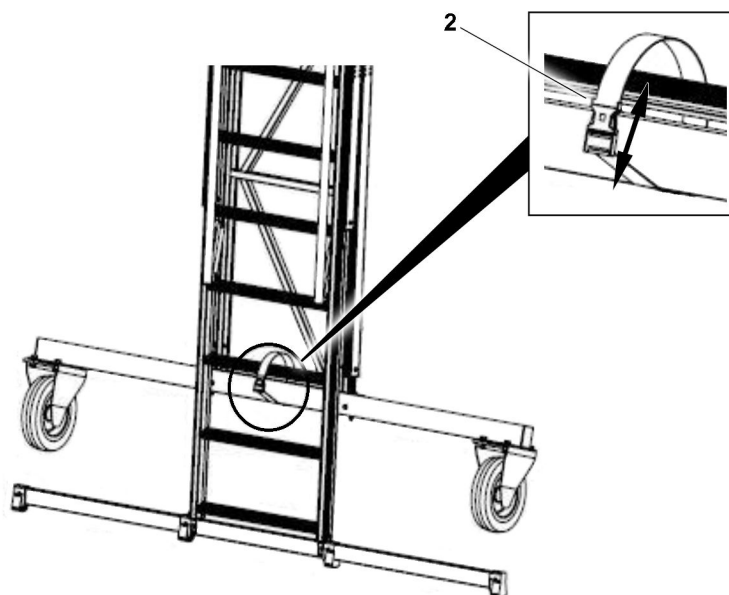

Fig.149600: Securing the ladder in the transport position

- ▶ Secure the rigging belt 2 on the cross beam and rung.
- ▶ Make sure that the clasp on the rigging belt 2 is closed.

Result:

- The ladder is dismantled and secured in the transport position.

6.5 Hinged ladders

The hinged ladder can be used as a leaning ladder or stepladder.

To adjust a part of the ladder, both hinges on opposite sides must be actuated.

6.5.1 Using a hinged ladder as a leaning ladder

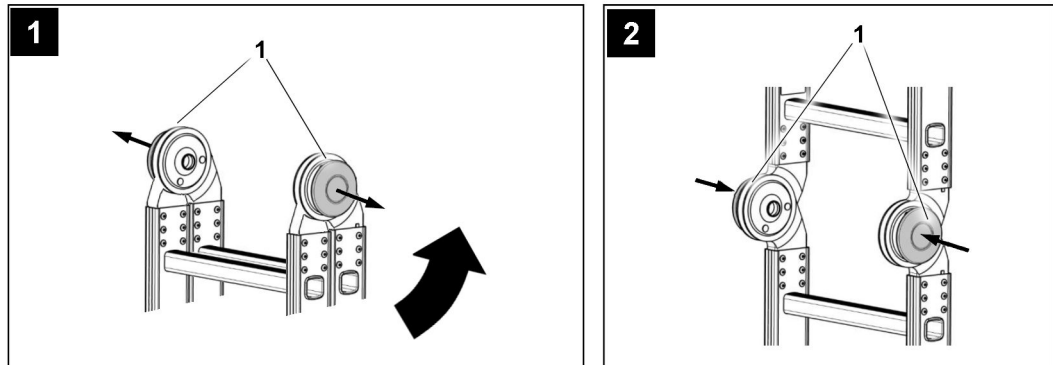

Fig.149567: Using a hinged ladder as a leaning ladder

- ▶ Release the hinges 1.
- ▶ Until the hinges 1 engage again: Spread out the legs to the stop.
- ▶ Before using the hinged ladder as a leaning ladder: Make sure that the hinges 1 have engaged.

6.5.2 Bringing the leaning ladder into the transport position

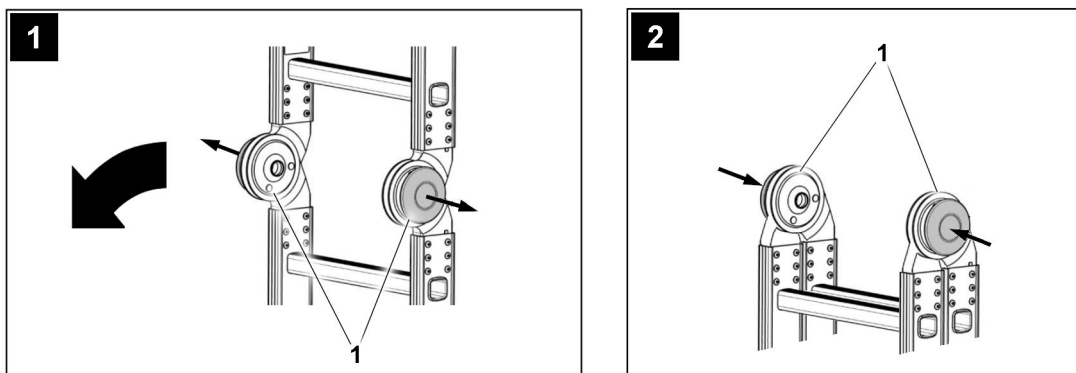

Fig.151625: Bringing the leaning ladder into the transport position

- ▶ Release the hinges 1.
- ▶ Until the legs lie together and the hinges 1 engage: Fold the legs together.

Result:

- The hinged ladder is now in the transport position. The hinged ladder can be stored.

6.5.3 Using a hinged ladders as a stepladder

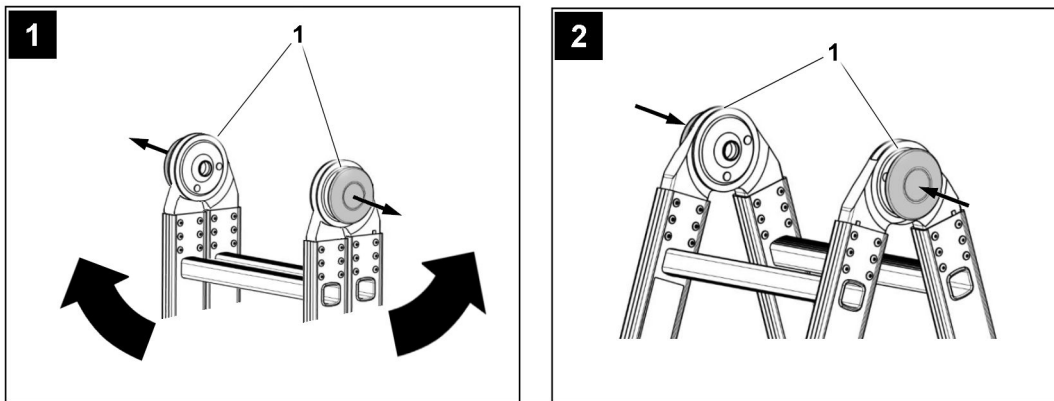

Fig.149568: Using a hinged ladders as a stepladder

- ▶ Release the hinges 1.
- ▶ Until the hinges 1 engage again: Spread out the legs.
- ▶ Before using the hinged ladder as a stepladder: Make sure that the hinges 1 have engaged.

6.5.4 Bringing the stepladder into the transport position

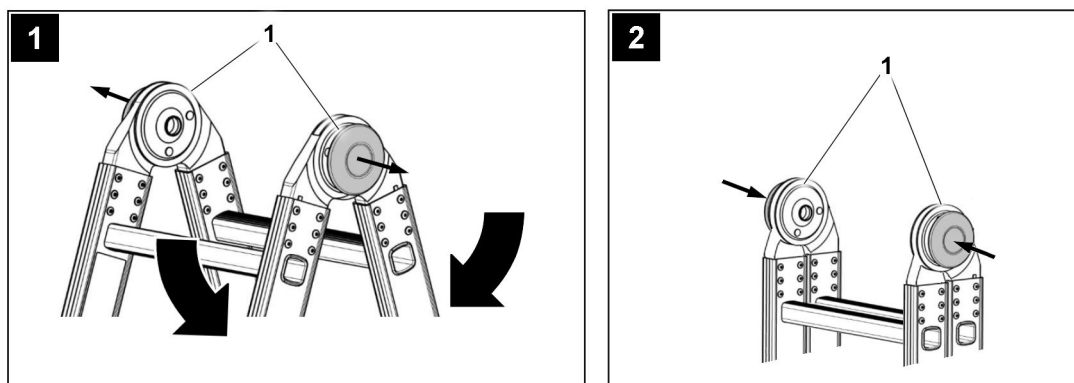

Fig.151607: Bringing the stepladder into the transport position

- ▶ Release the hinges 1.
- ▶ Until the legs lie together and the hinges 1 engage: Fold the legs together.

Result:

- The ladder is now in the transport position. The ladder can be stored.

6.6 Multi-purpose ladder with height adjustment

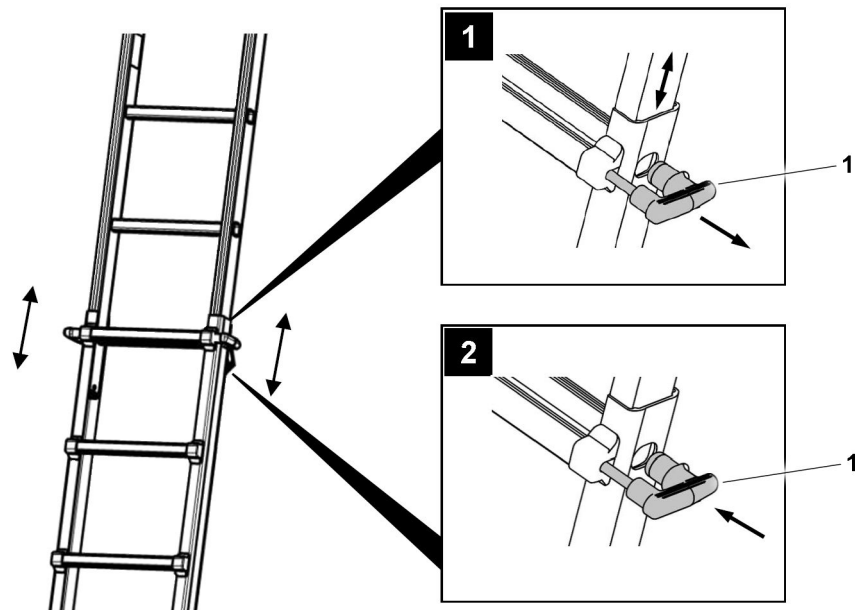

Fig.149570: Ladder with height adjustment

Multi-purpose ladders have a height adjustment device.

- ▶ Release the handle **1** on both sides.
- ▶ Pull out or push in the ladder to the desired length.
- ▶ Lock the ladder with the handle **1** on both sides.
- ▶ Before using the ladder: Make sure that both handles **1** have engaged.

6.7 Three-part multi-purpose ladder

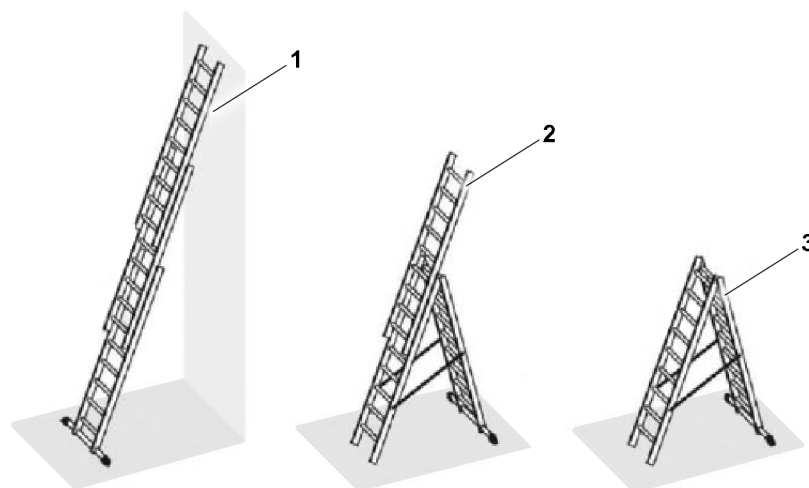

Fig.152833: Three-part multi-purpose ladder

The three-part multi-purpose ladder can be used as a leaning ladder **1**, stepladder with integrated extension ladder **2** or as a stepladder **3**.

6.7.1 Using the three-part multi-purpose ladder as a leaning ladder

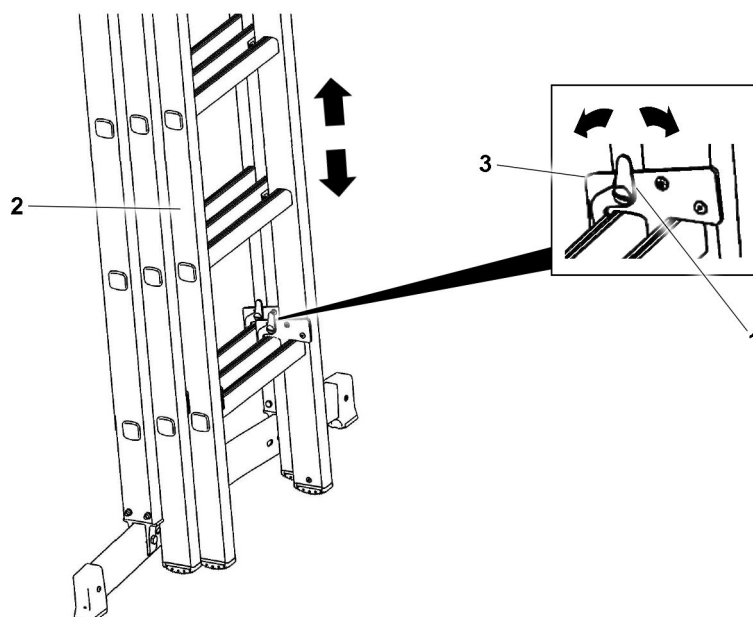

Fig.152834: Pushing out the ladder

Push out the upper ladder section 2:

- ▶ Release the lock 1. Slightly lift up the upper ladder section 2 at the same time.
- ▶ Swing out the upper ladder section 2 and push it out to the desired length.
- ▶ Refit the securing hooks 3.
- ▶ Make sure that the lock 1 engages.

Push out the middle ladder section:

- ▶ Pull out and lock the middle ladder section in the same manner.
- ▶ Make sure that the lock 1 engages.

Result:

- The ladder can now be used.

Push the ladder together:

- ▶ Push together and lock the middle ladder section.
- ▶ Subsequently push together and lock the upper ladder section.
- ▶ Make sure that the lock 1 engages.

Result:

- The ladder is now in the transport position. The ladder can be stored.

6.7.2 Using the three-part multi-purpose ladder as a stepladder

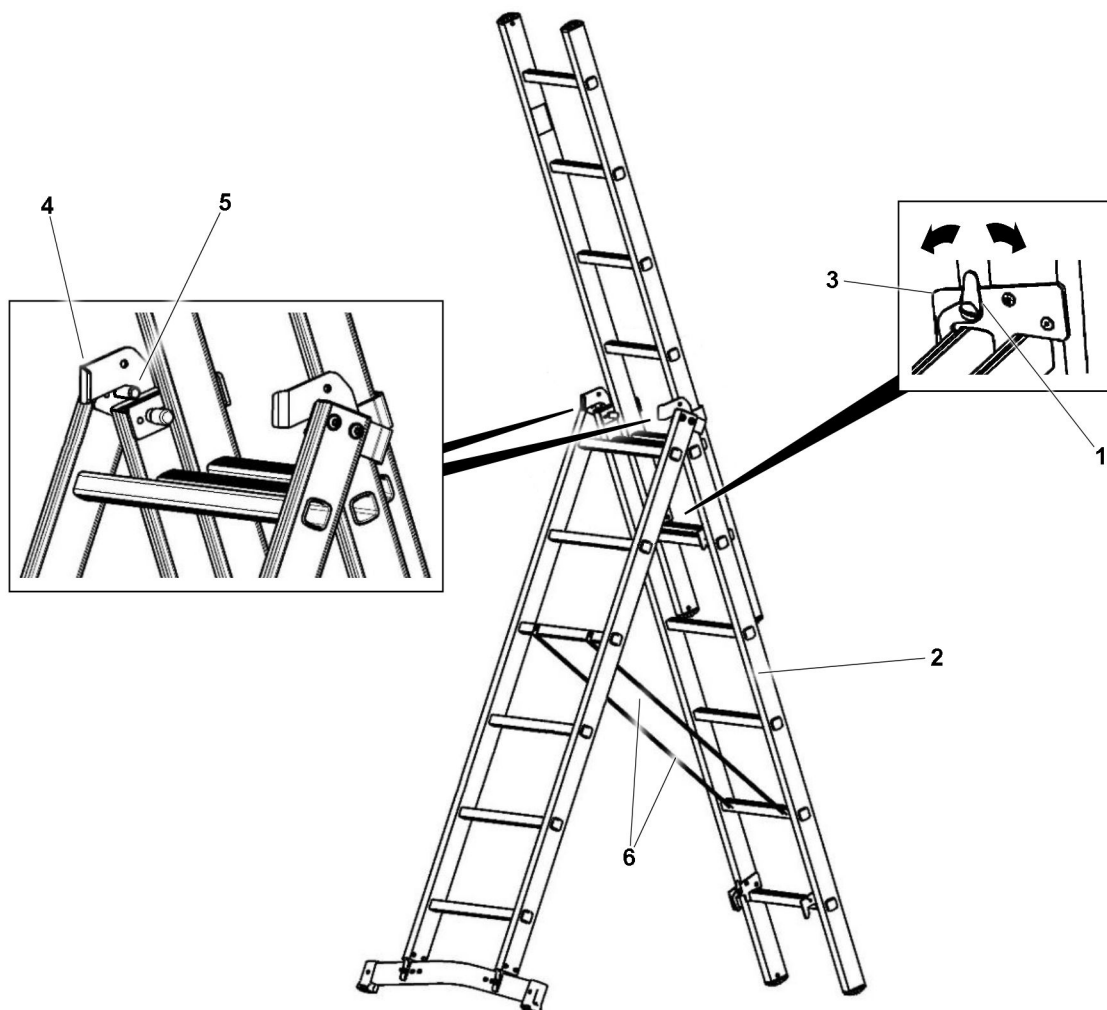

Fig.152835: Setting up the ladder

Push out the upper ladder section:

- ▶ Push out the upper ladder section to the desired length. See section „Using the three-part multi-purpose ladder as a leaning ladder“.

Swing out the middle ladder section **2**:

- ▶ Release the lock **1**. Slightly lift up the middle ladder section **2** at the same time.
- ▶ Until the contact point **5** of the bottom ladder section slides along the guide fitting **4** on both sides into the storage position: Spread out the legs.
- ▶ Make sure that the belt straps of the ladder locks **6** are tensioned.

Result:

- The ladder can now be used.

Bring the ladder into the transport position:

- ▶ Fold the middle and bottom ladder sections together.
- ▶ Push the upper ladder section together again.

Result:

- The ladder is now in the transport position. The ladder can be stored.

6.8 Extension ladder

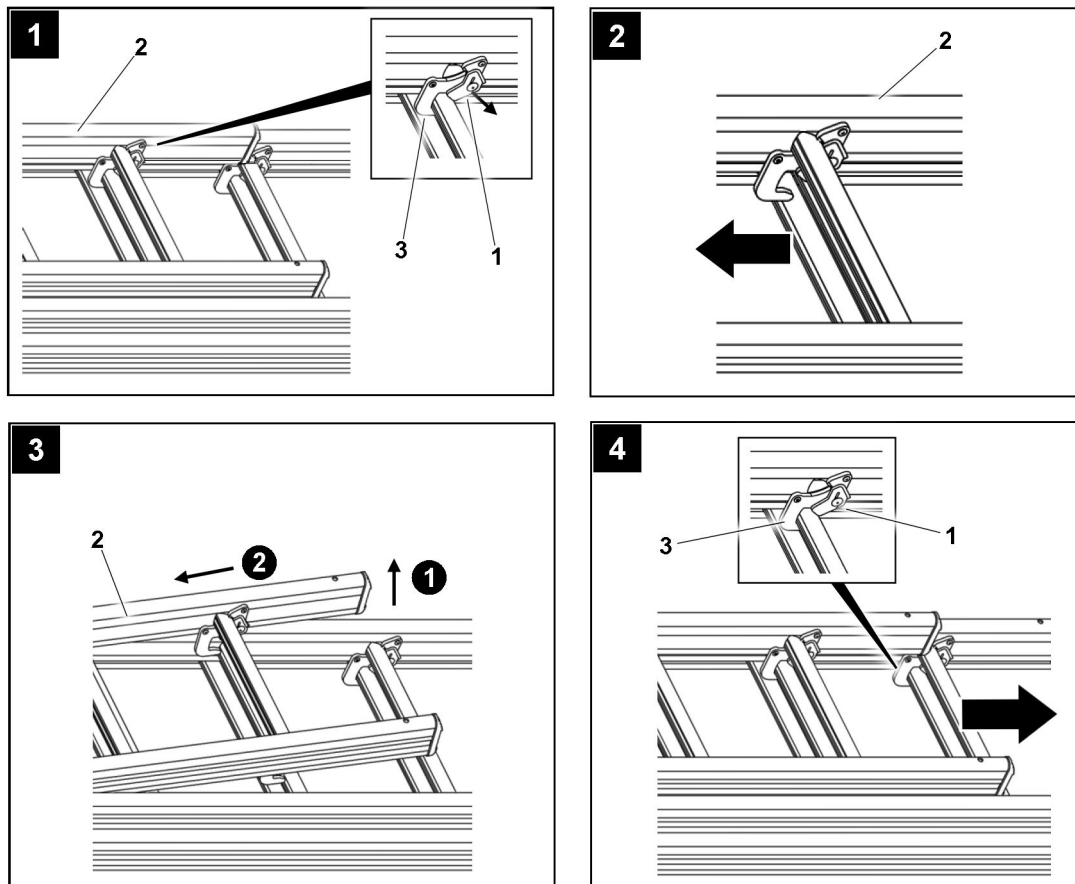

Fig.149569: Pushing out the ladder

Only pull out or push in the ladder when it is laid down.

Push out the upper ladder section:

- ▶ Release the lock 1 on the securing hook 3 on the upper ladder section 2.
- ▶ Move the upper ladder section 2 slightly at the same time.
- ▶ Now swing the ladder section 2 outward and push it out to the desired length.
- ▶ Refit the securing hooks 3.
- ▶ Make sure that the lock 1 re-engages.

Push out the middle ladder section:

- ▶ Pull out and lock the middle ladder section in the same manner.
- ▶ Make sure that the lock 1 engages.

Result:

- The ladder can now be used.

Push the extension ladder together:

- ▶ Push together and lock the middle ladder section.
- ▶ Subsequently push together and lock the upper ladder section.
- ▶ Make sure that the lock 1 engages.

Result:

- The ladder is now in the transport position. The ladder can be stored.

7 Ladder access

Wearing the personal protection equipment to prevent falling and the ladder safeguard depend on the type of work, among others.

7.1 Ladder safeguards

The ladder can be secured to prevent it from sliding away to the side by:

- Restraint device, for example: Tether or side stops on component
- Friction lock, for example: Rubber caps or plastic caps on the end of the ladder beam at direct placement on a surface

The ladder can be secured to prevent it from tipping to the rear by:

- The correct placement angle

7.2 3-point support

A 3-point support is ensured when:

- Two hands have a safe hold and one leg is standing safely.
- Two legs are standing safely and one hand has a safe hold.
- Two legs are standing safely in straddle position on a stepladder which can be accessed from both sides, on the third respective rungs / steps from the top. The user locks the ladder with the knees.
- Two legs are standing safely and at the same time, the body is leaned on higher rungs / steps of the leaning (extension) ladder. The center of gravity of the body must always be between the two ladder beams.
- A WORK POSITIONING SYSTEM (WPS) is used.

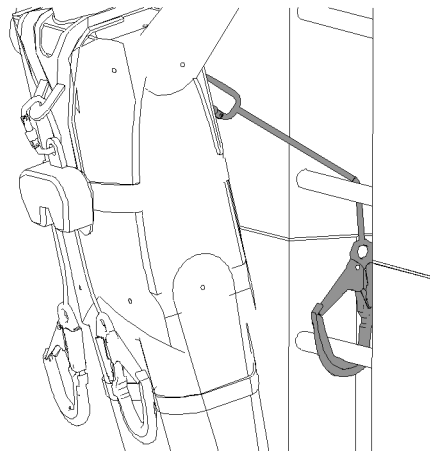

Fig.126746: Example of how to use the WPS

7.3 Light and / or heavy work

The following lists various light and heavy work

Examples for light work:

- Installing / removing retaining pins or spring retainers
- Fastening components, disengaging fastening equipment
- Pushing the transition aid out / in
- Establishing / disconnecting electrical or hydraulic connection between components
- Actuating the hand pump for the folding jib
- Reeving the auxiliary winch in / out
- Setting up / taking down foldable railings
- Carrying out maintenance and inspection work
- Refueling the crane chassis and / or crane superstructure

Examples for heavy work:

- Knocking the connector pins in / out
- Installing / removing the wind warning
- Reeving the hoist rope in / out
- Installing / removing the connector pin with assembly aid (hydraulic cylinder or mechanical assembly tool)
- Assembling / disassembling the rope lock

7.4 Using the stepladder

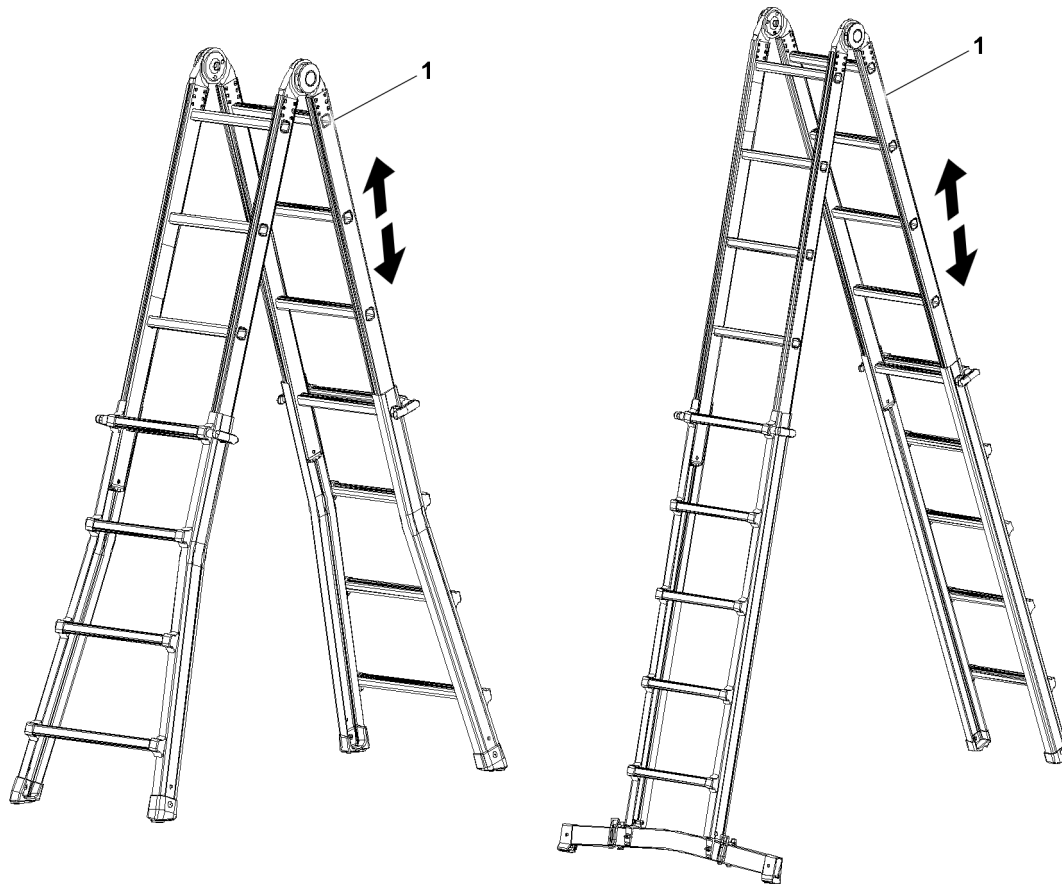

Fig.149996: Example of stepladders 1



WARNING

Transitioning from a stepladder to other components!
Personnel can fall, death, severe bodily injuries.

- ▶ Do **not** transition from a stepladder to other components.



WARNING

3-point support not adhered to!
Personnel can fall, death, severe bodily injuries.

- ▶ Adhere to the 3-point support.
- ▶ Adhere to the prerequisites and conditions for the use of stepladders.

Prerequisites for the use of stepladders 1:

- Make sure that the weight of the tool carried along does not weigh more than 10 kg.
- Make sure that stepladder 1 is set up stably.

Access	Work
Maximum rise to the third rung / step from the top	Maximum rise to the third rung / step from the top
3-point support required	3-point support required
	Rise to 1 m: Personal protective equipment to prevent falling not required
	Step height above 1 m to 7 m Light work: Personal protective equipment to prevent falling not required
	Step height above 1 m to 7 m Heavy work: Personal protective equipment to prevent falling required

Conditions for access and work on stepladders 1

7.5 Using the Leaning ladder

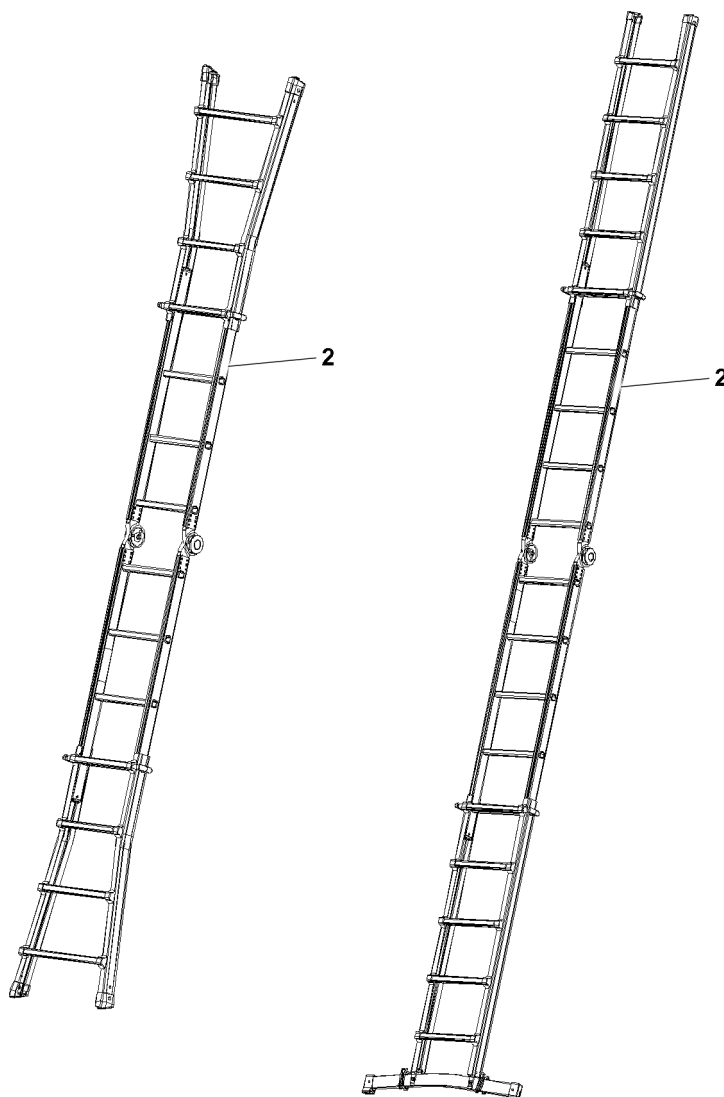

Fig.149997: Example of leaning ladders 2



WARNING

3-point support not adhered to!
Personnel can fall, death, severe bodily injuries.

- ▶ Adhere to the 3-point support.
- ▶ Adhere to the prerequisites and conditions for the use of leaning ladders.

Prerequisites for the use of leaning ladders 2:

- Make sure that the 3-point support is complied with.
- Make sure that the leaning ladder 2 is positioned on a level placement surface.
- Make sure that the leaning ladder 2 is placed at an incline angle of 65° to 75° (approx. 1:4) to the horizontal.
- Make sure that the ladder overhang when leaning it on components is selected in such a way that the leaning ladder 2 is safely placed when subjected to a load / flexation due to ascending persons.
- Make sure that the weight of the tool carried along does not weigh more than 10 kg.

Access	Work
Maximum rise to the fourth rung / step from the top, in reference to the placement point	Maximum rise to the fourth rung / step from the top, in reference to the placement point
3-point support required	3-point support required
	Rise to 1 m: Ladder safeguard not required Personal protective equipment to prevent falling not required
	Step height above 1 m to 7 m Light work: Ladder safeguard required Personal protective equipment to prevent falling not required
	Step height above 1 m to 7 m Heavy work: Ladder safeguard and protection to prevent it from tipping to the rear required Personal protective equipment to prevent falling required

Conditions for access and work on leaning ladders 2

7.5.1 Using the leaning ladder without the conical end section

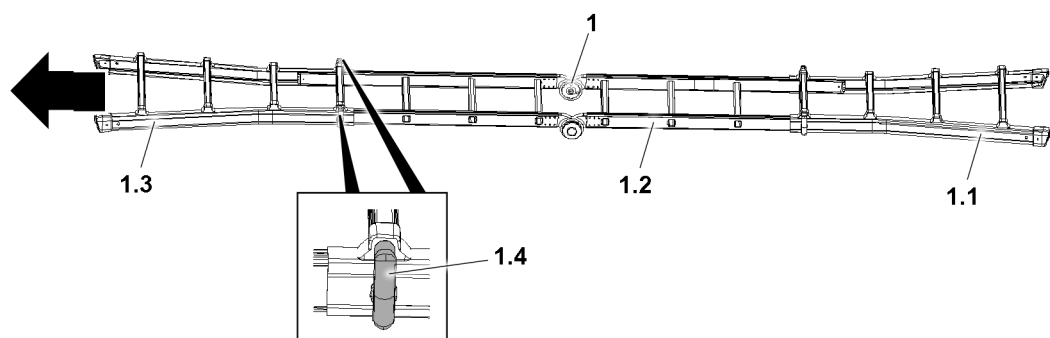

Fig.126873: Disassemble the conical end section 1.3.

The leaning ladder 1 consists of the following components:

- 1.1 Base
- 1.2 Center section
- 1.3 End section
- 1.4 Locks

When the conic end section 1.3 is wider than the leaning tube on the telescopic boom or the intended placement surface, the leaning ladder 1 cannot be placed fully expanded.

In order to position the leaning ladder 1 fully expanded, the end section 1.3 must be disassembled and removed.



CAUTION

Fingers in the spring range of the lock 1.4!
Finger crushing when locking and unlocking.
► Grip the lock 1.4 outside of the spring range.

- ▶ Release the locks **1.4** on the left and right.
- ▶ Slide the end section **1.3** out of the center section **1.2** and remove it.

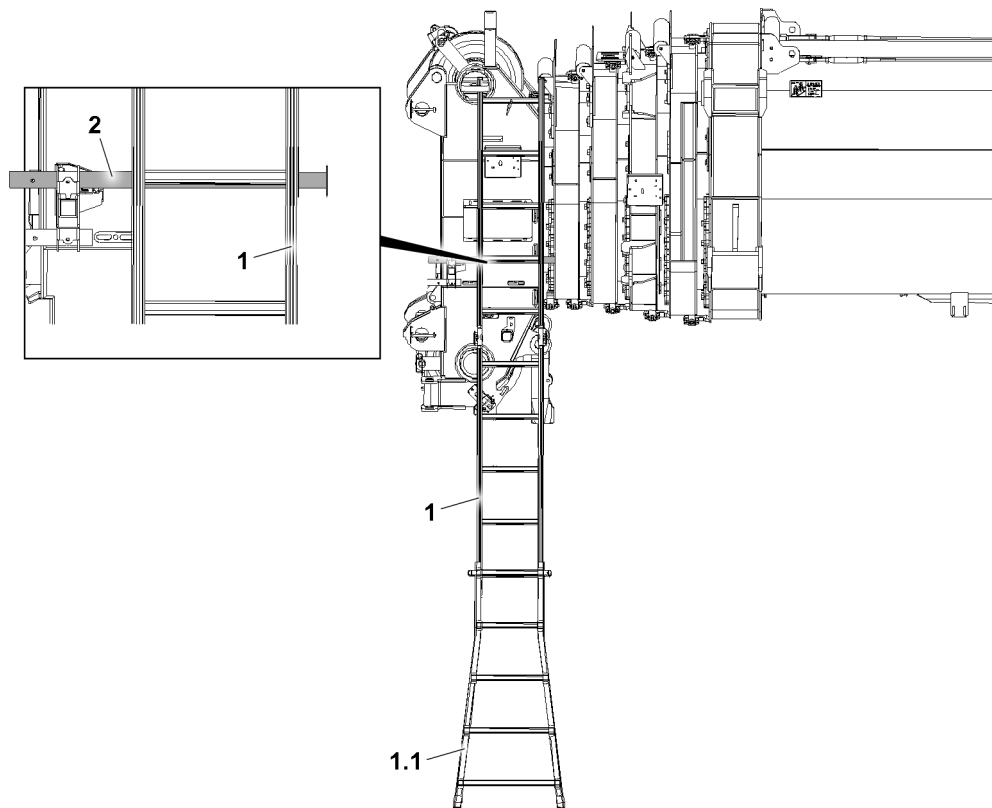

Fig.126874: Place the leaning ladder **1** on the leaning tube **2**

When placing the leaning ladder **1**, the base **1.1** must be placed on the ground.

- ▶ Place the leaning ladder **1** on the leaning tube **2** or the intended placement surface.



WARNING

The leaning ladder **1** is wider than the leaning tube **2** or the intended placement surface! The leaning ladder **1** can slip away when stepping on it and assembly personnel can fall down and be severely injured.

- ▶ When stepping on the leaning ladder **1** make sure that the leaning ladder **1** is **not** wider than the leaning tube **2** or the intended placement surface.
- ▶ Climb on the leaning ladder **1**. Carry out the assembly work.

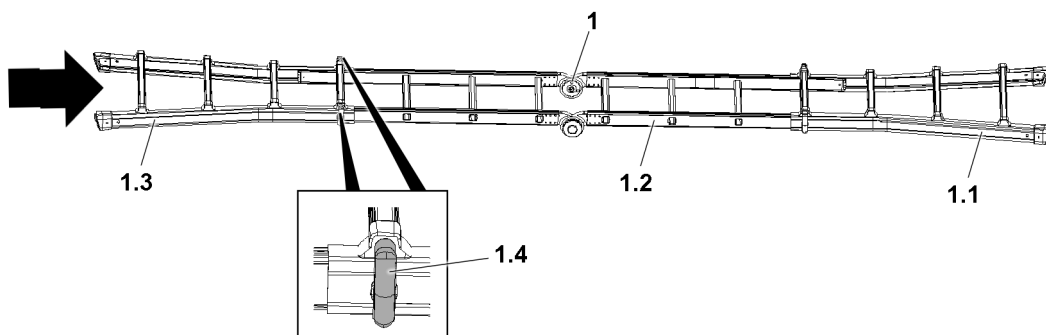

Fig.158064: Assemble the conical end section **1.3**.

Before leaving the jobsite, the conical end section **1.3** must be reinstalled.

**CAUTION**

Fingers in the spring range of the lock **1.4**!

Finger crushing when locking and unlocking.

- ▶ Grip the lock **1.4** outside of the spring range.
-
- ▶ Release the lock **1.4** on the left and right.
 - ▶ Insert the end section **1.3** in the central section **1.2** and push them together.
 - ▶ Secure the leaning ladder **1** in the transport position on the crane.

7.5.2 Using the leaning ladder as a transition

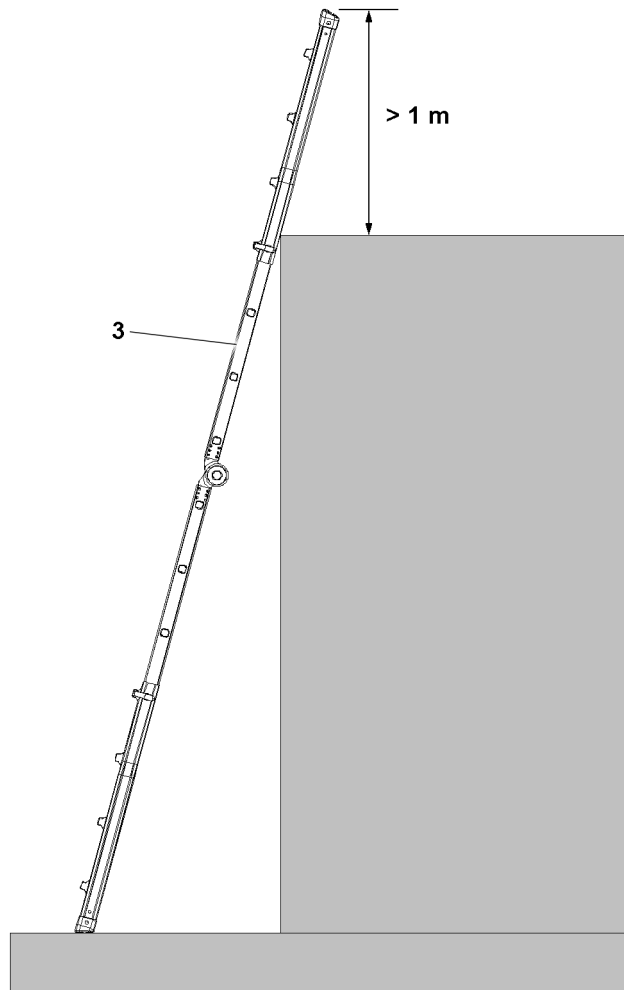

Fig.151626: Examples for leaning ladders with ladder overhang above the exit level

The leaning ladder can be used for transitioning.

**WARNING**

3-point support not adhered to!

Personnel can fall, death, severe bodily injuries.

- ▶ When transitioning, adhere to the 3-point support.
- ▶ Adhere to the prerequisites and conditions for the use of leaning ladders as a transition **3**.

Prerequisites for the use of leaning ladders as a transition **3**:

- Make sure that the leaning ladder **3** is positioned on a level placement surface.
- Make sure that the leaning ladder **3** is placed at an incline angle of 65° to 75° (approx. 1:4) to the horizontal.

- Make sure, for transitioning to higher work locations, when no other safehold possibilities are available, that the ladders beams of the leaning ladder go past the placement location by at least 1 m.
- Make sure that the transition area is slip-resistant.
- Make sure that the ladder position can be recognized from above.
- Make sure that the contact point of the ladder on the component is selected such that it will not be deformed or swing away due to the load of the person climbing up the ladder.
- Make sure that the weight of the tool carried along does not weigh more than 10 kg.

Access	Transition
Maximum rise to a rung / step below the placement edge	Maximum rise to a rung / step below the placement edge
3-point support required	3-point support required
Personal protective equipment to prevent falling not required	Personal protective equipment to prevent falling not required
	Rise to 1 m: Ladder safeguard not required
	Step height above 1 m to 7 m: Ladder safeguard required

Conditions for access and transition to leaning ladders with transition 3

7.5.3 Connecting and climbing up the leaning ladder

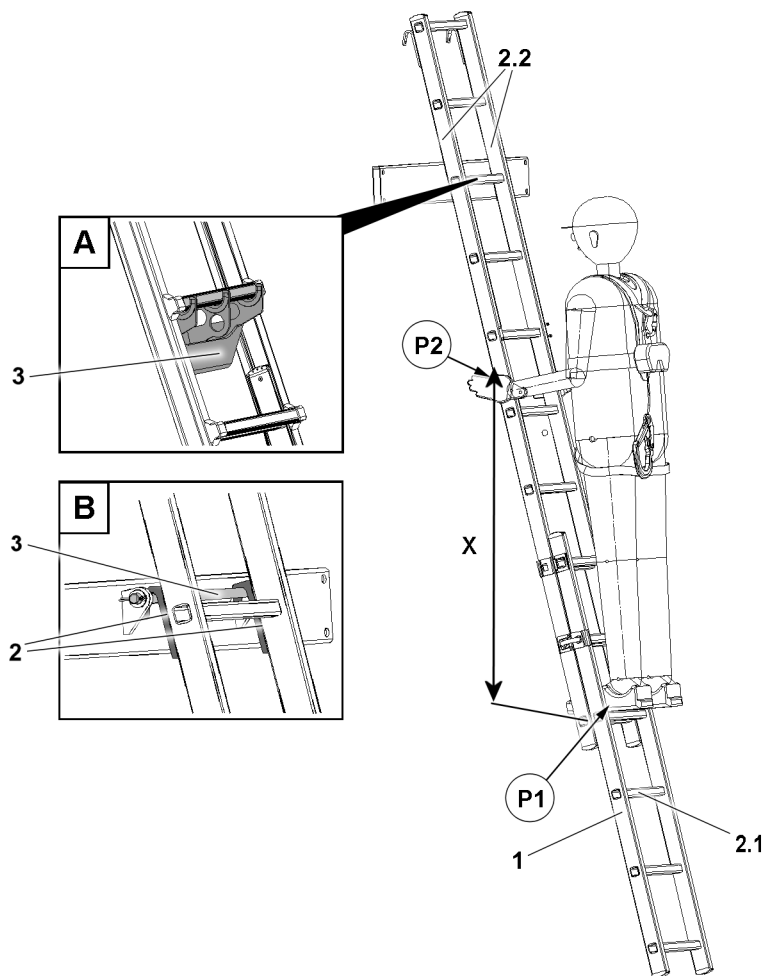

Fig.162714: Connecting the ladder to the suspension device

1	Leaning ladder	X	Length	2.1	Rung
2	Hook	P1	Standing position	2.2	Ladder beam
3	Suspension device	P2	Grip position		

Connected variations:

- Variation **A** rung **2.1** is connected to the suspension device **3**.
- Variation **B** hook **2** is connected to the suspension device **3**.

Prerequisites for the use of leaning ladders **1** when connected to the suspension device **3**:

- Make sure that leaning ladder **1** is set up stably.
- Make sure that the leaning ladder **1** is connected securely to the respective suspension device **3**.
- When ascending and descending: 3-point support observed.
- Make sure that the vertical mass **X** between the standing position **P1** on the rung **2.1** and the grip position **P2** on the ladder beam **2.2** is at least 1 m.
- Make sure that personnel holds the grip position **P2** on the ladder beam **2.2**.
- Do not use the rung **2.1** on the suspension device **3** as a standing position.
- Make sure that the last rung **2.1** below the suspension device **3** may only be used as a standing position if there is at least 1 m between the stopping position and the standing position.

Transition is only permissible if:

- The leaning ladder **1** is located at least 1 m above the higher work surface.
- **Or** safeholds are available when transitioning to the higher work surface.

**WARNING**

The leaning ladder **1** is not correctly connected and used!
Personnel can fall, death, severe bodily injuries.

When the leaning ladder **1** is connected to the suspension device **3**:

- ▶ Adhere to the prerequisites and conditions for the use of the leaning ladder **1** in the suspension device **3**.
- ▶ Adhere to the 3-point support.

Access	Work
Maximum step height up to the last free rung below the suspension device 3	Maximum step height up to the last free rung below the suspension device 3
3-point support required	3-point support required
	Rise to 1 m: Personal protective equipment to prevent falling not required
	Step height above 1 m to 7 m Light work: Personal protective equipment to prevent falling not required
	Step height above 1 m to 7 m Heavy work: Personal protective equipment to prevent falling required

*Conditions for access and work on the leaning ladders **1** when connected to the suspension device **3**.*

7.6 Using the vertical ladder with transition aid

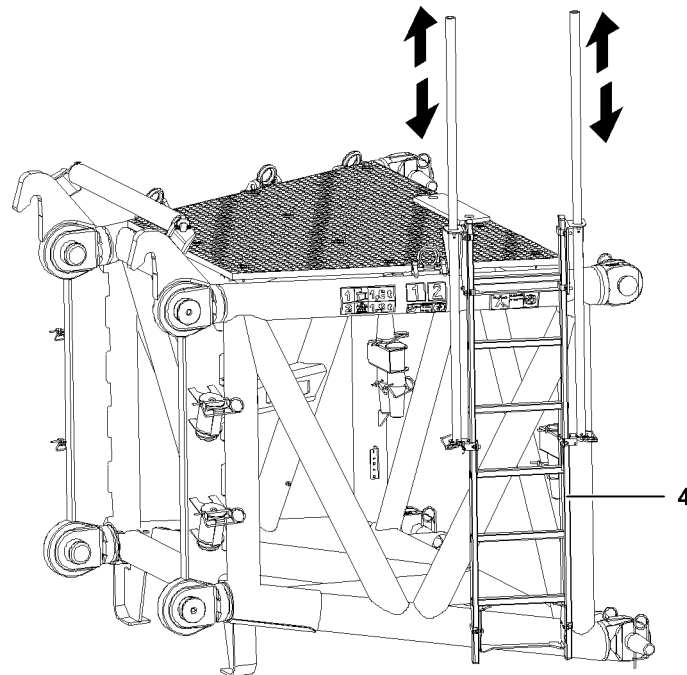

Fig.121178: Example for vertical ladder with transition aid



WARNING

Persons not secured!
Personnel can fall, death, severe injuries.

When using vertical ladders with transition aid 4:

- ▶ Adhere to the 3-point support.

Before transitioning:

- ▶ Hook the personal protective equipment to prevent falling on a suitable location (for example: uppermost rung, safety rope or separate hook point).
- ▶ Adhere to the prerequisites and conditions for the use of vertical ladders with transition aid 4.

Prerequisites for the use of vertical ladders with transition aid 4:

- Make sure, a centered grip reachable from the transition edge and a possibility to support oneself with the second hand is present for transitioning.
- Make sure that the transition area is slip-resistant.
- Make sure that the ladder position can be recognized from above.
- Make sure that the weight of the tool carried along does not weigh more than 10 kg.

Access	Work
3-point support required	3-point support required
If necessary: Use a WORK POSITIONING SYSTEM (WPS) at a suitable hook point	If necessary: Use a WORK POSITIONING SYSTEM (WPS) at a suitable hook point

Conditions for access and work on vertical ladders with transition aid 4

Ascent	Transition
3-point support required	3-point support required
Rise to 5 m: Personal protective equipment to prevent falling not required	Rise to 1.8 m: Without transition aid: Personal protective equipment to prevent falling not required
Rise above 5 m: Fall arrest system with moving along fall arrest device or back protection required	Rise above 1.8 m: Without transition aid: Personal protective equipment to prevent falling required

Conditions for ascent and transition to vertical ladders with / without transition aid 4

7.7 Using the platform ladder

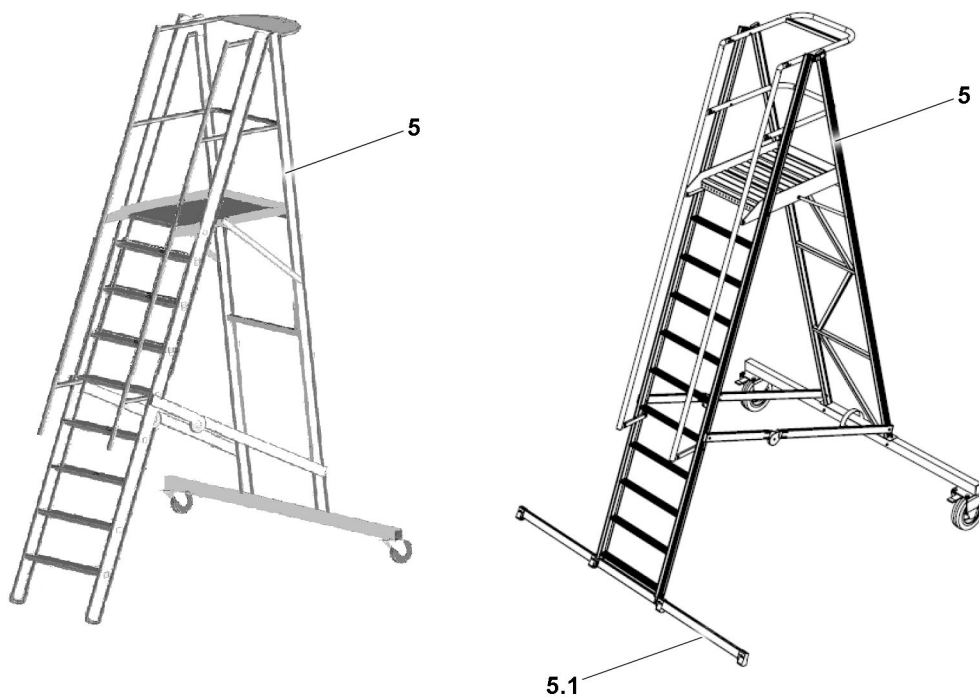

Fig. 149995: Example of platform ladders

A platform ladder **5** with a cross beam **5.1** offers more stability. It is recommended to use a platform ladder with a cross beam.



WARNING

Transitioning from a platform ladder **5** to other components!
Personnel can fall, death, severe bodily injuries.

- ▶ Do **not** transition from a platform ladder **5** to other components.



WARNING

3-point support not adhered to!
Personnel can fall, death, severe bodily injuries.

When using platform ladders **5**:

- ▶ Adhere to the 3-point support.
- ▶ Adhere to the prerequisite and conditions for the use of platform ladders **5**.

Prerequisite for the use of platform ladders **5**:

- Make sure that the weight of the tool carried along does not weigh more than 10 kg.

Access	Working on the ladder	Working on the platform
Maximum rise to platform height	Maximum rise to platform height	Maximum height: Platform height
3-point support required	3-point support required	
	Rise to 1 m: Personal protective equipment to prevent falling not required	
	Step height above 1 m to 7 m Light work: Personal protective equipment to prevent falling not required	Platform height Light work: Personal protective equipment to prevent falling not required
	Step height above 1 m to 7 m Heavy work: Personal protective equipment to prevent falling required	Platform height Heavy work: Personal protective equipment to prevent falling required

Conditions for access and work on platform ladders 5

Empty page!

LWE/LR 13000-001/19503-01-02/en

2.05 Signs on the crane

1 Signs

2

1 Signs

1.1 Note regarding the signs

All signs must be complete and always legible. Replace any damaged or missing signs immediately.

Order damaged or missing signs from Customer Service at Liebherr-Werk Ehingen GmbH.

Always provide the ID no. when ordering. For example: 11952500.

Customer-specific special equipment*: See the supplied spare parts catalog.

1.2 11952500 – California Proposition 65 Label

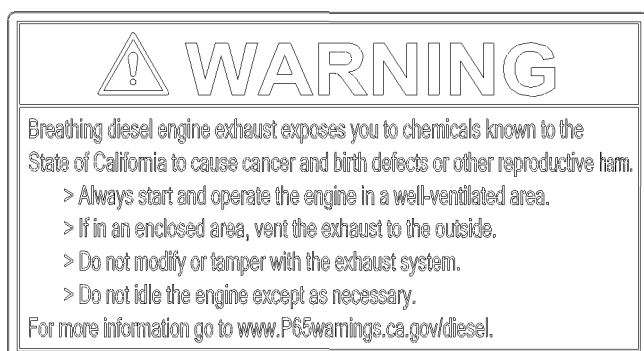

Fig.156191: California Proposition 65 Label



WARNING

Diesel engine exhaust emissions!

Damage to health such as cancer and birth defects or other reproductive harm.

- ▶ Always start and operate the diesel engine in properly ventilated spaces.
- ▶ If in enclosed areas: Direct the exhaust gas to the outside.
- ▶ Do not convert the exhaust system or make any other changes.
- ▶ Do not run the engine at idle speed for longer than necessary.

1.3 7725039 – Warning of high voltage



Fig.116269: Warning of high voltage



Note

- ▶ Only for certain countries.

1.4 772564008 – Slewing range



Fig.116270: Slewing range



Note

► Only for certain countries.

1.5 772580408 – Limitation of maximum travel speed



Fig.106035: Limitation of maximum travel speed

1.6 Vehicle height

ID no.	Vehicle height
970610408	
970629508	
970596108	
970608708	
979459108	

Vehicle height

LWE/LR 13000-001/19503-01-02/en

**Note**

- ▶ Vehicle height x.x m (x.x ft).

1.7 97137170 – Luffing cylinder and counterweight collision

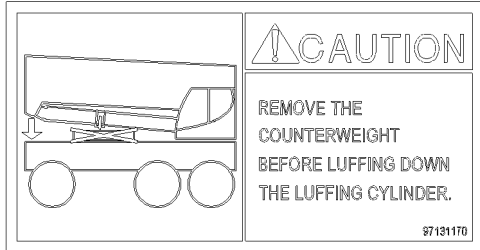

Fig.158141: Luffing cylinder and counterweight collision

NOTICE

Counterweight not disassembled from the crane chassis!

When taking the telescopic boom down, the luffing cylinder collides with the counterweight.
Damage to the luffing cylinder and counterweight.

- ▶ Before taking the luffing cylinder down: Disassemble the counterweight.

1.8 97124295 – Load stop

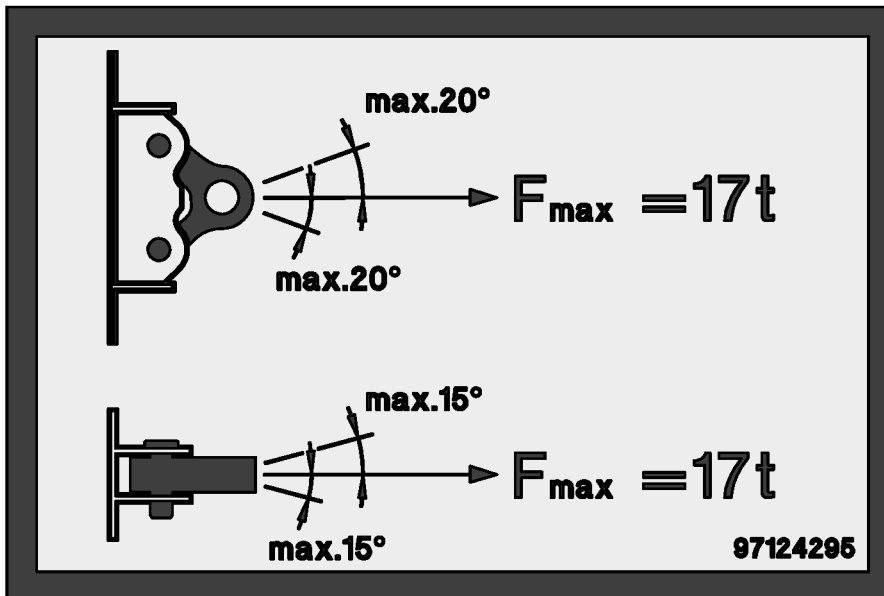

Fig.154929: Fastening the load according to the specifications on the sign

1.9 Assembly aid

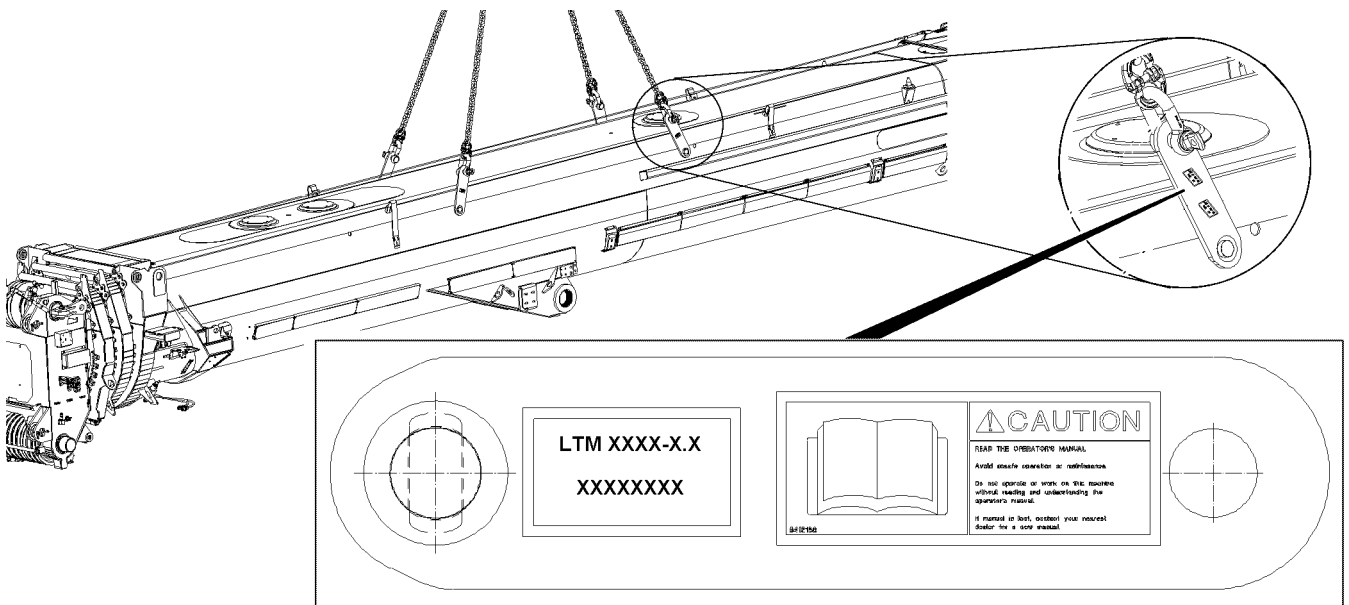

Fig.122741: Assembly aid



WARNING

Wrong assembly aids used!

The telescopic boom can fall down. Death, property damage.

- ▶ To assemble and disassemble the telescopic boom: Use solely the assembly aids that belong to the crane.

1.10 97127242 – Assembly aid

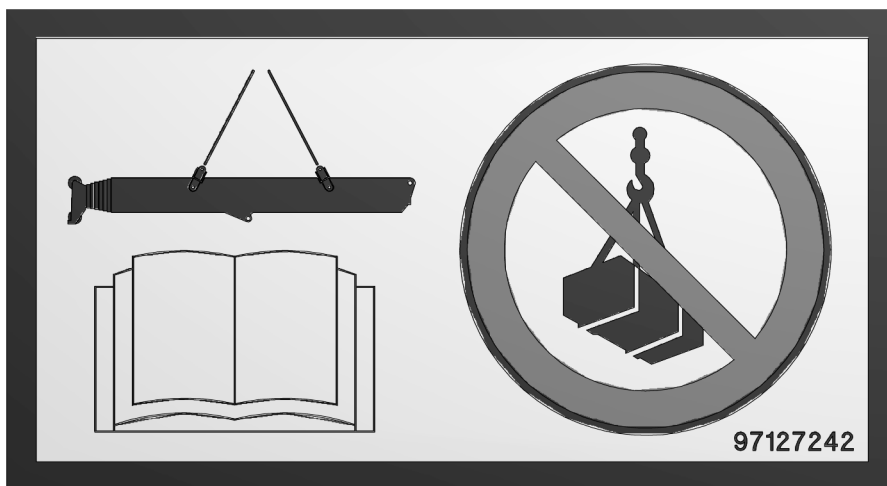

Fig.154928: Assembly aid



WARNING

Wrong assembly aids used!

The telescopic boom can fall down. Death, property damage.

- ▶ To assemble and disassemble the telescopic boom: Use solely the assembly aids that belong to the crane.
- ▶ Only use the assembly aids to assemble and disassemble the telescopic boom.

LWE/LR 13000-001/19503-01-02/en

1.11 97151252 – Hoist device

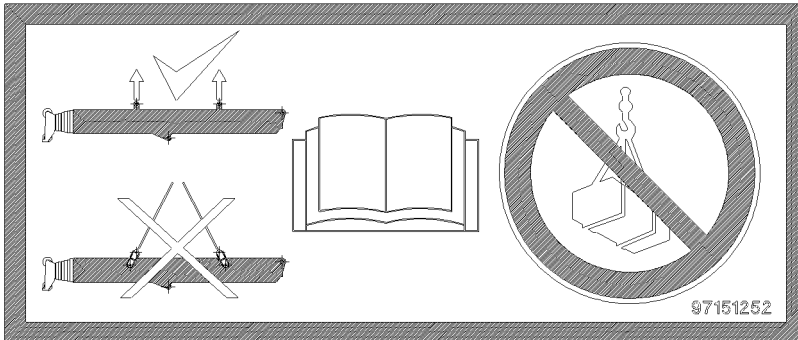

Fig.160978: Hoist device



WARNING

Faulty assembly and disassembly!

The telescopic boom can fall down. Death, property damage.

- ▶ Use a hoist device to assemble and disassemble the telescopic boom.
- ▶ To assemble and disassemble the telescopic boom: Use solely the assembly aids that belong to the crane.
- ▶ Only use the assembly aids to assemble and disassemble the telescopic boom.
- ▶ Guide the fastening equipment for the assembly aid only in a vertical position.
- ▶ Angular pull with the fastening equipment und the assembly aid is **prohibited**.
- ▶ Replace lost or incomplete operating instructions immediately.
- ▶ Observe and adhere to the operating instructions.

1.12 97133617 – Hydraulic connection

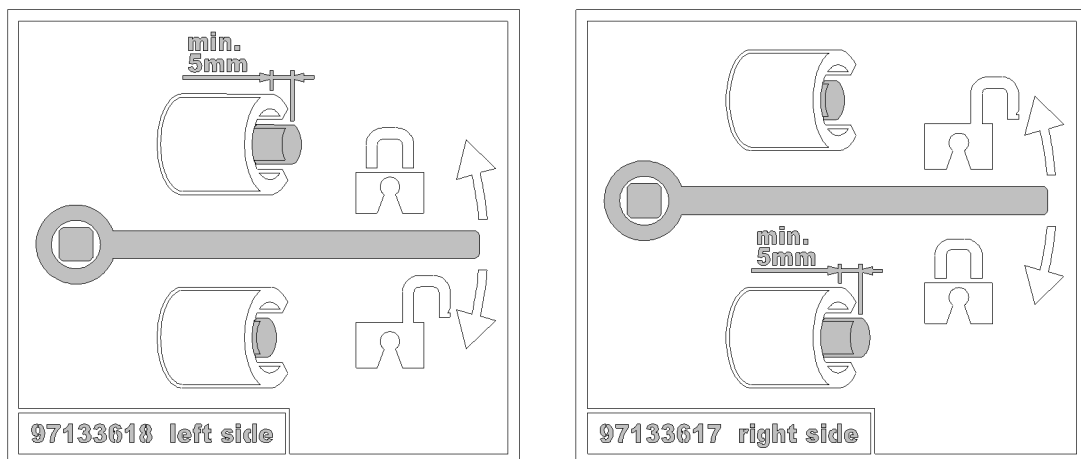

Fig.162452: Hydraulic connection

NOTICE

The crawler center section und crawler carrier hydraulic lines are not completely connected!
Emerging hydraulic oil, crawler carrier malfunction.

- ▶ The left and right side crawler center section and crawler carrier hydraulic lines are completely connected.
- ▶ After connecting the hydraulic lines: The threaded pins must project at least 5 mm over the sheath.

1.13 9412158 – Reading the operating instructions

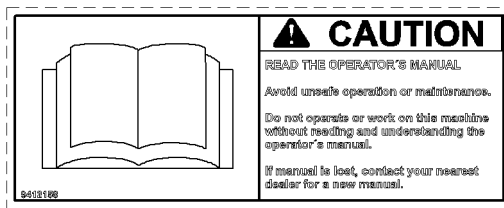

Fig.106048: Reading the operating instructions



WARNING

Danger of accident due to non-observance of operating instructions!

If the operating instructions are not read or understood, then this can lead to unsafe operation and improper maintenance.

Accidents with bodily injuries and property damage can result.

- ▶ The crane may only be operated if the contents of the operating instructions have been read and understood.
- ▶ Replace lost or incomplete operating instructions immediately.

1.14 97004046 – Safety harness, maximum two persons



Fig.115119: Safety harness, maximum two persons



DANGER

Danger of accidents due to overloaded safety ropes!

If safety ropes are used by more than two persons, then the safety ropes can be overloaded and fail in case of an accident.

Personnel can be severely injured or killed.

- ▶ A maximum of two people may use the safety ropes on the left and right to secure themselves against falling.

1.15 97017585 – Falling telescopic boom during disassembly / assembly

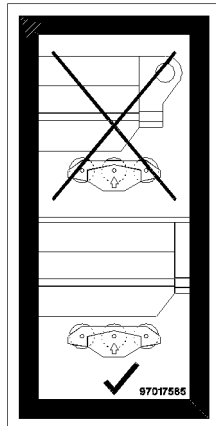

Fig.118467: Falling telescopic boom during disassembly / assembly



WARNING

Death due to falling telescopic boom!

- Make sure that all pulleys are touching and supporting during the assembly and disassembly of the telescopic boom.

1.16 97018351 – Falling telescopic boom during transport!

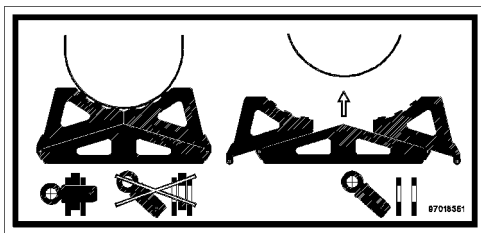

Fig.118466: Falling telescopic boom during transport



WARNING

Fatal accidents due to falling telescopic boom during transport!

- Pin and secure the transport bracket on the left and right.

1.17 97018564 – Falling telescopic boom during transport!

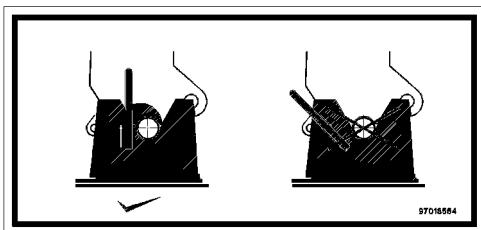

Fig.118533: Falling telescopic boom during transport

**WARNING**

Fatal accidents due to falling telescopic boom during transport!

- ▶ Lock the telescopic boom in the head receptacle.

1.18 97027147 – Overloading of the combi box is prohibited

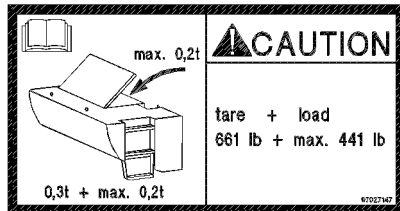

Fig.113829: Overloading of the combi box is prohibited

**WARNING**

Danger of overload!

If the combi box is subjected to a load of more than 0.2 t , the combi box can be damaged!

- ▶ The own weight of the combi box is 0.3 t and may be loaded with a maximum payload of 0.2 t.
- ▶ Do not subject the combi box to a weight of more than 0.2 t.

1.19 97036733 – Fastening point

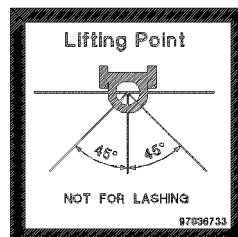

Fig.121184: Fastening point

**WARNING**

Damage to the fastening points!

- ▶ Use the fastening point solely to lift the load.
- ▶ Observe the maximum permissible fastening angle.

**Note**

- ▶ Fastening points and fastening angle.

1.20 Suspended load fastening point

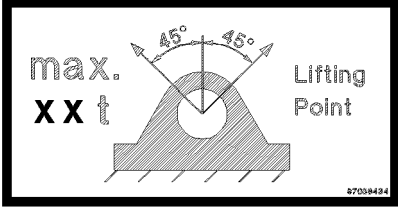
ID no.	Suspended load fastening point
97038434	 <p data-bbox="890 613 1082 645" style="text-align: center;"><i>Fastening point</i></p>
97037482	
97039068	



WARNING

Mortal danger if the load falls down!

If the maximum suspended load or the maximum fastening angle is exceeded, the load can fall down and kill personnel.

- ▶ Observe the maximum permissible suspended load and fastening angle.

1.21 Suspended load fastening point

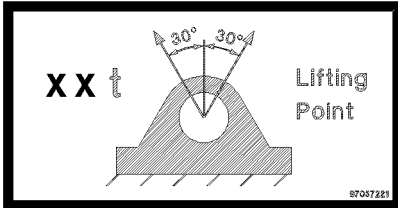
ID no.	Suspended load fastening point
97037221	 <p data-bbox="890 1442 1082 1473" style="text-align: center;"><i>Fastening point</i></p>
97037223	



WARNING

Mortal danger if the load falls down!

If the maximum suspended load or the maximum fastening angle is exceeded, the load can fall down and kill personnel.

- ▶ Observe the maximum permissible suspended load and fastening angle.

1.22 Suspended load fastening point

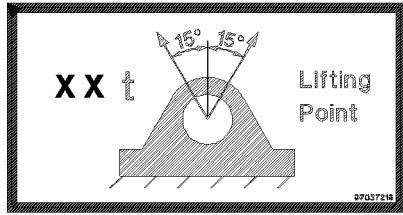
ID no.	Suspended load fastening point
97037219	 <p style="text-align: center;">Fastening point</p>



WARNING

Mortal danger if the load falls down!

If the maximum suspended load or the maximum fastening angle is exceeded, the load can fall down and kill personnel.

- Observe the maximum permissible suspended load and fastening angle.

1.23 97037625 – Suspended load Fastening points / rigging points

LIFTING AND LASHING			
Type III	Lashing Capacity		
	LC-N [daN]	LC-G [daN]	
4	4 000	2 800	
6,7	6 700	4 690	
10	10 000	7 000	
16	16 000	11 200	
31,5	31 500	22 050	

Fig.119988: Fastening points / rigging points



Note

- Fastening points and rigging points.

1.24 9402377 – Fastening point / lifting point

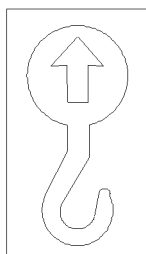

Fig.127586: Fastening point / lifting point



Note

- Fastening point / lifting point.

LWE/LR 13000-001/19503-01-02/en

1.25 97140080 – Assembling the fixed lattice jib

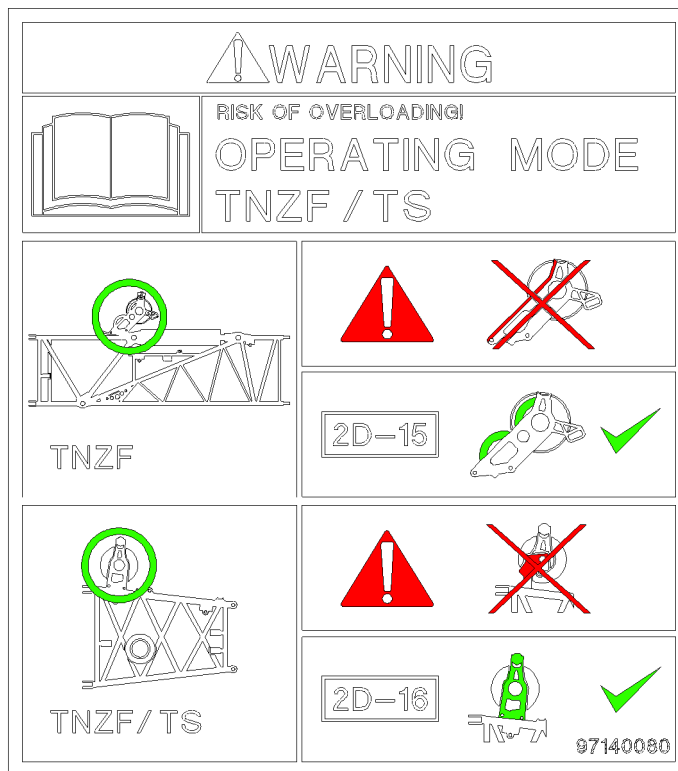

Fig.163345: Permissible components



WARNING

Incorrect assembly of the lattice sections!
The boom can break and the load can fall down.
Death or severe bodily injuries.

- ▶ Assemble the lattice sections according to the separately supplied assembly drawings.
- ▶ Any other arrangement of the lattice sections than specified in the separately supplied assembly drawings is prohibited.
- ▶ Assemble the lattice jib according to its descriptions.

1.26 97106824 – Installing the N-assembly unit

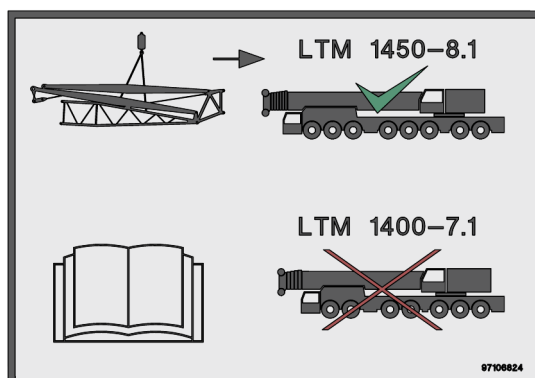

Fig.147594: Installing the N-assembly unit!

**WARNING**

N-assembly unit installed on an impermissible crane type!
Death, severe bodily injuries, property damage.

- ▶ Use N-assembly units marked with this sign only for crane type LTM 1450-8.1.
- ▶ Observe and adhere to the operating instructions.

1.27 97096132 – Fastening points for N-assembly unit

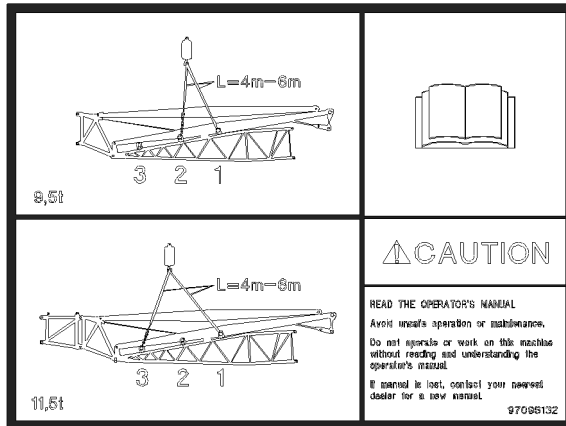

Fig.144774: Fastening points for N-assembly unit!

**WARNING**

Incorrectly selected fastening points!

The N-assembly unit can tip over and kill personnel.

- ▶ Fasten the N-assembly unit only on the intended fastening points.
- ▶ Use fastening equipment with the correct strand length.
- ▶ Observe and adhere to the operating instructions.
- ▶ Replace lost or incomplete operating instructions immediately.

1.28 97036735 – Fastening point for lattice section

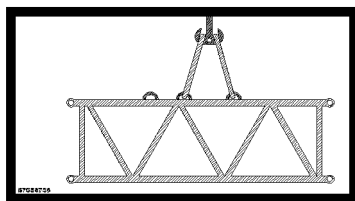

Fig.116266: Fastening point for lattice section

**Note**

- ▶ Fastening points for lattice section.

1.29 97036736 – Fastening point for lattice sections

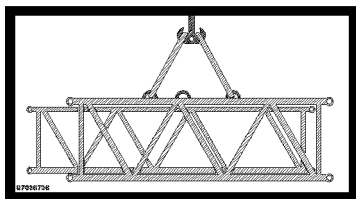

Fig.116267: Fastening point for lattice sections



Note

- ▶ Fastening points for lattice sections.

1.30 97038442 – Fastening point for lattice section

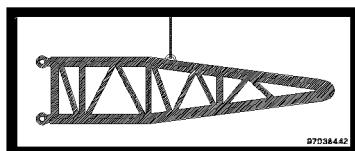

Fig.116288: Fastening point for lattice sections



Note

- ▶ Fastening point for lattice section.

1.31 97038452 – Fastening point for lattice sections

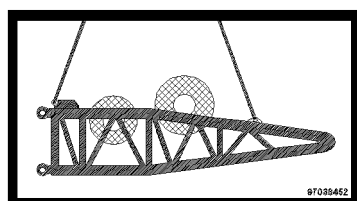

Fig.116289: Fastening point for lattice sections



Note

- ▶ Fastening points for lattice sections.

1.32 97038454 – Fastening point for lattice sections

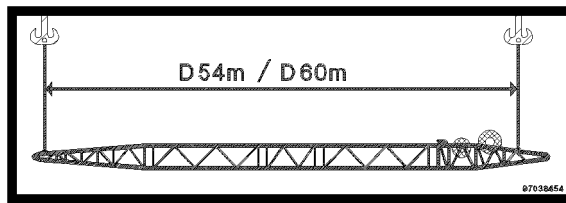

Fig.116290: Fastening point for lattice sections



Note

- ▶ Fastening points for lattice sections.

1.33 97037871 – Fastening points for lattice sections

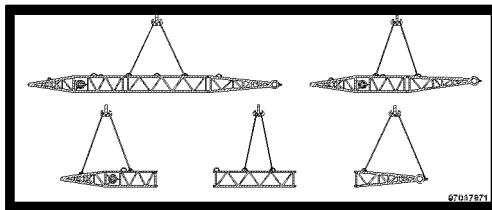

Fig.116292: Fastening points for lattice sections



Note

- ▶ Fastening points for lattice sections.

1.34 97053410 – Fastening equipment

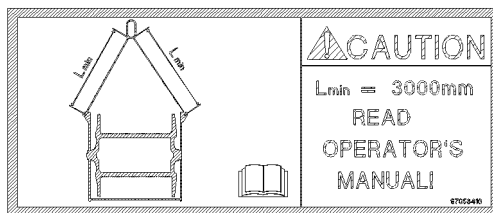

Fig.155031: Fastening equipment

NOTICE

The fastening equipment is too short!

The fastening equipment is overloaded, the load can fall down.

The assembly procedure cannot be carried out.

- ▶ Use fastening equipment with a minimum length of 3000 mm.
- ▶ Use only authorized fastening equipment with a suitable load bearing capacity.
- ▶ Observe and adhere to the operating instructions.

1.35 97057767 – Fastening points for lattice sections

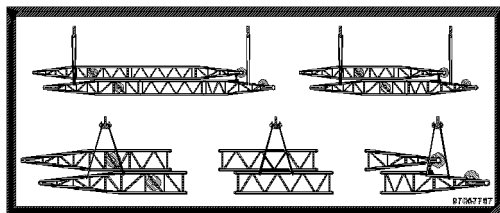

Fig.121181: Fastening points for lattice sections



Note

- ▶ Fastening points for lattice sections.

1.36 97057524 – Fastening point for assembly of lattice sections

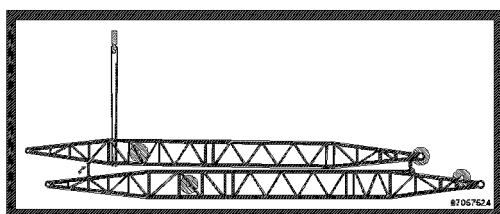

Fig.121182: Fastening point for assembly of lattice sections



Note

- ▶ Fastening point for assembly of lattice sections.

1.37 97057097 – Fastening point to turn the component

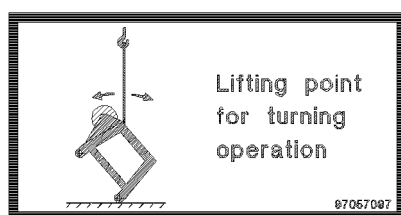

Fig.119987: Fastening point to turn the component



Note

- ▶ Fastening point to turn the component.

1.38 97039035 – Suspended load Assembly unit

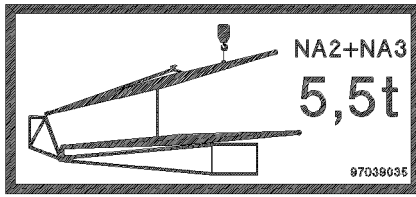

Fig.117348: Suspended load Assembly unit



Note

- ▶ Notice the suspended load.

1.39 97059339 – Suspended load Derrick pivot section

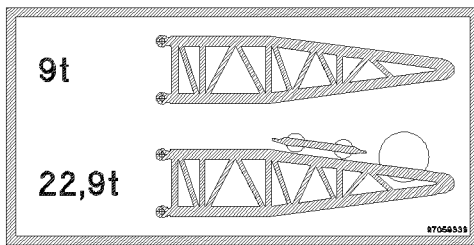

Fig.127469: Suspended load Derrick pivot section



Note

- ▶ Suspended load Derrick pivot section.
- ▶ Suspended load Derrick pivot section with rope winch and luffing pulley block.

1.40 Fastening point for end section

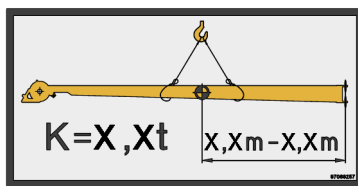

Fig.147595: Fastening point for end section

K = Weight in tons (t)

X.X to X.X = Distance of center of gravity in meters (m)



WARNING

End section improperly fastened!
 The end section can tip over and fall down.
 Death, severe bodily injuries, property damage.

- ▶ Fasten the end section only with two hooks.
- ▶ Select the fastening point such that the center of gravity is located within the fastening points.

LWE/LR 13000-001/19503-01-02/en

1.41 97095312 – Suspended load and fastening points for counterweight frame

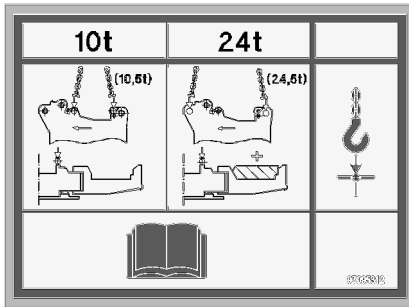

Fig.148126: Suspended load and fastening points for counterweight frame



Note

- ▶ Observe the suspended load and fastening points for counterweight frame.
- ▶ Observe and adhere to the operating instructions.

1.42 97003109 – Accessing the step ladder



Fig.109032: Accessing the step ladder



WARNING

Danger of falling!

If the step ladder is accessed before it is completely folded out, the assembly personnel can fall and be fatally injured.

- ▶ Before accessing the step ladder, fold the lowest step out.

1.43 97003110 – Folding the step ladder in and out



Fig.109033: Folding the step ladder in and out

**WARNING**

Danger of falling!

When folding the step ladder in or out or when driving the crane, no persons may remain on the step ladder or within the entire danger zone! Persons can fall from the step ladder or be killed as the step ladder folds in or out.

- ▶ Fold the step ladder in and out only if there are no persons within the danger zone.

1.44 97006167 – Identifying the support base

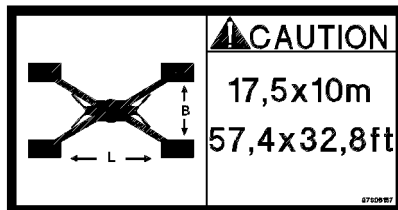

Fig.116285: Identifying the support base

**Note**

- ▶ The support beams are swung out / extended to a support base of 17.50 m x 10.0 m ; (57.4 ft x 32.8 ft).

1.45 97006167 – Identifying the support base

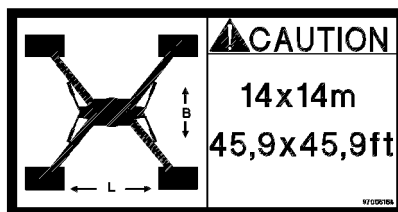

Fig.116286: Identifying the support base

**Note**

- ▶ The support beams are swung out / extended to a support base of 14.0 m x 14.0 m ; (45.9 ft x 45.9 ft).

1.46 97008514 – Warning of head injuries



Fig.110550: Warning of head injuries

**WARNING**

Head injuries!

Due to falling parts, personnel can be killed or severely injured.

Hitting the head can cause injuries.

- ▶ Protect your head with a hard hat.
- ▶ Proceed in an aware and safe manner.

1.47 97009799 – Data logger

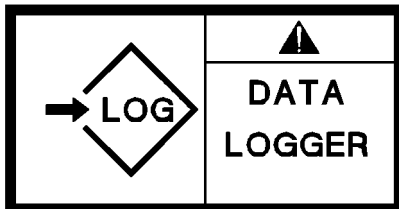

Fig.116261: Data logger

**Note**

- ▶ Data logger.

1.48 97012949 – Maximum load

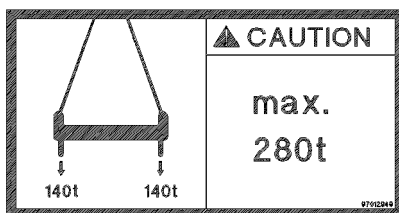

Fig.116263: Maximum load

**CAUTION**

Property damage due to overload!

If the cross beam is subjected to a higher load than permissible, damage can occur.

- ▶ Do not overload the cross beam.

1.49 97012095 – Maximum load

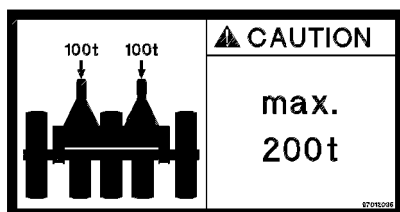

Fig.116265: Maximum load

**CAUTION**

Property damage due to overload!

If the roller cart is subjected to a higher load than permissible, damage can occur.

- ▶ Do not overload the roller cart.

1.50 97069053 – Storage boxes open

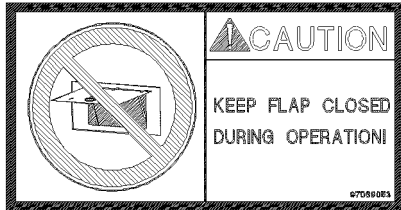

Fig.144736: Storage boxes open

NOTICE

Storage boxes open!

Damage of storage boxes.

- ▶ Before crane operation and before driving the crane, close the storage boxes.

1.51 97068370 – Closing the cab door

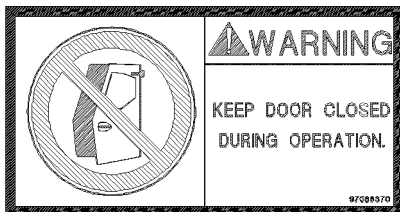

Fig.144737: Closing the cab door

**WARNING**

Cab door during crane operation **not** closed!

The crane operator can fall down.

Death, severe bodily injuries.

- ▶ Close the cab door during crane operation.

1.52 97053409 – Entanglement hazard during winch operation



Fig.144738: Entanglement hazard during winch operation

**DANGER**

Entanglement hazard during winch operation!
Body parts can be caught and entangled.
Death, severe bodily injuries, property damage.
▶ Do **not** stand in the hazard area of the winch.

1.53 97011689 – Danger of crushing

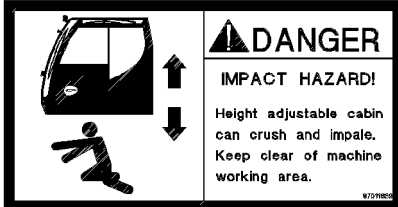

Fig.111047: Danger of crushing

**DANGER**

Danger of fatal injury!
▶ It is prohibited to remain within the danger zone of the cab.
▶ Stay away from the movement range of the cab.

1.54 97011690 – Overload of cab is prohibited

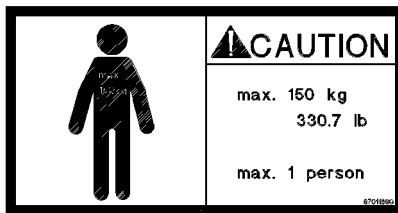

Fig.111048: Overload of cab is prohibited

**WARNING**

Danger of overload!
If the cab is subjected to a load of more than 150 kg then the cab or the telescoping arm can be damaged!
▶ Only one person at a time may remain in the cab!
▶ Do not subject the cab to a weight of more than 150 kg.

1.55 97016304 – Refueling

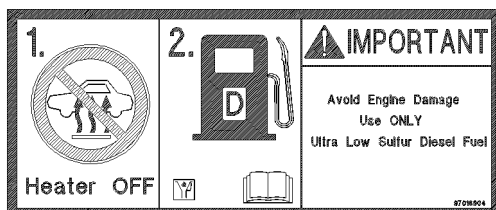

Fig.155029: Refueling

**WARNING**

Danger of fire and explosion!

- ▶ Turn the auxiliary heater* off approx. 3 min before refueling the fuel tank.
- ▶ Before refueling the fuel tank, turn the engine off.

NOTICE

Property damage to the engine!

If incorrect fuel is added, the engine can be severely damaged.

- ▶ Refuel with fuel according to the Engine manufacturer's operating instructions.

1.56 97046488 – Corrosion inhibitor - antifreeze fluids

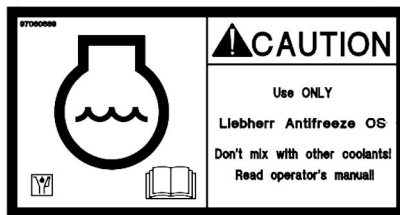

Fig.127585: Corrosion inhibitor - antifreeze fluids

NOTICE

Mixing of different corrosion inhibitor-antifreeze agents!

Damage to the cooling system.

- ▶ Fill the cooling system with corrosion inhibitor-antifreeze, see Service fill list.

1.57 97016392 – Crushing danger for feet



Fig.112474: Crushing danger for feet

**WARNING**

Crushing danger for feet!

Feet can be trapped or crushed.

- ▶ Keep feet away from the crushing area.

1.58 97012737 – Danger of accident



Fig.111748: Danger of accident



WARNING

Danger of accident!

- ▶ Close the windshield when driving.

1.59 97023034 – Disassembling

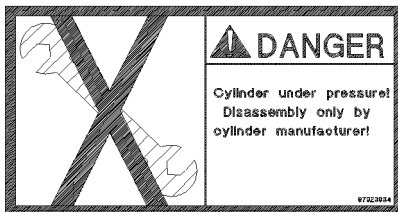

Fig.116264: Disassembling



DANGER

Danger of fatal injury due to repair!

Cylinder is pressurized.

Disassembly of the cylinder can result in death or serious injuries.

- ▶ The cylinder may only be removed by the manufacturer.

1.60 97036732 – Access via 3-point support

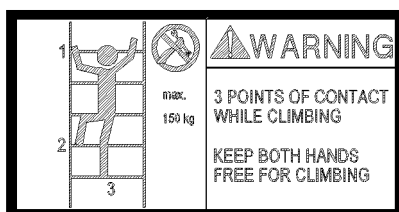

Fig.115172: Access via 3-point support



DANGER

Access via 3-point support!

While climbing up and down via a ladder, assembly personnel can fall down and be injured severely.

- ▶ When climbing up and down, a 3-point support must be ensured.
- ▶ Use ladders only up to a weight of 150 kg.
- ▶ When climbing up and down, hands must be free.

A 3-point support is ensured when:

- Two legs are standing safely and one hand has a safe hold.
- Two hands have a safe hold and one leg is standing safely.

1.61 97003112 – Maximum suspended load

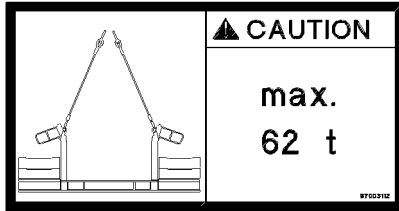

Fig.116282: Maximum suspended load



WARNING

Maximum suspended load!

If the maximum suspended load of 62 t is exceeded, the load can fall down and kill personnel.

- ▶ Observe the maximum permissible suspended load.

1.62 97036917 – Maximum suspended load

ID no.	Suspended load fastening point
97047630	
97036917	
97047630	
97077237	



WARNING

Mortal danger if the load falls down!

If the maximum suspended load is exceeded, the load can fall down and kill personnel.

- ▶ Observe the maximum permissible suspended load.

LWE/LR 13000-001/19503-01-02/en

1.63 97037383 – Urea

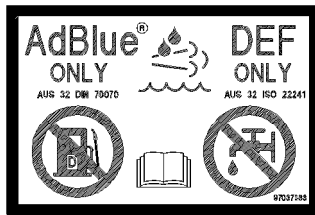

Fig.115173: Urea



CAUTION

Property damage due to incorrect operating fluids!
When refilling urea and the urea that is specified by the engine manufacturer is not used, then damage can occur.

- ▶ Refill **exclusively** urea.
- ▶ See the engine manufacturer's operating instructions.

1.64 97037952 – Warning of fatal electric shock

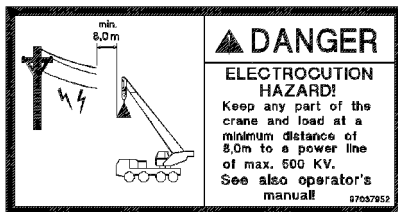

Fig.116280: Warning of fatal electric shock



DANGER

Danger of fatal injury due to electric shock!

If the boom or the hoist rope is powered with electric voltage, then death or severe injuries can occur if anyone touches the crane, the vehicle or the load.

- ▶ Keep a minimum distance of 8.0 m from current carrying parts.

1.65 97042730 – Falling luffing cylinder

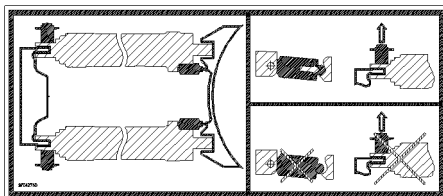

Fig.118465: Falling luffing cylinder



WARNING

Mortal danger if the luffing cylinders fall down!

- ▶ Make sure, before unpinning the luffing cylinder, that the erection cylinders are placed on both luffing cylinders.

1.66 97047810 – Pinning brackets

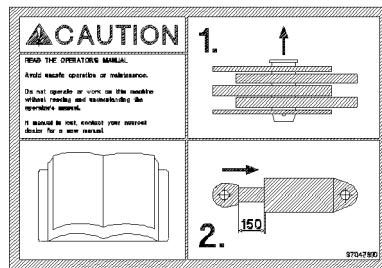

Fig.121709: Pinning brackets

NOTICE

Damage of brackets due to collision!

- ▶ Make sure, before pinning and unpinning, that the hydraulic cylinder is set to a distance of 150 mm.

1.67 97042797 – Overload of components

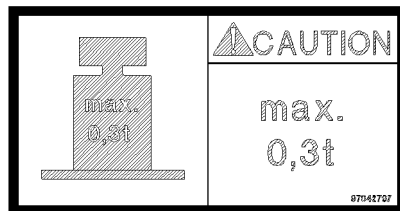

Fig.117347: Overload of components



DANGER

Danger of falling due to overload!

If a component, such as a sliding beam platform, is subjected to a weight of more than 0.3 t , then the sliding beam platform can break.

Personnel can fall down and be severely injured or killed.

- ▶ Subject the component (sliding beam platform) to no more than maximum 0.3 t.

1.68 97041305 – Overload of components

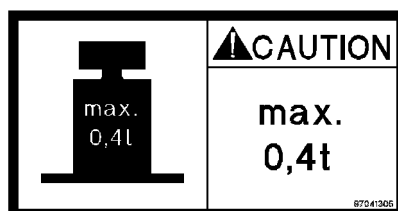

Fig.116792: Warning of overload of components



DANGER

Danger of falling due to overload!

If a component, such as a sliding beam platform, is subjected to a weight of more than 0.4 t , then the sliding beam platform can break.

Personnel can fall down and be severely injured or killed.

- ▶ Subject the component (sliding beam platform) to no more than maximum 0.4 t.

1.69 97070905 – Disassembling the auxiliary jib (boom nose)

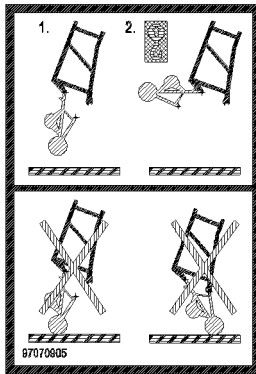

Fig.122645: Disassembling the auxiliary jib (boom nose)

NOTICE

Property damage

Before taking the N-head down:

- ▶ Disassemble the auxiliary jib (boom nose).

1.70 97077304 – Positioning the outrigger pad

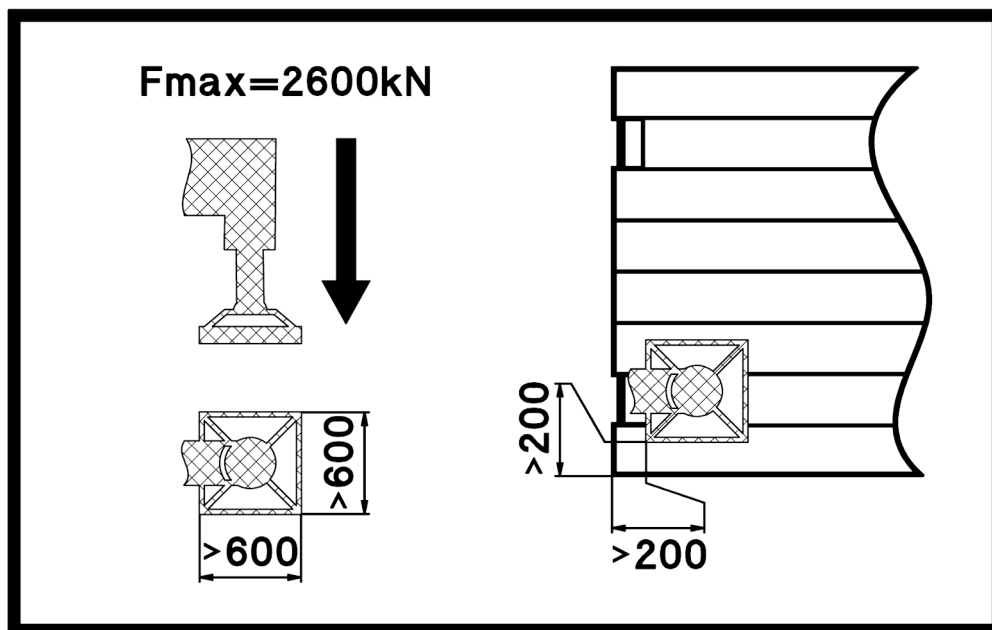

Fig.154913: Positioning the outrigger pad



WARNING

Outrigger pad incorrectly positioned!
The crane can topple over. Death, property damage.

- ▶ Position the outrigger pad **in the center** or according to the description in chapter 1.03.10 under the support plate.

1.71 9707704 – Driving with the outrigger pad

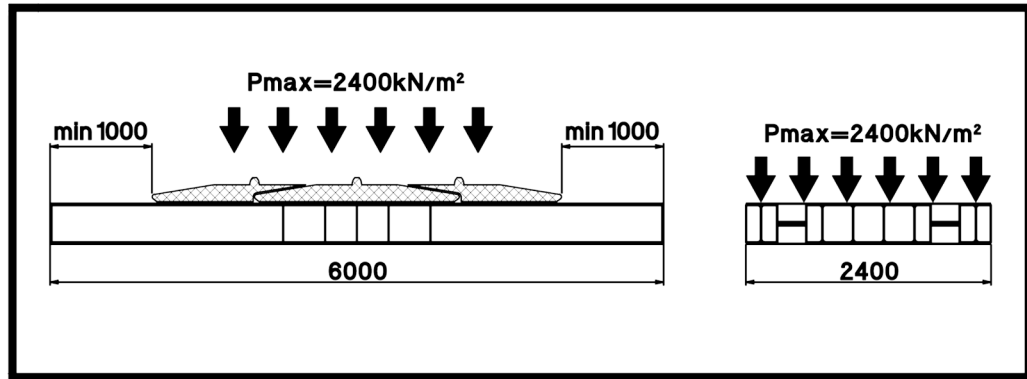

Fig.154912: Driving with the outrigger pad



WARNING

Outrigger pad incorrectly driven!
The crane can topple over. Death, property damage.

- ▶ Drive with the outrigger pad according to the specifications on the sign.

1.72 Permissible support pressures on the outrigger pad [A-B-C]

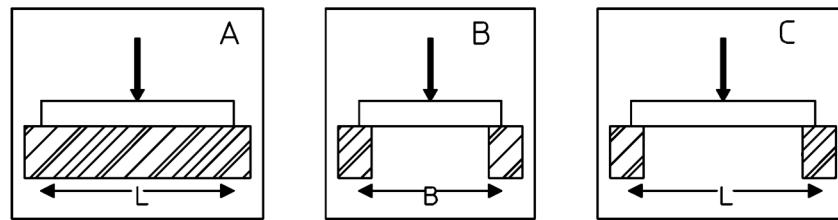

Fig.154815: Permissible support pressures on the outrigger pad for application cases [A-B-C]

1.73 Permissible support pressures on the outrigger pad [A-B-C-D]

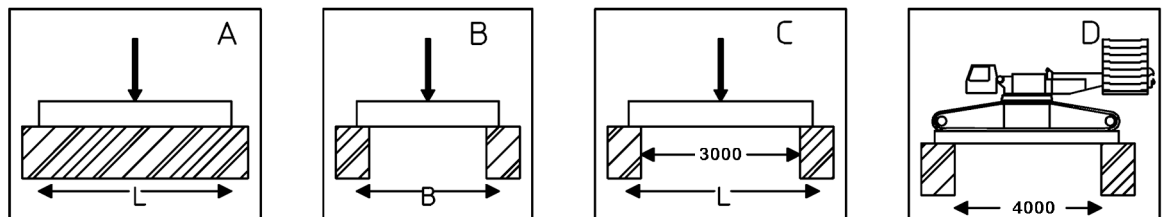

Fig.154816: Permissible support pressures on the outrigger pad for application cases [A-B-C-D]

LWE/LR 13000-001/19503-01-02/en

1.74 97033982 – Assembling / disassembling the Derrick pivot section

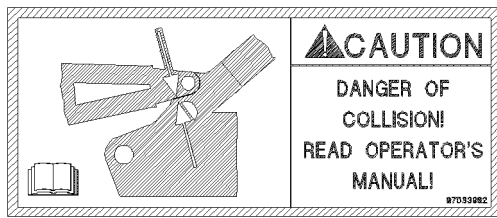

Fig.127470: Assembling / disassembling the Derrick pivot section

NOTICE

Derrick pivot section assembly procedure carried out incorrectly!

Damage to the Derrick pivot section receptacle.

- ▶ Perform the assembly procedure according to the operating instructions.

1.75 Maximum sound power level

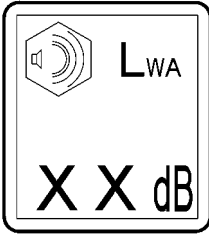
ID no.	Maximum sound power level
975809508	 <p>Maximum sound power level</p>
971693308	
971693408	
971693508	
971693608	



Note

- ▶ The maximum sound power level can be read on the outside of the crane operator's cab or in the CE declaration of conformity.

1.76 97097951 – Counterweight

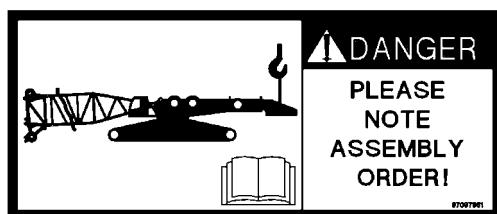

Fig.146805: Counterweight

**DANGER**

Counterweight not secured!
Falling counterweight death, property damage.

- ▶ Observe and adhere to the operating instructions.
- ▶ Do not remove the auxiliary crane until the counterweight is pinned and secured on both sides with the turntable.

1.77 9710047 – Retaining pins for erection rack



Fig.158614: Retaining pins for erection rack

**DANGER**

Retaining pins not inserted!
Falling ladder and erection rack, death, property damage.

- ▶ Before stepping on the erection rack ladder: Insert and secure the erection rack retaining pins.

1.78 97100629 – Connector pins for erection rack / guy rods



Fig.158615: Connector pins for erection rack / guy rods

**DANGER**

Unpin the erection rack / guy rods connector pins!
Falling ladder and erection rack, death, property damage.

Before unpinning the erection rack / guy rods:

- ▶ Insert and secure the erection rack retaining pins.

1.79 97107101 – Unlocking the telescopic boom locking pin

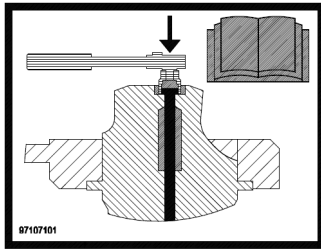

Fig.148421: Unlocking the telescopic boom locking pin



Note

- ▶ The locking pin may be unlocked according to the operating instructions.
- ▶ Observe and adhere to the operating instructions.

1.80 97107199 – Do not unlock the telescopic boom locking pin

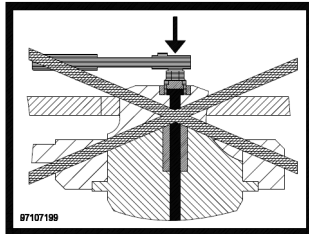

Fig.148422: Do not unlock the telescopic boom locking pin



WARNING

Impermissible telescopic boom locking pin unlocked!
The telescopic boom can retract in an uncontrolled manner.
Death, severe bodily injuries, property damage.

If a locking pin is marked with this sign:

- ▶ **Never** unlock the locking pin.

1.81 97128894 – Counterweight and counterweight radius

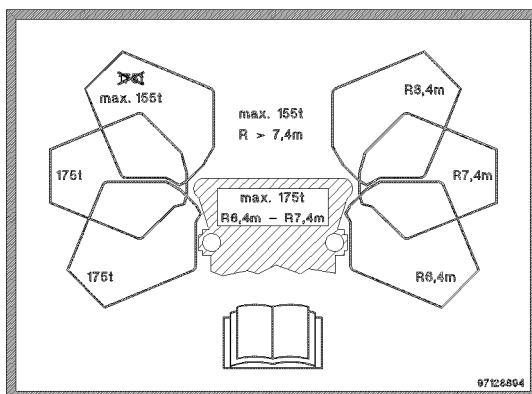

Fig.155030: Counterweight and counterweight radius

Counterweight radius	Maximum permissible counterweight
R- 6.4 m – R- 7.4 m	175.0 t
R- > 7.4 m	155.0 t

**Note**

- ▶ This notice sign indicates the maximum permissible counterweight for the different weight radii.
- ▶ Observe and adhere to the operating instructions.

1.82 97131530 – Reduced crawler crane track width

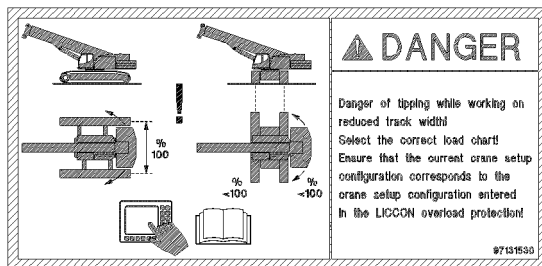

Fig.156174: Reduced crawler crane track width

**DANGER**

Danger of tipping when working with a reduced track width!

- ▶ Select the correct load chart.
- ▶ Make sure that the actual crane set up configuration and the set up configuration entered in the LICCON overload protection match.

1.83 977055908 – Fastening point for swingable sliding beam

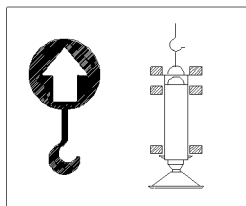

Fig.106894: Fastening point for swingable sliding beam

1.84 971494208 – Limitation of maximum travel speed

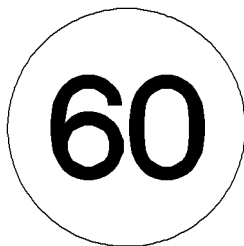

Fig.106034: Limitation of maximum travel speed

1.85 971539808 – Warning notice for unpinning the auxiliary boom on the pulley head

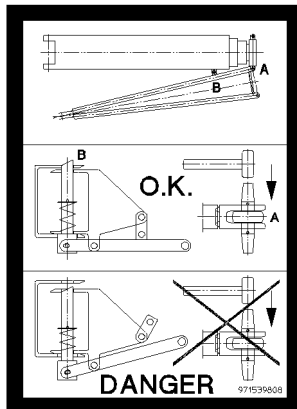

Fig.106040: Warning notice for unpinning the auxiliary boom on the pulley head



DANGER

Danger of fatal injury!

If the auxiliary boom is not locked correctly to the pivot section, it can fall down. Personnel can be severely injured or killed.

- ▶ Unpinning the auxiliary boom on the pulley head is prohibited.

1.86 971539908 – Warning notice for unlocking the auxiliary boom

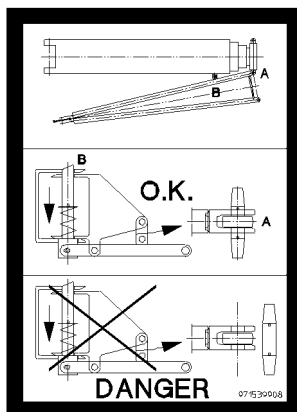

Fig.106041: Warning notice for unlocking the auxiliary boom



DANGER

Danger of fatal injury!

If the auxiliary boom is not locked correctly to the pulley head, it can fall down. Personnel can be severely injured or killed.

- ▶ Unpinning the auxiliary boom on the pivot section is prohibited.

1.87 978673908 – Warning of suspended load

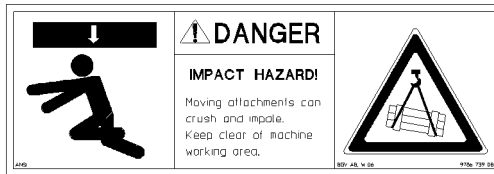

Fig.106026: Warning of suspended load



DANGER

Danger of fatal injury under suspended load!

- ▶ Standing under a suspended load is prohibited.
- ▶ Stay away from the working range of the machine.

1.88 978674008 – Access for unauthorized personnel prohibited



Fig.106037: Access for unauthorized personnel prohibited



DANGER

Danger of fatal injury!

If the crane or the working area is accessed by unauthorized personnel, life threatening injuries can occur as a result.

- ▶ It is prohibited for unauthorized personnel to enter the crane or the working area.

1.89 97039753 – Danger of stumbling

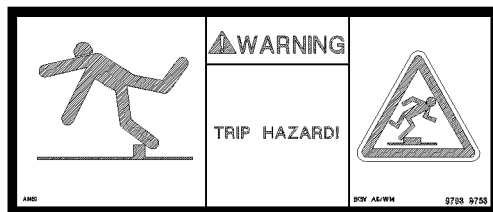

Fig.117346: Danger of stumbling



WARNING

Danger of stumbling!

- ▶ Move with caution.

1.90 978674108 – Warning of crushing danger

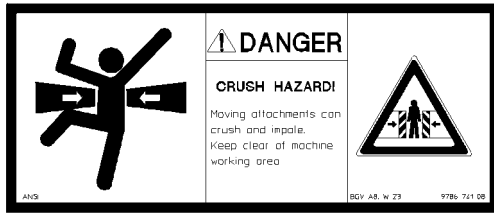

Fig.106027: Danger of crushing



DANGER

Danger of fatal injury when remaining in areas with crushing danger!

- ▶ It is prohibited for anyone to remain in areas where there is a crushing danger.
- ▶ Stay away from the working range of the machine.

1.91 97016911 – Danger of collision

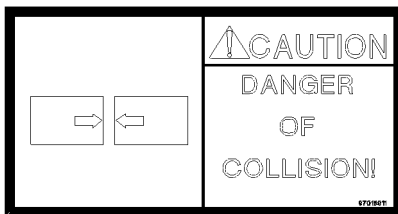

Fig.117344: Danger of collision

NOTICE

Danger of collision!

- ▶ Avoid a collision.

1.92 978674308 – Radio remote control

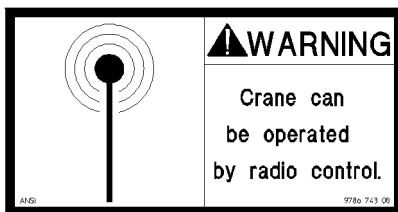

Fig.106047: Radio remote control



WARNING

Danger of injury due to crane operation with radio remote control!

- ▶ The crane can be operated with radio remote control!
- ▶ During crane operation, it is prohibited for anyone to remain in the danger zone!

1.93 978674408 – Danger of burns to hands



Fig.106028: Danger of burns to hands



WARNING

Danger of burns when touching hot surfaces!

- ▶ Do not touch hot surfaces.

1.94 978674508 – Warning of rotating parts

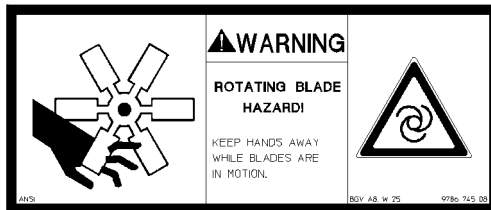

Fig.106029: Warning of rotating parts



WARNING

Rotating parts!

The rotating fan blade can cause finger and hand injuries.

- ▶ Keep your hands away from the rotating fan blade.

1.95 978674608 - Crushing danger for hands



Fig.106030: Crushing danger for hands



WARNING

Danger of injuries for hands!

Hands can be caught, trapped or crushed within the danger zone.

- ▶ Keep hands away from the danger zone!

1.96 978674808 – Personal protective equipment



Fig.123900: Personal protective equipment



DANGER

Danger of falling!

- ▶ Use personal protective equipment.

1.97 978674908 – Accessing the area is prohibited



Fig.106038: Accessing the area is prohibited



WARNING

Danger of accident!

If the prohibited area is accessed, accidents can occur.
Personnel can be severely injured or killed.

- ▶ Do not access the prohibited area.

1.98 978675008 – Access prohibited



Fig.106039: Access prohibited



WARNING

Danger of falling!

If the crane is accessed by unauthorized personnel, life threatening injuries can occur.

- ▶ Do not get on the crane.

1.99 978687408 – Rigging point



Fig.112475: Rigging point



WARNING

Rigging point!

- ▶ Use the rigging point **solely** for rigging.
- ▶ Lifting at the rigging point is **prohibited**.

1.100 97036734 – Rigging point

NOT FOR LIFTING!			
Type (t)	Lashing Capacity		LC-Q (daN)
	LC-N (daN)	LC-Q (daN)	
4	4 000	2 800	
6,7	6 700	4 690	
10	10 000	7 000	
16	16 000	11 200	
31,5	31 500	22 050	

Fig.116287: Rigging point



WARNING

Rigging point!

- ▶ Use the rigging point **solely** for rigging.
- ▶ Lifting at the rigging point is **prohibited**.

1.101 978867108 – Warning of fatal electric shock

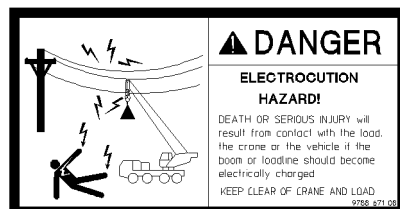

Fig.106814: Warning of fatal electric shock



DANGER

Danger of fatal injury due to electric shock!

If the boom or the hoist rope is powered with electric voltage, then death or severe injuries can occur if anyone touches the crane, the vehicle or the load.

- ▶ Stay away from the crane and load.

1.102 97094940 – Spark catcher

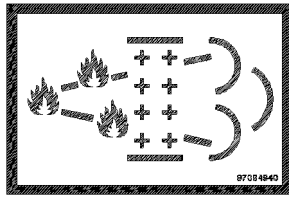

Fig.144735: Spark catcher



Note

► The exhaust system is equipped with an integrated spark catcher.

1.103 979383308 – Oil change

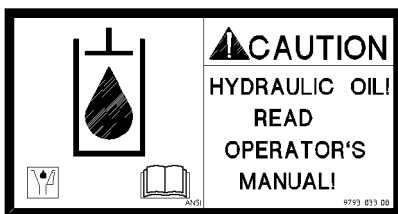

Fig.113827: Oil change



CAUTION

Property damage due to oil change!

If the oil specified in the operating instructions is not used during the oil change, it can lead to damage.

► See the Crane operating instructions, chapter 7.07.

1.104 979561108 – Counterweight

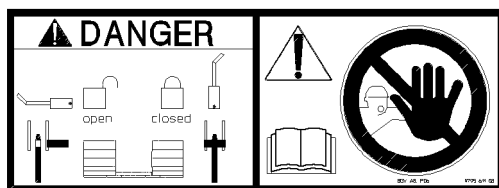

Fig.109026: Counterweight



WARNING

The counterweight can fall down!

If the auxiliary crane is removed on the counterweight before the counterweight is locked on both sides with the turntable, then the counterweight will fall down and can fatally injure assembly personnel.

► Do not remove the auxiliary crane until the counterweight is locked and secured on both sides with the turntable. See the Crane operating instructions, chapter 4.07.

1.105 97001802 – Falling platform

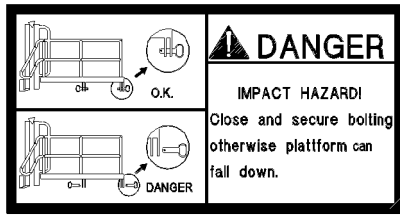

Fig.117345: Falling platform



WARNING

Falling platform!

- ▶ Pin and secure the platform in assembly / disassembly position.

1.106 973974408 - Transport weights of the components

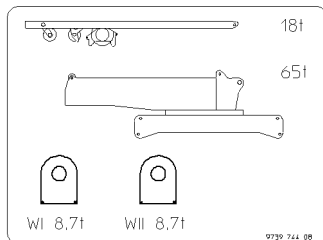

Fig.112440: Transport weights of the components

1.107 973974608 - Transport weights of the components

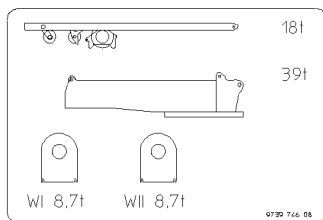

Fig.112441: Transport weights of the components

1.108 97011336 - Transport weights of the components

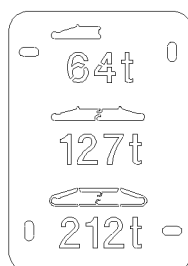

Fig.116271: Transport weights of the components

LWE/LR 13000-001/19503-01-02/en

1.109 97068839 - Transport weights of the components / fastening length of the fastening equipment

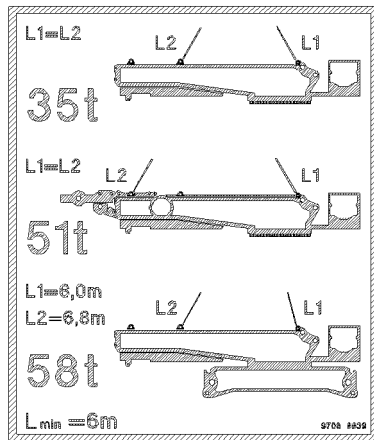
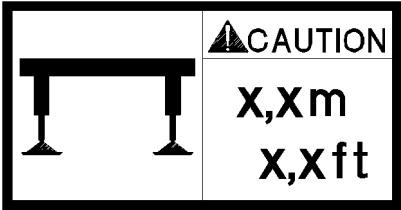

Fig.127587: Transport weights of the components / fastening length of the fastening equipment

1.110 Identification of sliding beam

ID no.	Identification of sliding beam
978675108	 <p data-bbox="817 1258 1158 1290">Identification of sliding beam</p>
978675208	
978772808	
978772908	
978809308	
978809408	
978809508	
978818408	
978818508	
978875908	
978902608	
978903108	
97029203	
978903208	
979126008	
979126108	
979210508	

ID no.	Identification of sliding beam
979210608	
979210608	
979210708	
979309108	
979309208	
97019140	
97003224	
979410808	

Identification of sliding beam



Note

- ▶ Extend the sliding beams to a support width of X.X m (X.X ft).

1.111 Identification of track width retracted

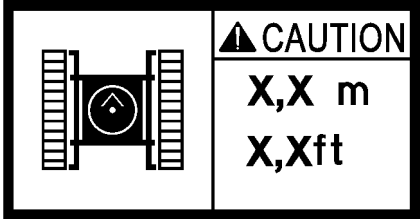
ID no.	Identification of track width retracted
97009840	 <p>Identification of track width</p>
97009841	
97017044	
97017045	
97017046	

Identification of track width



Note

- ▶ Track width retracted to x.xx m (x.x ft).

1.112 976624808 – Fastening the load

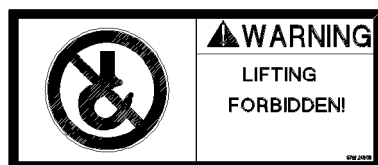

Fig.116283: Fastening the load

LWE/LR 13000-001/19503-01-02/en



WARNING

Fastening the load is prohibited!
 If the load is lifted on this point, the load can fall down and kill personnel.
 ▶ Lifting the load on unmarked locations is prohibited.

1.113 Note of sliding beam weight

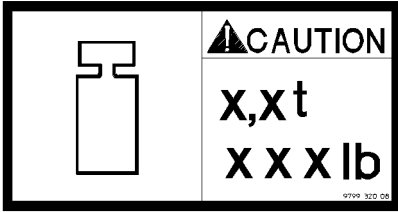
ID no.	Weight of sliding beams
979932008	 <p style="text-align: center;"><i>Weight of sliding beams</i></p>
979932108	
979932708	
979932808	



Note

▶ Pay attention to the weight of the sliding beams.

1.114 Center of gravity of the counterweight

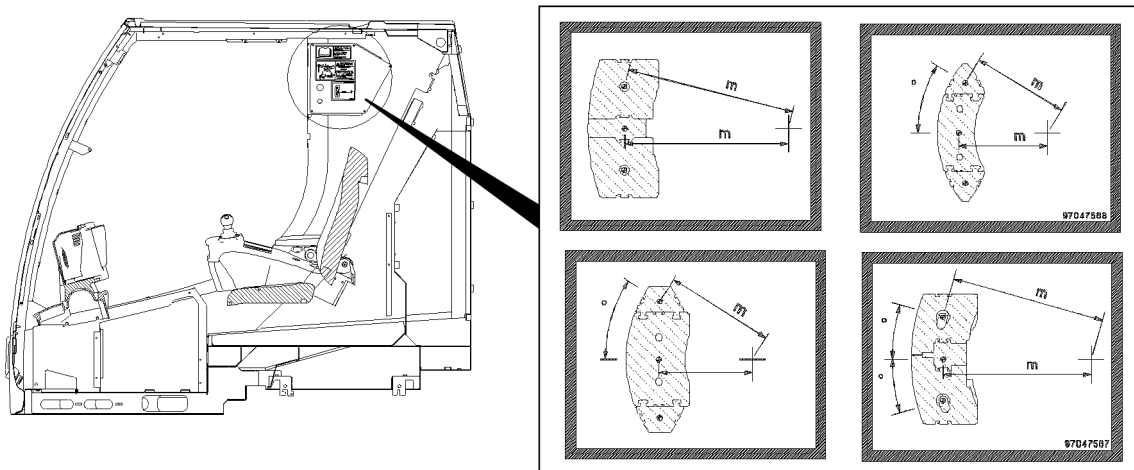

Fig.154058: Notice sign: Distance between center of gravity of counterweight and center of rotation

The depicted notice sign are only examples and can differ depending on the crane type.

The notice signs are displayed in the crane operator's cab.



Note

▶ This notice sign indicates the distance between the center of rotation and the center of gravity of the counterweight.

LWE/LR 13000-001/19503-01-02/en

Notice sign: Distance between center of gravity of counterweight and center of rotation			
Crane type	ID number notice sign	Crane type	ID number notice sign
LTM 1030-2.1	97096584	LTM 1230-5.1	97103719
LTM 1040-2.1	97095218		97103720
LTM 1050-3.1	97094881	LTM 1250-5.1	97070214
LTM 1055-3.1	97047566		97070215
LTM 1060-3.1	97051053	LTM 1300-6.2	97064080
LTM 1070-4.1	97095971	LTM 1350-6.1	97128099
LTM 1090-4.1	97092106	LTM 1450-8.1	97093816
	97092109		
LTM 1095-5.1	97047565	LTC 1050-3.1	97095960
LTM 1100-4.2	97094364	LTF 1045-4.1	97095046
LTM 1100-5.2	97095763	LTF 1060-4.1	97096030
LTM 1130-5.1	97055765	LTR 1060	97128100
LTM 1160-5.2	97081129		

1.115 Minimum rope reeving / minimum hook block weight



⚠ CAUTION					
LTM 1400-7.1			LTM 1450-8.1		
	 $W_{T_{min}}=?$	 $n_{min}=?$		 $W_{T_{min}}=?$	 $n_{min}=?$
TN			TN		
N-14,0m	3,1 t	n = 5	N-14,0m	3,1 t	n = 5
N-21,0m	2,6 t	n = 4	N-17,5m	2,6 t	n = 5
N-28,0m	1,4 t	n = 2	N-21,0m	2,6 t	n = 4
TN + 			N-24,5m	2,6 t	n = 4
N-14,0m	2,3 t	n = 3	N-28,0m	1,4 t	n = 2
N-21,0m	2,3 t	n = 2	TNH		
			N-14,0m	2,3 t	n = 3
			N-17,5m	1,8 t	n = 3
			N-21,0m	2,3 t	n = 2
			N-24,5m	1,8 t	n = 2

Fig.127972: Minimum rope reeving / minimum hook block weight with luffing lattice jib / boom nose

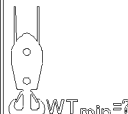
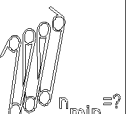
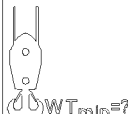
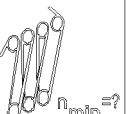

WARNING

Minimum rope reeving / minimum hook block weight not adhered to!

Too low hook block weight leads to the formation of slack rope.

Rope reeving too low, hoist rope is overloaded.

► Adhere to the hook block weight and hoist rope reeving.

Example: LTM 1400-7.1

With a luffing lattice jib -TN **N-21 m** a hook block with a weight of **2.6 t** must be installed and minimum rope reeving of **4** must be used.

With a luffing lattice jib **N-21 m** and boom nose a hook block with a weight of **2.3 t must** be installed and minimum rope reeving of **2** must be used.

2.05.10 Labeling of the load carriers

1	Identifications on the hook block or load hook	3
2	Identifications on single hook or double hook	4
3	Identifications on auxiliary weights	5

Fig.195219

LWE/LR 13000-001/19503-01-02/en

1 Identifications on the hook block or load hook

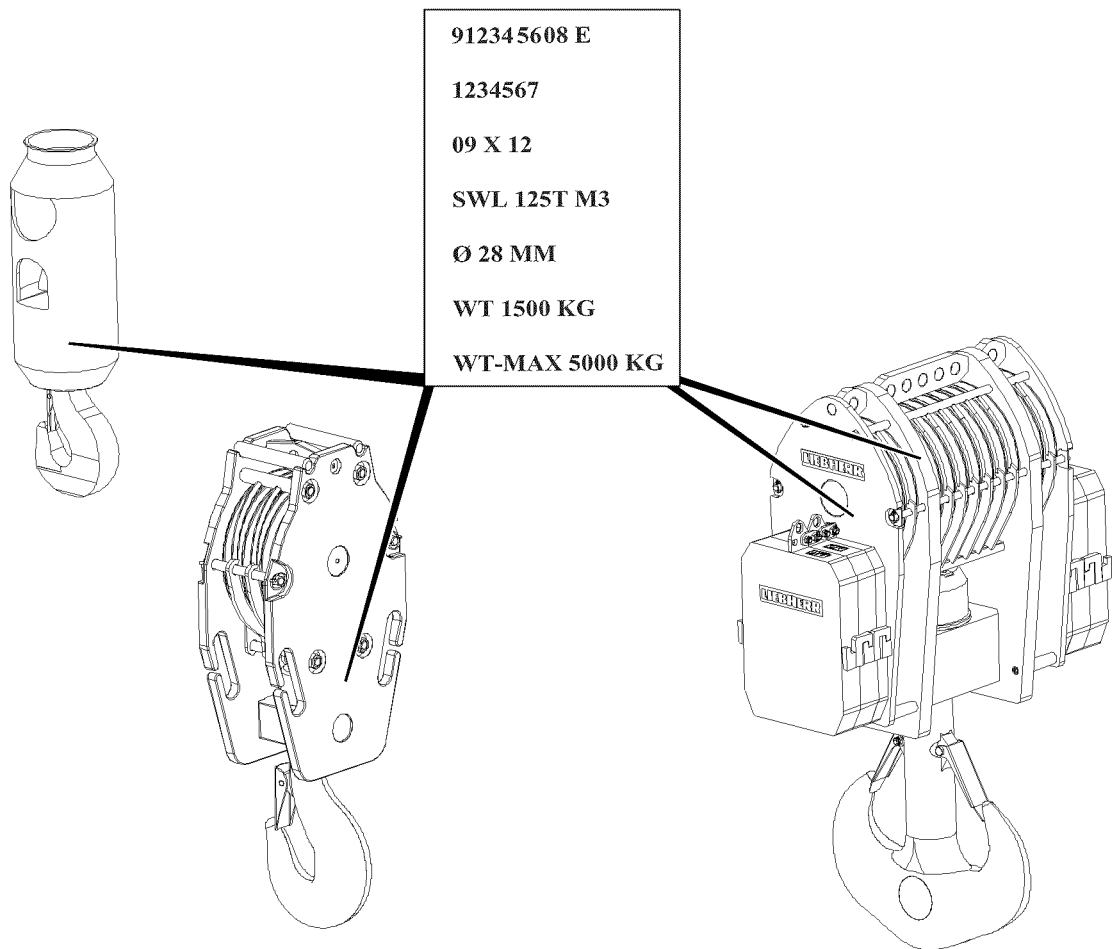

Fig.118509: Identifications on the hook block or load hook



Note

- ▶ The load hooks and hook blocks approved for this crane type can be found in the load chart.
- ▶ The hook blocks shown are examples only and can deviate from the existing hook block.

Punch mark area	Explanation
912345608 E	Liebherr ID no., „E = entschärft (deburred)“
123456	Series or factory test number
09 X 12	Month of construction / supplier marks / year of construction
SWL 125T M3	SWL (Safe Working Load) = Load carrying capacity for power train group M3
Ø 28 mm	Hoist rope diameter
WT 1500 Kg	WT (Weight Tare) = Own weight (without auxiliary weights)

Punch mark area	Explanation
WT-MAX 5000 Kg	WT-Max = Maximum permissible own weight of lower pulley block and total number of progressively installed auxiliary weights
	Limits the number of installed auxiliary weights
	Determination via addition of assembled own weights (number of auxiliary weights + hook block)

Identifications on the hook block or load hook

2 Identifications on single hook or double hook

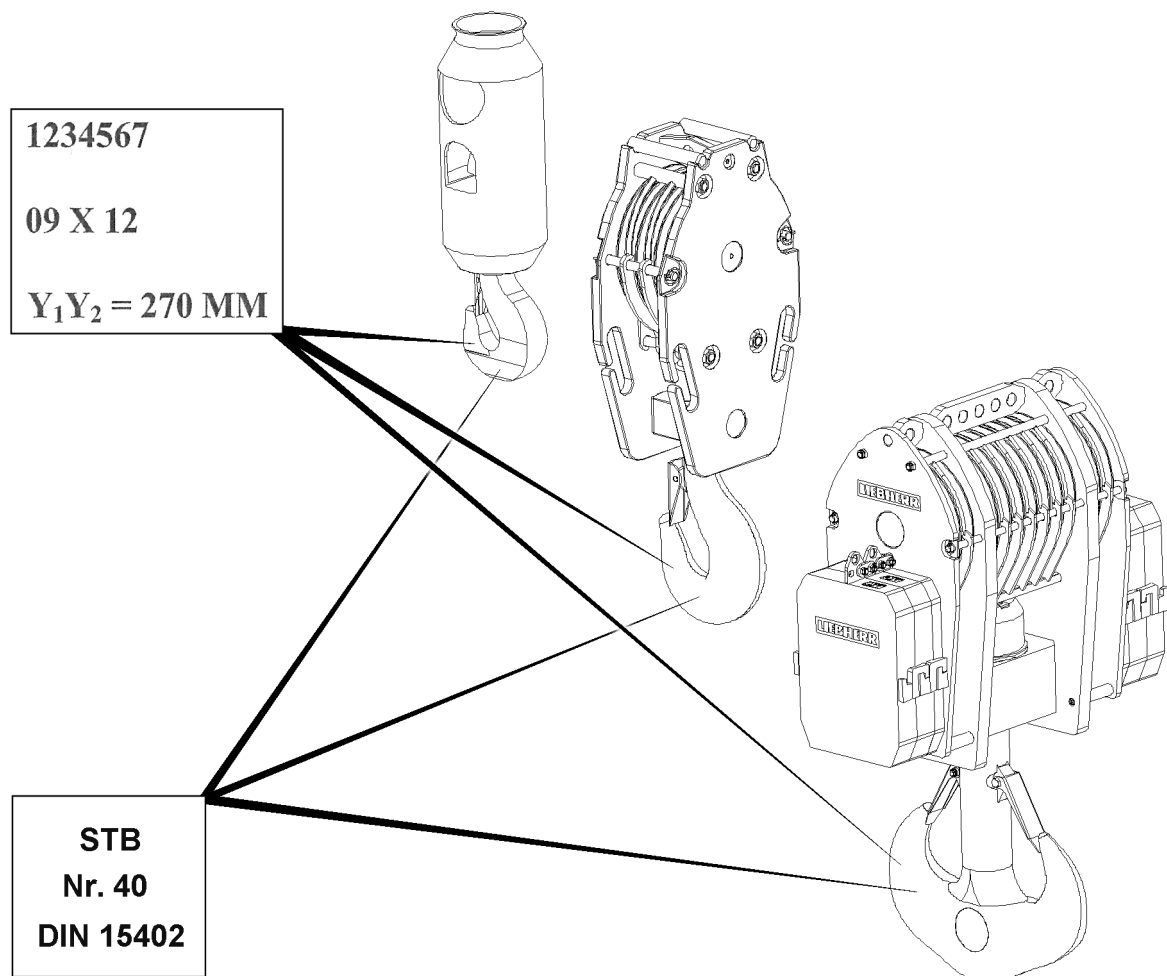

Fig.149061: Identifications on single hook or double hook

Punch mark area	Explanation
STB	Hook manufacturer
40-T	Hook number + strength class according to DIN 15 400
DIN	Hook shape according to DIN 15 401 /DIN 15 402
123456	Series or factory test number

Punch mark area	Explanation
09 X 12	Month of construction / supplier marks / year of construction
Y1Y2 = 270 mm	Dimension Y or dimension Y1 and dimension Y2 according to DIN (= Test dimensions for recurrent tests)

Identifications on single hook or double hook

3 Identifications on auxiliary weights

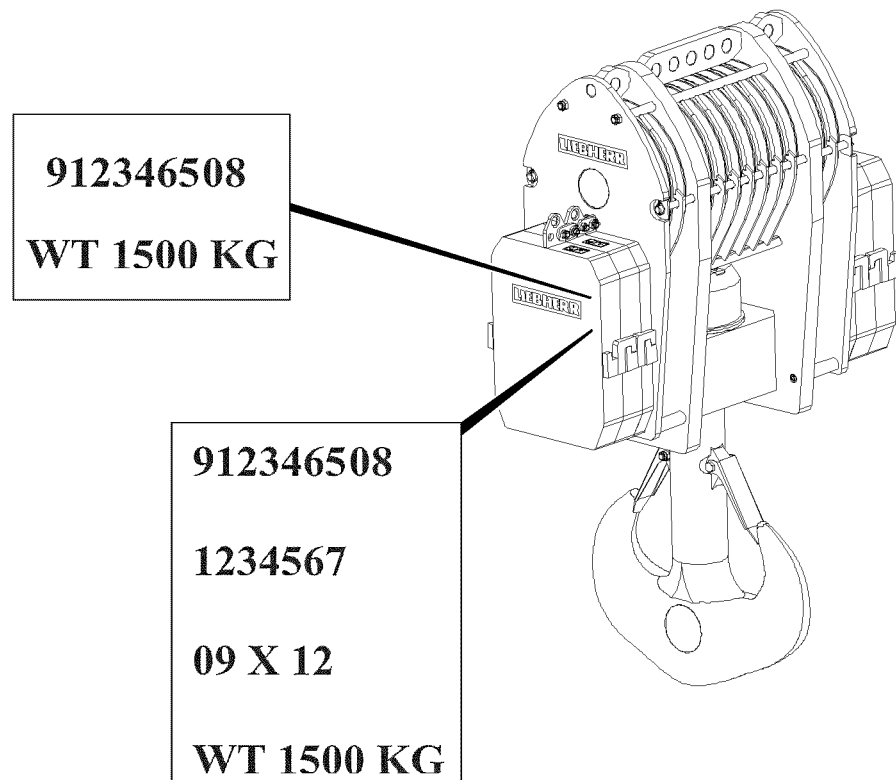

Fig.118511: Identifications on auxiliary weights



Note

- The own weight of the individual auxiliary weight is noted on the side on the respective auxiliary weight.

3.1 Identifications on auxiliary weights at delivery

Punch mark area	Explanation
912346508	Liebherr ID no.
WT 1500 Kg	WT (Weight Tare) = Own weight of individual auxiliary weight

Identifications of auxiliary weights at delivery

3.2 Identifications on auxiliary weights for reorder

Punch mark area	Explanation
912346508	Liebherr ID no.
123456	Series or factory test number
09 X 12	Month of construction / supplier marks / year of construction
WT 1500 Kg	WT (Weight Tare) = Own weight of individual auxiliary weight

Identifications of auxiliary weights at reorder

2.06 Fall protection equipment on the crane

1	Personal protective equipment	3
2	Safety ropes as fall protection equipment	5
3	Fall protection equipment and ladders on the crane chassis	9
4	Fall protection equipment and ladders on the crane superstructure	43
5	Fall protection equipment and ladders on the D-boom	83
6	Fall protection equipment and ladders on the S-boom	131



Fig.112104

1 Personal protective equipment



WARNING

Danger of falling!

During assembly / disassembly, inspection and maintenance work, assembly personnel must be secured with appropriate aids to prevent them from falling!

If this is not observed, assembly personnel could fall and be killed or seriously injured!

- ▶ The assembly personnel must always move carefully and anticipatory on the crane, the crane components or lattice sections!
 - ▶ All work at a height, when there is a danger of falling, must be carried out with suitable aids!
 - ▶ If fall protection equipment is available, then it must be used!
 - ▶ If aids are not available and work cannot be carried out from the ground, then assembly personnel must secure themselves with the permissible fall arrest system to prevent falling, see the Crane operating instructions, chapter 2.04!
 - ▶ The fall arrest system must be attached in the fastening and hook points as well as to the safety ropes!
 - ▶ Only step on the aids, ladders and catwalks with clean shoes!
 - ▶ Keep aids, ladders and catwalks free of heavy dirt, snow and ice!
-



Note

- ▶ The sign **3** marks the fastening points, where assembly personnel must connect with a fall arrest system to secure themselves against falling!
-

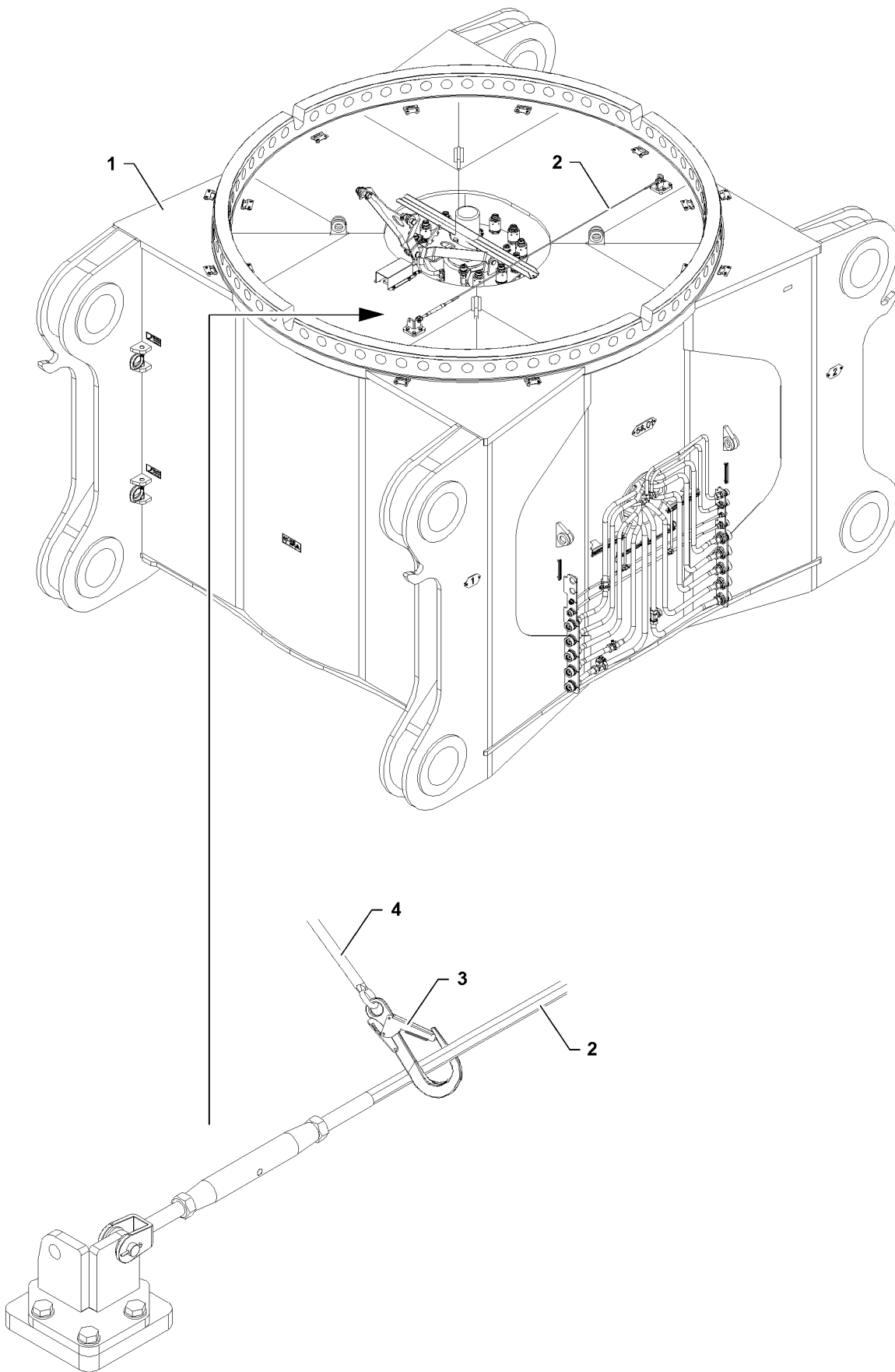

Fig.113623

LWE/LR 13000-001/19503-01-02/en

2 Safety ropes as fall protection equipment

2.1 Safety rope

NOTICE

Danger of damage!

- ▶ Never hang loads or objects on the safety ropes **2**!
-



WARNING

Danger of falling!

During assembly and disassembly, assembly personnel must be secured with appropriate aids to prevent them from falling. If this is not observed, assembly personnel could fall and be killed or seriously injured!

- ▶ Any work, where there is a danger of falling, must be carried out with suitable aids (for example: lifting platform, scaffolding, ladder, auxiliary crane)!
 - ▶ If the work cannot be carried out with such aids or from the ground, then assembly personnel must secure themselves with approved fall arrest systems **4** to avoid falling, see the Crane operating instructions, chapter 2.04!
 - ▶ The assembly personnel must hook themselves for all assembly / disassembly work, maintenance work and inspections with approved fall arrest systems **4** on the safety rope **2** with both snap hooks **3** and secure themselves to prevent them from falling. (For example: safety harness with self-actuating blocking function and an automatic tension and pull in device for the connectors)
 - ▶ The connector must be set to a length as short as possible so that it is impossible to hit the ground in case of a fall!
 - ▶ Fall absorbers may not be used, because they stretch too much in case of a fall!
 - ▶ Transferring the snap hooks **3** is only permissible in the connection points!
 - ▶ When transferring the snap hook **3**, one snap hook **3** must always be hooked to one safety rope **2**!
 - ▶ Never release both snap hooks **3** simultaneously from the safety rope **2**!
 - ▶ Before any assembly / disassembly work, maintenance and inspection work it must be ensured that all obstacles below have been removed from the work place and that there is sufficient clearance in case of a fall!
 - ▶ During all assembly / disassembly work, maintenance work and inspections, travel or crane operation is prohibited!
-

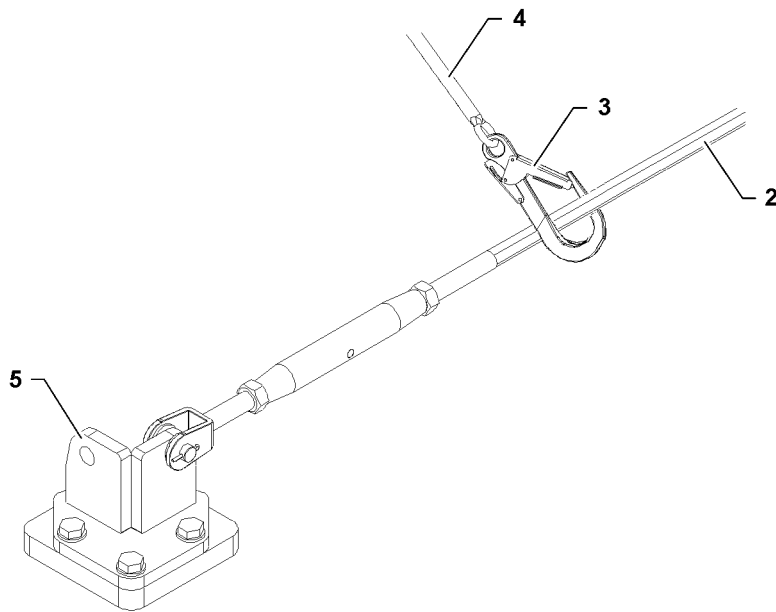

Fig.113624

LWE/LR 13000-001/19503-01-02/en

2.2 Replacing safety ropes subjected to a fall



WARNING

Danger of accident due to fall subjected safety ropes!

If fall subjected safety ropes are not replaced after a fall, then the safety ropes **2** can fail in case of another fall! Assembly personnel can be killed or severely injured!

- ▶ **Expert personnel** must immediately replace any safety ropes **2** that were subjected to a fall and inspect the respective anchor points **5** for damage!
- ▶ If the anchor points **5** are damaged, then they must be replaced immediately by **expert personnel!**

2.3 Checking the safety ropes and anchor points

For a detailed description of "Inspection of safety ropes and anchor points" refer to the Crane operating instructions, chapter 8.01.

Fig.195219

LWE/LR 13000-001/19503-01-02/en

3 Fall protection equipment and ladders on the crane chassis



WARNING

When working at a height, there is a danger of falling!

- ▶ Properly assemble and secure all fall protection equipment, such as platforms, catwalks, ladders and railings on the crane chassis.



WARNING

Danger of accident!

If the following notes are not observed, the ladder can tip and assembly personnel can fall from the ladder with danger of fatal injury!

- ▶ Replace damaged ladders immediately!
- ▶ The ladder must be set up stable and safely accessible!
- ▶ For the safe handling of the ladder, observe the safety instructions on the ladder!



CAUTION

Danger of crushed limbs!

When assembling / disassembling fall protection equipment and ladders, limbs can be crushed!

- ▶ Do not reach with your hands into the danger zone!
- ▶ Swing the fall protection equipment and the ladders especially carefully!

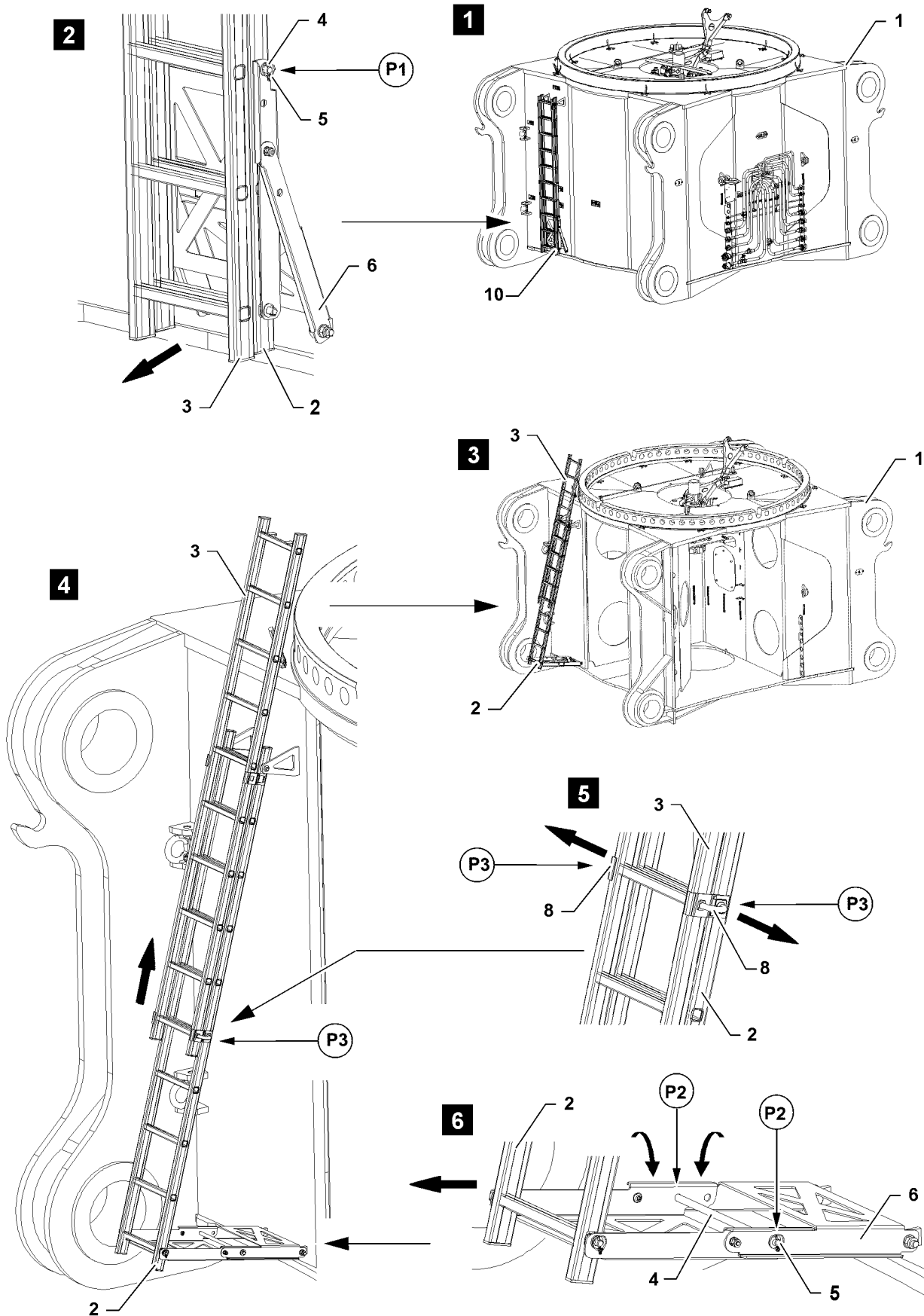

Fig.113126

LWE/LR 13000-001/19503-01-02/en

3.1 Extension ladder on crawler center section

3.1.1 Swinging the extension ladder on the crawler center section in position of assembly / disassembly

- ▶ Release the extension ladder **10** from the vertical position: Remove the locking pin **5** in point **1** and pull out the rod **4**, see illustration **2**.



WARNING

Danger of crushed limbs!

The folding mechanism **6** can fold down by itself due to its own weight when it is folded out!

Fingers and hands can be crushed!

- ▶ When swinging the extension ladder **10** hold the folding mechanism **6** and fold it down slowly!

- ▶ Swing the extension ladder **10** into position for assembly / disassembly: Fold the folding mechanism **6** out.
- ▶ Insert the rod **4** in points **P2** through the intended bores and secure with the locking pin **5**, see illustration **6**.

Result:

- The folding mechanism **6** is secured.
- ▶ Pull the two sided lock **8** out in points **P3** of the extension ladder and turn to the side, see illustration **5**.



WARNING

Danger of crushed limbs!

When sliding the upper ladder section **3**, fingers and hands can be crushed!

- ▶ Do not reach with your hands into the danger zone!
- ▶ Slide the upper ladder section **3** up **five** rungs, see illustration **4**.
- ▶ Engage the two sided lock **8** again in points **P3**.

Result:

- The extension ladder **10** is set up and secured in position for assembly / disassembly.

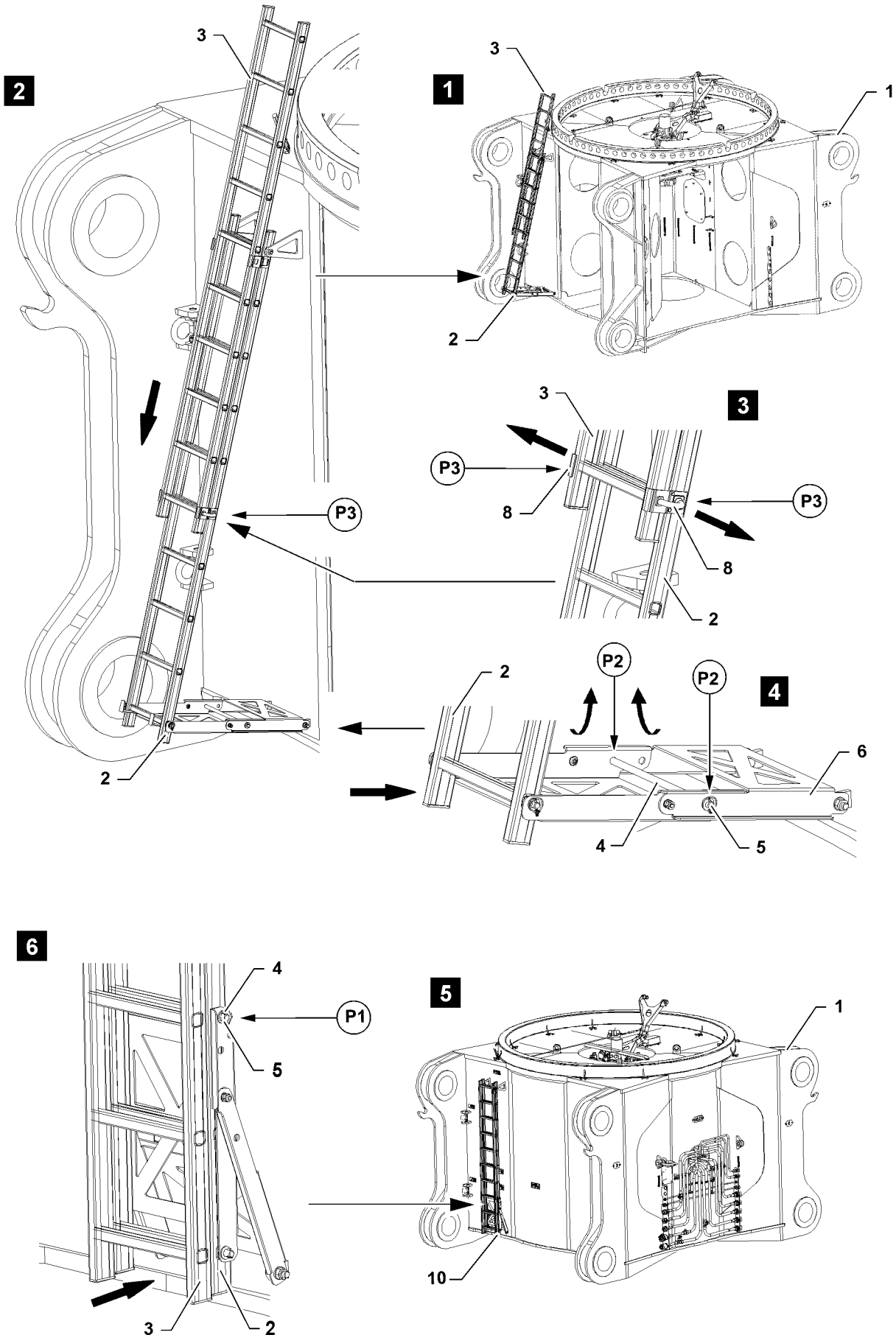

Fig.113127

LWE/LR 13000-001/19503-01-02/en

3.1.2 Swinging the extension ladder on the crawler center section into the vertical position



WARNING

Danger of crushed limbs!

The upper ladder section **3** can fall down by itself due to its own weight when pulling the locks **8** out! Fingers and hands can be crushed!

- ▶ When pulling the locks out **8**, hold the extension ladder **10** and slide it down slowly!
- ▶ Pull the two sided lock **8** out in points **P3** of the extension ladder and turn to the side, see illustration **3**.



WARNING

Danger of crushed limbs!

When sliding the upper ladder section **3**, fingers and hands can be crushed!

- ▶ Do not reach with your hands into the danger zone!
- ▶ Slide the upper ladder section **3** down **five** rungs, see illustration **2**.
- ▶ Engage the two sided lock **8** again in points **P3**.
- ▶ Release the extension ladder **10** from the position for assembly / disassembly: Remove the locking pin **5** in point **2** and pull out the rod **4**, see illustration **4**.



WARNING

Danger of crushed limbs!

When folding in the locking mechanism **6**, fingers and hands can be crushed!

- ▶ When swinging the extension ladder **10** hold the folding mechanism **6** and fold it up slowly!
- ▶ Do not reach with your hands into the danger zone!
- ▶ Swing the extension ladder **10** into the vertical position: Fold the folding mechanism **6** in.
- ▶ Insert the rod **4** in point **P1** through the rungs of the lower ladder section **2** and secure with locking pin **5**, see illustration **6**.

Result:

- The extension ladder **10** is folded in the vertical position and secured.

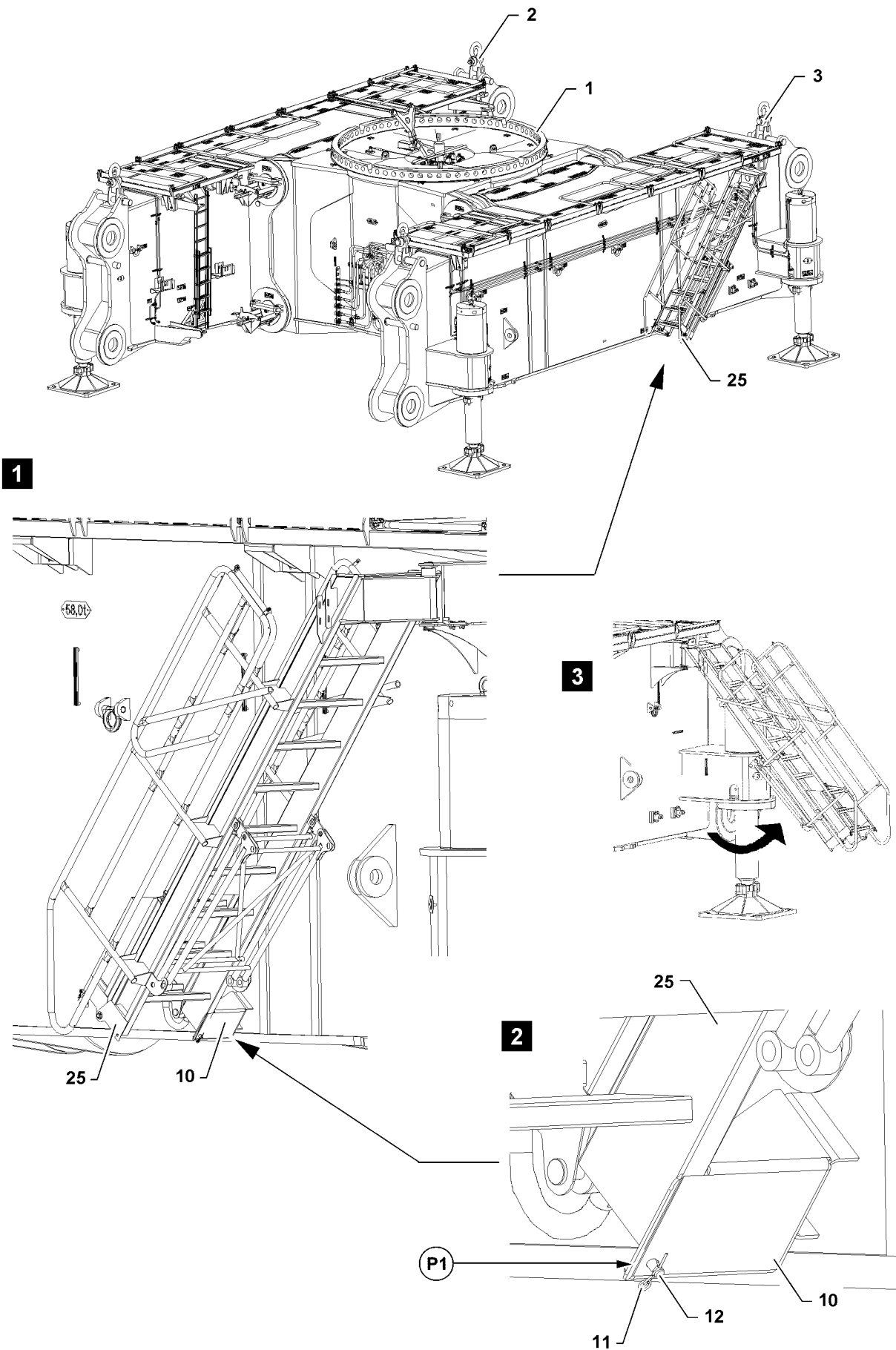

Fig.113130

LWE/LR 13000-001/19503-01-02/en

3.2 Access ladder on the cross carrier

3.2.1 Swinging the access ladder on the cross carrier into the operating position

Make sure that the following prerequisite is met:

- For the assembly / disassembly of the access ladder **25** two person are on site.
- ▶ Release the access ladder **25** from the transport position on the support **10**: Remove the cotter pin **11** in point **P1** and unpin the pin **12**, see illustration **2**.



WARNING

Danger of crushed limbs!

When swinging the access ladder **25**, fingers and hands can be crushed!

- ▶ Do not reach with your hands into the danger zone!
-
- ▶ Swing the access ladder **25** from the transport position to the stop, see illustration **3**.

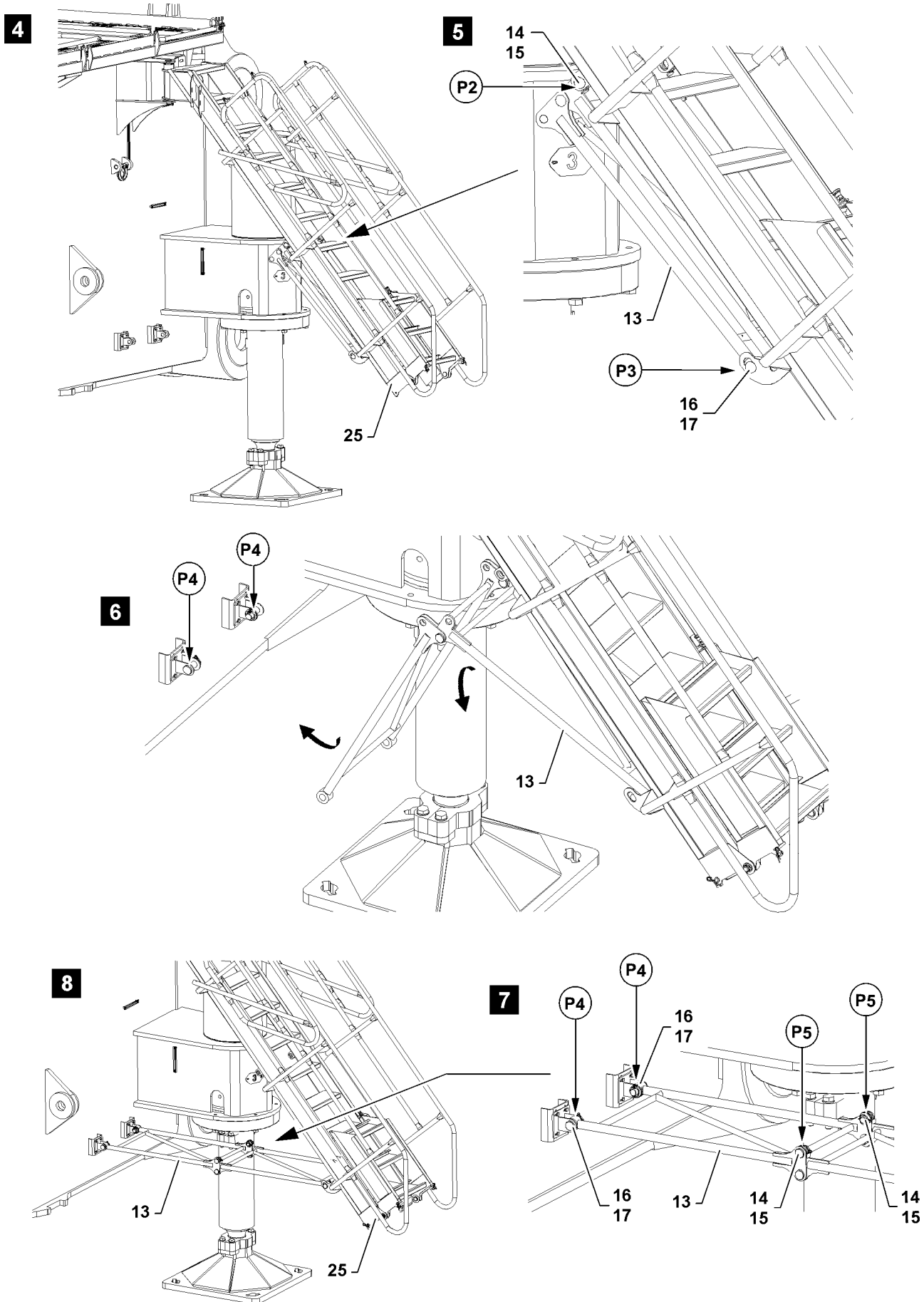

Fig.113131

LWE/LR 13000-001/19503-01-02/en

**WARNING**

Support swinging down!

The support **13** can swing down by itself due to its own weight when unpinning the center pin connection in point **P2**, see illustration **5!**

Personnel can be severely injured!

Fingers and hands can be crushed!

- ▶ For safety reasons, always assemble the support **13** with **two** people!
- ▶ When unpinning the center pin connection, hold the support **13!**
- ▶ Do not reach with your hands into the danger zone!
- ▶ Use personal protective equipment!

▶ Hold the support **13**.

▶ Release the center pin connection in point **P2**: Remove the split pin **14** and unpin the pin **15** .

**WARNING**

Folding components!

The support **13** can fold down by itself due to its own weight when unpinning the lower pin connection in point **P3**, see illustration **5!**

Personnel can be severely injured!

Fingers and hands can be crushed!

- ▶ For safety reasons, always assemble the support **13** with **two** people!
- ▶ When unpinning the lower pin connection, hold the support **13!**
- ▶ Do not reach with your hands into the danger zone!
- ▶ Use personal protective equipment!

▶ Push the support **13** upwards.

Result:

– The lower pin connection is relieved in point **P3**.

▶ Release the lower pin connection in point **P3**: Remove the split pin **16** and unpin the pin **17** .

Result:

– The support **13** is unpinned and can be folded out.

▶ Fold the support **13** out, see illustration **6**.

▶ Pin the support **13** in points **P4**. Insert the pin **17** and secure with the cotter pin **16**, see illustration **7**.

▶ Secure the center pin connection in point **P5**: Insert the pin **15** and secure with the cotter pin **14**, see illustration **7**.

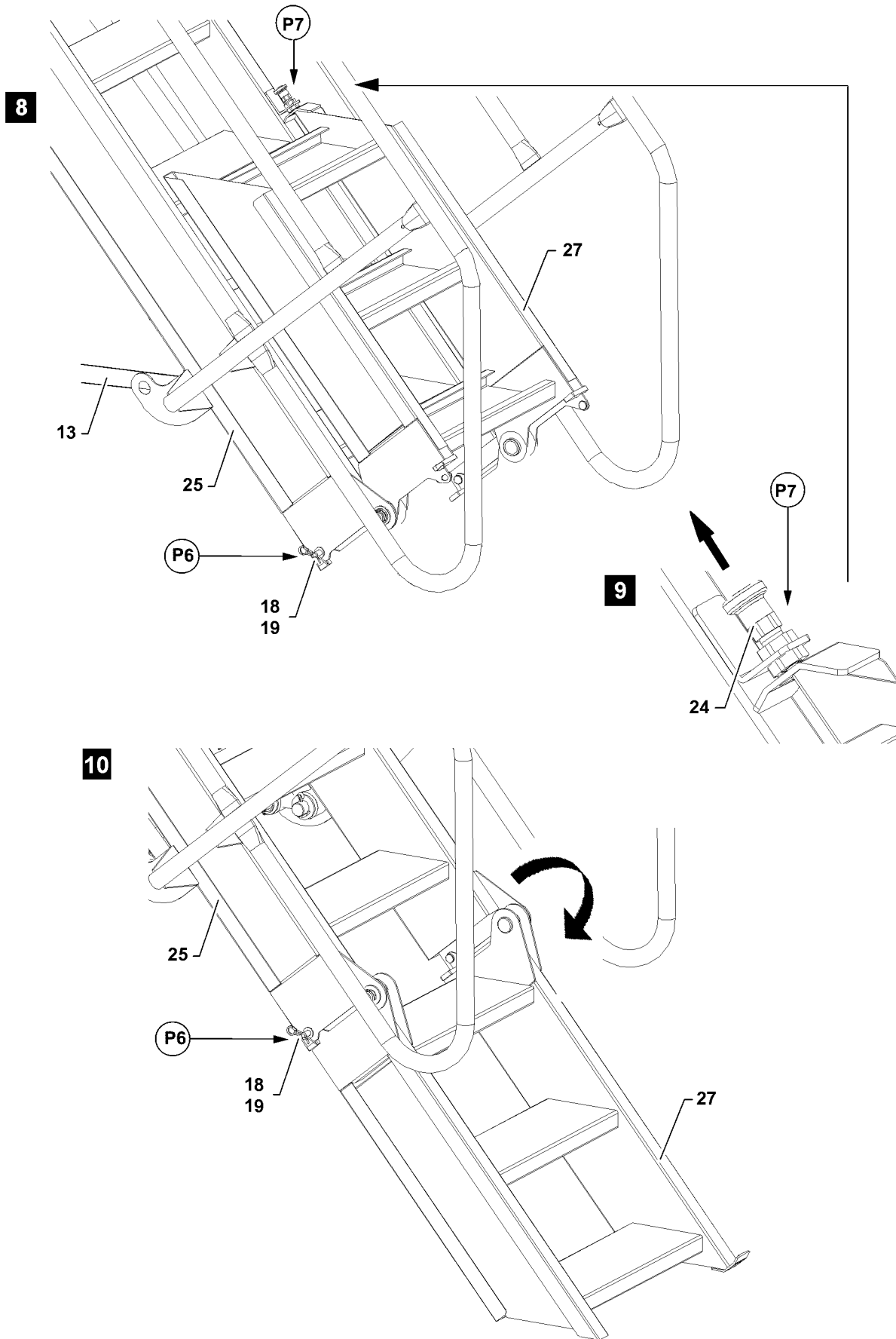

Fig.113132

LWE/LR 13000-001/19503-01-02/en

Make sure that the following prerequisite is met:

- The access ladder **25** is supported with the support **13**.
- ▶ Remove the cotter pin **18** on the lower end of the access ladder in point **P6** and unpin the pin **19**, see illustration **8**.
- ▶ Pull the detent pin **24**, see illustration **9**.

Result:

- The folding section **27** is unlocked.



WARNING

Folding components!

When folding out the folding section **27**, fingers and hands can be crushed!

- ▶ Do not reach with your hands into the danger zone!

-
- ▶ Fold the folding section **27** out downward, see illustration **10**.
 - ▶ Insert the pin **19** in point **P6** and secure with the cotter pin **18**, see illustration **10**.

Result:

- The folding section **27** is secured.

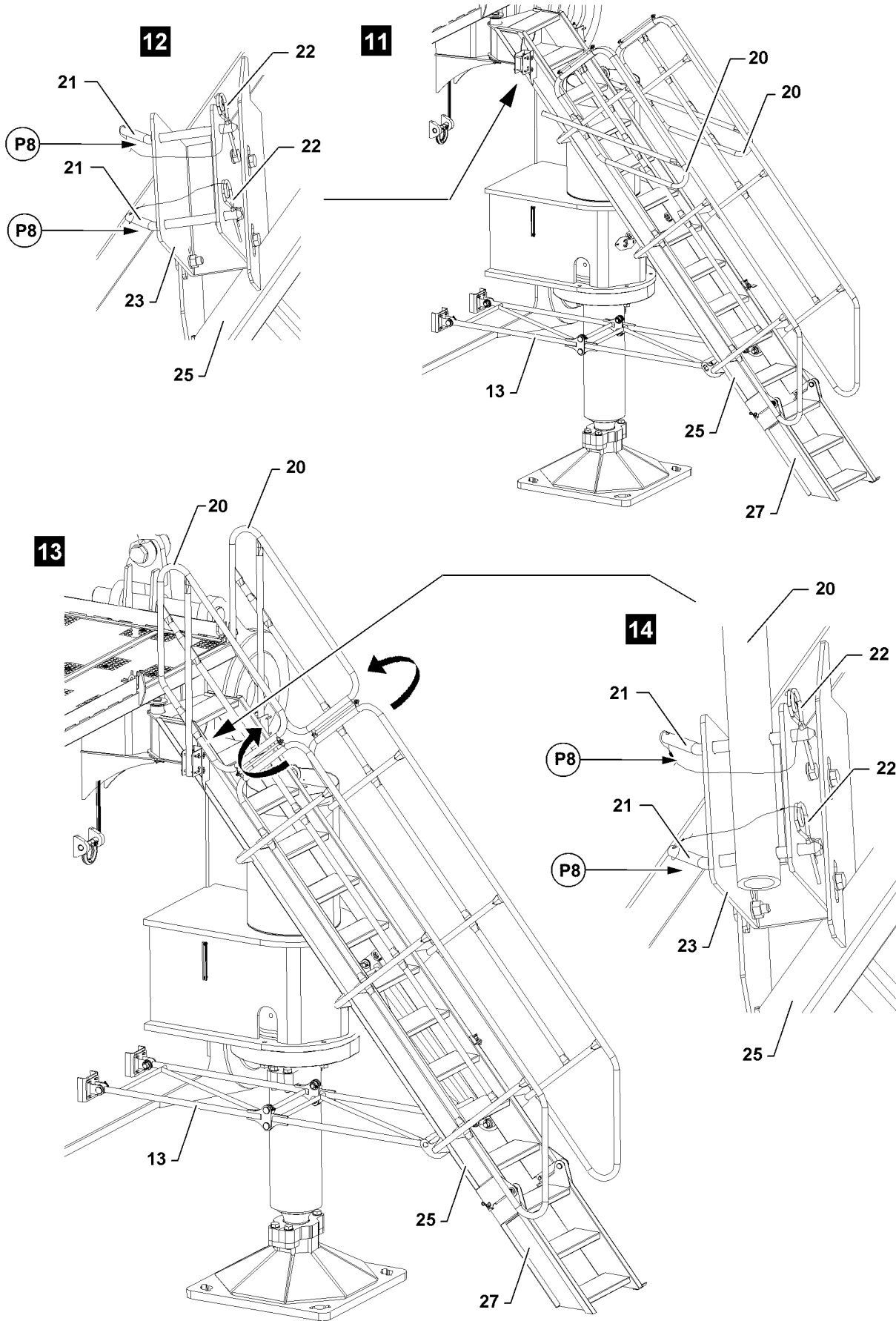

Fig.113133

LWE/LR 13000-001/19503-01-02/en

Make sure that the following prerequisite is met:

- The folding section **27** is pinned and secured on the access ladder **25**.



Note

- ▶ The assembly of the railings **20** is described based on the example of one railing!
-

**WARNING**

Danger of falling!

During assembly and disassembly of the railing, personnel must be secured with appropriate aids to prevent them from falling!

Even during the assembly of protective devices there is a danger of falling!

Assembly personnel can fall and be severely injured or killed!

- ▶ Use personal protective equipment!
-

- ▶ Remove the cotter pin **22** on the U-profile **23** in point **P8** and unpin the plug **21**, see illustration **12**.
-

**WARNING**

Danger of crushed limbs!

When swinging the railings **20**, fingers and hands can be crushed!

- ▶ Do not reach with your hands into the danger zone!
-

- ▶ Swing the railing **20** into the operating position, see illustration **13**.

- ▶ Secure the railing **20** in the operating position: Pin the connector **21** in point **P8** and secure with the cotter pin **22**, see illustration **14**.

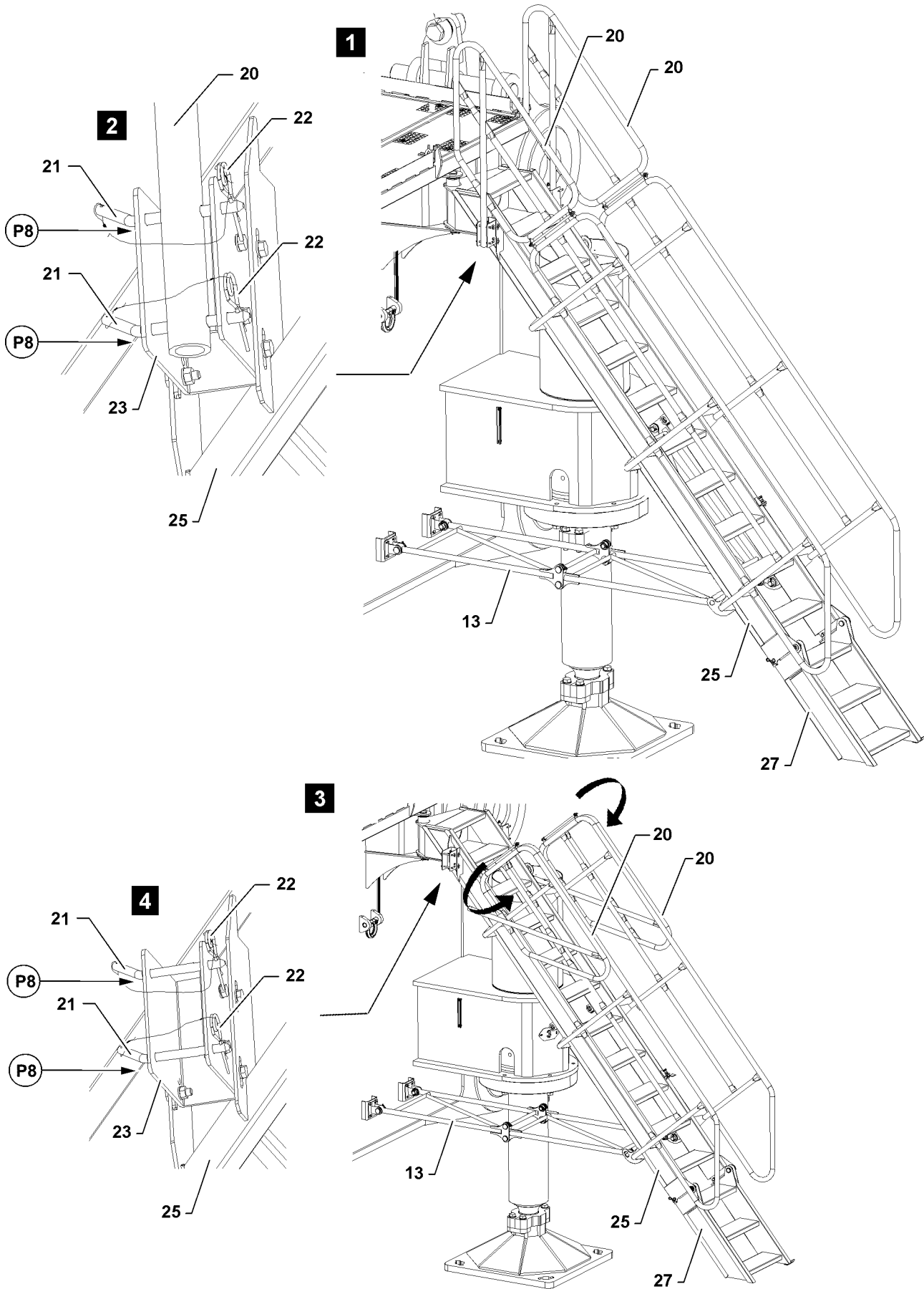

Fig.113134

LWE/LR 13000-001/19503-01-02/en

3.2.2 Swinging the access ladder on the cross carrier into the transport position

Make sure that the following prerequisite is met:

- For the assembly / disassembly of the access ladder **25**, **two** people are on site.



Note

- ▶ The disassembly of the railings **20** is described based on the example of one railing!



WARNING

Danger of falling!

During assembly and disassembly of the railing, personnel must be secured with appropriate aids to prevent them from falling!

Even during the assembly of protective devices there is a danger of falling!

Assembly personnel can fall and be severely injured or killed!

- ▶ Use personal protective equipment!



WARNING

Folding components!

The railing **20** can fold down by itself due to its own weight when unpinning in point **P8**, see illustration **1**!

Personnel can be severely injured!

Fingers and hands can be crushed!

- ▶ For safety reasons, always swing the railing **20** with **two** people!
- ▶ When unpinning the pin connection, hold the railing **20**!
- ▶ Do not reach with your hands into the danger zone!

- ▶ Hold the railing **20**.
- ▶ Remove the cotter pin **22** in point **P8** and unpin the connector **21** on the U-profile **23**, see illustration **2**.
- ▶ Swing the railing **20** into the transport position, see illustration **3**.
- ▶ Insert the connector **21** in point **P8** again and secure with the cotter pin **22**, see illustration **4**.

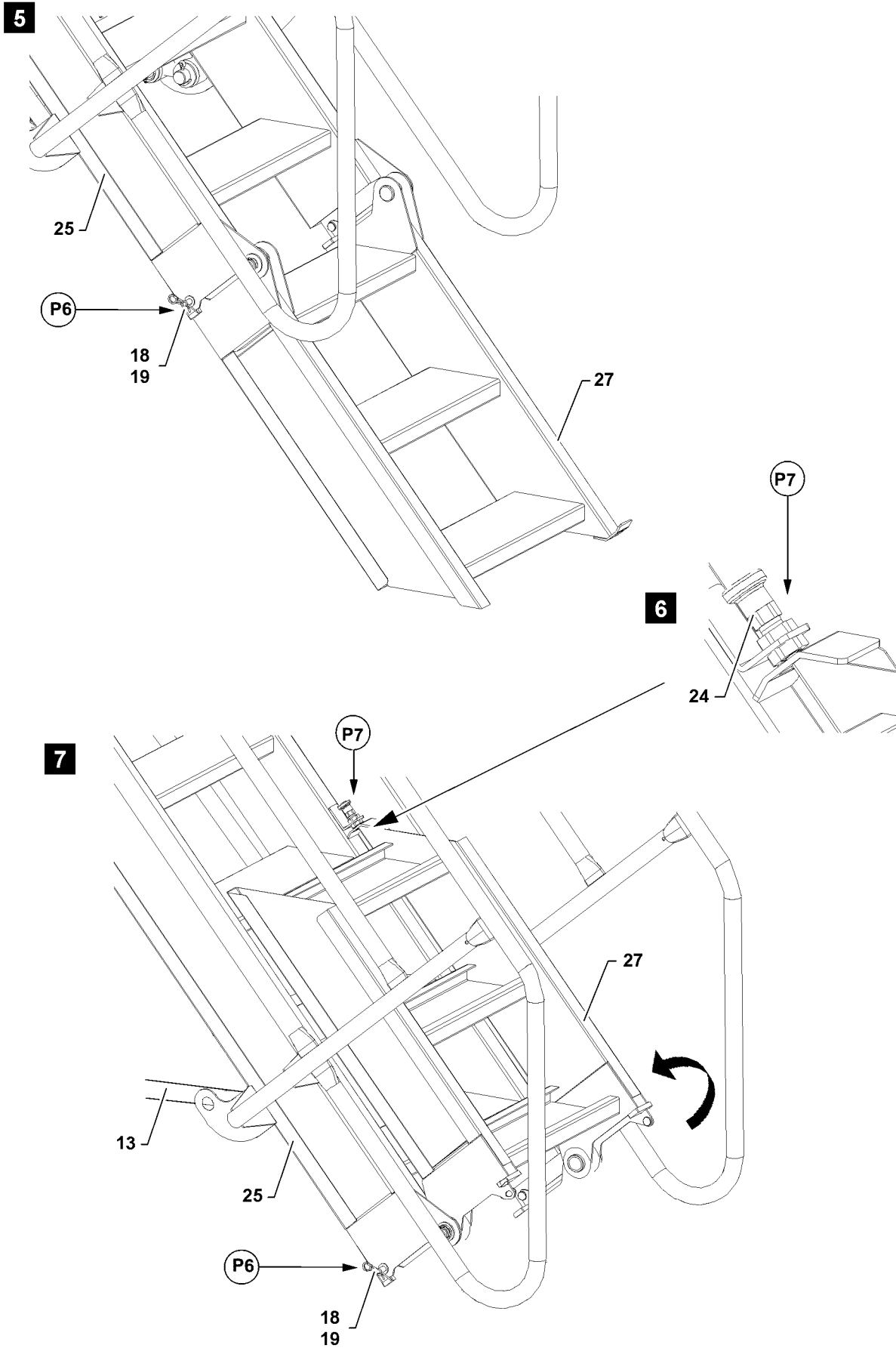

Fig.113135

LWE/LR 13000-001/19503-01-02/en

- ▶ Remove the cotter pin **18** on the lower end of the access ladder in point **P6** and unpin the pin **19**, see illustration **5**.



WARNING

Folding components!

When folding in the folding section **27**, fingers and hands can be crushed!

- ▶ Do not reach with your hands into the danger zone!
-
- ▶ Fold the folding section **27** in upward until the folding section engages in point **P7** on the locking pin **24**, see illustration **6**.

Result:

- The folding section **27** is secured.
- ▶ Insert the pin **19** in point **P6** again and secure with the cotter pin **18**, see illustration **7**.

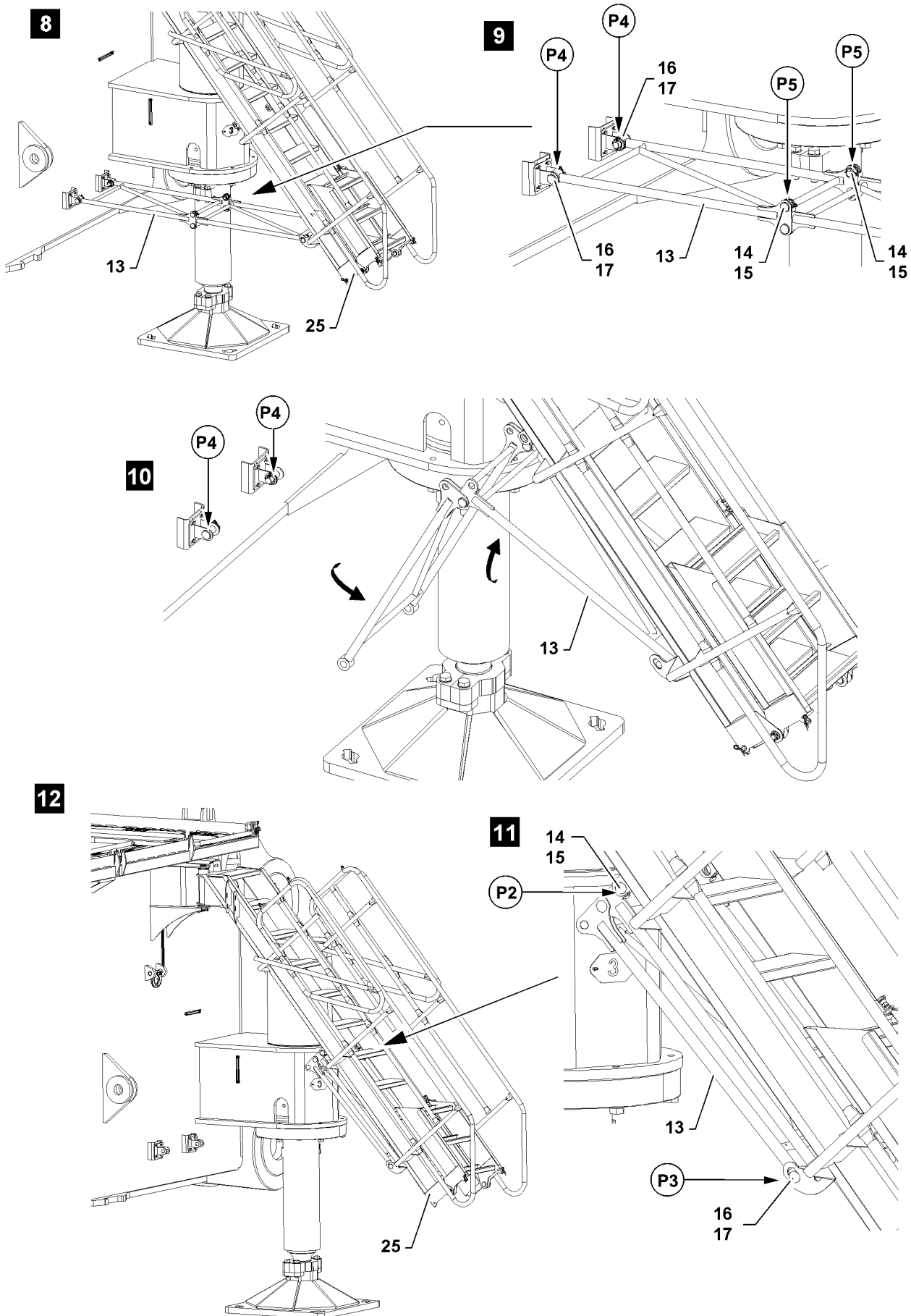

Fig.113136

LWE/LR 13000-001/19503-01-02/en

- ▶ Release the center pin connection in point **P5**: Remove the split pin **14** and unpin the pin **15**, see illustration **9**.



WARNING

Folding components!

The support **13** can fold down by itself due to its own weight when unpinning the pin connection in point **P4**, see illustration **9**!

Personnel can be severely injured!

Fingers and hands can be crushed!

- ▶ For safety reasons, always disassemble the support **13** with **two** people!
 - ▶ When unpinning the pin connection, hold the support **13**!
 - ▶ Do not reach with your hands into the danger zone!
 - ▶ Use personal protective equipment!
-

- ▶ Hold the support **13**.
- ▶ Unpin the support **13** in points **P4**. Remove the split pin **16** and unpin the pin **17**, see illustration **9**.
- ▶ Fold the support **13** in, see illustration **10**.
- ▶ Swing the support **13** until it can be pinned in point **P3**, see illustration **11**.
- ▶ Pin the lower pin connection in point **P3**: Insert the pin **17** and secure with the cotter pin **16**.
- ▶ Swing the support **13** up until it can be pinned in point **P2**.
- ▶ Pin the center pin connection in point **P2**: Insert the pin **15** and secure with the cotter pin **14**.

Result:

- The support **13** is folded in and secured.

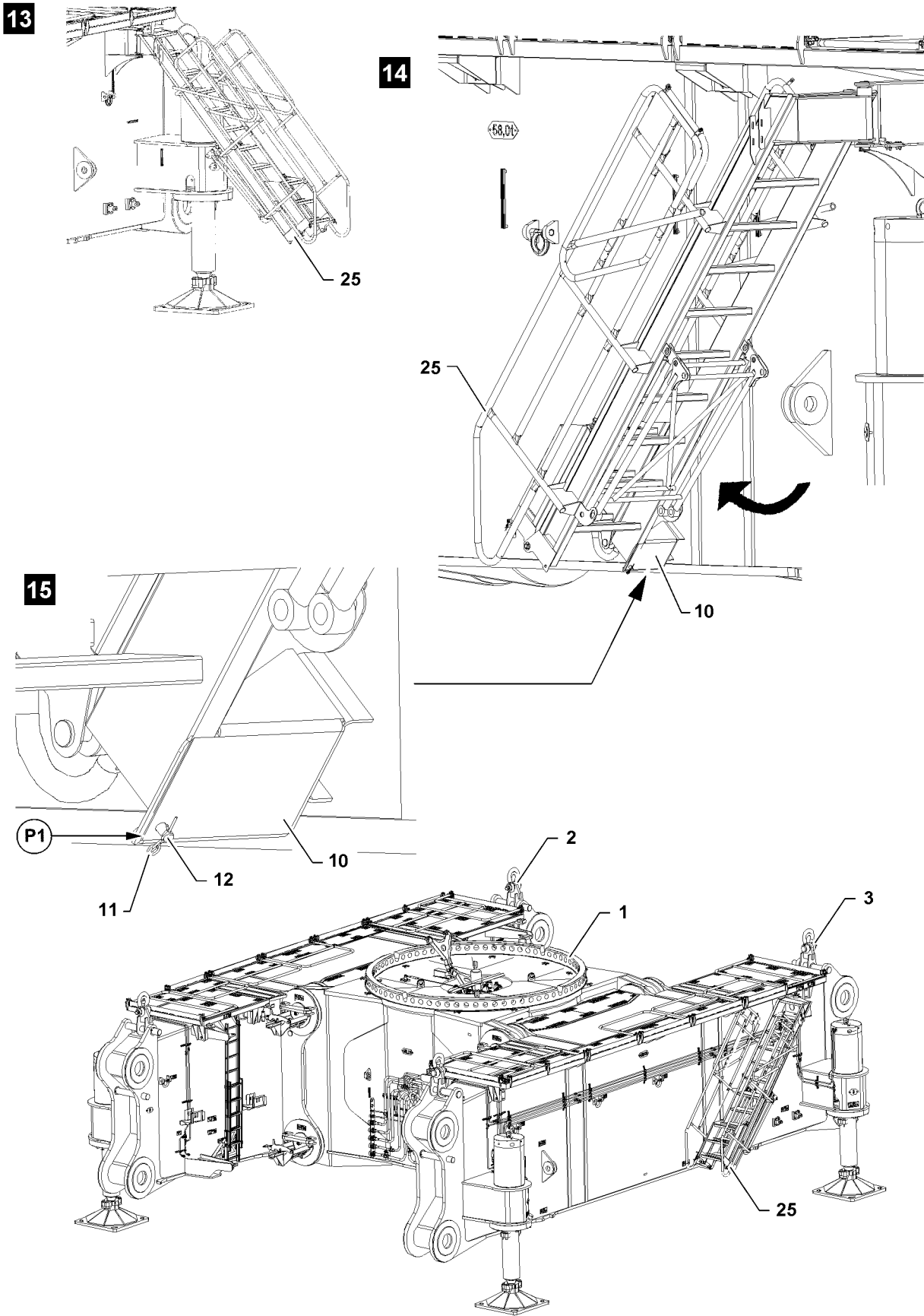

Fig.113137

LWE/LR 13000-001/19503-01-02/en

- ▶ Remove the cotter pin **11** in point **P1** and unpin the pin **12**.



WARNING

Danger of crushed limbs!

When swinging the access ladder **25**, fingers and hands can be crushed!

- ▶ Do not reach with your hands into the danger zone!
-
- ▶ Swing the access ladder **25** from the operating position to the stop, see illustration **14**.
 - ▶ Secure the access ladder **25** in the transport position on the support **10**: Insert the pin **12** in point **P1** and secure with the cotter pin **11**, see illustration **15**.

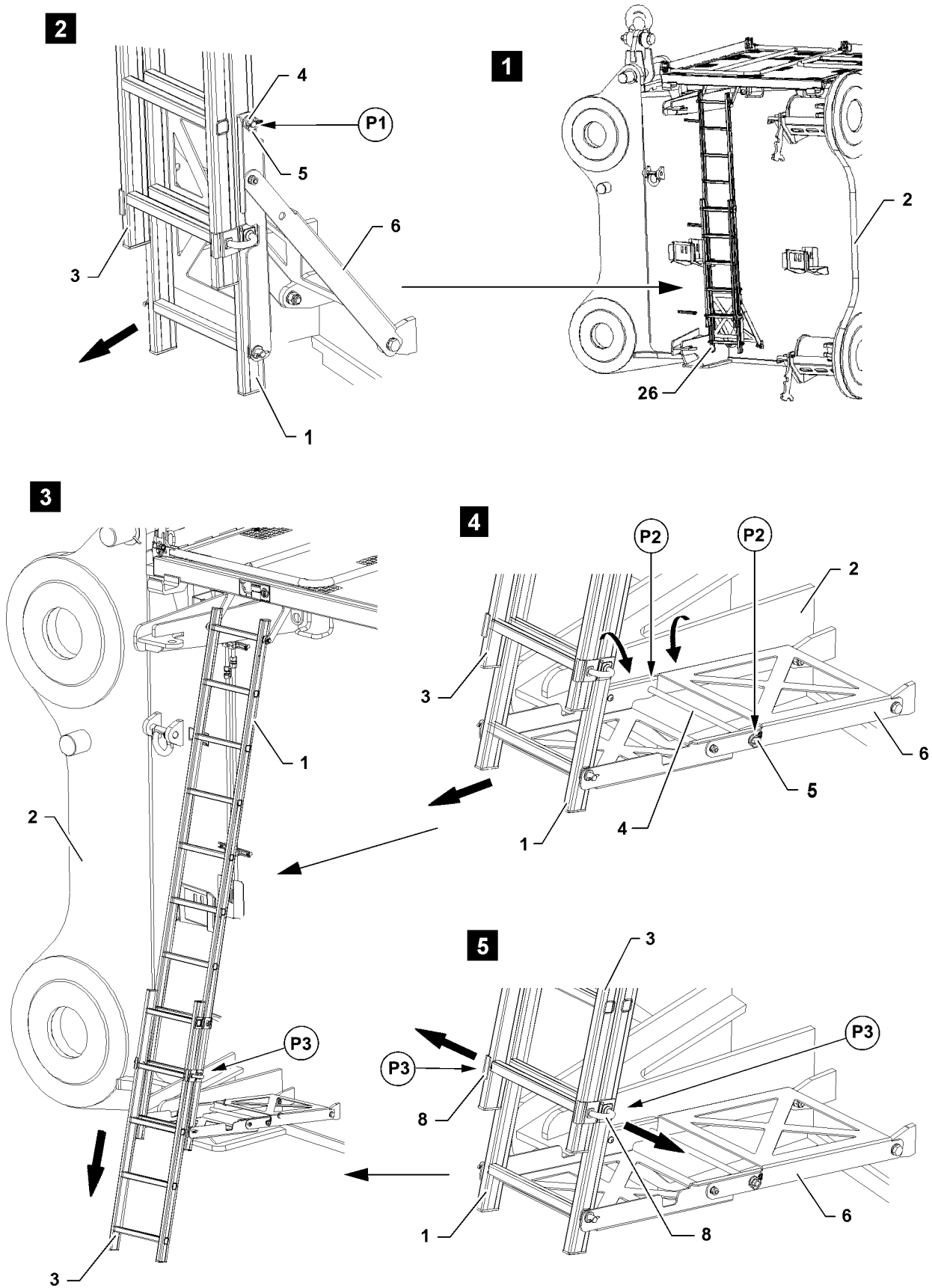

Fig.113128

LWE/LR 13000-001/19503-01-02/en

3.3 Extension ladder on the cross carrier

3.3.1 Swinging the extension ladder on the cross carrier in position for assembly / disassembly

- ▶ Release the extension ladder **26** from the vertical position: Remove the locking pin **5** in point **1** and pull out the rod **4**, see illustration **2**.



WARNING

Danger of crushed limbs!

The folding mechanism **6** can fold down by itself due to its own weight when it is folded out!

Fingers and hands can be crushed!

- ▶ When swinging the access ladder **26**, hold the folding mechanism **6** and fold it down slowly!

- ▶ Swing the extension ladder **26** into position for assembly / disassembly: Fold the folding mechanism **6** out.
- ▶ Insert the rod **4** in points **P2** through the intended bores and secure with the locking pin **5**, see illustration **4**.

Result:

- The folding mechanism **6** is secured.
- ▶ Pull the two sided lock **8** out in points **P3** of the extension ladder and turn to the side, see illustration **5**.



WARNING

Danger of crushed limbs!

The upper ladder section **3** can fall down by itself due to its own weight when pulling the locks **8** out!

Fingers and hands can be crushed!

- ▶ When pulling the locks out **8**, hold the extension ladder **26** and slide it down slowly!

- ▶ Slide the upper ladder section **3** down **three** rungs, see illustration **3**.
- ▶ Engage the two sided lock **8** again in points **P3**.

Result:

- The extension ladder **26** is set up and secured in position for assembly / disassembly.

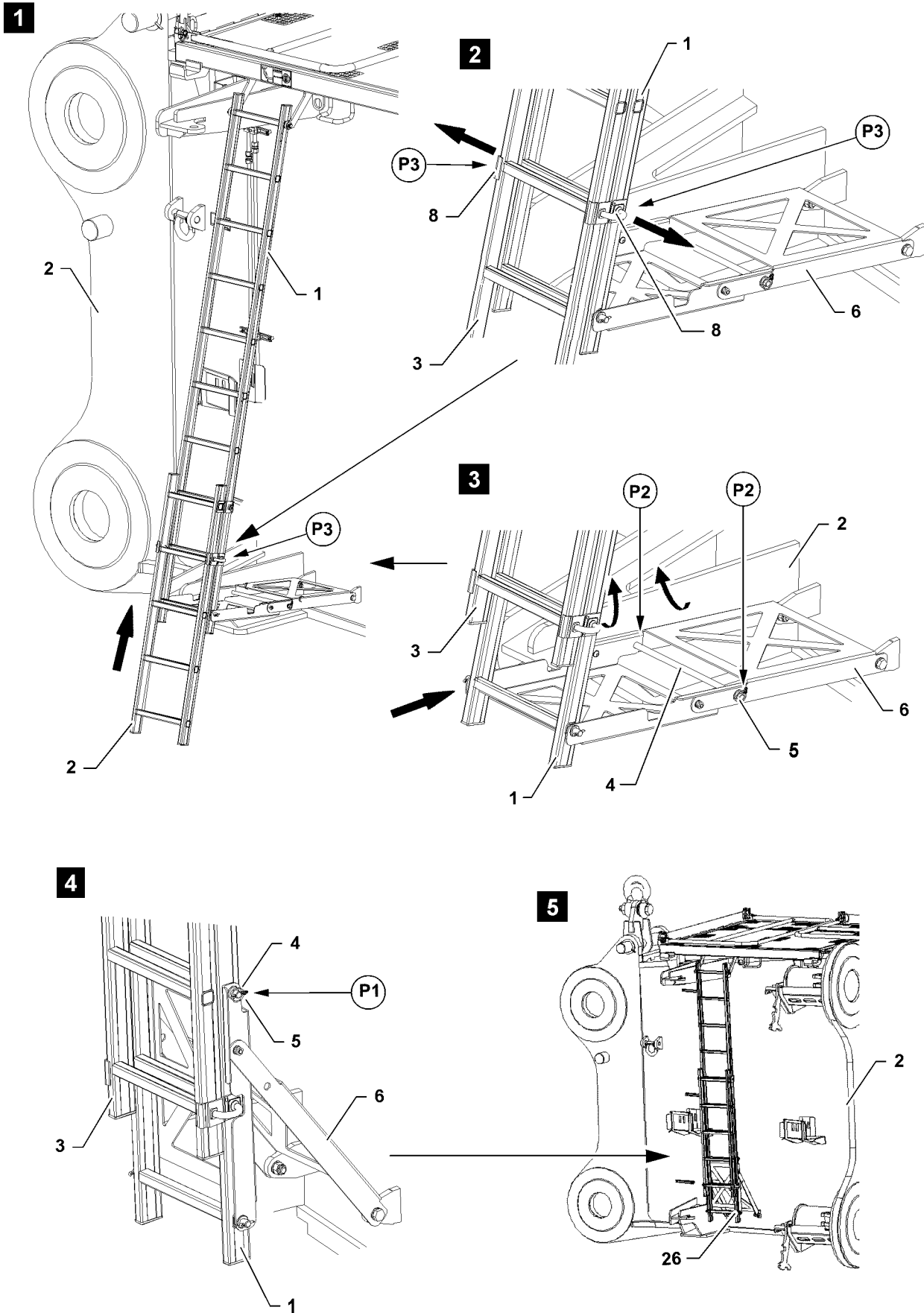

Fig.113129

LWE/LR 13000-001/19503-01-02/en

3.3.2 Swinging the extension ladder on the cross carrier into the vertical position

- ▶ Pull the two sided lock **8** out in points **P3** of the extension ladder and turn to the side, see illustration **2**.



WARNING

Danger of crushed limbs!

When sliding the upper ladder section **3**, fingers and hands can be crushed!

- ▶ Do not reach with your hands into the danger zone!
-
- ▶ Slide the upper ladder section **3** up **three** rungs, see illustration **1**.
 - ▶ Engage the two sided lock **8** again in points **P3**.
 - ▶ Release the extension ladder **26** from the position for assembly / disassembly: Remove the locking pin **5** in point **2** and pull out the rod **4**, see illustration **3**.



WARNING

Danger of crushed limbs!

When folding in the locking mechanism **6**, fingers and hands can be crushed!

- ▶ When swinging the access ladder **26**, hold the folding mechanism **6** and fold it up slowly!
 - ▶ Do not reach with your hands into the danger zone!
-
- ▶ Swing the extension ladder **26** into the vertical position: Fold the folding mechanism **6** in.
 - ▶ Insert the rod **4** in point **P1** through the rungs of the lower ladder section **1** and secure with locking pin **5**, see illustration **4**.

Result:

- The extension ladder **29** is folded in the vertical position and secured.

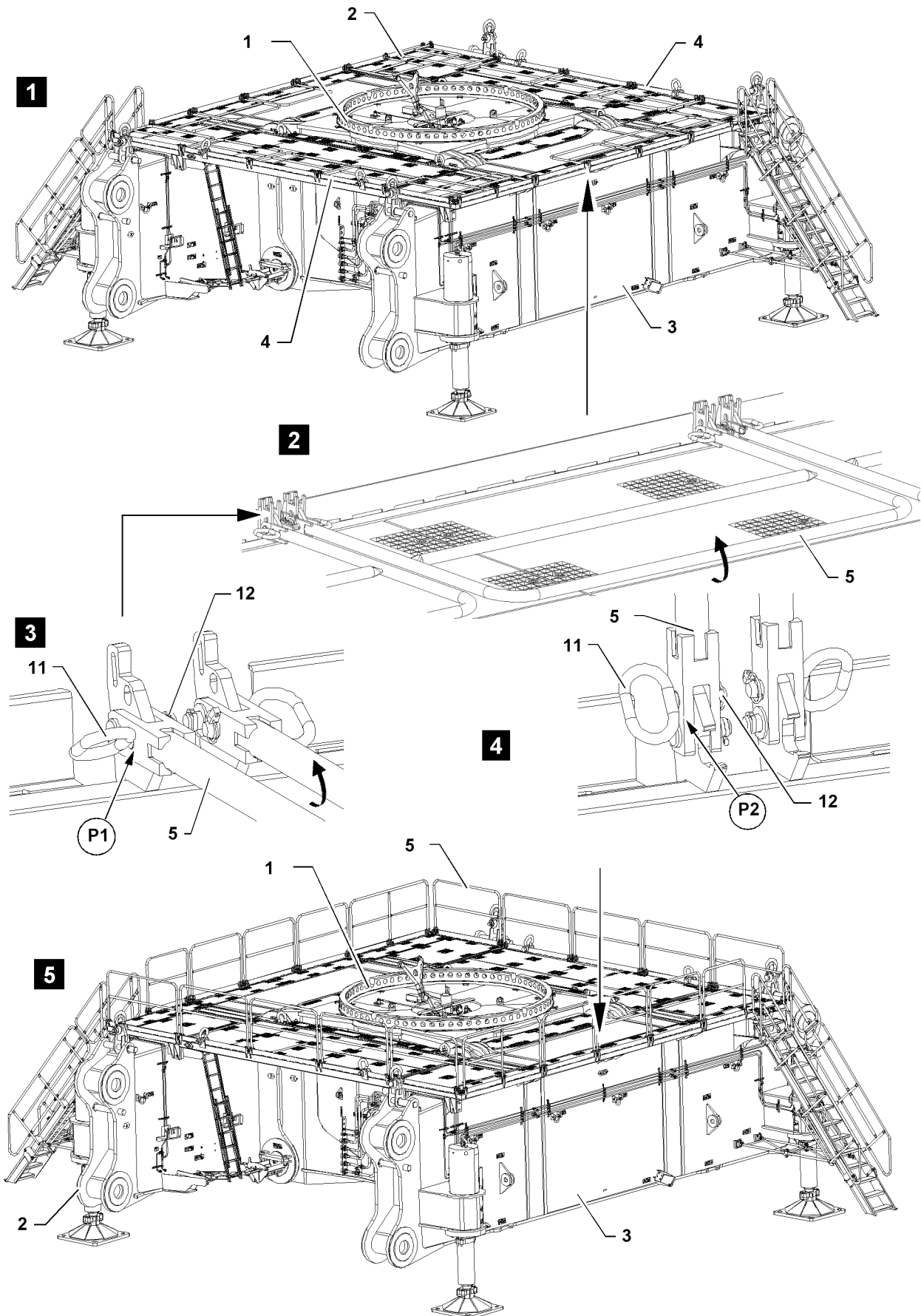

Fig.164528

LWE/LR 13000-001/19503-01-02/en

3.4 Railings on crawler center section with cross carriers

3.4.1 Swinging the railings on the crawler center section with cross carriers into the operating position

Make sure that the following prerequisites are met:

- The catwalks **4** are properly installed, see illustration **1**.
- The folding frames on the catwalks are swung out.



WARNING

Danger of falling!

During assembly and disassembly of the railing, personnel must be secured with appropriate aids to prevent them from falling!

Even during the assembly of protective devices there is a danger of falling!

Assembly personnel can fall and be severely injured or killed!

- ▶ Use personal protective equipment!



WARNING

The grating flap is open!

If the grating flap is open on the catwalks, there is a danger that personnel fall down!

Personnel can be severely injured or killed!

- ▶ Make sure that all grating flaps on the catwalks are closed!
- ▶ Release the railing **5** from the transport position: Remove the spring retainer **12** in point **P1** and unpin the connector **11**, see illustration **3**.



WARNING

Danger of crushed limbs!

When swinging the railings **5**, fingers and hands can be crushed!

- ▶ Do not reach with your hands into the danger zone!
- ▶ Swing the railing **5** into the operating position.
- ▶ Secure the railing **5** in the operating position: Pin the connector **11** in point **P2** and secure with the spring retainer **12**, see illustration **4**.
- ▶ Swing all railings **5** into the operating position, see illustration **5**.

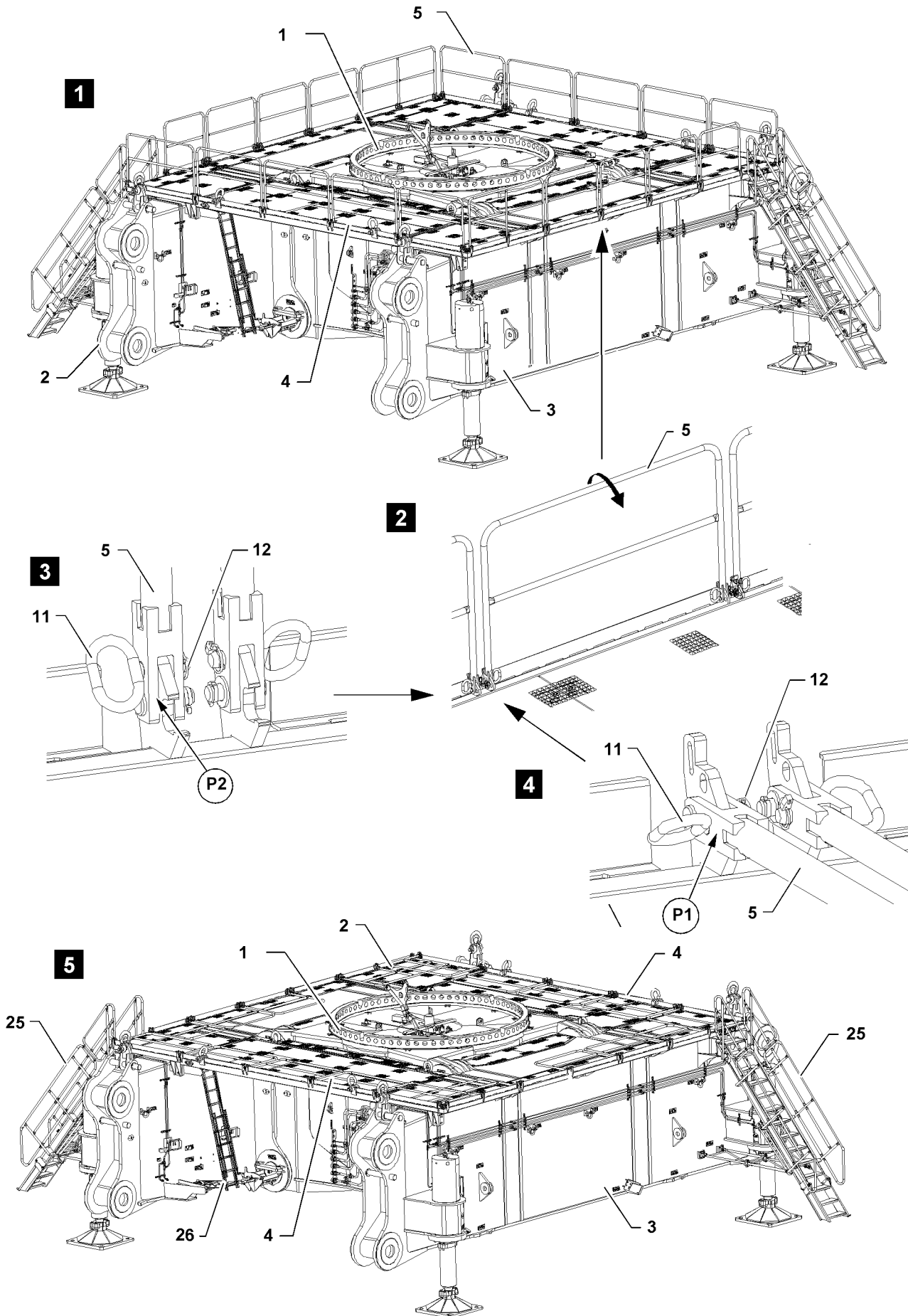

Fig.164529

LWE/LR 13000-001/19503-01-02/en

3.4.2 Swinging the railings on the crawler center section with cross carriers into the transport position

Make sure that the following prerequisite is met:

- Both crawler carriers are removed.



WARNING

Danger of falling!

During assembly and disassembly of the railing, personnel must be secured with appropriate aids to prevent them from falling!

There is a danger of falling even during the disassembly of protective devices!

Assembly personnel can fall and be severely injured or killed!

- ▶ Use personal protective equipment!



WARNING

The grating flap is open!

If the grating flap is open on the catwalks, there is a danger that personnel fall down!

Personnel can be severely injured or killed!

- ▶ Make sure that all grating flaps are closed!



WARNING

Danger of crushed limbs!

The railing **5** can swing down by itself due to its own weight when it is unpinned!

Fingers and hands can be crushed!

- ▶ Before unpinning, hold the railing and swing it down slowly!
- ▶ Release the railing **5** from the operating position: Remove the spring retainer **12** in point **P2** and unpin the connector **11**, see illustration **3**.
- ▶ Swing the railing **5** into the transport position.
- ▶ Secure the railings **5** in the transport position: Pin the connector **11** in point **P1** and secure with the spring retainer **12**, see illustration **4**.
- ▶ Swing all railings **5** into the transport position, see illustration **5**.

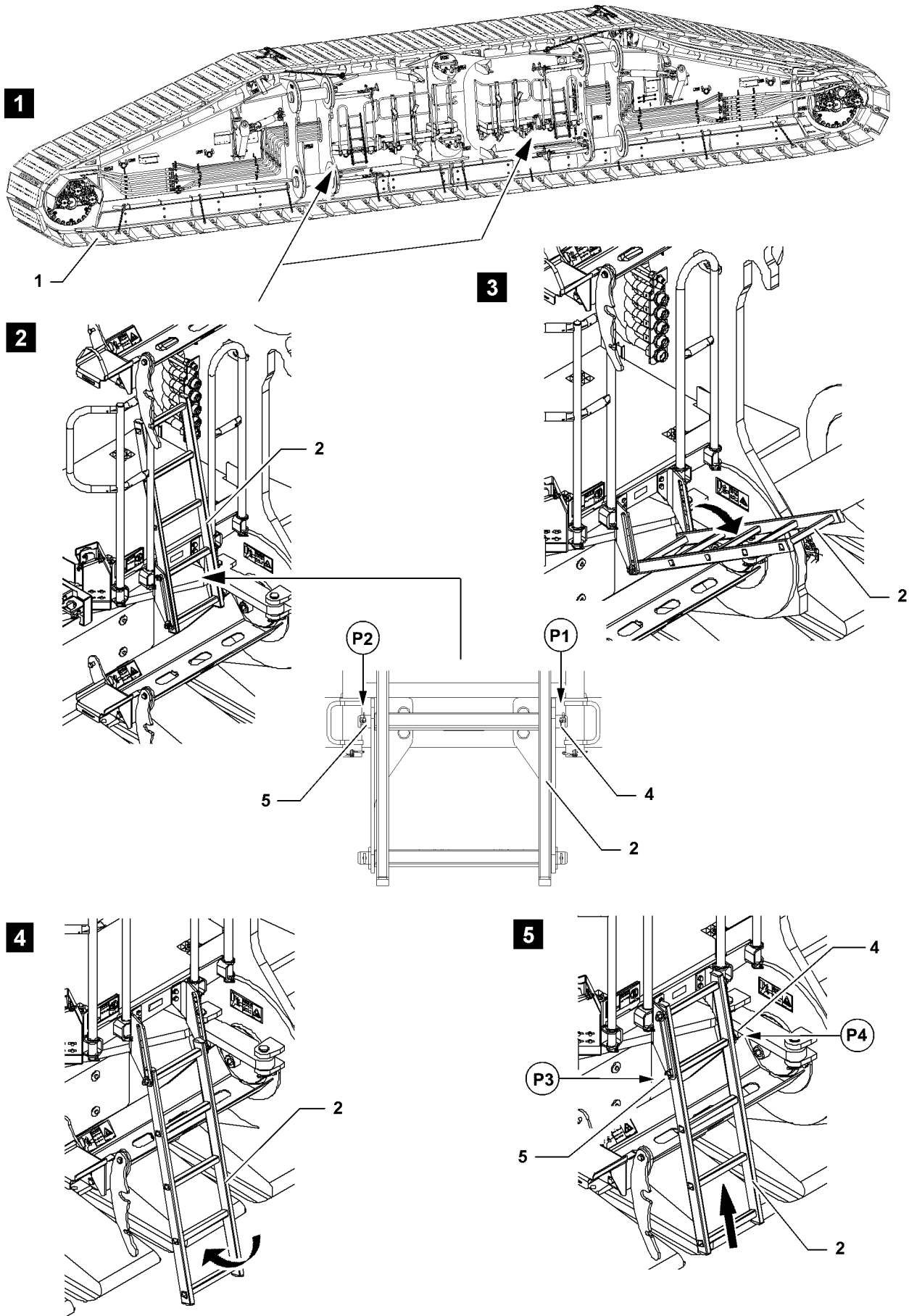

Fig.113138

3.5 Ladder on the crawler carrier

3.5.1 Swinging the ladder on the crawler carrier into position for assembly / disassembly



WARNING

Folding ladder!

The ladder **2** can fold down due to its own weight when swinging it!

Personnel can be severely injured!

Fingers and hands can be crushed!

▶ Hold the ladder **2** when swinging it and slowly fold it out downward!

▶ Remove the locking pin **4** in point **P1** and unpin the pin **5** in point **P2**, see illustration **2**.

▶ Hold the ladder **2** and slowly fold it out downward, see illustration **3**.

▶ Slide the ladder **2** up to the stop, see illustration **5**.



WARNING

Danger of falling!

If the pin **5** is not inserted and secured, then the ladder **2** can swing in when the assembly personnel climbs up!

Assembly personnel can fall and be severely injured!

▶ Make sure that the pin **2** is inserted and secured with the safety locking pin **4**!

▶ Insert the pin **5** in point **P3** through the rungs of the ladder **2** and secure with the safety locking pin **4** in point **P4**, see illustration **5**.

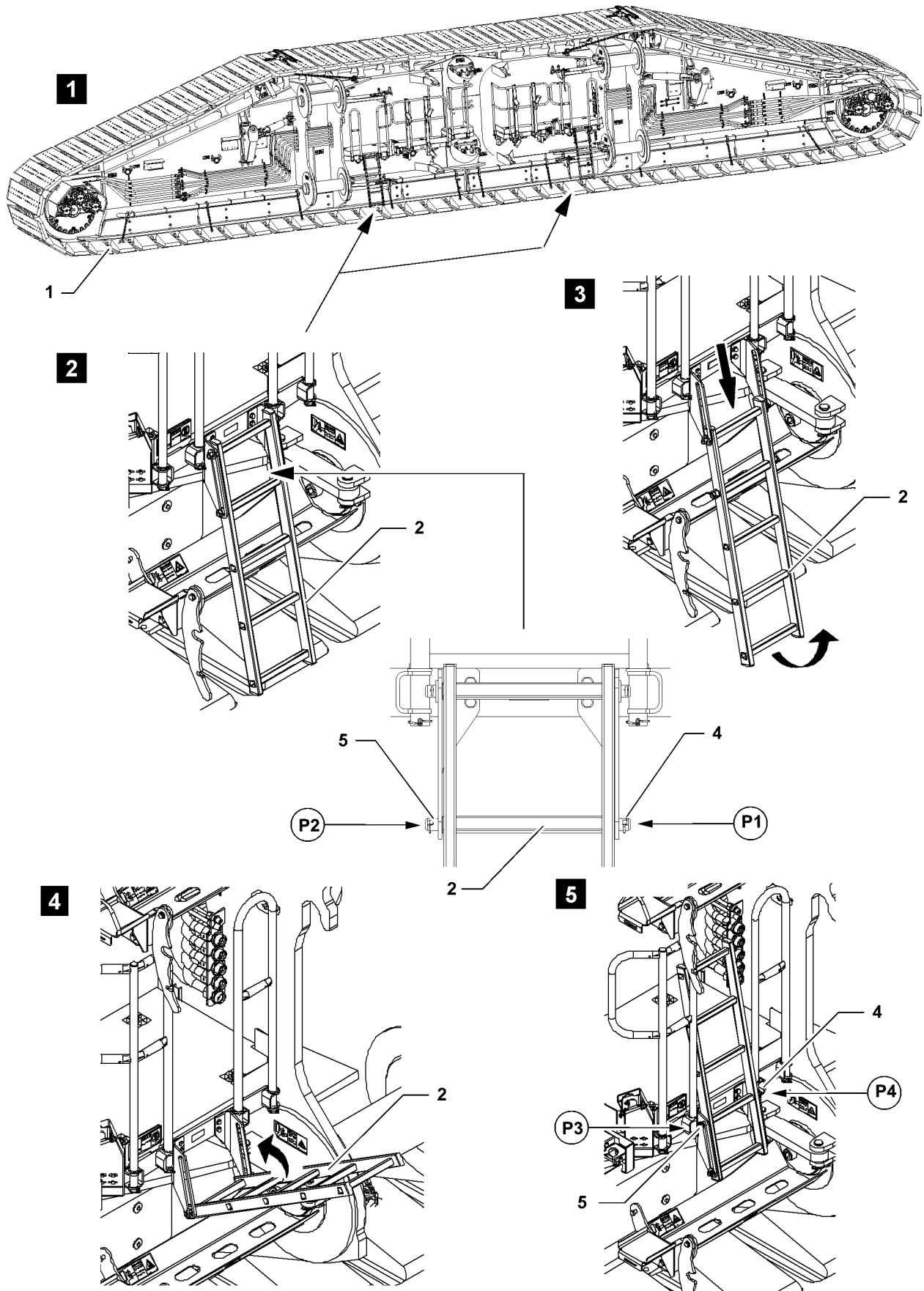

Fig.113139

3.5.2 Swinging the ladder on the crawler carrier into the transport position

**WARNING**

Danger of crushed limbs!

The ladder **2** can fall down by itself due to its own weight when it is unpinned!

Fingers and hands can be crushed!

▶ Before unpinning, hold the ladder and lower it slowly!

- ▶ Hold the ladder **2**.
- ▶ Remove the locking pin **4** in point **P1** and unpin the pin **5** in point **P2**, see illustration **2**.
- ▶ Set the ladder **2** down to the stop, see illustration **3**.

**WARNING**

Folding ladder!

If the ladder **2** is not held in the „top“ position, then it can fold down uncontrolled!

Personnel can be severely injured!

Fingers and hands can be crushed!

▶ Hold the ladder **2** on „top“ until the pin is inserted and secured!

- ▶ Fold the ladder **2** slowly in upward and hold, see illustration **5**.
- ▶ Insert the pin **5** in point **P3** through the rungs of the ladder **2** and secure with the safety locking pin **4** in point **P4**, see illustration **5**.

Fig.195219

LWE/LR 13000-001/19503-01-02/en

4 Fall protection equipment and ladders on the crane superstructure



WARNING

When working at a height, there is a danger of falling!

- ▶ Properly assemble and secure all fall protection equipment, such as platforms, catwalks, ladders and railings on the crane chassis.
-



WARNING

Danger of accident!

If the following notes are not observed, the ladder can tip and assembly personnel can fall from the ladder with danger of fatal injury!

- ▶ Replace damaged ladders immediately!
 - ▶ The ladder must be set up stable and safely accessible!
 - ▶ For the safe handling of the ladder, observe the safety instructions on the ladder!
-



CAUTION

Danger of crushed limbs!

When assembling / disassembling fall protection equipment and ladders, limbs can be crushed!

- ▶ Do not reach with your hands into the danger zone!
 - ▶ Swing the fall protection equipment and the ladders especially carefully!
-

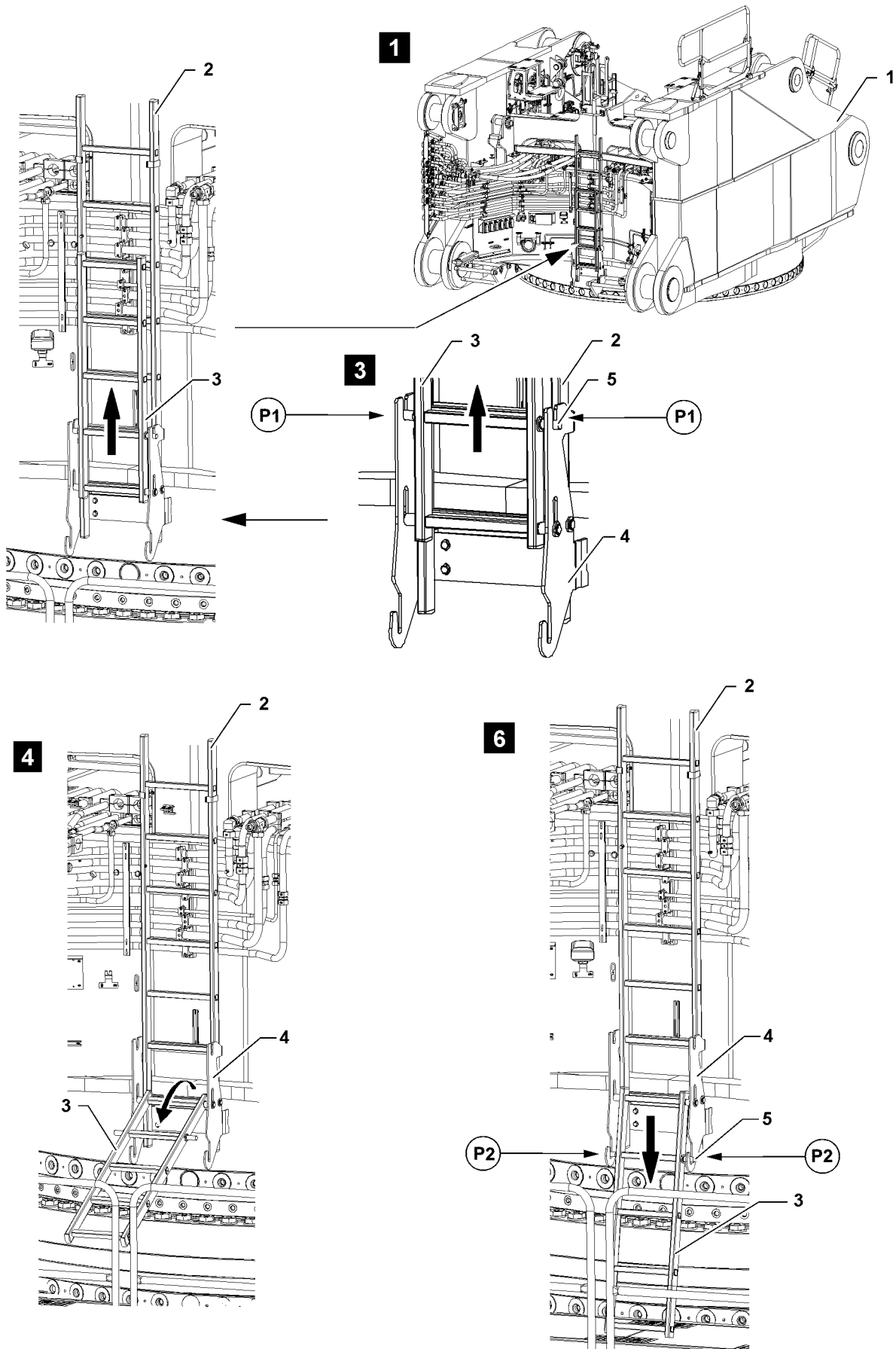

Fig.113145

LWE/LR 13000-001/19503-01-02/en

4.1 Ladder on the turntable frame front section

4.1.1 Folding the ladder on the turntable frame front section out into the operating position



WARNING

Folding ladder!

If the ladder **3** is not held when pulling it from the pockets in points **P1**, then it can fall down by itself due to its own weight!

Personnel can be severely injured!

Fingers and hands can be crushed!

▶ When pulling the ladder **3** from the pockets in points **P1**, the ladder must be held to prevent it from falling down!

- ▶ Slide the ladder **3** from the pockets on the ladder mount **4** in points **P1** upward, see illustration 3.
- ▶ Hold the ladder **3** and slowly fold it out downward, see illustration 4.
- ▶ Guide the ladder **3** with the pipe **5** in the pockets on the ladder mount **4** in points **P2**, see illustration 5.

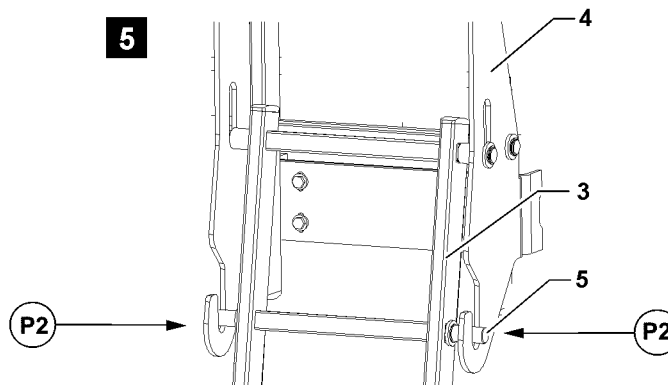

Fig.113147: Ladder in the operating position

- ▶ Set the ladder **3** down to the stop, see illustration 5 and illustration 6.

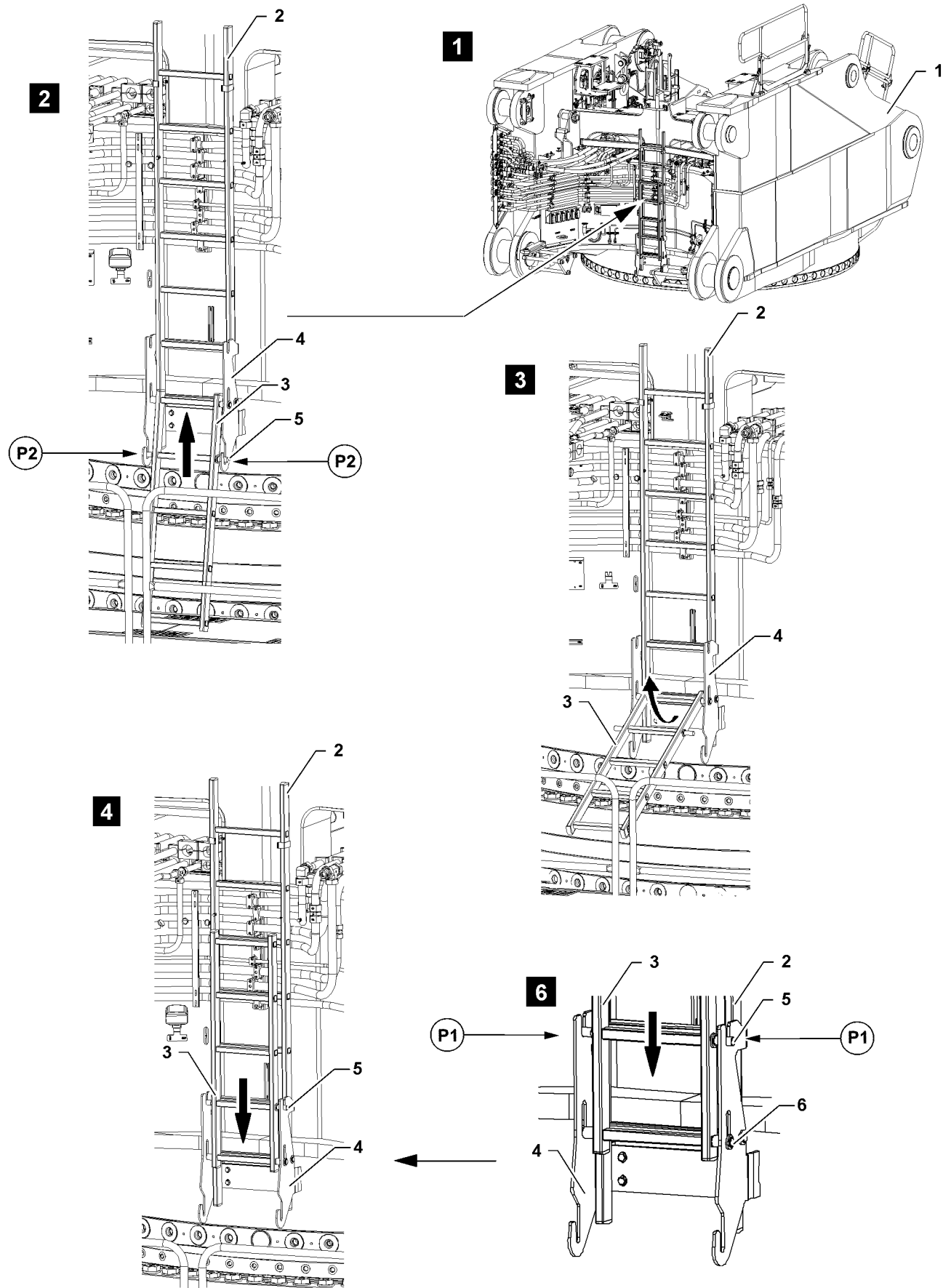

Fig.113146

LWE/LR 13000-001/19503-01-02/en

4.1.2 Folding the ladder on the turntable frame front section into the transport position

- ▶ Slide the ladder **3** from the pockets on the ladder mount **4** in points **P2** upward, see illustration **2**.



WARNING

Folding ladder!

The ladder **3** can fall down due to its own weight when folding it in!

Personnel can be severely injured!

Fingers and hands can be crushed!

- ▶ When folding the ladder **3** in, it must be held to prevent it from falling down!

- ▶ Hold the ladder **3** and slowly fold it in upward, see illustration **3**.
- ▶ Guide the ladder **3** with the pipe **5** in the pockets on the ladder mount **4** in points **P1**, see illustration **5**.

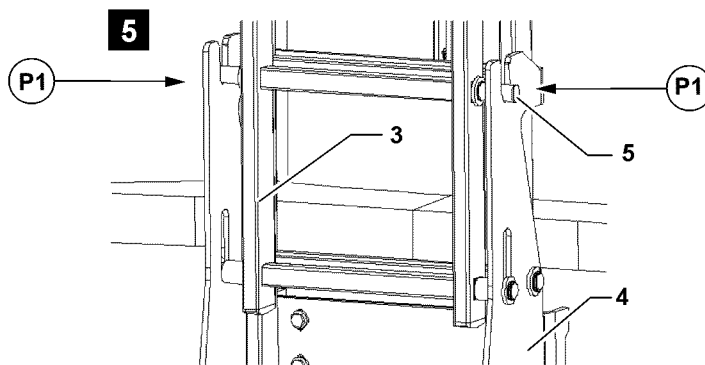

Fig.113148: Ladder in the transport position

- ▶ Set the ladder **3** down to the stop, see illustration **5** and illustration **6**.

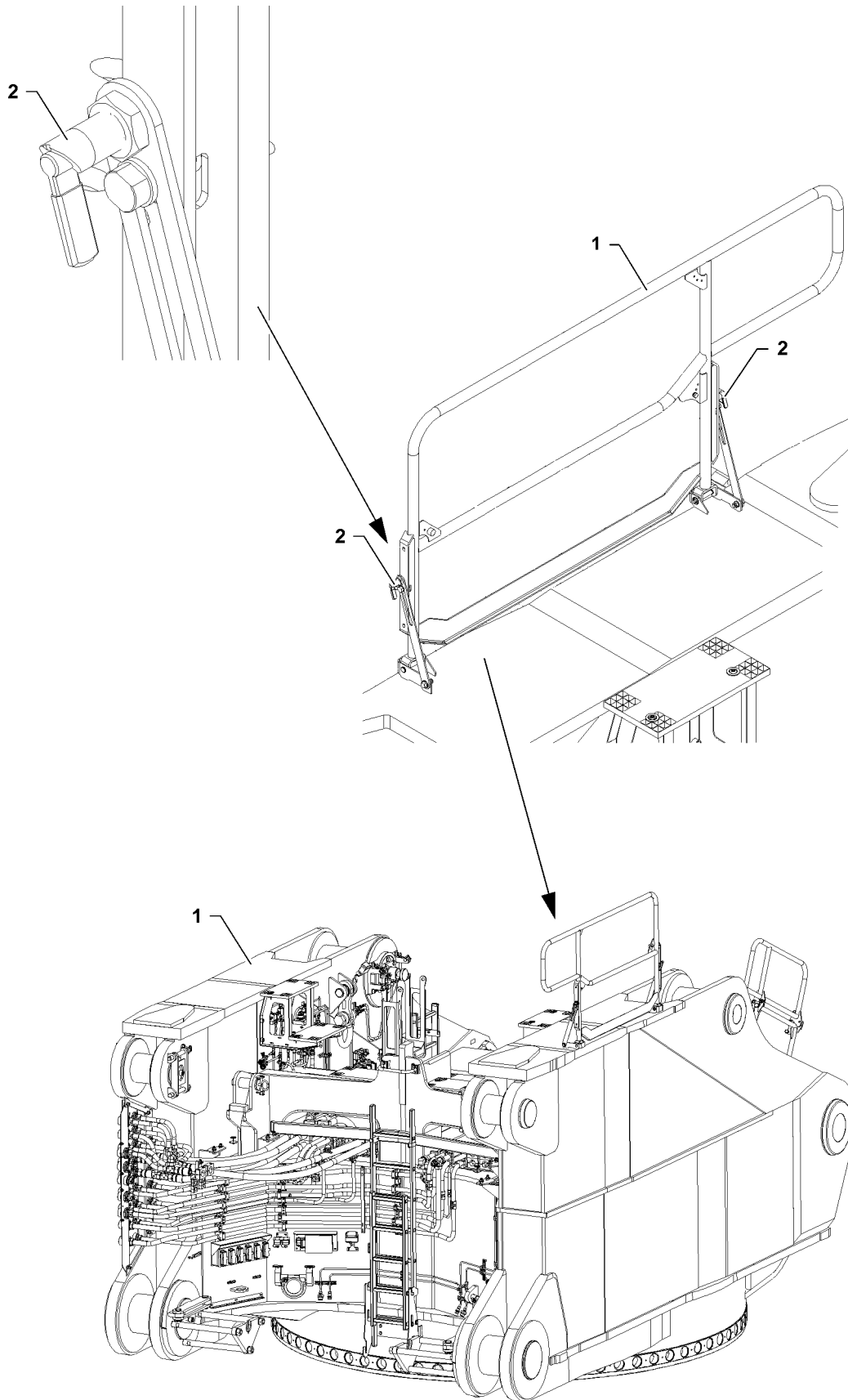

Fig.113625

LWE/LR 13000-001/19503-01-02/en

4.2 Railing on the turntable frame front section

4.2.1 Swinging the railing on the turntable frame front section into the operating position



WARNING

Danger of falling!

During assembly and disassembly of the railing, personnel must be secured with appropriate aids to prevent them from falling!

Even during the assembly of protective devices there is a danger of falling!

Assembly personnel can fall and be severely injured or killed!

▶ Use personal protective equipment!

▶ Release the railing **1** from the transport position: Release the clamping lever **2**.



WARNING

Danger of crushed limbs!

When swinging the railings **1**, fingers and hands can be crushed!

▶ Do not reach with your hands into the danger zone!

▶ Swing the railing **1** into the operating position.

▶ Secure the railing **1** in the operating position: Lock the clamping lever **2**.

4.2.2 Swinging the railing on the turntable frame front section into the transport position



WARNING

Danger of falling!

During assembly and disassembly of the railing, personnel must be secured with appropriate aids to prevent them from falling!

There is a danger of falling even during the disassembly of protective devices!

Assembly personnel can fall and be severely injured or killed!

▶ Use personal protective equipment!



WARNING

Danger of crushed limbs!

The railing **1** can swing down by itself due to its own weight when the locking lever is released!

Fingers and hands can be crushed!

▶ Before unpinning, hold the railing and swing it down slowly!

▶ Release the railing **1** from the operating position: Release the clamping lever **2**.

▶ Swing the railing **1** into the transport position.

▶ Secure the railings **1** in the transport position: Lock the clamping lever **2**.

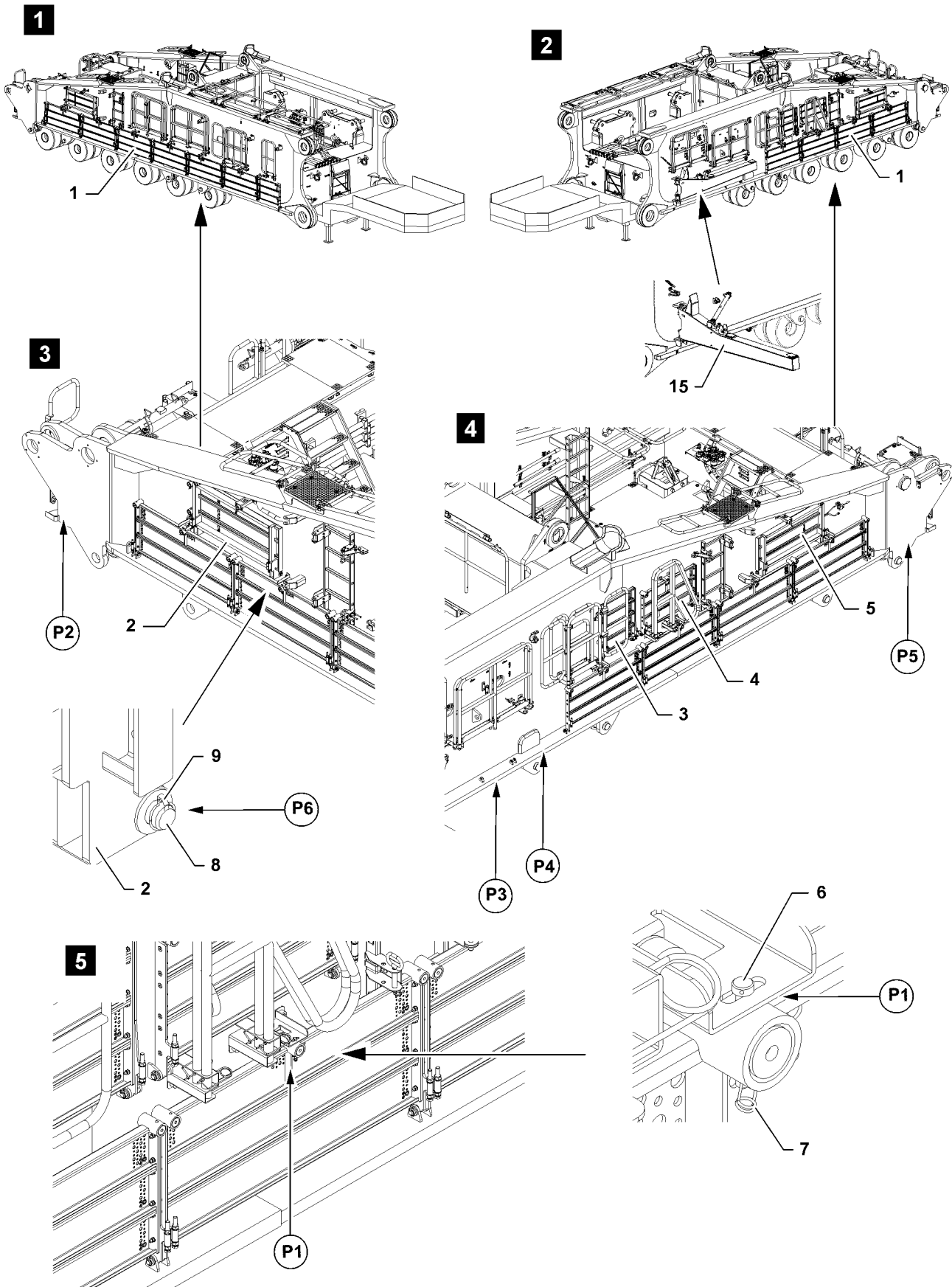

Fig.113621

LWE/LR 13000-001/19503-01-02/en

4.3 Platforms on the turntable frame rear section

4.3.1 Assembling the platforms on the turntable frame rear section

Make sure that the following prerequisite is met:

- The bracket **15** is folded out in the operating position.



WARNING

Folding down of the platform!

If the platform **1** folds down by itself, then personnel can be severely injured or killed!

- ▶ Fold the platform **1** carefully by hand!
 - ▶ Make sure that there is no one under the platform **1** during the folding procedure!
-
- ▶ Unpin the platforms **1** from the transport position: Remove the spring retainer **7** in point **P1** and unpin the connector **6**, see illustration **5**.
 - ▶ Fold the platforms **1** into the horizontal position.
 - ▶ Pin the connector **6** in point **P1** and secure with the spring retainer **7**.
 - ▶ Release the platform in the transport position, see illustration **3**: remove the spring retainer **2** in point **P1** and unpin the connector **6**, see illustration **5**.
 - ▶ Fold the platform **2** into the horizontal position.
 - ▶ Unpin the platform **2**: Remove the locking pin **9** in point **P6** and unpin the pin **8**, see illustration **3**.
 - ▶ Pin the platform **2** in point **P2** on the mounting lugs: Insert the pin **8** and secure with the locking pin **9**.



Note

- ▶ The assembly of the platform **3**, platform **4** and platform **5** is the same as the working steps for the platform **2**, see illustration **4**!
-
- ▶ Install platform **3** in point **P3**, platform **4** in point **P4** and platform **5** in point **P5**.

4.3.2 Disassembling the platforms on the turntable frame rear section

Make sure that the following prerequisite is met:

- All railings have been removed.
- ▶ Unpin the platform **2** from the operating position in point **P2** on the mounting lugs: Remove the locking pin **9** and unpin the pin **8**, see illustration **3**.
- ▶ Pin the platform **2** in the transport position: Insert the pin **8** and secure with the locking pin **9**.
- ▶ Fold the platform **2** into the vertical position.



WARNING

Folding down of the platform!

If the platform **2** folds down by itself, then personnel can be severely injured or killed!

- ▶ Fold the platform **2** carefully by hand!
 - ▶ Make sure that the platform is secured after the folding procedure!
-
- ▶ Pin the platform **2**: Pin the connector **6** in point **P1** and secure with the spring retainer **7**, see illustration **5**.



Note

- ▶ The disassembly of the platform **3**, platform **4** and platform **5** is the same as the working steps for the platform **2**, see illustration **4**!
-
- ▶ Remove platform **3**, platform **4**, platform **5**.
 - ▶ Fold the platforms **1** into the vertical position.



WARNING

Folding down of the platform!

If the platform **1** folds down by itself, then personnel can be severely injured or killed!

- ▶ Fold the platform **1** carefully by hand!
 - ▶ Make sure that the platform is secured after the folding procedure!
-
- ▶ Secure the platforms **1** in the transport position: Pin the connector **6** in point **P1** and secure with the spring retainer **7**, see illustration **5**.

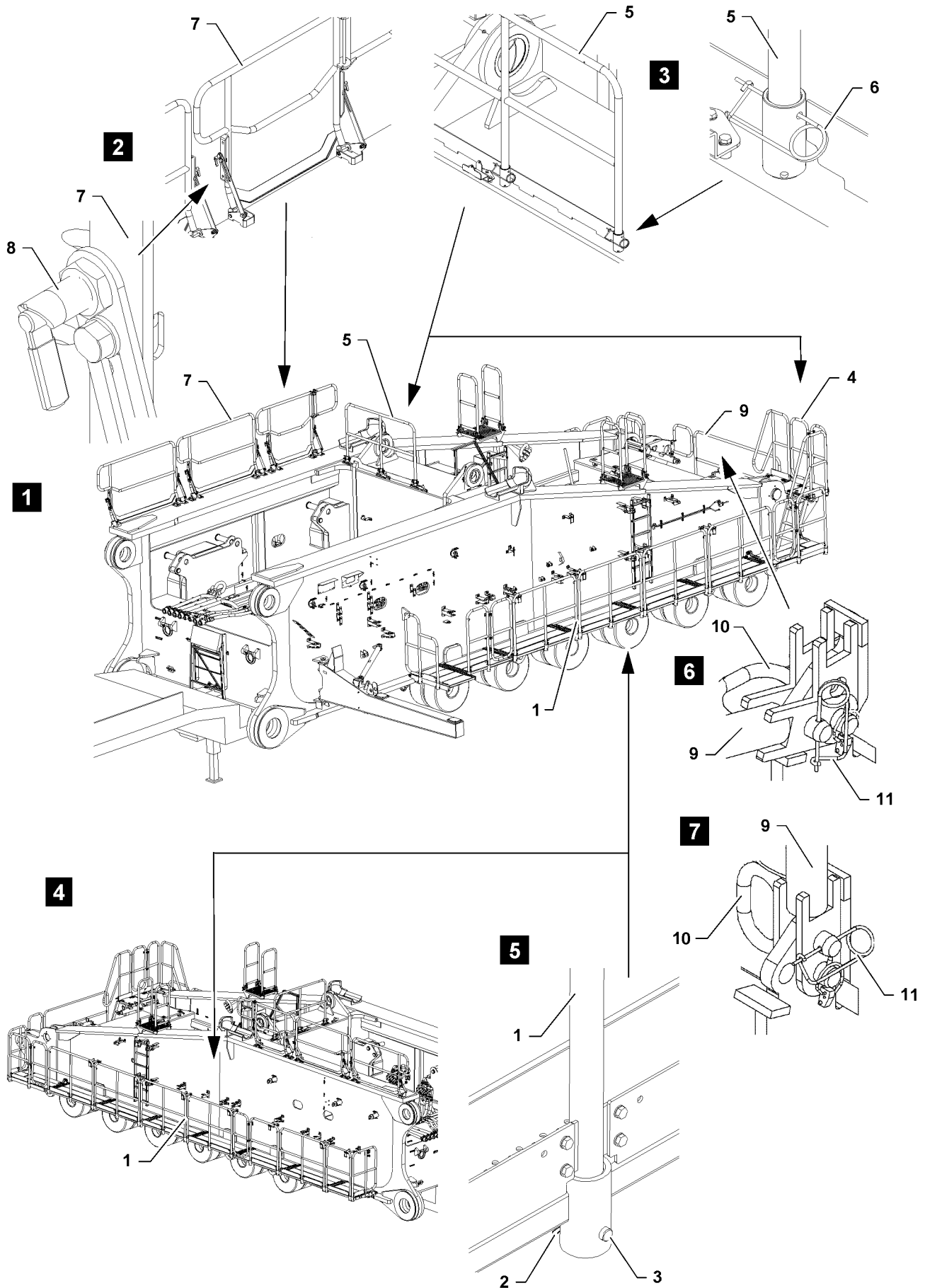

Fig.113627

LWE/LR 13000-001/19503-01-02/en

4.4 Railings on the turntable frame rear section

4.4.1 Swinging the railing on the turntable frame rear section into the operating position



WARNING

Danger of falling!

During assembly and disassembly of the railing, personnel must be secured with appropriate aids to prevent them from falling!

Even during the assembly of protective devices there is a danger of falling!

Assembly personnel can fall and be severely injured or killed!

- ▶ Use personal protective equipment!



WARNING

Danger of crushed limbs!

When swinging the railings, fingers and hands can be crushed!

- ▶ Do not reach with your hands into the danger zone!

Assembling the railing on the catwalk in the operating position

- ▶ Release the railing **1** on the retainers on the turntable frame rear section.
- ▶ Insert the railing **1** into the receptacles on the platforms.
- ▶ Pin the railing **1** with pins **3** on the platforms and secure with spring retainers **2**, see illustration **4** and illustration **5**.

Swinging the railing (on top) into the operating position

- ▶ Release the railing (on top) **7** from the transport position: Release the clamping lever **8**.
- ▶ Swing the railing (on top) **7** into the operating position.
- ▶ Secure the railing (on top) **7** in the operating position: Lock the clamping lever **8**, see illustration **2**.

Swinging the railing (on top) and (rear) into the operating position

- ▶ Release the railing (on top) **5** and railing (rear) **4** from the transport position.
- ▶ Insert the railing (on top) **5** and railing (rear) **4** in the receptacles.
- ▶ Secure the railing (on top) **5** and railing (rear) **4** with spring retainers **6**, see illustration **3**.

Swinging the railing (rear) into the operating position

- ▶ Release the railing (rear) **9** from the transport position: Remove the spring retainer **11** and unpin the connector **10**, see illustration **6**.
- ▶ Swing the railing (rear) **9** into the operating position.
- ▶ Secure the railing (rear) **9** in the operating position: Pin the connector **10** and secure with spring retainer **11**, see illustration **7**.

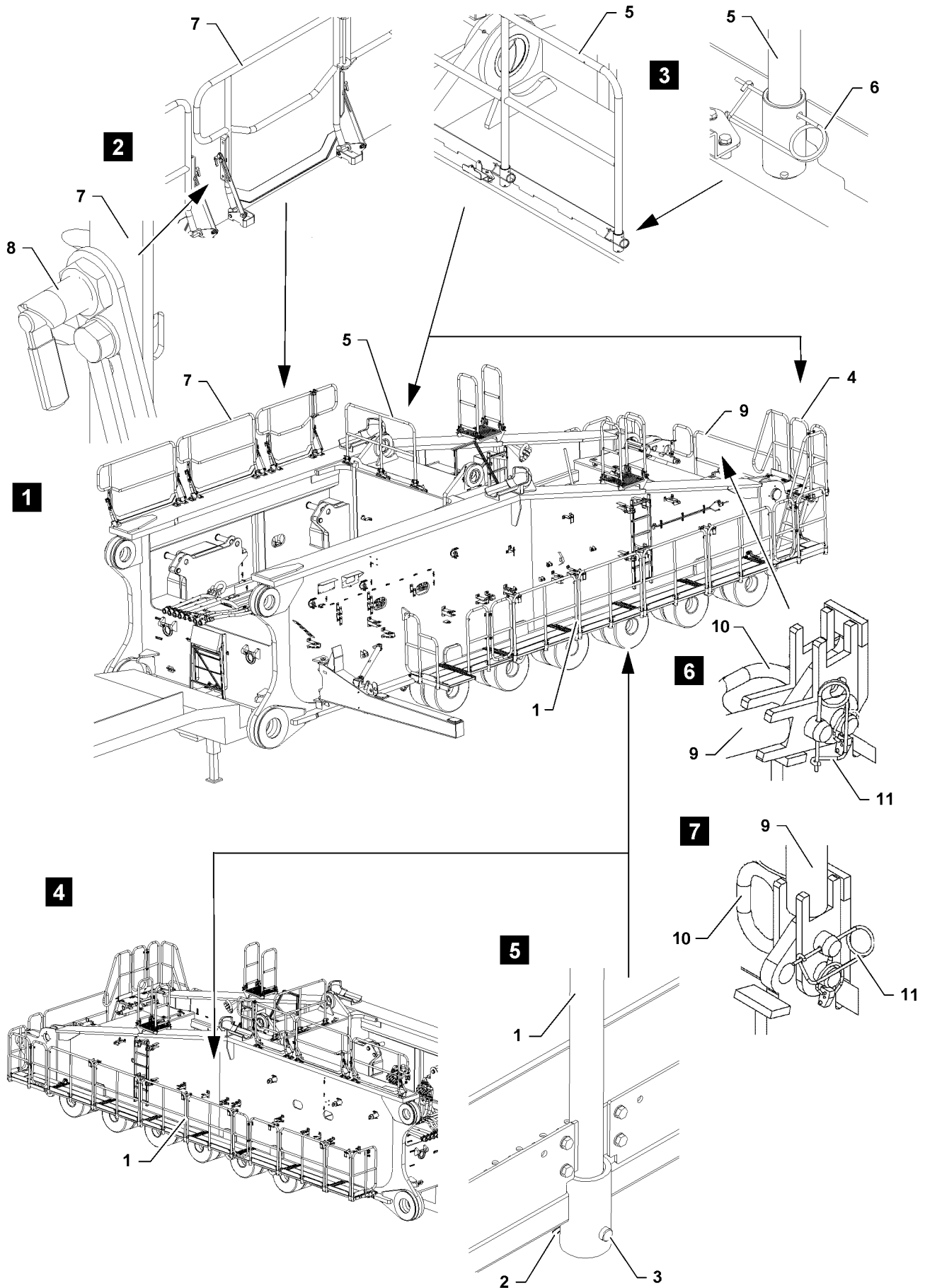

Fig.113627

LWE/LR 13000-001/19503-01-02/en

4.4.2 Swinging the railing on the turntable frame rear section into the transport position



WARNING

Danger of falling!

During assembly and disassembly of the railing, personnel must be secured with appropriate aids to prevent them from falling!

There is a danger of falling even during the disassembly of protective devices!

Assembly personnel can fall and be severely injured or killed!

- ▶ Use personal protective equipment!



WARNING

Danger of crushed limbs!

The railing can swing down by itself due to its own weight when it is unpinned!

Fingers and hands can be crushed!

- ▶ Before unpinning, hold the railing and swing it down slowly!

Disassembling the railing on the catwalk in the transport position

- ▶ Unpin the railing **1**: Remove the spring retainers **2** and unpin the pin **3**, see illustration **4** and illustration **5**.
- ▶ Pull the railing **1** from the platforms.
- ▶ Attach the railing **1** on the retainers on the turntable frame rear section.

Swinging the railing (on top) into the transport position

- ▶ Release the railing (on top) **7** from the operating position: Release the clamping lever **5**, see illustration **2**.
- ▶ Swing the railing (on top) **7** into the transport position.
- ▶ Secure the railing (on top) **7** in the transport position: Lock the clamping lever **8**.

Swinging the railing (on top) and (rear) into the transport position

- ▶ Unpin the railing (on top) **5** and railing (rear) **4**: Remove the spring retainers **6**, see illustration **3**.
- ▶ Pull the railing (on top) **5** and railing (rear) **4** from the platforms.
- ▶ Attach the railing (on top) **5** and railing (rear) **4** on the retainers on the turntable.

Swinging the railing (rear) into the transport position

- ▶ Release the railing (rear) **9** from the operating position: Remove the spring retainer **11** and unpin the connector **10**, see illustration **7**.
- ▶ Swing the railing (rear) **9** into the transport position.
- ▶ Secure the railing (rear) **9** in the transport position: Pin the connector **10** and secure with spring retainer **11**, see illustration **6**.

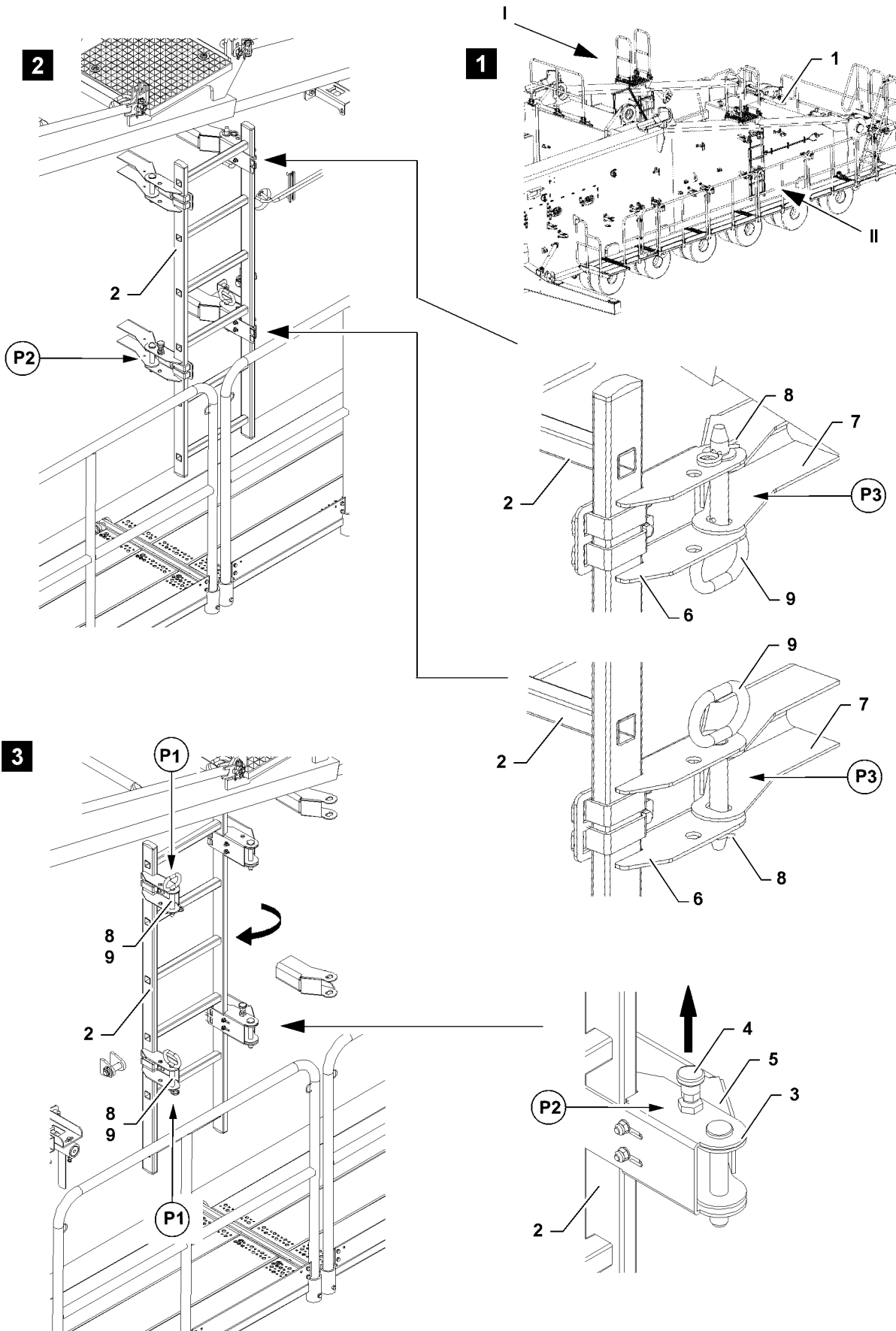

Fig.113150

LWE/LR 13000-001/19503-01-02/en

4.5 Ladder on the turntable frame rear section



Note

- ▶ The assembly and disassembly of the two ladders is identical and is described based on the example of one ladder, see illustration 1!

4.5.1 Folding the ladder on the turntable frame rear section out into the operating position

- ▶ Remove the cotter pin **8** and unpin the grip pin **9** in points **P1** from the parking position, see illustration 2.
- ▶ Release the ladder **2** from the transport position: Pull the detent pin **4** up in point **P2**, see illustration 2.



WARNING

Danger of crushed limbs!

When swinging the ladder **2**, fingers and hands can be crushed!

- ▶ Do not reach with your hands into the danger zone!

- ▶ Swing the ladder **2** to the mountings **7**, see illustration 3.

When the pin bores on the mounting **6** align in point **P3** and on the mounting **7**:

- ▶ Insert the grip pin **9** in point **P3** and secure with cotter pin **8**, see illustration 3.

Result:

- The ladder **2** is secured in the operating position.

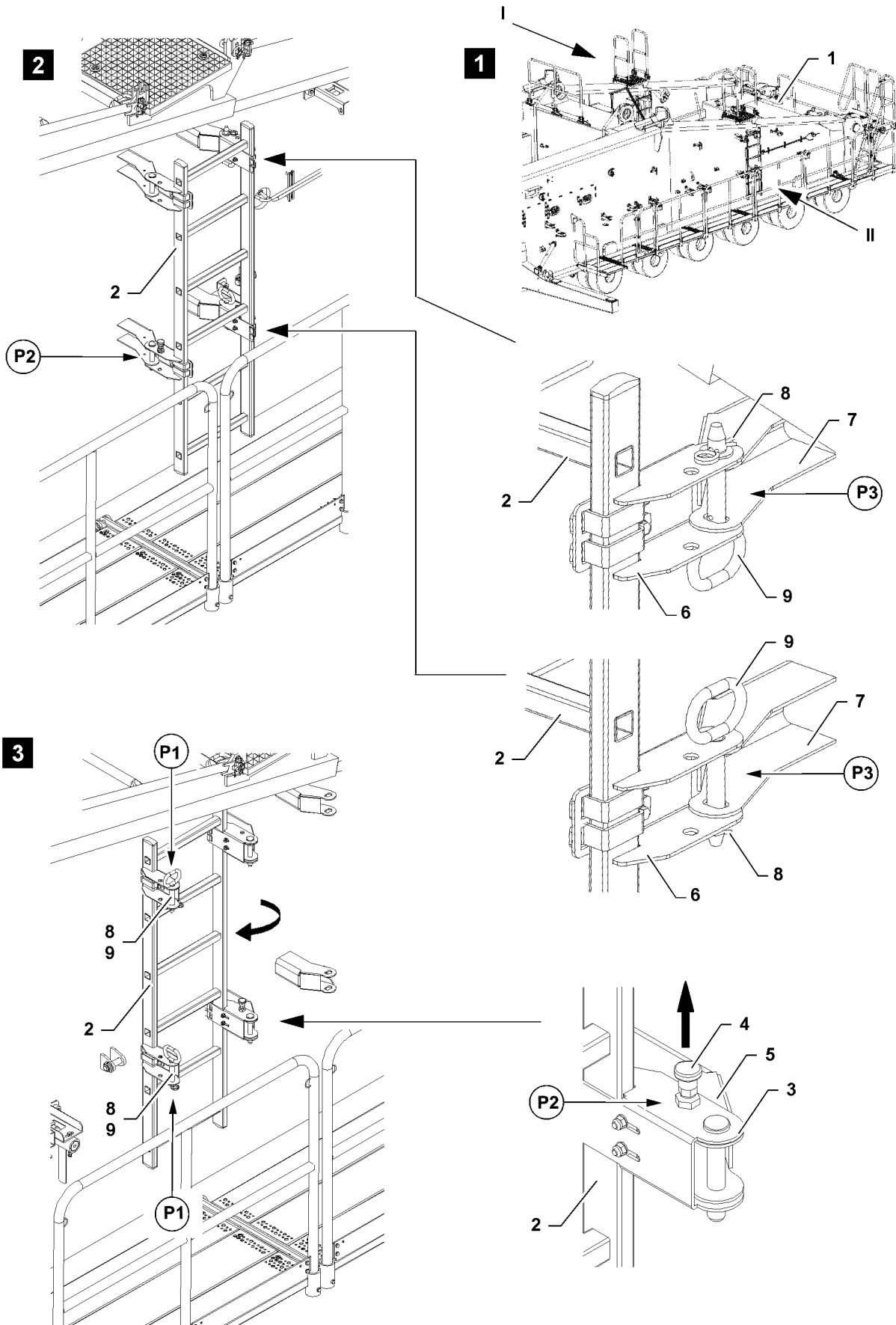

Fig.113150

LWE/LR 13000-001/19503-01-02/en

4.5.2 Folding the ladder on the turntable frame rear section into the transport position

- ▶ Remove the cotter pin **8** in points **P3** and unpin the grip pin **9**, see illustration **2**.



WARNING

Danger of crushed limbs!

When swinging the ladder **2**, fingers and hands can be crushed!

- ▶ Do not reach with your hands into the danger zone!
-
- ▶ Swing the ladder **2** out of the operating position, see illustration **3**.
 - ▶ Before the detent pin **4** collides with the mounting **5**, pull the detent pin **4** in point **P2** upward, see illustration **3**.
 - ▶ Continue to swing the ladder **2** until the detent pin **4** engages.

Result:

- The ladder **2** is secured in the transport position.
- ▶ Insert the grip pin **9** in points **P1** in the park position and secure with the cotter pin **8**, see illustration **3**.

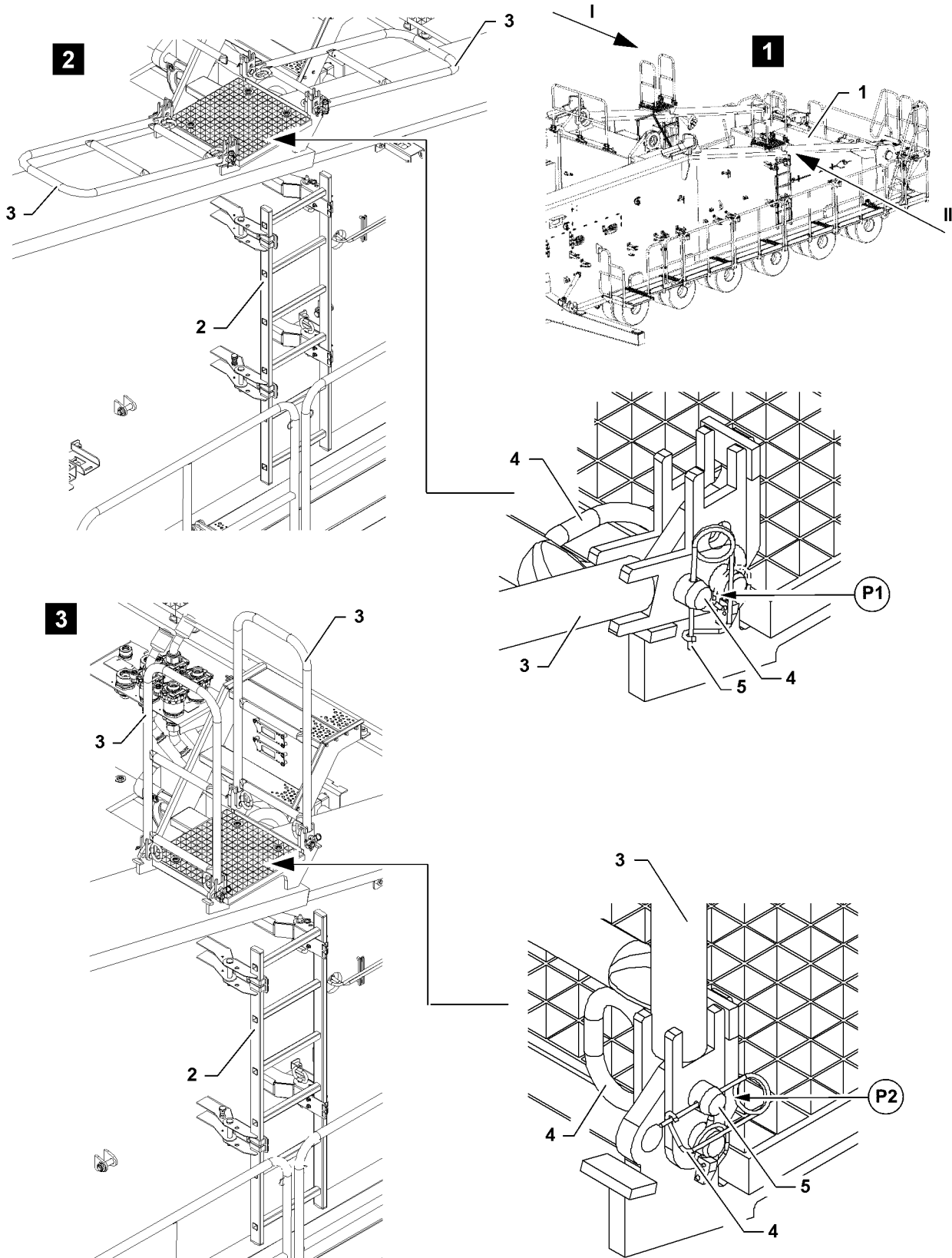

Fig.113620

LWE/LR 13000-001/19503-01-02/en

4.6 Railings on the turntable frame rear section



Note

- ▶ The assembly and disassembly of the two railings is identical and is described based on the example of one railing, see illustration 1!

Make sure that the following prerequisite is met:

- The ladder 2 is properly installed and secured, see illustration 2.



WARNING

Danger of falling!

During assembly and disassembly of the railing, personnel must be secured with appropriate aids to prevent them from falling!

Even during the assembly of protective devices there is a danger of falling!

Assembly personnel can fall and be severely injured or killed!

- ▶ Use personal protective equipment!



WARNING

Danger of crushed limbs!

When swinging the railings 3, fingers and hands can be crushed!

- ▶ Do not reach with your hands into the danger zone!

4.6.1 Swinging the railing on the turntable frame rear section into the operating position

- ▶ Release the railing 3 from the transport position: Remove the spring retainer 5 in point P1 and unpin the connector 4, see illustration 2.
- ▶ Swing the railing 3 into the operating position.
- ▶ Secure the railing 3 in the operating position: Pin the connector 4 in point P2 and secure with the spring retainer 5, see illustration 3.

4.6.2 Swinging the railing on the turntable frame rear section into the transport position



WARNING

Danger of crushed limbs!

The railing 3 can swing down by itself due to its own weight when it is unpinned!

Fingers and hands can be crushed!

- ▶ Before unpinning, hold the railing and swing it down slowly!

- ▶ Release the railing 3 from the operating position: Remove the spring retainer 5 in point P2 and unpin the connector 4, see illustration 3.
- ▶ Swing the railing 3 into the transport position.
- ▶ Secure the railings 3 in the transport position: Pin the connector 4 in point P1 and secure with the spring retainer 12, see illustration 2.

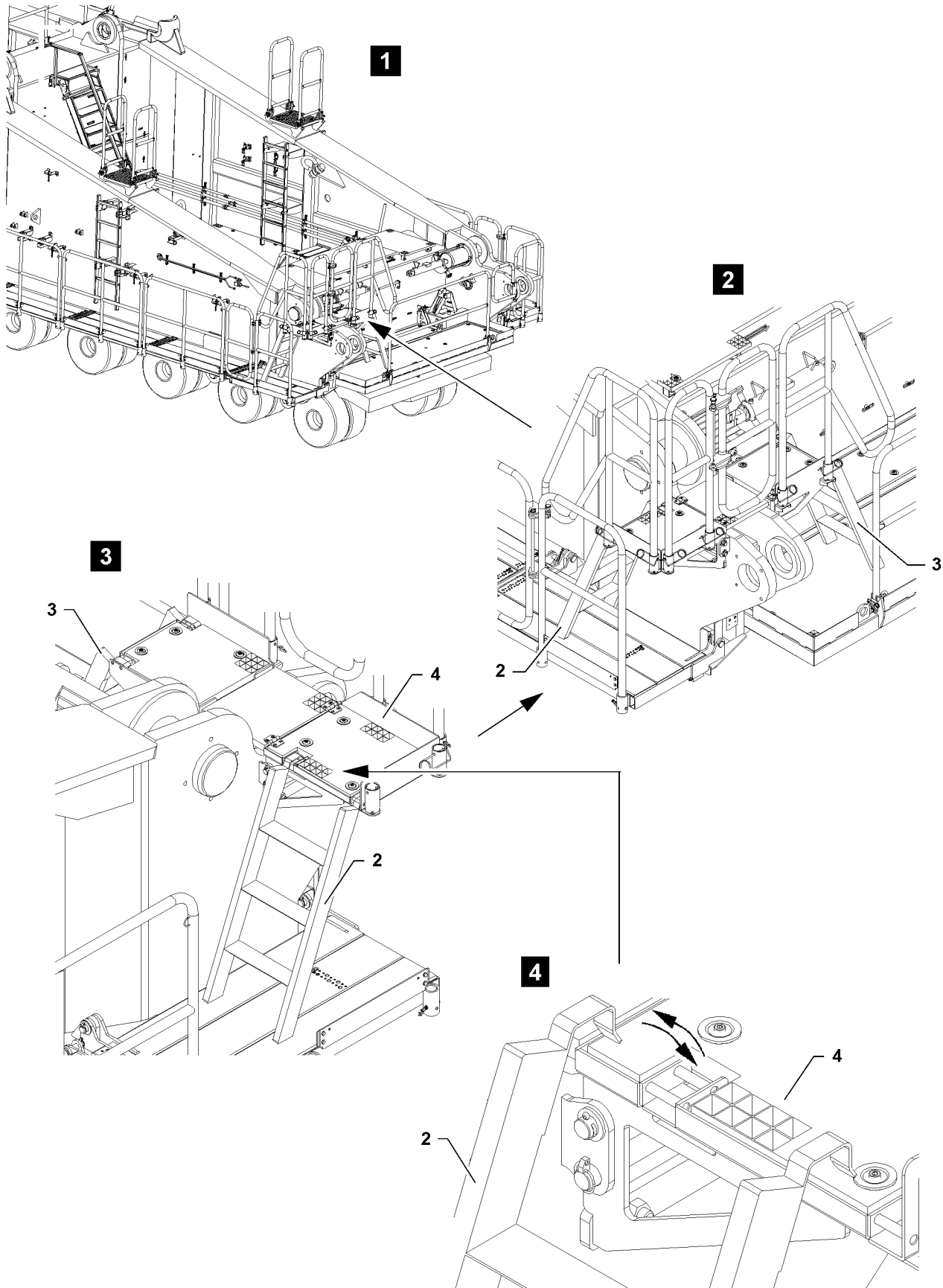

Fig.113628

LWE/LR 13000-001/19503-01-02/en

4.7 Ladder (small) on the turntable frame rear section



WARNING

Danger of falling!

During assembly and disassembly of the ladders, assembly personnel must be secured with appropriate aids to prevent them from falling!

Assembly personnel can fall and be severely injured or killed!

- ▶ Use personal protective equipment!



Note

- ▶ The assembly and disassembly of the two ladders is identical and is described based on the example of one ladder, see illustration 2!

4.7.1 Connecting the ladder (small) to the turntable frame rear section

- ▶ Connect the ladder (small) 2 to the notch of the platform 4, see illustration 4.

4.7.2 Unhooking the ladder (small) on the turntable frame rear section

- ▶ Unhook the ladder (small) 2 from the notch of the platform 4, see illustration 4.

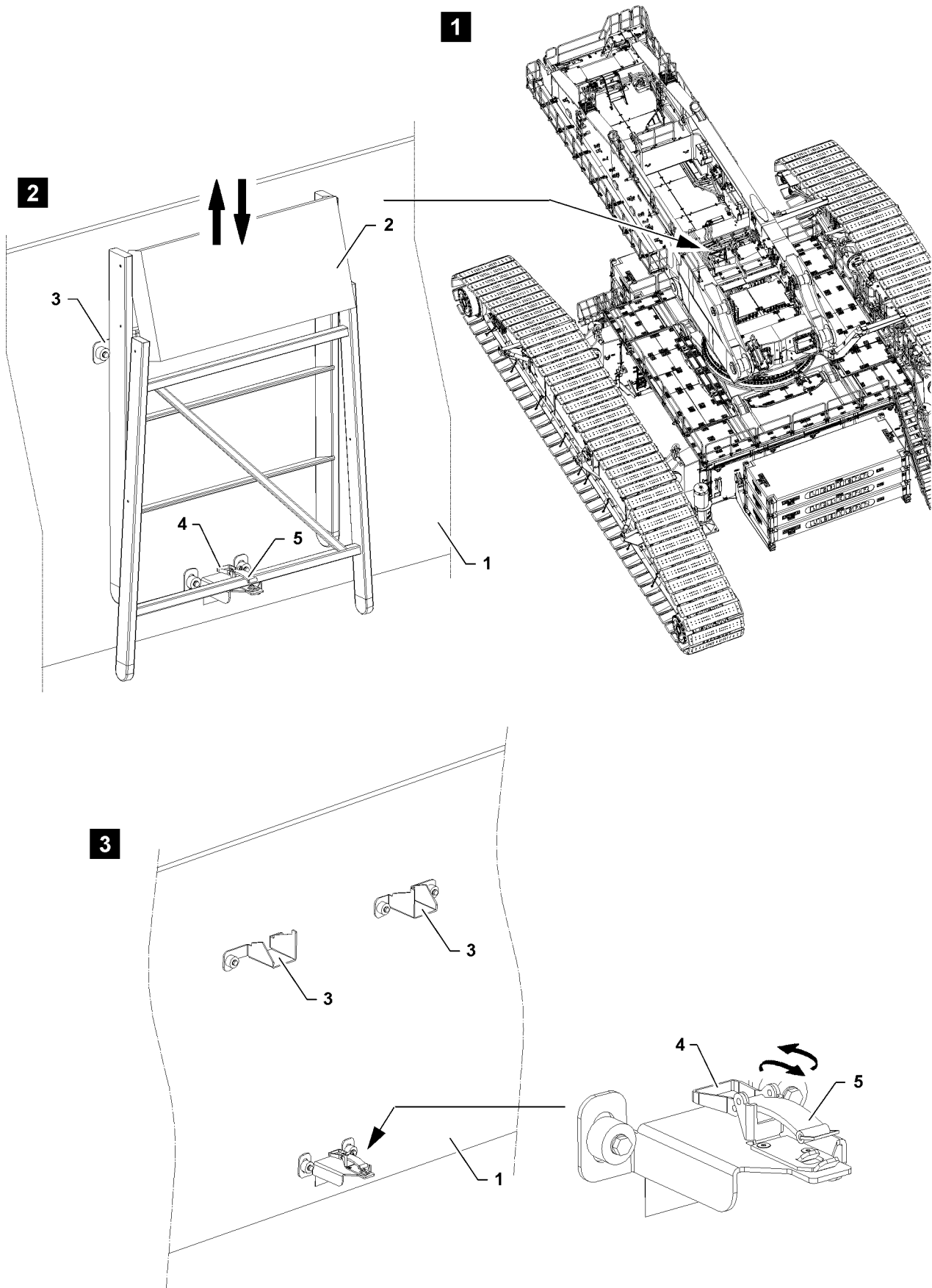

Fig.113622

LWE/LR 13000-001/19503-01-02/en

4.8 Work platform on the turntable frame rear section



WARNING

Danger of falling!

If the following safety guidelines are not observed, personnel can fall down and be killed or severely injured!

- ▶ Observe and adhere to the assembly and safety guidelines for work platforms!
- ▶ Observe and adhere to the safety signs on the work platforms!
- ▶ Assemble and secure the work platforms properly!
- ▶ Do not use damaged work platforms and replace them immediately!

4.8.1 Setting up the work platform

- ▶ Open the locking latch **5**: Pull the lever **4** up and unhook the rubber band **5**, see illustration **2** and illustration **3**.



Note

- ▶ The weight of the work platform is 11 kg.
- ▶ Lift the work platform **2** up.
- ▶ Unhook the work platform **2** on the fastening hook **3**s and set it down.



WARNING

Danger of crushed limbs!

When assembling / removing work platforms, limbs can be crushed!

- ▶ Do not reach with your hands into the danger zone!
- ▶ Fold the work platform **2** out.

4.8.2 Removing the work platform



WARNING

Danger of crushed limbs!

When assembling / removing work platforms, limbs can be crushed!

- ▶ Do not reach with your hands into the danger zone!
- ▶ Fold the work platform **2** in.



Note

- ▶ The weight of the work platform is 11 kg.
- ▶ Connect the work platform **2** to the fastening hook **3**, see illustration **2** and illustration **3**.
- ▶ Close the locking latch **5**: Push the rubber band **5** over the bar of the work platform **2** and engage it, push the lever **4** down, see illustration **2** and illustration **3**.

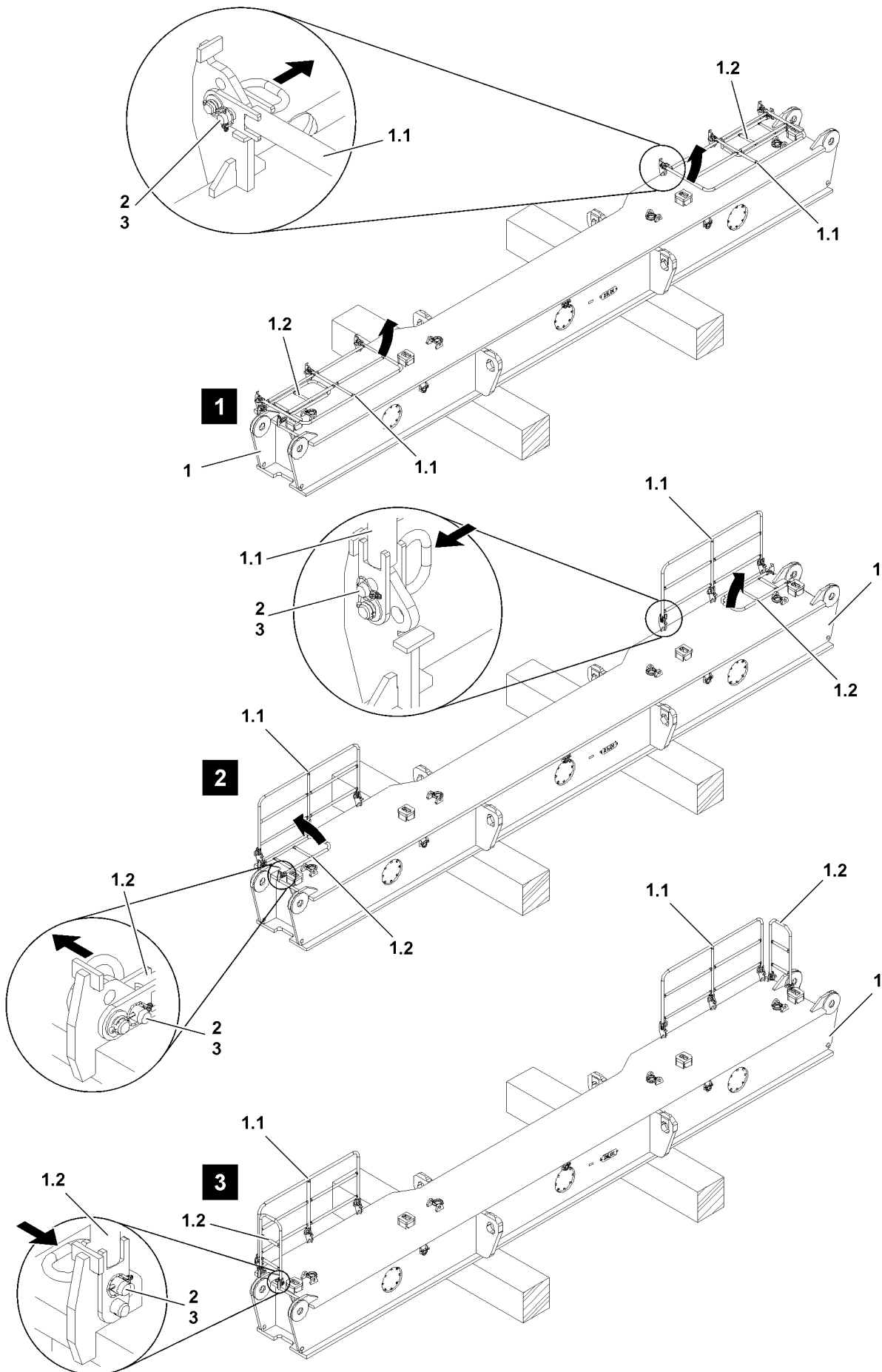

Fig.114771

LWE/LR 13000-001/19503-01-02/en

4.9 Railings on the carriers for the counterweight



Note

- ▶ The assembly and disassembly of the railings on the two carriers **1** is identical and is described based on the example of one carrier!

4.9.1 Swinging the railings into the operating position

The railings on the carriers must be brought into operating position - before assembly of the carriers **1** on the turntable - on the ground or on a flatbed trailer.

Make sure that the following prerequisites are met:

- The carrier is lying on the substructure on the ground or on the transport vehicle.
- ▶ Release both railings **1.1** in the transport position: Remove the locking pin **3** and unpin the pin **2**.
- ▶ When all pins **2** are unpinned: Swing the railings **1.1** up into the operating position, see illustration **1**.
- ▶ Secure the railing **1.1** in the operating position: Insert the pin **2** in the operating position and secure with the locking pin **3**, see illustration **2**.

When the railings **1.1** are pinned in the operating position and secured:

- ▶ Release both railings **1.2** in the transport position: Remove the locking pin **3** and unpin the pin **2**.
- ▶ When all pins **2** are unpinned: Swing the railings **1.2** up into the operating position, see illustration **2**.
- ▶ Secure the railing **1.2**: Insert the pin **2** in the operating position and secure with the locking pin **3**, see illustration **3**.

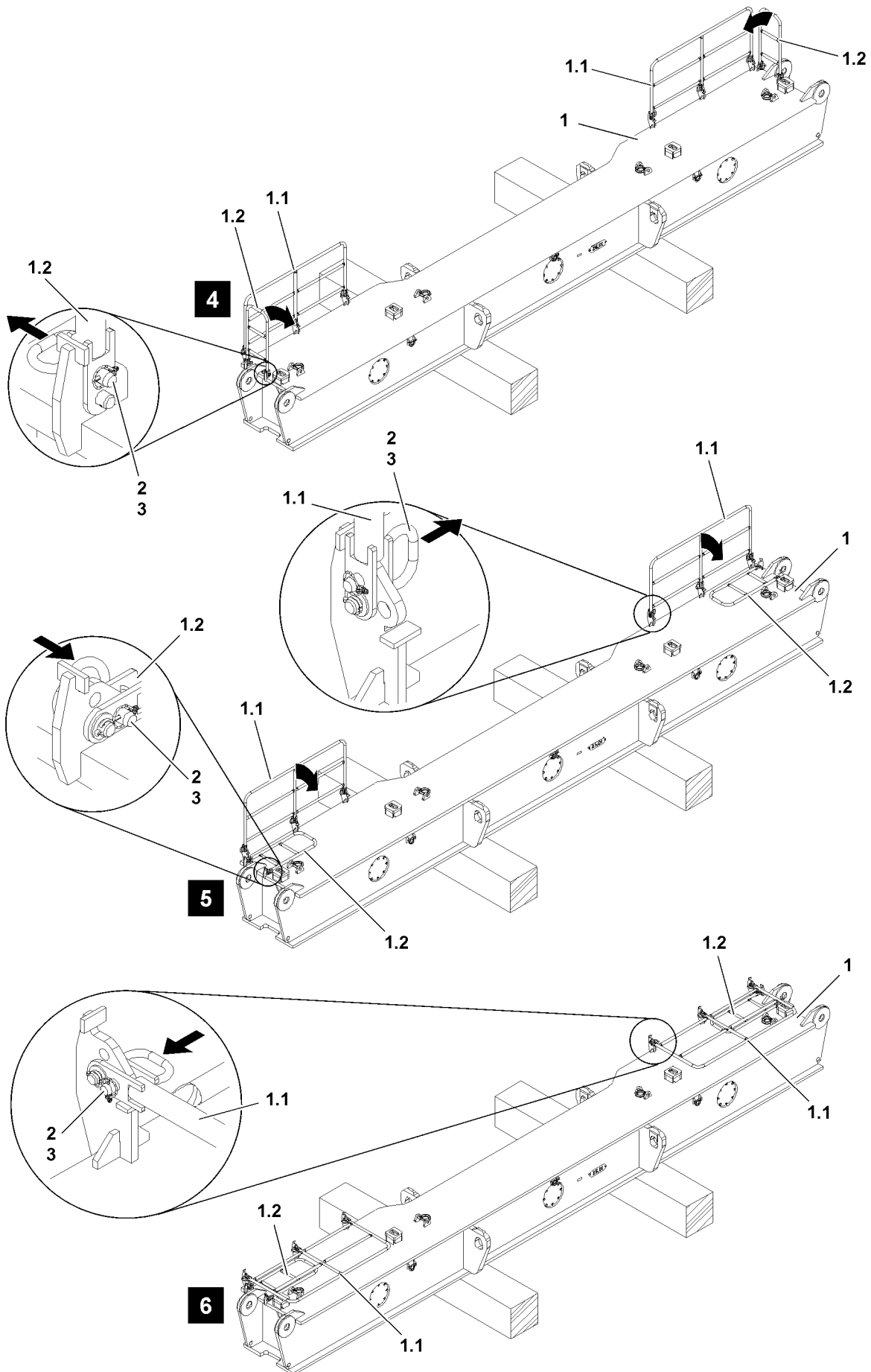

Fig.114772

LWE/LR 13000-001/19503-01-02/en

4.9.2 Swinging the railings into the transport position

The railings on the carriers must be brought into transport position - before disassembly of the carriers **1** from the turntable - on the ground or on a flatbed trailer.

Make sure that the following prerequisites are met:

- The carrier is lying on the substructure on the ground or on the transport vehicle.



Note

- ▶ When taking the railings down into the transport position, it must be observed that the railings **1.2** must be swung first into the transport position!
- ▶ If this is not observed, the railings cannot be pinned and secured in the transport position!

-
- ▶ Release both railings **1.2** in the operating position: Remove the locking pin **3** and unpin the pin **2**.
 - ▶ When all pins **2** are unpinned: Swing the railings **1.2** down into the transport position, see illustration **4**.
 - ▶ Secure the railings **1.2** in the transport position: Insert the pin **2** in the transport position and secure with the locking pin **3**, see illustration **5**.

When the railings **1.2** are pinned in the transport position and secured:

- ▶ Release both railings **1.1** in the operating position: Remove the locking pin **3** and unpin the pin **2**.
- ▶ When all pins **2** are unpinned: Swing the railings **1.1** down into the transport position, see illustration **5**.
- ▶ Secure the railing **1.1**: Insert the pin **2** in the transport position and secure with the locking pin **3**, see illustration **6**.

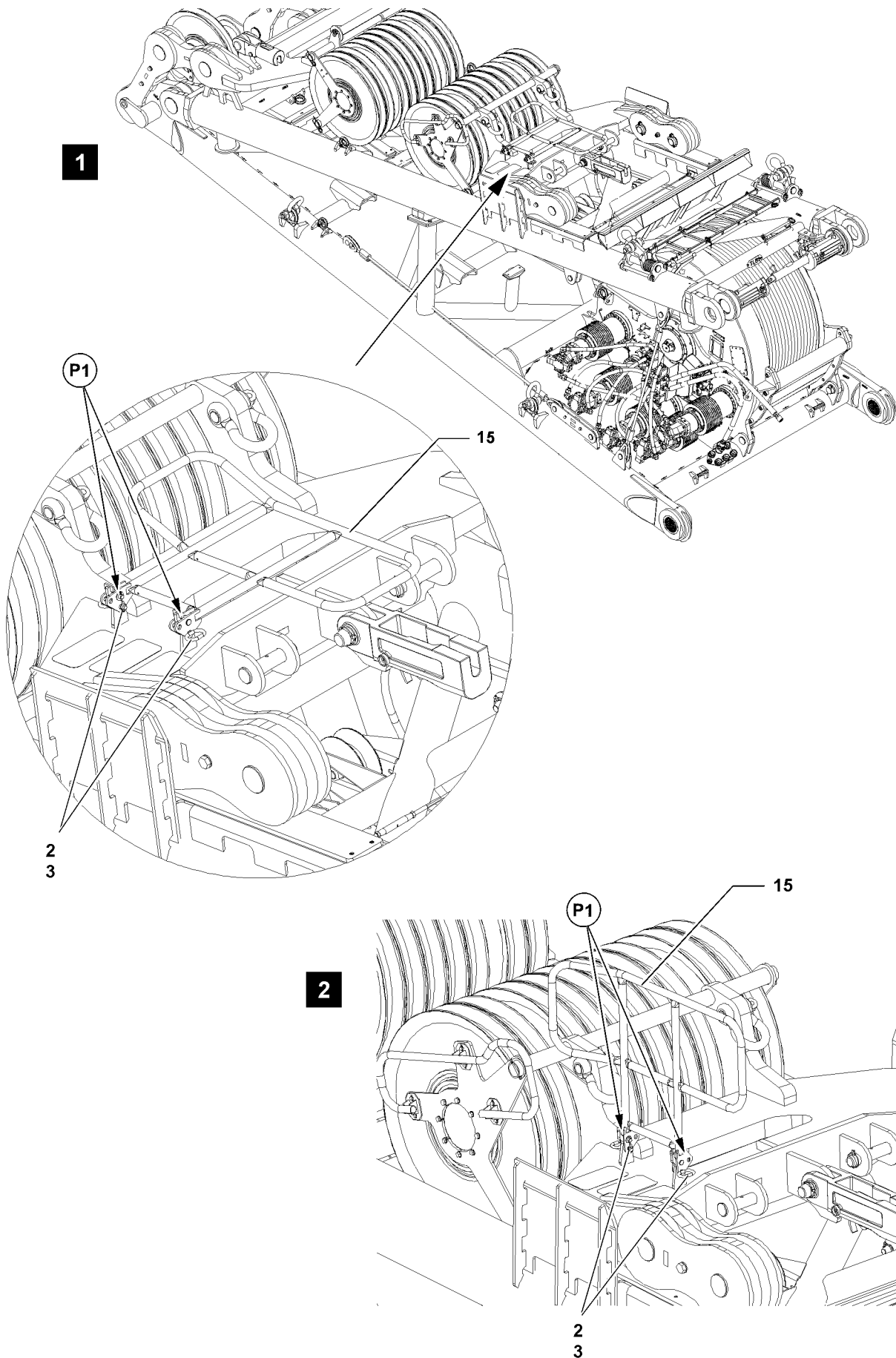

Fig.113659

LWE/LR 13000-001/19503-01-02/en

4.10 Railing on the A-frame

4.10.1 Swinging the railing on the A-frame into the operating position



WARNING

Danger of falling!

During assembly and disassembly of the ladders, assembly personnel must be secured with appropriate aids to prevent them from falling!

Assembly personnel can fall and be severely injured or killed!

▶ Use personal protective equipment!

▶ Release the railing **15** from the transport position: Remove the safety locking pin **3** in point **P1** and unpin the pin **2**, see illustration **1**.



WARNING

Danger of crushed limbs!

When swinging the railings **15**, fingers and hands can be crushed!

▶ Do not reach with your hands into the danger zone!

▶ Swing the railing **15** into the operating position.

▶ Secure the railing **15** in the operating position: Insert the pin **2** in point **P1** again and secure with the safety locking pin **3**, see illustration **2**.

4.10.2 Swinging the railing on the A-frame into the transport position



WARNING

Danger of falling!

During assembly and disassembly of the ladders, assembly personnel must be secured with appropriate aids to prevent them from falling!

Assembly personnel can fall and be severely injured or killed!

▶ Use personal protective equipment!

▶ Release the railing **15** from the operating position: Remove the safety locking pin **3** in point **P1** and unpin the pin **2**, see illustration **2**.



WARNING

Danger of crushed limbs!

The railing **15** can swing down by itself due to its own weight when the unpinning the pin **2**!

Fingers and hands can be crushed!

▶ Before unpinning, hold the railing and swing it down slowly!

▶ Swing the railing **15** into the transport position.

▶ Secure the railings **15** in the transport position: Insert the pin **2** in point **P1** again and secure with the safety locking pin **3**, see illustration **1**.

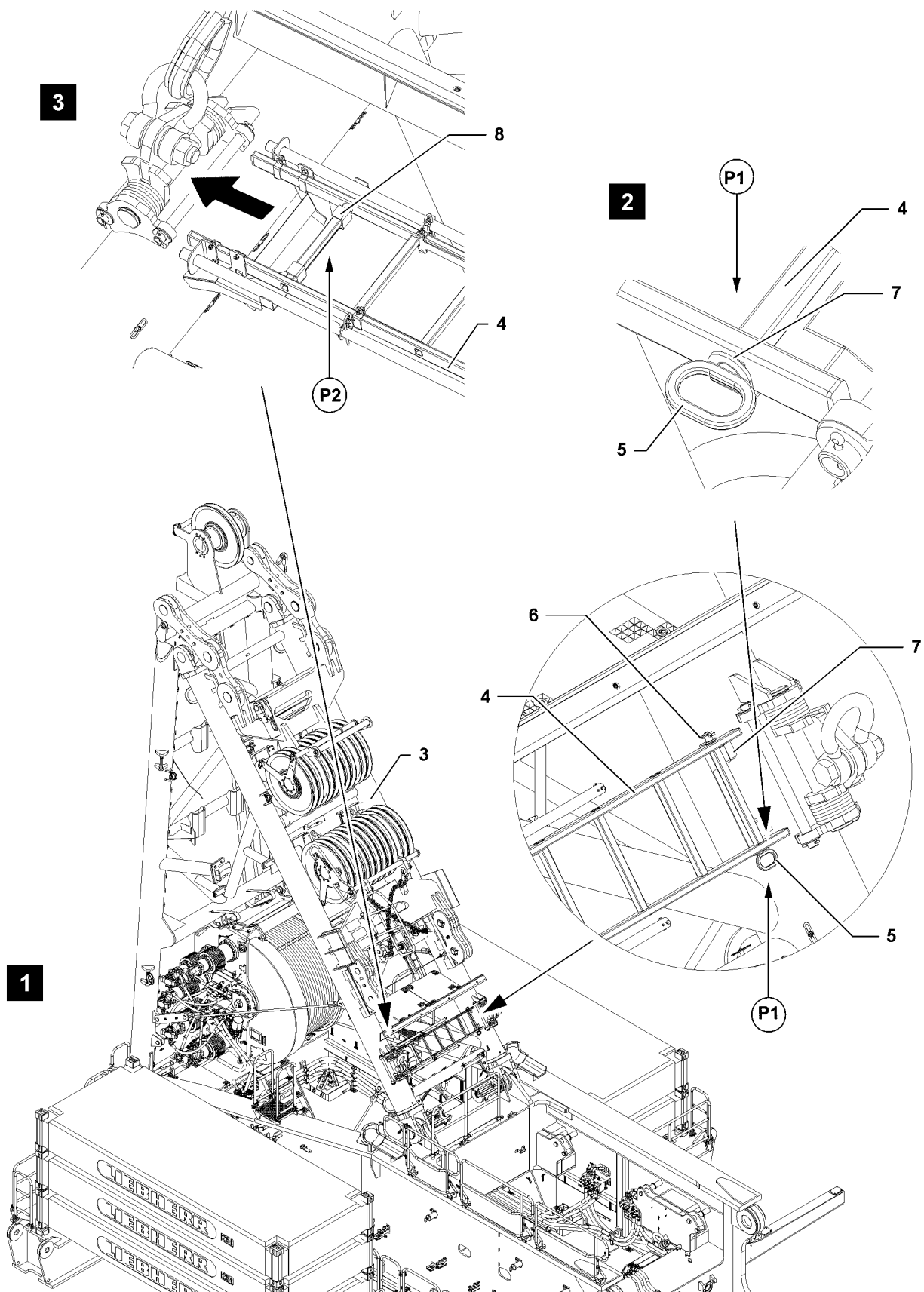

Fig.113660

LWE/LR 13000-001/19503-01-02/en

4.11 Ladder on the A-frame

4.11.1 Connecting the ladder to the A-frame in the operating position



WARNING

Danger of falling!

During assembly and disassembly of the ladders, assembly personnel must be secured with appropriate aids to prevent them from falling!

Assembly personnel can fall and be severely injured or killed!

▶ Use personal protective equipment!

▶ Remove the safety locking pin **6** and unpin the pin **5** in point **P1** from the mounting **7**, see illustration **1** and illustration **2**.

Result:

– The ladder **4** can be pulled out on the side from the mounting **8**.

**Note**

▶ The weight of the ladder **4** is 23 kg !

▶ Pull the ladder **2** from the mounting **8** in point **P2**, see illustration **3**.

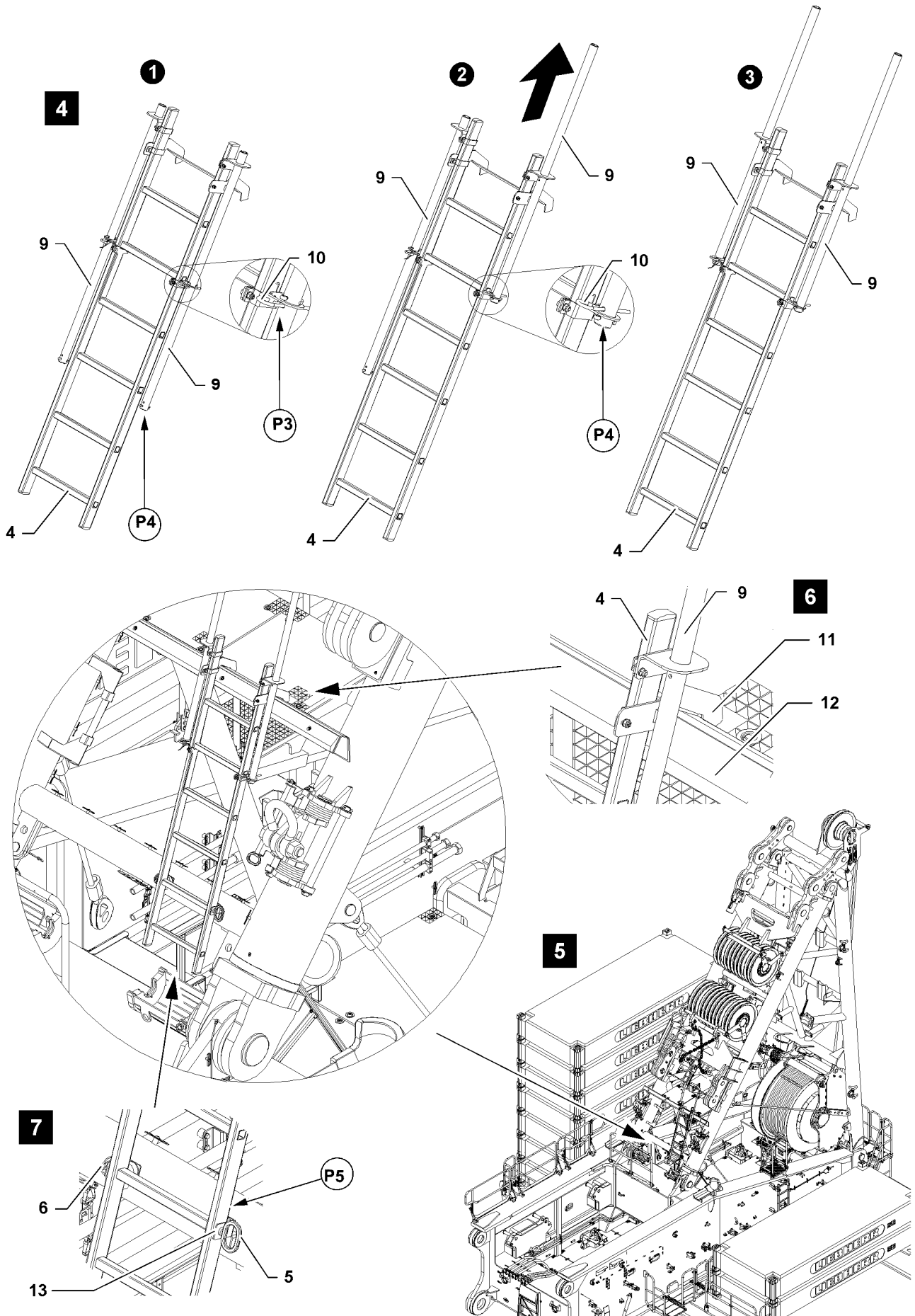

Fig.113661

LWE/LR 13000-001/19503-01-02/en

Pull out the pipes **4**:

- ▶ Remove the cotter pin **10** in point **P3**, see step **1** illustration **4**.
- ▶ Pull the pipe **4** out to the stop, see step **2** illustration **4**.
- ▶ Secure the pipe **9** with the cotter pin **10** in point **P4**, see step **2** illustration **4**.
- ▶ Pull the pipe **9** out, see step **3** illustration **4**.
- ▶ Connect the ladder **4** with the hooks **11** on the platform **12** of the A-frame, see illustration **6**.



WARNING

Danger of crushed limbs!

When swinging the ladder **4**, fingers and hands can be crushed!

- ▶ Do not reach with your hands into the danger zone!
-
- ▶ Swing the ladder **4** to the mounting **13**, see illustration **7**.
 - ▶ Insert the pin **5** through the mounting **13** in point **P5** and through the rungs of the ladder, see illustration **7**.
 - ▶ Secure the pin **5** with the safety locking pin **6**, see illustration **7**.

Result:

- The ladder **4** is secured in the operating position.

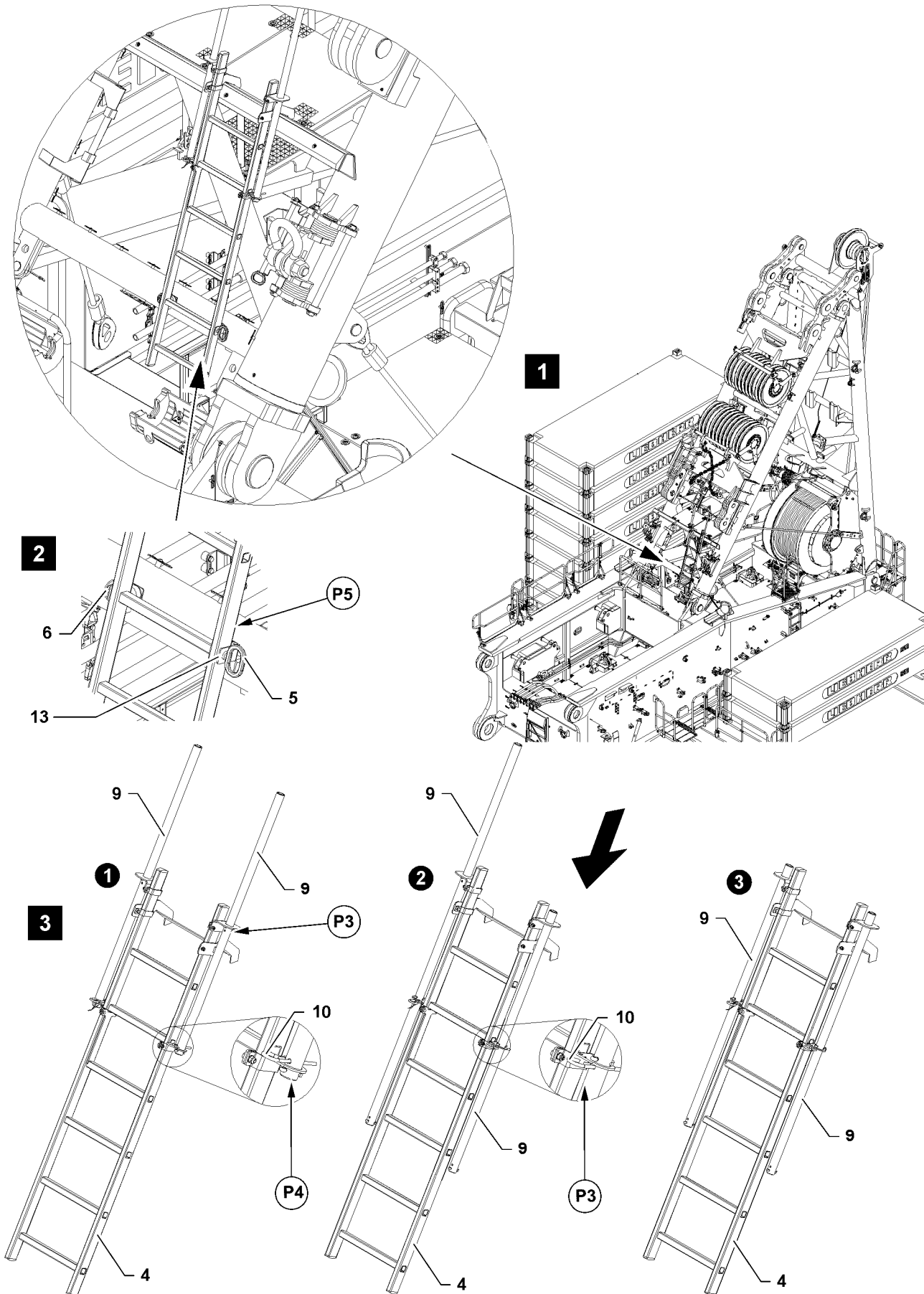

Fig.113662

LWE/LR 13000-001/19503-01-02/en

4.11.2 Fastening the ladder on the A-frame in the transport position



WARNING

Danger of falling!

During assembly and disassembly of the ladders, assembly personnel must be secured with appropriate aids to prevent them from falling!

Assembly personnel can fall and be severely injured or killed!

▶ Use personal protective equipment!

▶ Release the ladder **4** from the operating position: Remove the safety locking pin **6** and unpin the pin **5**, see illustration **2**.



Note

▶ The weight of the ladder **4** is 23 kg !

▶ Unhook the ladder **4** from the platform **12**, see illustration **1**.

Push in the pipes **9**:



WARNING

Danger of crushed limbs!

The pipe **4** can fall down by itself due to its own weight when it is released!

Fingers and hands can be crushed!

▶ Before releasing, hold the pipe **4** and lower it slowly!

▶ Remove the cotter pin **10** in point **P4**, see step **1** illustration **3**.

▶ Lower the pipe **9** to the stop, see step **2** illustration **3**.

▶ Secure the pipe **9** with the cotter pin **10** in point **P3**, see step **2** illustration **3**.

▶ Push the second pipe **9** in, see step **3** illustration **3**.

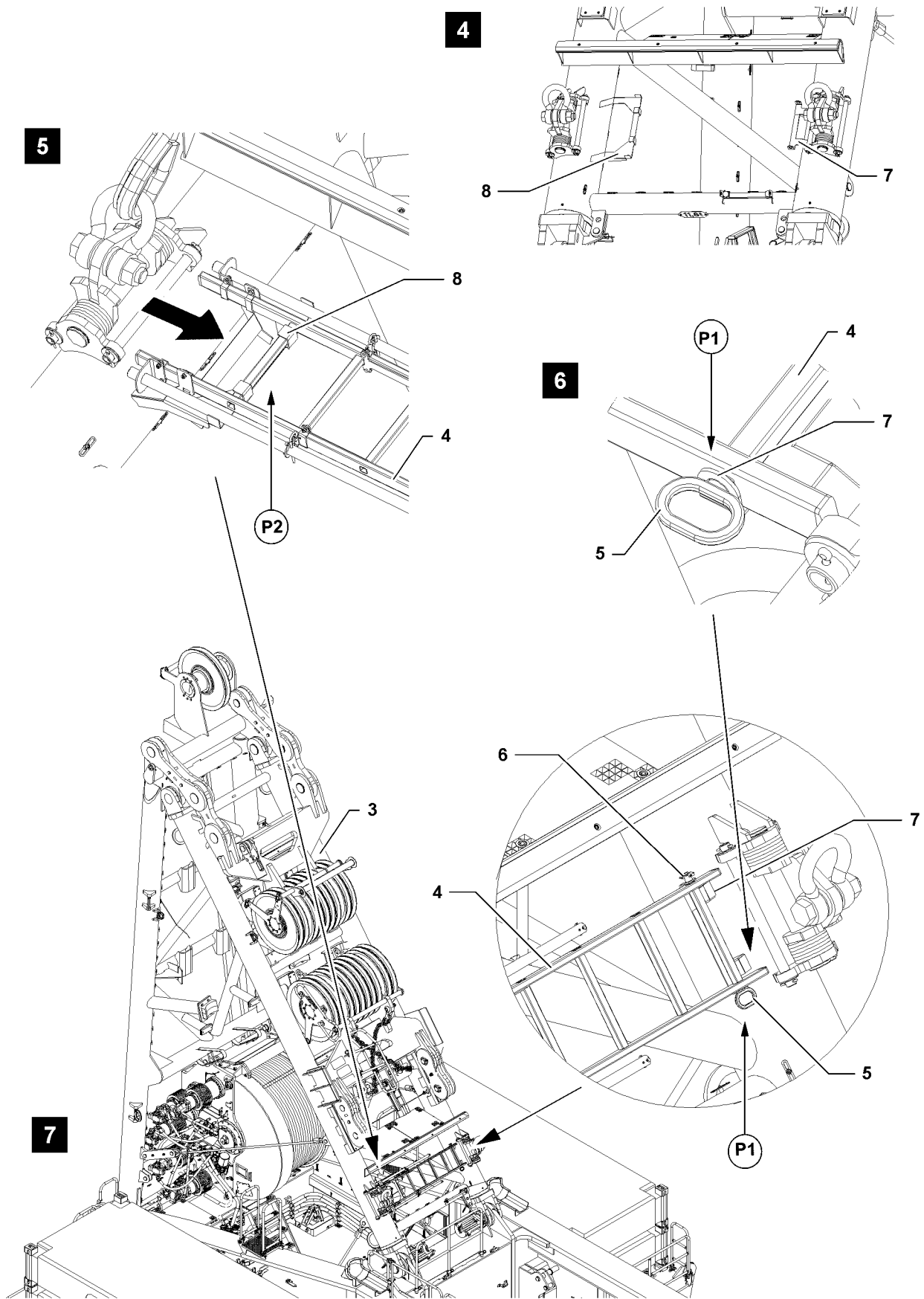

Fig.113663

LWE/LR 13000-001/19503-01-02/en

- ▶ Place the ladder **4** on the mounting **7** and mounting **8**, see illustration **4**.



WARNING

Danger of crushed limbs!

When pushing in the ladder **4**, fingers and hands can be crushed!

- ▶ Do not reach with your hands into the danger zone!
-
- ▶ Push the ladder **4** in the mounting **8** in point **P2**, see illustration **5**.
 - ▶ Insert the pin **5** in point **P1** through the mounting **7** and through the rungs of the ladder **4**, see illustration **6**.
 - ▶ Secure the pin **5** with the safety locking pin **6**, see illustration **7**.

Result:

- The ladder **4** is secured in the transport position.

Fig.195219

LWE/LR 13000-001/19503-01-02/en

5 Fall protection equipment and ladders on the D-boom



WARNING

When working at a height, there is a danger of falling!

- ▶ Assemble and secure all fall protection equipment, such as platforms, catwalks, ladders and railings properly.



WARNING

Danger of accident!

If the following notes are not observed, the ladder can tip and assembly personnel can fall from the ladder with danger of fatal injury!

- ▶ Replace damaged ladders immediately!
- ▶ The ladder must be set up stable and safely accessible!
- ▶ For the safe handling of the ladder, observe the safety instructions on the ladder!



CAUTION

Danger of crushed limbs!

When assembling / disassembling fall protection equipment and ladders, limbs can be crushed!

- ▶ Do not reach with your hands into the danger zone!
- ▶ Swing the fall protection equipment and the ladders especially carefully!

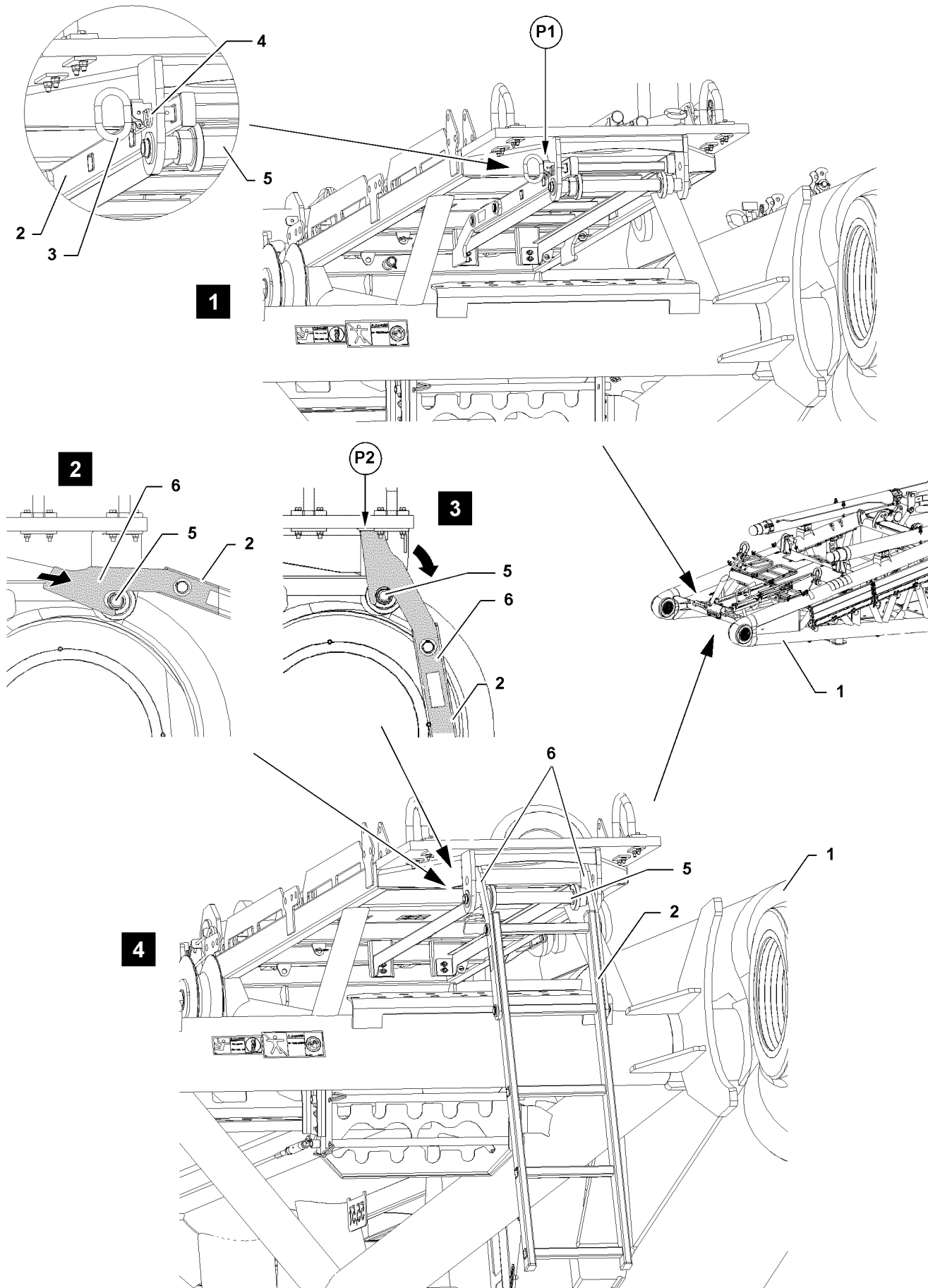

Fig.113677

LWE/LR 13000-001/19503-01-02/en

5.1 Ladder on the D-pivot section

5.1.1 Pulling out the ladder on the D-pivot section into the operating position

- ▶ Release the ladder **2**: Remove the spring retainer **4** and unpin the pin **3**, see illustration **1**.



WARNING

Falling ladder!

If the ladder **2** is not held when pulling it from the transport receptacle, then it can fall down by itself due to its own weight!

Personnel can be severely injured!

Fingers and hands can be crushed!

- ▶ When pulling the ladder **2** out from the transport receptacle, the ladder must be held to prevent it from falling down!
-
- ▶ Pull the ladder **2** out of the transport receptacle until the ladder **2** engages positive locking with the pockets on the metal plates **6** on the axle **5**, see illustration **2**.
 - ▶ Turn the ladder **2** on its axis **5** until the metal plates **6** on the platform lock in point **P2**, see illustration **3** and illustration **4**.

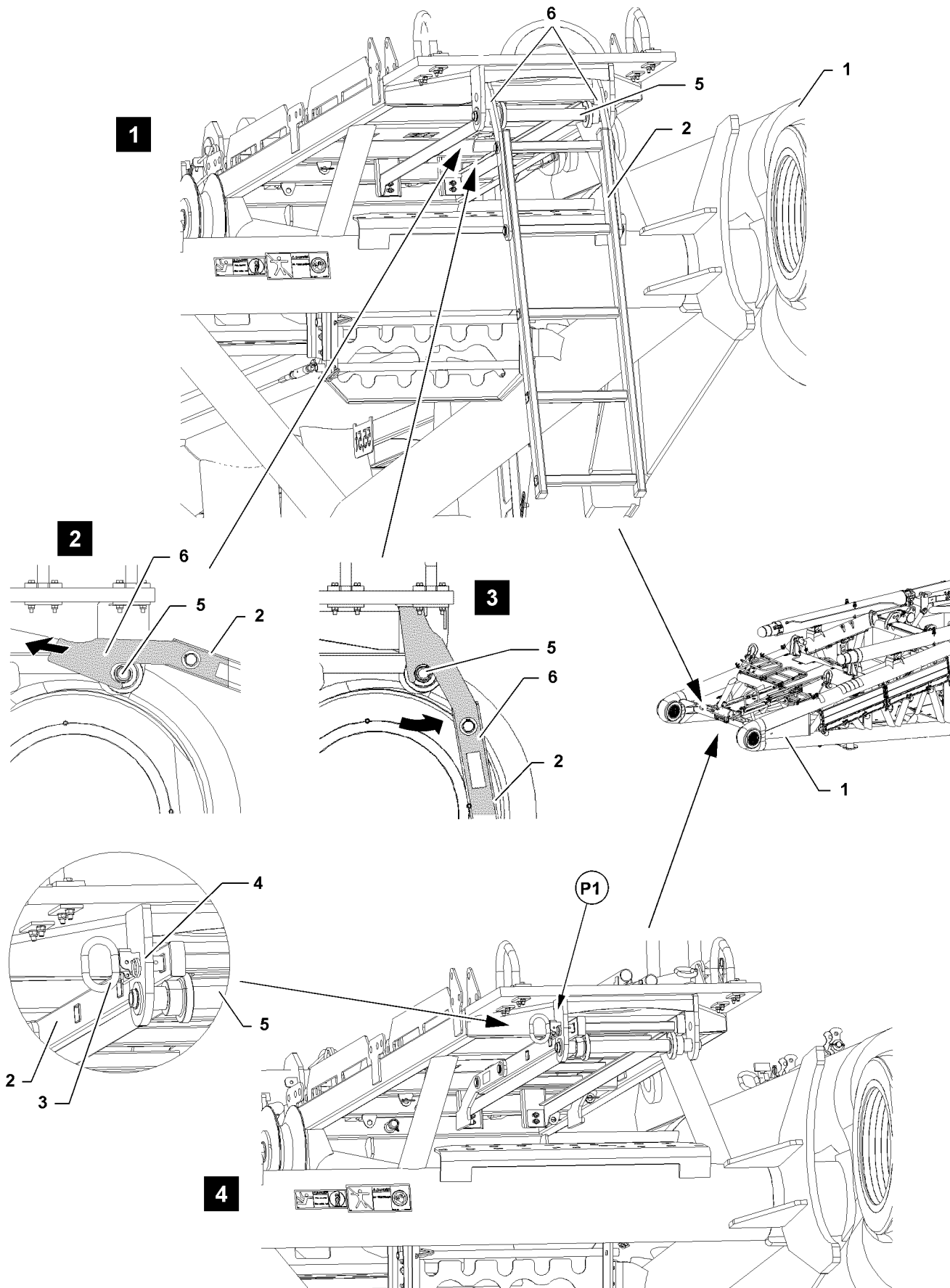

Fig.113678

LWE/LR 13000-001/19503-01-02/en

5.1.2 Sliding the ladder on the D-pivot section into the transport position



WARNING

Falling ladder!

The ladder **2** can fall down due to its own weight when lifting it into position!

Personnel can be severely injured!

Fingers and hands can be crushed!

▶ When lifting the ladder **2** into position, it must be held to prevent it from falling down!

- ▶ Hold the ladder **2** and lift it up slowly.
- ▶ Slide the ladder **2** from the pockets on the metal plates **6**, see illustration **2** and illustration **3**.
- ▶ Slide the ladder **2** in until it can be pinned in point **P1**, see illustration **4**.
- ▶ Insert the pin **3** in point **P1** through the ladder mounting and through the rung of the ladder **2**, see illustration **4**.
- ▶ Secure the pin **3** with spring retainer **4**, see illustration **4**.

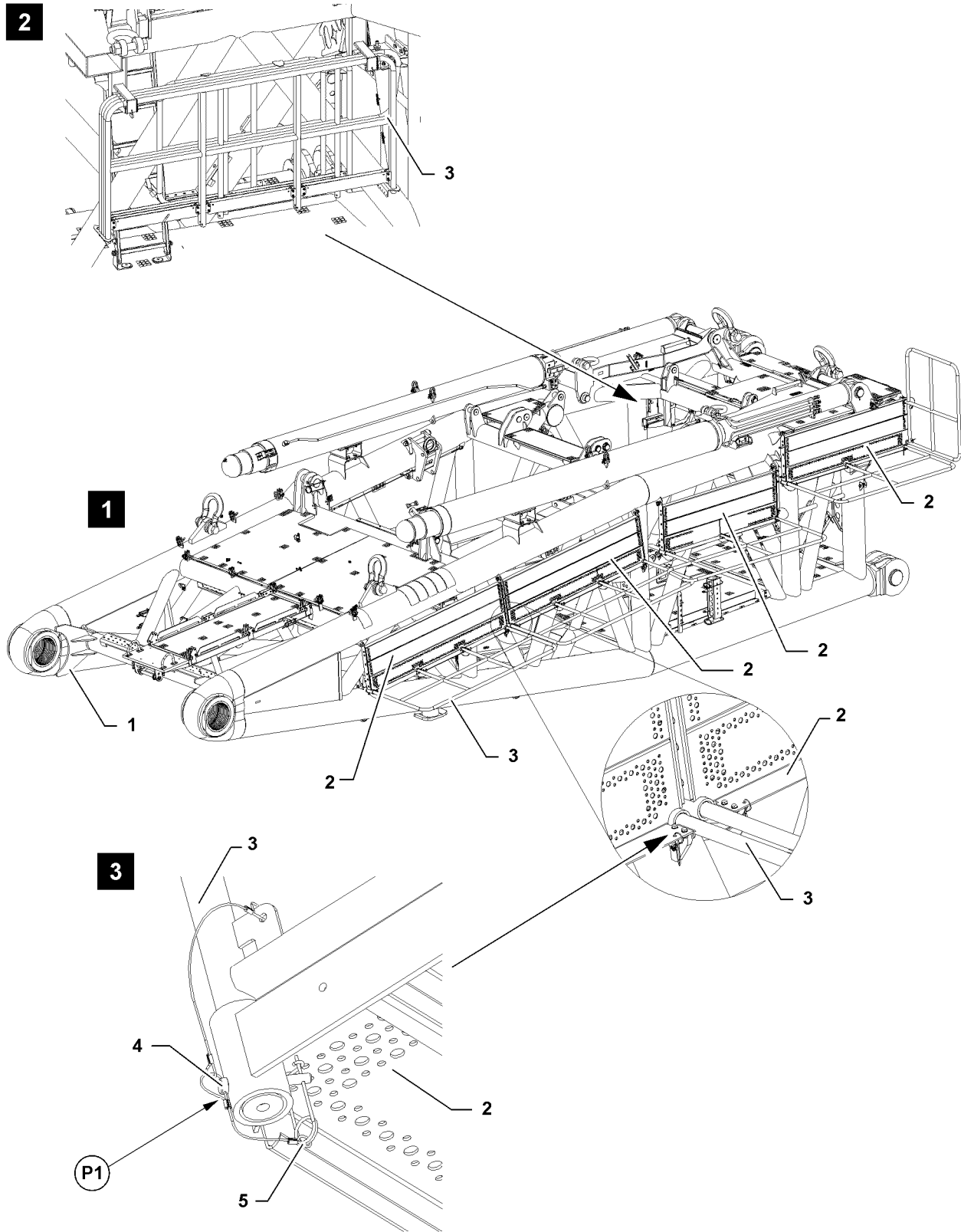

Fig.113679

LWE/LR 13000-001/19503-01-02/en

5.2 Railing on the catwalk

5.2.1 Assembling the railing on the platforms



WARNING

Danger of falling!

During assembly and disassembly of the railing, personnel must be secured with appropriate aids to prevent them from falling!

There is a danger of falling even during the disassembly of protective devices!

Assembly personnel can fall and be severely injured or killed!

▶ Use personal protective equipment!

▶ Fasten the railing **3** on the retainers, see illustration **2**.



Note

▶ For the assembly and disassembly of the railings, use a work platform!

▶ The work platform with 1 m height is located on the turntable frame rear section, see section „Work platform on the turntable frame rear section“!

▶ Insert the railing **3** into the receptacles **2** on the platforms, see illustration **1**.

▶ Secure the railing: Insert the pin **4** inpoint **P1** and secure with the spring retainer **5**, see illustration **3**.

5.2.2 Disassembling the railing on the platforms



WARNING

Danger of falling!

During assembly and disassembly of the railing, personnel must be secured with appropriate aids to prevent them from falling!

There is a danger of falling even during the disassembly of protective devices!

Assembly personnel can fall and be severely injured or killed!

▶ Use personal protective equipment!



Note

▶ For the assembly and disassembly of the railings, use a work platform!

▶ The work platform with 1 m height is located on the turntable frame rear section, see section „Work platform on the turntable frame rear section“!



WARNING

Falling railing!

The railing can fall down due to its own weight when it is unpinned!

Personnel can be severely injured!

▶ Before unpinning the railing it must be held to prevent it from falling!

▶ Release the railing **3**: Remove the spring retainer **5** in point **P1** and unpin the pin **4**, see illustration **3**.

▶ Pull the railing **3** from the platforms **2**, see illustration **1**.

▶ Fasten the railing **3** to the retainers, see illustration **2**.

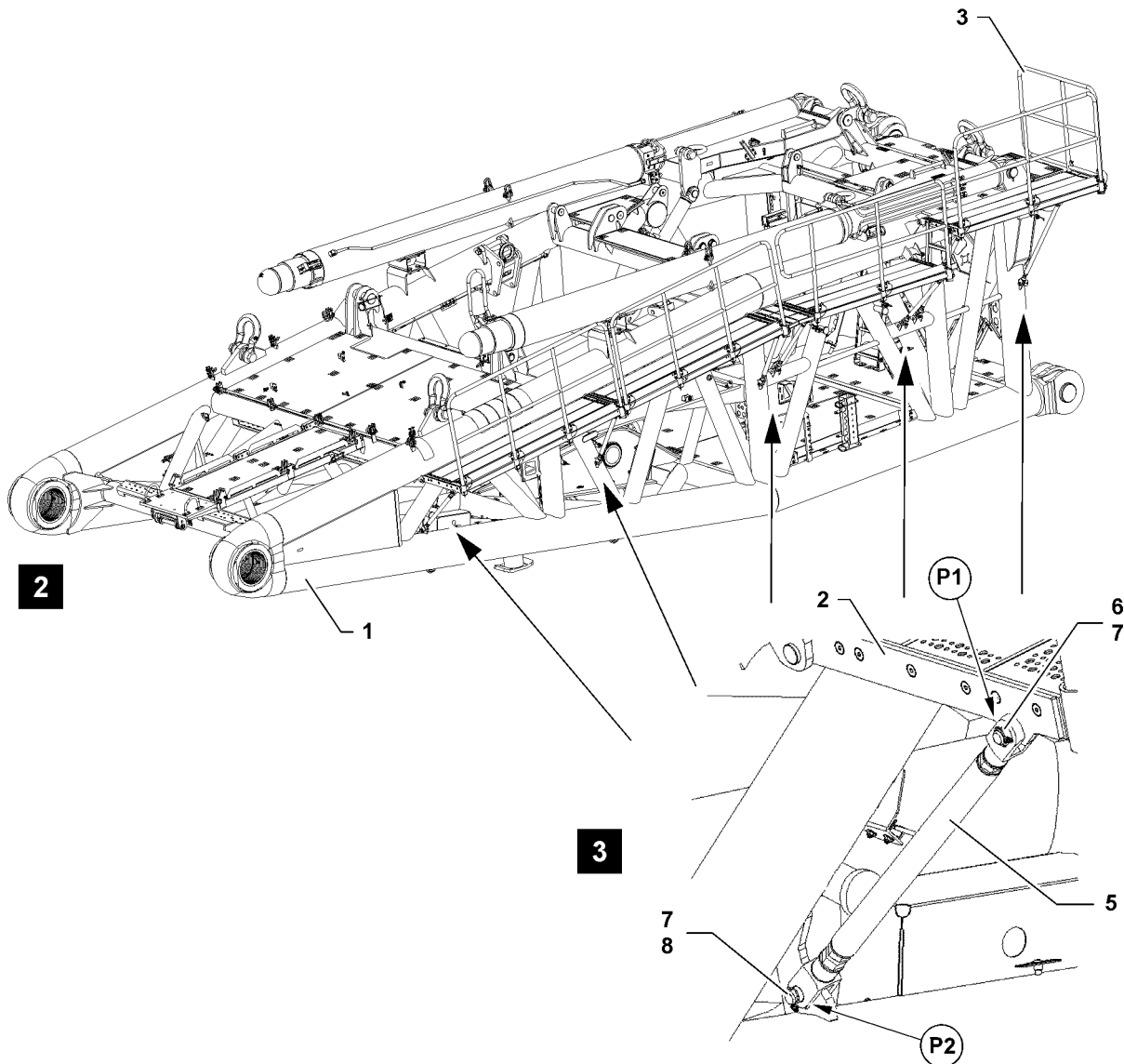
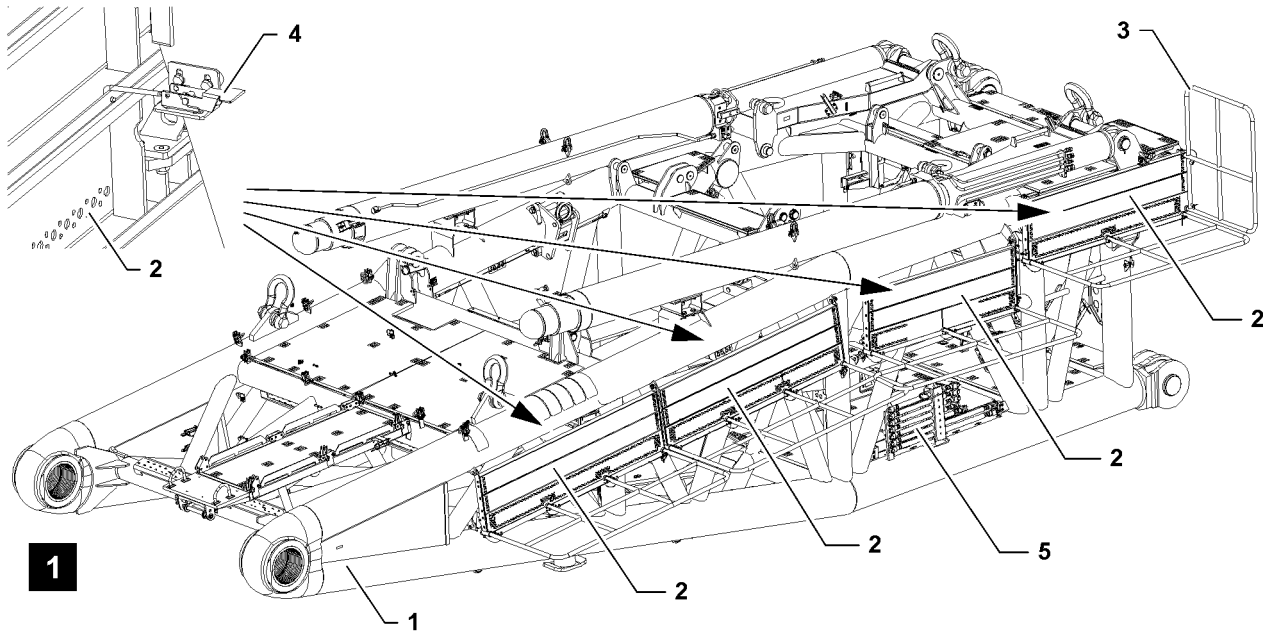

Fig.114353

5.3 Platforms on the D-pivot section

5.3.1 Swinging the platforms on the D-pivot section into the operating position

Make sure that the following prerequisite is met:

- The railings **3** are properly installed and secured.



WARNING

Danger of falling!

During assembly and disassembly of the platforms, assembly personnel must be secured with appropriate aids to prevent them from falling!

There is a danger of falling even during the disassembly of protective devices!

Assembly personnel can fall and be severely injured or killed!

- ▶ Use personal protective equipment!



Note

- ▶ Use a work platform for the assembly and disassembly of the platforms and ladders!
- ▶ The work platform with 1 m height is located on the turntable frame rear section, see section „Work platform on the turntable frame rear section“!

Folding the platforms up



Note

- ▶ The assembly of the platforms is described based on the example of one platform!

- ▶ Fasten the auxiliary crane to the platform **2**.
- ▶ Release the platform **2**: Open the latch **4**, see illustration **1**.
- ▶ Fold the platform **2** up with the auxiliary crane.



Note

- ▶ The weight of the support is 17 kg !

- ▶ Remove the supports **5** from the transport receptacle, see illustration **1**.
- ▶ Pin the support **5** in point **P1**: Insert the pin **6** and secure with the safety locking pin **7**, see illustration **3**.
- ▶ Pin the support **5** in point **P2**: Insert the pin **8** and secure with the safety locking pin **7**, see illustration **3**.
- ▶ Fold all platforms **2** up and support with the supports **5**, see illustration **2**.

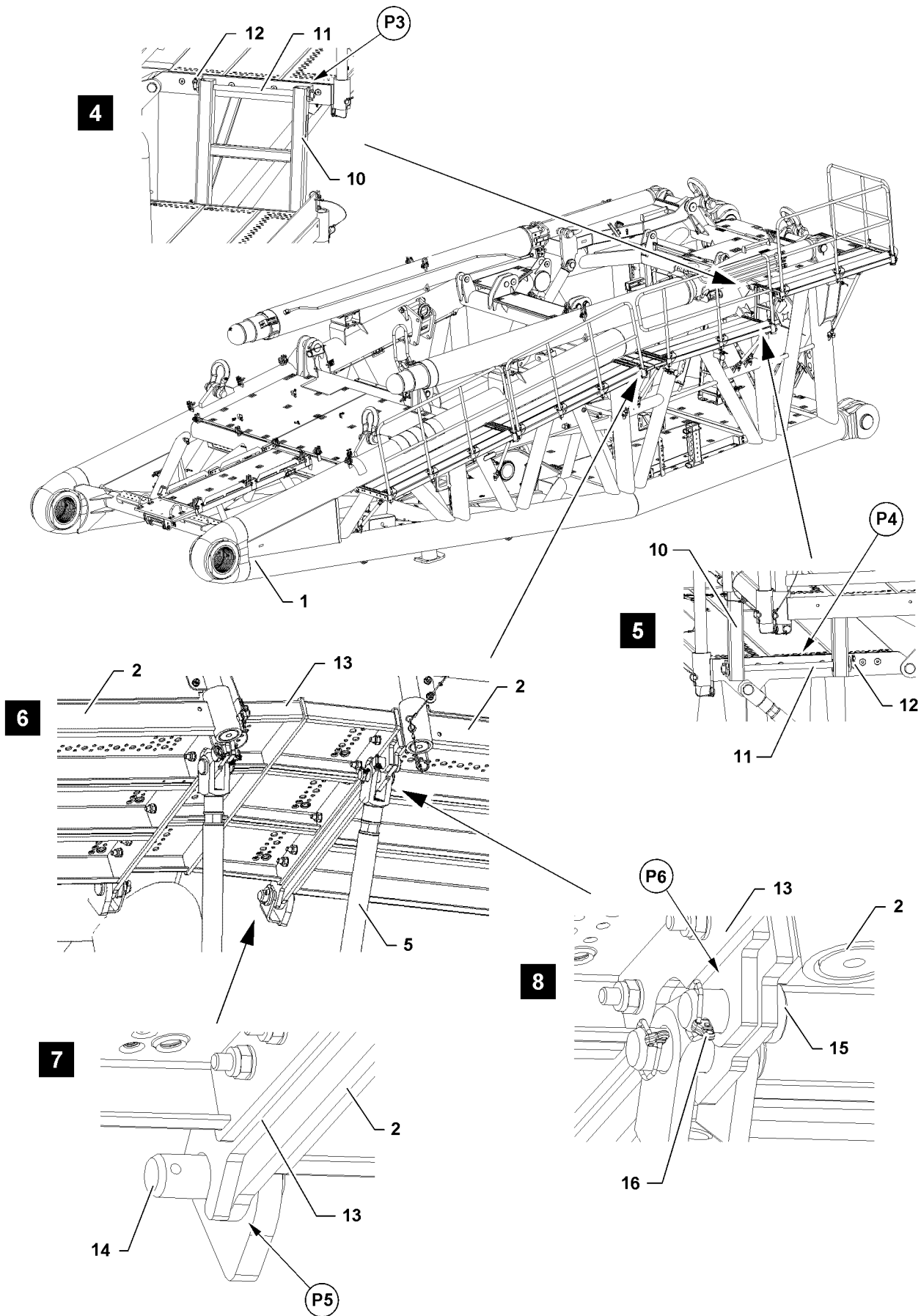

Fig.114354

LWE/LR 13000-001/19503-01-02/en

Assembling the ladder

Make sure that the following prerequisite is met:

- The platforms **2** are properly installed and secured.



WARNING

Danger of falling!

During assembly and disassembly, assembly personnel must be secured with appropriate aids to prevent them from falling!

There is a danger of falling even during the disassembly of protective devices!

Assembly personnel can fall and be severely injured or killed!

- ▶ Use personal protective equipment!

- ▶ Remove the ladder **10** from the transport receptacle: Remove the safety locking pin **12** and pull out the axle **11**, see illustration **9**.

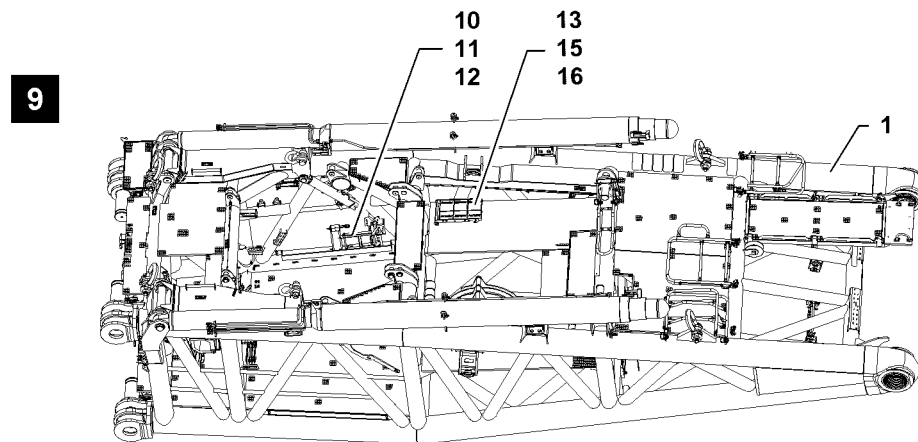

Fig. 114356



WARNING

Danger of falling!

If the axles **11** are not secured with the safety locking pins **12**, the axles can move during crane operation! The ladder **10** can release from the platform!

Personnel can fall and be severely injured or killed when climbing up!

- ▶ Make sure that the axles **11** are secured!

- ▶ Fasten the ladder **10** on the platform in point **P3**: Insert the axle **11** through the mounting of the platform and through the rung of the ladder, see illustration **4**.
- ▶ Secure the axle with the safety locking pin **12**, see illustration **4**.
- ▶ Fasten the ladder **10** on the platform in point **P4**: Insert the axle **11** through the mounting of the platform and through the rung of the ladder, see illustration **5**.
- ▶ Secure the axle with the safety locking pin **12**, see illustration **5**.

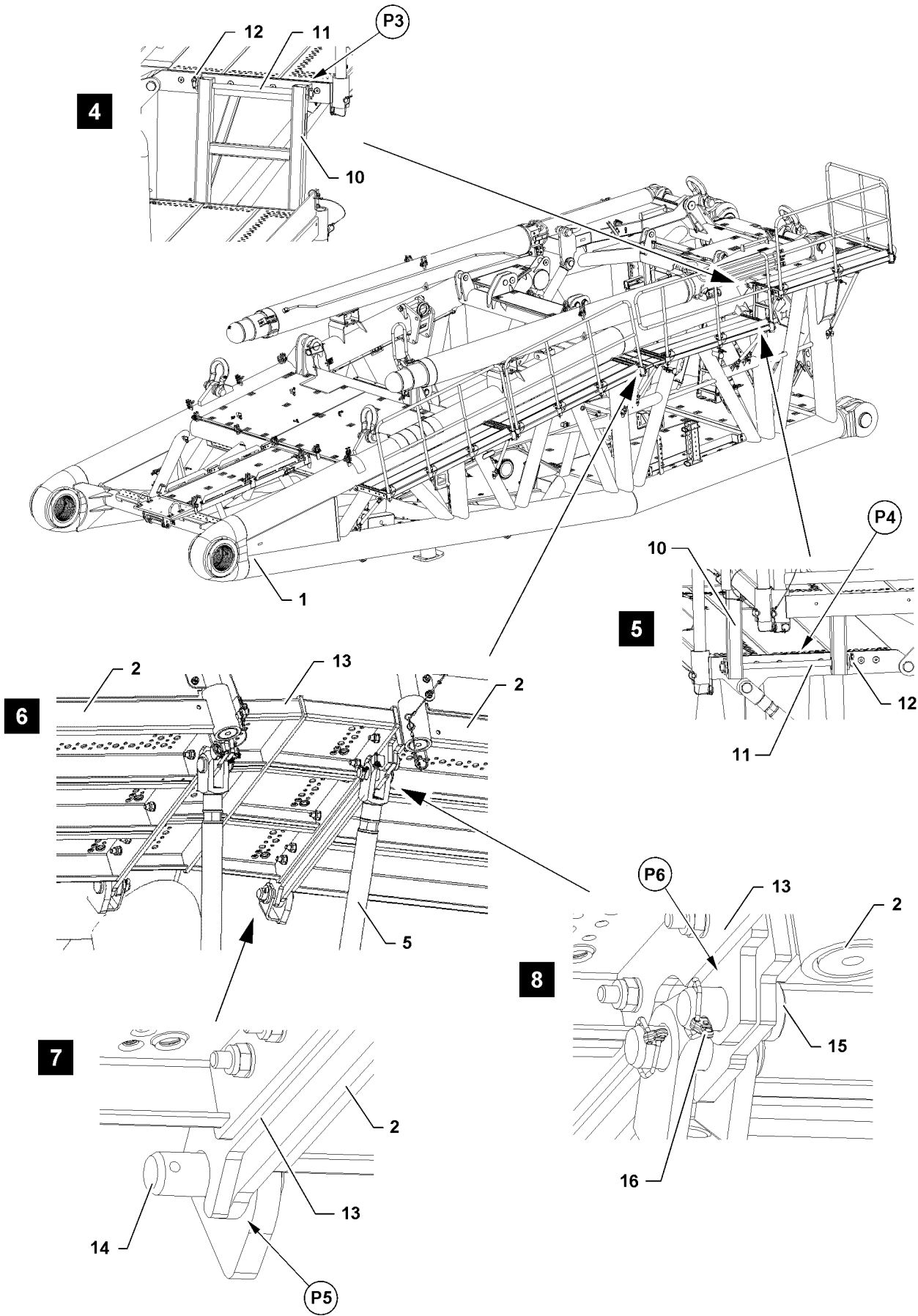

Fig.114354

LWE/LR 13000-001/19503-01-02/en

Assembling the platform

Make sure that the following prerequisite is met:

- The platforms **2** are properly installed and secured.



WARNING

Danger of falling!

During assembly and disassembly, assembly personnel must be secured with appropriate aids to prevent them from falling!

There is a danger of falling even during the disassembly of protective devices!

Assembly personnel can fall and be severely injured or killed!

- ▶ Use personal protective equipment!

- ▶ Remove the platform **13** from the transport receptacle: Remove the safety locking pin **16** and unpin the pin **15**, see illustration **9**.

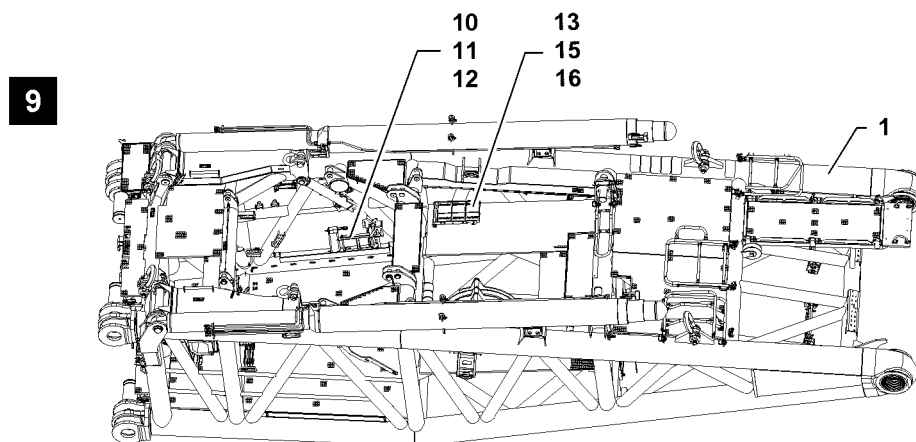

Fig. 114356

- ▶ Set the platform **13** on pin **14** in point **P5** on both sides, see illustration **7**.



WARNING

Danger of falling!

If the pins **15** are not secured with the safety locking pins **16**, the axles can release during crane operation! The platform **13** can fold down when accessed by personnel!

Personnel can fall and be severely injured or killed!

- ▶ Make sure that the pins **15** are inserted and secured!

- ▶ Pin the platform **13** on the front with the platform **2** in point **P6** on both sides: Insert the pin **15** and secure with the safety locking pin **16**, see illustration **8**.

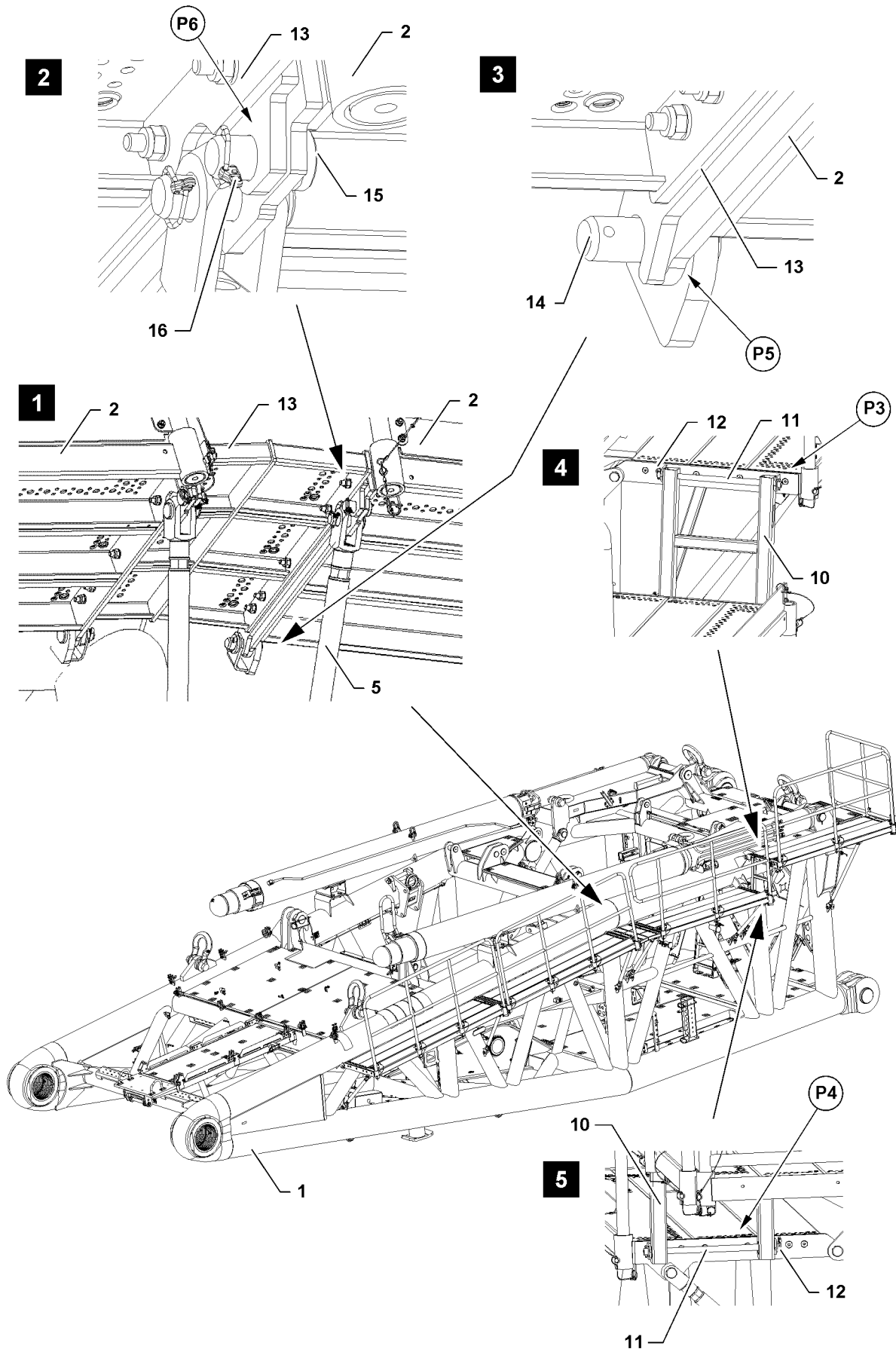

Fig.114357

LWE/LR 13000-001/19503-01-02/en

5.3.2 Swinging the platforms on the D-pivot section into the operating position

Disassembling the platform



WARNING

Danger of falling!

During assembly and disassembly, assembly personnel must be secured with appropriate aids to prevent them from falling!

There is a danger of falling even during the disassembly of protective devices!

Assembly personnel can fall and be severely injured or killed!

- ▶ Use personal protective equipment!



Note

- ▶ Use a work platform for the assembly and disassembly of the platforms and ladders!
- ▶ The work platform with 1 m height is present on the turntable frame rear section, see section „Work platform on the turntable frame rear section“!



WARNING

Folding platform!

The platform **13** can fold down by itself due to its own weight when it is unpinned!

Personnel can be severely injured!

Fingers and hands can be crushed!

- ▶ Hold the platform **13** when unpinning!

- ▶ Unpin the platform **13** on the front from the platform **2** in point **P6** on both sides: Remove the safety locking pin **16** and unpin the pin **15**, see illustration **1** and illustration **2**.
- ▶ Unpin the platform **13** in point **P5** on both sides, see illustration **3**.

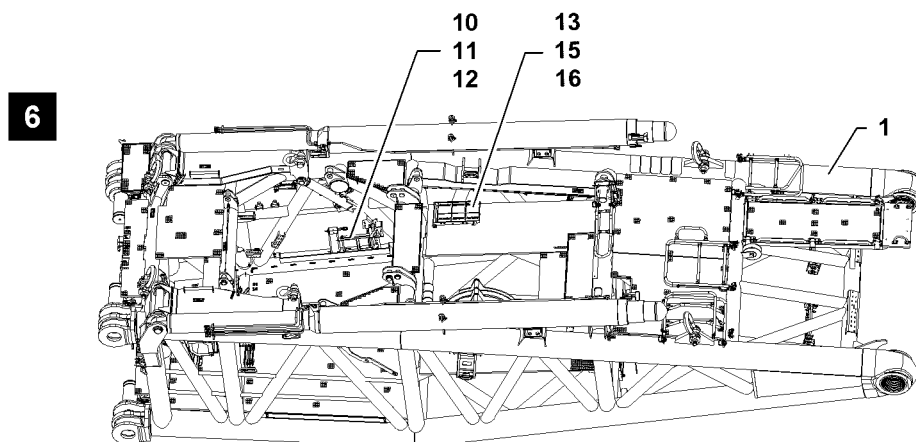

Fig.114359

- ▶ Pin the platform **13** in the transport receptacle: Insert the pin **15** and secure with the safety locking pin **16**, see illustration **6**.

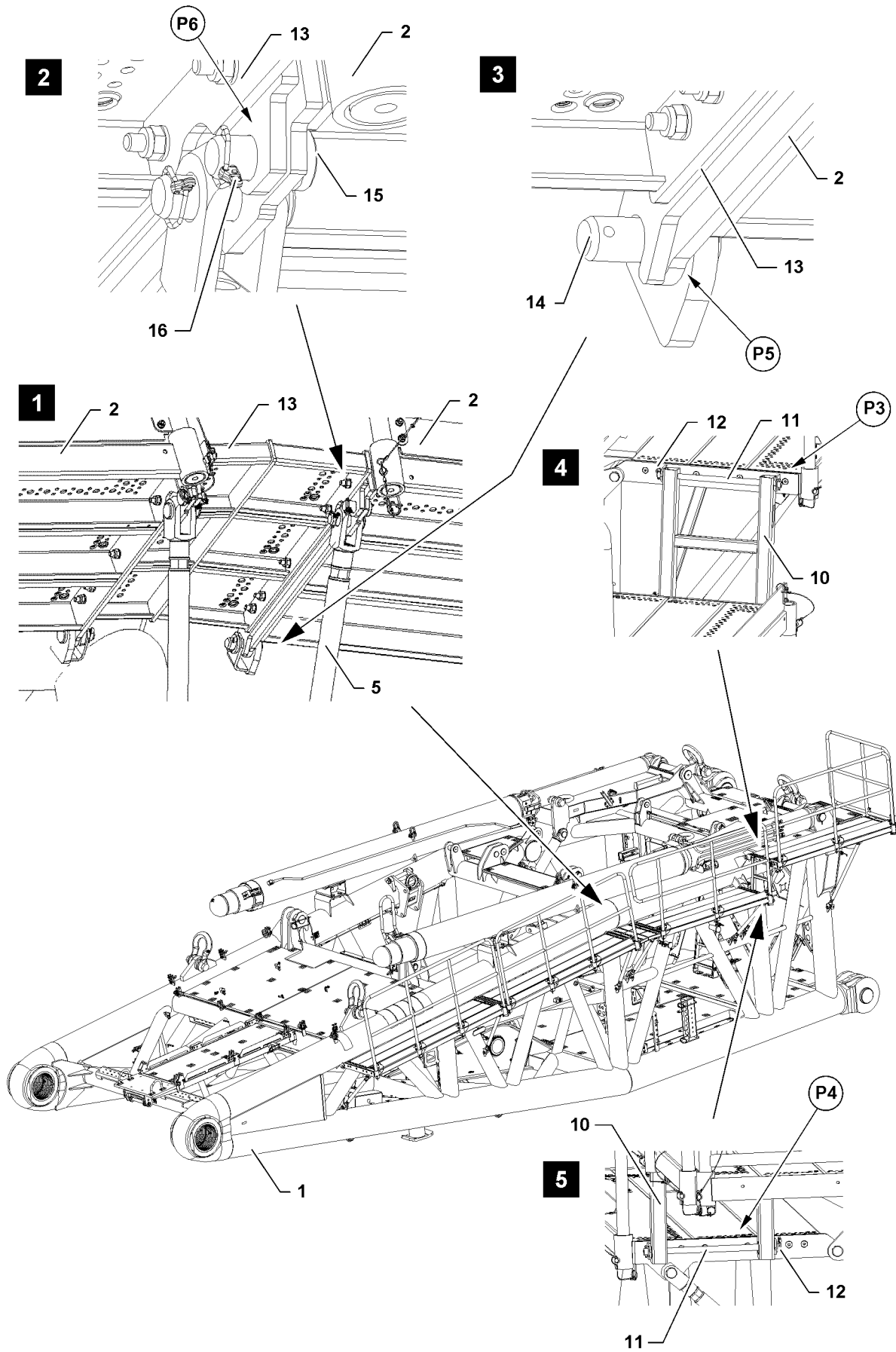

Fig.114357

LWE/LR 13000-001/19503-01-02/en

Disassembling the ladder



WARNING

Danger of falling!

During assembly and disassembly, assembly personnel must be secured with appropriate aids to prevent them from falling!

There is a danger of falling even during the disassembly of protective devices!

Assembly personnel can fall and be severely injured or killed!

► Use personal protective equipment!

- Unpin the ladder **10** on the platform in point **P4**: Remove the safety locking pin **12** and pull out the axle **11**, see illustration **4**.



WARNING

Falling platform!

The platform **13** can fold down by itself due to its own weight when it is unpinned!

Personnel can be severely injured!

Fingers and hands can be crushed!

► Hold the platform **13** when unpinning!

- Unpin the ladder **10** on the platform in point **P3**: Remove the safety locking pin **12** and pull out the axle **11**, see illustration **5**.

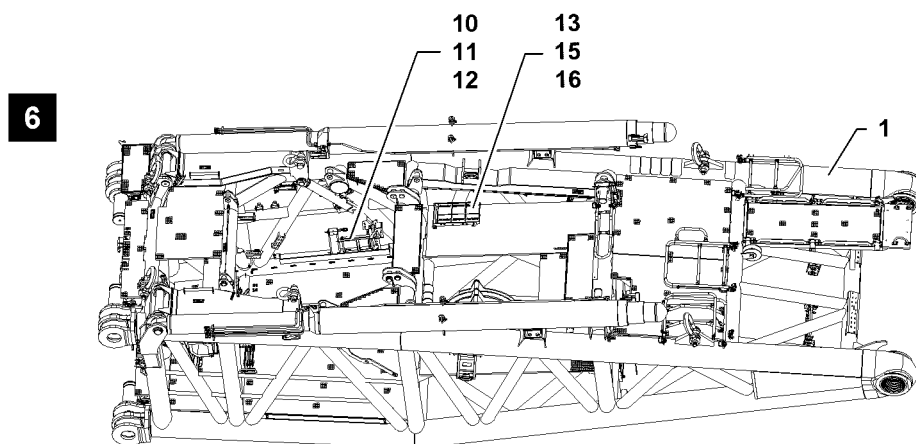

Fig. 114359

- Pin the ladder **10** in the transport receptacle: Insert the axle **11** and secure with the safety locking pin **12**, see illustration **6**.

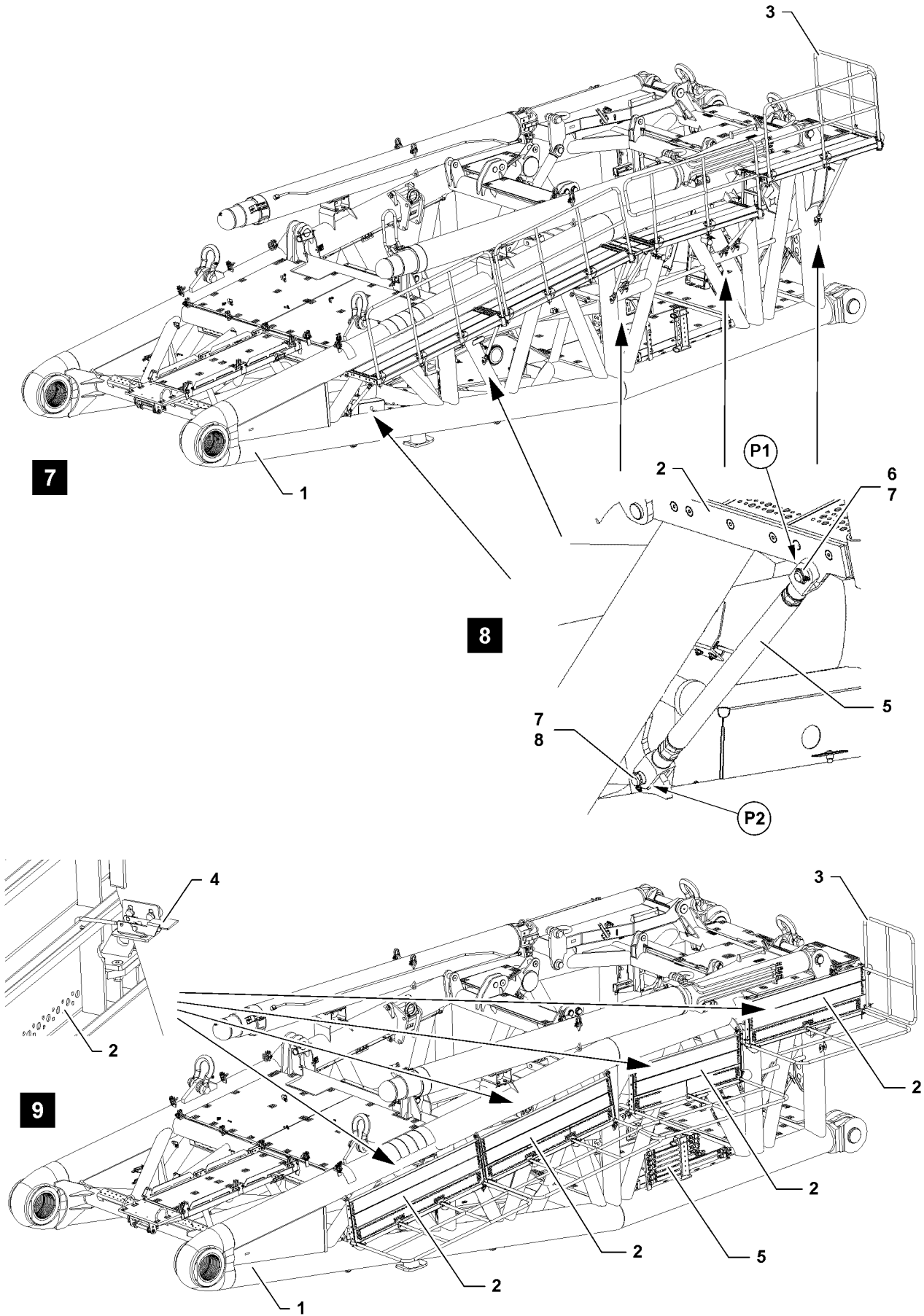

Fig.114358

LWE/LR 13000-001/19503-01-02/en

Folding the platforms down



Note

- ▶ The disassembly of the platforms is described based on the example of one platform!



WARNING

Danger of falling!

During assembly and disassembly, assembly personnel must be secured with appropriate aids to prevent them from falling!

There is a danger of falling even during the disassembly of protective devices!

Assembly personnel can fall and be severely injured or killed!

- ▶ Use personal protective equipment!
- ▶ Fasten the auxiliary crane to the platform **2**.



WARNING

Folding down platform!

The platform **2** can swing down by itself due to its own weight when it is unpinned!

Personnel can be severely injured!

Fingers and hands can be crushed!

- ▶ Make sure that the platform **2** is fastened to the auxiliary crane before unpinning!



WARNING

Swinging support!

When releasing the support **5** in point **P2** it can swing forward uncontrolled!

Personnel can be severely injured or killed!

- ▶ Assembly personnel must be to the side of the assembly unit!
- ▶ Unpin the support **5** in point **P2**: Remove the safety locking pin **7** and unpin the pin **8**, see illustration **7** and illustration **8**.



Note

- ▶ The weight of the support is 17 kg !



WARNING

Folding down platform!

The support **5** can fall down by itself due to its own weight when it is unpinned!

Personnel can be severely injured or killed!

- ▶ Hold the support **5** when unpinning!
- ▶ Unpin the support **5** in point **P1**: Remove the safety locking pin **7** and unpin the pin **6**, see illustration **8**.
- ▶ Fold the platform **2** down with the auxiliary crane.
- ▶ Secure the platform **2** with the latch **4**, see illustration **9**.
- ▶ Secure the supports **5** in the transport receptacle, see illustration **9**.
- ▶ Fold all platforms **2** down, see illustration **9**.

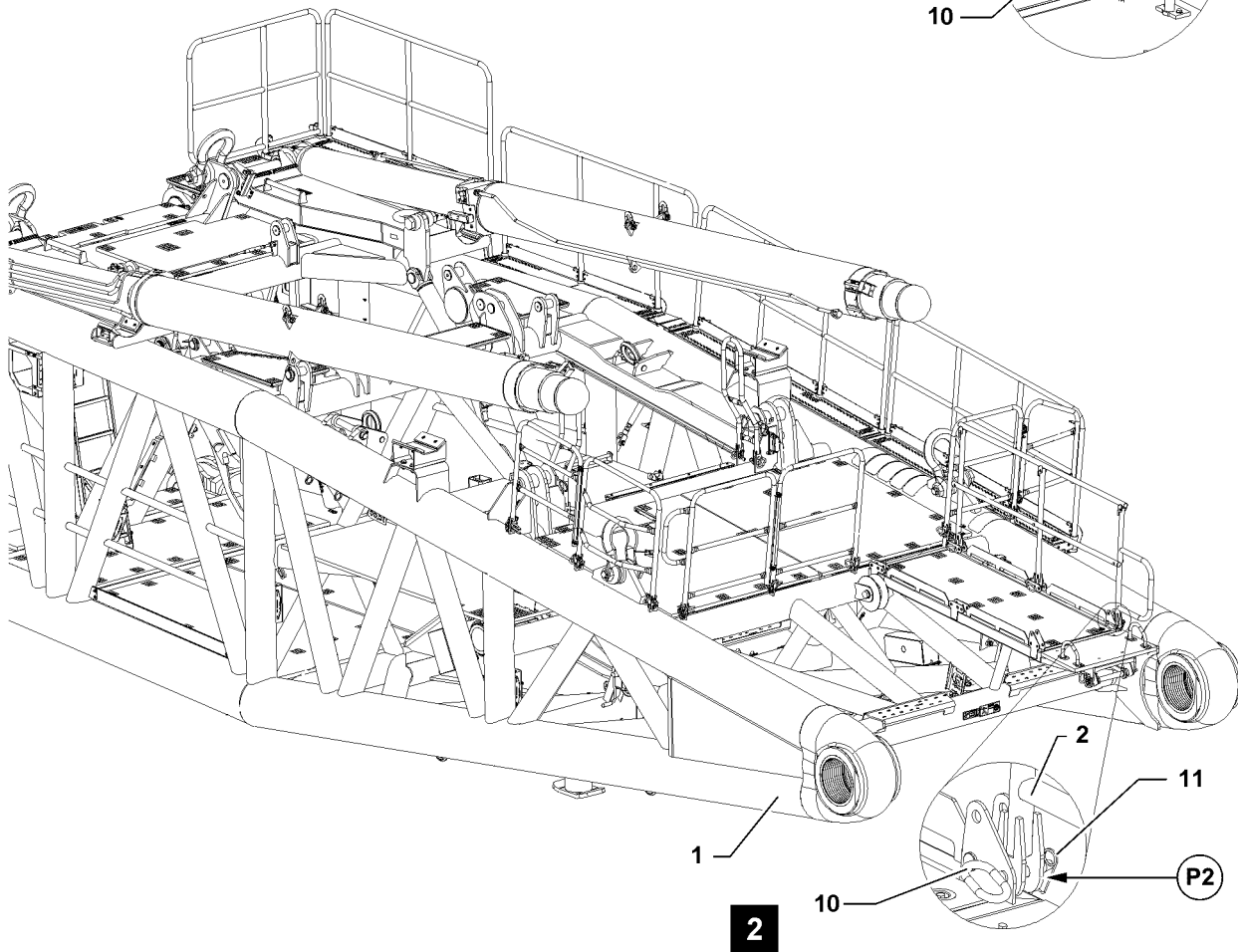
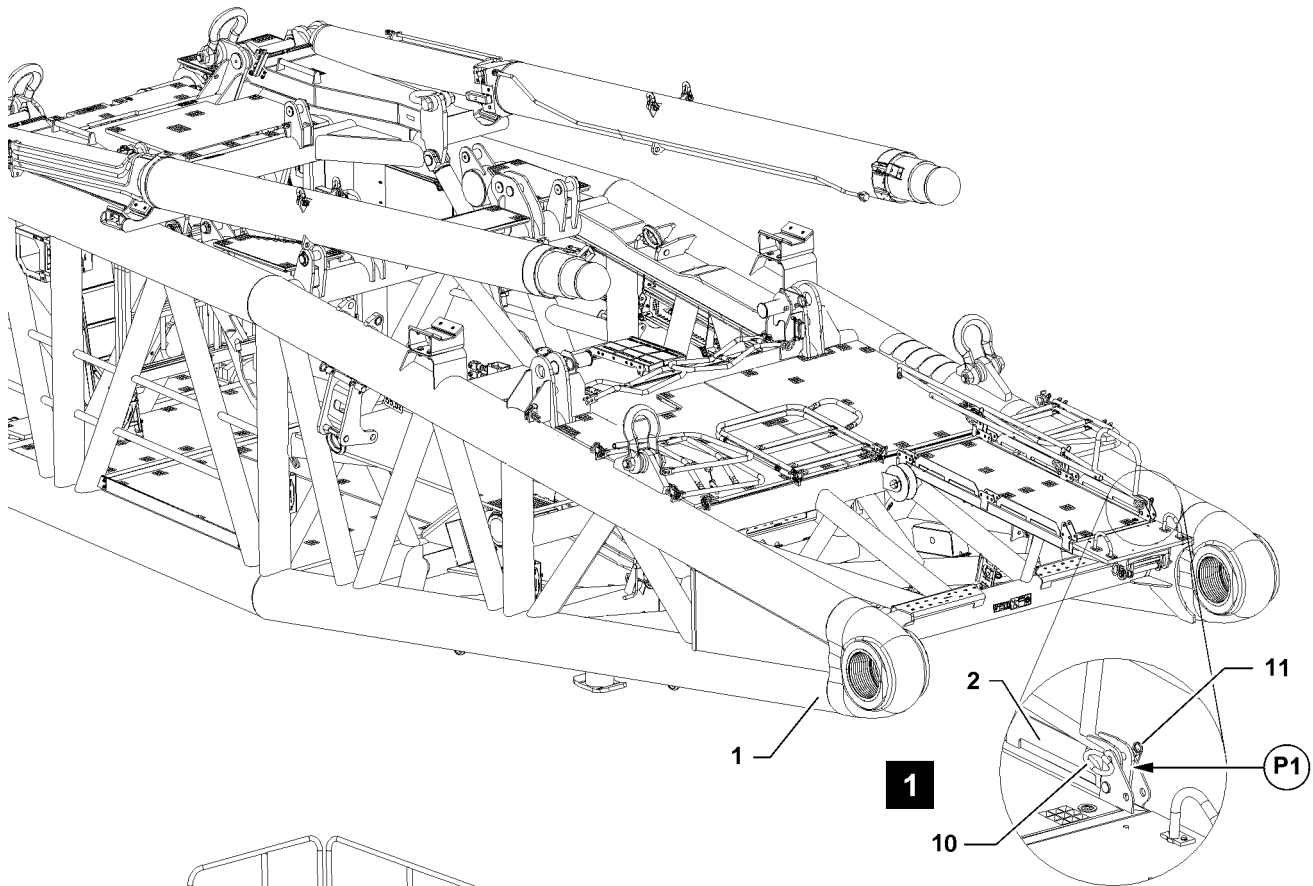

Fig.114360

LWE/LR 13000-001/19503-01-02/en

5.4 Railing on the D-pivot section

5.4.1 Swinging the railings into the operating position

**WARNING**

Danger of falling!

During assembly and disassembly of the railing, personnel must be secured with appropriate aids to prevent them from falling!

There is a danger of falling even during the disassembly of protective devices!

Assembly personnel can fall and be severely injured or killed!

- ▶ Use personal protective equipment!

**Note**

- ▶ The railings must be set up starting from the coupling point!

Railing 2**Note**

- ▶ The railing receptacles are described based on the example of one railing receptacle!

- ▶ Release the railing **2** from the transport position: Remove the spring retainer **11** in point **P1** and unpin the connector **10**, see illustration **1**.

**WARNING**

Danger of crushed limbs!

When swinging the railings, fingers and hands can be crushed!

- ▶ Do not reach with your hands into the danger zone!
- ▶ Swing the railing **2** into the operating position.
- ▶ Secure the railing **2** in the operating position: Pin the connector **10** in point **P2** and secure with the spring retainer **11**, see illustration **2**.

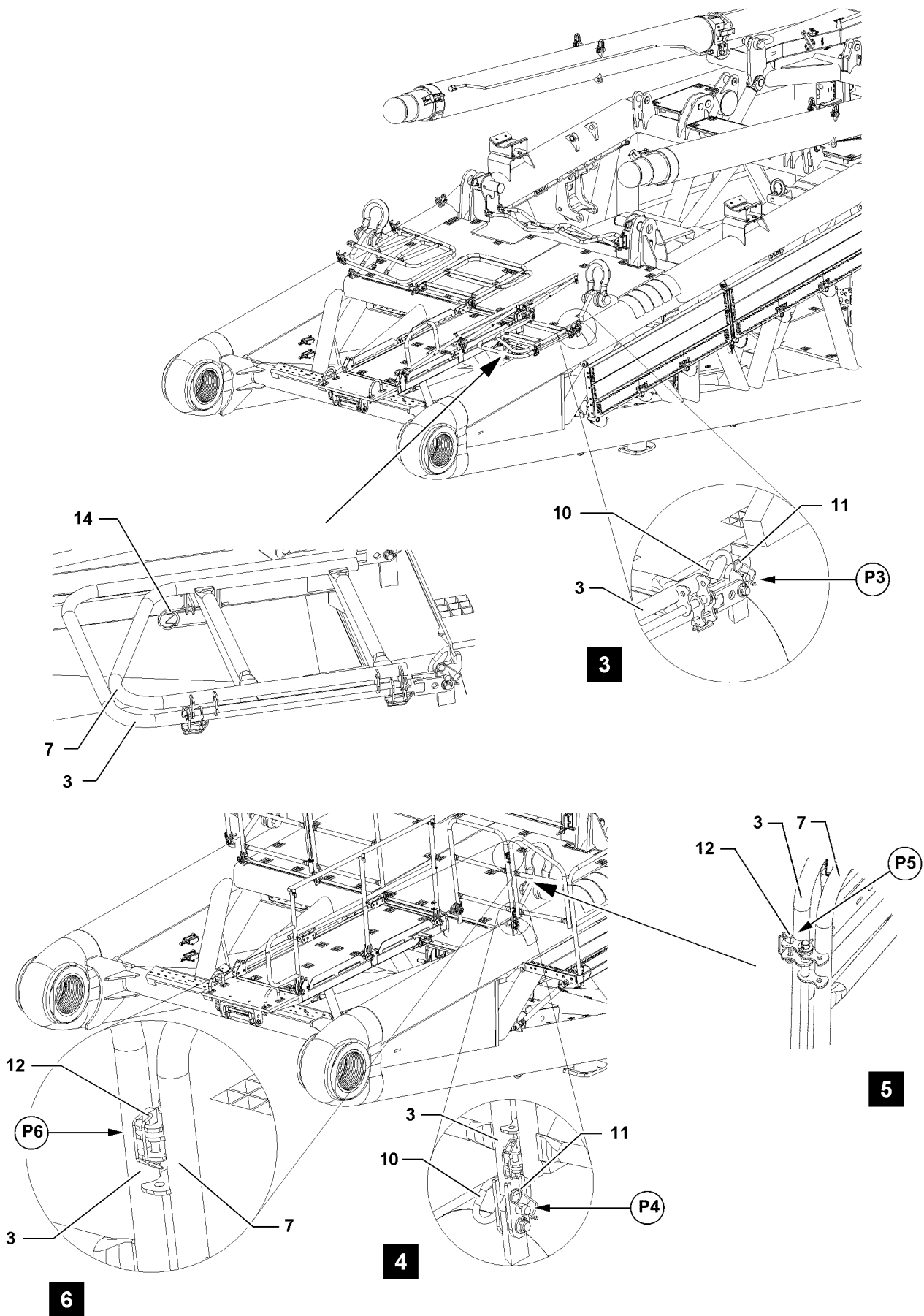

Fig.114361

LWE/LR 13000-001/19503-01-02/en

Railing 3

**Note**

- ▶ The railing receptacles are described based on the example of one railing receptacle!
- ▶ Release the railing **3** in the transport position: Remove the spring retainer **14**.
- ▶ Release the railing **3**: Remove the spring retainer **11** in point **P3** and unpin the connector **10**, see illustration **3**.

**WARNING**

Danger of crushed limbs!

When swinging the railings, fingers and hands can be crushed!

- ▶ Do not reach with your hands into the danger zone!
- ▶ Swing the railing **3** into the operating position.
- ▶ Secure the railing **3** in the operating position: Pin the connector **10** in point **P4** and secure with the spring retainer **11**, see illustration **4**.
- ▶ Release the clip **12** in point **P5** and pull out from the hinges, see illustration **5**.

**WARNING**

Danger of crushed limbs!

When swinging the railings, fingers and hands can be crushed!

- ▶ Do not reach with your hands into the danger zone!
- ▶ Fold the railing **7** out into the operating position.
- ▶ Secure the railing **7**: Insert the clip **12** in point **P6** and secure, see illustration **6**.

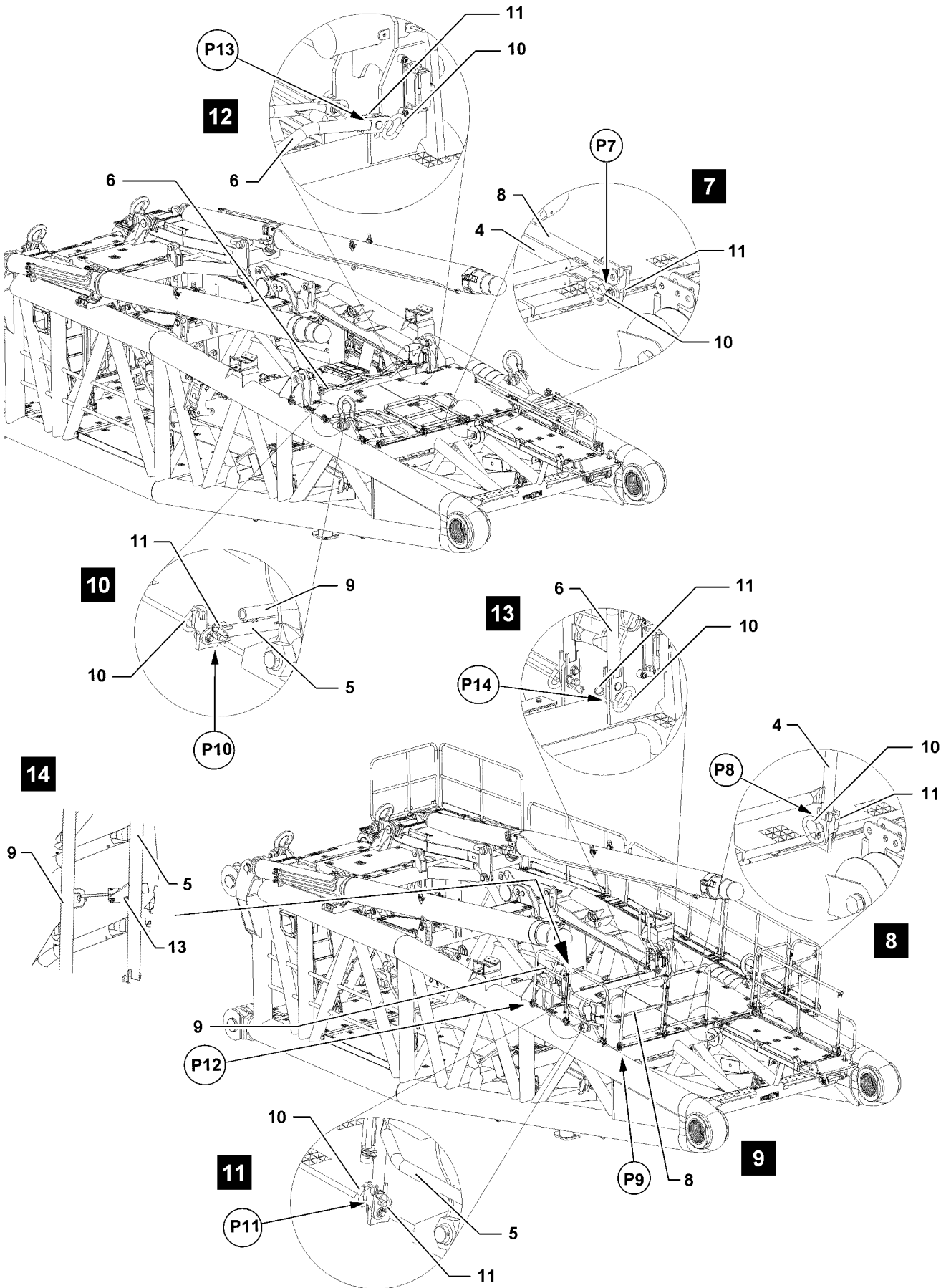

Fig.114362

LWE/LR 13000-001/19503-01-02/en

Railing 4



Note

- ▶ The railing receptacles are described based on the example of one railing receptacle!
- ▶ Release the railing **4** from the transport position: Remove the spring retainer **11** in point **P7** and unpin the connector **10**, see illustration 7.



WARNING

Danger of crushed limbs!

When swinging the railings, fingers and hands can be crushed!

- ▶ Do not reach with your hands into the danger zone!
- ▶ Swing the railing **4** into the operating position.
- ▶ Secure the railing **4** in the operating position: Pin the connector **10** in point **P8** and secure with the spring retainer **11**, see illustration 8.



WARNING

Danger of crushed limbs!

When swinging the railings, fingers and hands can be crushed!

- ▶ Do not reach with your hands into the danger zone!
- ▶ Fold the railing **8** out.
- ▶ Secure the railing **8** in point **P9**: Pin the connector **10** and secure with spring retainer **11**, see illustration 9.

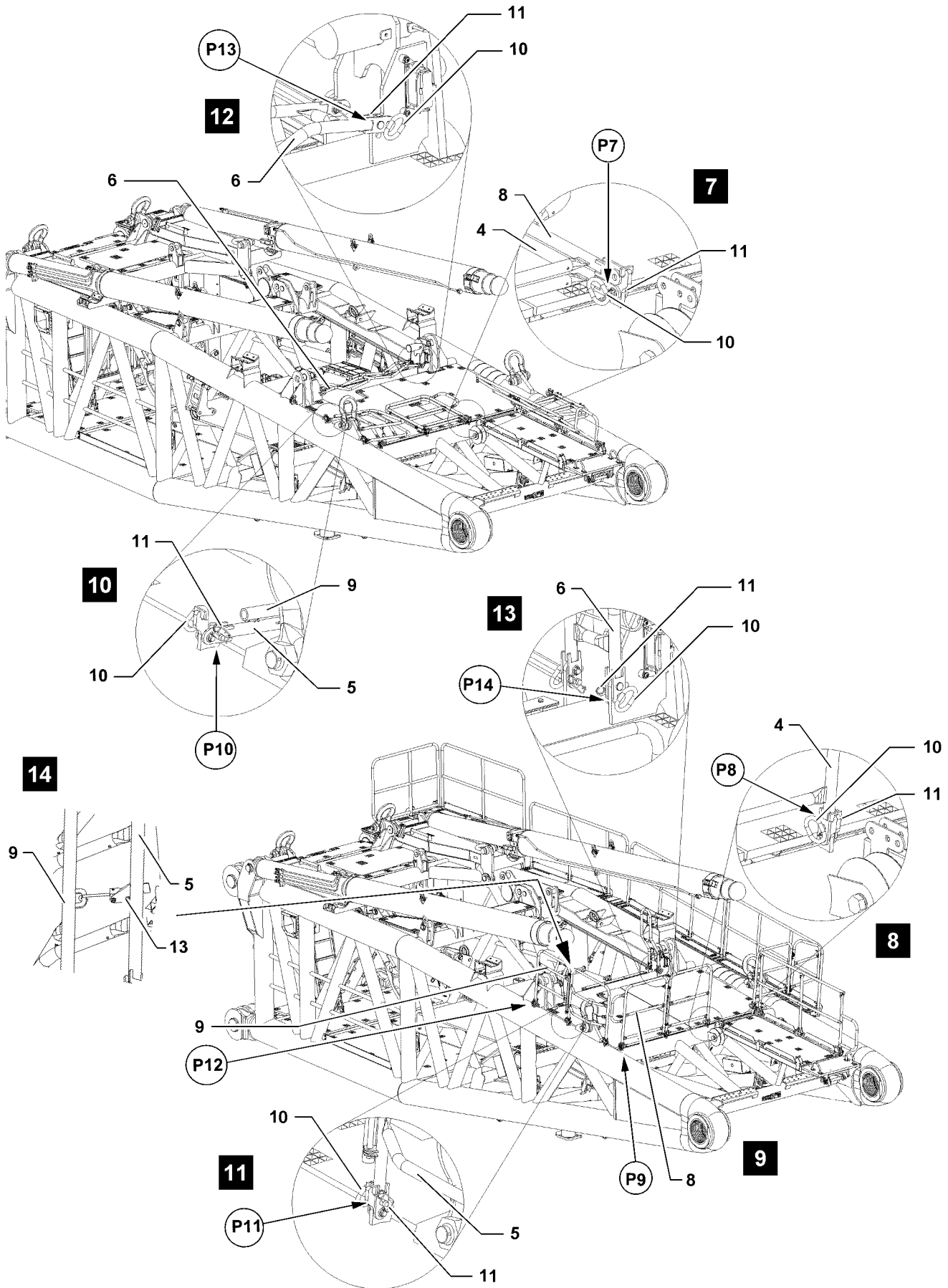

Fig.114362

LWE/LR 13000-001/19503-01-02/en

Railing 5



Note

- ▶ The railing receptacles are described based on the example of one railing receptacle!
- ▶ Release the railing **5** from the transport position: Remove the spring retainer **11** in point **P10** and unpin the connector **10**, see illustration **10**.



WARNING

Danger of crushed limbs!

When swinging the railings, fingers and hands can be crushed!

- ▶ Do not reach with your hands into the danger zone!
- ▶ Swing the railing **5** into the operating position.
- ▶ Secure the railing **5** in the operating position: Pin the connector **10** in point **P11** and secure with the spring retainer **11**, see illustration **11**.



WARNING

Danger of crushed limbs!

When swinging the railings, fingers and hands can be crushed!

- ▶ Do not reach with your hands into the danger zone!
- ▶ Release the railing **9**: Open the latch **13**, see illustration **14**.
- ▶ Fold the railing **9** out.
- ▶ Secure the railing **9** in point **P12**: Pin the connector **10** and secure with spring retainer **11**, see illustration **9**.

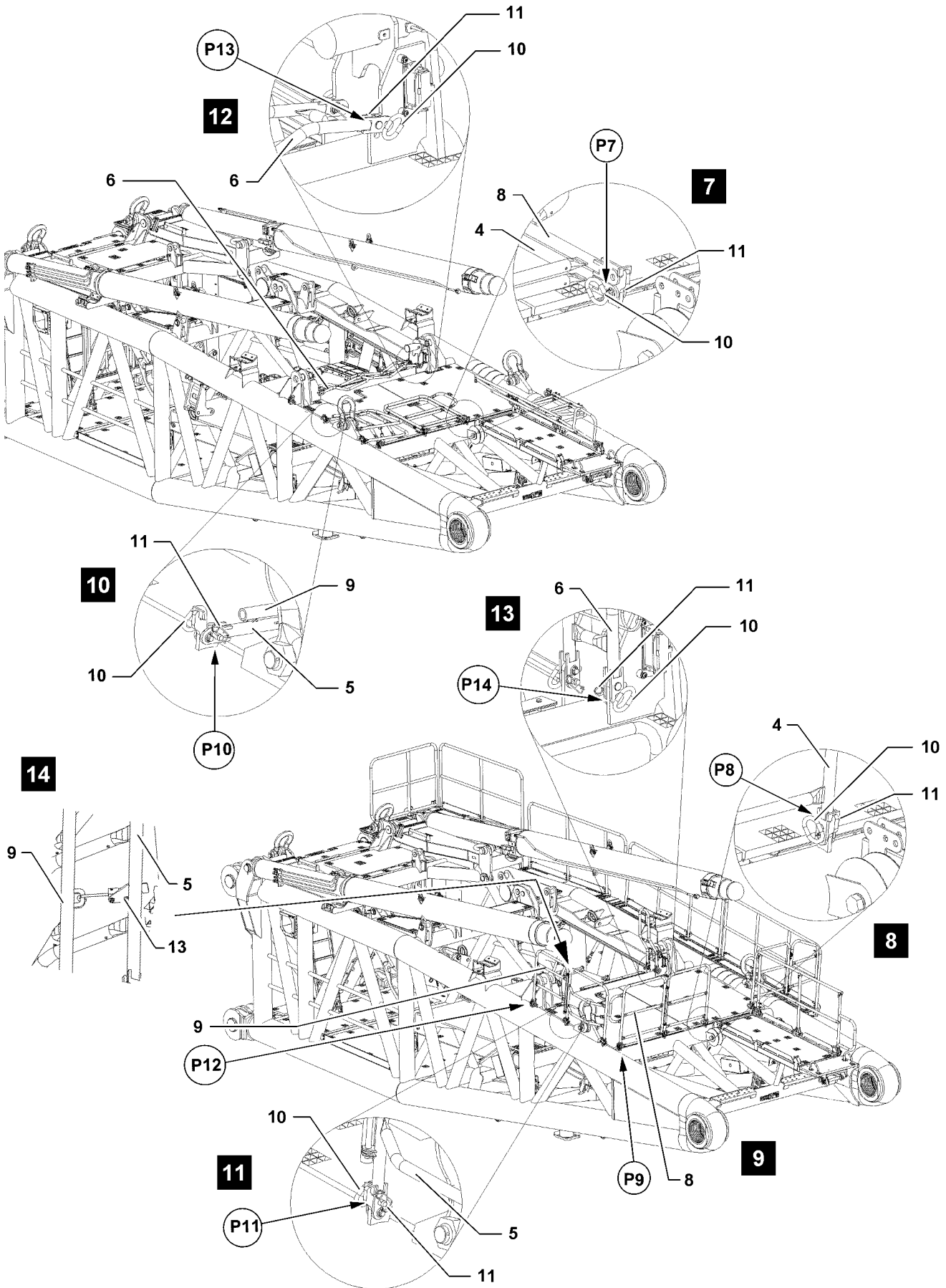

Fig.114362

LWE/LR 13000-001/19503-01-02/en

Railing 6



Note

- ▶ The railing receptacles are described based on the example of one railing receptacle!
- ▶ Release the railing **6** from the transport position: Remove the spring retainer **11** in point **P13** and unpin the connector **10**, see illustration **12**.



WARNING

Danger of crushed limbs!

When swinging the railings, fingers and hands can be crushed!

- ▶ Do not reach with your hands into the danger zone!
- ▶ Swing the railing **6** into the operating position.
- ▶ Secure the railing **6** in the operating position: Pin the connector **10** in point **P14** and secure with the spring retainer **11**, see illustration **13**.
- ▶ Swing the second railing **6** into the operating position.

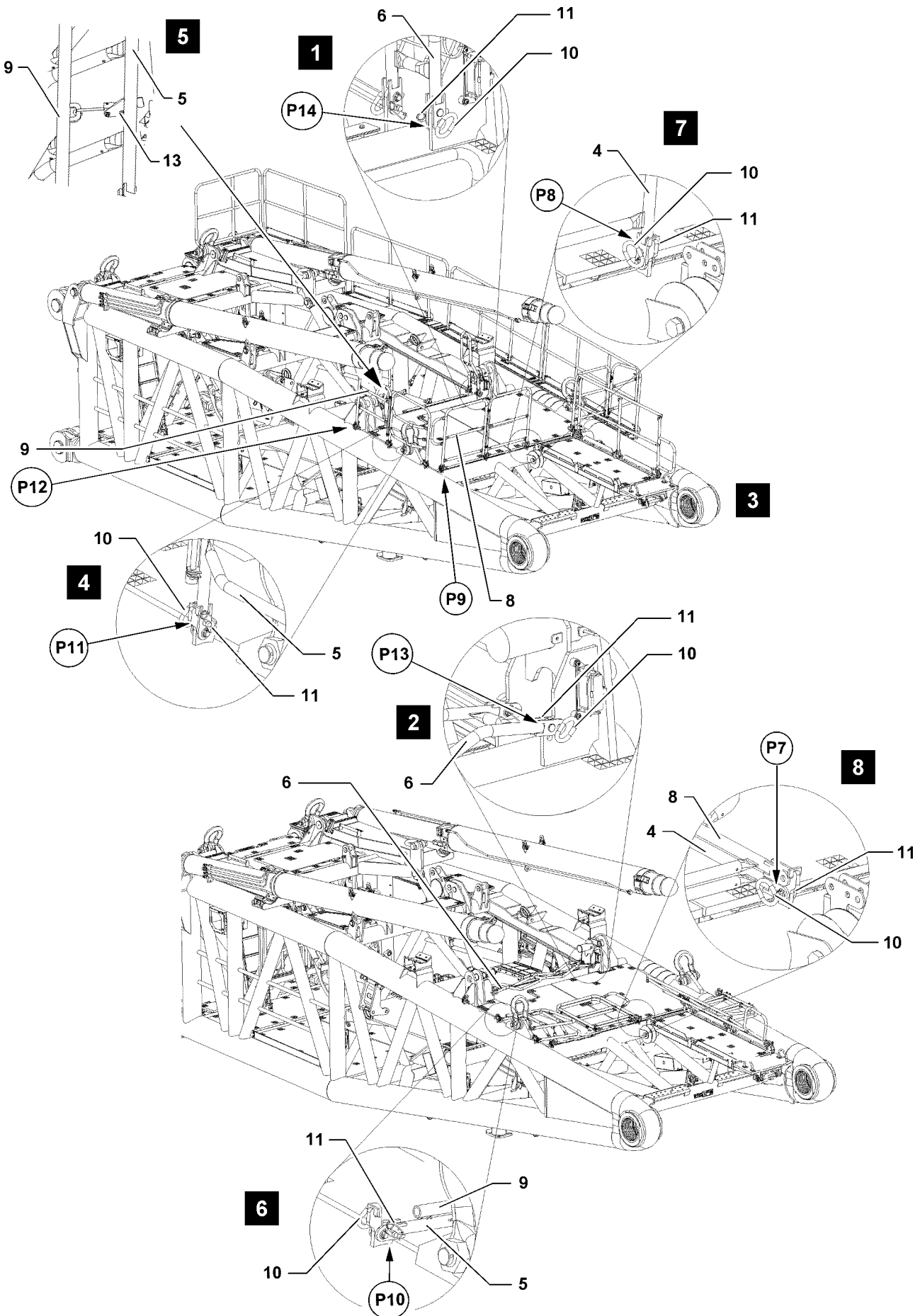

Fig.114363

LWE/LR 13000-001/19503-01-02/en

5.4.2 Swinging the railings into the transport position



WARNING

Danger of falling!

During assembly and disassembly of the railing, personnel must be secured with appropriate aids to prevent them from falling!

There is a danger of falling even during the disassembly of protective devices!

Assembly personnel can fall and be severely injured or killed!

- ▶ Use personal protective equipment!



Note

- ▶ The railings must be removed starting from railing **6** in direction of the coupling point!

Railing 6



Note

- ▶ The railing receptacles are described based on the example of one railing receptacle!



WARNING

Folding down railing!

The railing can swing down by itself due to its own weight when it is unpinned!

Personnel can be severely injured!

Fingers and hands can be crushed!

- ▶ Hold the railing when unpinning!

- ▶ Release the railing **6** from the operating position: Remove the spring retainer **11** in point **P14** and unpin the connector **10**, see illustration **1**.
- ▶ Swing the railing **6** into the transport position.
- ▶ Secure the railing **6** in the transport position: Pin the connector **10** in point **P13** and secure with the spring retainer **11**, see illustration **2**.
- ▶ Swing the second railing **6** into the transport position.

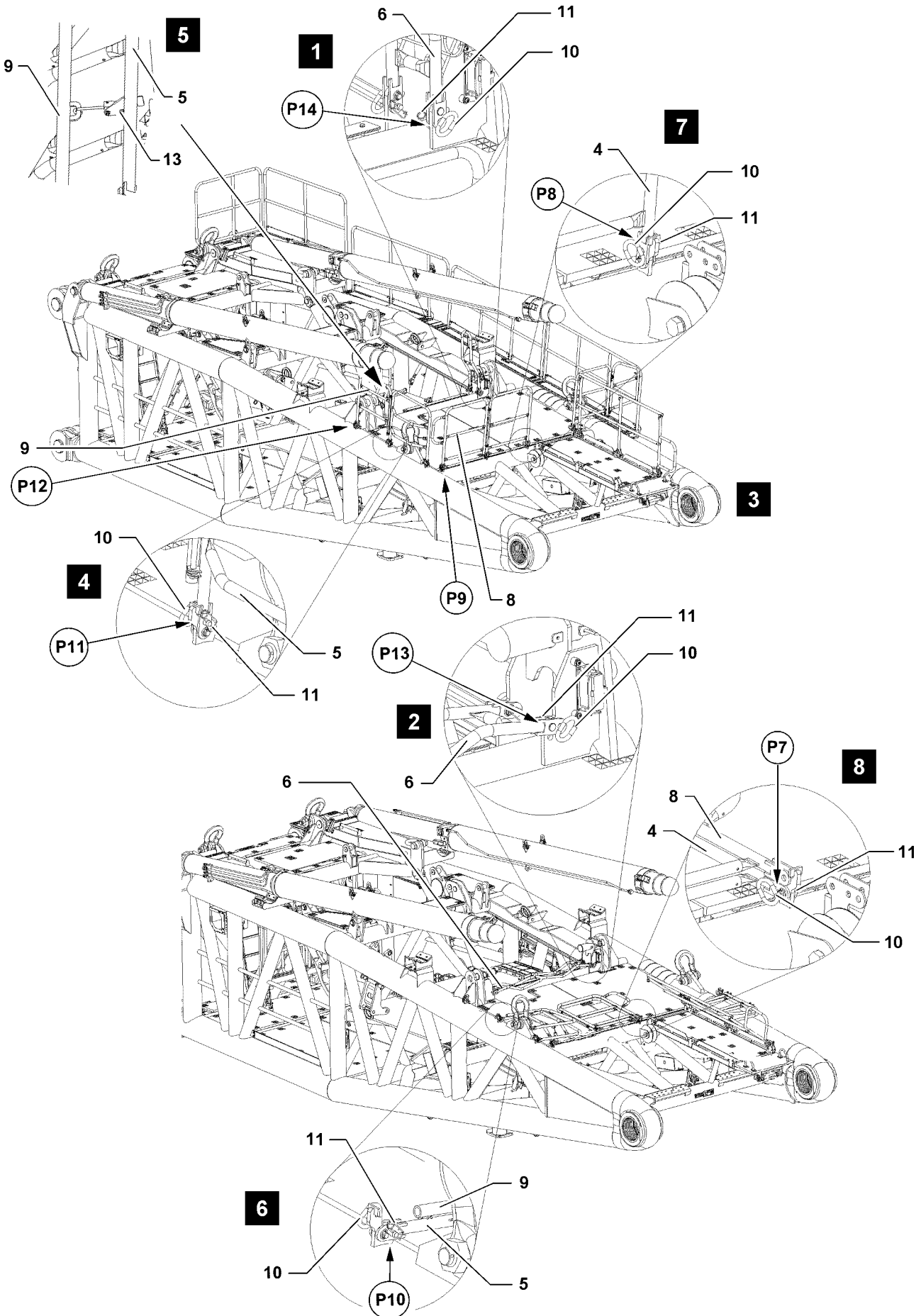

Fig.114363

LWE/LR 13000-001/19503-01-02/en

Railing 5



Note

- ▶ The railing receptacles are described based on the example of one railing receptacle!
- ▶ Release the railing **9** in point **P12**: Remove the spring retainer **11** and unpin the connector **10**, see illustration **3**.



WARNING

Danger of crushed limbs!

When swinging the railings, fingers and hands can be crushed!

- ▶ Do not reach with your hands into the danger zone!
- ▶ Fold the railing **9** in.
- ▶ Secure the railing **9** with the latch **13**, see illustration **5**.



WARNING

Folding down railing!

The railing can swing down by itself due to its own weight when it is unpinned!

Personnel can be severely injured!

Fingers and hands can be crushed!

- ▶ Hold the railing when unpinning!
- ▶ Release the railing **5** from the operating position: Remove the spring retainer **11** in point **P11** and unpin the connector **10**, see illustration **4**.
- ▶ Swing the railing **5** into the transport position.
- ▶ Secure the railing **5** in the transport position: Pin the connector **10** in point **P10** and secure with the spring retainer **11**, see illustration **6**.

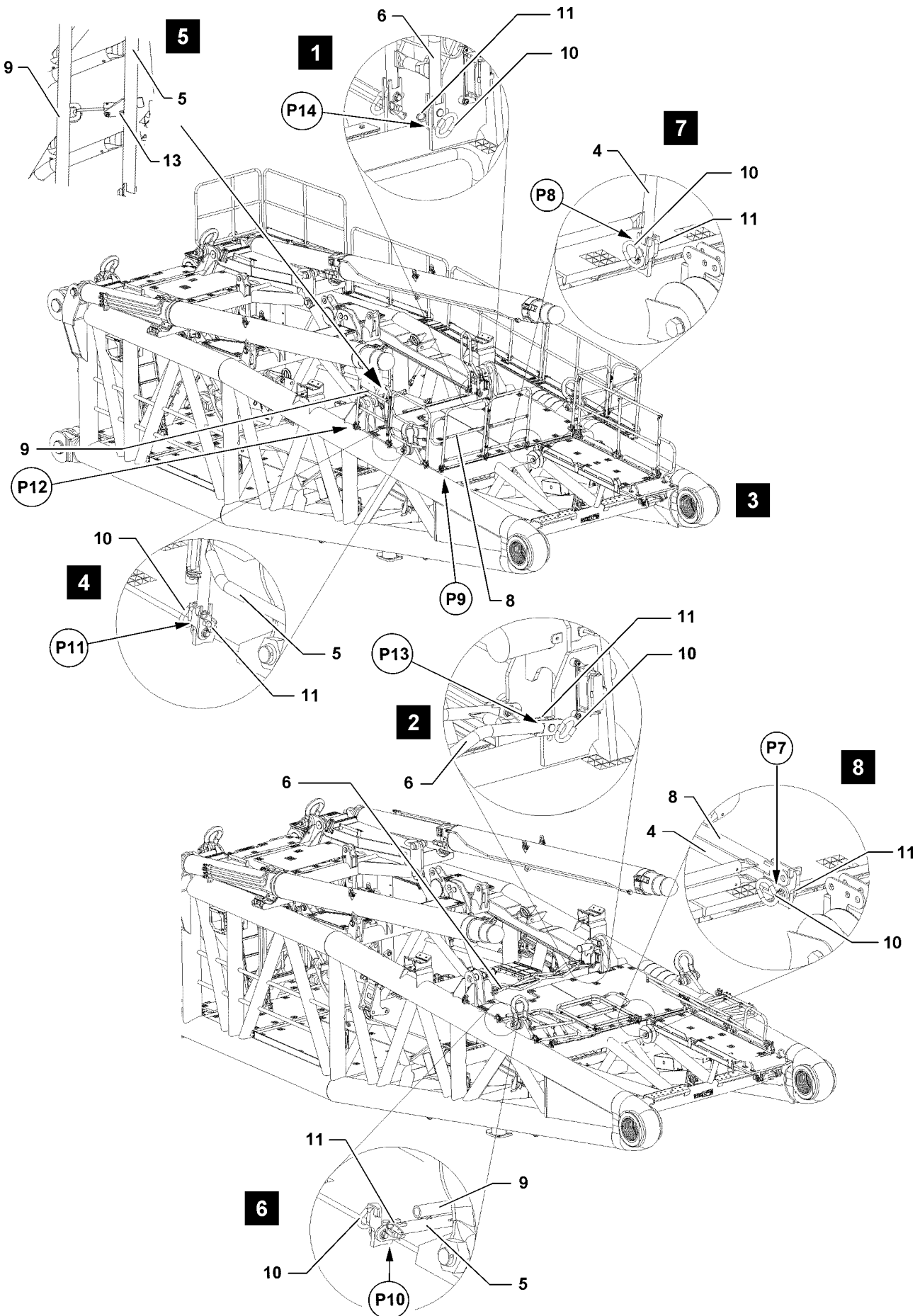

Fig.114363

LWE/LR 13000-001/19503-01-02/en

Railing 4



Note

- ▶ The railing receptacles are described based on the example of one railing receptacle!
- ▶ Release the railing **8** in point **P9**: Remove the spring retainer **11** and unpin the connector **10**, see illustration **3**.



WARNING

Danger of crushed limbs!

When swinging the railings, fingers and hands can be crushed!

- ▶ Do not reach with your hands into the danger zone!
- ▶ Fold the railing **8** in.



WARNING

Folding down railing!

The railing can swing down by itself due to its own weight when it is unpinned!

Personnel can be severely injured!

Fingers and hands can be crushed!

- ▶ Hold the railing when unpinning!
- ▶ Release the railing **4** from the operating position: Remove the spring retainer **11** in point **P8** and unpin the connector **10**, see illustration **7**.
- ▶ Swing the railing **4** into the transport position.
- ▶ Secure the railing **4** in the transport position: Pin the connector **10** in point **P7** and secure with the spring retainer **11**, see illustration **8**.

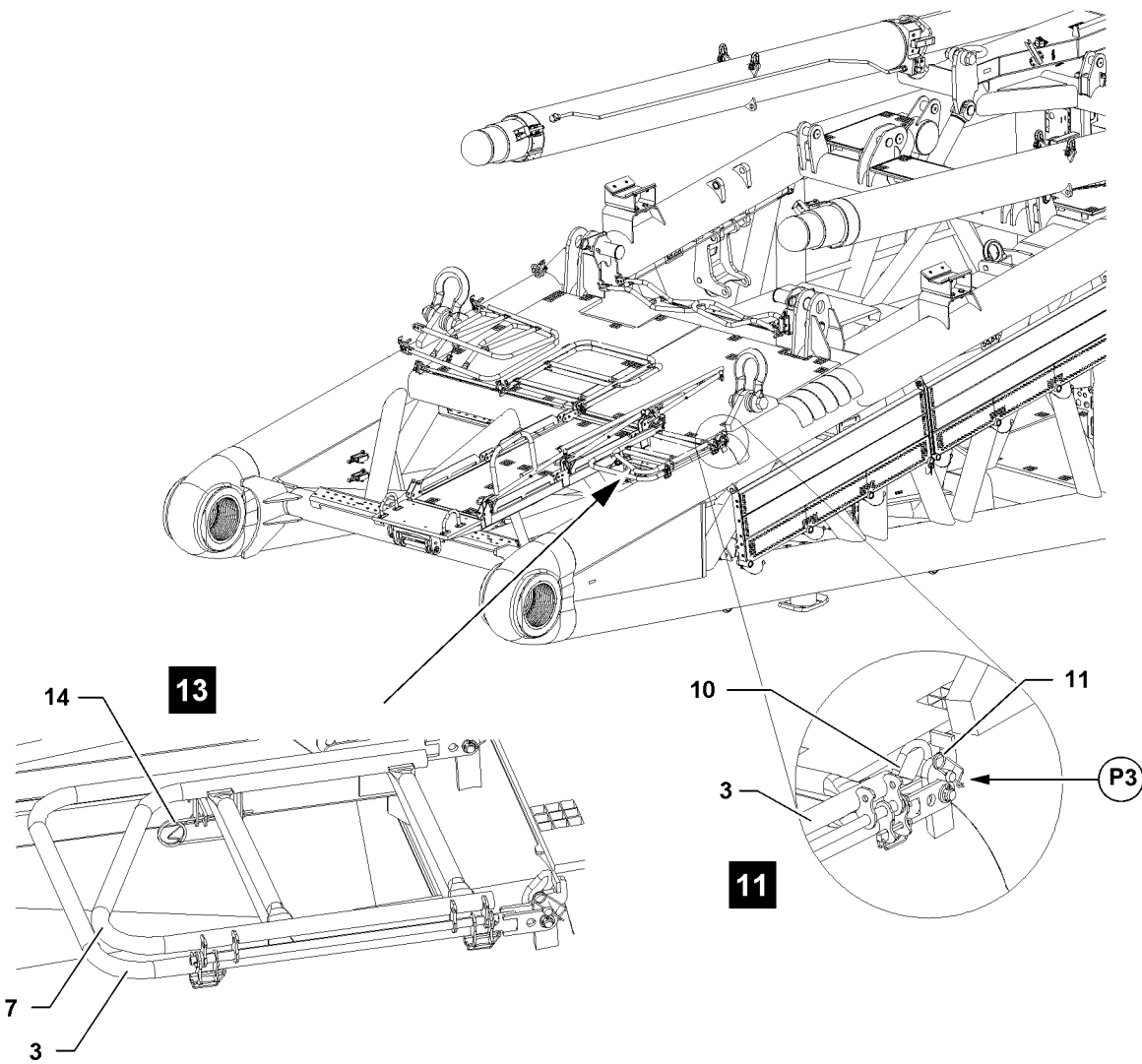
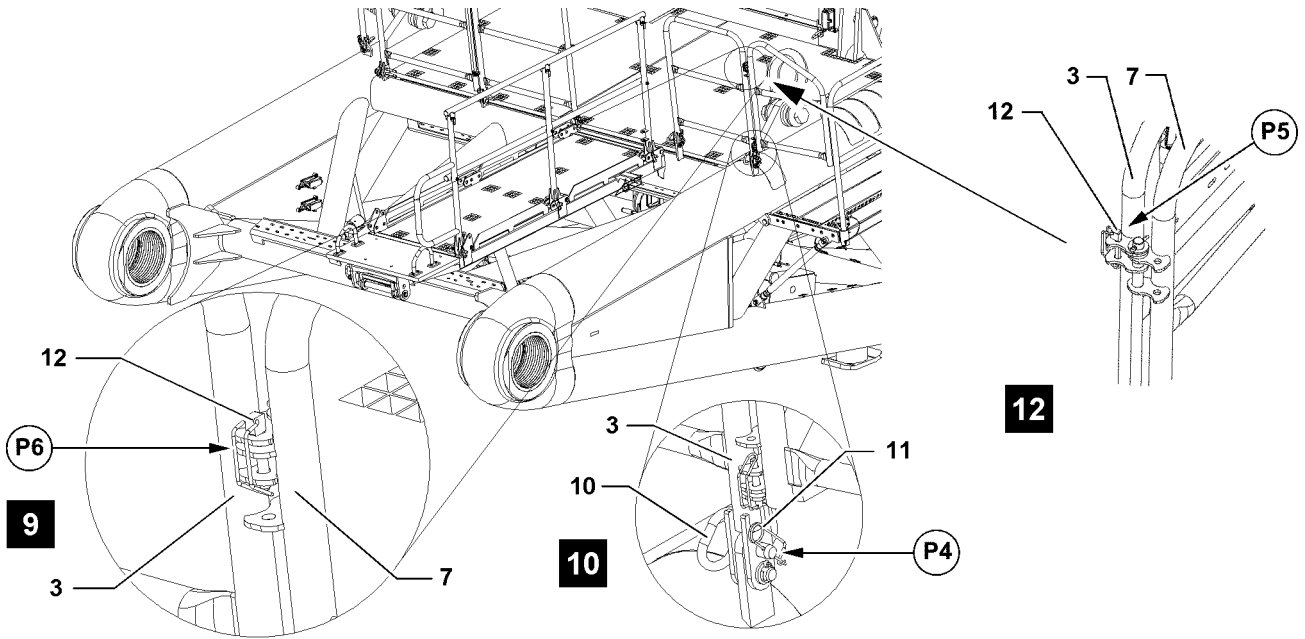

Fig.114364

LWE/LR 13000-001/19503-01-02/en

Railing 3

**Note**

- ▶ The railing receptacles are described based on the example of one railing receptacle!
- ▶ Release the railing 7: Pull out the clip 12 in point P6, see illustration 9.

**WARNING**

Danger of crushed limbs!

When swinging the railings, fingers and hands can be crushed!

- ▶ Do not reach with your hands into the danger zone!
- ▶ Fold the railing 3 in.
- ▶ Insert the clip 12 in point P5 and secure, see illustration 12.

**WARNING**

Folding down railing!

The railing can swing down by itself due to its own weight when it is unpinned!

Personnel can be severely injured!

Fingers and hands can be crushed!

- ▶ Hold the railing when unpinning!
- ▶ Release the railing 3 from the operating position: Remove the spring retainer 11 in point P4 and unpin the connector 10, see illustration 10.
- ▶ Swing the railing 3 into the transport position.
- ▶ Pin the connector 10 in point P3 and secure with the spring retainer 11, see illustration 11.
- ▶ Secure the railing 3 with the spring retainer 14 in the transport position, see illustration 13.

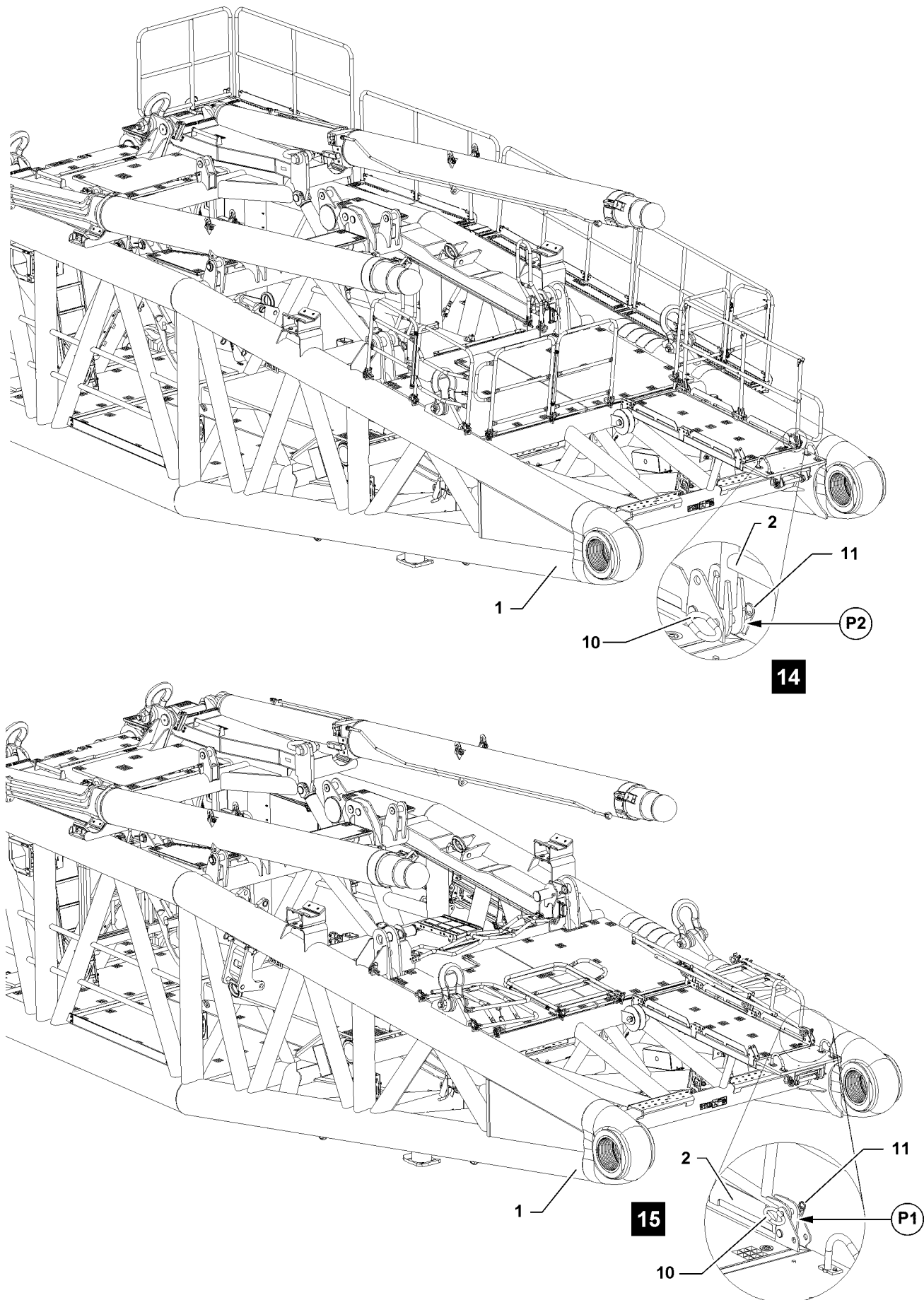

Fig.114365

LWE/LR 13000-001/19503-01-02/en

Railing 2



Note

- ▶ The railing receptacles are described based on the example of one railing receptacle!
- ▶ Release the railing **2** from the operating position: Remove the spring retainer **11** in point **P2** and unpin the connector **10**, see illustration **14**.



WARNING

Danger of crushed limbs!

When swinging the railings, fingers and hands can be crushed!

- ▶ Do not reach with your hands into the danger zone!
- ▶ Swing the railing **2** into the transport position.
- ▶ Secure the railing **2** in the transport position: Pin the connector **10** in point **P1** and secure with the spring retainer **11**, see illustration **15**.

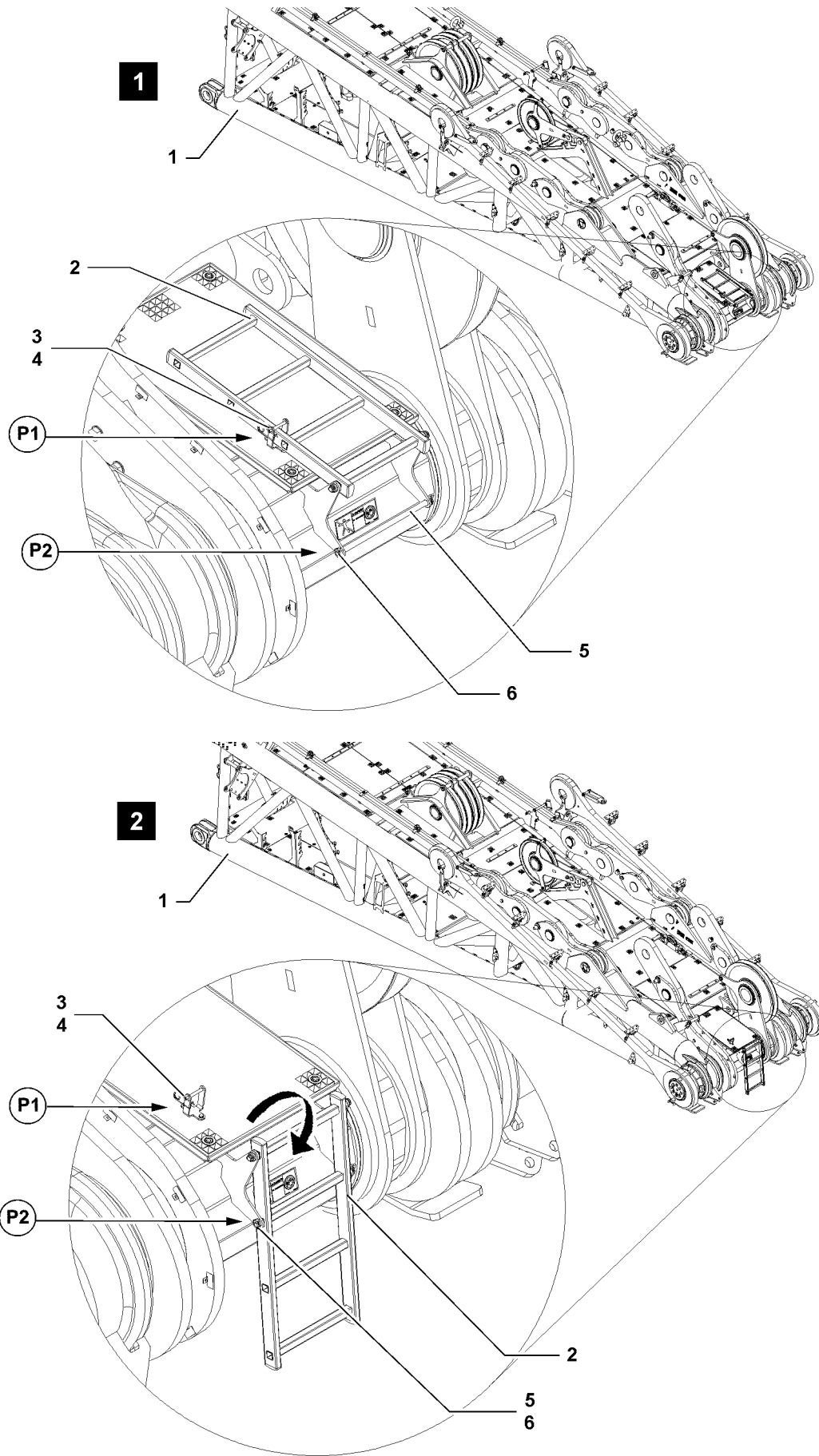

Fig.114371

LWE/LR 13000-001/19503-01-02/en

5.5 Ladder on the D-end section

5.5.1 Swinging the ladder on the D-end section into the operating position

- ▶ Release the ladder **2** from the transport position in point **P1**: Remove the spring retainer **4** and unpin the pin **3**, see illustration **1**.
- ▶ Remove the safety locking pin **6** in point **P2** and unpin the pin **5**.



WARNING

Danger of crushed limbs!

When swinging the ladder **2**, fingers and hands can be crushed!

- ▶ Do not reach with your hands into the danger zone!
-



WARNING

Danger of crushed limbs!

The ladder **2** can fall down by itself due to its own weight when swinging it!

Fingers and hands can be crushed!

- ▶ Hold the ladder **2** and swing it down slowly!
-

- ▶ Swing the ladder **2** to the mounting in point **P2**, see illustration **2**.

When the pin bores on the mounting align in point **P2** with the rung of the ladder **2**:

- ▶ Insert the pin **5** in point **P2** and secure with the safety locking pin **6**, see illustration **2**.

Result:

- The ladder **2** is secured in the operating position.

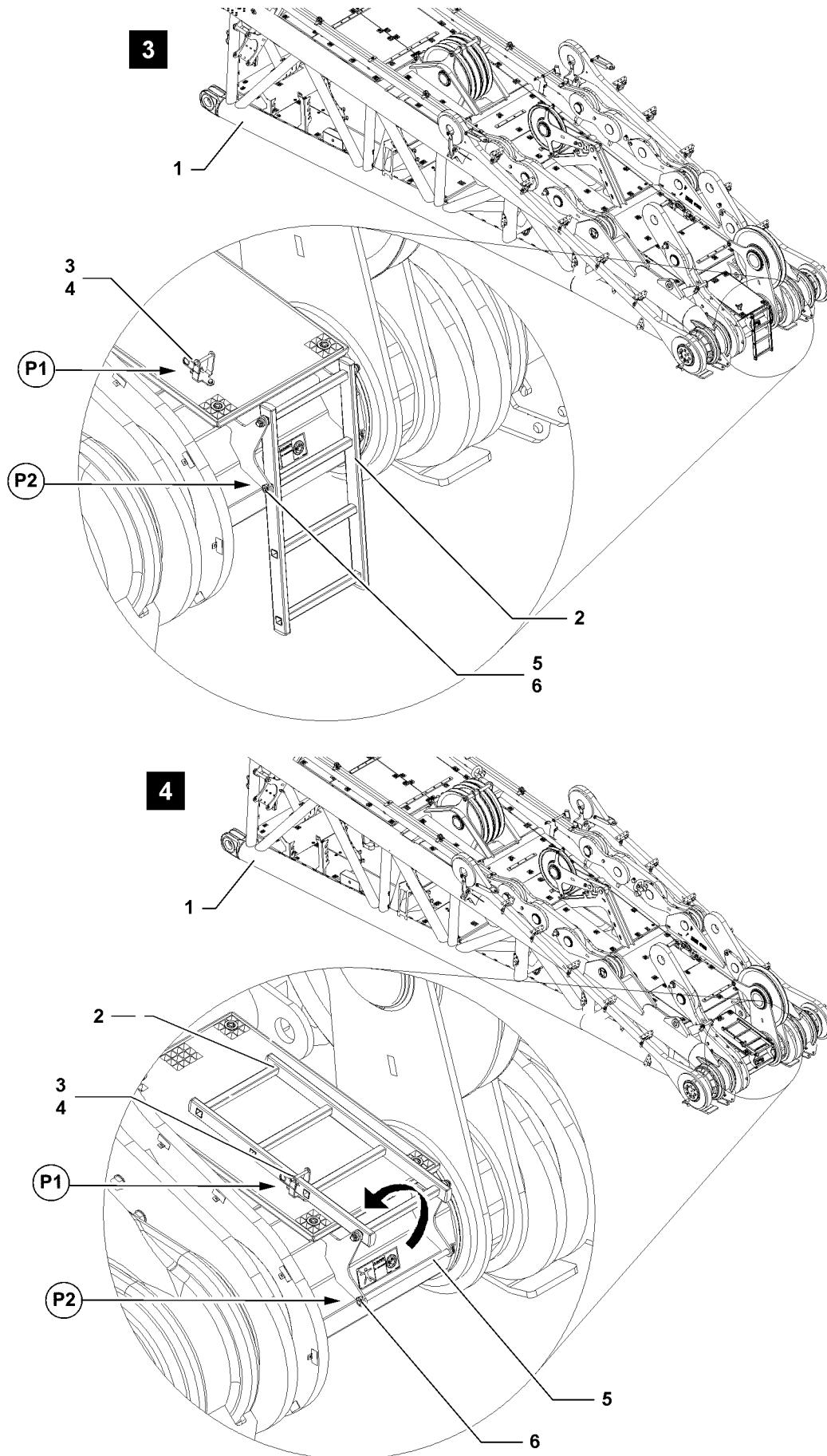

Fig.114372

LWE/LR 13000-001/19503-01-02/en

5.5.2 Swinging the ladder on the D-end section into the transport position

- ▶ Release the ladder **2** from the operating position in point **P2**: Remove the safety locking pin **6** in point **P2** and unpin the pin **5**, see illustration **3**.
- ▶ Remove the spring retainer **4** in point **P1** and unpin the pin **3**, see illustration **3**.



WARNING

Danger of crushed limbs!

When swinging the ladder **2**, fingers and hands can be crushed!

- ▶ Do not reach with your hands into the danger zone!
-



WARNING

Danger of crushed limbs!

The ladder **2** can fall down by itself due to its own weight when swinging it!

Fingers and hands can be crushed!

- ▶ Hold the ladder **2** and swing it up slowly!
-

- ▶ Swing the ladder **2** out of the operating position, see illustration **4**.

When the ladder **2** is lying on the platform:

- ▶ Insert the pin **3** in point **P1** and secure with the spring retainer **4**, see illustration **4**.

Result:

- The ladder **2** is secured in the transport position.

- ▶ Insert the pin **5** again in point **P2** and secure with a safety locking pin **6**, see illustration **4**.

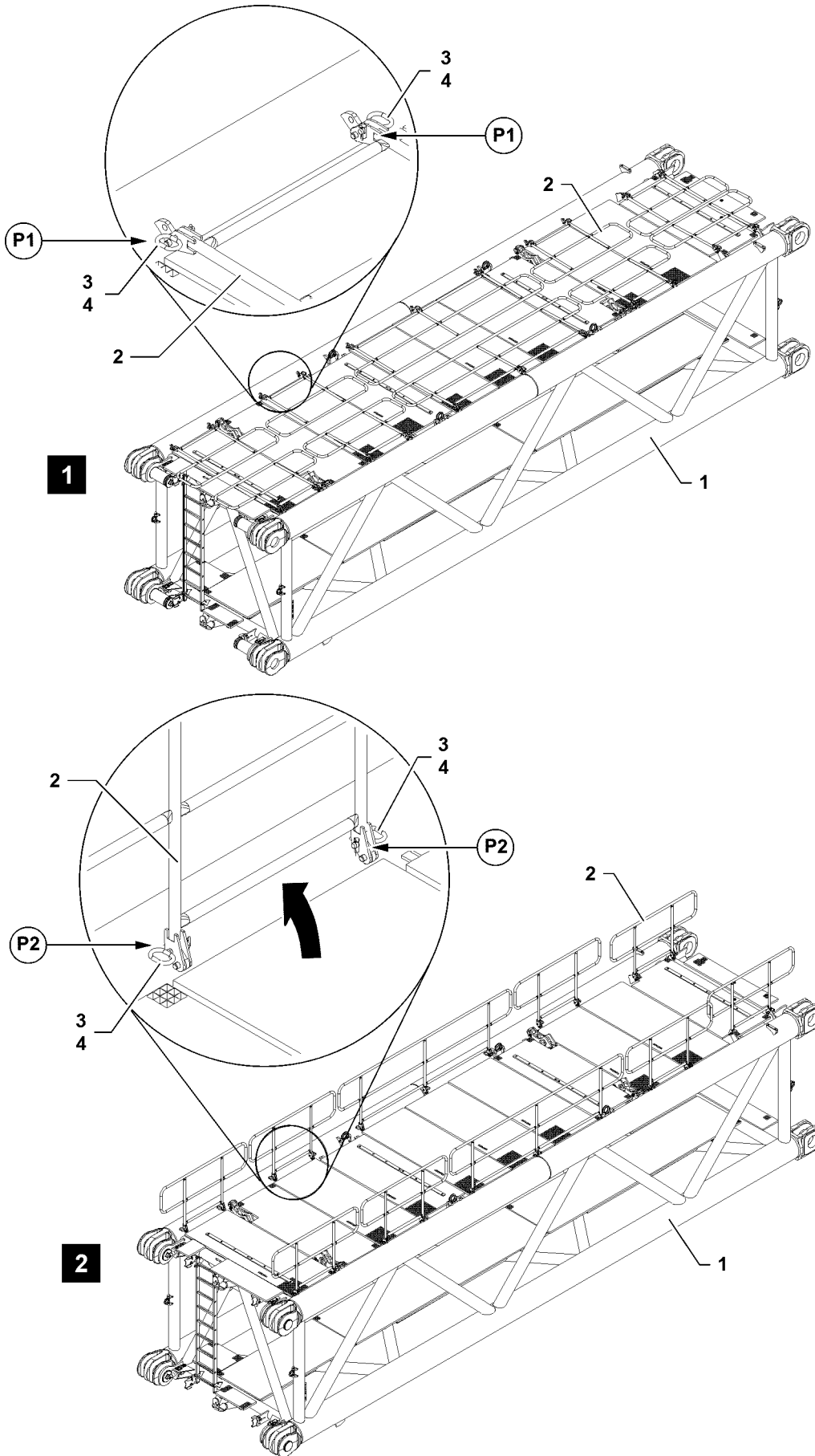

Fig.114378

LWE/LR 13000-001/19503-01-02/en

5.6 Railing on the D-intermediate section

5.6.1 Swinging the railing on the D-intermediate section into the operating position

**WARNING**

Danger of falling!

During assembly and disassembly of the railing, personnel must be secured with appropriate aids to prevent them from falling!

Even during the assembly of protective devices there is a danger of falling!

Assembly personnel can fall and be severely injured or killed!

▶ Use personal protective equipment!

▶ Release the railing **2** from the transport position: Remove the safety locking pin **4** in point **P1** and unpin the connector **3**, see illustration **1**.

**WARNING**

Danger of crushed limbs!

When swinging the railings **2**, fingers and hands can be crushed!

▶ Do not reach with your hands into the danger zone!

▶ Swing the railing **2** into the operating position.

▶ Secure the railing **2** in the operating position: Pin the connector **3** in point **P2** and secure with the safety locking pin **4**, see illustration **2**.

▶ Swing all railings **2** into the operating position, see illustration **2**.

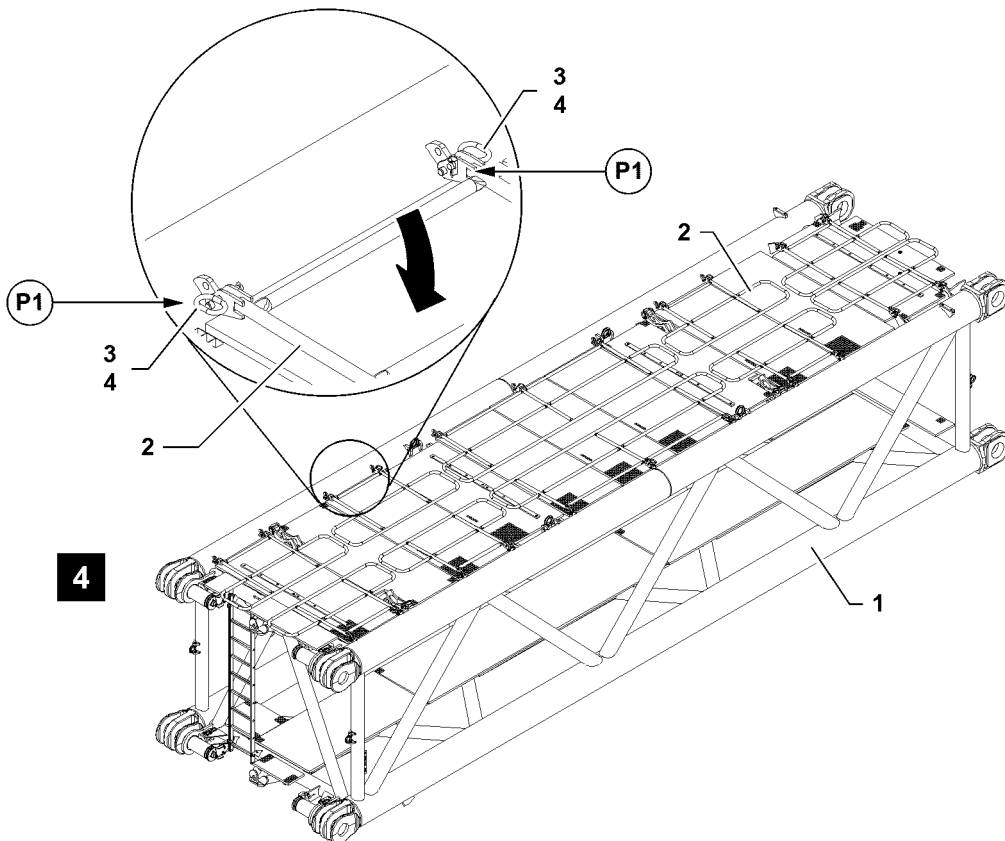
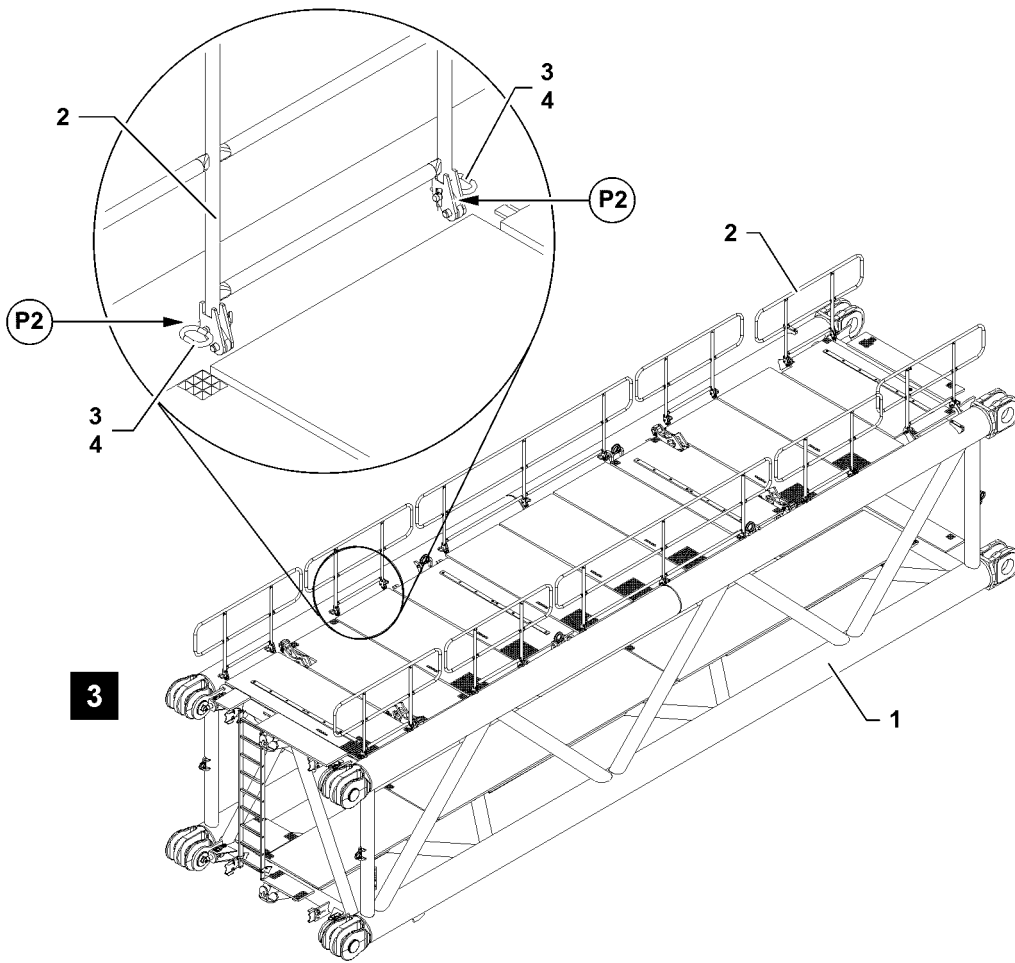

Fig.114379

LWE/LR 13000-001/19503-01-02/en

5.6.2 Swinging the railing on the D-intermediate section into the transport position



WARNING

Danger of falling!

During assembly and disassembly of the railing, personnel must be secured with appropriate aids to prevent them from falling!

There is a danger of falling even during the disassembly of protective devices!

Assembly personnel can fall and be severely injured or killed!

- ▶ Use personal protective equipment!



WARNING

Danger of crushed limbs!

The railing **2** can swing down by itself due to its own weight when it is unpinned!

Fingers and hands can be crushed!

- ▶ Before unpinning, hold the railing and swing it down slowly!
- ▶ Release the railing **2** from the operating position: Remove the safety locking pin **4** in point **P2** and unpin the connector **3**, see illustration **3**.
- ▶ Swing the railing **2** into the transport position.
- ▶ Secure the railings **2** in the transport position: Pin the connector **3** in point **P1** and secure with the safety locking pin **4**, see illustration **4**.
- ▶ Swing all railings **2** into the transport position, see illustration **4**.

Fig.195219

LWE/LR 13000-001/19503-01-02/en

6 Fall protection equipment and ladders on the S-boom



WARNING

When working at a height, there is a danger of falling!

- ▶ Assemble and secure all fall protection equipment, such as platforms, catwalks, ladders and railings properly.



WARNING

Danger of accident!

If the following notes are not observed, the ladder can tip and assembly personnel can fall from the ladder with danger of fatal injury!

- ▶ Replace damaged ladders immediately!
- ▶ The ladder must be set up stable and safely accessible!
- ▶ For the safe handling of the ladder, observe the safety instructions on the ladder!



CAUTION

Danger of crushed limbs!

When assembling / disassembling fall protection equipment and ladders, limbs can be crushed!

- ▶ Do not reach with your hands into the danger zone!
- ▶ Swing the fall protection equipment and the ladders especially carefully!

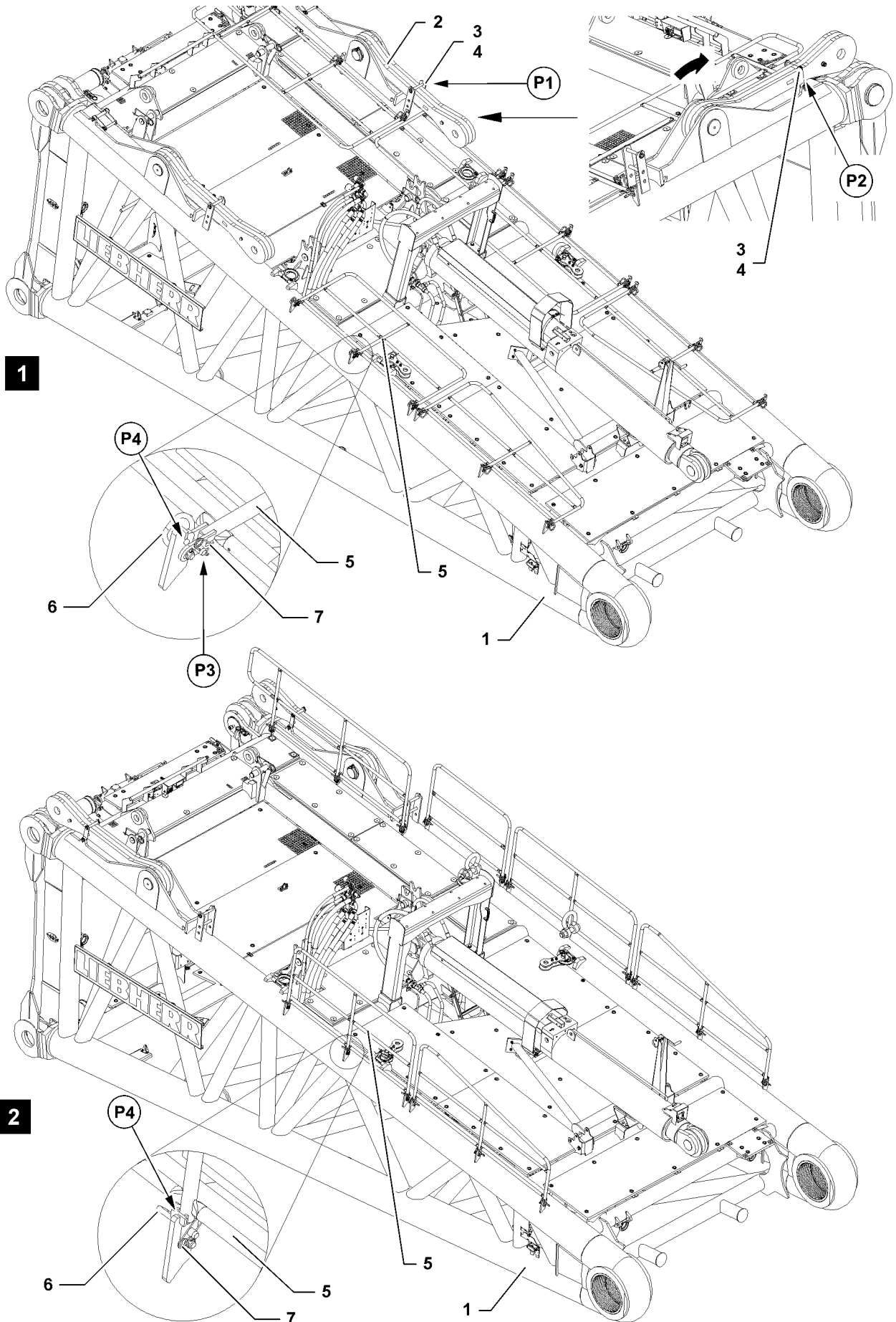

Fig.115651

LWE/LR 13000-001/19503-01-02/en

6.1 Railings on the S-pivot section

6.1.1 Swinging the railing on the S-pivot section into the operating position



WARNING

Danger of falling!

During assembly and disassembly of the railing, personnel must be secured with appropriate aids to prevent them from falling!

There is a danger of falling even during the disassembly of protective devices!

Assembly personnel can fall and be severely injured or killed!

▶ Use personal protective equipment!

- ▶ Release the rod **2**: Remove the safety locking pin **4** in point **P1** and unpin the pin **3**, see illustration **1**.
- ▶ Fasten the rod **2** to the auxiliary crane.
- ▶ Unpin the pin **3** in point **P2**.



WARNING

Danger of crushed limbs!

When swinging the rods, limbs can be crushed!

▶ Do not reach with your hands into the danger zone!

- ▶ Swing the rod **2** with the auxiliary crane and secure: Insert the pin **3** again in point **P2** and secure with a safety locking pin **4**, see illustration **1**.
- ▶ Swing the second rod **2**.



Note

▶ The railings must be set up starting from the coupling point!



Note

▶ The railing receptacles are described based on the example of one railing receptacle!

- ▶ Release the railing **5** from the transport position: Remove the spring retainer **7** in point **P3** and unpin the connector **6**, see illustration **1**.



WARNING

Danger of crushed limbs!

When swinging the railings, fingers and hands can be crushed!

▶ Do not reach with your hands into the danger zone!

- ▶ Swing the railing **5** into the operating position.
- ▶ Secure the railing **5** in the operating position: Pin the connector **6** in point **P4** and secure with the spring retainer **7**, see illustration **2**.
- ▶ Swing all railings into the operating position.

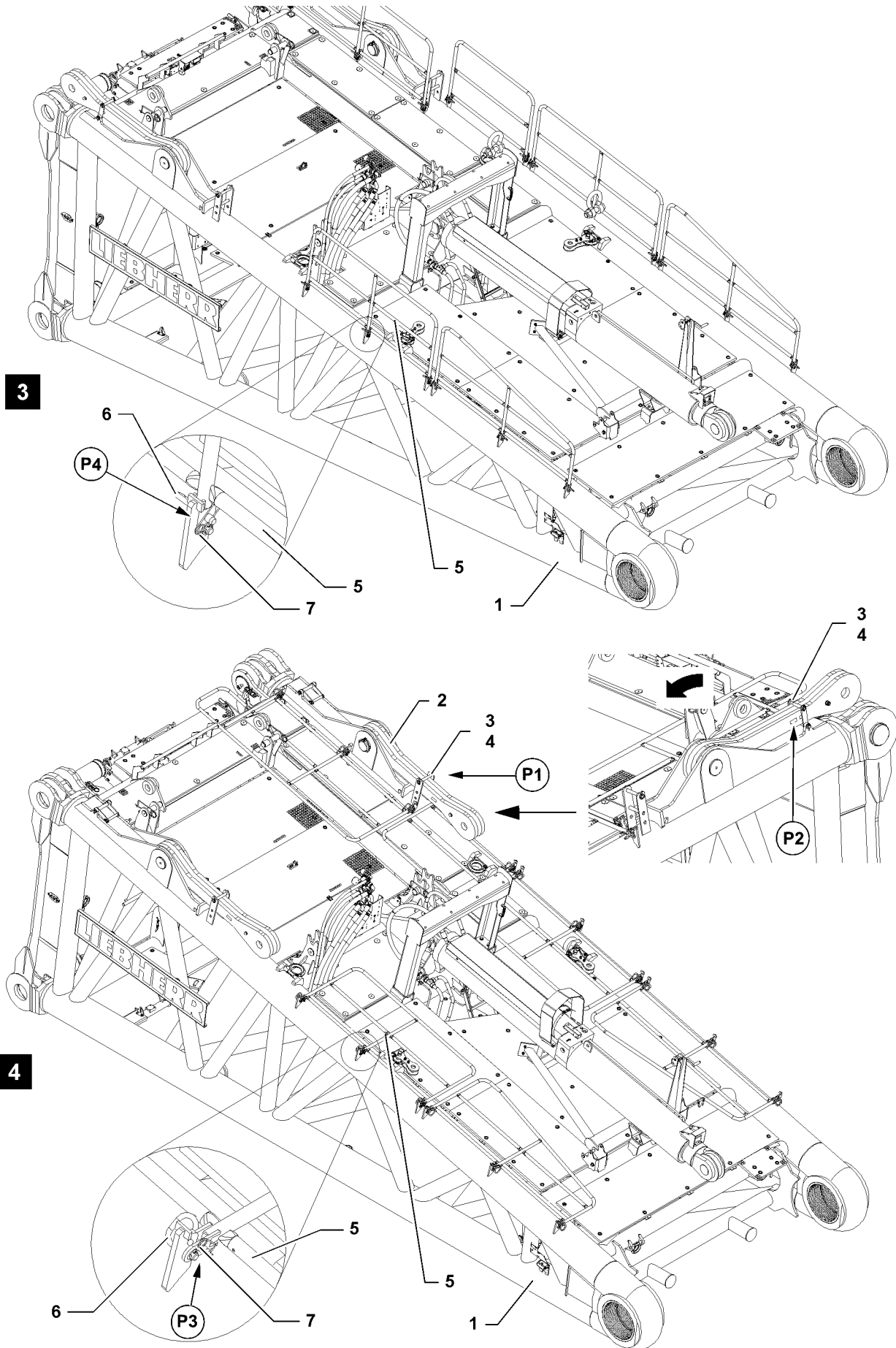

Fig.115652

LWE/LR 13000-001/19503-01-02/en

6.1.2 Swinging the railing on the S-pivot section into the transport position



Note

- ▶ The railing receptacles are described based on the example of one railing receptacle!



WARNING

Folding down railing!

The railing can swing down by itself due to its own weight when it is unpinned!

Personnel can be severely injured!

Fingers and hands can be crushed!

- ▶ Hold the railing when unpinning!

- ▶ Release the railing **5** from the operating position: Remove the spring retainer **7** in point **P4** and unpin the connector **6**, see illustration **3**.
- ▶ Swing the railing **5** into the transport position.
- ▶ Secure the railing **5** in the transport position: Pin the connector **6** in point **P3** and secure with the spring retainer **7**, see illustration **4**.
- ▶ Swing all railings into the transport position.
- ▶ Release the rod **2**: Remove the safety locking pin **4** in point **P2** and unpin the pin **3**, see illustration **4**.
- ▶ Fasten the rod **2** to the auxiliary crane.
- ▶ Unpin the pin **3** in point **P1**.



WARNING

Danger of crushed limbs!

When swinging the rods, limbs can be crushed!

- ▶ Do not reach with your hands into the danger zone!

- ▶ Swing the rod **2** with the auxiliary crane and secure: Insert the pin **3** in point **P1** and secure with the safety locking pin **4**, see illustration **4**.
- ▶ Swing the second rod **2**.

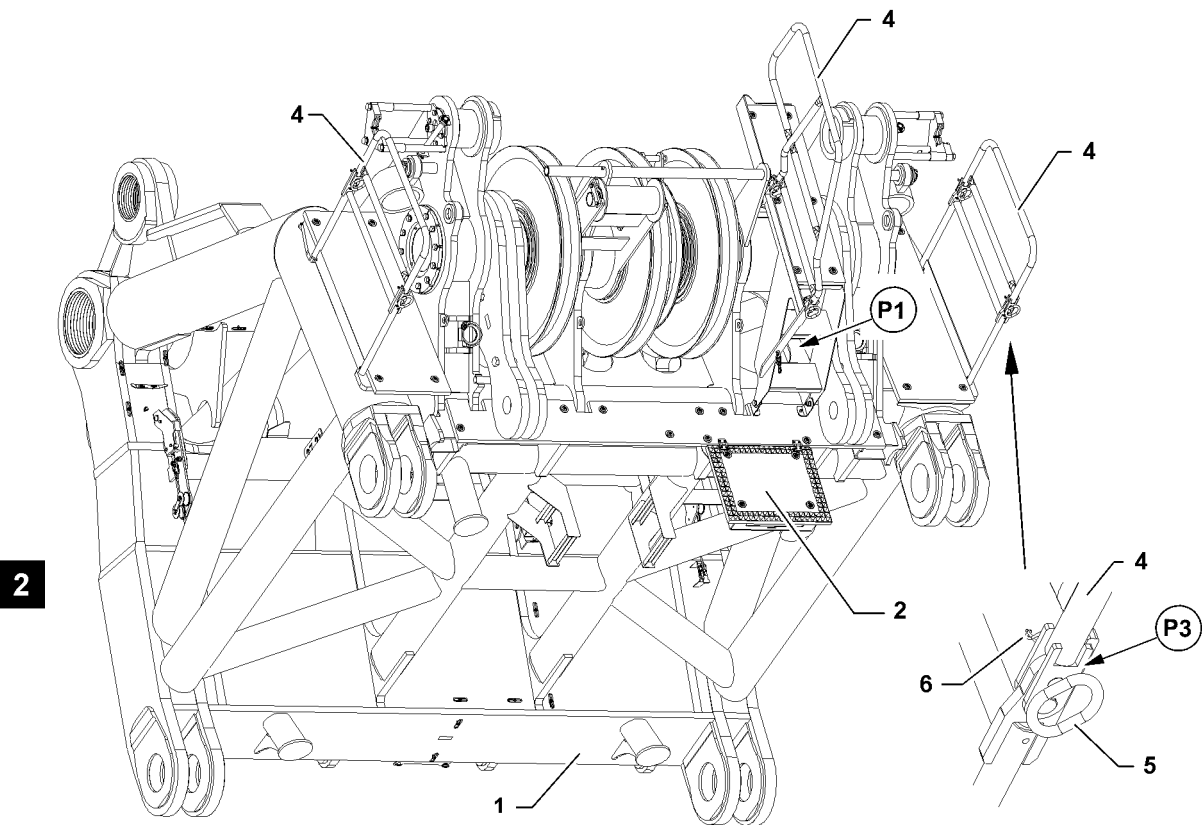
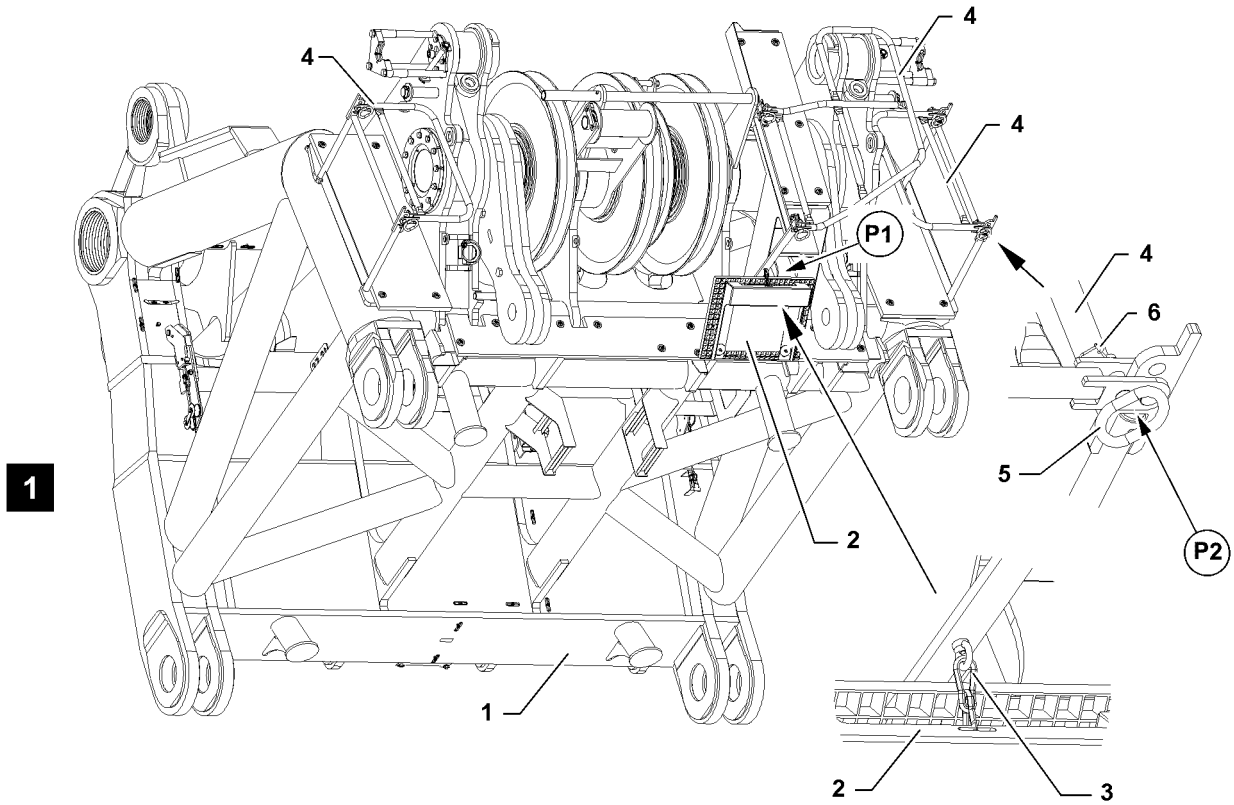

Fig.115653

LWE/LR 13000-001/19503-01-02/en

6.2 Railings on the S-end section

6.2.1 Swinging the railing on the S-end section into the operating position



WARNING

Danger of falling!

During assembly and disassembly of the railing, personnel must be secured with appropriate aids to prevent them from falling!

There is a danger of falling even during the disassembly of protective devices!

Assembly personnel can fall and be severely injured or killed!

- ▶ Use personal protective equipment!



Note

- ▶ The railings must be set up!



Note

- ▶ The railing receptacles are described based on the example of one railing receptacle!



WARNING

Falling grating!

The grating **2** can fall down by itself due to its own weight when it is released!

Personnel can be severely injured!

Fingers and hands can be crushed!

- ▶ Hold the grating when releasing!

- ▶ Release the grating **2** from the transport position: Open the carabiner **3** in point **P1** and swing the grating down to the stop, see illustration **1**.
- ▶ Release the railing **4** from the transport position: Remove the spring retainer **6** in point **P2** and unpin the connector **5**, see illustration **1**.



WARNING

Danger of crushed limbs!

When swinging the railings, fingers and hands can be crushed!

- ▶ Do not reach with your hands into the danger zone!

- ▶ Swing the railing **4** into the operating position.
- ▶ Secure the railing **4** in the operating position: Pin the connector **5** in point **P3** and secure with the spring retainer **6**, see illustration **2**.
- ▶ Swing all railings into the operating position.

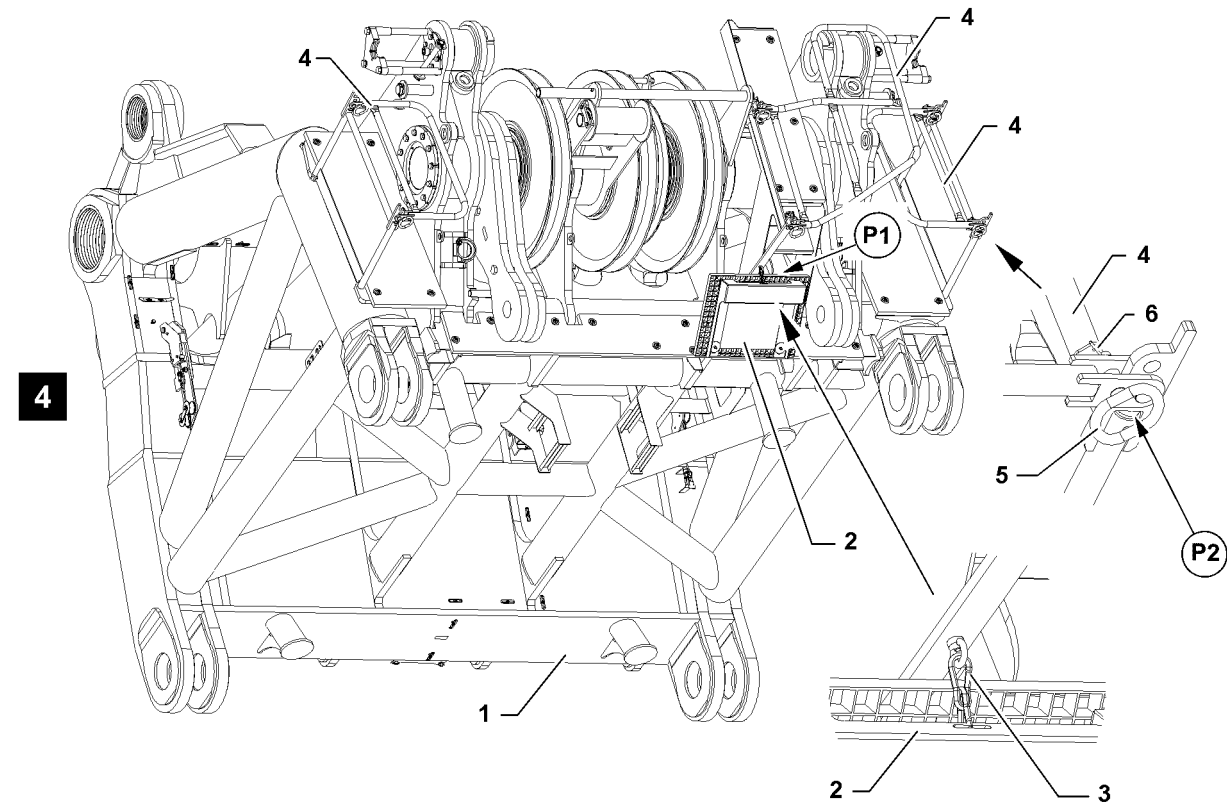
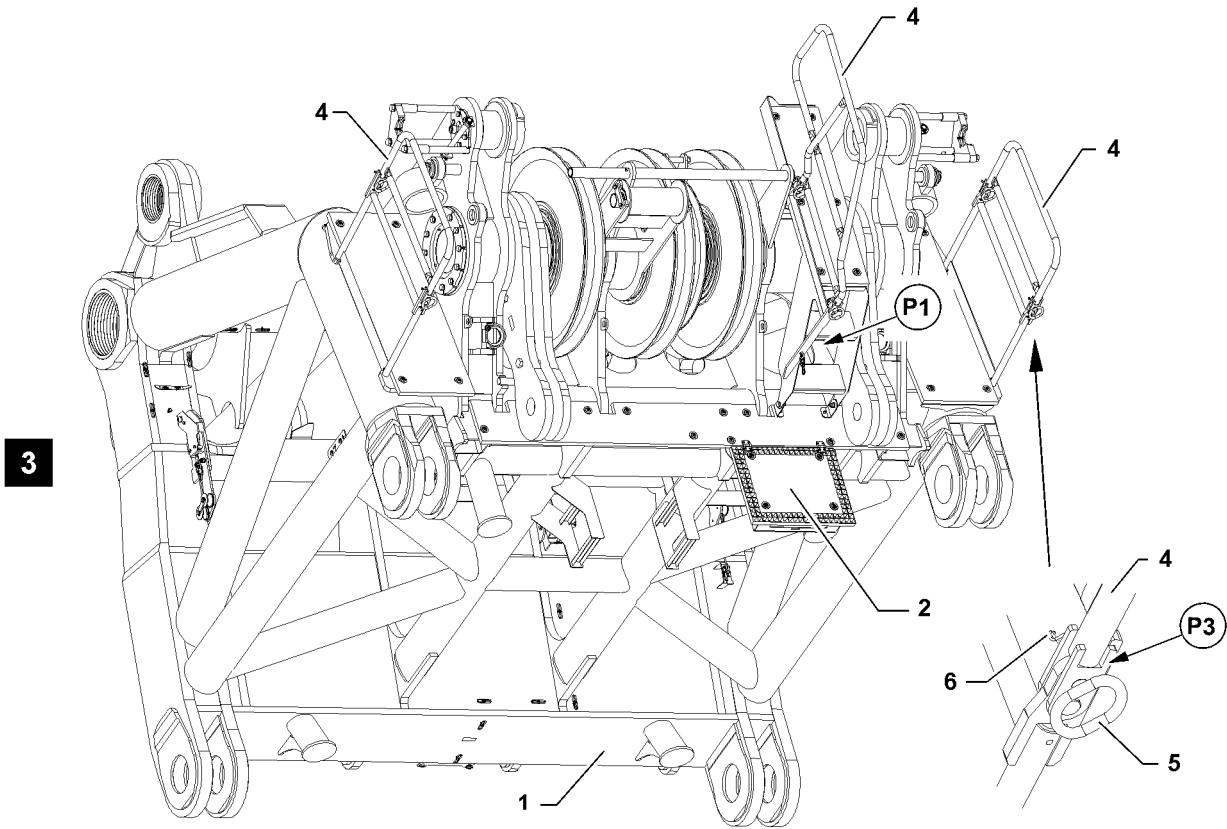

Fig.115654

LWE/LR 13000-001/19503-01-02/en

6.2.2 Swinging the railing on the S-end section into the transport position



Note

- ▶ The railing receptacles are described based on the example of one railing receptacle!

- ▶ Release the railing **4** from the operating position: Remove the spring retainer **6** in point **P3** and unpin the connector **5**, see illustration **3**.



WARNING

Folding down railing!

The railing can swing down by itself due to its own weight when it is unpinned!

Personnel can be severely injured!

Fingers and hands can be crushed!

- ▶ Hold the railing when unpinning!

- ▶ Swing the railing **4** into the transport position.
- ▶ Secure the railing **4** in the transport position: Pin the connector **5** in point **P2** and secure with the spring retainer **6**, see illustration **4**.
- ▶ Swing all railings into the transport position.



WARNING

Danger of crushed limbs!

When swinging the grating, fingers and hands can be crushed!

- ▶ Do not reach with your hands into the danger zone!

- ▶ Swing the grating **2** up into the transport position and secure with the carabiner **3** in point **P1**, see illustration **4**.

Empty page!

LWE/LR 13000-001/19503-01-02/en

2.08 Working in low temperatures

1	Auxiliary equipment	2
2	Safety	2
3	Environmental / component temperature below -20 °C	3
4	Maintenance	7

1 Auxiliary equipment

At ambient temperatures between -20 °C and $+50\text{ °C}$ the crane can be operated and stored „without auxiliary equipment for working in low temperatures“.

At ambient temperatures below -20 °C , the crane must be modified and equipped with „auxiliary equipment for working at low temperatures“.



WARNING

Working at low temperatures without the corresponding auxiliary equipment!
The crane components can be damaged and fail. The load can rip off.
Death, severe bodily injuries, property damage.

If the crane is operated at an ambient temperature lower than -20 °C :

- ▶ Make sure that the crane is equipped with the corresponding „auxiliary equipment for working at low temperatures“.
- ▶ Match the operating fluids in time to the ambient temperature.

2 Safety

Temperature changes cause technological changes to material properties in the case of steel / cast steel and many other materials.

Crane components made of steel / cast steel are very sensitive to sudden movements, impacts and shocks at decreasing negative temperatures.

This effect increases if the crane compacts are impacted with a load and / or large weights.

To ensure safe operation at low temperatures, the crane structure must be checked at short intervals for cracks.



Note

- ▶ Observe and adhere to the instructions in chapter 8.01.



DANGER

The crane can topple over!

Due to decreasing negative temperatures, crane components reach their technological load limits much earlier.

Crane components can break.

The crane can topple over.

Death, severe bodily injuries, property damage.

- ▶ For safe crane operation, the **temperature of the crane components is the deciding factor** and not the ambient temperature.
- ▶ For safe crane operation with component temperatures **down to -40 °C** , the crane must be equipped with „auxiliary equipment for working at low temperatures“.
- ▶ With component temperatures **below -40 °C** , do not operate the crane. In the case of doubt, contact Customer Service at Liebherr-Werk Ehingen GmbH.

3 Environmental / component temperature below -20 °C

3.1 Winter operation

Low temperatures, as well as snow, frost and ice can impair crane operation and cause problems on the crane.

Freezing takes place often at low temperatures.



WARNING

Snow, frost and ice on the accesses!

Personnel can fall from the accesses.

Death, severe bodily injuries, property damage.

- ▶ Remove the snow, frost and ice from all accesses, steps and catwalks.
- ▶ Remove the snow, frost and ice from the crane.

NOTICE

Snow, frost and ice on the crane components!

The crane components can be damaged and fail.

Cylinder seals can be destroyed by frozen piston rods.

- ▶ Remove the snow, frost and ice from the piston rods.
- ▶ Remove the snow, frost and ice from all rope pulleys and winches.
- ▶ Remove the snow, frost and ice from the hose drums and limit switches.



WARNING

Snow, frost and ice below the support plates or the crawler carriers!

The crane can slide.

Death, severe bodily injuries, property damage.

- ▶ Remove the snow, frost and ice on top and below the support plates.
- ▶ Remove the snow, frost and ice on top and below the crawler carrier.
- ▶ Remove the snow, frost and ice from the roadway.

Prerequisites for crane start up with component temperatures below -20 °C

- The hose drums and cables are easy to move.
- All rope pulleys are easily movable.
- The view from the crane cab is free.
- The mirrors are free of snow, frost and ice.
- Fastening equipment is approved for the ambient temperatures present.
- The load fastening points are approved for the ambient temperatures present.

3.2 Preheating time



WARNING

Limited crane control during radio operation!

In the case of falling negative temperatures, the LCD displays react increasingly slowly to changes made to images and icons on the displays.

In the case of minus temperatures below -25 °C, changes made to images and icons could be displayed with a considerable delay or not at all.

This can lead to dangerous situations if warnings are displayed with a delay.

Death, severe bodily injuries, property damage.

- ▶ If the component temperature of the radio remote control is below -25 °C: Preheat the radio remote control prior to start up.
- ▶ In the case of increasing sluggishness of the LCD displays during radio operation with temperatures below -25 °C: Warm up or preheat the radio remote control occasionally.

Crane components	Preheating time
Engine preheating up to start at -40 °C component temperature	45 minutes
Preheat the hydraulic system in the crane superstructure and the crane chassis	30 minutes
Preheat the crane cab / driver's cab for start up at the same time up to 5 °C	10 minutes
Total preheating time	75 minutes

- ▶ To ensure safe crane operation: Adhere to the preheating times.

3.3 Engine preheating

If the components temperature is lower than -20 °C the chassis engine and / or superstructure engine must be preheated before starting.

Depending on the crane type, a chassis engine and / or a superstructure engine is installed.

Pre-warming the chassis engine is described in chapter 6.01.

Pre-warming the superstructure engine is described in chapter 6.02.

- ▶ Preheat the chassis engine and / or the superstructure engine.
- ▶ Start the chassis engine and / or the superstructure engine.

When the chassis engine and / or the superstructure engine has reached its operating temperature:

- ▶ Turn off engine preheating.

3.4 Preheating the hydraulic oil

If the ambient temperature is lower than -20 °C the hydraulic oil must be preheated prior to crane operation.

NOTICE

Hydraulic oil **not** preheated!

The hydraulic system can be damaged during crane operation.

- ▶ Before starting crane operation, preheat the hydraulic oil to at least 20 °C.
- ▶ Retract and extend all the hydraulic cylinders in an unloaded state over the entire stroke multiple times.



WARNING

Persons in the area of the hoist movement!

Death, severe bodily injuries, property damage.

- ▶ Observe the area of the hoist movement.
- ▶ Make sure that there are **no** persons in the area of the hoist movement.

3.4.1 Turning the hydraulic oil preheating on

Make sure that the following prerequisites are met:

- The engine is running.
- Hydraulic oil preheating is available.

Hydraulic oil preheating is described in chapter 4.03.

- ▶ Turn the hydraulic oil preheating on.

When the hydraulic oil is preheated:

- ▶ Turn the hydraulic oil preheating off.

3.4.2 Supporting the crane

Supporting the crane vehicle is described in chapter 3.05.

All support plates must be supported with suitable and stable materials.

If moveable support plates are not available, the support plates must be supported **on one side of the crane** with greased polyamide plates.



WARNING

No movable support plates or crane **not** supported with greased polyamide plates!

The sliding beams can bend. The support plates can suddenly move to the side.

The load can oscillate.

Death, severe bodily injuries, property damage.

- ▶ Use moveable support plates.

If there are no movable support plates available:

- ▶ Support the support plates **on one side of the crane** with greased polyamide plates.

If not sure if the crane has been equipped with support cylinders for an operating temperature down to $-40\text{ }^{\circ}\text{C}$, contact Customer Service at Liebherr-Werk Ehingen GmbH.

If the crane is **not** equipped with support cylinders for an operating temperature down to $-40\text{ }^{\circ}\text{C}$:

- ▶ When supporting, extend the support cylinder a maximum of 50 %.

The wheels must not come in to contact with the ground after the crane is supported.

- ▶ Support the support plates when necessary.
- ▶ Support the crane.

3.4.3 Cranes with lattice mast boom

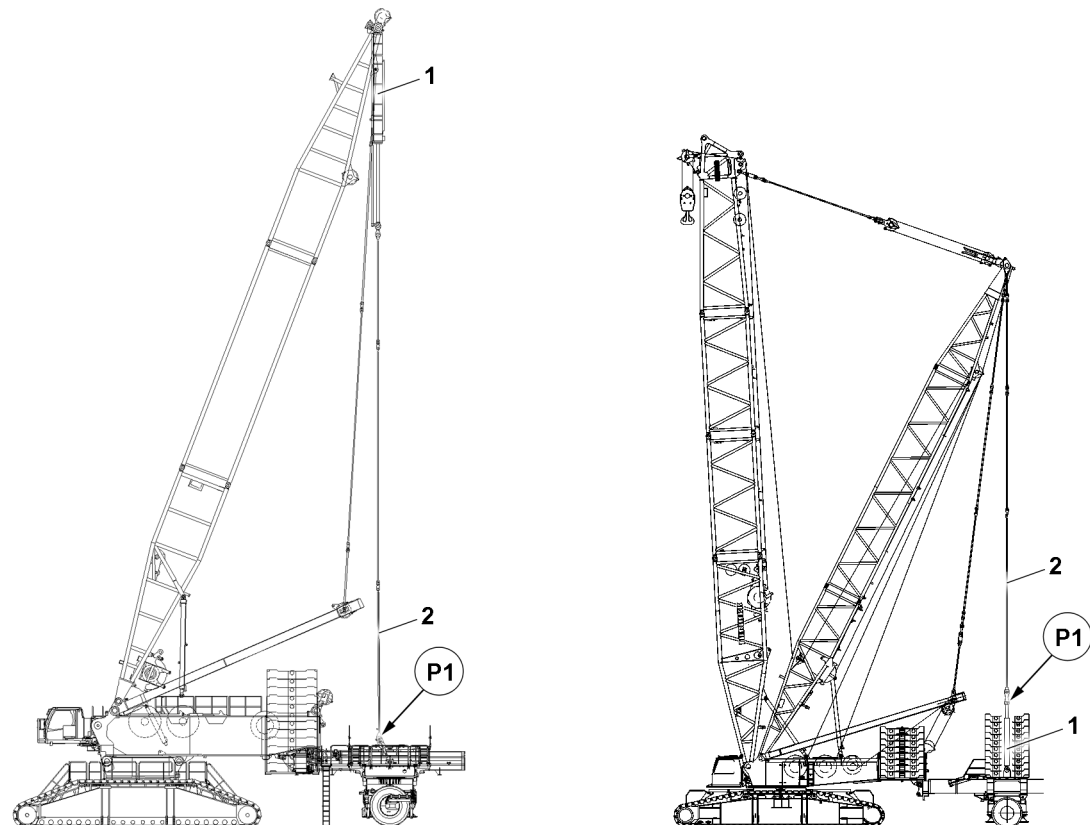

Fig.126875: Removing the guy rods on the derrick ballast

With component temperatures of less than $-20\text{ }^{\circ}\text{C}$, the pull cylinders must be preheated by means of retraction and extension. Before the pull cylinders can be preheated, the guy rods **2** must be removed in position **P1** on the derrick ballast.

Disassembly and assembly of the guy rods **2** on the derrick ballast is described in the Crane operating instructions, chapter 5.35 and chapter 5.36.

- ▶ Remove the guy rods **2** at position **P1** on the derrick ballast.

NOTICE

Danger of collision!

Damage of the guy rods, derrick ballast or other components.

- ▶ When retracting and extending the guy rods, avoid contact with other components.

- ▶ Retract and extend the pull cylinders **1** in an unloaded state over the entire stroke multiple times.

When additional hydraulic cylinders are installed on the crane with lattice mast:

- ▶ Retract and extend the hydraulic cylinders in an unloaded state over the entire stroke multiple times.

3.4.4 Cranes with a telescopic boom

Make sure that the following prerequisites are met:

- The crane is supported and horizontally aligned.
- There is no load on the hook.
- ▶ Retract and extend the luffing cylinder in an unloaded state over the entire stroke multiple times.
- ▶ Retract and extend the telescoping cylinder in an unloaded state over the entire stroke multiple times.

3.5 Assembling / disassembling the crane components

If the component temperature is lower than $-20\text{ }^{\circ}\text{C}$, there is an increased danger that in the case of impact and / or strong component contact that the crane components will be damaged as a result of their changed technological material properties. In particular counterweights and crane components made of cast steel are subject to a greater risk of damage due to impact at component temperatures below $-20\text{ }^{\circ}\text{C}$.

NOTICE

Striking of the crane component during assembly or disassembly!

Crane components can be damaged.

- ▶ Do **not** strike the crane component during assembly and disassembly.
 - ▶ Carry out all work slowly and with utmost caution.
-

3.6 Reducing rope pull

When working with rope / component temperature below $-20\text{ }^{\circ}\text{C}$, Liebherr-Werk Ehingen GmbH recommends reducing the rope pull.

The rope pull on the hoist rope can be reduced by increasing the rope reeving.



Note

Increase of rope reeving!

Due to the increased rope reeving, the hoist rope length may not be sufficient for lowering the hook block to the ground.

- ▶ Pay attention to rope length.
-

NOTICE

Rope reeving higher than specified in the load chart!

Danger of slack rope formation due to a too low hook block weight. Damage to the hoist rope.

- ▶ Increase the hook block weight accordingly.
 - ▶ Increase the rope reeving specified in the load chart.
 - ▶ If necessary: Increase the hook block weight.
-

3.7 Increasing the hook block weight

The calculation of the minimum required hook block weight is described in the load chart.

Rope / component temperature	Increasing the hook block weight
-21 °C to +30 °C	Increase the minimum required hook block weight by 10 %
-31 °C to +40 °C	Increase the minimum required hook block weight by 15 %

- ▶ Increase the required hook block weight depending on the rope or component temperature.
- ▶ Observe and adhere to the „hook block weight“ charts.



Note

- ▶ Observe and comply with the permissible hook block weights for erection and take-down of the boom systems in the erection and take down charts.

3.8 Crane operation

In case of an ambient / component temperature below -20 °C , crane operation requires an anticipatory working procedure adapted to the weather conditions.



WARNING

Sudden acceleration and deceleration of crane movements!

Crane components can break.

Death, severe bodily injuries, property damage.

- ▶ Accelerate and decelerate crane movements sensitively and with utmost caution.

3.8.1 Reducing the maximum load

Cranes with lattice mast boom

In the case of cranes with pull cylinders in the derrick ballast guying, if the component temperature is between -30 °C and -40 °C the maximum derrick ballast must be reduced. The maximum load is also reduced due to the reduction of the maximum derrick ballast.



Note

- ▶ Take load reduction into account during job planning.

- ▶ Reduce the maximum derrick ballast by 15 % in case of component temperatures between -30 °C and -40 °C.

Cranes with a telescopic boom

Cranes with a telescopic boom: For component temperatures between -30 °C and -40 °C the maximum load must be reduced.

- ▶ Reduce the maximum load by 15 % in the case of component temperatures between -30 °C and -40 °C.

4 Maintenance

4.1 Load bearing crane structures

Checking the load bearing crane structure is described in Chapter 8.01.

- ▶ The load bearing crane structure must be visually inspected more often at low temperatures.

4.2 Rope pulleys and hydraulic cylinders

Checking the rope pulleys and hydraulic cylinders is described in Chapter 8.01.

- ▶ Rope pulleys and hydraulic cylinders must be visually inspected more often at low temperatures.

2.25 Crane on floating body

1	Non-intended use	2
2	Intended use	2
3	Floating device	2
4	Operating conditions	2
5	Crane transport on floating devices	3
6	Increased corrosion	4

1 Non-intended use



WARNING

Non-intended use!

The boom can break off. The crane can topple over.
Death, severe injuries, property damage.

- ▶ Use the crane only as intended.
- ▶ Comply with the operating conditions and notes in this chapter.

Liebherr mobile cranes and crawler cranes are **not** designed for special requirements according to „EN 13852-2, Cranes - Offshore cranes“ or other offshore specifications and regulations.

For a precise definition of **non**-intended use, see the preface.

2 Intended use

Liebherr mobile cranes and crawler cranes are only designed for assembly work and erection work and can only withstand a limited number of load cycles.

Liebherr mobile cranes and crawler cranes are designed for special properties and movements: Evenly distributed drive forces, only occasional operation and load conditions according to „EN 13000, Cranes - Mobile cranes“ and comparable international standards.

For a precise definition of intended use, see the preface.

3 Floating device

The term floating device includes all floating devices such as barges and ships.

The floating device must fulfil the prerequisites for crane operation.

4 Operating conditions

4.1 Areas of responsibility for operating conditions

Observe the areas of responsibility:

- The crane contractor and crane operator are responsible for ensuring that the conditions for crane operation at the job site are fulfilled. Liebherr-Werk Ehingen GmbH strongly recommends involving a shipbuilding engineer.
- The correct functional, technical and static interaction between the crane and the floating device is the sole responsibility of the crane contractor and the crane operator.
- The correct functional, technical and static interaction between the crane and the floating device must be clarified and checked before operating the crane on a floating device.

4.2 Basic requirements

Observe the following to ensure the safe operation of the crane on floating devices:

- Comply with all country-specific, legal specifications and conditions.
- Perform a risk assessment according to the Occupational Safety and Health Act to ensure safe working conditions.
- Outrigger forces or crawler pressures generated by crane operation must be safely supported by the steel construction of the floating device.
- Assemble and operate the crane according to manufacturer specifications.
- Secure the crane to prevent it from slipping and lifting up.

- The conditions when working on a floating device must correspond with the conditions on land.
- Crane operation is only permissible in very calm waters and therefore on very calmly moving floating devices.
- Comply with the maximum permissible ground incline according to the load charts.
- Implement precautions that permit the boom system to be taken down at any time, for example if the wind and sea start to be strong.

4.2.1 Floating device, supported

Observe the following additional notes to ensure the safe operation of the crane on supported floating devices:

- Design the supported floating device such that if the wind and sea start to be strong it will not cause the floating device to buoy upward.

4.2.2 Floating device, not supported

Observe the following to ensure the safe operation of the crane on a **non** supported floating device:

- Crane operation on a **non** supported floating device is only permissible in very calm waters.
- Crane operation on a **non** supported floating device is only permissible with the main boom or alternatively a boom nose. No other additions on the main boom are permissible.
- Crane operation with the main boom in combination with the derrick ballast is only permitted with one derrick ballast that is set down and secured.

Note: The derrick ballast must be secured in all four horizontal directions (forward / backward / right / left). The height of the horizontal retainer must be implemented such that it is not possible to lift out by derrick ballast by lifting it. Keep in mind that the crane superstructure may not rotate.

- The incline of the floating device may **not** exceed the maximum permissible ground inclination of the crane according to the load chart.
- Before the crane is operated on the floating device: Calculate the incline of the floating device in the lateral direction and in the longitudinal direction in advance. The incline results from the interaction of the crane with the floating device.
- If the wind and sea start to be strong, the crane with the taken down boom system must also be secured against slipping and against oscillations.

5 Crane transport on floating devices

5.1 Areas of responsibility for crane transport on floating devices

Observe the areas of responsibility:

- The crane contractor is solely responsible for transporting the crane on a floating device.
- The crane contractor and crane operator are responsible for the assembly, securing and removal of the crane on the floating device.

5.2 Safety of crane transport on floating devices

Transport at sea can have a negative impact on the structural strength / stability and the fatigue limit of the crane.

Observe the following to ensure the safe transport of the crane on floating devices.

Secure the crane during „transport on a floating device“ so that the following is prevented:

- Damage and releasing of components on the crane
- Slipping of the crane
- Inadvertent turning (swinging) of the crane superstructure
- Capsizing of the floating device

Make sure that the following measures are carried out prior to „transport on a floating device“:

- Take the boom system down and support it using adequate means.
- With telescope cranes:
Disassemble the counterweight plates and secure on the floating device.

- Disassemble the separate counterweight brackets and secure on the floating device.
- With cranes with lattice mast / crawler cranes:
 - Secure the turntable using adequate means.
 - Disassemble the counterweight brackets and counterweight plates and secure on the floating device.
 - Disassemble the central ballast brackets and central ballast plates and secure on the floating device.
 - Support the installed counterweight brackets and counterweight plates separately using adequate means and secure against slipping.
 - Support the installed central ballast brackets and central ballast plates separately using adequate means and secure against slipping.
- Observe and adhere to the specifications for transporting the crane and the crane components, see chapter 3.80.

6 Increased corrosion

Extremely salty air near the sea can cause severe corrosion on the crane.

Increased corrosion can cause premature damage to the components (for example, the hydraulic cylinder, wire ropes, electrical and electronic components, driver's cab).

Submerging the hook block in water causes damage to the hook block and the rope.

The crane contractor and the crane operator are solely responsible for preventing severe corrosion.

Measures for preventing corrosion:

- Avoid direct contact between the crane and its components with salt water.
- Do **not** submerge the hook block in water.

Measures for detecting premature damage:

- Have the crane checked regularly and extensively by a qualified person.

3 Crane assembly

LWE/LR 13000-001/19503-01-02/en

LWE/LR 13000-001/19503-01-02/en

3.01.10 Assembling crawler carrier halves and track chain

1	Components of the crawler carrier	3
2	Crawler carrier fastening points	5
3	Assembling the crawler carrier	7
4	Installing the crawler carrier on the preassembled crawler center section	47
5	Disassembling the crawler carriers	47

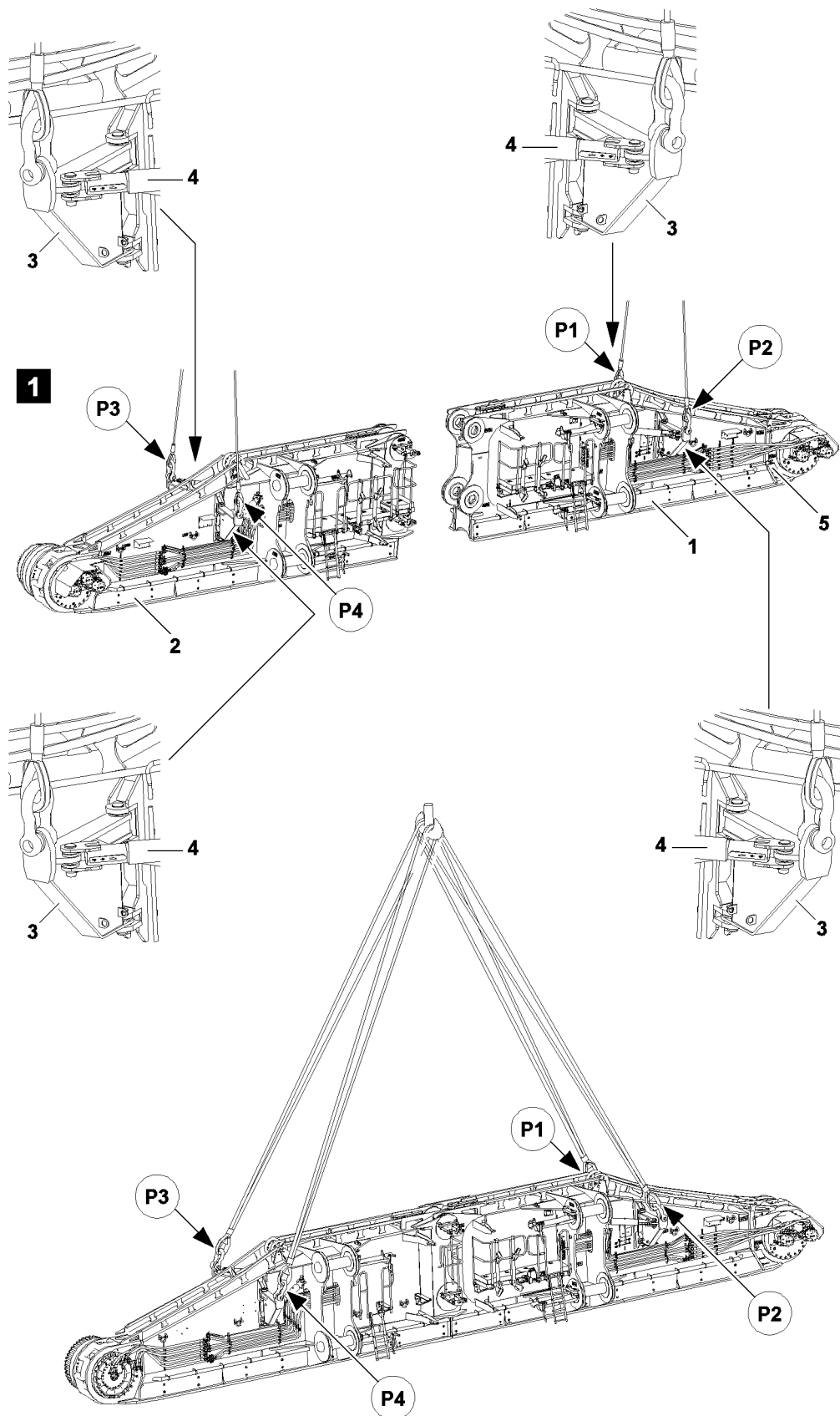

Fig.113035

LWE/LR 13000-001/19503-01-02/en

1 Components of the crawler carrier



Note

► For the dimensions and weights, see the Crane operating instructions, chapter 1.03.

1.1 Components of the crawler carrier front section

Position	Component
1	Crawler carrier front section
3	Towing bracket
4	Adjustment spindle
5	Sliding section

1.2 Components of the crawler carrier rear section

Position	Component
2	Crawler carrier rear section
3	Towing bracket
4	Adjustment spindle

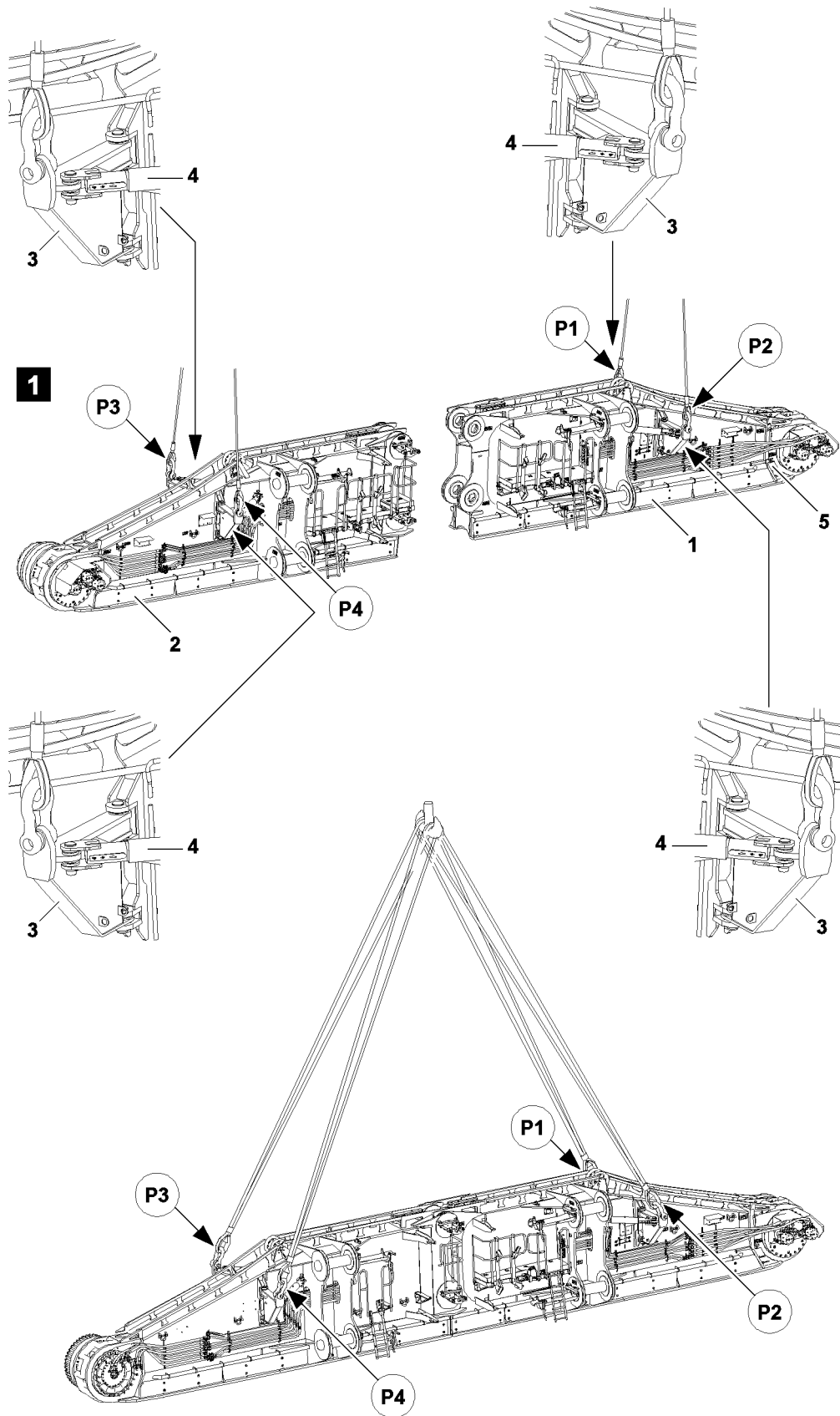

Fig.113035

2 Crawler carrier fastening points



Note

- ▶ When fastening the individual crawler carrier components, it must be ensured that the adjustment spindles **4** are set correctly according to the marking arrows.

2.1 Crawler carrier front section fastening points

Fastening points	
P1 and P2	Crawler carrier front section

2.2 Crawler carrier rear section fastening points

Fastening points	
P3 and P4	Crawler carrier rear section

2.3 Complete crawler carrier fastening points

Fastening points	
P1, P2, P3, P4	Complete crawler carrier

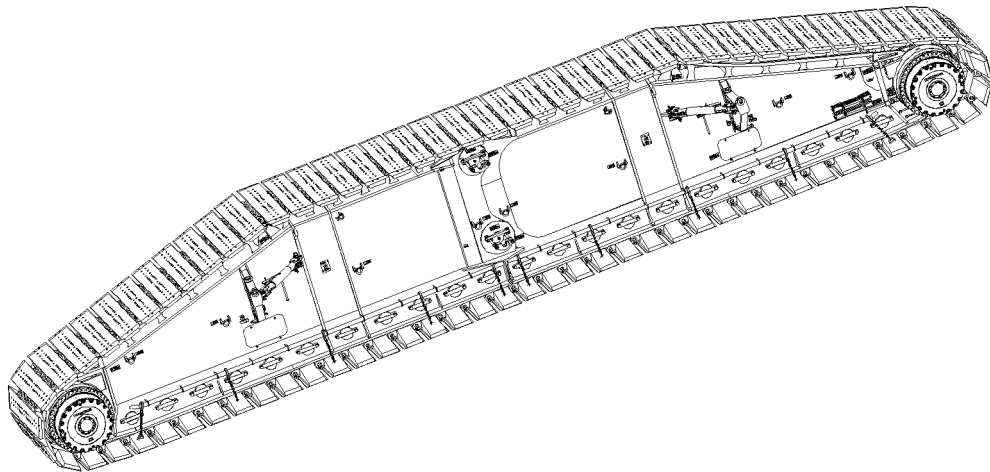
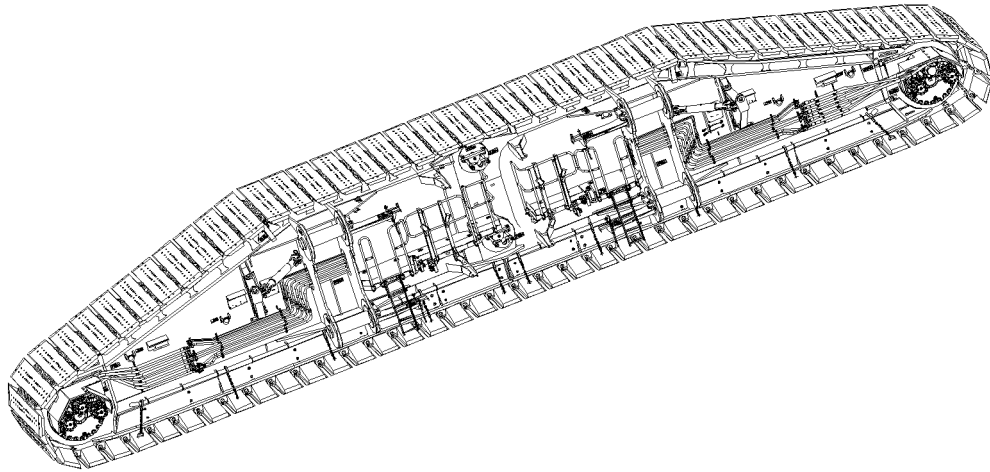

Fig.113036

LWE/LR 13000-001/19503-01-02/en

3 Assembling the crawler carrier



WARNING

Danger of falling!

During assembly / disassembly, inspection and maintenance work, assembly personnel must be secured with appropriate aids to prevent them from falling! If this is not observed, assembly personnel could fall and be killed or seriously injured!

- ▶ The assembly personnel must always move carefully and anticipatory on the crane, the crane components or lattice sections!
- ▶ All work at a height, when there is a danger of falling, must be carried out with suitable aids!
- ▶ If fall protection equipment is available, then it must be used!
- ▶ If aids are not available and work cannot be carried out from the ground, then assembly personnel must secure themselves with the permissible fall arrest system to prevent falling, see the Crane operating instructions, chapter 2.04!
- ▶ The fall arrest system must be attached in the fastening and hook points as well as to the safety ropes!
- ▶ Only step on the aids, ladders and catwalks with clean shoes!
- ▶ Keep aids, ladders and catwalks free of heavy dirt, snow and ice!



WARNING

Danger of impact / crushing!

When assembling / disassembling crane components with the auxiliary crane, crane components can start to swing back and forth!

When lifting / lowering and positioning crane components, there is an increased danger of impact / crushing!

Personnel can be caught and thereby injured or killed!

- ▶ Make sure that personnel cannot be caught by components!
- ▶ When working in danger zones: Use aids to protect limbs!
- ▶ Guide components with suitable aids to minimize oscillation!

Make sure that the following prerequisites are met:

- The ground is level and of sufficient load bearing capacity.
- An auxiliary crane is available.

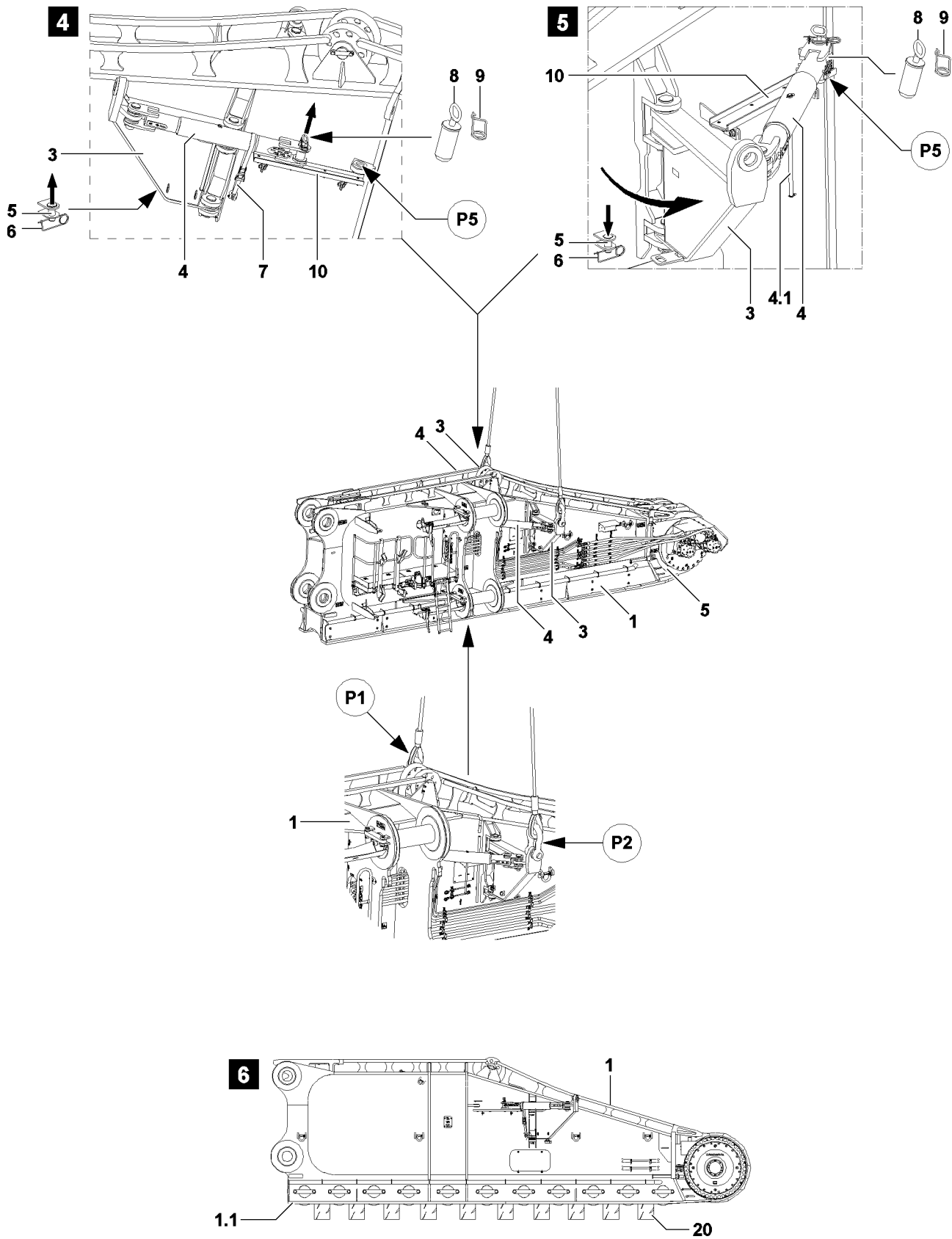

Fig.113029

LWE/LR 13000-001/19503-01-02/en

3.1 Lifting the crawler carrier front section from the flatbed trailer



Note

- ▶ To lift the crawler carrier front section from the flatbed trailer, bring the outer tow coupling into the operating position.
- ▶ The inner tow coupling remains permanently in the operating position, since the contour of the inner two coupling is within the contour of the pinning to the cross carriers and therefore there are not any interfering edges during transport.



WARNING

Toppling of the crawler carrier front section!
Personnel can be severely injured or killed!

- ▶ Make sure that the transport retainers of the crawler carrier front section are released only from the flatbed trailer when the crawler carrier front section is fastened to the auxiliary crane and safely held by the auxiliary crane.
- ▶ Move the work platform on the outer swung-in tow coupling.
- ▶ Release the transport retainer for the tow coupling **3**: Release the spring retainer **6** and unpin the pin **5**, illustration **4**.
- ▶ Release and remove the tension belt **7**.
- ▶ Unpin the pin **8** on the adjustment spindle **4**. Remove the spring retainer **9** and unpin the pin **8**.



WARNING

Danger of crushing!
When swinging out the tow coupling **3**, limbs can be crushed or trapped!
Personnel can be severely injured or killed!

- ▶ Use personal protective equipment.
- ▶ Release the transport retainer for the tow coupling only when the crawler carrier front section is horizontally aligned and the tow coupling can therefore not swing out by itself.
- ▶ Swing the tow coupling **3** out completely until the pin bore for the adjustment spindle **4** aligns with the pin bore in point **P5**: Insert the pin **8** and secure with the spring retainer **9**.
- ▶ Reinsert the pin **5** into the bracket on the crawler carrier and secure with the spring retainer **6**, illustration **5**.

When the adjustment spindle **4** is pinned in point **P5**:

- ▶ Fasten the crawler carrier front section to the auxiliary crane in point **P1** and point **P2**.
- ▶ Carefully tension the fastening equipment.

When the crawler carrier front section is safely held by the auxiliary crane:

- ▶ Release and remove the transport retainers for the crawler carrier front section on the flatbed trailer.
- ▶ Remove the work platform from the assembly and slewing range of the auxiliary crane.

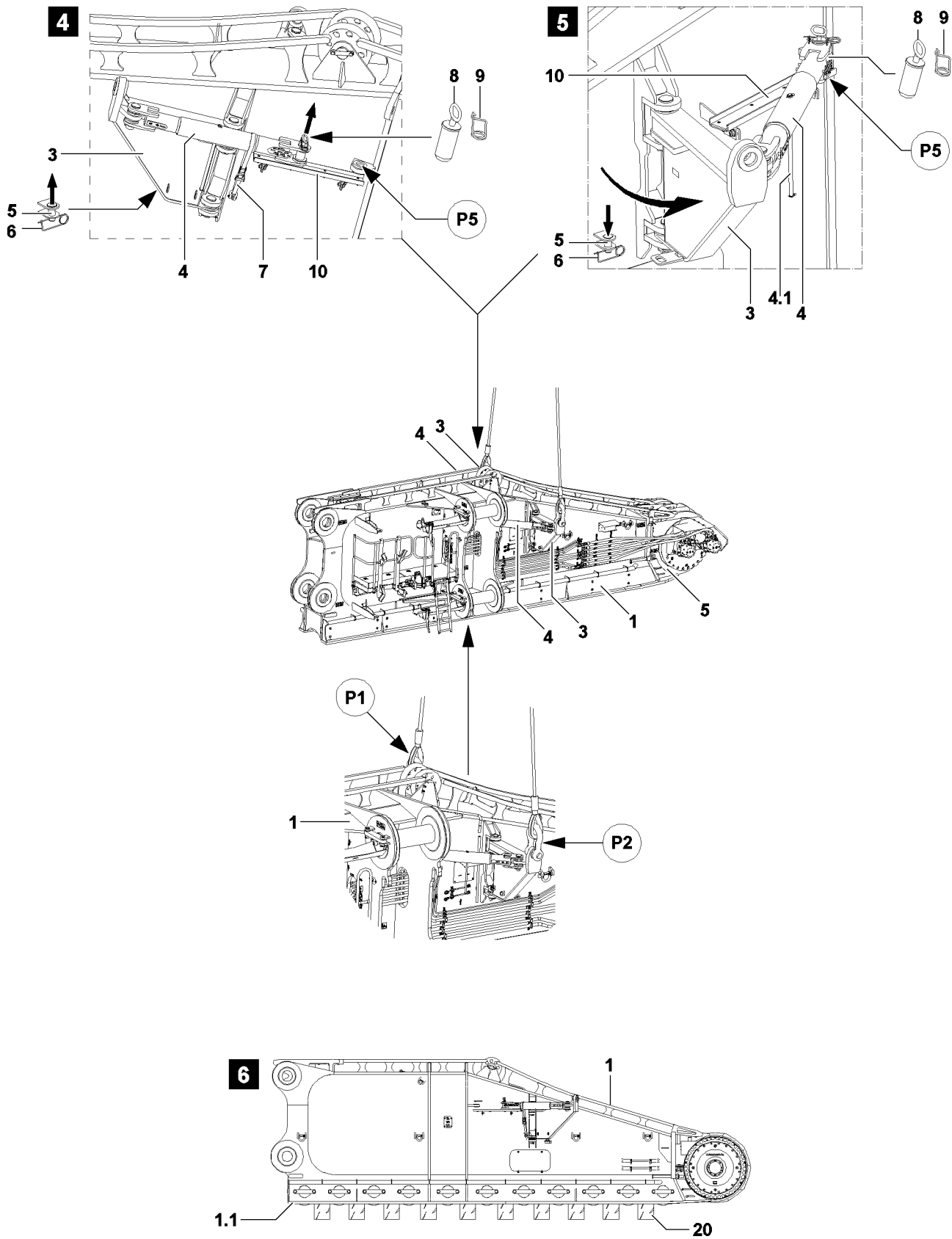

Fig.113029

LWE/LR 13000-001/19503-01-02/en

**WARNING**

Oscillating crane components!

When lifting the crawler carrier front section from the flatbed trailer, it can start to swing back and forth! Personnel can be severely injured or killed!

- ▶ Make sure that there are no persons in the danger zone of the crawler carrier front section.
- ▶ Make sure that there are no obstacles in the danger zone.

- ▶ Carefully lift the crawler carrier front section and check the horizontal alignment.

Problem remedy

Does the crawler carrier front section not hang horizontally when lifting it with the auxiliary crane?

The adjustment spindles **4** on the tow couplings **3** were not adjusted.

- ▶ Set the crawler carrier front section down again, check the adjustments on the adjustment spindles and readjust, if necessary.

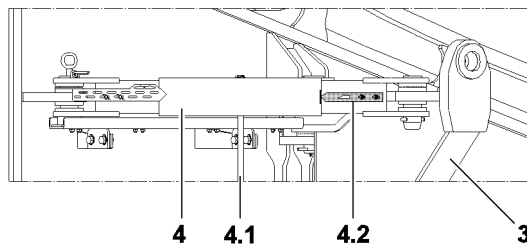

Fig.113033: Adjustment of the adjustment sleeve on one half of the crawler carrier

- ▶ Turn the adjustment spindle **4** with the tap **4.1** until the collar of the adjustment spindle **4** reaches the tip of the arrow on the arrow **4.2**.

When the crawler carrier front section hangs horizontally on the auxiliary crane:

- ▶ Lift the crawler carrier front section from the flatbed trailer and swing it into the prepared assembly location of the crawler carrier.
- ▶ Support the crawler carrier front section: Insert a hardwood beam **20** between the track rollers in such a way that the set down crawler carrier front section is lying on the base belt **1.1**, illustration **6**.

**WARNING**

Danger of toppling of the crawler carrier front section!

If the load bearing capacity of the base is not sufficient, the crawler carrier front section can tip over! Personnel can be severely injured or killed!

- ▶ Make sure that the ground is level and of sufficient load bearing capacity.
- ▶ Make sure that the substructure for the crawler carrier front section is prepared properly.
- ▶ Make sure that the crawler carrier front section is secured additionally to prevent it from tipping over if the base is questionable.

- ▶ Set the crawler carrier front section with the auxiliary crane on the substructure- hardwood beams **20**.

When the crawler carrier front section has been set down completely on the substructure:

- ▶ Remove the auxiliary crane.

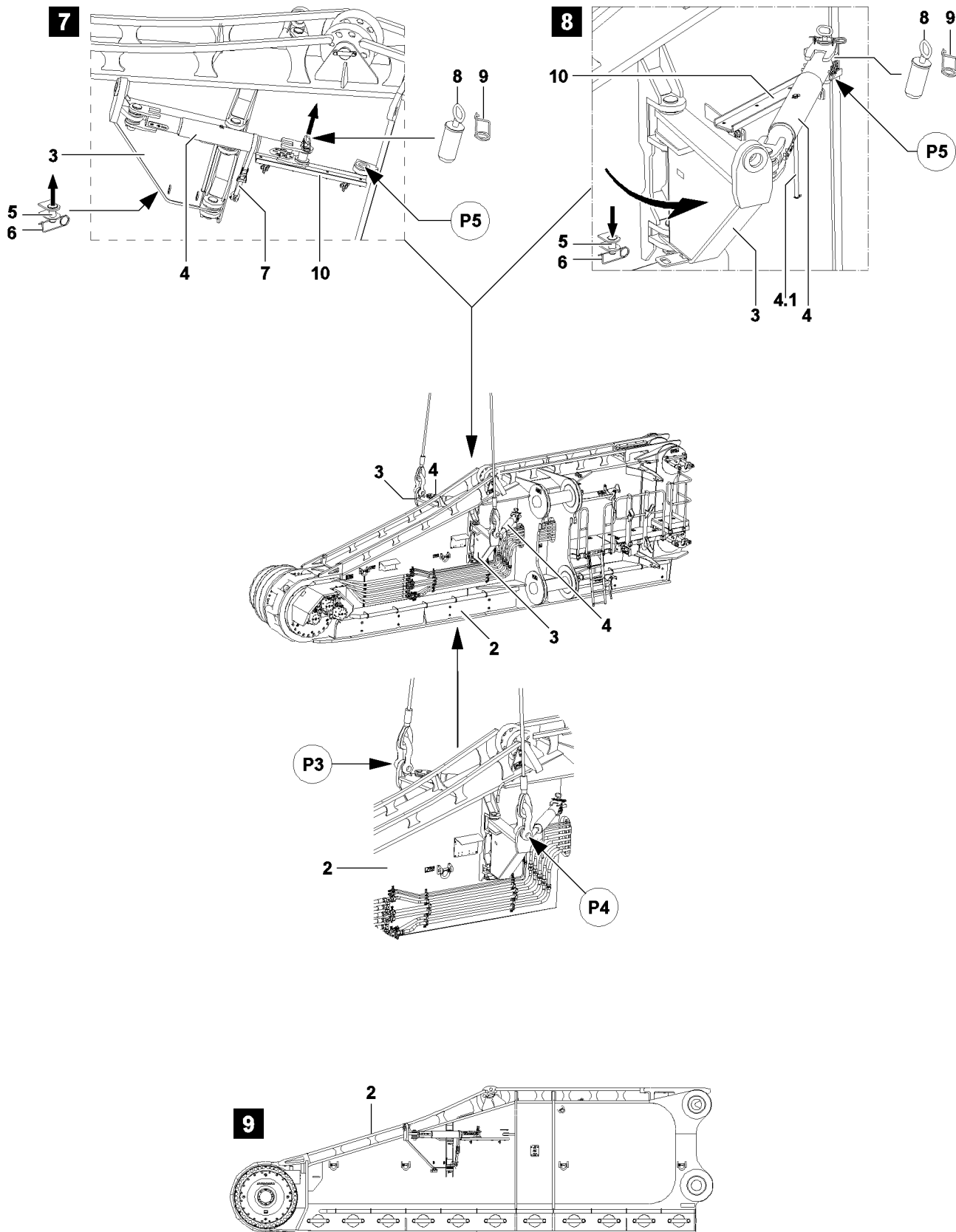

Fig.113044

LWE/LR 13000-001/19503-01-02/en

3.2 Lifting the crawler carrier rear section from the flatbed trailer



Note

- ▶ To lift the crawler carrier rear section from the flatbed trailer, bring the outer tow coupling into the operating position.



WARNING

Toppling of the crawler carrier rear section!
Personnel can be severely injured or killed!

- ▶ Make sure that the transport retainers of the crawler carrier rear section are released only from the flatbed trailer when the crawler carrier rear section is fastened to the auxiliary crane and safely held by the auxiliary crane.

Make sure that the following prerequisites are met:

- The crawler carrier rear section is rigged and secured on the flatbed trailer.
- An auxiliary crane is available.
- A work platform is available.
- The inner tow couplings on the crawler carrier rear section is in the operating position.



WARNING

Falling assembly personnel!

If assembly personnel does not wear an approved fall arrest system during assembly, then assembly personnel can fall down.

Personnel can be severely injured or killed!

- ▶ Use an approved fall arrest system.
- ▶ Move the work platform on the outer swung-in tow coupling.
- ▶ Release the tow coupling **3**: Release the spring retainer **6** and unpin the pin **5**, illustration **8**.
- ▶ Release and remove the tension belt **7**.
- ▶ Unpin the pin **8** on the adjustment spindle **4**. Remove the spring retainer **9** and unpin the pin **8**.

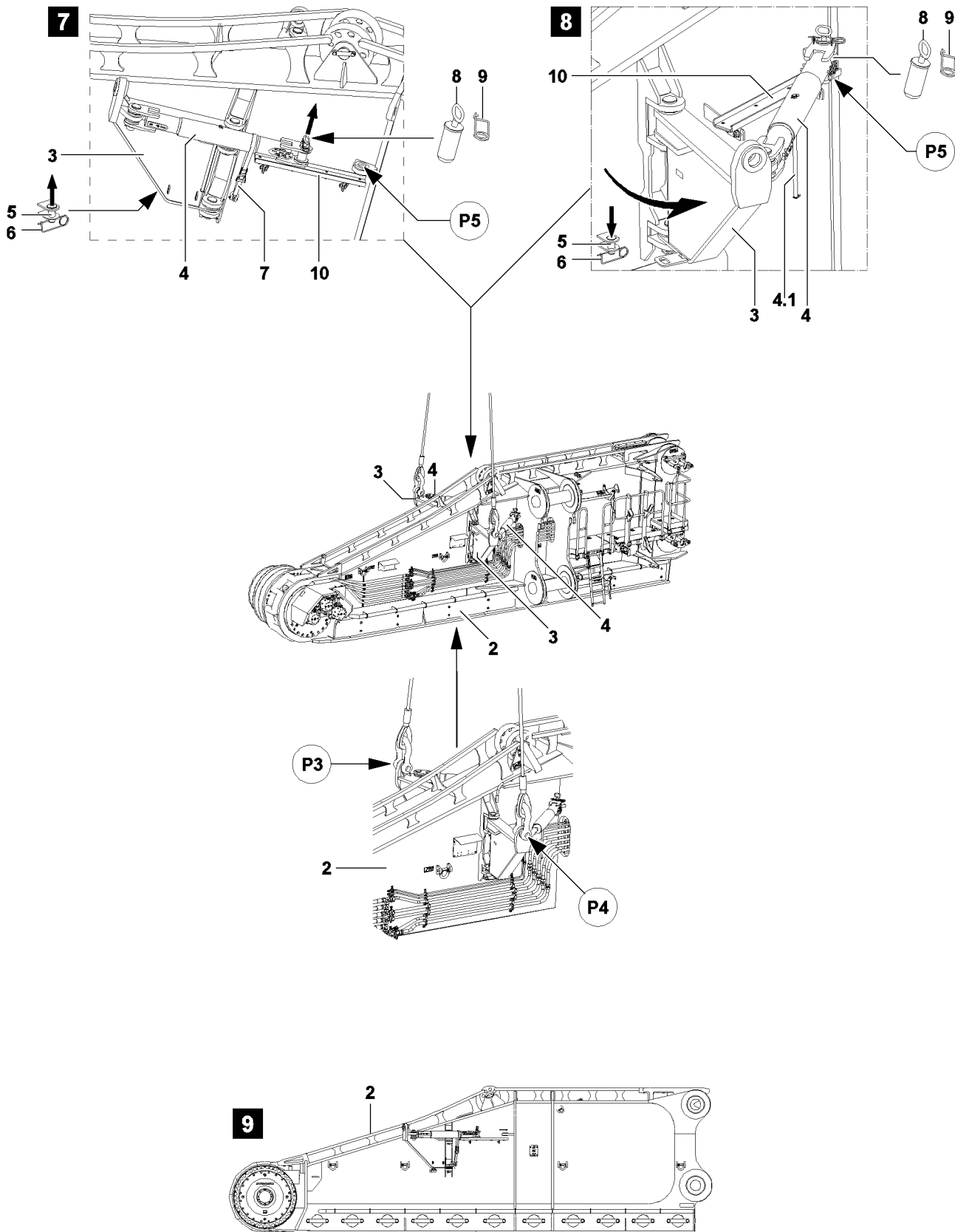

Fig.113044

**WARNING**

Danger of crushing!

When swinging the tow coupling out, especially if the crawler carrier front section is not horizontally aligned, limbs can be crushed or trapped!

Personnel can be severely injured or killed!

- ▶ Use personal protective equipment.
- ▶ Release the transport retainer for the tow coupling only when the crawler carrier front section is horizontally aligned and the tow coupling can therefore not swing out by itself.

- ▶ Swing the tow coupling **3** out completely until the pin bore for the adjustment spindle **4** aligns with the pin bore in point **P5**: Insert the pin **8** and secure with the spring retainer **9**.
- ▶ Reinsert the pin **5** into the bracket on the crawler carrier and secure with the spring retainer **6**, illustration **8**.

When the adjustment spindle **4** is pinned in point **P5**:

- ▶ Fasten the crawler carrier rear section to the auxiliary crane in point **P3** and point **P4**.
- ▶ Carefully tension the fastening equipment.

When the crawler carrier rear section is safely held by the auxiliary crane:

- ▶ Release and remove the transport retainers for the crawler carrier rear section on the flatbed trailer.
- ▶ Remove the work platform from the assembly and slewing range of the auxiliary crane.

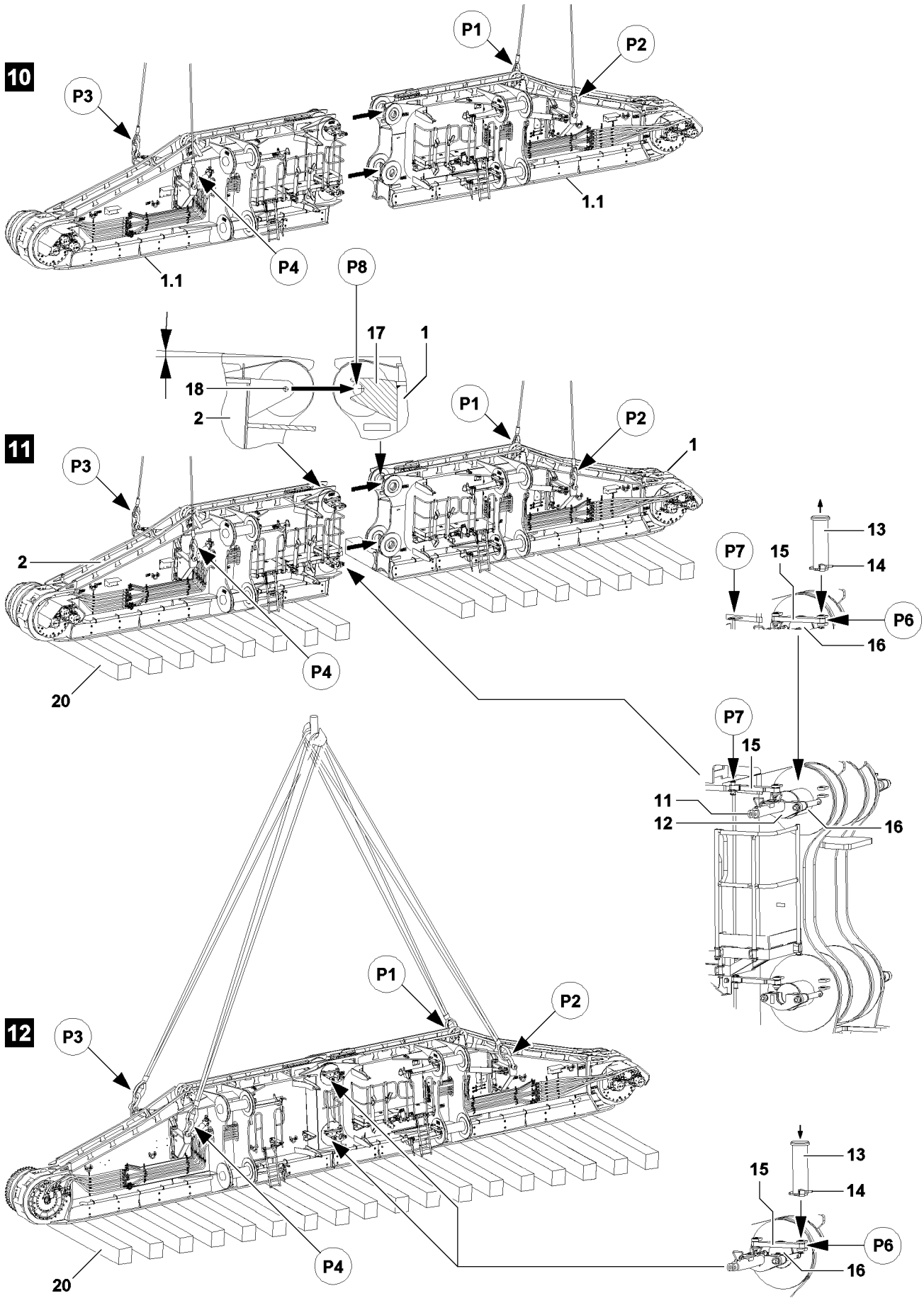

Fig.113030

LWE/LR 13000-001/19503-01-02/en

**WARNING**

Oscillating crane components!

When lifting the crawler carrier rear section from the flatbed trailer, it can start to swing back and forth! Personnel can be severely injured or killed!

- ▶ Make sure that there are no persons in the danger zone of the crawler carrier rear section.
- ▶ Make sure that there are no obstacles in the danger zone.

- ▶ Carefully lift the crawler carrier rear section and check the horizontal alignment.

**Note**

- ▶ The crawler carrier rear section must be tilted slightly downward toward the pin side when lifting it from the flatbed trailer.

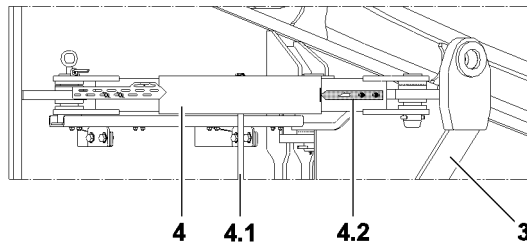

Fig.113033: Adjustment of adjustment sleeve for lifting one of the crawler carrier halves

- ▶ Turn the adjustment spindle with the tap **4.1** until the collar of the adjustment spindle **4** just reaches the tip of the arrow on the arrow **4.2**.

When the crawler carrier rear section hangs with a slight incline on the auxiliary crane:

- ▶ Lift the crawler carrier rear section from the flatbed trailer and swing it into the prepared assembly location of the crawler carrier.
- ▶ Align the crawler carrier rear section on the crawler carrier front section.

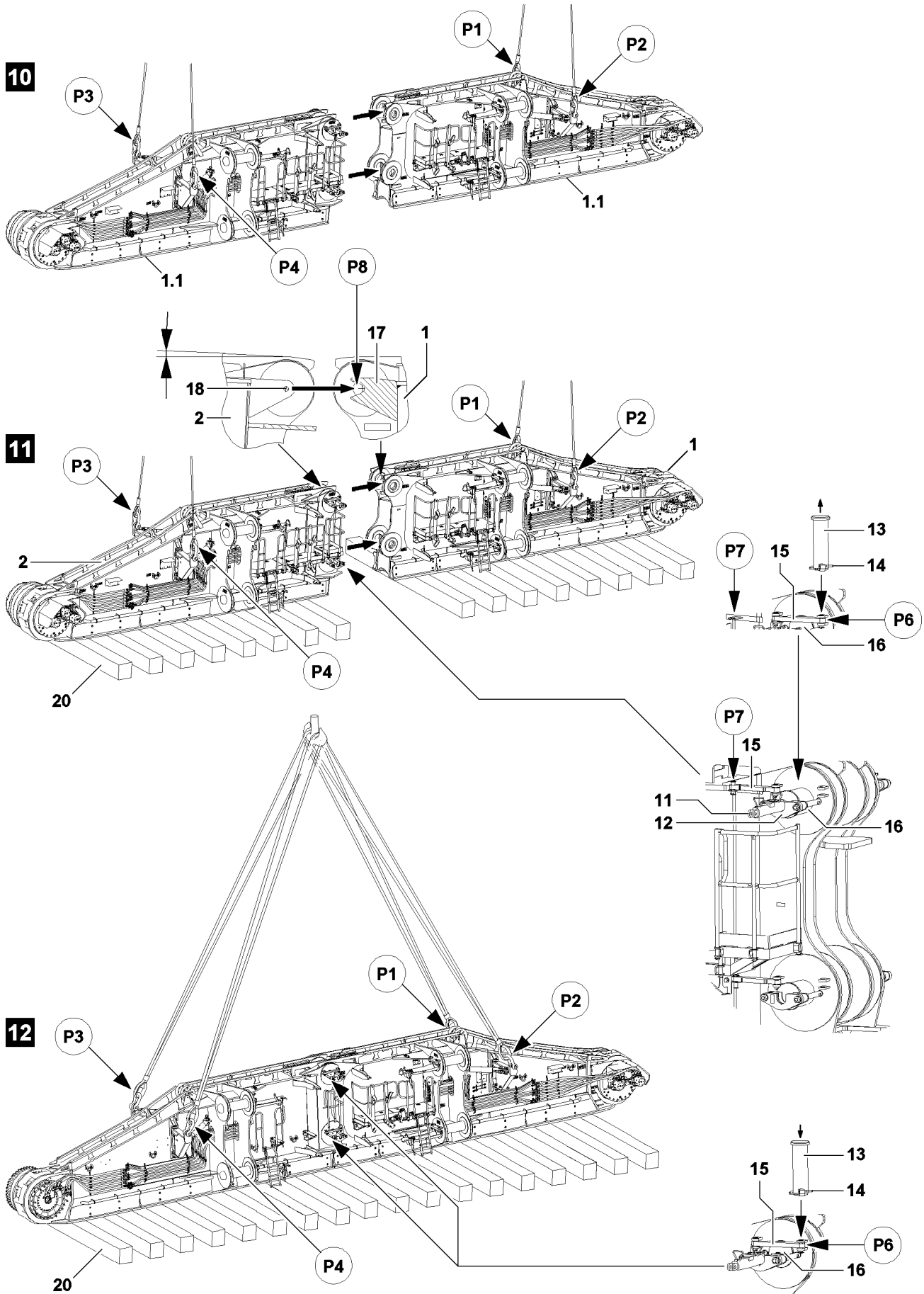

Fig.113030

LWE/LR 13000-001/19503-01-02/en

3.3 Combining the crawler carrier front section and the crawler carrier rear section

NOTICE

Danger of property damage!

If the connector pins - when retracting the crawler carrier rear section **2** into the crawler carrier front section **1** - are in the **pinned** position, the components can be severely damaged.

- ▶ Make sure that the connector pin **16** on the crawler carrier rear section **2** is in the **unpinned** position when retracting into the crawler carrier front section **1**!

When the crawler carrier rear section is aligned with the crawler carrier front section:

- ▶ Retract the crawler carrier rear section **2** into the crawler carrier front section **1** to until the centering pin **18** engages in the pocket receptacle **17** in point **P8** without play.



WARNING

Risk of crawler carrier tipping!

If the load bearing capacity of the base is not sufficient, the installed crawler carrier can tip over! Personnel can be severely injured or killed!

- ▶ Make sure that the ground is level and of sufficient load bearing capacity.
 - ▶ Make sure that the substructure for the crawler carrier is prepared properly.
 - ▶ Make sure that the crawler carrier is secured additionally to prevent it from tipping over if the base is questionable.
 - ▶ The crawler carrier rear section must remain fastened to the auxiliary crane until both crawler carrier halves are completely pinned with each other.
-
- ▶ Support the crawler carrier rear section **2**: Insert a hardwood beam **20** between each track roller in such a way that the set down crawler carrier rear section is laying on the base belt, illustration **12**.

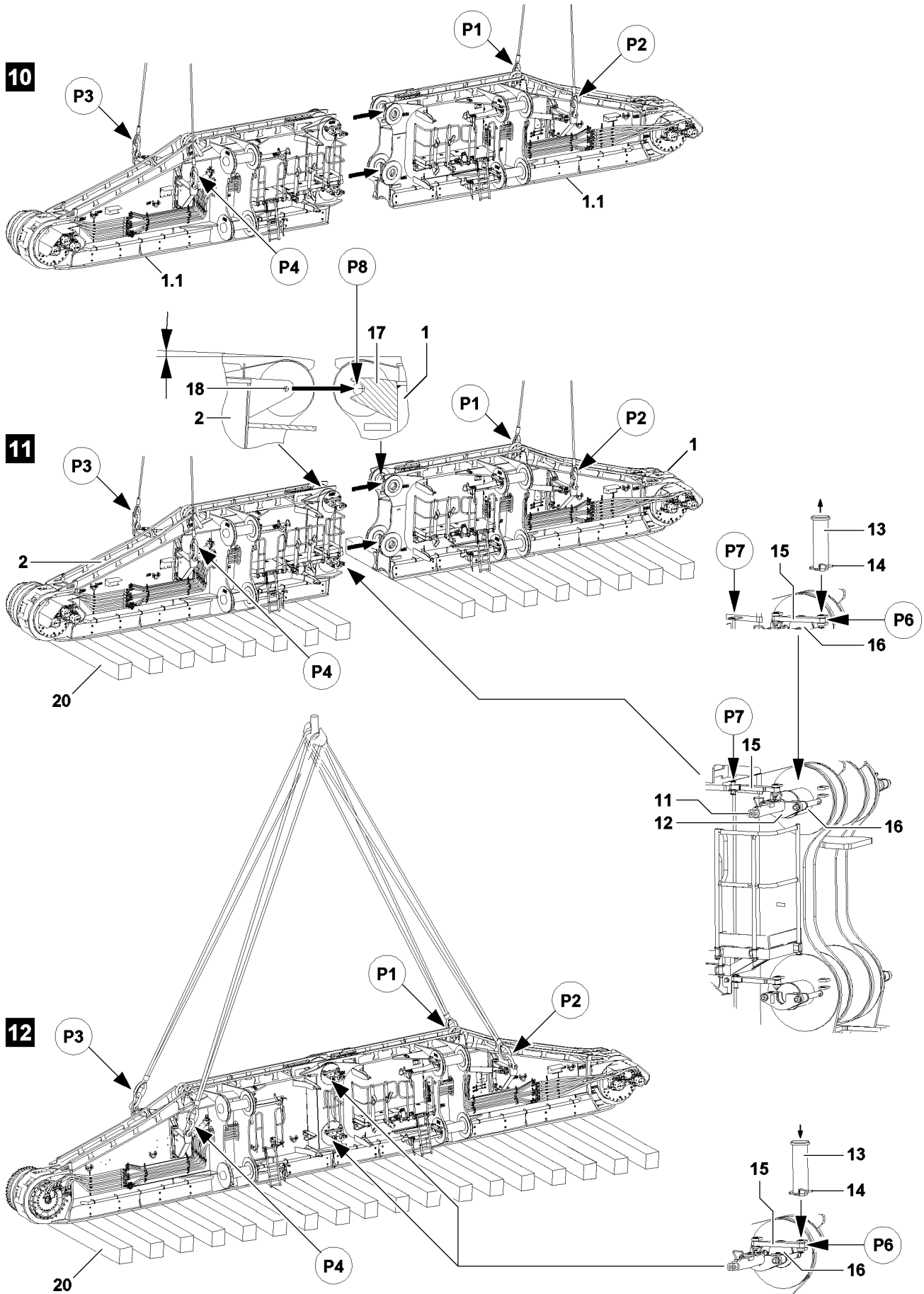

Fig.113030

LWE/LR 13000-001/19503-01-02/en

3.4 Pinning the crawler carrier front section with the crawler carrier rear section

Make sure that the following prerequisites are met:

- The two crawler carrier halves are properly supported from below.
- The pin pulling cylinder and the pin pulling aggregate are in immediate vicinity of the crawler carrier.

3.4.1 Pinning and securing the inner connector pins

Make sure that the following prerequisites are met:

- The centering pin **18** engages without play in the pocket receptacle **17** in point **P8**.
- The securing bracket **15** is pinned and secured in the transport position (point **P7**).
- The upper pin bores of the crawler carrier rear section and the crawler carrier front section align.



WARNING

Danger of falling for assembly personnel!

During the pin procedure on the inner pin points of the crawler carrier, assembly personnel can fall down!

Personnel can be severely injured or killed!

- ▶ The assembly work on the inside of the two crawler carrier halves may only be carried out using the factory installed assembly pedestals and catwalks.
 - ▶ Assembly personnel is obligated to carry out all assembly tasks only when using the personal protective equipment.
 - ▶ Improvisations are prohibited.
-
- ▶ Fasten the pin pulling cylinder **11** to the auxiliary crane and align with the upper cylinder receptacle **12** on the inside of the crawler carrier.
 - ▶ Slowly lower the pin pulling cylinder with the auxiliary crane into the upper cylinder receptacle **12** on the inside of the crawler carrier.
 - ▶ Establish the hydraulic supply from the pin pulling cylinder **11** to the pin pulling aggregate, see the Crane operating instructions, chapter 5.30.
 - ▶ Actuate the control lever on the pin pulling cylinder **11**.

Result:

- The piston rod on the pin pulling cylinder **11** extends and the connector pin **16** is pinned.

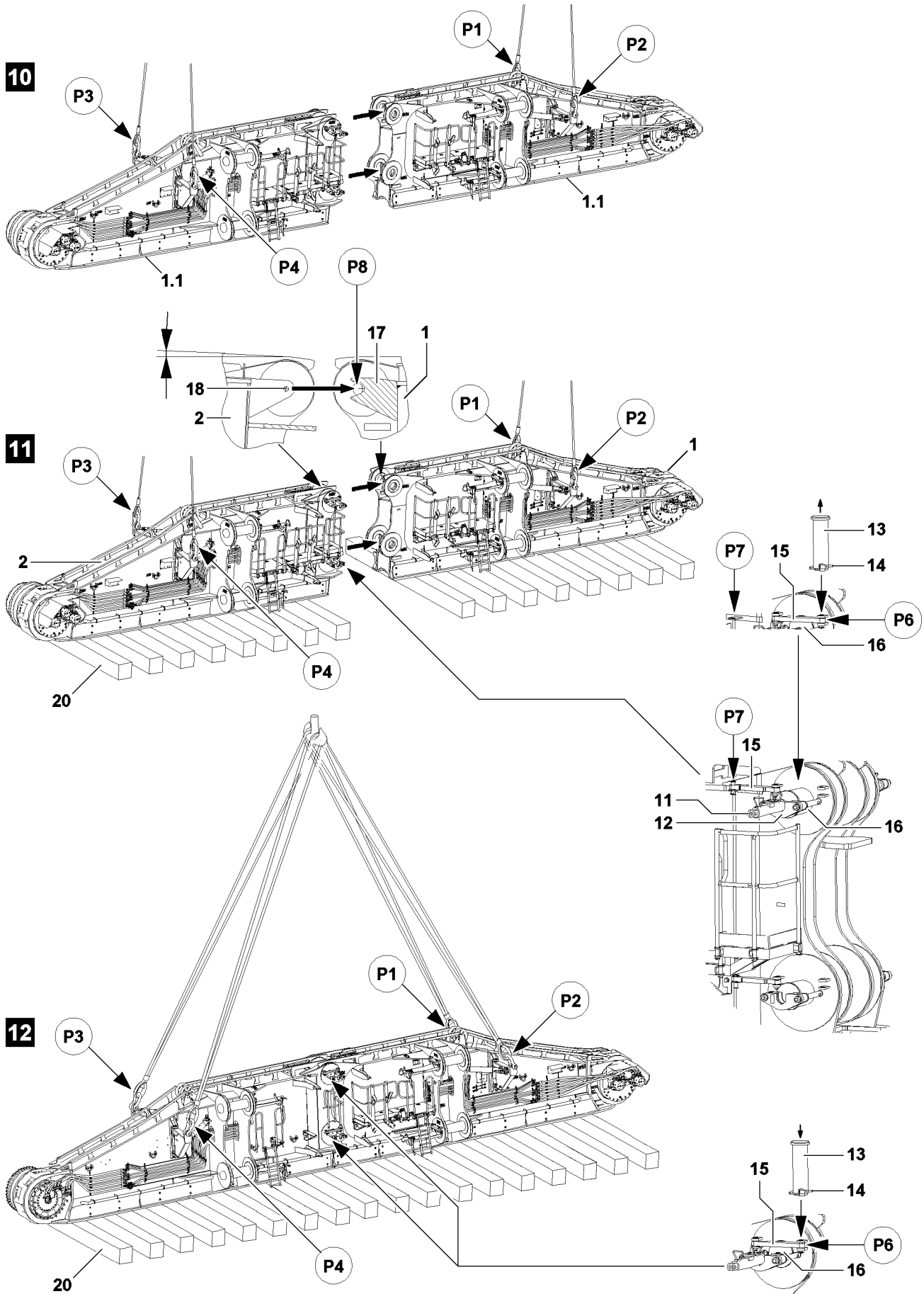

Fig.113030

LWE/LR 13000-001/19503-01-02/en

When the connector pin **16** is completely pinned:

- ▶ Fasten the pin pulling cylinder **11** to the auxiliary crane and lift it out of the cylinder receptacle.
- ▶ Completely retract the piston rod on the pin pulling cylinder **11**.
- ▶ Secure the connector pin **16**: Release the securing bracket **15** in the transport position in point **P7** and unpin.
- ▶ Swing the securing bracket **15** in front of the connector pin **16**.
- ▶ Secure the securing bracket **15** in point **P6**: Insert the pin **13** and secure with the spring retainer **14**.

Result:

- The connector pin **16** is secured.
- ▶ Lower the crawler carrier front section with the auxiliary crane completely onto the substructure until the fastening surfaces of both crawler carrier halves combine.

Result:

- The lower pin bores of both crawler carrier halves align.
- ▶ Slowly lower the pin pulling cylinder with the auxiliary crane into the lower cylinder receptacle **12** on the inside of the crawler carrier.



Note

- ▶ The subsequent procedure to pin the lower inner connector pins is identical to the procedure on the upper inner connector pin.
-

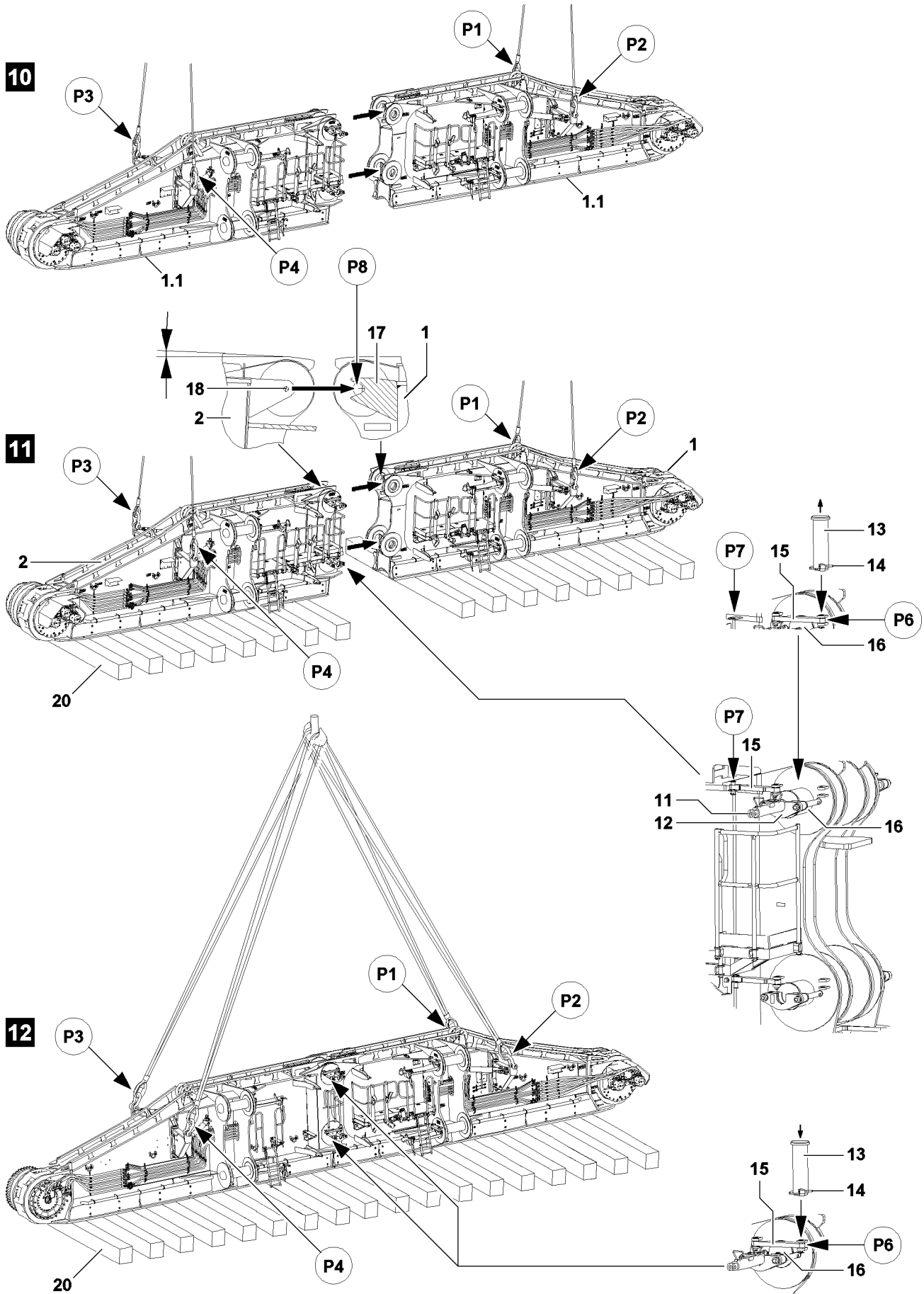

Fig.113030

LWE/LR 13000-001/19503-01-02/en

3.4.2 Pinning and securing the outer connector pins

Make sure that the following prerequisites are met:

- The inner connector pins are completely pinned and secured.
- The crawler carrier rear section is fastened to the auxiliary crane.
- A work platform is available.



WARNING

Danger of falling for assembly personnel!

During the pin procedure on the outer pin points of the crawler carrier, assembly personnel can fall down!

Personnel can be severely injured or killed!

- ▶ The assembly work on the outside of the two crawler carrier halves may only be carried out using a work platform.
 - ▶ Assembly personnel is obligated to carry out all assembly tasks only when using the personal protective equipment.
 - ▶ Improvisations are prohibited.
-



Note

- ▶ The pinning of the outer connector pins is identical to the pinning of the inner connector pins.
-
- ▶ Pin the outer connector pin according to the procedure of the inner connector pins and secure with securing bracket.

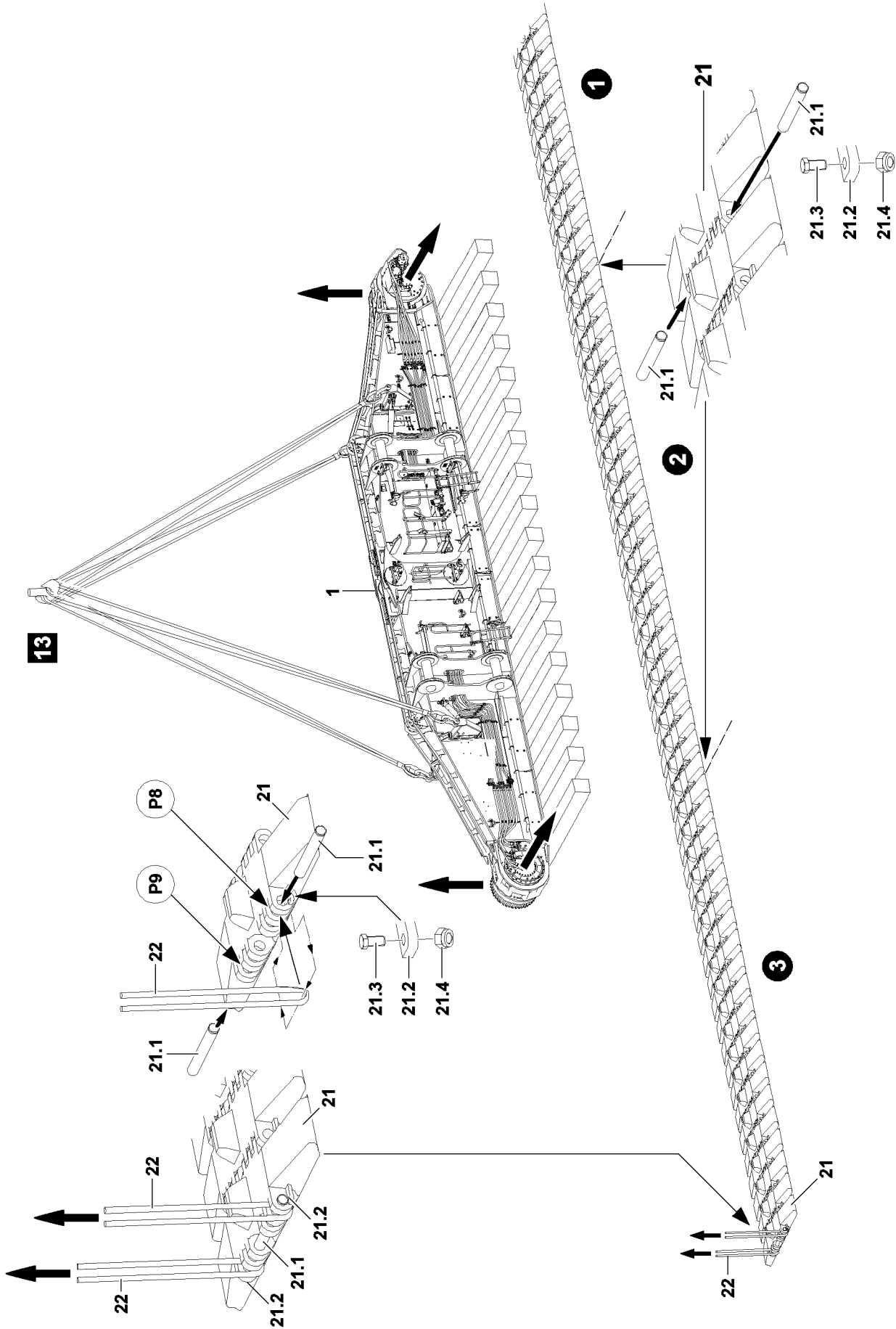

Fig.113037

LWE/LR 13000-001/19503-01-02/en

3.5 Assembling the crawler chain



WARNING

Toppling of the crawler carrier!

If the load bearing capacity and the condition of the support base is not clarified before assembly of the crawler chain, then the crawler chain can sink into the ground and the completely assembled crawler carrier can topple over!

Personnel can be killed or seriously injured!

- ▶ Check the ground before assembly of the crawler chain for load bearing capacity!
- ▶ Make sure that the assembly location for the crawler chain has sufficient load bearing capacity to take on the weight of the completely assembled crawler carrier.
- ▶ Lay the crawler chain out in the immediate vicinity to the crawler carrier and assemble.

3.5.1 Laying the chain segments out and pinning



Note

- ▶ The crawler chain is disassembled in chain segments for transport, according to the permissible total maximum weight of the available transport units.
- ▶ Weight of the crawler chain and individual outrigger pads, see the Crane operating instructions, chapter 1.03.

Make sure that the following prerequisites are met:

- The ground is level and of sufficient load bearing capacity.
- An auxiliary crane is available.
- Fastening equipment with sufficient load carrying capacity is available.

Fasten the first chain segment to the auxiliary crane:

- ▶ Unpin the two connector pins **21.1** on the outrigger pad.
- ▶ Position the loop of the first fastening equipment **22** in point **P8**.

NOTICE

Increased wear on the pin connections of the crawler chain!

If the connector pins are not sufficiently greased before pinning, increased wear and run in damage can result!

- ▶ Before pinning, grease the connector pins evenly with **GLEITMO 100S!**
- ▶ Observe the wear limits, see the Crane operating instructions, chapter 7.04!

- ▶ Slide in the first connector pin **21.1** on the outrigger pad **21** so that the connector pin **21.1** is runs through the loop of the fastening equipment.
- ▶ Slide in the connector pin **21.1** on the outrigger pad to the retaining bracket **21.2**.
- ▶ Position the loop of the second fastening equipment **22** in point **P9**.
- ▶ Slide in the connector pin **21.1** on the outrigger pad **21** from the other side completely so that the connector pin **21.1** also runs through the loop of the second fastening equipment.

Result:

- The fastening equipment **22** is fixed to the chain segment.

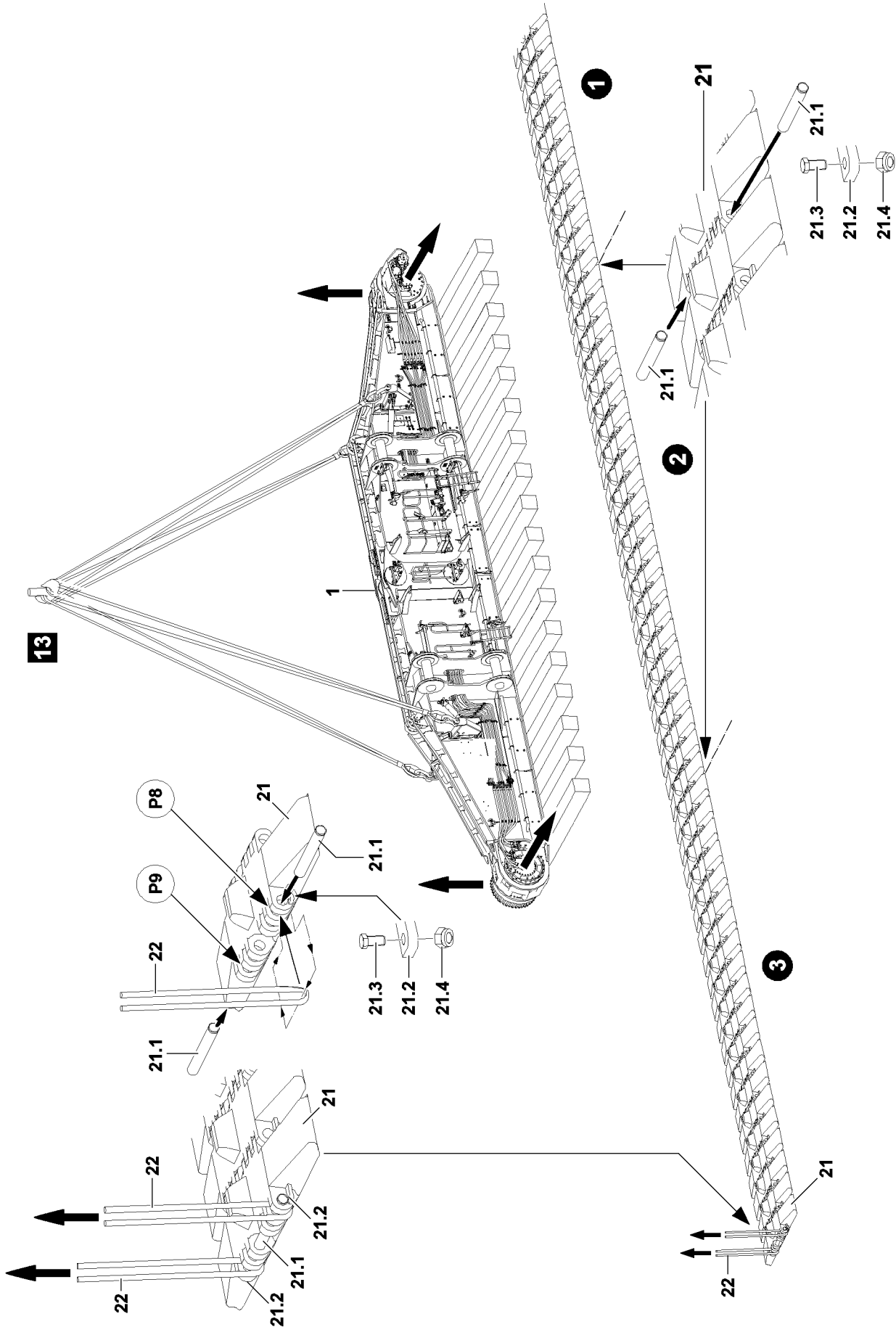

Fig.113037

LWE/LR 13000-001/19503-01-02/en

**WARNING**

Falling chain segment!

If the connector pins **21.1** are not secured with the auxiliary crane during transport of the individual chain segments, the connector pins can loosen up and the respective chain segment can fall down. Personnel can be severely injured or killed.

- ▶ Make sure that the connector pins **21.1** are properly pinned and secured for transport of the chain segments.

**Note**

- ▶ The tightening torque of the hex head screws **21.3** is: **1050 Nm !**
- ▶ Do **not** grease the hex head screws **21.3** and nuts **21.4!**

Secure the connector pin **21.1**:

- ▶ Insert the hex head screw **21.3** on both sides into the retaining bracket **21.2** and secure with the nut **21.4**.

Result:

- The connector pins **21.1** are secured.

**WARNING**

Oscillating crane components!

When lifting the chain segments from the transport vehicle, the chain segments can start to swing back and forth.

Personnel can be severely injured or killed!

- ▶ Make sure that there are no persons or obstacles in the danger zone.
- ▶ Carefully lift the first chain segment with the auxiliary crane from the transport vehicle and take it down in direct vicinity to the preassembled crawler carrier.

When the first chain segment has been taken down completely on the ground:

- ▶ Release and unpin the connector pin **21.1** and remove the fastening equipment on the first chain segment.
- ▶ Lift the additional chain segment with the auxiliary crane from the transport vehicle and take it down to extend the first chain segment.
- ▶ Pin the chain segments with each other: Insert the connector pin **21.1** and secure with hex head screw **21.3** and nut **21.4** on both sides.

**Note**

- ▶ The chain segments are to be assembled to the maximum chain length according to the assembly description.

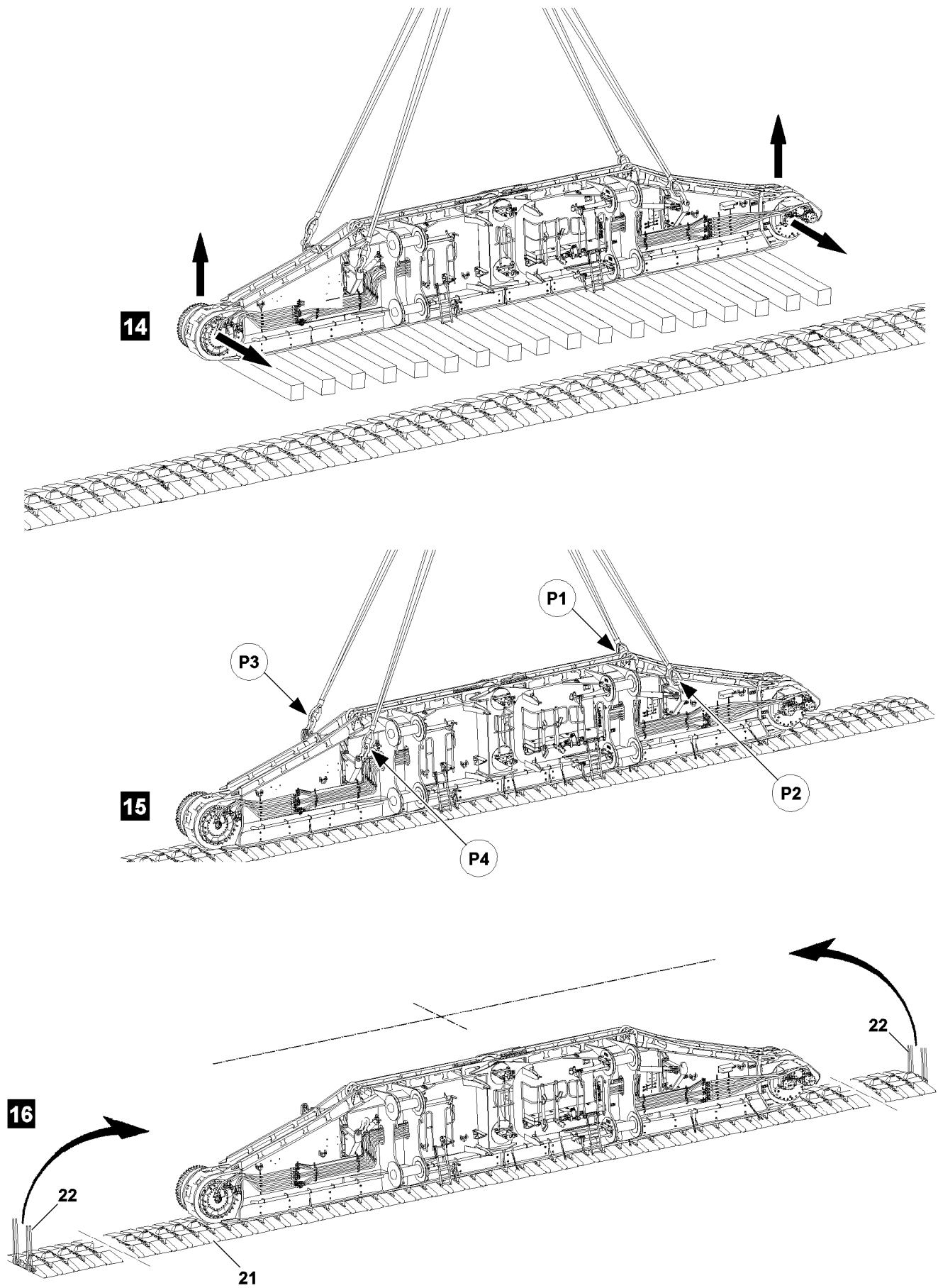

Fig.113038

LWE/LR 13000-001/19503-01-02/en

3.6 Transferring the crawler carrier from the substructure to the crawler chain

Make sure that the following prerequisites are met:

- The crawler chain is positioned on the ground in its full length.
 - The chain segments are properly pinned and secured.
 - The two crawler carrier halves are properly pinned with each other and secured.
 - The sliding section **5** on the crawler carrier is fully retracted and secured.
 - No personnel or objects are in the danger zone.
- ▶ Fasten the crawler carrier to the auxiliary crane in the fastening points, point **P1**, point **P2**, point **P3** and point **P4**.



Note

- ▶ Adjust the adjustment spindles **4** so that the crawler carrier hangs in a horizontal direction on the auxiliary crane when transferring it from the substructure to the crawler chain.
- ▶ Turn the adjustment spindles **4** until the collar of the adjustment spindle is at the height of the tip of the arrow **4.3**.
- ▶ Make sure that the four fastening ropes are tensioned the same when lifting the crawler carrier.

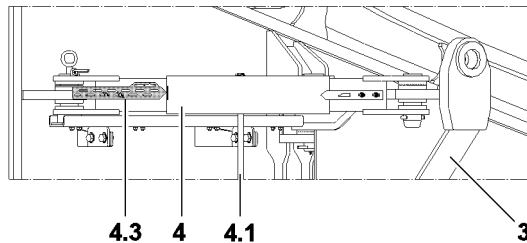

Fig.113052: Adjustment of adjustment sleeves for lifting the **complete crawler carrier**

- ▶ Adjust the adjustment spindles on the tip of the arrow **4.3**.

When the crawler carrier is fastened properly to the auxiliary crane:

- ▶ Lift the crawler carrier from the substructure with the auxiliary crane.

NOTICE

Damage to travel gear components!

If the crawler carrier is not properly set onto the cams of the crawler chain, the cams of the outrigger pads, the track rollers or the sprocket on the crawler carrier can be damaged.

- ▶ Align the crawler carrier and set it centered on the crawler chain.
-
- ▶ Set the crawler carrier with the auxiliary crane completely in the center of the positioned crawler chain.
 - ▶ The crawler carrier remains fastened to the auxiliary crane.
 - ▶ Secure the crawler carrier to prevent it from tipping over.

When the crawler carrier is secured to prevent it from tipping over:

- ▶ Release the fastening equipment in the fastening points on the crawler carrier.
- ▶ Remove the auxiliary crane.

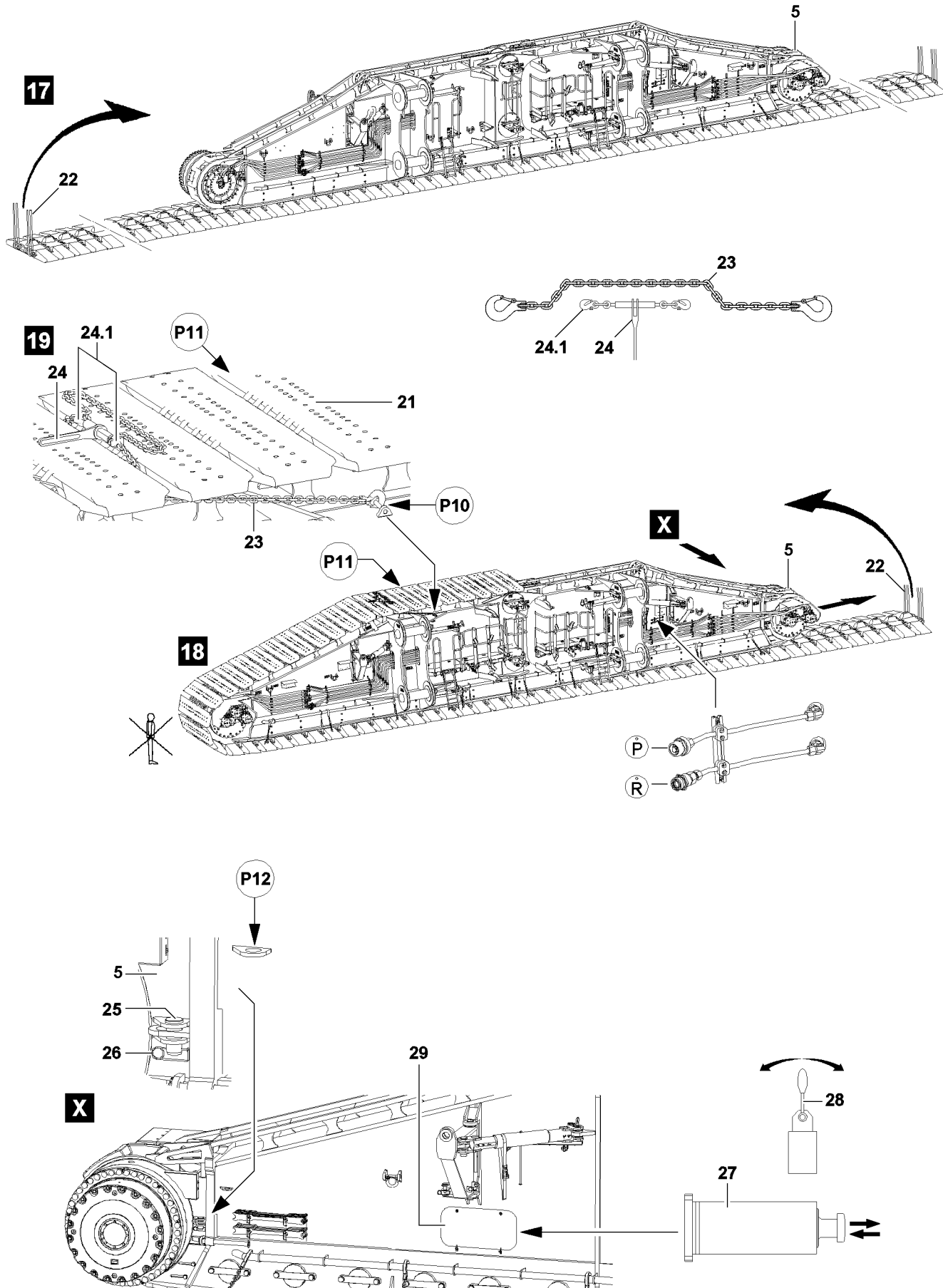

Fig.113040

LWE/LR 13000-001/19503-01-02/en

3.7 Assembling the crawler chain on the crawler carrier

The crawler chain must be installed first on the crawler carrier rear section and then on the crawler carrier front section.

The crawler carrier front section is the part of the crawler carrier where the sliding section is located.

Make sure that the following prerequisites are met:

- The crawler carrier is set in the center on the laid out crawler chain.
- The crawler carrier is secured to prevent it from tipping over.
- An external hydraulic aggregate is available.

3.7.1 Positioning the crawler chain on the crawler carrier rear section

- ▶ Fasten the crawler chain to the auxiliary crane: Use fastening equipment **22**, illustration **17**.

NOTICE

Danger of property damage to crawler chain or crawler carrier!

If it is not ensured when mounting the crawler chain on the crawler carrier that the cams of the outrigger pads mesh completely into the sprocket, then the crawler chain or the crawler carrier can be damaged.

- ▶ Make sure that the cams of the outrigger pads engage completely and without sagging into the sprocket when mounting the crawler chain, check visually.

- ▶ Lift the crawler chain off the ground with the auxiliary crane and pull it over the crawler carrier rear section.

When the crawler chain is taken down on the crawler carrier rear section, illustration **18**:

- ▶ Connect the rigging chain **23** to the eye ring in point **P10** and place it over the crawler chain.
- ▶ Connect the rigging chain **23** to the rear of the crawler carrier on the eye ring in point **P11**.
- ▶ Position the rigging chain **23** on both sides from the bottom to the top between two outrigger pads and tension it.



Note

- ▶ The reducer **24** must be connected with the hook **24.1** to the rigging chain **23** in such a way that the rigging chain **23** is tensioned as far as possible!
- ▶ The „chain play“ still in the rigging chain **23** must be removed with the reducer so that the crawler chain cannot slip from the crawler carrier rear section!

- ▶ Connect the reducer **24** with the hook **24.1** to the rigging chain **23**.

When the reducer is installed in the rigging chain **23**:

- ▶ Actuate the ratchet until the rigging chain **23** is tensioned without play.



WARNING

Slipping crawler chain!

Due to improper safety measures of the crawler chain on the crawler carrier rear section, the crawler chain can slip off from the crawler carrier rear section.

Personnel can be severely injured or killed!

- ▶ Make sure that the crawler chain is held safely by the rigging chain before removing the auxiliary crane from the crawler chain.
- ▶ It is prohibited for personnel to remain on the end of the crawler carrier rear section.

When the rigging chain **23** is tensioned without play:

- ▶ Remove the auxiliary crane.

3.7.2 Establishing the hydraulic connections to the tension cylinder

The hydraulic connections are established with quick couplings.

When connecting hydraulic lines with quick couplings, make sure that the coupling procedure is carried out correctly.

The matching quick couplings are marked.



WARNING

Pressure in the hydraulic lines!

If the pressure supply is not interrupted before connecting / releasing the hydraulic lines, the hydraulic oil can escape with high pressure.

Death, severe bodily injuries, property damage.

- ▶ Release the pressure in the hydraulic system before connecting / disconnecting: Interrupt the pressure supply and wait a short time.
-



WARNING

Loss of pressure or leakage!

Incorrectly coupled or self-loosening quick couplings (particularly return lines) can result in serious accidents due to component failure.

Death, severe bodily injuries, property damage.

- ▶ Check that the quick couplings have been properly connected before using the crane.
 - ▶ Connect the coupling components (sleeve and connector) and screw together with the knurled nut.
 - ▶ Tighten the hydraulic coupling by hand. Turn the knurled nut until it reaches a tangible, fixed stop position.
 - ▶ Establish the hydraulic connections to the tension cylinder **27**: Connect the supply lines of the external hydraulic aggregate to the supply lines of the tension cylinder **27**, hydraulic connection **P** and hydraulic connection **R**.
-

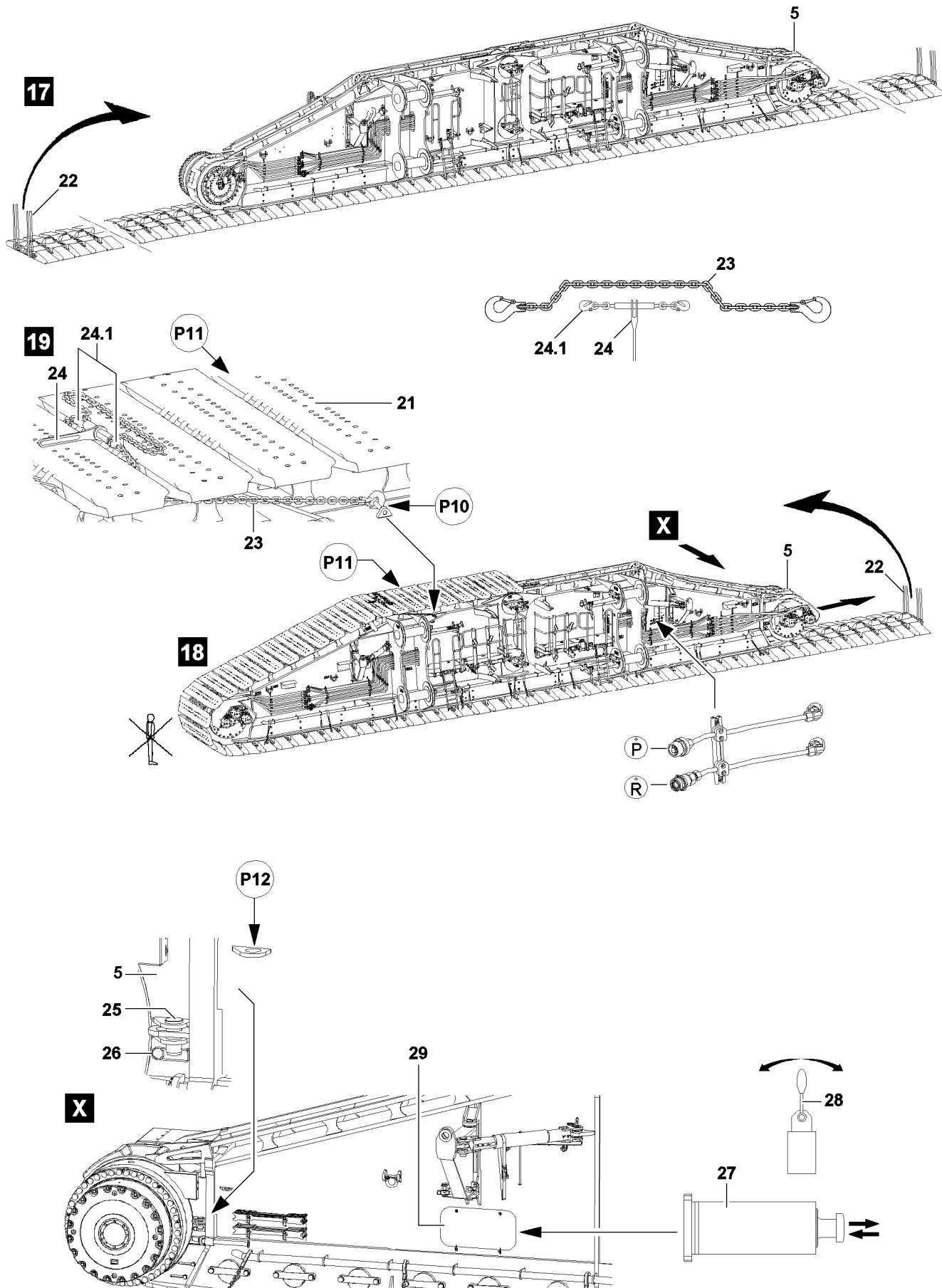

Fig.113040

LWE/LR 13000-001/19503-01-02/en

3.7.3 Extend the sliding section on the crawler carrier front section



Note

- ▶ When extending the sliding section, depending on the position of the sprocket, the travel drive must be driven on the sliding section side of the crawler carrier momentarily to correctly engage the sprocket on the „first“ cam of the crawler chain!
- ▶ The travel drive on the crawler carrier is actuated via the hydraulic aggregate, see the Hydraulic diagram.

To assemble the crawler chain, extend the sliding section **5** if necessary until the sprocket aligns with the chain.

The sliding section **5** is controlled via the hand lever **28**, which is used to actuate the tension cylinder **27** and retract or extend the sliding section **5**.

NOTICE

Damage to the transport retainer!

If the tension cylinder **27** of the sliding section **5** is actuated before the transport retainer is released, the crawler carrier can be damaged!

- ▶ Make sure that the transport retainer is released on the sliding section **5** before the tension cylinder **27** is actuated.
- ▶ Release the transport retainer: Release and unpin the pin **25**, illustration **X**.
- ▶ Insert the pin **25** in the park position, point **P12** and secure with the spring retainer **26**.

When the hydraulic connections are properly established:

- ▶ Fold the control opening **29** open.
- ▶ Start the motor for the external hydraulic aggregate.
- ▶ Move the hand lever **28** carefully.

Result:

- The sliding section **5** moves out.

When the sprocket and the cams of the crawler chain align:

- ▶ Return the hand lever **28** to the zero position.

Result:

- The extension movement of the tension cylinder is stopped.
- ▶ Turn the motor for the external hydraulic aggregate off.

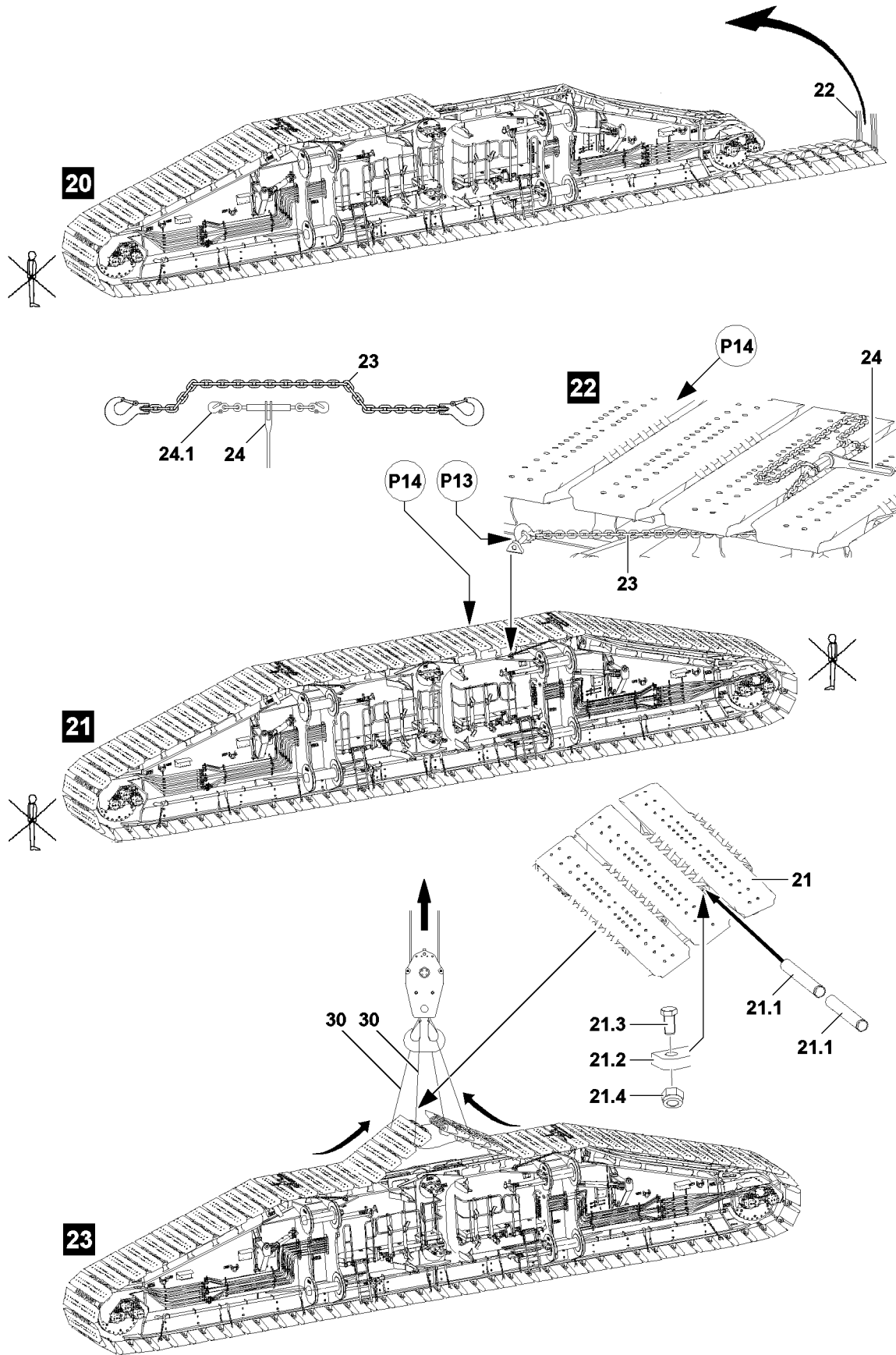

Fig.113041

LWE/LR 13000-001/19503-01-02/en

3.7.4 Positioning crawler track chain on the crawler carrier front section

Make sure that the following prerequisites are met:

- The crawler chain is properly positioned on the crawler carrier rear section and secured with the rigging chain.
 - The sliding section on the crawler carrier front section is moved out to the point where the cams align with the sprocket.
- ▶ Fasten the crawler chain to the auxiliary crane: Use the fastening equipment **22**.

NOTICE

Danger of property damage to crawler chain or crawler carrier!

If it is not ensured when mounting the crawler chain on the crawler carrier that the cams of the outrigger pads mesh completely into the sprocket, then the crawler chain or the crawler carrier can be damaged.

- ▶ Make sure that the cams of the outrigger pads engage completely and without sagging into the sprocket when mounting the crawler chain, check visually.
-
- ▶ Lift the crawler chain off the ground with the auxiliary crane and pull it over the crawler carrier front section.

When the crawler chain is taken down on the crawler carrier front section, illustration **21**:

- ▶ Connect the rigging chain **23** to the eye ring in point **P13** and place it over the crawler chain.
- ▶ Connect the rigging chain **23** to the rear of the crawler carrier on the eye ring in point **P14**.
- ▶ Position the rigging chain **23** on both sides from the bottom to the top between two outrigger pads and tension it.



Note

- ▶ The reducer **24** must be connected with the hook **24.1** to the rigging chain **23** in such a way that the rigging chain **23** is tensioned as far as possible!
- ▶ The „chain play“ still in the rigging chain **23** must be removed with the reducer so that the crawler chain cannot slip from the crawler carrier front section!

-
- ▶ Connect the reducer **24** with the hook **24.1** to the rigging chain **23**.

When the reducer is installed in the rigging chain **23**:

- ▶ Actuate the ratchet until the rigging chain **23** is tensioned without play.



WARNING

Slipping crawler chain!

Due to improper safety measures of the crawler chain on the crawler carrier front section, the crawler chain can slip off from the crawler carrier front section.

Personnel can be severely injured or killed!

- ▶ Make sure that the crawler chain is held safely by the rigging chain before removing the auxiliary crane from the crawler chain.
- ▶ It is prohibited for any personnel to remain on the end of the crawler carrier front section.

When the rigging chain **23** is tensioned without play:

- ▶ Remove the auxiliary crane.

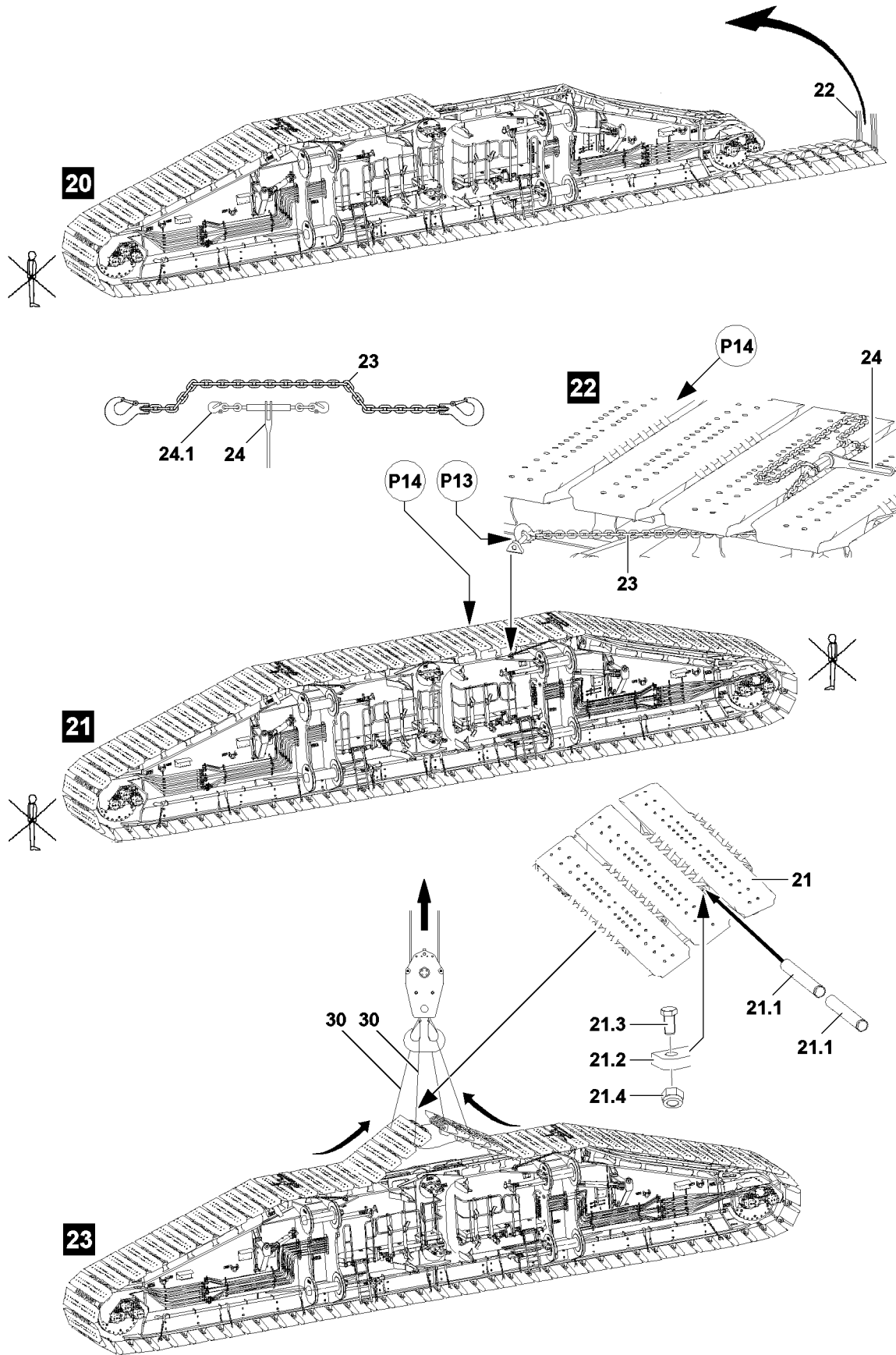

Fig.113041

LWE/LR 13000-001/19503-01-02/en

3.7.5 Connecting / closing the crawler chain

Before connecting or closing the ends of the chain, eliminate the chain play from the crawler chain with the auxiliary crane.

Make sure that the following prerequisites are met:

- One end of the chain is lying on the crawler carrier rear section and is properly secured to prevent it from slipping off.
- One end of the chain is lying on the crawler carrier front section and is properly secured to prevent it from slipping off.
- ▶ Place two rope loops **30** around the two outer outrigger pads on the ends of the chain, illustration **23**.



WARNING

Danger of accident due to angular pull!

- ▶ Make sure that the hook block is centered with the longitudinal axle of the crawler carrier.
- ▶ Make sure that the hook block of the auxiliary crane is centered above the joint of the crawler chain when pulling the two ends of the chain together.
- ▶ Angular pull is prohibited!

- ▶ Fasten the rope loops **30** to the auxiliary crane.

When the rope loops are fastened to the auxiliary crane:

- ▶ Slowly pull the ends of the chain together with the auxiliary crane.

Result:

- The chain play in the crawler chain is eliminated.
- ▶ Carefully take the ends of the chain down again on the crawler carrier with the auxiliary crane.

NOTICE

Increased wear on the pin connections of the crawler chain!

If the connector pins are not sufficiently greased before pinning, increased wear and run in damage can result!

- ▶ Before pinning, grease the connector pins evenly with **GLEITMO 100S!**
- ▶ Observe the wear limits, see the Crane operating instructions, chapter 7.04!



Note

- ▶ The tightening torque of the hex head screws **21.3** is: **1050 Nm !**
- ▶ Do **not** grease the hex head screws **21.3** and nuts **21.4!**
- ▶ Pin the chain ends together: Insert the connector pins **21.1** and secure with a hex head screw **21.3** and nut **21.4** on both sides.

When the ends of the chain are properly pinned and secured:

- ▶ Remove the rigging chains **23** on the crawler carrier rear section and on the crawler carrier front section.

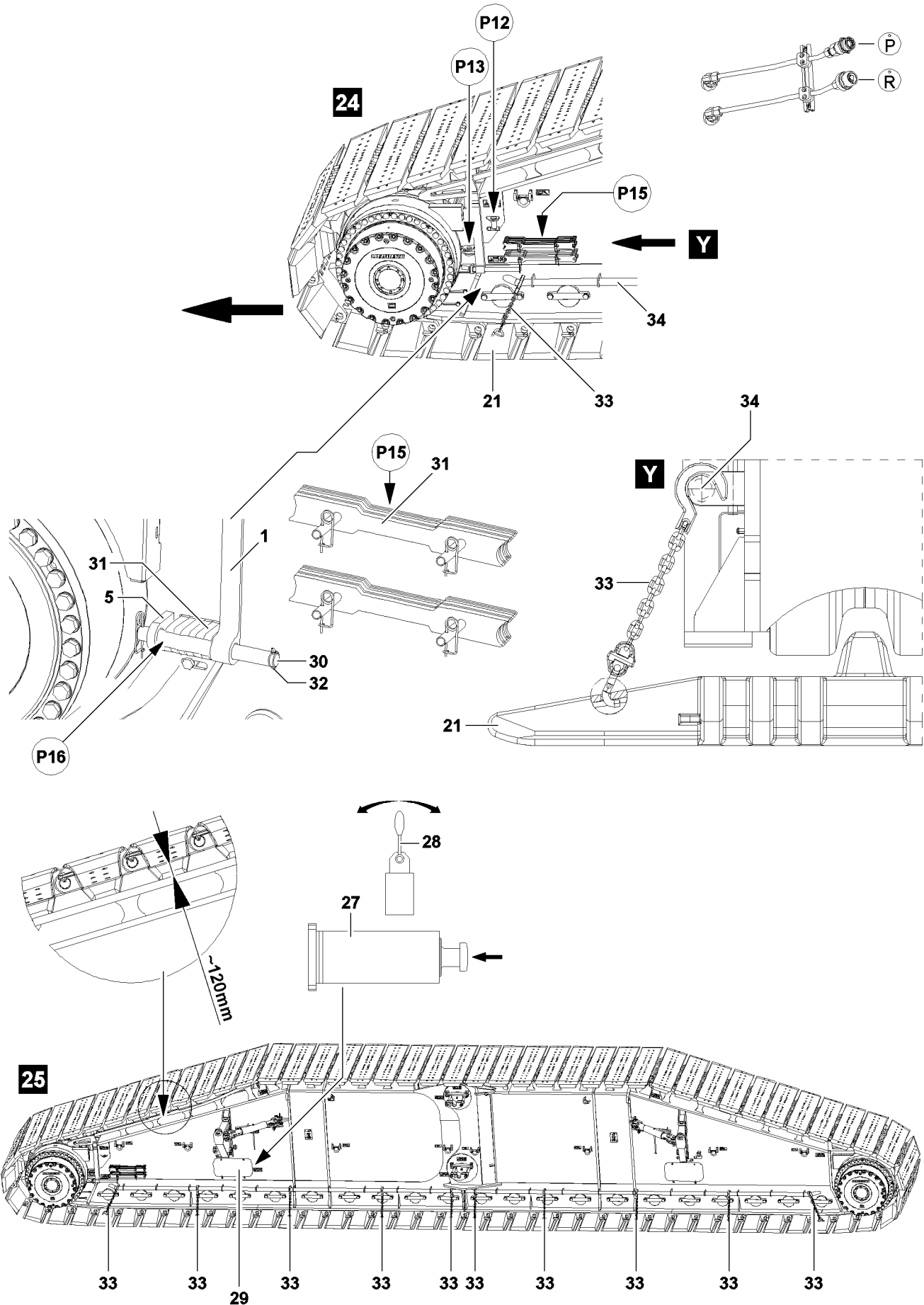

Fig.113042

LWE/LR 13000-001/19503-01-02/en

3.7.6 Tensioning the crawler chain

The crawler chain must be tensioned after chain installation according to the following description.

Make sure that the following prerequisites are met:

- The ends of the chain are properly pinned and secured.
- The rigging chains have been removed.

NOTICE

Damage to the crawler carrier!

Since the sprocket does not turn along by itself during the tension procedure of the crawler chain, the travel drive must be actuated for a short time again on the sliding section!

If this is not observed, severe property damage can occur to the sprocket or the travel drive!

- ▶ When tensioning the crawler chain, the travel drive must always be actuated for a short time on the sliding section side of the crawler carrier to correctly engage the sprocket on the cams of the crawler chain!
- ▶ The travel drive on the crawler carrier is actuated via the hydraulic aggregate, see the Hydraulic diagram.

-
- ▶ Actuate the hand lever **28**.

Result:

- The tension cylinder moves the sliding section out.
- The crawler chain is tensioned by the sliding section.

When the crawler chain is no longer lying on the side, inclined glide rails:

- ▶ Bring the hand lever **28** in the neutral position.
- ▶ Repeat the tensioning procedure until the dimension between the glide rail and the crawler chain is approx. 120 mm.

NOTICE

Component wear due to **insufficient** chain tension!

If the track chain sags too much after the tensioning procedure, the outrigger pads as well as the glide rails can wear significantly during travel operation!

- ▶ Make sure that the crawler chain always has sufficient tension.
- ▶ Observe the maintenance intervals and maintenance guidelines, see the Crane operating instructions, chapter 7.02 and chapter 7.04.

NOTICE

Component wear due to **high** chain tension!

If the crawler chain is tensioned too much after the tensioning procedure, the pin connections can wear significantly!

In addition, the pitch on the sprocket changes, which also can lead to significant wear or significant damage to the sprocket!

- ▶ Make sure that the crawler chain is not tensioned too much.
 - ▶ Observe the maintenance intervals and maintenance guidelines, see the Crane operating instructions, chapter 7.02 and chapter 7.04.
-

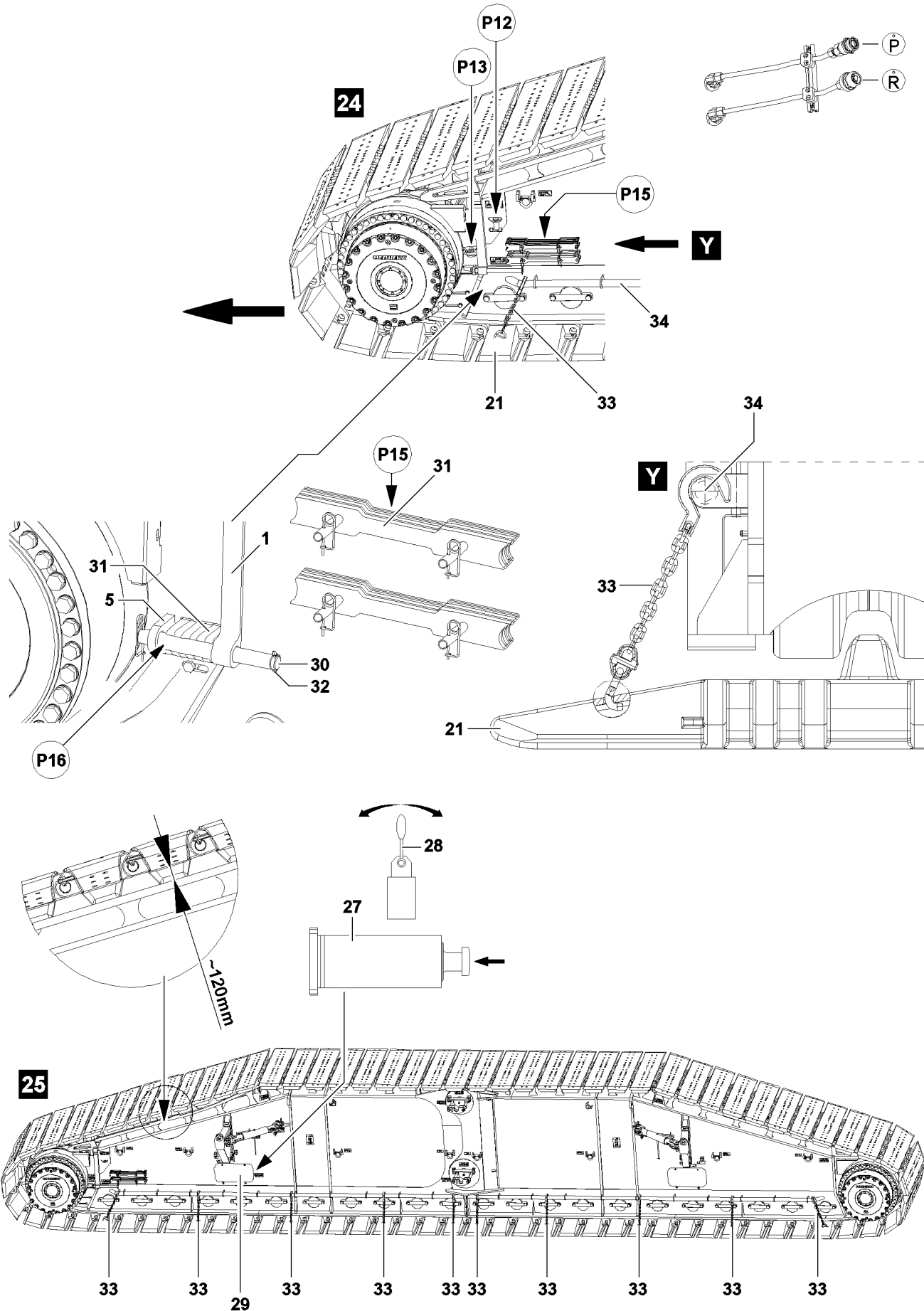

Fig.113042

LWE/LR 13000-001/19503-01-02/en

When the distance between the crawler chain and the glide rail is approx. 120 mm , install as many spacer elements **31** in the gap created between the crawler carrier **1** and the sliding section **5** until the gap is filled without play.

- ▶ Remove the spacer elements **31** from the transport receptacle in point **P15**.
- ▶ In point **P16**, insert as many spacer elements **31** as fit into the gap between the sliding section **5** and the crawler carrier **1**.
- ▶ Secure the spacer elements **31** with the pin **30** and spring retainer **32**.



WARNING

Danger of crushing!

When releasing the tension cylinder **27**, body parts, such as: fingers, hands and arms can be crushed or severed!

- ▶ When relieving the tension cylinder **27**, any work on the crawler carrier is prohibited!

- ▶ Retract the tension cylinder **27** completely.
- ▶ Close the control opening **29**, illustration **25**.
- ▶ Relieve the pressure in the hydraulic connections from the hydraulic aggregate to the tension cylinder **27**.



Note

- ▶ When the crawler carriers on the crane are installed, move the crane by approx. two crawler lengths forward and reverse to relieve the tension in the lower chain area.
- ▶ Check the chain tension again and retension the chain if necessary, see the Crane operating instructions, chapter 7.04.

- ▶ Disconnect the hydraulic supply lines from the hydraulic aggregate to the tension cylinder **27**, hydraulic connection **P** and hydraulic connection **R**.

NOTICE

Damage to crawler chain and crawler carrier!

If the safety chains **33** are not properly installed after assembly of the crawler chain on the crawler carrier, the crawler chain **21** can sag significantly!

This can cause damage on the crawler chain or on the crawler carrier after assembly of the crawler carriers on the cross carriers!

- ▶ Make sure after crawler carrier installation that the safety chains **33** (ten each) are properly hooked between the outrigger pads **21** and the crawler carrier (pipe **34**), illustration **Y**!
- ▶ Connect the safety chains **33** properly on both crawler carrier sides.
- ▶ Connect the safety chains **33** at even distances between the crawler carrier and the crawler chain.

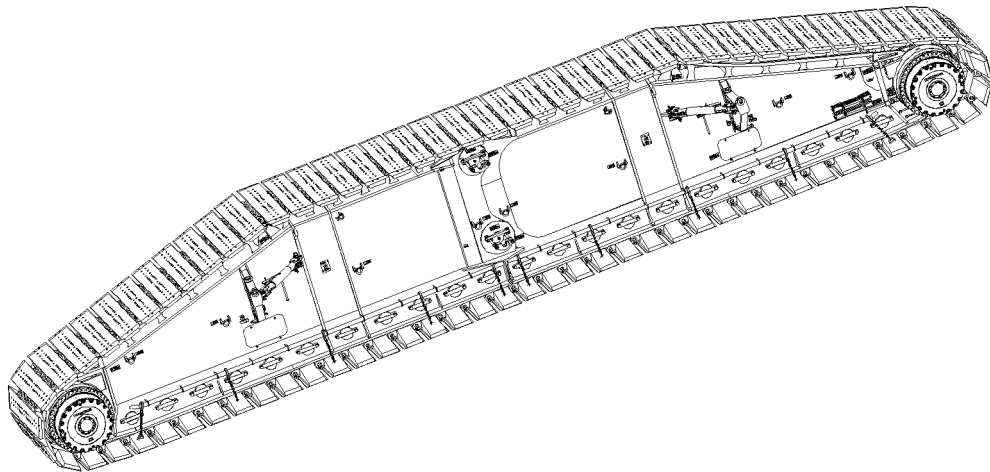
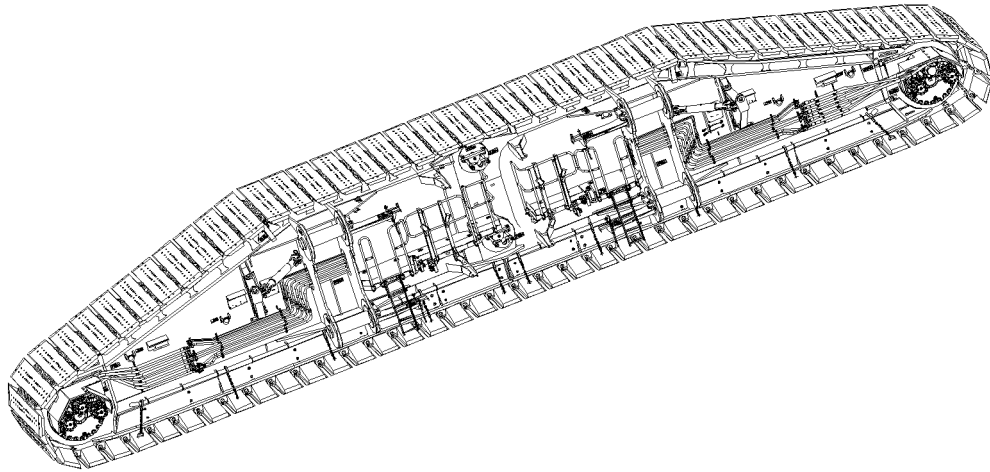

Fig.113036

LWE/LR 13000-001/19503-01-02/en

4 Installing the crawler carrier on the preassembled crawler center section



Note

- ▶ Assembly of the crawler carrier on the preassembled crawler center section, see the Crane operating instructions, chapter 3.01.30!

5 Disassembling the crawler carriers



WARNING

Danger of falling!

During assembly / disassembly, inspection and maintenance work, assembly personnel must be secured with appropriate aids to prevent them from falling! If this is not observed, assembly personnel could fall and be killed or seriously injured!

- ▶ The assembly personnel must always move carefully and anticipatory on the crane, the crane components or lattice sections!
- ▶ All work at a height, when there is a danger of falling, must be carried out with suitable aids!
- ▶ If fall protection equipment is available, then it must be used!
- ▶ If aids are not available and work cannot be carried out from the ground, then assembly personnel must secure themselves with the permissible fall arrest system to prevent falling, see the Crane operating instructions, chapter 2.04!
- ▶ The fall arrest system must be attached in the fastening and hook points as well as to the safety ropes!
- ▶ Only step on the aids, ladders and catwalks with clean shoes!
- ▶ Keep aids, ladders and catwalks free of heavy dirt, snow and ice!



WARNING

Danger of impact / crushing!

When assembling / disassembling crane components with the auxiliary crane, crane components can start to swing back and forth!

When lifting / lowering and positioning crane components, there is an increased danger of impact / crushing!

Personnel can be caught and thereby injured or killed!

- ▶ Make sure that personnel cannot be caught by components!
- ▶ When working in danger zones: Use aids to protect limbs!
- ▶ Guide components with suitable aids to minimize oscillation!

Make sure that the following prerequisites are met:

- The ground is level and of sufficient load bearing capacity.
- An auxiliary crane is available.

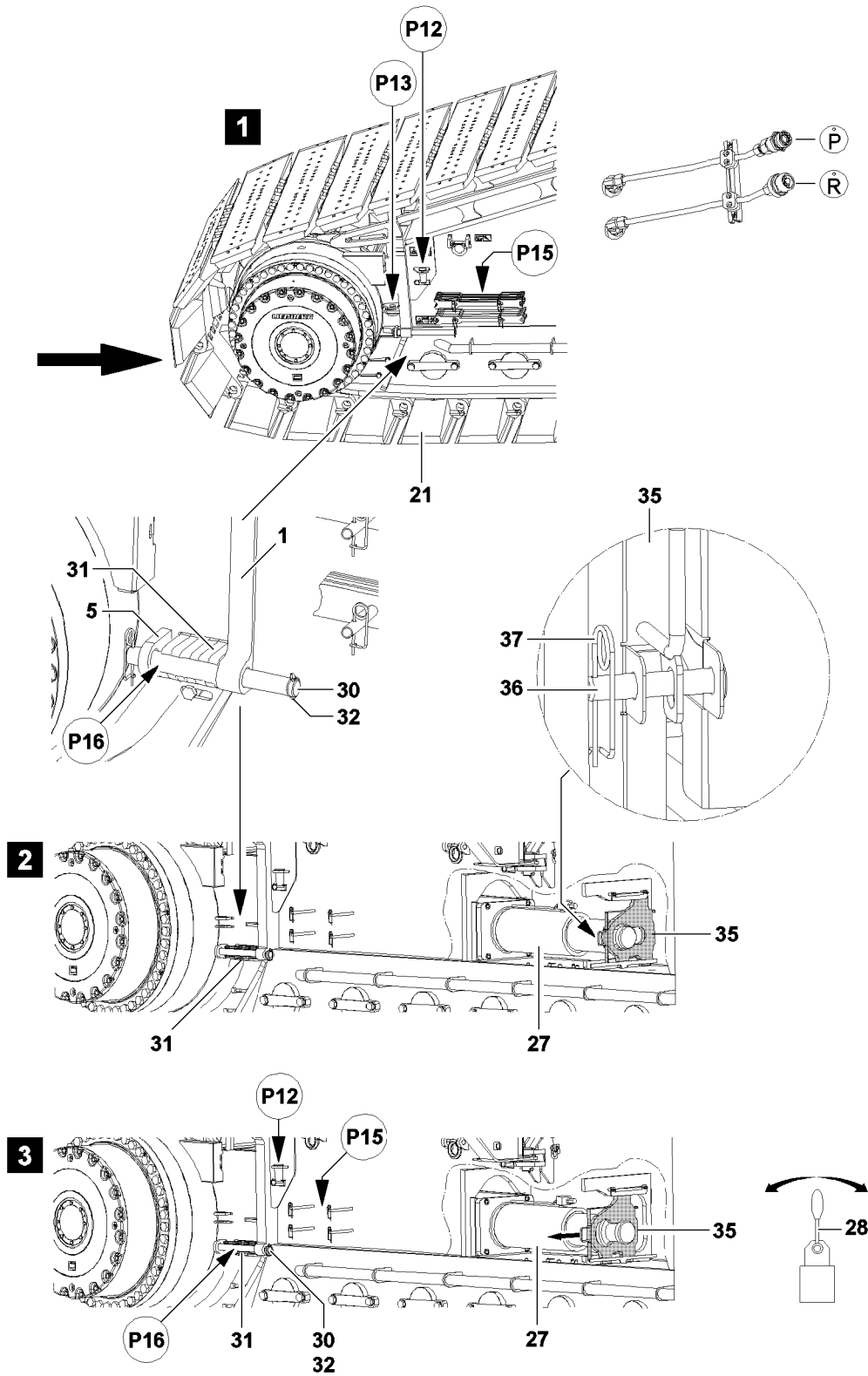

Fig.113045

LWE/LR 13000-001/19503-01-02/en

5.1 Disassembling the crawler chain on the crawler carrier

Make sure that the following prerequisites are met:

- The crawler carrier is placed on level and load bearing ground.
- The safety chains between the crawler carrier and the crawler chain are removed.
- An external hydraulic aggregate is available.

5.1.1 Establishing the hydraulic connections to the tension cylinder

The hydraulic connections are established with quick couplings.

When connecting hydraulic lines with quick couplings, make sure that the coupling procedure is carried out correctly.

The matching quick couplings are marked.



WARNING

Pressure in the hydraulic lines!

If the pressure supply is not interrupted before connecting / releasing the hydraulic lines, the hydraulic oil can escape with high pressure.

Death, severe bodily injuries, property damage.

- ▶ Release the pressure in the hydraulic system before connecting / disconnecting: Interrupt the pressure supply and wait a short time.



WARNING

Loss of pressure or leakage!

Incorrectly coupled or self-loosening quick couplings (particularly return lines) can result in serious accidents due to component failure.

Death, severe bodily injuries, property damage.

- ▶ Check that the quick couplings have been properly connected before using the crane.
- ▶ Connect the coupling components (sleeve and connector) and screw together with the knurled nut.
- ▶ Tighten the hydraulic coupling by hand. Turn the knurled nut until it reaches a tangible, fixed stop position.
- ▶ Establish the hydraulic connections to the tension cylinder **27**: Connect the supply lines of the external hydraulic aggregate to the supply lines of the tension cylinder, hydraulic connection **P** and hydraulic connection **R**.

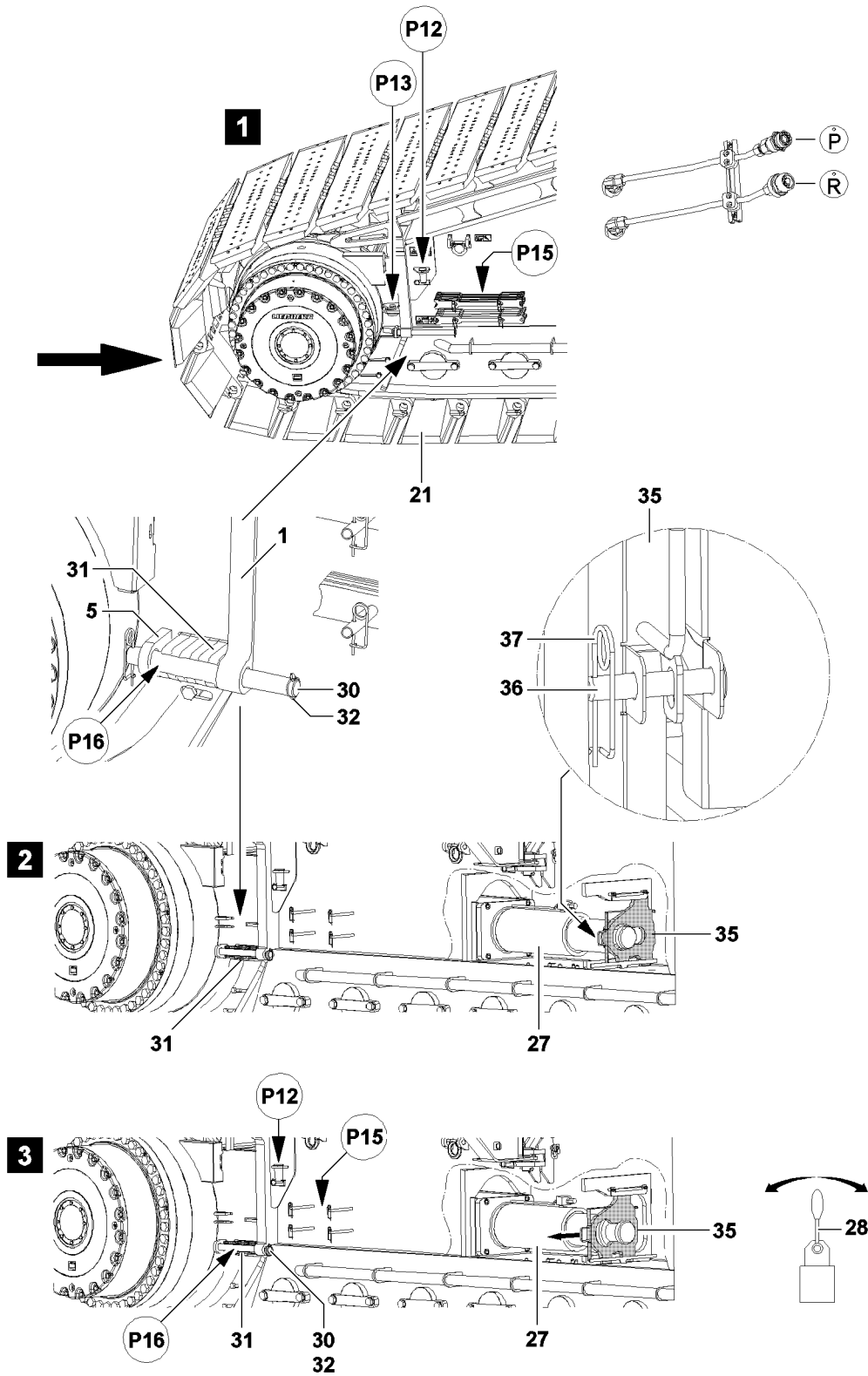

Fig.113045

LWE/LR 13000-001/19503-01-02/en

5.1.2 Relieving the crawler chain

Make sure that the following prerequisites are met:

- The hydraulic connections to the supply lines of the tension cylinders are established.
- The control opening is folded open.

NOTICE

Damage to the crawler carrier!

Since the sprocket does not turn along by itself during the relieve procedure of the crawler chain, the travel drive must be actuated for a short time again on the sliding section!

If this is not observed, severe property damage can occur to the sprocket or the travel drive!

- ▶ When relieving the crawler chain, the travel drive must always be actuated for a short time on the sliding section side of the crawler carrier to correctly engage the sprocket on the cams of the crawler chain!
- ▶ The travel drive on the crawler carrier is actuated via the hydraulic aggregate, see the Hydraulic diagram.

-
- ▶ Actuate the hand lever **28**.

Result:

- The tension cylinder extends.
- The crawler chain is tensioned by the tension cylinder.

If a small gap is created between the crawler carrier and the sliding section, point **P16**:

- ▶ Bring the hand lever **28** in the neutral position.

Result:

- The tension cylinder remains „positioned“ in the extended position.

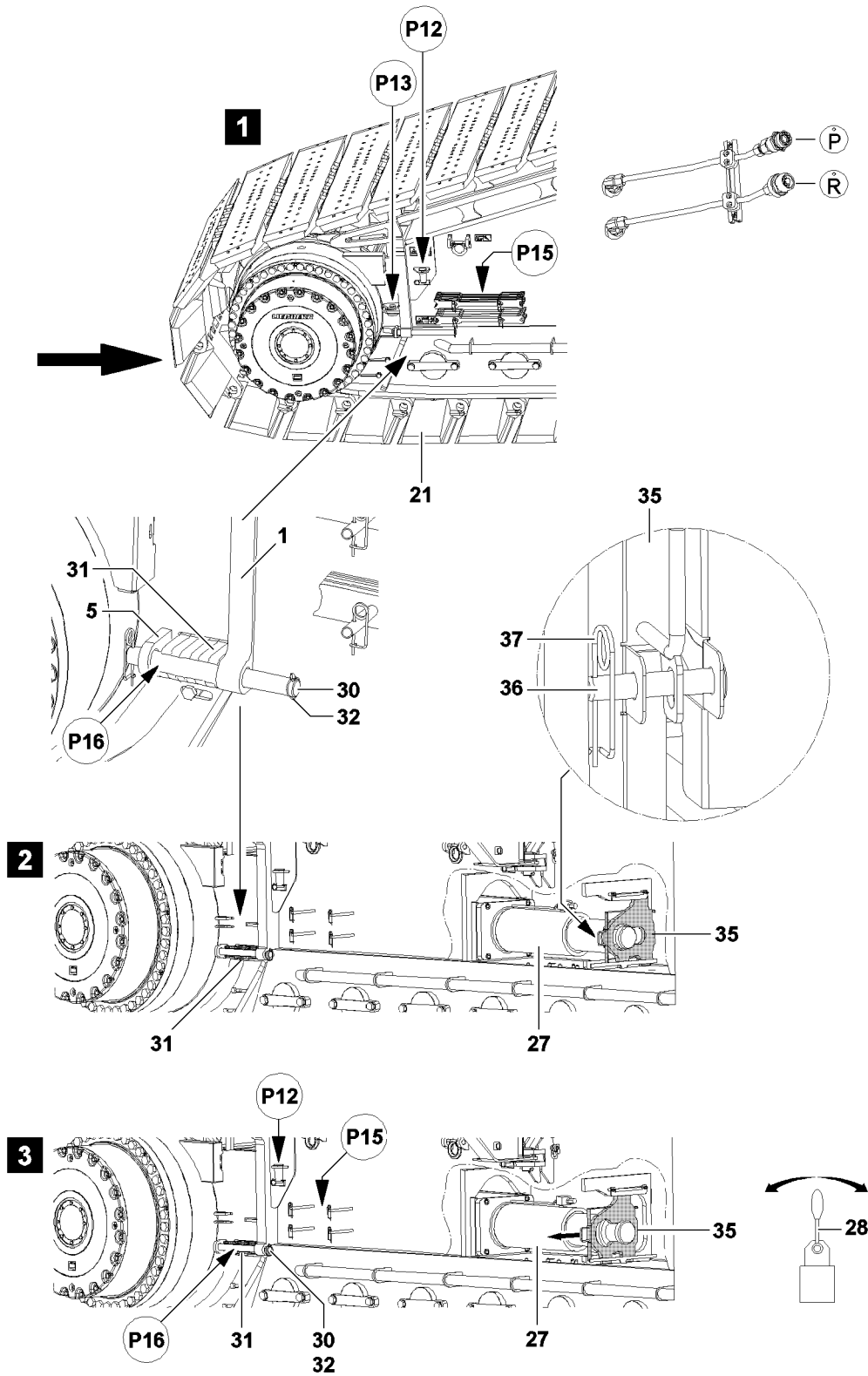

Fig.113045

LWE/LR 13000-001/19503-01-02/en

After the crawler chain is tensioned, release and unpin the pin **30**. Remove the spacer elements **31** completely from the created gap (point **P16**) from the crawler carrier **1** and sliding section **5**.

- ▶ Remove all spacer elements **31** in point **P16**.
- ▶ Install and secure the removed spacer elements **31** in the transport receptacle in point **P15**.
- ▶ Release the slider **35**: Remove the spring retainer **37** and unpin the pin **36**.

By pulling the slider **35** the extended tension cylinder **27** is locked. When the tension cylinder **27** subsequently retracts, the sliding section **5** is pulled in and the crawler chain is relieved.



WARNING

Danger of crushing!

When retracting the sliding section **5**, body parts, such as: fingers, hands and arms can be crushed or severed!

- ▶ When retracting the sliding section, all work on the crawler carrier is prohibited!
- ▶ Pull the slider **35** on the handle outward - in direction of the arrow, illustration **3**.

Result:

- The tension cylinder **27** is locked by the slider for retracting the sliding section.
- ▶ Retract the tension cylinder **27** until the crawler chain is relieved.

5.1.3 Disconnecting the hydraulic connections from the tension cylinder

The hydraulic connections are established with quick couplings.

When disconnecting hydraulic lines with quick couplings, make sure that the uncoupling procedure is carried out correctly.



WARNING

Pressure in the hydraulic lines!

If the pressure supply is not interrupted before connecting / releasing the hydraulic lines, the hydraulic oil can escape with high pressure.

Death, severe bodily injuries, property damage.

- ▶ Release the pressure in the hydraulic system before connecting / disconnecting: Interrupt the pressure supply and wait a short time.
- ▶ Release the hydraulic coupling by hand.
- ▶ Disconnect the hydraulic supply lines from the hydraulic aggregate to the tension cylinder **27**, hydraulic connection **P** and hydraulic connection **R**.
- ▶ Protect the hydraulic connections against contamination with caps.

5.1.4 Disconnecting the crawler chain

Before disconnecting the crawler chain, the rigging chains must be assembled and tensioned on the crawler carrier front section and on the crawler carrier rear section. Slightly lift the crawler chain in the center with the auxiliary crane so that the connector pins are relieved and can be unpinned.

Make sure that the following prerequisites are met:

- The sliding section is retracted completely and is pinned and secured in transport position.
- The control opening is closed.
- The hydraulic supply lines to the tension cylinder are disconnected.

The crawler chain must be disconnected in point **P17** in the center, at the height of the pin points of both crawler carrier halves.

- ▶ Place two rope loops around the two outrigger pads, on which the crawler chain is to be separated, illustration **5**.



WARNING

Danger of accident due to angular pull!

- ▶ Make sure that the hook block is centered with the longitudinal axle of the crawler carrier.
- ▶ Make sure that the hook block of the auxiliary crane is centered above the joint of the crawler chain when pulling the two ends of the chain together.
- ▶ Angular pull is prohibited!

- ▶ Fasten the rope loops **30** to the auxiliary crane.

When the rope loops **30** are fastened to the auxiliary crane:

- ▶ Carefully lift the crawler chain **21** with the auxiliary crane until the connector pins **21.1** can be relieved and unpinned in the „separation location“ (point **P17**).
- ▶ Unpin the connector pin **21.1** in point **P17** and take the crawler chain down again on the crawler carrier with the auxiliary crane.

Result:

- The crawler chain is separated.
- ▶ Remove the rope loops **30** from the chain ends.

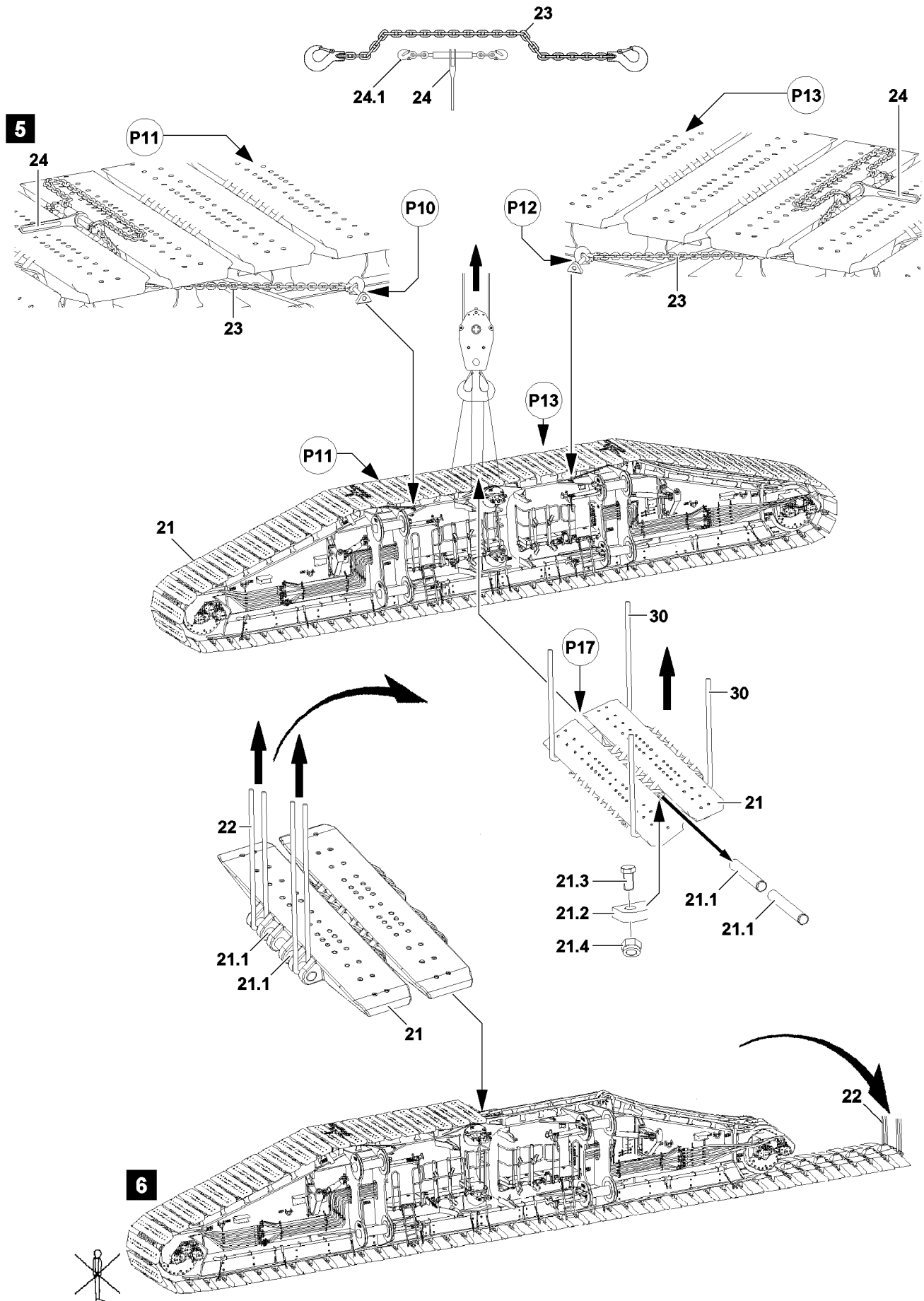

Fig.113046

LWE/LR 13000-001/19503-01-02/en

5.1.5 Removing the crawler chain from the crawler carrier front section

Make sure that the following prerequisite is met:

- The crawler chain is properly separated and secured with the rigging chains **23** on both sides to prevent it from slipping off.
- ▶ Fasten the crawler chain to the auxiliary crane: Use the fastening equipment **22**, see illustration **6**.



WARNING

Slipping crawler chain!

Due to improper safety measures of the crawler chain on the crawler carrier front section, the crawler chain can slip off from the crawler carrier front section!

Personnel can be severely injured or killed!

- ▶ Make sure that the crawler chain is held safely by the auxiliary crane before removing the rigging chain **23** from the crawler carrier front section.
- ▶ It is prohibited for any personnel to remain on the end of the crawler carrier front section.

-
- ▶ When the crawler chain is safely held by the auxiliary crane: Relieve the rigging chain.
 - ▶ Remove the reducer **24** and remove the rigging chain **23** from the crawler carrier.
 - ▶ Lift the crawler chain from the crawler carrier with the auxiliary crane and take it down on the ground with extreme caution, see illustration **6**.

When the crawler chain is taken down on the ground:

- ▶ Remove the fastening equipment **22**.

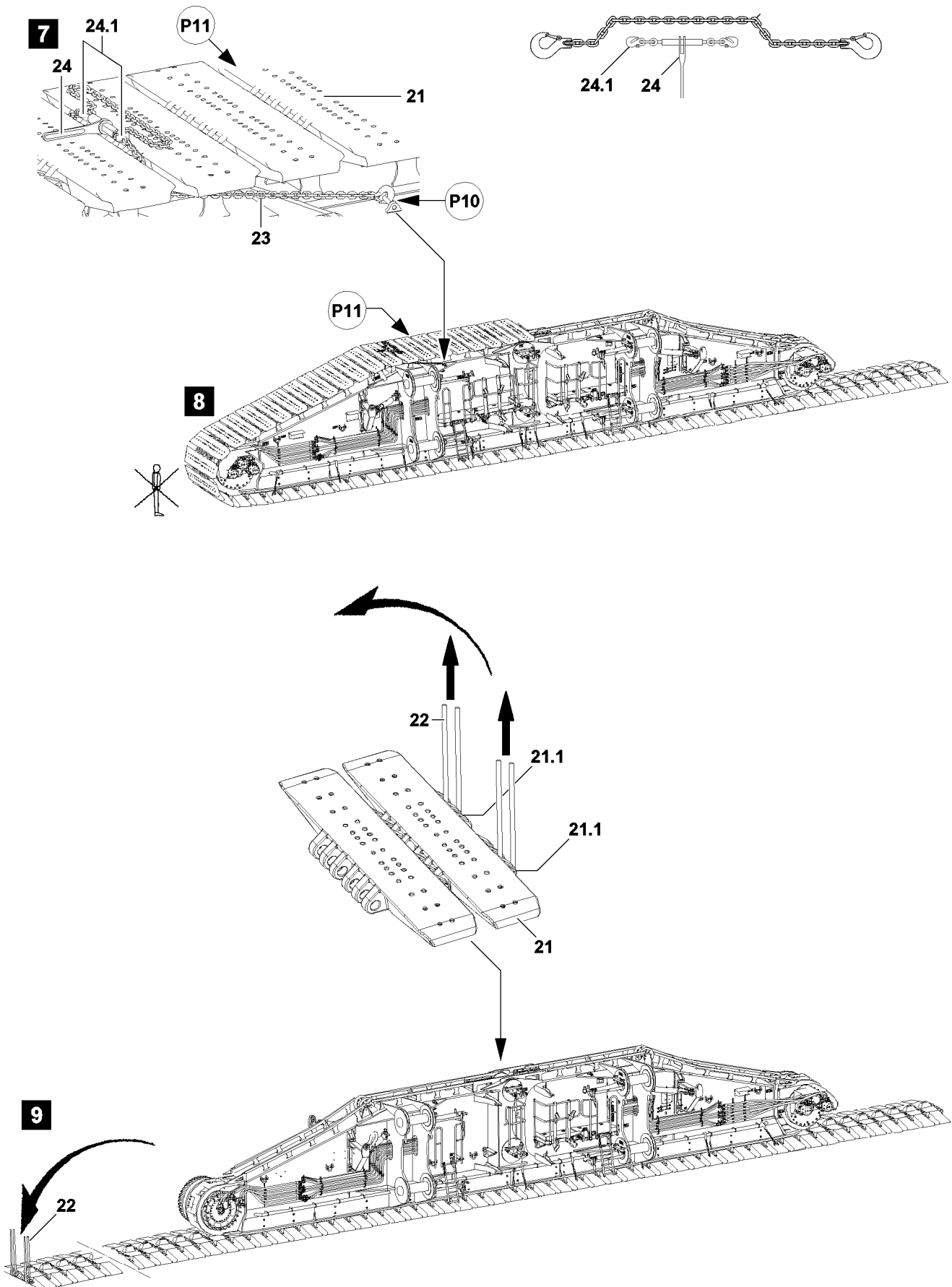

Fig.113047

LWE/LR 13000-001/19503-01-02/en

5.1.6 Removing the crawler chain from the crawler carrier rear section

Make sure that the following prerequisite is met:

- The crawler chain is removed from the crawler carrier front section and is taken down on the ground.
- ▶ Fasten the crawler chain to the crawler carrier rear section on the auxiliary crane: Use the fastening equipment **22**, see illustration **9**.



WARNING

Slipping crawler chain!

Due to improper safety measures of the crawler chain on the crawler carrier rear section, the crawler chain can slip off from the crawler carrier rear section!

Personnel can be severely injured or killed!

- ▶ Make sure that the crawler chain is held safely by the auxiliary crane before removing the rigging chain **23** from the crawler carrier rear section.
- ▶ It is prohibited for personnel to remain on the end of the crawler carrier rear section.

-
- ▶ When the crawler chain is safely held by the auxiliary crane: Relieve the rigging chain.
 - ▶ Remove the reducer **24** and remove the rigging chain **23** from the crawler carrier.
 - ▶ Lift the crawler chain from the crawler carrier with the auxiliary crane and take it down on the ground with extreme caution, see illustration **9**.

When the crawler chain is taken down on the ground:

- ▶ Remove the fastening equipment **22**.

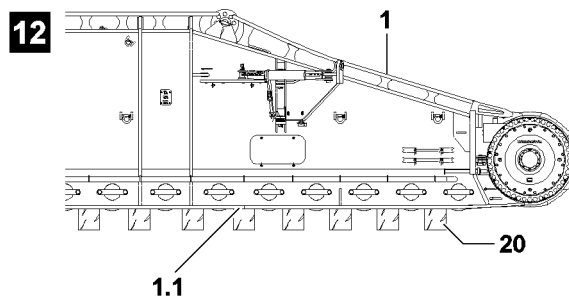
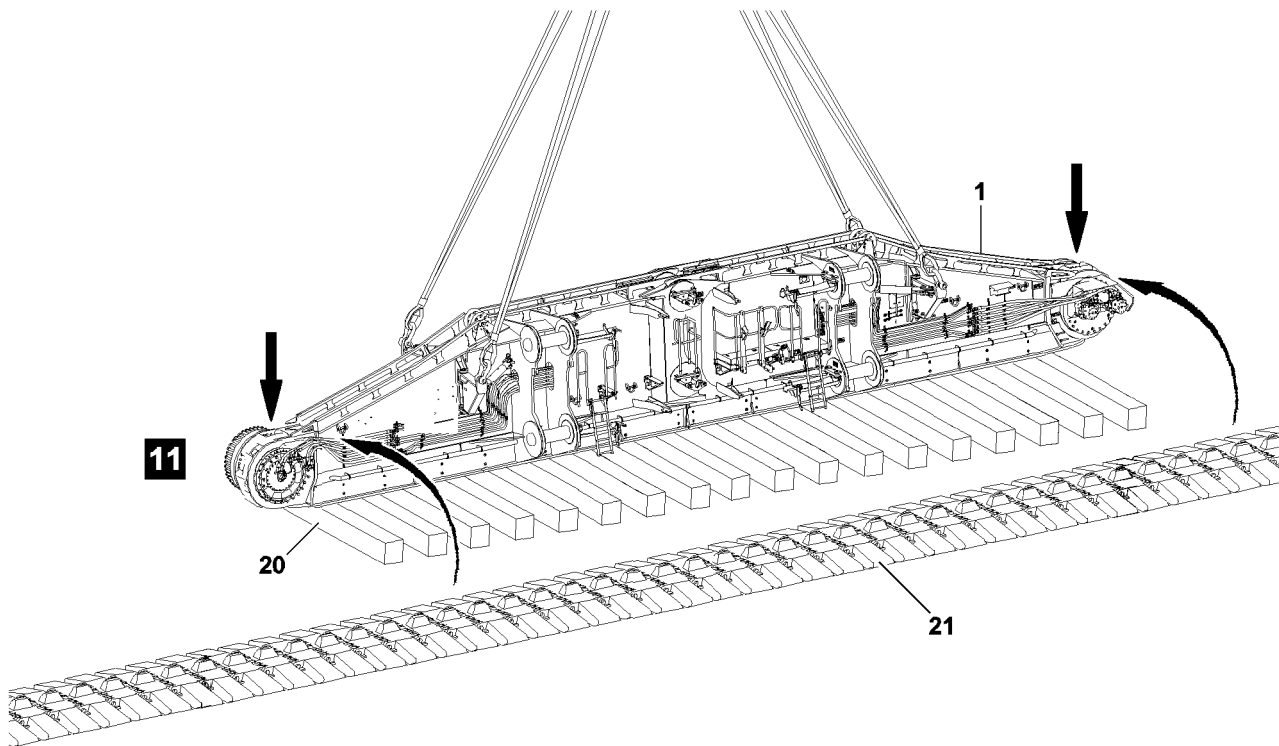
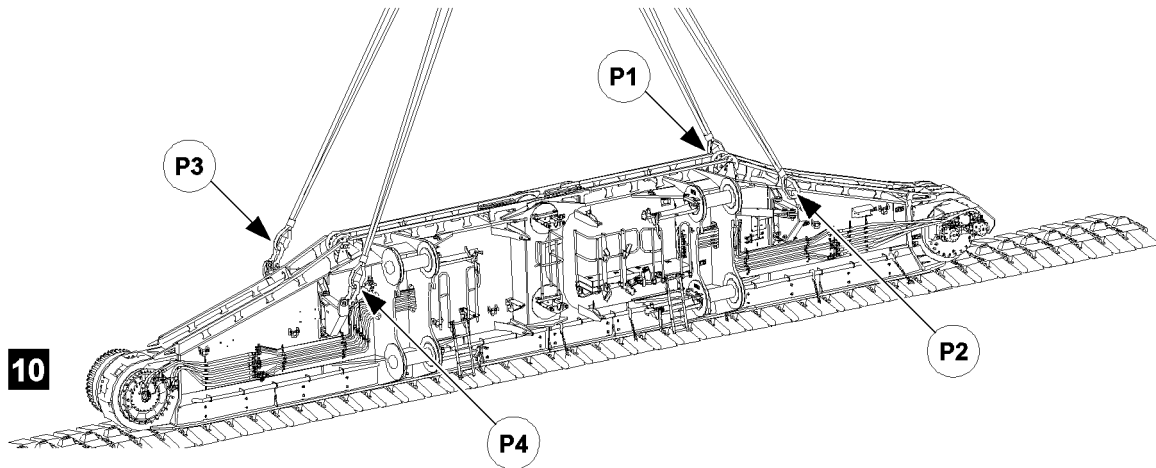

Fig.113048

LWE/LR 13000-001/19503-01-02/en

5.2 Transferring the crawler carrier from the crawler chain to the substructure

Make sure that the following prerequisites are met:

- The crawler chain is taken down completely onto the ground on both sides.
- There is sufficient material (hardwood beams) available for the substructure of the crawler carrier.
- The ground for disassembly of the crawler carrier is level and of sufficient load bearing capacity.
- No personnel or objects are in the danger zone.
- The tow brackets of the crawler carrier are pinned and secured in the operating position.
- The adjustment spindles are set for transport of the entire crawler carrier.



Note

- ▶ Adjust the adjustment spindles **4** so that the crawler carrier hangs in the horizontal direction on the auxiliary crane when transferring it from the crawler chain to the substructure.
- ▶ Make sure that the four fastening ropes are tensioned the same when lifting the crawler carrier.

5.2.1 Transferring the crawler carrier

- ▶ Fasten the crawler carrier to the auxiliary crane in the fastening points, point **P1**, point **P2**, point **P3** and point **P4**.



WARNING

Danger due to oscillating crawler carrier!

When lifting the crawler carrier from the crawler chain, the crawler carrier can start to swing back and forth!

Personnel can be severely injured or killed!

- ▶ Make sure that no persons or objects are in the danger zone.
- ▶ Carefully lift the crawler carrier with the auxiliary crane from the crawler chain **21** and swing it out.
- ▶ Support the crawler carrier: Insert a hardwood beam **20** between the track rollers in such a way that the set down crawler carrier is laying on the base belt **1.1**, illustration **12**.
- ▶ Lower the crawler carrier completely on the substructure.

When the crawler carrier has been set down completely on the substructure:

- ▶ Remove the auxiliary crane.

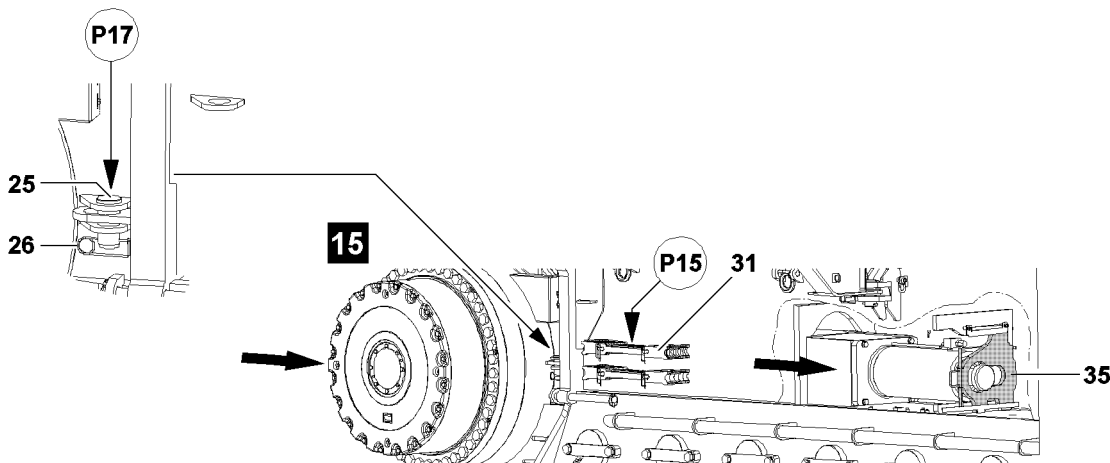
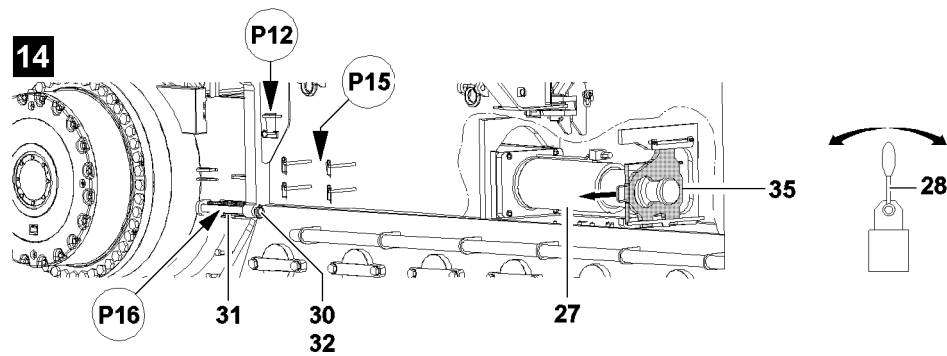
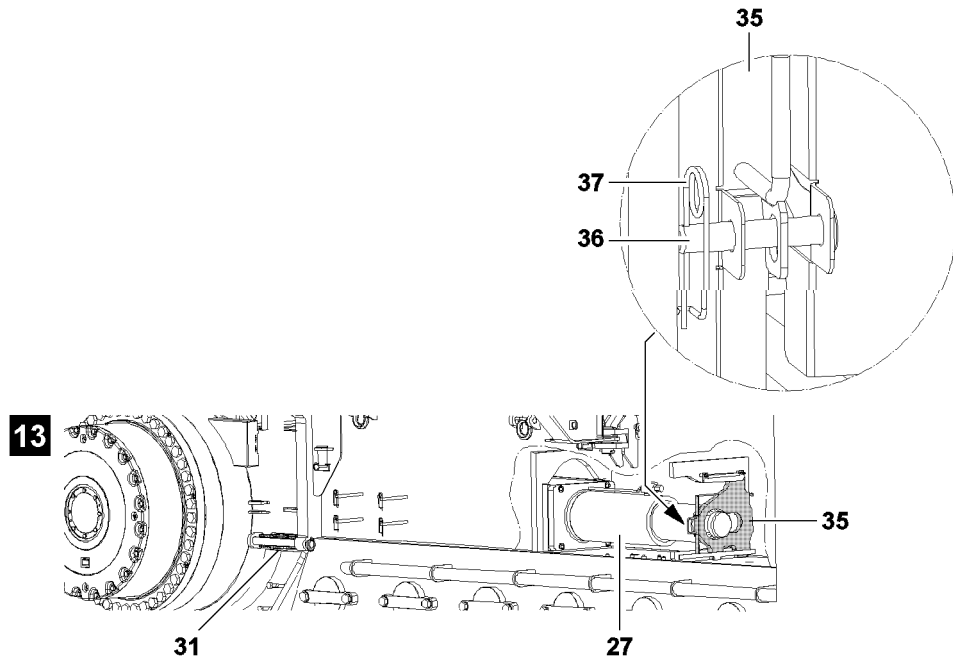

Fig.113063

LWE/LR 13000-001/19503-01-02/en

5.2.2 Bringing the sliding section into the transport position

Make sure that the following prerequisite is met:

- The hydraulic connections to the tension cylinder **27** are established, see section „Removing the crawler chain on the crawler carrier“.
- ▶ Retract the sliding section completely - to the stop.

When the sliding section is completely retracted:

- ▶ Secure the sliding section in the transport position: Unpin the pin **25** from the park position point **P12** and insert in point **P17** and secure with the spring retainer **26**.

Result:

- The sliding section **5** is secured in the transport position.

NOTICE

Damage to the crawler carrier!

If, when relieving the slider **35**, the tension cylinder is extended too far, components of the crawler carrier or the tension cylinder **27** can be damaged.

- ▶ Make sure that the tension cylinder is only extended to the point where the slider **35** is relieved.
- ▶ Extend the tension cylinder with extreme caution!

-
- ▶ Extend the tension cylinder a few millimeters: Actuate the hand lever **28**.

Result:

- The slider **35** is relieved.
- ▶ Push the slider **35** in completely.
- ▶ Secure the slider **35**: Insert the pin **36** and secure with the spring retainer **37**.
- ▶ Close the control opening.
- ▶ Disconnect the hydraulic connections from the tension cylinder, see section „Disassembling the crawler chain on the crawler carrier“.

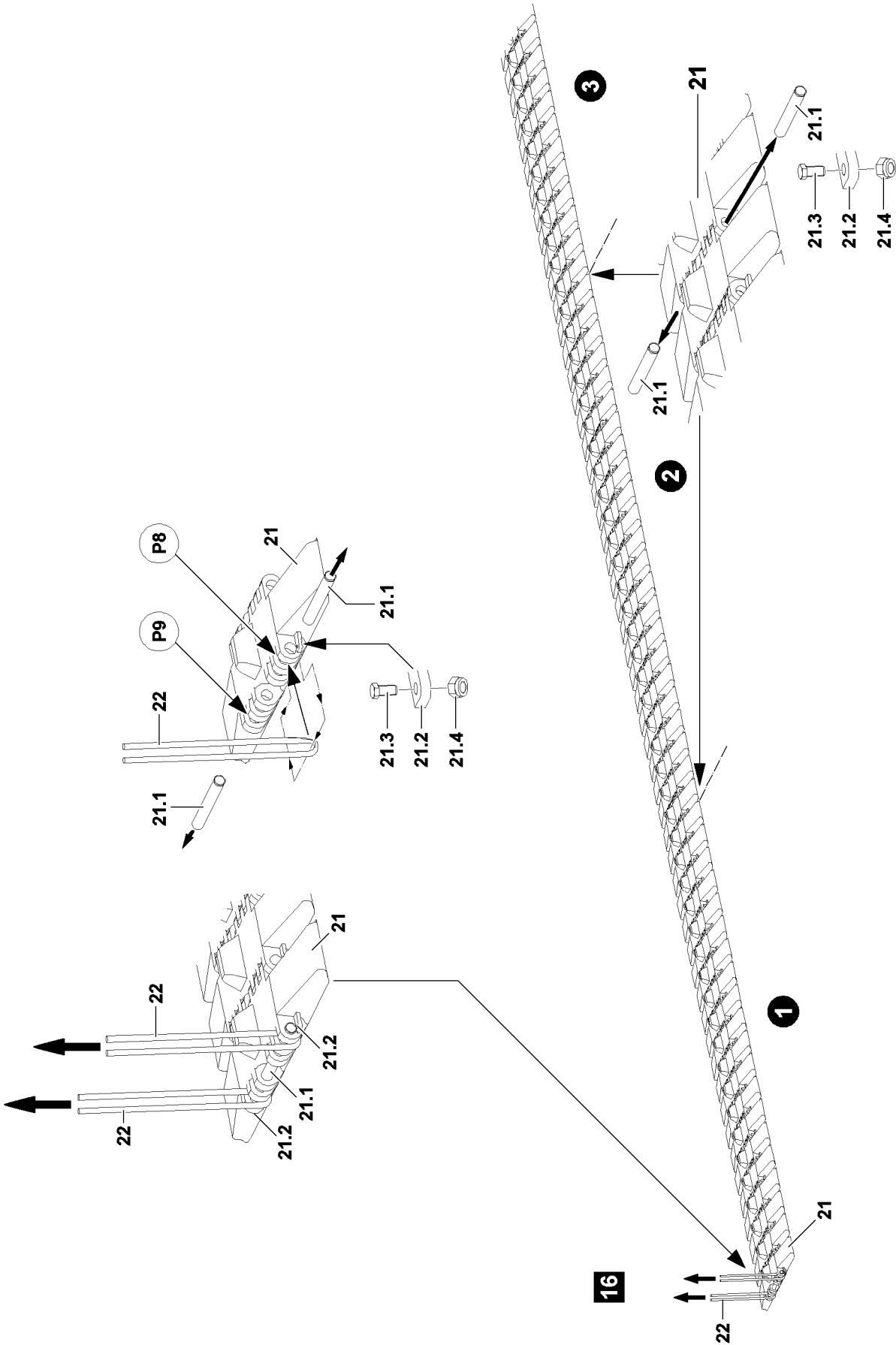

Fig.113049

LWE/LR 13000-001/19503-01-02/en

5.3 Disassembling the crawler chain

Make sure that the following prerequisites are met:

- The crawler chain is positioned on the ground in its full length.
- The crawler carrier is lifted off of the crawler chain.
- Fastening equipment with sufficient load carrying capacity is available.
- A transport vehicle (flatbed trailer) is in the immediate vicinity of the crawler chain.

5.3.1 Disassembling the crawler chain into chain segments



Note

- ▶ The crawler chain is to be disassembled in chain segments for transport, according to the permissible total maximum weight of available transport units.
- ▶ Weight of the crawler chain and individual outrigger pads, see the Crane operating instructions, chapter 1.03.

Disassemble the crawler chain into several chain segments - depending on the transport capacity of the available transport units.

- ▶ Disassemble the crawler chain: Release the nut **21.4** and remove the hex head screw **21.3** on the retaining bracket **21.2**.
- ▶ Unpin the connector pins **21.1** in the separating locations.

Fasten the first chain segment to the auxiliary crane:

- ▶ Position the loop of the first fastening equipment **22** in point **P8**.
- ▶ Slide in the first connector pin **21.1** on the outrigger pad **21** so that the connector pin **21.1** is runs through the loop of the fastening equipment.
- ▶ Position the loop of the second fastening equipment **22** in point **P9**.
- ▶ Slide in the connector pin **21.1** on the outrigger pad **21** so that the connector pin **21.1** is runs through the loop of the second fastening equipment.

Result:

- The fastening equipment **22** is fixed to the chain segment.

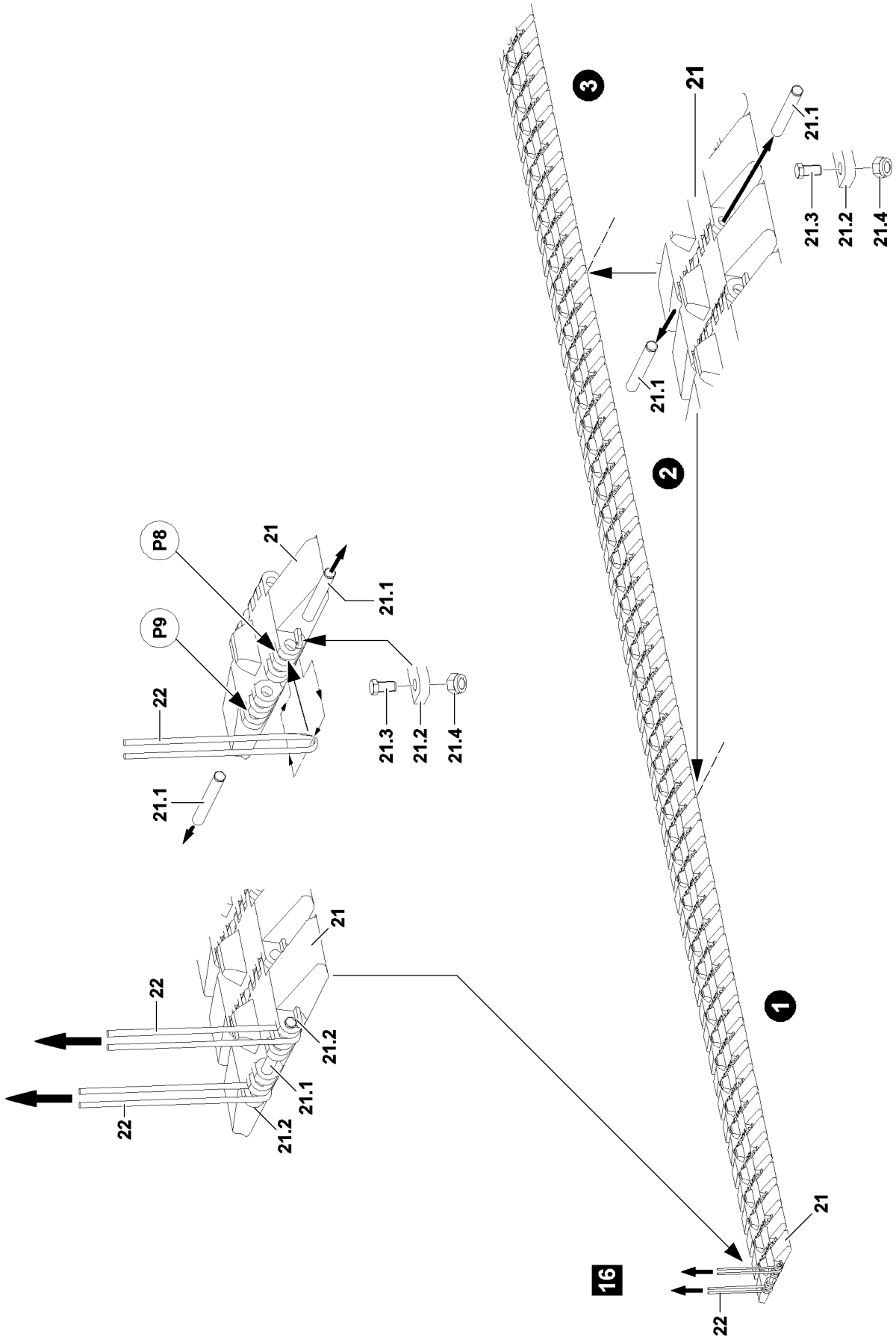

Fig.113049

LWE/LR 13000-001/19503-01-02/en

**WARNING**

Falling chain segment!

If the connector pin **21.1** is not secured with the auxiliary crane during transport of the individual chain segments, the connector pin can loosen up and the respective chain segment can fall down.

Personnel can be severely injured or killed.

- ▶ Make sure that the connector pins **21.1** are properly pinned and secured for transport of the chain segments.

Secure the connector pin **21.1**:

- ▶ Insert the hex head screw **21.3** on both sides into the retaining bracket **21.2** and secure with the nut **21.4**.

Result:

- The connector pins **21.1** are secured.

**WARNING**

Oscillating crane components!

When transporting the chain segments to the transport vehicle, the chain segments can start to swing back and forth.

Personnel can be severely injured or killed!

- ▶ Make sure that there are no persons or obstacles in the danger zone.

- ▶ Lift the first chain segment with the auxiliary crane carefully off the ground and take it down on / in the available transport unit.

When the first chain segment is properly loaded:

- ▶ Release and unpin the connector pin **21.1** and remove the fastening equipment on the first chain segment.

**WARNING**

Danger of accident due to incorrect load securing!

If the chain segments are not secured properly, they can slip off from the transport units!

Personnel can be severely injured or killed!

- ▶ Make sure that the chain segments are properly stored and secured on the transport units.

- ▶ Load the additional chain segments with the auxiliary crane.

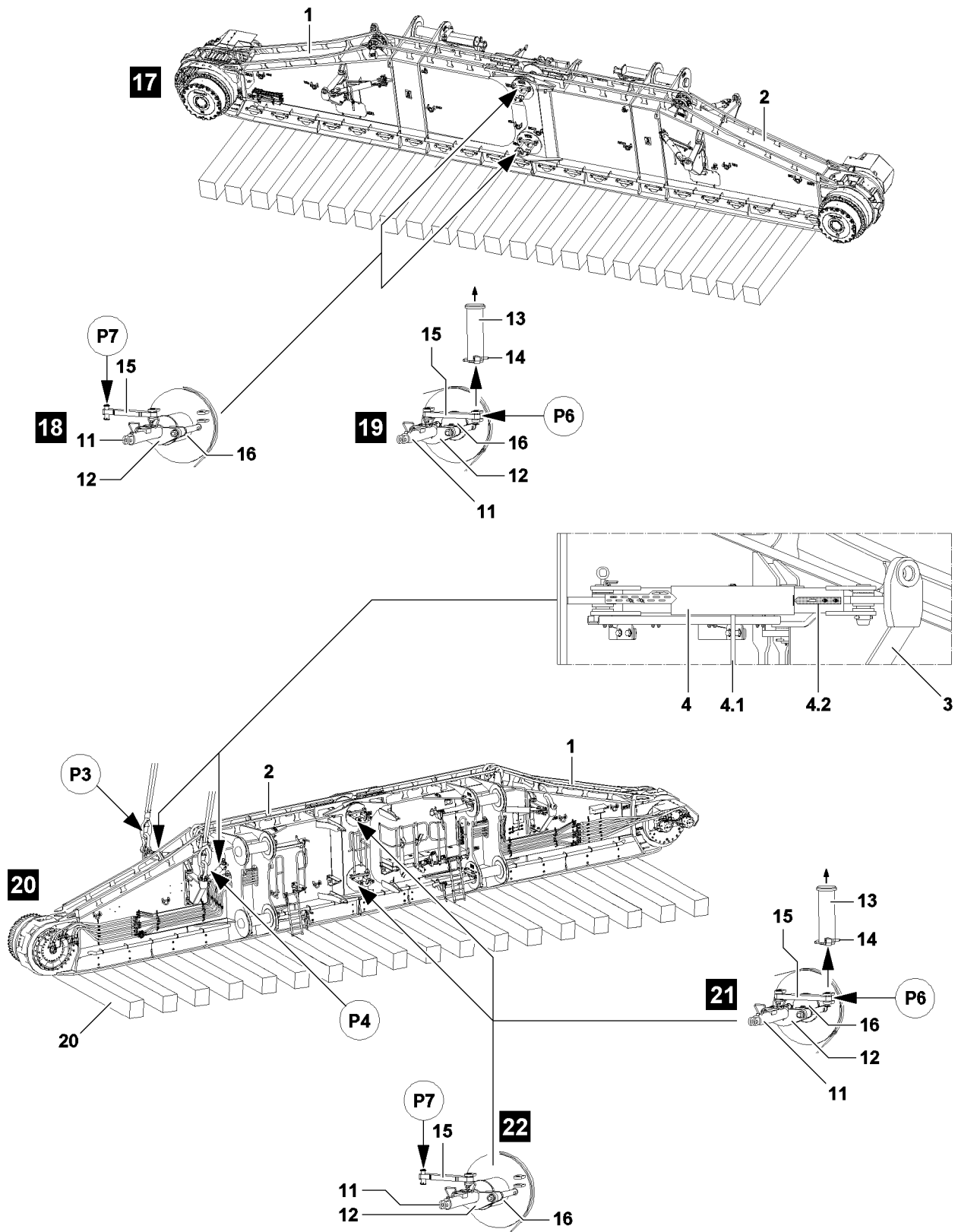

Fig.113050

LWE/LR 13000-001/19503-01-02/en

5.4 Unpinning the crawler carrier front section and the crawler carrier rear section

Make sure that the following prerequisites are met:

- The pin pulling cylinder and the pin pulling aggregate are in the immediate vicinity of the crawler carrier.

5.4.1 Release and unpin the outer connector pins

Make sure that the following prerequisites are met:

- The inner connector pins are pinned and secured.
- The crawler carrier rear section **2** is fastened to the auxiliary crane.
- The adjustment spindles **4.1** on the crawler carrier rear section **2** are set to the tip of the arrow **4.2**.
- A work platform is available.
- The piston rod of the pin pulling cylinder is extended.



WARNING

Danger of falling for assembly personnel!

During the unpinning procedure on the outer pin points of the crawler carrier, assembly personnel can fall down!

Personnel can be severely injured or killed!

- ▶ The assembly work on the outside of the two crawler carrier halves may only be carried out using a work platform.
 - ▶ Assembly personnel is obligated to carry out all assembly tasks only when using the personal protective equipment.
 - ▶ Improvisations are prohibited.
-
- ▶ Release and unpin the securing bracket **15** on the outside of the crawler carrier in point **P6**.
 - ▶ Swing out the securing bracket **15** in the park position (point **P7**), pin with the pin **13** and secure with the locking pin.
 - ▶ Fasten the pin pulling cylinder **11** to the auxiliary crane and align with the lower cylinder receptacle on the outside of the crawler carrier.
 - ▶ Slowly lower the pin pulling cylinder with the auxiliary crane into the lower cylinder receptacle on the outside of the crawler carrier.
 - ▶ Establish the hydraulic supply from the pin pulling cylinder **11** to the pin pulling aggregate, see the Crane operating instructions, chapter 5.30.
 - ▶ Actuate the control lever on the pin pulling cylinder **11**.

Result:

- The piston rod on the pin pulling cylinder **11** retracts and the connector pin **16** is unpinned.

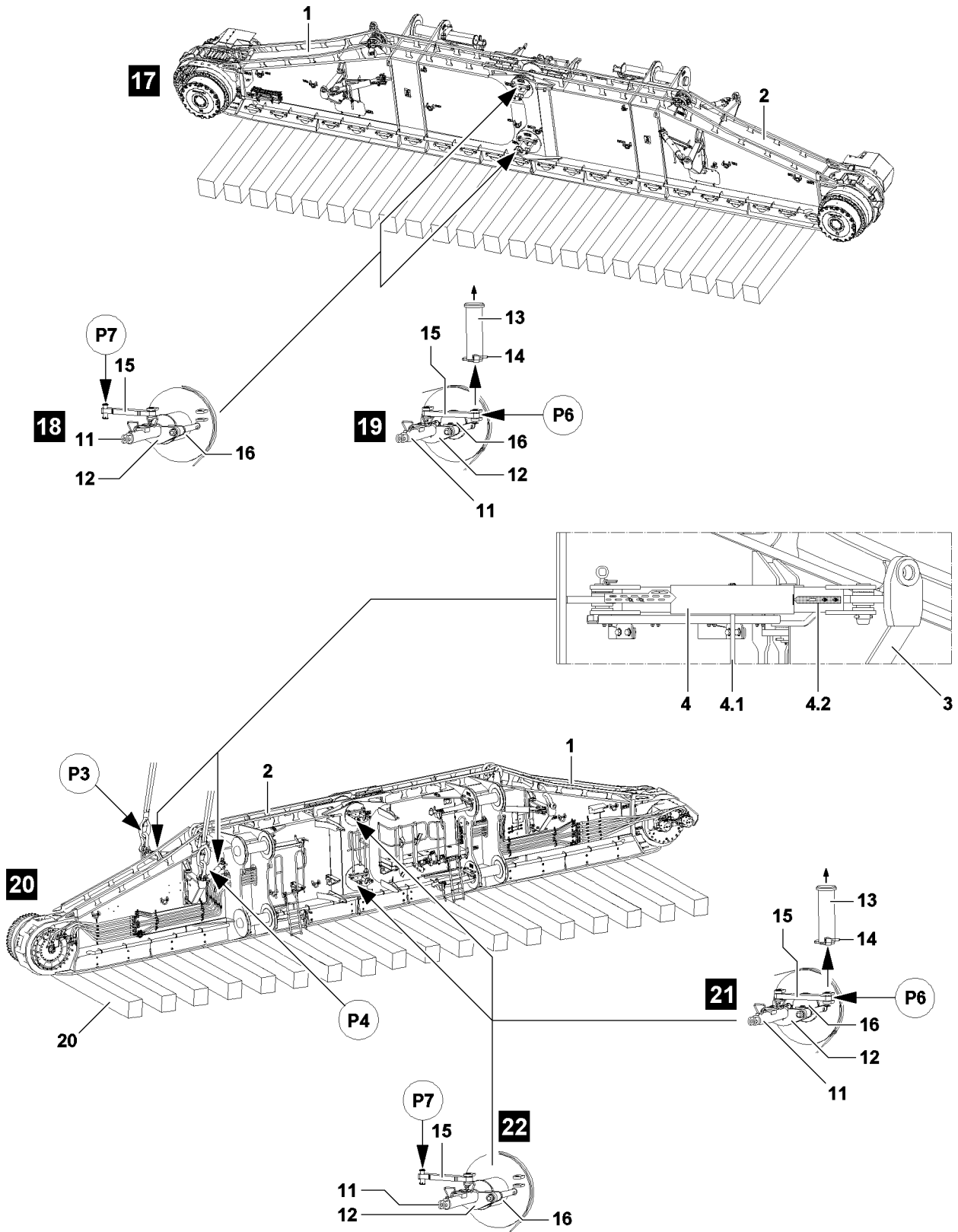

Fig.113050

LWE/LR 13000-001/19503-01-02/en

When the connector pin **16** is completely unpinned:

- ▶ Fasten the pin pulling cylinder **11** to the auxiliary crane and lift it out of the cylinder receptacle.
- ▶ Extend the piston rod **11** completely again on the pin pulling cylinder .
- ▶ Lower the pin pulling cylinder with the auxiliary crane slowly into the upper cylinder receptacle **12** on the outside of the crawler carrier.

**Note**

- ▶ The subsequent procedure to unpin the lower outer connector pin is identical to the procedure on the lower outer connector pin.
-
- ▶ Release and unpin the inner connector pins **16** according to the unpinning procedure of the outer connector pins.

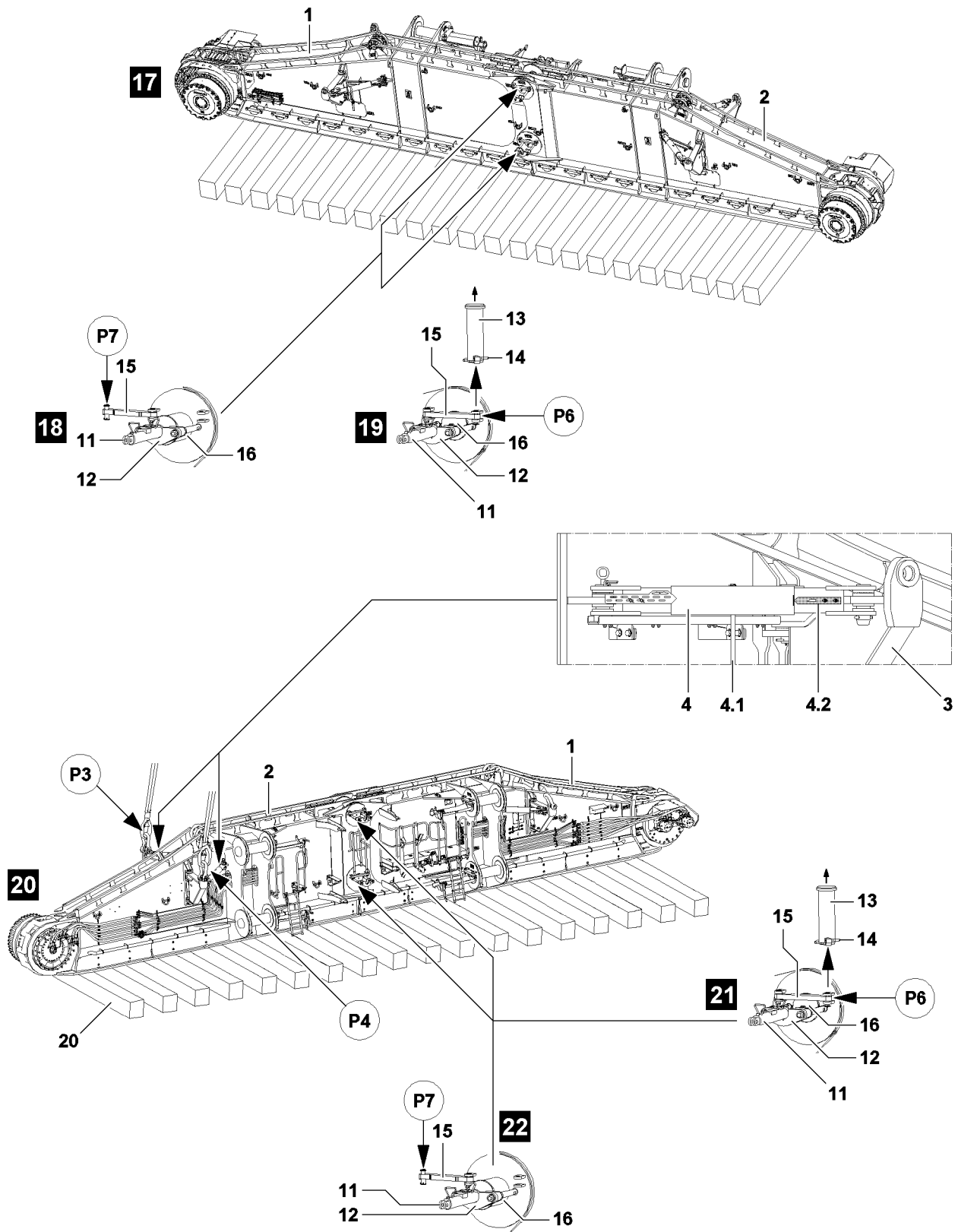

LWE/LR 13000-001/19503-01-02/en

Fig.113050

5.4.2 Releasing and unpinning the inner connector pins

Make sure that the following prerequisites are met:

- The outer connector pins **16** are unpinned.
- The crawler carrier rear section **2** is fastened to the auxiliary crane.



WARNING

Danger of falling for assembly personnel!

During the unpinning procedure on the inner pin points of the crawler carrier, assembly personnel can fall down!

Personnel can be severely injured or killed!

- ▶ The assembly work on the inside of the two crawler carrier halves may only be carried out using the factory installed assembly pedestals and catwalks.
 - ▶ Assembly personnel is obligated to carry out all assembly tasks only when using the personal protective equipment.
 - ▶ Improvisations are prohibited.
-
- ▶ Release and unpin the inner connector pins according to the unpinning procedure of the outer connector pins.

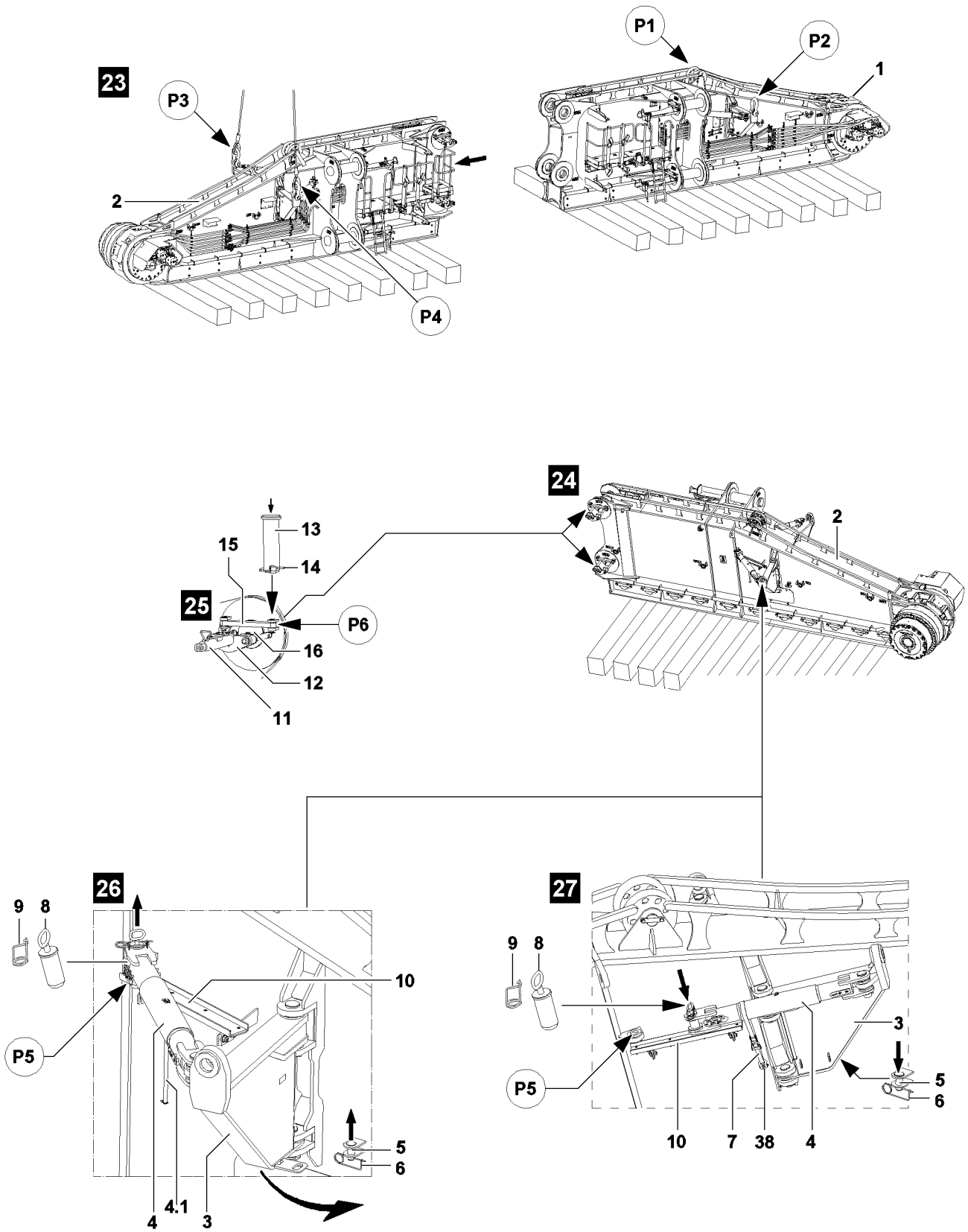

Fig.113051

LWE/LR 13000-001/19503-01-02/en

5.5 Disconnecting the crawler carrier rear section and the crawler carrier front section

Make sure that the following prerequisites are met:

- The crawler carrier front section is secured to prevent it from falling over.
- The crawler carrier rear section is fastened to the auxiliary crane.
- All connector pins between the crawler carrier front section and the crawler carrier rear section are unpinned.

NOTICE

Danger of property damage!

If the connector pins are not completely unpinned - when disconnecting the crawler carrier rear section **2** from the crawler carrier front section **1**, the components can be severely damaged!

The crawler carrier can topple over and personnel can be severely injured or killed!

- ▶ Make sure that the connector pins **16** between the crawler carrier rear section **2** and the crawler carrier front section **1** are completely **unpinned** before the separation procedure!
-

When all connector pins between the crawler carrier rear section and the crawler carrier front section are unpinned:

- ▶ Carefully lift the crawler carrier rear section **2** with the auxiliary crane, extend from the crawler carrier front section **1** and set down on the substructure.

When the crawler carrier rear section and the crawler carrier front section are separated:

- ▶ Pin all four connector pins **16** on the crawler carrier rear section **2** completely with the pin pulling cylinder.

When all four connector pins **16** are completely pinned:

- ▶ Secure the connector pins **16** with securing brackets **15**: Insert the pins **13** in point **P6** and secure with locking pins **14**, illustration **25**.
- ▶ Swing the crawler carrier rear section **2** out with the auxiliary crane and set it on the transport vehicle and secure.
- ▶ Remove the auxiliary crane.

When the auxiliary crane is removed on the tow brackets:

- ▶ Unpin the adjustment spindle **4** in the operating position: Release pin **8** in point **P5** and unpin, illustration **26**.
- ▶ Release and unpin the pin **5**.
- ▶ Swing the tow bracket **3** in to the crawler carrier in direction of the arrow, illustration **26**.

When the tow bracket **3** is completely swung in:

- ▶ Pin the tow bracket **3** in the transport position: Insert the pin **5** and secure with spring retainer **6**, see illustration **27**.
- ▶ Insert the pin **8** again in the adjustment spindle **4** and secure with the spring retainer **9**.

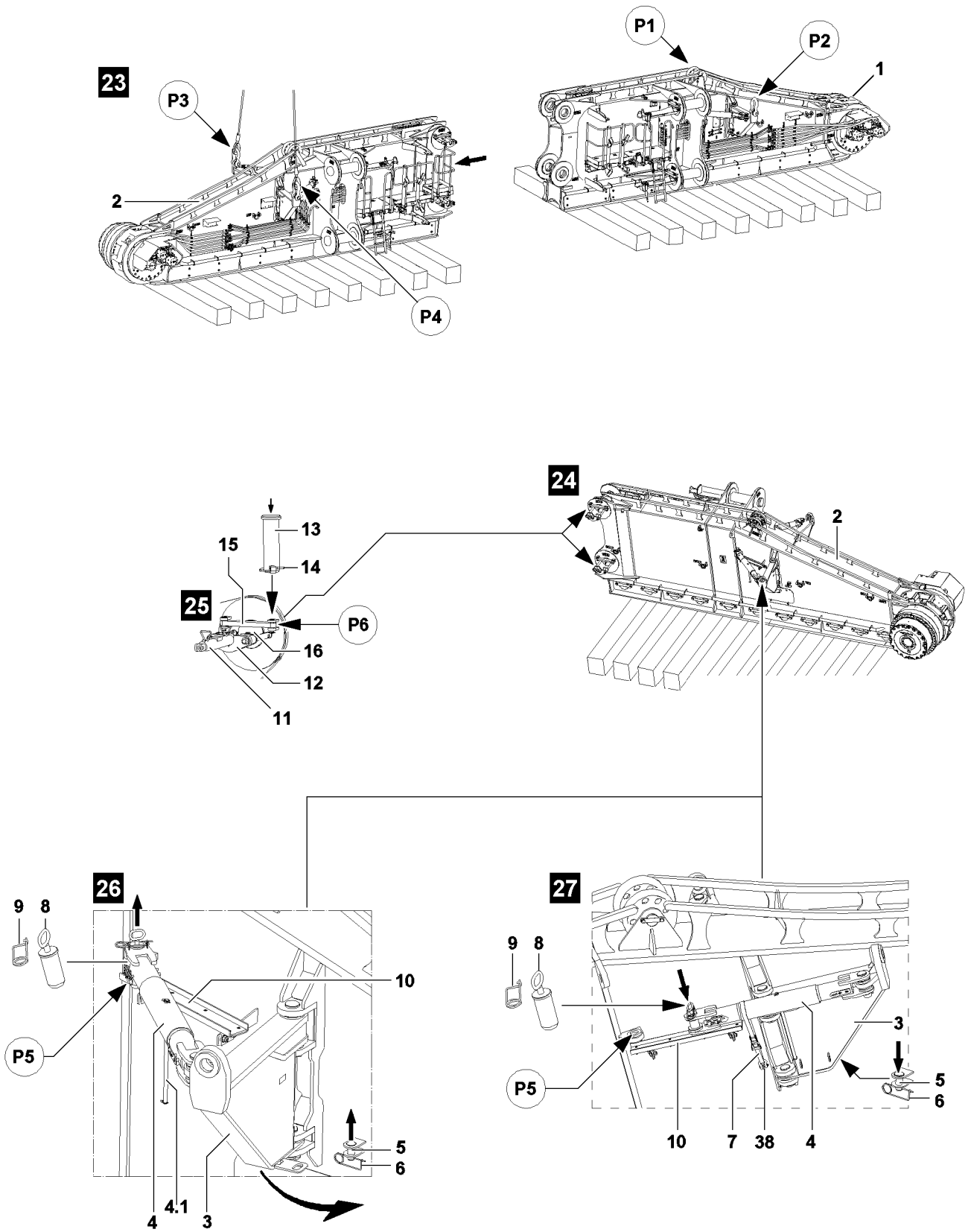

Fig.113051

LWE/LR 13000-001/19503-01-02/en

- ▶ Secure the adjustment spindle **4** for transport: Place the tension belt **7** over the adjustment spindle **4** and through the shackle **38** and tension with the ratchet on the tension belt **7**.

Result:

- The adjustment spindle **4** is secured for transport in the guide rail **10**.

**Note**

- ▶ The tow bracket **3** on the inside of the crawler carrier rear section can remain in the operating position during transport.
-
- ▶ Fasten the crawler carrier front section **1** to the auxiliary crane.
 - ▶ Set the crawler carrier front section **1** with the auxiliary crane on the transport vehicle and secure.
 - ▶ Remove the auxiliary crane.

When the auxiliary crane is removed on the tow brackets:

- ▶ Bring the tow bracket **3** on the outside of the crawler carrier front section **1** in transport position and secure.

**Note**

- ▶ The tow bracket **3** on the inside of the crawler carrier front section **1** can remain in the operating position during transport.

Empty page!

LWE/LR 13000-001/19503-01-02/en

3.01.20 Assembling the cross carrier on the crawler center section

1	Component overview	3
2	Component fastening points	3
3	Assembling the cross carrier on the crawler center section	5
4	Disassembling the cross carrier on the crawler center section	29

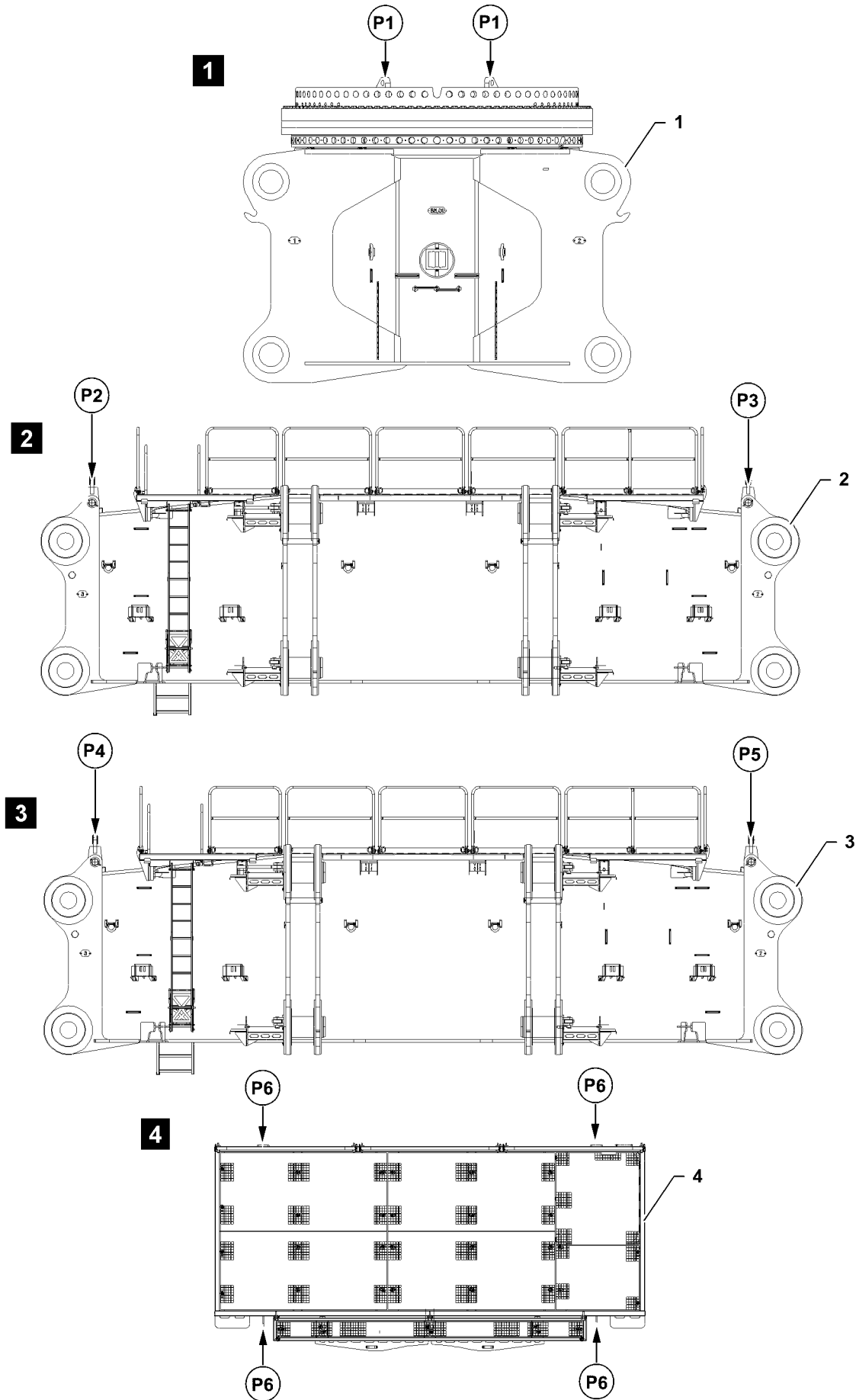

Fig.113109

LWE/LR 13000-001/19503-01-02/en

1 Component overview



Note

- ▶ For the dimensions and weights, see the Crane operating instructions, chapter 1.03!

Position	Component
1	Crawler center section
2	Cross carrier, front
3	Cross carrier, rear
4	Catwalk

2 Component fastening points



WARNING

Component incorrectly fastened!

Life-threatening situations can arise due to improper or incorrect fastening of the corresponding components!

Personnel can be severely injured or killed!

- ▶ Fasten the components only in the intended fastening points on both sides!
- ▶ Fastening of components and description of fastening points, see the Crane operating instructions, chapter 5.01!

Fastening points	
P1 (4X)	Crawler center section
P2 and P3	Cross carrier, front
P4 and P5	Cross carrier, rear
P6 (4X)	Catwalk

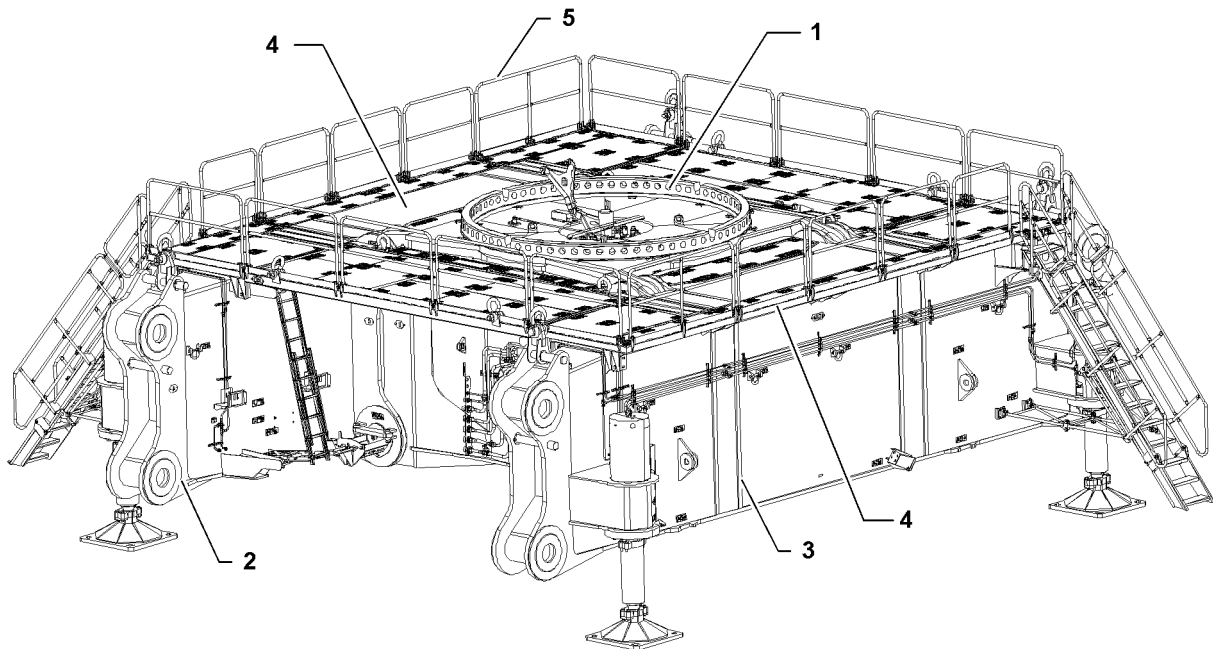

Fig.113110

3 Assembling the cross carrier on the crawler center section



WARNING

Danger of falling!

During assembly / disassembly, inspection and maintenance work, assembly personnel must be secured with appropriate aids to prevent them from falling! If this is not observed, assembly personnel could fall and be killed or seriously injured!

- ▶ The assembly personnel must always move carefully and anticipatory on the crane, the crane components or lattice sections!
- ▶ All work at a height, when there is a danger of falling, must be carried out with suitable aids!
- ▶ If fall protection equipment is available, then it must be used!
- ▶ If aids are not available and work cannot be carried out from the ground, then assembly personnel must secure themselves with the permissible fall arrest system to prevent falling, see the Crane operating instructions, chapter 2.04!
- ▶ The fall arrest system must be attached in the fastening and hook points as well as to the safety ropes!
- ▶ Only step on the aids, ladders and catwalks with clean shoes!
- ▶ Keep aids, ladders and catwalks free of heavy dirt, snow and ice!



WARNING

Danger of impact / crushing!

When assembling / disassembling crane components with the auxiliary crane, crane components can start to swing back and forth!

When lifting / lowering and positioning crane components, there is an increased danger of impact / crushing!

Personnel can be caught and thereby injured or killed!

- ▶ Make sure that personnel cannot be caught by components!
- ▶ When working in danger zones: Use aids to protect limbs!
- ▶ Guide components with suitable aids to minimize oscillation!



WARNING

Improper substructure!

If the crawler center section is not properly supported from below, it can sink into the ground and severely injure personnel!

- ▶ The substructure must be able to safely absorb the weight of the crawler center section, the turntable and the crawler carrier!
- ▶ The support must be made large enough for the ground conditions, with solid materials, such as wood, steel or concrete slabs, see the Crane operating instructions, chapter 2.04!

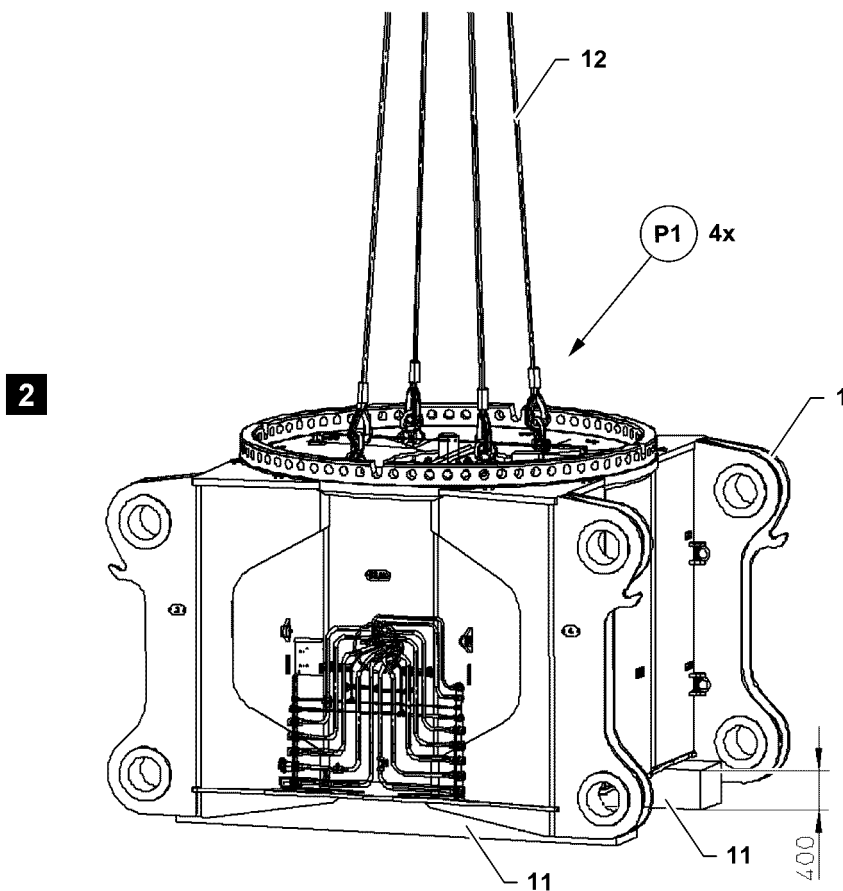
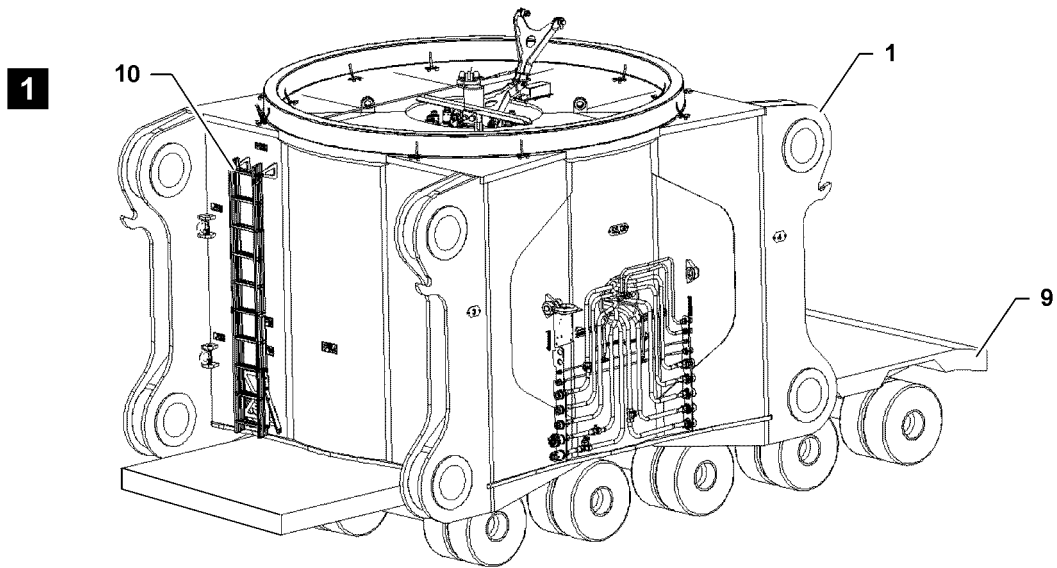

Fig.113111

LWE/LR 13000-001/19503-01-02/en

3.1 Unloading and supporting the crawler center section

Make sure that the following prerequisites are met:

- The ground must be level and have adequate load bearing capacity.
- An auxiliary crane is available.
- Suitable material must be available for the substructure of the crawler center section.



Note

- ▶ For assembly and disassembly work on the crawler center section use the extension ladder **10**, see illustration **1**!
 - ▶ Observe and adhere to the assembly and safety instructions for the extension ladder, see the Crane operating instructions, chapter 2.06!
-
- ▶ Fold the extension ladder **10** out and set the sliding section upward, see the Crane operating instructions, chapter 2.06.



WARNING

Danger of falling!

During assembly and disassembly of crane components, personnel must be secured with appropriate aids to prevent them from falling!

Assembly personnel can fall and be severely injured or killed!

- ▶ Use personal protective equipment!
-
- ▶ Fasten the fastening equipment **12** to the lashing lugs in points **P1** of the crawler center section.
 - ▶ Tension the fastening equipment **12** with the auxiliary crane.
 - ▶ Lift the crawler center section **1** with the auxiliary crane from the transport vehicle **9**.



Note

- ▶ Support the crawler center section at least 400 mm high with hardwood beams **11**, see illustration **2**!
 - ▶ Place the wood substructure as far out as possible to obtain the best possible stability!
 - ▶ It must be constructed in such a way that the cross carriers can be installed on the left and right without interference.
-
- ▶ Support the crawler center section **1** with hardwood beams **11**.
 - ▶ Set the crawler center section **1** carefully with the auxiliary crane on the support, see illustration **2**.
 - ▶ Release the fastening equipment **12** on the lashing lugs in points **P1** of the crawler center section.
 - ▶ Set the extension ladder **10** vertical and secure it, see the Crane operating instructions, chapter 2.06.

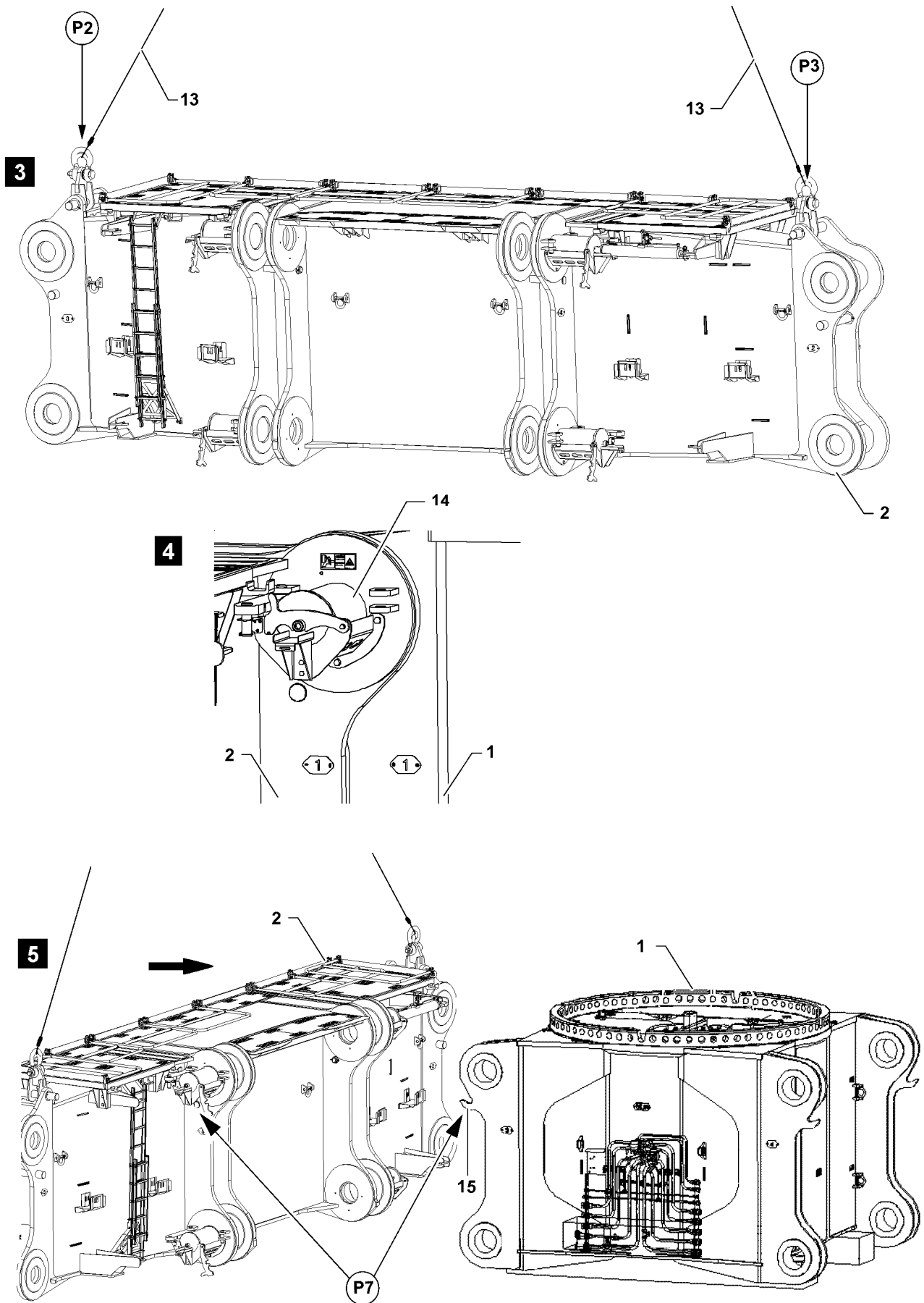

Fig.113112

LWE/LR 13000-001/19503-01-02/en

3.2 Assembling the first cross carrier

3.2.1 Connecting the cross carrier to the crawler center section

Make sure that the following prerequisites are met:

- The crawler center section is properly supported and horizontally aligned.
 - A work platform is available.
 - The pins **14** on the cross carrier are unpinned.
- ▶ Move the work platform to the first hook point of the cross carrier.



WARNING

Danger of falling!

During assembly and disassembly of crane components, personnel must be secured with appropriate aids to prevent them from falling!

Assembly personnel can fall and be severely injured or killed!

▶ Use personal protective equipment!

- ▶ Fasten the fastening equipment **13** to the hook bracket in point **P2** of the cross carrier **2**, see illustration **3**.
- ▶ Move the work platform to the second hook point of the cross carrier.
- ▶ Fasten the fastening equipment **13** to the hook bracket in point **P3** of the cross carrier **2**, see illustration **3**.



WARNING

Danger of crushing!

When retracting the cross carrier **2**, there is an increased danger of accident due to crushing!

Personnel can be severely injured or killed!

- ▶ It is prohibited for anyone to remain between the cross carrier **2** and the crawler center section **1**!
- ▶ Swing the cross carrier **2** in with the auxiliary crane to the crawler center section **1**.



Note

- ▶ The crawler center section **1** and the cross carriers **2** are identified with numbers, see illustration **4**!
- ▶ Note the identification on the crawler center section **1** and on the cross carrier **2**!

NOTICE

Danger of property damage!

If the pins **14** - when retracting the cross carriers **2** in the crawler center section **1** - are in the **pinned** position, components can be severely damaged.

- ▶ Make sure that the pins **14** on the cross carrier **2** are in the unpinned **1** position when moving into the **crawler center section**, see illustration **4**!
- ▶ Connect the cross carrier **2** to the pre-centering **15** in point **P7** of the crawler center section **1**, see illustration **5**.

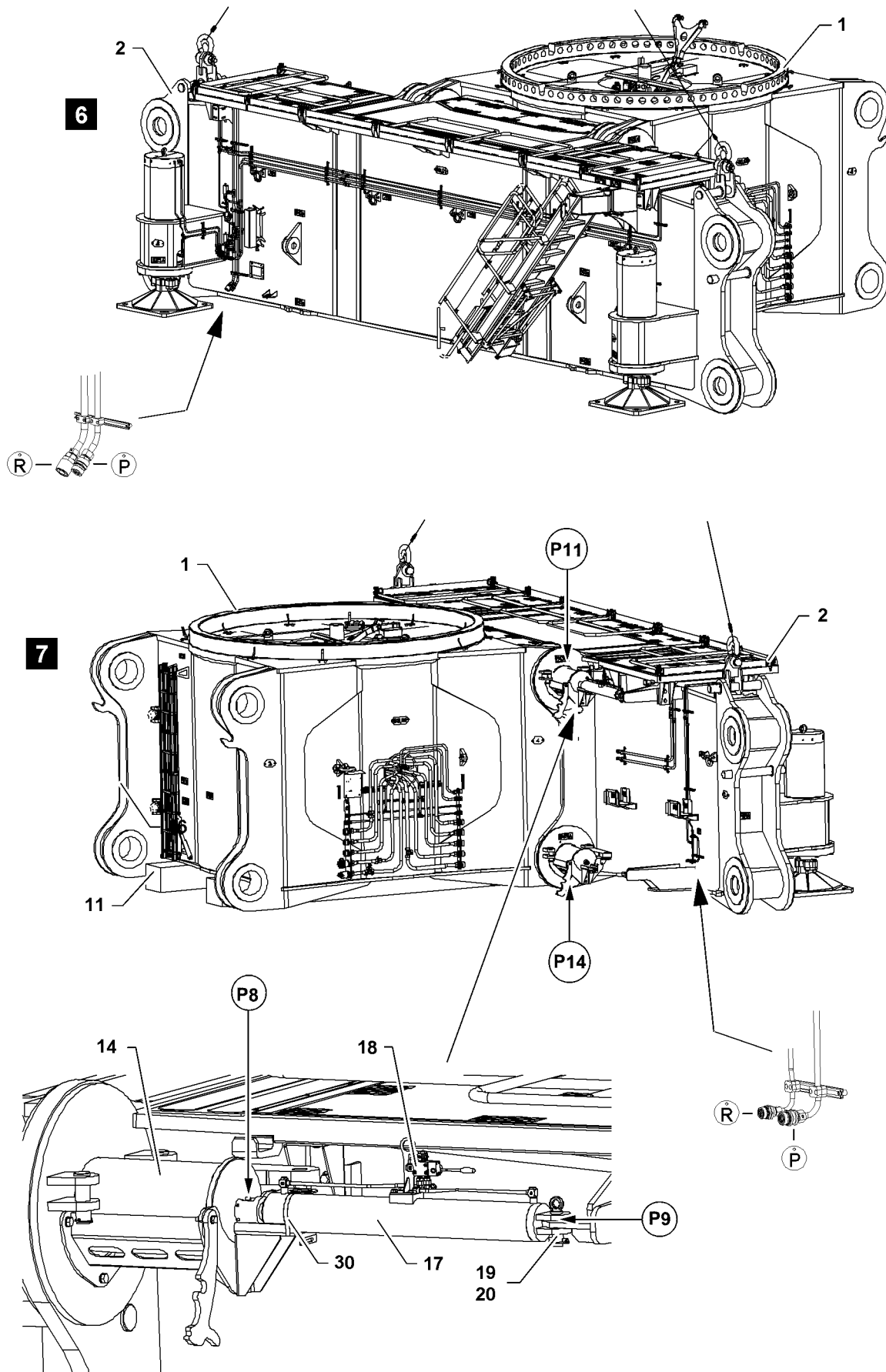

Fig.113140

LWE/LR 13000-001/19503-01-02/en

3.2.2 Establishing the hydraulic connections to the cross carrier



Note

- ▶ The hydraulic supply for the assembly support is provided via the external hydraulic aggregate or the operational engine house!

The hydraulic connections are established with quick couplings.

When connecting hydraulic lines with quick couplings, make sure that the coupling procedure is carried out correctly.

The matching quick couplings are marked.



WARNING

Pressure in the hydraulic lines!

If the pressure supply is not interrupted before connecting / releasing the hydraulic lines, the hydraulic oil can escape with high pressure.

Death, severe bodily injuries, property damage.

- ▶ Release the pressure in the hydraulic system before connecting / disconnecting: Interrupt the pressure supply and wait a short time.



WARNING

Loss of pressure or leakage!

Incorrectly coupled or self-loosening quick couplings (particularly return lines) can result in serious accidents due to component failure.

Death, severe bodily injuries, property damage.

- ▶ Check that the quick couplings have been properly connected before using the crane.
- ▶ Connect the coupling components (sleeve and connector) and screw together with the knurled nut.
- ▶ Tighten the hydraulic coupling by hand. Turn the knurled nut until it reaches a tangible, fixed stop position.
- ▶ Establish the hydraulic connection: Connect the supply lines of the external hydraulic aggregate to the supply lines of the cross carrier, hydraulic connection **R** and hydraulic connection **P**, see illustration **6**.

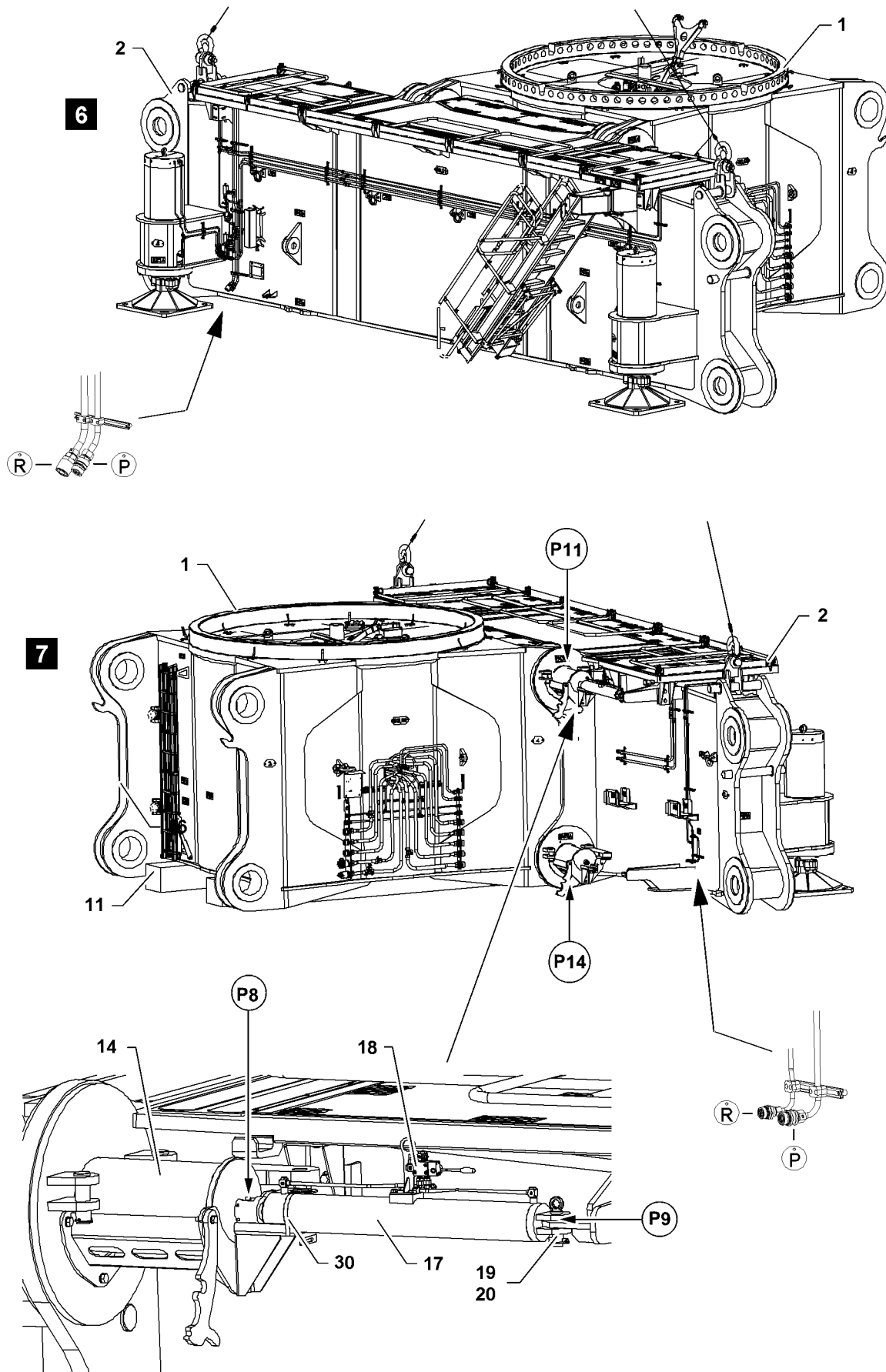

Fig.113140

LWE/LR 13000-001/19503-01-02/en

3.2.3 Establishing the hydraulic connections to the pin pulling cylinder

Make sure that the following prerequisite is met:

- The external hydraulic aggregate or the operational engine house are connected to the supply lines of the cross carrier.



Note

- ▶ Hydraulic connection of the pin pulling device, see the Crane operating instructions, chapter 5.30!



Note

- ▶ The pin pulling cylinder **17** is positioned in the transport position in the „upper right“ pin location **P11**, see illustration **6**!
- ▶ The pin pulling cylinder **17** is secured in the transport position with the tension belt **30**!

- ▶ Move the work platform to the first pin location **P11** of the cross carrier.



WARNING

Pressure in the hydraulic lines!

If the pressure supply is not interrupted before connecting / releasing the hydraulic lines, the hydraulic oil can escape with high pressure.

Death, severe bodily injuries, property damage.

- ▶ Release the pressure in the hydraulic system before connecting / disconnecting: Interrupt the pressure supply and wait a short time.
- ▶ Connect the coupling components (sleeve and connector) and screw together with the knurled nut.
- ▶ Tighten the hydraulic couplings by hand. Turn the knurled nut until it reaches a tangible, fixed stop position.
- ▶ Establish the hydraulic connection: Connect the supply lines of the pin pulling cylinder **17** to the supply lines of the cross carrier, hydraulic connection **R** and hydraulic connection **P**, see illustration **7**.
- ▶ Fasten the pin pulling cylinder **17** to the auxiliary crane.
- ▶ Remove the tension belt **30**, see illustration **7**.

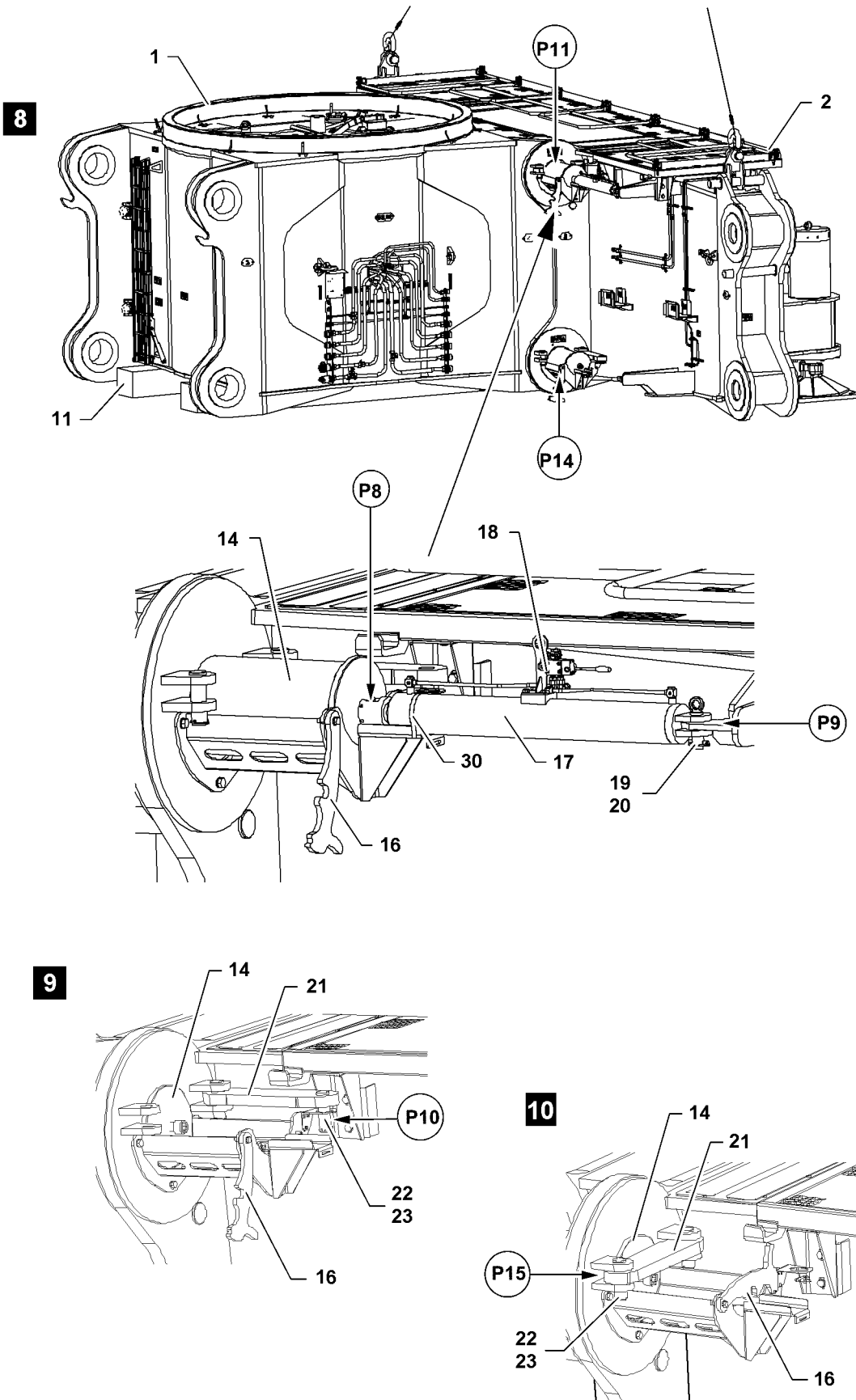

Fig.113113

LWE/LR 13000-001/19503-01-02/en

3.2.4 Pinning the cross carrier to the crawler center section

Make sure that the following prerequisite is met:

- The hydraulic connections to the pin pulling cylinder are established.
- ▶ Extend the pin pulling cylinder **17**: Actuate the control lever **18** of the pin pulling cylinder, see illustration **8**.

Result:

- The pin **14** is inserted.

When the pin **14** is inserted to the stop:

- ▶ Release the pin pulling cylinder **17** from the inserted pin **14**.
- ▶ Disconnect the hydraulic connections from the pin pulling cylinder **17**, see the Crane operating instructions, chapter 5.30.
- ▶ Push the pin pulling cylinder **17** on the „front“ in point **P8** upward.
- ▶ Retract the pin pulling cylinder **17**: Actuate the control lever **18** of the pin pulling cylinder.
- ▶ Release the „rear“ connection on the pin pulling **17** cylinder in point **P9**: Remove the locking pin **20** and unpin the pin **19**.

Result:

- The pin pulling cylinder **17** hangs freely on the auxiliary crane.
- ▶ Swing the pin pulling cylinder **17** from the pin location **P11**.
- ▶ Insert the pin **19** again in point **P9** and secure with the locking pin **20**.



WARNING

The pin is not secured!

If the pins **14** are not secured, the pins can loosen up by themselves during crane operation!

This can cause the crane to topple over!

Personnel can be severely injured or killed!

- ▶ Make sure that all four pins **14** are secured with securing brackets **21**!

- ▶ Unpin the securing bracket **21**: Remove the locking pin **23** in point **P10** and unpin the pin **22**, see illustration **9**.
- ▶ Swing the securing bracket **21** to the pin **14**.
- ▶ Insert the pin **22** in point **P15** and secure with the locking pin **23**, see illustration **10**.

Result:

- The pin location **P11** is pinned and secured.
- ▶ Fold the retainer **16** in, see illustration **10**.

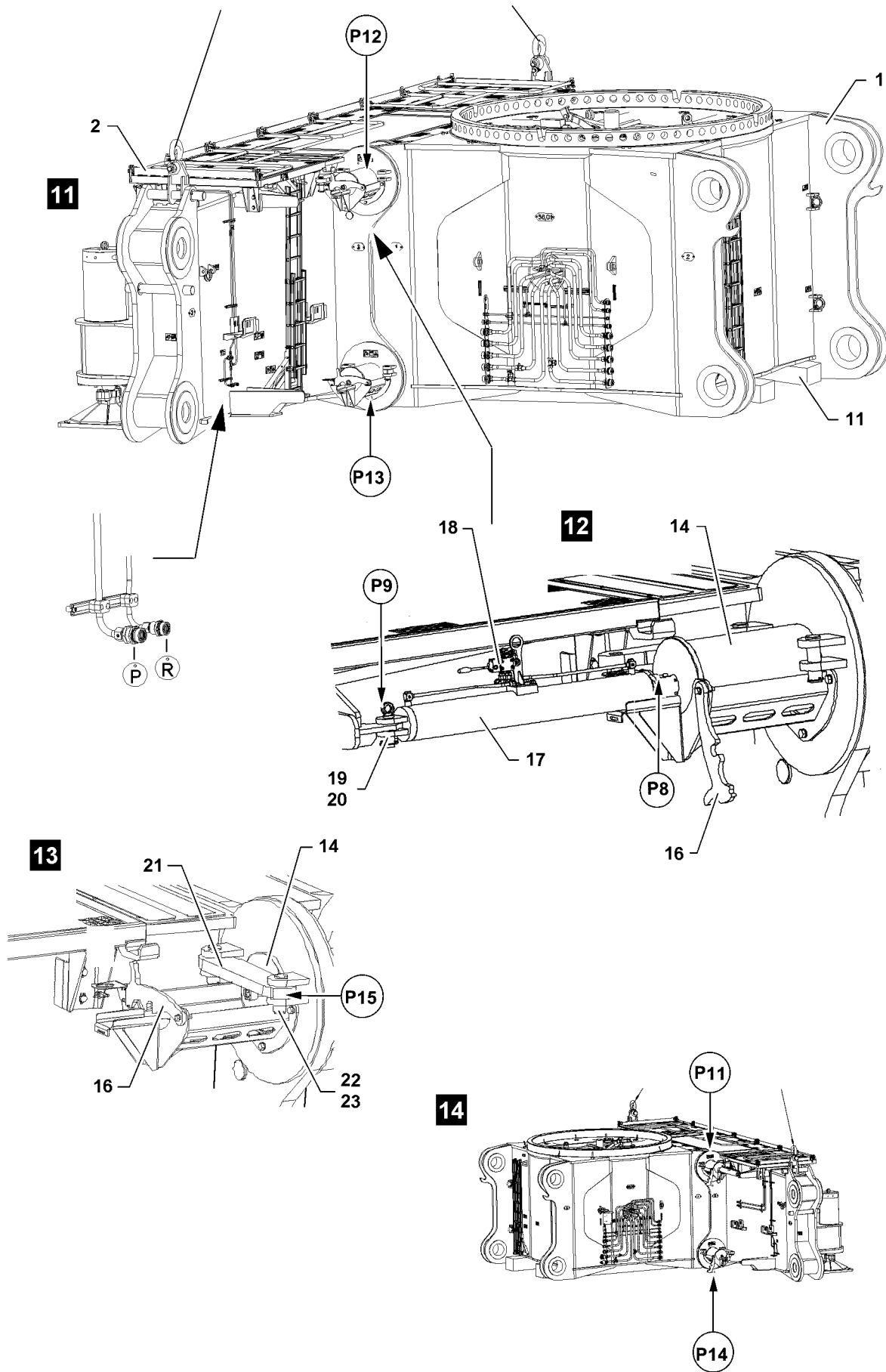

Fig.113114

LWE/LR 13000-001/19503-01-02/en

- ▶ Move the work platform to the second pin location **P12** „upper left“ of the cross carrier, see illustration **11**.
- ▶ Swing the pin pulling cylinder **17** with the auxiliary crane to the pin location **P12**.

**WARNING**

Danger of falling!

During assembly and disassembly of crane components, personnel must be secured with appropriate aids to prevent them from falling!

Assembly personnel can fall and be severely injured or killed!

- ▶ Use personal protective equipment!

- ▶ Connect the pin pulling cylinder **17** on the „front“ in point **P8** to the extended pin **14**, see illustration **12**.
- ▶ Pin the pin pulling cylinder **17** on the „rear“ in point **P9**: Insert the pin **19** and secure with the locking pin **20**, see illustration **12**.
- ▶ Establishing the hydraulic connection, see illustration **11**: Connect the supply lines of the pin pulling cylinder **17** to the supply lines of the cross carrier **R**, hydraulic connection and hydraulic connection **P**, see the Crane operating instructions, chapter 5.30.
- ▶ Extend the pin pulling cylinder **17**: Actuate the control lever **18** of the pin pulling cylinder, see illustration **12**.

Result:

- The pin **14** is inserted.

When the pin **14** is inserted to the stop:

- ▶ Release the pin pulling cylinder **17** on the „front“ and on the „rear“.
- ▶ Swing the pin pulling cylinder **17** from the pin location **P12**.

**WARNING**

The pin is not secured!

If the pins **14** are not secured, the pins can loosen up by themselves during crane operation!

This can cause the crane to topple over!

Personnel can be severely injured or killed!

- ▶ Make sure that all four pins **14** are secured with securing brackets **21**!

- ▶ Secure the pin **14**: Swing the securing bracket **21** to the pins **14** and insert the pin **22** in point **P15** and secure with the locking pin **23**, see illustration **13**.

Result:

- The pin location **P12** is pinned and secured.

- ▶ Fold the retainer **16** in, see illustration **13**.

**Note**

- ▶ The procedure in the pin location **P13** and pin location **P14** is the same as the work steps for the pin location **P11** and pin location **P12**!

- ▶ Insert the pin **14** in the pin location **P13** and pin location **P14**.
- ▶ Disconnect the hydraulic connections from the pin pulling cylinder **17**, see the Crane operating instructions, chapter 5.30.
- ▶ Release the pin pulling cylinder **17** and swing it away from the cross carrier with the auxiliary crane.

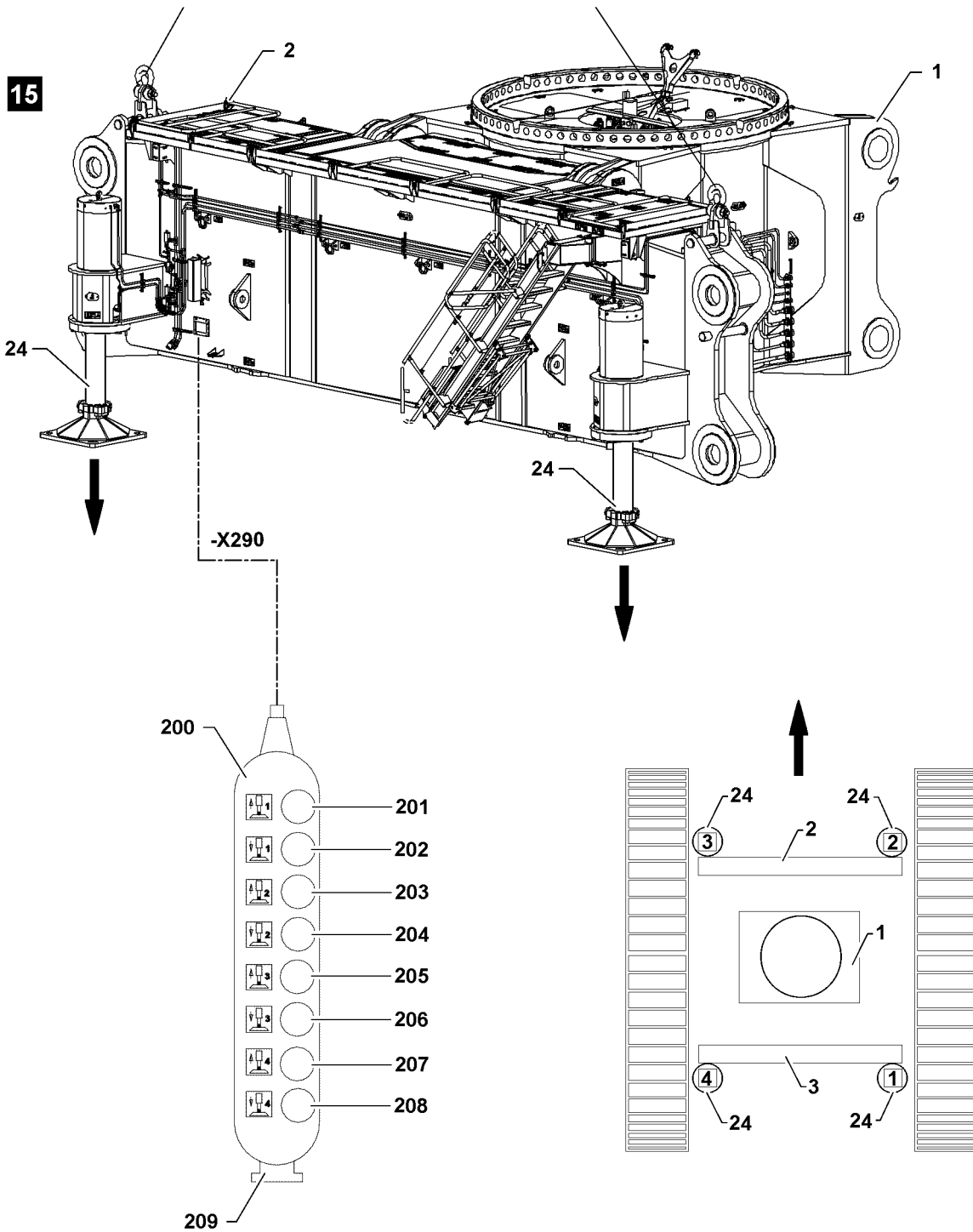

Fig.113141

LWE/LR 13000-001/19503-01-02/en

3.2.5 Extending the assembly supports

Make sure that the following prerequisite is met:

- The pins are completely inserted and secured.



WARNING

Danger of accident due to improper support!

If the assembly supports **24** are not properly supported, then there is an increased danger of accident! The assembly supports **24** can sink into the ground and severely injure personnel!

- ▶ The substructure must be able to safely absorb the weight of the crawler center section, the cross carrier and the crawler carrier!
 - ▶ Use stable materials such as wood, steel plates or concrete slabs of a suitable size for support, depending on the ground conditions!
 - ▶ The support forces for pinning the first crawler carrier per assembly support are approx. 170 t!
-
- ▶ Properly support the assembly supports **24**.



WARNING

Tipping of the center section and cross carrier!

Without the support with the assembly supports or without the substructure, the installed cross carrier **2** can tip over with the crawler center section **1**!

Personnel can be severely injured or killed!

- ▶ Support the cross carrier with the assembly supports or support it properly from below!
-
- ▶ Extend the assembly supports **24**: Actuate the control panel **200**.

Result:

- The cross carrier **2** is supported, see illustration **15**.

When the cross carrier **2** is supported, the auxiliary crane can now be removed.

- ▶ Retract the work platform to the hook bracket of the cross carrier **2** and remove the fastening equipment **13**.

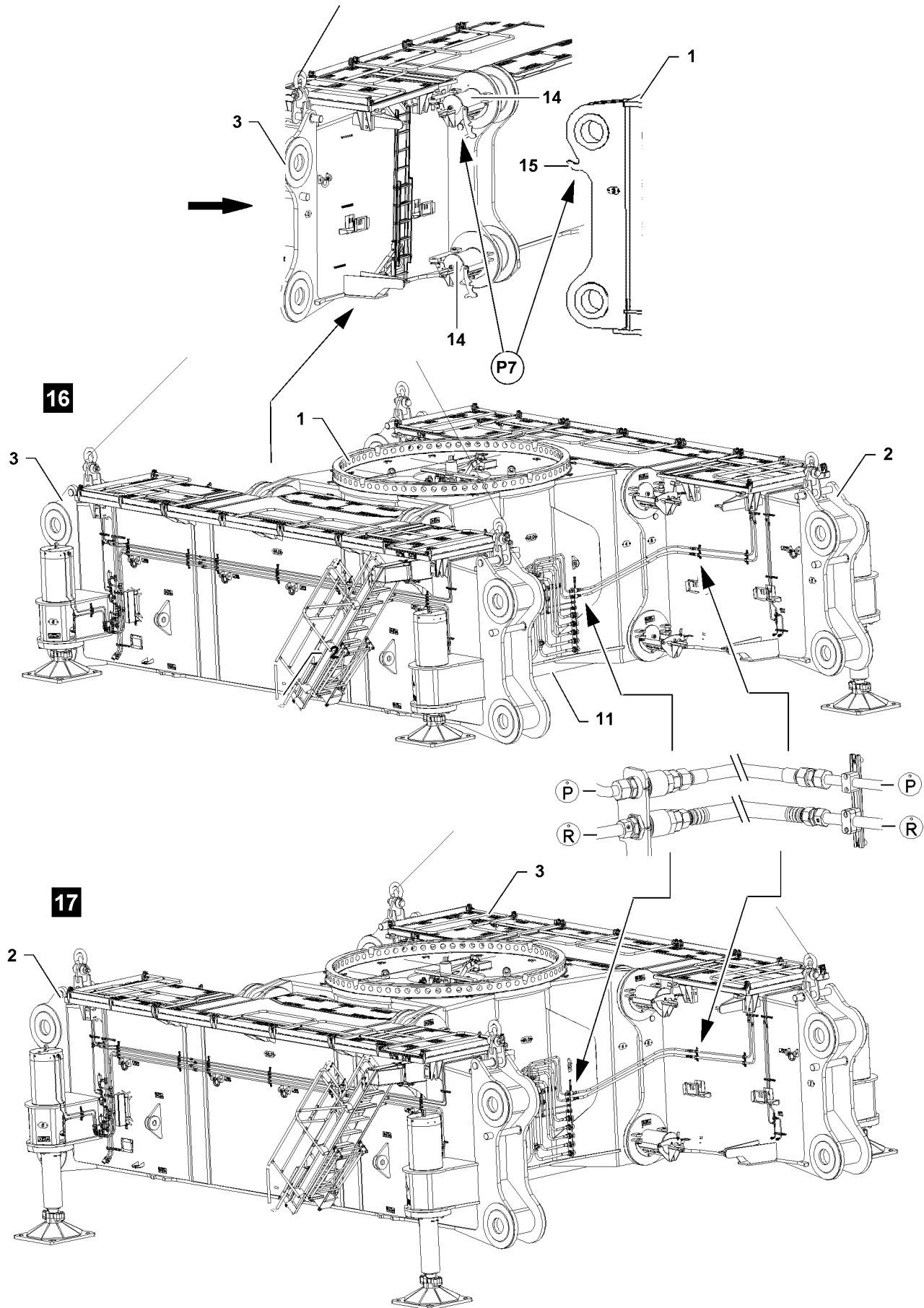

Fig.113142

LWE/LR 13000-001/19503-01-02/en

3.3 Assembling the second cross carrier

Make sure that the following prerequisites are met:

- The first cross carrier is properly pinned and secured on the crawler center section.
- The first cross carrier is supported.

3.3.1 Connecting the cross carrier to the crawler center section



WARNING

Danger of falling!

During assembly and disassembly of crane components, personnel must be secured with appropriate aids to prevent them from falling!

Assembly personnel can fall and be severely injured or killed!

- ▶ Use personal protective equipment!

- ▶ Fasten the cross carrier **3** to the auxiliary crane.

NOTICE

Danger of property damage!

If the pins **14** - when retracting the cross carriers **3** in the crawler center section **1** - are in the **pinned** position, components can be severely damaged.

- ▶ Make sure that the pins **14** on the cross carrier **3** are in the unpinned **1** position when moving into the **crawler center section**!



WARNING

Danger of crushing!

When retracting the cross carrier **3**, there is an increased danger of accident due to crushing!

Personnel can be severely injured or killed!

- ▶ It is prohibited for anyone to remain between the cross carrier **3** and the crawler center section **1**!
- ▶ Swing the cross carrier **3** in with the auxiliary crane to the crawler center section **1**.
- ▶ Connect the cross carrier **3** to the pre-centering **15** in point **P7** of the crawler center section **1**, see illustration **16**.

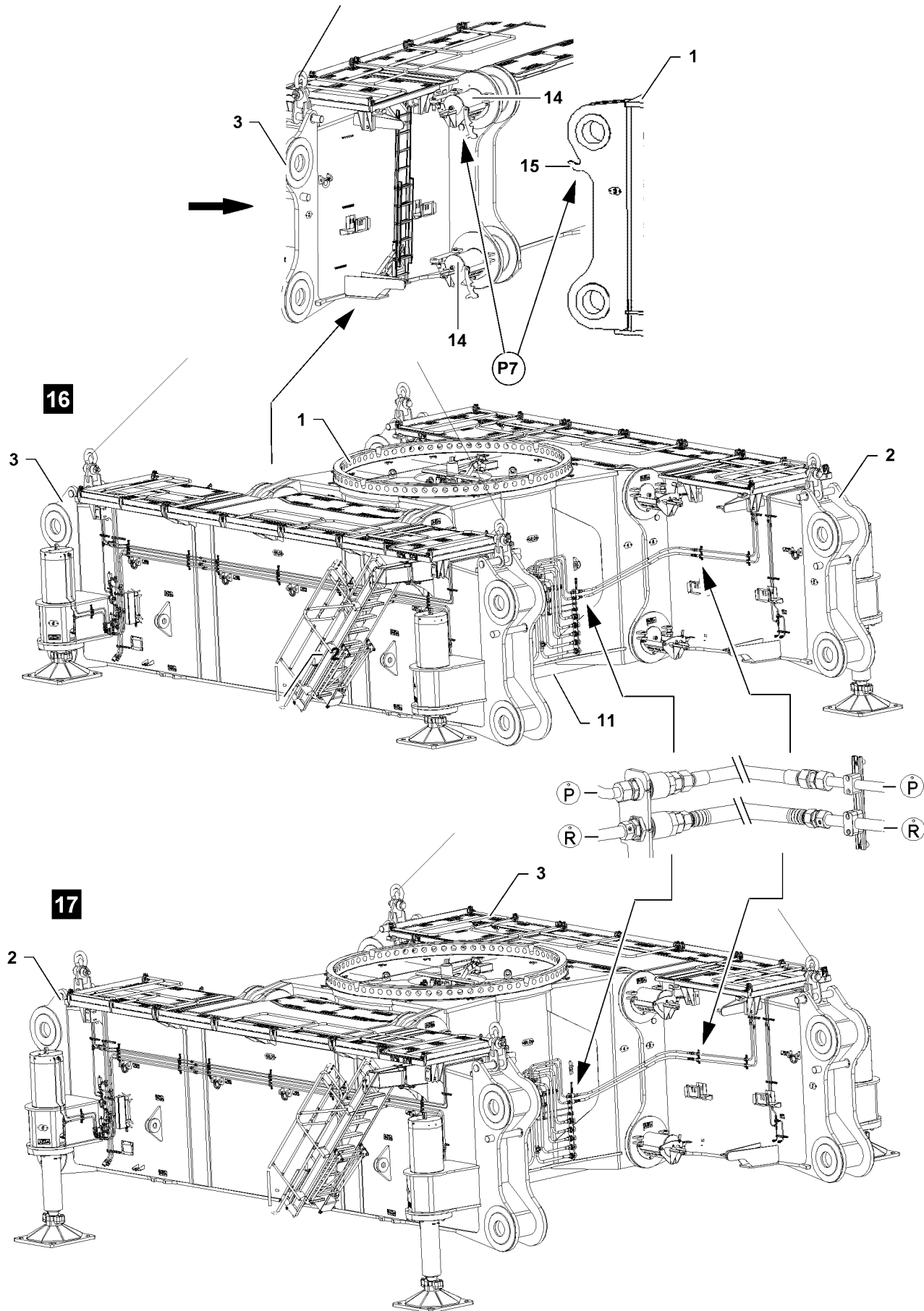

Fig.113142

LWE/LR 13000-001/19503-01-02/en

3.3.2 Establishing the hydraulic connections to the cross carrier and crawler center section

The hydraulic connections are established with quick couplings.

When connecting hydraulic lines with quick couplings, make sure that the coupling procedure is carried out correctly.

The matching quick couplings are marked.



WARNING

Pressure in the hydraulic lines!

If the pressure supply is not interrupted before connecting / releasing the hydraulic lines, the hydraulic oil can escape with high pressure.

Death, severe bodily injuries, property damage.

- ▶ Release the pressure in the hydraulic system before connecting / disconnecting: Interrupt the pressure supply and wait a short time.



WARNING

Loss of pressure or leakage!

Incorrectly coupled or self-loosening quick couplings (particularly return lines) can result in serious accidents due to component failure.

Death, severe bodily injuries, property damage.

- ▶ Check that the quick couplings have been properly connected before using the crane.
- ▶ Connect the coupling components (sleeve and connector) and screw together with the knurled nut.
- ▶ Tighten the hydraulic coupling by hand. Turn the knurled nut until it reaches a tangible, fixed stop position.

Establish the hydraulic connection from the cross carrier **2** to the crawler center section **1**:

- ▶ Connect the supply lines of the crawler center section **1** to the supply lines of the cross carrier **2**, hydraulic connection **R** and hydraulic connection **P**, see illustration **16**.

Establish the hydraulic connection from the cross carrier **3** to the crawler center section **1**:

- ▶ Connect the supply lines of the crawler center section **1** to the supply lines of the cross carrier **3**, hydraulic connection **R** and hydraulic connection **P**, see illustration **17**.

3.3.3 Pinning the cross carrier to the crawler center section



Note

- ▶ The assembly of the second cross carrier **3** is the same as the work steps for the first cross carrier **2**!
- ▶ Procedure for assembly of the second cross carrier **3**, see section „Assembling the first cross carrier“!

- ▶ Pin the second cross carrier **3**.
- ▶ Remove the pin pulling cylinder after assembly of the two cross carriers with the auxiliary crane and take it down.

3.3.4 Extending the assembly supports



Note

- ▶ The support of the second cross carrier **3** is the same as the work steps for the first cross carrier **2**!
- ▶ Procedure for supporting the second cross carrier **3**, see section „Assembling the first cross carrier“ - „Extending the assembly supports“!

- ▶ Extend the assembly supports of the second cross carrier **3**.

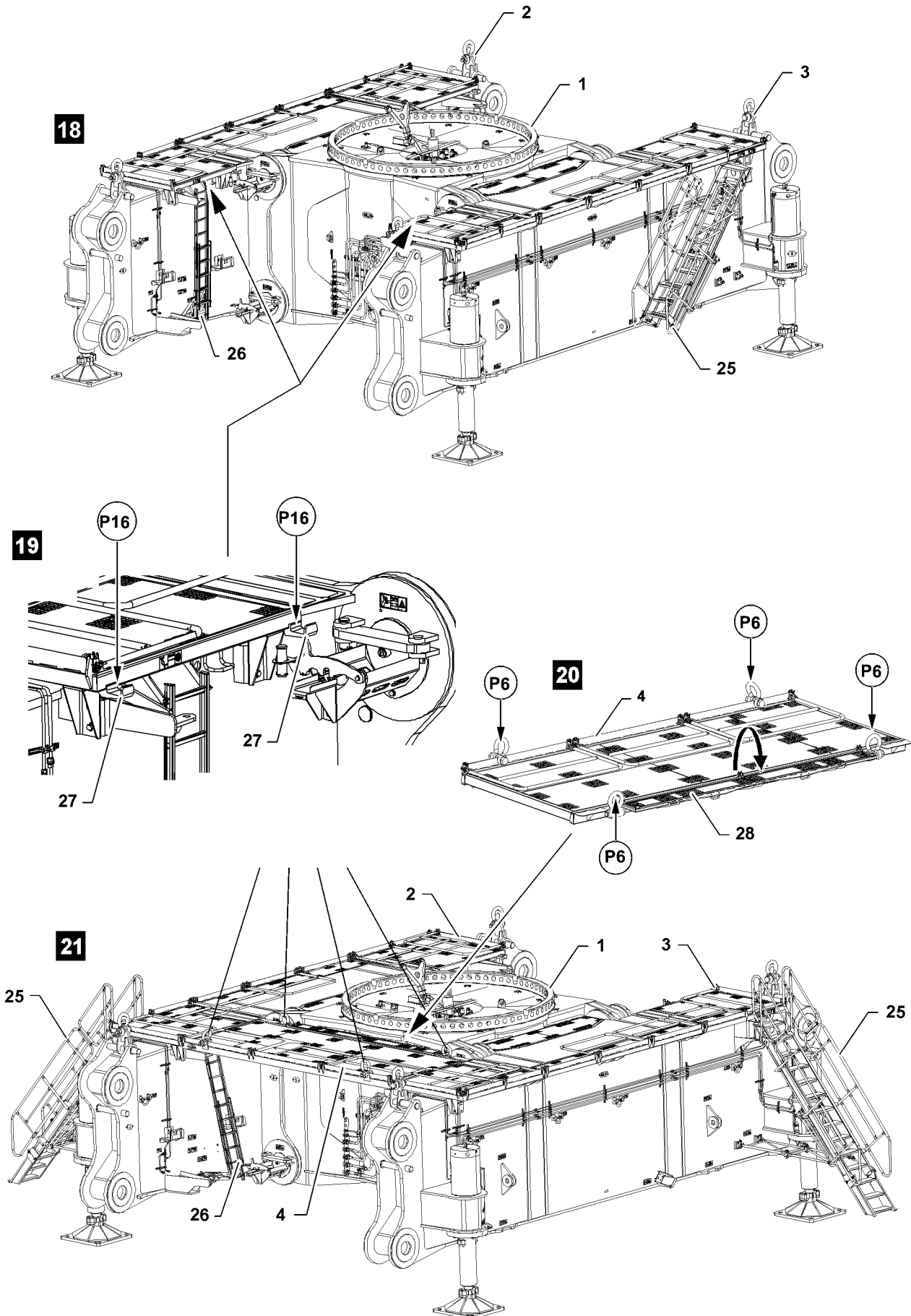

Fig.113116

LWE/LR 13000-001/19503-01-02/en

3.4 Positioning the access ladder and the extension ladder in the operating position



Note

- ▶ Observe and adhere to the assembly and safety instructions for the access ladder and for the extension ladder, see the Crane operating instructions, chapter 2.06!

See illustration **18**:

- ▶ Position the access ladder **25** on the two cross carriers in front of the transport position in the operating position, see the Crane operating instructions, chapter 2.06.
- ▶ Fold the extension ladder **26** out on the two cross carriers and set the sliding section downward, see the Crane operating instructions, chapter 2.06.

3.5 Assembling the catwalks

- ▶ Fasten the fastening equipment to the lashing lugs in points **P6** of the catwalk **4**, see illustration **20**.
- ▶ Swing the folding frame **28** out, see illustration **20**.
- ▶ Lift the catwalk **4** with the auxiliary crane and move it to the assembly location.



WARNING

Danger of falling!

During assembly and disassembly of crane components, personnel must be secured with appropriate aids to prevent them from falling!

Assembly personnel can fall and be severely injured or killed!

- ▶ Use personal protective equipment!



WARNING

Danger of crushed limbs!

When connecting the catwalk **4**, fingers and hands can be crushed or limbs can be severed!

- ▶ Do not reach with your hands into the danger zone!
- ▶ Make sure that the components do not swing back and forth during assembly!

- ▶ Connect the catwalk **4** to the hook **27** between the cross carrier, see illustration **19**.

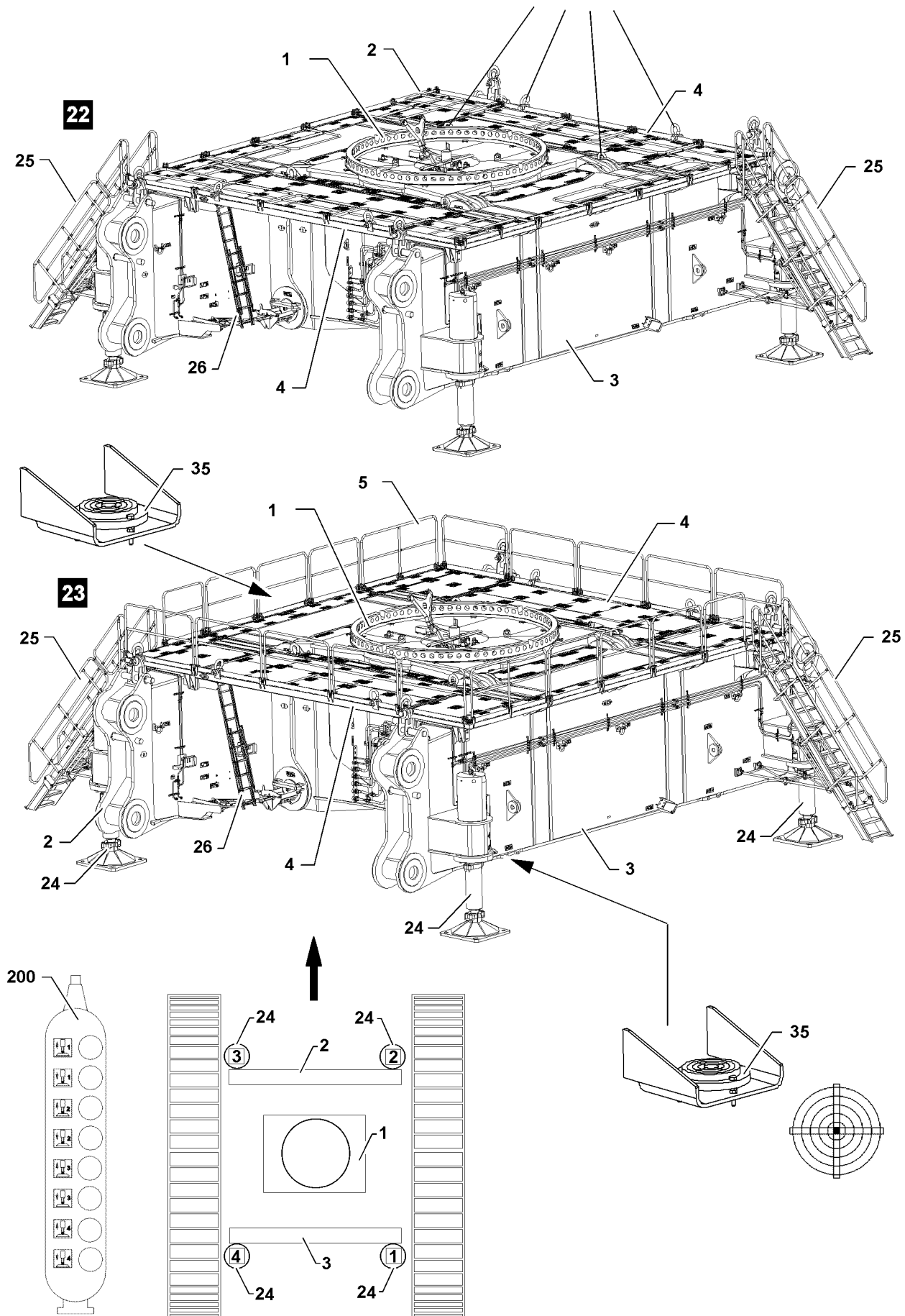

Fig.113117

**Note**

- ▶ The assembly of the second catwalk **4** is the same as the work steps for the first catwalk!

**WARNING**

The grating flap is open!

If the grating flap is open on the catwalks, there is a danger that personnel fall down!

Personnel can be severely injured or killed!

- ▶ Make sure that all grating flaps are closed after assembly of the catwalks!
- ▶ Install the catwalk **4**, see illustration **22**.

3.6 Swinging the railings into the operating position

**Note**

- ▶ Observe and adhere to the assembly and safety instructions for railings, see the Crane operating instructions, chapter 2.06!
- ▶ Swing the railing **5** from the transport position into the operating position, see the Crane operating instructions, chapter 2.06.

3.7 Aligning the crawler center section with the cross carriers in the horizontal direction

**Note**

- ▶ The horizontal alignment of the crawler center section with the cross carriers is checked and aligned with the aid of the sight gauge **35**, see illustration **23**!
- ▶ The center of the sight gauge **35** shows the precise incline value.
- ▶ Extend the assembly supports **24** individually by actuating the corresponding button on the control panel **200** to the point where the crawler carriers can be safely assembled on the crawler center section with the cross carriers without touching the ground.
- ▶ Align the crawler center section with the cross carriers in the horizontal direction: Retract or extend the assembly supports **24** individually.

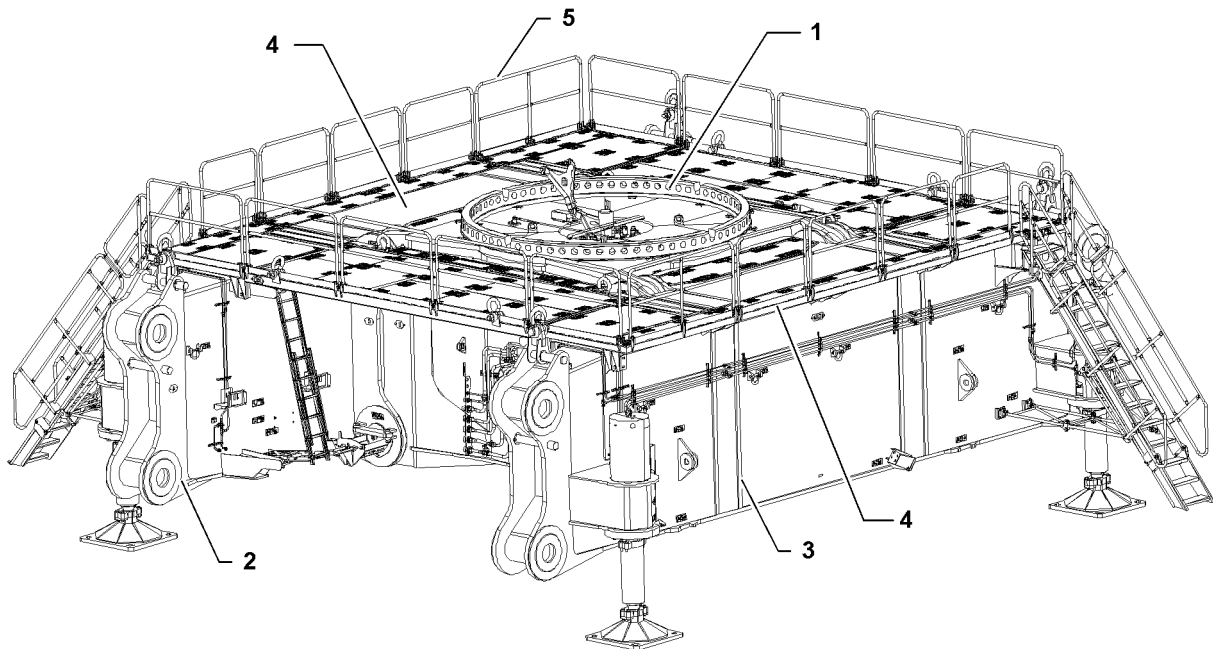

Fig.113110

4 Disassembling the cross carrier on the crawler center section



WARNING

Danger of falling!

During assembly / disassembly, inspection and maintenance work, assembly personnel must be secured with appropriate aids to prevent them from falling! If this is not observed, assembly personnel could fall and be killed or seriously injured!

- ▶ The assembly personnel must always move carefully and anticipatory on the crane, the crane components or lattice sections!
- ▶ All work at a height, when there is a danger of falling, must be carried out with suitable aids!
- ▶ If fall protection equipment is available, then it must be used!
- ▶ If aids are not available and work cannot be carried out from the ground, then assembly personnel must secure themselves with the permissible fall arrest system to prevent falling, see the Crane operating instructions, chapter 2.04!
- ▶ The fall arrest system must be attached in the fastening and hook points as well as to the safety ropes!
- ▶ Only step on the aids, ladders and catwalks with clean shoes!
- ▶ Keep aids, ladders and catwalks free of heavy dirt, snow and ice!



WARNING

Danger of impact / crushing!

When assembling / disassembling crane components with the auxiliary crane, crane components can start to swing back and forth!

When lifting / lowering and positioning crane components, there is an increased danger of impact / crushing!

Personnel can be caught and thereby injured or killed!

- ▶ Make sure that personnel cannot be caught by components!
- ▶ When working in danger zones: Use aids to protect limbs!
- ▶ Guide components with suitable aids to minimize oscillation!

Make sure that the following prerequisites are met:

- The crawler carriers are disassembled.
- The ground must be level and have adequate load bearing capacity.
- An auxiliary crane is available.
- A work platform is available.

4.1 Swinging the railings into the transport position



WARNING

The grating flap is open!

If the grating flap is open on the catwalks, there is a danger that personnel fall down!

Personnel can be severely injured or killed!

- ▶ Make sure that all grating flaps are closed!



Note

- ▶ Observe and adhere to the disassembly and safety instructions for the railings, see the Crane operating instructions, chapter 2.06!
- ▶ Swing the railing **5** from the operating position into the transport position, see the Crane operating instructions, chapter 2.06.

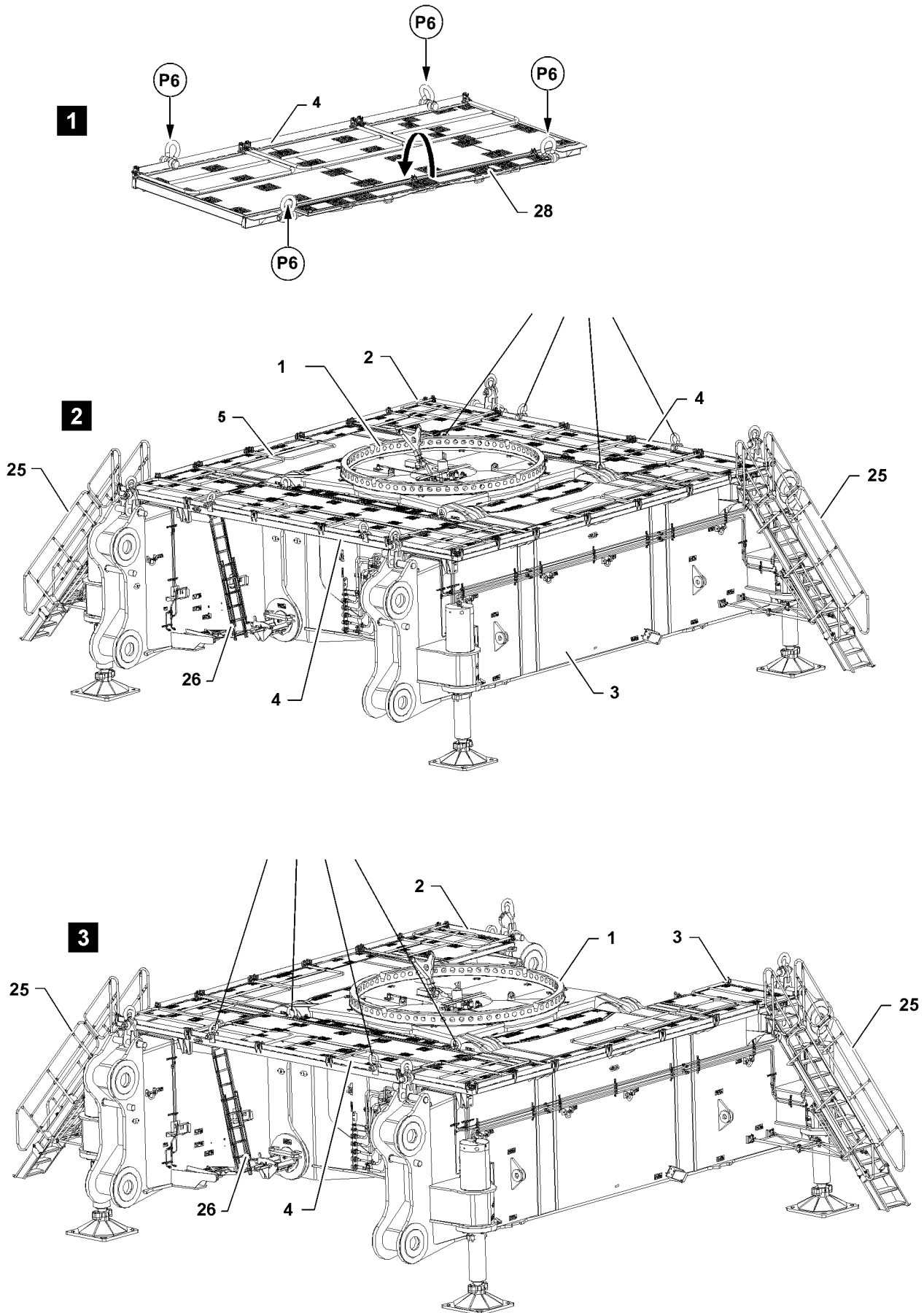

Fig.113120

LWE/LR 13000-001/19503-01-02/en

4.2 Disassembling the catwalks

Make sure that the following prerequisite is met:

- The railings **5** are taken down in the transport position and are secured.



WARNING

Danger of falling!

During assembly and disassembly of crane components, personnel must be secured with appropriate aids to prevent them from falling!

Assembly personnel can fall and be severely injured or killed!

- ▶ Use personal protective equipment!

- ▶ Fasten the fastening equipment to the lashing lugs in points **P6** of the catwalk **4**, see illustration **1**.
- ▶ Swing the folding frame **28** in, see illustration **1**.
- ▶ Lift the catwalk **4** with the auxiliary crane and take it down on the flatbed trailer, see illustration **2**.



Note

- ▶ The disassembly of the second catwalk **4** is the same as the work steps for the first catwalk!
- ▶ Disassemble the catwalk **4**, see illustration **3**.

4.3 Positioning the access ladder and the extension ladder in the transport position



Note

- ▶ Observe and adhere to the disassembly and safety instructions for the access ladder and the extension ladder, see the Crane operating instructions, chapter 2.06!

See illustration **3**:

- ▶ Position the access ladder **25** on both cross carriers in front of the operating position in the transport position, see the Crane operating instructions, chapter 2.06.
- ▶ Fold the extension ladder **26** in on the two cross carriers and set the sliding section upward, see the Crane operating instructions, chapter 2.06.

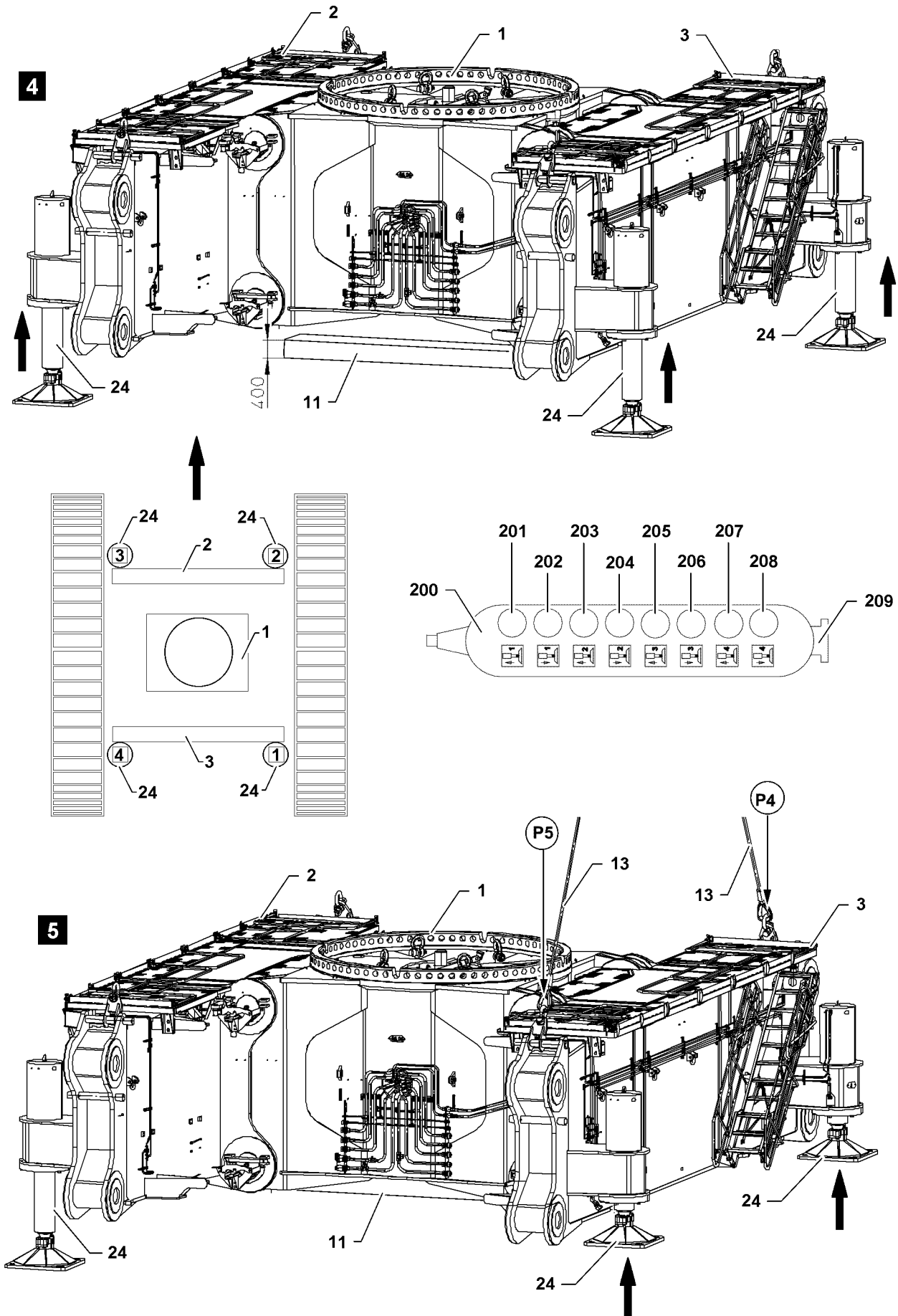

Fig.113121

LWE/LR 13000-001/19503-01-02/en

4.4 Retracting the assembly supports and supporting the crawler center section

Make sure that the following prerequisites are met:

- The catwalks are disassembled.
- The access ladder and the extension ladder are positioned in the transport position.
- Suitable material must be available for the substructure of the crawler center section.



Note

- ▶ Support the crawler center section at least 400 mm high with hardwood beams **11**, see illustration 4!
 - ▶ Place the wood substructure as far out as possible to obtain the best possible stability!
-
- ▶ Support the crawler center section **1** with hardwood beams **11**.



WARNING

Tipping of the center section and cross carrier!

Without the support with the assembly supports or without the substructure, the crawler center section **1** with installed cross carrier **2** can tip over at disassembly of the cross carrier **3**!

Personnel can be severely injured or killed!

- ▶ Support the cross carrier with the assembly supports or support it properly from below!

- ▶ Retract all assembly supports **24** until the crawler center section **1** is lying on the hardwood beams **11**: Actuate the control panel **200**, see illustration 4.

Result:

- The crawler center section **1** is lying on the hardwood beams **11** and is supported by the assembly supports **24**.

4.5 Disassembling the first cross carrier

Make sure that the following prerequisite is met:

- The crawler center section **1** is lying on the hardwood beams **11**.

4.5.1 Retracting the assembly supports

- ▶ Move the work platform to the first hook point of the cross carrier **3**.



WARNING

Danger of falling!

During assembly and disassembly of crane components, personnel must be secured with appropriate aids to prevent them from falling!

Assembly personnel can fall and be severely injured or killed!

- ▶ Use personal protective equipment!

- ▶ Fasten the fastening equipment **13** to the hook bracket in point **P5** of the cross carrier **3**, see illustration 5.
- ▶ Move the work platform to the second hook point of the cross carrier **3**.
- ▶ Fasten the fastening equipment **13** to the hook bracket in point **P4** of the cross carrier **3**, see illustration 5.
- ▶ Completely retract the assembly supports **24** of the cross carrier **3**.

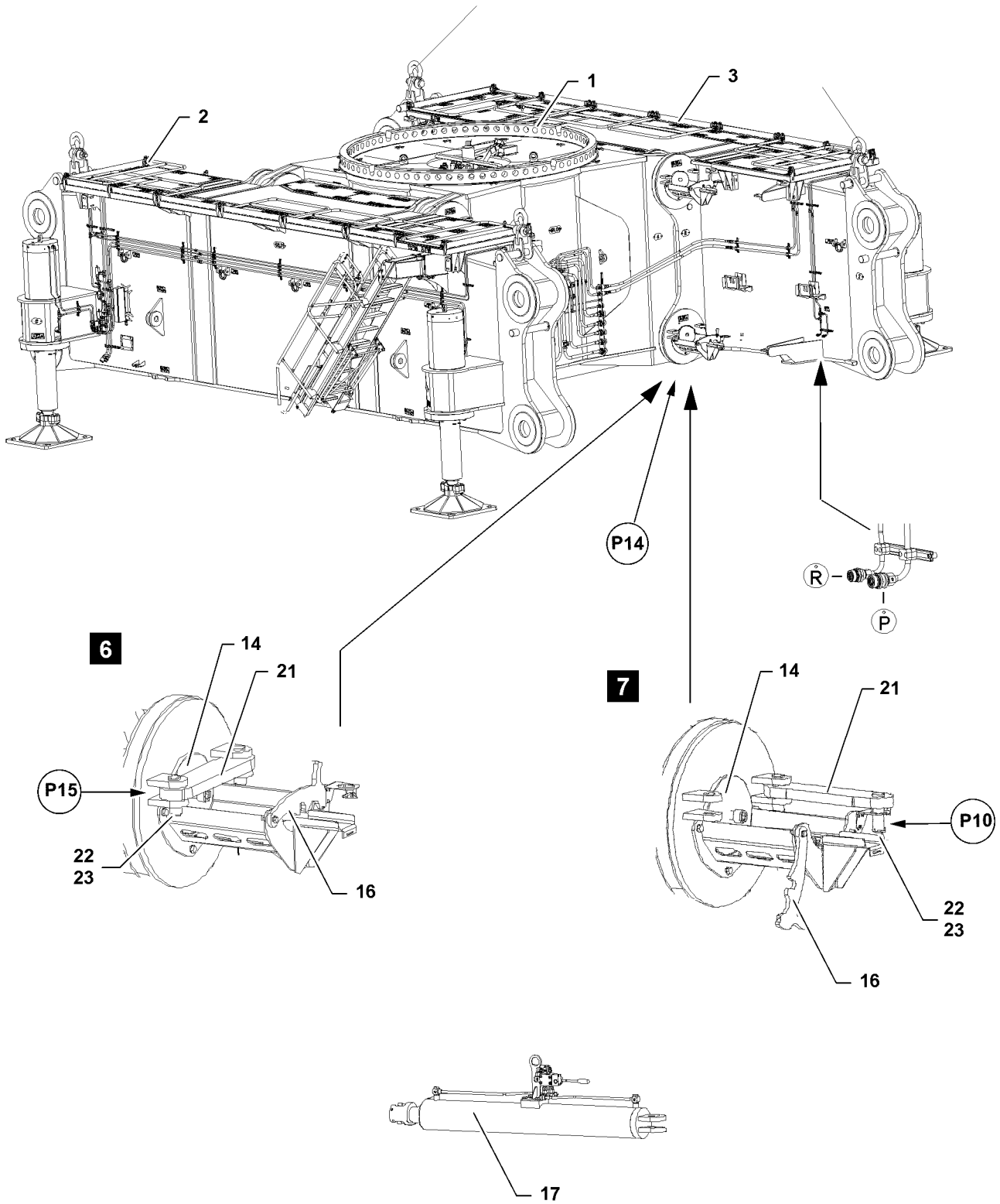

Fig.113122

4.5.2 Establishing the hydraulic connections to the pin pulling cylinder

- ▶ Move the pin pulling cylinder **17** with the auxiliary crane to the first pin location **P14** of the cross carrier **3**.



Note

- ▶ Hydraulic connection of the pin pulling device, see the Crane operating instructions, chapter 5.30!



WARNING

Pressure in the hydraulic lines!

If the pressure supply is not interrupted before connecting / releasing the hydraulic lines, the hydraulic oil can escape with high pressure.

Death, severe bodily injuries, property damage.

- ▶ Release the pressure in the hydraulic system before connecting / disconnecting: Interrupt the pressure supply and wait a short time.
- ▶ Connect the coupling components (sleeve and connector) and screw together with the knurled nut.
- ▶ Tighten the hydraulic coupling by hand. Turn the knurled nut until it reaches a tangible, fixed stop position.
- ▶ Establish the hydraulic connection: Connect the supply lines of the pin pulling cylinder **17** to the supply lines of the cross carrier, hydraulic connection **R** and hydraulic connection **P**.

4.5.3 Unpinning the cross carrier on the crawler center section



WARNING

Danger of falling!

During assembly and disassembly of crane components, personnel must be secured with appropriate aids to prevent them from falling!

Assembly personnel can fall and be severely injured or killed!

- ▶ Use personal protective equipment!
- ▶ Fold the retainer **16** out.
- ▶ Release the pin **14**: Remove the locking pin **23** in point **P15**, unpin the pin **22** and swing the securing bracket **21** from the pins **14**, see illustration **6**.
- ▶ Secure the securing bracket **21** in the transport position: Insert the pin **22** in point **P10** and secure with the locking pin **23**, see illustration **7**.

Result:

- The pin **14** is released.

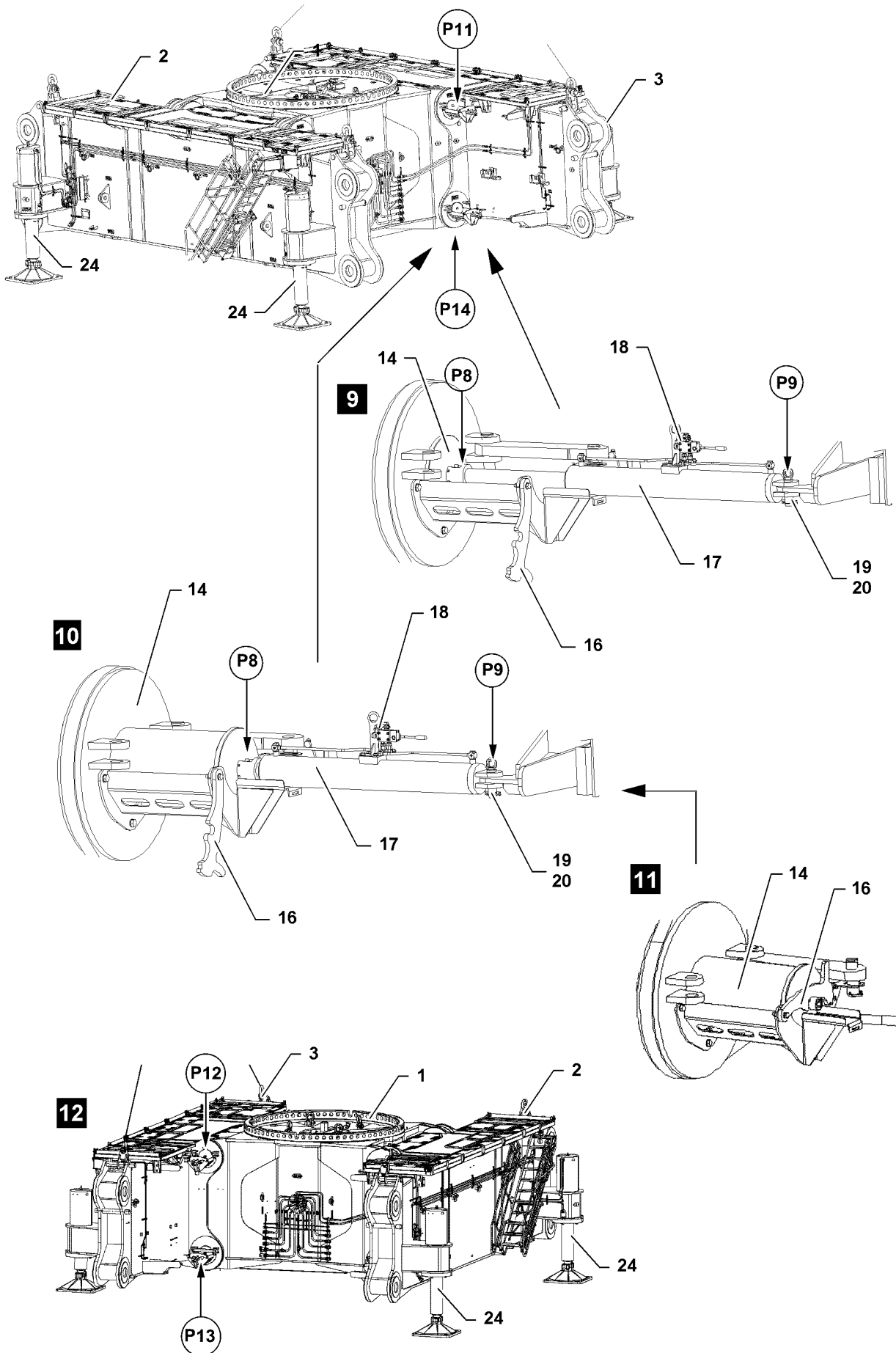

Fig.113123

LWE/LR 13000-001/19503-01-02/en

- ▶ Connect the pin pulling cylinder **17** on the „front“ in point **P8** to the inserted pin **14**, see illustration **9**.
- ▶ Extend the pin pulling cylinder: Actuate the control lever **18** of the pin pulling cylinder, see illustration **9**.
- ▶ Pin the pin pulling cylinder **17** on the „rear“ in point **P9**: Insert the pin **19** and secure with the locking pin **20**, see illustration **9**.
- ▶ Retract the pin pulling cylinder **17**: Actuate the control lever **18** of the pin pulling cylinder, see illustration **11**.

Result:

- The pin **14** is unpinned.

When the pin **14** is unpinned to the stop:

- ▶ Release the pin pulling cylinder **17** on the „front“ and on the „rear“.
- ▶ Push the pin pulling cylinder **17** on the „front“ in point **P8** upward, see illustration **10**.
- ▶ Release the „rear“ connection on the pin pulling **17** cylinder in point **P9**: Remove the locking pin **20** and unpin the pin **19**, see illustration **10**.

Result:

- The pin pulling cylinder **17** hangs freely on the auxiliary crane.
- ▶ Disconnect the hydraulic connections from the pin pulling cylinder **17**, see the Crane operating instructions, chapter 5.30.
- ▶ Swing the pin pulling cylinder **17** from the pin location **P14**.
- ▶ Insert the pin **19** again in point **P9** and secure with the locking pin **20**.
- ▶ Fold the retainer **16** in, see illustration **11**.

Result:

- The pin **14** is secured in the unpinned condition.
- ▶ Swing the pin pulling cylinder **17** with the auxiliary crane to the pin location **P13**, see illustration **12**.

**Note**

- ▶ The procedure in the pin location **P13**, pin location **P12** and pin location **P11** is the same as the work steps for the pin location **P14**!
- ▶ Unpin the pin **14** in the pin location **P13**, pin location **P12** and pin location **P11**.
- ▶ Disconnect the hydraulic connections from the pin pulling cylinder **17**, see the Crane operating instructions, chapter 5.30.
- ▶ Release the pin pulling cylinder **17** and swing it with the auxiliary crane to the second cross carrier.

Result:

- The cross carrier **3** is unpinned.

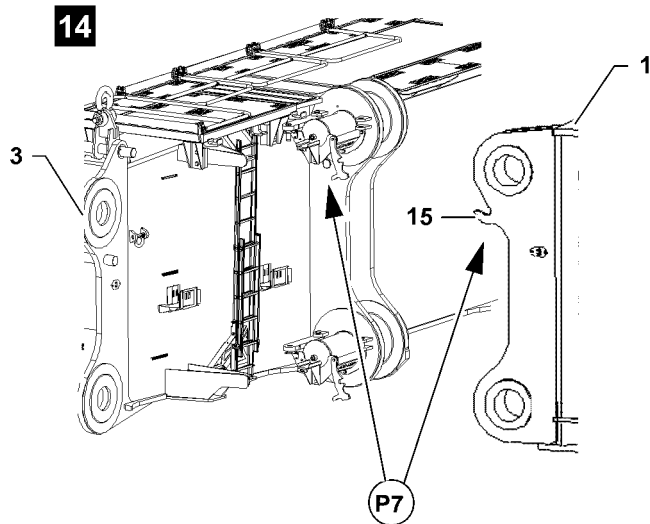
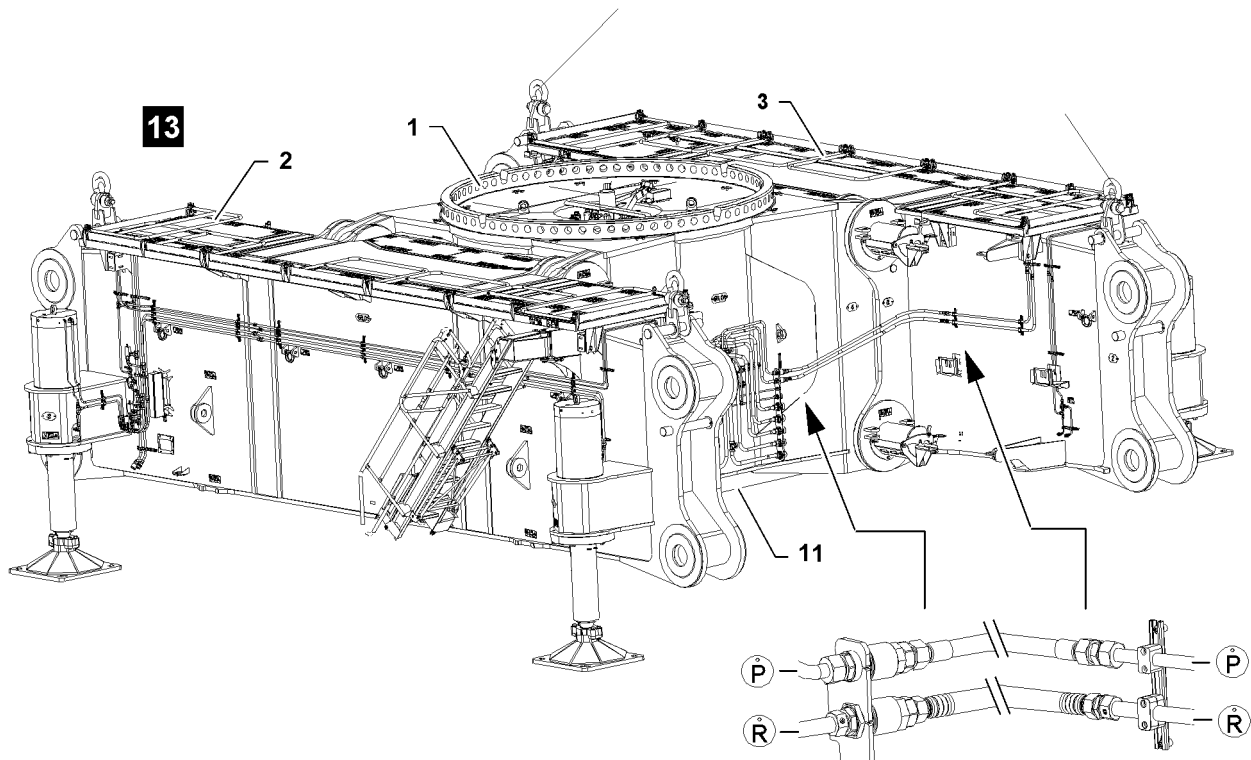

Fig.113143

LWE/LR 13000-001/19503-01-02/en

4.5.4 Disconnecting the hydraulic connections from the cross carrier and crawler center section

The hydraulic connections are established with quick couplings.

When disconnecting hydraulic lines with quick couplings, make sure that the uncoupling procedure is carried out correctly.



WARNING

Pressure in the hydraulic lines!

If the pressure supply is not interrupted before connecting / releasing the hydraulic lines, the hydraulic oil can escape with high pressure.

Death, severe bodily injuries, property damage.

▶ Release the pressure in the hydraulic system before connecting / disconnecting: Interrupt the pressure supply and wait a short time.

▶ Release the hydraulic coupling by hand.

Disconnect the hydraulic connection from the cross carrier **3** to the crawler center section **1**:

▶ Disconnect the supply lines of the crawler center section **1** from the supply lines of the cross carrier **3**, hydraulic connection **R** and hydraulic connection **P**, see illustration **13**.



WARNING

Tipping of the center section and cross carrier!

Without the support with the assembly supports or without the substructure, the crawler center section **1** with installed cross carrier **2** can tip over at disassembly of the cross carrier **3**!

Personnel can be severely injured or killed!

▶ Make sure that the cross carrier **2** is supported with the assembly supports or properly supported from below!

▶ Unhook the cross carrier **3** with the auxiliary crane from the pre-centering **15** in point **P7** and take it down on the flatbed trailer, see illustration **14**.

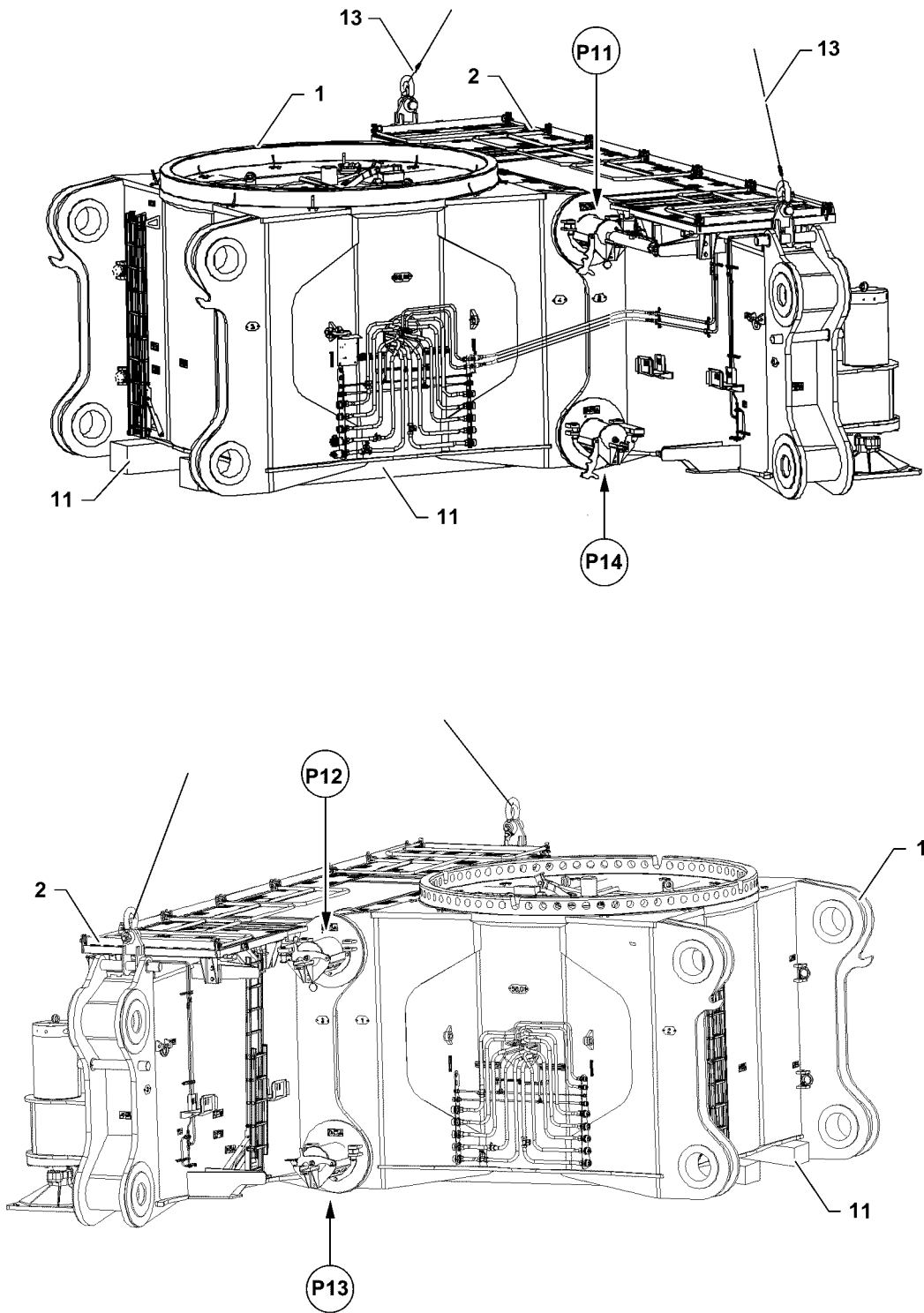

Fig.113144

LWE/LR 13000-001/19503-01-02/en

4.6 Disassembling the second cross carrier

Make sure that the following prerequisites are met:

- The first cross carrier has been removed on the crawler center section.
- The second cross carrier is supported.

4.6.1 Unpinning the cross carrier on the crawler center section



WARNING

Danger of falling!

During assembly and disassembly of crane components, personnel must be secured with appropriate aids to prevent them from falling!

Assembly personnel can fall and be severely injured or killed!

- ▶ Use personal protective equipment!

- ▶ Fasten the cross carrier **3** to the auxiliary crane.



Note

- ▶ The disassembly of the second cross carrier **2** is the same as the work steps for the first cross carrier **3**!
- ▶ Procedure for disassembly of the second cross carrier **2**, see section „Disassembling the first cross carrier“!

- ▶ Unpin the second cross carrier **2**.

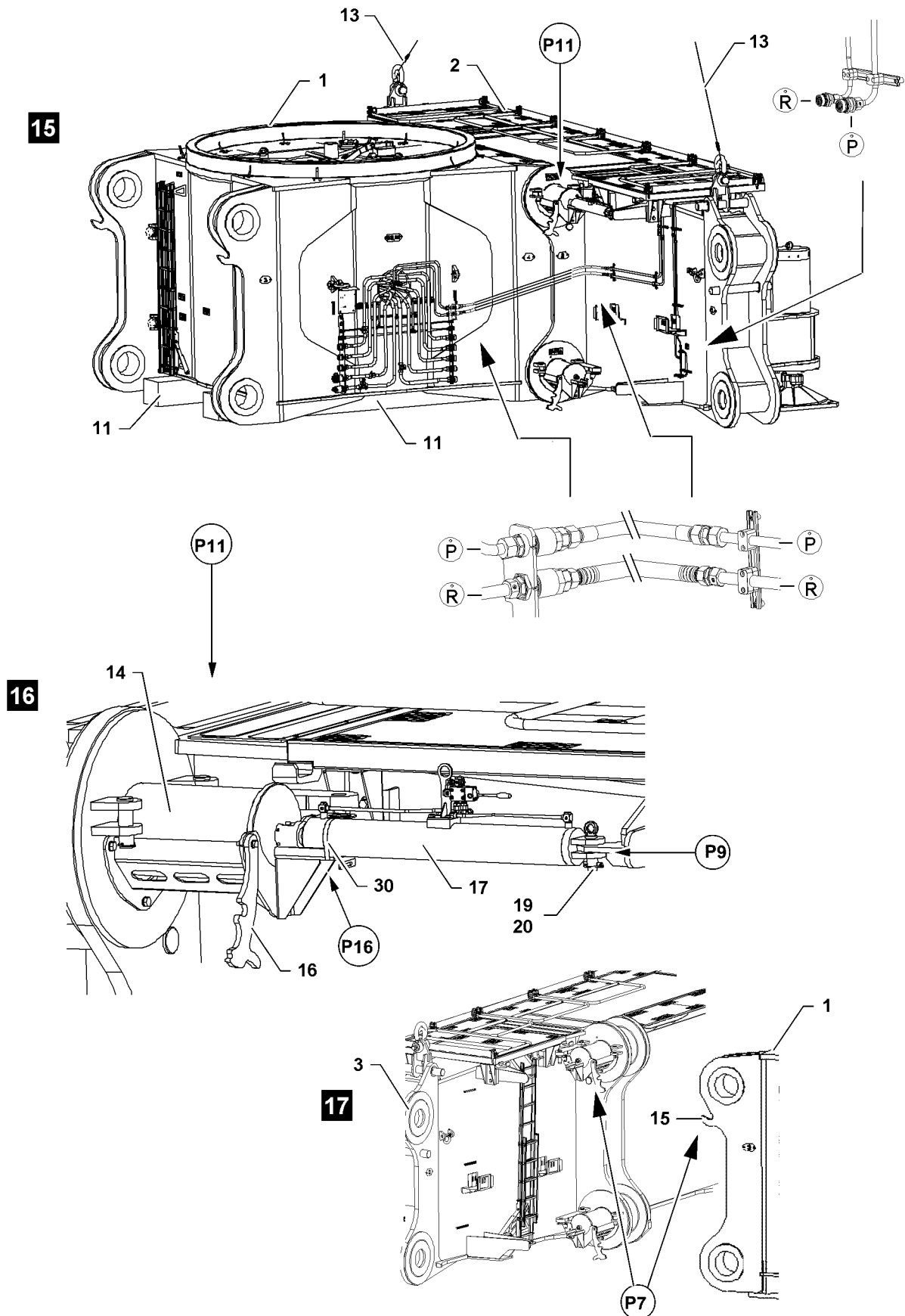

Fig.113124

LWE/LR 13000-001/19503-01-02/en

4.6.2 Disconnecting the hydraulic connections from the pin pulling cylinder

When all pins **14** of the cross carrier **2** are unpinned:

- ▶ Attach the pin pulling cylinder **17** in the pin point **P11** and the cross carrier **2**.



Note

- ▶ Hydraulic connection: see the Crane operating instructions, chapter 5.30.



WARNING

Pressure in the hydraulic lines!

If the pressure supply is not interrupted before connecting / releasing the hydraulic lines, the hydraulic oil can escape with high pressure.

Death, severe bodily injuries, property damage.

- ▶ Release the pressure in the hydraulic system before connecting / disconnecting: Interrupt the pressure supply and wait a short time.
- ▶ Disconnect the hydraulic connection: Disconnect the supply lines of the pin pulling cylinder **17** from the supply lines of the cross carrier, hydraulic connection **R** and hydraulic connection **P**.
- ▶ Take the pin pulling cylinder **17** down on the „front“ on the support in point **P16**, see illustration **16**.
- ▶ Secure the pin with tension belt **30**, see illustration **16**.
- ▶ Pin the pin pulling cylinder **17** on the „rear“ in point **P9**: Insert the pin **19** and secure with the locking pin **20**, see illustration **16**.

4.6.3 Disconnecting the hydraulic connections from the cross carrier and crawler center section

The hydraulic connections are established with quick couplings.

When disconnecting hydraulic lines with quick couplings, make sure that the uncoupling procedure is carried out correctly.



WARNING

Pressure in the hydraulic lines!

If the pressure supply is not interrupted before connecting / releasing the hydraulic lines, the hydraulic oil can escape with high pressure.

Death, severe bodily injuries, property damage.

- ▶ Release the pressure in the hydraulic system before connecting / disconnecting: Interrupt the pressure supply and wait a short time.
- ▶ Release the hydraulic coupling by hand.

Disconnect the hydraulic connection from the cross carrier **2** to the crawler center section **1**:

- ▶ Disconnect the supply lines of the crawler center section **1** from the supply lines of the cross carrier **2**, hydraulic connection **R** and hydraulic connection **P**, see illustration **15**.
- ▶ Unhook the cross carrier **2** with the auxiliary crane from the pre-centering **15** in point **P7** and take it down on the flatbed trailer, see illustration **17**.

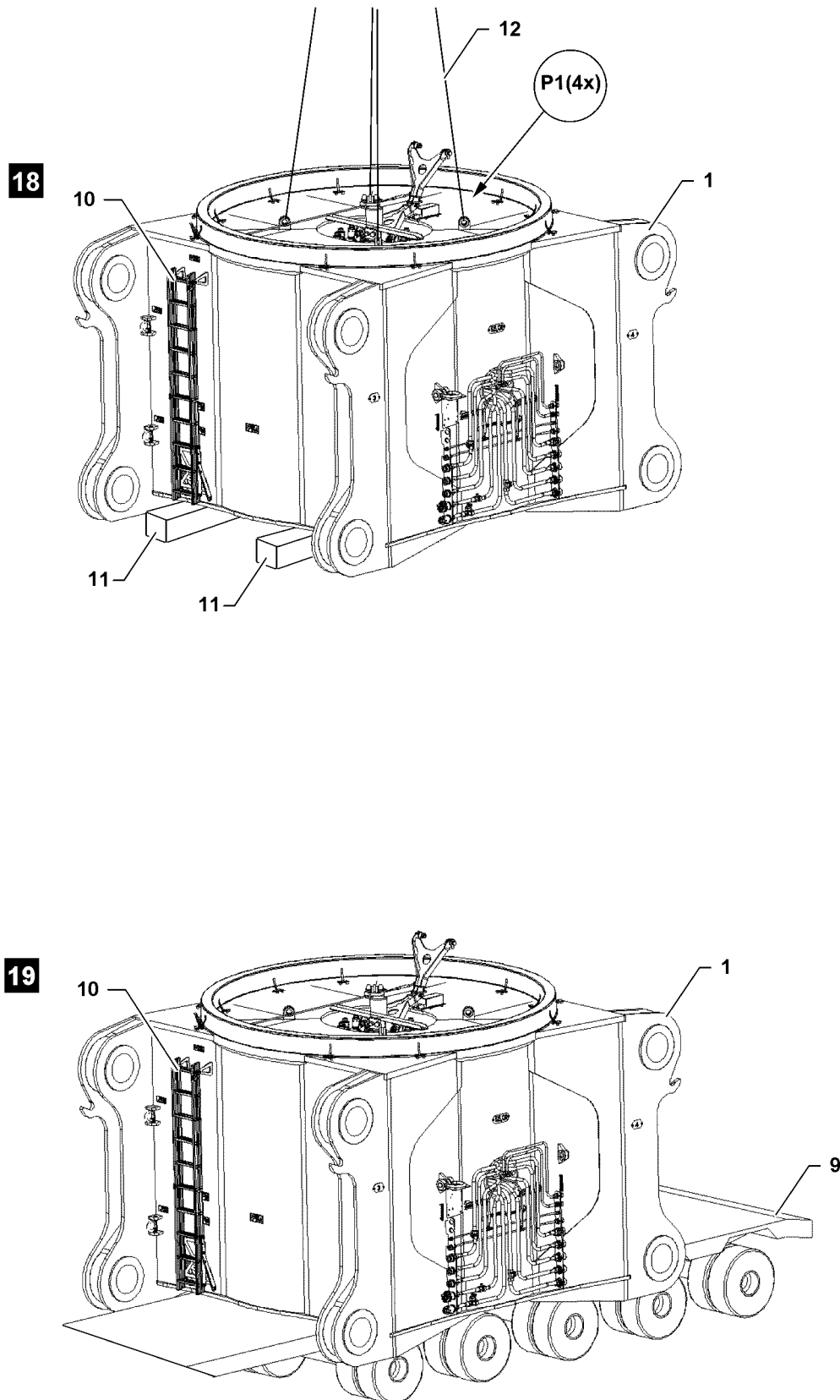

Fig.113125

4.7 Loading the crawler center section on the transport vehicle



Note

- ▶ For assembly and disassembly work on the crawler center section use the extension ladder **10**, see illustration **18**!
 - ▶ Observe and adhere to the assembly and safety instructions for the extension ladder, see the Crane operating instructions, chapter 2.06!
-
- ▶ Fold the extension ladder **10** out and set the sliding section upward, see the Crane operating instructions, chapter 2.06.



WARNING

Danger of falling!

During assembly and disassembly of crane components, personnel must be secured with appropriate aids to prevent them from falling!

Assembly personnel can fall and be severely injured or killed!

- ▶ Use personal protective equipment!
-
- ▶ Fasten the fastening equipment **12** to the lashing lugs in points **P1** of the crawler center section, see illustration **18**.
 - ▶ Tension the fastening equipment **12** with the auxiliary crane.
 - ▶ Lift the crawler center section **1** with the auxiliary crane and set it onto the transport vehicle **9**.
 - ▶ Release the fastening equipment **12** on the lashing lugs in points **P1** of the crawler center section, see illustration **19**.
 - ▶ Set the extension ladder **10** vertical and secure it, see the Crane operating instructions, chapter 2.06.

Empty page!

LWE/LR 13000-001/19503-01-02/en

3.01.30 Assembling the crawler carrier on the preassembled crawler center section

1	Assembling the crawler carrier on the cross carrier	3
2	Assembling the roller ring connection	23
3	Disassembling the roller ring connection	33
4	Disassembling the crawler carrier on the cross carrier	39

1

Fig.113022: Crawler center section with installed cross carriers, supported

1 Assembling the crawler carrier on the cross carrier

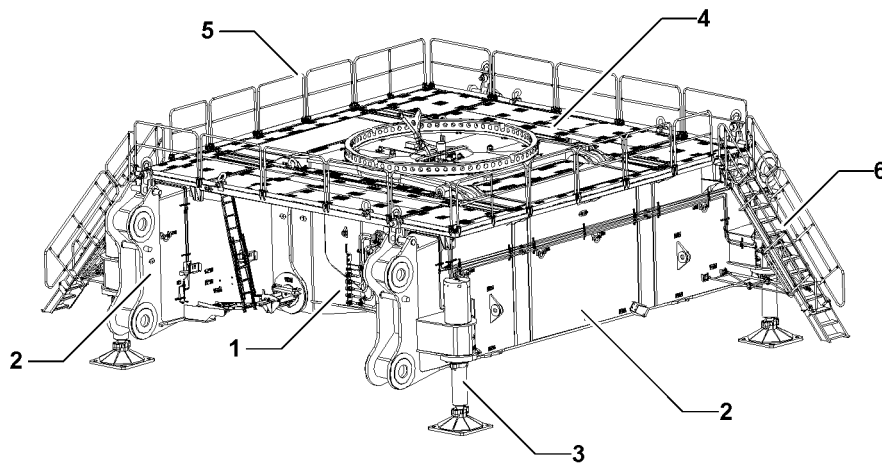

WARNING

Danger of falling!

During assembly / disassembly, inspection and maintenance work, assembly personnel must be secured with appropriate aids to prevent them from falling! If this is not observed, assembly personnel could fall and be killed or seriously injured!

- ▶ The assembly personnel must always move carefully and anticipatory on the crane, the crane components or lattice sections!
- ▶ All work at a height, when there is a danger of falling, must be carried out with suitable aids!
- ▶ If fall protection equipment is available, then it must be used!
- ▶ If aids are not available and work cannot be carried out from the ground, then assembly personnel must secure themselves with the permissible fall arrest system to prevent falling, see the Crane operating instructions, chapter 2.04!
- ▶ The fall arrest system must be attached in the fastening and hook points as well as to the safety ropes!
- ▶ Only step on the aids, ladders and catwalks with clean shoes!
- ▶ Keep aids, ladders and catwalks free of heavy dirt, snow and ice!



WARNING

Danger of impact / crushing!

When assembling / disassembling crane components with the auxiliary crane, crane components can start to swing back and forth!

When lifting / lowering and positioning crane components, there is an increased danger of impact / crushing!

Personnel can be caught and thereby injured or killed!

- ▶ Make sure that personnel cannot be caught by components!
- ▶ When working in danger zones: Use aids to protect limbs!
- ▶ Guide components with suitable aids to minimize oscillation!

Make sure that the following prerequisites are met:

- Both cross carriers **2** are assembled on the crawler center section **1**.
- The assembly support **3** is extended to the point where the crawler plates do not scrape on the ground during assembly.
- Catwalks **4**, railings **5** and access ladders **6** are installed and in the operating position.
- The crane is aligned in the horizontal direction.
- An auxiliary crane is available.
- The hydraulic pin pulling device is connected to the cross carrier.

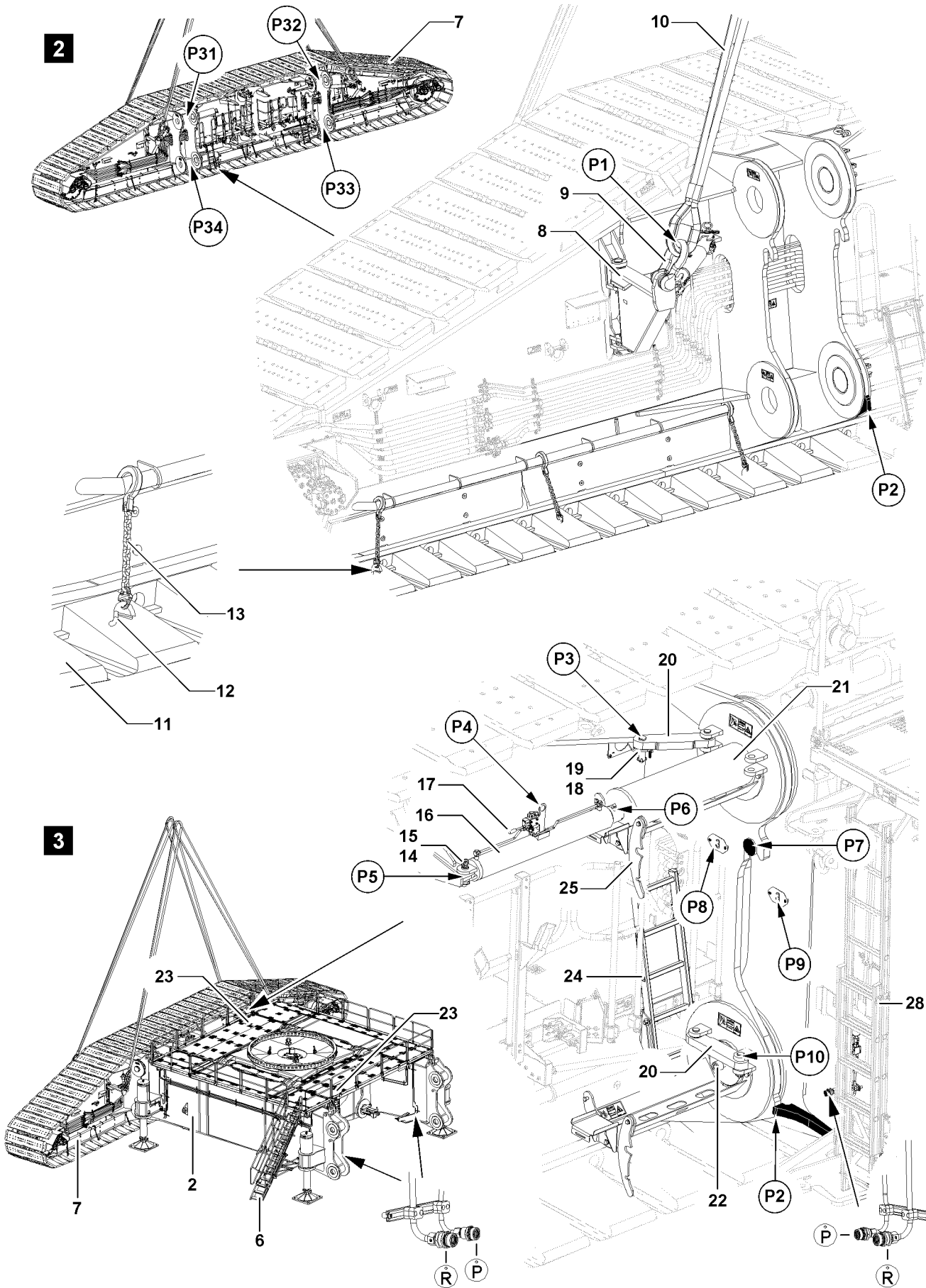

LWE/LR 13000-001/19503-01-02/en

Fig.113020: Assembling the first crawler carrier

1.1 Preparing the crawler carrier for assembly



Note

- ▶ Before assembly of the crawler carriers, on each side of the crawler carrier, the outrigger pads must be secured with **ten** chains **13**!

- ▶ Connect the chains **13** with the brackets **12** to the outrigger pads, see illustration **2**.

1.2 Assembling the first crawler carrier

Make sure that the following prerequisite is met:

- The outrigger pads are secured to prevent them from sagging.

1.2.1 Fastening the crawler carrier to the auxiliary crane



Note

- ▶ The crawler carrier **7** and the cross carriers **2** are marked with numbers, point **P8** and point **P9**, see illustration **3**!
- ▶ The numbers on the crawler carrier **7** and on the cross carrier **2** must match!

The fastening points are reached with the aid of the work platform.

- ▶ Position the work platform in the first fastening point of the crawler carrier.



WARNING

Assembly personnel not secured!

Assembly personnel can fall and be severely injured or killed!

- ▶ Secure assembly personnel with suitable aids to prevent them from falling!
- ▶ Use personal protective equipment!

- ▶ Fasten the fastening equipment to the auxiliary crane.
- ▶ Fasten the crawler carrier **7** to the auxiliary crane in point **P1**: Fasten the fastening equipment **10** to the shackle **9**, point **P1**, see illustration **2**.
- ▶ Fasten the crawler carrier **7** to the auxiliary crane in the four fastening points.

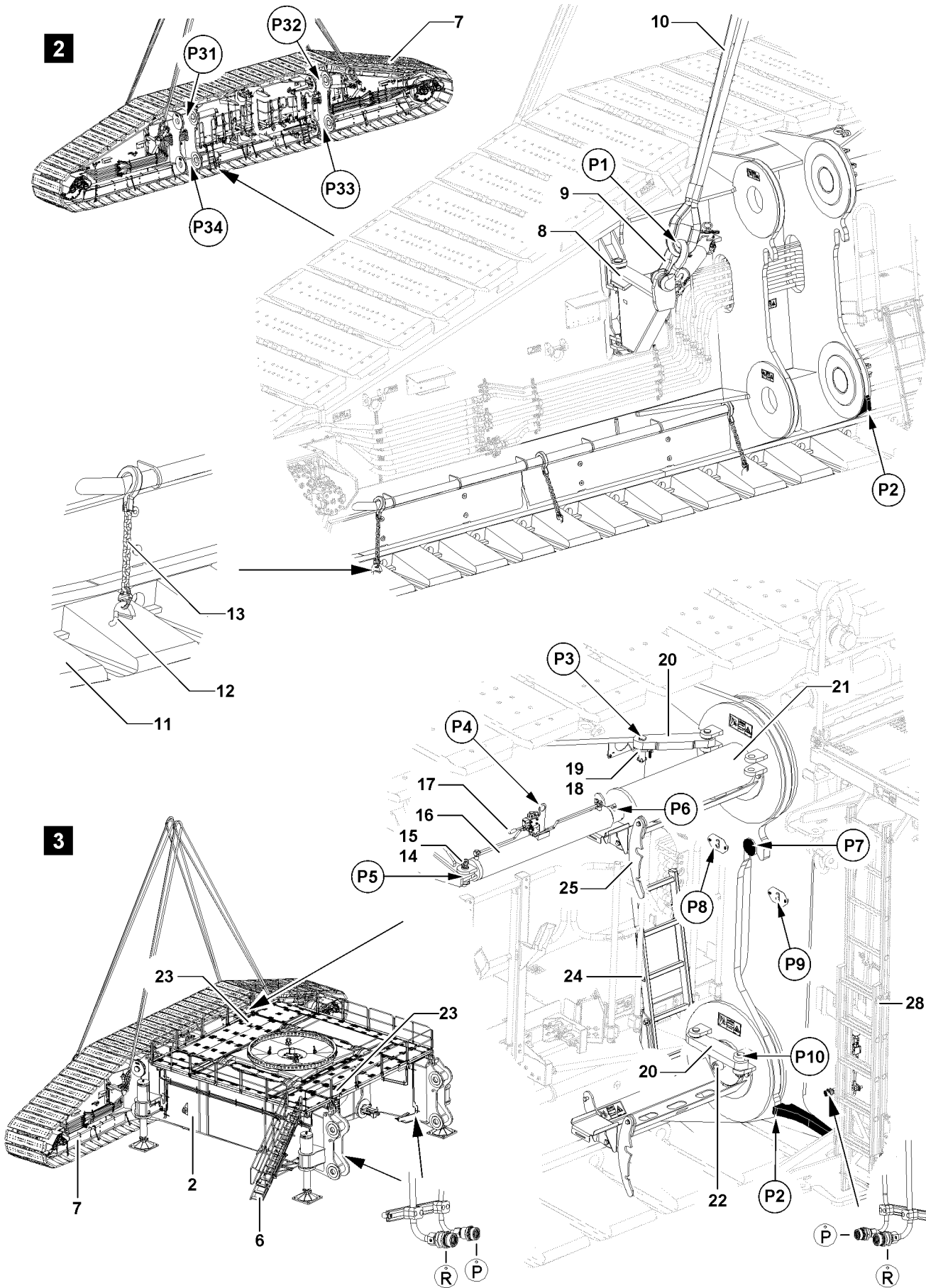

LWE/LR 13000-001/19503-01-02/en

Fig.113020: Assembling the first crawler carrier

1.2.2 Connecting the crawler carrier to the cross carrier

NOTICE

Pin inserted!

If the pins **21** are inserted when connecting the crawler carrier **7** to the cross carrier **2**, components can be severely damaged!

- ▶ Make sure that the pins **21** on the crawler carrier **7** are unpinned before connecting the cross carrier **2**, point **P31**, point **P32**, point **P33** and point **P34**, see illustration **2**!
- ▶ Make sure that the pins **21** are unpinned.
- ▶ Remove the work platform.



Note

- ▶ To make sure that the crawler carrier hangs on the auxiliary crane in the horizontal direction, adjust the adjustment spindles **8.2** on the tow bracket **8**.
- ▶ Turn the adjustment spindles **8.2** until the collar of the adjustment spindle is at the height of the tip of the arrow **8.1**.
- ▶ Make sure that the four fastening ropes are tensioned the same when lifting the crawler carrier.

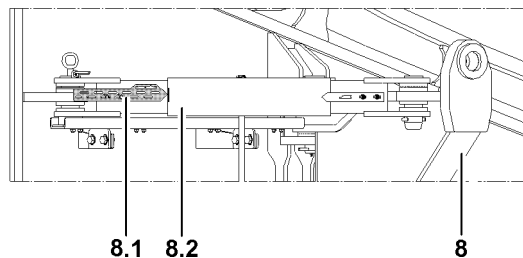

Fig. 113858: Adjustment of adjustment sleeves for lifting the **complete crawler carrier**

- ▶ Adjust the adjustment spindles on the tip of the arrow **8.1**.

When the crawler carrier is fastened properly to the auxiliary crane:

- ▶ Lift the crawler carrier from the substructure with the auxiliary crane.



WARNING

Danger of crushing!

When retracting the crawler carrier **7**, there is an increased danger of accident due to crushing! Personnel can be severely injured or killed!

- ▶ It is prohibited for anyone to remain between the crawler carrier **7** and the cross carrier **2** !
- ▶ Observe the crane movements diligently!
- ▶ It is prohibited to remain in the slewing range of the auxiliary crane!
- ▶ The crane operator and guide must maintain visual contact!
- ▶ Lift the crawler carrier and connect to the cross carrier in points **P7**, see illustration **3**.
- ▶ Lower the crawler carrier until the crawler carrier touches the cross carrier, points **P2**.

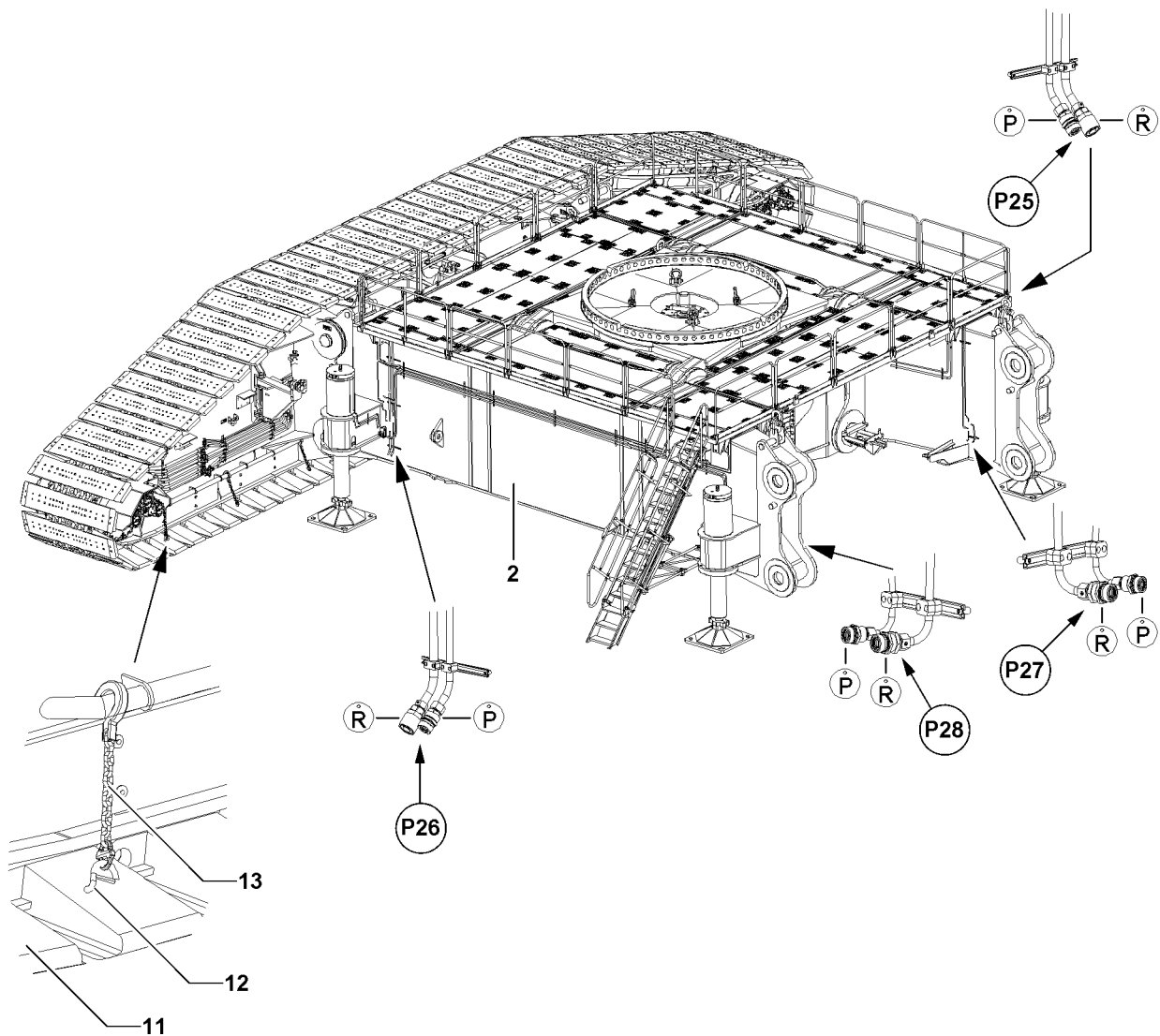

Fig.113853: Hydraulic connections on the cross carrier

1.2.3 Hydraulic connections to the pin pulling cylinder



Note

- ▶ The hydraulic supply for the assembly support is provided via the external hydraulic aggregate or the operational engine house!
- ▶ Hydraulic connection of the pin pulling device, see the Crane operating instructions, chapter 5.30!

Make sure that the following prerequisite is met:

- The external hydraulic aggregate or the operational engine house are connected to the supply lines of the cross carrier, point **P25** or point **P26**.

Establishing the hydraulic connections to the pin pulling cylinder

On the inside of the cross carriers **2**, there are two hydraulic connections for the pin pulling cylinder, a total of four connection possibilities, point **P27** and point **P28**, see illustration.

The hydraulic connections are established with quick couplings.

When connecting hydraulic lines with quick couplings, make sure that the coupling procedure is carried out correctly.

The matching quick couplings are marked.



WARNING

Pressure in the hydraulic lines!

If the pressure supply is not interrupted before connecting / releasing the hydraulic lines, the hydraulic oil can escape with high pressure.

Death, severe bodily injuries, property damage.

- ▶ Release the pressure in the hydraulic system before connecting / disconnecting: Interrupt the pressure supply and wait a short time.



WARNING

Loss of pressure or leakage!

Incorrectly coupled or self-loosening quick couplings (particularly return lines) can result in serious accidents due to component failure.

Death, severe bodily injuries, property damage.

- ▶ Check that the quick couplings have been properly connected before using the crane.
- ▶ Connect the coupling components (sleeve and connector) and screw together with the knurled nut.
- ▶ Tighten the hydraulic coupling by hand. Turn the knurled nut until it reaches a tangible, fixed stop position.
- ▶ Make sure that the connection point is selected in such a way that the length of the hydraulic hoses is sufficient.
- ▶ Establish the hydraulic connection: Connect the supply lines of the pin pulling cylinder **16** to the supply lines of the cross carrier, hydraulic connection **R** and hydraulic connection **P** in point **P27** or point **P28**, see illustration.

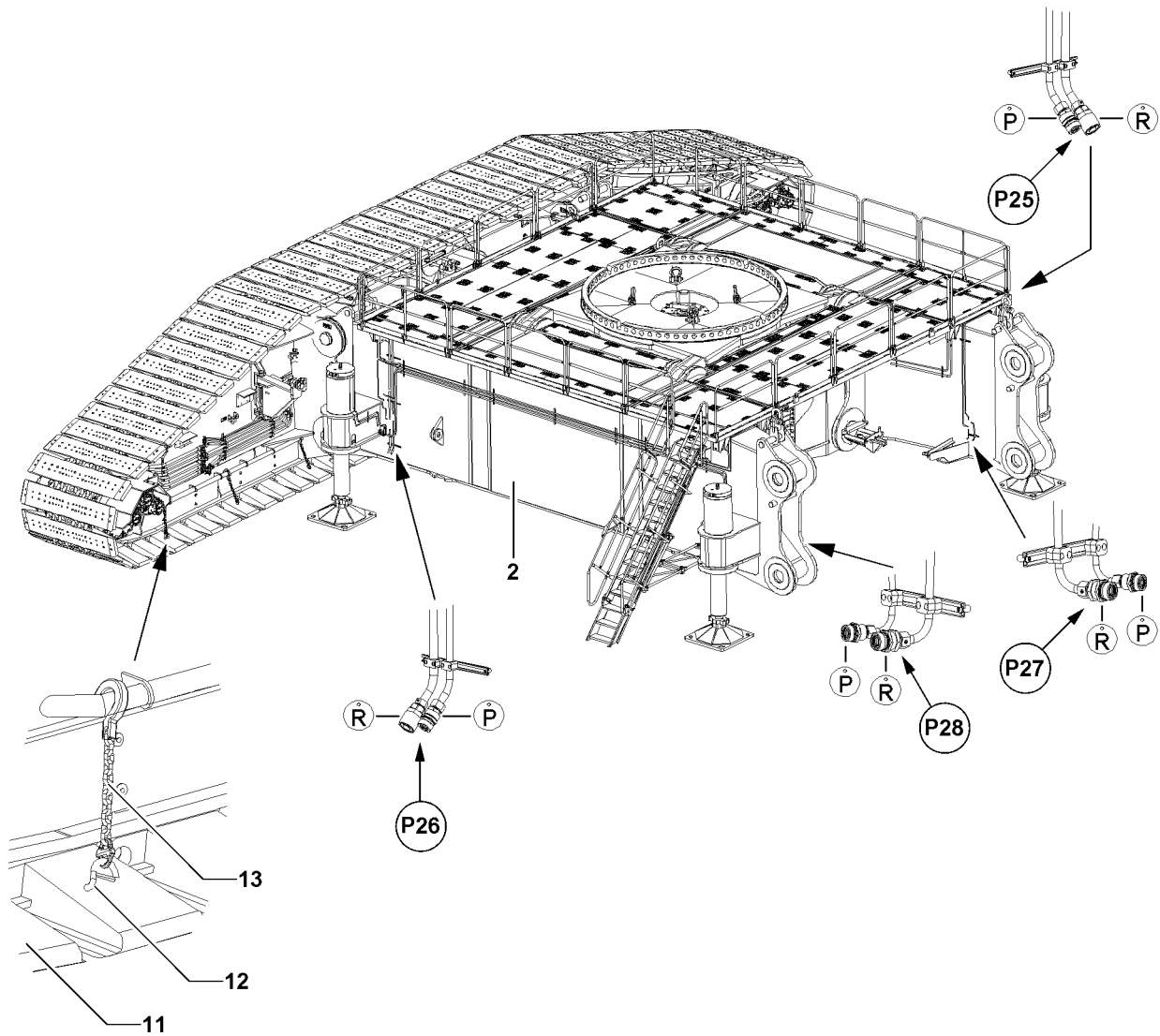

Fig.113853: Hydraulic connections on the cross carrier

LWE/LR 13000-001/19503-01-02/en

Disconnecting the hydraulic connections from the pin pulling cylinder

On the inside of the cross carriers **2**, there are two hydraulic connections for the pin pulling cylinder, a total of four connection possibilities, point **P27** and point **P28**, see illustration.

The hydraulic connections are established with quick couplings.

When disconnecting hydraulic lines with quick couplings, make sure that the uncoupling procedure is carried out correctly.



WARNING

Pressure in the hydraulic lines!

If the pressure supply is not interrupted before connecting / releasing the hydraulic lines, the hydraulic oil can escape with high pressure.

Death, severe bodily injuries, property damage.

- ▶ Release the pressure in the hydraulic system before connecting / disconnecting: Interrupt the pressure supply and wait a short time.
-
- ▶ Release the hydraulic coupling by hand.
 - ▶ Make sure that the hydraulic system pressure has been released.
 - ▶ Unscrew and separate the coupling components (sleeve and connector) with the knurled nut.
 - ▶ Disconnect the hydraulic connection: Disconnect the supply lines of the pin pulling cylinder **16** from the supply lines of the cross carrier, hydraulic connection **R** and hydraulic connection **P** in point **P27** or point **P28**, see illustration.

1.2.4 Pinning the crawler carrier to the cross carrier

Make sure that the following prerequisite is met:

- The hydraulic connection to the pin pulling cylinder is established, see section „Establishing the hydraulic connection to the pin pulling cylinder“



Note

- ▶ Observe and adhere to the assembly and safety instructions for the access ladder **6** and for the extension ladder **28**, see the Crane operating instructions, chapter 2.06!
- ▶ Climb onto the catwalk and open the grating flap **23**, climb via the extension ladder **28** to the inside of the crawler carrier, see illustration **3**.



WARNING

The grating flap is open!

If the grating flap is open on the catwalks, there is a danger that personnel can fall down!

Personnel can be severely injured or killed!

- ▶ After climbing off / on, close the grating flap **23**!

When assembly personnel is inside the crawler carrier:

- ▶ Close the grating flap **23**.

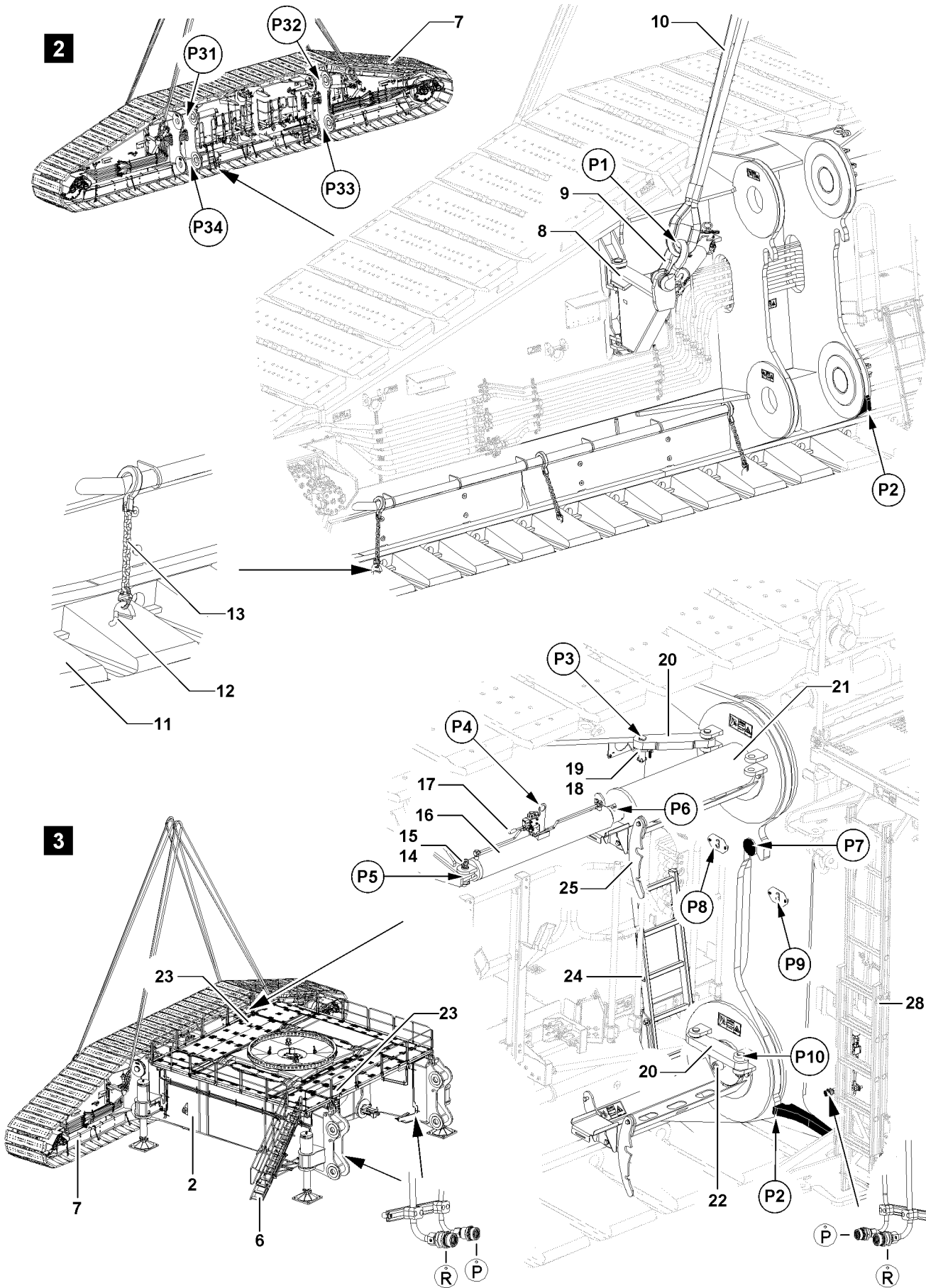

LWE/LR 13000-001/19503-01-02/en

Fig.113020: Assembling the first crawler carrier

This section describes the unpinning of the first pin, as an example.



Note

- ▶ The pin points on the crawler carrier are in point **P31**, point **P32**, point **P33** and point **P34**!
- ▶ The upper pin points on the crawler carrier are reached via the ladder **24** and the catwalk on the crawler carrier, see illustration **3**!
- ▶ Access to the upper pin points: The ladder **24** on the crawler carrier is folded down!
- ▶ Access to the lower pin points: The ladder **24** on the crawler carrier is folded up!
- ▶ For description of the positions of the ladder **24**, see the Crane operating instructions, chapter 2.06!

5

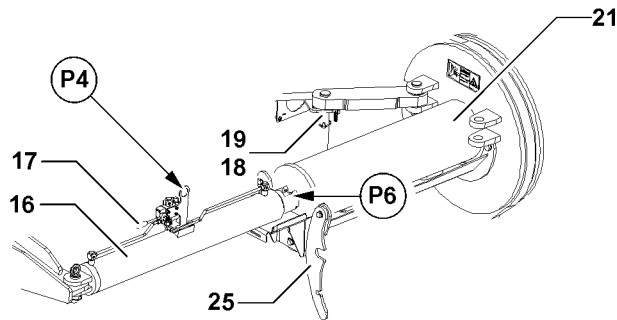

Fig. 113857: Pin pulling cylinder on the pin location

- ▶ Fasten the pin pulling cylinder **16** to the auxiliary crane in point **P4**, see illustration **3**.
- ▶ Fold the retainer **25** down.
- ▶ Pin the pin pulling cylinder **16** on the crawler carrier: Insert the pin **15** in point **P5** and secure with the locking pin **14**.
- ▶ Connect the pin pulling cylinder **16** to the screw **22** on the pin **21**.
- ▶ Extend the pin pulling cylinder **16**: Actuate the control lever **17**.

Result:

- The pin **21** is inserted.

When the pin **21** is inserted to the stop:

- ▶ Unhook the pin pulling cylinder **16** on the pinned pin **21** in point **P6**.
- ▶ Retract the pin pulling cylinder **16**: Actuate the control lever **17**.
- ▶ Unpin the pin pulling cylinder **16** in point **P5**: Remove the locking pin **14** and the pin **15**.

Result:

- The pin pulling cylinder **16** hangs freely on the auxiliary crane.
- ▶ Remove the pin pulling cylinder **16** from the assembly area and take it down.
- ▶ Insert the pin **15** in point **P5** and secure with the locking pin **14**.



WARNING

The pin is not secured!

If the pins **21** are not secured, the pins **21** can loosen up by themselves during crane operation! The crane can topple over, personnel can be severely injured or killed!

- ▶ Secure the pins **21** with securing brackets **20**!
- ▶ Unpin the securing bracket **20**: Remove the locking pin **18** in point **P3** and the pin **19**.
- ▶ Swing the securing bracket **20** in front of the pin **21**.
- ▶ Insert the pin **19** in point **P10** and secure with the locking pin **18**.
- ▶ Fold the retainer **25** up.

Result:

- The pin location is pinned and secured.

**Note**

- ▶ Every crawler carrier is pinned on the cross carrier with four pins!
- ▶ The subsequent procedure to pin the next pin is identical to the procedure for the first pin!

When the pin pulling cylinder must be transported to the other side of the crawler carrier:

- ▶ Disconnect the hydraulic connection of the pin pulling cylinder from the cross carrier.
- ▶ Transport the pin pulling cylinder with the auxiliary crane to the next pin point of the crawler carrier and insert the next pin as described in the previous procedure.

**WARNING**

The grating flap is open!

If the grating flap is open on the catwalks, there is a danger that personnel can fall down! Personnel can be severely injured or killed!

When assembly personnel has left the inside of the crawler carrier:

- ▶ Close the grating flap **23**.

When the crawler carrier is pinned and secured:

- ▶ Open the grating flap and climb onto the catwalk via the extension ladder **28**.
- ▶ Close the grating flap and leave the crawler travel gear via the access ladder **6**.

6

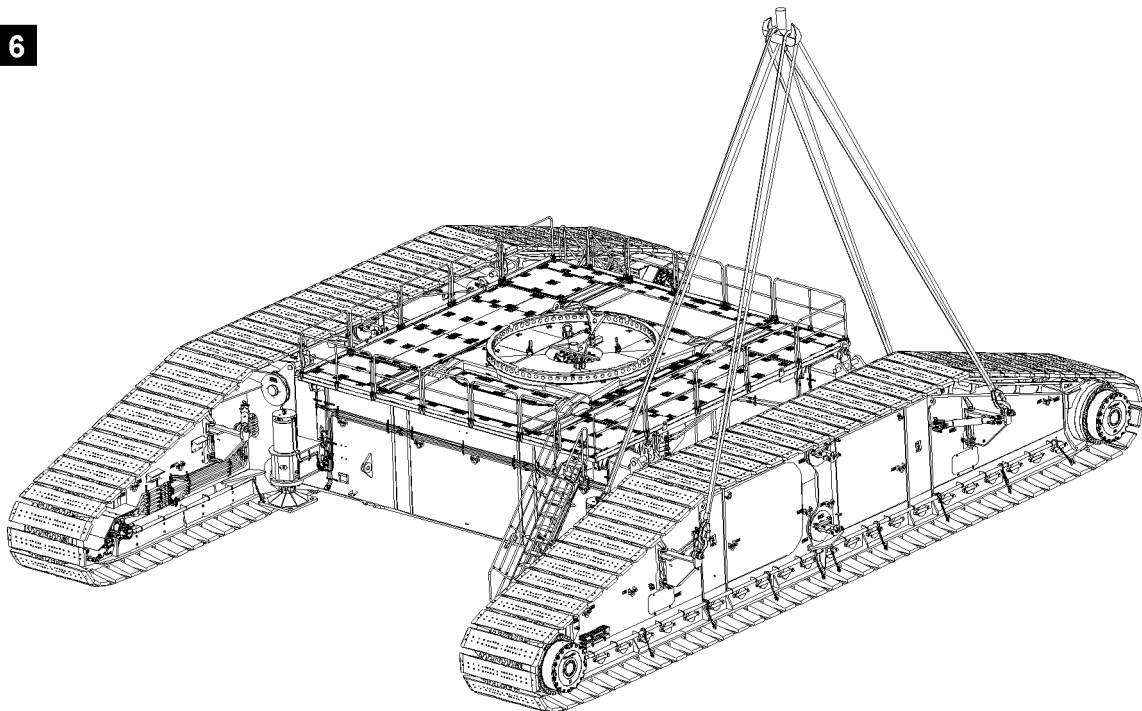

Fig.113021: Assembling the second crawler carrier

1.3 Assembling the second crawler carrier

Make sure that the following prerequisite is met:

- The outrigger pads of the crawler carrier are secured to prevent them from sagging.

**Note**

- ▶ The subsequent procedure for pinning the second crawler carrier is identical to the procedure for the first crawler carrier!

7

Fig.113023: Secure the pin pulling cylinder in the last pin location.

When the last pin is pinned and secured:

- ▶ Secure the pin pulling cylinder **16** with the strap **26**.
- ▶ Disconnect the pin pulling cylinder **16** from the auxiliary crane and the hydraulic connections.
- ▶ Remove the hydraulic hoses and store them properly.

1.4 Retracting the assembly support

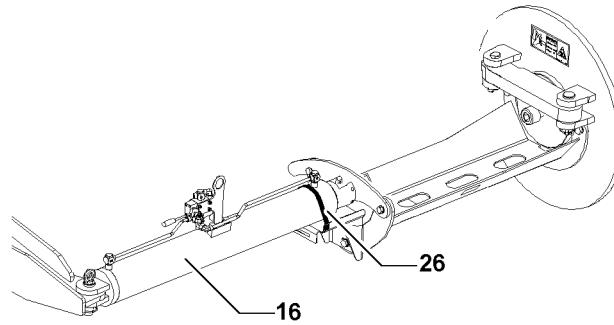

CAUTION

Collision with components!

When retracting the assembly support, access ladders, other access aids or objects can collide with the crawler travel gear! Personnel can be severely injured! Components can be severely damaged!

- ▶ Make sure that the persons, objects and components are outside of the movement range of the crawler travel gear when retracting the assembly cylinder!
- ▶ It is prohibited to remain in the danger zone of the travel gear!



Note

- ▶ The hydraulic supply for the assembly support is provided via the external hydraulic aggregate or the operational engine house!

NOTICE

Oil tank filled at the start of the hydraulic aggregate!

If the hydraulic aggregate is changed or the operational engine house is connected, the required amount of oil exceeds the tank volume of the new connected hydraulic system when retracting the assembly support! Hydraulic oil runs over and contaminates the environment!

- ▶ Extend and retract the assembly support with the same hydraulic aggregate!
- ▶ Before the hydraulic aggregate is separated from the crane or the operational engine house is connected: Retract the assembly support with the connected hydraulic aggregate!
- ▶ Retract the assembly support completely and set the crawler carrier on the ground.

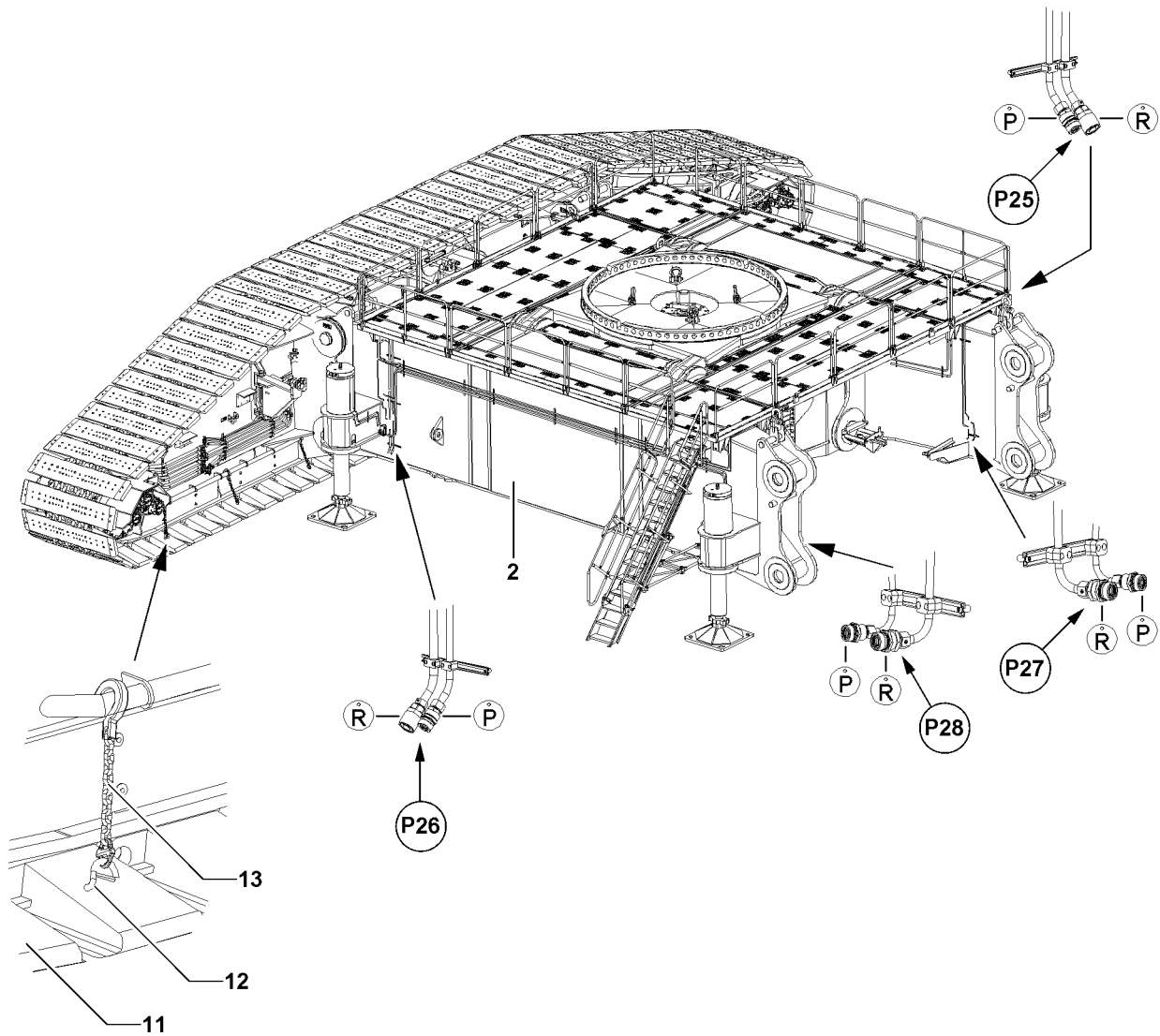

Fig.113853: Hydraulic connections on the cross carrier

1.5 Disconnecting the hydraulic connections from the cross carrier



Note

- ▶ The hydraulic supply for the assembly support is provided via the external hydraulic aggregate or the operational engine house!

NOTICE

Oil tank filled at the start of the hydraulic aggregate!

If the hydraulic aggregate is changed or the operational engine house is connected, the required amount of oil exceeds the tank volume of the new connected hydraulic system when retracting the assembly support! Hydraulic oil runs over and contaminates the environment!

- ▶ Extend and retract the assembly support with the same hydraulic aggregate!
- ▶ Before the hydraulic aggregate is separated from the crane or the operational engine house is connected: Retract the assembly support with the hydraulic aggregate!

The hydraulic connections are established with quick couplings.

When disconnecting hydraulic lines with quick couplings, make sure that the uncoupling procedure is carried out correctly.



WARNING

Pressure in the hydraulic lines!

If the pressure supply is not interrupted before connecting / releasing the hydraulic lines, the hydraulic oil can escape with high pressure.

Death, severe bodily injuries, property damage.

- ▶ Release the pressure in the hydraulic system before connecting / disconnecting: Interrupt the pressure supply and wait a short time.
- ▶ Release the hydraulic coupling by hand.
- ▶ Make sure that the hydraulic system pressure has been released.
- ▶ Unscrew and separate the coupling components (sleeve and connector) with the knurled nut.
- ▶ Disconnect the hydraulic connection: Disconnect the supply lines of the external hydraulic aggregate from the supply lines of the cross carrier, hydraulic connection **R** and hydraulic connection **P** in point **P25** or point **P26**, see illustration.

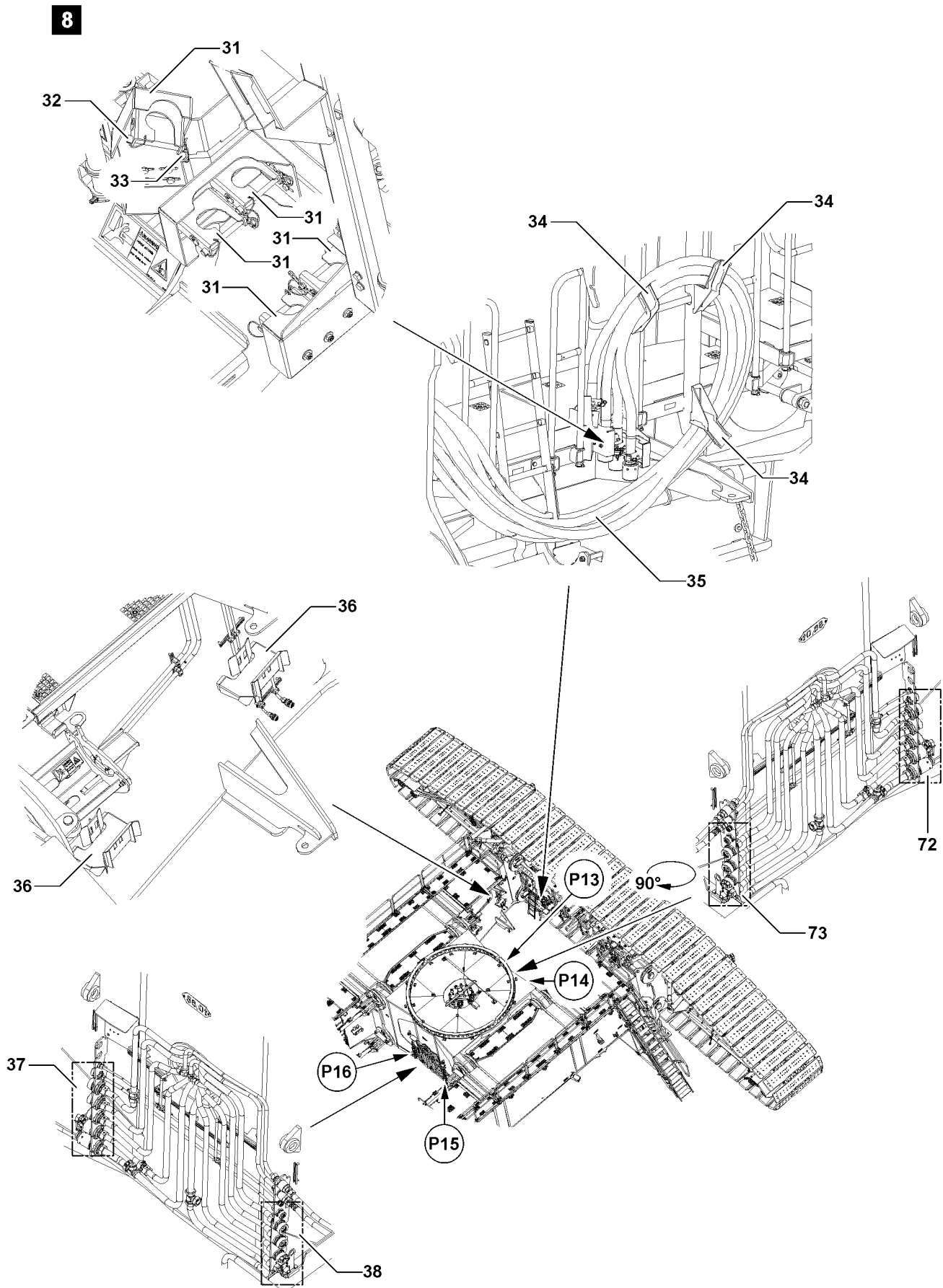

Fig.113027: Establishing the hydraulic connection to the crawler carriers

LWE/LR 13000-001/19503-01-02/en

1.6 Establishing the hydraulic connections to the crawler carriers

Make sure that the following prerequisite is met:

- Both crawler carriers are pinned and are placed on the ground.
- ▶ Release the hydraulic hoses **35** from the transport retainers **31** on the crawler carrier: Remove each cotter pin **33** and unpin the pin **32**.
- ▶ Take the hydraulic hoses **35** from the retainers **34** and place them in the retainers **36** on the cross carrier.

The hydraulic connections are established with quick couplings.

When connecting hydraulic lines with quick couplings, make sure that the coupling procedure is carried out correctly.

The matching quick couplings are marked.



WARNING

Pressure in the hydraulic lines!

If the pressure supply is not interrupted before connecting / releasing the hydraulic lines, the hydraulic oil can escape with high pressure.

Death, severe bodily injuries, property damage.

- ▶ Release the pressure in the hydraulic system before connecting / disconnecting: Interrupt the pressure supply and wait a short time.



WARNING

Loss of pressure or leakage!

Incorrectly coupled or self-loosening quick couplings (particularly return lines) can result in serious accidents due to component failure.

Death, severe bodily injuries, property damage.

- ▶ Check that the quick couplings have been properly connected before using the crane.



Note

- ▶ For every crawler carrier half, five hydraulic hoses are connected to the hydraulic couplings on the crawler center section!
 - ▶ The descriptions on the hydraulic hoses must match the descriptions on the connections!
 - ▶ The hydraulic hoses of the crawler carrier half on the front are connected to the connections **38** in point **P15** on the crawler center section!
 - ▶ The hydraulic hoses of the crawler carrier half on the rear are connected to the connections **37** in point **P16** on the crawler center section!
 - ▶ The hydraulic hoses of the crawler carrier half on the rear are connected to the connections **72** in point **P13** on the crawler center section!
 - ▶ The hydraulic hoses of the crawler carrier half on the front are connected to the connections **73** in point **P14** on the crawler center section!
-
- ▶ Establish the hydraulic connections.
 - ▶ Connect the coupling components (sleeve and connector) and screw together with the knurled nut.
 - ▶ Tighten the hydraulic coupling by hand. Turn the knurled nut until it reaches a tangible, fixed stop position.
 - ▶ Secure the hydraulic hoses **35** with tension belts in the retainers **36** on the cross carrier.
 - ▶ Repeat the procedure for every crawler carrier half and connect the hydraulic hoses in the connection locations: Point **P13**, point **P14**, point **P15** and point **P16**.

1.7 Establishing the electrical connections to the crawler carriers

- ▶ Establish the electrical connection, see the Electrical wiring diagram.

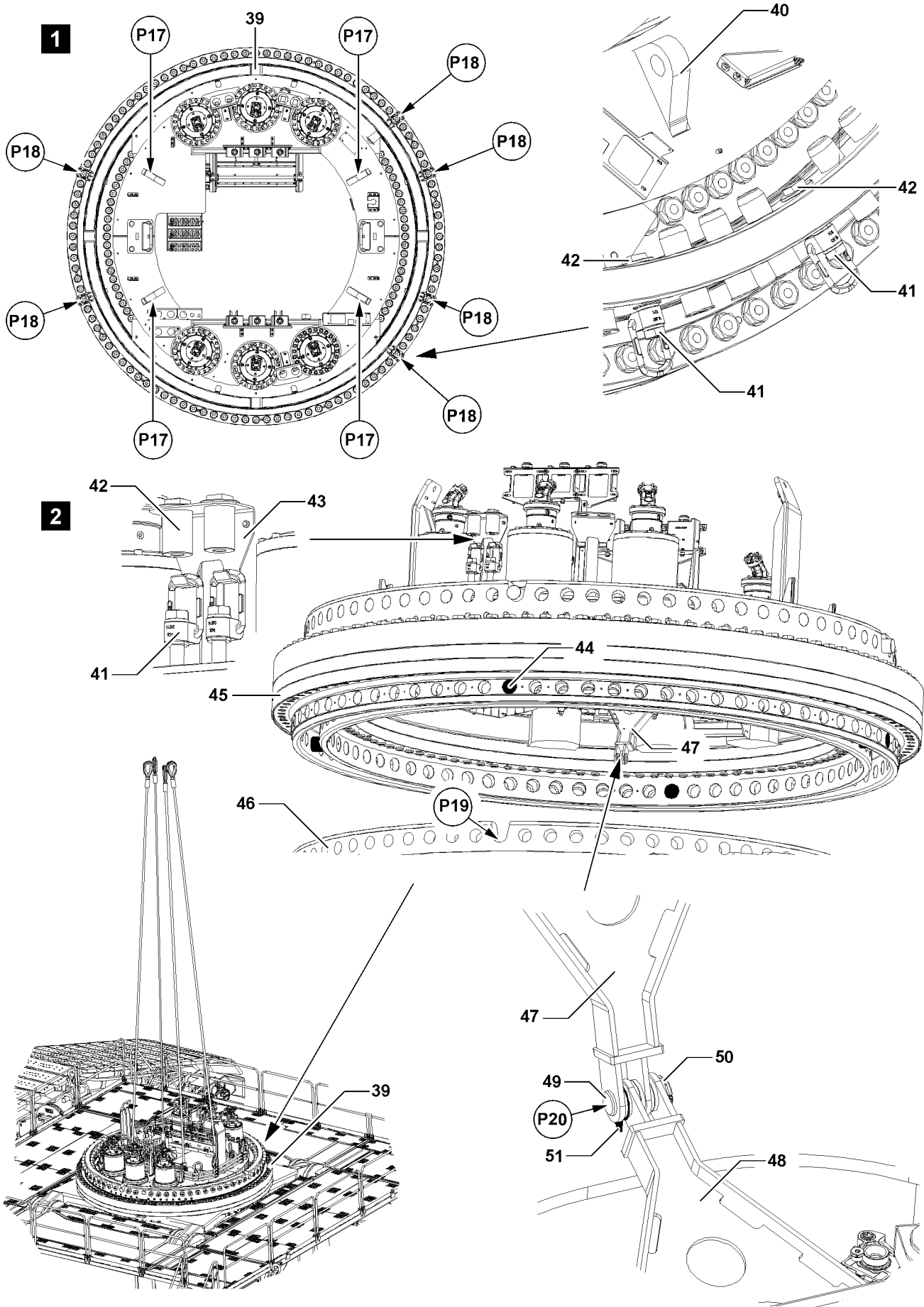

Fig.113024: Assembling the roller ring connection

2 Assembling the roller ring connection



WARNING

Danger of falling!

During assembly / disassembly, inspection and maintenance work, assembly personnel must be secured with appropriate aids to prevent them from falling! If this is not observed, assembly personnel could fall and be killed or seriously injured!

- ▶ The assembly personnel must always move carefully and anticipatory on the crane, the crane components or lattice sections!
- ▶ All work at a height, when there is a danger of falling, must be carried out with suitable aids!
- ▶ If fall protection equipment is available, then it must be used!
- ▶ If aids are not available and work cannot be carried out from the ground, then assembly personnel must secure themselves with the permissible fall arrest system to prevent falling, see the Crane operating instructions, chapter 2.04!
- ▶ The fall arrest system must be attached in the fastening and hook points as well as to the safety ropes!
- ▶ Only step on the aids, ladders and catwalks with clean shoes!
- ▶ Keep aids, ladders and catwalks free of heavy dirt, snow and ice!



WARNING

Danger of impact / crushing!

When assembling / disassembling crane components with the auxiliary crane, crane components can start to swing back and forth!

When lifting / lowering and positioning crane components, there is an increased danger of impact / crushing!

Personnel can be caught and thereby injured or killed!

- ▶ Make sure that personnel cannot be caught by components!
- ▶ When working in danger zones: Use aids to protect limbs!
- ▶ Guide components with suitable aids to minimize oscillation!

Make sure that the following prerequisites are met:

- Both crawler carriers are installed on the cross carriers.
- The assembly support is retracted and the crawler travel gear is positioned on the ground.
- Catwalks, railings and ladders are assembled and in the operating position.
- An auxiliary crane is available.

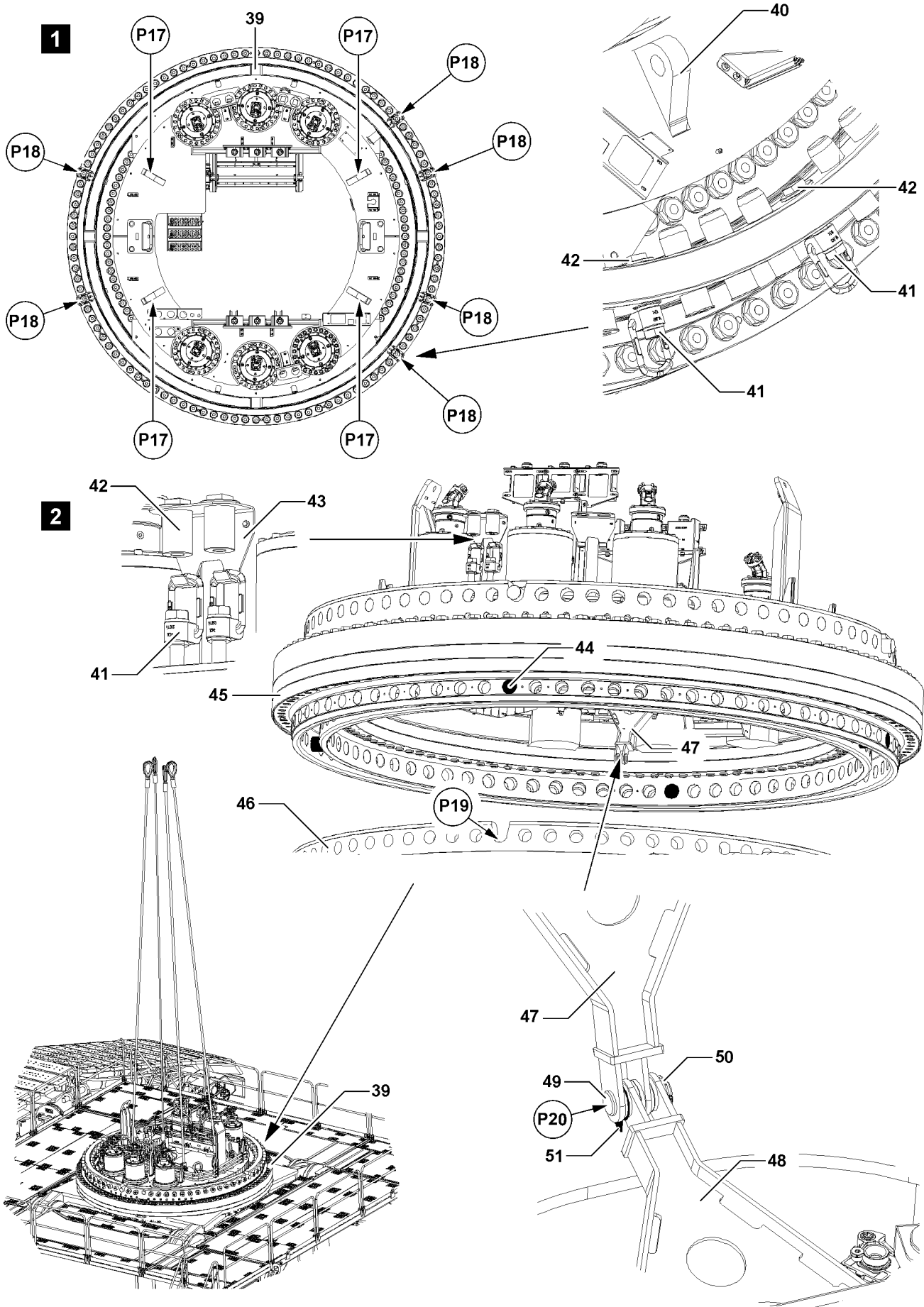

Fig.113024: Assembling the roller ring connection

LWE/LR 13000-001/19503-01-02/en

2.1 Cleaning the roller ring connection

NOTICE

Dirty roller ring connection!

If the roller ring connection is dirty, severe damage can occur, and it might even require replacement!

- ▶ Thoroughly clean the pin bores and surfaces on the ring gear **46** of the crawler center section, lower section **45** of the slewing ring connection and the pins!
-
- ▶ Disassemble the transport retainer eyes **41**, points **18**, see illustration **1**.
 - ▶ Secure the transport retainer eyes **41** and pins **42** in the transport retainers **43**, see illustration **2**.
 - ▶ Before setting the roller ring connection on the crawler center section: Clean the placement surfaces or contact surfaces as well as the pin bores on the ring gear **46** on the crawler center section and on the lower section **45** of the roller ring connection.
 - ▶ Grease the centering pin **44** with water repellent grease.

2.2 Setting the roller ring connection on the crawler center section

Make sure that the following prerequisites are met:

- The crawler travel gear is horizontally aligned.
- The four centering pins **44** are assembled and secured on the lower section **45** of the roller ring connection, see illustration **2**.
- The four centering pins **44** are greased with water repellent grease.
- ▶ Fasten the roller ring connection **39** to the auxiliary crane: Fasten the fastening equipment to the lashing lugs **17**, **40** points, see illustration.

The roller ring connection can be set on the crawler center section in increments of 90°. The roller ring connection must be aligned in such a way that the rotary connection **48** can be pinned with the drawbar **47** of the slewing ring connection, see illustration **2**.



WARNING

Do not stay in danger zone!

It is prohibited for anyone to remain within the slewing range of the auxiliary crane or under the roller ring connection when swinging in the roller ring connection! Personnel can be severely injured or killed!

- ▶ Swing the roller ring connection **39** in slowly with the auxiliary crane over the horizontally aligned crawler center section!
-
- ▶ Lift the roller ring connection **39** and position it over the crawler center section.
 - ▶ Set the roller ring connection on the ring **46** on the crawler center section so that the four pins **44** are lying in the centerings, see point **P19**.

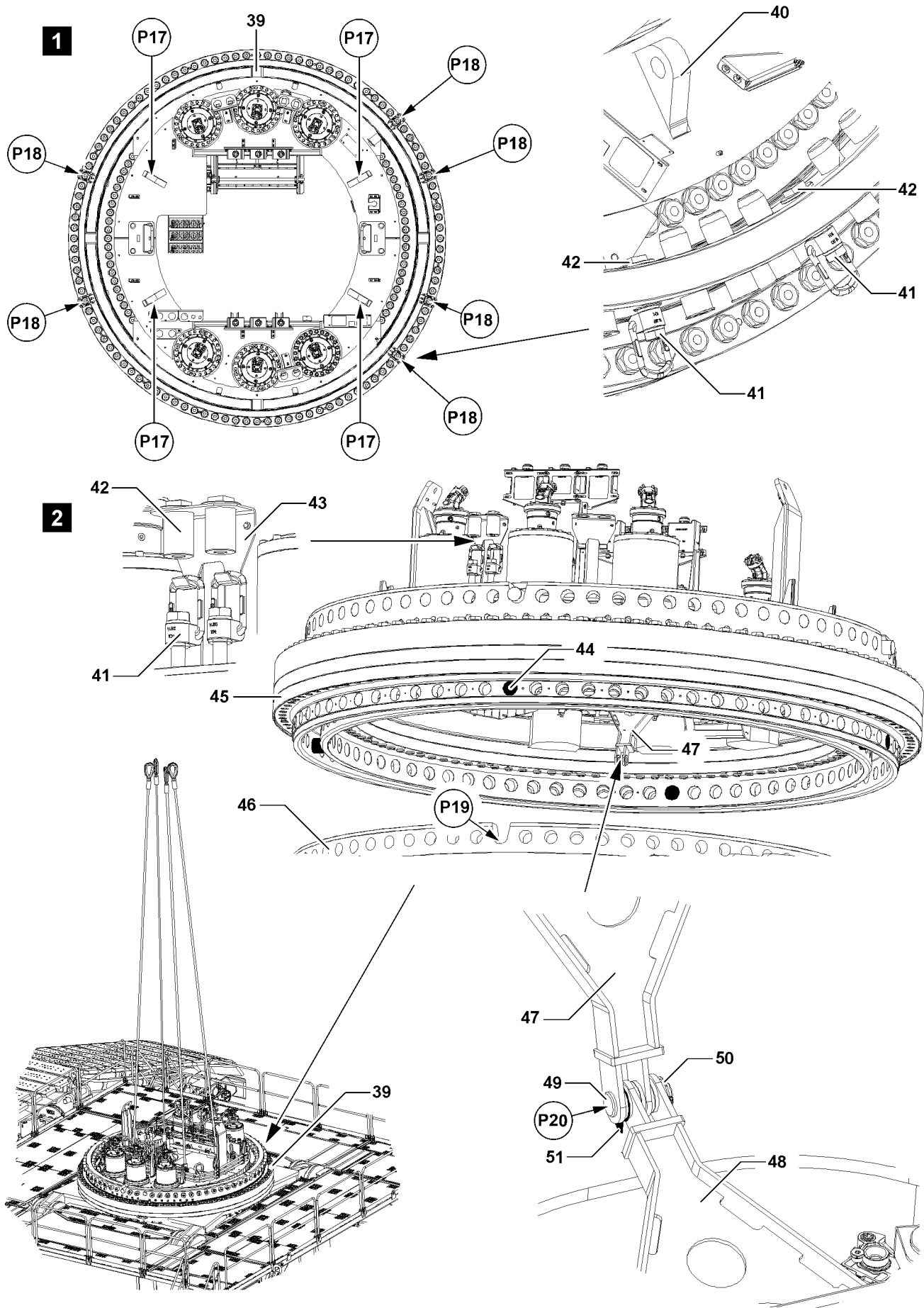

Fig.113024: Assembling the roller ring connection

LWE/LR 13000-001/19503-01-02/en

2.3 Pinning the rotary connection with drawbar of the roller ring connection



WARNING

Hands in the danger zone!

During assembly of the upper and lower section of the roller ring connection, fingers and hands can be crushed and limbs can be severed!

- ▶ Do **not** reach with your hands into the danger zone!
-
- ▶ Pin the drawbar **47** with the rotary connection **48**: Insert the plate **51**, insert the pin **49** in point **P20** and secure with the locking pin **50**.

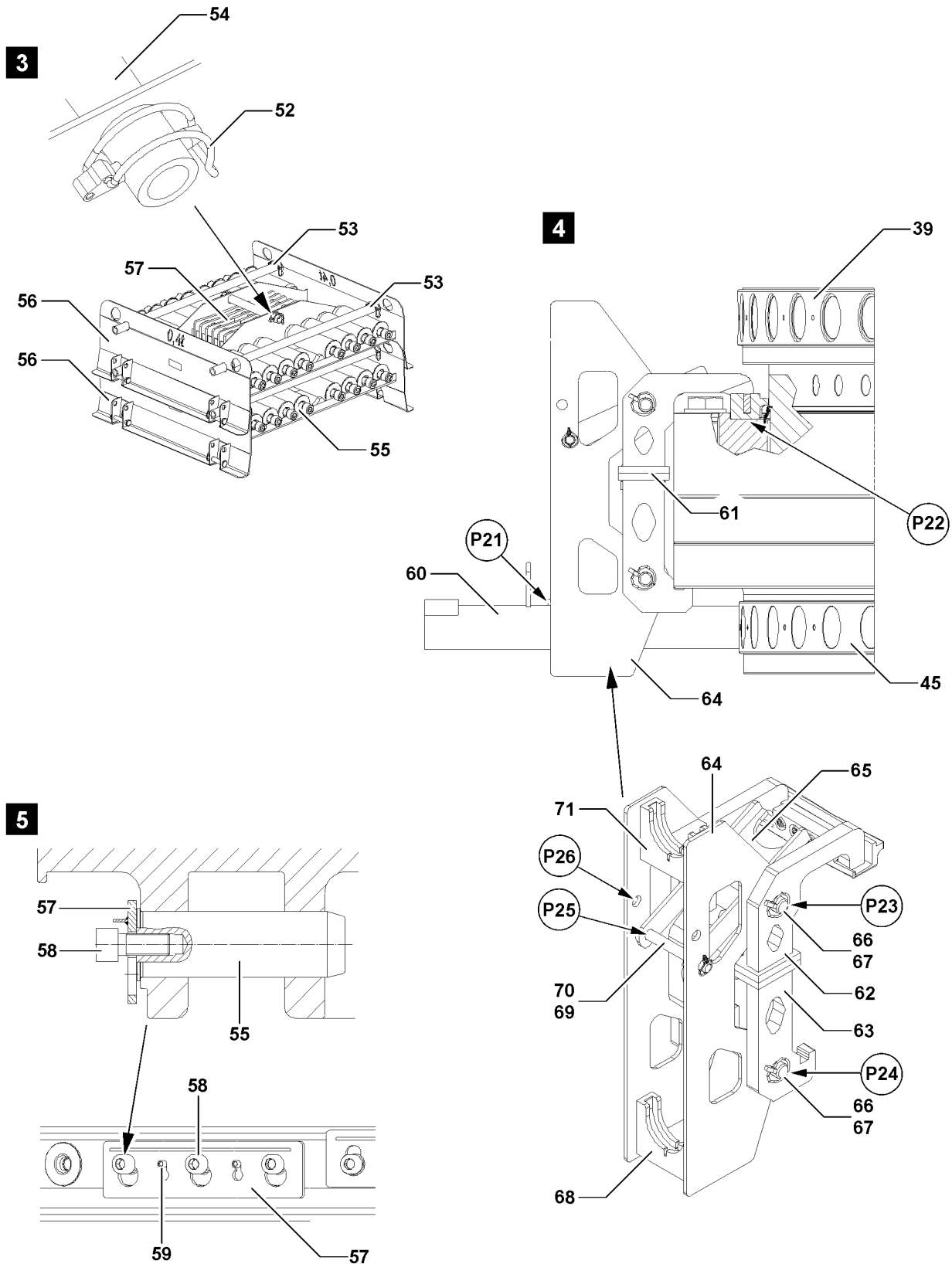

Fig.113026: Pinning the roller ring connection on the crawler center section

LWE/LR 13000-001/19503-01-02/en

2.4 Pinning the roller ring connection on the crawler center section

2.4.1 Pinning the Quick-Connection by hand



WARNING

Retaining pins and retaining plates are not secured!

During transport, the retaining pins and the retaining plates must be secured in the pin pallet! Components can fall down! Personnel can be severely injured or killed!

- ▶ Secure the retaining plates **57** with the pin **54**, see illustration **3**!
- ▶ Secure the retaining pins **55** with the pins **53**!
- ▶ Secure each pin **54** and pin **53** with tube locking pins **52**!



Note

- ▶ A transport device for pins from the Quick-connection can pick up seventeen pins and six retaining plates!
 - ▶ For transport, the individual pallets are pinned with each other!
 - ▶ For transport with the auxiliary crane, maximum four pallets may be interconnected!
 - ▶ Maximum eight pallets may be stacked above each other on the storage location!
- ▶ Have the transport device with the pins for the Quick-Connection on stand-by, see illustration **3**.



Note

When the pins can **not** be pinned by hand:

- ▶ Pin and unpin the pin **55** with the hydraulic pin pulling device, see next section!
- ▶ Pin the roller ring connection with the crawler center section: Insert the pin **55** on the lower ring gear **45**, see illustration **4**.
- ▶ Insert the pins **55** on the roller ring connection by hand.
 - ▶ Make sure that every pin **55** for the Quick-Connection is inserted.

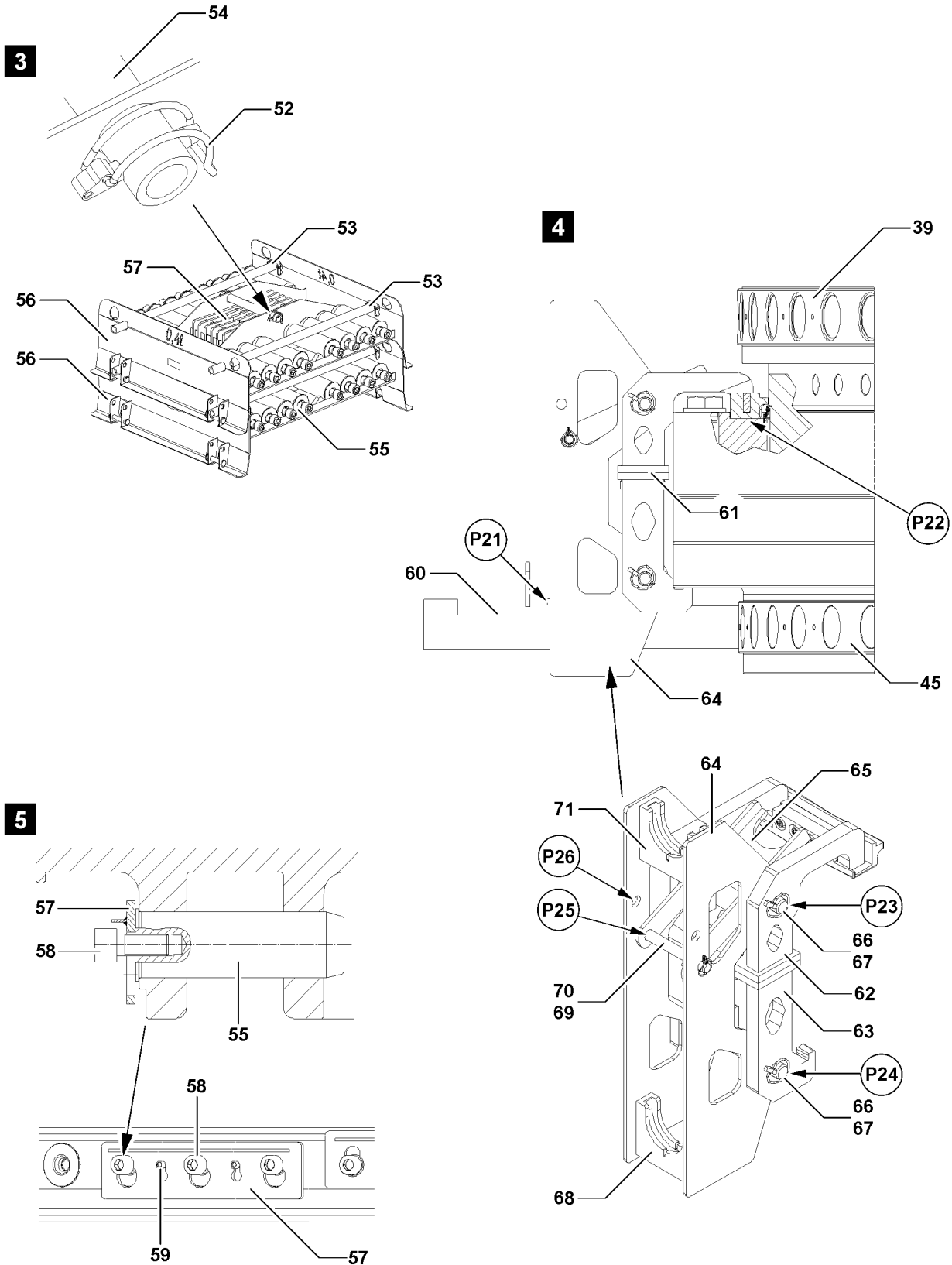

Fig.113026: Pinning the roller ring connection on the crawler center section

LWE/LR 13000-001/19503-01-02/en

2.4.2 Pinning the Quick-Connection with the pin pulling device

Make sure that the following prerequisites are met:

- The pins **55** can not be inserted by hand.
- The bracket **61** is assembled: The bracket **62** and bracket **63** are screwed together.
- The bracket **61** is connected to the roller ring connection in point **P22**.
- The hydraulic connection to the pin pulling cylinder is established, see section „Establishing the hydraulic connection to the pin pulling cylinder“



Note

- ▶ Hydraulic connection of the pin pulling device, see the Crane operating instructions, chapter 5.30!



Note

- ▶ For transport retention, the retainer **65** is pinned in point **P26!**
- ▶ For pinning and unpinning, the retainer **65** is pinned in point **P25!**
- ▶ Make sure that the retainer **65** is pinned and secured in point **P25** with the retainer **64**.
- ▶ Pin the retainer **65** on the retainer **64** and the bracket **61**: Insert the pin **66** in point **P23** and point **P24** and secure with the locking pin **67**.

Result:

- The pin pulling cylinder can be connected to the pin pulling device.
- ▶ Connect the pin pulling cylinder **60** in point **P21** to the retainer **68**.
- ▶ Pin the roller ring connection with the crawler center section: Insert the pin **55** with the pin pulling cylinder in the lower ring gear **45**.
- ▶ Insert sixty eight pins **55** around the circumference of the roller ring connection with the pin pulling device.
- ▶ Make sure that every pin **55** for the Quick-Connection is inserted.

2.4.3 Securing the pins on the Quick-Connection



WARNING

The connector pins can loosen up by themselves!
Tipping of the turntable! Personnel can be severely injured or killed!

- ▶ Secure the pins **55** after inserting them with the retaining plate **57!**
- ▶ Secure the pins **55** on the roller ring connection: Set the retaining plates **57** on the screws **58** and on the screws **59**, see illustration **5**
- ▶ Make sure that every pin **55** of the Quick-Connection is secured with the retaining plates **57**, illustration **2**.

Result:

- The roller ring connection is assembled.

1

Fig.113025: Crawler travel gear before disassembly of the roller ring connection

3 Disassembling the roller ring connection

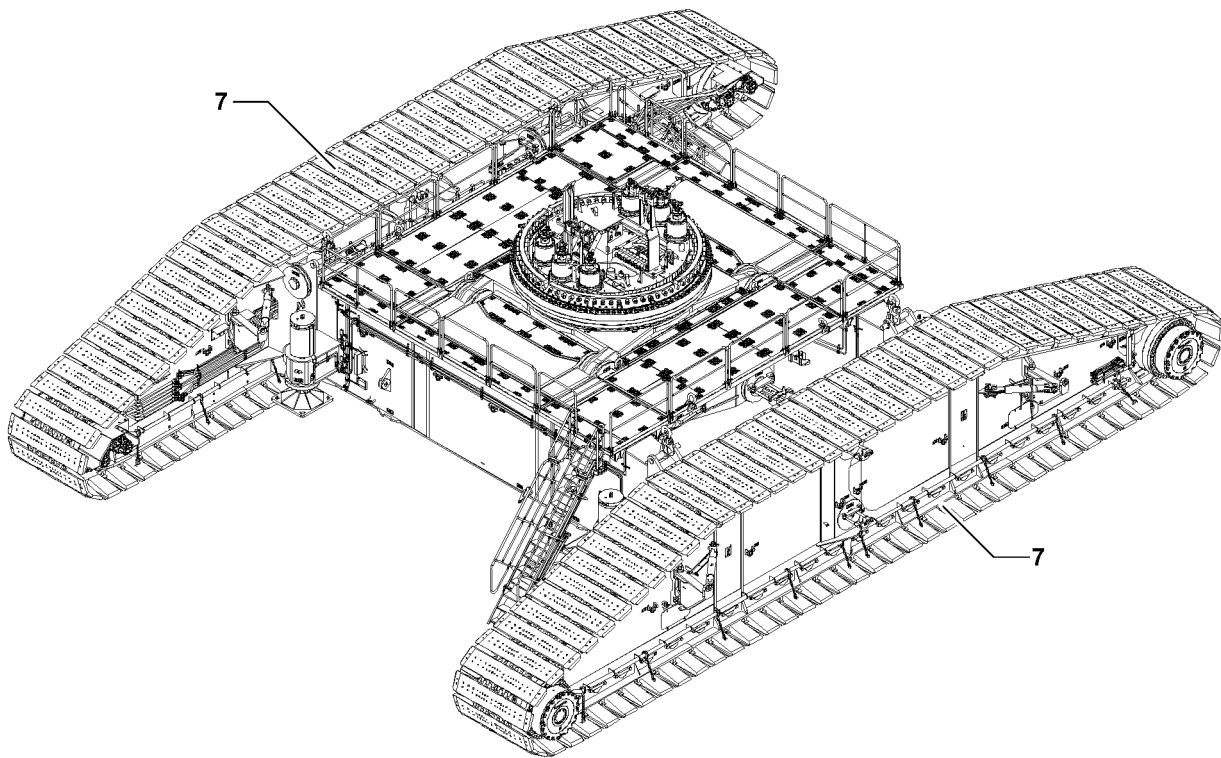

WARNING

Danger of falling!

During assembly / disassembly, inspection and maintenance work, assembly personnel must be secured with appropriate aids to prevent them from falling! If this is not observed, assembly personnel could fall and be killed or seriously injured!

- ▶ The assembly personnel must always move carefully and anticipatory on the crane, the crane components or lattice sections!
- ▶ All work at a height, when there is a danger of falling, must be carried out with suitable aids!
- ▶ If fall protection equipment is available, then it must be used!
- ▶ If aids are not available and work cannot be carried out from the ground, then assembly personnel must secure themselves with the permissible fall arrest system to prevent falling, see the Crane operating instructions, chapter 2.04!
- ▶ The fall arrest system must be attached in the fastening and hook points as well as to the safety ropes!
- ▶ Only step on the aids, ladders and catwalks with clean shoes!
- ▶ Keep aids, ladders and catwalks free of heavy dirt, snow and ice!



WARNING

Danger of impact / crushing!

When assembling / disassembling crane components with the auxiliary crane, crane components can start to swing back and forth!

When lifting / lowering and positioning crane components, there is an increased danger of impact / crushing!

Personnel can be caught and thereby injured or killed!

- ▶ Make sure that personnel cannot be caught by components!
- ▶ When working in danger zones: Use aids to protect limbs!
- ▶ Guide components with suitable aids to minimize oscillation!

Make sure that the following prerequisites are met:

- The turntable is disassembled.
- The central ballast and the carriers for the central ballast are disassembled.
- The crawler carriers **7** are positioned on the ground.
- An auxiliary crane is available.
- The hydraulic pin pulling device is available.

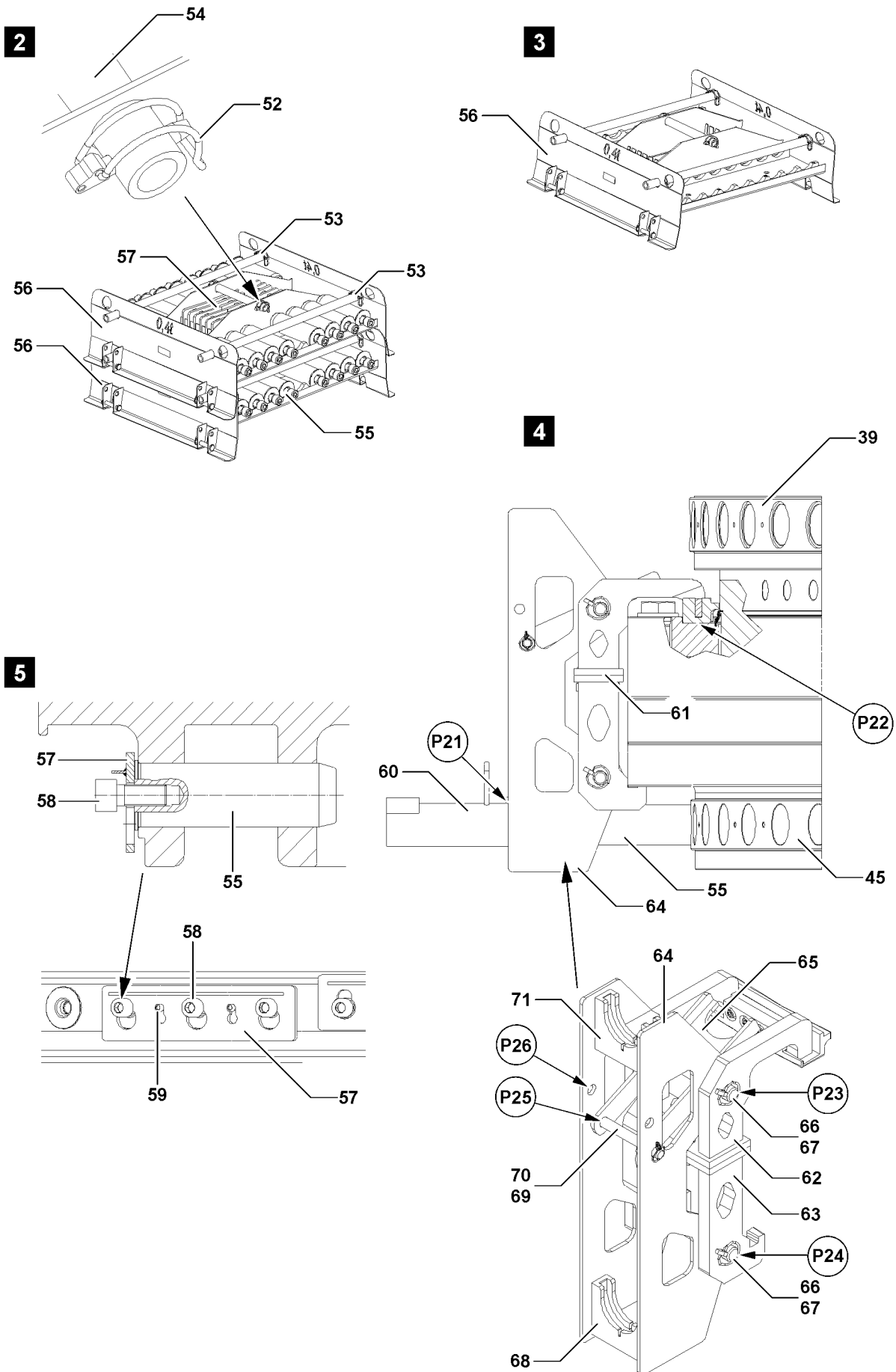

Fig.113028: Unpinning the roller ring connection on the crawler center section

LWE/LR 13000-001/19503-01-02/en

3.1 Unpinning the roller ring connection on the crawler center section

3.1.1 Releasing the pins on the Quick-Connection



WARNING

Retaining pins and retaining plates are not secured!

During transport, the retaining pins and the retaining plates must be secured in the pin pallet! Components can fall down! Personnel can be severely injured or killed!

- ▶ Secure the retaining plates **57** with the pin **54**, see illustration **2**!
- ▶ Secure the retaining pins **55** with the pins **53**!
- ▶ Secure each pin **54** and pin **53** with tube locking pins **52**!



Note

- ▶ A pin pallet **56** can take on seventeen pins and six retaining plates!
 - ▶ For transport, the individual pin pallets are pinned with each other!
 - ▶ For transport with the auxiliary crane, a maximum of four pin pallets may be connected together!
 - ▶ A maximum of eight pin pallets may be stacked on each other in the storage location!
-
- ▶ Have an empty pin pallet **56** on hand for the pins and retaining plates of the Quick-Connection, see illustration **3**.
 - ▶ Release the pins **55** on the roller ring connection: Remove the retaining plates **57** from the screws **58** and screws **59**.
 - ▶ Take the retaining plates **57** down in the pin pallet **56**.
 - ▶ Make sure that every retaining plate **57** for the Quick-Connection is removed.

3.1.2 Unpinning the pins on the Quick-Connection by hand



Note

- ▶ If the pins **55** are hard to move, use the hydraulic pin pulling device to insert and unpin, see next section!
-
- ▶ Unpin the roller ring connection on the crawler center section: Unpin the pins **55** on the lower ring gear **45**, see illustration **4**.
 - ▶ Unpin sixty eight pins **55** on the roller ring connection by hand.
 - ▶ Make sure that every pin **55** for the Quick-Connection is unpinned.
 - ▶ Secure the retaining plates **57** and pins **55** in the pin pallet **56**, see illustration **2**.

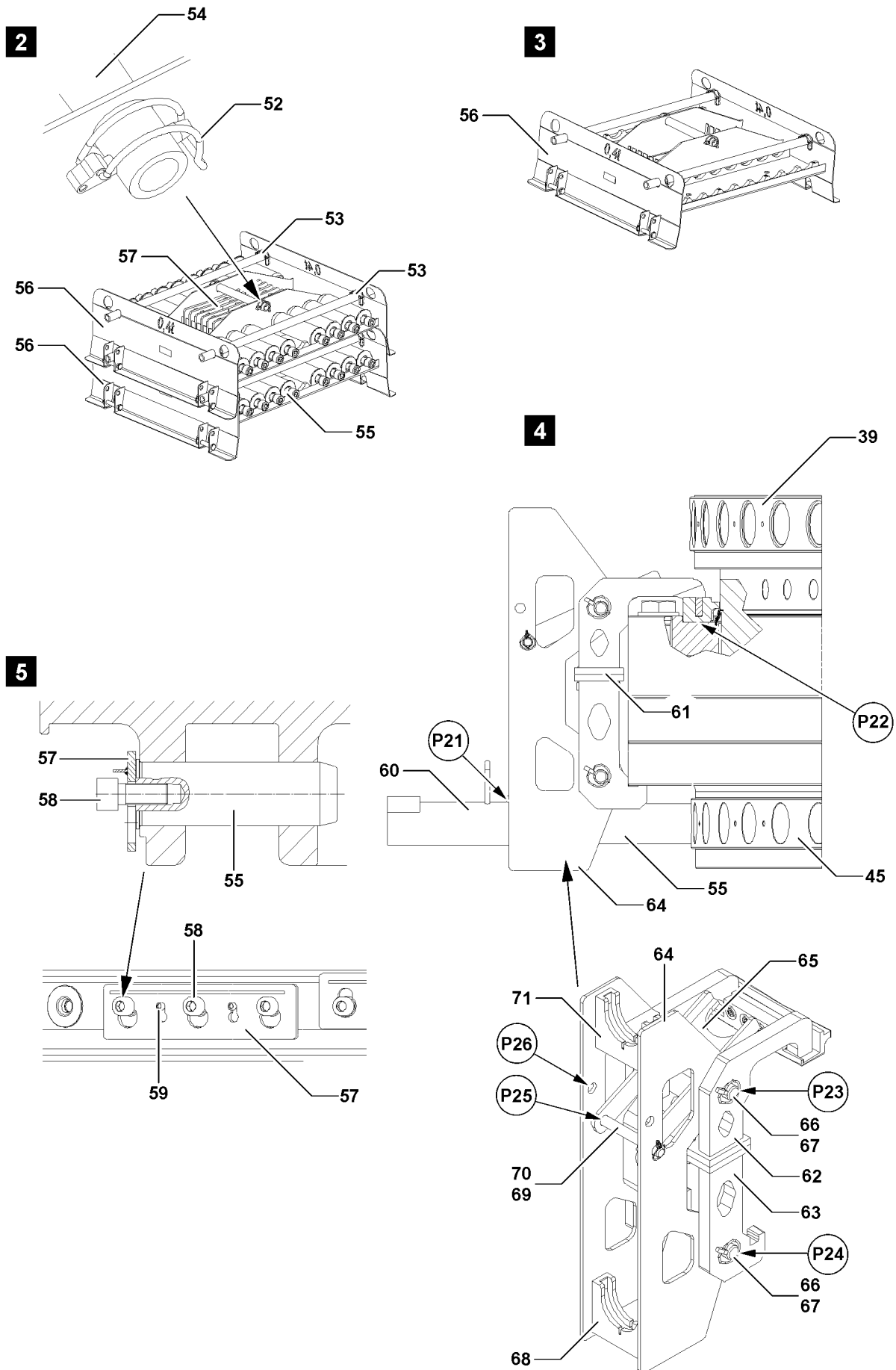

Fig.113028: Unpinning the roller ring connection on the crawler center section

3.1.3 Unpinning the pins on the Quick-Connection with the pin pulling device

Make sure that the following prerequisites are met:

- The pins **55** can **not** be unpinned by hand.
- The bracket **61** is assembled: The bracket **62** and bracket **63** are screwed together.
- The bracket **61** is connected to the roller ring connection in point **P22**.



Note

- ▶ For transport retention, the retainer **65** is pinned in point **P26**!
 - ▶ For pinning and unpinning, the retainer **65** is pinned in point **P25**!
-
- ▶ Make sure that the retainer **65** is pinned and secured with the retainer **64** in point **P25**.
 - ▶ Pin the retainer **65** on the bracket **61**: Insert the pin **66** in point **P23** and point **P24** and secure with the locking pin **67**.

Result:

- The pin pulling cylinder can be connected to the pin pulling device.
- ▶ Connect the pin pulling cylinder **60** in point **P21** to the retainer **68**.
- ▶ Unpin the roller ring connection on the crawler center section: Unpin the pins **55** on the lower ring gear **45**.
- ▶ Unpin sixty eight pins **55** around the circumference of the roller ring connection with the pin pulling device.
- ▶ Make sure that every pin **55** for the Quick-Connection is unpinned.
- ▶ Secure the retaining plates **57** and pins **55** in the pin pallet **56**.

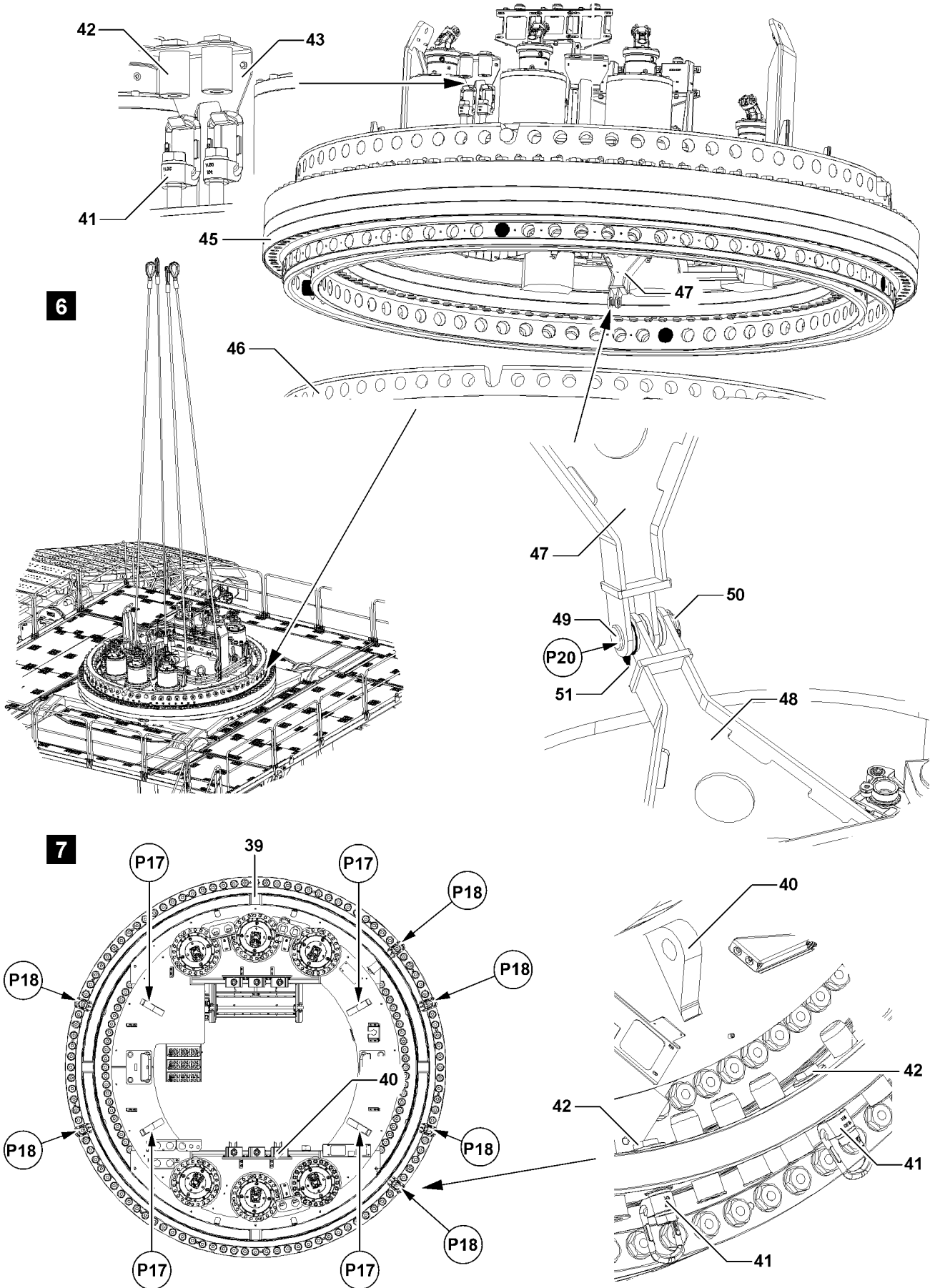

Fig.113851: Disassembling the roller ring connection

LWE/LR 13000-001/19503-01-02/en

3.1.4 Unpinning the drawbar for the roller ring connection on the rotary connection



WARNING

Hands in the danger zone!

During the assembly / disassembly of the roller ring connection, fingers and hands can be crushed and limbs can be severed!

- ▶ Do **not** reach with your hands into the danger zone!

- ▶ Unpin the drawbar **47** on the rotary connection **48**: Remove the locking pin **50**, hold the plate **51** and unpin the pin **49** in point **P20**, see illustration **6**.



Note

- ▶ The transport retainer eyes **41** and the pins **42** are inserted in points **P18**, see illustration **7**.
- ▶ The transport retainer eyes **41** and the pins **42** are located in the transport retainers **43**, see illustration **6**!
- ▶ Assemble the transport retainer eyes **41**: Insert the pins **42** on the inside on the lower gear ring and screw the transport retainer eyes **41** from the outside with the hex head screw on the pin **42**, see illustration **7**!

3.2 Removing the roller ring connection from the crawler center section

- ▶ Fasten the roller ring connection **39** to the auxiliary crane: Fasten the fastening equipment to the lashing lugs **40**, points **P17**, see illustration **7**.



WARNING

Do not stay in danger zone!

It is prohibited for anyone to remain within the slewing range of the auxiliary crane and under the roller ring connection when swinging and removing the roller ring connection! Personnel can be severely injured or killed!

- ▶ Slowly lift the roller ring connection **39** from the crawler center section with the auxiliary crane and remove!
- ▶ Slowly lift the roller ring connection **39** from the crawler center section with the auxiliary crane and remove!

4 Disassembling the crawler carrier on the cross carrier

4.1 Disconnecting the electrical connections from the crawler carriers

- ▶ Disconnect the electrical connection, see the Electrical wiring diagram.

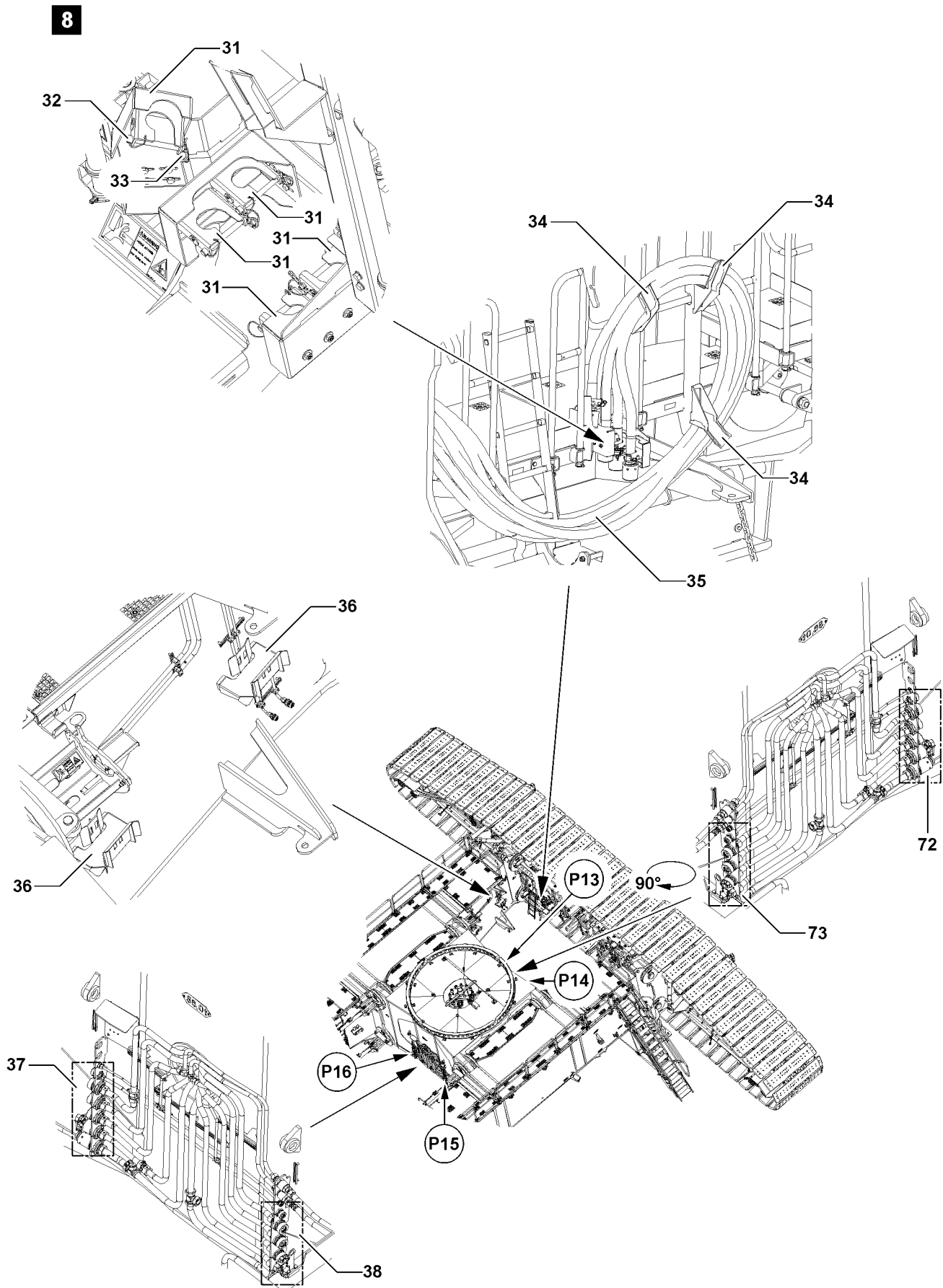

Fig.113027: Disconnecting the hydraulic connection from the crawler carriers

LWE/LR 13000-001/19503-01-02/en

4.2 Disconnecting the hydraulic connections from the crawler carriers

The hydraulic connections are established with quick couplings.

When disconnecting hydraulic lines with quick couplings, make sure that the uncoupling procedure is carried out correctly.



WARNING

Pressure in the hydraulic lines!

If the pressure supply is not interrupted before connecting / releasing the hydraulic lines, the hydraulic oil can escape with high pressure.

Death, severe bodily injuries, property damage.

- ▶ Release the pressure in the hydraulic system before connecting / disconnecting: Interrupt the pressure supply and wait a short time.



Note

- ▶ For every crawler carrier half, five hydraulic hoses are connected to the hydraulic couplings on the crawler center section!
 - ▶ The hydraulic hoses of the crawler carrier half on the front are connected to the connections **38** in point **P15** on the crawler center section!
 - ▶ The hydraulic hoses of the crawler carrier half on the rear are connected to the connections **37** in point **P16** on the crawler center section!
 - ▶ The hydraulic hoses of the crawler carrier half on the rear are connected to the connections **72** in point **P13** on the crawler center section!
 - ▶ The hydraulic hoses of the crawler carrier half on the front are connected to the connections **73** in point **P14** on the crawler center section!
-
- ▶ Release the hydraulic coupling by hand.
 - ▶ Make sure that the hydraulic system pressure has been released.
 - ▶ Unscrew and separate the coupling components (sleeve and connector) with the knurled nut.
 - ▶ Remove the tension belts on the retainers **36** on the cross carrier.
 - ▶ Repeat the procedure for every crawler carrier half and disconnect the hydraulic hoses on the connection locations: Point **P13**, point **P14**, point **P15** and point **P16**.
 - ▶ Remove the hydraulic hoses **35** from the retainers **36** on the cross carrier and connect them to the retainers **34** on the crawler carrier, see illustration **8**.
 - ▶ Secure the hydraulic hoses **35** in the transport retainers **31** on the crawler carrier: For each, insert a pin **32** and secure with a cotter pin **33**.
 - ▶ Make sure that the hoses cannot release from the retainer.

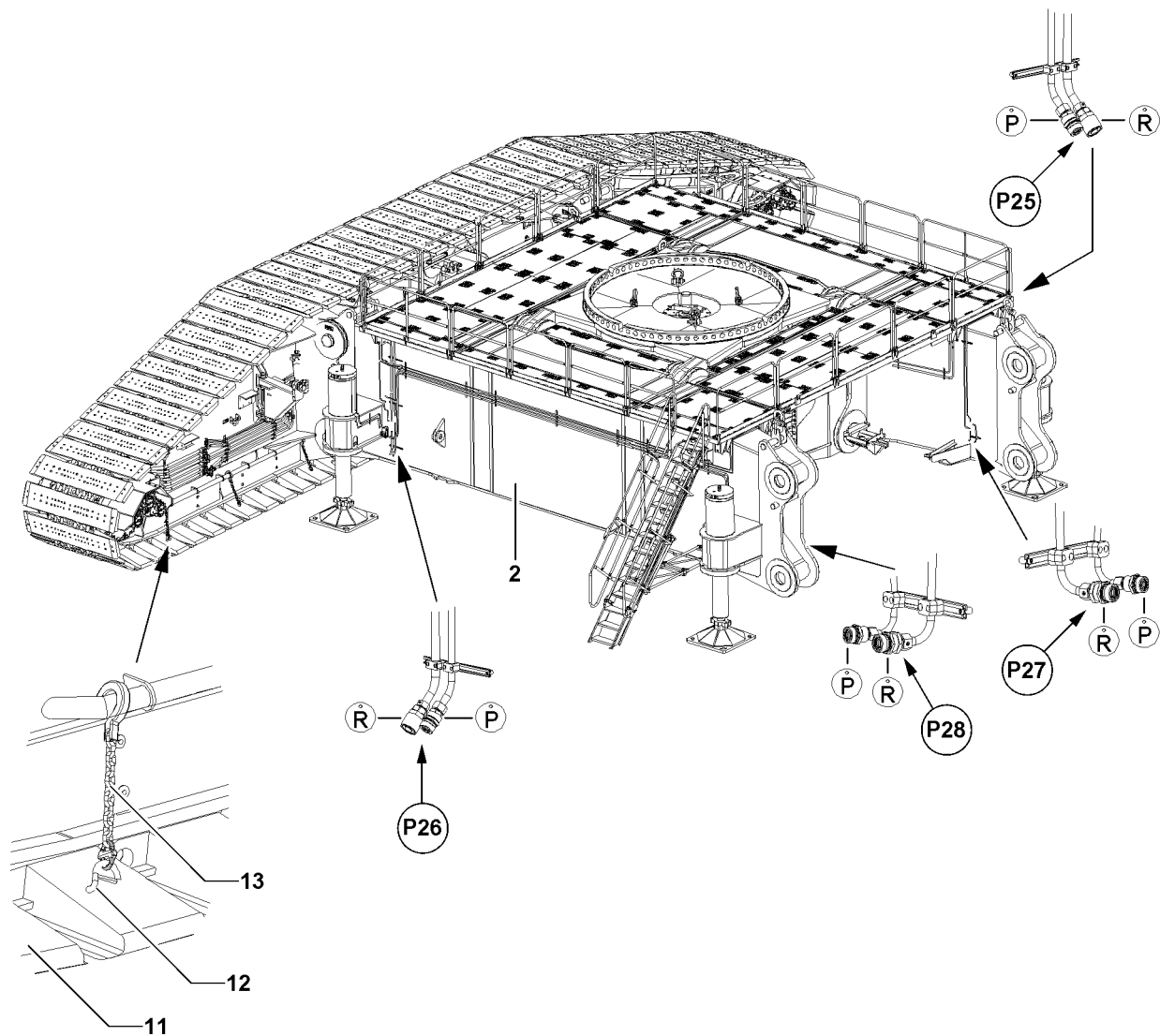

Fig.113853: Hydraulic connections on the cross carrier

4.3 Establishing the hydraulic connections to the cross carrier



Note

- ▶ The hydraulic supply for the assembly support is provided via the external hydraulic aggregate or the operational engine house!

NOTICE

Oil tank filled at the start of the hydraulic aggregate!

If the hydraulic aggregate is changed or the operational engine house is connected, the required amount of oil exceeds the tank volume of the new connected hydraulic system when retracting the assembly support! Hydraulic oil runs over and contaminates the environment!

- ▶ Extend and retract the assembly support with the same hydraulic aggregate!
- ▶ Before the hydraulic aggregate is separated from the crane or the operational engine house is connected: Retract the assembly support with the hydraulic aggregate!

The hydraulic connections are established with quick couplings.

When connecting hydraulic lines with quick couplings, make sure that the coupling procedure is carried out correctly.

The matching quick couplings are marked.



WARNING

Pressure in the hydraulic lines!

If the pressure supply is not interrupted before connecting / releasing the hydraulic lines, the hydraulic oil can escape with high pressure.

Death, severe bodily injuries, property damage.

- ▶ Release the pressure in the hydraulic system before connecting / disconnecting: Interrupt the pressure supply and wait a short time.



WARNING

Loss of pressure or leakage!

Incorrectly coupled or self-loosening quick couplings (particularly return lines) can result in serious accidents due to component failure.

Death, severe bodily injuries, property damage.

- ▶ Check that the quick couplings have been properly connected before using the crane.
- ▶ Connect the coupling components (sleeve and connector) and screw together with the knurled nut.
- ▶ Tighten the hydraulic coupling by hand. Turn the knurled nut until it reaches a tangible, fixed stop position.
- ▶ Establish the hydraulic connection: Connect the supply lines of the external hydraulic aggregate to the supply lines of the cross carrier, hydraulic connection **R** and hydraulic connection **P** in point **P25** or point **P26**, see illustration.

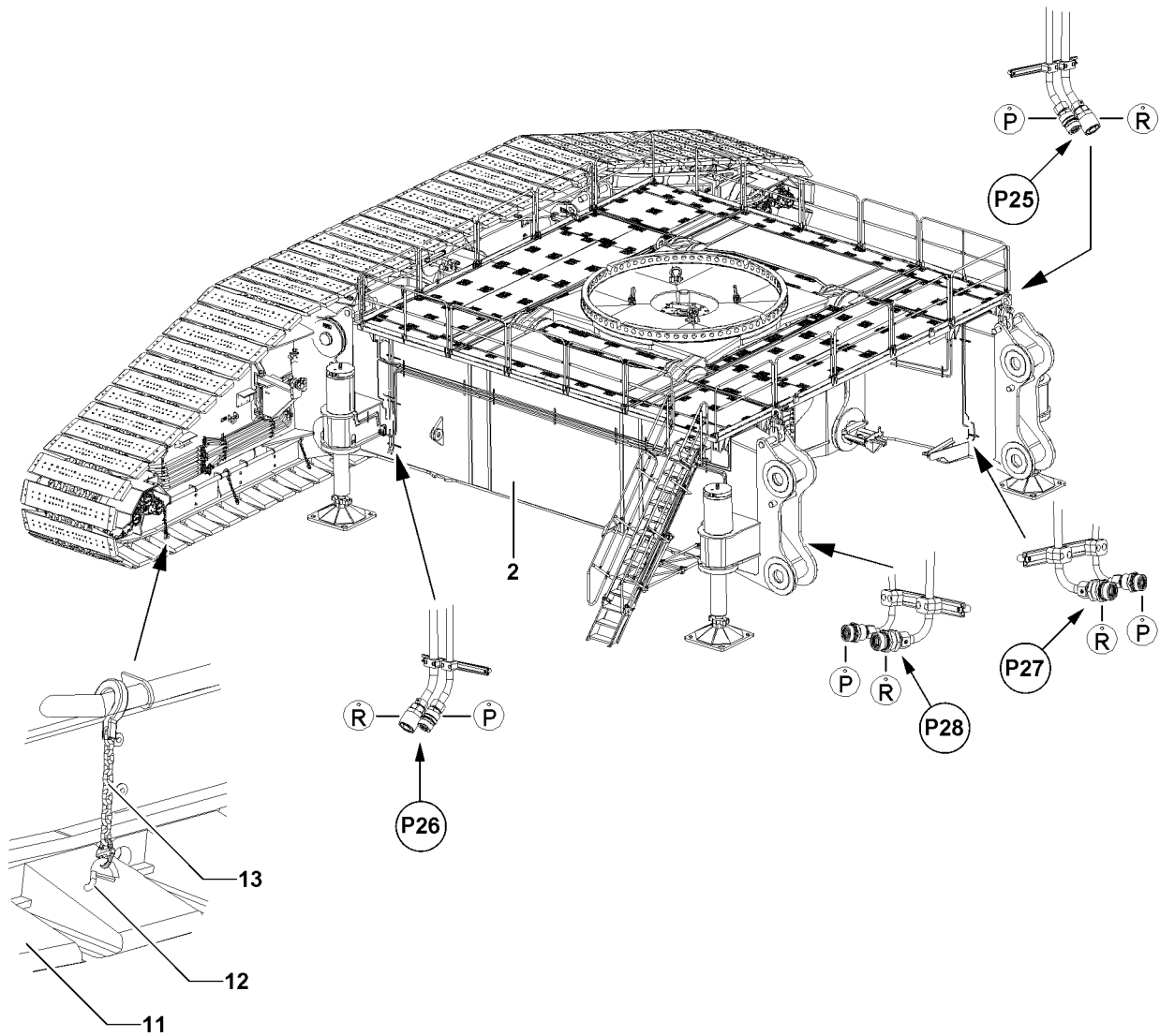

Fig.113853: Securing the outrigger pads / extending the assembly support

4.4 Preparing the crawler carrier for disassembly



Note

- ▶ Before assembly of the crawler carriers, on each side of the crawler carrier, the outrigger pads must be secured with **ten** chains **13**!
-
- ▶ Connect the chains **13** with the brackets **12** to the outrigger pads **11**, see illustration.

4.5 Extending the assembly support



CAUTION

Collision with components!

When extending the assembly support, access ladders, other access aids or objects can collide with the crawler travel gear! Personnel can be severely injured! Components can be severely damaged!

- ▶ Make sure that the persons, objects and components are outside of the movement range of the crawler travel gear when extending the assembly cylinder!
 - ▶ It is prohibited to remain in the danger zone of the travel gear!
-
- ▶ The assembly support is extended to the point where the crawler plates do not scrape on the ground during disassembly.

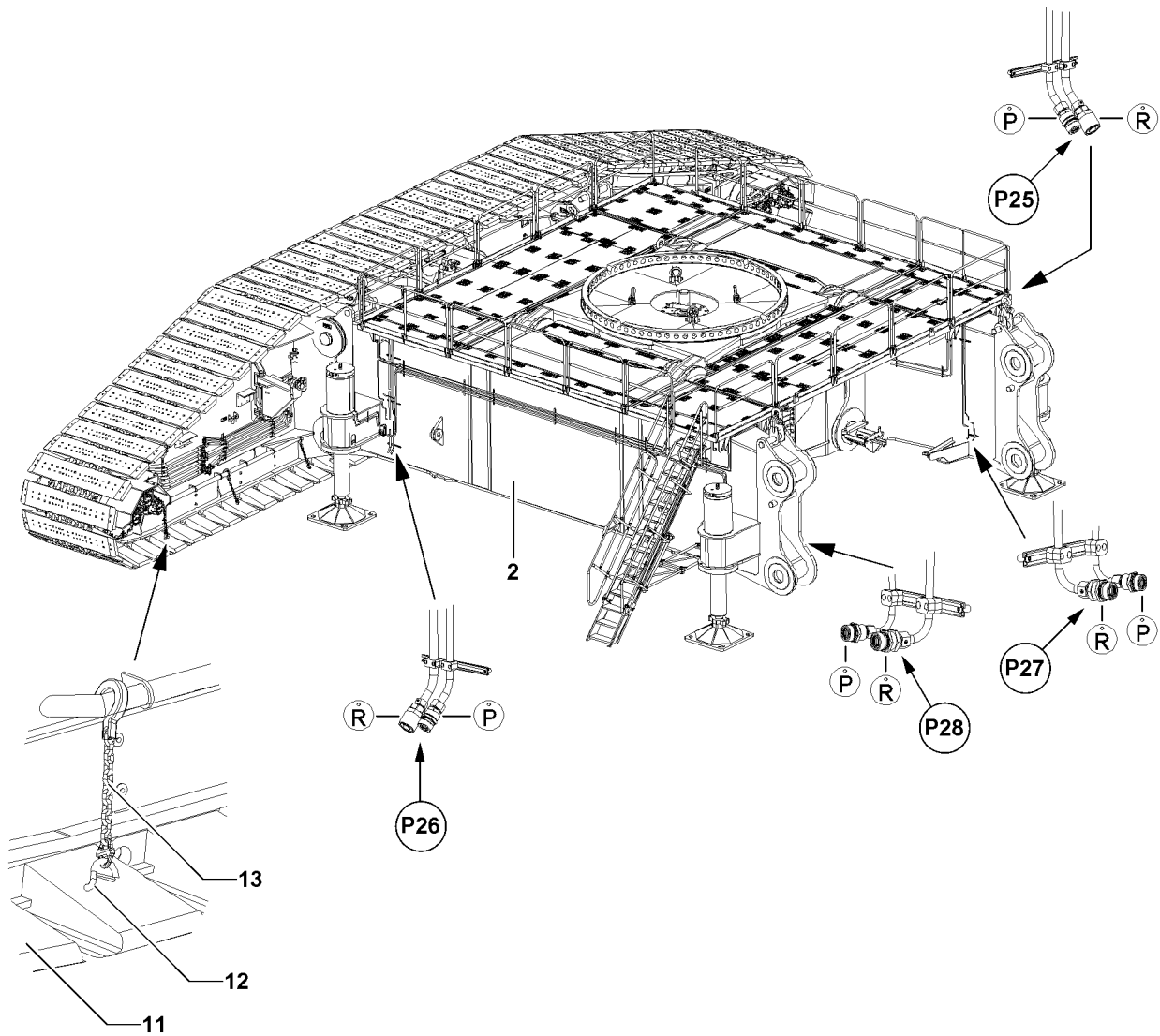

Fig.113853: Hydraulic connections on the cross carrier

LWE/LR 13000-001/19503-01-02/en

4.6 Hydraulic connections to the pin pulling cylinder



Note

- ▶ The hydraulic supply for the assembly support is provided via the external hydraulic aggregate or the operational engine house!
- ▶ Hydraulic connection of the pin pulling device, see the Crane operating instructions, chapter 5.30!

Make sure that the following prerequisite is met:

- The external hydraulic aggregate or the operational engine house are connected to the supply lines of the cross carrier, point **P25** or point **P26**.

4.6.1 Establishing the hydraulic connections to the pin pulling cylinder

On the inside of the cross carriers **2**, there are two hydraulic connections for the pin pulling cylinder, a total of four connection possibilities, point **P27** and point **P28**, see illustration.

The hydraulic connections are established with quick couplings.

When connecting hydraulic lines with quick couplings, make sure that the coupling procedure is carried out correctly.

The matching quick couplings are marked.



WARNING

Pressure in the hydraulic lines!

If the pressure supply is not interrupted before connecting / releasing the hydraulic lines, the hydraulic oil can escape with high pressure.

Death, severe bodily injuries, property damage.

- ▶ Release the pressure in the hydraulic system before connecting / disconnecting: Interrupt the pressure supply and wait a short time.



WARNING

Loss of pressure or leakage!

Incorrectly coupled or self-loosening quick couplings (particularly return lines) can result in serious accidents due to component failure.

Death, severe bodily injuries, property damage.

- ▶ Check that the quick couplings have been properly connected before using the crane.
- ▶ Make sure that the connection point is selected in such a way that the length of the hydraulic hoses is sufficient.
- ▶ Connect the coupling components (sleeve and connector) and screw together with the knurled nut.
- ▶ Tighten the hydraulic coupling by hand. Turn the knurled nut until it reaches a tangible, fixed stop position.
- ▶ Establish the hydraulic connection: Connect the supply lines of the pin pulling cylinder **16** to the supply lines of the cross carrier, hydraulic connection **R** and hydraulic connection **P** in point **P27** or point **P28**, see illustration.

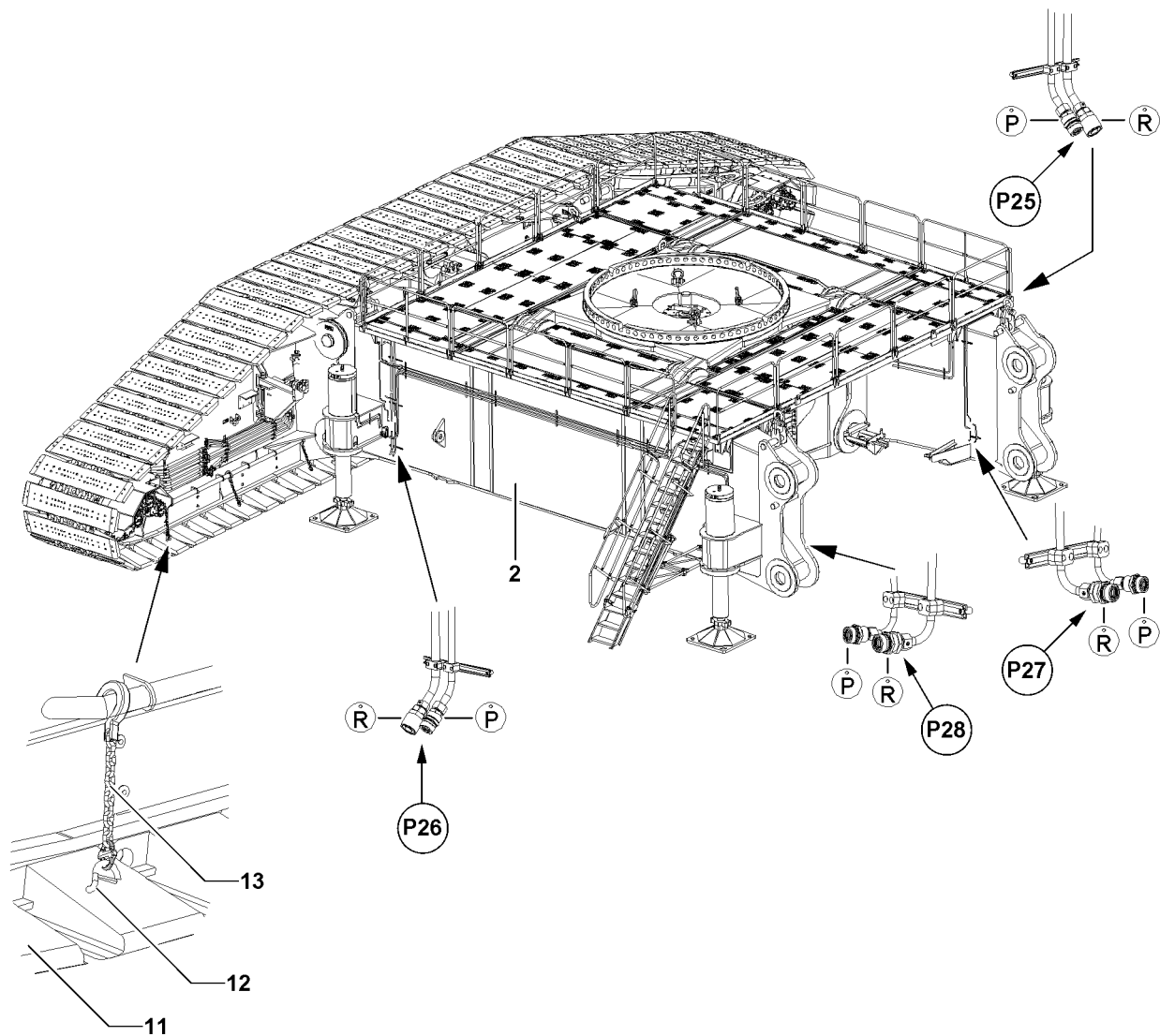

Fig.113853: Hydraulic connections on the cross carrier

4.6.2 Disconnecting the hydraulic connections from the pin pulling cylinder

On the inside of the cross carriers **2**, there are two hydraulic connections for the pin pulling cylinder, a total of four connection possibilities, point **P27** and point **P28**, see illustration.

The hydraulic connections are established with quick couplings.

When disconnecting hydraulic lines with quick couplings, make sure that the uncoupling procedure is carried out correctly.



WARNING

Pressure in the hydraulic lines!

If the pressure supply is not interrupted before connecting / releasing the hydraulic lines, the hydraulic oil can escape with high pressure.

Death, severe bodily injuries, property damage.

- ▶ Release the pressure in the hydraulic system before connecting / disconnecting: Interrupt the pressure supply and wait a short time.
-
- ▶ Make sure that the hydraulic system pressure has been released.
 - ▶ Release the hydraulic coupling by hand.
 - ▶ Disconnect the hydraulic connection: Disconnect the supply lines of the pin pulling cylinder **16** from the supply lines of the cross carrier, hydraulic connection **R** and hydraulic connection **P** in point **P27** or point **P28**, see illustration.

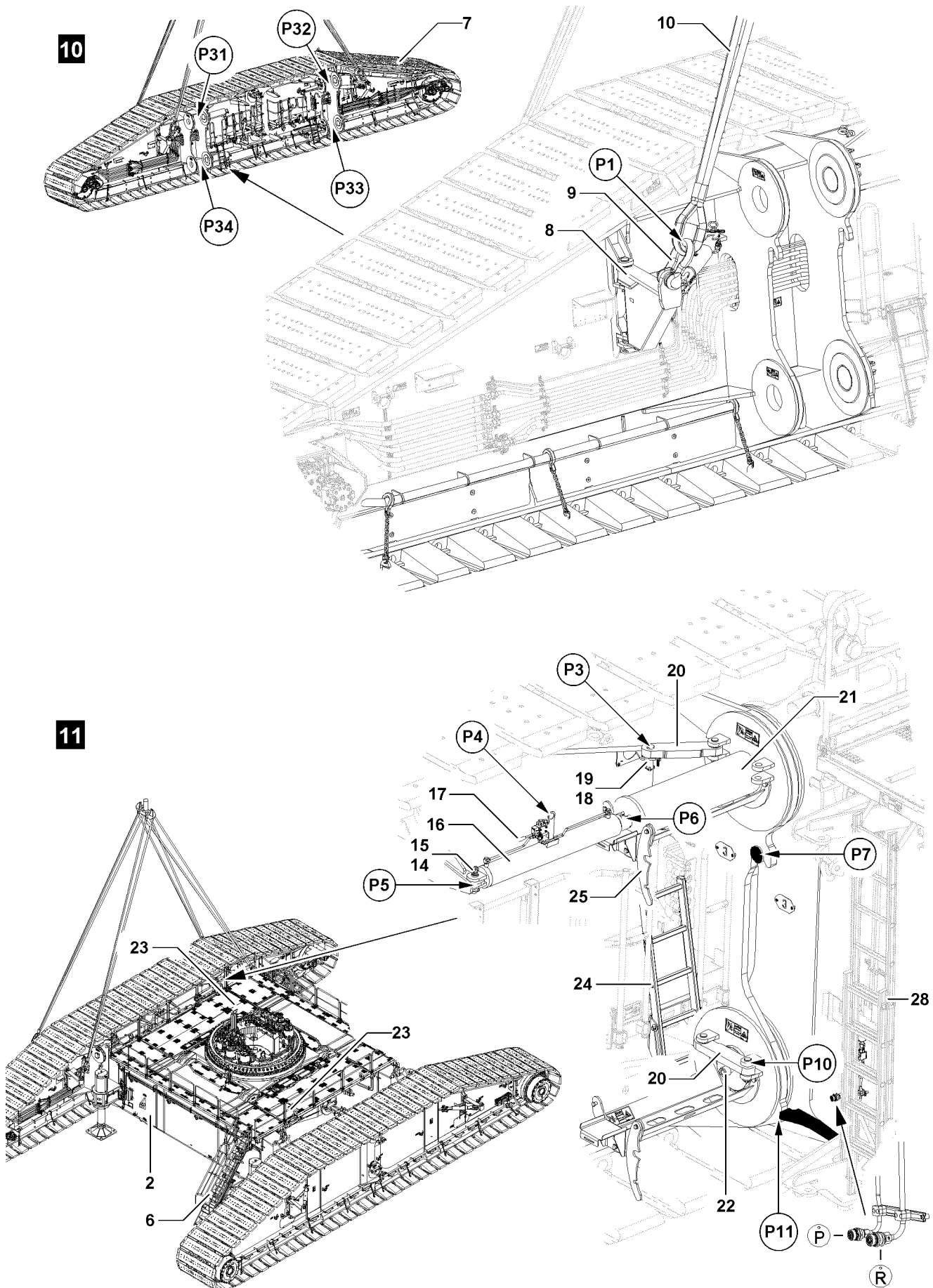

LWE/LR 13000-001/19503-01-02/en

Fig.113854: Disassembling the first crawler carrier

4.7 Disassembling the first crawler carrier

4.7.1 Fastening the crawler carrier to the auxiliary crane



WARNING

Assembly personnel not secured!

Assembly personnel can fall and be severely injured or killed!

- ▶ Secure assembly personnel with suitable aids to prevent them from falling!
- ▶ Use personal protective equipment!

The fastening points on the inside of the crawler carriers can be reached via the catwalks.

The fastening points on the outside of the crawler carriers can be reached via a work platform.

- ▶ Fasten the fastening equipment **10** to the auxiliary crane.
- ▶ Fasten the crawler carrier **7** to the auxiliary crane in point **P1**: Fasten the fastening equipment **10** to the shackle **9**, see illustration **10**.
- ▶ Fasten the crawler carrier **7** to the auxiliary crane in the four fastening points.

4.7.2 Unpinning the crawler carrier on the cross carrier

Make sure that the following prerequisites are met:

- The assembly supports are extended.
- The crawler carrier is fastened to the auxiliary crane, the fastening equipment is tensioned.
- The hydraulic connection to the pin pulling cylinder is established, see section „Establishing the hydraulic connection to the pin pulling cylinder“
- The pins are inserted and secured, see illustration **12**.

12

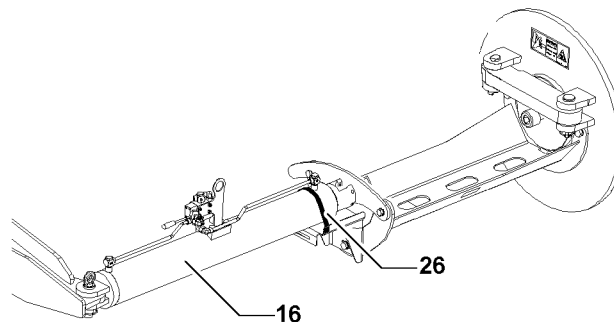

Fig. 114062: Pin pulling cylinder on the first unpin location

- ▶ Release the pin pulling cylinder **16**: Remove the strap **26**.

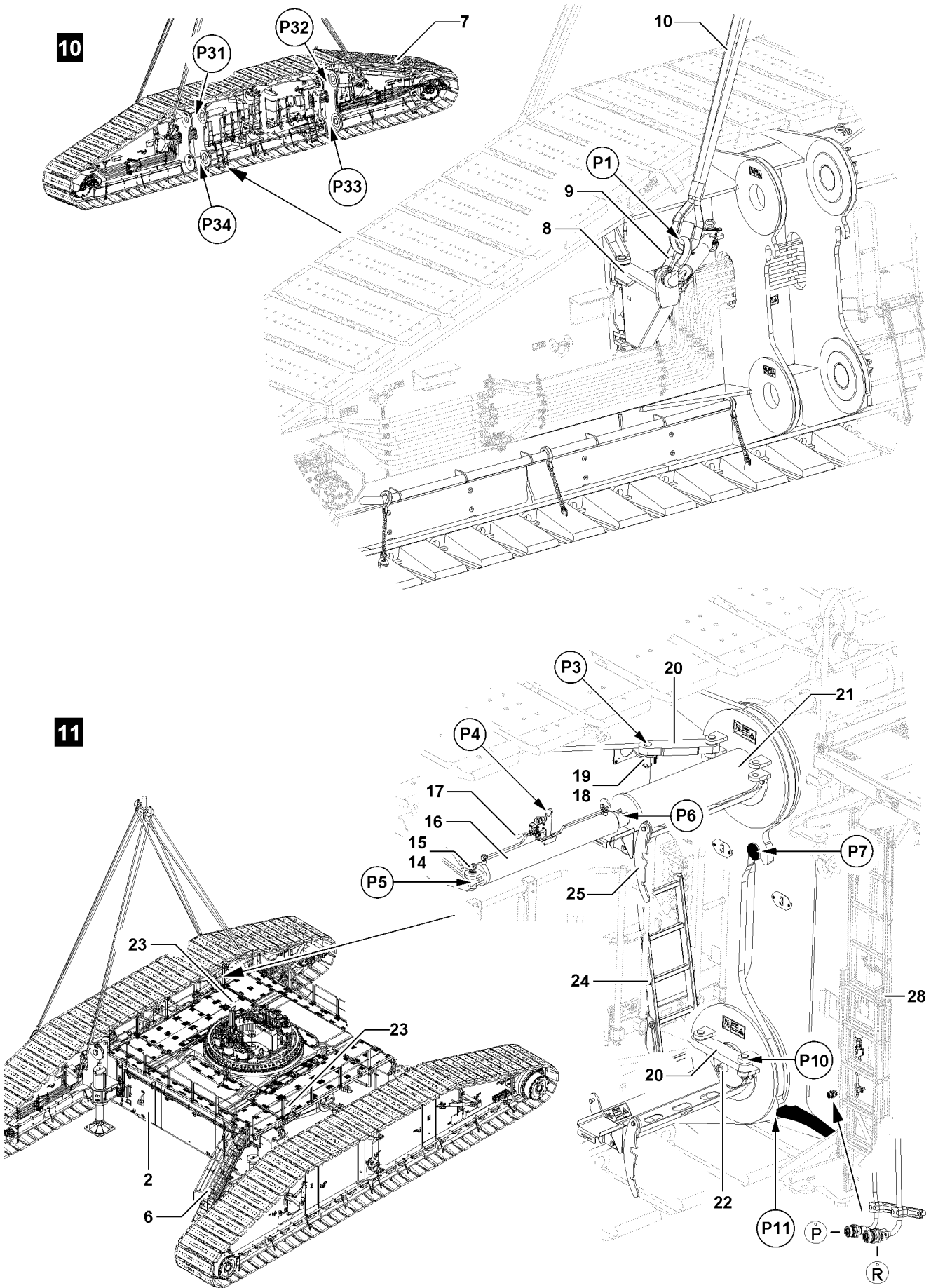

Fig.113854: Disassembling the first crawler carrier

LWE/LR 13000-001/19503-01-02/en

**Note**

- ▶ Observe and adhere to the assembly and safety instructions for the access ladder **6** and for the extension ladder **28**, see the Crane operating instructions, chapter 2.06!
- ▶ Climb onto the catwalk and open the grating flap **23**, climb via the extension ladder **28** to the inside of the crawler carrier.

**WARNING**

The grating flap is open!

If the grating flap is open on the catwalks, there is a danger that personnel can fall down!
Personnel can be severely injured or killed!

- ▶ After climbing off / on, close the grating flap **23**!
- ▶ Close the grating flap **23**.

**Note**

- ▶ The pin points on the crawler carrier are in point **P31**, point **P32**, point **P33** and point **P34**!
- ▶ The upper pin points on the crawler carrier are reached via the ladder **24** and the catwalk on the crawler carrier!
- ▶ Access to the upper pin points: The ladder **24** on the crawler carrier is folded down!
- ▶ Access to the lower pin points: The ladder **24** on the crawler carrier is folded up!
- ▶ For description of the positions of the ladder **24**, see the Crane operating instructions, chapter 2.06!

The pin **19** is released by unpinning the securing bracket **20**.

- ▶ Unpin the securing bracket **20**: Remove the locking pin **18** in point **P10** and unpin the pin **19**, see illustration **3**.
- ▶ Swing the securing bracket **20** in the retainer in point **P3**.
- ▶ Secure the securing bracket **20**: Insert the pin **19** in point **P3** and secure with the locking pin **18**.

Result:

- The pin is released.
- ▶ Fold the retainer **25** down.
- ▶ Fasten the pin pulling cylinder **16** to the auxiliary crane in point **P4**.

When the pin pulling cylinder **16** is lifted, it is easier to connect the piston rods to the pin **21**.

- ▶ Extend the pin pulling cylinder **16** until the piston rod on the screw **22** can be connected to the pin **21**: Actuate the control lever **17**.
- ▶ Connect the pin pulling cylinder **16** to the screw **22** on the pin **21**.
- ▶ Unpin the pin **21**: Actuate the control lever **17** and retract the pin pulling cylinder **16**.

Result:

- The pin **21** is unpinned.

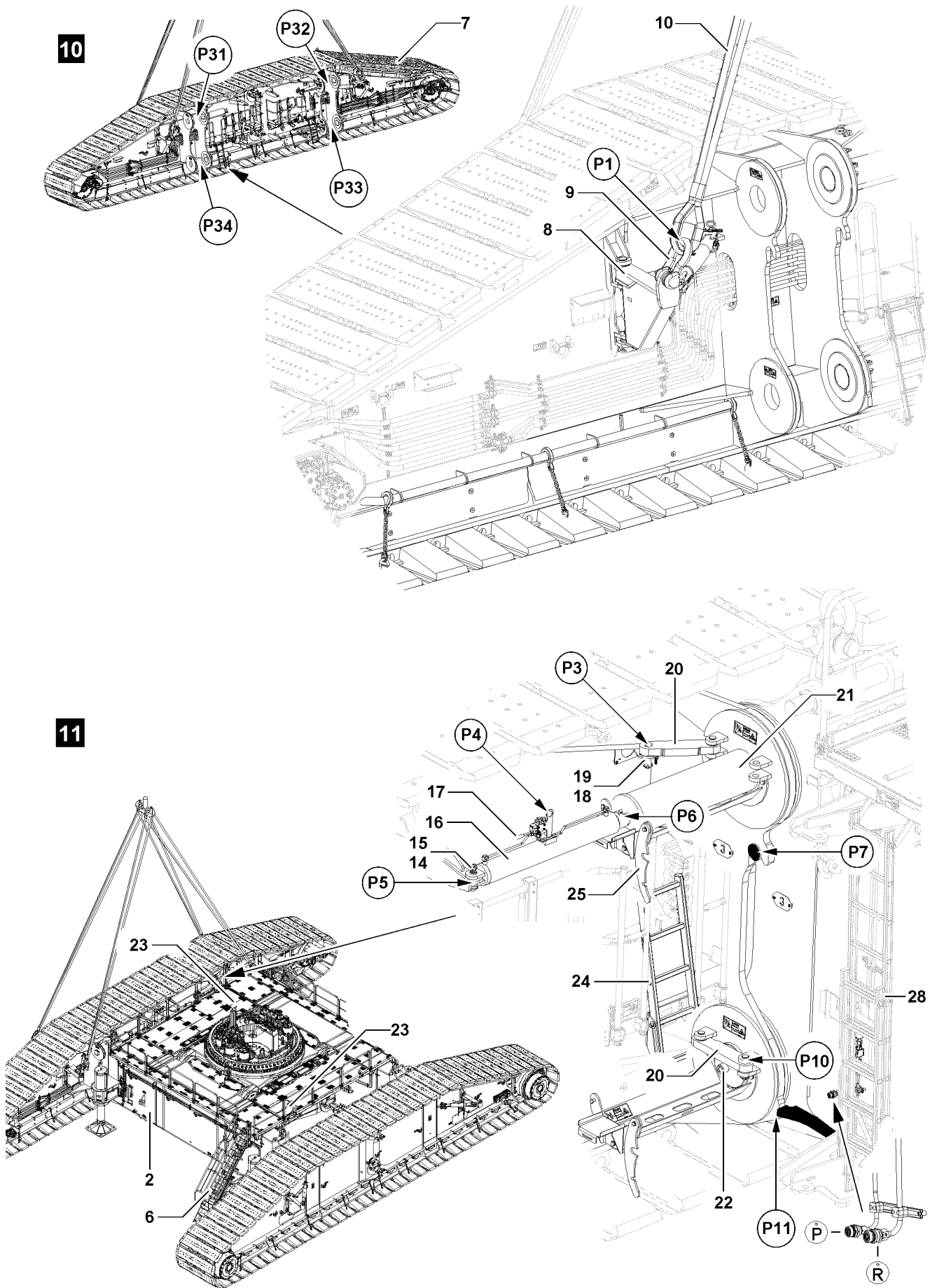

LWE/LR 13000-001/19503-01-02/en

Fig.113854: Disassembling the first crawler carrier

When the pin **21** is secured with the retainer **25**:

- ▶ Unpin the pin pulling cylinder **16** on the crawler carrier: Remove the locking pin **14** and unpin the pin **15** in point **P5**.
- ▶ Lift the pin pulling cylinder **16** with the auxiliary crane and disconnect from the screw **22**.

Result:

- The pin pulling cylinder **16** hangs freely on the auxiliary crane.
- ▶ Fold the retainer **25** up so that the pin **21** is secured on the screw **22**.

Every crawler carrier is pinned on the cross carrier with four pins.



Note

- ▶ The subsequent procedure for unpinning the next pin is identical to the procedure for the first pin!
-



WARNING

The grating flap is open!

If the grating flap is open on the catwalks, there is a danger that personnel can fall down!

Personnel can be severely injured or killed!

- ▶ After climbing off / on, close the grating flap!
 - ▶ Transport the pin pulling cylinder with the auxiliary crane to the next pin point of the crawler carrier and insert the next pin as described in the previous procedure.
-

When the crawler carrier is unpinned:

- ▶ Open the grating flap and climb onto the catwalk via the extension ladder **28**.
- ▶ Close the grating flap and leave the crawler travel gear via the access ladder **6**.

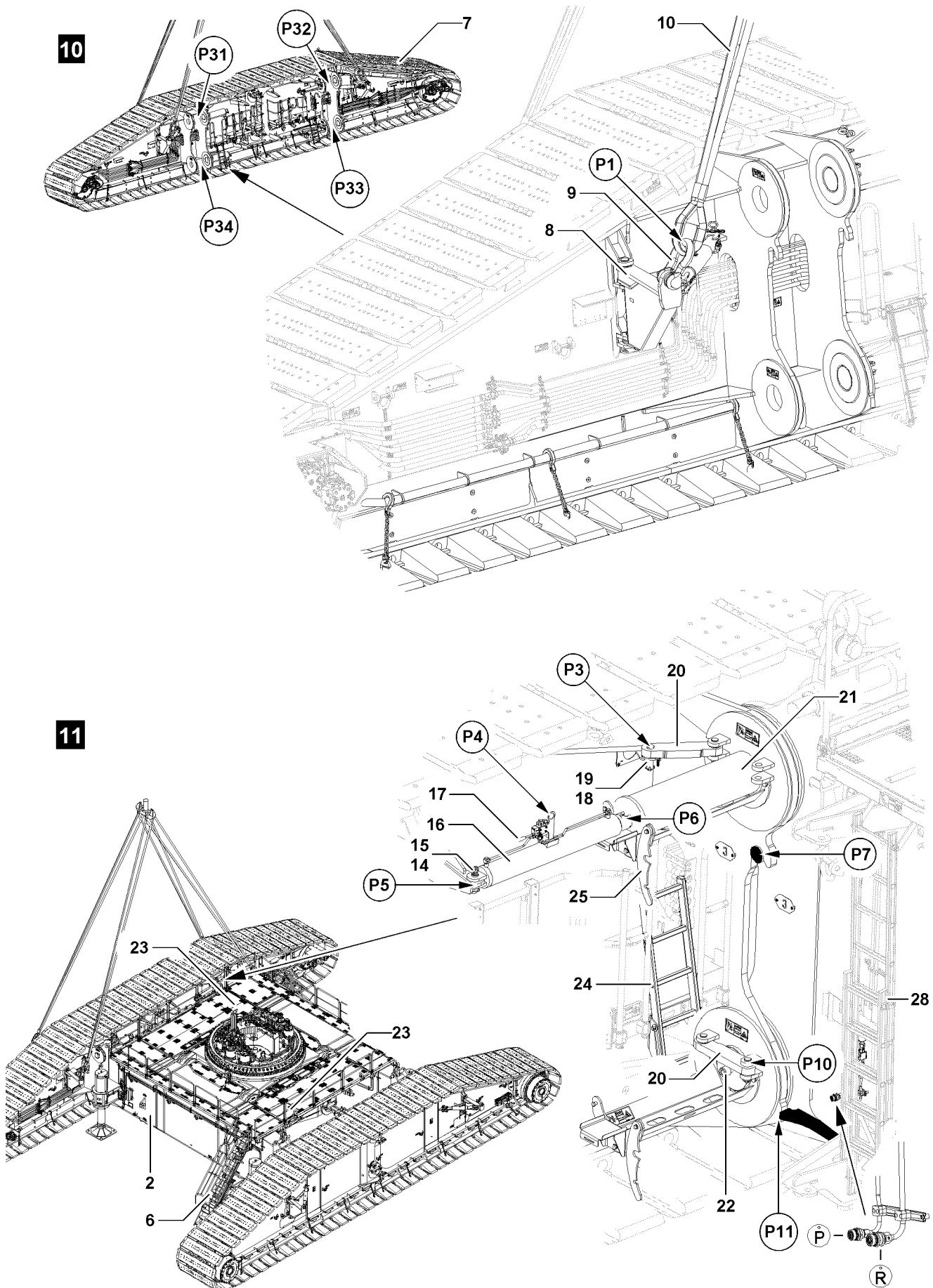

Fig.113854: Disassembling the first crawler carrier

LWE/LR 13000-001/19503-01-02/en

4.7.3 Disconnect the crawler carrier on the cross carrier

NOTICE

Pin inserted!

If the pins **21** are inserted when disconnecting the crawler carrier **7** from the cross carrier **2**, components can be severely damaged!

- ▶ Make sure that the pins **21** on the crawler carrier **7** are unpinned before disconnecting the cross carrier **2**, see illustration **10**!

- ▶ Make sure that the pins **21** are unpinned.



Note

- ▶ To make sure that the crawler carrier hangs on the auxiliary crane in the horizontal direction, adjust the adjustment spindles **8.2** on the tow bracket **8**.
- ▶ Turn the adjustment spindles **8.2** until the collar of the adjustment spindle is at the height of the tip of the arrow **8.1**.
- ▶ Make sure that all fastening ropes are tensioned the same when lifting the crawler carrier.

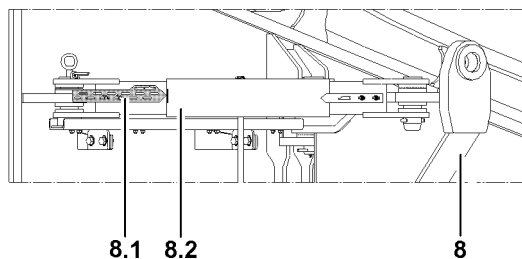

Fig. 113858: Adjustment of adjustment sleeves for lifting the **complete crawler carrier**

- ▶ Adjust the adjustment spindles on the tip of the arrow **8.1**.
- ▶ Remove the work platform.
- ▶ Carefully lift the crawler carrier **7** until the crawler carrier **7** is removed from points **P7** and points **P11** and can be removed safely.



WARNING

Danger of crushing!

When removing the crawler carrier **7**, there is an increased danger of accident due to crushing! Personnel can be severely injured or killed!

- ▶ It is prohibited for anyone to remain between the crawler carrier **7** and the cross carrier **2** !
- ▶ Observe the crane movements diligently!
- ▶ It is prohibited to remain in the slewing range of the auxiliary crane!
- ▶ The crane operator and guide must maintain visual contact!

- ▶ Remove the crawler carrier.

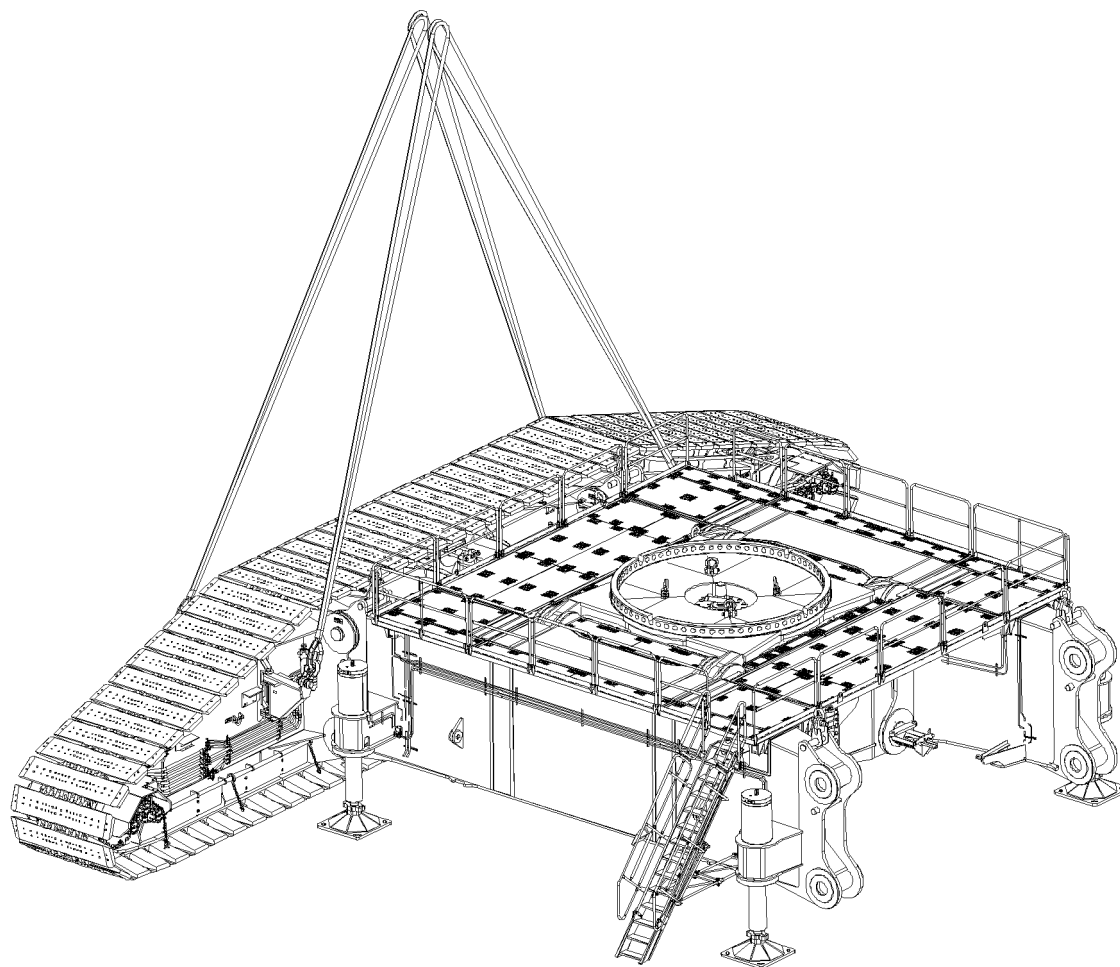

Fig.113855: Disassembling the second crawler carrier

4.8 Disassembling the second crawler carrier

Make sure that the following prerequisite is met:

- The outrigger pads are secured to prevent them from sagging.



Note

- The subsequent procedure for pinning the second crawler carrier is identical to the procedure for the first crawler carrier!

3.02 Turntable assembly

1	Turntable components	3
2	Fastening points	5
3	Assembling the turntable	11
4	Assembling the carrier for the counterweight on the turntable	75
5	Assembling the A-frame on the turntable	75
6	Assembling the counterweight on the turntable	75
7	Disassembling the counterweight on the turntable	77
8	Disassembling the A-frame on the turntable	77
9	Disassembling the carriers for the counterweight on the turntable	77
10	Disassembling the turntable	79

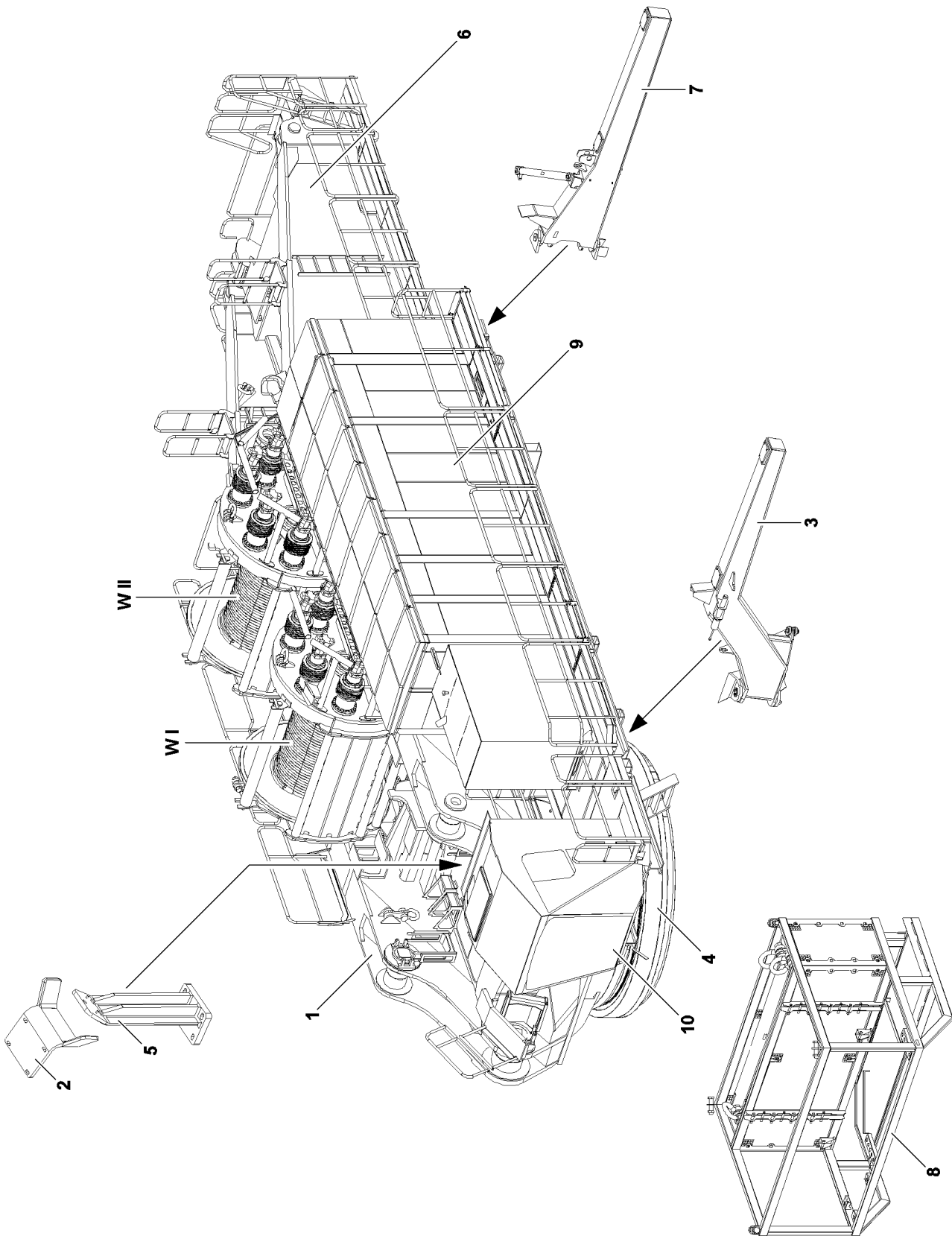

Fig.113053

LWE/LR 13000-001/19503-01-02/en

1 Turntable components



Note

- ▶ Dimensions and weights, see chapter 1.03.

1.1 Turntable frame components, front section

Position	Component
1	Turntable frame, front section
2	Deflector (turntable frame, front section)
3	Bracket (turntable frame, front section)

1.2 Roller ring connection components



Note

- ▶ The roller ring connection **4** is already installed on the crawler travel gear, see, chapter 3.01.30.
- ▶ The deflectors - ROD **5** are permanently installed on the roller ring connection.

1.3 Components of turntable frame, rear section

Position	Component
6	Turntable frame - rear section
7	Bracket (turntable frame, rear section)
W I	Winch 1 ¹⁾
W II	Winch 2 ¹⁾

1) Not included in the transport unit „Turntable frame - rear section“.

1.4 Components of transport frame / engine house / crane operator's cab

Position	Component
8	Transport frame
9	Engine house
10	Crane operator's cab

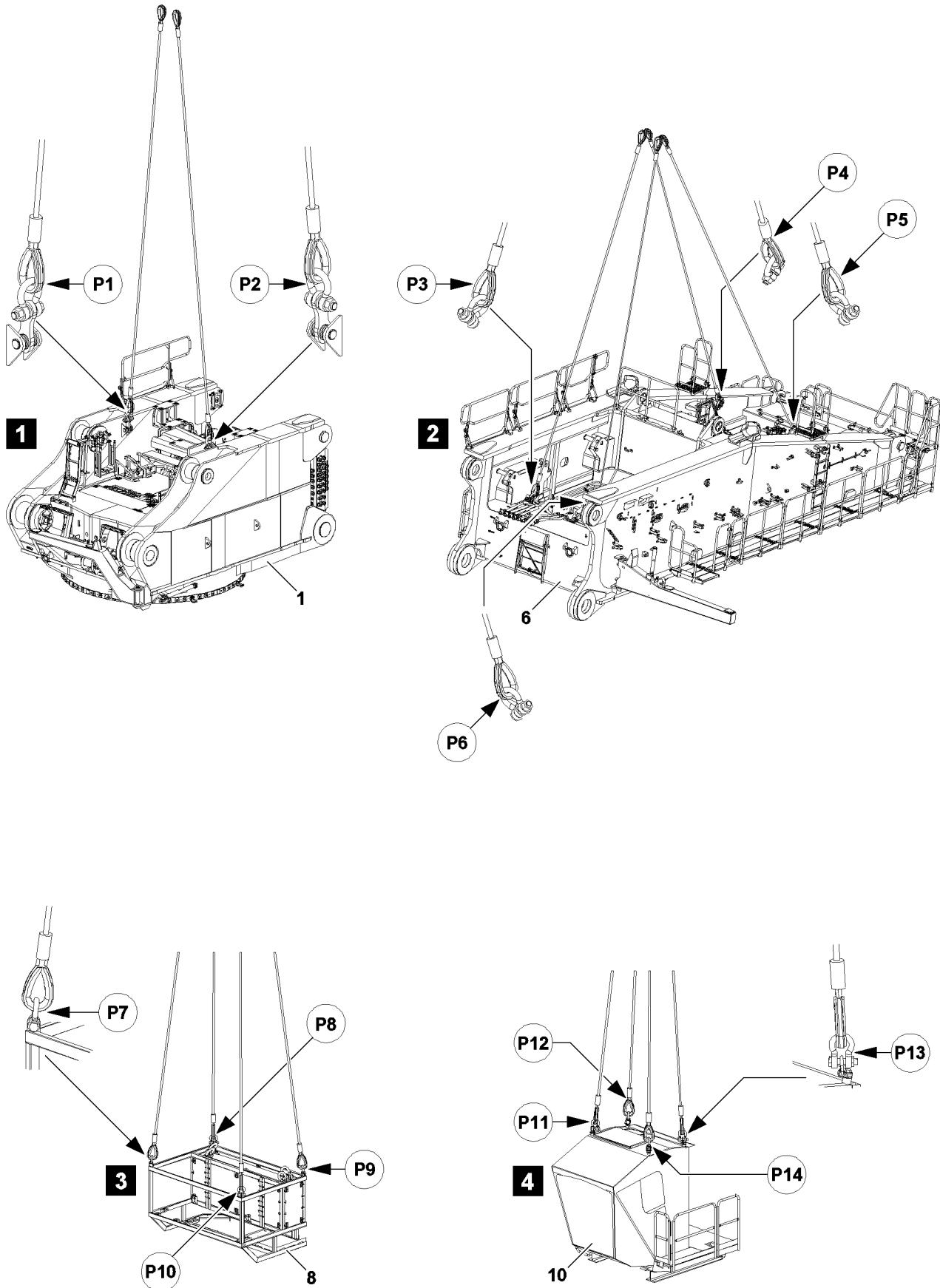

Fig.113054

LWE/LR 13000-001/19503-01-02/en

2 Fastening points



WARNING

Incorrectly fastened components!

Life-threatening situations can arise if the components are incorrectly or improperly fastened. The components can fall down, become unbalanced or move in an uncontrolled manner.

Death, severe bodily injuries, property damage.

- ▶ Fasten the component with the provided fastening equipment in the corresponding length.
- ▶ Fasten the components in the intended fastening points.
- ▶ Make sure that the fastening equipment is properly attached to the components and that it is secured sufficiently to prevent it from loosening up.



WARNING

Tipping of components!

If the fastening equipment is not kept tensioned, the incompletely fitted component can tip over. Death, severe bodily injuries, property damage.

- ▶ During assembly, keep the fastening equipment tensioned until the component is installed so it does not tip over.
- ▶ Prior to disassembly, tension the fastening equipment to secure the component.

2.1 Turntable frame front section fastening points

1 Illustration

Fastening points	
P1 and P2	Turntable frame, front section

2.2 Fastening points, turntable frame - rear section

2 Illustration

Fastening points	
P3, P4, P5, P6	Turntable frame - rear section

2.3 Fastening points - transport frame

3 Illustration

Fastening points	
P7, P8, P9, P10	Transport frame

2.4 Fastening points - crane operator's cab

4 Illustration

Fastening points	
P11, P12, P13, P14	Crane operator's cab

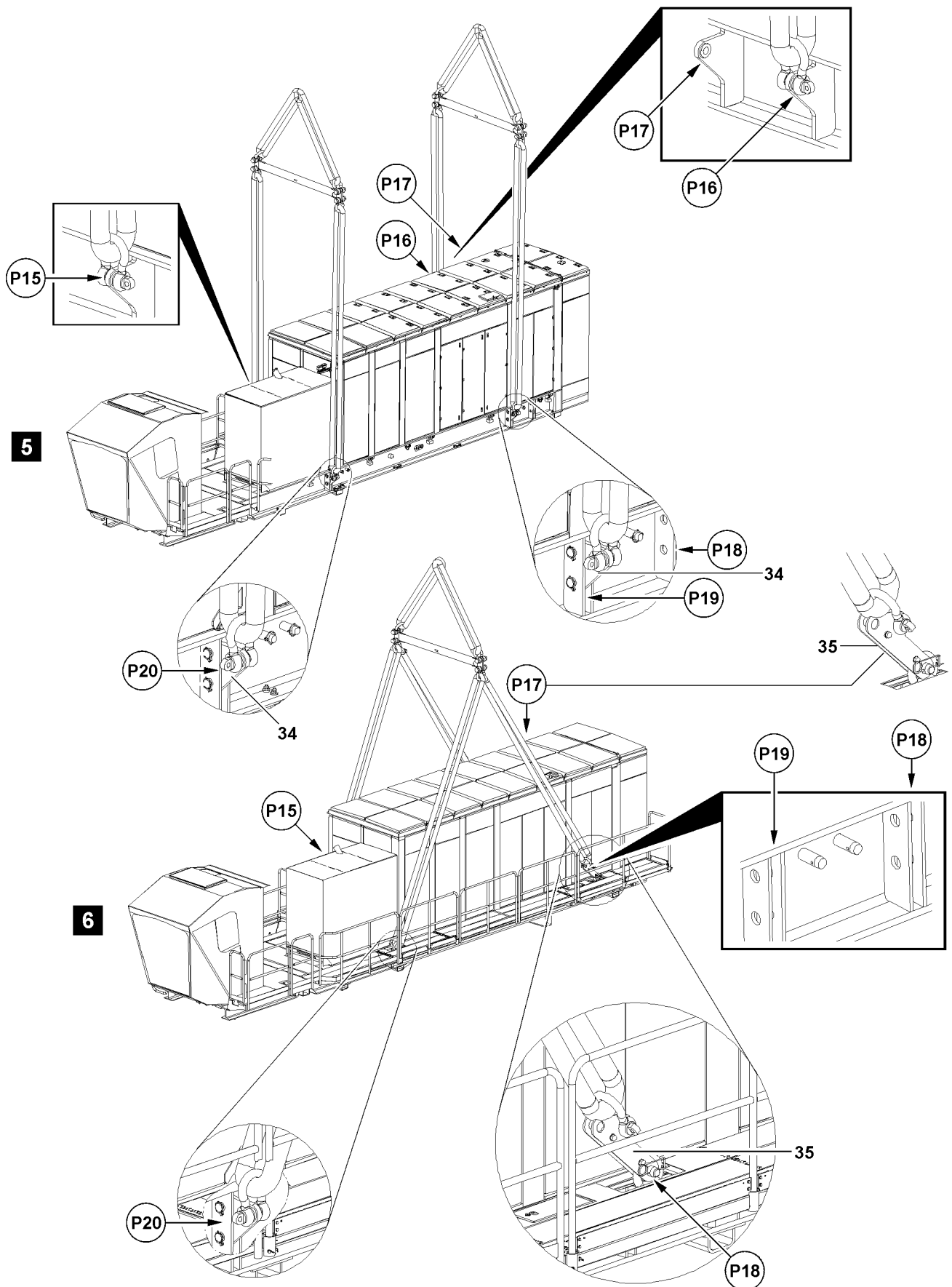

Fig.152263

LWE/LR 13000-001/19503-01-02/en

2.5 Engine house with crane operator's cab fastening points



Note

- ▶ If the engine house is lifted from the transport vehicle, then the horizontal alignment of the engine house must be constantly monitored by a guide from a safe distance!

2.5.1 Fastening the engine house with two auxiliary cranes

5 Illustration

Fastening points	
P15, P16, P19, P20	Engine house, complete

2.5.2 Fastening the engine house with one auxiliary crane

6 Illustration



WARNING

Alignment of the engine house!

If the overall center of gravity for the engine house is not observed, then dangerous situations can arise during transport with **one** auxiliary crane!

Death, severe bodily injuries, property damage.

- ▶ The overall center of gravity of the engine house depends on the fill level of the fuel tank.
- ▶ Depending on the center of gravity location, the fastening points must be determined according to the following chart and the compensation brackets **35** must be installed accordingly.

	Fastening points with a full fuel tank	
	Front	Rear
	P15, P20	P17, P18
On shackle	X	
to the compensation bracket 35		X

LWE/LR 13000-001/19503-01-02/en

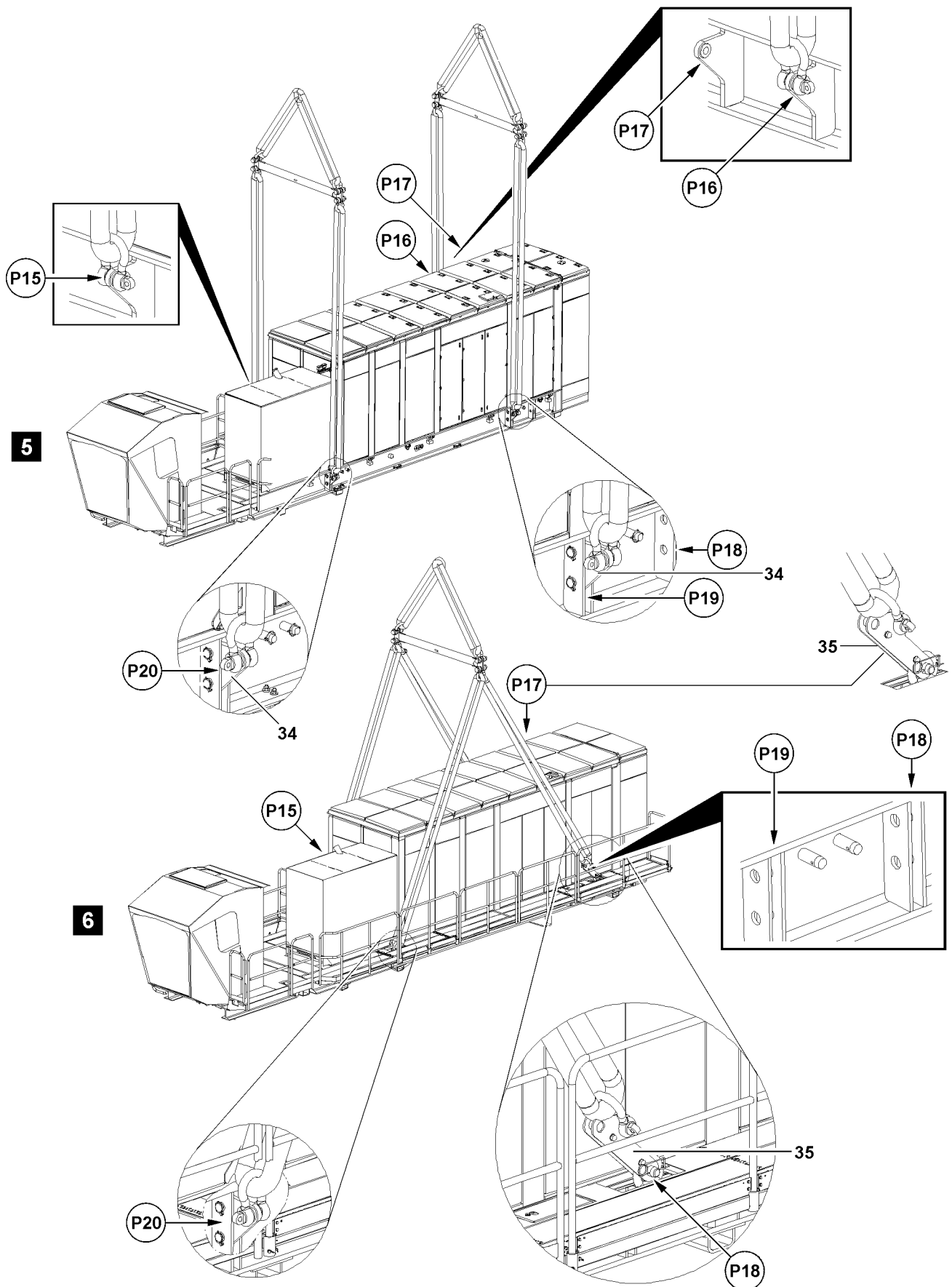

Fig.152263

LWE/LR 13000-001/19503-01-02/en

	Fastening points with empty fuel tank	
	Front	Rear
	P15, P20	P17, P18
On shackle	X	X

	Fastening points with a half full fuel tank	
	Front	Rear
	P15, P20	P17, P18
On shackle	X	
to the compensation bracket 35*		X

* Compensation bracket turned

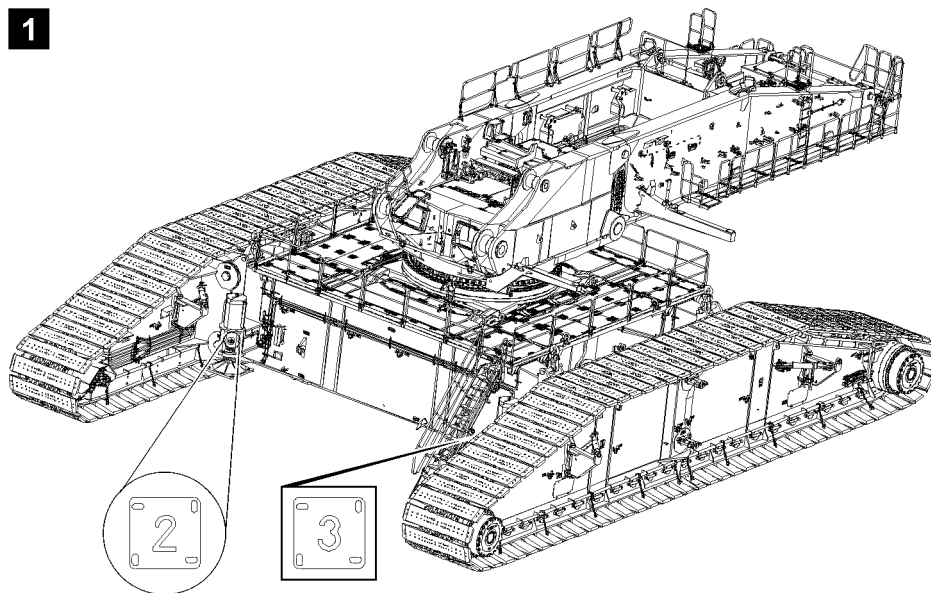

Fig.113061

LWE/LR 13000-001/19503-01-02/en

3 Assembling the turntable



WARNING

Danger of falling!

During assembly / disassembly, inspection and maintenance work, assembly personnel must be secured with appropriate aids to prevent them from falling.

Death, severe bodily injuries, property damage.

- ▶ All work at a height, when there is a danger of falling, must be carried out with suitable aids.
- ▶ If aids are not available and work cannot be carried out from the ground, then assembly personnel must secure themselves with the supplied fall arrest system to prevent falling, see the Crane operating instructions, chapter 2.04.
- ▶ If fall protection equipment is available, then it must be used, see the Crane operating instructions, chapter 2.06.
- ▶ When lifting, lowering, swinging crane parts in and out, no persons may remain in the danger zone.
- ▶ When closing or opening boom systems during boom assembly or boom disassembly, no persons may remain on the boom system or in the danger zone.
- ▶ If railings are present on the components, then they must be brought into the corresponding position and secured for assembly / disassembly work.
- ▶ Only step on the aids, ladders and catwalks with clean shoes.
- ▶ Keep aids, ladders and catwalks free of heavy dirt, snow, frost and ice.
- ▶ During all assembly and disassembly work, maintenance work and inspections, travel or crane operation is prohibited.
- ▶ Remaining on a suspended load is prohibited.
- ▶ Stepping or walking on crane components and lattice sections with an incline of more than 20° is prohibited.
- ▶ For all assembly work, the crane driver of the main crane must be in voice contact with the crane driver / crane drivers of the auxiliary crane / auxiliary cranes.
- ▶ For assembly tasks, the crane driver may only initiate crane movements when the responsible guide has explicitly released the movement.



WARNING

Danger of impact / crushing!

When assembling / disassembling crane components with the auxiliary crane, crane components can start to swing back and forth.

When lifting / lowering and positioning crane components, there is an increased danger of impact / crushing.

Death, severe bodily injuries, property damage.

- ▶ Make sure that personnel cannot be caught by components.
- ▶ Make sure that the crane is horizontally aligned.
- ▶ When working in danger zones: Use aids to protect limbs.
- ▶ Guide components with suitable aids to minimize oscillation.

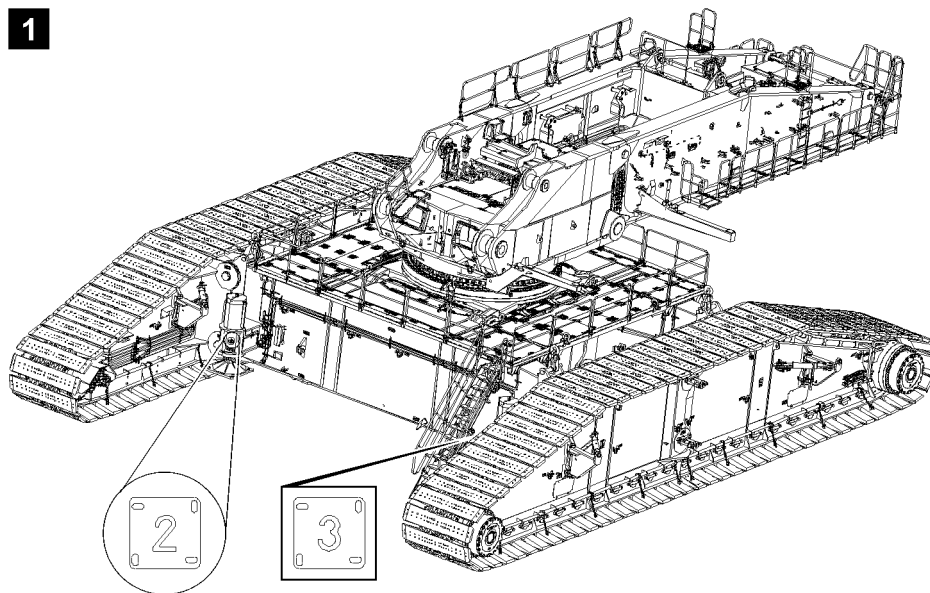

Fig.113061

**WARNING**

Danger of accident!

If no guide is present during assembly work who has voice connection to the crane operator as well as to the drivers of the auxiliary units, then there is a great danger of accident.

Crane movements that are carried out without the approval of the guide can cause accidents.

Death, severe bodily injuries, property damage.

- ▶ For all assembly work, observe the instructions of the guide.
- ▶ Make sure that the danger zone can be seen completely by the crane operator and / or the guide.

**WARNING**

Danger of fatal injury if anyone remains within the slewing range of the auxiliary crane or under the components!

When swinging in and lowering the components onto the fastening points, people can be caught in the danger zone.

Death, severe bodily injuries, property damage.

- ▶ It is prohibited to remain within the slewing range of the auxiliary crane or under the components.
- ▶ Make sure that there is no personnel in the danger zone.

**DANGER**

The components can fall down!

Death, severe bodily injuries, property damage.

- ▶ Do not detach the auxiliary crane until the respective component is pinned and secured.

Make sure that the following prerequisites are met:

- The crawler travel gear is completely assembled.
- All pin connections on the crawler travel gear are properly pinned and secured.
- The crawler chain is tensioned.
- The ground is level and of sufficient load bearing capacity.
- The crawler travel gear is horizontally aligned.
- The roller ring connection (ROD) is properly installed on the crawler travel gear, see chapter 3.01.30.
- An auxiliary crane is available.
- The hydraulic connections on the crawler travel gear are completely established.
- The pin bores of the Quick-Connection (QC) on the front section of the turntable frame have been cleaned.
- The connector pins for the Quick-Connection (QC) have been cleaned.

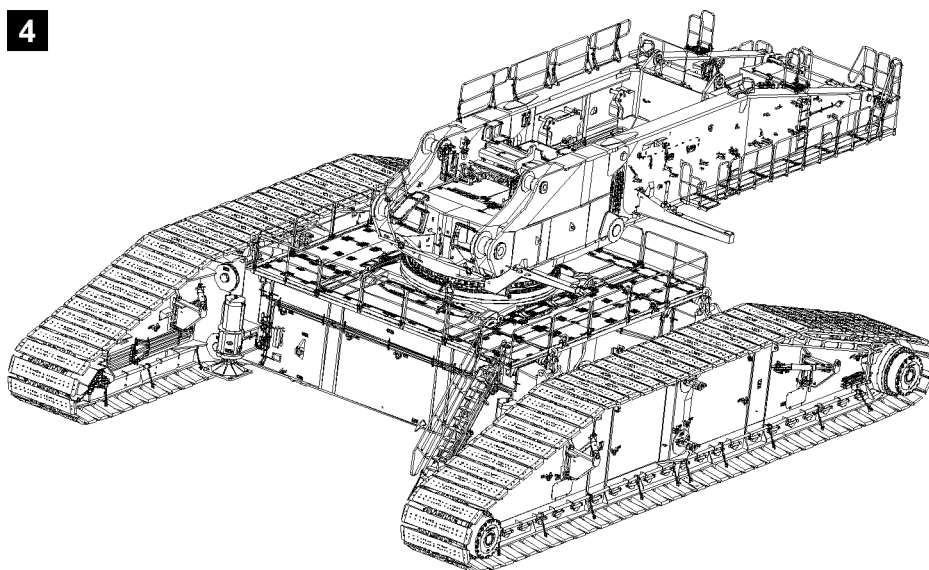
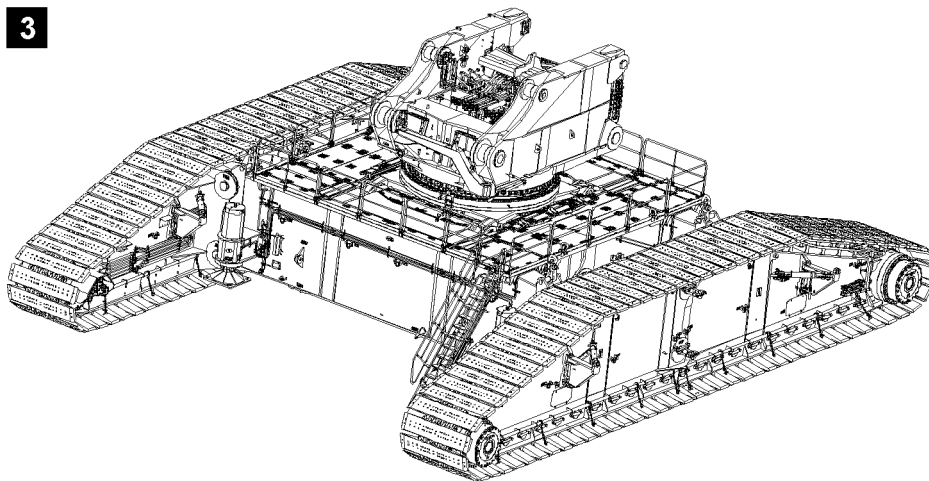
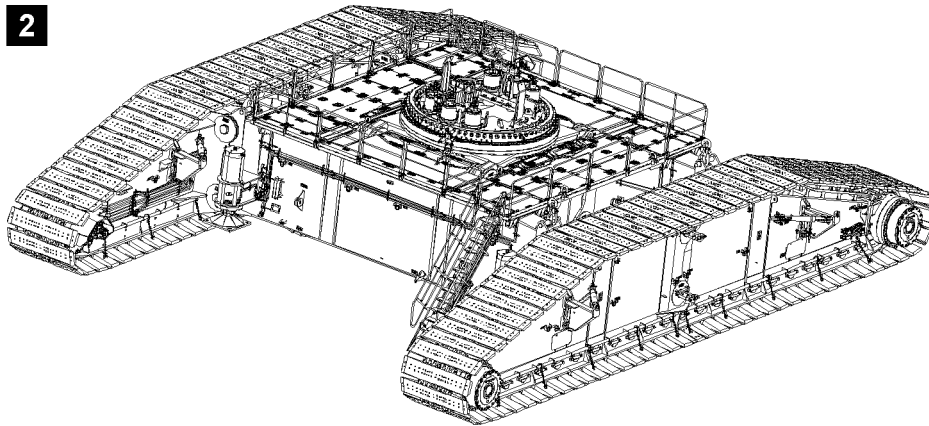

Fig.113059

LWE/LR 13000-001/19503-01-02/en

3.1 Assembling the central ballast

If a central ballast is required for the planned crane operation, then the central ballast can be installed completely on the travel gear before the installation of the turntable. This ensures better accessibility for the assembly of the central ballast brackets as well as the central ballast on the travel gear.

Installation possibilities of the central ballast on the travel gear for crane status:

1. Without turntable, see illustration **2**
2. With installed turntable frame front section, illustration **3**
3. With completely installed turntable, illustration **4**

The assembly of the entire central ballast is in principle also possible after turntable assembly has been completed, this will however require a somewhat increased assembly effort.



Note

- ▶ The assembly of the central ballast is described in detail in chapter 3.03.
-

When a central ballast is required in the erection / take-down charts or in the respective load chart:

- ▶ Install the central ballast on the crawler travel gear.

3.2 Installing the turntable frame front section on the crawler travel gear

NOTICE

Danger of property damage to the roller ring connection!

If the roller ring connection **4** is dirty, then severe damage can occur to the roller ring connection during assembly as well as during crane operation!

This can result in replacement of the roller ring connection!

- ▶ Thoroughly clean the upper and lower section of the roller ring connection as well as the associated pins before assembly.

Before setting the turntable onto the roller ring connection on the crawler center section, the placement surfaces or the contact surfaces as well as the pin bores on the upper section and the lower section on the roller ring connection must be cleaned.

Make sure that the following prerequisites are met:

- The central ballast is installed according to the load chart and the erection and take-down charts.
- The roller ring connection **4** is properly pinned and secured to the crawler travel gear.
- The centering pins **1.1** are assembled and secured on the turntable frame front section **1**.
- The centering pins **1.1** are greased with water repellent grease.
- The transport device with the connector pins for the Quick-Connection is in the vicinity of the roller ring connection.
- The access ladders on the crawler travel gear are in the operating position.
- The grating flaps on the „platform“ of the crawler travel gear are closed.
- All railings on the crawler travel gear are in the operating position.

3.2.1 Setting the turntable frame front section on the crawler travel gear

- ▶ Fasten the turntable frame front section **1** to the auxiliary crane, see section „Fastening points“.



WARNING

Incorrect fastening of the turntable frame front section!

Life-threatening situations can arise if the turntable frame front section **1** is incorrectly or improperly fastened.

The turntable frame front section **1** can fall down, become unbalanced or move in an uncontrolled manner.

Death, severe bodily injuries, property damage.

- ▶ Fasten the turntable frame front section **1** with the provided fastening equipment in the corresponding length, see section „Fastening points“.
- ▶ Fasten the turntable frame front section **1** in the provided fastening points.
- ▶ Make sure that the fastening equipment is properly attached to the turntable frame front section **1** and that it is secured sufficiently to prevent it from loosening up.

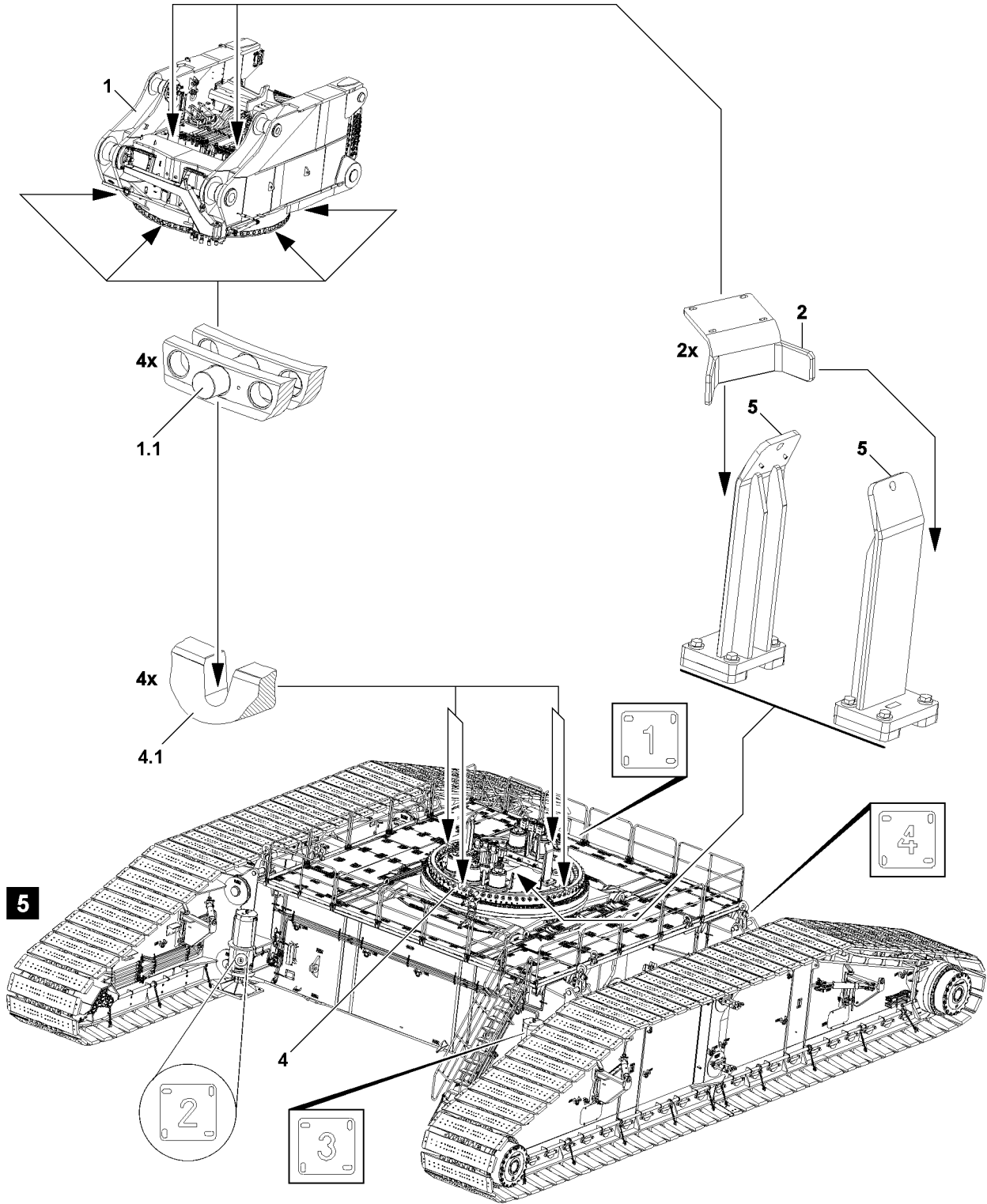

Fig.113056

LWE/LR 13000-001/19503-01-02/en

**WARNING**

Danger of accident!

When lifting, swinging in and setting down the turntable frame front section **1**, components can fall down or start to swing back and forth. Personnel in the danger zone can be caught or hit.

Death, severe bodily injuries, property damage.

- ▶ Make sure that no persons are within the working and slewing range of the auxiliary crane as well as in the assembly area of the turntable frame front section **1**.
- ▶ Make sure that no people, objects or obstacles are within the danger zone.

- ▶ Lift the turntable frame front section **1** with the auxiliary crane and swing it over the railing on the crawler center section to the roller ring connection **4** on the crawler travel gear.
- ▶ Align the longitudinal axle of the turntable frame front section approximately to the center axle between the assembly supports two and three.

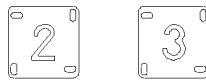

Fig.114473: B114473: Assembly supports two and three „front“

- ▶ Align the turntable frame front section **1** so that the turntable is pre-centered with the deflectors **2** on the deflectors **5** of the roller ring connection **4**.

**WARNING**

Crushing, sheering off of limbs!

During the assembly of the turntable frame front section **1**, fingers, hands or arms can be crushed or limbs can even be severed.

Death, severe bodily injuries, property damage.

- ▶ Keep limbs out of the danger zone.

When the turntable is aligned / pre-centered on the deflectors:

- ▶ Lower the turntable frame front section **1** slowly with the auxiliary crane to the upper edge of the roller ring connection **4**.

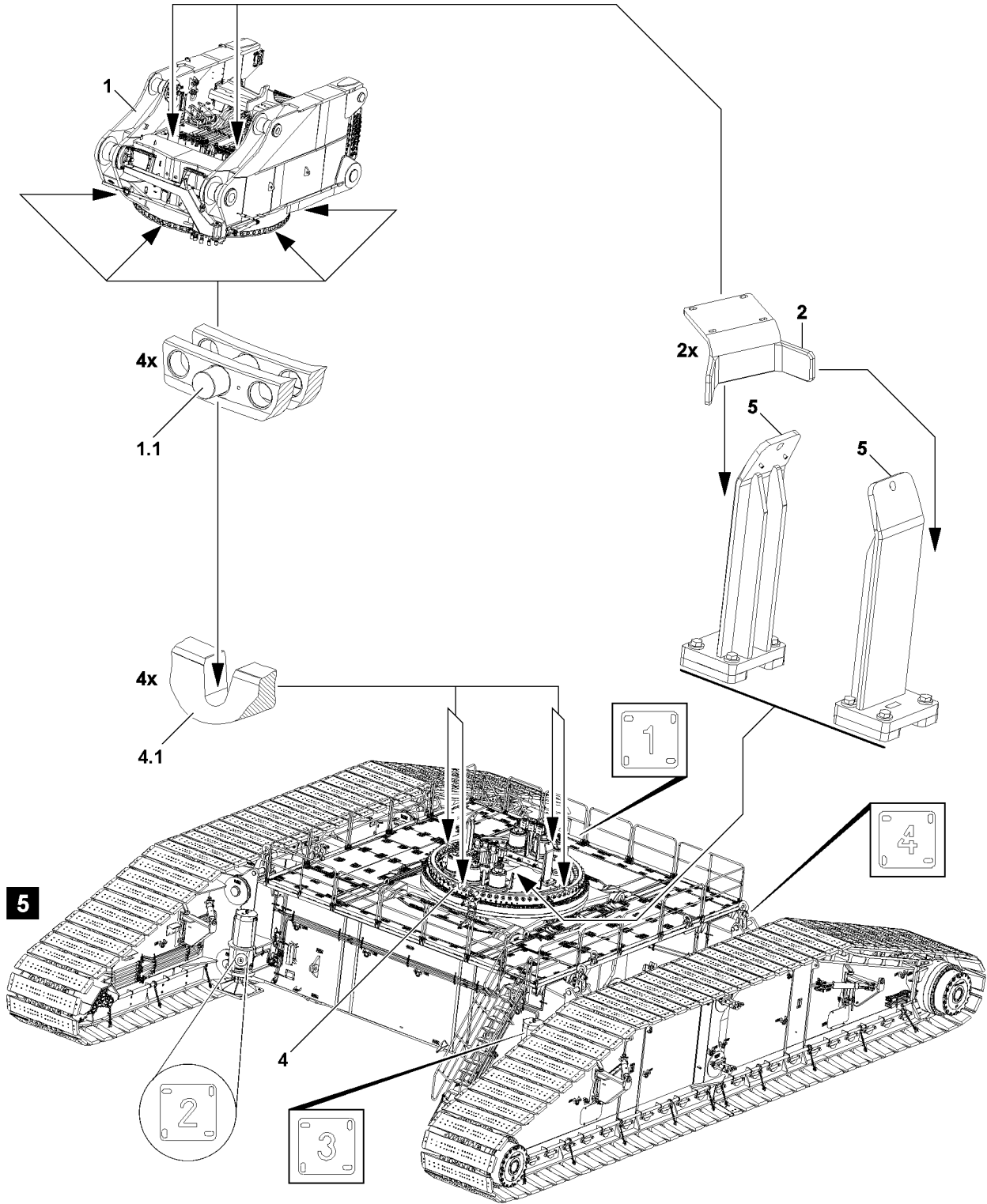

LWE/LR 13000-001/19503-01-02/en

Fig.113056

NOTICE

Damage to the roller ring connection 4!

By completely lowering the turntable frame front section 1 on the roller ring connection 4, the centering pins 1.1 or other components in the area of the roller ring connection 4 or the rotary connection can be damaged!

- ▶ Lower the turntable slowly onto the roller ring connection 4.
-

**Note**

- ▶ Pay utmost attention to the exact alignment of the centering pin 1.1 on the turntable frame front section 1 to the pocket receptacles 4.1 on the roller ring connection 4.
-

When the centering pins 1.1 are aligned on the pocket receptacles 4.1:

- ▶ Slowly lower the turntable frame front section 1 completely on the lower section of the roller ring connection.
-

**DANGER**

Tipping of the turntable frame front section 1!

If the fastening equipment is removed on the turntable frame front section before the turntable frame front section 1 is pinned via the Quick-Connection on the lower section of the roller ring connection, then the turntable frame front section tips over!

Death, severe bodily injuries, property damage.

- ▶ Make sure that the fastening equipment on the turntable frame front section 1 remains „tensioned“ until the turntable frame front section is properly pinned and secured.
-

When the turntable frame front section is laying completely on the roller ring connection:

- ▶ Keep the fastening equipment tensioned.

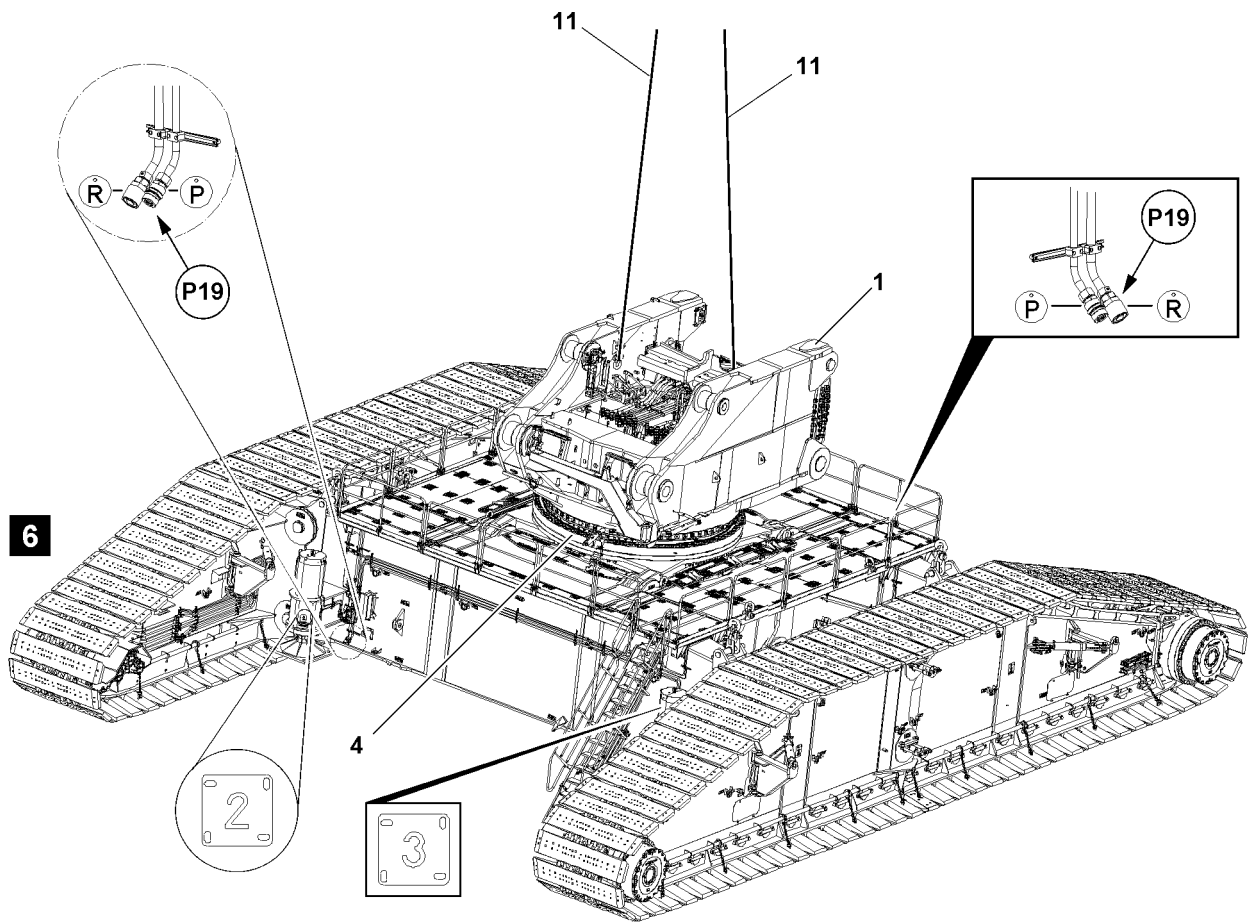

Fig.113066

3.2.2 Pinning the turntable frame front section with the Quick-Connection on the crawler travel gear

Make sure that the following prerequisites are met:

- The turntable frame front section **1** is seated completely on the roller ring connection **4** (ROD).
- The pin bores along the circumference of the roller ring connection are free.
- The fastening equipment **11** on the turntable frame front section **1** is tensioned.

Establishing the hydraulic connections to the pin pulling cylinder

On every cross carrier, on the outside, is a central hydraulic connection **P19** for the hydraulic oil supply for assembly purposes. The supply occurs via the operational engine house or the external hydraulic aggregate, see Hydraulic diagram.

There are two connection possibilities on the inside of the cross carriers for the pin pulling cylinder.

The hydraulic connections are established with quick couplings.

When connecting hydraulic lines with quick couplings, make sure that the coupling procedure is carried out correctly.

The matching quick couplings are marked.



WARNING

Pressure in the hydraulic lines!

If the pressure supply is not interrupted before connecting / releasing the hydraulic lines, the hydraulic oil can escape with high pressure.

Death, severe bodily injuries, property damage.

- ▶ Release the pressure in the hydraulic system before connecting / disconnecting: Interrupt the pressure supply and wait a short time.



WARNING

Loss of pressure or leakage!

Incorrectly coupled or self-loosening quick couplings (particularly return lines) can result in serious accidents due to component failure.

Death, severe bodily injuries, property damage.

- ▶ Check that the quick couplings have been properly connected before using the crane.
- ▶ Make sure that the connection point is selected in such a way that the length of the hydraulic hoses is sufficient.
- ▶ Connect the coupling components (sleeve and connector) and screw together with the knurled nut.
- ▶ Tighten the hydraulic coupling by hand. Turn the knurled nut until it reaches a tangible, fixed stop position.

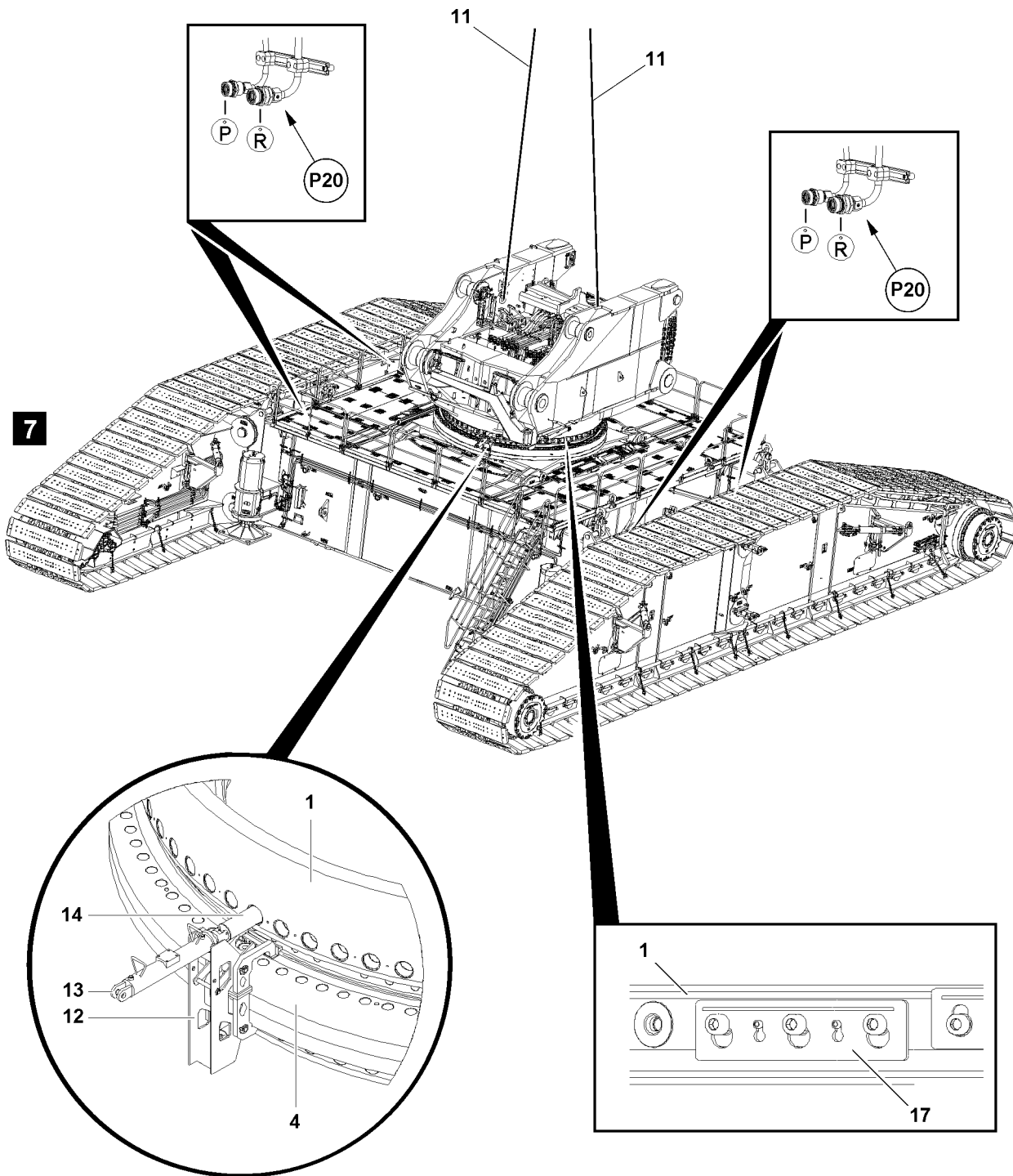

Fig.113064

LWE/LR 13000-001/19503-01-02/en

- ▶ Establish the hydraulic connection: Connect the supply lines of the pin pulling cylinder **13** to one of the coupling points **P20** on the hydraulic connection **R** and hydraulic connection **P**.

Inserting the connector pins on the Quick Connection



WARNING

Personnel in the danger zone!

When pinning, there is a danger of accident for personnel in the Quick Connection.
Death, severe bodily injuries.

- ▶ Work from **outside** the turntable to insert the connector pins **14**.

- ▶ Insert all connector pins **14** along the circumference of the roller ring connection **4** by hand.

Problem remedy

The connector pins cannot be pinned?

- ▶ Raise the turntable frame front section slightly with the auxiliary crane and lower it again if necessary until the pin bores align.



Note

- ▶ If the connector pins **14** still cannot be inserted easily by hand, use the pin pulling device!
- ▶ For information about the pin pulling device, see chapter 5.30.



WARNING

The connector pins are not secured!

Unsecured connector pins can become unpinned on their own.

The Quick Connection can fail, the turntable can release from the crawler travel gear.

Death, severe bodily injuries, property damage.

After inserting the connector pins **14**:

- ▶ Secure the all connector pins **14** with the retaining plate **17**.
- ▶ Perform a visual inspection.

When the connector pins **14** are properly pinned on the Quick Connection:

- ▶ Secure the connector pins **14** with retaining plates **17**.

Disconnecting the hydraulic connections from the pin pulling cylinder

The hydraulic connections are established with quick couplings.

When disconnecting hydraulic lines with quick couplings, make sure that the uncoupling procedure is carried out correctly.



WARNING

Pressure in the hydraulic lines!

If the pressure supply is not interrupted before connecting / releasing the hydraulic lines, the hydraulic oil can escape with high pressure.

Death, severe bodily injuries, property damage.

- ▶ Release the pressure in the hydraulic system before connecting / disconnecting: Interrupt the pressure supply and wait a short time.

- ▶ Make sure that the hydraulic system pressure has been released.
- ▶ Release the hydraulic coupling by hand.
- ▶ Disconnect the hydraulic connection: Disconnect the supply lines of the pin pulling cylinder **13** on the supply lines of the cross carrier, hydraulic connection **R** and hydraulic connection **P** on point **P20**.

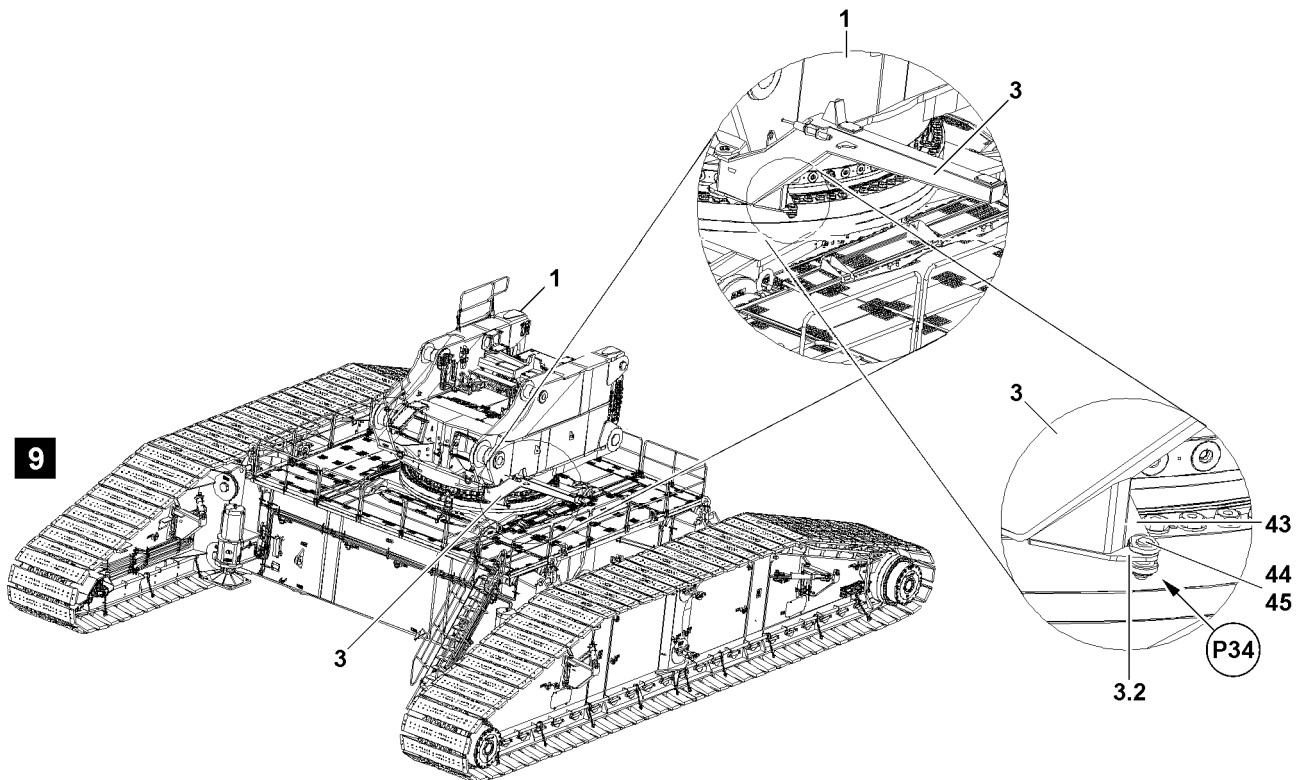
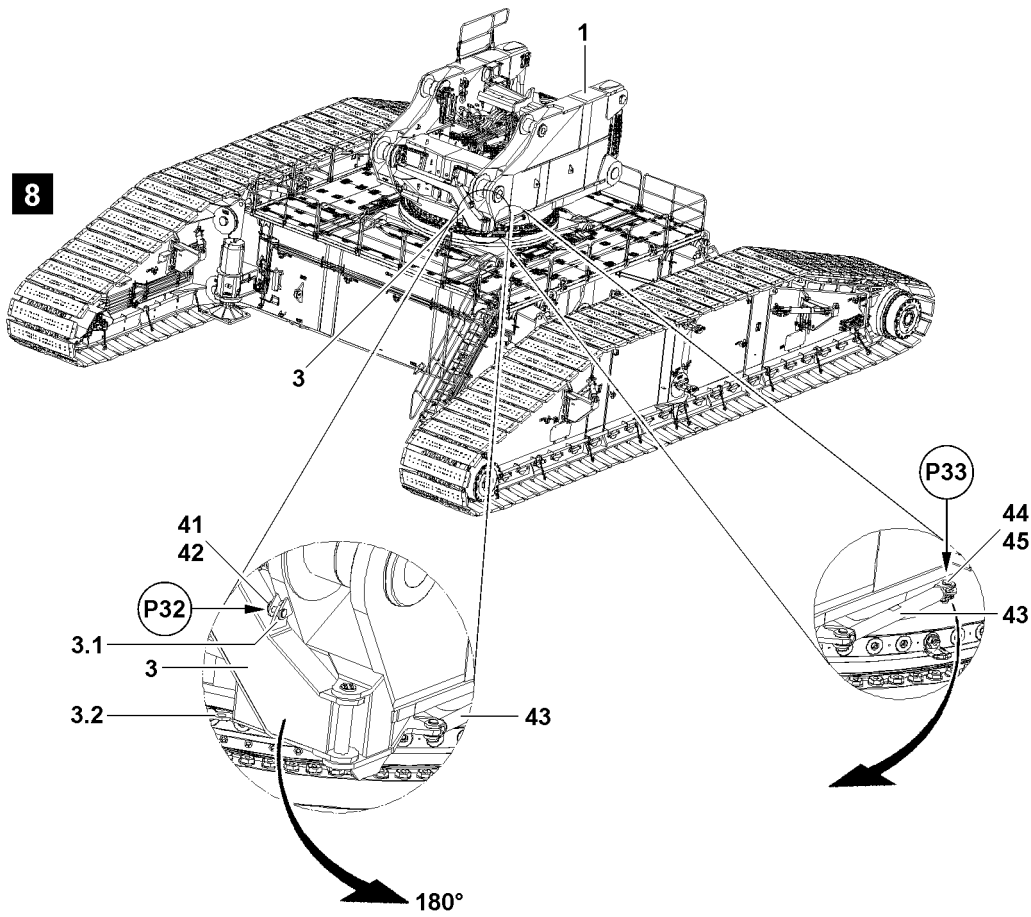

Fig.114155

LWE/LR 13000-001/19503-01-02/en

3.2.3 Bringing the bracket for the engine house into the operating position



WARNING

Danger of accident due to swinging bracket **3**!

If the crawler travel gear is not standing on level and horizontal ground, then the bracket **3** can swing out by itself during unpinning!

Death, severe bodily injuries, property damage.

- ▶ Make sure that the crawler travel gear is set down on level and horizontal ground.

Release and swing the bracket **3** on the turntable frame front section **1** out.

- ▶ Release the bracket **3**: Remove the locking pin **42** on the bracket **3.1** (point **P32**) and unpin the pin **41**, see illustration **8**.
- ▶ Swing the bracket **3** outward by approx. 180°.

When the bracket **3** has been swung out:

- ▶ Release the strut **43**: Remove the locking pin **45** in point **P33** and unpin the pin **44**.



Note

- ▶ Insert the pin **41** again in point **P32** and secure with the locking pin **42**.
- ▶ Reuse the pin **44** and locking pin **45** to pin the strut **43** in point **P34**.
- ▶ Swing the strut **43** outward in direction of the bracket **3**.
- ▶ Position the strut **43** on the receptacle **3.2** of the bracket **3** at point **P34**, illustration **9**.
- ▶ Pin the strut **43** at point **P34**: Insert the pin **44** on the receptacle **3.2** and secure with locking pin **45**.

Result:

- The bracket **3** is in the operating position.

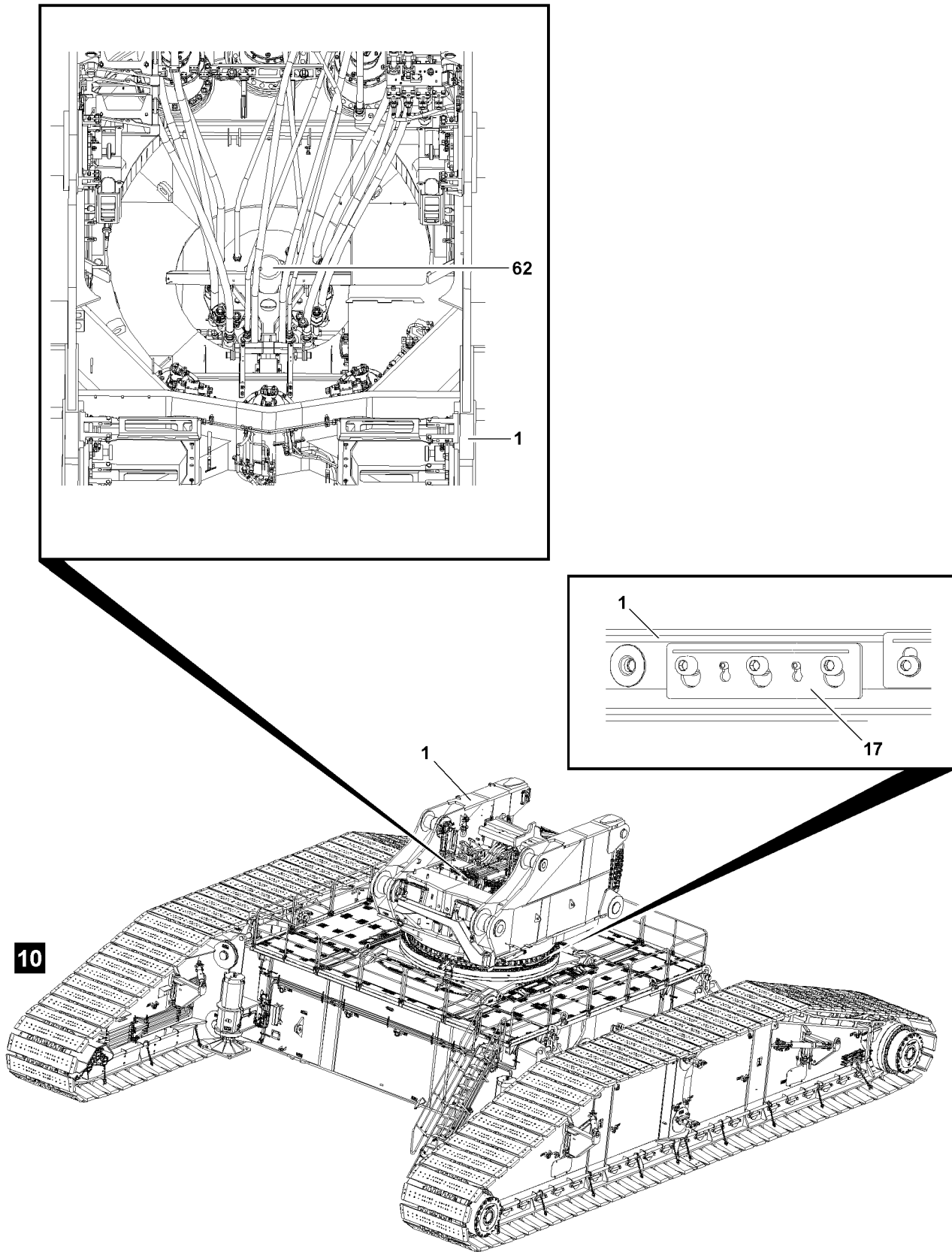

Fig.113067

LWE/LR 13000-001/19503-01-02/en

3.2.4 Connecting the hydraulic and electrical connections to the rotary connection

Make sure that the following prerequisites are met:

- The turntable frame front section **1** is installed on the crawler travel gear.
- All the connector pins of the Quick-Connection (QC) are completely pinned on the circumference of the roller ring connection and secured with the retaining plates **17**.
- The pin pulling device has been removed.

Establishing the hydraulic connections

The hydraulic connections are established with quick couplings.

When connecting hydraulic lines with quick couplings, make sure that the coupling procedure is carried out correctly.

The matching quick couplings are marked.



WARNING

Pressure in the hydraulic lines!

If the pressure supply is not interrupted before connecting / releasing the hydraulic lines, the hydraulic oil can escape with high pressure.

Death, severe bodily injuries, property damage.

- ▶ Release the pressure in the hydraulic system before connecting / disconnecting: Interrupt the pressure supply and wait a short time.



WARNING

Loss of pressure or leakage!

Incorrectly coupled or self-loosening quick couplings (particularly return lines) can result in serious accidents due to component failure.

Death, severe bodily injuries, property damage.

- ▶ Check that the quick couplings have been properly connected before using the crane.
- ▶ Release the pressure in the hydraulic system before connecting or disconnecting. Turn the engine off and wait a short time.
- ▶ Connect the coupling components (sleeve and connector) and screw together with the knurled nut.
- ▶ Tighten the hydraulic coupling by hand. Turn the knurled nut until it reaches a tangible, fixed stop position.
- ▶ Establishing the hydraulic connections: Connect the hydraulic lines for the turntable frame front section **1** on the rotary connection **62** on the crawler travel gear, see Hydraulic diagram.

Establishing the electrical connections



Note

- ▶ To establish the electrical connections, use the Electric wiring diagram.
- ▶ Establish the electrical connections from the turntable frame front section to the terminal boxes: Connect the electrical connections according to their identification.
- ▶ Establish the electrical connections from the crawler travel gear to the terminal boxes: Connect the electrical connections according to their identification.

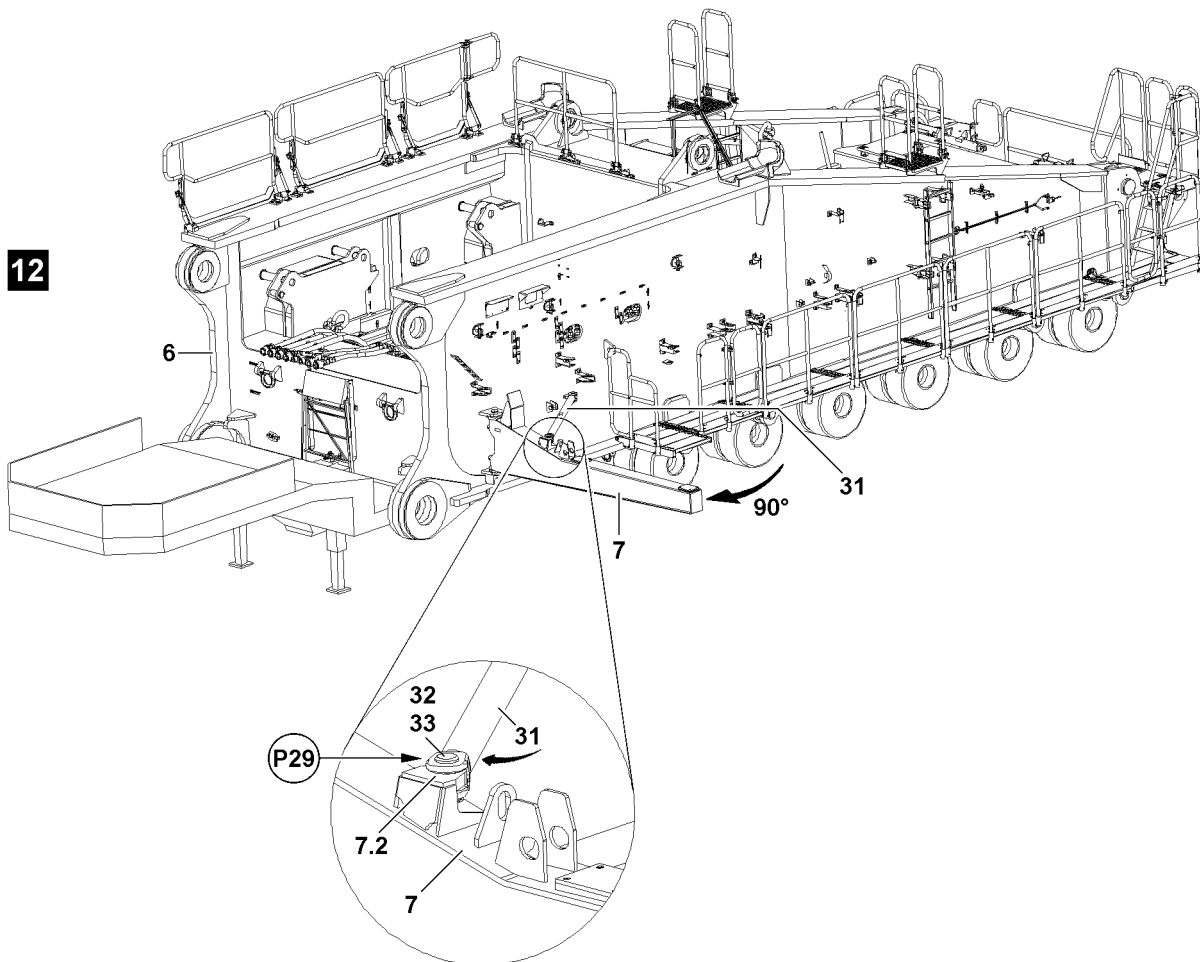
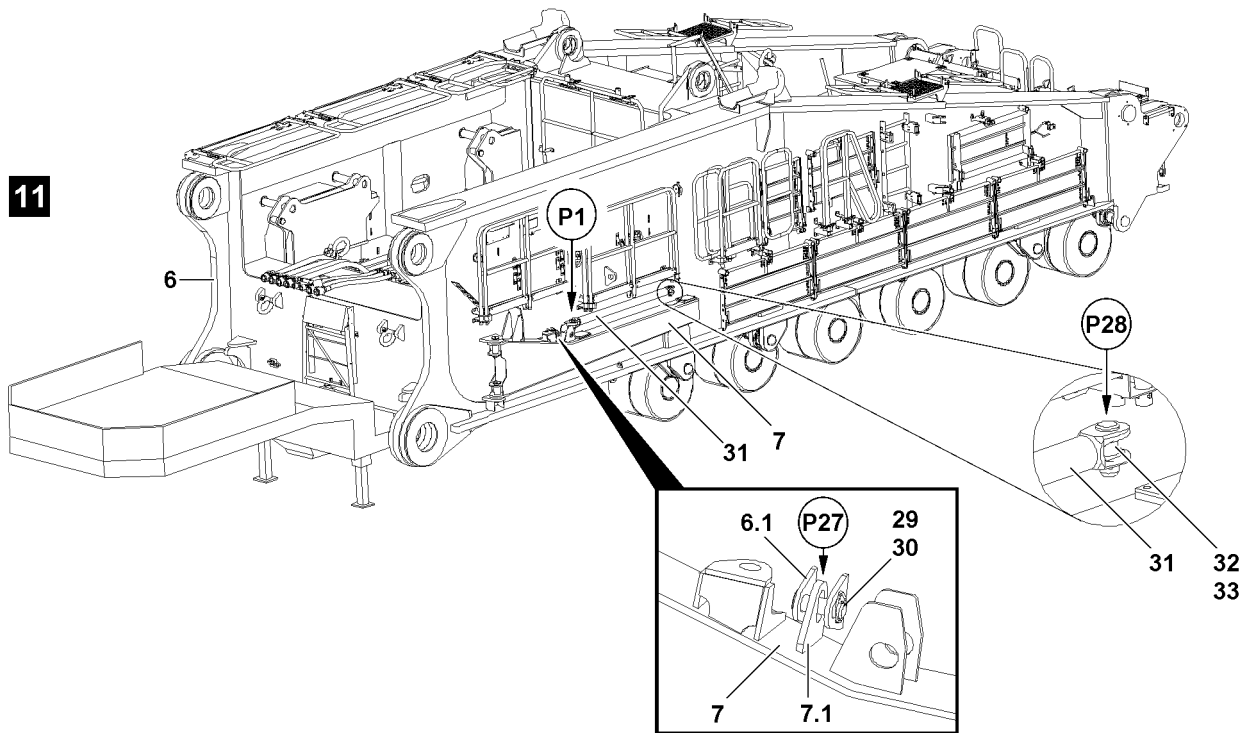

Fig.114153

LWE/LR 13000-001/19503-01-02/en

3.3 Preparing the turntable frame rear section for assembly

The preparatory work on the turntable frame rear section **6** is made while the turntable frame rear section **6** is still on the flatbed trailer.

First swing the bracket **7** for the engine house from transport position into operating position and pin.

Then bring the folding platforms, gratings and railings on the turntable frame rear section into the operating position.

Make sure that the following prerequisites are met:

- The flatbed trailer is parked on level and horizontal ground.
- The turntable frame rear section is on the flatbed trailer.
- All components, such as brackets, platforms, catwalks and railings are in the transport position.
- No objects are in the assembly area.

3.3.1 Bringing the bracket for the engine house into the operating position



WARNING

Danger of accident due to the bracket swinging out by itself!

If the flatbed trailer is not standing on level and horizontal ground, then the bracket **7** can swing out by itself during unpinning!

Death, severe bodily injuries, property damage.

- ▶ Make sure that the flatbed trailer is parked on level and horizontal ground.

Release and swing the bracket **7** on the turntable frame rear section **6** out, illustration **11**.

- ▶ Release the bracket **7**: Remove the locking pin **30** in point **P27** and unpin the pin **29**.
- ▶ Swing the bracket **7** outward by approx. 90°.

When the bracket **7** has been swung out:

- ▶ Release the strut **31**: Remove the locking pin **33** in point **P28** and unpin the pin **32**.



Note

- ▶ Reuse the pin **32** and locking pin **33** to pin the strut **31** in point **P29**.

- ▶ Swing the strut **31** outward in direction of the bracket.
- ▶ Position the strut **31** on the receptacle **7.2** of the bracket **7** at point **P29**, illustration **12**.
- ▶ Pin the strut **31** at point **P29**: Insert the pin **32** on the receptacle **7.2** and secure with locking pin **33**.

Result:

- The bracket **7** is in the operating position.

3.3.2 Bringing platforms, gratings, ladders and railings into the operating position

Make sure that the following prerequisite is met:

- The bracket **7** is pinned and secured in the operating position.



Note

- ▶ For the assembly of platforms, gratings, ladders and railings see chapter 2.06.

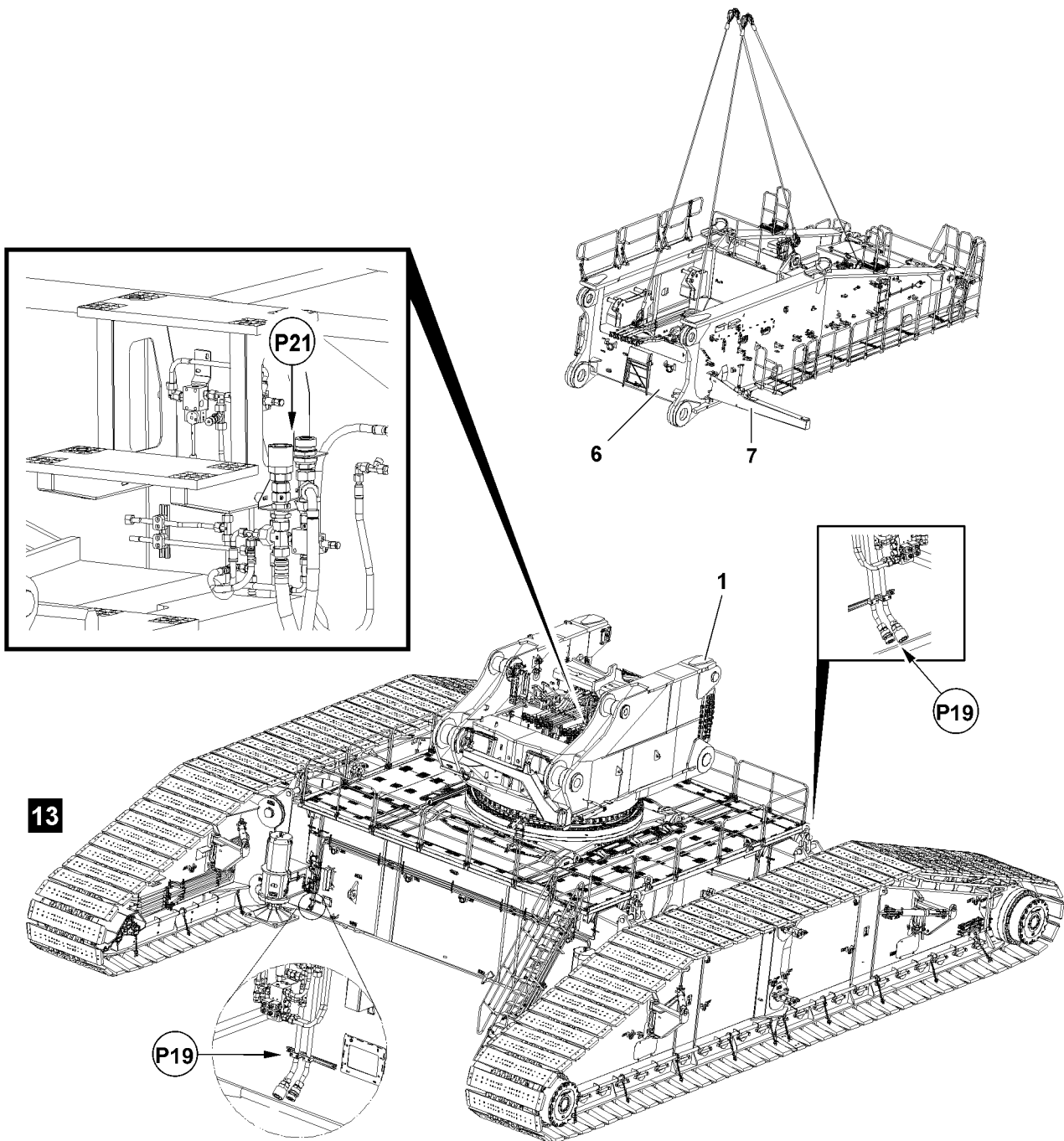

Fig.113057

LWE/LR 13000-001/19503-01-02/en

3.4 Installing the turntable frame rear section on the turntable frame front section

Make sure that the following prerequisites are met:

- The turntable frame front section **1** is properly pinned and secured on the roller ring connection **4**.
- The grating flaps on the catwalks of the crawler travel gear are closed.
- The hydraulic connections between the turntable frame front section **1** and the rotary connection are properly established.
- The access ladders on the turntable frame front section **1** are in the operating position.
- The railings on the turntable frame front section **1** are in the operating position.
- The bracket **7** on the turntable frame rear section **6** is in the operating position.
- The platforms, gratings, ladders and railings on the turntable frame rear section **6** are in the operating position.

3.4.1 Connecting the hydraulic supply lines for assembly



Note

- ▶ Before assembly of the turntable frame rear section **6** on the turntable frame front section **1**, establish the hydraulic connections to the pin pulling cylinders.
- ▶ The pressure supply to the pin pulling cylinders can be ensured either via the external hydraulic aggregate or the installation connections on the operational engine house.
- ▶ Connect the supply lines for the pressure supply either to a cross carrier (point **P19**) or to the turntable frame front section **1** (point **P21**).

Make sure that the following prerequisite is met:

- The pressure in the hydraulic system has been released.

Establishing the hydraulic connections from the external hydraulic aggregate to the assembly circuit

- ▶ Connect the supply lines of the external hydraulic aggregate on the front cross carrier at point **P19**.
or
Connect the supply lines of the hydraulic aggregate on the rear cross carrier at point **P19**.
or
Connect the supply lines of the pin pulling aggregate on the turntable frame rear section **1** at point **P21**.

Establishing the hydraulic connections from the engine house to the installation circuit

- ▶ Connect the supply lines of the engine house on the front cross carrier at point **P19**.
or
Connect the supply lines of the engine house on the rear cross carrier at point **P19**.
or
Connect the supply lines of the engine house on the turntable frame front section at point **P21**.

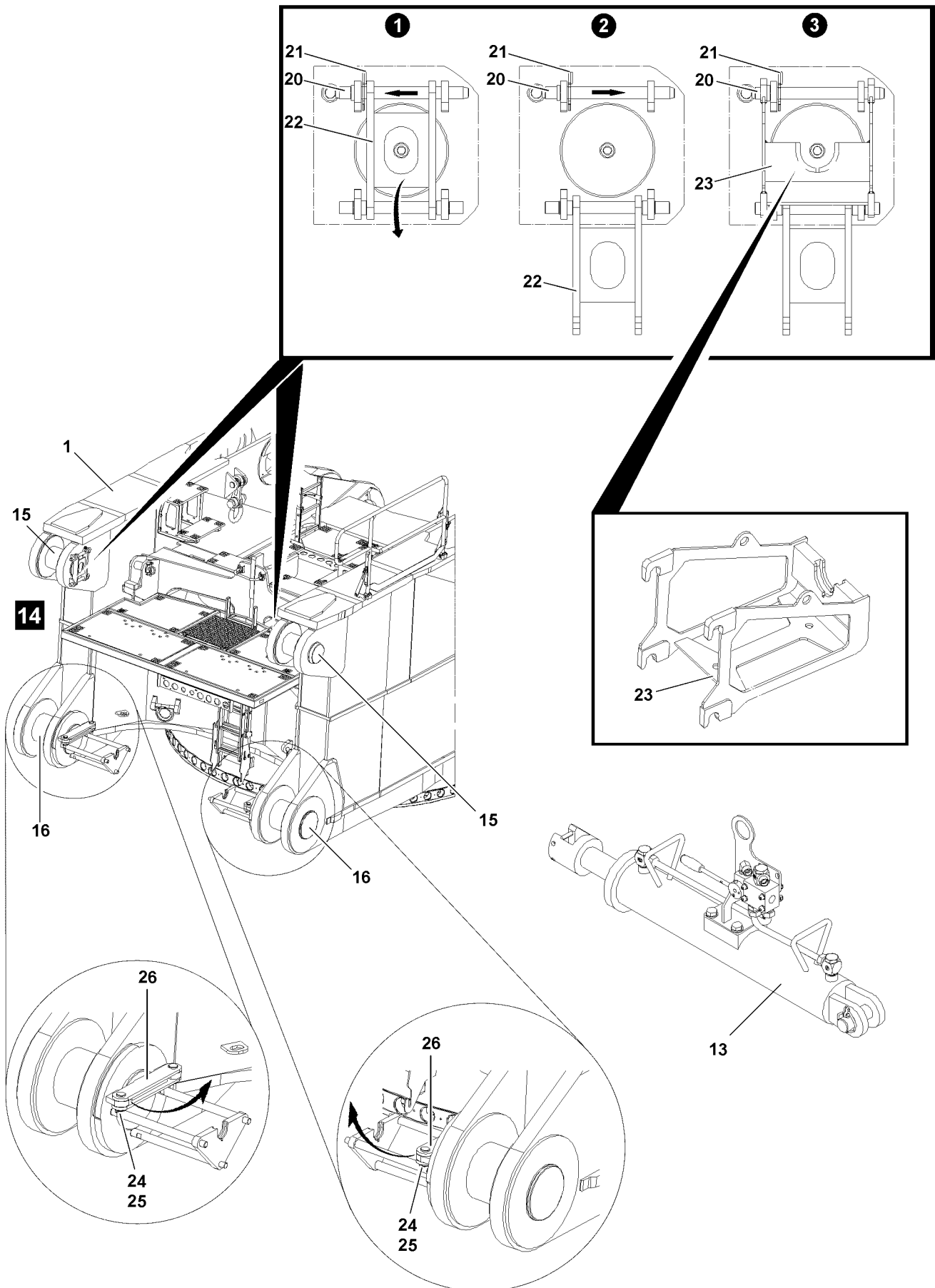

Fig.113058

LWE/LR 13000-001/19503-01-02/en

Releasing and unpinning the connector pins on the „turntable top“

- ▶ Release the securing bracket **22** for the pin retainer on the „upper right“ and „upper left“: Remove spring retainer **21** on pin **20**.



WARNING

Danger of crushing!

When releasing the securing bracket **22**, it can fold down by itself and crush hands, fingers and arms. Death, severe bodily injuries, property damage.

- ▶ Before unpinning the pin **20**, hold the securing bracket **22** and then lower it.

- ▶ Release the securing bracket **22** and lower it downward.
- ▶ Reinsert the pin **20** in the original position.

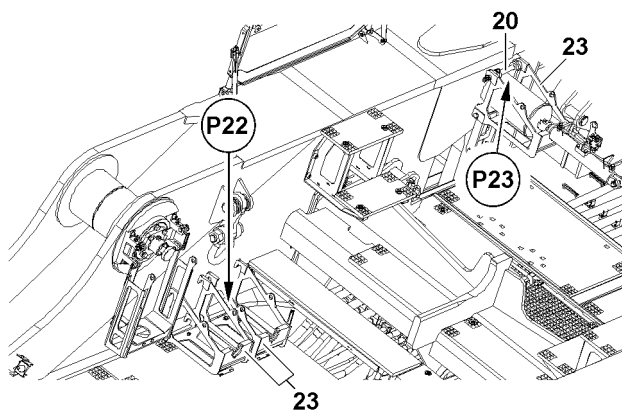

Fig.113068: B113068: Brackets **23** for pin pulling cylinder, right side

When the pin **20** is pinned and secured again:

- ▶ Take the brackets **23** at point **P22** from the transport retainer and hang in on the „upper right“ and „upper left“ on the receptacle points **P23** - pin **20**.

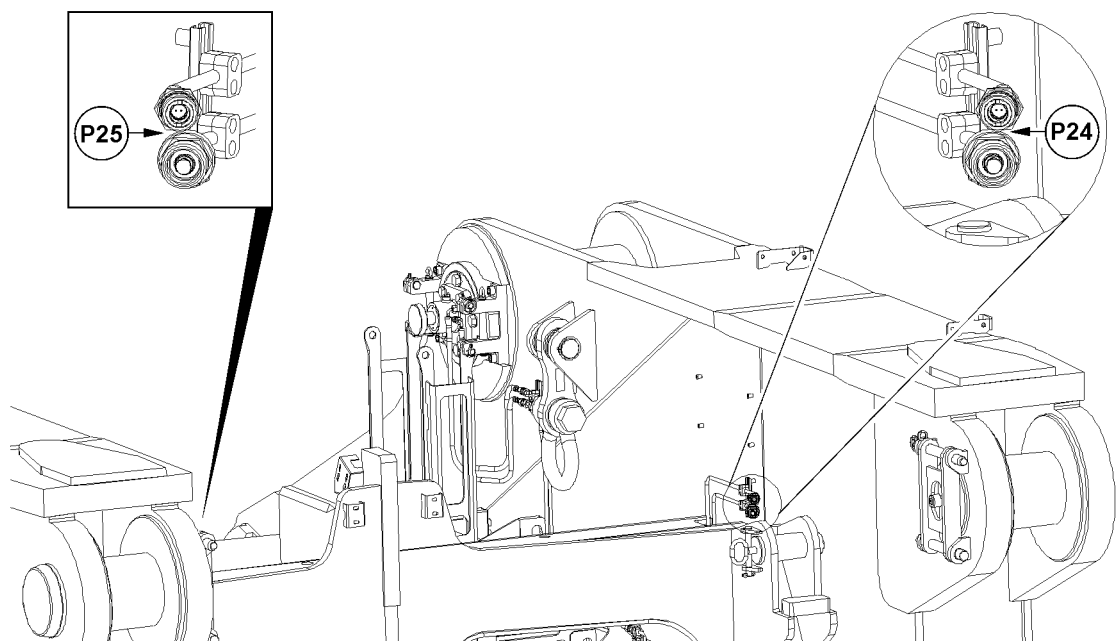

Fig.113062: B113062: Turntable frame front section from the rear - pinning on top

- ▶ Establish the hydraulic connections to the pin pulling cylinders „upper right“ and „upper left“: Connect the supply lines for the pin pulling cylinder on the hydraulic connections at point **P24** and point **P25**.

When the hydraulic connections to the pin pulling cylinders **13** are established:

- ▶ Extend the piston rods for the pin pulling cylinders **13**.
- ▶ Place the pin pulling cylinders **13** in the receptacles for the brackets **23** „upper right“ and „upper left“.
- ▶ Unpin the connector pins „on top“ **15** with the pin pulling cylinder **13** on both sides completely.

When the connector pins „on top“ **15** are completely unpinned:

- ▶ Disconnect the hydraulic connections to the pin pulling cylinders **13**.
- ▶ Remove the pin pulling cylinder **13** from the brackets **23**.

Empty page!

LWE/LR 13000-001/19503-01-02/en

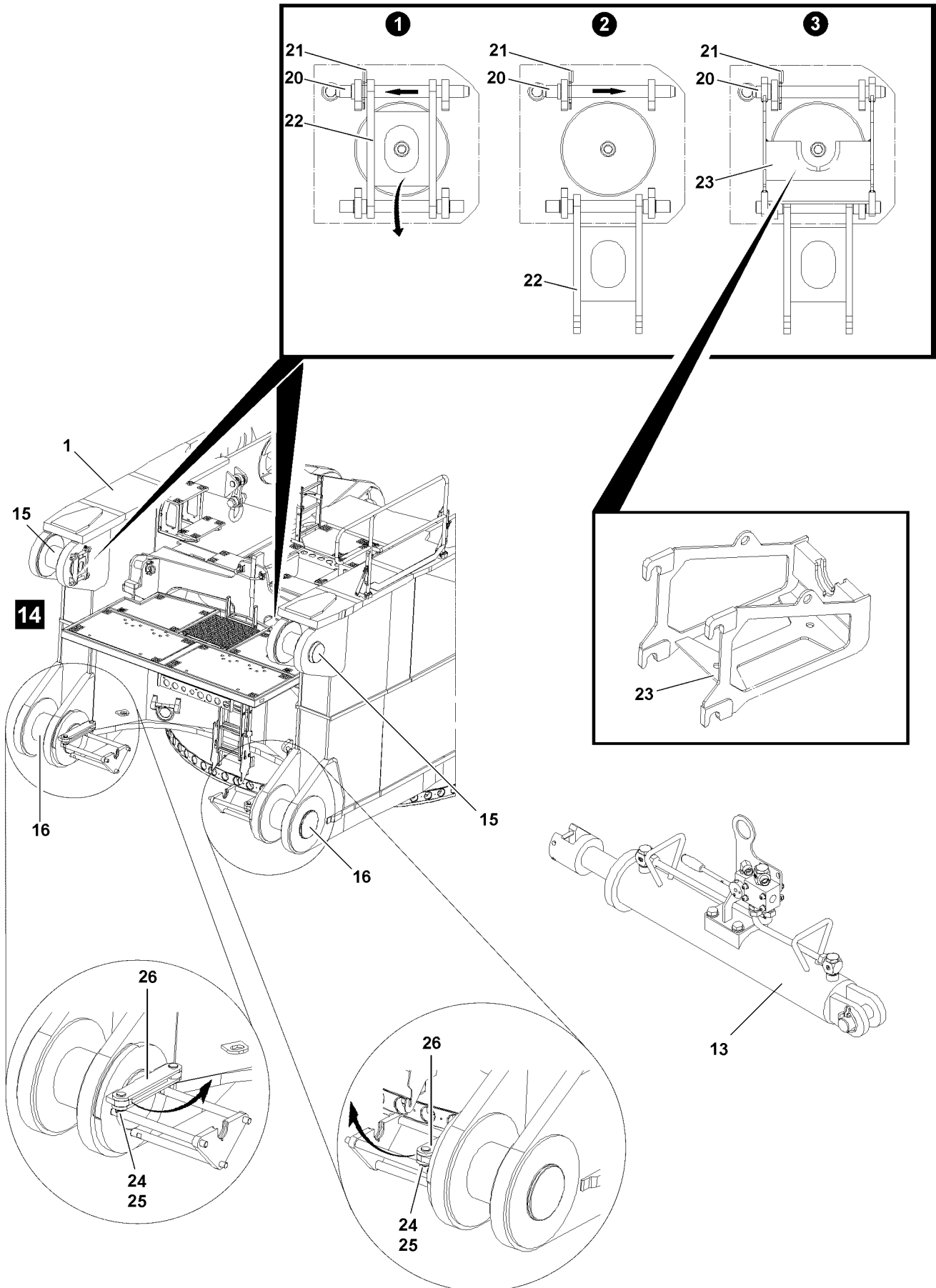

Fig.113058

LWE/LR 13000-001/19503-01-02/en

Releasing and unpinning the connector pins „turntable bottom“

- ▶ Release the securing bracket **26** for the pin retainer on the „lower right“ and „lower left“: Remove the locking pin **25** on the pin **24**.
- ▶ Unpin the securing bracket **26** and swing inward to the turntable frame.

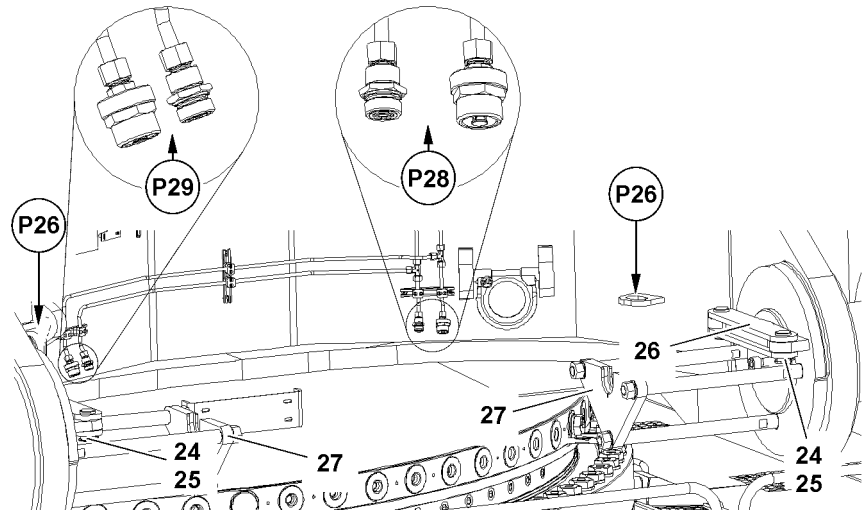

Fig.113069: B113069: Turntable frame front section from the rear - pinning on the bottom

- ▶ Pin and secure the securing bracket **26** on both sides with pins **24** at position **P26**.
- ▶ Establish the hydraulic connections to the pin pulling cylinders „lower right“ and „lower left“: Connect the supply lines for the pin pulling cylinder on the hydraulic connections at point **P28** and point **P29**.

When the hydraulic connections to the pin pulling cylinders **13** are established:

- ▶ Extend the piston rods for the pin pulling cylinders **13**.

When the piston rods for the pin pulling cylinders are extended:

- ▶ Place the pin pulling cylinders **13** in the cylinder receptacles **27** for the pin pulling device „lower right“ and „lower left“.
- ▶ Unpin the connector pins on the bottom **16** completely.
- ▶ Leave the pin pulling cylinders **13** in the cylinder receptacles **27**.



Note

- ▶ Leave the pin pulling cylinders in the cylinder receptacles **27** since, after combining the turntable frame rear section with the turntable front section, the connector pins on the bottom **16** must be pinned immediately.

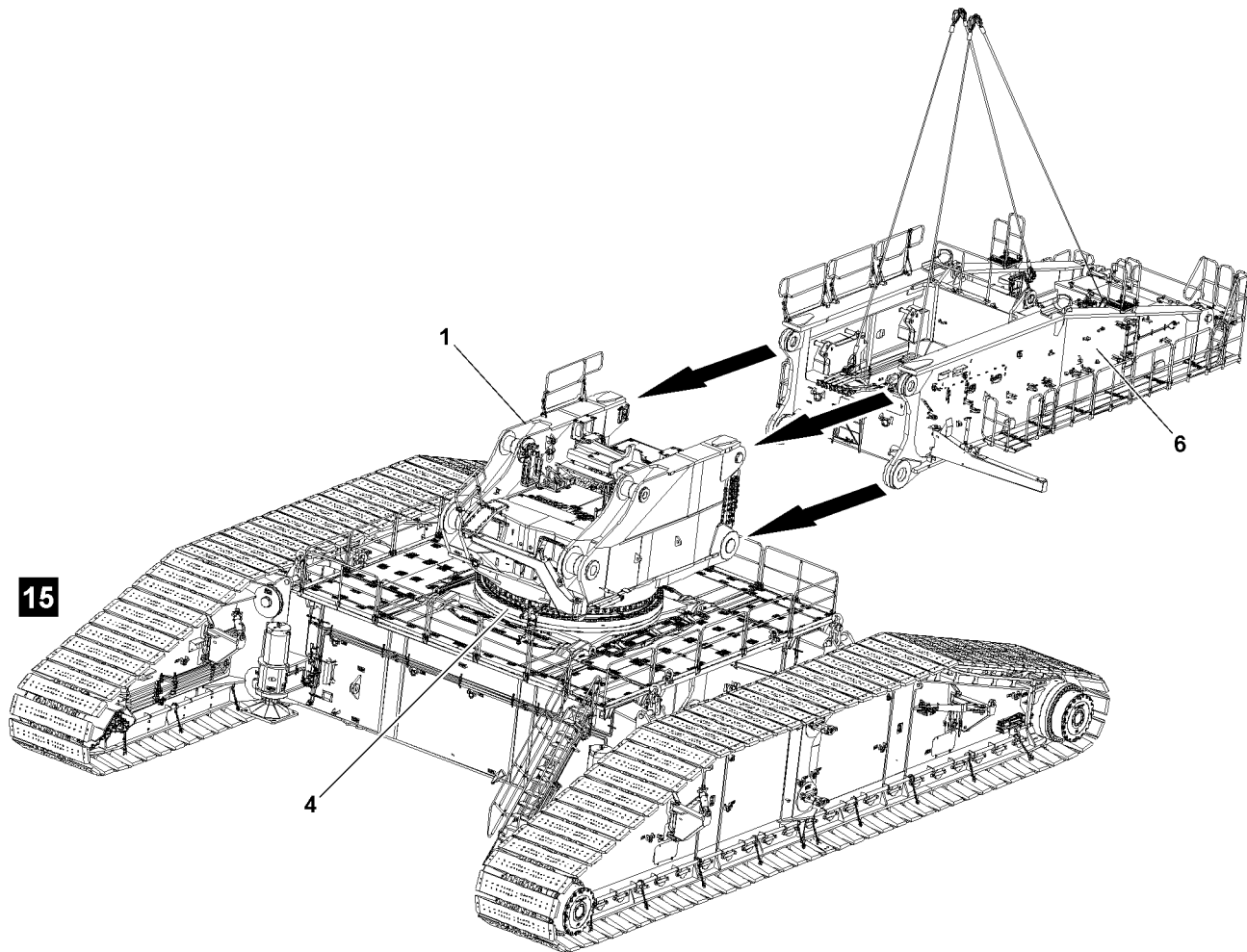

Fig.113060

3.4.2 Swinging the turntable frame rear section to the turntable frame front section

Make sure that the following prerequisites are met:

- The hydraulic connections between the turntable frame front section and the crawler travel gear are established on the rotary connection.
- The connector pins to the turntable frame rear section **6** are completely unpinned on the turntable frame front section **1** „on top“ and „bottom“.
- The pin pulling cylinders are in the cylinder receptacles of the connector pins on the „bottom“.
- ▶ Attach the turntable frame rear section **6** to the auxiliary crane, see section „Fastening points“.



WARNING

Danger of crushing!

When lifting and swinging in the turntable frame rear section **6** to the turntable frame front section **1**, components can fall down or start to swing back and forth!

Fingers, hands and arms can be crushed or entire limbs can be severed.

Death, severe bodily injuries, property damage.

- ▶ Make sure that no persons are within the working and slewing range of the auxiliary crane as well as within the assembly area of the turntable frame rear section **6**.
 - ▶ Make sure that no objects or obstacles are within the danger zone.
 - ▶ Do not reach into the danger zone.
-
- ▶ Lift the turntable frame rear section **6** with the auxiliary crane and swing it in to the turntable frame front section **1**, illustration **15**.
 - ▶ Align the turntable frame rear section **6** on the turntable frame front section **1** and position via the pre-centerings.

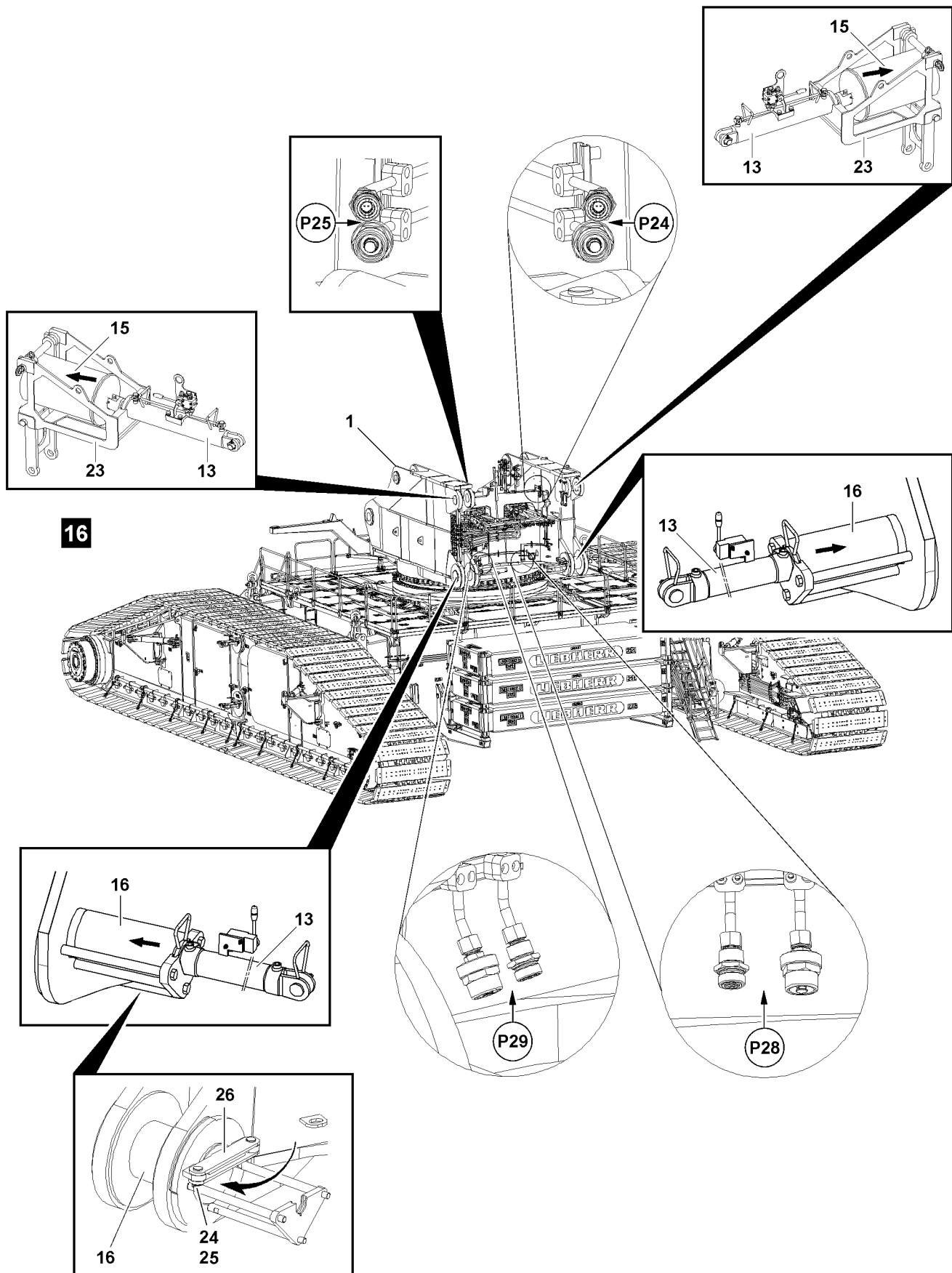

Fig.113070

LWE/LR 13000-001/19503-01-02/en

3.4.3 Pinning the turntable frame rear section on the turntable frame front section



Note

- ▶ Each of the four pin points between the turntable frame front section **1** and the turntable frame rear section has its own pressure supply for the pin pulling cylinder.
- ▶ For the assignment of pin points, observe the illustration **16**.

Dot	Assignment of the hydraulic connections
P24	Pin pulling cylinder, upper right
P25	Pin pulling cylinder, upper left
P28	Pin pulling cylinder, lower right
P29	Pin pulling cylinder, lower left

Make sure that the following prerequisites are met:

- The turntable frame rear section is positioned on the turntable frame front section **1**.
- The pin bores between the turntable frame rear section and the turntable frame front section **1** align.
- The hydraulic connections to the pin pulling cylinders are established.
- The motor of the external hydraulic aggregate is running.
- **or**
- The engine / engines in the engine house are running.



WARNING

Danger of accident!

If the connector pins are not properly secured after pinning, then they can release by themselves. The crane can topple over.

Death, severe bodily injuries, property damage.

- ▶ Make sure that all connector pins are properly secured directly after pinning, **CHECK VISUALLY**.

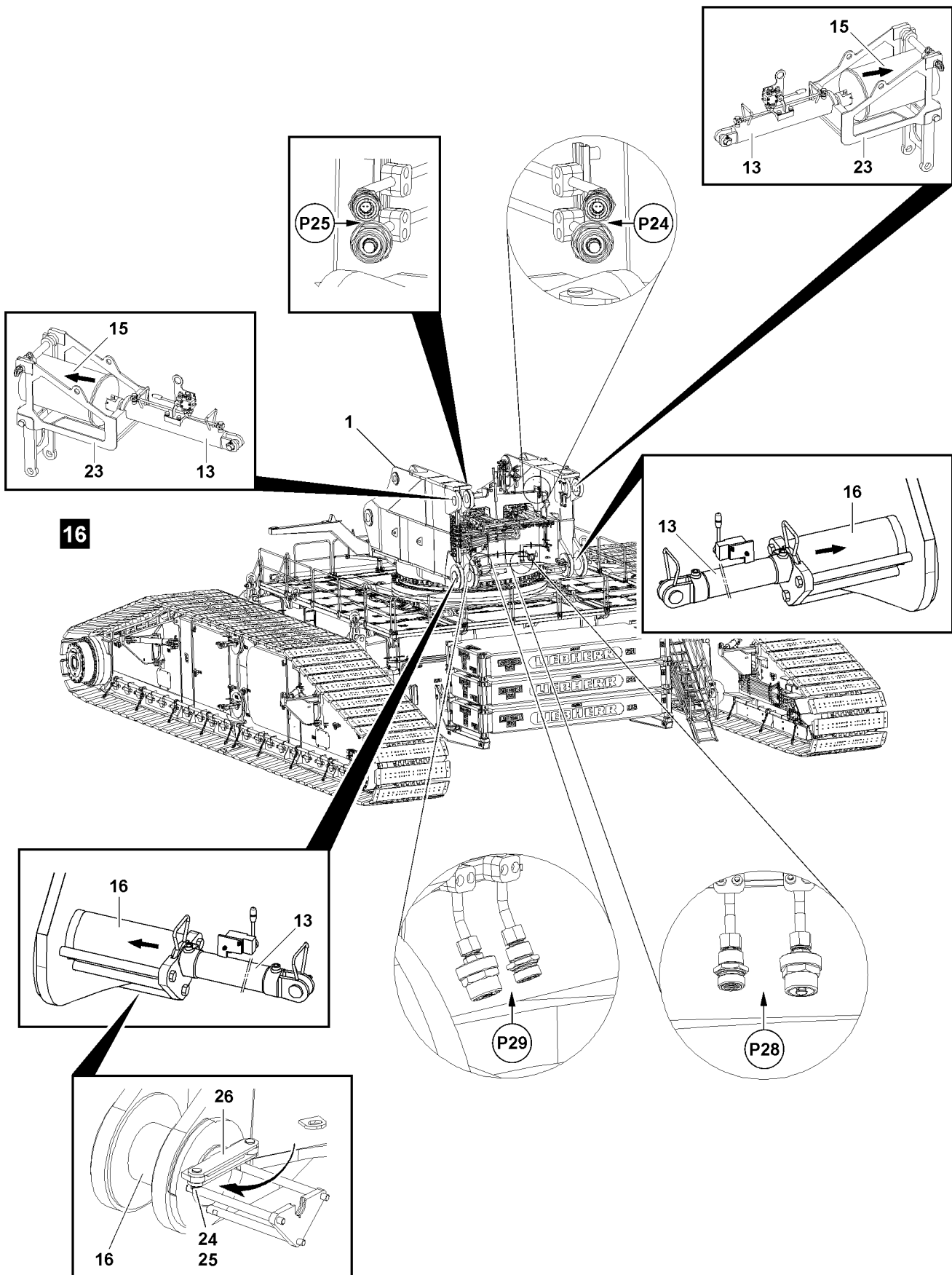

Fig.113070

LWE/LR 13000-001/19503-01-02/en

Pinning the connector pins, lower left

- ▶ Establish the hydraulic connection to the pin pulling cylinder **13** „lower left“: Connect the supply lines of the pin pulling cylinder **13** on the hydraulic connections at point **P29**.

When the hydraulic connection to the pin pulling cylinder **13** is established.

- ▶ Extend the piston rod of the pin pulling cylinder **13**: Actuate the hand lever on the pin pulling cylinder.

Result:

- The piston rod on the pin pulling cylinder **13** extends and the connector pin **16** „lower left“ is pinned.

- ▶ Actuate the hand lever on the pin pulling cylinder **13**.

Result:

- The piston rod on the pin pulling cylinder **13** extends and the connector pin **16** „lower left“ is pinned.

When the connector pin **16** „lower left“ is completely pinned:

- ▶ Lift the pin pulling cylinder **13** with the auxiliary crane out of the cylinder receptacle „lower left“.
- ▶ Retract the piston rod of the pin pulling cylinder completely.

When the piston rod is fully retracted:

- ▶ Place the pin pulling cylinder **13** with the auxiliary crane into the bracket „upper left“.
- ▶ Remove the auxiliary crane.
- ▶ Secure the connector pin **16**: Swing the securing bracket **26** in front of the connector pin **16**.
- ▶ Secure the securing bracket **26**: Insert the pin **24** and secure with the locking pin **25**.

Result:

- The connector pin **16** „lower left“ is secured.

Pinning the connector pins, lower right



Note

- ▶ The procedure to pin the connector pin „lower right“ is identical with the procedure on the connector pin „lower left“.
- ▶ The hydraulic connections for the pin pulling cylinder **13** „lower right“ are at point **P28**.

Closing the turntable frame rear section on the turntable frame front section

Make sure that the following prerequisites are met:

- The connector pin **16** „lower left“ is pinned and secured.
- The connector pin **16** „lower right“ is pinned and secured.

When the connector pins **16** are fully pinned and secured on both sides:

- ▶ Slowly and carefully pull the turntable frame rear section with the auxiliary crane upward toward the stop until the pin bores „on top“ align on both sides.

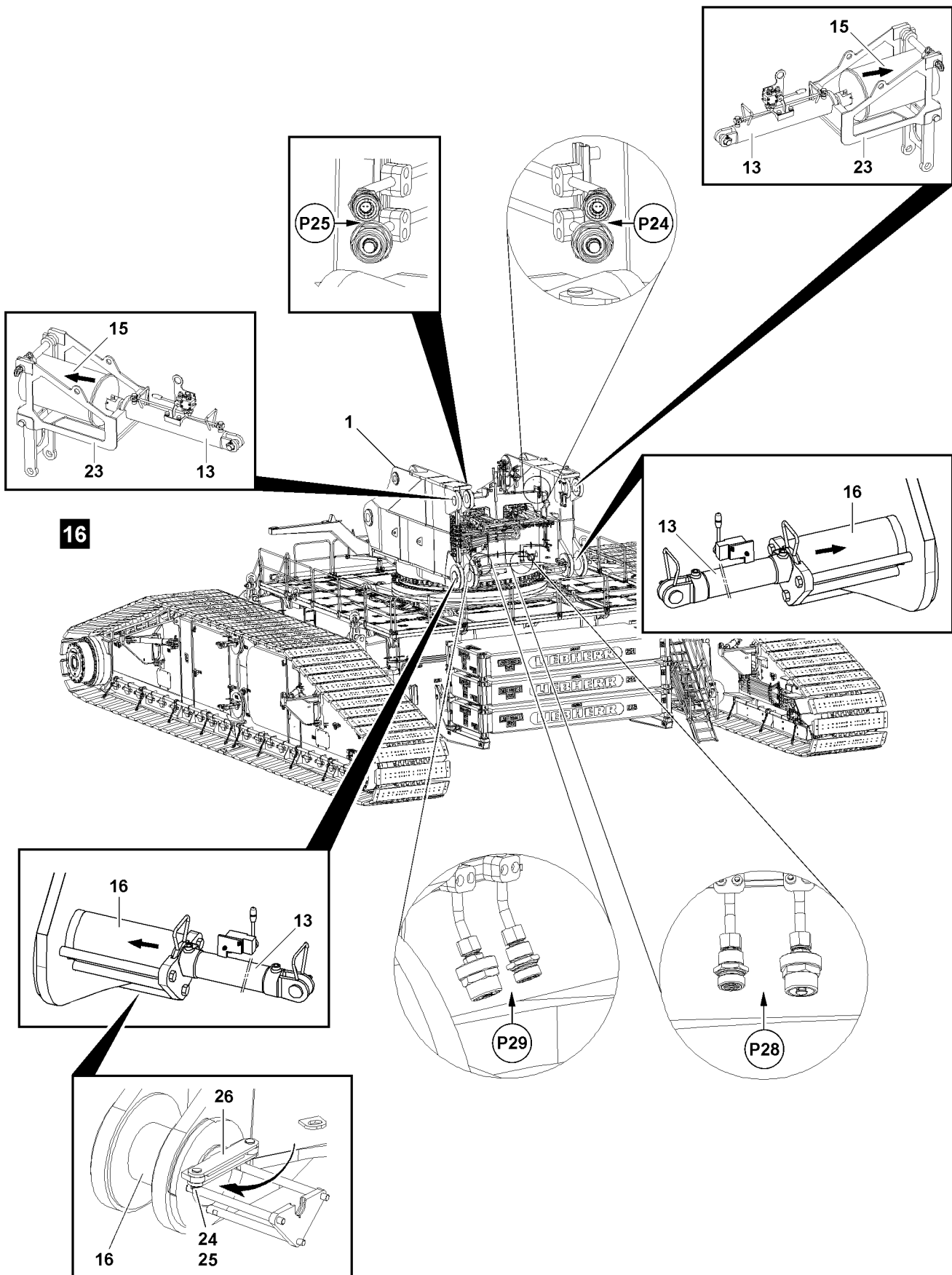

Fig.113070

LWE/LR 13000-001/19503-01-02/en

Pinning the connector pins, upper left

Make sure that the following prerequisites are met:

- The pin bores align on „top“.
- The pin pulling cylinders **13** are in the brackets **23**.
- ▶ Establish the hydraulic connection to the pin pulling cylinder **13** „upper left“: Connect the supply lines of the pin pulling cylinder **13** on the hydraulic connections at point **P25**.

When the hydraulic connection to the pin pulling cylinder **13** is established.

- ▶ Extend the piston rod of the pin pulling cylinder **13**: Actuate the hand lever on the pin pulling cylinder.

Result:

- The piston rod on the pin pulling cylinder **13** extends and the connector pin **15** „upper left“ is pinned.

When the connector pin **15** „upper left“ is completely pinned:

- ▶ Lift the pin pulling cylinder **13** with the auxiliary crane out of the bracket „upper left“.
- ▶ Retract the piston rod of the pin pulling cylinder **13** completely.

When the piston rod is fully retracted:

- ▶ Remove pin pulling cylinder **13** with the auxiliary crane and take it down.
- ▶ Remove the auxiliary crane.
- ▶ Fasten the bracket **23** to the auxiliary crane, lift off upward and remove.
- ▶ Take the bracket **23** down in the park position on the turntable and secure.
- ▶ Unpin the pin **20** on the bracket retainer.

When the pin on the bracket retainer is removed:

- ▶ Fold securing bracket **22** completely up and secure with pin **20**. Insert the pin **20** and secure with the spring retainer **21**.

Result:

- The connector pin **15** „upper left“ is secured.

Pinning the connector pins, upper right



Note

- ▶ The procedure to pin the connector pin „upper right“ is identical with the procedure on the connector pin „upper left“.
- ▶ The hydraulic connections for the pin pulling cylinder **13** „upper right“ are at point **P24**.

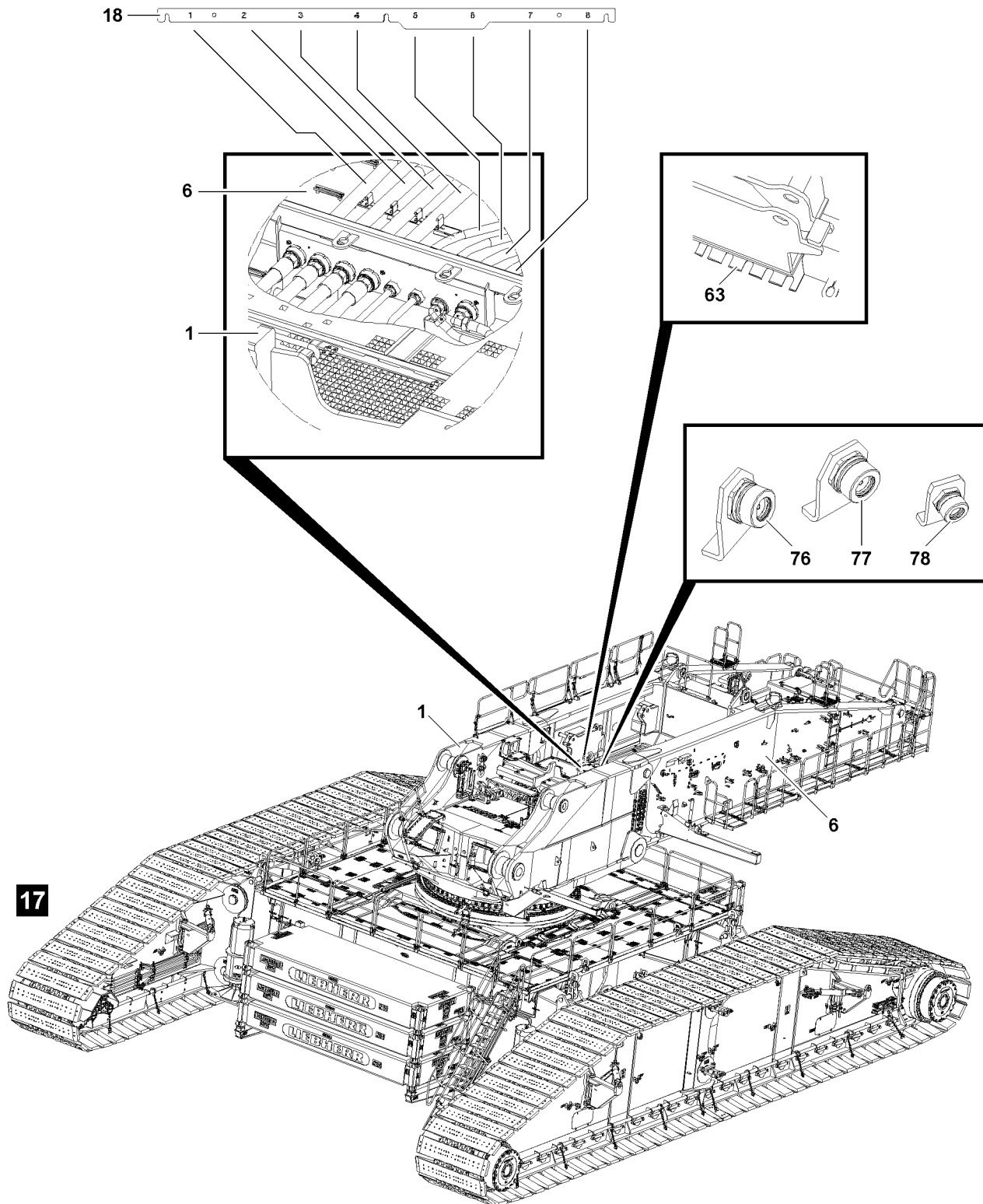

Fig.113065

LWE/LR 13000-001/19503-01-02/en

3.5 Establishing the hydraulic connections from the turntable frame rear section to the turntable frame front section

To ensure the hydraulic supply for the entire turntable, establish the hydraulic connections on the connection location between the turntable frame rear section **6** and the turntable frame front section **1**.



Note

- ▶ Establish the hydraulic connections according to the identification of hydraulic hose lines and the identification on the connector bar **18**.

The hydraulic connections are established with quick couplings.

When connecting hydraulic lines with quick couplings, make sure that the coupling procedure is carried out correctly.



WARNING

Pressure in the hydraulic lines!

If the pressure supply is not interrupted before connecting / releasing the hydraulic lines, the hydraulic oil can escape with high pressure.

Death, severe bodily injuries, property damage.

- ▶ Release the pressure in the hydraulic system before connecting / disconnecting: Interrupt the pressure supply and wait a short time.



WARNING

Loss of pressure or leakage!

Incorrectly coupled or self-loosening quick couplings (particularly return lines) can result in serious accidents due to component failure.

Death, severe bodily injuries, property damage.

- ▶ Check that the quick couplings have been properly connected before using the crane.
- ▶ Connect the coupling components (sleeve and connector) and screw together with the knurled nut.
- ▶ Tighten the hydraulic coupling by hand. Turn the knurled nut until it reaches a tangible, fixed stop position.
- ▶ Remove the hydraulic hose lines from the transport receptacle **63** and screw on the coupling locations on the connector bar **18**.
- ▶ Release the remaining hose lines on the dummy plug **76**, dummy plug **77** and dummy plug **78** and screw on the coupling locations on the connector bar **18**.

3.6 Establishing the electrical connections between the turntable frame front section and the turntable frame rear section



Note

- ▶ To establish the electrical connections, use the Electric wiring diagram.
- ▶ Establish the electrical connections from the turntable frame front section to the terminal boxes: Connect the electrical connections according to their identification.
- ▶ Establish the electrical connections from the crawler travel gear to the terminal boxes: Connect the electrical connections according to their identification.

3.7 Installing the winches

The winches must be assembled before assembly of the engine house on the turntable.



Note

- ▶ The assembly of the hoist winches is described in chapter 3.07.

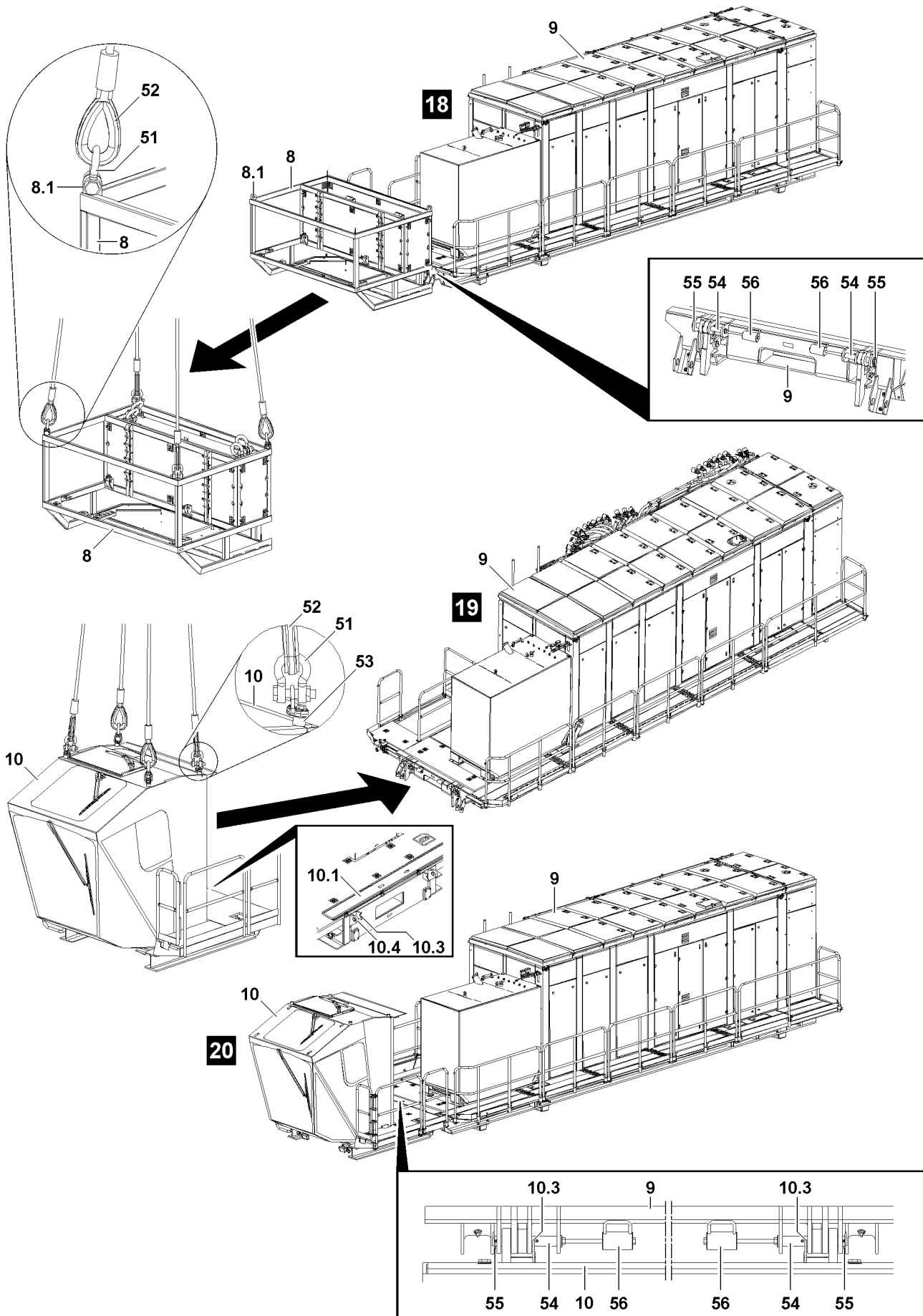

Fig.114154

LWE/LR 13000-001/19503-01-02/en

3.8 Preparing the engine house for assembly on the turntable

The preparatory work on the engine house **9** is made while the engine house **9** is still on the flatbed trailer.

First remove the transport frame **8** on the engine house **9** with the auxiliary crane. Then assemble the crane operator's cab **10** on the base frame of the engine house **9** with the auxiliary crane.

Make sure that the following prerequisites are met:

- The flatbed trailer is parked on level and horizontal ground.
- The transport retainers are removed from the engine house **9**.
- The transport retainers are removed from the transport frame **8**.
- The area around the transport frame **8** is freely accessible.
- No objects are in the assembly area.

3.8.1 Disassembling the transport frame on the engine house

18 Illustration

- ▶ Fasten the fastening equipment **52** with the shackle **51** on the brackets **8.1** of the transport frame **8**, see section „Fastening points“.
- ▶ Bring the fastening equipment with the auxiliary crane carefully to tension.

When the fastening equipment is tensioned on the transport frame **8**:

- ▶ Remove the locking pin **55** on the base frame of the engine house **9** on both sides.
- ▶ Unpin the pins **54** on both sides with the mechanical pin pulling device **56**.

When the pins **54** are unpinned on both sides:

- ▶ Swing the transport frame **8** with the auxiliary crane out and place it on a suitable storage location.
- ▶ Remove the fastening equipment.

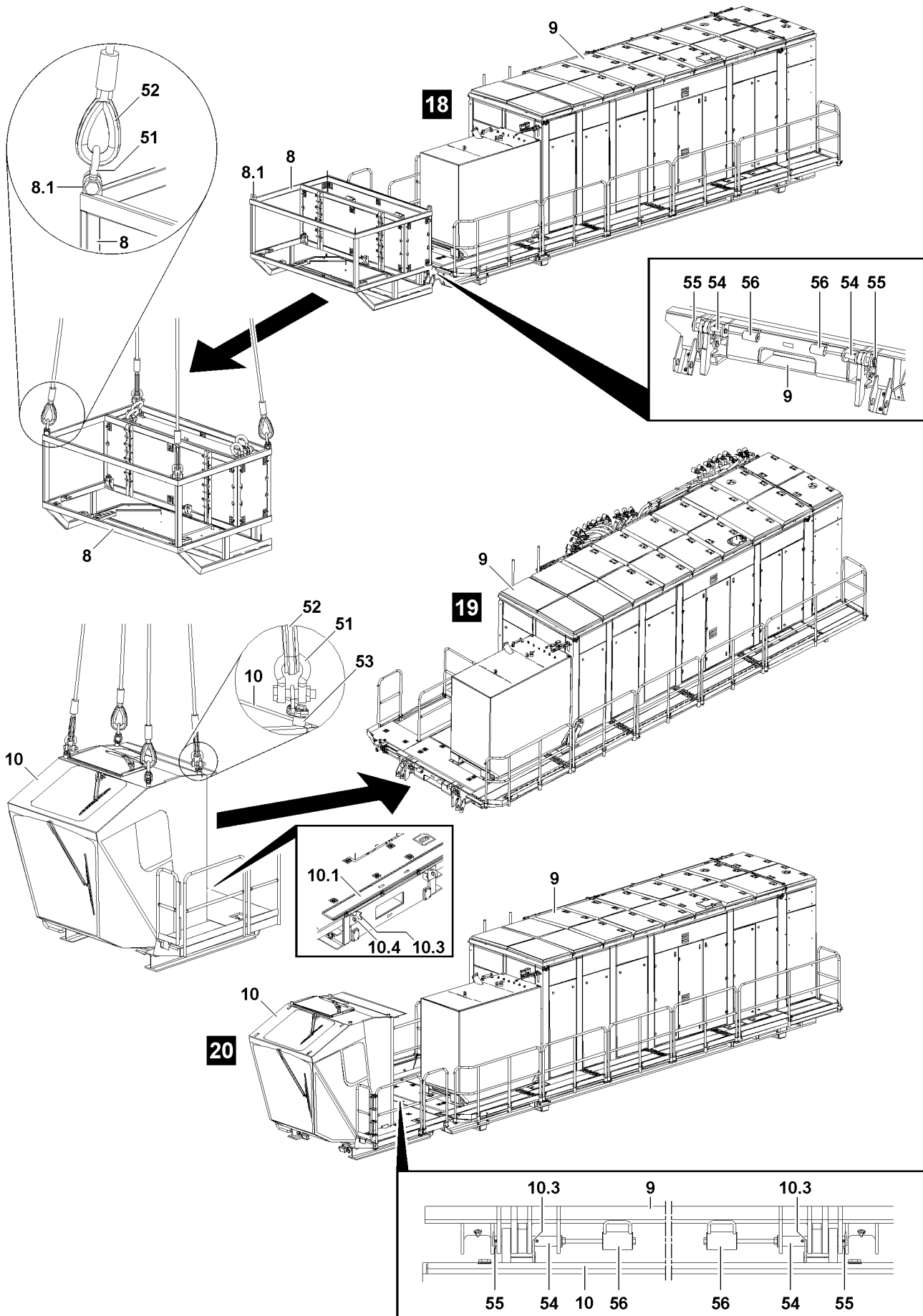

Fig.114154

LWE/LR 13000-001/19503-01-02/en

3.8.2 Installing the crane operator's cab on the engine house

19 Illustration

Make sure that the following prerequisites are met:

- The transport retainers for the crane operator's cab **10** on the transport vehicle are removed.
- The step **10.1** on the crane operator's cab **10** is in the transport position.
- ▶ Fasten the fastening equipment **52** with the shackle **51** on the mounting suspensions **53** of the crane operator's cab **10**, see also section „Fastening points“.
- ▶ Bring the fastening equipment with the auxiliary crane carefully to tension.

When the fastening equipment is tensioned on the crane operator's cab **10**:

- ▶ Lift the crane operator's cab **10** carefully from the transport vehicle.
- ▶ Swing the crane operator's cab **10** carefully in with the auxiliary crane to the pin points on the engine house **9**.
- ▶ Position the crane operator's cab **10** with the centerings **10.3** on the pins **54** of the engine house.

When the crane operator's cab **10** is positioned on the engine house:

- ▶ Insert the pins **54** on both sides and secure with locking pins **55**.



Note

- ▶ If the pins **54** are hard to move, use a mechanical pin pulling device **56**.

When the crane operator's cab **10** is pinned with pins **54** on both sides on the base frame of the engine house **9** and secured with locking pins **55**, illustration **20**:

- ▶ Remove the fastening equipment **52** on the crane operator's cab **10**.
- ▶ Take the fastening equipment down.

3.8.3 Establishing the electrical connections between the engine house and the crane operator's cab



Note

- ▶ To establish the electrical connections, use the Electric wiring diagram.
- ▶ Establish the electrical connection from the crane operator's cab to the terminal boxes and connections on the engine house: Connect the electrical connections according to their identification.

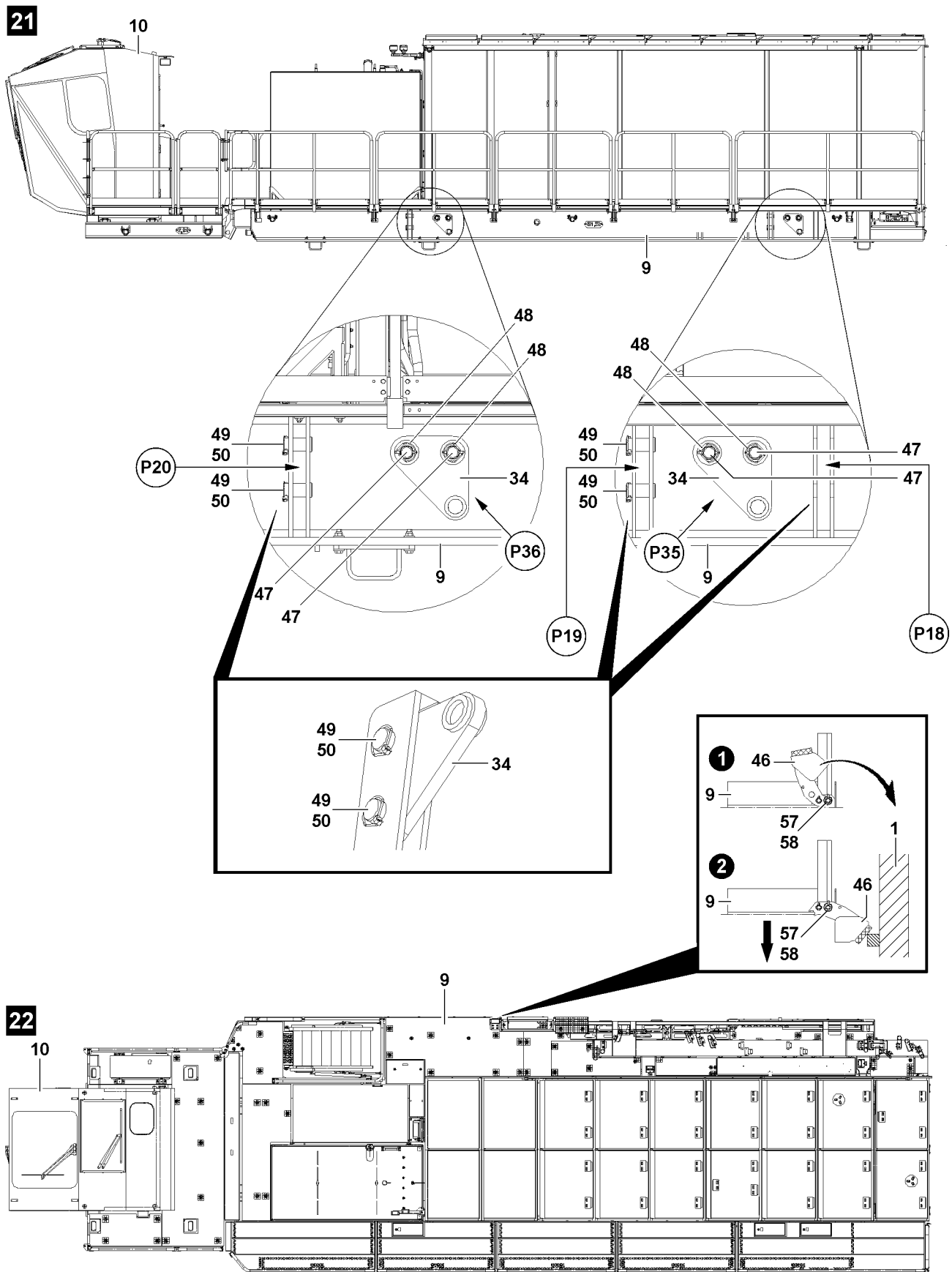

Fig.114156

LWE/LR 13000-001/19503-01-02/en

3.8.4 Installing the transport lugs on the base frame of the engine house

The transport lugs **34** are required for transport or assembly of the engine house on the turntable. Remove the transport lugs **34** from the park position on the base frame of the engine house and install in the intended positions. Before assembly of the transport lugs **34**, the total mass or the center of gravity of the engine house must be known.



Note

- ▶ The assembly of the fastening equipment on the base frame of the engine house is essentially dependent on the total center of gravity and on the transport weight of the engine house.
 - ▶ Observe the section „Fastening points“ in this chapter.
-

Assembling the transport lugs for the assembly of the engine house with two auxiliary cranes

- ▶ Remove the locking pin **48** on the park position of the transport lug **34** at point **P36**.
 - ▶ Pull the transport lug **34** from the pin **47** in point **P36**.
 - ▶ Insert and secure the transport lug **34** in point **P20**: Use pin **49** and locking pin **50**.
 - ▶ Remove the locking pin **48** on the park position of the transport lug **34** at point **P35**.
 - ▶ Pull the transport lug **34** from the pin **47** in point **P35**.
 - ▶ Insert and secure the transport lug **34** in point **P19**: Use pin **49** and locking pin **50**.
-

**Note**

- ▶ To fasten the engine house on the two auxiliary cranes, attach the fastening equipment with shackles on the transport lugs **34**, see section „Fastening points“.
-

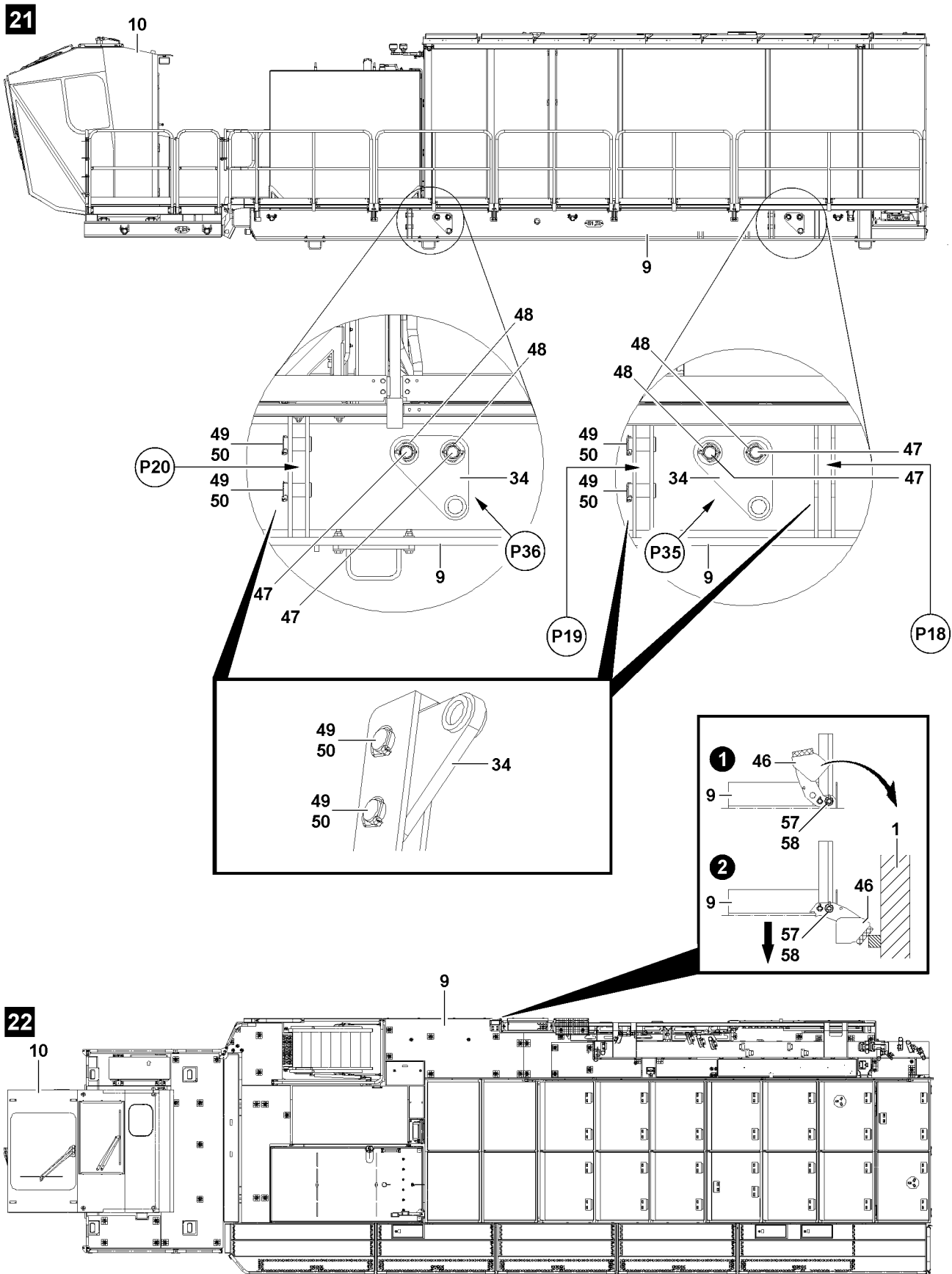

Fig.114156

LWE/LR 13000-001/19503-01-02/en

Assembling the transport lugs for the assembly of the engine house with one auxiliary crane

- ▶ Remove the locking pin **48** on the park position of the transport lug **34** at point **P36**.
- ▶ Pull the transport lug **34** from the pin **47** in point **P36**.
- ▶ Insert and secure the transport lug **34** in point **P20**: Use pin **49** and locking pin **50**.
- ▶ Remove the locking pin **48** on the park position of the transport lug **34** at point **P35**.
- ▶ Pull the transport lug **34** from the pin **47** in point **P35**.



Note

- ▶ Insert and secure the transport lug **34** depending on the center of gravity of the engine house, either in point **P18** or in point **P19**.

- ▶ Insert and secure the transport lug **34** in point **P18**: Use pin **49** and locking pin **50**.
or
Insert and secure the transport lug **34** in point **P19**: Use pin **49** and locking pin **50**.



Note

- ▶ To fasten the engine house on the auxiliary crane, attach the fastening equipment with shackles on the transport lugs **34**, see section „Fastening points“.

3.8.5 Bringing the deflector on the engine house into operating position

22 Illustration

The deflector **46** must be brought into operating position before assembly of the engine house **9** on the turntable, pinned and secured.

- ▶ Remove the locking pin **58** and unpin the retaining pin **57**.
- ▶ Fold the deflector **46** into operating position.

When the deflector is in operating position:

- ▶ Insert the retaining pin **57** in operating position and secure with locking pin **58**.

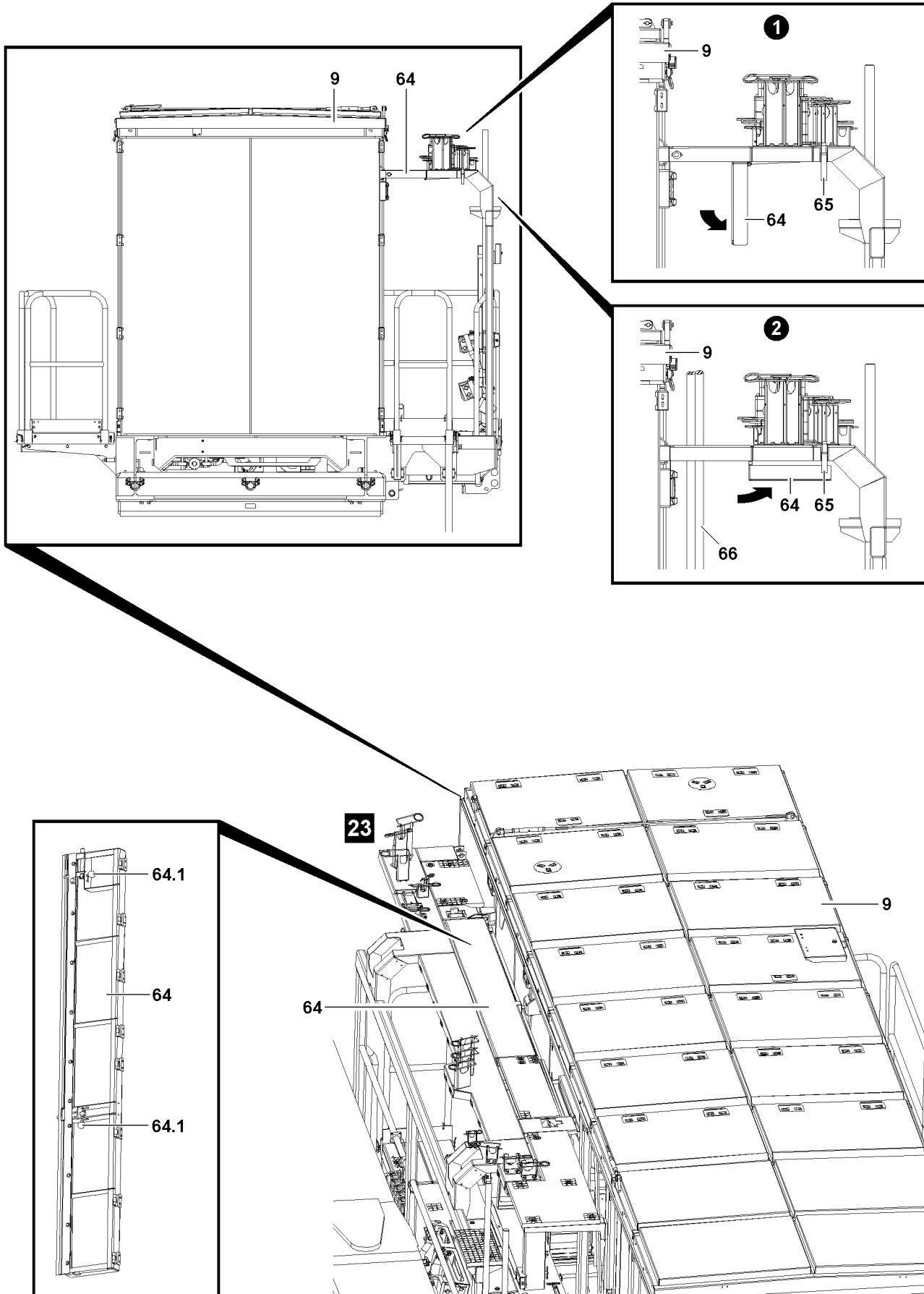

Fig.114157

LWE/LR 13000-001/19503-01-02/en

3.8.6 Bringing the upper catwalk on the engine house into assembly position

The upper catwalk **64** of the engine house **9** must be folded down and secured before assembly of the engine house on the turntable. This makes it possible to route the fastening equipment **66** for the assembly along the engine house without restrictions.



DANGER

Danger of accident due to the catwalk!

If the catwalk **64** is not held when unlocking it, the catwalk will fold down by itself.

Death, severe bodily injuries, property damage.

- ▶ Make sure, when unlocking the catwalk, that no one is on the catwalk.
- ▶ Make sure that the catwalk is safety held by a person when unlocking it.

-
- ▶ Unlock the catwalk **64** with the locking pins **64.1** from below.

- ▶ Lower the catwalk downward and secure it in the assembly position with the tension bar **65**.



Note

- ▶ The catwalk **64** must be brought into the operating position again after assembly of the engine house on the turntable and after removing the fastening equipment on the engine house and secured with the locking pins **64.1**.

3.8.7 Assembling the catwalks and railings on the engine house



Note

- ▶ For the assembly of the catwalks and railings on the engine house refer to chapter 2.06.
-

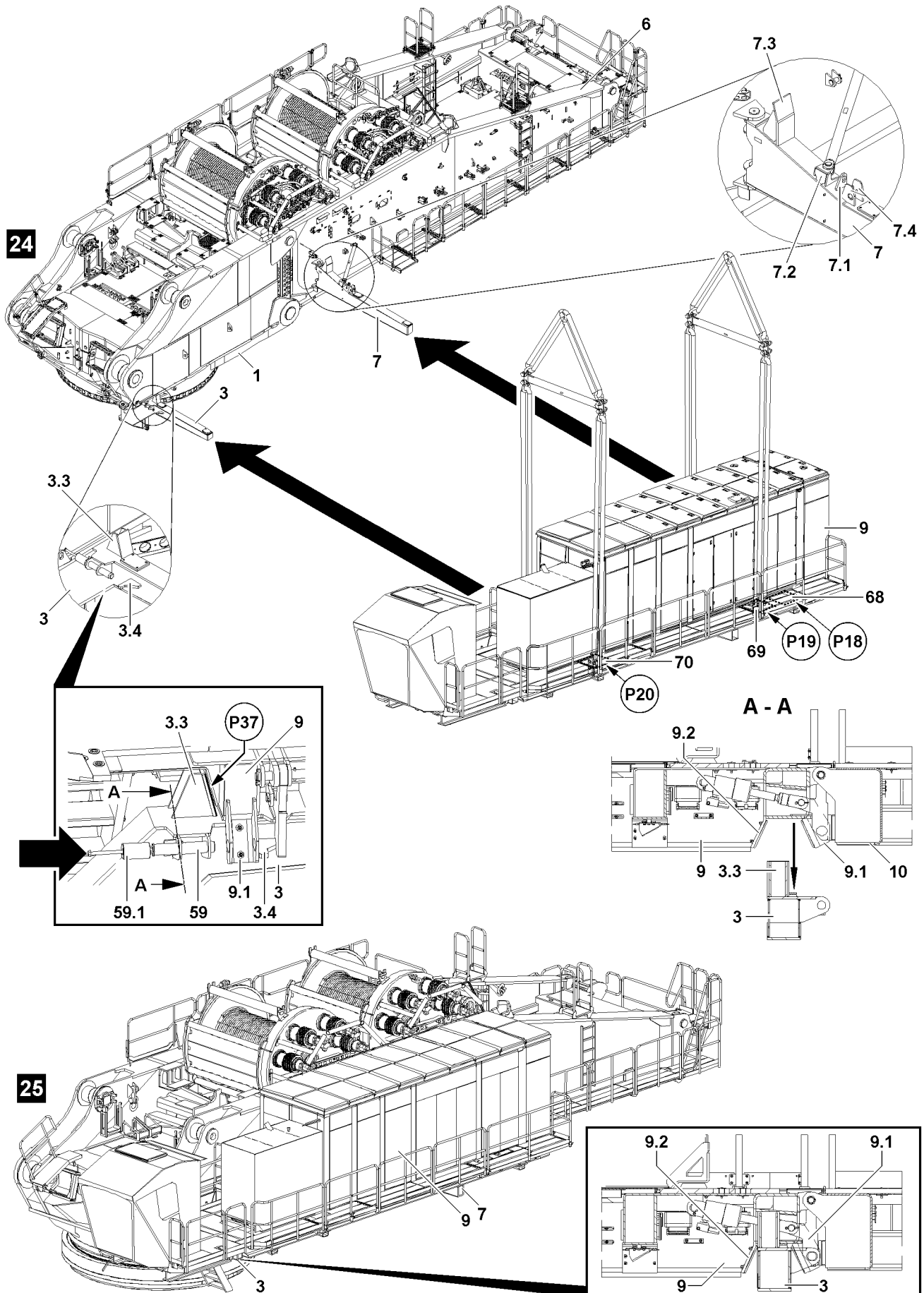

Fig.114158

LWE/LR 13000-001/19503-01-02/en

3.9 Assembling the engine house on the turntable

Make sure that the following prerequisites are met:

- The turntable frame rear section **6** is properly pinned and secured on the turntable frame lower section **1**.
- The bracket **3** on the turntable frame front section **1** is in the operating position.
- The locking pin **59** is unpinned and in the assembly position.
- The bracket **7** on the turntable frame rear section **6** is in the operating position.
- The locking pin **60** on the engine house is unpinned and in the assembly position.
- Winch 1 **WI** and winch 2 **WII** are properly assembled on the turntable.
- The transport lugs **34** are properly assembled and secured on the base frame of the engine house **9**.
- The deflector **46** on the base frame of the engine house **9** is in the operating position.
- The upper catwalk **9.3** on the engine house **9** is in the assembly position.
- The crane operator's cab **10** is properly pinned and secured to the engine house **9**.
- The catwalks and railings are assembled and secured on the engine house **9**.

3.9.1 Setting the engine house on the brackets with the auxiliary crane and pinning it

We recommend to install the engine house with two auxiliary cranes on the turntable.



Note

- ▶ If the engine house is to be installed with only one auxiliary crane on the turntable, use the compensation brackets for the horizontal alignment of the engine house during the transfer procedure from the flatbed trailer on the turntable, see section „Fastening points“.

- ▶ Open the cover **68** on the fastening point **P18**.
or
Open the cover **69** on the fastening point **P19**.
- ▶ Open the cover **70** on the fastening point **P20**.



Note

- ▶ Open the covers on the fastening points on the opposite side accordingly.

- ▶ Attach the engine house **9** with the intended fastening equipment on the **two** auxiliary cranes, see section „Fastening points - engine house, complete“.
or
Attach the engine house **9** with the intended fastening equipment, and using the compensation brackets on **one** auxiliary crane, see section „Fastening points - engine house, complete“.

When the engine house **9** is attached on the auxiliary crane / auxiliary cranes:

- ▶ Carefully tension the fastening equipment.

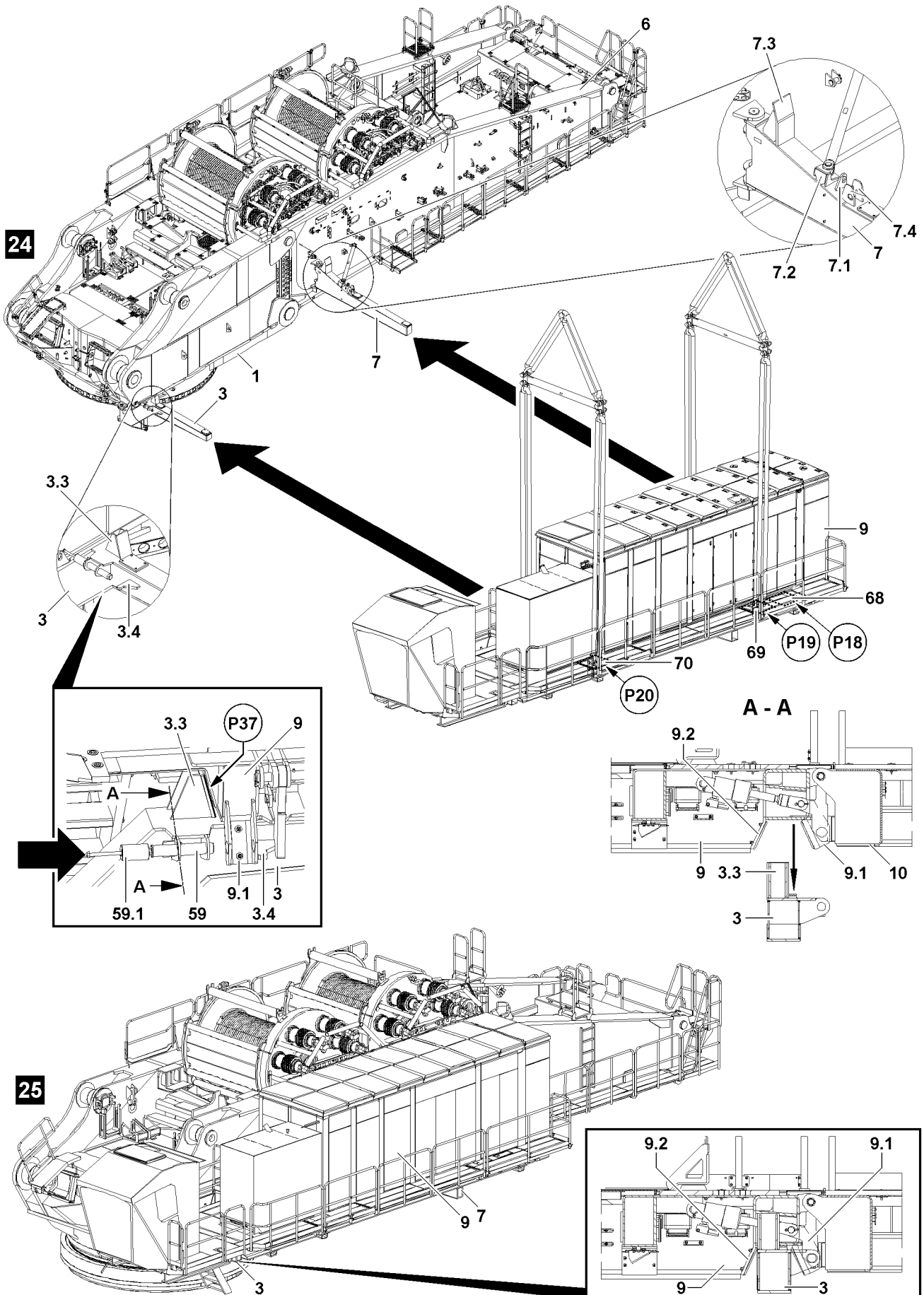

Fig.114158

LWE/LR 13000-001/19503-01-02/en

**WARNING**

Oscillating load!

When lifting the engine house from the flatbed trailer, the engine house can start to swing back and forth.

Death, severe bodily injuries, property damage.

- ▶ Secure the engine house with a guide rope to prevent it from swinging.
- ▶ Make sure that there are no persons within the danger zone of the crane and the engine house.
- ▶ Make sure that there are no obstacles within the assembly area of the crane.

When the fastening equipment is tensioned:

- ▶ Carefully lift the engine house **9** and with the least possible speed from the flatbed trailer.

When the engine house **9** is completely lifted off the flatbed trailer:

- ▶ Carefully swing the engine house **9** in with the auxiliary crane / auxiliary cranes to the brackets on the turntable.
- ▶ Align the engine house **9** parallel to the turntable.
- ▶ Position the engine house **9** in longitudinal direction to the turntable.

NOTICE

Damage to the pinning device!

If the locking pin, locking pin **59** and locking pin **60**, are not unpinned before the assembly of the engine house **9**, crane components and especially the locking pins can be damaged.

- ▶ Before setting the engine house **9** on the brackets, make sure that the locking pins are unpinned.

When the engine house is positioned via the brackets:

- ▶ Lower the engine house carefully and with slow speed on the brackets.

Result:

- In longitudinal direction, the engine house **9** is centered by the centering **9.1** and the centering **9.2** on the bracket **3** in pin position, illustration **25**.
- In lateral direction, the engine house **9** is centered by the centering **7.3** on the bracket **7** and the centering **3.3** on the bracket **3** in pin position, illustration **24**.

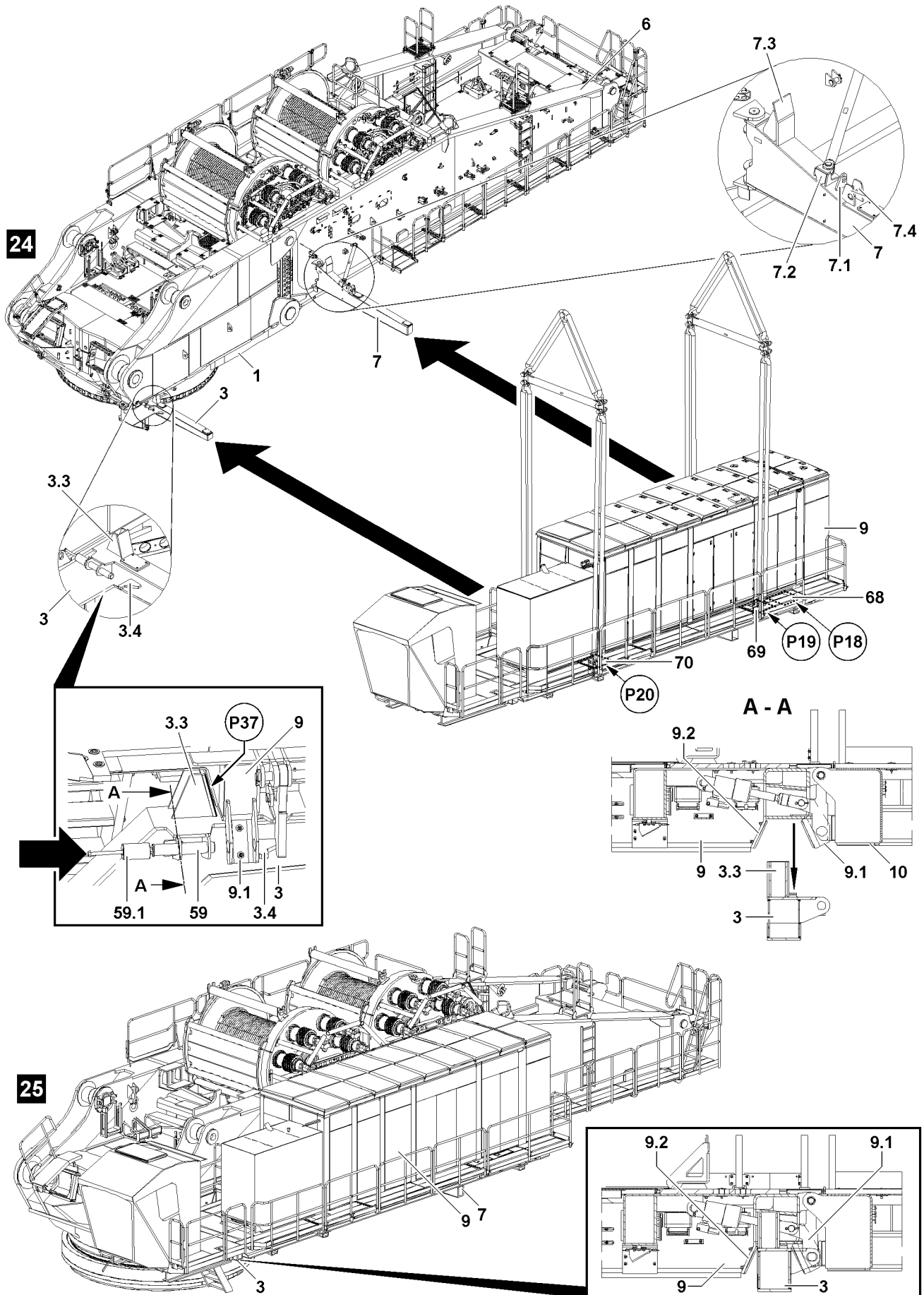

Fig.114158

LWE/LR 13000-001/19503-01-02/en

The engine house **9** must be pinned and secured on the bracket **7** in the area of the turntable frame rear section **6** and on the bracket **3** in the area of the turntable frame front section **1** with one locking pin each.

When the engine house is laying in the required alignment completely on the brackets and the pin bore align:

- ▶ Insert the front locking pin **59** completely on the centering **9.1**.

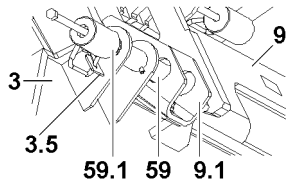

Fig.114163: B114163: Engine house **9** pinned with the bracket **3**, locking pin **59** secured

- ▶ Secure the locking pin **59**: Slide the pull device **59.1** in direction of the locking pin and turn the handle of the pull device **59.1** in the setting of the retaining plate **3.5**.

Result:

- The engine house **9** is pinned and secured on the front bracket **3**.

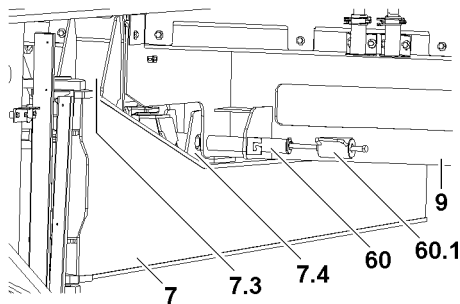

Fig.114161: B114161: Pin engine house **9** with bracket **7**

- ▶ Insert the rear locking pin **60** on the base frame of the engine house **9** completely into the pin lugs **7.4** on the bracket **7**.

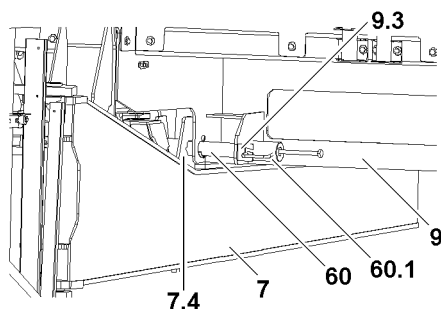

Fig.114162: B114162: Engine house **9** pinned with the bracket **7**, locking pin **60** secured

- ▶ Secure the locking pin **60**: Slide the pull device **60.1** in direction of the locking pin **60** and turn the handle of the pull device **60.1** in the setting of the retaining plate **9.3**.

Result:

- The engine house is pinned and secured on the rear bracket **7**.

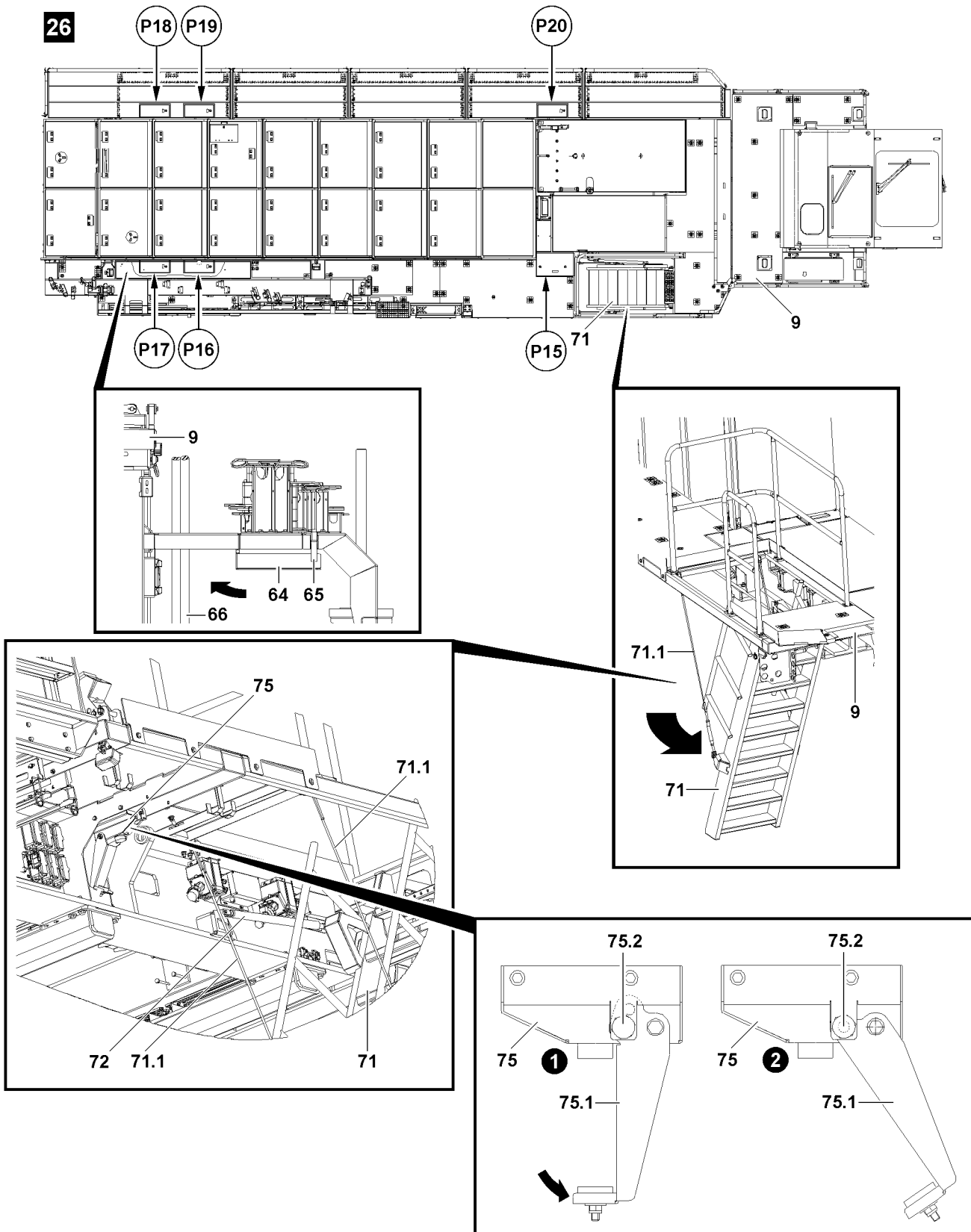

Fig.114159

LWE/LR 13000-001/19503-01-02/en

3.9.2 Bringing the step into operating position and removing the fastening equipment on the engine house



WARNING

Danger of accident due to folding step!

Death, severe bodily injuries, property damage.

- ▶ Make sure that there are no persons within the danger zone when folding the step down.
- ▶ It is prohibited for anyone to remain directly under the step when folding the step down.
- ▶ The step must always be folded up or down completely, intermediate positions are prohibited.
- ▶ Access the step only when the lower end position is reached.

When the engine house **9** is pinned and secured properly on the brackets:

- ▶ Open the step retainer: Pull the detent pin **75.2** and fold the securing bracket **75.1** back until the detent pin **75.2** engages again.

Result:

- The step retainer is open.

- ▶ Pull the foldable step **71** - against the pressure in the pneumatic spring **72** - from the transport position downward and lower it completely to stop (operating position).

Result:

- The retraining ropes **71.1** are completely tensioned.

- ▶ Climb via the foldable step **71** to the platform on the engine house **9** and remove the fastening equipment on the engine house.

When the fastening equipment is removed on the engine house **9**:

- ▶ Close the covers of the fastening points (cover **P15**, cover **P16** or cover **P17**, cover **P18** or cover **P19**, and cover **P20**).

3.9.3 Bringing the upper catwalk into operating position



DANGER

Danger of accident due to upper catwalk **64**!

If the upper catwalk **64** is not held when unlocking it, the catwalk **64** will fold down by itself.

Death, severe bodily injuries, property damage.

- ▶ Make sure that the upper catwalk **64** is safety held by a person when unlocking it.
- ▶ Release the tension bar **65** on the upper catwalk **64**.
- ▶ Fold the upper catwalk down.
- ▶ Bring the upper catwalk in operating position (arrow) and pin on the engine house **9** with the locking latches.

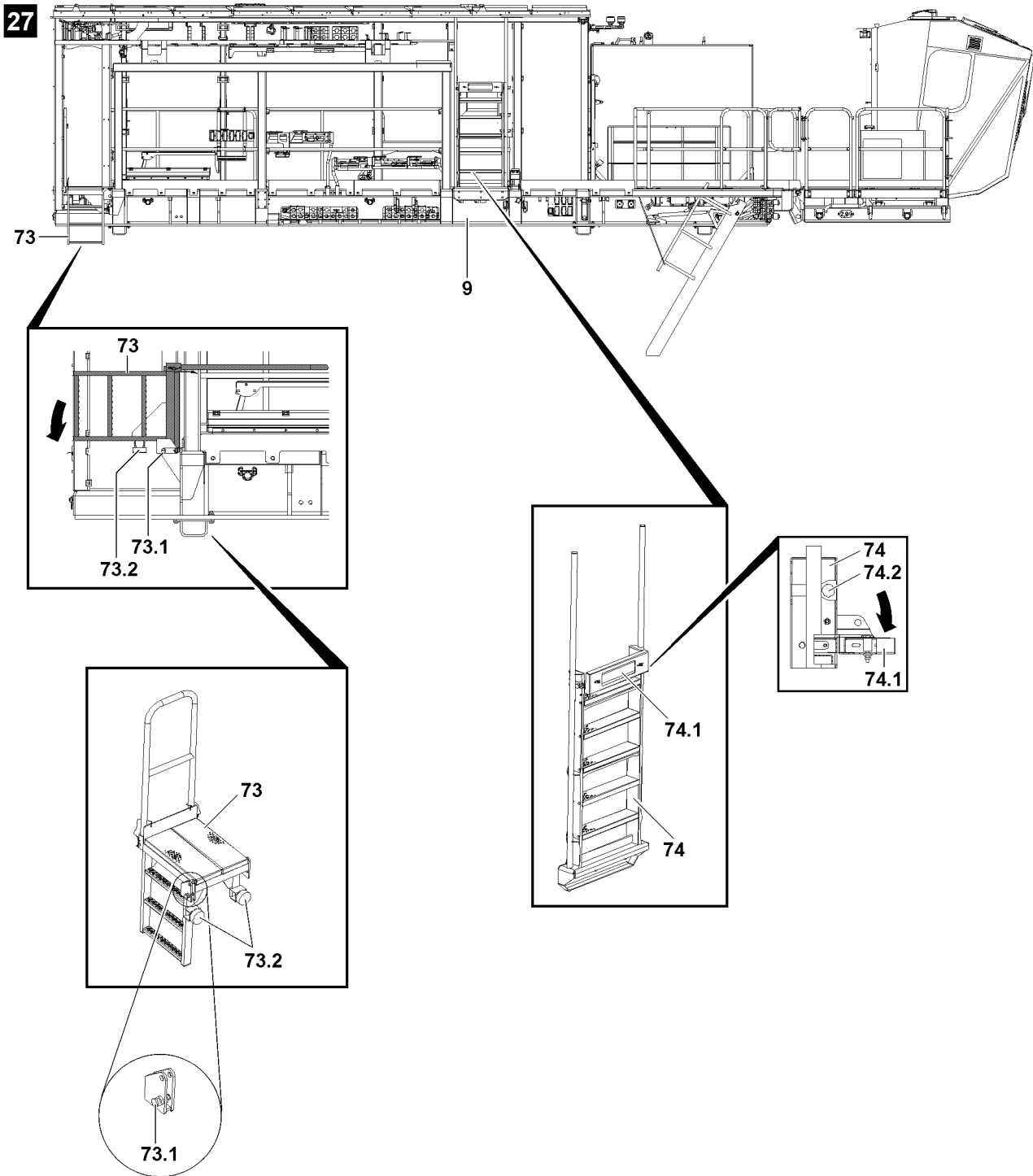

Fig.114165

LWE/LR 13000-001/19503-01-02/en

3.9.4 Bringing the folding bracket into operating position



WARNING

Danger of accident due to the folding platform **73**!

If the folding platform **73** is not held when unlocking it, it will fold down by itself.

Arms and hands can be crushed.

Death, severe bodily injuries, property damage.

▶ Make sure that the folding platform **73** is safety held by a person when unlocking it.

▶ Fold the folding bracket **73** the lower catwalk down in operating position: Pull the detent pin **73.1** and lower the folding bracket **73** in operating position until the bumper stops **73.2** touch in end position on the base from of the engine house.

Result:

– The folding bracket **73** is affixed in end position by the detent pin **73.1**.

3.9.5 Bringing the folding step on the access ladder into operating position

The folding step **74.1** on the access ladder **74** must be brought into operating position for a safe transition from the engine house **9** to the top box section on the turntable.

▶ Pull the detent pin **74.2** and fold the folding step **74.1** down into the operating position.

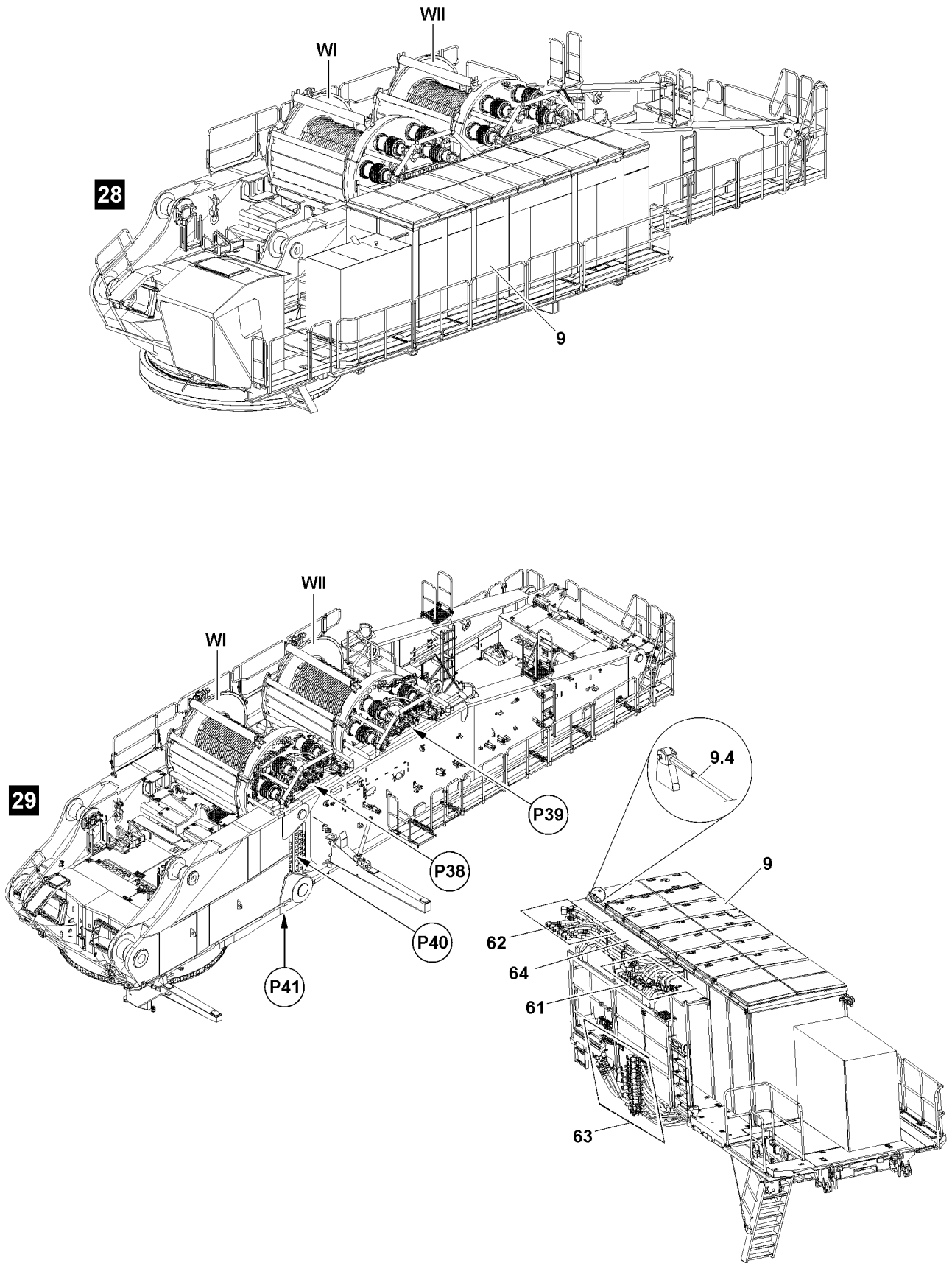

Fig.114160

LWE/LR 13000-001/19503-01-02/en

3.9.6 Establishing the hydraulic and electrical connections

**Note**

- ▶ Establishing the hydraulic and electrical connections from the engine house to the turntable requires that the engine house is already firmly assembled on the turntable.
- ▶ For a simpler and better illustration, the engine house **9** is released from the turntable and turned outward in the illustration **28**.

Establishing the hydraulic connections from the engine house to the turntable

The hydraulic connections are established with quick couplings.

When connecting hydraulic lines with quick couplings, make sure that the coupling procedure is carried out correctly.

The matching quick couplings are marked.

**WARNING**

Pressure in the hydraulic lines!

If the pressure supply is not interrupted before connecting / releasing the hydraulic lines, the hydraulic oil can escape with high pressure.

Death, severe bodily injuries, property damage.

- ▶ Release the pressure in the hydraulic system before connecting / disconnecting: Interrupt the pressure supply and wait a short time.

**WARNING**

Loss of pressure or leakage!

Incorrectly coupled or self-loosening quick couplings (particularly return lines) can result in serious accidents due to component failure.

Death, severe bodily injuries, property damage.

- ▶ Check that the quick couplings have been properly connected before using the crane.

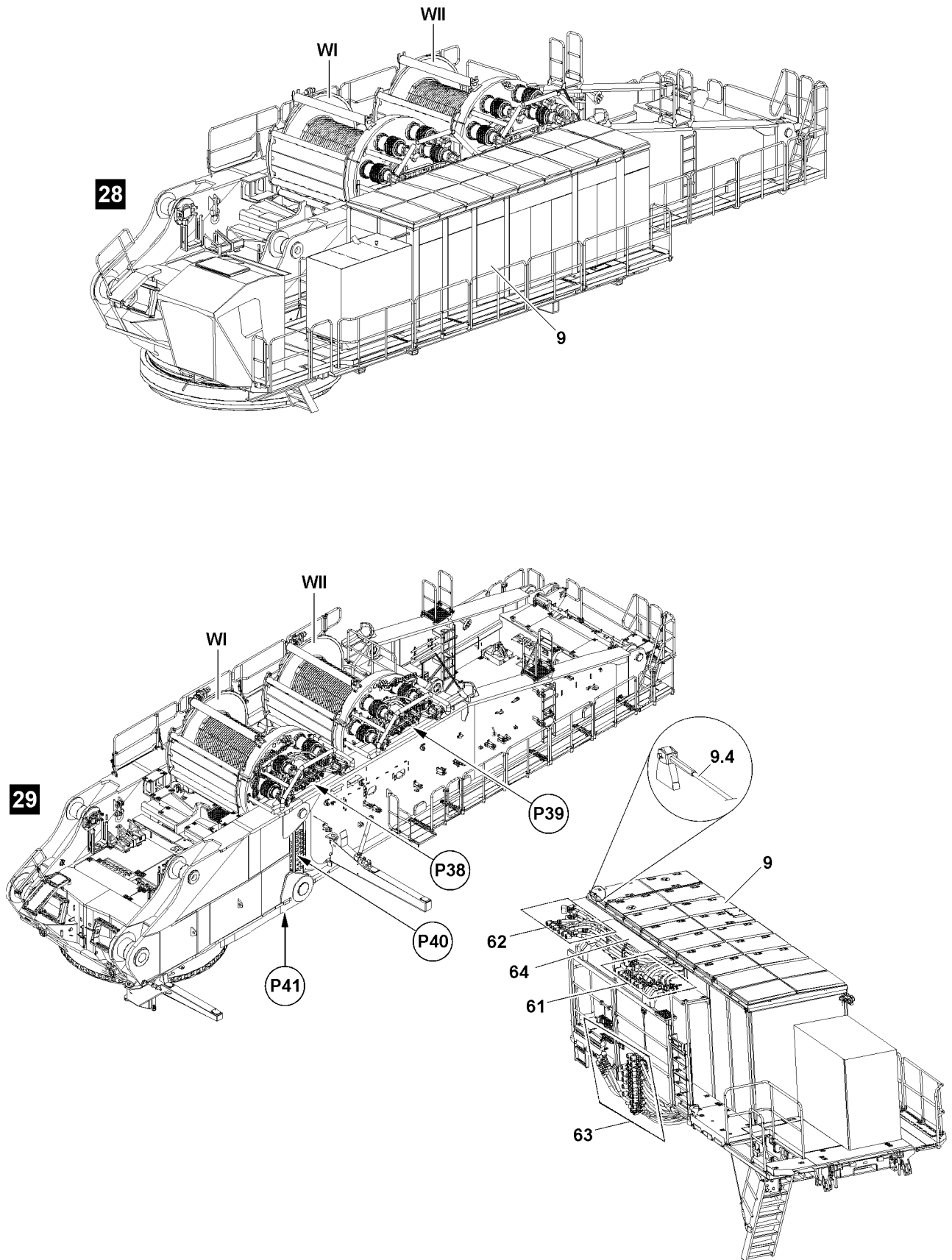

Fig.114160

LWE/LR 13000-001/19503-01-02/en

Make sure that the following prerequisites are met:

- The engine house **9** is properly assembled and secured on the turntable.
- The upper catwalk **9.3** is pinned and secured in the operating position.



DANGER

Danger of falling!

Assembly personnel can fall down when connecting or releasing hydraulic hose lines on winch 1 **WI** and winch 2 **WII** and be killed or severely injured.

- ▶ Assembly personnel, after climbing on the upper catwalk, must secure themselves immediately with the fall arrest system to the safety rope **9.4** to prevent them from falling.



Note

- ▶ Connect the hydraulic hose lines **61** at point **P38**.
 - ▶ Connect the hydraulic hose lines **62** at point **P39**.
 - ▶ Connect the hydraulic hose lines **63** at point **P40**.
-
- ▶ Release the pressure in the hydraulic system before connecting or disconnecting. Turn the engine off and wait a short time.
 - ▶ Remove the hydraulic hose lines from the park positions.
 - ▶ Connect the coupling components (sleeve and connector) and screw together with the knurled nut.
 - ▶ Tighten the hydraulic coupling by hand. Turn the knurled nut until it reaches a tangible, fixed stop position.

Establishing the electrical connections from the engine house to the turntable



Note

- ▶ To establish the electrical connections, use the Electric wiring diagram.
 - ▶ The electrical connections for the engine house are located on the inside of the turntable, in point **P41**.
-
- ▶ Establish the electrical connections from the engine house to the turntable: Connect the electrical connections according to their identification.

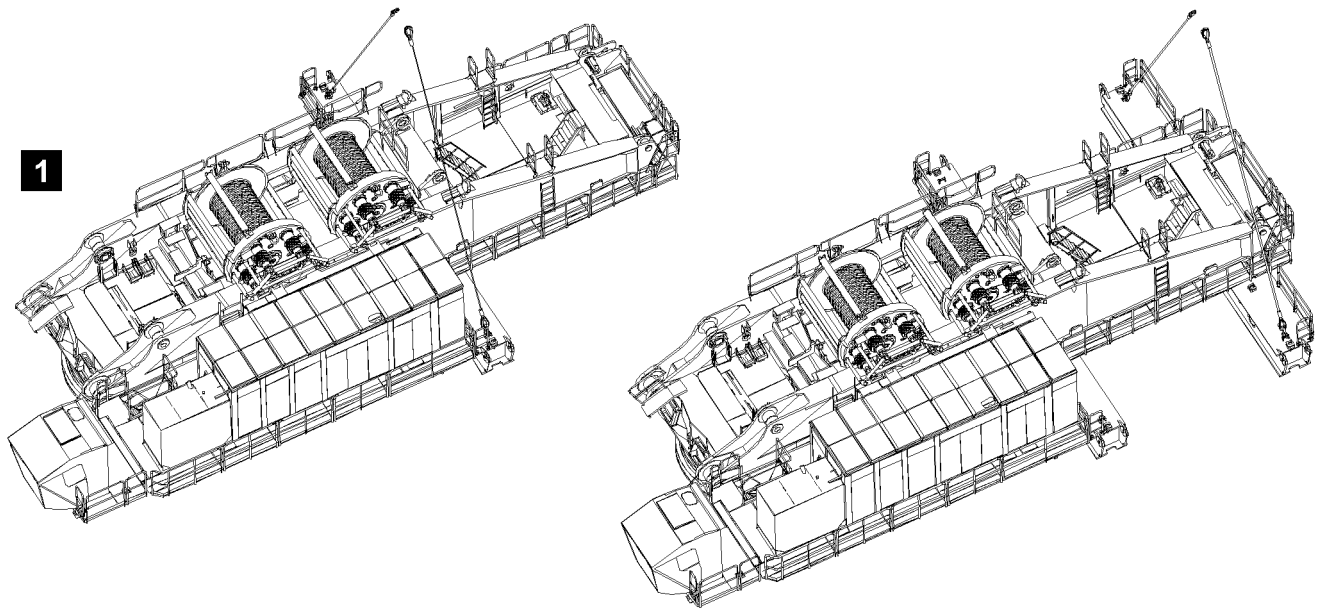

2

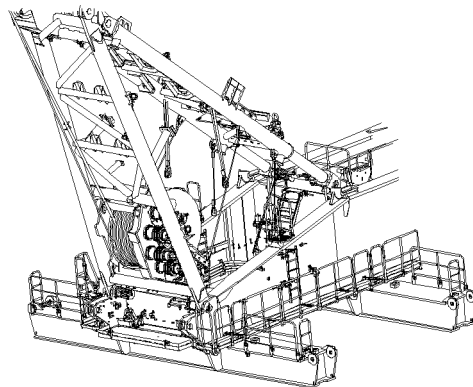

3

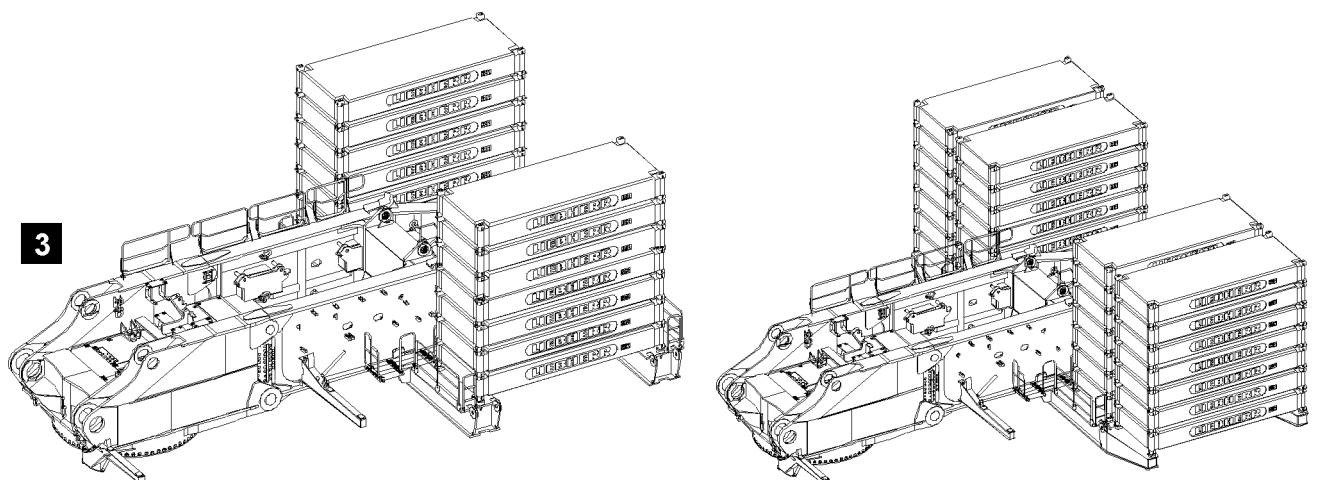

Fig.114164

4 Assembling the carrier for the counterweight on the turntable

**Note**

- ▶ For the assembly of the carriers - see illustration 1 - to take on the counterweight, refer to chapter 4.07.

5 Assembling the A-frame on the turntable

**Note**

- ▶ For the assembly of the A-frame - see illustration 2 - on the turntable, refer to the Crane operating instructions, chapter 3.05.

6 Assembling the counterweight on the turntable

**Note**

- ▶ For the assembly of the counterweight on the turntable - see illustration 3, refer to chapter 4.07.

1

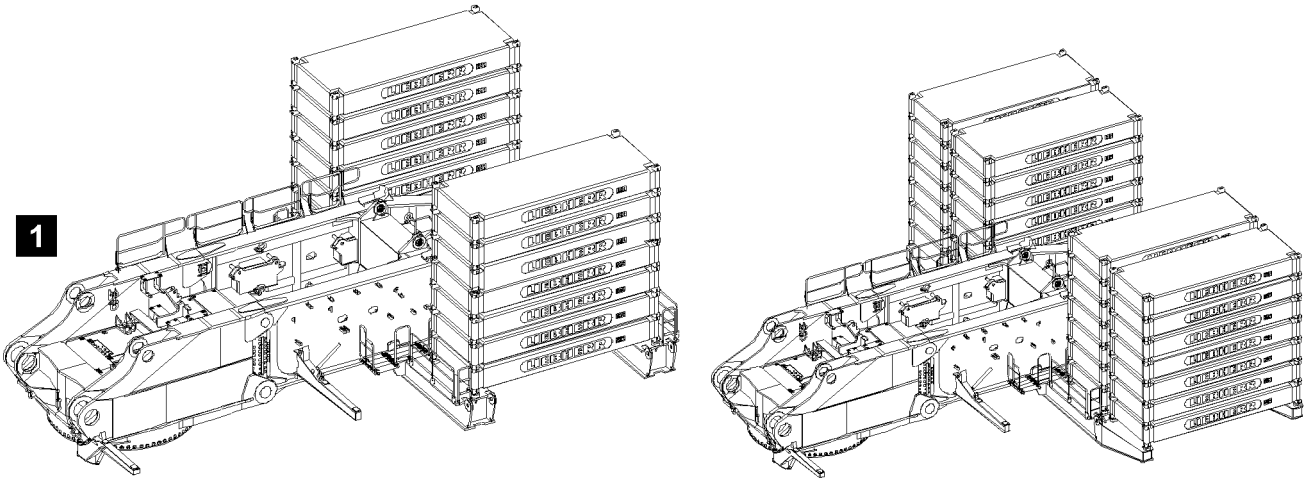

2

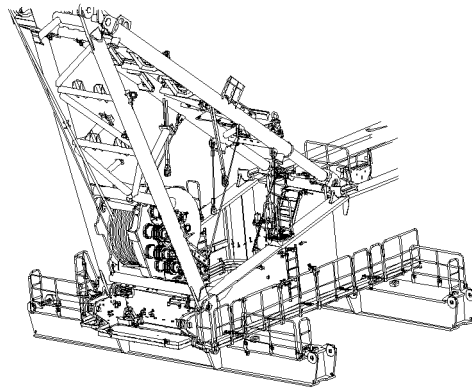

3

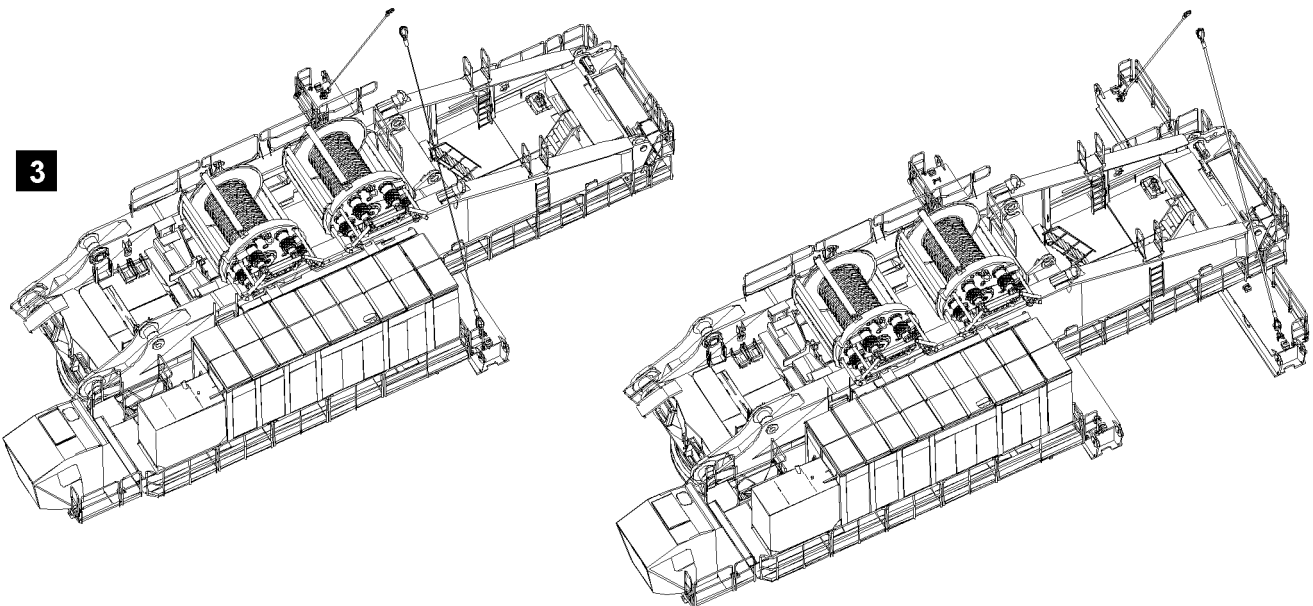

Fig.114472

LWE/LR 13000-001/19503-01-02/en

7 Disassembling the counterweight on the turntable

**Note**

- ▶ For the disassembly of the counterweight on the turntable - see illustration 1, refer to chapter 4.07.

8 Disassembling the A-frame on the turntable

**Note**

- ▶ For the disassembly of the A-frame - see illustration 2 - on the turntable, refer to chapter 3.05!

9 Disassembling the carriers for the counterweight on the turntable

**Note**

- ▶ For the disassembly of the carriers - see illustration 3 - to take on the counterweight, refer to chapter 4.07.

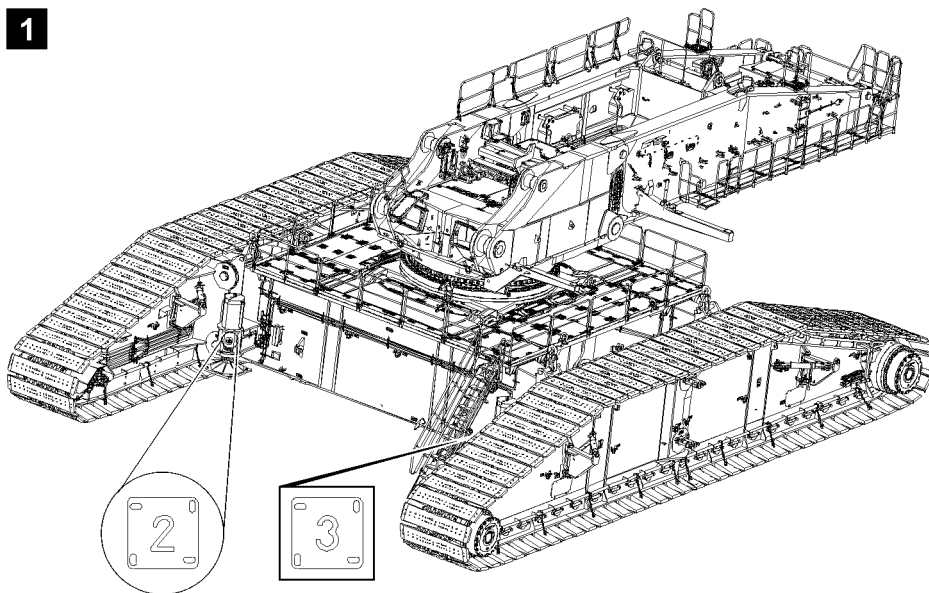

Fig.113061

LWE/LR 13000-001/19503-01-02/en

10 Disassembling the turntable



WARNING

Danger of falling!

During assembly / disassembly, inspection and maintenance work, assembly personnel must be secured with appropriate aids to prevent them from falling.

Death, severe bodily injuries, property damage.

- ▶ All work at a height, when there is a danger of falling, must be carried out with suitable aids.
- ▶ If aids are not available and work cannot be carried out from the ground, then assembly personnel must secure themselves with the supplied fall arrest system to prevent falling, see the Crane operating instructions, chapter 2.04.
- ▶ If fall protection equipment is available, then it must be used, see the Crane operating instructions, chapter 2.06.
- ▶ When lifting, lowering, swinging crane parts in and out, no persons may remain in the danger zone.
- ▶ When closing or opening boom systems during boom assembly or boom disassembly, no persons may remain on the boom system or in the danger zone.
- ▶ If railings are present on the components, then they must be brought into the corresponding position and secured for assembly / disassembly work.
- ▶ Only step on the aids, ladders and catwalks with clean shoes.
- ▶ Keep aids, ladders and catwalks free of heavy dirt, snow, frost and ice.
- ▶ During all assembly and disassembly work, maintenance work and inspections, travel or crane operation is prohibited.
- ▶ Remaining on a suspended load is prohibited.
- ▶ Stepping or walking on crane components and lattice sections with an incline of more than 20° is prohibited.
- ▶ For all assembly work, the crane driver of the main crane must be in voice contact with the crane driver / crane drivers of the auxiliary crane / auxiliary cranes.
- ▶ For assembly tasks, the crane driver may only initiate crane movements when the responsible guide has explicitly released the movement.



DANGER

The components can fall down!

Death, severe bodily injuries, property damage.

- ▶ Do not detach the auxiliary crane until the respective component is pinned and secured.

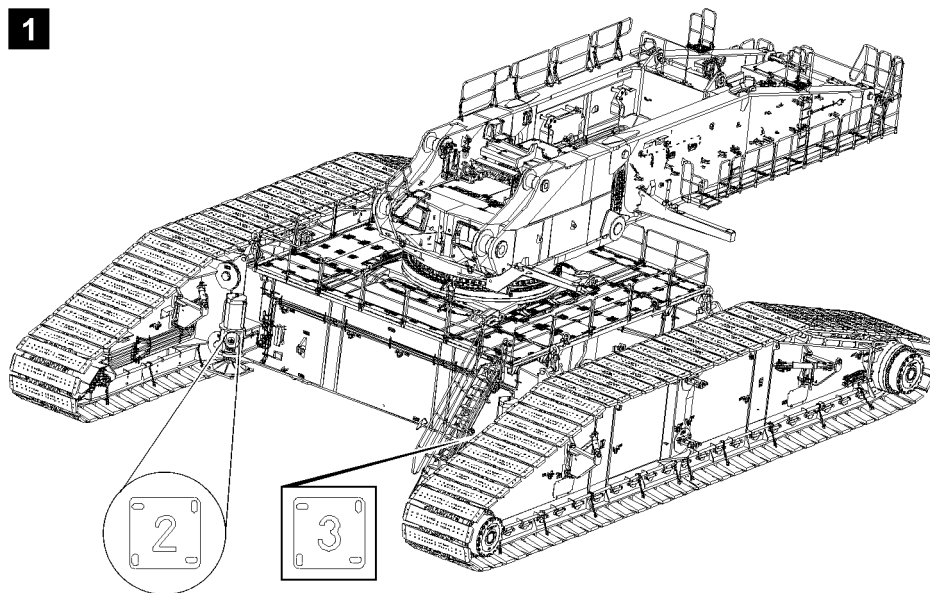

Fig.113061

**WARNING**

Danger of impact / crushing!

When assembling / disassembling crane components with the auxiliary crane, crane components can start to swing back and forth.

When lifting / lowering and positioning crane components, there is an increased danger of impact / crushing.

Death, severe bodily injuries, property damage.

- ▶ Make sure that personnel cannot be caught by components.
- ▶ Make sure that the crane is horizontally aligned.
- ▶ When working in danger zones: Use aids to protect limbs.
- ▶ Guide components with suitable aids to minimize oscillation.

**WARNING**

Danger of accident!

If no guide is present during assembly work who has voice connection to the crane operator as well as to the drivers of the auxiliary units, then there is a great danger of accident.

Crane movements that are carried out without the approval of the guide can cause accidents.

Death, severe bodily injuries, property damage.

- ▶ For all assembly work, observe the instructions of the guide.
- ▶ Make sure that the danger zone can be seen completely by the crane operator and / or the guide.

Make sure that the following prerequisites are met:

- The ground is level and of sufficient load bearing capacity.
- The crane is horizontally aligned.
- An auxiliary crane is available.
- The counterweight on the turntable has been disassembled.
- The A-frame on the turntable has been disassembled.
- The carriers to take on the counterweight on the turntable have been disassembled.

10.1 Aligning the turntable for disassembly

Before disassembly of the turntable on the crawler travel gear, it is required to align the turntable to 0°.

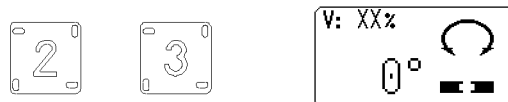

Fig.114743: B114743: Assembly supports two and three „front“ and icon „Turning range“

- ▶ Align the turntable to position 0°.

Result:

- The longitudinal axle of the turntable is between the assembly supports two and three.
- The icon „Turning range“ shows 0°.

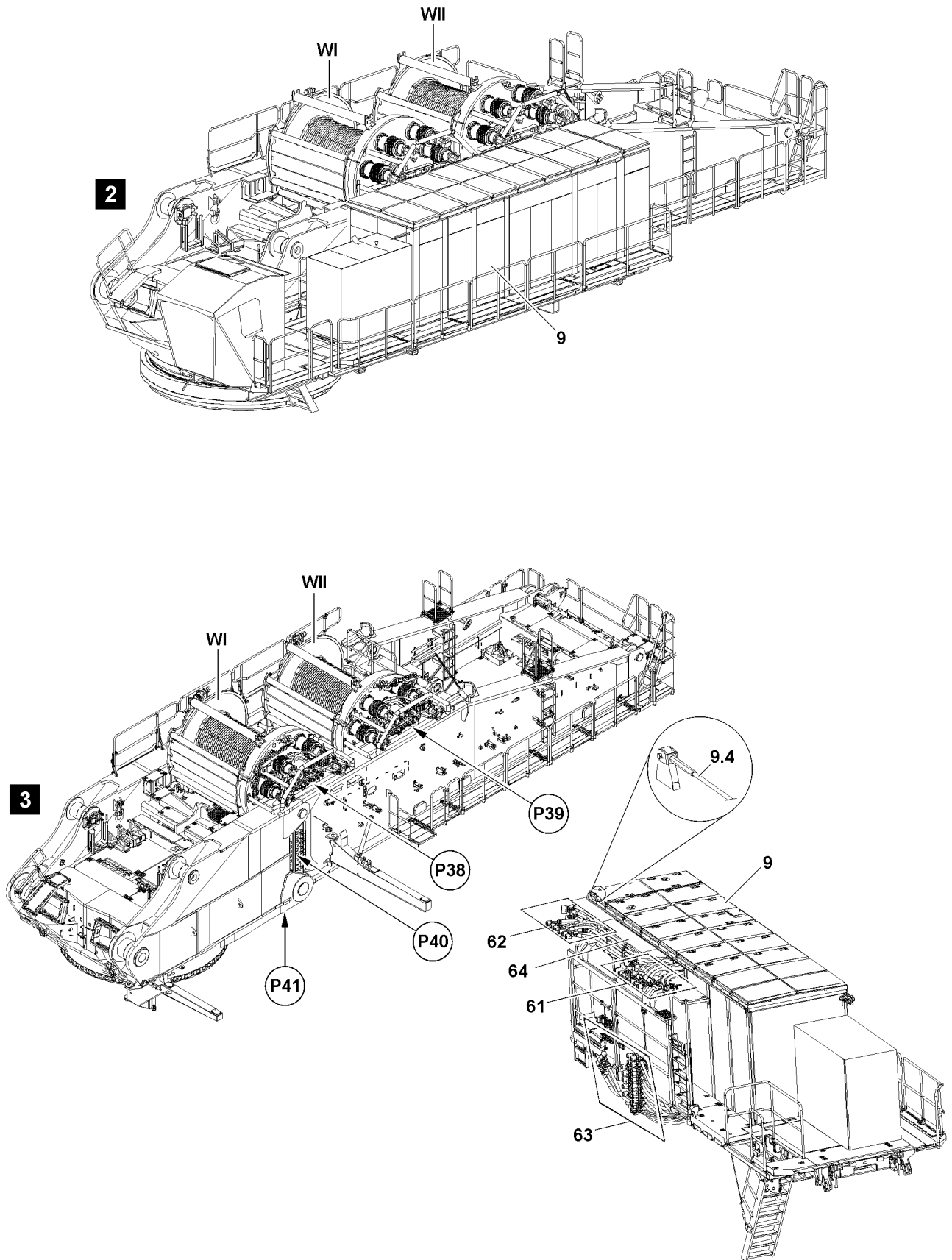

Fig.114166

LWE/LR 13000-001/19503-01-02/en

10.2 Preparing the engine house for disassembly on the turntable

10.2.1 Disconnecting the hydraulic and electrical connections



Note

- ▶ For simpler and better illustration, the engine house **9** is released from the turntable and turned outward in the illustration **3**.
-

Disconnecting the hydraulic connections between the engine house and the turntable

The hydraulic connections are established with quick couplings.

When disconnecting hydraulic lines with quick couplings, make sure that the uncoupling procedure is carried out correctly.



WARNING

Pressure in the hydraulic lines!

If the pressure supply is not interrupted before connecting / releasing the hydraulic lines, the hydraulic oil can escape with high pressure.

Death, severe bodily injuries, property damage.

- ▶ Release the pressure in the hydraulic system before connecting / disconnecting: Interrupt the pressure supply and wait a short time.
-

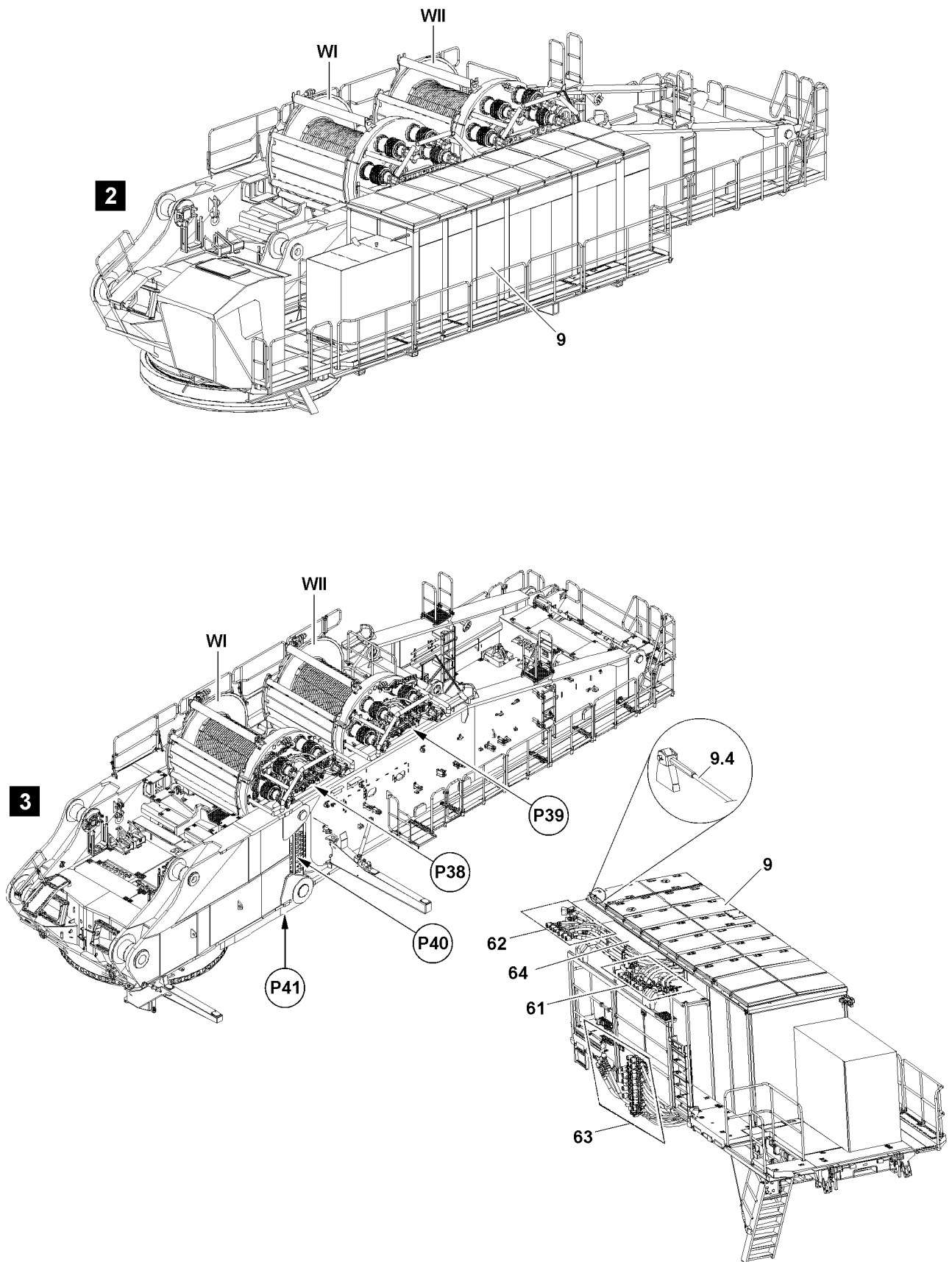

Fig.114166

LWE/LR 13000-001/19503-01-02/en

**DANGER**

Danger of falling!

Assembly personnel can fall down when connecting or releasing hydraulic hose lines on winch 1 **WI** and winch 2 **WII** and be killed or severely injured.

- ▶ Assembly personnel, after climbing on the upper catwalk **64**, must secure themselves immediately with the fall arrest system to the safety rope **9.4** to prevent them from falling.

NOTICE

Damage to the hydraulic hose lines!

If the hydraulic hose lines are not immediately placed in the specified park positions and secured after the separation procedure, then they can be severely damaged.

- ▶ Take the hydraulic hose lines down after separation immediately in the park positions and secure.
- ▶ Install the dust caps on the hydraulic connection.

**Note**

- ▶ Disconnect the hydraulic hose lines **61** at point **P38**.
 - ▶ Disconnect the hydraulic hose lines **62** at point **P39**.
 - ▶ Disconnect the hydraulic hose lines **63** at point **P40**.
-
- ▶ Release the pressure in the hydraulic system before connecting or disconnecting. Turn the engine off and wait a short time.
 - ▶ Release the hydraulic coupling by hand.
 - ▶ Take the hydraulic hose lines down in the respective park positions and secure.

Disconnecting the electrical connections from the engine house to the turntable

- ▶ Disconnect the electrical connections from the engine house to the turntable and store them properly.

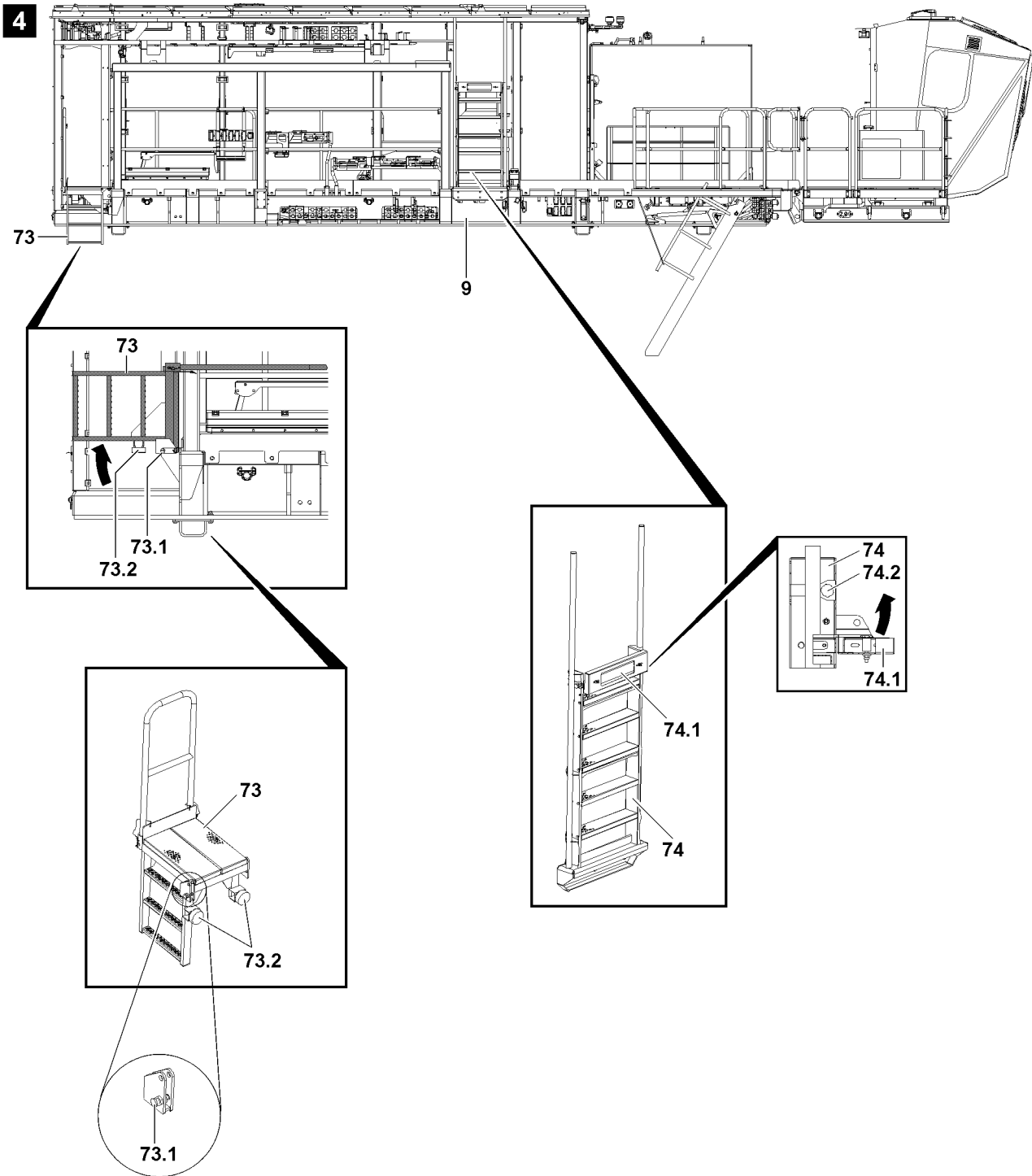

Fig.114167

LWE/LR 13000-001/19503-01-02/en

10.2.2 Bringing the folding step on the access ladder into transport position

- ▶ Swing the folding step **74.1** on the access ladder **74** upward.
- ▶ Secure the folding step **74.1** in transport position with the detent pin.

10.2.3 Bringing the folding bracket into transport position



WARNING

Danger of accident due to the folding platform!

If the folding platform is not held sufficiently when swinging it, then it can fold down by itself.

Death, severe bodily injuries, property damage.

- ▶ Hold the folding platform **73** until the detent pin is completely engaged in transport position.
-
- ▶ Pull the detent pin **73.1** and swing the folding bracket **73** in transport position upward until the detent pin engages in transport position.

Result:

- The folding bracket is secured in transport position.

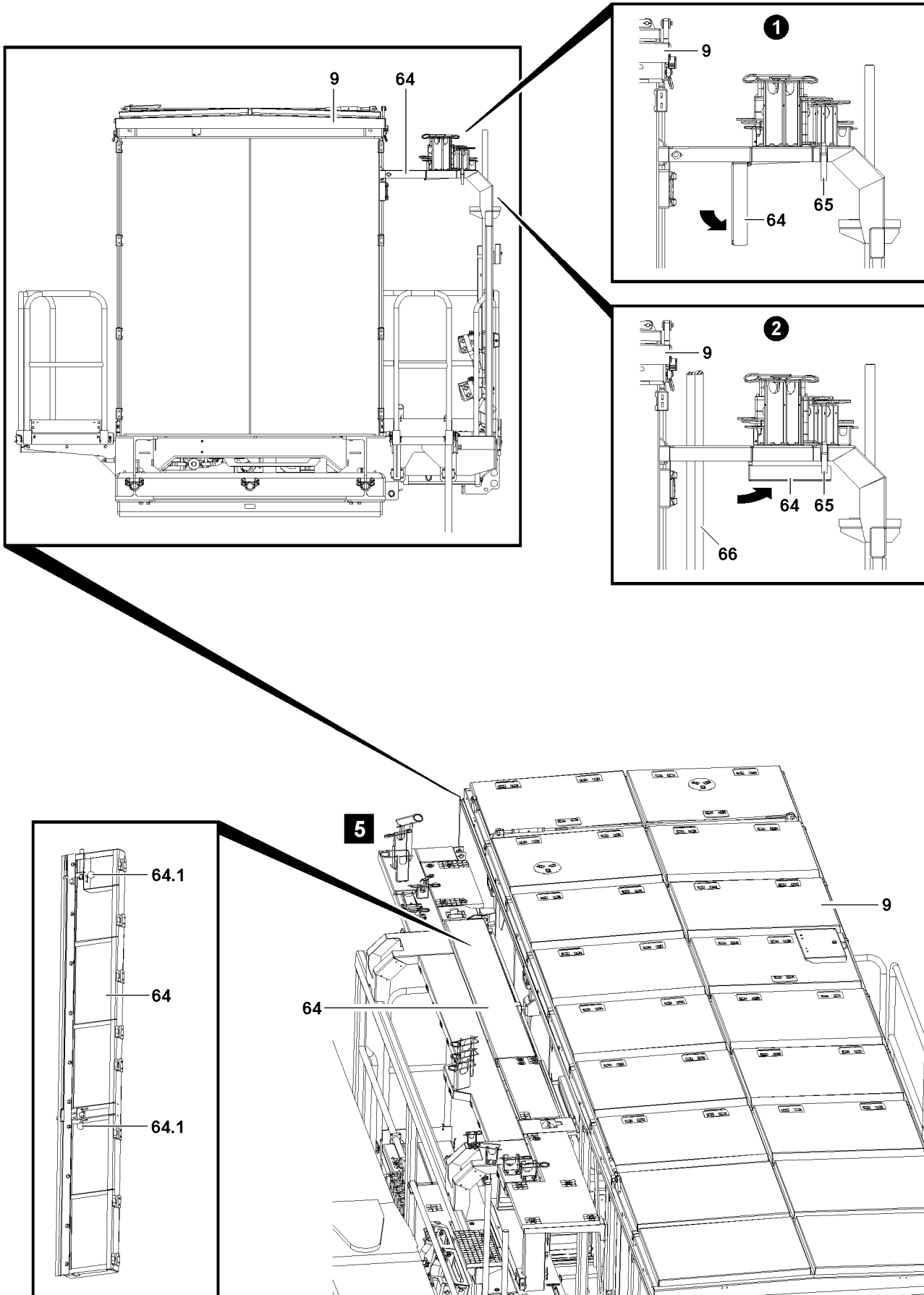

Fig.114461

LWE/LR 13000-001/19503-01-02/en

10.2.4 Bringing the upper catwalk on the engine house into assembly position

The upper catwalk **64** of the engine house **9** must be folded down and secured before disassembly of the engine house on the turntable. This makes it possible to route the fastening equipment **66** for the disassembly along the engine house without restrictions.



DANGER

Danger of accident due to the catwalk!

If the catwalk **64** is not held when unlocking it, the catwalk will fold down by itself.

Death, severe bodily injuries, property damage.

- ▶ Make sure, when unlocking the catwalk, that no one is on the catwalk.
- ▶ Make sure that the catwalk is safety held by a person when unlocking it.

-
- ▶ Unlock the catwalk **64** with the locking pins **64.1**.
 - ▶ Lower the catwalk downward and secure it in the assembly position with the tension bar **65**.



Note

- ▶ The catwalk **64** must be brought into the operating position again and secured after the disassembly of the engine house and after removing the fastening equipment on the engine house.
-

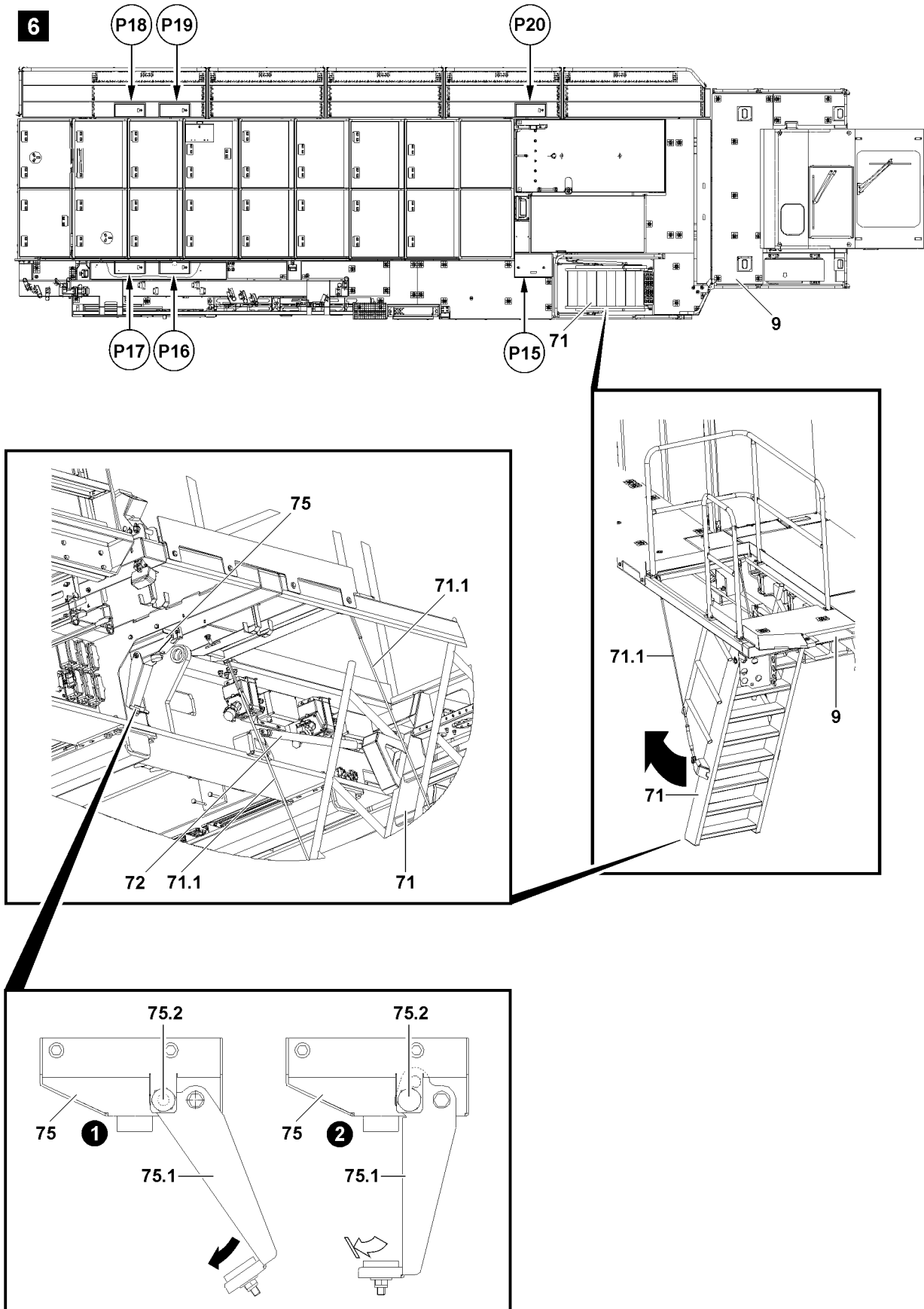

Fig.114462

LWE/LR 13000-001/19503-01-02/en

10.2.5 Attaching the fastening equipment on the engine house

We recommend to remove the engine house with two auxiliary cranes on the turntable.



Note

- ▶ If the engine house is to be removed with only one auxiliary crane on the turntable, use the compensation brackets for the horizontal alignment of the engine house during the transfer procedure from the turntable to the flatbed trailer, see section „Fastening points“.
-
- ▶ Open the cover on the fastening point **P18**.
 - or**
 - Open the cover on the fastening point **P19**.
 - ▶ Open the cover on the fastening point **P20**.



Note

- ▶ Open the covers on the fastening points on the opposite side accordingly.
-
- ▶ Attach the engine house **9** with the intended fastening equipment on the **two** auxiliary cranes, see section „Fastening points - engine house, complete“.
 - or**
 - Attach the engine house **9** with the intended fastening equipment, and using the compensation brackets on **one** auxiliary crane, see section „Fastening points - engine house, complete“.
- When the engine house is attached on the auxiliary crane / auxiliary cranes:
- ▶ Carefully tension the fastening equipment.

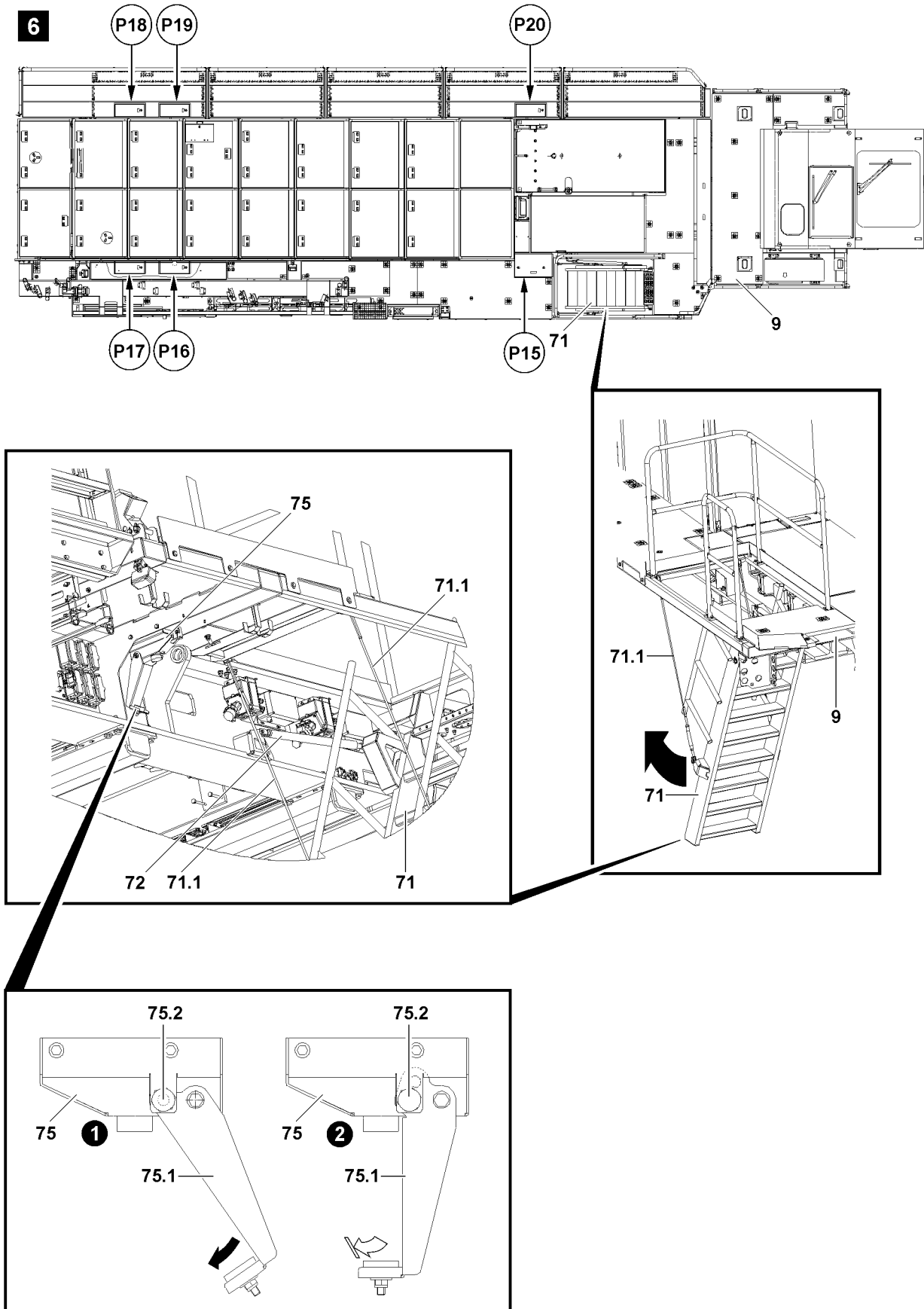

Fig.114462

LWE/LR 13000-001/19503-01-02/en

10.2.6 Bringing the stairs into the transport position

Make sure that the following prerequisites are met:

- The fastening equipment is properly fastened to the engine house.
- The fastening equipment on the engine house is tensioned.
- The securing bracket of the stairs is in the „open“ position.
- There are no persons on the engine house, in the control cabinet or in the crane operator's cab.



WARNING

Danger of accident due to folding step!

Death, severe bodily injuries, property damage.

- ▶ Make sure that there are no persons within the danger zone when folding the stairs **71** up.
 - ▶ It is prohibited for anyone to remain directly under the step **71** when folding the step **71** up.
 - ▶ The step **71** must always be folded up or down completely, intermediate positions are prohibited.
 - ▶ Make sure that the step **71** in transport position is always secured with the securing bracket **75** to prevent it from folding down.
-
- ▶ Fold the step up to the stop.
 - ▶ Secure the step **71** with securing bracket **75** in end position. Pull the detent pin **75.2** and move the securing bracket **75.1** downward.
 - ▶ Release the detent pin **75.2**.
 - ▶ Fold the securing bracket **75.1** down to the end position until the detent pin engages.

Result:

- The step is secured in transport position.

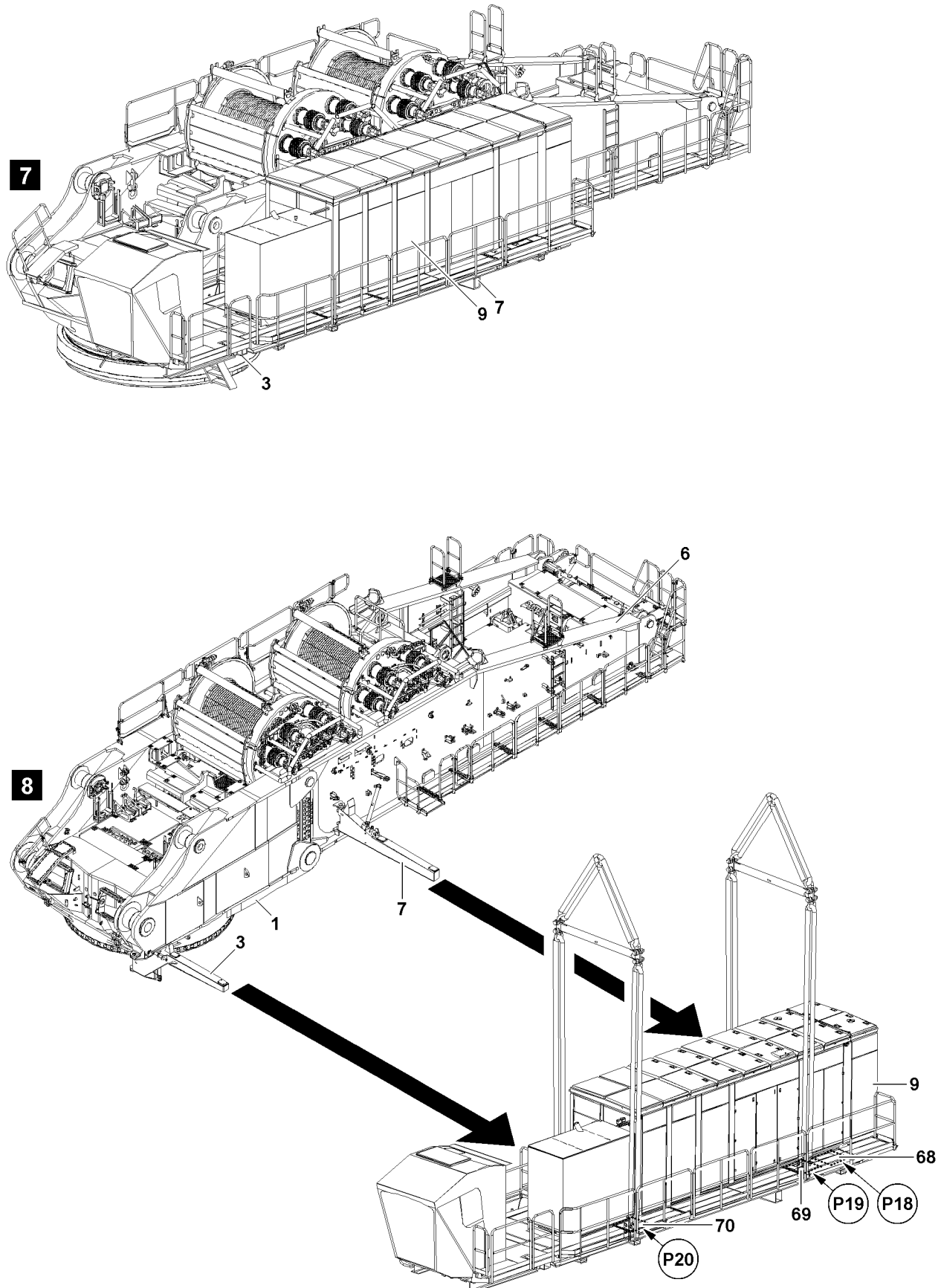

Fig.114465

LWE/LR 13000-001/19503-01-02/en

10.3 Disassembling the engine house on the turntable

Make sure that the following prerequisites are met:

- All the hydraulic connections from the engine house to the turntable are separated and properly stored.
- The electrical connections from the engine house to the turntable are separated and properly stored.
- The fastening equipment is properly fastened to the transport lugs.
- The stairs are in transport position and secured.
- The folding platform is in transport position and secured.
- The folding step on the access ladder is in the transport position and secured.
- There are no loose parts on the engine house.
- A flatbed trailer to take on the engine house is in the immediate vicinity.
- No objects are in the assembly area.

10.3.1 Lifting the engine house with the auxiliary crane from the brackets

Make sure that the following prerequisite is met:

- The fastening equipment is tensioned.

NOTICE

Damage to the pinning device!

If the locking pin, locking pin **59** and locking pin **60**, are not unpinned before disassembly of the engine house **9**, crane components and especially the locking pins can be damaged.

- ▶ Before lifting the engine house **9** from the brackets, make sure that the locking pins are completely unpinned.
-



WARNING

Oscillating load!

When lifting the engine house from the turntable, the engine house can start to swing back and forth. Death, severe bodily injuries, property damage.

- ▶ Secure the engine house with a guide rope to prevent it from swinging.
 - ▶ Make sure that there are no persons within the danger zone of the crane and the engine house.
 - ▶ Make sure that there are no obstacles within the assembly area of the crane.
-

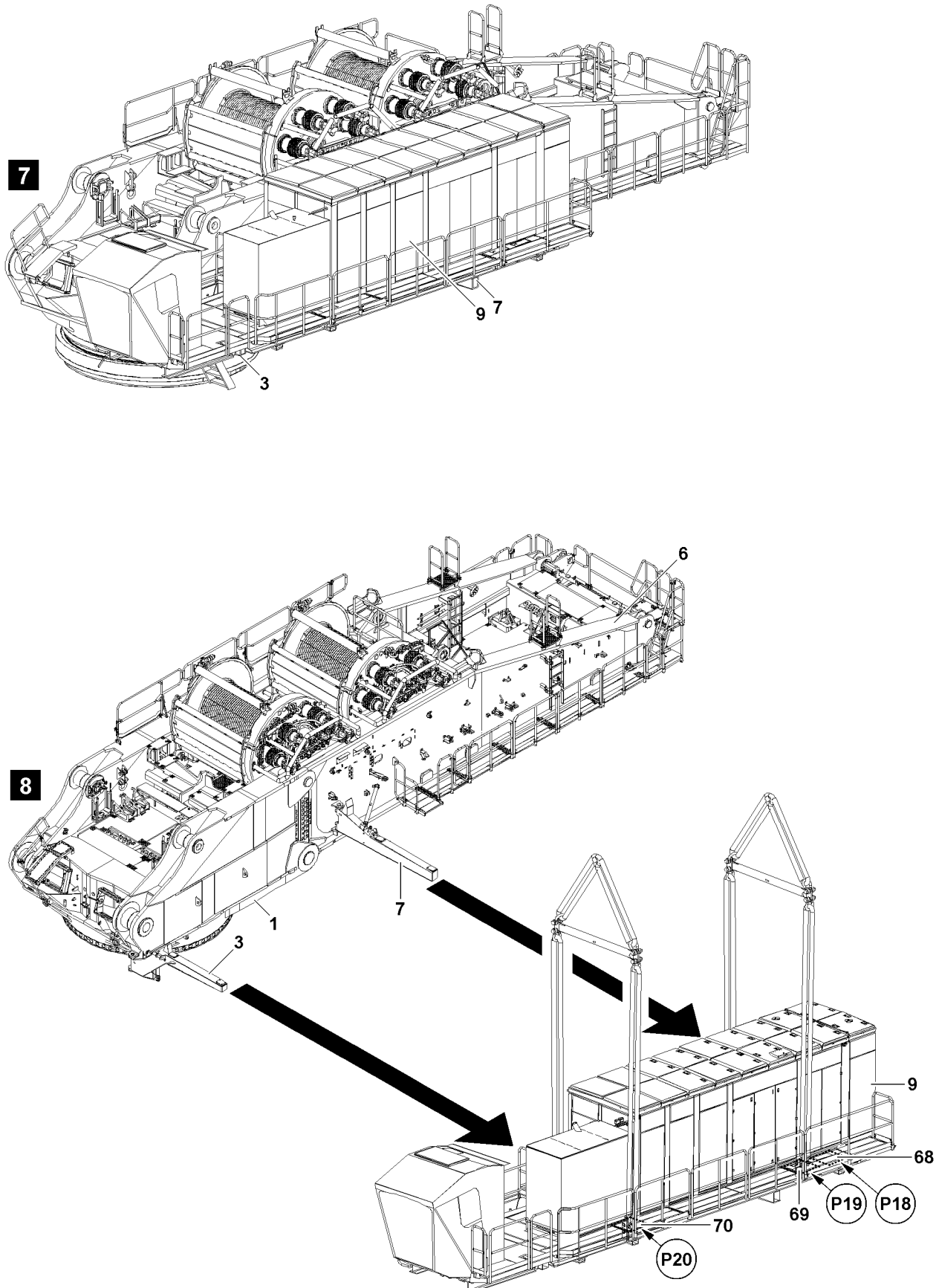

Fig.114465

LWE/LR 13000-001/19503-01-02/en

The engine house **9** must be unpinned on the bracket **7** in the area of the turntable frame rear section **6** and on the bracket **3** in the area of the turntable frame front section **1**.

- ▶ Unpin the front locking pin **59** completely.

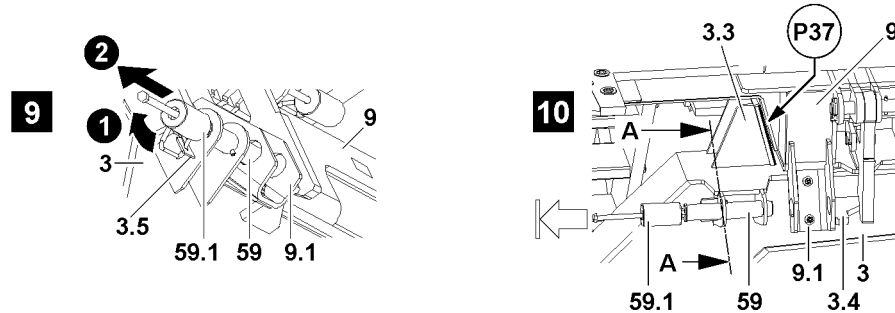

Fig.114463: B114463: Engine house **9** unpinned on bracket **3**

- ▶ Release the front locking pin **59**: Turn the pull device **59.1** with the handle out from the setting of the retaining plate **3.5**, illustration.

When the locking pin is released:

- ▶ Unpin the locking pin **59** with the pull device **59.1**.

Result:

- The engine house **9** is unpinned on the front bracket **3**.

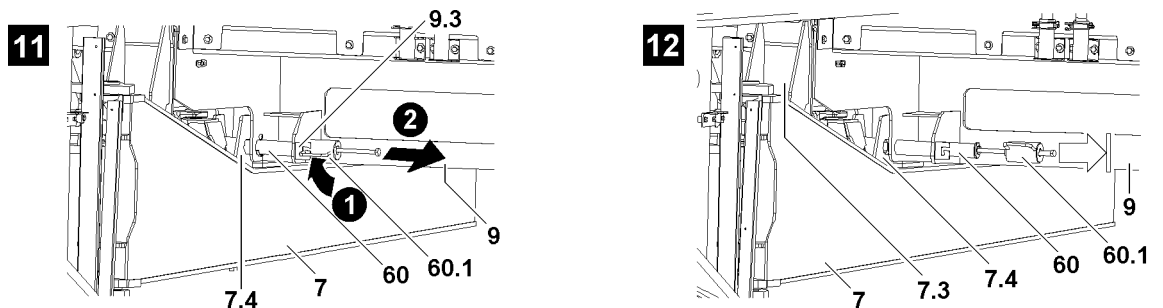

Fig.114464: B114464: Engine house **9** with bracket **7**

- ▶ Release the rear locking pin **60**: Turn the pull device **60.1** with the handle out from the setting of the retaining plate **9.3**, illustration **11**.

When the locking pin is released:

- ▶ Unpin the locking pin **60** with the pull device **60.1**.

Result:

- The engine house **9** is unpinned on the rear bracket **7**.

When the engine house is unpinned on the brackets:

- ▶ Carefully lift the engine house **9** and with the least possible speed from the turntable.

When the engine house **9** is completely lifted off the turntable:

- ▶ Carefully swing the engine house **9** with the auxiliary crane / auxiliary cranes in to the flatbed trailer.
- ▶ Set the engine house **9** carefully and with slow speed on the flatbed trailer.

When the engine house is set down completely on the flatbed trailer:

- ▶ Remove the fastening equipment on the transport lugs.

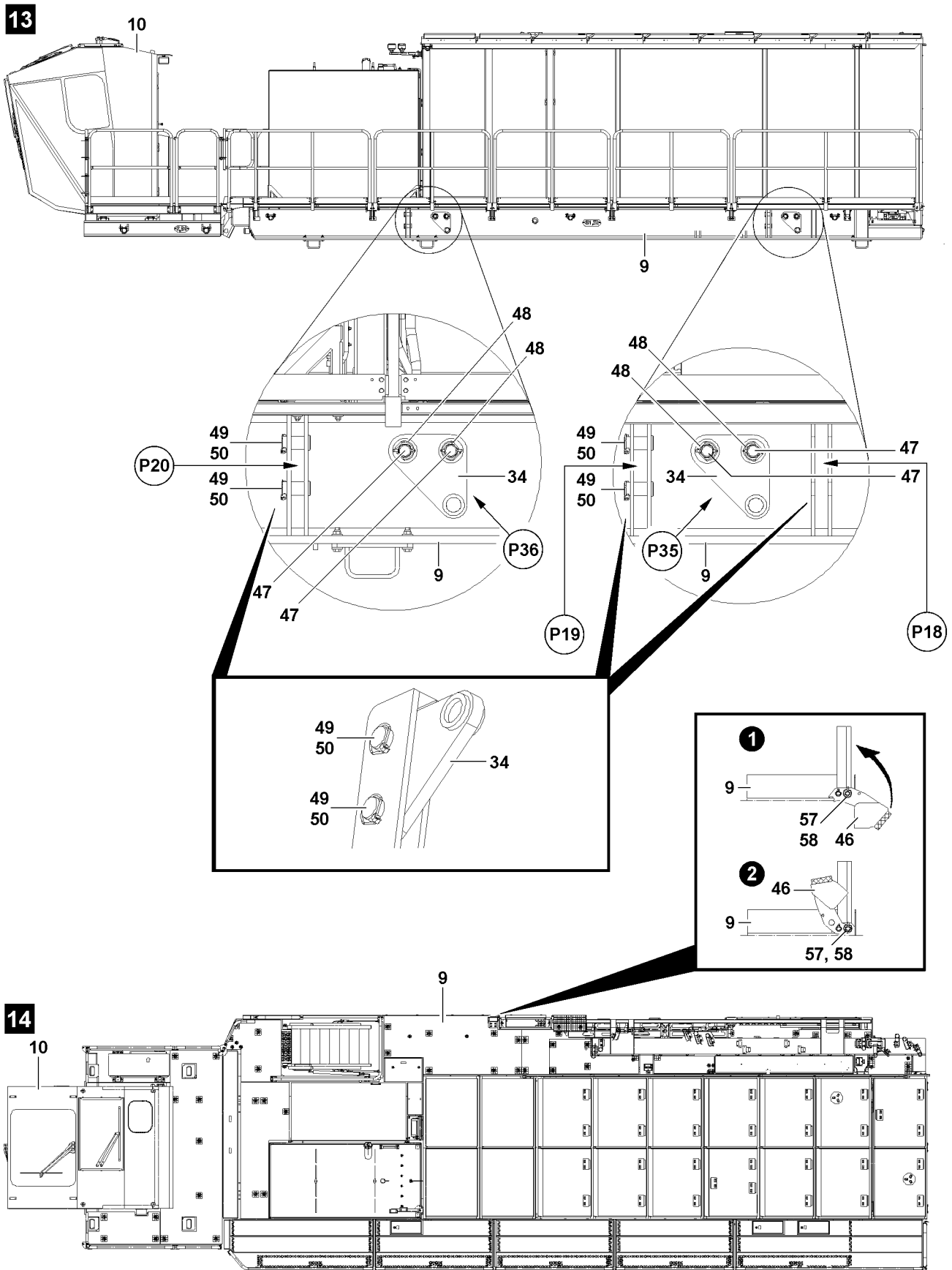

Fig.114466

LWE/LR 13000-001/19503-01-02/en

10.3.2 Removing the transport lugs on the base frame of the engine house

The transport lugs **34** must be removed on the base frame of the engine house after transport or setting the engine house on the flatbed trailer.

Make sure that the following prerequisites are met:

- The fastening equipment on the transport lugs have been removed.

Disassembling the transport lugs and storing them on the base frame of the engine house

- ▶ Remove the locking pins **50** on the pins **49** in point **P19** and in point **20**.



WARNING

Falling transport lugs!

When unpinning the transport lugs **34** they can fall down.

Death, severe bodily injuries, property damage.

- ▶ Make sure that there are no persons in the danger zone.
- ▶ Hold the transport lugs **34** before unpinning.

- ▶ Release the pin **49** at point **P19** and unpin at point **P20**.
- ▶ Set the transport lugs **34** on the pins **47** at point **P35** and point **P36**.
- ▶ Secure the transport lugs **34** at point **P35** and point **P36** immediately with locking pins **48** to prevent them from falling.

10.3.3 Disconnecting the electrical connections between the engine house and the crane operator's cab

- ▶ Disconnect the electrical connections between the engine house and the crane operator's cab.
- ▶ Store the cable properly.

10.3.4 Bringing the deflector on the engine house into transport position

14 Illustration

The deflector **46** must be brought into transport position after disassembly of the engine house **9**, pinned and secured.

- ▶ Remove the locking pin **58** and unpin the retaining pin **57**.
- ▶ Fold the deflector **46** up in transport position.

When the deflector is in transport position:

- ▶ Insert the retaining pin **57** in transport position and secure with locking pin **58**.

10.3.5 Disassembling the catwalks and railings on the engine house



Note

- ▶ For the disassembly of the catwalks and railings on the engine house, refer to chapter 2.06.

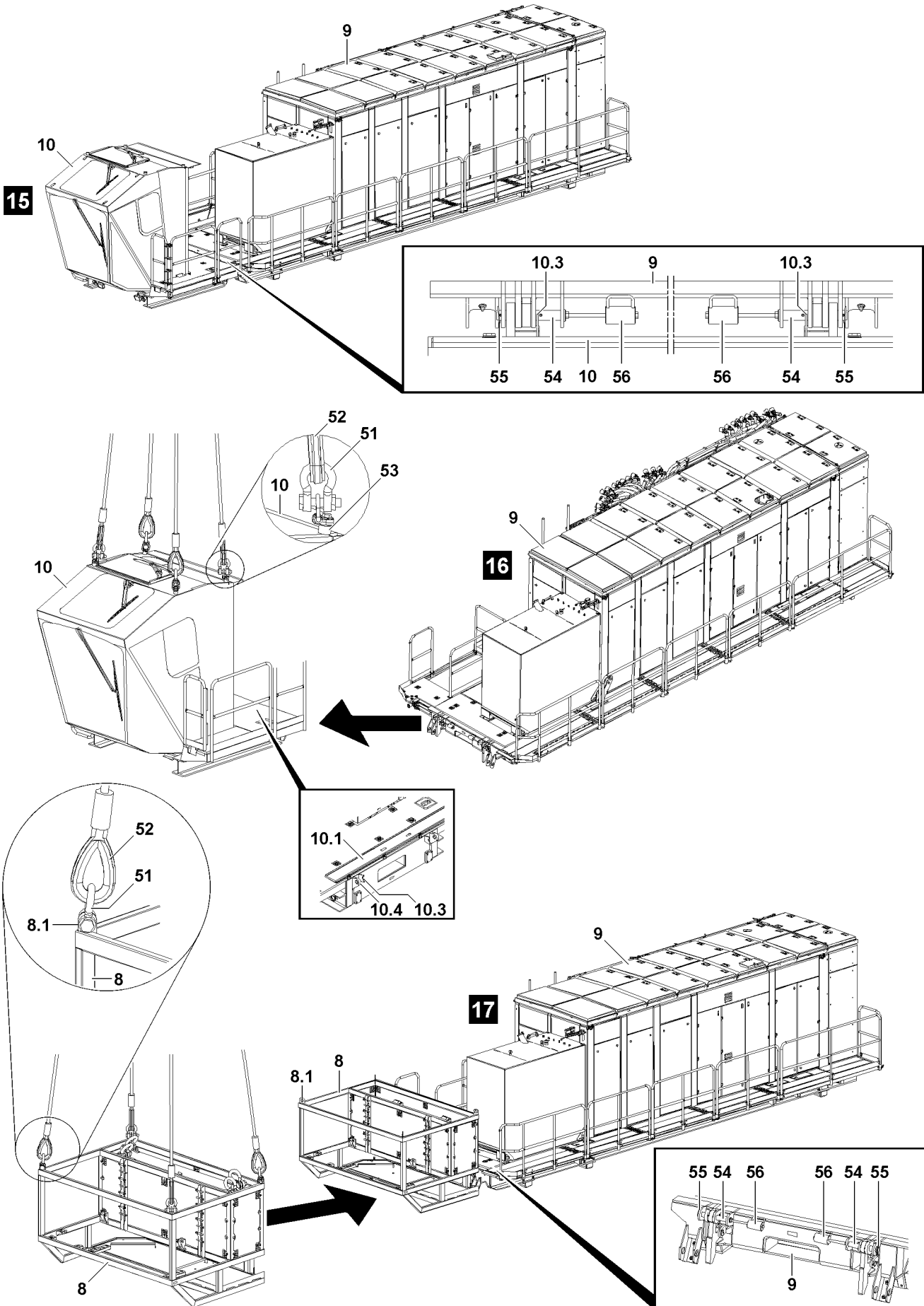

Fig.114467

LWE/LR 13000-001/19503-01-02/en

10.4 Disassembling the crane operator's cab on the engine house

Illustration 15 / illustration 16

Make sure that the following prerequisites are met:

- All electrical connections between engine house and crane operator's cab **10** are separated.
 - All cables are properly stored.
 - The step **10.1** on the crane operator's cab **10** is in the transport position.
 - A flatbed trailer or a suitable transport vehicle to take on the crane operator's cab is in the immediate vicinity of the crane.
- ▶ Fasten the fastening equipment **52** with the shackle **51** on the mounting suspensions **53** of the crane operator's cab **10**, see also section „Fastening points“.
 - ▶ Bring the fastening equipment with the auxiliary crane carefully to tension.

When the fastening equipment is tensioned on the crane operator's cab **10**:

- ▶ Unpin the crane operator's cab **10** on the engine house **9**: Release and unpin the pins **54** on both sides.



Note

- ▶ If the pins **54** are hard to move, use a mechanical pin pulling device **56**.
-

When the crane operator's cab is unpinned:

- ▶ Swing the crane operator's cab **10** carefully out with auxiliary crane.
- ▶ Position the crane operator's cab **10** on the flatbed trailer.
- ▶ Set the crane operator's cab **10** carefully and with slow speed on the flatbed trailer.
- ▶ Remove the auxiliary crane.
- ▶ Remove the fastening equipment **52** on the crane operator's cab **10**.
- ▶ Take the fastening equipment down.

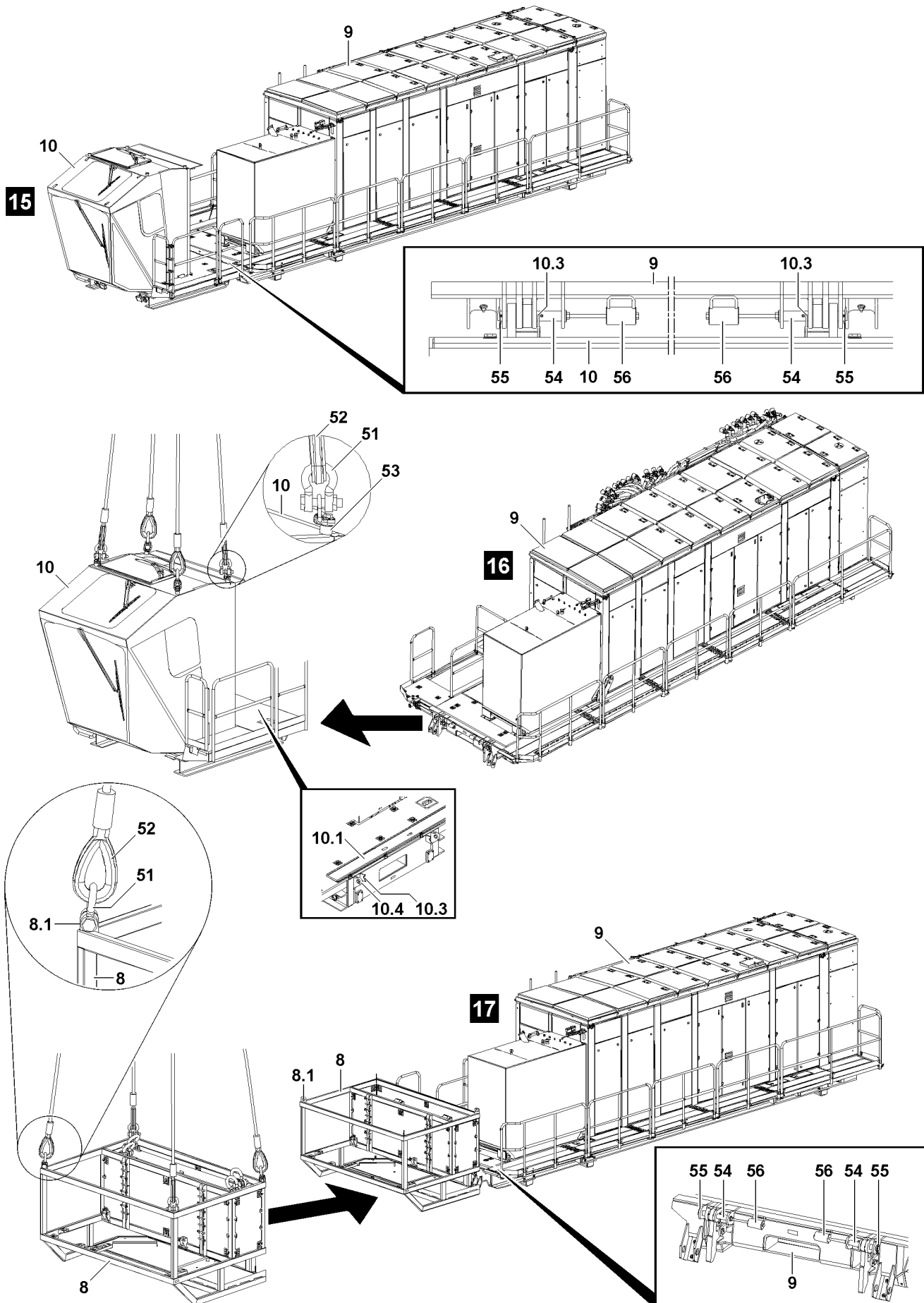

Fig.114467

LWE/LR 13000-001/19503-01-02/en

10.5 Installing the transport frame on the engine house

17 Illustration

Make sure that the following prerequisite is met:

- The pins **54** are completely unpinned.
- ▶ Fasten the fastening equipment **52** with the shackle **51** on the brackets **8.1** of the transport frame **8**, see section „Fastening points“.
- ▶ Bring the fastening equipment with the auxiliary crane carefully to tension.

When the fastening equipment is tensioned on the transport frame **8**:

- ▶ Swing the transport frame **8** with the auxiliary crane in to the receptacles on the engine house.

When the transport frame **8** is positioned on the base frame of the engine house:

- ▶ Insert the pins **54** on both sides and secure with locking pins **55**.



Note

- ▶ If the pins **54** are hard to move, use a mechanical pin pulling device.
-

When the transport frame **8** is pinned with pins **54** on both sides on the base frame of the engine house and secured with locking pins **55**, illustration:

- ▶ Remove the fastening equipment on the transport frame **8**.
- ▶ Take the fastening equipment down.

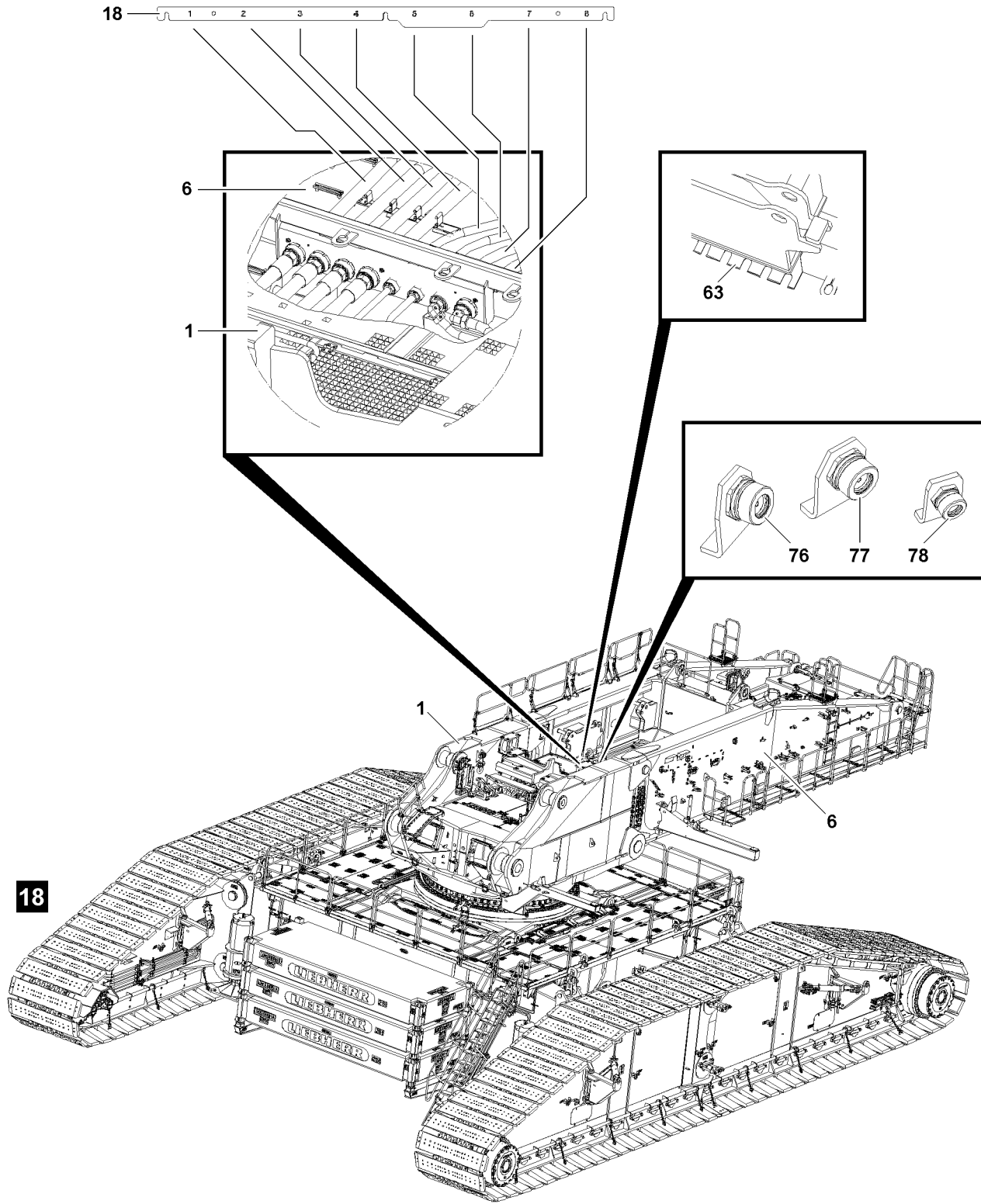

LWE/LR 13000-001/19503-01-02/en

Fig.114468

10.6 Removing the winches

The winches must be disassembled before disassembly of the turntable.



Note

- ▶ The disassembly of the hoist winches is described in chapter 3.07.

10.7 Disconnecting the electrical connections between the turntable frame rear section and the turntable frame front section

- ▶ Disconnect the electrical connections between the turntable frame front section and the turntable frame rear section and store properly.

10.8 Disconnecting the hydraulic connections from the turntable frame rear section to the turntable frame front section

The hydraulic connections are established with quick couplings.

When disconnecting hydraulic lines with quick couplings, make sure that the uncoupling procedure is carried out correctly.



WARNING

Pressure in the hydraulic lines!

If the pressure supply is not interrupted before connecting / releasing the hydraulic lines, the hydraulic oil can escape with high pressure.

Death, severe bodily injuries, property damage.

- ▶ Release the pressure in the hydraulic system before connecting / disconnecting: Interrupt the pressure supply and wait a short time.
- ▶ Release the hydraulic coupling by hand.
- ▶ Connect the hydraulic hose lines properly to the transport receptacle **63** and screw the remaining hydraulic hose lines on dummy plug **76**, dummy plug **77** and dummy plug **78**.

10.9 Preparing the turntable frame rear section for disassembly

Make sure that the following prerequisites are met:

- A flatbed trailer is in the direct vicinity of the crane.
- The flatbed trailer is parked on level and horizontal ground.
- The ground is of sufficient load bearing capacity to take on the flatbed trailer including the turntable frame rear section.
- No objects are in the assembly area.

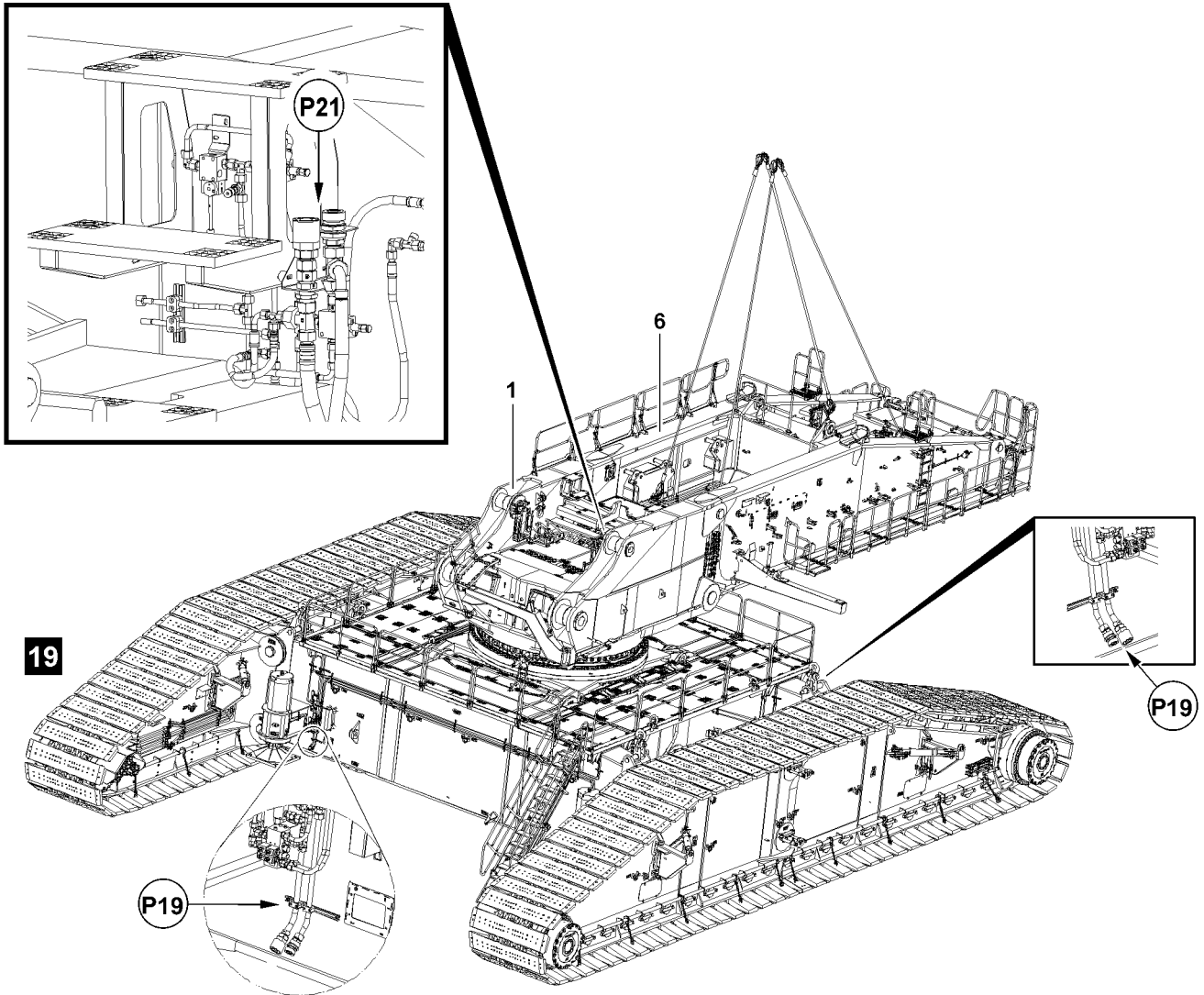

Fig.114471

10.9.1 Fastening the turntable frame rear section to the auxiliary crane



WARNING

Falling turntable frame rear section!

If the pin retainers for the connector pins are removed before the turntable frame rear section **6** is secured with the auxiliary crane, then the turntable frame rear section can fall down.

Death, severe bodily injuries, property damage.

- ▶ Make sure that the turntable frame rear section is secured by the auxiliary crane before the pin retainers are removed.
-
- ▶ Attach the turntable frame rear section to the auxiliary crane, see section „Fastening points“.
 - ▶ Bring the fastening equipment on the turntable frame rear section to tension.

10.9.2 Connecting the hydraulic supply lines



Note

- ▶ Before disassembly of the turntable frame rear section **6** on the turntable frame front section **1**, establish the hydraulic connections to the pin pulling cylinders.
- ▶ The pressure supply to the pin pulling cylinders can be ensured either via the external hydraulic aggregate or the installation connections on the operational engine house.
- ▶ Connect the supply lines for the pressure supply either to a cross carrier (point **P19**) or to the turntable frame front section **1** (point **P21**).

Make sure that the following prerequisite is met:

- The pressure in the hydraulic system has been released.

Establishing the hydraulic connections from the external hydraulic aggregate to the assembly circuit

- ▶ Connect the supply lines of the external hydraulic aggregate on the cross carrier - front at point **P19**.
or
Connect the supply lines of the hydraulic aggregate on the cross carrier - rear at point **P19**.
or
Connect the supply lines of the pin pulling aggregate on the turntable frame rear section **1** at point **P21**.

Establishing the hydraulic connections from the engine house to the installation circuit

- ▶ Connect the supply lines of the engine house on the cross carrier - front at point **P19**.
or
Connect the supply lines of the engine house on the cross carrier - rear at point **P19**.
or
Connect the supply lines of the engine house on the turntable frame front section at point **P21**.

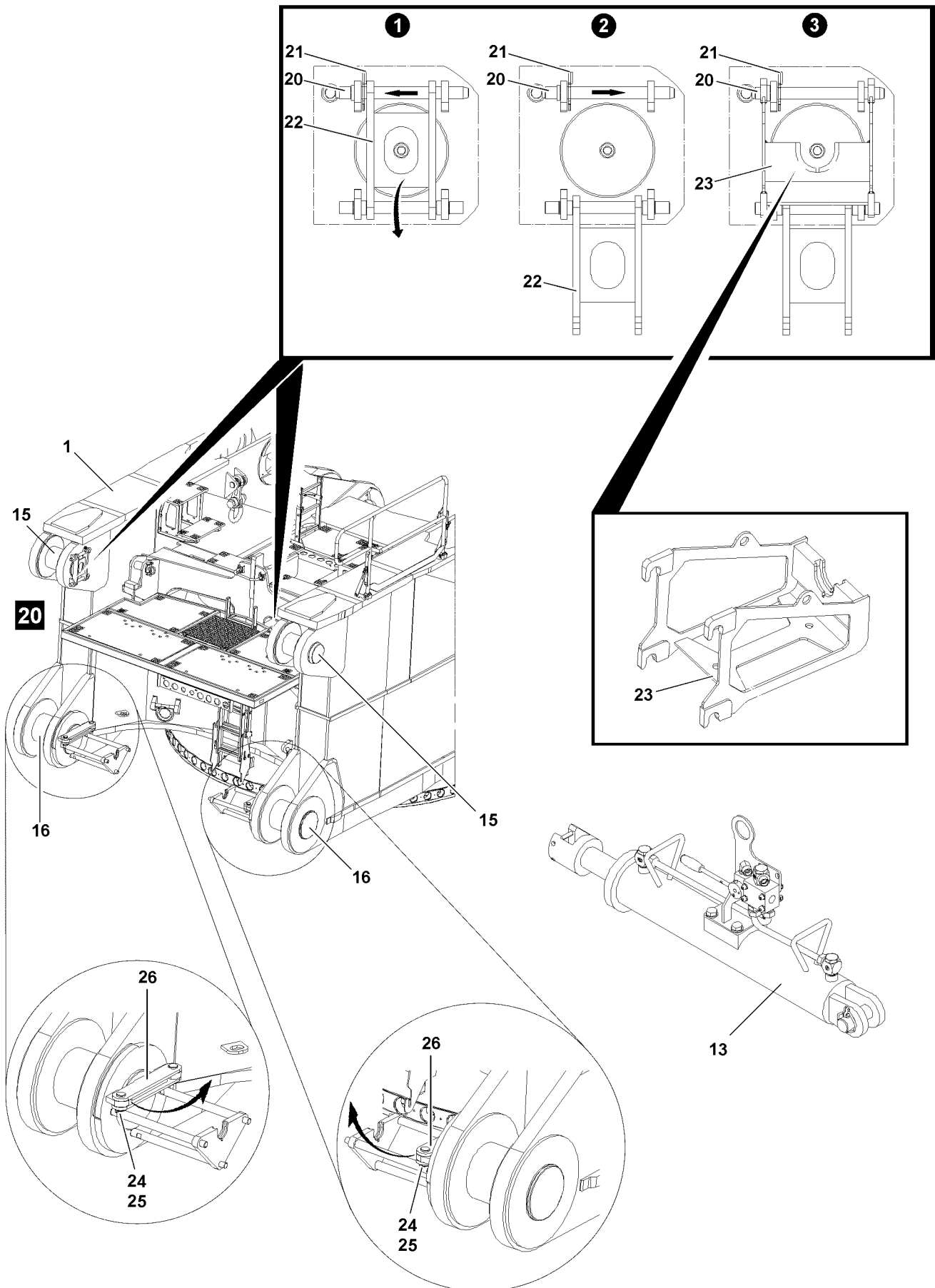

Fig.114476

LWE/LR 13000-001/19503-01-02/en

10.10 Disassembling the turntable frame rear section on the turntable frame front section

Make sure that the following prerequisite is met:

- The fastening equipment on the turntable frame rear section is „tensioned“.

10.10.1 Releasing and unpinning the connector pins on the „turntable top“

Before unpinning the connector pins **15**, the pin retainer - securing bracket **22** - must be folded down.

- ▶ Release the securing bracket **22** for the pin retainer on the „upper right“ and „upper left“: Remove spring retainer **21** on pin **20**.



WARNING

Danger of crushing!

When releasing the securing bracket **22**, it can fold down by itself and crush hands, fingers and arms. Death, severe bodily injuries, property damage.

- ▶ Before unpinning the pin **20**, hold the securing bracket **22** and then lower it.

- ▶ Release the securing bracket **22** and lower it downward.
- ▶ Reinsert the pin **20** in the original position.

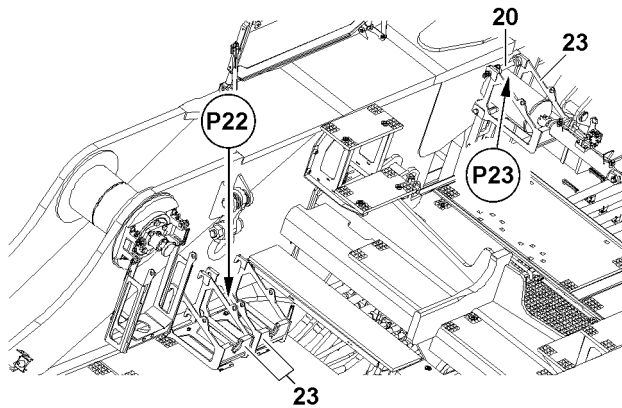

Fig. 113068: B113068: Brackets **23** for pin pulling cylinder

When the pin **20** is pinned and secured again:

- ▶ Take the brackets **23** at point **P22** from the transport retainer and hang in on the „upper right“ and „upper left“ on the receptacle points **P23** - pin **20**.

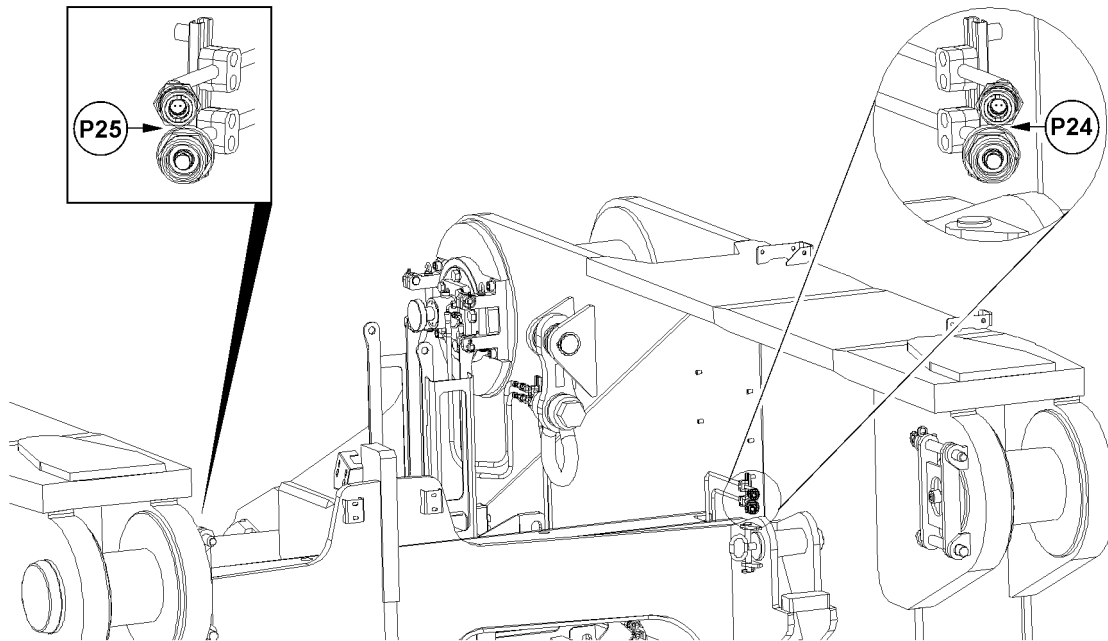

Fig.113062: B113062: Turntable frame front section from the rear - pinning on top

- ▶ Extend the piston rods for the pin pulling cylinders.
- ▶ Place the pin pulling cylinders **13** in the brackets **23** „upper right“ and „upper left“.
- ▶ Establish the hydraulic connections to the pin pulling cylinders „upper right“ and „upper left“: Connect the supply lines for the pin pulling cylinder on the hydraulic connections at point **P24** and point **P25**.

When the hydraulic connections to the pin pulling cylinders **13** are established:

- ▶ Retract the piston rods for the pin pulling cylinders **13**.
- ▶ Unpin the connector pins „on top“ **15** with the pin pulling cylinder **13** completely.

When the connector pins „on top“ **15** are completely unpinned:

- ▶ Remove the pin pulling cylinder **13** from the brackets **23**.
- ▶ Leave the fastening equipment between auxiliary crane and turntable frame rear section tensioned.

10.10.2 Releasing and unpinning the connector pins „turntable bottom“

- ▶ Release the securing bracket **26** for the pin retainer on the „lower right“ and „lower left“: Remove the locking pin **25** on the pin **24**.
- ▶ Unpin the securing bracket **26** and swing inward to the turntable frame.

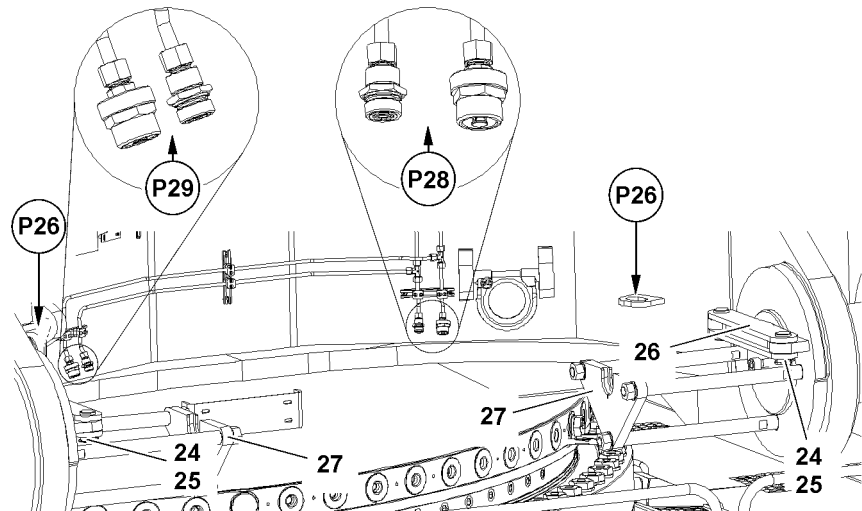

Fig.113069: B113069: Turntable frame front section from the rear - pinning on the bottom

- ▶ Pin and secure the securing bracket **26** with pin **24** at position **P26**.
- ▶ Establish the hydraulic connections to the pin pulling cylinders „lower right“ and „lower left“: Connect the supply lines for the pin pulling cylinder on the hydraulic connections at point **P28** and point **P29**.

When the hydraulic connections to the pin pulling cylinders **13** are established:

- ▶ Extend the piston rods for the pin pulling cylinders **13**.

When the piston rods for the pin pulling cylinders are extended:

- ▶ Place the pin pulling cylinders **13** in the cylinder receptacles **27** for the pin pulling device „lower right“ and „lower left“.



WARNING

Falling turntable frame rear section!

If the fastening equipment is not tensioned when unpinning the turntable frame rear section, then the turntable frame rear section can suddenly fall down.

Death, severe bodily injuries, property damage.

- ▶ Make sure that the fastening equipment on the turntable frame rear section is tensioned before unpinning.

- ▶ Unpin the connector pins „on the bottom“ **16** with the pin pulling cylinder **13** completely.

Result:

- The turntable frame rear section is unpinned on the turntable frame front section and hangs on the auxiliary crane.
- ▶ Swing the turntable frame rear section carefully out with the auxiliary crane.
- ▶ Position the turntable frame rear section with the auxiliary crane over the flatbed trailer on stand by.
- ▶ Set the turntable frame rear section carefully and with slow speed on the flatbed trailer.

When the turntable frame rear section is laying completely on the flatbed trailer:

- ▶ Remove the fastening equipment.

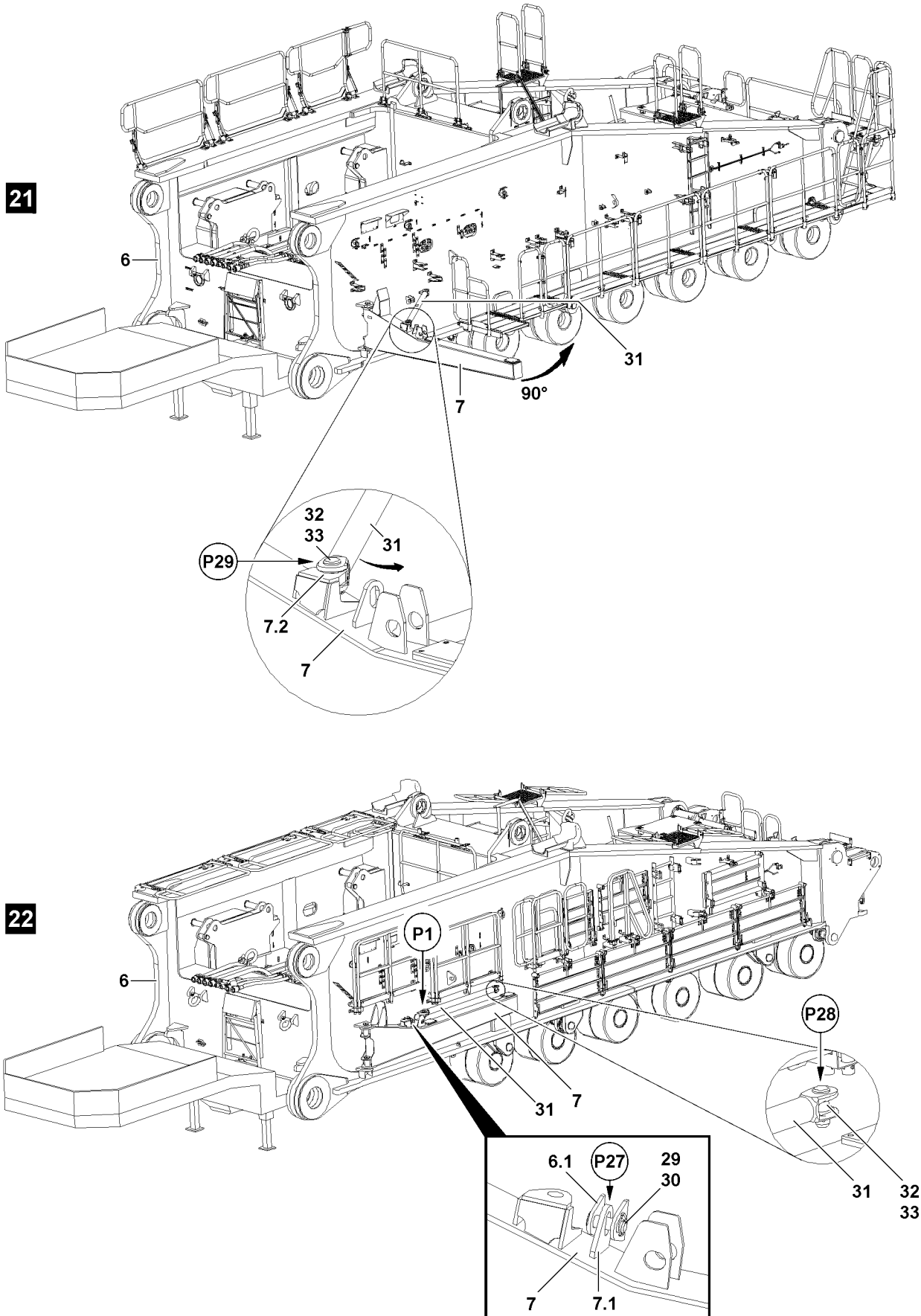

Fig.114478

LWE/LR 13000-001/19503-01-02/en

10.10.3 Disassembling platforms, gratings, ladders and railings on the turntable frame rear section and bringing them into the transport position

Make sure that the following prerequisite is met:

- The bracket **7** is pinned and secured in the operating position.



Note

- ▶ For the disassembly of platforms, gratings, ladders and railings see chapter 2.06.

10.10.4 Bringing the bracket for the engine house on the turntable frame rear section into the transport position

Make sure that the following prerequisites are met:

- The turntable frame rear section is set on the flatbed trailer.
- The platforms, gratings, ladders and railings on the turntable frame rear section are removed and / or are in the respective transport position.



WARNING

Danger of accident due to the bracket swinging in by itself!

If the flatbed trailer is not standing on level and horizontal ground, then the bracket **7** can swing in by itself during unpinning.

Death, severe bodily injuries, property damage.

- ▶ Make sure that the flatbed trailer is parked on level and horizontal ground.
- ▶ It is prohibited for anyone to remain between the turntable frame rear section **6** and the bracket **7** when swinging the bracket **7** in.

Release and swing the bracket **7** on the turntable frame rear section **6** in, illustration **21**.

- ▶ Release the bracket **7**: Remove the locking pin **33** in point **P29** and unpin the pin **32**.



Note

- ▶ Reuse the pin **32** and locking pin **33** to pin the strut **31** in the transport position in point **P28**.
- ▶ Swing the strut **31** in to the turntable frame rear section **6**.
- ▶ Secure the strut **31** in transport position at point **P28**: Insert the pin **32** and secure with the locking pin **33**.
- ▶ Swing the bracket **7** in to the turntable frame rear section.

When the bracket **7** has been swung in completely:

- ▶ Secure the bracket **7** in transport position at point **P27** with pin **29** and locking pin **30**.

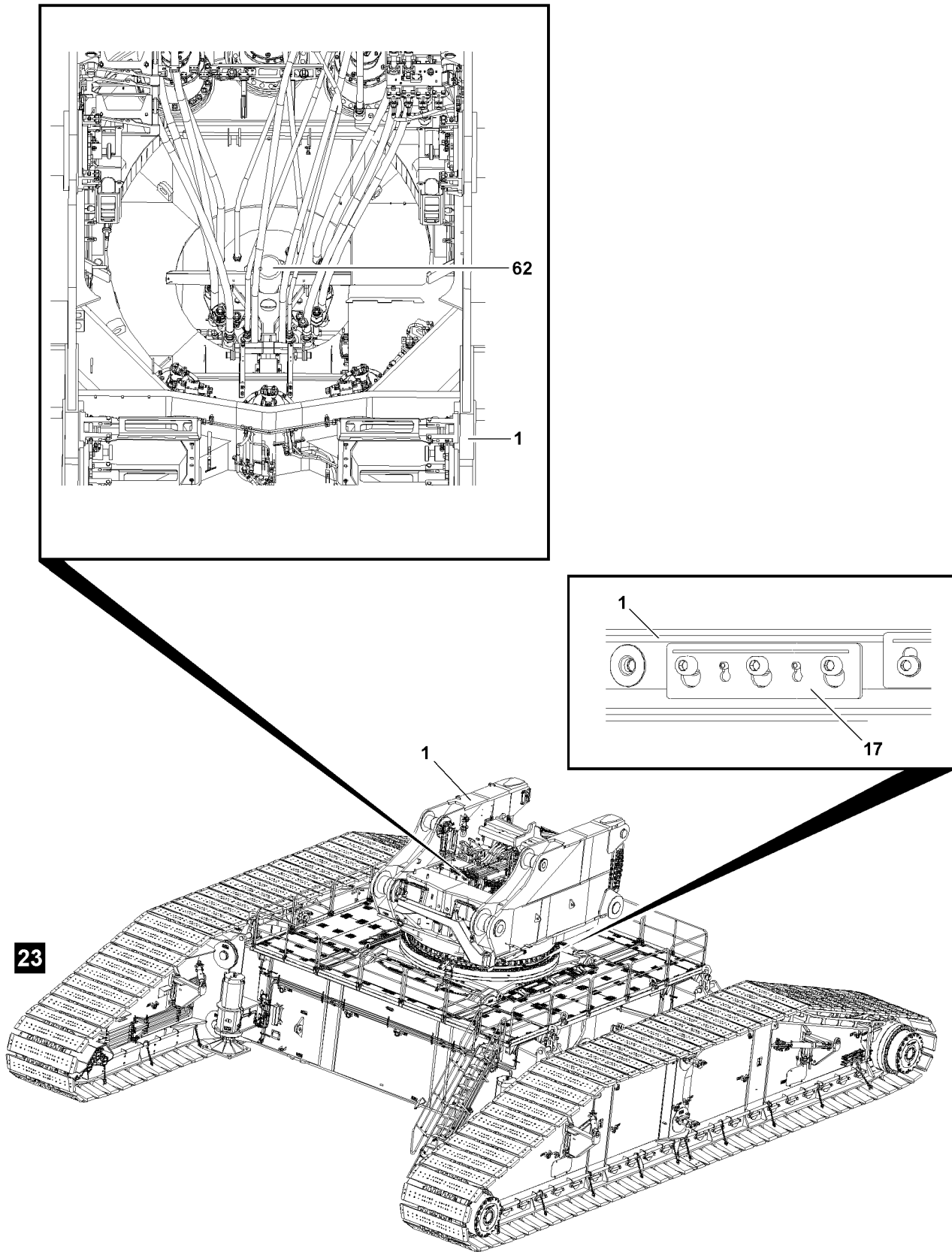

Fig.114744

LWE/LR 13000-001/19503-01-02/en

10.11 Disconnect the hydraulic and electrical connections on the rotary connection

Make sure that the following prerequisite is met:

- The turntable frame rear section has been disassembled.

10.11.1 Disconnecting the hydraulic connections

The hydraulic connections are established with quick couplings.

When disconnecting hydraulic lines with quick couplings, make sure that the uncoupling procedure is carried out correctly.



WARNING

Pressure in the hydraulic lines!

If the pressure supply is not interrupted before connecting / releasing the hydraulic lines, the hydraulic oil can escape with high pressure.

Death, severe bodily injuries, property damage.

- ▶ Release the pressure in the hydraulic system before connecting / disconnecting: Interrupt the pressure supply and wait a short time.
-
- ▶ Release the pressure in the hydraulic system before connecting or disconnecting. Turn the engine off and wait a short time.
 - ▶ Release the hydraulic coupling by hand.
 - ▶ Take the hydraulic hose lines down in the respective park positions and secure.

10.11.2 Disconnecting the electrical connections

- ▶ Disconnect the electrical connections on the rotary connection and store them properly.

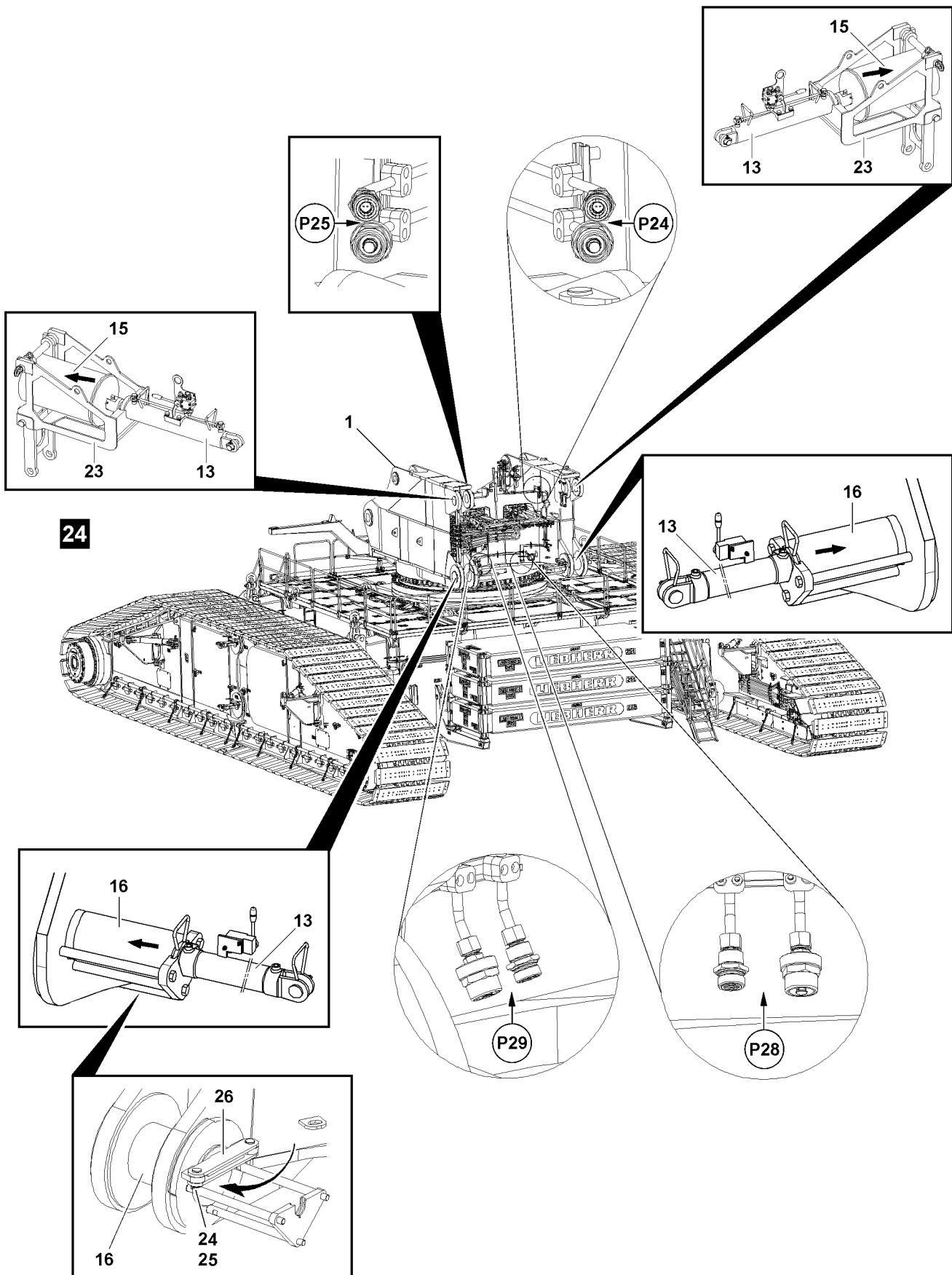

Fig.114477

LWE/LR 13000-001/19503-01-02/en

10.12 Pinning and securing the connector pins on the turntable frame front section

After disassembly of the turntable frame rear section on the turntable frame front section, immediately pin and secure the connector pins on the turntable frame front section „on top“ and „bottom“.

- ▶ Insert the connector pin „on top“ **15** with the pin pulling device and secure with securing bracket **22**, see section „Pinning the connector pin on the lower left“.
- ▶ Insert the connector pin „on the bottom“ **16** with the pin pulling device and secure with securing bracket **26**.

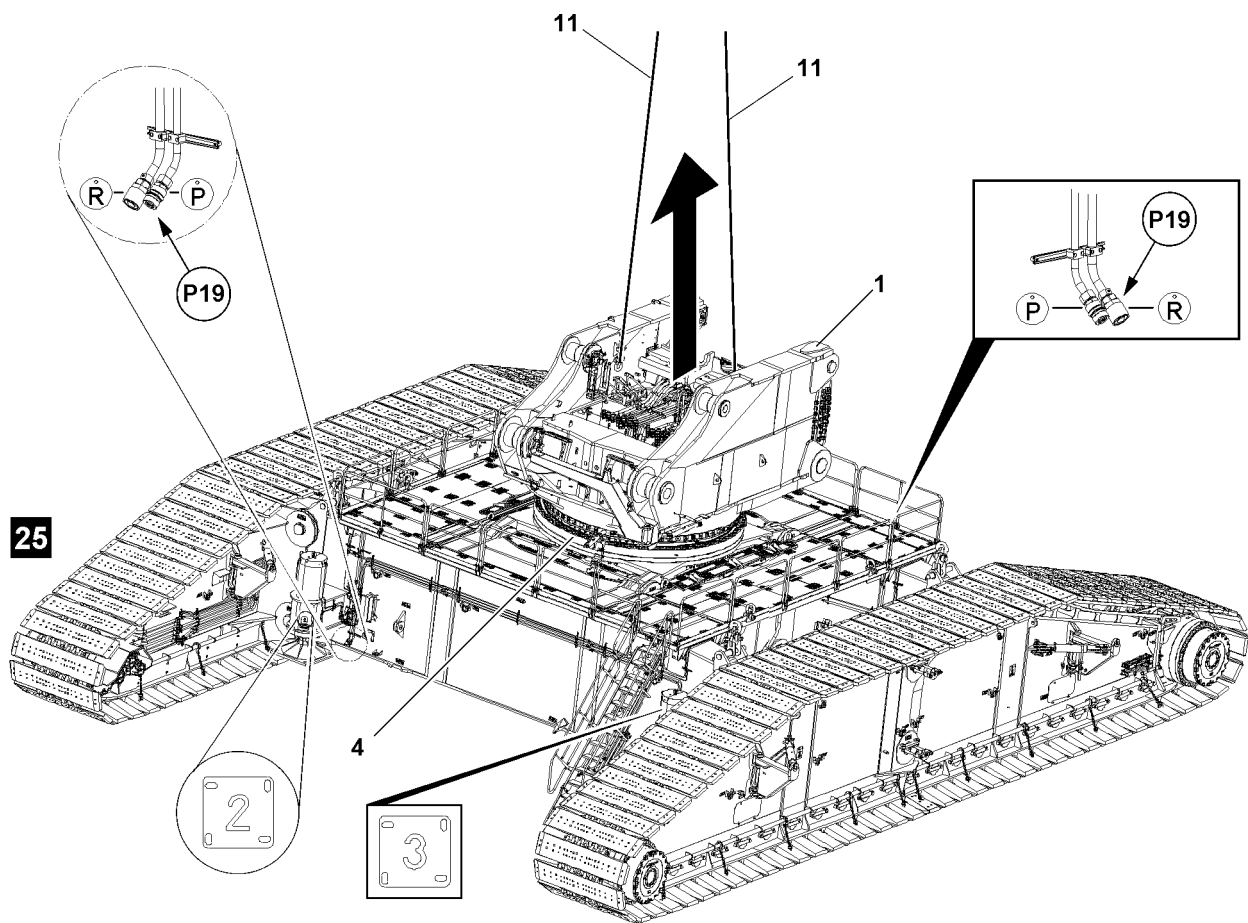

25

Fig.114480

LWE/LR 13000-001/19503-01-02/en

10.13 Disassembling the turntable frame front section on the crawler travel gear

Make sure that the following prerequisites are met:

- The turntable frame rear section has been disassembled.
- The hydraulic connections from the engine house or the external hydraulic aggregate to the hydraulic assembly circuit have been established.
- The transport device for the connector pins for the Quick-Connection is in the vicinity of the roller ring connection.
- The grating flaps on the „platform“ of the crawler travel gear are closed.
- All railings on the crawler travel gear are in the operating position.

10.13.1 Unpinning the turntable frame front section with the Quick Connection on the crawler travel gear



WARNING

Falling of the turntable frame front section!

If an unsecured turntable frame front section is unpinned, it can fall down.

Death, severe bodily injuries, property damage.

- ▶ Fasten the turntable frame front section to the auxiliary crane and secure. Unpin the turntable frame front section only afterward.



WARNING

Incorrect fastening of the turntable frame front section!

Accidents can occur if the turntable frame front section **1** is incorrectly or improperly fastened.

The turntable frame front section **1** can fall down, become unbalanced or move in an uncontrolled manner.

Death, severe bodily injuries, property damage.

- ▶ Fasten the turntable frame front section **1** with the provided fastening equipment in the corresponding length, see section „Fastening points“.
- ▶ Fasten the turntable frame front section **1** in the provided fastening points.
- ▶ Make sure that the fastening equipment is properly attached to the turntable frame front section **1** and that it is secured sufficiently to prevent it from loosening up.

NOTICE

The connections on the rotary connection are not disconnected!

If not all connections are disconnected, the rotary connection will be damaged when lifting the turntable.

- ▶ Before lifting the turntable frame front section **1**, make sure that connections to the rotary connection are disconnected.

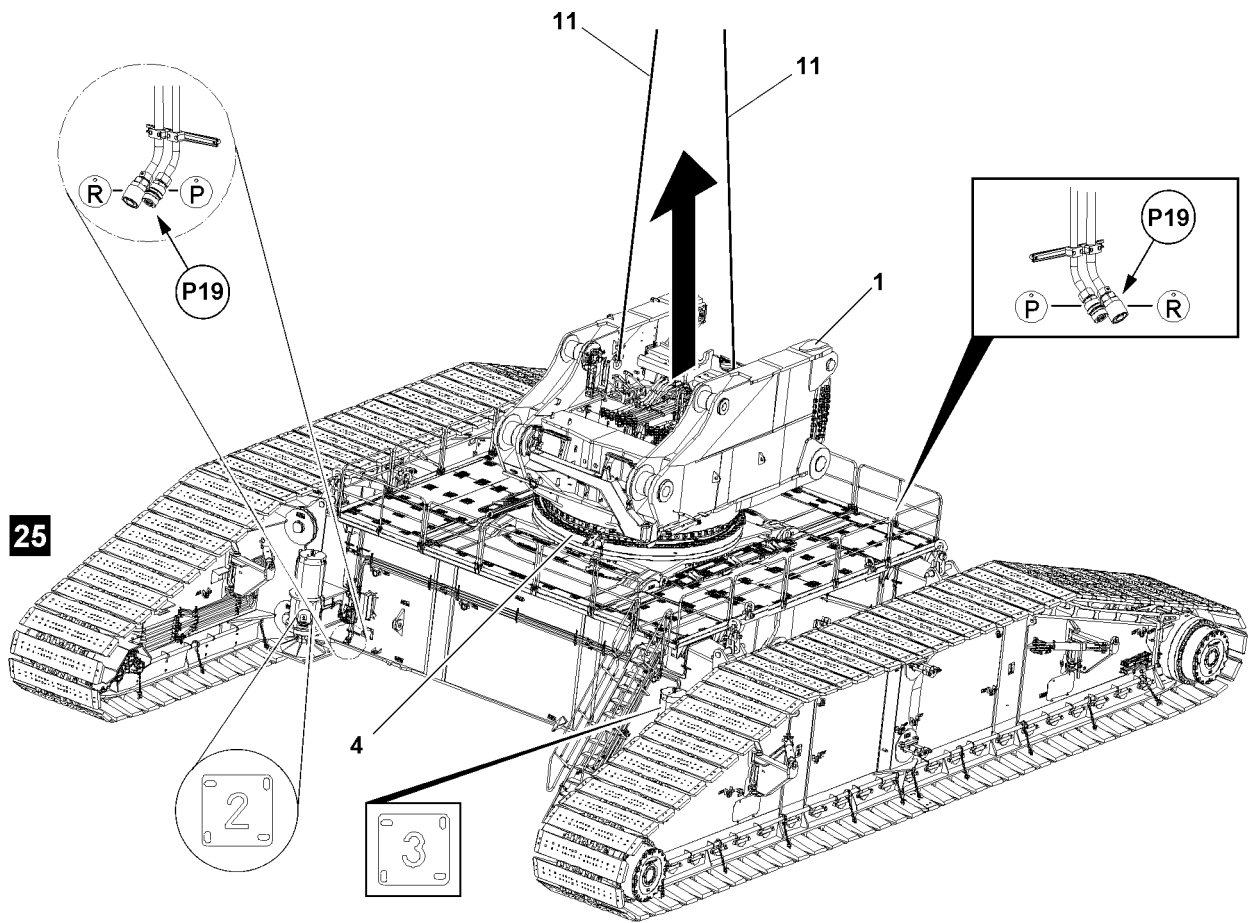

Fig.114480

Make sure that the following prerequisites are met:

- The turntable frame front section **1** is fastened to the auxiliary crane, see section „Fastening points“.
- The fastening equipment **11** on the turntable frame front section **1** is tensioned.
- The bracket on the turntable frame front section **1** is in the transport position.

Establishing the hydraulic connections to the pin pulling cylinder

On every cross carrier, on the outside, is a central hydraulic connection **P19** for the hydraulic oil supply for assembly purposes. The supply occurs via the operational engine house or the external hydraulic aggregate, see Hydraulic diagram.

There are two connection possibilities on the inside of the cross carriers for the pin pulling cylinder.

The hydraulic connections are established with quick couplings.

When connecting hydraulic lines with quick couplings, make sure that the coupling procedure is carried out correctly.

The matching quick couplings are marked.



WARNING

Pressure in the hydraulic lines!

If the pressure supply is not interrupted before connecting / releasing the hydraulic lines, the hydraulic oil can escape with high pressure.

Death, severe bodily injuries, property damage.

- ▶ Release the pressure in the hydraulic system before connecting / disconnecting: Interrupt the pressure supply and wait a short time.



WARNING

Loss of pressure or leakage!

Incorrectly coupled or self-loosening quick couplings (particularly return lines) can result in serious accidents due to component failure.

Death, severe bodily injuries, property damage.

- ▶ Check that the quick couplings have been properly connected before using the crane.
- ▶ Make sure that the connection point is selected in such a way that the length of the hydraulic hoses is sufficient.
- ▶ Connect the coupling components (sleeve and connector) and screw together with the knurled nut.
- ▶ Tighten the hydraulic coupling by hand. Turn the knurled nut until it reaches a tangible, fixed stop position.

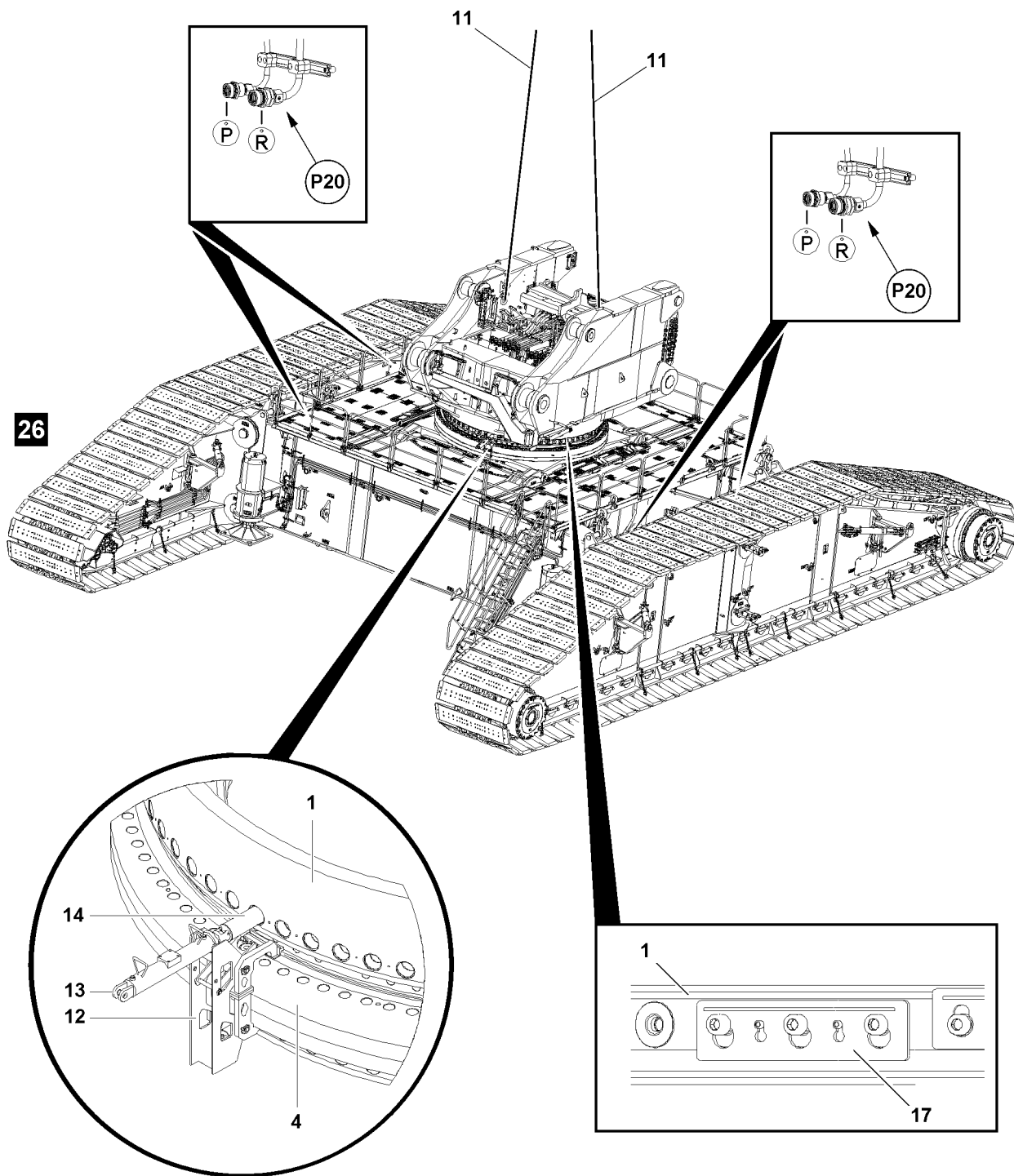

Fig.114481

Unpinning the connector pin



WARNING

Incorrect location for unpinning!

When unpinning, there is a danger of accident for personnel in the Quick Connection. Death, severe bodily injuries.

- ▶ Work from **outside** the turntable to unpin the connector pins **14**.



WARNING

Forceful unpinning of jammed pins!

If a connector pin **14** cannot be unpinned using the pin pulling device, it can be jammed.

If a jammed pin is unpinned in a forceful and violent manner without knowledge the cause of the jamming, this can have dangerous consequences. This applies in particular if it is the last connector pin **14** to be unpinned.

Death, severe bodily injuries, property damage.

If it is the last connector pin **14** to be unpinned:

- ▶ To be safe, insert two easy to move connector pins **14** on opposite sides back in the Quick Connection (QC).
 - ▶ Before using increase force on the jammed connector pin **14** determine the cause for the jamming and remedy it.
 - ▶ Loosen and unpin the jammed connector pin **14**.
 - ▶ Only unpin the last connector pin **14** to be loosened when it is not jammed and can be easily unpinned from the outside.
-
- ▶ Establish the hydraulic connection: Connect the supply lines of the pin pulling cylinder **13** to one of the coupling points **P20** on the hydraulic connection **R** and hydraulic connection **P**.
 - ▶ Remove the retaining plates **17** around the entire circumference of the Quick Connection.
 - ▶ Take the retaining plates **17** down in the available transport devices.
 - ▶ Unpin all connector pins **14** around the circumference of the roller ring connection **4** by hand.

Problem remedy

The connector pins cannot be unpinned?

- ▶ Raise the turntable frame front section slightly with the auxiliary crane and lower it again if necessary until the connector pins can be unpinned.



Note

- ▶ If the connector pins **14** still cannot be unpinned easily by hand, use the pin pulling device.
- ▶ For information about the pin pulling device, see chapter 5.30.

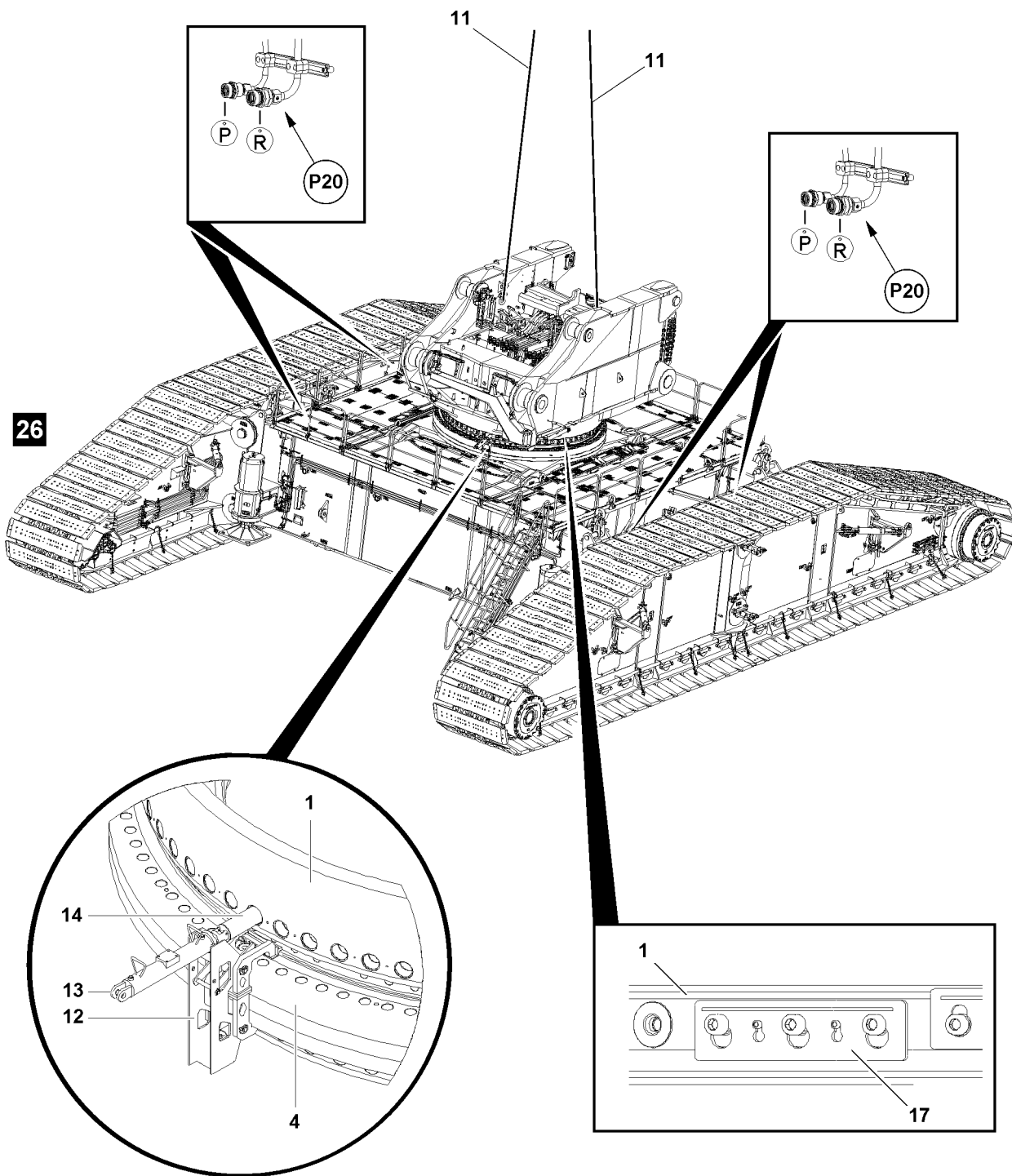

Fig.114481

LWE/LR 13000-001/19503-01-02/en

When the connector pins **14** are properly unpinned on the Quick-Connection:

- ▶ Place the connector pins **14** in the transport device and secure in the receptacles.
- ▶ Lift the transport devices for the connector pins with the auxiliary crane from the crawler travel gear and store properly.

Lifting the turntable frame front section from the roller ring connection on the crawler travel gear

Make sure that the following prerequisites are met:

- All connector pins on the Quick-Connection are unpinned.
- The pin pulling device on the Quick-Connection is removed.
- There are no loose objects on the turntable frame front section.



WARNING

Oscillating load!

When lifting the turntable frame front section from the crawler travel gear, the turntable frame front section can start to swing back and forth.

Death, severe bodily injuries, property damage.

- ▶ Secure the turntable frame front section with a guide rope to prevent it from swinging.
- ▶ Make sure that no persons are inside the Quick Connection.
- ▶ Make sure that there are no persons within the danger zone of the crane and the turntable frame front section.
- ▶ Make sure that there are no obstacles within the assembly area of the crane.

NOTICE

The connector pins on the Quick Connection (QC) are not unpinned!

If not all connector pins are unpinned, the Quick Connection (QC) will be damaged when lifting the turntable.

- ▶ Before lifting the turntable, make sure that all connector pins on the Quick Connection (QC) are fully unpinned.
- ▶ Slowly lift the turntable frame front section with the auxiliary crane and with slow speed from the crawler travel gear.

When the turntable frame front section has been lifted off completely from the crawler travel gear:

- ▶ Swing the turntable frame front section with the auxiliary crane out and set it on the flatbed trailer or transport vehicle.

When the turntable frame front section is properly set down on the flatbed trailer or the transport vehicle:

- ▶ Remove the fastening equipment.

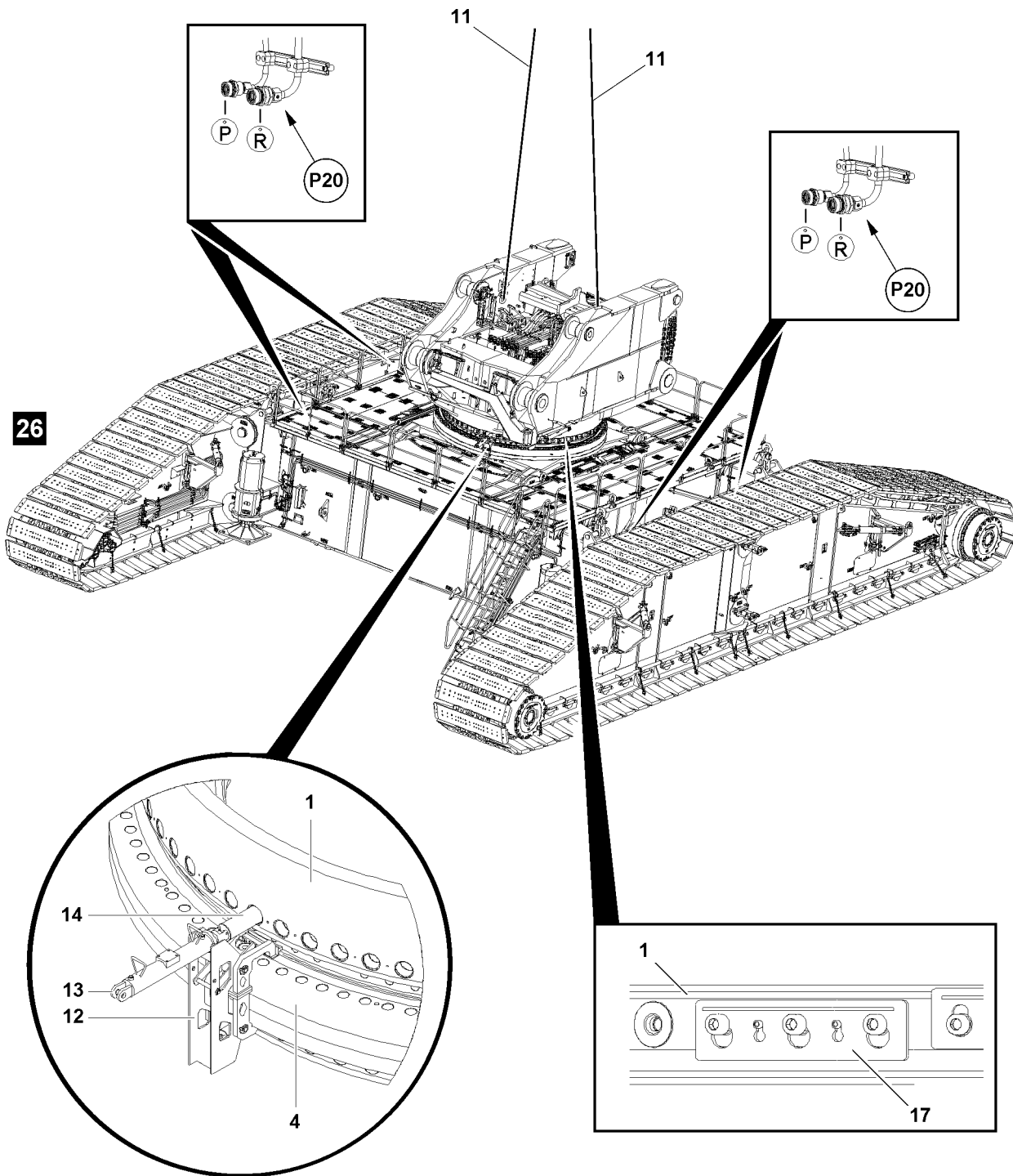

Fig.114481

Disconnecting the hydraulic connections from the pin pulling cylinder

The hydraulic connections are established with quick couplings.

When disconnecting hydraulic lines with quick couplings, make sure that the uncoupling procedure is carried out correctly.



WARNING

Pressure in the hydraulic lines!

If the pressure supply is not interrupted before connecting / releasing the hydraulic lines, the hydraulic oil can escape with high pressure.

Death, severe bodily injuries, property damage.

- ▶ Release the pressure in the hydraulic system before connecting / disconnecting: Interrupt the pressure supply and wait a short time.
-
- ▶ Make sure that the hydraulic system pressure has been released.
 - ▶ Release the hydraulic coupling by hand.
 - ▶ Disconnect the hydraulic connection: Disconnect the supply lines of the pin pulling cylinder **13** on the supply lines of the cross carrier, hydraulic connection **R** and hydraulic connection **P** on point **P20**.

10.14 Disassembling the central ballast



Note

- ▶ The disassembly of the central ballast is described in detail in chapter 3.03.
-
- ▶ Disassemble the central ballast on the crawler travel gear.

Empty page!

LWE/LR 13000-001/19503-01-02/en

3.03 Central ballast

1	Component overview	3
2	Installing the central ballast	5
3	Removing the central ballast	15

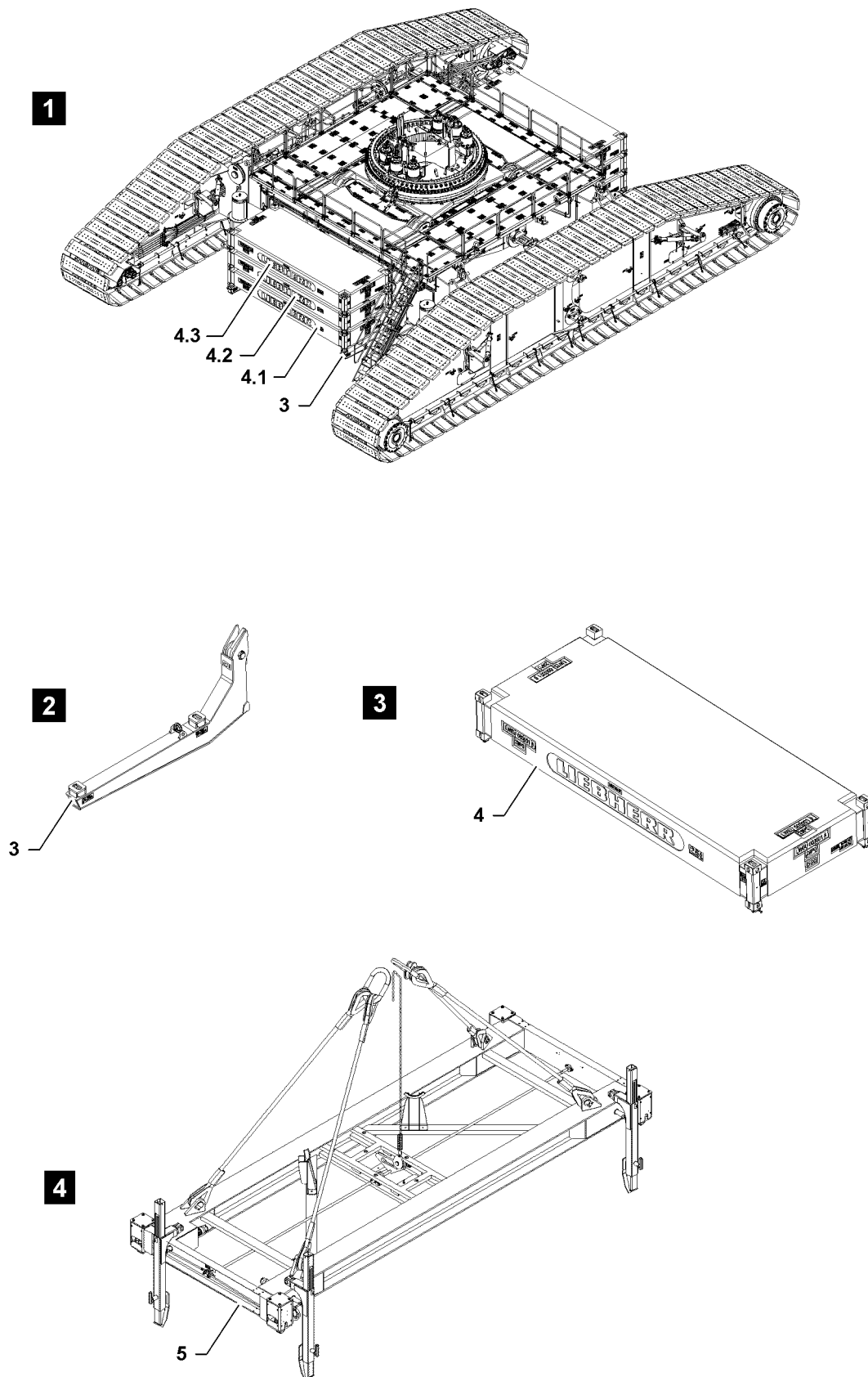

Fig.113629

LWE/LR 13000-001/19503-01-02/en

1 Component overview

Note

- ▶ Dimensions and weights, see Crane operating instructions, chapter 1.03!

Note

- ▶ The central ballast plates **4** and the central ballast mountings **3** are marked with their own weight!

Note

- ▶ Container spreader, see separately supplied Container spreader Operating instructions!

Position	Component
3	Central ballast mounting
4	Central ballast plate
5	Container spreader

Fig.195219

LWE/LR 13000-001/19503-01-02/en

2 Installing the central ballast



WARNING

Danger of slipping / falling during assembly / disassembly work!

During assembly / disassembly work, personnel must be secured with appropriate aids to prevent them from falling!

Weather influences, such as wetness, wind, snow, frost increase the slipping / falling danger!

Personnel can be severely injured or killed!

- ▶ All assembly / disassembly work must be carried out using suitable aids (lifting platforms, scaffolding, ladders, auxiliary crane, etc.)!
- ▶ If work cannot be carried out on the ground or using such aids, then assembly personnel must be secured with the personal fall arrest system (see Crane operating instructions, chapter 2.04) to protect against falling!
- ▶ If railings are present on the components, then they must be brought into the corresponding position and secured for assembly / disassembly work!
- ▶ Step on aids and fall protection equipment only with clean shoes!
- ▶ Keep aids and fall protection equipment clean and free from snow and ice!



WARNING

Falling components and central ballast plates!

At assembly / disassembly, the components and central ballast plates can fall down!

Personnel can be severely injured or killed!

- ▶ Make sure that no persons or objects are within the danger zone!



WARNING

Incorrect handling of the fastening equipment!

If fastening equipment cannot be attached correctly and if it is not secured sufficiently to prevent it from loosening up, loads can fall down. Personnel can be severely injured or killed!

- ▶ Make sure that the fastening equipment is correctly attached on the fastening points and that it is secured sufficiently to prevent it from loosening up!



WARNING

Danger of impact / crushing!

If anyone remains within the assembly / disassembly area of the ballast, they would be exposed to a danger of impact / crushing!

Personnel can be severely injured or killed!

- ▶ Make sure that there are no persons between the components which are to be assembled / disassembled and the cross carrier!

Make sure that the following prerequisites are met:

- Both crawler carriers are standing on the ground.
- The crane is aligned in horizontal direction.

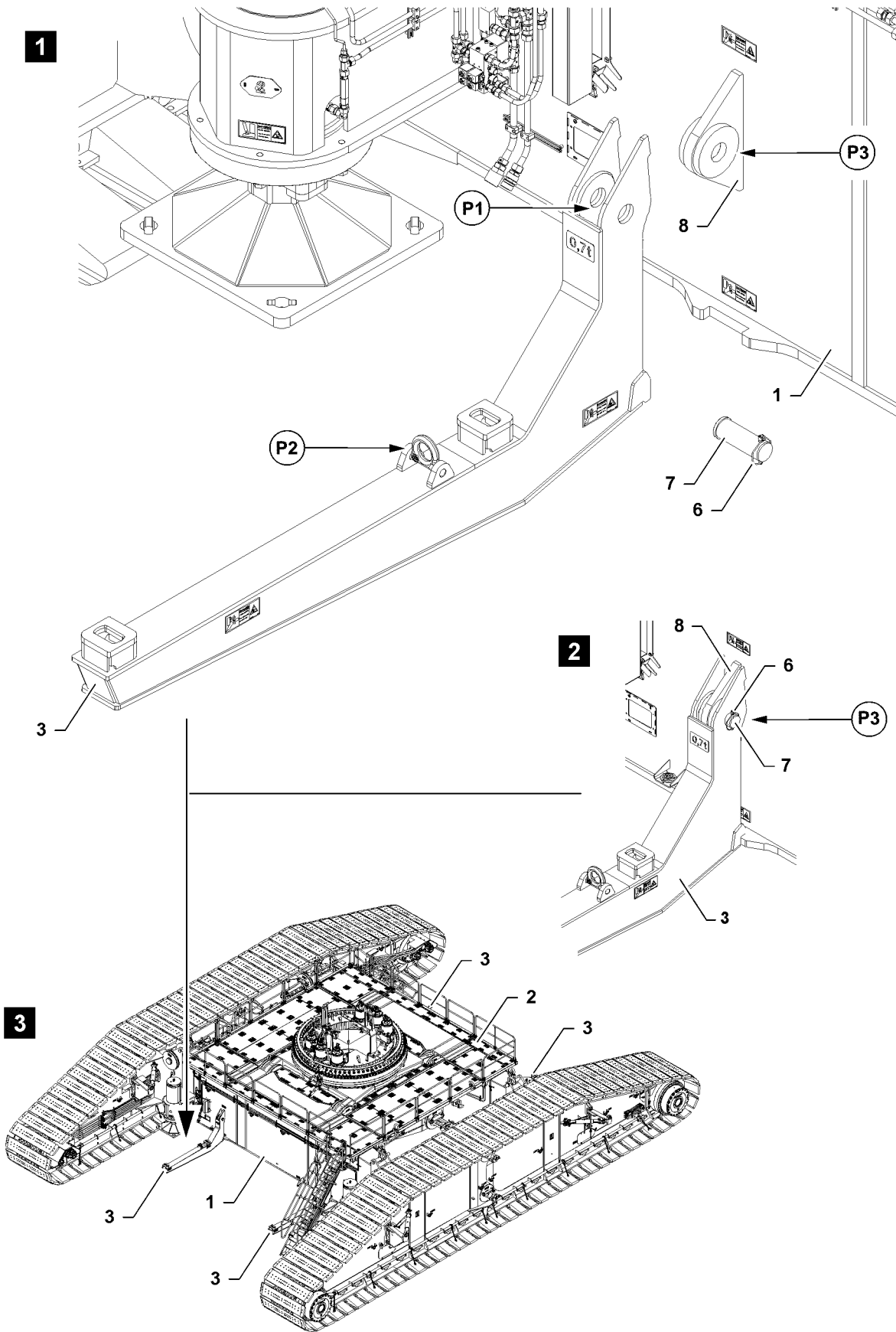

Fig.113630

LWE/LR 13000-001/19503-01-02/en

2.1 Assembling the central ballast mounting

Make sure that the following prerequisite is met:

- The pin **7** is unpinned at point **P1**
- ▶ Attach the central ballast mounting **3** on the auxiliary cane at point **P2**, see illustration **1**.
- ▶ Guide the central ballast mounting **3** with the auxiliary crane to the bracket **8** at point **P3** and position in the perforation.



WARNING

The pin is not secured!

If the pin **7** is not secured, the pin can loosen up by themselves during crane operation!

This can cause the crane to topple over!

Personnel can be severely injured or killed!

- ▶ Make sure that the pin **7** is secured with the locking pin **6**.

-
- ▶ Insert the pin **7** and secure with locking pin **6**, see illustration **2**.



Note

- ▶ The assembly of the other central ballast mountings is the same as the work steps for the Central ballast mounting **3**!

-
- ▶ Install all central ballast mountings **3**, see illustration **3**.

Fig.195219

LWE/LR 13000-001/19503-01-02/en

2.2 Placing the central ballast plates



DANGER

Danger of impact and crushing!

Due to presence near the ballast assembly, there is an increased danger of impact and crushing when the ballast plates are „placed“.

- ▶ Exercise extreme caution when lifting the ballast.
- ▶ Never allow people to stand under a suspended ballast.
- ▶ Exercise extreme caution when lowering the ballast. Danger of crushing people in the immediate area of the ballast being lowered.



WARNING

Central ballast too low / too high!

If the placed central ballast deviates from the specified data in the load charts or the assembly conditions, then the crane can be damaged or topple over!

Personnel can be severely injured or killed!

- ▶ Make sure that the central ballast is placed according to the load chart!



WARNING

Damaged central ballast plates!

Damage on the central ballast plates can cause the fastening equipment to release!

Central ballast plates can fall down!

Personnel can be severely injured or killed!

- ▶ Do not use damaged central ballast plates and replace them immediately!



WARNING

Overload attachment points central ballast plates!

If more than the permissible number of central ballast plates are lifted together, then the fastening points can be overloaded!

The central ballast plates and components can fall down!

Personnel can be severely injured or killed!

- ▶ Attach no more than maximum „two“ central ballast plates per lift!

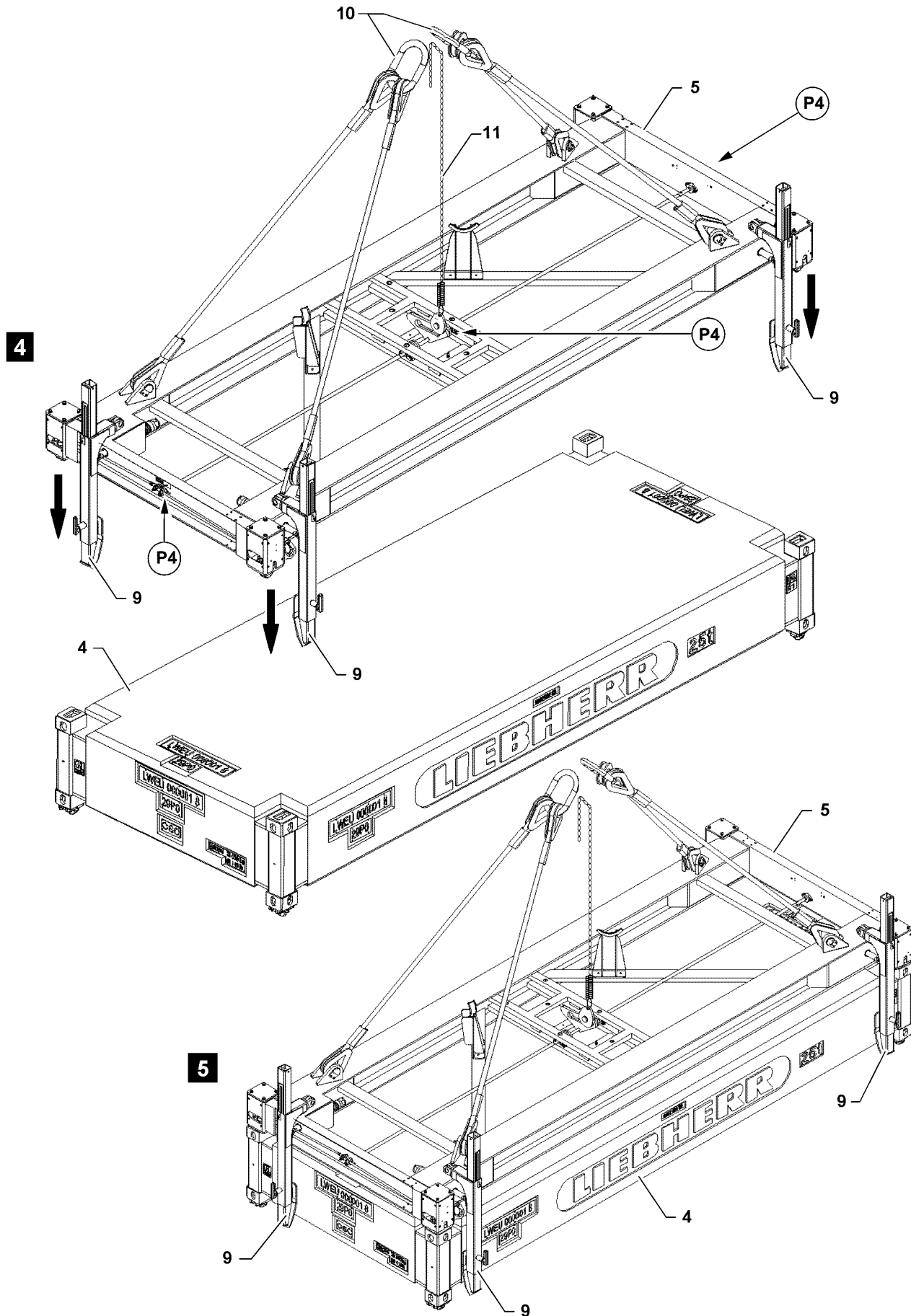

Fig.113631

LWE/LR 13000-001/19503-01-02/en

2.2.1 Attaching the container spreader on the auxiliary crane



WARNING

Danger of accident!

If the operating instructions for the container spreader are not observed, severe injuries or crane damage can occur!

- ▶ Before operation of the container spreader, the assembly personnel must read and observe the separately supplied container spreader Operating instructions!



Note

- ▶ The strut guides **9** serve as guide stops on the central ballast plates **4** and can be telescoped depending on application!
 - ▶ The height of the central ballast plate **4** is 800 mm !
 - ▶ For adjustment of strut guide **9**, see separately supplied Container spreader Operating instructions!
-
- ▶ Adjust the strut guide **9** to the central ballast plate size.



Note

- ▶ For adjustment of spring load lock **11**, see separately supplied Container spreader Operating instructions!
-
- ▶ Fasten the fastening ropes **10** of the container spreader **5** and the chain of the spring load lock **11** on the hook of the auxiliary crane.

For a visual check, **red** and **green** color marks are provided to recognize the respective locking position in the swing range of the axle lever on the respective front side and on the locking rocker, see points **P4** illustration **4**.



Note

- ▶ Make sure, before setting the container spreader **5** on the central ballast plate **4**, that a corresponding locking position is selected.
-
- ▶ Set the container spreader **5** with the auxiliary crane on the central ballast plate **4**.



Note

- ▶ For function and warning notes for the Self-lock fixture lock, see separately supplied Container spreader Operating instructions!
-
- ▶ The locking procedure is carrier out fully automatic by the Self-lock fixture lock.

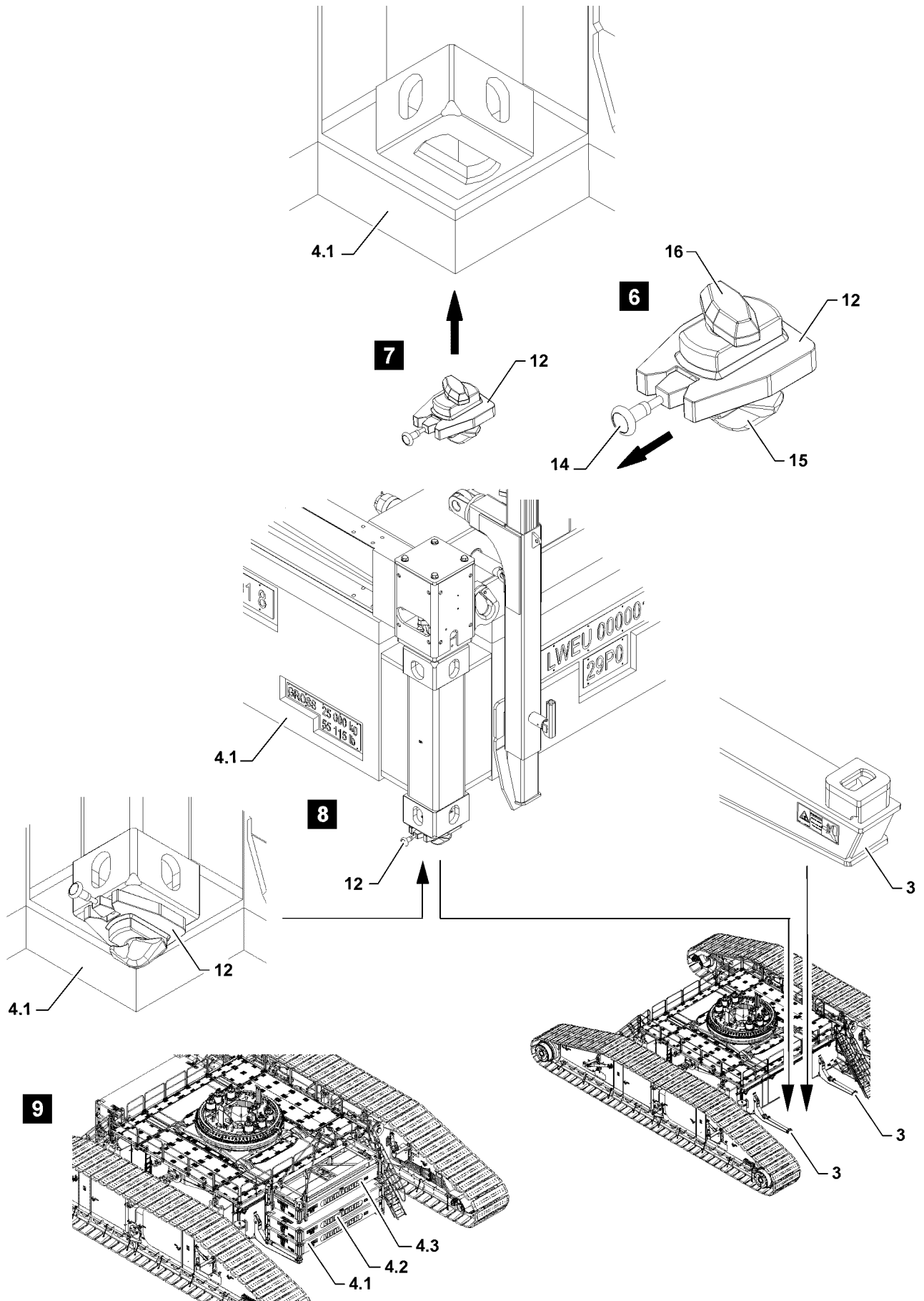

Fig.113632

LWE/LR 13000-001/19503-01-02/en

2.2.2 Guiding the Twistlock in

Make sure that the following prerequisites are met:

- The central ballast mountings **3** are pinned and secured on the cross carriers.
- The container spreader **5** is set on the first central ballast plate **4.1** and is locked.
- ▶ Lift the central ballast plate **4.1** with the auxiliary crane until it hangs just above the ground.

Result:

- The Twistlock **12** can be installed from below on the container base.
- ▶ Guide the Twistlock **12** in: Pull the control lever **14** until the Twistlock **12** can be guided with the lock **16** into the container base, see illustration **6**.
- ▶ Guide the Twistlock **12** into the container base of the central ballast plate **4.1**, see illustration **7**.
- ▶ Activate the locking mechanism of the Twistlock **12**: Slowly let the control lever **14** return to its original position.

Result:

- The lock **16** turns and can be connected in positive-fit with the container base **13**.
- ▶ Guide the Twistlock **12** into all container bases **13**.

2.2.3 Setting the first central ballast plate

Make sure that the following prerequisite is met:

- The Twistlocks **12** are guided into all container bases **13**.
- ▶ Swing the central ballast plate **4.1** to the central ballast mountings **3**.



Note

- ▶ During the placement procedure, the lock **15** on the Twistlock **12** can turn by itself due to its special shape!
 - ▶ Set the central ballast plate **4.1** with the Twistlock **12** on the bases of the central ballast mountings **3**, see illustration **8**.
 - ▶ Remove the container spreader **5**.
-

2.2.4 Setting the second and third central ballast plate



Note

- ▶ The installation of the second central ballast plate **4.2** and the third central ballast plate **4.3** is the same as the work steps for the first central ballast plate **4.1**!
 - ▶ Install all central ballast plates, see illustration **9**.
-

Fig.195219

LWE/LR 13000-001/19503-01-02/en

3 Removing the central ballast



WARNING

Danger of slipping / falling during assembly / disassembly work!

During assembly and disassembly work, personnel must be secured with appropriate aids to prevent them from falling!

Weather influences, such as wetness, wind, snow, frost increase the slipping / falling danger!

Personnel can be severely injured or killed!

- ▶ All assembly / disassembly work must be carried out using suitable aids (lifting platforms, scaffolding, ladders, auxiliary crane, etc.)!
- ▶ If work cannot be carried out on the ground or using such aids, then assembly personnel must be secured with the personal fall arrest system (see Crane operating instructions, chapter 2.04) to protect against falling!
- ▶ If railings are present on the components, then they must be brought into the corresponding position and secured for assembly / disassembly work!
- ▶ Step on aids and fall protection equipment only with clean shoes!
- ▶ Keep aids and fall protection equipment clean and free from snow and ice!



WARNING

Falling components and central ballast plates!

At assembly / disassembly, the components and central ballast plates can fall down!

Personnel can be severely injured or killed!

- ▶ Make sure that no persons or objects are within the danger zone!



WARNING

Incorrect handling of the fastening equipment!

If fastening equipment cannot be attached correctly and if it is not secured sufficiently to prevent it from loosening up, loads can fall down. Personnel can be severely injured or killed!

- ▶ Make sure that the fastening equipment is correctly attached on the fastening points and that it is secured sufficiently to prevent it from loosening up!



WARNING

Danger of impact / crushing!

If anyone remains within the assembly / disassembly area of the ballast, they would be exposed to a danger of impact / crushing!

Personnel can be severely injured or killed!

- ▶ Make sure that there are no persons between the components which are to be assembled / disassembled and the cross carrier!

Make sure that the following prerequisites are met:

- Both crawler carriers are standing on the ground.
- The crane is aligned in horizontal direction.

Fig.195219

LWE/LR 13000-001/19503-01-02/en

3.1 Removing the central ballast plates

**DANGER**

Danger of impact and crushing!

Due to presence near the ballast assembly, there is an increased danger of impact and crushing when the ballast plates are „placed“.

- ▶ Exercise extreme caution when lifting the ballast.
- ▶ Never allow people to stand under a suspended ballast.
- ▶ Exercise extreme caution when lowering the ballast. Danger of crushing people in the immediate area of the ballast being lowered.

**WARNING**

Central ballast too low / too high!

If the placed central ballast deviates from the specified data in the load charts or the assembly conditions, then the crane can be damaged or topple over!

Personnel can be severely injured or killed!

- ▶ Make sure that the central ballast is placed according to the load chart!

**WARNING**

Damaged central ballast plates!

Damage on the central ballast plates can cause the fastening equipment to release!

Central ballast plates can fall down!

Personnel can be severely injured or killed!

- ▶ Do not use damaged central ballast plates and replace them immediately!

**WARNING**

Overload attachment points central ballast plates!

If more than the permissible number of central ballast plates are lifted together, then the fastening points can be overloaded!

The central ballast plates and components can fall down!

Personnel can be severely injured or killed!

- ▶ Attach no more than maximum „two“ central ballast plates per lift!

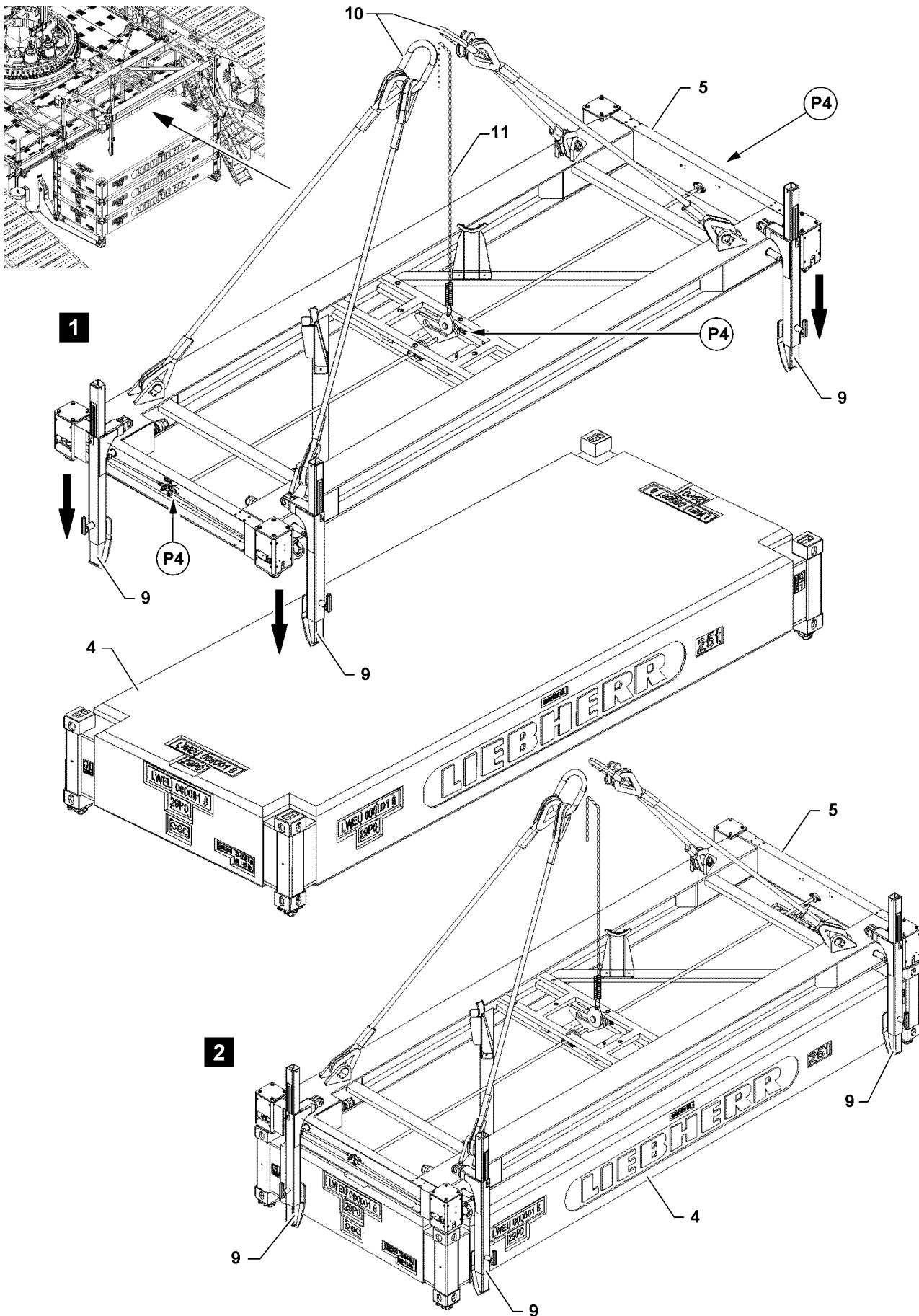

Fig.113634

LWE/LR 13000-001/19503-01-02/en

3.1.1 Attaching the container spreader on the auxiliary crane



WARNING

Danger of accident!

If the operating instructions for the container spreader are not observed, severe injuries or crane damage can occur!

- ▶ Before operation of the container spreader, the assembly personnel must read and observe the separately supplied container spreader Operating instructions!



Note

- ▶ The strut guides **9** serve as guide stops on the central ballast plates **4** and can be telescoped depending on application!
 - ▶ The height of the central ballast plate **4** is 800 mm !
 - ▶ For adjustment of strut guide **9**, see separately supplied Container spreader Operating instructions!
-
- ▶ Adjust the strut guide **9** to the central ballast plate size.



Note

- ▶ For adjustment of spring load lock **11**, see separately supplied Container spreader Operating instructions!
-
- ▶ Fasten the fastening ropes **10** of the container spreader **5** and the chain of the spring load lock **11** on the hook of the auxiliary crane.

For a visual check, **red** and **green** color marks are provided to recognize the respective locking position in the swing range of the axle lever on the respective front side and on the locking rocker, see points **P4** illustration **4**.



Note

- ▶ Make sure, before setting the container spreader **5** on the central ballast plate **4**, that a corresponding locking position is selected.
-
- ▶ Set the container spreader **5** with the auxiliary crane on the central ballast plate **4**.



Note

- ▶ For function and warning notes for the Self-lock fixture lock, see separately supplied Container spreader Operating instructions!
-
- ▶ The locking procedure is carrier out fully automatic by the Self-lock fixture lock.

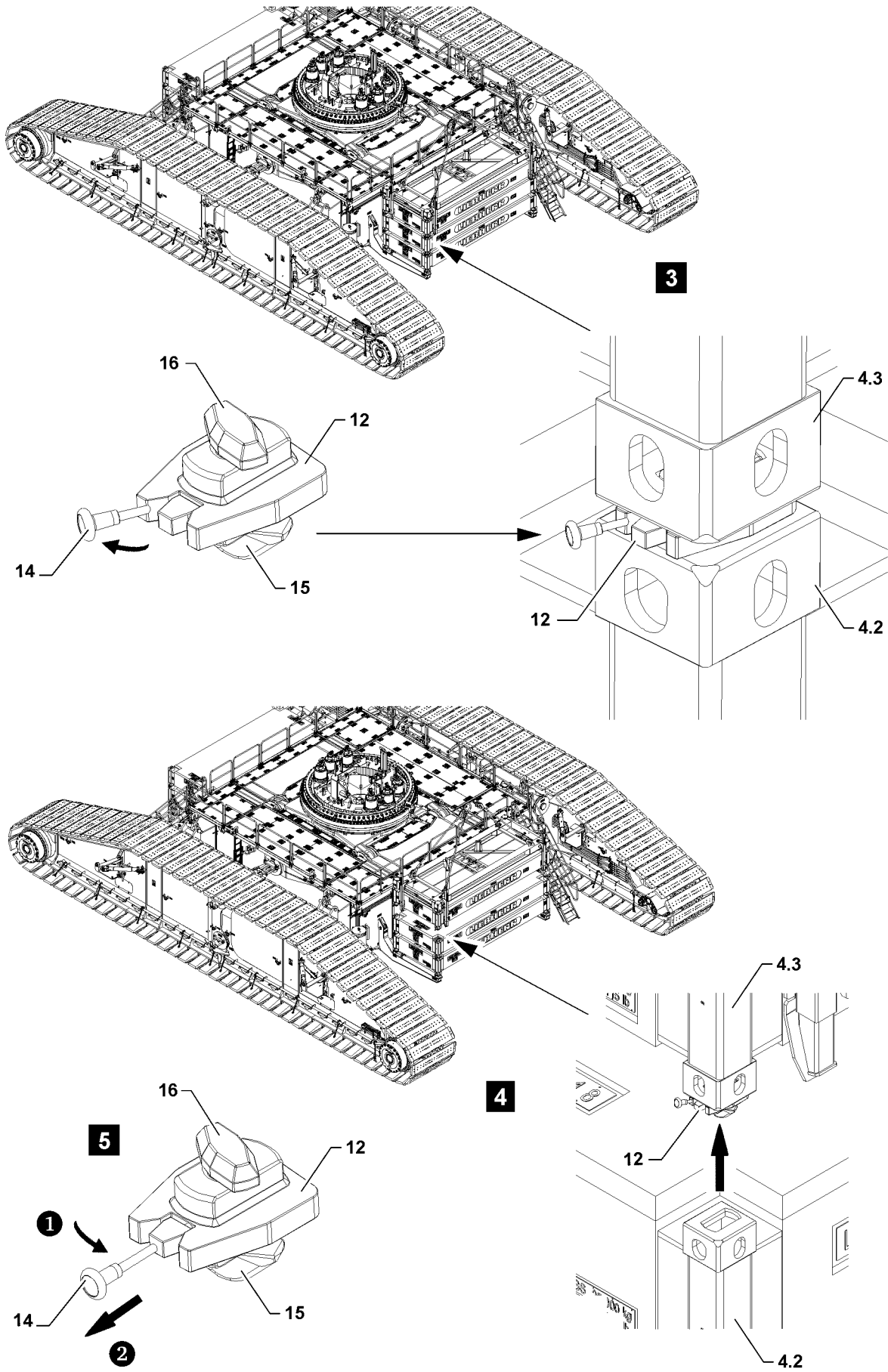

Fig.113633

LWE/LR 13000-001/19503-01-02/en

3.1.2 Removing the first central ballast plate

Make sure that the following prerequisite is met:

- The container spreader **5** is set on the first central ballast plate **4.3** and is locked.

Lifting the central ballast plate



WARNING

Danger of falling!

During disassembly of the central ballast plates, personnel must be secured with appropriate aids to prevent them from falling!

Assembly personnel can fall and be severely injured or killed!

- ▶ Use personal protective equipment!

-
- ▶ Move the work platform in.
 - ▶ Unlock the Twist lock **12**: Pull the control lever **14** and engage it on the side, see illustration **3**.

Result:

- The lock **15** turns.

NOTICE

Danger of property damage!

If the following notes are not observed, the central ballast plate **4.3** and Twistlock **12** can be damaged!

- ▶ Make sure that all four Twistlocks **12** are unlocked before lifting the central ballast plate **4.3**!
- ▶ Unlock all Twistlocks **12** between the central ballast plate **4.2** and the central ballast plate **4.3**, see illustration **3**.
- ▶ Lift the central ballast plate **4.3**.
- ▶ Swing the central ballast plate to the side and lower it until the central ballast plate **4.3** hangs just above the ground.

Result:

- The Twistlocks **12** are in reach for the subsequent removal steps.

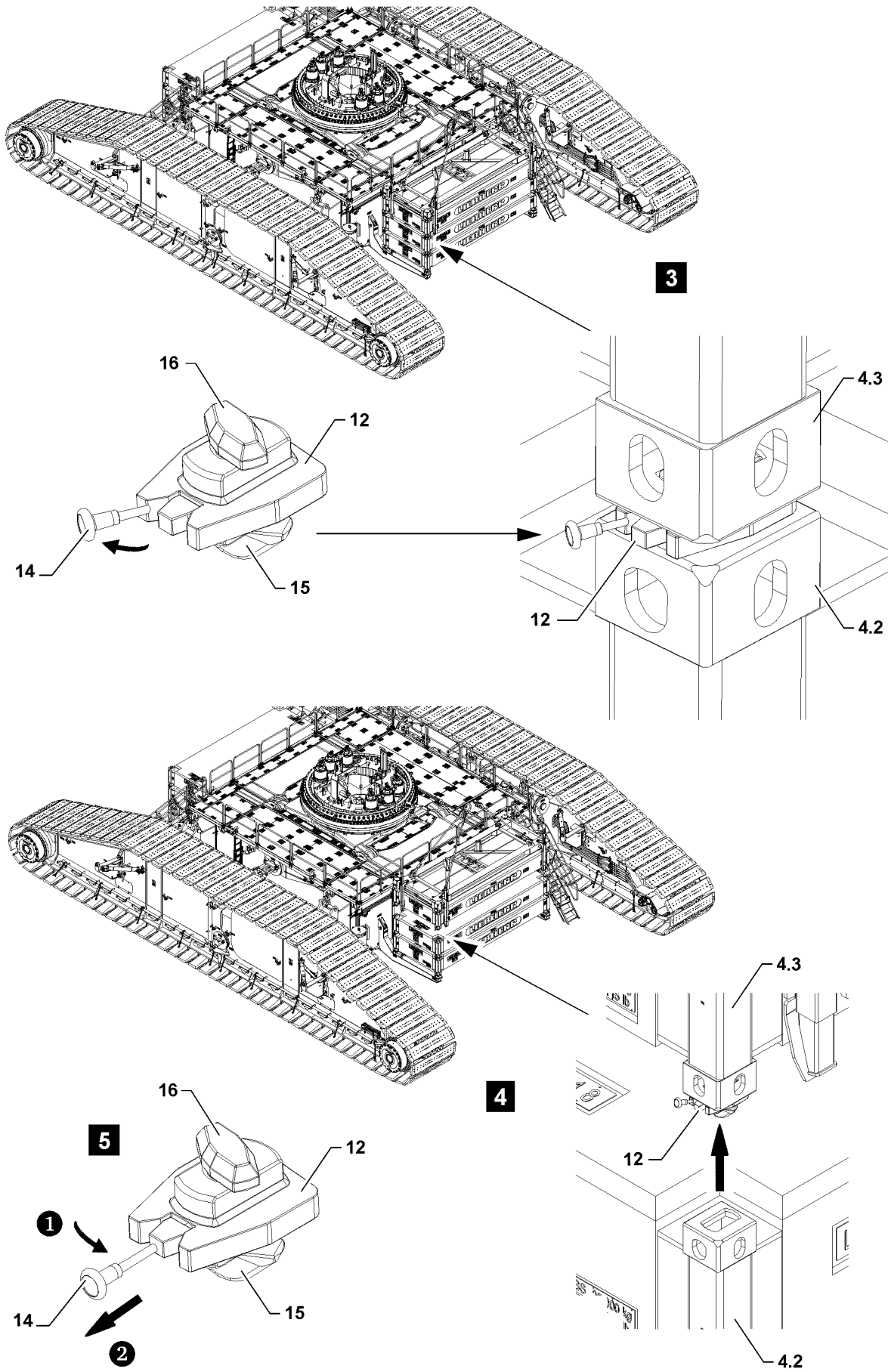

Fig.113633

LWE/LR 13000-001/19503-01-02/en

Placing the central ballast plate down, without Twistlock

- ▶ Remove the Twist lock **12**: Pull the control lever **14** and position it again in the center in its original position, step **1**, see illustration **5**.
- ▶ Pull the control lever **14**, step **2**, until the Twistlock **12** can be pulled from the container base, see illustration **5**.
- ▶ Remove the Twistlock **12** and let the control lever **14** slowly return to its original position.
- ▶ Remove all Twistlocks **12** and place the central ballast plate **4.2** down.
- ▶ Remove the container spreader.

Placing the central ballast plate down, with Twistlock

- ▶ Activate the locking mechanism of the Twistlock **12**: Pull the control lever **14** momentarily and position it again in the center in its original position, step **1**, see illustration **5**.



Note

- ▶ During the placement procedure, the lock **15** on the Twistlock **12** can turn by itself due to its special shape!
-
- ▶ Activate all Twistlocks **12** and set the central ballast plate **4.2** on the container base of the transport bracket.
 - ▶ Remove the container spreader.

3.1.3 Removing the second and third central ballast plate



Note

- ▶ The removal of the second central ballast plate **4.2** and the third central ballast plate **4.1** is the same as the work steps for the first central ballast plate **4.3**!

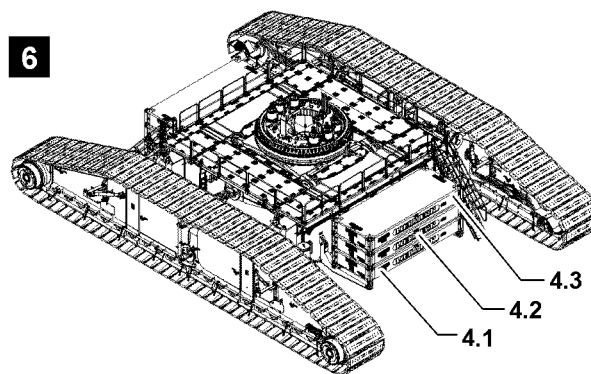

Fig. 113636

- ▶ Remove all central ballast plates, see illustration **6**.

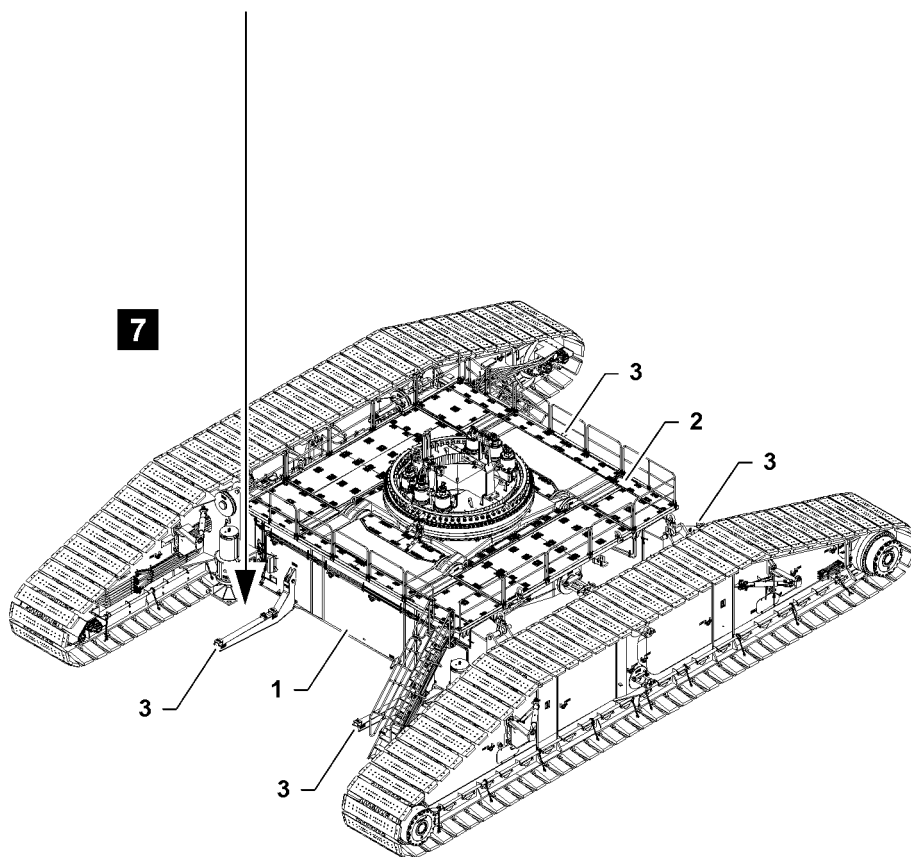
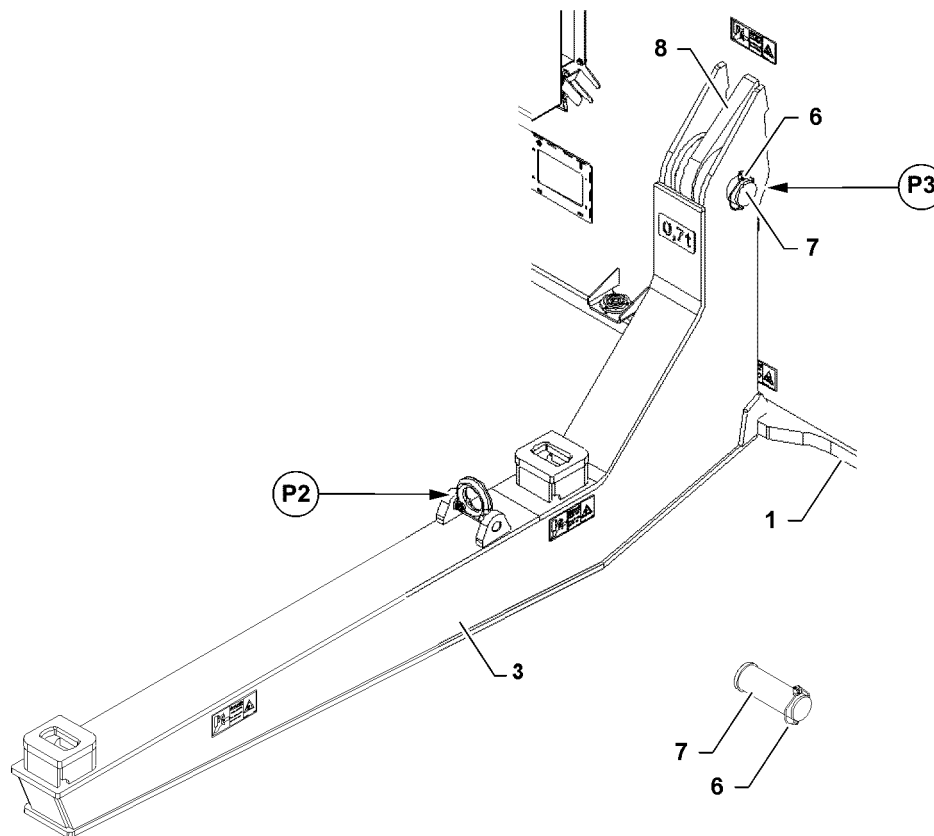

Fig.113635

LWE/LR 13000-001/19503-01-02/en

3.2 Disassembling the central ballast mounting

- ▶ Attach the central ballast mounting **3** on the auxiliary cane at point **P2**, see illustration **7**.
- ▶ Tension the fastening equipment.



WARNING

Falling central ballast mounting!

When unpinning the central ballast mounting **3** on the cross carrier **1** the central ballast mounting can fall down!

Personnel can be severely injured or killed!

- ▶ The central ballast mounting **3** must be safely held by the auxiliary crane before unpinning!
- ▶ The fastening equipment must be tensioned before unpinning!

-
- ▶ Remove the locking pin **6** at point **P3** and unpin the pin **7**, see illustration **7**.
 - ▶ Swing the central ballast mounting **3** with the auxiliary crane from the cross carrier and place it down.



Note

- ▶ The disassembly of the other central ballast mountings is the same as the work steps for the Central ballast mounting **3**!
-
- ▶ Remove all central ballast mountings **3**, see illustration **7**.

Empty page!

LWE/LR 13000-001/19503-01-02/en

3.05 A-frame assembly

1	Component overview	3
2	Fastening points A-frame - assembly	3
3	Fastening points A-frame - assembly	5
4	Assembling the A-frame	7
5	Disassembling the A-frame	33

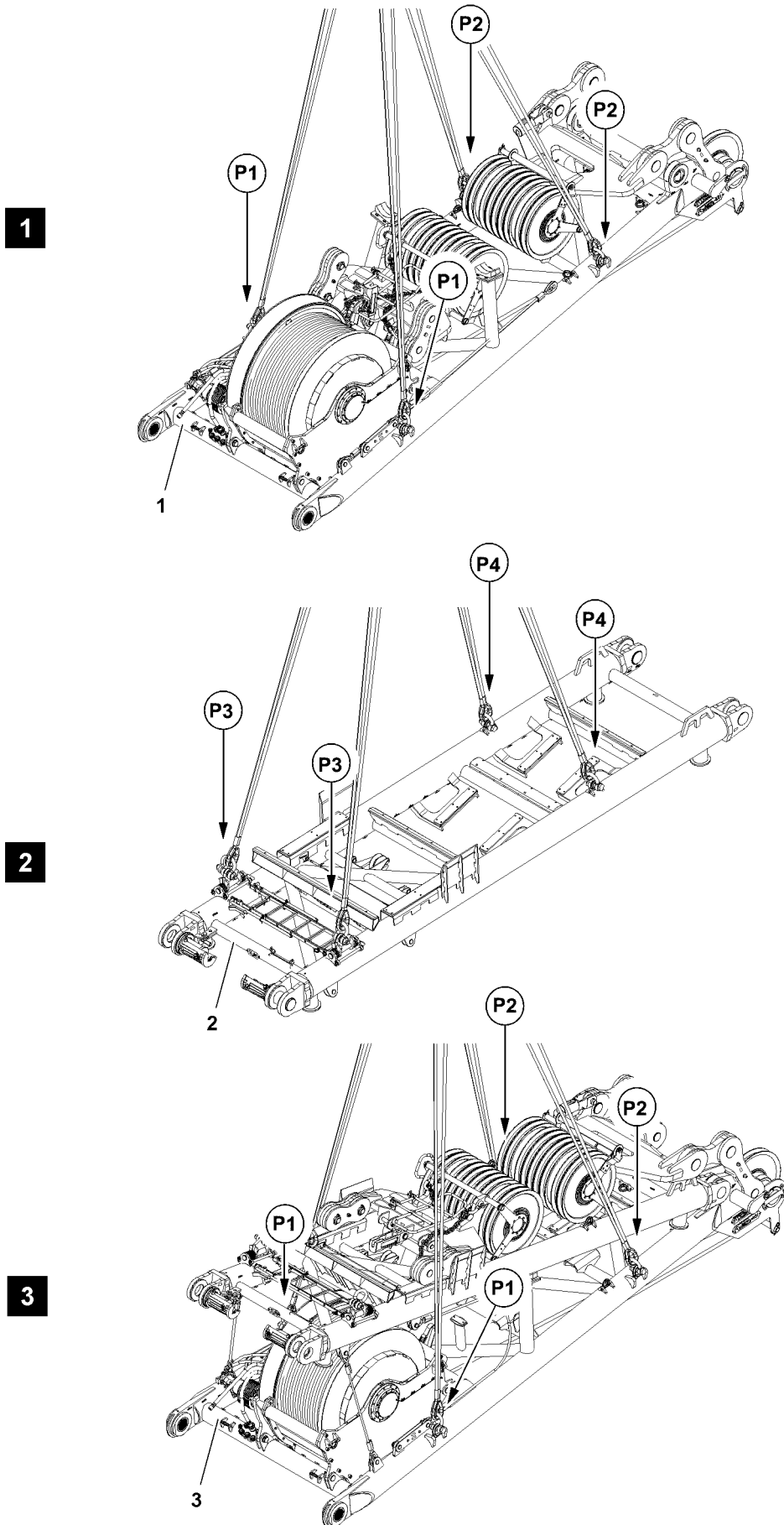

Fig.113645

LWE/LR 13000-001/19503-01-02/en

1 Component overview



Note

- ▶ For the dimensions and weights, see the Crane operating instructions, chapter 1.03!

Position	Component
1	Frame with winch 4
2	Support
3	A-frame, complete

2 Fastening points A-frame - assembly



WARNING

Component incorrectly fastened!

Life-threatening situations can arise due to improper or incorrect fastening of the corresponding components!

Personnel can be severely injured or killed!

- ▶ Fasten the components only in the intended fastening points on both sides!
- ▶ Fastening of components and description of fastening points, see the Crane operating instructions, chapter 5.01!

Component	„Assembly“ fastening points
Frame with winch 4	P1 and P2
Support	P3 and P4
A-frame, complete	P1 and P2

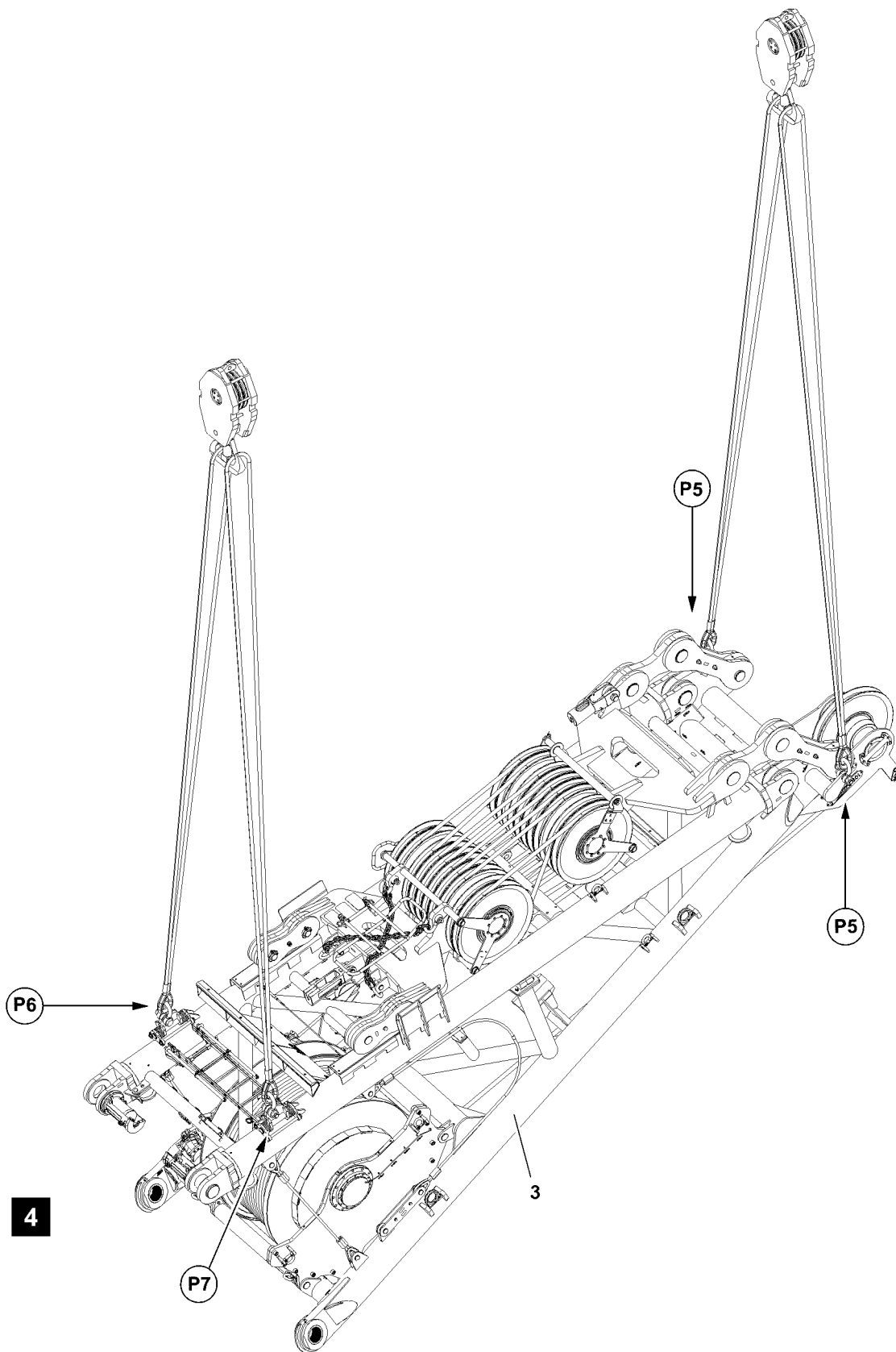

Fig.113646

3 Fastening points A-frame - assembly



WARNING

Component incorrectly fastened!

Life-threatening situations can arise due to improper or incorrect fastening of the corresponding components!

Personnel can be severely injured or killed!

- ▶ Fasten the components only in the intended fastening points on both sides!
- ▶ Fastening of components and description of fastening points, see the Crane operating instructions, chapter 5.01!

Component	„Assembly“ fastening points
A-frame, complete	P5, P6 and P7

Fig.195219

LWE/LR 13000-001/19503-01-02/en

4 Assembling the A-frame



WARNING

Danger of falling!

During assembly / disassembly work, personnel must be secured with appropriate aids to prevent them from falling. If this is not observed, assembly personnel could fall and suffer life-threatening or fatal injuries!

- ▶ Any assembly work, where there is a danger of falling must be carried out with suitable aids (for example lifting platform, scaffolding, ladder, auxiliary crane)!
- ▶ If the work cannot be carried out with such aids or from the ground, then assembly personnel must secure themselves with approved fall arrest systems to avoid falling, see the Crane operating instructions, Chapter 2.04!
- ▶ Approved fall arrest systems must be connected to the respective fastening points on the crane, see the Crane operating instructions, chapter 2.06!
- ▶ If railings are present on the components, then they must be brought into the corresponding position and secured for assembly / disassembly work!
- ▶ Only step on aids and fall protection equipment with clean shoes!
- ▶ Keep aids and fall protection equipment clean and free of snow and ice!
- ▶ During all assembly and disassembly work, maintenance work and inspections, travel and crane operation is prohibited!



WARNING

Components not pinned and secured!

If a component is released from the auxiliary crane before being pinned and secured, the component will fall down! Personnel can be severely injured or killed!

- ▶ Do not detach the auxiliary crane until the respective component is pinned and secured!



WARNING

Danger of impact / crushing!

When assembling / disassembling crane components with the auxiliary crane, crane components can start to swing back and forth!

When lifting / lowering and positioning crane components, there is an increased danger of impact / crushing!

Personnel can be caught and thereby injured or killed!

- ▶ Make sure that personnel cannot be caught by components!
- ▶ When working in danger zones: Use aids to protect limbs!
- ▶ Guide components with suitable aids to minimize oscillation!



WARNING

Slipping luffing pulley block!

If the A-frame is taken down at an angle, the luffing pulley block can start to slip in the receptacle!

Personnel can be severely injured or killed!

The A-frame can be severely damaged!

- ▶ Make sure that the A-frame is taken down horizontally!
- ▶ Make sure that the luffing pulley block is always secured except for assembly / disassembly!

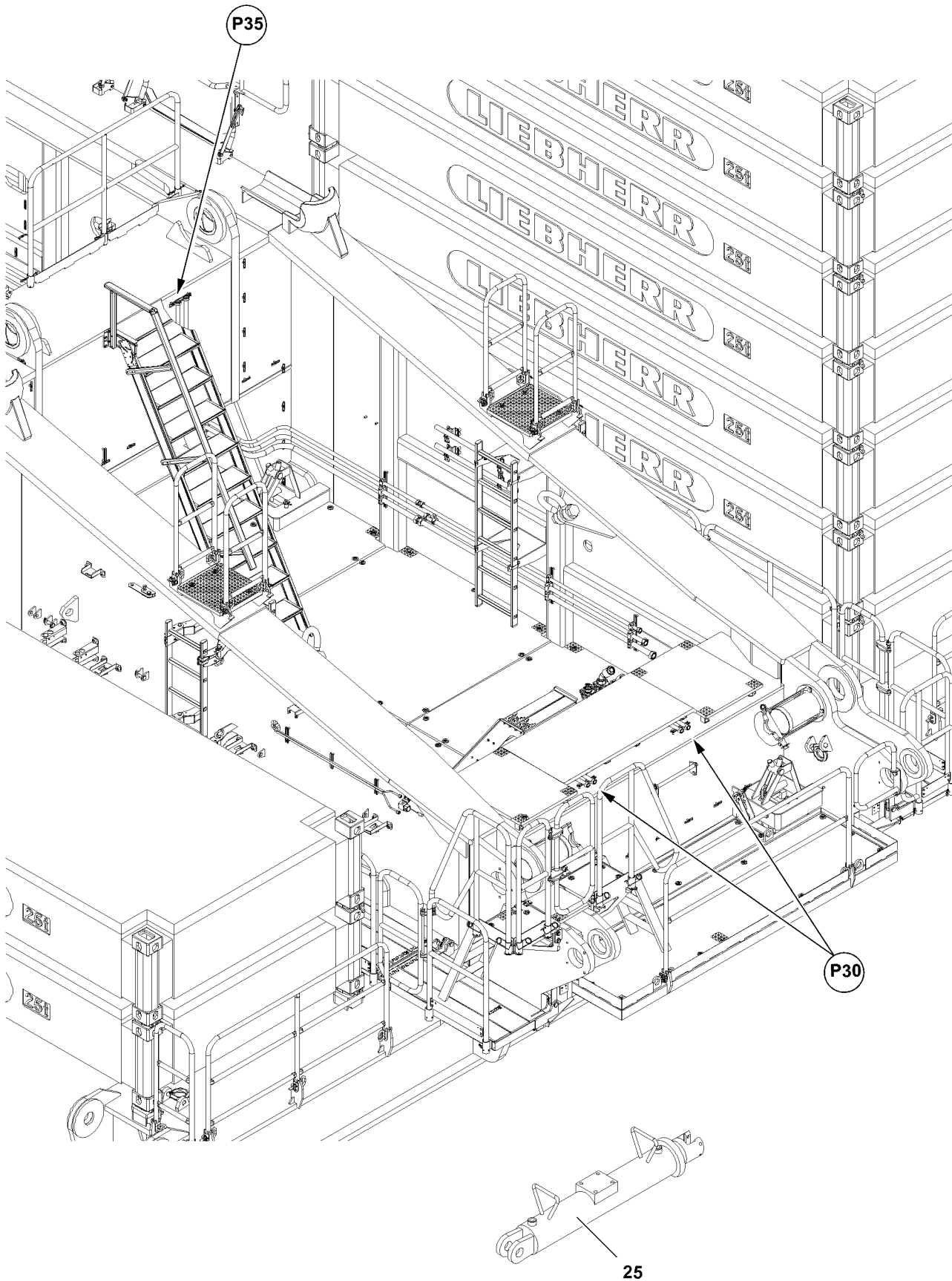

Fig.113652

LWE/LR 13000-001/19503-01-02/en

4.1 Hydraulic connections to the pin pulling cylinder



Note

- ▶ Hydraulic connection: see the Crane operating instructions, chapter 5.30.



Note

- ▶ Hydraulic connections to the „frame“ pin location, see point **P30!**
- ▶ Hydraulic connections to the „support“ pin location, see point **P35!**

4.1.1 Establishing the hydraulic connections to the pin pulling cylinder

- ▶ When connecting hydraulic lines with quick couplings, make sure that the coupling procedure is carried out correctly.



WARNING

Pressure in the hydraulic lines!

If the pressure supply is not interrupted before connecting / releasing the hydraulic lines, the hydraulic oil can escape with high pressure!

Personnel can be severely injured or killed!

- ▶ Release the pressure in the hydraulic system before connecting / disconnecting: Interrupt the pressure supply and wait a short time!
- ▶ Connect the coupling components (sleeve and connector) and screw together with the knurled nut.
- ▶ Make sure that the description on the connections matches.
- ▶ Tighten the hydraulic couplings by hand. Turn the knurled nut until it reaches a tangible, fixed stop position.
- ▶ Establish the hydraulic connection: Connect the supply lines of the pin pulling cylinder **25** to the supply lines of the turntable **R**, hydraulic connection and hydraulic connection **P**, see illustration.

4.1.2 Disconnecting the hydraulic connections from the pin pulling cylinder

- ▶ When disconnecting hydraulic lines with quick couplings, make sure that the coupling procedure is carried out correctly.



WARNING

Pressure in the hydraulic lines!

If the pressure supply is not interrupted before connecting / releasing the hydraulic lines, the hydraulic oil can escape with high pressure!

Personnel can be severely injured or killed!

- ▶ Release the pressure in the hydraulic system before connecting / disconnecting: Interrupt the pressure supply and wait a short time!
- ▶ Make sure that the hydraulic system pressure has been released.
- ▶ Unscrew and separate the coupling components (sleeve and connector) with the knurled nut.
- ▶ Disconnect the hydraulic connection: Disconnect the supply lines of the pin pulling cylinder **25** from the supply lines of the turntable **R**, hydraulic connection and hydraulic connection **P**, see illustration.

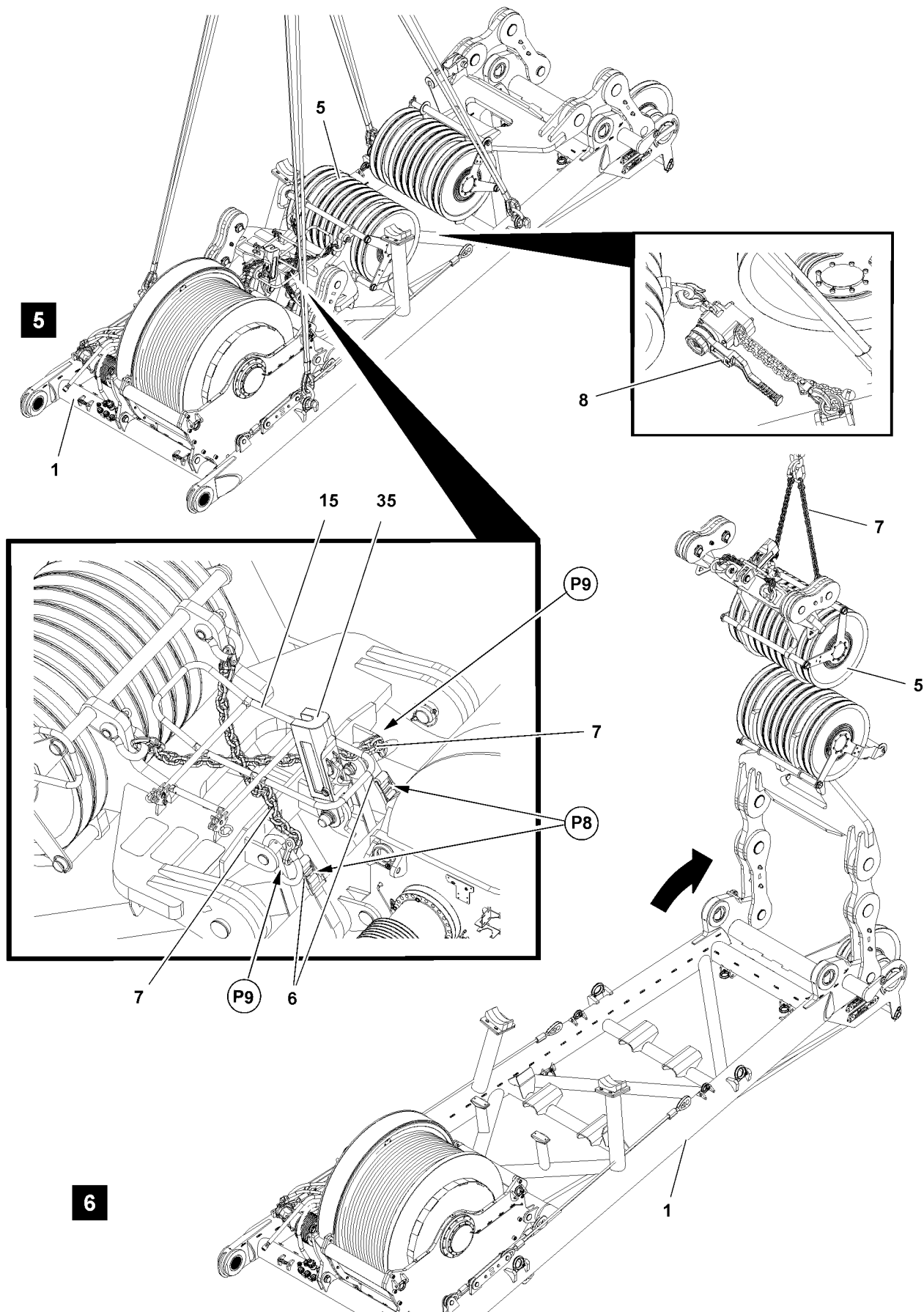

Fig.113647

LWE/LR 13000-001/19503-01-02/en

4.2 Erecting the A-frame



Note

- ▶ To reduce the overall weight, the support can be removed and transported separately, see the Component overview!
- ▶ If the A-frame is transported complete, the following steps are eliminated!

Make sure that the following prerequisite is met:

- Two auxiliary cranes with the respective load carrying capacity are available.



WARNING

Danger of falling!

During assembly and disassembly of crane components, personnel must be secured with appropriate aids to prevent them from falling!

Assembly personnel can fall and be severely injured or killed!

- ▶ Use personal protective equipment!
- ▶ Fasten the fastening equipment to the frame **1**.
- ▶ Tension the fastening equipment with the auxiliary crane.
- ▶ Lift the frame **1** with the auxiliary crane from the transport vehicle and take it down on level ground with sufficient load bearing capacity, see illustration **5**.



Note

- ▶ Observe and adhere to the assembly and safety instructions for the railings, see the Crane operating instructions, chapter 2.06!

- ▶ Swing the railing **15**, illustration **5**, from the transport position into the operating position, see the Crane operating instructions, chapter 2.06.
- ▶ Release the ratchet **8** on both sides from the luffing pulley block **5** and remove, see illustration **5**.
- ▶ Remove the tension belts **6** from the luffing pulley block **5** in points **P8**, see illustration **5**.
- ▶ Release the chains **7** in points **P9**, see illustration **5**.



Note

- ▶ The weight of the luffing pulley block **5** is approximately 17 t!

- ▶ Connect the fastening equipment with the chains **7**.
- ▶ Lift the luffing pulley block **5**, see illustration **6**.

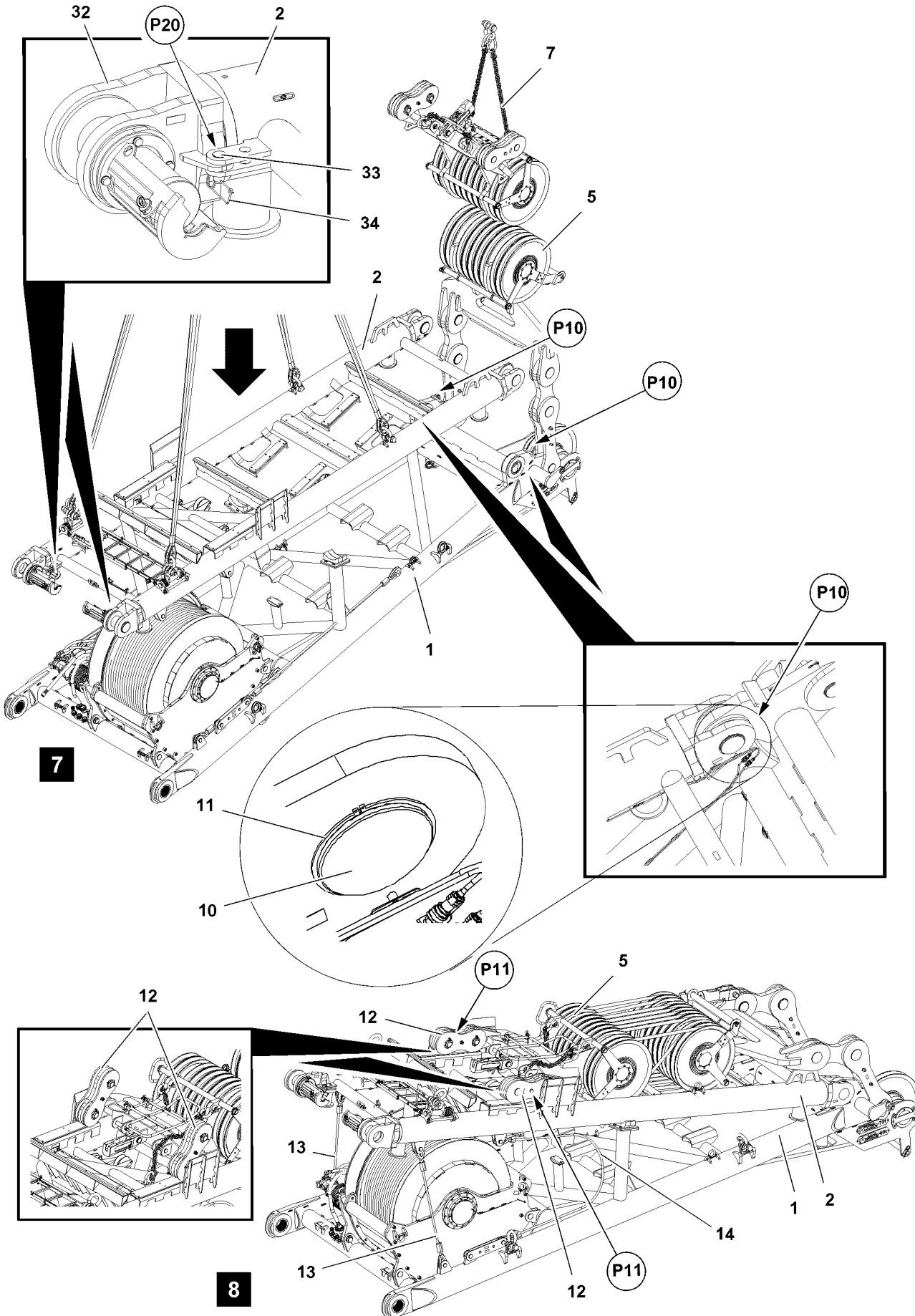

Fig.113648

LWE/LR 13000-001/19503-01-02/en

**WARNING**

The guide pipe drives out by itself!

When the pins **33** are not pinned in point **P20**, then the guide pipes **32** can drive out by themselves at assembly!

Personnel can be severely injured or killed!

- ▶ Make sure that the pins **33** are inserted and secured in point **P20**, see illustration **7**!

- ▶ Fasten the fastening equipment of the second auxiliary crane to the support **2**.
- ▶ Tension the fastening equipment with the auxiliary crane.
- ▶ Lift the support **2** with the auxiliary crane from the transport vehicle.
- ▶ Lift the support **2** with the auxiliary crane to the frame **1**.
- ▶ Guide the support **2** to the pin location in points **P10**, see illustration **7**.

**WARNING**

The pin is not secured!

If pins are not secured, the pins can loosen up by themselves during crane operation!

This can cause the crane to topple over!

Personnel can be severely injured or killed!

- ▶ Make sure that the pins **10** are secured with the retaining rings **11**!

- ▶ Insert the pins **10** in points **P10** and secure with the retaining ring **11**, see illustration **7**.
- ▶ Remove the fastening equipment from the support **2**.
- ▶ Take the luffing pulley block **5** down on the support **2**, see illustration **8**.

NOTICE

Tipping connector brackets!

If the connector brackets **12** are not taken down, then they can tip to the front uncontrolled when assembling the A-frame on the turntable!

This can result in damage to the connector brackets **12** and the support **2**!

- ▶ Make sure, before assembly of the A-frame on the turntable, that the connector brackets **12** are taken down!
- ▶ Take the connector brackets **12** down in points **P11** with the auxiliary crane, see illustration **8**.
- ▶ Assemble the assembly ropes **13** between the frame **1** and support **2**, see illustration **8**.
- ▶ Assemble the assembly ropes **14** between the frame **1** and support **2**, see illustration **8**.

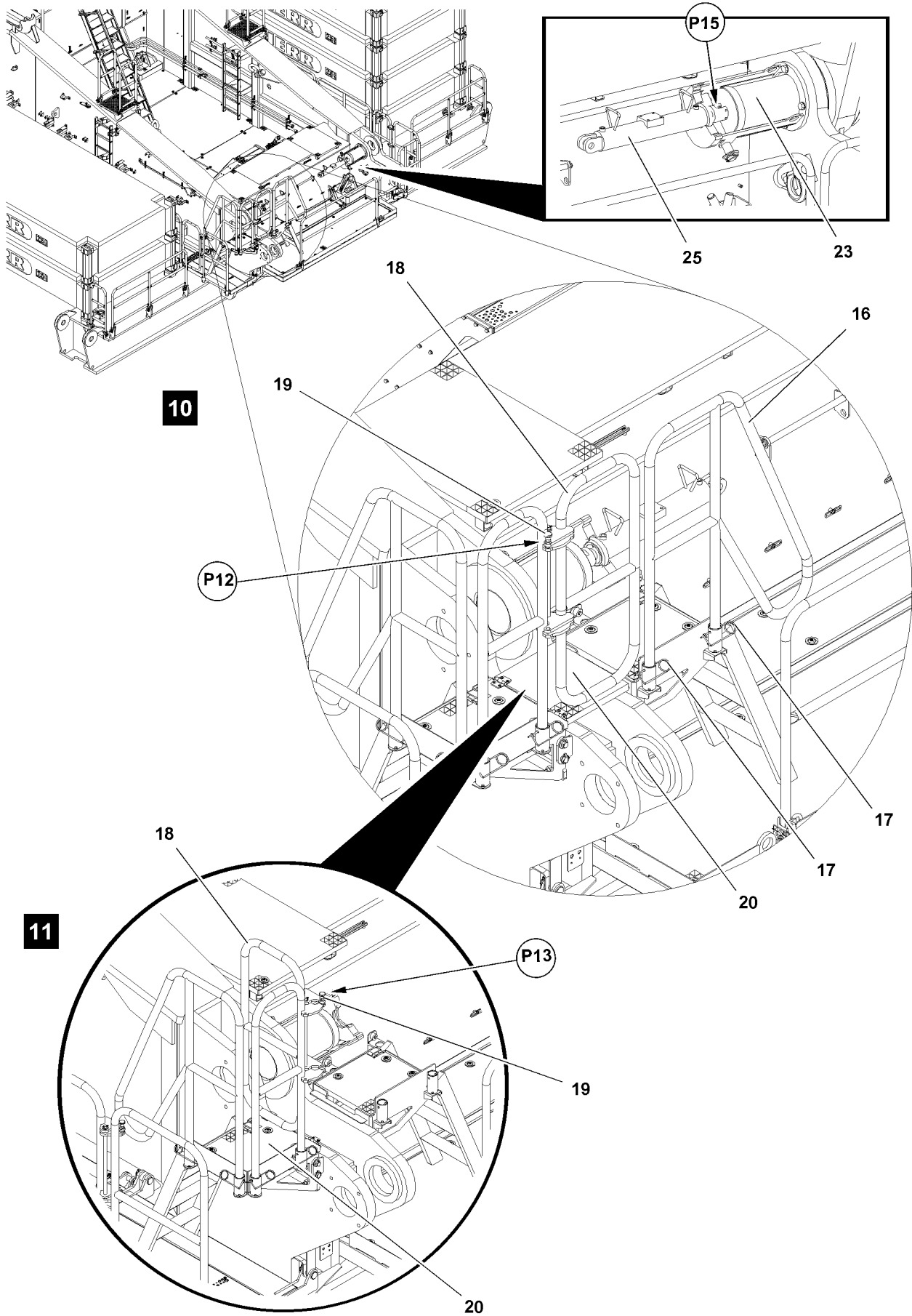

Fig.113649

LWE/LR 13000-001/19503-01-02/en

4.3 Assembling the pin pulling cylinder

- ▶ Establish the hydraulic connection in point **30** on the „frame“ pin location: Connect the supply lines of the pin pulling cylinder **25** to the supply lines of the turntable, hydraulic connection **R** and hydraulic connection **P**, see section „Hydraulic connections to the pin pulling cylinder“.
- ▶ Connect the pin pulling cylinder **25** to the „front“ in point **10** to the pin **P15** on both sides and guide with the flange into the groove of the pin retainer, see illustration **23**.

4.4 Removing the railing on the turntable

Make sure that the following prerequisites are met:

- The assembly of the turntable is completed.
- The crane is aligned in the horizontal direction.
- The pin pulling cylinders are assembled.



WARNING

Danger of falling!

During assembly and disassembly of the railing, personnel must be secured with appropriate aids to prevent them from falling!

Assembly personnel can fall and be severely injured or killed!

- ▶ Use personal protective equipment!

- ▶ Remove the railing **16**: Remove the spring retainers **17** and pull the railing **16** up, see illustration **10**.



WARNING

Danger of crushed limbs!

When opening the grating flap, fingers and hands can be crushed!

- ▶ Do not reach with your hands into the danger zone!

- ▶ Open the grating flap **20**, see illustration **10** and illustration **11**.



WARNING

Danger of crushed limbs!

When swinging the railings, fingers and hands can be crushed!

- ▶ Do not reach with your hands into the danger zone!

- ▶ Swing the railing **18**: Pull the detent pin **19** up in point **P12**, see illustration **10**.

- ▶ Swing the railing **18** in until the detent pin **19** engages in point **P13**, see illustration **11**.

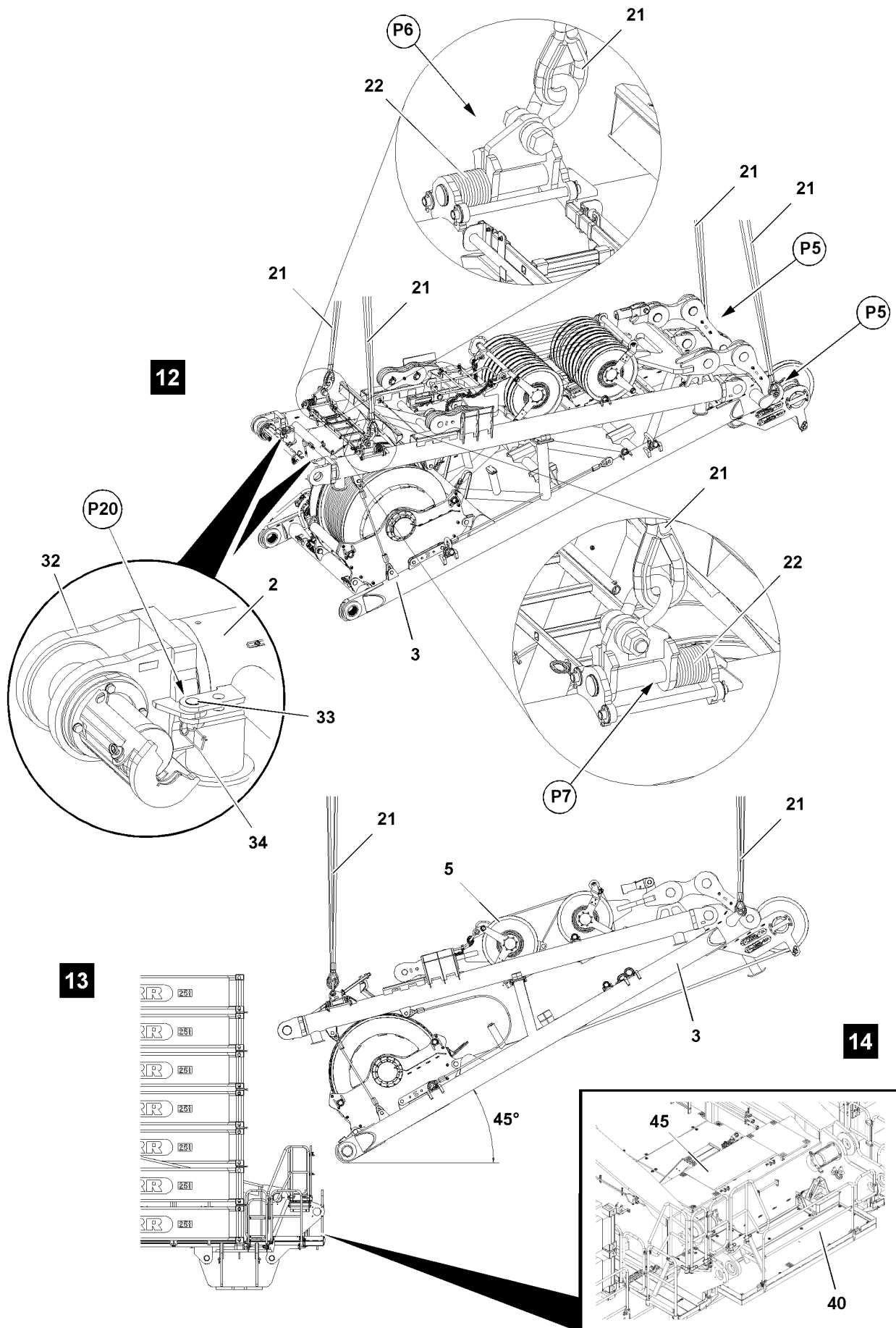

Fig.164530

4.5 Fastening the A-frame to the auxiliary cranes

Make sure that the following prerequisites are met:

- Two auxiliary cranes with the respective load carrying capacity are available.
- The guide pipes **32** are secured with pins **33**, see illustration **12**.



WARNING

The guide pipe drives out by itself!

When the pins **33** are not pinned in point **P20**, then the guide pipes **32** can drive out by themselves at assembly!

Personnel can be severely injured or killed!

- ▶ Make sure that the pins **33** are inserted and secured in point **P20**, see illustration **12**!

- ▶ Fasten the first auxiliary crane in points **P5**, see illustration **12**.
- ▶ Fasten the fastening equipment **21** of the second auxiliary crane in point **P6**, see illustration **12**.
- ▶ Fasten the fastening equipment **21** of the second auxiliary crane in point **P7**, see illustration **12**.



WARNING

Danger of crushing!

During assembly of the A-frame, there is an increased crushing danger!

Personnel can be severely injured or killed!

- ▶ It is prohibited for anyone to remain on the platform **40** and on the platform **45**, see illustration **14**!

15

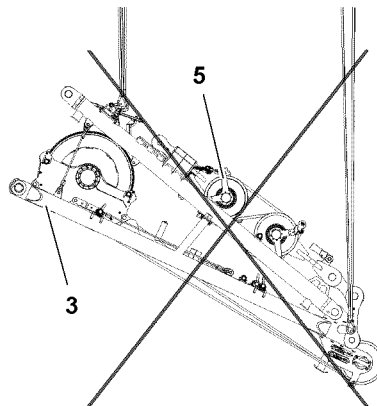

Fig.113674: Impermissible suspension



WARNING

Slipping luffing pulley block!

If the A-frame **3** is not lifted horizontally or tipped toward the tip, then the luffing pulley block **5** can slip out of the receptacle, see illustration **15**!

Personnel can be severely injured or killed!

The A-frame can be severely damaged!

- ▶ Make sure that the A-frame **3** is raised horizontally or tipped toward the bottom section!

- ▶ Lift the A-frame and swing it under an angle of approx. 30° to the turntable, see illustration **13**.

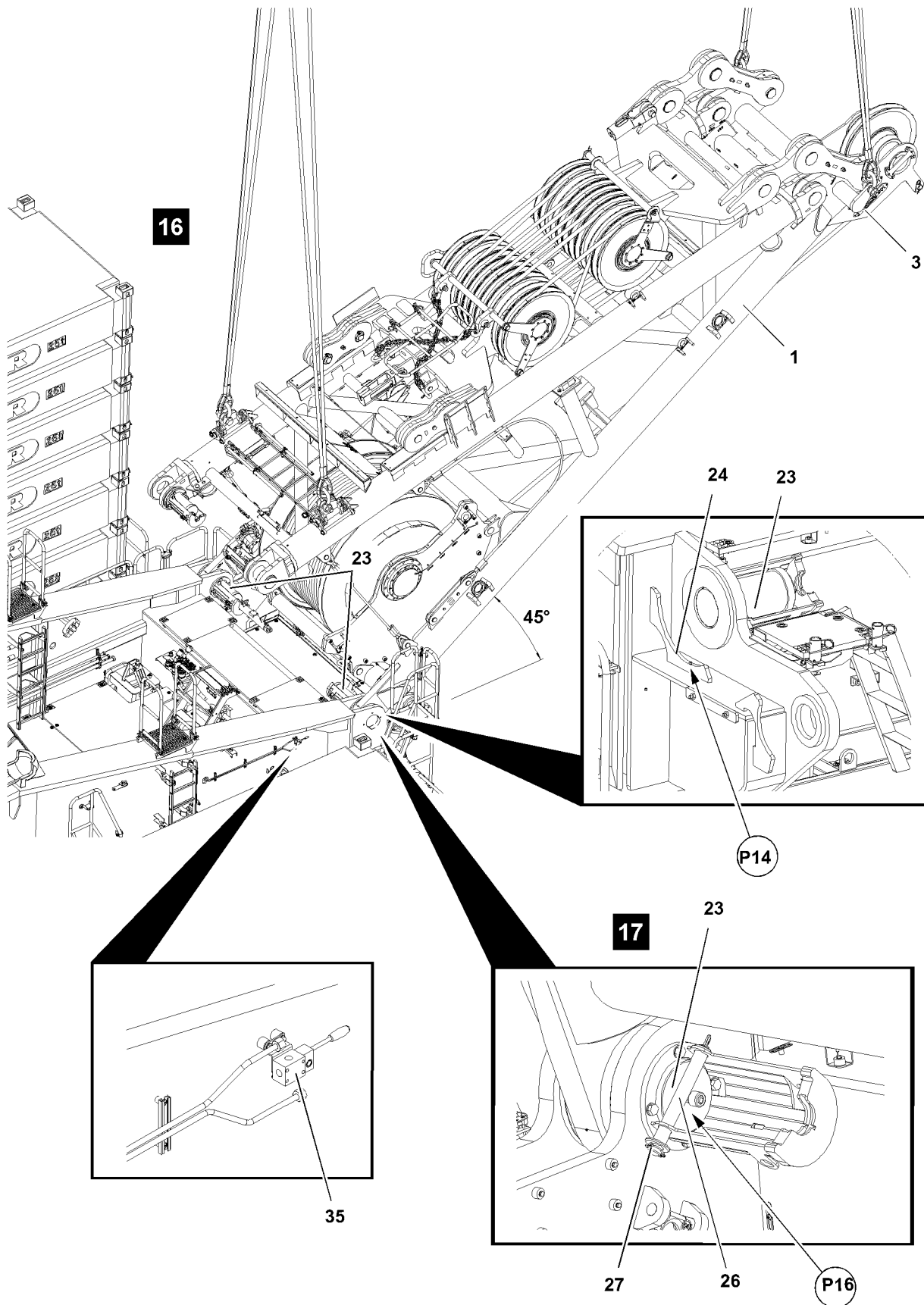

Fig.164531

LWE/LR 13000-001/19503-01-02/en

4.6 Pinning the frame with the turntable

Make sure that the following prerequisites are met:

- The pins **23** are unpinned.
- The railings are changed over for assembly.

NOTICE

Danger of property damage!

If the pins **23** - when retracting the A-frame **3** in the turntable - are in the **pinned** position, components can be severely damaged.

- ▶ Make sure that the pins **23** on the turntable are in the **unpinned** position when retracting the A-frame **3**!

-
- ▶ Set the frame **1** on the centering **24** in the points **P14** of the turntable, see illustration **16**.

Result:

- Align the pin bores.
- ▶ Extend the pin pulling cylinder **25**: Move the hand lever **35**, see illustration **16**.

Result:

- The pins **23** are inserted.



WARNING

The pin is not secured!

If the pins **23** are not secured, the pins can loosen up by themselves during crane operation!

This can cause the crane to topple over!

Personnel can be severely injured or killed!

- ▶ Make sure that the pins **23** are secured with pins **26**!
-
- ▶ Secure the pin **23**: Insert the pin **26** in point **P16** and secure with the safety locking pin **27**, see illustration **17**.

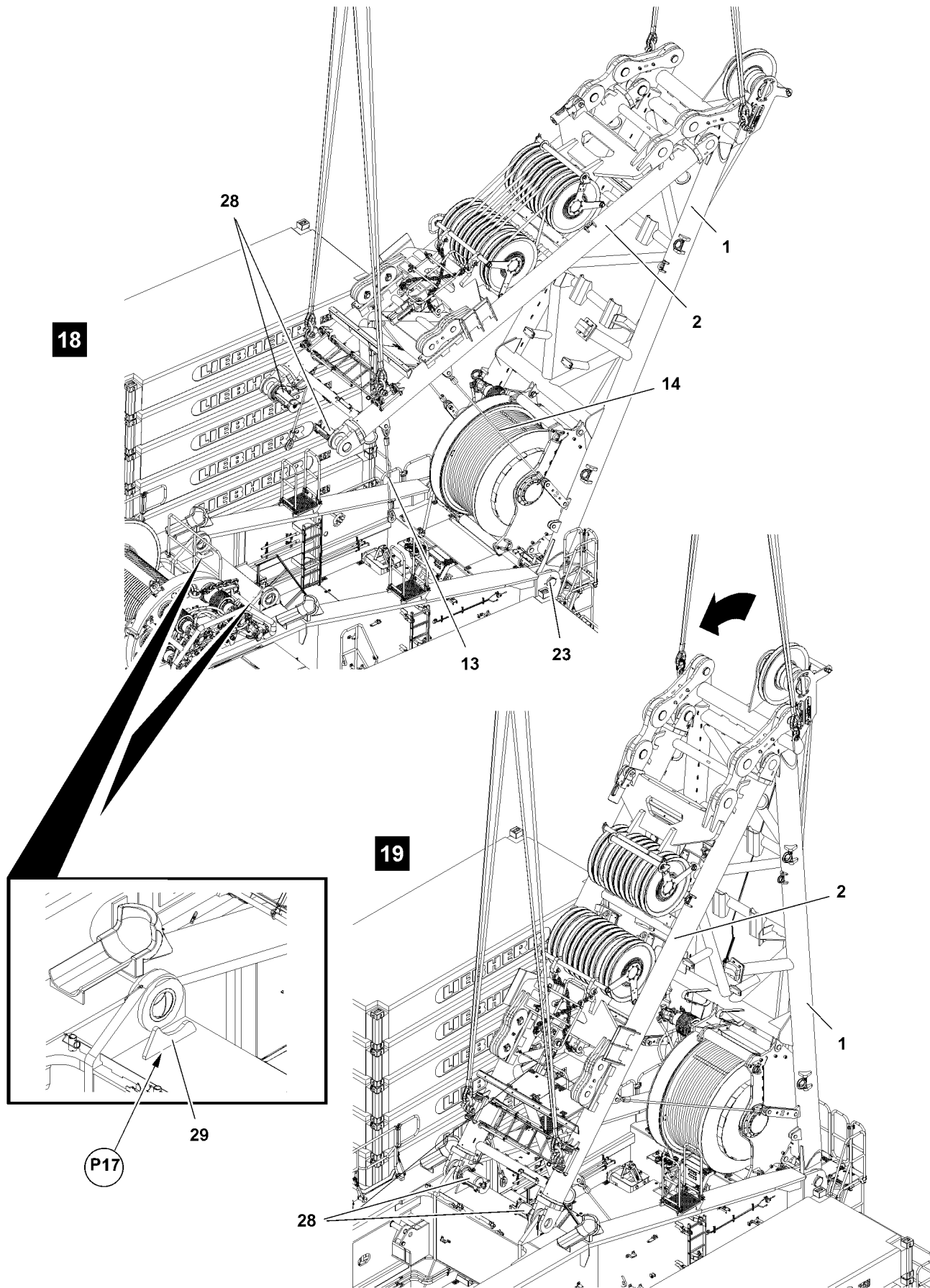

LWE/LR 13000-001/19503-01-02/en

Fig.113653

4.7 Tipping the A-frame

Make sure that the following prerequisite is met:

- The pins **23** are inserted and secured.



WARNING

Swinging assembly rope!

When releasing the assembly rope **13**, it can swing back uncontrolled!

Personnel can be severely injured or killed!

- ▶ Assembly personnel must be to the side of the assembly unit!

- ▶ Release the assembly ropes **13** from the frame **1** and let them hang freely on the support **2**, see illustration **18**.



WARNING

Entangled assembly ropes!

During the folding procedure, the assembly rope **14** can get tangled on the A-frame or on winch **4**!

- ▶ Make sure that the assembly rope **14** does not get tangled during the folding procedure!

- ▶ Lift the support **2** with the second auxiliary crane until the assembly ropes **14** tighten, see illustration **18**.

NOTICE

Tighten the assembly rope!

When tipping the A-frame forward, the A-frame can collapse!

The A-frame can be severely damaged!

- ▶ Tip the A-frame forward with both auxiliary cranes so that the assembly rope is always tight, but not overloaded!

- ▶ Tip the A-frame **3** forward.



WARNING

Danger of crushing!

When retracting the support **2**, there is a danger of crushing!

Personnel can be severely injured or killed!

- ▶ It is prohibited for anyone to remain between the support **2** and the turntable!

NOTICE

Danger of property damage!

If the pins **28** - when retracting the support **2** in the turntable - are in the **pinned** position, components can be severely damaged.

- ▶ Make sure that the pins **28** on the turntable are in the **unpinned** position when retracting the support **2**!

- ▶ Set the support **2** on the centering **29** in the points **P17** of the turntable, see illustration **19**.

Result:

- Align the pin bores.

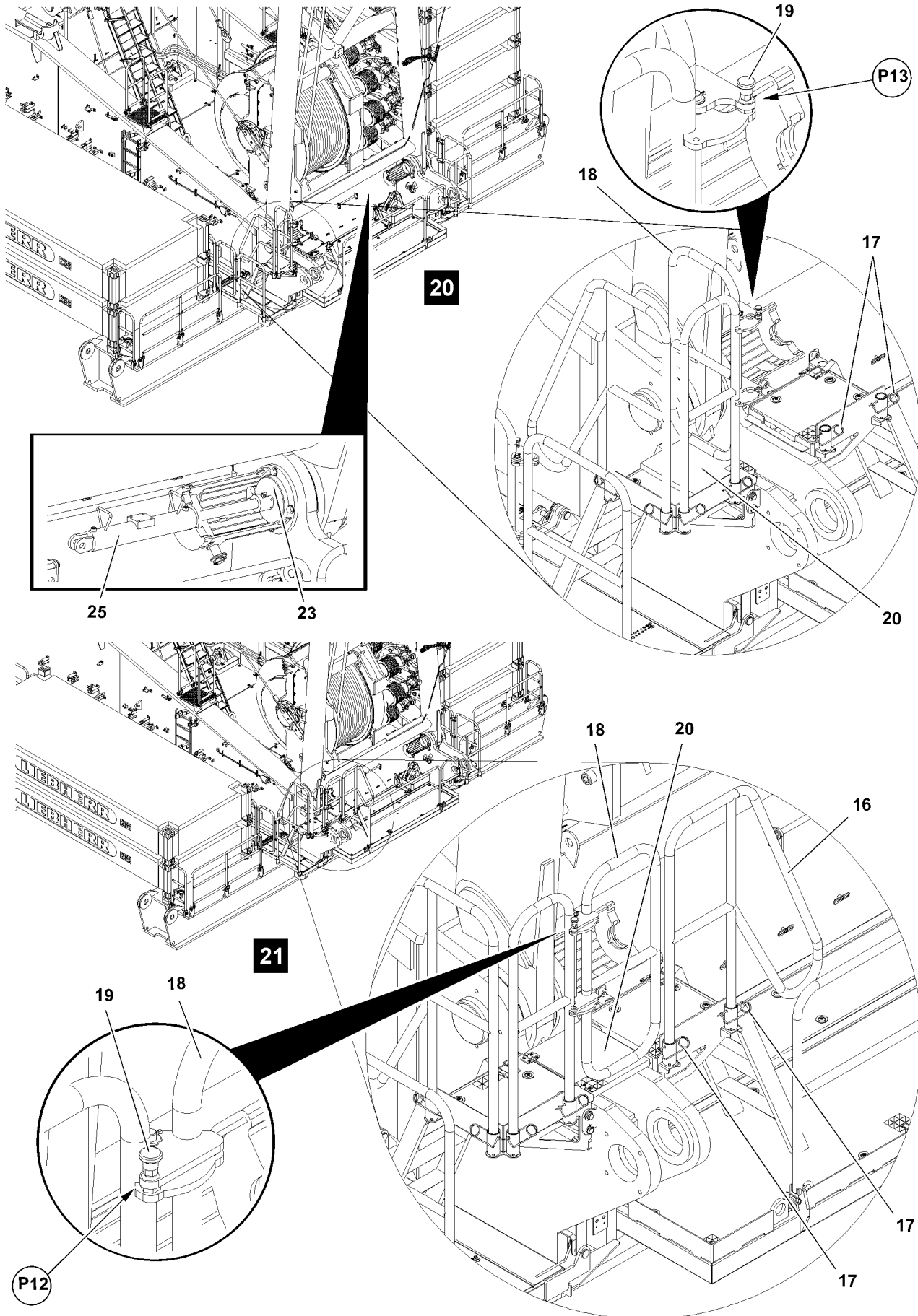

Fig.113657

LWE/LR 13000-001/19503-01-02/en

4.8 Assembling the railing on the turntable

Make sure that the following prerequisite is met:

- The support is set on the centering.



WARNING

Danger of falling!

During assembly and disassembly of the railing, personnel must be secured with appropriate aids to prevent them from falling!

Assembly personnel can fall and be severely injured or killed!

- ▶ Use personal protective equipment!



WARNING

Danger of crushed limbs!

When swinging the railings, fingers and hands can be crushed!

- ▶ Do not reach with your hands into the danger zone!
- ▶ Swing the railing **18**: Pull the detent pin **19** up in point **P13**, see illustration **20**.
- ▶ Swing the railing **18** out until the detent pin **19** engages in point **P12**, see illustration **21**.



WARNING

Danger of crushed limbs!

When opening and closing the grating flap, fingers and hands can be crushed!

- ▶ Do not reach with your hands into the danger zone!
- ▶ Close the grating flap **20**, see illustration **20** and illustration **21**.
- ▶ Assemble the railing **16**: Insert the railing **16** into the platform and secure with spring retainers **17**, see illustration **21**.

4.9 Disassembling the pin pulling cylinder

- ▶ Disconnect the hydraulic connections in point **P30** from the „frame“ pin location: Disconnect the supply lines of the pin pulling cylinder **25** from the supply lines of the turntable, hydraulic connection **R** and hydraulic connection **P**, see section „Hydraulic connections to the pin pulling cylinder“.
- ▶ Pull the pin pulling cylinder **25** up on „front“ and unhook from the pin **23**, see illustration **20**.
- ▶ Remove the pin pulling cylinder **25**.

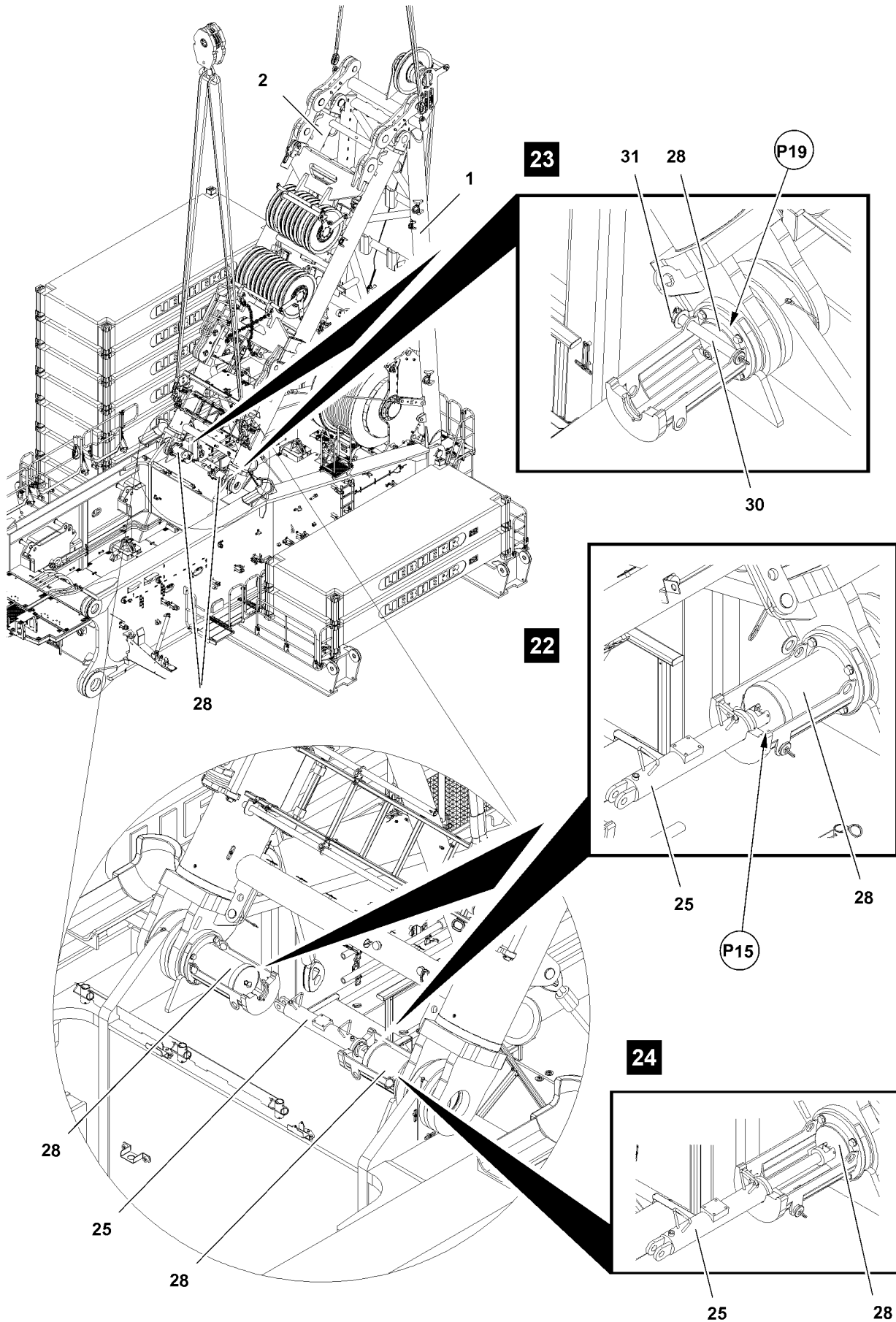

Fig.113654

LWE/LR 13000-001/19503-01-02/en

4.10 Assembling the pin pulling cylinder

- ▶ Establish the hydraulic connection in point **P35** on the „support“ pin location: Connect the supply lines of the pin pulling cylinder **25** to the supply lines of the turntable, hydraulic connection **R** and hydraulic connection **P**, see section „Hydraulic connections to the pin pulling cylinder“.
- ▶ Connect the pin pulling cylinder **25** to the „front“ in point **P15** to the pin **28** and guide with the flange into the groove of the pin retainer, see illustration **22**.

4.11 Pinning the support with the turntable

Make sure that the following prerequisite is met:

- The support is set on the centering.
- ▶ Insert the pin **28**: Extend the pin pulling cylinder **25**.



WARNING

The pin is not secured!

If the pins **28** are not secured, the pins can loosen up by themselves during crane operation!

This can cause the crane to topple over!

Personnel can be severely injured or killed!

- ▶ Make sure that the pins **28** are secured with pins **30**!
- ▶ Secure the pin **28**: Insert the pin **30** in point **P19** and secure with the safety locking pin **31**, see illustration **23**.

4.12 Disassembling the pin pulling cylinder

- ▶ Disconnect the hydraulic connection in point **35** from the „support“ pin location: Disconnect the supply lines of the pin pulling cylinder **25** from the supply lines of the turntable, hydraulic connection **R** and hydraulic connection **P**, see section „Hydraulic connections to the pin pulling cylinder“.
- ▶ Pull the pin pulling cylinder **25** up on „front“ and unhook from the pin **28**, see illustration **24**.
- ▶ Remove the pin pulling cylinder **25**.

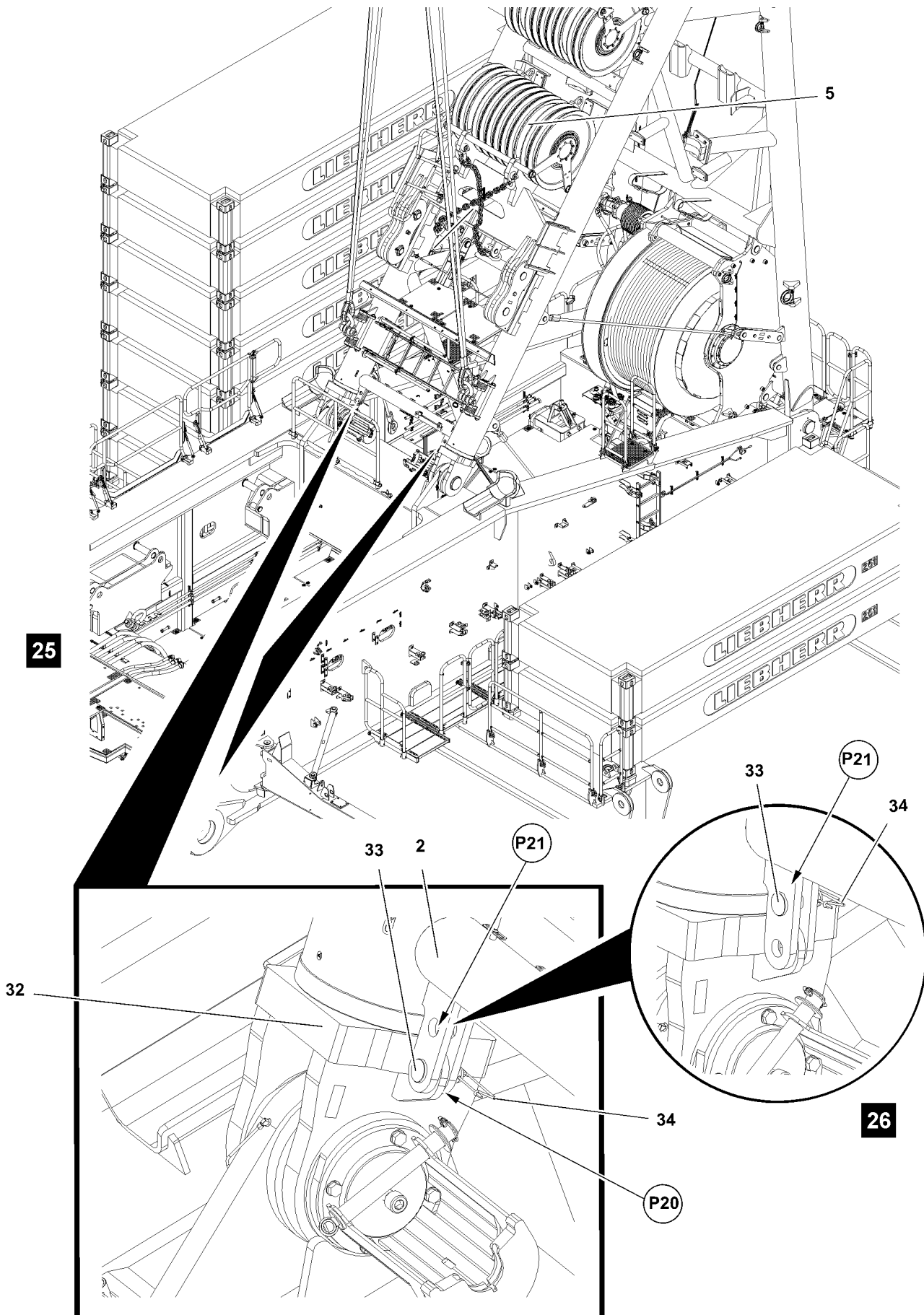

Fig.113655

LWE/LR 13000-001/19503-01-02/en

4.13 Releasing the guide pipe

Make sure that the following prerequisite is met:

- The support is pinned and secured.



Note

- ▶ The pin connection in point **P20**, between the support **2** and the guide pipe **32** may only be released before pulling up the derrick!
-



WARNING

Damage to the A-frame!

If the pin **33** on the guide pipe **32** is not unpinned before pulling the derrick up, then the pin connection will be destroyed when the guide pipe extends!

- ▶ Make sure, before pulling up the derrick, that the pin **33** is unpinned!
-
- ▶ Release the guide pipe **32**: Remove the spring retainer **34** in point **P20** and unpin the pin **33**, see illustration **25**.
 - ▶ Store the pin **33**: Insert the pin **33** in point **P21** and secure with the spring retainer **34**, see illustration **26**.

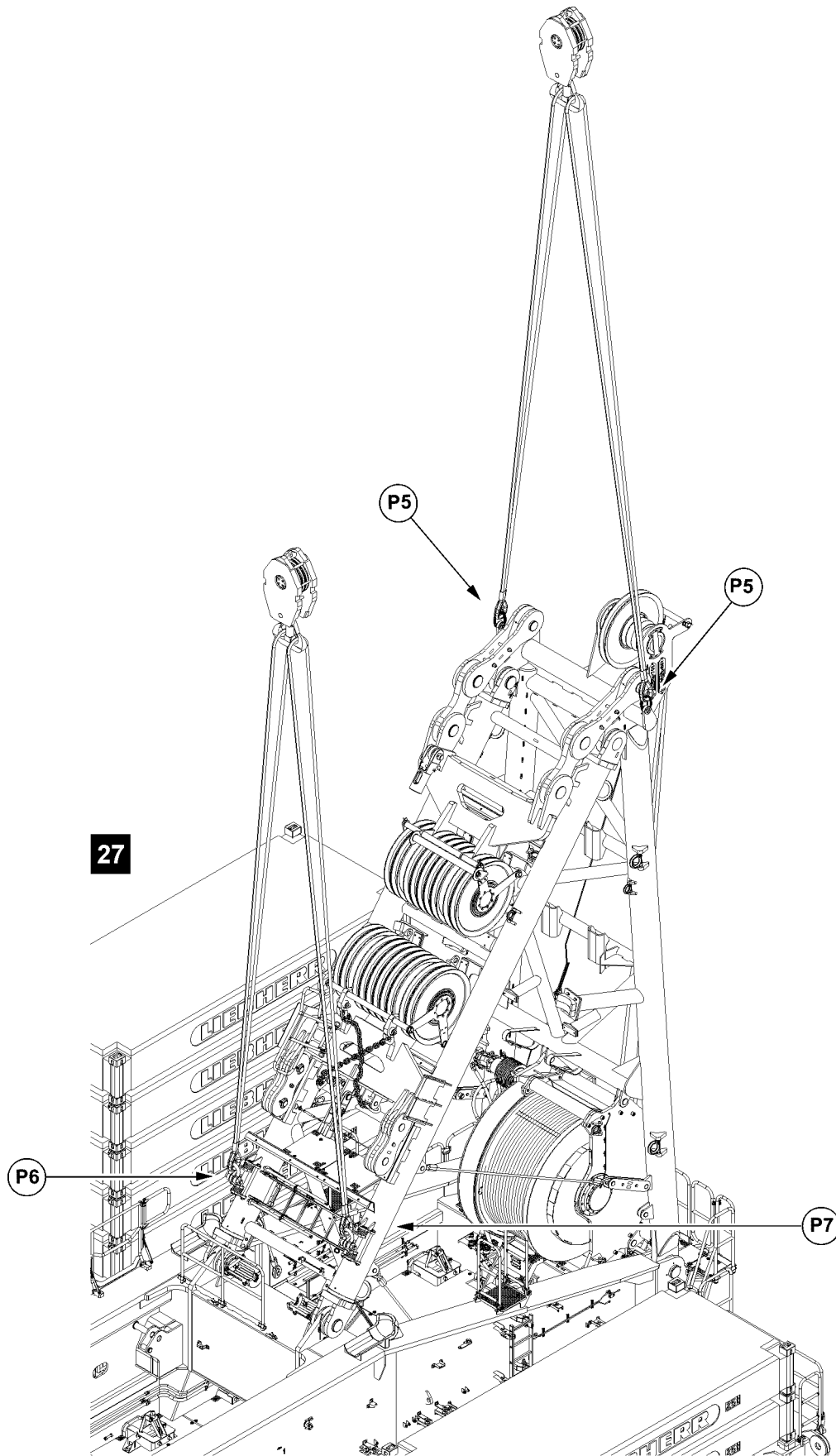

Fig.113656

LWE/LR 13000-001/19503-01-02/en

4.14 Removing the auxiliary crane

Make sure that the following prerequisite is met:

- The A-frame is pinned and secured.



WARNING

Danger of falling!

During disassembly of the fastening equipment, assembly personnel must be secured with appropriate aids to prevent them from falling!

Assembly personnel can fall and be severely injured or killed!

- ▶ Use personal protective equipment!
-
- ▶ Move the work platform to the fastening points **P5**.
 - ▶ Release the fastening equipment from the fastening points **P5**, see illustration **27**.
 - ▶ Remove the first auxiliary crane.
 - ▶ Release the fastening equipment in the fastening points **P6**, see illustration **27**.
 - ▶ Release the fastening equipment in the fastening points **P7**, see illustration **27**.
 - ▶ Remove the second auxiliary crane.

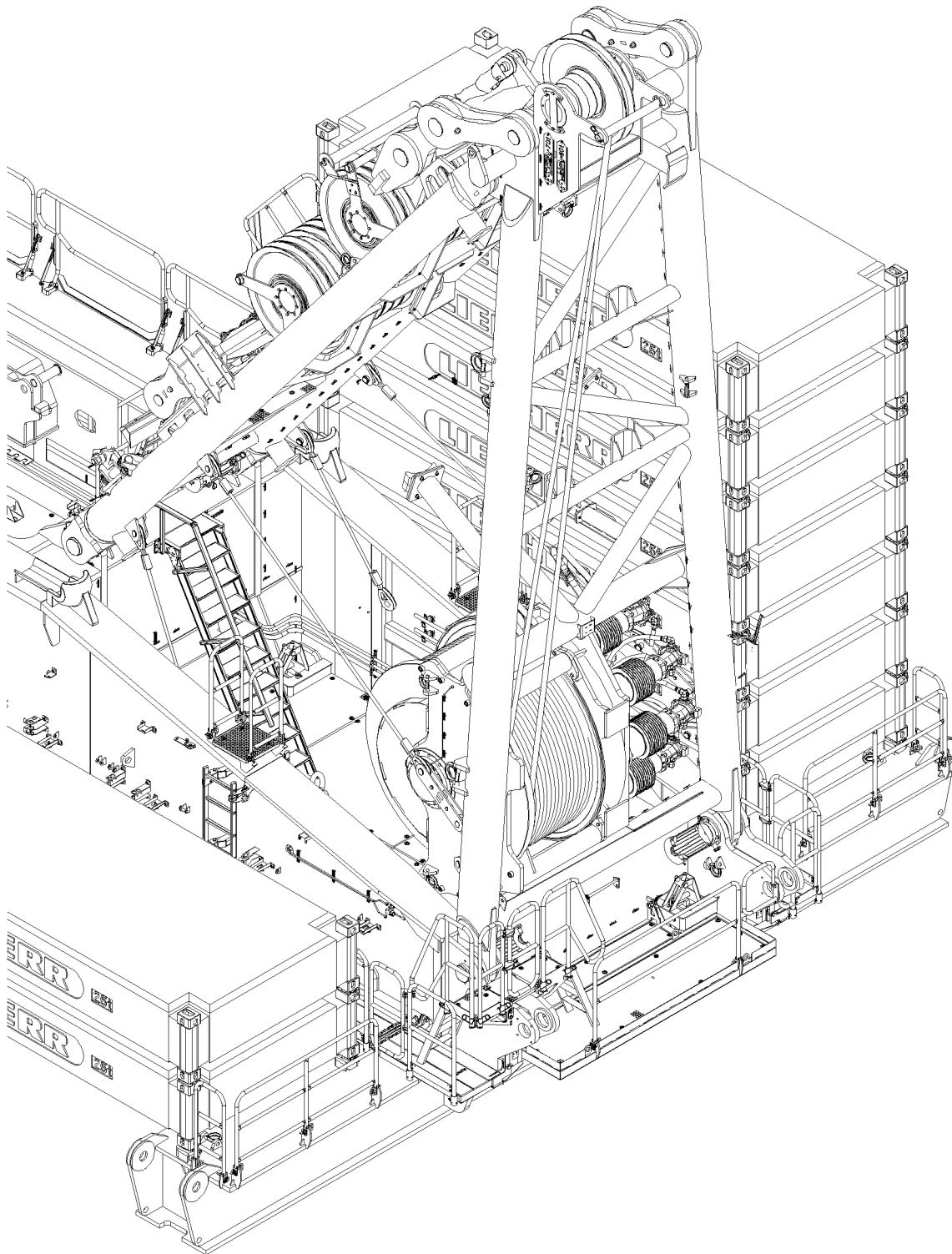

Fig.113658

LWE/LR 13000-001/19503-01-02/en

4.15 Establishing the connections to winch 4

Make sure that the following prerequisite is met:

- The A-frame is properly installed, pinned and secured.

4.15.1 Establishing the hydraulic connections to winch 4

The hydraulic connections for winch 4 are established with quick couplings.

When connecting hydraulic lines with quick couplings, make sure that the coupling procedure is carried out correctly.



WARNING

Pressure in the hydraulic lines!

If the pressure supply is not interrupted before connecting / releasing the hydraulic lines, the hydraulic oil can escape with high pressure!

Personnel can be severely injured or killed!

- ▶ Release the pressure in the hydraulic system before connecting / disconnecting: Interrupt the pressure supply and wait a short time!



WARNING

Loss of pressure or leakage!

Incorrectly coupled or self-loosening quick couplings (particularly return lines) can result in serious accidents due to component failure!

- ▶ Check that the quick couplings have been properly connected before using the crane!
- ▶ Connect the coupling components (sleeve and connector) and screw together with the knurled nut.
- ▶ Make sure that the description on the connections matches.
- ▶ Tighten the hydraulic couplings by hand. Turn the knurled nut until it reaches a tangible, fixed stop position.
- ▶ Establish the hydraulic connections to winch 4.

4.15.2 Establishing the electrical connections to winch 4

- ▶ Establish the connections to winch 4, see the Electric wiring diagram.

4.15.3 Establishing the connections of the central lubrication system to winch 4

- ▶ Establish the connections of the central lubrication system to winch 4.

Fig.195219

LWE/LR 13000-001/19503-01-02/en

5 Disassembling the A-frame



WARNING

Danger of falling!

During assembly / disassembly work, personnel must be secured with appropriate aids to prevent them from falling. If this is not observed, assembly personnel could fall and suffer life-threatening or fatal injuries!

- ▶ Any assembly work, where there is a danger of falling must be carried out with suitable aids (for example lifting platform, scaffolding, ladder, auxiliary crane)!
- ▶ If the work cannot be carried out with such aids or from the ground, then assembly personnel must secure themselves with approved fall arrest systems to avoid falling, see the Crane operating instructions, Chapter 2.04!
- ▶ Approved fall arrest systems must be connected to the respective fastening points on the crane, see the Crane operating instructions, chapter 2.06!
- ▶ If railings are present on the components, then they must be brought into the corresponding position and secured for assembly / disassembly work!
- ▶ Only step on aids and fall protection equipment with clean shoes!
- ▶ Keep aids and fall protection equipment clean and free of snow and ice!
- ▶ During all assembly and disassembly work, maintenance work and inspections, travel and crane operation is prohibited!



WARNING

Components not pinned and secured!

If a component is released from the auxiliary crane before being pinned and secured, the component will fall down! Personnel can be severely injured or killed!

- ▶ Do not detach the auxiliary crane until the respective component is pinned and secured!



WARNING

Danger of impact / crushing!

When assembling / disassembling crane components with the auxiliary crane, crane components can start to swing back and forth!

When lifting / lowering and positioning crane components, there is an increased danger of impact / crushing!

Personnel can be caught and thereby injured or killed!

- ▶ Make sure that personnel cannot be caught by components!
- ▶ When working in danger zones: Use aids to protect limbs!
- ▶ Guide components with suitable aids to minimize oscillation!



WARNING

Slipping luffing pulley block!

If the A-frame is taken down at an angle, the luffing pulley block can start to slip in the receptacle!

Personnel can be severely injured or killed!

The A-frame can be severely damaged!

- ▶ Make sure that the A-frame is taken down horizontally!
- ▶ Make sure that the luffing pulley block is always secured except for assembly / disassembly!

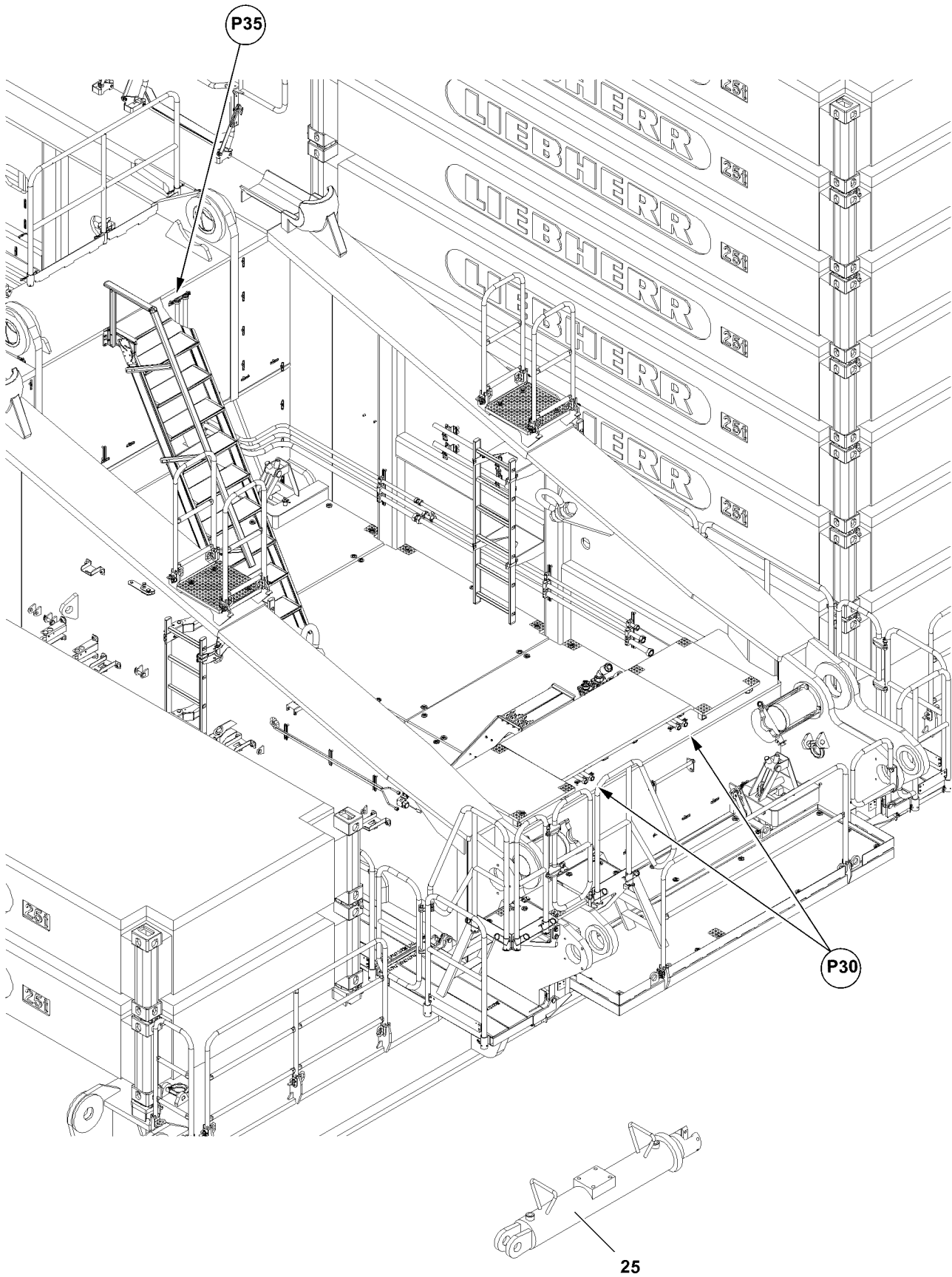

Fig.113652

LWE/LR 13000-001/19503-01-02/en

5.1 Hydraulic connections to the pin pulling cylinder



Note

- ▶ Hydraulic connection: see the Crane operating instructions, chapter 5.30.



Note

- ▶ Hydraulic connections to the „frame“ pin location, see point **P30!**
- ▶ Hydraulic connections to the „support“ pin location, see point **P35!**

5.1.1 Establishing the hydraulic connections to the pin pulling cylinder

- ▶ When connecting hydraulic lines with quick couplings, make sure that the coupling procedure is carried out correctly.



WARNING

Pressure in the hydraulic lines!

If the pressure supply is not interrupted before connecting / releasing the hydraulic lines, the hydraulic oil can escape with high pressure!

Personnel can be severely injured or killed!

- ▶ Release the pressure in the hydraulic system before connecting / disconnecting: Interrupt the pressure supply and wait a short time!
- ▶ Connect the coupling components (sleeve and connector) and screw together with the knurled nut.
- ▶ Make sure that the description on the connections matches.
- ▶ Tighten the hydraulic couplings by hand. Turn the knurled nut until it reaches a tangible, fixed stop position.
- ▶ Establish the hydraulic connection: Connect the supply lines of the pin pulling cylinder **25** to the supply lines of the turntable **R**, hydraulic connection and hydraulic connection **P**, see illustration.

5.1.2 Disconnecting the hydraulic connections from the pin pulling cylinder

- ▶ When disconnecting hydraulic lines with quick couplings, make sure that the coupling procedure is carried out correctly.



WARNING

Pressure in the hydraulic lines!

If the pressure supply is not interrupted before connecting / releasing the hydraulic lines, the hydraulic oil can escape with high pressure!

Personnel can be severely injured or killed!

- ▶ Release the pressure in the hydraulic system before connecting / disconnecting: Interrupt the pressure supply and wait a short time!
- ▶ Make sure that the hydraulic system pressure has been released.
- ▶ Unscrew and separate the coupling components (sleeve and connector) with the knurled nut.
- ▶ Disconnect the hydraulic connection: Disconnect the supply lines of the pin pulling cylinder **25** from the supply lines of the turntable **R**, hydraulic connection and hydraulic connection **P**, see illustration.

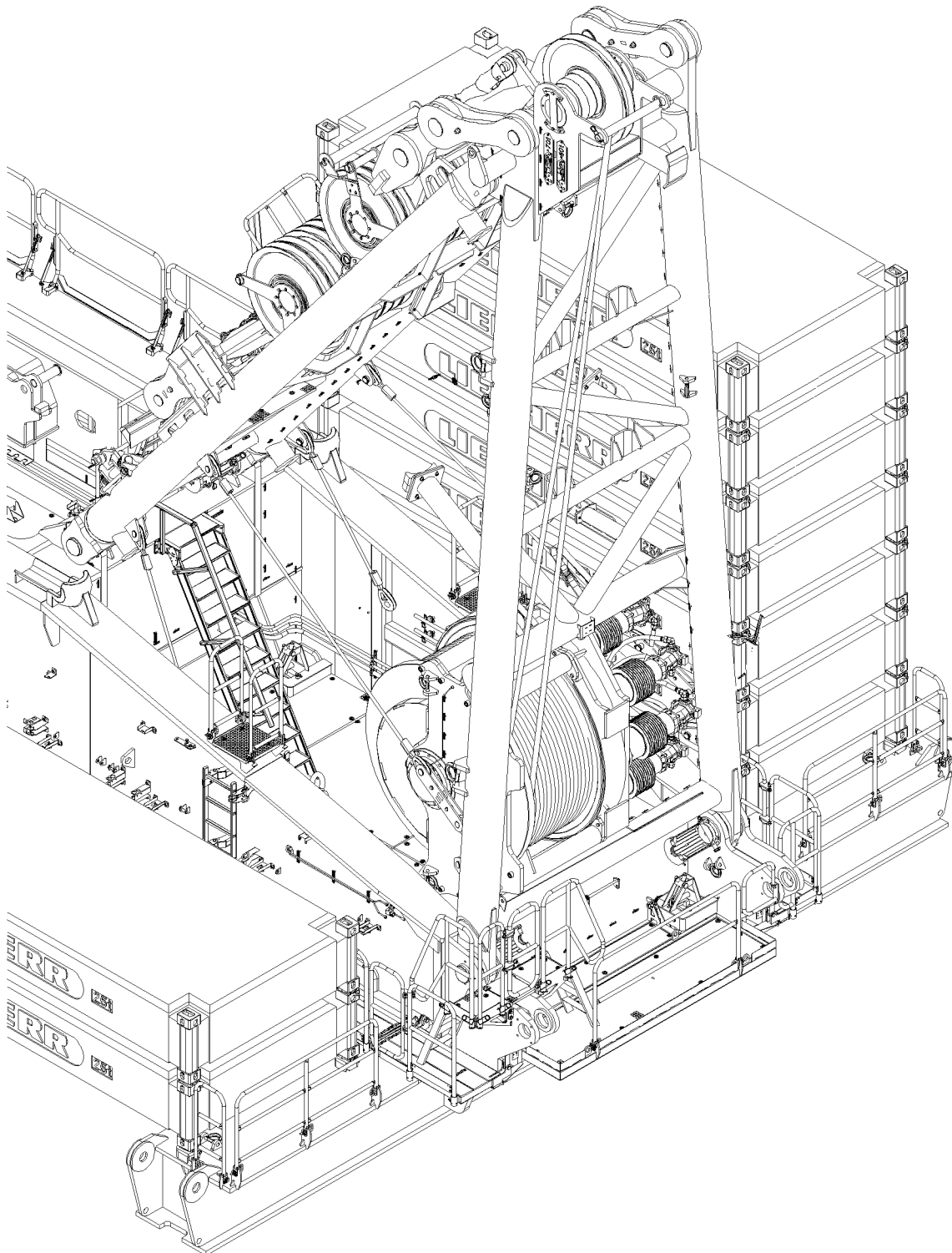

Fig.113658

LWE/LR 13000-001/19503-01-02/en

5.2 Disconnecting the connections from winch 4

Make sure that the following prerequisite is met:

- The hoist rope is spooled up completely.

5.2.1 Disconnecting the hydraulic connections from winch 4

When releasing hydraulic lines with quick couplings, make sure that the coupling procedure is carried out correctly.



WARNING

Pressure in the hydraulic lines!

If the pressure supply is not interrupted before connecting / releasing the hydraulic lines, the hydraulic oil can escape with high pressure!

Personnel can be severely injured or killed!

- ▶ Release the pressure in the hydraulic system before connecting / disconnecting: Interrupt the pressure supply and wait a short time!

-
- ▶ Make sure that the hydraulic system pressure has been released.
 - ▶ Unscrew and separate the coupling components (sleeve and connector) with the knurled nut.
 - ▶ Disconnect the hydraulic connections from winch 4.

5.2.2 Disconnecting the electrical connections from winch 4

- ▶ Disconnect the connections from winch 4.

5.2.3 Disconnecting the connections of the central lubrication system from winch 4

- ▶ Disconnect the connections from winch 4.

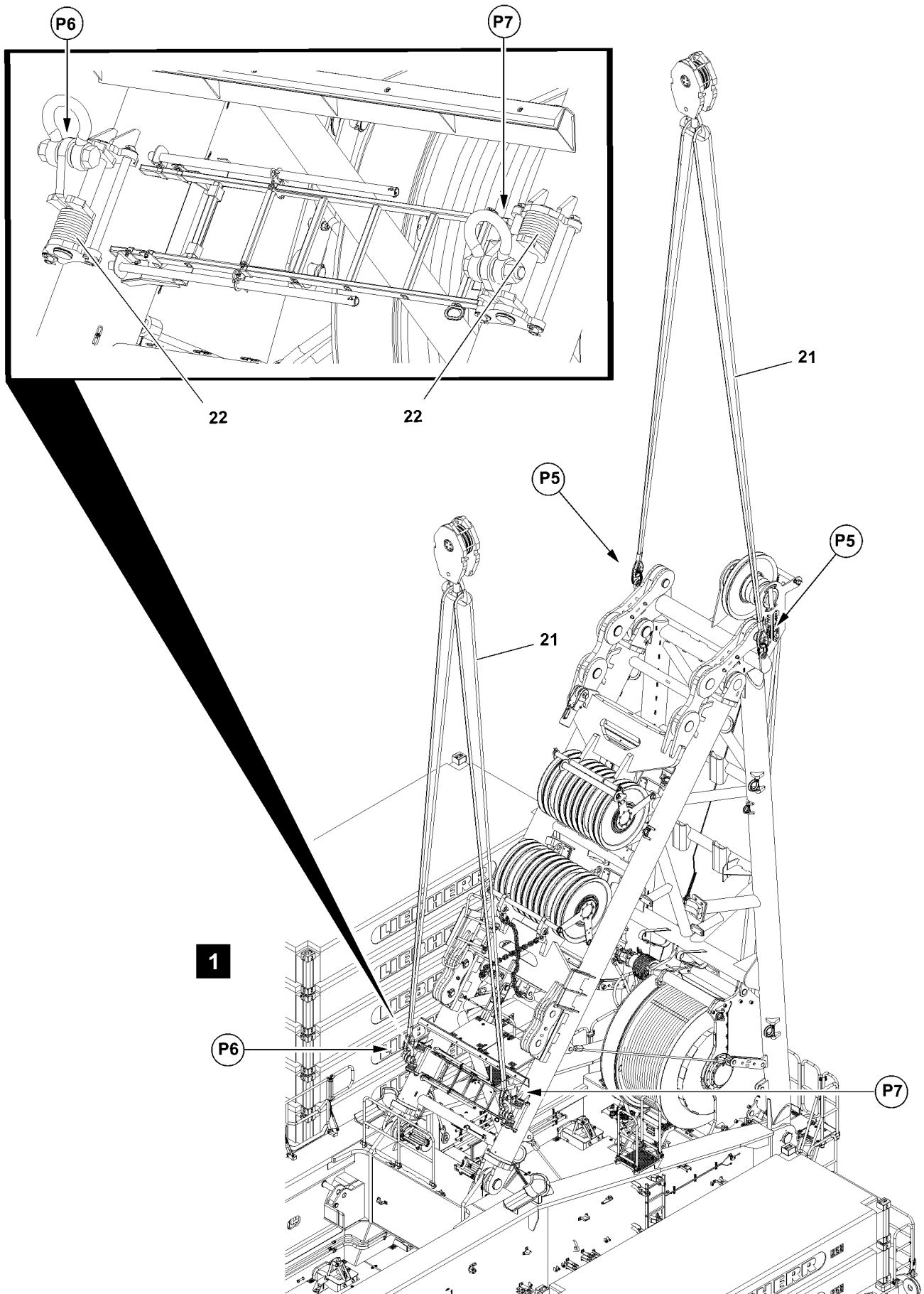

Fig.113664

LWE/LR 13000-001/19503-01-02/en

5.3 Fastening the A-frame to the auxiliary cranes

Make sure that the following prerequisites are met:

- The hydraulic connections are disconnected.
- The electrical connections are disconnected.
- The connections of the central lubrication system are disconnected.
- Two auxiliary cranes with the respective load carrying capacity are available.



WARNING

Danger of falling!

During assembly of the fastening equipment, assembly personnel must be secured with appropriate aids to prevent them from falling!

Assembly personnel can fall and be severely injured or killed!

▶ Use personal protective equipment!

-
- ▶ Move the work platform to the fastening points **P5**.
 - ▶ Fasten the fastening equipment **21** of the first auxiliary crane in points **P5**, see illustration 1.
 - ▶ Fasten the fastening equipment **21** of the second auxiliary crane in point **P6**, see illustration 1.
 - ▶ Fasten the fastening equipment **21** of the second auxiliary crane in point **P7**, see illustration 1.

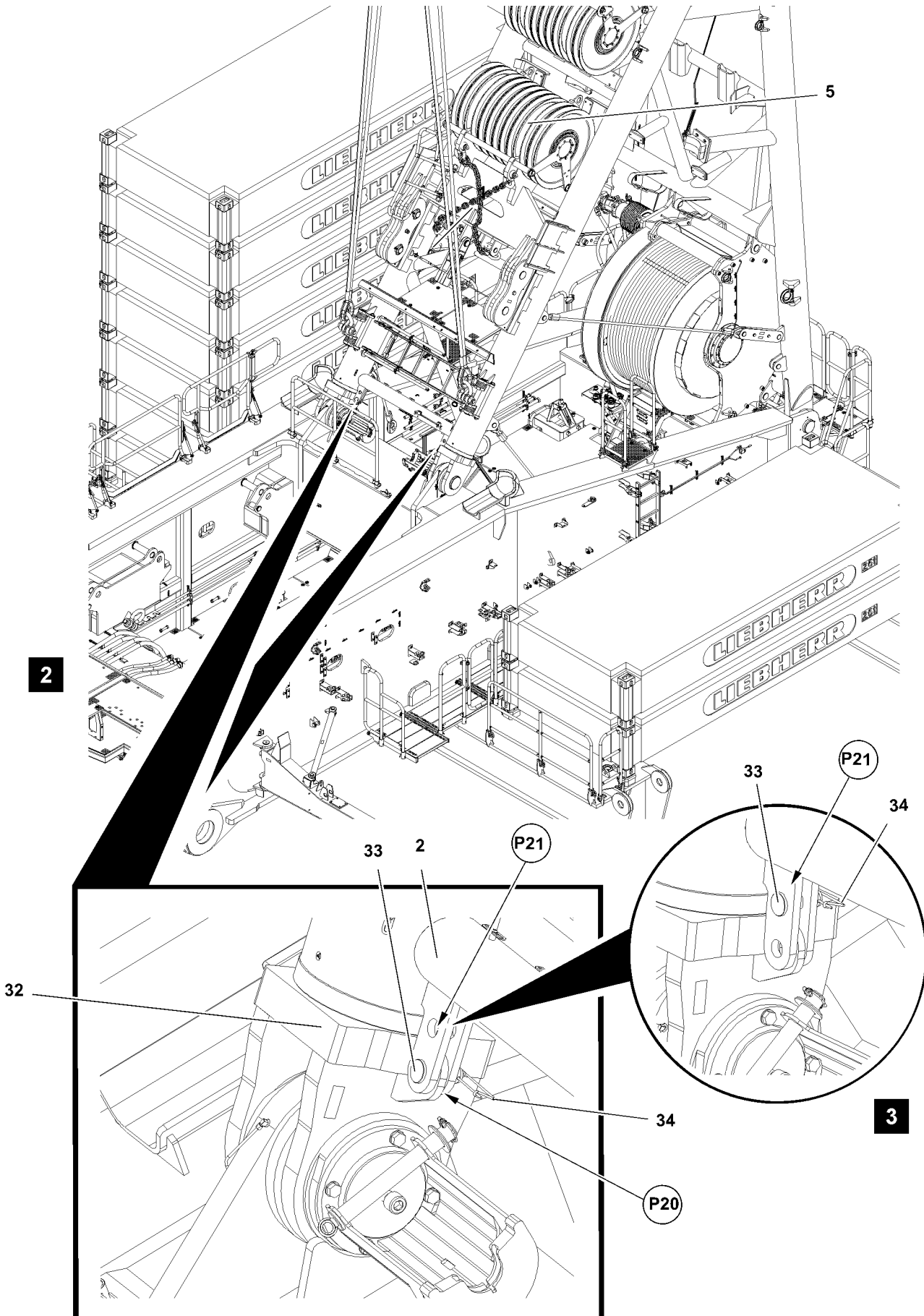

Fig.113665

LWE/LR 13000-001/19503-01-02/en

5.4 Securing the guide pipe

Make sure that the following prerequisite is met:

- The luffing pulley block is taken down.
- ▶ Remove the spring retainer **34** in point **P21** and unpin the pin **33**, see illustration **3**.



WARNING

The guide pipe drives out by itself!

When the pins **33** are not pinned in point **P20**, then the guide pipes **32** can drive out by themselves at disassembly!

Personnel can be severely injured or killed!

- ▶ Make sure that the pins **33** are inserted and secured in point **P20**!
-
- ▶ Secure the guide pipe **32**: Insert the pin **33** in point **P20** and secure with the spring retainer **34**, see illustration **2**.

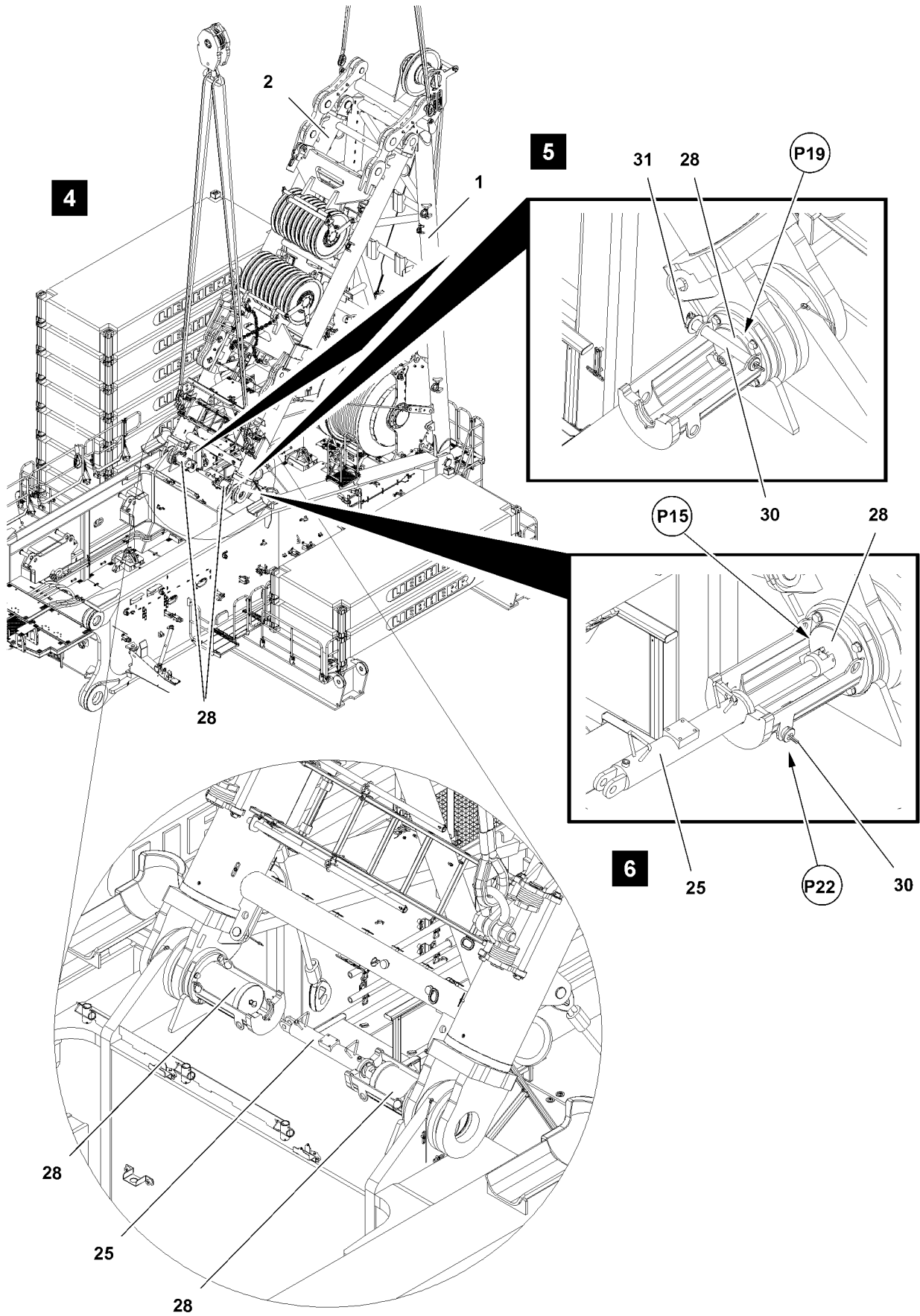

Fig.113667

LWE/LR 13000-001/19503-01-02/en

5.5 Assembling the pin pulling cylinder

- ▶ Establish the hydraulic connection in point **P35** on the „support“ pin location: Connect the supply lines of the pin pulling cylinder **25** to the supply lines of the turntable, hydraulic connection **R** and hydraulic connection **P**, see section „Hydraulic connections to the pin pulling cylinder“.
- ▶ Connect the pin pulling cylinder **25** to the „front“ in point **P15** to the pin **28** and guide with the flange into the groove of the pin retainer, see illustration **6**.

5.6 Unpinning the support on the turntable

Make sure that the following prerequisite is met:

- The guide pipes are pinned and secured.
- ▶ Tension the fastening equipment with the auxiliary crane.
- ▶ Release the pin **28**: Remove the safety locking pin **31** in point **P19** and unpin the pin **30**, see illustration **5**.
- ▶ Insert the pin **30** in point **P22** and secure with the safety locking pin **31**, see illustration **6**.
- ▶ Unpin the pin **28**: Retract the pin pulling cylinder **25**, see illustration **4**.

5.7 Disassembling the pin pulling cylinder

- ▶ Disconnect the hydraulic connection in point **P35** from the „support“ pin location: Disconnect the supply lines of the pin pulling cylinder **25** from the supply lines of the turntable, hydraulic connection **R** and hydraulic connection **P**, see section „Hydraulic connections to the pin pulling cylinder“.
- ▶ Pull the pin pulling cylinder **25** up on „front“ and unhook from the pin **28**, see illustration **4**.
- ▶ Remove the pin pulling cylinder **25**.

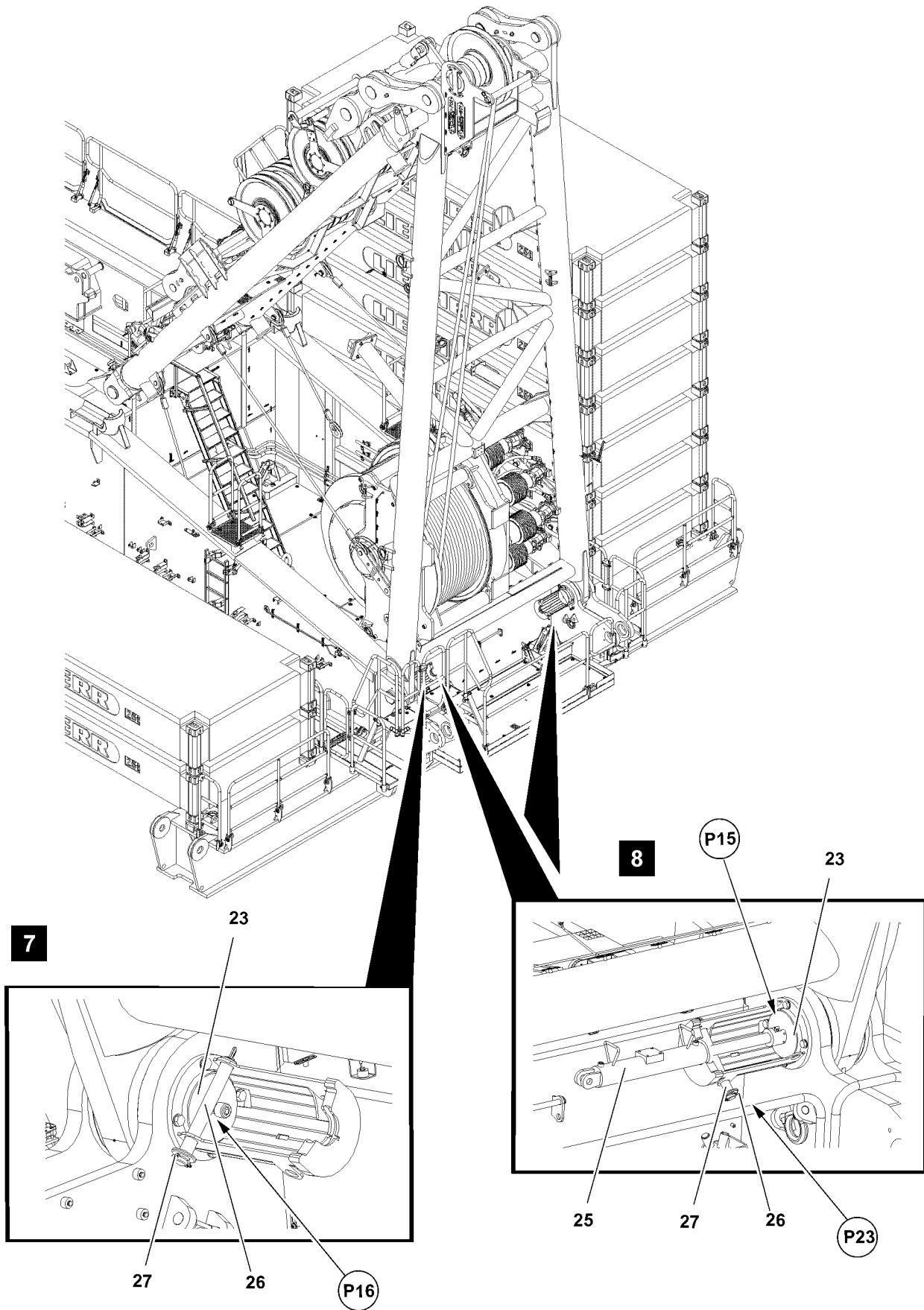

Fig.113673

5.8 Releasing the frame on the turntable

- ▶ Release the pin **23**: Remove the safety locking pin **27** in point **P16** and unpin the pin **26**, see illustration **7**.
- ▶ Insert the pin **26** in point **P23** and secure with the safety locking pin **27**, see illustration **8**.

5.9 Assembling the pin pulling cylinder

- ▶ Establish the hydraulic connection in point **P30** on the „frame“ pin location: Connect the supply lines of the pin pulling cylinder **25** to the supply lines of the turntable, hydraulic connection **R** and hydraulic connection **P**, see section „Hydraulic connections to the pin pulling cylinder“.
- ▶ Connect the pin pulling cylinder **25** to the „front“ in point **P15** to the pin **23** on both sides and guide with the flange into the groove of the pin retainer, see illustration **8**.

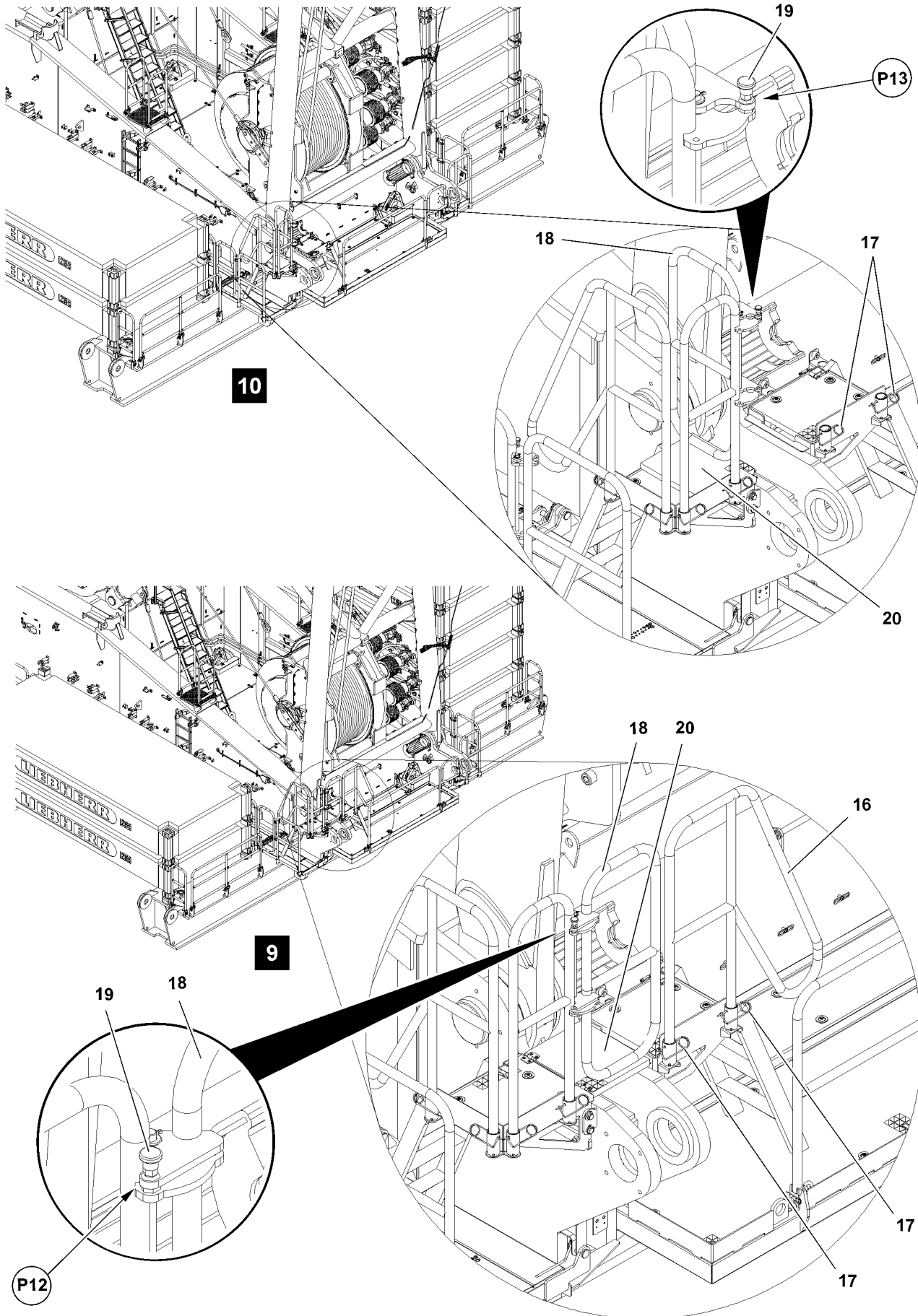

Fig.113666

LWE/LR 13000-001/19503-01-02/en

5.10 Removing the railing from the turntable



WARNING

Danger of falling!

During assembly and disassembly of the railing, personnel must be secured with appropriate aids to prevent them from falling!

Assembly personnel can fall and be severely injured or killed!

▶ Use personal protective equipment!

▶ Remove the railing **16**: Remove the spring retainers **17** and pull the railing **16** up, see illustration **9**.



WARNING

Danger of crushed limbs!

When opening the grating flap, fingers and hands can be crushed!

▶ Do not reach with your hands into the danger zone!

▶ Open the grating flap **20**, see illustration **9** and illustration **10**.



WARNING

Danger of crushed limbs!

When swinging the railings, fingers and hands can be crushed!

▶ Do not reach with your hands into the danger zone!

▶ Swing the railing **18**: Pull the detent pin **19** up in point **P12**, see illustration **9**.

▶ Swing the railing **18** in until the detent pin **19** engages in point **P13**, see illustration **10**.

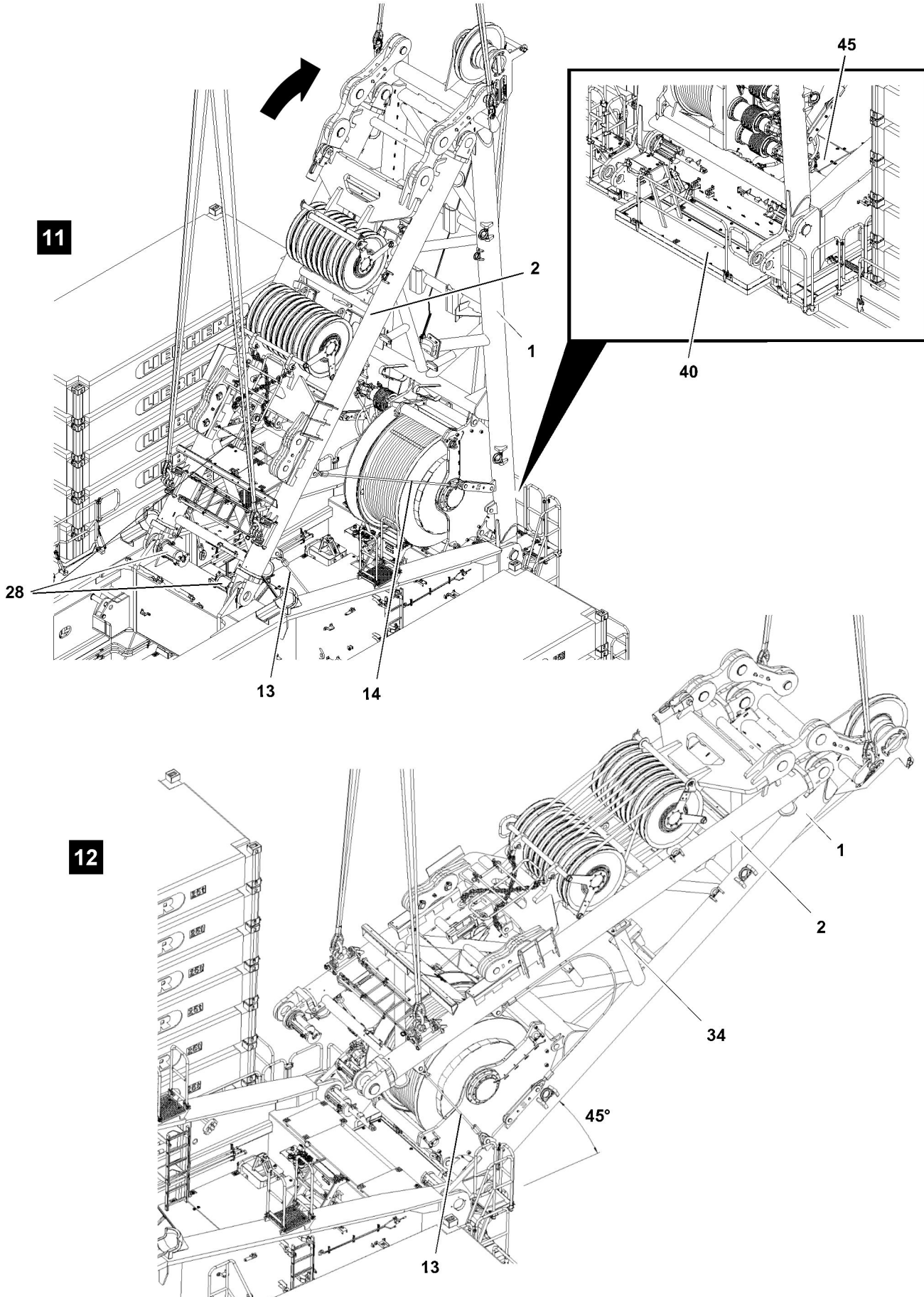

Fig.164532

LWE/LR 13000-001/19503-01-02/en

5.11 Tipping the A-frame

Make sure that the following prerequisites are met:

- The guide pipes are pinned and secured.
- The railings have been removed.



WARNING

Danger of crushing!

During disassembly of the A-frame, there is an increased crushing danger!

Personnel can be severely injured or killed!

- ▶ It is prohibited for anyone to remain on the platform **40** and on the platform **45**, see illustration **11**!
-

NOTICE

Tighten the assembly rope!

When tipping the A-frame to the rear, the A-frame can collapse!

The A-frame can be severely damaged!

- ▶ Tip the A-frame with both auxiliary cranes backward so that the assembly rope is always tight, but not overloaded!
-
- ▶ Lift the support **2** with the second auxiliary crane until the assembly ropes **14** tighten, see illustration **11**.
 - ▶ Tip the A-frame with two auxiliary cranes until the angle between the frame **1** and the horizontal is approx. 30°.

When the angle setting of the A-frame of approx. 30° is reached:

- ▶ Take the support **2** down with the second auxiliary crane on the supports **34** on the frame **1**, see illustration **12**.
- ▶ Connect the assembly rope **13** with the frame **1**, see illustration **12**.

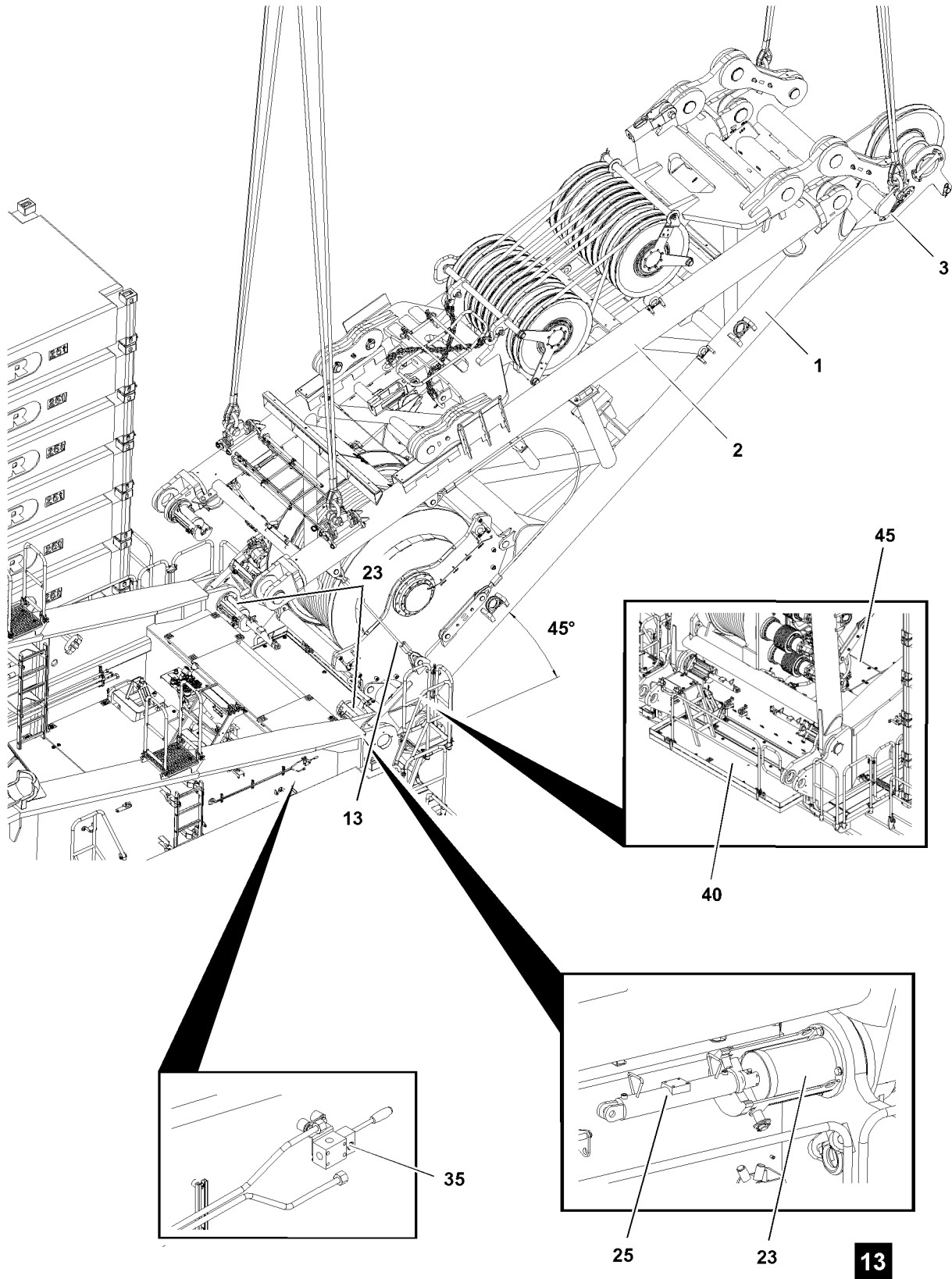

Fig.164533

LWE/LR 13000-001/19503-01-02/en

5.12 Unpinning the frame on the turntable

Make sure that the following prerequisites are met:

- The support **2** is taken down.
- The assembly ropes **13** are connected with the frame **1**.
- ▶ Retract the pin pulling cylinder **25**: Actuate the hand lever **35**.

Result:

- The pins **23** are unpinned, see illustration **13**.



WARNING

Danger of crushing!

During disassembly of the A-frame, there is an increased crushing danger!
Personnel can be severely injured or killed!

- ▶ It is prohibited for anyone to remain on the platform **40** and on the platform **45**!

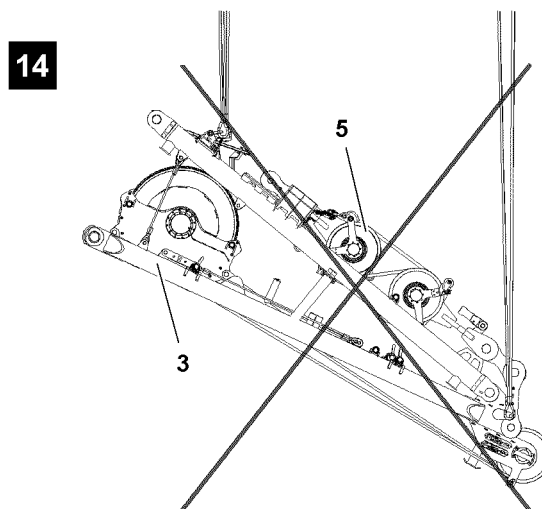

Fig.113675: Impermissible suspension



WARNING

Slipping luffing pulley block!

If the A-frame **3** is not taken down horizontally or tipped toward the tip, then the luffing pulley block **5** can slip out of the receptacle, see illustration **14**!

Personnel can be severely injured or killed!

The A-frame can be severely damaged!

- ▶ Make sure that the A-frame **3** is taken down horizontally or tipped toward the bottom section!
- ▶ Swing the A-frame with the auxiliary cranes from the turntable and take it down.

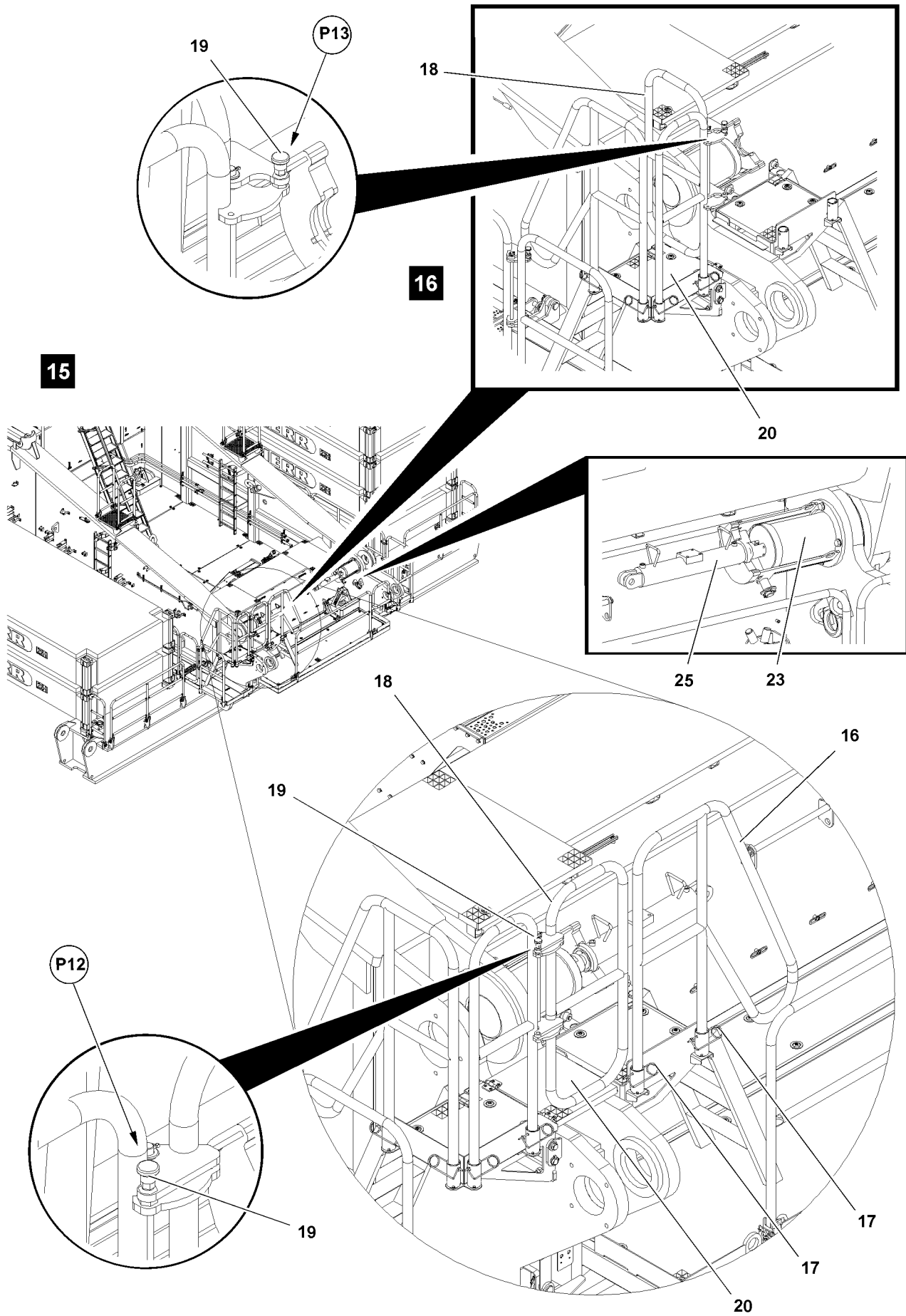

Fig.113672

LWE/LR 13000-001/19503-01-02/en

5.13 Assembling the railing on the turntable



WARNING

Danger of falling!

During assembly and disassembly of the railing, personnel must be secured with appropriate aids to prevent them from falling!

Assembly personnel can fall and be severely injured or killed!

- ▶ Use personal protective equipment!



WARNING

Danger of crushed limbs!

When swinging the railings, fingers and hands can be crushed!

- ▶ Do not reach with your hands into the danger zone!
- ▶ Swing the railing **18**: Pull the detent pin **19** up in point **P13**, see illustration **16**.
- ▶ Swing the railing **18** out until the detent pin **19** engages in point **P12**, see illustration **15**.



WARNING

Danger of crushed limbs!

When opening and closing the grating flap, fingers and hands can be crushed!

- ▶ Do not reach with your hands into the danger zone!
- ▶ Close the grating flap **20**, see illustration **15** and illustration **16**.
- ▶ Assemble the railing **16**: Insert the railing **16** into the platform and secure with spring retainers **17**, see illustration **15**.

5.14 Disassembling the pin pulling cylinder

- ▶ Disconnect the hydraulic connection in point **P30** from the „frame“ pin location: Disconnect the supply lines of the pin pulling cylinder **25** from the supply lines of the turntable, hydraulic connection **R** and hydraulic connection **P**, see section „Hydraulic connections to the pin pulling cylinder“.
- ▶ Pull the pin pulling cylinder **25** up on „front“ and unhook from the pin **23**, see illustration **15**.
- ▶ Remove the pin pulling cylinder **25**.

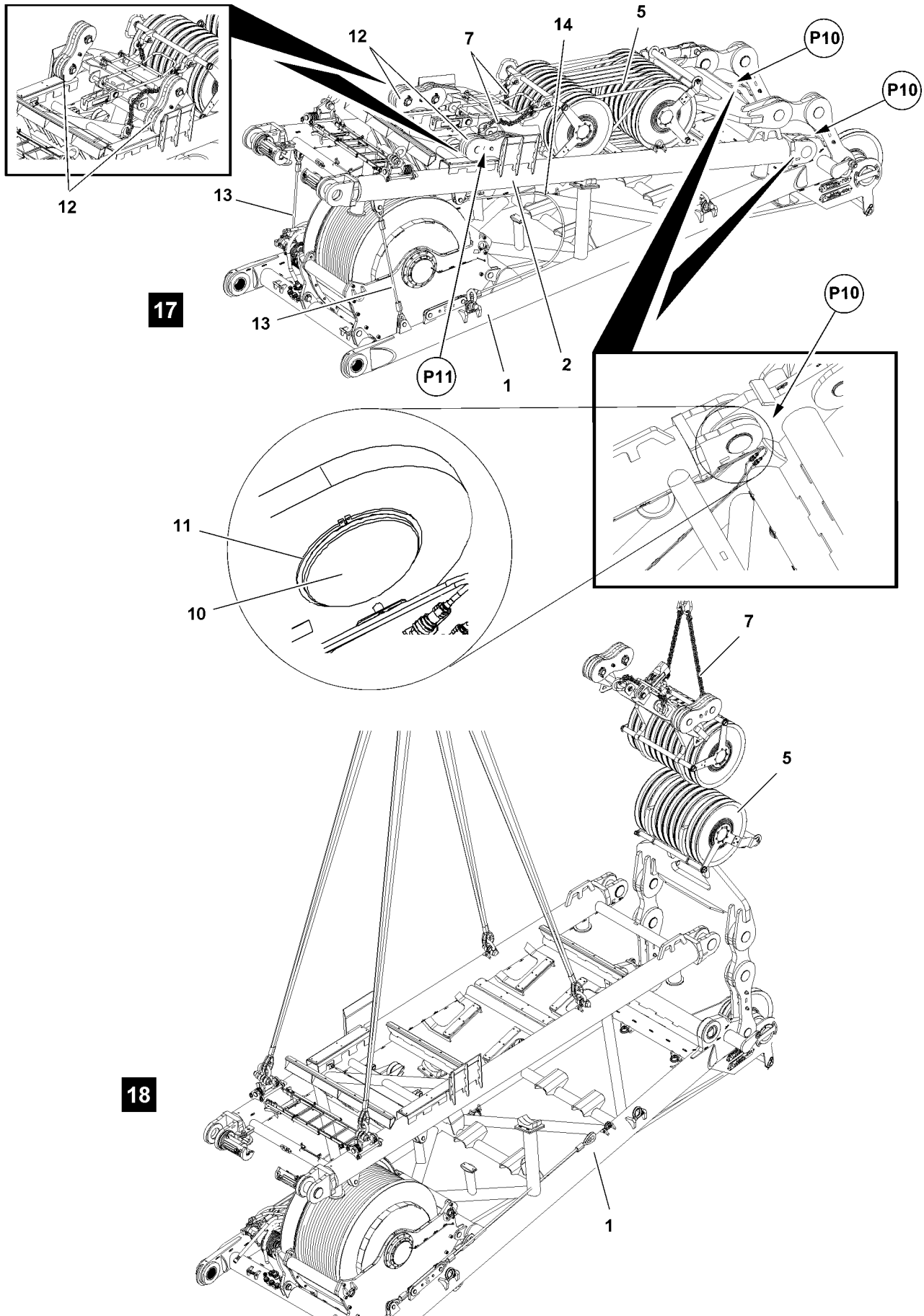

Fig.113670

LWE/LR 13000-001/19503-01-02/en

5.15 Removing the A-frame



Note

- ▶ To reduce the overall weight, the support can be removed and transported separately, see the Component overview!
- ▶ If the A-frame is transported complete, the following steps are eliminated!

- ▶ Remove the assembly ropes **14** between the frame **1** and support **2**, see illustration **17**.
- ▶ Remove the assembly ropes **13** between the frame **1** and support **2**, see illustration **17**.



Note

- ▶ The weight of the luffing pulley block **5** is approximately 17 t!

- ▶ Connect the fastening equipment with the chains **7**.



WARNING

Damage to the winch!

If the connector brackets **12** are not raised, then they can collide with winch 4 when taking the frame **1** down!

This can result in damage to winch 4 and the connector brackets **2**!

- ▶ Make sure that the connector brackets **12** are raised!
- ▶ Raise the connector brackets **12** in points **P11** with the auxiliary crane, see illustration **17**.
- ▶ Lift the luffing pulley block **5**, see illustration **18**.
- ▶ Fasten the fastening equipment of the second auxiliary crane to the support **2**.
- ▶ Tension the fastening equipment with the auxiliary crane.
- ▶ Unpin the support **2**: Remove the retaining ring **11** in points **P10** and unpin the pin **10**, see illustration **17**.
- ▶ Lift the support **2** and take it down on the transport vehicle, see illustration **18**.

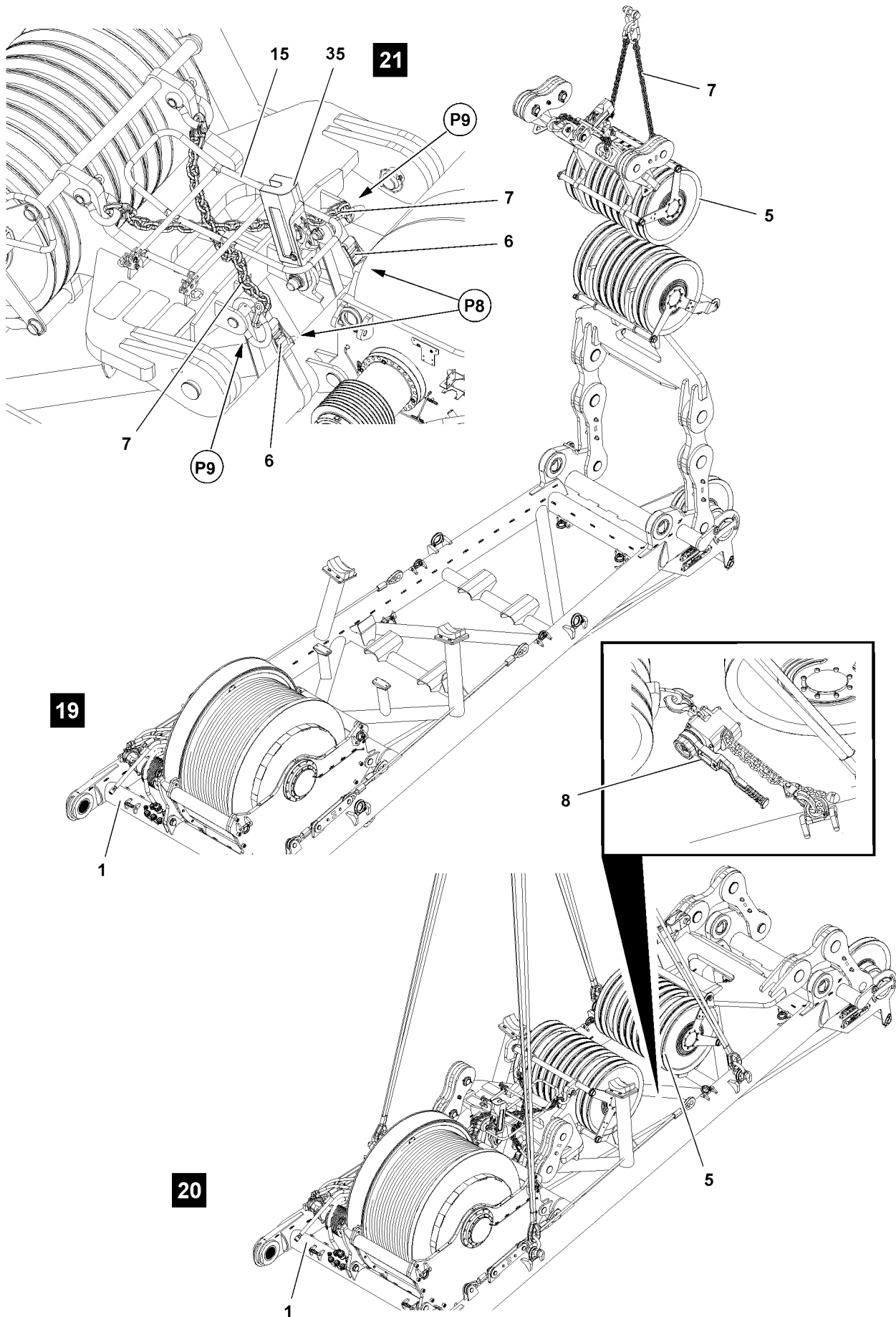

Fig.113671

LWE/LR 13000-001/19503-01-02/en

- ▶ Take the luffing pulley block **5** down on the frame **1**, see illustration **19**.
- ▶ Secure the luffing pulley block **5** on the frame **1** with the aid of the ratchet **8**, illustration **20**.
- ▶ Secure the chains **7** in points **P9**, see illustration **21**.
- ▶ Secure the luffing pulley block **5** in points **P8** on the frame **1** with the aid of the tension belts **6**, see illustration **21**.
- ▶ Raise the lock **35**, see illustration **21**.

**Note**

- ▶ Observe and adhere to the assembly and safety instructions for the railings, see the Crane operating instructions, chapter 2.06!
-
- ▶ Swing the railing **15**, see illustration **21**, from the operating position into the transport position, see the Crane operating instructions, chapter 2.06.

Empty page!

LWE/LR 13000-001/19503-01-02/en

3.06 Assembly conditions

1 Assembly configurations on the crawler carrier

3

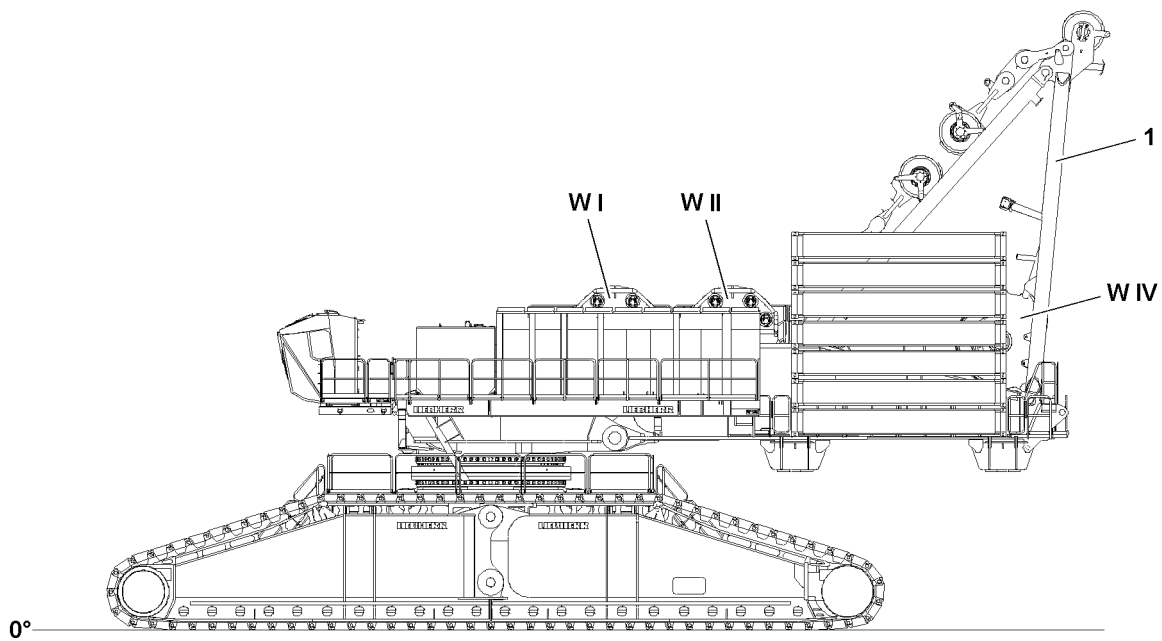

Fig.116326

1 Assembly configurations on the crawler carrier

1.1 Permissible counterweight / permissible central ballast



WARNING

Impermissible travel operation!

If the assembly configuration is not specifically approved for travel operation, the crane can tip over while driving if in the assembly configuration.

If a pivot section is installed lying on the ground, a crane can be severely damaged in the assembly configuration when driving.

Death, severe bodily injuries, property damage.

- ▶ Only approved assembly configurations are permitted for travel operation.
- ▶ Assembly configurations with an installed pivot section ballast are not permitted for travel operation.

The following components are taken into account in the assembly configurations or installed on the turntable:

- 1 A-frame
- Winch 4 **W IV** with rope



Note

- ▶ In addition, winch 1 **W I** and winch 2 **W II** - including the rope - can be assembled within the assembly configurations.



WARNING

The crane can topple over!

Within the assembly configurations of 750 t, a counterweight is placed on the turntable, the crane can topple over!

Personnel can be severely injured or killed.

Before placing the 750 t counterweight:

- ▶ Make sure that the maximum central ballast is assembled on the crane, see the Crane operating instructions, chapter 3.03.
- ▶ Make sure that the derrick boom is installed, see Crane operating instructions, chapter 5.05.
- ▶ Make sure that the main boom is installed, see the Crane operating instructions, chapter 5.39 / 5.44.
- ▶ Make sure that the guying of the main boom that is still on the ground is properly assembled.
- ▶ Make sure that the SD-guying - from the derrick boom to the main boom - is tensioned before placing the 750 t counterweight.

Assembly configuration	Ballast combinations		Total weight	Maximum ground pressure
	Counterweight	Central ballast		
1 ¹⁾	0 t	0 t	920 t	310 kN/m ²
2 ¹⁾	400 t	0 t	1270 t	633 kN/m ²
3	400 t	150 t	1420 t	660 kN/m ²
4 ^{1), 2)}	500 t	150 t	1520 t	750 kN/m ²

Counterweight / central ballast depending on the assembly configuration

1) Anticipatory driving is possible in this assembly configuration up to an incline of 0.3°.

2) Central ballast must be assembled, then position the counterweight.

Empty page!

LWE/LR 13000-001/19503-01-02/en

3.07.10 Winch 1 assembly

1	Component overview	3
2	Fastening points for winch 1	3
3	Installing the winch	5
4	Removing the winch	15

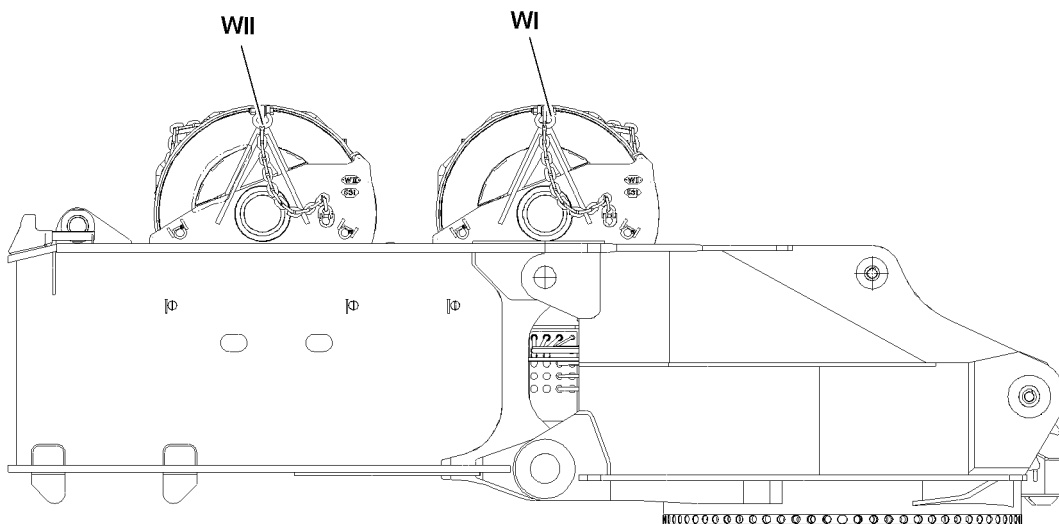
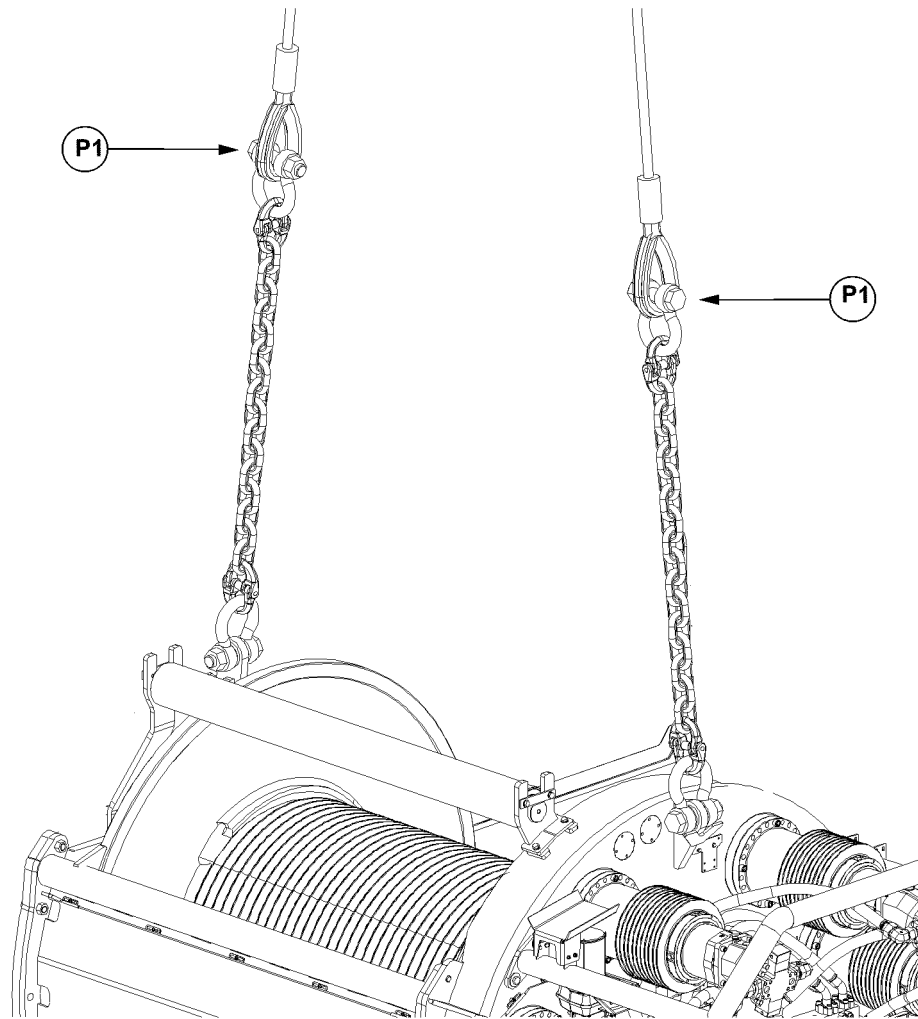

Fig.113638

LWE/LR 13000-001/19503-01-02/en

1 Component overview



Note

- ▶ The assembly sections are marked with their own weights!



Note

- ▶ Dimensions and weights, see Crane operating instructions, chapter 1.03!

1.1 Winch 1

Position	Component
W I	Winch 1

2 Fastening points for winch 1



WARNING

Component incorrectly attached!

Life-threatening situations can arise due to improper or incorrect attachment of the corresponding components!

Personnel can be severely injured or killed!

- ▶ The chains for the winch may not be directly fastened on the crane hook, rather they must always be extended with additional fastening equipment between chain and hook!
- ▶ Attach the components only on the intended fastening points on both sides!
- ▶ Fastening of components and description of fastening points, see Crane operating instructions, chapter 5.01!

Fastening points	
P1	Winch 1

Fig.195219

LWE/LR 13000-001/19503-01-02/en

3 Installing the winch



WARNING

Danger of falling!

During assembly / disassembly work, personnel must be secured with appropriate aids to prevent them from falling. If this is not observed, assembly personnel can fall and suffer life-threatening or fatal injuries!

- ▶ Any assembly work, where there is a danger of falling must be carried out with suitable aids (for example lifting platform, scaffolding, ladder, auxiliary crane)!
- ▶ If the work cannot be carried out with such aids nor from the ground, then the assembly personnel must secure themselves with approved fall arrest systems to avoid falling, see Crane operating instructions, Chapter 2.04!
- ▶ Approved fall arrest systems must be hung into the respective fastening points on the crane, see Crane operating instructions, chapter 2.06!
- ▶ If railings are present on the components, then they must be brought into the corresponding position and secured for assembly / disassembly work!
- ▶ Step on aids and fall protection equipment only with clean shoes!
- ▶ Keep aids and fall protection equipment clean and free from snow and ice!
- ▶ During all assembly and disassembly work, maintenance work and inspections, travel and crane operation is prohibited!



WARNING

Components not pinned and secured!

If a component is released from the auxiliary crane before having been pinned and secured, the component will fall down! Personnel can be severely injured or killed!

- ▶ Do not disengage the auxiliary crane until the corresponding component is pinned and secured!



WARNING

Danger of impact / crushing!

When installing / removing crane components with the auxiliary crane, crane components can start to swing back and forth!

When lifting / lowering and positioning crane components, there is an increased danger of impacts / crushing!

Personnel can be caught and severely injured or killed!

- ▶ Make sure that personnel cannot be caught by components!
- ▶ When working in danger zones: Use aids to protect limbs!
- ▶ Guide components with suitable aids to minimize oscillation!

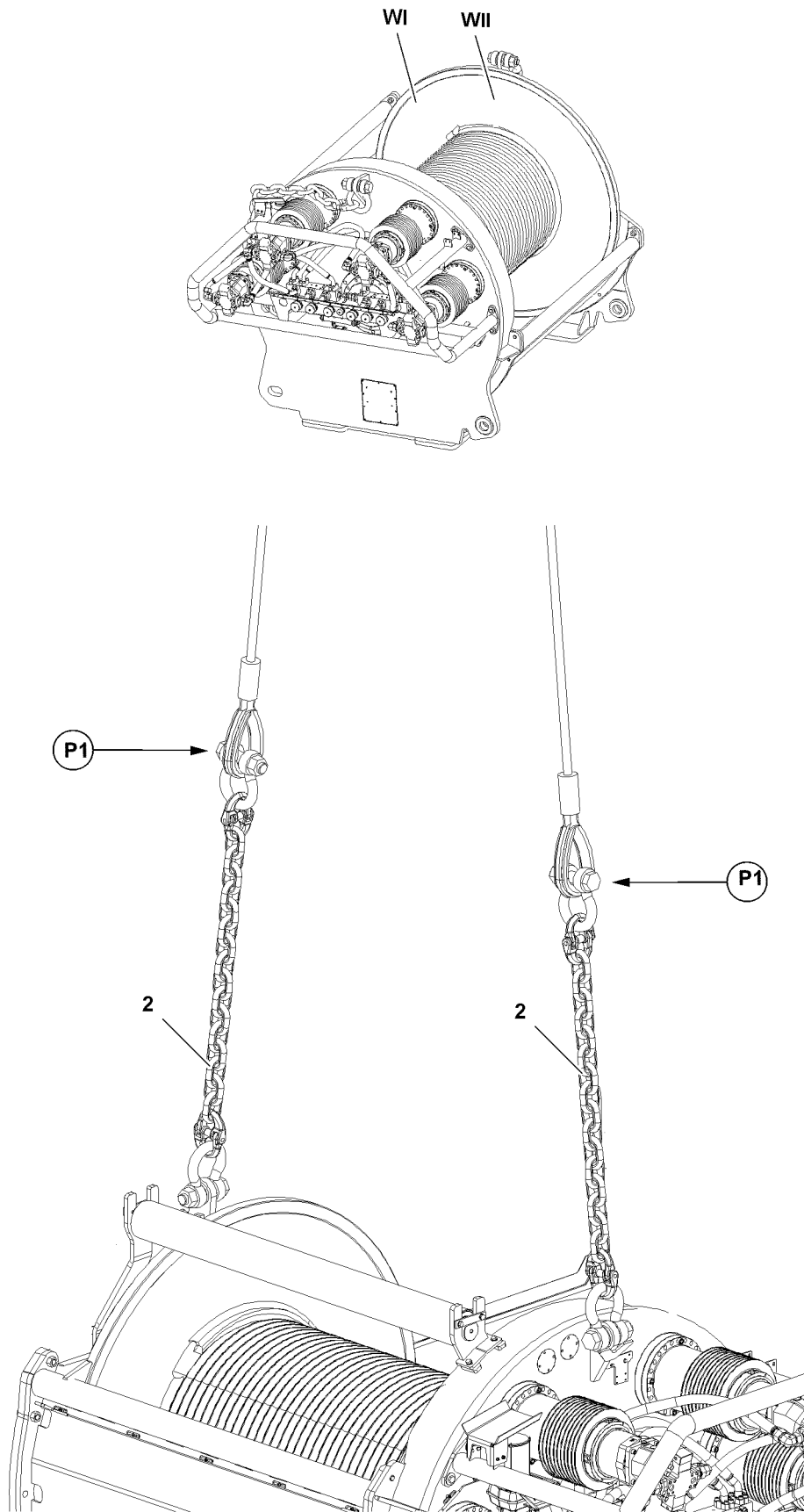

Fig.113639

LWE/LR 13000-001/19503-01-02/en

3.1 Assembling winch 1

3.1.1 Lifting winch 1 from the flatbed trailer

Make sure that the following prerequisites are met:

- The installation of the turntable is completed.
- The crane is aligned in horizontal direction.
- An auxiliary crane with sufficient load carrying capacity is available.



WARNING

Danger of accident due to incorrect attachment!

Life-threatening situations can arise if the winch 1 is incorrectly or improperly attached!

Personnel can be severely injured or killed!

- ▶ Winch 1 must be attached on the intended chains **2** at point **P1**!
 - ▶ Make sure that the fastening equipment is correctly attached on winch 1 and that it is secured sufficiently to prevent it from loosening up!
-
- ▶ Attach the fastening equipment on the chains **2** at point **P1**.
 - ▶ Bring the fastening equipment to „tension“.
 - ▶ Release and remove the transport retainers on the flatbed trailer.



WARNING

Falling components!

When lifting winch 1 from the flatbed trailer, components or winch 1 can fall down!

Personnel can be severely injured or killed!

- ▶ Make sure that there are no persons within the danger zone!
-
- ▶ Lift winch 1 with the auxiliary crane from the flatbed trailer.

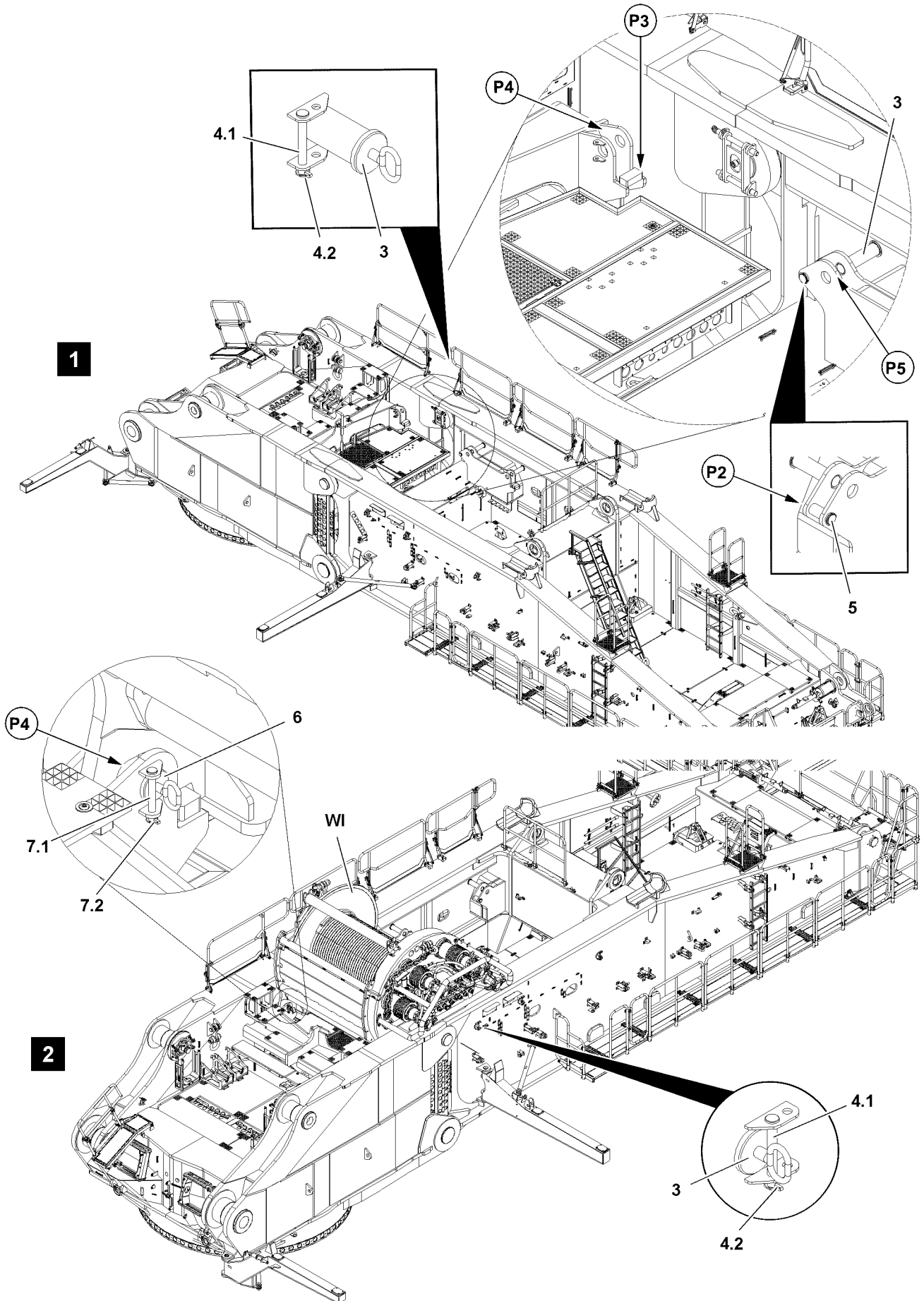

Fig.113640

LWE/LR 13000-001/19503-01-02/en

3.1.2 Positioning winch 1

Make sure that the following prerequisite is met:

- The pin bores are clear.



WARNING

Danger of accident when swinging in and lowering winch 1!

When swinging in and lowering winch 1 on the turntable, limbs can be crushed or even severed!

Personnel can be severely injured or killed!

- ▶ Make sure that there are no persons within the danger zone!
 - ▶ Do not reach with your hands into the danger zone!
-

NOTICE

Property damage!

If the following note is not observed, damage can result to the crane or winch 1!

- ▶ When retracting winch 1, it must be ensured that winch 1 does not hit against the turntable!
-



Note

- ▶ The guide must be in constant visual and acoustic contact with the crane operator!
-



Note

- ▶ Make sure that the alignment of winch 1 or the receptacles to the centering pins **5** at point **P2** on the turntable is exact, see illustration **1**!
 - ▶ Before lowering, bring winch 1 into position that the receptacles are over the centering pins **5** at point **P2** on the turntable!
-

- ▶ Retract winch 1 with the auxiliary crane.

- ▶ Lower winch 1 slowly.

When winch 1 is aligned:

- ▶ Carefully set winch 1 on the centering pins **5** at point **P2** and on the receptacle plates at point **P3** on the turntable, see illustration **1**.

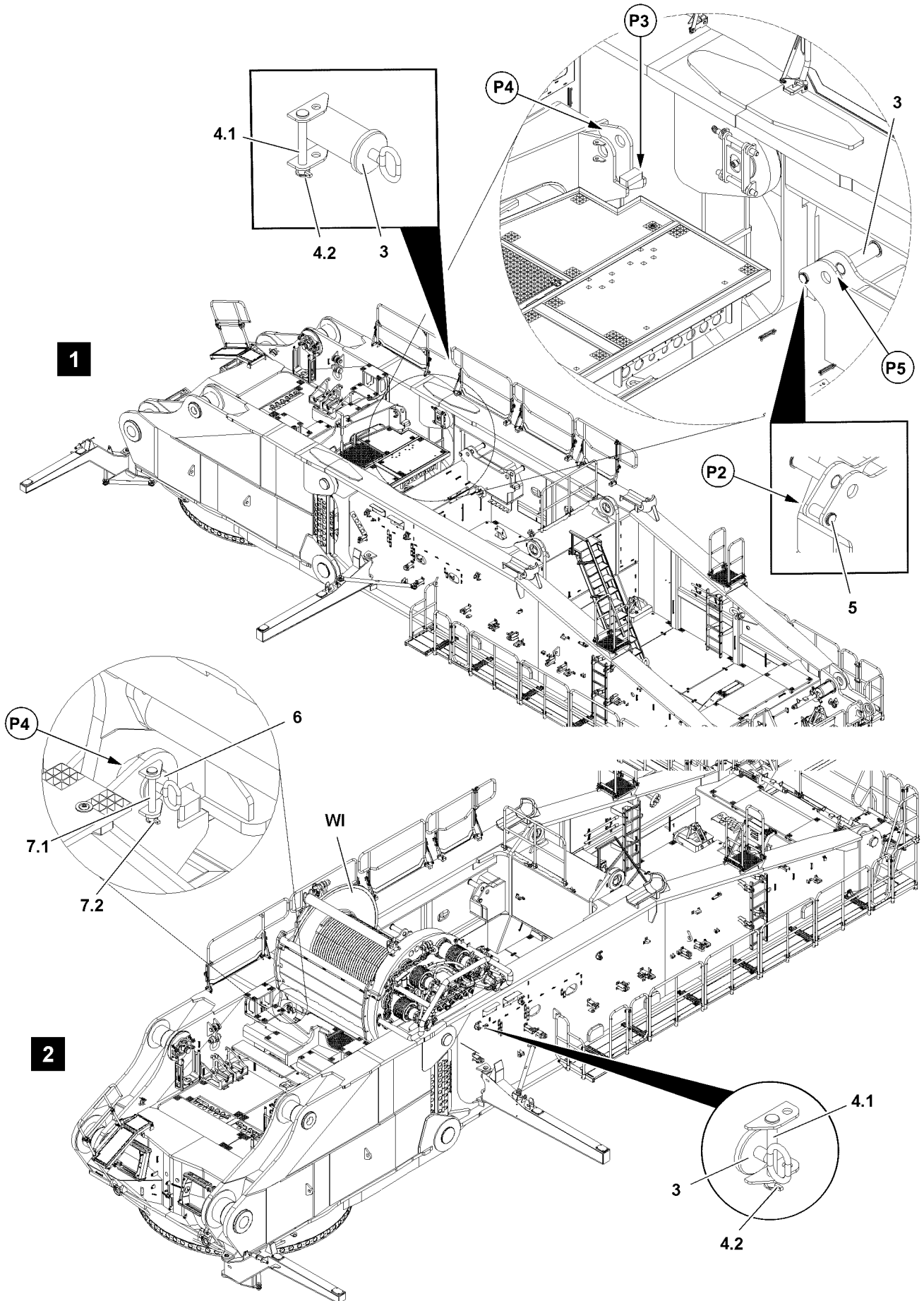

Fig.113640

LWE/LR 13000-001/19503-01-02/en

3.1.3 Pinning winch 1

Make sure that the following prerequisites are met:

- Winch 1 is seated on the centering pins **5**, point **P2**.
 - Winch 1 is laying on the receptacle plates, point **P3**
- ▶ Insert pins **6** on both sides at point **P4** on the turntable, see illustration **2**.



WARNING

The pins can loosen up by themselves!

- ▶ Secure pins **6** immediately after pinning with pins **7.1**!
-

When the pins **6** are completely pinned on both sides on the turntable:

- ▶ Insert the pin **7.1** and secure with locking pin **7.2**, see illustration **2**.
- ▶ Insert pins **3** on both sides at point **P5** on the turntable, see illustration **2**.
-

**WARNING**

The pins can loosen up by themselves!

- ▶ Secure pins **3** immediately after pinning with pins **4.1**!
-

When the pins **3** are completely pinned on both sides on the turntable:

- ▶ Insert the pin **4.1** and secure with locking pin **4.2**, see illustration **2**.
- ▶ Remove the fastening equipment on winch 1.

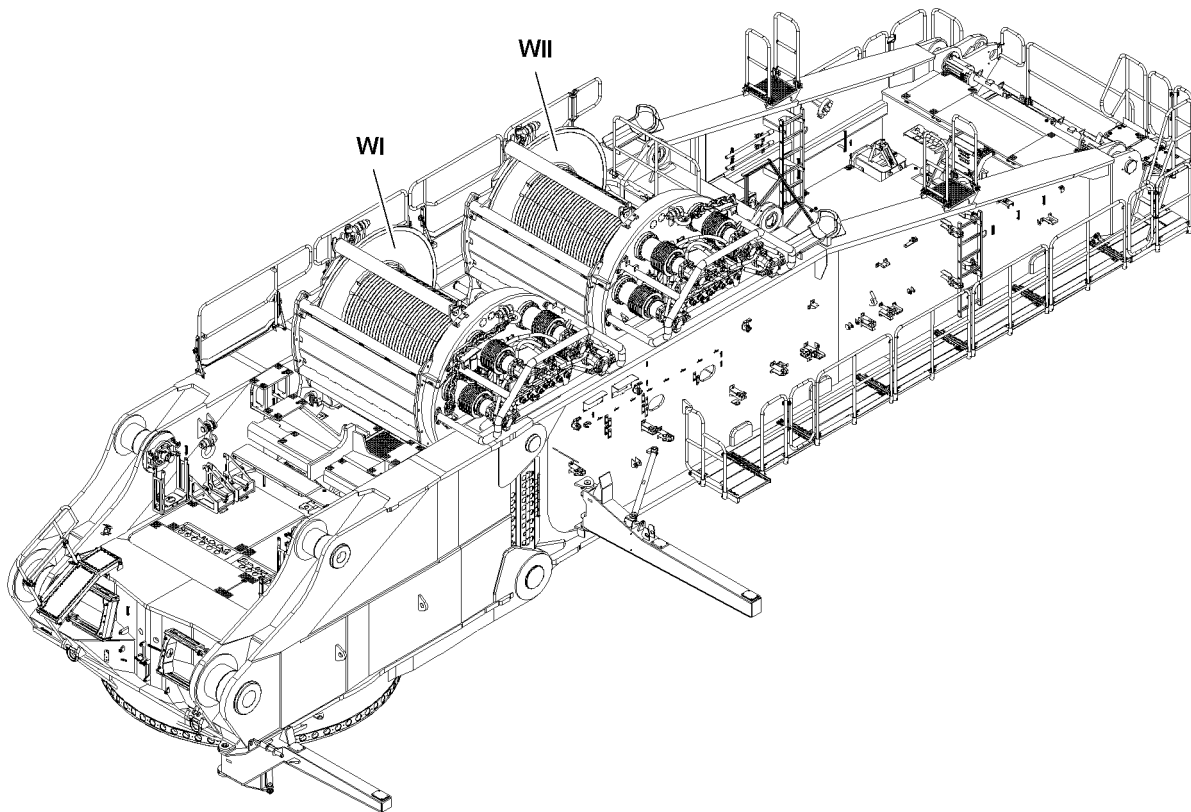

Fig.113641

3.2 Establishing the connections to the winch



Note

- ▶ Establish the connections to the winch only when the engine house is installed!

Make sure that the following prerequisites are met:

- The winch is properly installed, pinned and secured.
- The engine house is installed.

3.2.1 Establishing the hydraulic connections to the winch



Note

- ▶ After the hydraulic connections to the winch are established, the expansion tank must be checked and emptied!

The hydraulic connections for the winch are made with quick couplings.

When connecting hydraulic lines with quick-release couplings, make sure that the coupling procedure is carried out correctly.



WARNING

Pressure in the hydraulic lines!

If the pressure supply is not interrupted before connecting / releasing the hydraulic lines, the hydraulic oil can escape with high pressure!

Personnel can be severely injured or killed!

- ▶ Release the pressure in the hydraulic system before connecting / disconnecting: Interrupt the pressure supply and wait for a short time!



WARNING

Loss of pressure or leakage!

Incorrectly coupled or self-loosening quick-release couplings (particularly return lines) can result in serious accidents due to component failure!

- ▶ Check that the quick couplings have been properly connected before using the crane!
- ▶ Connect the coupling components (sleeve and connector) and screw together with the hand-tightened nut.
- ▶ Tighten the hydraulic coupling by hand. Rotate the hand-tightened nut until it reaches a tangible, fixed stop position.
- ▶ Establish the hydraulic connections to the winch.

3.2.2 Establishing the connections to the winch

- ▶ Establish the electrical connections to the winch, see Electrical wiring diagram.

3.2.3 Establishing the connections for the central lubrication system to the winch

- ▶ Establish the connections for the central lubrication system to the winch.

Fig.195219

LWE/LR 13000-001/19503-01-02/en

4 Removing the winch



WARNING

Danger of falling!

During assembly / disassembly work, personnel must be secured with appropriate aids to prevent them from falling. If this is not observed, assembly personnel can fall and suffer life-threatening or fatal injuries!

- ▶ Any assembly work, where there is a danger of falling must be carried out with suitable aids (for example lifting platform, scaffolding, ladder, auxiliary crane)!
- ▶ If the work cannot be carried out with such aids nor from the ground, then the assembly personnel must secure themselves with approved fall arrest systems to avoid falling, see Crane operating instructions, Chapter 2.04!
- ▶ Approved fall arrest systems must be hung into the respective fastening points on the crane, see Crane operating instructions, chapter 2.06!
- ▶ If railings are present on the components, then they must be brought into the corresponding position and secured for assembly / disassembly work!
- ▶ Step on aids and fall protection equipment only with clean shoes!
- ▶ Keep aids and fall protection equipment clean and free from snow and ice!
- ▶ During all assembly and disassembly work, maintenance work and inspections, travel and crane operation is prohibited!



WARNING

Components not pinned and secured!

If a component is released from the auxiliary crane before having been pinned and secured, the component will fall down! Personnel can be severely injured or killed!

- ▶ Do not disengage the auxiliary crane until the corresponding component is pinned and secured!



WARNING

Danger of impact / crushing!

When installing / removing crane components with the auxiliary crane, crane components can start to swing back and forth!

When lifting / lowering and positioning crane components, there is an increased danger of impacts / crushing!

Personnel can be caught and severely injured or killed!

- ▶ Make sure that personnel cannot be caught by components!
- ▶ When working in danger zones: Use aids to protect limbs!
- ▶ Guide components with suitable aids to minimize oscillation!

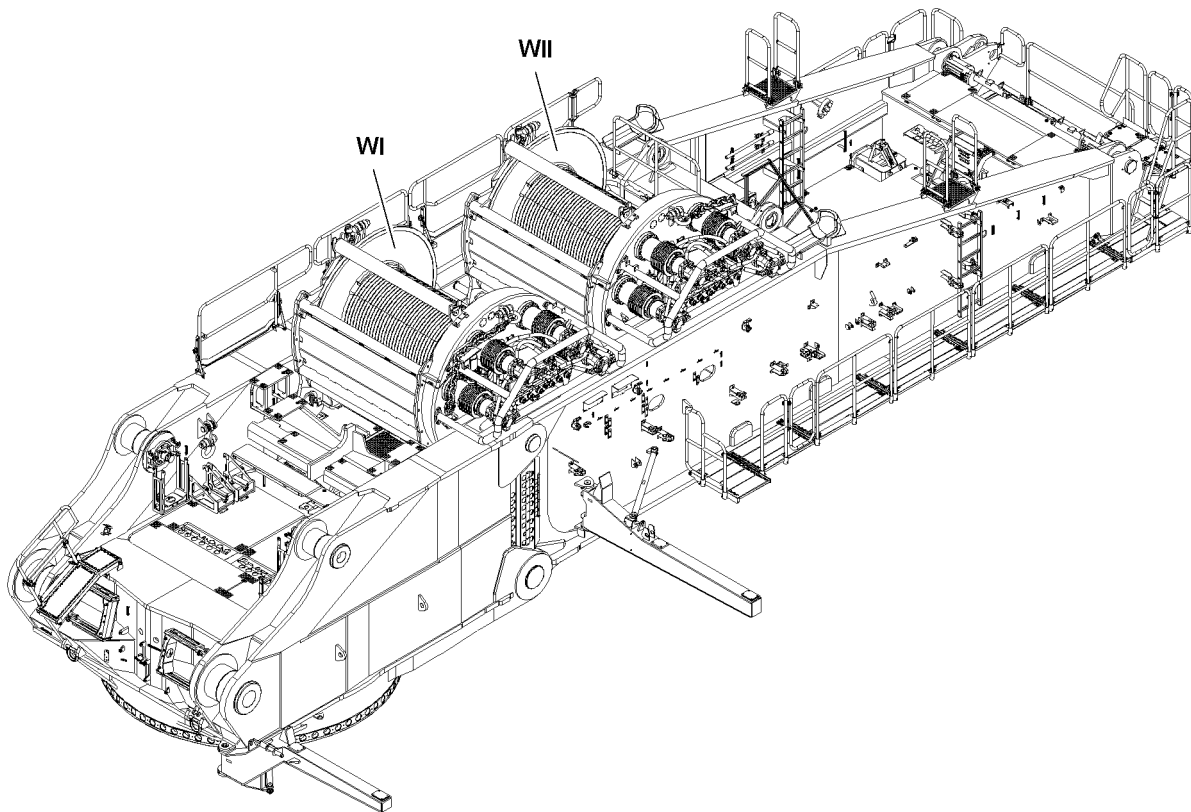

Fig.113641

4.1 Disconnecting the connections to the winch

Make sure that the following prerequisite is met:

- The rope is spooled up completely.

4.1.1 Disconnecting the hydraulic connections to the winch

When releasing hydraulic lines with quick-release couplings, make sure that the uncoupling procedure is carried out correctly.



WARNING

Pressure in the hydraulic lines!

If the pressure supply is not interrupted before connecting / releasing the hydraulic lines, the hydraulic oil can escape with high pressure!

Personnel can be severely injured or killed!

- ▶ Release the pressure in the hydraulic system before connecting / disconnecting: Interrupt the pressure supply and wait for a short time!
-
- ▶ Release the hydraulic coupling by hand.
 - ▶ Disconnect the hydraulic connections to the winch.

4.1.2 Disconnecting the electrical connections to the winch

- ▶ Disconnect the electrical connections to the winch.

4.1.3 Disconnecting the connections for the central lubrication system to the winch

- ▶ Disconnect the connections to the winch.

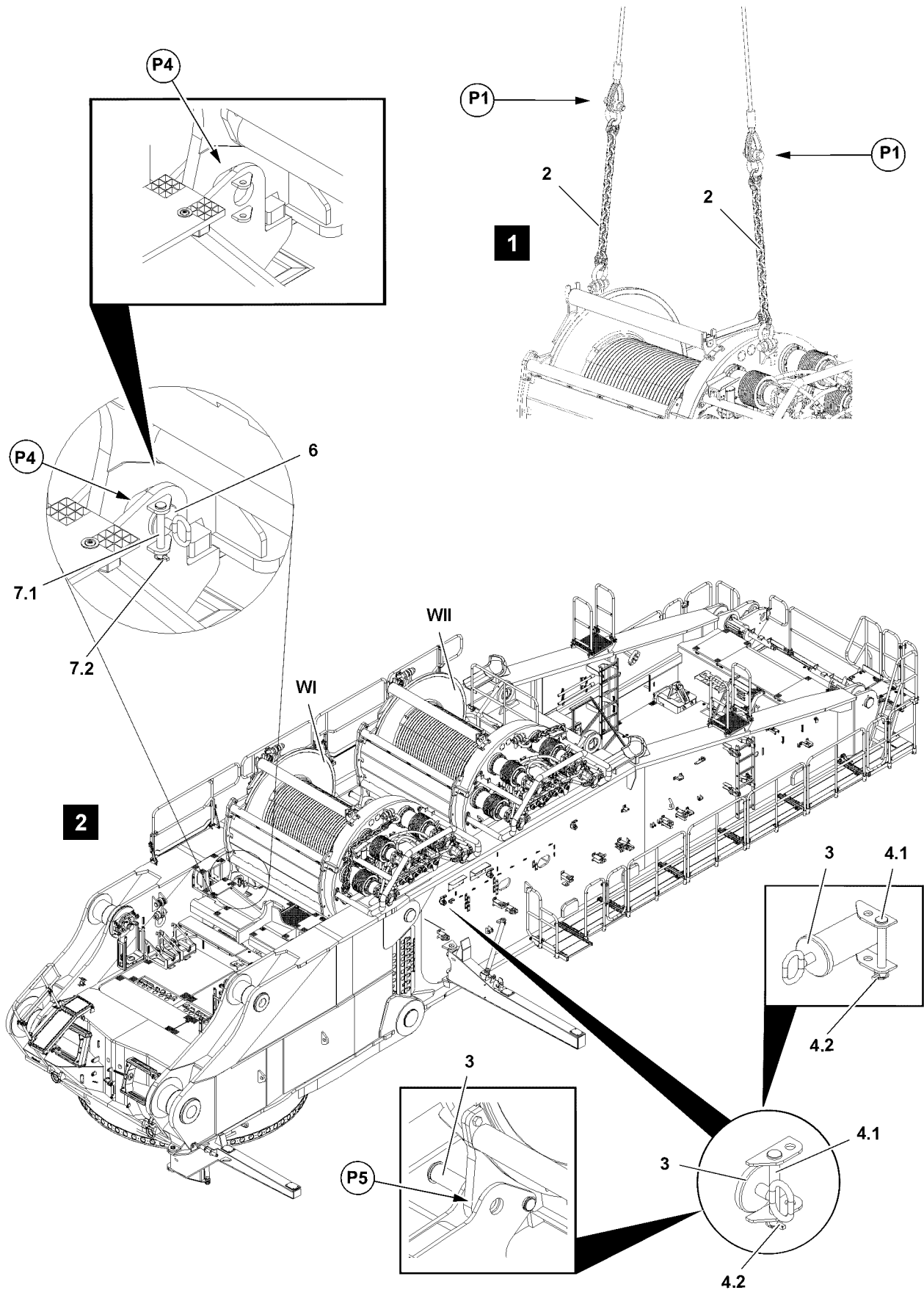

Fig.113643

LWE/LR 13000-001/19503-01-02/en

4.2 Removing winch 1

4.2.1 Unpinning winch 1

Make sure that the following prerequisites are met:

- The hydraulic connections are disconnected.
- The electrical connections are disconnected.
- The connections of the central lubrication system are disconnected.
- An auxiliary crane with sufficient load carrying capacity is available.



WARNING

Danger of accident due to incorrect attachment!

Life-threatening situations can arise if the winch 1 is incorrectly or improperly attached!

Personnel can be severely injured or killed!

- ▶ The chains for the winch may not be directly fastened on the crane hook, rather they must always be extended with additional fastening equipment between chain and hook!
- ▶ Winch 1 must be attached on the intended chains **2** at point **P1**!
- ▶ Make sure that the fastening equipment is correctly attached on winch 1 and that it is secured sufficiently to prevent it from loosening up!

- ▶ Attach the fastening equipment on the chains **2** at point **P1**.
- ▶ Bring the fastening equipment with the auxiliary crane to „tension“, see illustration 1.
- ▶ Release the pins **6** on both sides on the turntable: Remove the locking pin **7.2** at point **P4** and unpin the pin **7.1**, see illustration 2.
- ▶ Unpin the pin **6**.
- ▶ Release the pins **3** on both sides on the turntable: Remove the locking pin **4.2** at point **P5** and unpin the pin **4.1**, see illustration 2.
- ▶ Unpin the pin **3**.

4.2.2 Removing winch 1

When the pins are unpinned:

- ▶ Lift winch 1 carefully with the auxiliary crane.



WARNING

Falling components!

When lifting winch 1 from the turntable, components or winch 1 can fall down!

Personnel can be severely injured or killed!

- ▶ Make sure that there are no persons within the danger zone!

- ▶ Move winch 1 out.

When winch 1 is moved out:

- ▶ Set winch 1 on the flatbed trailer.
- ▶ Remove the auxiliary crane.

Empty page!

LWE/LR 13000-001/19503-01-02/en

3.07.20 Winch 2 assembly

1	Component overview	3
2	Fastening points for winch 2	3
3	Installing the winch	5
4	Removing the winch	15

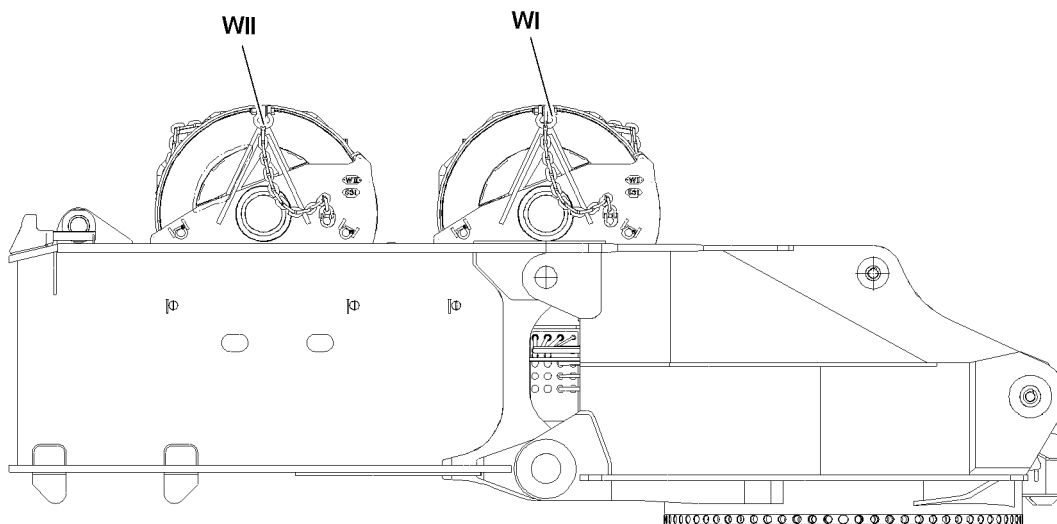
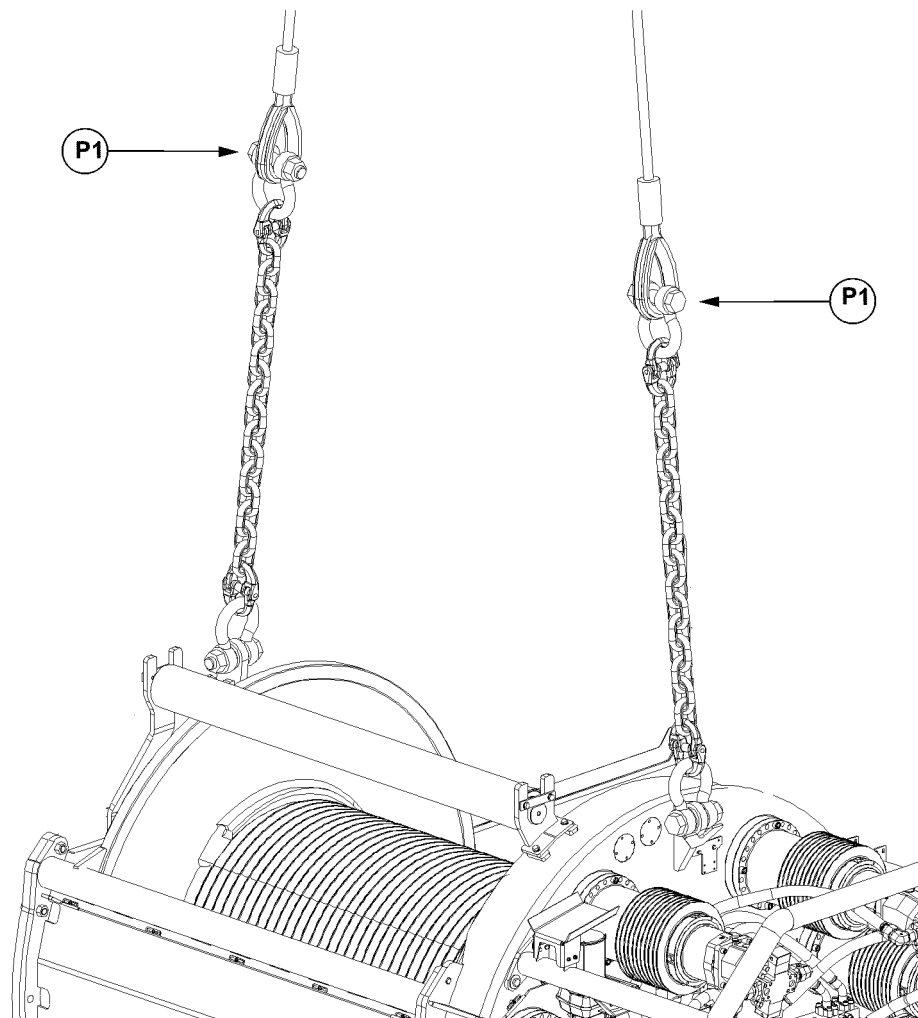

Fig.113638

LWE/LR 13000-001/19503-01-02/en

1 Component overview



Note

- ▶ The assembly sections are marked with their own weights!



Note

- ▶ Dimensions and weights, see Crane operating instructions, chapter 1.03!

1.1 Winch 2

Position	Component
W II	Winch 2

2 Fastening points for winch 2



WARNING

Component incorrectly attached!

Life-threatening situations can arise due to improper or incorrect attachment of the corresponding components!

Personnel can be severely injured or killed!

- ▶ The chains for the winch may not be directly fastened on the crane hook, rather they must always be extended with additional fastening equipment between chain and hook!
- ▶ Attach the components only on the intended fastening points on both sides!
- ▶ Fastening of components and description of fastening points, see Crane operating instructions, chapter 5.01!

Fastening points	
P1	Winch 2

Fig.195219

LWE/LR 13000-001/19503-01-02/en

3 Installing the winch



WARNING

Danger of falling!

During assembly / disassembly work, personnel must be secured with appropriate aids to prevent them from falling. If this is not observed, assembly personnel can fall and suffer life-threatening or fatal injuries!

- ▶ Any assembly work, where there is a danger of falling must be carried out with suitable aids (for example lifting platform, scaffolding, ladder, auxiliary crane)!
- ▶ If the work cannot be carried out with such aids nor from the ground, then the assembly personnel must secure themselves with approved fall arrest systems to avoid falling, see Crane operating instructions, Chapter 2.04!
- ▶ Approved fall arrest systems must be hung into the respective fastening points on the crane, see Crane operating instructions, chapter 2.06!
- ▶ If railings are present on the components, then they must be brought into the corresponding position and secured for assembly / disassembly work!
- ▶ Step on aids and fall protection equipment only with clean shoes!
- ▶ Keep aids and fall protection equipment clean and free from snow and ice!
- ▶ During all assembly and disassembly work, maintenance work and inspections, travel and crane operation is prohibited!



WARNING

Components not pinned and secured!

If a component is released from the auxiliary crane before having been pinned and secured, the component will fall down! Personnel can be severely injured or killed!

- ▶ Do not disengage the auxiliary crane until the corresponding component is pinned and secured!



WARNING

Danger of impact / crushing!

When installing / removing crane components with the auxiliary crane, crane components can start to swing back and forth!

When lifting / lowering and positioning crane components, there is an increased danger of impacts / crushing!

Personnel can be caught and severely injured or killed!

- ▶ Make sure that personnel cannot be caught by components!
- ▶ When working in danger zones: Use aids to protect limbs!
- ▶ Guide components with suitable aids to minimize oscillation!

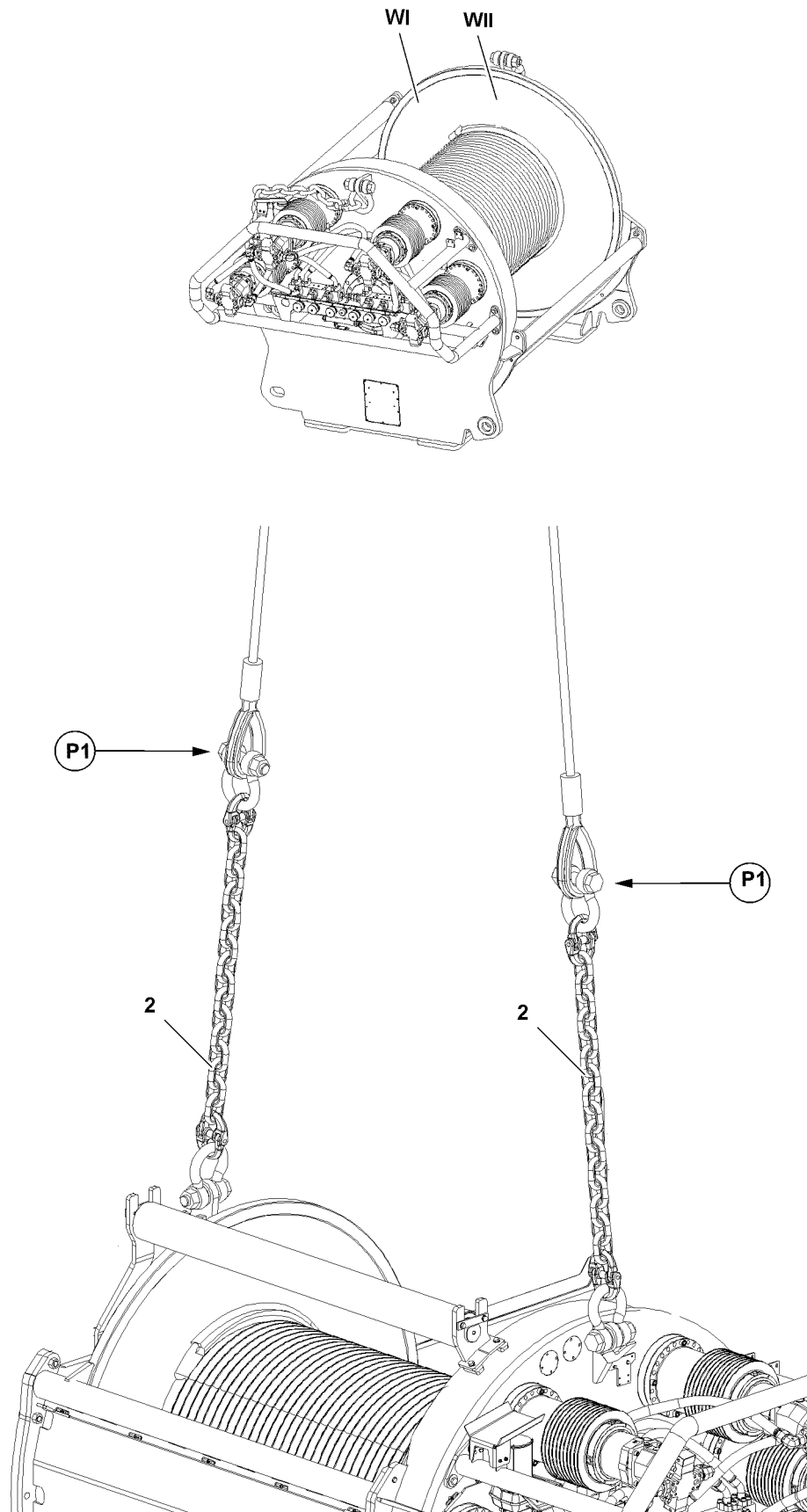

Fig.113639

LWE/LR 13000-001/19503-01-02/en

3.1 Assembling winch 2

3.1.1 Lifting winch 2 from the flatbed trailer

Make sure that the following prerequisites are met:

- The installation of the turntable is completed.
- The crane is aligned in horizontal direction.
- An auxiliary crane with sufficient load carrying capacity is available.



WARNING

Danger of accident due to incorrect attachment!

Life-threatening situations can arise if the winch 2 is incorrectly or improperly attached!

Personnel can be severely injured or killed!

- ▶ Winch 2 must be attached on the intended chains **2** at point **P1**!
- ▶ Make sure that the fastening equipment is correctly attached on winch 2 and that it is secured sufficiently to prevent it from loosening up!

-
- ▶ Attach the fastening equipment on the chains **2** at point **P1**.
 - ▶ Bring the fastening equipment to „tension“.
 - ▶ Release and remove the transport retainers on the flatbed trailer.



WARNING

Falling components!

When lifting winch 2 from the flatbed trailer, components or winch 2 can fall down!

Personnel can be severely injured or killed!

- ▶ Make sure that there are no persons within the danger zone!
-
- ▶ Lift winch 2 with the auxiliary crane from the flatbed trailer.

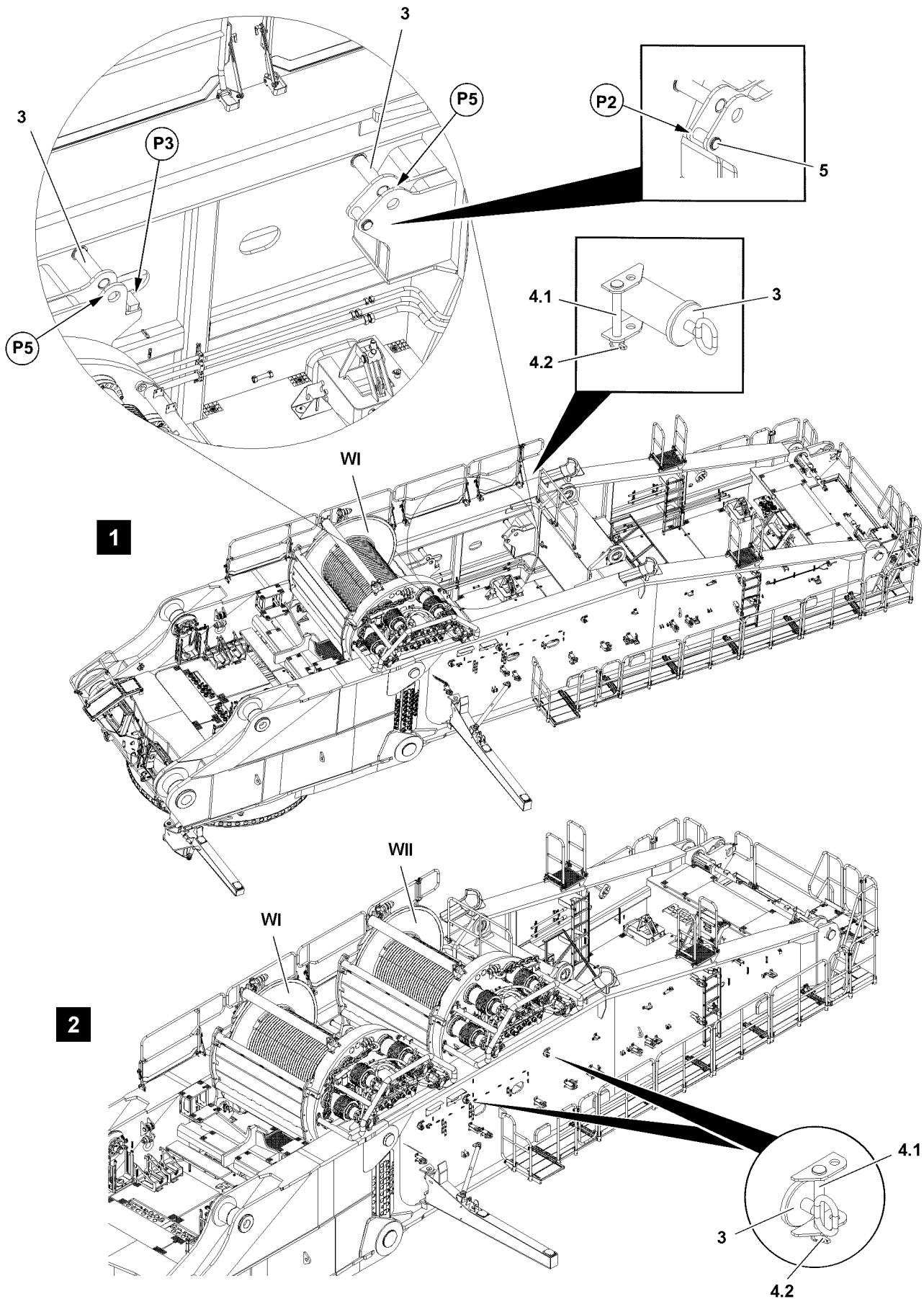

Fig.113642

LWE/LR 13000-001/19503-01-02/en

3.1.2 Positioning winch 2

Make sure that the following prerequisite is met:

- The pin bores are clear.



WARNING

Danger of accident when swinging in and lowering winch 2!

When swinging in and lowering winch 2 on the turntable, limbs can be crushed or even severed!

Personnel can be severely injured or killed!

- ▶ Make sure that there are no persons within the danger zone!
 - ▶ Do not reach with your hands into the danger zone!
-

NOTICE

Property damage!

If the following note is not observed, damage can result to the crane or winch 2!

- ▶ When retracting winch 2, it must be ensured that winch 2 does not hit against the turntable!
-



Note

- ▶ The guide must be in constant visual and acoustic contact with the crane operator!
-



Note

- ▶ Make sure that the alignment of winch 2 or the receptacles to the centering pins **5** at point **P2** on the turntable is exact, see illustration **1**!
 - ▶ Before lowering, bring winch 2 into position that the receptacles are over the centering pins **5** at point **P2** on the turntable!
-

- ▶ Retract winch 2 with the auxiliary crane.

- ▶ Lower winch 2 slowly.

When winch 2 is aligned:

- ▶ Carefully set winch 2 on the centering pins **5** at point **P2** and on the receptacle plates at point **P3** on the turntable, see illustration **1**.

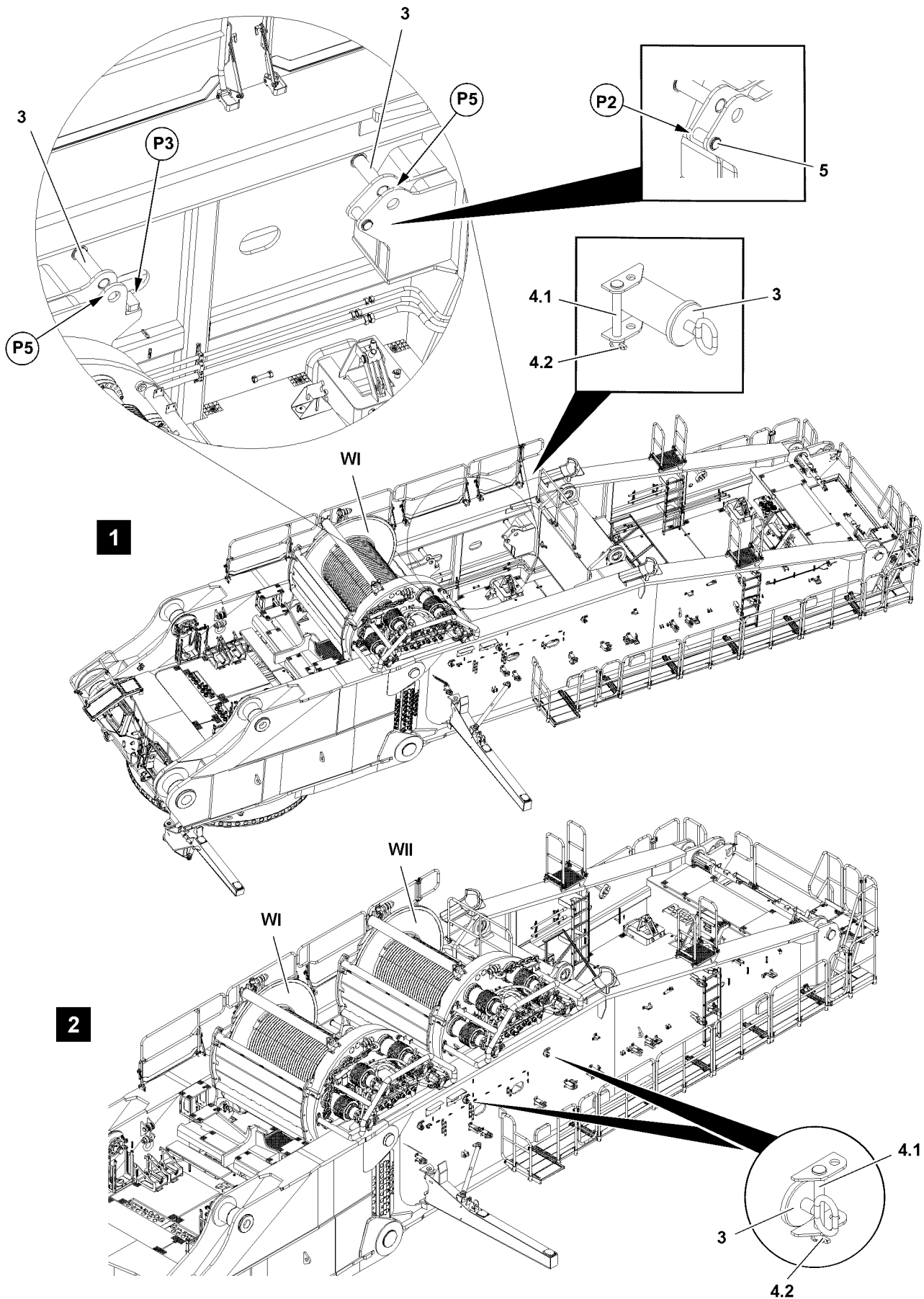

Fig.113642

LWE/LR 13000-001/19503-01-02/en

3.1.3 Pinning winch 2

Make sure that the following prerequisites are met:

- Winch 2 is seated on the centering pins **5**, point **P2**
 - Winch 2 is laying on the receptacle plates, point **P3**
- ▶ Insert pins **3** on both sides at point **P5** on the turntable, see illustration 1.



WARNING

The pins can loosen up by themselves!

- ▶ Secure the pins **3** after pinning immediately with pins **4.1**, see illustration 2!
-

When the pins **3** are completely pinned on both sides on the turntable:

- ▶ Insert the pins **4.1** on all four pin points and secure with locking pin **4.2**, see illustration 2.
- ▶ Remove the fastening equipment on winch 2.

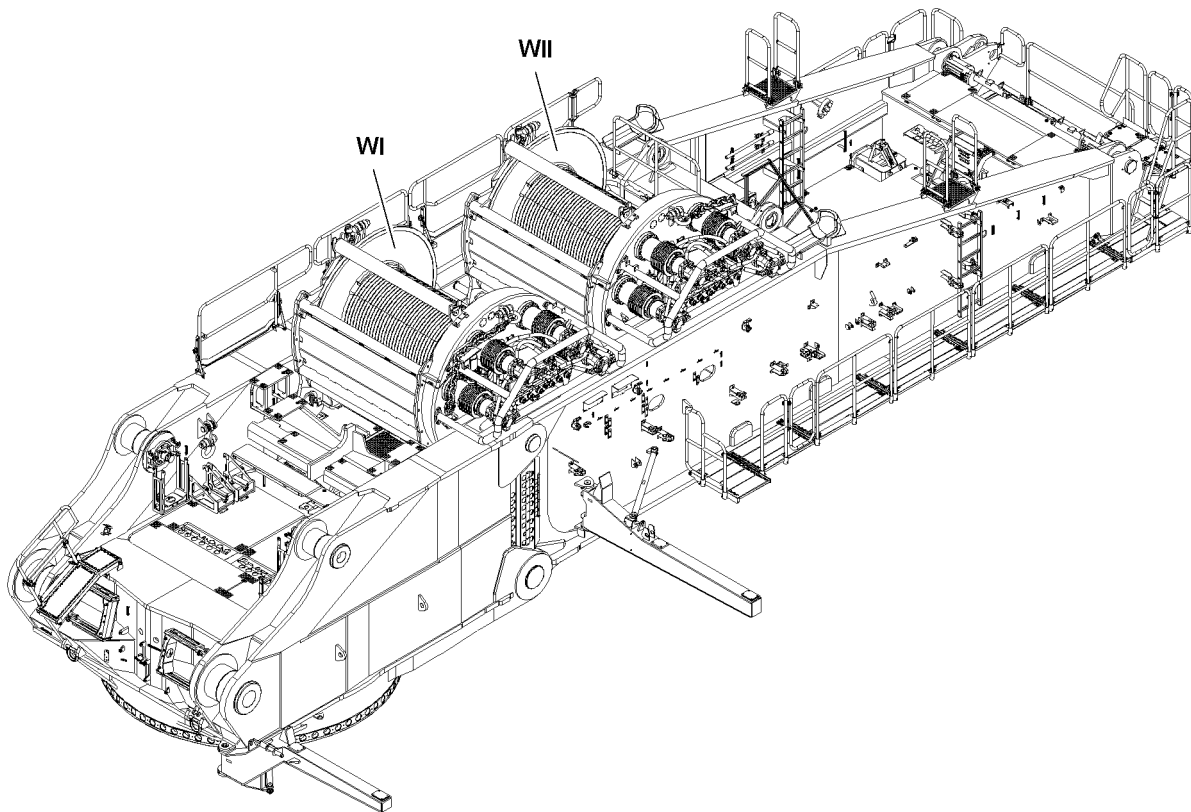

Fig.113641

LWE/LR 13000-001/19503-01-02/en

3.2 Establishing the connections to the winch



Note

- ▶ Establish the connections to the winch only when the engine house is installed!

Make sure that the following prerequisites are met:

- The winch is properly installed, pinned and secured.
- The engine house is installed.

3.2.1 Establishing the hydraulic connections to the winch



Note

- ▶ After the hydraulic connections to the winch are established, the expansion tank must be checked and emptied!

The hydraulic connections for the winch are made with quick couplings.

When connecting hydraulic lines with quick-release couplings, make sure that the coupling procedure is carried out correctly.



WARNING

Pressure in the hydraulic lines!

If the pressure supply is not interrupted before connecting / releasing the hydraulic lines, the hydraulic oil can escape with high pressure!

Personnel can be severely injured or killed!

- ▶ Release the pressure in the hydraulic system before connecting / disconnecting: Interrupt the pressure supply and wait for a short time!



WARNING

Loss of pressure or leakage!

Incorrectly coupled or self-loosening quick-release couplings (particularly return lines) can result in serious accidents due to component failure!

- ▶ Check that the quick couplings have been properly connected before using the crane!
- ▶ Connect the coupling components (sleeve and connector) and screw together with the hand-tightened nut.
- ▶ Tighten the hydraulic coupling by hand. Rotate the hand-tightened nut until it reaches a tangible, fixed stop position.
- ▶ Establish the hydraulic connections to the winch.

3.2.2 Establishing the connections to the winch

- ▶ Establish the electrical connections to the winch, see Electrical wiring diagram.

3.2.3 Establishing the connections for the central lubrication system to the winch

- ▶ Establish the connections for the central lubrication system to the winch.

Fig.195219

LWE/LR 13000-001/19503-01-02/en

4 Removing the winch



WARNING

Danger of falling!

During assembly / disassembly work, personnel must be secured with appropriate aids to prevent them from falling. If this is not observed, assembly personnel can fall and suffer life-threatening or fatal injuries!

- ▶ Any assembly work, where there is a danger of falling must be carried out with suitable aids (for example lifting platform, scaffolding, ladder, auxiliary crane)!
- ▶ If the work cannot be carried out with such aids nor from the ground, then the assembly personnel must secure themselves with approved fall arrest systems to avoid falling, see Crane operating instructions, Chapter 2.04!
- ▶ Approved fall arrest systems must be hung into the respective fastening points on the crane, see Crane operating instructions, chapter 2.06!
- ▶ If railings are present on the components, then they must be brought into the corresponding position and secured for assembly / disassembly work!
- ▶ Step on aids and fall protection equipment only with clean shoes!
- ▶ Keep aids and fall protection equipment clean and free from snow and ice!
- ▶ During all assembly and disassembly work, maintenance work and inspections, travel and crane operation is prohibited!



WARNING

Components not pinned and secured!

If a component is released from the auxiliary crane before having been pinned and secured, the component will fall down! Personnel can be severely injured or killed!

- ▶ Do not disengage the auxiliary crane until the corresponding component is pinned and secured!



WARNING

Danger of impact / crushing!

When installing / removing crane components with the auxiliary crane, crane components can start to swing back and forth!

When lifting / lowering and positioning crane components, there is an increased danger of impacts / crushing!

Personnel can be caught and severely injured or killed!

- ▶ Make sure that personnel cannot be caught by components!
- ▶ When working in danger zones: Use aids to protect limbs!
- ▶ Guide components with suitable aids to minimize oscillation!

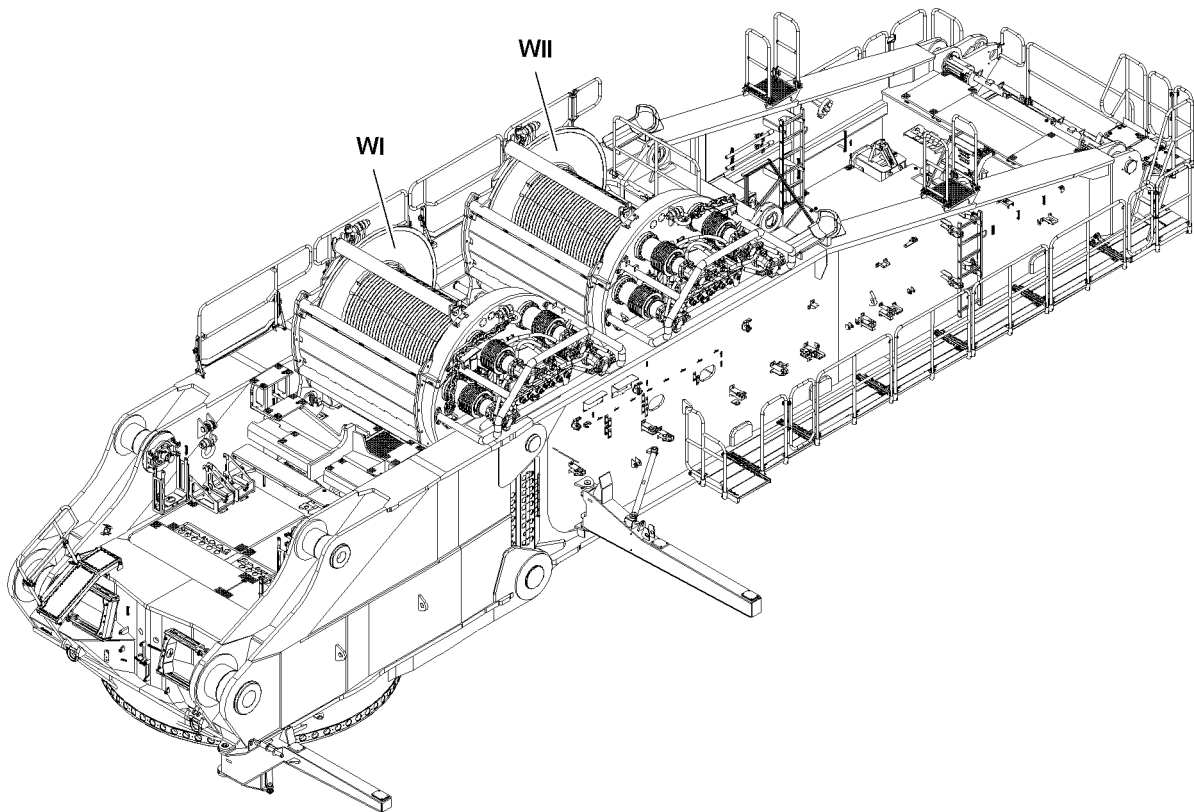

Fig.113641

4.1 Disconnecting the connections to the winch

Make sure that the following prerequisite is met:

- The rope is spooled up completely.

4.1.1 Disconnecting the hydraulic connections to the winch

When releasing hydraulic lines with quick-release couplings, make sure that the uncoupling procedure is carried out correctly.



WARNING

Pressure in the hydraulic lines!

If the pressure supply is not interrupted before connecting / releasing the hydraulic lines, the hydraulic oil can escape with high pressure!

Personnel can be severely injured or killed!

- ▶ Release the pressure in the hydraulic system before connecting / disconnecting: Interrupt the pressure supply and wait for a short time!
-
- ▶ Release the hydraulic coupling by hand.
 - ▶ Disconnect the hydraulic connections to the winch.

4.1.2 Disconnecting the electrical connections to the winch

- ▶ Disconnect the electrical connections to the winch.

4.1.3 Disconnecting the connections for the central lubrication system to the winch

- ▶ Disconnect the connections to the winch.

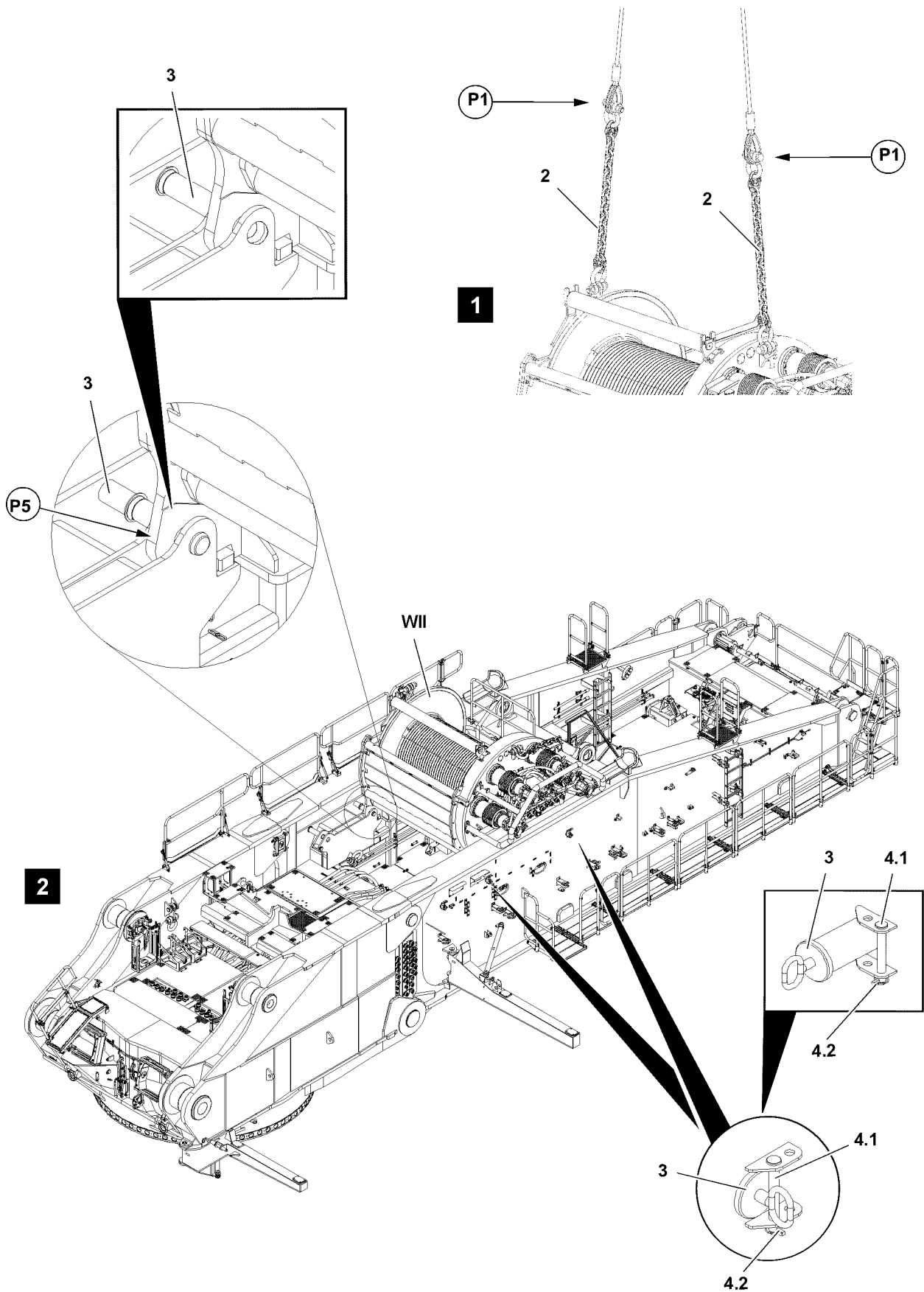

Fig.113644

LWE/LR 13000-001/19503-01-02/en

4.2 Removing winch 2

4.2.1 Unpinning winch 2

Make sure that the following prerequisites are met:

- The hydraulic connections are disconnected.
- The electrical connections are disconnected.
- The connections of the central lubrication system are disconnected.
- An auxiliary crane with sufficient load carrying capacity is available.



WARNING

Danger of accident due to incorrect attachment!

Life-threatening situations can arise if the winch 2 is incorrectly or improperly attached!

Personnel can be severely injured or killed!

- ▶ The chains for the winch may not be directly fastened on the crane hook, rather they must always be extended with additional fastening equipment between chain and hook!
- ▶ Winch 2 must be attached on the intended chains **2** at point **P1**!
- ▶ Make sure that the fastening equipment is correctly attached on winch 2 and that it is secured sufficiently to prevent it from loosening up!

- ▶ Attach the fastening equipment on the chains **2** at point **P1**.
- ▶ Bring the fastening equipment with the auxiliary crane to „tension“, see illustration **1**.
- ▶ Release the pins **3** on both sides on the turntable: Remove the locking pin **4.2** at point **P5** and unpin the pin **4.1**, see illustration **2**.
- ▶ Unpin all four pins **3**.

4.2.2 Removing winch 2

When the pins are unpinned:

- ▶ Lift winch 2 carefully with the auxiliary crane.



WARNING

Falling components!

When lifting winch 2 from the turntable, components or winch 2 can fall down!

Personnel can be severely injured or killed!

- ▶ Make sure that there are no persons within the danger zone!

- ▶ Move winch 2 out.

When winch 2 is moved out:

- ▶ Set winch 2 on the flatbed trailer.
- ▶ Remove the auxiliary crane.

Empty page!

LWE/LR 13000-001/19503-01-02/en

3.07.30 Winch 3 assembly

1	Component overview	3
2	Fastening points for winch 3	3
3	Installing the winch	5
4	Removing the winch	15

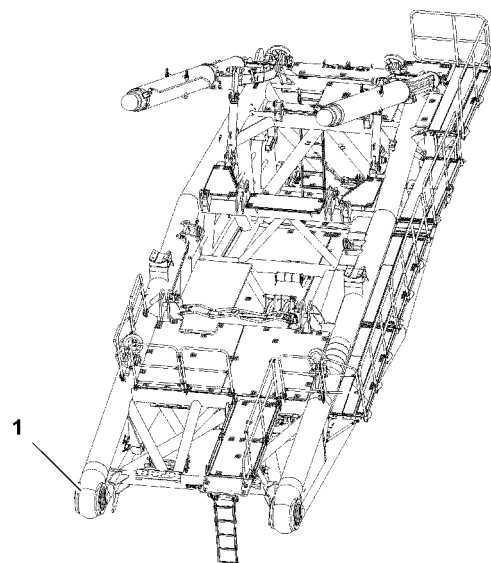
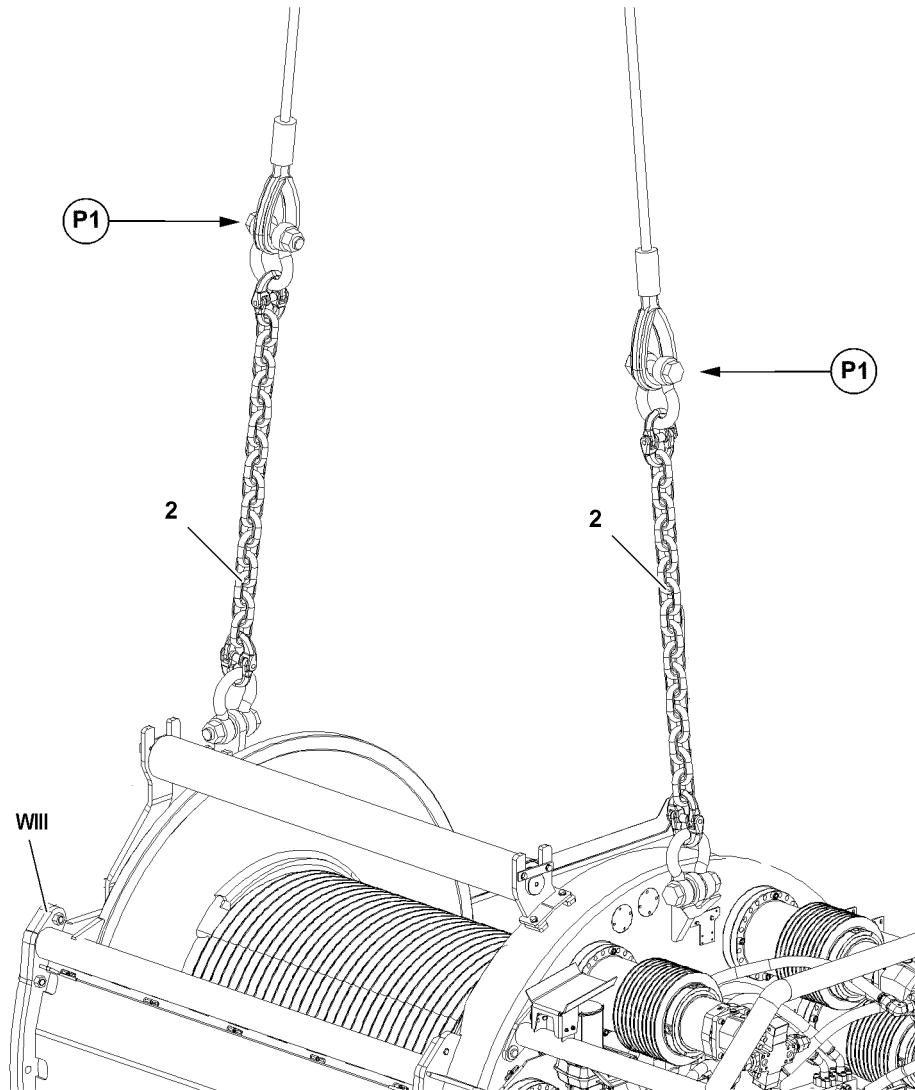

Fig.115607

LWE/LR 13000-001/19503-01-02/en

1 Component overview



Note

- ▶ The assembly sections are marked with their own weights!



Note

- ▶ Dimensions and weights, see Crane operating instructions, chapter 1.03!

1.1 Winch 3

Position	Component
W III	Winch 3

2 Fastening points for winch 3



WARNING

Component incorrectly attached!

Life-threatening situations can arise due to improper or incorrect attachment of the corresponding components!

Personnel can be severely injured or killed!

- ▶ The chains for the winch may not be directly fastened on the crane hook, rather they must always be extended with additional fastening equipment between chain and hook!
- ▶ Attach the components only on the intended fastening points on both sides!
- ▶ Fastening of components and description of fastening points, see Crane operating instructions, chapter 5.01!

Fastening points	
P1	Winch 3

Fig.195219

LWE/LR 13000-001/19503-01-02/en

3 Installing the winch



WARNING

Danger of falling!

During assembly / disassembly work, personnel must be secured with appropriate aids to prevent them from falling. If this is not observed, assembly personnel can fall and suffer life-threatening or fatal injuries!

- ▶ Any assembly work, where there is a danger of falling must be carried out with suitable aids (for example lifting platform, scaffolding, ladder, auxiliary crane)!
- ▶ If the work cannot be carried out with such aids nor from the ground, then the assembly personnel must secure themselves with approved fall arrest systems to avoid falling, see Crane operating instructions, Chapter 2.04!
- ▶ Approved fall arrest systems must be hung into the respective fastening points on the crane, see Crane operating instructions, chapter 2.06!
- ▶ If railings are present on the components, then they must be brought into the corresponding position and secured for assembly / disassembly work!
- ▶ Step on aids and fall protection equipment only with clean shoes!
- ▶ Keep aids and fall protection equipment clean and free from snow and ice!
- ▶ During all assembly and disassembly work, maintenance work and inspections, travel and crane operation is prohibited!



WARNING

Components not pinned and secured!

If a component is released from the auxiliary crane before having been pinned and secured, the component will fall down! Personnel can be severely injured or killed!

- ▶ Do not disengage the auxiliary crane until the corresponding component is pinned and secured!



WARNING

Danger of impact / crushing!

When installing / removing crane components with the auxiliary crane, crane components can start to swing back and forth!

When lifting / lowering and positioning crane components, there is an increased danger of impacts / crushing!

Personnel can be caught and severely injured or killed!

- ▶ Make sure that personnel cannot be caught by components!
- ▶ When working in danger zones: Use aids to protect limbs!
- ▶ Guide components with suitable aids to minimize oscillation!

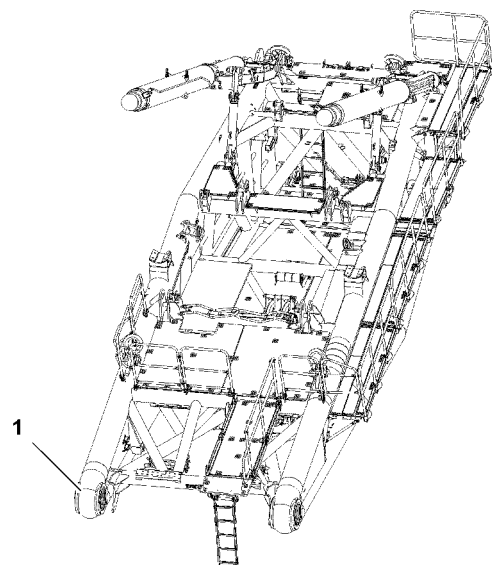
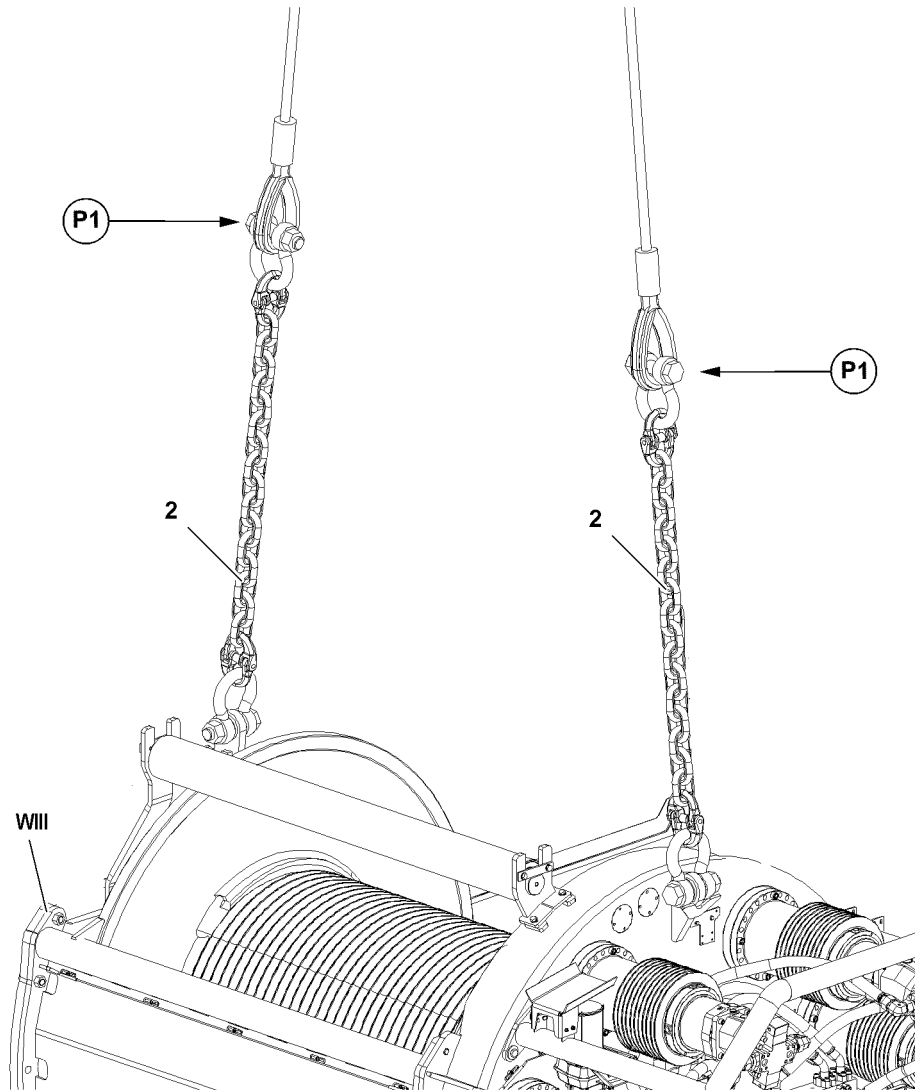

Fig.115607

LWE/LR 13000-001/19503-01-02/en

3.1 Assembling winch 3

3.1.1 Lifting winch 3 from the flatbed trailer

Make sure that the following prerequisites are met:

- The relapse retainers are properly set up and secured.
- An auxiliary crane with sufficient load carrying capacity is available.



WARNING

Danger of accident due to incorrect attachment!

Life-threatening situations can arise if the winch 3 is incorrectly or improperly attached!

Personnel can be severely injured or killed!

- ▶ Winch 3 must be attached on the intended chains **2** at point **P1**!
- ▶ Make sure that the fastening equipment is correctly attached on winch 3 and that it is secured sufficiently to prevent it from loosening up!

-
- ▶ Attach the fastening equipment on the intended chains **2**.
 - ▶ Bring the fastening equipment to „tension“.
 - ▶ Release and remove the transport retainers on the flatbed trailer.



WARNING

Falling components!

When lifting winch 3 from the flatbed trailer, components or winch 3 can fall down!

Personnel can be severely injured or killed!

- ▶ Make sure that there are no persons within the danger zone!
-
- ▶ Lift winch 3 with the auxiliary crane from the flatbed trailer.

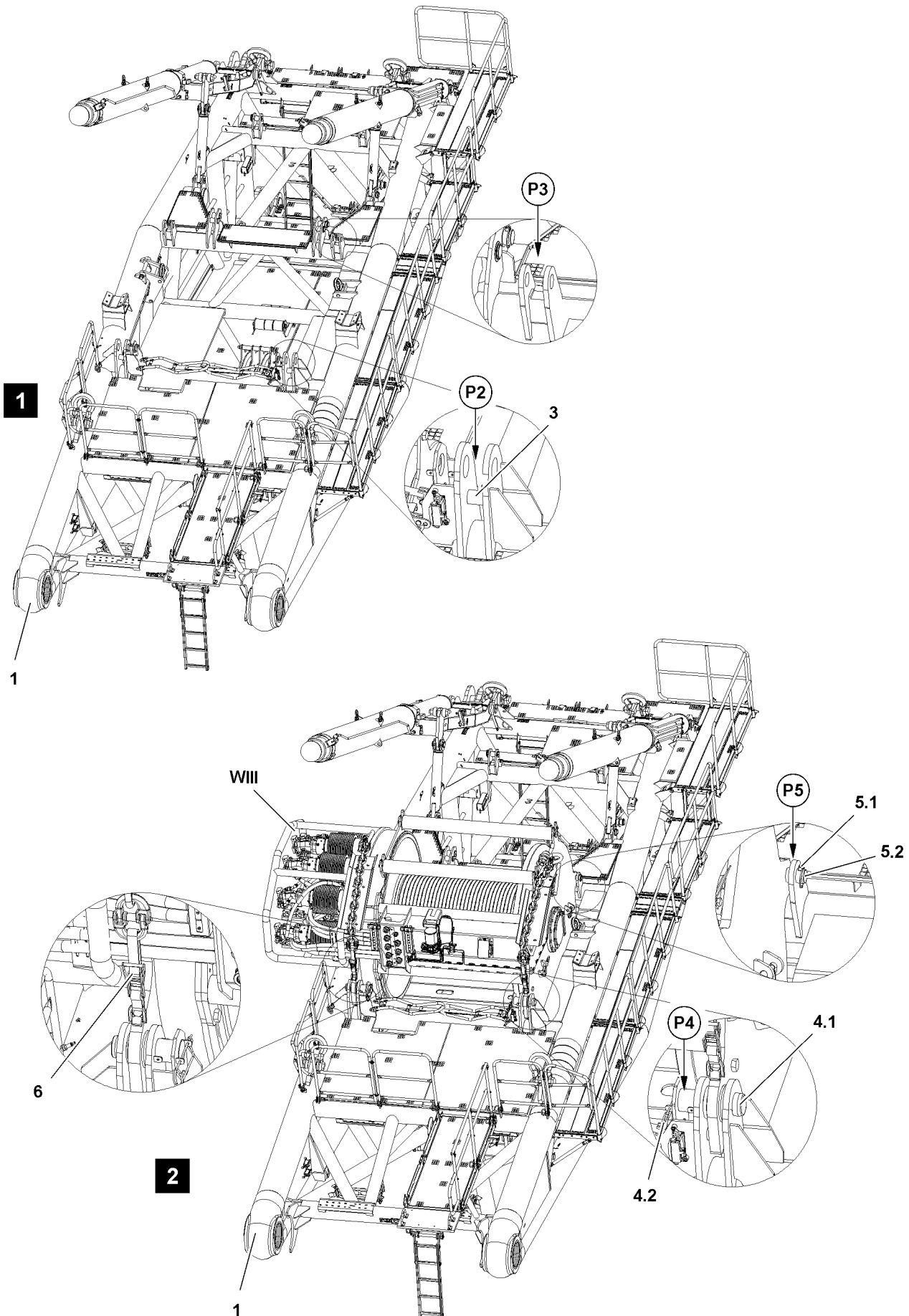

Fig.114369

LWE/LR 13000-001/19503-01-02/en

3.1.2 Positioning winch 3

Make sure that the following prerequisite is met:

- The pin bores are clear.



WARNING

Danger of accident when swinging in and lowering the winch!

When swinging in and lowering winch 3 on the D-pivot section, limbs can be crushed or even severed! Personnel can be severely injured or killed!

- ▶ Make sure that there are no persons within the danger zone!
 - ▶ Do not reach with your hands into the danger zone!
-

NOTICE

Property damage!

If the following note is not observed, damage can result on the D-pivot section or winch 3!

- ▶ When retracting winch 3, it must be ensured that winch 3 does not hit against the D-pivot section!
-



Note

- ▶ The guide must be standing on the catwalk and be in constant visual and acoustic contact with the crane operator!
-



Note

- ▶ Make sure that the alignment of winch 3 or the receptacles to the centering pins **3** at point **P2** on the D-pivot section is exact, see illustration **1**!
 - ▶ Before lowering, bring winch 3 into position that the receptacles are over the centering pins **3** at point **P2** on the D-pivot section!
-

- ▶ Retract winch 3 with the auxiliary crane.
- ▶ Lower winch 3 slowly.

When winch 3 is aligned:

- ▶ Carefully set winch 3 on the centering pins **3** at point **P2** and on the receptacle plates at point **P3** on the D-pivot section.

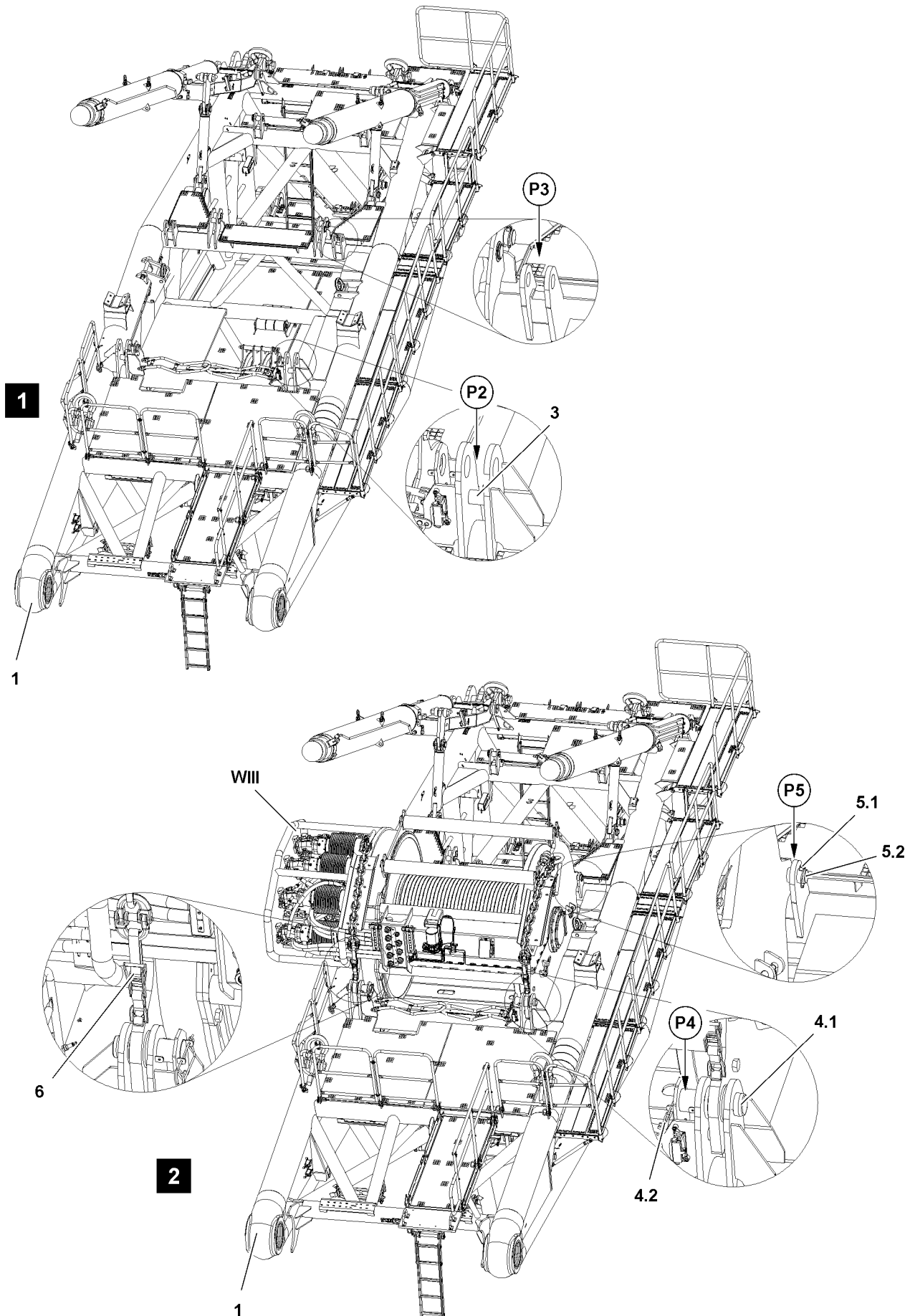

Fig.114369

LWE/LR 13000-001/19503-01-02/en

3.1.3 Pinning winch 3

Make sure that the following prerequisites are met:

- Winch 3 is seated on the centering pins **3**, point **P2**
- Winch 3 is laying on the receptacle plates, point **P3**



WARNING

The pins can loosen up by themselves!

- ▶ Secure pins **4.1** immediately after pinning with safety locking pins **4.2!**
- ▶ Insert the pins **4.1** on both sides at point **P4** on the D-pivot section and secure with safety locking pins **4.2**, see illustration **2**.



WARNING

The pins can loosen up by themselves!

- ▶ Secure pins **5.1** immediately after pinning with safety locking pins **5.2!**
- ▶ Insert the pins **5.1** on both sides at point **P5** on the D-pivot section and secure with safety locking pins **5.2**, see illustration **2**.
- ▶ Remove the fastening equipment on winch 3.



WARNING

Damage to crane!

If the fastening chains are not secured after installation of winch 3, the fastening chains can swing uncontrolled during crane operation!

This could result in property damage!

Personnel can be severely injured or killed!

- ▶ Make sure that the fastening chains are secured with the rigging belts **6!**
- ▶ Secure the chain with the rigging belts **6** on both sides, see illustration **2**.

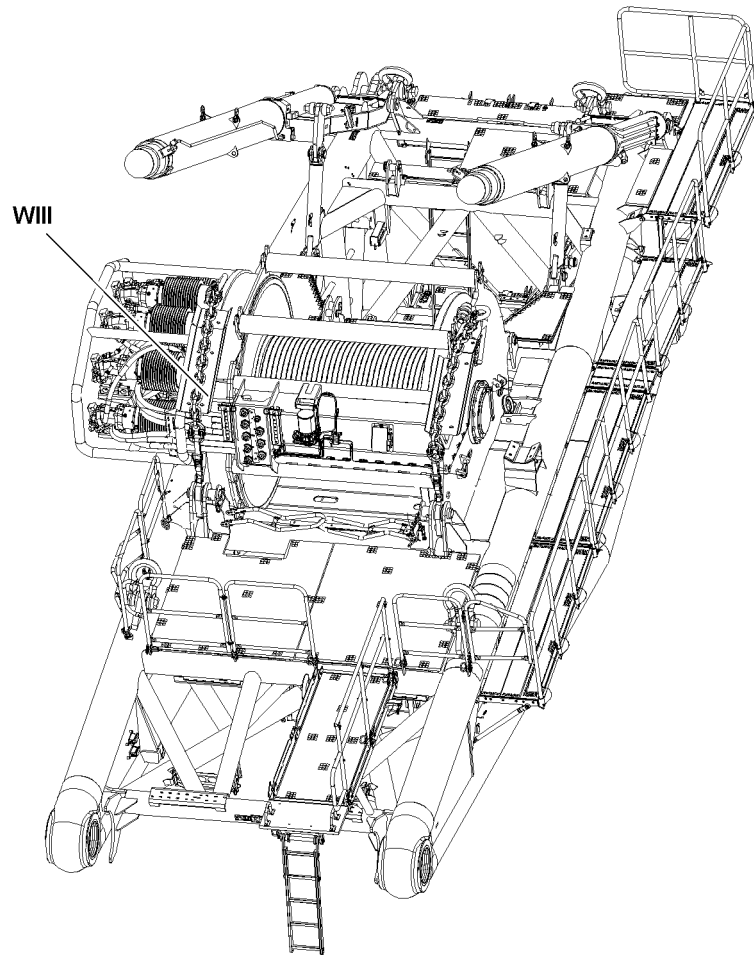

Fig.115608

LWE/LR 13000-001/19503-01-02/en

3.2 Establishing the connections to the winch

Make sure that the following prerequisites are met:

- The winch is properly installed, pinned and secured.
- The D-boom is installed.

3.2.1 Establishing the hydraulic connections to the winch



Note

- ▶ After the hydraulic connections to the winch are established, the expansion tank must be checked and emptied!

The hydraulic connections for the winch are made with quick couplings.

When connecting hydraulic lines with quick-release couplings, make sure that the coupling procedure is carried out correctly.



WARNING

Pressure in the hydraulic lines!

If the pressure supply is not interrupted before connecting / releasing the hydraulic lines, the hydraulic oil can escape with high pressure!

Personnel can be severely injured or killed!

- ▶ Release the pressure in the hydraulic system before connecting / disconnecting: Interrupt the pressure supply and wait for a short time!



WARNING

Loss of pressure or leakage!

Incorrectly coupled or self-loosening quick-release couplings (particularly return lines) can result in serious accidents due to component failure!

- ▶ Check that the quick couplings have been properly connected before using the crane!
- ▶ Connect the coupling components (sleeve and connector) and screw together with the hand-tightened nut.
- ▶ Tighten the hydraulic coupling by hand. Rotate the hand-tightened nut until it reaches a tangible, fixed stop position.
- ▶ Establish the hydraulic connections to the winch.

3.2.2 Establishing the connections to the winch

- ▶ Establish the electrical connections to the winch, see Electrical wiring diagram.

3.2.3 Establishing the connections for the central lubrication system to the winch

- ▶ Establish the connections for the central lubrication system to the winch.

Fig.195219

LWE/LR 13000-001/19503-01-02/en

4 Removing the winch



WARNING

Danger of falling!

During assembly / disassembly work, personnel must be secured with appropriate aids to prevent them from falling. If this is not observed, assembly personnel can fall and suffer life-threatening or fatal injuries!

- ▶ Any assembly work, where there is a danger of falling must be carried out with suitable aids (for example lifting platform, scaffolding, ladder, auxiliary crane)!
- ▶ If the work cannot be carried out with such aids nor from the ground, then the assembly personnel must secure themselves with approved fall arrest systems to avoid falling, see Crane operating instructions, Chapter 2.04!
- ▶ Approved fall arrest systems must be hung into the respective fastening points on the crane, see Crane operating instructions, chapter 2.06!
- ▶ If railings are present on the components, then they must be brought into the corresponding position and secured for assembly / disassembly work!
- ▶ Step on aids and fall protection equipment only with clean shoes!
- ▶ Keep aids and fall protection equipment clean and free from snow and ice!
- ▶ During all assembly and disassembly work, maintenance work and inspections, travel and crane operation is prohibited!



WARNING

Components not pinned and secured!

If a component is released from the auxiliary crane before having been pinned and secured, the component will fall down! Personnel can be severely injured or killed!

- ▶ Do not disengage the auxiliary crane until the corresponding component is pinned and secured!



WARNING

Danger of impact / crushing!

When installing / removing crane components with the auxiliary crane, crane components can start to swing back and forth!

When lifting / lowering and positioning crane components, there is an increased danger of impacts / crushing!

Personnel can be caught and severely injured or killed!

- ▶ Make sure that personnel cannot be caught by components!
- ▶ When working in danger zones: Use aids to protect limbs!
- ▶ Guide components with suitable aids to minimize oscillation!

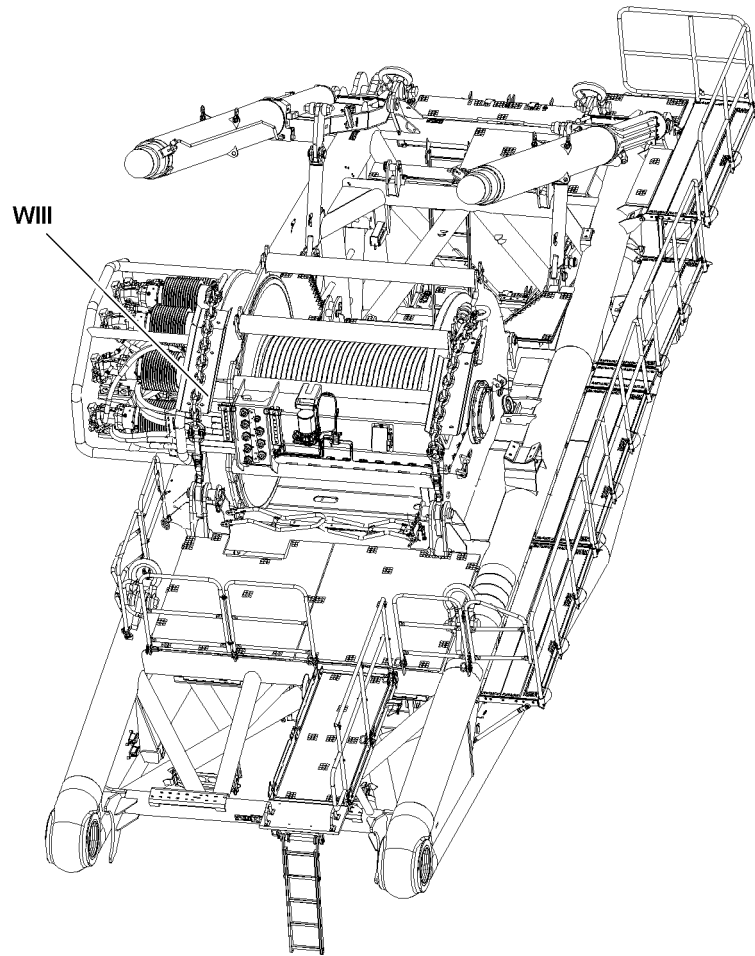

Fig.115608

LWE/LR 13000-001/19503-01-02/en

4.1 Disconnecting the connections to the winch

Make sure that the following prerequisite is met:

- The rope is spooled up completely.

4.1.1 Disconnecting the hydraulic connections to the winch

When releasing hydraulic lines with quick-release couplings, make sure that the uncoupling procedure is carried out correctly.



WARNING

Pressure in the hydraulic lines!

If the pressure supply is not interrupted before connecting / releasing the hydraulic lines, the hydraulic oil can escape with high pressure!

Personnel can be severely injured or killed!

- ▶ Release the pressure in the hydraulic system before connecting / disconnecting: Interrupt the pressure supply and wait for a short time!
-
- ▶ Release the hydraulic coupling by hand.
 - ▶ Disconnect the hydraulic connections to the winch.

4.1.2 Disconnecting the electrical connections to the winch

- ▶ Disconnect the electrical connections to the winch.

4.1.3 Disconnecting the connections for the central lubrication system to the winch

- ▶ Disconnect the connections to the winch.

4.2 Removing winch 3

4.2.1 Unpinning winch 3

Make sure that the following prerequisites are met:

- The hydraulic connections are disconnected.
- The electrical connections are disconnected.
- The connections of the central lubrication system are disconnected.
- An auxiliary crane with sufficient load carrying capacity is available.



WARNING

Danger of accident due to incorrect attachment!

Life-threatening situations can arise if the winch 3 is incorrectly or improperly attached!

Personnel can be severely injured or killed!

- ▶ The chains for the winch may not be directly fastened on the crane hook, rather they must always be extended with additional fastening equipment between chain and hook!
- ▶ Winch 3 must be attached on the intended chains **2** at point **P1**!
- ▶ Make sure that the fastening equipment is correctly attached on winch 3 and that it is secured sufficiently to prevent it from loosening up!

- ▶ Release the rigging belts **6** on both sides, see illustration **2**.
- ▶ Attach the fastening equipment on the chains **2** at point **P1**.
- ▶ Bring the fastening equipment with the auxiliary crane to „tension“, see illustration **1**.
- ▶ Remove the locking pin **5.2** at point **P5** and unpin the pin **5.1** on both sides, see illustration **2**.
- ▶ Remove the locking pin **4.2** at point **P4** and unpin the pin **4.1** on both sides, see illustration **2**.

4.2.2 Removing winch 3

When the pins are unpinned:

- ▶ Lift winch 3 carefully with the auxiliary crane.



WARNING

Falling components!

When lifting winch 3 from the D-pivot section, components or winch 3 can fall down!

Personnel can be severely injured or killed!

- ▶ Make sure that there are no persons within the danger zone!

- ▶ Move winch 3 out.

When winch 3 is moved out:

- ▶ Set winch 3 on the flatbed trailer.
- ▶ Remove the auxiliary crane.

Empty page!

LWE/LR 13000-001/19503-01-02/en

3.07.50 Winch 5 assembly

1	Component overview	3
2	Fastening points for winch 5	3
3	Assembling the winch	5
4	Disassembling the winch	17

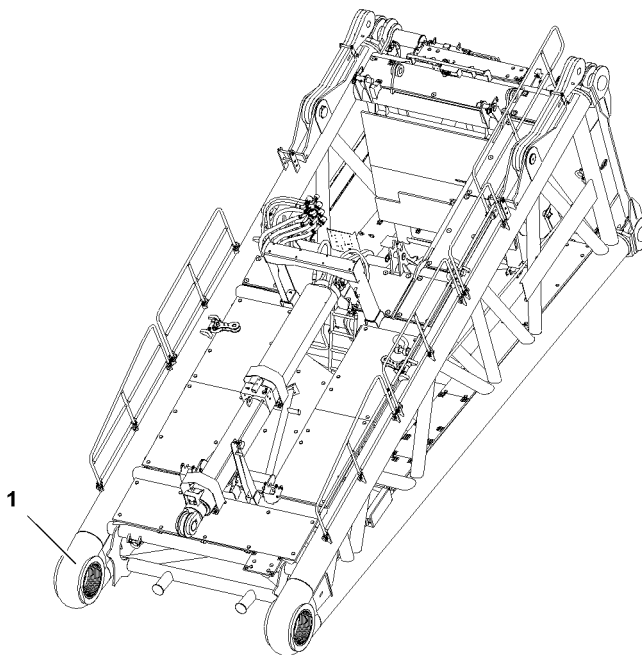
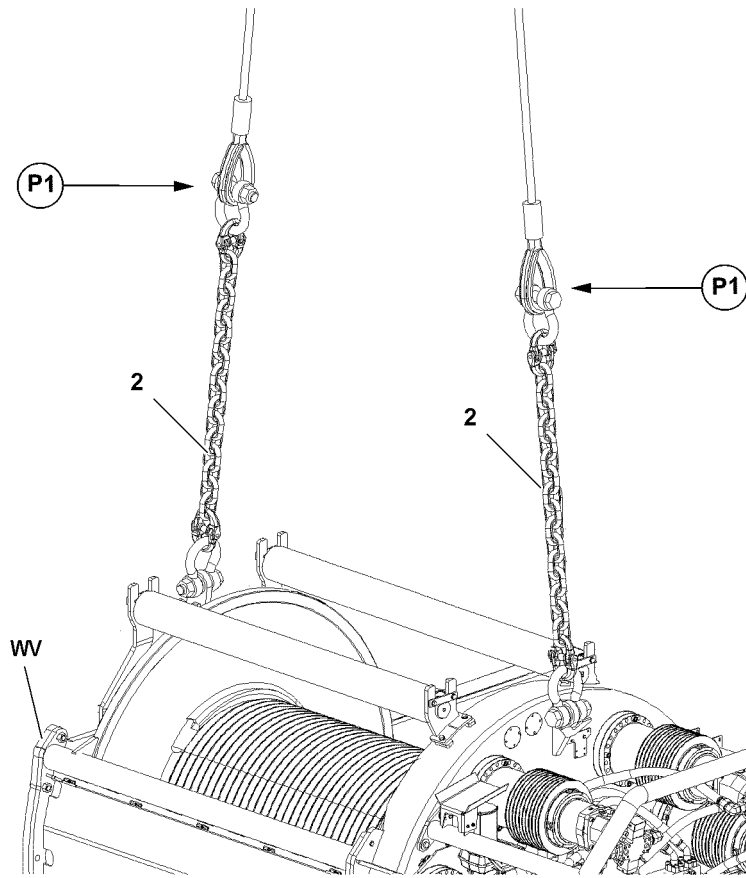

Fig.115614

LWE/LR 13000-001/19503-01-02/en

1 Component overview



Note

- ▶ The assembly sections are marked with their own weights!



Note

- ▶ For the dimensions and weights, see the Crane operating instructions, chapter 1.03!

1.1 Winch 5

Position	Component
W V	Winch 5

2 Fastening points for winch 5



WARNING

Component incorrectly fastened!

Life-threatening situations can arise due to improper or incorrect fastening of the corresponding components!

Personnel can be severely injured or killed!

- ▶ The chains for the winch may not be directly fastened to the crane hook, rather they must always be extended with additional fastening equipment between the chain and hook!
- ▶ Fasten the components only in the intended fastening points on both sides!
- ▶ For assembly of winch 5, use fastening equipment with a minimum length of 5 m !
- ▶ Fastening of components and description of fastening points, see the Crane operating instructions, chapter 5.01!

Fastening points	
P1	Winch 5

Fig.195219

LWE/LR 13000-001/19503-01-02/en

3 Assembling the winch



WARNING

Danger of falling!

During assembly / disassembly work, personnel must be secured with appropriate aids to prevent them from falling. If this is not observed, assembly personnel could fall and suffer life-threatening or fatal injuries!

- ▶ Any assembly work, where there is a danger of falling must be carried out with suitable aids (for example lifting platform, scaffolding, ladder, auxiliary crane)!
- ▶ If the work cannot be carried out with such aids or from the ground, then assembly personnel must secure themselves with approved fall arrest systems to avoid falling, see the Crane operating instructions, Chapter 2.04!
- ▶ Approved fall arrest systems must be connected to the respective fastening points on the crane, see the Crane operating instructions, chapter 2.06!
- ▶ If railings are present on the components, then they must be brought into the corresponding position and secured for assembly / disassembly work!
- ▶ Only step on aids and fall protection equipment with clean shoes!
- ▶ Keep aids and fall protection equipment clean and free of snow and ice!
- ▶ During all assembly and disassembly work, maintenance work and inspections, travel and crane operation is prohibited!



WARNING

Components not pinned and secured!

If a component is released from the auxiliary crane before being pinned and secured, the component will fall down! Personnel can be severely injured or killed!

- ▶ Do not detach the auxiliary crane until the respective component is pinned and secured!



WARNING

Danger of impact / crushing!

When assembling / disassembling crane components with the auxiliary crane, crane components can start to swing back and forth!

When lifting / lowering and positioning crane components, there is an increased danger of impact / crushing!

Personnel can be caught and thereby injured or killed!

- ▶ Make sure that personnel cannot be caught by components!
- ▶ When working in danger zones: Use aids to protect limbs!
- ▶ Guide components with suitable aids to minimize oscillation!

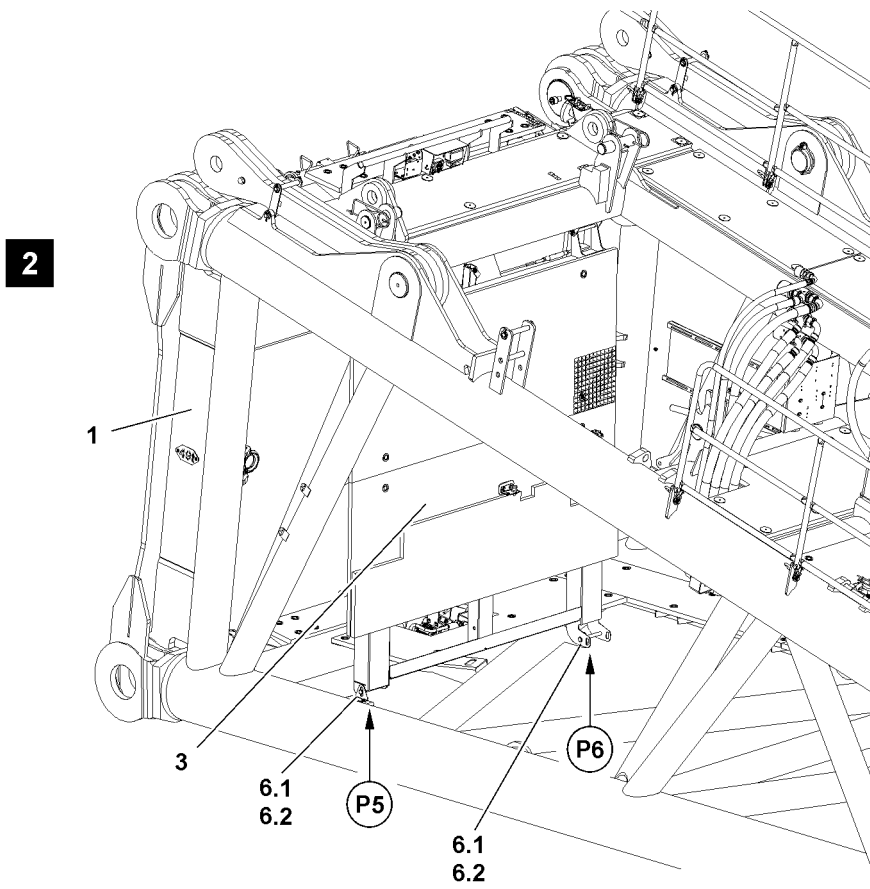
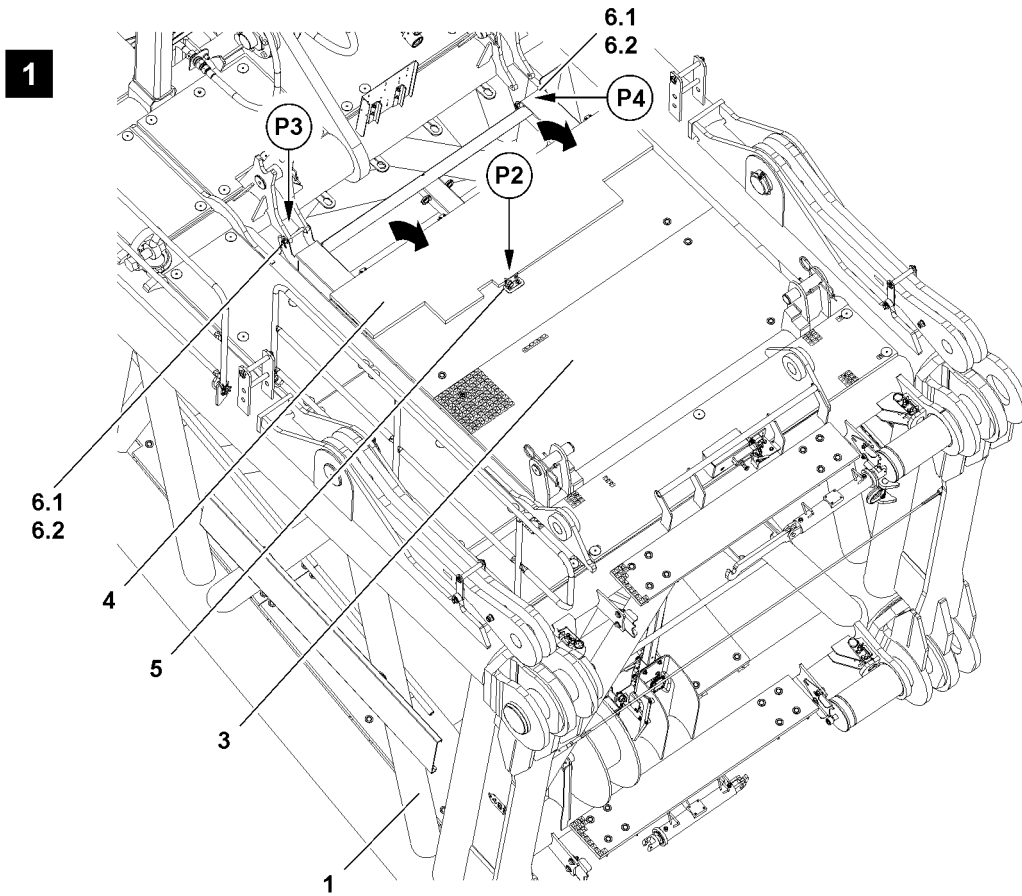

Fig.115615

LWE/LR 13000-001/19503-01-02/en

3.1 Assembling winch 5

3.1.1 S-pivot section before installation of winch 5

Make sure that the following prerequisite is met:

- The catwalk **3** is pinned and secured in the transport position.
- ▶ Fold the grating **4** up and secure in point **P2** with detent pin **5**, see illustration.
- ▶ Fasten the auxiliary crane to the catwalk **3** in point **P2**.

When the catwalk **3** is safely held by the auxiliary crane:

- ▶ Remove the safety locking pin **6.2** in point **P3** and unpin the pin **6.1**.
- ▶ Remove the safety locking pin **6.2** in point **P4** and unpin the pin **6.1**.
- ▶ Lower the catwalk **3** downward and remove the auxiliary crane.
- ▶ Pin the catwalk **3** in point **P5** and in point **P6**: Insert the pin **6.1** and secure with the safety locking pin **6.2**.

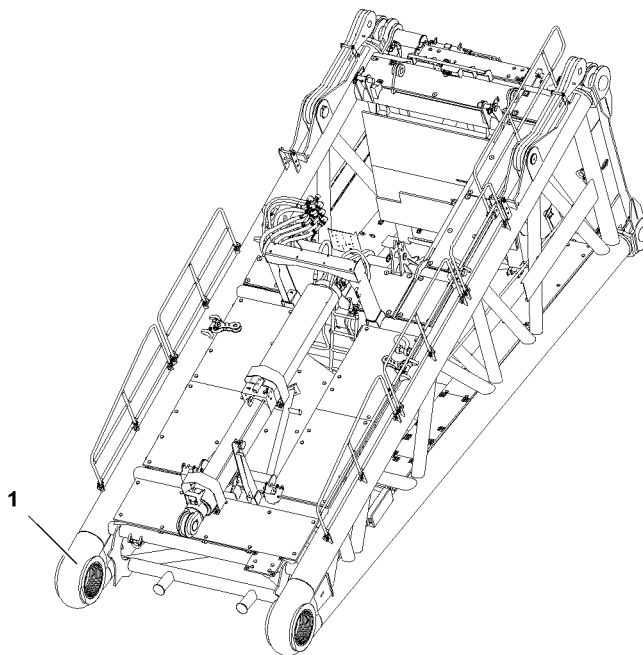
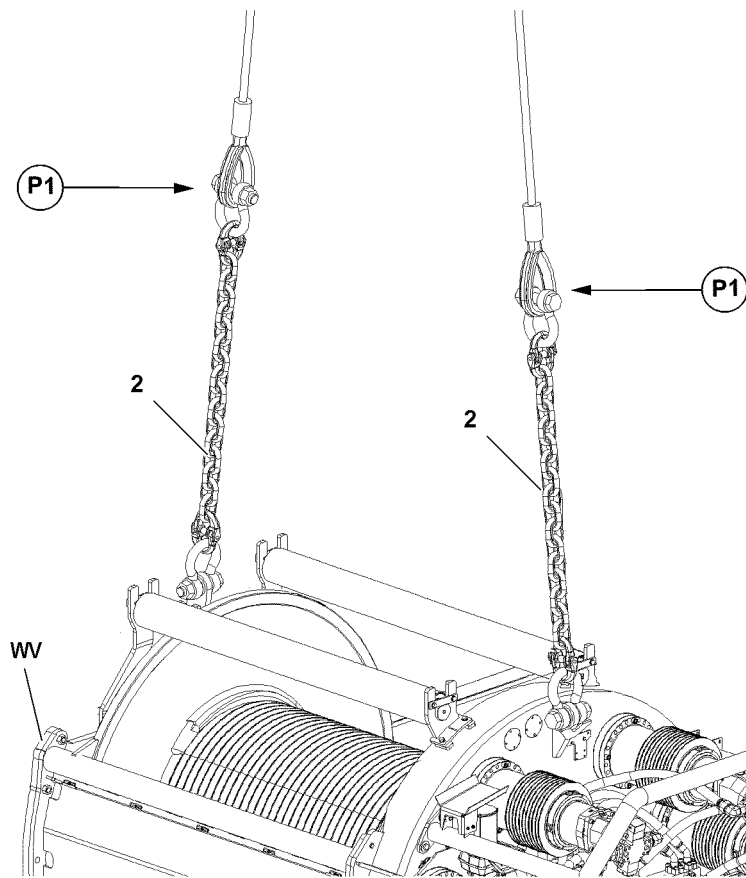

Fig.115614

LWE/LR 13000-001/19503-01-02/en

3.1.2 Lifting winch 5 from the flatbed trailer

Make sure that the following prerequisite is met:

- An auxiliary crane with appropriate load carrying capacity is available.



WARNING

Danger of accident due to incorrect fastening!

Life-threatening situations can arise if the winch 5 is incorrectly or improperly fastened!

Personnel can be severely injured or killed!

- ▶ Winch 5 must be attached to the intended chains **2** in point **P1**!
- ▶ Make sure that the fastening equipment is correctly attached to winch 5 and that it is secured sufficiently to prevent it from loosening up!

-
- ▶ Fasten the fastening equipment to the chains **2** in point **P1**.
 - ▶ Use the auxiliary crane to „tension“ the fastening equipment.
 - ▶ Release and remove the transport retainers on the flatbed trailer.



WARNING

Falling components!

When lifting winch 5 from the flatbed trailer, components or winch 5 can fall down.

Personnel can be severely injured or killed!

- ▶ Make sure that there is no personnel in the danger zone!
-
- ▶ Lift winch 5 with the auxiliary crane from the flatbed trailer.

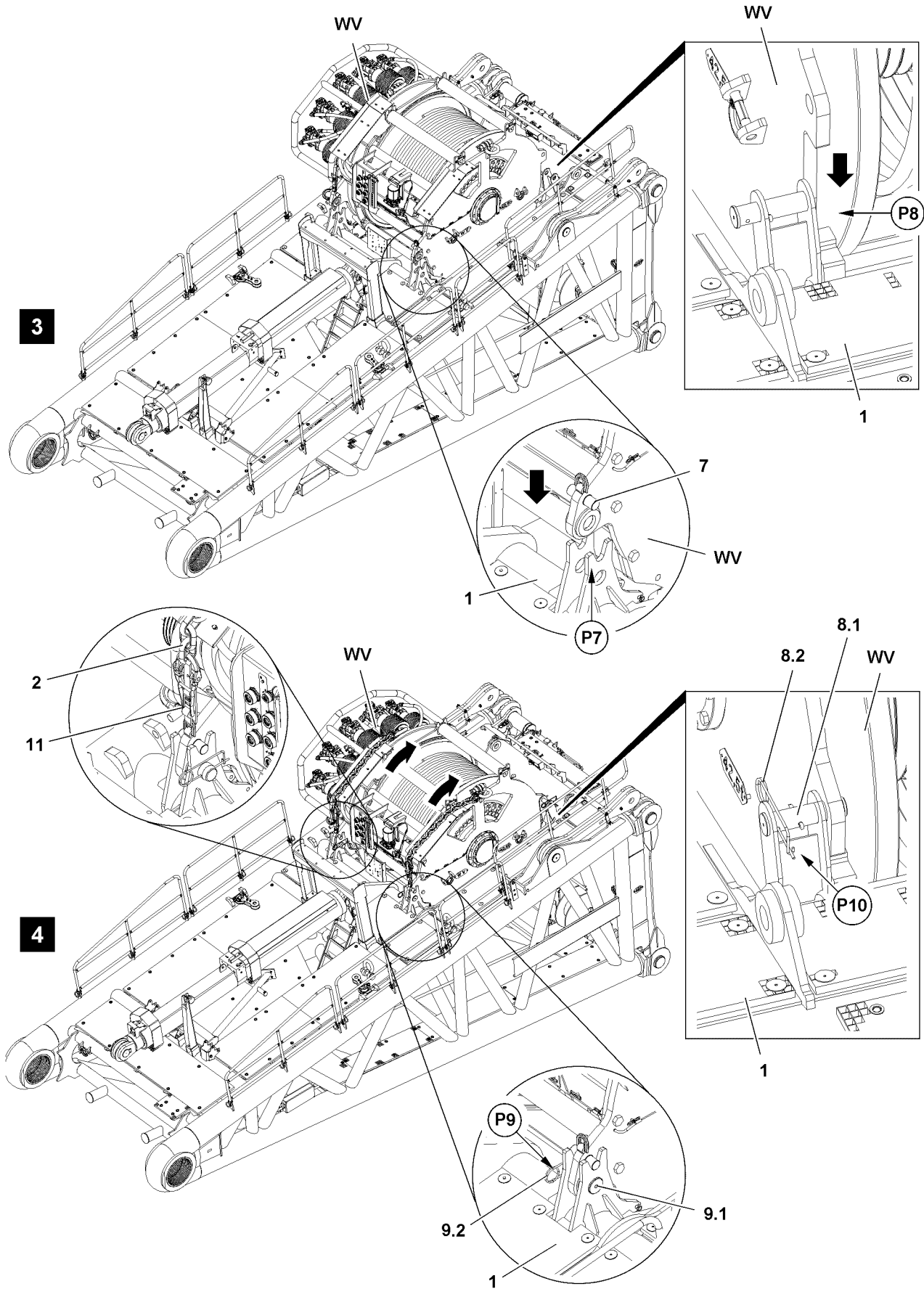

Fig.115616

3.1.3 Positioning winch 5

Make sure that the following prerequisite is met:

- The pin bores are clear.



WARNING

Danger of accident when swinging in and lowering the winch!

When swinging in and lowering winch 5 on the S-pivot section, limbs can be crushed or even severed! Personnel can be severely injured or killed!

- ▶ Make sure that there is no personnel in the danger zone!
 - ▶ Do not reach with your hands into the danger zone!
-

NOTICE

Property damage!

If the following note is not observed, the S-pivot section or winch 5 can be damaged!

- ▶ When retracting winch 5, it must be ensured that winch 5 does not hit against the S-pivot section!
-



Note

- ▶ The guide must be in constant visual and acoustic contact with the crane operator!
-



Note

- ▶ Make sure that winch 5 or the pocket receptacles are aligned exactly with the centering pins **7** in point **P7** on the S-pivot section, see illustration **3**!
 - ▶ Before lowering, bring winch 5 into position so that the pocket receptacles are over the centering pins **7** in point **P7** on the S-pivot section!
-

- ▶ Retract winch 5 with the auxiliary crane.

- ▶ Lower winch 5 slowly.

When winch 5 is aligned:

- ▶ Set winch 5 carefully with the centering pins **7** in point **P7** into the pocket receptacles on the S-pivot section, see illustration **3**.
- ▶ Continue to lower winch 5 and set it on the receptacle plates in point **P8** on the S-pivot section, see illustration **3**.

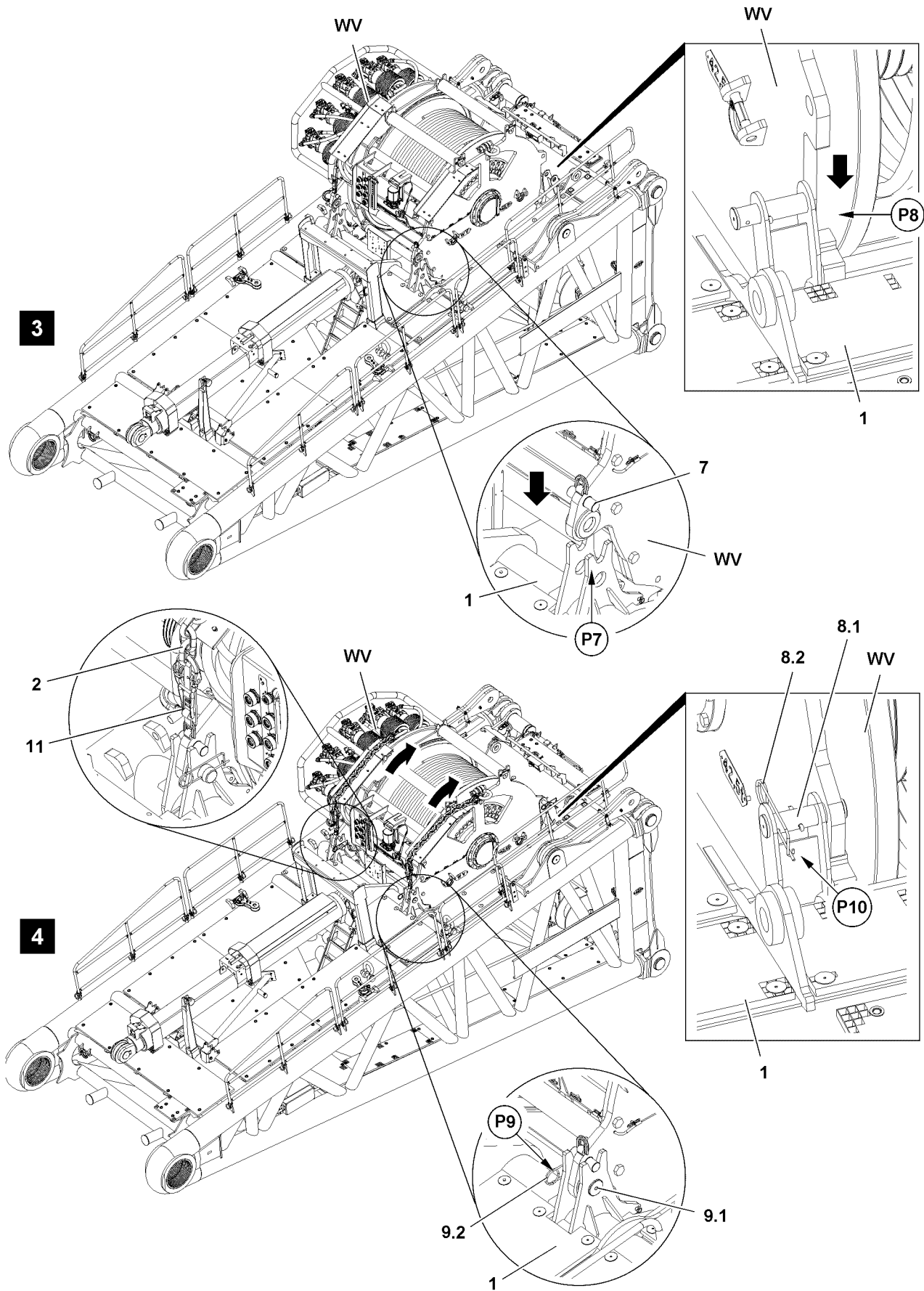

Fig.115616

3.1.4 Pinning winch 5

Make sure that the following prerequisites are met:

- Winch 5 is positioned on the centering pins 7, point **P7**
- Winch 5 is lying on the receptacle plates, point **P8**



WARNING

The pins can loosen up by themselves!

- ▶ Secure the pins **9.1** immediately after pinning with the spring retainer **9.2!**
- ▶ Insert the pins **9.1** on both sides in point **P9** on the S-pivot section and secure with spring retainers **9.2**, see illustration 4.



WARNING

The pins can loosen up by themselves!

- ▶ Secure the pins **8.1** immediately after pinning with the spring retainer **8.2!**
- ▶ Insert the pins **8.1** on both sides in point **P10** on the S-pivot section and secure with spring retainers **8.2**, see illustration 4.
- ▶ Remove the fastening equipment from winch 5 .



WARNING

Damage to the crane!

If the fastening chains are not secured after assembly of winch 5, the fastening chains can swing uncontrolled during crane operation!

This could result in property damage!

Personnel can be severely injured or killed!

- ▶ Make sure that the fastening chains are secured with the rigging belts **11!**
- ▶ Secure the chains **2** with the rigging belts **11** on both sides, see illustration 4.

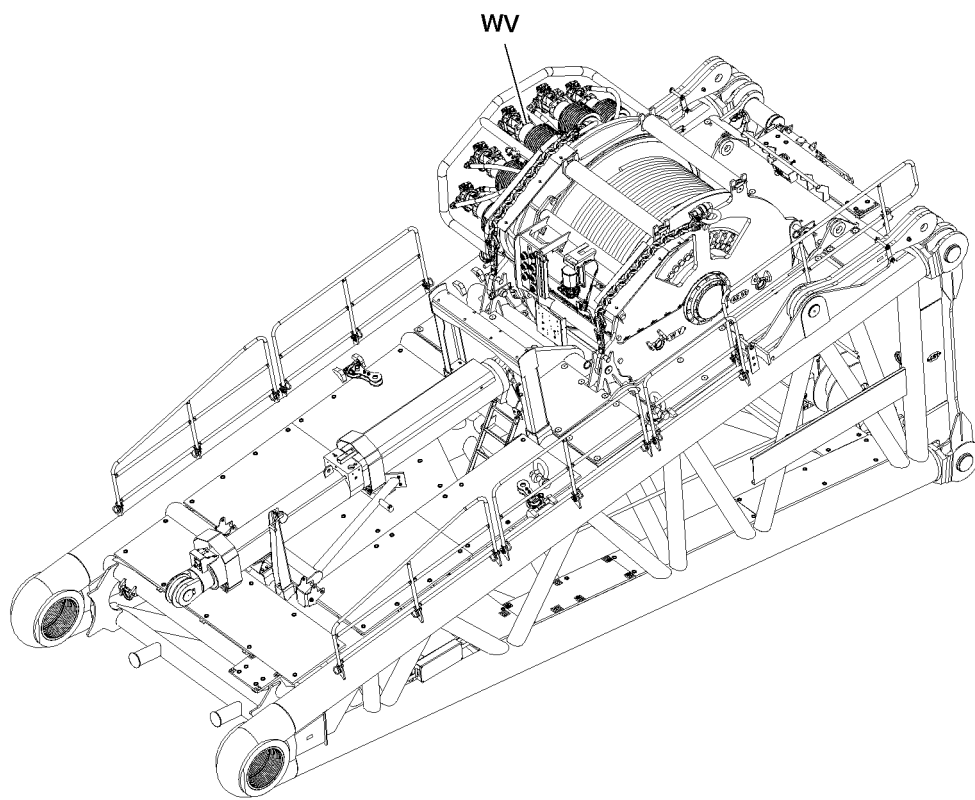

Fig.115617

LWE/LR 13000-001/19503-01-02/en

3.2 Establishing the connections to the winch

Make sure that the following prerequisites are met:

- The winch is properly installed, pinned and secured.
- The S-boom is assembled.

3.2.1 Establishing the hydraulic connections to the winch



Note

- ▶ After the hydraulic connections to the winch are established, the expansion tank must be checked and emptied!

The hydraulic connections for the winch are established with quick couplings.

When connecting hydraulic lines with quick couplings, make sure that the coupling procedure is carried out correctly.



WARNING

Pressure in the hydraulic lines!

If the pressure supply is not interrupted before connecting / releasing the hydraulic lines, the hydraulic oil can escape with high pressure!

Personnel can be severely injured or killed!

- ▶ Release the pressure in the hydraulic system before connecting / disconnecting: Interrupt the pressure supply and wait a short time!



WARNING

Loss of pressure or leakage!

Incorrectly coupled or self-loosening quick couplings (particularly return lines) can result in serious accidents due to component failure!

- ▶ Check that the quick couplings have been properly connected before using the crane!

- ▶ Connect the coupling components (sleeve and connector) and screw together with the knurled nut.
- ▶ Tighten the hydraulic coupling by hand. Turn the knurled nut until it reaches a tangible, fixed stop position.
- ▶ Establish the hydraulic connections to the winch.

3.2.2 Establishing the electrical connections to the winch

- ▶ Establish the electrical connections to the winch, see the Electrical wiring diagram.

3.2.3 Establishing the connections for the central lubrication system to the winch

- ▶ Establish the connections for the central lubrication system to the winch.

Fig.195219

LWE/LR 13000-001/19503-01-02/en

4 Disassembling the winch



WARNING

Danger of falling!

During assembly / disassembly work, personnel must be secured with appropriate aids to prevent them from falling. If this is not observed, assembly personnel could fall and suffer life-threatening or fatal injuries!

- ▶ Any assembly work, where there is a danger of falling must be carried out with suitable aids (for example lifting platform, scaffolding, ladder, auxiliary crane)!
- ▶ If the work cannot be carried out with such aids or from the ground, then assembly personnel must secure themselves with approved fall arrest systems to avoid falling, see the Crane operating instructions, Chapter 2.04!
- ▶ Approved fall arrest systems must be connected to the respective fastening points on the crane, see the Crane operating instructions, chapter 2.06!
- ▶ If railings are present on the components, then they must be brought into the corresponding position and secured for assembly / disassembly work!
- ▶ Only step on aids and fall protection equipment with clean shoes!
- ▶ Keep aids and fall protection equipment clean and free of snow and ice!
- ▶ During all assembly and disassembly work, maintenance work and inspections, travel and crane operation is prohibited!



WARNING

Components not pinned and secured!

If a component is released from the auxiliary crane before being pinned and secured, the component will fall down! Personnel can be severely injured or killed!

- ▶ Do not detach the auxiliary crane until the respective component is pinned and secured!



WARNING

Danger of impact / crushing!

When assembling / disassembling crane components with the auxiliary crane, crane components can start to swing back and forth!

When lifting / lowering and positioning crane components, there is an increased danger of impact / crushing!

Personnel can be caught and thereby injured or killed!

- ▶ Make sure that personnel cannot be caught by components!
- ▶ When working in danger zones: Use aids to protect limbs!
- ▶ Guide components with suitable aids to minimize oscillation!

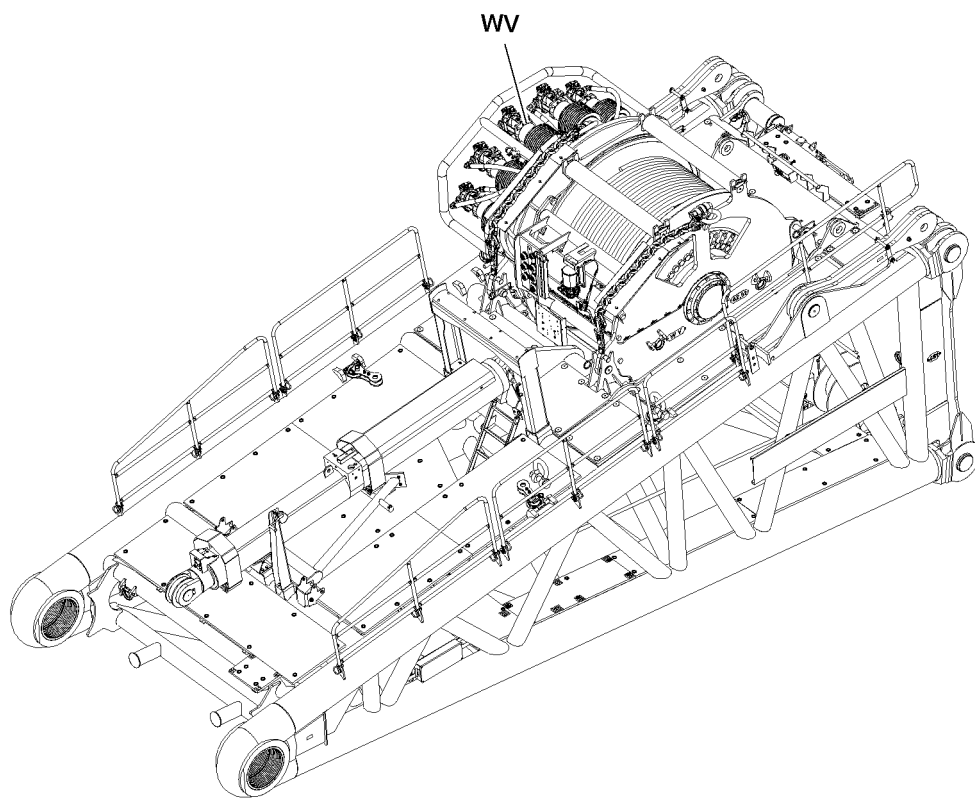

Fig.115617

LWE/LR 13000-001/19503-01-02/en

4.1 Disconnecting the connections from the winch

Make sure that the following prerequisite is met:

- The rope is spooled up completely.

4.1.1 Disconnecting the hydraulic connections from the winch

When releasing hydraulic lines with quick couplings, make sure that the coupling procedure is carried out correctly.



WARNING

Pressure in the hydraulic lines!

If the pressure supply is not interrupted before connecting / releasing the hydraulic lines, the hydraulic oil can escape with high pressure!

Personnel can be severely injured or killed!

- ▶ Release the pressure in the hydraulic system before connecting / disconnecting: Interrupt the pressure supply and wait a short time!
-
- ▶ Release the hydraulic coupling by hand.
 - ▶ Disconnect the hydraulic connections from the winch.

4.1.2 Disconnecting the electrical connections from the winch

- ▶ Disconnect the electrical connections from the winch.

4.1.3 Disconnecting the connections for the central lubrication system from the winch

- ▶ Disconnect the connections from the winch.

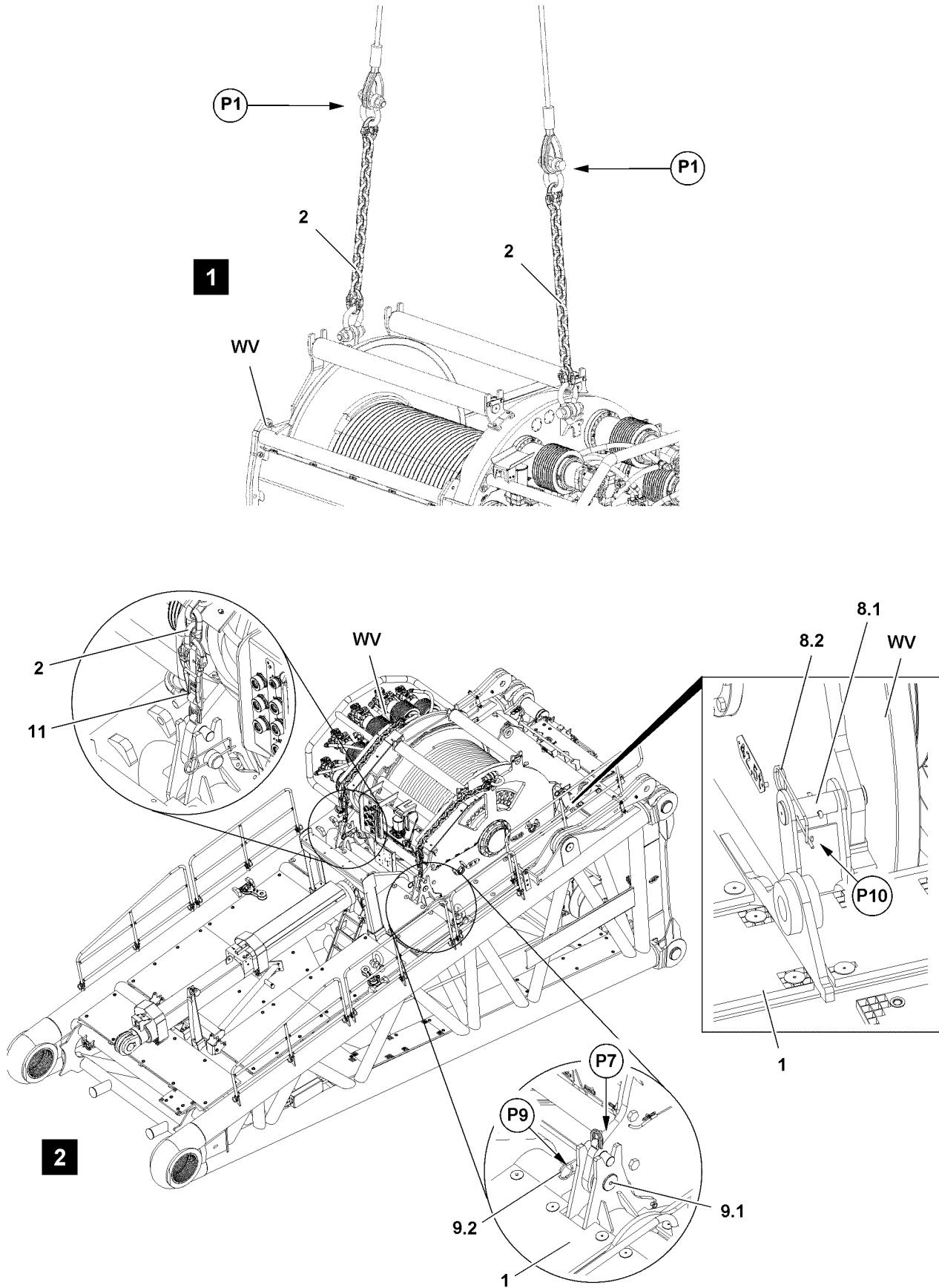

Fig.115618

LWE/LR 13000-001/19503-01-02/en

4.2 Disassembling winch 5

4.2.1 Unpinning winch 5

Make sure that the following prerequisites are met:

- The hydraulic connections are disconnected.
- The electrical connections are disconnected.
- The connections of the central lubrication system are disconnected.
- An auxiliary crane with appropriate load carrying capacity is available.



WARNING

Danger of accident due to incorrect fastening!

Life-threatening situations can arise if the winch 5 is incorrectly or improperly fastened!

Personnel can be severely injured or killed!

- ▶ The chains for the winch may not be directly fastened to the crane hook, rather they must always be extended with additional fastening equipment between the chain and hook!
 - ▶ Winch 5 must be attached to the intended chains **2** in point **P1**!
 - ▶ Make sure that the fastening equipment is correctly attached to winch 5 and that it is secured sufficiently to prevent it from loosening up!
-
- ▶ Release the rigging belts **11** on both sides, see illustration **2**.
 - ▶ Fasten the fastening equipment to the chains **2** in point **P1**.
 - ▶ „Tension“ the fastening equipment with the auxiliary crane, see illustration **1**.
 - ▶ Remove the spring retainer **8.2** in point **P10** and unpin the pin **10.1** on both sides, see illustration **2**.
 - ▶ Remove the spring retainer **9.2** in point **P9** and unpin the pin **9.1** on both sides, see illustration **2**.

4.2.2 Removing winch 5

When all pins are unpinned:



WARNING

Crushing danger when lifting!

When lifting winch 5 from the S-pivot section, winch 5 carries out a turning movement around the centering in point **P7**!

- ▶ Make sure that there is no personnel in the danger zone!
-
- ▶ Lift winch 5 carefully with the auxiliary crane.



WARNING

Falling components!

When lifting winch 5 from the S-pivot section, components or winch 5 can fall down!

Personnel can be severely injured or killed!

- ▶ Make sure that there is no personnel in the danger zone!
-
- ▶ Extend winch 5:

When winch 5 is extended:

- ▶ Place winch 5 on the flatbed trailer.
- ▶ Remove the auxiliary crane.

Empty page!

LWE/LR 13000-001/19503-01-02/en

3.07.60 Winch 6 assembly

1	Component overview	3
2	Fastening points for winch 6	3
3	Installing the winch	5
4	Removing the winch	15

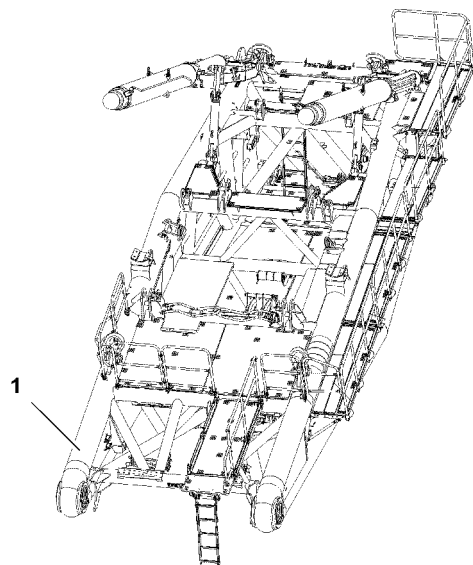
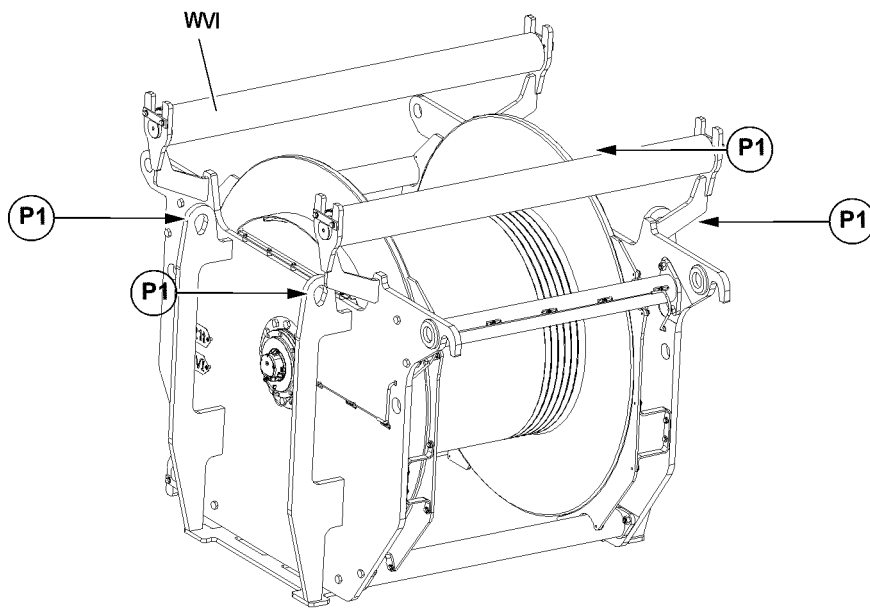

Fig.115611

LWE/LR 13000-001/19503-01-02/en

1 Component overview



Note

- ▶ The assembly sections are marked with their own weights!



Note

- ▶ Dimensions and weights, see Crane operating instructions, chapter 1.03!

1.1 Winch 6

Position	Component
W VI	Winch 6

2 Fastening points for winch 6



WARNING

Component incorrectly attached!

Life-threatening situations can arise due to improper or incorrect attachment of the corresponding components!

Personnel can be severely injured or killed!

- ▶ Attach the components only on the intended fastening points on both sides!
- ▶ Fastening of components and description of fastening points, see Crane operating instructions, chapter 5.01!

Fastening points	
P1	Winch 6

Fig.195219

LWE/LR 13000-001/19503-01-02/en

3 Installing the winch



WARNING

Danger of falling!

During assembly / disassembly work, personnel must be secured with appropriate aids to prevent them from falling. If this is not observed, assembly personnel can fall and suffer life-threatening or fatal injuries!

- ▶ Any assembly work, where there is a danger of falling must be carried out with suitable aids (for example lifting platform, scaffolding, ladder, auxiliary crane)!
- ▶ If the work cannot be carried out with such aids nor from the ground, then the assembly personnel must secure themselves with approved fall arrest systems to avoid falling, see Crane operating instructions, Chapter 2.04!
- ▶ Approved fall arrest systems must be hung into the respective fastening points on the crane, see Crane operating instructions, chapter 2.06!
- ▶ If railings are present on the components, then they must be brought into the corresponding position and secured for assembly / disassembly work!
- ▶ Step on aids and fall protection equipment only with clean shoes!
- ▶ Keep aids and fall protection equipment clean and free from snow and ice!
- ▶ During all assembly and disassembly work, maintenance work and inspections, travel and crane operation is prohibited!



WARNING

Components not pinned and secured!

If a component is released from the auxiliary crane before having been pinned and secured, the component will fall down! Personnel can be severely injured or killed!

- ▶ Do not disengage the auxiliary crane until the corresponding component is pinned and secured!



WARNING

Danger of impact / crushing!

When installing / removing crane components with the auxiliary crane, crane components can start to swing back and forth!

When lifting / lowering and positioning crane components, there is an increased danger of impacts / crushing!

Personnel can be caught and severely injured or killed!

- ▶ Make sure that personnel cannot be caught by components!
- ▶ When working in danger zones: Use aids to protect limbs!
- ▶ Guide components with suitable aids to minimize oscillation!

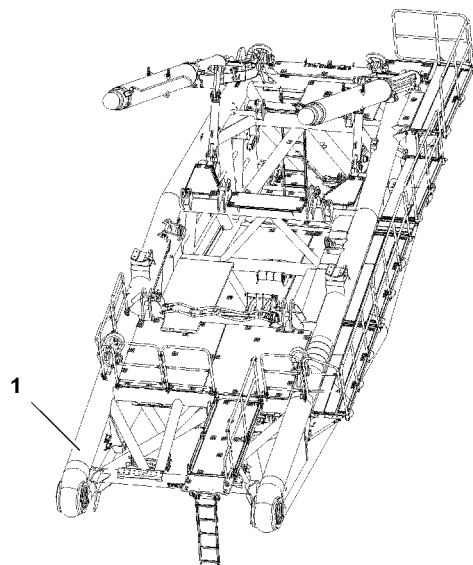
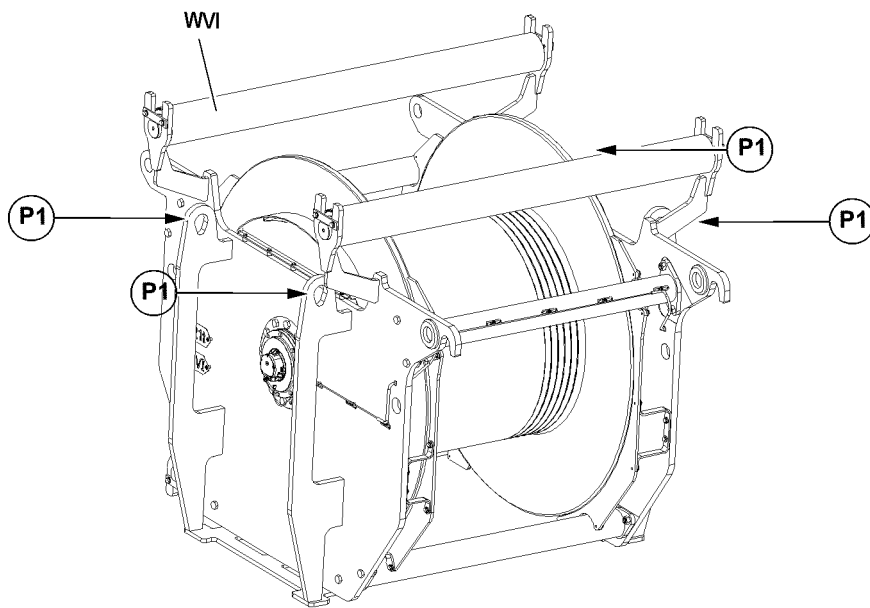

Fig.115611

LWE/LR 13000-001/19503-01-02/en

3.1 Assembling winch 6

3.1.1 Lifting winch 6 from the flatbed trailer

Make sure that the following prerequisites are met:

- The relapse retainers are properly set up and secured.
- An auxiliary crane with sufficient load carrying capacity is available.



WARNING

Danger of accident due to incorrect attachment!

Life-threatening situations can arise if the winch 6 is incorrectly or improperly attached!

Personnel can be severely injured or killed!

- ▶ Winch 6 must be attached on the intended eyes at point **P1**!
- ▶ Make sure that the fastening equipment is correctly attached on winch 6 and that it is secured sufficiently to prevent it from loosening up!

-
- ▶ Attach the fastening equipment on the intended eyes at point **P1**.
 - ▶ Bring the fastening equipment to „tension“.
 - ▶ Release and remove the transport retainers on the flatbed trailer.



WARNING

Falling components!

When lifting winch 6 from the flatbed trailer, components or winch 6 can fall down!

Personnel can be severely injured or killed!

- ▶ Make sure that there are no persons within the danger zone!
-
- ▶ Lift winch 6 with the auxiliary crane from the flatbed trailer.

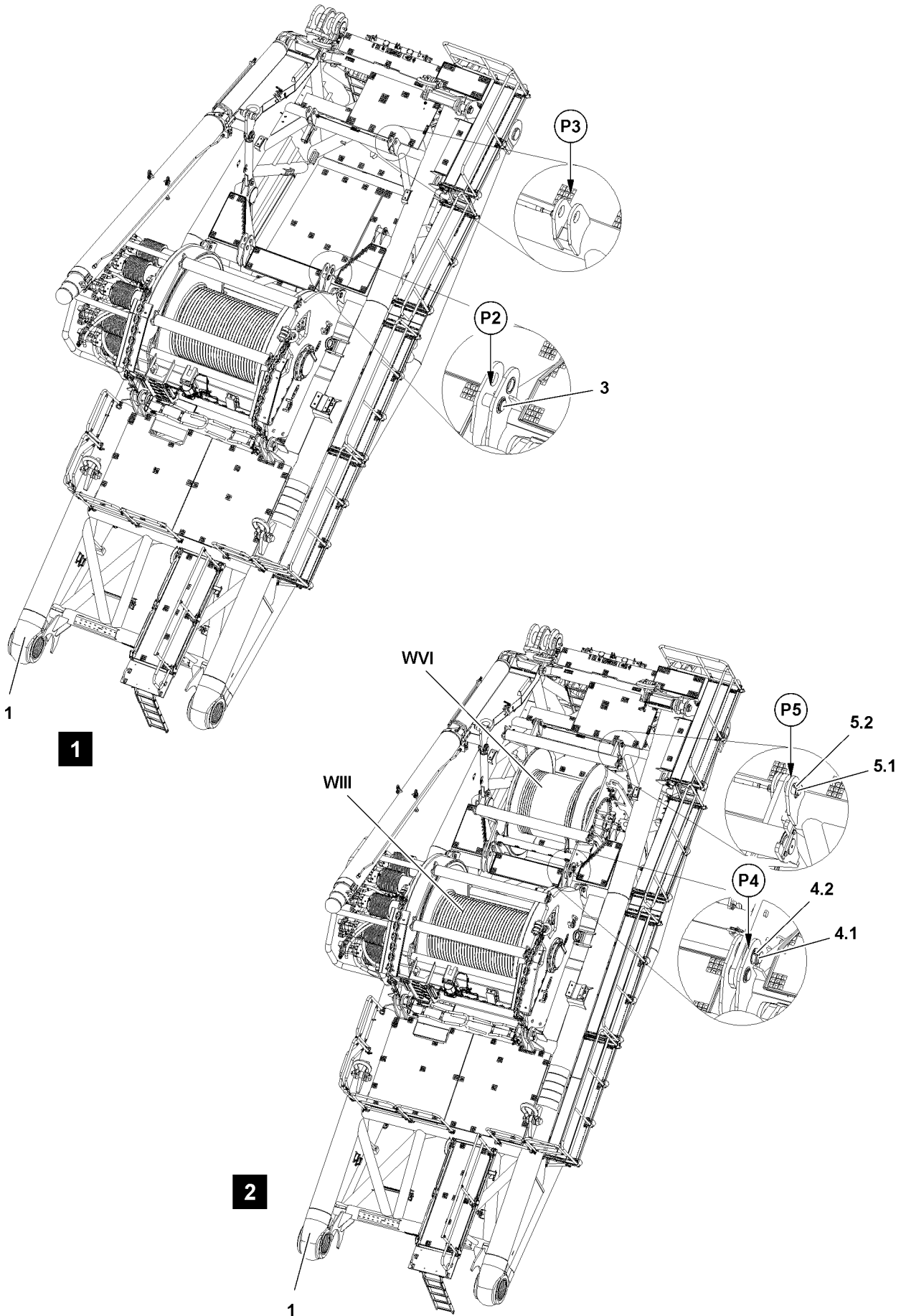

Fig.114370

LWE/LR 13000-001/19503-01-02/en

3.1.2 Positioning winch 6

Make sure that the following prerequisite is met:

- The pin bores are clear.



WARNING

Danger of accident when swinging in and lowering the winch!

When swinging in and lowering winch 6 on the D-pivot section, limbs can be crushed or even severed! Personnel can be severely injured or killed!

- ▶ Make sure that there are no persons within the danger zone!
 - ▶ Do not reach with your hands into the danger zone!
-

NOTICE

Property damage!

If the following note is not observed, damage can result on the D-pivot section or winch 6!

- ▶ When retracting winch 6, it must be ensured that winch 6 does not hit against the D-pivot section!
-



Note

- ▶ The guide must be standing on the catwalk and be in constant visual and acoustic contact with the crane operator!
-



Note

- ▶ Make sure that the alignment of winch 6 or the receptacles to the centering pins **3** at point **P2** on the D-pivot section is exact, see illustration **1**!
 - ▶ Before lowering, bring winch 6 into position that the receptacles are over the centering pins **3** at point **P2** on the D-pivot section!
-

- ▶ Retract winch 6 with the auxiliary crane.
- ▶ Lower winch 6 slowly.

When winch 6 is aligned:

- ▶ Carefully set winch 6 on the centering pins **3** at point **P2** and on the receptacle plates at point **P3** on the D-pivot section, see illustration **1**.

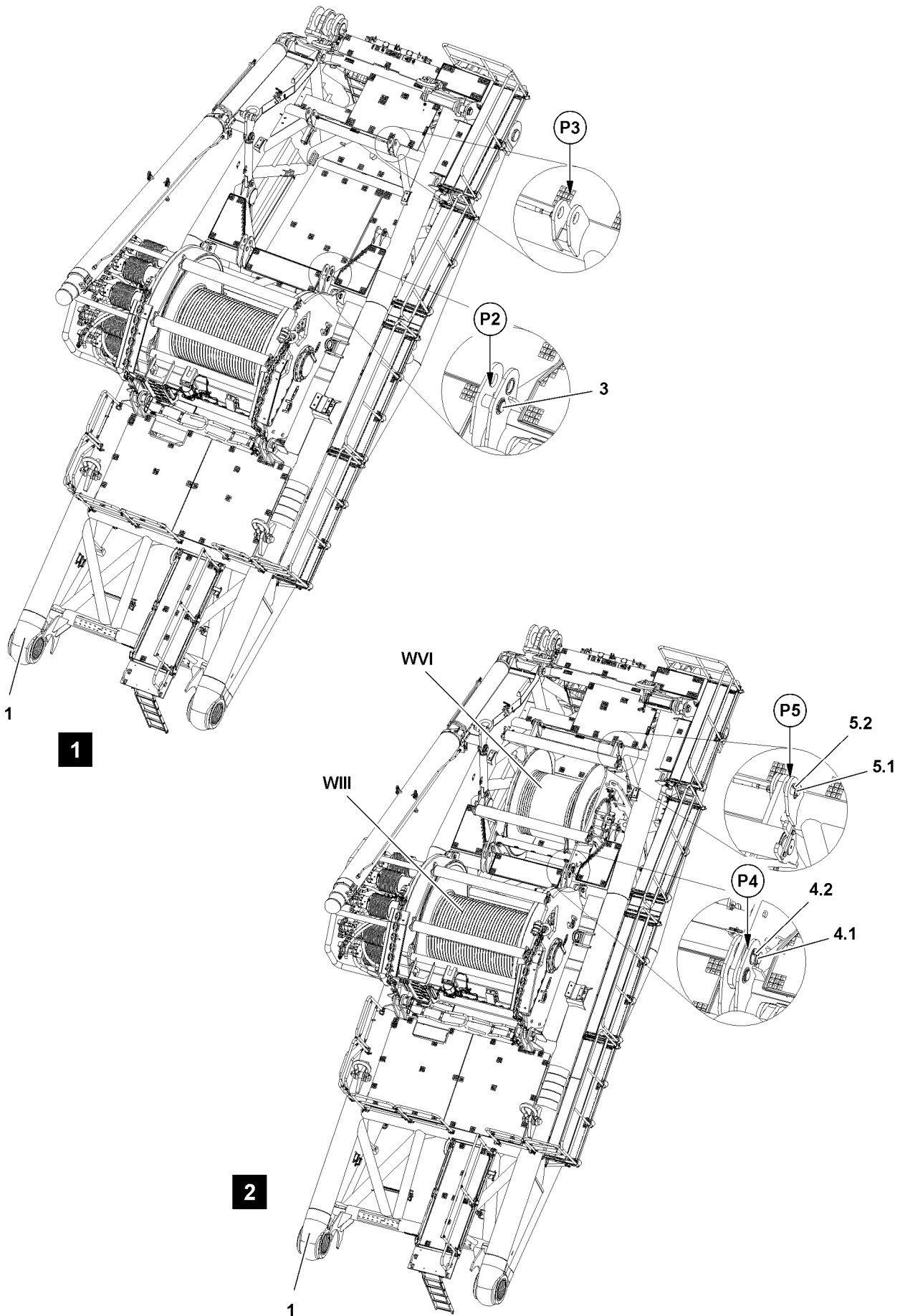

Fig.114370

LWE/LR 13000-001/19503-01-02/en

3.1.3 Pinning winch 6

Make sure that the following prerequisites are met:

- Winch 6 is seated on the centering pins **3**, point **P2**.
- Winch 6 is laying on the receptacle plates, point **P3**



WARNING

The pins can loosen up by themselves!

- ▶ Secure pins **4.1** immediately after pinning with safety locking pins **4.2!**
- ▶ Insert the pins **4.1** on both sides at point **P4** on the D-pivot section and secure with safety locking pins **4.2**, see illustration **2**.



WARNING

The pins can loosen up by themselves!

- ▶ Secure pins **5.1** immediately after pinning with safety locking pins **5.2!**
- ▶ Insert the pins **5.1** on both sides at point **P5** on the D-pivot section and secure with safety locking pins **5.2**, see illustration **2**.
- ▶ Remove the fastening equipment on winch 6.

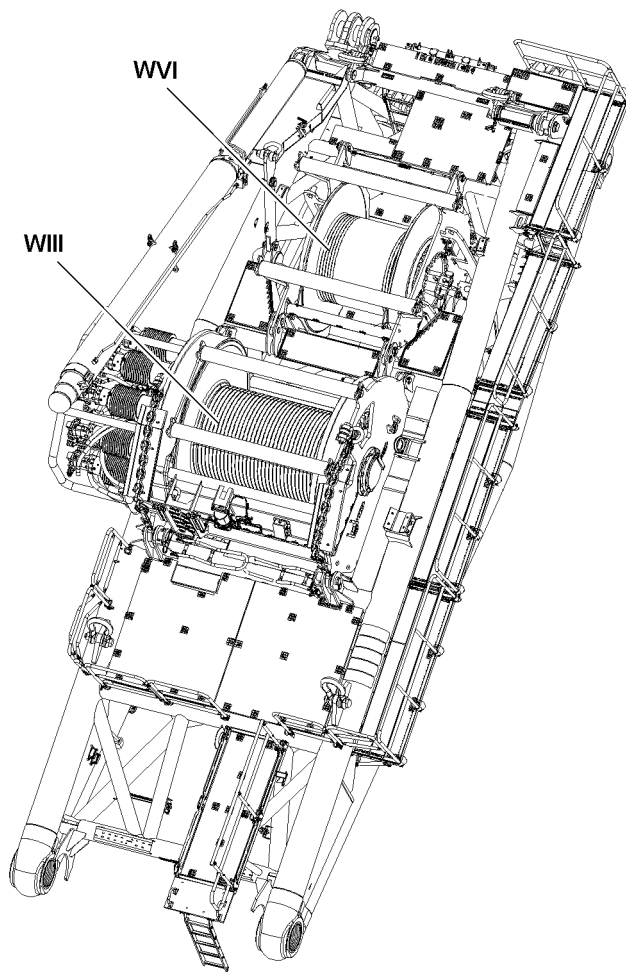

Fig.115610

LWE/LR 13000-001/19503-01-02/en

3.2 Establishing the connections to the winch

Make sure that the following prerequisites are met:

- The winch is properly installed, pinned and secured.
- The D-boom is installed.

3.2.1 Establishing the hydraulic connections to the winch



Note

- ▶ After the hydraulic connections to the winch are established, the expansion tank must be checked and emptied!

The hydraulic connections for the winch are made with quick couplings.

When connecting hydraulic lines with quick-release couplings, make sure that the coupling procedure is carried out correctly.



WARNING

Pressure in the hydraulic lines!

If the pressure supply is not interrupted before connecting / releasing the hydraulic lines, the hydraulic oil can escape with high pressure!

Personnel can be severely injured or killed!

- ▶ Release the pressure in the hydraulic system before connecting / disconnecting: Interrupt the pressure supply and wait for a short time!



WARNING

Loss of pressure or leakage!

Incorrectly coupled or self-loosening quick-release couplings (particularly return lines) can result in serious accidents due to component failure!

- ▶ Check that the quick couplings have been properly connected before using the crane!
- ▶ Connect the coupling components (sleeve and connector) and screw together with the hand-tightened nut.
- ▶ Tighten the hydraulic coupling by hand. Rotate the hand-tightened nut until it reaches a tangible, fixed stop position.
- ▶ Establish the hydraulic connections to the winch.

3.2.2 Establishing the connections to the winch

- ▶ Establish the electrical connections to the winch, see Electrical wiring diagram.

3.2.3 Establishing the connections for the central lubrication system to the winch

- ▶ Establish the connections for the central lubrication system to the winch.

Fig.195219

LWE/LR 13000-001/19503-01-02/en

4 Removing the winch



WARNING

Danger of falling!

During assembly / disassembly work, personnel must be secured with appropriate aids to prevent them from falling. If this is not observed, assembly personnel can fall and suffer life-threatening or fatal injuries!

- ▶ Any assembly work, where there is a danger of falling must be carried out with suitable aids (for example lifting platform, scaffolding, ladder, auxiliary crane)!
- ▶ If the work cannot be carried out with such aids nor from the ground, then the assembly personnel must secure themselves with approved fall arrest systems to avoid falling, see Crane operating instructions, Chapter 2.04!
- ▶ Approved fall arrest systems must be hung into the respective fastening points on the crane, see Crane operating instructions, chapter 2.06!
- ▶ If railings are present on the components, then they must be brought into the corresponding position and secured for assembly / disassembly work!
- ▶ Step on aids and fall protection equipment only with clean shoes!
- ▶ Keep aids and fall protection equipment clean and free from snow and ice!
- ▶ During all assembly and disassembly work, maintenance work and inspections, travel and crane operation is prohibited!



WARNING

Components not pinned and secured!

If a component is released from the auxiliary crane before having been pinned and secured, the component will fall down! Personnel can be severely injured or killed!

- ▶ Do not disengage the auxiliary crane until the corresponding component is pinned and secured!



WARNING

Danger of impact / crushing!

When installing / removing crane components with the auxiliary crane, crane components can start to swing back and forth!

When lifting / lowering and positioning crane components, there is an increased danger of impacts / crushing!

Personnel can be caught and severely injured or killed!

- ▶ Make sure that personnel cannot be caught by components!
- ▶ When working in danger zones: Use aids to protect limbs!
- ▶ Guide components with suitable aids to minimize oscillation!

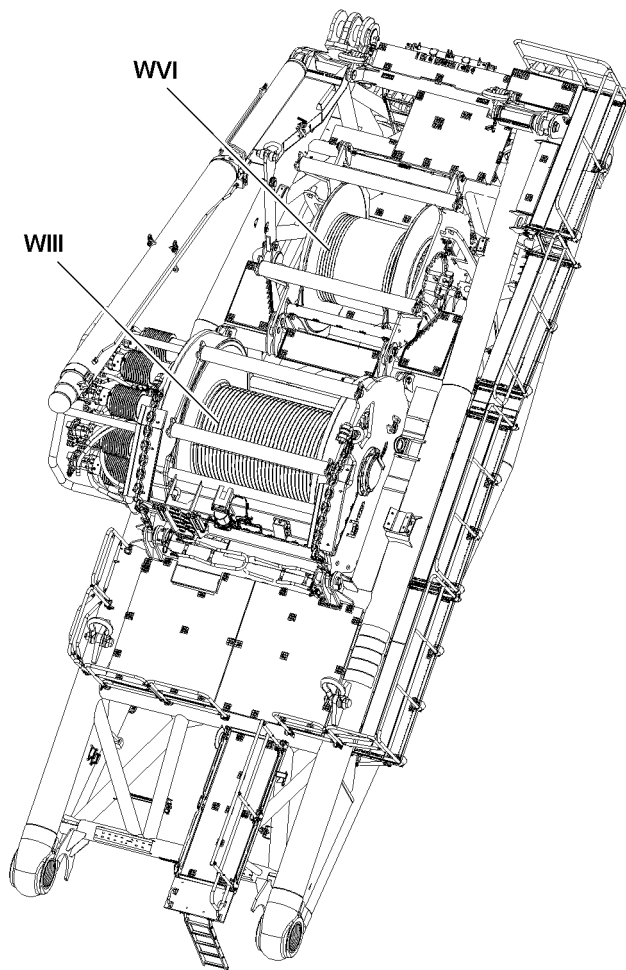

Fig.115610

LWE/LR 13000-001/19503-01-02/en

4.1 Disconnecting the connections to the winch

Make sure that the following prerequisite is met:

- The rope is spooled up completely.

4.1.1 Disconnecting the hydraulic connections to the winch

When releasing hydraulic lines with quick-release couplings, make sure that the uncoupling procedure is carried out correctly.



WARNING

Pressure in the hydraulic lines!

If the pressure supply is not interrupted before connecting / releasing the hydraulic lines, the hydraulic oil can escape with high pressure!

Personnel can be severely injured or killed!

- ▶ Release the pressure in the hydraulic system before connecting / disconnecting: Interrupt the pressure supply and wait for a short time!
-
- ▶ Release the hydraulic coupling by hand.
 - ▶ Disconnect the hydraulic connections to the winch.

4.1.2 Disconnecting the electrical connections to the winch

- ▶ Disconnect the electrical connections to the winch.

4.1.3 Disconnecting the connections for the central lubrication system to the winch

- ▶ Disconnect the connections to the winch.

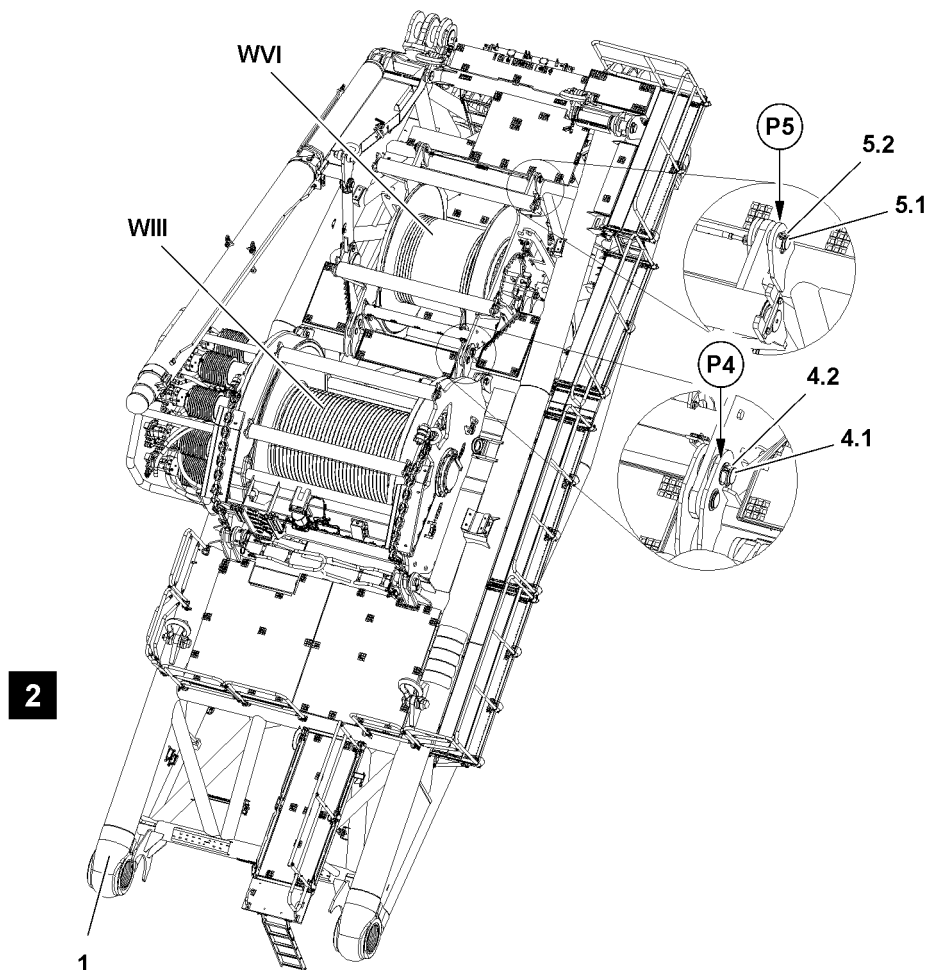
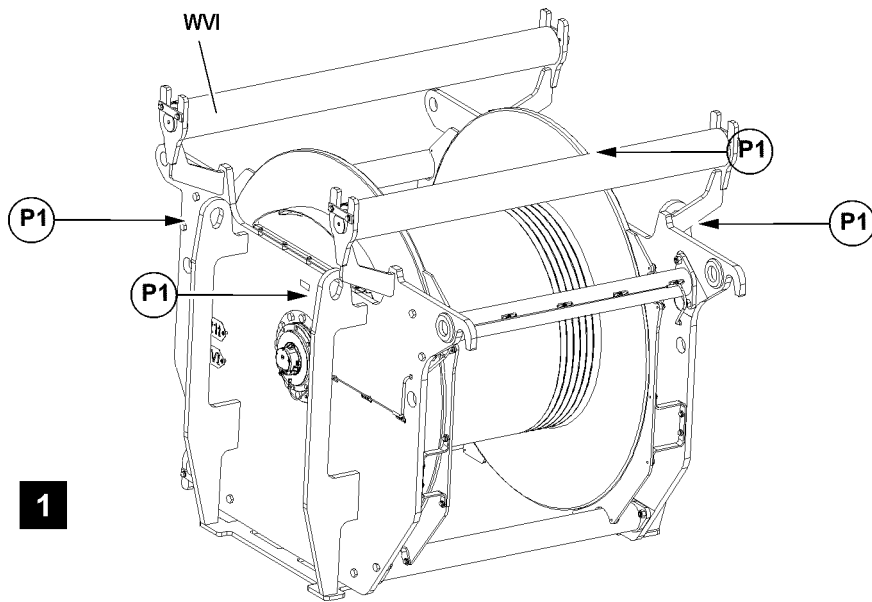

Fig.115613

LWE/LR 13000-001/19503-01-02/en

4.2 Removing winch 6

4.2.1 Unpinning winch 6

Make sure that the following prerequisites are met:

- The hydraulic connections are disconnected.
- The electrical connections are disconnected.
- The connections of the central lubrication system are disconnected.
- An auxiliary crane with sufficient load carrying capacity is available.



WARNING

Danger of accident due to incorrect attachment!

Life-threatening situations can arise if the winch 6 is incorrectly or improperly attached!

Personnel can be severely injured or killed!

- ▶ Winch 6 must be attached on the intended eyes at point **P1**!
- ▶ Make sure that the fastening equipment is correctly attached on winch 6 and that it is secured sufficiently to prevent it from loosening up!

- ▶ Attach the fastening equipment on the intended eyes at point **P1**.
- ▶ Bring the fastening equipment with the auxiliary crane to „tension“, see illustration 1.
- ▶ Remove the locking pin **5.2** at point **P5** and unpin the pin **5.1** on both sides, see illustration 2.
- ▶ Remove the locking pin **4.2** at point **P4** and unpin the pin **4.1** on both sides, see illustration 2.

4.2.2 Removing winch 6

When the pins are unpinned:

- ▶ Lift winch 6 carefully with the auxiliary crane.



WARNING

Falling components!

When lifting winch 6 from the D-pivot section, components or winch 6 can fall down!

Personnel can be severely injured or killed!

- ▶ Make sure that there are no persons within the danger zone!

- ▶ Move winch 6 out.

When winch 6 is moved out:

- ▶ Set winch 6 on the flatbed trailer.
- ▶ Remove the auxiliary crane.

Empty page!

LWE/LR 13000-001/19503-01-02/en

3.80 Crane and crane component transport

1	Safety	3
2	Rigging plans	3

Fig.195219

LWE/LR 13000-001/19503-01-02/en

1 Safety

Observe and adhere to the transport safety instructions. See Crane operating instructions, chapter 2.04.

2 Rigging plans

Observe and adhere to the rigging plans, see the separate rigging plans.

Empty page!

LWE/LR 13000-001/19503-01-02/en

4 Operation of crane superstructure

LWE/LR 13000-001/19503-01-02/en

LWE/LR 13000-001/19503-01-02/en

4.01 Operating and monitoring instruments on the crane superstructure

1	Cab equipment	3
2	Equipment in engine house	7
3	Cab operating units overview	9
4	Instrument panel	11
5	Operating and control unit (BKE)	15
6	LICCON computer system monitors	21
7	Camera monitoring	21
8	Pedal carrier	25
9	Touch displays	27
10	Master switch assignment MS1	29
11	Master switch assignment MS2	39
12	Master switch assignment MS3	53

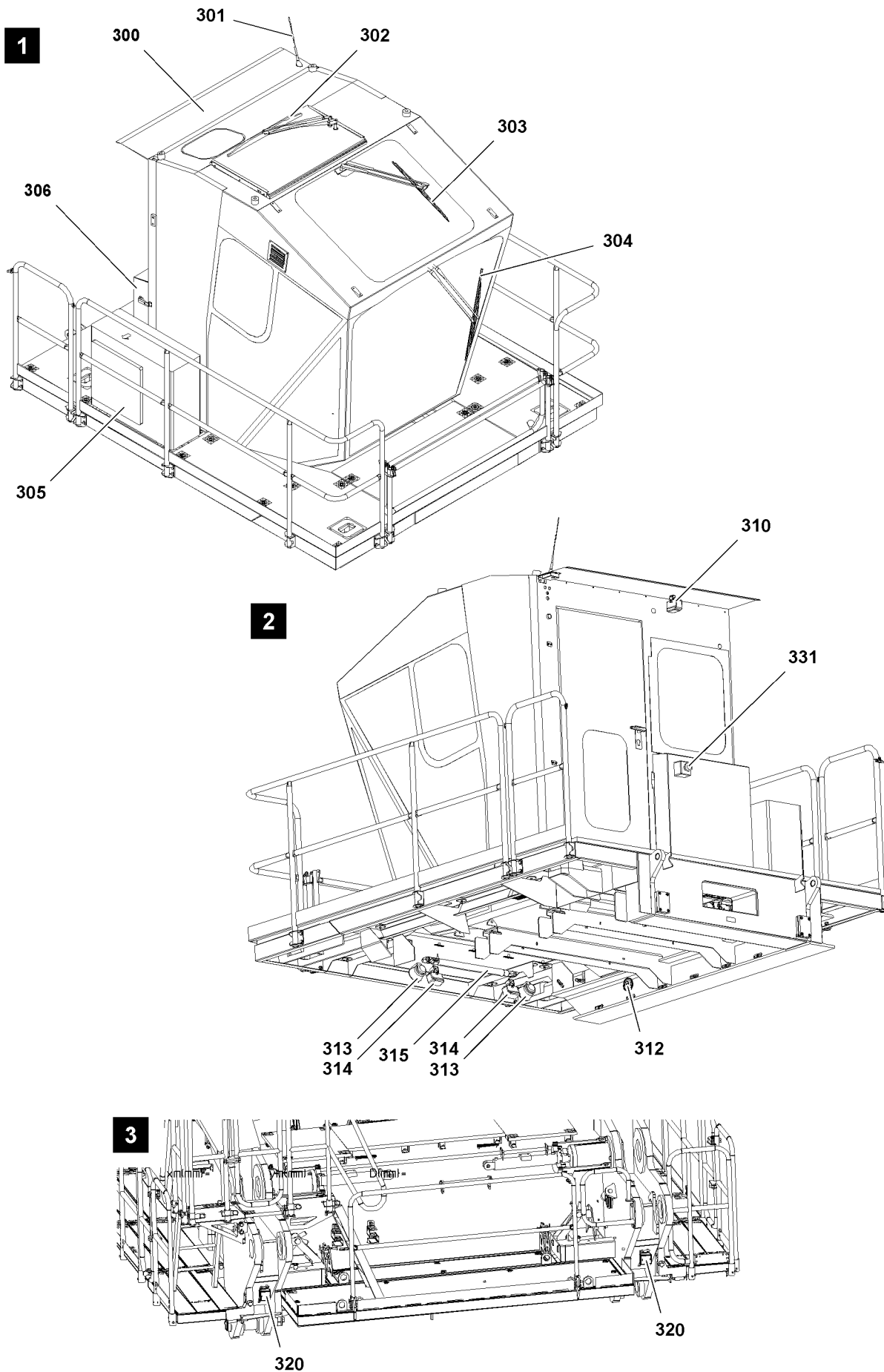

Fig.114869

LWE/LR 13000-001/19503-01-02/en

1 Cab equipment

1.1 Cab attachment parts

- 300** Cab
- 301** Antenna
- 302** Window wiper for skylight
- 303** Window wiper for roof window
- 304** Window wiper for front window
- 305** Climate control system
 - Outer unit
- 306** Auxiliary heater
 - With expansion tank
- 310** Floodlight, rear
- 331** EMERGENCY OFF switch
 - Cab, outside
- 312** Horn
- 313** Loudspeaker, outside
- 314** Floodlight, front
- 315** Three color light
 - LMB-warnings are displayed visually
- 320** LMB warning lights
 - The LMB warning lights are located on the turntable rear section

1.2 Rear of turntable attachment parts

- 320** LMB warning lights
 - Active together with the LMB warning light on the cab

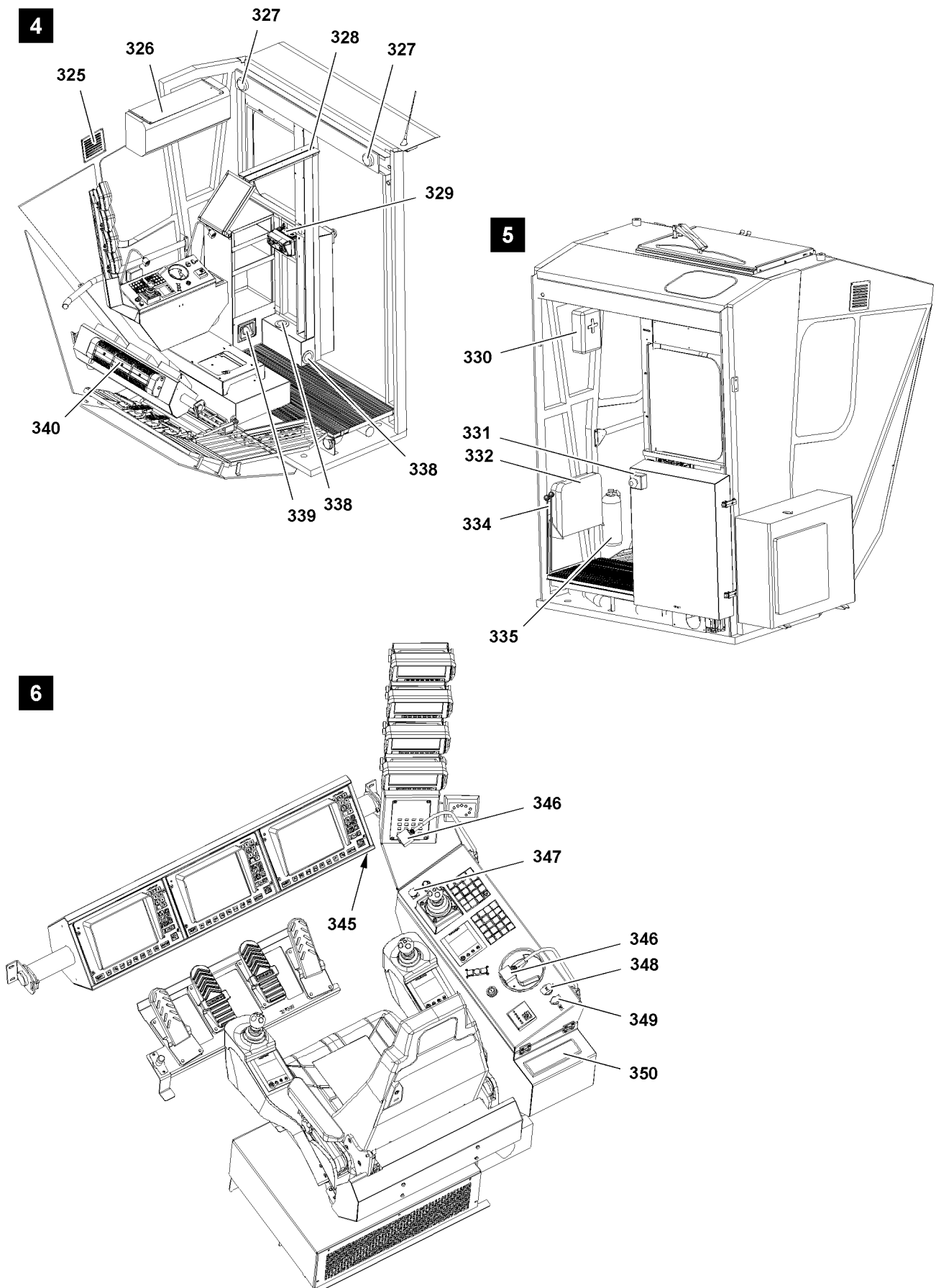

Fig.114870

LWE/LR 13000-001/19503-01-02/en

1.3 Emergency equipment

- 330 First aid kit
- 331 EMERGENCY OFF switch
 - Cab, outside
- 335 Fire extinguisher
- 347 EMERGENCY OFF switch
 - Instrument panel

1.4 Interfaces

- 329 Sub distributor
 - Power aggregate / supply subdistribution
 - Automatic fuse for climate control system
 - Automatic fuse for socket combination 230 V , 16 A
 - Socket combination 230 V , 16 A
- 345 Socket
 - Diagnostic interface for BSE
- 348 Cigarette lighter
 - 12 V
- 349 Socket
 - 12 V , 16 A

1.5 Interior equipment

- 325 Ventilation grid
- 326 Electric climate control system
- 327 Speaker
- 328 Interior lighting
- 332 Emergency seat
- 334 Manual control lever
- 338 Climate control system
 - Fan opening
- 339 Reservoir
 - Window washer fluid
- 340 Fan
 - Heat exchanger front window
- 346 Reading lights
- 350 Radio

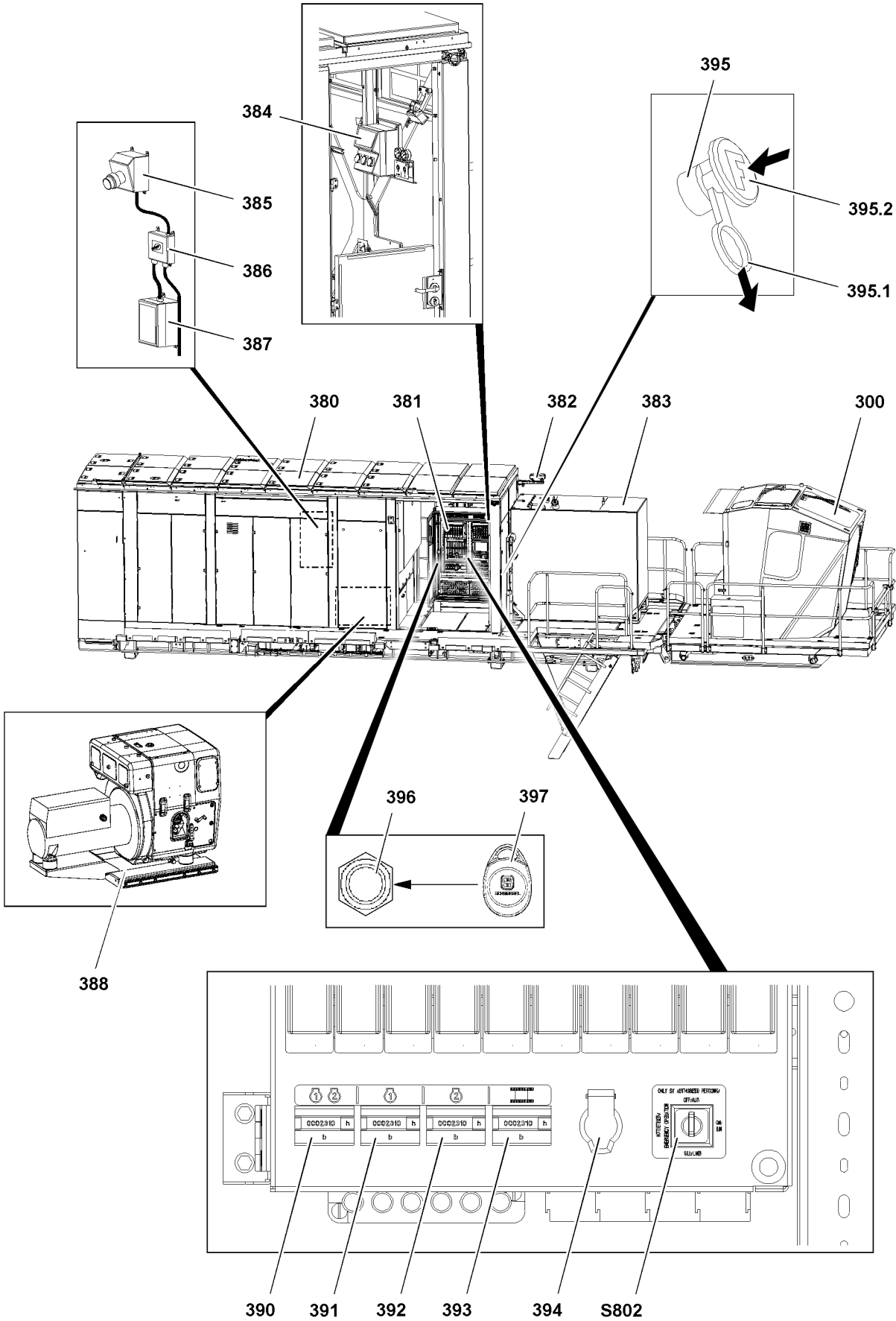

Fig.164432

LWE/LR 13000-001/19503-01-02/en

2 Equipment in engine house

2.1 Power aggregate / supply

- 300** Cab
- 380** Engine house
- 381** Control cabinet
- 382** Floodlights
- 383** Fuel tank aggregate
- 384** Distributor box
 - Power aggregate / supply main distributor
 - Sockets 230 V , 16 A
- 385** Plug connection
 - External power supply for climate control system
- 386** Switch
 - Supply of climate control system with external power supply or HATZ-DIESEL power aggregate
- 387** Engine circuit breaker
 - Engine circuit breaker 16 A for the climate control system
- 388** Power aggregate
 - HATZ-DIESEL power aggregate

2.2 Control cabinet

- 390** Operating hour meter
 - Display of crane operating hours
 - Note:** This operating hour meter runs, as soon as an aggregate is turned on.
- 391** Operating hour meter
 - Aggregate 1 operating hours display
- 392** Operating hour meter
 - Aggregate 2 operating hours display
- 393** Operating hour meter
 - Crawler operating hours display
- 394** Socket 24 V
- 395** Fire extinguishing system trigger
 - In the case of fire:**
 - 1.Pull out the retaining ring **395.1**.
 - 2.Press firmly on the button **395.2**
- 396** Sensor
 - Operating element for LMB emergency operation
 - Description of LMB emergency operation, see the Crane operating instructions, chapter 4.02 and 4.20.
- 397** Transponder
 - For LMB emergency operation
 - Control element for sensor **396**
 - Description of LMB emergency operation, see the Crane operating instructions, chapter 4.02 and 4.20.
- S802** Key switch
 - Emergency operation via AMS

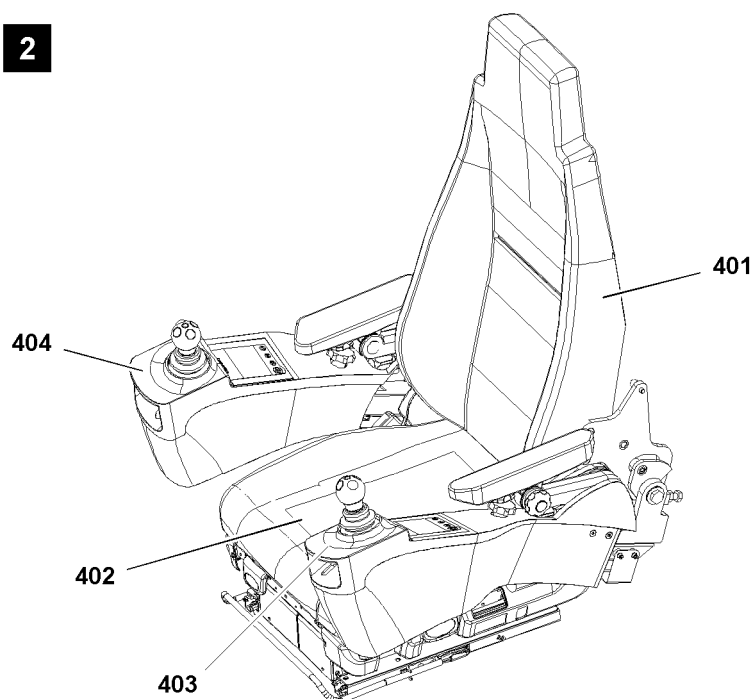
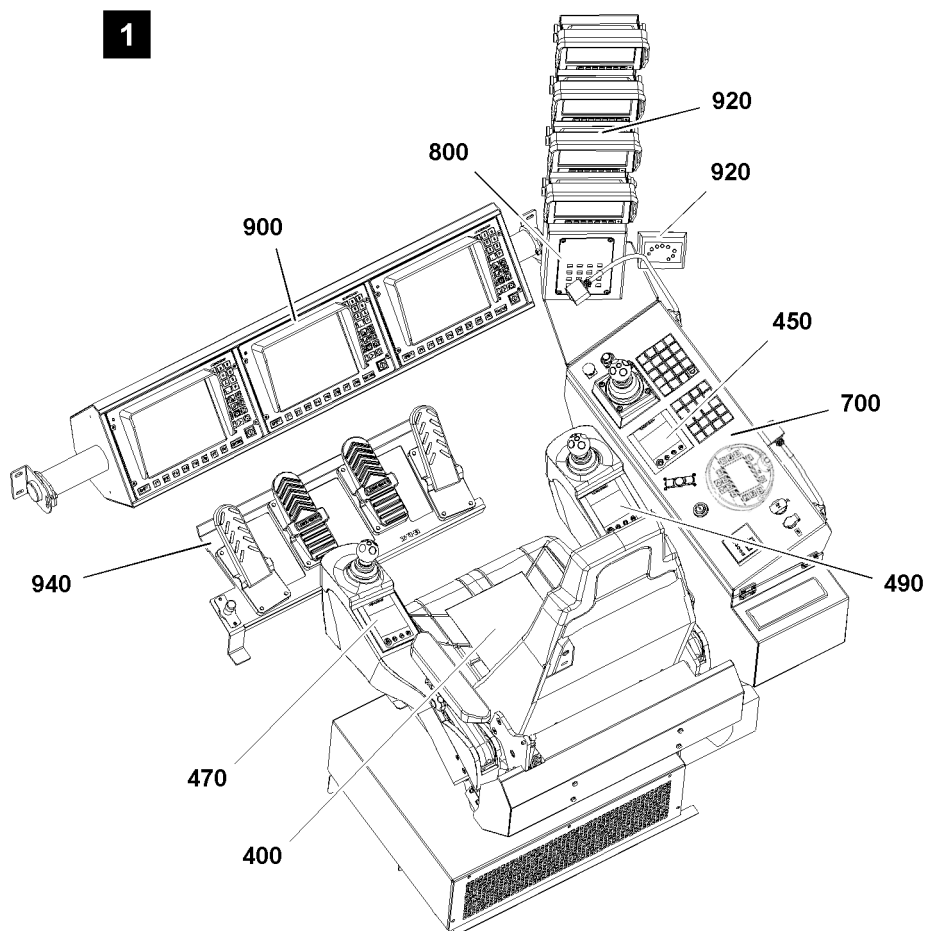

Fig.164433

3 Cab operating units overview

The following operating units are in the cab, see illustration 1:

- 940** Pedal carrier
- 900** Monitors
 - LICCON computer system
- 920** Camera monitoring
 - Monitors and control units
- 400** Control platform
- 700** Instrument panel
- 800** BKE
 - Operating and control unit

3.1 Touch display overview

The touch displays are assigned with the following functions, see illustration 1:

- 490** Touch display
 - Control panel, right: Assignment MS1, parallel operation, lock winch
- 470** Touch display
 - Control panel, left: Assignment MS2, slewing gear parking brake, LMB bypass, climate control settings, floodlight, hydraulic oil pre-heating/diesel particle filter
- 450** Touch display
 - Instrument panel: Assignment MS3, drive crawler

3.2 Control platform overview



Note

- ▶ For a detailed description of operating elements for adjusting the crane operator's seat, see the Crane operating instructions, chapter 4.03.
-

The control platform consists of the following elements, see illustration 2:

- 401** Crane operator's seat
- 402** Seat contact switch
- 403** Control panel, left
- 404** Control panel, right

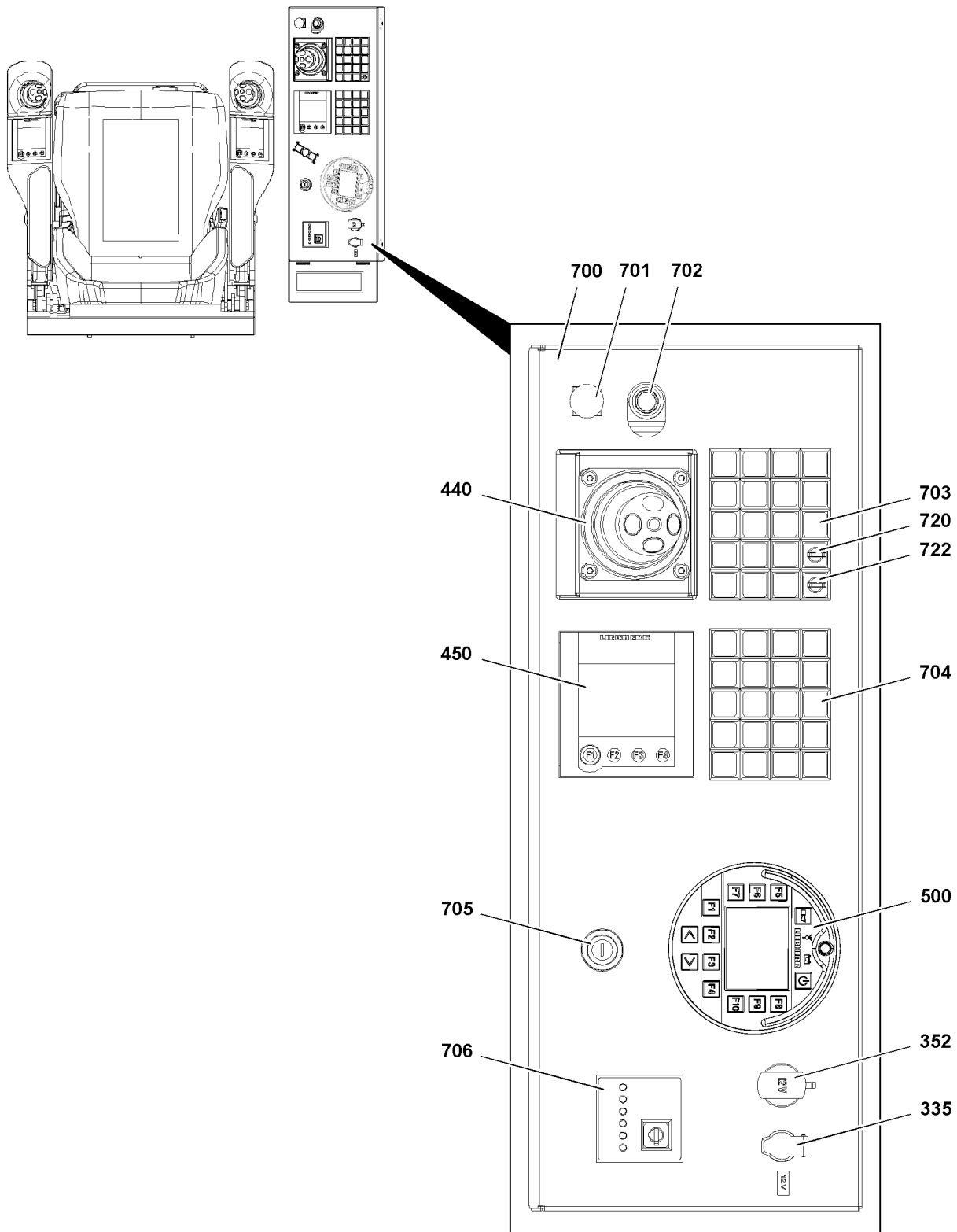

Fig.164431





LWE/LR 13000-001/19503-01-02/en

4 Instrument panel











The instrument panel **700** consists of the following elements:



- 440** Master switch MS3
- 450** Touch display TE3
- 500** BTT
 - For a description of the BTT control unit, see chapter 5.31.
- 701** EMERGENCY STOP button
- 702** Instrument panel opener
- 703** Keypad
 - Indicator lights and operating buttons
- 704** Keypad
 - Indicator lights and operating buttons
- 705** Ignition key switch
- 706** HATZ-DIESEL starter box
 - Power aggregate - Diesel generator operating unit, see the HATZ-DIESEL operating instructions
- 352** Cigarette lighter
- 335** Socket 12 V

4.1 Indicator lights and operating buttons

Position	Button	Function	LED	Description
720*	 „SPMT-release“ key button*	Off	–	Vertical position „SPMT-release“ is inactive
		On	–	Horizontal position: „SPMT-release“ is activated: Slewing gear freewheeling foot button is actuated self-retaining At slewing gear shut off: Slewing gear shut-off is bypassed
721*	 „SPMT-release“ indicator light*	Off	Off	„Derrick ballast“ is inactive
		On	Lights up	„SPMT-release“ is activated
722	 „Boom on the ground“ key button	Off	–	Vertical position „Boom on the ground“ is inactive
		On	–	Horizontal position: „Boom on the ground“ is activated
723	 „Boom on the ground“ indicator light	Off	Off	„Boom on the ground“ is inactive
		On	Lights up	„Boom on the ground“ is activated

LWELR 13000-001/19503-01-02/en

Position	Button	Function	LED	Description
724	 Engine house preheating	Off	–	By actuating the switch
		On	–	By actuating the switch
725	 Engine 2 preheating	Off	–	By actuating the switch
		On	–	By actuating the switch
726	 Engine 1 preheating	Off	–	By actuating the switch
		On	–	By actuating the switch
728	 Instrument panel lighting	Off	–	By actuating the switch
		On	–	By actuating the switch
729	 Access ladder lighting	Off	–	By actuating the switch
		On	–	By actuating the switch
730	 Engine house lighting	Off	–	By actuating the switch
		On	–	By actuating the switch
731	 Lower the derrick ballast button	Off	–	Releasing the button interrupts the movement
		On	–	Pressing and holding the button lowers the derrick ballast
732	 Pick up derrick ballast button	Off	–	Releasing the button interrupts the movement
		On	–	Pressing and holding the button lifts the derrick ballast
733	 Block derrick ballast compensation cylinder A button	Off	–	Releasing the button releases compensation cylinder A on the derrick ballast
		On	–	Pressing and holding the button blocks compensation cylinder A on the derrick ballast
734	 Block derrick ballast compensation cylinder B button	Off	–	Releasing the button releases compensation cylinder B on the derrick ballast
		On	–	Pressing and holding the button blocks compensation cylinder B on the derrick ballast.

Position	Button	Function	LED	Description
735	 Engine stop request indicator light		Lights up or blinks	In case of a warning occurrence
				Note: Pay attention to the system error, remedy the cause of the error immediately, turn the engine off if necessary.
736	 Remote diagnostics GSM module	On	Lights up	Pressing the switch activates the remote diagnostics GSM module. The remote diagnostics GSM module switches off automatically after 10 hours.
				Note: Observe the Diagnostics manual.
		Off	Off	The remote diagnostics GSM module is turned off.
		Note:		Not available on all crane types. For certain crane types, the remote diagnostics is switched on in another manner, see the Diagnostics manual.

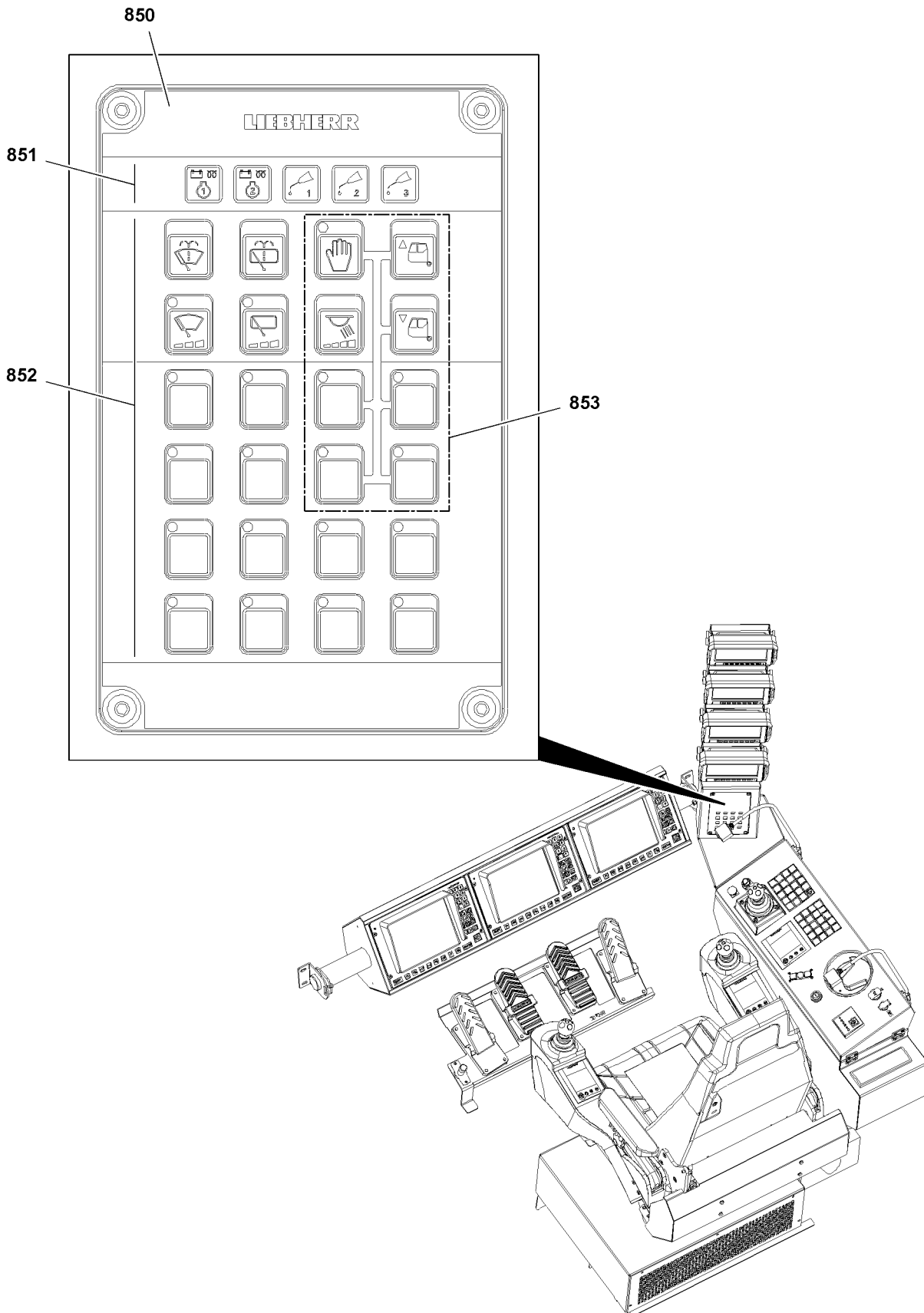

Fig.114874

LWE/LR 13000-001/19503-01-02/en

5 Operating and control unit (BKE)

5.1 Operating console overview







Note

► The indicator lights as well as the operating buttons are described in detail in the following sections!

- 850** Operating console
 - Housing with indicator lights and buttons
- 851** Indicator lights on the BKE
- 852** Operating buttons on the BKE
 - Standard assignment
- 853** Operating buttons on the BKE
 - Standard assignment for release controls

5.2 Indicator lights on the BKE

Here you find the description of the indicator lights **851**.

Position	Button	LED condition	Description
860	 Aggregate 1 engine monitoring	Yellow	Engine preheating active
		Yellow / red blinking	Engine ready to start
		Yellow blinking	Engine preheating Error / problem
		Off	Engine is running (after engine has been started)
		Red	The engine is running, the alternator does not charge
		Red blinking	Engine is running in emergency operation
861	 Aggregate 2 engine monitoring	Yellow	Engine preheating active
		Yellow / red blinking	Engine ready to start
		Yellow blinking	Engine preheating Error / problem
		Off	Engine is running (after engine has been started)
		Red	The engine is running, the alternator does not charge
		Red blinking	Engine is running in emergency operation
862	 Central lubrication 1 for: Winch 1, Winch 2 Winch 3/6, winch 5	Yellow + red (orange)	Functional readiness (shown after engine start for 1.5 s)
		Yellow	Lubrication active
		Red	Error / problem
		Off	Central lubrication not active
863		Yellow + red (orange)	Functional readiness (shown after engine start for 1.5 s)

Position	Button	LED condition	Description
	Central lubrication 2 for: Winch 4, A-frame	Yellow	Lubrication active
		Red	Error / problem
		Off	
864		Yellow + red (orange)	Functional readiness (shown after engine start for 1.5 s)
		Yellow	Lubrication active
		Red	Error / problem
		Off	Central lubrication not active





5.3 Operating buttons on the BKE, standard assignment





Here you find the description of the Operating keys, standard assignment **852**.











Note

- ▶ With the LEDs in the operating buttons, the operating conditions and problems can be recognized quickly and reliably by the crane driver!

Position	Button	Function	LED	Description
870	 „Front“ washer pump	On	–	Clean the window: By pressing and holding the „Front“ or „Roof“ button
		Note: After releasing the „Front“ or „Roof“ button, three additional wipe movements are carried out before the wiper blades return to their original position.		
871	 „Roof“ washer pump	Off	–	By releasing the „Front“ or „Roof“ button
872	 „Front“ window wiper	Note: There are three different wipe stages: 1. Wiper „On“: Continuous operation 2. Intermittent 1: Wipe with long pauses 3. Intermittent 2: Wipe with short pauses 4. Wiper „Off“		
873	 „Roof“ / „Skylight“ window wiper			
		On	Lights up	By pressing the „Front“ or „Roof“ button
		Off	Off	By pressing the „Front“ or „Roof“ button longer than one second until a „beep“ sounds or

Position	Button	Function	LED	Description
				By pressing the „Front“ or „Roof“ button until the LED is off or Ignition „Off“
874	 Cab interior light	On (100 %)	–	By opening the door or By pressing the button
		Dim	–	There are three different dimmer stages: 1. 75 percent 2. 50 percent 3. 25 percent 4. Interior light „Off“ When the interior light is turned on: Each time the button is pressed, the brightness is reduced incrementally.
		Off	–	By pressing the button for longer than one second or By pressing the button until the lighting turns „Off“ or If the following conditions are present simultaneously for longer than 30 s: – Driver's seat not occupied – Door closed – Engine „Off“
875	 Camera lighting	Off	Off	By pressing the button
		On	Lights up	By pressing the button
		On	Blinks	Error / problem
876	 Crawler travel gear lighting	Off	Off	By pressing the button
		On	Lights up	By pressing the button
		On	Blinks	Error / problem
877	 Airplane warning light	Off	Off	By pressing the button
		On	Lights up	By pressing the button

LWE/LR 13000-001/19503-01-02/en

Position	Button	Function	LED	Description
		On	Blinks	Error / problem
878	 Lighting cab outside	Off	Off	By pressing the button
		On	Lights up	By pressing the button
		On	Blinks	Error / problem
879	 Auxiliary users pressure supply	Note: For all functions, which are actuated with the hydraulic manual control levers, the pressure supply must be changed over.		
		Off	Off	By pressing the button
		On	Lights up	By pressing the button
		On	Blinks	Error / problem
880	 Exterior engine house lighting	Off	Off	By pressing the button
		On	Lights up	By pressing the button
		On	Blinks	Error / problem
881	 Central lubrication intermediate lubrication	Off	Off	By pressing the button
		On	Lights up	By pressing the button
		On	Blinks	Error / problem
882	 Turntable lighting	Off	Lights up	By pressing the button
		On	Lights up	By pressing the button
		On	Blinks	Error / problem
883	 Increase the engine rpm	Off	Off	By releasing the button
		On	Lights up	By actuating and holding the button
		On	Blinks	Error / problem
884	 Lower engine rpm	Off	Off	By releasing the button
		On	Lights up	By actuating and holding the button
		On	Blinks	Error / problem
885	 Ignition „On“ and „engine stop“ over these buttons corresponds to Stand-By mode			

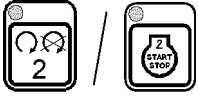
Position	Button	Function	LED	Description
	Engine 1 START / STOP	Off	Off	Stop engine 1: By pressing the button
		On	Lights up	Start engine 1: By pressing the button
		On	Blinks	Nominal rpm not reached
886	 Engine 2 START / STOP			Ignition „On“ and „engine stop“ over these buttons corresponds to Stand-By mode
		Off	Off	Stop engine 2: By pressing the button
		On	Lights up	Start engine 2: By pressing the button
		On	Blinks	Nominal rpm not reached



5.4 Operating buttons on the BKE for release actuations

Here you find the description of the Operating buttons for release actuations **853**.



Note

- ▶ The following functions require the activation of the „release button“.
- ▶ The „release button“ is active for 30 seconds. If the operating button is pressed during this time, the release time is reset to 30 seconds. The release stops after 30 seconds.
- ▶ A function is triggered by activation of the „release button“ and then pressing the corresponding operating button.
- ▶ For the listed key combinations, hold the corresponding operating button until the desired end position is reached.

Position	Key combination	Function	LED	Description
890	 Release button			Note: After pressing the release button, the functions, which require a release can be activated. The release is indicated by the green LED on the release button.
		On	Lights up	Press the release button
		Off	Off	By pressing the button or as long as no button is pressed that requires a release: Automatically after 30 seconds
890+891	 Lift the cab	Off	Off	Function not active
		On	Blinks	Error / problem
		On	Lights up	The cab is lifted
890+892	 Lower the cab	Off	Off	Function not active
		On	Blinks	Error / problem
		On	Lights up	The cab is lowered

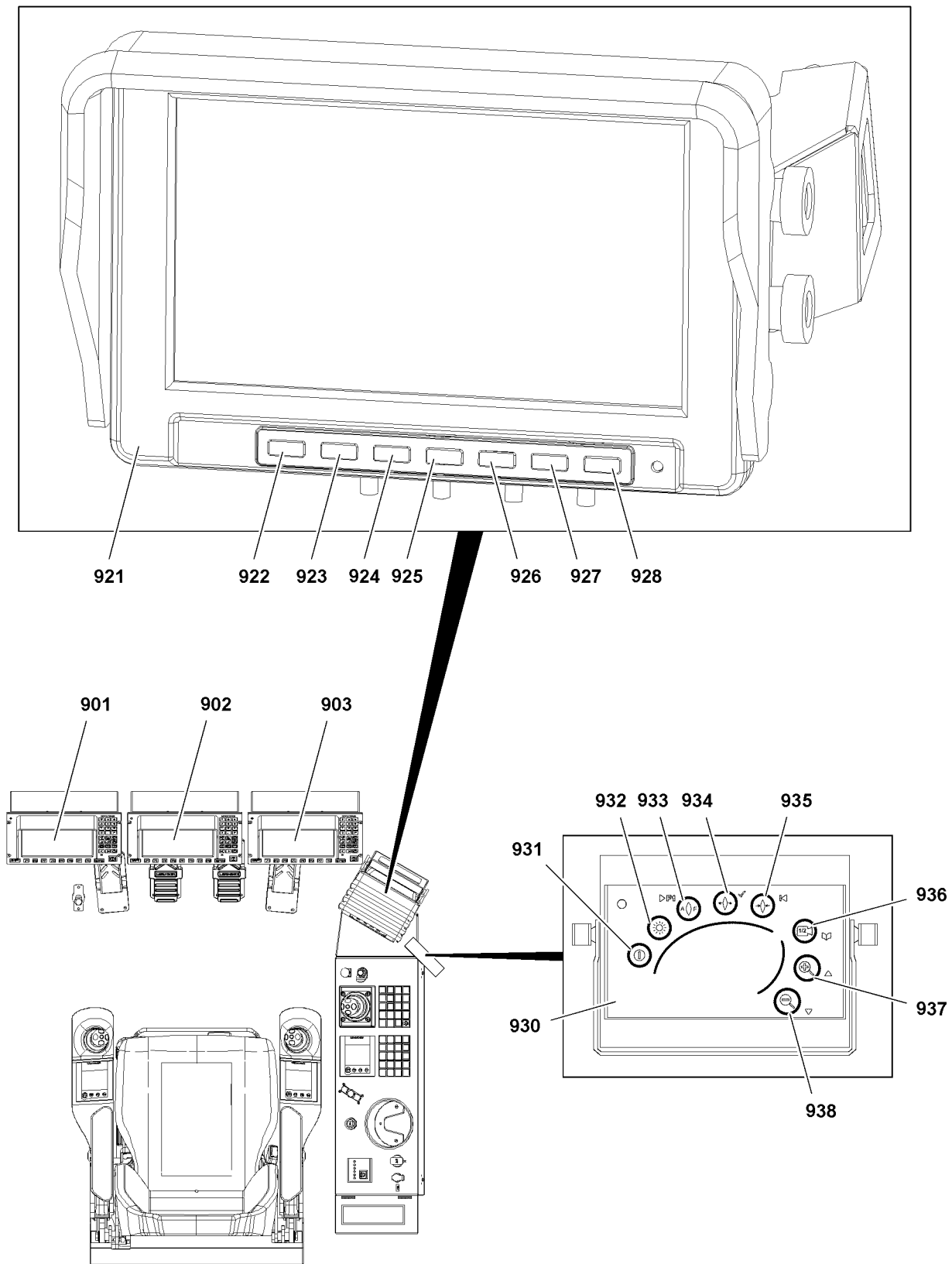

Fig.114871

LWE/LR 13000-001/19503-01-02/en

6 LICCON computer system monitors



Note

- ▶ For a detailed description of the operating elements and functions on the LICCON monitors, see the Crane operating instructions, chapter 4.02!

901 LICCON monitor 2

902 LICCON monitor 1

903 LICCON monitor 0

7 Camera monitoring

7.1 Camera monitoring control unit



Note

- ▶ The control unit is used to operate the zoom camera on the S-pivot section.
- ▶ The zoom camera can be aligned and set together with the floodlights, see section „TE2 floodlight menu (touch display left)“
- ▶ The zoom camera supports monitoring of the hook block, when the view is blocked by the P-boom.
- ▶ The video picture of the zoom camera is displayed on a camera monitor in the crane cab.

930 Operating unit

- Camera monitoring

931 On / Off button

- Turn camera monitoring on, off

932 Screen brightness button

- Turn the screen brightness of the zoom camera on or off

933 Auto focus key / function key

- Turn the auto focus of the zoom camera on or off
- Monitor output: „Auto focus AF OFF“ or „Auto focus AF ON“
- Function key in combination with other keys

934 Manual focusing button

- Manual focusing of camera in „Auto focus AF OFF“ mode

935 Manual focusing / language selection button

- Manual focusing of camera in „AF OFF mode“
- Language selection of monitor output (German / English): Function key button **933** and button **935** button combination

936 „1/2“ changeover button

- When a second camera is connected to the operating unit: Switch between camera 1 and camera 2 by pressing the „1/2 “ button.

937 Zoom „+“ button

- By pressing the button „+“, the camera picture is zoomed in.

938 Zoom „-“ button

- By pressing the button „-“, the camera picture is zoomed out.

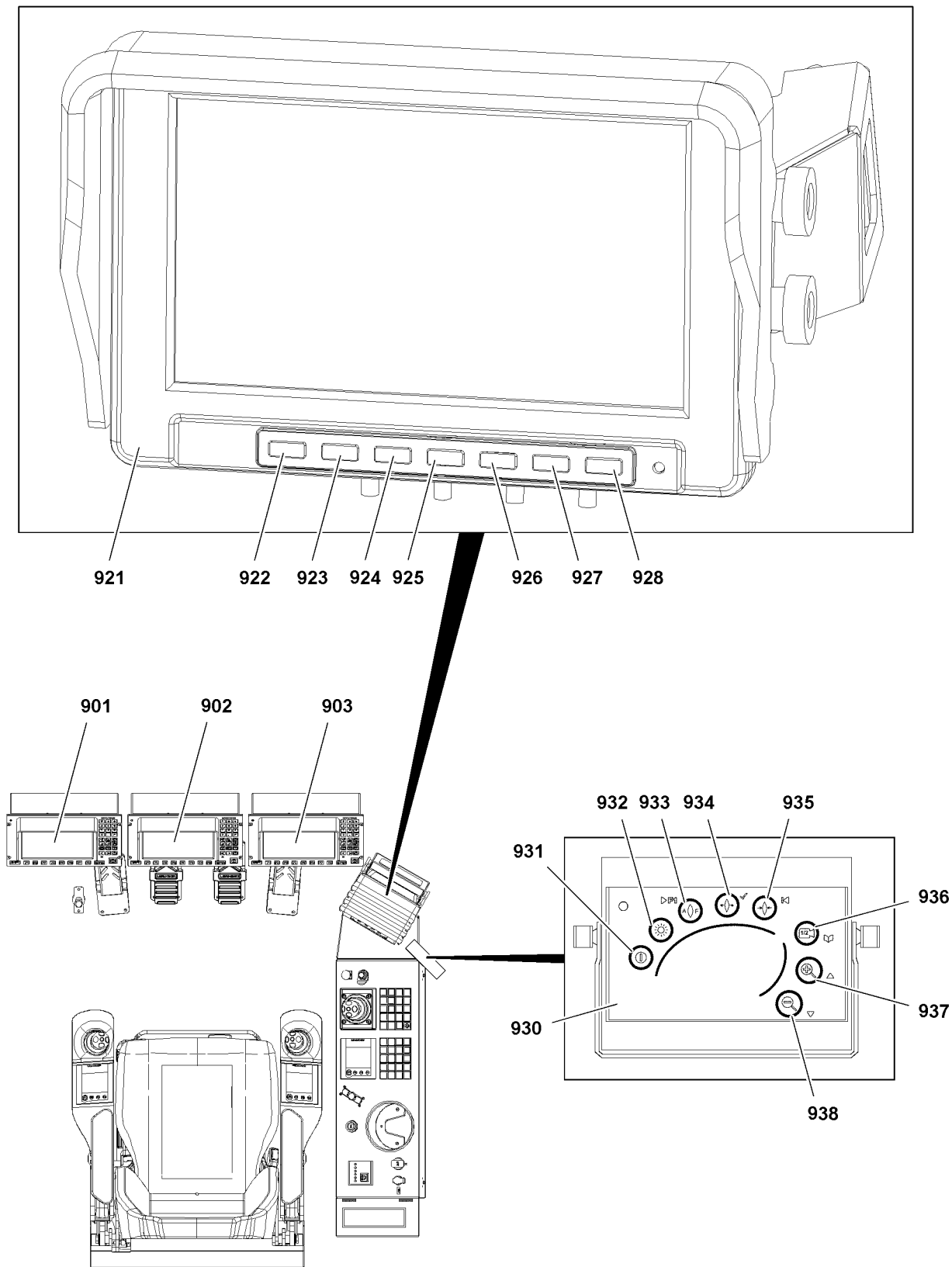

Fig.114871

LWE/LR 13000-001/19503-01-02/en

7.2 Camera monitoring monitors

- 921** TFT monitor
- 928** Button
 - Monitor on / off
- 922** „MODE“ button
 - By pressing the „MODE“ button, the system changes between the individual display modes:
 - Single picture
 - Split picture
 - Tripled or quadrupled picture
- 923** „SELECT“ button
 - By pressing the „SELECT“ button the system changes between the cameras:
 - Single display mode: Change between camera 1 and camera 2
 - Split display mode: Change between cameras 1/2, cameras 2/3, cameras 3/4 and camera 4/1
 - Tripled or quadrupled display mode: The button has no function.
- 924** Menu button
 - By pressing the „Menu“ button, menus for various adjustments are called up and changed over, in the following order:
 - Brightness: Brightness adjustment
 - Contrast: Contrast adjustment
 - Color: Adjustment of color saturation
 - Standard: Reset to works settings
 - Volume: Volume adjustment
 - Language: Language adjustment (English, French, German, Spanish, Italian, Portuguese, Polish)
- 925** „Minus“ button
 - By pressing the „Minus“ button, the value of a setting is reduced.
- 926** „Plus“ key
 - By pressing the „Plus“ button, the value of a setting is increased.
- 927** Button „Change between day / night“
 - Press the „Change between day / night“ button to match the brightness of the display to the time of day.

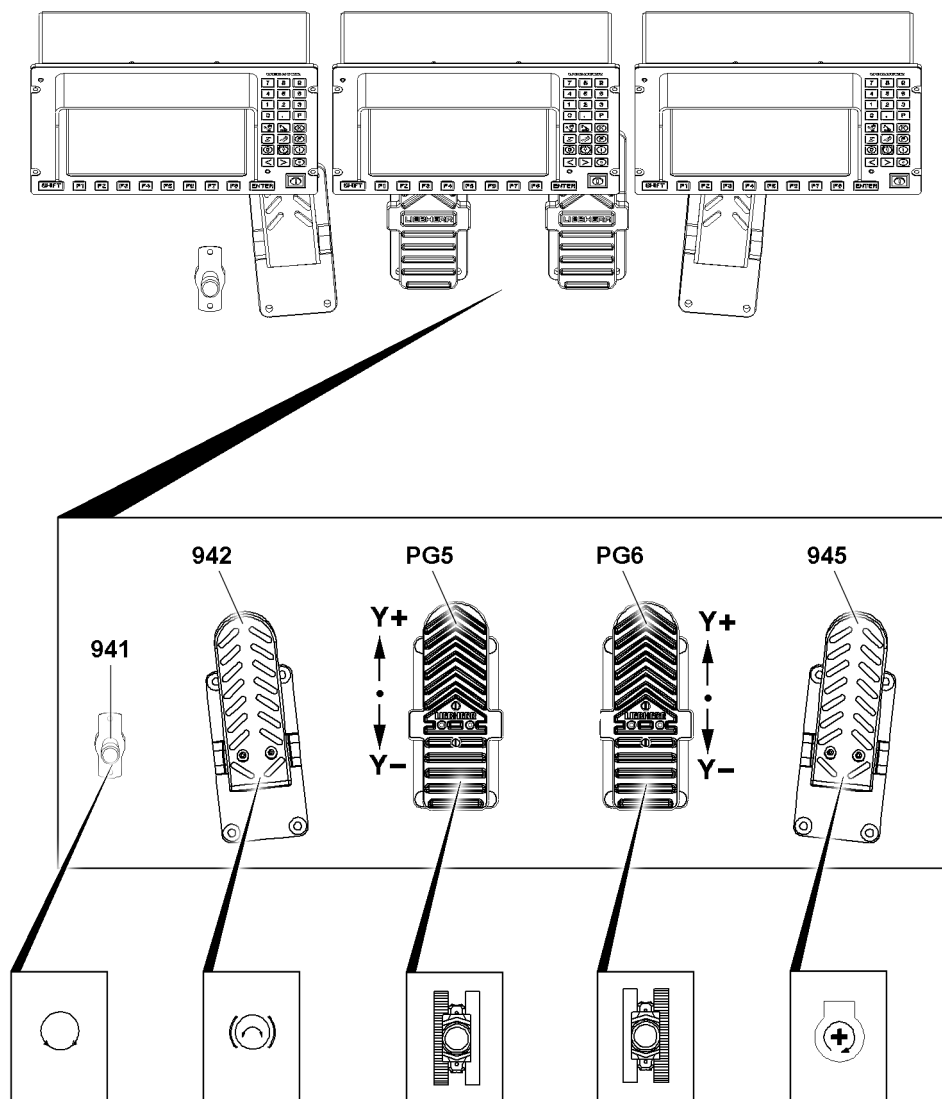

Fig.128218

8 Pedal carrier

- 941** Foot button
- Slewing gear freewheeling

- 942** Pedal
- Slewing gear parking brake

- PG5** Pedal sensor 5

Drive the left crawler:

Actuate pedal sensor 5 **PG5** in the Y+ direction (forward): The left crawler drives forward.

Actuate pedal sensor 5 **PG5** in the Y- direction (backward): The left crawler drives backward.

- PG6** Pedal sensor 6

Drive the right crawler:

Actuate pedal sensor 6 **PG6** in the Y+ direction (forward): The right crawler drives forward.

Actuate pedal sensor 6 **PG6** in the Y- direction (backward): The right crawler drives backward.

- 945** Pedal
- Engine regulation

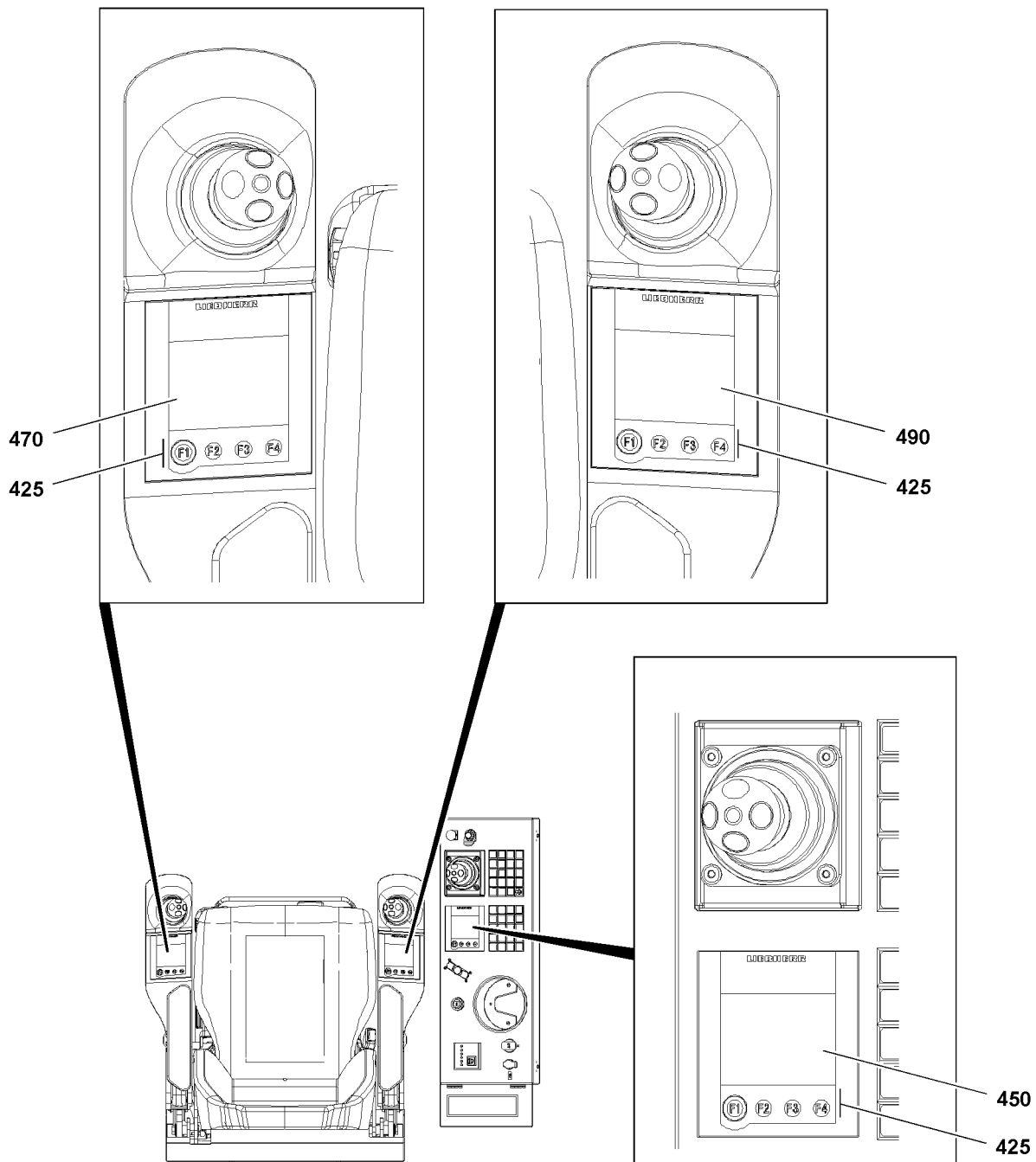

Fig.114879

9 Touch displays

The touch displays are combined display and operating elements. The touch displays are operated using the function key line „F1“ to „F4“ and by direct „touch“ (fingertip) on the corresponding display icons.



Note

- ▶ The illustrations or icons on the touch displays are only examples.
- ▶ The illustrations may differ depending on the crane!
- ▶ If the F1 key is continuously pressed, the system switches continuously between the existing menu items.

Various menus can be called up using touch display TE1 **490**, touch display TE2 **470** and touch display TE3 **450**. In these menus you can select or preselect different crane functions, turn them on and off or control them directly.



Note

- ▶ At low temperatures, it is possible that the touch displays initially change to the menu items with a delay and that the touch functions remain deactivated for that time.
- ▶ Wait a few minutes after ignition „ON“ until the menu items are shown on the touch display.

425 Function keys

- The assignment of the function keys depends on the icons or the functions, which are visible on the individual touch displays.
- Additional functions can be called up via the menus on all touch displays.

490 Right touch display TE1

- See section „Master switch assignment MS1“

470 Left touch display TE2

- See section „Master switch assignment MS2“

450 Touch display TE3, instrument panel

- See section „Master switch assignment MS3“

9.1 Touch functions

9.1.1 Selecting and deselecting touch functions



Note

- ▶ Touch functions are identified by the double border (empty frame) of the touch display icons. The function is selected / deselected with the press of a finger („touch“) on the icon.
- ▶ See chapter 4.01.10

9.2 Starting up the LICCON computer system and the touch displays

After turning on and correct boot up of the LICCON computer system, a static crane picture appears momentarily on the touch display. From here the system automatically switches to the master switch assignment for the relevant master switch, MS1 (right), MS2 (left) and MS3 (instrument panel).

The touch display always displays the master switch assignment on the touch displays that was set or „active“ before the LICCON computer system was shut off.

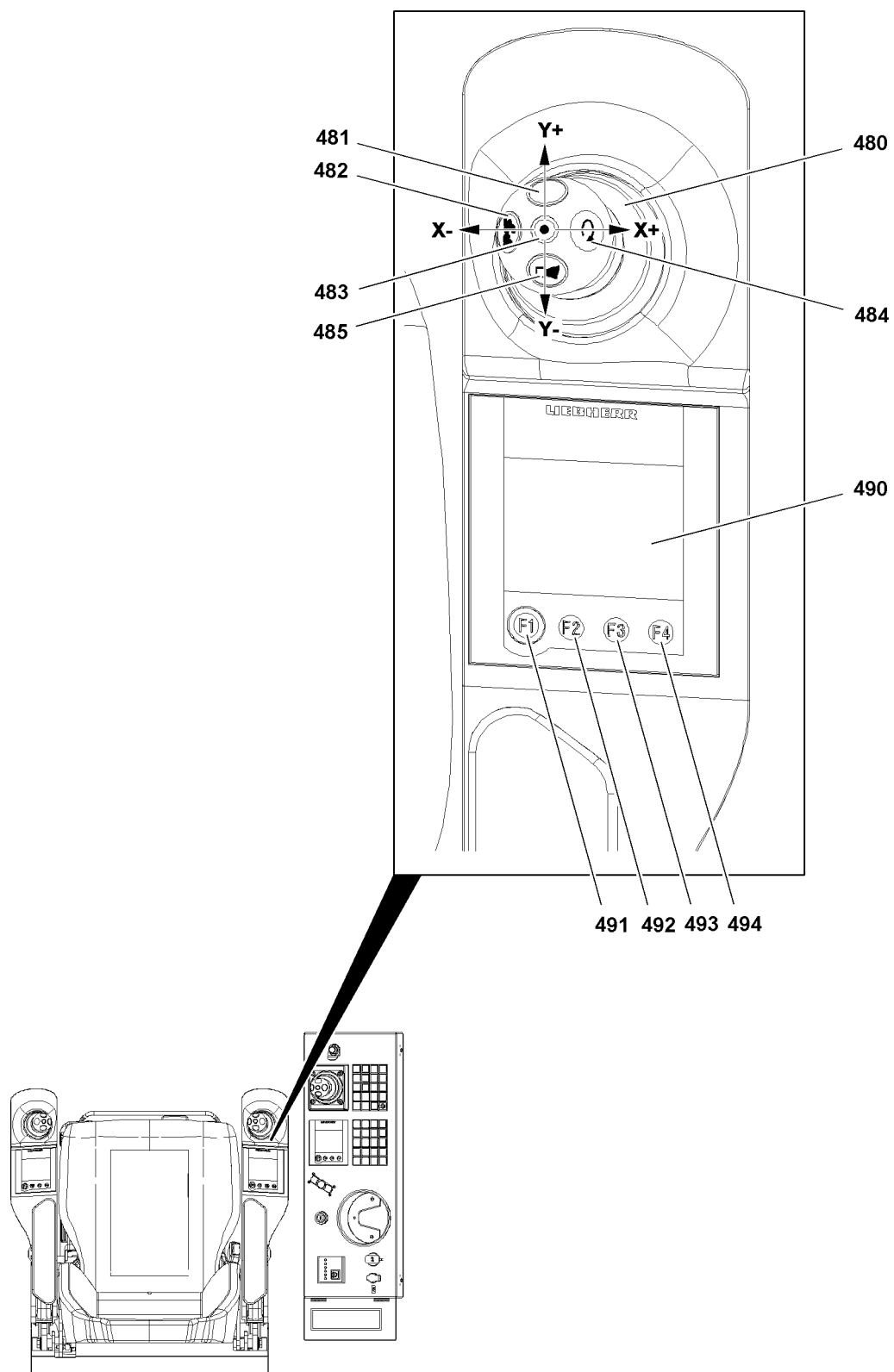

Fig.114881

LWE/LR 13000-001/19503-01-02/en

10 Master switch assignment MS1



Note

Change of master switch assignment!

The assignment of the master switches to the respective units on the crane can change, depending on the set up configuration and winch application!

► **Check the assignment before actuating the master switch on the TE!**



Note

► For a description of the functions of the master switches, see the Crane operating instructions, chapter 4.05.

480 Master switch right (MS1)

- The functions for master switch MS1 depend on the set up configuration and the selected master switch assignment on TE1.

481 Button

- Bypass of the seat contact button
- **Or:** When the seat contact button is actuated: Activation of the vibration sensor **483**

482 Button

- „Power Plus“ activation, crane operation

483 Vibration sensor

- Turn sensor and winches



Note

► Pressing the button **484** locks the engine regulation in the current position.

484 Button

- Locking the engine regulation of the superstructure engine
The idling speed can be increased up to the maximum rpm.
- Can be „overridden“ by the engine regulation (gas pedal).
- With continued actuation of the engine regulation (gas pedal), the current rpm is taken over.
- By pressing the button **484** with the engine regulation (gas pedal) **NOT actuated**, the manual throttle is cancelled.
- If the engine rpm is locked, a „+“ appears on the LICCON monitor on the „dynamic engine rpm display“ (travel operation) and the „dynamic load utilization bar display“ (crane operation).
- Delete the lock by touching the gas pedal momentarily.

485 Button

- Horn

10.1 TE1 Function key assignment

490 Touch display (TE1)

491 F1 key

- On TE1, no function

492 F2 key

- Change to the „Lock winch“ menu



Note

► The winch status (winch activated / blocked) can be seen on the touch display. Blocked winches are recognizable on the icon.

493 F3 key

- Change master switch assignment; identification by letters in the icon

The number of possible master switch assignments depends on the set up configuration configured in the LICCON computer system.



Conditions:

Zero position Master switch 1 (MS1 **480**), master switch 2 (MS2) and master switch 3 (MS3)







494 F4 key

- If a touch function of assembly winch 1 is activated on the touch display: Spool out, spool up or constantly spool up assembly winch 1.
When parallel operation winch 1 || winch 2 is activated: „Adjust the winches“









10.2 TE1 main menu: Functions and assignment

Position	Icon	TE1 assignment
1.01		Display of master switch with deflection directions; icon in main menu visible on every touch display
1.02		Identification of master switch assignment, example „D“







10.2.1 TE1 Touch functions







Position	Icon	TE1 Main menu assignment: Touch functions
1.10		Adjust winch 1 and winch 2
1.11		Winch 1 and winch 2 are adjusted
1.12		Spool assembly winch 1 up
1.13		Spool assembly winch 1 out
1.14		Spool assembly winch 1 up constantly
1.15		Parallel operation of assembly winch 1 and assembly winch 2, spool up constantly

10.2.2 TE1 winch assignment

Position	Icon	TE1 Main menu assignment: Winches
1.20		Spool winch 1 up
1.21		Spool winch 1 out, display of winch speed in percentages
1.22		Spool winch 1 and winch 2 up in parallel operation
1.23		Spool out winch 1 and winch 2 in parallel operation, display of winch speed in percentages
1.24	 	Winch 1 is blocked Note: If a winch is blocked, the „spool winch up“ and „spool winch out“ functions can NOT be carried out!
1.25	 	Parallel operation of winch 1 and winch 2 is blocked Note: If parallel operation is blocked, the „spool winch up“ and „spool winch out“ functions can NOT be carried out!

10.2.3 TE1 boom and equipment assignment

Position	Icon	TE1 Main menu assignment: Boom and equipment
1.30		Luff the main boom up
1.31		Luff the main boom down; display of maximum winch speed as a percentage
1.32		Luff the luffing jib up
1.33		Luff the luffing jib down; display of maximum winch speed as a percentage
1.34		Luff the main boom up
1.35		Luff the main boom down; display of maximum winch speed as a percentage

Position	Icon	TE1 Main menu assignment: Boom and equipment
1.36		Luff the main boom up
1.37		Luff the main boom down; display of maximum winch speed as a percentage
1.38		Luff the luffing jib up
1.39		Luff the luffing jib down; display of maximum winch speed as a percentage
1.40		Luff the main boom up
1.41		Luff the main boom down; display of maximum winch speed as a percentage
1.42		<p>If a crane movement is blocked, the „luffing up“ and „luffing down“ functions can NOT be carried out!</p> <p>Note: Boom and equipment: Crane movement is blocked, example SW, „luff luffing jib up“ and „luff luffing jib down“ can NOT be carried out.</p>

Empty page!

LWE/LR 13000-001/19503-01-02/en

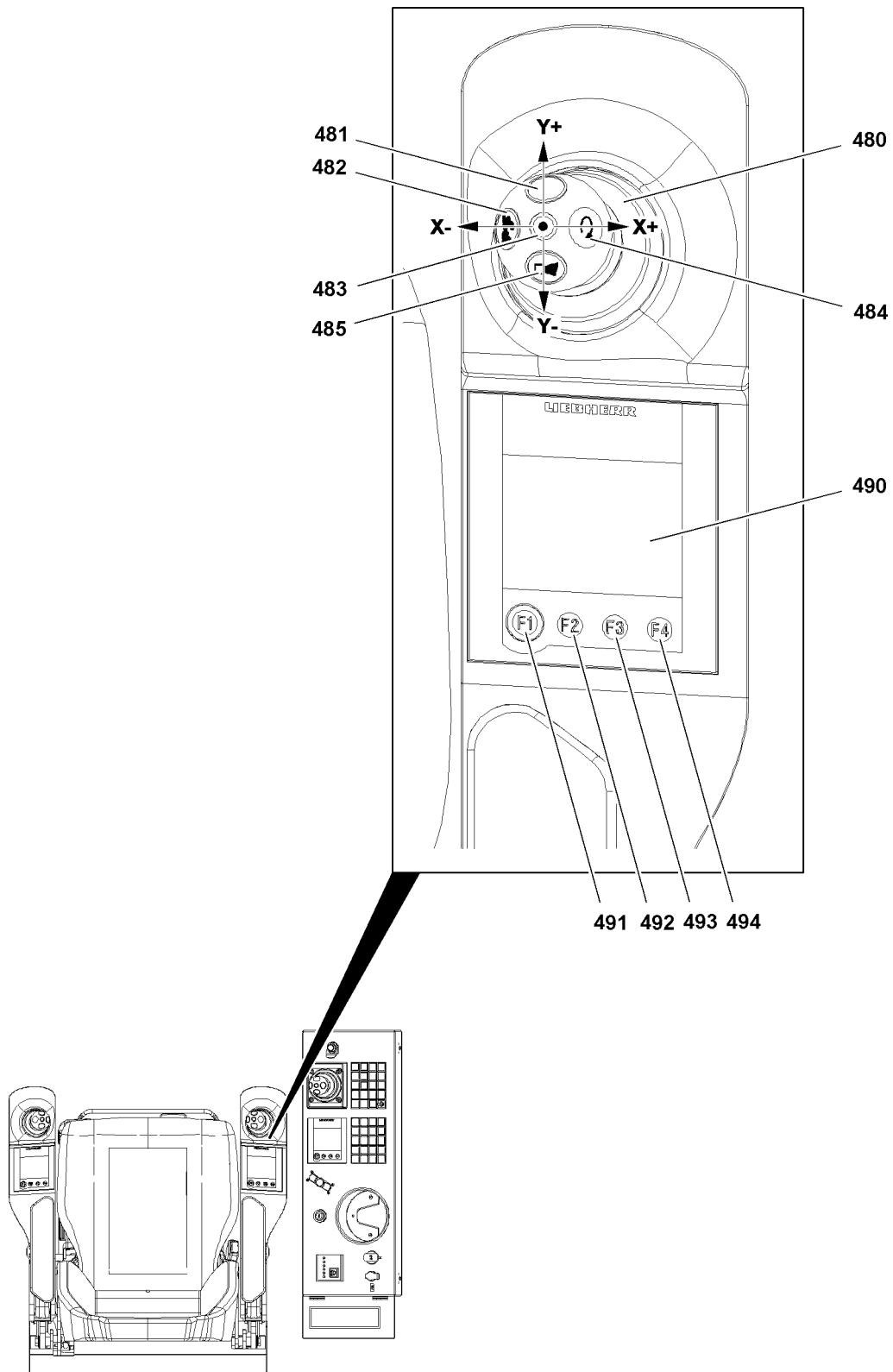

Fig.114881

LWE/LR 13000-001/19503-01-02/en

10.3 TE1 „Block winch“ menu (right touch display)

The crane operator has the possibility to block a winch that is not needed in the „Block winch“ menu.



Note

- ▶ „Touching“ a touch function activates the function.
- ▶ Only an activated winch can be blocked or released with the F4 function key **494**.
- ▶ The touch display changes 20 seconds after the last button actuation in the main menu.

10.3.1 TE1 „Block winch“ menu function key assignment

You can reach the „block winch“ menu via TE1 **490**.

- 491** F1 key
 - Change to the main menu
- 492** F2 key
 - No function in this menu
- 493** F3 key
 - No function in this menu
- 494** F4 key
 - Block / release the winch: When the winch is blocked, the winch is shown as in the icon **541**.



10.3.2 TE1 „Block winch“ menu assignment

Position	Icon	TE1 „Block winch“ menu assignment
530		Block the selected winches

10.3.3 TE1 „Block winch“ menu touch functions

Position	Icon	TE1 „Block winch“ menu touch functions
535		Winch 1
536		Winch 2
537		Winch 3
538		Winch 4

LWE/LR 13000-001/19503-01-02/en

Position	Icon	TE1 „Block winch“ menu touch functions
539	 The icon shows a rectangular winch symbol with diagonal hatching and the number 5 above it.	Winch 5
540	 The icon shows a rectangular winch symbol with diagonal hatching and the number 6 above it.	Winch 6
541	 The icon shows a rectangular winch symbol with diagonal hatching and the number 3 above it. The entire symbol is crossed out with a large 'X'.	Winch 3 is blocked

Empty page!

LWE/LR 13000-001/19503-01-02/en

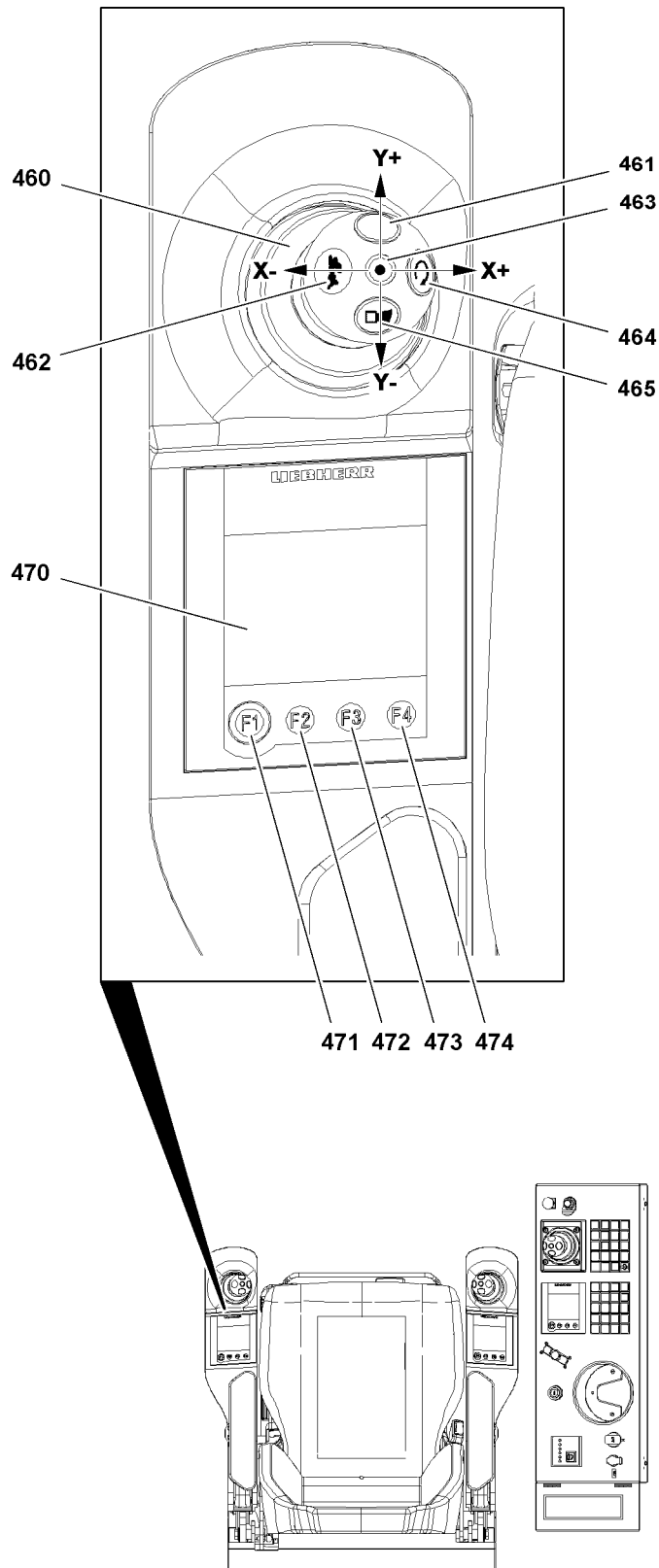

Fig.114880

LWE/LR 13000-001/19503-01-02/en

11 Master switch assignment MS2



Note

Change of master switch assignment!

The assignment of the master switches to the respective units on the crane can change, depending on the set up configuration and winch application!

► **Check the assignment before actuating the master switch on the TE!**

11.1 Master switch MS2 functions



Note

► For a description of the functions of the master switches, see the Crane operating instructions, chapter 4.05.

460 Left master switch (MS2)

- The functions for master switch MS2 depend on the set up configuration and the selected master switch assignment on TE2.

461 Button

- Bypass of the seat contact button
- **Or:** When the seat contact button is actuated: Activation of the vibration sensor **463**

462 Button

- „Power Plus“ activation, crane operation

463 Vibration sensor

- Turn sensor and winches



Note

► Pressing the button **464** locks the engine regulation in the current position.

464 Button

- Locking the engine regulation of the superstructure engine
The idling speed can be increased up to the maximum rpm.
- Can be „overridden“ by the engine regulation (gas pedal).
- With continued actuation of the engine regulation (gas pedal), the current rpm is taken over.
- By pressing the button **464** with the engine regulation (gas pedal) **NOT actuated**, the manual throttle is cancelled.
- If the engine rpm is locked, a „+“ appears on the LICCON monitor on the „dynamic engine rpm display“ (travel operation) and the „dynamic load utilization bar display“ (crane operation).
- Delete the lock by touching the gas pedal momentarily.

465 Button

- Horn

11.2 TE2 Function key assignment

470 Touch display (TE2)

471 F1 key

- You can change to the next menu in this sequence:
 - „Climate control settings“ menu
 - „Floodlight“ menu
 - „Hydraulic oil preheating / Diesel particle filter“ menu

472 F2 key

- In the main menu TE2, no function

473 F3 key

- Apply / release the slewing gear parking brake





474 F4 key

- Spool the assembly winch out / up
- Luffing in with suspended load (icon **2.14**), see Crane operating instructions, chapter 4.20





11.3 TE2 main menu: Functions and assignment



Position	Icon	TE2 assignment
2.01		Display of the master switch with deflection directions: Icon visible in main menu on every touch display

11.3.1 TE2 Touch functions





Position	Icon	TE2 main menu assignment: Touch functions
2.10		Spool assembly winch 2 up
2.11		Spool assembly winch 2 out
2.12		Spool assembly winch 2 up constantly
2.13		Parallel operation of assembly winch 1 and assembly winch 2, spool up constantly
2.14		Luffing in with a suspended load

11.3.2 TE2 winch assignment

Position	Icon	TE2 main menu assignment: Winches
2.20		Spool winch 2 up
2.21		Spool winch 2 out; display of maximum winch speed as a percentage
2.22		Spool winch 6 up
2.23		Spool winch 6 out; display of maximum winch speed as a percentage

Position	Icon	TE2 main menu assignment: Winches
2.24		Winch 2 is blocked
		Note: If a winch is blocked, the „spool winch up“ and „spool winch out“ functions can NOT be carried out!

11.3.3 TE2 assignment slewing gear

Position	Icon	TE2 main menu assignment: Slewing gear
2.30		Turn the slewing gear to the left
2.31		Turn the slewing gear to the right, display of maximum slewing gear speed as a percentage
2.32		The slewing gear parking brake is released
2.33		The parking brake slewing gear is applied

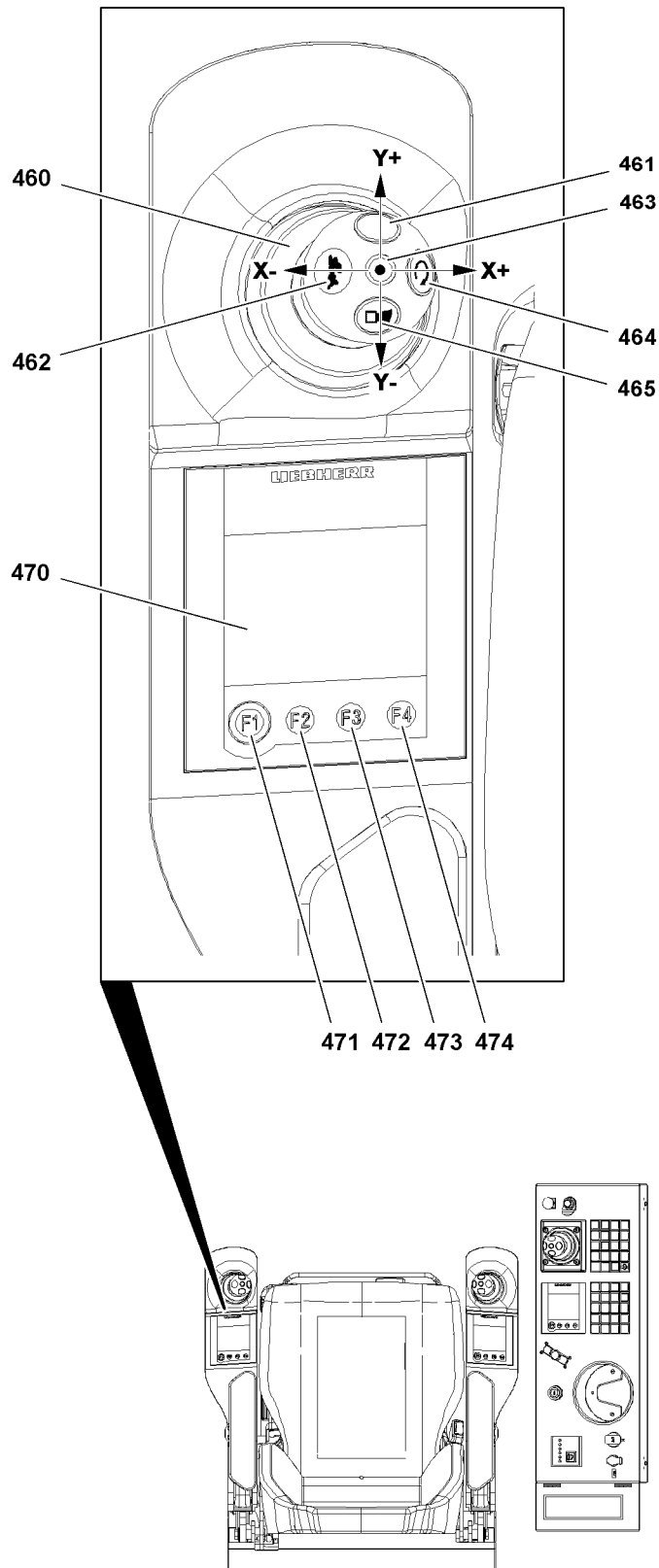

Fig.114880

LWE/LR 13000-001/19503-01-02/en

11.4 TE2 Menu: „Climate control settings“ (Left touch display)

In the „Climate control settings“ menu the crane driver has the opportunity to make any heater, air conditioning and ventilation settings.



Note

- ▶ Refer to chapter 6.01 for a detailed description of the heater / air conditioning and ventilation settings.
- ▶ The floodlight menu is only available if the floodlight is installed and connected.
- ▶ „Touching“ a touch function activates the function.
- ▶ Only an activated winch can be turned off or reduced in value with the F3 key **473**.
- ▶ Only an activated winch can be turned on or increased in value with the F4 key **474**.
- ▶ The touch display changes 20 seconds after the last button actuation in the main menu.

11.4.1 TE2 „Climate control settings“ menu function key assignment

471 F1 key

- Switch to the next menu

472 F2 key

- Automatic climate control „ON“ / „OFF“



Note

- ▶ The **automatic** climate control can only be turned on if the Climate control system **551** has been selected.

473 F3 key

- „Minus“ - reduce stage / temperature or turn „OFF“

474 F4 key

- „Plus“ - increase stage / temperature or turn „ON“

11.4.2 TE2 „Climate control settings“ menu touch functions





Note



- ▶ „Touching“ a function in the „Climate control settings“ menu causes a black border to appear around the relevant icon (function selection) and at the same time the current setting, the selected level or the on / off status („ON“ / „OFF“) for a function is displayed in the Status display **555**.
- ▶ Only one function at a time can be selected or edited in the „Climate control settings“ menu.

Position	Icon	TE2 „Climate control settings“ menu touch functions
551		Climate control system
552		Fan / blower
553		Heater function selection

LWE/LR 13000-001/19503-01-02/en

Position	Icon	TE2 „Climate control settings“ menu touch functions
554		Auxiliary heater function selection
556		Ventilation
557		Recirculating air / fresh air

11.4.3 TE2 „Climate control settings“ menu assignment

Position	Icon	TE2 „Climate control settings“ menu assignment
555		Status display: The status display shows the different icons, depending on the selected function. Standard display status display: MANUAL heating mode: The temperature setting, Heater „ON“ status, Stage 15
558		Reduce current size or conditions of a function, change status of a function
559		Increase current size or conditions of a function, change status of a function

Empty page!

LWE/LR 13000-001/19503-01-02/en

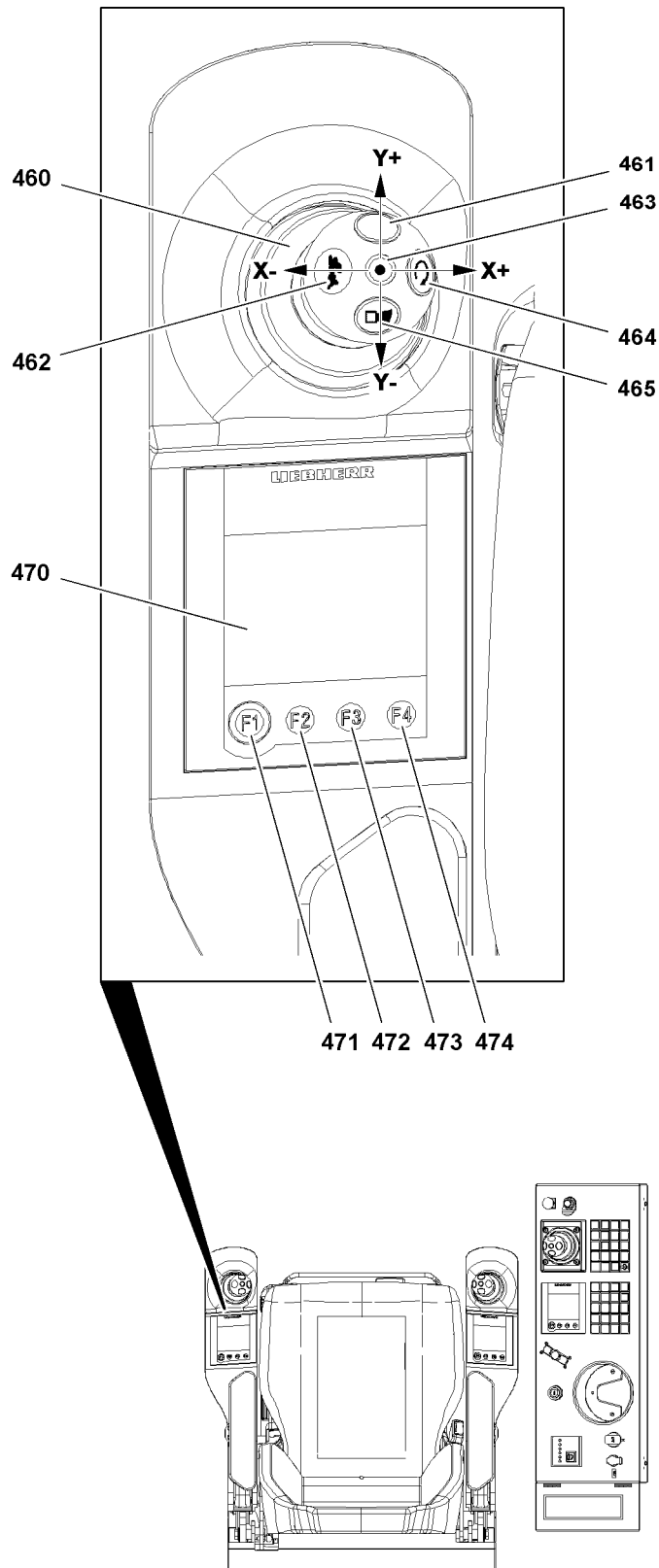

Fig.114880

LWE/LR 13000-001/19503-01-02/en

11.5 TE2 „floodlight“ menu (left touch display)



Note

- ▶ The floodlight on the S-pivot section is assembled together with the zoom camera on one control drive.
- ▶ The alignment and the adjustment of the floodlight transfers automatically to the zoom camera.
- ▶ Functions of the zoom camera, see section „Control unit camera monitoring“

In the floodlight menu, the crane driver has the opportunity to manually align the floodlight to suit the current load or the planned working range. During crane operation, the previously aligned floodlight changes its position according to the movement direction of the load (load-following) or the working range (fixed to working range).



Note

- ▶ The floodlight menu is only available if the floodlight is installed and connected.
- ▶ „Touching“ a touch function activates the function.
- ▶ Only an activated function can be turned on or off with the F4 key **474**.
- ▶ The touch display changes 20 seconds after the last button actuation in the main menu.

11.5.1 TE2 „floodlight“ menu function key assignment

- 471** F1 key
 - Switch to the next menu
- 472** F2 key
 - **No** function
- 473** F3 key
 - **No** function
- 474** F4 key
 - Turn the floodlight on / off

11.5.2 TE2 „floodlight“ menu assignment



Position	Icon	TE2 „floodlight“ menu assignment
510		Turn the floodlight on / off

11.5.3 TE2 „floodlight“ menu touch functions



Note

- ▶ Before the desired operating mode of the floodlight is selected, set the initial position of the floodlight manually.
- ▶ Set the initial position: In the „Manual floodlight“ operating mode, deflect master switch 2 **460** (MS2) left in direction Y+ or Y-.

Position	Icon	TE2 „floodlight“ menu touch functions
515		Align the floodlight „manually“
516		Set the floodlight „load-following“
517		Set the floodlight „fixed to working range“.

Empty page!

LWE/LR 13000-001/19503-01-02/en

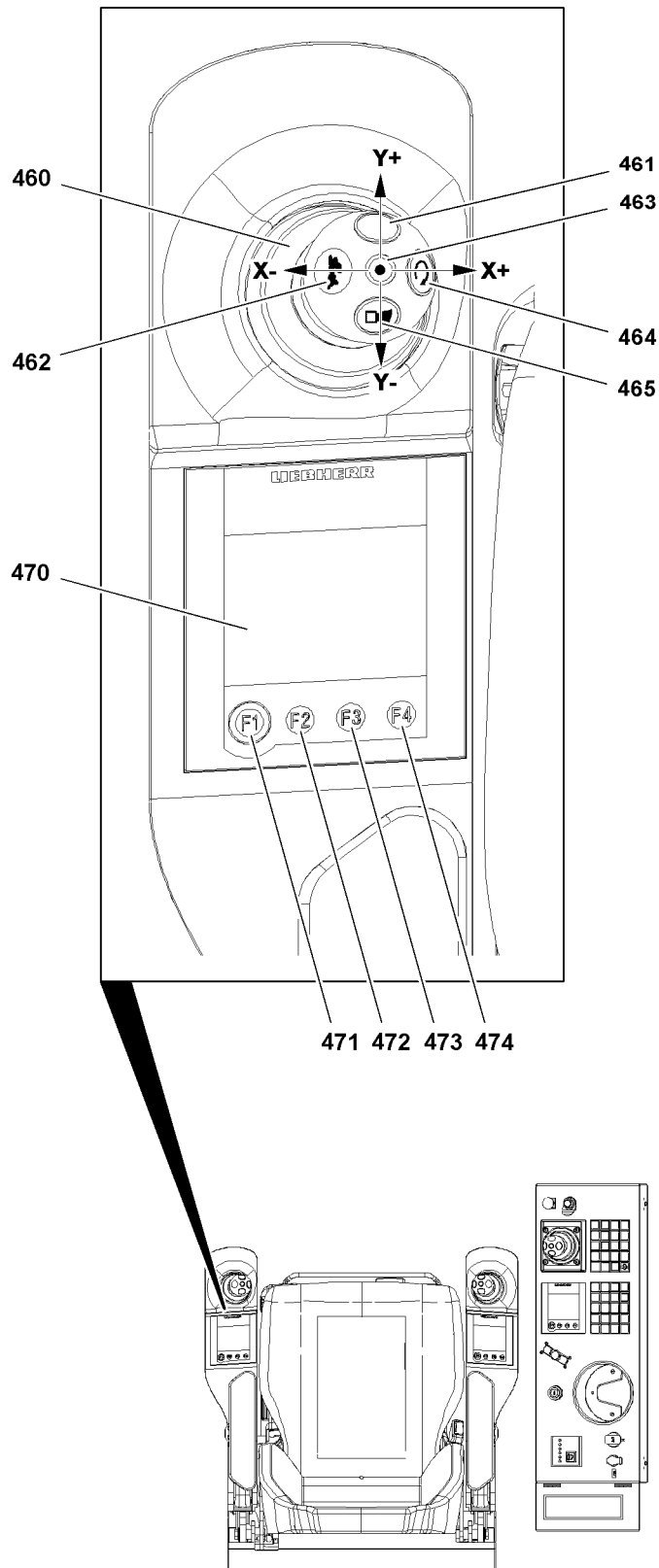

Fig.114880

LWE/LR 13000-001/19503-01-02/en

11.6 TE2 Menu: „Hydraulic oil preheating / diesel particle filter“ (left touch display)



Note

- ▶ „Touching“ a touch function activates the function.
- ▶ Only an activated function can be turned on or off with the F4 key **474**.
- ▶ The touch display changes 20 seconds after the last button actuation in the main menu.

11.6.1 TE2 „Hydraulic oil preheating / diesel particle filter“ menu function key assignment

- 471** F1 key
 - Switch to the next menu
- 472** F2 key
 - **No** function
- 473** F3 key
 - **No** function
- 474** F4 key
 - Turn function on / off

11.6.2 TE2 „Hydraulic oil preheating / diesel particle filter“ menu assignment

Position	Icon	TE2 „Hydraulic oil preheating / diesel particle filter“ menu assignment
570		Turn selected function on / off

11.6.3 TE2 „Hydraulic oil preheating / diesel particle filter“ menu touch functions

Position	Icon	TE2 „Hydraulic oil preheating / diesel particle filter“ menu touch functions
575		Select / deselect hydraulic oil preheating
576		Select / deselect <i>Engine 1 diesel particle filter regeneration at a standstill</i> function
577		Select / deselect <i>Engine 2 diesel particle filter regeneration at a standstill</i> function
578		Select / deselect <i>Disable diesel particle filter regeneration</i> function

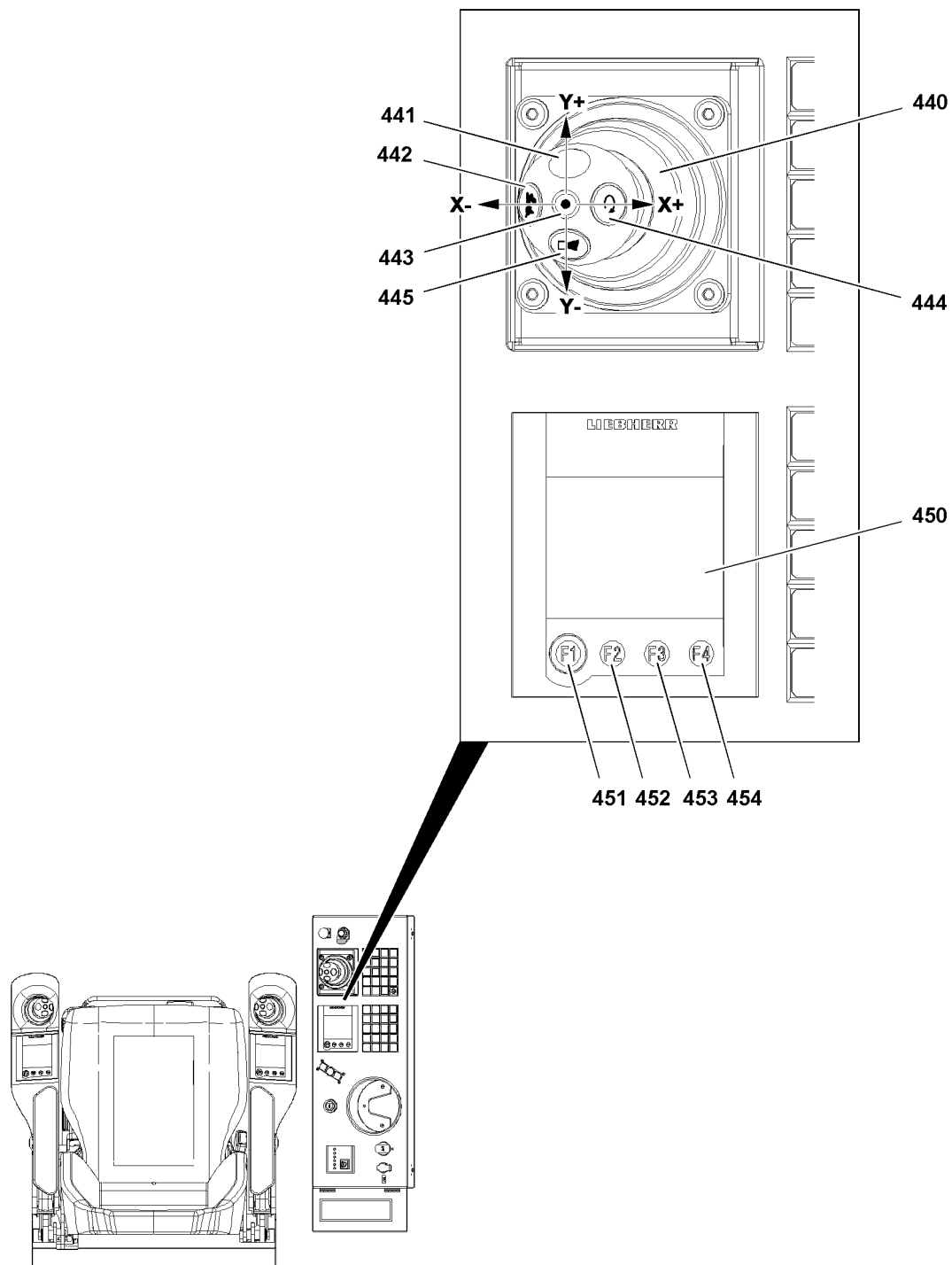

Fig.114882

12 Master switch assignment MS3



Note

Change of master switch assignment!

The assignment of the master switches on the control platform to the respective units on the crane can change, depending on the set up configuration and winch application!

▶ **Check the assignment before actuating the master switch on the TE!**



Note

▶ For a description of the functions of the master switches, see the Crane operating instructions, chapter 4.05.

440 Instrument panel master switch (MS3)

- The functions for master switch MS3 depend on the set up configuration and the selected master switch assignment on TE3.

441 Button

- Bypass of the seat contact button **or** if the seat contact button is actuated: Activation of the vibration sensor **443**

442 Button

- Activation of „Power Plus“ for winch(es) and luffing up.

443 Vibration sensor

- Winch turn sensor, (vibrator) winch **or** turn sensor



Note

▶ Pressing the button **444** locks the engine regulation in the current position.

444 Button

- Locking the engine regulation of the superstructure engine
The idling speed can be increased up to the maximum rpm.
- Can be „overridden“ by the engine regulation (gas pedal).
- With continued actuation of the engine regulation (gas pedal), the current rpm is taken over.
- By pressing the button **444** with the engine regulation (gas pedal) **NOT actuated**, the manual throttle is cancelled.
- If the engine rpm is locked, a „+“ appears on the LICCON monitor on the „dynamic engine rpm display“ (travel operation) and the „dynamic load utilization bar display“ (crane operation).
- Delete the lock by touching the gas pedal momentarily.

445 Button

- Horn

12.1 Function key assignment TE3

450 Touch display (TE3)

451 F1 key

- No function on TE3

452 F2 key

- No function on TE3

453 F3 key

- No function on TE3

**WARNING**

Incorrect travel direction!

If the travel direction is interpreted incorrectly, the crane moves in the opposite direction.

Persons and objects can be run over.

- ▶ Before driving off, make sure that the correct travel direction is actuated.
- ▶ In case of uncertainty, monitor the drive path in both directions.
- ▶ Initiate travel movement very slowly and check the travel direction at the slowest speed.







454 F4 key



- Drive the crawler

12.2 TE3 main menu: Functions and assignment







Position	Icon	TE3 assignment
3.01		Display of the master switch with deflection directions: Continuously visible icon on every touch display

12.2.1 TE3 touch functions



Position	Icon	TE3 main menu: Touch functions
3.10		Crawler operation normal travel turned off
		Crawler operation normal travel preselected
		Crawler operation normal travel activated, icon blinks
3.11		Crawler operation rapid gear turned off
		Crawler operation rapid gear preselected
		Crawler operation rapid gear activated, icon blinks









Position	Icon	TE3 main menu: Touch functions
3.12		Crawler operation parallel travel turned off
		Crawler operation parallel travel preselected
		Crawler operation parallel travel activated, icon blinks

12.2.2 TE3 winch assignment

Position	Icon	TE3 main menu: Winch assignment
3.20		Not present on LR 13000: Spool winch 5 out; display of maximum winch speed as a percentage
3.21		Not present on LR 13000: Spool winch 5 up
3.20		Spool winch 6 out; display of maximum winch speed as a percentage
3.21		Spool winch 6 up
3.22		Winch 6 blocked
		Note: If a winch is blocked, the „spool winch up“ and „spool winch out“ functions can NOT be carried out!

12.2.3 TE3 boom and equipment assignment

Position	Icon	TE3 main menu: Boom and equipment assignment
3.30		Luff the luffing jib up
3.31		Luff the luffing jib down; display of maximum winch speed as a percentage
3.32		Luff the main boom up

Position	Icon	TE3 main menu: Boom and equipment assignment
3.33		Luff the main boom down; display of maximum winch speed as a percentage
3.34		Luff the derrick boom up
3.35		Luff the derrick boom down; display of maximum winch speed as a percentage
3.36		Luff the luffing jib up
3.37		Luff the luffing jib down; display of maximum winch speed as a percentage
3.38		Luff the derrick boom up
3.39		Luff the derrick boom down; display of maximum winch speed as a percentage
3.40		If a crane movement is blocked, the „luffing up“ and „luffing down“ functions can NOT be carried out!
		Note: Boom and equipment: Crane movement is blocked, example SW, „luff luffing jib up“ and „luff luffing jib down“ can NOT be carried out.

4.01.10 Touch display menu operation

1	Touch display	2
2	Operating variations	2

1 Touch display

The touch displays are combined display and operating elements.

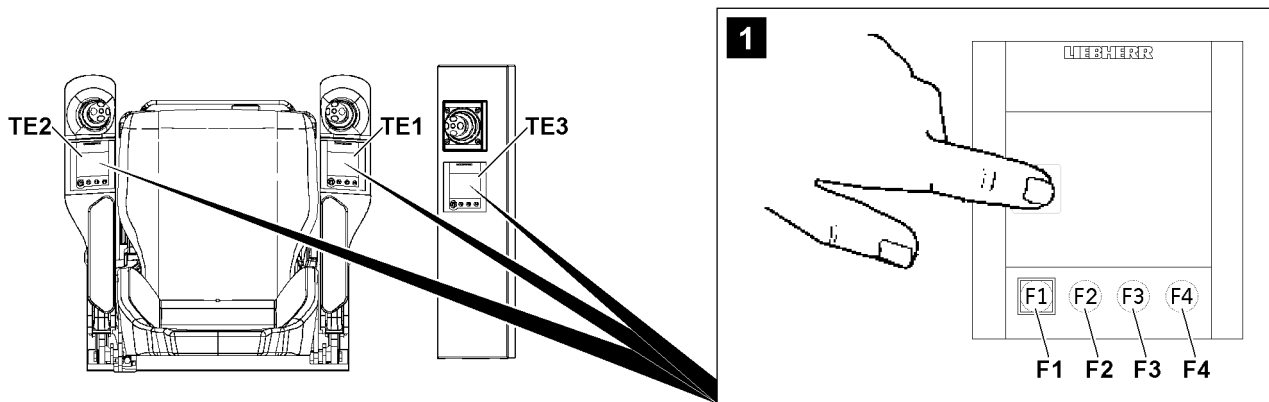

Fig.156276: F-keys on the touch display

Various menus are opened using the touch display **TE1**, touch display **TE2** and touch display **TE3**.

In these menus, various crane functions are:

- selected
- deselected
- turned on
- turned off
- directly controlled

The touch display is operated using the F-keys **F1-F4** and the touch functions.

The touch functions are performed by pressing the corresponding icon with a finger tip, see illustration 1.

2 Operating variations

Depending on the function, operation takes place using one of the following variations:

- Operating the function with the F-keys
- Operating the function using the touch function
- Select the function using the touch function and then operate using the F-keys

2.1 Operating the function with the F-keys

In this section, the variation is explained using the *close the slewing gear brake* function.

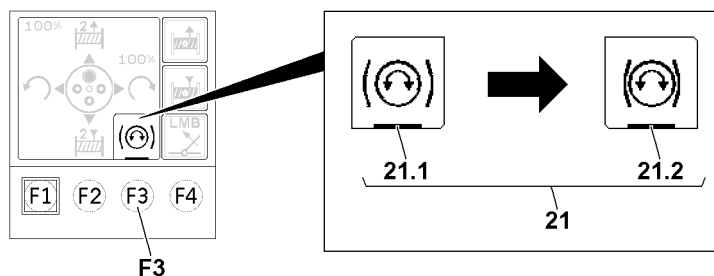

Fig.156272: Example: Closing the slewing gear brake

Make sure that the following prerequisite is met:

- The corresponding display is shown on the touch display.

- ▶ Press the F key **F3**

Result:

- The display of the *slewing gear brake* icon **21** changes from *slewing gear brake open 21.1* to *slewing gear brake closed 21.2*.
- Close the slewing gear brake is set.

2.2 Operating the function using the touch function

In this section, the variation is explained using the a function for the setting of the floodlight.

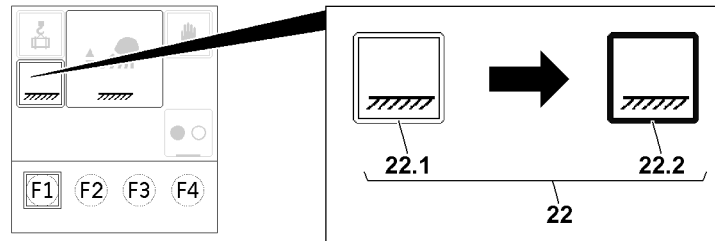

Fig.156273: Example: Adjusting the floodlight

Make sure that the following prerequisite is met:

- The corresponding display is shown on the touch display.

- ▶ Tap the *illuminate the work area* icon **22**.

Result:

- The frame around the *illuminate the work area* icon **22** switches from an empty frame **22.1** to a filled frame **22.2**.
- The illuminate the work area setting is selected.

2.3 Select the function using the touch function and then operate using the F-keys

In this section, the two different operating sequences of the variation is explained.

- Operating sequence 1: Example based on the *turning the hydraulic oil preheating on* function
- Operating sequence 2: Example based on the *spool the assembly winch up* function

2.3.1 Operating sequence 1

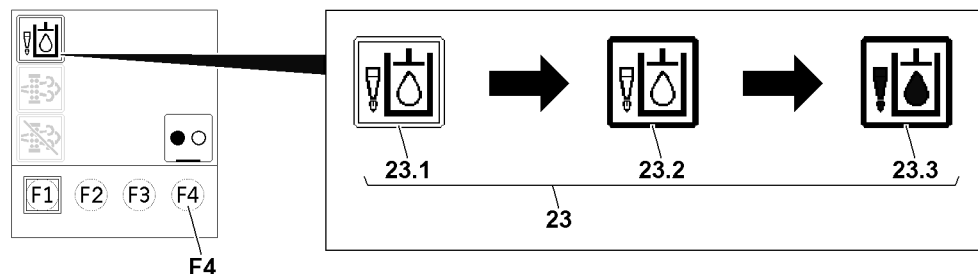

Fig.156274: Operating sequence 1: Example based on the turning the hydraulic oil preheating on function

Make sure that the following prerequisite is met:

- The corresponding display is shown on the touch display.

- ▶ Tap the hydraulic oil preheating icon **23**.

Result:

- The frame around the hydraulic oil preheating icon **23** switches from an empty frame **23.1** to a filled frame **23.2**.
- Hydraulic oil prewarming is preselected.

▶ Press the F key **F4**

Result:

- The display of the hydraulic oil preheating icon **23** switches with the filled frame **23.2** to hydraulic oil preheating turned on **23.3**.
- Hydraulic oil preheating is turned on.

2.3.2 Operating sequence 2

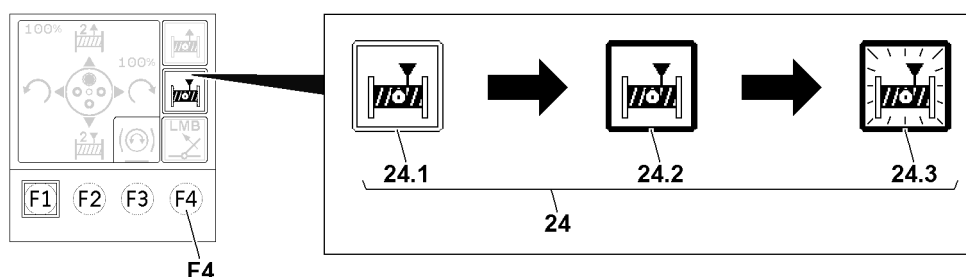

Fig.156275: Operating sequence 2: Example based on the spool the assembly winch up function

Make sure that the following prerequisite is met:

- The corresponding display is shown on the touch display.

▶ Tap the spool the assembly winch up icon **24**.

Result:

- The frame of the *spool the assembly winch up* icon **24** switches from an empty frame **24.1** to a filled frame **24.2**.
- *Spool the assembly winch up* is preselected.

▶ Press and hold the F key **F4**.

Result:

- The display with the filled frame **24.2** starts to blink **24.3**.
- *The assembly winch spools up*.

4.02 LICCON computer system

1	General	2
2	System start of the LICCON computer system	4
3	Operating elements on the LICCON monitors	6
4	<i>Set up</i> program	11
5	The <i>Crane operation</i> program on LICCON monitor 0	77
6	The <i>Crane operation</i> program on LICCON monitor 1	163
7	The <i>Crane operation</i> program on LICCON monitor 2	185
8	<i>Curve illustration</i> program	197
9	<i>Working range limitation</i> program	201
10	Master switch / pedal sensor speed reduction	209
11	Power-save mode and Stand-by mode in the LICCON computer system	219

1 General



Note

- ▶ The illustrations, icons and monitor illustrations in this chapter are only examples.
- ▶ The numerical values in the individual icons and charts do not have to necessarily match the crane exactly.
- ▶ Numbers and letters can be replaced by place holders.
- ▶ The display and assignment of the icons can deviate, depending on the set up configuration, operating status and configuration of the crane.
- ▶ In addition, many of the illustrations show the maximum configuration of the LICCON monitor with icons.
- ▶ During crane operation, an identical display will **not** appear on the LICCON monitor.

The LICCON computer system is a computer system for controlling and monitoring mobile and crawler cranes. In addition to the use of overload protection and load bearing capacity display there are a number of application programs that can be used for controlling and monitoring the crane movements.

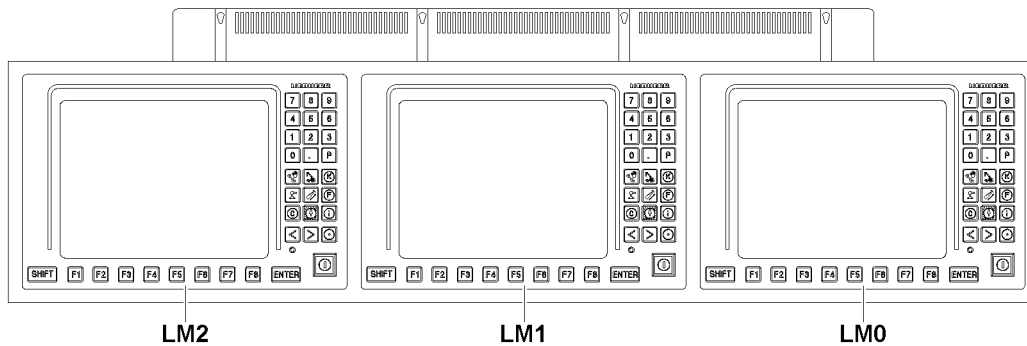

Fig.119921: Three LICCON monitors

The LICCON computer system is visualized among other possibilities via three LICCON monitors:

- **LM0** LICCON monitor 0
 - Located on the right side of the monitor
- **LM1** LICCON monitor 1
 - Located in the center of the monitor
- **LM2** LICCON monitor 2
 - Located on the left side of the monitor



Note

- ▶ The electrical and electronic components are linked via data bus transmission technology (Liebherr-System-Bus = LSB).

1.1 Overload protection

The overload protection includes limiters and displays (for example load capacity displays), which also alert to danger conditions via acoustical and optical warning signals.

The computer controlled part of the overload protection is called the LICCON overload protection. The LICCON overload protection is set by entering the set up configuration in the LICCON computer system.

The LICCON overload protection works, among other possibilities, according to the principle of comparing the current and actual load with the maximum load (also *Maximum load according to the load chart and reeving*) of the crane

1.1.1 Acoustic and optical warning signals

The crane is equipped with acoustical and optical warning device to warn crane operator, auxiliary personnel and any person nearby.

Overview of acoustic / optical warnings, see Crane operating instructions, chapter 4.20.

1.1.2 Actual load

The actual load is determined by recording changing dimensions, the set up configuration and situational influences.

The **load on the crane** results from the load momentum, boom momentum as well as environmental and mechanical influences. The occurring moments and forces are measured and processed by the LICCON computer system.

The **load momentum** results from load and boom radius. The load includes load, fastening equipment and hook block / load hook. The boom radius is calculated with aid of the angle sensor information (boom angle) and the length of the boom system. This also takes into account the boom deflection due to its own weight and the weight of the load.

The **boom momentum** is calculated from the length of the boom system, the crane data (boom weights) and angle sensor information (boom angle).

Environmental and mechanical influences are recorded, determined and taken into account individually.

1.1.3 Maximum load according to the load chart and reeving



Note

- ▶ The *Maximum load according to load chart and reeving* is also called *Maximum load* in the description.

The crane data such as load charts (also called load capacity charts), boom weights and geometry data is stored in the central data memory of the LICCON computer system.

The *maximum load according to load chart and reeving* value (maximum load) is constantly determined, based on the load charts, for the set up configuration, the set reeving, the calculated boom radius and additional influences.

1.1.4 Comparison

The *actual load* value and *maximum load* value are compared. When they approach the specified limit, an advance warning is issued by the overload protection. If this limit is exceeded, the overload protection turns the load moment increasing crane movements off.

1.2 Error messages

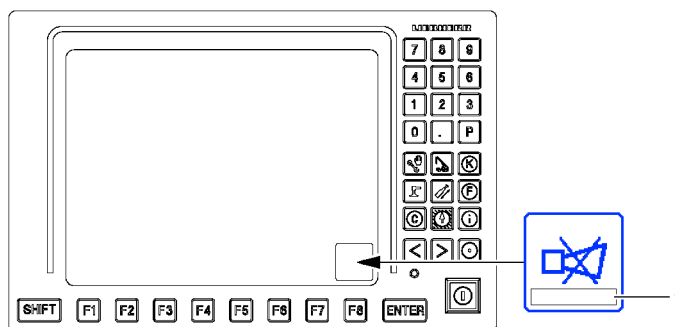

Fig. 119922

The LICCON computer system monitors the crane permanently for operating and system errors.

If operating and / or system errors occur, error messages **1** are displayed. Error messages appear in the *Horn* icon of the LICCON monitor.



Note

- ▶ Always pay attention to error messages **1**.
- ▶ For procedure in case of error messages, see the Diagnostics manual and the respective chapter in the Crane operating instructions.

2 System start of the LICCON computer system

There are two operating modes for the LICCON computer system:

- The LICCON computer system in normal mode (crane engine turned on).
- LICCON computer system in Stand-by mode (crane engine turned off).

Start normal mode:

- System start of LICCON computer system in connection with a started crane engine.

Start Stand-by mode:

- See section „Power-Save mode and Stand-by mode in the LICCON computer system“.

2.1 LICCON monitors at system start

After turning the ignition on, the LICCON computer system boots up and carries out a self test.

After successful self test and system start of the LICCON computer system, each LICCON monitor changes to a separate view.



Note

If an error is detected during the system start of the LICCON computer system, an error message appears on the LICCON monitor.

- ▶ Consult Liebherr Customer Service if an error occurs during system start.

2.1.1 LICCON monitor 0

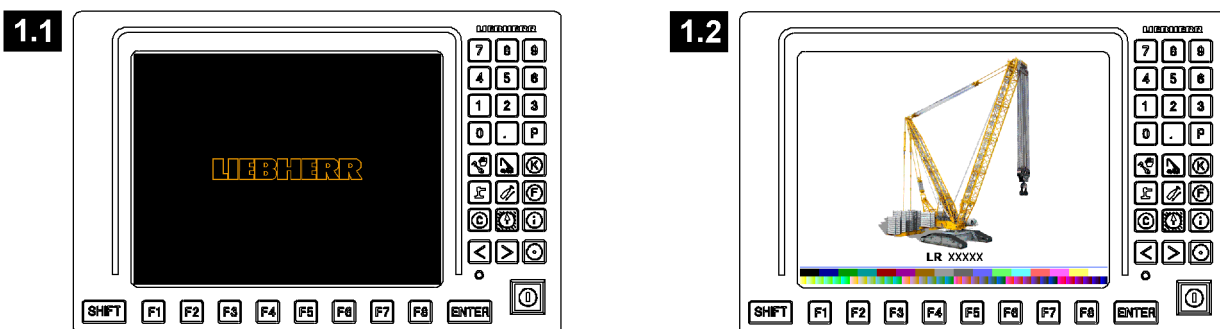

Fig.161581: LICCON Monitor 0 system start

During the self test and system start, the start screen appears, see illustration 1.1.

After a successful starting procedure, a wall paper of the crane appears on **LICCON monitor 0** for a few seconds, see illustration 1.2.

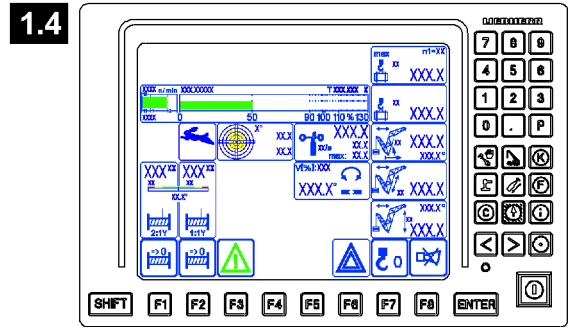
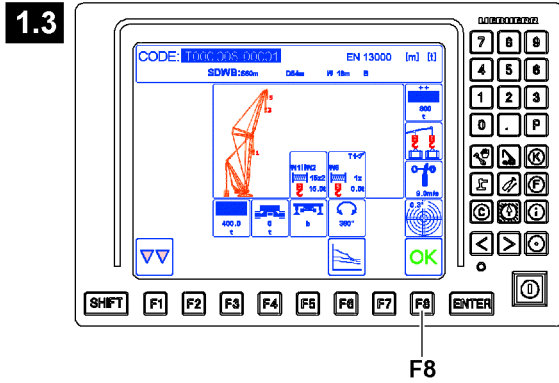

Fig.119936: LICCON monitor 0 system start completed

When the last set up configuration appears (see example illustration 1.3), then system start on LICCON monitor 0 is completed.

The existing set up configuration or a newly entered set up configuration must be confirmed with the function key F8.

Then the Crane operation operating screen appears on the LICCON monitor 0, see illustration 1.4.

2.1.2 LICCON monitor 1

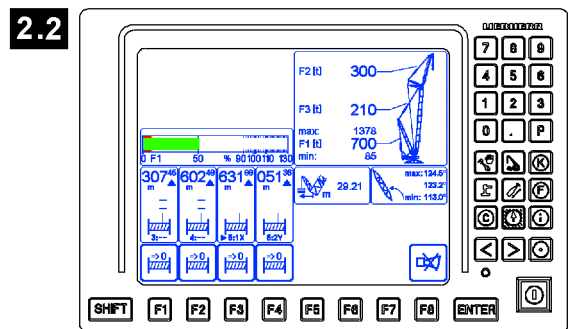
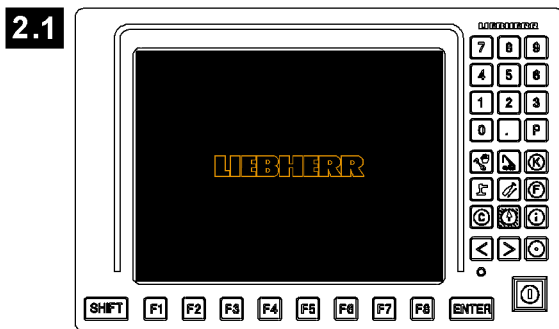

Fig.161582: LICCON Monitor 1 system start

During the self test and system start, the start screen appears, see illustration 2.1.

After a successful starting procedure, the corresponding operating screen appears on LICCON monitor 1, see example illustration 2.2.

2.1.3 LICCON monitor 2

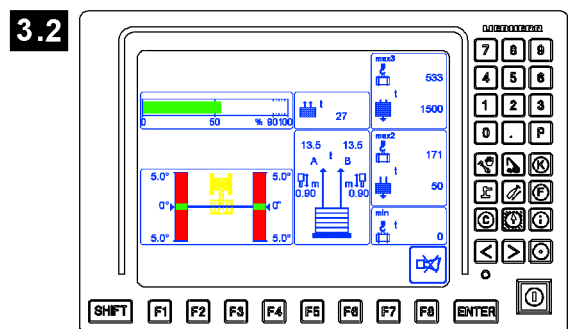
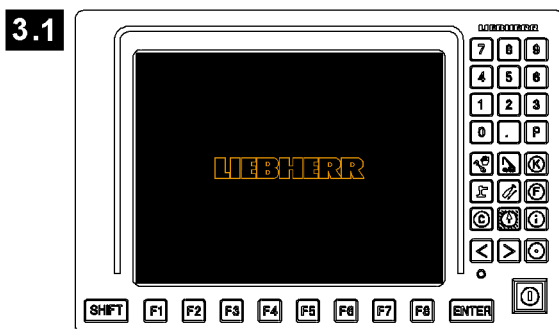

Fig.161583: LICCON monitor 2 system start

During the self test and system start, the start screen appears, see illustration 3.1.

After a successful starting procedure, the corresponding operating screen appears on LICCON monitor 1, see example illustration 3.2.

LWE/LR_13000-001/19503-01-02/en

3 Operating elements on the LICCON monitors

All LICCON monitors are optically the same, the installation location is the deciding factor for the function of the operating elements.

In addition, the functions of the individual monitor operating elements are program-dependent and can differ, depending on the currently running LICCON program. This will be described in more detail in the description of the individual LICCON programs.

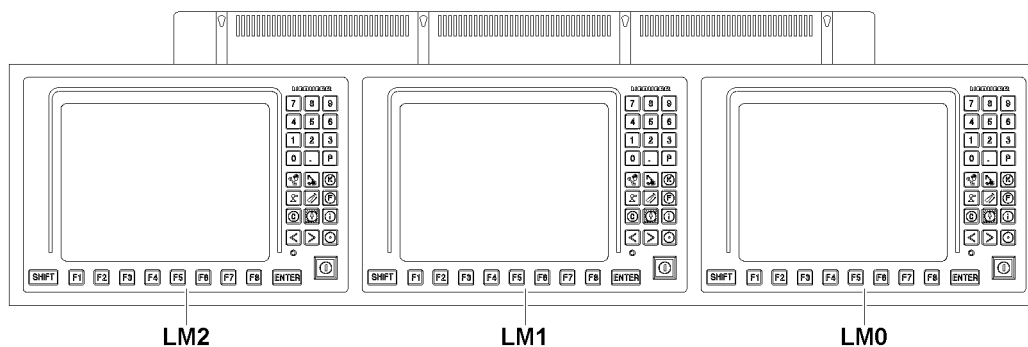

Fig.119921: Three LICCON monitors

- LM0** LICCON monitor 0
 - Located on the right side of the monitor
- LM1** LICCON monitor 1
 - Located in the center of the monitor
- LM2** LICCON monitor 2
 - Located on the left side of the monitor

3.1 Operating element on LICCON monitor 0

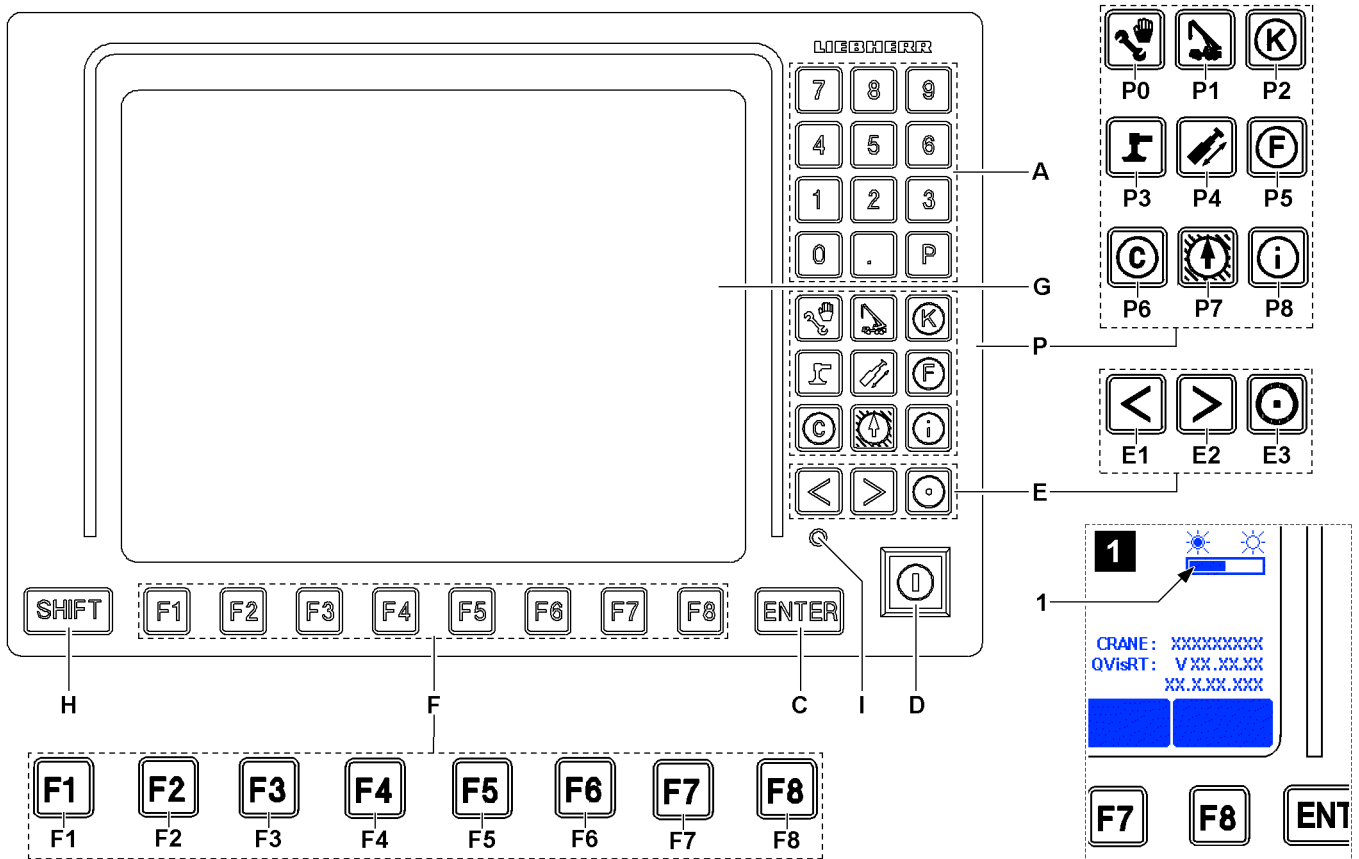

Fig.120677: Operating element on LICCON monitor 0

- A** Keypad
 - The function is program dependent
- P** Program keys
 - Selection of the individual LICCON programs
- P0** Set up
 - Call up the *Set up* program
- P1** Crane operation
 - Call up the *Crane operation* program
- P2** Chart illustration of load charts
 - Call up the *Curve illustration* program
- P3** —
 - Program key not assigned.
- P4** —
 - Program key not assigned.
- P5** —
 - Program key not assigned.
- P6** —
 - Program key not assigned.
- P7** Working range limitation*
 - Call up the *Working range limitation* program
- P8** BSE test system
 - Call up the *BSE test system* program
 - **Note:** Description of the BSE test system, see the Diagnostics manual.

LWE/LR 13000-001/19503-01-02/en

- C** ENTER key
 - Confirmation of changes in the running program
- D** Set up key
 - Zero position (not actuated):
Normal operation.
 - Touching:
The *Exceedance of shut off limits of LICCON overload protection* function is released and / or the hoist limit switch is bypassed

**Note**

- ▶ By pressing the set up key **D**, all erection / take-down procedures can be carried out within the erection / take-down charts, for which no load charts are available.

- E** Special function keys
 - The functions of the special function keys are program-dependent and are further explained in the description of the individual LICCON programs.
 - **Monitor brightness adjustment:**
 - Press **E3** (hold down) and **E1**: Change night design incrementally
 - Press **E3** (hold down) and **E2**: Brightness setting in several stages
The brightness setting can be made from all available programs (for example: set up, crane operation).

**Note**

Automatic brightness adjustment of the LICCON monitor

The brightness of the LICCON monitor can be adapted to the existing light conditions automatically or manually.

The current brightness setting of the LICCON monitor can be seen via the bar display **1** on the starting screen of the *BSE test system program* (illustration 1).

- ▶ Press the *BSE test system* button **P8** to call up the *BSE test system* program.
- ▶ With the *medium brightness* brightness setting, automatic brightness adjustment is **activated**.
- ▶ With the *lowest brightness* brightness setting, automatic brightness adjustment is **inactive**.
- ▶ With the *highest brightness* brightness setting, automatic brightness adjustment is **inactive**.

- F** Function keys
 - The function keys should always be viewed in conjunction with the function key icon line on the display **G**.
- G** Display
 - A program-dependent operating screen appears on the display
- H** SHIFT key
 - Second-level key assignments, for example Supervisory function
- I** Indicator light
 - Indicator light for the monitor supply voltage

3.2 Operating element on LICCON monitor 1

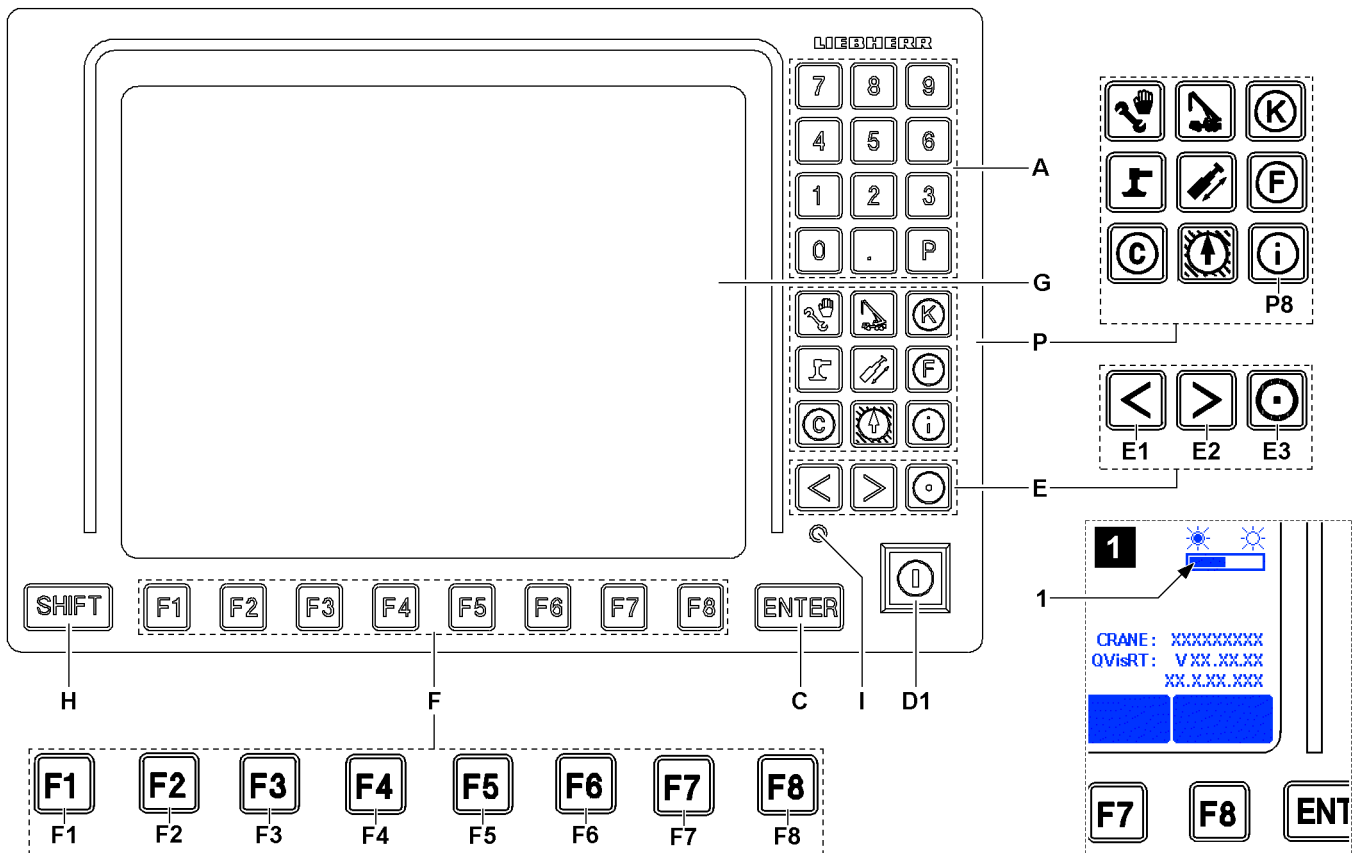

Fig.125385: Operating element on LICCON monitor 1

- A** Keypad
 - The function is program dependent
- P** Program keys
 - Only the *BSE test system* program key **P8** with function
- P8** BSE test system
 - Call up the *BSE test system* program
 - **Note:** Description of the BSE test system, see the Diagnostics manual.
- C** ENTER key
 - Confirmation of changes in the running program
- D1** Key button
 - No function
- E** Special function keys
 - The functions of the special function keys are program-dependent and are further explained in the description of the individual LICCON programs.
 - **Monitor brightness adjustment:**
 - Press **E3** (hold down) and **E1**: Change night design incrementally
 - Press **E3** (hold down) and **E2**: Brightness setting in several stages
 - The brightness setting can be made from all available programs (for example: set up, crane operation). The current brightness setting of the LICCON monitor can be seen via the bar display **1** on the starting screen of the *BSE test system program* (illustration **1**).
 - **Note:** See also section „Operating elements on LICCON monitor 0“
- F** Function keys
 - The function keys should always be viewed in conjunction with the function key icon line on the display **G**.

- G** Display
 - A program-dependent operating screen appears on the display
- H** SHIFT key
 - Second-level key assignments, for example Supervisory function
- I** Indicator light
 - Indicator light for the monitor supply voltage

3.3 Operating element on LICCON monitor 2

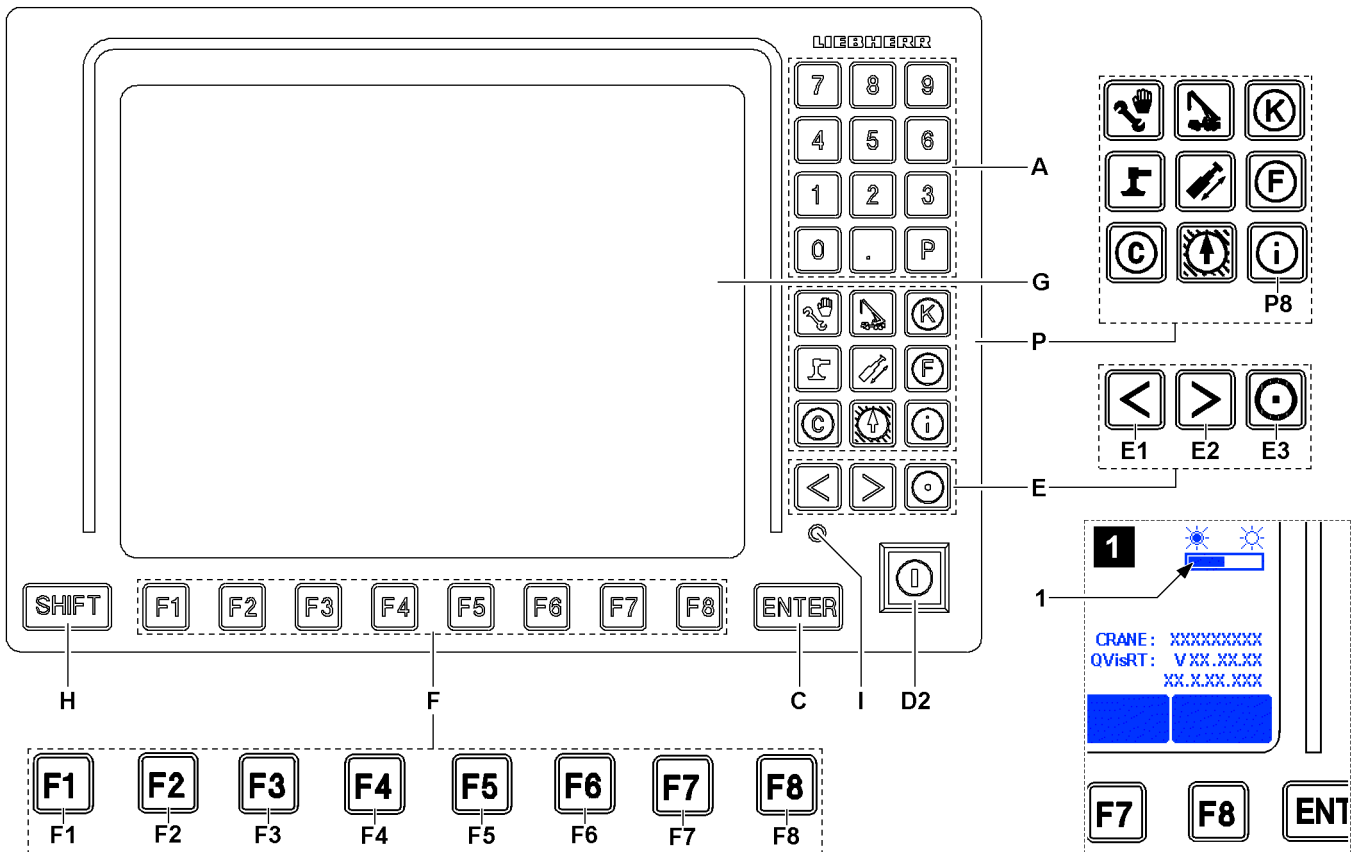

Fig.125386: Operating element on LICCON monitor 2

- A** Keypad
 - The function is program dependent
- P** Program keys
 - Only the *BSE test system* program key **P8** with function
- P8** BSE test system
 - Call up the *BSE test system* program
 - **Note:** Description of the BSE test system, see the Diagnostics manual.
- C** ENTER key
 - Confirmation of changes in the running program
- D2** Key button
 - Change over winch 1 and winch 2 parallel operation regulation.
 - **Note:** Only active for crane types with winch 1 and winch 2 parallel operation. Only active for parallel operation of winch 1 and winch 2.
- E** Special function keys
 - The functions of the special function keys are program-dependent and are further explained in the description of the individual LICCON programs.
 - **Monitor brightness adjustment:**
 - Press **E3** (hold down) and **E1**: Change night design incrementally

- Press **E3** (hold down) and **E2**: Brightness setting in several stages
The brightness setting can be made from all available programs (for example: set up, crane operation). The current brightness setting of the LICCON monitor can be seen via the bar display **1** on the starting screen of the *BSE test system program* (illustration **1**).
 - **Note:** See also section „Operating elements on LICCON monitor 0“
- F** Function keys
- The function keys should always be viewed in conjunction with the function key icon line on the display **G**.
- G** Display
- A program-dependent operating screen appears on the display
- H** SHIFT key
- Second-level key assignments, for example Supervisory function
- I** Indicator light
- Indicator light for the monitor supply voltage

4 Set up program



Note

- ▶ The monitor illustrations in this chapter are only examples.
- ▶ The numerical values in the individual icons and charts do not have to necessarily match the crane exactly.
- ▶ Numbers and letters can be replaced by place holders.
- ▶ The programmed load charts for the crane are binding.



WARNING

Danger of accident due to deviating set up configuration!

If the actual set up configuration of the crane deviates from the entries and settings in the *Set up* program, then the overload protection is not correctly set.

An incorrectly set overload protection calculates the actual load incorrectly and transmits faulty display values.

The crane can be overloaded without being noticed and topple over. Personnel can be severely injured or killed.

- ▶ The entries and settings in the *set up* program must match the actual set up configuration of the crane.

After correct system start of the LICCON computer system, it changes automatically to the *Set up* program. The set up screen is shown in the *Set up* program.

The program can also be called up via the program key, see section „LICCON Monitor 0 operating elements“.

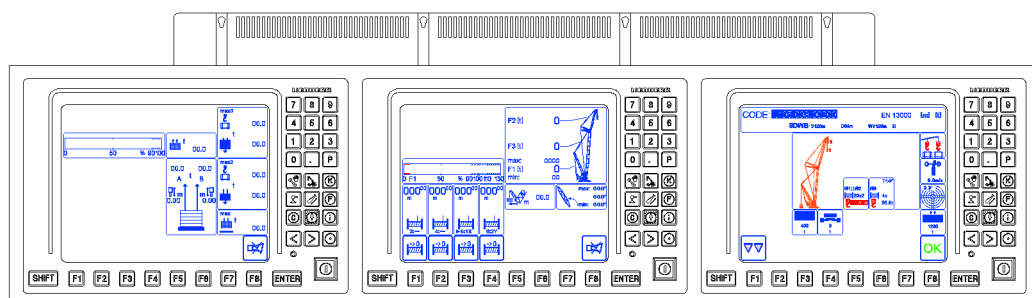

Fig.146956: Three LICCON monitors

**Note**

- ▶ All entries and settings to be made by the crane operator in the *Set up* program can only be carried out on **LICCON monitor 0**.
- ▶ LICCON monitor 0 is located on the right of the monitor arrangement.

**Note**

Adjustment and display of set up configuration and reeving.

- ▶ Normally, after booting up the LICCON computer system, the most recently used set up configuration and the reeving used at that time will be automatically set and displayed.

The crane operator must enter and set the actual set up configuration of the crane in the *Set up* program. The LICCON computer system will then set the overload protection accordingly with these entries and settings.

4.1 Screen display in the *Set up* program

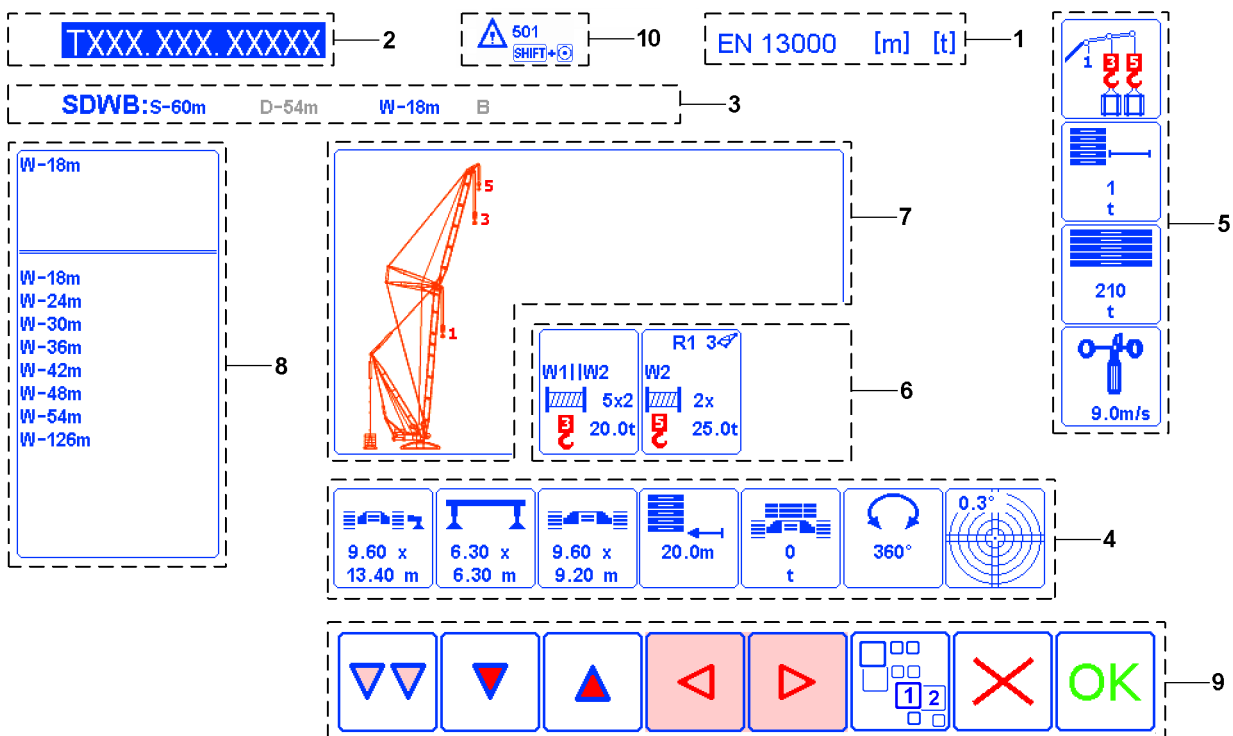

Fig.161570: Example of a screen display in the *Set up* program

The screen display in the *Set up* program consists of the following program categories:

- 1** Unit category
 - The measuring units with which the crane control works are displayed.
- 2** Chart name category
 - The set chart name (chart number) is displayed.
- 3** Operating mode category
 - The set operating mode is displayed.
- 4/5** Set up functions
 - **4** Set up completion category
 - The set values for the set up completion are displayed.
 - **5** Environmental / mechanical influence category
 - The set values for environmental influence / mechanical influence are displayed.
- 6** Lifting category
 - The set hoist winch operation is displayed.
 - The set hoist winch assignment is displayed.

- The set reeving is displayed.
- The set hook weight is displayed.

As well as program comprehensive:

- 7 Display window
 - The set operating mode is symbolized.
 - The possible hook positions are displayed.
- 8 Editing / selection window
 - Possible settings and values for editing or selecting are displayed.
- 9 *Function key icons*
 - Functions assigned to the function keys are displayed as icons.
- 10 Code for limitations and notes
 - There may be limitations and notes for the set up configuration that is set. If limitations and notes are available, they are specified by codes. The reference texts describe the corresponding codes.
Display reference texts, see section „Reference texts“.

4.2 Operating elements in the Set up program

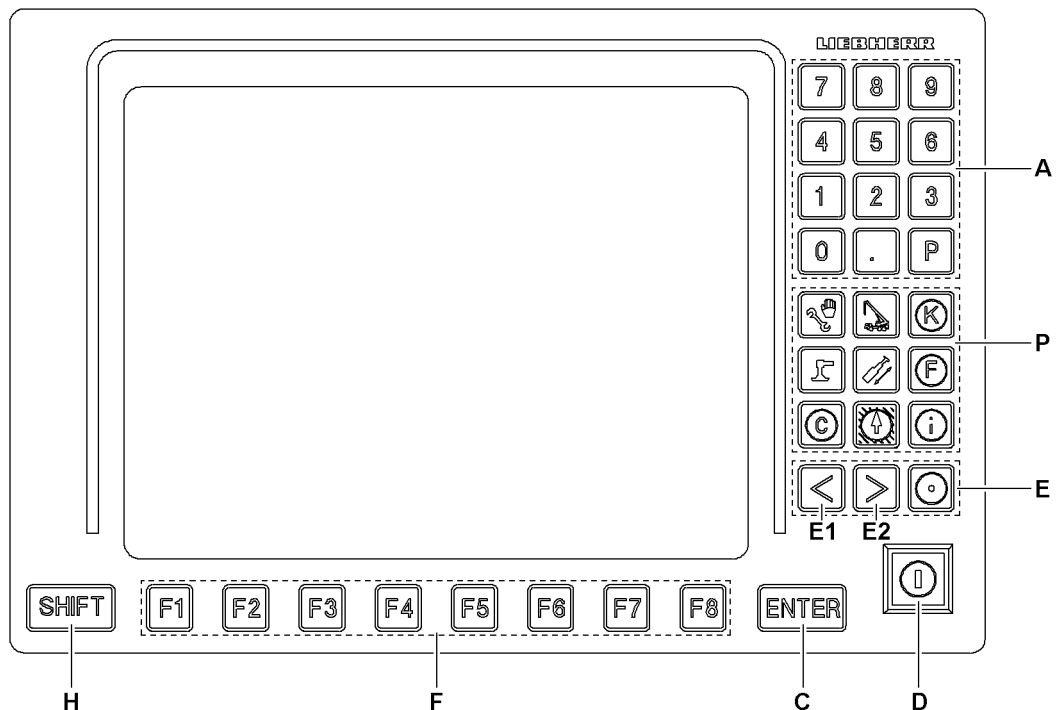

Fig.119927: Operating elements in the Set up program

- A Keypad**
 - The keys **0** to **9** on the keypad can be used to enter the respective number directly.
 - Decimal digits can be created with the key „.“
 - The „P“ button has no function in the *Set up* program.
- P Program keys**
 - Selection of individual programs. The settings made in the set up program are discarded and the set up configuration that was confirmed last with the function key **F8** (OK) is used.
A program that is currently running **cannot** be called up again using its program key.
- C ENTER key**
 - Entry confirmation for selections made or for edited values.
 - After entering the chart name (chart number), the ENTER key **C** searches the corresponding operating mode. If an error is present, a short beep sounds.

- After changing / editing within a category, the ENTER key **C** sets the new value.
- D** Set up key
- Has no function in the *Set up* program
- E** Special function keys
- The key **E1**: has the same function as function key F4 in the *Set up* program.
 - The key **E2**: has the same function as function key F5 in the *Set up* program.
 - The key **E3**: in combination with the SHIFT key **H** is used to display reference texts in the *Set up* program
- Note:** Only when a code for limitations and notes is available.
- F** Function keys
- The function key line consists of function keys **F1** to **F8** and the function key icon bar above it.
 - The function keys correspond to the various function key icons above them.
- H** SHIFT key
- In combination with the key **E3**, it is used to display reference texts in the *Set up* program
- Note:** Only when a code for limitations and notes is available.

4.3 Function key line in the *Set up* program

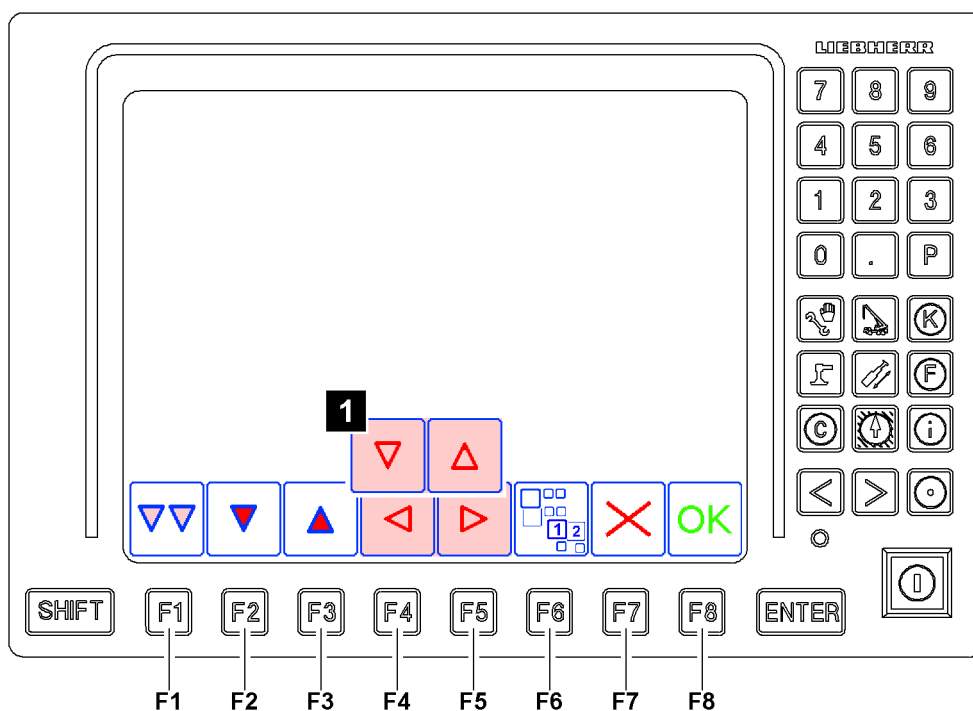

Fig.119928: Function key line in the *Set up* program

The function key line consists of function keys **F1** to **F8** and the function key icon bar above it. The function keys correspond to the various function key icons above them.



Note

- Not all function keys on the LICCON monitor are always active and assigned with icons. Only when a function key is presently available is the corresponding icon shown.

F1 Function key

- Change to the next category by pressing the function key **F1**.
- **Note:** The active category is always highlighted in pink.

- F2** Function key
- Navigation in the Editing / selection window: change downward
 - **Note:** If it is not possible to change further downward, a short beep sounds.
- F3** Function key
- Navigation in the Editing / selection window: change upward
 - **Note:** If it is not possible to change further upward, a short beep sounds.
- F4** Function key
- Navigation in the pink highlighted (active) program category
 - Left arrow: change within the selection to the left
 - Down arrow, Illustration 1: change within the selection downward
 - **Note:** If it is not possible to change further in that direction, a short beep sounds.
- F5** Function key
- Navigation in the pink highlighted (active) program category
 - Right arrow: change within the selection to the left
 - Up arrow, Illustration 1: change upward within the selection
 - **Note:** If it is not possible to change further in that direction, a short beep sounds.
- F6** Function key
- If additional levels are present, then they can be selected by pressing the function key **F6**.
- F7** Function key
- Reset the *Set up* program to the last valid set up configuration
- F8** Function key
- Take over the current settings as the new set up configuration.
 - **Note:** By pressing the function key **F8**, the *Set up* program is completed and the *Crane operation* program is called up.

4.4 Setting the set up configuration in general

Make sure that the following prerequisite is met:

- There is no load on the hook.

The set up configuration is set in the following program categories:

- Operating mode category
- Set up completion category
- Environmental / mechanical influence category
- Lifting category



WARNING

Incorrect operation in the *Set up* program!

The *Set up* program is only correctly carried out when **all** program categories are set and the actual configurations for crane and environment are depicted.

Incorrect operation in the *Set up* program leads to an incorrectly set overload protection.

An incorrectly set overload protection calculates the actual load incorrectly and transmits faulty display values.

The crane can be overloaded without being noticed and topple over. Personnel can be severely injured or killed.

- ▶ In the *Set up* program, always set **all** program categories according to the actual configurations of the crane and the environment.
- ▶ Before taking over the settings in the *Set up* program, check all program categories.



Note

The following sections describe by means of an example how to change from the crane basic setting to a more extensive operating mode.

All entries and settings can therefore be explained by example.

- ▶ If the required operating mode deviates, make your own entries and settings and do not skip required steps.

4.5 Structure of the operating mode category

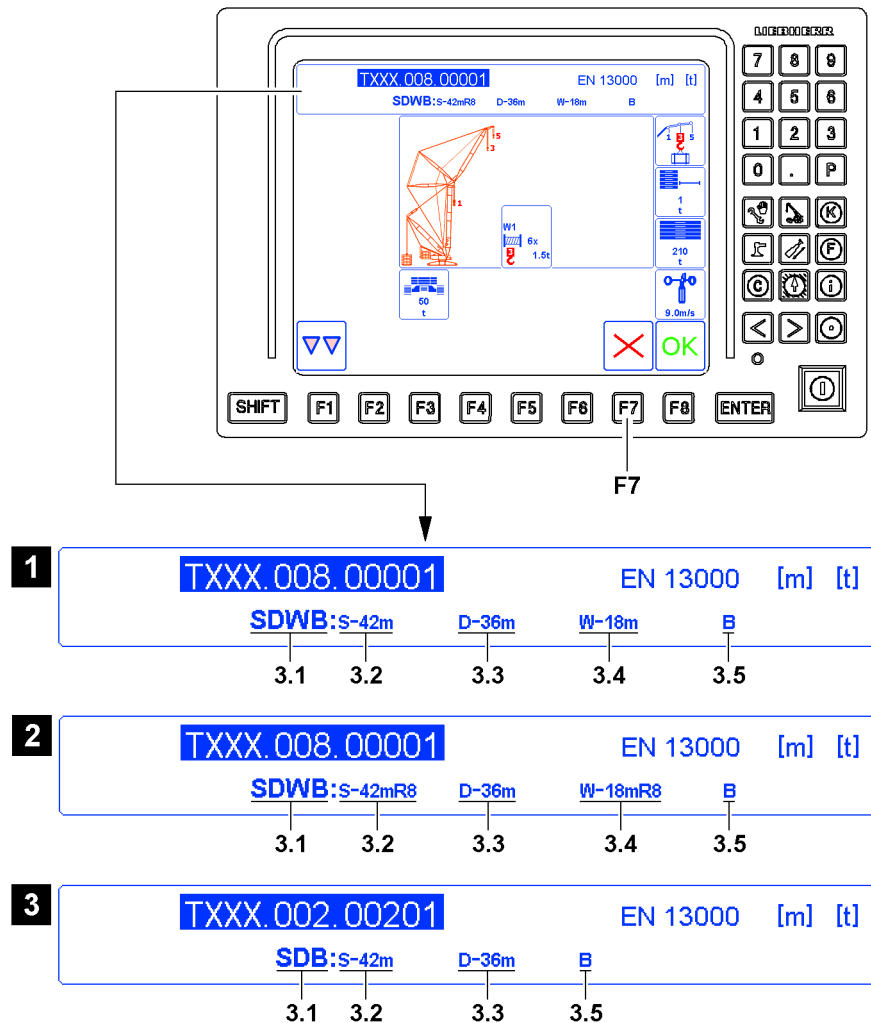

Fig.119915

The components of the boom system can be combined with each other to operating modes according to certain rules.

The individual components are coded via markers.

The operating mode consists of up to five markers, see illustration 1.

The operating mode is set in the operating mode category.

Markers for operating mode in the *Set up* program:

- 3.1 Abbreviation
 - Abbreviation of the operating mode
- 3.2 Main boom
 - Type and length of the main boom
 - **Note:** On some main booms, various roller sets can be set up additionally, see illustration 2
- 3.3 Derrick boom
 - Length of the derrick boom
 - **Note:** This appears only in the corresponding operating mode.
- 3.4 Auxiliary boom / accessory
 - Type and length of the auxiliary boom / accessory
 - **Note:** On some auxiliary booms, various roller sets can be set up additionally, see illustration 2.

- **Note:** This appears only in the corresponding operating mode.
- 3.5 Derrick ballast**
- Derrick ballast version
 - **Note:** This appears only in the corresponding operating mode.



Note

- ▶ If a marker for an operating mode does not appear, then the following markers move up, see example illustration 3.
- ▶ If the *Abort* icon appears above a function key **F7**, then the procedure can be aborted at any time. All entries and settings made up to that point are discarded.

The operating mode can be set two ways:

- Setting the operating mode via chart names (chart number)
- Setting the operating mode via the function keys

4.6 Setting the operating mode via chart name (chart number)

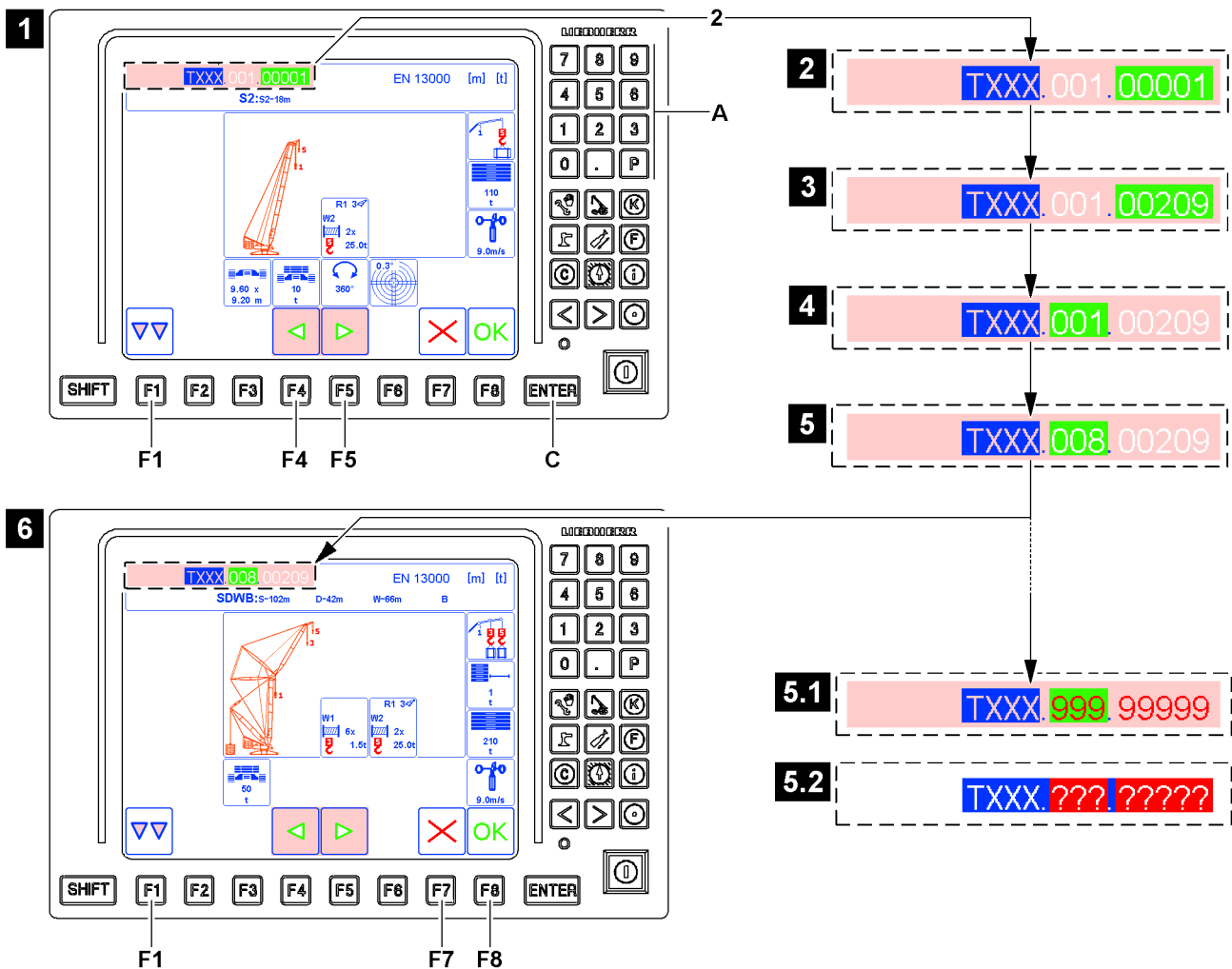

Fig.120679



Note

- The following section describes by example how a certain chart name (chart number) is entered.
- ▶ Always enter the required chart name (chart number).
 - ▶ If the *Abort* icon appears above a function key **F7**, then the procedure can be aborted at any time. All entries and settings made up to that point are discarded.

LWE/LR_13000-001/19503-01-02/en

Make sure that the following prerequisites are met:

- The *Set up* program is called up.
- The required chart name (chart number) is known.
- ▶ Press the function key **F1** until the chart name category **2** is highlighted in pink, see illustration 1.

Result:

- The chart name category **2** is active. The editable area of the chart name (chart number) is highlighted additionally in green.



Note

Navigation in the chart name category **2**

- ▶ Press the function key **F4**: The editable area changes to the left.
- ▶ Press the function key **F5**: The editable area changes to the right.

When the rear five digits of the chart name (chart number) are highlighted in green (illustration 2):

- ▶ Enter the number sequence using the keypad **A**, in example „00209“.

Result:

- The entered number sequence is shown in the editable area of the chart name (chart number), see illustration 3.
- ▶ Press the function key **F4**.

Result:

- The editable area of the chart name (chart number) changes, see illustration 4.

When the center three digits of the chart name (chart number) are highlighted in green (illustration 4):

- ▶ Enter the number sequence using the keypad **A**, in example „008“.

Result:

- The entered number sequence is shown in the editable area of the chart name (chart number), see illustration 5.
- ▶ Accept the chart name (chart number) with the ENTER key **C**.

Result:

- The chart name (chart number) is accepted.
- The screen display is matched, see illustration 6.

Problem remedy

Invalid chart name (chart number)

When trying to accept an invalid number sequence, the numbers are displayed in red (illustration 5.1) or replaced by red question marks („?“) (illustration 5.2).

- ▶ Enter and accept only a valid chart name (chart number).

4.7 Setting the operating mode via the function keys



Note

The following section describes by example how a certain operating mode is entered.
 ▶ Always enter the required operating mode.

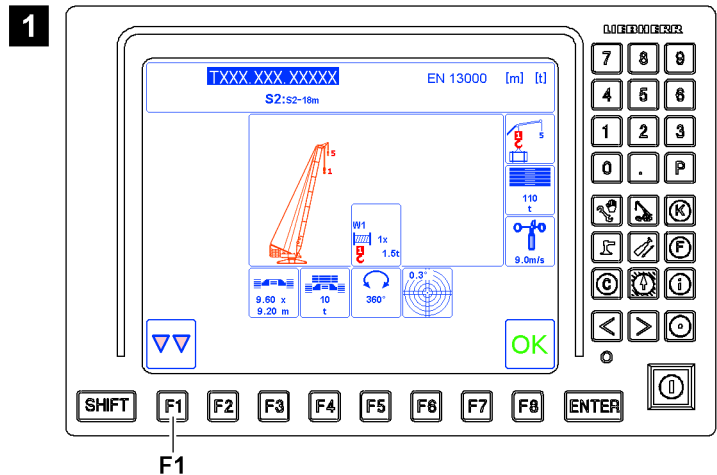

Fig. 119929

Make sure that the following prerequisite is met:

- The Set up program is called up, see illustration 1.

4.7.1 Selecting the operating mode category

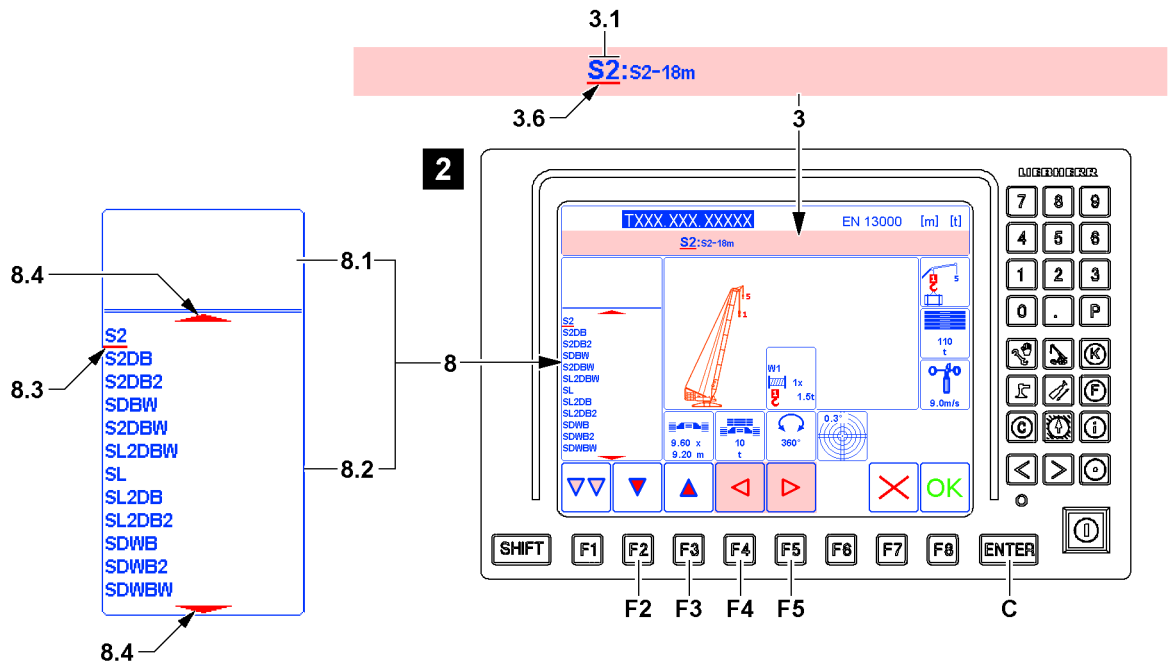

Fig. 119919

- ▶ Press the function key **F1** until the operating mode category **3** is highlighted in pink, see illustration 2.

Result:

- The operating mode category **3** is selected.
 The selection bar **3.6** automatically underlines the first marker: Abbreviation **3.1**

LWE/LR 13000-001/19503-01-02/en

- The Editing / selection window **8** appears.
- The abbreviations available for selection are displayed in the lower area **8.2** of the Editing / selection window **8**.
- The icons for navigation in the individual program categories appear above function key **F2**, function key **F3**, function key **F4** and function key **F5**.

**Note**

Navigation in the operating mode category **3**

- ▶ Press the function key **F4**: The selection bar **3.6** moves to the left.
- ▶ Press the function key **F5**: The selection bar **3.6** moves to the right.

**Note**

Navigation in the Editing / selection window **8**

- ▶ Press the function key **F2**: The selection bar **8.3** changes downward by one line.
- ▶ Press the function key **F3**: The selection bar **8.3** changes upward by one line.
- ▶ If a directional triangle **8.4** appears on the upper and lower end of a window, additional selection possibilities are present in this direction.
- ▶ When the upper area **8.1** and the lower area **8.2** are assigned: Press the ENTER key **C** and switch between the upper area **8.1** and the lower area **8.2**.

4.7.2 Selecting the abbreviation for the boom system

Make sure that the following prerequisite is met:

- The operating mode category **3** is selected.
- ▶ Press the function key **F5** or function key **F4** until the abbreviation **3.1** is underlined with the selection bar **3.6** (in the example „S2“), see illustration **2**.

Result:

- The abbreviations available for selection are displayed in the lower area **8.2** of the Editing / selection window **8**.

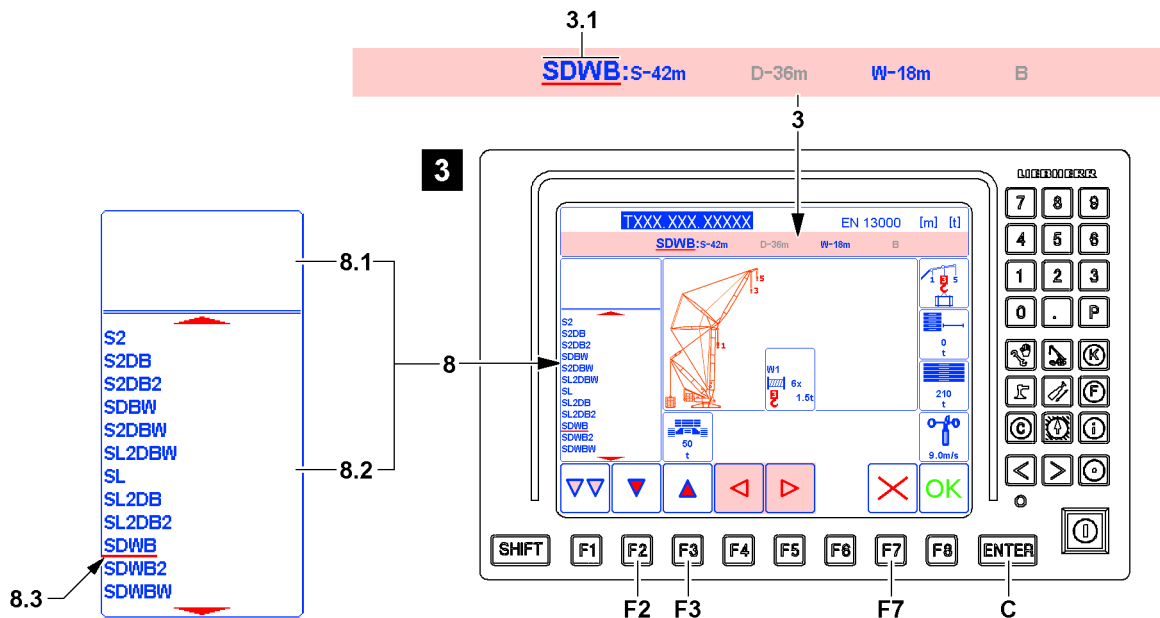

Fig. 119930

- ▶ Press the function key **F2** or function key **F3** until the required abbreviation is underlined with the selection bar **8.3**. In the example „SDWB“, see illustration **3**.

When the required abbreviation is underlined with the selection bar **8.3**:

- ▶ Press the ENTER key **C**.

Result:

- The abbreviation is selected (example „SDWB“).
- The newly selected abbreviation 3.1 appears in the operating mode category 3.
- The graphic display of the crane in the display window changes accordingly.

4.7.3 Determining the main boom variation

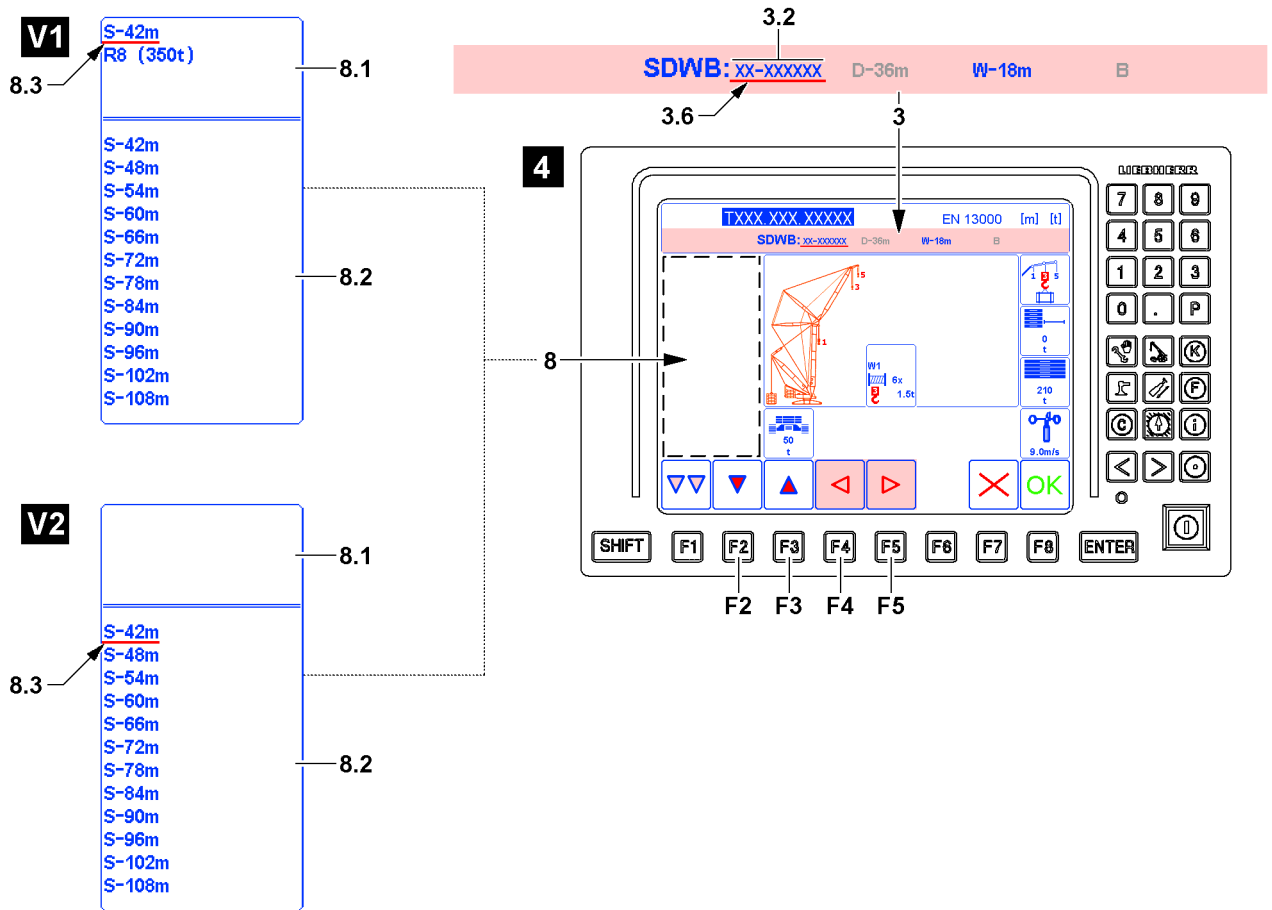

Fig.119935

At first, the main boom 3.2 must be selected in the operating mode category 3.

- ▶ Press the function key F5 or function key F4 until the main boom 3.2 is underlined with the selection bar 3.6, see illustration 4.

Result:

- First variation, illustration V1

Note: The first variation appears only when various roller sets can be assigned to the main boom in the Set up program.

- The preselection options are displayed in the upper area 8.1 of the Editing / selection window 8. The first preselection option is automatically underlined and activated with the selection bar 8.3.
- The main booms available for section are displayed in the lower area 8.2 of the Editing / selection window 8.

- Second variation, illustration V2

Note: The second variation appears only when no various roller sets can be assigned to the main boom in the Set up program.

- No selection option appears in the upper area 8.1 of the Editing / selection window 8.
- The main booms available for section are displayed in the lower area 8.2 of the Editing / selection window 8.

LWE/LR 13000-001/19503-01-02/en

Depending on the view of the Editing / selection window **8** you must proceed differently:

- ▶ If the first variation is shown (illustration **V1**), proceed with section „Selecting the main boom for the first variation (V1)“.
- ▶ If the second variation is shown (illustration **V2**), proceed with section „Selecting the main boom for the second variation (V2)“.

4.7.4 Selecting the main boom for the first variation (V1)

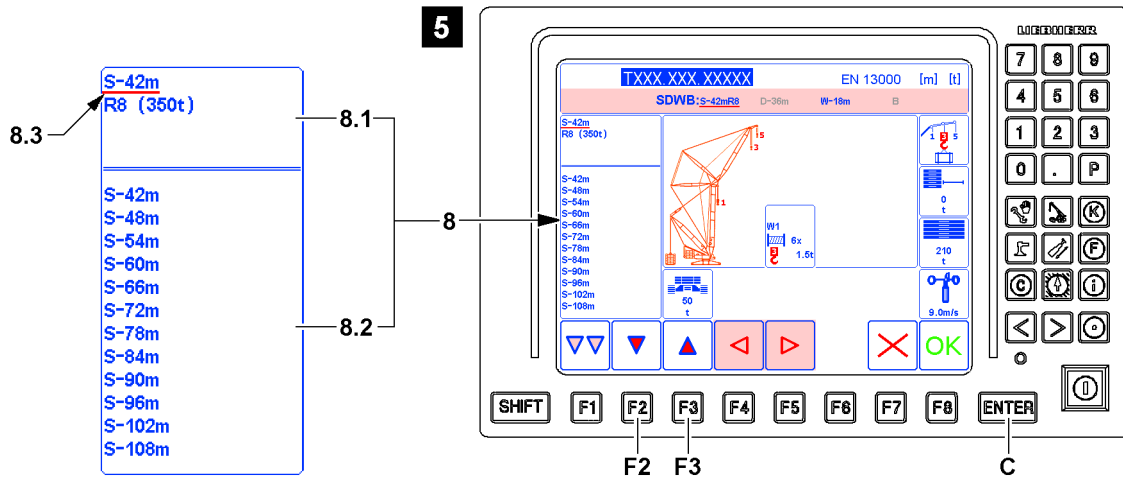

Fig.119920

- ▶ Press the function key **F2** or function key **F3** until the required preselection option in the upper area **8.1** is underlined with the selection bar **8.3** (in the example „S-42m“), see illustration **5**.

When the required preselection option is underlined with the selection bar **8.3**:

- ▶ Press the ENTER key **C**.

Result:

- The selection bar **8.3** changes in the lower area **8.2** of the Editing / selection window **8**.

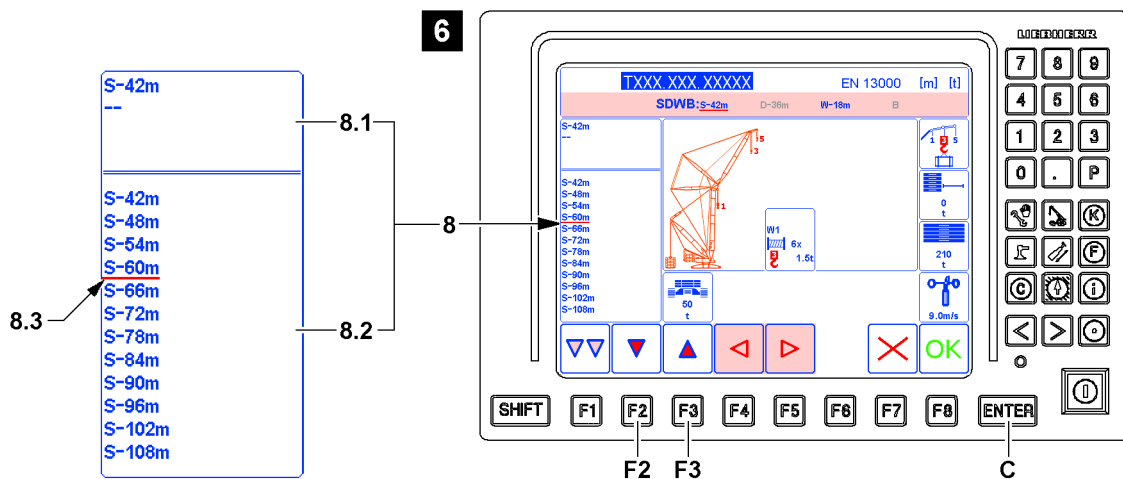

Fig.119937

- ▶ Press the function key **F2** or function key **F3** until the required main boom is underlined with the selection bar **8.3** (in the example „S60m“), see illustration **6**.

When the required main boom is underlined with the selection bar **8.3**:

- ▶ Press the ENTER key **C**.

Result:

- The main boom is selected (in example „S60m“).
- The selection bar 8.3 changes in the upper area 8.1 of the Editing / selection window 8.

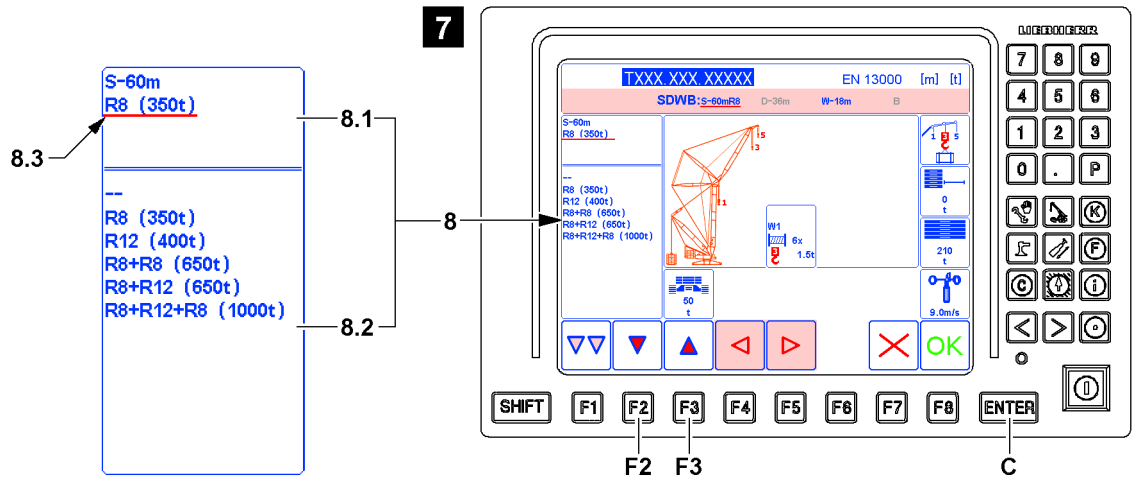

Fig.119938

- ▶ Press the function key **F2** or function key **F3** until the required preselection option in the upper area 8.1 is underlined with the selection bar 8.3 (in the example „R8 (350t)“, see illustration 7).

When the required preselection option is underlined with the selection bar 8.3:

- ▶ Press the ENTER key **C**.

Result:

- The selection bar 8.3 changes in the lower area 8.2 of the Editing / selection window 8.

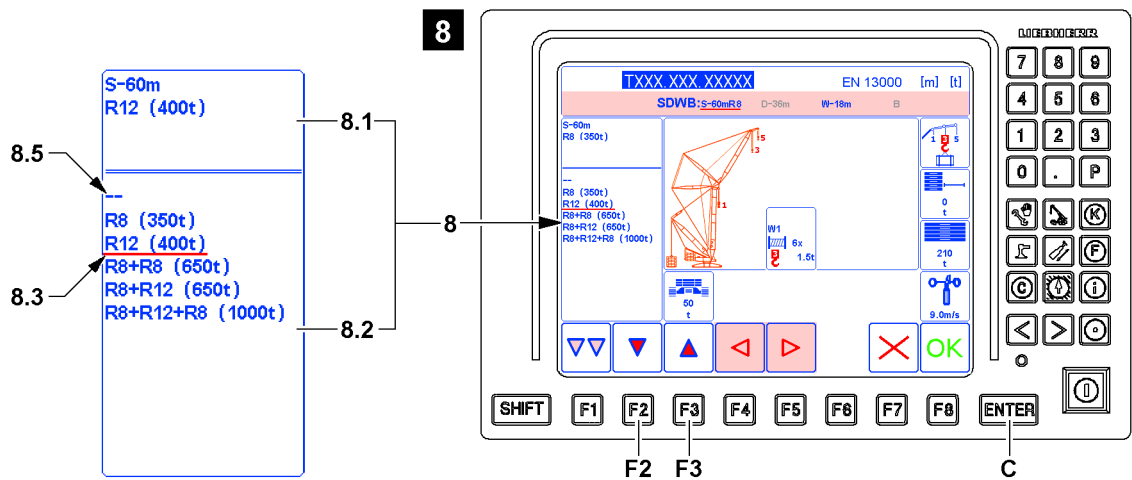

Fig.164448

- ▶ Press the function key **F2** or function key **F3** until the required roller set is underlined with the selection bar 8.3 (in the example „R12 (400t)“, see illustration 8).



Note

- ▶ Selection „--“ 8.5 means that **no** roller set is assembled on the corresponding boom.

LWE/LR_13000-001/19503-01-02/en

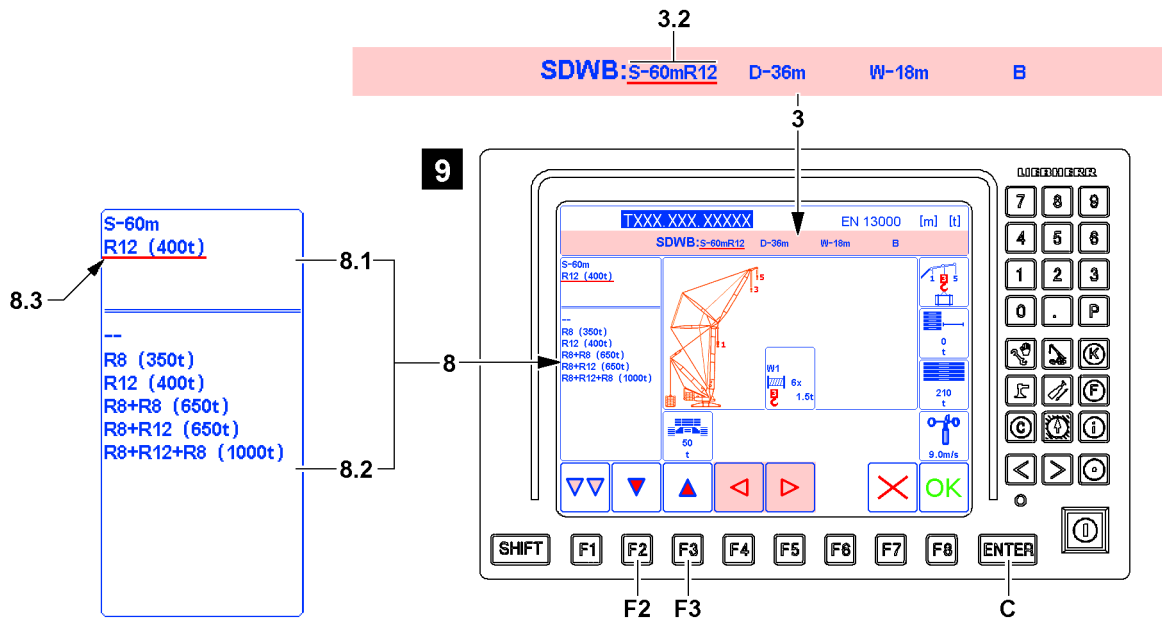

Fig.119940

When the required roller set is underlined with the selection bar 8.3:

- ▶ Press the ENTER key C.

Result:

- The roller set is selected (in example „R12 (400t)“).
- The selection bar 8.3 changes in the upper area 8.1 of the Editing / selection window 8.
- The operating mode category 3 includes the newly selected main boom with roller set 3.2, see illustration 9.

4.7.5 Selecting the main boom for the second variation (V2)

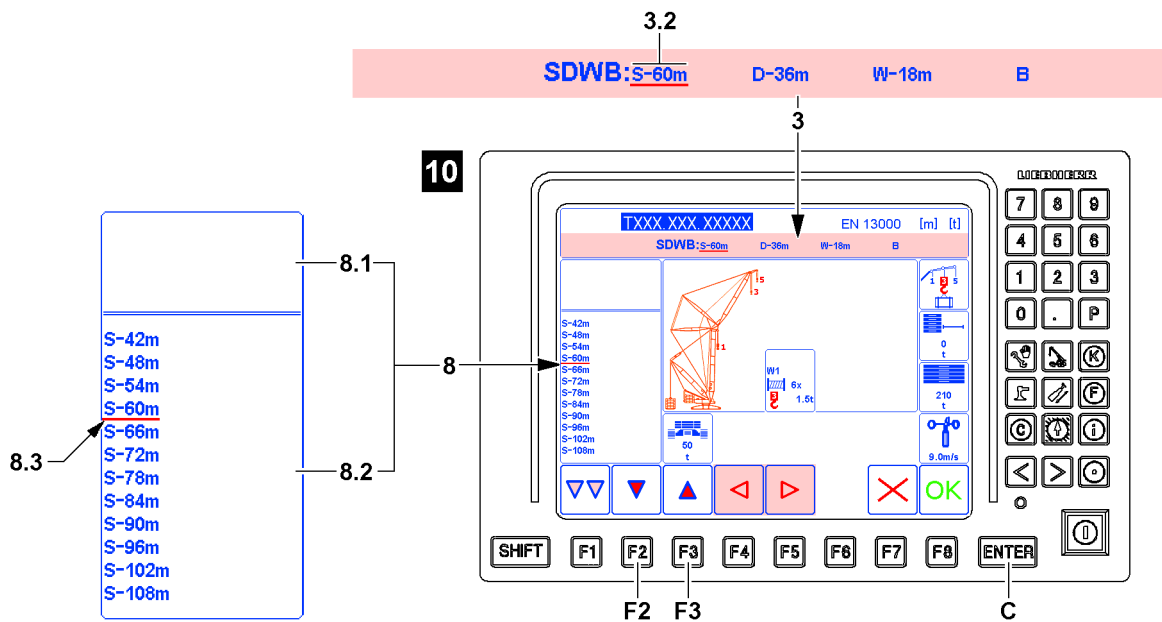

Fig.119931

- ▶ Press the function key F2 or function key F3 until the required main boom is underlined with the selection bar 8.3 (in the example „S-60m“), see illustration 10.

LWE/LR 13000-001/19503-01-02/en

When the required main boom is underlined with the selection bar **8.3**:

- ▶ Press the ENTER key **C**.

Result:

- The main boom is selected (in example „S-60m“).
- The newly selected main boom **3.2** appears in the operating mode category **3**.

4.7.6 Invalid chart name

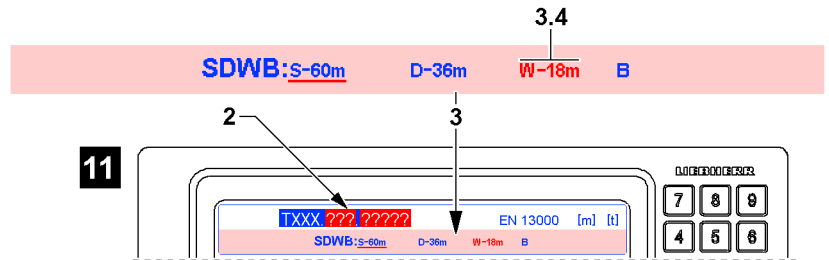

Fig.119932

- ▶ Check if the chart name **2** is displayed in blue lettering.

Problem remedy

After pressing the ENTER key **C**, is the chart name **2** replaced by the red highlighted question mark („?“ - see illustration **11**)?

Additional entries and settings must be made to obtain a valid set up configuration. If a valid set up configuration is prevented by a certain marker, then this marker is highlighted in red. In the example, the marker for auxiliary boom / accessory **3.4** must still be processed.

- ▶ Continue making entries and settings normally until it is the turn for the red highlighted marker.

4.7.7 Selecting the derrick boom

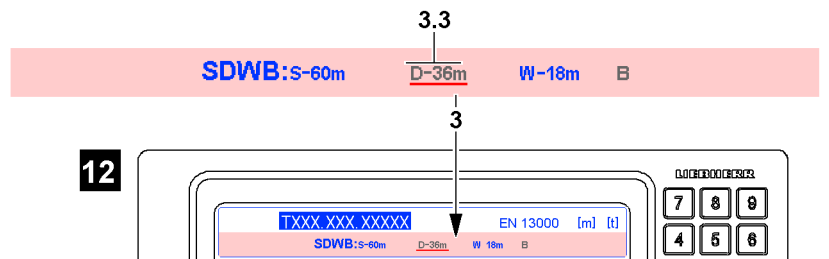

Fig.119933



Note

Illustration **3.3**: If the text for the derrick boom **12** appears in gray, then no additional entries and settings for this marker are possible.

- ▶ Correctly selected markers with gray lettering can be skipped.

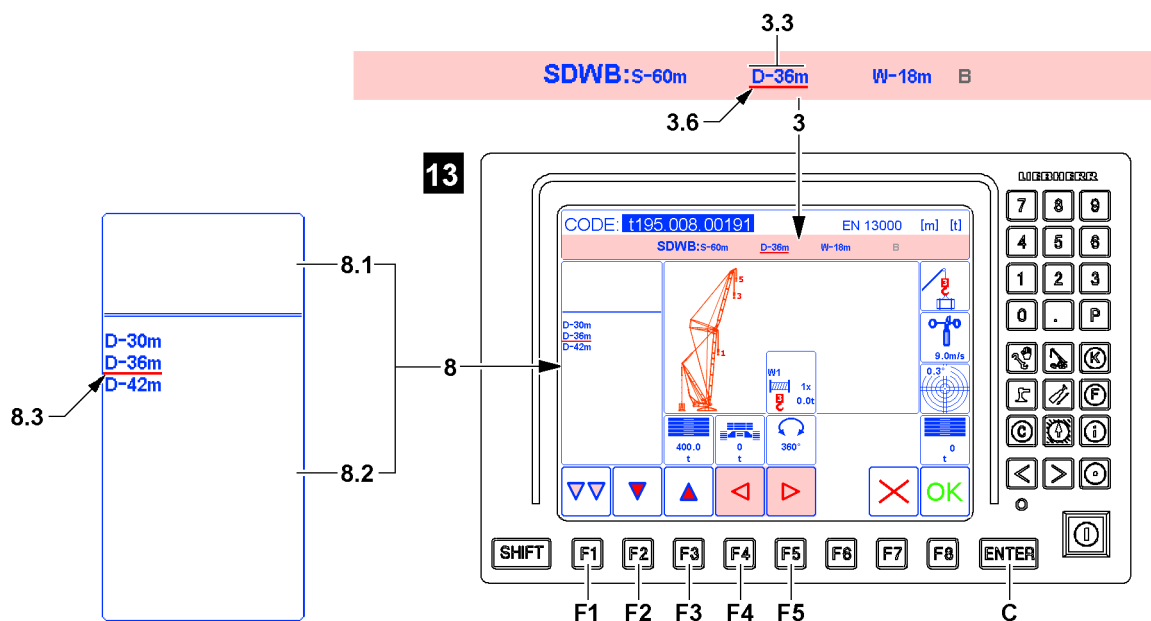

Fig.119934

**Note**

If the correct derrick boom **3.3** already appears, then the entries and settings for this marker can be skipped.

- ▶ Press the function key **F5** or function key **F4** until the next marker to be changed is underlined with the selection bar **3.6**.
- ▶ If all entries and settings in the operating mode category **3** are correct, press the function key **F1** and switch to the next category.

First, the operating mode category **3** for the derrick boom **3.3** must be selected.

- ▶ Press the function key **F5** or function key **F4** until the derrick boom **3.3** is underlined with the selection bar **3.6** (in the example „D-36m“), see illustration **13**.

Result:

- The derrick booms available for selection are displayed in the lower area **8.2** of the editing / selection window **8**.

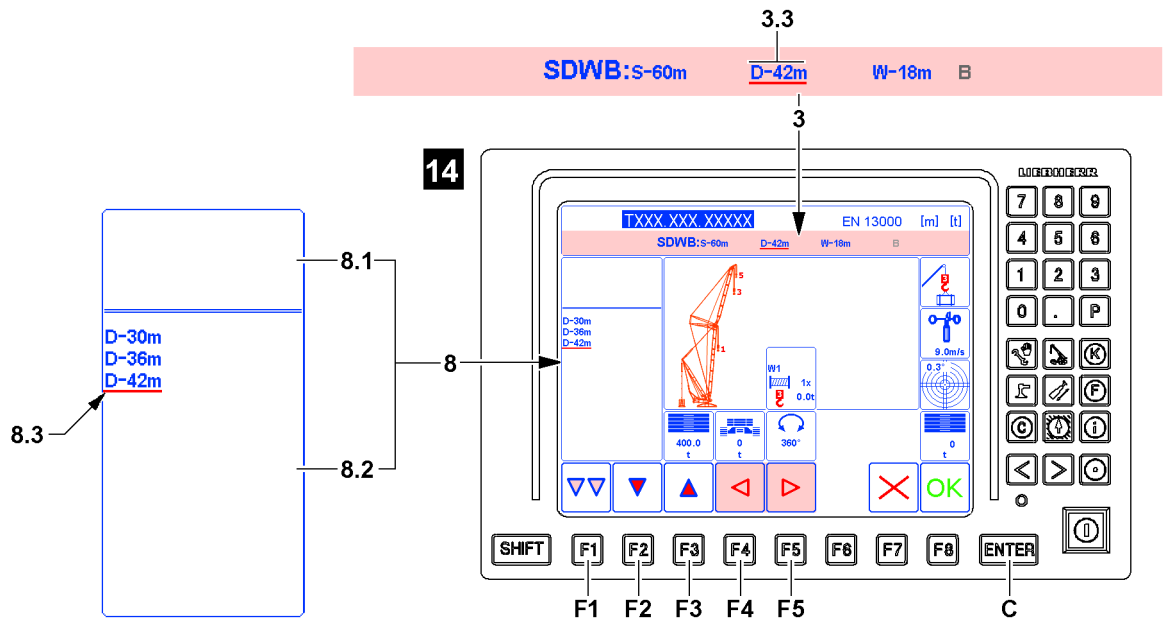

Fig.119941

- ▶ Press the function key **F2** or function key **F3** until the required derrick boom is underlined with the selection bar **8.3**. (In the example „D-42m“, see illustration **14**.)

When the required derrick boom is underlined with the selection bar **8.3**:

- ▶ Press the ENTER key **C**.

Result:

- The derrick boom is selected (example „D-42m“).
- The newly selected derrick boom **3.3** appears in the operating mode category **3**.

Problem remedy

Is the required selection for a market not available in the operating mode category **3**?

The previously made entries and settings were not made correctly.

In the *Set up* program only entries and settings can be made for which load charts are available.

- ▶ Correct the previously made entries and settings.

4.7.8 Selecting the auxiliary boom / accessory

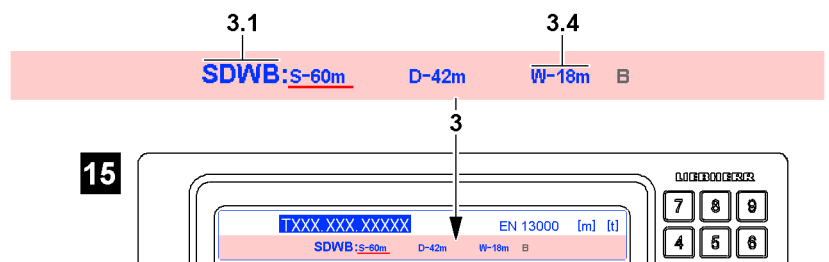

Fig.119942

The auxiliary boom / accessory **3.4** marker only appears when a corresponding abbreviation **3.1** is selected, see illustration **15**.



Note

If the text for the auxiliary boom / accessory **3.4** appears in gray, then no additional entries and settings for this marker are possible.

- ▶ Correctly selected markers with gray lettering can be skipped.

LWE/LR_13000-001/19503-01-02/en

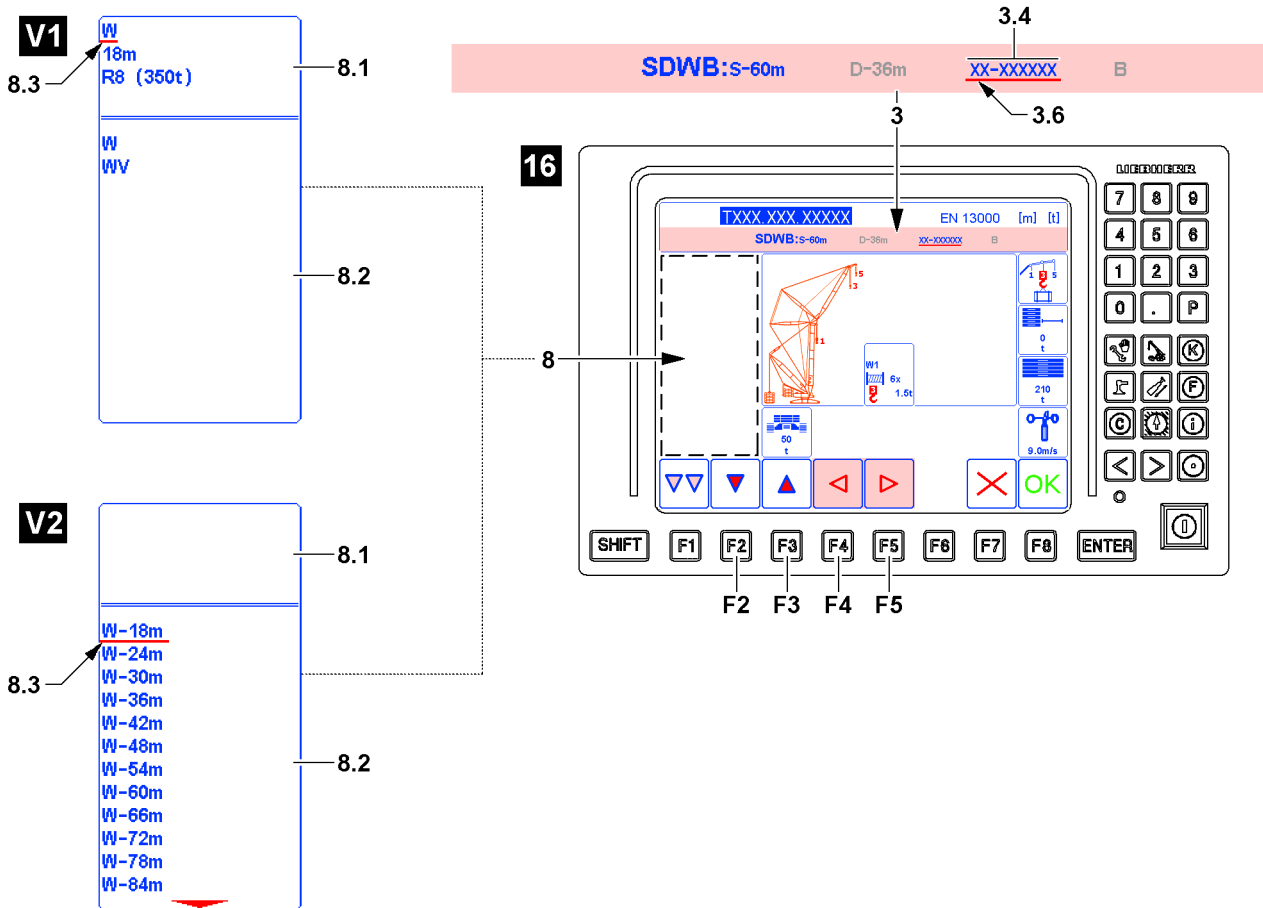

Fig.119943

**Note**

If the correct auxiliary boom / accessory 3.4 already appears, then the entries and settings for this marker can be skipped.

- ▶ Press the function key **F5** or function key **F4** until the next marker to be changed is underlined with the selection bar 3.6.
- ▶ If all entries and settings in the operating mode category 3 are correct, press the function key **F1** and switch to the next category.

4.7.9 Determining the auxiliary boom / accessory variation

At first, the operating mode category 3 for the auxiliary boom / accessory 3.4 must be selected.

- ▶ Press the function key **F5** or function key **F4** until the auxiliary boom / accessory 3.4 marker is underlined with the selection bar 3.6, see illustration 16.

Result:

- First variation, illustration **V1**

Note: The first variation appears solely when various operating modes and / or roller sets can be assigned to the auxiliary boom / accessory in the *Set up* program.

- The preselection options are displayed in the upper area 8.1 of the Editing / selection window 8. The first preselection option is automatically underlined and activated with the selection bar 8.3.
- The settings available for selection are displayed in the lower area 8.2 of the Editing / selection window 8

- Second variation, illustration **V2**

Note: The second variation appears solely when no various operating modes and roller sets can be assigned to the auxiliary boom / accessory in the *Set up* program.

- No selection option appears in the upper area 8.1 of the Editing / selection window 8.

- The settings available for selection are displayed in the lower area **8.2** of the Editing / selection window **8**

Depending on the view of the Editing / selection window **8** you must proceed differently:

- ▶ If the first variation is shown (illustration **V1**), proceed with section „Selecting the auxiliary boom / accessory for the first variation (V1)“.
- ▶ If the second variation is shown (illustration **V2**), proceed with section „Selecting the auxiliary boom / accessory for the second variation (V2)“.

4.7.10 Selecting the auxiliary boom / accessory for the first variation (V1)

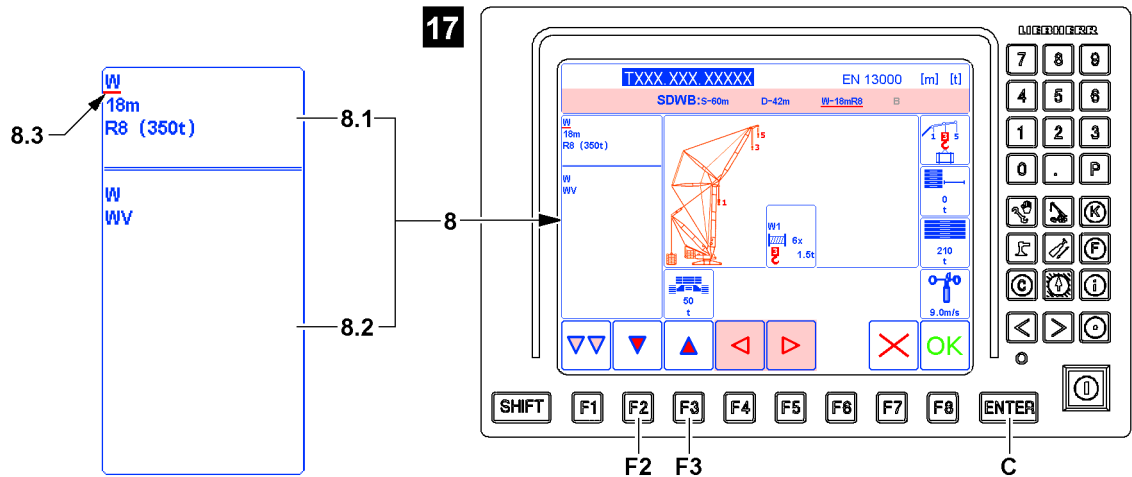

Fig.119944

- ▶ Press the function key **F2** or function key **F3** until the required preselection option in the upper area **8.1** is underlined with the selection bar **8.3** (in the example „W“), see illustration **17**.

When the required preselection option is underlined with the selection bar **8.3**:

- ▶ Press the ENTER key **C**.

Result:

- The selection bar **8.3** changes in the lower area **8.2** of the Editing / selection window **8**.

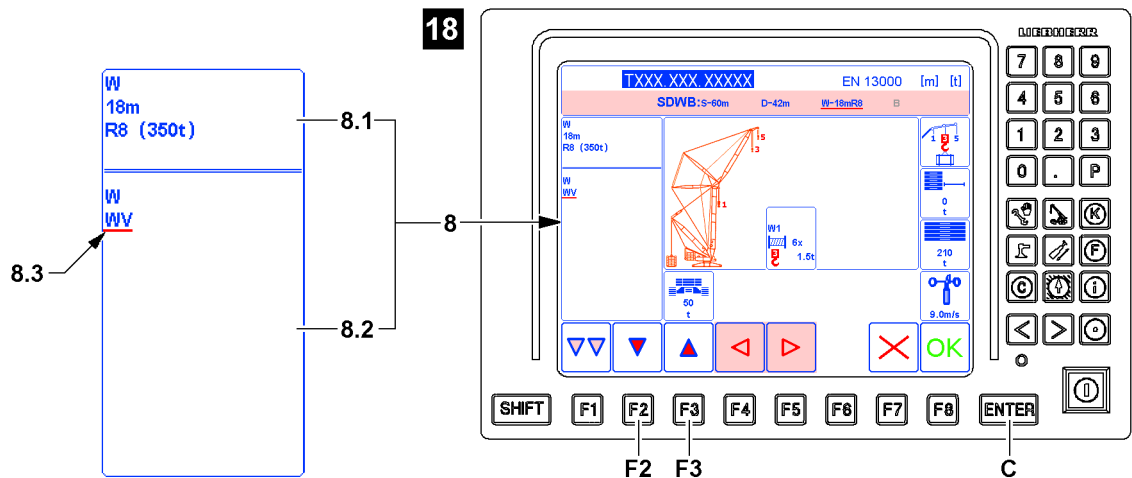

Fig.119945

- ▶ Press the function key **F2** or function key **F3** until the required setting is underlined with the selection bar **8.3** (in the example „WV“), see illustration **18**.

LWE/LR_13000-001/19503-01-02/en

When the required setting is underlined with the selection bar **8.3**:

- ▶ Press the ENTER key **C**.

Result:

- The setting is selected.
- The selection bar **8.3** changes in the upper area **8.1** of the Editing / selection window **8**.

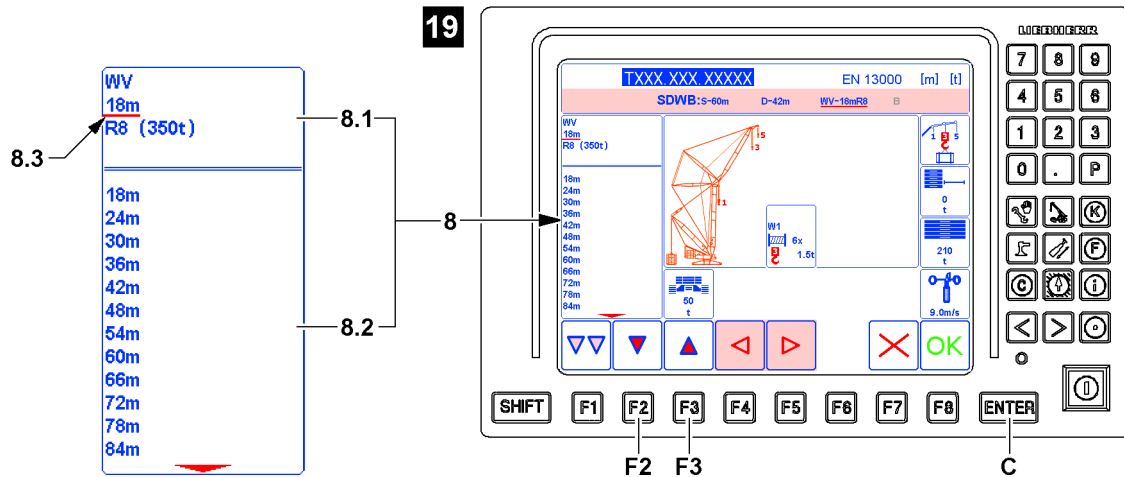

Fig.119946

- ▶ Press the function key **F2** or function key **F3** until the required preselection option in the upper area **8.1** is underlined with the selection bar **8.3** (in the example „18m“), see illustration **19**.

When the required preselection option is underlined with the selection bar **8.3**:

- ▶ Press the ENTER key **C**.

Result:

- The selection bar **8.3** changes in the lower area **8.2** of the Editing / selection window **8**.

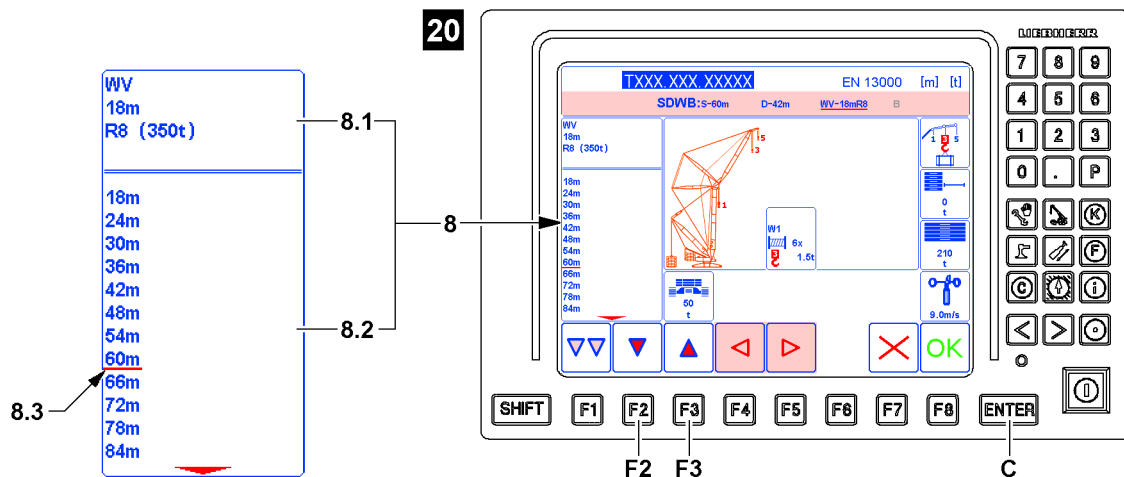

Fig.120576

- ▶ Press the function key **F2** or function key **F3** until the required setting is underlined with the selection bar **8.3** (in the example „60m“), see illustration **20**.

When the required roller set is underlined with the selection bar **8.3**:

- ▶ Press the ENTER key **C**.

Result:

- The setting is selected.

- The selection bar **8.3** changes in the upper area **8.1** of the Editing / selection window **8**.

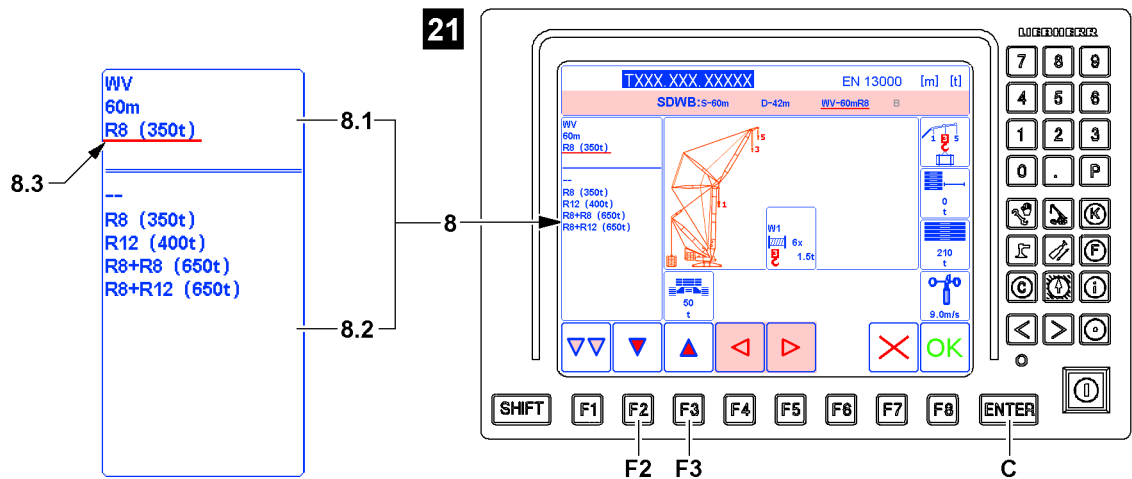

Fig.120577

- ▶ Press the function key **F2** or function key **F3** until the required preselection option in the upper area **8.1** is underlined with the selection bar **8.3** (in the example „R8 (350t)“, see illustration **21**).

When the required preselection option is underlined with the selection bar **8.3**:

- ▶ Press the ENTER key **C**.

Result:

- The selection bar **8.3** changes in the lower area **8.2** of the editing / selection window **8**.

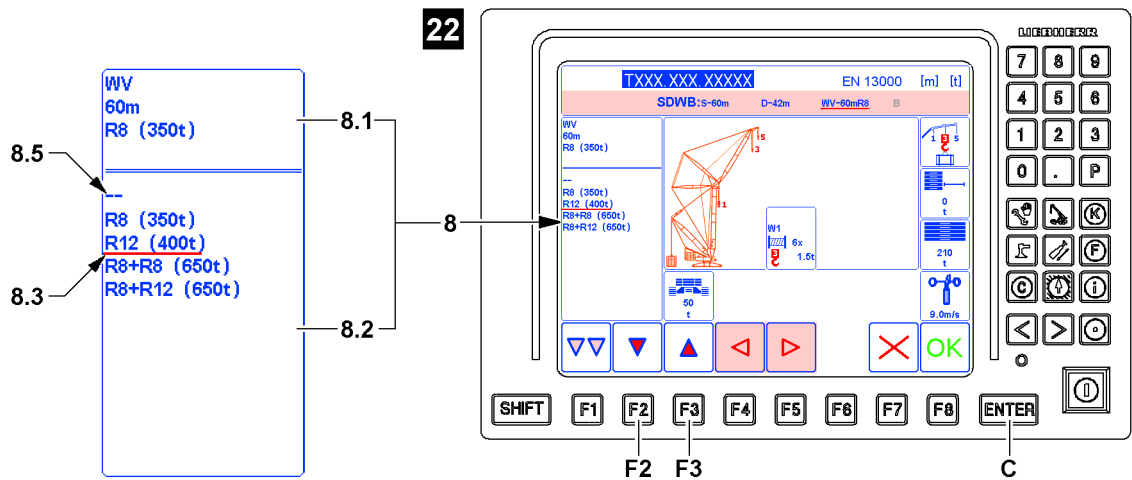

Fig.164449

- ▶ Press the function key **F2** or function key **F3** until the required setting is underlined with the selection bar **8.3** (in the example „R12 (400t)“, see illustration **22**).



Note

- ▶ Selection „-“ **8.5** means that **no** roller set is assembled on the corresponding boom.

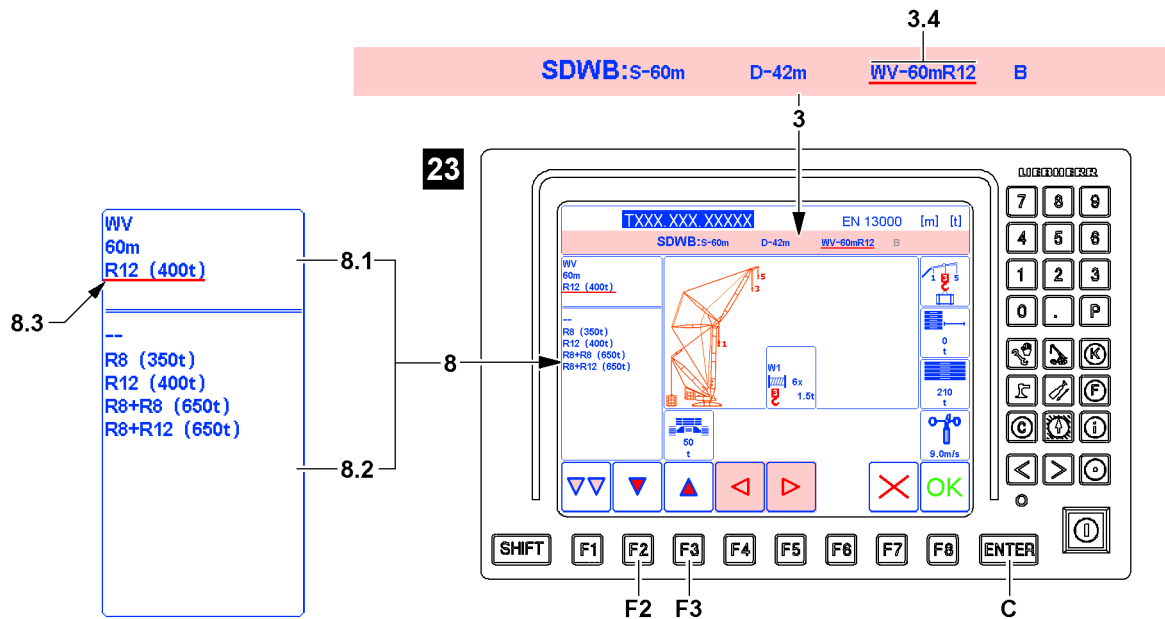

Fig.120579

When the required setting is underlined with the selection bar 8.3:

- Press the ENTER key C.

Result:

- The setting is selected.
- The selection bar 8.3 changes in the upper area 8.1 of the Editing / selection window 8.
- The operating mode category 3 shows the selected settings for auxiliary boom / accessory 3.4, see illustration 23.

4.7.11 Selecting the auxiliary boom / accessory for the second variation (V2)

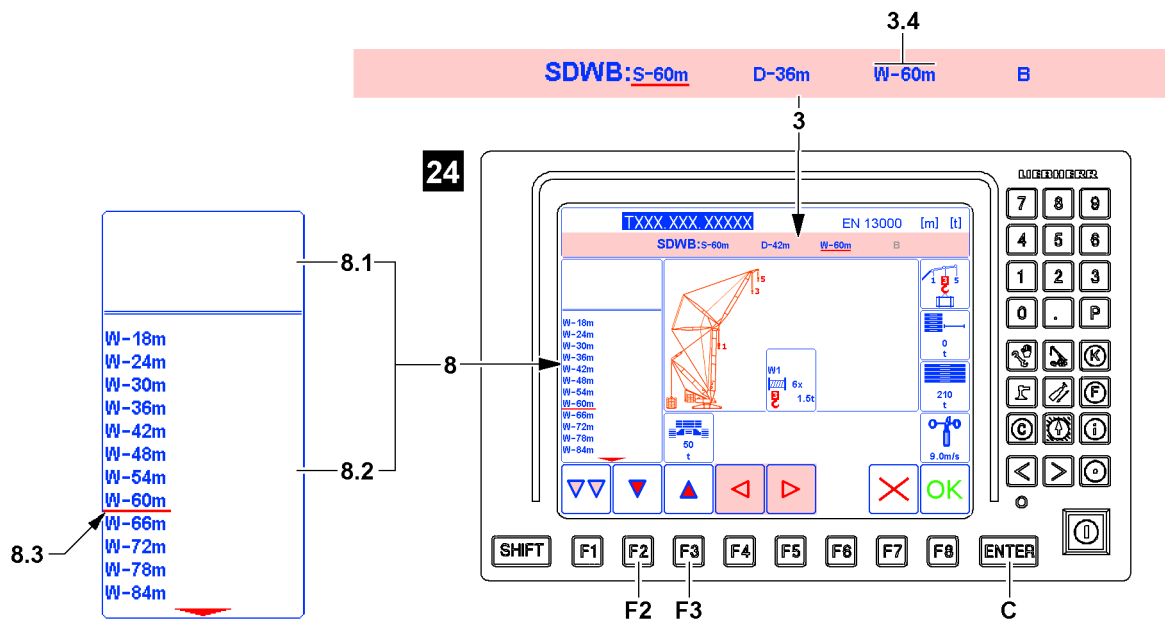

Fig.120580

- Press the function key F2 or function key F3 until the required main boom is underlined with the selection bar 8.3 (in the example „W-60m“, see illustration 24).

When the required main boom is underlined with the selection bar **8.3**:

- ▶ Press the ENTER key **C**.

Result:

- The auxiliary boom / accessory is selected (in example „W-60m“).
- The operating mode category **3** shows the selected settings for auxiliary boom / accessory **3.4**.

4.7.12 Selecting derrick ballast settings

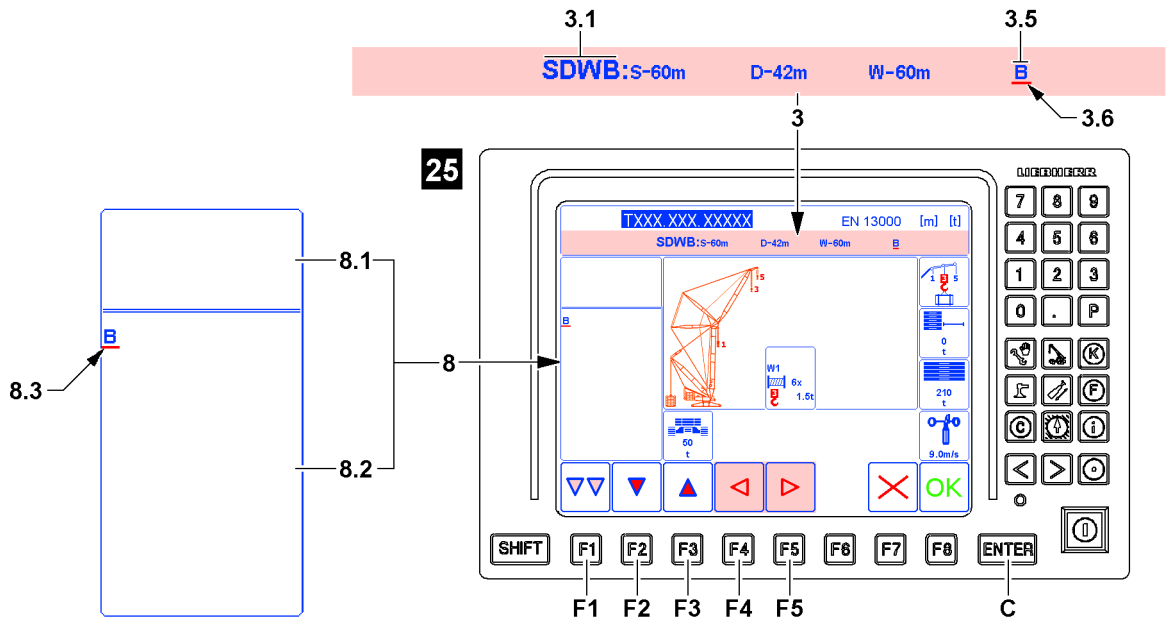

Fig.120581

The derrick ballast **3.5** marker only appears when a corresponding abbreviation **3.1** is selected.



Note

If the text for the derrick ballast **3.5** appears in gray, then no additional entries and settings for this marker are possible.

- ▶ Correctly selected markers with gray lettering can be skipped.



Note

If the correct derrick ballast **3.5** already appears, then the entries and settings for this marker can be skipped.

- ▶ Press the function key **F5** or function key **F4** until the next marker to be changed is underlined with the selection bar **3.6**.
- ▶ If all entries and settings in the operating mode category **3** are correct, press the function key **F1** and switch to the next category.



Note

Whether a suspended ballast or a ballast trailer or the operating mode with removed ballast pallet is used as a derrick ballast **3.5** depends on the selected abbreviation **3.1**.

- ▶ To change between suspended ballast, ballast trailer or the operating mode with removed ballast pallet, see section: „Selecting the abbreviation for the boom system“.
- ▶ Settings regarding the derrick ballast weight are made via the set up functions, see section „Setting the set up functions“.

At first, the operating mode category **3** for the derrick ballast **3.5** must be selected.

- ▶ Press the function key **F5** or function key **F4** until the derrick ballast **3.5** is underlined with the selection bar **3.6** (in the example „B“, see illustration **25**).

Result:

- The lower area **8.2** of the Editing / selection window **8** displays the abbreviations for derrick ballast settings available for selection.

When another derrick ballast setting is available for selection:

- ▶ Press the function key **F2** or function key **F3** until the required derrick ballast setting is underlined with the selection bar **8.3**.

When the required derrick ballast setting is underlined with the selection bar **8.3**:

- ▶ Press the ENTER key **C**.

Result:

- The derrick ballast setting is selected.
- The newly selected derrick ballast **3.5** appears in the operating mode category **3**.

Problem remedy

Are the required selection for the entries and settings of a marker not available in the operating mode category **3**?

The previously made entries and settings were not made correctly.

In the *Set up* program only entries and settings can be made for which load charts are available.

- ▶ Correct the previously made entries and settings.

4.7.13 Accepting the entries and settings of the operating mode category

Make sure that the following prerequisites are met:

- All selected entries and settings in the operating mode category **3** are correct and complete.
- ▶ Press the function key **F1**.

Result:

- The entries and settings of the operating mode category are completed.
- The set up completion category is automatically called up.

Problem remedy

After pressing the function key **F1**, was it determined that one or several markers are not correct?

By pressing the function key **F1**, the individual program categories can be switched through one after the other. The first program category is called up after the last one.

- ▶ Press the function key **F1** until the operating mode category **3** is called up again. Then all entries and settings can be changed.

4.8 Setting the set up functions

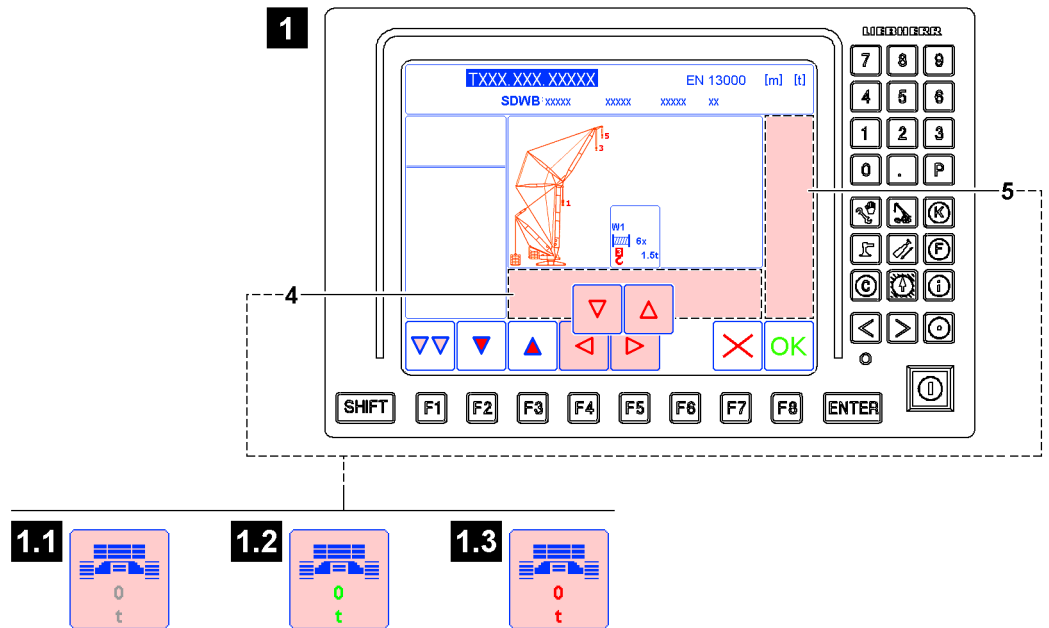

Fig.121745

The set up functions include the set up supplement category and the environmental influence / mechanical influence category.

The individual set up functions are described as markers.

- The set up supplement category **4** includes the lower area of the screen display.
- The environmental / mechanical influence category **5** includes the right area of the screen display.

Depending on the respective load chart, the individual set up functions are assigned to the respective program category.



Note

Values in gray letters

Sample illustration **1.1**: If the text of the value for the entries and settings appears in gray in one or several of the icons, then no additional entries and settings for this marker are presently possible. All entries and settings are specified by the operating mode category.

- ▶ Correctly selected markers with gray lettering can be skipped.



Note

Values in green letters

Sample illustration **1.2**: If the text of the value for the entries and settings appears in green in one or several of the icons, then additional entries and settings for this marker are possible.

- ▶ Correctly selected markers with green lettering can be skipped.



Note

Values in red letters







Sample illustration **1.3**: If the text of the value for the entries and settings appears in red in one or more of the icons, then additional entries and settings for this marker within the chart filter are required.

- ▶ A release for the set up configuration only occurs when none of the values for the entries and settings appear in red.

**Note**

The scope of the markers depends on the crane type and crane configuration.

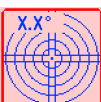
- Not all crane types have all listed monitoring functions.

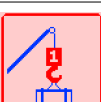
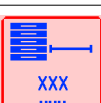
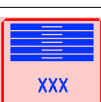
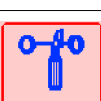
Overview of markers of the set up supplement category and the environmental / mechanical influence category	
	<p>Set up function <i>Crane chassis</i></p> <p>Adjustment option for the crane chassis (on crawler travel gear, auxiliary support or assembly support)</p> <p>Note: Adjustment option does not appear for all operating modes.</p>
	<p>Set up function <i>Derrick ballast radius</i></p> <p>Adjustment option for the derrick ballast radius</p> <p>Note: Adjustment option does not appear for all operating modes.</p>
	<p>Set up function <i>Central ballast</i></p> <p>Adjustment option for the central ballast</p> <p>Note: Adjustment option does not appear for all operating modes.</p>
	<p>Set up function <i>Slewing range</i></p> <p>Adjustment option for the crane superstructure slewing range</p> <p>Note: Adjustment option does not appear for all operating modes.</p>
	<p>Set up function <i>Incline range</i></p> <p>Adjustment option for the load chart incline range</p> <p>Note: Adjustment option does not appear for all operating modes.</p>
	<p><i>Project chart</i> set up function</p> <p>Adjustment option with an available project chart</p> <p>Note: Adjustment option does not appear for all crane types and operating modes.</p>
	<p><i>Load position</i> set up function</p> <p>Adjustment option for the position of the load on the boom system</p> <p>Note: Adjustment option does not appear for all operating modes.</p>
	<p>Set up function <i>Weight derrick ballast</i></p> <p>Adjustment option for the weight of the derrick ballast on the derrick boom</p> <p>Note: Adjustment option does not appear for all operating modes.</p>
	<p>Set up function <i>Counterweight</i></p> <p>Adjustment option for the weight of the counterweight on the crane superstructure</p> <p>Note: Adjustment option does not appear for all operating modes.</p>
	<p>Set up function <i>Wind speed</i></p> <p>Adjustment option for the maximum permissible wind speed of the load chart</p> <p>Note: Adjustment option does not appear for all operating modes.</p>

4.8.1 Selecting the program category

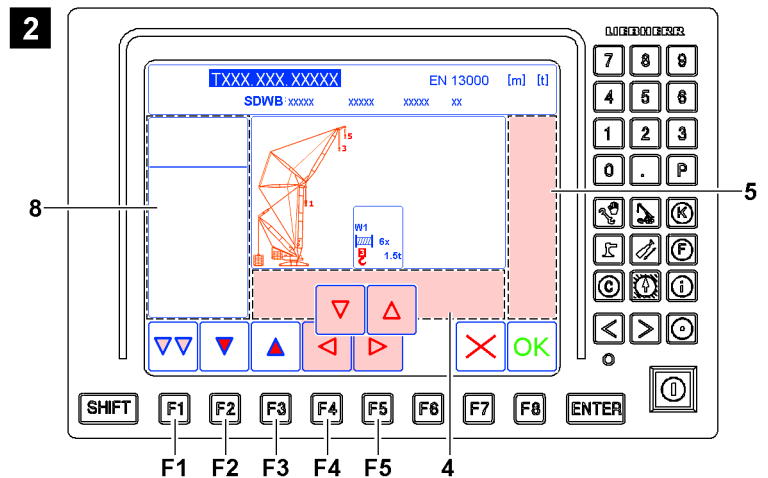

Fig.121746

Selecting the set up completion category

- ▶ Press the function key **F1** until the set up completion category **4** is highlighted in pink.

Result:

- The set up completion category **4** is selected. A red selection frame surrounds the first marker.
- The Editing / selection window **8** appears.
- The icons for navigation in the individual program categories appear above function key **F2**, function key **F3**, function key **F4** and function key **F5**.



Note

Navigation in the set up completion category **4**

- ▶ Press the function key **F4**: The red selection frame moves by one icon to the left.
- ▶ Press the function key **F5**: The red selection frame moves by one icon to the right.
- ▶ If the red selection frame is moved in one direction past the edge of the set up completion category **4** then it enters again from the other direction.



Note

Navigation in the Editing / selection window **8**

- ▶ Press the function key **F2**: The selection bar changes downward by one line.
- ▶ Press the function key **F3**: The selection bar changes upward by one line.

Selecting the environmental / mechanical influence category

- ▶ Press the function key **F1** until the environmental / mechanical influence category **5** is highlighted in pink.

Result:

- The environmental / mechanical influence category **5** is selected. The red selection frame surrounds the first marker.
- The Editing / selection window **8** appears.
- The icons for navigation in the individual program categories appear above function key **F2**, function key **F3**, function key **F4** and function key **F5**.

**Note**

Navigation in the environmental / mechanical influence category **5**

- ▶ Press the function key **F4**: The red selection frame moves down by one icon.
- ▶ Press the function key **F5**: The red selection frame moves up by one icon.
- ▶ If the red selection frame is moved in one direction past the edge of the environmental / mechanical influence category **5** then it enters again from the other direction.

**Note**

Navigation in the Editing / selection window **8**

- ▶ Press the function key **F2**: The selection bar changes downward by one line.
- ▶ Press the function key **F3**: The selection bar changes upward by one line.

4.8.2 Setting the crane chassis

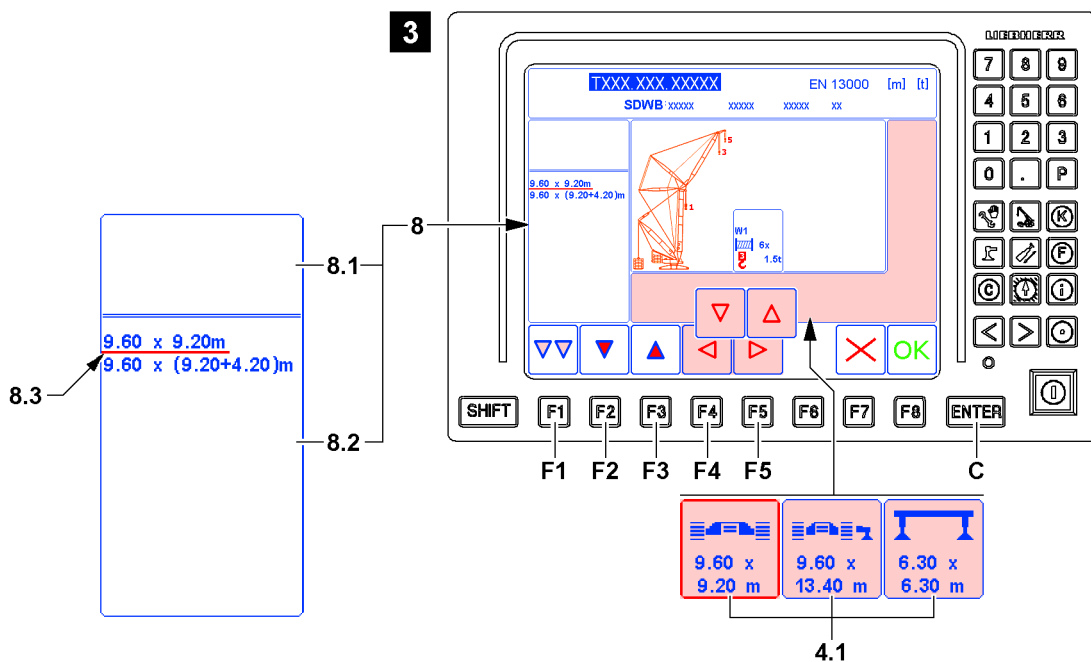

Fig.121747

**Note**



If the correct set up configuration crane chassis **4.1** already appears, then the entries and settings for this marker can be skipped.

- ▶ Press the function key **F5** or the function key **F4** and select the next marker to be changed.

**Note**

The following section describes by example how a certain set up configuration for the crane chassis is set.

- ▶ Always set the required set up configuration for the crane chassis.

Crane chassis set up configuration icons	
	Crane on crawler travel gear ¹⁾
	Crane on crawler travel gear with auxiliary support installed on one side ¹⁾
	Crane on assembly support ¹⁾

1) Only for certain crane types and / or operating modes.

When the respective program category is not yet highlighted in pink:

- ▶ Press the function key **F1** until the respective program category is highlighted in pink.

When the *Set up configuration crane chassis* icon **4.1** is not yet bordered in red:

- ▶ Press the function key **F5** or the function key **F4** until the *Set up configuration crane chassis* icon **4.1** is bordered in red.

Result:

- The settings available for selection are displayed in the lower area **8.2** of the Editing / selection window **8**, see example illustration **3**.
- ▶ Press the function key **F2** or function key **F3** until the required setting is underlined with the selection bar **8.3** (in the example „9.60 x 9.20m“).

When the required main boom is underlined with the selection bar **8.3**:

- ▶ Press the ENTER key **C**.

Result:

- The set up configuration for the crane chassis is selected, the respective icon for the set up configuration crane chassis **4.1** (in the example Crane on crawler travel gear, „9.60 x 9.20m“) appears.

4.8.3 Setting the derrick ballast radius

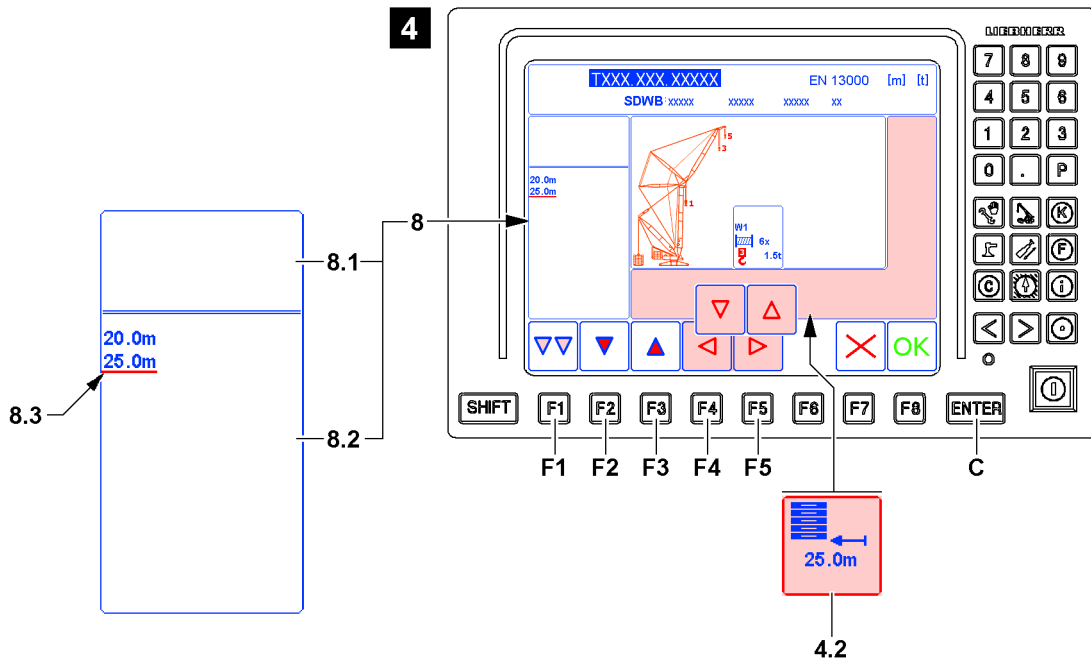

Fig.121756



Note

- ▶ The *setting the derrick ballast radius* marker appears only for certain derrick ballast versions.



Note

If the correct derrick ballast radius **4.2** already appears, then the entries and settings for this marker can be skipped.

- ▶ Press the function key **F5** or the function key **F4** and select the next marker to be changed.



Note

The following section describes by example how a certain derrick ballast radius is set.

- ▶ Always set the required derrick ballast radius.

When the respective program category is not yet highlighted in pink:

- ▶ Press the function key **F1** until the respective program category is highlighted in pink.

When the *Derrick ballast radius* icon **4.2** is not yet bordered in red:

- ▶ Press the function key **F5** or the function key **F4** until the *Derrick ballast radius* icon **4.2** is bordered in red.

Result:

- The settings available for selection are displayed in the lower area **8.2** of the Editing / selection window **8**, see example illustration **4**.

- ▶ Press the function key **F2** or function key **F3** until the required setting is underlined with the selection bar **8.3** (in the example „25.0m“).

When the required derrick ballast radius is underlined with the selection bar **8.3**:

- ▶ Press the ENTER key **C**.

Result:

- The derrick ballast radius is selected, the respective *Derrick ballast radius* icon **4.2** (in the example „25.0m“) appears.

4.8.4 Setting the central ballast

Depending on the crane type and load chart there are two possibilities to set the central ballast:

- Specified settings distances: The central ballast must be selected from a list, see section „Setting the central ballast: Specified settings distances“.
- Stepless settings distances: The central ballast must be entered within a specified range, see section „Setting the central ballast: Stepless settings distances“.

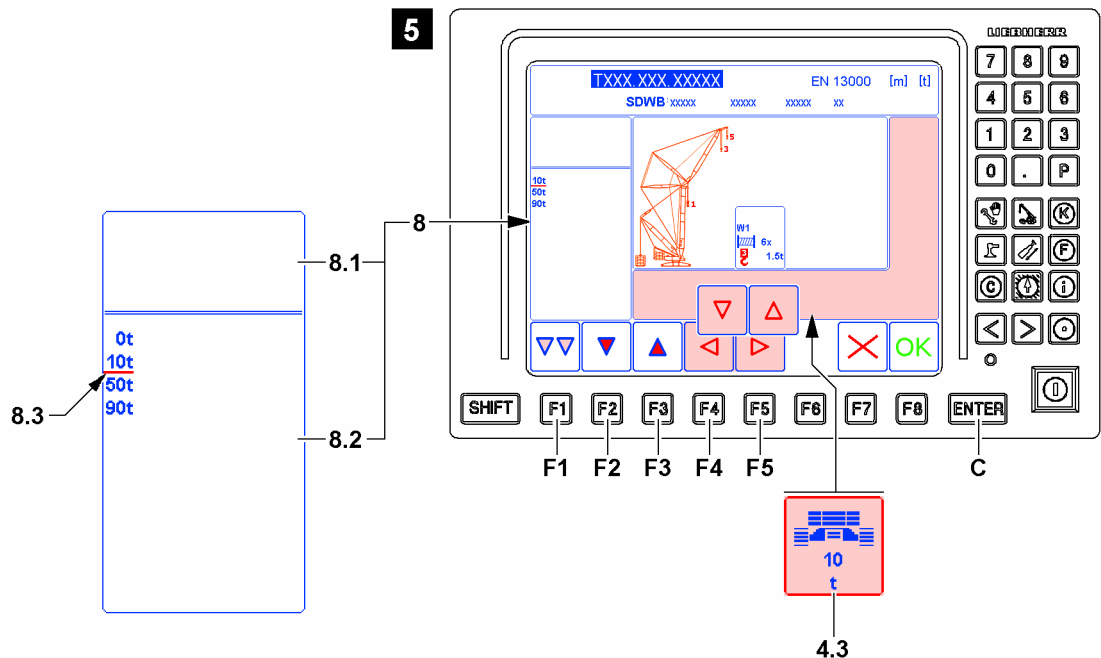

Fig.128075



Note

If the correct central ballast **4.3** already appears, then the entries and settings for this marker can be skipped.

- ▶ Press the function key **F5** or the function key **F4** and select the next marker to be changed.



Note

The following section describes by example how a certain central ballast is set.

- ▶ Always set the required central ballast.

Setting the central ballast: Specified settings distances

When the respective program category is not yet highlighted in pink:

- ▶ Press the function key **F1** until the respective program category is highlighted in pink.

When the *central ballast radius* icon **4.3** is not yet bordered in red:

- ▶ Press the function key **F5** or the function key **F4** until the *Central ballast* icon **4.3** is bordered in red.

Result:

- The settings available for selection are displayed in the lower area **8.2** of the Editing / selection window **8**, see example illustration **5**.

- ▶ Press the function key **F2** or function key **F3** until the required setting is underlined with the selection bar **8.3**, (in the example „10t“).

When the required central ballast is underlined with the selection bar **8.3**:

- ▶ Press the ENTER key **C**.

Result:

- The central ballast is selected, the respective *Central ballast* icon **4.3** (in the example „10t“) appears.

Setting the central ballast: Stepless settings distances

Fig.121758

When the respective program category is not yet highlighted in pink:

- ▶ Press the function key **F1** until the respective program category is highlighted in pink.

When the *central ballast radius* icon **4.3** is not yet bordered in red:

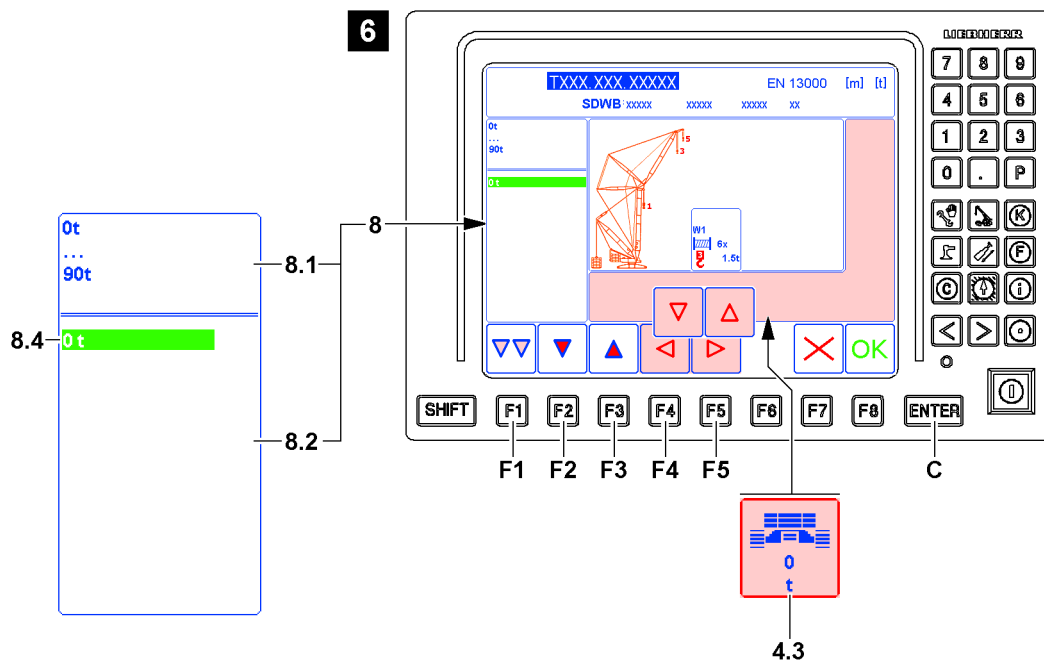
- ▶ Press the function key **F5** or the function key **F4** until the *Central ballast* icon **4.3** is bordered in red.

Result:

- Illustration **6**:
 - The permissible range of the central ballast is displayed in the upper area **8.1** of the Editing / selection window **8**.
 - A green field **8.4** with the currently selected central ballast appears in the lower area **8.2** of the Editing / selection window **8**.

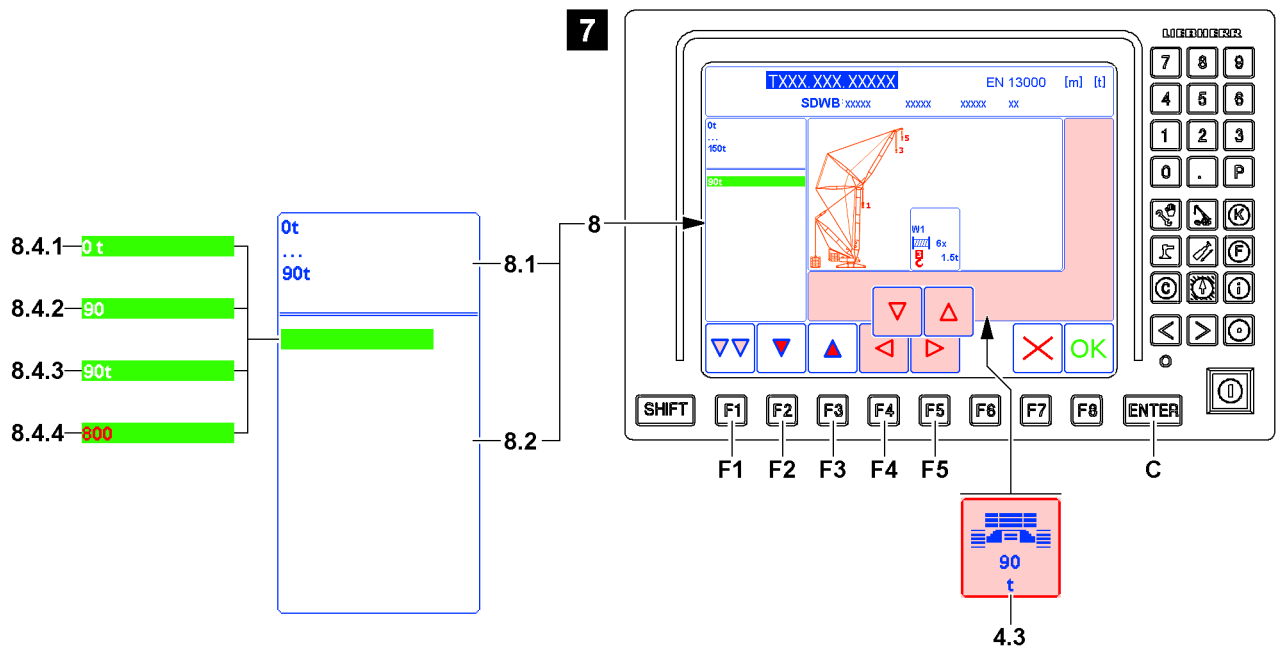

Fig.121744

Illustration 7: The entry is made without the weight unit.

- ▶ Enter the required number sequence using the keypad **A**, in the example „90“.

Result:

- The original value **8.4.1** (in example „0t“) turns off.
- The entered value **8.4.2** (in the example „90“) appears.

- ▶ Press the ENTER key **C**.

Result:

- The new value **8.4.3** is taken over and displayed in the *Central ballast* icon **4.3**.

Problem remedy

Invalid input value

When trying to accept an invalid input value **8.4.4**, the numbers are shown in red.

Enter only permissible values according to the specifications from the upper area **8.1** of the Editing / selection window **8**.

- ▶ Enter the permissible value via the keypad **A**.

4.8.5 Setting the slewing range

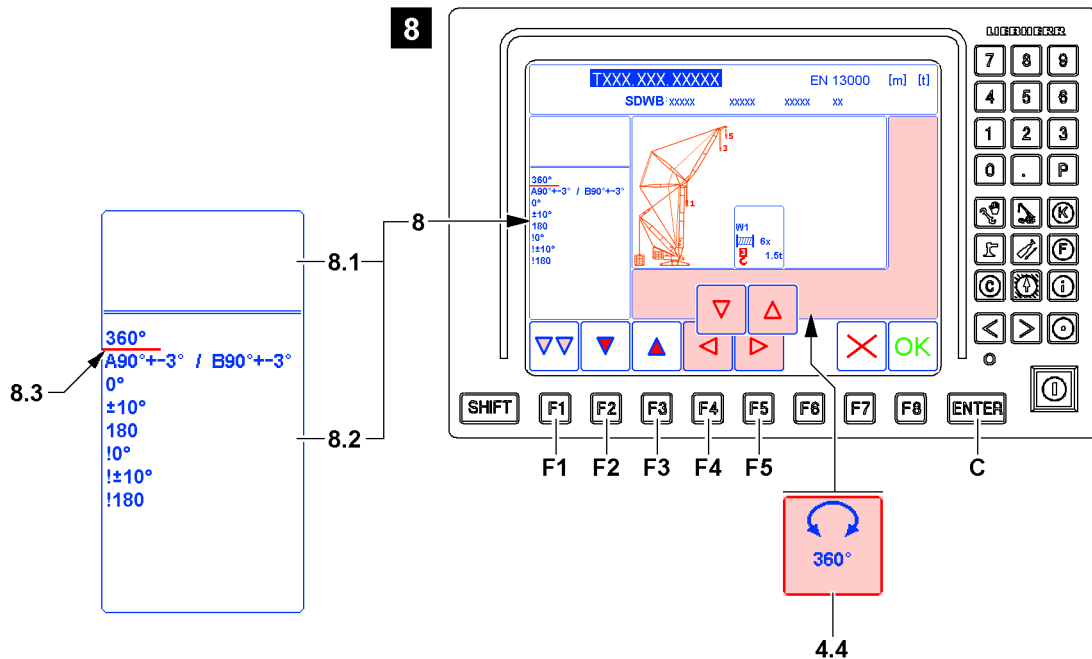

Fig.121759

The turning range **4.4** marker only appears when an alternative setting is possible.



Note

If the correct slewing range **4.4** already appears, then the entries and settings for this marker can be skipped.

- ▶ Press the function key **F5** or the function key **F4** and select the next marker to be changed.



Note

The following section describes by example how a certain turning range is selected.

- ▶ Always select the required slewing range.

When the respective program category is not yet highlighted in pink:

- ▶ Press the function key **F1** until the respective program category is highlighted in pink.

When the *Slewing range* icon **4.4** is not yet bordered in red:

- ▶ Press the function key **F5** or the function key **F4** until the *Slewing range* icon **4.4** is bordered in red.

Result:

- The settings available for selection are displayed in the lower area **8.2** of the Editing / selection window **8**, see the sample list illustration **8**.

When another setting for the slewing range is to be set:

- ▶ Press the function key **F2** or function key **F3** until the required setting is underlined with the selection bar **8.3**, in the example „360°“.

When the required slewing range setting is underlined with the selection bar **8.3**:

- ▶ Press the ENTER key **C**.

Result:

- The new value is taken over and displayed in the *Slewing range* icon **4.4**.

4.8.6 Setting the incline range



WARNING

Impermissible incline exceeded!

When no incline range is shown, then $\pm 0.3^\circ$ applies as the largest permissible incline.

▶ Never exceed the permissible incline.

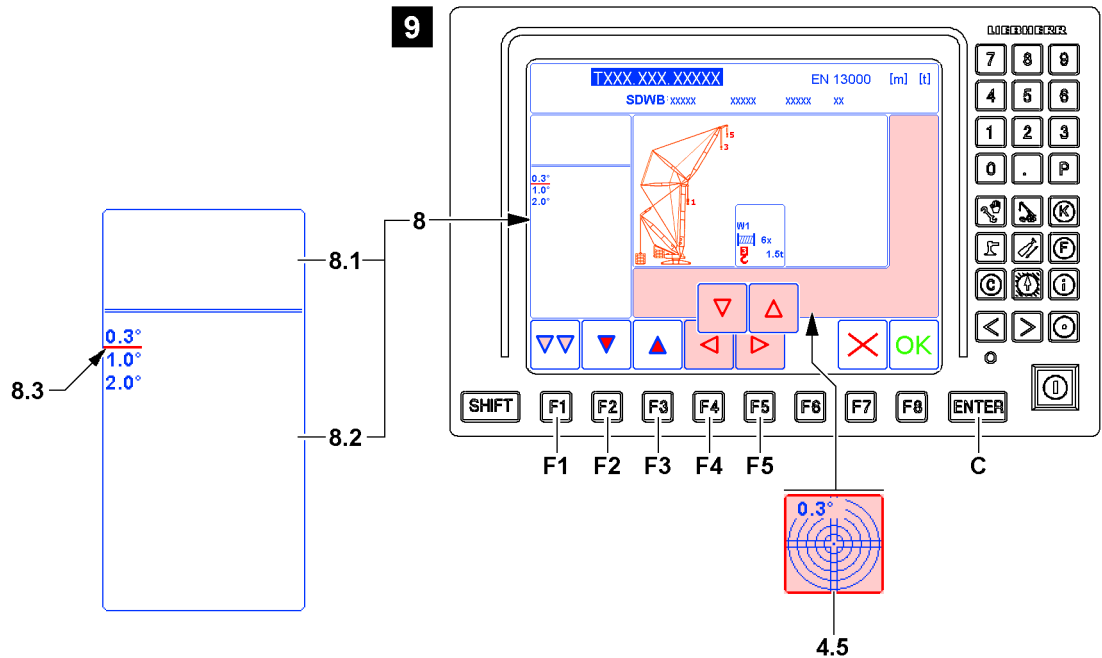

Fig.121760

The incline range cannot be set in all operating modes. If the incline range is not adjustable, then the icon *Incline range* 4.5 is not shown in some operating modes.

There are two possibilities to set the incline range depending on the crane type and load chart:

- Specified settings distances: The incline range must be selected from a list, see section „Setting the incline range: Specified settings distances“.
- Stepless settings distances: The incline range must be entered within a specified range, see section „Setting the incline range: Stepless settings distances“.



Note

If the correct incline range 4.5 already appears, then the entries and settings for this marker can be skipped.

▶ Press the function key **F5** or the function key **F4** and select the next marker to be changed.



Note

The following section describes by example how a certain incline range is set.

▶ Always set the required incline range.

Setting the incline range: Specified settings distances

When the respective program category is not yet highlighted in pink:

▶ Press the function key **F1** until the respective program category is highlighted in pink.

When the *Incline range* icon 4.5 is not yet bordered in red:

▶ Press the function key **F5** or the function key **F4** until the *Incline range* icon 4.5 is bordered in red.

Result:

- The settings available for selection are displayed in the lower area **8.2** of the Editing / selection window **8**, see example illustration **9**.

- ▶ Press the function key **F2** or function key **F3** until the required setting is underlined with the selection bar **8.3**, (in the example „0.3°“).

When the required incline range is underlined with the selection bar **8.3**:

- ▶ Press the ENTER key **C**.

Result:

- The incline range is selected, the respective *Incline range* icon **4.5** (in the example „0.3°“) appears.

Setting the incline range: Stepless settings distances

Fig.121761

When the respective program category is not yet highlighted in pink:

- ▶ Press the function key **F1** until the respective program category is highlighted in pink.

When the *Incline range* icon **4.5** is not yet bordered in red:

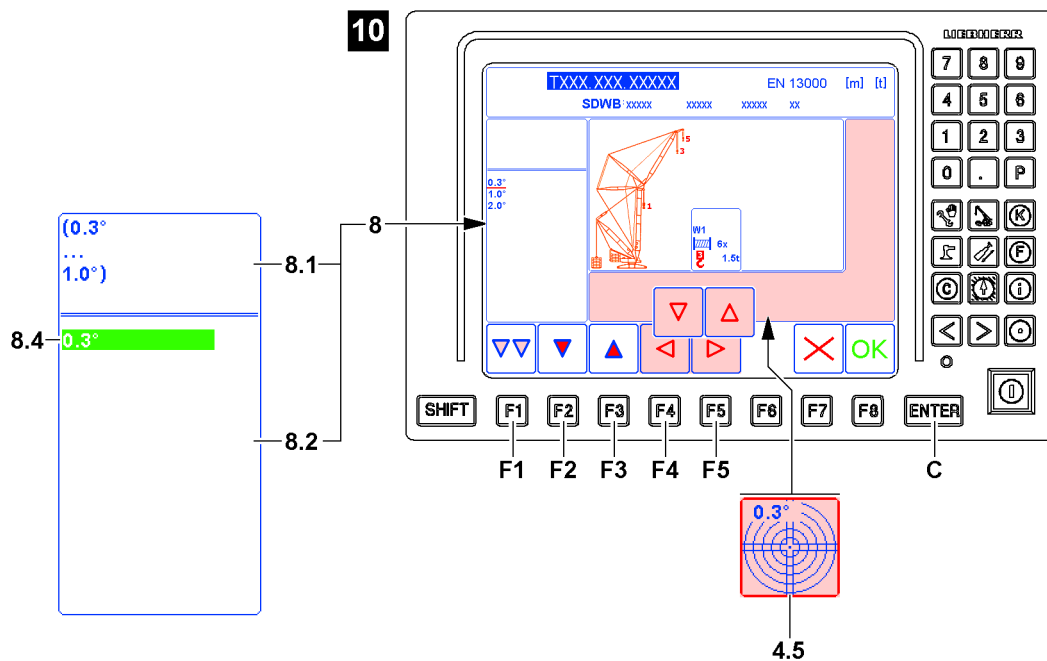
- ▶ Press the function key **F4** or the function key **F5** until the *Incline range* icon **4.5** is bordered in red.

Result:

Illustration **10**:

- The permissible incline range is displayed in the upper area **8.1** of the Editing / selection window **8**.
- A green field **8.4** with the currently selected incline range appears in the lower area **8.2** of the Editing / selection window **8**.

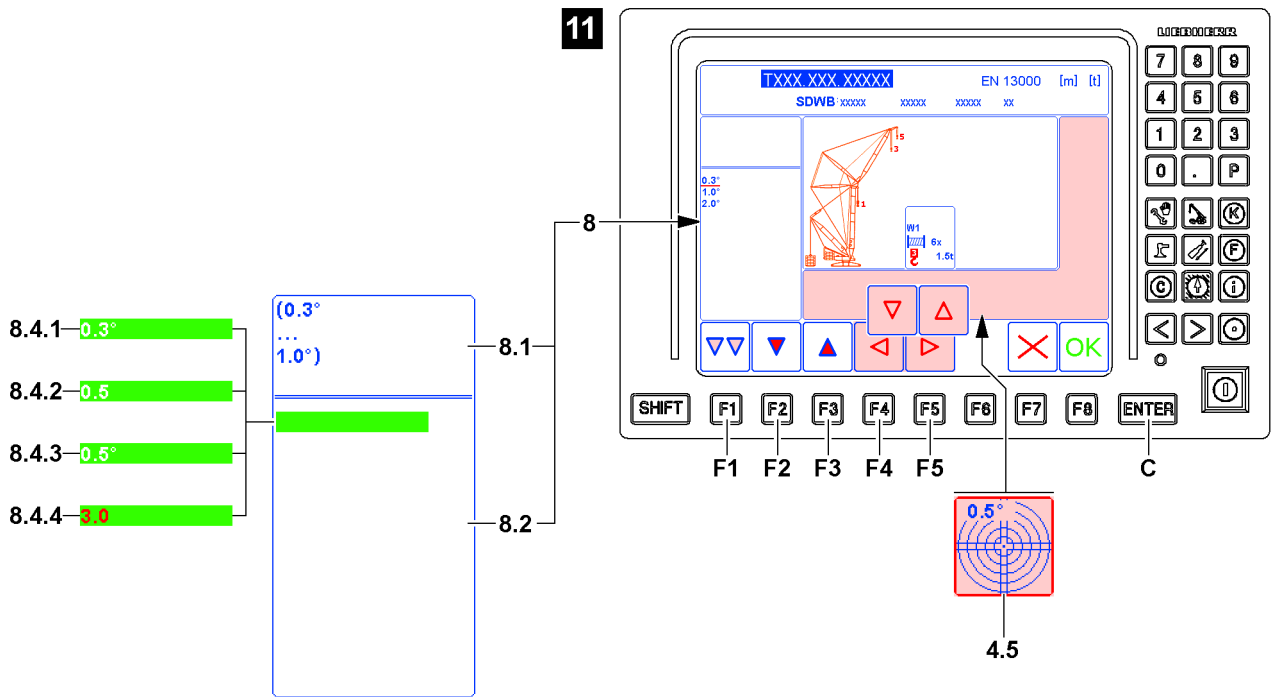

Fig.121762

Illustration 11, the entry is made without the measuring unit:

- ▶ Enter the required number sequence using the keypad **A**, in the example „0.5“.

Result:

- The original value **8.4.1** (in example „0.3°“) turns off.
- The entered value **8.4.2** (in the example „0.5“) appears.

- ▶ Press the ENTER key **C**.

Result:

- The new value **8.4.3** (in example „0.5°“) is taken over and shown in the *Incline range* icon **4.5**.

Problem remedy

Invalid input value

When trying to accept an invalid input value **8.4.4**, the numbers are shown in red.

Enter only values according to the specifications from the upper area **8.1** of the Editing / selection window **8**.

- ▶ Enter the permissible value via the keypad **A**.

4.8.7 Setting the project chart

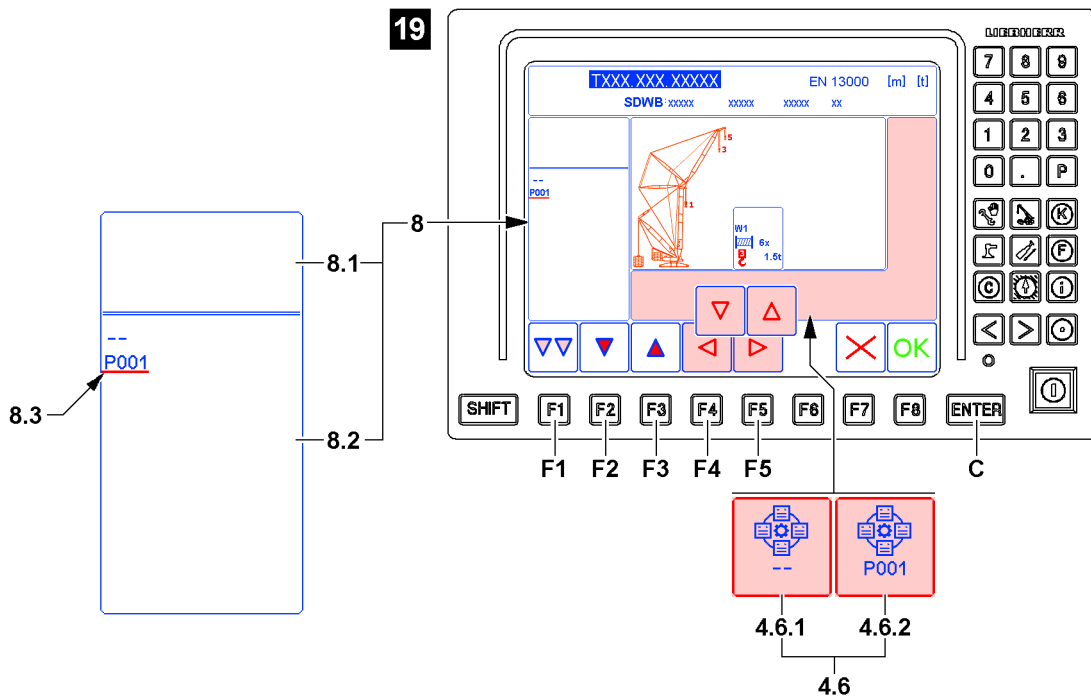

Fig.161656: Setting the project chart



Note

- ▶ There are project charts only for certain crane types and certain operating modes.

Project charts are load charts for special projects. A project chart results from a set up configuration that was created only for a special project.

If an operating mode is selected for which there is a project chart:

- The *project chart 4.6* marker appears.

Project chart marker **4.6**:

- **4.6.1** No project chart set.
It appears when a general set up configuration is set.
- **4.6.2** Project chart set.
It appears when a set up configuration for a project chart is set.
The number of the corresponding project is displayed in the icon (in the example „P001“).

For certain set up conditions, a selection appears in the lower area **8.2** of the editing/selection window **8**. If this is the case, the correct project chart must be set.



Note

If the correct project chart **4.6** already appears, then the entries and settings for this marker can be skipped.

- ▶ Press the function key **F5** or the function key **F4** and select the next marker to be changed.



Note

The following section describes by example how a certain project chart is set.

- ▶ Always set the required project chart.

When the respective program category is not yet highlighted in pink:

- ▶ Press the function key **F1** until the respective program category is highlighted in pink.

When the *Project chart* icon **4.6** is not yet bordered in red:

- ▶ Press the function key **F5** or the function key **F4** until the *Project chart* icon **4.6** is bordered in red.

Result:

- The settings available for selection are displayed in the lower area **8.2** of the Editing / selection window **8**, see the sample list illustration **19**.

When another setting for the project chart should be set:

- ▶ Press the function key **F2** or function key **F3** until the required setting is underlined with the selection bar **8.3** (in the example „P001“).

When the required project chart setting is underlined with the selection bar **8.3**:

- ▶ Press the ENTER key **C**.

Result:

- The new load project chart setting is taken over and displayed in the *project chart* icon **4.6**.

4.8.8 Setting the load position

Fig.128082

**Note**

If the correct load position **5.1** already appears, then the settings for this marker can be skipped.

- ▶ Press the function key **F5** or the function key **F4** and select the next marker to be changed.

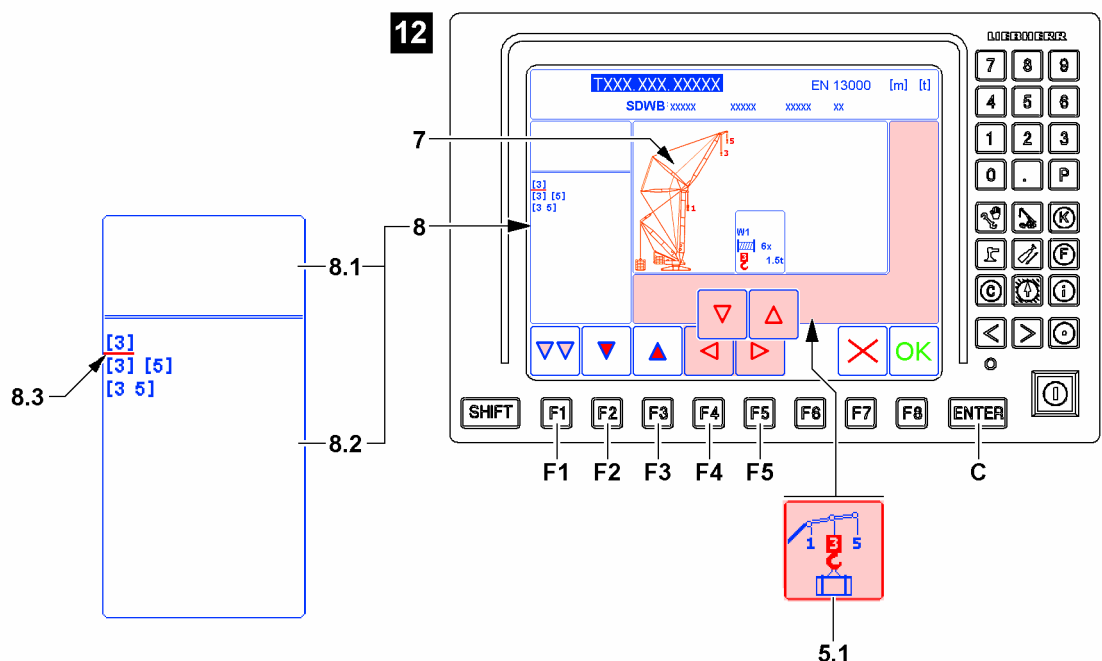
**Note**

The following section describes by example how a certain load position is selected.

- ▶ Always select the required load position.

When the respective program category is not yet highlighted in pink:

- ▶ Press the function key **F1** until the respective program category is highlighted in pink.

When the *Load position* icon **5.1** is not yet bordered in red:

- ▶ Press the function key **F4** or the function key **F5** until the *Load position* icon **5.1** is bordered in red.

Result:

Illustration **12**:

- The *load position* icon **5.1** is bordered in red and activated.
- The possible load positions are displayed in the lower area **8.2** of the Editing / selection window **8**.

**Note**

Possible load positions

- ▶ The possible load positions are visualized in the display window 7.
- ▶ The possible load positions depend on the selected operating mode.

Possible load positions		
	Possible icons	Description
[1]		Single hook operation: Hook 1 is reeved on load position 1. A load is fastened on hook 1.
[1] [3]		Two hook operation: Hook 1 is reeved on load position 1. Hook 3 is reeved on load position 3. First load is fastened on hook 1. A second load is fastened on hook 3.
[1] [4]		Two hook operation: Hook 1 is reeved on load position 1. Hook 4 is reeved on load position 4. First load is fastened on hook 1. A second load is fastened on hook 4.
[1] [5]		Two hook operation: Hook 1 is reeved on load position 1. Hook 5 is reeved on load position 5. First load is fastened on hook 1. A second load is fastened on hook 5.
[1 3]		Two hook operation: Hook 1 is reeved on load position 1. Hook 3 is reeved on load position 3. A combined load is fastened on hook 1 and hook 3.
[1 4]		Two hook operation: Hook 1 is reeved on load position 1. Hook 4 is reeved on load position 4. A combined load is fastened on hook 1 and hook 4.
[1 5]		Two hook operation: Hook 1 is reeved on load position 1. Hook 5 is reeved on load position 5. A combined load is fastened on hook 1 and hook 5.
[3]		Single hook operation: Hook 3 is reeved on load position 3. A load is fastened on hook 3.
[3] [5]		Two hook operation: Hook 3 is reeved on load position 3. Hook 5 is reeved on load position 5. First load is fastened on hook 3. A second load is fastened on hook 5.
[3 5]		Two hook operation: Hook 3 is reeved on load position 3. Hook 5 is reeved on load position 5. A combined load is fastened on hook 3 and hook 5.
[4]		Single hook operation: Hook 4 is reeved on load position 4. A load is fastened on hook 4.

Possible load positions		
	Possible icons	Description
[4] [5]		Two hook operation: Hook 4 is reeved on load position 4. Hook 5 is reeved on load position 5. First load is fastened on hook 4. A second load is fastened on hook 5.
[4] [5]		Two hook operation: Hook 4 is reeved on load position 4. Hook 5 is reeved on load position 5. A combined load is fastened on hook 4 and hook 5.
[5]		Single hook operation: Hook 5 is reeved on load position 5. A load is fastened on hook 5.

- ▶ Press the function key **F2** or function key **F3** until the required load position is underlined with the selection bar **8.3**. For example „[3]“.

When the required load position is underlined with the selection bar **8.3**:

- ▶ Press the ENTER key **C**.

Result:

- The load position is selected (example „[3]“).
- The load position is accepted and shown in the *Load position icon 5.1*.

4.8.9 Setting the derrick ballast weight

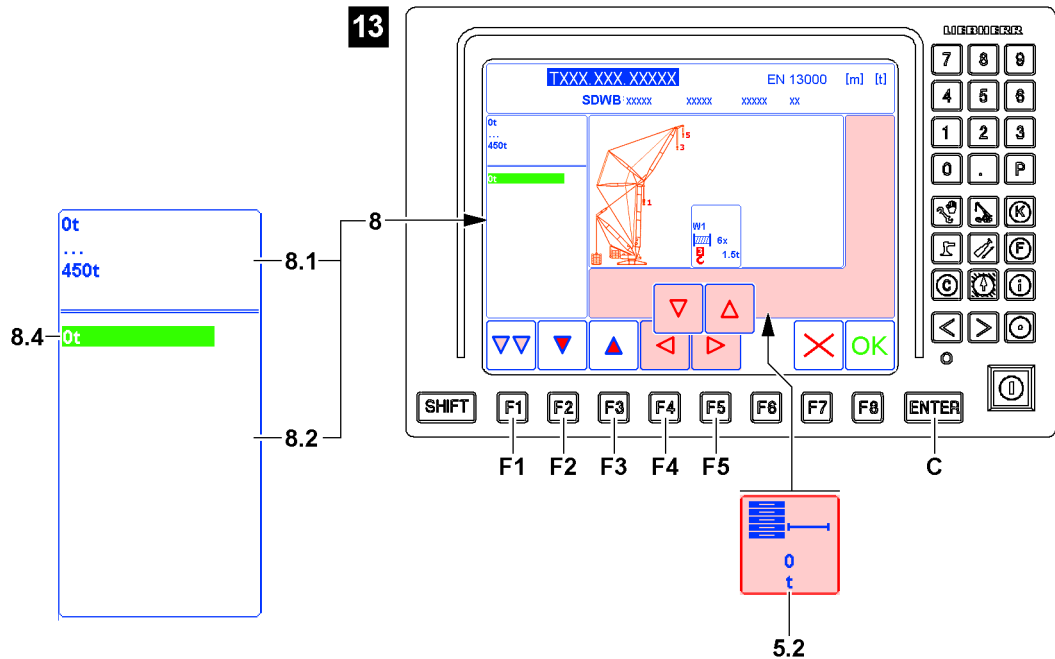

Fig.121764

The derrick ballast weight **5.2** marker only appears when an operating mode with derrick ballast is selected.

**Note**

If the correct derrick ballast weight **5.2** already appears, then the entries and settings for this marker can be skipped.

- ▶ Press the function key **F5** or the function key **F4** and select the next marker to be changed.

**Note**

The following section describes by example how a certain derrick ballast weight is entered.

- ▶ Always enter the required derrick ballast weight.

When the respective program category is not yet highlighted in pink:

- ▶ Press the function key **F1** until the respective program category is highlighted in pink.

When the *Derrick ballast weight* icon **5.2** is not yet bordered in red:

- ▶ Press the function key **F5** or the function key **F4** until the icon *Derrick ballast weight* **5.2** is bordered in red, see illustration **13**.

Result:

- The possible range of the derrick ballast weight is displayed in the upper area **8.1** of the Editing / selection window **8**.
- A green field **8.4** with the currently selected derrick ballast weight appears in the lower area **8.2** of the Editing / selection window **8**.

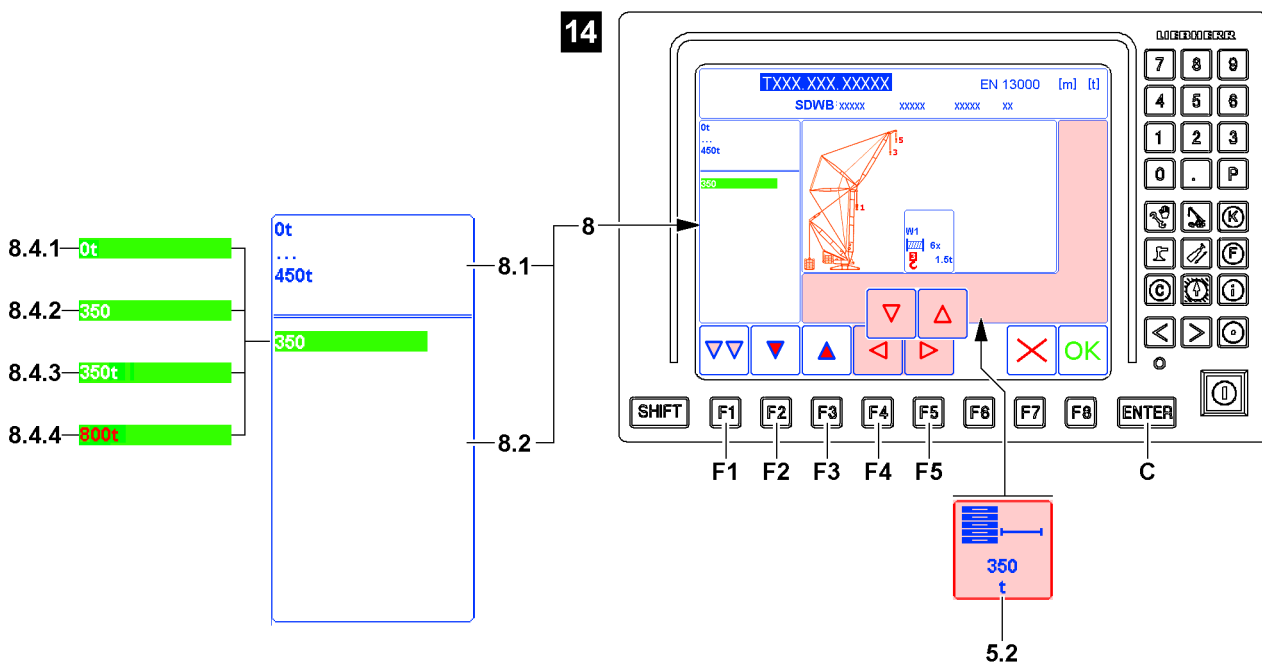

Fig.121765

Illustration **14**, the entry is made without the measuring unit:

- ▶ Enter the required number sequence using the keypad **A**, in the example „350“.

Result:

- The original value **8.4.1** (in example „0“) turns off.
- The entered value **8.4.2** (in the example „350“) appears.

- ▶ Press the ENTER key **C**.

Result:

- The new value **8.4.3** (in example „350t“) is taken over and shown in the *Derrick ballast weight* icon **5.2**.

Result:

- The settings available for selection are displayed in the lower area **8.2** of the Editing / selection window **8**, see example illustration **15**.
- ▶ Press the function key **F2** or function key **F3** until the required setting is underlined with the selection bar **8.3**, (in the example „210t“).

When the required counterweight is underlined with the selection bar **8.3**:

- ▶ Press the ENTER key **C**.

Result:

- The counterweight is selected, the respective *Counterweight* icon **5.3** (in the example „210t“) appears.

Setting the counterweight: Stepless settings distances

Fig.121767

When the respective program category is not yet highlighted in pink:

- ▶ Press the function key **F1** until the respective program category is highlighted in pink.

When the *Counterweight* icon **5.3** is not yet bordered in red:

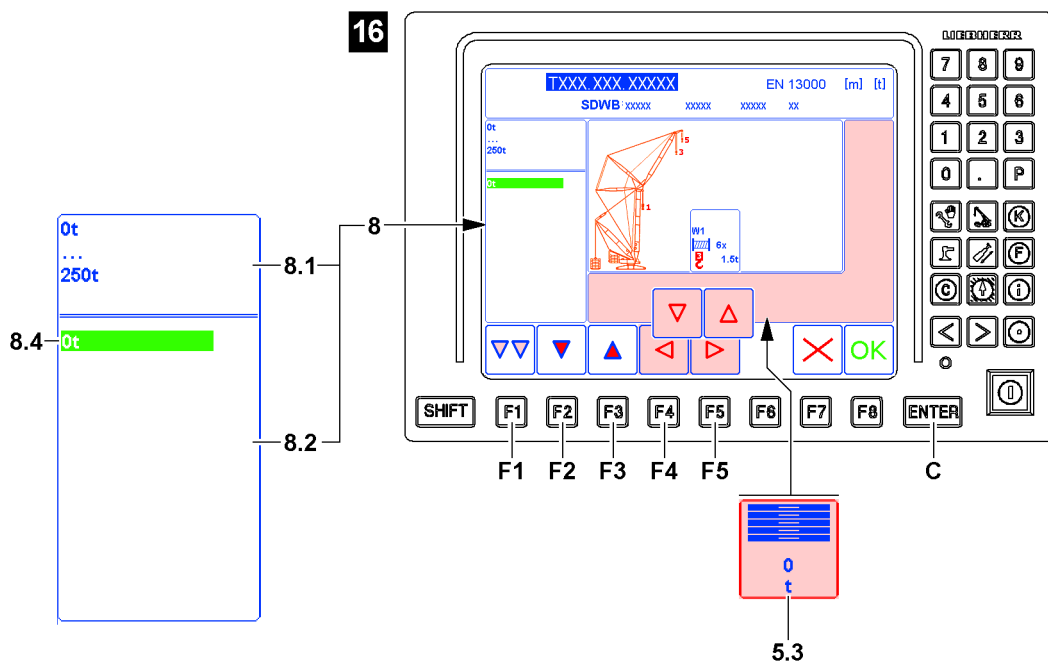
- ▶ Press the function key **F5** or the function key **F4** until the *Counterweight* icon **5.3** is bordered in red.

Result:

- Illustration **16**:
 - In the upper area **8.1** of the Editing / selection window **8** the permissible range of the counterweight is displayed.
 - A green field **8.4** with the currently selected counterweight appears in the lower area **8.2** of the Editing / selection window **8**.

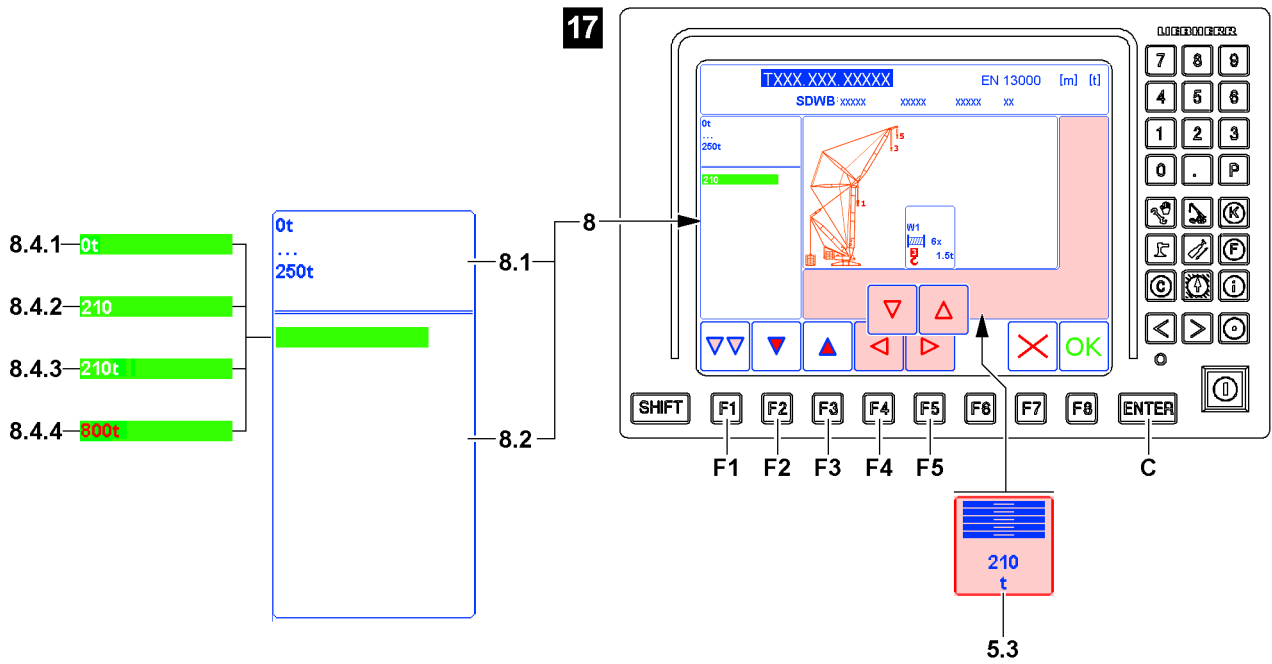

Fig.121768

Illustration 17: The entry is made without the weight unit.

- ▶ Enter the required number sequence using the keypad **A**, in the example „210“.

Result:

- The original value **8.4.1** (in example „0t“) turns off.
- The entered value **8.4.2** (in the example „210“) appears.

- ▶ Press the ENTER key **C**.

Result:

- The new value **8.4.3** is taken over and displayed in the *Counterweight* icon **5.3**.

Problem remedy

Invalid input value

When trying to accept an invalid input value **8.4.4**, the numbers are shown in red.

Enter only permissible values according to the specifications from the upper area **8.1** of the Editing / selection window **8**.

- ▶ Enter the permissible value via the keypad **A**.

4.8.11 Setting the wind speed

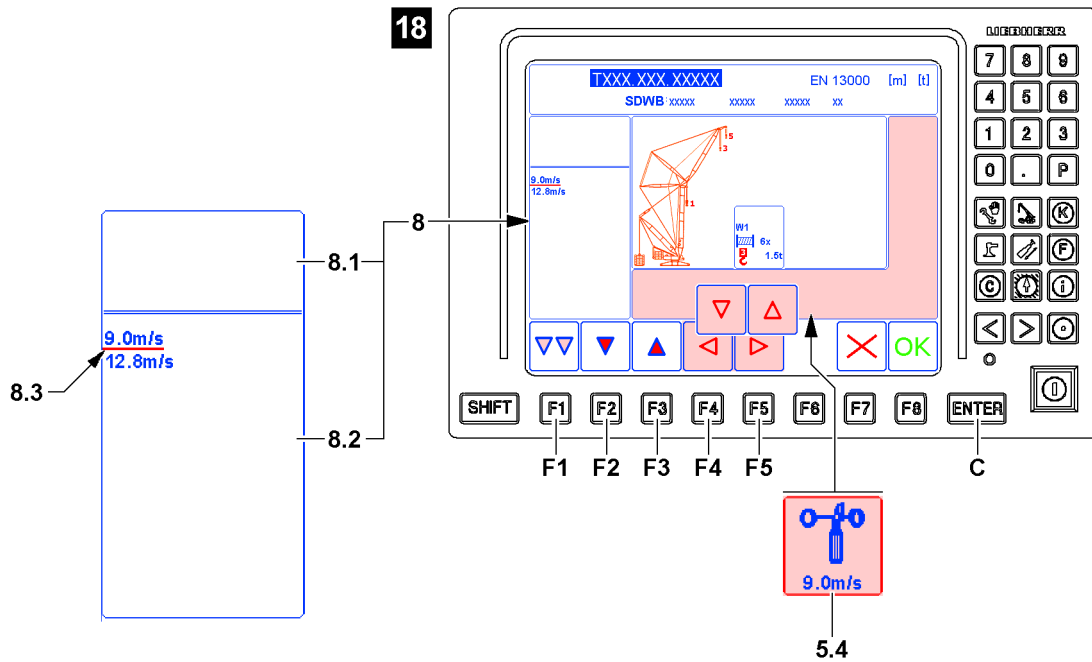

Fig.121769



Note

If the correct maximum wind speed **5.4** already appears, then the settings for this marker can be skipped.

- ▶ Press the function key **F5** or the function key **F4** and select the next marker to be changed.



Note

The following section describes by example how a certain wind speed is set.

- ▶ Always set the required wind speed.

When the respective program category is not yet highlighted in pink:

- ▶ Press the function key **F1** until the respective program category is highlighted in pink.

When the *Wind speed* icon **5.4** is not yet bordered in red:

- ▶ Press the function key **F4** or the function key **F5** until the *Wind speed* icon **5.4** is bordered in red, see illustration **18**.

Result:

- The possible maximum wind speeds are displayed in the lower area **8.2** of the Editing / selection window **8**.

- ▶ Press the function key **F2** or function key **F3** until the required wind speed is underlined with the selection bar **8.3**. In the example „9.0m/s“.

When the required wind speed is underlined with the selection bar **8.3**:

- ▶ Press the ENTER key **C**.

Result:

- The maximum wind speed is selected (example „9.0m/s“).
- The maximum wind speed is accepted and shown in the *Wind speed* icon **5.4**.

4.8.12 Accepting the entries and settings

Make sure that the following prerequisites are met:

- All entries and settings in the currently called up program category are correct and complete.

▶ Press the function key **F1**.

Result:

- Entries and settings are completed.
- The next category is automatically called up.

Problem remedy

After pressing the function key **F1**, was it determined that one or several markers are not correct? By pressing the function key **F1**, the individual program categories can be switched through one after the other. The first program category is called up after the last one.

▶ Press the function key **F1** until the respective program category is called up again. Then all entries and settings can be changed.

4.9 Lifting category

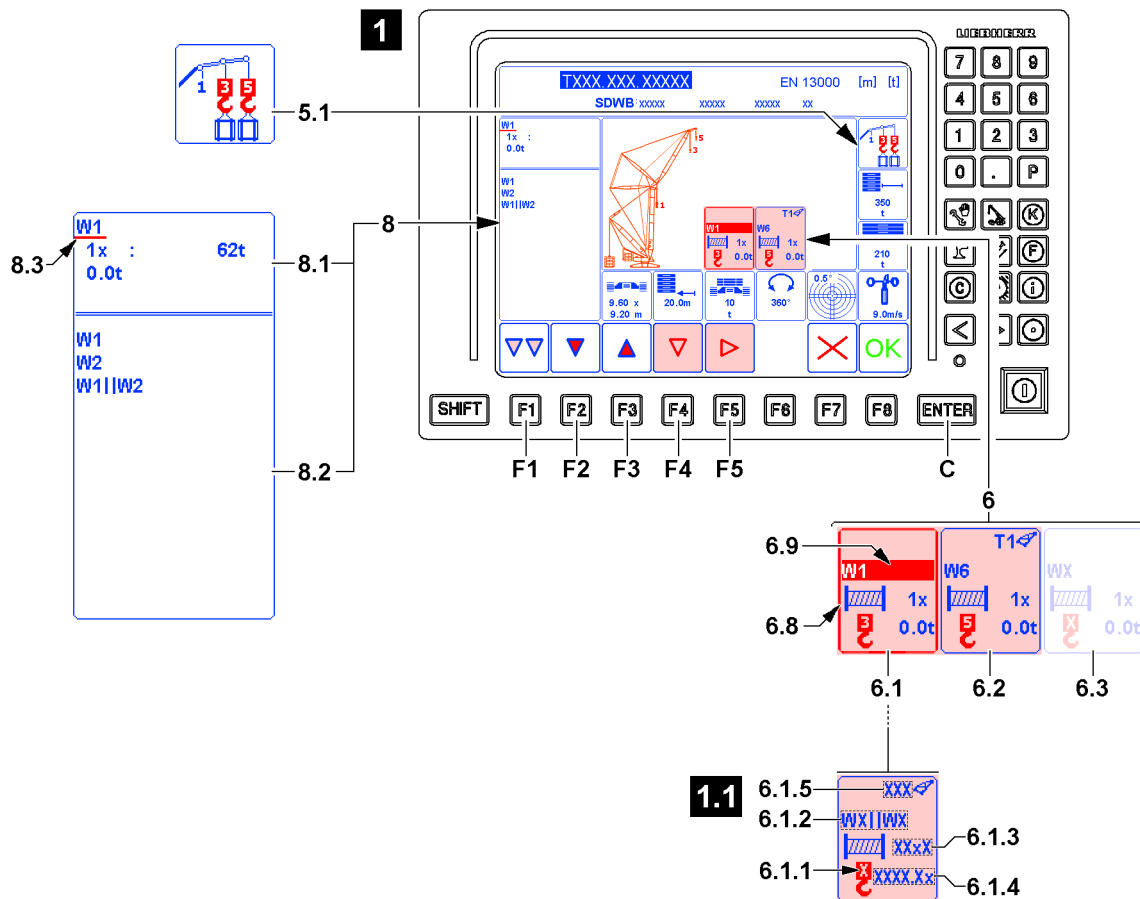

Fig.120603

The lifting category **6** includes, depending on the number of selected load positions, one to three display windows, see illustration **1**.

The display windows are always dependent on the settings for the *Load position* icon **5.1**.

- 6.1** Display window
 - The display window for the first load position
- 6.2** Display window
 - The display window for the second load position

LWE/LR_13000-001/19503-01-02/en

- **Note:** Appears only when a second load position was selected.

6.3 Display window

- Display window for the third load position
- **Note:** Appears only when a third load position was selected.

Markers in the display window of the respective load position, see illustration 1.1:

6.1.1 Load position

- Selected load position

6.1.2 Hoist winch

- Assigned hoist winch, during parallel operation both assigned hoist winches are shown.

6.1.3 Reeving

- Reeving of an assigned hoist winch

6.1.4 Hook block weight

- Weight of reeved hook block

6.1.5 Fixed accessory

- Type / kind of fixed accessory
- **Note:** Appears only when a fixed accessory (load position 5) was selected.

4.9.1 Selecting the lifting category



Note

If the correct hoist winch, reeving and accessory, if applicable, are already assigned to a load position, then the settings for this marker can be skipped.

- ▶ Press function key **F2** or function key **F3** until the display window for the next load position is activated.
- ▶ If no other settings are required: Change to the following section „Taking over the entries and settings from the lift category“.

- ▶ Press the function key **F1** until the lifting category **6** is highlighted in pink, see illustration 1.

Result:

- The lifting category **6** is selected.
The red selection frame **6.8** surrounds the first display window **6.1**.
The first marker in the first display window **6.1** is set to active.
The active marker is always highlighted with a red surface **6.9**.
- The Editing / selection window **8** appears.
- The preselection options are displayed in the upper area **8.1** of the Editing / selection window **8**.
The first preselection option is automatically underlined and activated with the selection bar **8.3**.
- The lower area **8.2** of the Editing / selection window **8** displays the respective selection possibilities.
- The icons for navigation in the individual program categories appear above function key **F2**, function key **F3**, function key **F4** and function key **F5**.



Note

Navigation in the lifting category **6**

Applies only when several display windows are shown.

- ▶ Press the function key **F4**: The red selection frame **6.8** moves by one icon to the left.
- ▶ Press the function key **F5**: The red selection frame **6.8** moves by one icon to the right.
- ▶ If the red selection frame **6.8** is moved in one direction past the edge of the lifting category **6** then it enters again from the other direction.

**Note**

Navigation in the Editing / selection window **8**

- ▶ Press the function key **F2**: The selection bar **8.3** changes downward by one line.
- ▶ Press the function key **F3**: The selection bar **8.3** changes upward by one line.
- ▶ When the upper area **8.1** and the lower area **8.2** are assigned: Press the ENTER key **C** and switch between the upper area **8.1** and the lower area **8.2**.

4.9.2 Assigning the hoist winch (normal operation of hoist winch)

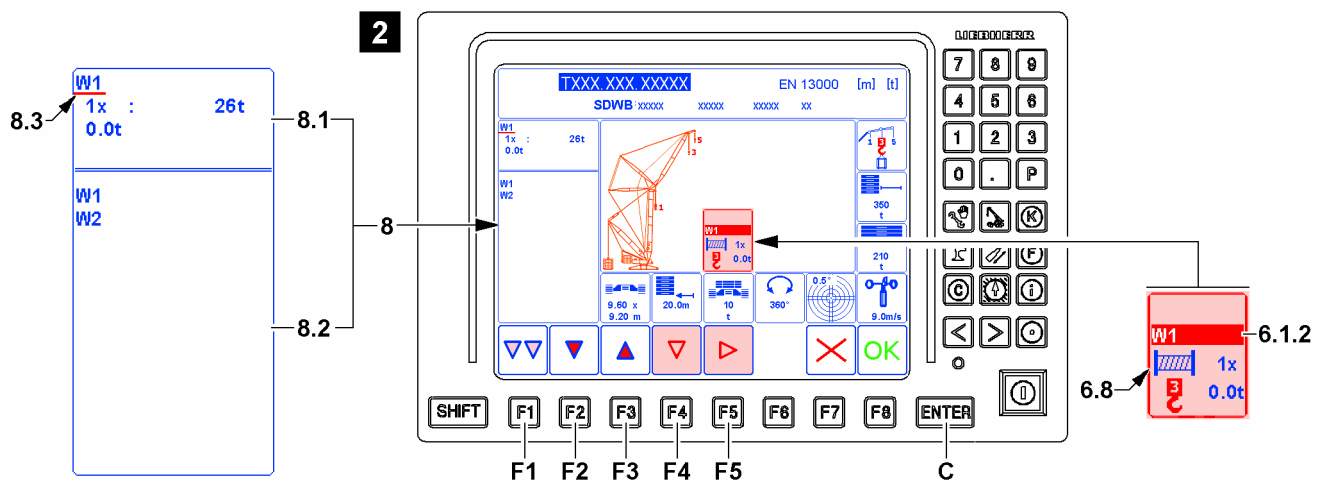

Fig.128076

**Note**

The following section describes by example how **one** certain hoist winch is assigned to a certain load position (normal operation of hoist winch).

- ▶ Always assign the hoist winch to the required load position.

**Note**

Assigning abbreviations for the hoist winches

- ▶ W1: Abbreviation for winch 1.
- ▶ W2: Abbreviation for winch 2*.
- ▶ W6: Abbreviation for winch 6*.

Make sure that the following prerequisite is met:

- All entries and settings in the previous program category are correct and complete.

When the desired display window is not marked with the red selection frame **6.8**:

- ▶ Press the function key **F5** or function key **F4** until the red selection frame **6.8** marks the desired display window (in example „load position 3“), see illustration **2**.

Result:

- The preselection options are displayed in the upper area **8.1** of the Editing / selection window **8**. The first preselection option is automatically underlined and activated with the selection bar **8.3**.
- The lower area **8.2** of the Editing / selection window **8** displays the respective selection possibilities.

- ▶ Press the function key **F2** or function key **F3** until the hoist winch selection in the upper area **8.1** is underlined with the selection bar **8.3**. (In the example „W1“).

Result:

- The display for the assigned hoist winch **6.1.2** is highlighted in red in the active display window.

When the hoist winch selection is underlined with the selection bar **8.3**:

► Press the ENTER key **C**.

Result:

- The selection bar **8.3** changes in the lower area **8.2** of the Editing / selection window **8**.

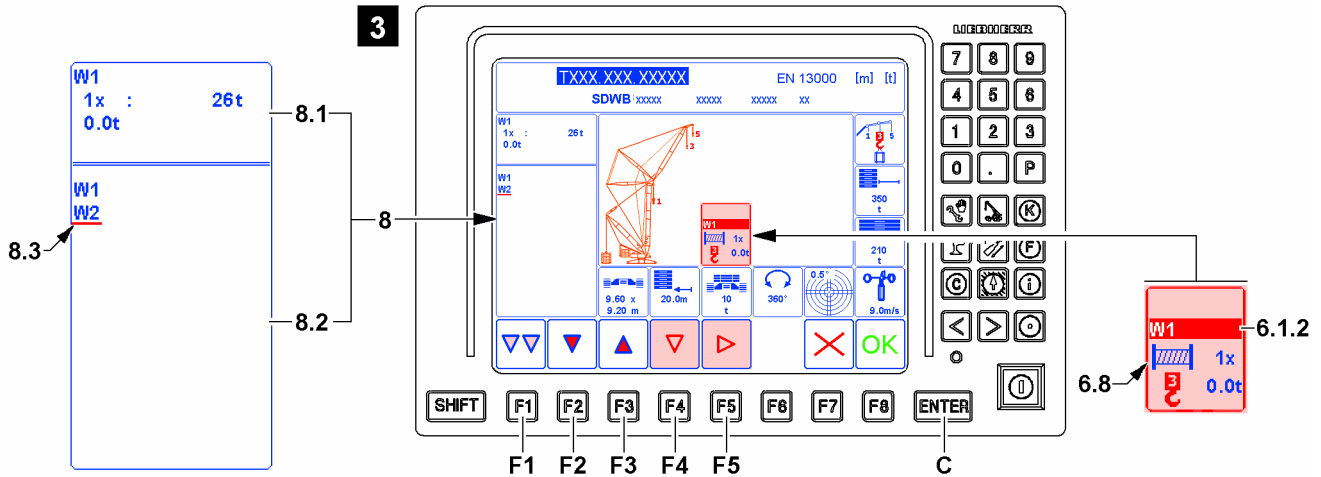

Fig.128077

► Press the function key **F2** or function key **F3** until the required selection in the lower area **8.2** is underlined with the selection bar **8.3**, see illustration **3**.

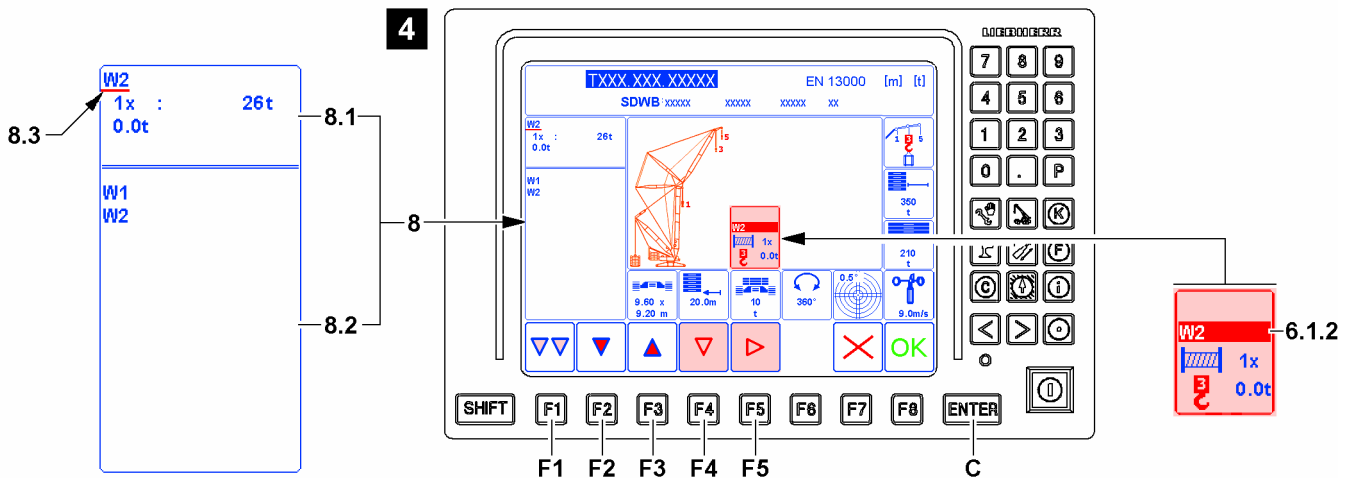

Fig.128078

When the required preselection option is underlined with the selection bar **8.3**:

► Press the ENTER key **C**.

Result:

- The preselection possibility is defined.
- The new setting appears in the icon for load position 3 as the assigned hoist winch **6.1.2**, see illustration **4**.
- The selection bar **8.3** changes again in the upper area **8.1** of the Editing / selection window **8**.

4.9.3 Assigning the hoist winch (parallel operation of hoist winches)

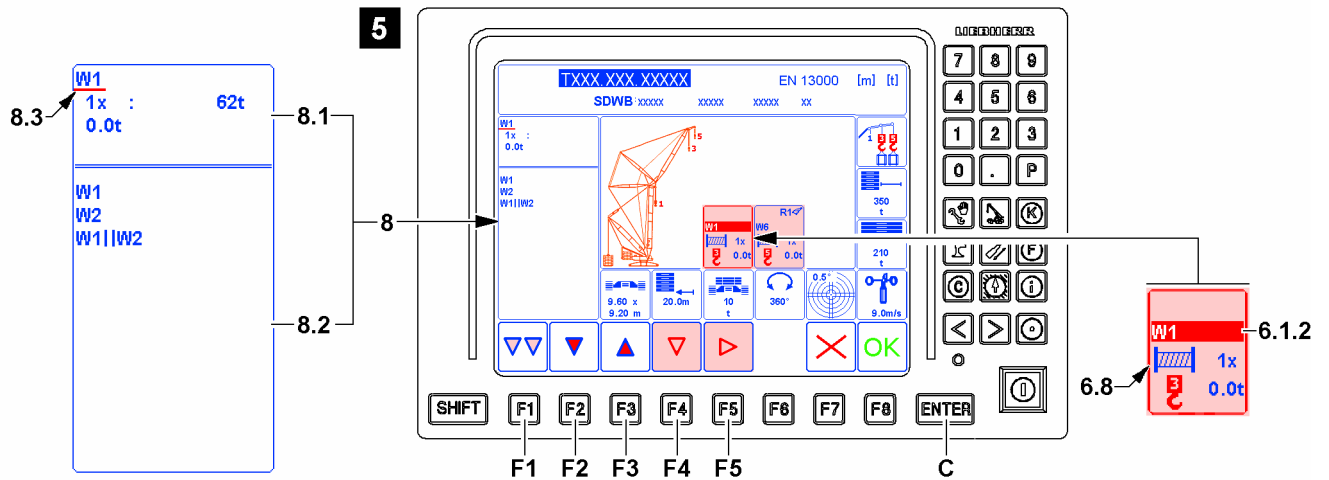

Fig.128079



Note

Only active for crane types with winch 1 and winch 2 parallel operation
 The following section describes as an example how **two** hoist winches are assigned to a certain load position (parallel operation of hoist winches).
 ▶ Always assign the hoist winches to the required load position.



Note

Assigning abbreviations for the hoist winches
 ▶ W1: Abbreviation for winch 1.
 ▶ W2: Abbreviation for winch 2*.
 ▶ W6: Abbreviation for winch 6*.

Make sure that the following prerequisite is met:

- All entries and settings in the previous program category are correct and complete.

When the desired display window is not marked with the red selection frame 6.8:

- ▶ Press the function key **F5** or function key **F4** until the red selection frame 6.8 marks the desired display window (in example „load position 3“, see illustration 5).

Result:

- The preselection options are displayed in the upper area 8.1 of the Editing / selection window 8. The first preselection option is automatically underlined and activated with the selection bar 8.3.
- The lower area 8.2 of the Editing / selection window 8 displays the respective selection possibilities.
- ▶ Press the function key **F2** or function key **F3** until the hoist winch selection in the upper area 8.1 is underlined with the selection bar 8.3. (In the example „W1“).

Result:

- The display for the assigned hoist winch 6.1.2 is highlighted in red in the active display window.

When the hoist winch selection is underlined with the selection bar 8.3:

- ▶ Press the ENTER key **C**.

Result:

- The selection bar 8.3 changes in the lower area 8.2 of the Editing / selection window 8.

LWE/LR_13000-001/19503-01-02/en

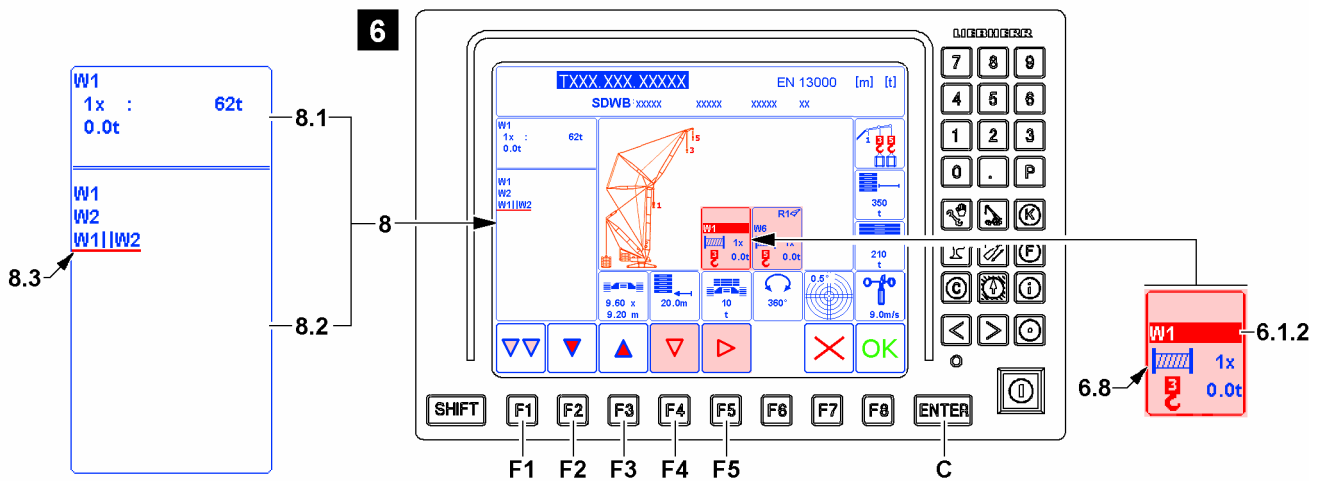

Fig.128080

- ▶ Press the function key **F2** or function key **F3** until the required selection in the upper area **8.2** is underlined with the selection bar **8.3**. (For example „Parallel operation WI and WII“), see illustration **6**.

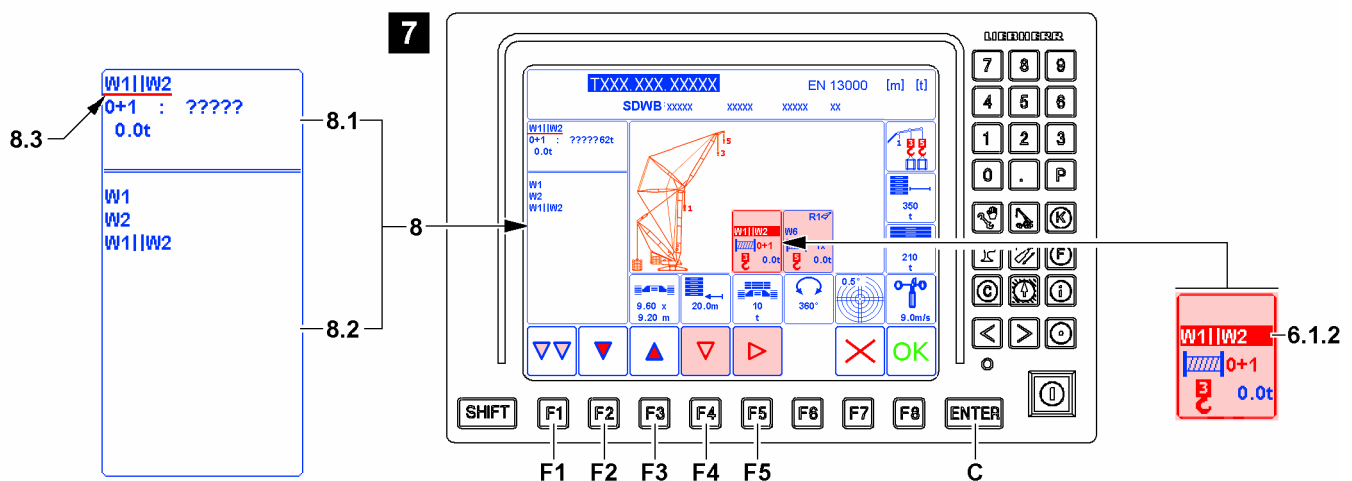

Fig.128081

When the required preselection option is underlined with the selection bar **8.3**:

- ▶ Press the ENTER key **C**.

Result:

- The preselection possibility is defined (In example „Parallel operation WI and WII“).
- The new setting appears in the icon for load position 3 as the assigned hoist winch **6.1.2**, see illustration **7**.
- The selection bar **8.3** changes again in the upper area **8.1** of the Editing / selection window **8**.

4.9.4 Assigning the reeving (normal operation of hoist winch)

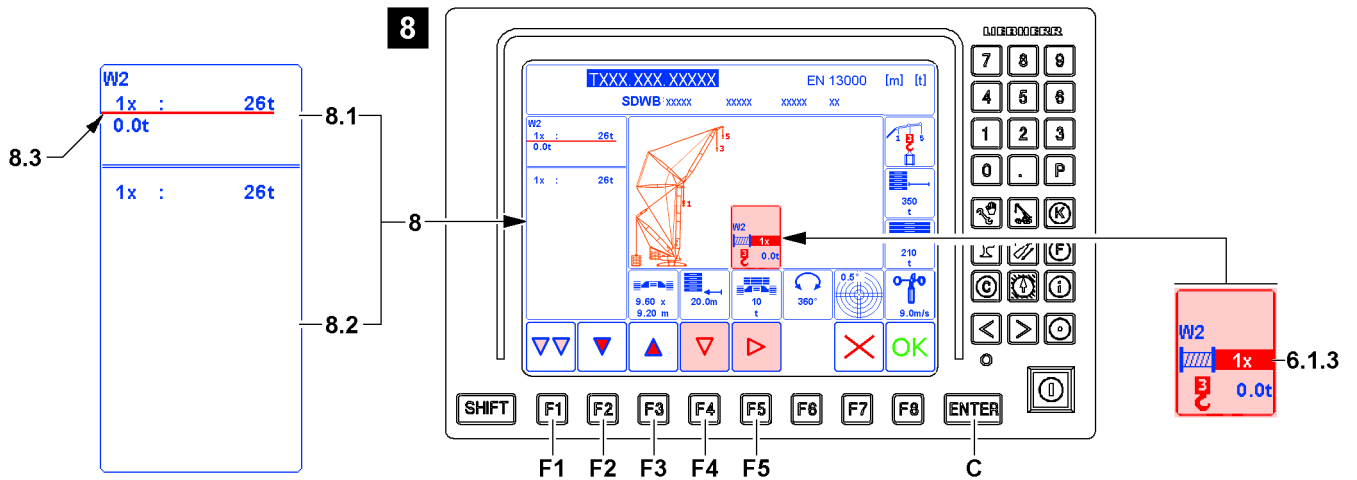

Fig.128083



Note

The following section describes by example how a certain reeving for normal operation of hoist winch is assigned.

- ▶ Always assign the required reeving.



Note

If the correct reeving **6.1.3** already appears, then the settings for this marker can be skipped.

Change to the next marker (if present):

- ▶ Press the function key **F2** or function key **F3** until the next marker to be changed is underlined with the selection bar **8.3**.

Change to the next display window (if present):

- ▶ Press the function key **F5** or the function key **F4** and select the next display window.

End the *Set up* program (when all entries and settings are made):

- ▶ When all entries and settings in the lifting category **6** are correct, see section „Taking over entries and settings from the set up program“.

- The preselection options are displayed in the upper area **8.1** of the Editing / selection window **8**. The first preselection option is automatically underlined and activated with the selection bar **8.3**.
- The lower area **8.2** of the Editing / selection window **8** displays the respective selection possibilities.



Note

The following section describes by means of an example how a certain reeving is entered.

- ▶ Always enter the required reeving.

- ▶ Press the function key **F2** or function key **F3** until the reeving in the upper area **8.1** is underlined with the selection bar **8.3**. (For example „1x : 12.6t“), see illustration **8**.

Result:

- The display for the reeving **6.1.3** is highlighted in red in the active display window.

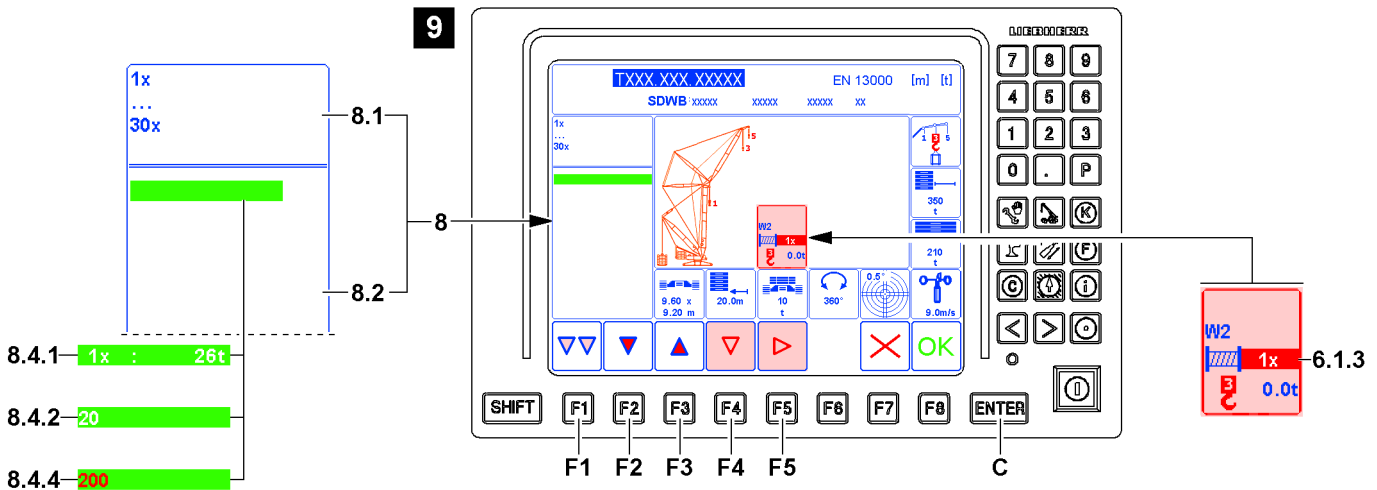

Fig.128084

When the reeving is underlined with the selection bar 8.3:

► Press the ENTER key C.

Result:

- The permissible reeving values are displayed in the upper area 8.1 of the Editing / selection window 8, see illustration 9.
- A green input field with the reeving value from the upper area 8.1 appears in the lower area 8.2 of the Editing / selection window 8.

► Enter the required number sequence using the keypad A, in the example „20“.

Result:

- The original value 8.4.1 (in example „1x : 12.6t“) disappears.
- The new value 8.4.2 (in the example „20“) appears.

Problem remedy

Invalid input value

When trying to accept an invalid input value 8.4.4, the numbers are shown in red.

Enter only values according to the specifications from the upper area 8.1 of the Editing / selection window 8.

► Enter the permissible value via the keypad A.

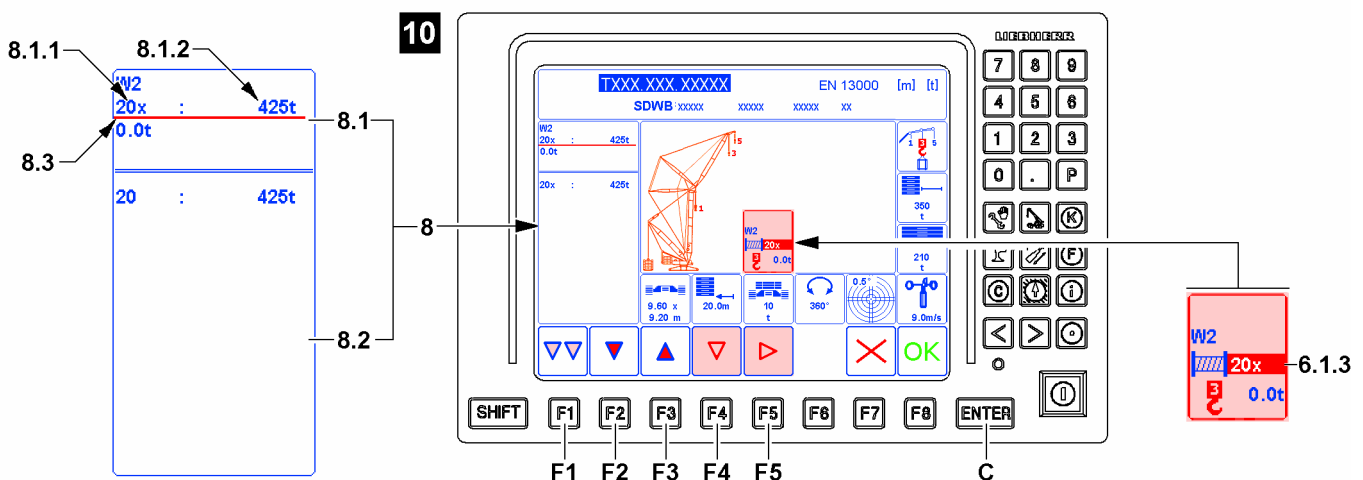

Fig.128085

► Press the ENTER key C.

Result:

- The new value is taken over, see illustration 10.
- The new value for the reeving 6.1.3 appears in the display window.
- The upper area 8.1 displays the entered reeving 8.1.1. In addition, the maximum load 8.1.2 that could be lifted with this reeving under ideal conditions appears.

4.9.5 Assigning the reeving (parallel operation of hoist winch)

Fig.128086

**Note**

Only active for crane types with winch 1 and winch 2 parallel operation

The following section describes as an example how a certain reeving for parallel operation of hoist winch is assigned.

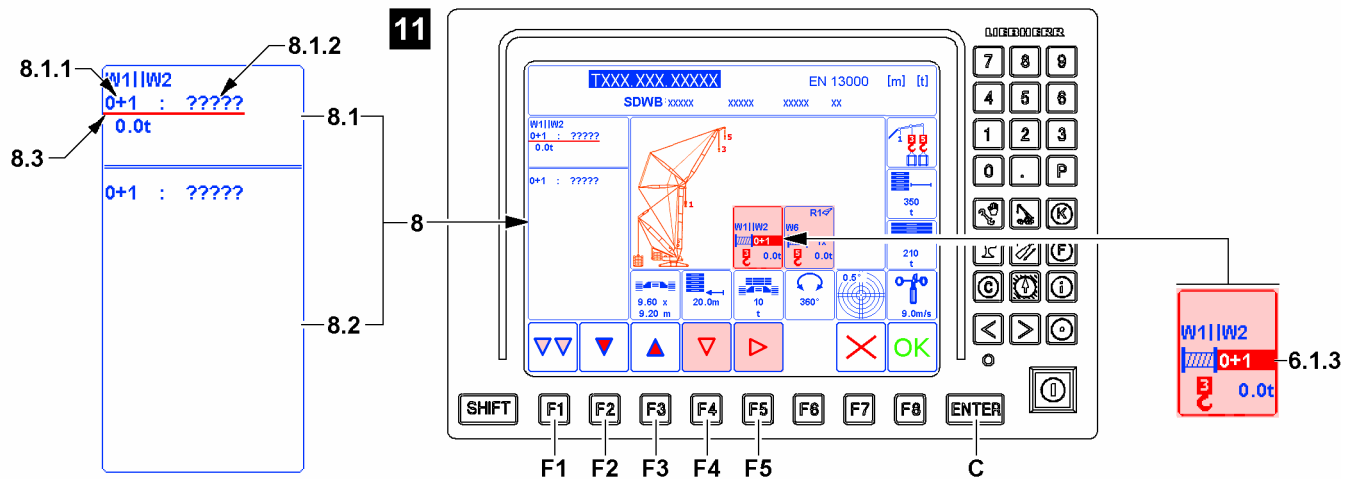
- ▶ Always assign the required reeving.

**Note**

Illustration 11: If question marks („?“) appear behind the reeving number 8.1.1, then no valid reeving has been entered.

If the icon OK turns off above the function key F8, then an invalid selection is active.

- ▶ A valid reeving must now be entered.

**Note****Effect of single / parallel operation of hoist winches for the reeving line**

Changes for values for the reeving 8.1.1 and the maximum load 8.1.2:

The current reevings are added together when changing from the parallel operation of hoist winches to single operation of one hoist winch.

When changing from single operation of one hoist winch to parallel operation of two hoist winches, the current reeving 8.1.1 is divided.

If the number cannot be divided, question marks („?“) or the value „0.0“ appear instead of a maximum load 8.1.2, see illustration 11.

- ▶ A valid reeving must be entered.
- ▶ For the subsequent procedure, see the following section „Assigning reeving“.

- The preselection options are displayed in the upper area 8.1 of the Editing / selection window 8.
- The first preselection option is automatically underlined and activated with the selection bar 8.3.
- The lower area 8.2 of the editing / selection window 8 displays the respective selection possibilities.

**Note**

The following section describes by means of an example how a certain reeving is entered.

► Always enter the required reeving.

► Press the function key **F2** or function key **F3** until the reeving in the upper area **8.1** is underlined with the selection bar **8.3**. (For example „0+1 : ?????“).

Result:

– The display for the reeving **6.1.3** is highlighted in red in the active display window.

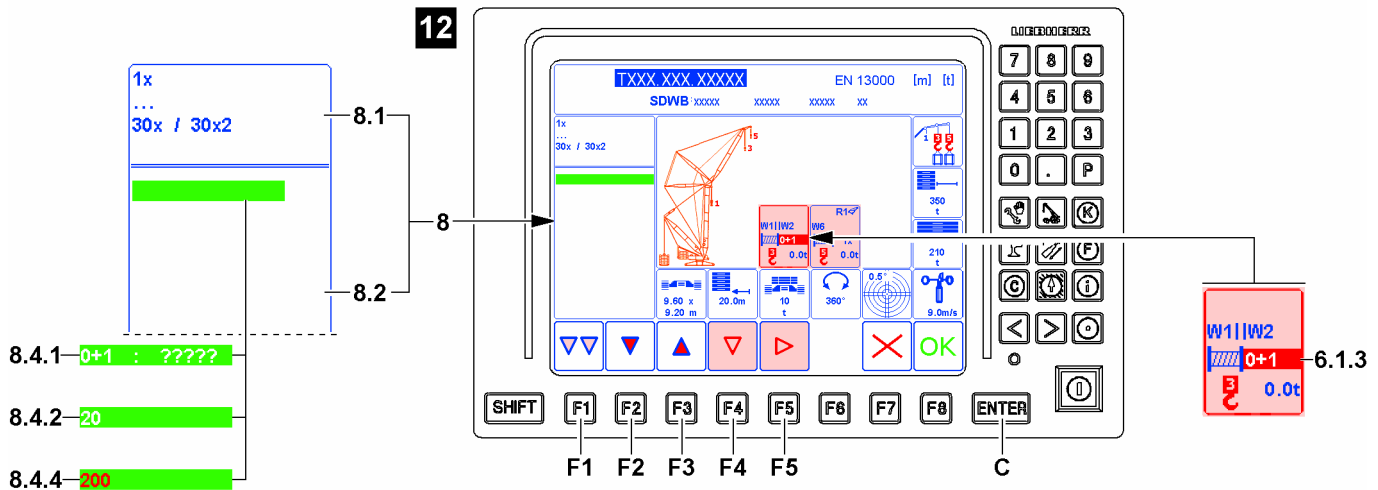

Fig.128087

When the reeving is underlined with the selection bar **8.3**:

► Press the ENTER key **C**.

Result:

- The permissible reeving values are displayed in the upper area **8.1** of the Editing / selection window **8**, see illustration **12**.
- A green input field with the reeving value from the upper area **8.1** appears in the lower area **8.2** of the Editing / selection window **8**.

**Note**

► Always only one value must be entered for the reeving. In parallel operation*, the abbreviation „x2“ is automatically added to the value and the value is assigned to both hoist winches.

► Enter the required number sequence using the keypad **A**, in the example „20“.

Result:

- The original value **8.4.1** (in the example „0+1 : ?????“) disappears.
- The new value **8.4.2** (in the example „20“) appears.

Problem remedy

Invalid input value

When trying to accept an invalid input value **8.4.4**, the numbers are shown in red.

Enter only values according to the specifications from the upper area **8.1** of the Editing / selection window **8**.

► Enter the permissible value via the keypad **A**.

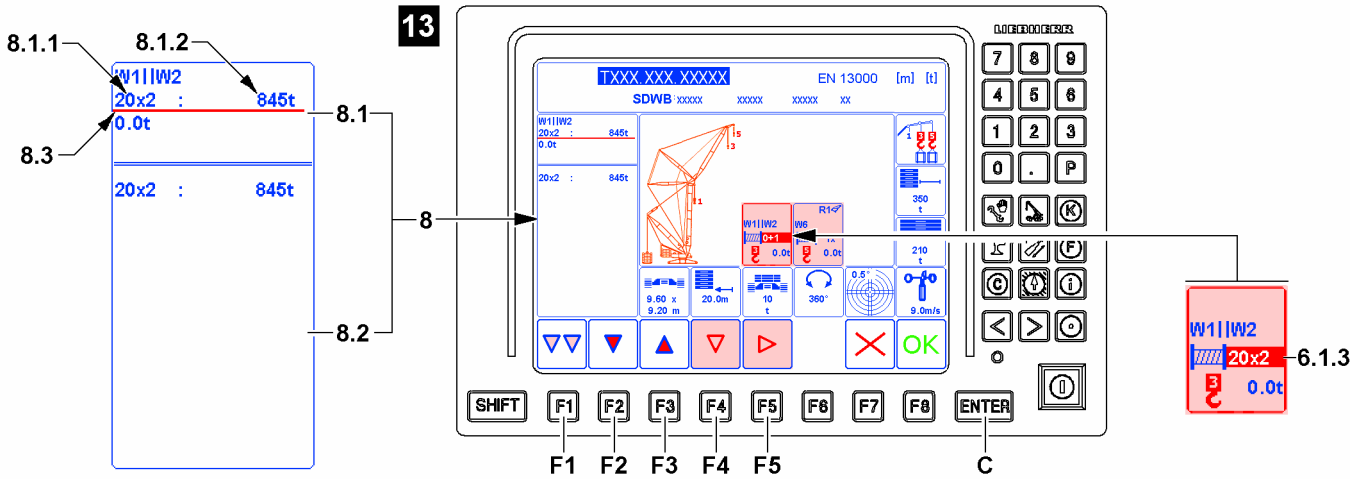

Fig.128088

► Press the ENTER key C.

Result:

- The new value is accepted and changed for parallel operation if necessary, see illustration 13.
- The new value for the reeving 6.1.3 appears in the display window.
- The upper area 8.1 displays the entered reeving 8.1.1. In addition, the maximum load 8.1.2 that could be lifted with this reeving under ideal conditions appears.

4.9.6 Entering the hook block weight

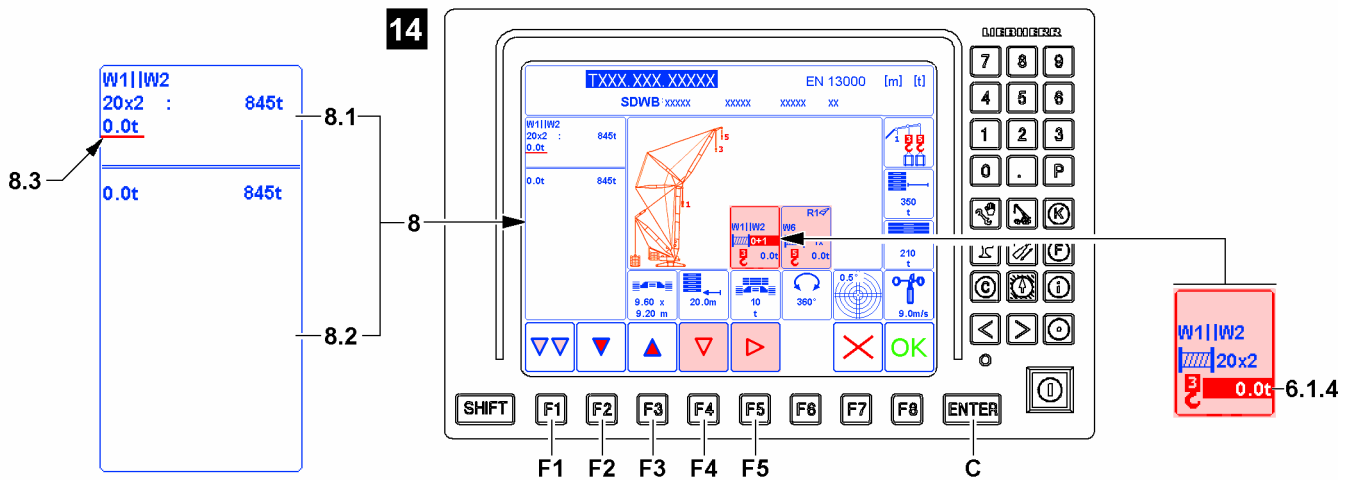

Fig.128089

LWE/LR 13000-001/19503-01-02/en

**Note**

If the correct hook block weight **6.1.4** already appears, then the settings for this marker can be skipped.

Change to the next marker (if present):

- ▶ Press the function key **F2** or function key **F3** until the next marker to be changed is underlined with the selection bar **8.3**.

Change to the next display window (if present):

- ▶ Press the function key **F5** or the function key **F4** and select the next display window.

End the *Set up* program (when all entries and settings are made):

- ▶ When all entries and settings in the lifting category **6** are correct, see section „Taking over entries and settings from the set up program“.

- The preselection options are displayed in the upper area **8.1** of the Editing / selection window **8**. The first preselection option is automatically underlined and activated with the selection bar **8.3**.
- The lower area **8.2** of the Editing / selection window **8** displays the respective selection possibilities.

**Note**

The following section describes by example how a certain hook block weight is entered.

- ▶ Always enter the required hook block weight.

- ▶ Press the function key **F2** or function key **F3** until the hook block weight in the upper area **8.1** is underlined with the selection bar **8.3**. (In the example „0.0t“).

Result:

- The display for the hook block weight **6.1.4** is highlighted in red in the active display window.

When the hook block weight is underlined with the selection bar **8.3**, see illustration **14**:

- ▶ Press the ENTER key **C**.

Result:

- The permissible hook block weight is displayed in the upper area **8.1** of the Editing / selection window **8**.
- A green input field with the hook block weight from the upper area **8.1** appears in the lower area **8.2** of the Editing / selection window **8**.

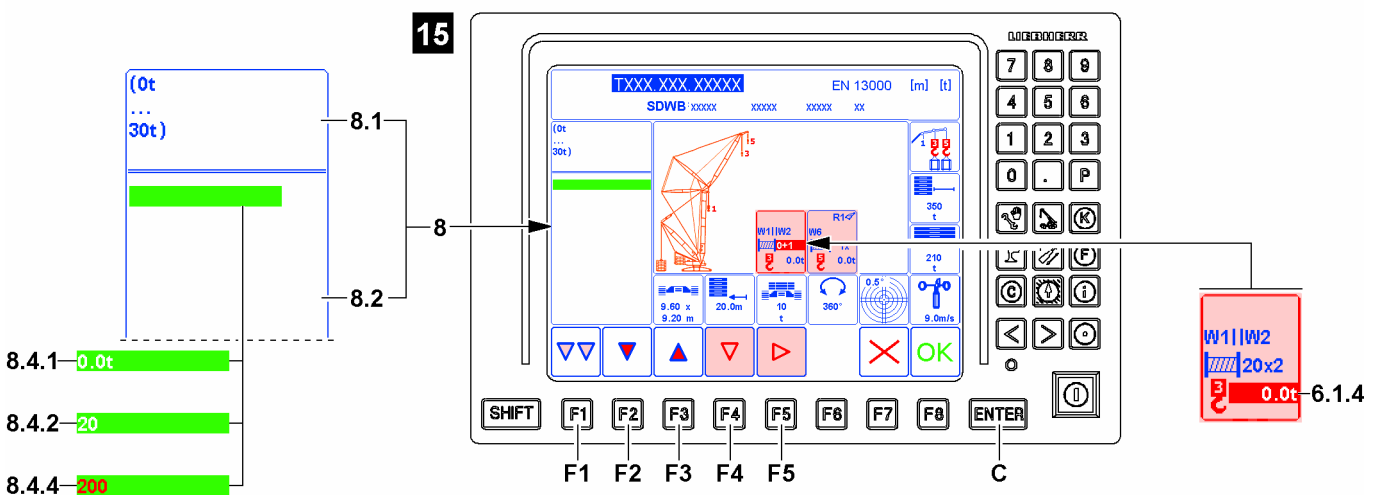

Fig.128090

The entry is made without the measuring unit:

- ▶ Enter the required number sequence using the keypad **A**, in the example „20“.

Result:

Illustration 15:

- The original value **8.4.1** (in example „0t“) turns off.
- The new value **8.4.2** (in the example „20“) appears.

Problem remedy

Invalid input value

When trying to accept an invalid input value **8.4.4**, the numbers are shown in red.

Enter only values according to the specifications from the upper area **8.1** of the Editing / selection window **8**.

- ▶ Enter the permissible value via the keypad **A**.

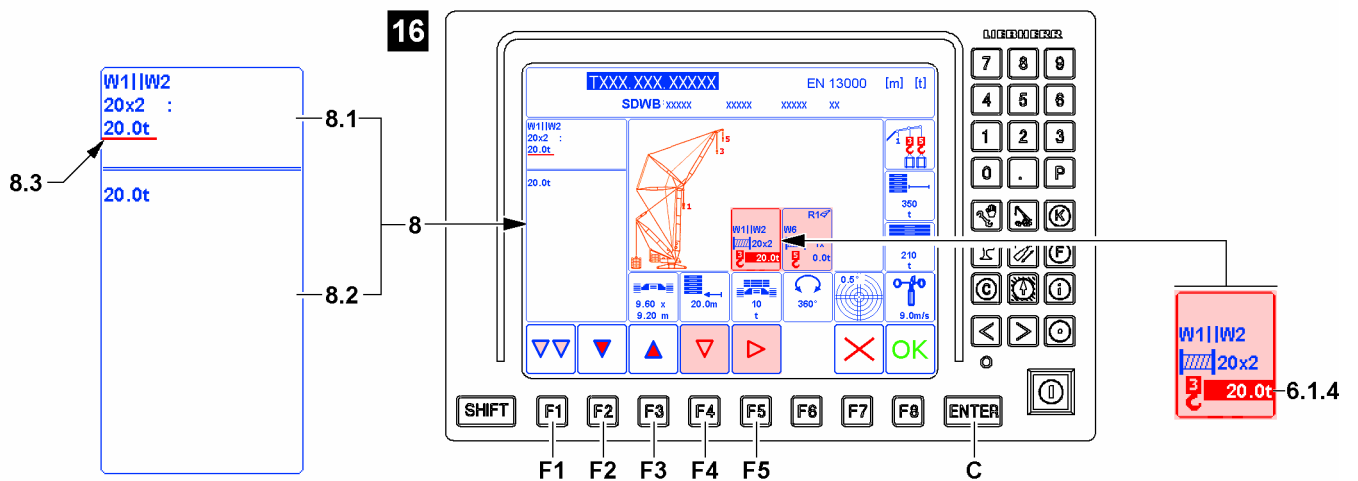

Fig.128091

- ▶ Press the ENTER key **C**.

Result:

- The new value is taken over, see illustration **16**.
- The new value for the hook block weight **6.1.4** appears in the display window.
- The new value for the hook block weight appears in the upper area **8.1**.

4.9.7 Assigning the fixed accessory

LWE/LR_13000-001/19503-01-02/en

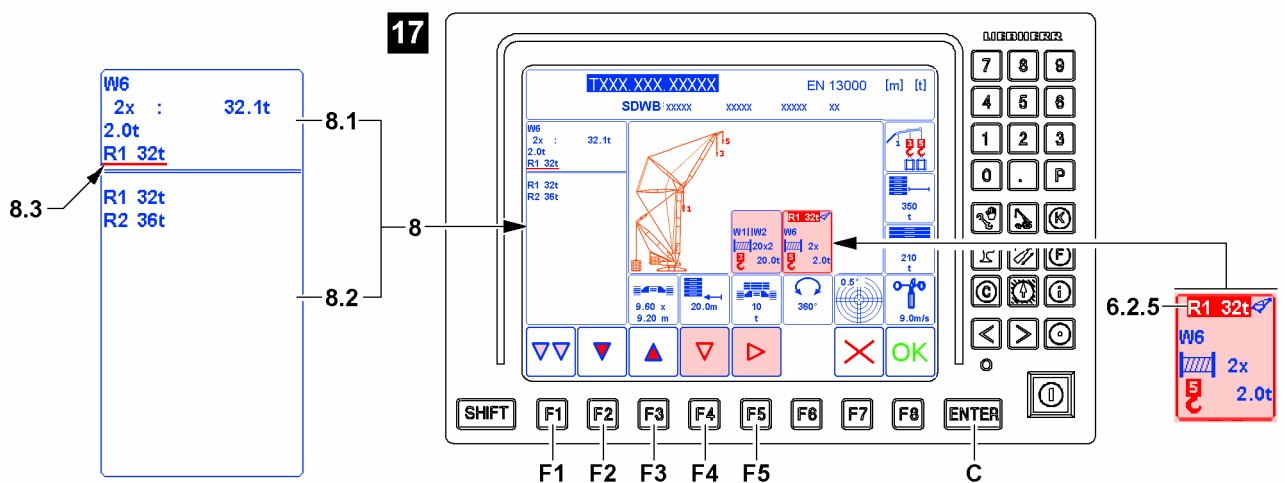

Fig.128092

The marker for the fixed accessory **6.2.5** only appears when a corresponding load position is selected.

**Note**

If the correct maximum fixed accessory **6.2.5** already appears, then the settings for this marker can be skipped.

Change to another marker (if necessary):

- ▶ Press the function key **F2** or function key **F3** until the next marker to be changed is underlined with the selection bar **8.3**.

Change to the next display window (if present):

- ▶ Press the function key **F5** or the function key **F4** and select the next display window.

End the *Set up* program (when all entries and settings are made):

- ▶ When all entries and settings in the lifting category **6** are correct, see section „Taking over entries and settings from the set up program“.

- The preselection options are displayed in the upper area **8.1** of the Editing / selection window **8**. The first preselection option is automatically underlined and activated with the selection bar **8.3**.
- The lower area **8.2** of the Editing / selection window **8** displays the respective selection possibilities.

**Note**

Abbreviations for fixed accessories

Only the fixed accessory is listed for which a load chart is available.

For example, the following can appear corresponding to the load chart name (chart number):

- ▶ R1: Abbreviation for boom nose 1. (Appears only when a valid load chart for boom nose 1 is available).
- ▶ R2: Abbreviation for boom nose 2. (Appears only when a valid load chart for boom nose 2 is available).

Make sure that the following prerequisite is met:

- The desired display window is marked with the red selection frame **6.8**.

When the desired display window is not marked with the red selection frame **6.8**:

- ▶ Press the function key **F5** or function key **F4** until the red selection frame **6.8** marks the desired display window (in example „load position 5“, see illustration **17**).
- ▶ Press the function key **F2** or function key **F3** until the fixed accessory in the upper area **8.1** is underlined with the selection bar **8.3**. (In the example „R1 32t“).

Result:

- The display for the fixed accessory **6.2.5** is highlighted in red in the active display window.

When the fixed accessory is underlined with the selection bar **8.3**:

- ▶ Press the ENTER key **C**.

Result:

- The selection bar **8.3** changes in the lower area **8.2** of the Editing / selection window **8**.

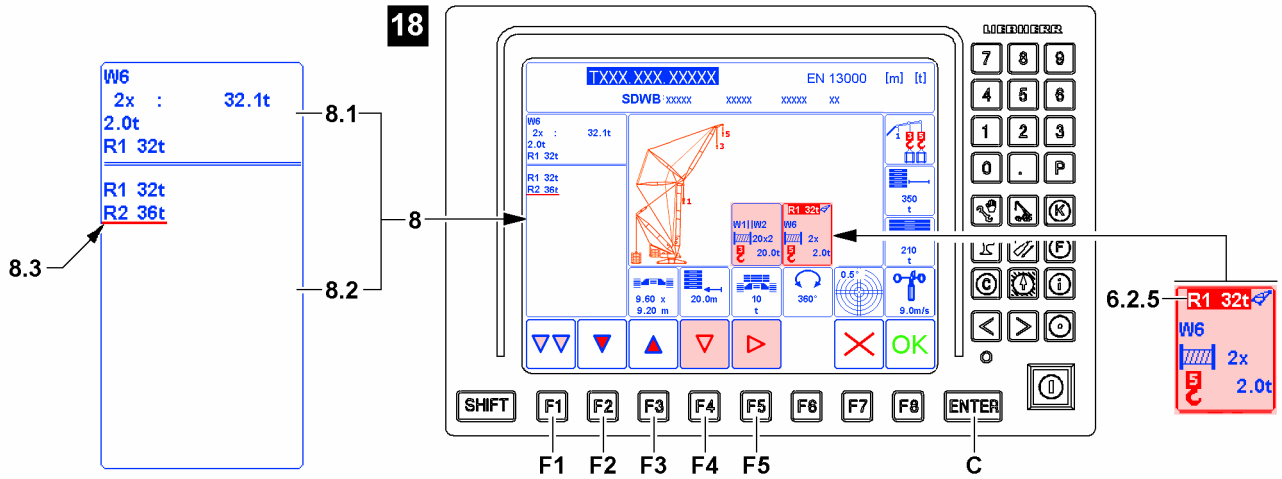

Fig.128093

- ▶ Press the function key **F2** or function key **F3** until the required selection in the upper area **8.2** is underlined with the selection bar **8.3**. (In the example „R2 36t“, see illustration **18**.)

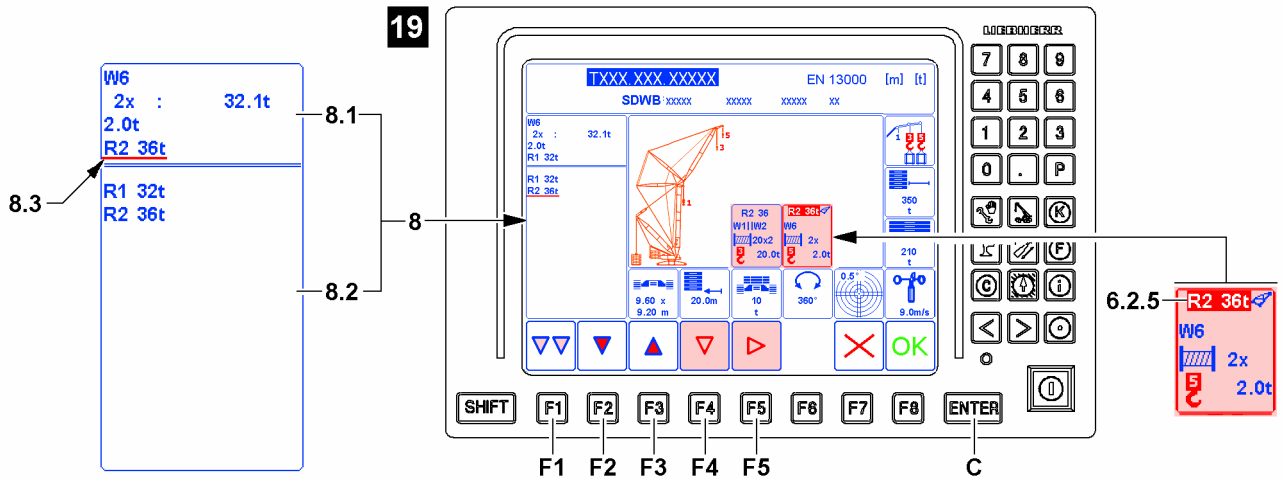

Fig.128094

- ▶ Press the ENTER key **C**.

Result:

- The selection is defined (example „R2 36t“).
- The selected setting appears as the fixed accessory **6.2.5** in the icon for load position 5, see illustration **19**.
- The selection bar **8.3** changes again in the upper area **8.1** of the Editing / selection window **8**.

LWE/LR 13000-001/19503-01-02/en

4.9.8 Taking over the entries and settings of the lifting category

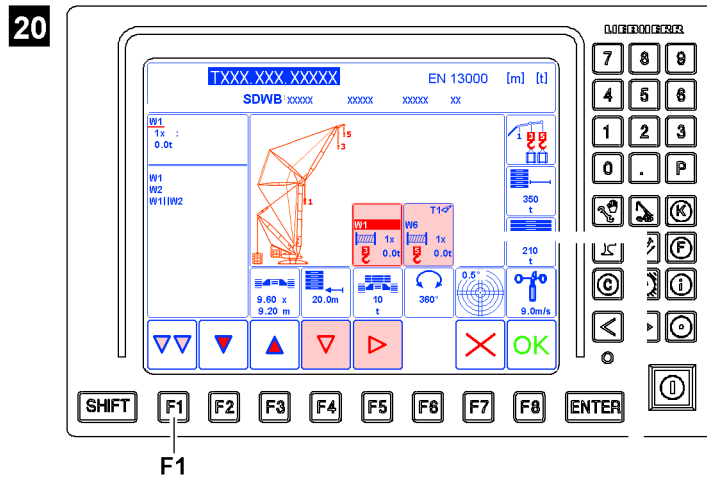

Fig.128096

Make sure that the following prerequisites are met:

- All selected entries and settings in the lifting category are correct and complete.

- ▶ Change to the following section „Taking over the entries and settings from the set up program“.

Problem remedy

Was it determined that one or more markers are not correct?

By pressing the function key **F1**, the individual program categories can be switched through one after the other. The first program category is called up after the last one.

- ▶ Press the function key **F1** until the lifting category is called up again. Then all entries and settings can be changed, see illustration 20.

4.10 Taking over the entries and settings from the Set up program

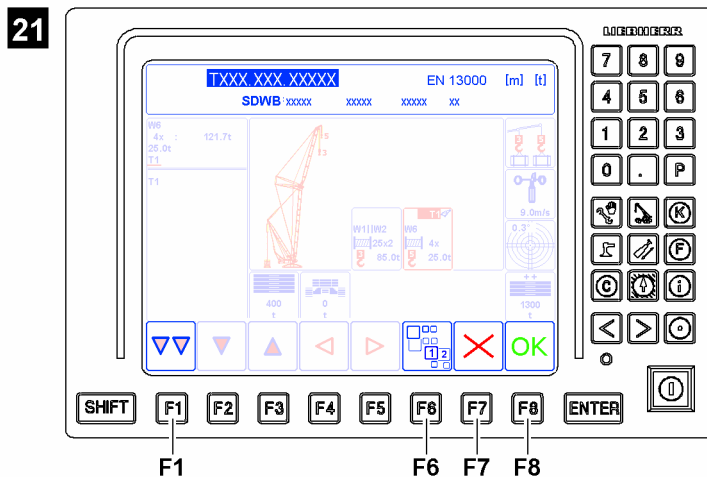

Fig.128095

**WARNING**

Danger of accident due to deviating set up configuration!

If the actual set up configuration of the crane deviates from the entries and settings in the *Set up* program, then the overload protection is not correctly set.

An incorrectly set overload protection calculates the actual load incorrectly and transmits faulty display values.

The crane can be overloaded without being noticed and topple over. Personnel can be severely injured or killed.

- ▶ The entries and settings in the *set up* program must match the actual set up configuration of the crane.

Make sure that the following prerequisite is met:

- There is no load on the hook.

- ▶ Check all entries and settings on the screen to ensure they are correct.

If the icon for additional levels appears above the function key **F6** (see illustration **21**), then they must be checked also.

When the icon for additional levels appears:

- ▶ Press the function key **F6** and check all entries and settings on the screen to ensure they are correct.

When all entries and settings have been checked to ensure that they are correct:

- ▶ Press the function key **F8** (below the *OK* icon) and take over the entries and settings from the *Set up* program.

Result:

- The *Set up* program is ended.
- Entries and settings from the *Set up* program have been taken over on the crane operating screen.
- The crane operating screen is called up.

Problem remedy

Was it determined that one or more markers are not correct?

By pressing the function key **F1**, the individual program categories can be switched through one after the other. The first program category is called up after the last one.

- ▶ Press the function key **F1** until the category to be changed is called up. Then all entries and settings can be changed.

**Note**

Caution Program abort.

- ▶ By pressing the function key **F7**, the process is aborted and the last valid entries and settings from the *Set up* program are called up.

4.11 Reference texts

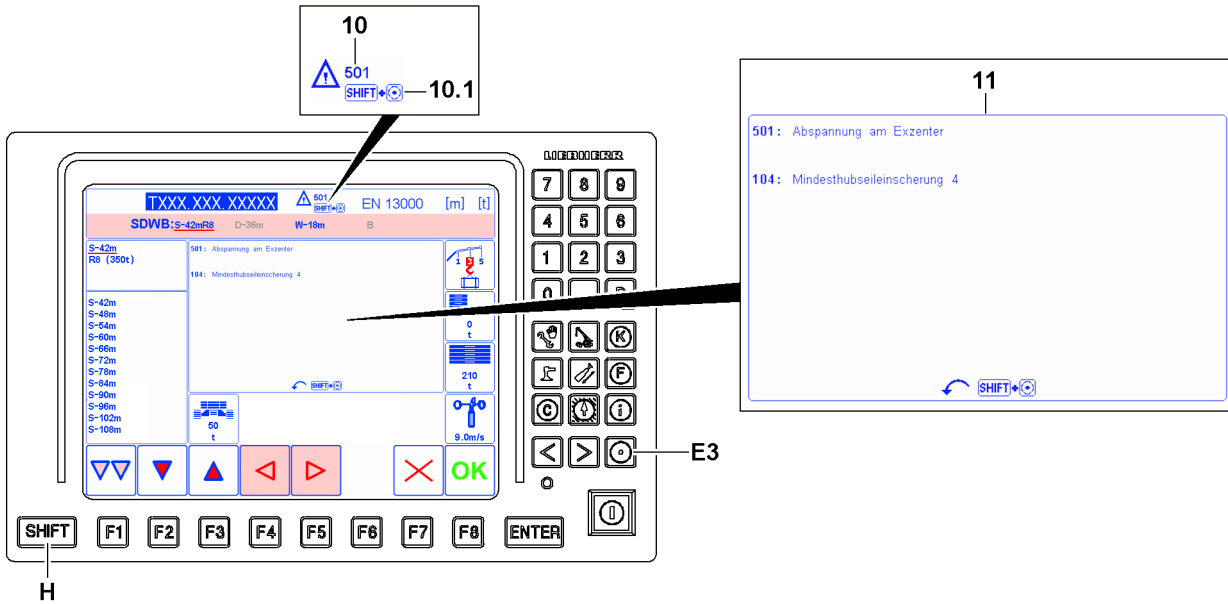

Fig.161571: Displaying the reference texts



WARNING

Disregard of limitations and notes!
 Toppling crane, failure of crane structures.
 Death or severe injuries, high property damage.
 ► Adhere to the limitations and notes.

There may be limitations and notes for the set up configuration that is set. If limitations and notes are available, they are specified by codes **10**. The reference texts **11** describe the corresponding codes **10**. Reference texts can be displayed and hidden with the key combination **10.1**.

The limitations and notes in the *Set up* program are identical to the limitations and notes in the load charts.

When at last one Code **10** is specified:

- Hold down the Shift key **H** and subsequently press the key **E3**.

Result:

- The reference texts **11** are displayed.

When reference texts **11** are displayed:

- Hold down the Shift key **H** and subsequently press the key **E3**.

Result:

- The reference texts **11** are hidden.

Empty page!

LWE/LR 13000-001/19503-01-02/en

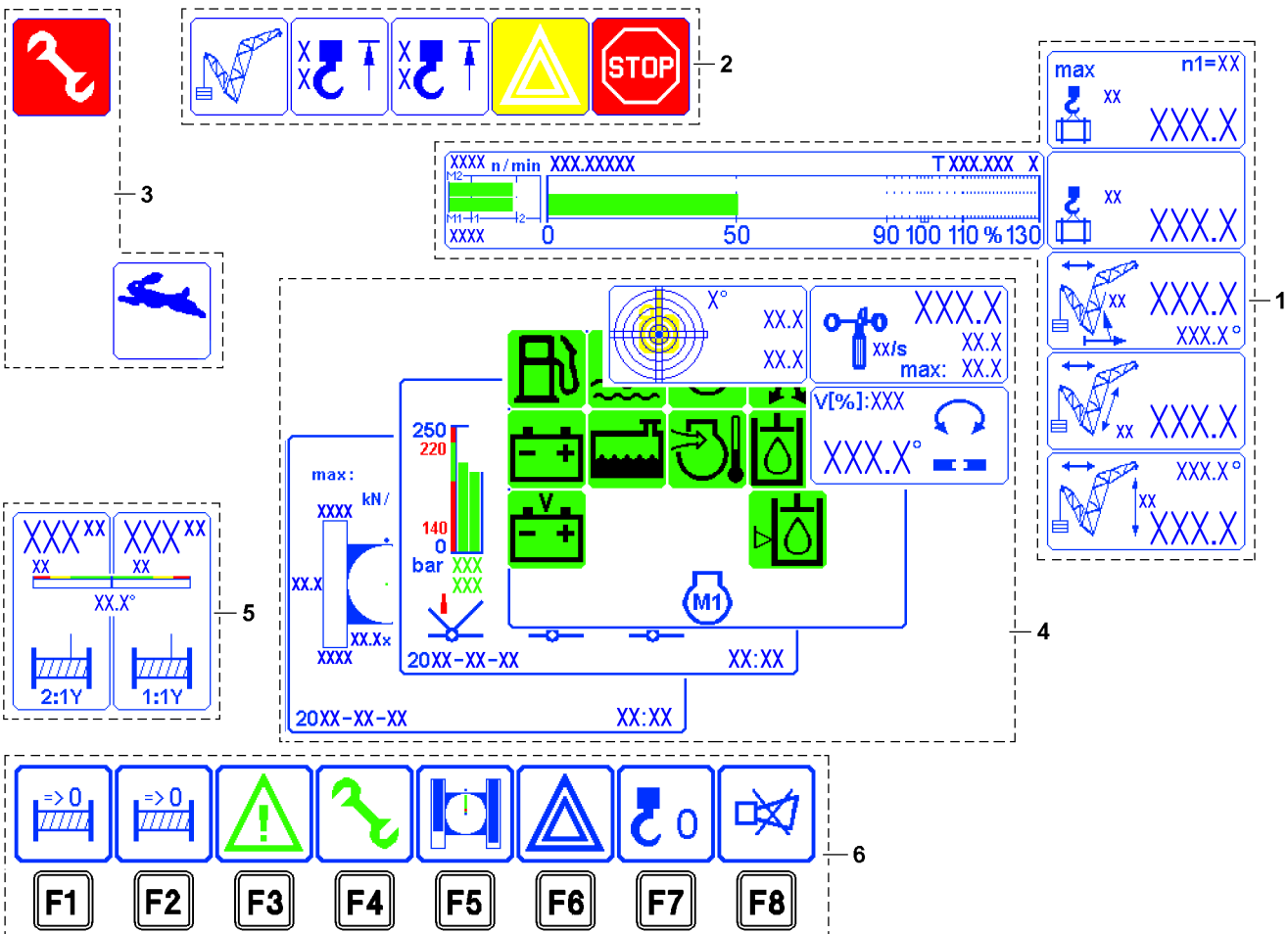
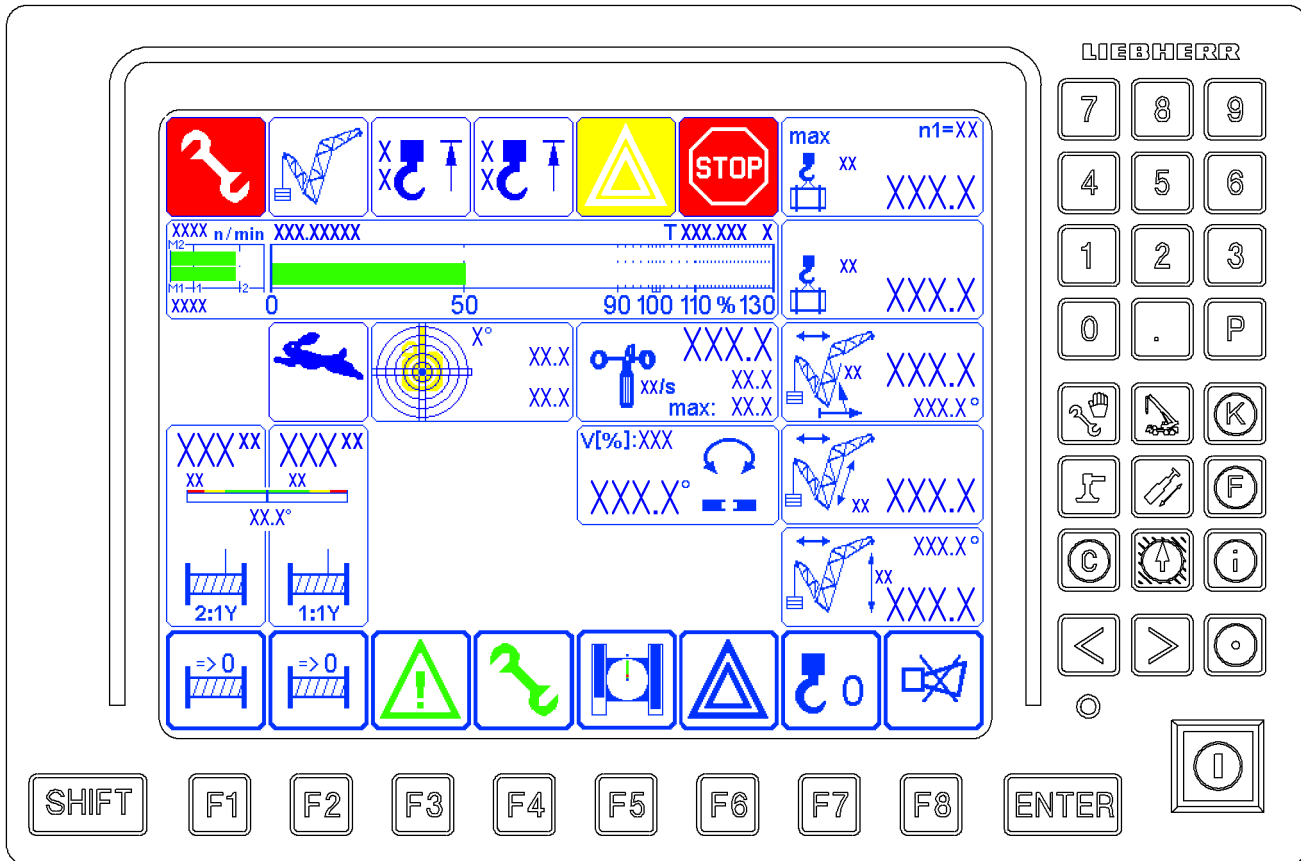

Fig.113426

LWE/LR 13000-001/19503-01-02/en

5 The *Crane operation* program on LICCON monitor 0

The *Crane operation* program assists the crane operator by displaying the data relevant for crane operation clearly on three LICCON monitors. An acoustic signal accompanies all critical displays. Depending on the equipment, a range of other icons may also be turned on as additional displays, either as required by the crane operator, or automatically in case of a problem.

It also alerts the crane operator to imminent overload conditions. In the event of overload and many error conditions, which could be hazardous during crane operation, the system shuts off.

The LICCON monitor 0 is divided into six areas in the *Crane operation* program:

- 1 Crane geometry and load information
- 2 Alarm functions
- 3 LICCON Monitor 0 special functions
- 4 Monitoring field
 - Monitoring functions during crane operation
 - Monitoring of relapse cylinders
 - Monitoring the surface pressure and center of gravity
 - Monitored auxiliary functions
- 5 Winch display
 - Winch 1 and winch 2
- 6 Function key line
 - The function keys always refer to the icons shown directly above them
 - **Note:** If no icon is shown on the line directly above the function key, then no function is assigned in the program to the function key.



Note

- ▶ The monitor illustrations in this chapter are only examples.
 - ▶ The numerical values in the individual icons and charts do not have to necessarily match the crane exactly.
 - ▶ The configuration of the LICCON monitor with icons is only descriptive.
 - ▶ An identical icon display will **not** appear during crane operation.
-

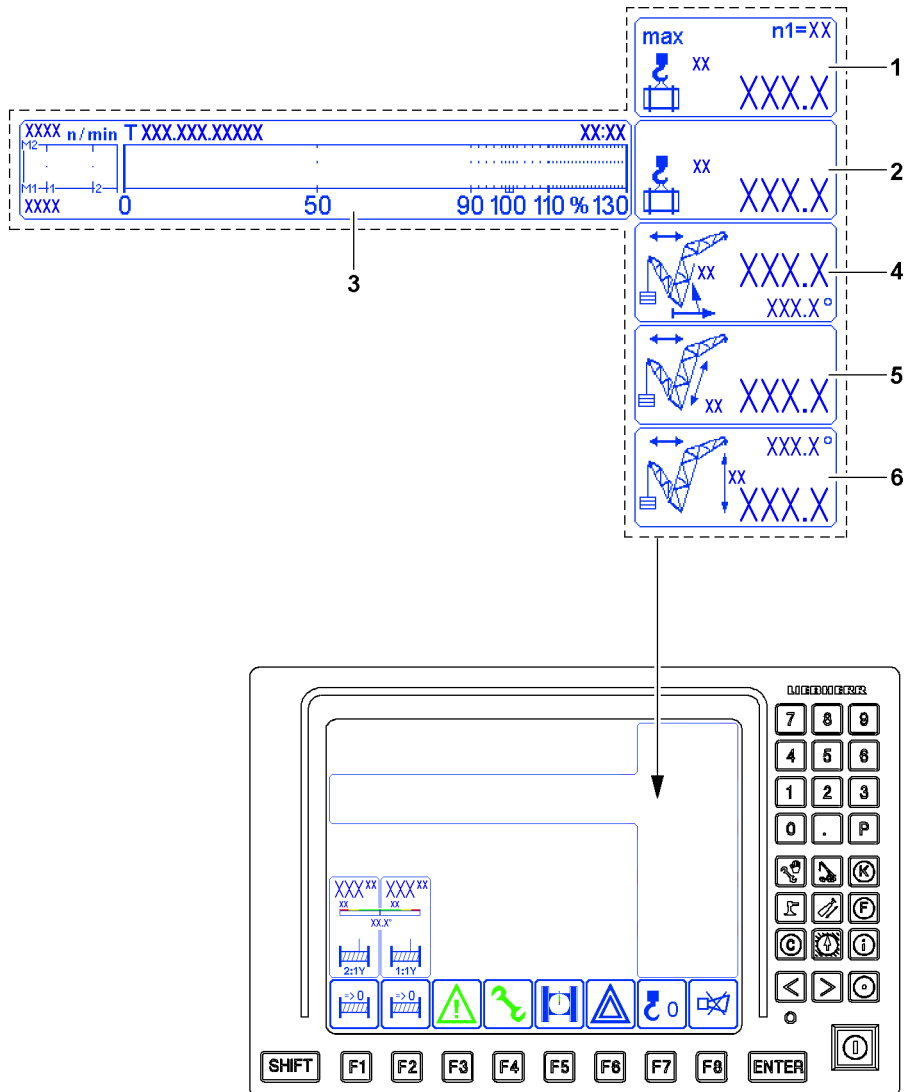

Fig.161659

5.1 Crane geometry and load information

Display on LICCON monitor 0



Note

- ▶ The crane illustrations in this section are only examples and are generalized.
 - ▶ They may differ from the crane type and equipment.
-

The information regarding crane geometry and load involves six icons:

- 1 Maximum load
- 2 Actual load
- 3 Utilization bar diagram
- 4 Boom radius
- 5 Boom length
- 6 Pulley head height



Note

- ▶ A question mark (?) is shown instead of values when no load chart value can be accessed. Example: The crane is not in the range of the load chart.
 - ▶ A question mark (?) is shown instead of values if the value cannot be calculated / determined. Example: A sensor error can be present - pay attention to the error messages.
-

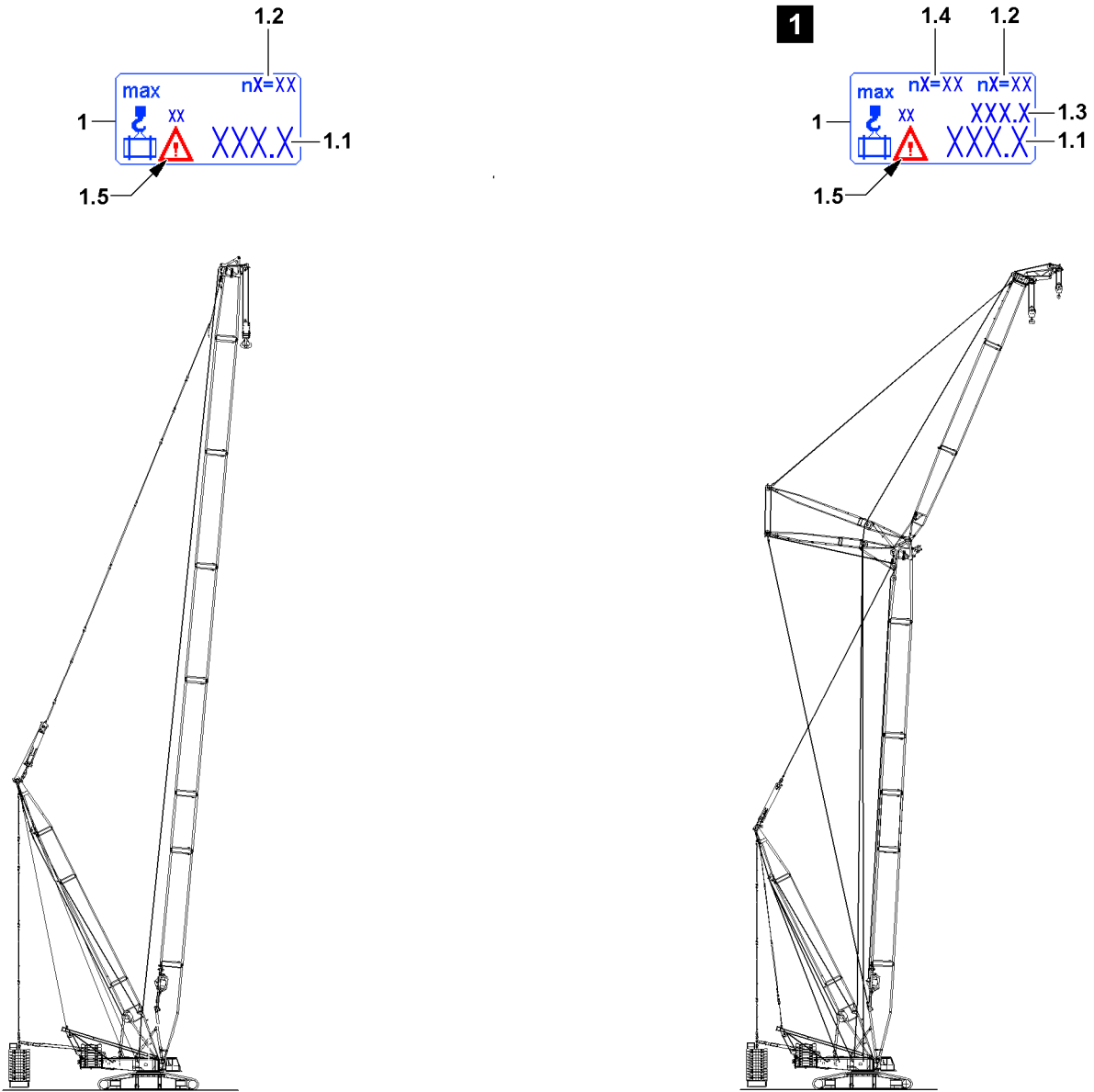

Fig.121770

5.1.1 Maximum load

According to the set up configuration, the following changes:

- The illustration of the icon
- The position of values in the icon, see sample illustration 1.

1 Maximum load icon

- In [t] or [lb]

1.1 Maximum load

- Maximum load in the **first** load position
- In [t] or [lb]

1.2 Reeving

- Reeving in the **first** load position
- Load position (n1 to n5) and assigned reeving number (settings from the *Set up* program)
 - n1= Load position 1
 - n2= Load position 2
 - n3= Load position 3
 - n4= Load position 4
 - n5= Load position 5

1.3 Maximum load

- **Note:** Appears only when a second load position is selected (settings from the *Set up* program).
- Maximum load in the **second** load position
- In [t] or [lb]

1.4 Reeving

- Reeving on the **second** load position
- Load position (n1 to n5) and assigned reeving number (settings from the *Set up* program)
 - n1= Load position 1
 - n2= Load position 2
 - n3= Load position 3
 - n4= Load position 4
 - n5= Load position 5

1.5 Warning icon*

- **Note:** Appears solely for certain crane types.
- Appears possibly when:
 - The permissible wind speed is exceeded
 - The permissible crane incline is exceeded



Note

- ▶ The *Maximum load* (also *Maximum load according to the load chart and the reeving*) is the load, which the crane can lift in its current operating condition with the maximum utilized ballast / counterweight.

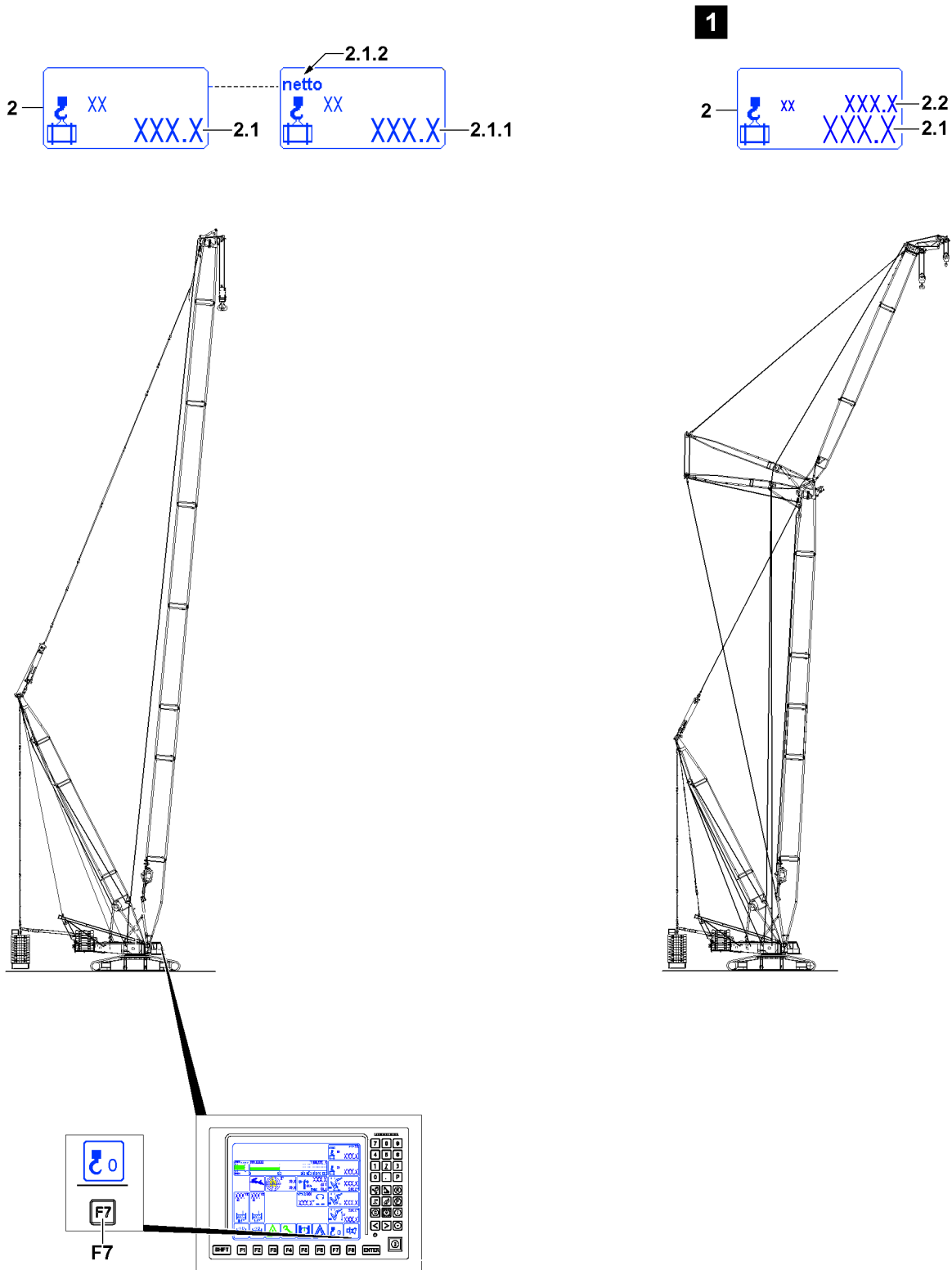

Fig.123759

LWE/LR 13000-001/19503-01-02/en

5.1.2 Actual load (current load) / net load

According to the set up configuration, the following changes:

- The illustration of the icon
- The position and number of values in the icon, see sample illustration 1.

2 Actual load / net load icon

- With text for the measuring unit [t] or [lb]

2.1 Actual load display

- *Actual load* display = load (in [t] or [lb]) that is currently suspended on the **first** load position.
- Display of the calculated total load including the weights of the load carrying, load taking on and / or fastening equipment.

2.1.1 Net load display

- *Net load* display = the *Actual load* display 2.1 can be changed at any time to *Net load* display 2.1.1 (tared) by pressing the function key **F7**.
- After pressing the function key **F7** the display value is set to zero and the word *net* 2.1.2 is shown.
- As long as the net load is set, the icon above the function key **F7** is shown in red.
- If taring is cancelled, the word *net* 2.1.2 disappears from the icon and the gross load value is displayed.

The change to net load is cancelled by the following actions:

- By pressing the function key **F7** again.
- By telescoping the boom more than three LE (LE= 1 decimeter or 1/10 ft).
- Luffing more than $\pm 4^\circ$.
- **Note:** This makes it possible to eliminate the weights of the load handling, load taking on and / or fastening equipment in the display value. The maximum load is not increased / adjusted.



WARNING

Incorrectly determined weight of the load!

Due to operating errors or tolerances, deviations can occur for the displayed values in the *Actual load / net load* icon 2.

- ▶ The *Actual load / Net load* display is not a calibrated weighing device.
- ▶ Always observe the actual weight of the load in connection with the load charts and the set up configuration of the crane.



Note

- ▶ The *Actual load* display 2.2 for the **second** load position appears only for certain crane types with special load charts for two load positions.

2.2 Actual load display

- **Note:** Appears only when a second load position is selected (settings from the *Set up* program).
- *Actual load* display = load (in [t] or [lb]) that is currently suspended on the **second** load position.
- Display of the calculated total load including the weights of the load carrying, load taking on and / or fastening equipment.

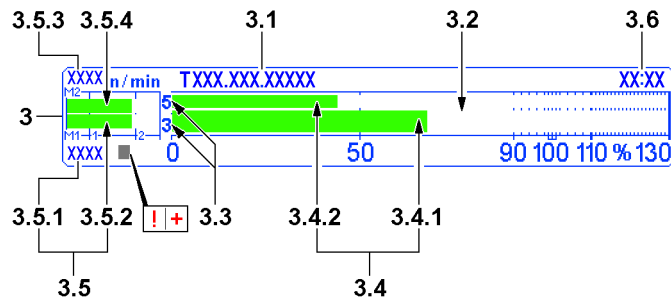

Fig.161657

5.1.3 Utilization bar diagram

- 3 Bar diagram of utilization icon
 - In percent
- 3.1 Chart names
 - Note to the set chart name (chart number) with associated operating mode
- 3.2 Utilization scale
 - Marking from a utilization of 90 %: Advance warning
 - Marking at a utilization of 100 %: STOP shut-off
- 3.3 Load position
 - The load position assigned to the respective utilization bar
- 3.4 Utilization bar
 - Current utilization of the crane
 - Appears in blue, green, yellow and red, depending on the situation
 - Utilization bar 3.4 blue / green: Utilization in the permissible range
 - Utilization bar 3.4 yellow: Advance warning! Utilization just before impermissible range
 - Utilization bar 3.4 red: Warning! Utilization in the impermissible range
 - For two load positions:
 - 3.4.1 Utilization bar for the **first** load position
 - 3.4.2 Utilization bar for the **second** load position



Note

- The set up configuration of the crane can only be changed when the utilization bar 3.4 is blue.

Utilization of the crane	
	Actual load
Current utilization of the crane	= $\frac{\quad}{\quad}$
	Maximum load

- 3.5 Engine rpm
 - In revolutions per minute
 - The engine rpm is always shown numerically and graphically
 - If the icon „+“ appears on the rpm display, the engine rpm is locked
 - If the „!“ symbol appears on the rpm display, the engine rpm is limited
 - The engine rpm can be limited in ECO mode, see section „ECO mode“
 - **Note:** Only for certain crane types.
 - **NOTICE!** If the display is in red, an error is present.
 - **Note:** Question marks („?“) appear if there is an error in the rpm recording. Then the system switches to an engine rpm specified by the control for the output regulation of the drives. The specified engine rpm is displayed blinking. An error message is output.
 - 3.5.1 numeric display
 - 3.5.2 graphic display, in the form of a bar diagram
 - Only for crane types with two engines:
 - 3.5.3 numeric display for engine 2
 - 3.5.4 graphic display for engine 2, in the form of a bar diagram
- 3.6 Time

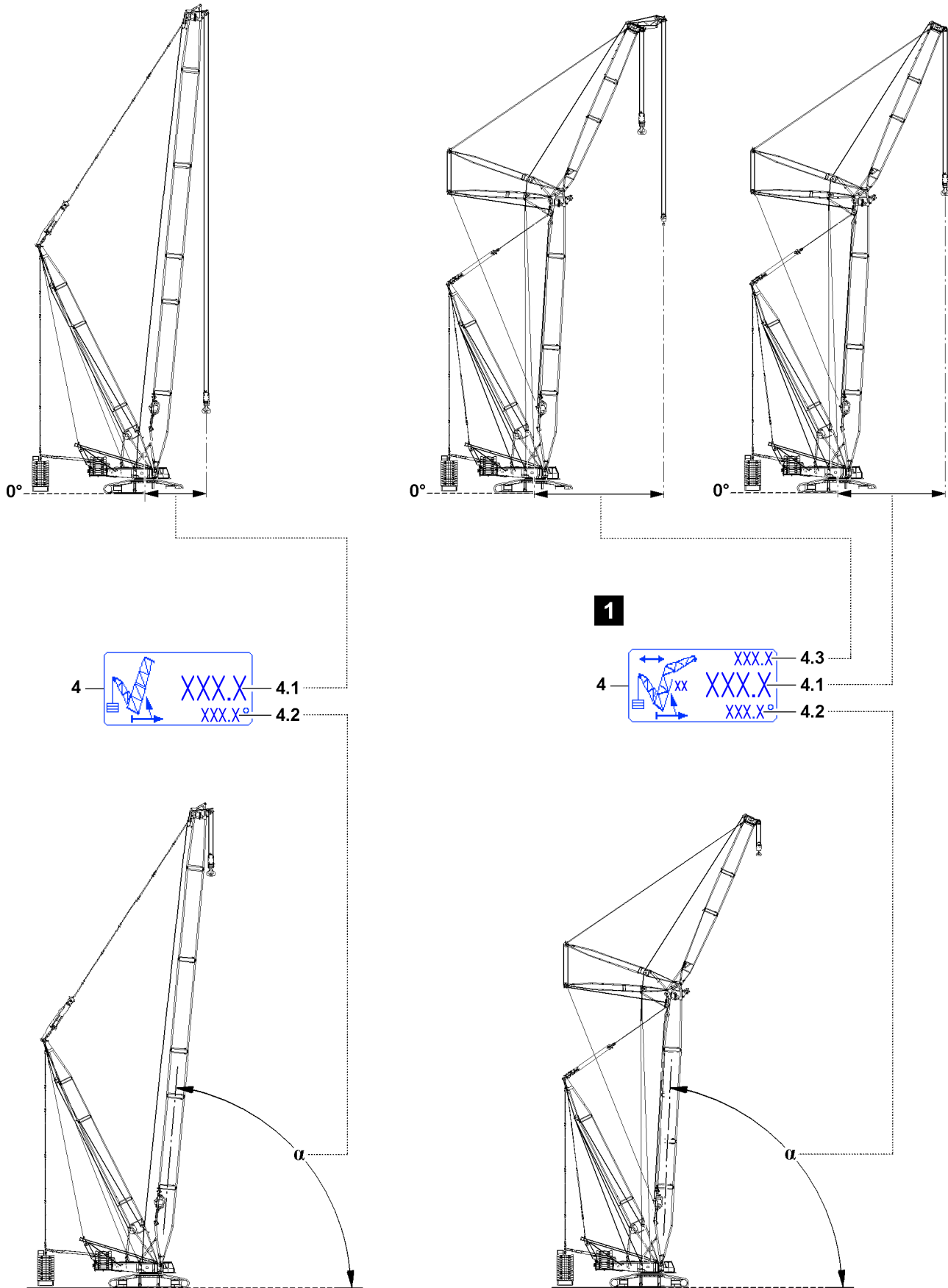

Fig.114264

LWE/LR 13000-001/19503-01-02/en

5.1.4 Boom radius

According to the set up configuration, the following changes:

- The illustration of the icon
- The position and number of values in the icon, see sample illustration 1.

4 Boom radius icon

4.1 Boom radius

- **First** load position boom radius
- In [m] or [ft]

Denotes the horizontal distance of the load hook from the rotation axis of the crane superstructure. This also takes the boom flexation due to its own weight and the suspended weight of the load into account.

4.2 Main boom angle

- In [°]
- The angle of the main boom (angle α) to the horizontal is displayed

4.3 Boom radius

- **Note:** Appears only when a **second** load position is selected (settings from the *Set up* program).
- **Second** load position boom radius
- In [m] or [ft]

Denotes the horizontal distance of the load hook from the rotation axis of the crane superstructure. This also takes the boom flexation due to its own weight and the suspended weight of the load into account.

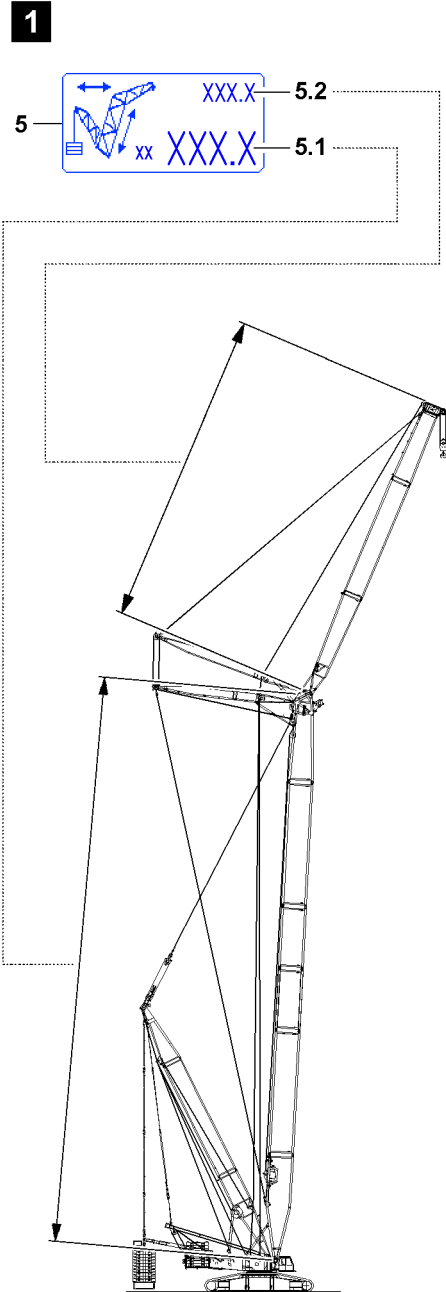
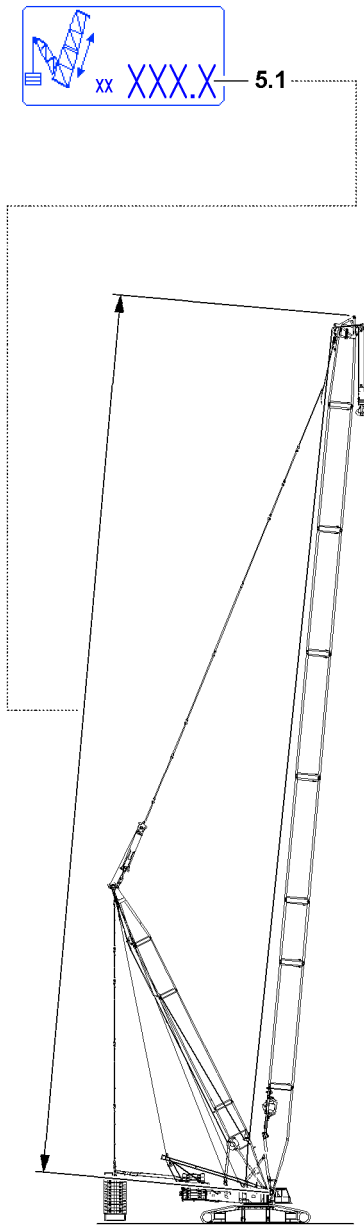

Fig.114265

LWE/LR 13000-001/19503-01-02/en

5.1.5 Boom length

According to the set up configuration, the following changes:

- The illustration of the icon
- The position of values in the icon, see sample illustration 1.

5 Boom length icon

5.1 Main boom length

- In [m] or [ft]

5.2 Length of auxiliary boom / accessory

- In [m] or [ft]

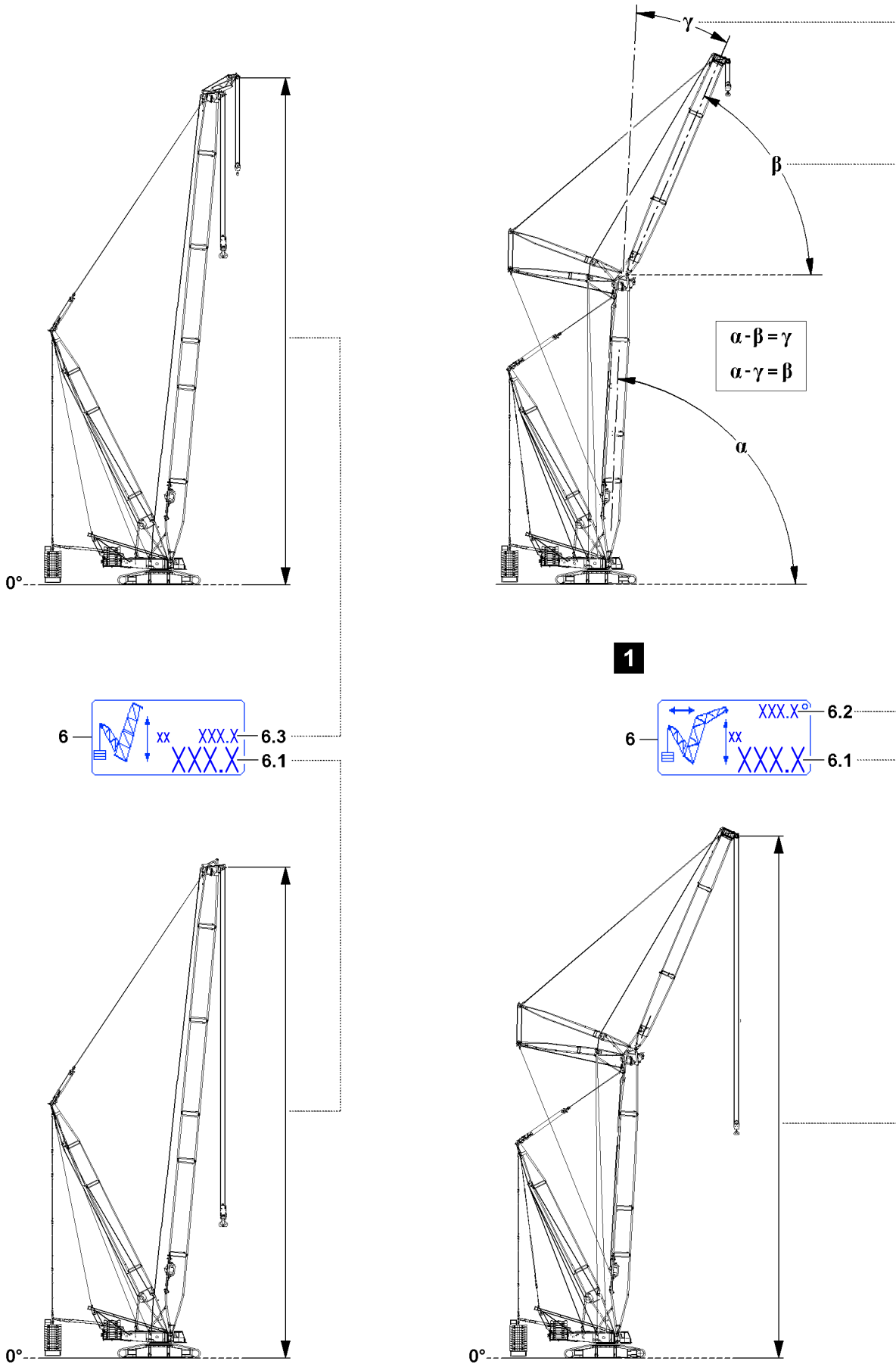

Fig.114266

LWE/LR 13000-001/19503-01-02/en

5.1.6 Pulley head height



Note

- ▶ Main boom angle α : The angle of the main boom to the horizontal
- ▶ Auxiliary boom / accessory angle β : The angle of the auxiliary boom / accessory to the horizontal.
- ▶ Auxiliary boom / accessory relative angle γ : The angle of the auxiliary boom / accessory is determined relative to the main boom.

According to the set up configuration, the following changes:

- The illustration of the icon
- The position of values in the icon, see sample illustration 1.

6 Pulley head height icon

6.1 Pulley head height

- **First** load position pulley head height
- In [m] or [ft]
- Marks the vertical distance from the placement surface of the crane to the selected pulley head axle.

6.2 Auxiliary boom / accessory angle

- In [°]



Note

- ▶ Depending on the set up configuration and the load chart, a differentiation is made between an absolute angle display or a relative angle display.

β Auxiliary boom / accessory absolute angle

- The angle of the auxiliary boom / accessory to the horizontal in [°]
- Display absolute angle: For operating modes with load chart for a fixed defined main boom angle.

or

γ Auxiliary boom / accessory relative angle

- Angle between the main boom and the auxiliary boom / accessory in [°]
- Display relative angle: For operating modes with load chart for a fixed defined angle auxiliary boom / accessory.

6.3 Pulley head height

- **Note:** Appears only when a second load position is selected (settings from the *Set up* program).
- **Second** load position pulley head height
- In [m] or [ft]
- Marks the vertical distance from the placement surface of the crane to the selected pulley head axle.

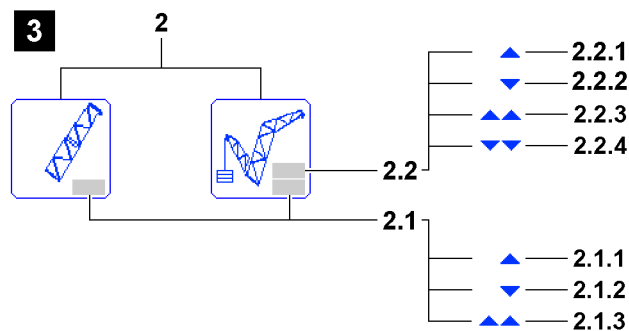
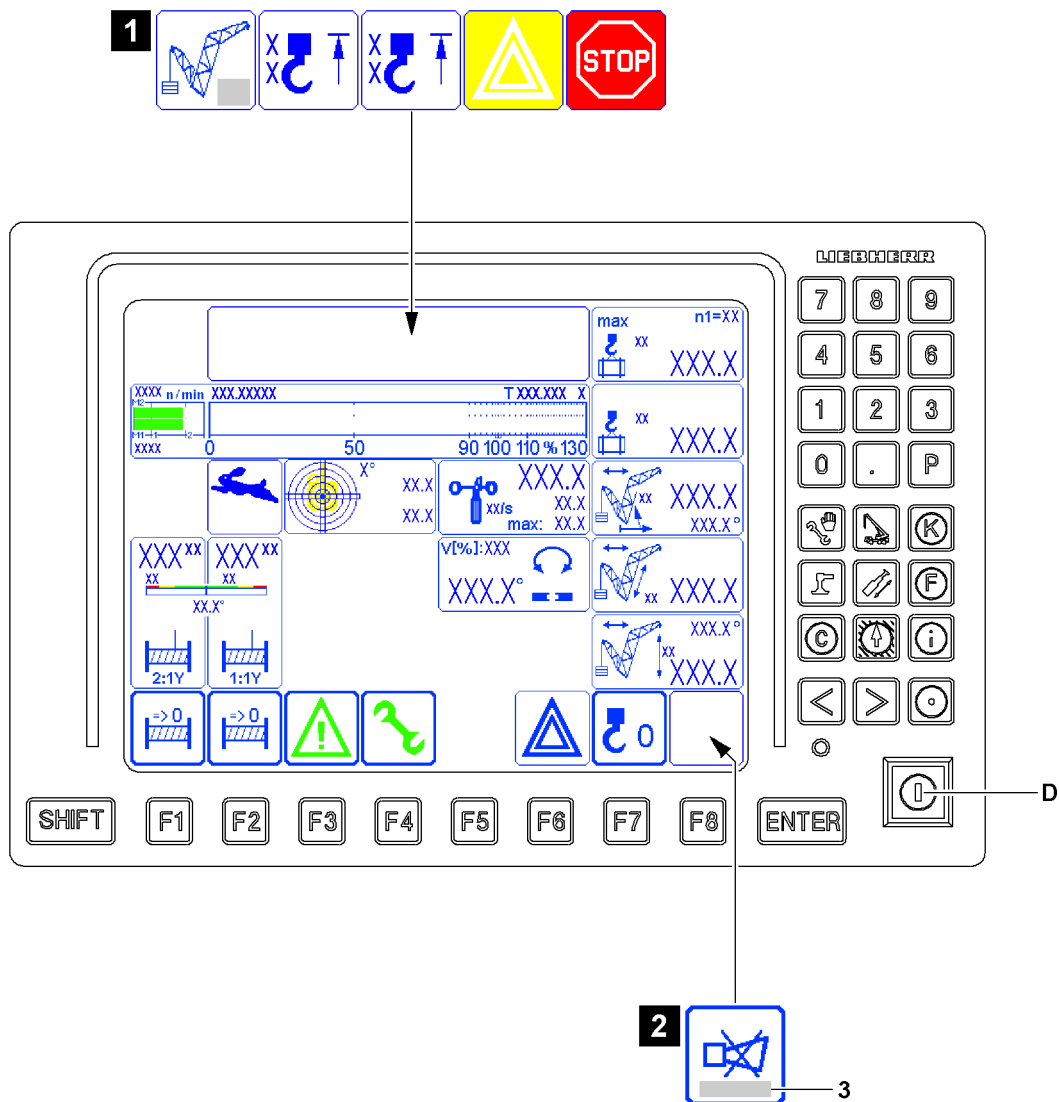

Fig.114267

LWE/LR 13000-001/19503-01-02/en

5.2 Alarm functions

NOTICE

Triggered alarm function!

If an alarm function is triggered (for example an advance warning occurrence or shut off of crane movement), the cause must be determined.

- ▶ Always pay attention to triggered alarm functions.
 - ▶ Alarm function can flash over the monitor.
-

The limit ranges of the crane movements are monitored. When the limit ranges are reached, the crane operator is warned by the alarm functions.

The alarm functions are shown by the LICCON monitor:

- Optically with icons, see illustration 1.
- Acoustically by a *horn* warning sound, see illustration 2.

In case of a failure of the relevant sensors / limit switches, special error messages 3 are added.

5.2.1 Boom limitation

See illustration 3

Main boom limit signs



Note

- ▶ The *Boom limitation* icon 2 can change in different operating modes, but it is shown always in the same position on the LICCON monitor.
 - ▶ The field *on the bottom* 2.1 refers to the main boom.
 - ▶ The field *on the top* 2.2 refers to the auxiliary boom / accessory.
-

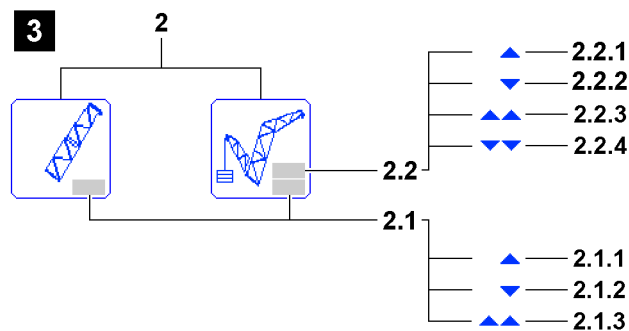
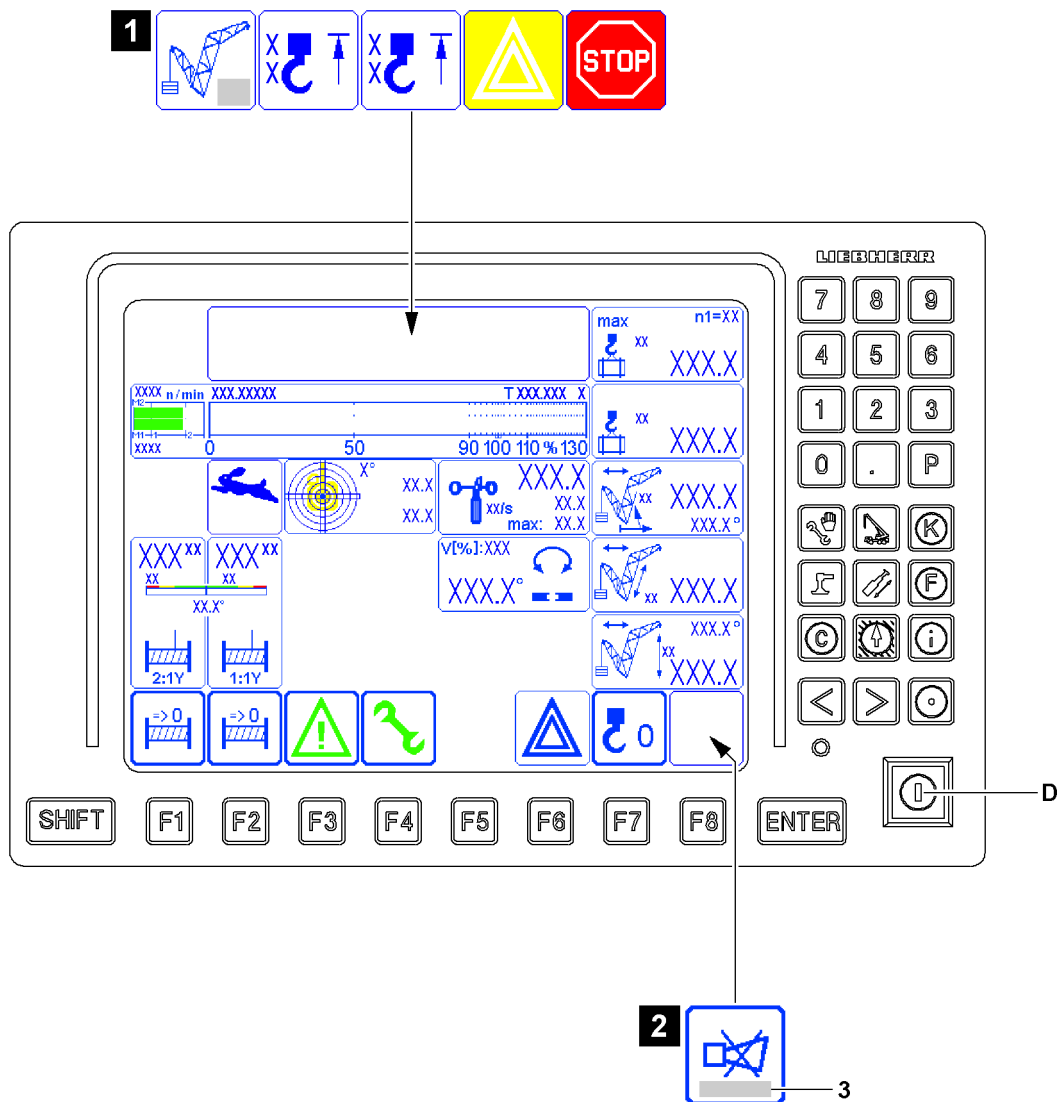



Fig.114267

LWE/LR 13000-001/19503-01-02/en

2.1 Main boom boom limitation icon

- The luffing range of the main boom is limited both upward and downward.
- This icon appears if an end position determined by the load chart is reached when luffing the boom or when luffing the boom is disabled by a proximity switch.

Position	Icon	Description
2.1.1		The <i>Luffing up the main boom</i> shut-off takes place when running against the upper load chart limit or The <i>Luff main boom up</i> shut-off takes place due to utilization greater than 95 % and falling load capacity when luffing up the main boom ¹⁾ . Note: Luffing down the main boom is still possible.
2.1.2		The <i>Luffing down the main boom</i> shut-off is triggered by running against the lower load chart limit Note: Luffing up the main boom is still possible.

1) Only for certain crane types and boom systems.



WARNING

Alarm function deactivated!

When the set up key **D** is actuated, there is no shut-off of crane movement via position **2.1.1** and position **2.1.2**.

► Observe the Crane operating instructions, chapter 4.20.

Position	Icon	Description
2.1.3		The <i>Luffing up the main boom</i> shut-off is triggered by running against the block limit switch of the main boom relapse cylinders on the left / right (boom steep) or due to an error in one block limit switch of the main boom relapse cylinders Note: Luffing down the main boom is still possible.

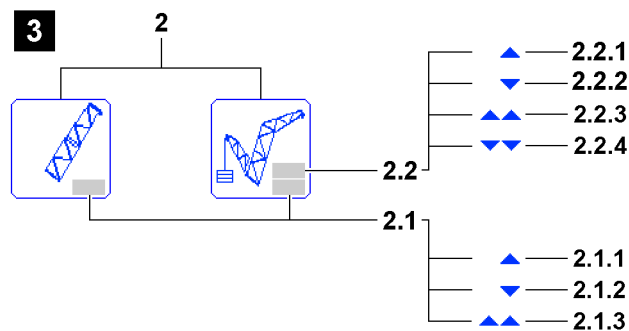
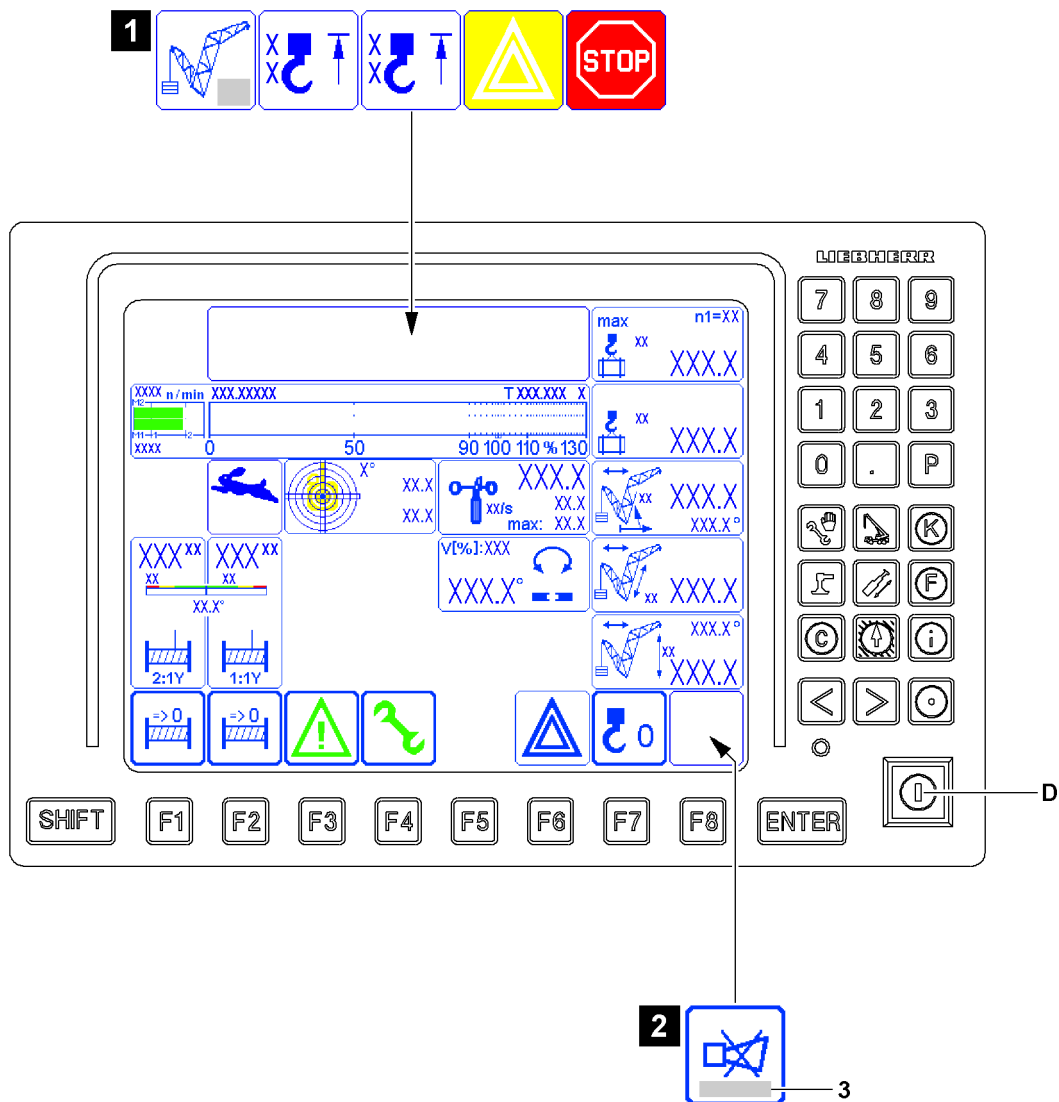

Fig.114267

LWE/LR 13000-001/19503-01-02/en

Auxiliary boom / accessory limit signs



Note

- ▶ The *Boom limitation* icon **2** can change in different operating modes, but it is shown always in the same position on the LICCON monitor.
- ▶ The field *on the bottom* **2.1** refers to the main boom limit sign.
- ▶ The field *on top* **2.2** refers to the limit sign auxiliary boom / accessory.

2.2 Auxiliary boom / accessory boom limitation icon

- The luffing range of the auxiliary boom / accessory is limited both upward and downward.
- This icon appears if an end position determined by the load chart is reached when luffing the auxiliary boom / accessory or when luffing is disabled by a limit switch.

Position	Icon	Description
2.2.1	▲	The <i>Luffing up the auxiliary boom / accessory</i> shut-off takes place by reaching the upper load chart limit. Note: Luffing the auxiliary boom / accessories down remains possible.
2.2.2	▼	The <i>Luffing down the auxiliary boom / accessory</i> shut-off is triggered by running against the lower load chart limit Note: Luffing up the auxiliary boom / accessories remains possible.



WARNING

Alarm function deactivated!

When the set up key **D** is actuated, there is no shut-off of crane movement via position **2.2.1** and position **2.2.2**.

- ▶ Observe the Crane operating instructions, chapter 4.20.

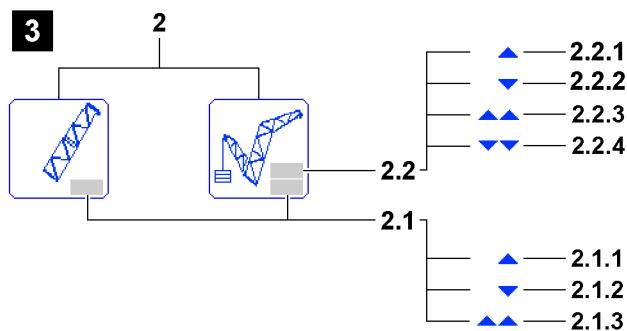
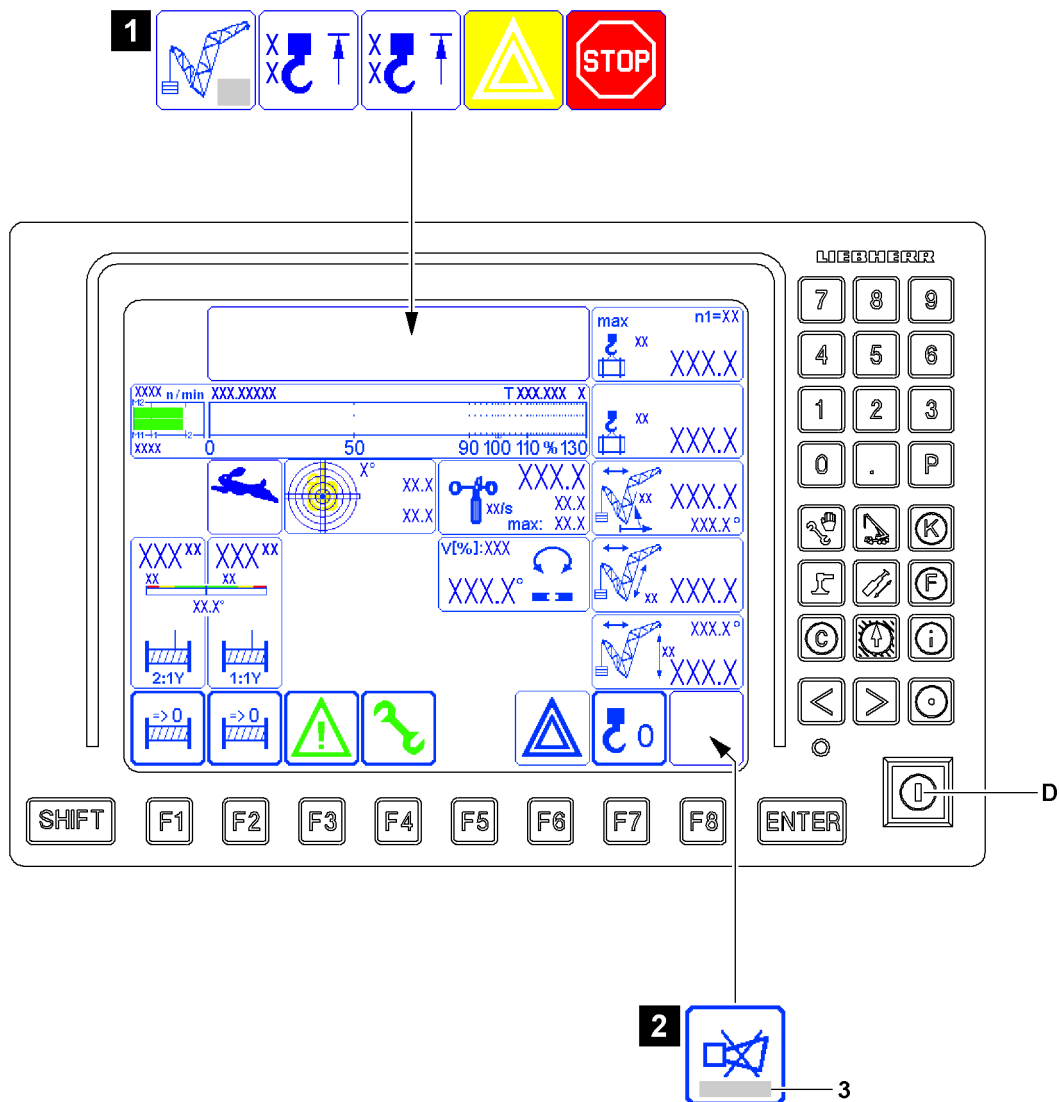



Fig.114267

Position	Icon	Description
2.2.3		<p>The <i>Luffing up the auxiliary boom / accessory</i> shut-off is triggered by running against a block limit switch of the auxiliary boom / accessory relapse cylinders</p> <p>or</p> <p>the relapse flap</p> <p>or</p> <p>an error on one limit switch occurs.</p> <p>Note: Luffing the auxiliary boom / accessories down remains possible.</p>
2.2.4		<p>The <i>Luffing down the auxiliary boom / accessory</i> shut-off is triggered by running against a block limit switch (on auxiliary boom / accessory lower left / right)</p> <p>or</p> <p>an error occurs on one of these limit switches.</p> <p>Note: Luffing up the auxiliary boom / accessories remains possible.</p>

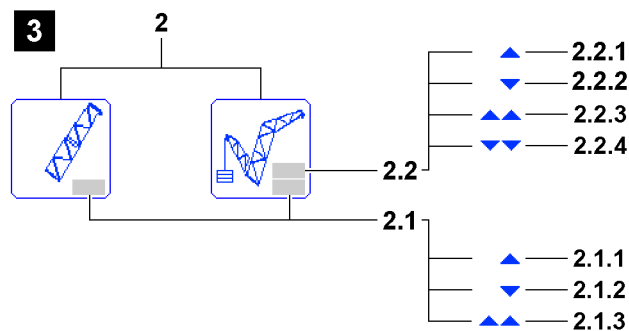
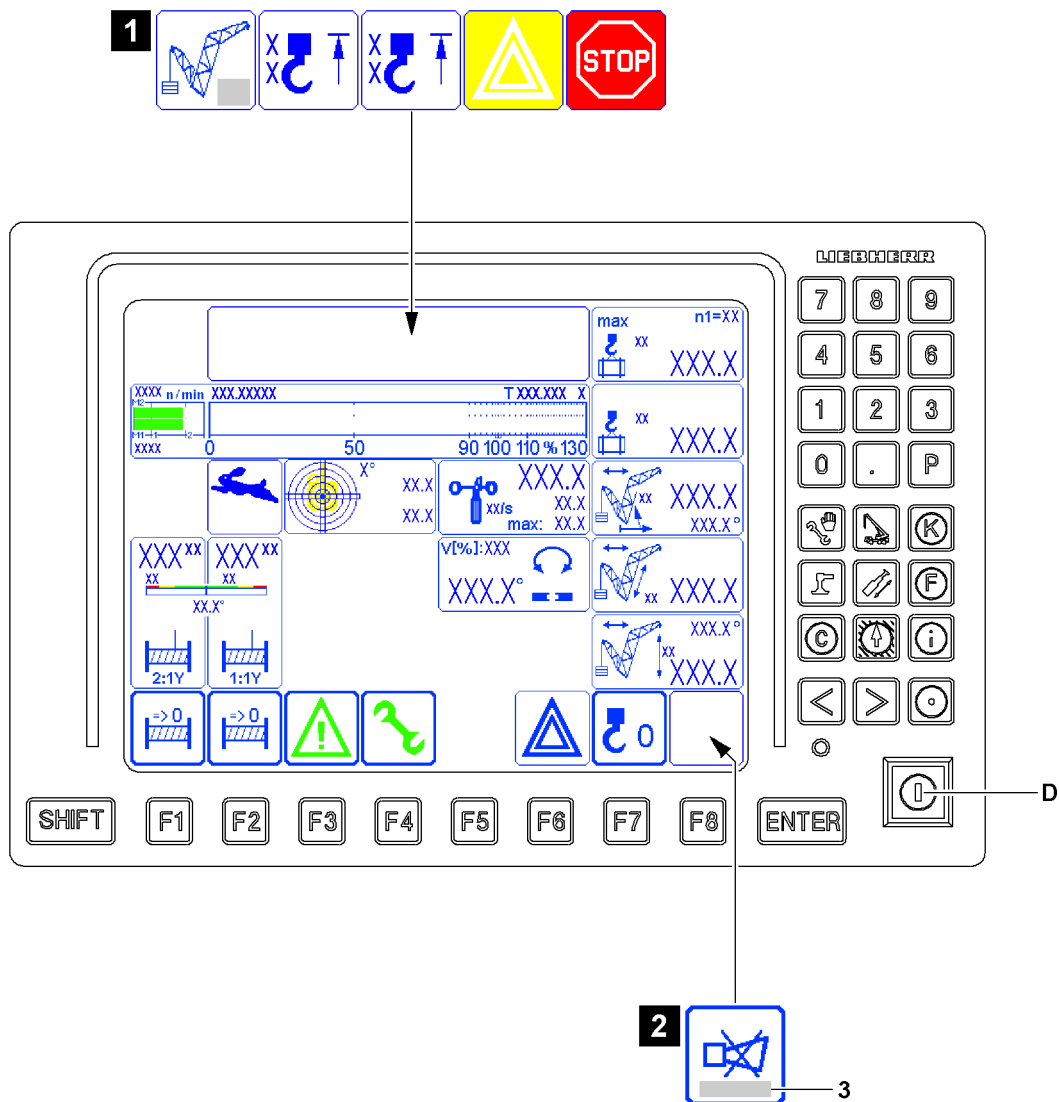

Fig.114267

LWE/LR 13000-001/19503-01-02/en

5.2.2 Failure of sensor / limit switch

NOTICE

Failure of sensor / limit switch!

Depending on the classification of the sensor / limit switch, the crane can continue to be operated with limitation or is shut off by the control.

An error message is issued in the *Horn* icon **3**, see illustration **2**.

The error message shows defective sensors / limit switches, see the Diagnostics manual.

- ▶ The error must be remedied immediately.
- ▶ Crane movements after a failure of a sensor / limit switch must be carried out anticipatorily and with extreme caution.

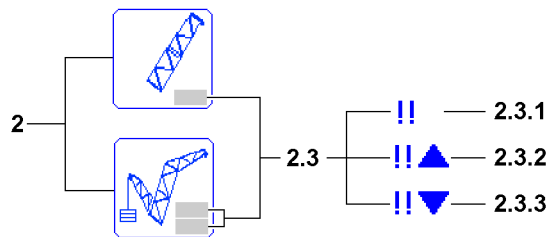

Fig.114275

Position	Icon	Description
2.3.1	!!	At least one associated sensor / limit switch is defective / missing on the auxiliary boom / accessory. If an alarm function occurs at the same time, then the icon can be shown differently, see position 2.3.1, position 2.3.2 or position 2.3.3.
2.3.2	!!▲	
2.3.3	!!▼	



Note

- ▶ Not every failure of a sensor / limit switch on the boom is shown in the *Boom limitation* icon **2**. Observe the error message in the *Horn* icon **3**.
- ▶ Depending on the classification of the sensor / limit switch, the respective crane movement is shut off in case of a failure and **cannot be bypassed**.
- ▶ When deflecting the master switch, an operating error message is issued in the *Horn* icon **3**. The operating error message shows defective sensors / limit switches.
- ▶ If the error cannot be remedied by yourself, contact Liebherr Service.

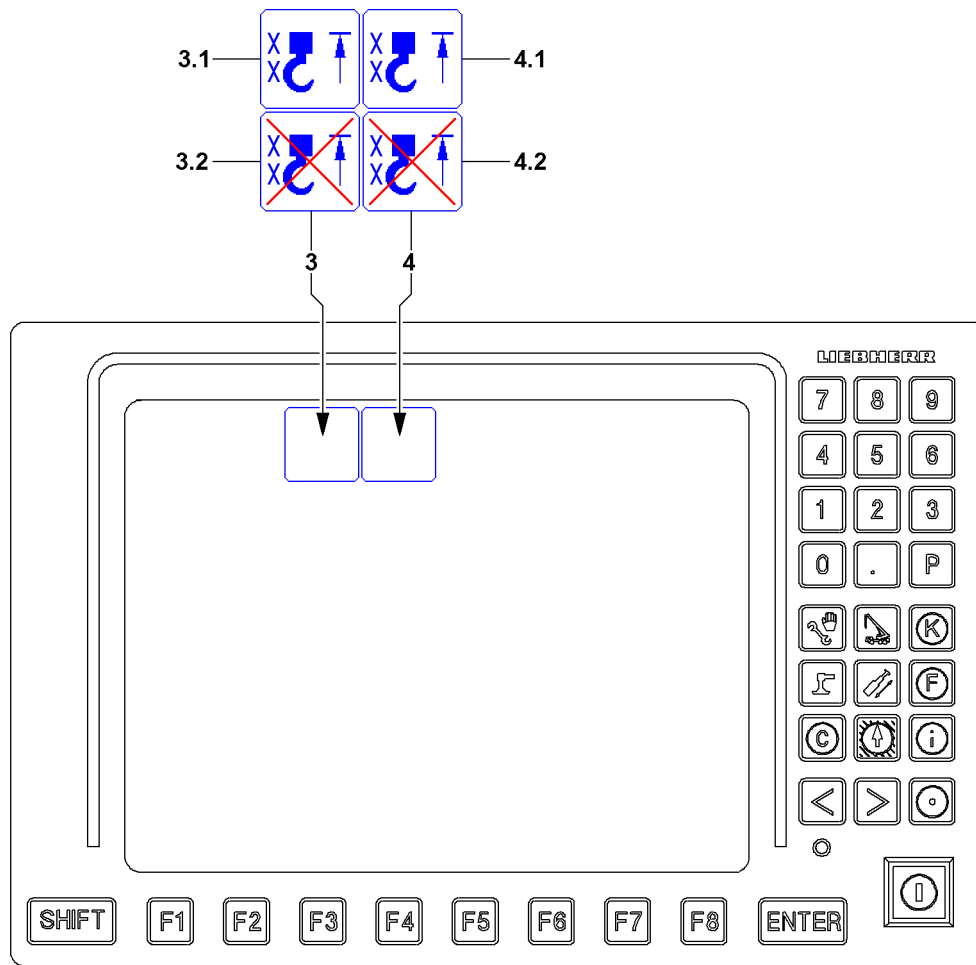

Fig.114276

LWE/LR 13000-001/19503-01-02/en

5.2.3 Hoist limit switch

In order to prevent the crane from being operated without a hoist limit switch (HES), the presence of the hoist limit switch is continuously monitored by the crane control. If a hoist limit switch required for a particular operating mode is not plugged in, therefore not active on the LSB bus system, the corresponding crane movements are stopped and an operating error message is also issued.

The identification of the triggered hoist limit switch (for example HES1 for hoist limit switch 1) appears in the respective icon.



WARNING

Hoist limit switch not functioning!

- ▶ Before crane operation, check the hoist limit switches for function and correct assembly.

3 Hoist top icon

Hoist limit switch for the first load position

3.1 Hoist top triggered icon

- The *Hoist top triggered icon* appears when:
 - The hook block is pulled against the hoist limit switch weight.
 - The hoist limit switch weight is not attached freely (for example on placed down boom).
 - The hoist limit switch is not recognized by the crane control, even though it is required for the operating mode.
 - The hoist limit switch has an internal error.
- **Note:** Spool up hoist winches is turned off. Additional crane movements can be turned off.

3.2 Hoist top bypassed icon

- The *hoist top bypassed icon* appears if the hoist limit switch is bypassed, see section „Special functions LICCON monitor 0“.

4 Hoist top icon

Hoist limit switch for the second load position

4.1 Hoist top triggered icon

- The *Hoist top triggered icon* appears when:
 - The hook block is pulled against the hoist limit switch weight.
 - The hoist limit switch weight is not attached freely (for example on placed down boom).
 - The hoist limit switch is not recognized by the crane control, even though it is required for the operating mode.
 - The hoist limit switch has an internal error.
- **Note:** Spool up hoist winches is turned off. Additional crane movements can be turned off.

4.2 Hoist top bypassed icon

- The *hoist top bypassed icon* appears if the hoist limit switch is bypassed, see section „Special functions LICCON monitor 0“.

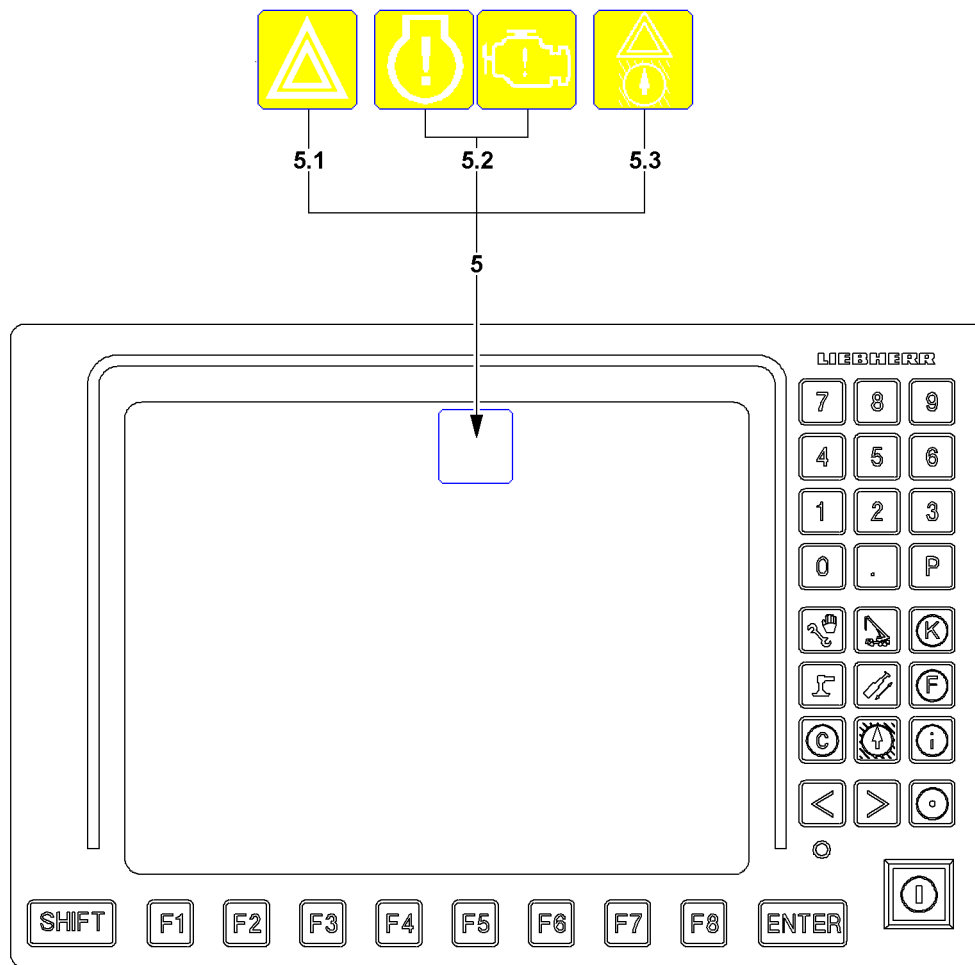

Fig.121772

5.2.4 Occurrence of an advance warning

5 Advance warning icons

5.1 Utilization advance warning icon

- The current utilization of the crane results from the *actual load* value and the *maximum load* value.
- The *Utilization advance warning* icon appears if:
 - The current utilization of the crane exceeds the limit programmed for the advance warning (standard value **90 percent**).

5.2 Engine monitoring advance warning icon

- The *Engine monitoring advance warning* icon appears if:
 - an advance warning for one or more monitoring functions in the engine monitoring occurs
 - or**
 - a load reduction is triggered by the exhaust aftertreatment (only for engines with an SCR system for exhaust aftertreatment)
- **NOTICE!** If the engine monitoring advance warning **5.2** appears, the monitoring functions must be checked.
- **Note:** Depending on the respective crane, either the right or the left *engine monitoring advance warning* icon **5.2** appears.

5.3 Working range limitation* advance warning

- Appears if an advance warning in the *Working range limitation* program occurs.
- **NOTICE!** Pay attention to the set working range.
- **Note:** Does not appear on all crane types with Working range limitation*.



WARNING

Non-observance of advance warnings!

If advance warnings are not observed, then this can result in a sudden shut-off of the crane movement.

A sudden shut off of the crane movement can result in high stress and strain for crane and load. High strain for the crane and load can cause accidents.

- ▶ Operate the crane in such a way that there is no shut off of crane movements by the crane control.
- ▶ Pay attention to advance warnings and approach a possible shut off of crane movements extremely cautiously.

NOTICE

Shut off engine monitoring!

Outside of the *crane operation* program, the engine monitoring is turned off.

When the engine monitoring is turned off, problems and warning occurrences are not recognized.

This could result in crane failure.

- ▶ If work is not carried out in the *Crane operation* program, then turn the crane engine off and operate the LICCON computer system in stand-by mode, see section „Power-Save mode and Stand-by mode on the LICCON computer system“.
- ▶ If work has to be carried out for a longer period outside of the *Crane operation* program, with the crane engine running, then switch regularly to the engine monitoring screen.

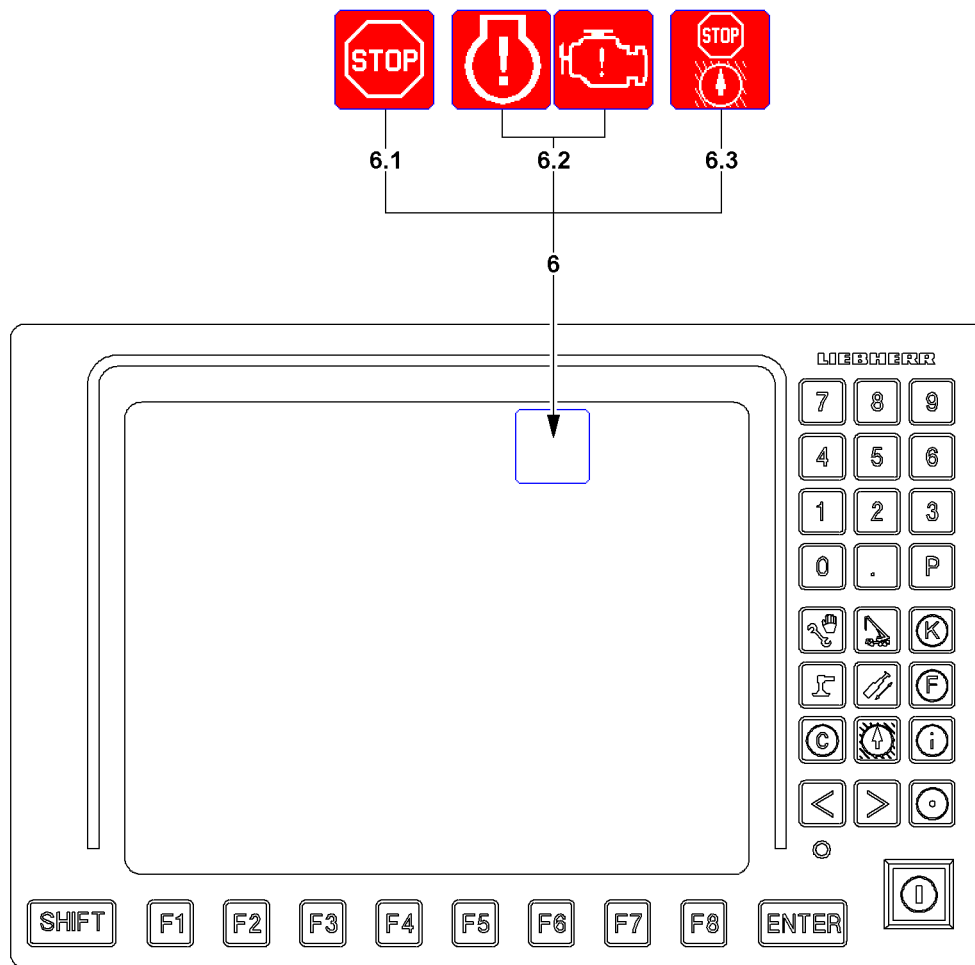

Fig.121773

5.2.5 Shutting off the crane movement

6 STOP icons

6.1 LMB-STOP icon

- The *LMB-STOP* icon appears when the crane movement is turned off via the overload protection

Possible causes:

- **Utilization of the crane:** The *LMB-STOP* icon appears when the current utilization of the crane exceeds the programmed limit for the overload protection (Standard 100 percent).
- **Sensor error:** The *LMB-STOP* icon appears when a sensor which is required to monitor the load chart has an error (*LMB-STOP* is triggered).
- **No load chart:** The *LMB-STOP* icon appears if no load chart is available (*LMB-STOP* is triggered).



WARNING

Crane movements with active LMB-STOP!

With active LMB-STOP **6.1**, not all crane movements are necessarily turned off. In certain circumstances, load moment decreasing crane movements are possible.

- ▶ Always determine the exact cause for the LMB-STOP **6.1**.
- ▶ Carry out any crane movements that are still possible with extreme caution.

6.2 6.2 Engine STOP icon

- The *Engine-STOP* icon appears if:
 - A STOP event takes place in engine monitoring.
- or
- a load reduction is triggered by the exhaust aftertreatment (only for engines with an SCR system for exhaust aftertreatment)

Note: Depending on the respective crane, either the right or the left *Engine STOP* icon **6.2** appears.

6.3 Working range limitation STOP icon

- Appears if a STOP event takes place in the working range limitation
- **Note:** Appears only on crane types with Working range limitation*



WARNING

Shut off of the crane movement!

A sudden shut off of the crane movement can result in high stress and strain for crane and load. High strain for the crane and load can cause accidents.

- ▶ Operate the crane in such a way if possible that there is no shut off of crane movements by the crane control.
- ▶ Monitor the display instruments constantly.
- ▶ If not otherwise possible, approach a possible shut off of crane movements with extreme caution.

NOTICE

Shut off engine monitoring!

Outside of the *crane operation* program, the engine monitoring is turned off.

When the engine monitoring is turned off, problems and warning occurrences are not recognized.

This could result in crane failure.

- ▶ If work is not carried out in the *Crane operation* program, then turn the crane engine off and operate the LICCON computer system in stand-by mode, see section „Power-Save mode and Stand-by mode on the LICCON computer system“.
- ▶ If work has to be carried out for a longer period outside of the *Crane operation* program, with the crane engine running, then switch regularly to the engine monitoring screen.

5.2.6 Acoustic warning on LICCON monitor 0

Acoustic warnings on LICCON monitor 0 are indicated by the *Horn* warning sound.

The *horn* warning sound is divided into two categories:

- The *horn* is a beeping sound that lasts approximately 0.5 seconds and that is repeated every second.
- A *short horn* is a beeping sound of a duration of approximately 0.1 seconds, which is repeated in a second cycle.

7 Horn icon

- When the *Horn* icon **7** is shown on the LICCON monitor, any acoustic signals that occur can be shut off by LICCON monitor 0 by pressing the function key **F8**.
- If an error message is shown in the *Horn* icon **7** in the field **7.1**, then it can be used to determine the present error. Pressing the function key **F8** twice automatically switches to the error determination screen of the BSE test system. The error is displayed there in documentary form.

Horn warning sound

- Sounds in addition to the visual display of an error message in the field **7.1** in case of operational errors are found that lead to a shut-off of a crane movement.
Operational errors are, for example:
 - Overload
 - Boom outside of the angle / boom radius range of the load chart
- In case of application errors with error number (LICCON Error Code LEC). For example sensor errors, which occur due to insufficient sensor signals or a defective sensor.
Monitored sensors are, for example:
 - Length sensor
 - Angle sensor
 - Pressure sensor
 - Pull test brackets (force test boxes)
 - Inductive sensors
 - Hoist limit switch
 - Wind sensor
 - Battery voltage

Short horn warning sound

Sounds in addition to the visual display of error messages that do not have an error number and do not lead directly to crane movement shut-off by the LICCON overload protection

Monitored error messages are, for example:

- Maximum permissible wind speed exceeded (only with an activated wind sensor*)
- Crane utilization value for advance warning (90 %) has been reached

Acoustic warning priority

- The *Horn* warning around has higher priority than the *Short horn* warning sound, i.e. *Horn* takes preference over *Short horn*.
- Both the *Horn* warning sound as well as the *Short horn* warning sound become active again after shut down if a new error occurs.

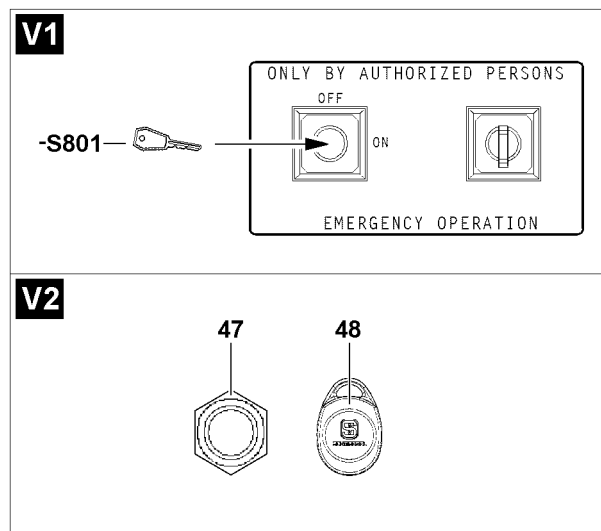
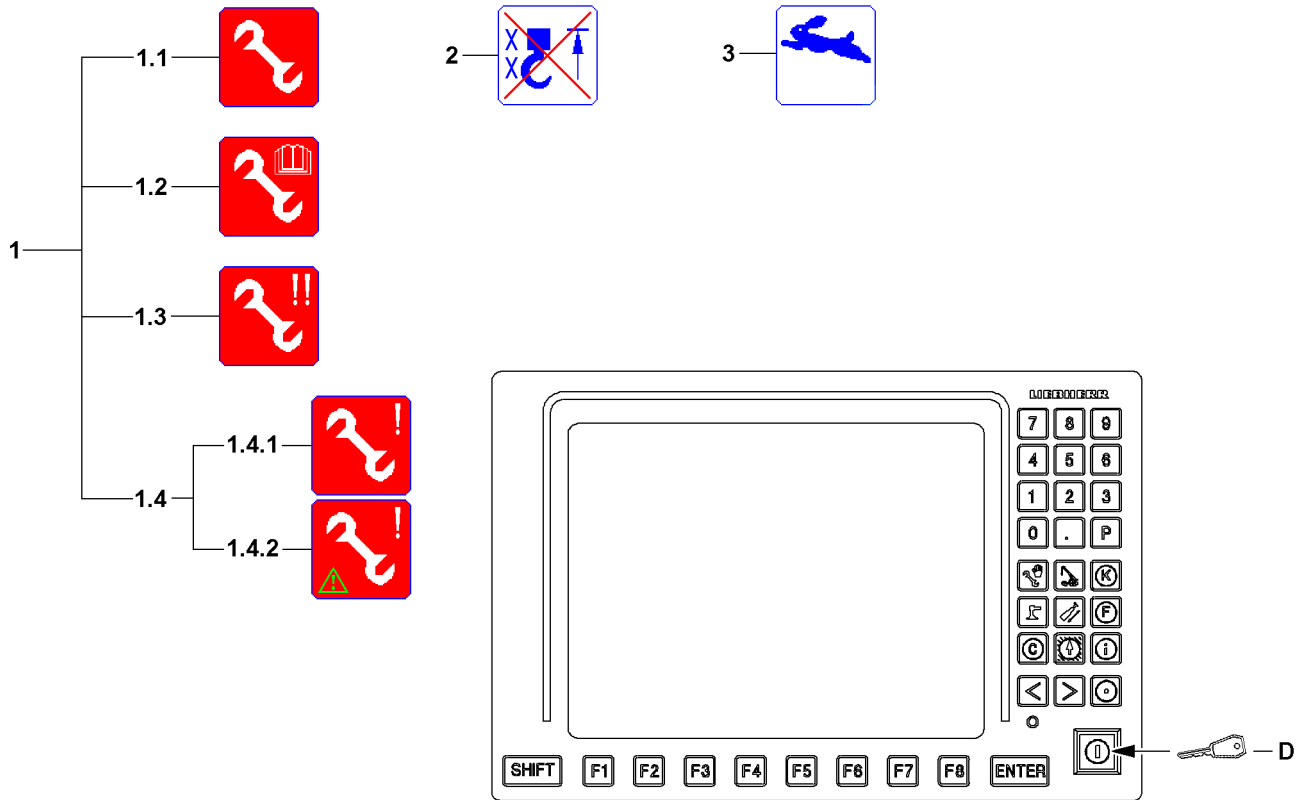

Fig.120622

5.3 LICCON Monitor 0 special functions



Note

Additional special functions

- ▶ Observe section „Special function LICCON monitor 2“.



WARNING

Danger of accident due to the *Exceedance of shut-off limits of the LICCON overload protection* function!

If the shut off limits of the LICCON overload protection are exceeded, there is no additional protection against crane overload.

Due to erroneous operation or deliberate misuse, the crane could collapse, the boom can break off or the crane can topple over.

Personnel can be severely injured or killed.

- ▶ The *Exceeding the shut-off limits of the LICCON overload protection* function is only permissible in emergencies and for assembly purposes.
- ▶ The set up key **D** may only be actuated by persons who are aware of the effects of their acts regarding the function *Exceedance of shut off limits of the LICCON overload protection*.
- ▶ The *Exceedance of shut off limits of the LICCON overload protection* function requires the presence of an authorized person and must be performed with utmost caution.
- ▶ Crane operation with the *Exceedance of shut-off limits of the LICCON overload protection* function activated is prohibited.

Before pressing the set up key **D** make sure that:

- Operation and specifications to use the set up key **D** from the Crane operating instructions, chapter 4.20 and 7.15 are known to the crane operator and have been understood.



Note

- ▶ The various *Assembly operation* icons **1** are shown on the same position in the LICCON monitor, depending on the operating mode, illustration **2**.

5.3.1 Exceeding the shut-off limits of the LICCON overload protection

1.1 Assembly icon

- The *Assembly* icon **1.1** appears when a special case for operation of the LICCON overload protection was activated, for example the shut-off limits of the LICCON overload protection were bypassed by the set up key **D**.



Note

- ▶ The *Assembly* icon **1.1** appears on the LICCON monitor 2, when the difference monitoring of the derrick ballast guying is bypassed, see Crane operating instructions, chapter 5.35 / 5.36.

5.3.2 No load chart is available

1.2 Assembly - no load chart icon

- The *Assembly - no load chart* icon **1.2** appears when the shut off limits of the LICCON overload protection are bypassed via the set up key **D** and no load chart is available.
- The crane may only be operated according to the specifications of the respective chapter in the Crane operating instructions and / or the erection / take-down charts.
- **Note:** By pressing the set up key **D**, all erection / take-down procedures can be carried out within the erection / take-down charts, for which no load charts are available.

5.3.3 LICCON overload protection emergency operation (according to EN 13000:2010)



WARNING

Increased danger of accident during emergency operation of the LICCON overload protection! In emergency operation, the crane movements are no longer monitored by the LICCON overload protection.

- ▶ The emergency operation may only be activated by persons who are aware of the consequences of their actions.
- ▶ A shut-off by the LICCON overload protection may not be circumvented by the emergency operation.
- ▶ If normal crane operation is possible, then the emergency operation may not be activated.
- ▶ All crane movements must be carried out with extreme caution and anticipatorily.

1.3 Emergency operation activated icon

- The *Emergency operation activated* icon **1.3** appears:
 - When the emergency operation of the LICCON overload protection is activated via the key button **S801** or by actuation of the transponder **48** on the sensor **47**.



Note

Activating emergency operation

- ▶ If emergency operation of the LICCON overload protection is activated via the key button **S801** or by actuation of the transponder **48** on a sensor **47** depends on the crane type. For the location, see the Crane operating instructions, chapter 4.01.

5.3.4 Additional emergency operating modes



WARNING

Improper crane operation!

If one of the *additional emergency operating modes* icon **1.4** appears, then there is a high danger of accident due to erroneous operation of the crane.

Safety equipment could be deactivated.

Personnel can be killed or injured.

This could result in property damage.

- ▶ Deactivate the *additional emergency operating modes* **1.4** icon again or contact Liebherr Service and coordinate further procedure.

1.4 Additional emergency operating modes icon

- The icon **1.4.1** or icon **1.4.2** appears if additional emergency operation modes were activated.

5.3.5 Bypassing the difference force monitoring of derrick ballast guying



WARNING

Overload of crane!

Erroneous operation when bypassing the difference force monitoring for the derrick ballast guying.

- ▶ Observe the Crane operating instructions, chapter 5.35 / 5.36.

- D** The shut-off *Difference force monitoring derrick ballast guying* is bypassed by the set up key **D**. Observe the Crane operating instructions, chapter 5.35 / 5.36.

5.3.6 Bypass of hoist limit switch

2 Hoist top bypassed icon

- The *Hoist top bypassed* icon **2** appears when the *Hoist top* shut-off is bypassed by the set up key **D**.

Note: The *Crane operation* program is locked, meaning that no other program can be turned on via the program keys.

5.3.7 Rapid gear



Note

- ▶ **Crane operation without rapid gear:** The speeds of the individual crane movements are independent of each other. There is no interference of the movement speeds.
- ▶ **Crane operation with rapid gear:** If the rapid gear is activated, the individual crane movements can reach the highest possible movement speed. As a result, it can happen that during several simultaneous crane movements individual speed movements are slowed down.

Add the rapid gear only when:

- If the highest possible movement speed is to be made possible for individual crane movements **and**
- An interference between the movement speeds creates no problem.

3 Rapid gear icon

- The *Rapid gear* icon 3 appears if the rapid gear is enabled for one or several crane movements.

5.4 Crane operation monitoring functions

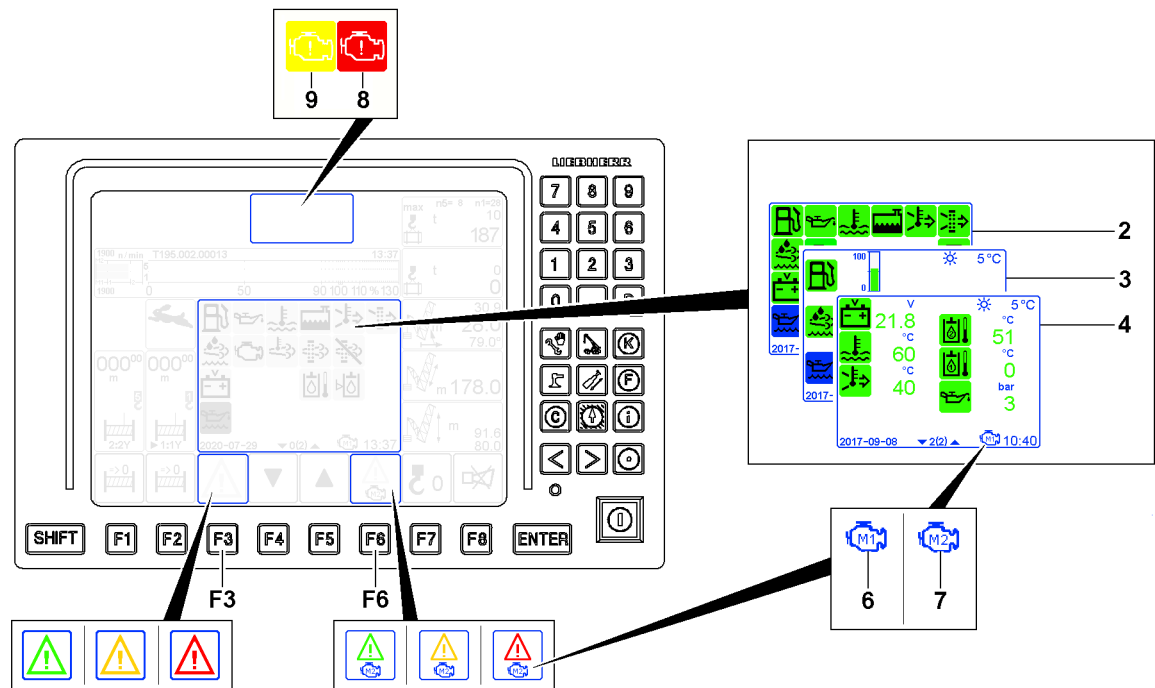

Fig.161658: Crane operation monitoring functions

The crane operation monitoring functions include the following displays:

- 2 Monitoring function icons
- 3 *Fill level* individual control displays
- 4 *Actual value displays* individual control displays

For crane types with two engines, observe the following:

- 6 *Engine1* icon
 - The displays are assigned to the first engine
- 7 *Engine2* icon
 - The displays are assigned to the second engine

The monitoring functions are always active and can be displayed in the monitoring field, if necessary. The crane operator is automatically alerted in case of a warning occurrence by the color of the icon over the function key **F3** and function key **F6**.

**Note**

For crane types with two engines, the following applies:

- ▶ Pay attention to the assignment of the crane operation monitoring functions to the respective engine.
- ▶ Keep in mind that not all components are present double, for example there is only one fuel tank. The fuel reserve is for both engines from the same tank.

Meaning of the color of the warning icon over the function key **F3**:

- Green warning icon: All monitoring functions are ok.
- Warning icon yellow: Advance warning for one or several monitoring functions.
- Warning icon red: Warning for one or several monitoring functions.

For crane types with two engines, an additional warning icon can appear over the function key **F6**:

- Green warning icon: All monitoring functions are ok.
- Warning icon yellow: Advance warning for one or several monitoring functions.
- Warning icon red: Warning for one or several monitoring functions.

**WARNING**

Non-observance of alarm functions!

If alarm functions are not observed, then it can result in a sudden shut off of the crane movement. A sudden shut off of the crane movement can result in high stress and strain for crane and load. High strain for the crane and load can cause accidents.

- ▶ If the *engine monitoring advance warning 9* icon appears, the monitoring functions must be checked.
- ▶ If the *engine stop 8* icon appears, crane operation must be stopped, the engine must be turned off and the problems must be resolved.

NOTICE

Danger of severe crane engine damage!

If the monitoring functions report a problem and / or warning occurrence, then you must react immediately and remedy the problem.

- ▶ React to problems and / or warning occurrences immediately and remedy the problem.
- ▶ If necessary, stop crane operation and turn the crane engine off.

NOTICE

Shut off engine monitoring!

Outside of the crane operation program, the monitoring functions are turned off.

When the engine monitoring is turned off, problems and warning occurrences are not recognized. This could result in crane failure.

- ▶ If work is not carried out in the crane operation program, then turn the crane engine off and operate the LICCON computer system in stand-by mode, see section „Power-Save mode and Stand-by mode on the LICCON computer system“.
- ▶ If work has to be carried out for a longer period outside of the crane operation program, with the crane engine running, then switch continuously to the engine monitoring screen and check the display values.
- ▶ Register changes in the display values mindfully and proceed anticipatorily, for example, refuel in time.

5.4.1 Order of the displays in the crane operation monitoring functions

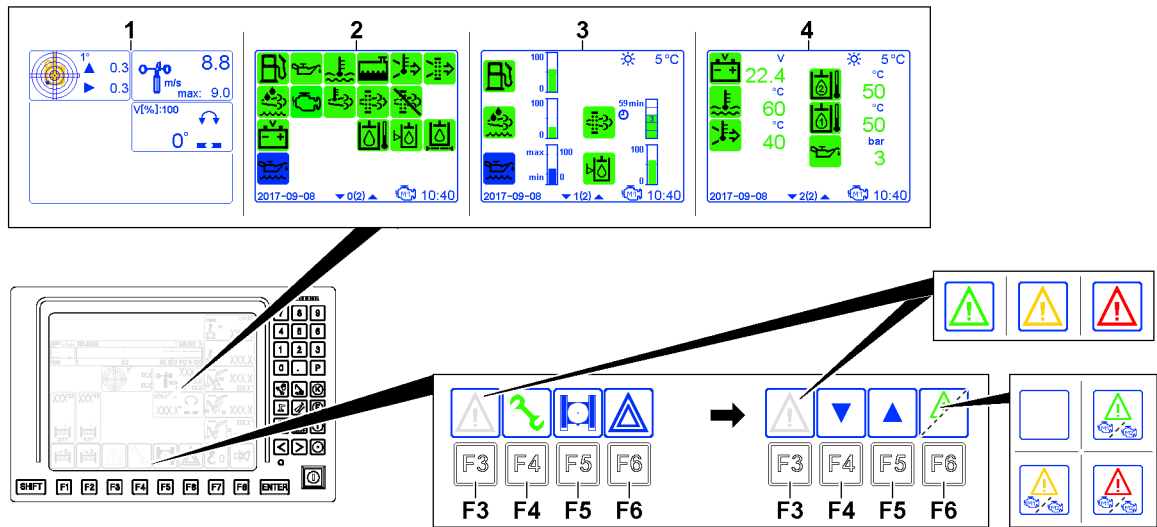

Fig.161660: Displays in the crane operation monitoring functions

The order of the displays in the crane operation monitoring functions is specified by the LICCON computer system according to the current situation.

- By pressing the function key **F3**, the monitored auxiliary functions **1** are masked, the crane operation monitoring functions are displayed. The function assignments of the function keys **F4-F6** change.
- By pressing the function key **F4** and function key **F5**, it is possible to switch between the following displays:
 - **2** Monitoring function icons
 - **3** Fill level individual control displays
 - **4** Actual value displays individual control displays
- For crane types with two engines, the following applies:
 - If a corresponding icon appears of the function key **F6**, it is possible to switch between the crane operation monitoring functions for both engines.
- By pressing the function key **F3** again, the crane operation monitoring functions are masked again. The monitored auxiliary functions **1** are displayed again.

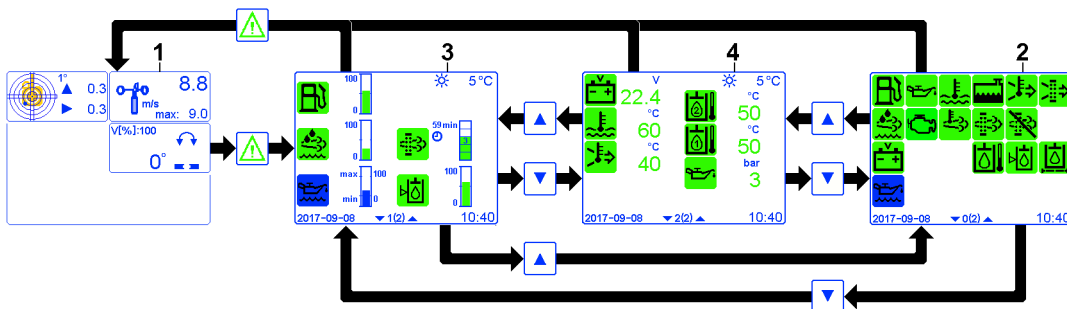

Fig.157717: Example for the order of the displays, when the warning icon over function key F3 is green

LWE/LR 13000-001/19503-01-02/en

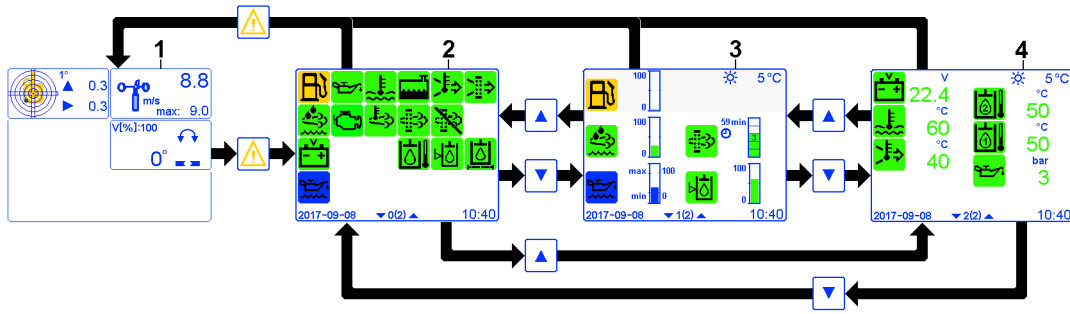

Fig.157719: Example for the order of the displays, when the warning icon over function key F3 is yellow

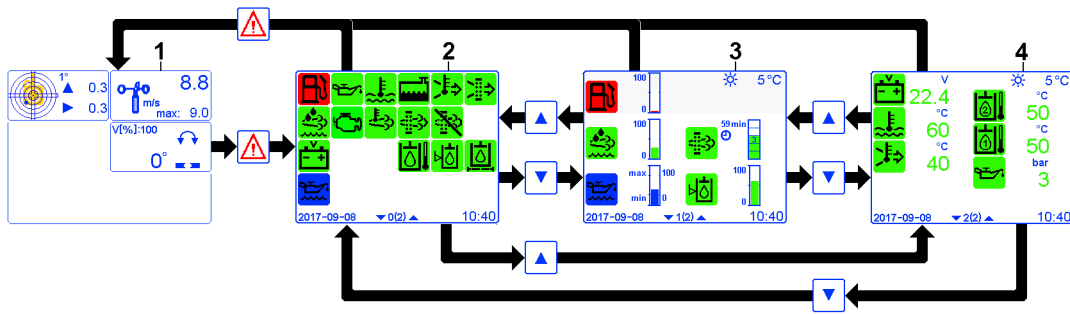

Fig.157718: Example for the order of the displays, when the warning icon over function key F3 is red

► Press the function keys in the corresponding order.

5.4.2 Calling up / masking / switching the crane operation monitoring functions

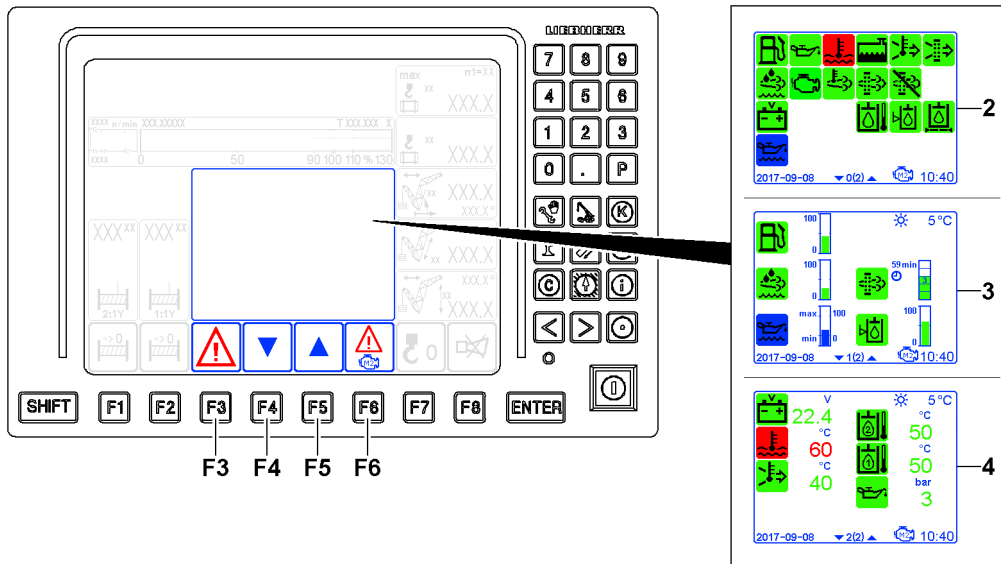

Fig.161661: Example of the Coolant temperature too high warning event

If a warning event occurs on one or on several monitoring functions, then this is indicated by the color of the warning icon over the function key **F3**. The warning icon is displayed statically and in the color of the monitoring function that triggered the warning event.

Example of the *Coolant temperature too high* warning event:

- The icon above the function key **F3** is red.
- Warning triangle in the icon above the function key **F6** is red and the concerned engine is displayed.
- In the monitoring functions icon **2**, the *coolant temperature* icon appears in red.

- The *fill level* individual control displays **3** do not provide any information regarding this warning event.
- In the *actual value displays* individual control displays **4** the *coolant temperature* icon appears and the assigned display value appears in red.

Calling up / masking the crane operation monitoring functions

- ▶ Press the function keys in the corresponding order, see section „Order of the displays in the crane operation monitoring functions“

Result:

- By pressing the function key **F3**, the crane operation monitoring functions can be immediately masked again.
- By pressing the function key **F4** and function key **F5**, it is possible to switch between the displays.
- By pressing the function key **F3** again, the crane operation monitoring functions can be immediately masked again.
- For a description of the monitoring function icons **2**, see the following section „Overview of icons for monitoring functions“.
- Description of the *fill level* individual control displays **3**, see the following section „Overview of the individual control displays“.
- Description of the *actual value displays* individual control displays **4**, see the following section „Overview of individual control displays“.

Switching the crane operation monitoring functions

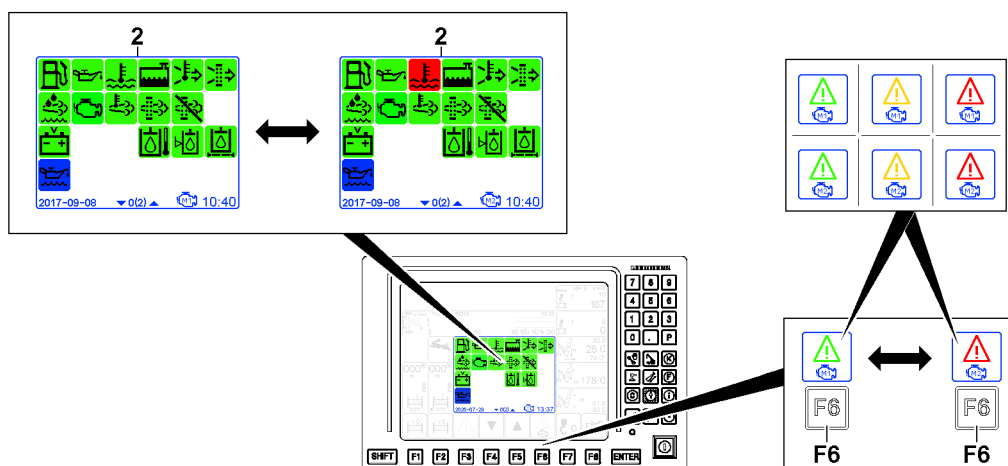

Fig.161662: Example for switching the crane operation monitoring functions: Coolant temperature of engine 2 too high warning event



Note

- ▶ Only possible for crane types with two engines.

Example for the monitoring function icons **2** for engine 1 and engine 2:

- ▶ Press the function key **F6**.

Result:

- The assignment between the engines is switched.

5.4.3 Overview of monitoring function icons

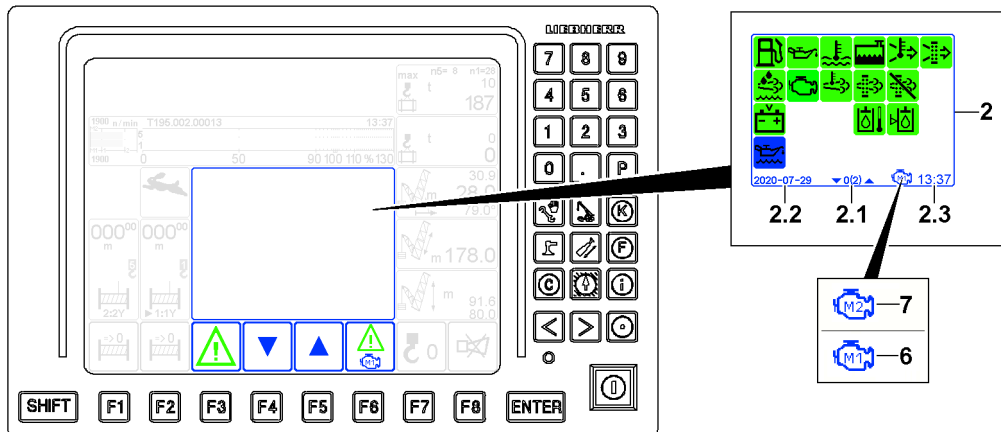

Fig.161663: Monitoring function icons

- 2 Monitoring function icons
 - The following appears in addition to the monitoring function icons:
 - 2.1 Page counter
 - 2.2 Date
 - 2.3 Time
- Assignment for crane types with two engines
 - 6 Engine1 icon
 - The displayed monitoring function icons 2 are assigned to the first engine
 - 7 Engine2 icon
 - The displayed monitoring function icons 2 are assigned to the second engine

NOTICE

Occurring warning occurrence!

At every change of the icon display, a signal sound and possibly an error message are issued.

- ▶ Pay attention to the signal sounds and error messages.





Note

The scope of the monitoring function icons 2 depends on the crane type and crane configuration.

- ▶ Not all crane types have all listed monitoring functions.

	Fuel reserve
Green:	Fuel reserve sufficient
Yellow:	Fuel reserve is short
Red:	Fuel reserve low / depleted / system error NOTICE! Add fuel immediately / Immediately bring the crane to a standstill, turn the crane engine off and remedy the problem. Pay attention to the error message.

 Engine oil pressure	
Green:	Engine oil pressure OK (engine on)
Red:	Engine oil pressure too low (engine on) NOTICE! Immediately bring the crane to a standstill, turn the engine off and remedy the problem. Pay attention to the error message.

 Coolant temperature	
Green:	Coolant temperature OK
Red:	Coolant temperature too high / system error NOTICE! Immediately bring the crane to a standstill, turn the engine off and remedy the problem. Pay attention to the error message.

 Coolant level	
Green:	Coolant level OK
Red:	Coolant level too low / system error NOTICE! Immediately bring the crane to a standstill, turn the engine off and remedy the problem. Pay attention to the error message.

 Charge air temperature	
Green:	Charge air temperature OK
Red:	Charge air temperature too high / system error NOTICE! Immediately bring the crane to a standstill, turn the engine off and remedy the problem. Pay attention to the error message.

 Engine air filter	
Green:	Air intake opening / air filter OK (engine on)
Yellow	Air intake opening / air filter dirty (engine on) / system error NOTICE! Immediately bring the crane to a standstill, turn the engine off and remedy the problem. Pay attention to the error message.

 Urea tank / exhaust aftertreatment¹⁾	
Green:	Urea reserve sufficient
Yellow:	The urea reserve is low or erroneous function of exhaust aftertreatment ²⁾ Advance warning! Add urea or remedy the erroneous function of the exhaust aftertreatment. Pay attention to the error message.
Red:	Urea level too low / depleted or erroneous function of exhaust aftertreatment system ²⁾ / system error NOTICE! Add urea or remedy the erroneous function of the exhaust aftertreatment / immediately bring the crane to a standstill, turn the engine off and remedy the problem. Pay attention to the error message.

1) Applies only for engines with the SCR system.

2) Under some circumstances a power reduction or start block of the engine is triggered. The type and scope of a power reduction or start block of the engine depends on the respectively valid national / regional regulations and the vehicle configuration.



WARNING

Triggers power reduction or start block of the engine!

If the urea level is too low or if there is a malfunction in the exhaust aftertreatment, then a power reduction or starting block of the engine can be triggered.

The mobile crane can significantly obstruct traffic.

The crane operation and travel operation can be limited or disabled.

- ▶ Replenish the Urea level in time.
- ▶ Remedy the faulty function of the exhaust aftertreatment immediately.
- ▶ Observe any valid national / regional regulations and the vehicle configuration.

 Exhaust aftertreatment¹⁾	
Green:	Exhaust aftertreatment OK
Yellow / red:	Urea level too low or erroneous function of exhaust aftertreatment system ²⁾ / system error NOTICE! Add urea or remedy the erroneous function of the exhaust aftertreatment. Under some circumstances a power reduction or start block of the engine ²⁾ is triggered, pay attention to the error message.

1) Applies only for engines with the SCR system.

2) Under some circumstances a power reduction or start block of the engine is triggered. The type and scope of a power reduction or start block of the engine depends on the respectively valid national / regional regulations and the vehicle configuration.

 Exhaust gas temperature⁴⁾	
Green:	Normal exhaust gas temperature
Yellow	High exhaust gas temperature, diesel particle filter regeneration is carried out Note: Engine noise may change slightly during regeneration. After generation is complete, the icon turns green again.

4) Only for engines with a diesel particle filter (DPF).

 Diesel particle filter⁴⁾	
Green:	Diesel particle filter ⁴⁾ OK
Yellow	Diesel particle filter ⁴⁾ reports an advance warning Note: Call up the individual control displays and check the load condition of the diesel particle filter ⁴⁾ . Pay attention to the error message.
Red:	Diesel particle filter ⁴⁾ reports a warning / problem NOTICE! Call up the individual control displays and check the load condition of the diesel particle filter ⁴⁾ . Remedy the problem. Pay attention to the error message.

4) Only for engines with a diesel particle filter (DPF).

 Disabling diesel particle filter regeneration⁴⁾	
Green:	Automatic regeneration of the diesel particle filter is not disabled
Yellow	Automatic regeneration of the diesel particle filter is disabled NOTICE! If automatic regeneration of the diesel particle filter is disabled for too long, damage can occur to the crane engine and the exhaust gas system.

4) Only for engines with a diesel particle filter (DPF).

 Battery voltage	
Green:	Battery voltage OK
Red:	Overtoltage or undervoltage in on-board power supply / system error NOTICE! Immediately bring the crane to a standstill, turn the engine off and remedy the problem. Pay attention to the error message.

 Hydraulic oil temperature	
Green:	Hydraulic oil temperature OK
Red:	Hydraulic oil temperature too high / system error NOTICE! Immediately bring the crane to a standstill, turn the engine off and remedy the problem. Pay attention to the error message.

 Hydraulic oil level³⁾	
Green:	Hydraulic oil level OK
Red:	Hydraulic oil level too low / error / system error NOTICE! Immediately bring the crane to a standstill, turn the engine off and remedy the problem. Pay attention to the error message.

3) Only for certain crane types.

LWE/LR 13000-001/19503-01-02/en

 Hydraulic oil filter	
Green:	Leak oil filter, return filter ³⁾ and charge pressure filter ³⁾ OK (engine on)
Red:	Leak oil filter, return filter ³⁾ and / or charge pressure filter ³⁾ dirty (engine on) / system error NOTICE! Immediately bring the crane to a standstill, turn the engine off and remedy the problem. Pay attention to the error message.

3) Only for certain crane types.

 Engine oil level	
Blue	The engine oil level can not be checked here on the display, call up the individual indicator light.

 Charge control display (alternator)⁵⁾	
Green:	Charge control OK (engine on)
Red:	Charge control has a problem (engine on) / system error NOTICE! Immediately bring the crane to a standstill, turn the engine off and remedy the problem. Pay attention to the error message.

5) Alternatively, the charge control display is located on the BKE, see the Crane operating instructions, chapter 4.01.

5.4.4 Overview of the individual control displays

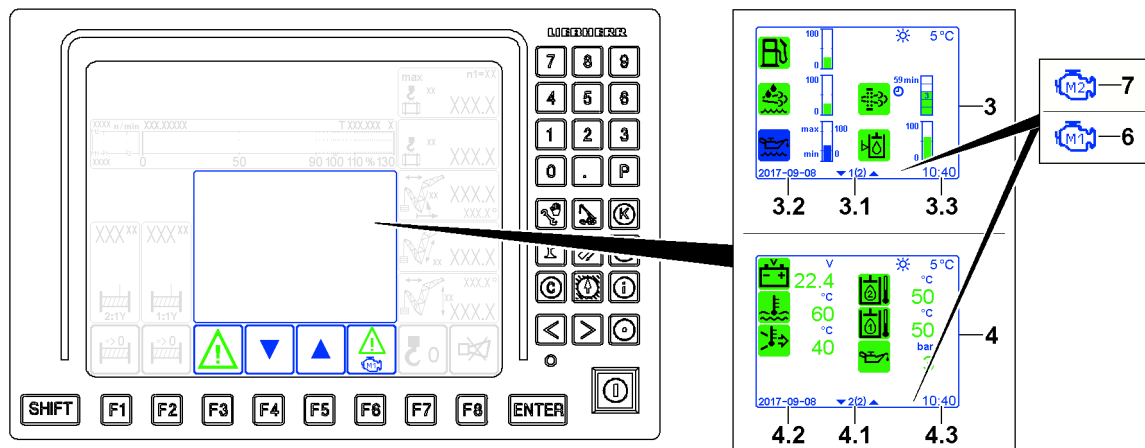

Fig.161664: Overview of the individual control displays

- **3 Fill level individual control displays**
 - The following also appears:
 - **3.1** Page counter
 - **3.2** Date
 - **3.3** Time
- **4 Actual value displays individual control displays**
 - The following also appears:

- 4.1 Page counter
 - 4.2 Date
 - 4.3 Time
- Assignment for crane types with two engines
- 6 Engine1 icon
 - The displayed monitoring function icons are assigned to the first engine
 - 7 Engine2 icon
 - The displayed monitoring function icons are assigned to the second engine



Note

- ▶ Detailed individual control displays can be displayed for some monitoring functions.
- ▶ The display values in the depicted individual indicator displays are examples.
- ▶ Some displays appear only for certain crane types.

Fuel reserve individual control display

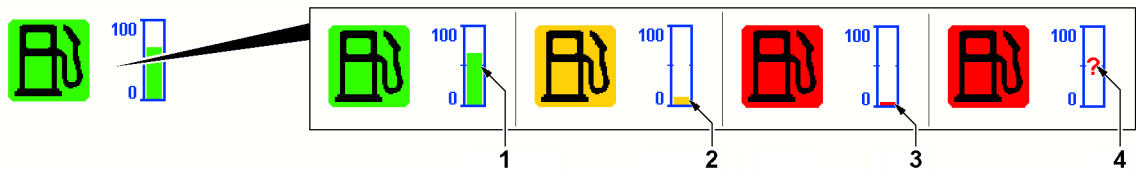

Fig.148374: Fuel reserve, bar graph

- Icon and bar 1 green: Fuel reserve sufficient
- Icon and bar 2 yellow: Fuel reserve is short
- Icon and bar 3 red: Fuel reserve low / depleted
- Icon and question mark 4 red: System error, the fill level cannot be determined

NOTICE! Add fuel immediately before it is depleted / Immediately bring the crane to a standstill, turn the crane engine off and remedy the problem. Pay attention to the error message.

The exact fill level can be read based on the scale of the bar chart:

- Scale value 100: The tank is completely full
- Scale value 0: The tank is completely empty

Urea tank individual control displays

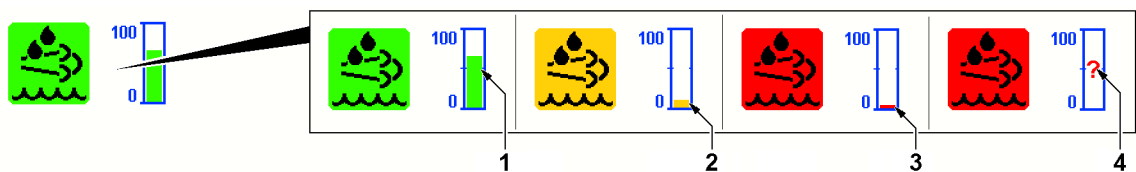

Fig.148376: Urea reserve, bar graph

- Icon and bar 1 green: Urea reserve sufficient
- Icon and bar 2 yellow: Urea reserve is short
- Icon and bar 3 red: Urea reserve low / depleted
- Icon and question mark 4 red: System error, the fill level cannot be determined, erroneous function of the exhaust aftertreatment

NOTICE! Add urea immediately before it is depleted / Immediately bring the crane to a standstill, turn the crane engine off and remedy the problem. Pay attention to the error message.

The exact fill level can be read based on the scale of the bar chart:

- Scale value 100: The tank is completely full
- Scale value 0: The tank is completely empty

Engine oil level individual control display

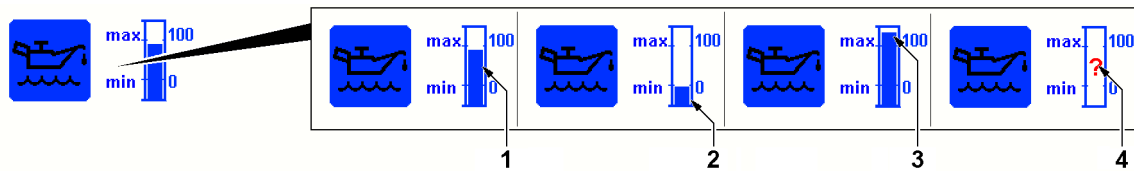

Fig.148378: Engine oil level, bar graph

- Icon and bar **1** blue, bar height between 0 and 100: Normal engine oil level
 - Icon and bar **2** blue, bar height below 0: Engine oil underfilled
 - Icon and bar **3** blue, bar height above 100: Engine oil overfilled
 - Icon blue and question mark **4** red: faulty measurement value, fill level cannot be determined
- Note:** When the engine is running an erroneous test value appears, to check the engine oil level align the crane horizontally and turn the engine off.

NOTICE! Do not start the engine if the engine oil is underfilled or overfilled. Remedy the problem and observe the error message.

The exact fill level can be read based on the scale of the bar chart:

- Scale value 100: Engine oil fill level upper limit
- Scale value 0: Engine oil fill level lower limit

Diesel particle filter individual control display

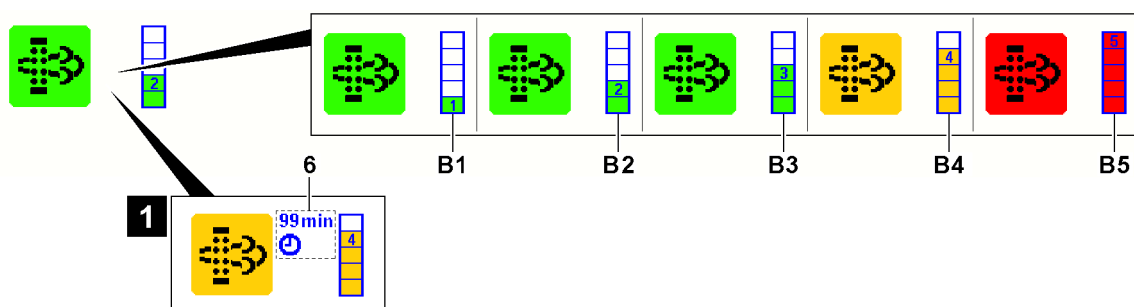

Fig.152687: Diesel particle filter load condition, bar graph

- **B1** Load condition 1 (green)
 - Load condition OK, diesel particle filter minimally loaded
- **B2** Load condition 2 (green)
 - Load condition OK, diesel particle filter slightly loaded
- **B3** Load condition 3 (green)
 - Load condition OK, diesel particle filter half loaded
- **B4** Load condition 4 (yellow)
 - Increased load condition, diesel particle filter strongly loaded
- **B5** Load condition 5 (red)
 - Critical load condition, diesel particle filter with maximum load
- **6** Regeneration time
 - This appears only when regeneration at a standstill of the diesel particle filter has started, see illustration **1**
 - The remaining time (regeneration time) of regeneration at a standstill of the diesel particle filter is displayed continuously.
 - **Note:** Start regeneration at a standstill of the diesel particle filter, see the Crane operating instructions, chapter 4.03.

If load condition 4 **B4** appears, Liebherr-Werk Ehingen GmbH recommends carrying out regeneration at a standstill as soon as possible (during the work day).

If load condition 5 **B5** appears and regeneration at a standstill is no longer possible:

- Stop engine operation.
- Contact Liebherr-Werk Ehingen GmbH Customer Service.



Note

Load condition 5 **B5**

- ▶ The engine torque is reduced to protect the engine against damage.

Hydraulic oil level individual control display

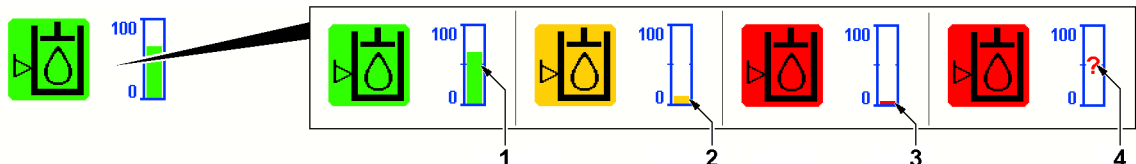

Fig.152689: Hydraulic oil level, bar graph

- Icon and bar 1 green: Hydraulic oil level OK
- Icon and bar 2 yellow: Hydraulic oil level low
- Icon and bar 3 red: Hydraulic oil level too low
- Icon and question mark 4 red: System error, the hydraulic oil level cannot be determined

NOTICE! Stop crane operation if the hydraulic oil level is too low. Remedy the problem and observe the error message.

The exact fill level can be read based on the scale of the bar chart:

- Scale value 100: The tank is completely full
- Scale value 0: The tank is completely empty

Battery voltage individual control display



Fig.148382: Battery voltage icon, display value and unit of measure

Icon and display value

- Green: Battery voltage OK
- Red: Overvoltage or undervoltage in on-board power supply / system error

NOTICE! Immediately bring the crane to a standstill, turn the crane engine off and remedy the problem. Pay attention to the error message.

Coolant temperature individual control display



Fig.148383: Coolant temperature icon, display value and unit of measure

Icon and display value

- Green: Coolant temperature OK
- Red: Charge air temperature too high / system error

NOTICE! Immediately bring the crane to a standstill, turn the crane engine off and remedy the problem. Pay attention to the error message.

Charge air temperature individual control display



Fig.148384: Charge air temperature icon, display value and measuring unit

Icon and display value

- Green: Charge air temperature OK
 - Red: Charge air temperature too high / system error
- NOTICE!** Immediately bring the crane to a standstill, turn the crane engine off and remedy the problem. Pay attention to the error message.

Hydraulic circuit 1 hydraulic oil temperature individual control display



Fig.148386: Hydraulic oil temperature, hydraulic circuit 1 icon, display value and unit of measure

Icon and display value

- Green: Hydraulic temperature in hydraulic circuit 1 OK
 - Red: Hydraulic temperature in hydraulic circuit 1 too high
- NOTICE!** Immediately bring the crane to a standstill, turn the crane engine off and remedy the problem. Pay attention to the error message.

Hydraulic circuit 2 hydraulic oil temperature individual control display



Fig.148387: Hydraulic oil temperature, hydraulic circuit 2 icon, display value and unit of measure

Icon and display value

- Green: Hydraulic temperature in hydraulic circuit 2 OK
 - Red: Hydraulic temperature in hydraulic circuit 2 too high
- NOTICE!** Immediately bring the crane to a standstill, turn the crane engine off and remedy the problem. Pay attention to the error message.

Engine oil pressure individual control display



Fig.148388: Engine oil pressure, display value and unit of measure

Icon and display value

- Green: Engine oil pressure OK
 - Red: Engine oil pressure too low
- NOTICE!** Immediately bring the crane to a standstill, turn the crane engine off and remedy the problem. Pay attention to the error message.

Empty page!

LWE/LR 13000-001/19503-01-02/en

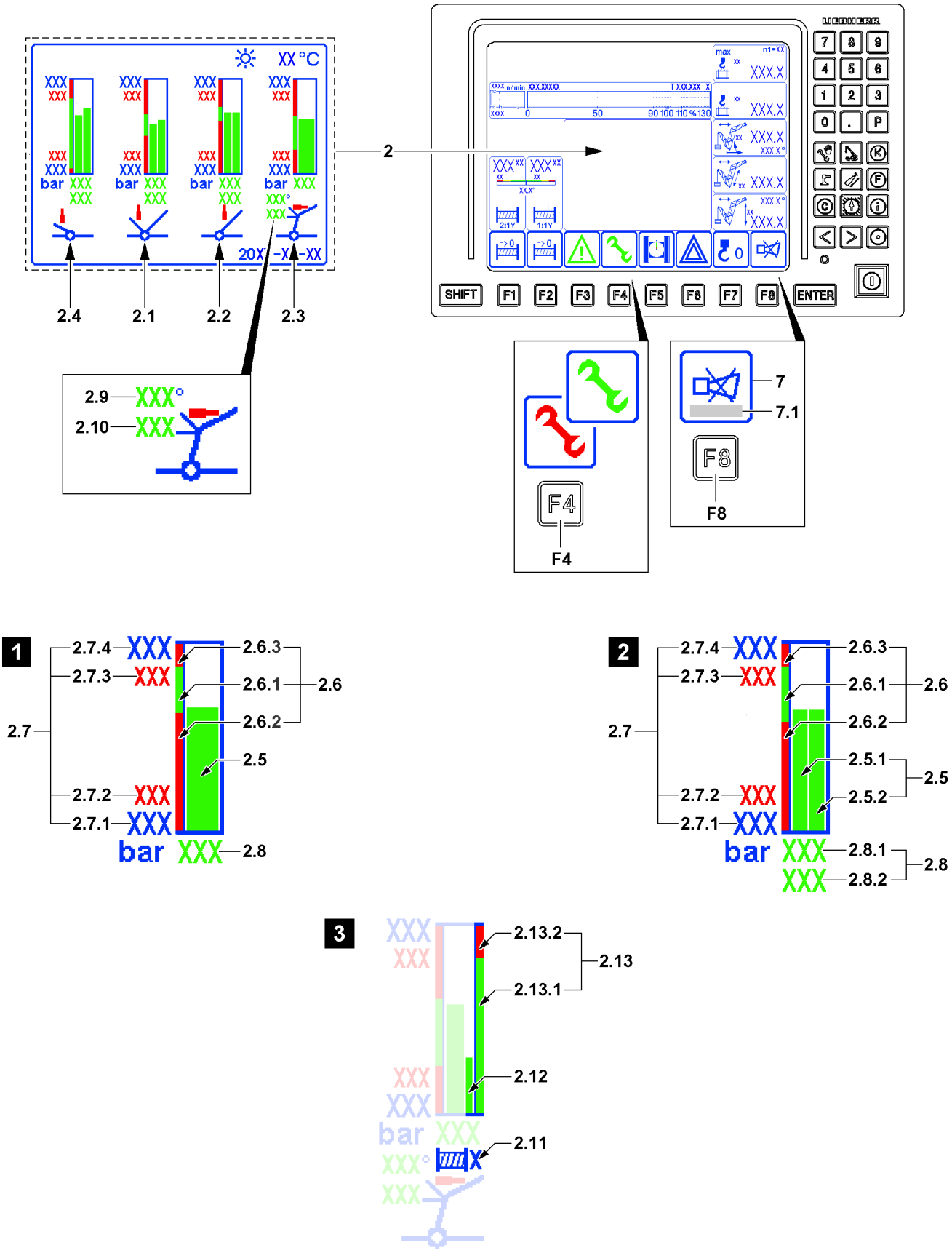

Fig.125388

5.5 Relapse cylinder / erection cylinder monitoring

The monitoring of the relapse cylinders **2** is always active and can be displayed in the monitoring field, if necessary. The crane operator is automatically alerted in case of a warning occurrence by the color of the icon over the function key **F4**.

The monitoring field has its fixed position on the LICCON monitor and can be hidden or assigned with other functions.

By pressing the function key **F4**, the relapse cylinder monitoring **2** is displayed in the monitoring field.



WARNING

Pressure in impermissible range!

- ▶ Make sure that the pressure displays are always in the permissible range.
- ▶ Counteract an impermissible pressure immediately.



WARNING

Shut off monitoring of relapse cylinders!

- ▶ Outside of the *Crane operation* program, the monitoring of the relapse cylinders is turned off!
- ▶ When the monitoring of the relapse cylinders is turned off, warning events are not recognized!

Color key of warning icon above function key **F4**

- Green warning icon: Monitoring of relapse cylinders is ok.
 - Warning icon red: Warning for one or several relapse cylinders.
 - If a warning occurs, an error message **7.1** is issued in the *Horn* icon **7** for some errors. The error message **7.1** includes an acoustic signal through the LICCON monitor and an error description.
 - Press the function key **F8** once: The acoustic signal is turned off.
Press the function key **F8** twice: The error description for the error message **7.1** that occurred last is called up.
- 2** Display field
- Depending on the set up configuration and crane type, up to four pressure displays appear.
 - The individual pressure displays always refer to the relapse cylinder / erection cylinder, which are highlighted in the icon directly underneath.
- 2.1** Derrick relapse cylinder
- 2.2** Main boom relapse cylinder
- 2.3** Auxiliary boom / accessory relapse cylinder
- 2.4** Erection cylinder SA-frame
- **Note:** Only present for certain crane types



Note

- ▶ **Illustration 1:** Example of display of individual relapse cylinders
- ▶ **Illustration 2:** Example of display of double relapse cylinders
- ▶ **Illustration 3:** Example supplementary Winch pressure display* during erection procedures (only for certain crane types)

2.5 Actual pressure bar graph

- Actual pressure on relapse cylinder bar graph
- For double relapse cylinders:
 - 2.5.1** Bar graph of first relapse cylinder
 - 2.5.2** Bar graph of second relapse cylinder
- **Note:** When the actual pressure is in the permissible range, the actual pressure bar graph **2.5** is shown in green.
Warning! When the actual pressure is in the impermissible range, the actual pressure bar graph **2.5** is shown in red. Immediately counteract the high pressure.

2.6 Pressure display scale

- **2.6.1** Ideal pressure range

- **2.6.2** Minimum pressure range fallen below
Note: Appears only if a minimum pressure is monitored.
- **2.6.3** Highest pressure range exceeded
- 2.7** Pressure display values
 - **2.7.1** Lowest display value
 - **2.7.2** Minimum pressure value
Note: Appears only if a minimum pressure is monitored.
 - **2.7.3** Highest pressure value
 - **2.7.4** Highest display value
- 2.8** Relapse cylinder pressure
 - Relapse cylinder pressure actual value
 - For double relapse cylinders:
 - 2.8.1** Pressure of the first relapse cylinders
 - 2.8.2** Pressure of the second relapse cylinders
- 2.9** WA-frame 1 angle
- 2.10** WA-frame 2 angle

Winch pressure display* during erection procedures (only for certain crane types)

See illustration 3



Note

- ▶ The winch pressure is shown when the main boom is luffed below 10 degrees, the luffing jib was set up and no parallel operation was preselected.
- ▶ The winch moved last is always shown (winch 1 or winch 2).

2.11 Displayed winch

- Shows for which winch the winch pressure is shown

2.12 Winch pressure bar graph

- Bar graph for winch pressure of respectively shown winch **2.11**
- **Note:** When the actual pressure is in the permissible range, the winch pressure bar graph **2.12** is shown in green.
- **Warning!** When the actual pressure is in the impermissible range, the winch pressure bar graph **2.12** is shown in red. Immediately counteract the high pressure.

2.13 Pressure display scale

- **2.13.1** Ideal pressure range
- **2.13.2** Highest pressure range exceeded



Note

Additional display values on the *Relapse cylinder monitoring* display **2**

- ▶ Date and ambient temperature are also displayed.

Empty page!

LWE/LR 13000-001/19503-01-02/en

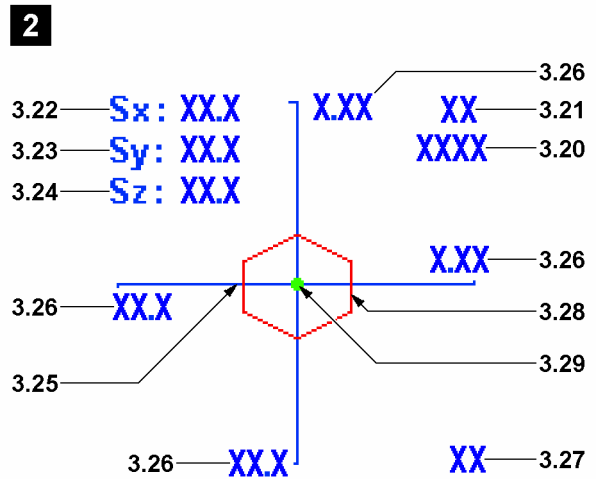
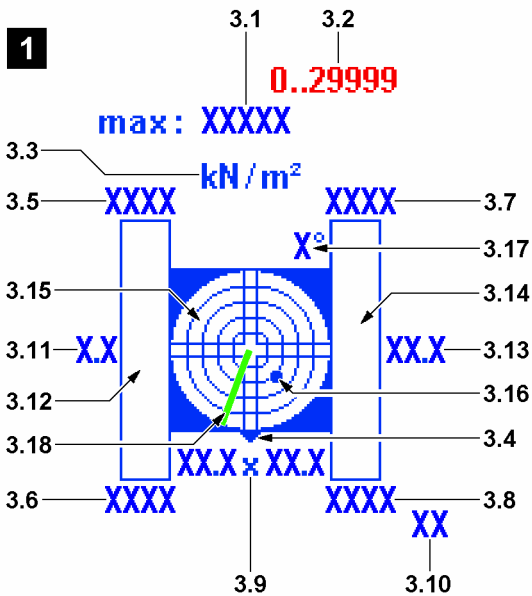
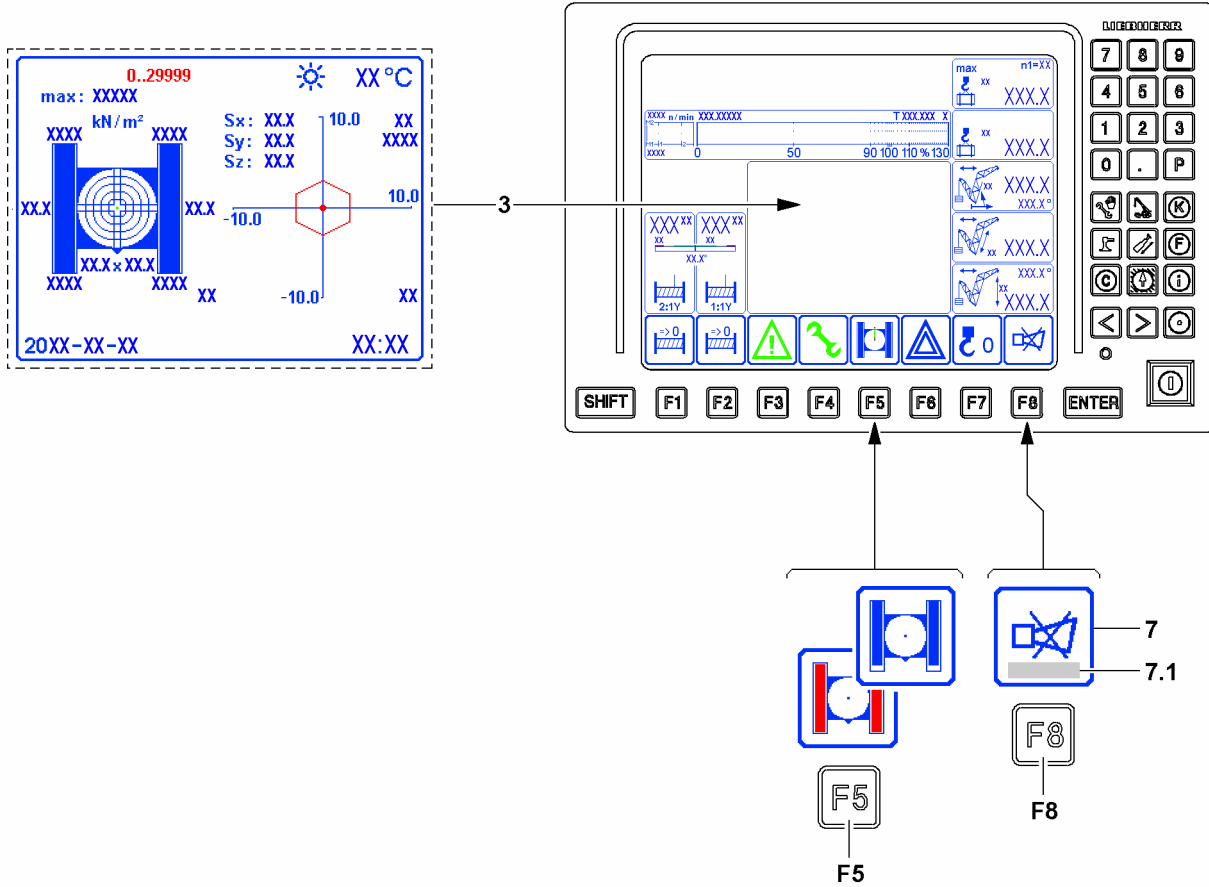

Fig.144107

5.6 Monitoring the surface pressure and center of gravity



WARNING

The crane can topple over!

When the programmed limit values are reached in the monitoring of surface pressure and center of gravity, there is no automatic shut-off of crane movements.

The displayed values are calculated and are informative. Calculated values are below the tolerances and unpredictable influences, for example crane control, surrounding and environmental influences. Due to the resulting tolerance field of the values, the monitoring of surface pressure and center of gravity may not be used to determine the limit values of the crane.

If this is disregarded, then the crane can topple over.

Personnel can be severely injured or killed.

- ▶ Do not use the displayed values to determine the limit values of the crane and to utilize the crane to its tipping limit or until it sinks in.
- ▶ Make sure that all values are within the programmed limit values.



WARNING

Increased surface pressure!

The calculation of the values for the display of the surface pressure in the LICCON monitor are based on ideal assumptions.

- ▶ Side deformations of the boom system due to wind, inclined position and elastic resilience of the steel structure are not taken into account but they can lead to an increase of the surface pressure.



WARNING

Shifting of the center of gravity!

The calculation of the values for the display of the center of gravity in the LICCON monitor are based on ideal assumptions.

- ▶ Side deformations of the boom system due to wind, inclined position and elastic resilience of the steel structure are not taken into account but they can lead to a shifting of the center of gravity.

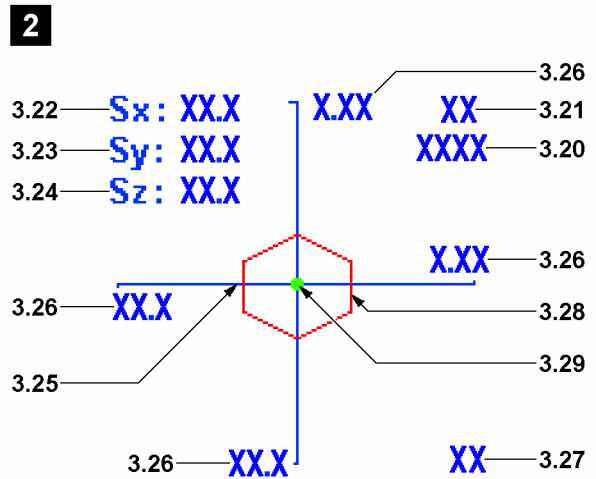
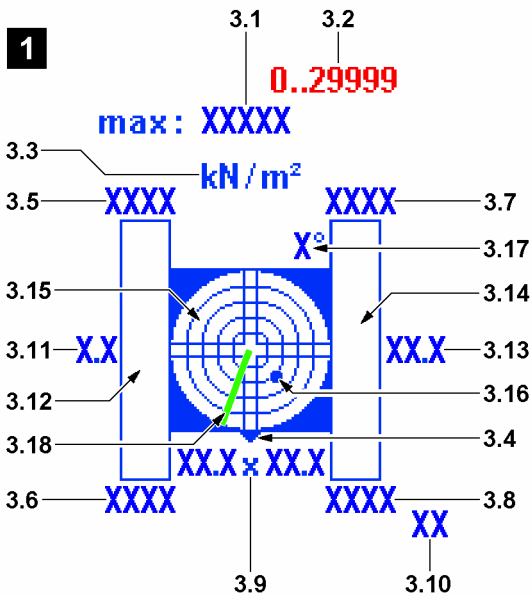
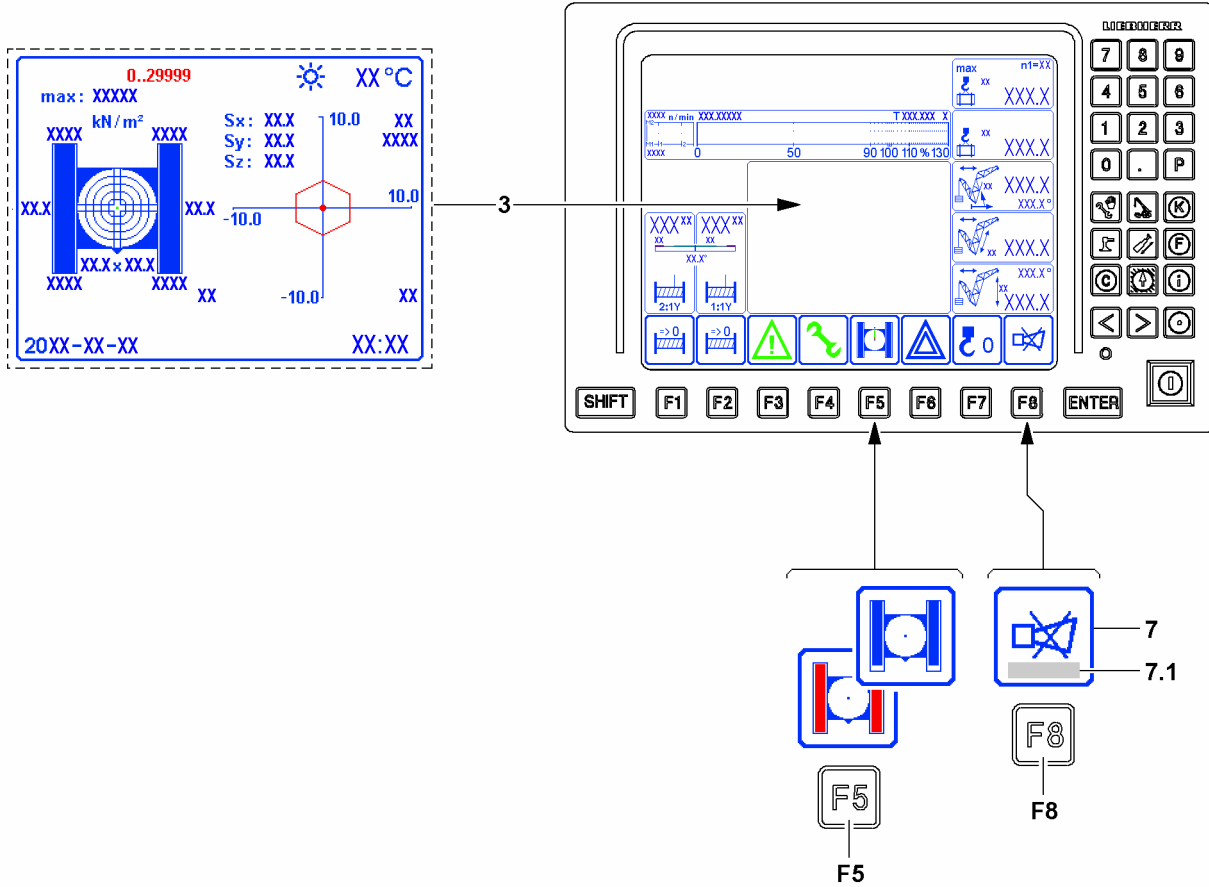

Fig.144107

The monitoring of surface pressure and center of gravity **3** is always active and can be displayed in the monitoring field, if necessary. The crane operator is automatically alerted in case of a warning occurrence by the color of the icon over the function key **F5**.

The monitoring field has its fixed position on the LICCON monitor and can be hidden or assigned with other functions.

By pressing the function key **F5**, the surface pressure and center of gravity monitoring **3** is displayed in the monitoring field.



Note

Turned off monitoring of surface pressure and center of gravity.

- ▶ Outside of the *Crane operation* program, the monitoring of surface pressure and center of gravity is turned off.
- ▶ When the monitoring of surface pressure and center of gravity is turned off, warning events are not recognized.

Color key of warning icon above function key **F5**:

- Blue warning icon: Monitoring the surface pressure and center of gravity is ok.
- Crawler carrier in warning icon red: Warning for monitoring of surface pressure and center of gravity.

Error messages:

- If a warning occurs, an error message **7.1** is issued in the *Horn* icon **7** for some errors. The error message **7.1** includes an acoustic signal through the LICCON monitor and an error description.
- Press the function key **F8** once: The acoustic signal is turned off.
- Press the function key **F8** twice: The error description for the error message **7.1** that occurred last is called up.



Note

- ▶ **Illustration 1:** Surface pressure display
- ▶ **Illustration 2:** *Center of gravity* display

3 Monitoring of surface pressure and center of gravity display

- The values are calculated depending on the set up configuration of the crane and the load.

Surface pressure display, illustration 1:

- 3.1 Permissible surface pressure
 - The value is entered by the crane operator via the keypad.
- 3.2 Input area
 - Input area for the permissible surface pressure **3.1**.
- 3.3 Measuring unit for surface pressure
 - Measuring unit for the pressure data in the display surface pressure (illustration **1**).
- 3.4 Direction specification
 - The triangle symbolizes where the front of the crawler travel gear is in the illustration.
 - **Note:** The front on the crawler travel gear is always on the side where the chain tensioning devices for the crawler carriers are located. The position of the turntable has no influence on this. The position of the turntable can be derived from the boom direction **3.18**.
- 3.5 Surface pressure
 - Calculated actual value of surface pressure on the crawler travel gear, left rear.
- 3.6 Surface pressure
 - Calculated actual value of surface pressure on the crawler travel gear, left front.
- 3.7 Surface pressure
 - Calculated actual value of surface pressure on the crawler travel gear, right rear.
- 3.8 Surface pressure
 - Calculated actual value of surface pressure on the crawler travel gear, right front.

- 3.9** Travel gear base
 - Base dimensions of the crawler travel gear.
- 3.10** Length data measuring unit
 - Measuring unit for the measuring data in the display surface pressure (illustration 1).
- 3.11** Placement surface
 - Calculated placement surface of crawler carrier right as value.
- 3.12** Placement surface
 - Calculated placement surface of crawler carrier right as graphic.
- 3.13** Placement surface
 - Calculated placement surface of crawler carrier left as value.
- 3.14** Placement surface
 - Calculated placement surface of crawler carrier left as graphic.
- 3.15** Incline indicator
 - The graphic display is in the form of a spirit level, with a moving dot **3.16** representing the air bubble.
 - **Note:** Incline display with number values, see section „Monitored auxiliary functions“.
- 3.16** Dot
 - The center of the dot **3.16** shows the incline.
- 3.17** Display resolution
 - This value indicates the resolution of the graphic display of the incline indicator. This displayed value corresponds with the outermost ring of the spirit level. The resolution is matched automatically to the inclination.
- 3.18** Boom direction
 - Current boom direction in reference to the displayed icon.
 - The boom direction corresponds to the viewing direction *to the front* from the crane cab.



Note

Example for the incline indicator **3.15**:

- ▶ **Example:** The dot **3.16** lies on the second ring from the inside in the lower right quadrant. The display resolution **3.17** is 1°. Therefore an inclination of 0.4° is displayed. The highest point on the placement surface of the crawler travel gear is on the front left side. Therefore, the crane is inclined back to the right 0.4° from the point of view of the crawler travel gear.



WARNING

The crane can topple over!

If the permissible incline of the crane is exceeded, the crane can topple over.

- ▶ Do not exceed the permissible incline from the load chart.
- ▶ Do not exceed the permissible incline for driving the crane, see Crane operating instructions, chapter 4.10.

Center of gravity display, illustration 2:

- 3.20** Weight data
 - Calculated total weight of the crane including load.
- 3.21** Weight unit
 - Weight unit for the weight data **3.20** in the display center of gravity (illustration 2).
- 3.22** Center of gravity position
 - Calculated center of gravity position in direction Sx
- 3.23** Center of gravity position
 - Calculated center of gravity position in direction Sy
- 3.24** Center of gravity position
 - Calculated center of gravity position in direction Sz

3.25 Axis of coordinates

- The axis of coordinates **3.25** is aligned according to the direction of the display surface pressure (illustration 1) centered to the slewing ring on the placement surface of the crane.

3.26 Scale value

- Scale value on the axis of coordinates **3.25**

3.27 Measuring unit

- Measuring unit in the display center of gravity (illustration 2)

3.28 Core area

- Calculated core area of the crane according to the set up configuration, load and ground conditions.
- **Note:** The core area is an important reference point for the center of gravity of the crane.

3.29 Center of gravity Sx/Sy

- Calculated center of gravity displayed graphically in direction Sx/Sy
- **Note:** The position is in direct relation to the center of gravity position **3.22** and center of gravity position **3.23** values

**Note**

Additional display values on the *Monitoring of surface pressure and center of gravity* display **3**

- ▶ Date, time and ambient temperature are also displayed.

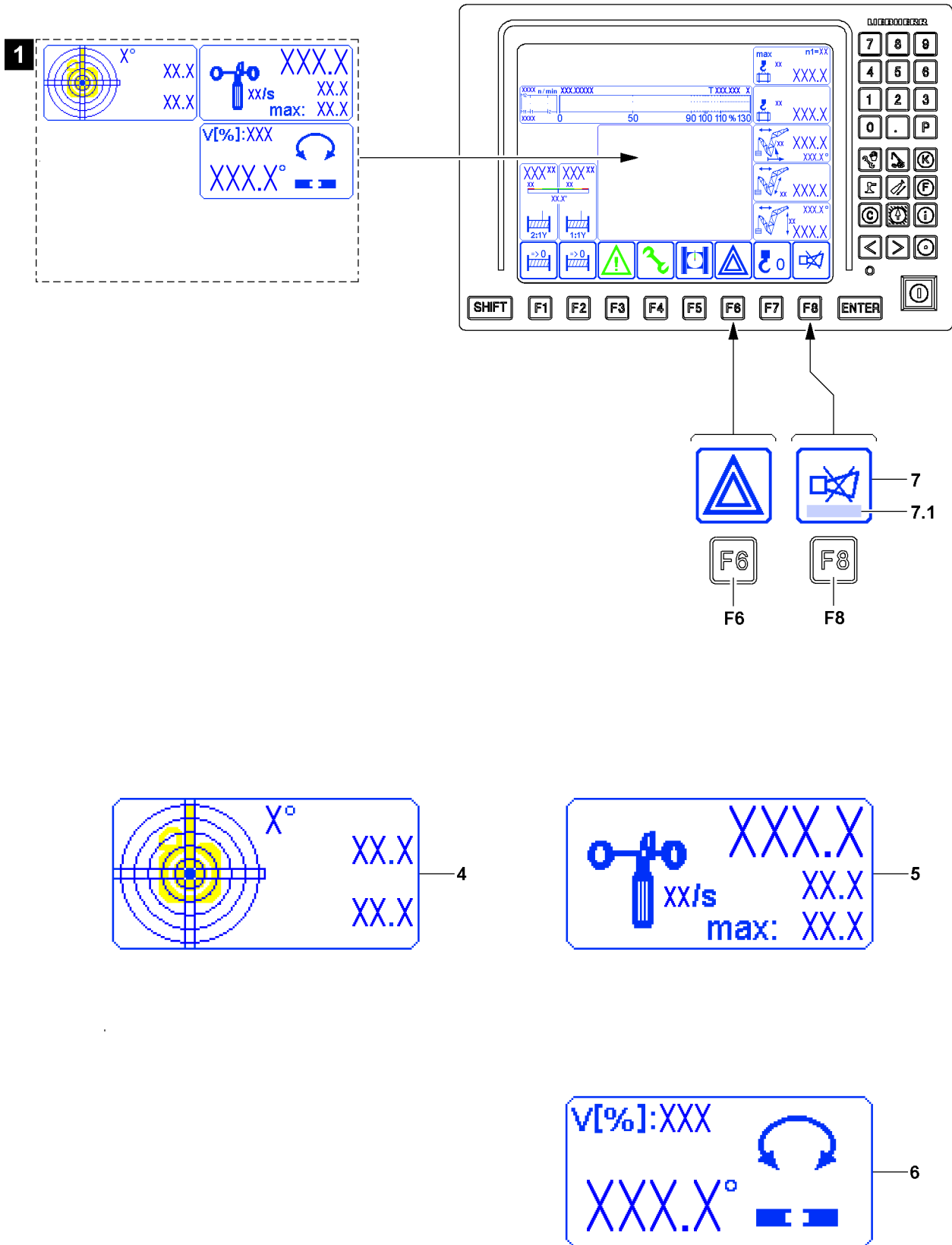

LWE/LR 13000-001/19503-01-02/en

Fig.116013

5.7 Monitored auxiliary functions

The monitored auxiliary functions (illustration 1) are always active and can be displayed in the monitoring field, if necessary.

The monitoring field has its fixed position on the LICCON monitor and can be hidden or assigned with other functions.

By pressing the function key **F6**, the monitored auxiliary functions are displayed / masked in the monitoring field.



Note

Shut off *Monitored auxiliary functions*

- ▶ Outside of the *Crane operation* program, the monitored auxiliary functions are turned off.
- ▶ When the monitored auxiliary functions are turned off, warning events are not recognized.

The appearance of the icon over function key **F6** changes according to the condition:

Icon with filled in frame = auxiliary functions icons turned off

Icon with frame not filled in = auxiliary functions icons turned on

Note: If a monitored limit has been exceeded, a warning is issued the corresponding icon is displayed, even if the monitoring icons have been hidden.

Error messages:

- If a warning occurs, an error message **7.1** is issued in the *Horn* icon **7** for some errors. The error message **7.1** includes an acoustic signal through the LICCON monitor and an error description.
- Press the function key **F8** once: The acoustic signal is turned off.
- Press the function key **F8** twice: The error description for the error message **7.1** that occurred last is called up.

Auxiliary functions:

- 4 Crane incline
- 5 Wind speed
- 6 Slewing range

5.7.1 Display of auxiliary functions

The display changes depending if the monitored auxiliary functions are turned on or off via the function key **F6**.

Monitored auxiliary functions turned off:

- No error:
Icons are not shown.
- Error in one function:
Icon with error message is shown.

Monitored auxiliary functions turned on:

- Icons are displayed permanently

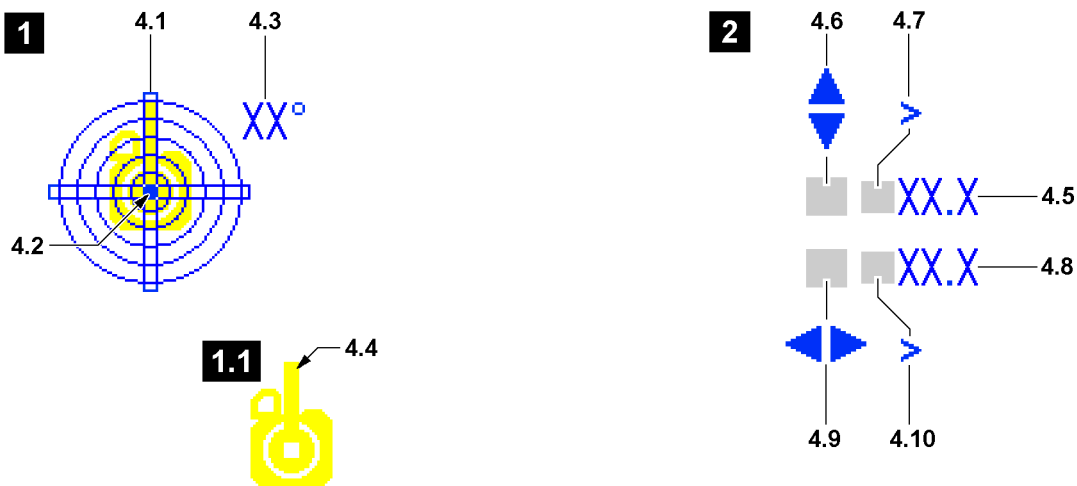
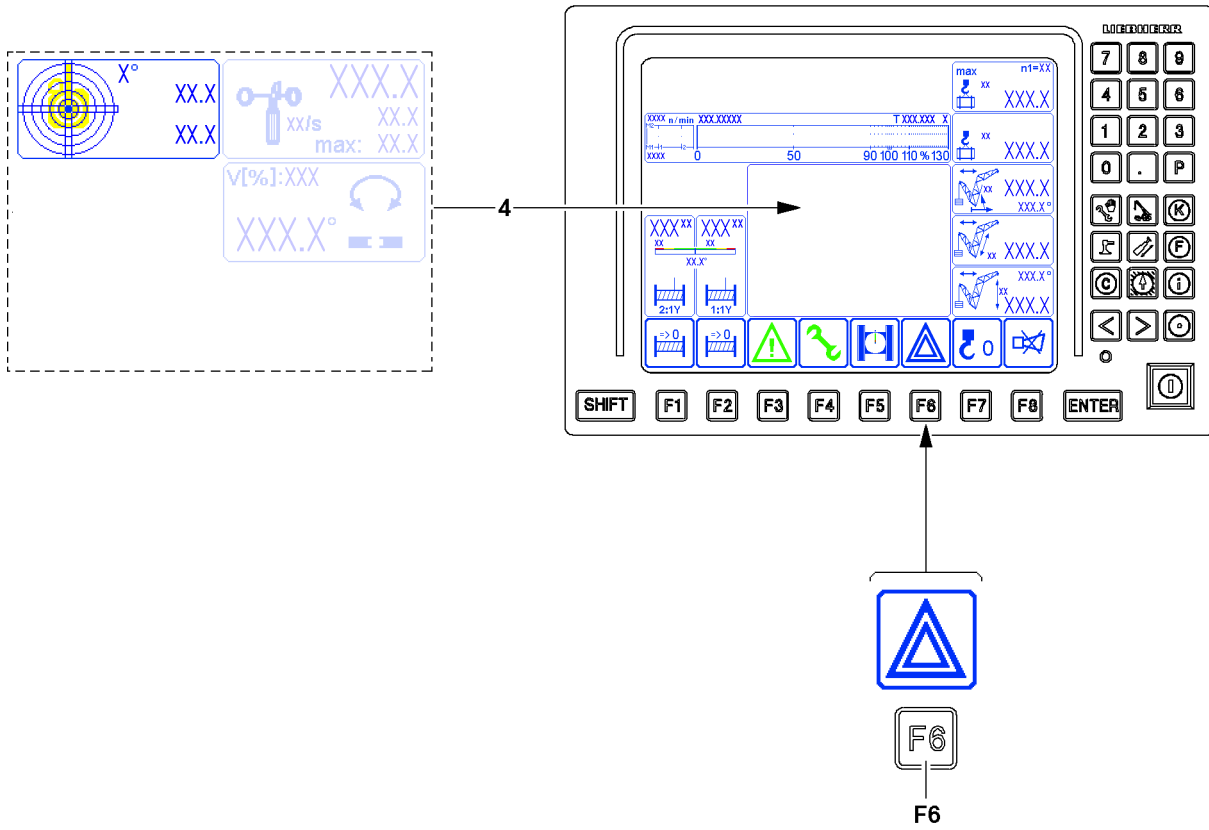

Fig.114292

5.7.2 Crane incline



WARNING

The crane can topple over!

If the permissible incline of the crane is exceeded, the crane can topple over.

The *larger than* icon shows that the crane is inclined further than can be shown.

The exact incline can then not be read.

- ▶ Do not exceed the permissible incline from the load chart.
- ▶ Do not exceed the permissible incline for driving the crane, see Crane operating instructions, chapter 4.10.

4 Incline icon

- Display of the incline of the crane to the horizontal in the longitudinal and lateral direction. The display is graphic as well as numeric.
- The display is divided in a graphic section (illustration 1) and a numeric section (illustration 2).
- The direction specification refers to the direction of the crane superstructure (view from the cab).

Graphical section(illustration 1):

4.1 Graphic display

- The graphic display is in the form of a spirit level, with a moving dot 4.2 representing the air bubble.

4.2 Dot

- The center of the dot 4.2 shows the incline value.

4.3 Display resolution

- This value indicates the resolution of the graphic display. The resolution is matched automatically to the inclination.

4.4 Boom direction

- In the graphic view 4.1, the overhead view of the imitated crane superstructure is highlighted, see illustration 1.1. The main boom direction 4.4 is symbolized by a wide yellow line and is provided for orientation in the display.

Numeric section (illustration 2):

4.5 Longitudinal direction

- Incline of crane in the longitudinal direction in [°].

4.6 Direction arrow

- The direction arrow shows the direction of the incline

4.7 Display range exceeded

- If the *greater than* icon appears, then the display range is exceeded.
- **Note:** The crane is inclined further than can be shown.

4.8 Lateral direction

- Incline of crane in lateral direction in [°]

4.9 Direction arrow

- The direction arrow shows the direction of the incline

4.10 Display range exceeded

- If the *greater than* icon appears, then the display range is exceeded
- **Note:** The crane is inclined further than can be shown.



Note

Orientation of the crane in the *Incline* icon 4.

- ▶ Observe the main boom direction 4.4.

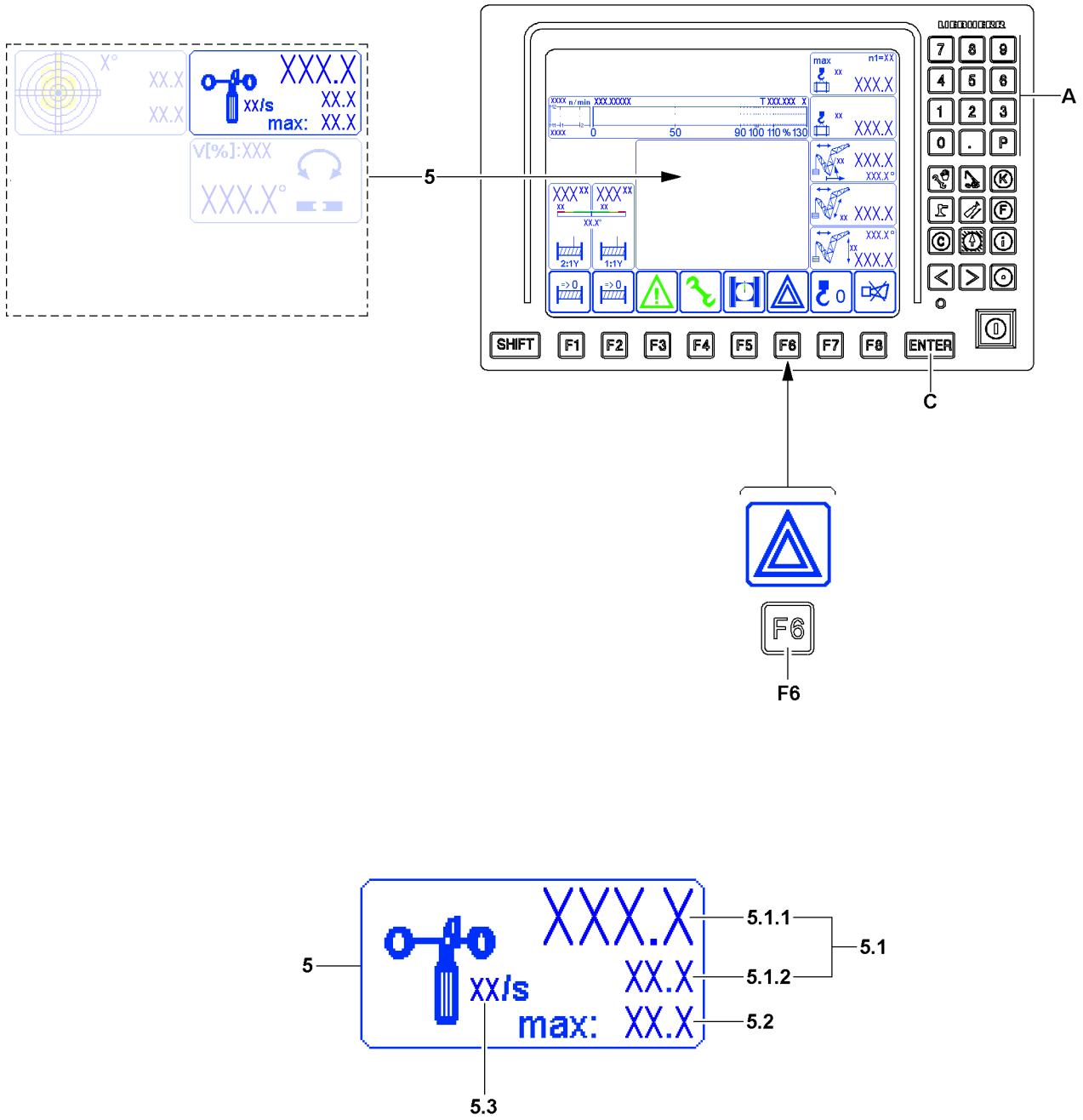

Fig.121798

5.7.3 Wind speed



WARNING

Wind speed too high!

If the maximum permissible wind speed is exceeded with an erected boom system, there is a danger of accident.

Dangerous situations can arise, such as oscillating load or shaking crane.

The crane can topple over, personnel can be severely injured or killed.

- ▶ **The crane movements will not be shut-off.**
- ▶ The boom system must be taken down in time before exceeding the maximum permissible wind speed of the crane.
- ▶ The danger notes, see Crane operating instructions, chapter 2.04 must be strictly observed and adhered to.

5 Wind speed icon

5.1 Current wind speed

- **Note:** If a wind sensor is connected, then the wind speed appears at **5.1.1** If two wind sensors are connected (Example: crane operation with an auxiliary boom / accessory), then a second wind speed is displayed at **5.1.2**
- **5.1.1** current wind speed WG1
- **5.1.2** current wind speed WG2



WARNING

Crane operation without the wind speed display value!

If a question mark (?) appears on the current wind speed **5.1** display instead of number values, then a wind sensor which must be present is missing or there is an error in the wind sensor.

- ▶ Before starting to work with the crane, make sure that all wind sensors that must be present are present and functioning.
- ▶ Remedy the error immediately.
- ▶ If an error cannot be remedied, then it must be ensured that the wind speed is monitored in another manner.

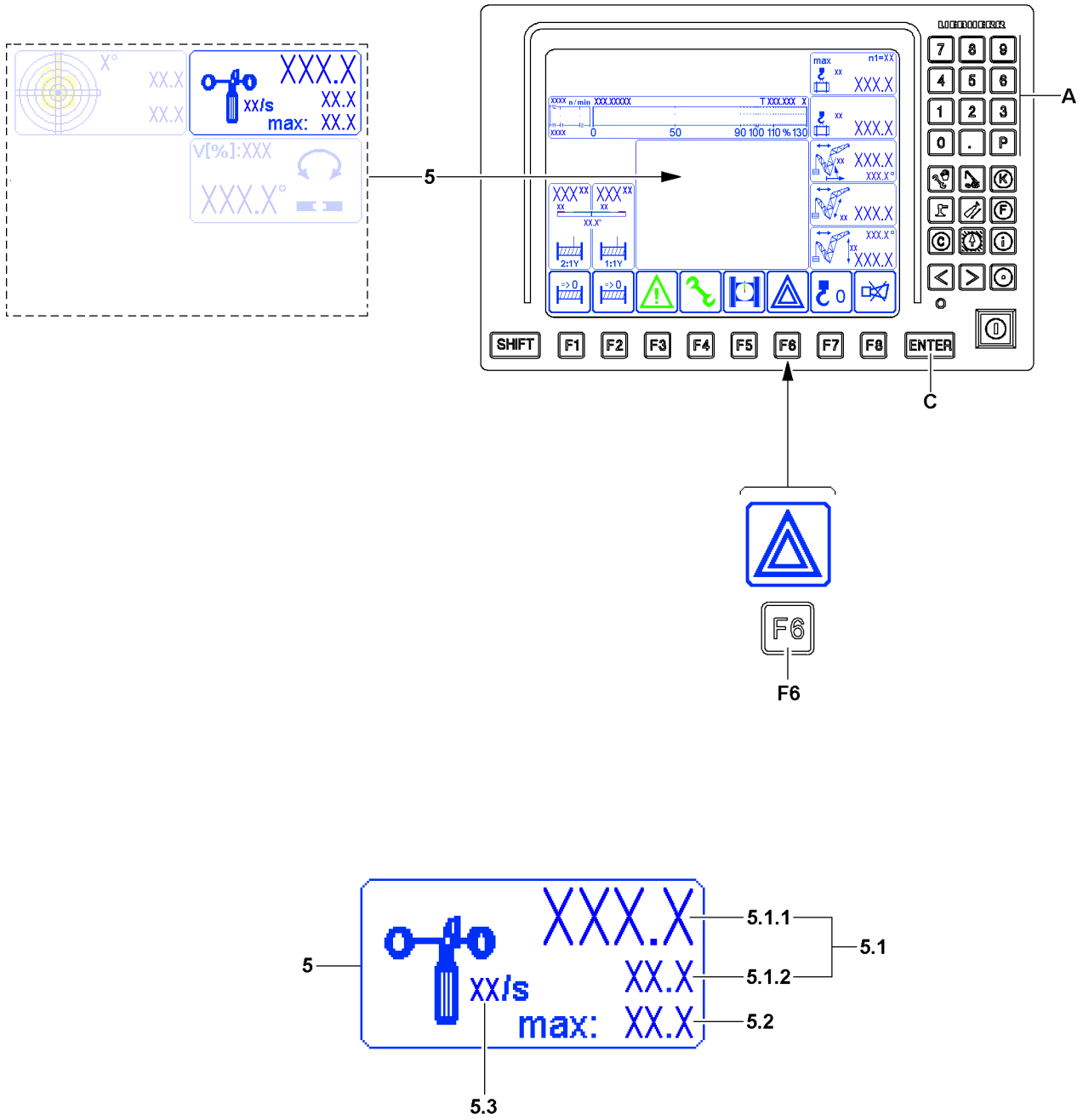

Fig.121798

**Note**

- ▶ If several wind sensors are connected, the installation location of the wind sensor determines the corresponding display in the *Wind speed* icon **5**.
- ▶ The priority depends on the installation location of the wind sensor, from the outside (auxiliary boom / accessory) to the inside (main boom). The wind speed for the outside wind sensor is shown independently from the inside wind sensor.

5.2 Maximum permissible wind speed

- The value depends on the operating mode and the set up configuration.
- If the current wind speed value exceeds the displayed maximum value, the maximum value starts to blink and the *Short horn* warning sound sounds.

**Note**

- ▶ If access to a load chart is not possible, then the maximum value starts to blink and the *Short horn* warning sound sounds.

5.3 Measuring unit

- [m/s] or [ft/s]

Reducing the maximum permissible wind speed***Note**

- ▶ This function is not available for all crane types.

The value for the maximum permissible wind speed **5.2** can possibly be reduced.

Ensure that the following prerequisite is met:

- The *Wind speed* icon **5** is shown.

Reduce the wind speed:

1. Press the ENTER key **C**.
2. As soon as the value for the maximum permissible wind speed **5.2** is highlighted in blue, enter the new value via the keypad **A**.
3. Press the ENTER key **C** again. The changed value for the maximum permissible wind speed **5.2** is shown in red.

Cancel reduce the wind speed:

1. Press the ENTER key **C**.
2. As soon as the value for the maximum permissible wind speed **5.2** is highlighted in blue, enter 0 (zero) as the new value via the keypad **A**.
3. Press the ENTER key **C** again. The original value from the load chart is taken over again.

**Note**

- ▶ If you try to enter a value for the maximum permissible wind speed **5.2** which is too high, then the highest possible value is taken over.

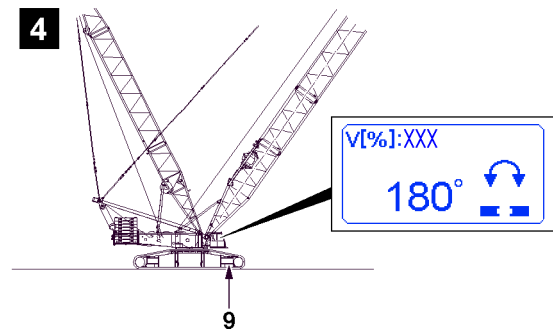
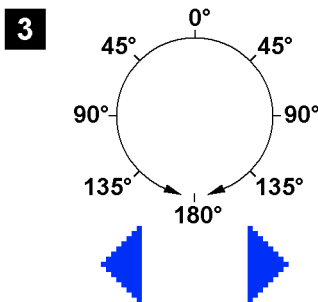
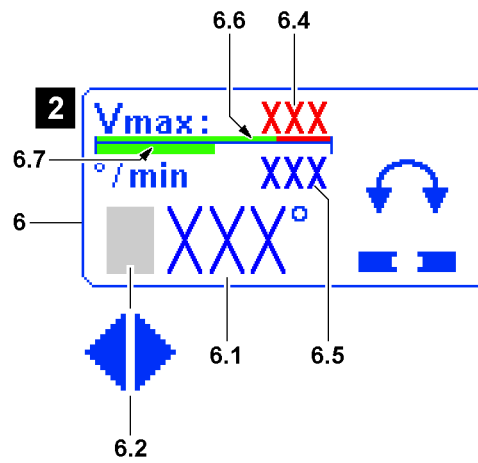
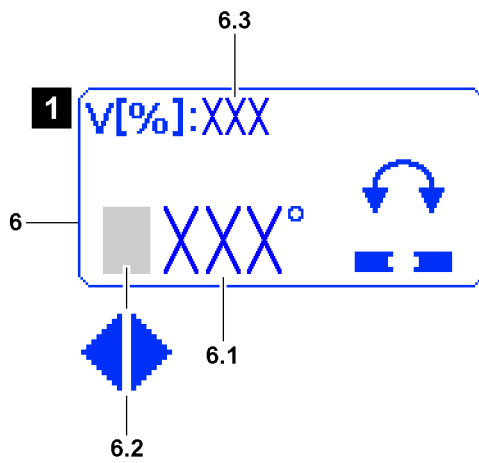
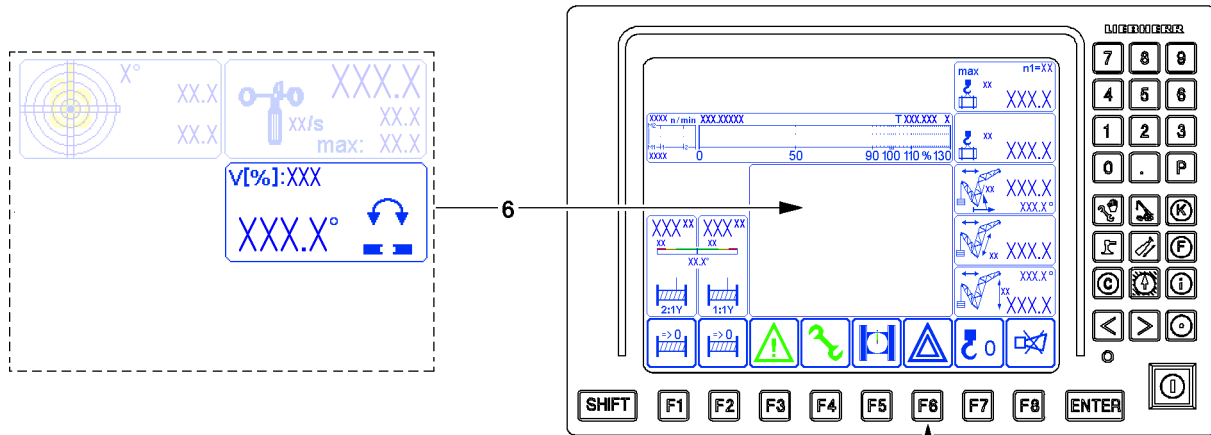

Fig.144105

LWE/LR 13000-001/19503-01-02/en

5.7.4 Slewing range

6 Slewing range icon

- depending on the crane type, either the illustration 1 or illustration 2 icon appears



WARNING

Danger of accident in case of excessive slewing speed!

Danger of toppling or collapsing crane.

Death, severe bodily injuries, property damage.

- ▶ Observe the slewing speed according to the specifications in the load chart manual.

6.1 Slewing angle

- Slewing angle of the crane superstructure in relation to the working direction *to the rear* (0°)
- The number value can increase on both sides to the maximum value of 180°, see illustration 3
- **Note:** At display value 180°, the crane superstructure is exactly in the forward position, see illustration 4. The front of the crawler travel gear is where the chain tensioning devices 9 are located.

6.2 Direction of rotation

- The direction arrow in front of the value indicates the direction of rotation of the crane superstructure.
- The direction arrow is in relation to the working direction *to the rear* (0°), see illustration 3
- Left arrow: The crane superstructure is turned to the left.
- Right arrow: The crane superstructure is turned to the right.
- **Note:** If the crane superstructure is positioned exactly to the front (display value 180°) or to the rear (display value 0°) there is no direction arrow.

6.3 Slewing speed

- Only for crane types with the illustration 1 icon
 - Maximum slewing speed in [%]
 - Identifies the set maximum slewing speed of the slewing gear with a fully deflected master switch, relating to the maximum attainable slewing speed of the slewing gear at a preselected speed of 100 %.
- This value can be infinitely preselected, see section „Master switch speed reduction setting window“.

6.4 Permissible slewing speed

- Only for crane types with the illustration 2 icon
- Number value for the permissible slewing speed in degrees per minute [°/min]. The permissible slewing speed is calculated depending on the current crane utilization and displayed.
- **Note:**
The permissible slewing speed is reduced depending on the load down until the permissible value indicated in the load chart manual is reached. The crane driver is responsible for making sure this value is never exceeded. The slewing speed is not reduced automatically with the help of the crane control.

6.5 Current slewing speed

- Only for crane types with the illustration 2 icon
- Number value for the current slewing speed in degrees per minute [°/min]
- Blue number value: Slewing speed in the permissible range
- Red number value (blinking): Slewing speed above the permissible range

6.6 Slewing speed scale

- Only for crane types with the illustration 2 icon
- Green range: Slewing speed in the permissible range
- Red range: Slewing speed above the permissible range

6.7 Slewing speed bar diagram

- Only for crane types with the illustration 2 icon
- Green bar: Slewing speed in the permissible range

- Red bar: Slewing speed above the permissible range

Empty page!

LWE/LR 13000-001/19503-01-02/en

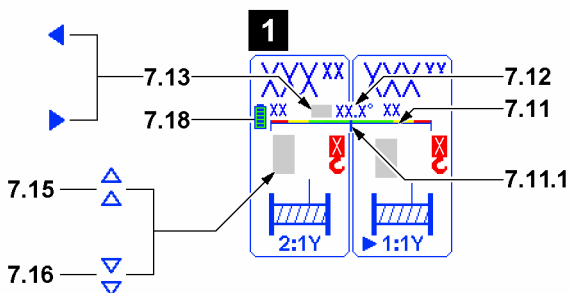
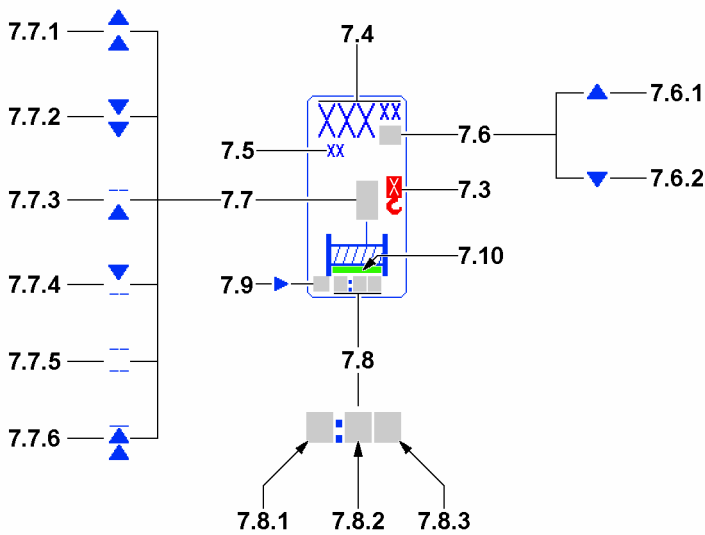
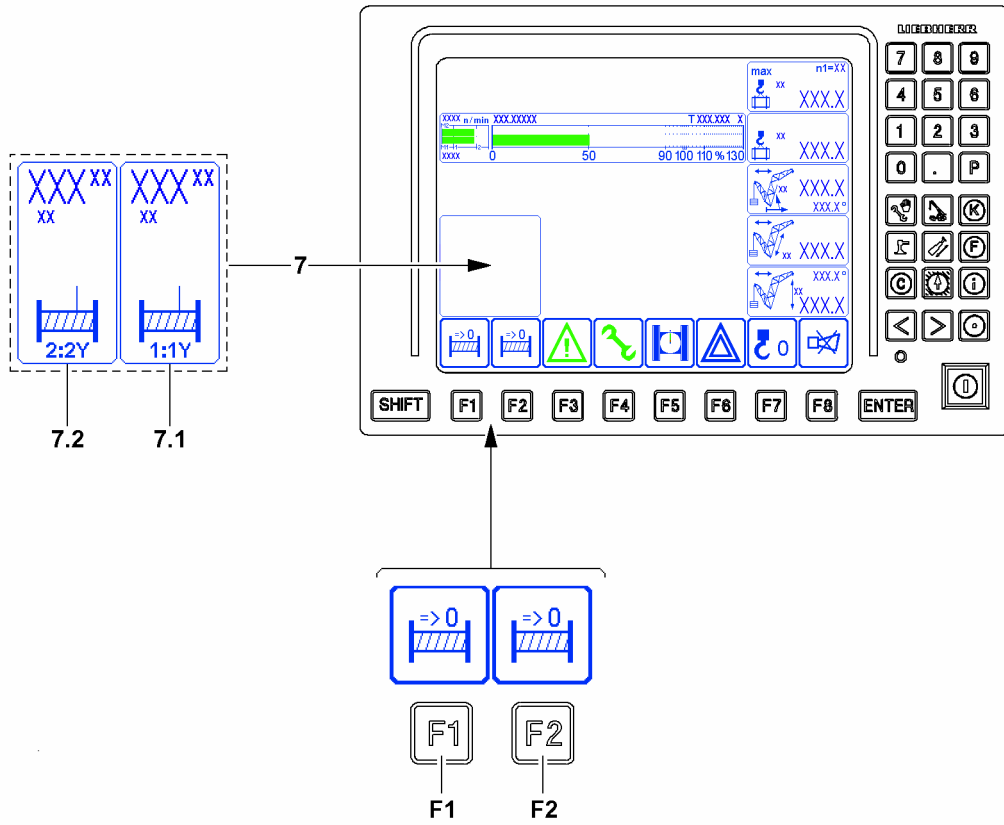

Fig.153663

LWE/LR 13000-001/19503-01-02/en

5.8 LICCON Monitor 0 winch display

The winch displays **7** have a fixed position on the LICCON monitor.

There are two values that can be displayed depending on the use of the winch:

- Using the winch as a hoist winch: The completed hook path is displayed.
 - The completed hook path is calculated with the reeving set in the *Set up* program. A prerequisite for a correct display is that the value entered matches the entered reeving and the actual number of rope strands between the boom head and the hook block.
- Using the winch as a control winch: The spooled out / up rope length of the winch is displayed.

The current position of each winch can be set as zero point.

F1 Function key

- The *reset winch display* icon appears above the function key **F1**. Pressing the button sets the *Completed path* display to zero. Path measurement applies from here.

F2 Function key

- The *reset winch display* icon appears above the function key **F2**. Pressing the button sets the *Completed path* display to zero. Path measurement applies from here.
- **Note:** When winch 1 and winch 2 work in parallel operation, then the *completed path* displays for winch 1 and winch 2 can only be set together to zero with the function key **F1**.
Then the function key **F2** has no function.

7 Winch display

7.1 Winch 1 icon

- Icon for winch 1 (WI)

7.2 Winch 2 icon

- Icon for winch 2 (WII)



Note

- ▶ The displays for winch 1 and winch 2 are identical and are explained for one icon element.

7.3 Load position

- Load position to which the winch is assigned.

7.4 Completed path

- Completed hook path from a selectable zero point.

or

Spooled out / spooled up rope length from a selectable zero point

- The positions before the decimal point are displayed with a maximum of three large digits. The digits after the decimal point are displayed in small digits. Setting to zero point, see also section „Function key line of LICCON monitor 0“).
- A prerequisite for a correct display is that the value entered matches the entered reeving and the actual number of rope strands between the boom head and the hook block.

7.5 Measuring unit

- Measuring unit of the *completed path* display in [m] or [ft]

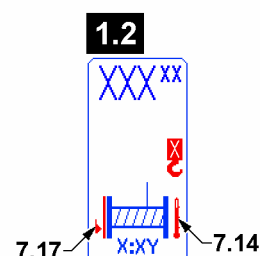
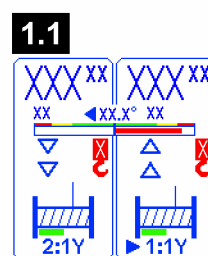
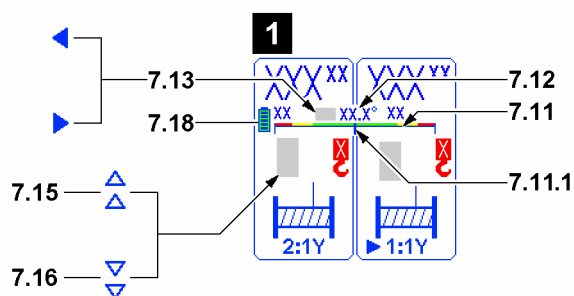
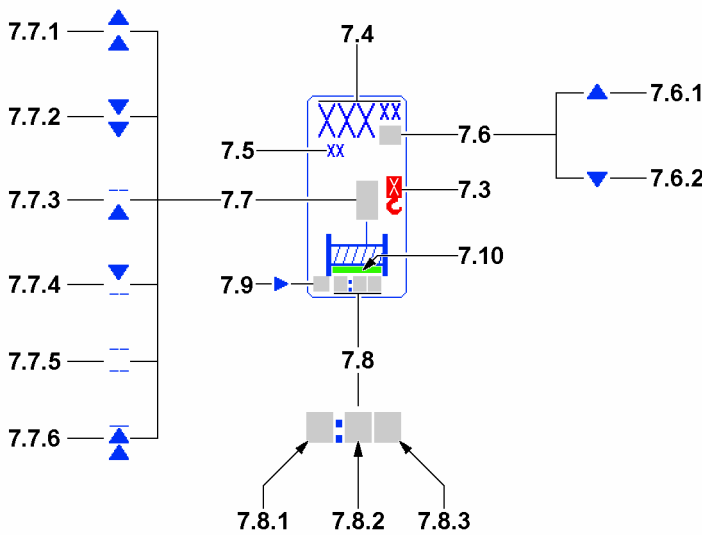
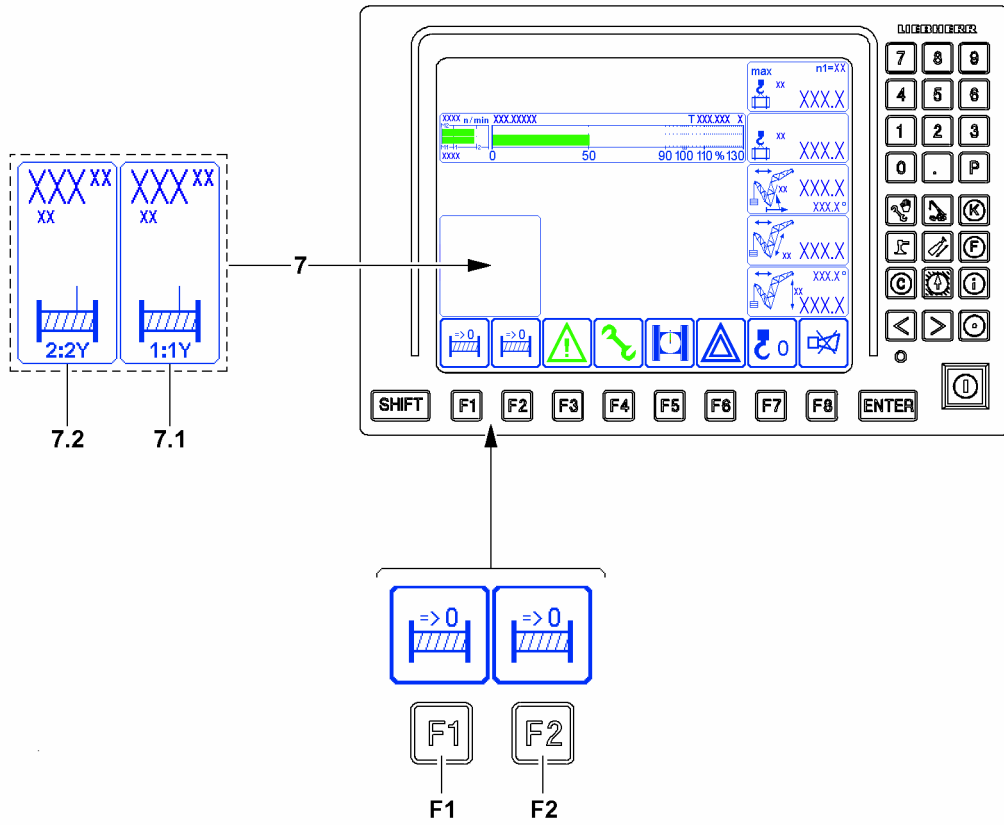

Fig.153663

LWE/LR 13000-001/19503-01-02/en

**Note**

Display area of winch displays.

- ▶ The completed path 7.4 display has only three positions before the decimal point, any positions before that are cut off. The crane operator must evaluate for himself if, for example 200 m of rope are spooled up on a winch or 1200 m. **The display in both cases would be identical with 200 m.**

For use as a hoist winch:

- ▶ The hook path calculation only works accurately if the load is suspended freely and is not luffed during the lifting procedure. Flexation and rope expansion are not taken into account.
- ▶ The *completed path* display is only correct when the winch is calibrated.

7.6 Direction of hook movement

- The arrows on the length value show the direction of the hook movement in relation to the zero point
- **Up arrow 7.6.1:** Hook moves upward from the zero point
- **Down arrow 7.6.2:** Hook moves downward from the zero point

7.7 Winch status display

- There are six winch condition icons, all blinking
- **Note:** If a winch status icon does not appear, the activated winch is inactive and is neither spooled up nor spooled out.

7.7.1 Spool out

- The winch is spooled out

7.7.2 Spool up

- The winch is spooled up

7.7.3 Spooled out

- Additional spooling out of the winch is blocked

7.7.4 Spooled up

- Additional spooling up of the winch is blocked

7.7.5 Winch deactivated

- The winch is deactivated or unplugged
- **Note:** The winch cannot be controlled.

7.7.6 Winch turned off in emergency

- Spooling out of the winch is blocked
- **Note:** Pay attention to the error message

7.8 Master switch assignment

- **7.8.1** First digit
 - First digit: Winch number, every winch icon is permanently assigned to a winch
- **7.8.2** Second digit
 - Master switch number, according to the assigned master switch
 - ? : No master switch assigned
- **7.8.3** Letter
 - Actuation direction of the master switch, see illustration
 - : No actuation direction assigned

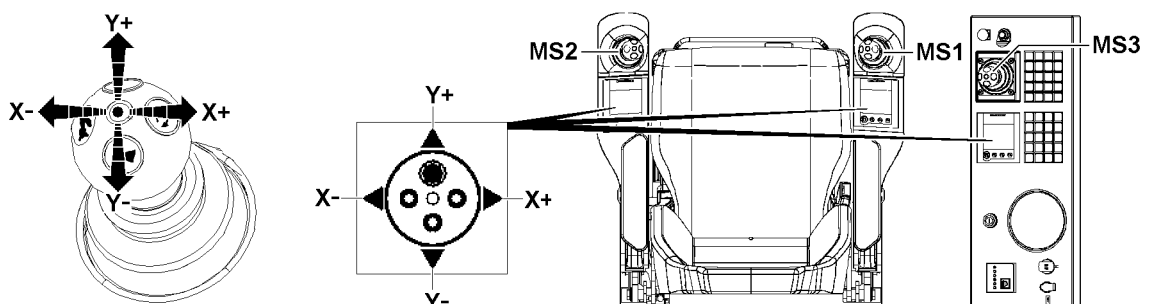

Fig.123758: Actuation directions Master switch

MS1 Master switch 1

X- To the left

[For continuation of legend for illustrations, see next page](#)

Maintenance displays, illustration 1.2:**7.14 Winch overheated icon**

- If the *Winch overheated* icon **7.14** appears, the temperature in the respective winch is too high.

Note: Only for certain crane types with temperature sensors in the winches.

7.17 Insufficient oil icon

- If the *Insufficient oil* icon **7.17** appears permanently after correct completion of the *Winch gear* oil level measurement, the oil level in the respective winch is too low.

Note: Only for certain crane types.

**WARNING**

Overheated winch!

If a winch is operated further, even though the *Winch overheated* icon **7.14** appears, the winch can be severely damaged.

The winch can fail and accidents can occur.

- ▶ Let the overheated winch cool off.

**WARNING**

Insufficient oil in the winch!

If a winch is operated further, even though the *Insufficient oil* icon **7.17** appears, the winch can be severely damaged.

The winch can fail and accidents can occur.

- ▶ Remedy the insufficient oil immediately.

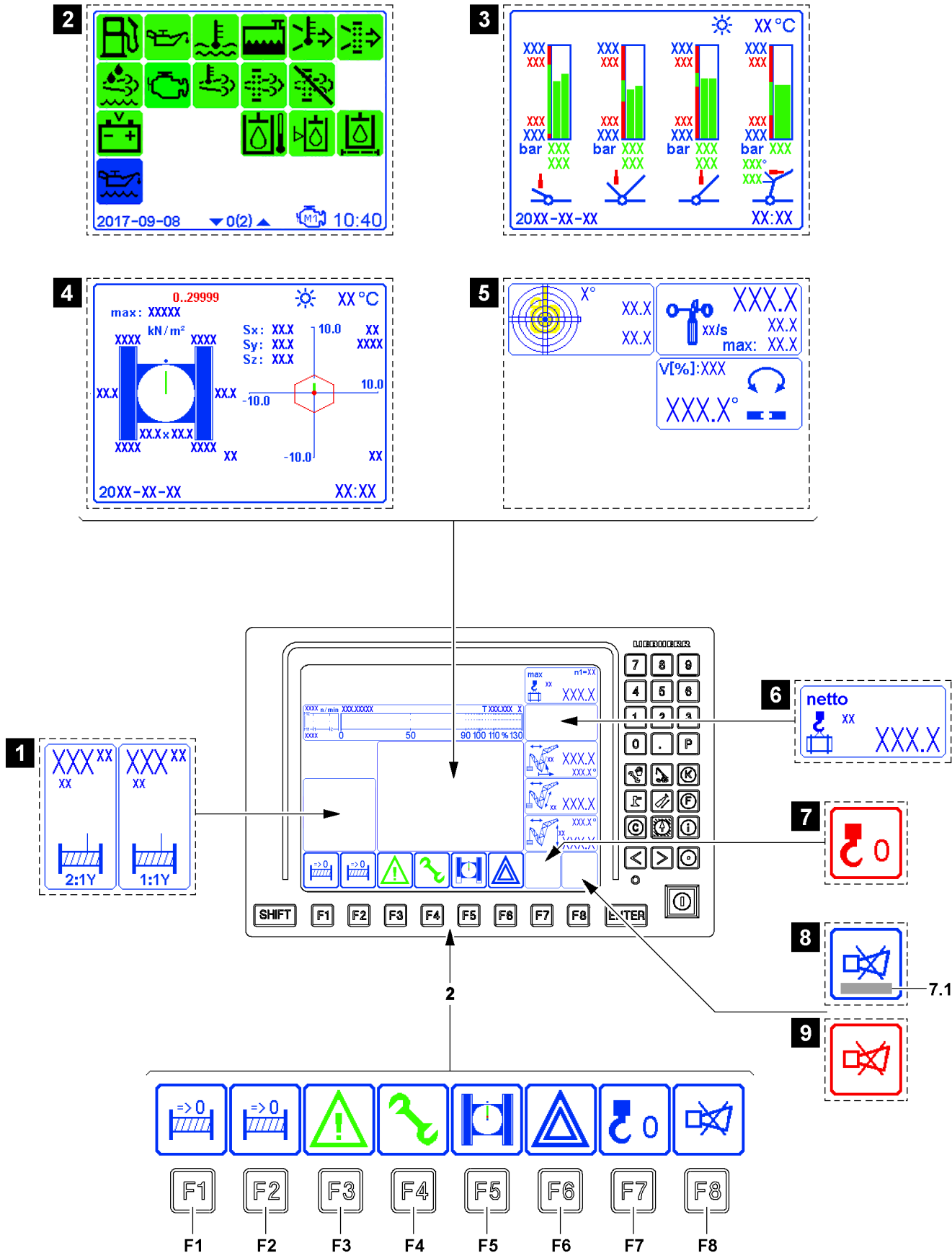

Fig.161665

LWE/LR 13000-001/19503-01-02/en

5.9 The function key line of LICCON monitor 0

The function key line consists of function keys **F1** to **F8** and the function key icon bar above it. The function keys correspond to the various function key icons above them.

The function key icons always show the functions which are activated by pressing the button.

The function is called up after pressing a button. In addition, the icon above it can change its display, its meaning or its text.

Not all function keys must have assigned icons. This depends on the respective program selection.

F1 Function key

- Determine the zero point for the Winch 2* *completed path* display, see illustration 1.
- The *reset winch display* icon appears above the function key **F1**. Pressing the button sets the *Completed path* display to zero. Path measurement applies from here.

F2 Function key

- Determine the zero point for the Winch 1 *completed path* display, see illustration 1.
- The *reset winch display* icon appears above the function key **F2**. Pressing the button sets the *Completed path* display to zero. Path measurement applies from here.
- **Note:** When winch 1 and winch 2 work in parallel operation, then the *completed path* displays for winch 1 and winch 2 can only be set together to zero with the function key **F1**.

Then the function key **F2** has no function.

F3 Function key

- Display or hide crane operation monitoring functions (illustration 2)
See also section „Crane operation monitoring functions“.

F4 Function key

- Display or hide relapse cylinder / erection cylinder monitoring (illustration 3).
See also section „Relapse cylinder / erection cylinder monitoring“.

F5 Function key

- Display or hide surface pressure and center of gravity monitoring (illustration 4).
See also section „Surface pressure and center of gravity monitoring“.

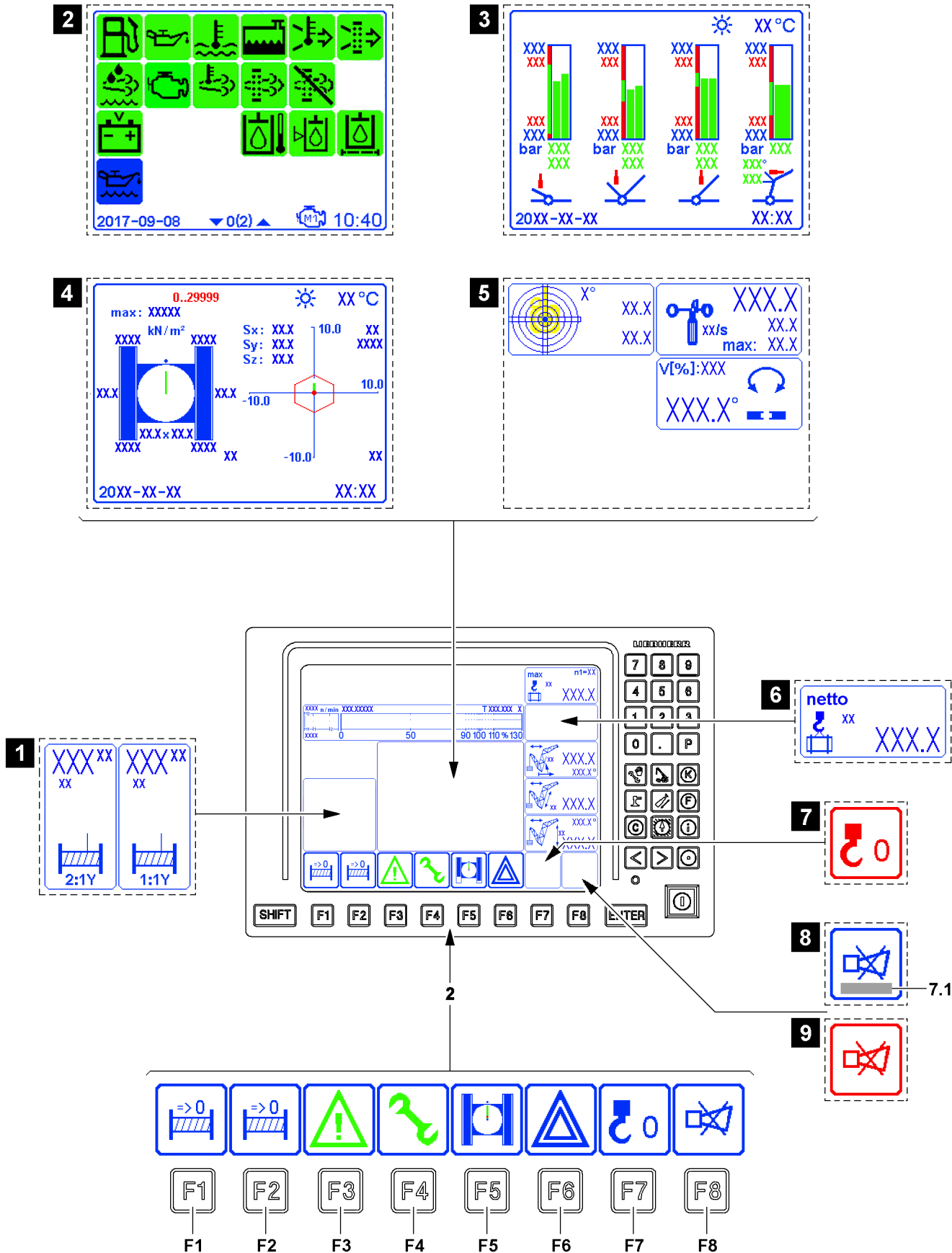

Fig.161665

F6 Function key

- Display or hide monitored auxiliary functions (illustration 5)
See also section „Monitored auxiliary functions“

**Note**

- ▶ The monitoring of all auxiliary functions is always active, even if the monitoring icons are hidden.
- ▶ When a monitored limit is exceeded, then an acoustic warning is issued by the LICCON monitor and the respective icon is shown continuously.

F7 Function key

- Taring: When the function key **F7** is pressed, the *Actual load* display is set to zero. At the same time, the word *net* appears in the display, see illustration 6.
If the taring is cancelled again, then the word *net* disappears from the display and the gross load value is displayed.
- Taring is cancelled by one of the following two actions:
 1. By pressing the function key **F7** again.
 2. Luffing more than $\pm 4^\circ$.

**Note**

By taring it is possible, for example, to eliminate weights of carrying equipment, load handling equipment or fastening equipment.

- ▶ Therefore the calculated weight of the load to be lifted (net load) can be displayed.
- ▶ As long as taring is active, the function key icon is shown in red, see illustration 7.

F8 Function key

- Shut-off of acoustic warning and possibly calling up of error message **7.1** (illustration 8).
Press the function key **F8** once: The acoustic signal is turned off.
Press the function key **F8** twice: The error description for the error message **7.1** that occurred last is called up.
- **Note:** A new error turns the acoustic warning on again.

**WARNING**

Malfunctions in the crane control!

A special program is available for LIEBHERR crane acceptance in the LICCON computer system. This program is blocked after completion of crane acceptance.

If the function key icon displays red permanently and without a visible reason (illustration 9), then the special program is activated.

- ▶ Contact Liebherr Customer Service immediately.
- ▶ In order to prevent error functions, access to the special program is only permitted for trained Liebherr personnel.

5.10 Other operating elements

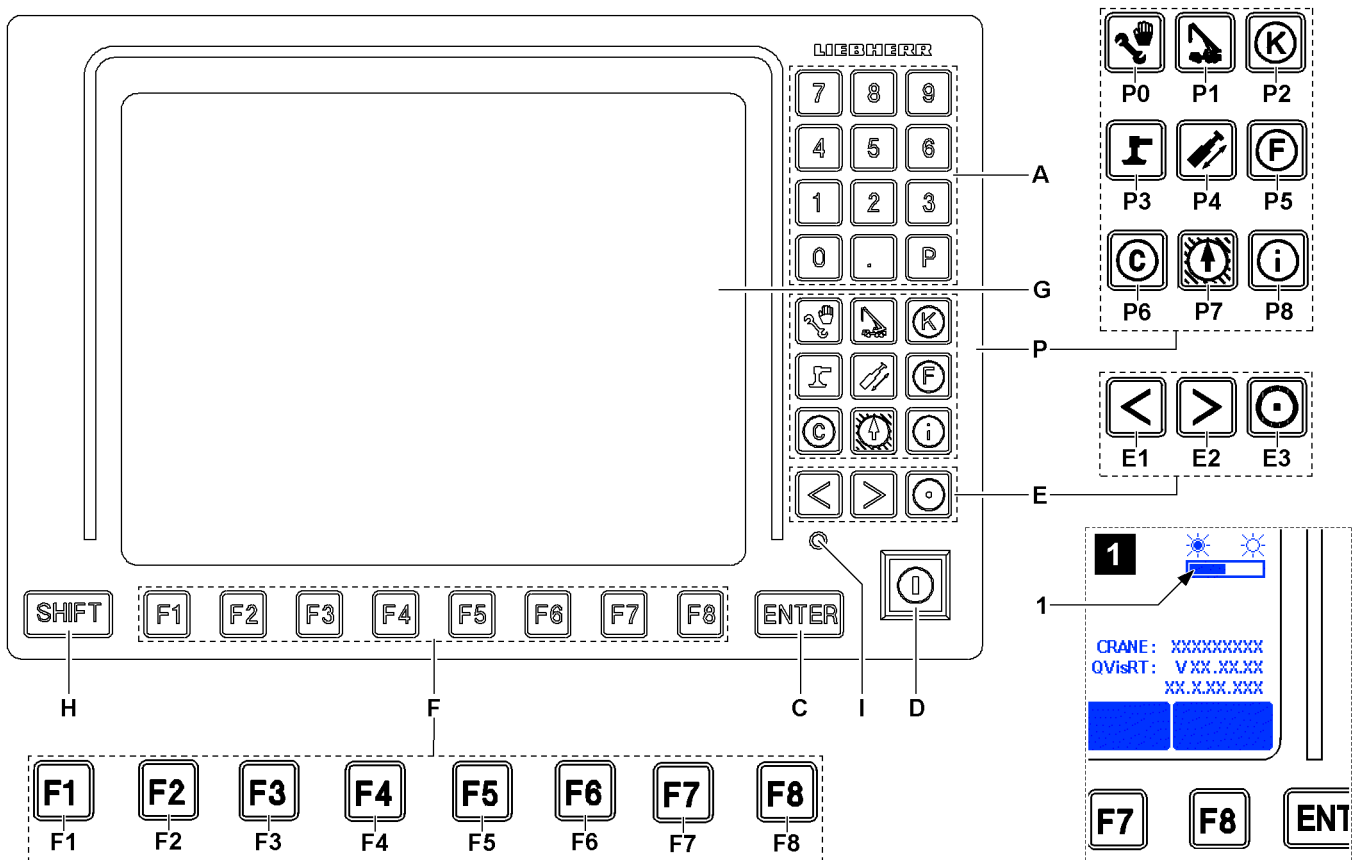

Fig.120677

The following functions are assigned to the other operating elements of the display and operating unit of the LICCON computer system in the *Crane operation* program.

- A Keypad**
 - Keys „0“ to „9“, „P“ and „.“ (illustration 1) have no function in the *Crane operation* program.
- P Program keys**
 - The program keys are used to select individual programs. The program specific peculiarities must be observed, see the respective sections of the programs in this chapter.
 - **Note:** The program currently running **cannot** be called up again using its program key. The programs can only be called up with the program key when no functions are activated via the set up key **D** at the same time.
- C ENTER key**
 - No function in *crane operation* program
- D Set up key**
 - Zero position (not actuated):
Normal operation.
 - Touching:
Function *Exceedance of shut-off limits of the LICCON overload protection* released.
 - **Exceeding the shut off limits of the LICCON overload protection**
If the shut-off limits of the LICCON overload protection are exceeded, the LICCON overload protection shuts the crane movements off.
These shut offs can be exceeded by the set up key **D** in the *right touching* position. To do so, chapter 4.20 in the *Crane operating instructions* must be observed.

**Note**

Carry out the erection / take-down procedures.

- ▶ By pressing the set up key **D**, all erection / take-down procedures can be carried out within the erection / take-down charts, for which no load charts are available.

- **Bypass of hoist limit switch**

The hoist limit switch turns the crane movement off when:

- The hook block is pulled against the hoist limit switch weight.
- The hoist limit switch weight is not attached freely (for example on placed down boom).
- The hoist limit switch has an internal error.

This shut-off can be bypassed by the set up key **D** in the *right touching* position. To do so, chapter 4.20 in the Crane operating instructions must be observed.

- E** Special function keys

- Monitor brightness adjustment (see section „Operating elements of the LICCON monitors“)

**Note**

- ▶ Additional functions of the special function keys **E** are program-dependent and are further explained in the description of the individual LICCON programs.

- F** Function keys

- The function key line consists of function keys **F1** to **F8** and the function key icon bar above it.

The function keys correspond to the various function key icons above them.

- H** SHIFT key

- Second level key assignments

6 The *Crane operation* program on LICCON monitor 1

The *Crane operation* LICCON program assists the crane operator by displaying the data relevant for crane operation clearly on three LICCON monitors. An acoustic signal accompanies all critical displays.

LICCON monitor 1 is divided into four areas in the *Crane operation* program:

- 1 F-load display
 - F1-load display
 - F2-load display
 - Note:** Appears only for the corresponding boom system
 - F3-load display
 - Note:** Appears only for the corresponding boom system
- 2 Derrick boom geometry
 - Boom radius and angle of the derrick boom
 - Note:** Appears only for the corresponding boom system
- 3 Winch display
 - Winch 3 to winch 6
- 4 Function key line
 - The function keys always refer to the icons shown directly above them
 - **Note:** If no icon is shown on the line directly above the function key, then no function is assigned in the program to the function key. See for example function key F5 to function key F7.
- 5 Alarm functions
 - Alarm functions of LICCON monitor 1



Note

- ▶ The monitor illustrations in this chapter are only examples.
 - ▶ The numerical values in the individual icons and charts do not have to necessarily match the crane exactly.
 - ▶ The configuration of the LICCON monitor with icons is only descriptive.
 - ▶ An identical icon display will **not** appear during crane operation.
-



Note

- ▶ The suspended ballast and the ballast trailer* are generally referred to as the **derrick ballast**.
-

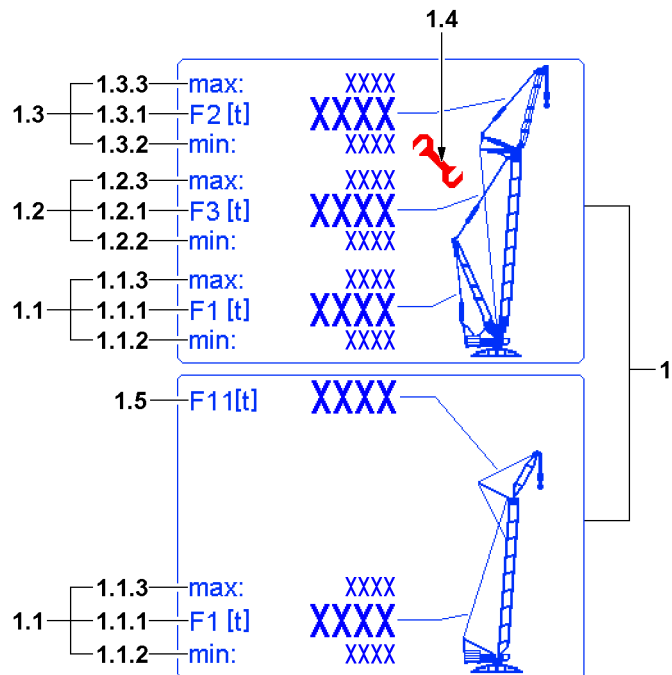
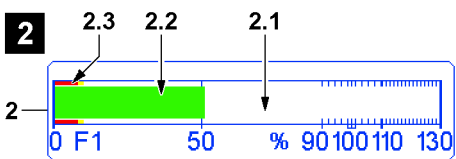
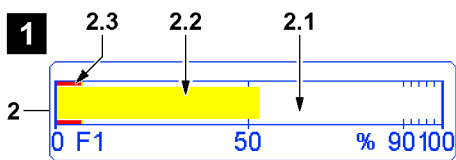
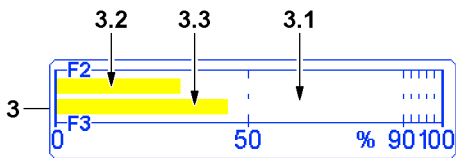
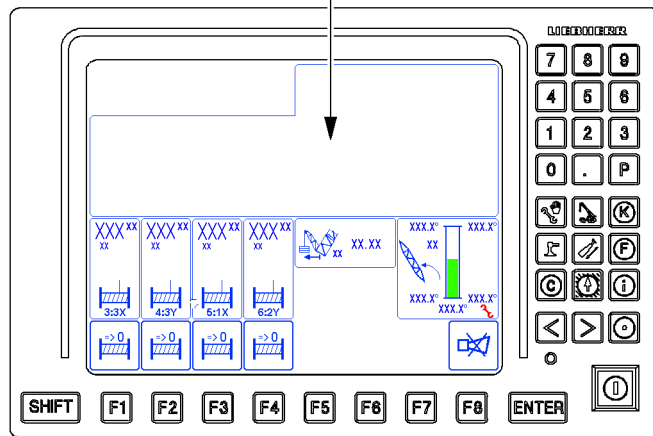
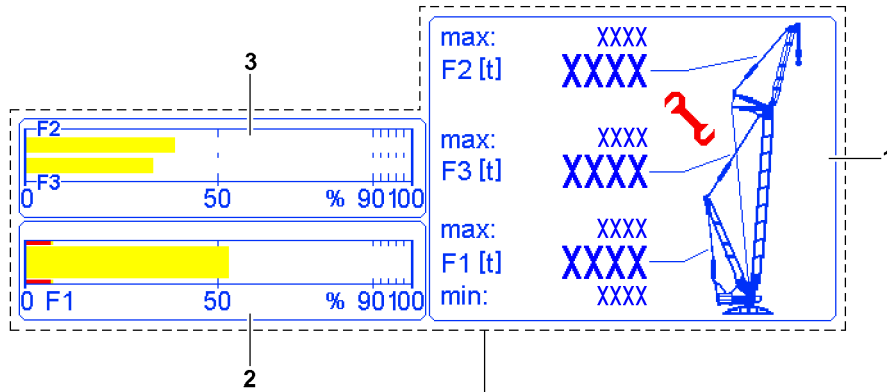

Fig.122454

LWE/LR 13000-001/19503-01-02/en

6.1 F-load display

From the ratio of the operating force F_{actual} to the permissible maximum force F_{max} results the respective F-utilization.

The F-load display includes various display modes:

- Numeric displays
- Bar diagrams, when a ratio of operating force F_{actual} to the permissible maximum force F_{max} is shown.



WARNING

Damage, overload and toppling of the crane!

If the permissible values of the F-load display are exceeded / fallen below, then the crane can be damaged or overloaded and topple over.

As long as the set up boom system is not completely assembled and not all sensors, which are required for this operating mode are electrically connected, no maximum forces and minimum forces are displayed in the F-load display.

In these cases it must be determined with the assembly drawing which maximum forces are permissible on the F-load display.

These maximum forces must be monitored by the crane operator and may not be exceeded during assembly / removal of the crane.

- ▶ The crane operator must ensure that the permissible values of the F-load display are not exceeded / fallen below.
- ▶ Observe and adhere to the maximum forces for the F-load display from the assembly drawings.



Note

The values of the F-load display depend on the set up configuration of the crane and the crane geometry.

The values of the F-load display change continuously when the crane is moved.

- ▶ Monitor the F-load display continuously.

6.1.1 Numeric F-load display

1 Numeric displays

- Type and scope of numeric displays depends on the set up configuration and the operating situation.

1.1 F1-display

1.1.1 F1-actual value ($F1_{\text{actual}}$)

- F1-force actual value

1.1.2 F1-minimum ($F1_{\text{min}}$)

- F1-force minimum value

Note: Appears only outside a load chart, at activated assembly operation or in special situations.

1.1.3 F1-maximum ($F1_{\text{max}}$)

- F1-force maximum value

Note: Appears only outside a load chart, at activated assembly operation or in special situations.

1.2 F3-display

- **Note:** Appears only for the corresponding boom system

1.2.1 F3-actual value ($F3_{\text{actual}}$)

- F3-force actual value

1.2.2 F3-minimum ($F3_{\text{min}}$)

- F3-force minimum value

Note: Appears only outside a load chart, at activated assembly operation or in special situations.

1.2.3 F3-maximum ($F3_{\text{max}}$)

- F3-force maximum value

Note: Appears only outside a load chart, at activated assembly operation or in special situations.

1.3 F2-display

- **Note:** Appears only for the corresponding boom system

1.3.1 F2-actual value ($F2_{\text{actual}}$)

- F2-force actual value

1.3.2 F2-minimum ($F2_{\text{min}}$)

- F2-force minimum value

Note: Appears only outside a load chart, at activated assembly operation or in special situations.

1.3.3 F2-maximum ($F2_{\text{max}}$)

- F2-force maximum value

Note: Appears only outside a load chart at activated assembly operation

1.4 Assembly icon

- Appears when assembly operation is activated

1.5 F11-display

- F11-force actual value
- **Note:** Appears only for the corresponding boom system

Empty page!

LWE/LR 13000-001/19503-01-02/en

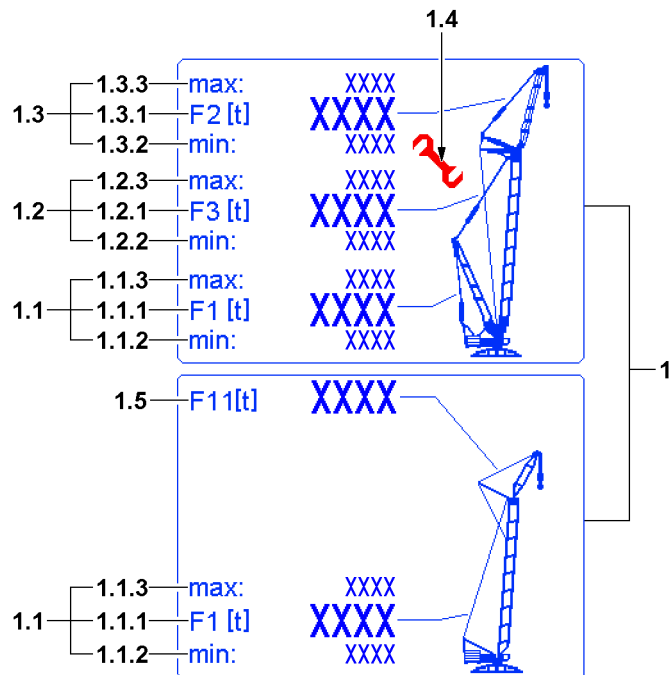
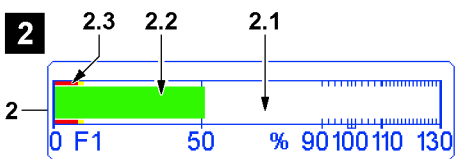
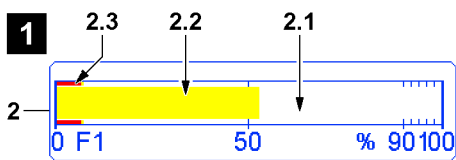
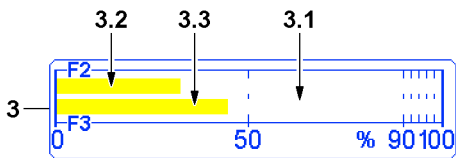
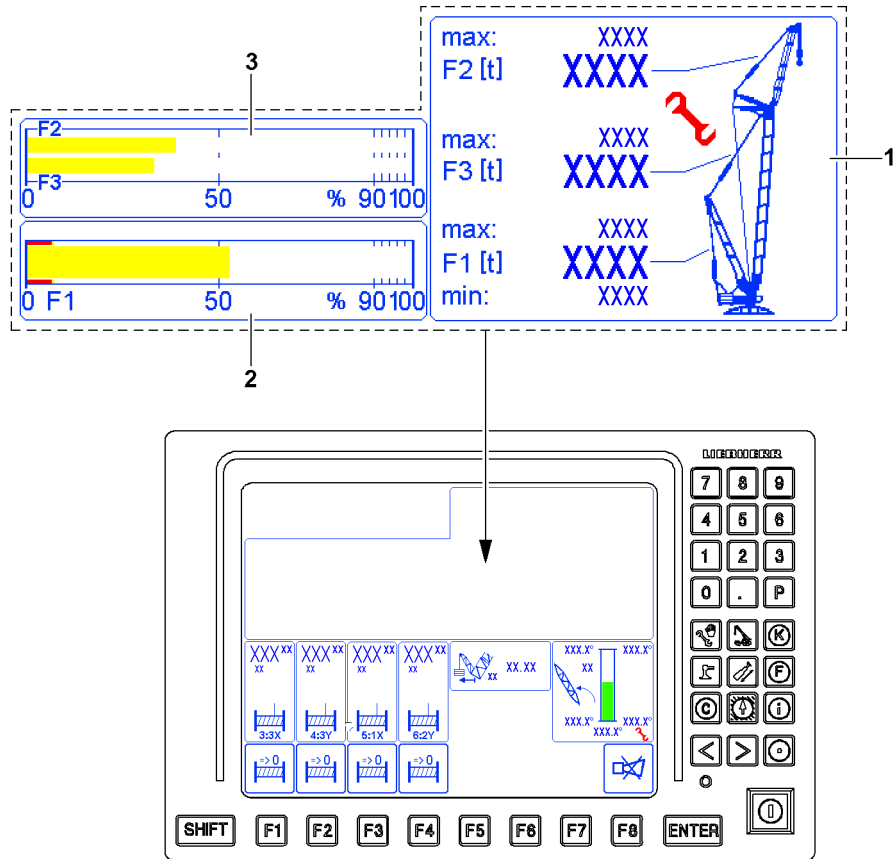

Fig.122454

6.1.2 F1-display bar

Pull test brackets Test point 1A and 1B (F1 force) are in the A-frame guying

- F1-display bar in assembly operation: Scale from 0 % to 100 % (outside a load chart), see illustration 1
- F1-display bar in crane operation: Scale from 0 % to 130 % (within a load chart), see illustration 2

2 Display bar

- Display bar for graphic illustration of F1-force

2.1 Display scale

- Crane operation: Scale from 0 % to 130 % (within a load chart)
- Assembly operation: Scale from 0 % to 100 % (outside a load chart)

2.2 F1-bar

- Graphic illustration of the F1-actual value ($F1_{\text{actual}}$)
- Appears in green, yellow and red, depending on the situation
- F1-bar **2.2** green: $F1_{\text{actual}}$ present in the permissible range and load chart
- F1-bar **2.2** yellow: **Advance warning!** $F1_{\text{actual}}$ shortly before the impermissible range
- **Note:** During assembly operation, the F1-bar **2.2** is also shown in yellow within the permissible range.
- F1-bar **2.2** red: **Warning!** $F1_{\text{actual}}$ in the impermissible range

2.3 F1-minimum

- Graphic illustration of range $F1_{\text{min}}$
 Yellow range: $F1_{\text{min-advance warning}}$ - advance warning for F1-minimum
 Red range: $F1_{\text{min-Stop}}$ - Warning / stop for F1-minimum

6.1.3 F2/F3-display bar

Pull test brackets test point 2A and 2B (F2 force) are in the N/W-guying

Pull test brackets test point 3A and 3B (F3 force) are in the guying derrick boom / main boom on the main boom head



Note

- ▶ The F2/F3-display bar appears only in certain situations, for example with activated assembly operation and corresponding boom system.

3 Display bar

- Display bar for graphic illustration of F2/F3-force

3.1 Display scale

- Scale from 0 % to 100 %

3.2 F2-bar

- Graphic illustration of the F2-actual value ($F2_{\text{actual}}$)
- Appears in yellow and red, depending on the situation
- F2-bar **3.2** yellow: Assembly operation - $F2_{\text{actual}}$ in the permissible range
- F2-bar **3.2** red: **Warning!** $F2_{\text{actual}}$ in the impermissible range

3.3 F3-bar

- Graphic illustration of F3-actual value
- Appears in yellow and red, depending on the situation
- F3-bar **3.3** yellow: Assembly operation - $F3_{\text{actual}}$ in the permissible range
- F3-bar **3.3** red: **Warning!** $F3_{\text{actual}}$ in the impermissible range

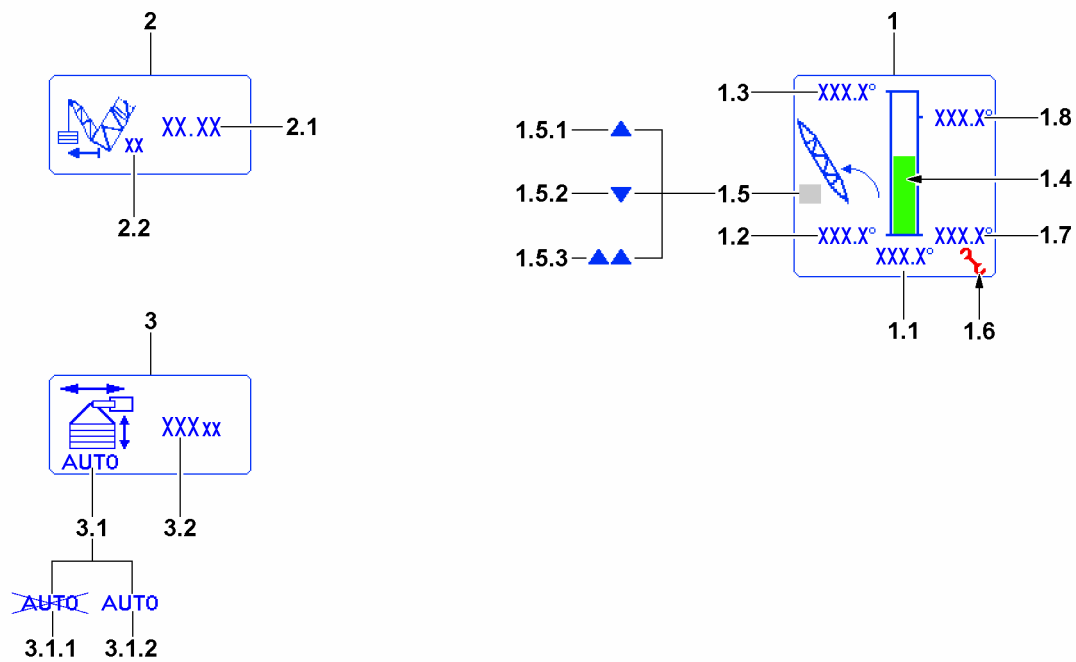
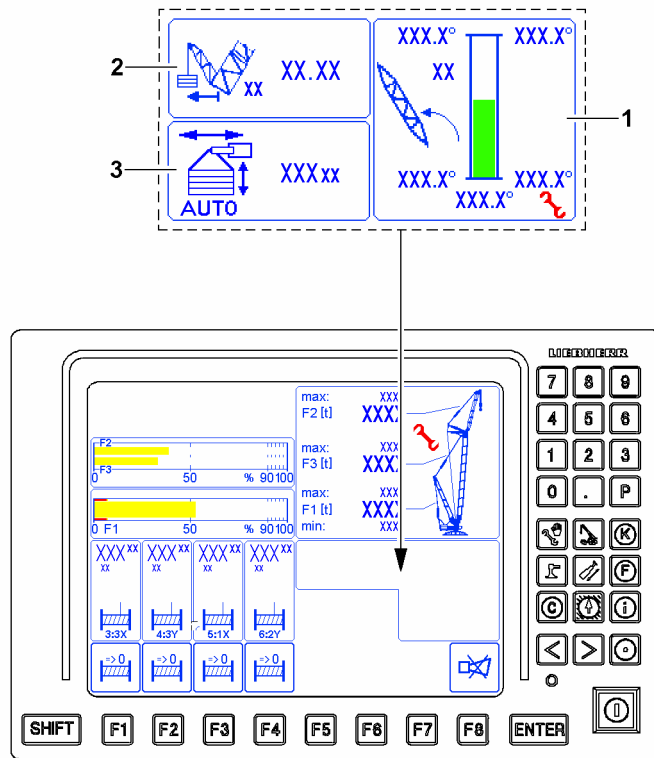

Fig.144127

LWE/LR_13000-001/19503-01-02/en

6.2 Derrick boom angle indicator

- 1 Derrick angle
 - 1.1 Actual angle
 - Current actual angle of the derrick boom
 - Actual angle **1.1** red: **Warning!** Angle derrick boom in the impermissible range
 - 1.2 Minimum angle
 - Minimum angle of the Derrick boom to the front (to the horizontal)
 - 1.3 Maximum angle
 - Maximum angle of the Derrick boom to the front (to the horizontal)
 - 1.4 Bar graph
 - Graphic illustration of derrick angle as bar graph in relation to the minimum / maximum value.
 - Appears in green and red, depending on the situation
 - Column **1.4** green: Derrick boom angle in the permissible range
 - Column **1.4** red: **Warning!** Angle derrick boom in the impermissible range
 - 1.5 Derrick alarm function
 - **1.5.1** Up arrow: Maximum angle derrick boom exceeded
 - **1.5.2** Arrow down: Minimum derrick angle fallen below
 - **1.5.3** Double up arrow: Derrick boom relapse press on block position
 - 1.6 *Assembly* icon
 - The *assembly* icon **1.6** appears when a defined angle range for the derrick boom for erection and take-down of the boom system is specified.
 - 1.7 Assembly minimum angle
 - Assembly: Minimum angle of the Derrick boom to the front (to the horizontal)
 - 1.8 Maximum angle Assembly
 - Assembly: Maximum angle of the Derrick boom to the front (to the horizontal)

6.3 Derrick ballast boom radius display

- 2 *Derrick ballast* boom radius
 - 2.1 Boom radius value
 - Current boom radius value of derrick ballast
 - Measured from the center of the slewing ring to the center of the derrick ballast
 - 2.2 Measuring unit
 - Measuring unit of boom radius value

6.4 Ballast automatic*

After selecting the ballast automatic (see the Crane operating instructions, chapter 4.01) the system saves the current F1-force and the ballast trailer incline.

If the ballast trailer is retracted or extended, the ballast automatic automatically regulates the ballast cylinders to keep the saved value (depending on the situation F1-force or ballast trailer incline).

- 3 Ballast automatic icon
 - 3.1 Ballast automatic status
 - **3.1.1** Ballast automatic turned off
 - **3.1.2** Ballast automatic turned on
 - 3.2 Saved value
 - Depending on the situation:
 - Saved F1-force
 - or**
 - Ballast trailer incline

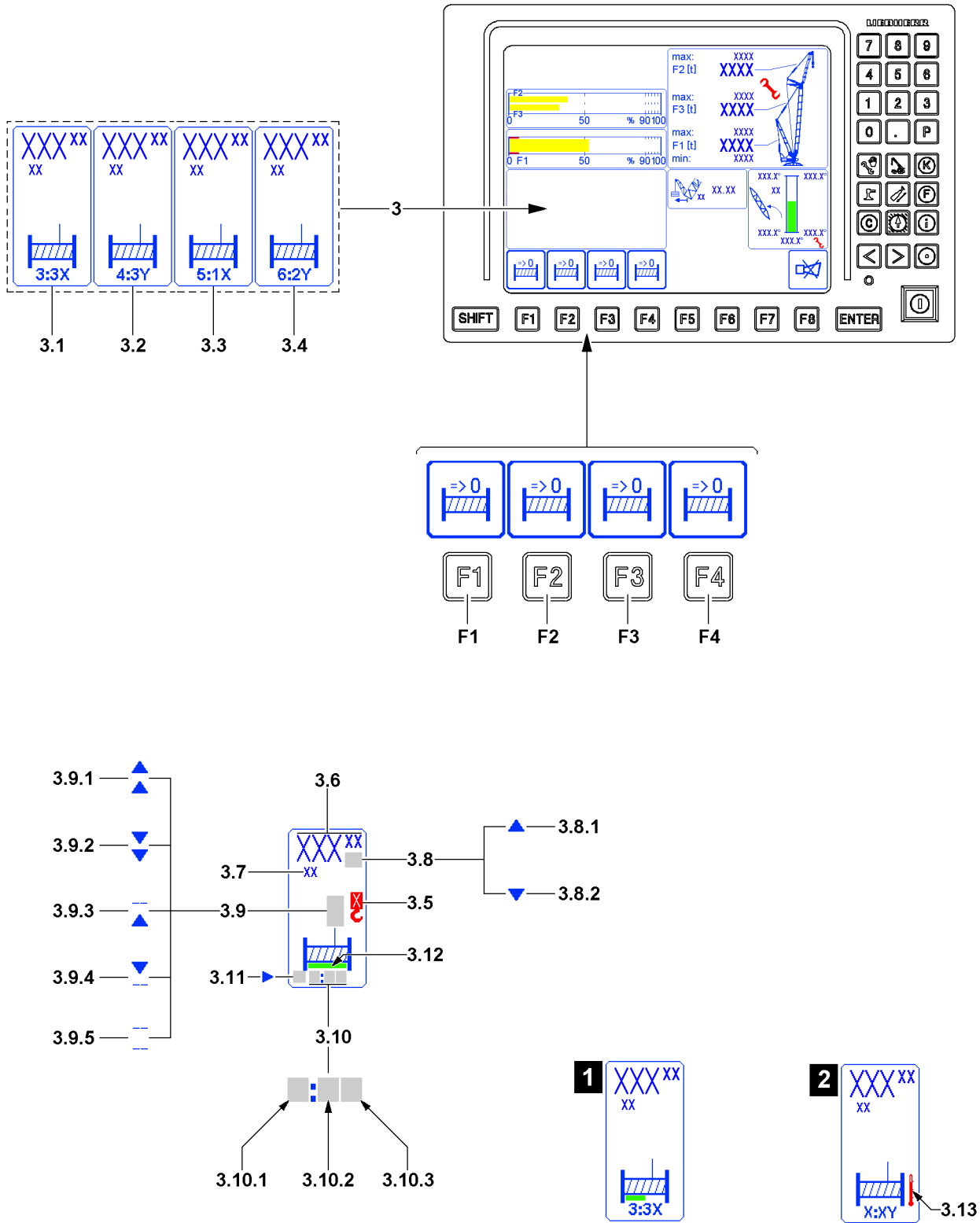

Fig.115251

6.5 LICCON Monitor 1 winch display

The winch displays **3** have a fixed position on the LICCON monitor.

There are two values that can be displayed depending on the use of the winch:

- Using the winch as a hoist winch: The completed hook path is displayed.
 - The completed hook path is calculated with the reeving set in the *Set up* program. A prerequisite for a correct display is that the value entered matches the entered reeving and the actual number of rope strands between the boom head and the hook block.
- Using the winch as a control winch: The spooled out / up rope length of the winch is displayed.

The current position of each winch can be set as zero point.

F1 Function key

- The *reset winch display* icon appears above the function key **F1**. Pressing the button sets the *Completed path* display to zero. Path measurement applies from here.

F2 Function key

- The *reset winch display* icon appears above the function key **F2**. Pressing the button sets the *Completed path* display to zero. Path measurement applies from here.

F3 Function key

- The *reset winch display* icon appears above the function key **F3**. Pressing the button sets the *Completed path* display to zero. Path measurement applies from here.

F4 Function key

- The *reset winch display* icon appears above the function key **F4**. Pressing the button sets the *Completed path* display to zero. Path measurement applies from here.

3 Winch display

3.1 Winch 3 icon

- Icon for winch 3 (WIII)

3.2 Winch 4 icon

- Icon for winch 4 (WIV)

3.3 Winch 5 icon

- Icon for winch 5 (WV)

3.4 Winch 6 icon

- Icon for winch 6 (WVI)



Note

- ▶ The displays for winch 3 to winch 6 are identical and are explained based on one icon element.

3.5 Load position

- Load position to which the winch is assigned.
- **Note:** Appears only when using it as hoist winch.

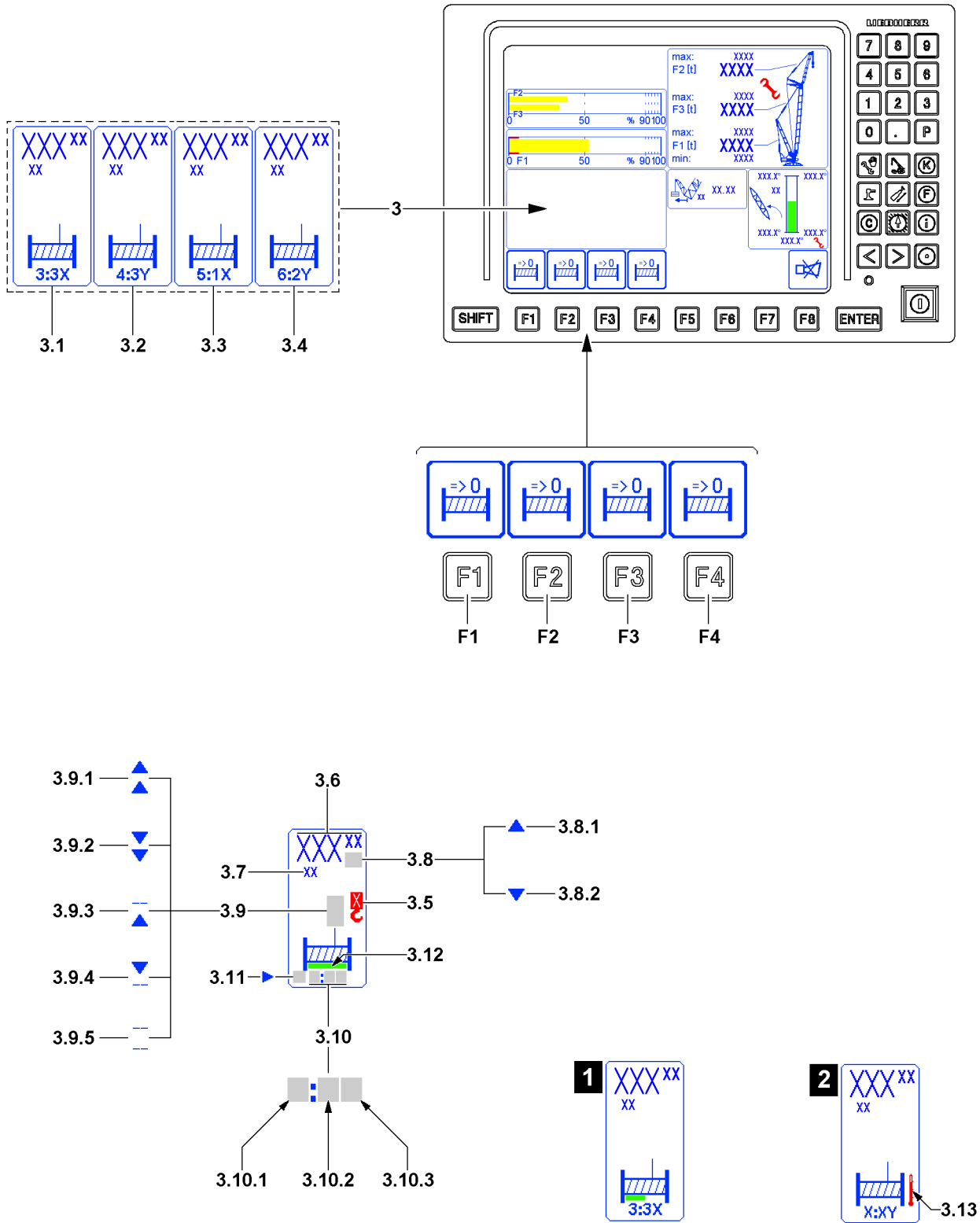

Fig.115251

3.6 Completed path

- Completed hook path from a selectable zero point.
or
Spooled out / spooled up rope length from a selectable zero point
- The positions before the decimal point are displayed with a maximum of three large digits. The digits after the decimal point are displayed in small digits. Setting to zero point, see also section „Function key line of LICCON monitor 1“).
- A prerequisite for a correct display is that the value entered matches the entered reeving and the actual number of rope strands between the boom head and the hook block.

3.7 Measuring unit

- Measuring unit of the *completed path* display in [m] or [ft]



Note

Display area of winch displays.

- ▶ The completed path **3.6** display has only three positions before the decimal point, any positions before that are cut off. The crane operator must evaluate for himself if, for example 200 m of rope are spooled up on a winch or 1200 m. **The display in both cases would be identical with 200 m.**

For use as a hoist winch:

- ▶ The hook path calculation only works accurately if the load is suspended freely and is not luffed during the lifting procedure. Flexation and rope expansion are not taken into account.
- ▶ The *completed path* display is only correct when the winch is calibrated.

3.8 Direction of hook movement

- The arrows on the length value show the direction of the hook movement in relation to the zero point
- Up arrow **3.8.1**: Hook moves upward from the zero point
- Down arrow **3.8.2**: Hook moves downward from the zero point

3.9 Winch status display

- There are five winch condition icons, all blinking
- **Note:** If a winch status icon does not appear, the activated winch is inactive and is neither spooled up nor spooled out.

3.9.1 Spool out

- The winch is spooled out

3.9.2 Spool up

- The winch is spooled up

3.9.3 Spooled out

- Additional spooling out of the winch is blocked

3.9.4 Spooled up

- Additional spooling up of the winch is blocked

3.9.5 Winch deactivated

- The winch is deactivated or unplugged
- **Note:** The winch cannot be controlled.

3.10 Master switch assignment

- **3.10.1** First digit
 - First digit: Winch number, every winch icon is permanently assigned to a winch
- **3.10.2** Second digit
 - Master switch number, according to the assigned master switch
 - ? : No master switch assigned
- **3.10.3** Letter
 - Actuation direction of the master switch, see illustration
 - : No actuation direction assigned

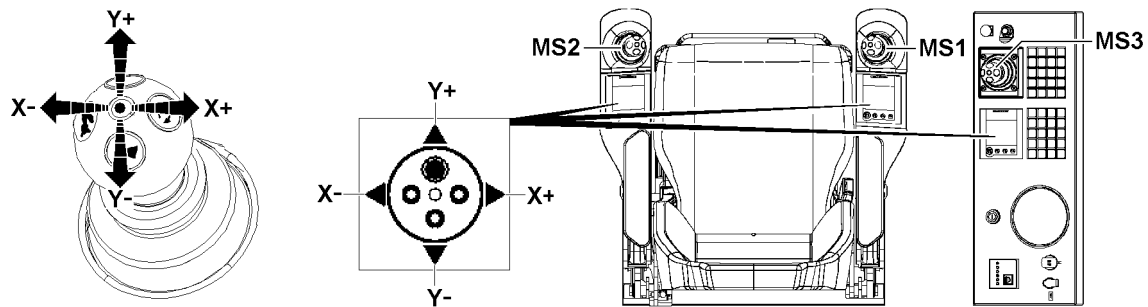

Fig.123758: Actuation directions Master switch

MS1 Master switch 1

MS2 Master switch 2

MS3 Master switch 3

X+ To the right

X- To the left

Y+ To the front

Y- To the rear

3.11 Vibration sensor

- If the vibration sensor for a winch is activated on the master switch, then an arrow appears in this winch icon for the activated vibration sensor.
- **Note:** The vibration sensor is activated at the first actuated crane function.

3.12 Winch speed

- If the maximum winch speed is reduced, a bar in the respective length appears on the bottom in the winch icon. Example: Half the length corresponds to a 50% reduction of the maximum winch speed, see the example in illustration 1.

Maintenance displays, illustration 2:

3.13 Winch overheated icon

- If the *Winch overheated* icon 3.13 appears, the temperature in the respective winch is too high.

Note: Only for certain crane types with temperature sensors in the winches.



WARNING

Overheated winch!

If a winch is operated further, even though the *Overheated* icon 3.13 appears, the winch can be severely damaged.

The winch can fail and accidents can occur.

- ▶ Let the overheated winch cool off.

Empty page!

LWE/LR 13000-001/19503-01-02/en

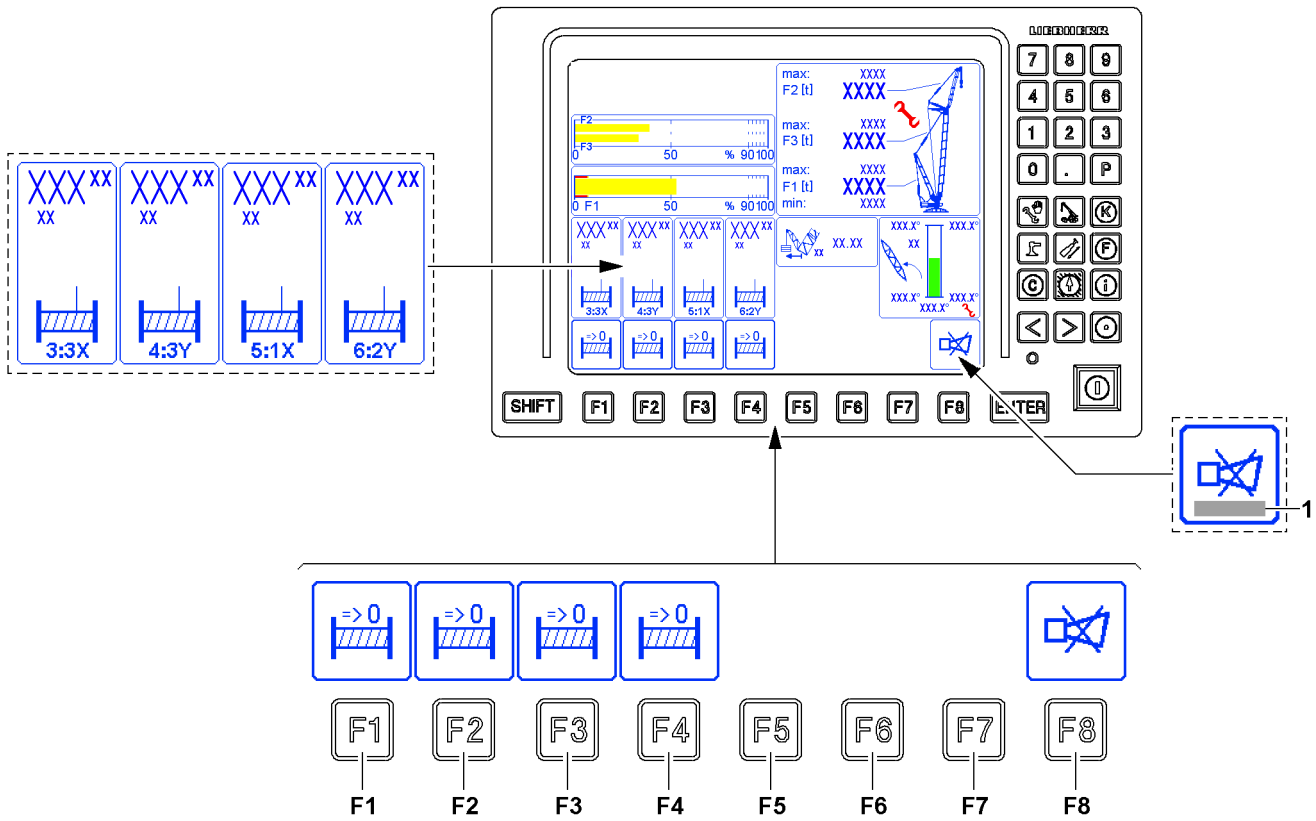

Fig.115252

6.6 The function key line of LICCON monitor 1

The function key line consists of function keys **F1** to **F8** and the function key icon bar above it. The function keys correspond to the various function key icons above them.

The function key icons always show the functions which are activated by pressing the button.

The function is called up after pressing a button. In addition, the icon above it can change its display, its meaning or its text.

Not all function keys must have assigned icons. This depends on the respective program selection.

F1 Function key

- Determine the zero point for the Winch 3* *completed path* display.
- The *reset winch display* icon appears above the function key **F1**. Pressing the button sets the *Completed path* display to zero. Path measurement applies from here.

F2 Function key

- Determine the zero point for the Winch 4* *completed path* display.
- The *reset winch display* icon appears above the function key **F2**. Pressing the button sets the *Completed path* display to zero. Path measurement applies from here.

F3 Function key

- Determine the zero point for the Winch 5* *completed path* display.
- The *reset winch display* icon appears above the function key **F3**. Pressing the button sets the *Completed path* display to zero. Path measurement applies from here.

F4 Function key

- Determine the zero point for the Winch 6* *completed path* display.
- The *reset winch display* icon appears above the function key **F4**. Pressing the button sets the *Completed path* display to zero. Path measurement applies from here.

F5 Function key

- No function

F6 Function key

- No function

F7 Function key

- No function

F8 Function key

- Shut-off of acoustic warning and possibly calling up of error messages **1**.
Press the function key **F8** once: The acoustic signal is turned off.
Press the function key **F8** twice: The error description for the error message **1** that occurred last is called up.
- **Note:** A new error turns the acoustic warning on again.

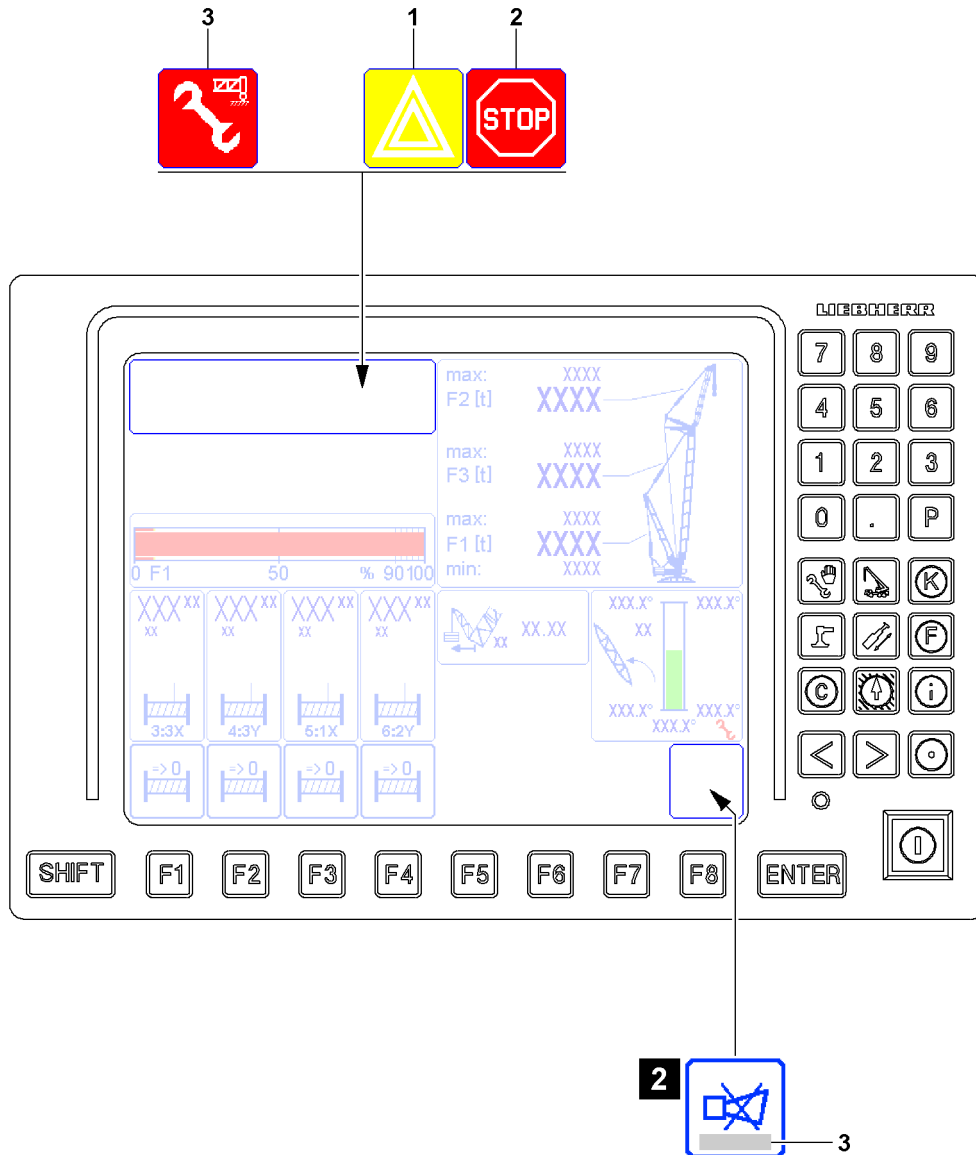

Fig.125389

6.7 Alarm functions of LICCON monitor 1



WARNING

Shut off of the crane movement!

If advance warnings are not observed, then this can result in a sudden shut-off of the crane movement.

A sudden shut off of the crane movement can result in high stress and strain for crane and load. High strain for the crane and load can cause accidents.

- ▶ Operate the crane in such a way if possible that there is no shut off of crane movements by the crane control.
- ▶ Monitor the display instruments constantly.
- ▶ If not otherwise possible, approach a possible shut off of crane movements with extreme caution.



Note

LMB-STOP shut off delay

- ▶ An LMB-STOP with shut off delay always remains for a certain period of time. Possible fluctuating movements of the crane can be thereby minimized.

6.7.1 Occurrence of an advance warning

1 *Advance warning icon*

- If an advance warning occurs, for example: $F1_{\text{actual}}$ less than $F1_{\text{min-warning value}}$
- $F1_{\text{min-warning value}}$ is prioritized to $F1_{\text{min}}$ as advance warning value.
- **Example:** $F1_{\text{min}}$ plus advance warning extra (approx. 15 t) results in $F1_{\text{min-warning value}}$.

6.7.2 Shutting off the crane movement

2 *LMB-STOP icon*

- The *LMB-STOP* icon **2** appears if a shut off limit is exceeded.
Example: $F1_{\text{actual}}$ less than $F1_{\text{min}}$
- **Note:** Individual crane movements are shut off. Pay attention to error messages **3** and display values.

6.7.3 *Boom on the ground function*

3 *Ausleger am Boden icon*

- The *Boom on the ground* icon **3** appears when the *Boom on ground function* is activated.
- **Note:** *Boom on ground* function operating elements, see the Crane operating instructions, chapter 4.01.

6.8 Acoustic warning on LICCON monitor 1

Acoustic warnings on LICCON monitor 1 are indicated by the *horn* warning sound.

The *horn* warning sound is divided into two categories:

- The *horn* is a beeping sound that lasts approximately 0.5 seconds and that is repeated every second.
- A *short horn* is a beeping sound of a duration of approximately 0.1 seconds, which is repeated in a second cycle.

7 Horn icon

- When the *Horn* icon **7** is shown on the LICCON monitor, any acoustic signals that occur can be shut off by LICCON monitor 1 by pressing the function key **F8**.
- If an error message is shown in the *Horn* icon **7** in the field **7.1**, then it can be used to determine the present error. Pressing the function key **F8** twice automatically switches to the error determination screen of the BSE test system. The error is displayed there in documentary form.

6.8.1 Horn warning sound

- Sounds in addition to the visual display of an error message in the field **7.1** in case of operational errors are found that lead to a shut-off of a crane movement.
Operational errors are, for example:
 - Exceeding of limit values in the F-load display
 - Exceeding of limit values in the geometry Derrick boom
- In case of application errors with error number (LICCON Error Code LEC)

6.8.2 Short horn warning sound

Sounds in addition to the visual display of error messages that do not have an error number and do not lead directly to crane movement shut-off by the LICCON overload protection

Monitored error messages are, for example:

- Advance warning by approaching the limit values in the F-load display

6.8.3 Acoustic warning priority

- The *Horn* warning around has higher priority than the *Short horn* warning sound, i.e. *Horn* takes preference over *Short horn*.
- Both the *Horn* warning sound as well as the *Short horn* warning sound become active again after shut down if a new error occurs.

7 The *Crane operation* program on LICCON monitor 2

The *Crane operation* LICCON program assists the crane operator by displaying the data relevant for crane operation clearly on three LICCON monitors. An acoustic signal accompanies all critical displays. Depending on the equipment, a range of other icons may also be turned on as additional displays, either as required by the crane operator, or automatically in case of a problem.

It also alerts the crane operator to imminent overload conditions. In the event of overload and many error conditions, which could be hazardous during crane operation, the system shuts off.



Note

- ▶ The suspended ballast and the ballast trailer* are generally referred to as the **derrick ballast**.
- ▶ The fixed compensation weight that is installed on the turntable is generally referred to as the **counterweight**.

The LICCON monitor 2 is divided into three areas in the *Crane operation* program:

- 1 Load max
 - Maximum load depending on the derrick ballast
- 2 Derrick ballast
 - Derrick ballast weight
 - Derrick guying forces
 - Utilization of the derrick ballast
 - Maximum liftable derrick ballast for the current crane condition, without falling below $F_{1_{min}}$ when lifting
- 3 Function key line
 - The function keys always refer to the icons shown directly above them
 - **Note:** If no icon is shown on the line directly above the function key, then no function is assigned in the program to the function key.
- 4 LICCON Monitor 2 special functions



Note

- ▶ The monitor illustrations in this chapter are only examples.
- ▶ The numerical values in the individual icons and charts do not have to necessarily match the crane exactly.
- ▶ The configuration of the LICCON monitor with icons is only descriptive.
- ▶ An identical icon display will **not** appear during crane operation.

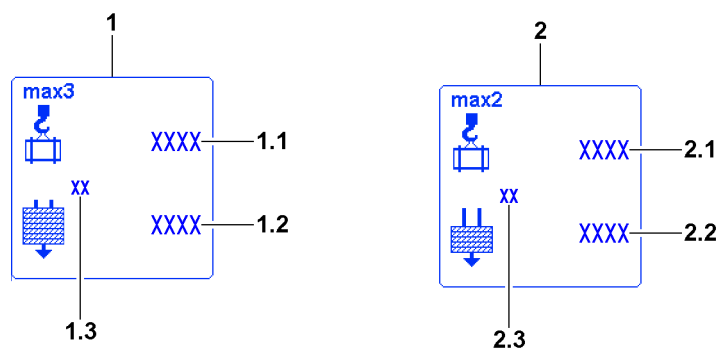
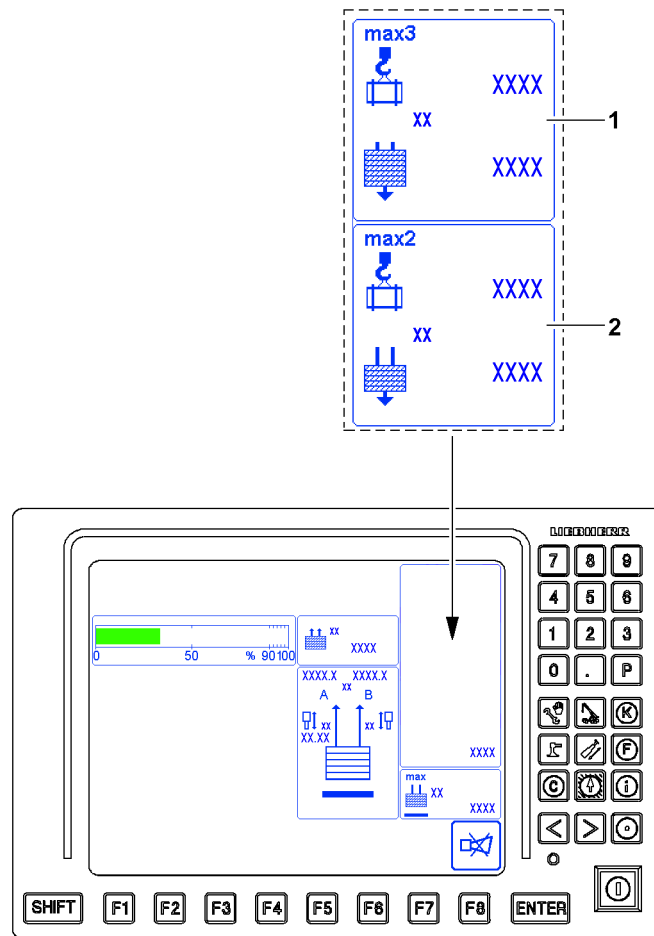

Fig.146958

7.1 Load max

The information regarding crane geometry and load involves two icons:

1 Load max3

Note: This is hidden as soon as two hook operation is set in the *set up* program.

2 Load max2

Note: This is hidden as soon as two hook operation is set in the *set up* program.



Note

- ▶ Question marks (?) are shown instead of values if the value cannot be calculated / determined.
Example: A sensor error can be present - pay attention to the error messages.

7.1.1 Load max3

The *load max3* icon **1** shows the maximum load with maximum derrick ballast within the framework of the load chart.

The *load max3* icon **1** is hidden as soon as two hook operation is set in the *set up* program.

1 *Load max3* icon

1.1 Possible load_{max3}

- Is the load which the crane could currently lift when the maximum derrick ballast according to the load chart would have been placed
- In [t] or [lbs]

1.2 Maximum derrick ballast

- Maximum derrick ballast according to the load chart

1.3 Measuring unit

- Measuring unit for the display values in the *Load max3* icon **1**: [t] or [lbs]

7.1.2 Load max2

The *load max2* icon **2** displays the highest possible load in the current operating status (**current derrick ballast** fully utilized).

The *load max2* icon **2** is hidden as soon as two hook operation is set in the *set up* program.

2 *Load max2* icon

2.1 Possible load_{max2}

- This is the maximum load that the crane can lift in the current operating status. For that, the placed derrick ballast must be fully utilized (Derrick ballast lifted off the ground).
- In [t] or [lbs]

2.2 Placed derrick ballast

- Currently placed derrick ballast

2.3 Measuring unit

- Measuring unit for the display values in the *Load max2* icon **2**: [t] or [lbs]

7.2 Derrick ballast



Note

- ▶ A question mark (?) is shown instead of values if the value cannot be calculated / determined.
Example: A sensor error can be present - pay attention to the error messages.

The force components / load of the guying derrick ballast is recorded on guying A and guying B of the derrick ballast.

Test points guying A are:

- Test point 4A = pressure sensor ring surface left F4A
- Test point 5A = pressure sensor piston surface left F5A

Test points guying B are:

- Test point 4B = pressure sensor ring surface right F4B
- Test point 5B = pressure sensor piston surface right F5B

7.2.1 Derrick ballast utilization display

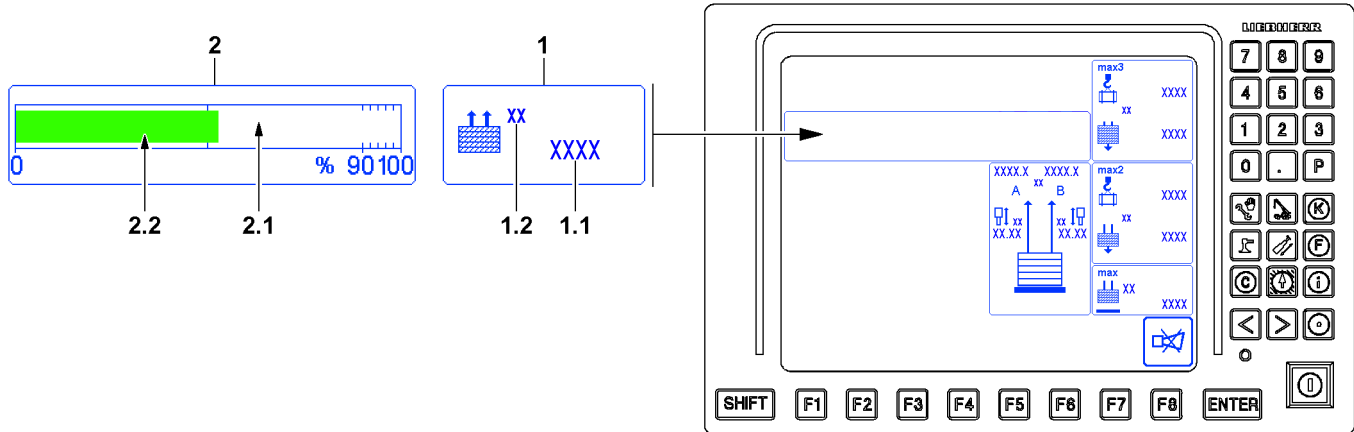

Fig.146959

In the icon *Pulled derrick ballast 1* the currently pulled derrick ballast is shown. The value results from the vertical force components / load on guying A and guying B of the derrick ballast.

- 1** *Pulled derrick ballast* icon
 - 1.1** *Pulled derrick ballast*
 - Currently pulled derrick ballast
 - Sum of forces / load from guying A and guying B
 - 1.2** *Measuring unit*
 - Measuring unit for display values in the *pulled derrick ballast* icon 1: [t] or [lbs]

The *Derrick ballast utilization bar* icon 2 depicts the ratio of the pulled derrick ballast (BA_{pulled}) to the placed derrick ballast (BA_{placed}) as a percentage.

- 2** *Derrick ballast utilization bar* icon
 - Display bar for graphic display of derrick ballast utilization
- 2.1** *Display scale*
 - Scale from 0 % to 100 %
- 2.2** *Pulled derrick ballast*
 - Graphic illustration of pulled derrick ballast
 - If the derrick ballast is completely pulled, the derrick ballast lifts off the ground

7.2.2 Suspended ballast*

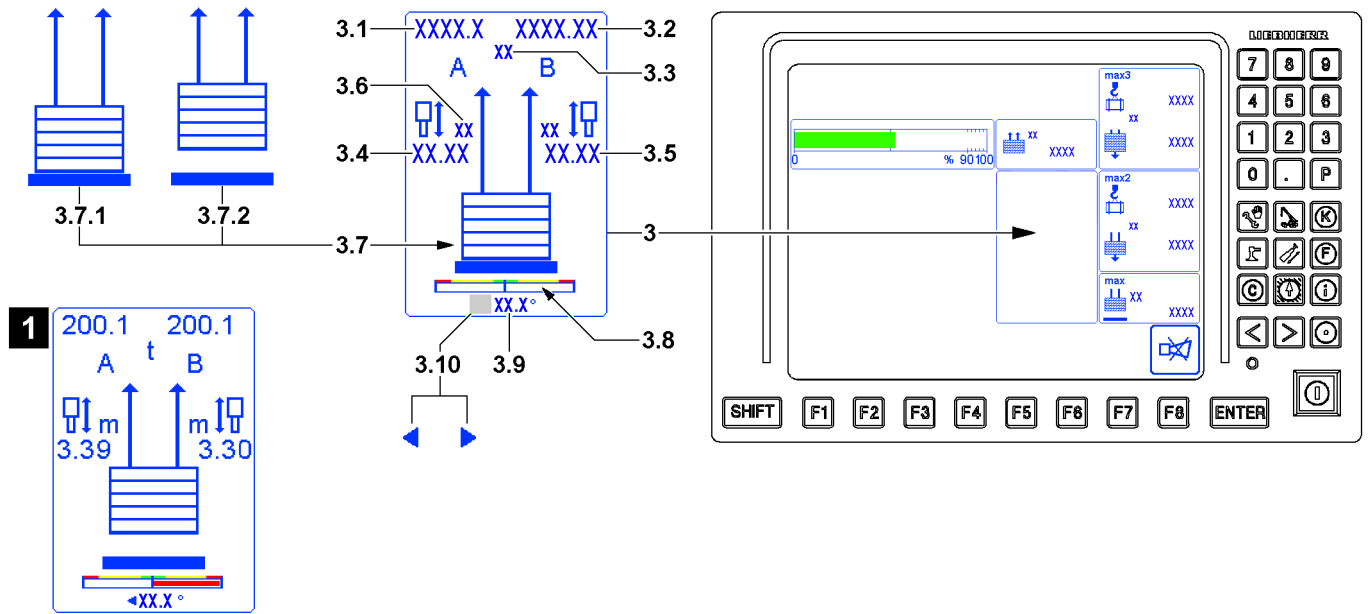

Fig. 146960

If the crane is set up with suspended ballast*, then the displays in the *Guying derrick ballast* icon 3 are automatically adapted by the LICCON computer system.



WARNING

Derrick ballast on unsuitable ground!

If the derrick ballast gets so far into a sloped position in lateral direction that the red range (example illustration 1) is reached in the incline display, then there is a danger of accident.

If the derrick ballast sinks too far into the ground, then there is a danger of accident.

- ▶ Always correct the position of the derrick ballast in time. Hold the extension length A and extension length B even.
- ▶ The derrick ballast may only be set down if the ground is sufficiently load bearing and even.

- 3 *Derrick ballast guying icon*
- 3.1 Guying A
 - Current force / load on guying A
- 3.2 Guying B
 - Current force / load on guying B
- 3.3 Measuring unit
 - Measuring unit for guying A and guying B display values: [t] or [lbs]
- 3.4 Extension length A
 - Current extension length of pull cylinder of guying A
- 3.5 Extension length B
 - Current extension length of pull cylinder of guying B
- 3.6 Measuring unit
 - Measuring unit for extension length of pull cylinders of guying A and guying B: [m] or [ft]
- 3.7 Ground contact
 - Display for ground contact of derrick ballast
 - 3.7.1 Derrick ballast has ground contact
 - 3.7.2 Derrick ballast lifted
- 3.8 Incline indicator
 - Graphic display of incline of derrick ballast in the lateral direction
 - **Note:** Not for the suspended ballast for the *Ballast Constant* version

3.9 Incline value

- Incline value of the derrick ballast in the lateral direction
The incline value appears in degrees [°].



Note

- ▶ The incline direction **3.10** appears only when the derrick ballast is inclined in the lateral direction.

3.10 Incline direction

- Incline direction of the derrick ballast in the lateral direction
- Appears only when the derrick ballast is inclined in the lateral direction

7.2.3 Ballast trailer*

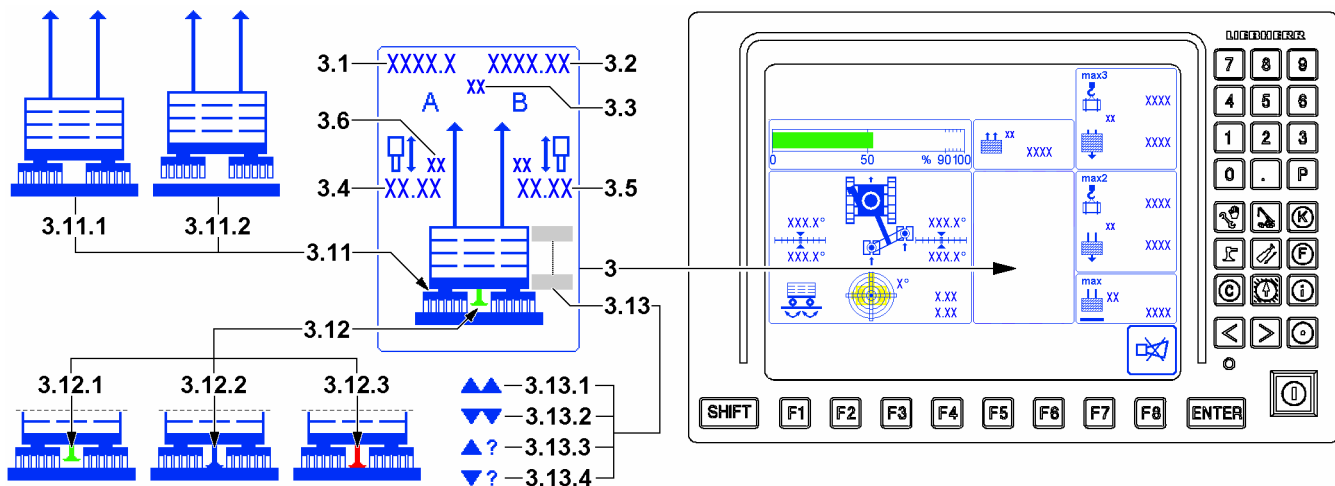

Fig.146961

If the crane is set up with a ballast trailer*, then the displays in the *Guying derrick ballast* icon **3** are automatically adapted by the LICCON computer system.



WARNING

Ballast trailer on unsuitable ground!

If the ballast trailer gets too far into an incline position, then there is a danger of accident.

If the ballast trailer sinks too far into the ground, then there is a danger of accident.

- ▶ Always correct the position of the ballast trailer in time. Hold the extension length A and extension length B even.
- ▶ The ballast trailer may only be set down if the ground is sufficiently load bearing and even.

3 Derrick ballast guying icon

3.1 Guying A

- Current force / load on guying A

3.2 Guying B

- Current force / load on guying B

3.3 Measuring unit

- Measuring unit for display values guying A and guying B: [t] or [lbs]

3.4 Extension length A

- Current extension length of pull cylinder of guying A

3.5 Extension length B

- Current extension length of pull cylinder of guying B

3.6 Measuring unit

- Measuring unit for extension length of pull cylinders of guying A and guying B: [m] or [ft]

3.11 Ground contact

- Display for ground contact of ballast trailer

- 3.11.1 Ballast trailer has contact with the ground
- 3.11.2 Ballast trailer lifted
- 3.12 Ballast trailer support
 - Display for the status of the support ballast trailer
 - 3.12.1 Support retracted, ballast trailer not supported
 - 3.12.2 Support extended, ballast trailer is supported
 - 3.12.3 Support not in nominal position

Notice! Support not completely retracted and selection travel gear, slewing gear or sliding cylinder selected



Note

Ballast trailer limit signs 3.13

► The permissible level difference between the placement surface of the crane and the ballast trailer is limited both upward and downward. In order to avoid damaging the crane or the ballast trailer, the upper and lower stop positions are monitored by limit switches. If one of the end positions is reached, the corresponding limit sign appears. The movements on the crane, or on the ballast trailer, are turned off.

3.13 Ballast trailer limit signs

- 3.13.1 Upper end position limit switch triggered (ballast trailer too far above the crane placement surface)
- 3.13.2 Lower end position limit switch triggered (ballast trailer too far below the crane placement surface)
- 3.13.3 Upper end position limit switch defective
- 3.13.4 Lower end position limit switch defective

Notice! There is no shut-off when reaching the upper end position. Remedy the error immediately.

• 3.13.4 Lower end position limit switch defective

Notice! There is no shut-off when reaching the lower end position. Remedy the error immediately.

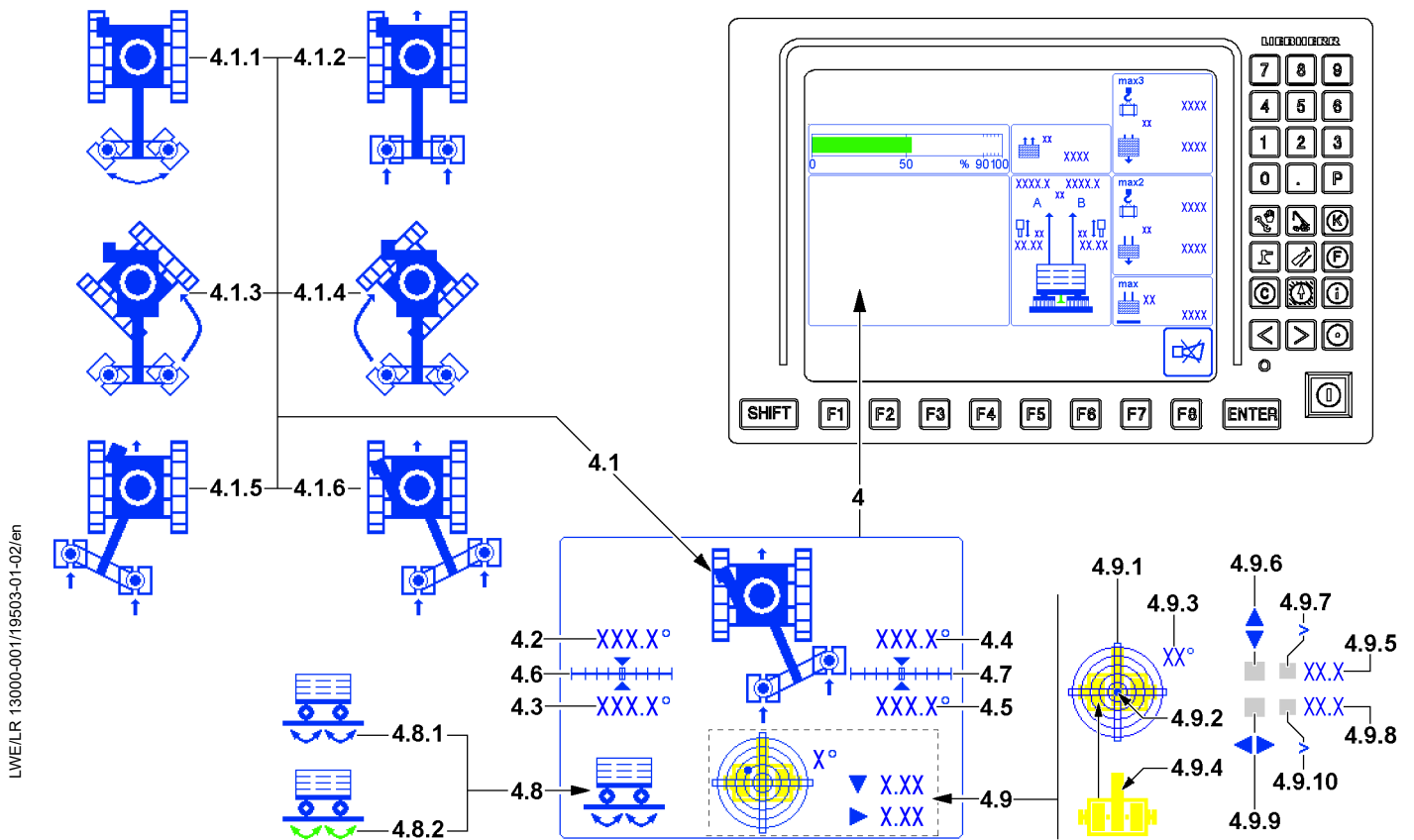

Fig.146962

4 *Ballast trailer icon*

4.1 Steering operating modes

- Display for a set steering operating mode
- **4.1.1** Ballast trailer circular travel
- **4.1.2** Ballast trailer towing
- **4.1.3** Ballast trailer corrective steering (crane drives left)
- **4.1.4** Ballast trailer corrective steering (crane drives right)
- **4.1.5** Ballast trailer parallel travel (ballast trailer offset left)
- **4.1.6** Ballast trailer parallel travel (ballast trailer offset right)

4.2 Left nominal angle

- Nominal angle for the left wheel set

4.3 Actual angle left

- Actual angle for the left wheel set
- If the left nominal angle **4.2** is not reached:
 - The left actual angle **4.3** is shown in red
 - In the left graphic display **4.6** the *actual value* position arrow is not the same as the *nominal value* arrow

4.4 Right nominal angle

- Nominal angle for the right wheel set

4.5 Actual angle right

- Actual angle for the right wheel set
- If the right nominal angle **4.2** is not reached:
 - The right actual angle **4.5** is shown in red
 - In the right graphic display **4.7** the *actual value* position arrow is not the same as the *nominal value* arrow

4.6 Left graphic display

- Actual angle and nominal angle graphic display for the left wheel set

4.7 Graphic display right

- Actual angle and nominal angle graphic display for the right wheel set

4.7 Drive status

- Status display for the ballast trailer drive
- **4.8.1** Drive turned on (not active)
- **4.8.2** Drive turned on and active

4.9 *Ballast trailer incline* display

- Display of the incline of the ballast trailer to the horizontal in longitudinal and lateral direction.
- The display is divided in a graphic section and a numeric section.
- The direction specification refers to the overhead view of the ballast trailer on the graphic display.

Graphic part:

4.9.1 Graphic display

- The graphic display is in the form of a spirit level, with a moving dot **4.2** representing the air bubble.

4.9.2 Dot

- The center of the dot **4.9.2** shows the incline value.

4.9.3 Display resolution

- This value indicates the resolution of the graphic display. The resolution is matched automatically to the inclination.

4.9.4 Ballast trailer guide position

- An overhead view of the ballast trailer is highlighted in the graphic illustration **4.9.1**. The displayed position of the ballast trailer guide **4.9.4** serves as orientation on the display.

Numeric part:

4.9.5 Longitudinal direction

- Incline of crane in the longitudinal direction in [°].

- 4.9.6 Direction arrow
 - The direction arrow shows the direction of the incline
- 4.9.7 Display range exceeded
 - If the *greater than* icon appears, then the display range is exceeded
 - **Note:** The crane is inclined further than can be shown.
- 4.9.8 Lateral direction
 - Incline of crane in lateral direction in [°]
- 4.9.9 Direction arrow
 - The direction arrow shows the direction of the incline
- 4.9.10 Display range exceeded
 - If the *greater than* icon appears, then the display range is exceeded
 - **Note:** The crane is inclined further than can be shown.



Note

Orientation of the crane on the *ballast trailer incline* display 4.9.

- Pay attention to the position of the ballast trailer guide 4.9.4.

7.2.4 Maximum liftable derrick ballast

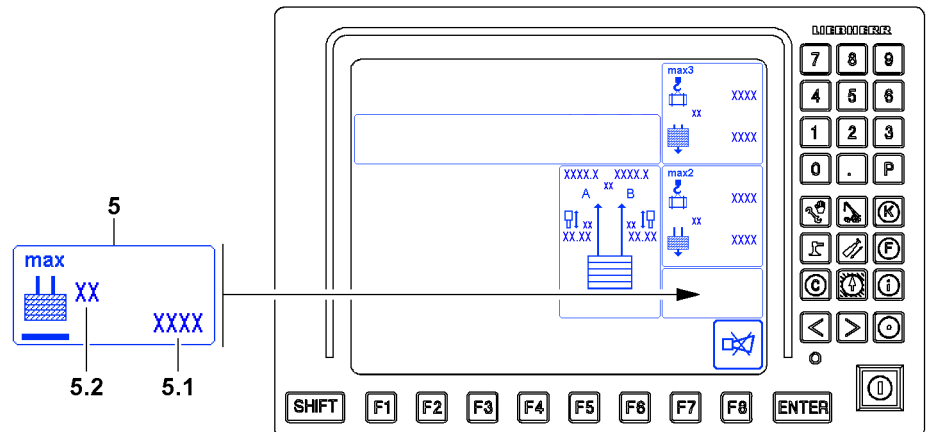

Fig.146950

The *maximum liftable derrick ballast* icon 5 displays the derrick ballast that, with reference to the current crane condition, can be lifted off the ground with the pull cylinder or off the suspended ballast palette in case of the VarioTray without falling below the $F1_{\min}$ force.

- 5 *Maximum liftable derrick ballast* icon
- 5.1 Maximum liftable derrick ballast
 - Maximum derrick ballast
- 5.2 Measuring unit
 - Measuring unit for display values in the *Maximum liftable derrick ballast* icon 5: [t] or [lb]

7.3 LICCON Monitor 2 special functions

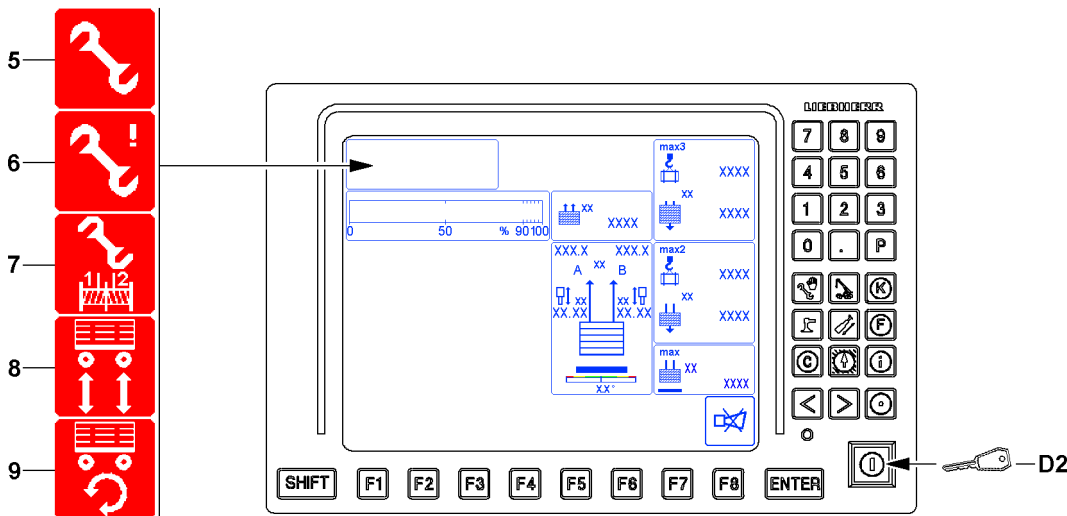

Fig.146963

7.3.1 Derrick ballast guying difference force monitoring shut-off

5 Assembly icon

- The *assembly* icon 5 appears when the *derrick ballast guying difference force monitoring* shut-off is bypassed. The bypass of the shut-off is made via the key button (set up key) of LICCON monitor 0 (right monitor), see section „Special functions LICCON monitor 0“.



Note

Derrick ballast guying difference force monitoring shut-off

- Observe the Crane operating instructions, chapter 5.35 / 5.36.

7.3.2 Changing over winch 1 and winch 2 parallel operation regulation

The parallel operation of winch 1 and winch 2 is regulated from a pulley head height of more than 20 m over the test pulleys. If a problem occurs, switch over to a regulation via the winch speed sensors.



WARNING

Impermissible change over of *winch 1 and winch 2 parallel operation* regulation!

- Changing the *winch 1 and winch 2 parallel operation* regulation is only permissible if - due to contamination, icing or failure of the path measurement system of the test pulleys - a correct path measurement of the hoist ropes of winch 1 and winch 2 is not possible.
- Changing the *parallel operation winch 1 and winch 2* regulation is only permissible if it is not possible to immediately clean or de-ice the test pulleys or repair the path measurement system.
- As long as the *winch 1 and winch 2 parallel operation* regulation is changed over, the crane driver must align the position of the hook block manually in general.

D2 Key button

- Change over winch 1 and winch 2 parallel operation regulation.
- Note:** At a pulley head height below 20 m the function is deactivated, since the system is already regulated via the winch speed sensors.
- Note:** After switching the regulation, winch 1 and winch 2 must be adjusted, see chapter 4.05.

The function is turned off by pressing the key button **D2** again.

The function is also turned off if the engine or the ignition is turned off.

7 *Parallel operation regulation switched over icon*

- The *Parallel operation regulation switched over icon 7* appears when the winch 1 and winch 2 parallel operation regulation is switched over.
- **Note:** After turning the function off, the icon turns off.

7.3.3 Ballast trailer emergency operation

6 *Assembly icon*

- The *Assembly icon 6* appears when the ballast trailer emergency operation is engaged, see the Crane operating instructions, chapter 5.35.

8 *Drive clear emergency operation icon*

- The *Drive clear emergency operation icon 8* appears when:
 - The ballast trailer emergency operation is engaged
 - *Drive clear emergency operation* is engaged

9 *Turn clear emergency operation icon*

- The *Turn clear emergency operation icon 9* appears when:
 - The ballast trailer emergency operation is engaged
 - *Emergency operation turn clear* is engaged

7.4 Acoustic warning on LICCON monitor 2

Acoustic warnings on LICCON monitor 2 are indicated by the *horn* warning sound.

The *horn* warning sound is divided into two categories:

- The *horn* is a beeping sound that lasts approximately 0.5 seconds and that is repeated every second.
- A *short horn* is a beeping sound of a duration of approximately 0.1 seconds, which is repeated in a second cycle.

7 Horn icon

- When the *horn* icon **7** is shown on the LICCON monitor, any acoustic signals that occur can be shut off by LICCON monitor 2 by pressing the function key **F8**.
- If an error message is shown in the *Horn* icon **7** in the field **7.1**, then it can be used to determine the present error. Pressing the function key **F8** twice, automatically switches to the error determination screen of the test system. The error is displayed there in documentary form.

7.4.1 Horn warning sound

1. Sounds in addition to the visual display of an error message in the field **7.1** in case of operational errors are found that lead to a shut-off of a crane movement.

Operational errors are, for example:

- Difference between *Force / load on guying A* and *Force / load on guying B* is too large

2. In case of application errors with error number (LICCON Error Code LEC)

7.4.2 Short horn warning sound

Sounds in addition to the visual display of error messages that do not have an error number and do not lead directly to crane movement shut-off by the LICCON overload protection

Monitored error messages are, for example:

- Advance warning by approaching the limit values in the F-load display

7.4.3 Acoustic warning priority

- The *Horn* warning around has higher priority than the *Short horn* warning sound, i.e. *Horn* takes preference over *Short horn*.
- Both the *Horn* warning sound as well as the *Short horn* warning sound become active again after shut down if a new error occurs.

8 Curve illustration program

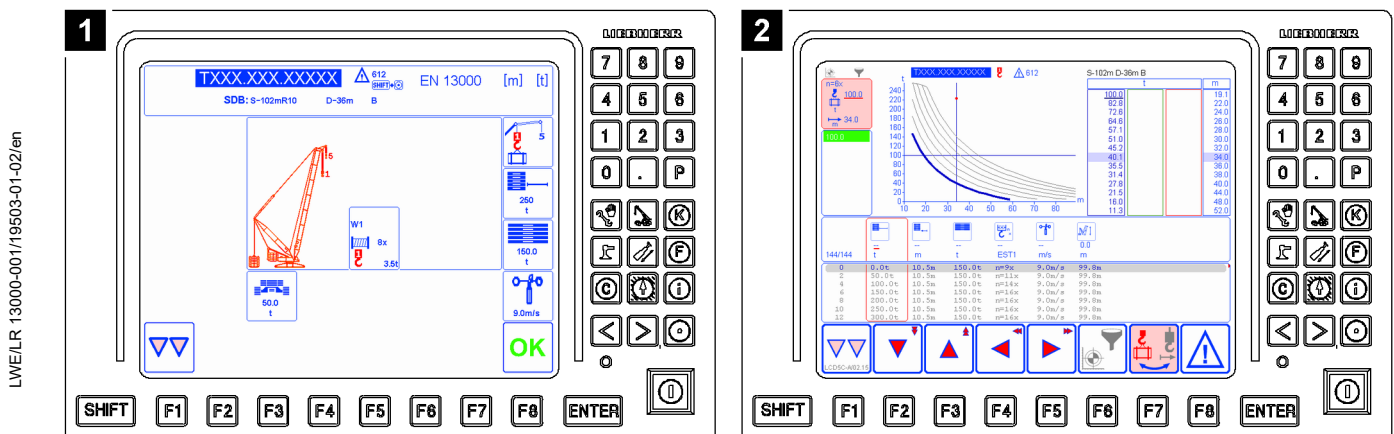

Fig.164420: Exemplary illustration of displays in the Curve illustration program

LWE/LR 13000-001/19503-01-02/en

In the *Curve illustration* program, the load charts appear on the LICCON monitor as curves and as numerical values, see illustration 2.

The curve illustration of the load charts is based on:

- The load charts
- The entries and settings in the *Set up* program, see illustration 1
- The entries and settings in the *Curve illustration* program, see illustration 2

The following can be carried out in the *Curve illustration* program:

- Curve illustration and numeric illustration of load charts
- Filtering of load columns
- Filtering of a set load case
- Comparison of different load columns

For a description of the *Curve illustration* program, see the LICCON job planner operating instructions / load chart illustration.

Empty page!

LWE/LR 13000-001/19503-01-02/en

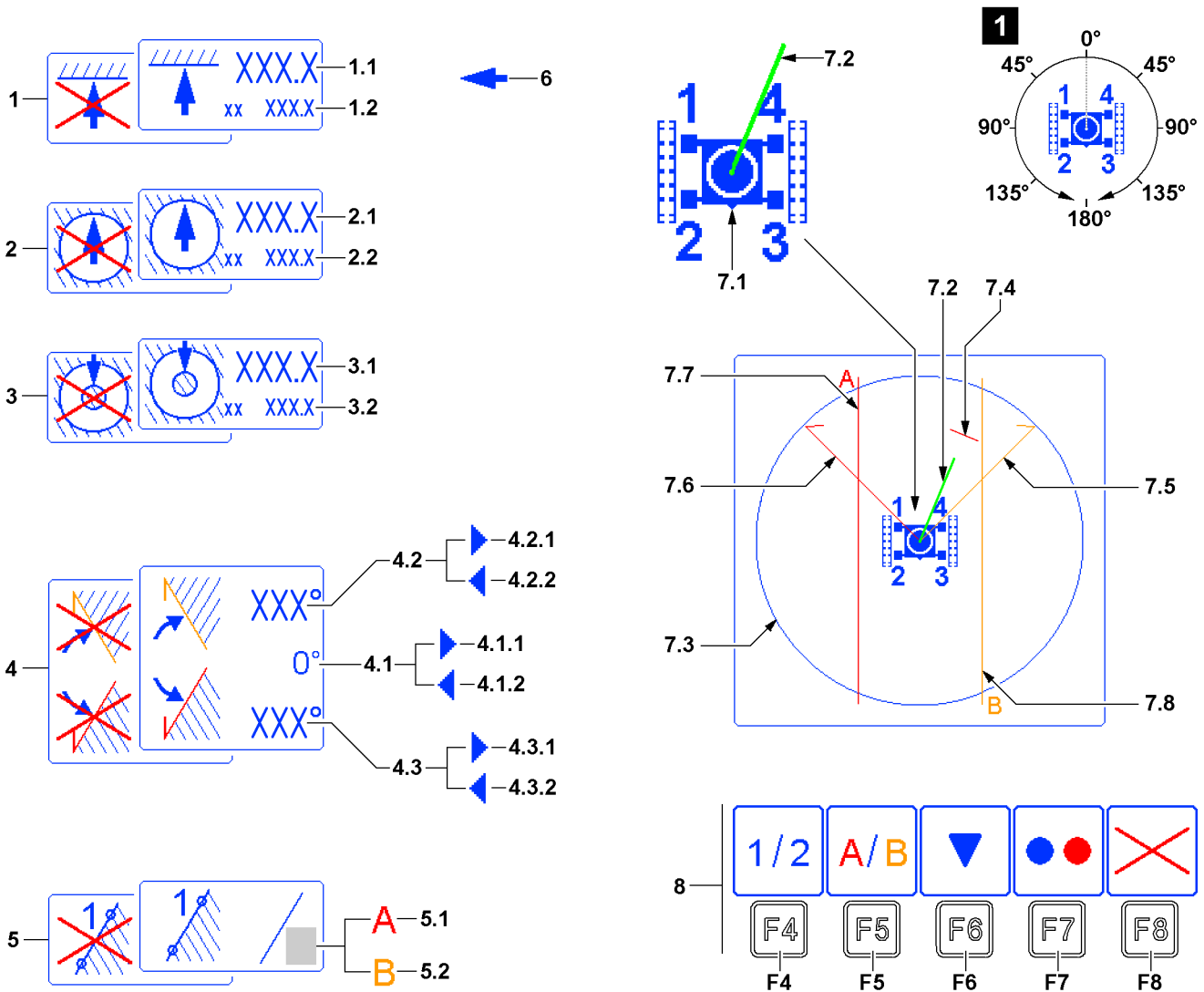
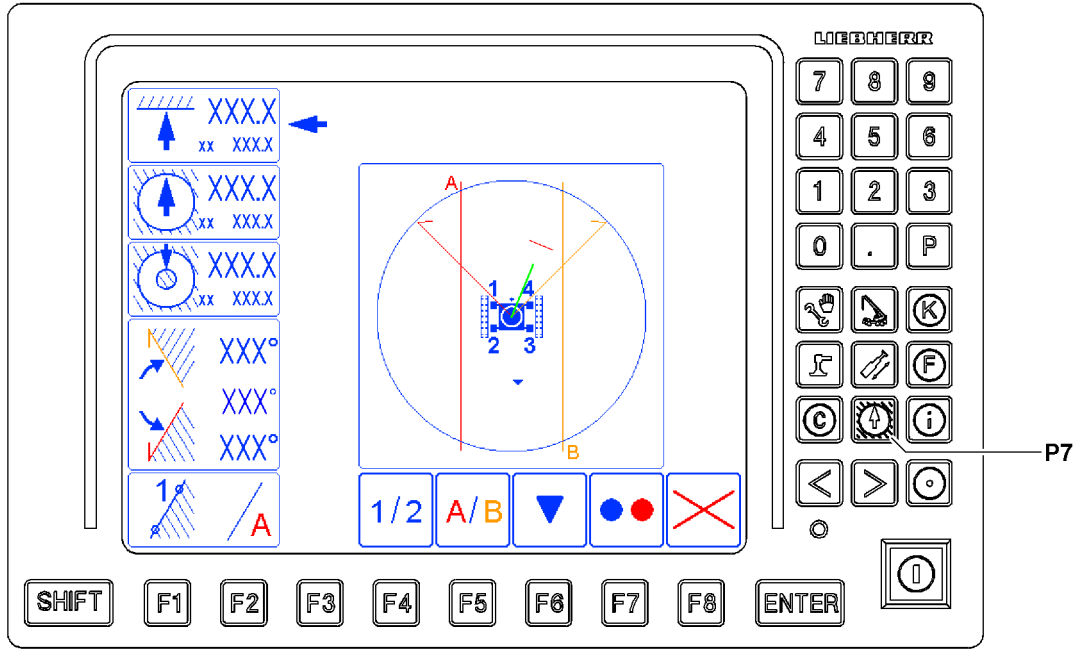

Fig.116057

LWE/LR 13000-001/19503-01-02/en

9 Working range limitation program

For a detailed description of the *Working range limitation* program, see the separate Operating instructions for the Working range limitation.

9.1 Starting the program

- ▶ Press the program key P7.

9.2 Operating interface



Note

- ▶ The limit function icons are shown crossed out if they are inactive.

- 1 Pulley head height
 - Limitation of pulley head height
 - Limits the height of the load pulley to a predetermined dimension
- 1.1 Limit value
 - The limitation is made by reaching the limit value of the pulley head height
- 1.2 Actual value
 - Current pulley head height
- 2 Working radius_{max}
 - Limitation of the maximum working radius (maximum boom radius)
 - Limits the working radius of the load hook to a predetermined upper limit
- 2.1 Limit value
 - The limitation is made by reaching the limit value for the maximum working radius
- 2.2 Actual value
 - Current working radius
- 3 Working radius_{min}
 - Limitation of the minimum working radius (minimum boom radius)
 - Limits the working radius of the load hook to a predetermined lower limit
- 3.1 Limit value
 - The limitation is made by reaching the limit value for the minimum working radius
- 3.2 Actual value
 - Current working radius

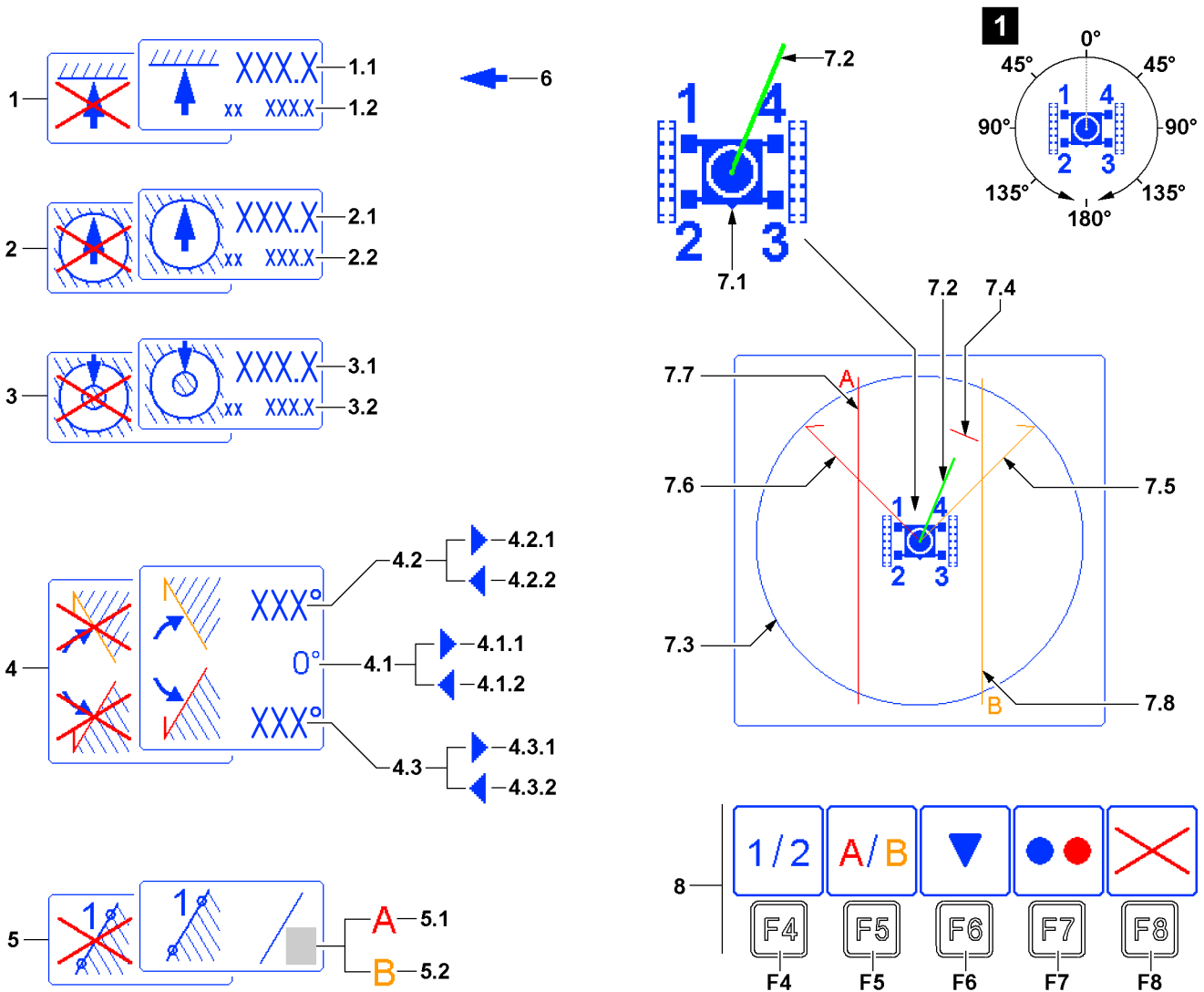
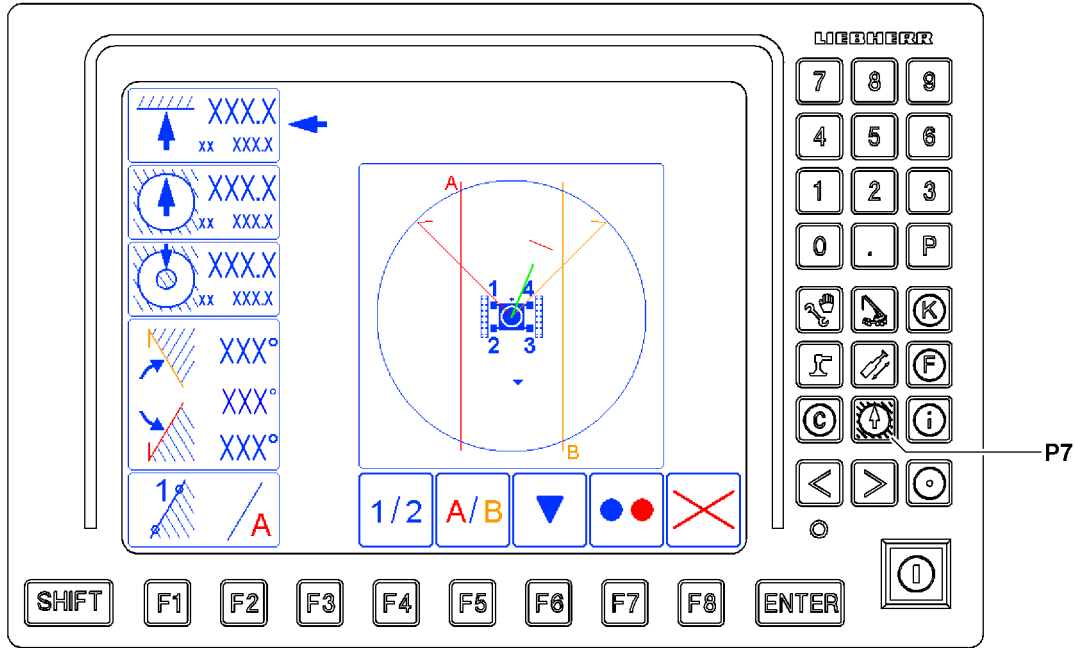

Fig.116057

LWE/LR 13000-001/19503-01-02/en

- 4 Turning limitation
 - Limitation of the slewing range
 - Limits the slewing range of the crane superstructure to a predetermined angle range.
 - Each consists of one right limit angle **4.2** and one left limit angle **4.3**.
- 4.1 Slewing angle
 - Current slewing angle of the crane superstructure
 - Main working direction of the crane = slewing angle 0°
Slewing angle 0° is displayed when the crane superstructure is oriented exactly to the rear.
 - The slewing angle increases on both sides up to 180° when the crane superstructure is turned. When turning past 180°, the side is changed on the Scaling display, see illustration 1.
 - Right arrow **4.1.1**: *Crane superstructure turned to the right range*
 - Left arrow **4.1.2**: *Crane superstructure turned to the left range*
- 4.2 Right limit angle
 - The limitation is made by reaching this right limit angle
 - Right arrow **4.2.1**: The limit angle is in the *Crane superstructure turned to the right range*
 - Left arrow **4.2.2** The limit angle is in the *Crane superstructure turned to the left range*
- 4.3 Left limit angle
 - The limitation is made by reaching this left limit angle
 - Right arrow **4.3.1**: The limit angle is in the *Crane superstructure turned to the right range*
 - Left arrow **4.3.2** The limit angle is in the *Crane superstructure turned to the left range*
- 5 Edge limitation
 - Limitation of freely selectable edges (limitations)
 - Consists of up to two edges („edge A **5.1**“ and „edge B **5.2**“), which do not have to run through the center of the slewing ring.



Note

- ▶ Due to the edge limitation it is possible to determine the working range limits, which allow turning 360° compared to the slewing angle limitation. If necessary, the boom radius must be shorted for turning.
-

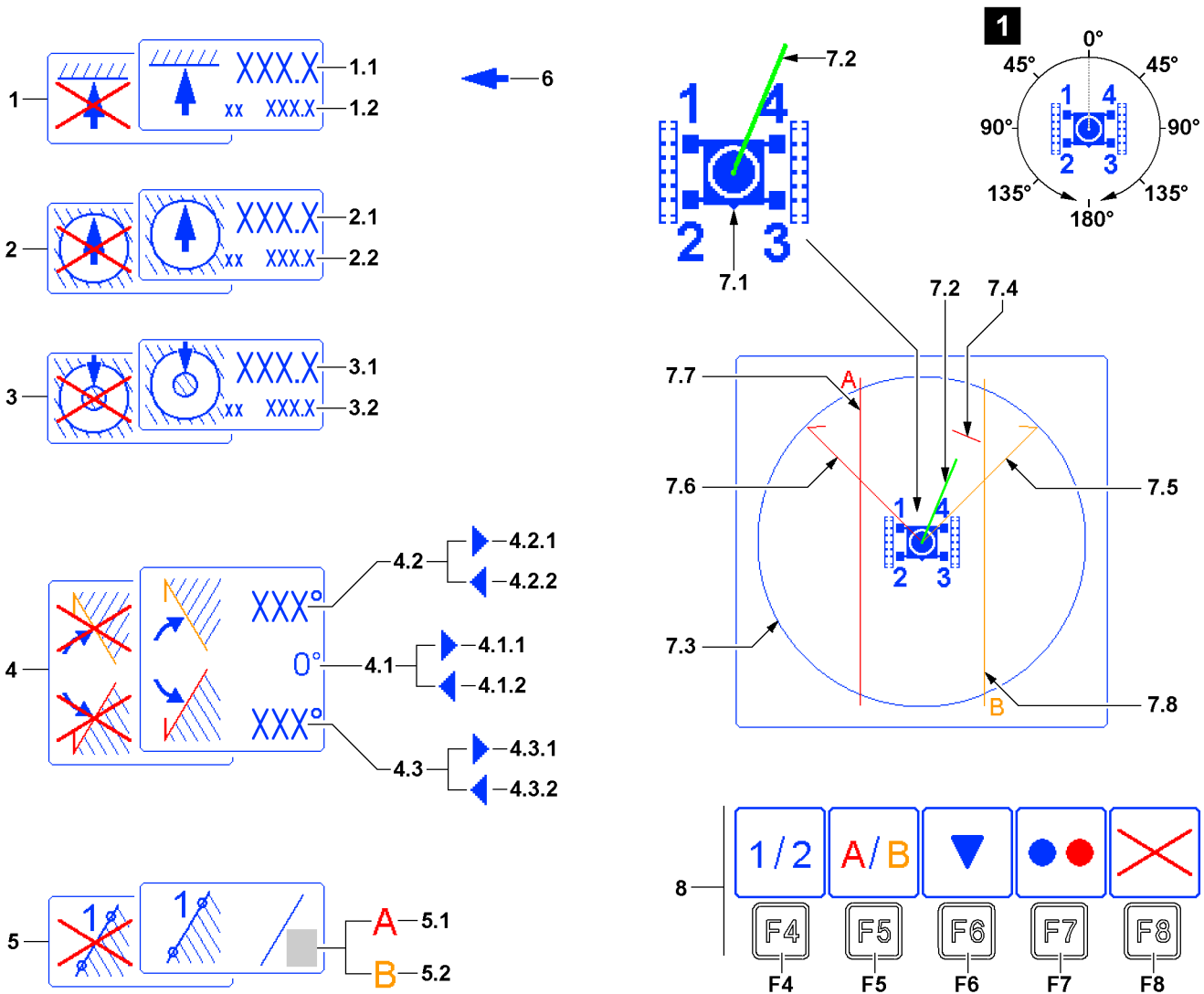
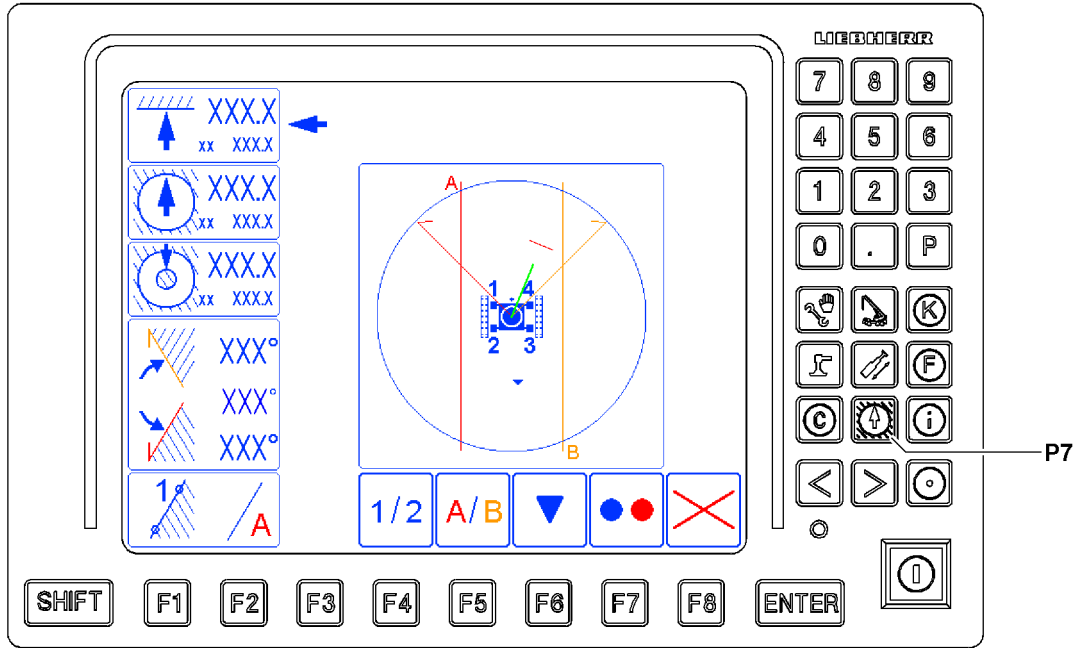

Fig.116057

LWE/LR 13000-001/19503-01-02/en

- 6 Function selector
 - To select the limitation functions (Position 1 to 5)
- 7 Graphic display
 - Graphic display of programmed working range limits viewed from above. The crawler travel gear is shown in the center.
 - The triangle 7.1 shows where the front is on the crawler travel gear.
 - The green bar 7.2 shows the current direction and boom radius of the main boom. The longer the green bar, the larger the boom radius of the crane.
- 7.3 Crane working radius
 - Graphic illustration of the maximum working radius (maximum boom radius) of the crane under ideal conditions.
 - **Note:** The setting cannot be changed in the program.
- 7.4 Working radius_{max}
 - Graphic illustration of the maximum working radius (maximum boom radius).
 - Based on the limit value 2.1 from the *Working radius_{max}* icon 2
 - **Note:** If the green bar 7.2 crosses the red line of the working radius_{max} 7.4, a shut-off occurs.
- 7.5 Right limit angle
 - Graphic illustration of the right limit angle.
 - Based on the limit angle right 4.2 from the *Turning limit* icon 4
 - **Note:** If the green bar 7.2 and the orange line of the right limit angle 7.5 are superimposed, a shut-off occurs.
- 7.6 Left limit angle
 - Graphic illustration of the left limit angle.
 - Based on the left limit angle 4.3 from the *Turning limit* icon 4
 - **Note:** If the green bar 7.2 and the red line of the left limit angle 7.6 are superimposed, a shut-off occurs.
- 7.7 Edge A
 - Graphic illustration of edge A
 - Based on edge A 5.1 from the *Edge limitation* icon 5
 - **Note:** If the green bar 7.2 crosses the red line of edge A 7.7, a shut-off occurs.
- 7.8 Edge B
 - Graphic illustration of edge B
 - Based on edge B 5.2 from the *Edge limitation* icon 5
 - **Note:** If the green bar 7.2 crosses the orange line of edge B 7.8, a shut-off occurs.

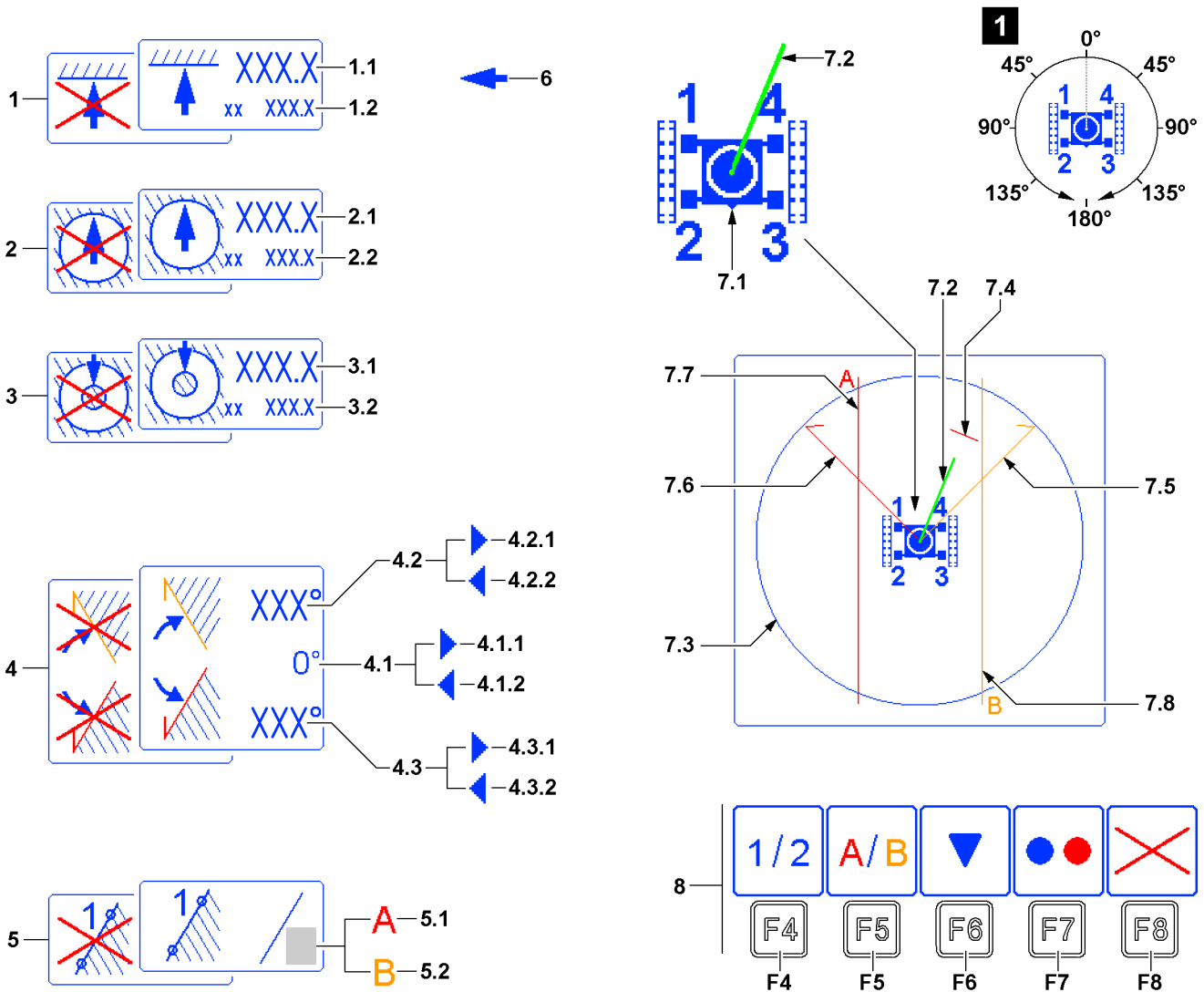
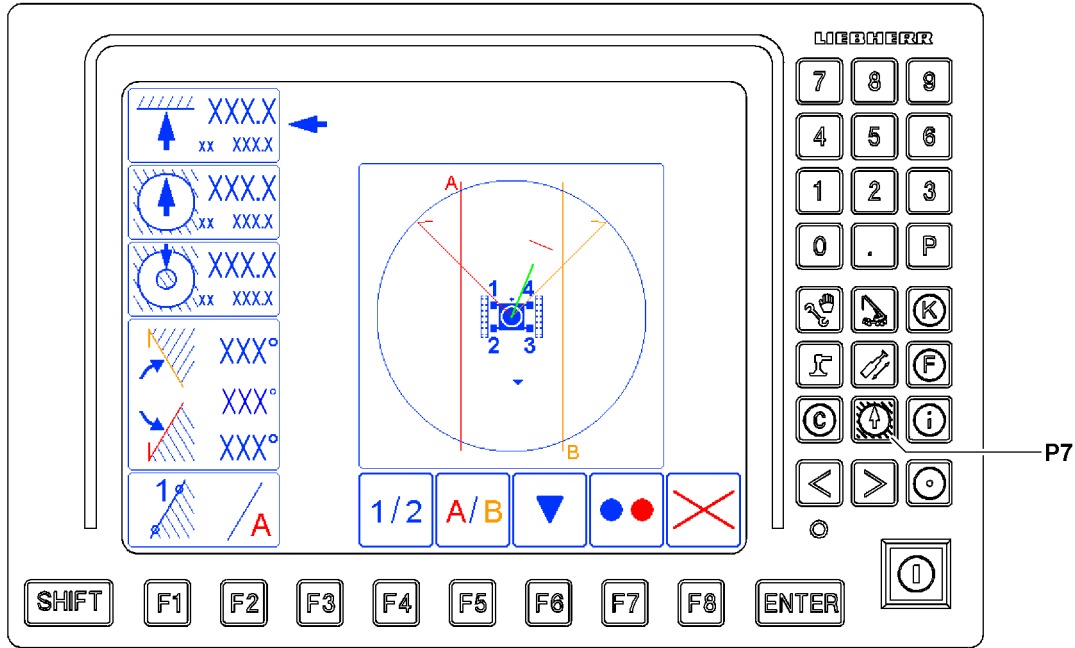

Fig.116057

LWE/LR 13000-001/19503-01-02/en

9.2.1 Function key line in the *Working range limitation* program

F4 Function key

- Selection of point 1 or 2 of selected edge A (red) or B (black)

F5 Function key

- Selection of edge A (red) or B (black) that is being programmed

F6 Function key

- The function selector is moved down by one limit function

F7 Function key

- ON / OFF

The limitation function selected with the function selector **6** changes its status. If previously active, it will now be inactive when the function key **F7** is pressed, and vice versa. An inactive limit function is identified by a crossed out icon. If the function selector **6** shows a turning limit to the left or the right, then both limits will always be switched.

Note: For the edge limit **5**, only the preselected edge will be switched. The edge that is not displayed can be active or inactive at the same time.



Note

- ▶ Limit functions can only be added via the function key **F7** when the boom is in the respective permissible range.

F8 Function key

- All limit functions become inactive

9.3 Occurrence of a shut-off in the working range limitation

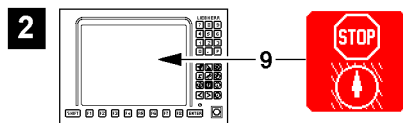

Fig.115262

If the programmed working range limitation is actuated, then this status is shown in the crane operating screen by a STOP icon **9**, see illustration **2**.

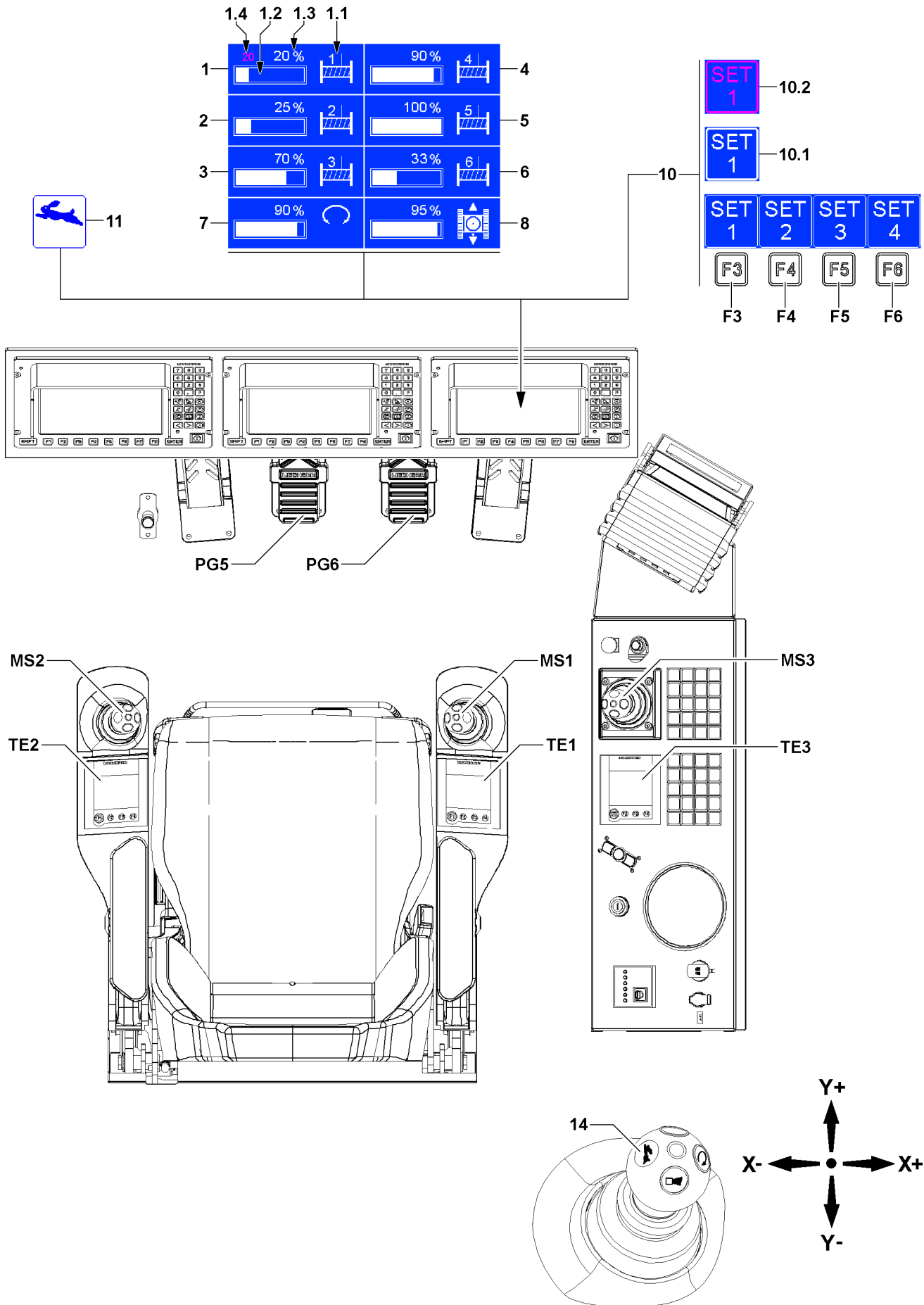

Fig.161666

LWE/LR 13000-001/19503-01-02/en

10 Master switch / pedal sensor speed reduction

The speed reduction of master switches / pedal sensor is made in the settings window. The speeds of the displayed crane movements / crane functions can be limited steplessly to the desired value.

This reduces the maximum speed of the crane function to the value set in the settings window.



WARNING

Deactivated speed reduction of master switches!

When the rapid gear **11** is engaged, the speed reductions of the master switches can be ineffective. Too high a crane speed can cause accidents.

- ▶ Turn the rapid gear **11** off when a speed reduction of the master switches is necessary.



WARNING

Danger of accident!

- ▶ Make the preselection of the slewing speed according to the specifications in the load chart manual.
- ▶ The following applies: The longer the boom and / or the greater the load, the lower the set maximum slewing speed must be.
- ▶ **Never** deflect the master switch for the slewing gear to the stop with a long boom and / or great load.

10.1 Operating elements with master switch / pedal sensor speed reduction

MS1 Master switch 1

TE1 Touch display 1

MS2 Master switch 2

TE2 Touch display 2

MS3 Master switch 3

TE3 Touch display 3

PG5 Pedal sensor 5

PG6 Pedal sensor 6

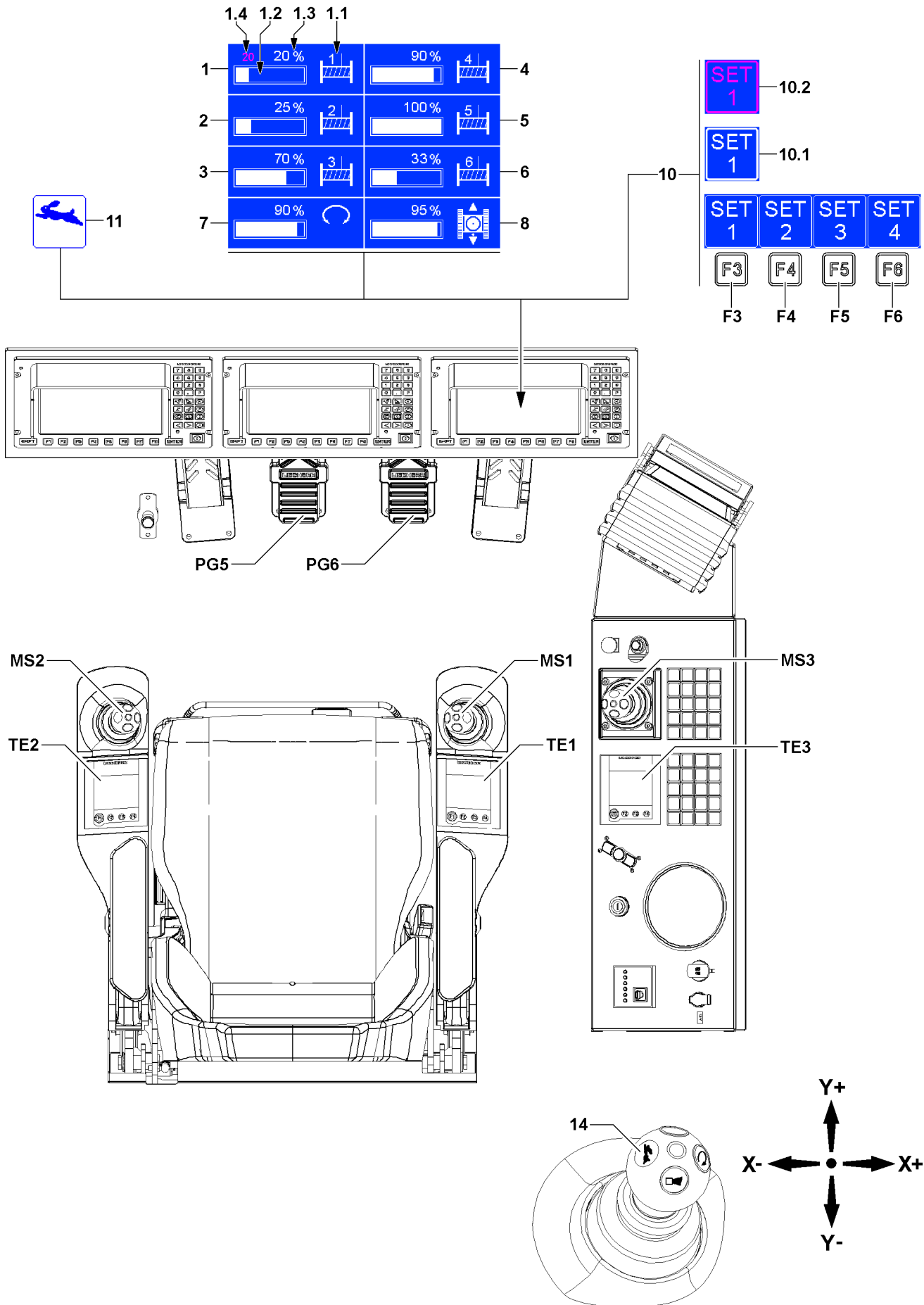

Fig.161666

LWE/LR 13000-001/19503-01-02/en

10.2 Operating interface in the settings window for master switch / pedal sensor speed reduction



Note

- ▶ The structure of the individual settings windows is always the same. The assembly is explained based on the settings window for winch 1 and the SET1 fast setting.

- 1 Winch 1 settings window
 - **Note:** Appears only when the winch is active.
- 1.1 *Assignment* icon
 - Icon of the assigned crane movement / crane function
 - The icon corresponds to the illustration in the respective TE-display
- 1.2 Bar diagram
 - Graphic illustration of the current speed reduction
- 1.3 Display value
 - Numeric display of the current speed reduction in [%]
- 1.4 Saved value
 - Previous saved value of the current speed reduction in [%]
 - **Note:** Appears only when setting the fast settings*.
- 2 Winch 2 settings window
 - **Note:** Appears only when the winch is active.
- 3 Winch 3 settings window
 - **Note:** Appears only when the winch is active.
- 4 Winch 4 settings window
 - **Note:** Appears only when the winch is active.
- 5 Winch 5 settings window
 - **Note:** Appears only when the winch is active.
- 6 Winch 6 settings window
 - **Note:** Appears only when the winch is active.
- 7 Slewing gear settings window
- 8 Crawler settings window
- 10 Fast setting
 - Four freely programmable fast settings are possible.
- 10.1 Fast setting selected
 - The bold frame marks the currently selected fast setting
- 10.2 Changeable fast setting
 - The red highlighting marks the changeable fast setting

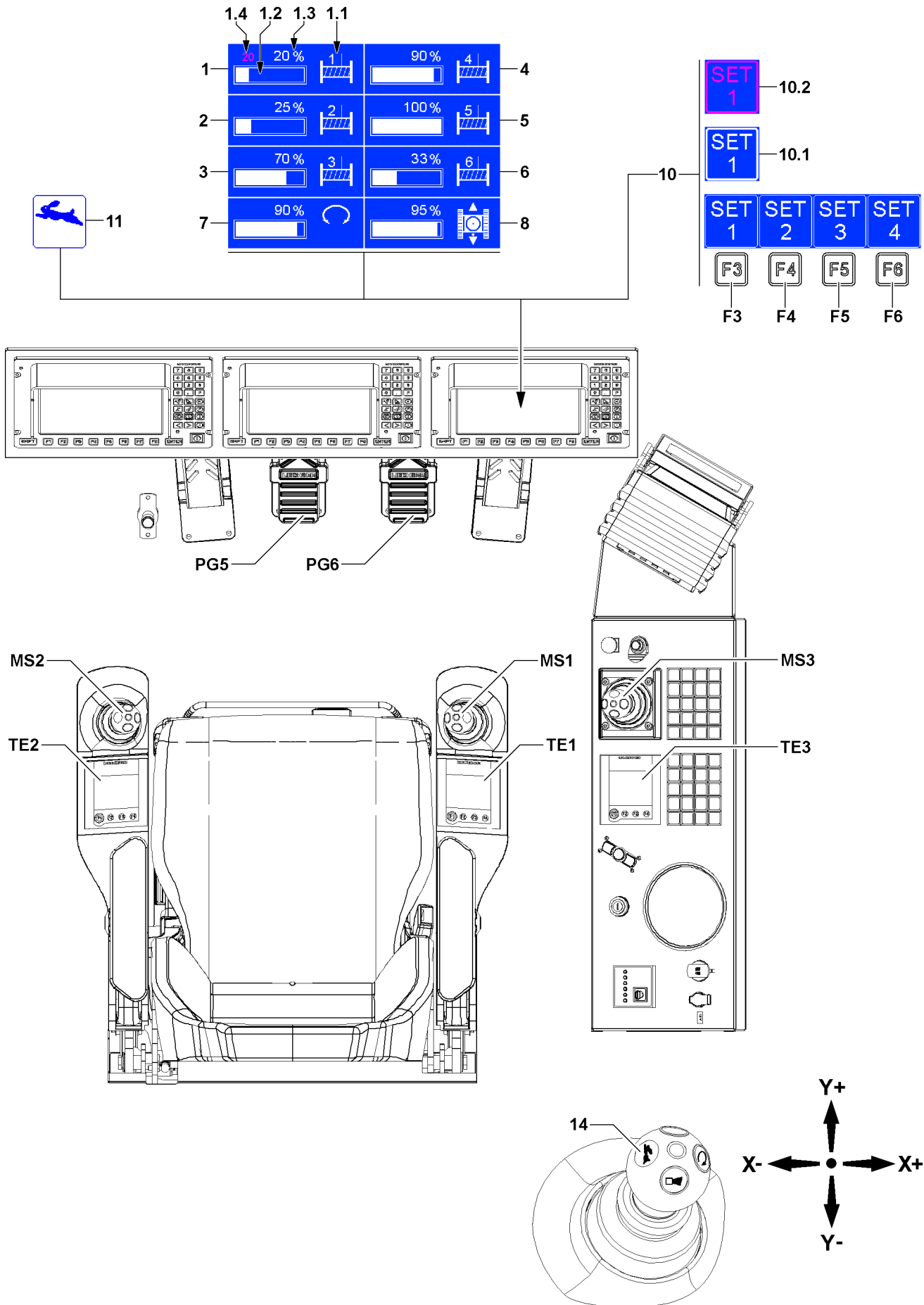

Fig.161666

LWE/LR 13000-001/19503-01-02/en

10.3 Editing the speed reduction

**Note**

Only the settings for the displayed crane movements / crane functions can be carried out.

- ▶ If necessary, activate required crane movements / crane functions before calling up the settings windows.

10.3.1 Displaying the settings window

- ▶ Press the rapid gear **14** button on a master switch at least two seconds.

Result:

- The settings window for the master switch / pedal sensor speed reduction is shown for ten seconds.

**Note**

The settings window is automatically hidden after ten seconds if during that time there is no access to the speed reduction of a crane function.

- ▶ Continue in time with the next steps.

10.3.2 Operating the fast settings

Four different fast settings for the master switch / pedal sensor speed reduction can be saved and called up by pressing a button.

Operating elements:

- **F3** Function key
 - Select / operate fast setting 1 (SET1)
- **F4** Function key
 - Select / operate fast setting 2 (SET2)
- **F5** Function key
 - Select / operate fast setting 3 (SET3)
- **F6** Function key
 - Select / operate fast setting 4 (SET4)

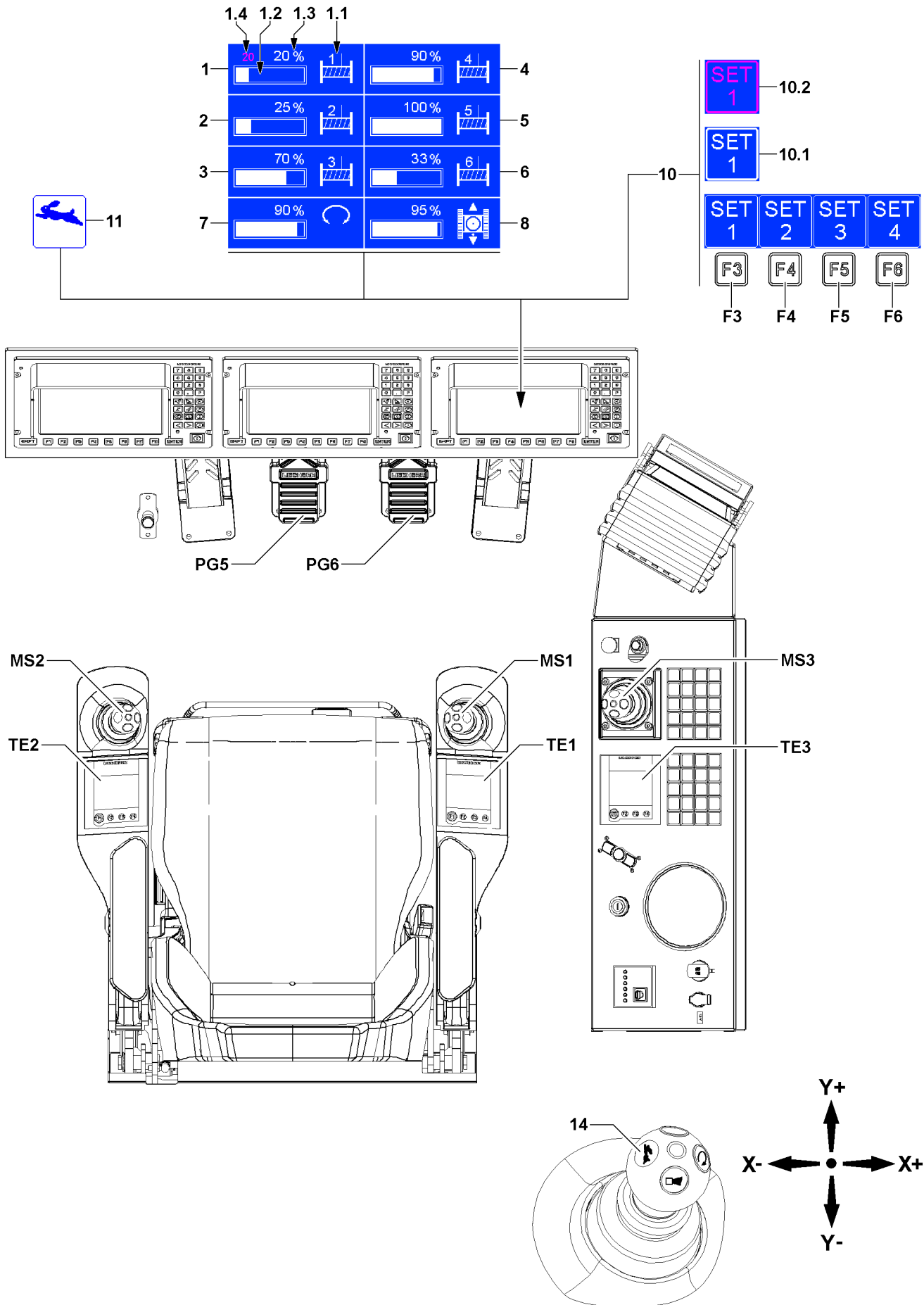

Fig.161666

LWE/LR 13000-001/19503-01-02/en

Selecting the fast setting

Select fast setting 1 (SET1):

- ▶ Press the function key **F3**.

Result:

- Fast setting 1 (SET1) is selected.
- The frame around the *SET1* icon is shown in bold, see the example fast setting selected **10.1**.

Select fast setting 2 (SET2):

- ▶ Press the function key **F4**.

Result:

- Fast setting 2 (SET2) is selected.
- The frame around the *SET2* icon is shown in bold.

Select fast setting 3 (SET3):

- ▶ Press the function key **F5**.

Result:

- Fast setting 3 (SET3) is selected.
- The frame around the *SET3* icon is shown in bold.

Select fast setting 4 (SET4):

- ▶ Press the function key **F6**.

Result:

- Fast setting 4 (SET4) is selected.
- The frame around the *SET4* icon is shown in bold.

Changing and saving settings

The speed reduction is always set via the master switch / pedal sensor that controls the crane movement.

**Note**

- ▶ If the master switch / pedal sensor is deflected lightly, the value is slowly increased / reduced.
- ▶ If the master switch / pedal sensor is deflected strongly, the value is quickly increased / reduced.

As an example, a new setting for the *spool winch 1* crane movement is programmed in fast setting 1 (SET1). The crane movement is carried out via the master switch **MS1**.

The procedure is identical for all crane functions.

**Note**

- ▶ The change that is made applies only for the selected fast setting, in the example fast setting 1 (SET1). Each of the four fast settings must be set and saved separately.

If the frame around the *SET1* icon is not yet shown in bold:

- ▶ Press the function key **F3**.

Result:

- Fast setting selected **10.1** appears.

Reduce the value of the speed reduction:

- ▶ Move the master switch **MS1** in direction Y- (to the rear).

Result:

- Changeable fast setting **10.2** appears.
- The previous saved value **1.4** is displayed in red.

- The bar in the bar diagram **1.2** becomes shorter.
- The display value **1.3** is reduced.

Increase the speed reduction value:

- ▶ Move the master switch **MS1** in direction Y+ (forward).

Result:

- Changeable fast setting **10.2** appears.
- The previous saved value **1.4** is displayed in red.
- The bar in the bar diagram **1.2** becomes longer.
- The display value **1.3** is increased.



Note

- ▶ All settings can be changed one after the other as desired.
-

When the desired setting is reached:

- ▶ Press the function key **F3**.

Result:

- Fast setting selected **10.1** appears.
- All current settings are saved as fast setting 1 (SET1).
- The previous saved values **1.4** are hidden

10.3.3 Hiding the settings window



Note

- ▶ If the settings window is hidden, the last changes are discarded as long as changeable fast setting **10.2** is displayed.
-

- ▶ Press the rapid gear **14** button on a master switch at least two seconds.
or
Wait ten seconds without further steps.

Result:

- The settings window for the speed reduction of the master switch / pedal sensor is hidden.

Empty page!

LWE/LR 13000-001/19503-01-02/en

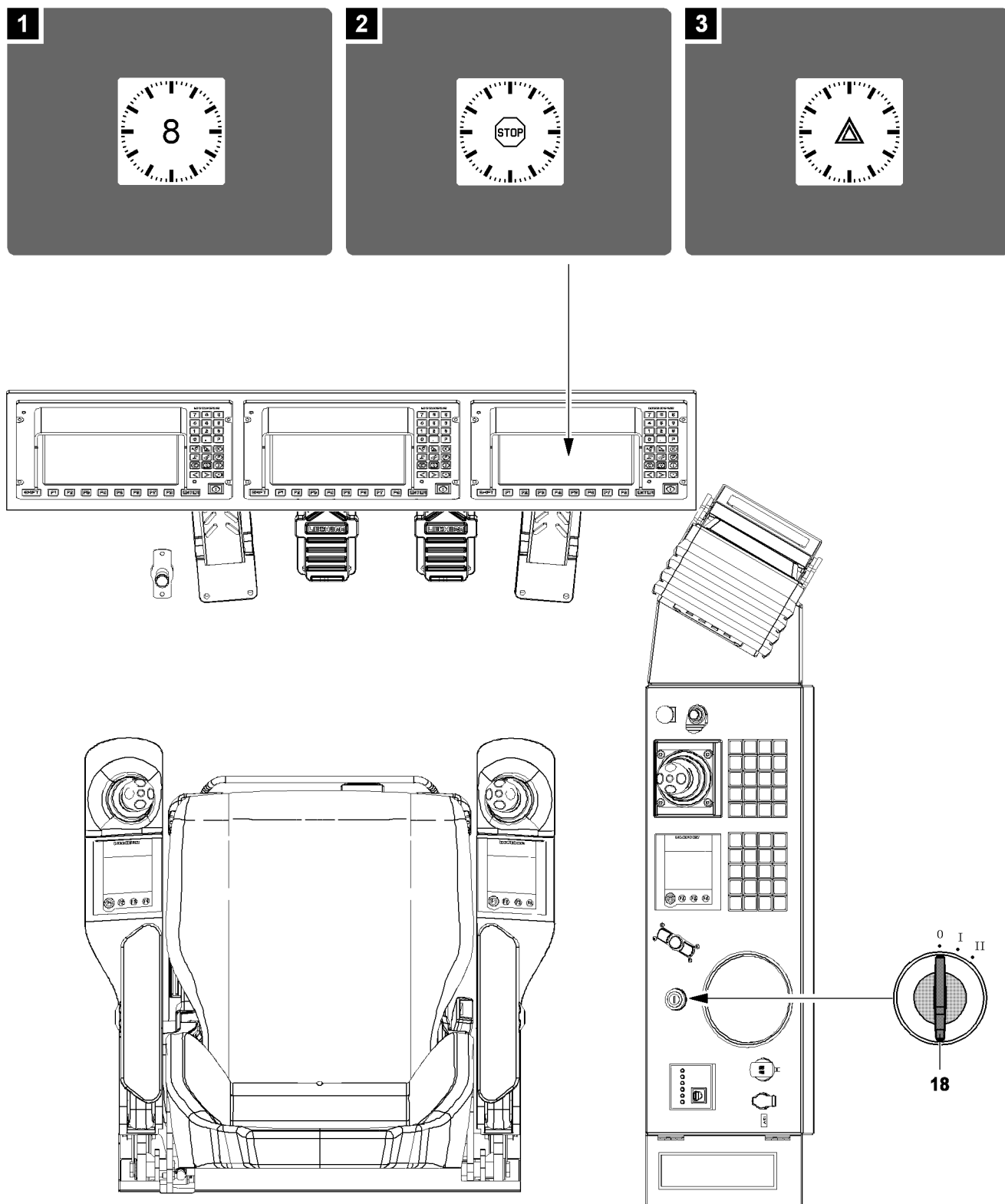

Fig.115263

LWE/LR 13000-001/19503-01-02/en

11 Power-save mode and Stand-by mode in the LICCON computer system

11.1 The Power-Save mode

If the crane engine - by turning the ignition switch **18** - is turned off to position 0 (ignition **OFF**), the LICCON computer system changes to the Power-Save mode.

The Power-Save mode enables the crane operator - within approx. eight seconds after turning the ignition off - either to change to Stand-by mode or to start the crane engine again without having to start the LICCON computer system again.

If no program key is actuated within eight seconds, then the LICCON computer system turns off completely.



Note

- ▶ No crane movements are possible in Power Save mode.
-

Turn the crane engine off

- ▶ Turn the ignition switch **18** to position 0 (ignition **OFF**).

Result:

- The crane engine is turned off.
 - The **Power-Save mode** is active.
 - The clock with a Power-Save run time (approx. eight seconds) appears, illustration **1**.
-

**Note**

- ▶ After eight seconds have expired, a clock appears briefly with an integrated STOP icon, which displays the complete turning off of the LICCON computer system.
-
- The clock with integrated STOP icon appears for a few seconds, illustration **2**.
 - All processes on the LICCON computer system are stopped.
 - The LICCON computer system turns off completely.

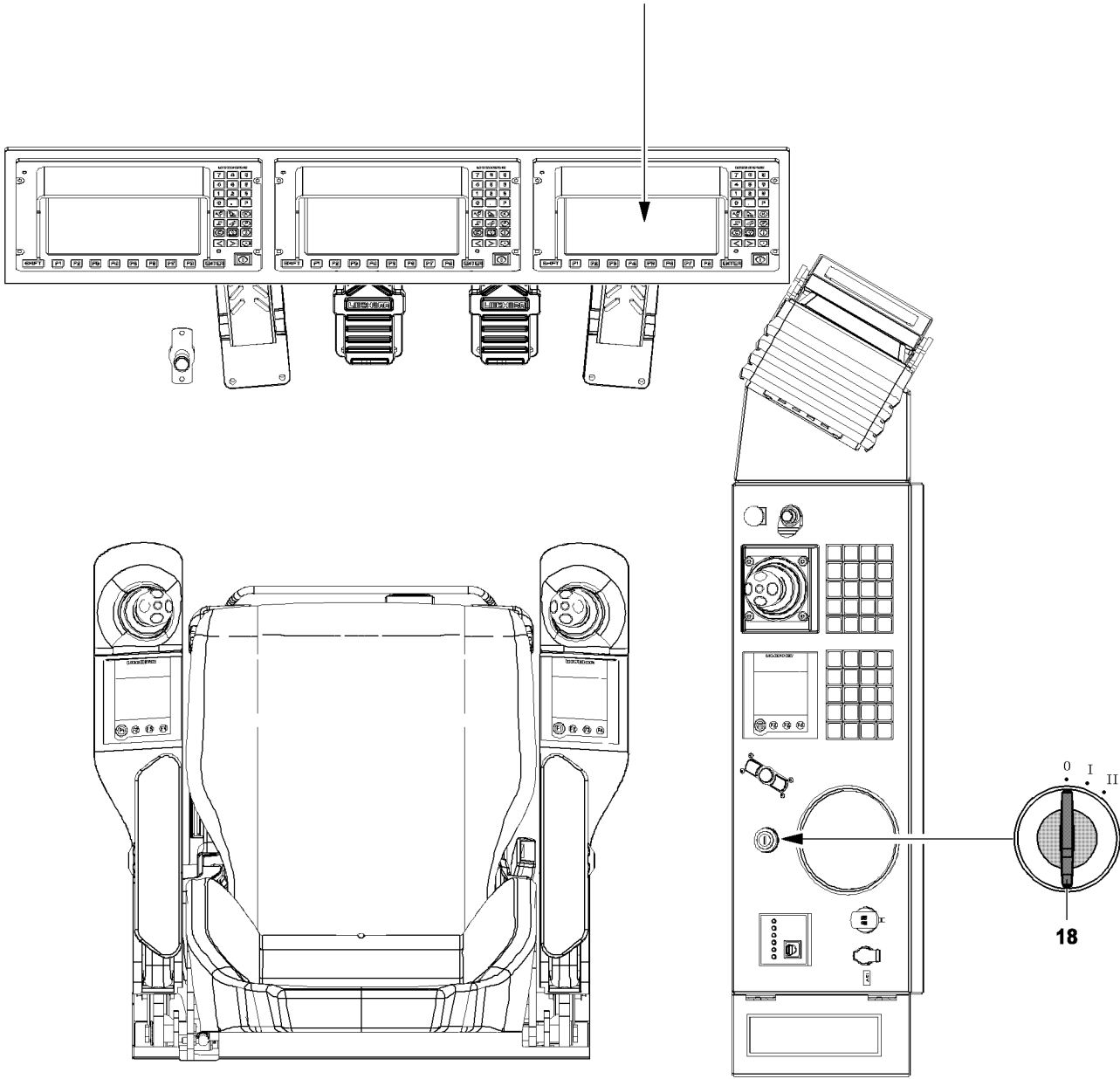
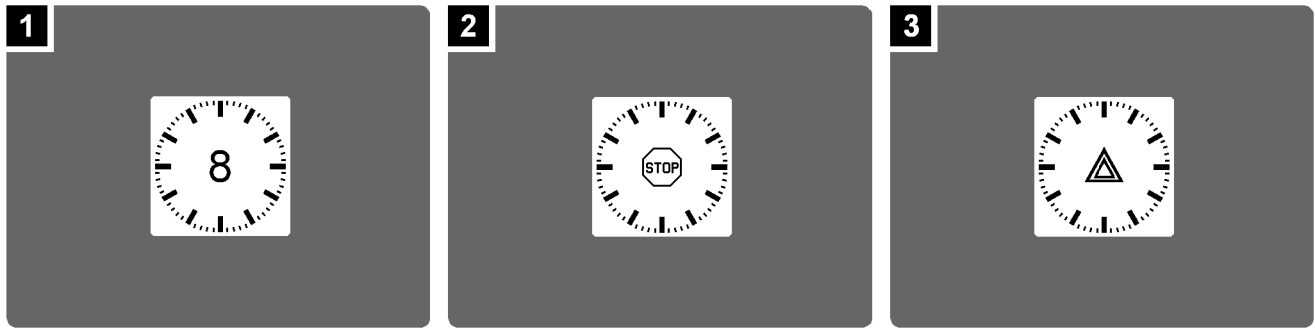

Fig.115263

LWE/LR 13000-001/19503-01-02/en

Press any key in Power-save mode once**Note**

▶ Pressing a key in Power-Save mode once shortens the Power-Save alarm time to five seconds.

▶ Press any key.

Result:

– The Power-Save alarm time is shortened to five seconds.

Press any key twice in Power-save mode

▶ Press any key twice in succession.

Result:

- The Power-Save alarm time is set to zero.
- The clock with integrated STOP icon appears for a few seconds, illustration 2.
- All processes on the LICCON computer system are stopped.
- The LICCON computer system turns off completely.

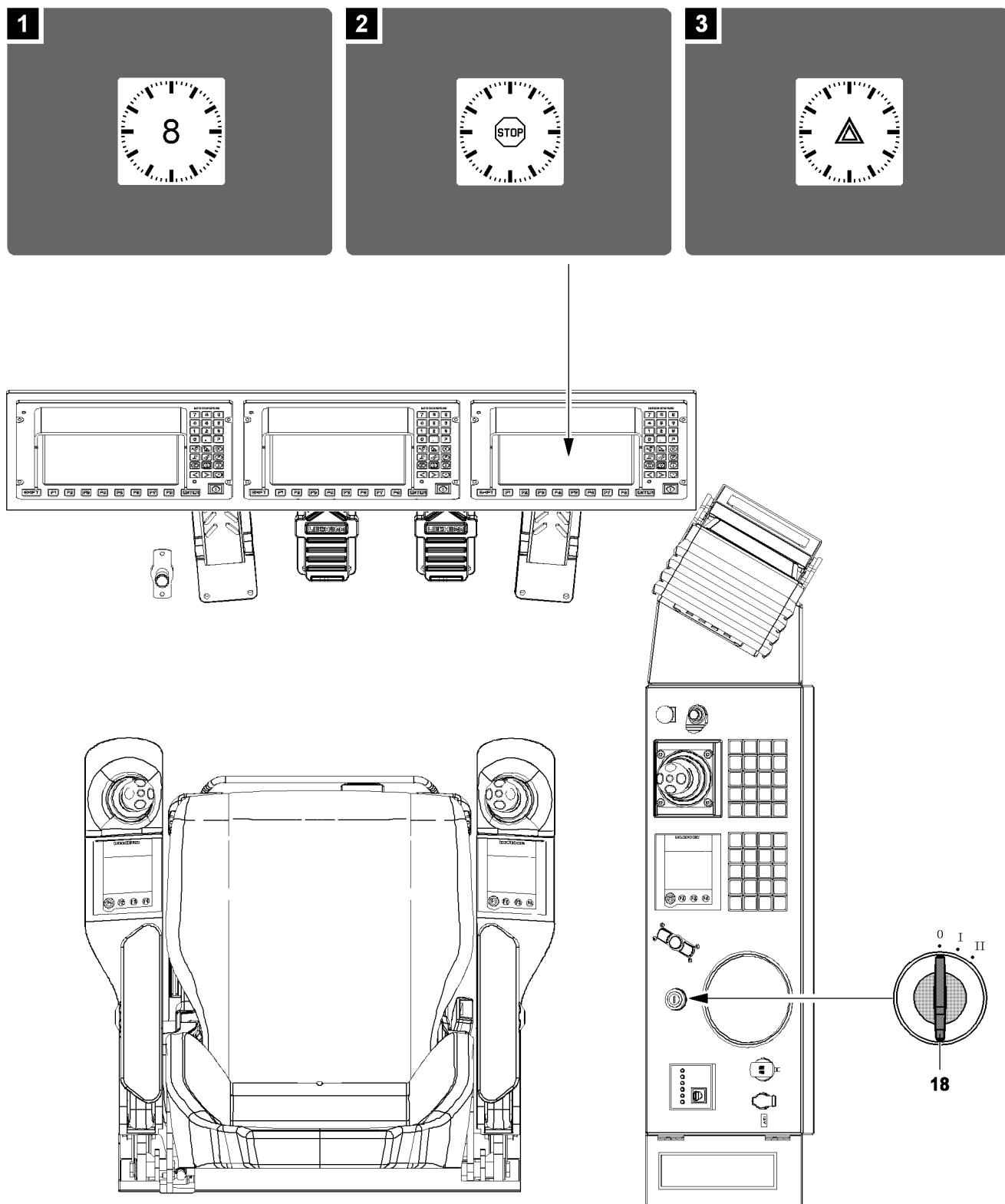

Fig.115263

LWE/LR 13000-001/19503-01-02/en

11.2 Stand-by mode

After pressing the Engine STOP key - the crane engine is turned off - on the LICCON monitor, the operating interface of the most recently active application program continues to be displayed for an additional 10 minutes, illustration 3.

Stand-by mode is reached after 10 minutes have elapsed. The Stand-by mode is displayed by the Stand-by clock + warning icon on the LICCON monitor and by a repeated short acoustic signal (*short horn*) with longer intervals.



Note

- ▶ In Stand-by mode, no crane movements are possible.

There are two ways of achieving Stand-by mode with the LICCON computer system.

Turn the crane engine off

Turning the engine off with the engine STOP key:

- ▶ Press the engine STOP key.
- ▶ Leave the ignition key **18** in position „I“.

Result:

- The crane engine is turned off.
- The ten minute period is over.
- ▶ Within the ten minute time frame, press **any key**.

Result:

- The ten minute time period is reset and starts again.
- ▶ Do **not** press any key during the ten minute period.

Result:

- After the period is over, **stand-by mode** is reached.
- The display area on the LICCON monitor turns black.
- The stand-by clock with a warning icon is displayed, illustration 3.
- Every half a minute a repeating acoustic signal from the LICCON monitor sounds.



Note

- ▶ Stand-by mode does not lead to the automatic shut-off of the LICCON computer system.

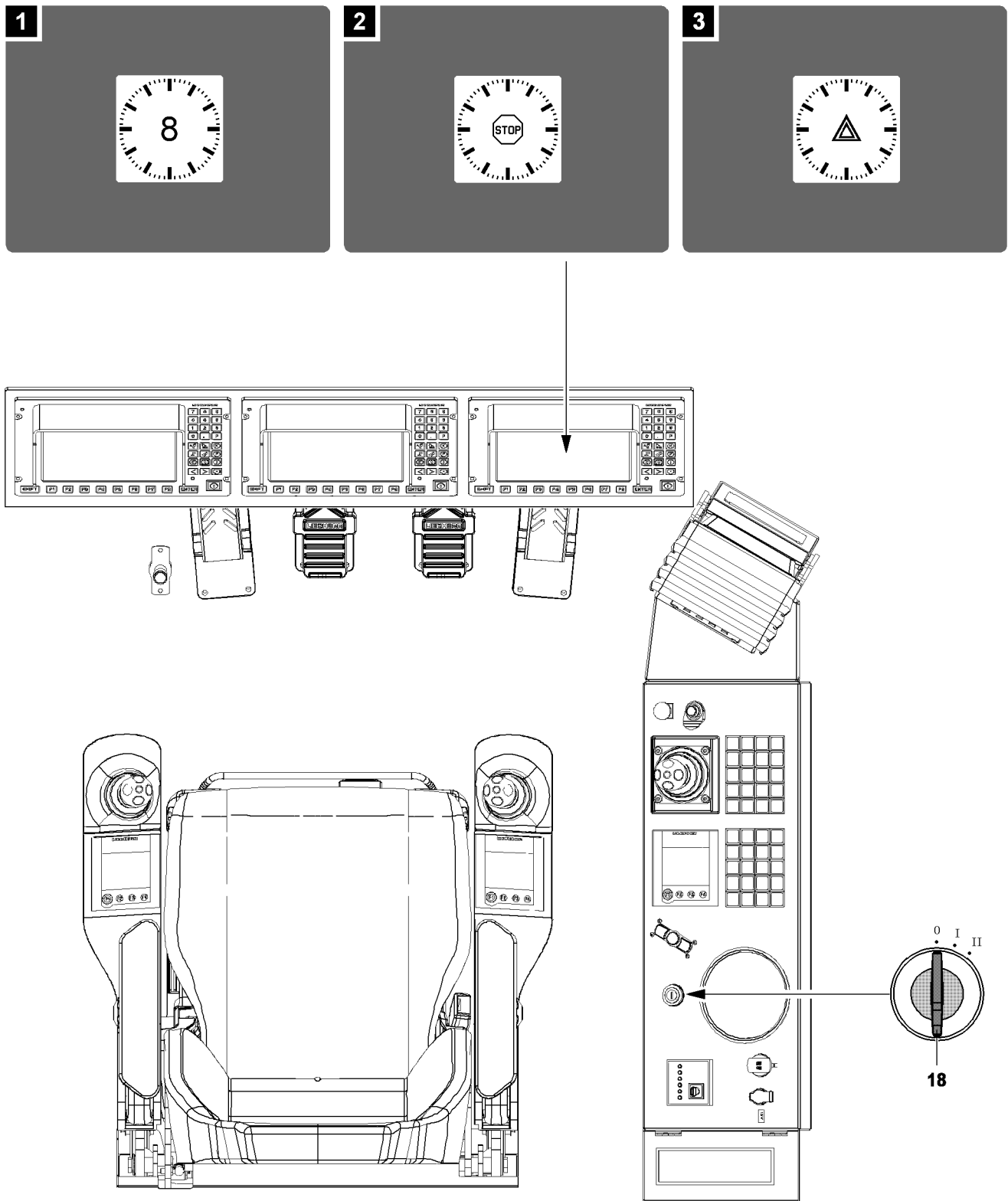

Fig.115263

LWE/LR 13000-001/19503-01-02/en

Turn the LICCON computer system off from the Stand-by mode

- ▶ Turn the ignition switch to position 0.

Result:

- Power-Save mode becomes active.

**Note**

- ▶ See section „Power-Save mode“.

Empty page!

LWE/LR 13000-001/19503-01-02/en

4.03 Start up and shut down of crane

1	Checking before start up	2
2	Diesel particle filter (DPF)*	13
3	<i>Exhaust system cleaning procedure</i>	18
4	Crane operator's cab work station	21
5	Supply via external feed / power aggregate	33
6	Preheating the hydraulic oil with Hydraulic oil preheating*	37
7	Starting the LICCON computer system (before engine start)	38
8	Starting and turning off the engine	41
9	Starting the LICCON computer system parallel to the engine	48

1 Checking before start up

Various checks must be performed every time before crane start up.

If an item is low or lacking during an inspection, then it must be refilled or brought to normal status before crane start-up.

If the inspection shows a very dirty filter, then it must be replaced before crane start-up.



WARNING

Operating safety of the crane!

Defects on components, missing quantities or dirty filters affect the operating safety of the crane!

- ▶ If a defect is found in a component during the check, the defect must be remedied before crane start-up.
- ▶ If an item is low or lacking during an inspection, then it must be refilled or brought to normal status before crane start-up.
- ▶ If the inspection shows a very dirty filter, then it must be replaced before crane start-up.



WARNING

Heated crane components!

When the engine is running, crane components can heat up significantly! This applies especially to exhaust systems, the engines, the coolant circuit and the respective gears in the crane chassis and in the crane superstructure!

Touching heated crane components can cause severe injuries!

- ▶ Carry out the checks before starting the crane, when the crane components are cold!
- ▶ Let already heated components cool off before checking!
- ▶ Proceed with particular caution near heated crane components!



WARNING

Emergency devices not operational!

If emergency devices, such as the EMERGENCY OFF switch, ladders etc. are not accessible or operational, then they cannot be used in case of an emergency!

Personnel can be injured or killed because the emergency devices are not operational!

- ▶ Check emergency devices before start up for accessibility or operational readiness!
- ▶ Open or remove anti-heft devices, such as locks on the emergency devices!



Note

- ▶ The illustrations, icons and monitor illustrations in this chapter are only examples!
- ▶ The numerical values in the individual icons and charts do not have to necessarily match the crane exactly!
- ▶ Numbers and letters can be replaced by place holders!
- ▶ The display and assignment of the icons can deviate, depending on the set up configuration, operating status and configuration of the crane!
- ▶ In addition, many of the illustrations show the maximum configuration of the LICCON monitor with icons!
- ▶ During crane operation, an identical display will **not** appear on the LICCON monitor.



Note

- ▶ For a detailed description of fill quantities, service items and lubricants, see chapter 7.06 and chapter 7.07 of the Crane operating instructions and the separately supplied drawings!

Make sure that the following prerequisites are met:

- The ignition switches are in position „I“.
- The engine is off.
- The engine is at ambient temperature.
- The LICCON computer system is in stand-by mode.

1.1 Checking the general condition of the crane



WARNING

Danger of accident due to falling parts!

Loose parts, such as pins, spring retainers or ice, which are on the boom or crane superstructure can fall down during crane operation and hit personnel!

Personnel can be killed or seriously injured!

- ▶ Before starting crane operation, make sure that there are no loose parts on the boom and crane superstructure!

- ▶ Check the crane for visible damage before starting crane operation.
- ▶ Carry out a function test of available safety equipment.
- ▶ Make sure that the crane is standing on level, load bearing ground.
- ▶ Make sure that the crane is properly supported and horizontally aligned.
- ▶ Make sure that the gear ring of the slewing ring connection is clean and greased.
- ▶ Make sure that the air supply to the oil and water cooler is clear.
- ▶ Make sure that side covers are closed and locked.
- ▶ Make sure that no persons or objects are in the danger zone of the crane.
- ▶ Make sure that the cable, hose and rope drum as well as the limit switches are free of snow, frost and ice.
- ▶ Make sure that there are no loose parts on the boom and the crane superstructure.

1.2 Performing a visual inspection



WARNING

Avoidable low quantities / problems can cause critical situations unnecessarily.

- ▶ Carry out visual inspections properly and completely.

Make sure that the following prerequisites are met:

- The engine is off.
- The engine is at ambient temperature.

1.2.1 Checking the engine oil levels

Crane types with an electronic engine oil level display



Note

Crane types with an electronic engine oil level display

- ▶ Check the engine oil level, see section „Calling up and checking the monitoring functions of the LICCON computer system“.

Crane types without an electronic engine oil level display

For a detailed description of checking the engine oil level, see chapter 7.05.

For detailed description of the crane engine, see the Operating instructions of the engine manufacturer.

The oil level must be checked on both engines.

- ▶ Check the oil level on engine 1.
- ▶ Check the oil level on engine 2.

1.2.2 Checking the winch oil level

For a detailed description of checking the oil level, see chapter 7.05.

- ▶ Check the oil level on the winches.

1.2.3 Checking the hydraulic tank

For detailed description of checking the filters on the hydraulic tank, see chapter 7.05.

Checking the oil level in the hydraulic tank

- ▶ Check the oil level in the hydraulic tank on the sight gauge.

Checking the filter for the hydraulic tank

- ▶ Check the hydraulic tank filter.

1.2.4 Checking the coolant level



WARNING

Danger of injury due to scalding of the skin!

- ▶ Check the coolant level only when the engine is cold.
- ▶ Never open the cap on the coolant reservoir as long as the engine is warm! The cooling system is under pressure!
- ▶ To protect face, hands and arms from hot steam of hot coolant, cover the cap with a large rag when opening!

The coolant expansion tanks must be filled up to the overflow on the filler neck.

- ▶ Check the coolant level on engine 1.
- ▶ Check the coolant level on engine 2.

If the coolant level is too low:

- ▶ Add coolant, see chapter 7.05.

1.2.5 Checking the central lubrication system

NOTICE

Damage to crane components!

Missing or insufficient lubrication can cause damage on the crane components.

Expensive and extensive repairs can result.

- ▶ Make sure that the grease containers for the central lubrication system always show a sufficient fill level.
- ▶ Replace missing lubricant.

The grease container must be filled at all times with sufficient lubricant.

- ▶ Check the grease container.

If the grease container level is too low:

- ▶ Add lubricant, see chapter 7.04 and chapter 7.05.

1.2.6 Checking the window cleaning fluid

NOTICE

Frozen window cleaning fluid!

If the window cleaning fluid is not frost resistant, then the window washer system can freeze during the cold time of the year!

Failure of the window washer system is the result!

The window washer system can be damaged!

- ▶ Change the window cleaning fluid in time to a frost resistant type!

Before the start of the cold season:

- ▶ Empty the container for the window cleaning fluid and refill it with a commercially available, frost resistant window cleaning fluid.

1.2.7 Checking the HATZ-DIESEL generator

For the scope of the inspection, see the separate Operating instructions for the HATZ-DIESEL generator.

- ▶ Carry out the inspections according to the specifications in the separate Operating instructions for the HATZ-DIESEL generator.

1.3 Calling up and checking the monitoring functions of the LICCON computer system

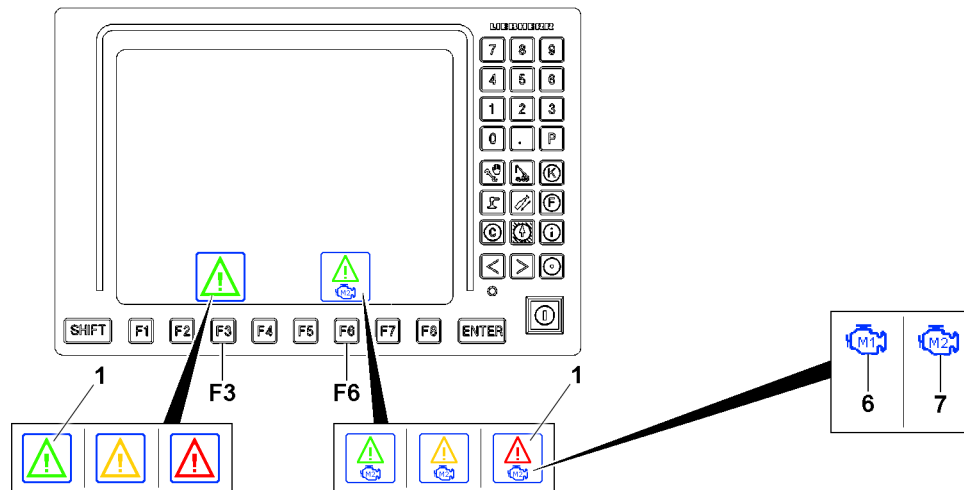

Fig.164447: Monitoring function warning icon

The monitoring functions are described in detail in chapter 4.02.

The selected crane components and operating conditions are monitored in the crane operation program. Monitoring functions can be called up if required with the function key **F3**. With the function key **F6**, it is possible to switch between the monitoring functions of engine 1 **6** and engine 2 **7**.

The warning icon **1** above the function key **F3** and function key **F6** is displayed in green when all monitoring functions are ok. If a control value reached a limit range, or if there is a malfunction or warning, the warning icon **1** above the function key is displayed in yellow or red.

NOTICE

The warning icon **1** is displayed in yellow or red - malfunction / warning!

Damage to components.

- ▶ End crane movement.
- ▶ Turn the engine off.
- ▶ Remedy the cause of the error.
- ▶ Observe and adhere to the instructions in chapter 4.02.

The monitoring functions do not replace the visual inspections:

- Levels close to being too low can be recognized during visual inspections.
- Imminent problems can be recognized better through visual inspections.

The monitoring functions react in general only when a missing amount / problem is present. Avoidable missing amounts / problems impede crane operation and cause unnecessary delays and / or downtime.

Make sure that the following prerequisites are met:

- The ignition switch in the crane operator's cab is in position „I“.
- The engine is off.
- The engine is at ambient temperature.
- The LICCON computer system is in stand-by mode.
- The LICCON computer system is in the „Crane operation“ program.



Note

- ▶ For a detailed description of the displays on the LICCON monitor, see chapter 4.02.
- ▶ For a detailed description of the safety equipment, see chapter 4.04.

1.3.1 Checking the fuel level



WARNING

Danger of fire and explosion!

- ▶ Turn the engine independent heater* off approx. 3 minutes before refueling the fuel tank.
- ▶ Before refueling the fuel tank, turn the engine off.



Note

If the fuel tank has run dry, then the fuel system must be bled!

- ▶ Refuel in time.

Make sure that the following prerequisite is met:

- The LICCON computer system is booted up and in the „Crane operation“ program.

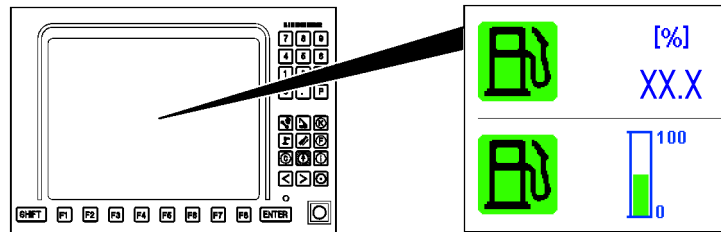

Fig.147669: Fuel reserve display - both variations

Depending on the crane type, the fuel reserve is displayed as a percentage value or a bar graph.

- ▶ Call up the monitoring functions, see chapter 4.02.
- ▶ Check the fuel reserve.

1.3.2 Checking the urea reserve



Note

- ▶ Valid only for engines that are equipped with an exhaust aftertreatment with SCR system.



WARNING

Power reduction or starting block of the engine!

Insufficient urea reserve can trigger a power reduction or starting block of the engine. Crane and / or travel operation can be limited.

- ▶ Add Urea in time.

Make sure that the following prerequisite is met:

- The LICCON computer system is booted up and in the „Crane operation“ program.

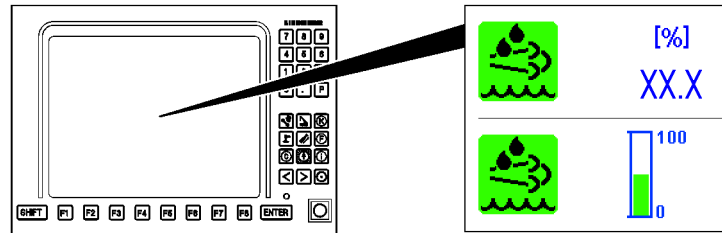

Fig.147670: Urea reserve display - both variations

Depending on the crane type, the urea reserve is displayed as a percentage value or a bar graph.

- ▶ Call up the monitoring functions, see chapter 4.02.
- ▶ Check the urea reserve.

1.3.3 Checking the diesel particle filter load condition (DPF)

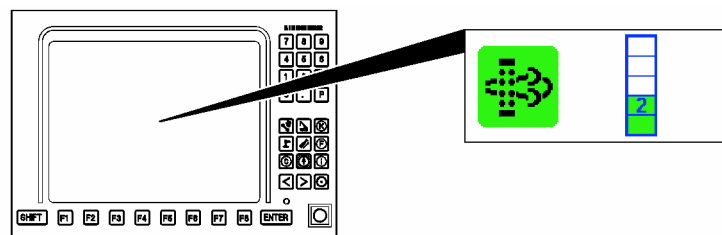

Fig.152660: Diesel particle filter load condition, example for load condition 2 (green)



Note

- ▶ Applies only for engines with a diesel particle filter (DPF).

Make sure that the following prerequisite is met:

- The LICCON computer system is booted up and in the „Crane operation“ program.

The load condition of the diesel particle filter is displayed as a bar graph.

Explanation of the bar graph:

- Load condition 1 (green): Load condition OK, diesel particle filter minimally loaded
- Load condition 2 (green): Load condition OK, diesel particle filter slightly loaded
- Load condition 3 (green): Load condition OK, diesel particle filter half loaded
- Load condition 4 (yellow): Increased load condition, diesel particle filter strongly loaded
- **Note:** Prompt need for action required regarding the load condition of the diesel particle filter.
- Load condition 5 (red): Critical load condition, diesel particle filter with maximum load
- **Note:** Immediate need for action required regarding the load condition of the diesel particle filter.

- ▶ Call up the monitoring functions, see chapter 4.02.

Before starting the engine:

- ▶ Check the diesel particle filter load condition.

1.3.4 Checking the engine oil level

Make sure that the following prerequisite is met:

- The LICCON computer system is booted up and in the „Crane operation“ program.

Engine oil level display, variation 1

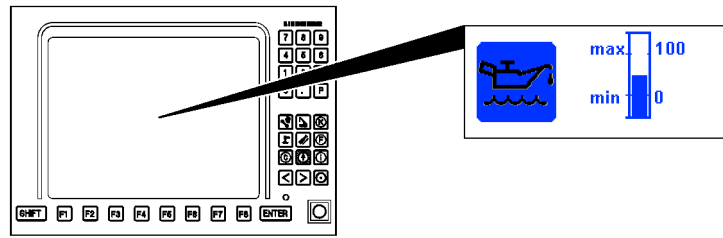

Fig.147671: Engine oil level display, example for engine oil level between min and max

The engine oil level is displayed as a bar graph.

Explanation of the bar graph:

- Under *min*: Engine oil level too low
- Between *min* and *max*: Engine oil level OK
- Over *max*: Engine oil level overfilled



Note

- ▶ The engine oil level can only be displayed when the engine is turned off.

- ▶ Call up the monitoring functions, see chapter 4.02.

Before starting the engine:

- ▶ Check the engine oil level.
- ▶ Adjust the engine oil, if necessary.

Engine oil level display, variation 2

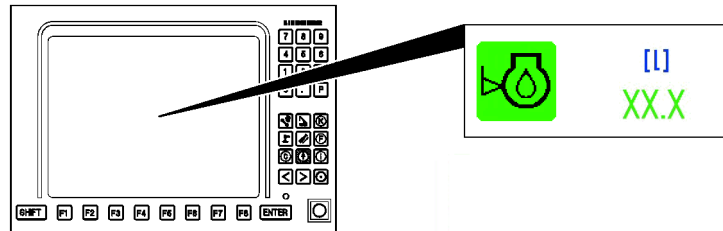

Fig.153666: Engine oil level in liters

On the LICCON monitor, the engine oil level is indicated in liters.

- ▶ Call up the screen display monitoring functions in the LICCON computer system and check the engine oil level.

The engine oil level can be read on the analog display:

- If „0.0“ is shown on the analog display, then the engine oil level is ok.
- If „-1.0“ is shown on the analog display, then 1 liter of engine oil must be drained.
- If „+1.5“ is shown on the analog display, then 1.5 liter of engine oil must be added.

- ▶ Adjust the engine oil, if necessary.

1.3.5 Checking the hydraulic oil level

Make sure that the following prerequisite is met:

- The LICCON computer system is booted up and in the „Crane operation“ program.

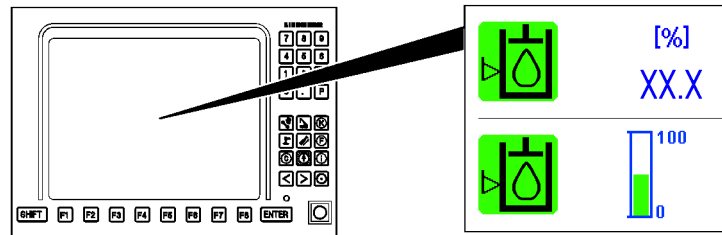

Fig.153667: Hydraulic oil level as a percentage

Depending on the crane type, the hydraulic oil level is displayed as a percentage value or a bar graph.

- ▶ Call up the monitoring functions, see chapter 4.02.
- ▶ Check the hydraulic oil level.

1.3.6 Checking the battery voltage

When the crane has been „out of operation“ for a longer period of time and users, such as the airplane warning light are turned on, the batteries can discharge significantly.

At low ambient temperatures, there is a greater power requirement opposed by reduced battery power.

- The battery voltage must be checked at regular intervals and the batteries must be recharged, if necessary.
- At low ambient temperatures, make sure that the batteries are well charged.



Note

HATZ-DIESEL generator battery

- ▶ The HATZ-DIESEL generator has its own battery, see the separate Operating instructions for the HATZ-DIESEL generator.

Checking the battery voltage on the LICCON monitor

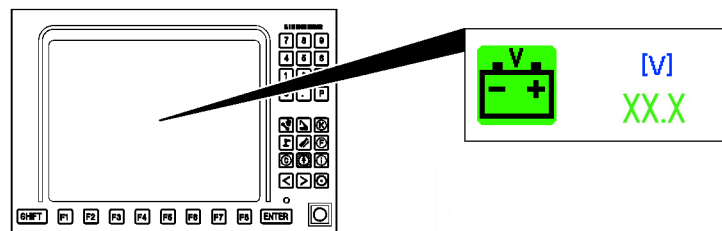

Fig.153668: Battery voltage

The battery voltage is shown in Volt on the LICCON monitor.

For a detailed description see chapter 4.02.

- ▶ Call up the monitoring functions screen display on the LICCON computer system and check the battery voltage.

Checking the battery voltage on the batteries

- ▶ Checking the battery voltage on the batteries, see chapter 7.05.

1.3.7 Checking the center of gravity display on the LICCON monitor



WARNING

Shifting of the center of gravity!

The calculation of the values for the display of the center of gravity in the LICCON monitor are based on ideal assumptions.

- ▶ Side deformations of the boom system due to wind, inclined position and elastic resilience of the steel structure are not taken into account but they can lead to a shifting of the center of gravity.

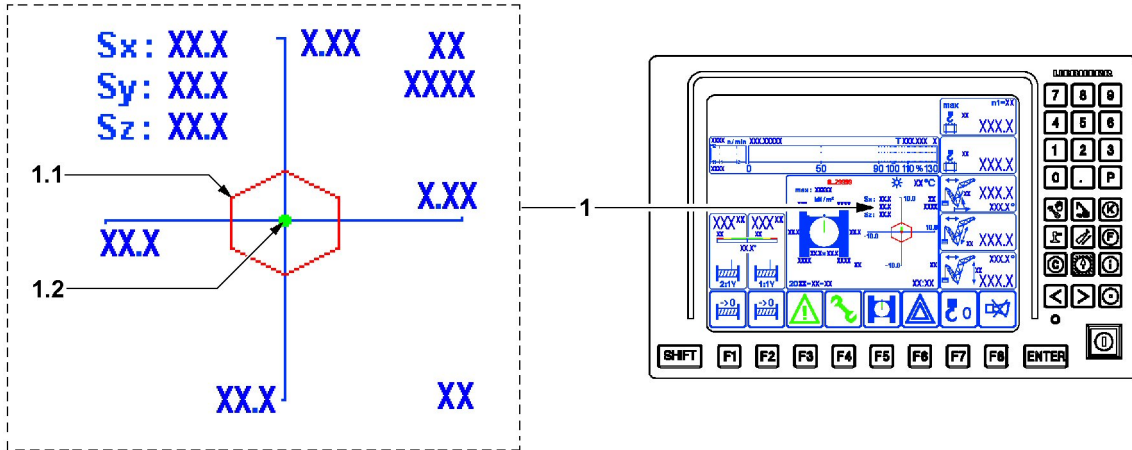

Fig.115325

Center of gravity display	
Position	Name
1.1	Core area
1.2	Center of gravity



WARNING

The center of gravity of the crane is outside the core area!

If the center of gravity 1.2 of the crane is outside the core area 1.1, then the crane can topple over. Death, severe bodily injuries, property damage.

- ▶ The center of gravity 1.2 must always be within the core area 1.1.



Note

- ▶ If the center of gravity 1.2 of the crane is within the core area 1.1, then the center of gravity 1.2 is shown in green.
- ▶ If the center of gravity 1.2 of the crane is outside the core area 1.1, then the center of gravity 1.2 is shown in red.

1.3.8 Checking the display for the surface pressure on the LICCON monitor



WARNING

Increased surface pressure!

The calculation of the values for the display of the surface pressure in the LICCON monitor are based on ideal assumptions.

- ▶ Side deformations of the boom system due to wind, inclined position and elastic resilience of the steel structure are not taken into account but they can lead to an increase of the surface pressure.

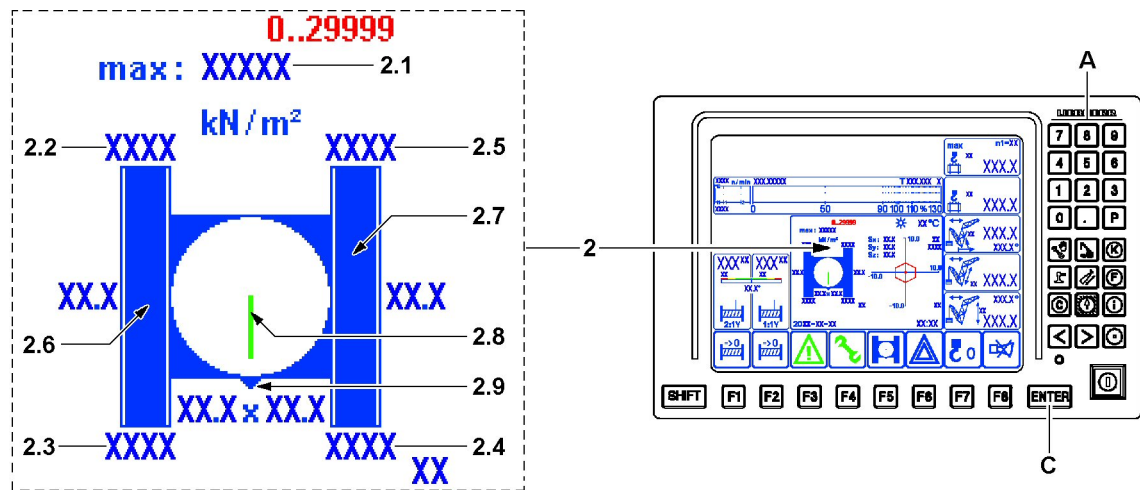

Fig.115326

Surface pressure display	
Position	Name
2.1	Maximum surface pressure
2.2	Right rear surface pressure
2.3	Front right surface pressure
2.4	Front left surface pressure
2.5	Rear left surface pressure
2.6	Right crawler carrier support
2.7	Left crawler carrier support
2.8	Boom position ¹⁾
2.9	„Front side of crawler travel gear“ ²⁾ marker

1) The boom position corresponds to the „viewing direction to the front“ from the crane cab.

2) The side where the chain tension device for the crawler carrier is located is always at the front on the crawler travel gear.



WARNING

Surface pressure too high!

If the maximum surface pressure 2.1 is exceeded, the crane can topple over.

Death, severe bodily injuries, property damage.

- ▶ Do not exceed the maximum value for the surface pressure.



Note

- ▶ The support of the crawler carrier is shown graphically.
- ▶ If the resulting surface pressure can be distributed so that the maximum surface pressure is not exceeded **and** the resulting forces can be transferred safely into the ground, then the stability of the crane is ensured.

The following specifications and instructions must be observed:

- The highest possible surface pressure, which may be obtained on the travel route must be entered as the maximum surface pressure 2.1.

Entering / changing the maximum permissible surface pressure

Make sure that the following prerequisite is met:

- The Crane operation program is called up.
- The maximum permissible surface pressure of the ground is known.

- ▶ Press the enter key **C**.

Result:

- The value for the maximum surface pressure **2.1** can be changed.

- ▶ Enter the value for the maximum permissible surface pressure using the keypad **A**.
- ▶ Press the enter key **C**.

Result:

- The new value for the maximum surface pressure **2.1** appears.
- ▶ Check the value for the maximum permissible surface pressure.

1.3.9 Checking the display for the incline in the LICCON monitor

Display of the inclination of the crane to the horizontal in the longitudinal and lateral direction. The display is graphic as well as numeric.

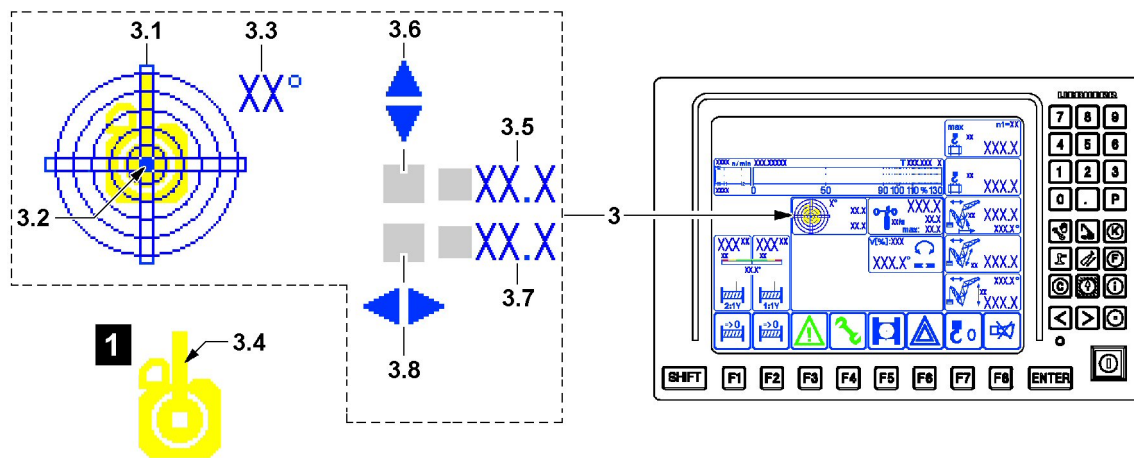

Fig.115327

Surface pressure display	
Position	Name
3.1	Sight gauge
3.2	Bubble
3.3	Display resolution
3.4	Boom position ³⁾
3.5	Incline in the longitudinal direction
3.6	Incline direction
3.7	Incline in the lateral direction
3.8	Incline direction

3) The boom position in the sight gauge **3.1** is highlighted as orientation aid, see detail **1**. The boom position corresponds to the „viewing direction to the front“ from the crane cab in relation to the spirit level **3.1**.



WARNING

The crane can topple over!

If the permissible inclines are exceeded, the crane can topple over.

Death, severe bodily injuries, property damage.

- ▶ Make sure that the permissible inclines are never exceeded.

2 Diesel particle filter (DPF)*



Note

- Applies only for engines with a diesel particle filter (DPF).

2.1 Calling up the diesel particle filter load condition

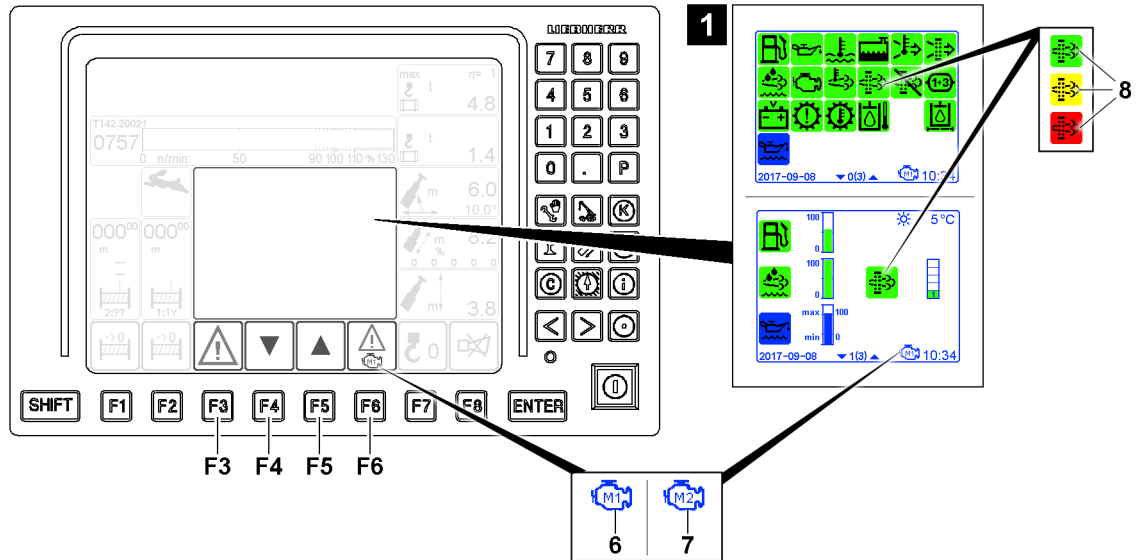

Fig.164436: Calling up the diesel particle filter load condition

Make sure that the following prerequisites are met:

- The ignition is turned on.
- The *Crane operation* program is active.

- Press the function key **F3**.

Result:

- The monitoring functions / individual control displays are displayed on the LICCON monitor, see illustration 1.

For crane types with two engines, the following applies:

- Pay attention to the assignment of the monitoring functions / individual control displays to the respective engine.
- With the function key **F6**, it is possible to switch between the monitoring functions / individual control displays of engine 1 **6** and engine 2 **7**.



Note

- By pressing the function key **F4** / function key **F5**, it is possible to switch between the monitoring functions and individual control displays.

If the icon **8** appears / blinks yellow or red:

- Check the diesel particle filter load condition
- Observe the error messages and evaluate in the BSE test system

2.2 Diesel particle filter load conditions

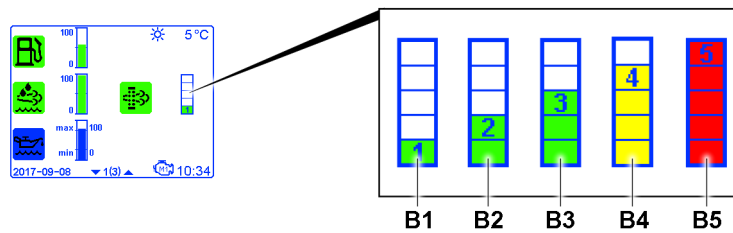

Fig.164437: Diesel particle filter load conditions

There are five load conditions for the diesel particle filter.

Read the load condition on the LICCON monitor:

- Load condition 1 **B1** (green): Load condition OK, diesel particle filter minimally loaded
- Load condition 2 **B2** (green): Load condition OK, diesel particle filter slightly loaded
- Load condition 3 **B3** (green): Load condition OK, diesel particle filter half loaded
- Load condition 4 **B4** (yellow): Increased load condition, diesel particle filter strongly loaded
- Load condition 5 **B5** (red): Critical load condition, diesel particle filter with maximum load

If the load condition 4 **B4** icon appears, Liebherr-Werk Ehingen GmbH recommends carrying out regeneration at a standstill as soon as possible (during the work day).

If the load condition 5 **B5** icon appears and regeneration at a standstill is no longer possible:

- ▶ Stop engine operation.
- ▶ Contact Liebherr-Werk Ehingen GmbH Customer Service.



Note

Load condition 5 **B5**

- ▶ The engine torque is reduced to protect the engine against damage.

2.3 Automatic regeneration of the diesel particle filter



WARNING

Regeneration of the diesel particle filter* in an environment with a fire hazard!

High exhaust gas temperature. Danger of fire.

- ▶ In an environment with a fire hazard, disable or stop automatic regeneration.

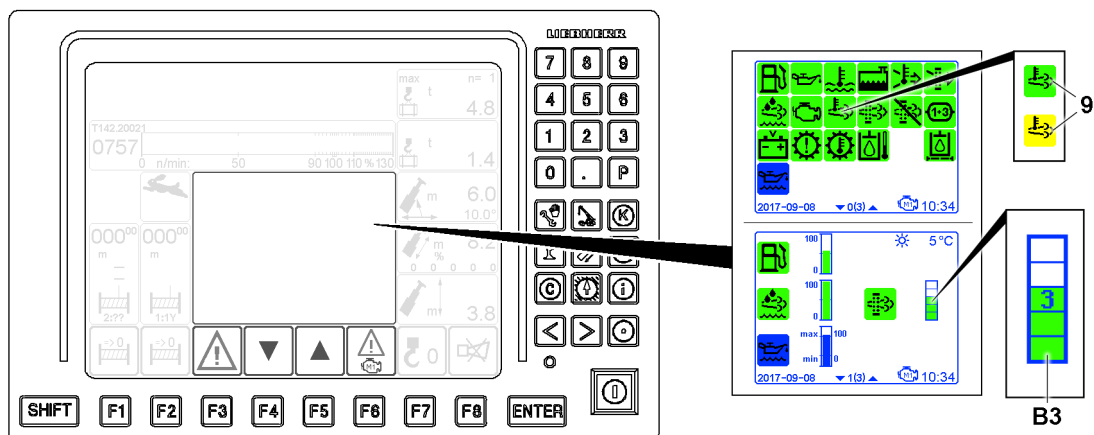

Fig.164438: Possible displays during automatic regeneration of the diesel particle filter

From load condition 3 **B3**, automatic regeneration is carried out automatically during engine operation. This means no limitations to crane operation. Engine noise may change slightly during automatic regeneration.

Automatic Regeneration is triggered only when the ambient conditions (load profile) of the engine permit regeneration. The engine must be operated continuously for at least one hour to complete automatic regeneration.

While the diesel particle filter is being regenerated, the icon **9** in the crane operation monitoring functions turns yellow. When generation is complete, the icon **9** turns green.

2.4 Disabling automatic regeneration of the diesel particle filter

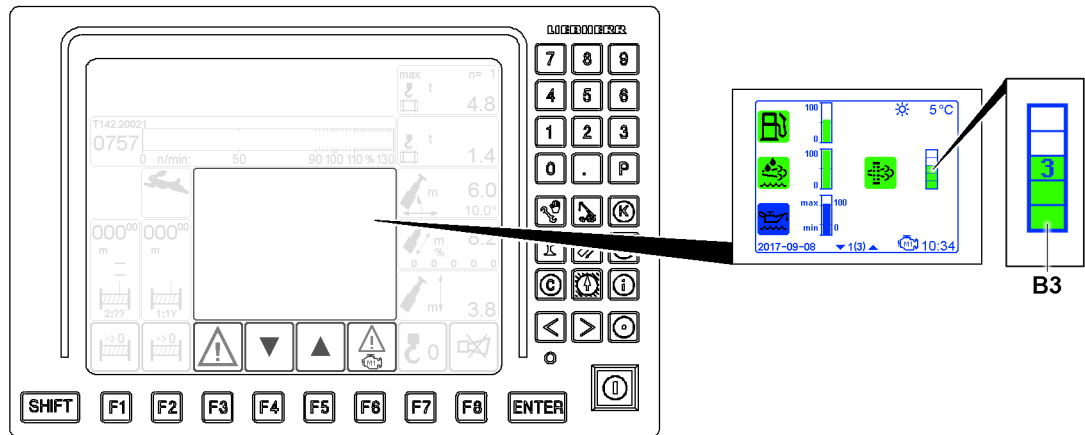

Fig. 164439: Displays for load condition 3

From load condition 3 **B3**, automatic regeneration is carried out automatically during engine operation.

If needed, automatic regeneration can be:

- disabled as a precaution
- interrupted and disabled while it is being carried out

Make sure that the following prerequisites are met:

- The crane is at a standstill.
- The monitoring functions are displayed on the LICCON monitor.

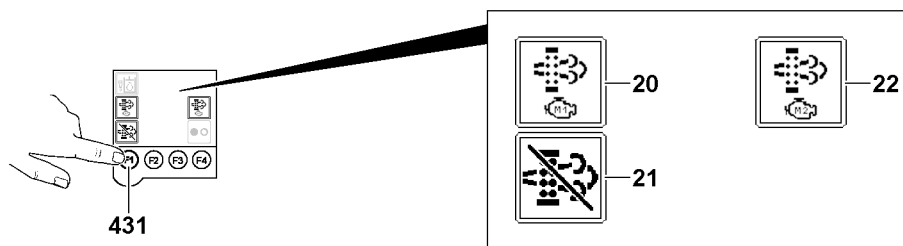

Fig. 164440: Icons for controlling diesel particle filter regeneration on TE2

- ▶ Press the F1-button **431** on the left touch display (TE2) until the *engine 1 diesel particle filter regeneration at a standstill icon 20*, *engine 2 diesel particle filter regeneration at a standstill icon 22* und *Disable diesel particle filter regeneration icon 21* are displayed.

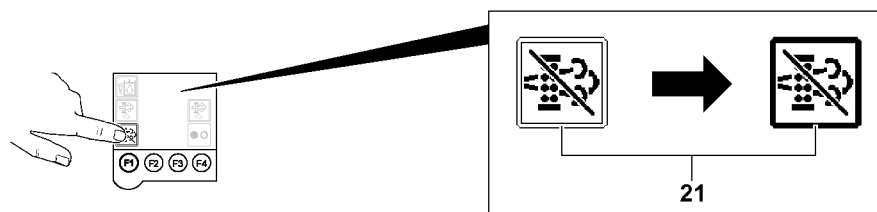

Fig. 164441: Selecting disabling regeneration of the diesel particle filter

- ▶ Tap the *disable diesel particle filter regeneration icon 21* to select it.

Result:

- The frame of the *disable diesel particle filter regeneration* icon **21** is displayed in bold.
- Disabling regeneration of the diesel particle filter is selected.

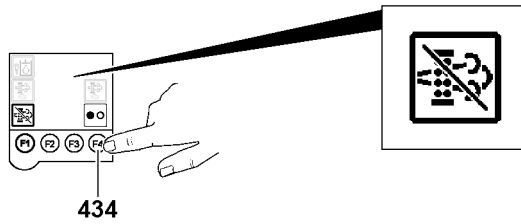

Fig.164442: Disabling automatic regeneration of the diesel particle filter

- ▶ Press the F4 key **434**.

Result:

- Automatic regeneration of the diesel particle filter is disabled.

**Note**

- ▶ Automatic regeneration is disabled on both engines.

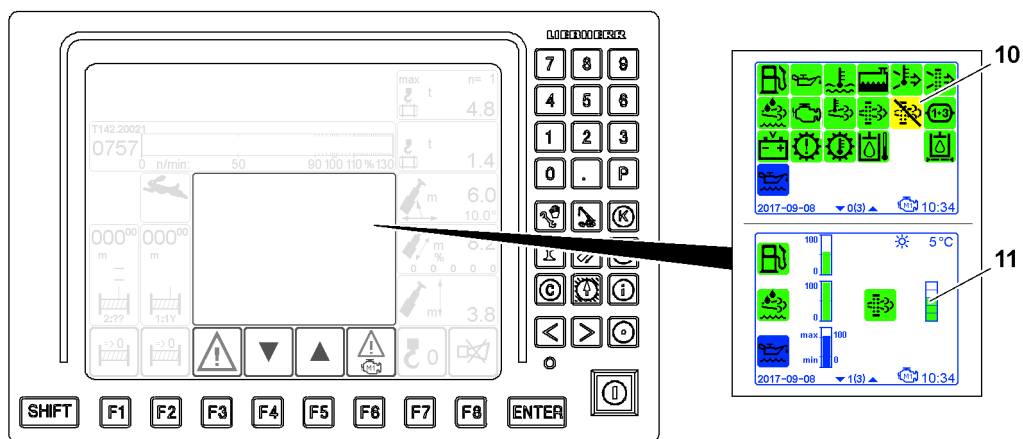

Fig.164443: Displays during disabling automatic regeneration of the diesel particle filter

As long as the automatic regeneration of the diesel particle filter is disabled, the *disable diesel particle filter regeneration* icon **10** appears yellow.

If automatic regeneration of the diesel particle filter is disabled:

- ▶ Monitor the *load condition* display **11** on both engines. As soon as the load condition is increased (yellow), Liebherr-Werk Ehingen GmbH recommends carrying out regeneration at a standstill as soon as possible (during the work day).

2.5 Regenerating at a standstill of the diesel particle filter

**WARNING**

Regeneration of the diesel particle filter* in an environment with a fire hazard!
High exhaust gas temperature. Danger of fire.

- ▶ In an environment with a fire hazard, do not carry out regeneration at a standstill of the diesel particle filter.

NOTICE

Turn off the engine during regeneration at a standstill!

Interrupting the regeneration at a standstill by turning off the engine destroys the diesel particle filter (DPF).

- ▶ Do **not** interrupt regeneration at a standstill by turning off the engine.

**Note**

High temperatures at the exhaust outlet

- ▶ Only if necessary: Carry out regeneration at a standstill.

Regeneration at a standstill of the diesel particle filter must be started on touch display 2. Regeneration at a standstill can be started and carried out on each engine individually or on both engines at the same time. To do so, each engine must be selected separately.

Regeneration at a standstill can be carried out at the earliest from load condition 2 and at the latest at load condition 4. In addition, no crane movement or travel movement may be started. The engine rpm may not be increased (idle).

**Note**

- ▶ Do **not** carry out any crane operation or travel operation during regeneration at a standstill!

Make sure that the following prerequisites are met:

- The crane is at a standstill, no master switch or pedal sensor has been actuated.
- The BTT is in the charging cradle.
- The engine rpm is not increased, the engine is idling.
- The load condition of the diesel particle filter is displayed on the LICCON monitor.
- At least load condition 2 is reached.

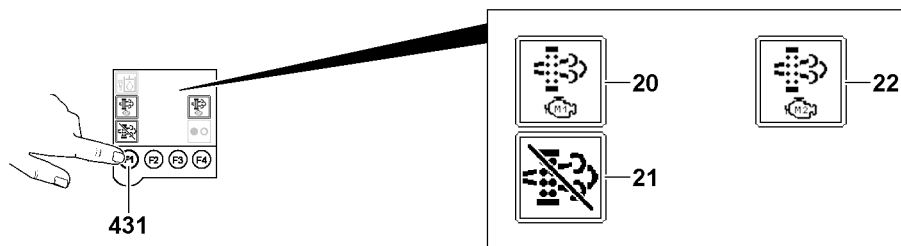

Fig.164440: Icons for controlling diesel particle filter regeneration on TE2

- ▶ Press the F1-button **431** on the left touch display (TE2) until the *engine 1 diesel particle filter regeneration at a standstill* icon **20**, *engine 2 diesel particle filter regeneration at a standstill* icon **22** und *Disable diesel particle filter regeneration* icon **21** are displayed.

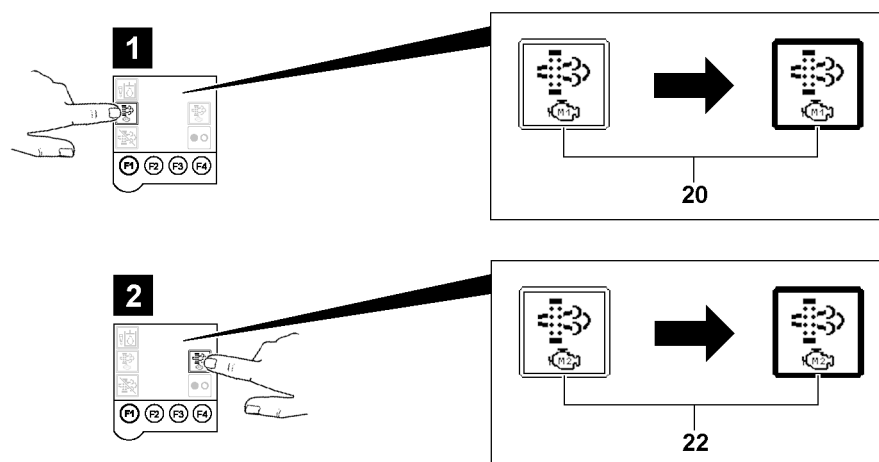

Fig.164444: Selecting regeneration at a standstill of the diesel particle filter

- ▶ Tap the *engine 1 diesel particle filter regeneration at a standstill* icon **20** to select it, see illustration 1.
- ▶ Tap the *engine 2 diesel particle filter regeneration at a standstill* icon **22** to select it, see illustration 2.

Result:

- The frame of the selected icon is displayed in bold.
- Regenerating at a standstill of the diesel particle filter von Engine 1 and / or Engine 2 is selected.

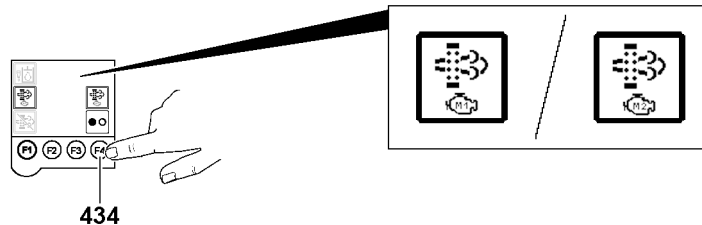

Fig.164445: Activating regeneration at a standstill of the diesel particle filter

- ▶ Press the F4 key **434**.

Result:

Fig.164446: Example of carrying out the regeneration at a standstill of the diesel particle filter with load condition 4

- Regenerating at a standstill of the diesel particle filter for the selected engine is started.
- The crane operation monitoring functions 7 icon 9 turns yellow.
- The remaining regeneration time 12 is displayed on the individual control displays 6.

**Note**

- ▶ Check the individual control displays **6** for both engines if necessary.
- ▶ Wait until the regeneration time **12** for the selected engine has elapsed.

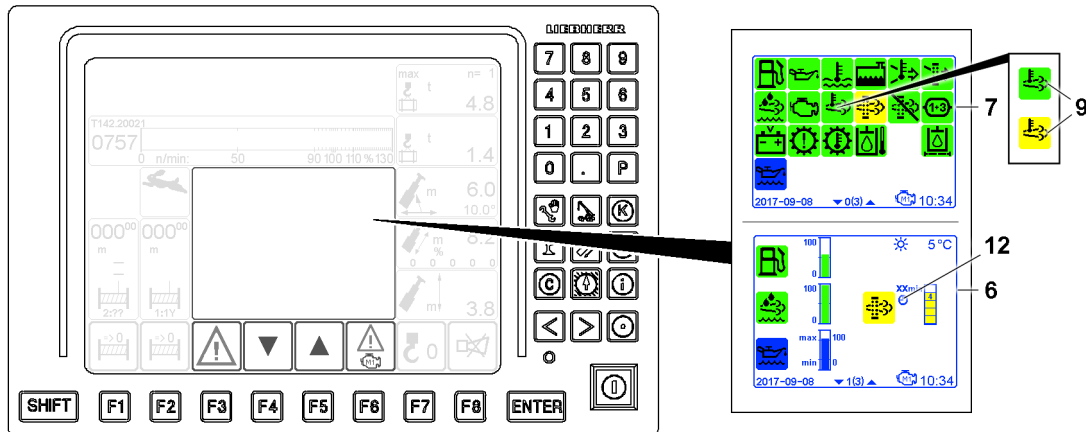
Result:

- The icon **9** turns green.
- After successful regeneration, a permissible load condition is reached.

3 Exhaust system cleaning procedure

The automatic cleaning procedure for the *exhaust system* prevents damaging the exhaust system.

Prior to the *exhaust system* cleaning procedure, the engine rpm is increased for 10 to 20 minutes by the crane control. A message **1** is displayed.

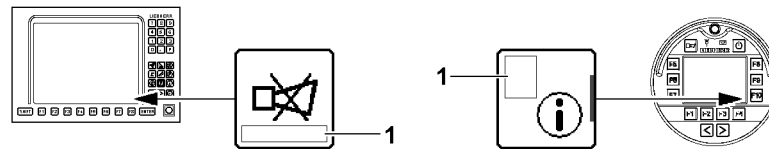

Fig.154108: Note regarding the message 1 in the display field

If the engine is turned off during the cleaning procedure, the cleaning procedure restarts the next time the engine is started.

NOTICE

Exhaust system cleaning procedure active!
Hot exhaust system. Property damage.

If the *exhaust system* cleaning procedure active message is displayed:

- ▶ Do **not** turn the engine off.

If the *exhaust system* cleaning procedure active message disappears:

- ▶ The engine can be turned off.
-

1

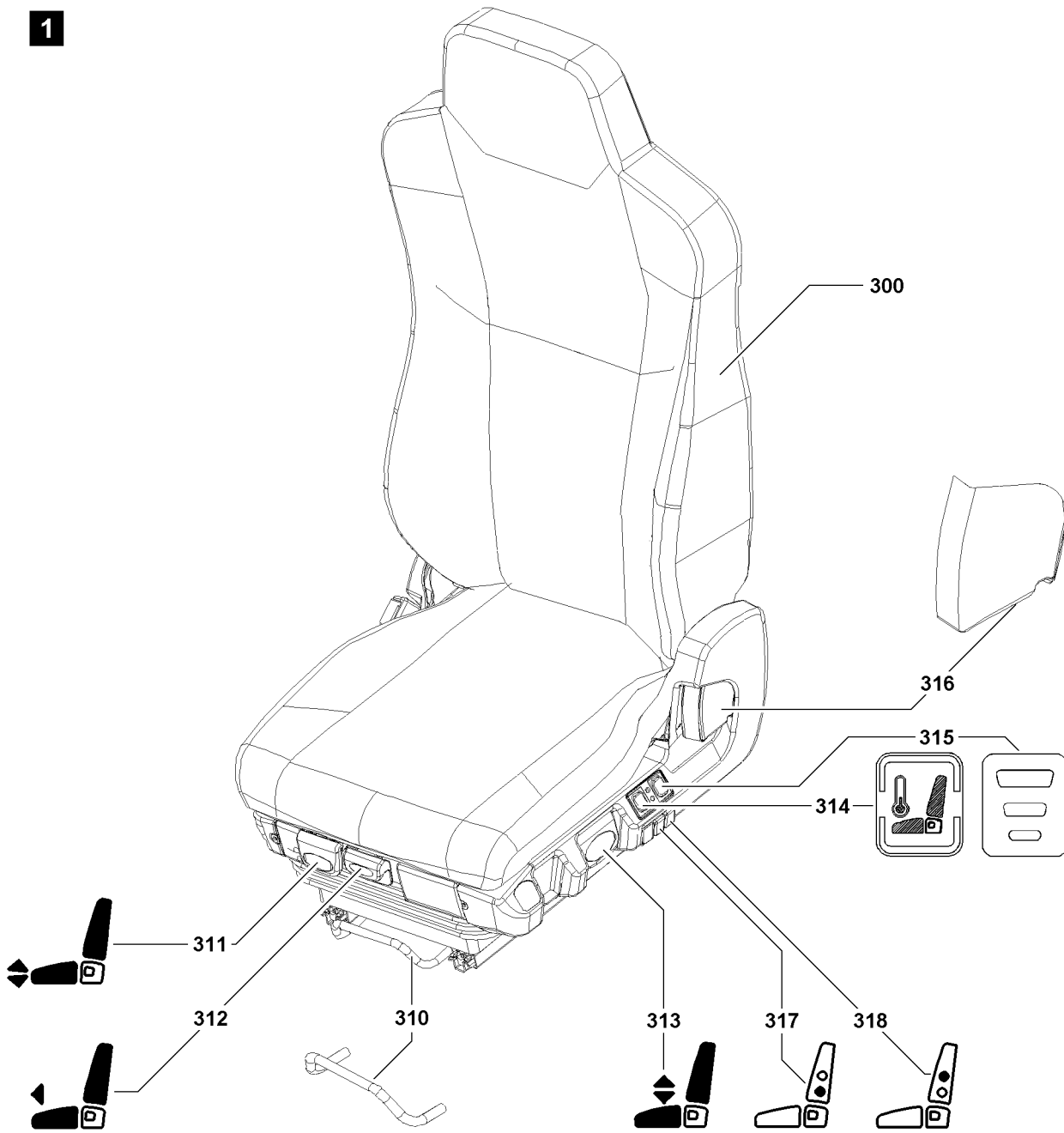

2

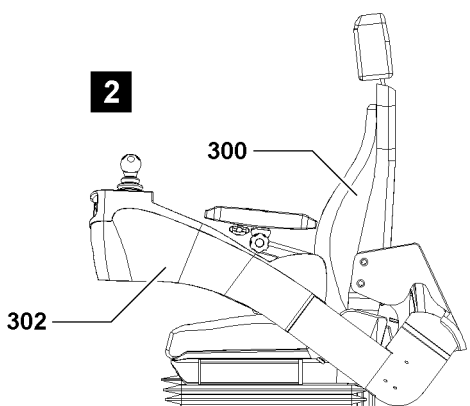

3

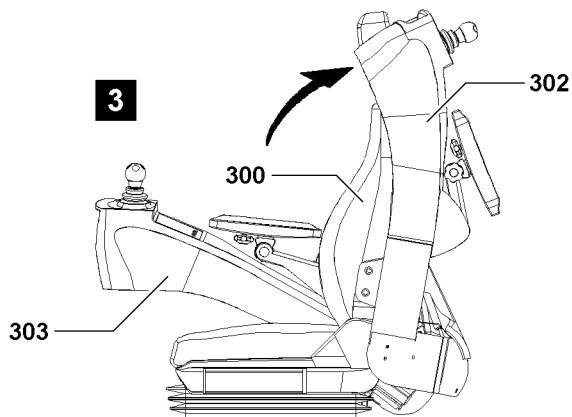

Fig.110462

LWE/LR 13000-001/19503-01-02/en

4 Crane operator's cab work station

4.1 Adjusting the crane operator's seat



WARNING

Danger of injury!

When the crane operator's cab is inclined and when the crane is standing on an incline, the crane operator's seat can move suddenly when adjusting it!

Limbs can be caught and injured!

- ▶ Carry out adjustments on the crane operator's seat only when the crane operator's cab is in horizontal position!

Adjust the seat position

- ▶ With the bracket **310** adjust the seat in the horizontal direction by moving it back or forth.
- ▶ Use the lever **311** to adjust the seat cushion incline.
- ▶ Use the lever **312** to adjust the position of the seat cushion.
- ▶ Use the lever **313** to adjust the seat height.
- ▶ Use the lever **316** to adjust the angle of the backrest.
- ▶ With the button **317**, adjust the lumbar area support „on the bottom“.
- ▶ With the button **318**, adjust the lumbar area support „on top“.

Turning the seat heater* / seat climate control* on

The seat heater or climate control is turned on / off with the switch* **314**.

There are three switch positions:

- Center position: Seat heater and seat climate control turned off.
- Pushed on top: Seat heater turned on (red light).
- Pushed on the bottom: Seat climate control turned on (blue light).
- ▶ Select the seat heater / seat climate control with the switch* **314**.
- ▶ Adjust the seat heater / seat climate control with the fan stage switch* **315**.

1

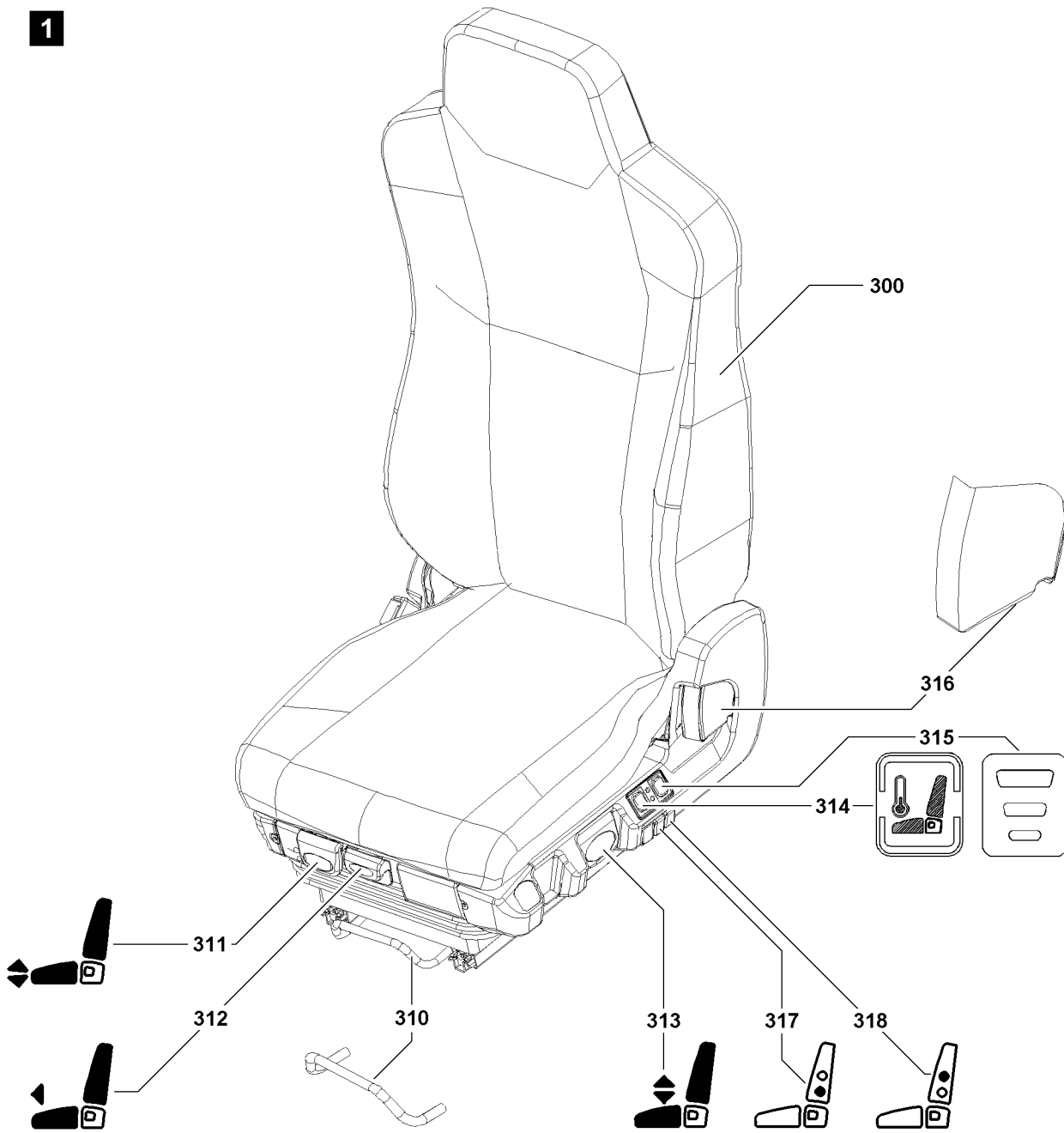

2

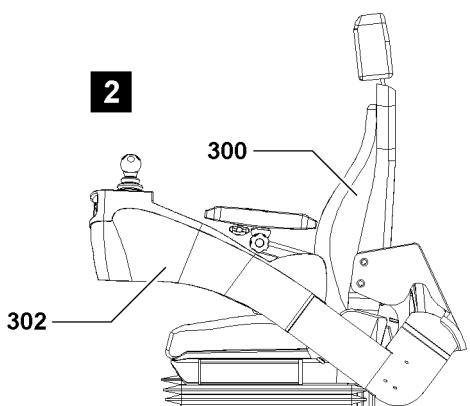

3

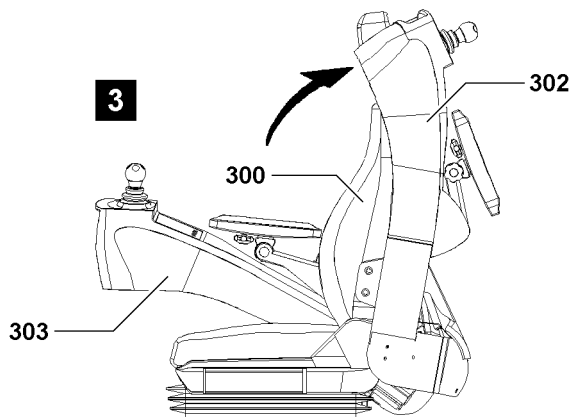

Fig.110462

LWE/LR 13000-001/19503-01-02/en

4.2 Adjusting the consoles

The control platform, with the consoles on the left and right hand side of the crane operator's seat **300** allows the crane driver to adjust the consoles to suit his body size optimally.

Two different console positions are possible:

- Crane operating position (both consoles down), see illustration **2**.
- Entering / exiting position, see illustration **3**.



WARNING

Danger of accident!

A raised console (for example console **302** in the entering / exiting position), can swing down uncontrolled if jolted (for example strong braking)!

Personal injury and property damage can result!

- ▶ Driving the crane and crane operation with raised consoles is prohibited!
 - ▶ Always bring the consoles into the „Crane operating position“ immediately!
 - ▶ Hold the consoles when swinging them until the respective end position is reached!
-

The consoles can be brought into another position by swinging them up:

- Move the console **302** (left) from the „crane operating position“ to „enter / exit“ position by swinging it up.
 - Move the console **303** (right) from the „crane operating“ position to the „up“ position by swinging it up.
-



Note

- ▶ If the consoles are swung down, the last set positions are used.
-

4

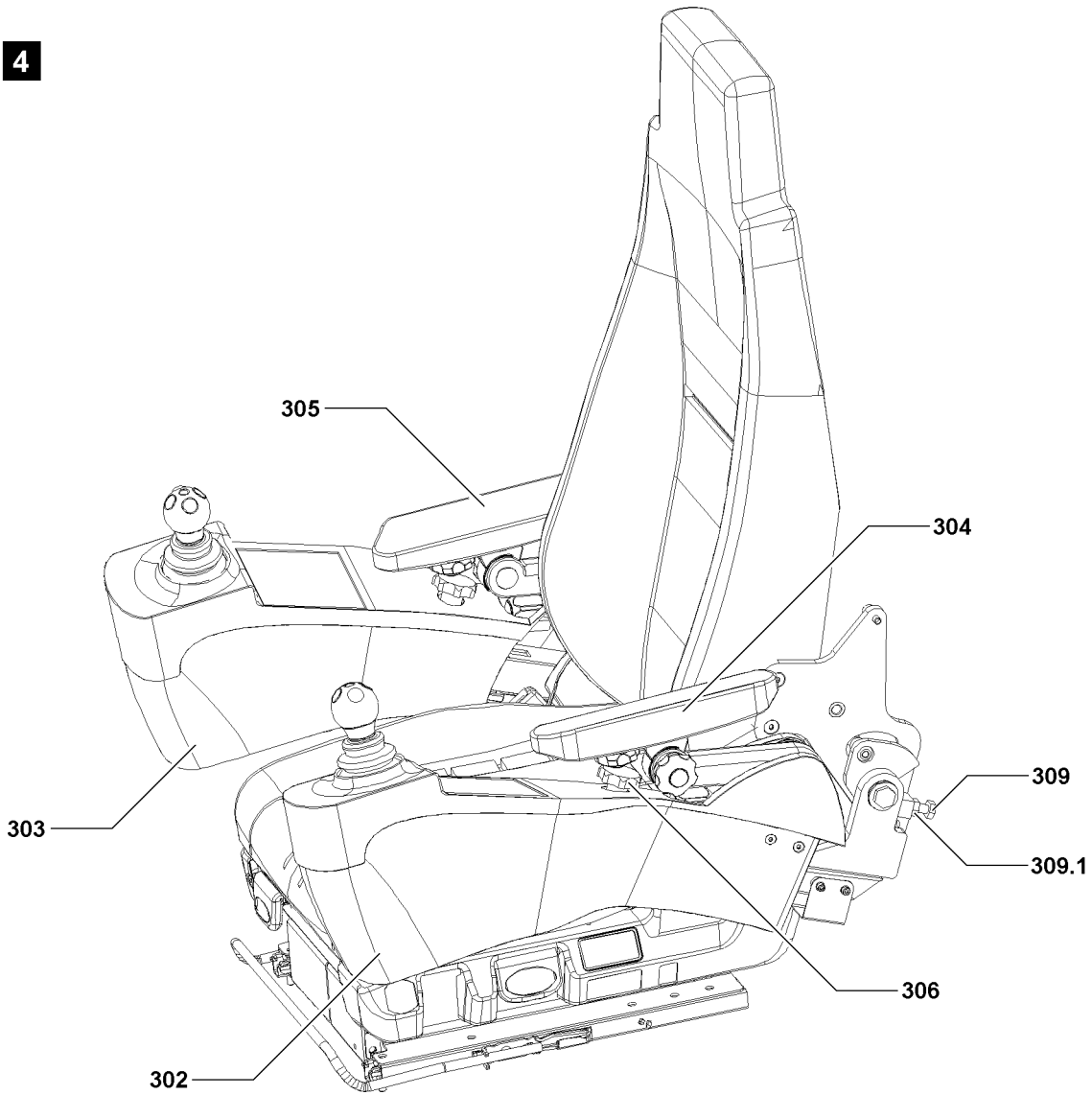

5

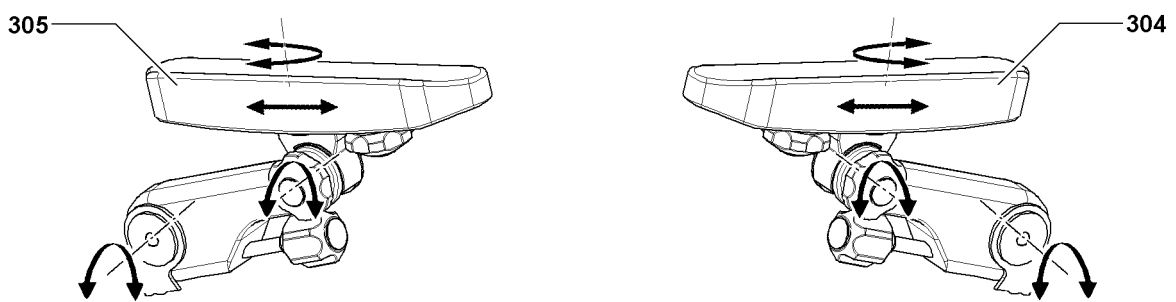

Fig.110463

LWE/LR 13000-001/19503-01-02/en

4.2.1 Adapting the consoles to the crane operator



Note

- ▶ The consoles can be adjusted individually to suit. Every crane operator can set their work place optimally to their body size!
- ▶ The left console **302** and the right console **303** can be adjusted independently of each other!



Note

- ▶ The consoles can be adjusted to suit the crane operator as described for the left console **302**, see illustration 4!
- ▶ The procedure for the right console **303** is carried out accordingly.

Adjust the incline of the console

- ▶ Release the nut **309.1**.
- ▶ Adjust the stop screw **309** until the console **302** has reached the desired incline .
- ▶ Secure the stop screw **309** with the nut **309.1**.

Move the console horizontally

- ▶ Fold the armrest **304** up.
- ▶ Pull the locking pin **306** until the console **302** can be moved.
- ▶ Adjust the horizontal position of the console **302** by moving it forward / backward.
- ▶ Release the locking pin **306** and let it engage.
- ▶ Fold the armrest **304** down.

Result:

- The console **302** is adjusted.

4.2.2 Armrests

The left armrest **304** and the right armrest **305** offer a multitude of adjustment possibilities, see illustration 5.



Note

- ▶ To ensure fatigue free and concentrated work with the crane, the armrests should be adjusted in such a way to be able to comfortably reach and operate the master switches.
- ▶ The left armrest **304** and the right armrest **305** can be adjusted with the adjustment screws, see illustration 5.

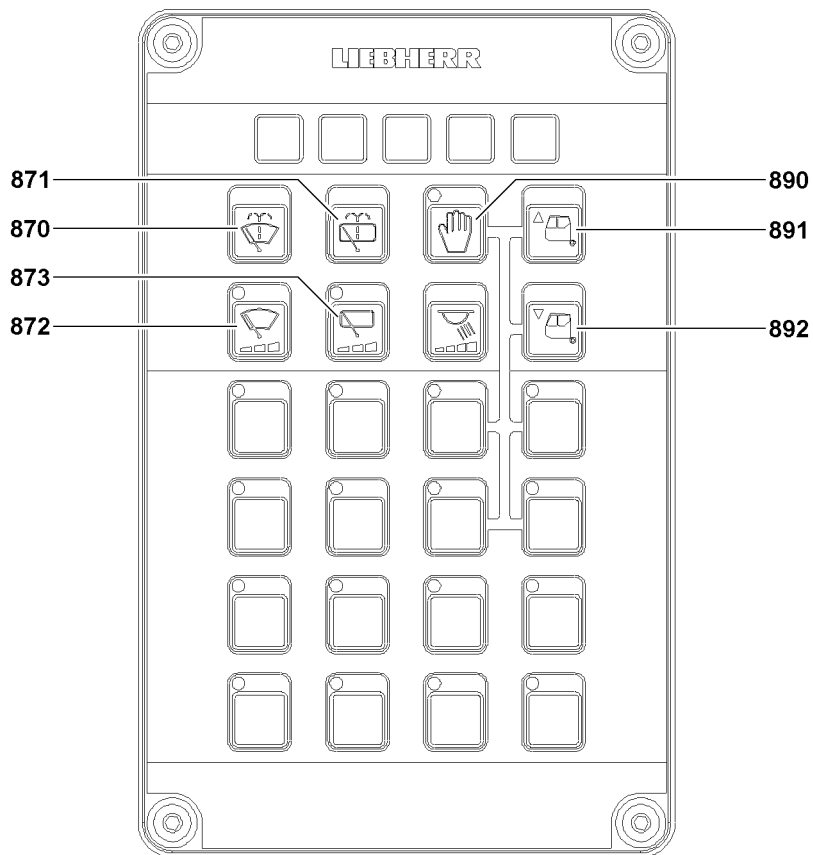

Fig.115317

LWE/LR 13000-001/19503-01-02/en

4.3 Tilting the crane cab*

To give the crane driver a better field of vision, the crane cab can be tilted upwards.

When the crane cab is tilted up, the catwalk around the cab is also inclined.

The incline of the crane cab can be adjusted via the function keys on the operating and control unit (BKE), see illustration.



WARNING

Danger of accident!

When the crane cab is tilted or tilting, personnel who are moving freely in the cab can fall.

When the crane cab is tilted or tilting, the cab door can start to move suddenly when opening it.

Injuries to persons and property damage can result.

- ▶ Tilt the crane operator's cab only when properly seated in the crane operator's seat.
- ▶ Before getting up from the crane operator's seat, return the crane operator's cab to the horizontal position.
- ▶ When work with the crane is complete, set the cab horizontally.

When the cab door must be opened with tilted crane cab:

- ▶ Grasp the cab door handle safely and carefully open the cab door.



WARNING

Inclined catwalk!

If persons are on a tilted or tilting catwalk, they can fall.

Personnel can be severely injured or killed.

- ▶ It is prohibited for anyone to remain under the catwalk when tilting the crane cab.
- ▶ It is prohibited for anyone to remain on a tilted catwalk.
- ▶ Before stepping on the catwalk, set it to the horizontal position.

When work with the crane is complete, set the cab horizontally.

Make sure that the following prerequisite is met:

- There are no persons in the incline range of the cab and the catwalk.

4.3.1 Tilting the cab upward

- ▶ Activate the release button **890** and then press the operating button **891**.

Result:

- The cab swings upward.

4.3.2 Move the cab to the horizontal position.

- ▶ Activate the release button **890** and then press the operating button **892**.

Result:

- The cab swings downward.

4.4 Window wiper / window washer system

4.4.1 Operating the window wipers

The window wipers on the front and roof window can be operated via the function buttons on the operating and control unit (BKE), see illustration. Each window has a button assigned to it.

Turning the window wiper on

There are four different wipe stages.

Pressing the button **872** or the button **873** (less than 0.5 seconds) reduces the wiper speed incrementally:

1. Continuous operation
2. Short interval
3. Long interval
4. Wiper off

- When the wipe stage „Wiper off“ is reached, an acoustical signal sounds on the BKE.

To activate the window wiper on the front window:

- ▶ Press the button **872** until the desired wipe stage is reached.
- or**

To activate the window wiper on the roof window:

Press the button **873** until the desired wipe stage is reached.

Turning the window wiper off

- ▶ Press the button **872** or the button **873** for at least one second.
- or**

Press the button **872** or button **873** until an acoustical signal sounds on the BKE (less than 0.5 seconds).

4.4.2 Operating the window washer system

The window washer system on the front and roof window can be operated using the function buttons on the operating and control unit. Each window has a button assigned to it.

The wiper motor and the water pump run as long as the button **870** or button **871** is pressed.

After pressing the button **870** or the button **871**, three additional wipe movements are carried out before the wiper arms return to their original position.

To activate the window washer system for the front window:

- ▶ Press the button **870**.
- or**

To activate the window washer system for the roof window:

Press the button **871**.

4.4.3 Filling the window washer system

For the location of the reservoir for the window cleaning fluid, see the Crane operating instructions, chapter 4.01!

NOTICE

Frozen window cleaning fluid!

If the window cleaning fluid is not frost resistant, then the window washer system can freeze during the cold time of the year!

Failure of the window washer system is the result!

The window washer system can be damaged!

- ▶ Change the window cleaning fluid in time to a frost resistant type!
-

Before the start of the cold season:

- ▶ Fill the reservoir with a frost resistant window cleaning fluid.

4.5 Checking the horn



WARNING

Improper use of horn!

If the horn is used outside of danger situations, it can lose its warning effect!

If the horn loses its warning effect, severe injuries can occur as a result!

If the horn is to be checked:

- ▶ Notify all personnel in the vicinity that the horn is being checked for function.

When the horn test is completed:

- ▶ Notify all personnel in the vicinity that the testing of the horn has been completed.
- ▶ Do not use the horn unnecessarily!

Make sure that the following prerequisite is met:

- All personnel in the vicinity have been notified that the horn is being checked for function.

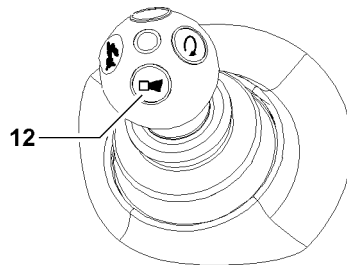

Fig.115322: Horn button

Before starting to work, check that the horn is functioning:

- ▶ Press the button **12** on any master switch.

Result:

- The horn sounds.

Problem remedy

Does the horn not sound?

The horn is not functioning.

- ▶ Repair the horn before starting crane operation.

After successful testing of the horn:

- ▶ Notify any personnel in the vicinity that the testing of the horn has been completed.

4.6 Opening / closing cab doors and cab windows

Unsecured or unlocked cab doors or cab windows can move suddenly if, for example:

- The crane is driven / decelerated.
- The cab or the entire crane is at an incline.



WARNING

Danger of accident!

Unsecured or unlocked cab doors or cab windows that move suddenly can catch personnel and cause accidents.

If the crane is driven with open window or open crane door, the crane cab can be damaged!

- ▶ Secure or lock the cab doors or cab windows to prevent them from moving suddenly.

**WARNING**

Danger of crushing!

When closing the cab door and cab window, hands can be trapped.

- ▶ When closing the cab door and cab windows, make sure that no limbs are injured.

Open the cab door:

- ▶ Unlock and open the cab door.

Close the cab door:

- ▶ Pull the cab door closed and lock.

Open the cab window:

- ▶ Unlock and open the cab window.

Close the cab window:

- ▶ Pull the cab window closed and lock it.

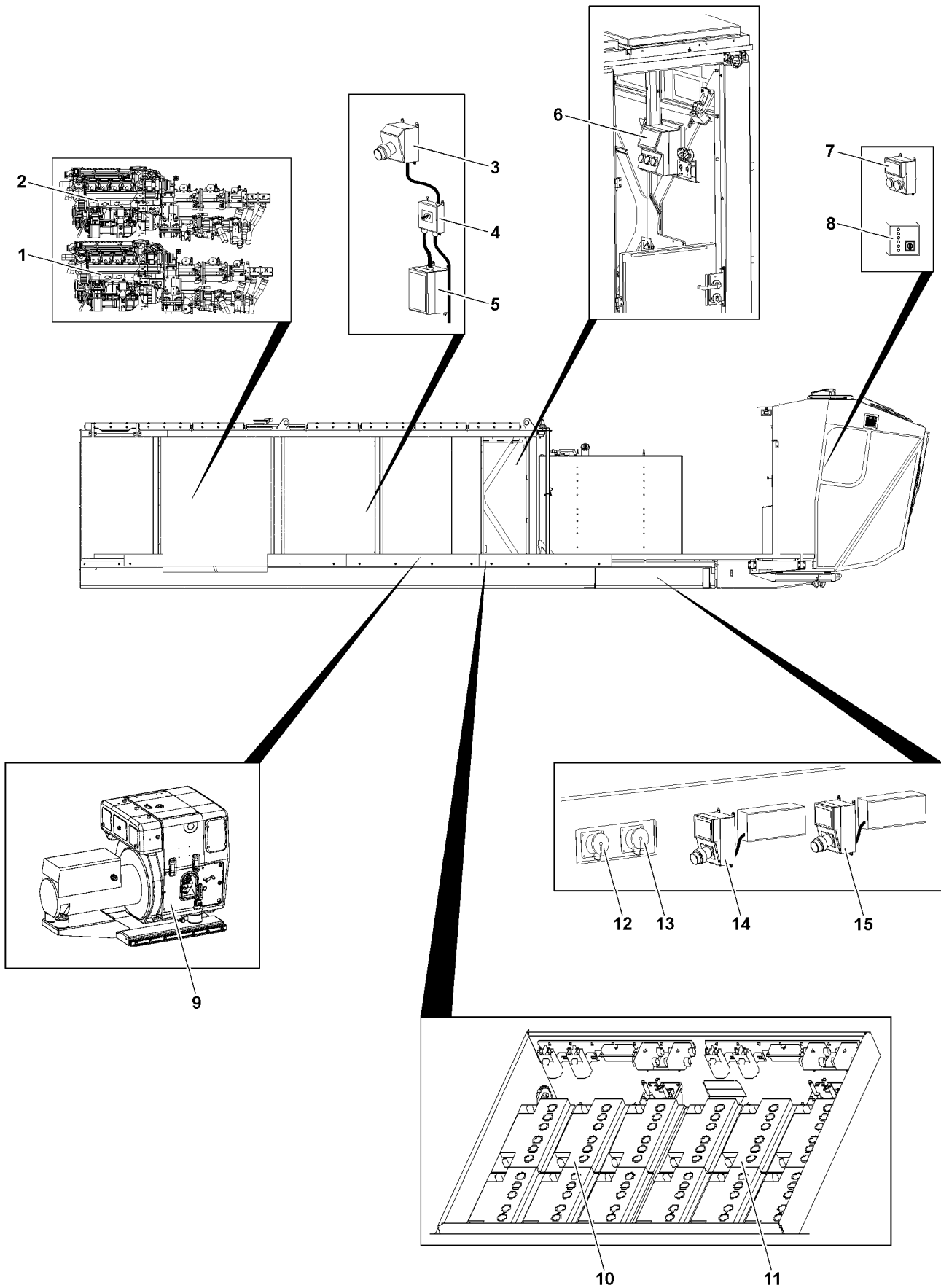

Fig.115316

LWE/LR 13000-001/19503-01-02/en

5 Supply via external feed / power aggregate

The following types of supply are available:

- Supply via plug connection for external feed from the power supply system
- Supply via power aggregate (HATZ-DIESEL)

Position	Description
1	Aggregate no.1 (bottom)
2	Aggregate no.2 (top)
3	Plug connection for external power supply (32A 400V - feed in)
4	Change over switch (supply either via an external power supply or via the HATZ-DIESEL generator)
5	Circuit breaker
6	Power aggregate / supply main distribution
7	Power aggregate / supply subdistribution
8	HATZ-DIESEL starter box
9	HATZ-DIESEL generator (including own starter battery)
10	Aggregate no.1 battery system
11	Aggregate no.2 battery system
12	Feed for jump starting (24V), aggregate no. 1
13	Feed for jump starting (24V), aggregate no. 2
14	Feed (16A-230V/110V) for charging unit / coolant preheating aggregate no. 1
15	Feed (16A-230V/110V) for charging unit / coolant preheating aggregate no. 2

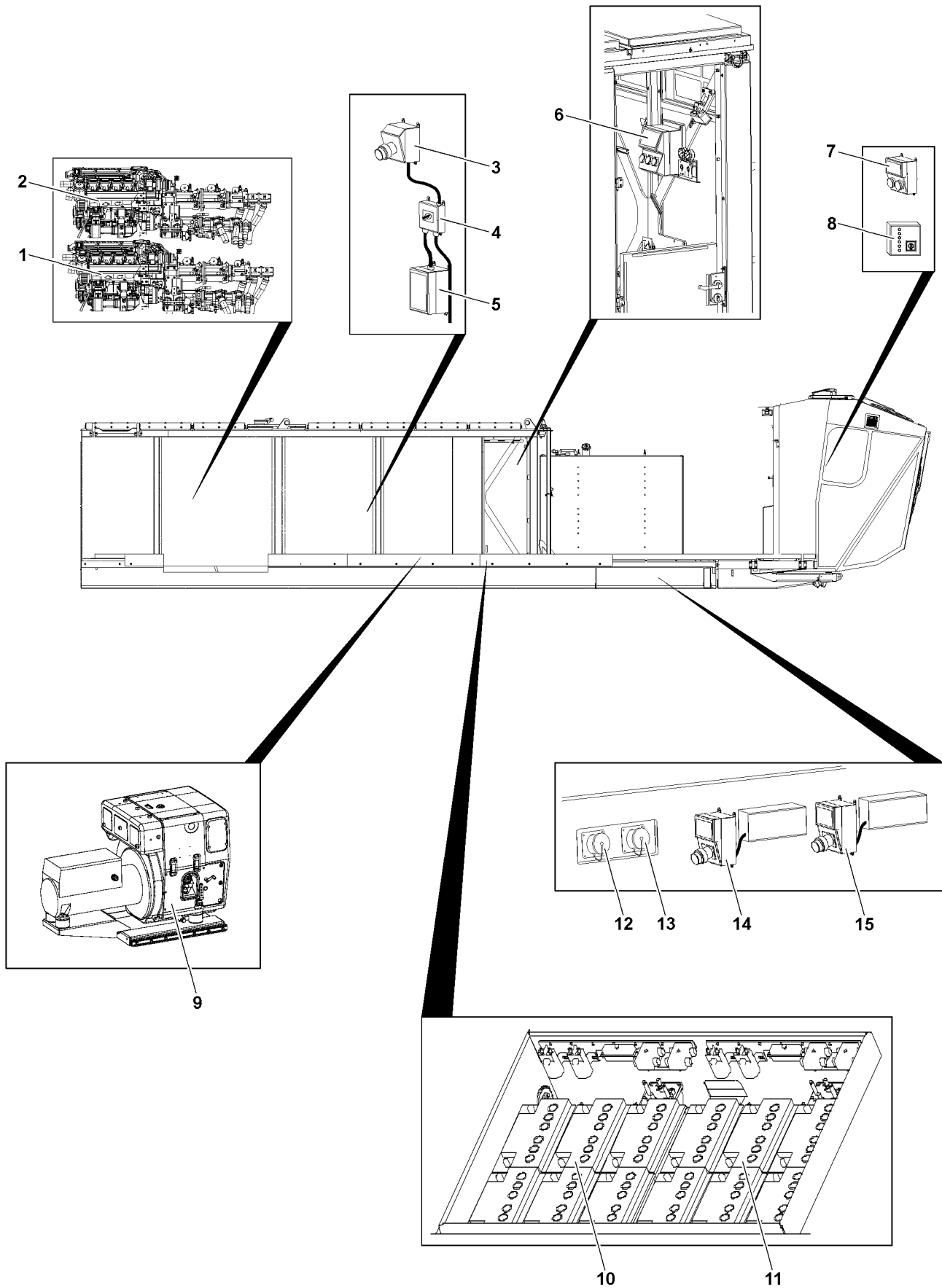

Fig.115316

LWE/LR 13000-001/19503-01-02/en

5.1 Connecting the supply

- ▶ Turn the circuit breaker **5** to position „0“.
- ▶ Switch the change over switch supply **4** to the selected supply mode.

Depending on the selected supply mode:

- ▶ Plug in the power supply line on the plug connection **3**.
or
Turn on the HATZ-DIESEL generator on the starter box **8**.
- ▶ Turn the circuit breaker **5** to position „1“.

Result:

- The supply is established.

5.2 Turning the supply off

- ▶ Turn the circuit breaker **5** to position „0“.

Depending on the selected supply mode:

- ▶ Unplug the power supply line on plug connection **3**.
or
Turn the HATZ-DIESEL generator off on the starter box **8**.

Result:

- The supply is turned off.

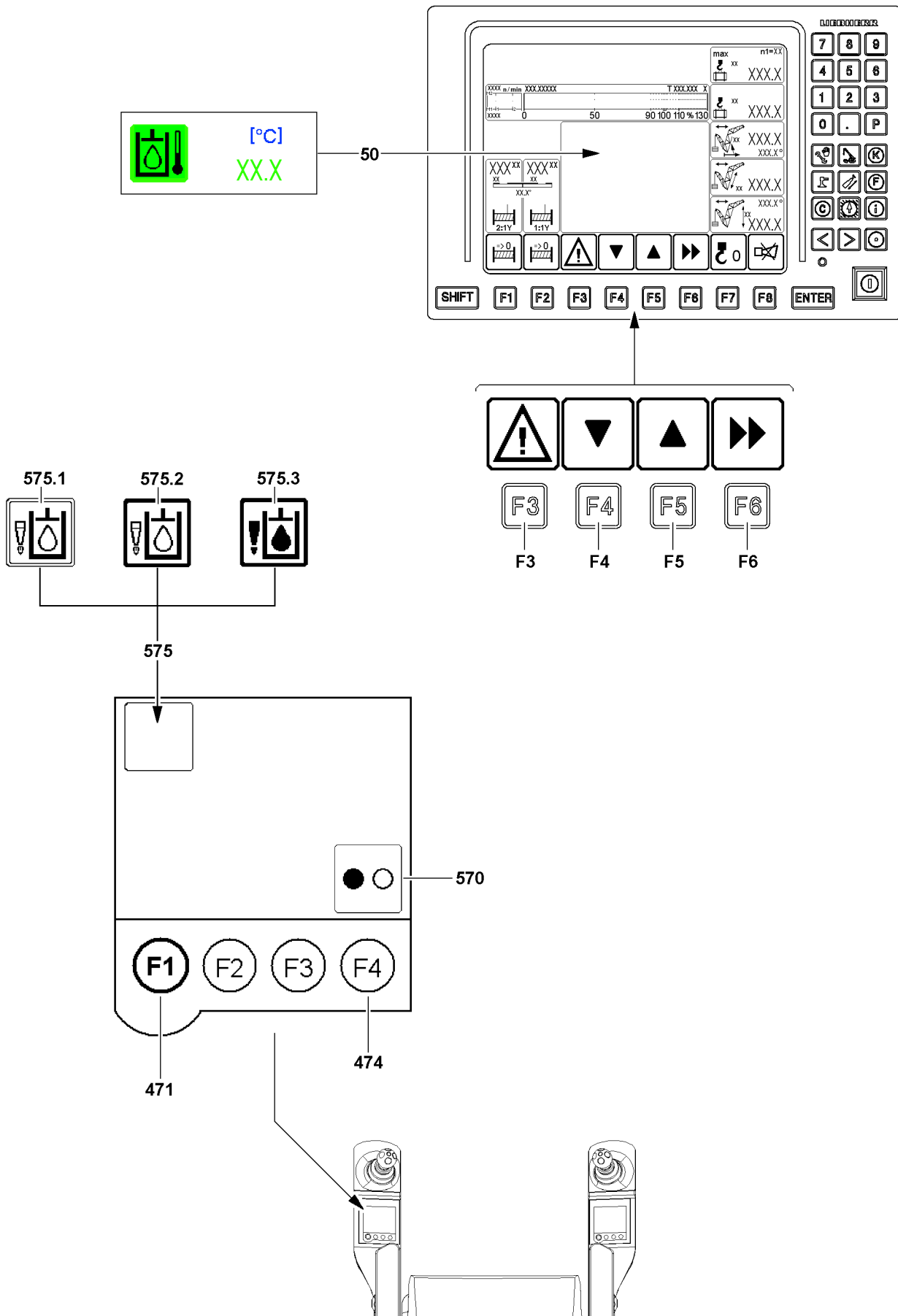

Fig.164435

LWE/LR 13000-001/19503-01-02/en

6 Preheating the hydraulic oil with Hydraulic oil preheating*

The hydraulic oil can be preheated with the Hydraulic oil preheating*.



Note

- ▶ Always preheat the hydraulic oil at low ambient temperatures.
- ▶ From a hydraulic oil temperature above 25 °C , do not turn the Hydraulic oil preheating* on.
- ▶ The current hydraulic oil temperature can be called up via the individual control display on the LIC-CON monitor.

6.1 Turning hydraulic oil preheating* on

Make sure that the following prerequisite is met:

- The crane engine is running.



Note

When the Hydraulic oil preheating* is turned on, various crane movements are turned off.

- ▶ If necessary, turn hydraulic oil preheating* off.

- ▶ In the „Crane operation“ program, press the function key **F3**.

Result:

- The monitoring field with monitoring functions is displayed on the LICCON monitor.
- ▶ Press the function key **F4** until the individual control display for the hydraulic oil temperature is shown on the LICCON monitor.

Result:

- The current hydraulic oil temperature can be read.
- ▶ Press the F1 key **471** on the left touch display until the „hydraulic oil preheating“ menu appears.



Fig.115320

- ▶ Select the „hydraulic oil preheating“ **575** function by touching the icon **575.1** on the display.

Result:

- The icon **575.1** changes to icon **575.2** (icon bordered in black).

- ▶ Press the F4 key **474**.

Result:

- The icon **575.2** changes to icon **575.3** (icon filled out).
- The hydraulic oil preheating is turned on.

When the hydraulic oil temperature on the individual control display **50** has reached the operating temperature:

- ▶ Press the F4 key **474**.

Result:

- Hydraulic oil preheating is turned off.

- The icon **575.2** appears (icon not filled out)
- ▶ Press the function key **F3**.
or
Press the function key **F6** twice.

Result:

- The monitoring field with monitoring functions is hidden.
- ▶ At low ambient temperatures, run through required hydraulic crane functions without a load for approx. 15 minutes. This will warm up the cylinders, valves, oil motors and hoses.

7 Starting the LICCON computer system (before engine start)

There are two operating modes for the LICCON computer system:

- The LICCON computer system in stand-by mode (crane engine turned off).
- The LICCON computer system in normal mode (crane engine turned on).

7.1 System start of the LICCON computer system

After the ignition is turned on, the LICCON computer system boots up and carries out a self-test, see the Crane operating instructions, chapter 4.02.

Ensure that the following prerequisite is met:

- Do not operate any operating elements during the system start of the LICCON computer system.

**Note**

During the boot up phase, if an operating element is actuated (for example the master switch is moved from the zero position), the system start may be aborted as a result.

- ▶ After an abort at system start: Turn the engine and ignition off and then start again.

- ▶ Wait for the boot up phase.

Result:

- The set up screen appears on the LICCON monitor.
- Normally the previously selected set up configuration is displayed.

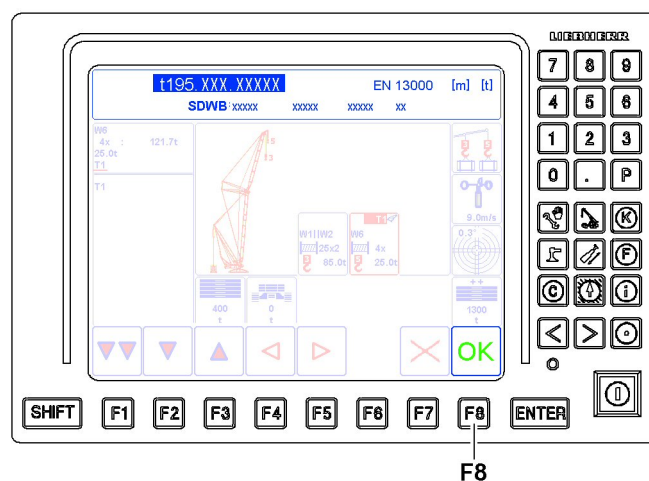

Fig.115323

- ▶ Check the set up configuration.

Problem remedy

Does the LICCON monitor not show the required set up configuration?

- ▶ Set the required set up configuration, see section „Changing the set up configuration“.

Problem remedy

Does an error message appear on the LICCON monitor?

- ▶ Turn the engine and ignition off and then start again.

When an error message appears again:

- ▶ Contact Liebherr Customer Service.

7.2 Taking over the set up configuration that was previously set

Make sure that the following prerequisite is met:

- The entries and settings in the set up program match the actual set up configuration of the crane.

When the entries and settings in the Set up program are correct:

- ▶ Press the function key **F8**.

Result:

- The entries and settings are taken over and the „Set up“ program is ended. The crane operation program is called up and the crane operating screen is shown.

7.3 Changing the set up configuration

The entries and settings for the set up configuration can be changed in the Set up program.

- ▶ Call up the set up program and make the entries and settings for the set up configuration.

**Note**

- ▶ For detailed description of the entries and settings in the Set up program, see the Crane operating instructions, chapter 4.02.

When the entries and settings in the Set up program are correct:

- ▶ Press the function key **F8**.

Result:

- The entries and settings are taken over and the „Set up“ program is ended. The crane operation program is called up and the crane operating screen is shown.

7.4 Setting the master switch speed reduction

**Note**

- ▶ For detailed description to set the master switch speed reduction, see the Crane operating instructions, chapter 4.02.

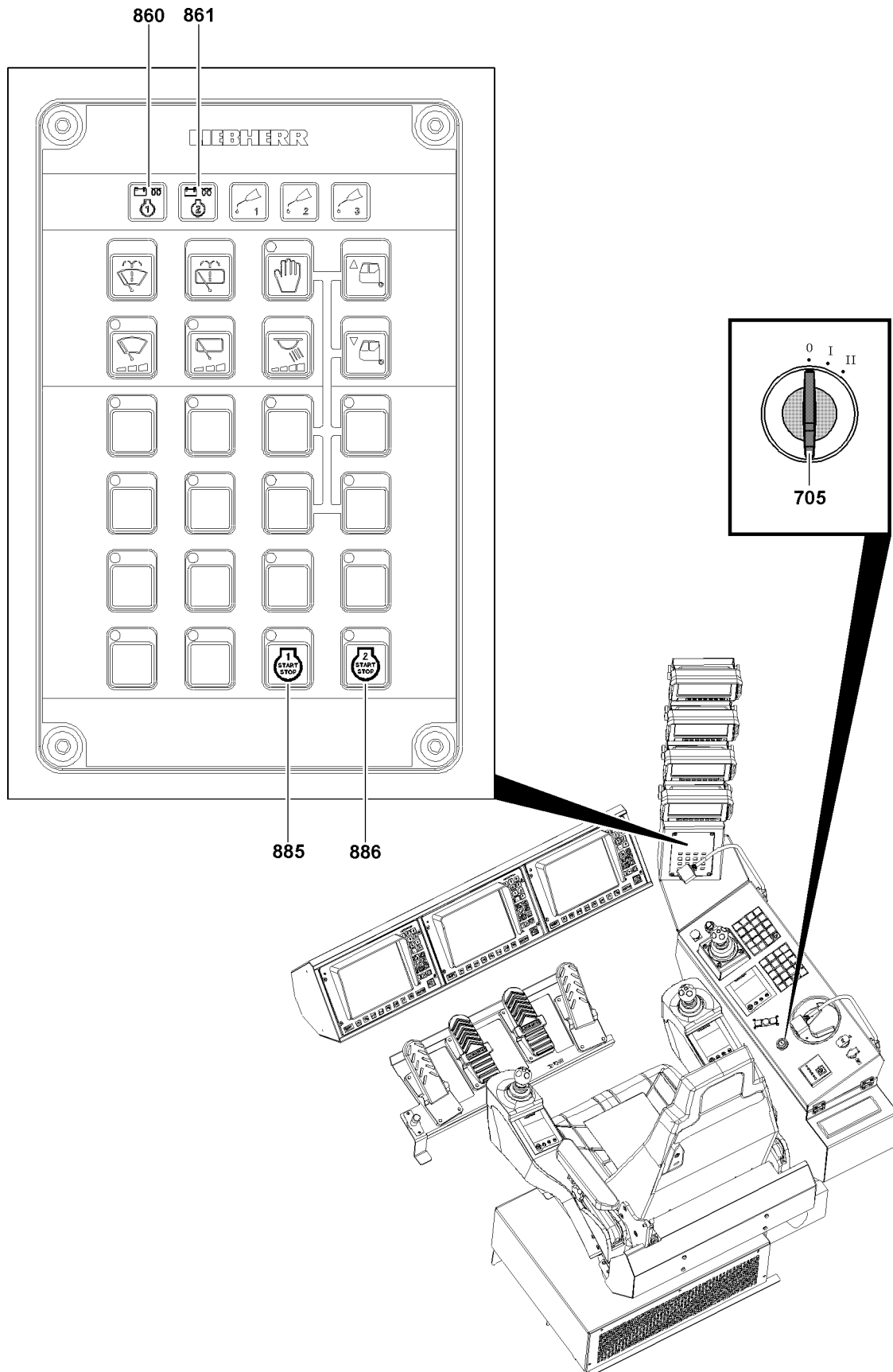

Fig.115321

LWE/LR 13000-001/19503-01-02/en

8 Starting and turning off the engine

The engine must be operated according to the specifications, see the separate operating instructions of the engine manufacturer.



Note

- ▶ As long as the indicator lights (indicator light **860** and indicator light **861**) light up yellow, engine preheating is active.
-

Make sure that the following prerequisites are met:

- The ignition switch **705** is in position „I“.
 - In the LICCON computer system, the Crane operation program is called up and the crane operation screen is shown.
 - Indicator light **860** blinks yellow (1 Hz)
 - Indicator light **861** blinks yellow (1 Hz)
-

NOTICE

Danger of property damage!

- ▶ Start the engine only if the indicator lights (indicator light **860** and indicator **861** light) blink yellow (1 Hz).
 - ▶ Do not press down on the gas pedal when starting.
 - ▶ Do not actuate the starter motor too long and pause in between starting attempts, see the Operating instructions from the engine manufacturer.
 - ▶ Let the engine warm up before subjecting the engine to a full load, see the Operating instructions from the engine manufacturer.
-

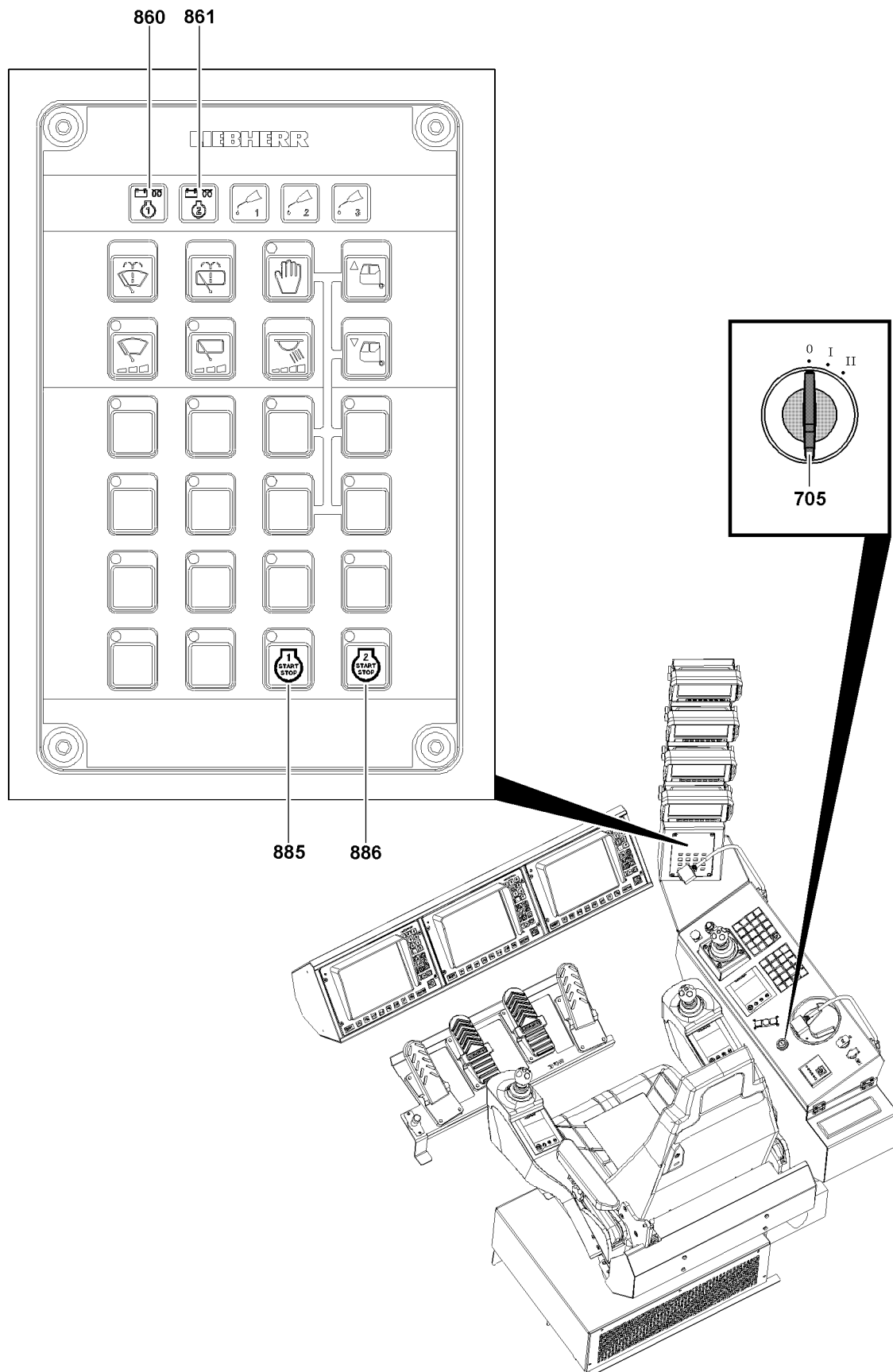

Fig.115321

LWE/LR 13000-001/19503-01-02/en

8.1 Starting the engines individually

To start the engines individually, use the operating and control unit (BKE).

When the indicator light **860** blinks yellow (1 Hz), engine 1 is ready to start.

- ▶ Press the „Engine 1 START / STOP“ operating button **885**.

Result:

- Engine 1 starts.

As soon as engine 1 is running:

- ▶ Release the operating button **885**.

When the indicator light **861** blinks yellow (1 Hz), engine 2 is ready to start.

- ▶ Press the „Engine 2 START / STOP“ operating button **886**.

Result:

- Engine 2 starts.

As soon as engine 2 is running:

- ▶ Release the operating button **886**.
- ▶ Check the instruments after starting.

8.2 Starting the engines together

To start the engines together, use the ignition switch **705**.

When the indicator lights (indicator light **860** and indicator light **861**) blink yellow (1 Hz).

- ▶ Turn the ignition switch **705** to position „II“.

Result:

- Engine 1 starts.
- Engine 2 starts.

As soon as both engines are running:

- ▶ Turn the ignition switch **705** to position „I“.
- ▶ Check the instruments after starting.

8.3 Checking the operating and control instruments after starting

- LICCON monitor: If a control value has reached a limit value, then the monitoring functions are automatically called up in the Crane operation program and the error or problem are pointed out.
- Operating and control unit (BKE): If an error or a problem occurs, then the error or the problem are pointed out.



Note

- ▶ For a detailed description of the operating and control instruments, see chapter 4.01.

8.3.1 Checking the monitoring functions on the LICCON monitor

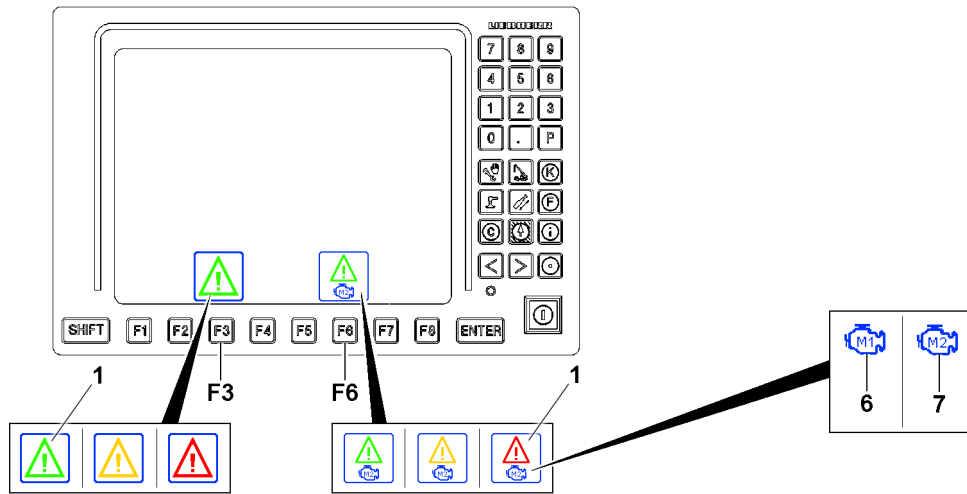

Fig.164447: Monitoring function warning icon

The monitoring functions are described in detail in chapter 4.02.

The selected crane components and operating conditions are monitored in the crane operation program. Monitoring functions can be called up if required with the function key **F3**. With the function key **F6**, it is possible to switch between the monitoring functions of engine 1 **6** and engine 2 **7**.

The warning icon **1** above the function key **F3** and function key **F6** is displayed in green when all monitoring functions are ok. If a control value reached a limit range, or if there is a malfunction or warning, the warning icon **1** above the function key is displayed in yellow or red.

NOTICE

The warning icon **1** is displayed in yellow or red - malfunction / warning!
Damage to components.

- ▶ End crane movement.
- ▶ Turn the engine off.
- ▶ Remedy the cause of the error.
- ▶ Observe and adhere to the instructions in chapter 4.02.



Note

- ▶ The monitoring functions react in general only when an error or problem is present. Avoidable missing amounts / problems impede crane operation and cause unnecessary delays and / or down-time.

- ▶ Check the warning icon of the function key **F3**.

When the warning icon for the function key **F3** is shown in „yellow“ or „red“ and the monitoring functions are not automatically shown:

- ▶ Press the function key **F3** and evaluate the monitoring functions, see chapter 4.02.

Empty page!

LWE/LR 13000-001/19503-01-02/en

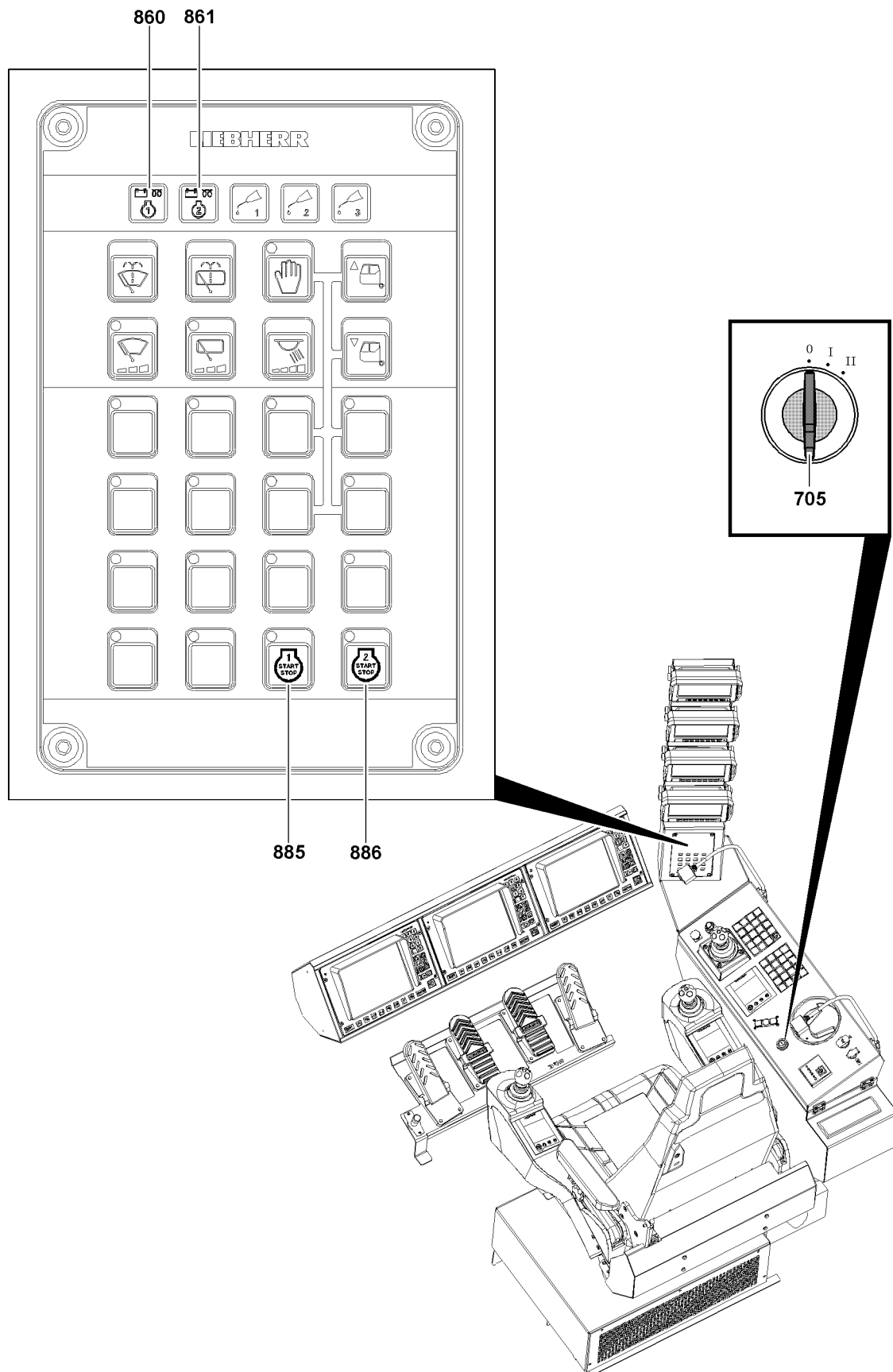

Fig.115321

LWE/LR 13000-001/19503-01-02/en

8.4 Turning the engine off

NOTICE

Increased engine wear!

If the engines are suddenly turned off after operation with full engine load or in case of increased coolant temperature (above 95 °C), then this can lead to increased wear over time!

- ▶ Before turning the engines off, let the engines run for approximately three to five minutes at idling speed without a load.



Note

LICCON computer system in stand-by mode

- ▶ If the engines are turned off, the LICCON computer system can continue to be operated in Stand-by mode, see the Crane operating instructions, chapter 4.02.

8.4.1 Turning the engines off individually

To turn the engines off individually, use the operating and control unit (BKE).

If engine 1 is running:

- ▶ Press the „Engine 1 START / STOP“ operating button **885**.

Result:

- Engine 1 turns off.
- ▶ Release the operating button **885**.

If engine 2 is running:

- ▶ Press the „Engine 2 START / STOP“ operating button **886**.

Result:

- Engine 2 turns off.
- ▶ Release the operating button **886**.

8.4.2 Turning the engines off together

To turn the engines off together, use the ignition switch **705**.

- ▶ Turn the ignition switch **705** to position „0“.

Result:

- Engine 1 turns off.
- Engine 2 turns off.

8.4.3 Turning the engine off in the event of danger

NOTICE

Improper use of the EMERGENCY OFF switch!

Repeated improper use of the EMERGENCY OFF switch can cause increased wear on the crane!

- ▶ Use of the EMERGENCY OFF switch for normal operation is not permitted!
- ▶ Use the EMERGENCY OFF switch only in emergency situations!

If an emergency situation occurs:

- ▶ Actuate the EMERGENCY STOP switch.

Result:

- The crane is turned off.

After pressing an EMERGENCY OFF switch, it may be necessary to reset the LICCON computer system.

Reset the LICCON computer system after an EMERGENCY STOP:

- ▶ Release the actuated EMERGENCY OFF switch.
- ▶ Turn the ignition switch **705** momentarily to position „0“ and then again to position „I“.

9 Starting the LICCON computer system parallel to the engine



Note

If the engines are started together with the ignition switch **705** without having started the LICCON computer system first, then a system start is carried out parallel to the engine start.

- ▶ Start the LICCON computer system first, see section „Starting the LICCON computer system (before engine start)“
-

4.04 Safety equipment

1	General	3
2	Quick test Crane geometry	3
3	Quick test Overload protection	3
4	LICCON computer system	3
5	Safety systems on the crane	9

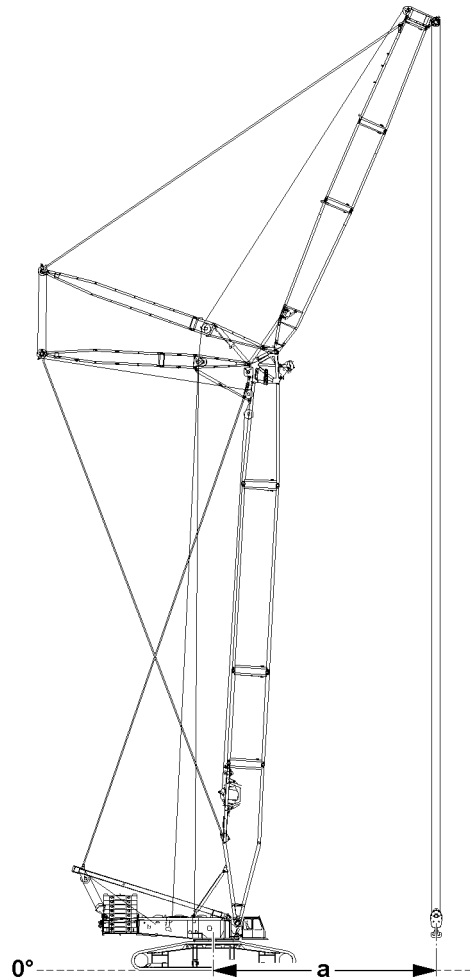
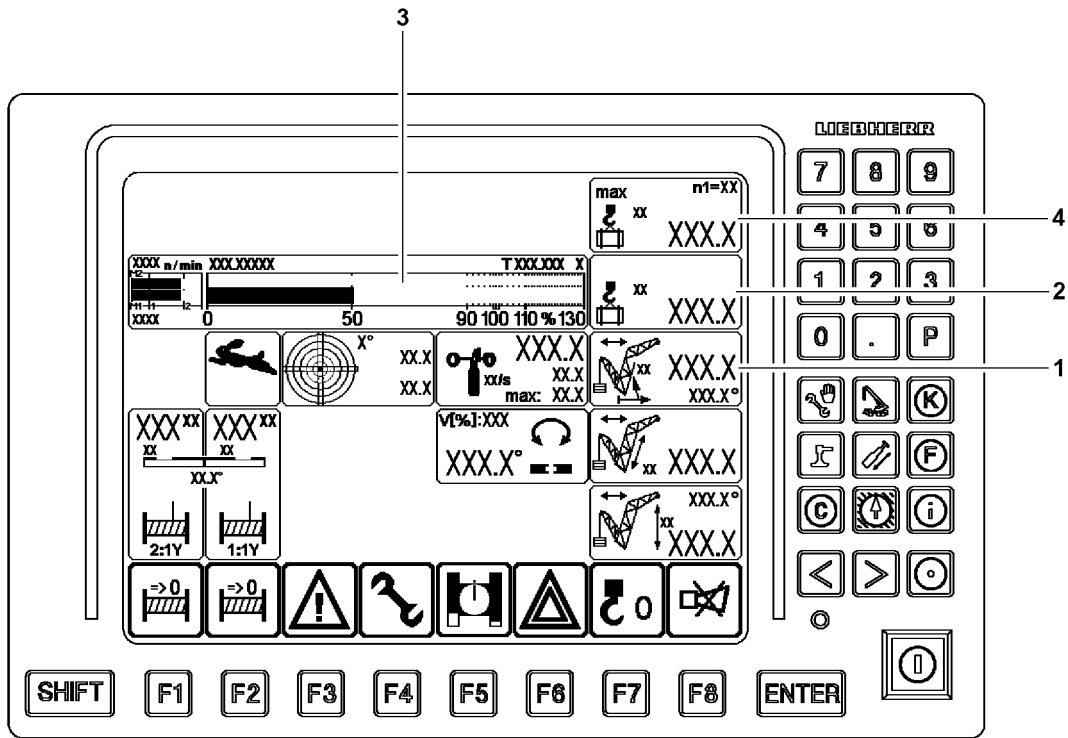

Fig.115293

LWE/LR 13000-001/19503-01-02/en

1 General

The crane operator is obligated before every crane operation to ensure that the warning and safety equipment are functioning.



WARNING

Danger of accident due to defective warning and safety systems!

If the crane is operated with defective warning and safety equipment, then there is a danger of accidents!

Personnel can be killed or seriously injured!

This could result in property damage!

- ▶ Make sure that all warning and safety equipment are functioning.
- ▶ Make sure that the overload protection is functioning.

2 Quick test Crane geometry

Make sure that the following prerequisites are met:

- The crane is aligned in horizontal direction.
- The set up configuration has been entered correctly into the LICCON computer system.
- There is no load on the hook.

Measure the horizontal distance of the load hook from the center of rotation of the crane superstructure on the ground:

- The value display radius **1** must match the measured value **a**.

3 Quick test Overload protection

Fasten a known weight, for example a counterweight plate. Then lift the counterweight plate completely and then set it down.

Make sure that the following prerequisite is met:

- The crane is aligned in horizontal direction.

The respective displayed values must be plausible:

- **2** Actual load display
- Utilization bar **3**: Ratio of value of Actual load display **2** to maximum load value **4**
- Example:

Value Actual load display **2** is 100 t.

Maximum load value **4** is 200 t.

Utilization bar **3** shows 50 %.

4 LICCON computer system

The LICCON computer system is a system for controlling and monitoring mobile cranes. In addition to the LICCON overload safety device (Load torque limiter = LMB), there are a number of application programs that can be used for controlling and monitoring the crane movements. For a detailed description see Crane operating instructions, chapter 4.02 and chapter 4.20.

4.1 LICCON overload safety device

The LICCON overload safety device is programmed to **shut off** the crane movements if the permissible load moment is exceeded (LMB-STOP).

The LICCON overload safety device may not be used as an operational shut off device for crane movements of any kind.

An overload protection cannot detect all occurring conditions by itself. Careful and diligent crane operation by the crane operator is important.

The basis for the calculation of the utilization of the crane are:

- The currently data and values recorded by the crane control.
- The set up configuration entered by the crane operator.

Direct influence is taken, among others:

- Failure of a test device (for example: Pull test brackets, angle sensor, pressure sensor).
- A set up configuration incorrectly or deviating entered by the crane operator.
- Environmental influences not considered (such as wind influence, ground with insufficient load bearing capability).
- Assembly and operating errors.



WARNING

Danger of accident due to assembly and operating errors!

Due to assembly and operating errors it is possible that the overload protection is not effective or shut off is delayed!

A set up configuration which deviates from the load chart cannot be detected by the overload protection!

Environmental influences which are not considered cannot be detected by the overload protection!

Dangerous situations and accidents can result!

Personnel can be killed or seriously injured!

This could result in property damage!

- ▶ Always assemble and operate the crane carefully!



WARNING

Operational utilization of the overload protection!

If the LICCON overload safety device is utilized as an operational shut off device for crane movements, then there is a danger of accidents!

For example, crane movements can be shut off abruptly or uncontrolled!

The behavior of load and crane cannot be foreseen in such a case!

Personnel can be killed or seriously injured!

This could result in property damage!

- ▶ Do not use the LICCON overload safety device as an operational shut off device for crane movements!



WARNING

Lifting of unknown loads!

The presence of the overload protection does not relieve the crane operator of his obligation for care and attention!

The crane may not only be operated according to the displays of the LICCON overload safety device!

Lifting of loads with unknown weight and unknown properties can lead to accidents!

Personnel can be killed or seriously injured!

This could result in property damage!

- ▶ Before lifting a load, its weight and properties must be known to the crane operator!
- ▶ The crane operator must check with the load chart if the crane is able to carry out the work safely!

The LICCON computer system detects various values, which result in optical and acoustical warnings if exceeded:

Within the crane operator's cab:

- Acoustic warning „Horn / short horn“ on the LICCON monitor
- Optical warning „blinking value / display“ on the LICCON monitor

Outside the crane operator's cab:

- Acoustic warning via the horn on the turntable
- Optical warning via the warning light on the turntable

All warnings, even those which do not lead to an immediate shut off must be noted by the crane operator and personnel within the danger zone.

The overload protection can **not** detect (examples of cases):

- The hooking of the load or the load handling equipment
- Excessive retarding forces
- Loads falling onto the rope
- Angular pulling
- Driving the crane on ground with large slope
- Collapsing ground

4.1.1 Failure of the overload protection



WARNING

Crane operation without overload protection!

If the LICCON overload safety device is no longer functioning properly because of one or more errors, then there is a danger of accidents if crane operation is continued!

Due to operation of the crane with failed LICCON overload safety device, the crane can be overloaded and collapse!

Personnel can be killed or seriously injured!

This could result in property damage!

- ▶ Crane operation without overload protection is prohibited!
- ▶ Place the boom system down if necessary according to the specification in the crane documentation!
- ▶ Do not take up crane operation again until the overload protection is functioning again!

A failed overload protection:

- Must be repaired before the crane can be operated again.
- May only be bypasses in emergency cases or emergency situations.

4.2 Bypass of overload protection

The overload protection can be bypassed in case of:

- Failure of the overload protection
- In an emergency situation (according to EN 13000:2010)

4.2.1 Bypass of overload protection: Failure of the overload protection



Note

- ▶ Applies **not** for cranes with configuration according to EN 13000:2010!

To bring the crane into safe condition after failure of a component required for the overload protection, it can be necessary that the overload protection has to be bypassed.



WARNING

Bypassed overload protection!

If the overload protection is bypassed, crane movements are no longer monitored!

The crane can be overloaded and collapse!

Personnel can be killed or seriously injured!

This could result in property damage!

- ▶ Then carry out only crane movements in the range of a valid load chart!
- ▶ Place the boom system down if necessary according to the specification in the crane documentation!

4.2.2 Bypass of overload protection: Failure of overload protection (according to EN 13000:2010)



Note

- ▶ Applies **only** for cranes with configuration according to EN 13000:2010!

To bring the crane into safe condition after failure of a component required for the overload protection, it can be necessary that the overload protection has to be bypassed.

With the specification that:

- The bypass is automatically reset at engine stop.
- The bypass is automatically reset after no later than 30 minutes.
- The bypass of the overload protection limits the working speed to no more than maximum 15 %.



WARNING

Bypassed overload protection!

If the overload protection is bypassed, crane movements are no longer monitored!

The crane can be overloaded and collapse!

Personnel can be killed or seriously injured!

This could result in property damage!

- ▶ Then carry out only crane movements in the range of a valid load chart!
- ▶ Place the boom system down if necessary according to the specification in the crane documentation!

4.2.3 Bypass of overload protection: Emergency situation (according to EN 13000:2010)

In an emergency situation, a bypass of the overload protection may become necessary.

With the specification that:

- The bypass is automatically reset at engine stop.
- The bypass is automatically reset after no later than 30 minutes.
- The bypass of the overload protection limits the working speed to no more than maximum 15 %.



DANGER

Overload of crane!

After a bypass of the overload protection, the crane movements are no longer shut off in case of a danger of overload of the crane!

An overload of the crane can result in severe damage or collapse!

Personnel can be killed or seriously injured!

This could result in property damage!

- ▶ Do not subject the crane to such a load that it collapses!
- ▶ Clear and secure the danger zone of the crane!



Note

- ▶ Location of bypass device, see Crane operating instructions, chapter 4.01 and chapter 4.02.

Empty page!

LWE/LR 13000-001/19503-01-02/en

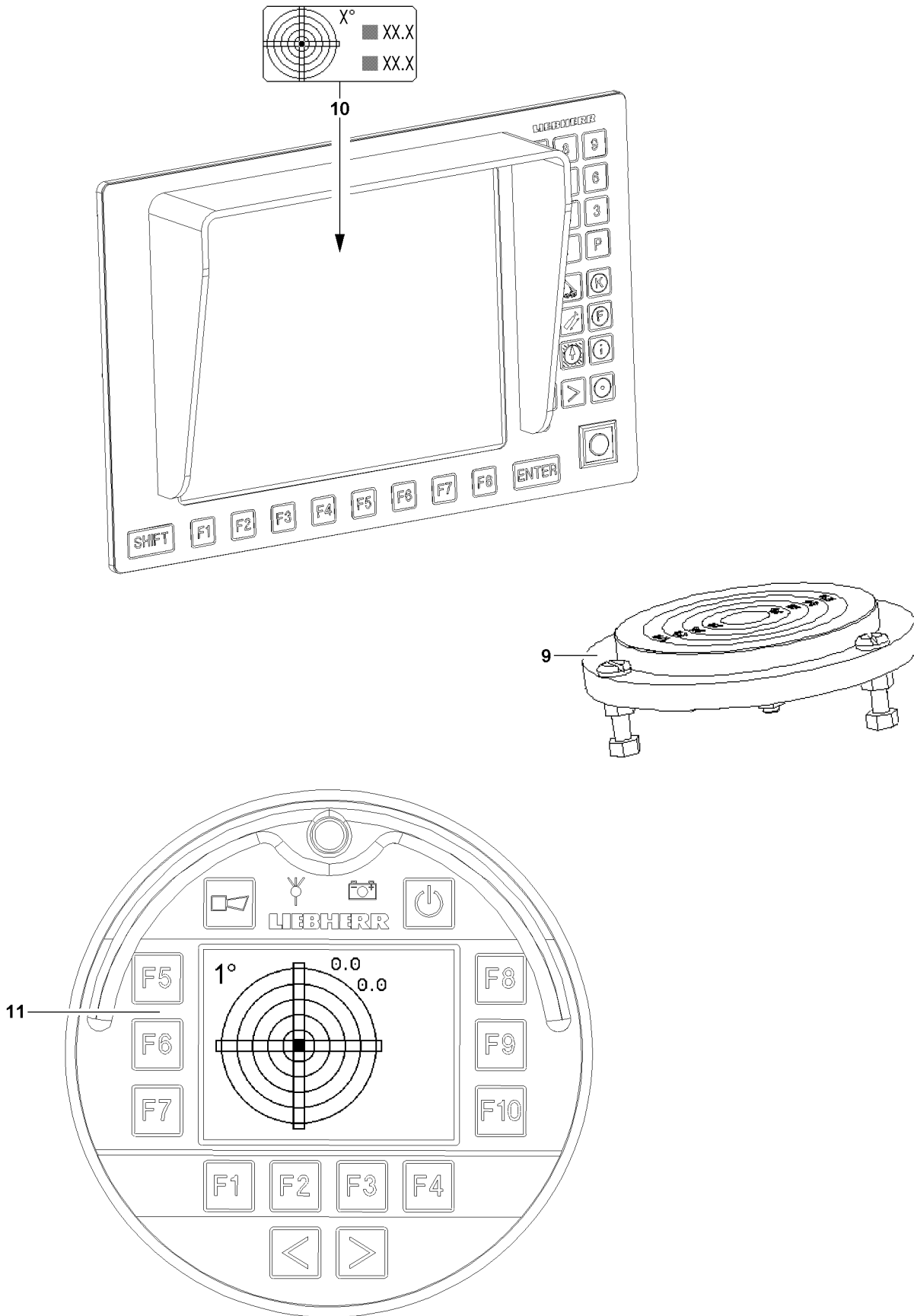

LWE/LR 13000-001/19503-01-02/en

Fig.115294

5 Safety systems on the crane

5.1 Leveling instruments

To ensure the working safety of the crane, the crane must be aligned on level ground with sufficient load bearing capacity according to the load chart.

The current values are continuously shown in the Incline icon **10**, see Crane operating instructions, chapter 4.02.

The incline is shown manually in the sight gauge **9** on the crawler travel gear.



WARNING

The crane can topple over!

If the leveling instruments are defective or incorrectly adjusted, there is a danger that the crane is not aligned according to the load chart!

A crane which is not aligned according to the load chart can topple over!

Personnel can be killed or seriously injured!

This could result in property damage!

- ▶ Make sure to align the crane according to the load chart!

5.1.1 Leveling instruments in the LICCON monitor

The incline of the crane is shown in the Incline icon **10** graphically as well as numerically, see Crane operating instructions, chapter 4.02.

5.1.2 Leveling instrument in the Bluetooth™ Terminal (BTT)



Note

- ▶ Applies only for cranes with Bluetooth™ Terminal (BTT).

The incline of the crane is shown in the Incline display menu **11** graphically as well as numerically, see Crane operating instructions, chapter 3.05 and 5.31.

5.1.3 Quick test Leveling instrument



Note

The horizontal alignment of the crane can be checked with a spirit level on the top of the slewing ring, for example.

- ▶ The alignment of the top of the slewing ring is the determining factor for the incline display.

Make sure that the following prerequisites are met:

- The crane is aligned in horizontal direction.
- There is no load on the hook.

For horizontally aligned crane:

- The sight gauge **9** on the crawler travel gear must show 0°.
- In the incline icon **10** 0° must always be shown.

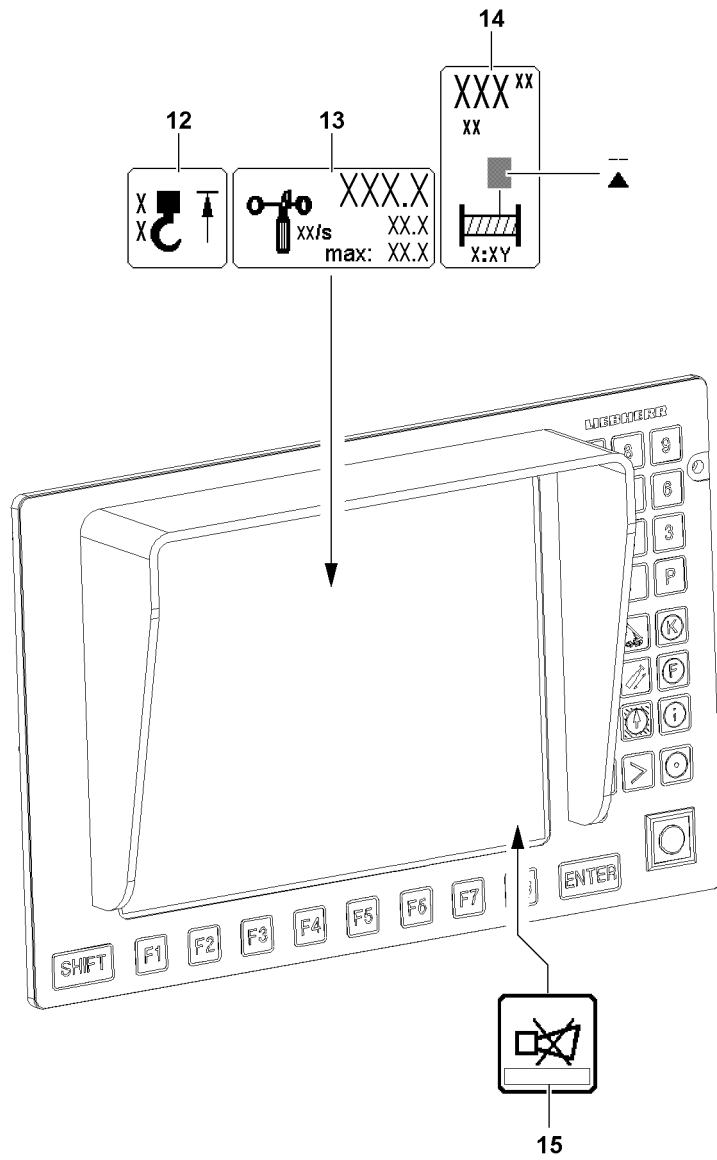

Fig.115295

LWE/LR 13000-001/19503-01-02/en

5.2 Acoustic and optical warning devices



Note

► Overview of acoustic and optical warnings, see Crane operating instructions, chapter 4.20.

- The acoustic and optical warning devices must be functioning and operational.
- Take care of any possible detriments in function, such as snow on the warning lights.

5.3 Hoist limit switch „Hoist top“

The hoist limit switch is intended to prevent the hook block from running against the boom head.

Before every crane application, the function of the hoist limit switch must be checked by running against the switch weight with the hook block.

For installation purposes and in emergency cases, the hoist limit switch can be bypassed, see Crane operating instructions, chapter 4.20.



WARNING

Falling load and property damage!

If the hoist limit switch is defective, there is the danger that the hook block or the load hook is pulled against the pulley head!

Falling load and property damage can result!

Personnel can be severely injured or killed!

- Crane operation without or with defective hoist limit switch is prohibited!
- Repair or replace a defective hoist limit switch!

The hoist limit switch must actuate when the hoist limit switch weight is lifted by the load hook / hook block:

- When the hoist limit switch is actuated, the icon **12** „Hoist top“ appears in the operating screen. The crane movement „Spool winch up“ as well as other crane movements which have an influence on the hoist rope are shut off.

5.3.1 Quick test Hoist limit switch

When the hoist limit switch weight is lifted:

- The icon **12** „Hoist top“ must appear in the operating screen.
- The actuated crane movement must be shut off.

5.4 Error messages by the LICCON computer system

Two types are differentiated (all crane types except LR1400/2):

- Operating errors
 - Displayed in field **15** by error number / LEC: B.....
- System errors in LICCON computer system
 - Displayed in field **15** by error number / LEC: E.....

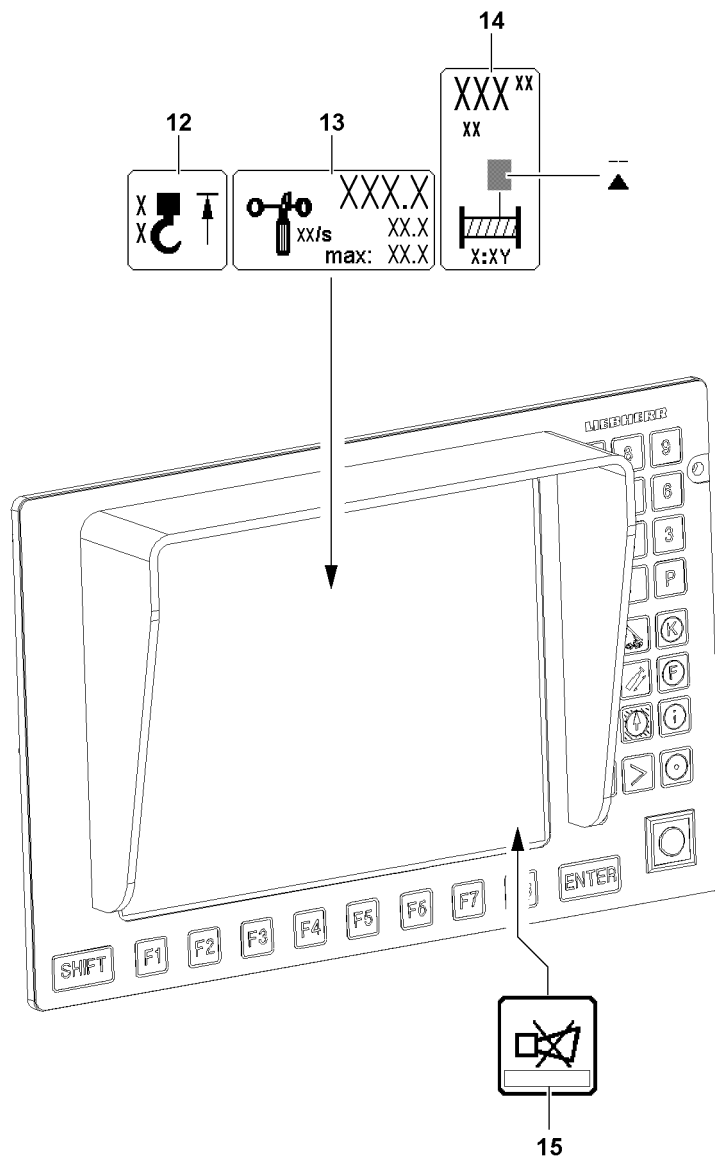

Fig.115295

LWE/LR 13000-001/19503-01-02/en

5.5 Wind speed sensor

The wind warning by the wind speed sensor appears in the operating screen of the LICCON computer system.



WARNING

The crane can topple over!

If the crane is operated with a defective wind speed sensor, then there is the danger that excessively high wind speeds are not recognized!

The crane can topple over!

Personnel can be killed or seriously injured!

This could result in property damage!

- ▶ Crane operation with a defective wind speed sensor is prohibited!
- ▶ Repair / replace a defective wind speed sensor!

If wind occurs, then the wind speed sensor must report it speed:

- If the actual wind speed value exceeds the displayed maximum value, the value in the icon **13** „Wind speed“ starts to blink and the acoustic alarm „Short horn“ sounds on the LICCON monitor. But there is **no shut off** of crane movements.



Note

- ▶ To set the wind speed, see Crane operating instructions, chapter 4.02.

5.5.1 Quick test Wind speed sensor

When blowing in the cups:

- The wind speed sensor must start to move.
- An actual value must be shown in the icon **13** „Wind speed“.

5.6 Limit switch winch spooled out

The limit switches for the winches are adjusted at the factory. If used properly, the winches will not need readjustment.



Note

Minimum rope coils on the shut off point!

For the winches, a minimum of three rope coils are set for each drum.

- ▶ The shut off must occur **before** reaching the third minimum rope coil.



WARNING

The load can fall off!

If the limit switch „Winch spooled out“ does not turn off **before** three minimum rope coils are reached, then there is the danger, when it is further spooled out, that the rope mounting locks are ripped out and the load falls down!

Falling load can cause the crane to sway and / or topple over!

Personnel can be severely injured or killed!

This could result in property damage!

- ▶ Crane operation with an incorrectly or non-adjusted winch is strictly prohibited!
- ▶ If the winch falls below the three minimum rope coils per winch, have it readjusted by **Liebherr Service!**

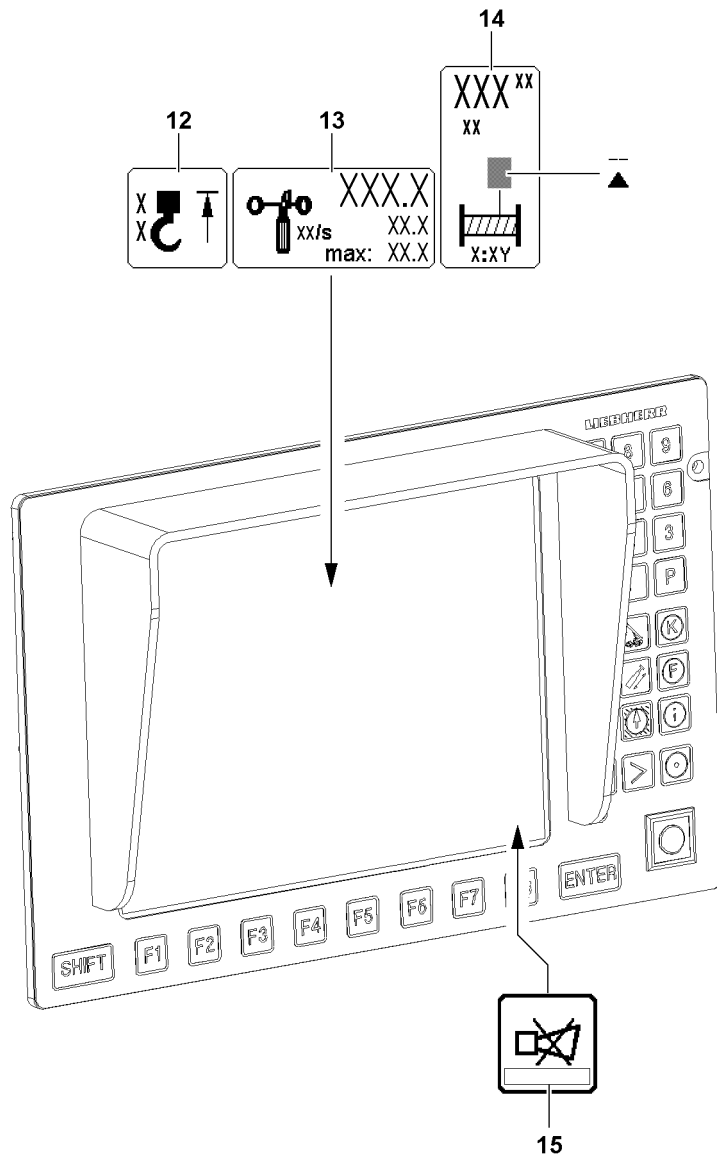

Fig.115295

LWE/LR 13000-001/19503-01-02/en

**WARNING**

The load can fall off!

If the rope is not spooled up or out properly, then the adjustment of the limit switch „Winch spooled out“ is changed!

If the adjustment of the limit switch „Winch spooled out“ has changed, then the minimum rope coils are fallen below!

The load can fall down!

Falling load can cause the crane to sway and / or topple over!

Personnel can be severely injured or killed!

This could result in property damage!

- ▶ **Never** pull the end of rope underneath the winch by spooling up the rope winch!
- ▶ **Never** pull the rope from the „stationary“ winch!
- ▶ If you suspect that the limit switch „Winch spooled out“ is not adjusted correctly: Check the shut off without a load on the hook!

The limit switch „Winch spooled out“ must shut off when the minimum rope coils for the winch are reached:

- When the minimum rope coil for the winch is reached, then the display „Winch spooled out“ appears in the Winch icon **14**, see illustration. The crane movement „Spool winch out“ is shut off.

5.6.1 Quick test Limit switch winch

When the minimum rope coil is reached:

- The display „Winch spooled out“ must appear in the Winch icon **14**.
- The crane movement „Spool winch out“ must be shut off.

5.7 Servo oil pressure monitoring in the winches

- If no servo oil pressure is present when the master switch is actuated, a corresponding error message appears in field **15**.

5.8 Pressure monitoring in the relapse cylinders

Pressure sensors are installed in the hydraulic cylinders. The pressure measured with the pressure sensor is shown on the LICCON monitor, see Crane operating instructions, chapter 4.02.

**WARNING**

Danger of accident due to crane toppling over or destruction of the crane!

If the pressure drops, the relapse cylinder can no longer stabilize the boom!

The crane can topple over or be destroyed!

Personnel can be severely injured or killed!

- ▶ During crane operation: Constantly monitor the pressure in the relapse cylinders!

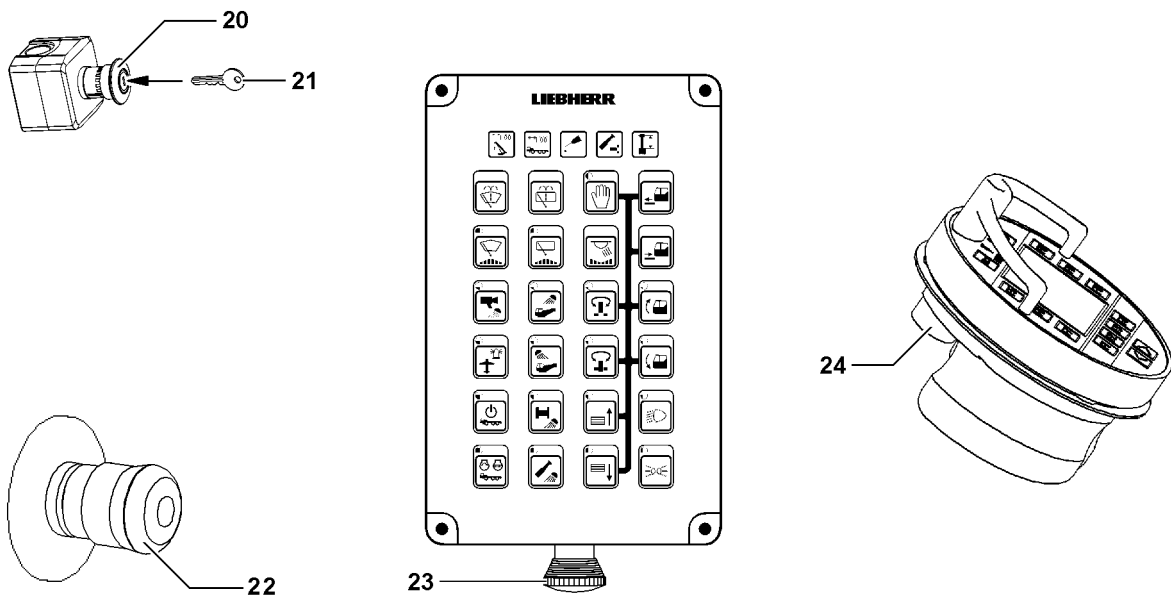
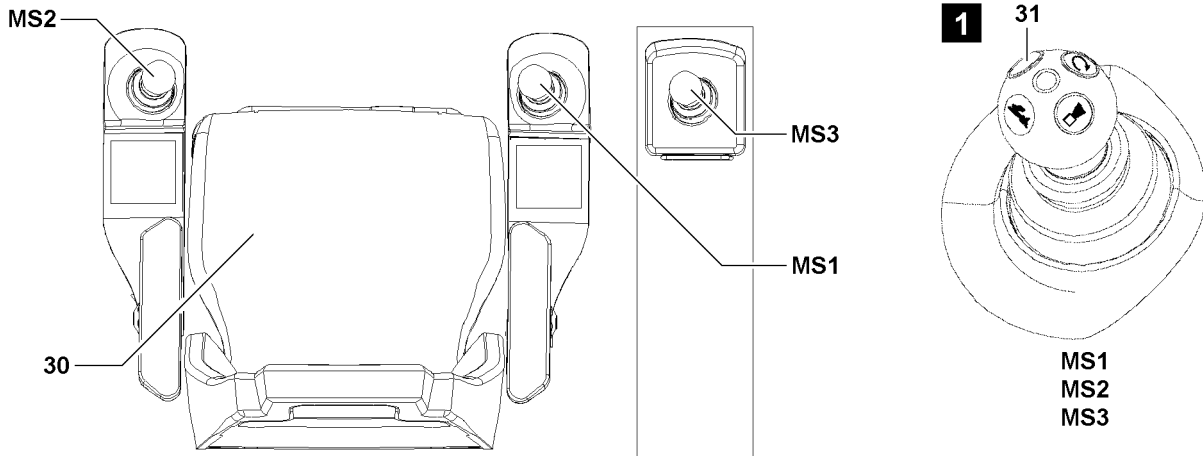

Fig.115296

LWE/LR 13000-001/19503-01-02/en

5.9 EMERGENCY STOP switch / EMERGENCY OFF switch

If an EMERGENCY STOP switch / EMERGENCY OFF switch is actuated, then the crane movement can be stopped with it.



WARNING

Defective EMERGENCY STOP switch / EMERGENCY OFF switch!

If the crane is operated with a defective EMERGENCY STOP switch / EMERGENCY OFF switch, then the crane movement cannot be stopped by actuating the EMERGENCY STOP switch!

This could result in accidents!

Personnel can be killed or seriously injured!

This could result in property damage!

- ▶ Crane operation with a defective EMERGENCY STOP switch / EMERGENCY OFF switch is prohibited!
- ▶ Repair or replace a defective EMERGENCY STOP switch / EMERGENCY OFF switch!

NOTICE

Operational actuation of the EMERGENCY STOP switch / EMERGENCY OFF switch

Actuation of the EMERGENCY STOP switch / EMERGENCY OFF switch causes the crane movement to stop abruptly!

Abruptly stopping the crane movement can cause the load to swing!

Swinging loads can cause accidents!

- ▶ Do not use the EMERGENCY STOP switch / EMERGENCY OFF switch operationally!
- ▶ Use the EMERGENCY STOP switch / EMERGENCY OFF switch only in emergency situations!

The EMERGENCY STOP switch / EMERGENCY OFF switch is available in various versions, depending on the crane type:

- After actuation of a switch of version* **20**, the release is only obtained by an authorized person with key **21** and by subsequently turning the ignition „Off - On“ momentarily.
- After actuation of the switch of version* **22**, the release is obtained by turning and unlocking the knob and subsequently turning the ignition „Off - On“ momentarily.
- After actuation of the switch of version* **23**, the release is obtained by turning and unlocking the knob and subsequently turning the ignition „Off - On“ momentarily.
- After actuation of the switch of version* **24**, the release is obtained by turning and unlocking the knob and subsequently turning the ignition „Off - On“ momentarily.



Note

- ▶ Which EMERGENCY STOP switch / EMERGENCY OFF switch is on the crane depends on the crane type.
- ▶ The switch **24** on the BTT is only activated when working with the BTT.

5.9.1 Quick test EMERGENCY STOP switch / EMERGENCY OFF switch

After actuation of the EMERGENCY STOP switch / EMERGENCY OFF switch:

- The crane movements must be stopped.
- No crane movements must be possible until the release was issued by turning and unlocking the knob and then turning the ignition „Off - On“ momentarily.

5.10 Control release

The control release can be made via the following switches:

- **30** Seat contact button
- Button **31** on master switch **MS1** and **MS2** and **MS3**.

The seat contact button **30** shuts down the crane control as soon as the crane operator gets up from the seat.

This prevents unintended crane movements by accidentally touching the master switch, for example when getting in or out of the cab.

Each one of the buttons **31** on master switch **MS1**, **MS2** and **MS3** bypasses the seat contact button **30** if needed, for example when it is necessary to work while standing up.

5.11 Hydraulic safety valves

A differentiation is made between three types:

- Pressure limiting valves
 - Prevent pipe and hose bursts due to excessive pressure.
- Shut off valves
 - Control and secure the working cylinders.
- Check valves
 - Control and secure the flow direction.



Note

- ▶ See separate Hydraulic schematic.

5.12 Gravity actuated relapse retainer



Note

- ▶ Only for cranes with luffing accessories.

The gravity actuated relapse retainer (oscillation guard / flap / relapse support) prevent luffing accessory from tipping to the rear in „steepest position“.



WARNING

The crane can topple over!

If the gravity actuated relapse retainer (oscillation guard / flap / relapse support) is hard to move, then it will no longer function!

Shut off and limit functions can be set out of service!

The crane can be overloaded and topple over!

Personnel can be killed or seriously injured!

This could result in property damage!

- ▶ Before erecting the crane, check the relapse retainer for easy movement!
- ▶ Crane operation with hard to move relapse retainer is prohibited!

5.13 Angle sensors



Note

- ▶ See separate Electrical diagram.

5.14 Test brackets (force test boxes)



Note

- ▶ See separate Electrical diagram.

5.15 Limit switch Boom system



WARNING

Danger of toppling or destroying the crane!

If the crane movement is stopped by the block limit switches, then the load forces cannot be absorbed and calculated by the control!

The crane can be overloaded and topple over!

Personnel can be hit and killed or seriously injured!

This could result in property damage!

- ▶ Do **not** use the hoist limit switch as an operational shut off device!
 - ▶ Do not actuate the block limit switches!
-

Empty page!

LWE/LR 13000-001/19503-01-02/en

4.05 Crane operation

1	LICCON computer system	3
2	Master switch functions	5
3	Lifting and lowering	17
4	Luffing	43
5	Turning	51

Fig.195219

LWE/LR 13000-001/19503-01-02/en

1 LICCON computer system

**WARNING**

Danger of accident due to overload!

- ▶ Constantly monitor the displays on the LICCON monitor.
- ▶ Observe changing utilization conditions and forces.

**WARNING**

Danger of accident!

- ▶ The crane driver must evaluate constantly if the data shown on the operating screen can even be correct. He may not rely blindly on the LICCON system but must think for himself and must recognize a possible error or overload conditions.

For detailed description of the operation of the LICCON computer system, refer to Crane operating instructions, chapter 4.02.

Make sure that the following prerequisites are met:

- The crane is horizontally aligned.
- The ground is able to carry the weight of the crane, the load and the load handling equipment.
- The counterweight is attached and secured according to the data in the load chart.
- The crane engine is running.
- The crawler operation is turned off.
- The hook block is correctly reeved in according to the reeving plan.
- All safety equipment has been adjusted according to the data in the load chart.
- The winches are correctly assigned to the respective pulley heads, see Crane operating instructions, chapter 4.02.
- The crane is properly put into operation, see Crane operating instructions, chapter 4.03.
- The set up configuration has been entered in the LICCON computer system and all displays are within the permissible range, see the Crane operating instructions, chapter 4.02.
- There are no persons or objects in the danger zone.

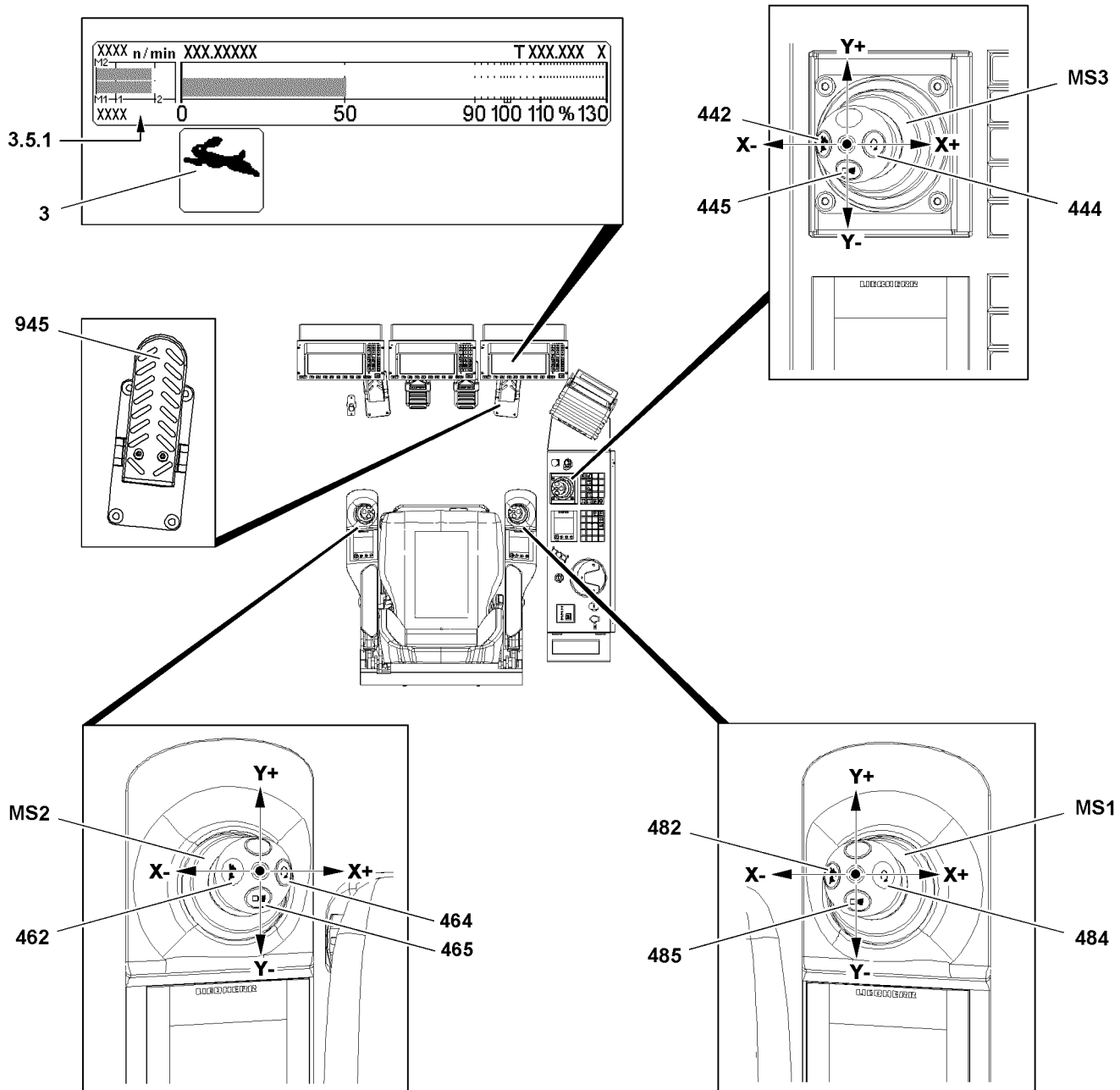

Fig.115852

2 Master switch functions



WARNING

Danger of fatal injury!

- ▶ It is prohibited for personnel to remain in the danger zone.
- ▶ Make sure that there are no obstacles within the working area of the crane.
- ▶ Give a short warning signal (horn) before starting a crane movement.
- ▶ Observe the danger notes for crane operation, see Crane operating instructions, chapter 5.01.



Note

Change of master switch assignment!

The assignment of the master switches to the respective units on the crane can change, depending on the set up configuration and winch application.

- ▶ **Check the assignment before actuating the master switch on the TE.**



Note

- ▶ In order to protect the crane and reduce the danger of accident always use the master switch slowly and sensitively.

2.1 Giving a warning signal



WARNING

Crane movement without warning signal!

Without a warning signal, persons in the danger zone of the crane can be surprised by a crane movement and be severely injured or killed.

- ▶ Before initiating a crane movement, give a warning signal (horn).
- ▶ Press the button **485** on the master switch **MS1**.
- or**
- Press the button **465** on the master switch **MS2**.
- or**
- Press the button **445** on the master switch **MS3**.

Result:

- Warning signal sounds.

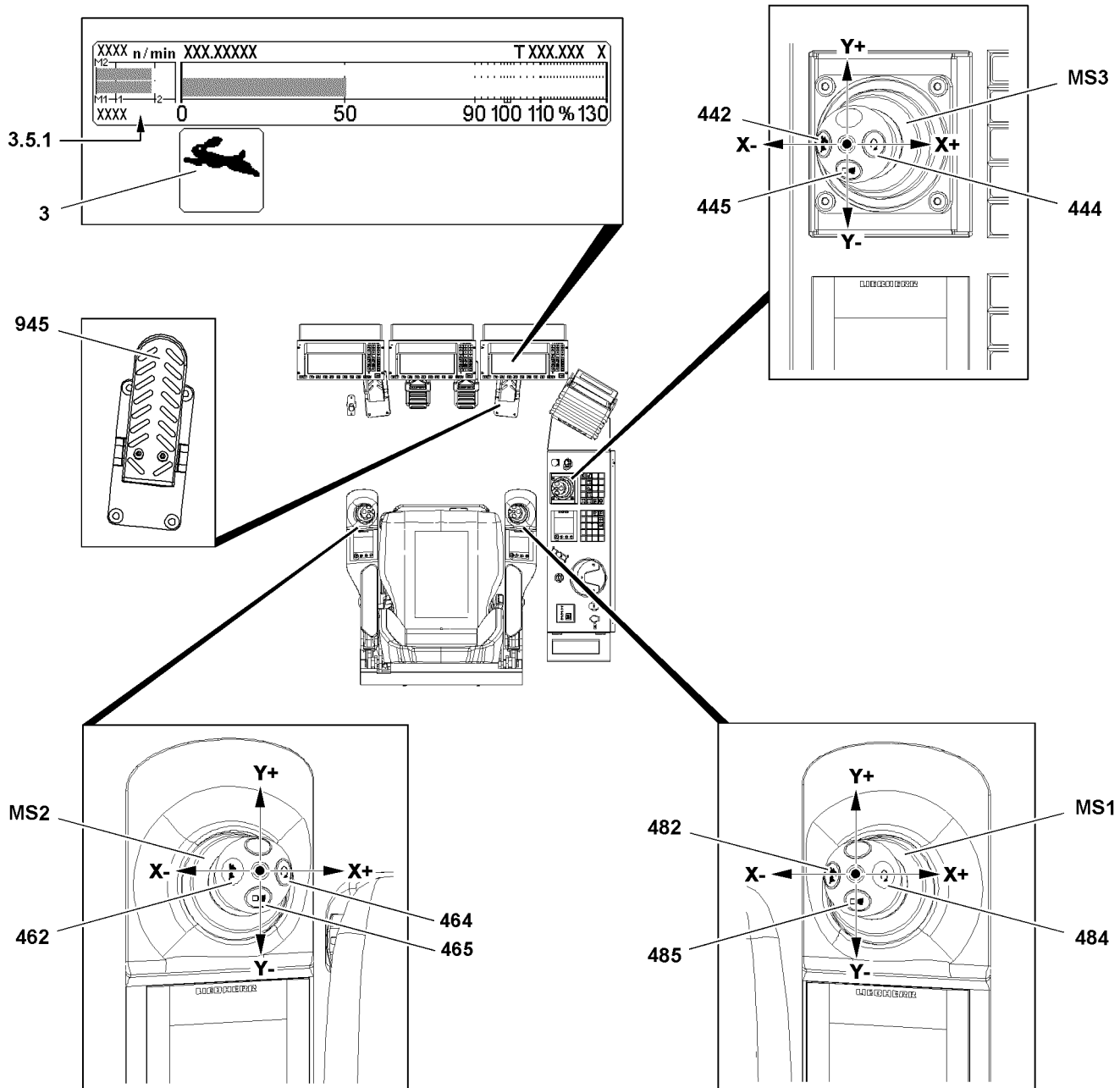

Fig.115852

LWE/LR 13000-001/19503-01-02/en

2.2 Engine rpm

2.2.1 Locking the engine rpm

Locking the engine rpm relieves the crane operator if he needs to work for an extended period with constant rpm. The engine regulation can be locked in any position.

- ▶ Press the pedal **945** for the engine regulation down until the desired rpm is reached.
- ▶ Press the button **484**.
 - or
 - Press the button **464**.
 - or
 - Press the button **444**.

Result:

- The pedal **945** is locked and the engine rpm is saved.
- The icon „+“ appears behind the rpm display **3.5.1** on the LICCON monitor.



Note

- ▶ The locked engine rpm can be overridden by pressing the pedal **945**. If the button **484**, the button **464** or the button **444** is pressed during the override, the current rpm will be used.
-

2.2.2 Releasing the engine rpm lock

Make sure that the following prerequisite is met:

- The pedal **945** is not actuated.

When the engine rpm is locked:

- ▶ Press the button **484**.
 - or
 - Press the button **464**.
 - or
 - Press the button **444**.
 - or
 - Tap the pedal **945** momentarily.

Result:

- The engine rpm lock is revoked.
- The icon „+“ turns off behind the rpm display **3.5.1** on the LICCON monitor.

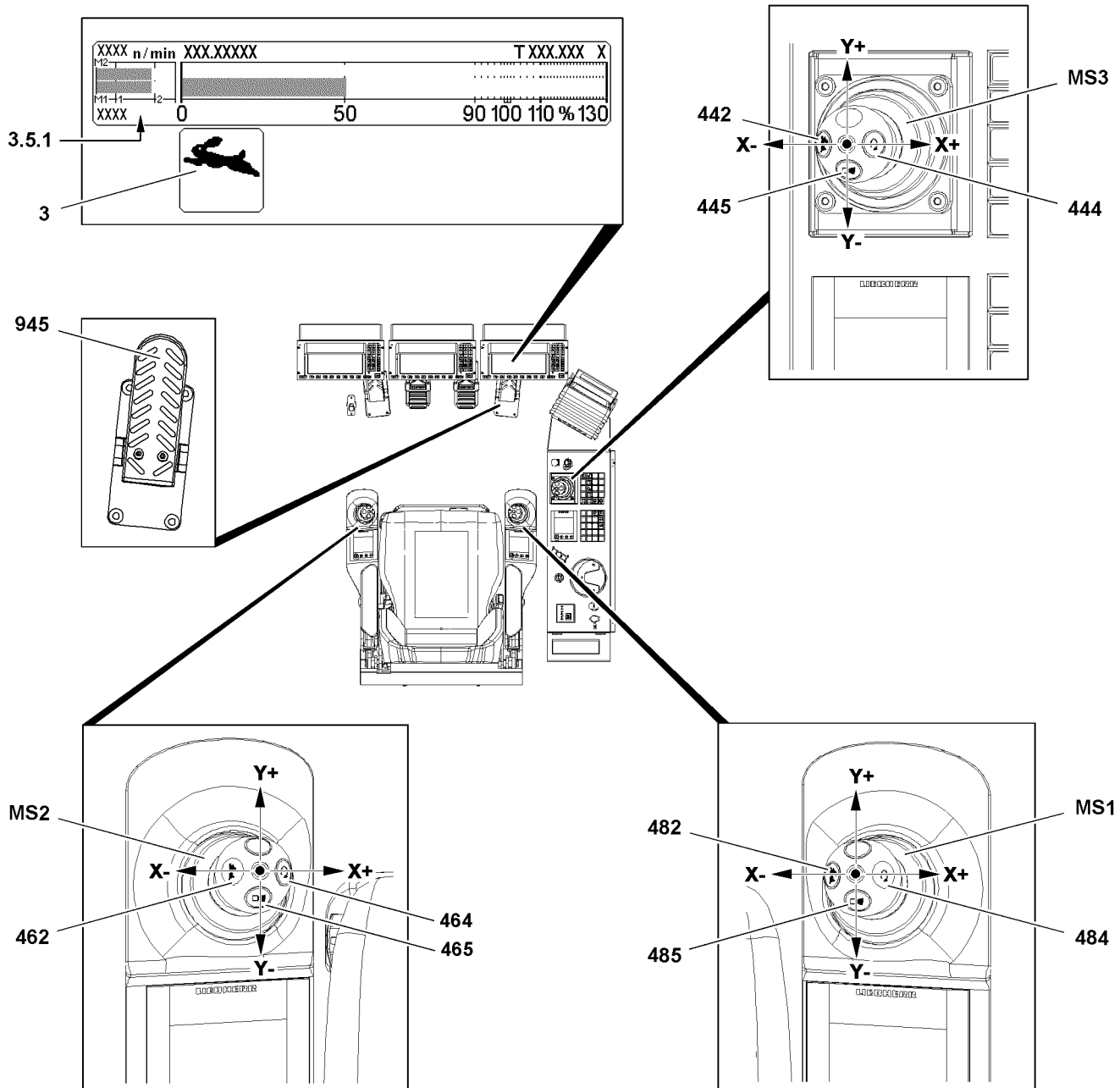

Fig.115852

2.3 „Power Plus“ rapid gear

Using the button **482**, the button **462** or the button **442** will increase the speed of the crane movement for „luffing up“ and „lift / lower“.



WARNING

Danger of accident in the event of one to three strand reeving!

- ▶ Do **NOT** turn the rapid gear on if the crane is loaded to more than 50 % of its maximum permitted load bearing capacity for the respective boom radius.



Note

When „Power Plus“ is turned on, observe the following:

- ▶ If a crane movement has reached its maximum speed due to the current utilization, then no speed increase is possible by adding the „Power Plus“.
- ▶ If the total power requirement of all actuated crane movements is larger than the available power, then those crane movements are reduced which require the most power.
- ▶ If another crane movement is added or taken back to one or more actuated crane movements then this has an influence on the other movements. For that reason we recommend in situations in which an interference of the individual crane movements is troublesome, not to add the „Power Plus“ or to turn the „Power Plus“ off.



Note

- ▶ The rapid gear „Power Plus“ is only effective if the movement luffing up and lifting / lowering is **NOT** reduced in the adjustment window „Speed reduction master switch“.
- ▶ When the „Power Plus“ rapid gear is active and various crane movements are actuated at the same time, then speed reductions can occur.

2.3.1 Turning on „Power Plus“ rapid gear

- ▶ Press the button **482**.
or
Press the button **462**.
or
Press the button **442**.

Result:

- The rapid gear is switched on.
- The icon **3** appears on the LICCON monitor.

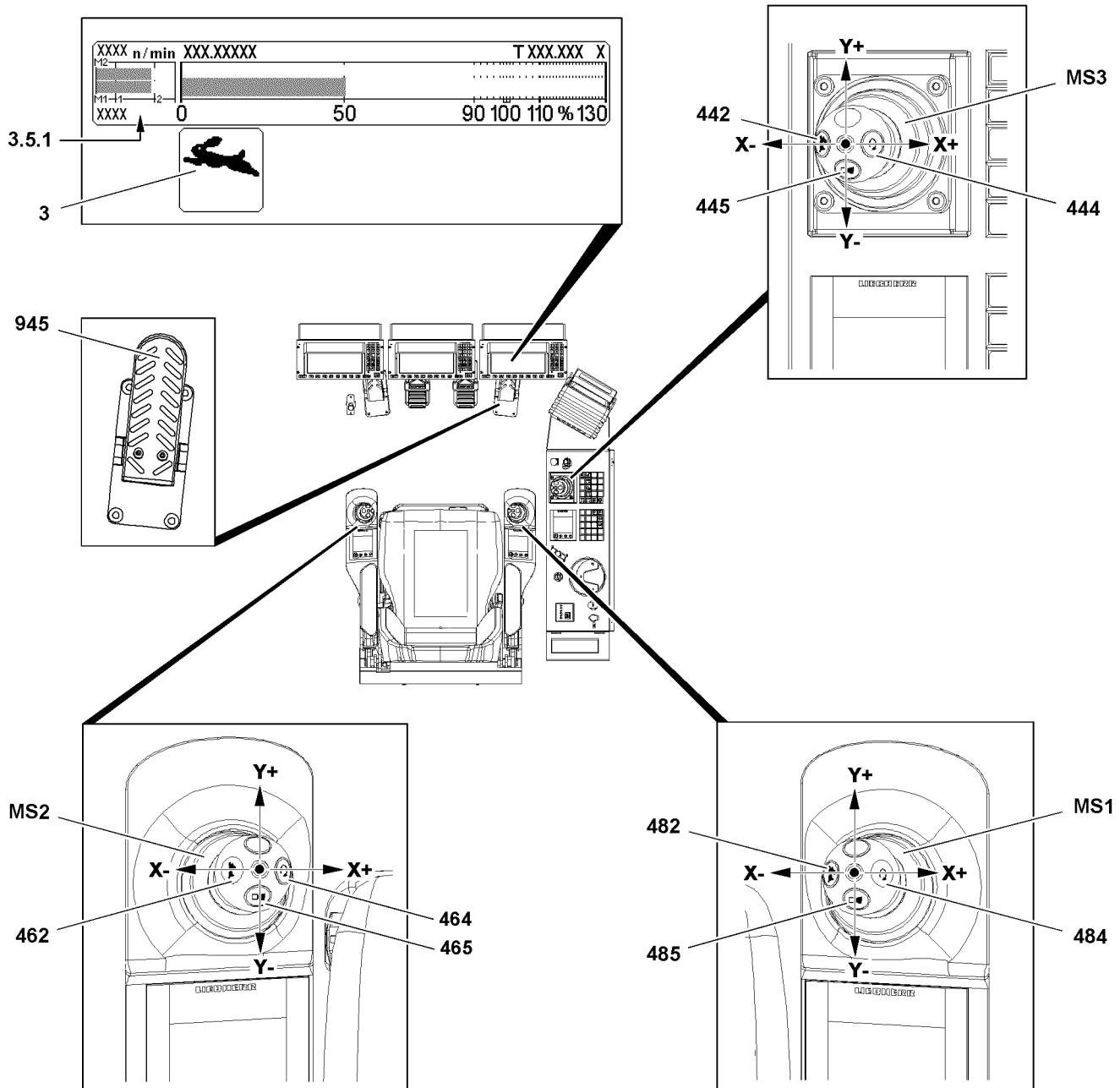

Fig.115852

LWE/LR 13000-001/19503-01-02/en

2.3.2 Turning off „Power Plus“ rapid gear

When the rapid gear is turned on:

- ▶ Press the button **482**.
- or**
- Press the button **462**.
- or**
- Press the button **442**.

Result:

- The rapid gear is turned off.
- The icon **3** turns off on the LICCON monitor.

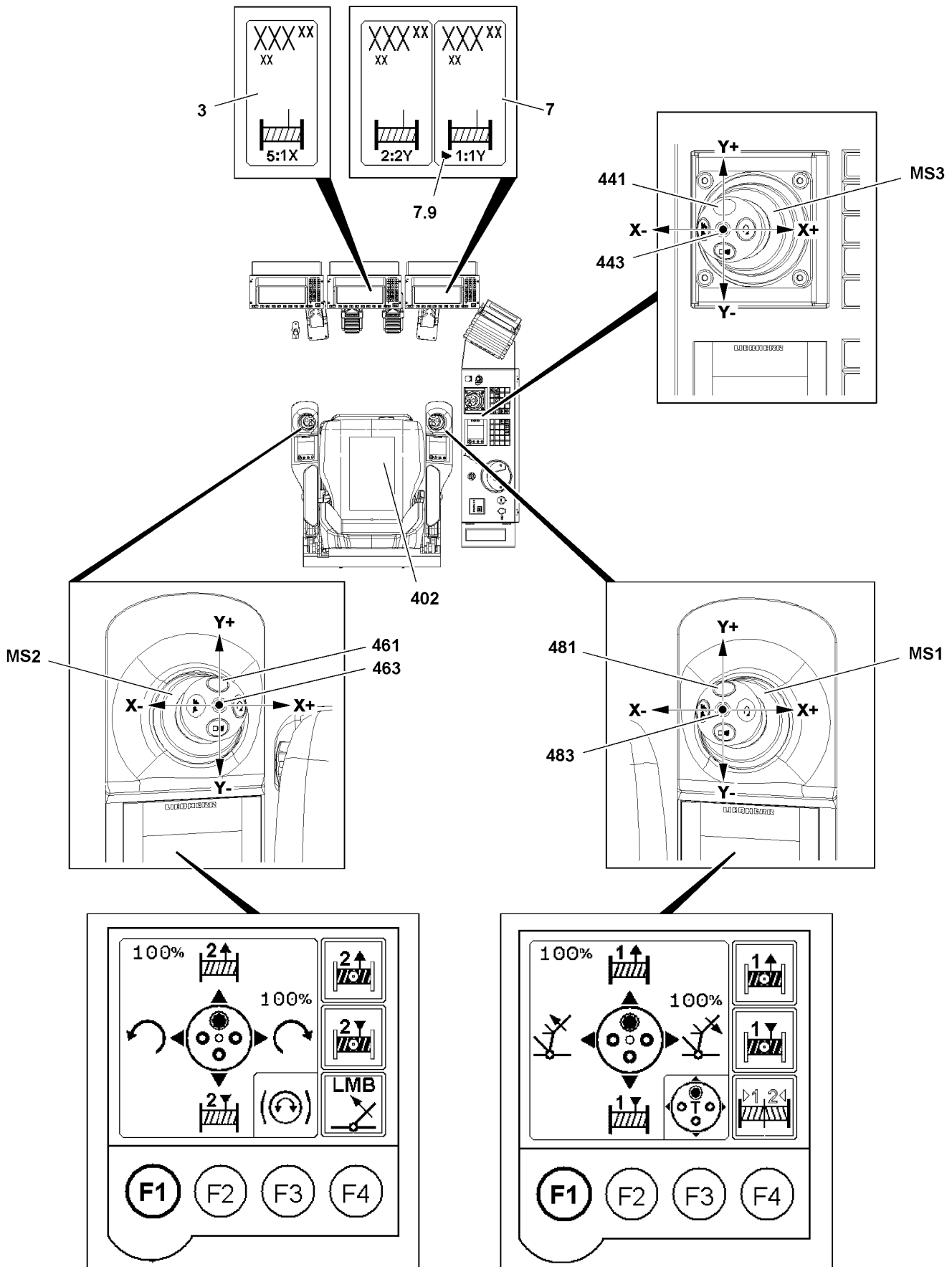

Fig.115853

LWE/LR 13000-001/19503-01-02/en

2.4 Vibration sensor

By adding on the vibration sensor, crane movements also can be detected via master switch vibration.



Note

- ▶ After the vibration sensor on the master switch is activated, the vibration sensor can be assigned to a deflection axle. To assign the vibration sensor to another deflection axle, the master switch must first be brought back into zero position. Then the master switch must be deflected in the other deflection axle.

Make sure that the following prerequisite is met:

- The seat contact button **402** is actuated.

2.4.1 Vibration sensor winches

This section applies for the deflection axles for hoist winches and for the control winches on the master switches:

- **MS1** Master switch
- **MS2** Master switch
- **MS3** Master switch



Note

When the vibration sensor is activated on one master switch:

- ▶ For very winch, which is assigned to the master switch, the icon **7.9** before every winch display appears on the LICCON monitors, see example for winch 1 in the illustration.
- ▶ The vibration sensor is activated on one master switch only for the movement axle, which was deflected first.
- ▶ When a movement axle is deflected and a winch is actuated, the icon **7.9** for the other winches turns off on the winch displays.
- ▶ For description of winch displays on the LICCON monitors, see sections „Winch display“, Crane operating instructions, chapter 4.02.

Adding the vibration sensor winch 1

This example shows how the vibration sensor for winch 1 is added, master switch **MS1** at master switch assignment „T“.

- ▶ Press the button **481**.

Result:

- The vibration sensor **483** on the master switch **MS1** is turned on.
- In the winch display **7** for winch 1 and in the winch display **3** for winch 5, luffing jib, appears the icon **7.9**, see illustration.

- ▶ Deflect the master switch **MS1** in Y-direction.

Result:

- In the winch display **7** for winch 1, the icon **7.9** remains visible, the other icons turn off.
- The vibration sensor for winch 1 is activated.

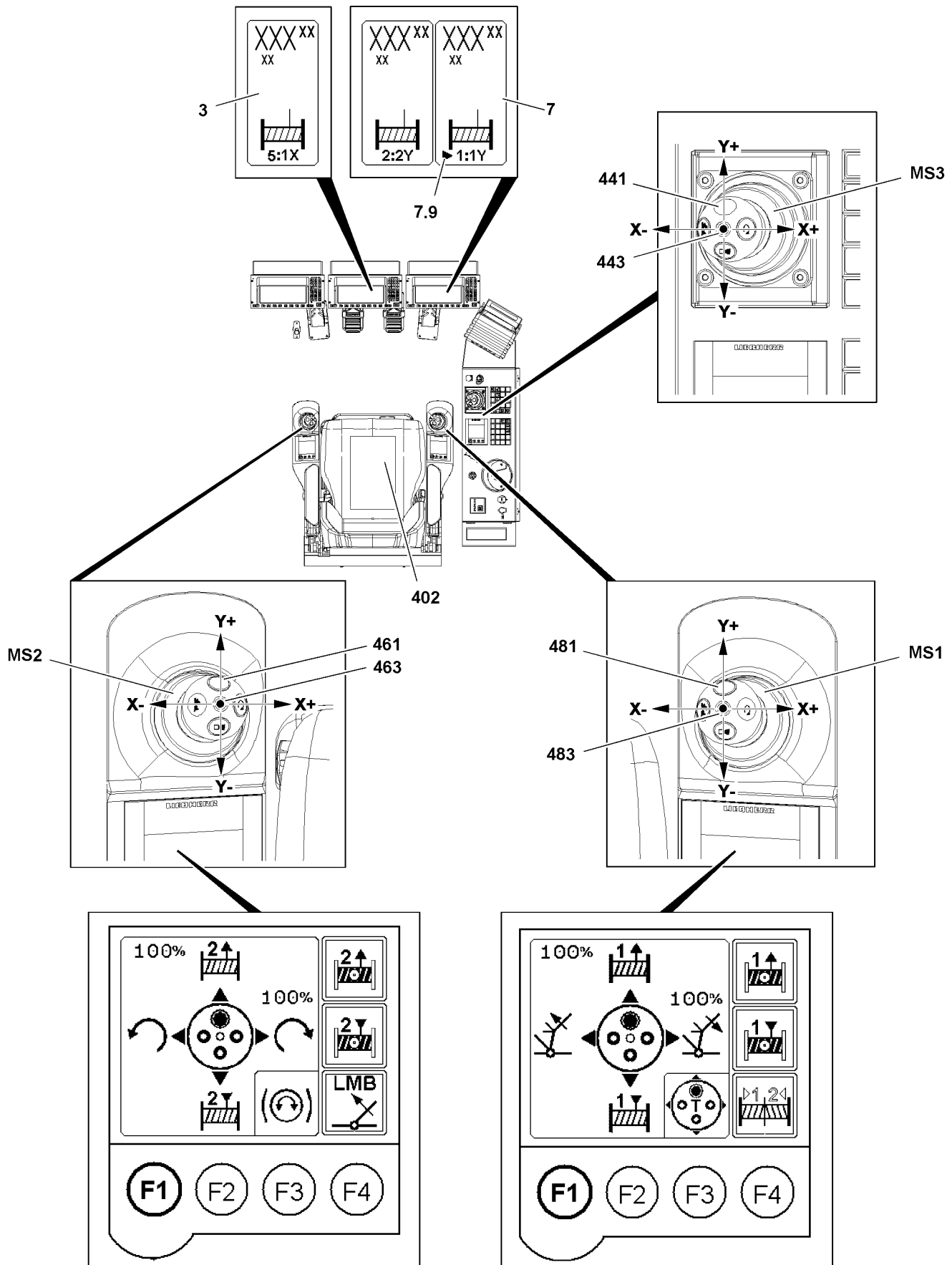

Fig.115853

LWE/LR 13000-001/19503-01-02/en

Turning the vibration sensor winch 1 off

When the vibration sensor **483** for winch 1 is turned on:

- ▶ Press the button **481**.

Result:

- The vibration sensor **483** on the master switch **MS1** is deactivated and turned off.
- The icon **7.9** turns off in the winch display **7** for winch 1.

2.4.2 Vibration sensor slewing gear

This section applies for the deflection axle for the slewing gear on master switch **MS2**.



Note

- ▶ The vibration sensor for the slewing gear is **NOT** displayed by an icon on the LICCON monitor.
- ▶ The vibration sensor is activated on one master switch only for the movement axle, which was deflected first.
- ▶ If a movement for the slewing gear is deflected, then the icons **7.9** for the winches on the winch displays turn off.

Adding the vibration sensor for the slewing gear

This example shows how the vibration sensor for the slewing gear is added, master switch **MS2** at master switch assignment „T“.

- ▶ Press the button **461**.

Result:

- The vibration sensor **463** on the master switch **MS2** is turned on.
- ▶ Deflect the master switch **MS2** in X-direction.

Result:

- The vibration sensor for the slewing gear is activated.

Turning the vibration sensor for the slewing gear off

When the vibration sensor **463** for the slewing gear is turned on:

- ▶ Press the button **461**.

Result:

- The vibration sensor **463** on the master switch **MS2** is deactivated and turned off.

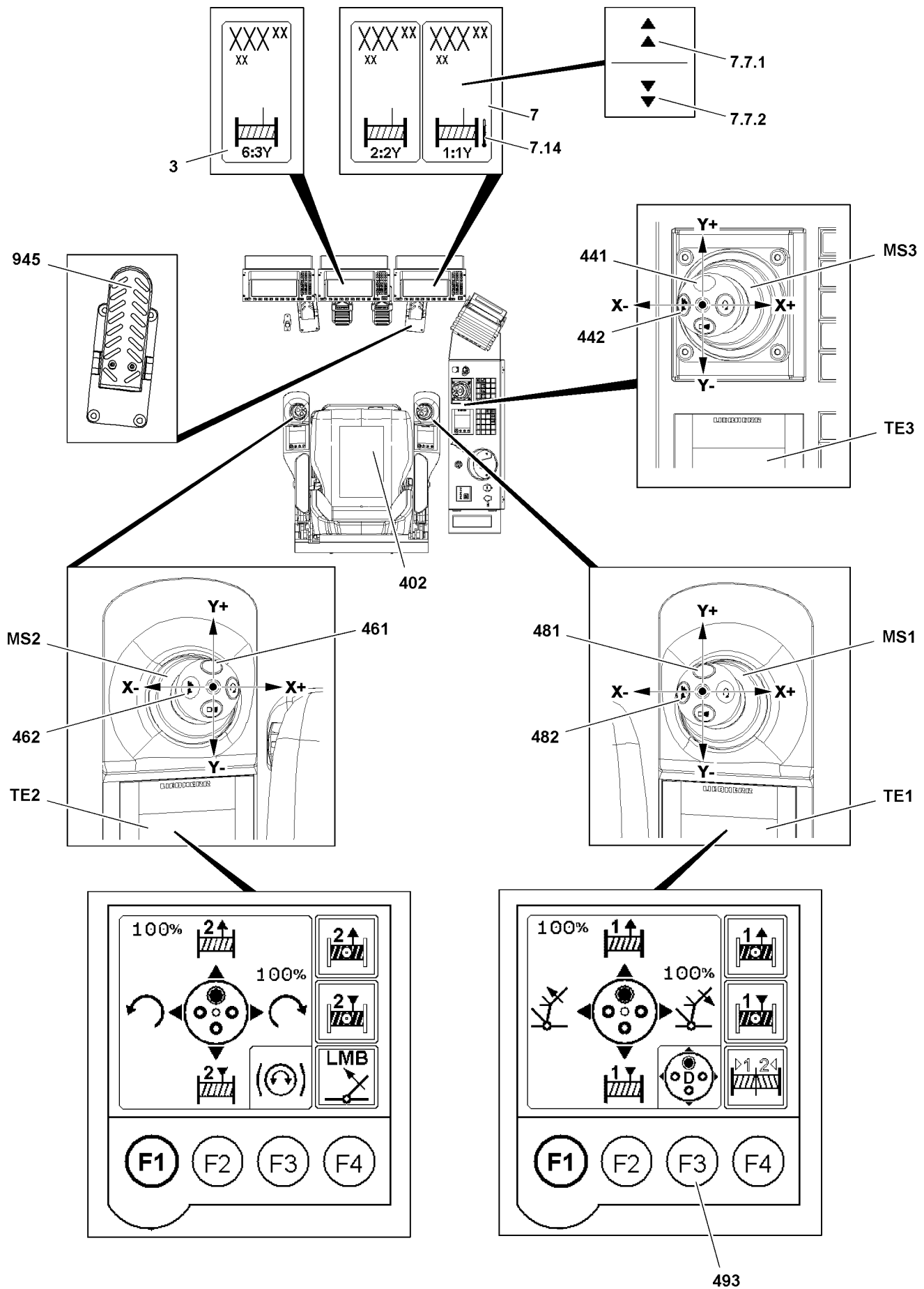

Fig.115854

LWE/LR 13000-001/19503-01-02/en

3 Lifting and lowering

The speed of crane movement „lifting and lowering“ is controlled via the deflection of the corresponding master switch and via the pedal **945** of the engine regulation.

The maximum winch speed can be reduced or increased in the „Speed reduction master switch“ menu, see Crane operating instructions, chapter 4.02.

Every winch can be blocked or released, see section „TE1 block winch menu“, Crane operating instructions, chapter 4.01.



WARNING

Winch is overheated!

If a winch is continued to be operated, even though the icon **7.14** in the winch display **7** or in the winch display **3** appears, then the winch can be significantly damaged. The winch can fail and accidents can result.

- ▶ Stop the crane movement and let the winch cool off until the icon turns off.



Note

- ▶ The seat contact button **402** in the crane operator's seat can be bypassed by the button **481** on the master switch **MS1** or the button **461** on the master switch **MS2** or the button **441** on the master switch **MS3**.
- ▶ For description of winch displays on the LICCON monitors, see Crane operating instructions, chapter 4.02.
- ▶ For description of the touch functions and the icons on the individual touch displays, see Crane operating instructions, chapter 4.01.



Note

- ▶ With the button **482**, the button **462** or the button **442** the speed of the crane movement „lift / lower“ is increased, see section „Rapid gear Power Plus“.

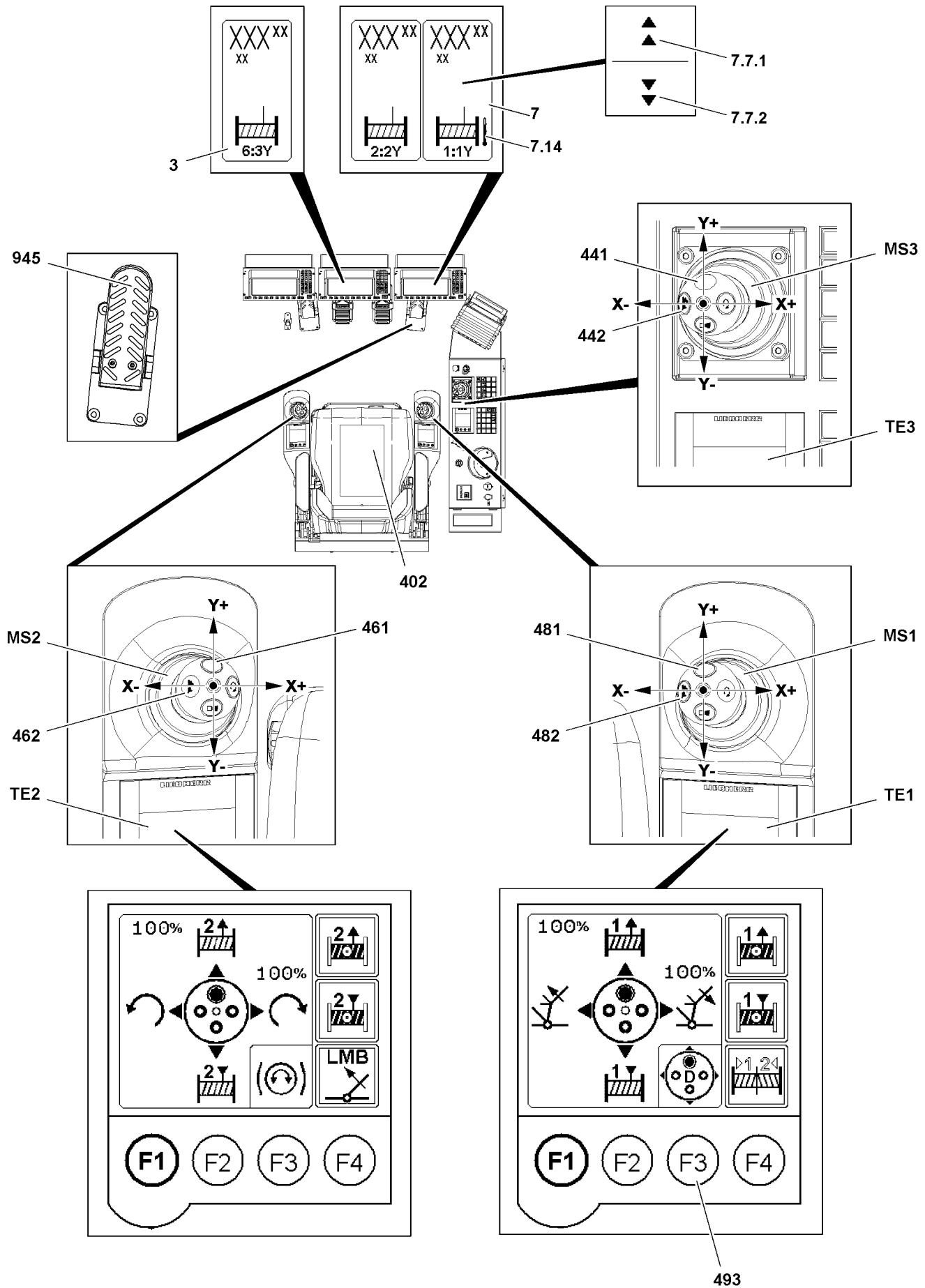

Fig.115854

LWE/LR 13000-001/19503-01-02/en

3.1 Spooling the hoist winches up and out



Note

Change of master switch assignment!

The assignment of the master switches to the respective units on the crane can change, depending on the set up configuration and winch application.

► **Check the assignment before actuating the master switch on the TE.**

This section is valid for the following winches:

- Winch 1 and winch 2
- Winch 6 as a hoist winch

The winch display **7** and the winch display **3** on the LICCON monitors show that the winch is turning, even if no hook movement is visible due to multiple reeving and low speed:

- Winch display **7** for winch 1 and winch 2
- Winch display **3** for winch 6 and the control winches

Make sure that the following prerequisites are met:

- The master switches are in the neutral position.
- The crane is at a standstill.
- On the touch displays, the assignment of the main menu is visible.
- The seat contact switch **402** is activated or the button **481**, button **461** or button **441** are pressed.

3.1.1 Spooling the hoist winch out

This example shows how the winch 1 is spooled out, master switch **MS1** at master switch assignment „D“.

In this assignment, winch 2 on master switch **MS2** and winch 6 on master switch **MS3** are spooled out the same way.

- Select the master switch assignment: Press the F3-key **493** on the touch display **TE1** until the master switch assignment „D“ appears.
- Deflect the master switch **MS1** in direction Y+.

Result:

- The icon **7.7.1** appears in the winch display and blinks.
- The winch spools out, the load is lowered.

Problem remedy

The icon **7.14** „Winch overheated“ appears in the winch display?

The Winch is overheated.

- Let the winch cool off.

Problem remedy

Winch blocked?

When a winch is blocked, then the crane movement is also blocked.

- Release the winch, see section „Blocking the winch (touch display right)“, Crane operating instructions, chapter 4.01.

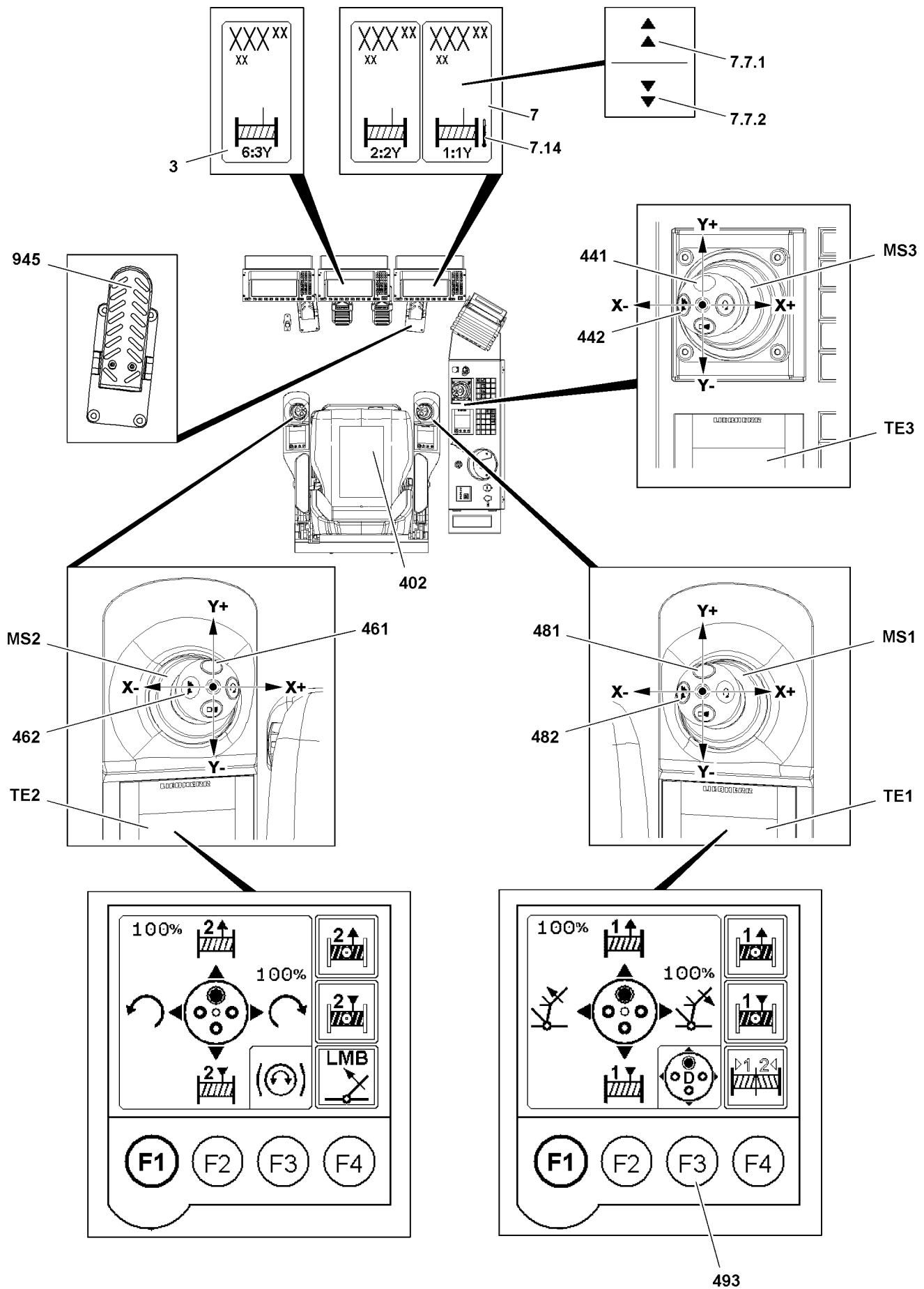

Fig.115854

LWE/LR 13000-001/19503-01-02/en

3.1.2 Spooling the hoist winch up

This example shows how the winch 1 is spooled out, master switch **MS1** at master switch assignment „D“.

In this assignment, winch 2 on master switch **MS2** and winch 6 on master switch **MS3** are spooled out the same way.

- ▶ Deflect the master switch **MS1** in direction Y-.

Result:

- The icon 7.7.2 appears in the winch display and blinks.
- Winch spools up and the load is lifted.

Problem remedy

The icon 7.14 „Winch overheated“ appears in the winch display?

The Winch is overheated.

- ▶ Let the winch cool off.
-

3.2 Setting up parallel operation

For parallel operation, winch 1 and winch 2 are used.

In parallel operation, winch 1 and winch 2 are actuated simultaneously with the master switch **MS1**.

Make sure that the following prerequisites are met:

- All rope pulleys, change over pulleys and test pulleys on the boom system are free of contamination, snow, frost and ice.
- The pulley blocks of the hook block are installed together, see Crane operating instructions, chapter 5.19 or separate operating instructions.
- The pulley blocks of the hook block are reeved according to the load charts.
- The pulley blocks of the hook block are properly reeved according to the reeving plan, see separate reeving plan.
- The total reeving has been entered on the LICCON monitor.
- The number of the reeving of the hoist ropes for every winch must be identical and even.



WARNING

Danger of accident!

Death, severe bodily injuries, property damage.

- ▶ The number of the reeving of the hoist ropes for every winch in parallel operation must be identical and even.
 - ▶ Make sure to unpin the transport pins on the roller blocks before the horizontal alignment and before crane operation.
 - ▶ Make sure that the danger zone of the hook blocks is free of any personnel.
-

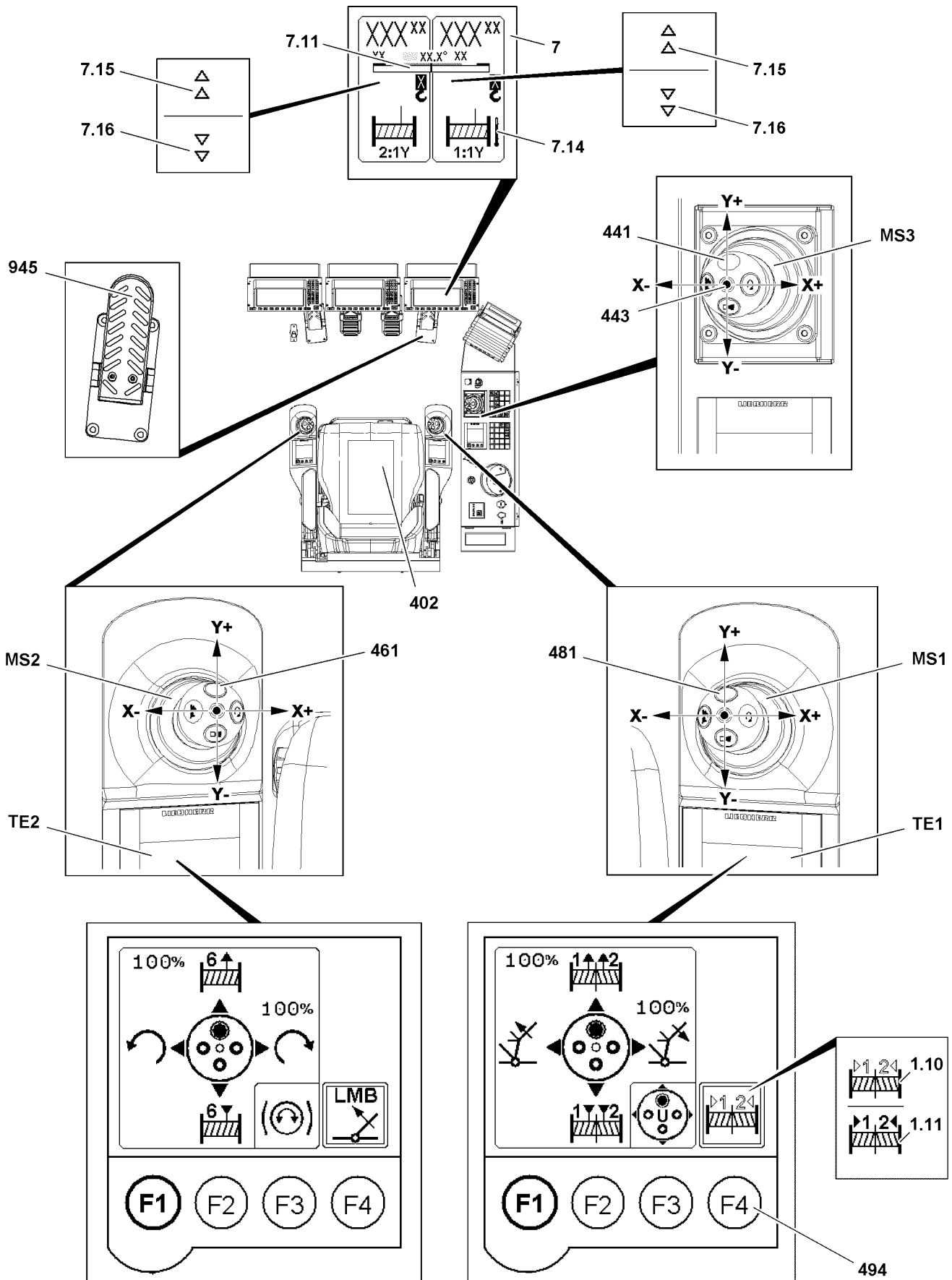

Fig.122121

LWE/LR 13000-001/19503-01-02/en

3.2.1 Adapting to the wind speed

In the case of rope reeving > 2 x 20-way, the wind speed must be reduced to 70 %.

- ▶ Call up the setting window Speed reduction Master switch / pedal sensor, see Crane operating instructions, chapter 4.02.
- ▶ Reduce the master switch for crane movement *Spooling winch 1/12 up / out* to 70 %.

3.2.2 Horizontally aligning the hook block

Make sure that the following prerequisite is met:

- Winch 1 and winch 2 are **NOT** adjusted.

The hook blocks align horizontally through visual check and the icons on the winch display.

To align the hook blocks horizontally, proceed depending on the icons in the winch display 7:

- If the icon **7.15** appears in the winch display, you have to spool the winch out.
- If the icon **7.16** appears in the winch display, you have to spool the winch up.

Set individual operation for winch 1 and winch 2:

- ▶ Press the F3 key **493** until the master switch assignment for individual operation of winch 1 and winch 2 is displayed.

Winch 1 can only be controlled if the seat contact switch **402** and the button **481** are actuated at the same time:

- ▶ Spool winch 1 out or up until the hook block is aligned horizontally.
- or**

Winch 2 can only be controlled if the seat contact switch **402** and the button **461** are actuated at the same time:

Spool winch 2 out or up until the hook block is aligned horizontally.



Note

- ▶ In order to horizontally align winch 1 or winch 2 for the alignment of the hook block, the seat contact switch **402** and the button **481** must be actuated at the same time.

-
- ▶ Press the F3 key **493** until the master switch assignment for the parallel operation of winch 1 and winch 2 is displayed.

Result:

- Winch 1 and winch 2 can be adjusted.

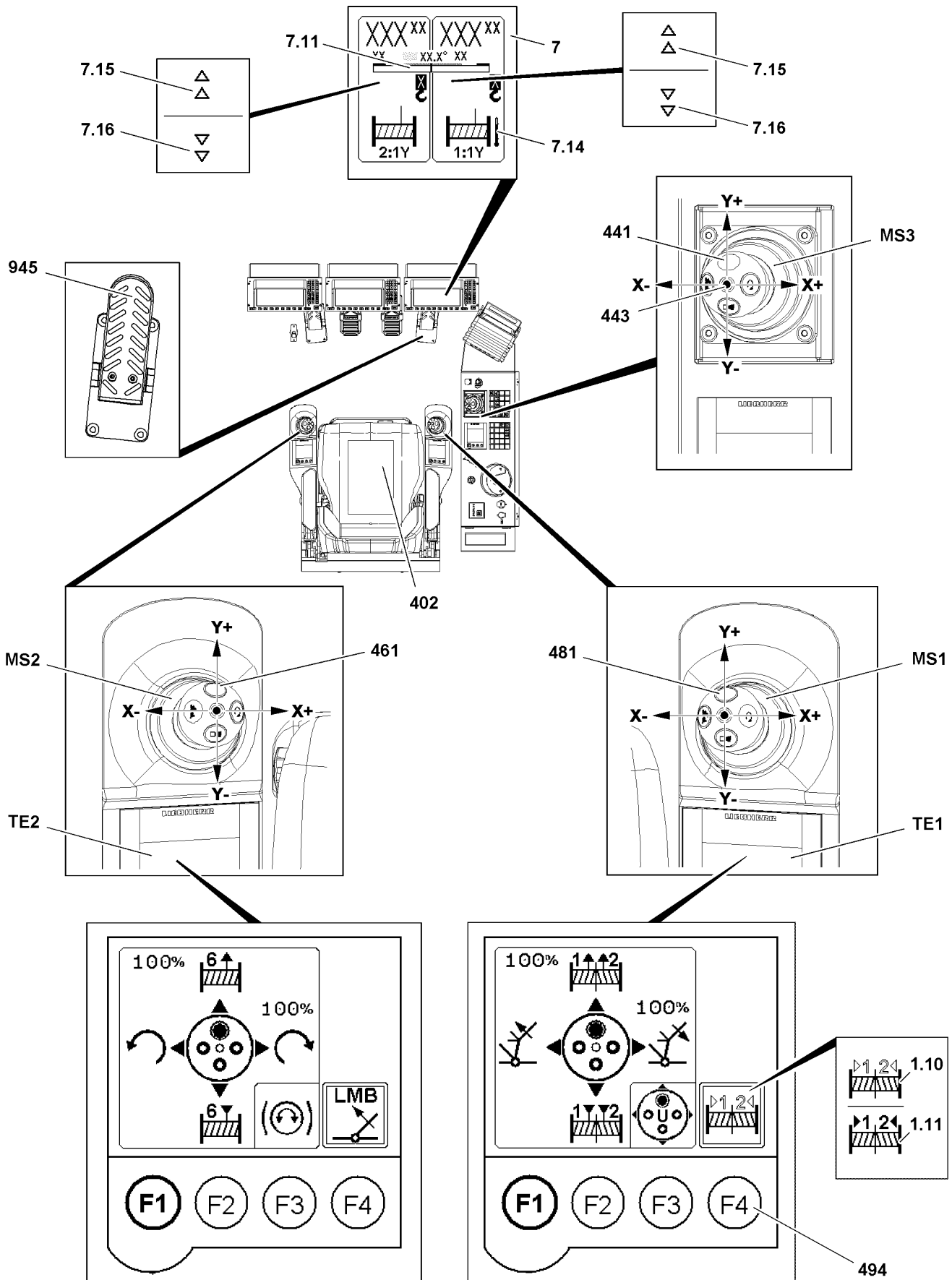

Fig.122121

LWE/LR 13000-001/19503-01-02/en

3.2.3 Adjusting winch 1 and winch 2



Note

- ▶ At master switch assignment with parallel operation of winch 1 and winch 2 both winches can **NOT** be spooled up or out individually.
- ▶ In parallel operation, the winch display **7** changes. For description of winch displays on the LIC-CON monitors, see Crane operating instructions, chapter 4.02.

Make sure that the following prerequisites are met:

- The hook blocks are horizontally aligned, check visually.
- A master switch assignment with parallel operation winch 1 and winch 2 is set on the touch display **TE1**.

This example shows how the winches are adjusted, master switch assignment „U“ on the touch display **TE1**.

- ▶ Preselect the touch function „Adjust winch 1 and winch 2“ by „touching“ the icon **1.10**.

Result:

- The icon **1.10** is bordered in black.
- ▶ Activate the touch function „Adjust winch 1 and winch 2“: Press the F4 key **494** on the touch display **TE1**.

Result:

- Instead of the icon **1.10**, the icon **1.11** is shown.
- Winch 1 and winch 2 are adjusted.

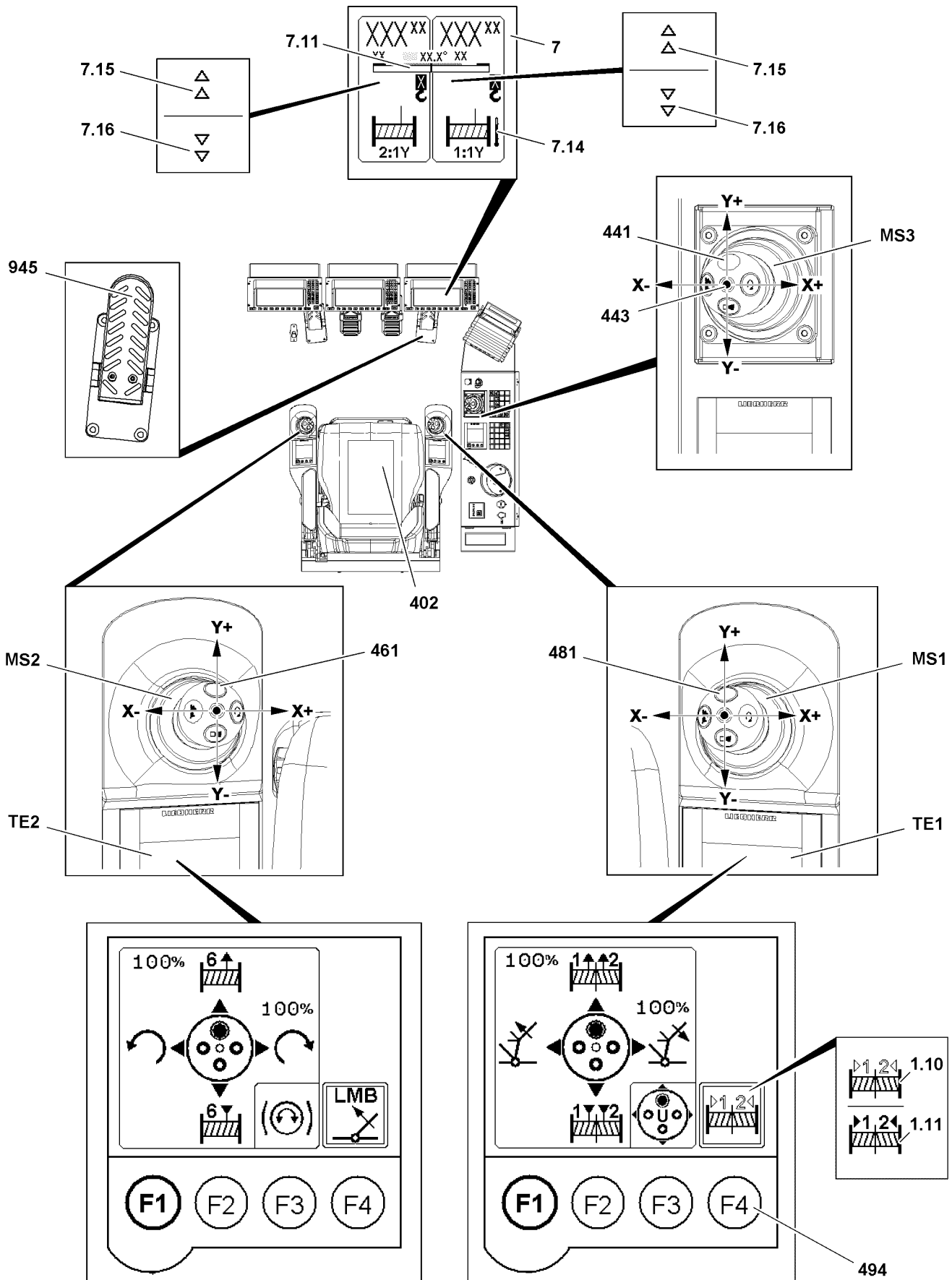

Fig.122121

LWE/LR 13000-001/19503-01-02/en

3.3 Parallel operation: Spooling the hoist winches up and out



WARNING

Incline position of the hook block!

If the balance bar on the roller blocks is inclined, then the load on the individual roller blocks is significantly increased. The boom, hook block or ropes can be overloaded.

Death, severe bodily injuries, property damage.

- ▶ Make sure that the number of reevings on winch 1 and winch 2 is identical and even.
- ▶ Unpin the transport pin on the roller blocks before crane operation.
- ▶ Make sure that the balance bar is always aligned horizontally on the roller blocks. Visual inspection hook block.
- ▶ Always correct the position of the hook block in time.



WARNING

Hook block in sloped position!

If the hook block gets so far into a sloped position that the red range is reached in the incline display, then there is a danger of accident.

Death, severe bodily injuries, property damage.

- ▶ The incline of the hook block is displayed in the winch display 7 on the LICCON monitor.
- ▶ When the incline display 7.11 of the hook block is in the red range, then there is a danger of accidents.
- ▶ Make sure that the incline display 7.11 of the hook block is always in the green range.



Note

- ▶ The LICCON computer system monitors in parallel operation the rope length of winch 1 and winch 2 with the aid of test pulleys.



WARNING

Hook block in sloped position!

Due to dirty or iced-up test pulleys it is possible that the rope length of winch 1 and winch 2 is incorrectly measured.

This incorrect measurement causes the hook block to move into an impermissible incline position and the winches are not automatically stopped.

Death, severe bodily injuries, property damage.

- ▶ Make sure that the test pulleys on the D-pivot section are free of dirt, snow, frost and ice.

The crane operator must ensure that the hook block is always aligned in parallel operation:

- ▶ Monitor the incline indicator of the hook block on the LICCON computer system.
- ▶ Monitor the hook block.

If incline position is present:

- ▶ Stop the winch movement and align the hook block.



WARNING

Winch is overheated!

If a winch is operated further, even though the icon 7.14 appears, the winch can be severely damaged. The winch can fail and severe accidents can result.

Death, severe bodily injuries, property damage.

- ▶ Stop the parallel operation and let the winch cool off until the icon turns off.

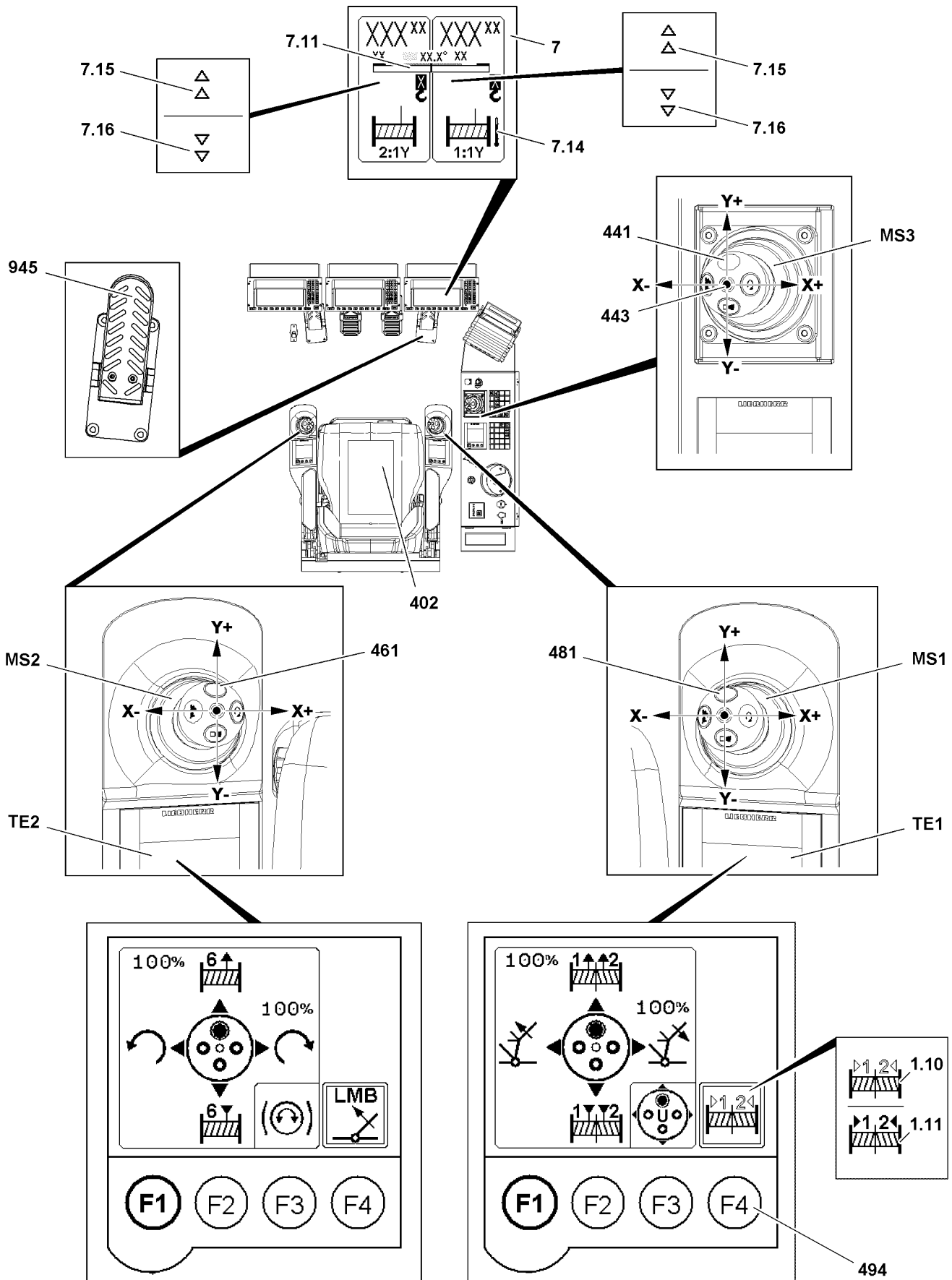

Fig.122121

LWE/LR 13000-001/19503-01-02/en

**Note**

- ▶ In parallel operation, the winch display changes. For description of winch displays on the LICCON monitors, see Crane operating instructions, chapter 4.02.
- ▶ There are several master switch assignments, in which parallel operation is possible.
- ▶ In the master switch assignment „U“, you can actuate winch 1 and winch 2 simultaneously (parallel), winch 6 can be actuated with the master switch **MS2** independent of master switch **MS1**.

Make sure that the following prerequisites are met:

- The parallel operation is set, see section „Setting up parallel operation“.
- The total reeving has been entered on the LICCON monitor.
- Winch 1 and winch 2 are adjusted.
- The seat contact switch **402** is activated or the button **481**, button **461** or button **441** are pressed.

3.3.1 Parallel operation: Spooling the hoist winches up

This example shows how the hoist winches are spooled up parallel, master switch **MS1** at master switch assignment „U“.

- ▶ Deflect the master switch **MS1** in direction Y-.

Result:

- Winch 1 and winch 2 spool up simultaneously: The load is lifted.

Problem remedy

Parallel operation is blocked?

Winch 1 and / or winch 2 is blocked.

- ▶ Release the winches, see section „Blocking the TE1 winches“, Crane operating instructions, chapter 4.01.

Problem remedy

Incline of hook block in red range of winch display?

When the incline value of the hook block is in the red range, there is an increased danger of damage to persons and property.

- ▶ Stop parallel operation.
- ▶ Align the hook block horizontally.
- ▶ Adjust winch 1 and winch 2.

Problem remedy

Path measurement in parallel operation is faulty?

- ▶ Switch the regulation for the path measurement over, see Crane operating instructions, chapter 4.02.

Problem remedy

The icon 7.14 „Winch overheated“ appears in the winch display?

The Winch is overheated.

- ▶ Let the winch cool off.

3.3.2 Parallel operation: Spooling the hoist winches out

Notes for problem remedy are in section „Parallel operation: Spooling the hoist winches up“.

This example shows how the hoist winches are spooled out parallel, master switch **MS1** at master switch assignment „U“.

- ▶ Deflect the master switch **MS1** in direction Y+.

Result:

- Winch 1 and winch 2 spool out simultaneously: The load is lowered.

3.3.3 Changing over regulation Parallel operation winch 1 and winch 2

The parallel operation of winch 1 and winch 2 is regulated from a pulley head height of more than 20 m via the change over pulleys. If there is a problem, the regulation can be switched over by the winch speed sensors, see Crane operating instructions, chapter 4.02.



WARNING

Impermissible change over of regulation *parallel operation winch 1 and winch 2!*

- ▶ Changing the regulation *parallel operation winch 1 and winch 2* is only permissible if - due to contamination, icing or failure of the path measurement system of the test pulleys - a correct path measurement of the hoist ropes of winch 1 and winch 2 is not possible.
 - ▶ Changing the regulation *parallel operation winch 1 and winch 2* is only permissible if it is not possible to immediately clean or de-ice the test pulleys or repair the path measurement system.
 - ▶ As long as the regulation *parallel operation winch 1 and winch 2* is changed over, the crane driver must align the position of the hook block generally manually.
-

Empty page!

LWE/LR 13000-001/19503-01-02/en

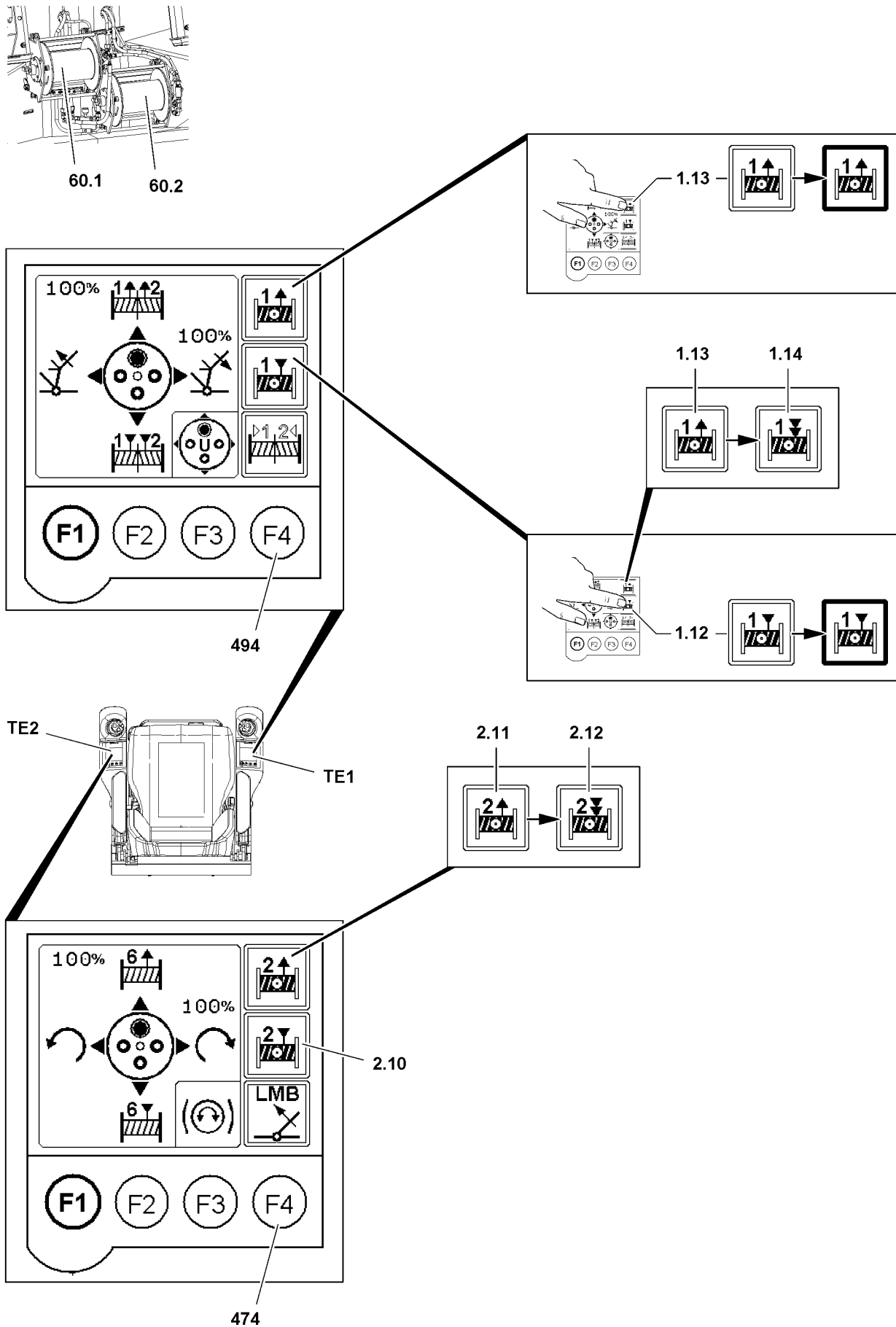

Fig.115856

LWE/LR 13000-001/19503-01-02/en

3.4 Spooling the assembly winch up and out



WARNING

Overload of assembly winches!

When the assembly winches are used for hoisting work, then the assembly winches can be overloaded. Personnel can be severely injured or killed.

- ▶ Use the assembly winches only for reeving work.

On the front side of the turntable are two assembly winches installed:

- Assembly winch 1: Position **60.1**
- Assembly winch 2: Position **60.2**

The assembly winch is actuated from the crane operator's cab.



Note

- ▶ Assembly winch 1 is operated with the touch display **TE1**.
- ▶ Assembly winch 2 is operated with the touch display **TE2**.
- ▶ Assembly winch 1 and assembly winch 2 can be spooled up simultaneously (parallel).

Make sure that the following prerequisite is met:

- The touch functions for the assembly winches are visible on touch display **TE1** and on touch display **TE2**, see illustration.

3.4.1 Spooling the assembly winch out

The description refers to assembly winch 1. The procedure for assembly winch 2 is the same.

The icon **2.11** and the F4-key **474** are assigned to assembly winch 2 on the touch display **TE2**.

- ▶ Select the touch function „Spooling the assembly winch out“ by „touching“ the icon **1.13**.

Result:

- The icon **1.13** is bordered in black.
- ▶ Press the F4 key **494**.

Result:

- The assembly winch is spooled out as long as the F4 key **494** is actuated.
- The winch in the icon **1.13** blinks as long as the F4-key **494** is actuated.

Deselect the touch function „Spooling the assembly winch out“

- ▶ Deselect the touch function „Spooling the assembly winch out“ by „touching“ the icon **1.13**.
or
Select other touch functions on the touch display **TE1**.

Result:

- The icon **1.13** is no longer bordered in black.

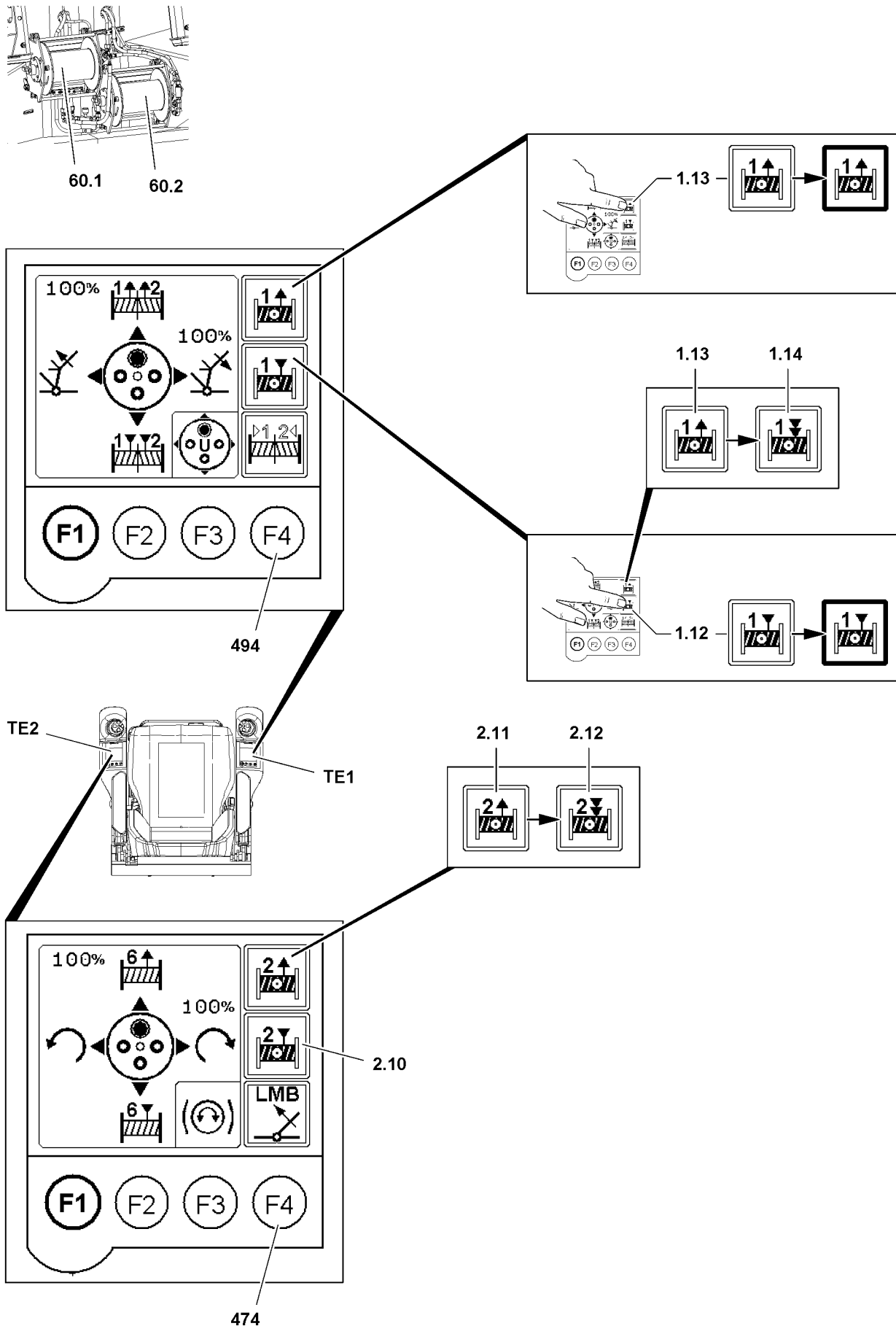

Fig.115856

LWE/LR 13000-001/19503-01-02/en

3.4.2 Spooling the assembly winch up

The description refers to assembly winch 1. The procedure for assembly winch 2 is the same.

The icon **2.10** and the F4-key **474** are assigned to assembly winch 2 on the touch display **TE2**.

- ▶ Select the touch function „Spooling the assembly winch up“ by „touching“ the icon **1.12**.

Result:

- The icon **1.12** is bordered in black.
- Instead of the icon **1.13**, the icon **1.14** is shown, see section „Spooling the assembly winch up constantly“.

- ▶ Press the function key **494**.

Result:

- The assembly winch is spooled up as long as the function key **494** is actuated.
- The winch in the icon **1.12** blinks as long as the function key **494** is actuated.

Deselect the touch function „Spooling the assembly winch up“

- ▶ Deselect the touch function „Spooling the assembly winch up“ by „touching“ the icon **1.12**.
or
Select other touch functions on the touch display **TE1**.

Result:

- The icon **1.12** is no longer bordered in black.

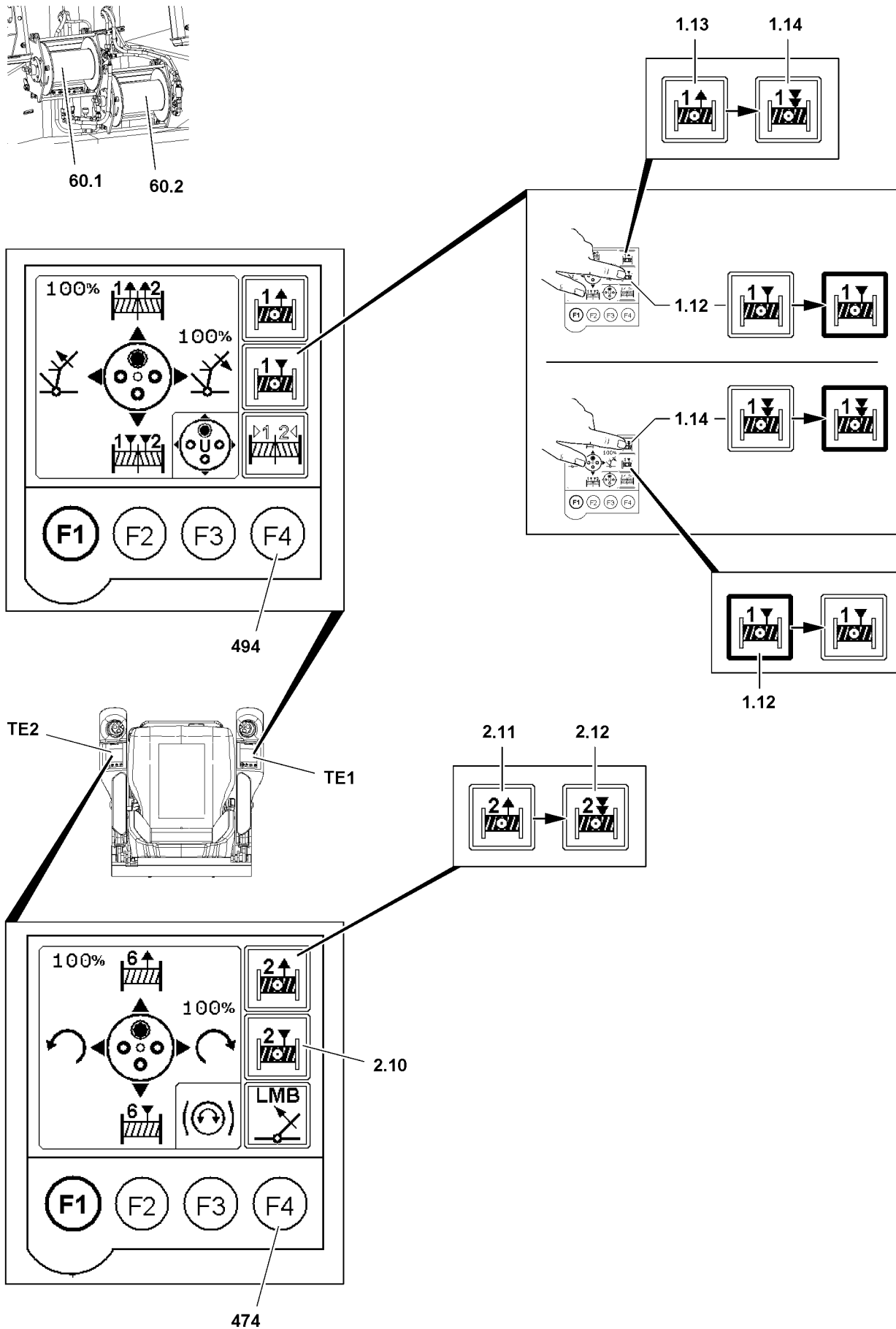

Fig.115860

LWE/LR 13000-001/19503-01-02/en

3.4.3 Spooling the assembly winch up constantly

The description refers to assembly winch 1. The procedure for assembly winch 2 is the same.

The icon **2.10**, the icon **2.11**, the icon **2.12** and the F4-key **474** are assigned to assembly winch 2 on the touch display **TE2**.

- ▶ Select the touch function „Spooling the assembly winch up“ by „touching“ the icon **1.12**.

Result:

- The icon **1.12** is bordered in black.
- Instead of the icon **1.13**, the icon **1.14** is shown.

- ▶ Select the touch function „Spooling the assembly winch up constantly“ by „touching“ the icon **1.14**.

Result:

- The icon **1.14** is bordered in black.
- The icon **1.12** is no longer bordered in black.

- ▶ Press the function key **494** for at least 1 s.

Result:

- The assembly winch is spooled up constantly.
- The winch in the icon **1.14** blinks.

Stop the constant spooling up of the assembly winch

- ▶ Deselect the touch function „Spooling the assembly winch up constantly“ by „touching“ the icon **1.14**.

Result:

- The assembly winch is no longer spooled up.
- The icon **1.14** is no longer bordered in black.

or

- ▶ Press the function key **494**.

Result:

- The assembly winch is no longer spooled up.
- The icon **1.14** remains bordered in black.

or

- ▶ Select other touch functions on the touch display **TE1**.

Result:

- The assembly winch is no longer spooled up.
- The icon **1.14** is no longer bordered in black.

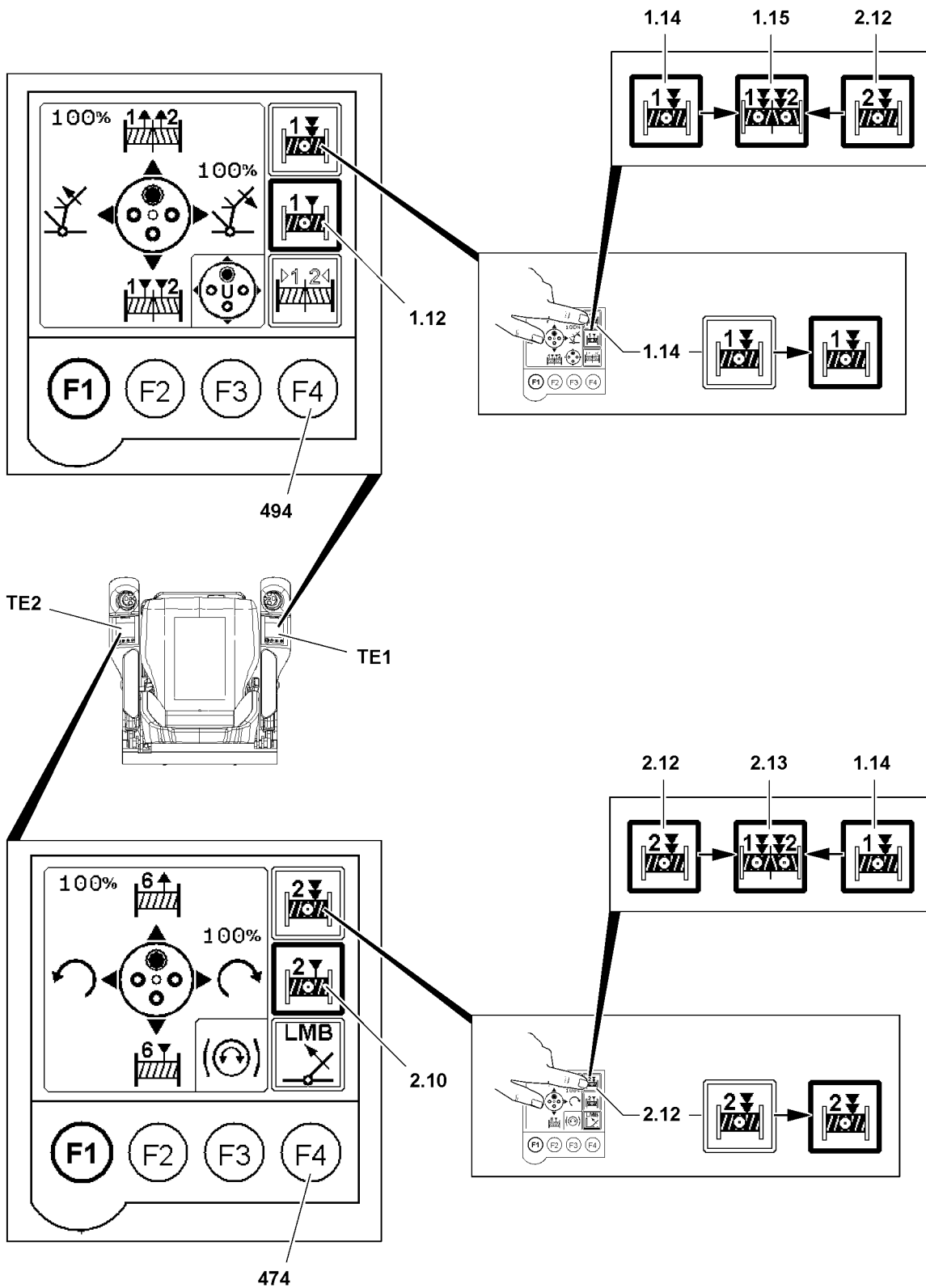

Fig.115857

3.4.4 Spooling the assembly winches up constantly and parallel

On both touch displays, both touch functions „Spooling the assembly winch up constantly“ must be selected so that the icons for the touch functions „Spooling the assembly winches up constantly and parallel“ appear.

The constant parallel spool up procedure can be initiated by both touch displays with the F4-key.

Make sure that the following prerequisites are met:

- The touch function „Spooling up the assembly winch“ is selected on the touch display **TE1**, icon **1.12**.
 - The touch function „Spooling up the assembly winch constantly“ is visible on the touch display **TE1**, icon **1.14**.
 - The touch function „Spooling up the assembly winch“ is selected on the touch display **TE2**, icon **2.10**.
 - The touch function „Spooling up the assembly winch constantly“ is visible on the touch display **TE2**, icon **2.12**.
- ▶ Select the touch function „Spooling the assembly winch up constantly“ by „touching“ the icon **1.14** on the touch display **TE1**.

Result:

- The icon **1.14** is bordered in black.
- ▶ Select the touch function „Spooling the assembly winch up constantly“ by „touching“ the icon **2.12** on the touch display **TE2**.

Result:

- The icon **2.12** is bordered in black.
 - Instead of the icon **2.12**, the icon **2.13** is shown.
 - Instead of the icon **1.14**, the icon **1.15** on the touch display **TE1** is shown.
 - The assembly winches can be spooled up constantly and parallel.
- ▶ Spool the assembly winches up constantly and parallel: Press the F4-key **494** or F4-key **474** at least for 1 s.

Result:

- The assembly winches are spooled up constantly and parallel.
- The winches in icon **1.15** and in icon **2.13** blink.

Stop the constant and parallel spooling up of the assembly winches

If the constant spool up motion of the assembly winch is to be stopped:

- ▶ Deselect the touch function „Spooling the assembly winch up constantly and parallel“ by „touching“ the icon **1.15** or the icon **2.13**.

Result:

- The assembly winches are no longer spooled up.
- Instead of the icon which was deselected, the touch function „Spooling the assembly winch out“ appears. The icon is no longer bordered in black.
- Instead of the icon which was **NOT** deselected, the touch function „Spooling the assembly winch up constantly“ appears. The icon is no longer bordered in black.

or

- ▶ Press the F4 key **494** or F4-key **474**.

Result:

- The assembly winches are no longer spooled up.
- The icon **1.15** and the icon **2.13** remain bordered in black.

or

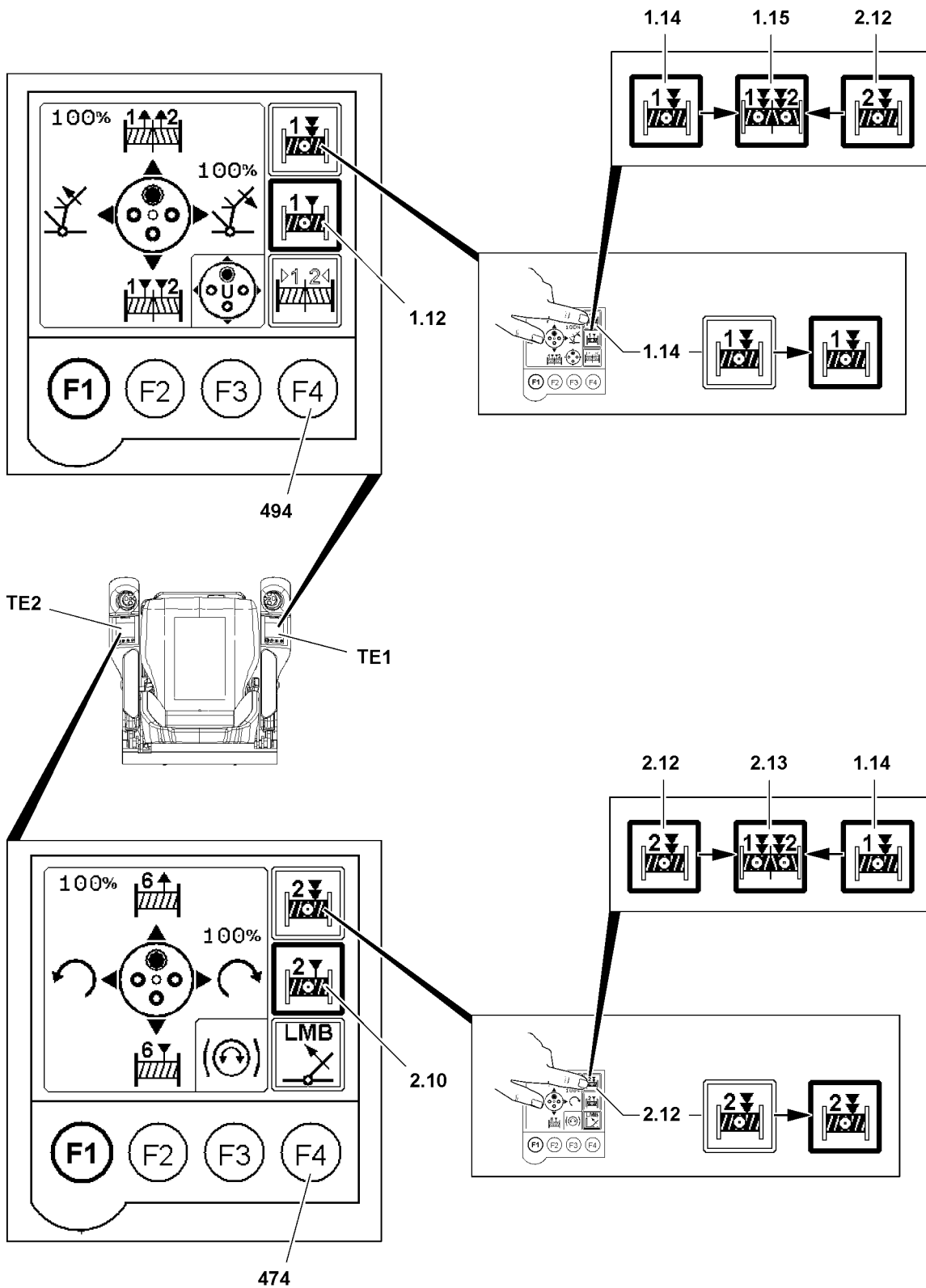

Fig.115857

LWE/LR 13000-001/19503-01-02/en

- ▶ Select other touch functions on the touch display **TE1** or touch display **TE2** by „touching“.

Result:

- Instead of the icon **1.15** or the icon **2.13**, depending on the touch display, the icon for the touch function „Spooling the assembly winch out“ appears. The icon is not bordered in black.
- The touch function „Spooling the assembly winch up constantly“ appears on the touch display, which was **NOT** actuated, instead of the icon **1.15** or the icon **2.13**. The icon remains bordered in black.

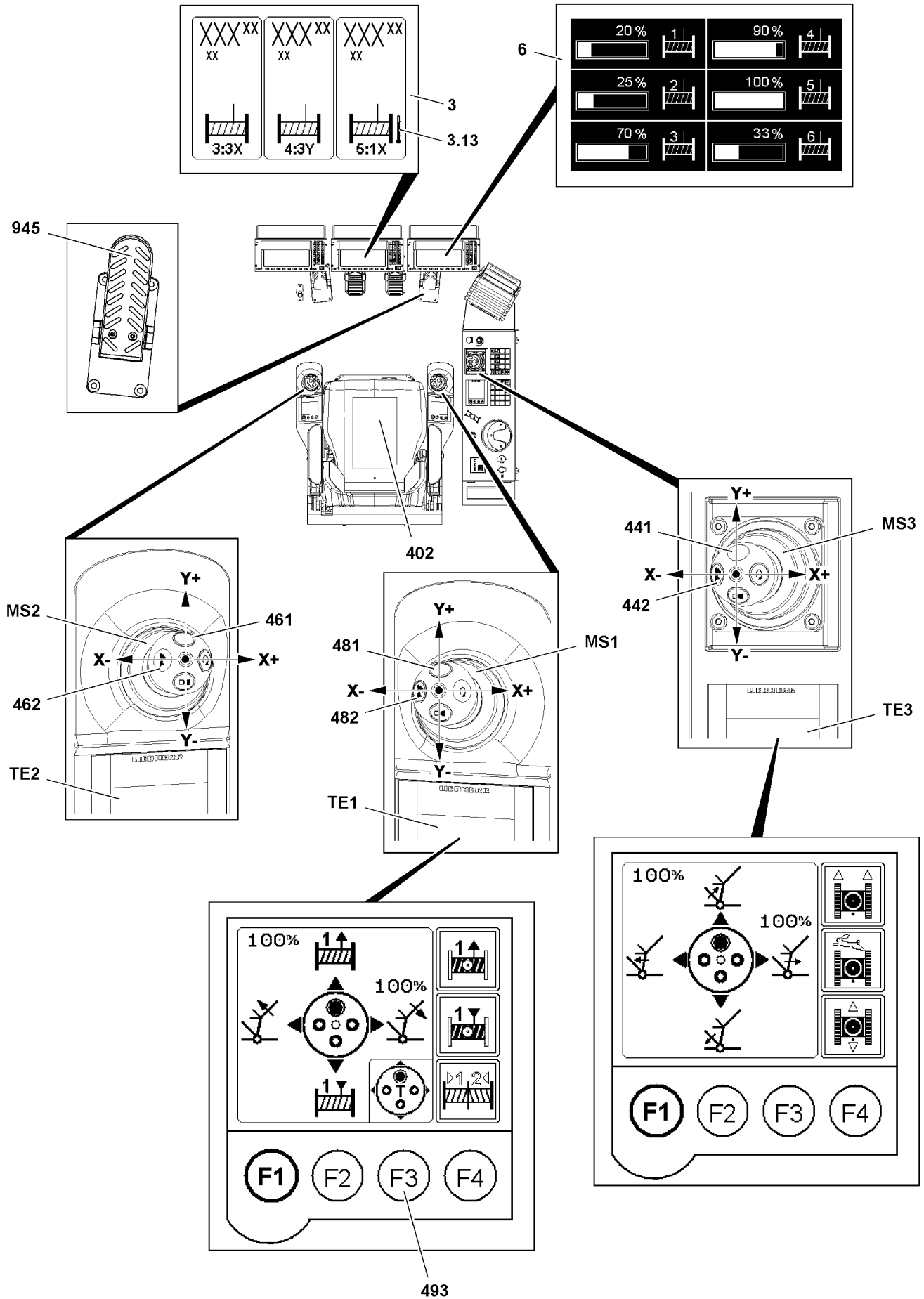

Fig.115859

LWE/LR 13000-001/19503-01-02/en

4 Luffing



WARNING

Luffing the boom up!

If the LICCON overload protection turns off while trying to lift the load with the winch, then a subsequent luffing movement can cause the crane to topple over or damage it. Personnel can be severely injured or killed.

- ▶ Do **NOT** luff up the boom to lift a load off the ground.

The speed of the „luffing“ crane movement is controlled by deflecting the corresponding master switch and via the engine regulation pedal **945**.

The maximum winch speed can be reduced or increased in the „Speed reduction master switch“ menu, see Crane operating instructions, chapter 4.02.

Every winch can be blocked or released, see section „TE1 block winch menu“, Crane operating instructions, chapter 4.01.



WARNING

Winch is overheated!

If a winch is operated further, even though the icon **3.13** appears in the winch display **3**, the winch can be severely damaged. The winch can fail and accidents can result.

- ▶ Stop the crane movement and let the winch cool off until the icon turns off.



Note

- ▶ The seat contact button **402** in the crane operator's seat can be bypassed by the button **481** on the master switch **MS1** or the button **461** on the master switch **MS2** or the button **441** on the master switch **MS3**.
- ▶ For description of winch displays on the LICCON monitors, see Crane operating instructions, chapter 4.02.
- ▶ For description of the touch functions and the icons on the individual touch displays, see Crane operating instructions, chapter 4.01.



Note

- ▶ With the button **482**, the button **462** or the button **442** the speed of the crane movement „luffing up“ is increased, see section „Rapid gear Power Plus“.

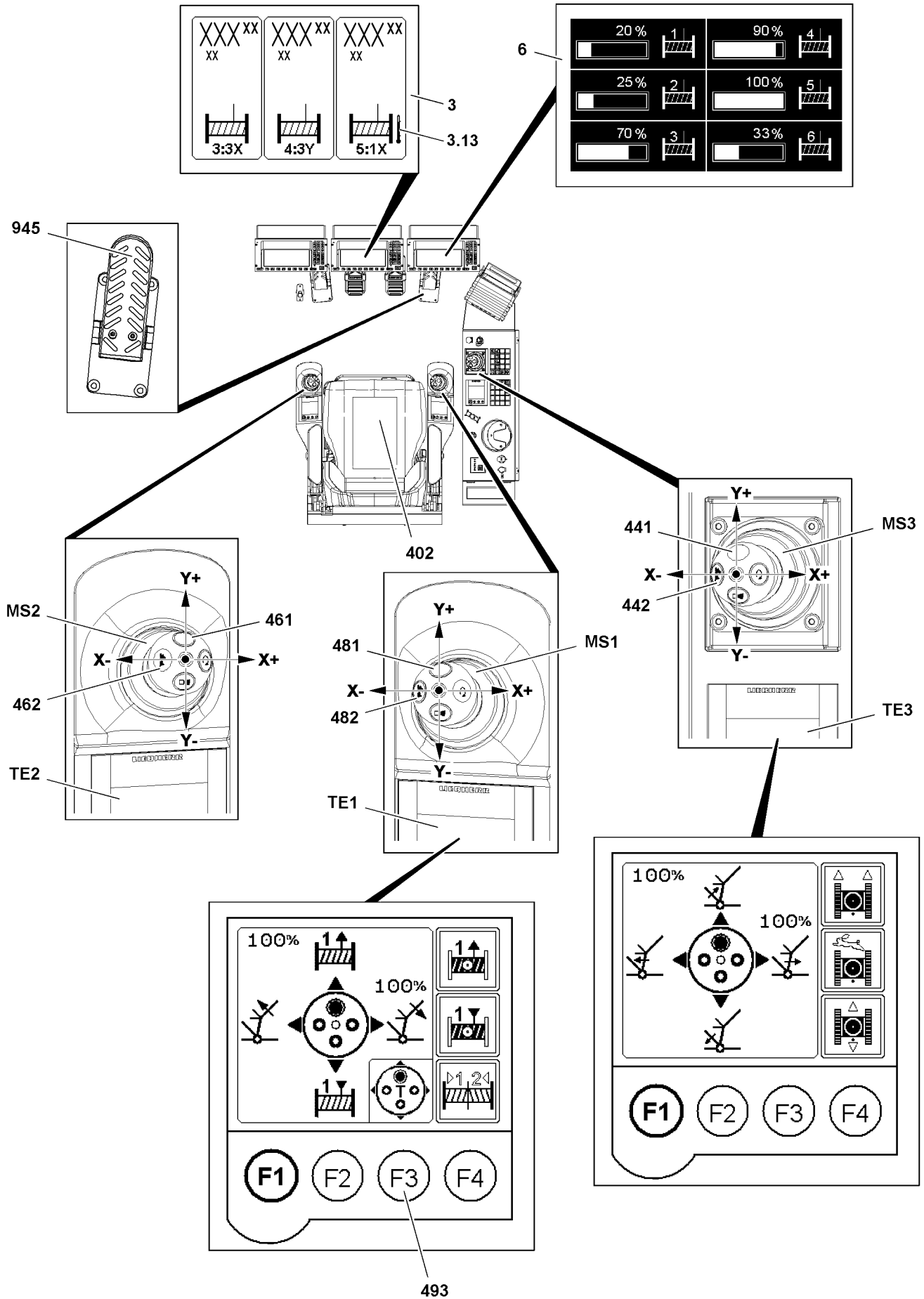

Fig.115859

LWE/LR 13000-001/19503-01-02/en

4.1 Luffing the main boom



Note

Change of master switch assignment!

The assignment of the master switches to the respective units on the crane can change, depending on the set up configuration and winch application.

- ▶ **Check the assignment before actuating the master switch on the TE.**
- ▶ The following sections describe the luffing movement in the master switch assignment „T“.

The maximum luffing speed of the main boom can be preselected in the setting window „Speed reduction master switch“ **6**, see Crane operating instructions, chapter 4.02.

Make sure that the following prerequisites are met:

- The master switch is in the zero position.
- The seat contact switch **402** is activated or the button **481**, button **461** or button **441** are pressed.

4.1.1 Luffing the main boom up

This example shows how the main boom is luffed up, master switch **MS3** at master switch assignment „T“.

- ▶ Press the F3-key on the touch display **TE1** until the master switch assignment „T“ appears.
- ▶ Deflect the master switch **MS3** in direction X-.

Result:

- The main boom is luffed up.

Problem remedy

The icon **3.13** „Winch overheated“ appears in the winch display?

The Winch is overheated.

- ▶ Let the winch cool off.

4.1.2 Luffing the main boom down

This example shows how the main boom is luffed down, master switch **MS3** at master switch assignment „T“.

- ▶ Deflect the master switch **MS3** in direction X+.

Result:

- The main boom is luffed down.

Problem remedy

The icon **3.13** „Winch overheated“ appears in the winch display?

The Winch is overheated.

- ▶ Let the winch cool off.

4.2 Luffing the derrick boom



Note

Change of master switch assignment!

The assignment of the master switches to the respective units on the crane can change, depending on the set up configuration and winch application.

- ▶ **Check the assignment before actuating the master switch on the TE.**
- ▶ The following sections describe the luffing movement in the master switch assignment „T“.

The maximum luffing speed of the derrick boom can be preselected in the setting window „Speed reduction master switch“ **6**, see Crane operating instructions, chapter 4.02.

Make sure that the following prerequisites are met:

- The master switch is in the zero position.
- The seat contact switch **402** is activated or the button **481**, button **461** or button **441** are pressed.

4.2.1 Luffing the derrick boom up

This example shows how the derrick boom is luffed up, master switch **MS3** at master switch assignment „T“.

- ▶ Press the F3-key on the touch display **TE1** until the master switch assignment „T“ appears.
- ▶ Deflect the master switch **MS3** in direction Y+.

Result:

- The derrick boom is luffed up.

Problem remedy

The icon **3.13** „Winch overheated“ appears in the winch display?

The Winch is overheated.

- ▶ Let the winch cool off.

4.2.2 Luffing the derrick boom down

This example shows how the derrick boom is luffed down, master switch **MS3** at master switch assignment „T“.

- ▶ Deflect the master switch **MS3** in direction Y-.

Result:

- The derrick boom is luffed down.

Problem remedy

The icon **3.13** „Winch overheated“ appears in the winch display?

The Winch is overheated.

- ▶ Let the winch cool off.

4.3 Luffing the luffing jib



Note

Change of master switch assignment!

The assignment of the master switches to the respective units on the crane can change, depending on the set up configuration and winch application.

- ▶ **Check the assignment before actuating the master switch on the TE.**
- ▶ The following sections describe the luffing movement in the master switch assignment „T“.

The maximum luffing speed of the luffing jib can be preselected in the setting window „Speed reduction master switch“ **6**, see Crane operating instructions, chapter 4.02.

Make sure that the following prerequisites are met:

- The master switch is in the zero position.
- The seat contact switch **402** is activated or the button **481**, button **461** or button **441** are pressed.

4.3.1 Luffing the luffing jib up

This example shows how the luffing jib is luffed up, master switch **MS1** at master switch assignment „T“.

- ▶ Press the F3-key on the touch display **TE1** until the master switch assignment „T“ appears.
- ▶ Deflect the master switch **MS1** in direction X-.

Result:

- The luffing jib is luffed up.

Problem remedy

The icon **3.13** „Winch overheated“ appears in the winch display?

The Winch is overheated.

- ▶ Let the winch cool off.

4.3.2 Luffing the luffing jib down

This example shows how the luffing jib is luffed down, master switch **MS1** at master switch assignment „T“.

- ▶ Deflect the master switch **MS1** in direction X+.

Result:

- The luffing jib is luffed down.

Problem remedy

The icon **3.13** „Winch overheated“ appears in the winch display?

The Winch is overheated.

- ▶ Let the winch cool off.

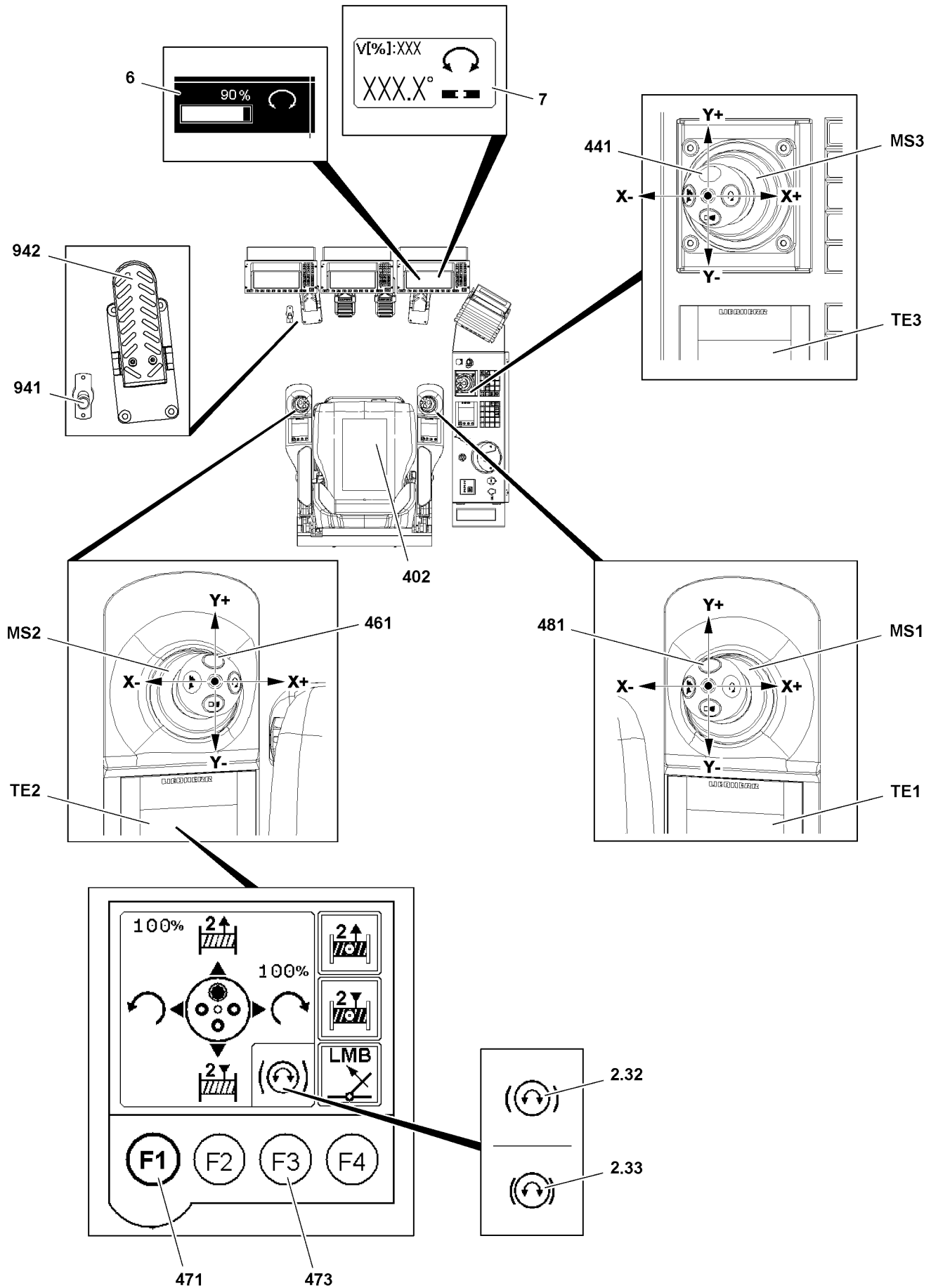

Fig.115858

LWE/LR 13000-001/19503-01-02/en

5 Turning

The slewing gear can be operated with the parking brake **released** or **applied**, see section „Parking brake slewing gear“.



WARNING

Uncontrolled turning of the crane superstructure!

As long as the „parking brake of the slewing gear“ is released, the slewing gear can turn in an uncontrolled manner due to wind, incline position or angular pull. Personnel can be severely injured or killed.

- ▶ Close the „parking brake slewing gear“ by pressing the F3-key **473** on the touch display **TE2**.



Note

- ▶ Once the parking brake is released, it remains released, regardless of whether the slewing gear is actuated with the master switch **MS2** or if it is not actuated. This is to prevent a sudden stop.
- ▶ If the parking brake is applied, it is released as soon as the master switch **MS2** is deflected. The parking brake engages again as soon as the master switch **MS2** is moved to the zero position and the slewing gear is **NO** longer actuated.



Note

- ▶ The seat contact button **402** in the crane operator's seat can be bypassed by the button **481** on the master switch **MS1** or the button **461** on the master switch **MS2** or the button **441** on the master switch **MS3**.
- ▶ For description of winch displays on the LICCON monitors, see Crane operating instructions, chapter 4.02.
- ▶ For description of the touch functions and the icons on the individual touch displays, see Crane operating instructions, chapter 4.01.

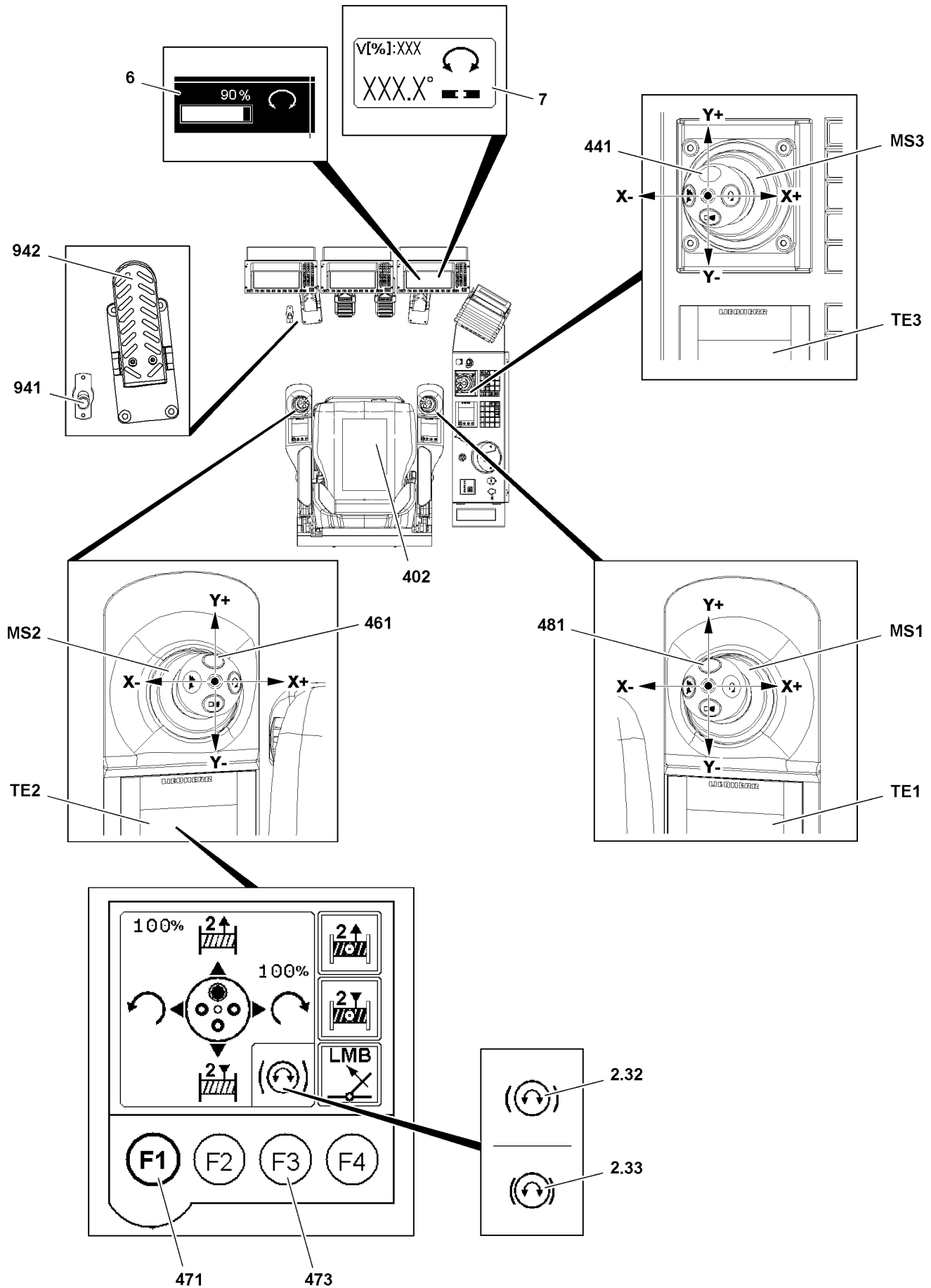

Fig.115858

LWE/LR 13000-001/19503-01-02/en

5.1 Opening and closing the parking brake slewing gear

The parking brake of the slewing gear can be „applied“ or „released“ with the F3-key **473** on the touch display **TE2**.

The status of the parking brake can be seen on the icon on the touch display **TE2**:

- Icon **2.32** shows that the parking brake is released.
- Icon **2.33** shows that the parking brake is applied.

The parking brake closes automatically if:

- The crane operator gets up from the crane operator's seat (seat contact button **402** no longer actuated).
- The engine is turned off.

The parking brake can **NOT** be released if:

- The working range limitation is active.
- A load chart with a limited slewing range is selected.

5.1.1 Releasing the parking brake

Make sure that the following prerequisites are met:

- The parking brake is applied.
- The icon **2.33** appears on the touch display **TE2**.
- The seat contact button **402** or button **441** or button **461** or button **481** is actuated.
- The engine is running.

▶ Press the F3 key **473**.

Result:

- The parking brake is released.
- The Icon **2.32** appears on the touch display **TE2**.

5.1.2 Applying the parking brake

Make sure that the following prerequisites are met:

- The parking brake is released.
- The icon **2.32** appears on the touch display **TE2**.

▶ Press the F3 key **473**.

or

Turn the engine off.

or

Do not actuate the seat contact button **402** or button **441** or button **461** or button **481** any longer.

Result:

- The parking brake is applied.
- The Icon **2.33** appears on the touch display **TE2**.

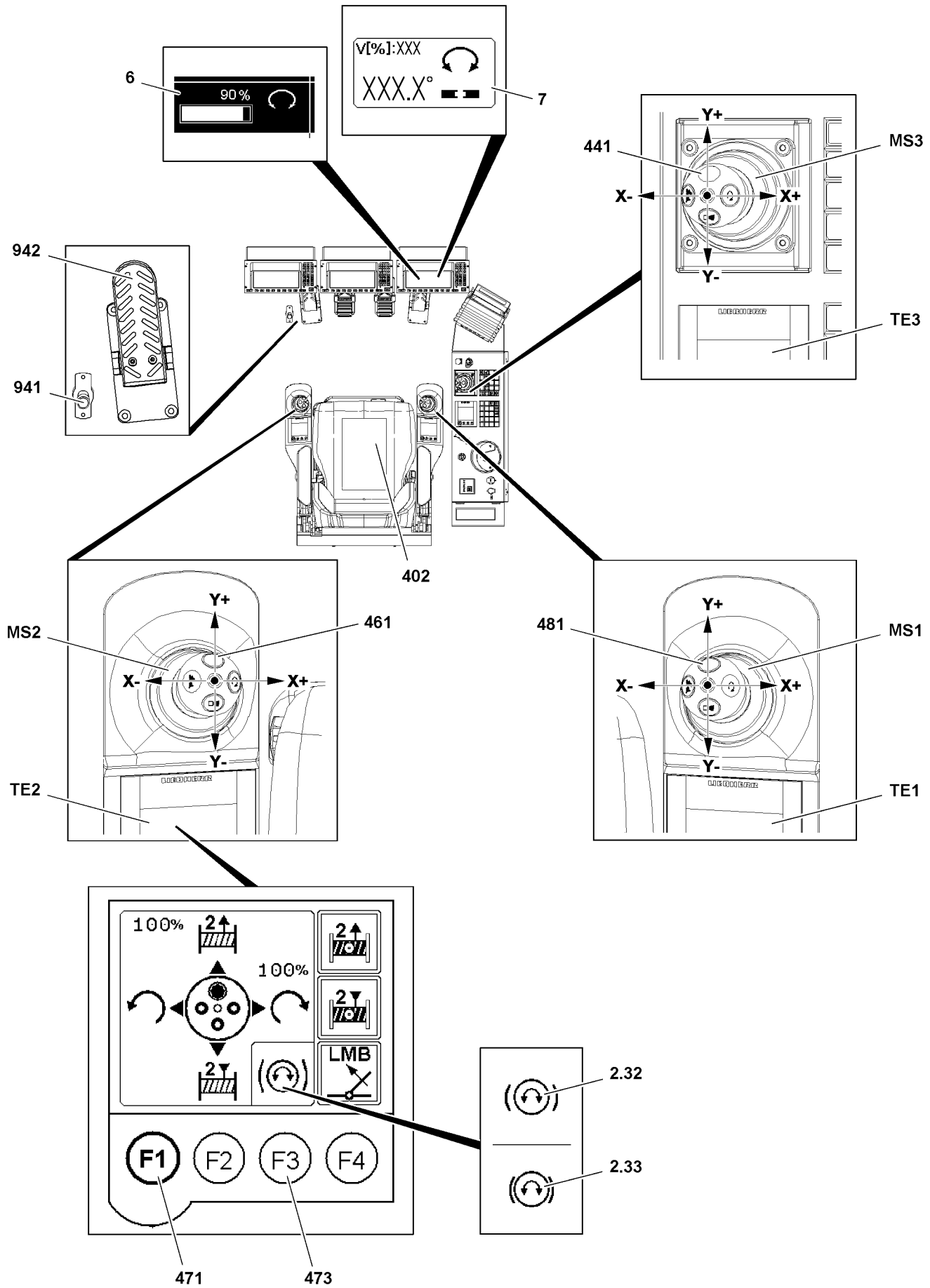

Fig.115858

LWE/LR 13000-001/19503-01-02/en

5.2 Actuating the slewing gear brake with the pedal



CAUTION

Risk of damaging the slewing gear or the roller ring connection!

The slewing gear brake cannot brake the full turning momentum. Failure to comply with the following instructions could damage the slewing gear or roller ring connection.

- ▶ The pedal **942** may only be used at minimal rotational speeds, in other words with master switch **MS2** almost at the neutral position.
- ▶ Do **NOT** abruptly brake the turning movement of the crane by moving the master switch **MS2** back to the neutral position and by simultaneously applying the pedal **942**.

Use the pedal **942** to actuate the slewing gear brake only in the following cases:

- Starting out with a strong side wind
- Stopping the slewing movement with a strong side wind

5.2.1 Starting out with a strong side wind

When turning against the wind with a strong side wind and with a long boom system, the superstructure will turn to the opposite direction due to leaks in the hydraulic motor.

This can be avoided as follows:

- ▶ Actuate the pedal **942** and deflect the master switch **MS2** into the desired turning direction.
- ▶ Slowly release the pedal **942** until the superstructure turns in the desired turning direction.

5.2.2 Stopping the slewing movement with a strong side wind

- ▶ Slow down the crane with master switch **MS2** to minimum slewing speed.
- ▶ Apply the pedal **942** carefully, until the crane has come to a standstill at the desired position.

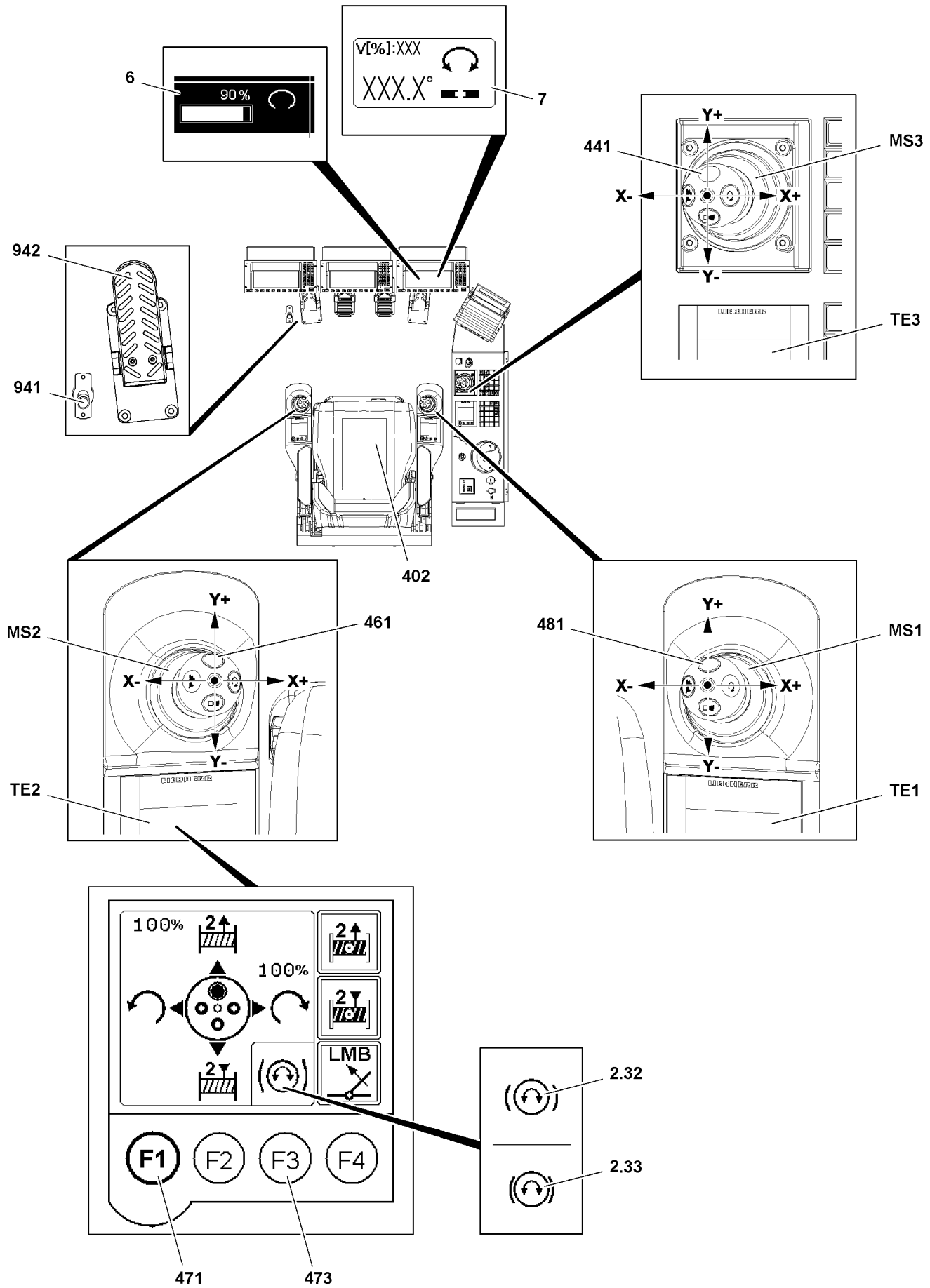

Fig.115858

LWE/LR 13000-001/19503-01-02/en

5.3 Switching the slewing gear to freewheeling

In order to position the boom over the load more easily, the slewing gear can be switched to freewheeling.

Make sure that the following prerequisites are met:

- The seat contact button **402** or button **441** or button **461** or button **481** is actuated.
- The engine is running.
- The master switch **MS2** is **NOT** deflected.



Note

The activation of the freewheel and actuation of the slewing movement via the master switch **MS2** are mutually exclusive.

- ▶ When the master switch **MS2** is deflected, the slewing gear cannot be switched to freewheeling via the foot button **941**.
- ▶ When pressing the foot button **941**, the slewing movement can **NOT** be carried out by deflecting the master switch **MS2**.

The slewing gear can **NOT** be switched to freewheeling / coasting if:

- A load chart with a limited slewing range is selected.
- The working range limitation is active.
- ▶ Press the foot button **941**.

Result:

- The slewing gear is switched to freewheeling.

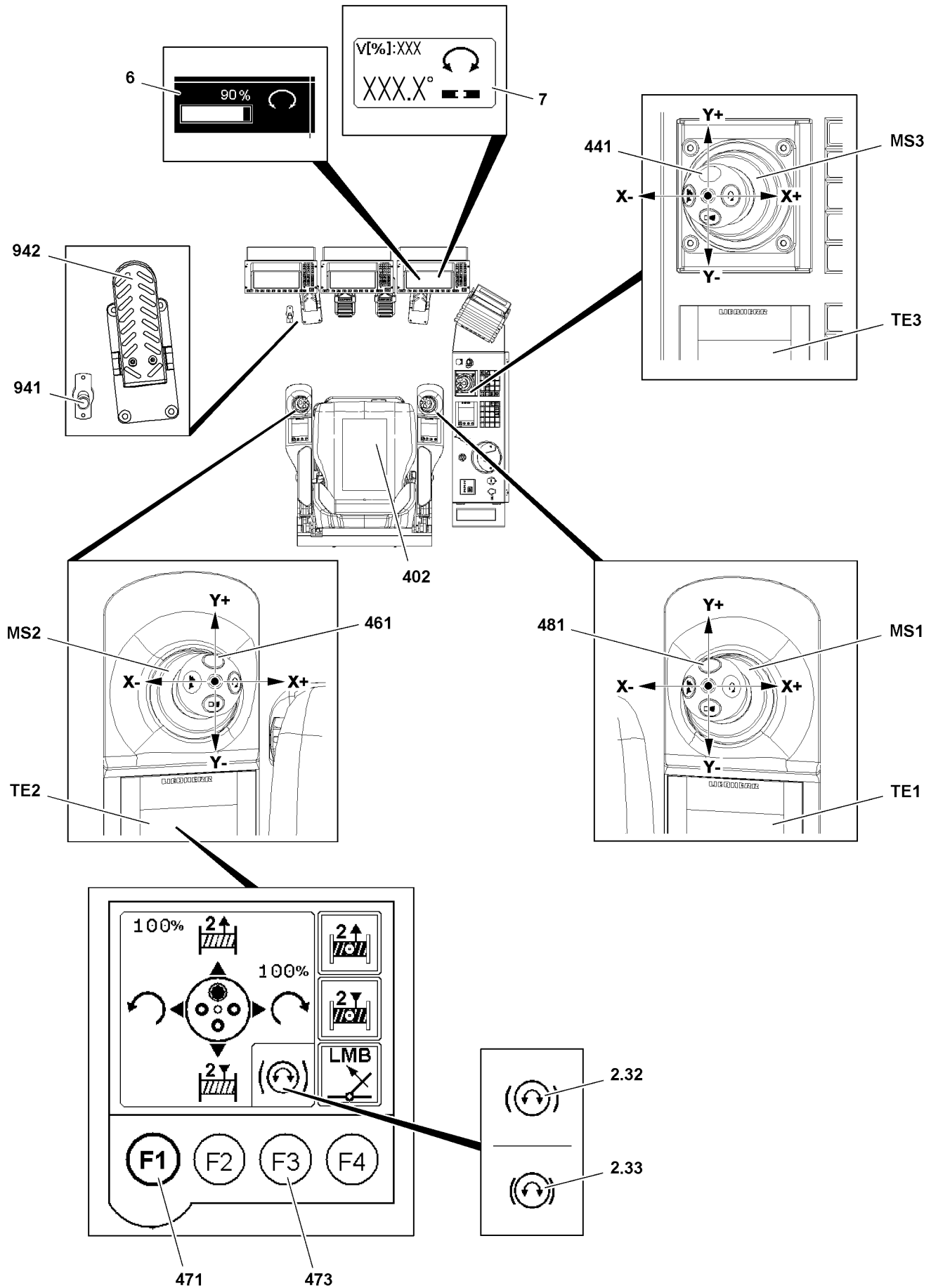

Fig.115858

LWE/LR 13000-001/19503-01-02/en

5.4 Turning the crane superstructure

5.4.1 Preselection of slewing speed



WARNING

The crane can topple over!

If the following instructions are not observed, life threatening situations could arise even causing the crane to topple over.

- ▶ Set the slewing speed specified in the load chart manual.
- ▶ Do **NOT** exceed the specified maximum speed.

The load chart manual lists the maximum slewing speeds in percentages. The maximum permissible slewing speeds can be set on the LICCON computer system in the „Speed reduction master switch“ setting window **6**, see the Crane operating instructions, chapter 4.02.

Basic rule: With a longer boom and a larger load, you have to turn with a slower speed.

5.4.2 Turning the crane superstructure



WARNING

Persons or obstacles within the danger zone!

If there are any persons or obstacles on the crane chassis during turning or in any other danger zone of the crane, then these persons can be killed or severely injured.

- ▶ It is prohibited for personnel to remain in the danger zone.
- ▶ Make sure that there are no obstacles within the working area of the crane.
- ▶ Give a short warning signal (horn) before starting a crane movement.
- ▶ When turning with a load: Initiate and slow down a turning movement extremely sensitively.



WARNING

Oscillating loads!

If the slewing speed is exceeded, there is the danger that the loads start to swing. The crane can be damaged or topple over. Personnel can be severely injured or killed.

- ▶ Turning with a load: Initiate and slow down a turning movement extremely sensitively.
- ▶ Longer boom and larger load: Operate the crane with a lower slewing speed.
- ▶ Observe and adhere to the values in the load chart manual.

The maximum rotational speed is shown in the slewing range **7** on the LICCON monitor, see Crane operating instructions, chapter 4.02.

Make sure that the following prerequisite is met:

- The maximum permissible slewing speed is set on the LICCON computer system in the „Speed reduction master switch“ setting window **6**, see the Crane operating instructions, chapter 4.02.
- The seat contact switch **402** is activated or the button **481**, button **461** or button **441** are pressed.

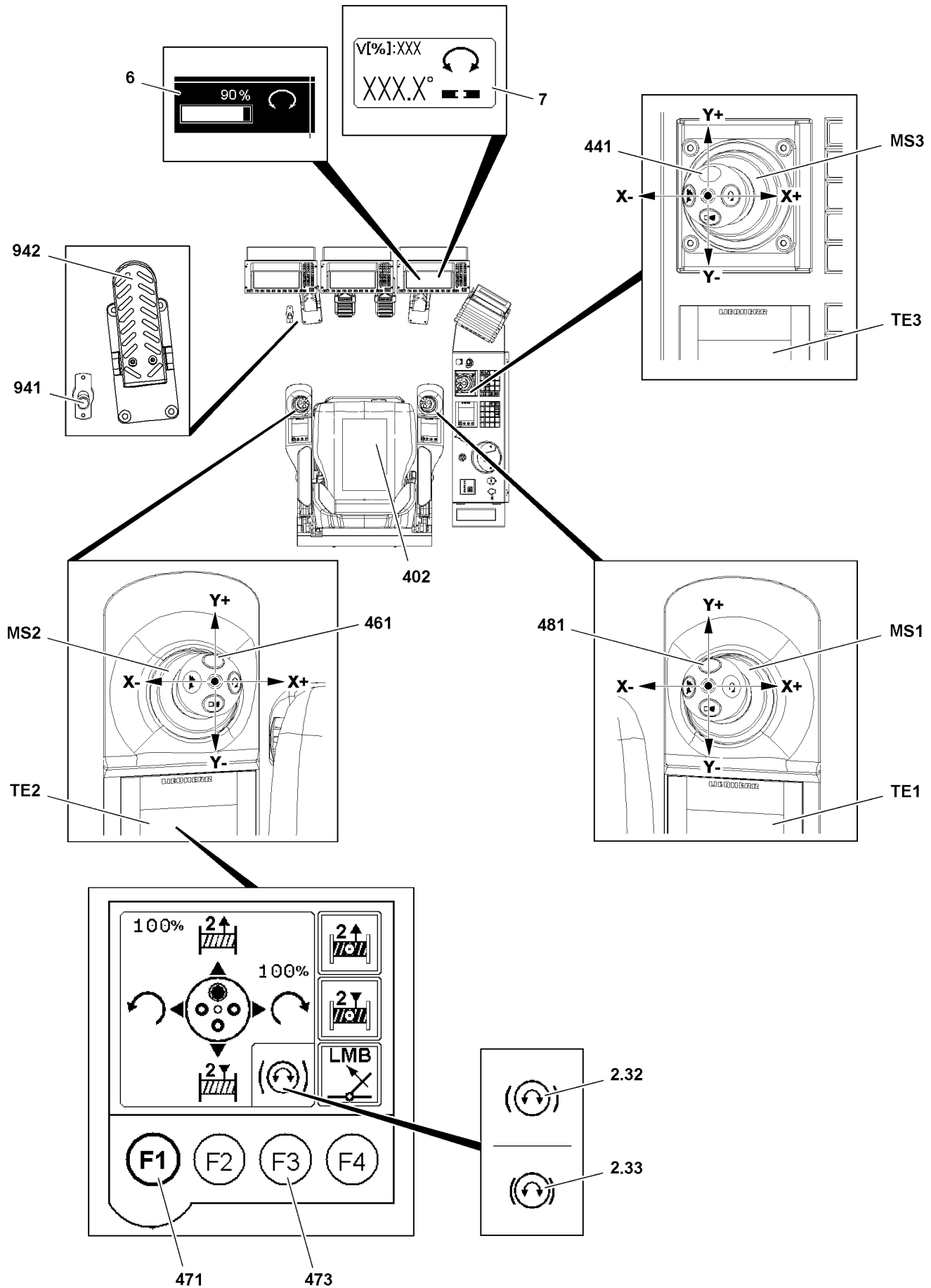

Fig.115858

LWE/LR 13000-001/19503-01-02/en

Turning the crane superstructure to the right

- ▶ Press the F1-key **471** on the touch display **TE2** until the „master switch assignment“ TE2 menu appears.
- ▶ Deflect the master switch **MS2** in direction X+.

Result:

- The crane superstructure turns to the right.

Turning the crane superstructure to the left

- ▶ Press the F1-key **471** on the touch display **TE2** until the „master switch assignment“ TE1 menu appears.
- ▶ Deflect the master switch **MS2** in direction X-.

Result:

- The crane superstructure turns to the left.

Empty page!

LWE/LR 13000-001/19503-01-02/en

4.06 Rope reeving

1	Wire ropes and rope end connections	2
2	Reeving in the hoist rope	5
3	Reeving in / reeving out the hook block, rope end connection in the standard version	8
4	Reeving in / reeving out the hook block, rope end connection with L-shaped rope lock	11
5	Attaching and removing the load hook*	15
6	Two-part hoist limit switch weight	18
7	One-part hoist limit switch weight	21
8	Assembling / disassembling the wedge lock	23
9	Rope reeving	35

1 Wire ropes and rope end connections

1.1 Wire ropes

Check if a **rotating resistant** or a **non-rotating** rope is required for the application. The selected type of rope then requires the corresponding rope end connections, see the Crane operating instructions, chapter 8.04.



Note

- ▶ The correct choice and use of the wire rope and the rope end connections are a decisive precondition for proper and accident-free crane operation.



DANGER

Incorrect rope type!

Danger of severe injuries to personnel and property damage.

- ▶ **Never** use rotation-resistant ropes with a rotating rope end connection.
- ▶ **Never** install a twist compensator / swivel.

1.2 Rope end connections

Rope end connections are grouped into:

- Rope lock (standard version), with locking clamp or locking cast sleeve
- L-shaped rope lock, with locking clamp or locking cast sleeve
- Wedge lock, on the rope end
 - Without locking clamp / locking cast sleeve



Note

- ▶ A locking clamp is pressed on the rope.
- ▶ A locking cast sleeve is cast with the rope.
- ▶ A wedge lock is wedged with the rope.



WARNING

The load can be ripped off!

If the rope end connection is installed incorrectly, the rope can rip off.

Death, severe bodily injuries, property damage.

- ▶ Only use the provided fastening points.
- ▶ Use the respective rope end connection only at the correspondingly implemented fastening points.

1.2.1 Rope lock (standard version)

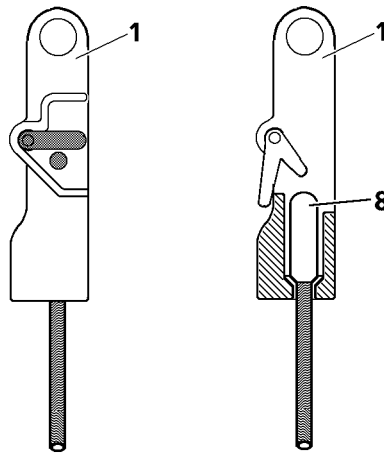

Fig.144019: Rope lock (standard version) with locking clamp / locking cast sleeve

The rope end connection consists of:

- Rope lock (standard version) **1** with locking clamp / locking cast sleeve **8**
Only use them on the conventional fastening points for rope end connections.

1.2.2 L-shaped rope lock



WARNING

The load can be ripped off!
Death, severe bodily injuries, property damage.

- ▶ The rope end connection with L-shaped rope lock is only permitted for use on appropriately designed fastening points.
- ▶ Make sure that the rope end connection with L-shaped rope lock is only used on appropriately designed fastening points.

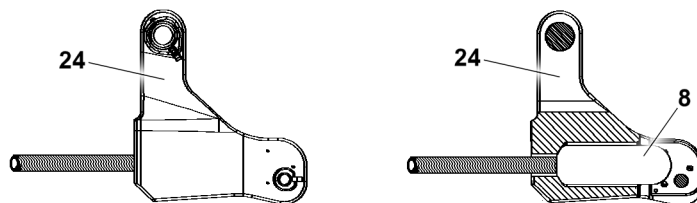

Fig.158793: L-shaped rope lock, with locking clamp / locking cast sleeve

The rope end connection consists of:

- L-shaped rope lock, **24** with locking clamp / locking cast sleeve **8**
Only use on the appropriately designed fastening points for rope end connection with L-shaped rope lock.



Note

Fastening points for rope end connection with L-shaped rope lock

- ▶ Fastening points that are designed accordingly have a guide surface for the L-shaped rope lock.
- ▶ If the rope lock is touching the guide surface, the rope does not bend with a load.

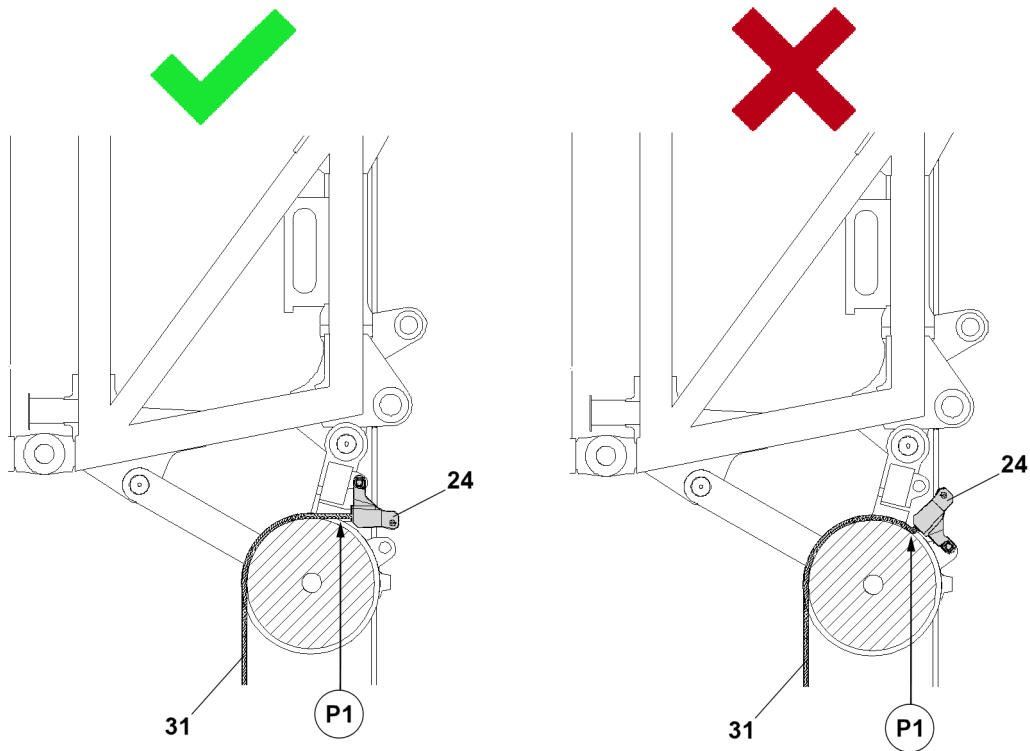

Fig.158794: Example for the correct / wrong use of the rope end connection with an L-shaped rope lock **24**

Make sure that the L-shaped rope lock **24** is used in the correct pin point.

- The pin point must be selected according to the reeving plan.
- The pin point is designed as a fastening point for rope end connections with L-shaped rope lock.
- By using the correct pin point, the bending of the hoist rope **31** in point **P1** prevented.

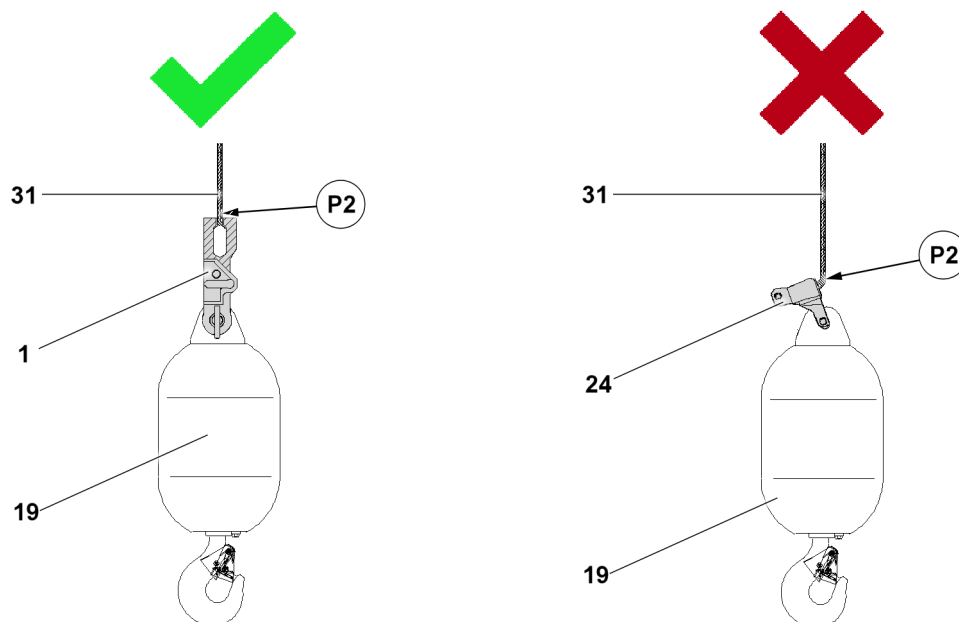

Fig.158795: Example for the correct / wrong use of the rope end connections

Make sure that the L-shaped rope lock **24** is used on the correct component:

- The L-shaped rope lock **24** may only be pinned in an appropriately designed fastening point.
- By using the correct rope end connection on the load hook **19**, in the provided example for the rope lock (standard version) **1**, a bending of the hoist rope **31** in point **P2** is prevented.

1.2.3 Wedge lock

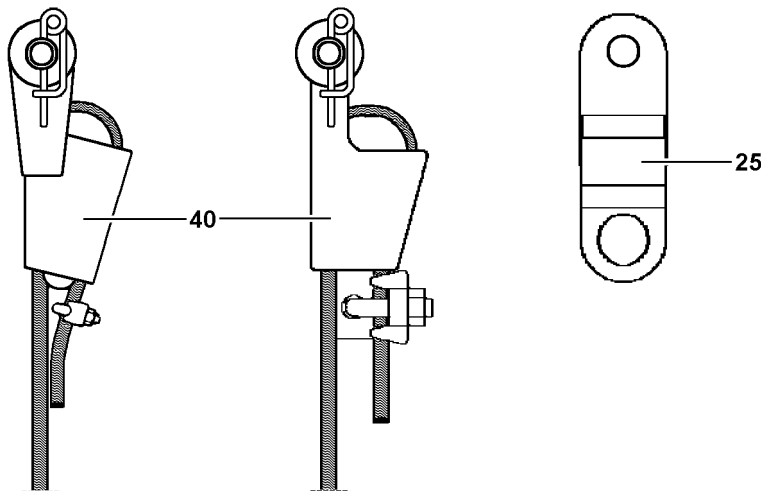

Fig.160486: Wedge locks installed on the rope (rope without locking clamp / locking cast sleeve), adapter* separate

The rope end connection consists of:

- Wedge lock **40**, installed without locking clamp / locking cast sleeve on the rope
Only use them on the conventional fastening points for rope end connections.
Note: Exemplary illustration for possible construction forms.
- Adapter wedge lock **25**, when the pin bore of the wedge lock does not have the required diameter.



Note

- ▶ Observe the section „Assembling / disassembling the wedge lock“.

2 Reeving in the hoist rope



WARNING

Slipping during assembly work!
Danger of falling.

Death, severe injury, property damage.

- ▶ The boom system may only be accessed if assembly personnel is protected with suitable safety measures to prevent them from falling.
- ▶ If safety ropes are present on the boom system, then assembly personnel must connect an approved fall arrest system to the retaining ropes of the boom system on the left and right with both snap hooks and secure themselves to prevent them from falling.
- ▶ Without appropriate safety measures it is **strictly** prohibited to step on the boom system.
- ▶ If railings are present for the crane, then they must be brought into the corresponding position and secured for assembly / disassembly.
- ▶ Carry out all assembly work from a safe location.
- ▶ Observe the assembly guidelines in the Crane operating instructions, chapter 5.01.



WARNING

Danger of accident due to a running rope!

People can be caught due to a turning rope pulley and / or a running rope.

Death, severe bodily injuries, property damage.

- ▶ Adhere to the safety distance from ropes and turning rope pulleys.
- ▶ Do not remain in the danger zone.

**WARNING**

Danger of accident due to uneven spooling during reeving in / reeving out!
The rope can catch components and personnel.
Death, severe bodily injuries, property damage.

- ▶ Spool the winches synchronously.
- ▶ Observe the rope run.
- ▶ Do not remain in the danger zone.

Make sure that the following prerequisites are met:

- The ground is level and of sufficient load bearing capacity.
- **Only for cranes with crane support:** The crane is properly supported.
- The crane is horizontally aligned.
- The slewing gear brake is applied.
- The boom end section is just above the ground.

2.1 Reeving in the hoist rope with the assembly winch

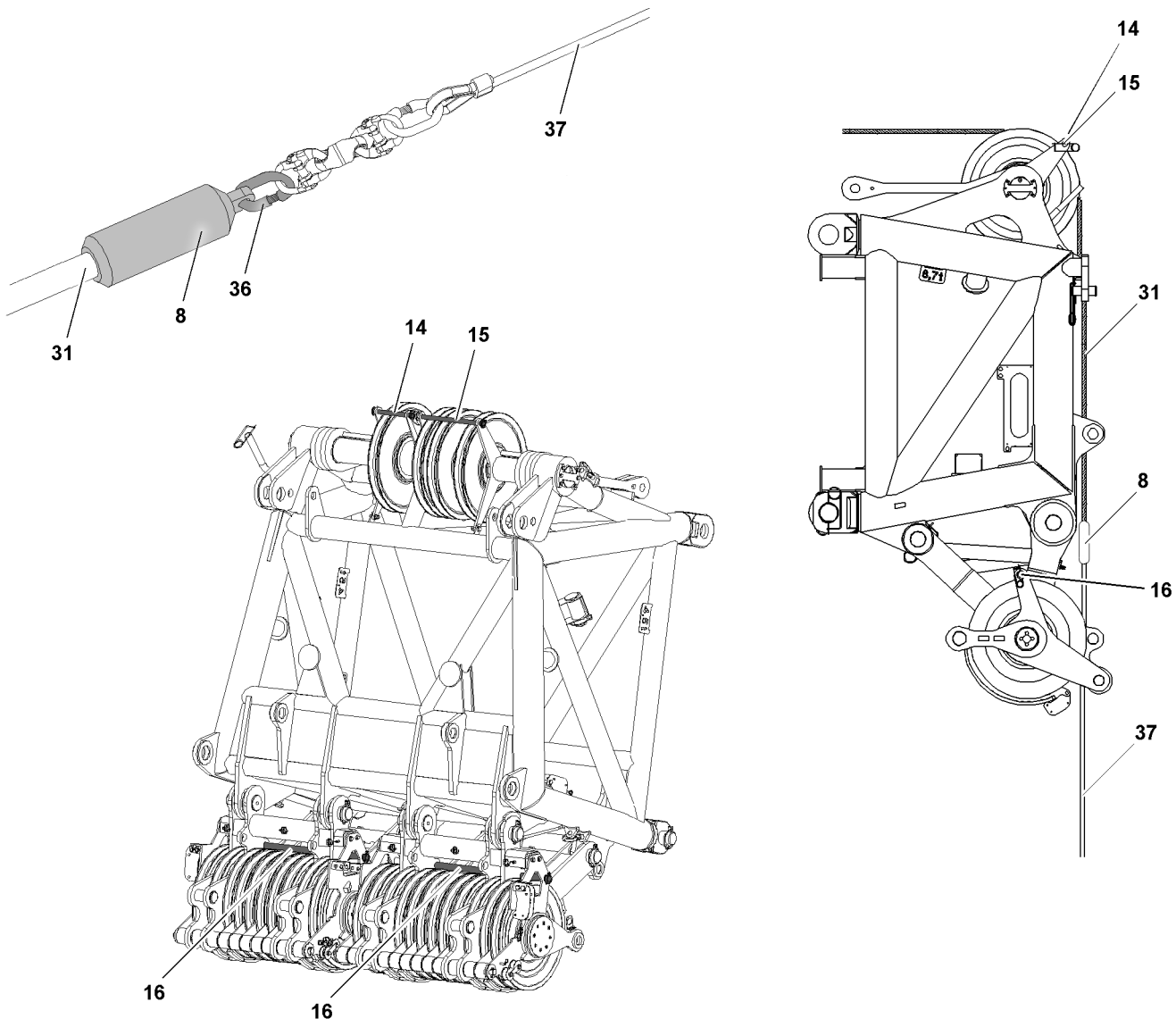

Fig.158792: Reeving in with assembly winch

- ▶ Wear an approved fall arrest system and protective equipment, see the Crane operating instructions, chapter 2.04.

- ▶ Bring the fall protection equipment on the crane superstructure and on the lattice boom in operating position and secure, see Crane operating instructions, chapter 2.06.
- ▶ Properly hang the fall arrest system on the intended safety ropes and / or fastening points.
- ▶ Switch the assembly winch to freewheeling.
- ▶ Remove the rope retaining pin **14**, rope retaining pin **15** and rope retaining pin **16**.
- ▶ Connect the auxiliary rope **37** with the auxiliary reeving rope (hemp rope).
- ▶ Reeve in the auxiliary rope **37** in the reverse direction between the hook block and the pulley head.
- ▶ Bring the auxiliary rope **37** with the auxiliary reeving rope (hemp rope) upward over the back pulley, which is to be reeved in according to the reeving plan.
- ▶ Pull the auxiliary rope **37** to the rear to the hoist winch.
- ▶ Release the auxiliary reeving rope (hemp rope) from the auxiliary rope **37**.

When the auxiliary rope **37** is on the hoist winch:

- ▶ Connect the auxiliary rope **37** with the hoist rope **31**: Open the connecting link **36**, connect it with the eyehook of the locking clamp / locking cast sleeve **8** and close the connecting link **36**.
- ▶ Turn freewheeling off on the assembly winch.

NOTICE

Hoist rope tension too low!

Slack rope formation.

- ▶ Do not permit any slack rope formation on the hoist winch and the assembly winch.

-
- ▶ Reeve the hoist rope **31** in: Spool the hoist rope **31** out from the hoist winch and simultaneously spool up the auxiliary rope **37** on the assembly winch.

When the hoist rope **31** is reeved in:

- ▶ Release the auxiliary rope **37** from the hoist rope **31**.
- ▶ Spool the auxiliary rope **37** up on the assembly winch.
- ▶ Pin and secure the rope retaining pin **14**, rope retaining pin **15** and rope retaining pin **16**.
- ▶ Connect the hoist rope **31** properly to the rope lock, see the following sections.

When the hoist rope **31** is properly connected to the rope lock:

- ▶ Attach the hoist limit switch weight, see the following sections.



Note

Parallel operation of winch 1 and winch 2!

- ▶ Repeat the above described reeving procedure with the second hoist rope.
 - ▶ Observe the reeving plan.
-

3 Reeving in / reeving out the hook block, rope end connection in the standard version

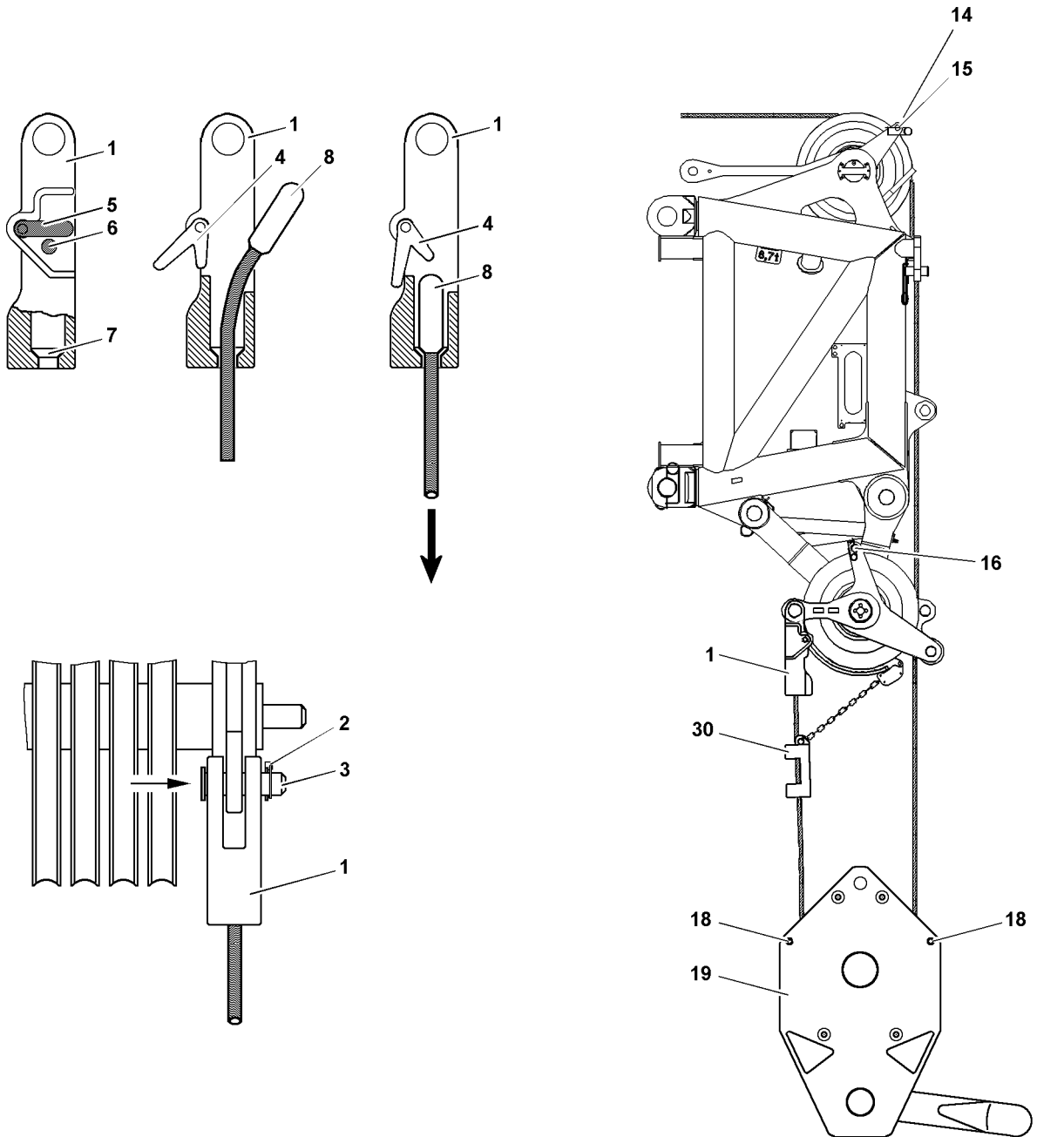

Fig.144024: Detailed view of reeving the hook block in

LWE/LR 13000-001/19503-01-02/en

3.1 Reeving the hook block in



WARNING

Toppling of the hook block!

If the retaining pins are **not** pinned in the roller block / roller blocks of the hook block before putting the hook block down, then the roller blocks / hook block can topple over when reeving out the hoist rope. Death, severe injury, property damage.

- ▶ Insert the retaining pins, see the Crane operating instructions, chapter 5.19 or the separate operating instructions of the hook block.

3.1.1 Preparing the hook block

Make sure that the following prerequisites are met:

- The crane is horizontally aligned.
- The slewing gear brake is applied.
- The hook block is set down on the ground properly.
- The boom is luffed down to the point where the pulley head is above the hook block.
- An assistant is present to guide the hoist rope.



WARNING

Danger of accident due to side wind!

If the slewing gear brake is released after reeving in / reeving out the hook block / load hook, then the crane can turn uncontrolled in strong side wind.

The crane can collide with near-by structures or objects.

Death, severe injury, property damage.

- ▶ Make sure that the current wind speed does not exceed the values from the wind speed chart when releasing the slewing gear brake.

NOTICE

Hook block incorrectly reeved in!

Damage to the hoist rope.

- ▶ Carry out the reeving of the hoist rope according to the reeving plan.
- ▶ Select the rope fixed point on the hook block is in such a way that the last strand runs parallel to the remaining rope strands, as much as possible.
- ▶ Set the required hook block under the boom head.
- ▶ On the hook block **19**, remove the spring retainers **18** for both rope retaining pins and pull them both out.



WARNING

Slipping during assembly work!

Danger of falling.

Death, severe injury, property damage.

- ▶ The boom system may only be accessed if assembly personnel is protected with suitable safety measures to prevent them from falling.
- ▶ If safety ropes are present on the boom system, then assembly personnel must connect an approved fall arrest system to the retaining ropes of the boom system on the left and right with both snap hooks and secure themselves to prevent them from falling.
- ▶ Without appropriate safety measures it is **strictly** prohibited to step on the boom system.
- ▶ If railings are present for the crane, then they must be brought into the corresponding position and secured for assembly / disassembly.
- ▶ Carry out all assembly work from a safe location.
- ▶ Observe the assembly guidelines in the Crane operating instructions, chapter 5.01.

- ▶ Reeve in the hook block.
- ▶ Insert the rope retaining pins again and secure with spring retainers.

3.1.2 Connecting the hoist rope to the rope lock

NOTICE

The hoist rope is incorrectly installed!

Damage to the hoist rope.

- ▶ Always insert the pin **3** from the „inside to the outside“ and secure from the outside.
-
- ▶ The rope lock **1** must be reeved either on the pulley head or on the hook block and secured with locking pins **2**, depending on reeving.
 - ▶ On the rope lock **1**, push in the safety pin **6**.
 - ▶ Swing the lever **5** „down“ and hold it in this position.

Result:

- The locking pawl **4** is swung „downward“.
- ▶ Attach the rope end with the locking clamp / locking cast sleeve **8** in the rope lock **1** and pull „down“ firmly (in direction of arrow), until the locking clamp / locking cast sleeve **8** is touching in the cone **7**.



WARNING

Locking clamp / locking cast sleeve incorrectly installed!

Danger of accident.

Death, severe injuries, property damage.

- ▶ The locking clamp / locking cast sleeve **8** must touch on the cone **7** after connecting it to the rope lock **1** and must be secured by the locking pawl **4**.

- ▶ Release the lever **5**.

Result:

- The lever **5** returns to the initial position and is locked by the safety pin **6**.
- ▶ Check the rope retainer. Visual inspection.

3.2 Reeving the hook block out



WARNING

Toppling of the hook block!

If the retaining pins are **not** pinned in the roller block / roller blocks of the hook block before putting the hook block down, then the roller blocks / hook block can topple over when reeving out the hoist rope.

Death, severe injury, property damage.

- ▶ Insert the retaining pins, see the Crane operating instructions, chapter 5.19 or the separate operating instructions of the hook block.

Make sure that the following prerequisites are met:

- The ground is level and of sufficient load bearing capacity.
- **Only for cranes with crane support:** The crane is properly supported.
- The crane is horizontally aligned.
- The slewing gear brake is applied.
- The boom end section is just above the ground.



WARNING

Danger of accident due to side wind!

If the slewing gear brake is released after reeving in / reeving out the hook block / load hook, then the crane can turn uncontrolled in strong side wind.

The crane can collide with near-by structures or objects.

Personnel can be severely injured or killed.

- ▶ Make sure that the current wind speed does not exceed the values from the wind speed chart when releasing the slewing gear brake.

3.2.1 Lowering the hook block



WARNING

Crushing of hands!

When reeving out the hook block, it can topple over.
Death, severe injury, property damage.

- ▶ Use the handles in the safe area of the hook block.
- ▶ Make sure the hook block is safely positioned.

- ▶ Lower the hook block and place it on the ground.
- ▶ Remove the hoist limit switch weight.

3.2.2 Detaching the hoist rope

- ▶ On the rope lock **1**, push in the safety pin **6**.
- ▶ Swing the lever **5** „down“ and hold it in this position.

Result:

- The locking pawl **4** is swung downward.
- The locking clamp / locking cast sleeve **8** is released.
- ▶ Push the hoist rope up and detach the locking clamp / locking cast sleeve **8**.
- ▶ Release and unpin the rope retaining pin on the hook block.
- ▶ Reeve out the hoist rope from the hook block and the pulley head.
- ▶ Insert the rope retaining pins again and secure with spring retainers.

4 Reeving in / reeving out the hook block, rope end connection with L-shaped rope lock



WARNING

The load can be ripped off!

Death, severe bodily injuries, property damage.

- ▶ The rope end connection with L-shaped rope lock is only permitted for use on appropriately designed fastening points.
- ▶ Make sure that the rope end connection with L-shaped rope lock is only used on appropriately designed fastening points.
- ▶ Do not combine an L-shaped rope lock with other components.

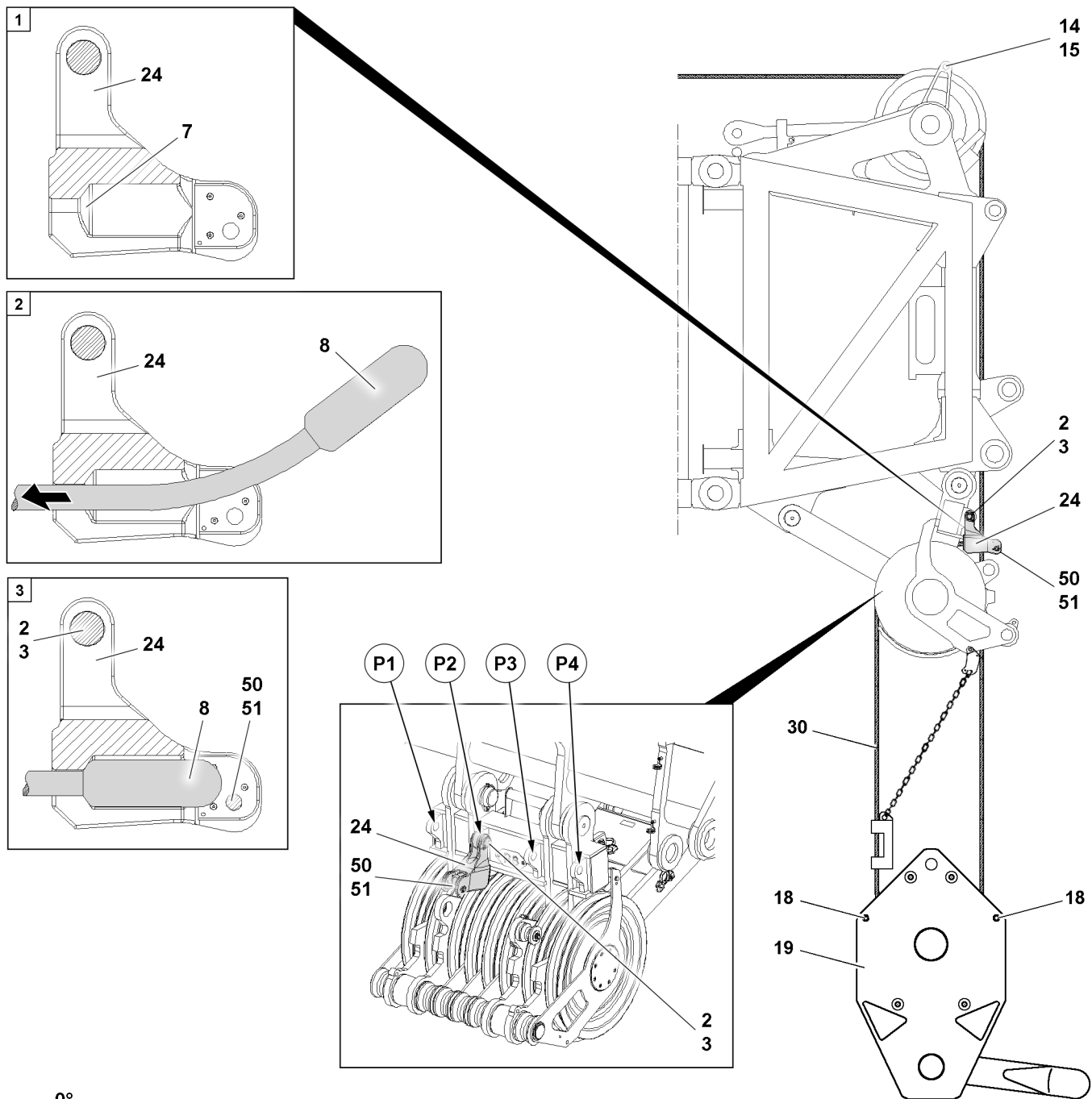

0°

Fig.144022: Detailed view of the hook block reeving, rope end connection with L-shaped rope lock

The rope end connection with L-shaped rope lock **24** must be installed in one of the appropriately designed fastening points (e.g. pin point **P1** to pin point **P4**) on the roller set / sets.

4.1 Reeving the hook block in



WARNING

Toppling of the hook block!

If the retaining pins are **not** pinned in the roller block / roller blocks of the hook block before putting the hook block down, then the roller blocks / hook block can topple over when reeving out the hoist rope. Death, severe injury, property damage.

- ▶ Insert the retaining pins, see the Crane operating instructions, chapter 5.19 or the separate operating instructions of the hook block.

4.1.1 Preparing the hook block

Make sure that the following prerequisites are met:

- The crane is horizontally aligned.
- The slewing gear brake is applied.
- The hook block is set down on the ground properly.
- The boom is luffed down to the point where the pulley head is above the hook block.
- An assistant is present to guide the hoist rope.



WARNING

Danger of accident due to side wind!

If the slewing gear brake is released after reeving in / reeving out the hook block / load hook, then the crane can turn uncontrolled in strong side wind.

Death, severe injury, property damage.

The crane can collide with near-by structures or objects.

- ▶ Make sure that the current wind speed does not exceed the values from the wind speed chart when releasing the slewing gear brake.

NOTICE

Hook block incorrectly reeved in!

Damage to the hoist rope.

- ▶ Carry out the reeving of the hoist rope according to the reeving plan.

If there are no specifications for the rope fixed point on the hook block in the reeving plan:

- ▶ Select the rope fixed point on the hook block is in such a way that the last strand runs parallel to the remaining rope strands, as much as possible.

- ▶ Set the required hook block under the boom head.
- ▶ On the hook block **19**, remove the spring retainers **18** for both rope retaining pins and pull them both out.



WARNING

Slipping during assembly work!

Danger of falling.

Death, severe injury, property damage.

- ▶ The boom system may only be accessed if assembly personnel is protected with suitable safety measures to prevent them from falling.
 - ▶ If safety ropes are present on the boom system, then assembly personnel must connect an approved fall arrest system to the retaining ropes of the boom system on the left and right with both snap hooks and secure themselves to prevent them from falling.
 - ▶ Without appropriate safety measures it is **strictly** prohibited to step on the boom system.
 - ▶ If railings are present for the crane, then they must be brought into the corresponding position and secured for assembly / disassembly.
 - ▶ Carry out all assembly work from a safe location.
 - ▶ Observe the assembly guidelines in the Crane operating instructions, chapter 5.01.
- ▶ Reeve in the hook block.
 - ▶ Insert the rope retaining pins again and secure with spring retainers.

4.1.2 Connecting the hoist rope to the rope lock

NOTICE

The hoist rope is incorrectly installed!

Damage to the hoist rope.

- ▶ Always insert the pin **50** from the „inside to the outside“ and secure from the outside.
- ▶ Pin the rope lock **24** only to the roller set / roller sets and secure with a locking pin **2**.
- ▶ On the rope lock **24**, release and unpin the retaining pin **50**.

- ▶ Attach the rope end with the locking clamp / locking cast sleeve **8** in the rope lock **24** and pull in the direction of arrow, until the locking clamp / locking cast sleeve **8** is touching in the cone **7**.

**WARNING**

Locking clamp / locking cast sleeve incorrectly installed!
Danger of accident.

Death, severe injuries, property damage.

- ▶ The locking clamp / locking cast sleeve **8**, after being connected to the rope lock **24**, must touch the cones **7** and be secured by the retaining pin **50**.
- ▶ Insert the retaining pin **50** and secure properly with the retaining element **51**.
- ▶ Check the rope retainer. Visual inspection.

4.2 Reeving the hook block out

**WARNING**

Toppling of the hook block!

If the retaining pins are **not** pinned in the roller block / roller blocks of the hook block before putting the hook block down, then the roller blocks / hook block can topple over when reeving out the hoist rope.
Death, severe injury, property damage.

- ▶ Insert the retaining pins, see the Crane operating instructions, chapter 5.19 or the separate operating instructions of the hook block.

Make sure that the following prerequisites are met:

- The ground is level and of sufficient load bearing capacity.
- **Only for cranes with crane support:** The crane is properly supported.
- The crane is horizontally aligned.
- The slewing gear brake is applied.
- The boom end section is just above the ground.

**WARNING**

Danger of accident due to side wind!

If the slewing gear brake is released after reeving in / reeving out the hook block / load hook, then the crane can turn uncontrolled in strong side wind.

Personnel can be severely injured or killed.

The crane can collide with near-by structures or objects.

- ▶ Make sure that the current wind speed does not exceed the values from the wind speed chart when releasing the slewing gear brake.

4.2.1 Lowering the hook block

**WARNING**

Crushing of hands!

When reeving out the hook block, it can topple over.

Death, severe injury, property damage.

- ▶ Use the handles in the safe area of the hook block.
- ▶ Make sure the hook block is safely positioned.
- ▶ Lower the hook block and place it on the ground.
- ▶ Remove the hoist limit switch weight.

4.2.2 Detaching the hoist rope

- ▶ On the rope lock **24**, release and unpin the retaining pin **50**.

Result:

- The locking clamp / locking cast sleeve **8** is released.

- ▶ Push the hoist rope forward and detach the locking clamp / locking cast sleeve 8.
- ▶ Release and unpin the rope retaining pin on the hook block.
- ▶ Reeve out the hoist rope from the hook block and the pulley head.
- ▶ Insert the rope retaining pins again and secure with spring retainers.

5 Attaching and removing the load hook*

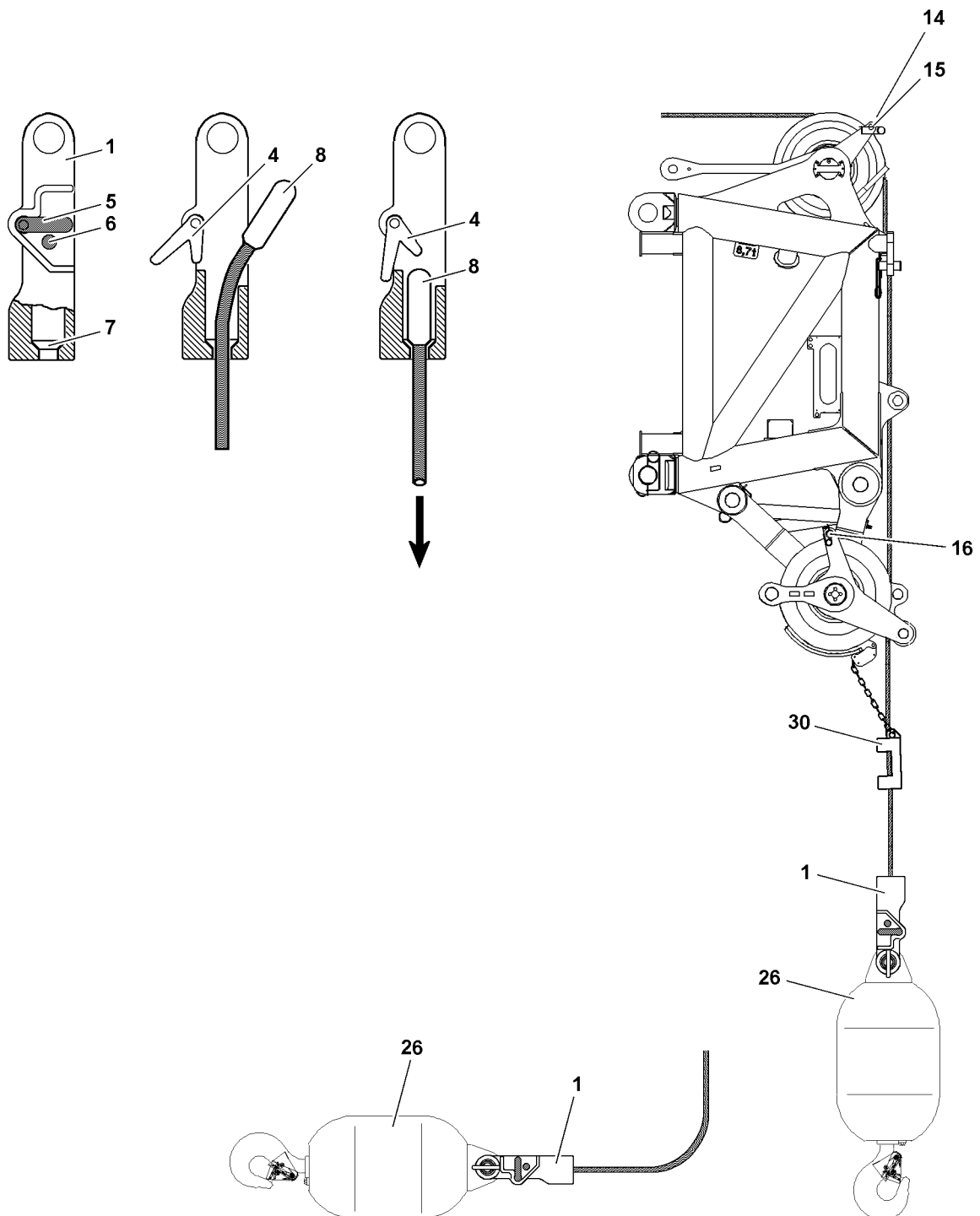

Fig.121854: Load hook fastening

5.1 Fastening the load hook*

5.1.1 Assembling the load hook*

- ▶ Place the load hook under the pulley head of the boom.
- ▶ Release and unpin the rope retaining pins on the back pulley and on the pulley head.



WARNING

Slipping during assembly work!
Danger of falling.

Death, severe injury, property damage.

- ▶ The boom system may only be accessed if assembly personnel is protected with suitable safety measures to prevent them from falling.
- ▶ If safety ropes are present on the boom system, then assembly personnel must connect an approved fall arrest system to the retaining ropes of the boom system on the left and right with both snap hooks and secure themselves to prevent them from falling.
- ▶ Without appropriate safety measures it is **strictly** prohibited to step on the boom system.
- ▶ If railings are present for the crane, then they must be brought into the corresponding position and secured for assembly / disassembly.
- ▶ Carry out all assembly work from a safe location.
- ▶ Observe the assembly guidelines in the Crane operating instructions, chapter 5.01.

- ▶ Place the hoist rope over the back pulley on the boom head.
- ▶ Insert the rope retaining pins again and secure with spring retainers.
- ▶ Pin the rope lock **1** in the load hook **26** and secure with spring retainers.

5.1.2 Connecting the hoist rope

Make sure that the following prerequisites are met:

- The crane is horizontally aligned.
- The slewing gear brake is applied.
- The hook block is set down on the ground properly.
- The boom is luffed down to the point where the pulley head is above the hook block.
- An assistant is present to guide the hoist rope.



WARNING

Danger of accident due to side wind!

If the slewing gear brake is released after reeving in / reeving out the hook block / load hook, then the crane can turn uncontrolled in strong side wind.

Personnel can be severely injured or killed.

The crane can collide with near-by structures or objects.

- ▶ Make sure that the current wind speed does not exceed the values from the wind speed chart when releasing the slewing gear brake.

- ▶ On the rope lock **1**, push in the safety pin **6**.
- ▶ Swing the lever **5** „down“ and hold it in this position.

Result:

- The locking pawl **4** is swung „downward“.
- ▶ Attach the rope end with the locking clamp / locking cast sleeve **8** in the rope lock and pull „down“ firmly (in direction of arrow), until the locking clamp / locking cast sleeve **8** is touching in the cone **7**.



WARNING

Locking clamp / locking cast sleeve incorrectly secured!

Damage to the locking clamp / locking cast sleeve.

Death, severe injuries, property damage

- ▶ The locking clamp / locking cast sleeve **8** must touch on the cone **7** after connecting it to the rope lock **1** and must be secured by the locking pawl **4**.

- ▶ Release the lever **5**.

Result:

- The lever **5** returns to the initial position and is locked by the safety pin **6**.

5.2 Removing the load hook*

Make sure that the following prerequisites are met:

- The ground is level and of sufficient load bearing capacity.
- **Only for cranes with crane support:** The crane is properly supported.
- The crane is horizontally aligned.
- The slewing gear brake is applied.
- The load hook is prepared for assembly.
- An assistant is present to guide the hoist rope.

5.2.1 Lowering the load hook



WARNING

Crushing of hands!

When reeving out the hook block, it can topple over.

Death, severe injury, property damage.

- ▶ Use the handles in the safe area of the hook block.
 - ▶ Make sure the hook block is safely positioned.
-
- ▶ Take the load hook **26** down on the ground.
 - ▶ Remove the hoist limit switch weight.

5.2.2 Detaching the hoist rope



WARNING

Danger of accident due to side wind!

If the slewing gear brake is released after reeving in / reeving out the hook block / load hook, then the crane can turn uncontrolled in strong side wind.

Death, severe injury, property damage.

The crane can collide with near-by structures or objects.

- ▶ Make sure that the current wind speed does not exceed the values from the wind speed chart when releasing the slewing gear brake.
-
- ▶ On the rope lock **1**, push in the safety pin **6**.
 - ▶ Swing the lever **5** „down“ and hold it in this position.

Result:

- The locking pawl **4** is swung „downward“.
 - The locking clamp / locking cast sleeve **8** is released.
- ▶ Push the hoist rope in the direction of the load hook and detach the locking clamp / locking cast sleeve **8**.
 - ▶ Remove the rope retaining pins on the pulley head and on the back pulley.
 - ▶ Lift the hoist rope from the rope pulleys.
 - ▶ Insert the rope retaining pins again and secure with spring retainers.

6 Two-part hoist limit switch weight

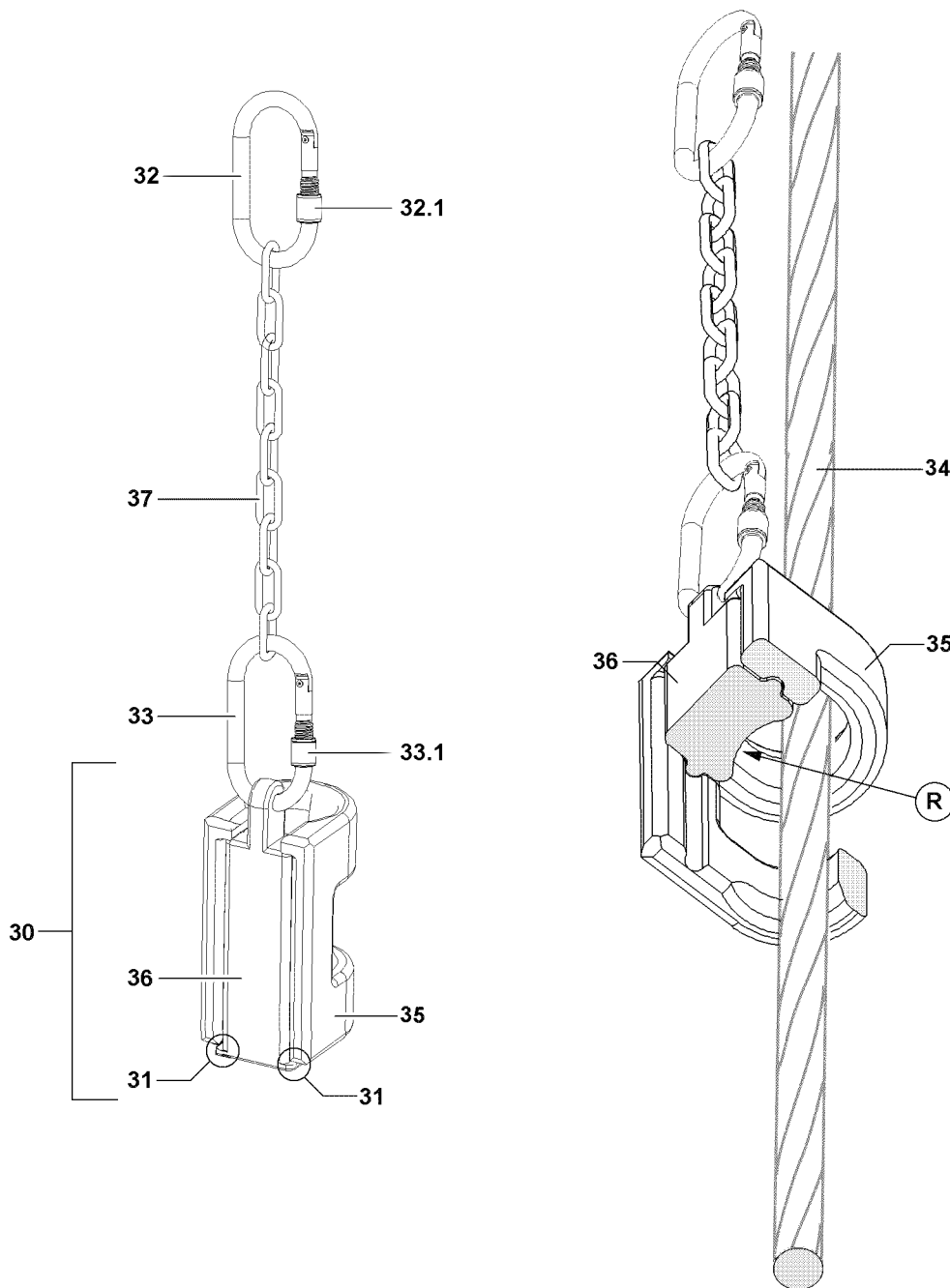

Fig.156691: Detailed view of the hoist limit switch weight

The hoist limit switch weight is connected to the hoist limit switch. By connecting the hoist limit switch weight **30** to the hoist limit switch, the *Spool winch up* crane movement is released. As soon as the hoist limit switch weight **30** is lifted, the hoist limit switch switches off the *Spool winch up* crane movement.

The following parts are required:

- **30** Hoist limit switch weight
- **32** Upper carabiner
- **33** Lower carabiner
- **37** Chain

The hoist limit switch weight **30** consists of two parts, which are pushed into each other:

- The weight **35**

- The carrier section **36**

**WARNING**

Incorrect parts installed!

The crane movement is **not** switched off or is switched off too late.

Death, severe bodily injuries, property damage.

- ▶ Do **not** replace the hoist limit switch weight **30**, carabiner and chain **37** with other parts.

The chain **37** must be attached with its full length during crane operation and may not be shortened.

**WARNING**

Chain **37** shortened!

The crane movement is **not** switched off or is switched off too late.

Death, severe bodily injuries, property damage.

- ▶ Do **not** shorten the chain **37**.

6.1 Attaching the hoist limit switch weight

**WARNING**

Hoist limit switch weight is incorrectly installed!

The hoist limit switch weight can fall down. Death, severe injuries.

- ▶ When detaching or attaching the hoist limit switch weight **30** make sure that the weight **35** and the carrier section **36** do not fall down.
- ▶ Make sure that the curvature **R** of the carrier section **36** points to the hoist rope **34**.
- ▶ Make sure that the noses **31** of the carrier section **36** is placed on the weight **35**.

**WARNING**

Knurled nut installed closing upward!

The carabiner could loosen up itself by itself. The hoist limit switch weight **30** can fall down.

Death or severe bodily injuries.

- ▶ **Assemble the knurled nut closing downward.**

- ▶ Connect the chain **37** to the upper carabiner **32** on the hoist limit switch.

- ▶ Secure the upper carabiner **32** with the knurled nut **32.1**.

The attachment of the hoist limit switch weight **30** depends on the position of the rope fixed point.

Rope fixed point on the pulley head:

- In the event of multiple hoist rope reeving, the hoist limit switch weight **30** must always be laid around the „stationary rope strand“, in other words around the rope strand that leads directly to the cable lock.

Rope fixed point on the hook block:

- The hoist limit switch weight **30** is laid around the outer strand that has the least angular pull, i.e. the one with the smallest angle between the connected hoist limit switch weight and the hoist rope.
 - ▶ Release and unscrew the knurled nut **33.1** from the lower carabiner **33**.
 - ▶ Push the weight **35** with one hand on the hoist rope **34** and hold.
 - ▶ With the other hand, guide the carrier section **36** behind the hoist rope **34** and under the weight **35**. The curvature **R** of the carrier section **36** must point to the hoist rope **34**.
 - ▶ Push the weight **35** on the carrier section **36**.
 - ▶ Fit the hoist limit switch weight **30** with the carrier section **36** in the lower carabiner **33**.
 - ▶ Secure the lower carabiner **33** with the knurled nut **33.1**.

6.2 Removing the hoist limit switch weight

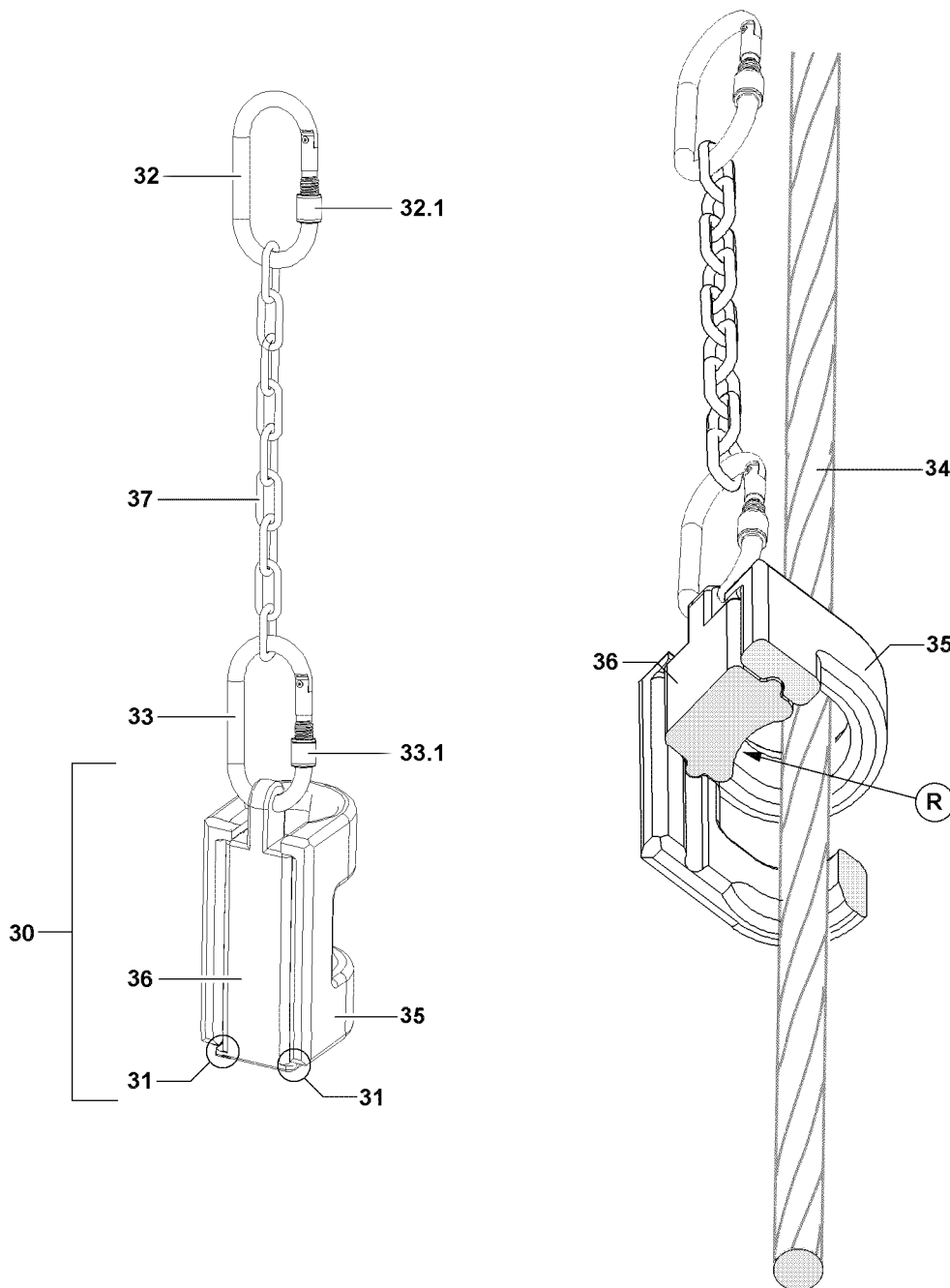

Fig.156691: Detailed view of the hoist limit switch weight



WARNING

Hoist limit switch weight is incorrectly installed!
The hoist limit switch weight can fall down. Death, severe injuries.

- ▶ When detaching or attaching the hoist limit switch weight **30** make sure that the weight **35** and the carrier section **36** do not fall down.
 - ▶ It is prohibited to remain in the danger zone.
-
- ▶ Release and unscrew the knurled nut **33.1** on the lower carabiner **33**.
 - ▶ Detach the hoist limit switch weight **30** from the lower carabiner **33**.
 - ▶ Hold the weight **35** with one hand and with the other hand, push the carrier section **36** out of the weight **35**.

- ▶ Remove the chain **37** with the upper carabiner **32** on the hoist limit switch.
- ▶ Store the weight **35**, carrier section **36** and chain **37** with the carabiner safely.

7 One-part hoist limit switch weight

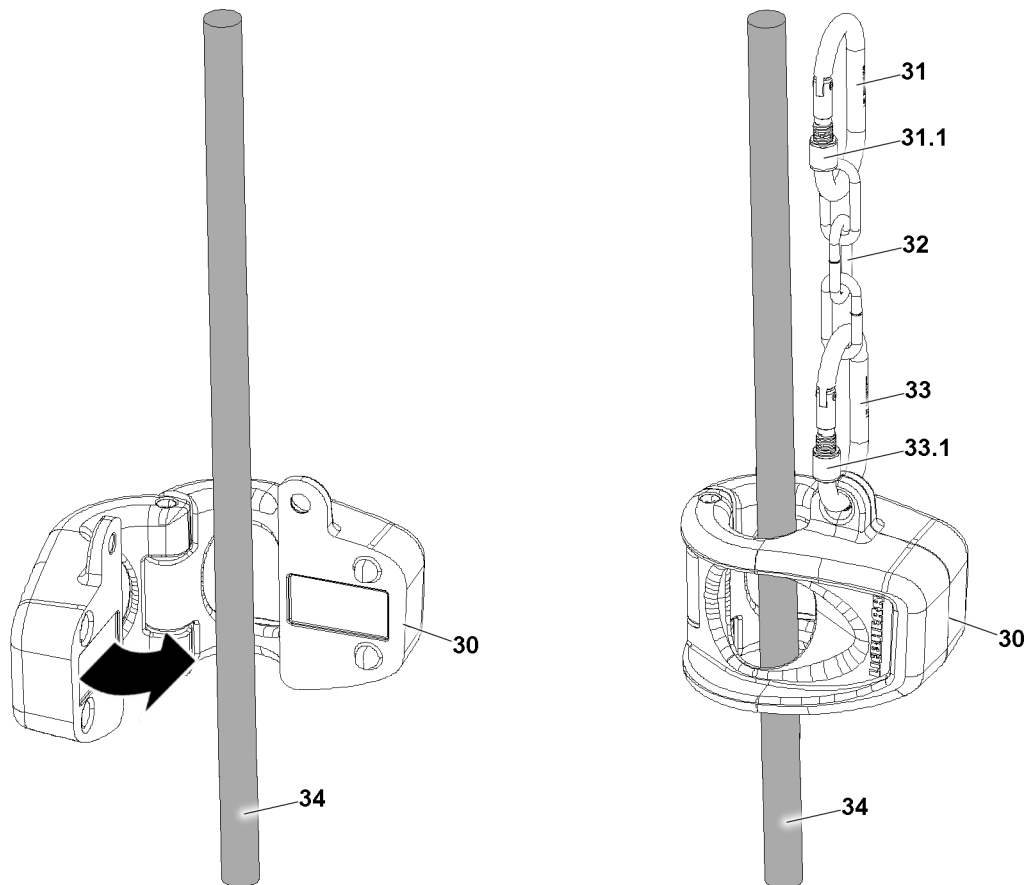

Fig.127727: Hoist limit switch weight

The hoist limit switch weight is connected to the hoist limit switch. By connecting the hoist limit switch weight **30** to the hoist limit switch, the crane movement *Spool winch up* is released. As soon as the hoist limit switch weight **30** is lifted, the hoist limit switch switches off the *Spool winch up* crane movement.

The following parts are required:

- **30** Hoist limit switch weight
- **31** Upper carabiner
- **32** Chain
- **33** Lower carabiner



WARNING

Incorrect parts installed!

The crane movement is **not** switched off or is switched off too late.

Death, severe bodily injuries, property damage.

- ▶ Do **not** replace the hoist limit switch weight **30**, carabiner and chain **32** with other parts.

The chain **32** must be attached with its full length during crane operation and may not be shortened.

**WARNING**

Chain **32** shortened!

The crane movement is **not** switched off or is switched off too late.
Death, severe bodily injuries, property damage.

- ▶ Do **not** shorten the chain **32**.

7.1 Attaching the hoist limit switch weight

**WARNING**

Hoist limit switch weight is incorrectly installed!

The hoist limit switch weight can fall down.
Death or severe bodily injuries.

- ▶ Makes sure that the hoist limit switch weight **30**, carabiner and chain **32** do not scrape against the hoist rope **34** after assembly.
- ▶ Do **not** let the hoist limit switch weight **30** fall down.

**WARNING**

Knurled nut installed closing upward!

The carabiner could loosen up itself by itself. The hoist limit switch weight **30** can fall down.
Death or severe bodily injuries.

- ▶ **Assemble the knurled nut closing downward.**

- ▶ Connect the chain **32** to the upper carabiner **31** on the hoist limit switch.
- ▶ Secure the upper carabiner **31** with the knurled nut **31.1**.

The attachment of the hoist limit switch weight **30** depends on the position of the rope fixed point.

Rope fixed point on the pulley head:

- In the event of multiple hoist rope reeving, the hoist limit switch weight **30** must always be laid around the „stationary rope strand“, in other words around the rope strand that leads directly to the cable lock.

Rope fixed point on the hook block:

- The hoist limit switch weight **30** is laid around the outer strand that has the least angular pull, i.e. the one with the smallest angle between the connected hoist limit switch weight **30** and the hoist rope **34**.
- ▶ Place the hoist limit switch weight **30** around the hoist rope **34**.
- ▶ Close the hoist limit switch weight **30**.
- ▶ Connect the chain **32** to the lower carabiner **33** on the hoist limit switch weight **30**.
- ▶ Secure the lower carabiner **33** with the knurled nut **33.1**.

Result:

- The hoist limit switch weight **30** is assembled and secured.

7.2 Removing the hoist limit switch weight

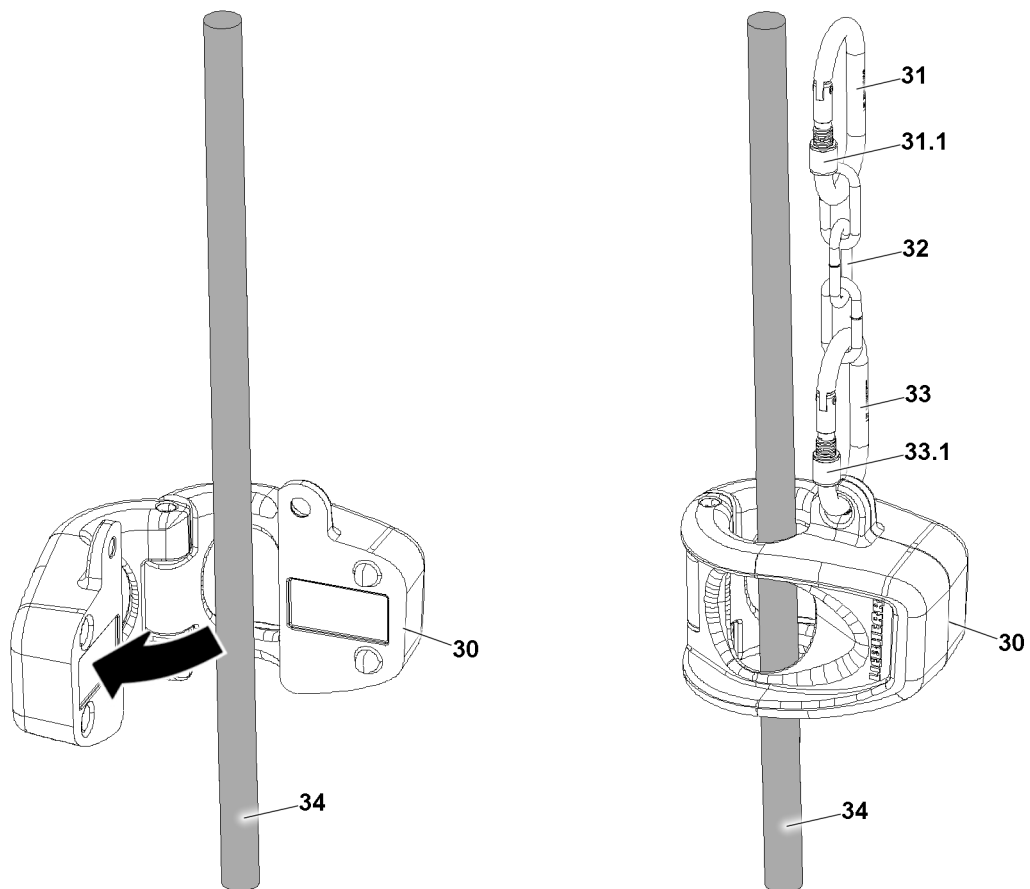

Fig.127728: Removing the hoist limit switch weight



WARNING

Hoist limit switch weight **not** secured during disassembly!
The hoist limit switch weight can fall down.

▶ Do **not** let the hoist limit switch weight **30** fall down during disassembly.

- ▶ Release and unscrew the knurled nut **33.1** on the lower carabiner **33**.
- ▶ Hold the hoist limit switch weight **30** with one hand and with the other hand, disconnect the lower carabiner **33** on the hoist limit switch weight **30**.
- ▶ Remove the chain **32** with the upper carabiner **31** on the hoist limit switch.
- ▶ Store the hoist limit switch weight **30**, chain **32** with the carabiner **31** and carabiner **33** safely.

8 Assembling / disassembling the wedge lock

Liebherr-Werk Ehingen GmbH does not have any safety concerns regarding the use of a wedge lock as a replacement for the lock. The wedge lock must be released by Liebherr-Werk Ehingen GmbH for use on the corresponding rope type. However, when using a wedge lock in connection with rotation-resistant hoist ropes, they do not have some of the positive characteristics of the lock, which can lead to a reduced service life of the rope. If a wedge lock is disassembled and then assembled again on the rope, the previously clamped part of the rope must first be cut off.

The utilized wedge lock can only be installed and assembled by authorized and trained personnel.

Make sure that the following prerequisites are met:

- The wedge lock is released for the rope diameter and rope type.
- The lock clamp / locking case sleeve has been properly disconnected.

8.1 Safety



DANGER

The rope is not suitable for the wedge lock!

If an unsuitable rope is used with a wedge lock as an end connection, the end connection will fail and lead to breakage.

- ▶ Do not provide unsuitable ropes, such as fiber ropes, plastic coated ropes or spiral ropes, with a wedge lock as an end connection.
- ▶ Only provide suitable wire ropes with a wedge lock as an end connection.
- ▶ The wedge lock must be released by Liebherr-Werk Ehingen GmbH for use on the corresponding rope type.
- ▶ The wire rope diameter must match the wedge lock.
- ▶ In case of lack of clarity, contact Liebherr Service.



WARNING

Faulty assembly / disassembly of a wedge lock!

- ▶ The utilized wedge lock can only be installed, assembled and disassembled by authorized and trained personnel.
- ▶ Wear protective clothing.
- ▶ In case of lack of clarity, contact Liebherr Service.



WARNING

Wrong components on the wedge lock!

If the housing and wedge do not match, a correct end connection with the wedge lock is not possible. Incorrect components on the wedge lock can lead to the failure of the end connection and to breakage.

- ▶ Only use housing with an appropriate wedge.
- ▶ Keep all components of the wedge lock so that they can't be mixed up.
- ▶ If there are uncertainties regarding the composition of the wedge lock, the wedge lock may not be used.
- ▶ Only use the wedge lock with unchanged original components.



WARNING

Damaged wedge lock!

The use of a damaged wedge lock can lead to the failure of the end connection and to breakage.

- ▶ Check all components for damage prior to assembly.
- ▶ A wedge lock with damaged components may not be installed or used.
- ▶ Do not use a wedge lock with an illegible manufacturer's mark or nominal size.



WARNING

Reuse of a jammed area!

If a rope is used a second time in the same position with a wedge lock, the end connection will fail and lead to breakage.

If a rope in a previously jammed area is provided with a locking clamp or locking cast sleeve, the end connection can fail and lead to breakage.

- ▶ Do not use the previously jammed area of the rope again and cut it off completely.

**WARNING**

Unsuitable position for attaching a wedge lock!

If a wedge lock is installed in an unsuitable position of the rope, the end connection can fail and lead to breakage.

- ▶ Pressure marks in the clamping area on the rope and wedge lock can lead to the failure of the wedge lock.
- ▶ The wedge lock may not be clamped on an annealing separated area or a trimming of the rope.
- ▶ The surface of the clamping area on the rope and wedge lock must be free of dirt and rust.
- ▶ The clamping area may not have rope breakage.

**WARNING**

The wedge lock releases!

If there is a collision on the side of the dead rope side while using the wedge lock, the wedge lock can release.

- ▶ Secure the wedge lock against collisions.
- ▶ Do not let the dead rope end stick out such that it rises or can get caught. Secure the dead rope end with a soft tie with tape or a soft binding wire.
- ▶ Stop the spool up movements of the winch before the wedge runs against the hoist limit switch weight.

**WARNING**

The rope end turns up!

If the rope end turns up, the rope can slide through the wedge lock. The end connection can fail and lead to breakage.

- ▶ Secure the rope end against untwisting and jumping up, for example injecting, welding or soldering.
- ▶ Comply with the specified length of the dead rope end.

NOTICE

The rope jumps up when shortening!

If the rope is not secured against jumping up when shortened, the rope can be damaged and become unusable.

- ▶ Secure the rope against jumping up and untwisting before shortening.

**Note**

Rope too short.

In the case of fixed rope lengths, pay attention to further usability after shortening.

- ▶ Each use of a wedge lock makes a section of the rope unusable.
- ▶ Do not replace missing wedge locks / locking case sleeves too often with a wedge lock.
- ▶ Contact Liebherr Customer Service for a proper rope repair with a locking cast sleeve.

**Note**

Minimum tensile strength of the rope decreased.

The minimum tensile strength of the rope is reduced 80 % by an end connection with a wedge lock.

- ▶ This reduction is permitted on an otherwise intact rope if the wedge lock is used correctly.

8.2 Nominal dimensions when assembling the wedge lock

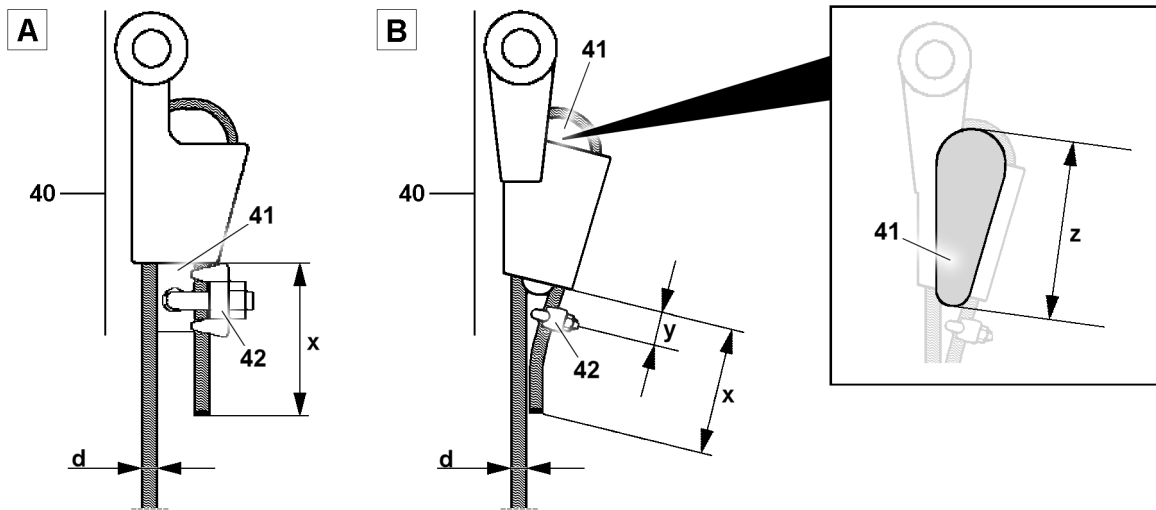

Fig.160488: Exemplary presentation of wedge locks

40	Wedge lock	x	Dead rope end length
41	Wedge	y	Distance
42	Clamp	z	Wedge length
d	Rope diameter		

- Variation **A**, Wedge lock **40** with bore for a Clamp **42** in the wedge **41**
- Variation **B**, wedge lock **40** without a bore for a clamp **42** in the wedge **41**

► Provide the long dead rope end **x** with the twentyfold rope diameter **d**. With a small rope diameter **d** not less than 150 mm.

For wedge locks **without** a bore for a clamp **42** in the wedge **41** (see variation **B**) additionally:

► Distance **y** from the rope clamp to the housing with the double rope diameter **d**. When doing so, do not exceed 75% of the wedge length **z**.



WARNING

Nominal dimensions when assembling the wedge lock not complied with!
The end connection can fail and lead to breakage.

► Comply with the specified length **x**.

With a wedge lock **40** **without** a bore for a clamp **42** additionally:

► Observe the specified distance **y**.

► Mark the dead rope end length **x** and distance **y** on the rope.

8.3 General notes for assembly

Observe the differences in the exemplary illustrations:

- Wedge lock **with** a bore for a clamp
- Wedge lock **without** a bore for a clamp

8.3.1 Wedge lock with a bore for a clamp

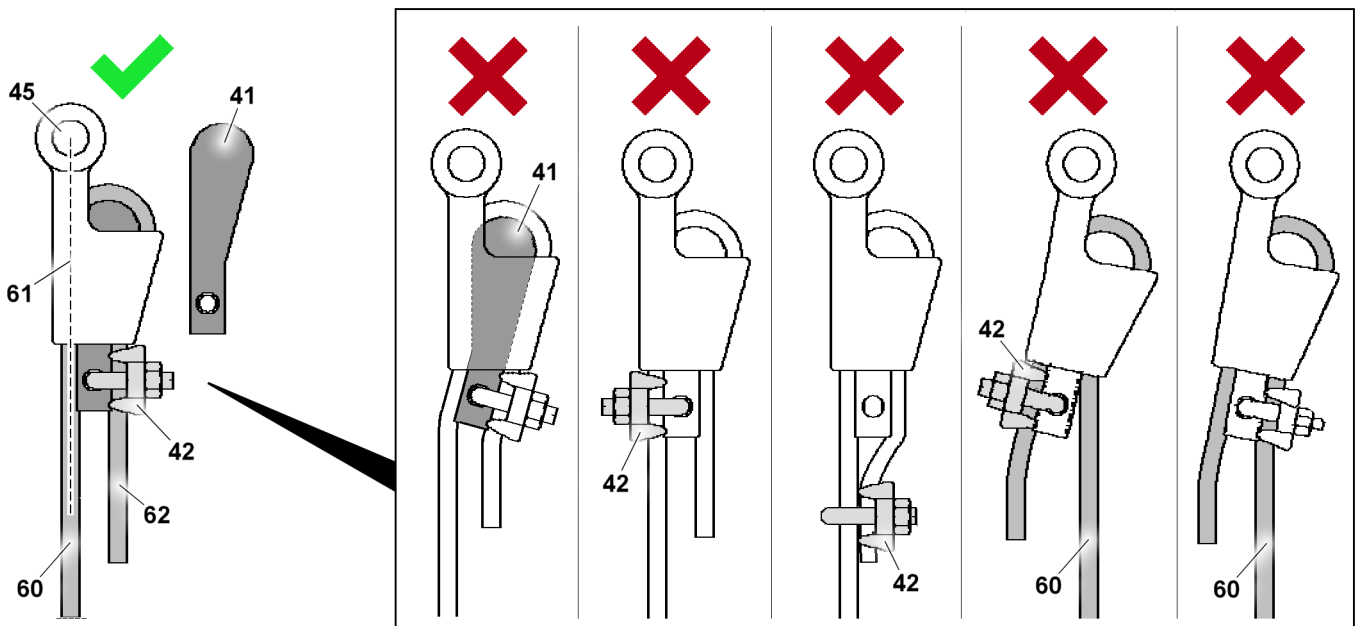

Fig.160493: Exemplary illustration with a correctly and incorrectly assembled wedge lock **with** a bore for a clamp

- 41 Wedge
- 42 Clamp
- 45 Pin bore
- 60 Rope strand, load bearing
- 61 Pull axle
- 62 Dead rope end

- Assemble the wedge **41** in the correct position. Position the wide side with a radius in the direction of the pin bore **45**. Position the long straight side toward the pull axle **61**.
- Assemble the clamp **42** in the correct position with the correct tightening torque. Screw the clamp on via the dead rope end **62** through the wedge bore.
- Run the load bearing rope strand **60** in the pull axle **61** of the wedge lock. The long axis of the load bearing rope strand **60** is perpendicular to the long axis of the pin bore **45**.

Diameter Rope	Nominal size Clamp size	Tightening torque Clamp ¹⁾
9 mm to 10 mm	3/8	61 Nm
11 mm to 13 mm	1/2	88 Nm
14 mm to 16 mm	5/8	129 Nm
18 mm to 19 mm	3/4	176 Nm
20 mm to 22 mm	7/8	305 Nm
24 mm to 26 mm	1	305 Nm
28 mm	1 1/8	305 Nm

1) Threads and support surfaces are clean, dry and free of lubricants.

Control bore auxiliary function*



Note

- ▶ Only for wedge locks with control bore auxiliary function*.

LWE/LR 13000-001/19503-01-02/en

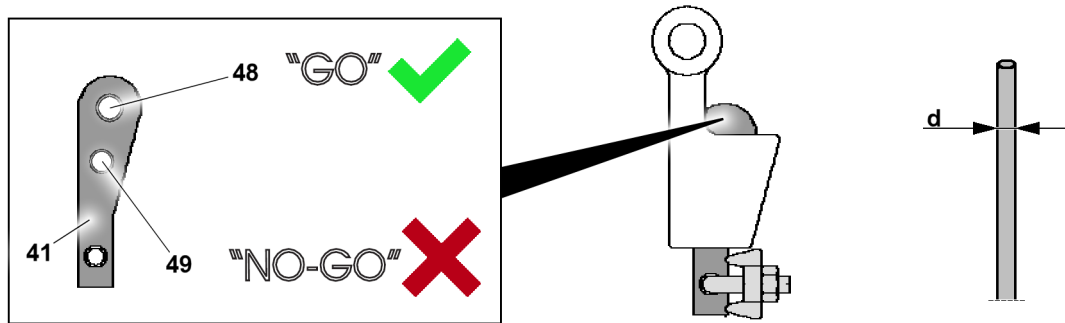

Fig.160497: Wedge lock with control bore auxiliary function*.

41	Wedge	49	Bore "NO-GO"
48	Bore "GO"	d	Rope diameter

The wedge and rope diameter d match when all of the following criteria are met:

- The rope diameter d passes through the bore "GO" 48.
- The rope diameter d does **not** pass through the bore "NO-GO" 49.

8.3.2 Wedge lock without a bore for a clamp

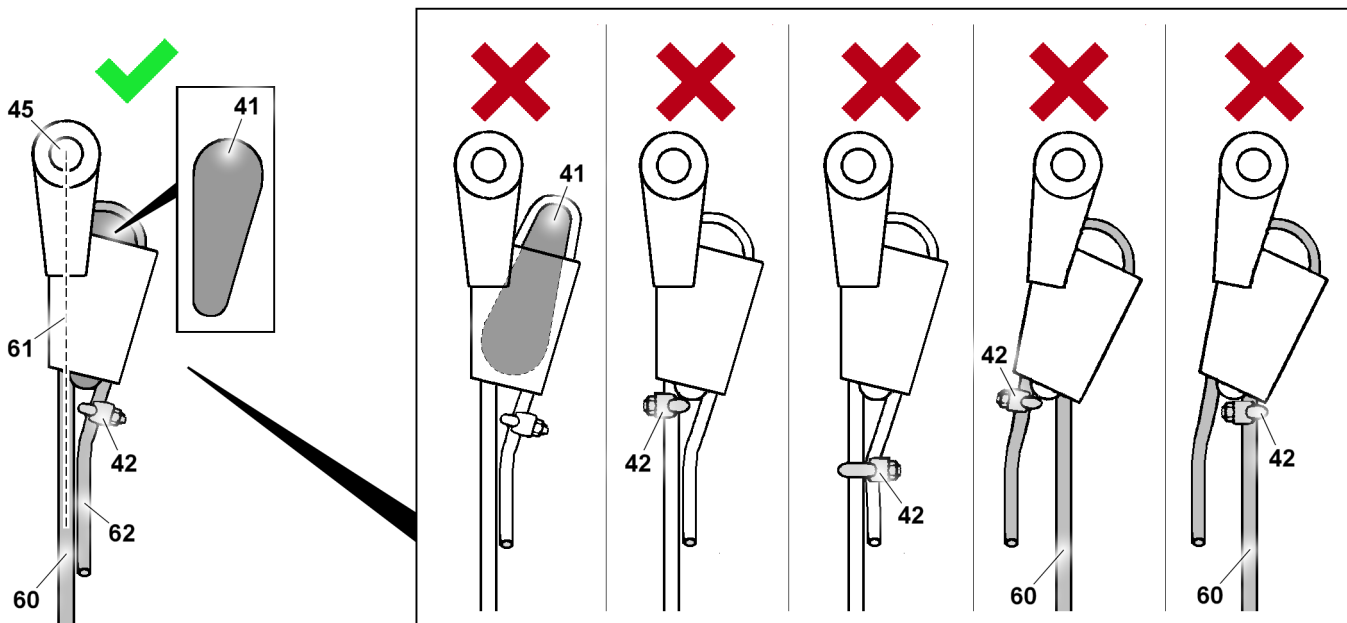

Fig.160492: Exemplary illustration with a correctly and incorrectly assembled wedge lock **without** a bore for a clamp

41	Wedge	45	Pin bore	61	Pull axle
42	Clamp	60	Rope strand, load bearing	62	Dead rope end

- Assemble the wedge 41 in the correct position. The wide side with a radius must point in the direction of the pin bore 45.
- Assemble the clamp 42 in the correct position with the correct tightening torque. Screw on with the correct distance over the dead rope end 62.
- Run the load bearing rope strand 60 in the pull axle 61 of the wedge lock. The long axis of the load bearing rope is perpendicular to the long axis of the pin bore 45.

Nominal size Wedge lock / wedge	Nominal size Clamp	Tightening torque Clamp ¹⁾
8/7	8	6 Nm
8/8	8	6 Nm
10/9	10	9 Nm
10/10	10	9 Nm
13/11	12	20 Nm
13/12	12	20 Nm
13/13	14	33 Nm
17/13	14	33 Nm
17/15	16	49 Nm
17/17	16	49 Nm
19/16	16	49 Nm
19/18	19	68 Nm
23/19	19	68 Nm
23/21	22	107 Nm
26/23	26	147 Nm
26/25	26	147 Nm
29/27	30	212 Nm
33/30	30	212 Nm
33/32	34	296 Nm

1) Threads and support surfaces are lubricated, rust-free and clean.

8.4 Assembling the wedge lock

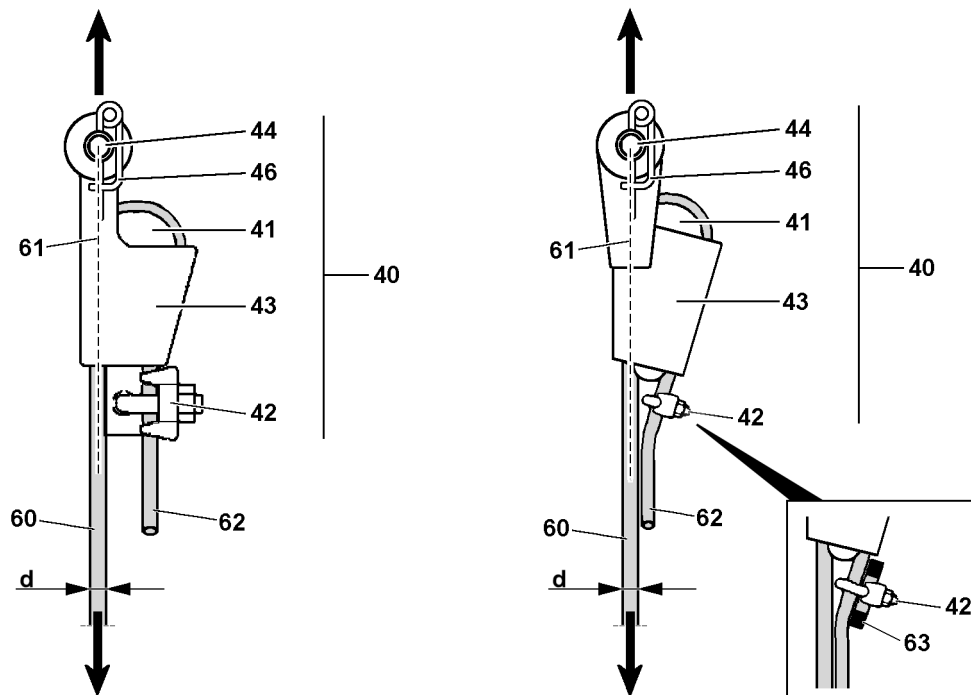

Fig.160494: Exemplary presentation, assembling the wedge lock

40	Wedge lock	60	Rope strand, load bearing
41	Wedge	61	Pull axle
42	Clamp	62	Dead rope end
43	Housing	63	Rope section
44	Pin	d	Rope diameter
46	Retaining element		



WARNING

Incorrect handling of the wedge lock!

An incorrectly or incompletely assembled wedge lock **40** can lead to an inadvertent releasing of the end connection.

An incorrectly used wedge lock **40** can lead to failure and an inadvertent releasing of the end connection.

The crane can lose stability! Persons in the danger zone are greatly endangered.

Hook blocks, load or components can fall down. Death, severe injuries, property damage.

- ▶ Use only a wedge lock **40** approved by Liebherr-Werk Ehingen GmbH.
- ▶ The wedge lock **40** must match the rope diameter.
- ▶ Do not use a wedge lock **40** with an operation temperature of below $-40\text{ }^{\circ}\text{C}$.
- ▶ Assemble the wedge lock **40** correctly.
- ▶ Place the rope with the wedge **41** into the housing **43** in such a way that the load bearing rope strand **60** runs in the pull axle **61** of the wedge lock **40**.
- ▶ Install the wedge **41** in the correct position.
- ▶ The clamp **42** must secure the dead rope end **62** from being pulled through.
- ▶ The clamp **42** must be tightened with the correct tightening torque.
- ▶ The clamp **42** may not be assembled on a trimming or an annealing separated area of the dead rope end **62**.
- ▶ The clamp **42** may not be assembled over both strands or on the load bearing rope strand **60**.
- ▶ The support surfaces of the clamp **42** must be rust-free and clean.
- ▶ When assembling the dead rope end **62**, secure it from jumping out of the housing **43**.
- ▶ Wear protective clothing.
- ▶ It is prohibited for personnel to remain in the danger zone.

- ▶ Select the matching wedge lock **40** for the rope diameter **d**.
- ▶ Observe the nominal dimensions when assembling the wedge lock.
- ▶ Insert the rope with the wedge **41** in the housing **43**. Observe the dead rope end length **62**

**Note**

- ▶ If applicable, insert the rope and wedge deeper into the housing by striking them carefully with a rubber hammer.

Assemble the clamp **42** depending on the wedge lock **40** version:

- ▶ Assemble the clamp **42** through the bore in the wedge **41** on the dead rope end **62**.
- or
- ▶ Assemble the clamp **42** with the specified distance from the housing **43** on the dead rope end **62**.

**Note**

- ▶ If the thread length of the clamp **42** is not sufficient, place a short, intact rope section **63** with tied ends parallel to the dead rope end **62** and assemble them together.
- ▶ The tightening torque for the clamp **42** depends on the nominal size.

NOTICE

Rope damage!

If the pin **44** has been assembled incorrectly, the rope may rub against the pin **44** or on the retaining element **46**.

- ▶ Always insert the pin **44** from the „inside to the outside“ and secure from the outside with a retaining element **46**.

When the pin point of the wedge lock **40** matches the fixed point:

- ▶ Pin and secure the wedge lock **40** in the fixed point depending on the reeving plan.

When the pin point of the wedge lock **40** does not match the fixed point:

- ▶ Use the supplied adapter, see the following section „Assembling / disassembling the adapter on the wedge lock“.

8.5 Additional work

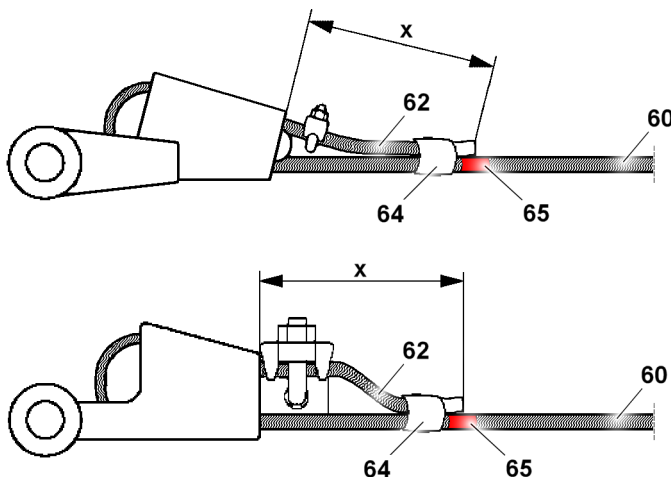

Fig.163420: Additional work: Applying the tie and marking

- | | |
|-------------------------------------|-------------------------------|
| 60 Rope strand, load bearing | 65 Color marking |
| 62 Dead rope end | x Dead rope end length |
| 64 Tie | |

- ▶ Also secure the dead rope end **62** with a soft tie **64** with tape or a soft binding wire.

- ▶ Permanently and clearly mark the dead rope end length **x**. Apply the color marking **65** on the load bearing rope strand **60** at the same height, see illustration.

**Note**

Use a well-visible signal color for the color marking **65**.

- ▶ The color marking **65** can be used to continuously identify the dead rope end length **x**.

8.6 Assembling / disassembling the adapter on the wedge lock

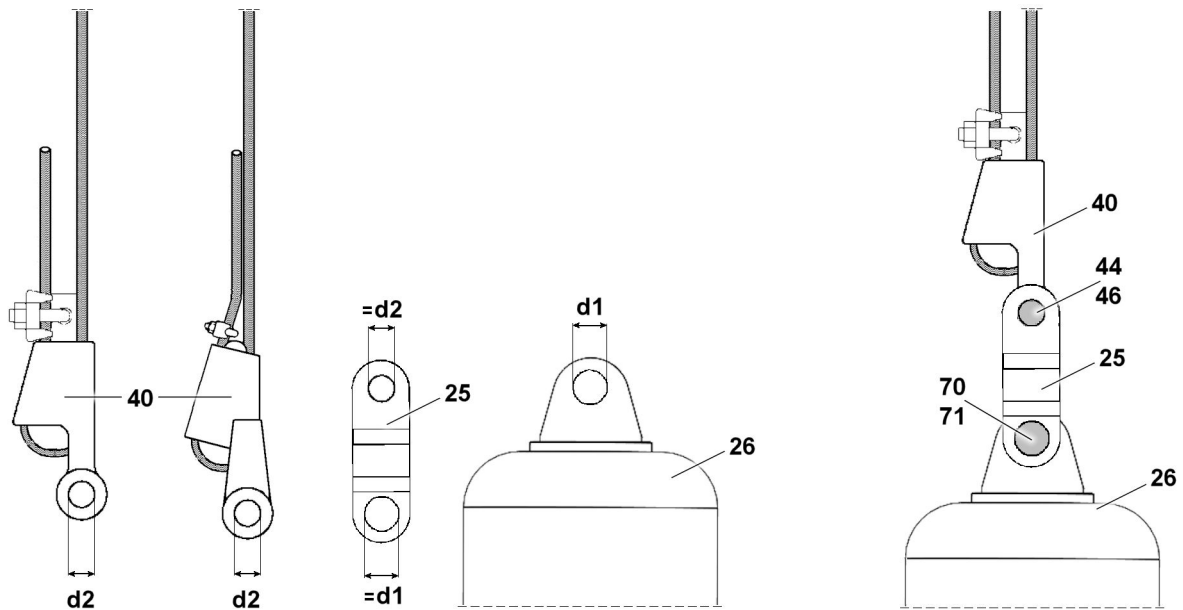

Fig.161444: Wedge lock with adapter, load hook example

25 Adapter	71 Retaining element (rope lock)
26 Load hook (example)	d1 Fixed point diameter (example)
40 Wedge lock	d2 Wedge lock diameter
44 Pin	=d1 Fixed point side diameter
46 Retaining element	=d2 Wedge lock side diameter
70 Pin (rope lock)	

**Note**

The fixed point for the wedge lock can be on the pulley head, hook block or load hook.

- ▶ In the shown example, the fixed point is on the load hook **26**.

If the assembled wedge lock **40** matches the rope diameter, but the wedge lock diameter **d2** does not match the fixed point diameter **d1**, the adapter **25** must be used. The pin **70** and retaining element **71** of the unutilized rope lock is needed for the adapter.

**WARNING**

Impermissible use of the adapter **25**!

If the adapter **25** is used with a rope lock, the end connection can fail and lead to breakage.

An L-shaped rope lock cannot be replaced by a wedge lock **40**. Also not with the aid of an adapter **25**. Death, severe bodily injuries, property damage.

- ▶ Use the adapter **25** only with a wedge lock **40**.

If a wedge lock **40** is needed as a replacement for an L-shaped rope lock:

- ▶ Increase / reduce the reeving by one rope strand to the extent necessary. In this way, a rope end point can be used that does not require an L-shaped rope lock.

8.6.1 Assembling the adapter on the wedge lock

Make sure that the following prerequisites are met:

- The rope is assembled properly on the wedge lock **40**.

If the wedge lock diameter **d2** does not match the fixed point diameter **d1**:

- ▶ Pin and secure the adapter **25** with the fixed point side diameter **=d1** to the hook block / load hook **26** or fixed point pin. To do so, use the pin **70** and retaining element **71** of the unutilized rope lock.
- ▶ Pin and secure the adapter **25** with the wedge lock side diameter **=d2** to the wedge lock **40**. To do so, use the pin **44** and retaining element **46** of the wedge lock.

Result:

- Wedge lock **40** pinned and secured via the adapter **25** with the fixed point.

8.6.2 Disassembling the adapter on the wedge lock



Note

If a retaining split that cannot be reused was used, it must be disposed of after a single assembly and disassembly.

- ▶ Replace the retaining splint with a reusable retaining element.

Make sure that the following prerequisites are met:

- The rope is not tensioned

Disassemble the adapter **25**:

- ▶ Unpin the adapter **25** from the hook block / load hook **26** or the fixed point. Feed the pin **70** and retaining element **71** again in the unused rope lock.
- ▶ Unpin the adapter **25** from the wedge lock **40**. Feed the pin **44** and retaining element **46** again in the wedge lock **40**.

Result:

- The adapter **25** is disassembled.

8.7 Using a wedge lock



WARNING

The end connection can loosen up inadvertently!

An incorrectly or incompletely assembled wedge lock can lead to an inadvertent releasing of the end connection.

- ▶ It is prohibited for personnel to remain in the danger zone.
- ▶ Supervise from a safe position when loading.

Make sure that the following prerequisites are met:

- The rope is assembled properly on the wedge lock.
- The rope is not tensioned
- The wedge lock is pinned in a permissible fixed point.
- ▶ Load the wedge lock under supervision with 10% of the minimum tensile strength of the rope.
- ▶ Wait for a two-minute setting time.
- ▶ Make sure after the setting time that there is no relative movement between the wedge and the rope.

**WARNING**

Wedge lock used incorrectly!

An incorrectly used wedge lock can lead to an inadvertent releasing of the end connection.

- ▶ Falling loads, shock loads and exceeding the permissible load bearing capacity are prohibited.
- ▶ Continuously check the components. In the case of damage, do not continue their use and replace them immediately.
- ▶ Side loads and angular pull are prohibited.
- ▶ Make sure the rope, wedge and pinning are positioned correctly.
- ▶ Check the positioning and tightening torque of the clamp at regular intervals.
- ▶ If tensile strength is lost, check that the wedge is positioned securely.

- ▶ Check all wedge lock components at regular intervals for high loads and loss of tensile strength. At least once a month.

8.8 Disassembling the wedge lock

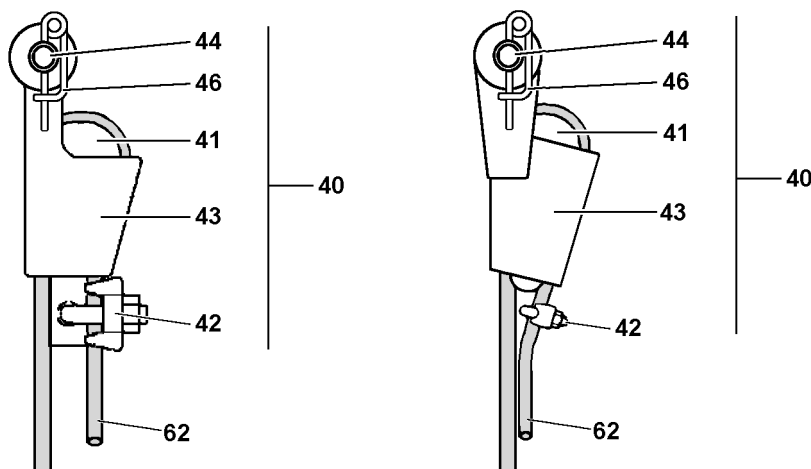

Fig. 160491: Exemplary presentation of wedge locks

40 Wedge lock	44 Pin
41 Wedge	46 Retaining element
42 Clamp	62 Dead rope end
43 Housing	

**WARNING**

The wedge lock is incorrectly disassembled!

- ▶ Wear protective clothing.
 - ▶ Disassemble the wedge lock **40** correctly. Check for wear and damage. In the case of damage, do not continue their use and replace them immediately.
 - ▶ When disassembling the dead rope end **62**, secure it from lashing out.
 - ▶ Do not use the previously jammed area of the rope again and cut it off completely.
-
- ▶ Unpin the wedge lock **40** in the fixed point.

**Note**

If a retaining split that cannot be reused was used to secure the pin **44**, it must be disposed of after a single assembly and disassembly.

- ▶ Replace the retaining splint with a matching reusable retaining element **46**.

**Note**

- ▶ Store all parts of the wedge lock **40** together so they cannot be mixed up.
- ▶ Disassemble the clamp **42**. Pull the rope with the clamp **41** out of the housing **43**.

8.9 Disposal

**Note**

The wedge lock can be disposed of as normal steel scrap.
▶ Observe the national guidelines.

9 Rope reeving

**Note**

▶ See separate reeving plans.

Empty page!

LWE/LR 13000-001/19503-01-02/en

4.07 Counterweight

1	Components of counterweight	3
2	Fastening points	5
3	Assembling the counterweight frame	7
4	Assembly of A-frame	17
5	Installing the counterweight	19
6	Removing the counterweight	31
7	Removal of A-frame	39
8	Disassembling the counterweight frame	41
9	Disassembling the brackets on the carriers	49

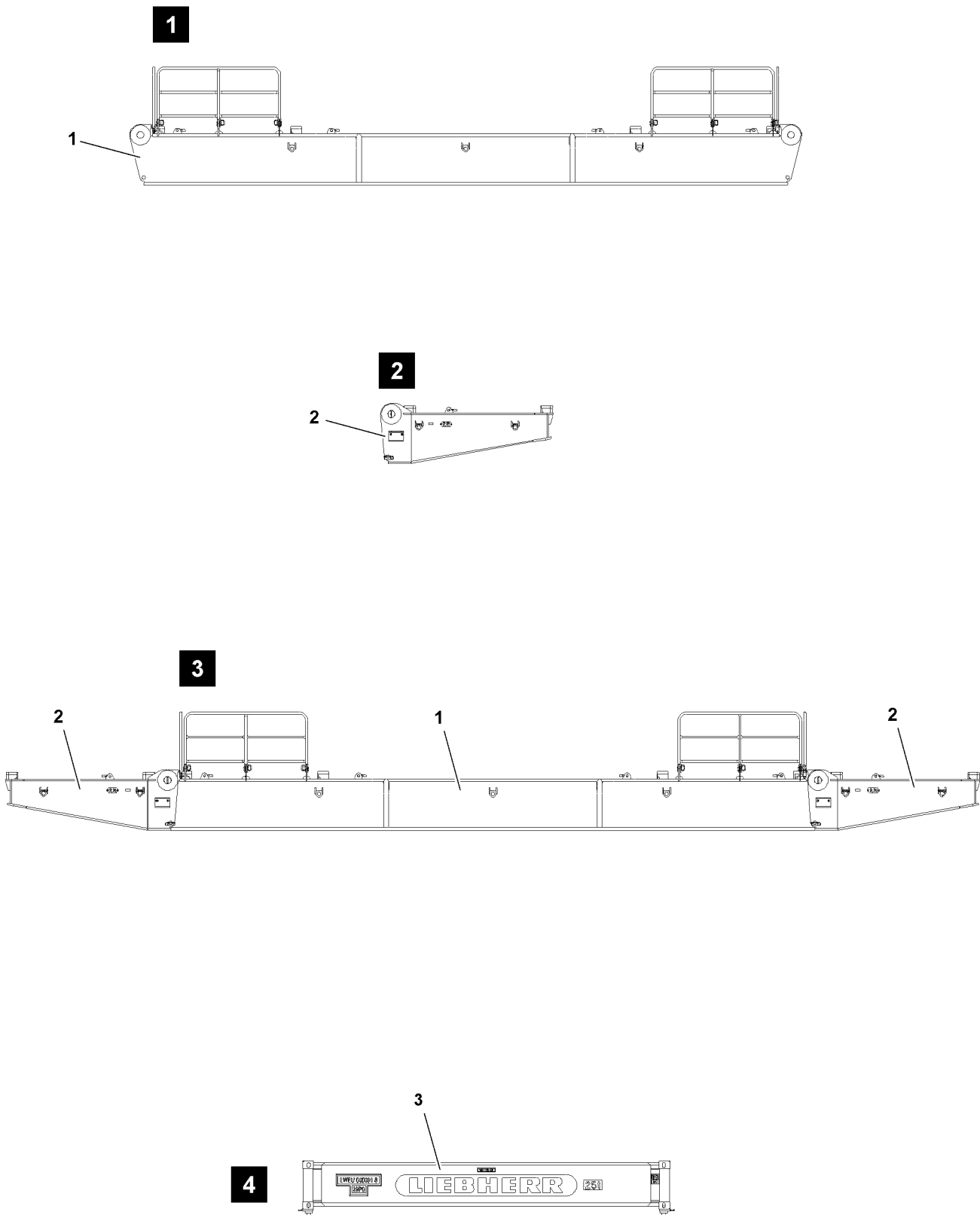

Fig.114745

1 Components of counterweight

**Note**

► Dimensions and weights, see Crane operating instructions, chapter 1.03.

1.1 Components of counterweight frame

Position	Component
1	Carrier
2	Bracket
3	Counterweight plate

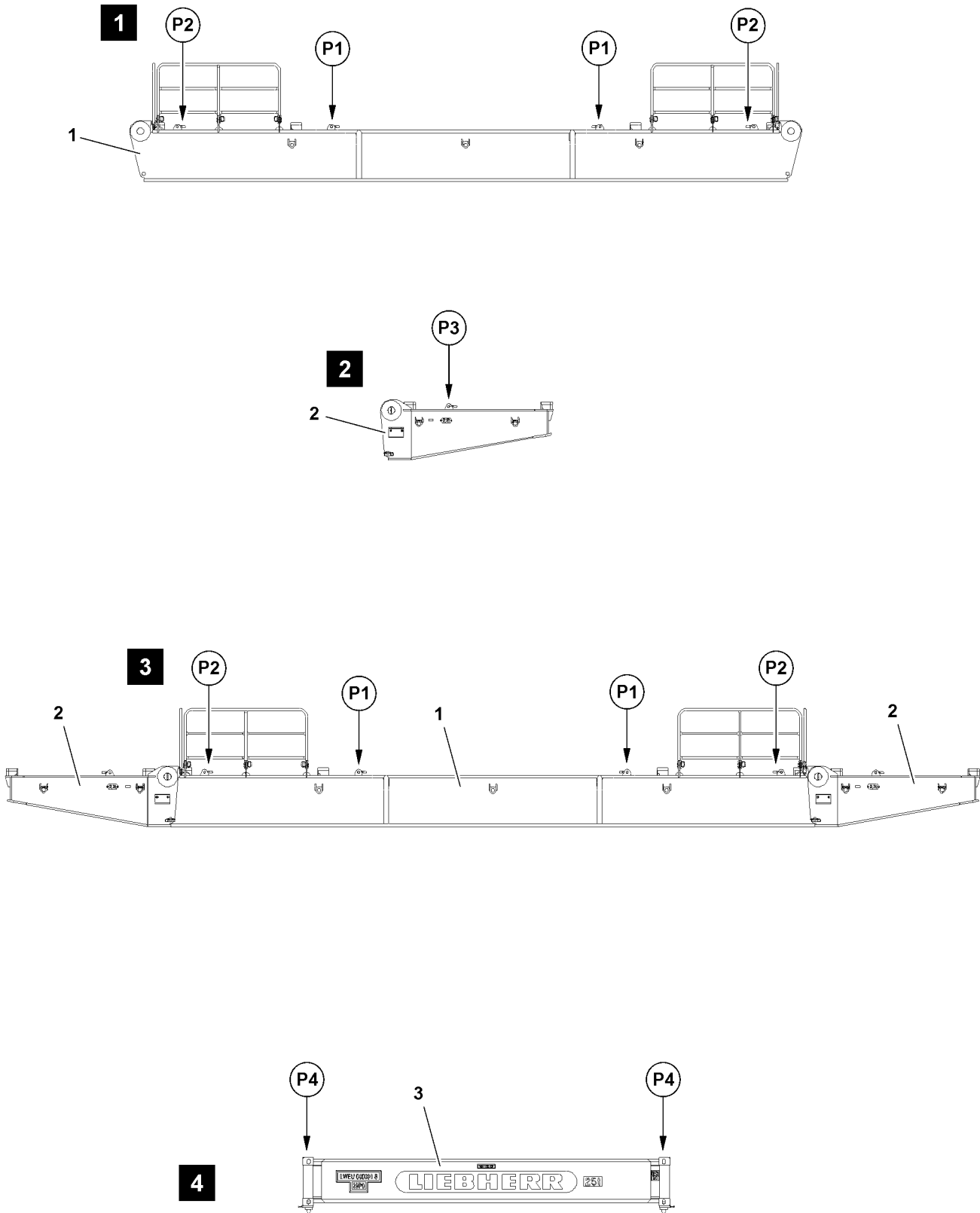

Fig.114746

LWE/LR 13000-001/19503-01-02/en

2 Fastening points

2.1 Fastening points carrier

1 Illustration

Fastening points	
P1	For transport
P2	For assembly on turntable frame

2.2 Fastening points bracket

2 Illustration

Fastening points	
P3	For transport and assembly

2.3 Fastening points Carrier with bracket

3 Illustration

Fastening points	
P1	For transport
P2	For assembly on turntable frame

2.4 Fastening points Counterweight plate

4 Illustration



Note

- ▶ The counterweight plates can be fastened with a chain suspension with a length of at least 6 m - in connection with a balancer - on points **P4**!
- ▶ Alternatively, the counterweight plates can also be fastened and ballasted with a container spreader, see Container spreader Operating instructions!

Fastening points	
P4	For transport and assembly

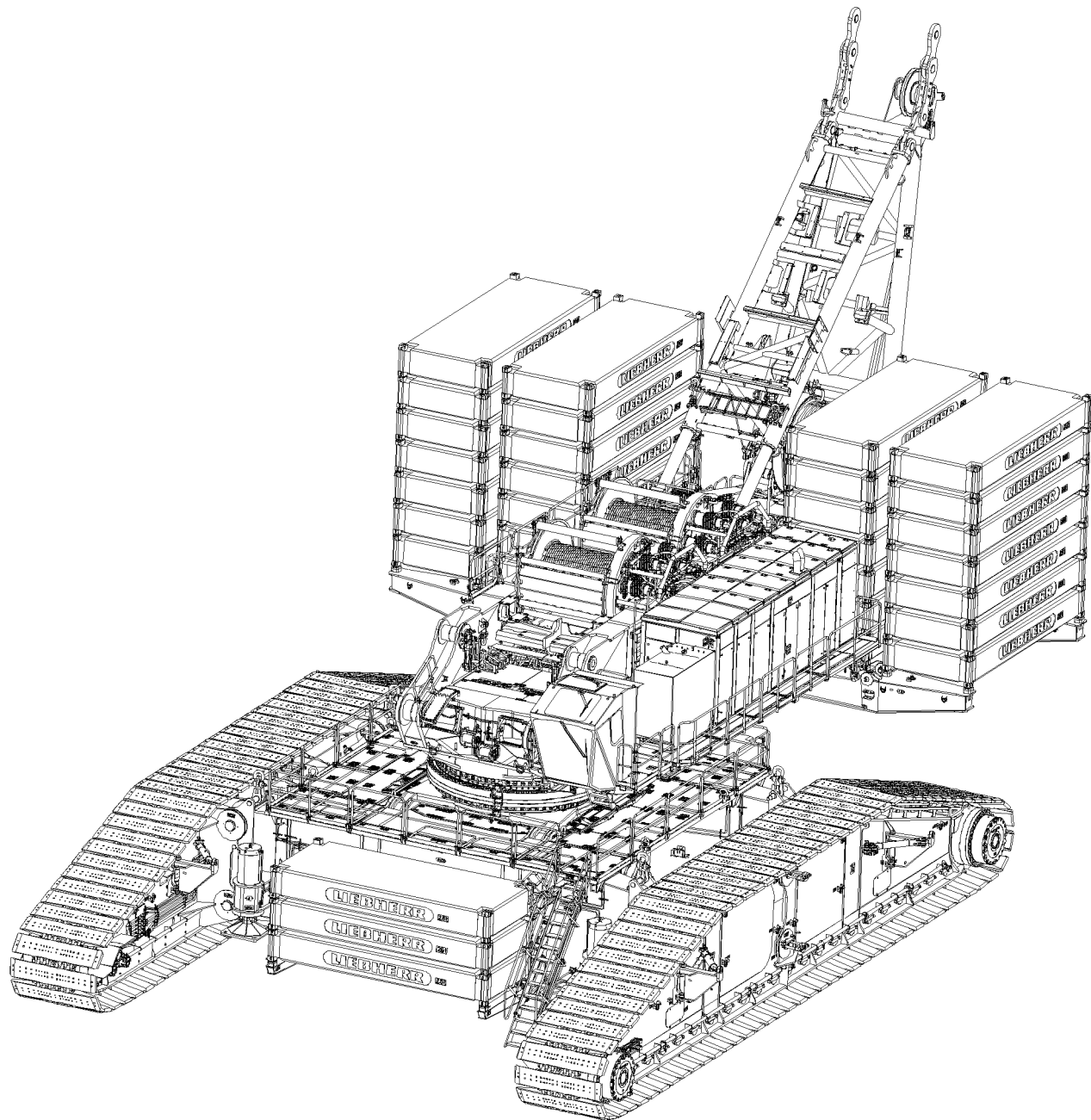

LWE/LR 13000-001/19503-01-02/en

Fig.114747

3 Assembling the counterweight frame



WARNING

Danger of slipping / falling during assembly / disassembly work!

During assembly / disassembly work, personnel must be secured with appropriate aids to prevent them from falling!

Weather influences, such as wetness, wind, snow, frost increase the slipping / falling danger!

Personnel can be severely injured or killed!

- ▶ All assembly / disassembly work must be carried out using suitable aids (lifting platforms, scaffolding, ladders, auxiliary crane, etc.)!
- ▶ If work cannot be carried out on the ground or using such aids, then assembly personnel must be secured with the personal fall arrest system (see Crane operating instructions, chapter 2.04) to protect against falling!
- ▶ If railings are present on the components, then they must be brought into the corresponding position and secured for assembly / disassembly work!
- ▶ Step on aids and fall protection equipment only with clean shoes!
- ▶ Keep aids and fall protection equipment clean and free from snow and ice!



WARNING

Falling components!

At assembly / disassembly, the components and counterweight plates can fall down!

Personnel can be severely injured or killed!

- ▶ Make sure that no persons or objects are within the danger zone!



WARNING

Incorrect handling of the fastening equipment!

If tackle cannot be attached correctly and if it is not secured sufficiently to prevent it from loosening up, loads can fall down!

Personnel can be severely injured or killed!

- ▶ Make sure that the fastening equipment is correctly attached on the fastening points and that it is secured sufficiently to prevent it from loosening up!



WARNING

Danger of impact / crushing!

By staying in the danger zone of the counterweight assembly there is an impact / crushing danger!

Personnel can be severely injured or killed!

- ▶ Make sure that there are no persons between the components which are to be assembled / disassembled!

Make sure that the following prerequisites are met:

- The ground is of sufficient load bearing capacity to take on the crane including the counterweight safely.
- Both crawler carriers are standing on the ground.
- The crane is aligned in horizontal direction.
- The A-frame on the turntable is **not** removed.

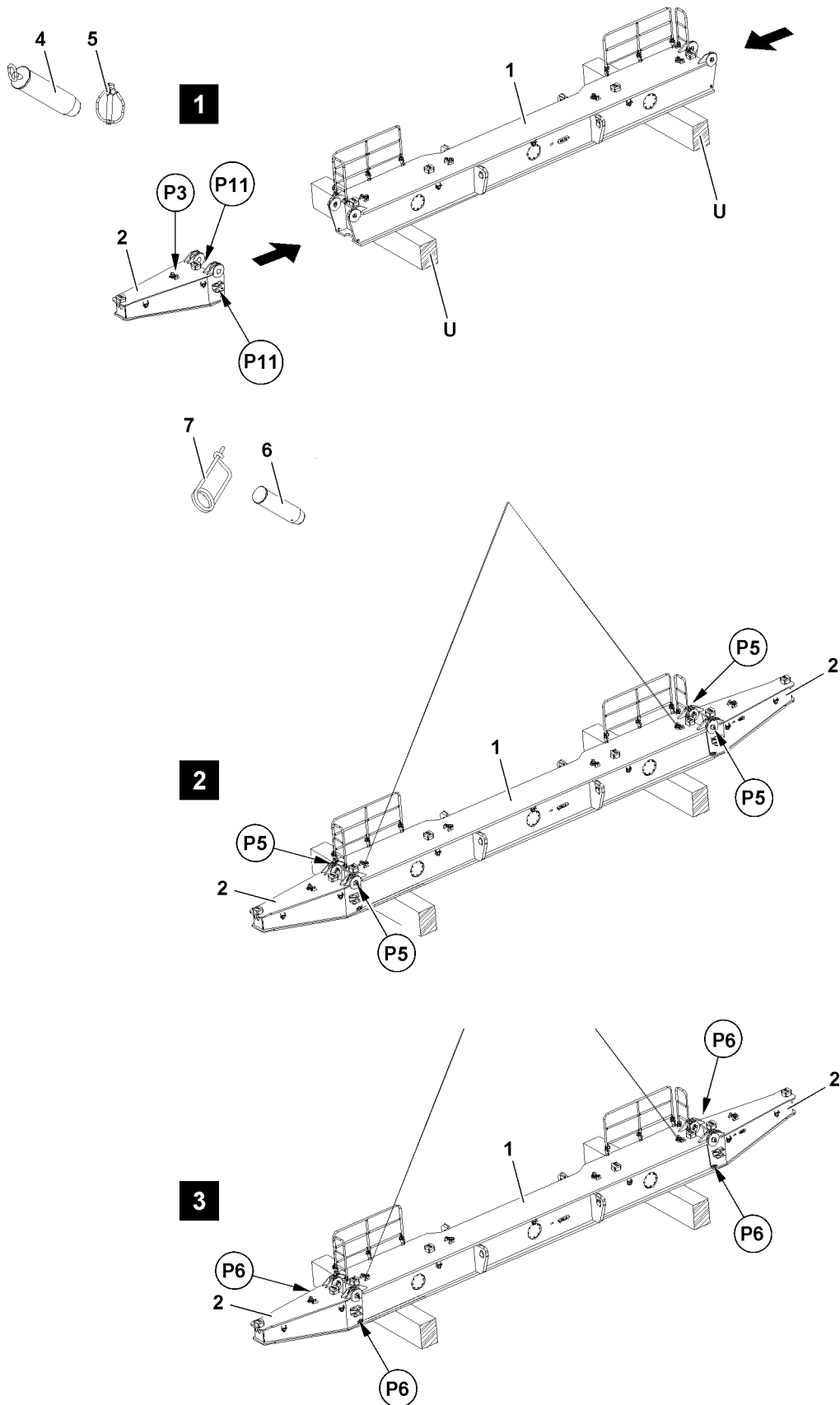

Fig.114751

LWE/LR 13000-001/19503-01-02/en

3.1 Assembling the carriers on the turntable

Make sure that the following prerequisites are met:

- The carriers are lifted off the flatbed trailer and placed on a sufficiently load bearing support **U** on the ground.
- An auxiliary crane with sufficient load carrying capacity is available.

3.1.1 Bringing the railings on the carriers into operating position



Note

- ▶ Bring the railings of the carriers **1** into operating position - before assembly of the carriers on the turntable frame!
-
- ▶ Bring the railings of the carriers **1** from transport position into operating position and secure, see Crane operating instructions, chapter 2.06.

3.1.2 Assembling the brackets on the carriers

If a counterweight of more than 400 t is required for the planned crane application, install the brackets **2** - to take on additional counterweight plates - on the carriers **1**. The assembly of the brackets on the carriers can be made on the ground or on the turntable. However, for safety reasons we recommend to install the brackets on the carriers on the ground. After successful assembly, install the preassembled carriers including the brackets - as one unit - on the turntable.



WARNING

Danger due falling components!

At assembly of the brackets aloft, components, such as pins, can fall down!

Personnel can be severely injured or killed!

- ▶ Use a lifting platform for the assembly of the brackets aloft.
- ▶ Make sure that there are no persons within the danger zone.

Assembling the first bracket on the carrier (ground assembly)

- ▶ Fasten the first bracket **2** on point **P3** on the auxiliary crane.

When the bracket **2** is properly fastened on the auxiliary crane:

- ▶ Lift the bracket with the auxiliary crane and swing it in to the carrier **1**, illustration 1.
- ▶ Center the bracket **2** on the carrier **1**.

When the bracket is centered on the carrier:

- ▶ Take the grip pin **4** at point **P11** from the transport receptacle and insert at point **P5**, illustration 2, on both sides.
- ▶ Secure the grip pin **4** with locking pin **5**.

When the grip pins **4** are properly pinned and secured:

- ▶ Take the retaining pin **6** at point **P11** from the transport receptacle and insert at point **P6**, illustration 3, on both sides.
- ▶ Secure the retaining pin **6** at point **P6** with spring retainer **7**.

Assembling the second bracket on the carrier



Note

- ▶ The assembly of the second bracket on the carrier is identical to the assembly of the first bracket!

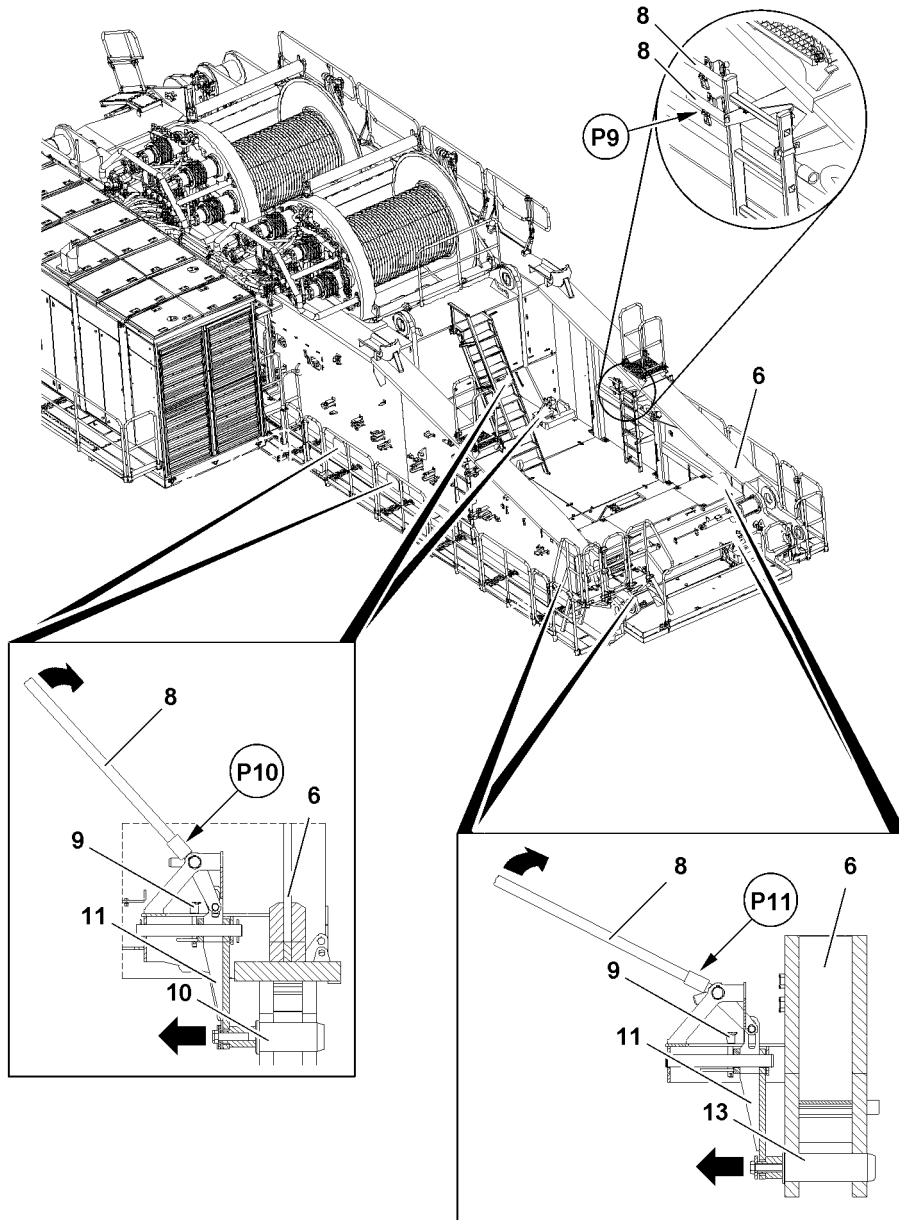

Fig.114749

LWE/LR 13000-001/19503-01-02/en

3.1.3 Preparing the turntable for the assembly of the carriers



Note

- ▶ The two assembled carriers **1** form the **counterweight frame** on the turntable!

Unpin the connector pin

- ▶ Remove the control lever **8** at point **P9** from the transport receptacle.



Note

- ▶ For the installation of the carriers **1** on the turntable frame **6**, the connector pins **10** and the connector pins **13** must be completely unpinned on the turntable frame.
- ▶ The pinning mechanism is identical on all pin points.
- ▶ The unpinning procedure of the connector pins is described on one connector pin, as an example.
- ▶ Set the control lever **8** on the upper adapter on the pin device at point **P10**.
- ▶ Release the pin guide **11**: Unpin the ball locking pins **9**.
- ▶ Unpin the connector pin **10**: Push the control lever **8** upward to the stop, if necessary switch the control lever **8** over and push it in actuation direction to the stop.

Result:

- The connector pin **10** on the turntable is unpinned.
- ▶ Unpin the other connector pins as described above.



WARNING

Danger of falling!

If it is intended to install the brackets **2** on the carriers **1** when they are already installed on the turntable **6**, then there is a danger of falling!

Personnel can be severely injured or killed!

- ▶ For safety reasons, if a counterweight of more than 400 t is required for the planned crane application, install the brackets **2** on the carriers **1** on the ground.



WARNING

Danger of accident!

When lifting, swinging in and setting down the carriers, they can start to swing back and forth!

Personnel can be severely injured or killed!

- ▶ Secure the carriers **1** with a guide rope to prevent them from swinging back and forth!
- ▶ Make sure that no persons are within the working and swing range of the auxiliary crane as well as within the installation range of the carriers.
- ▶ Make sure that no objects or obstacles are within the danger zone.
- ▶ If necessary, remove objects or obstacles from the danger zone.

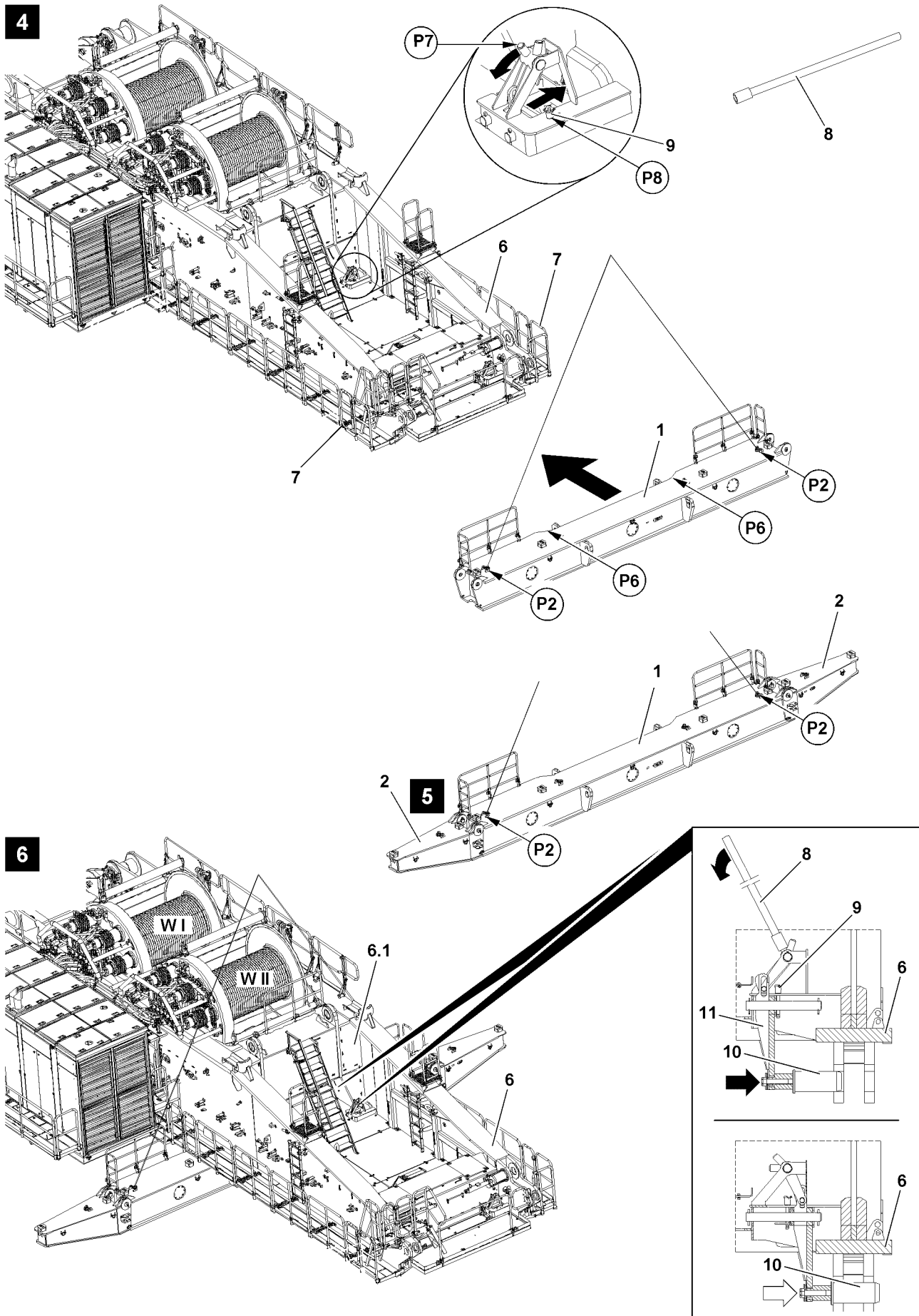

Fig.114750

LWE/LR 13000-001/19503-01-02/en

3.1.4 Assembling the first carrier on the turntable frame



Note

- ▶ The assembly of the carriers on the turntable frame **6** can be made individually, illustration **4**, or in connection with the brackets **2** - as a preassembled unit, see illustration **5**!
- ▶ At assembly of the carriers **1**, pay attention to the installation position: Move the carriers **1** with the constrictions on the upper belt ahead, points **P6**, in to the turntable, see illustration **4**.

Make sure that the following prerequisites are met:

- The connector pins **10** are completely unpinned (4x).
- ▶ Fasten the first carrier **1** on the auxiliary crane, see section „Fastening points“.
- ▶ Fasten the guide rope on the carrier.
- ▶ Lift the carrier **1** with the auxiliary crane and swing it in to the turntable **6**.
- ▶ Secure the carriers **1** with a guide rope to prevent them from swinging back and forth!
- ▶ Align the carrier **1** on the turntable **6**.

NOTICE

Damage of crane components!

When moving the first carrier in to the pin points on the turntable, there is a danger of property damage!

Railings and catwalks can be significantly damaged!

This could result in high repair costs!

- ▶ Always move the carriers **1** with sufficient safety clearance to the turntable **6** - especially to the railings and catwalks.
- ▶ Move the carriers **1** in with at very low speed to the pin points on the turntable.
- ▶ Secure the carrier **1** with the guide rope while moving it in to prevent it from swinging back and forth.

When the first carrier **1** is aligned on the turntable:

- ▶ Carefully move the carrier **1** with the auxiliary crane in to the pin points.

When the carrier is positioned under the pin points:

- ▶ Carefully and with very low speed lift the carrier **1** until it touches on the turntable frame, illustration **6**.

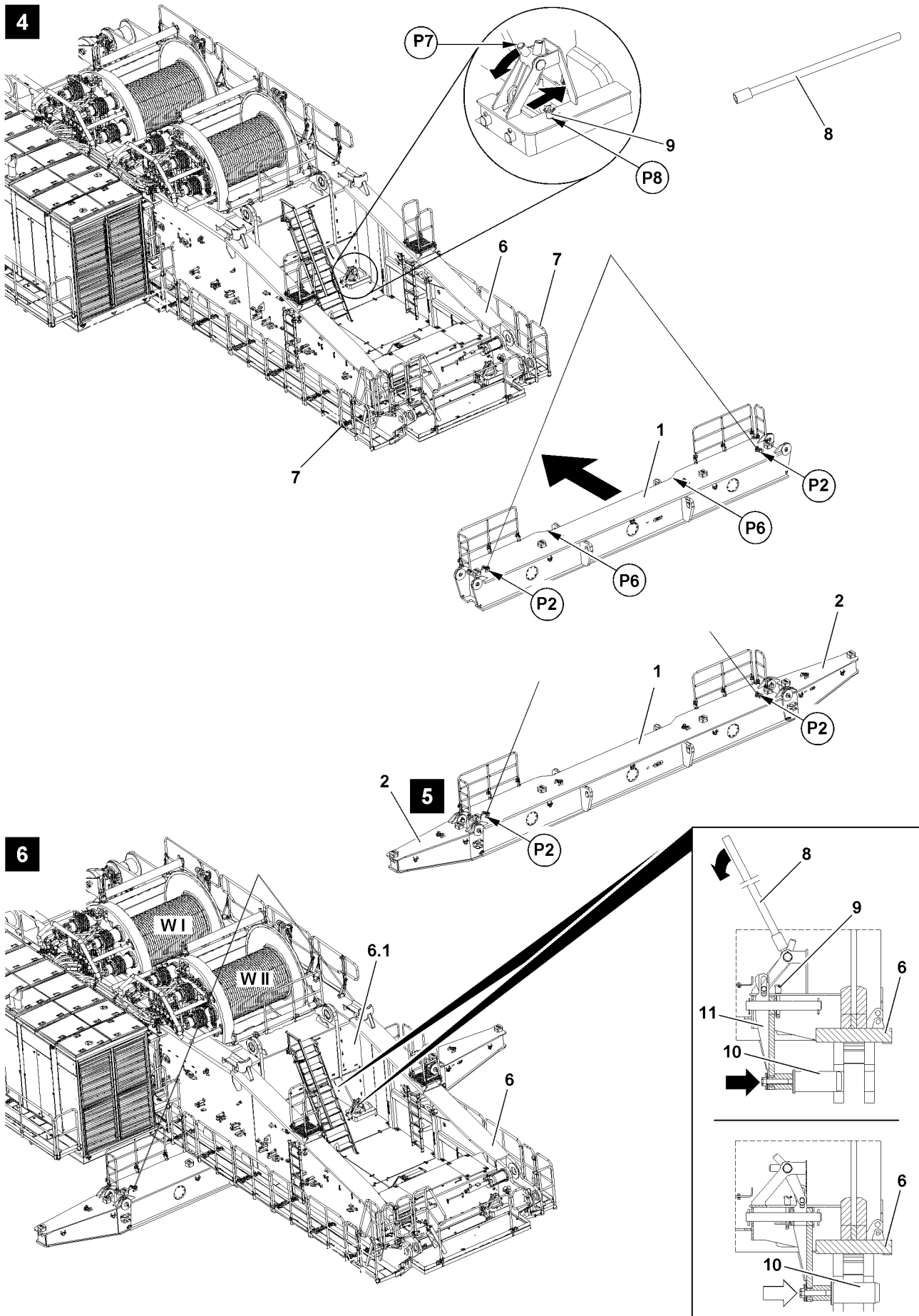

Fig.114750

LWE/LR 13000-001/19503-01-02/en

**DANGER**

Falling carrier!

When the carriers are not properly pinned and secured on the turntable, dangerous situations can occur, up to falling carriers!

Personnel can be severely injured or killed!

- ▶ Make sure that every carrier is properly pinned and secured with all four connector pins.

**Note**

- ▶ Two pin points of the first carrier are in front of the intermediate frame **6.1**, illustration **6**.
- ▶ Two additional pin points are between the intermediate frame **6.1** and winch **2 W II**.

When the first carrier is centered on the turntable and is placed completely on the turntable frame:

- ▶ Fully insert and secure the connector pins **10**! Set the control lever **8** on the lower adapter on the pin device at point **P7**.
- ▶ Release the pin guide **11**: Unpin the ball locking pin **9** at point **P8**.
- ▶ Insert the connector pin **10**: Push the control lever **8** downward to the stop, if necessary switch the control lever **8** over and push it in actuation direction.

Result:

- The connector pin **10** on the turntable **6** is pinned.

**WARNING**

Danger of falling!

When releasing the fastening equipment on the assembled carrier, assembly personnel can fall down!

Personnel can be severely injured or killed!

- ▶ Make sure, when working aloft, that all persons are secured with the personal fall arrest system to prevent them from falling.

Alternative:

- ▶ Use a lifting platform!
- ▶ Observe the safety regulations for the use of lifting platforms!

When the first carrier **1** is properly pinned and secured on all **four pin points**:

- ▶ Release the fastening equipment on the carrier **1**.
- ▶ Swing the fastening equipment out with auxiliary crane.

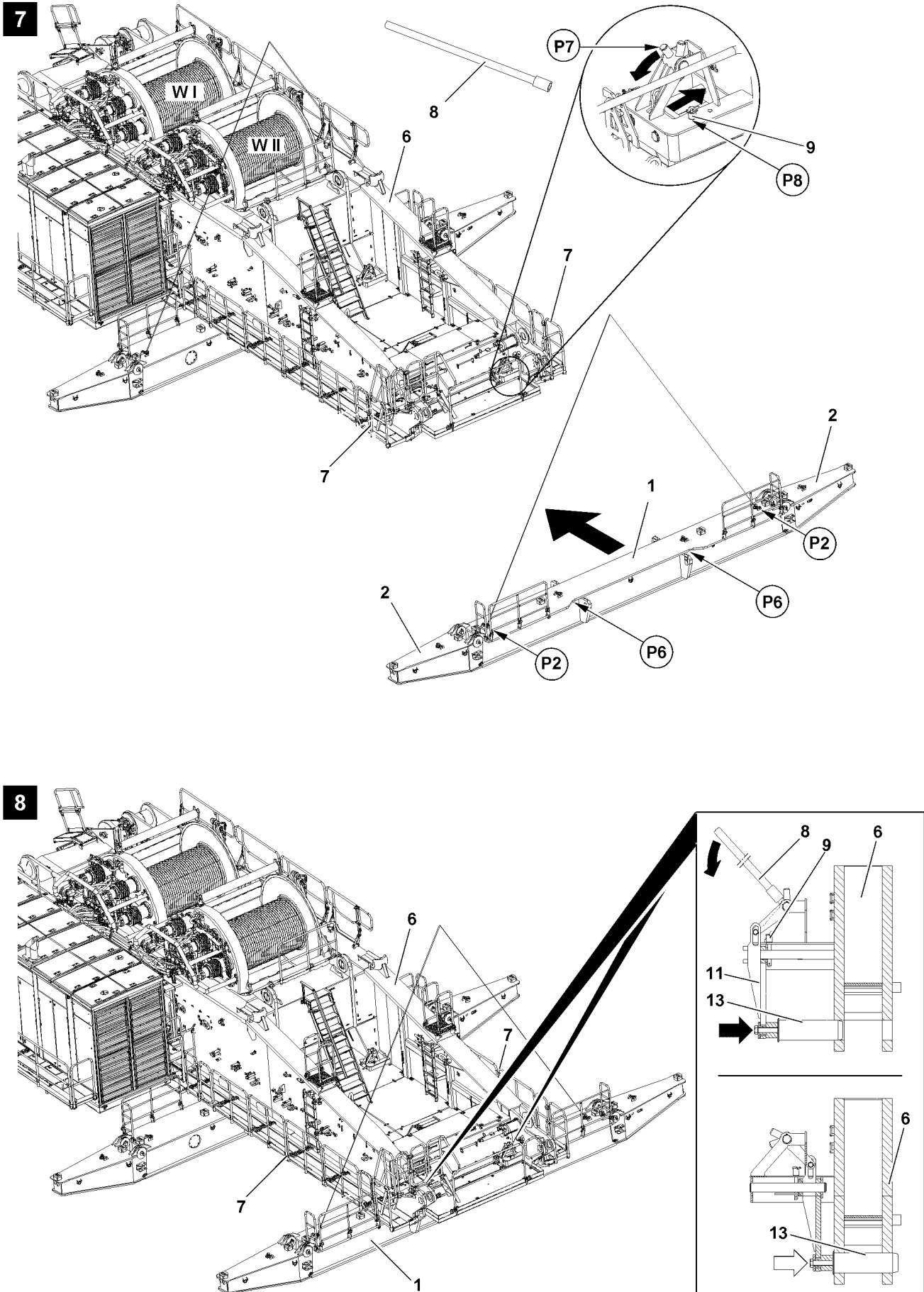

Fig.114752

LWE/LR 13000-001/19503-01-02/en

3.1.5 Assembling the second carrier on the turntable frame

Make sure that the following prerequisites are met:

- The connector pins **13** are completely unpinned (4x).



Note

- ▶ Pay attention to the installation position of the second carrier!
 - ▶ The constrictions on the upper belt of the second carrier, points **P6**, point to the outside for assembly of the second carrier! Otherwise the assembly of the second carrier on the turntable frame is identical with the assembly of the first carrier!
 - ▶ Observe and adhere to the danger notes in section „Assembling the first carrier on the turntable frame“!
-
- ▶ Pin and secure the carrier on the turntable.

4 Assembly of A-frame

4.1 Installing the A-frame



Note

- ▶ The assembly of the A-frame **12** on the turntable is described in detail on the Crane operating instructions, chapter 3.05!

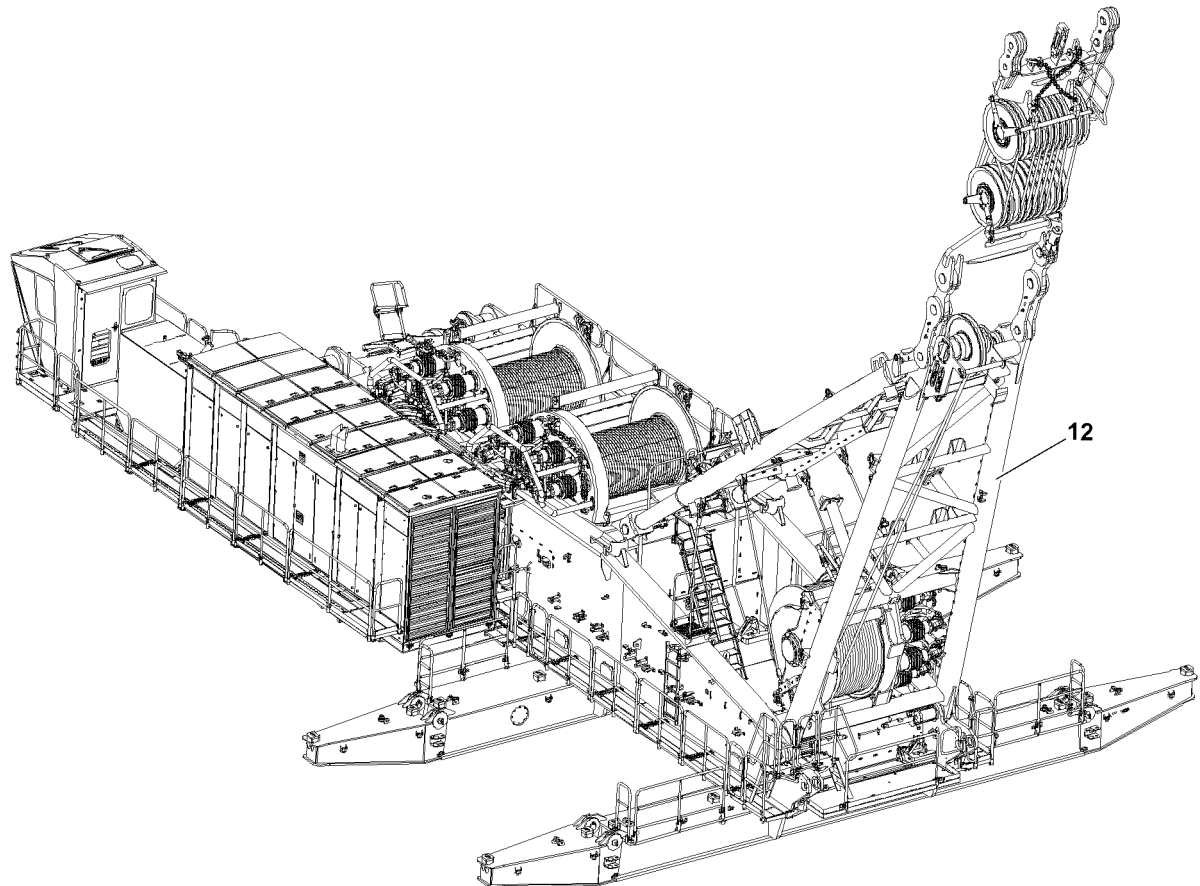

Fig.114753: Turntable with carriers for counterweight and A-frame

Fig.195219

LWE/LR 13000-001/19503-01-02/en

5 Installing the counterweight



DANGER

Danger of impact and crushing!

Due to presence near the counterweight assembly, there is an increased danger of impact and crushing when the counterweight plates are „placed“.

- ▶ Exercise extreme caution when lifting the counterweight.
- ▶ Make sure that there are no persons underneath the suspended counterweight plates.
- ▶ Exercise extreme caution when lowering the counterweight. Danger of crushing people in the immediate area of the counterweight being lowered.



WARNING

Counterweight too low / too high!

If the placed counterweight deviates from the specifications in the load charts or the erection and take down charts, then the crane can be damaged or topple over!

Personnel can be severely injured or killed!

- ▶ Make sure that the counterweight is placed according to the load chart or the erection and take down charts!



WARNING

Damaged counterweight plates!

Damage on the counterweight plates can cause the tackle to release!

Counterweight plates can fall down!

Personnel can be severely injured or killed!

- ▶ Do not use damaged counterweight plates and replace them immediately!



WARNING

Overload fastening points counterweight plates!

If more than the permissible number of counterweight plates are lifted together, then the fastening points can be overloaded!

The counterweight plates and components can fall down!

Personnel can be severely injured or killed!

- ▶ Attach no more than maximum „two“ counterweight plates per lift!

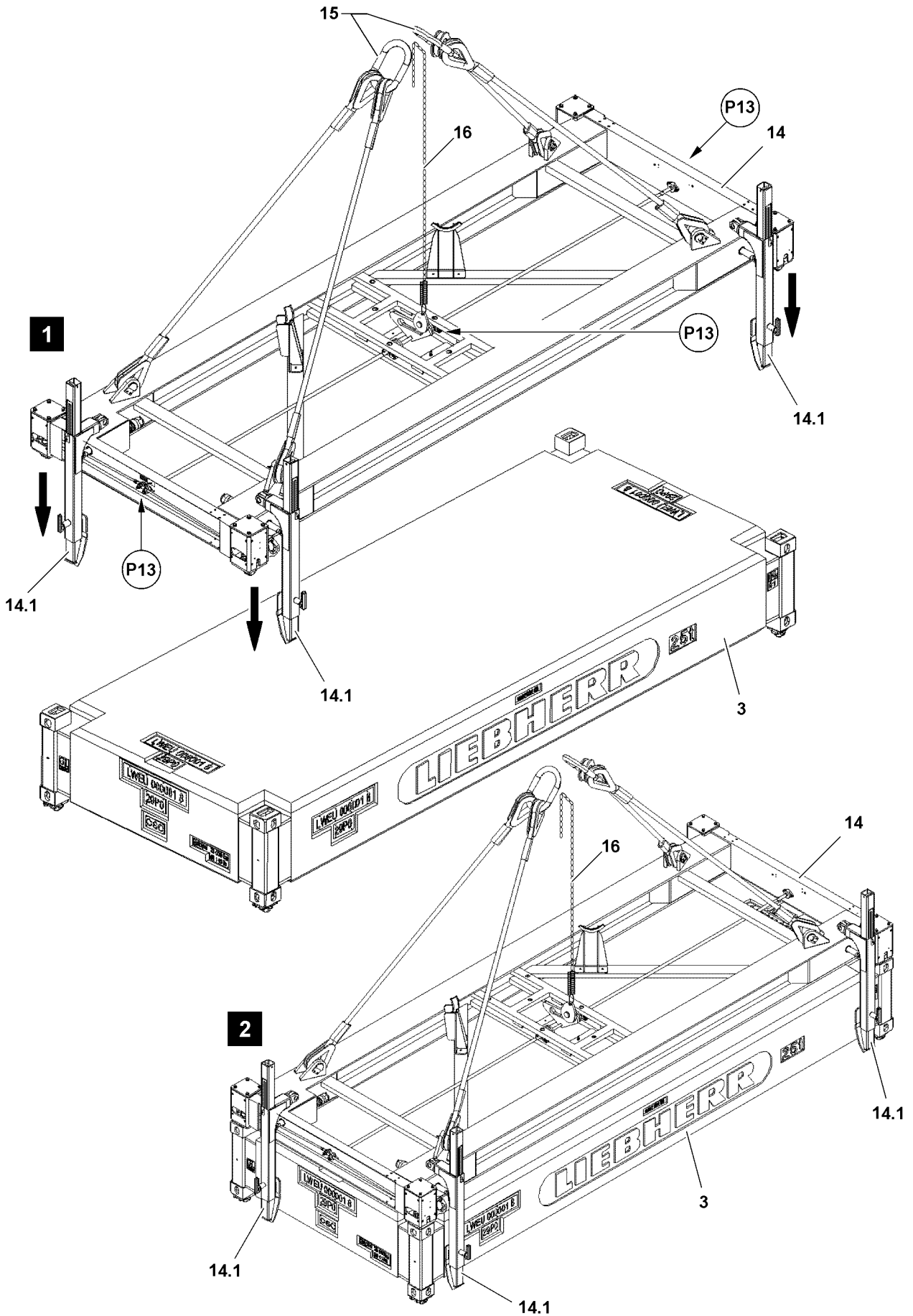

Fig.114754

LWE/LR 13000-001/19503-01-02/en

5.1 Use of container spreader



WARNING

Danger of accident!

If the container spreader operating instructions are not observed, personnel can be severely injured or killed!

Property damage on the crane can occur!

- ▶ Before operation of the container spreader, the assembly personnel must read and observe the separately supplied container spreader Operating instructions!



Note

- ▶ The strut guides **14.1** serve as guide stops on the counterweight plates **3** and can be telescoped depending on application!
- ▶ The height of the counterweight plate **3** is 800 mm !
- ▶ For adjustment of strut guide **14.1**, see separately supplied Container spreader Operating instructions!

- ▶ Adjust the strut guide **14.1** to the height of the counterweight plate.



Note

- ▶ For adjustment of spring load lock **16**, see separately supplied Container spreader Operating instructions!

- ▶ Fasten the fastening ropes **15** of the container spreader **14** and the chain of the spring load lock **16** on the hook of the auxiliary crane.

For a visual check, **red** and **green** color marks are provided to recognize the respective locking position in the swing range of the axle lever on the respective front side and on the locking rocker, see points **P13** illustration **1**.



Note

- ▶ Make sure, before setting the container spreader **14** on the counterweight plate **3**, that a corresponding locking position is selected.

- ▶ Set the container spreader **14** with the auxiliary crane on the counterweight plate **3**.



Note

- ▶ Observe the function and warning notes for the Self-lock fixture lock, see separately supplied Container spreader Operating instructions!

- ▶ The locking procedure is carrier out fully automatic by the Self-lock fixture lock.

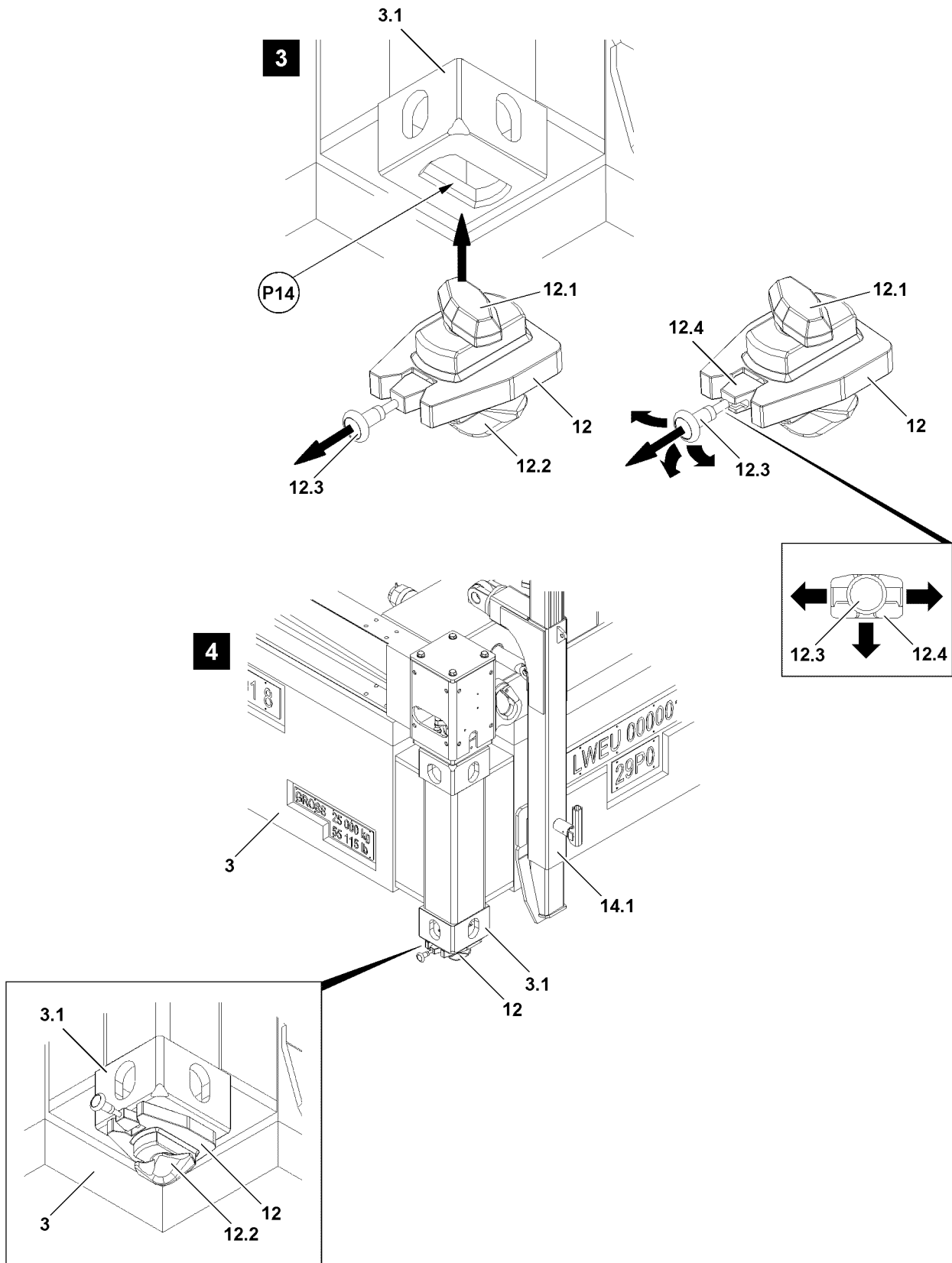

Fig.114755

LWE/LR 13000-001/19503-01-02/en

5.2 Installing the Twistlock on the counterweight plate

Make sure that the following prerequisites are met:

- The carriers **1** (counterweight frame) are pinned and secured on the turntable.
- The container spreader is set and locked on the first counterweight plate **3**.
- ▶ Lift the counterweight plate **3** with the auxiliary crane off the ground.

Result:

- The **12** can be inserted from below into the container corner fittings **3.1**.
- ▶ Unlock the Twist lock **12**: Pull the release **12.3** and engage it either to the left, to the right or downward into the bracket **12.4**.

Result:

- The Twistlock is unlocked.



Note

- ▶ Pay attention to the installation position of the Twistlock!
 - ▶ Make sure that the Twistlock **12** is inserted with the flat locking cone **12.1** upward into the container corner fitting **3.1**!
-
- ▶ Guide the Twistlock **12** at point **P14** into the container corner fitting **3.1** of the counterweight plate **3**.
 - ▶ Activate the locking mechanism of the Twistlock **12**: Slowly let the release **12.3** return to its original position.

Result:

- The locking cone **12.1** turns and locks the Twistlock **12** with the container corner fitting **3.1**.
- ▶ Guide the Twistlock **12** in the remaining container corner fittings **3.1** of the counterweight plate **3** and lock.

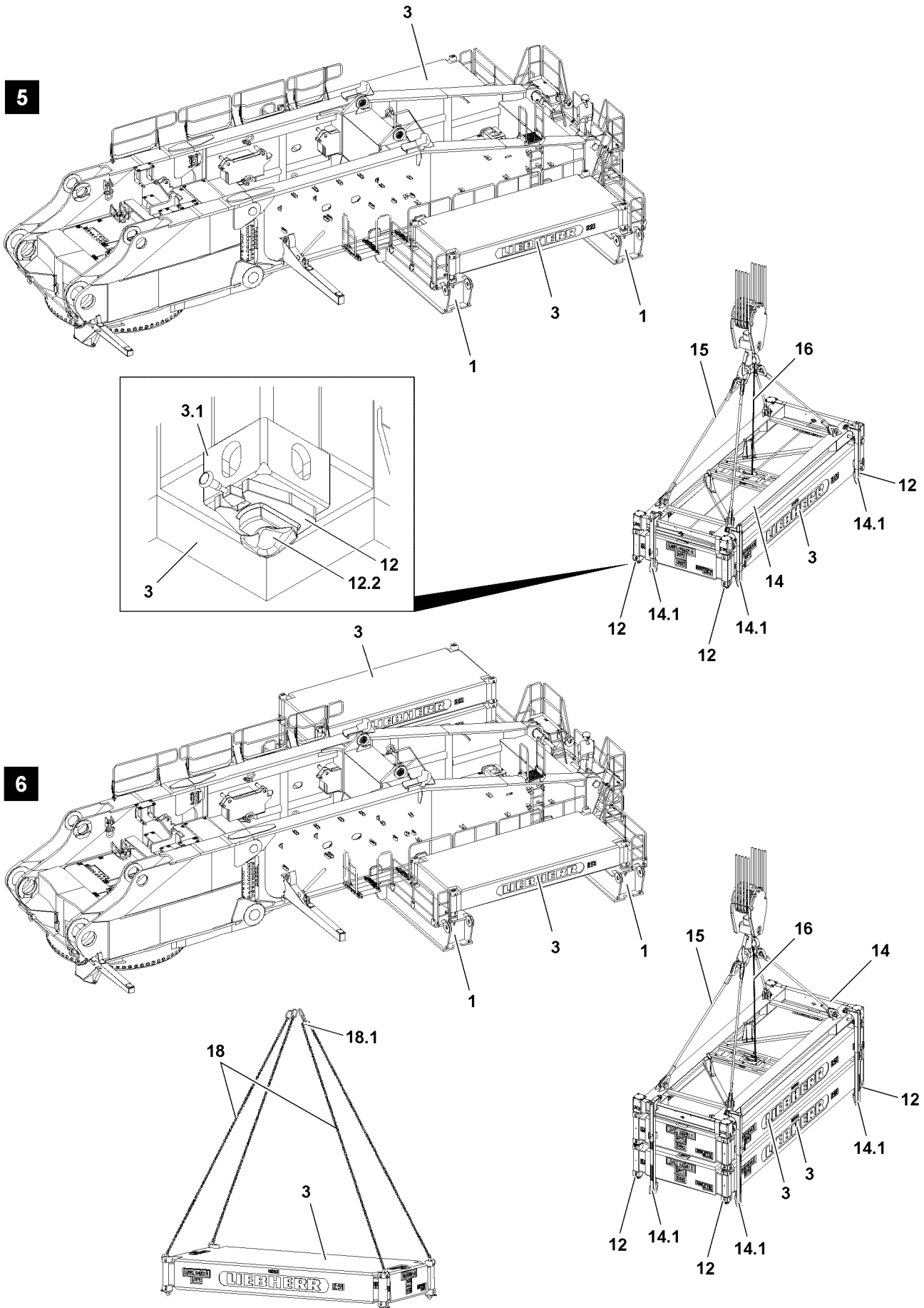

Fig.114757

LWE/LR 13000-001/19503-01-02/en

5.3 Ballasting the counterweight plates

The counterweight plates can be ballasted or placed with the following devices or fastening equipment:

1. **14** Container spreader
2. With a chain suspension **18** at least 6 m long with balancer **18.1**



WARNING

Danger of accidents due to overload!

If more than the permissible **two** counterweight plates are fastened on the container spreader **14**, the counterweight plates can fall down and the container spreader can be significantly damaged!

If more than **one** counterweight plate is fastened on the chain suspension **18**, then the chain suspension can rip off and the counterweight plates can fall down!

Personnel can be severely injured or killed!

- ▶ Make sure that no more than maximum **two** counterweight plates are fastened on the container spreader **14**.
- ▶ Make sure that no more than maximum **one** counterweight plate is are fastened on the chain suspension **18**.



WARNING

Risk of accident due to damaged counterweight plates!

If damaged counterweight plates are used for ballasting, they can break off or parts can fall down!

Personnel can be severely injured or killed!

- ▶ Replace damaged counterweight plates immediately.
- ▶ Continues use of damaged counterweight plates is prohibited.



Note

- ▶ The counterweight plates **3** are marked with their own weights!



WARNING

The crane can topple over!

If the placed counterweight deviates from the specifications in the load chart or the erection and take down chart, then the crane can be damaged or topple over!

Personnel can be severely injured or killed!

- ▶ Place the counterweight according to the specifications in the load chart or the erection and take down chart.

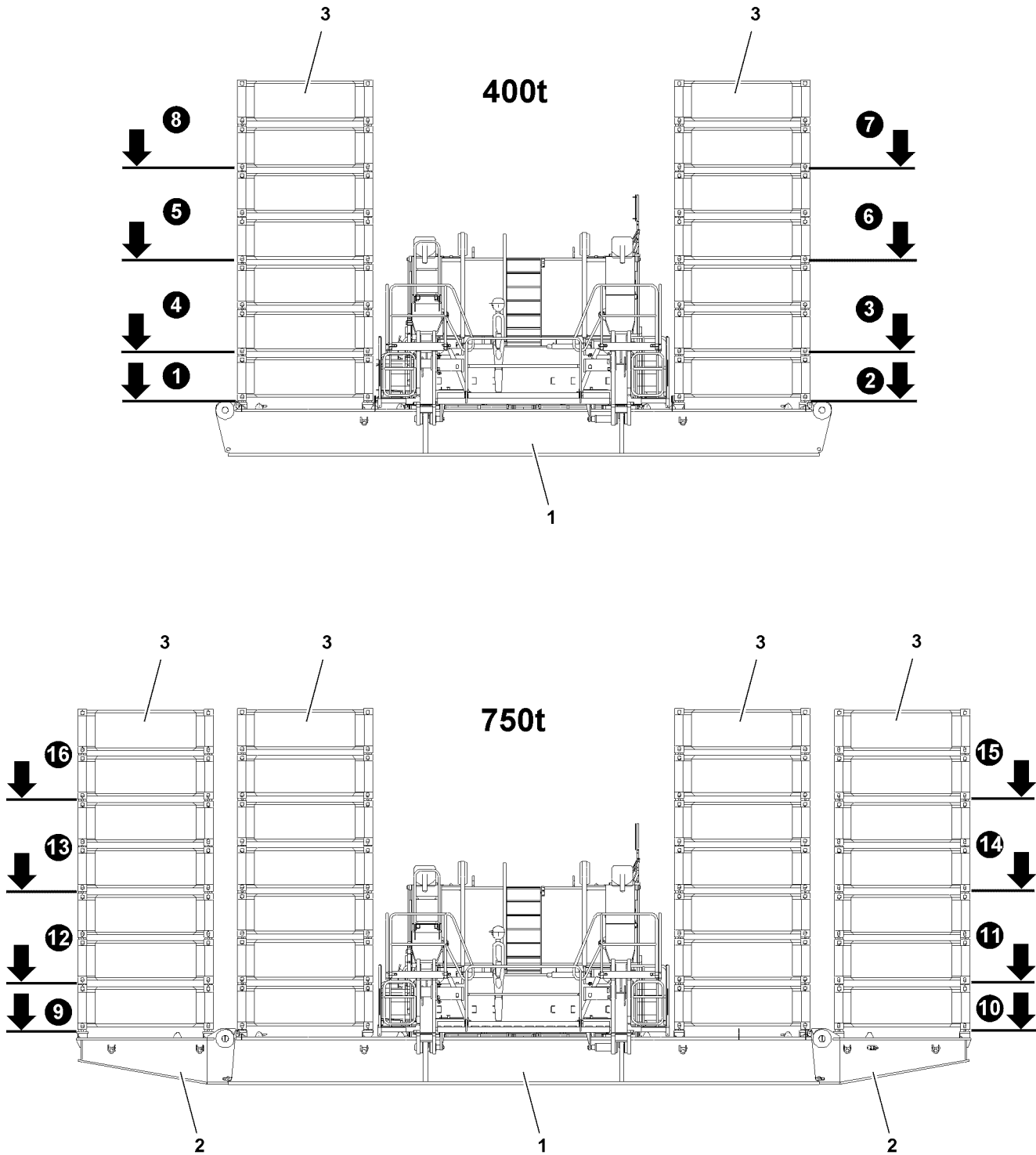

LWE/LR 13000-001/19503-01-02/en

Fig.114756

**WARNING**

The crane can topple over!

If more than 50 t are placed with one lift on the counterweight frame or on the counterweight plates **3** or if the counterweight is placed asymmetrically, then the crane can topple over!

Personnel can be severely injured or killed!

Counterweight 400 t:

- ▶ At the beginning of the ballasting procedure, place one each **single plate** on each side.
- ▶ During subsequent ballasting, a weight difference between the right and left counterweight stack of more than 50 t is prohibited.
- ▶ Alternately place no more than maximum 50 t counterweight assemblies on the counterweight stack, alternately symmetrically on the left and right.

Counterweight 750 t:

- ▶ At the beginning of the ballast procedure on the inner ballast positions, place one each **single plate** on each side, see counterweight 400 t.
- ▶ During subsequent ballasting, a weight difference between the right and left counterweight stack of more than 50 t is prohibited.
- ▶ Alternately place no more than maximum 50 t counterweight assemblies on the counterweight stack, alternately symmetrically on the left and right.
- ▶ Ballast the inner counterweight stack completely.

When the inner counterweight stacks are completely ballasted:

- ▶ Place one each single plate on the outer ballast positions.
- ▶ During subsequent ballasting, a weight difference between the right and left counterweight stack of more than 50 t is prohibited.

5.3.1 Ballasting sequence

**Note****400 t:**

- ▶ The ballasting sequence must be adhered to, you can also start with step **1** on the right!

750 t:

- ▶ The ballasting sequence must be adhered to, you can also start with step **9** on the right!

5.3.2 Placing the first counterweight plate per side on the counterweight frame

Make sure that the following prerequisites are met:

- The Twistlocks **12** are properly guided from below and locked in all container corner fittings **3.1** of the first counterweight plate.
 - Make sure that the telescope pipes of the strut guides **14.1** on the container spreader are moved in, see container spreader Operating instructions.
- ▶ Swing the first counterweight plate **3** with the auxiliary crane in to the counterweight frame.



Note

- ▶ The locks **12.2** of Twistlocks **12** lock by themselves when the counterweight plates are set correctly set on the base!
- ▶ Align the counterweight plate **3** and set it on the counterweight frame, see illustration **5**.



WARNING

Falling counterweight plates!

If the counterweight plates are not checked before removing the container spreader to ensure that they are locked properly, the counterweight plates can fall down!
Personnel can be severely injured or killed!

- ▶ Make sure that the counterweight plate is properly locked on all four locking points.

When the counterweight plate is properly locked on all four locking points:

- ▶ Remove the container spreader **17**.
or
Remove the chain suspension **18**.

5.3.3 Ballasting additional counterweight plates

Make sure that the following prerequisite is met:

- **Ballasting with container spreader:**
 - When ballasting two counterweight plates, pull the strut guides out to the required length, see Container spreader operating instructions.



Note

- ▶ The assembly of the other counterweight plates is the same as the work steps for the counterweight plate **3**!
- ▶ Ballasting the counterweight plates **3**.

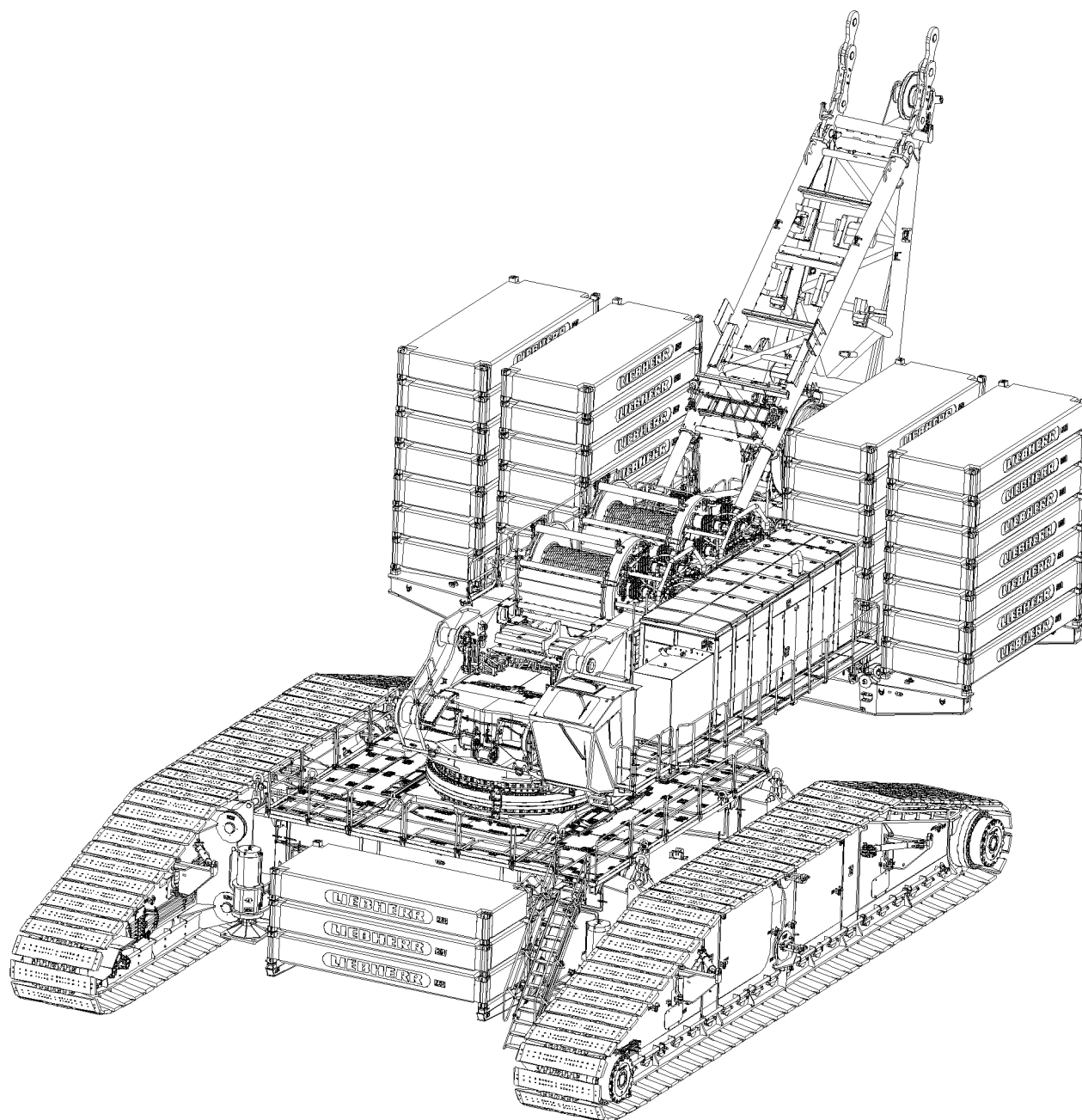

Fig.114747

LWE/LR 13000-001/19503-01-02/en

6 Removing the counterweight



WARNING

Danger of slipping / falling during assembly / disassembly work!

During assembly / disassembly work, personnel must be secured with appropriate aids to prevent them from falling!

Weather influences, such as wetness, wind, snow, frost increase the slipping / falling danger!

Personnel can be severely injured or killed!

- ▶ All assembly / disassembly work must be carried out using suitable aids (lifting platforms, scaffolding, ladders, auxiliary crane, etc.)!
- ▶ If work cannot be carried out on the ground or using such aids, then assembly personnel must be secured with the personal fall arrest system (see Crane operating instructions, chapter 2.04) to protect against falling!
- ▶ If railings are present on the components, then they must be brought into the corresponding position and secured for assembly / disassembly work!
- ▶ Step on aids and fall protection equipment only with clean shoes!
- ▶ Keep aids and fall protection equipment clean and free from snow and ice!



WARNING

Falling components!

At assembly / disassembly, the components and counterweight plates can fall down!

Personnel can be severely injured or killed!

- ▶ Make sure that no persons or objects are within the danger zone!



WARNING

Incorrect handling of the fastening equipment!

If fastening equipment cannot be attached correctly and if it is not secured sufficiently to prevent it from loosening up, loads can fall down. Personnel can be severely injured or killed!

- ▶ Make sure that the fastening equipment is correctly attached on the fastening points and that it is secured sufficiently to prevent it from loosening up!



WARNING

Danger of impact / crushing!

By staying in the danger zone of the counterweight assembly there is an impact / crushing danger!

Personnel can be severely injured or killed!

- ▶ Make sure that there are no persons between the components which are to be assembled / disassembled!

Make sure that the following prerequisites are met:

- The crane is aligned in horizontal direction.
- The container spreader operating instructions were read and understood.

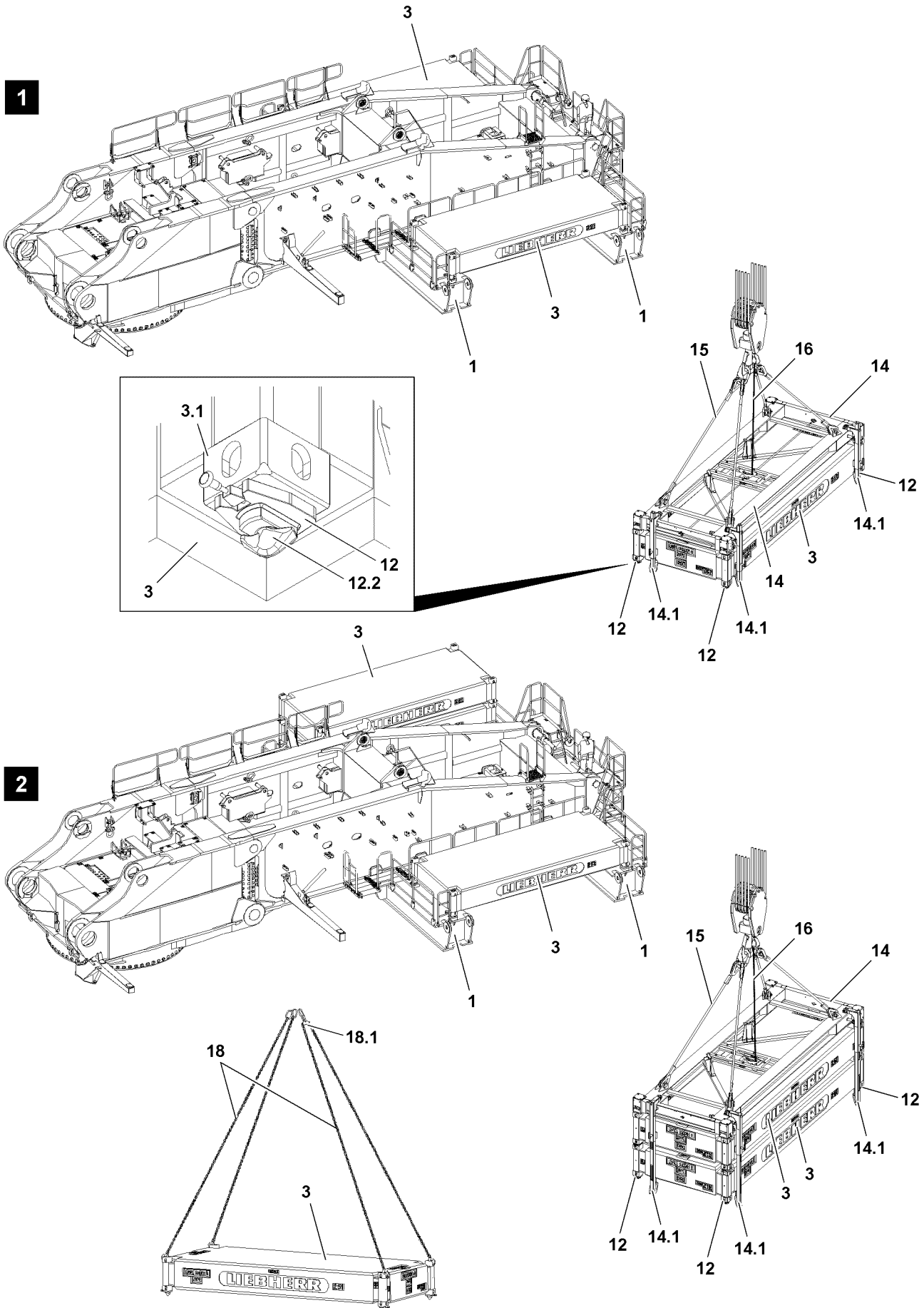

Fig.114758

LWE/LR 13000-001/19503-01-02/en

6.1 Disassembling / lifting the counterweight plates off

The counterweight plates can be removed or lifted off with the following devices or fastening equipment:

1. **14** Container spreader
2. With a chain suspension **18** at least 6 m long with balancer **18.1**



WARNING

Danger of accidents due to overload!

If more than the permissible **two** counterweight plates are fastened on the container spreader **14**, the counterweight plates can fall down and the container spreader can be significantly damaged!

If more than **one** counterweight plate is fastened on the chain suspension **18**, then the chain suspension can rip off and the counterweight plates can fall down!

Personnel can be severely injured or killed!

- ▶ Make sure that no more than maximum two counterweight plates are fastened on the container spreader **14**.
- ▶ Make sure that no more than maximum one counterweight plate is are fastened on the chain suspension **18**.



WARNING

Danger of accident!

If damaged counterweight plates are used for ballasting, they can break off or parts can fall down!

Personnel can be severely injured or killed!

- ▶ Replace damaged counterweight plates immediately.
- ▶ Continues use of damaged counterweight plates is prohibited.



Note

- ▶ The counterweight plates **3** are marked with their own weights!

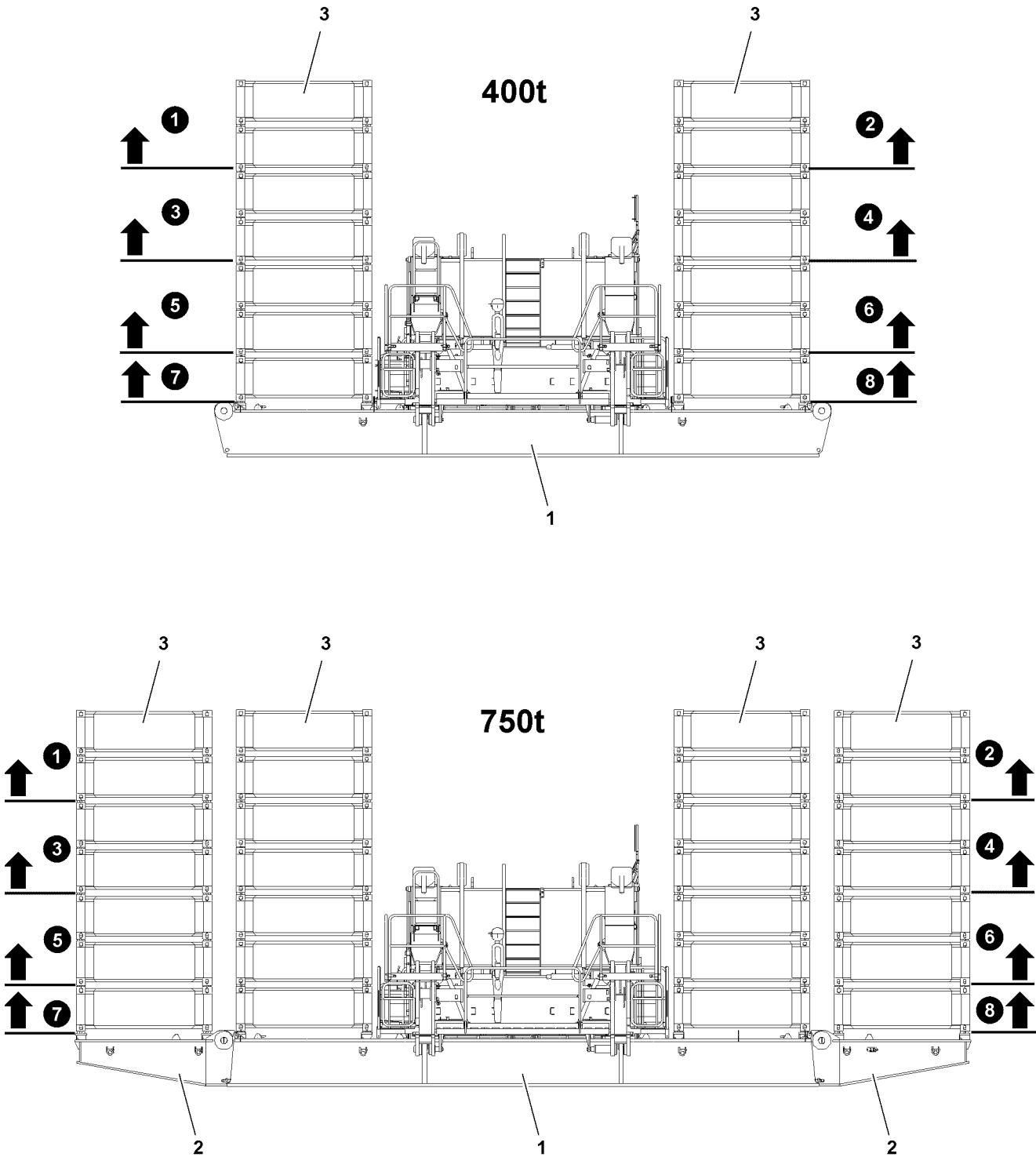

Fig.114759

LWE/LR 13000-001/19503-01-02/en

**WARNING**

The crane can topple over!

If more than 50 t are lifted off with one lift on the counterweight frame or on the counterweight stacks **3** or if the counterweight is removed asymmetrically, then the crane can topple over!

Personnel can be severely injured or killed!

Counterweight 400 t:

- ▶ During ballasting off, a weight difference between the right and left counterweight stack of more than 50 t is prohibited.
- ▶ Alternately remove no more than maximum 50 t counterweight assemblies from the counterweight stacks, alternately symmetrically on the left and right.

Counterweight 750 t:

- ▶ During ballasting off, a weight difference between the right and left counterweight stack of more than 50 t is prohibited.
- ▶ When ballasting off, first remove the outer counterweight stacks completely.
- ▶ Alternately remove no more than maximum 50 t counterweight assemblies from the counterweight stacks, alternately symmetrically on the left and right.

When the outer counterweight stacks are completely ballasted off:

- ▶ Ballast the inner counterweight stacks off completely. During ballasting off, a weight difference between the right and left counterweight stack of more than 50 t is prohibited.

6.1.1 Disassembly sequence of the counterweight

**Note****400 t:**

- ▶ The disassembly sequence must be adhered to, you can also start with step **1** on the right!

750 t:

- ▶ The disassembly sequence must be adhered to, you can also start with step **1** on the right!

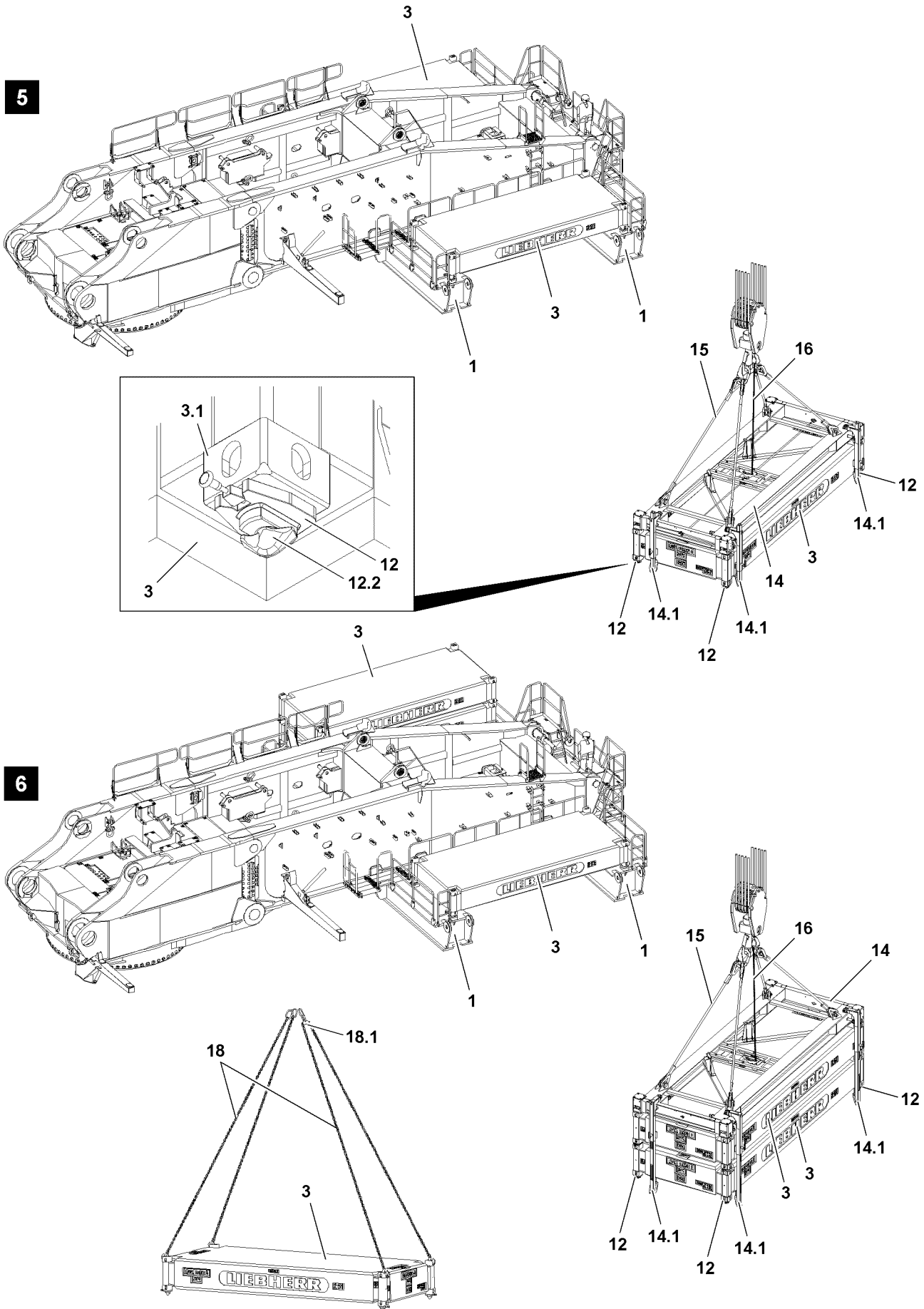

Fig.114757

LWE/LR 13000-001/19503-01-02/en

6.1.2 Lifting the counterweight plates from the counterweight stacks



WARNING

Danger of falling!

If the counterweight frame or one of the ballast stacks must be accessed by assembly personnel, the assembly personnel can fall down!

Personnel can be severely injured or killed!

- ▶ Walking or stepping on the counterweight frame and / or the ballast stack without personal protective equipment (fall protection equipment) is explicitly prohibited.
- ▶ Use a work platform.



Note

Lifting the counterweight plates individually from the counterweight stacks:

- ▶ Always unlock only the uppermost counterweight plate on the counterweight stack.

Lift the counterweight plates in assembly (maximum two counterweight plates together) from the counterweight stacks:

- ▶ Always unlock only every second counterweight plate on the counterweight stack.

Make sure that the following prerequisites are met:

- The required **12** are unlocked.
- Make sure that the telescope pipes of the strut guides **14.1** on the container spreader have the correct length, see container spreader Operating instructions.

NOTICE

Danger of property damage!

- ▶ Make sure that the strut guides are moved in to the point where they do not protrude past the contour of the counterweight plate / the counterweight assembly.



Note

- ▶ The lock between the counterweight plate(s) and the container spreader can be locked / unlocked via a kinematical-mechanical locking mechanism, see container spreader operating instructions.

NOTICE

Danger of property damage!

If the following notes are not observed, the counterweight plates and the can be damaged!

- ▶ Make sure that all four are unlocked before the individual counterweight plates or a counterweight assembly is lifted off.

When the are unlocked:

- ▶ Take on the first counterweight assembly **3** with the container spreader **14** and swing out.
- or**
- ▶ Take on the counterweight plates **3** individually with the chain suspension **18** and swing out.

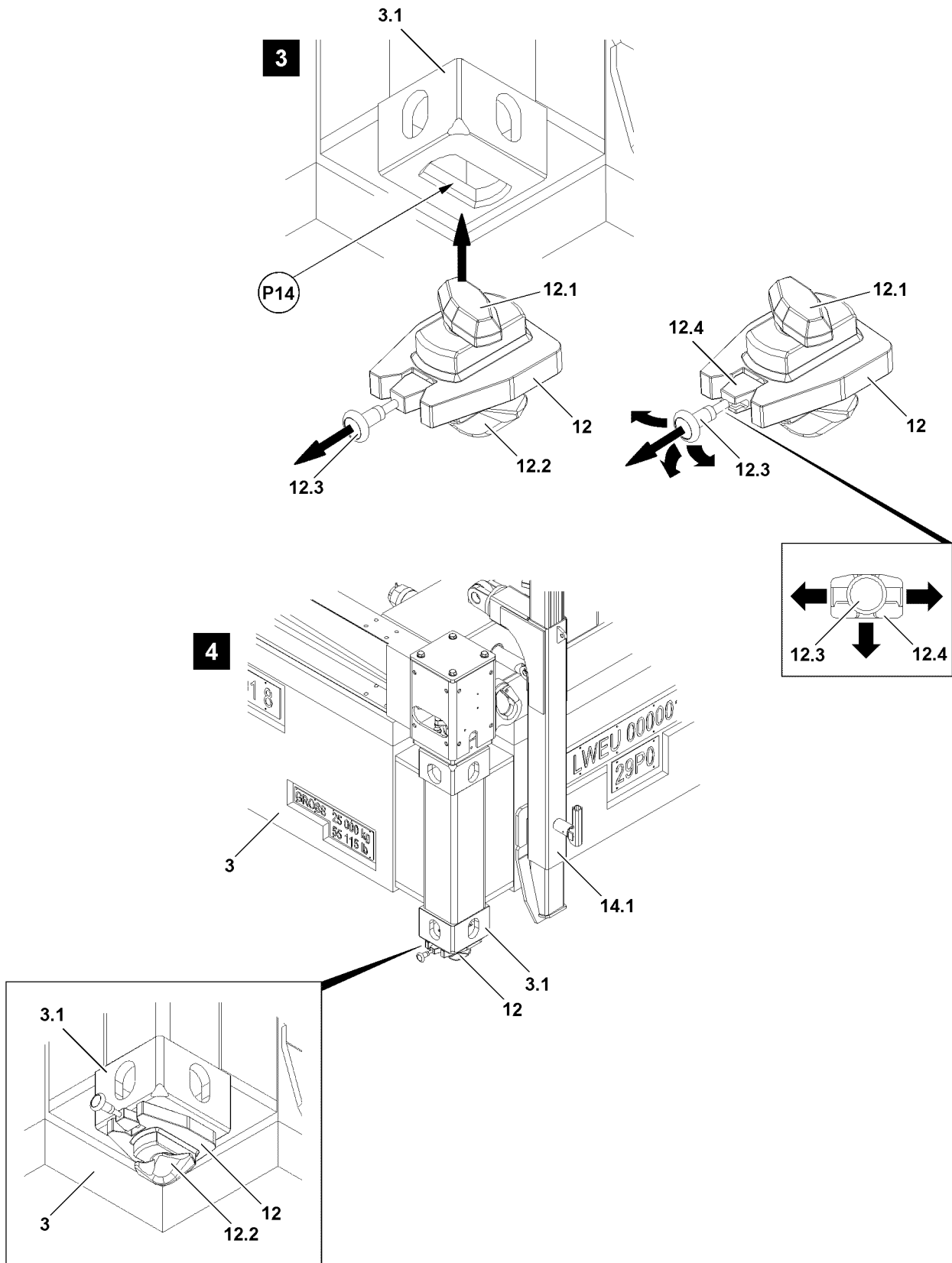

Fig.114755

LWE/LR 13000-001/19503-01-02/en

6.2 Removing the Twistlock on the counterweight plate(s)

Make sure that the following prerequisite is met:

- The lifted off counterweight plate / the counterweight assembly **3** is just above the ground.



WARNING

Falling Twistlock!

When unlocking the Twistlock, it can fall down!

Personnel can be severely injured!

- ▶ Secure the Twistlock before unlocking to prevent it from falling.
-
- ▶ Unlock the Twist lock **12**: Pull release pull **12.3** and hold and remove the Twistlock downward from the container corner fitting **3.1**.
 - ▶ Activate the locking mechanism of the Twistlock **12** again: Slowly let the release **12.3** return to its original position.
 - ▶ Place the Twistlock **12** into a suitable transport container.
 - ▶ Place the counterweight plates down.
 - ▶ Remove the container spreader.

7 Removal of A-frame

7.1 Removing the A-frame



Note

- ▶ The disassembly of the A-frame **12** on the turntable is described in detail on the Crane operating instructions, chapter 3.05!
-

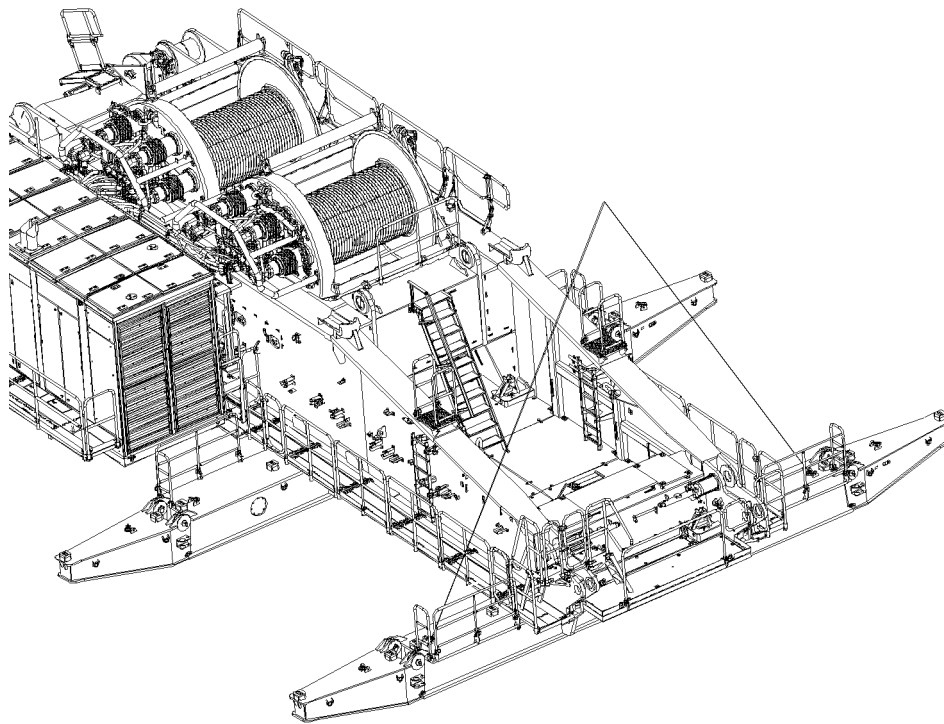

Fig.114761

LWE/LR 13000-001/19503-01-02/en

8 Disassembling the counterweight frame



WARNING

Danger of slipping / falling during assembly / disassembly work!

During assembly / disassembly work, personnel must be secured with appropriate aids to prevent them from falling!

Weather influences, such as wetness, wind, snow, frost increase the slipping / falling danger!

Personnel can be severely injured or killed!

- ▶ All assembly / disassembly work must be carried out using suitable aids (lifting platforms, scaffolding, ladders, auxiliary crane, etc.)!
- ▶ If work cannot be carried out on the ground or using such aids, then assembly personnel must be secured with the personal fall arrest system (see Crane operating instructions, chapter 2.04) to protect against falling!
- ▶ If railings are present on the components, then they must be brought into the corresponding position and secured for assembly / disassembly work!
- ▶ Step on aids and fall protection equipment only with clean shoes!
- ▶ Keep aids and fall protection equipment clean and free from snow and ice!



WARNING

Falling components!

At assembly / disassembly, the components and counterweight plates can fall down!

Personnel can be severely injured or killed!

- ▶ Make sure that no persons or objects are within the danger zone!



WARNING

Incorrect handling of the fastening equipment!

If fastening equipment cannot be attached correctly and if it is not secured sufficiently to prevent it from loosening up, loads can fall down.

Personnel can be severely injured or killed!

- ▶ Make sure that the fastening equipment is correctly attached on the fastening points and that it is secured sufficiently to prevent it from loosening up!



WARNING

Danger of impact / crushing!

By staying in the danger zone of the counterweight assembly there is an impact / crushing danger!

Personnel can be severely injured or killed!

- ▶ Make sure that there are no persons between the components which are to be assembled / disassembled!

Make sure that the following prerequisites are met:

- The crane is aligned in horizontal direction.
- The A-frame is removed.

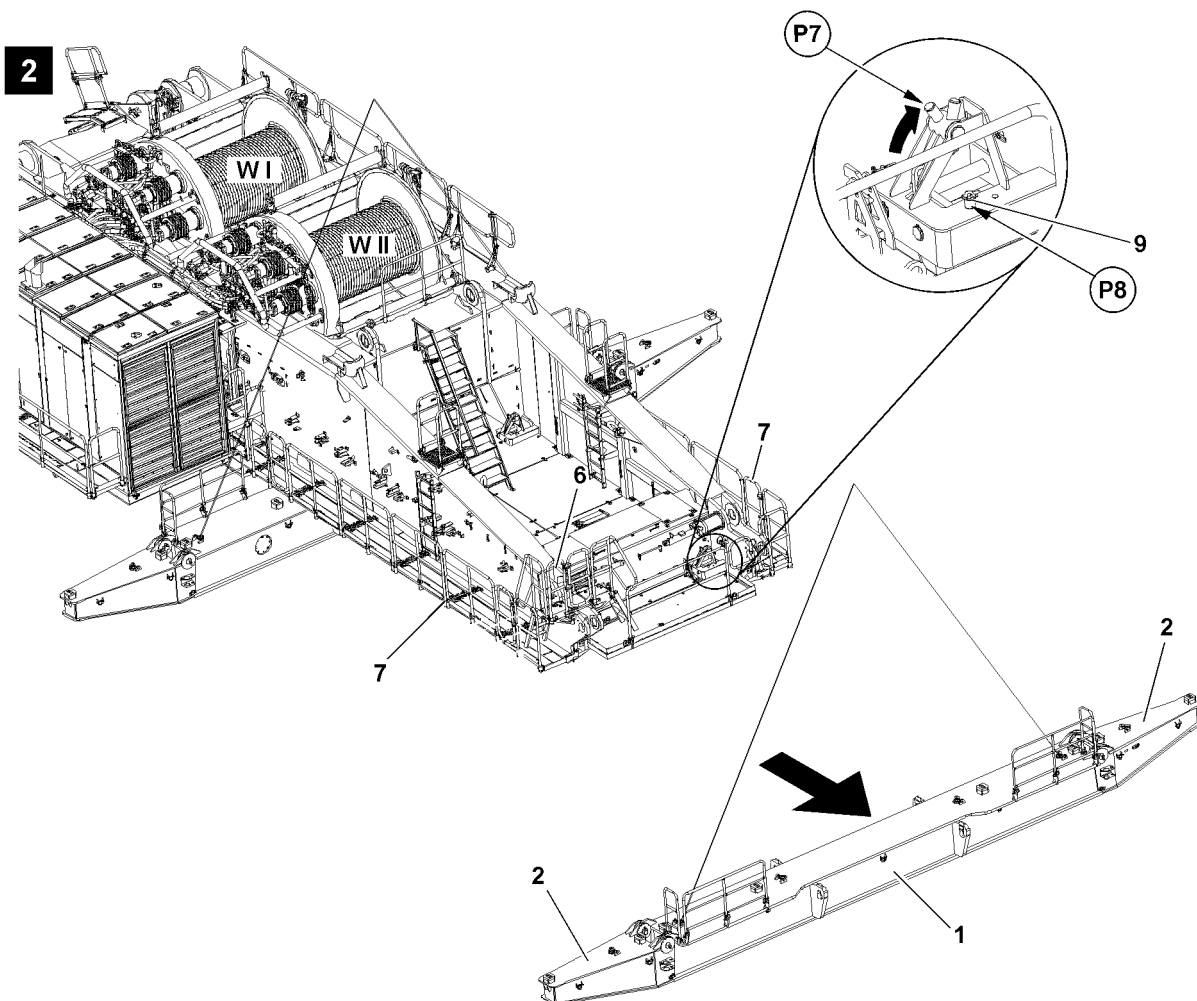
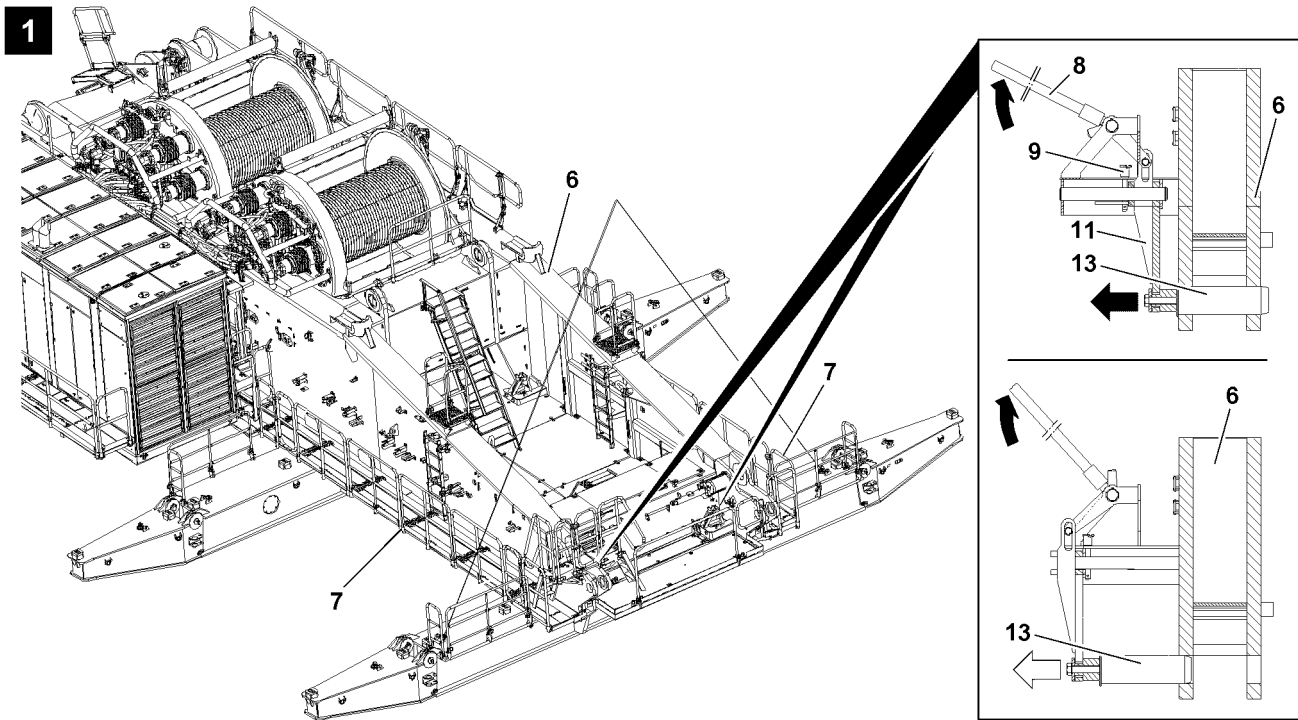

Fig.114762

LWE/LR 13000-001/19503-01-02/en

8.1 Disassembling the carriers on the turntable



Note

- ▶ For safety reasons, we recommend to carry out the disassembly of the brackets **2** on the ground!

Make sure that the following prerequisite is met:

- The counterweight is completely lifted off from the counterweight frame.

8.1.1 Disassembling the first carrier on the turntable frame



Note

- ▶ The brackets **2** remain on the carriers at disassembly of the carriers **1**!
- ▶ The brackets are removed on the ground!



WARNING

Danger of falling!

When fastening the carrier **1** for the removal, the assembly personnel can fall down!

Personnel can be severely injured or killed!

- ▶ Make sure that the assembly personnel is protected from falling with the personal protective equipment when fastening the carriers.

Alternative:

- ▶ Use a lifting platform!
 - ▶ Observe the safety regulations for the use of lifting platforms!
-
- ▶ Fasten the first carrier **1** on the auxiliary crane, see section „Fastening points“.
 - ▶ Fasten the guide rope on the carrier **1**.
 - ▶ Tension the fastening equipment.

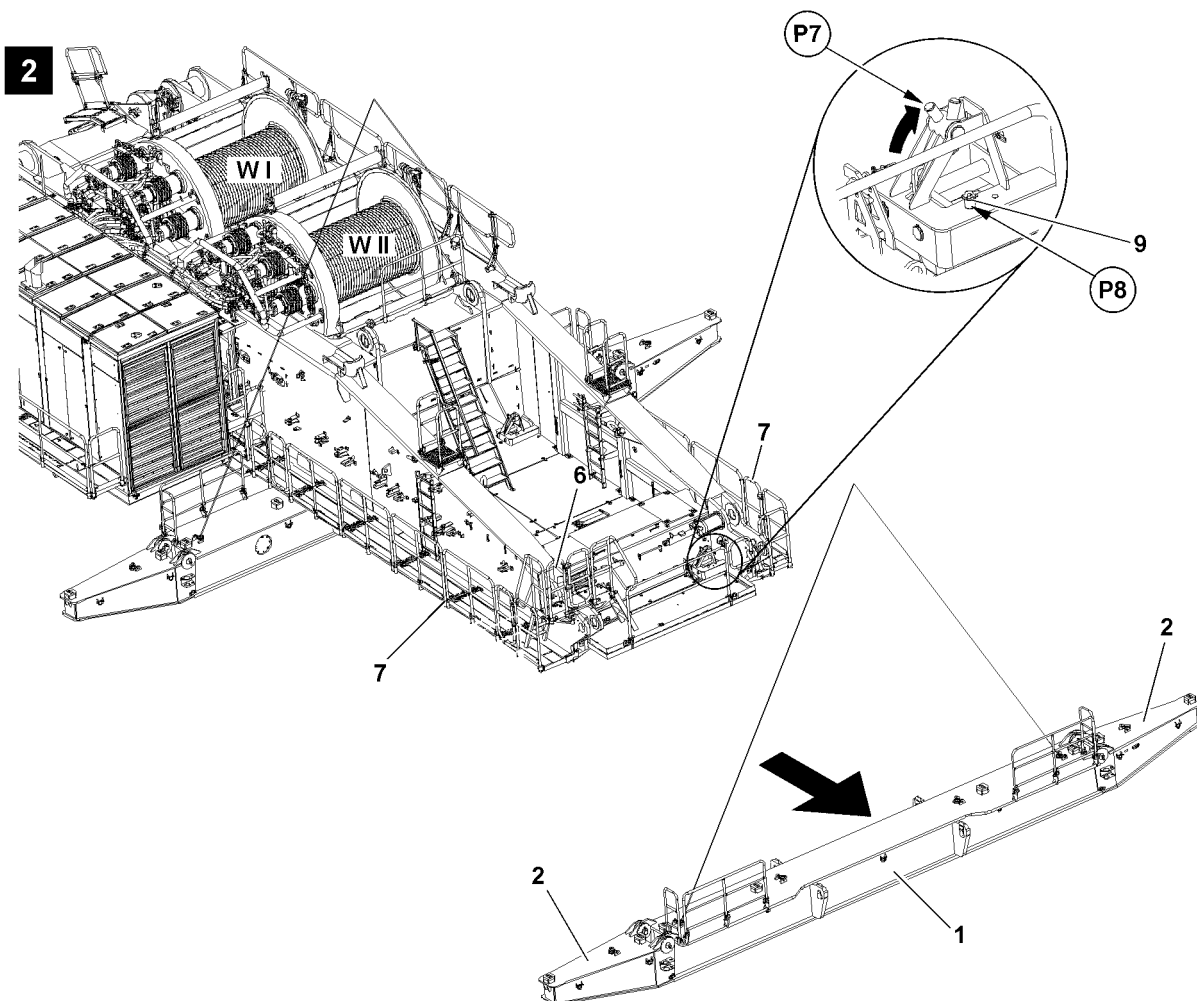
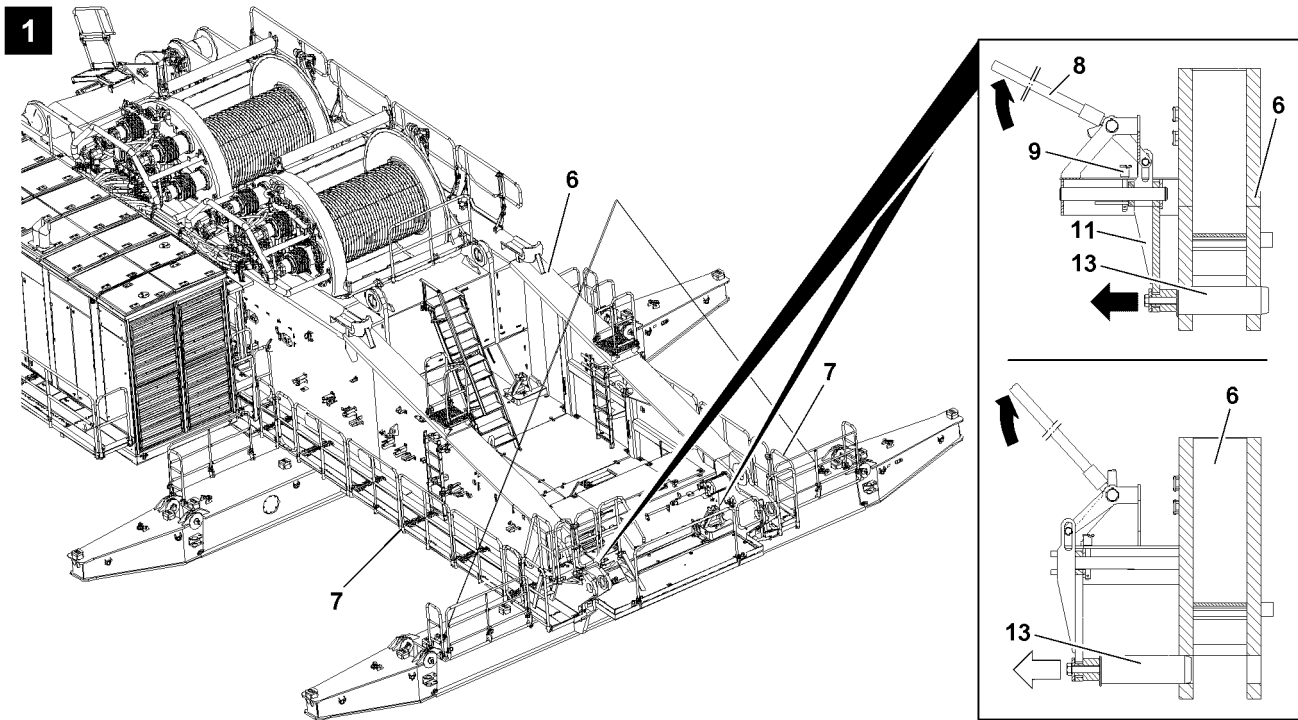

Fig.114762

LWE/LR 13000-001/19503-01-02/en

**WARNING**

Danger of accident due to carrier!

When unpinning the carrier, it can suddenly fall down into the fastening equipment!

Personnel can be severely injured or killed!

- ▶ Make sure that the fastening equipment is tensioned before unpinning the carrier **1**.

When the fastening equipment is tensioned:

- ▶ Unpin the first carrier **1** on the turntable.
- ▶ After the unpinning procedure, secure the guide **11** with the call locking pin **9** at point **P8**.

NOTICE

Damage of crane components!

When moving the first carrier **1** out on the turntable, there is a danger of property damage!

Railings and catwalks can be significantly damaged!

This could result in high repair costs!

- ▶ Always move the carriers **1** out with sufficient safety clearance to the turntable **6** - especially to the railings and catwalks.
- ▶ Move the carriers **1** out with very slow speed on the turntable.
- ▶ Secure the carriers **1** with the guide rope to prevent them from swinging back and forth!

When all four connector pins **13** are completely unpinned on the first carrier **1**:

- ▶ Lower the carrier **1** with the auxiliary crane and swing it out to the rear from the turntable **6**.
- ▶ Secure the carriers **1** during the swing out procedure with a guide rope to prevent them from swinging back and forth.
- ▶ Place the carrier **1** on a load bearing support on the ground.

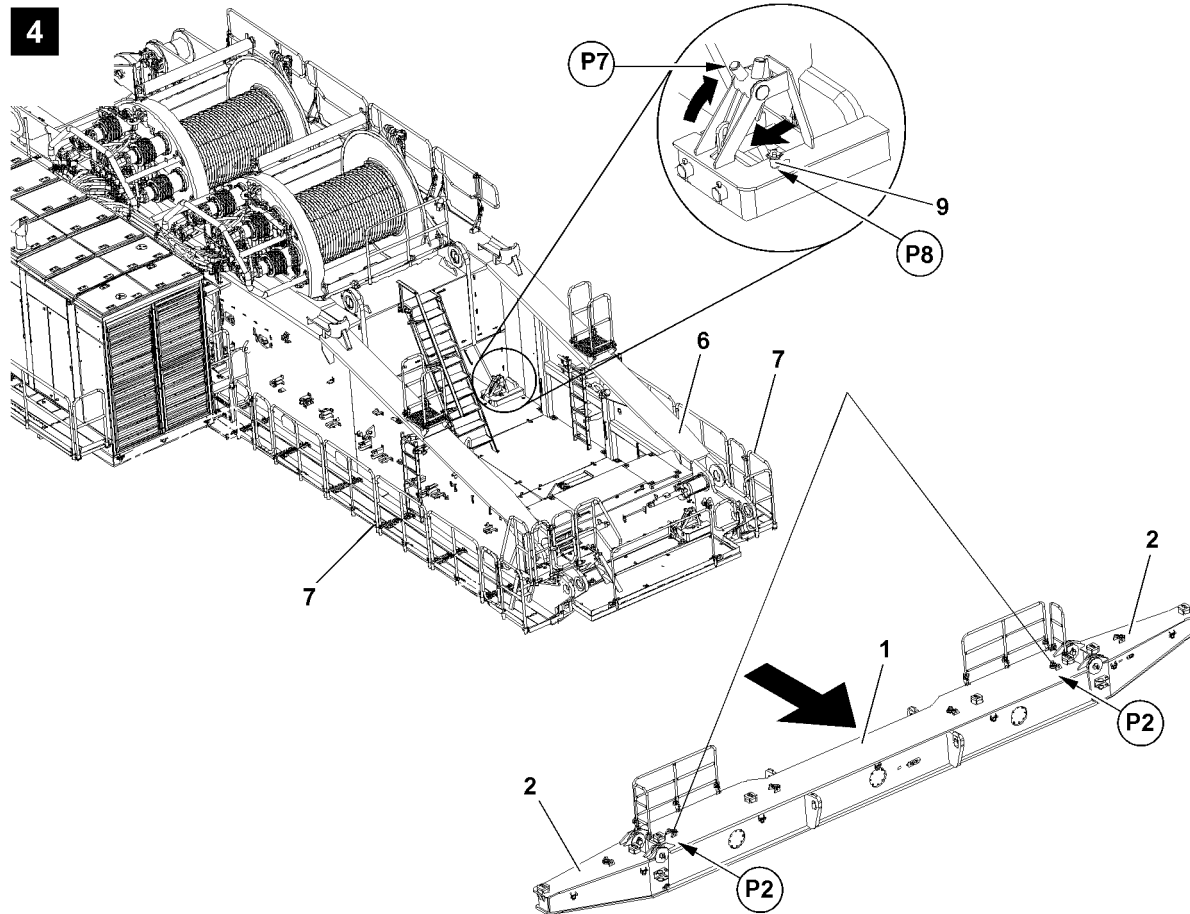
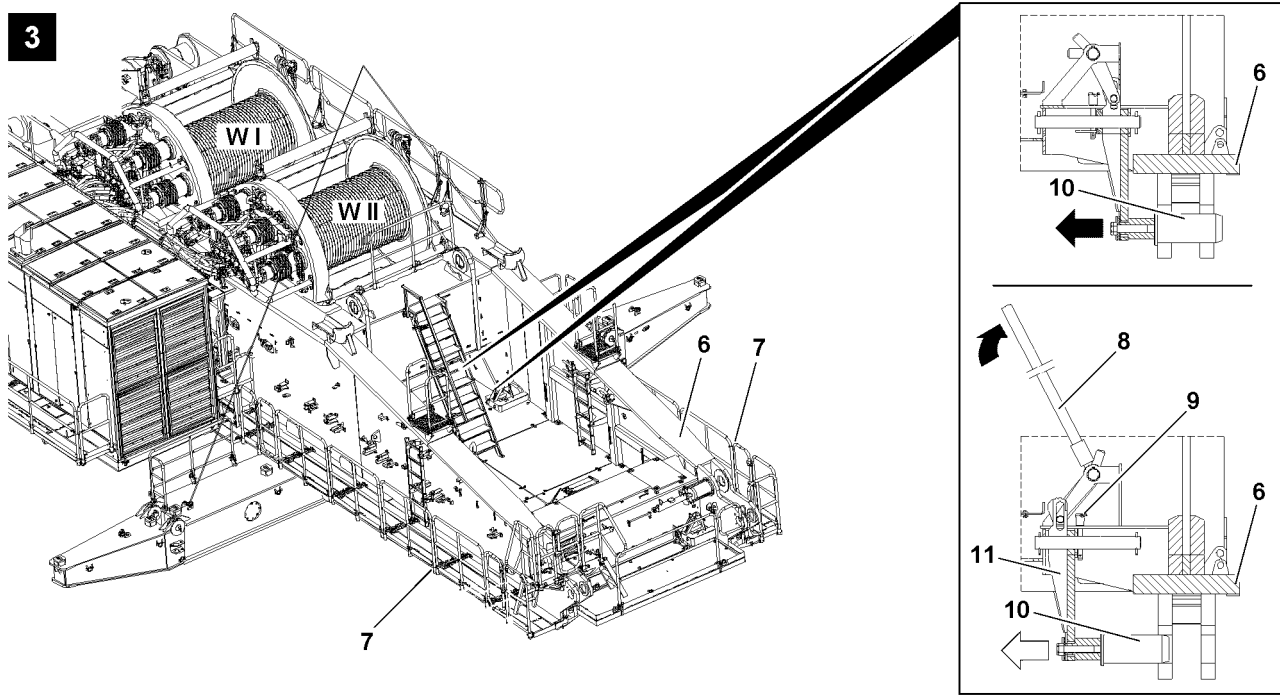

Fig.114763

LWE/LR 13000-001/19503-01-02/en

8.1.2 Disassembling the second carrier on the turntable frame



Note

- ▶ The disassembly of the second carrier **1** is identical with the disassembly of the first carrier!
 - ▶ Observe and adhere to the danger notes in section „Disassembling the first carrier on the turntable frame“!
-
- ▶ Remove the carrier **1** and place it on a load bearing support on the ground.
 - ▶ After unpinning the second carrier, place and secure the control lever **8** into the transport receptacle.

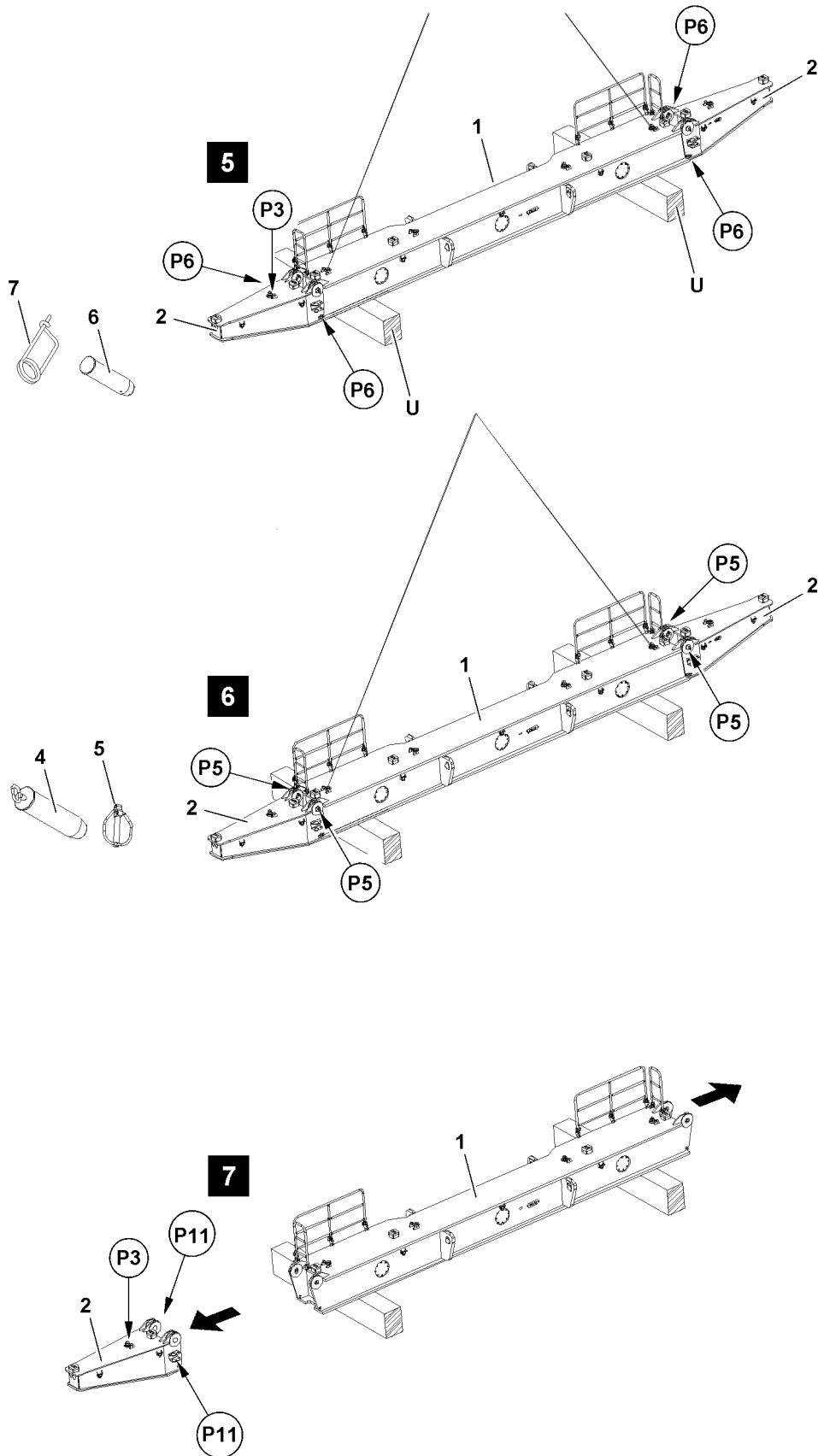

Fig.114764

LWE/LR 13000-001/19503-01-02/en

9 Disassembling the brackets on the carriers

Make sure that the following prerequisites are met:

- The carriers **1** have been removed on the turntable.
- The carriers **1** are placed on the ground on a load bearing support **U**.
- The carriers **1** are freely accessible.

9.1 Disassembling the first bracket on the carrier

- ▶ Fasten the first bracket **2** on point **P3** on the auxiliary crane.

When the bracket **2** is properly fastened on the auxiliary crane:

- ▶ Tension the fastening equipment.

When the fastening equipment is tensioned:

- ▶ Release retaining pins **6** on both sides at point **P6** and unpin.
- ▶ Insert the retaining pins **6** into the transport receptacle at point **P11** and secure.



WARNING

Danger due to oscillating crane components!

When unpinning the bracket **2**, it can start to swing back and forth due to angular pull!

Personnel can be severely injured or killed!

- ▶ It is prohibited to pull a load at an angle.

- ▶ Release and unpin the grip pins **4** on both sides at point **P5**.
- ▶ Insert the grip pins **4** at point **P11** on both sides and secure.
- ▶ Swing the bracket **2** out with the auxiliary crane and place it on a load bearing support or on a suitable transport vehicle.

9.2 Disassembling the second bracket on the carrier



Note

- ▶ The disassembly of the second bracket **2** is identical with the disassembly of the first bracket!

9.3 Bringing the railings on the carriers into transport position

Make sure that the following prerequisites are met:

- The brackets on the carriers are removed.
- The fastening equipment on the carriers has been removed.
- ▶ Bring the railings of the carriers **1** from operating position into transport position and secure, see Crane operating instructions, chapter 2.06.

Empty page!

LWE/LR 13000-001/19503-01-02/en

4.08 Working with a load

1	Safety instructions	3
2	Checks before starting to work with the crane	4
3	Telescoping crane movement	5
4	Taking on a load	7
5	Load weighing and load display	13
6	Crane operation	18
7	Ram work or pulling sheet piles	19
8	Crane rope pretension	20

Fig.195219

LWE/LR 13000-001/19503-01-02/en

1 Safety instructions

In addition, observe the general technical safety instructions in chapter 2.04.

In steep boom positions for which no loads are specified in the load charts, there is a danger of tipping to the rear to the counterweight side.

The danger of tipping to the rear exists especially in case of:

- Crane operation on tires
- Supported, with retracted sliding beams
- Reduced support base



WARNING

Crane operation in steep boom positions for which no loads are specified in the load charts!

The crane can tip to the rear and fatally injure personnel.

- ▶ Comply with the boom radius specified in the load chart.
- ▶ Crane operation outside the permissible set up configurations, boom radii and slewing ranges according to the load chart is prohibited.



WARNING

Incorrect reeving number set up!

If the reeving number on the pulley head is less than the reeving number set on the LICCON computer system, it can result in an overload of the hoist rope.

The hoist rope can rip. The load can fall down and fatally injure personnel.

- ▶ Comply with the reeving numbers specified in the load chart for maximum loads.
- ▶ Make sure that the reeving on the pulley head and the reeving set on the LICCON computer system match.

The minimum rope coils must remain on the rope winches. The number of minimum rope coils depends on if the rope winch is equipped with a cam limit switch or a winch speed sensor.



WARNING

Minimum rope coils fallen below!

The rope will be ripped out. The load falls down.

Personnel can be killed.

- ▶ Make sure that the minimum rope coils remain on the rope winch.
- ▶ Observe and comply with the number of the minimum rope coils in chapter 5.01.



WARNING

Lift the load by luffing up!

The crane can topple over and fatally injure personnel.

- ▶ Lift the load with the hoist gear.

Always comply with the maximum loads specified in the load chart.

The weight of the hook block according the load chart must be taken into account. Subtract the weight of the hook block from the load chart value. The minimum hook block weight must be determined according to the reeving number and the data in the load charts.

For the stroke, use the hook block which is suited best for the existing set up configuration in connection with the load chart.

Initiate all crane movements carefully. Also brake the crane movements carefully. That way you can avoid a swinging or pendulum motion in the suspended load.

2 Checks before starting to work with the crane

Before starting work with the crane, the crane operator must carry out a further inspection to satisfy himself about the crane's operational safety:

- Check that the crane is properly supported and level.
- Check that the set up configuration set in the control matches the actual set up configuration.
- Check that all values in the load chart that apply to the current equipment configuration have been entered and met.
- Ensure that there are no people or objects within the danger zone of the crane.



WARNING

Persons in the slewing range!
Crushing danger, death, severe bodily injuries.

- ▶ Monitor the slewing range.
- ▶ Make sure that there are **no** persons within the slewing range.
- ▶ Block off the slewing range if necessary.



WARNING

Obstacle in the slewing range!
Property damage on crane and on obstacle.

- ▶ Make sure that there are **no** obstacles within the turning range of the crane and the crane components.

2.1 Visual check for damage



WARNING

Danger of accident!

If the crane is operated despite existing defects, personnel can be severely injured or killed.

- ▶ In the event of deficiencies which threaten operational safety, stop crane operation immediately.

The following deficiencies threaten the crane's operational safety:

- Damage to load-bearing parts of the crane design, such as booms, supports etc.
- Failure of the hoist gear brake and consequent slipping of the load
- Functional failures in the crane control system
- Functional defects in the indicator and warning lights
- Damage to the hoist ropes
- Safety defects in the safety equipment
- Leaks on safety relevant components of the crane hydraulic

Inform the appropriate supervisor about the deficiencies on the crane and also inform your relief when crane operators are changed.

2.2 Operating with telescopic boom and auxiliary boom

When operating with a telescopic boom and auxiliary boom in the 0° position and with a steep luffed up telescopic boom, the hook blocks can collide with the telescopic boom or the auxiliary boom.

NOTICE

Operation with the telescopic boom and auxiliary boom in the 0° position and steep luffed up telescopic boom!

The hook block can collide with the telescopic boom or auxiliary boom.

- ▶ Make sure that the hook block is always at a sufficient distance from the crane structure.

Before collision of the hook block with the telescopic boom or the auxiliary boom:

- ▶ Stop spooling up the winch or end luffing up the boom.

With a hydraulic auxiliary boom:

- ▶ Increase the freedom of movement of the hook block with respect to the auxiliary boom by luffing down the auxiliary boom.

2.3 Telescopic boom distortion because of sunshine on one side

A temperature difference occurs between the side facing the sun and the side facing away from the sun for cranes with telescopic booms. This causes telescopic boom side distortion, which can reduce the load bearing capacity of the telescopic boom.

For example, a temperature difference between the two boom sides of 30 °C and a boom length of 60 m results in a length difference caused by the temperature difference between the two sides of the telescopic boom of approximately 22 mm. With narrow boom parts, this causes the profiles to bend sideways.

If the maximum load is being utilized during operation with a telescopic boom extension such as a fixed lattice jib, luffing lattice jib or folding jib, then it must be ensured through a visual inspection before picking up the load that the boom is not showing signs of side deformation due to one-sided sun exposure.

**WARNING**

Danger of accident due to component overload!

If the telescopic boom has become distorted because of one-sided sunlight, this can cause component overload and therefore accidents.

- ▶ Turn the crane so that both sides of the boom are heated up equally, eliminating side deformation due to temperature difference.

3 Telescoping crane movement

If the telescopic boom is telescoped with the jib boom or telescopic boom extension, before the telescoping procedure, ensure that:

- The crane is properly supported and horizontally aligned.
- The telescopic boom is evenly warmed up by solar radiation.
- There is no strong side wind.

**WARNING**

Damage to the telescopic boom or the hoist rope!

If these 3 factors are not adhered to, damage of the telescopic boom or the hoist rope can occur and lead to accidents.

- ▶ Support the crane properly and align it horizontally.
- ▶ Keep both sides of the boom at about the same temperature.
- ▶ Telescope only to the permissible wind speed according to the load chart.
- ▶ If the actual wind speed is higher than the permissible wind speed noted on the load chart, telescoping is prohibited.

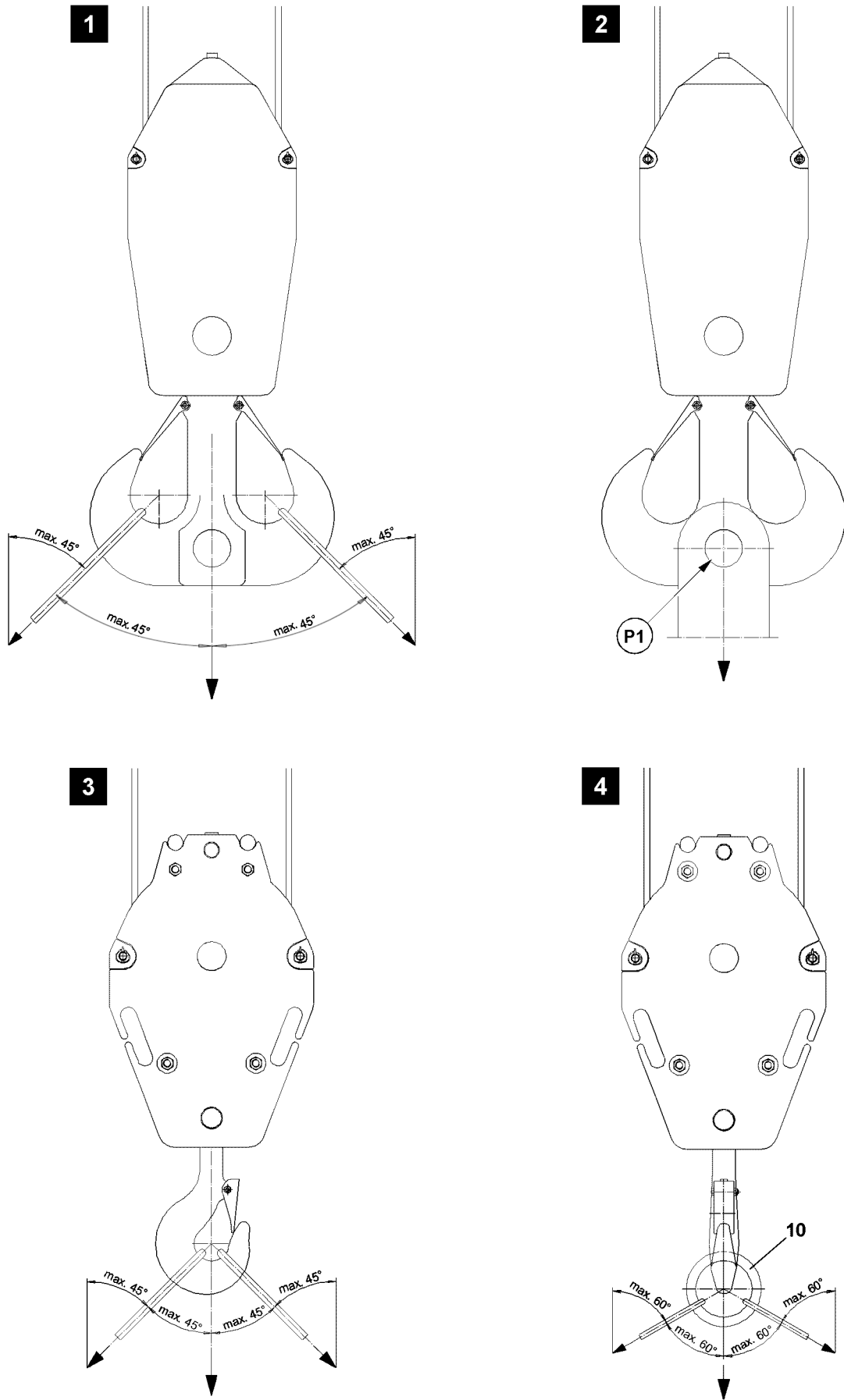

Fig.145147

LWE/LR 13000-001/19503-01-02/en

4 Taking on a load

The crane must always be operated in such a way that its load-bearing parts are not destroyed or damaged and its stability is ensured.

Make sure that the following prerequisites are met:

- The crane is supported and horizontally aligned.
- The LICCON overload protection has been set according to the load chart and the set up configuration.
- The LICCON overload protection is active.
- In the case of cranes with central ballast: The central ballast is installed according to the load chart.
- The counterweight is installed according to the load chart.
- In the case of cranes with derrick ballast: The derrick ballast is installed according to the load chart.
- The hook block or the load hook is correctly reeved.

4.1 Fastening the load



WARNING

Load can be ripped off!

If impermissible fastening and / or load handling equipment is used when taking on a load on the centric bore on the double hook at point **P1** (illustration **2**), then the double hook as well as the hook block can be damaged.

The load can rip off and fall down.

Personnel can be severely injured or killed.

- ▶ Lift the load via the centric bore on the double hook (point **P1**): For the technical requirements and the technical design of the fastening and / or load handling equipment contact the hook block manufacturer.



WARNING

The crane can topple over!

If the following conditions are not met, the crane can topple over.

Personnel can be severely injured or killed.

This could result in significant property damage.

- ▶ Pay attention to the own weight of the load handling equipment.
- ▶ Pay attention to the load bearing capacity of the load handling equipment.
- ▶ The maximum permissible incline of the strands fastened on the single or double hook in the hook jaws is 45°. See illustration **1** and illustration **3**.

If necessary for the single hook:

- ▶ Use fastening equipment with a suspension link **10**. The maximum permissible incline in this case is 60°. See illustration **4**.
- ▶ Load a single and double hook symmetrically. A maximum deviation of $\pm 3^\circ$ from the direction of the center of gravity is permissible.

If necessary:

- ▶ Use cross beam or two cranes for taking on the load.

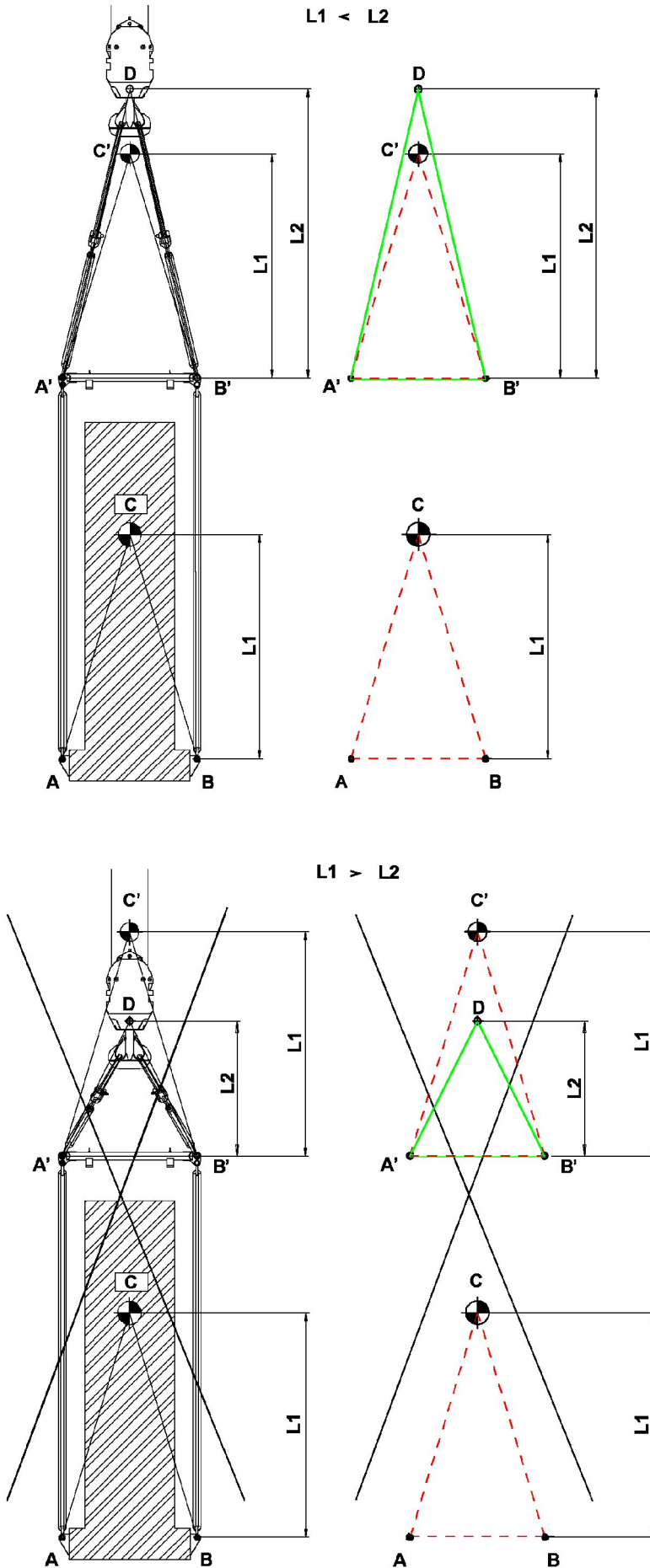

Fig.116274

LWE/LR 13000-001/19503-01-02/en

4.2 Taking on a load with cross beam

Cross beam are load handling equipment between crane hook and load.

The distance of the center of gravity **L1** is the vertical dimension from the fastening point of the load to the center of gravity of the load.

The cross beam height **L2** is the vertical dimension from the point of rotation of the crane hook to the next lower linkage point of the cross bar.



WARNING

Tipping of load to the side!

If fastening ropes are used which are too short, so that the load center of gravity is above the fastening point, then there is a danger of the load tipping to the side.

Personnel can be severely injured or killed.

- ▶ The load center of gravity must be below the crane hook.
- ▶ The distance of the center of gravity **L1** must be smaller than the cross beam height **L2** ($L1 < L2$).
- ▶ The triangle **A'B'C'** must be within the triangle **A'B'D**.

4.3 Transporting the hook block



WARNING

Danger of accident!

If a hook block is fastened incorrectly for transport, personnel can be injured.

- ▶ Fasten the hook block for transport on the fixed point in the center.
- ▶ Fastening the complete hook block on the auxiliary weights is prohibited.
- ▶ When setting down, secure the hook block against falling over.
- ▶ Prevent the load hook from rolling away.

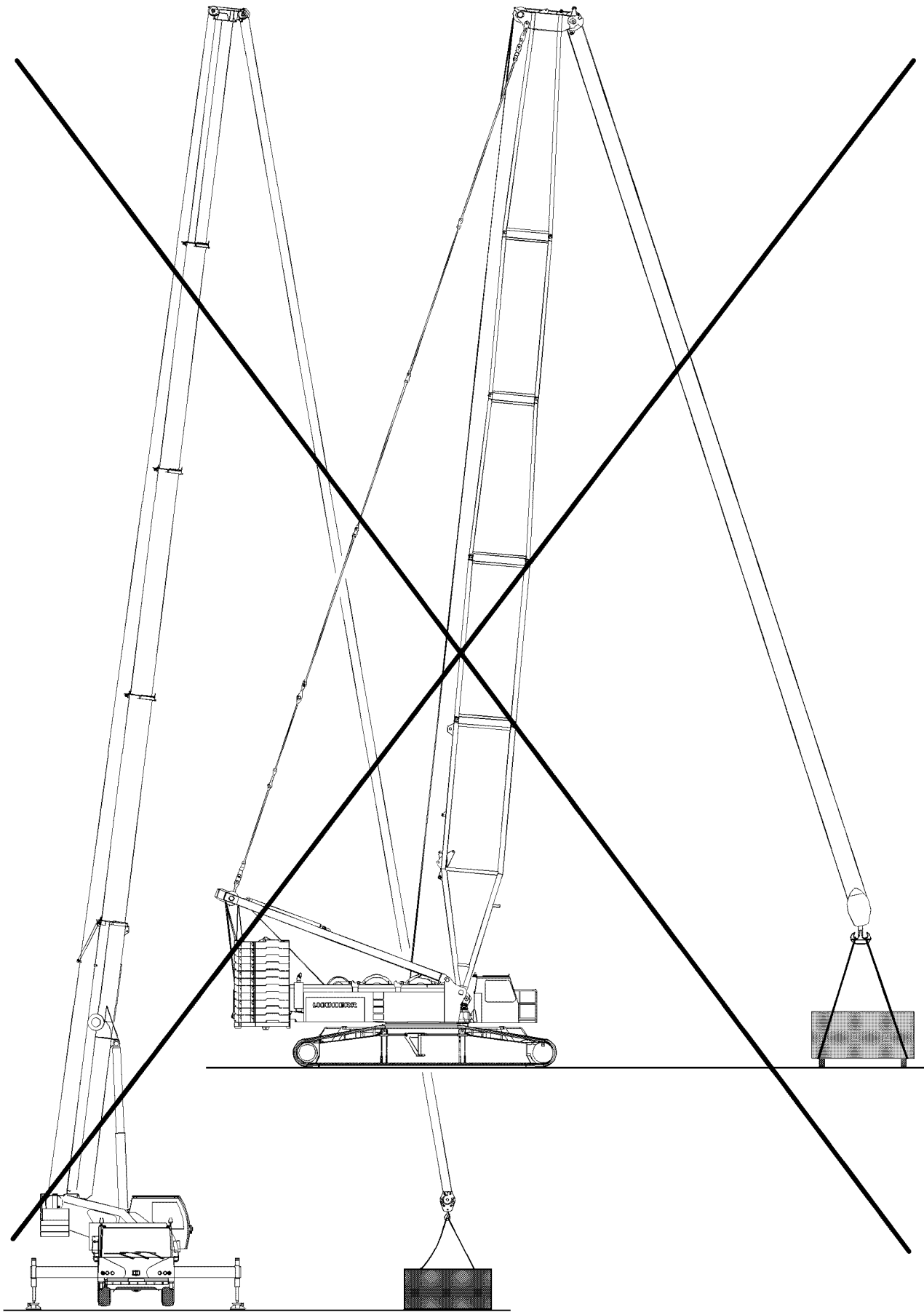

Fig.102716

LWE/LR 13000-001/19503-01-02/en

4.4 Lifting the load



WARNING

Danger of crushing for people in the load zone!

If personnel is located between the load to be lifted and a possible interfering edge (such as a wall of a building or similar) when the load is lifted, personnel can be severely injured or killed.

- ▶ Before lifting the load it must be ensured that there are no persons within the danger zone.
- ▶ It is prohibited to remain in the danger zone.
- ▶ It is prohibited for anyone to be under the load. Maintain a safe distance.
- ▶ Swinging the load is prohibited.
- ▶ Exercise extreme caution when lifting a load.



WARNING

The crane can topple over!

If an attempt to lift a load over the hoist gear causes the LICCON overload protection to turn off, then the load may not be lifted by luffing up the boom. This causes overload or toppling the crane. Personnel can be severely injured or killed.

- ▶ Do not lift the load by luffing up the boom off the ground.



Note

When using the assembly winch*, observe the following:

- ▶ Use the assembly winch* only for assembly and not for lifting loads.
- ▶ Lifting of loads with the auxiliary winch is prohibited.

If the fastening rope is manually attached by an assistant to the load to be lifted:

- Make sure that the assistant's hands are not crushed by the tightened ropes between the load and the fastening rope.
- Make sure that the assistant's body parts (hands, legs etc.) are not crushed by a swaying movement of the load during lifting.

4.5 Angular pull



WARNING

The crane can topple over!

Angular pulling can destroy the crane or cause it to topple over.

Personnel can be severely injured or killed.

- ▶ Fasten (hang) the hook block always vertically over the center of gravity of the load to be lifted.
- ▶ Do not use the slewing gear to pull and set up loads.
- ▶ When lifting, compensate for boom deflection.
- ▶ Angular pull is prohibited.

The crane is designed only to lift loads vertically. During angular pulling, regardless of whether this is done in the same direction as the boom or laterally, horizontal forces are generated from the load in addition to the vertical forces, for which the boom is not designed.

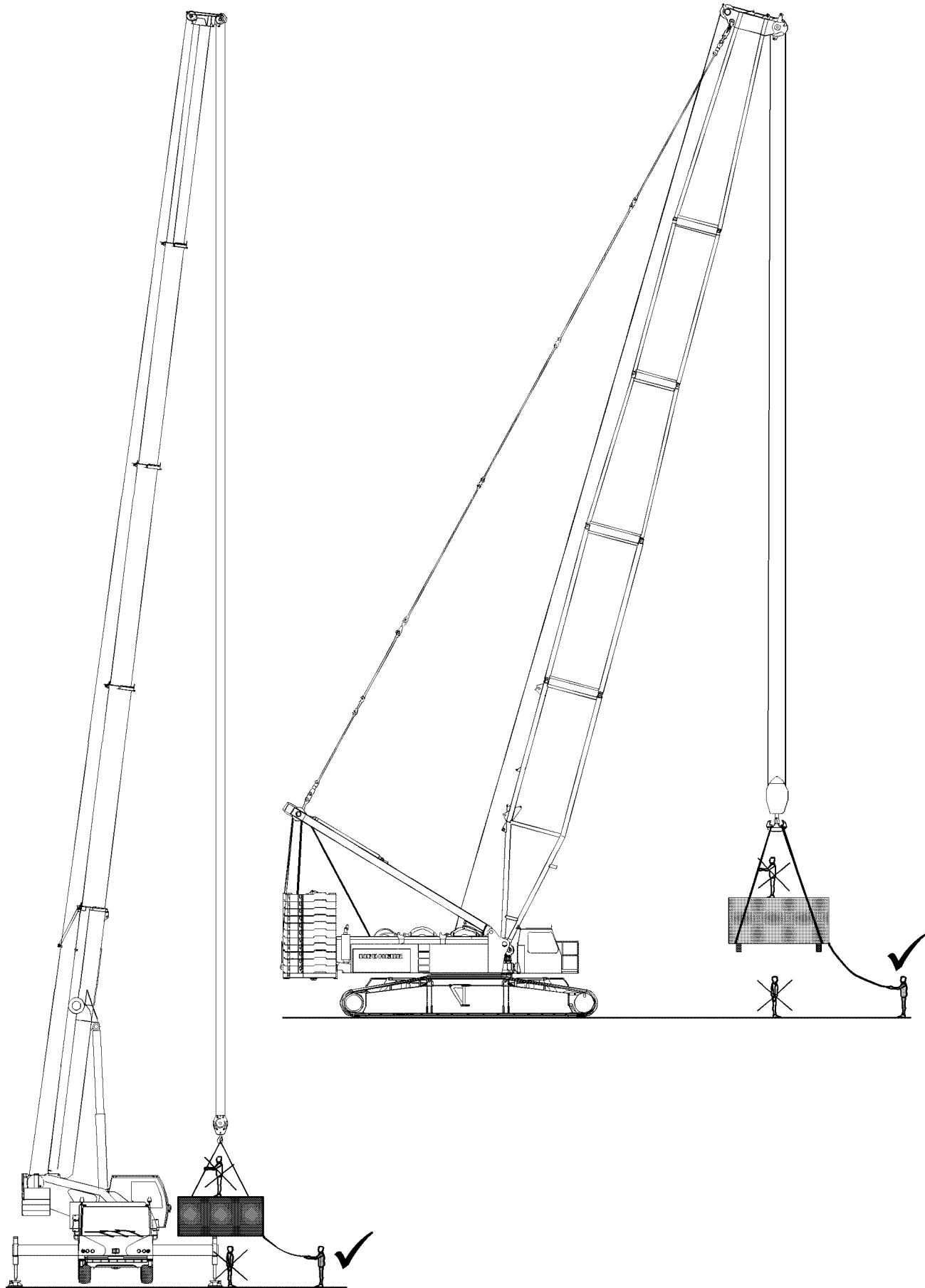

Fig.102717

LWE/LR 13000-001/19503-01-02/en

4.6 Breaking away fixed loads



WARNING

The crane can topple over!
 Ripping stuck loads free can destroy the crane or cause it to topple over.
 Personnel can be severely injured or killed.
 ► Ripping stuck loads free is prohibited.

5 Load weighing and load display

Load weighing and load display are described based on the example of a crane with a telescopic boom. The situation is the same for a crane with a telescopic boom and lattice mast boom.

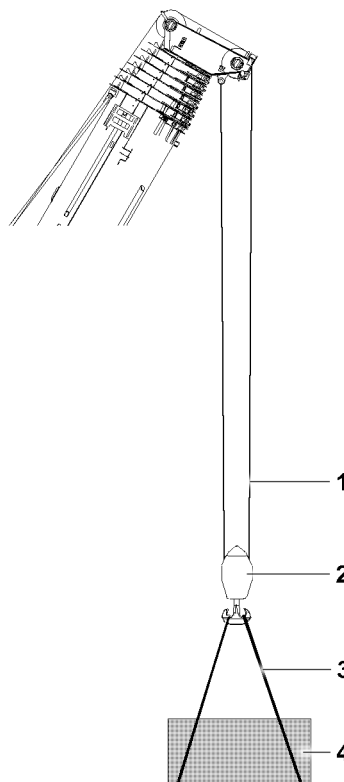

Fig.157473

- | | | | |
|---|------------------|---|---------------------------|
| 1 | Hoist rope | 3 | Fastening equipment 0.5 t |
| 2 | Hook block 1.5 t | 4 | Actual load capacity 48 t |

The loads indicated in the load chart take the weight of the hoist rope into account at nominal reeving.

The weight of the hook block and the weights of the fastening equipment must be subtracted from the load indicated in the load chart and are displayed as a load

Calculation of the actual load capacity of the crane	Load
Maximum permissible load according to the load chart	50 t
Hook block weight	- 1.5 t
Fastening equipment weight	- 0.5 t
Actual load capacity	= 48 t

LWE/LR 13000-001/19503-01-02/en

The weight of the actual load capacity (the component being lifted) may be not exceed **48 t** in this example.

5.1 Load weighing

Make sure that the following prerequisites are met:

- The angle sensors are functioning.
- The incline sensors are functioning.
- The turn sensor in the turntable is functioning.
- The pressure sensors are functioning.
- The length sensors are functioning.
- The pull sensors are functioning.



WARNING

The sensor is defective.
Load display and load weighing are not exact.
An error message is displayed.
► Stop crane operation. Replace the sensor.

5.1.1 Possible weighing errors

Exact sensor signals are required for precise load weighing.

Since all sensor values are always within a certain tolerance, a weighing error can occur.

The weighing error is increasingly larger if:

- The reeving is small.
- The boom, on which the load is suspended, is short.
- The boom, on which the load is suspended, is steep.



WARNING

Weighing error!
The crane can be overloaded.
► Plan and carry out the crane operation very carefully.

5.1.2 Adjusting the reeving

The number of reevings must be correctly set on the LICCON overload protection. If the reevings are higher than what is considered in the load chart, either the max load for LICCON 2 cranes are reduced or the actual load for LICCON 1 cranes is increased for the crane.

5.2 Actual load display

5.2.1 Hoist rope length

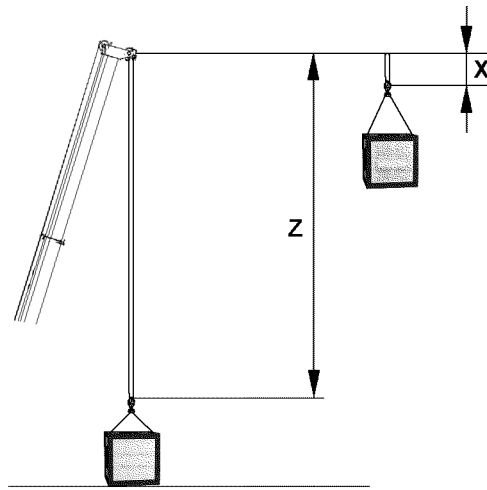

Fig.157474

Z Hoist rope length

X Hoist rope length

For the calculation of the displayed actual load, the hoist rope weight of the hoist rope length **Z** is deducted from the total load.

In that case, the number of the reevings set on the LICCON overload protection are taken into account, but no more than the nominal reeving.

If the load is raised far above the ground, (hoist rope length **X**), then the actual load display is smaller by the hoist rope weight of the load to the ground.

5.2.3 Lowering the load

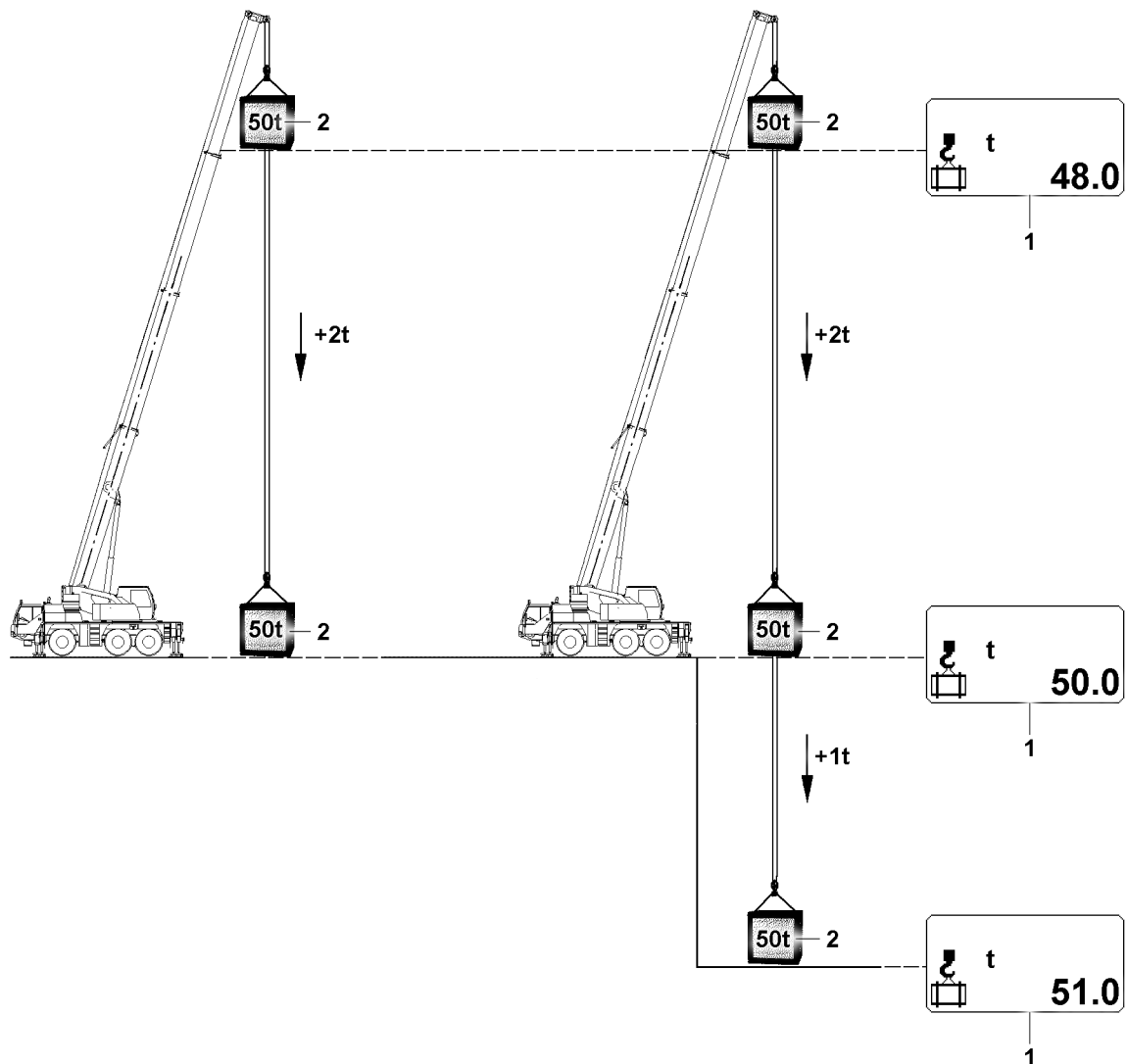

Fig.157502: Lowering the load

1 Actual load display

2 Load

The load consists of:

- Hook block
- Fastening equipment
- Actual load capacity (the component that is lifted)

When a load **2** with 100 percent utilization is picked up and then lowered, the weight of the hoist rope is calculated as the load and displayed. The utilization is then higher than 100%.



DANGER

When the load is lowered, the higher percentage of the hoist rope weight is **not** observed! The crane is overloaded. Death, property damage

When a load **2** is lowered:

- ▶ When taking on a load, do **not** utilize the crane 100%.
- ▶ During job planning, add the higher percentage of the hoist rope weight to the load **2**.

When lowering the load **2**, make sure that the actual load display **1** is correct and the crane overload is also displayed in the utilization bar, but the lowering movement is not shut off. In the case of an LMB overload, all crane movements are shut off, which would increase the danger of overload, however

load **2** lowering remains possible because the control assumes that the overload takes place due to lifting the load **2**.

However, the crane can also be overloaded by lowering the load **2**, especially in case of high reevings with a large hoist rope weight on the pulley head. The crane driver must observe this, so that he can relieve the crane by careful lifting again in this special case, even though the lifting and not the lowering of the load **2** is automatically shut off.

6 Crane operation

The maximum load capacity of the crane is not just limited by the stability, but in many cases a load-bearing component breaks when the crane is overloaded **before** the crane topples over. Components that are susceptible to buckling, such as the telescopic boom, may fail suddenly **without showing signs of distortion beforehand** if the crane is overloaded.



WARNING

Danger of accidents for cranes with luffing cylinders!

When the luffing cylinder is in the block position, the overload protection is not functioning.

- ▶ Crane operation at block position of luffing cylinders is prohibited.

6.1 General



WARNING

Load rip-off!

If the load accidentally detaches from the crane, there is a danger of fatal injury for personnel present in danger zone.

The falling load and flying debris can catch personnel.

In the event of a load rip-off, the boom system may shoot backwards, shake the crane severely or cause it to topple.

- ▶ Make sure that there is no personnel in the danger zone of the load and the crane.

A suspended load must always be kept under control. A fundamental requirement for this is the safe and delicate control of the crane's functions.



WARNING

Danger of accident due to swaying loads!

A swaying load can damage the crane and cause it to topple.

- ▶ All crane movements must be executed slowly and delicately.
- ▶ Initiate all crane movements slowly.
- ▶ Apply the brakes slowly in all crane movements.
- ▶ Crane operation with swaying load is prohibited.

NOTICE

Damage of rope pulleys!

- ▶ Place down hook blocks, booms, folding jibs, jib booms and boom noses in such a way that the rope pulleys do not lie on the ground and are damaged.

6.2 Guiding the load

The use of guide ropes is recommended to help the crane operator manage the load more precisely and to prevent the load from swaying. This will prevent undesirable movements of the load and consequent damage.

6.3 Danger of crushing



WARNING

Danger of fatal injury!

Extreme caution is needed when lowering a load. Danger of fatal injury exists for personnel in the immediate area of the load being lowered.

Personnel can be severely injured or killed.

- ▶ Standing under a suspended loads is strictly prohibited.
- ▶ Observe the danger of tipping when setting down the load. For example, small support surfaces or unsuitable ground.

6.4 Danger of falling



WARNING

Danger of fatal injury!

If persons are on the suspended load, then they can fall down and be severely injured or killed.

- ▶ Remaining on a suspended load is strictly prohibited.
- ▶ Remaining on or within crane components (for example: during assembly of boom sections, lattice sections) which are moved during lifting, lowering, turning or closing procedures is strictly prohibited.

6.5 Working in the vicinity of overhead electrical lines

If there are electricity transmission lines in the immediate vicinity of the building site, then the electrical transmission lines must be turned off by qualified electricians. If this is not possible, the danger area must be covered over or cordoned off.



WARNING

Danger of current transfer!

If overhead electrical lines are not shut off nor covered nor blocked off, then there is an increased danger of accident due to current transfer.

- ▶ For rated voltages up to 500 kV AC: Adhere to a safety distance of 8 m.

If the crane becomes electrified despite having taken all necessary precautions, proceed as follows:

- ▶ Remain calm.
- ▶ Do not leave the crane cab.
- ▶ Warn people outside: Stay in place and do not touch the crane.
- ▶ Move the crane away from the danger zone.

7 Ram work or pulling sheet piles

The cranes from Liebherr Werk Ehingen GmbH have been designed to lift loads. When working with a free-riding vibrating unit for ramming and pulling operations, vibrations may be transmitted to the load bearing steel structure even if a vibration damper is used. This vibration can cause premature fatigue of the material and therefore cracks in the supporting steel structure. Furthermore, the components can loosen and fall down due to the vibrations. This work should only be performed on the mobile crane in exceptional situations or when the use of machines built specially for this work is not possible.

Before performing this work, a risk assessment must be carried out that concerns the particular risks when driving and pulling the sheet piles and handling them.

Following higher loads on the crane, shorter inspection intervals for the mobile crane and the hook block must be defined by an authorized inspector. Before and after performing the work on the free-riding jogging unit, the crane, hook block and fastening equipment as well as the vibrating unit must be inspected for damage.

The free-riding vibrating unit must be equipped with vibration dampers. Rigid connections for this equipment to the crane are prohibited!

The following vibrating unit and vibration damper combinations are permissible:

- Free-riding vibrating unit with integrated vibration dampers.
- Free-riding jogging unit combined with a vibration damper designed for this equipment.

Specifications for working with the free-riding vibrator:

- Slack rope and angular pull on the hoist rope are prohibited.
- The vibrator may only be switched on if the vibrator is connected correctly with the ramming element and the ramming element is lying flush on the ground or is partially in the ground.
- Starting or stopping the vibrating unit must take place with an eccentric moment of zero (no vibrator vibration), in order to avoid peak vibration amplitudes and resonances due to the possibility of running through the natural frequency band of the vibrator. Only after reaching the nominal speed and the operating pressure of the unit may the eccentric moment be set to the desired value or amplitude.

NOTICE

No vibration dampers used!

The boom or the crane can be damaged.

- ▶ Use piling equipment and pulling equipment with vibration dampers.
 - ▶ The ramming equipment and pulling equipment may **not** pass on vibrations to the boom.
-

When pulling sheet piles, the maximum permissible pull force must be limited to 50% of the load chart value for the corresponding crane boom radius. The utilization of the hook block load may not exceed 50%.



Note

- ▶ When pulling sheet piles, **only** work in main boom operation or telescopic boom operation.
 - ▶ Do **not** use operating modes with a derrick, auxiliary boom or boom extensions.
-

NOTICE

Maximum permissible pull force exceeded when pulling sheet piles!

The boom or the crane can be damaged.

- ▶ Limit the maximum permissible pull force to 50% of the load chart value for the corresponding crane boom radius.
 - ▶ Additionally check the pull force by measuring it.
 - ▶ Do not limit the maximum pull force of the crane **exclusively** by means of the overload protection.
-

NOTICE

Hook block load utilization exceeded when pulling sheet piles!

The hook blocks or the crane can be damaged.

- ▶ Limit the utilization of the hook block load to maximum 50%.
-

Liebherr Werk Ehingen GmbH shall not be held liable for damage caused to the machine, to the used ramming and pulling equipment, on the piling element or in the surroundings (for example adjacent buildings) due to the installation and use of the free-riding vibrator.

8 Crane rope pretension

Damage that can occur with multi layer spooling:

- Abrasion
- Broken wires and loop formation
- Flattenings, deformations

NOTICE

Crane rope pretension too low!

Loosely coiled rope layers.

Rope damage. Reduced service life of the crane rope.

Cutting of the crane rope into the lower rope layers. The load can not be lowered any further.

- ▶ To maximize the service life of the crane rope, carry out the measures in the following sections.

**Note**

- ▶ Liebherr recommends to shorten crane ropes with damage in the cross over area of the coils, in order to lengthen the service life. Shortening the crane rope, see Crane operating instructions, chapter 7.05.50.

8.1 Working with a high rope pull

If multiple lifts are performed with a high rope pull, loosen the lower rope layers that are rarely or never spooled out.

NOTICE

Loosely spooled out rope layers!

Rope damage.

Upper rope layers with a high rope pull deform the lower rope layers in the cross over area of the crane rope.

Spooling deformed rope sections over rope pulleys reduces the service life of the crane rope.

- ▶ Place a shorter crane rope.

When the lower rope layers are **not** used during repeat work:

- ▶ Increase the pretension of the lower rope layers: Spool out the entire rope length and then spool back up with the highest rope pull possible. See section „Increasing the hoist rope pretension“.

8.1.1 Placing a shorter crane rope

**Note**

- ▶ Liebherr recommends using the entire rope length.

Unused rope sections cause the loosening of the lower rope layers.

When only a part of the crane rope length is used for a longer period of time:

- ▶ Place a shorter crane rope.

8.1.2 Reducing rope unwinding

Telescopic boom

When telescoping out less, then the smallest amount of fixed coiled up crane rope is spooled out.

- ▶ Telescope out as little as possible.

Picking up the fastening equipment

If the fastening equipment with a flat boom system must be picked up, then the smallest possible amount of crane rope is spooled up loose.

- ▶ Establish a flat boom system: Telescope out or luff up the boom.
- ▶ Pick up the fastening equipment.

8.1.3 Restoring hoist rope pretension

Brief description

If a multi-pulley hook block is reeved, then the entire hoist rope length can be spooled out from the rope drum.

- ▶ Spool the hoist rope out until three safety coils.
- ▶ Create 10 % maximum strand pull: Attach the load.

While the hoist rope is spooled up:

- Hold the load just off the ground.
 - In the permissible range of the load chart of the relevant set up configuration: Increase the load radius by luffing down.
- ▶ Spool the hoist rope up.

Description using the example LR 1600-2, SL3F

This section explains the procedure with the help of the set up configuration for LR 1600-2 with boom system SL3F.

The crane-specific parameters ensure that rope is spooled out until four rope coils and as many rope coils with pretension as possible can be spooled up.

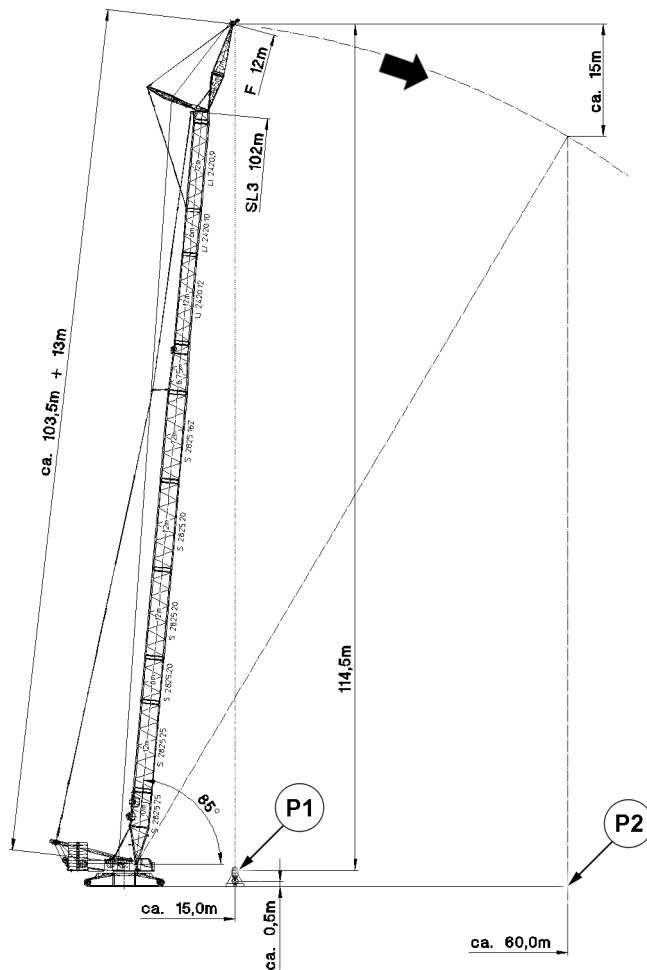

Fig.127131: LR 1600-2, SL3F: Spooling up hoist rope with pretension

Boom radius	Load	10 % of maximum strand pull
60 m	14.4 t	1.8 t

Load example: LR 1600-2, SL3 102, F12, according to the load chart

Hoist rope for this example:

- Hoist rope with a length of 1050 m

Hook block for this example:

- Hook block 200 DM, 5-pulley, reeved 8 times
- The weight of the hook block with ten auxiliary weights is 7.0 t

Make sure that the following prerequisites are met when hanging the load:

- Load is hung as short as possible.
- For a boom radius of 15.0 m, the hoist rope can be spooled out on the winch until four coils.

To reach sufficient rope pull, another load must be hung in addition to the hook block.

The additional load of 7.4 t is calculated from the difference between the load 14.4 t and the weight of the hook block 7.0 t.

- ▶ Fasten the load with 7.4 t.
- ▶ Until the load is 0.5 m above the ground: Lift the load.
- ▶ Set the boom system to boom radius 15.0 m.
- ▶ Spool the hoist rope out.

Result:

- In position **P1** there are 9 m of hoist rope (four coils) on the hoist winch:

Spoiled out rope section	Length
8-way reeving, distance of ground to the F-jib with boom radius 15 m	8 x 114.5 m = 916.0 m
Winch to FA-frame	103.5 m
F-head	13.0 m
Rope pulleys	7.5 m
Total of spoiled out hoist rope	1040.0 m

Rope lengths in position P1

While the hoist rope is spooled up:

- Hold the load just off the ground.
- In the permissible range of the load chart of the relevant set up configuration: Increase the load radius by luffing down.
- ▶ Until a boom radius of 60.0 m is reached: Spool up the hoist rope and luff down the boom at the same time.
- ▶ Set down the load.

Result:

- The pretension of the first and second position of the rope coils is restored.
- In position **P2** there are 130 m of hoist rope (23 coils) on the hoist winch:

Spoiled up rope section	Length
Four coils initial situation	9 m
8-way reeving, F-jib height difference with boom radius 60 m	8 x 15 m = 120 m
Total of spoiled up hoist rope	130 m

Rope lengths in position P2

- ▶ Make sure that the hoist rope on the winch remains pretensioned: Reeve out the hook block and reeve in with slower reeving. See Reeving plan.

8.2 Picking up and lowering overhead loads

The load is picked up overhead in the following application examples:

- Repowering wind power plants
- Disassembly of slewing tower cranes

NOTICE

Load picked up overhead with loosely coiled rope layers!

The rope pull increases when the load is picked up. The rope coils in the lower rope layers move laterally and are compressed. The hoist rope can cut into the lower rope layers.

- ▶ Spool up the hoist rope without a load only with rope pretension.
-

NOTICE

Load lowered with cut in rope layers!

The hoist rope is pulled jerkily from the lower rope layers. Vibrations are introduced into the crane system.

Cut in hoist rope clamped between the lower rope layers. The load can **not** be lowered any further.

- ▶ To prevent the cutting in of the hoist rope, carry out the measures in the following sections.
-

8.2.1 Increasing the reeving number

NOTICE

Higher reeving number than indicated on the load chart!

Slack rope formation.

The crane load drops due to additional weight from the rope strands and hook block.

If a higher reeving number is not considered in the set up configuration, the load display on the LIC-CON monitor no longer corresponds.

- ▶ Redetermine the hook block weight according to the load chart manual and adjust if necessary.
 - ▶ Check if the crane load is sufficient for higher reeving.
 - ▶ After telescoping out, check if the hook block can still reach the desired position for putting down the load.
-

A higher reeving number reduces the rope pull. A lower rope pull prevents the cutting in of the hoist rope in the lower rope layers.

- ▶ Select the highest reeving number possible for the hoist rope.

8.2.2 Increasing the hook block weight

NOTICE

Lift the hook block without a load!

The hoist rope is spooled up with a low rope pull. The rope layers are spooled up loose on the rope pulley.

- ▶ Increase the rope pull: Increase the hook block weight.
-

A higher hook block weight increases the rope pull.

- ▶ Increase the hook block weight.

If the crane load is sufficient:

- ▶ Attach an auxiliary weight between the load and hook block.

8.2.3 Pretensioning the hoist rope with pretensioning ballast with two hook operation

The pretensioning ballast is **not** included in the Liebherr delivery scope.

NOTICE

Lift the hook block without a load!

The hoist rope is spooled up with a low rope pull. The rope layers are spooled up loose on the rope drum.

- ▶ Pretension the hoist rope with pretensioning ballast with two hook operation.
-

Make sure that the following prerequisites are met:

- The crane is equipped for two hook operation.
- The pretensioning ballast is present.

Properties of the pretensioning ballast:

- Developed by Liebherr.
- The weight is 4 t.
- Special tow coupling

- ▶ Fasten the pretensioning ballast on the main hook and on the auxiliary hook.

The pretensioning ballast is lifted with the main hook, the auxiliary hook is carried along without a load.

- ▶ Lift the pretensioning ballast.

When the main hook has reached the required height:

- ▶ Stop the main hook.

After the load is completely transferred to the auxiliary hook, the main hook fastening ropes release automatically.

- ▶ Lift the auxiliary hook until the pretensioning ballast hangs completely on the auxiliary hook.

When the main hook fastening ropes have released:

- ▶ Lower the pretensioning ballast with the auxiliary hook and place it on the ground.

Result:

- The full load is present on the main hook.

Empty page!

LWE/LR 13000-001/19503-01-02/en

4.10 Driving from the crane cab

1	Prerequisites for driving the crane (crawler operation)	2
2	Displays on the LICCON monitor	6
3	Preparing for crane driving	11
4	Driving the crane: Load chart available	13
5	Driving the crane: No load chart is available	15
6	Driving the crawler crane	19

1 Prerequisites for driving the crane (crawler operation)

For driving the crane (crawler operation) the conditions of the travel route are the deciding factor.

- For **ground inclinations within the area of a valid load chart Driving with load** is possible at a slow speed. The ground must be sufficiently level and capable of supporting the load. The supplements to the load charts for driving the crane must be observed.
- For **ground inclinations outside the area of a valid load chart Driving without load** is possible at a slow speed up to certain inclination ranges. The ground must be sufficiently level and capable of supporting the load.

Driving the crane: Load chart available

- Valid and regular load chart available
- With load on the hook
- Without load on the hook

Driving the crane: No load chart is available

- Only without load on the hook
- Only without derrick ballast
- With specifications and limitations for the set up configuration of the crane



WARNING

The crane can topple over!

If the permissible inclinations of the crane are exceeded, the crane can topple over.

If the permissible surface pressures of the travel route are exceeded, the crane can topple over.

Death, severe bodily injuries, property damage.

- ▶ Do not exceed the permissible inclines of the crane.
- ▶ Do not exceed the permissible surface pressures for the travel route.



WARNING

The crane can topple over!

If the following specifications, instructions and prerequisites are not observed, then the crane can topple over or be overloaded.

Death, severe bodily injuries, property damage.

- ▶ The crane operator is responsible for adhering to all specifications, instructions and prerequisites in the crane documentation.
- ▶ The crane operator may not drive the crane if not all specifications, instructions and prerequisites in the crane documentation can be adhered to.
- ▶ The crane operator is responsible for the correct and complete data entry into the LICCON computer system and into the LICCON job planner, if applicable.
- ▶ All acceleration and delay maneuvers must be initiated with extreme caution and at the lowest possible speed.
- ▶ Depending on the situation, additional observers, who are acoustically or visually in contact with the crane operator (for example by radio or sight), may have to support the crane operator with shared responsibility.



WARNING

Combined crane movements during crawler operation!

- ▶ During crawler operation, do not carry out any additional crane movements.
- ▶ Carry out additional crane movements when the crane is at a standstill, if possible.

Make sure that the following prerequisites are met:

- No personnel or objects are in the danger zone.
- The crane is in an operational condition.
- The crane is in a set up configuration permitted for travel operation.
- The installed ballast (central ballast, counterweight and derrick ballast) is locked and secured.
- There are no loose objects on the crane.

1.1 Travel route



WARNING

The crane can topple over!

If the following specifications, instructions and prerequisites are not observed, then the crane can topple over or be overloaded.

Death, severe bodily injuries, property damage.

- ▶ The transition from the horizontal to an uphill slope and from an uphill slope to the horizontal must be made evenly, i.e.: There may be no edges that can cause the crane to topple over. Any inclination changes must be made continuously.
- ▶ If the travel route cannot safely absorb the surface pressure, then measures must be taken to be able to safely transfer the forces to the ground.
- ▶ If measures were taken to transfer the forces to the ground, then they must be checked by an expert before starting to drive for proper execution and sufficient supportability.
- ▶ An insufficient ground condition can cause accidents, for example the crane can slide away to the side and as a result get into an impermissible incline position.

Make sure that the following prerequisites are met:

- Before starting to drive, the travel route was determined.
- Before starting to drive, the condition of the ground has been checked.
- The entire travel route can safely absorb the surface pressure.
- All inclines occurring on the travel route can be driven safely by the crane.
- The entire travel route is free of obstacles.
- The friction coefficient between crawler travel gear and ground is sufficiently large to absorb the occurring drive forces or to exclude that the crane slips away in an incline position.
- Possible environmental influences for driving the crane (among others precipitation and wind) were taken into account for the travel route.
- The travel route was selected and prepared in such a way that the boom system can be taken down at any time.
- Select the travel route in such a way that no steering movements are required, if possible.
- With a load on the hook: It is possible to set down the load at any time.
- The entire travel route is secured as a danger zone.
- The travel route has been selected in such a way that it is possible to maintain a sufficient distance from local facilities (power lines, etc.).

For ground outside the range of a valid load chart, the following applies additionally:

- Before starting to drive, the travel route was checked in connection with the actual set up configuration of the crane on the LICCON job planner.
- Before starting to drive, the optimum positions for the boom system were determined to obtain as even a surface pressure as possible - the LICCON job planner can be used for this purpose.



Note

- ▶ For a detailed description of the LICCON job planner on the crane, see the LICCON Job planner operating instructions.
- ▶ For a detailed description of the LICCON job planner computer program, see the separate description.

1.1.1 Optimizing measures for the travel route

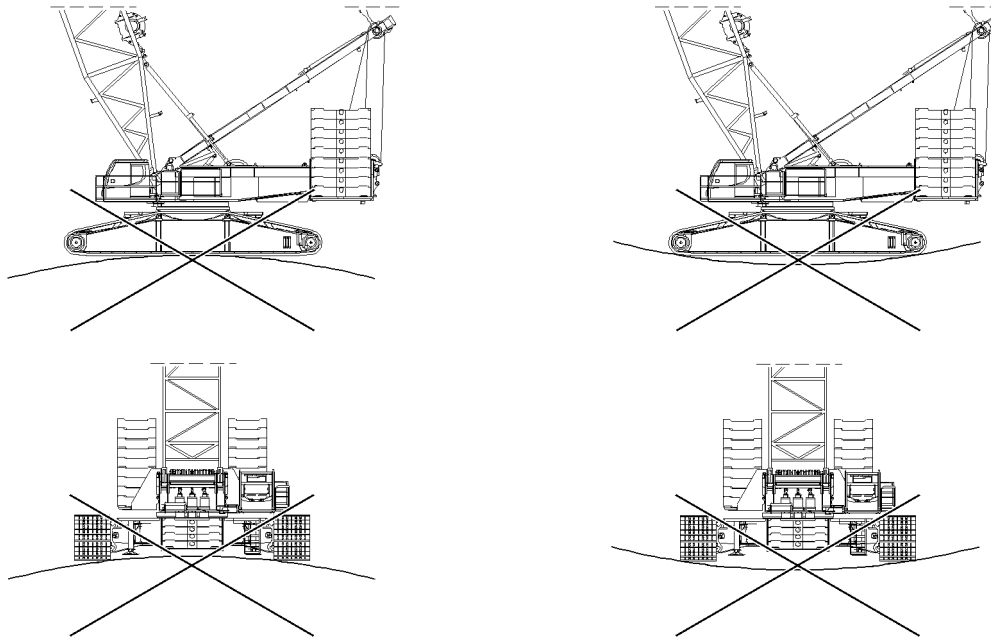

Fig.119598: Depressions, crests, track grooves and other uneven areas of the travel route cause localized pressure on the crawler travel gear

NOTICE

Damage to the crawler travel gear!

Continuous localized pressure on the crawler travel gear causes increased wear. Continuous increased wear can cause damage to the crawler travel gear.

- ▶ Set up the travel routes in such a way that the crawler travel gear is not subjected to continuous localized pressure.
- ▶ For extended travel operation shorten the maintenance intervals.

The following configuration features of the travel route can minimize wear on the crawler travel gear:

- Shapings of the travel route (such as depressions, crests, track grooves) have been eliminated via suitable measures.
- Lay out the travel route in such a way that no steering movements are required, if possible.

1.2 Calculating the required length of transitions on uphill / downhill slopes

The required length L for transfers results from the existing uphill angle α and the length of the crawlers LC .

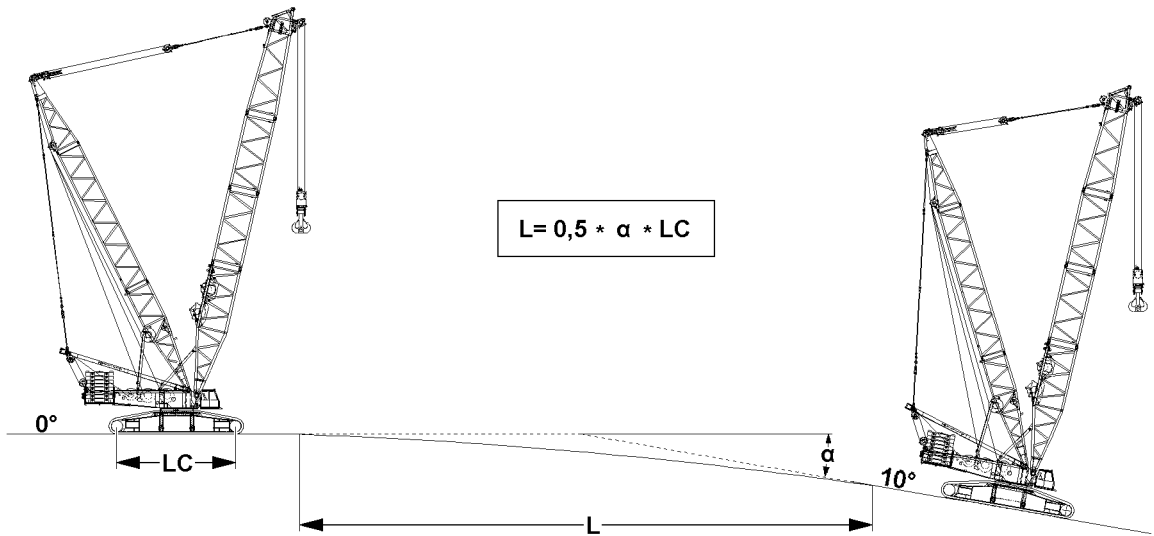

Fig.119612: Visualization: Length of transfers on uphill / downhill slopes

Abbreviation	Description
L	Required length of transfers
α	Angle rising / falling inclines in degrees
LC	Length of crawlers between drive wheels / steering wheels

1.2.1 Calculation example

Given:

$\alpha = 10^\circ$

LC = 17.3 m (use only the actual value of the crane!)

Required:

L = ?

Calculation formula						
L	=	0.5	*	α	*	LC
L	=	0.5	*	10	*	17.3 m
L	=	86.5 m				

LWE/LR 13000-001/19503-01-02/en

1.3 Travel gear / hydraulic motors / track rollers

NOTICE

Damage to the travel gear, hydraulic motors and track rollers!

On longer travel routes and / or when driving uphill / downhill, the travel gears, hydraulic motors and / or track rollers can be overheated and damaged.

- ▶ Make sure that the travel gears - before driving the crane - have the maximum fill level.
- ▶ Use suitable measuring devices to make sure that the maximum permissible temperature of the travel gears, hydraulic motors and / or track rollers in travel operation over longer distances is below 90 °C. For a short time (**maximum 10 minutes**), the temperature may increase to a value between 90 °C and 100 °C.
- ▶ As soon as the maximum permissible temperature in one position is exceeded, take a break from driving for cooling down.
- ▶ The crane operator is responsible for any damage to travel gears, hydraulic motors and / or track rollers.

When the maximum permissible temperature range on a travel gear and / or hydraulic motor is reached:

- ▶ Take a break until the temperature on travel gear(s), hydraulic motor(s) and / or track rollers had dropped considerably.

Maximum permissible temperature range on the travel gear(s) / hydraulic motor(s)		
	to 90 °C	between 90 °C and 100 °C
Duration of exposure	Continuous	No longer than 10 minutes

When the temperature of all travel gears / hydraulic motors has dropped below 90 °C:

- ▶ Travel operation is permissible again.

2 Displays on the LICCON monitor



WARNING

Danger of accident due to deviating set up configuration!

If the actual set up configuration of the crane deviates from the entries and settings in the Set up program, then the overload protection is not correctly set.

An incorrectly set overload protection calculates the actual load incorrectly and transmits faulty display values.

The crane can be overloaded without noticing it and topple over or collapse as a result.

Death, severe bodily injuries, property damage.

- ▶ The entries and settings in the set up program must match the actual set up configuration of the crane.



WARNING

Incorrect display values!

If the display values do not increase correspondingly when lifting known weights, an erroneous display value may be present.

If the crane is operated with erroneous display values, then the crane can be overloaded.

This could result in serious accidents.

Death, severe bodily injuries, property damage.

- ▶ When lifting the hook block off the ground, check if the display value for the actual load increases correspondingly.
- ▶ When lifting the derrick ballast off the ground check if the display value for the pulled derrick ballast BA_{pulled} increases correspondingly.
- ▶ When lifting the load off the ground, check if the display value for the actual load increases correspondingly.

Make sure that the following prerequisites are met:

- The actual set up configuration of the crane matches the entries and settings in the set up program.
- The assignment of the crane to the displays on the LICCON monitor is clear.
- All displays function perfectly.



Note

- ▶ For a detailed description of the displays on the LICCON monitor, see chapter 4.02.
- ▶ For a detailed description of the safety equipment, see chapter 4.04.

2.1 Center of gravity display on the LICCON monitor



WARNING

Shifting of the center of gravity!

The calculation of the values for the display of the center of gravity in the LICCON monitor are based on ideal assumptions.

- ▶ Side deformations of the boom system due to wind, inclined position and elastic resilience of the steel structure are not taken into account but they can lead to a shifting of the center of gravity.

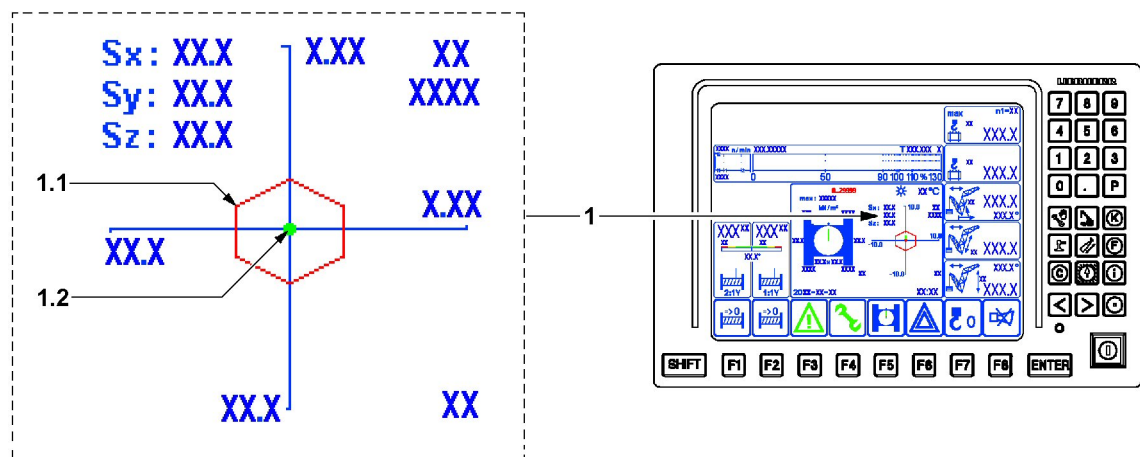

Fig.115325: Center of gravity display

Center of gravity 1 display	
Position	Name
1.1	Core area
1.2	Center of gravity

LWE/LR_13000-001/19503-01-02/en



WARNING

Center of gravity of the crane is outside the core area!

If the center of gravity **1.2** of the crane is outside the core area **1.1**, then the crane can topple over. Death, severe bodily injuries, property damage.

- ▶ To drive the crane, the center of gravity **1.2** must always be within the core area **1.1**.
- ▶ If the center of gravity **1.2** is outside of the core area **1.1**, then it is prohibited to drive the crane.

The following specifications and instructions must be observed:

- By luffing the boom system up and down, the position of the center of gravity **1.2** must be corrected in such a way that the overall center of gravity remains within the core area **1.1**.

2.2 Surface pressure display on the LICCON monitor



WARNING

Increased surface pressure!

The calculation of the values for the display of the surface pressure in the LICCON monitor are based on ideal assumptions.

- ▶ Side deformations of the boom system due to wind, inclined position and elastic resilience of the steel structure are not taken into account but they can lead to an increase of the surface pressure.

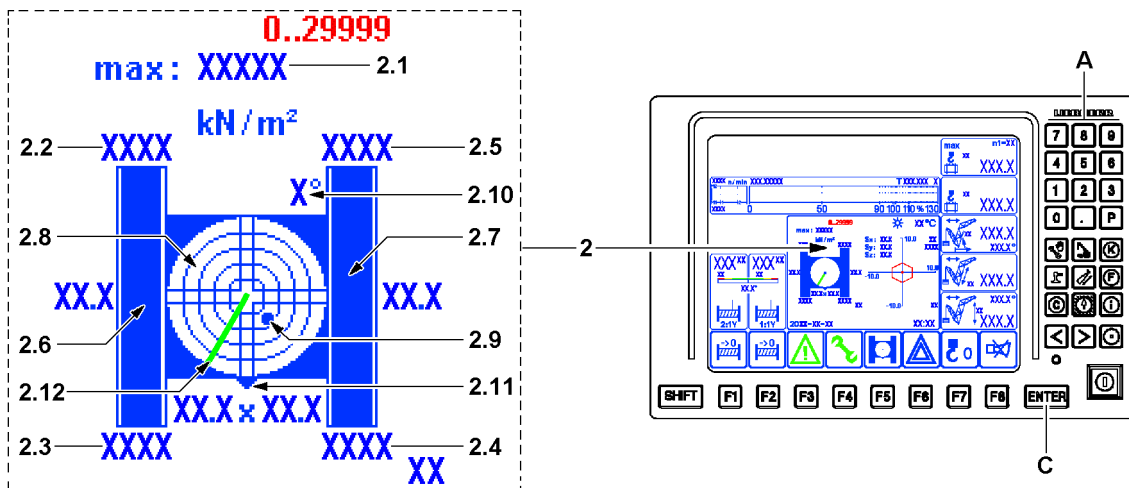

Fig.119613: Surface pressure display

Surface pressure 2 display	
Position	Name
2.1	Maximum surface pressure
2.2	Right rear surface pressure
2.3	Front right surface pressure
2.4	Front left surface pressure
2.5	Rear left surface pressure
2.6	Right crawler placement surface
2.7	Left crawler placement surface
2.8	Incline indicator ¹⁾
2.9	Dot ¹⁾

LWE/LR 13000-001/19503-01-02/en

Surface pressure 2 display	
Position	Name
2.10	Display resolution ²⁾
2.11	„Front side of crawler travel gear“ ³⁾ marker
2.12	Boom direction ⁴⁾

- 1) The graphic display is in the form of a spirit level with a moving dot **2.9** representing the air bubble.
 2) This value indicates the resolution of the graphic display. The resolution is matched automatically to the inclination
 3) The front of the track is always on the side where the chain tension devices for the crawler carriers are located.
 4) Current boom direction in reference to the displayed icon.

**WARNING**

Surface pressure too high!

If the maximum surface pressure is exceeded, the crane can topple over.

Death, severe bodily injuries, property damage.

- ▶ Do not exceed the maximum surface pressure.
- ▶ The value entered in the LICCON computer system for the maximum surface pressure **2.1** must match the actual conditions of the travel route.

**WARNING**

The crane can topple over!

If the permissible incline of the crane is exceeded, the crane can topple over.

- ▶ Do not exceed the permissible incline from the load chart.
- ▶ Do not exceed the permissible incline for driving the crane, see the following sections.

**Note**

- ▶ The placement surface of the crawler carriers is graphically shown on the surface pressure display.
- ▶ If the resulting surface pressure can be distributed so that the maximum surface pressure of the travel route is not exceeded **and** the resulting forces can be transferred safely to the ground, then the stability of the crane is ensured.
- ▶ Incline indicator **2.8** with number values, see section „Display of incline in LICCON monitor“.

The following specifications and instructions must be observed:

- The maximum surface pressure that may be reached must be entered as the maximum surface pressure **2.1**.
- By luffing the boom system up and down, the resulting surface pressure must be distributed in such a way that the maximum surface pressure of the travel route is not exceeded.
- The inclines that are reached on the travel route are known and are taken into account.
- As soon as the crane shows the tendency that the permissible incline could be exceeded, the load must be set down. If necessary, driving the crane must be interrupted.

2.2.1 Entering the maximum permissible surface pressure

Make sure that the following prerequisites are met:

- The Crane operation program is called up.
- The maximum permissible surface pressure of the travel route is known.

- ▶ Press the enter key **C**.

Result:

- The value for the maximum surface pressure **2.1** can be changed.
- ▶ Enter the value for the maximum permissible surface pressure using the keypad **A**.
- ▶ Press the enter key **C**.

Result:

- The new value for the maximum surface pressure **2.1** appears.

- ▶ Check the value for the maximum permissible surface pressure.

2.3 Display for the incline on the LICCON monitor

The incline display is also shown again for the monitored auxiliary functions.

Display of the incline of the crane to the horizontal in the longitudinal and lateral direction. The display is graphic as well as numeric.

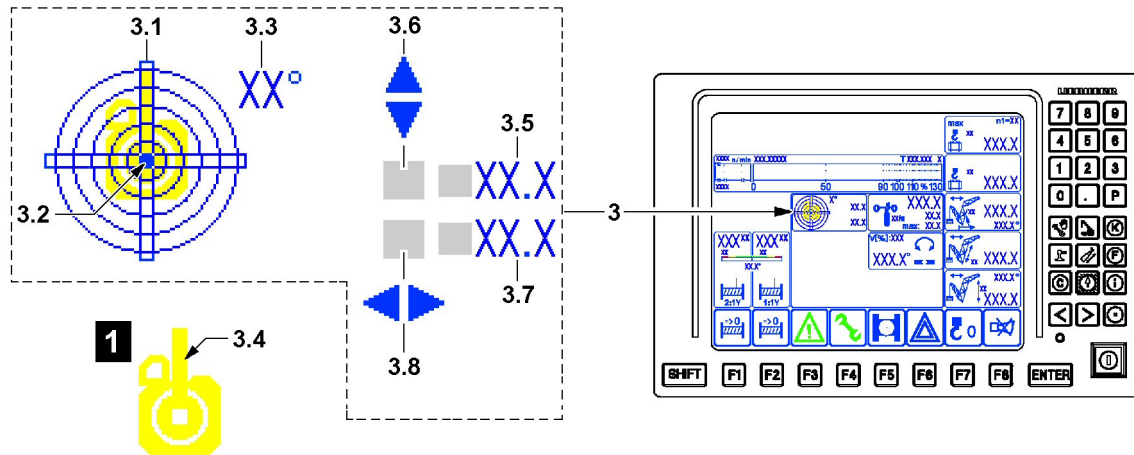

Fig.115327: Incline display

Incline 3 display	
Position	Name
3.1	Sight gauge
3.2	Bubble
3.3	Display resolution
3.4	Boom position ³⁾
3.5	Incline in the longitudinal direction
3.6	Incline direction
3.7	Incline in the lateral direction
3.8	Incline direction

3) The boom position in the spirit level 3.1 is highlighted as orientation aid, see detail 1. The boom position corresponds to the „viewing direction to the front“ from the crane cab in relation to the spirit level 3.1.



WARNING

The crane can topple over!

If the permissible incline of the crane is exceeded, the crane can topple over.

- ▶ Do not exceed the permissible incline from the load chart.
- ▶ Do not exceed the permissible incline for driving the crane, see the following sections.

The following specifications and instructions must be observed:

- The inclines that are reached on the travel route are known and are taken into account.
- As soon as the crane shows the tendency that the permissible incline could be exceeded, the load on the hook and / or the suspended ballast must be set down.

3 Preparing for crane driving

3.1 Distribution of the surface pressure

While driving, pay attention in all driving conditions to the ratio of the surface pressure between the front and the rear sides of both crawlers.

In the following examples it is assumed that the crawler travel gear and the turntable are oriented to the front.

Distribution of the surface pressure	
Position	Name
1	Center of gravity
2	Surface pressure on the front
3	Surface pressure on the rear
4	Boom position ¹⁾
5	„Front side of crawler travel gear“ ⁽²⁾ marker
6	Crawler carrier chain tension device
7	Main boom angle display
8	Core area
α	Main boom angle

1) The boom position corresponds to the „viewing direction to the front“ from the crane cab.

2) The side where the chain tension device for the crawler carrier is located is always at the front on the crawler travel gear.

Before driving the crane is it required to position the boom in such a way that a suitable distribution of surface pressure for driving is obtained.

3.1.1 Examples for the distribution of surface pressure

Surface pressure: Center of gravity in the middle

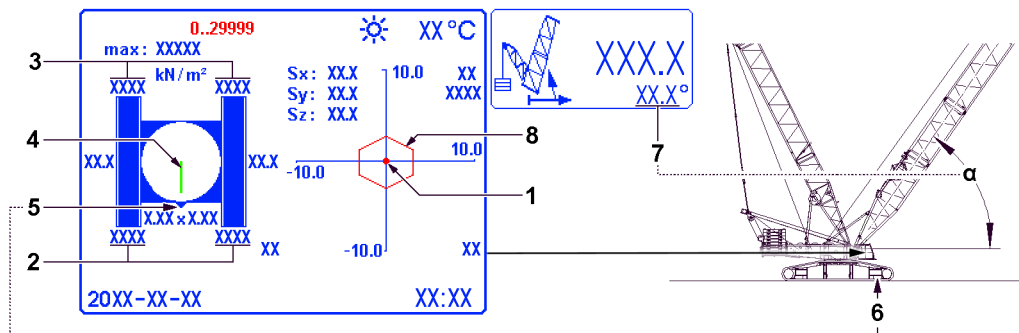

Fig.153785: Center of gravity 1 in the middle

- The surface pressure in the front 2 is the same as the surface pressure in the rear 3.

LWE/LR 13000-001/19503-01-02/en

Surface pressure: Center of gravity in the rear

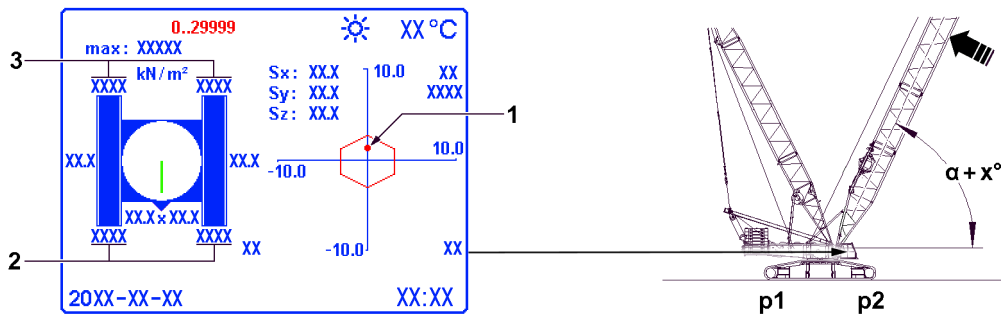

Fig.153786: Center of gravity 1 in the rear

- The main boom was luffed up.
- The surface pressure on the rear 3 is higher.

Surface pressure: Center of gravity in the front

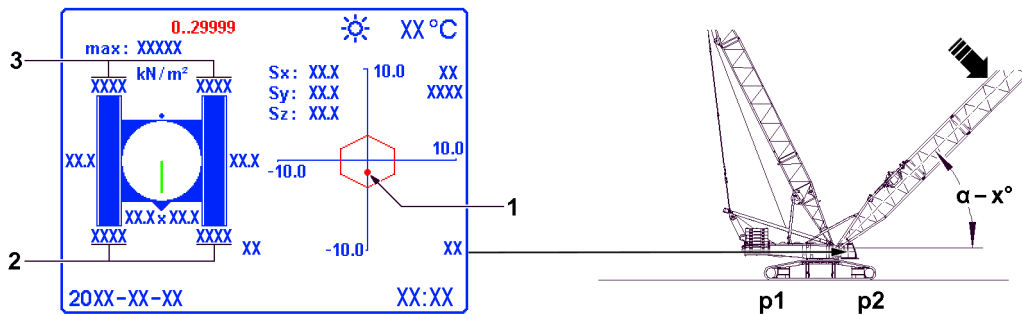

Fig.153787: Center of gravity 1 in the front

- The main boom was luffed down.
- The surface pressure on the front 2 is higher.

3.2 Suitable distribution of the surface pressure

If the distribution of the surface pressure is even (front surface pressure 2 and rear surface pressure 3 approx. the same value), then steering is difficult or not possible at all.

For the suitable distribution of the surface pressure, the following applies:

- p1 = Surface pressure on the side of both crawlers with less load.
- p2 = Surface pressure on the side of both crawlers with more load.
- The center of gravity 1 must always be within the core area 8.

Distribution of surface pressure p1 to p2		
p1	/	p2 = Should be greater than 0.3

In case of unfavorable distribution of surface pressure it is required to position the boom system in such a way that a suitable distribution of the surface pressure is reached for driving.

- ▶ The turntable should be turned while at a standstill: The boom system should be luffed in such a way that the crawlers are subjected to a load as evenly as possible.
- ▶ Driving uphill: The boom system should be luffed in such a way that the side of the two crawlers that has less load is in the rear.
- ▶ Driving downhill: The boom system should be luffed in such a way that the side of the two crawlers that has less load is in the front.

LWE/LR 13000-001/19503-01-02/en

**Note**

- ▶ The side with the higher surface pressure should be within the field of vision of the crane driver or auxiliary personnel. This will ensure that it will be recognized early on if the crawler carriers sink in and respective countermeasures can be initiated.

3.3 Steering ability

**Note**

High load on the crane!

When driving the crane, steering movements cause a high load on the crane travel gear.

- ▶ If possible, do not perform steering movements with a load on the hook and / or derrick ballast.
- ▶ Select the travel route in such a way that no steering movements are required, if possible.
- ▶ If not otherwise possible, before initiating a steering movement, set down the load and / or derrick ballast.

The steering ability depends on the following factors:

- Friction conditions under the chains.
- Evenness of the ground:
 - Steering is not possible if the crawler travel gear is only making contact with the ground in the front and rear.
- Load bearing capacity of the ground:
 - If the crawler travel gear sinks into the ground, then steering ability is significantly restricted.
- Position of the total center of gravity:
 - If the total center of gravity - taking the suspended load into account - is in the center of the crane, then steering is hard or not possible at all.

Steering ability can be improved by:

- Placing metal sheeting, sand, gravel, water underneath.
- Taking the load bearing capacity of the ground and the position of the center of gravity into account: Changing the center of gravity.

4 Driving the crane: Load chart available

**WARNING**

The crane can topple over!

If the following conditions are not observed, the crane can topple over.

Death, severe bodily injuries, property damage.

- ▶ The ground must be sufficiently level and within the range of the permissible incline.
- ▶ The ground must be able to safely absorb the maximum occurring surface pressures.

**WARNING**

The crane can topple over!

If the permissible inclinations of the load charts are exceeded when driving the crane, then the crane can topple over or be overloaded.

If the permissible wind speeds of the load charts are exceeded when driving, then the crane can topple over or be overloaded.

Death, severe bodily injuries, property damage.

- ▶ If the inclines are too large then driving the crane is prohibited.
- ▶ If the wind speeds are too high then driving the crane is prohibited.

Make sure that the following prerequisites are met:

- The permissible inclines from the load charts are adhered to.
- The maximum permissible wind speeds from the load charts are adhered to.
- The maximum permissible travel speed is adhered to.

- Straight-ahead driving: the turntable is aligned parallel to the crawler travel gear, 0° or 180° position.
- Driving in curves: slewing gear freewheeling is actuated.

Permissible inclines	
Total incline	Load charts for incline $\pm 0.3^\circ$
Total incline ¹⁾	Load charts for incline $\pm 1.0^\circ$

1) Only certain boom systems

Permissible wind speeds	
Wind speeds	See load charts

Driving with a load is possible under the conditions of the regular load chart:

- The permissible inclines from the load charts apply for driving.
- Take the maximum permissible wind speeds from the load charts.
- Take the maximum permissible driving speed from the following sections.

4.1 Driving with a load on the hook and / or derrick ballast



WARNING

The crane can topple over!

If the load on the hook or the suspended ballast collides with the crane, ground or obstacles when driving, then the crane can be damaged and topple over.

Death, severe bodily injuries, property damage.

- ▶ Make sure that the load on the hook or the suspended ballast does not collide with anything when driving.



WARNING

Danger of accident!

If the suspended load or the suspended derrick ballast starts to swing, the crane operator can lose control over the crane.

If the following prerequisites are not observed, the crane can topple over.

This could result in serious accidents.

- ▶ Do not exceed the maximum permissible driving speed.
- ▶ Avoid jerky driving movements.
- ▶ The attached load and suspended derrick ballast must be secured to prevent swinging. If oscillating movements should occur, set the load / derrick ballast as fast as possible down on the ground. When doing so, pay attention to the limit values of the load momentum display and the F-load display.
- ▶ Driving and steering the crawler at the same time with a suspended load and / or installed derrick ballast is prohibited.

Make sure that the following prerequisites are met:

- The permissible inclines from the load charts are adhered to.
- Without derrick ballast: the travel speed may **not** exceed 0.1 m/s **or** 6 m/min **or** 0.36 km/h.
- With derrick ballast: the travel speed may **not** exceed 0.05 m/s **or** 3 m/min **or** 0.18 km/h.
- Crawler operation rapid gear may **not** be engaged.
- The attached load hangs freely.
- The attached load must be secured to prevent it from swinging back and forth, if necessary.
- Keep the attached load as close to the ground as possible.
- Keep the attached load with the smallest boom radius as possible.
- Derrick ballast: the suspended ballast hangs freely.
- Derrick ballast: the suspended ballast is lifted off the ground maximum 250 mm.
- Derrick ballast: the derrick ballast must also be secured to prevent it from swinging back and forth.

4.2 Driving without a load on the hook and without derrick ballast

Make sure that the following prerequisites are met:

- Driving the crane takes place according to the inclines from the load charts.
- Take the maximum permissible wind speeds from the load charts.
- The travel speed may not exceed 0.4 m/s **or** 24 m/min **or** 1.44 km/h.
- The hook block is secured to prevent it from swinging back and forth.

5 Driving the crane: No load chart is available



WARNING

The crane can topple over!

If the following note is not observed, the crane can topple over.

Death, severe bodily injuries, property damage.

- ▶ Driving uphill must always be anticipatory, with utmost caution and at the slowest speed.
- ▶ Drive on the start of uphill and downhill slopes (for example ramps) at a right angle.
- ▶ It is prohibited to let the crane tip over an edge.



WARNING

The crane can topple over!

If the crane is driven outside the load chart with a load or with the derrick ballast, accidents can occur.

The crane can topple over or be overloaded.

Death, severe bodily injuries, property damage.

- ▶ Driving the crane with a load outside the load chart is prohibited.
- ▶ Driving the crane with derrick ballast outside the load chart is prohibited.

Make sure that the following prerequisites are met:

- There is no load on the hook.
- No derrick ballast is installed.
- The oil level of both crane engines is at the maximum level.
- The oil level in the hydraulic oil tank must be lowered by extending the cylinders so that overflow is not possible.
- The contents of the fuel tank must be reduced so that overflow is not possible, even with the largest crane incline.
- The travel speed may **not** exceed 0.1 m/s **or** 6 m/min **or** 0.36 km/h.
- Straight-ahead driving: the turntable is aligned parallel to the crawler travel gear, 0° or 180° position.
- Driving in curves: slewing gear freewheeling is actuated.
- The maximum permissible wind speed of 9 m/s is adhered to.
- The permissible lateral incline when driving without a load is adhered to.
- The permissible longitudinal incline when driving without a load is adhered to.

Permissible lateral inclination when driving without a load and without derrick ballast

Overall length of the main boom	Maximum permissible lateral incline	With a longitudinal incline
Shorter than / equal to 96 m	± 3°	± 0.3°
97 m to 150 m	± 2°	± 0.3°

Permissible longitudinal incline when driving without a load and without derrick ballast

Overall length of the main boom	Maximum permissible longitudinal inclination	With a lateral incline
Up to 150 m	± 10°	± 0.3°

LWE/LR 13000-001/19503-01-02/en

5.1 Driving uphill / downhill



WARNING

The crane can topple over!

If the following notes are not observed, the crane can topple over.

Death, severe bodily injuries, property damage.

- ▶ The deciding factor for driving on inclines is the exact knowledge of the operational conditions at the job site.
- ▶ Specifications, instructions and prerequisites in this chapter must be adhered to.
- ▶ Driving uphill / downhill must always be anticipatory, with utmost caution and at the slowest speed.



WARNING

The crane can topple over!

If the crane is driven uphill / downhill with a load or derrick ballast, the crane can topple over.

If the angle of the boom system is not matched to the incline when driving the crane on inclines, then the crane can topple over.

Death, severe bodily injuries, property damage.

- ▶ Match the angle of the boom system to the incline.
- ▶ Driving uphill with a load and / or derrick ballast is prohibited.



WARNING

The crane can topple over!

If the turntable is not parallel to the crawler travel gear when driving the crane on uphill / downhill slopes, then the crawler crane can topple over or be overloaded.

- ▶ For ground inclines of more than 0.3° , make sure that the turntable is aligned parallel to the crawler travel gear in the 0° or 180° position before driving the crawler crane.



WARNING

The crane can topple over!

On ground inclines of more than $\pm 0.3^\circ$ the travel direction may not be changed.

- ▶ On ground inclines of more than $\pm 0.3^\circ$ plan the travel route in such a way that a travel direction change is not necessary.



WARNING

The crane can topple over!

A longitudinal incline of more than $\pm 0.3^\circ$ and a lateral incline of more than $\pm 0.3^\circ$ may not be combined.

- ▶ For a longitudinal incline of more than $\pm 0.3^\circ$ a maximum lateral incline of $\pm 0.3^\circ$ always applies. For a lateral incline of more than $\pm 0.3^\circ$ a maximum longitudinal incline of $\pm 0.3^\circ$ always applies.

Make sure that the following prerequisites are met:

- The turntable is aligned parallel to the crawler travel gear, 0° or 180° position.
- Uphill / downhill slopes with more than $\pm 0.3^\circ$ can be driven without travel direction change.
- The maximum side incline of $\pm 0.3^\circ$ is adhered to.

There are two different possibilities for driving crawler cranes on uphill / downhill slopes:

- By adjusting the angle of the boom system.
- Without adjusting the angle of the boom system.

5.1.1 Maximum climbing ability

The maximum climbing ability of the crawler crane is limited by the following criteria:

- The location of the center of gravity for the complete crawler crane.
- The friction coefficient between the road and outrigger pads.
- The transition between the horizontal and the uphill incline.
- The maximum permissible uphill incline of 10° up to a boom length of 150 m.

5.1.2 Driving uphill / downhill by adjusting the angle of the boom system

The following specifications and instructions must be observed:

- On level ground, set the optimum angle of the boom system regarding the center of gravity and the surface pressure.
- Uphill / downhill slopes: As soon as the value of the displays for the center of gravity and the surface pressure become more unfavorable, adapt the boom angle to the permissible range.



WARNING

The crane can topple over!

If the limit values for the center of gravity and the surface pressure are exceeded, then the crane can topple over or be overloaded.

- ▶ Driving without display values for the center of gravity and the surface pressure is only permissible when the center of gravity and the surface pressure are otherwise monitored and ensured.



Note

Driving without display values for center of gravity and surface pressure!

- ▶ On level ground, set the optimum angle of the boom system regarding the center of gravity and the surface pressure.
- ▶ When driving into an uphill incline, during the transition between the horizontal into the incline, the original angle of the boom system must be changed continuously in such a way that the same angle ratio always remains between the boom system and the horizontal. This angle must be retained in the uphill incline.
- ▶ When driving out from an uphill incline, at the transition from incline to the horizontal, change the angle of the boom system continuously so that the same angle ratio is always retained.
- ▶ As a rule, the center of gravity and the surface pressure of the crane must be taken into account.

Positive longitudinal incline



Note

- ▶ When driving on positive longitudinal inclinations (uphill), the main boom must usually be luffed down.

Status	Transition	Boom angle
Driving horizontally	after uphill incline	match
Driving on the uphill incline		
Driving on the uphill incline	after horizontal	match
Driving horizontally		

Negative longitudinal inclination



Note

- ▶ When driving on negative longitudinal inclinations (downhill), the main boom must usually be luffed up.

Status	Transition	Boom angle
Driving horizontally	after downhill slope	match
Driving downhill		
Driving downhill	after horizontal	match
Driving horizontally		

5.1.3 Prerequisites for driving uphill / downhill without adjusting the angle of the boom system

The following specifications and instructions must be observed:

- Make sure that with the selected position of the boom system, the center of gravity and the surface pressure are within the permissible range.



WARNING

The crane can topple over!

If the limit values for the center of gravity and the surface pressure are exceeded, then the crane can topple over or be overloaded.

Death, severe bodily injuries, property damage.

- ▶ Before driving onto uphill and downhill slopes, check the change of the center of gravity and the surface pressure and ensure that it is permissible.
- ▶ Before driving the crane, determine if the crane may drive on the intended route without adjusting the boom system.
- ▶ If the intended uphill / downhill slope cannot be driven without adjusting the angle of the boom system, then the boom angle must be adjusted to be able to drive on the uphill / downhill slope.

5.2 Driving on side inclines



WARNING

The crane can topple over!

With inclines of more than $\pm 0.3^\circ$ the travel direction may not be changed.

- ▶ With inclines of more than $\pm 0.3^\circ$ plan the travel route in such a way that a travel direction change is not necessary.



WARNING

The crane can topple over!

A longitudinal incline of more than $\pm 0.3^\circ$ and a lateral incline of more than $\pm 0.3^\circ$ may not be combined.

- ▶ For a longitudinal incline of more than $\pm 0.3^\circ$ a maximum lateral incline of $\pm 0.3^\circ$ always applies. For a lateral incline of more than $\pm 0.3^\circ$ a maximum longitudinal incline of $\pm 0.3^\circ$ always applies.

Make sure that the following prerequisites are met:

- The turntable is aligned parallel to the crawler travel gear (0° or 180° position).
- Side inclines with more than $\pm 0.3^\circ$ can be driven without travel direction change.
- The maximum longitudinal incline of $\pm 0.3^\circ$ is adhered to.

6 Driving the crawler crane



WARNING

Danger of accident when driving the crane with the ballast trailer!

When driving the crane - this also applies for „circular travel“ - and the ballast trailer is raised due to ground unevenness, the force on test point 1 (F1-load display) increases immediately and the crane will be overloaded.

If the ballast trailer sinks while driving due to ground unevenness, the force in test point 1 (F1-load display) decreases and the ballast trailer lifts off the ground, or the entire boom system is pulled backward.

The crane can topple over.

Death, severe bodily injuries, property damage.

- ▶ The crane operator must constantly observe the displays on the LICCON monitor while driving the crawler crane.
- ▶ The crane operator must act anticipatorily. Already when an advance warning appears in test point 1 (F1-load display), it is necessary to act accordingly: By actuating the pull cylinders of the derrick ballast, correct the load / force on test point 1 (F1-load display) until it is in a permissible operating range. The permissible extension lengths of the pull cylinders must be observed.



WARNING

Danger of accident in an inclined position!

When the slewing gear brake is released, the crane superstructure can turn uncontrolled to the side. As a result the crane can topple over.

Death, severe bodily injuries, property damage.

- ▶ In an inclined position, crane operation or crawler operation with opened slewing gear brake is prohibited.
- ▶ In an inclined position, the slewing gear brake must be applied.



WARNING

The crane can topple over!

If the permissible incline of the crane is exceeded, the crane can topple over.

In the case of impermissible inclines, the LICCON computer system does **not** turn the travel operation off.

The crane driver carries sole responsibility for possible risks or dangers when working with impermissible inclines.

- ▶ Do not exceed the permissible incline from the load chart.
- ▶ Do not exceed the permissible incline for driving the crane.
- ▶ While driving the crane, monitor the displays for center of gravity, surface pressure and incline on the LICCON monitor constantly.



WARNING

The crane can topple over!

If the crane is driving too fast, then the crane can topple over.

This applies especially if the crane is driven too fast with a load and / or derrick ballast.

Death, severe bodily injuries, property damage.

- ▶ Observe the permissible highest speeds for driving the crawler crane.
- ▶ For the travel speed, take the actual crane operating conditions also into account.
- ▶ The data for permissible highest speeds for driving the crawler crane is based on ideal conditions. When the conditions are not ideal, then the travel speed of the crane must be reduced accordingly.
- ▶ Driving with a load and / or derrick ballast in rapid gear is prohibited.
- ▶ Driving and steering the crawler at the same time with suspended load and / or installed derrick ballast is prohibited.

**WARNING**

Personnel in the danger zone!

People who remain in the danger zone are exposed to considerable danger.

Death, severe bodily injuries, property damage.

- ▶ An additional observer in radio contact with the crane operator must ensure that there are no persons or objects within the danger zone of the crane.
- ▶ The observer may not remain in the danger zone of the crane.

In principle the following must be observed:

- If the derrick ballast is raised due to external influences, then this relieves the guying between the derrick head and the derrick ballast (force in test point 4/5 is reduced). This leads to an increased load on the guying between the derrick head and the A-frame (force in test point 1 increases).
- If the derrick ballast loses contact with the ground due to external influences, then this leads to a higher load of the guying between the derrick head and the derrick ballast (force in test point 4/5 is increased). This the guying to be relieved between the derrick head and the A-frame (force in test point 1 decreases).

6.1 Surface pressures and force distribution when driving the crane

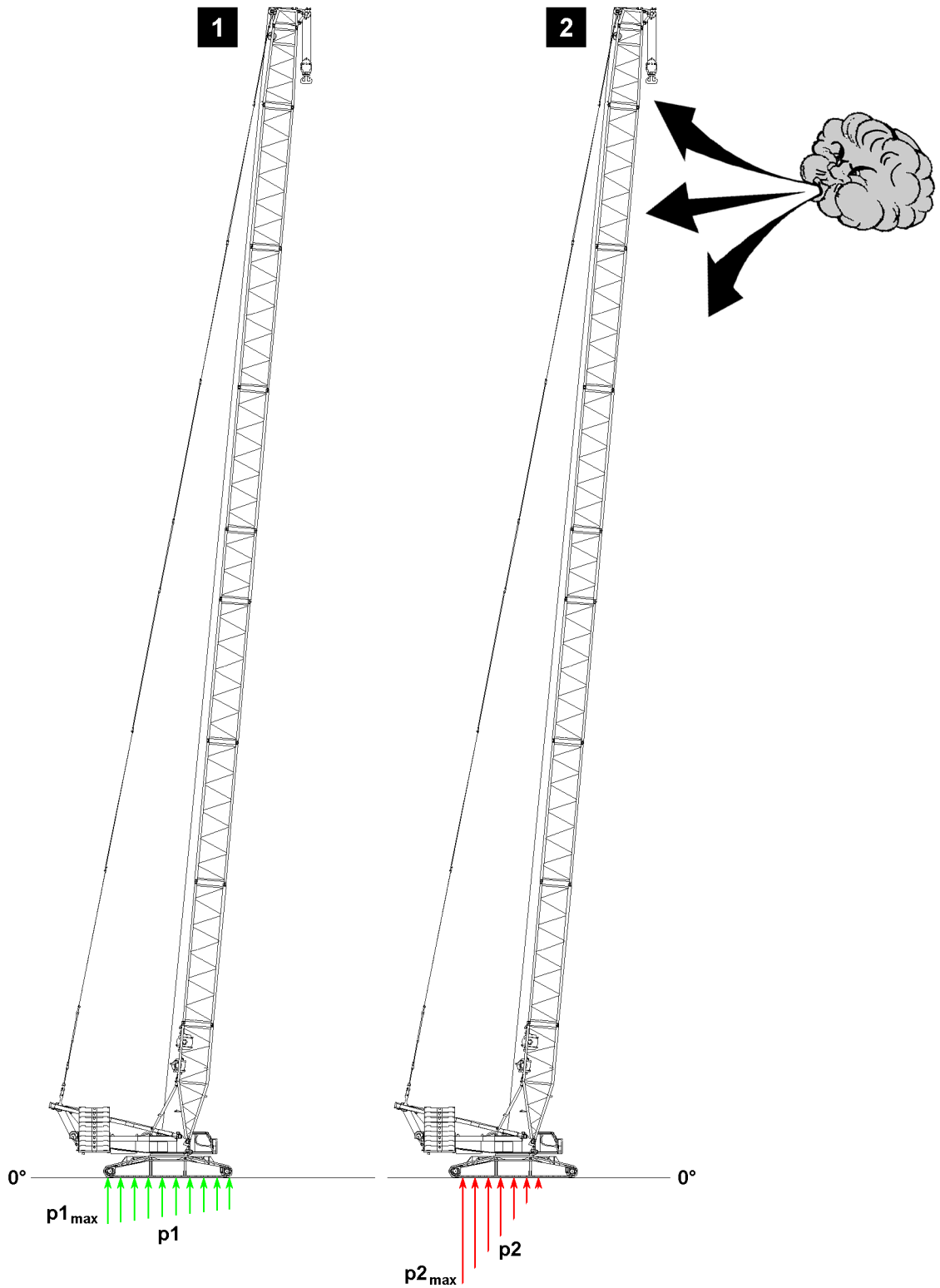

Fig. 153644: $p_{2_{max}}$ greater than $p_{1_{max}}$

LWE/LR 13000-001/19503-01-02/en

**WARNING**

The crane can topple over!

When driving crawler cranes, surface pressures can significantly increase or change due to different factors.

This can cause the crane to topple over.

Death, severe bodily injuries, property damage.

- ▶ Make sure that the ground has a sufficient load bearing capacity in the entire working range and / or over the entire travel route, to be able to safely absorb also increased surfaces pressures of the crane.
- ▶ Make sure that the center of gravity of the crane is always within the core area, see section „Prerequisites for crawler operation“ and LICCON job planner.

6.1.1 Surface pressures in case of wind load on the boom

**WARNING**

The crane can topple over!

When driving the crane with long boom lengths and / or when driving with large sized loads and / or at high wind speeds, the surface pressures can increase significantly.

This can cause the crane to topple over.

Death, severe bodily injuries, property damage.

- ▶ Make sure that the entire travel route of the crane is sufficiently load bearing to be able to absorb even increased surface pressures - for example if „wind is coming from the front on the boom“.
- ▶ Change of surface pressure on the crawler travel gear under wind load, see the adjacent graphic.

Illustration 1:

- Surface pressure **p1** on the crawler travel gear without wind load.

Illustration 2:

- Surface pressure **p2** on the crawler travel gear in case of wind load from the front.

6.1.2 Force distribution when driving on pressure distributor plates

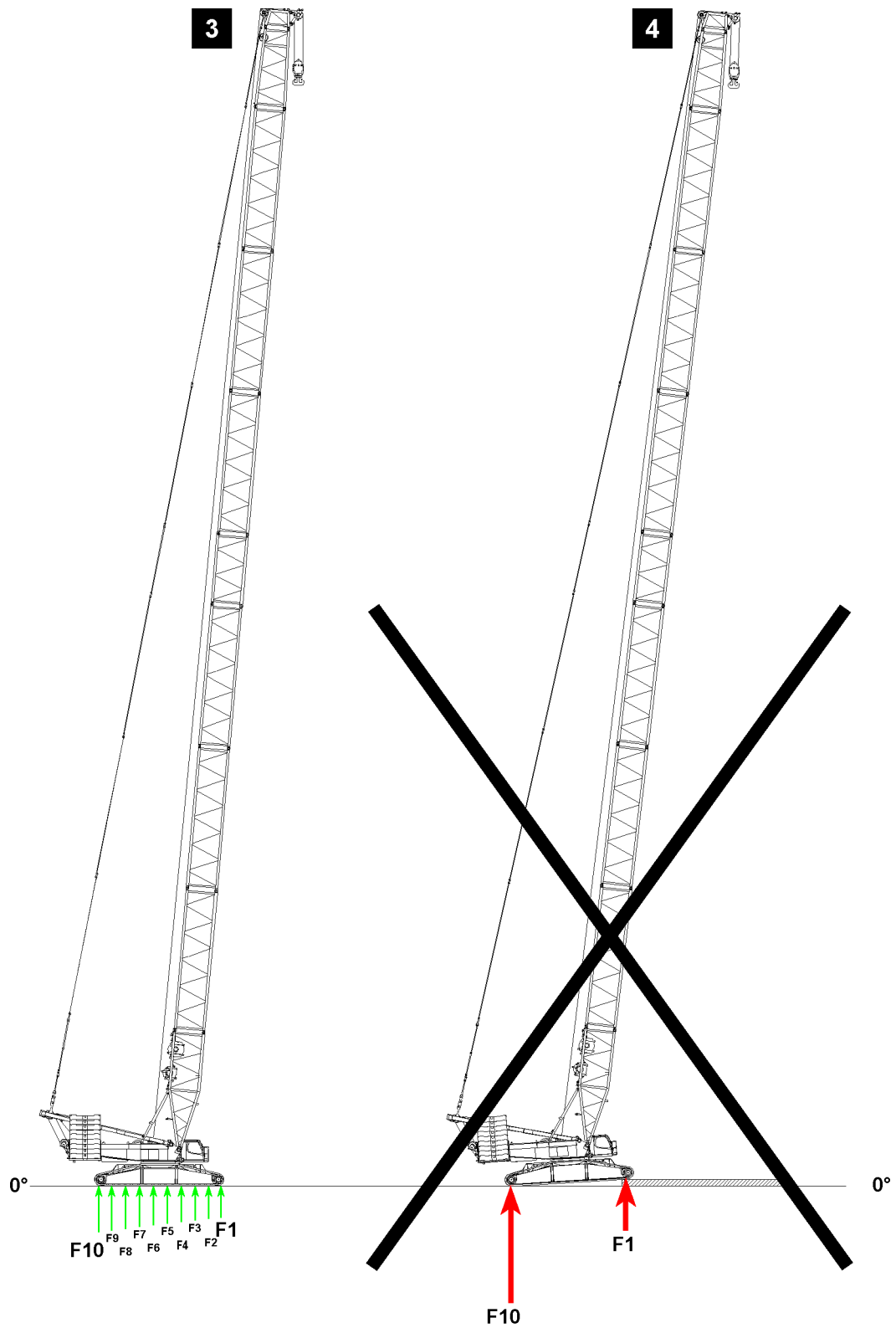

Fig. 153645: Force distribution during normal operation // driving on pressure distributor plates

LWE/LR 13000-001/19503-01-02/en



WARNING

The crane can topple over!

When driving the crane on pressure distributor plates, a movement of forces occurs due to the reduction of the ground contact surfaces on the crawler travel gear. The forces concentrate in force **F1** and force **F10**, see illustration 4.

This can cause the crane to topple over.

Death, severe bodily injuries, property damage.

- ▶ Make sure, before driving the crane on pressure distributor plates, that a load bearing transfer (height equalization) was established, see section „Calculation of required length of transfers“.
- ▶ Driving the crane on pressure distributor plates without transfer (height equalization) is prohibited.

Illustration 3:

- Force distribution on crawler travel gear of the crane (normal operation).
 - Without wind influence

Illustration 4:

- Not permissible

Make sure that the following prerequisites are met:

- The crane is ready to drive.
- The crane engine is running.
- The set up configuration of the crane has been entered correctly in the LICCON computer system.
- The displays for incline, surface pressure and center of gravity are shown.
- There are no persons or objects in the danger zone.

6.2 Operating elements for crawler operation

6.2.1 Pedal carrier

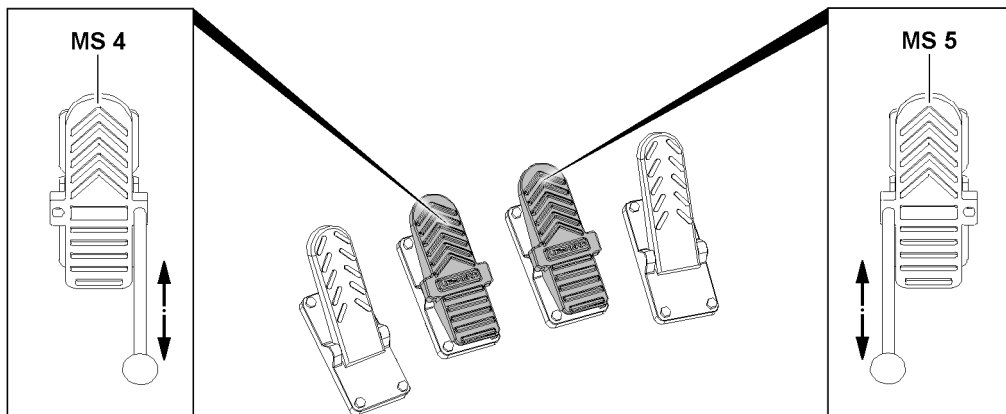
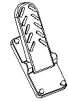





Fig.153646: Pedal carrier

Pedal carrier (Pedal assignment, see the adjacent illustration)				
				
	<i>Pedal</i>	<i>Foot rocker MS 4</i>	<i>Foot rocker MS 5</i>	<i>Pedal</i>
Function:	Slewing gear brake	„Left“ crawler travel	„Right“ crawler travel	Engine regulation:
	Note: see also chapter 4.01 and chapter 4.05.			

LWE/LR 13000-001/19503-01-02/en

6.2.2 Slewing gear brake

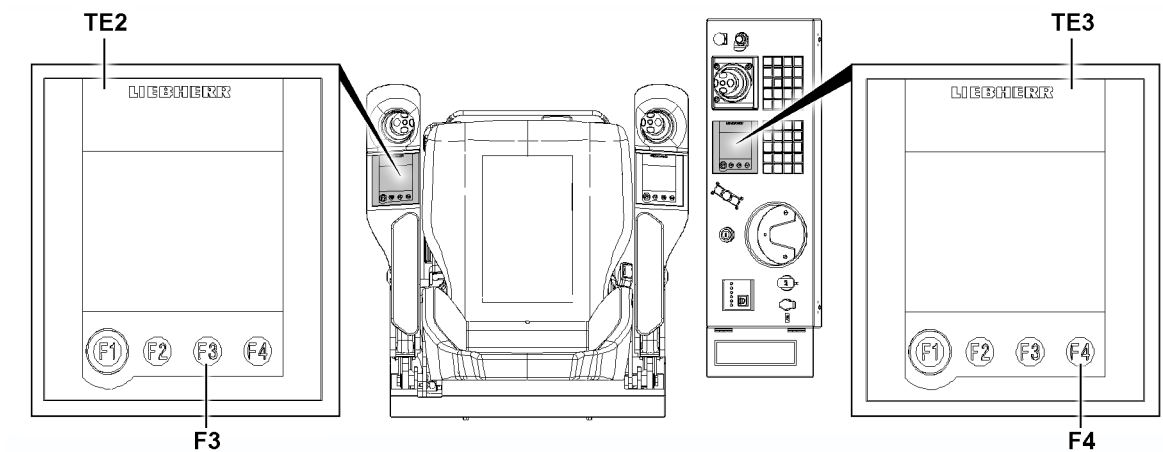

Fig.153788: Actuating the slewing gear brake on TE2

Icon	TE2 main menu assignment: Slewing gear
	Slewing gear brake opened
	Slewing gear brake closed

- ▶ Close the slewing gear brake: Press the button **F3** on touch display 2 **TE2**.

Result:

- The „slewing gear brake applied“ icon appears.

- ▶ Open the slewing gear brake: Press the button **F3** on touch display 2 **TE2** again.

Result:

- The „slewing gear brake released“ icon appears.

6.3 Switch for crawler operation

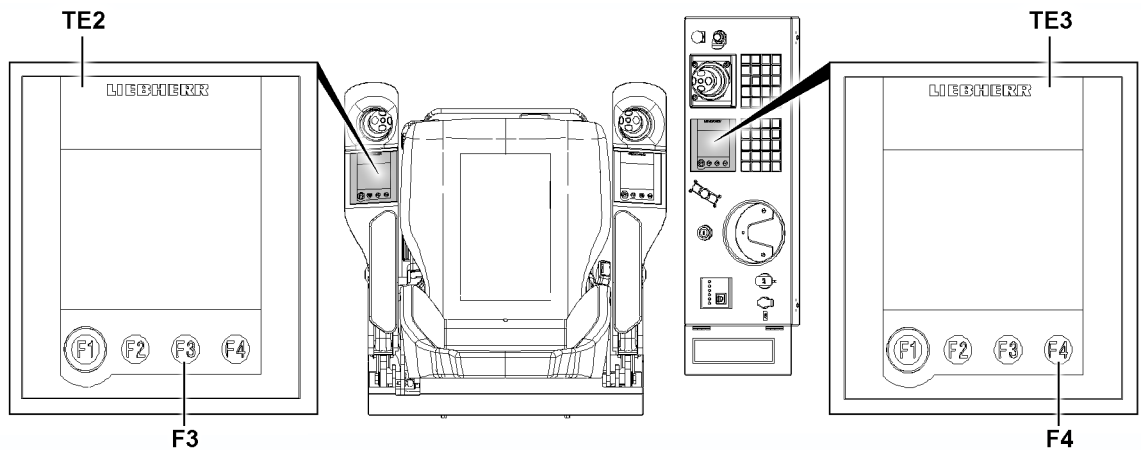





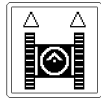



Fig.153788: Touch functions for crawler operation on TE3

LWE/LR 13000-001/19503-01-02/en

Icon	TE3 main menu: Touch functions
	Crawler operation normal travel turned off
	Crawler operation normal travel preselected
	Crawler operation normal travel activated, icon blinks
	Crawler operation rapid gear turned off
	Crawler operation rapid gear preselected
	Crawler operation rapid gear activated, icon blinks
	Crawler operation parallel travel turned off
	Crawler operation parallel travel preselected
	Crawler operation parallel travel activated, icon blinks

6.4 Selecting the function on the touch display

Select a function on the touch display, in the example „Crawler parallel operation“.



Fig.119615: Selecting the function on the touch display

- „Parallel travel crawler operation“ example: Select parallel travel crawler operation by touching the „parallel travel crawler operation“ icon on touch display 3 TE3, see illustration 1.

Result:

- The „parallel travel crawler operation“ icon is bordered completely.

- Parallel travel crawler operation is preselected.
- ▶ Press the button **F4** on touch display 3 **TE3**, see illustration 2.

Result:

- The „parallel travel crawler operation“ icon blinks.
- Parallel travel crawler operation is activated.

6.5 Turning normal travel crawler operation on / off

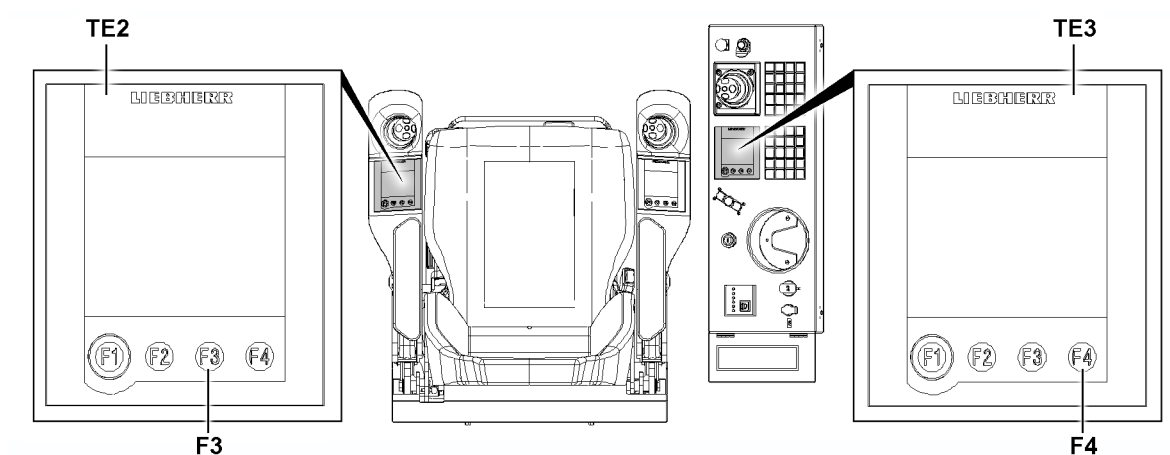

Fig.153788: Activating / deactivating crawler operation

Activate normal travel crawler operation:

- ▶ Select normal travel crawler operation by touching the „normal travel crawler operation“ icon on touch display 3 **TE3**.

Result:

- The „normal travel crawler operation“ icon is bordered all over.
- Normal travel crawler operation is preselected.

- ▶ Press the button **F4** on touch display 3 **TE3**.

Result:

- The „normal travel crawler operation“ icon blinks.
- Normal travel crawler operation is activated.

Turn normal travel crawler operation off:

- ▶ Press the button **F4** on touch display 3 **TE3**.

Result:

- The „normal travel crawler operation“ icon no longer blinks.
- Normal travel crawler operation is turned off.

- ▶ Deselect normal travel crawler operation by touching the „normal travel crawler operation“ icon on touch display 3 **TE3**.

Result:

- The complete border around the „normal travel crawler operation“ icon disappears.
- Preselection of normal travel crawler operation is cancelled.

6.6 Selecting the travel speed

This crawler crane has 2 possible speeds that can be selected:

1. Speed stage 1:

- Normal speed
- 2. Speed stage 2:
Rapid gear

6.6.1 Activating normal speed

Activate normal speed:

- Normal speed is activated in the basic setting.
- Check: If crawler operation is activated **and** the „rapid gear deactivated“ icon is displayed, then normal speed is activated.

6.6.2 Turning crawler operation rapid gear on / off



WARNING

Maximum permissible travel speed exceeded!

If the crane is driven in rapid gear with a load or derrick ballast, then the crane can topple over. Death, severe bodily injuries, property damage.

- ▶ Driving with a load or derrick ballast in rapid gear is prohibited.
- ▶ The maximum permissible travel speed is adhered to.

Make sure that the following prerequisites are met:

- „Parallel travel crawler operation“ is not preselected.
- Normal speed is active.

Activating the crawler operation rapid gear:

- ▶ Select rapid gear crawler operation by touching the „rapid gear crawler operation“ icon on touch display 3 **TE3**.

Result:

- The „rapid gear crawler operation“ icon is bordered all over.
- Rapid gear crawler operation is preselected.

- ▶ Press the button **F4** on touch display 3 **TE3**.

Result:

- The „rapid gear crawler operation“ icon blinks.
- Rapid gear crawler operation is activated.

Deactivating rapid gear crawler operation:

- ▶ Press the button **F4** on touch display 3 **TE3**.

Result:

- The „rapid gear crawler operation“ icon no longer blinks.
- Rapid gear crawler operation is turned off.

- ▶ Deselect rapid gear crawler operation by touching the „rapid gear crawler operation“ icon on touch display 3 **TE3**.

Result:

- The all over border of the „rapid gear crawler operation“ icon disappears.
- Preselection of rapid gear crawler operation is cancelled.

6.7 Drive the crawler



WARNING

Maximum permissible travel speed exceeded!

If the crane is driven in rapid gear with a load or derrick ballast, then the crane can topple over. Death, severe bodily injuries, property damage.

- ▶ Driving with a load or derrick ballast in rapid gear is prohibited.
- ▶ The maximum permissible travel speed is adhered to.



WARNING

The crane can topple over!

If the crane is driven in rapid gear with a load and / or derrick ballast, then it can topple over. Death, severe bodily injuries, property damage.

- ▶ Driving with a load and / or derrick ballast in rapid gear is prohibited.
- ▶ Steering the crawler with a suspended load and / or installed derrick ballast is prohibited.



WARNING

Personnel in the danger zone!

Death, severe bodily injuries, property damage.

- ▶ An additional observer in radio contact with the crane operator must ensure that there are no persons or objects within the danger zone of the crane.
- ▶ The observer may not remain in the danger zone of the crane.



Note

Use the hand levers

- ▶ Take the hand levers from the transport retainer in the crane operator's cab.
- ▶ The technical version of the hand levers is completely identical. The difference between the two hand levers relates only to their assignment to the corresponding foot rockers in the assembled (connected) condition.

Make sure that the following prerequisite is met:

- Crawler operation is activated.

6.7.1 Changing the travel direction

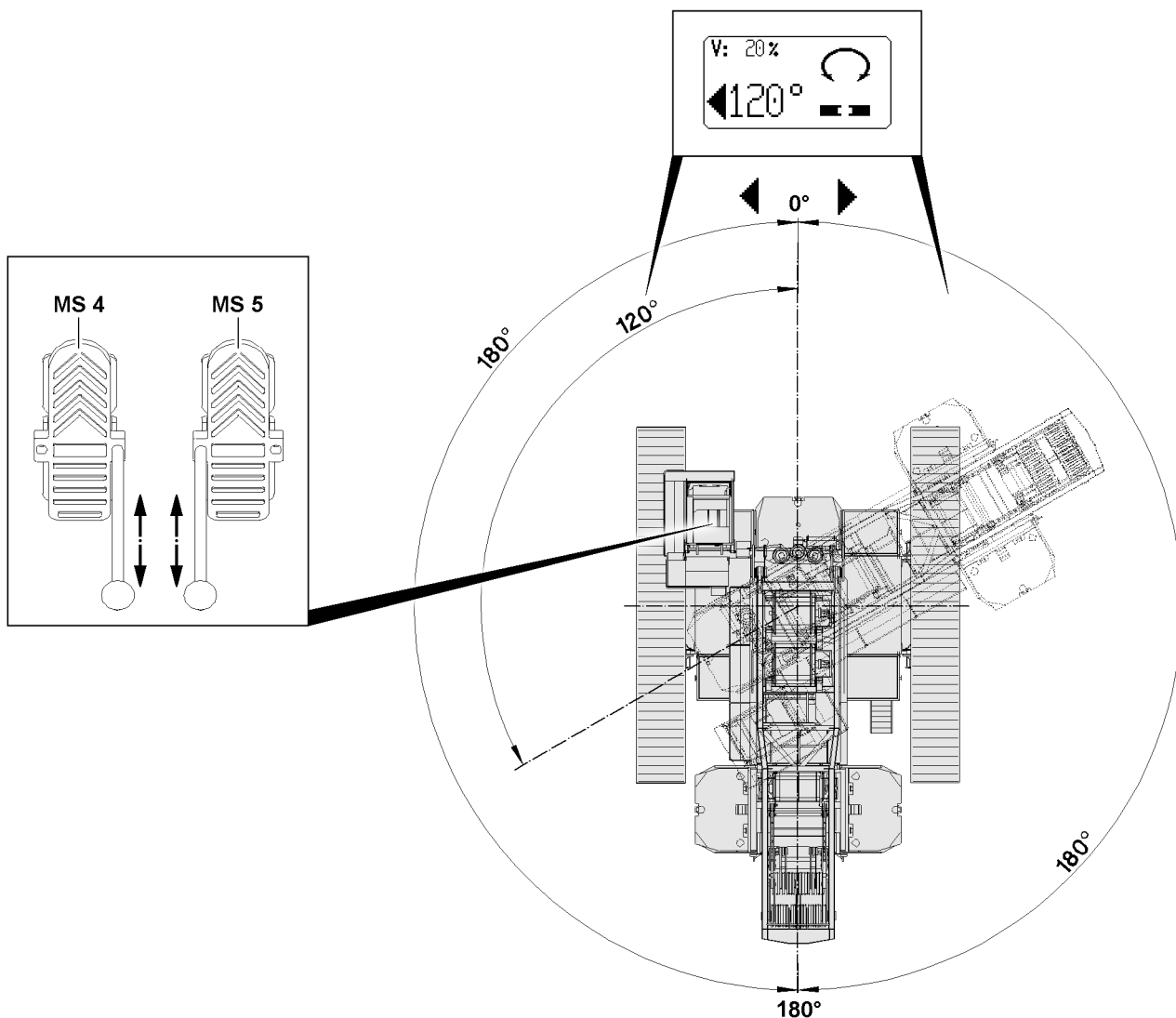

Fig.153652: Changing the travel direction



Note

- ▶ At 0°, the crane superstructure is exactly in position „to the front“.
- ▶ At 180°, the crane superstructure is exactly in position „to the rear“.

The travel direction relates to the position of the crane superstructure:

- A travel direction change may only be done when at a standstill.
- If the crane superstructure is swung past 90°, then the „forward / reverse“ travel direction changes.
- If the crane superstructure with actuated foot rocker **MS 4** or foot rocker **MS 5** is turned past 90°, then the travel direction remains until the corresponding foot rocker / manual control lever is „returned“ to the neutral position.

This means the new travel direction becomes active only if the corresponding foot rocker / manual control lever is no longer actuated.

6.7.2 Driving the crawler forward and backward

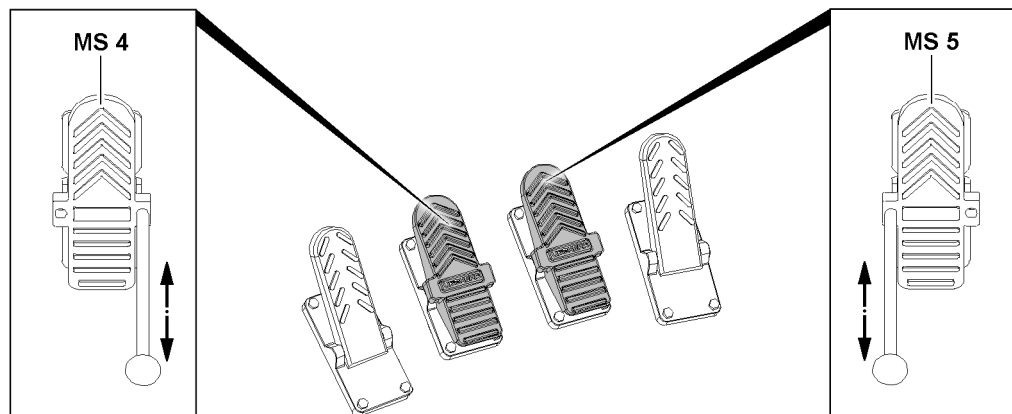

Fig.153646: Pedal carrier

The crawler travel gear can be operated with the foot rockers:

- Left crawler travel gear: Foot rocker **MS4**
- Right crawler travel gear: Foot rocker **MS5**

Alternatively, a hand lever can be assembled (inserted) on the foot rocker **MS4** and the foot rocker **MS5** in order to control the travel movements of the crawler precisely.

Driving the crawlers forward

- ▶ Move the right foot rocker **MS5** to the front.
or
Move the hand lever on the foot rocker **MS5** forward.

Result:

- The right crawler moves forward.
- ▶ Push the left foot rocker **MS4** forward.
or
Move the hand lever on the foot rocker **MS4** forward.

Result:

- The left crawler moves forward.

Drive the crawlers backward

- ▶ Push the right foot rocker **MS5** backward.
or
Move the hand lever on the foot rocker **MS5** backward.

Result:

- The right crawler moves backward.
- ▶ Push the left foot rocker **MS4** backward.
or
Move the hand lever on the foot rocker **MS4** backward.

Result:

- The left crawler moves backward.

6.7.3 Turning parallel travel crawler operation on / off

If „parallel travel crane operation“ is activated, both crawlers are simultaneously controlled by pressing down on foot rocker **MS4** or foot rocker **MS5**. The operating element that is actuated first serves as

the control for both crawler carriers. This makes it possible to drive the crawler exactly straight forward on suitable ground.



Note

- ▶ If, with the „rapid gear crawler operation“ turned on, the „parallel travel crawler operation“ function is activated, then the „rapid gear crawler operation“ function is deactivated.
- ▶ If the „parallel travel crawler operation“ function is turned off again, the „rapid gear crawler operation“ function activates automatically.

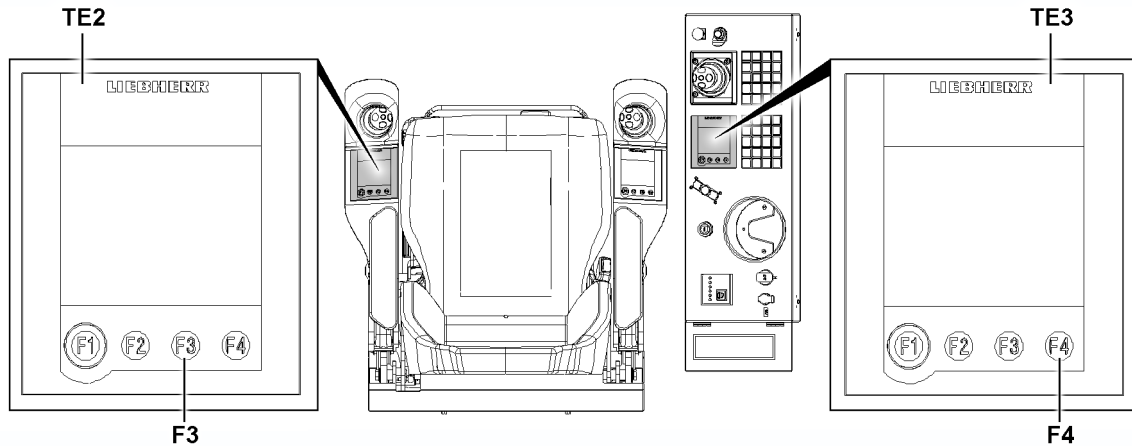

Fig.153788

Make sure that the following prerequisites are met:

- „Parallel travel crawler operation“ is not activated.
- Normal speed is active.

Turn parallel travel crawler operation on:

- ▶ Select parallel travel crawler operation by touching the „parallel travel crawler operation“ icon on touch display 3 **TE3**.

Result:

- The „parallel travel crawler operation“ icon is bordered completely.
- Parallel travel crawler operation is preselected.

- ▶ Press the button **F4** on touch display 3 **TE3**.

Result:

- The „parallel travel crawler operation“ icon blinks.
- Parallel travel crawler operation is activated.

Turn parallel travel crawler operation off:

- ▶ Press the button **F4** on touch display 3 **TE3**.

Result:

- The „Parallel travel crawler operation“ icon no longer blinks.
- Parallel travel crawler operation is turned off.

- ▶ Deselect parallel travel crawler operation by touching the „parallel travel crawler operation“ icon on touch display 3 **TE3**.

Result:

- The all over border of the „Parallel travel crawler operation“ icon disappears.
- Preselection of parallel travel crawler operation is cancelled.

6.7.4 Steering the crane



WARNING

The crane can topple over!

If the crane is steered with the slewing gear brake applied, then the boom system can be damaged due to high side acceleration.

Death, severe bodily injuries, property damage.

- ▶ When steering the crawler, always activate slewing gear freewheeling.



WARNING

The crane can topple over!

If the crawler chain sags on uneven ground, then the centering cams of the outrigger pads can no longer be centered and guided sufficiently in the track rollers.

The centering cams will be damaged and the chain can jump out of its guide.

Death, severe bodily injuries, property damage.

- ▶ Stop steering movements immediately.
- ▶ Drive straight forward until all centering cams are centered again.
- ▶ If possible, retighten the crawler chain, see chapter 7.04.



WARNING

The crane can topple over!

When steering in small radii or when steering on the spot, the crawler travel gear can „dig into the ground“ and cause the crane to topple over.

Death, severe bodily injuries, property damage.

- ▶ Steer the crawler travel gear with as large a radius as possible.
- ▶ Avoid turning on the spot.

Steering the crawler travel gear to the left

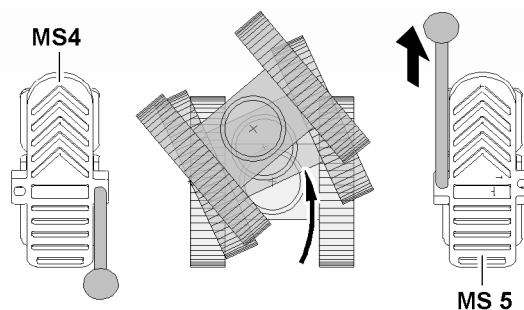

Fig.153648: Steering the crawler travel gear to the left

- ▶ Move the right foot rocker **MS5** to the front.
or
- ▶ Move the hand lever on the foot rocker **MS5** forward.

Steering the crawler travel gear to the right

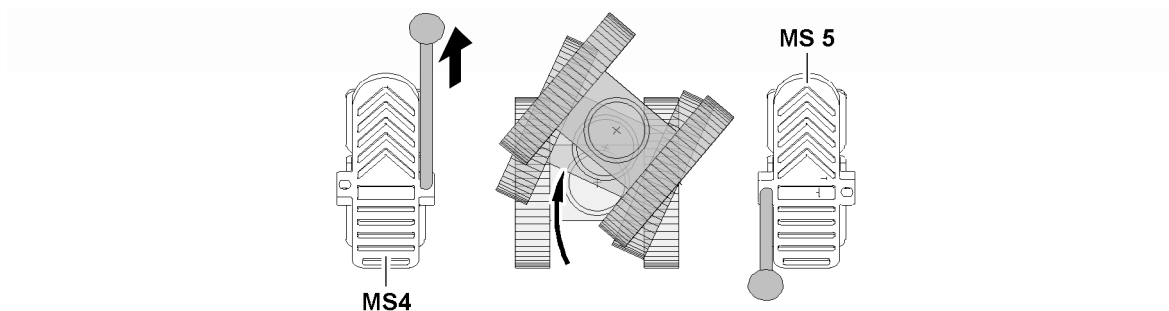

Fig.153649: Steering the crawler travel gear to the right

- ▶ Push the left foot rocker **MS4** forward.
- or
- Move the hand lever on the foot rocker **MS4** forward.

Turning the crawler travel gear on the spot to the left

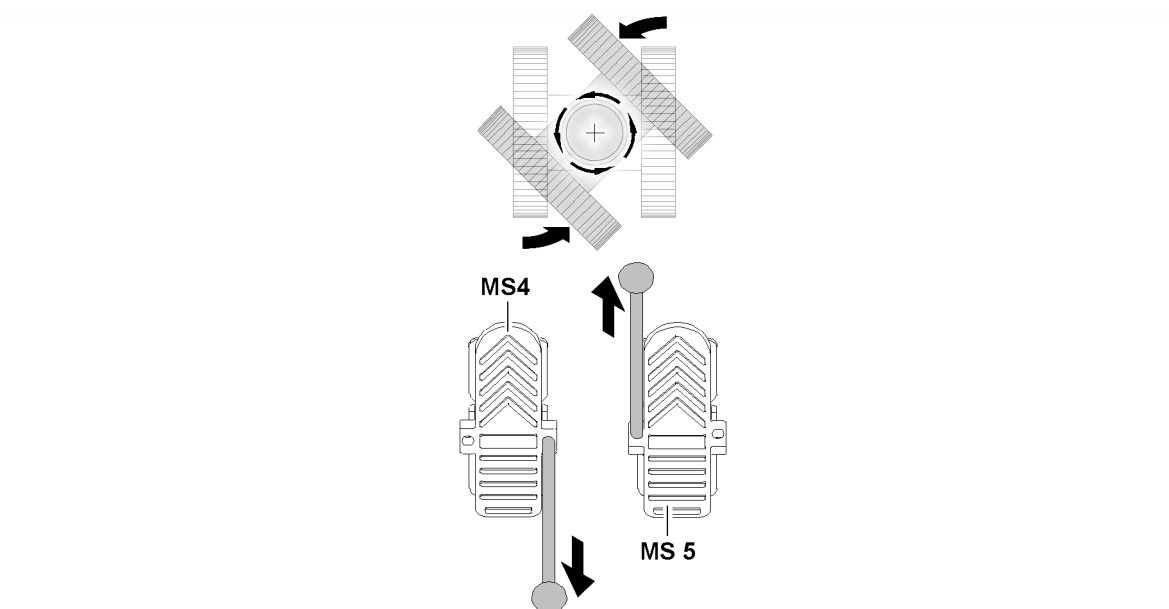

Fig.153650: Turning the crawler travel gear on the spot to the left

- ▶ Push the right foot rocker **MS5** forward and the left foot rocker **MS4** backward.
- or
- Move the hand lever on the foot rocker **MS5** forward and move the foot rocker **MS4** backward.

Turning the crawler travel gear on the spot to the right

Fig.153651: Turning the crawler travel gear on the spot to the right

- ▶ Push the left foot rocker **MS4** forward and the right foot rocker **MS5** backward.
or
Move the hand lever on the foot rocker **MS4** forward and move the foot rocker **MS5** backward.

Empty page!

LWE/LR 13000-001/19503-01-02/en

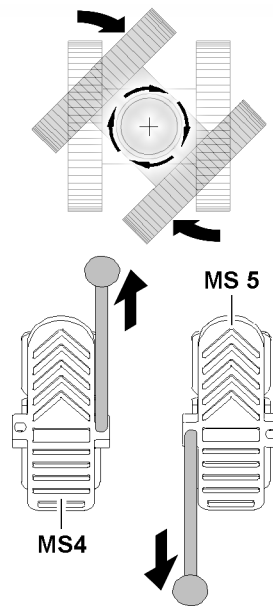
4.15 Reeving plans

1 Reeving plans

3

LWE/LR 13000-001/19503-01-02/en

Fig.195219

LWE/LR 13000-001/19503-01-02/en

1 Reeving plans



Note

- ▶ See separate reeving plans!
-

Empty page!

LWE/LR 13000-001/19503-01-02/en

4.20 Procedure for shut-off of crane movement

1	General	3
2	Instructions for resuming crane movement	17

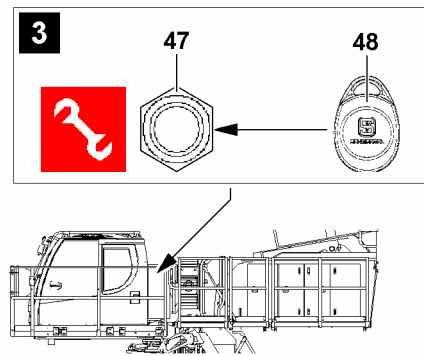
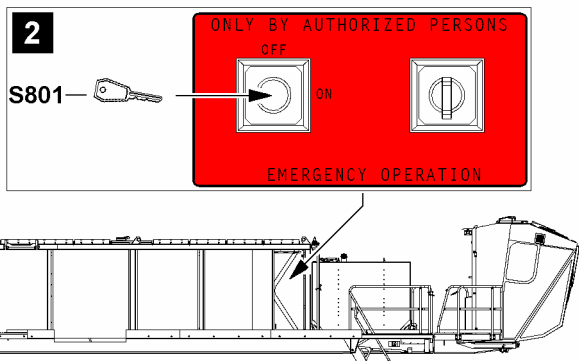
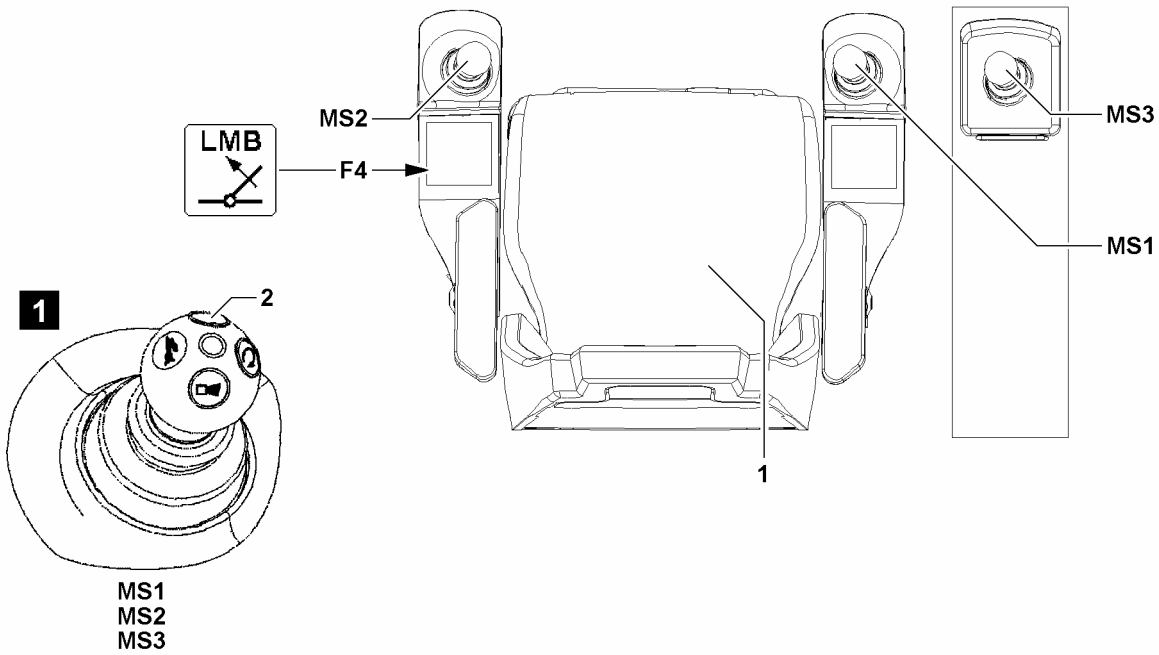
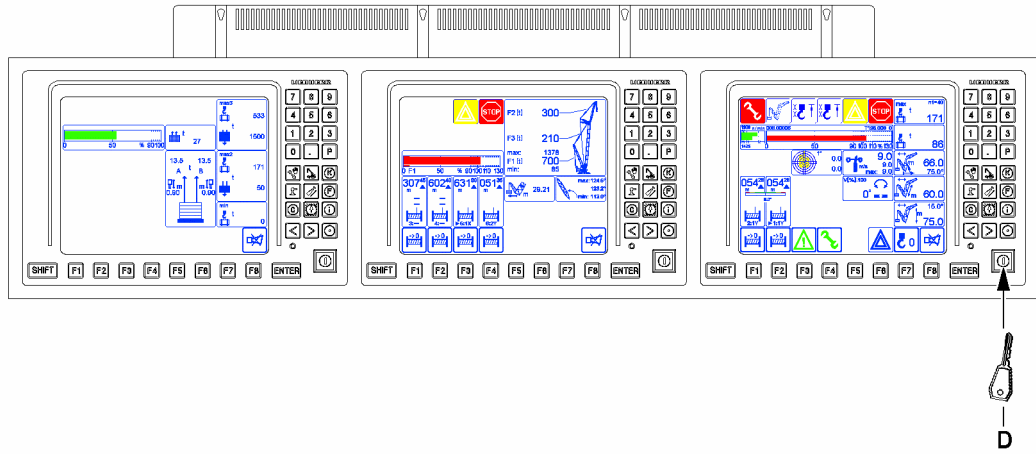

Fig.144109

LWE/LR 13000-001/19503-01-02/en

1 General



Note

- ▶ The monitor illustrations in this chapter are only examples.
- ▶ The numerical values in the individual icons and charts do not have to necessarily match the crane exactly.
- ▶ Numbers and letters can be replaced by place holders.
- ▶ The display and assignment of the icons can deviate, depending on the set up configuration, operating status and configuration of the crane.
- ▶ In addition, many of the illustrations show the maximum configuration of the LICCON monitor with icons.
- ▶ In crane operation, an identical display will **not** appear on the LICCON monitor.

For monitoring the crane, three LICCON monitors are available in the instrument panel.

LICCON monitor 0

- Placed on the right in the monitor arrangement

LICCON monitor 1

- Placed in the center in the monitor arrangement

LICCON monitor 2

- Placed to the left in the monitor arrangement

If a crane movement is to be carried out with a master switch (MS1, MS2 or MS3), then at least one of the following buttons must be pressed:

- **1** Seat contact button
 - Is actuated by sitting properly on the seat.
- **2** Button
 - To bypass the seat contact button **1**, to be able to work while standing up, if necessary.
 - Each master switch (MS1, MS2 or MS3) has a button **2**, see illustration **1**



Note

- ▶ Load hook and hook block are also generally described as hooks.

1.1 Operating elements for special cases at operation of the LICCON overload protection

Within the crane operator's cab, two buttons are installed as operating elements for „Special cases at operation of the LICCON overload protection“:

- Button **F4** on the left control panel
- Set up key **D** on LICCON monitor 0

Depending on the crane configuration, an additional operating element can be installed outside the crane operator's cab for „Special cases at operation of the LICCON overload protection“.

Depending on the crane type, either:

- Key button **S801** in the control cabinet, see illustration **2**
- or
- Sensor **47** and transponder **48** on the outside of the control cabinet, see illustration **3**

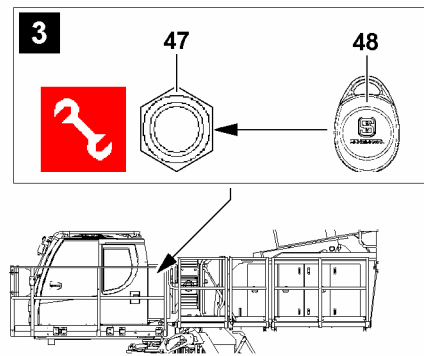
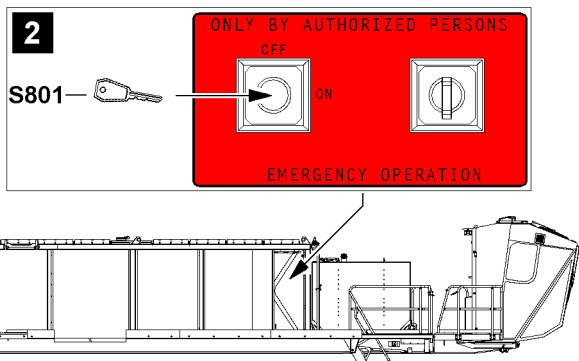
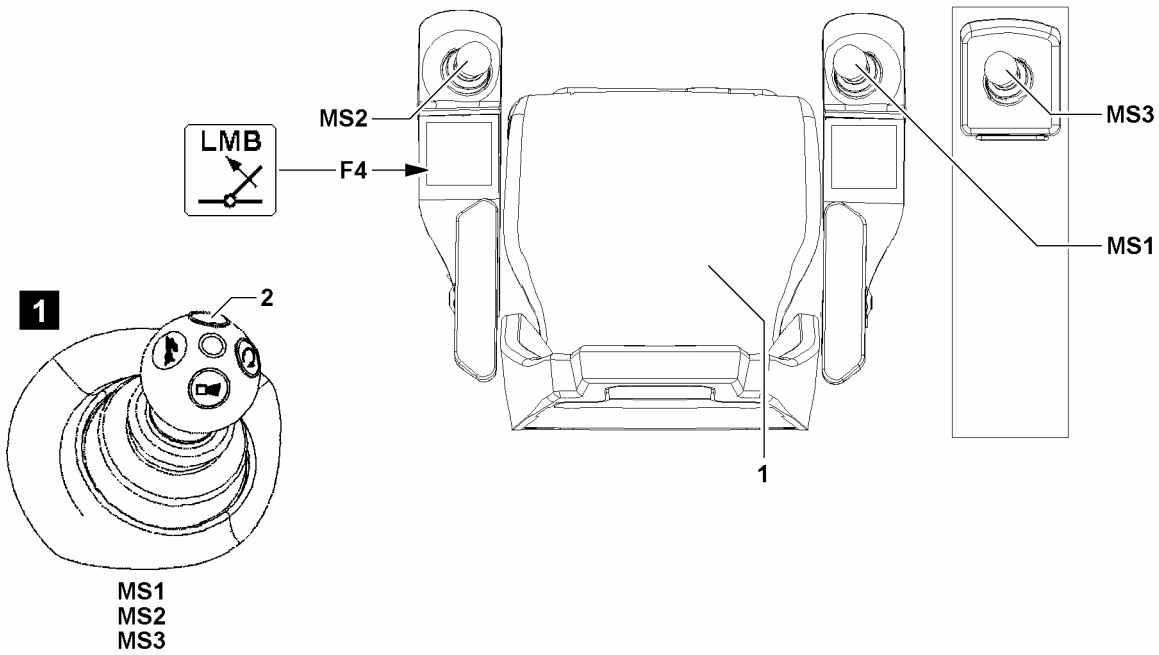
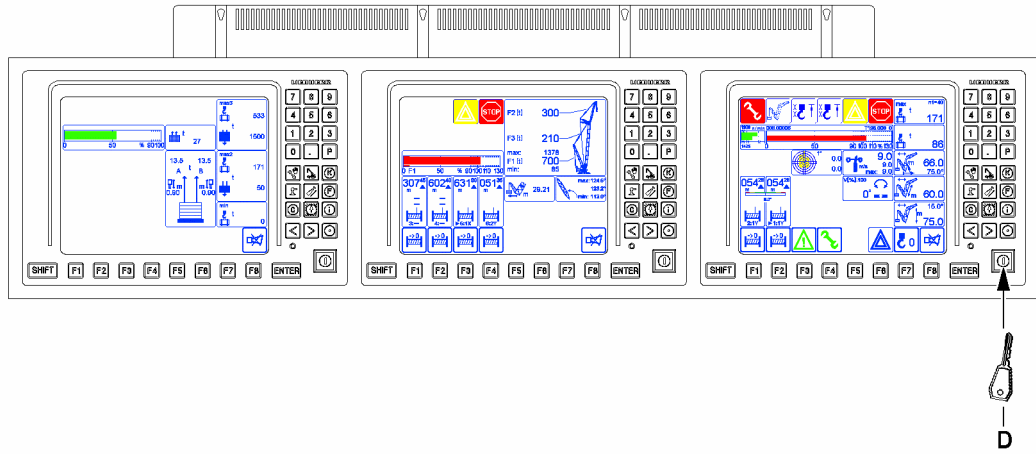

Fig.144109

LWE/LR 13000-001/19503-01-02/en

1.2 Special cases at operation of the LICCON overload protection

When special cases at operation of the LICCON overload protection occur, then the functionality of the LICCON overload protection is accessed.



WARNING

Access the functionality of the LICCON overload protection!

If the functionality of the LICCON overload protection is accessed by pressing the key **F4**, set up key **D**, the key switch **S801** or sensor **47** via transponder **48**, then the LICCON overload protection is entirely deactivated, bypassed or limited.

It is possible to exceed several shut-off limits of the LICCON overload protection simultaneously or one after the other.

It is possible to carry out crane movements that are not monitored by the LICCON overload protection. Without the LICCON overload protection, no additional protection against overload of the crane via the crane control is present.

- ▶ When accessing the functionality of the LICCON overload protection, take into account that the LICCON overload protection is deactivated totally or limited.
- ▶ Access the functionality of the LICCON overload protection exclusively according to the specifications in the crane documentation.

Possible limitation in the crane control:

- During certain „Special cases at operation of the LICCON overload protection“, the working speed of the crane is significantly reduced.
- During certain „Special cases at operation of the LICCON overload protection“, the possibility to control the crane is limited in time.
- During certain „Special cases at operation of the LICCON overload protection“, the individual display instruments show no values.

1.2.1 Special operating conditions

If a special operating condition occurs, such as self-blocking of overload protection („Deadlock“), pressing key **F4** or set up key **D** can provide a remedy.

By pressing the key **F4** you can:

- Luff in with suspended load

By pressing the set up key **D**, the function „Exceeding the shut-off limits of the LICCON overload protection“ is activated. This makes it possible:

- To exceed the maximum permissible load moment.
- To exceed the maximum value of the F-load display in crane operation.
- To make it possible to carry out some limited crane movements after shut-off *LMB-STOP* due to sensor errors, if the erroneous sensor is not required for monitoring by the LICCON overload protection.



Note

- ▶ If there is no sensor defect and a load chart is available, then the display values remain for the crane utilization (load capacity display).
- ▶ Depending on the crane configuration, exceeding the maximum permissible load moment is limited to 110 %.

1.2.2 Assembly / disassembly procedures

By pressing the set up key **D** you can:

- Bypass the LICCON overload protection to carry out erection / take down procedures and assembly procedures.
- Bypass *hoist top* shut-off (erection / take down procedures and assembly procedures)

**Note**

- ▶ For assembly / disassembly procedures, depending on the circumstances there may not be any display values or they may be significantly reduced.
- ▶ The display of the required display values or determination of required values is ensured when proceeding correctly.

1.2.3 Failure of components

**WARNING**

Erroneous operation of the crane!

If the LICCON overload protection turns the crane movement off due to failure of components, then the exact cause for the shut-off must be determined.

After a failure of components, no normal operating condition can be reached. No normal crane operation is possible.

- ▶ For the procedure, see Crane operating instructions, chapter 4.04.
- ▶ Assume normal crane operation only when the cause for the shut-off has been remedied and the crane control is fully functioning.

Depending on the crane configuration, a shut-off due to a failure of components can be bypassed by:

- Press the set up button **D**.
- or
- Actuate the key switch **S801**.
- or
- Actuate the sensor **47** through the transponder **48**.

The activated function includes the following:

- Allows crane movements in case of failure of components, for example sensors which are required for monitoring by the LICCON overload protection.

1.2.4 Emergency situations

**WARNING**

Overload of crane!

If the LICCON overload protection is bypassed, then the LICCON overload protection is entirely deactivated.

If the LICCON overload protection is bypassed, there is no further protection against crane overload. There is no longer a load torque limiter.

If the LICCON overload protection is bypassed, the crane can be overloaded readily.

Overloading the crane can lead to accidents.

During accidents, personnel could be killed or seriously injured.

- ▶ If the LICCON overload protection is bypassed, take into account that the LICCON overload protection is entirely deactivated.
- ▶ If the LICCON overload protection is bypassed, the crane operator assumes the full responsibility for his actions.

Depending on the crane configuration, the LICCON overload protection can be bypassed as follows:

- Press the set up button **D**.
- or
- Actuate the key switch **S801**.
- or
- Actuate the sensor **47** through the transponder **48**.

The activated function includes the following:

- Allowing crane movements in emergency situations without monitoring by the LICCON overload protection

**Note**

- ▶ Installation location of key switch **S801** or sensor **47**, see illustration. The transponder **48** (when sensor **47** is installed) is supplied at crane delivery and must be accessible to the respective personnel (for example the crane operator).
- ▶ For the procedure, see Crane operating instructions, chapter 4.04.

1.3 Operating condition of crane

A „**normal operating condition**“ can only be reached if all of the following statements apply:

- The crane is in a proper condition.
- The crane is set up according to the specifications in the crane documentation.
- The set up configuration of the crane has been entered correctly into the LICCON computer system.
- The crane is in the range of a valid load chart.
- The crane utilization is in the range of 0 % to 100 %.
- The F-load display is in the permissible range.
- All required displays in the LICCON monitors provide the correct display values.
- All required display instruments are functioning.
- The local conditions meet the specifications for crane application.

„**The operating condition is not normal**“, among others, if one or more of the following statements apply:

- The crane has defects that compromise operational safety.
- The crane is not set up according to the specifications in the crane documentation.
- The set up configuration of the crane deviates from the entries in the LICCON computer system.
- The limit values from the load charts are exceeded.
- The maximum permissible load moment is exceeded.
- The *hoist top* shut-off is bypassed.
- The limit values from the F-load display are exceeded.
- Required displays in the LICCON monitors provide no correct display values.
- Required display instruments are not functioning.
- The functionality of the LICCON overload protection has been accessed by pressing the key **F4**, set up key **D** or key switch **S801** or sensor **47** via transponder **48**.
- Crane movements are carried out without functioning overload protection.
- Crane movements are carried out outside of the load charts.
- A special case at operation of the LICCON overload protection has occurred.

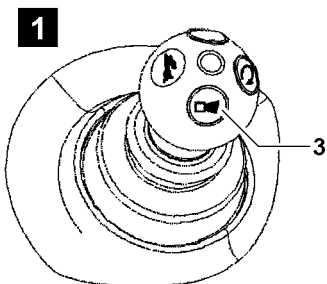
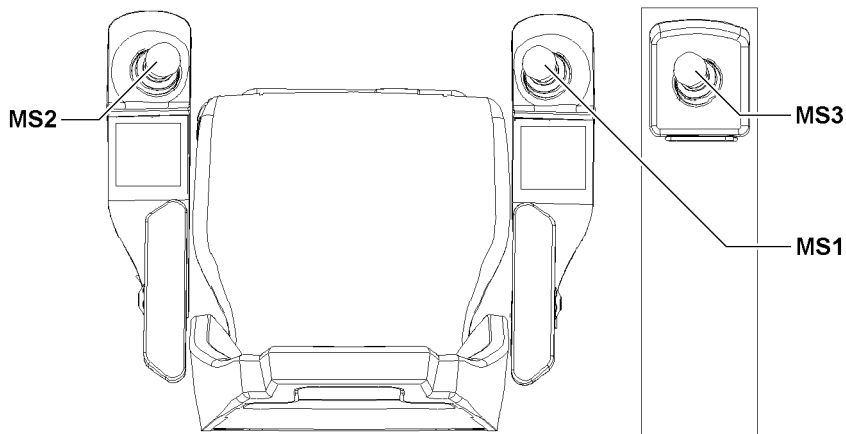
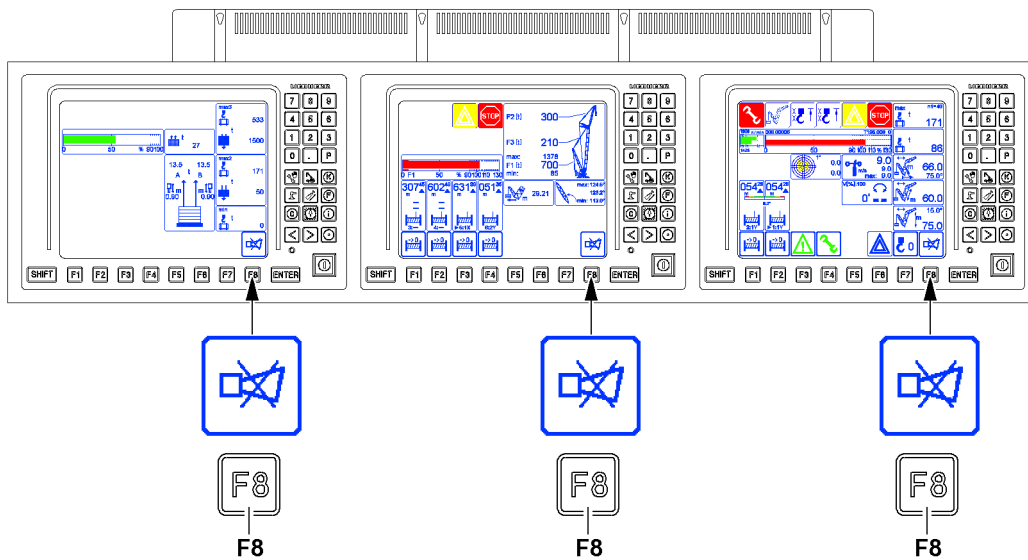
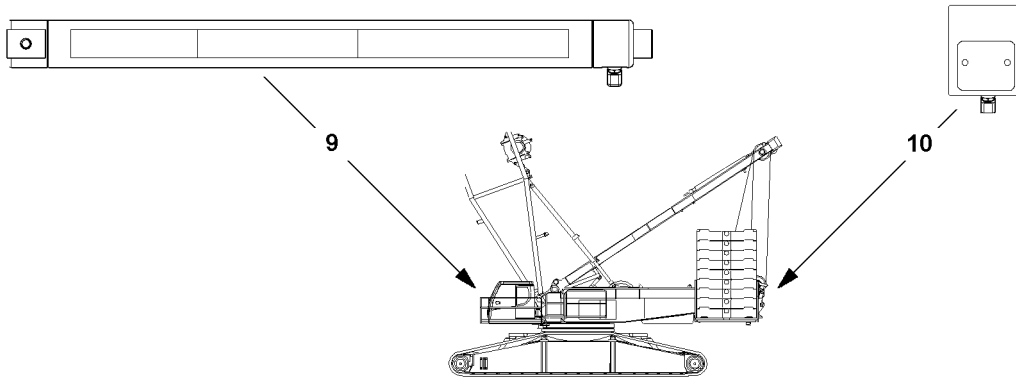

MS1
MS2
MS3

Fig.144108

LWE/LR 13000-001/19503-01-02/en

1.4 Overview of acoustic / optical warnings

- The acoustic warnings are issued to the crane operator via the signal sounds of the LICCON monitors.
- The acoustic warnings are issued to the crane surrounding area via a horn on the turntable.
- The optical warnings are issued to the crane operator via warning icons in the LICCON monitors.
- The LMB warning lights (three color light **9** on the crane cab and warning light **10** on the rear of the turntable) are used to issue optical warnings to the crane surrounding area.
- The acoustic warnings within the crane operator's cab are turned off by pressing the button **F8** on the corresponding LICCON monitor.
- The acoustic warnings outside the crane operator's cab are turned off by pressing the button **3**. Each master switch (MS1, MS2 or MS3) has a button **3**, see illustration **1**

1.4.1 General notes regarding the acoustic / optical warnings to the crane surrounding area



WARNING

Disregard of acoustic or optical warnings!

If persons in the crane surrounding area are not informed about the meaning of acoustic / optical warnings of the crane, then there is a danger of accidents.

- ▶ Only persons who have been informed about how to proceed correctly according to the acoustic / optical warnings may be in the crane surrounding area.

In reference to the horn on the turntable, the following applies:

- An intermittent sound is heard: A special case in the operation of the LICCON overload protection has occurred or the overload protection has turned the crane movement off.

In reference to the three color light **9**, the following applies:

- The three color light **9** lights up green: The crane is in normal operating condition.
- The three color light **9** lights up yellow: The crane is still in normal operating condition, an advance warning for upcoming shut-off exists.
- The three color light **9** lights up red: The crane movement was turned off by the overload protection.
- The three color light **9** blinks yellow: A special case at operation of the LICCON overload protection has occurred.
- The three color light **9** blinks red: A special case at operation of the LICCON overload protection has occurred.

In reference to the warning light **10** on the rear of the turntable, the following applies:

- The warning light **10** lights up red: The crane movement was shut off.
- The warning light **10** blinks red: A special case at operation of the LICCON overload protection has occurred.

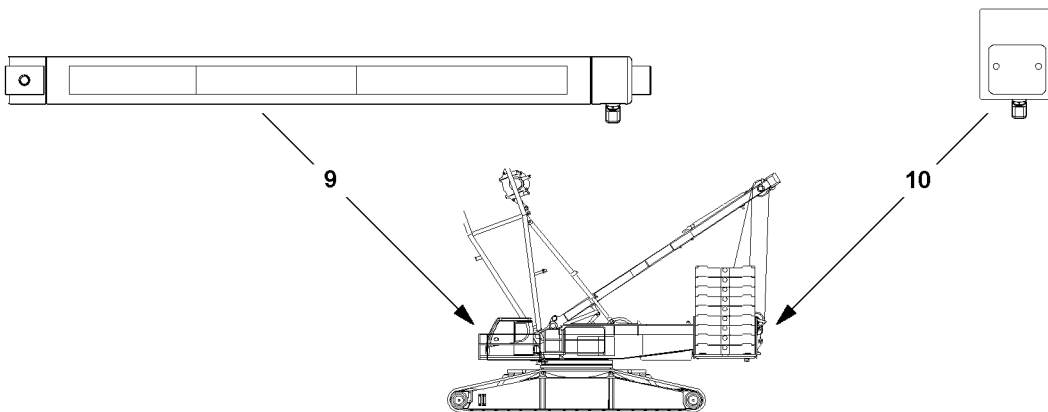
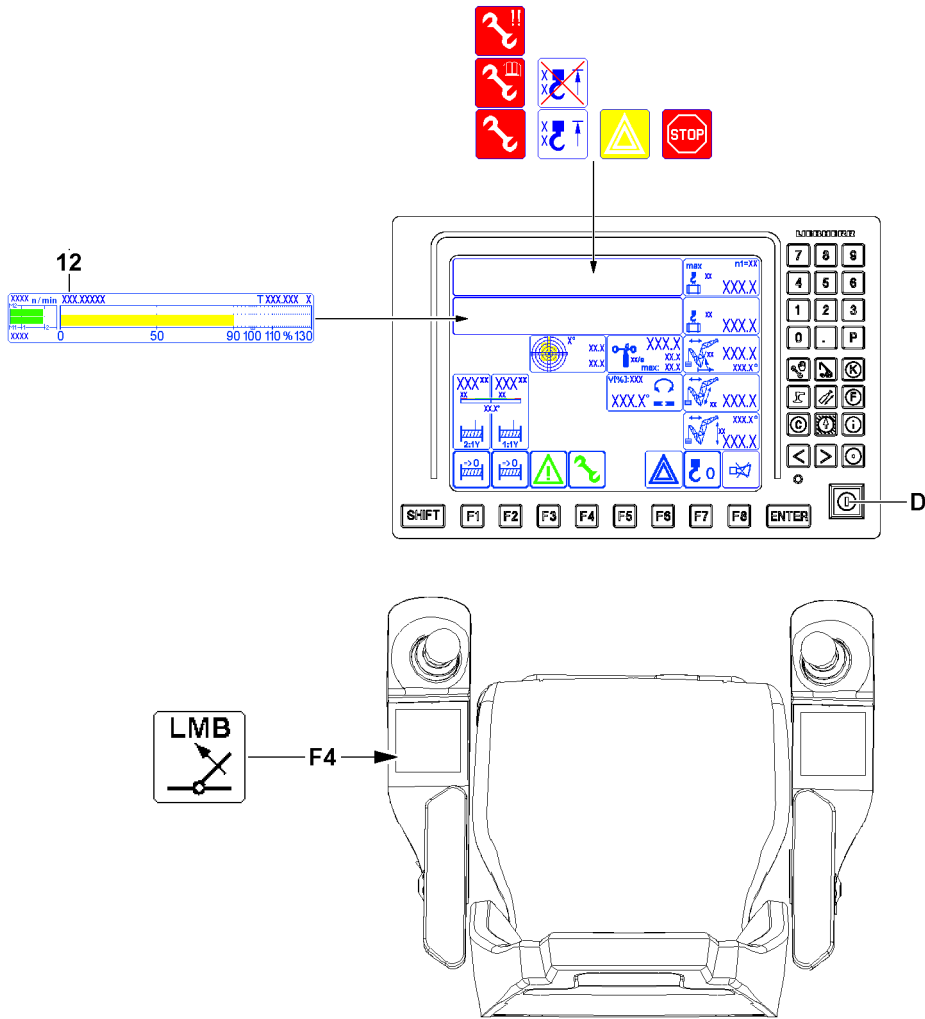

Fig.115284

LWE/LR 13000-001/19503-01-02/en

1.4.2 Description of acoustic / visual warnings

The occurrence of acoustic / optical warnings in crane operation is explained via sample situations. The situation numbers from the chart „Overview of possible situations“ is valid for the following charts in this chapter:

- Acoustic / visual warnings on the LICCON monitor
- LMB warning lights
- Horn on the turntable



Note

- ▶ The percentage values in the chart „Overview of possible situations“ refers to the crane utilization according to the display in the bar diagram for utilization **12**.

Overview of possible situations	
Situation number	Sample description of the situation
Situation 001	Normal operating condition with crane utilization of 0 % to 100 %.
Situation 003	The crane movement was turned off due to a crane utilization above 100 % - shut-off <i>LMB-STOP</i> was triggered.
Situation 004	The crane movement was turned off even though the crane utilization is below 100 % - shut-off <i>LMB-STOP</i> was triggered.
Situation 005	The crane movement „luffing in with suspended load“ is carried out at a crane utilization above 100 % via the F4 key.
Situation 006	Failure of components
Situation 010	The shut-off limits of the LICCON overload protection are deactivated / exceeded with the set up key D .
Situation 011	An actuated hoist limit switch (<i>hoist top</i> shut-off) is bypassed via the set up key D .
Situation 020	The assembly operation was activated via the set up key D to erect / take down the boom. No load chart is available.

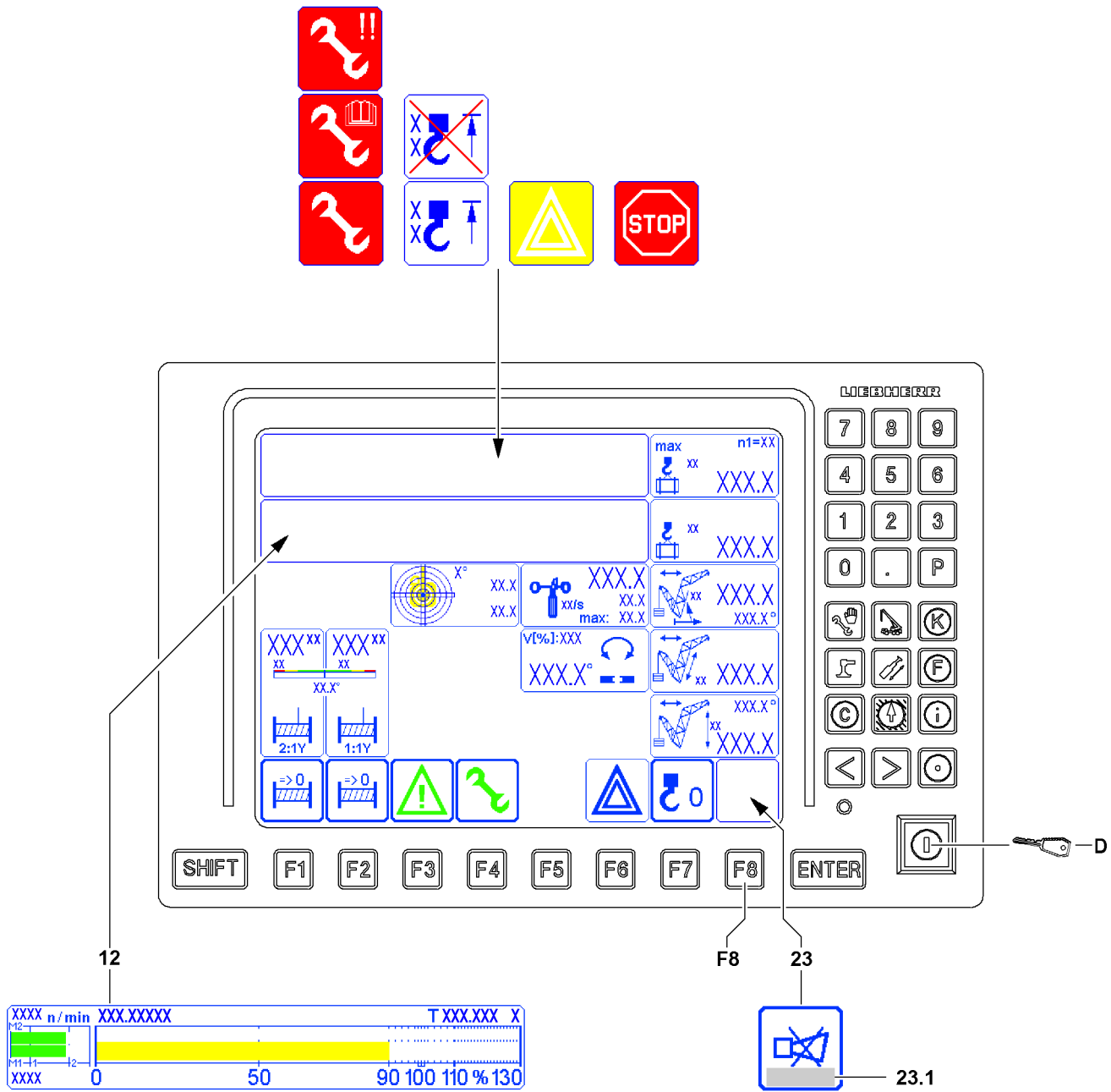

Fig.115267

LWE/LR 13000-001/19503-01-02/en

1.4.3 Acoustic / visual warnings within the crane operator's cab



Note







- For description of the situations assigned to the situation numbers, see chart „Overview of possible situations“
- The percentage values refer to the crane utilization according to the display in the bar diagram for utilization **12**.



WARNING

Erroneous operation of the crane!

- In relation with acoustic / optical warnings in the *Horn* icon **23**, observe the notes regarding error messages **23.1**.

Acoustic / visual warnings on the LICCON monitor							
Situation number	Acoustic warning		Visual warning LICCON monitor				
	Horn short ²⁾	Horn long ²⁾	Warning signs		Special signs		
							
Situation 001	From 90 %	-	From 90 %	-	-	-	-
Situation 003	From 90 %	From 101 %	From 90 %	From 101 %	-	-	-
Situation 004	-	Always	-	Always	-	-	-
Situation 005	-	From 101 %	From 101 %	From 101 %			
Situation 006				Always		Always ³⁾	
Situation 010	From 90 %	From 101 %	From 90 %	From 101 %	Always	-	-
Situation 011¹⁾	-	Always	-	-	-	-	Always
Situation 020	-	Always	-	-	-	Always	-

1) Is in part superseded by other warnings

2) Can be turned off immediately on the LICCON monitor key **F8**

3) Depending on the crane configuration, a similar icon appears, in which two exclamation marks (upper right) appear, see also Crane operating instructions, chapter 4.02

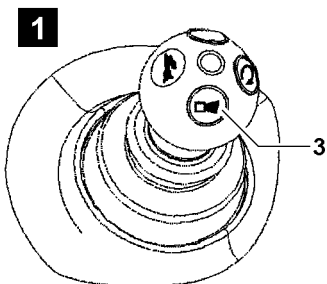
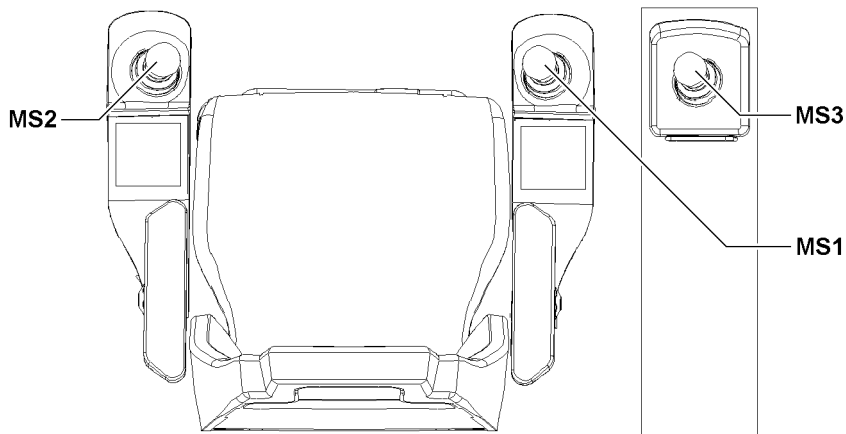
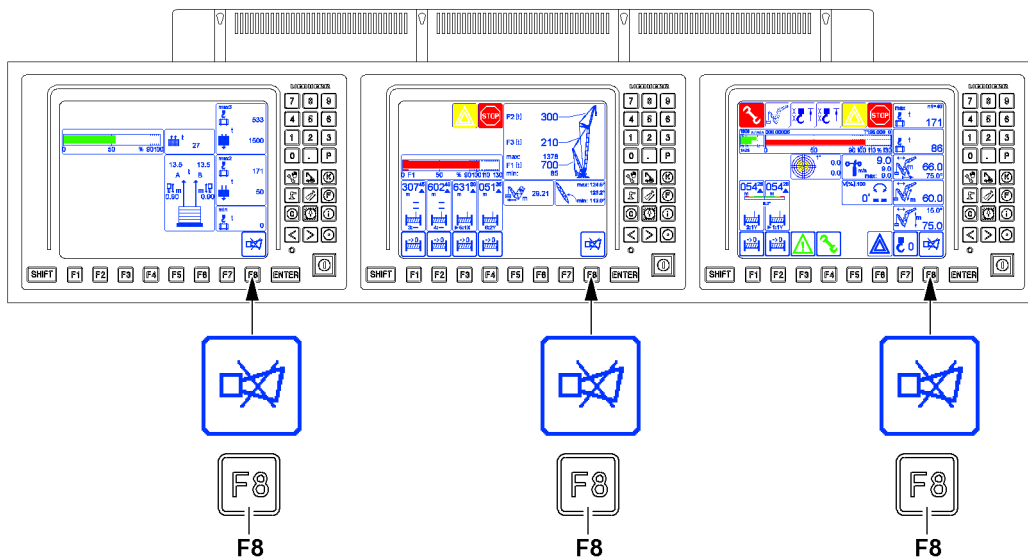
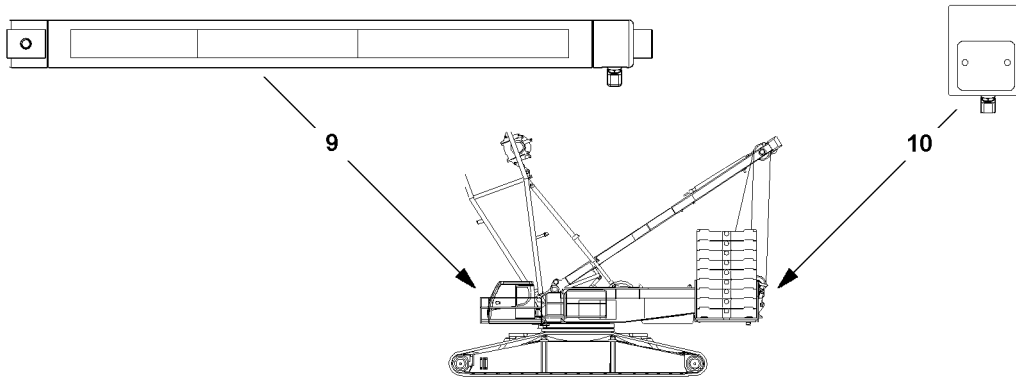

MS1
MS2
MS3

Fig.144108

LWE/LR 13000-001/19503-01-02/en

1.4.4 Acoustic / visual warnings outside the crane operator's cab



Note

- ▶ For description of the situations assigned to the situation numbers, see chart „Overview of possible situations“
- ▶ The percentage values refer to the crane utilization according to the display in the crane operating screen.

LMB warning lights					
Situation number	At utilization of crane	Three color light 9			Warning light 10
		Green	Yellow	Red	Red
Situation 001	0 % to 89 %	Lights up			
	90 % to 100 %		Lights up		
Situation 003	From 101 %			Lights up	Lights up
Situation 004	Always			Lights up	Lights up
Situation 005	From 101 %			Blinks	Blinks
Situation 006	Always			Blinks	Blinks
Situation 010 ⁴⁾	0 % to 89 %	Lights up			
	90 % to 100 %		Lights up		
	101 % to 110 %		Blinks		
	From 111 %			Lights up	Lights up
Situation 010	0 % to 89 %	Lights up			
	90 % to 100 %		Lights up		
	From 101 %			Blinks	Blinks
Situation 011 ¹⁾	Always		Blinks		
Situation 020	No display value		Blinks		

1) Is in part superseded by other warnings

4) Cranes according to EN13000:2010

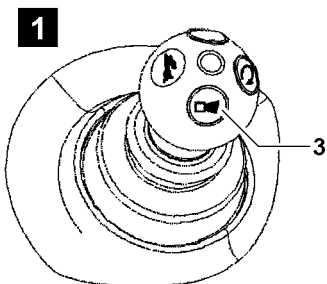
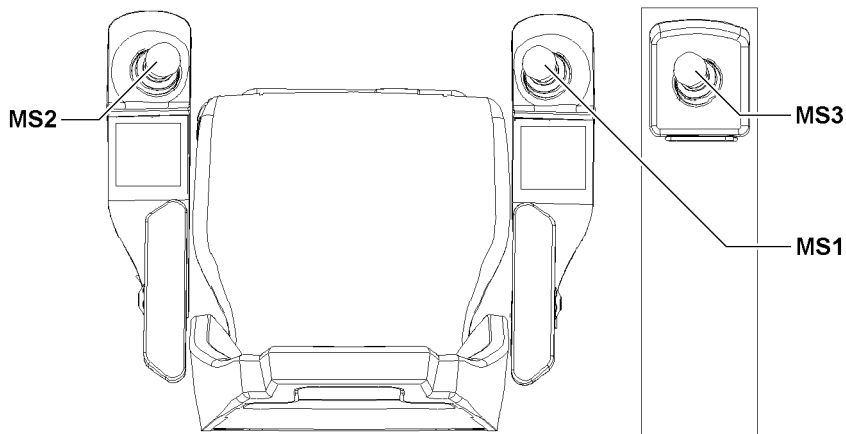
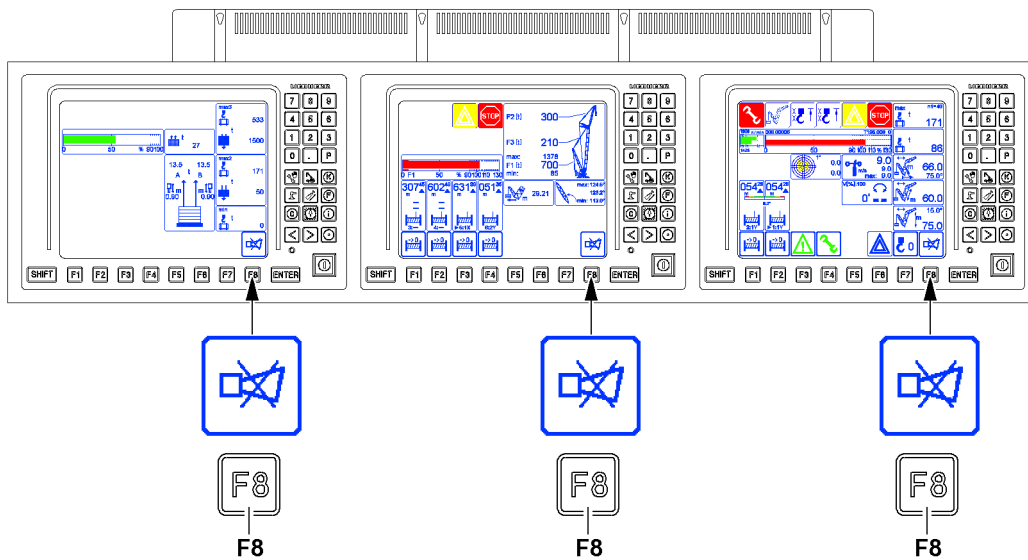
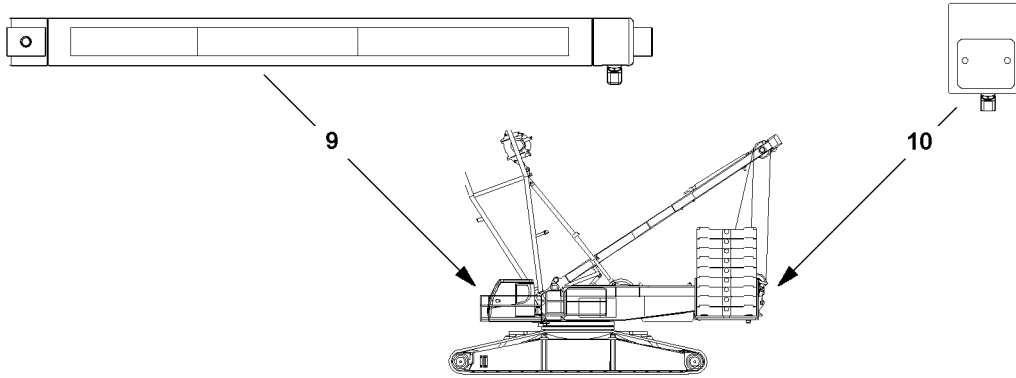

MS1
MS2
MS3

Fig.144108

LWE/LR 13000-001/19503-01-02/en

**Note**

- ▶ For description of the situations assigned to the situation numbers, see chart „Overview of possible situations“
- ▶ The percentage values refer to the crane utilization according to the display in the crane operating screen.

Acoustical signals on the turntable that can be shut off by actuating a button **3** (illustration **1**). The signal shut-off is effective no earlier than after five seconds.

Signal turntable		
Situation number	At utilization of crane	Signal type
Situation 001	0 % to 89 %	-
Situation 002	90 % to 100 %	-
Situation 003	From 101 %	Intermittent sound, can be shut off after five seconds
Situation 004	Always	-
Situation 005	From 101 %	Intermittent sound, can be shut off after five seconds
Situation 006	Always	Intermittent sound
Situation 010	From 111 %	Intermittent sound, can be shut off after five seconds
Situation 011 ¹⁾	Always	Intermittent sound, can be shut off after five seconds
Situation 020	No display value	-

1) Is in part superseded by other warnings

2 Instructions for resuming crane movement

**WARNING**

Danger of accident!

If the following points are not observed, personnel can be severely injured or killed.

- ▶ The crane operator bears the sole and full responsibility for the adherence to measures to be taken in case of shut-off of crane movement.

2.1 Overview Load chart

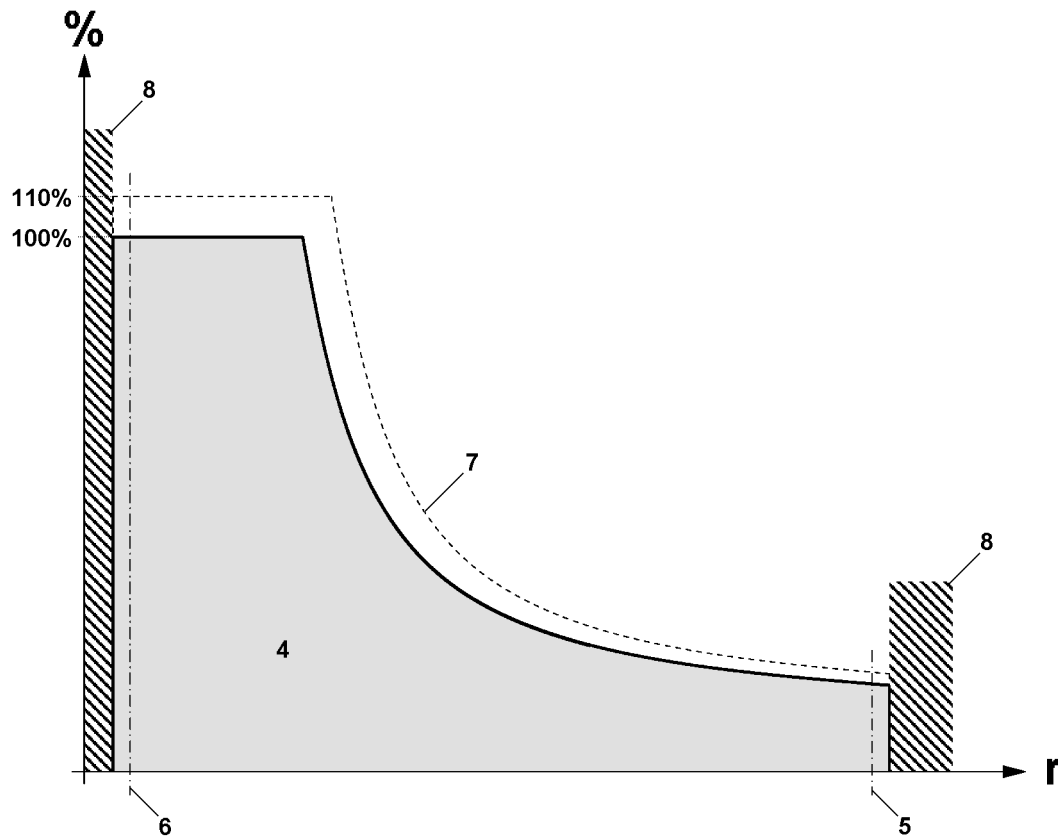

Fig.125392: Sample overview of a load chart

Axle	Description
r	Boom radius (working radius)
%	Utilization of the crane in percentages

Position	Description
4	Range „Load chart available“
5	Lower limit angle load chart
6	Upper limit angle load chart
7	Curve utilization 110 %
8	Range „No load chart available“

2.2 Shut-off of crane movement

The LICCON computer system carries out the following shut-offs if a limit value is exceeded in crane operation:

- Shut-off *overload*
- Shut-off *luffing the main boom up / down*
- Shut-off *luffing the auxiliary boom / accessory up / down*
- Shut off *maximum / minimum value F-load display*
- Shut-off *spooling the winch up / out*
- Shut-off hoist top

- Shut-off *luffing the derrick boom up / down*
- Shut-off *parallel operation winch 1 and winch 2*
- Shut-off *difference force monitoring of derrick ballast guying*
- Shut-off due to error message

**Note**

- ▶ For detailed description of the individually listed icons, see Crane operating instructions, chapter 4.02.

**WARNING**

Erroneous operation of the crane!

If the LICCON overload protection turns the crane movement off, then the exact cause for the shut-off must be determined first.

- ▶ Determine the cause for the shut-off and remedy it if possible without pressing the key **F4** „Luffing in with suspended load“ or the set up key **D**.
- ▶ If it is not possible to reset the crane movement causing the shut-off, see section „Procedure for special cases at operation of the LICCON overload protection“.

2.2.1 Shut-off overload

Fig.115274

In the bar diagram utilization **12** the utilization bar **12.1** exceeds the 100 % mark. The LICCON overload protection has turned off the crane movement, **LMB-STOP** icon **19** appears. The actual load **13** has exceeded the maximum load **14**.

- ▶ Wait for a short time until the crane movement has come to a complete standstill.

When the bar diagram utilization **12** shows less or equal 100 %:

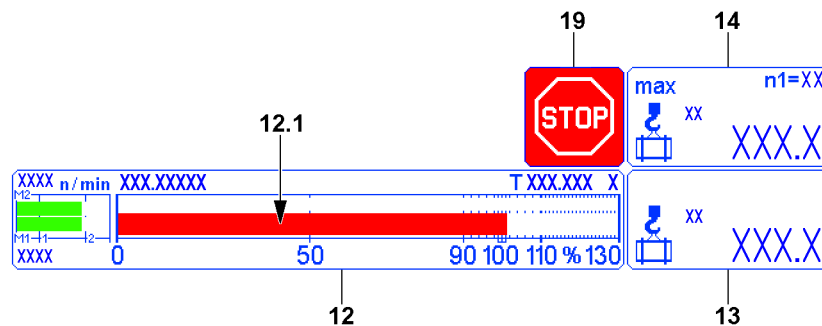
- ▶ Carry out crane movements in such a way that no repeated shut-off by the LICCON overload protection occurs.

When the bar diagram utilization **12** shows more than 100 %:

- ▶ Check if there are permissible tasks, which positively influence the utilization of the crane.

When necessary and possible:

- ▶ Set down the load.

**Note**

It is possible that the following tasks can positively influence the utilization of the crane:

- ▶ Set down the load and reduce the boom radius by driving the crane.
- ▶ Set down the load and reduce.
- ▶ Set down the load and reconfigure the crane to obtain higher load chart values.
- ▶ Carry out permissible tasks that positively influence the utilization of the crane.

Problem remedy

The crane operation is limited because the maximum load **14** is seemingly too low or reached too soon?

- ▶ Make sure that the load bearing capacity of the crane is sufficient for the upcoming crane application.
- ▶ Make sure that a valid set up configuration has been entered on the LICCON computer system.
- ▶ Make sure that the crane is assembled according to the specifications in the crane documentation.
- ▶ Make sure that the actual set up configuration and the entered set up status of the crane match.
- ▶ Make sure that all attachment parts and guy rods on the boom system, which are not needed, have been removed (weight).
- ▶ Make sure that the boom system is free of snow and ice (weight).
- ▶ Make sure that the environmental influences (for example wind influence) onto the crane are not too great.
- ▶ Contact Liebherr Service.

When the shut-off cannot be remedied despite the observance of all points listed here:

- ▶ Change to section „Procedure for special cases at operation of the LICCON overload protection“.

2.2.2 Shut-off luffing the main boom up / down**Note**

- ▶ The illustration of icon **15** depends on the set up configuration of the crane.

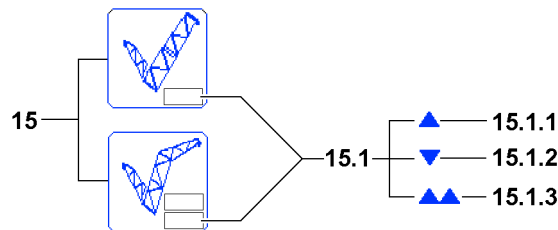

Fig.115275

In the icon **15** the arrow **15.1.1** or arrow **15.1.2** blinks and the LICCON overload protection has shut off the crane movement.

„Luffing the main boom up“ (arrow **15.1.1**) or „Luffing the main boom down“ (arrow **15.1.2**) was shut off because the upper / lower limit angle of the selected load chart was exceeded / fallen below.

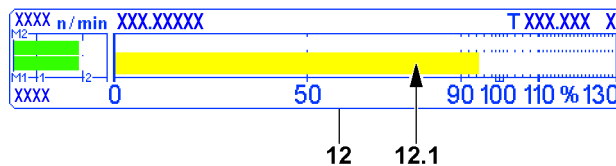

Fig.115276

**Note**

- ▶ If the utilization of the crane is more than 95 % (in bar diagram utilization **12** the utilization bar **12.1** exceeds 95 %) and the maximum load according to the load chart (falling load capacity) drops by continuing to luff up the boom, then the arrow **15.1.1** also appears and the crane movement „Luffing the main boom up“ is turned off.

If the double arrow **15.1.3** appears, then:

- **either** it was luffed up to a limit switch or the limit switch has turned off the crane movement „Luffing the main boom up“
- **or** there is an error on one of the limit switches „Main boom top“

The arrow **15.1.1** appears and the crane movement „Luffing the main boom up“ was turned off:

- ▶ Luff the main boom down.

Result:

- Crane operation is possible again.

The arrow **15.1.2** appears and the crane movement „Luffing the main boom down“ was turned off:

- ▶ Luff the main boom up.

Result:

- Crane operation is possible again.

The double arrow **15.1.3** appears and the crane movement „Luffing the main boom up“ was turned off:

- ▶ Luff the main boom down.

Result:

- Crane operation is possible again.

Problem remedy

The double arrow **15.1.3** appears continuously?

If a double arrow **15.1.3** appears without having luffed the main boom up to a limit switch, then there may be an error in the limit switches / sensors.

- ▶ Check if there is an error message from the LICCON computer system, see the Diagnostics manual.
- ▶ If yes: Remedy the error immediately.

**WARNING**

Limited warning functions!

If one of the double version limit switches / sensors is not OK and the crane is continued to be operated, then the warning functions of the LICCON overload protection are limited.

- ▶ The crane can only be operated in an emergency after failure of a double version limit switch.
- ▶ Carry out crane movements in such a way that no repeated shut-off by the LICCON overload protection occurs.

2.2.3 Shut-off luffing the auxiliary boom / accessory up / down

**Note**

- ▶ Only in operating modes with auxiliary boom / accessory
- ▶ The illustration of icon **15** depends on the set up configuration of the crane.
- ▶ The description „auxiliary boom / accessory“ comprises all boom types which can be luffed and are installed on the main boom.

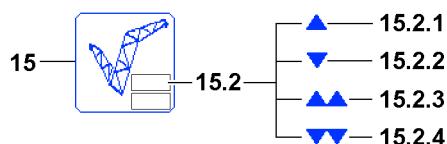

Fig.115277

In the icon **15** (upper field) the arrow **15.2.1** or arrow **15.2.2** blinks and the LICCON overload protection has shut off the crane movement.

„Luffing the equipment up“ (arrow **15.2.1**) or „Luffing the equipment down“ (arrow **15.2.2**) was shut off because the upper / lower limit angle of the selected load chart was exceeded or fallen below.

If the double arrow **15.2.3** appears, then:

- **either** it was luffed up to a limit switch or the limit switch has turned off the crane movement „Luffing the auxiliary boom / accessory up“

- **or** the mechanical relapse support has turned off the crane movement „Luffing the auxiliary boom / accessory up“
- **or** there is an error on one of the limit switches „Auxiliary boom / accessory top“.

If the double arrow **15.2.4** appears, then:

- **either** it was luffed down to a limit switch „Auxiliary boom / accessory bottom“ and the limit switch has turned off the crane movement „Luffing the auxiliary boom / accessory up“
- **or** there is an error on one of the limit switches „Auxiliary boom / accessory bottom“

The arrow **15.2.1** appears and the crane movement „Luffing the auxiliary boom / accessory up“ was turned off:

- ▶ Luff the auxiliary boom / accessory down.

Result:

- Crane operation is possible again.

The arrow **15.2.2** appears and the crane movement „Luffing the auxiliary boom / accessory down“ was turned off:

- ▶ Luff the auxiliary boom / accessory up.

Result:

- Crane operation is possible again.

The double arrow **15.2.3** appears and the crane movement „Luffing the auxiliary boom / accessory up“ was turned off:

- ▶ Luff the auxiliary boom / accessory down.

Result:

- Crane operation is possible again.

Problem remedy

The double arrow **15.2.3** appears continuously?

If a double arrow **15.2.3** appears without having luffed up to a limit switch, then there may be an error in the limit switches „Auxiliary boom / accessory top“.

- ▶ Check if there is an error message from the LICCON computer system, see the Diagnostics manual.
- ▶ If yes: Remedy the error immediately.

The double arrow **15.2.4** appears and the crane movement „Luffing the auxiliary boom / accessory down“ was turned off:

- ▶ Luff the auxiliary boom / accessory up.

Result:

- Crane operation is possible again.

Problem remedy

The double arrow **15.2.4** appears continuously?

If a double arrow **15.2.4** appears without having luffed down to a limit switch, then there may be an error in the limit switches / sensors.

- ▶ Check if there is an error message from the LICCON computer system, see the Diagnostics manual.
- ▶ If yes: Remedy the error immediately.

**WARNING**

Limited warning functions!

If one of the double version limit switches / sensors is not OK and the crane is continued to be operated, then the warning functions of the LICCON overload protection are limited.

- ▶ The crane can only be operated in an emergency after failure of a double version limit switch / sensor.
-
- ▶ Carry out crane movements in such a way that no repeated shut-off by the LICCON overload protection occurs.

2.2.4 Shut off *maximum / minimum value F-load display*

The illustration of the F-load display **17** depends on the set up configuration of the crane and can vary. The values for test point 2 (force F2) and test point 3 (force F3) are possibly shown.

**Note**

- ▶ The force determined on test point 1 is generally described as $F1_{\text{actual}}$ (actual value F1).
- ▶ In the icon **17** (F-load display), the force ratio is shown in number values as well as a bar display (called F-bar display).
- ▶ The value $F1_{\text{max}}$ **17.3** corresponds to 100 % in the F1-bar display.
- ▶ The F1-utilization bar **17.1** shows the relationship $F1_{\text{actual}}$ **17.2** to $F1_{\text{max}}$ **17.3**.
- ▶ The illustration of the F-load display **17** depends on the set up configuration of the crane and can vary.

Shut off *maximum value F1 in crane operation*

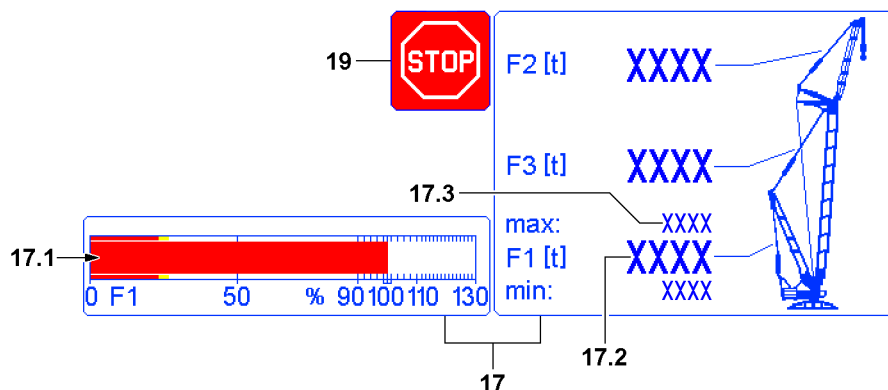

Fig. 115278

In the F-load display **17** the F1-utilization bar **17.1** exceeds the 100 % mark and the LICCON overload protection has shut off the crane movement. The value $F1_{\text{actual}}$ **17.2** has exceeded the value $F1_{\text{max}}$ **17.3**.

All other movements, which lead to a decline of the force ratio in the F-load display **17** are turned off.

- ▶ Reverse any crane movement that has caused the shut-off.
or
Alternatively initiate a crane movement that improves the force ratio in the F-load display **17**.

Result:

- Crane operation is possible again.
- ▶ Carry out crane movements in such a way that no repeated shut-off by the LICCON overload protection occurs.

Problem remedy

The crane operation is limited because the value $F1_{max}$ 17.3 apparently is being reached too early?

- ▶ Make sure that a valid set up configuration has been entered on the LICCON computer system.
- ▶ Make sure that the crane is assembled according to the specifications in the crane documentation.
- ▶ Make sure that the actual set up configuration and the entered set up status of the crane match.
- ▶ Make sure that all attachment parts and guy rods on the boom system, which are not needed, have been removed (weight).
- ▶ Make sure that the boom system is free of snow and ice (weight).
- ▶ Make sure that the wind influence on the crane is not too great.

If no irregularities can be found:

- ▶ Contact Liebherr Service.

When the shut-off cannot be remedied despite the observance of all points listed here:

- ▶ Change to section „Procedure for special cases at operation of the LICCON overload protection“.

Shut off minimum value F1 in crane operation**Note**

- ▶ A shut-off *minimum value F1* ($F1_{min}$) only occurs in operating modes with derrick ballast. The status $F1_{actual} = F1_{min}$ cannot be reached in all other operating modes.

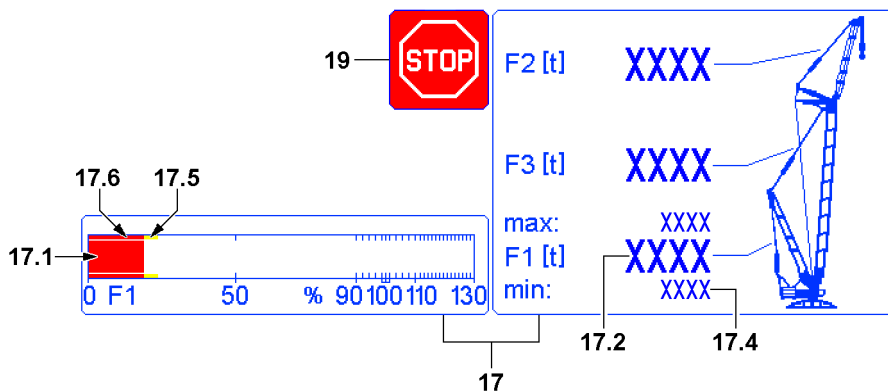

Fig.115279

In the F-load display 17, when falling below the $F1_{min}$ advance warning bar 17.5, a warning of the upcoming shut-off is issued by the F1-utilization bar 17.1.

If the F1-utilization bar 17.1 falls below the $F1_{min}$ -STOP bar 17.6, then the LICCON overload protection shuts off the crane movement. The value $F1_{actual}$ 17.2 has fallen below the value $F1_{min}$ 17.4.

All other movements, which lead to a decline of the force ratio in the F-load display 17 are turned off.

- ▶ Reverse any crane movement that has caused the shut-off.
or
Initiate an alternative crane movement that increases the force F1 (value $F1_{actual}$ 17.2).

Result:

- Crane operation is possible again.
- ▶ Carry out crane movements in such a way that no repeated shut-off by the LICCON overload protection occurs.

Problem remedy

The crane operation is limited because the value $F1_{\min}$ **17.4** apparently is being reached too early?

- ▶ Make sure that a valid set up configuration has been entered on the LICCON computer system.
- ▶ Make sure that the crane is assembled according to the assembly drawings.
- ▶ Make sure that the actual set up configuration and the entered set up status of the crane match.
- ▶ Make sure that all attachment parts and guy rods on the boom system, which are not needed, have been removed (weight).
- ▶ Make sure that the boom system is free of snow and ice (weight).
- ▶ Make sure that the wind influence on the crane is not too great.

If no irregularities can be found:

- ▶ Contact Liebherr Service.

When the shut-off cannot be remedied despite the observance of all points listed here:

- ▶ Change to section „Procedure for special cases at operation of the LICCON overload protection“.

2.2.5 Shut-off *spooling the winch up / out*

**Note**

- ▶ Applies independently for winch 1 to winch 6.
- ▶ For detailed description of winch 1 to winch 6, see Crane operating instructions, chapter 4.02.

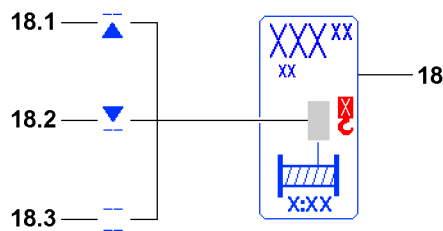

Fig.115280

In the icon **18**, the line / arrow **18.1**, arrow / line **18.2** or line / line **18.3** appears and the LICCON overload protection has shut off the crane movement.

„Spooling the winch out“ (line / arrow **18.1**) or „Spooling the winch up“ (arrow / line **18.2**) was shut off because the upper / lower limit value of the rope for the selected winch was exceeded or fallen below.

If line / line **18.3** appears blinking in the icon **18**, then the affected winch is deactivated.

The line / arrow **18.1** appears and the crane movement „Spooling the winch out“ was turned off:

- ▶ Spool the winch up.

Result:

- Crane operation is possible again.

The arrow / line **18.2** appears and the crane movement „Spooling the winch up“ was turned off:

- ▶ Spool the winch out.

Result:

- Crane operation is possible again.

The line / line **18.3** appears and the winch is deactivated:

- ▶ Activate the winch, see Crane operating instructions, chapter 4.02.

Result:

- Crane operation is possible again.

2.2.6 Shut off *hoist top*

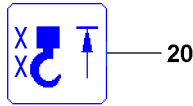

Fig.115281

The *hoist top* icon **20** appears in the LICCON monitor and the LICCON overload protection has turned off crane movement.

Spooling the hoist winch up was turned off because the hook (hook block / load hook) has touched a hoist limit switch weight during the upward movement and the affected hoist limit switch was triggered.



WARNING

Property damage / falling load!

- ▶ After shut-off *spool hoist winch up (hoist top)*, for every further crane movement, the distance between the hook (hook block / load hook) and the boom head must be checked.



Note

- ▶ After a *hoist top* shut-off occurred, further crane movements that affect the length of the hoist rope are also shut off.

- ▶ Spool the hoist winch out.

Result:

- Crane operation is possible again.

2.2.7 Shut-off *luffing the derrick boom up / down*



Note

- ▶ Only in operating modes with derrick boom.

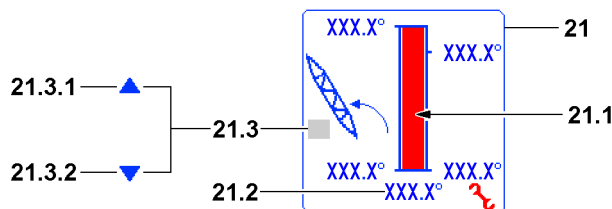

Fig.115282

In icon **21**, the column diagram **21.1** of the derrick angle has reached the minimum / maximum value. The actual angle **21.2** has left the permissible angle range.

Arrow **21.1** or arrow **21.2** appears and the movement of the derrick boom is turned off.

„Luffing the derrick boom up“ (arrow **21.1**) or „Luffing the derrick boom down“ (arrow **21.2**) was shut off because the upper / lower limit angle was reached.

The arrow **21.1** appears and „Luffing the derrick boom up“ was turned off:

- ▶ Luffing the derrick boom down.

Result:

- The shut off is nullified.

The arrow **21.2** appears and the crane movement „Luffing the derrick boom down“ was turned off:

- ▶ Luff the derrick boom up.

Result:

- The shut off is nullified.

Problem remedy

The derrick boom is to be placed down?

- ▶ See Crane operating instructions, chapter 5.05.

2.2.8 Shut-off parallel operation winch 1 and winch 2

Fig.122459

**WARNING**

Impermissible change over of regulation *parallel operation winch 1 and winch 2*!

- ▶ Changing the regulation *parallel operation winch 1 and winch 2* is only permissible if - due to contamination, icing or failure of the path measurement system of the test pulleys - a correct path measurement of the hoist ropes of winch 1 and winch 2 is not possible.
- ▶ Changing the regulation *parallel operation winch 1 and winch 2* is only permissible if it is not possible to immediately clean or de-ice the test pulleys or repair the path measurement system.
- ▶ As long as the regulation *parallel operation winch 1 and winch 2* is changed over, the crane driver must align the position of the hook block generally manually.

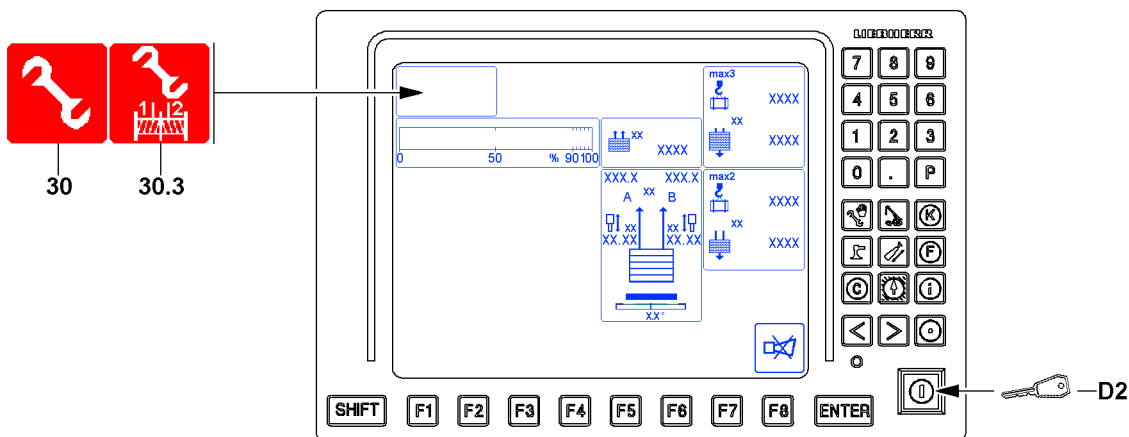
If a correct path measurement of the hoist ropes of winch 1 and winch 2 is not possible via the LIC-CON computer system, then spooling the winches is shut off and an error message is issued.

If an immediate cleaning or de-icing of the test pulleys or repair of the path measurement system is not possible:

- ▶ Reestablish parallel operation of winches, see Crane operating instructions, chapter 4.05.

Change over the regulation Parallel operation winch 1 and winch 2:

- ▶ Actuate the key button **D2**.

Result:

- The regulation of the parallel operation winch 1 and winch 2 is switched over by the change over pulleys to the winch speed sensors.
- Assembly icon **30.3** and possibly assembly icon **30** appear.
- ▶ Remedy the problem as quickly as possible.
- ▶ Turn the regulation off again via the winch speed sensors: Actuate the key button **D2** again.

Result:

- Assembly icon **30.3** and possibly assembly icon **30** turn off.

**Note**

- ▶ If the engine or the ignition is turned off, the regulation is also turned off via the winch speed sensors.

2.2.9 Shut-off *difference force monitoring of derrick ballast guying*

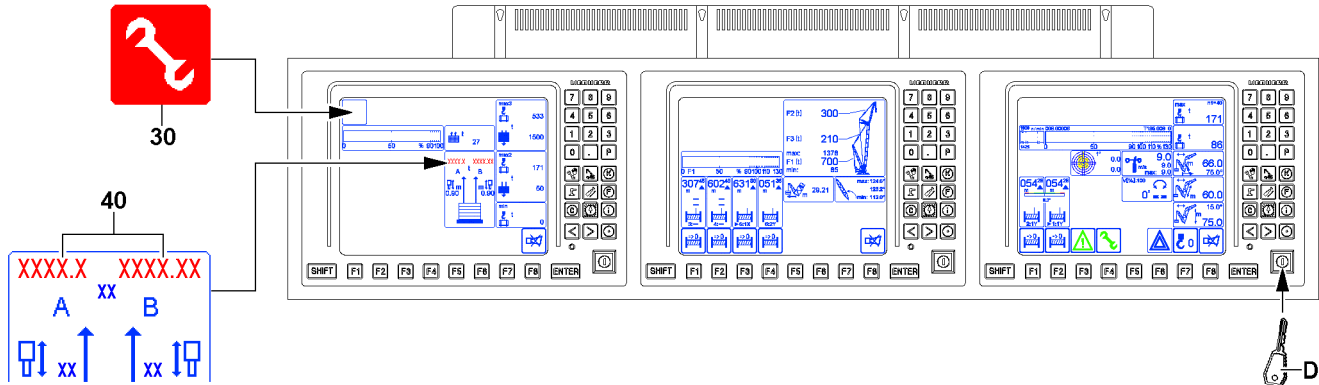

Fig.125390

**WARNING**

Danger of accident!

If the forces in the derrick ballast guying A and B are too high, then this can lead to an overload of the crane. Components can fail and severe accidents can be the result.

- ▶ Load the derrick ballast guying A and B evenly.

After reaching the specified limit value of the difference force threshold, the displays *guying A/B 40* blink and turn red, the function *ballast up / down* is stopped. The difference force must be lowered again.

The assembly icon **30** appears when the shut-off *difference force monitoring - derrick ballast guying* is bypassed. The shut-off is bypassed via the set up key **D** (right monitor).

Shut-off *difference force monitoring derrick ballast guying*:

- ▶ Observe the Crane operating instructions, chapter 5.35 / 5.36.

2.2.10 Shut-off due to error message

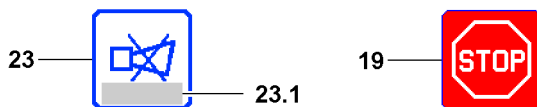

Fig.115283

In the icon **23** appears an error message, the icon **19** appears in the LICCON monitor and the LICCON overload protection has turned off crane movement.

- ▶ Determine the existing error with the help of the error message from the error field **23.1** in icon **23**, see Diagnostics manual.
- ▶ Rectify the error.

If the error cannot be remedied:

- ▶ Contact Liebherr Service.

Problem remedy

The erection of the crane, for example after assembly on a new job site or with another set up configuration, is not possible due to an error message?

- ▶ Evaluate the error message.
 - ▶ Make sure that all electrical connections are established correctly.
 - ▶ Check if all sensors or dummy plugs with integrated electric have been connected properly.
-

**Note**

If there is a defect on an involved sensor of the load torque limiter (LMB), then the crane can no longer be operated in normal operating condition.

- ▶ Fix / replace the sensor, contact Liebherr Service if necessary.
-

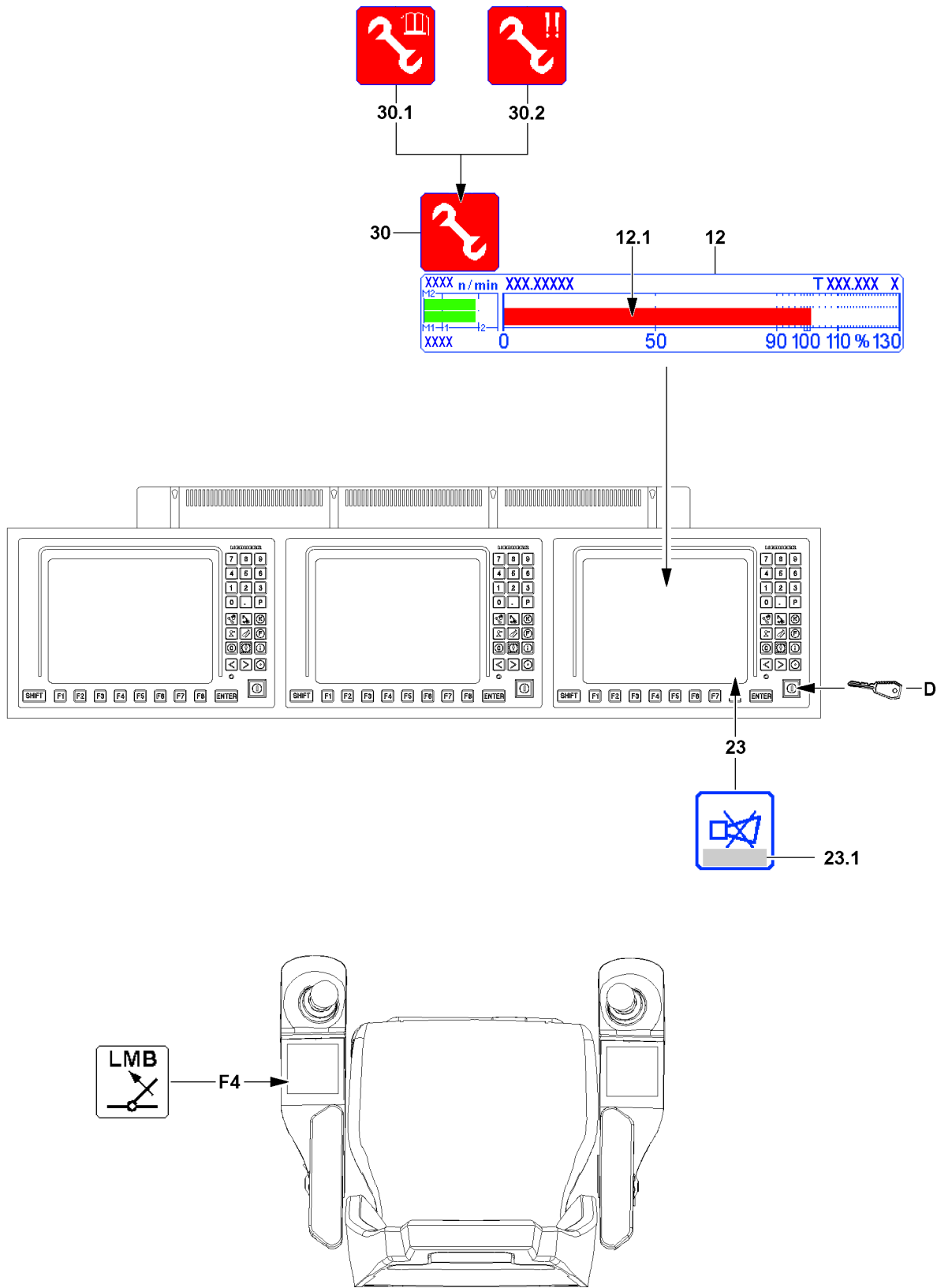

Fig.115285

LWE/LR 13000-001/19503-01-02/en

2.3 Procedure for special cases at operation of the LICCON overload protection

Within the crane operator's cab, the following operating elements available for Special cases at operation of the LICCON overload protection:

- Button **F4** on the left control panel
- Set up key **D** on the right LICCON monitor

By pressing key **F4** and set up key **D** the functionality of the LICCON overload protection is accessed. If the set up key **D** is actuated, the assembly icon **30** appears in the LICCON monitor 0.

The assembly icon **30** appears, depending on the situation, also as:

- Assembly icon **30.1** - no load chart / assembly condition / sensor defect
- Assembly icon **30.2** - emergency operation (also with only one exclamation mark)

The *horn* icon **23** possibly displays error messages **23.1**:

- Observe and evaluate the error messages **23.1**, see also Diagnostics manual.



WARNING

Risk of overloading and toppling of the crane!

If the functionality of the LICCON overload protection is accessed without knowing the exact cause for the shut-off, then the crane can be overloaded and topple over.

Personnel can be severely injured or killed.

- ▶ Before accessing the functionality of the LICCON overload protection, determine the exact cause for the shut-off.
- ▶ Observe and evaluate the error messages **23.1**.



WARNING

Access the functionality of the LICCON overload protection!

When accessing the functionality of the LICCON overload protection, the LICCON overload protection is deactivated totally or limited.

It is possible to exceed several shut-off limits of the LICCON overload protection simultaneously or one after the other.

It is possible to carry out crane movements that are not monitored by the LICCON overload protection. Without the LICCON overload protection, no additional protection against overload of the crane via the crane control is present.

- ▶ When accessing the functionality of the LICCON overload protection, take into account that the LICCON overload protection is deactivated totally or limited.
- ▶ Access the functionality of the LICCON overload protection exclusively according to the specifications in the crane documentation.
- ▶ Outside of the load charts, the data in the erection / take-down charts is binding.



WARNING

Leaving the load chart!

If the set up key **D** is actuated, it is possible that the crane leaves the range of the load charts.

Without a load chart, various display values are no longer displayed on the crane operating screen.

A load on the hook can no longer be monitored by the LICCON overload protection.

Severe accidents due to crane overload can result.

Personnel can be severely injured or killed.

- ▶ Do not leave the range of the load charts.

**WARNING**

Danger of accident due to incorrect procedure!

Due to erroneous operation or deliberate misuse, the crane could collapse, the boom can break off or the crane can topple over.

Key **F4** „Luffing in at suspended load“ and set up key **D** may only be actuated when it is ensured that without their actuation no normal operating status (see section „operating status of the crane“) can be reached.

- ▶ Actuate the set up key **D** only when no normal operating status can be reached with the key **F4** „Luffing in with suspended load“.
- ▶ The set up key **D** may only be actuated by persons who are aware of the effects of their acts regarding the access into the functionality of the LICCON overload protection.
- ▶ Accessing the functionality of the LICCON overload protection requires the presence of an authorized person and must be performed with utmost caution.
- ▶ Accessing the functionality of the LICCON overload protection is prohibited in normal crane operation.

**WARNING**

Expanded working / danger zone of the crane!

Due to an access the functionality of the LICCON overload protection it is possible that the working / danger zone of the crane is significantly expanded.

If these circumstances are not observed, collisions and accidents can occur.

Personnel can be severely injured or killed.

- ▶ During a special case at operation of the LICCON overload protection take an expanded working / danger zone of the crane into account and monitor it.

**WARNING**

Overload of crane!

Luffing in / pulling in of a load standing on the ground is not permissible.

When taking on a load by luffing the boom up, the crane can be overloaded.

This could result in serious accidents.

- ▶ Taking on load by luffing up the boom is prohibited.
- ▶ Take on a load solely via the hoist gear.

**WARNING**

Self-blockade of overload protection (Deadlock)!

After activation of the function „exceeding the shut-off limits of the LICCON overload protection“, if no crane movements that lead immediately to a normal operating status (see section „operating status of the crane“) are initiated, then the overload protection can be self-blocked (Deadlock).

At a self-blocked overload protection it is no longer possible to control the crane.

- ▶ After activation of the function „exceeding the shut-off limits of the LICCON overload protection“ initiate crane movements that lead immediately to a normal operating condition (see section „operating condition of the crane“).

NOTICE

Danger of mix up!

The individual functions of the set up key **D** can only be activated with this key button.

The key buttons on the other LICCON monitors are not assigned with this function.

- ▶ Do not mix up the set up key **D** with the other key buttons.
- ▶ In case of mix up: Deactivate the activated function immediately.

Possible limitation in the crane control during certain „Special cases at operation of the LICCON overload protection“:

- During certain „Special cases at operation of the LICCON overload protection“ the shut-off limits of the overload protection can be exceeded by pressing the set up key **D** maximum to 110 %.
- During certain „Special cases at operation of the LICCON overload protection“, the working speed of the crane is significantly reduced.

- During certain „Special cases at operation of the LICCON overload protection“, the possibility to control the crane is limited in time.
- During certain „Special cases at operation of the LICCON overload protection“, the individual display instruments show no values.



Note

Depending on the number of load positions, the display in the bar diagram utilization **12** changes.

- ▶ If an additional utilization bar appears next to the utilization bar **12.1**, then the description applies accordingly.
 - ▶ For a detailed description of the Bar diagram utilization **12**, see Crane operating instructions, chapter 4.02.
-

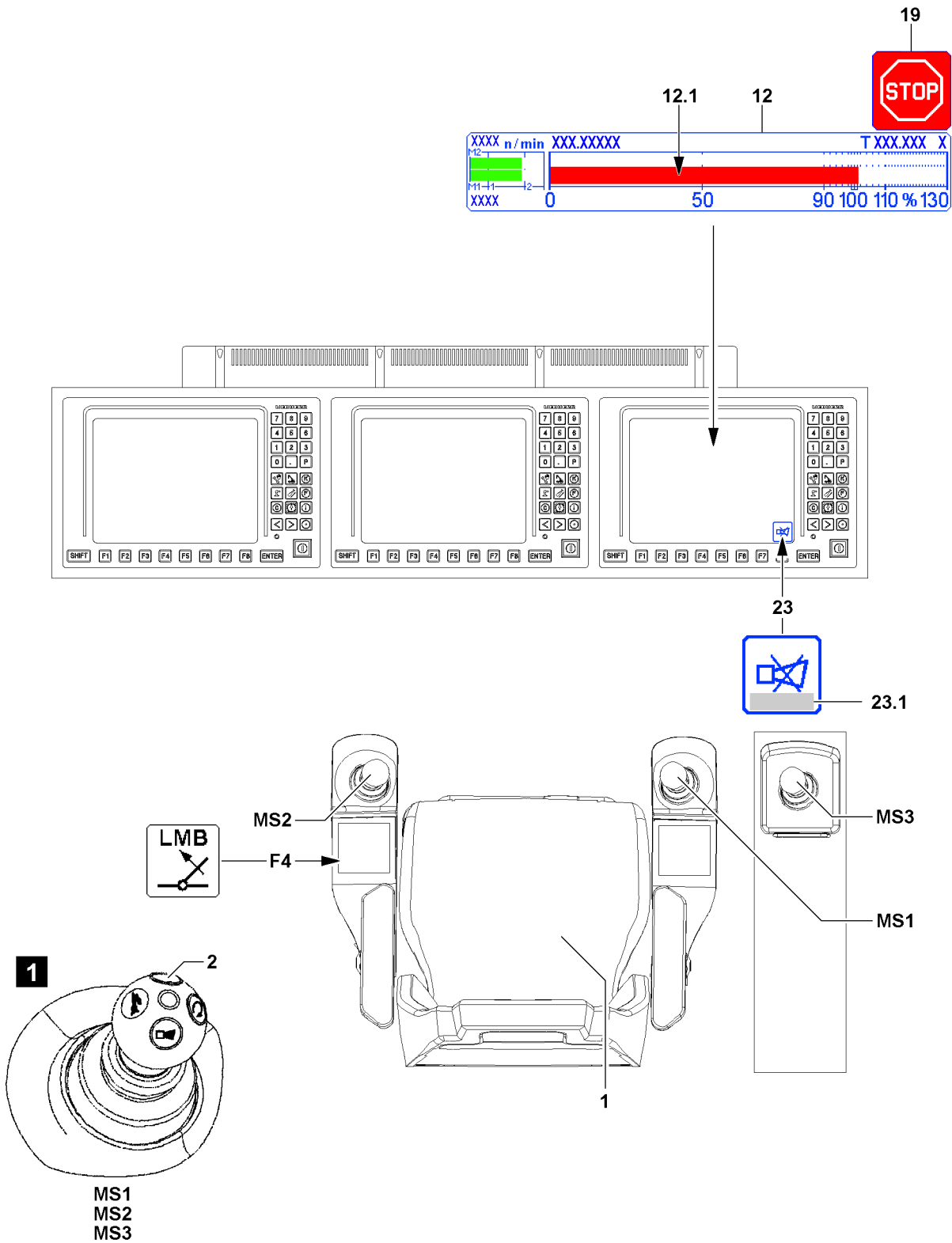

Fig. 115286

LWE/LR 13000-001/19503-01-02/en

2.3.1 Luff in with suspended load

If the maximum permissible load torque is exceeded, the LICCON overload protection turns off all crane movements that increase the load torque.

In the bar diagram utilization **12** (load moment display) the utilization bar **12.1** has exceeded the 100 % mark and in the LICCON monitor appears the icon **19**

This shut-off limit can be exceeded by actuating the button **F4** „Luffing in with suspended load“.

Make sure that the following prerequisites are met:

- The load hangs freely.
- The load hook / hook block and boom system have no ground contact.
- Either the seat contact button **1** or one of the buttons **2** (illustration **1**) of the master switches (MS1, MS2, MS3) is actuated.



Note

If the load is reduced by luffing up or the values in the bar diagram utilization **12** are exceeded too far, then the key **F4** „Luffing in with suspended load“ is possibly not functioning.

- ▶ Pay attention to notes regarding error messages **23.1** occurring in the *horn* icon **23**.
- ▶ For the procedure when the key **F4** „Luffing in with suspended load“ is not functioning, see section „Exceedance of maximum permissible load moment“.

- ▶ Press the key **F4** „Luffing in with suspended load“ and hold it.

Result:

- The LICCON overload protection is inactive.
- ▶ Luff the load in.

Result:

- If the crane reaches a normal operation condition, then the icon **19** turns off, normal crane operation is possible again.

The function „Luffing in with suspended load“ is deactivated:

- When the key **F4** „Luffing in with suspended load“ is not longer actuated.
- When neither the seat contact button **1** nor one of the buttons **2** of the master switches (MS1, MS2, MS3) is actuated.

The function „Luffing in with suspended load“ is deactivated:

- The LICCON overload protection is active.
- ▶ Carry out crane movements in such a way that no repeated shut-off by the LICCON overload protection occurs.

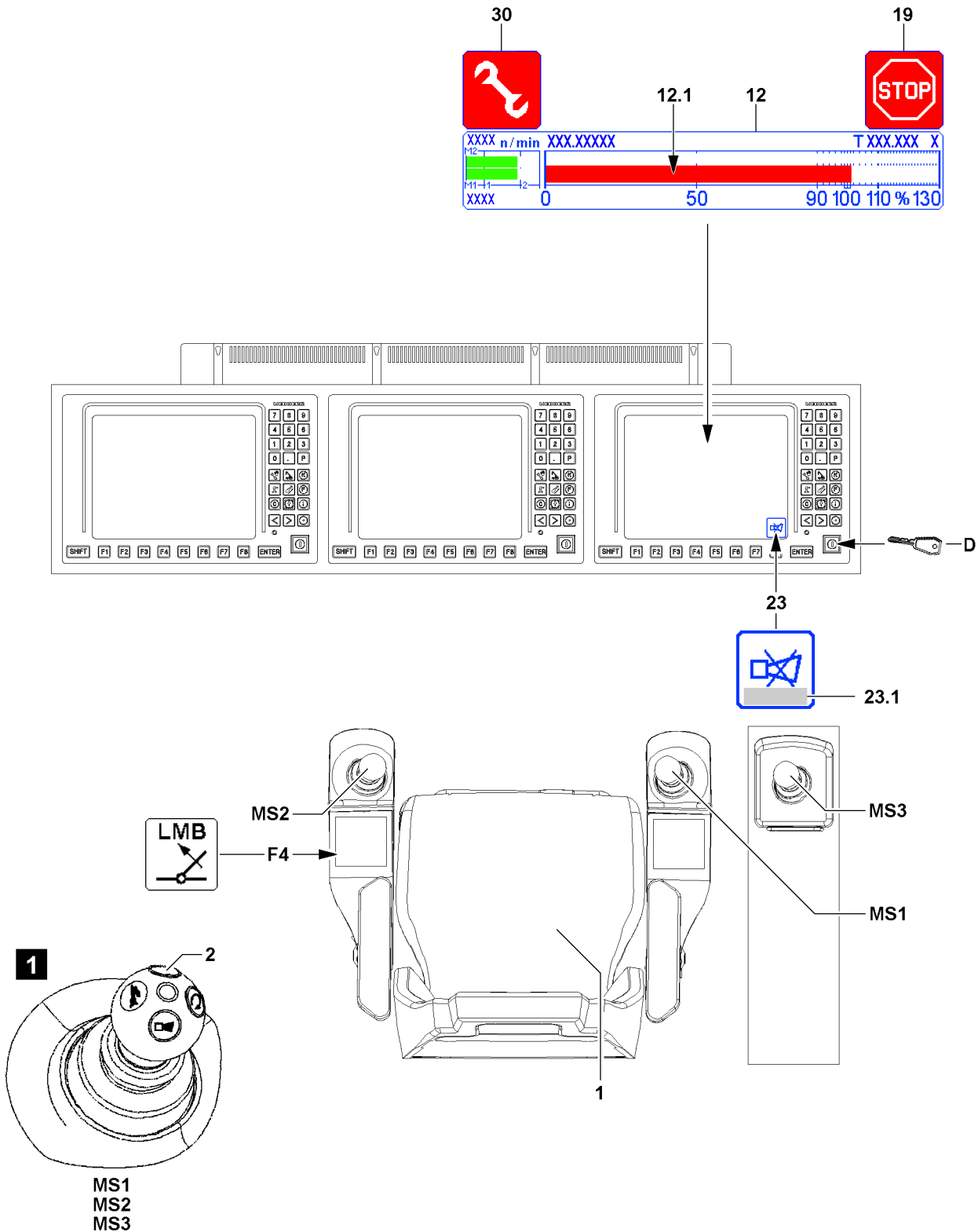

Fig. 115287

LWE/LR 13000-001/19503-01-02/en

2.3.2 To exceed the maximum permissible load moment.

If the maximum permissible load torque is exceeded, the LICCON overload protection turns off all crane movements that increase the load torque.

In the bar diagram utilization **12** (load moment display) the utilization bar **12.1** has exceeded the 100 % mark and in the LICCON monitor appears the icon **19**

This limit value can be exceeded by the set up key **D** in the „right touching“ position.



WARNING

Shut off safety device!

If the function „Exceedance of shut-off limits of LICCON overload protection“ is activated by actuating the set up key **D** then it is possible to exceed the maximum permissible load torque.

- ▶ All notes regarding the „Special cases at operation of LICCON overload protection“ must be observed.

The set up key **D** on the LICCON monitor has two positions:

- Operating position (not actuated): Crane is in normal operation.
- Position to right (touching): The function „Exceedance of shut-off limits of the LICCON overload protection“ is activated, the assembly icon **30** appears in the LICCON monitor.

Make sure that the following prerequisites are met:

- With the button **F4** „Luffing in with suspended load“ no normal operating condition (utilization below 100 % and no active shut-off) can be reached.
- All master switches (MS1, MS2, MS3) are in the zero position (not deflected).
- Either the seat contact button **1** or one of the buttons **2** (illustration **1**) of the master switches (MS1, MS2, MS3) is actuated.
- The crane is in the range of a load chart.



Note

If the values in the bar diagram utilization **12** are exceeded too far, then the functionality of the set up key **D** may be disabled.

- ▶ Pay attention to notes regarding error messages **23.1** occurring in the *horn* icon **23**.

- ▶ Turn the set up key **D** to the right (touching).

Result:

- The LICCON overload protection is inactive.
- The assembly icon **30** appears in the LICCON monitor.

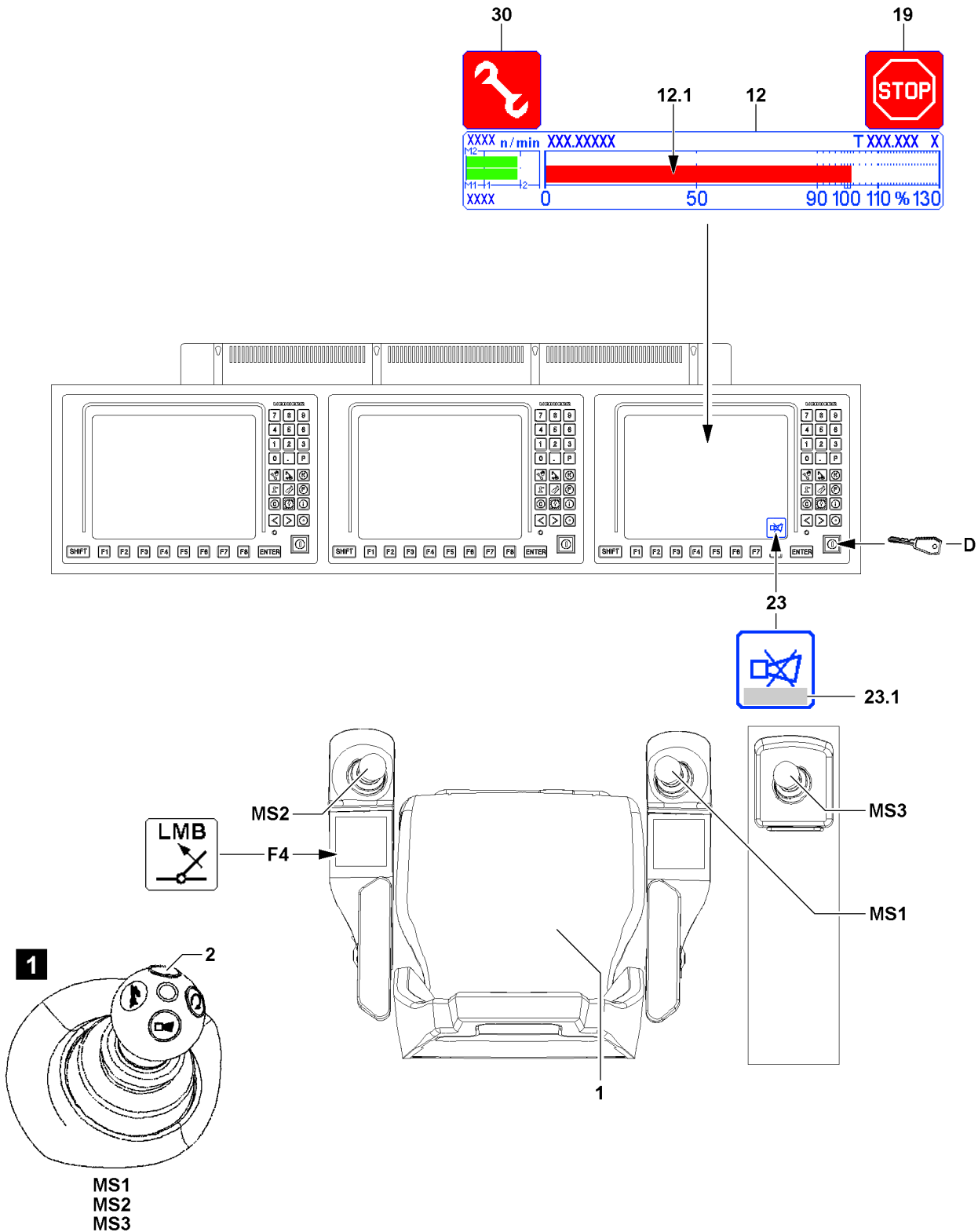

Fig.115287

LWE/LR 13000-001/19503-01-02/en

- ▶ Initiate crane movements which lead immediately to a normal operating condition (see section „operating condition of the crane“).

Result:

- If the crane reaches a normal operating condition, the function „Exceeding the shut-off limits of the LICCON overload protection“ turns off - the assembly icon **30** turns off.

The function „Exceedance of shut-off limits of LICCON overload protection“ turns off immediately also:

- If the set up key **D** is actuated again.
- If all master switches (MS1, MS2, MS3) are in zero position for 10 seconds.
- When neither the seat contact button **1** nor one of the buttons **2** of the master switches (MS1, MS2, MS3) is actuated.
- When a *hoist top* shut-off occurs.



Note

- ▶ The function „Exceedance of shut-off limits of the LICCON overload protection“ is only turned off when the assembly icon **30** in the LICCON monitor turns off.
- ▶ If the function „Exceedance of shut-off limits of the LICCON overload protection“ does not turn off after pressing the set up key **D** once, then press the set up key **D** again until the assembly icon **30** in the LICCON monitor turns off.

The function „Exceedance of shut-off limits of the LICCON overload protection“ has / was shut off:

- The assembly icon **30** in the LICCON monitor turns off.
- The working speed is possibly reduced until all master switches (MS1, MS2, MS3) are in the zero position at the same time.
- ▶ Make sure that the assembly icon **30** no longer appears in the LICCON monitor.
- ▶ Carry out crane movements in such a way that no repeated shut-off by the LICCON overload protection occurs.

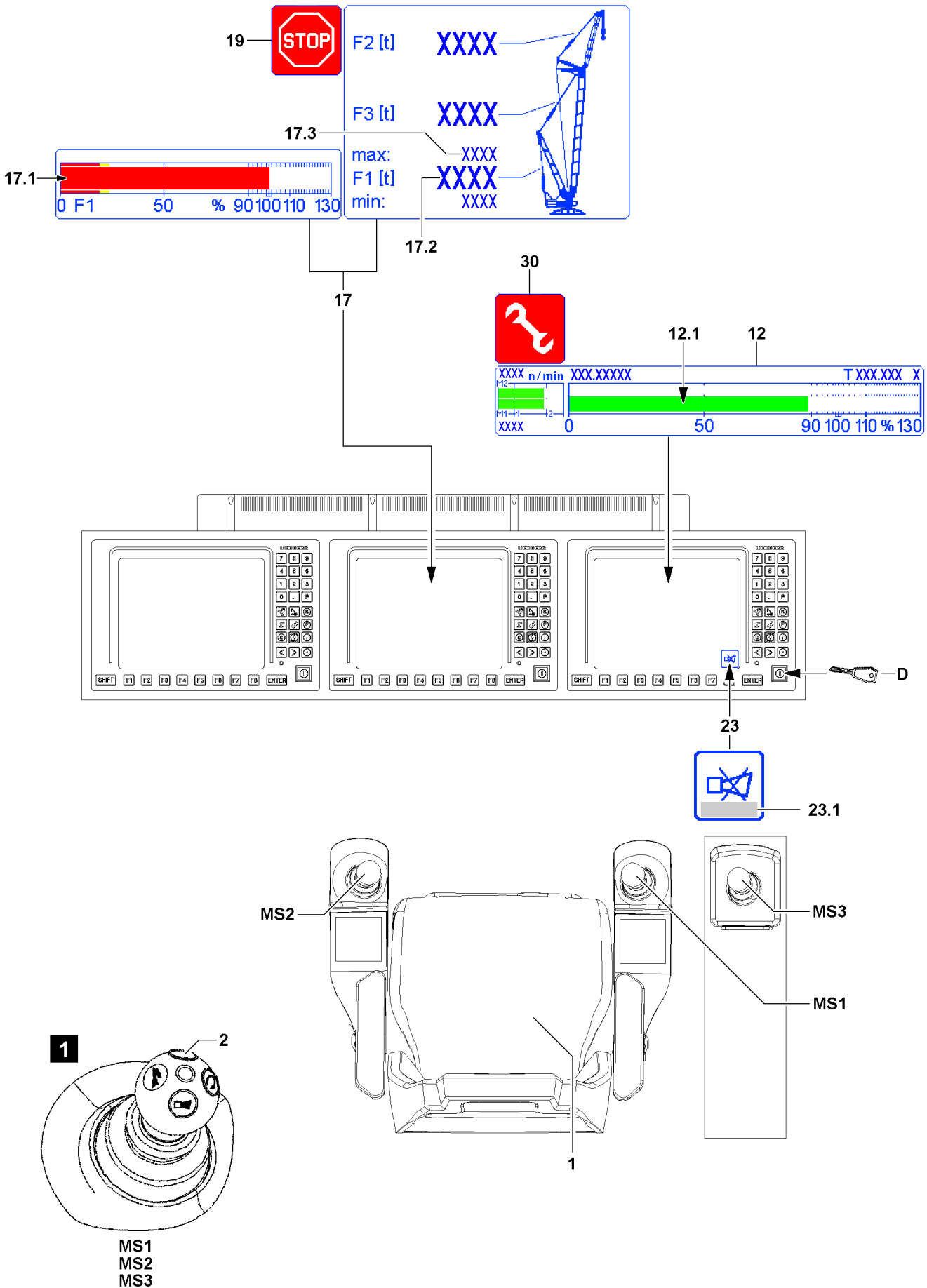

Fig.115288

LWE/LR 13000-001/19503-01-02/en

2.3.3 To exceed the maximum value of the F-load display in crane operation.

The illustration of the F-load display **17** depends on the set up configuration of the crane and can vary. The values for test point 2 (force F2) and test point 3 (force F3) are possibly shown.



WARNING

Shut off safety device!

By pressing the set up key **D** if the maximum value of the F-load display is exceeded, then the function „Exceedance of shut-off limits of the LICCON overload protection“ is automatically activated. Thus there is no shut-off if the maximum permissible load moment is exceeded.

- ▶ All notes regarding the „Special cases at operation of LICCON overload protection“ must be observed.
- ▶ The utilization bar **12.1** of the bar diagram utilization **12** must be observed.
- ▶ The F1-utilization bar **17.1** of the F-load display **17** must be observed.



Note

- ▶ The force determined on test point 1 is generally described as $F1_{actual}$ (actual value F1).
- ▶ In the F1-load display **17**, the force ratio is shown as number values as well as a bar display (called F1-bar display).
- ▶ The value $F1_{max}$ **17.3** corresponds to 100 % in the F1-bar display.
- ▶ The F1-utilization bar **17.1** shows the relationship $F1_{actual}$ **17.2** to $F1_{max}$ **17.3**.



Note

- ▶ See also section „Minimum values or maximum values of F-load display reached“.

In the F1-load display **17** the utilization bar $_{actual}$ **17.1** exceeds the 100 % mark and the LICCON overload protection has shut off the crane movement. The value $F1_{actual}$ **17.2** has exceeded the value $F1_{max}$ **17.3**.

All other movements, which lead to a decline of the force ratio in the F-load display **17** are turned off.

The LICCON monitor with the derrick operating screen displays the icon **19**.



Note

If the values in the F-load display **17** or in the bar diagram utilization **12** are outside the permissible range, then the functionality of the set up key **D** may be disabled.

- ▶ Pay attention to notes regarding error messages **23.1** occurring in the *horn* icon **23**.

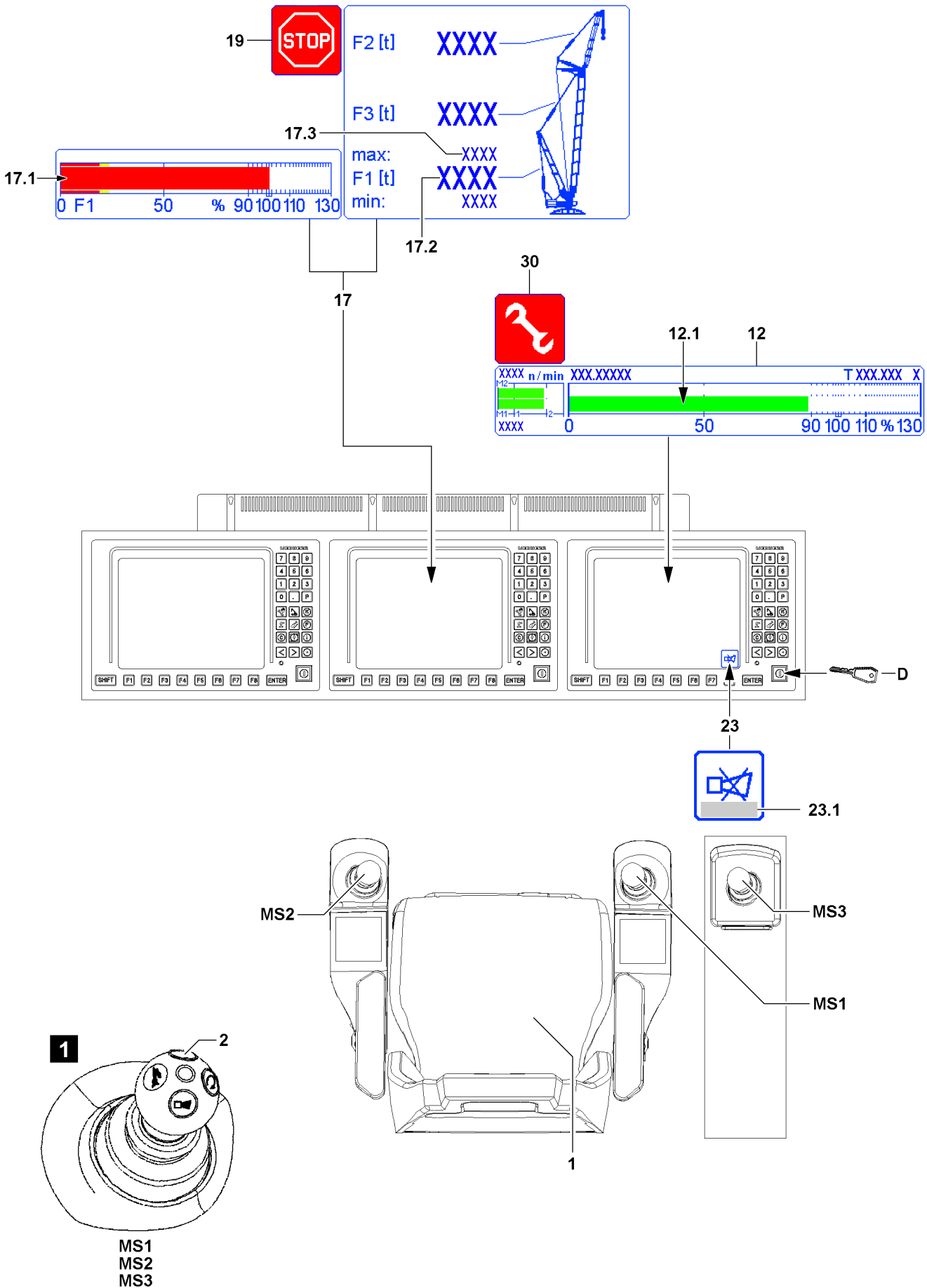

Fig.115288

LWE/LR 13000-001/19503-01-02/en

Make sure that the following prerequisites are met:

- All master switches (MS1, MS2, MS3) are in the zero position (not deflected).
- Either the seat contact button **1** or one of the buttons **2** (illustration **1**) of the master switches (MS1, MS2, MS3) is actuated.
- The crane is in the range of a load chart.
- ▶ Turn the set up key **D** to the right (touching).

Result:

- The function „Exceedance of shut-off limits of the LICCON overload protection“ is activated. As a result the maximum value of the F-load display can be exceeded.
- The assembly icon **30** appears.
- $F_{1_{\max}}$ **17.3** can be exceeded.
- ▶ Initiate crane movements which lead immediately to a normal operating condition (see section „operating condition of the crane“).

Result:

- If the crane reaches a normal operating condition, the function „Exceeding the shut-off limits of the LICCON overload protection“ turns off - the assembly icon **30** turns off.

The function „Exceedance of shut-off limits of LICCON overload protection“ turns off immediately also:

- If the set up key **D** is actuated again.
- If all master switches (MS1, MS2, MS3) are in the zero position for 10 seconds (with load chart available).
- When neither the seat contact button **1** nor one of the buttons **2** of the master switches (MS1, MS2, MS3) is actuated.
- When a *hoist top* shut-off occurs.



Note

- ▶ The function „Exceedance of shut-off limits of the LICCON overload protection“ is only turned off when the assembly icon **30** in the LICCON monitor turns off.
- ▶ If the function „Exceedance of shut-off limits of the LICCON overload protection“ does not turn off after pressing the set up key **D** once, then press the set up key **D** again until the assembly icon **30** in the LICCON monitor turns off.

The function „Exceedance of shut-off limits of the LICCON overload protection“ has / was shut off:

- The assembly icon **30** in the LICCON monitor turns off.
- The working speed is possibly reduced until all master switches (MS1, MS2, MS3) are in the zero position at the same time.
- ▶ Make sure that the assembly icon **30** no longer appears in the LICCON monitor.
- ▶ Carry out crane movements in such a way that no repeated shut-off by the LICCON overload protection occurs.

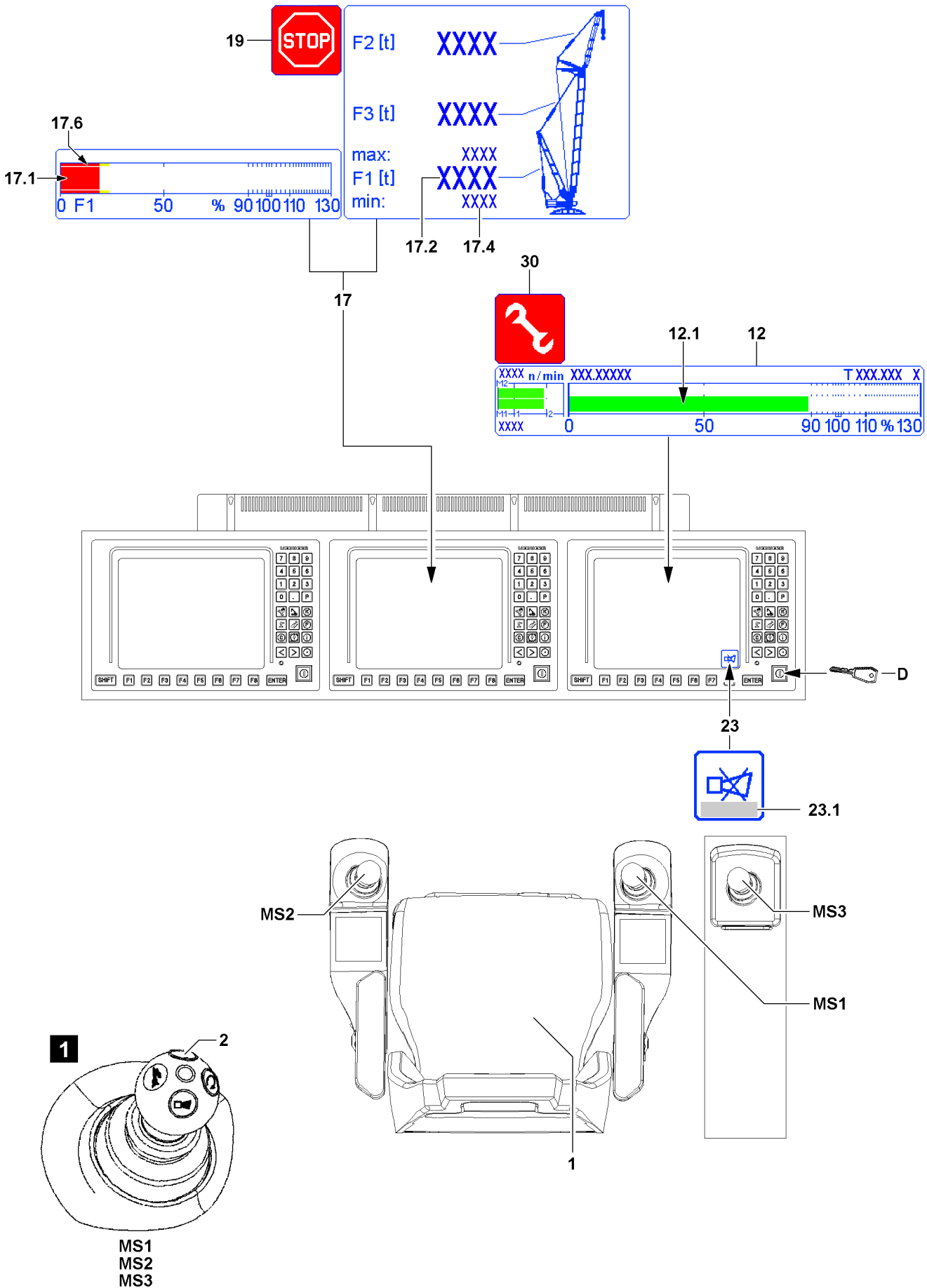

Fig.115307

LWE/LR 13000-001/19503-01-02/en

2.3.4 Falling below the minimum value of the F-load display in crane operation

The illustration of the F-load display **17** depends on the set up configuration of the crane and can vary. The values for test point 2 (force F2) and test point 3 (force F3) are possibly shown.



WARNING

Shut off safety device!

By pressing the set up key **D** if the minimum value of the F-load display is fallen below, then the function „Exceedance of shut-off limits of the LICCON overload protection“ is automatically activated. Thus there is no shut-off if the maximum permissible load moment is exceeded.

- ▶ All notes regarding the „Special cases at operation of LICCON overload protection“ must be observed.
- ▶ The utilization bar **12.1** of the bar diagram utilization **12** must be observed.
- ▶ The F1-utilization bar **17.1** of the F-load display **17** must be observed.



Note

- ▶ The force determined on test point 1 is generally described as $F1_{\text{actual}}$ (actual value F1).
- ▶ In the F1-load display **17**, the force ratio is shown as number values as well as a bar display (called F1-bar display).
- ▶ The value $F1_{\text{max}}$ **17.3** corresponds to 100 % in the F1-bar display.
- ▶ The F1-utilization bar **17.1** shows the relationship $F1_{\text{actual}}$ **17.2** to $F1_{\text{max}}$ **17.3**.



Note

- ▶ See also section „Minimum values or maximum values of F-load display reached“.

In the F1-load display **17** the utilization bar $_{\text{actual}}$ **17.1** falls below the $F1_{\text{min}}$ -STOP-Bar **17.6** and the LICCON overload protection has shut off the crane movement. The value $F1_{\text{actual}}$ **17.2** has fallen below the value $F1_{\text{min}}$ **17.4**.

All other movements, which lead to a decline of the force ratio in the F-load display **17** are turned off.

The LICCON monitor with the derrick operating screen displays the icon **19**.



Note

If the values in the F-load display **17** or in the bar diagram utilization **12** are outside the permissible range, then the functionality of the set up key **D** may be disabled.

- ▶ Pay attention to notes regarding error messages **23.1** occurring in the *horn* icon **23**.

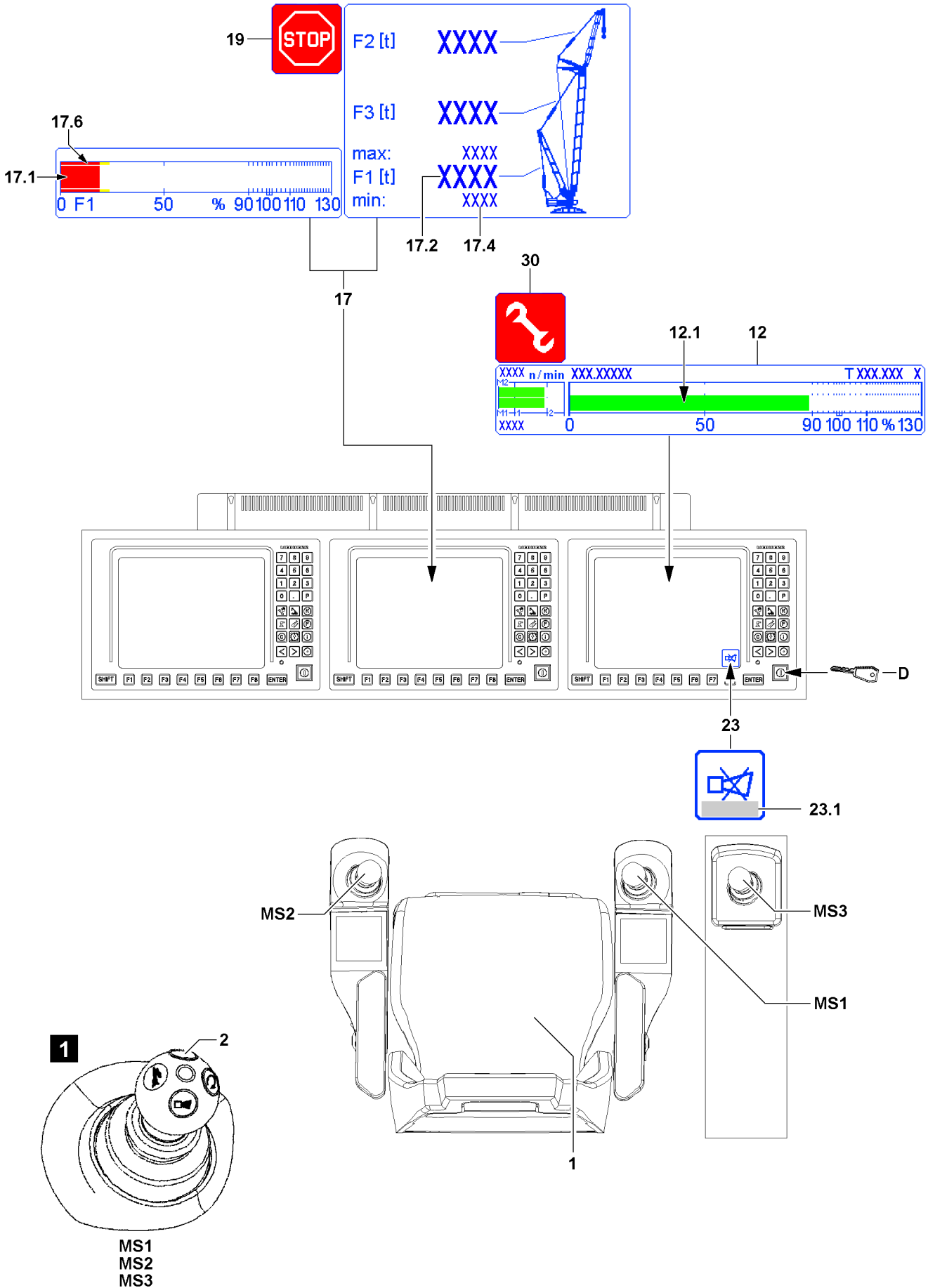

Fig.115307

LWE/LR 13000-001/19503-01-02/en

Make sure that the following prerequisites are met:

- All master switches (MS1, MS2, MS3) are in the zero position (not deflected).
- Either the seat contact button **1** or one of the buttons **2** (illustration **1**) of the master switches (MS1, MS2, MS3) is actuated.
- The crane is in the range of a load chart.
- ▶ Turn the set up key **D** to the right (touching).

Result:

- The function „Exceedance of shut-off limits of the LICCON overload protection“ is activated. As a result the minimum value of the F-load display can be fallen below.
- The assembly icon **30** appears.
- $F_{1_{\min}}$ **17.4** can be fallen below.

- ▶ Initiate crane movements which lead immediately to a normal operating condition (see section „operating condition of the crane“).

Result:

- If the crane reaches a normal operating condition, the function „Exceeding the shut-off limits of the LICCON overload protection“ turns off - the assembly icon **30** turns off.

The function „Exceedance of shut-off limits of LICCON overload protection“ turns off immediately also:

- If the set up key **D** is actuated again.
- If all master switches (MS1, MS2, MS3) are in the zero position for 10 seconds (with load chart available).
- When neither the seat contact button **1** nor one of the buttons **2** of the master switches (MS1, MS2, MS3) is actuated.
- When a *hoist top* shut-off occurs.



Note

- ▶ The function „Exceedance of shut-off limits of the LICCON overload protection“ is only turned off when the assembly icon **30** in the LICCON monitor turns off.
- ▶ If the function „Exceedance of shut-off limits of the LICCON overload protection“ does not turn off after pressing the set up key **D** once, then press the set up key **D** again until the assembly icon **30** in the LICCON monitor turns off.

The function „Exceedance of shut-off limits of the LICCON overload protection“ has / was shut off:

- The assembly icon **30** in the LICCON monitor turns off.
- The working speed is possibly reduced until all master switches (MS1, MS2, MS3) are in the zero position at the same time.
- ▶ Make sure that the assembly icon **30** no longer appears in the LICCON monitor.
- ▶ Carry out crane movements in such a way that no repeated shut-off by the LICCON overload protection occurs.

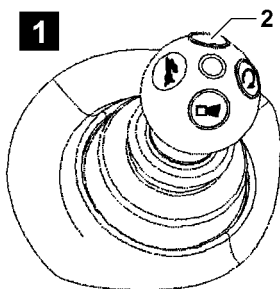
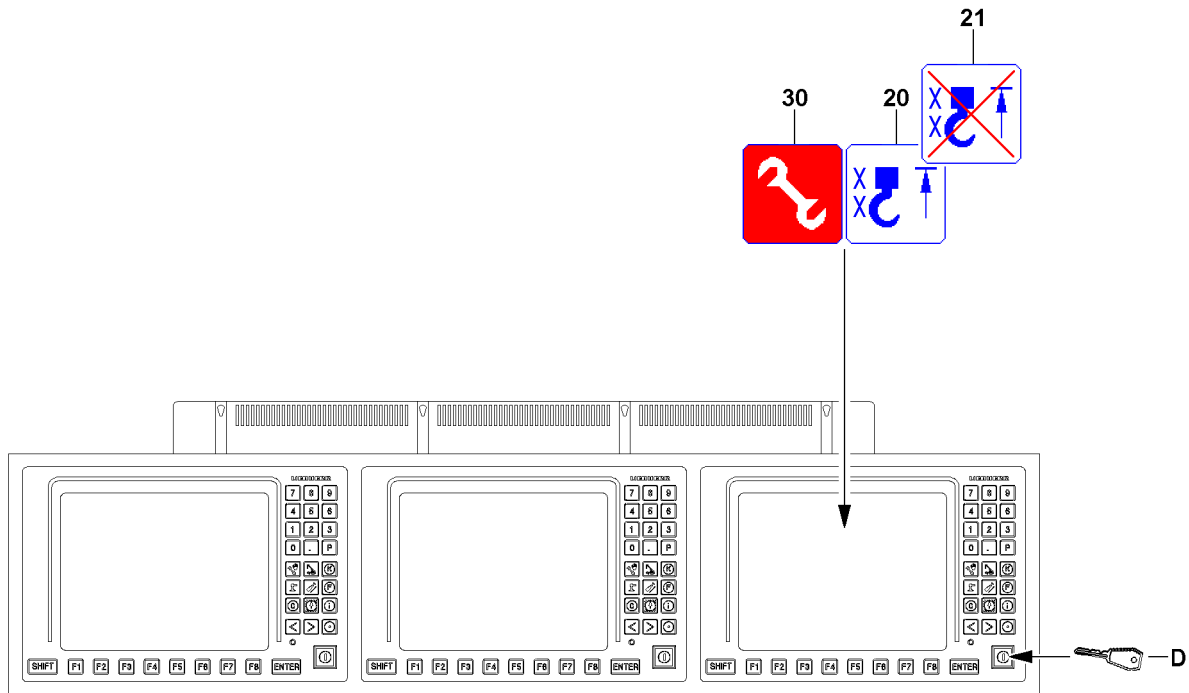

MS1
MS2
MS3

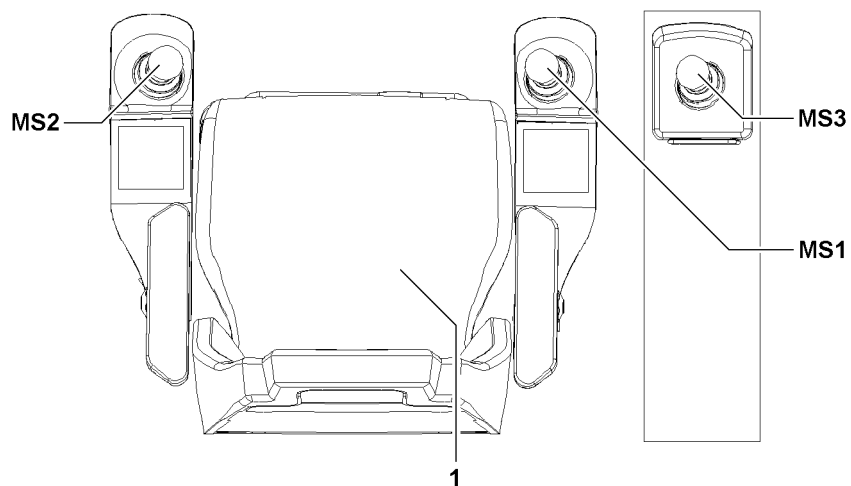

Fig.115289

LWE/LR 13000-001/19503-01-02/en

2.4 Bypassing the *hoist top* shut-off



WARNING

Improper use of the function „Bypass of hoist top shut-off“!

- ▶ The function „Bypass of hoist top shut-off“ may never be used to increase the lifting height during crane operation.



WARNING

Property damage and falling load!

If the function „Bypass of hoist top shut off“ is activated, there is the danger that the hook (hook block / load hook) is pulled against the pulley head.

This danger exists especially when the hoist winch is continued to be spooled up and for crane movements which have an influence on the hoist rope, for example luffing the boom, the auxiliary boom / accessory or the derrick boom.

Property damage and falling load can result.

Personnel can be severely injured or killed.

- ▶ The function „Bypass of hoist top shut-off“ may only be carried out by an authorized person, along with a guide. The guide must be in direct contact with the crane operator and must continually monitor the distance between the hook block / load hook and the boom head.
- ▶ Carry out all crane movements with utmost caution.



Note

- ▶ A bypass of the *hoist top* shut-off is only possible when the shut-off has already occurred due to a triggered hoist limit switch.
- ▶ With actuated set up key **D** (assembly icon **30** appears in the LICCON monitor) if a hoist limit switch is triggered, then there is a new shut-off of crane movements.
- ▶ For assembly purposes or in emergency cases, if the activation of the function „Bypass of hoist top shut-off“ **and** activation of the function „Exceedance of shut-off limits of the LICCON overload protection“ is necessary, then the set up key **D** must be actuated until the icon **21** and assembly icon **30** appear.

Spooling the hoist winch up was turned off because the hook (hook block / load hook) has touched a hoist limit switch weight during the upward movement and the affected hoist limit switch was triggered.

Make sure that the following prerequisites are met:

- A *hoist top* shut-off has occurred, the *hoist top* icon **20** appears in the LICCON monitor.
- Either the seat contact button **1** or one of the buttons **2** (illustration **1**) of the master switches (MS1, MS2, MS3) is actuated.
- All master switches (MS1, MS2, MS3) are in the zero position (not deflected).

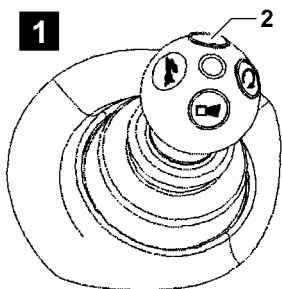
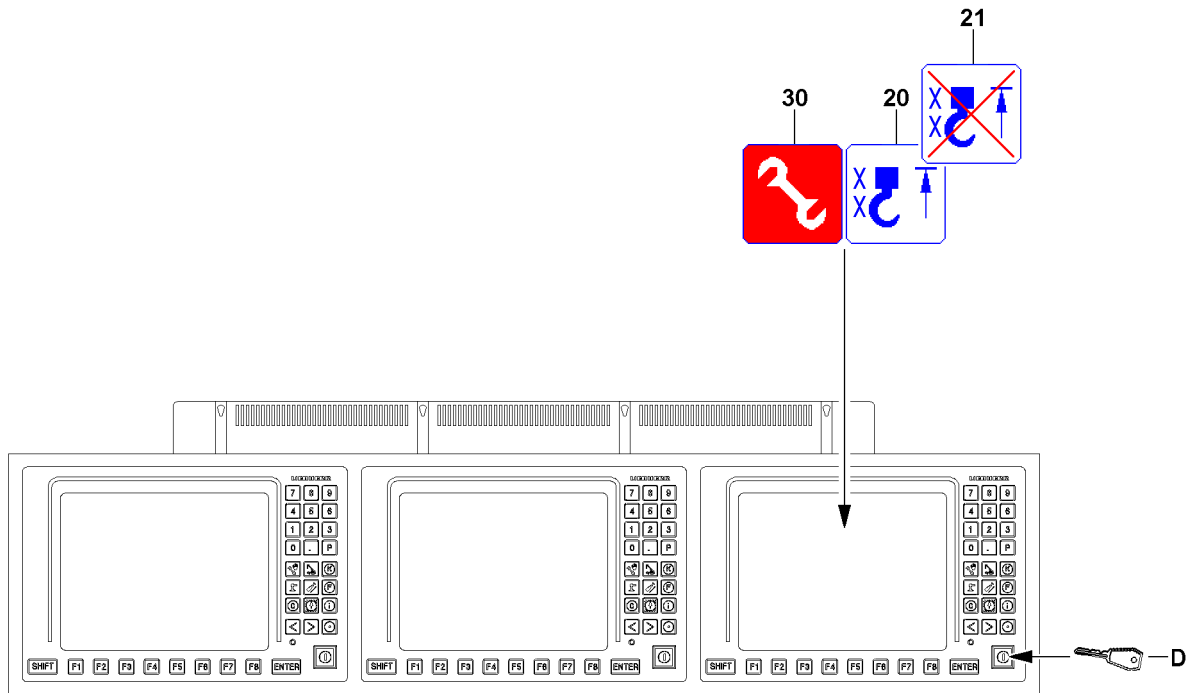

MS1
MS2
MS3

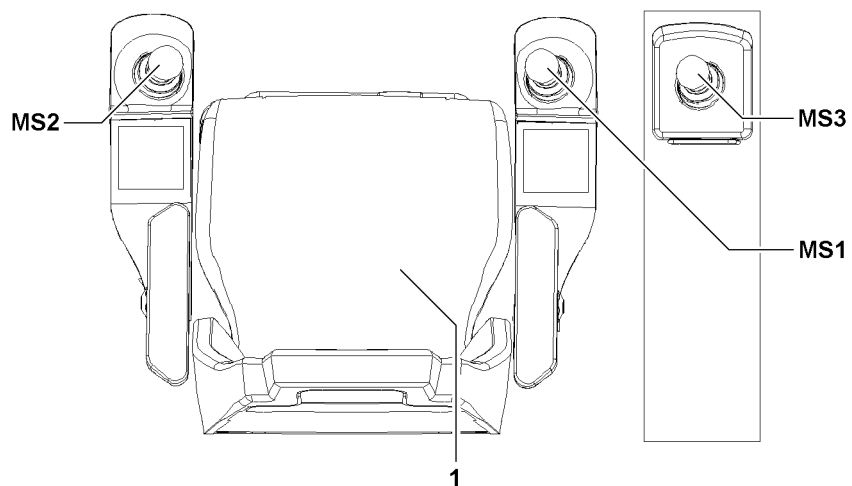

Fig.115289

LWE/LR 13000-001/19503-01-02/en

- To bypass the *hoist top* shut-off, a combined actuation of the set up key **D** and at least one master switch is required.
- ▶ Turn the set up key **D** to the right (touching).

Result:

- The assembly icon **30** (assembly operation) appears in the LICCON monitor.
- The *hoist top* icon **20** in the LICCON monitor changes to the icon **21**.

Within 10 seconds, if the master switch to lift the hoist gear is deflected, the hoist limit switches are bypassed. The bypass of the *hoist top* shut-off remains active only as long as the master switch is deflected.

- ▶ Carry out a crane movement with utmost caution and by taking the safety guidelines into account.

The function „Bypass of the hoist top shut-off“ turns off:

- If the set up key **D** is actuated again.
- When no master switch (MS1, MS2, MS3) was deflected for 10 seconds.
- When neither the seat contact button **1** nor one of the buttons **2** of the master switches (MS1, MS2, MS3) is actuated.
- If there is no longer a shut-off of a hoist limit switch.

The function „Bypass of the hoist top shut-off“ has / was turned off:

- The assembly icon **30** (assembly operation) in the LICCON monitor turns off.
- The icon **21** on the LICCON monitor turns off.
- ▶ Make sure that the assembly icon or the assembly icon **30** (assembly operation) as well as the icon **21** no longer appear in the LICCON monitor.
- ▶ Carry out the crane movements in such a way that no repeated *hoist top* shut-off occurs.

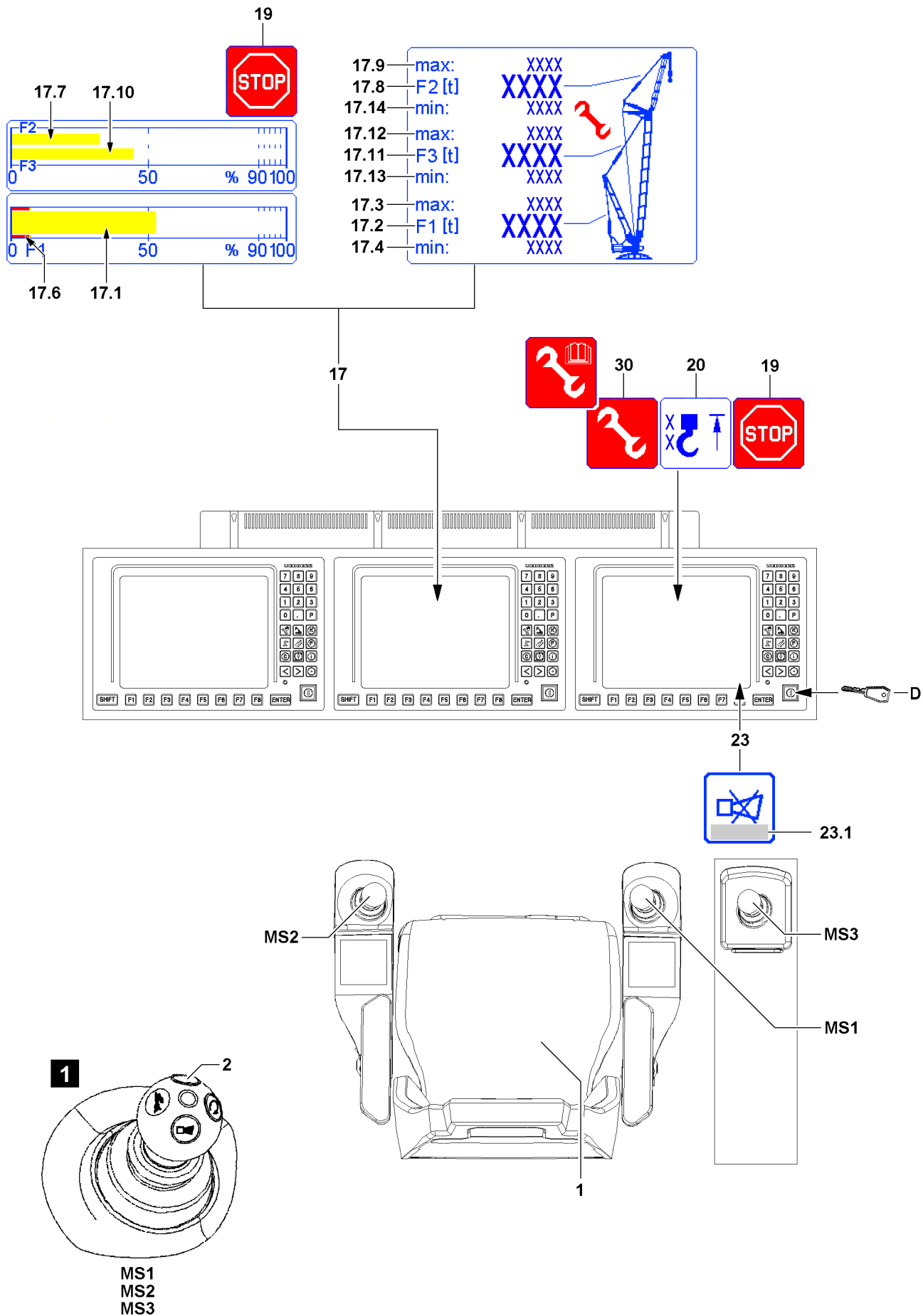

Fig.122457

2.5 Carrying out the erection / take down procedures

To carry out the erection / take down procedures and assembly procedures, the LICCON overload protection can be bypassed by the set up key **D**.



Note

- ▶ If the crane is in the range „No load chart available“ then there is a shut-off of the crane control by the LICCON overload protection. The icon **19** appears in the LICCON monitor.
- ▶ By pressing the set up key **D** all erection / take down procedures and assembly procedures can be carried out according to the specifications in the crane documentation.



WARNING

Danger of accident during erection / take down procedures!

If the specifications of the crane documentation are not observed, the crane can collapse, the boom can break off or the crane can topple over.

Personnel can be severely injured or killed.

- ▶ Make sure to adhere to all specifications in the crane documentation.
- ▶ Make sure to observe the data in the crane documentation (for example erection / take-down charts and assembly instructions).
- ▶ Press the set up key **D** only when the set up configuration has been entered correctly in the LICCON computer system and matches the actual situation.



WARNING

Damage, overload and toppling of the crane!

If the permissible values of the F-load display **17** are exceeded / fallen below, then the crane can be damaged or overloaded and topple over.

As long as the set up boom system is not completely assembled and not all sensors, which are required for this operating mode are electrically connected, no maximum forces and minimum forces are displayed in the F-load display **17**.

In these cases it must be determined with the assembly drawing which maximum forces are permissible in the F-load display **17**.

These maximum forces must be monitored by the crane operator and may not be exceeded during set up / take down of the crane.

- ▶ The crane operator must ensure that the permissible values of the F-load display **17** are not exceeded / fallen below.
- ▶ Observe and adhere to the maximum forces for the F-load display **17** from the assembly drawings.

Display area of F-load display **17**:

– F1-load display
The force determined on test point 1 is generally described as $F1_{actual}$.

– F2-load display
The force determined on test point 2 is generally described as $F2_{actual}$.

Note: Appears only for the corresponding boom system.

The F2-utilization bar **17.7** only appears in assembly operation (no load chart available and set up key **D** actuated).

– F3-load display
The force determined on test point 3 is generally described as $F3_{actual}$.

Note: Appears only for the corresponding boom system.

The F3-utilization bar **17.10** only appears in assembly operation (no load chart available and set up key **D** actuated).

**Note**

In the F-load display **17**, the force ratio is shown as number values as well as a bar display (called F-bar display).

The permissible maximum value corresponds to 100 % in the bar display.

- ▶ The F1-utilization bar **17.1** shows the relationship $F1_{\text{actual}}$ **17.2** to $F1_{\text{max}}$ **17.3**.
- ▶ The value $F1_{\text{min}}$ **17.4** corresponds to the $F1_{\text{min}}$ -STOP-bar **17.6**.
- ▶ The F2-utilization bar **17.7** shows the relationship $F2_{\text{actual}}$ **17.8** to $F2_{\text{max}}$ **17.9**.
- ▶ The F3-utilization bar **17.10** shows the relationship $F3_{\text{actual}}$ **17.11** to $F3_{\text{max}}$ **17.12**.
- ▶ The value $F3_{\text{min}}$ **17.13** appears solely in special situations, for example during the erection of the derrick boom. The value $F2_{\text{min}}$ **17.14** appears solely for certain crane types in special situations. If no minimum values F_{min} appear, then the data in the crane documentation (for example erection / take-down charts and assembly instructions) must be observed.
- ▶ When leaving the range „load chart available“ the display of the assembly icon **30** changes.

Empty page!

LWE/LR 13000-001/19503-01-02/en

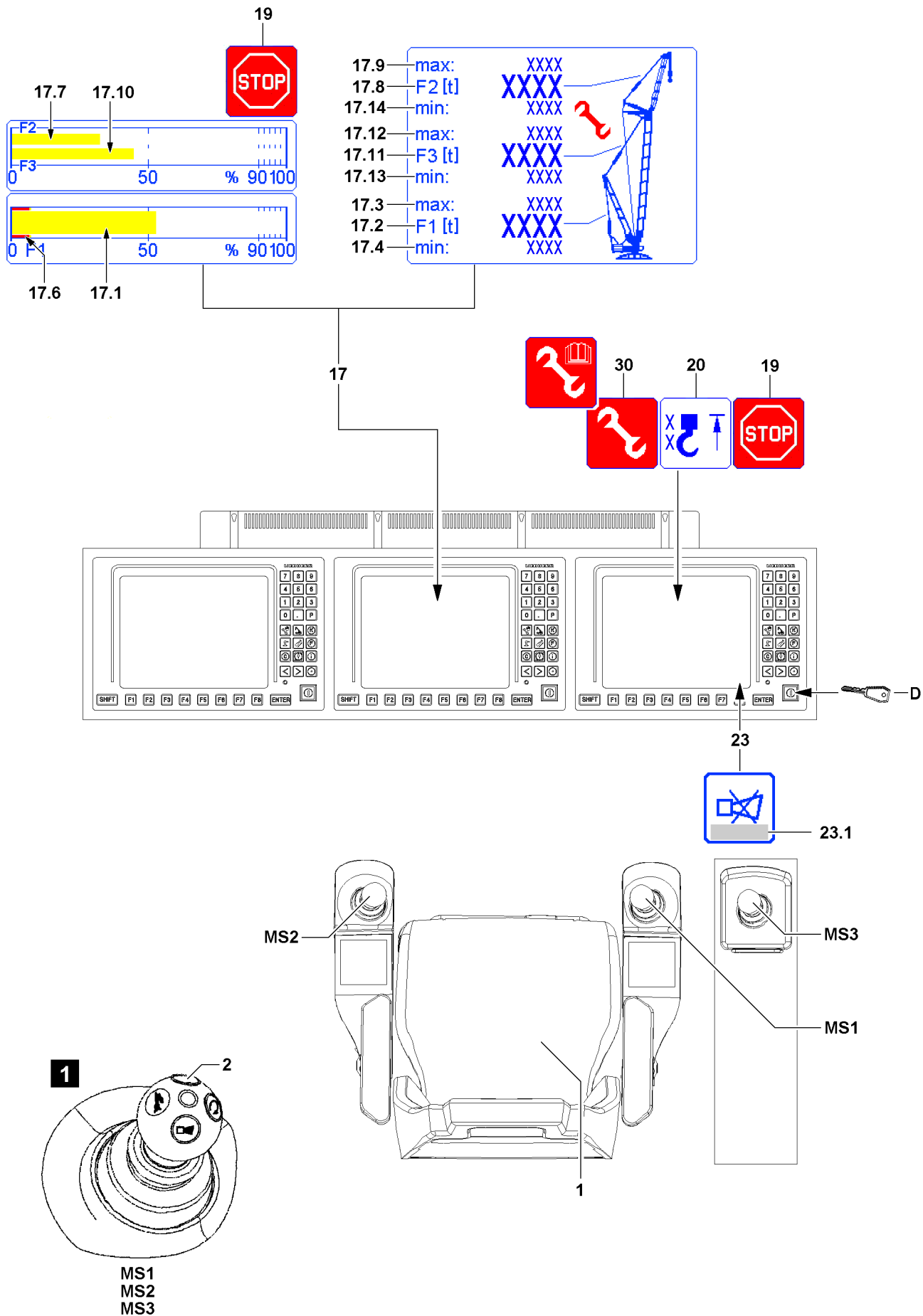

Fig.122457

LWE/LR 13000-001/19503-01-02/en

2.5.1 Carrying out erection procedures

Make sure that the following prerequisites are met:

- The set up configuration corresponds to the specifications in the crane documentation.
- The set up configuration has been entered correctly into the LICCON computer system.
- All master switches (MS1, MS2, MS3) are in the zero position (not deflected).
- Either the seat contact button **1** or one of the buttons **2** (illustration **1**) of the master switches (MS1, MS2, MS3) is actuated.



Note

- ▶ Depending on the situation, the *hoist top* shut-off (icon **20** appears) must be bypassed at the same time.

- ▶ Turn the set up key **D** to the right (touching).

Result:

- The assembly icon **30** appears.
- The erection procedure can be carried out.

Problem remedy

The functionality of the set up key **D** is disabled by the crane control?

- ▶ Pay attention to notes regarding error messages **23.1** occurring in the *horn* icon **23**.
- ▶ Check the electrical connections.
- ▶ Check if all sensors or dummy plugs with integrated electric have been connected properly.

- ▶ Luff the boom according to the specifications of the crane documentation.
- ▶ Monitor the F-load display **17**, all values must be within the minimum values and the maximum values.

Problem remedy

The erection / take down procedure cannot be carried out due to exceeding of the minimum or maximum values?

- ▶ See section „Minimum values or maximum values of F-load display reached“.

The „Bypass of the LICCON overload protection“ via the set up key **D** turns off:

- If the set up key **D** is actuated again.
- When an range with existing load chart is reached (erection procedure).
- If all master switches (MS1, MS2, MS3) are in the zero position for 10 seconds (with „Load chart available“).
- When neither the seat contact button **1** nor one of the buttons **2** of the master switches (MS1, MS2, MS3) is actuated.

The function „Exceedance of shut-off limits of the LICCON overload protection“ has / was shut off:

- The assembly icon **30** in the LICCON monitor turns off.
- ▶ After completion of the erection / take down procedures, make sure that the assembly icon **30** no longer appears in the LICCON monitor.

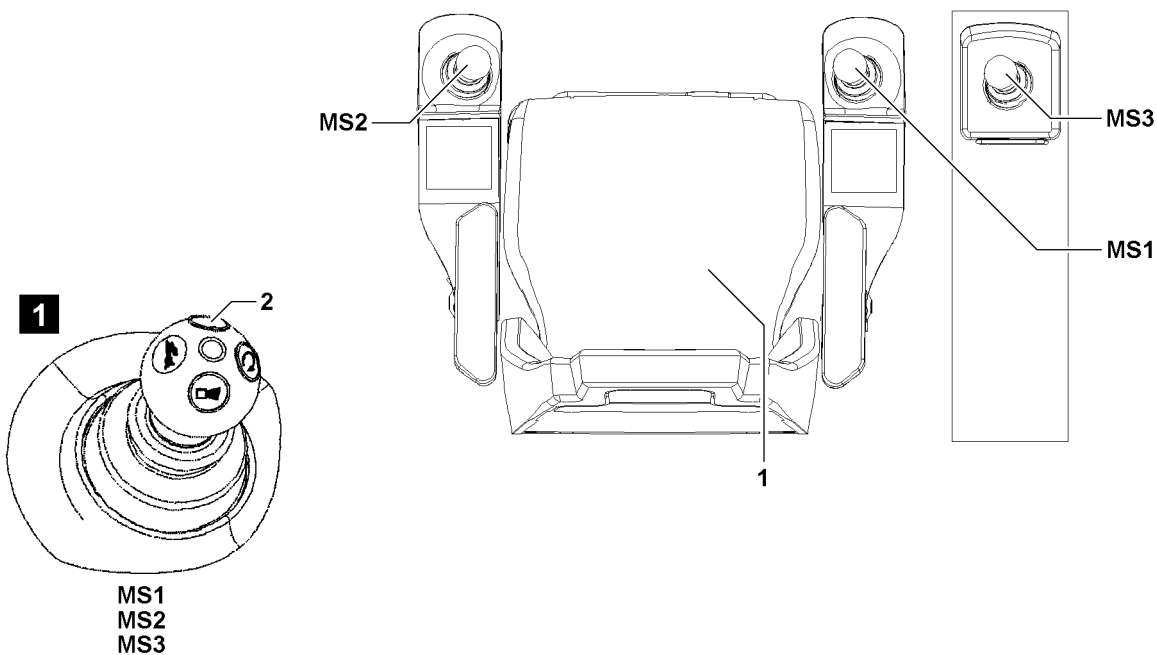
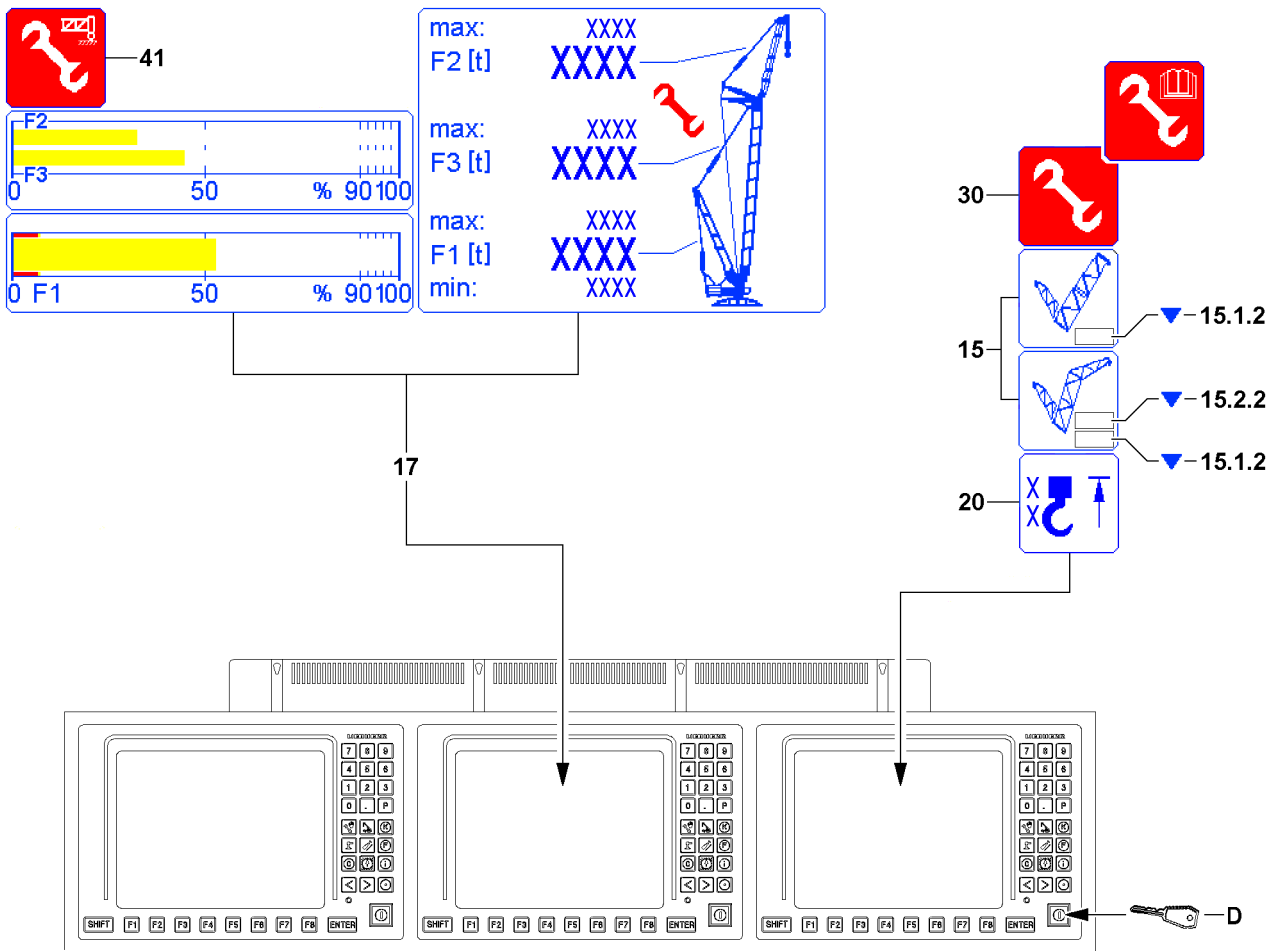

Fig.125391

LWE/LR 13000-001/19503-01-02/en

2.5.2 Carrying out take down procedures



WARNING

Danger of accidents when taking the boom system down!

When the shut-off *luffing the main boom / auxiliary boom / accessory down* is bypassed, then the LICCON overload protection as a whole is deactivated, bypassed or limited.

The main boom and / or auxiliary boom / accessory can be luffed from the range of the load chart.

In case of deviations from the specifications of the crane documentation, severe accidents can be the result.

Personnel can be severely injured or killed.

- ▶ Always proceed according to the specifications of the crane documentation.
- ▶ Carry out all crane movements with utmost caution.

Make sure that the following prerequisites are met:

- With installed main boom / auxiliary boom / accessory: In the icon **15** the arrow **15.1.2** or arrow **15.2.2** appears and the LICCON overload protection has shut off the crane movement.
- Either the seat contact button **1** or one of the buttons **2** (illustration **1**) of the master switches (MS1, MS2, MS3) is actuated.
- All master switches (MS1, MS2, MS3) are in the zero position (not deflected).
- There is no load on the hook (hook block / load hook).
- If necessary, the hook (hook block / load hook) is placed on the ground.
- The set up configuration corresponds to the specifications in the crane documentation.
- The set up configuration has been entered correctly into the LICCON computer system.



Note

- ▶ When leaving the range „load chart available“, the limit values and utilization displays for value F2 and value F3 will possibly appear.
- ▶ When leaving the range „load chart available“ the display of the assembly icon **30** changes.

- ▶ Turn the set up key **D** to the right (touching).

Result:

- The assembly icon **30** appears in the LICCON monitor.
- The take down procedure can be carried out.
- ▶ Luff the boom according to the specifications of the crane documentation.
- ▶ Monitor the F-load display **17**, all values must be within the minimum values and the maximum values.

Problem remedy

The erection / take down procedure cannot be carried out due to exceeding of the minimum or maximum values?

- ▶ See section „Minimum values or maximum values of F-load display reached“.

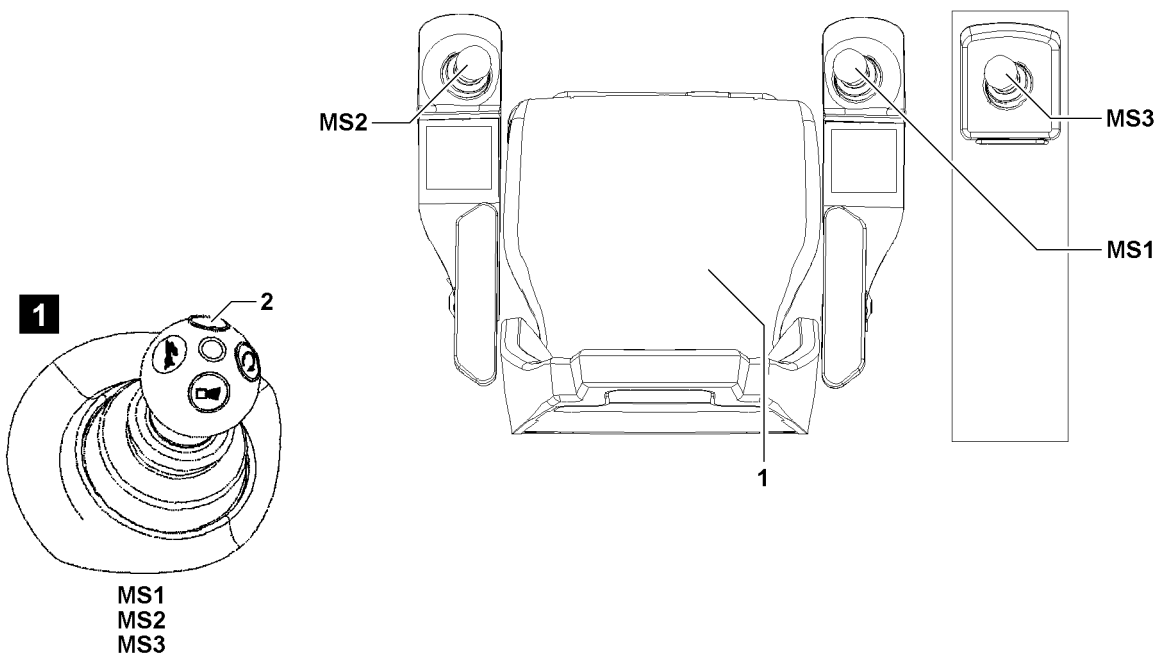
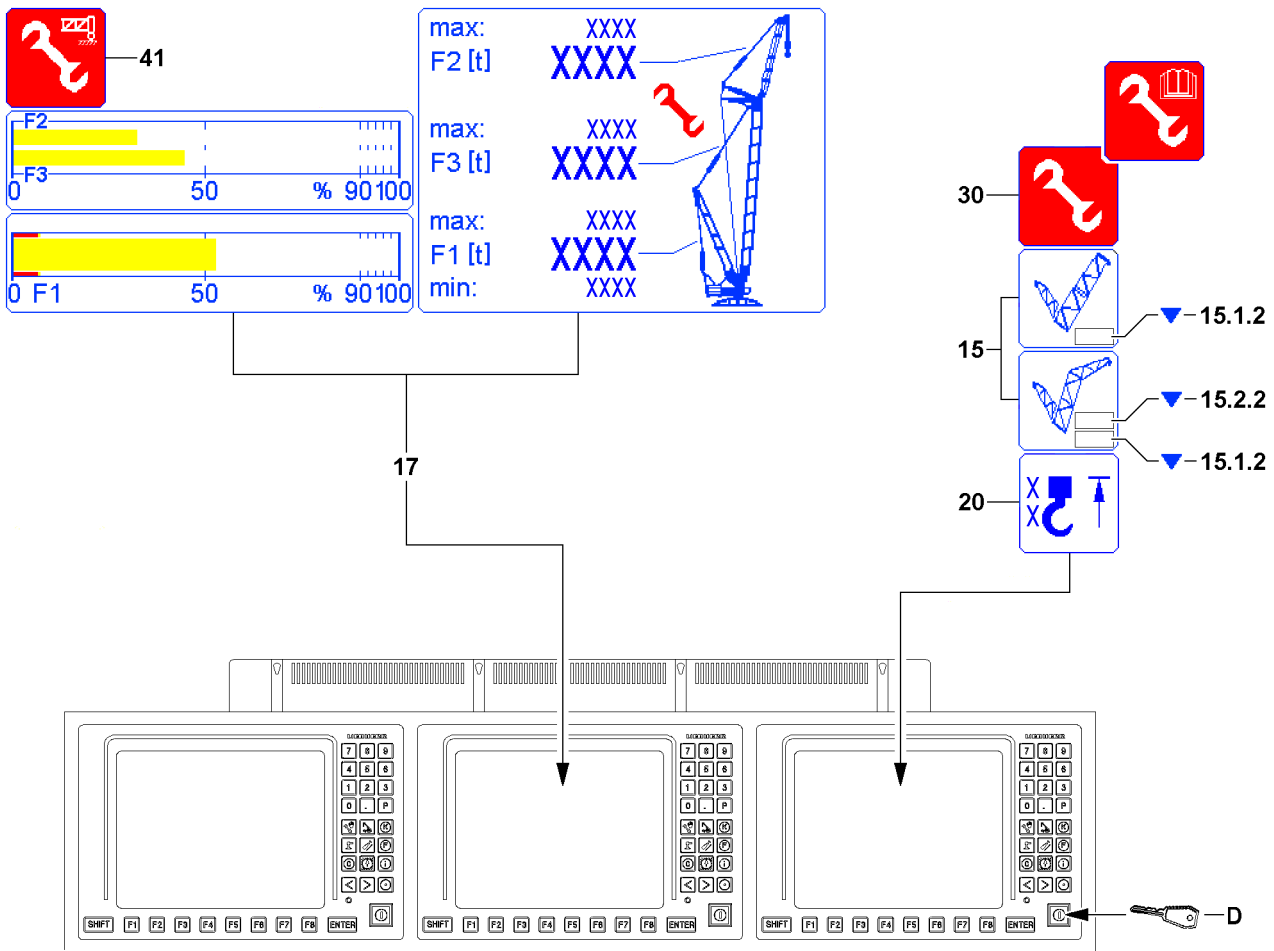

Fig.125391

LWE/LR 13000-001/19503-01-02/en

**Note**

- ▶ Depending on the situation, the *hoist top* shut-off (icon **20** appears) must be bypassed at the same time.

The „Bypass of the LICCON overload protection“ via the set up key **D** turns off:

- If the set up key **D** is actuated again.
- When neither the seat contact button **1** nor one of the buttons **2** of the master switches (MS1, MS2, MS3) is actuated.
- When an area with existing load chart is reached.

The bypass of the LICCON overload protection is / was turned off:

- The assembly icon **30** in the LICCON monitor turns off.
- ▶ Make sure that the assembly icon **30** no longer appears in the LICCON monitor.

2.5.3 Carrying out the assembly procedures

**WARNING**

Danger of accident during assembly procedures!

In case of deviations from the specifications of the crane documentation for the assembly procedures, severe accidents can be the result.

Personnel can be severely injured or killed.

- ▶ Always proceed according to the specifications of the crane documentation.
- ▶ **If you cannot proceed according to the crane documentation, contact Liebherr Service before carrying out any subsequent steps and agree on the procedure.**

Make sure that the following prerequisites are met:

- The set up configuration corresponds to the specifications in the crane documentation.
- The set up configuration has been entered correctly into the LICCON computer system.
- ▶ Actuate the set up key **D** only according to the corresponding specifications in the crane documentation.

2.5.4 Key button *Boom on the ground*

With the aid of the key button *Boom on the ground*, a shut-off can be bypassed in the lowest angle range of the boom, when:

- The boom has contact with the ground.
- At least 12.5 % of the boom weight is taken up by the ground contact.

Make sure that the following prerequisites are met:

- The set up configuration corresponds to the specifications in the crane documentation.
- The set up configuration has been entered correctly into the LICCON computer system.
- ▶ Actuate the key button *Boom on the ground* and erect / take-down the boom.

Result:

- Icon **41** appears as long as the shut-off is bypassed.

**Note**

- ▶ The key button *Boom on the ground* is on the instrument panel, see Crane operating instructions, chapter 4.01.

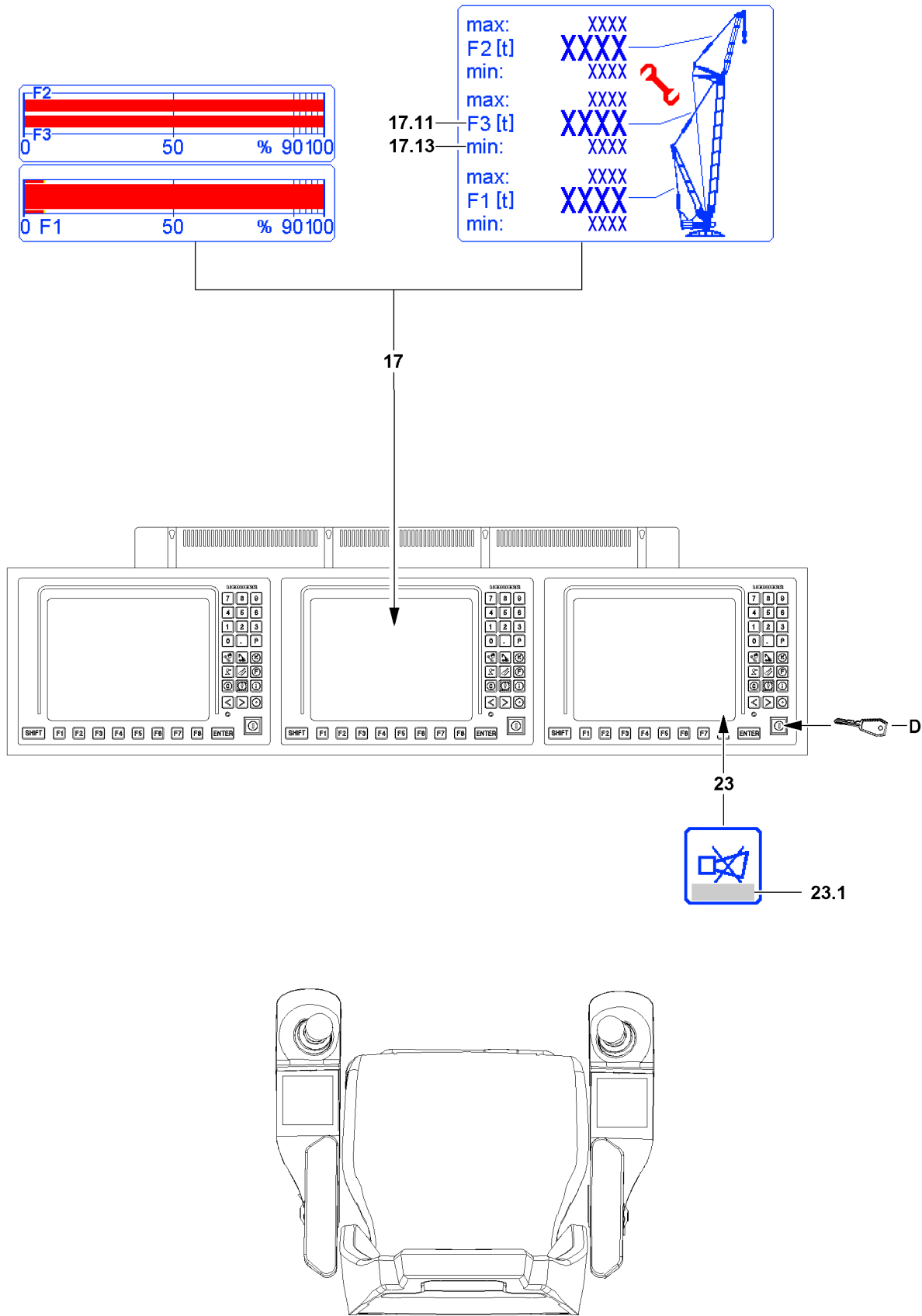

Fig.122458

2.6 Minimum values or maximum values of F-load display reached



Note

- ▶ The display and assignment of the F-load display **17** can deviate depending on the set up configuration, operating condition and configuration of the crane, see Crane operating instructions, chapter 4.02.

In the F-load display **17** the minimum and maximum values were reached.

Make sure that the following prerequisites are met:

- The crane is assembled according to the specifications in the crane documentation.
- A valid set up configuration has been entered on the LICCON computer system (Set up program).
- The actual set up configuration has been entered on the LICCON computer system (Set up program).
- The hook block / load hook is correctly installed and reeved in.
- All attachment parts and guy rods on the boom system, which are not needed, have been removed (weight).
- The boom system is free of snow and ice (weight).
- The wind influence on the crane is not too great.
- The local conditions (terrain incline) are in the permissible range.
- The notes regarding error messages **23.1** appearing in the *horn* icon **23** were observed.

2.6.1 Improvement of force ratio in the guying of the boom system

- ▶ Check if a crane movement was initiated, which leads to an improvement of the force ratio in the F-load display **17**.



Note

In the permissible framework of specifications of the crane documentation, a positive influence of the force ratio in the F-load display **17** can be reached by:

- ▶ Changing the pulled derrick ballast.
- ▶ Changing the derrick ballast radius (luffing the derrick boom up / down).
- ▶ Erecting the main boom: Carry the hook (hook block / load hook) along.
- ▶ Erection of the main boom with installed luffing jib: Spool the control winch for the luffing jib out to shift the weight of the guy rods more favorably.
- ▶ In difficult local conditions (terrain incline): Support the placed down boom system to obtain more favorable angle conditions.
- ▶ In difficult local conditions (terrain incline): Support the placed down boom system to reduce flexation.

2.6.2 Minimum value F3-load display during erection of the derrick boom fallen below

If the guying between the derrick boom and the main boom is not sufficiently tensioned, then it is possible that the value $F3_{\min}$ **17.13** is fallen below. The value $F3_{\min}$ **17.13** appears possibly only during the erection procedure of the derrick boom in steep boom position.



Note

- ▶ By targeted spooling winch 3 up / out during the erection procedure, the guying between the derrick boom and the main boom can be slightly pretensioned depending on the circumstances and the value $F3_{\text{actual}}$ **17.11** can be increased / held.

- ▶ Pretension the guying slightly between the derrick boom and the main boom so that the value $F3_{\min}$ **17.13** is not fallen below. A collision of the luffing pulley block / guy rods with the crane (for example during the erection procedure of the derrick boom) may not occur.

When $F3_{\min}$ **17.13** was fallen below and the movements winch 3 and winch 4 are fully or partially shut-off:

- ▶ Press the set up key **D** again at activated assembly operation.

Result:

- The value for $F3_{\min}$ **17.13** is reduced slightly once.
- ▶ Spool winch 3 up to increase the value $F3_{\text{actual}}$ **17.11**.

Problem remedy

The value for $F3_{\min}$ **17.13** is fallen below again:

It is not possible to reduce the value for $F3_{\min}$ **17.13** again.

- ▶ By spooling out winch 4 the derrick boom can be moved forward until the $F3_{\min}$ **17.13** is masked again and winch 3 can be spooled up / out again.
-

5 Equipment

LWE/LR 13000-001/19503-01-02/en

LWE/LR 13000-001/19503-01-02/en

5.01 Technical safety instructions for assembly and disassembly

1	Equipment	2
2	Rope pulleys	2
3	Ropes	2
4	Fiber guy ropes	4
5	Control measures before crane operation	8
6	Relapse cylinders	11
7	Pneumatic springs	11
8	Manual rope winches	11
9	Weights	12
10	Guy rods	12
11	Auxiliary guying	13
12	Bypassing the overload protection	13
13	Bypassing the hoist top shut-off	15
14	Pin connections	16
15	Retaining elements	21
16	Assembling / disassembling	29
17	Erecting / taking-down	91
18	Walking on a boom component	95

1 Equipment

1.1 Checking the steel structures

All components part of the crane's delivery scope must be checked regularly together with the crane.

If equipment or components are assembled that are part of the delivery scope of another crane: Prior to first time use, check load bearing crane structures, especially steel structures, see chapter 8.01.

1.2 Checking the labeling



WARNING

Labeling **not** legible or **not** present!

Components, especially guy rods, can be mixed up.

Death, severe bodily injuries, property damage.

- ▶ Do **not** continue to use the components, especially the guy rods.

2 Rope pulleys



WARNING

Danger of accident due to rotating rope pulleys!

Arms and legs can be caught and crushed or severed between the rope pulleys due to rotating rope pulleys.

- ▶ It is prohibited to touch the rope pulleys during operation.
- ▶ Adhere to the safety distance to the rotating rope pulleys.

3 Ropes



WARNING

Danger of accident due to a running rope!

People can be caught by running rope.

Death, severe bodily injuries, property damage.

- ▶ Adhere to the safety distance to the running ropes.
- ▶ It is prohibited for anyone to remain in the danger zone.



WARNING

Danger of accident!

- ▶ The ropes must be checked by an expert before assembly and checks must be performed at regular intervals in order to detect possible damage or wear and tear at an early stage. See chapter 8.04.

The ropes must be taken down immediately if any of the following damage is detected:

- Breakage of a strand
- Wire breaks
- Broken wire nests
- Reduction in the rope diameter by 10 % or more of the nominal size
- Rope deformations

3.1 Placing the hoist rope or the control rope

In order to guarantee safety and operating characteristics, only original Liebherr replacement parts or parts approved by Liebherr may be used.

NOTICE

Damage to the hoist rope or the control rope!

If a hoist rope or control rope is placed with worn rope pulleys, damage can occur.

- ▶ Before placing a rope, check the rope pulleys. See chapter 8.01.
- ▶ Replace worn or damaged rope pulleys.

3.2 Minimum rope coils

NOTICE

If the following notes are not observed, the cam limit switch / winch speed sensor must be readjusted!

- ▶ When the hoist rope is spooled up, the end of the hoist rope must remain in front of the winch and may not be pulled over the winch.
- ▶ Never pull the hoist rope end under the winch by spooling the winch up.
- ▶ Pull the hoist rope never off from the „stationary“ winch.
- ▶ The winch speed sensor must also be readjusted, if it is determined during operation or when changing the hoist rope that the winch does not shut off when the minimum rope coils are reached.

3.2.1 Cranes with cam limit switch

The cam limit switch is adjusted at the factory that it turns off before the minimum rope coils are reached (three hoist rope coils on the winch).

**WARNING**

Danger of accident due to falling load!

If the following instructions are not observed, the hoist rope end attachment may be torn out, causing the load to topple.

- ▶ If a new hoist rope is used, the cam limit switch must be reset.
- ▶ The cam limit switch must be adjusted so that it turns off when only 3 hoist rope coils remain on the winch.

3.2.2 Cranes with winch speed sensor

The winch speed sensor is adjusted at the factory that it turns off before the minimum rope coils are reached (four hoist rope coils on the winch). If used properly, the winch turn sensor will not need readjustment.

**WARNING**

Danger of accident due to falling load!

If the following instructions are not observed, the hoist rope end attachment may be torn out, causing the load to topple.

- ▶ If a new hoist rope is placed, the winch speed sensor must be checked.
- ▶ The winch speed sensor must be set to turn off when only 4 hoist rope coils remain on the winch.

4 Fiber guy ropes



WARNING

Impermissible assembly of fiber guy ropes!

The fiber guy ropes can rip.

Death, severe bodily injuries, property damage.

- ▶ Do **not** use buckled, knotted or twisted fiber guy ropes.
 - ▶ Do **not** assemble damaged fiber guy ropes.
 - ▶ Make sure that the identification of the fiber guy rope on the rod plan and the identification on the individual fiber guy ropes are identical. See section „Identifying the fiber guy rope“.
 - ▶ Make sure that the operating temperature of the fiber guy ropes of -40 °C to +60 °C is **not** fallen below or exceeded.
 - ▶ Check the fiber guy ropes for damage prior to assembly, after disassembly and after exceptional events, see chapter 8.16.
 - ▶ Comply with the maintenance intervals, see chapter 7.03.50.
 - ▶ Observe the notes regarding the proper transport and storage of the fiber guy ropes, see chapter 2.04.
 - ▶ Observe the instructions for the fiber guy ropes, see section „Instructions for proper handling“.
 - ▶ Only fasten the fiber guy ropes in the permissible range with belt loops, see section „Fastening the fiber guy ropes“.
-

Comply with the intended use and non-intended use of the fiber guy ropes.

- Only use fiber guy ropes as guy rope.
- Do **not** use fiber guy ropes for typical rope tasks, for example for lifting, fastening to hooks, as an auxiliary rope, diverting over rope pulley.

4.1 Identifying the fiber guy rope

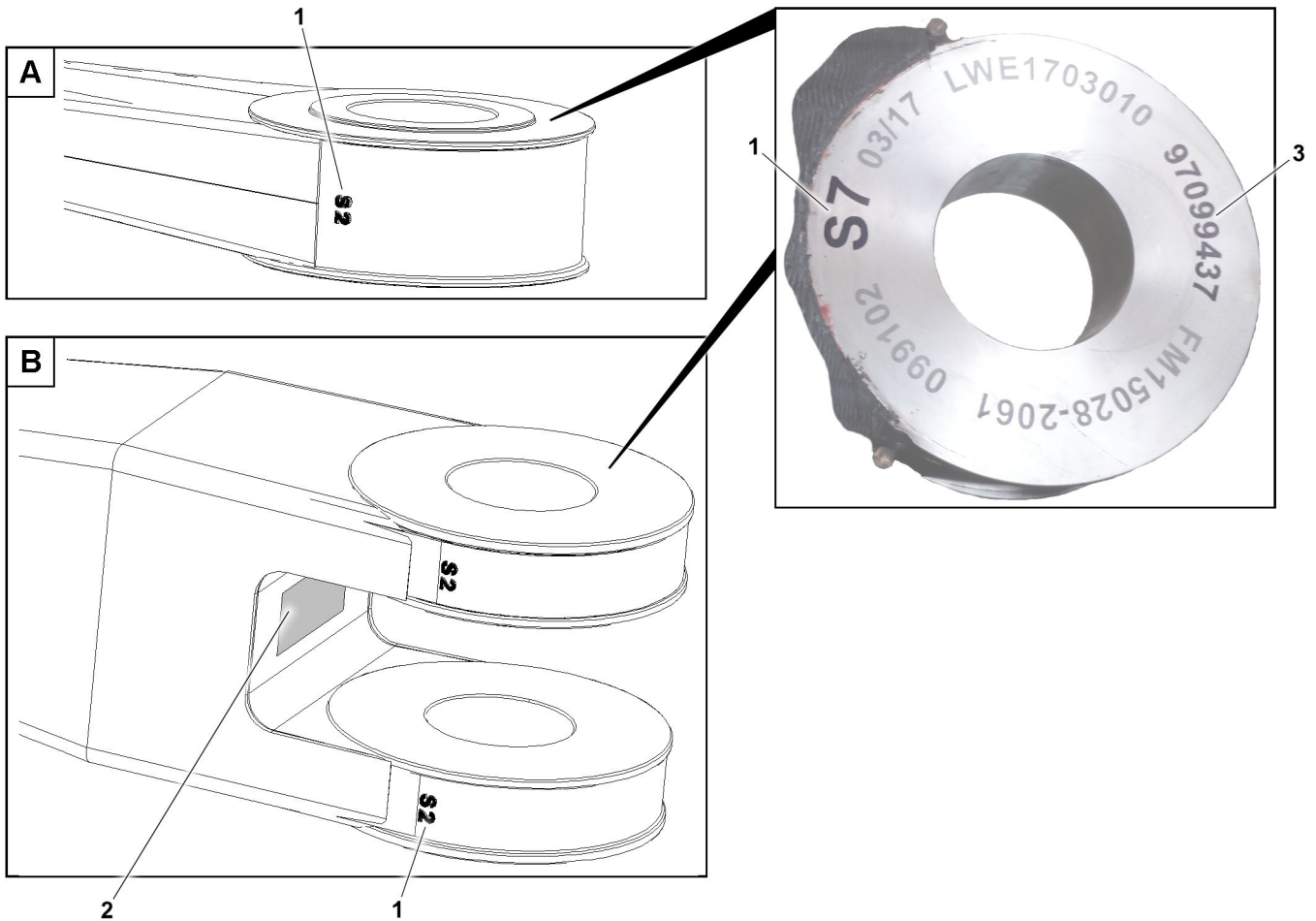

Fig. 160911: Fiber guy rope, identification

- 1 Rope number 2 Component group no. 3 Article number

Follow the instructions below for the correct identification of the fiber guy ropes:

- Make sure that rope number **1** on the rope thimble corresponds to the rope number on the rod plan.
- Make sure that article number **3** on the rope thimble corresponds to the article number on the rod plan.
- If there is an article number **3** and a component group no. **2** on the rope thimble: Make sure that component group no. **2** on the rope thimble corresponds to the component group no. on the rod plan.

4.2 Instructions for proper handling



Fig.160904: Fiber guy rope, twisting marking for permissible alignment of the rope

- | | | | |
|---|-------------------------|---|-----------------------------|
| 1 | Straight fiber guy rope | 3 | Fiber guy rope twisted 180° |
| 2 | Twisting marking | 4 | Fiber guy rope twisted 360° |

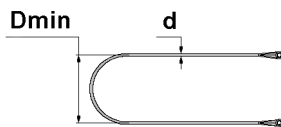

$$D_{min} = 20 \times d$$

Fig.160908: Fiber guy rope: Calculation of minimum permissible bending diameter

Formula element	Meaning
Dmin	Minimum permissible bending diameter
d	Rope diameter

Minimum permissible bending diameter: Definition of the formula elements

Comply with the instructions for the assembly and disassembly of the fiber guy ropes:

- When the fiber guy rope is wet: Prior to assembly, dry the fiber guy rope in the air at approx. 20 °C.
- Perform a visual inspection: Abrasion, cuts, kinks, knots, deformations, heat damage.
- Perform a visual inspection: Damage to the sheath layers and the rope end connections, gap formation between the rope thimble and the rope sheath.
- Do **not** bend, knot, twist or sever the fiber guy ropes.
- Never fall below the minimum permissible bending diameter **Dmin** of **20** x rope diameter **d**.
- Check the alignment of the rope end connections with respect to each other: Align the twisting marking **2** straight along the entire rope length.
- Do **not** drag the fiber guy ropes over the ground, rough surfaces or sharp edges.
- Do **not** let the fiber guy ropes fall down.
- Do **not** crush the fiber guy ropes.
- Do **not** remove the crushed fiber guy ropes out of the clamping point.
- Do **not** pull the fiber guy ropes with force to the pin point.
- Pin the fiber guy ropes only with permissible and lubricated pins.

- Only fasten the fiber guy ropes in the permissible range with belt loops, see section „Fastening the fiber guy ropes“.

4.3 Fastening the fiber guy ropes

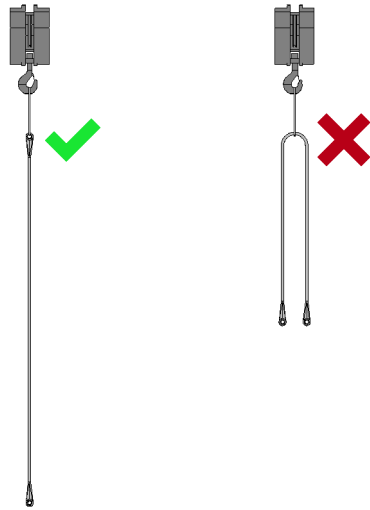

Fig.160907: Fastening the fiber guy ropes

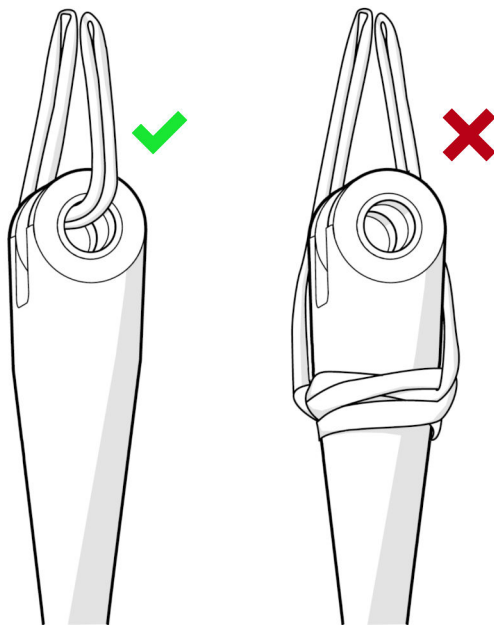

Fig.160905: Fasten the fiber guy rope: Rope end connection without ribs

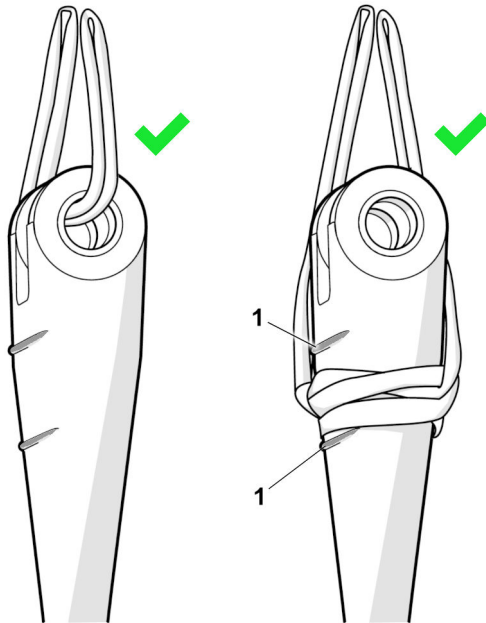

Fig.160906: Fasten the fiber guy rope: Rope end connection with ribs

1 Rib

5 Control measures before crane operation



WARNING

The crane can topple over!

If the following control measures and the crane-specific additional controls are not carried out before crane operation or if they are not carried out sufficiently, then accidents can occur.

The crane can topple over, be overloaded or damaged.

Loose parts, aids or ice can fall down from the boom or the crane superstructure.

Death, severe bodily injuries, property damage.

- ▶ Crane operation with safety equipment that is **not** functioning correctly is strictly prohibited.
- ▶ Start crane operation only after all safety equipment have been checked and are functioning correctly.
- ▶ Start crane operation only if the overload protection has been set according to the data in the load chart.
- ▶ Start crane operation only if the crane is properly supported and horizontally aligned.
- ▶ Only start crane operation after making sure that there are not loose parts on the boom, crane superstructure or crane chassis.
- ▶ Only start crane operation after making sure that there is no snow, frost or ice on the boom.
- ▶ Only start crane operation after making sure that all specifications, crane conditions and / or properties that are checked and required during the extensive control measures and additional controls have also been completely fulfilled.



WARNING

Interruption of crane operation!

If the following specifications for interruption of crane operation are not observed, accidents can occur.

- ▶ If the crane operator leaves the crane cab even if for just a short time, the crane must be secured to prevent unauthorized access.
- ▶ Before starting to work again with the crane, the crane operator is obligated to check the operating mode settings and to reset them, if necessary.



Fig.113437: Control displays

Make sure that the following prerequisites are met:

- The overload protection is not bypassed.
- No assembly operation is activated.

5.1 General controls before crane operation

- Make sure that no visible damage is present on the crane.
- Make sure that there are no loose parts on the boom, crane chassis and crane superstructure.
- Make sure that all hoist and control ropes are free of snow, frost and ice.
- Make sure that the boom system is free of snow, frost and ice.
- Make sure that exposed rope pulleys are free of snow, frost and ice.
- Make sure that the cable / rope drums as well as the limit switches are free of snow and ice.
- Make sure that the cylinders are free of ice.
- Make sure that the gear ring of the slewing ring connection is clean and greased.
- Make sure that the air supply to the oil and water cooler is clear.
- Make sure that steps, ladders and platforms are in the correct position for crane operation.
- Make sure that all tool boxes, compartments, coverings, covers and cabinet doors are closed.
- Make sure that no persons or objects are in the danger zone of the crane.
- Make sure that the crane is standing on level, load bearing ground.
- Make sure that the crane is sufficiently supported depending on the load case and the ground conditions.
- Make sure that there is a sufficient safety distance to excavations and slopes.
- Make sure that no obstacles are within the working range of the crane, which obstruct the required crane movements.
- Make sure that the crane has sufficient distance to live power lines.
- Make sure that the LICCON overload protection is set according to the data in the load chart.
- Make sure that the overload protection is set according to the actual set up configuration of the crane.
- Make sure that the electrical connections, the connector plug, the pull relief, the cables and the protective insulation function. Replace missing or defective parts.
- Make sure that the cable routings on the electrical connections are seated tightly. If necessary, tighten loose screw connections.
- Make sure that the existing safety equipment is functioning.
- Make sure that the overload protection is functioning.
- Make sure that the hoist limit switches are functioning.
- Make sure that the limit switch boom „steepest position“ is functioning.
- Make sure that the wind speed sensor moves easily and is functioning.

5.2 Additional controls for cranes with crane support

- Make sure that the folding / sliding beams are secured with pins to prevent them from sliding.
- Make sure that the support plates are secured in the operating position.
- Make sure that the crane is properly supported.
- Make sure that the crane is horizontally aligned.
- Make sure that the axle suspension is blocked (mobile crane).
- Make sure that the tires have no contact to the ground (mobile crane).
- Make sure that the track chains are secured to prevent them from sagging (crawler crane).

5.3 Additional controls for cranes on tires on the front and supported on the rear

- Make sure that the rear folding / sliding beams are secured with pins to prevent them from sliding.

- Make sure that the rear support plates are secured in the operating position.
- Make sure that the crane is properly supported on the rear.
- Make sure that the axle pressure compensation is correctly switched.
- Make sure that the axle suspension is blocked.
- Make sure that the tires of the rear axle group have no contact with the ground.
- Make sure that a sufficient tire pressure is present in the tires.
- Make sure that the ground for the front axle group is sufficiently level and has a sufficient load bearing capacity.

5.4 Additional controls for cranes supported on the front and on tires on the rear

- Make sure that the front folding / sliding beams are secured with pins to prevent them from sliding.
- Make sure that the front support plates are secured in the operating position.
- Make sure that the crane is properly supported on the front.
- Make sure that the axle pressure compensation is correctly switched.
- Make sure that the axle suspension is blocked.
- Make sure that the tires of the front axle group have no contact with the ground.
- Make sure that a sufficient tire pressure is present in the tires.
- Make sure that the ground for the rear axle group is sufficiently level and has a sufficient load bearing capacity.

5.5 Additional controls for freestanding crane operation (on tires)

- Make sure that all prerequisites for freestanding crane operation are met.
- Make sure that sufficient tire pressure is in all tires for crane operation on tires.
- Make sure that the ground is sufficiently level for crane operation on tires and has a sufficient load bearing capacity.

5.6 Additional controls for cranes with a derrick boom

- Make sure that the shut-off via the limit switch - derrick is functioning.
- Make sure that the entire slewing range of the suspended ballast / ballast trailer is free of personnel and obstacles.

5.7 Additional controls for cranes with luffing auxiliary boom / accessories

- Make sure that the shut-off via the luffing auxiliary boom / accessories „steepest position“ limit switch is functioning.
- Make sure that the shut-off via the luffing auxiliary boom / accessories „lowest position“ limit switch is functioning.
- Make sure that the shut-off via the limit switch flap in the „steepest position“ position is functioning.
- Make sure that the pendulum of the mechanical relapse retainer moves easily over the entire slewing range and is functioning.

5.8 Additional controls for certain crawler cranes

For existing crawler assembly key button:

- Make sure that the crawler assembly key button is turned off.

6 Relapse cylinders

6.1 Block position of the relapse cylinders when setting down the load

NOTICE

Damage to the boom or the relapse cylinders!

If the block position of the relapse cylinders is triggered by the boom or the derrick with attached, freely suspended load, then there is a danger of damaging the boom or the relapse cylinders when setting the load on the ground. By setting down the load, the crane is relieved, and this movement causes the boom system to move to the rear.

There is no shut-off of the hoist gear lowering function.

- ▶ Actuate the opposite direction of movement which caused the block position and eliminate the block position.

7 Pneumatic springs

Pneumatic springs are installed on various crane components to simplify the assembly of these components.



WARNING

Danger of crushing!

Defective pneumatic springs no longer provide the supporting properties on the movable components. Components can fall down.

Death, severe bodily injuries, property damage.

- ▶ Always check pneumatic springs for damage before actuating the corresponding components.
- ▶ Do not use components with defective pneumatic springs. Replace defective pneumatic springs immediately.
- ▶ Make sure that no persons or objects are in the movement range of the moving components which is supported by the pneumatic spring.
- ▶ It is strictly prohibited to remain or place any objects in the movement or other danger zone of the moving crane components which are supported by the pneumatic spring.

8 Manual rope winches

Manual rope winches are installed on various components to simplify the assembly or disassembly of these components.



WARNING

Danger of crushing!

Defective manual rope winches no longer provide the supporting action on the movable components. Components can fall down.

Death, severe bodily injuries, property damage.

- ▶ Always check manual rope winches for external and functional damage before actuating the respective components.
- ▶ Check the rope of the manual rope winch for damage.
- ▶ At least two rope coils must always remain on the rope drum.
- ▶ Do not use components with defective manual rope winches. Replace defective manual rope winches.
- ▶ It is strictly prohibited for personnel or objects to remain within the movement range of the components, which are supported by the manual rope winch.
- ▶ It is prohibited for personnel or objects to remain within the danger zone of the moving components.

9 Weights



Note

- ▶ The weight of each component is specified in the chapter 1.03 or the respective chapter in the Crane operating instructions or is stated on the tag attached to the corresponding component.
- ▶ If components are pushed into one another (for example the boom intermediate sections) or folded together (for example the folding jib), then the total weight is given by the sum of the individual components.

NOTICE

False estimation of weights

- ▶ Contact the Service department at **Liebherr-Werk Ehingen GmbH** if the weight of the respective component is not stated on the tag or in the Crane operating instructions.
- ▶ Use an auxiliary crane with sufficient load carrying capacity including a reasonable reserve.

10 Guy rods



WARNING

The boom can break off!

The arrangement of the guy rods for the boom or boom systems is stipulated in the rod plan. If the arrangement of the guy rods is not observed according to the rod plan, the crane can collapse, the boom can break off or the crane can topple over.

Death, severe bodily injuries, property damage.

- ▶ Always carry out the arrangement of the guy rods according to the rod plan.
- ▶ If an auxiliary guying is required for a certain boom length, then it must always be installed according to the rod plan on the position defined in the rod plan.



WARNING

Unutilized guy rods on boom!

If guy rods are on the lattice sections which are not used for operation, then there is a danger of accident.

Unused guy rods can loosen up and fall down.

Death, severe bodily injuries, property damage.

The load chart is invalid.

The load display of the LICCON computer system shows an incorrect value.

The weight of the boom is too heavy for erection.

- ▶ Disassemble and remove the guy rods that are not needed on the transport retainers before erecting the boom.



Note

- ▶ Inspection and maintenance of the guy rods, see chapter 8.15.
- ▶ In reference to the guy rods, observe section „Erection / take-down“.

10.1 Guy rods for telescopic cranes with luffing lattice jib

10.1.1 Long guy rods

This section applies only to cranes with a telescopic boom and luffing lattice jib.

- Illustration 1: LICCON monitor (only certain crane types)
- Illustration 2: indicator light „assembly“ on the crane cab instrument panel (only certain crane types)

The overload protection is considered bypassed for:

- All types of assembly operations.
- All types of exceeded shut off limits of the overload protection.
- All types of emergency operation.
- All types of crane operation with deactivated or defective sensors and limit switches.
- All types of deviation from specified set up configuration of the crane.



DANGER

Increased danger of accident due to bypass of the overload protection!

Proper and destined use of the crane is ensured due to the construction of the overload protection system and observance of the information in the Crane operating instructions. All **sensibly foreseeable erroneous operations** of the crane have been taken into consideration.

Impermissible crane operation with bypassed overload protection – with the aim of increasing the maximum load bearing capacity of the crane above the rated value in the load chart or of extending the designated working range of the crane – does not constitute a **reasonably foreseeable erroneous operation**, rather **deliberate improper use with high danger of accident**.

The possible risks and consequences of such improper use are detailed in the Crane operating instructions.

Such deliberate improper use can neither be prevented by means of the structural version nor by means of information in the Crane operating instructions.

- ▶ Bypass the overload protection only according to the Crane operating instructions.
- ▶ Exceed the shut off limits of the overload protection only according to the Crane operating instructions.
- ▶ Any other use of the crane with bypassed overload protection than that described in the Crane operating instructions is prohibited.

If the maximum permissible load moment is exceeded, the overload protection turns all load moment increasing crane movements off.

This shut-off can be bypassed or exceeded various ways, for example:

- Exceeding the shut off limits (utilization more than 100 % or leaving the load chart).
- Activating an assembly operation.
- Activating an emergency operation.

The displays of the LICCON overload protection remain functioning when all associated sensors and limit switches are active and a load chart is available.



WARNING

Increased danger of accident due to bypass of the overload protection!

If the overload protection is bypassed, there is no longer any protection against crane overload.

In the event of improper use, the crane could collapse, the boom can break off or the crane can topple over.

Death, severe bodily injuries, property damage.

This can result in significant property damage.

- ▶ It is only permitted to bypass the overload protection for assembly or in emergencies.
- ▶ The bypass of the overload protection may only be carried out by persons who are aware of the effects of their acts.
- ▶ Bypassing the overload protection requires the presence of a person authorized by the crane operator and must be performed with utmost caution.
- ▶ Crane operation is strictly prohibited when the overload protection is bypassed.

12.1 Bypassing the LICCON overload protection



Note

- ▶ This applies only for cranes with LICCON overload protection.

Depending on the crane version, one or more operating elements are available to bypass the overload protection:

- Button in the control panel.
- Key button on the LICCON monitor.
- Key button in the instrument panel.
- Key button in the control cabinet.
- Sensor for transponder on the crane cab.

The functions of the operating elements are described in chapter 4.20.

- ▶ Actuate the respective operating element.

Result:

- The LICCON overload protection is bypassed / inactive.
- The „Assembly“ icon appears on the LICCON monitor.
- Depending on the circumstances, acoustic and / or optical warning signals (blinkers, flashing beacons, horns and bells) sound.

If the LICCON overload protection is to be reactivated:

- ▶ No longer actuate the respective operating element or reset.

Result:

- The LICCON overload protection is active.
- The „Assembly“ icon no longer appears on the LICCON monitor.
- The acoustic and / or optical warning signals which were triggered by the bypass are turned off again.

12.2 Bypassing the PAT overload protection



Note

- ▶ Applies only for cranes with PAT overload protection.

- ▶ Actuate the bypass key button and turn the PAT overload protection off.

Result:

- The PAT overload protection is bypassed / inactive.

- ▶ Actuate the bypass key button and turn the PAT overload protection on.

Result:

- The PAT overload protection is active.

13 Bypassing the hoist top shut-off



Note

- ▶ Applies only for cranes with hoist limit switch.

If the hook block touches the hoist limit switch weight during the upward movement, the hoist limit switch reacts. The „Spool up winches“, „Luff boom down“ and „Telescope the telescopic boom out“ crane movements are turned off. The shut-off can be bypassed.

**WARNING**

Danger of accident due to bypass of hoist top shut-off!

When bypassing the hoist top shut-off, there is a danger that the hook block may be pulled against the pulley head when continuing to lift or luffing down the boom. This may damage the pulleys and cause the loads to fall.

- ▶ The bypass of the hoist top shut-off in crane operation with a load may only be carried out by a person authorized by the crane operator with the aid of a „Guide“. The guide must be in direct contact with the crane operator and must continually monitor the distance between the hook block and the boom head.
- ▶ Carry out all crane movements with maximum caution and minimum speed.

14 Pin connections

**WARNING**

Pin connections **not** lubricated!

If pins or pin connections are not properly greased or lubricated before assembly, then they can corrode.

The pins can be stuck in the pin bores and be damaged.

During the unpinning procedure, the pins can suddenly release.

Death, severe bodily injuries, property damage.

- ▶ Make sure that all pins, which are not supplied with grease via the central lubrication system are sufficiently greased before assembly.
- ▶ Make sure that all lube points, which are equipped with a grease fitting, are properly greased at assembly and according to the respective interval specification.
- ▶ Never insert or unpin pins by force.

**WARNING**

Pin **not** secured to prevent it from loosening up by itself!

The pin connection could loosen up suddenly.

Death, severe bodily injuries, property damage.

- ▶ Secure all pins with retaining elements against loosening up by itself.

**WARNING**

Distorted pin!

Angular pull or excessive or low hoisting force of the auxiliary crane may result in distortion of the pins. Distorted parts can suddenly fly off when the pins are unpinned.

Death, severe bodily injuries, property damage.

- ▶ When the pins are unpinned, the lifting force of the auxiliary crane must be adapted to the weight of the components being lifted.
- ▶ Do **not** unpin difficult to remove pins by force.
- ▶ Remedy the cause of the tension.

14.1 Inserting and unpinning the collar pins

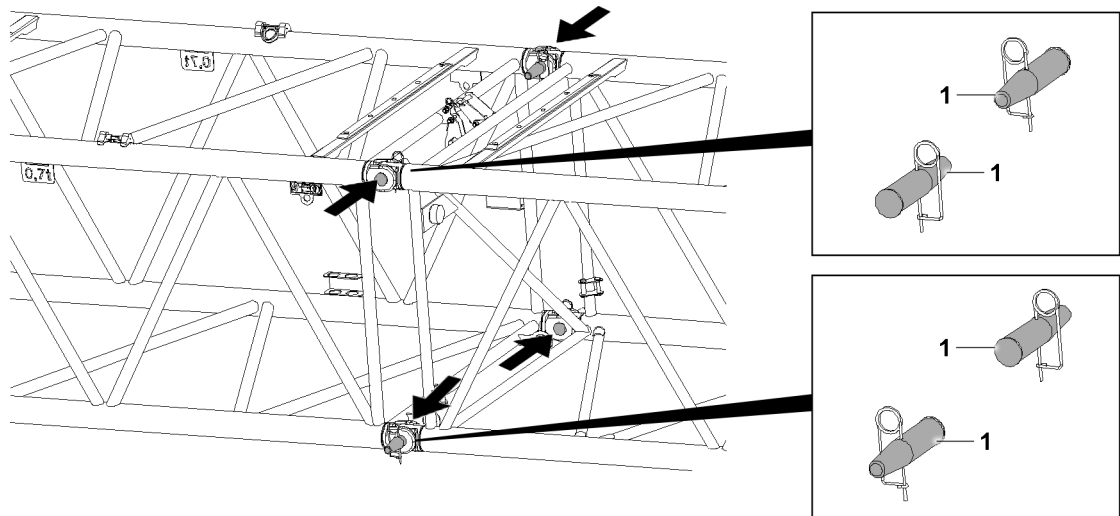

Fig.143114: Inserting the collar pins



WARNING

The collar pin is incorrectly pinned!
Death, severe bodily injuries, property damage.

- ▶ Insert or unpin both pins on the same horizontal level, i.e. **left and right**.
- ▶ Pin the upper collar pin **1** from the **outside to the inside** and unpin from the **inside to the outside**.
- ▶ Insert the lower collar pin **1** from the **inside to the outside** and unpin from the **outside to the inside**.

14.2 Inserting and unpinning the double cone pins horizontally

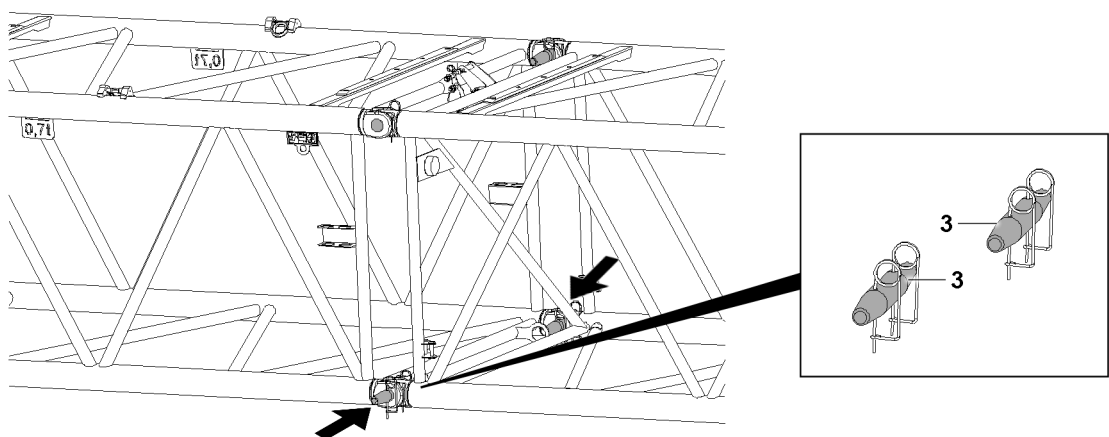

Fig.143115: Inserting the double cone pins horizontally



WARNING

Double cone pins incorrectly pinned!
Death, severe bodily injuries, property damage.

- ▶ Insert or unpin both pins on the same horizontal level, i.e. **left and right**.
- ▶ Insert and unpin the horizontally installable double cone pin **3** from the **outside to the inside**.

14.3 Inserting and unpinning the double cone pins vertically

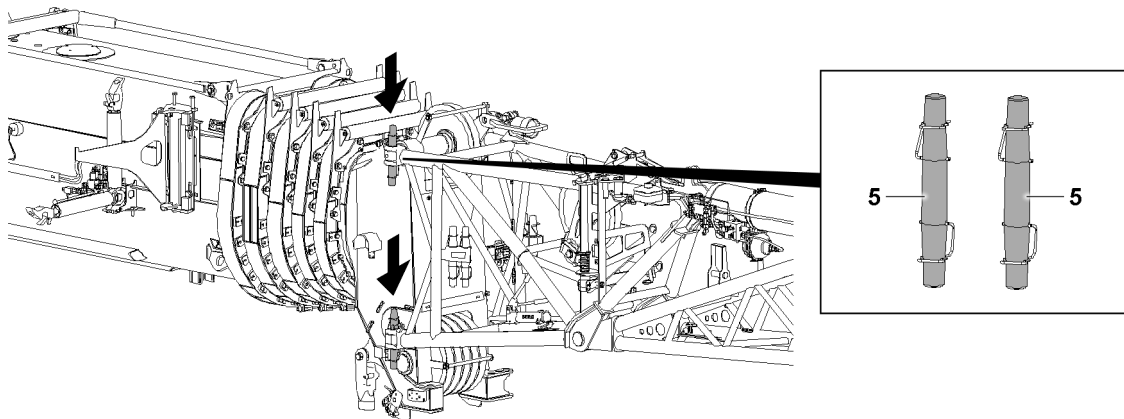

Fig.143116: Assembling the double cone pins vertically



WARNING

Double cone pins incorrectly pinned!
Death, severe bodily injuries, property damage.

- ▶ Pin and unpin the vertically installable double cone pins **5** from the **top to the bottom**.

14.4 Impact protection

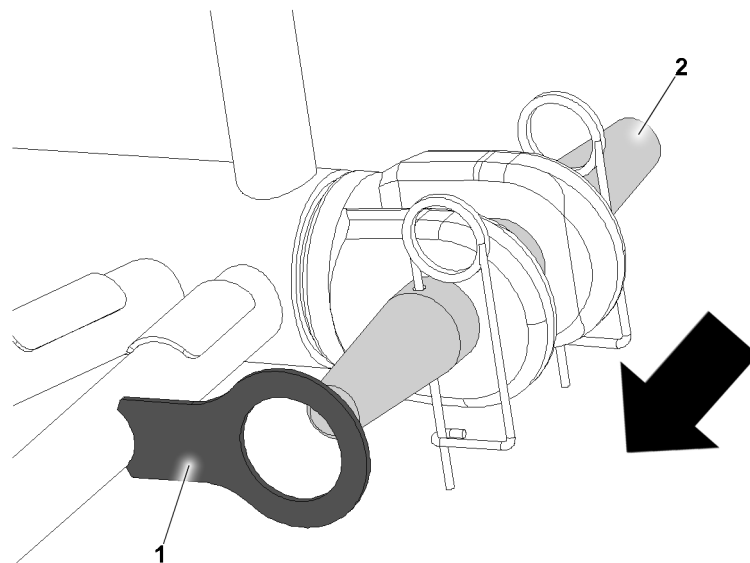

Fig.148194: Lattice section impact protection

Impact protection **1** is installed on certain lattice sections. The impact protection **1** should prevent the pins from being unpinned from the **inside to the outside**.

If impact protection **1** is installed:

- ▶ Only use double cone pins **2**.
- ▶ Only pin and unpin the double cone pins **2** from the **outside to the inside**.

14.5 Positioning the connecting forks for pinning

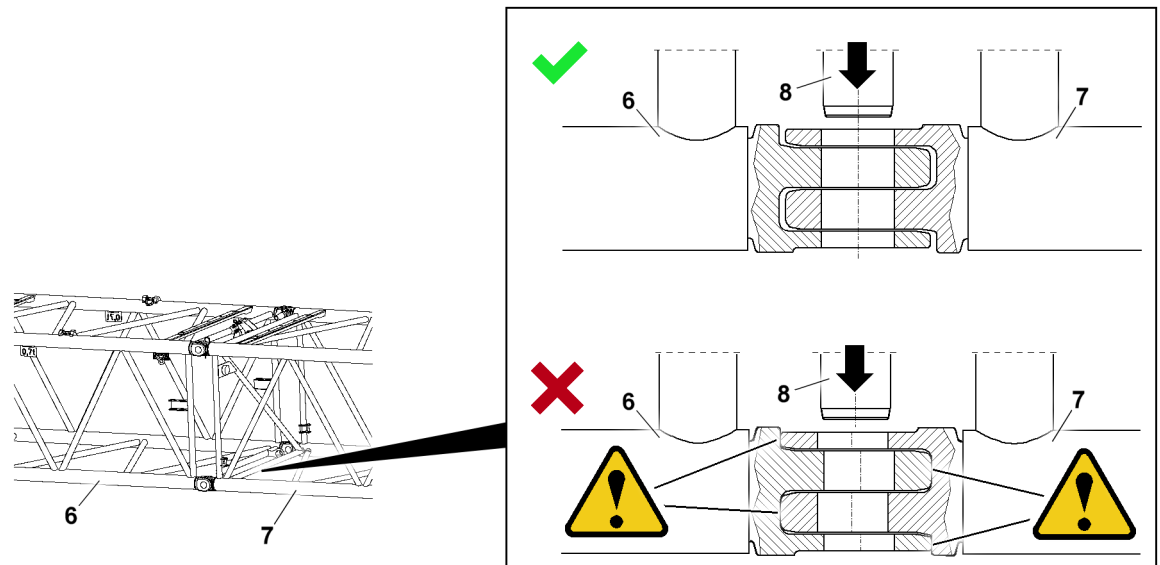

Fig.160395: Positioning the connecting forks for pinning



WARNING

The boom can break off!

If the connecting forks of the lattice section are seriously damaged, they can break under a high load. The connecting fork, lattice section and boom can break off.

Death, severe bodily injuries, property damage.

- ▶ Do not load or push the connecting forks into each other on the block.



Note

In the example, the pins **8** should be inserted from the inside to the outside.

On some lattice sections, they must be inserted from the outside to the inside!

- ▶ Observe the correct direction when pinning.

- ▶ Bring the lattice section **6** together with the lattice section **7** so that the bores align.



Note

- ▶ When the bores align, document the necessary force for disassembly.

- ▶ Insert and secure the pin **8** in the right direction.

14.6 Lattice section with walking surfaces and stepping surfaces

This section is valid solely for the telescopic boom cranes.

Certain lattice sections have walking surfaces and stepping surfaces. See chapter 2.07.

When the lattice sections have walking surfaces and stepping surfaces, the upper pin must be unpinned by assembly personnel on the lattice section. Not by assembly personnel on the ladder.

The procedure is described based on an example. Example of unpinning the N-assembly unit from the telescopic boom extension with eccentric.

Make sure that the following prerequisites are met:

- Person **1** is located on the telescopic boom extension with eccentric.
- Person **2** is located on the ladder.
- The F-assembly unit is unpinned.



Fig.159590: Unpinning the N-assembly unit

- Person 1 unpins the pin and at the same time Person 2 picks up the pin.

14.7 Pin transport position

The illustration in this section is an example. The transport position can be in another position depending on the lattice section.

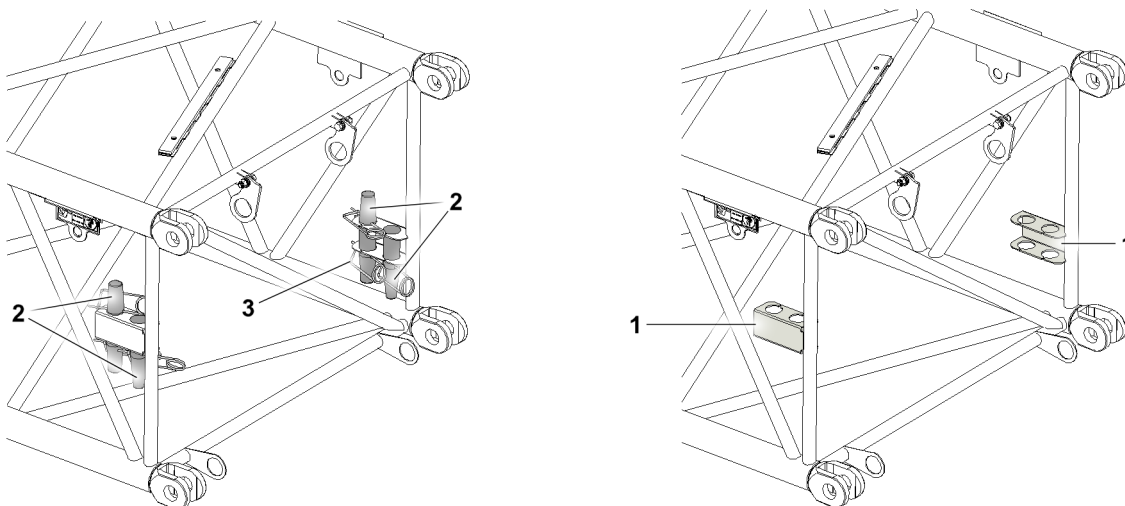

Fig.163330: Pin transport position

The retainer 1 is attached to the lattice sections. The pins 2 are inserted in the retainer 1 in the transport position and secured with retaining elements 3.

Before the lattice section is assembled:

- Make sure that the pins 2 are inserted in the retainer 1.

During disassembly of the lattice section:

- After the pin 2 is removed from the lattice section: Insert the pin 2 in the retainer 1.

15 Retaining elements

15.1 Checking the retaining elements

Retaining elements are used to secure the pins. Due to mechanical damage / distortion, the function of the retaining elements can be compromised. In addition, the spring force of the retaining elements can be reduced significantly. Do **not** re-use retaining elements if there is insufficient spring force. The pin retainer must be secured with a correctly **functioning** retaining element.



WARNING

Mechanical damage or deformation of the retaining elements!

The retaining elements can fail.

The pin can unpin by itself.

Death, severe bodily injury, property damage.

- ▶ Use exclusively functioning retaining elements in a proper condition.
- ▶ Replace defective retaining elements.

15.2 Overview of the retaining elements

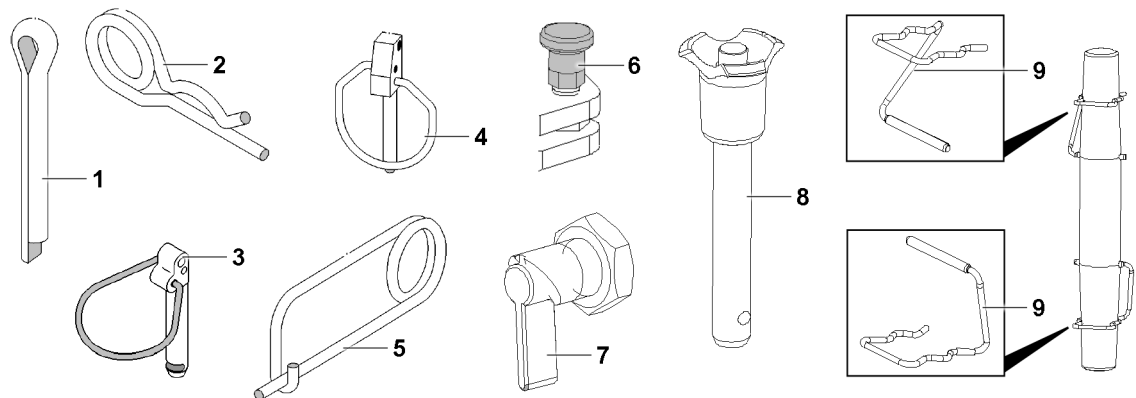

Fig.143102: Retaining elements

- | | | | |
|---|--------------------|---|------------------|
| 1 | Split pin | 6 | Detent pin |
| 2 | Cotter pin | 7 | Latch |
| 3 | Safety locking pin | 8 | Ball locking pin |
| 4 | Locking pin | 9 | Retaining clip |
| 5 | Spring retainer | | |

15.3 Split pin

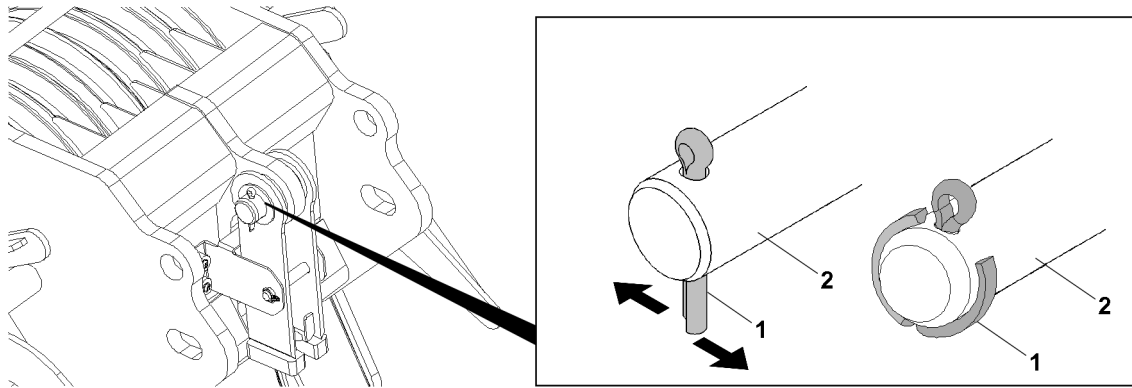

Fig.143105: Split pin

1 Split pin

2 Pin



WARNING

Multiple use of a split pin 1!
The split pin 1 can break.

- ▶ Assemble the split pin 1 only once.
 - ▶ Use a correctly sized split pin 1.
-
- ▶ Secure the pin 2: Insert the split pin 1.
 - ▶ Bend the end of the split pin 1 toward the outside.

Problem remedy

Defective split pin 1!
▶ Replace the split pin 1.

15.4 Cotter pin

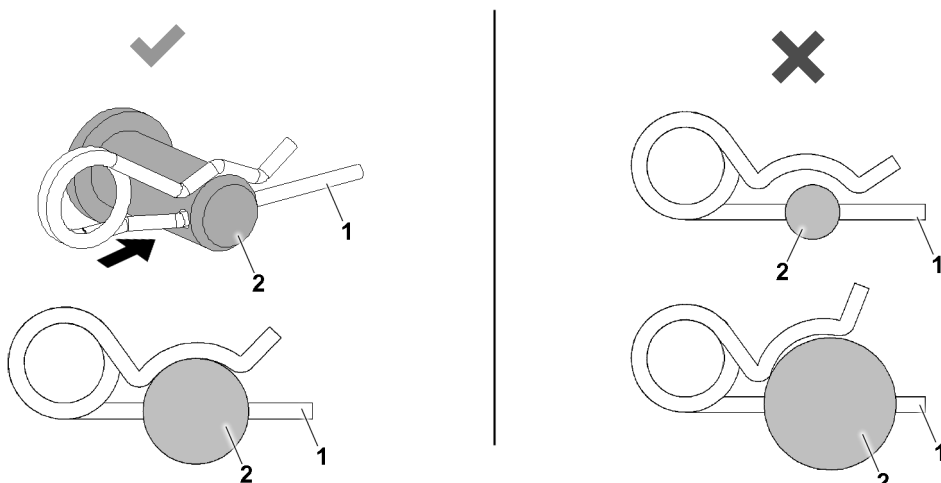

Fig.143106: Cotter pin, correct and incorrect dimensions

1 Cotter pin

2 Pin

**WARNING**

Improper dimensions of the cotter pin **1**!
The cotter pin **1** can loosen up by itself.

- ▶ Use a correctly sized cotter pin **1**.
-
- ▶ Secure the pin **2**: Insert the cotter pin **1**.

Problem remedy

Is the spring tension too low?
The cotter pin **1** is defective.

- ▶ Replace the cotter pin **1**.

15.5 Safety locking pin

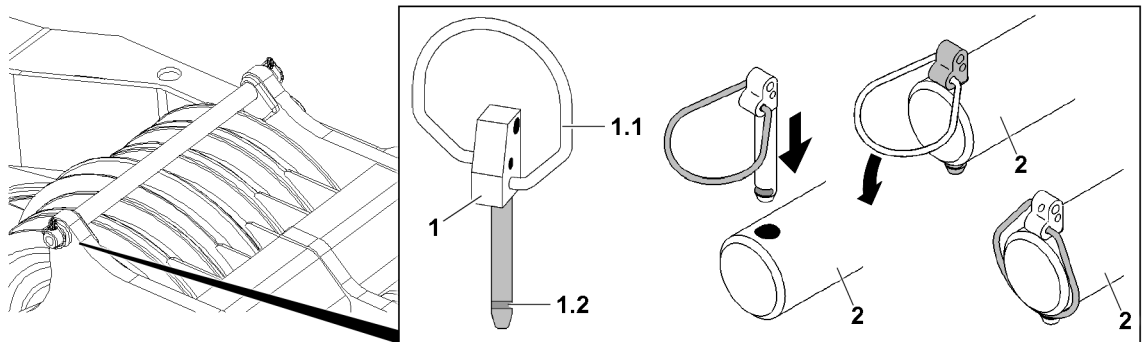

Fig.143103: Safety locking pin

- | | |
|-----------------------------|-------------------|
| 1 Safety locking pin | 1.2 Groove |
| 1.1 Spring clip | 2 Pin |

Increased effort is necessary for opening the safety locking pin **1**.

**WARNING**

Spring clip **1.1** **not** engaged!
The safety locking pin **1** can loosen up by itself.

- ▶ Engage the spring clip **1.1** completely in the groove **1.2**.
-
- ▶ Secure the pin **2**: Insert the safety locking pin **1**.
 - ▶ Close the spring clip **1.1** and engage it completely in the groove **1.2**.

Problem remedy

Does the spring clip **1.1** **not** engage completely?
The spring clip **1.1** tension is too low.

- ▶ Replace the safety locking pin **1**.

15.6 Locking pin

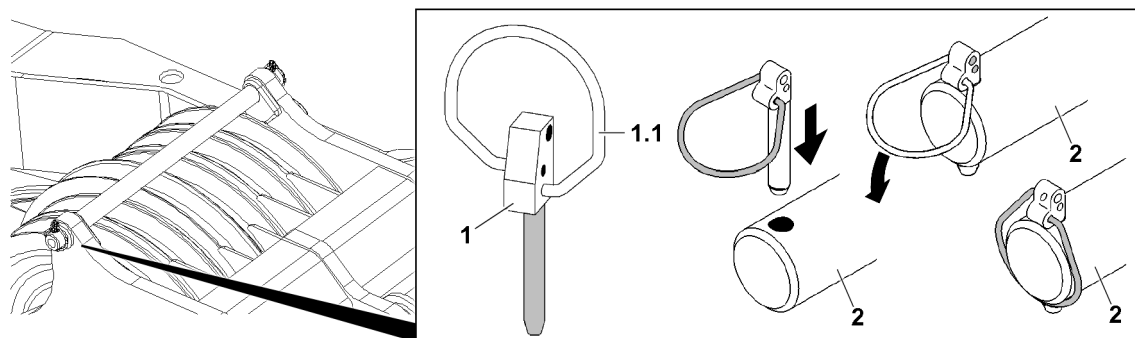

Fig.143104: Locking pin

1 Safety locking pin
1.1 Spring clip

2 Pin



WARNING

The locking pin **1** is **not** completely closed!
The locking pin **1** can loosen up by itself.

- ▶ Close the spring clip **1.1** completely.
- ▶ Secure the pin **2**: Insert the locking pin **1**.
- ▶ Close the spring clip **1.1** completely.

Problem remedy

Does the spring clip **1.1** not close completely?
The spring clip **1.1** tension is too low.

- ▶ Replace the locking pin **1**.

15.7 Spring retainer

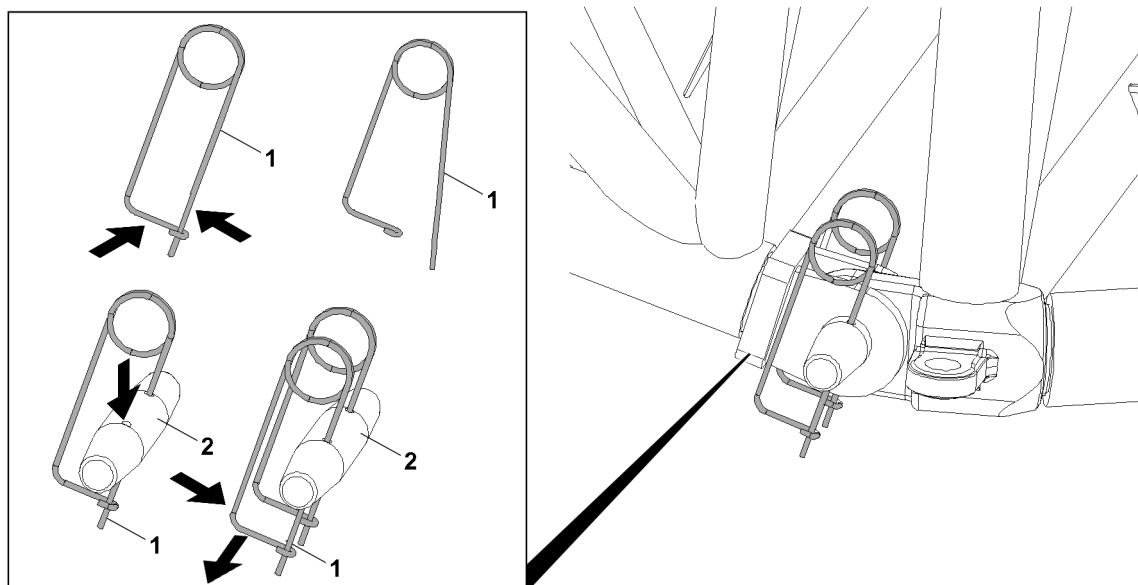

Fig.143108: Spring retainer

1 Spring retainer

**WARNING**

The spring retainer **1** is **not** closed!
 The spring retainer **1** can loosen up by itself.

- ▶ Close the spring retainer **1**.
-
- ▶ Secure the pin **2**: Insert the spring retainer **1**.
 - ▶ Close the spring retainer **1**.

Problem remedy

Is the spring tension too low?
 The spring retainer **1** is defective.

- ▶ Replace the spring retainer **1**.

15.8 Detent pin

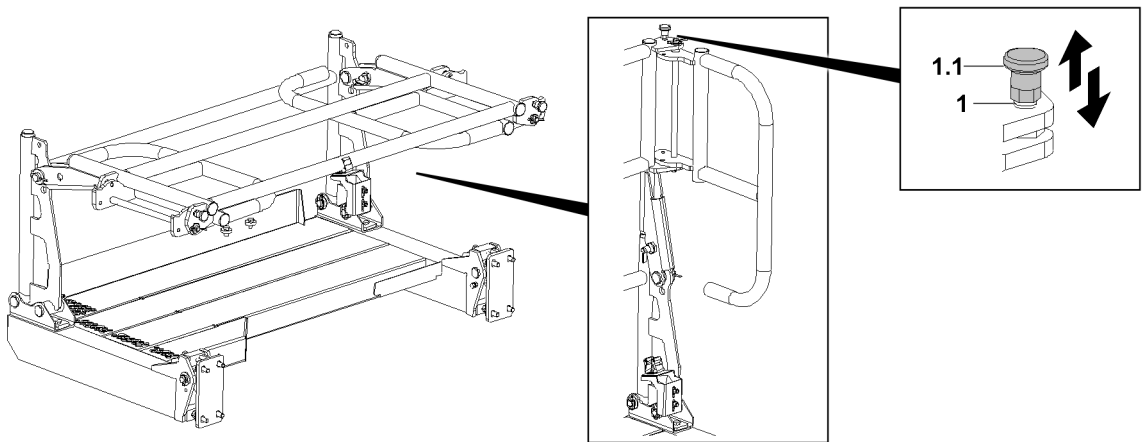

Fig.143110: Detent pin

1 Detent pin

1.1 Handle

**WARNING**

The handle **1.1** is **not** locked!
 The detent pin **1** can loosen up by itself.

- ▶ Lock the detent pin **1**.
-
- ▶ Pull the handle **1.1**.

Result:

– The detent pin **1** is unlocked.

- ▶ Insert the detent pin **1**: Release the handle **1.1**.

Result:

– The detent pin **1** is pinned.

Problem remedy

The handle **1.1** cannot be pulled.
 The detent pin **1** is defective.

- ▶ Replace the detent pin **1**.

15.9 Latch

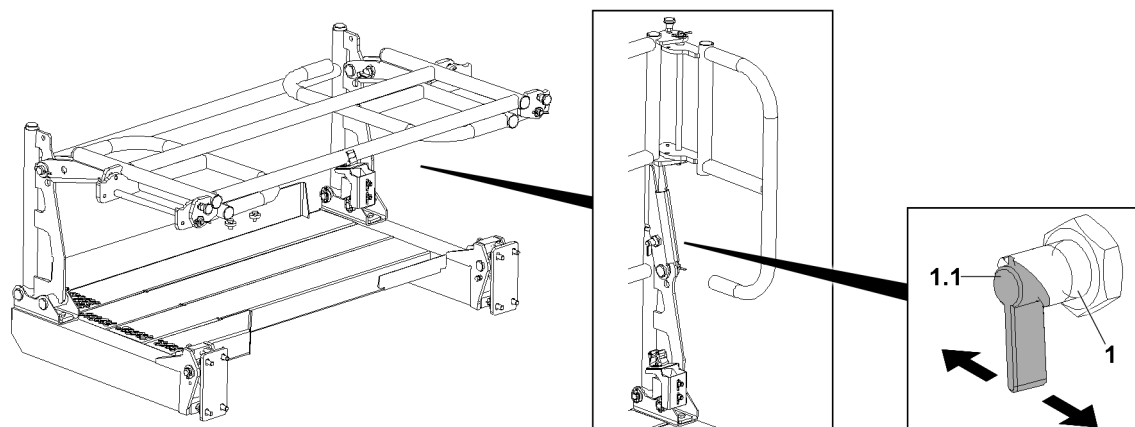

Fig.143111: Latch

1 Latch

1.1 Lever



WARNING

The latch **1** is **not** locked!
The latch **1** can loosen up by itself.

▶ Lock the latch **1**.

▶ Operate the lever **1.1**.

Result:

– The latch **1** is unlocked.

▶ Pin the latch **1**: Release the lever **1.1** and swing the railing until the latch is pinned.

Problem remedy

Can the lever **1.1** not be actuated?

The latch **1** is defective.

▶ Replace the latch **1**.

15.10 Ball locking pin

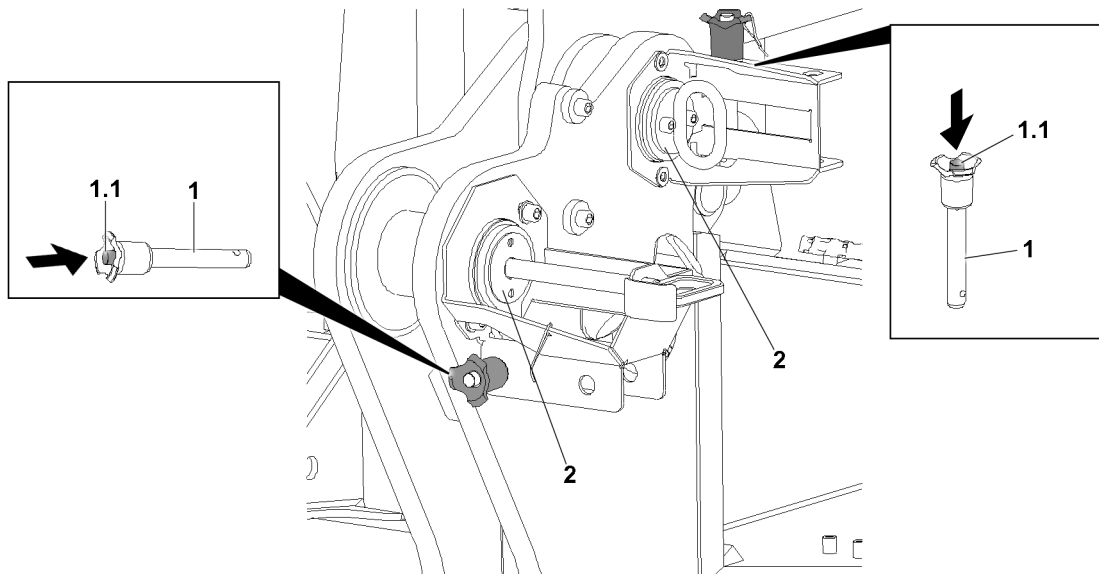

Fig.143109: Ball locking pin

1 Ball locking pin
1.1 Press button

2 Pin



WARNING

The ball locking pin **1** is **not** locked!
The ball locking pin **1** can loosen up by itself.
▶ Lock the ball locking pin **1**.

▶ Secure the pin **2**: Actuate the press button **1.1**.

Result:

- The ball locking pin **1** is unlocked.
- ▶ Insert the ball locking pin **1** and release the press button **1.1**.

Result:

- The ball locking pin **1** is pinned and secured.

Problem remedy

Can the press button **1.1** not be actuated?
The ball locking pin **1** is defective.
▶ Replace the ball locking pin **1**.

15.11 Retaining clips

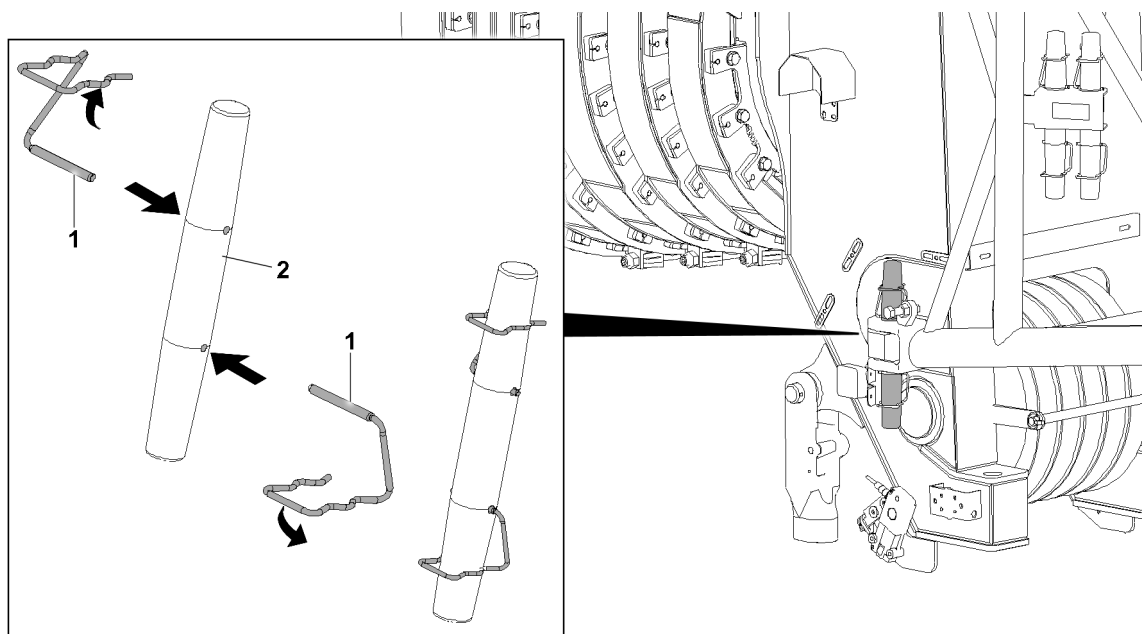

Fig.143107: Retaining clips 1

1 Retaining clip

2 Pin



WARNING

Incorrect retaining element!
Shearing off of the retaining element.

- ▶ To secure the folding jib pinning: Use retaining clips 1.
- ▶ The use of other retaining elements is **prohibited**.



WARNING

Retaining clip **not** engaged!
The retaining clip 1 can loosen up by itself.

- ▶ Engage the retaining clip 1.
- ▶ Secure the pin 2: Insert the retaining clip 1.
- ▶ Engage the retaining clip 1.

Problem remedy

Is the retaining clip 1 defective?
The spring force of the retaining clip 1 is too low.

- ▶ Replace the retaining clip 1.

16 Assembling / disassembling



WARNING

Danger of fatal injury due to incorrect assembly or disassembly!

The assembly / disassembly of lattice sections and / or components may never be performed by untrained personnel.

An erroneous assembly / disassembly of lattice sections and / or components can cause damage on load carrying crane structures.

Crane components can fail due to improper assembly / disassembly.

Death, severe bodily injuries, property damage.

- ▶ Make sure that the assembly / disassembly of lattice sections and / or components is carried out only by authorized and trained expert personnel.
- ▶ Make sure that the fastening equipment on lattice sections and / or components is always fastened properly.
- ▶ Make sure that lattice sections and / or components are always properly pinned and secured at assembly.
- ▶ For assembly / disassembly of individual components, also observe the chapters relating to those components.
- ▶ The boom combinations must be assembled according to the separately supplied rod plans.
- ▶ All components which must be transported separately must be transported with suitable auxiliary cranes and fastening equipment near ground level.



WARNING

Failure of auxiliary winch!

- ▶ Only use the auxiliary winch (assembly or reeving winch) for assembly and not to lift loads.
- ▶ Lifting of loads with the auxiliary winch is prohibited.



WARNING

Danger of impact / crushing!

When assembling / disassembling crane components with the auxiliary crane, crane components can start to swing back and forth.

When lifting / lowering and positioning crane components, there is an increased danger of impact / crushing.

Death, severe bodily injuries, property damage.

- ▶ Make sure that personnel cannot be caught by components.
- ▶ Make sure that the crane is horizontally aligned.
- ▶ When working in danger zones: Use aids to protect limbs.
- ▶ Guide components with suitable aids to minimize oscillation.
- ▶ During assembly / disassembly no one may be in the dangerous area around or underneath the suspended components before the load has been secured.

Part of the category „Aids for working at a height“ are, for example:

- Lifting platforms
- Scaffolding
- Auxiliary cranes
- Ladders

**WARNING**

Danger of falling!

During assembly / disassembly, inspection and maintenance work, assembly personnel must be secured with appropriate aids to prevent them from falling.

Death, severe bodily injuries, property damage.

- ▶ All work at a height, when there is a danger of falling, must be carried out with suitable aids.
- ▶ If aids are not available and work cannot be carried out from the ground, then assembly personnel must secure themselves with the supplied fall arrest system to prevent falling, see chapter 2.04.
- ▶ If fall protection equipment is available, then it must be used, see chapter 2.06.
- ▶ When lifting, lowering, swinging crane parts in and out, no persons may remain in the danger zone.
- ▶ When closing or opening boom systems during boom assembly or boom disassembly, no persons may remain on the boom system or in the danger zone.
- ▶ If railings are present on the components, then they must be brought into the corresponding position and secured for assembly / disassembly work.
- ▶ Only step on the aids, ladders and catwalks with clean shoes.
- ▶ Keep aids, ladders and catwalks free of heavy dirt, snow, frost and ice.
- ▶ During all assembly and disassembly work, maintenance work and inspections, travel or crane operation is prohibited.
- ▶ Remaining on a suspended load is prohibited.
- ▶ Stepping and walking on crane components and lattice sections, which have an incline of more than 20° is prohibited.
- ▶ For all assembly work, the crane driver of the main crane must be in voice contact with the crane driver / crane drivers of the auxiliary crane / auxiliary cranes.
- ▶ For all assembly work, the crane driver of the main crane must be in voice contact with the assembly personnel.
- ▶ For assembly tasks, the crane driver may only initiate crane movements when the responsible guide has explicitly released the movement.

**DANGER**

The components can fall down!

If the corresponding component is disengaged from the auxiliary crane before the corresponding component is pinned, then the corresponding component can fall down.

Death, severe bodily injuries, property damage.

- ▶ Do not detach the auxiliary crane and the fastening equipment until the respective component is pinned and secured.

**WARNING**

The components can fall down!

If the corresponding component is unpinned without being secured by an auxiliary crane, the corresponding component can fall down.

Death, severe bodily injuries, property damage.

- ▶ Do not unpin the components until they are secured by an auxiliary crane.

**WARNING**

Falling components and tools!

Whenever working at a height, for example on the crane or on an aerial platform, components or tools can fall down.

Death, severe bodily injuries, property damage.

- ▶ Make sure that the danger zone under the work area is blocked off and marked and that no personnel is located within it.

16.1 Assembly drawings



WARNING

Use of assembly drawings!

Due to sole use of assembly drawings, dangerous situations can arise up to toppling of the crane. Death, severe bodily injuries, property damage.

- ▶ Assembly drawings should only be considered to be **additional** and **supplementary** information.
- ▶ The respective chapters in the crane operating instructions are decisive for the assembly and disassembly of crane structures, lattice sections or crane components.
- ▶ The detailed information and danger notes in the respective chapters must be observed.

16.2 Guiding crane structures, lattice sections or crane components



WARNING

Danger due to oscillating load!

During the assembly of crane structures, lattice sections or crane components with the auxiliary crane, they can start to swing back and forth.

Death, severe bodily injuries, property damage.

- ▶ To guide and position crane structures, lattice sections or crane components always use a guide rope.
- ▶ Make sure that there are no persons or obstacles within the danger zone.
- ▶ Make sure that the guide rope is long enough.

16.3 Fastening the lattice sections



WARNING

Fastening equipment incorrectly attached to the fastening point!

If the fastening equipment incorrectly is attached to the fastening point, the lattice sections can loosen up and fall down.

Death, severe bodily injuries, property damage.

- ▶ Correctly attach suitable fastening equipment to the fastening point.

16.3.1 Eyehook fastening points

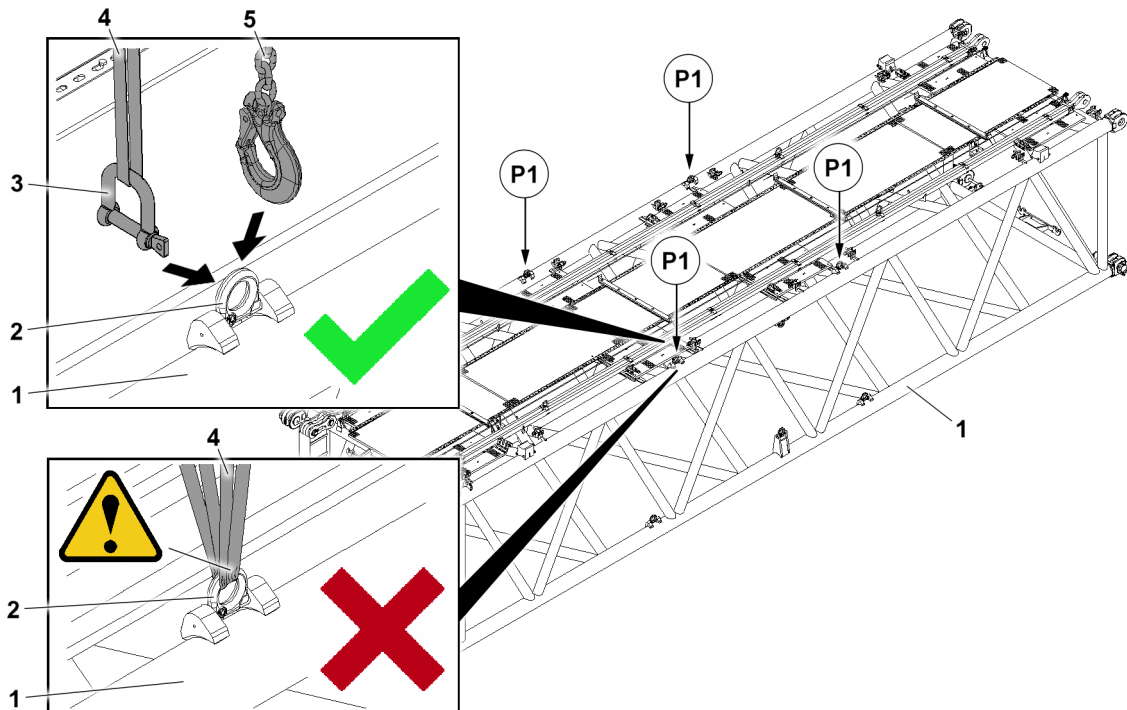

Fig.159190: Correct and incorrect fastening of an eyehook 2

P1	Fastening points	3	Shackle fastening equipment
1	Lattice section	4	Belt loop fastening equipment
2	Eyehook	5	Chain hanger fastening equipment

Make sure that the following prerequisites are met:

- The fastening equipment has been selected correctly for the load case.
- The fastening equipment is in a perfect condition.



WARNING

Fastening equipment incorrectly attached to the fastening point!

If the fastening equipment **4** is incorrectly attached to the fastening point, the lattice sections can loosen up and fall down.

The belt loop fastening equipment **4** can be crushed and rip.

Death, severe bodily injuries, property damage.

- ▶ Only attach the belt loop fastening equipment **4** with shackle fastening equipment **3** together to the eyehook **2**.

When the fastening points **P1** on the lattice section **1** correspond to the illustrated eyehooks **2**:

- ▶ Only fasten the belt loop fastening equipment **4** with shackle fastening equipment **3** to the eyehook **2**.

or

Fasten the chain hanger fastening equipment **5** to the eyehook **2**.

16.3.2 Bitt fastening point

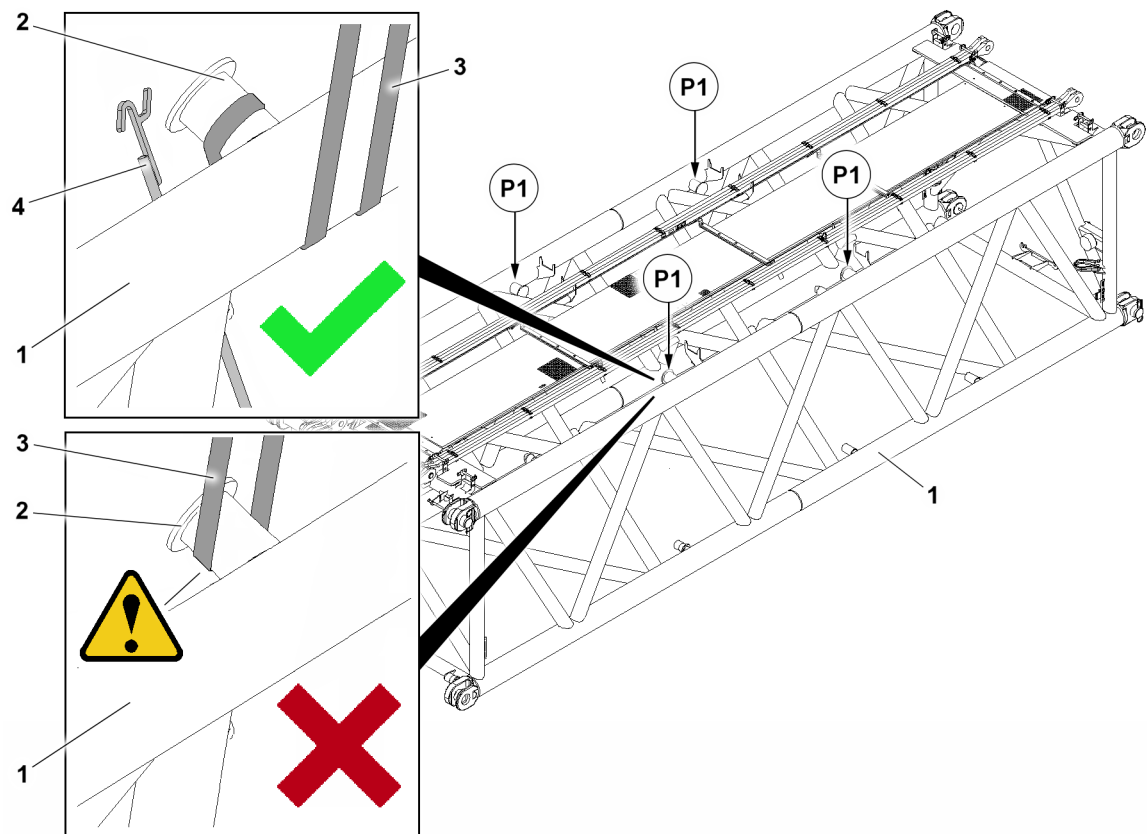

Fig.159189: Correct and incorrect fastening of a bitt 2

P1	Fastening points	3	Belt loop fastening equipment
1	Lattice section	4	Auxiliary rod
2	Bitt		

Make sure that the following prerequisites are met:

- The fastening equipment has been selected correctly for the load case.
- The fastening equipment is in a perfect condition.



WARNING

Fastening equipment incorrectly attached to the fastening point!

If the belt loop fastening equipment 3 is incorrectly attached to the bitt 2, the lattice sections can loosen up and fall down.

The belt loop fastening equipment 3 can slide down.

Death, severe bodily injuries, property damage.

- ▶ Fasten the belt loop fastening equipment 3 only by wrapping it on the corner pipe of the lattice section 1 on the bitt 2.

Use an auxiliary rod 4 to attach the belt loop fastening equipment 3 safely from the ground.

When the fastening points P1 on the lattice section 1 correspond to the illustrated bitts 2:

- ▶ Fasten the belt loop fastening equipment 3 by wrapping it on the corner pipe of the lattice section 1 on the bitt 2.

16.3.3 Fastening the lattice sections

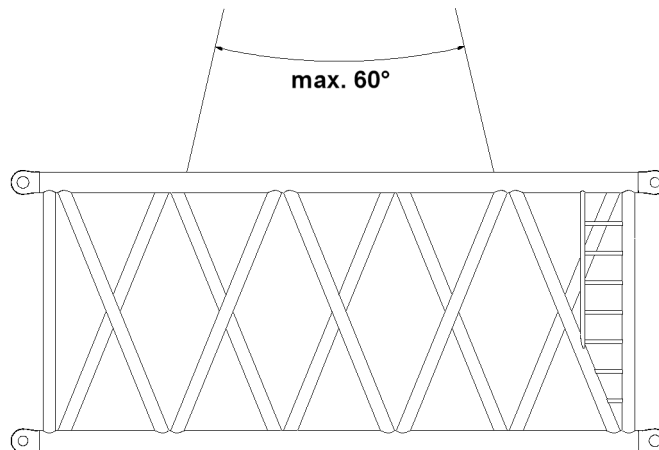

Fig. 164543: Fastening equipment, spreading angle maximum 60°

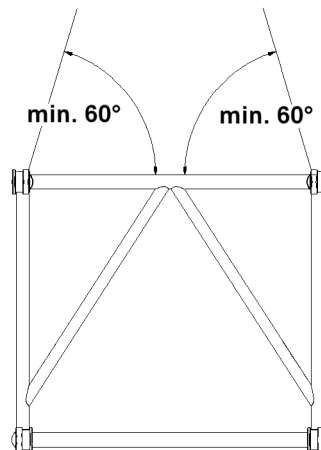

Fig. 164544: Fastening equipment, incline angle minimum 60°

Make sure that the following prerequisites are met:

- The fastening equipment has been selected correctly for the load case.
- The fastening equipment is in a perfect condition.



WARNING

Incorrect length of the fastening equipment!

The fastening points can be overloaded. The lattice sections can fall down.

- ▶ When fastening, observe a **maximum** spread angle of 60°.
- ▶ When fastening, observe a **minimum** incline angle of 60°.
- ▶ Select fastening equipment with a suitable length.

16.4 Fastening of guy rods

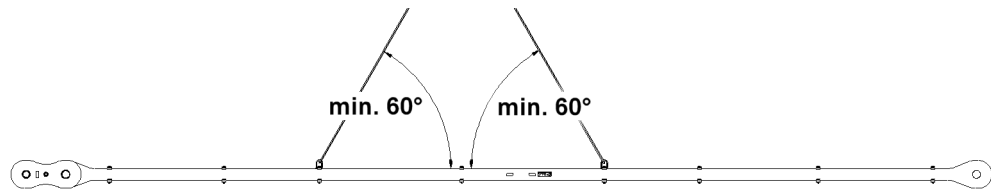

Fig.164542: Fastening equipment, incline angle minimum 60°

Make sure that the following prerequisites are met:

- The fastening equipment has been selected correctly for the load case.
- The fastening equipment is in a perfect condition.



WARNING

Incorrect length of the fastening equipment!

The fastening points can be overloaded. Guy rods can fall down.

- ▶ When fastening, observe a **minimum** incline angle of 60°.
- ▶ Select fastening equipment with a suitable length.

16.5 Assembling / disassembling the electrical lines



WARNING

The crane can topple over!

If mechanical crane components, which have electrical connections are not immediately electrically connected after assembly then the limit switches and / or electrical sensors are not functioning.

Safety relevant shut offs are not recognized by the LICCON computer system.

Any errors or safety relevant messages which might occur are not shown on the LICCON computer system.

Death, severe bodily injuries, property damage.

- ▶ Make sure that the electrical connections are made immediately after installation of the respective crane components on the crane.
- ▶ Make sure that the procedure to make the electrical connections to the boom end sections in the respective assembly and set up chapters are observed.

NOTICE

Damage to the electrical connections!

If the following measures are not adhered to, the electrical connections can be damaged.

- ▶ Do not plug in the plug connection or unplug them under tension.
- ▶ Do not pinch or crush electrical connections.

When pulling the cable out:

- ▶ Hold the plug and not the cable. Do not pull on the cable to release the plug connection.
- ▶ Relieve the electrical connections in operating condition.
- ▶ In case of defective or faulty electrical lines, contact Customer Service at Liebherr-Werk Ehingen GmbH.



WARNING

Malfunction if dummy plugs are not installed!

If the dummy plugs on the non-required electrical connections are not installed, then malfunctions or functional limitations can occur on the crane.

- ▶ Make sure that all non-required electrical connections, which have a dummy plug, are closed off with dummy plugs.
- ▶ Pay attention to the electrical wiring diagram.

NOTICE

Property damage due to dirt and / or corrosion!

The plug connections are only protected when plugged in. If the plug connections are not plugged in, then the contact surfaces can corrode.

This could result in malfunctions.

- ▶ Always plug or screw the plug connections together properly.
- ▶ Keep plug connections clean and dry. Clean contact surfaces provide the best signal transfer.
- ▶ Close off the plug connections that are not used with dust caps.

- ▶ Establish the electrical connections to the installed crane components properly.
- ▶ As a rule, close off on-required electrical connections (for example of accessories which are not installed) with the respective dummy plugs.
- ▶ Properly close off electrical connections, which have no dummy plugs, with the corresponding protective dust or cover caps.

If a pull relief for the cable drum is present:

- ▶ Connect the pull relief in the fixed point and relieve the plug connection from the pull strain.

After installing the plug connections:

- ▶ Check all plug connections for proper connection.

If a plug connection is not properly connected:

- ▶ Plug or screw the plug connection together properly.

After removing the plug connections:

- ▶ Protect the electrical connections with protective dust or cover caps or place them in intended storage retainers.
- ▶ After unplugging the electrical plug connections, install the dummy plugs, see Electrical wiring diagram.

If locking brackets are present:

- ▶ Close the locking bracket.

16.6 Assembling / disassembling of hydraulic lines

When connecting and releasing hydraulic lines with quick couplings, make sure that the coupling procedure is carried out correctly.

**WARNING**

Danger of accident due to loss of pressure or leakage!

Incorrectly coupled or self-loosening quick couplings (particularly return lines) can result in serious accidents due to component failure.

Death, severe bodily injuries, property damage.

- ▶ Check the quick couplings after assembly for correct connection.
- ▶ Make sure that the sleeve and plug are bolted with the knurled nut after assembly.

**WARNING**

Pressure in the hydraulic lines!

If the pressure supply is not interrupted before releasing the hydraulic lines, the hydraulic oil can escape with high pressure.

Death, severe bodily injuries, property damage.

- ▶ Release the pressure in the hydraulic system before releasing. Interrupt the pressure supply and wait a short time.
- ▶ Release the pressure in the hydraulic system before connecting or disconnecting: Turn the engine off and wait a short time.
- ▶ Connect the coupling components (sleeve and connector) and screw together with the knurled nut.
- ▶ Tighten the hydraulic coupling by hand. Turn the knurled nut until it reaches a tangible, fixed stop position.

16.7 Bypassing at crawler assembly / disassembly



Note

- ▶ Applies only for cranes with crawler assembly key button.



WARNING

High danger of accident in case of actuated crawler assembly key button!

If the crawler assembly key button is actuated, the overload protection is bypassed. No shut-off at overload will occur in assembly operation nor in crane operation.

In the event of misuse, the crane can topple over.

Death, severe bodily injuries, property damage.

- ▶ The crawler assembly key button may only be actuated for assembly tasks.
- ▶ All other usage of the crawler assembly key button other than as described in the operating instructions is prohibited.
- ▶ Crane operation with the crawler assembly key button enabled is strictly prohibited.

16.7.1 Activating the bypass at crawler assembly and crawler disassembly

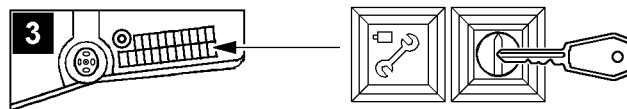

Fig.113441: Activating the bypass

- Illustration 3: Crawler assembly key button and *Crawler assembly* indicator light with *Crawler assembly off* touch function

- ▶ Actuate the crawler assembly key button.

Result:

- The LICCON overload protection is inactive.
- The indicator light *Crawler assembly* lights up.

16.7.2 Deactivating the bypass at crawler assembly and crawler disassembly

Make sure that the following prerequisites are met:

- The LICCON overload protection is bypassed / inactive and the „Bypass at assembly and disassembly“ is activated.
- The *crawler assembly* indicator light illuminates.

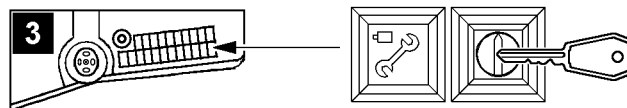

Fig.113441: Deactivating the bypass

If the bypass at crawler assembly is to be turned off:

- ▶ Turn the crawler assembly off by pressing the off button *Crawler assembly off*.

Result:

- The indicator light in the button *Crawler assembly* turns off.

16.8 Bypassing at assembly / disassembly

Depending on the crane version, the „Bypass at assembly and disassembly“ is activated by:

- The set up button (key button) on the LICCON monitor.
- The assembly key button in the instrument panel.

**Note**

- ▶ This applies only for cranes with LICCON overload protection.
- ▶ The *Assembly* indicator light is only present on the instrument panel for certain crane types.

**WARNING**

High danger of accident at crane operation with activated „Bypass at assembly and disassembly“! With the „Bypass at assembly and disassembly“ activated, the overload protection and, if applicable, also the hoist limit switches are bypassed.

In the event of improper use, the crane could collapse, the boom can break off or the crane can topple over.

Death, severe bodily injuries, property damage.

- ▶ The activation of the „Bypass at assembly and disassembly“ is only permissible for assembly and disassembly purposes.
- ▶ All other usage of the „Bypass at assembly and disassembly“ other than as described in the operating instructions is prohibited.
- ▶ The „Bypass at assembly and disassembly“ may only be activated by persons who are aware of the consequences of a bypass.
- ▶ Crane operation with activated „Bypass at assembly and disassembly“ is strictly prohibited.
- ▶ The „Bypass at assembly and disassembly“ must be deactivated immediately after assembly and disassembly work.
- ▶ The crane operator or a person authorized by him must make sure that no misuse of the bypass device is possible (remove the key and store it safely, if necessary).

16.8.1 Activating the bypass at assembly and disassembly



Fig.113438: Activating the bypass at assembly and disassembly

- Illustration 1: LICCON monitor (only certain crane types)
- Illustration 2: indicator light „assembly“ on the crane cab instrument panel (only certain crane types)
- ▶ Actuate the respective operating element.

Result:

- The LICCON overload protection is bypassed / inactive and the „Bypass at assembly and disassembly“ is activated.
- The „Assembly“ icon appears on the LICCON monitor and / or the „Assembly“ indicator light on the instrument panel lights up.
- Depending on the circumstances, acoustic and / or optical warning signals (blinkers, flashing beacons, horns and bells) sound.

16.8.2 Bypassing at assembly and disassembly



Fig.113437: Bypassing at assembly and disassembly

- ▶ No longer actuate the respective operating element or reset.

Result:

- The LICCON overload protection is active and the „Bypass at assembly and disassembly“ is deactivated.

- The „Assembly“ icon turns off on the LICCON monitor and / or the „Assembly“ indicator light on the instrument panel no longer lights up.
- The acoustic and / or optical warning signals which were triggered by the bypass are turned off again.

16.9 Actuation of winches and / or crane movements during assembly / disassembly



Note

- ▶ The winches and / or crane movements can be controlled from the crane cab or, depending on the crane set up configuration, with the Bluetooth™ Terminal (BTT) or the radio remote control*.
- ▶ Observe chapter 4.05, chapter 5.31 and chapter 6.08.



WARNING

Uncoordinated procedure for assembly tasks!
Death, severe bodily injuries, property damage.

- ▶ Before starting the assembly tasks, define the course of action and agree on all steps with all involved personnel.
- ▶ Monitor all steps and continuously check the course of action.
- ▶ In the case of unforeseen events, stop the course of action and agree on the new situation with all involved personnel.
- ▶ Make sure that winches and / or crane movements are only controlled by people who are aware of the effects on the crane and / or boom system as well as the connected dangers.
- ▶ Make sure that no persons, objects or obstacles are in the danger zone of the crane.
- ▶ Prewarn persons within the surrounding area of the crane, for example via a horn signal.
- ▶ Perform all winch and / or crane movements anticipatorily and at a low speed.

16.10 Assembling / disassembling the counterweight

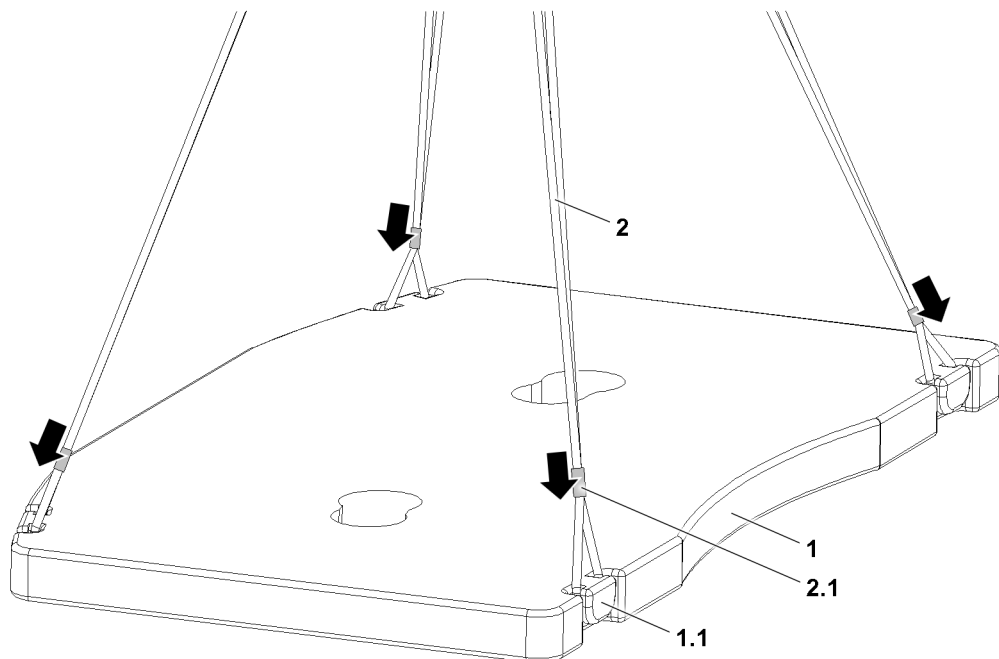

Fig.152587: Grommets and cable laid fastening rope

16.10.1 Grommets and cable laid fastening rope

Use the supplied fastening ropes **2** only for set up work on the crane.

The fastening ropes **2** are marked with the maximum load bearing capacity.



WARNING

Fastening ropes used incorrectly!

The fastening ropes can fail. The load can fall down.

- ▶ Do **not** exceed the load bearing capacity of the fastening ropes **2** when lifting the counterweight.
- ▶ **Never** fasten the fastening ropes **2** to the red marked impact points.
- ▶ **Never** cross or twist the fastening ropes **2**.

Depending on the structural form of the counterweight **1**, use two, three or four fastening ropes **2**.

- ▶ Lay the fastening rope **2** around the bits **1.1** of the counterweight **1** to be lifted.
- ▶ Until the fastening ropes **2** are positioned firmly on the fastening points: Push the mobile ferrules **2.1** in the direction of the fastening point of the counterweight **1**.

16.11 Assembling / disassembling the booms



WARNING

The crane can topple over!

Angular pull can overload the crane.

Overload can cause destruction of the crane or cause it to topple over.

Death, severe bodily injuries, property damage.

- ▶ The hook block must always be attached (hooked) vertically over the center of gravity of the load to be lifted.
- ▶ Angular pull is prohibited

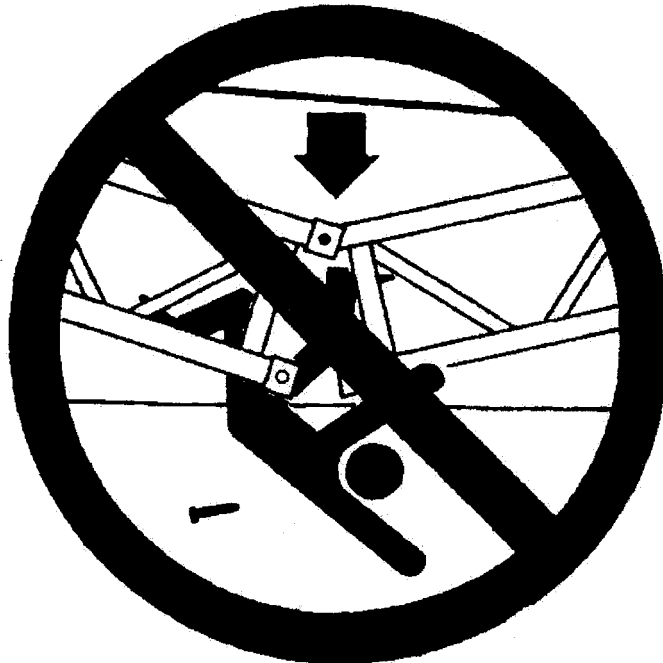

Fig.113444: Danger of accident during assembly / disassembly

**WARNING**

Danger of accident at assembly / disassembly of booms!

When you disassemble unsecured or unsupported booms, they can fall down.

Death, severe bodily injuries, property damage.

- ▶ Never unpin the pins under unsecured or unsupported booms.
- ▶ Never unpin the connector pins on unsecured or unsupported booms.
- ▶ Do not stand under the booms or within the complete danger zone during the pinning and unpinning procedure of the booms.
- ▶ Secure the pins in the bearing points and in the receptacles.
- ▶ The railing must be horizontal during the assembly and disassembly of the booms.
- ▶ Do not lean the ladder against the component being disassembled.

Make sure that the following prerequisites are met for the closing assembly:

- If parts of the equipment (for example lattice sections) are not in contact with the ground during assembly / disassembly, then they must be supported with suitable, stable materials.
- Take down the parts of the equipment with rope pulleys in such a way that the rope pulleys are not damaged.
- During disassembly make sure that the auxiliary crane can lift the load vertically.
- Have an auxiliary crane with sufficient load bearing capacity available to be able to hold the load at the corresponding radius.

16.12 Fastening positions for assembly / disassembly of the lattice jib

**WARNING**

Danger of fatal accidents due falling components!

The maximum permissible tensile load on the fastening eye is engraved on the fastening eye.

The maximum permissible fastening load of the respective components can differ to the maximum permissible tensile load of the fastening eye.

Components can be damaged at overload and fall down during lifting.

- ▶ Observe the maximum permissible fastening load according to the operating instructions and the tags on the components.
- ▶ Fasten the lattice jib only according to the following descriptions.
- ▶ Do not overload the components.

16.12.1 Closing the end section

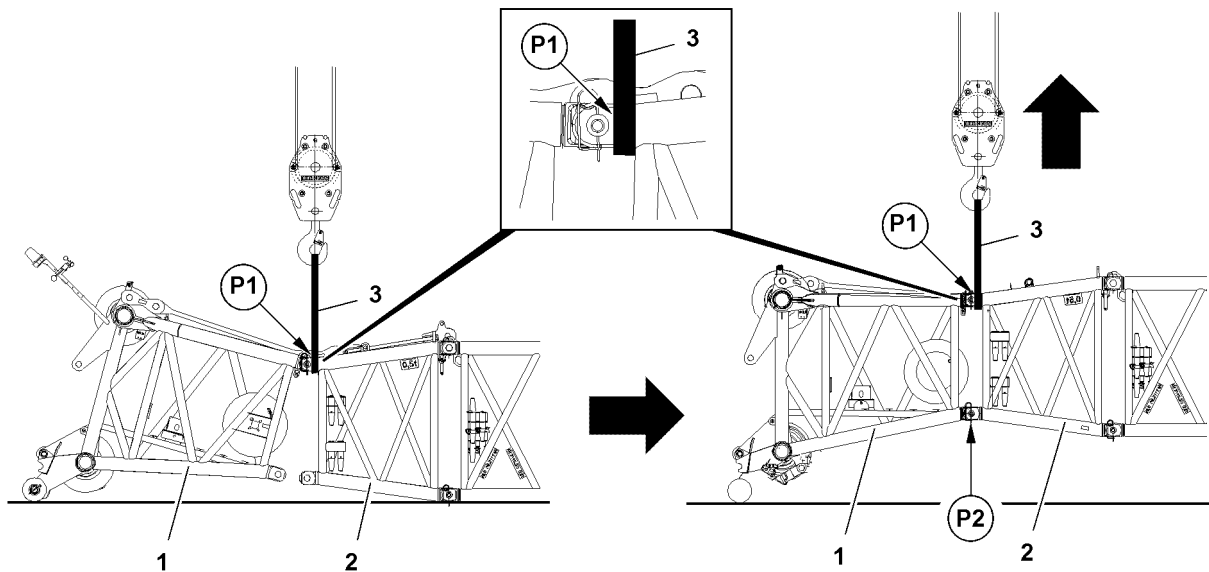

Fig.117840: Closing the end section

Observe the following for closing the end section:

- Use textile type fastening equipment **3**.
- Loop the textile type fastening equipment **3** on the left and right around on the pin points.

Before fastening:

- ▶ Check the position of the spring retainers and correct, if necessary.
- ▶ Fasten the textile type fastening equipment **3** on the upper pin points **P1** between the end section **1** and the pinned component **2**.
- ▶ Lift the lattice jib until the lower pin points **P2** align between the end section **1** and the component **2**.
- ▶ Pin the end section **1** and component **2** on the lower pin points **P2** on the left and right.

After pinning:

- ▶ Remove the textile type fastening equipment **3**.

16.12.2 Taking the lattice jib down into the roller cart



Note

- ▶ The following illustrations are examples and may not match your crane exactly.

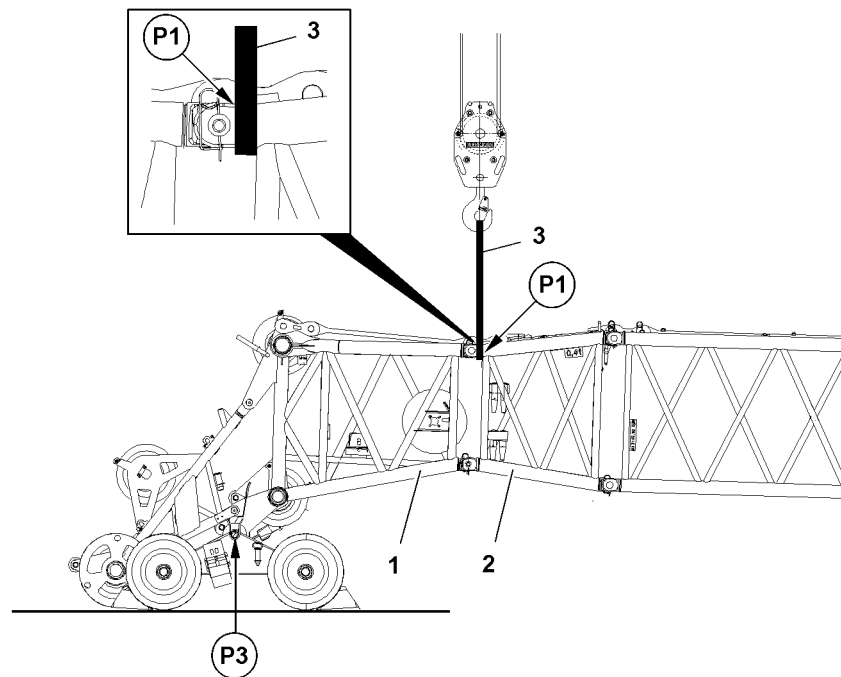

Fig.117842: Taking the lattice jib down into the roller cart (telescopic crane with lattice jib)

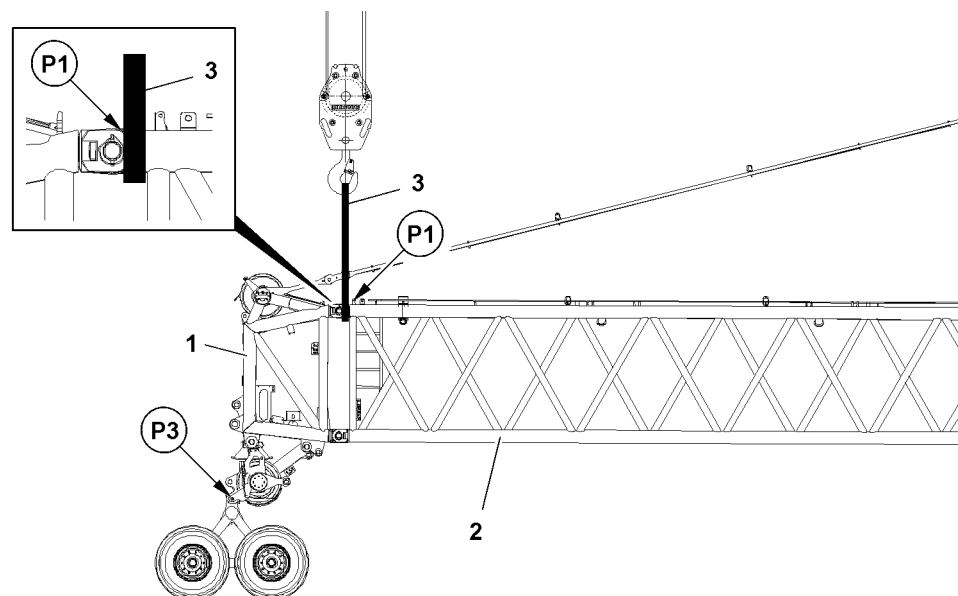

Fig.121550: Taking the lattice jib down into the roller cart (crane with lattice mast)

When taking it down into the roller cart, observe the following:

- The end section 1 is completely assembled.
- Use textile type fastening equipment 3.
- Loop the textile type fastening equipment 3 on the left and right around on the pin points.

Before fastening:

- ▶ Check the position of the spring retainers and correct, if necessary.
- ▶ Fasten the textile type fastening equipment 3 on the upper pin points P1 between the end section 1 and the pinned component 2.
- ▶ Lift the lattice jib and take it down into the roller cart 4.
- ▶ Pin the end section 1 with the roller cart 4 on the pin points P3 on the left and right.
- ▶ Remove the textile type fastening equipment 3.

**Note**

- ▶ The disassembly and removal of the roller cart 4 is must be carried out accordingly.

16.12.3 Opening the end section

Fig.117841: Opening the end section

For opening the end section, observe the following:

- The roller cart is disassembled and removed.
- Use textile type fastening equipment 3.
- Loop the textile type fastening equipment 3 on the left and right around on the pin points.

Before fastening:

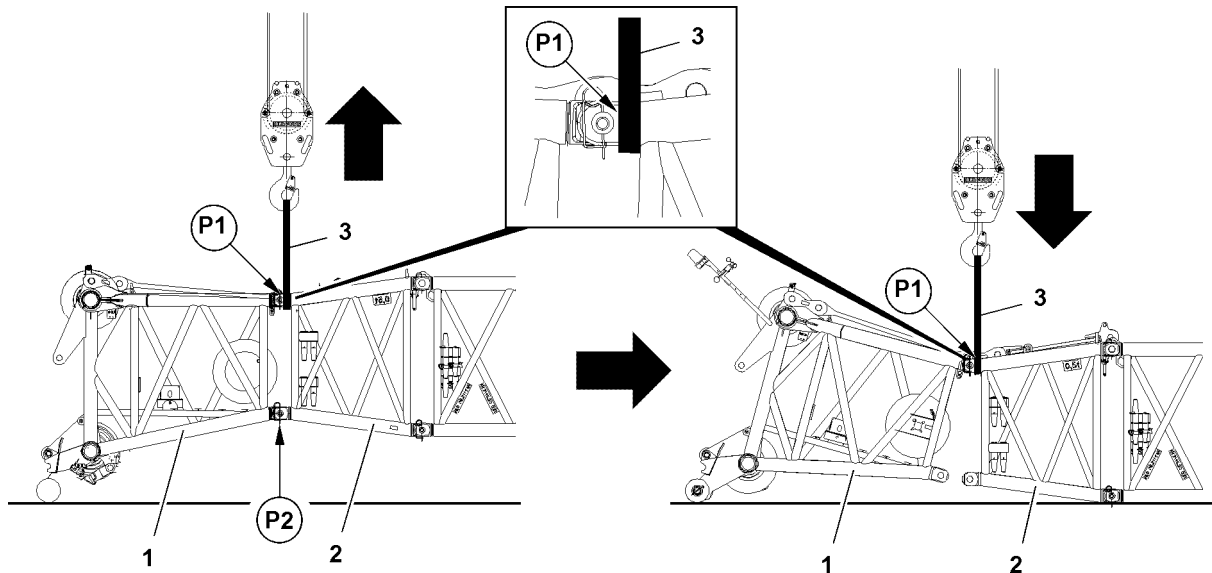
- ▶ Check the position of the spring retainers and correct, if necessary.
- ▶ Fasten the textile type fastening equipment 3 on the upper pin points P1 between the end section 1 and the pinned component 2.
- ▶ Lift the lattice jib and relieve the pins on the lower pin points P2.
- ▶ Unpin the end section 1 and the component 2 on the lower pin points P2 on the left and right.
- ▶ Take the lattice jib down onto the ground.
- ▶ Remove the textile type fastening equipment 3.

16.12.4 Holding the luffing lattice jib

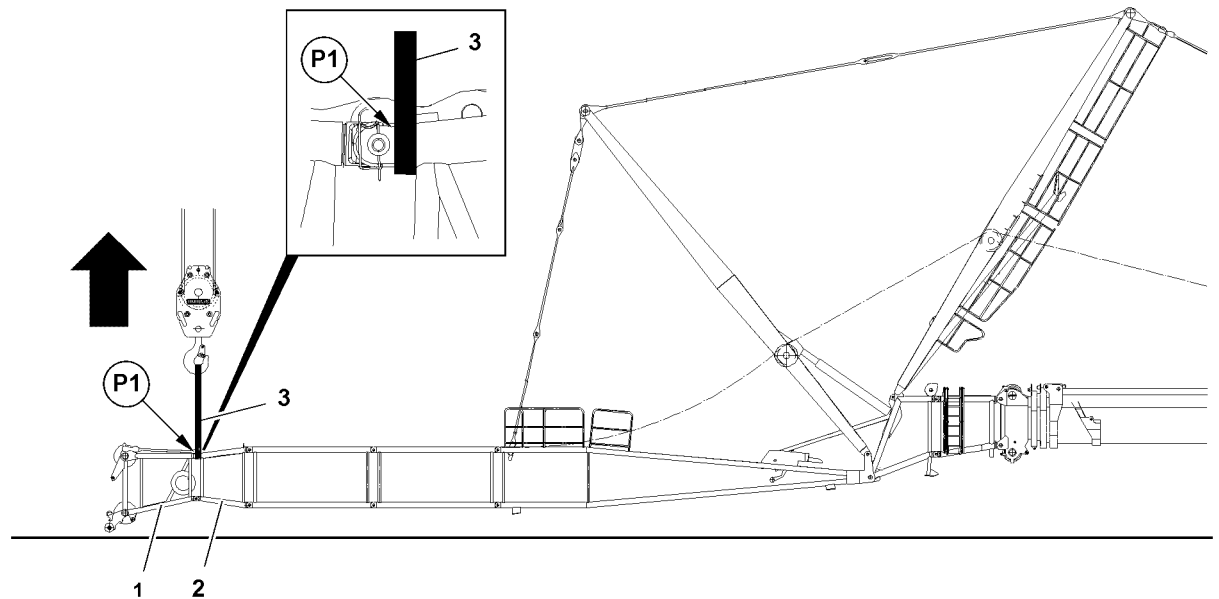

Fig.117843: Holding the luffing lattice jib

To be able to install or remove the guy rods and "flying assembly", the luffing lattice jib must be held on the upper pin points **P1**.

When holding the luffing lattice jib, observe the following:

- The lattice jib has been completely assembled.
- Use textile type fastening equipment **3**.
- Loop the textile type fastening equipment **3** on the left and right around on the pin points.

Before fastening:

- ▶ Check the position of the spring retainers and correct, if necessary.
- ▶ Fasten the textile type fastening equipment **3** on the upper pin points **P1** between the end section **1** and the pinned component **2**.
- ▶ Lift the lattice jib and assemble the guy rods.

When the guy rods are assembled:

- ▶ Remove the textile type fastening equipment **3**.



Note

- ▶ The disassembly of the guy rods must be carried out accordingly.

16.12.5 Assembling the fixed lattice jib on the TF-adapter



WARNING

Mortal danger if the lattice jib tilts over!

Due to unfavorable center of gravity, only certain lattice jib lengths can be installed / removed as an assembled lattice jib.

If a lattice jib length cannot be installed / removed as an assembled lattice jib, then they must be installed / removed individually in flying mode.

- ▶ Check if the respective lattice jib length can be installed / removed as an assembled lattice jib. See charts in chapter 5.01.10.

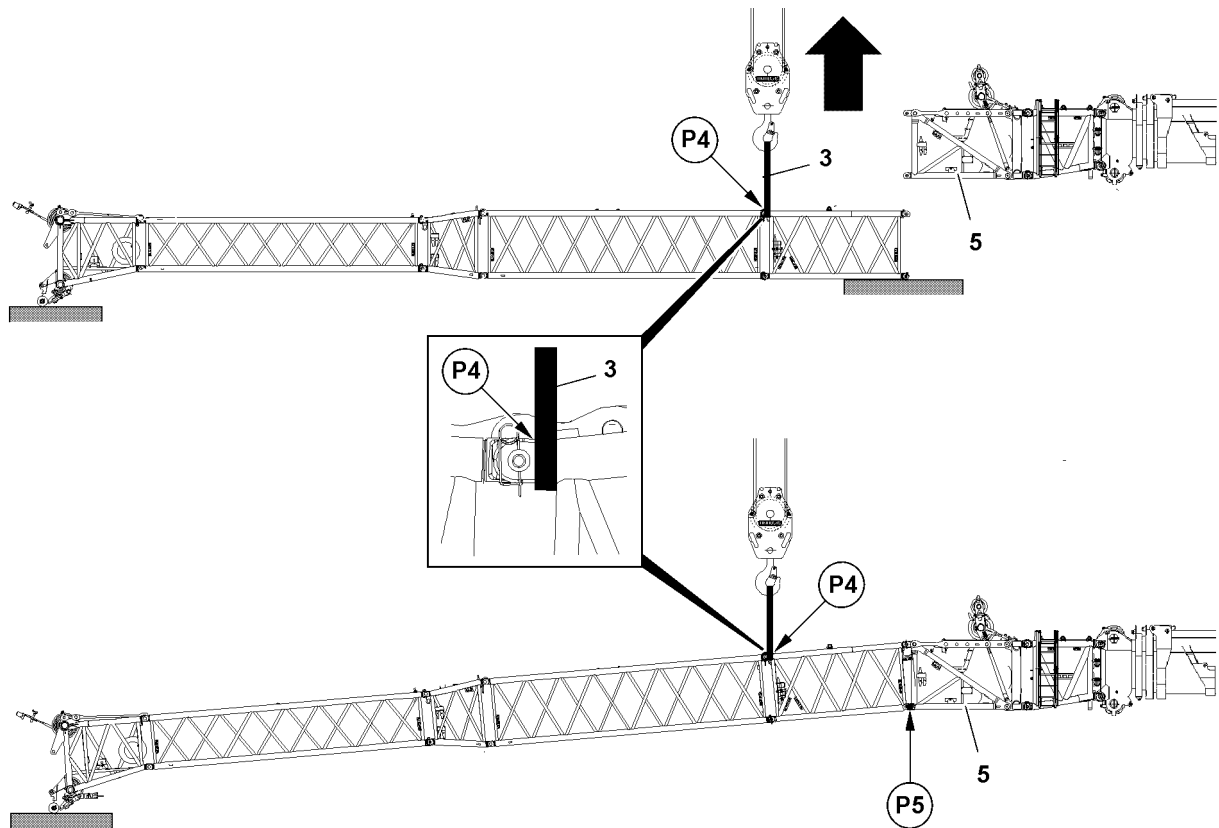

Fig.117844: Assembling the lattice jib on the TF-adapter

Observe the following when assembling the TF-adapter:

- The lattice jib is assembled.
- The TF-adapter **5** is assembled.
- Use textile type fastening equipment **3**.
- Loop the textile type fastening equipment **3** on the left and right around on the pin points.

Before fastening:

- ▶ Check the position of the spring retainers and correct, if necessary.

Fasten between the lattice sections, which are installed directly on the TF-adapter.

- ▶ Fasten the textile type fastening equipment **3** to the upper pin points **P4**.
- ▶ Lift the lattice jib and fit it in the lower pin point **P5** on the TF-adapter **5**.
- ▶ Pin the lattice jib in the lower pin point **P5** with the TF-adapter **5**.

After pinning:

- ▶ Remove the textile type fastening equipment **3**.



WARNING

Mortal danger if the lattice jib tilts over!

- ▶ Make sure to always observe the permissible lattice jib length at disassembly.
- ▶ Disassemble accordingly.

16.12.6 Closing the fixed lattice jib

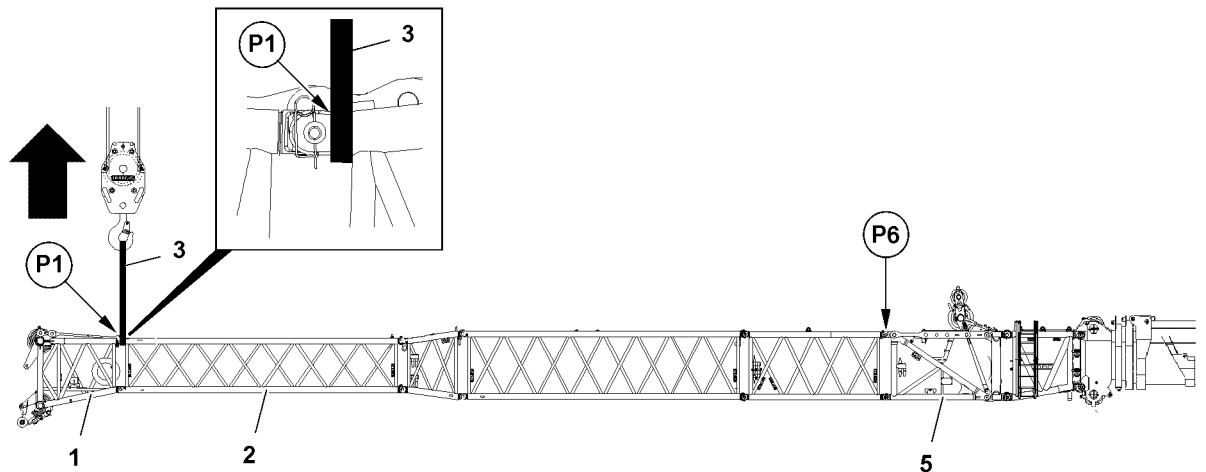

Fig.117850: Closing the lattice jib

Observe the following when assembling the TF-adapter:

- The lattice jib is pinned in the lower pin points of the TF-adapter **5**.
- Use textile type fastening equipment **3**.
- Loop the textile type fastening equipment **3** on the left and right around on the pin points.

Before fastening:

- ▶ Check the position of the spring retainers and correct, if necessary.
- ▶ Fasten the textile type fastening equipment **3** on the upper pin points **P1** between the end section **1** and the pinned component **2**.
- ▶ Lift the lattice jib and fit it in the upper pin point **P6** on the TF-adapter **5**.
- ▶ Pin the lattice jib in the upper pin point **P6** with the TF-adapter **5**.

After pinning:

- ▶ Remove the textile type fastening equipment **3**.



Note

- ▶ Disassemble accordingly.

16.12.7 Angle adjustment on the fixed lattice jib with mechanical adjustment

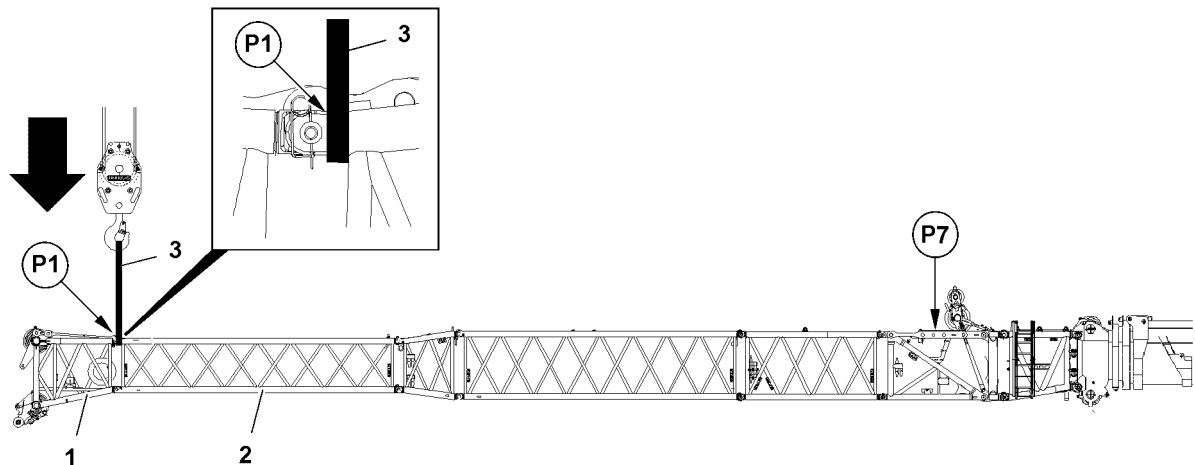

Fig.117851: Angle adjustment on the fixed lattice jib

For the angle adjustment on the fixed lattice jib, observe the following:

- The lattice jib has been completely assembled.
- Use textile type fastening equipment 3.
- Loop the textile type fastening equipment 3 on the left and right around on the pin points.

Before fastening:

- ▶ Check the position of the spring retainers and correct, if necessary.
- ▶ Fasten the textile type fastening equipment 3 on the upper pin points P1 between the end section 1 and the pinned component 2.
- ▶ Lift the lattice jib and relieve the pins on the angle adjustment P7.
- ▶ Unpin the angle adjustment P7, see chapter 5.03.
- ▶ Set and pin a new angle on the angle adjustment P7, see chapter 5.03.
- ▶ Lower the lattice jib.

After lowering:

- ▶ Remove the textile type fastening equipment 3.

16.12.8 Loading the preassembled lattice jib

For loading the lattice jib, observe the following:

- The lattice jib has been preassembled.
- Use textile type fastening equipment.
- Loop the textile type fastening equipment on the left and right around on the pin points.

Before fastening:

- ▶ Check the position of the spring retainers and correct, if necessary.
- ▶ Fasten the preassembled lattice jib according to the fastening points, chapter 5.03.

16.13 Assembling / disassembling the lattice sections on telescopic cranes with a luffing lattice jib

16.13.1 Guy rod transport retainer during assembly

The illustrations in this section are an example and may not exactly match each lattice section.

A description is provided by means of an example of the moment at which the guy rod transport retainers may be unpinned.

If the sequence is not observed, the guy rods can fall from the lattice sections and kill personnel and cause serious injuries and property damage.

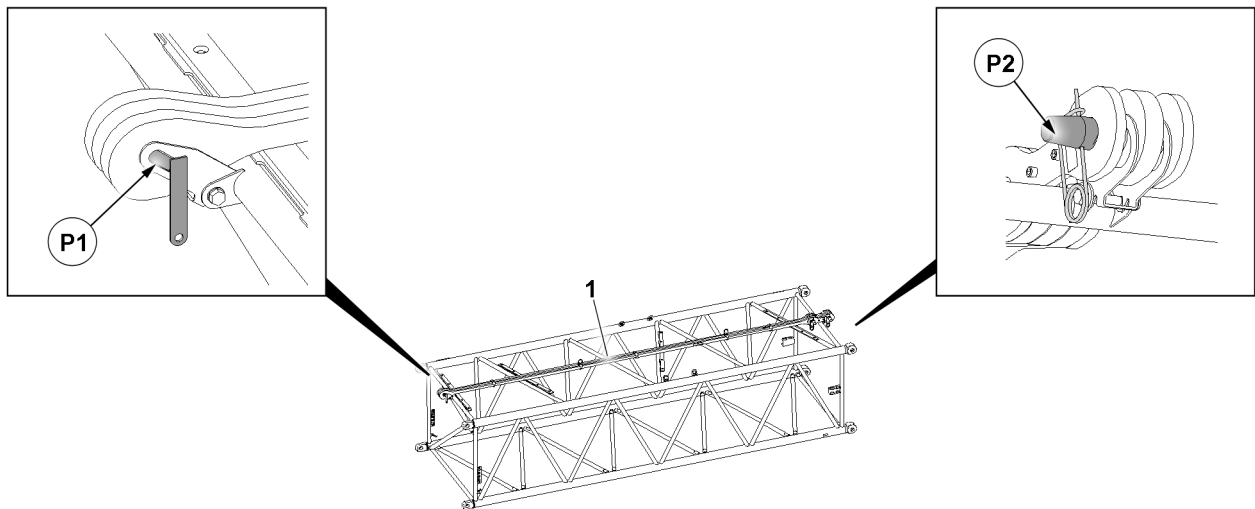

Fig.159460: Guy rod transport retainer

Before a lattice section is fastened:

- ▶ Make sure that the guy rod **1** is secured on both sides in position **P1** and position **P2**.

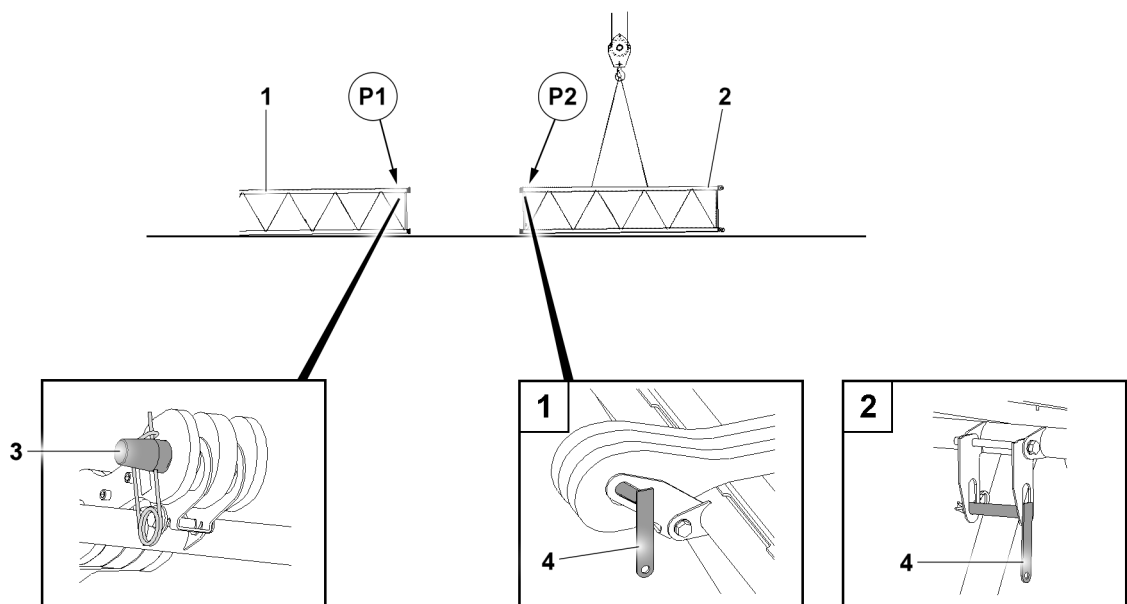

Fig.159592: Disassembling the guy rod transport retainer

Make sure that the following prerequisites are met:

- The lattice section **1** is pinned with the crane.
- The lattice section **2** is taken approx. 2 m from the lattice section **1** onto the ground.

- ▶ In position **P1**: Unpin the pin **3**.

When the lattice section **2** is taken approx. 2 m from the lattice section **1** onto the ground:

- ▶ In position **P2**: Unpin the pins **4** and insert it into the transport position and secure.

Result:

- The lattice section **1** guy rod transport retainer is uninned on the side of the lattice section **2**.
- The lattice section **2** guy rod transport retainer is uninned on the side of the lattice section **1**.

**WARNING**

Guy rods on the lattice section **not completely** secured against falling down!
Death, severe bodily injuries, property damage.

If the lattice section is moved:

- ▶ Carry out the movements slowly and carefully.
- ▶ Comply with the safety distance from the lattice section and guy rods.

- ▶ Position the lattice section **2** in the pin position.

Further procedure

Pin the lattice sections.

16.13.2 Guy rod transport retainer during disassembly

The illustrations in this section are an example and may not exactly match each lattice section.

A description is provided by means of an example of the moment at which the guy rod transport retainers must be pinned.

If the sequence is not observed, the guy rods can fall from the lattice sections and kill personnel and cause serious injuries and property damage.

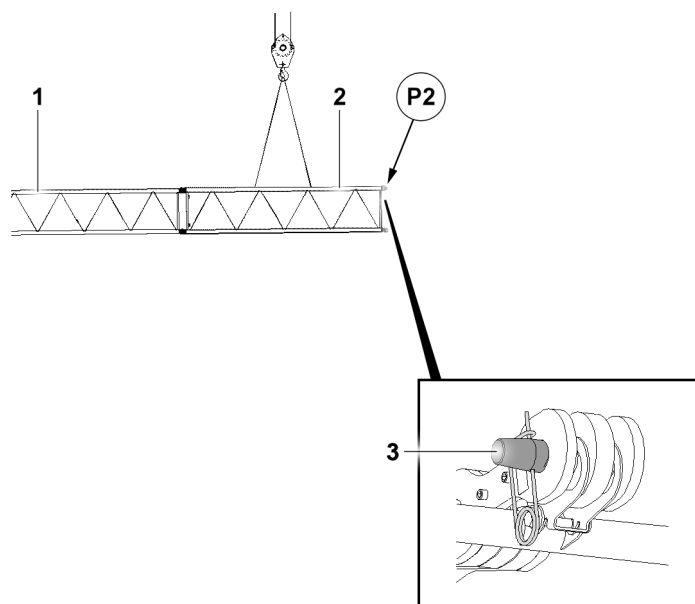

Fig.159591: Assembling the guy rod transport retainer

Make sure that the following prerequisites are met:

- The lattice section **1** is pinned with the crane.
- The lattice section **2** is pinned with the lattice section **1**.
- ▶ Secure the guy rod in the transport position in position **P2**: Insert and secure the pin **3**.

Result:

- The lattice section **2** guy rod is secured on one side in the transport position.

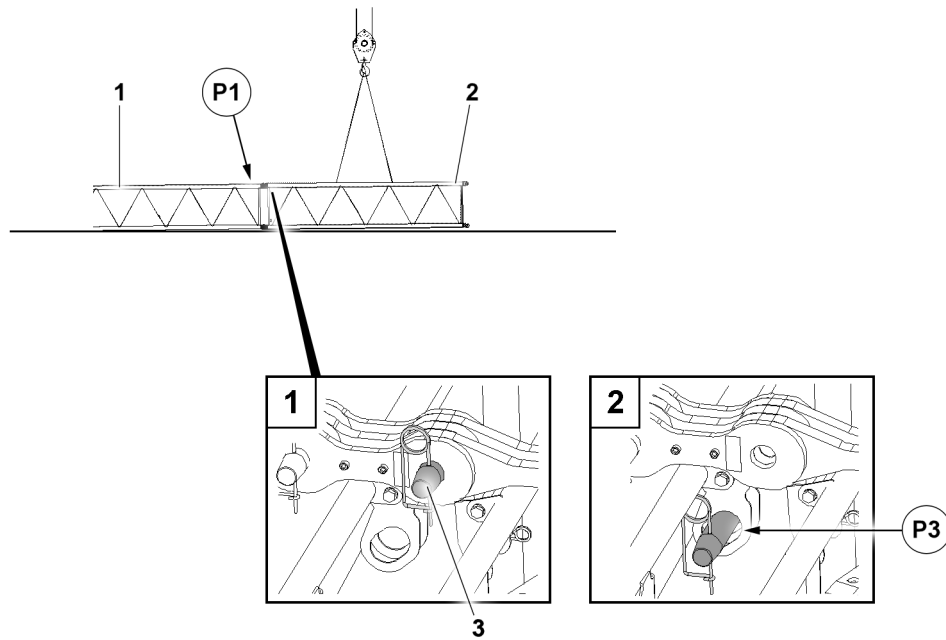

Fig. 159587: Disassembling the guy rod transport retainer

- ▶ Unpin the lattice section 2 guy rod from the lattice section 1 guy rod: Release and unpin the pin 3.
- ▶ In position P3: Insert and secure the pin 3.
- ▶ Unpin the lattice section 2 from the lattice section 1.



WARNING

Guy rods on the lattice section **not completely** secured against falling down!
Death, severe bodily injuries, property damage.

If the lattice section is moved:

- ▶ Carry out the movements slowly and carefully.
- ▶ Comply with the safety distance from the lattice section and guy rods.

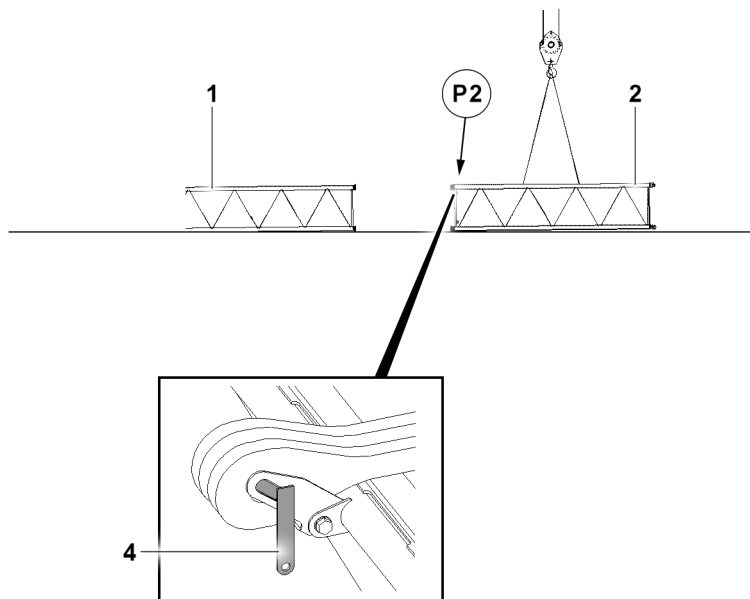

Fig. 159588: Assembling the guy rod transport retainer

- ▶ Move the lattice section 2 approx. 2 m away from the lattice section 1.
- ▶ Take the lattice section 2 down onto the ground.

- ▶ Secure the lattice section 2 guy rod in the transport position in position **P2**: Insert and secure the pin 4.

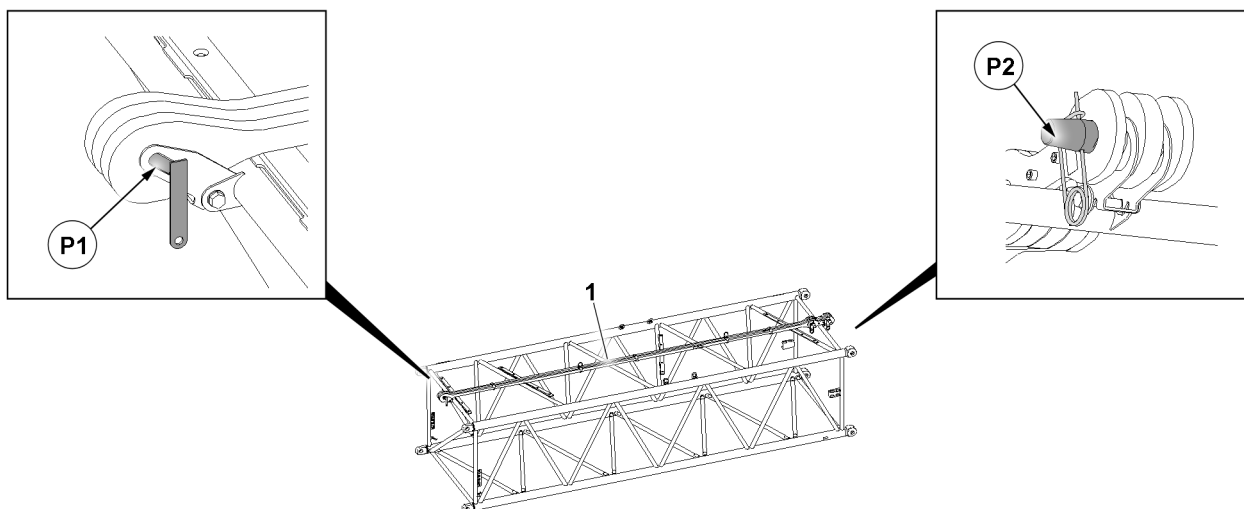

Fig.159460: Guy rod transport retainer

- ▶ Make sure that the guy rod 1 is secured on both sides in position **P1** and position **P2**.

Result:

- The lattice section 2 guy rod is secured on both sides in the transport position.

Empty page!

LWE/LR 13000-001/19503-01-02/en

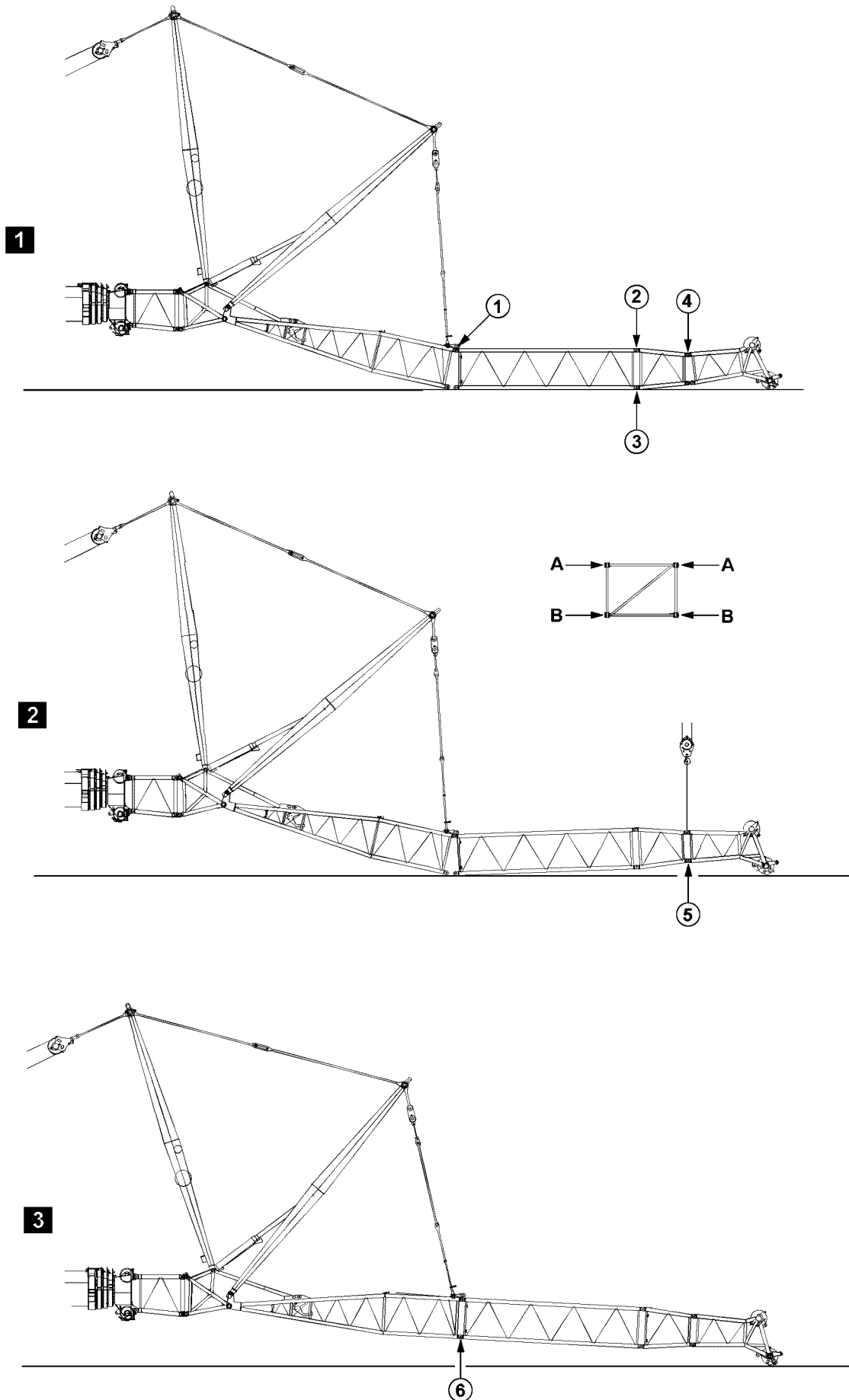

Fig.197718: Example of cranes with a telescopic boom

16.13.3 Assembling the lattice sections on a luffing lattice jib

The illustrations serve as examples. The illustrations may differ depending on the crane.



WARNING

Danger of fatal injury when assembling auxiliary booms!

If the pins are not pinned in the given sequence, then lattice sections may suddenly fold down or fall down.

Death, severe bodily injuries, property damage.

▶ Pins must be pinned in the order specified.

- ▶ Pin and secure pins on both sides (level **A**) in point **1**, illustration **1**.
- ▶ Pin and secure pins on both sides (level **A**) in point **2**, illustration **1**.
- ▶ Pin and secure pins on both sides (level **B**) in point **3**, illustration **1**.
- ▶ Pin and secure pins on both sides (level **A**) in point **4**, illustration **1**.
- ▶ Close the end section with the auxiliary crane, illustration **2**.
- ▶ Pin and secure pins on both sides (level **B**) in point **5**, illustration **2**.
- ▶ Lift the lattice sections, illustration **3**.
- ▶ Pin and secure pins on both sides (level **B**) in point **6**, illustration **3**.

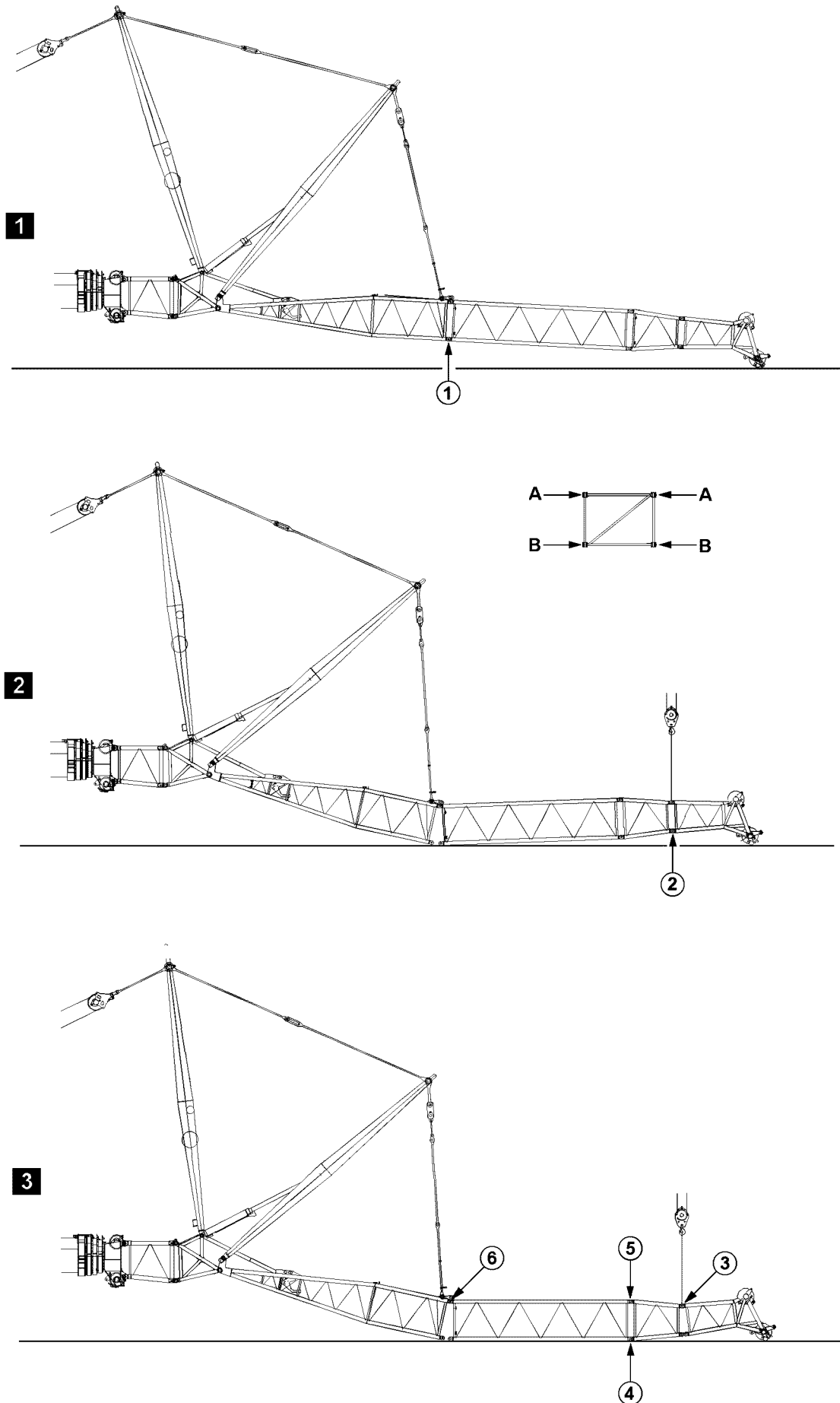

Fig.197719: Example of cranes with a telescopic boom

LWE/LR 13000-001/19503-01-02/en

16.13.4 Disassembling the lattice sections on a luffing lattice jib

The illustrations serve as examples. The illustrations may differ depending on the crane.



WARNING

Danger of fatal injury when disassembling auxiliary booms!

If the pins are not unpinned in the given sequence, then lattice sections may suddenly fold down or fall down.

Death, severe bodily injuries, property damage.

▶ Pins must be unpinned in the specified order.

- ▶ Luff the boom down until the end section touches the ground slightly, illustration 1.
- ▶ Guy the boom with NA-frame I, illustration 1.
- ▶ Release and unpin the pins on both sides (level **B**) in point 1, illustration 1.
- ▶ Open the boom with the NA-frame I and take the boom down completely, illustration 2.
- ▶ Lift the end section with the auxiliary crane, illustration 2.
- ▶ Release and unpin the pins on both sides (level **B**) in point 2, illustration 2.
- ▶ Release and unpin the pins on both sides (level **A**) in point 3, illustration 3.
- ▶ Release and unpin the pins on both sides (level **B**) in point 4, illustration 3.
- ▶ Release and unpin the pins on both sides (level **A**) in point 5, illustration 3.
- ▶ Release and unpin the pins on both sides (level **A**) in point 6, illustration 3.

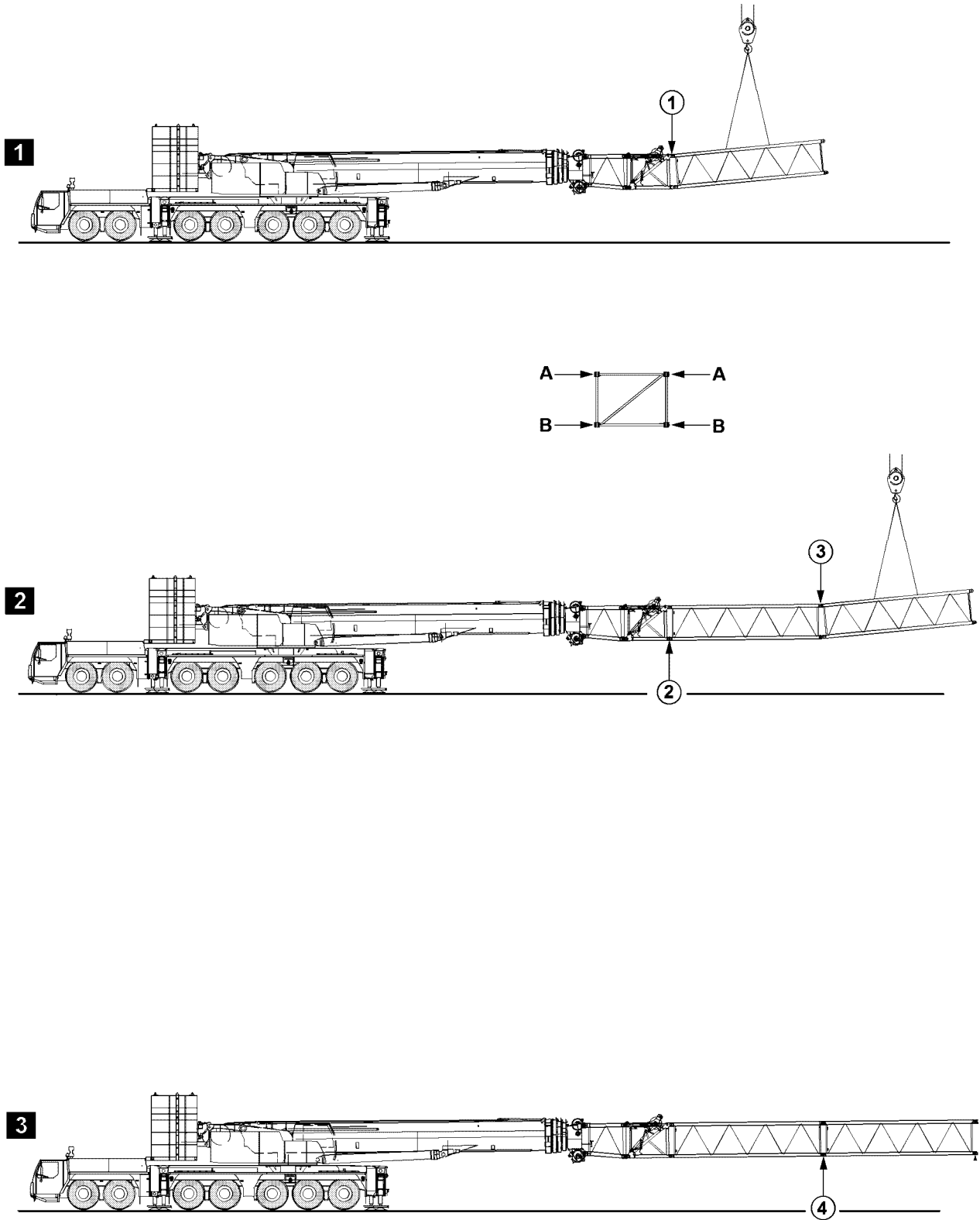

Fig.197705: Example of cranes with a telescopic boom

LWE/LR 13000-001/19503-01-02/en

16.14 Assembling / disassembling the lattice sections on telescopic cranes with an auxiliary boom, with an auxiliary crane

16.14.1 Assembling the lattice sections on an auxiliary boom with an auxiliary crane

The illustrations serve as examples. The illustrations may differ depending on the crane.



WARNING

Danger of fatal injury when assembling auxiliary booms!

If the pins are not pinned in the given sequence, then lattice sections may suddenly fold down or fall down.

Death, severe bodily injuries, property damage.

▶ Pins must be pinned in the order specified.

- ▶ Pin and secure pins on both sides (level **A**) in point **1**, illustration **1**.
- ▶ Pin and secure pins on both sides (level **B**) in point **2**, illustration **2**.
- ▶ Pin and secure pins on both sides (level **A**) in point **3**, illustration **2**.
- ▶ Pin and secure pins on both sides (level **B**) in point **4**, illustration **3**.

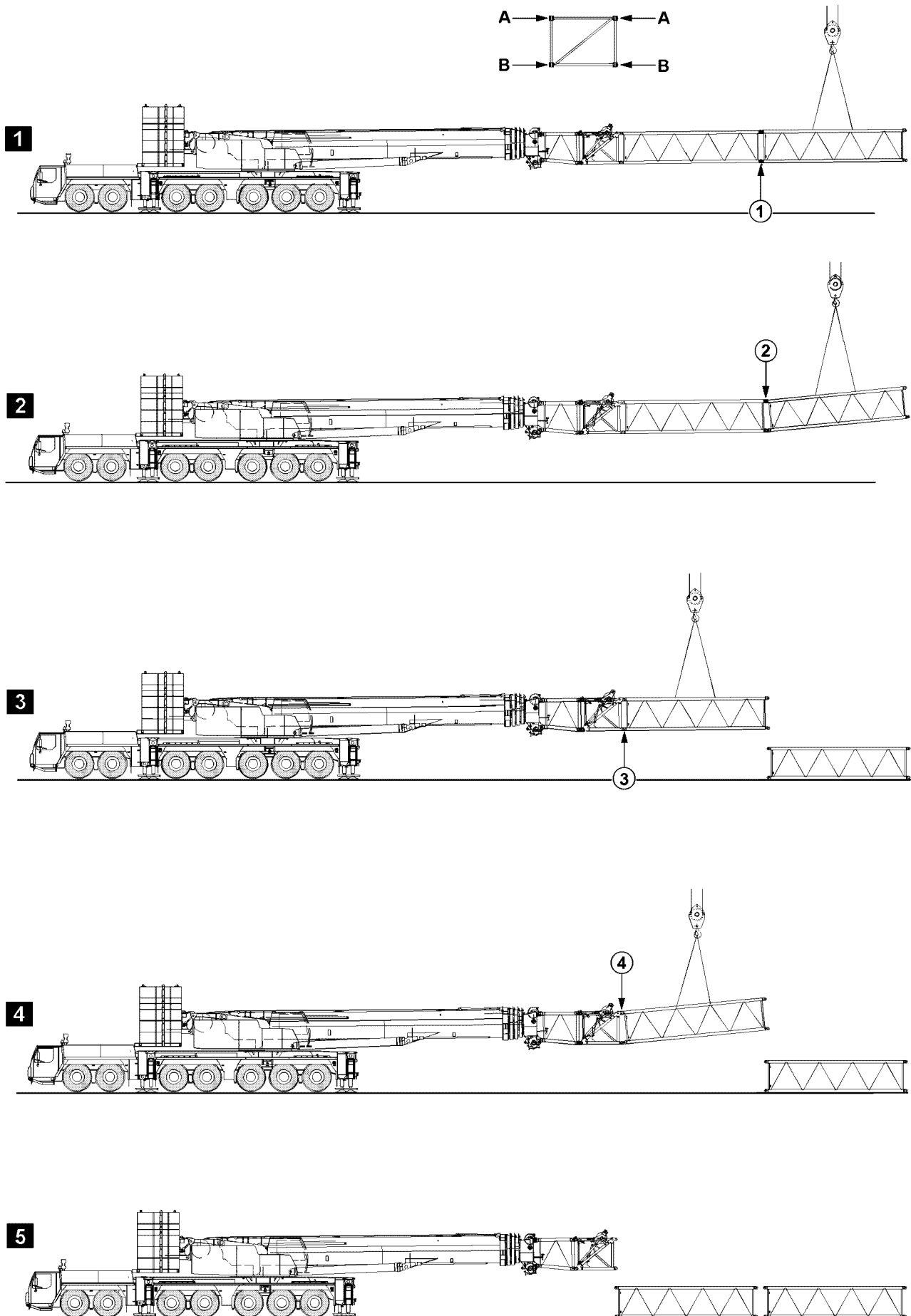

Fig.105510: Example of cranes with a telescopic boom

LWE/LR 13000-001/19503-01-02/en

16.14.2 Disassembling the lattice sections on an auxiliary boom with an auxiliary crane

The illustrations serve as examples. The illustrations may differ depending on the crane.



WARNING

Danger of fatal injury when disassembling auxiliary booms!

If the pins are not unpinned in the given sequence, then lattice sections may suddenly fold down or fall down.

Death, severe bodily injuries, property damage.

▶ Pins must be unpinned in the specified order.

- ▶ Release and unpin the pins on both sides (level **B**) in point **1**, illustration **1**.
- ▶ Release and unpin the pins on both sides (level **A**) in point **2**, illustration **2**.
- ▶ Release and unpin the pins on both sides (level **B**) in point **3**, illustration **3**.
- ▶ Release and unpin the pins on both sides (level **A**) in point **4**, illustration **4**.

1**2****3**

Fig.197712: Example of cranes with a telescopic boom

16.15 Assembling / disassembling the lattice sections on telescopic cranes with an auxiliary boom, without an auxiliary crane

16.15.1 Assembling the lattice sections on an auxiliary boom without an auxiliary crane

The illustrations serve as examples. The illustrations may differ depending on the crane.

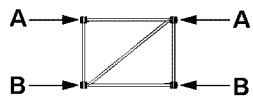
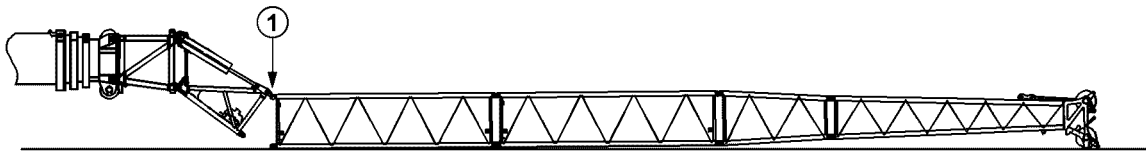
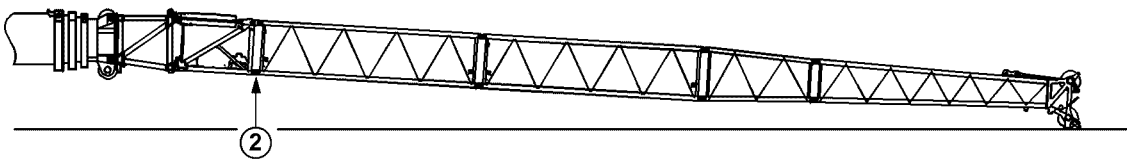
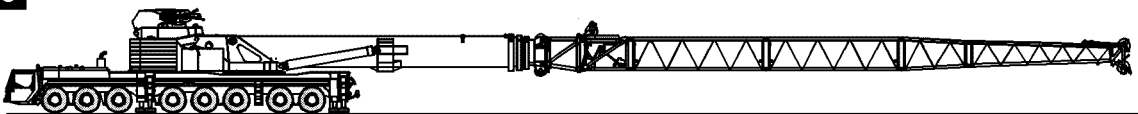

WARNING

Danger of fatal injury when assembling auxiliary booms!

If the pins are not pinned in the given sequence, then lattice sections may suddenly fold down or fall down.

Death, severe bodily injuries, property damage.

- ▶ Pins must be pinned in the order specified.
-

For cranes with hydraulic angle adjustment and self-supporting auxiliary boom, the assembly / disassembly of additional lattice sections may be performed using the crane itself.

In order to do so, proceed as follows.

- ▶ Assemble the lattice sections to the required length.
- ▶ Pin and secure pins on both sides (level **A**) in point **1**, illustration 1.
- ▶ Close the auxiliary boom until the pins can be pinned in point **2**, illustration 2.
- ▶ Pin and secure pins on both sides (level **B**) in point **2**, illustration 2.

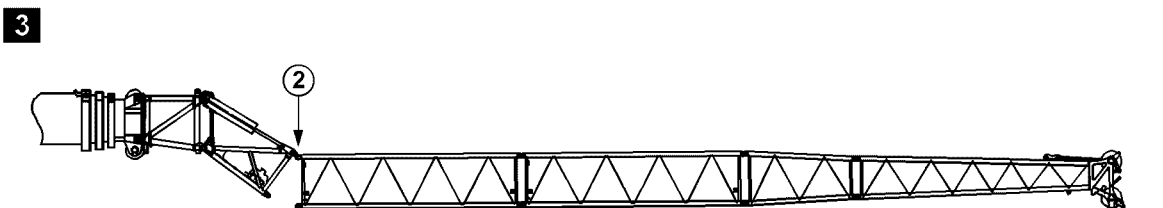
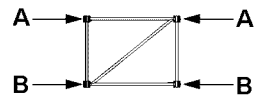
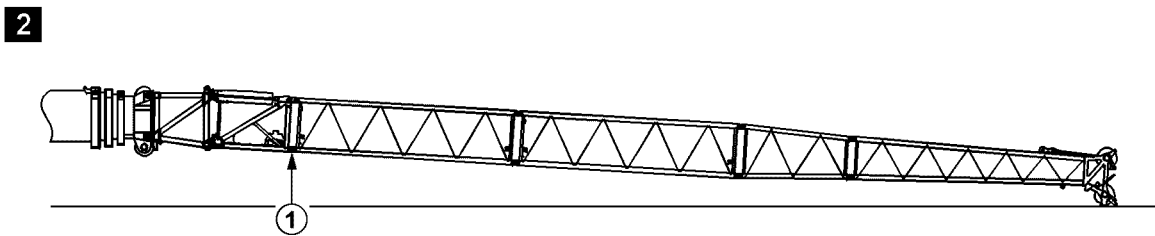
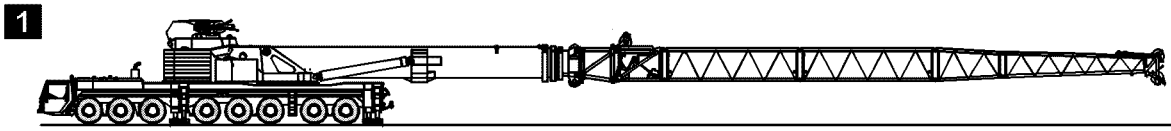

Fig.197713: Example of cranes with a telescopic boom

16.15.2 Disassembling the lattice sections on an auxiliary boom without an auxiliary crane

The illustrations serve as examples. The illustrations may differ depending on the crane.



WARNING

Danger of fatal injury when disassembling auxiliary booms!

If the pins are not unpinned in the given sequence, then lattice sections may suddenly fold down or fall down.

Death, severe bodily injuries, property damage.

- ▶ Pins must be unpinned in the specified order.

For cranes with hydraulic angle adjustment and self-supporting auxiliary boom, the assembly / disassembly of additional lattice sections may be performed using the crane itself.

In order to do so, proceed as follows.

NOTICE

Damage to the hydraulic cylinders on the TF-adapter!

- ▶ As soon as the lattice jib is placed, stop the luff down movement.
- ▶ It is prohibited to set down the fixed lattice jib „roughly“.

- ▶ Luff the main boom down until the end section touches the ground slightly, illustration 2.

If it is not possible to luff down that far:

- ▶ Adjust the TF-adapter until the end section touches the ground slightly, illustration 2.
- ▶ Release and unpin the pins on both sides (level **B**) in point 1, illustration 2.

NOTICE

Damage to the hydraulic cylinders on the TF-adapter.

- ▶ As soon as the lattice jib is placed, stop the opening movement.

- ▶ Open the auxiliary boom until the lattice sections to be removed are lying on the ground completely, illustration 3.
- ▶ Release and unpin the pins on both sides (level **A**) in point 2, illustration 3.
- ▶ Completely remove the auxiliary boom.

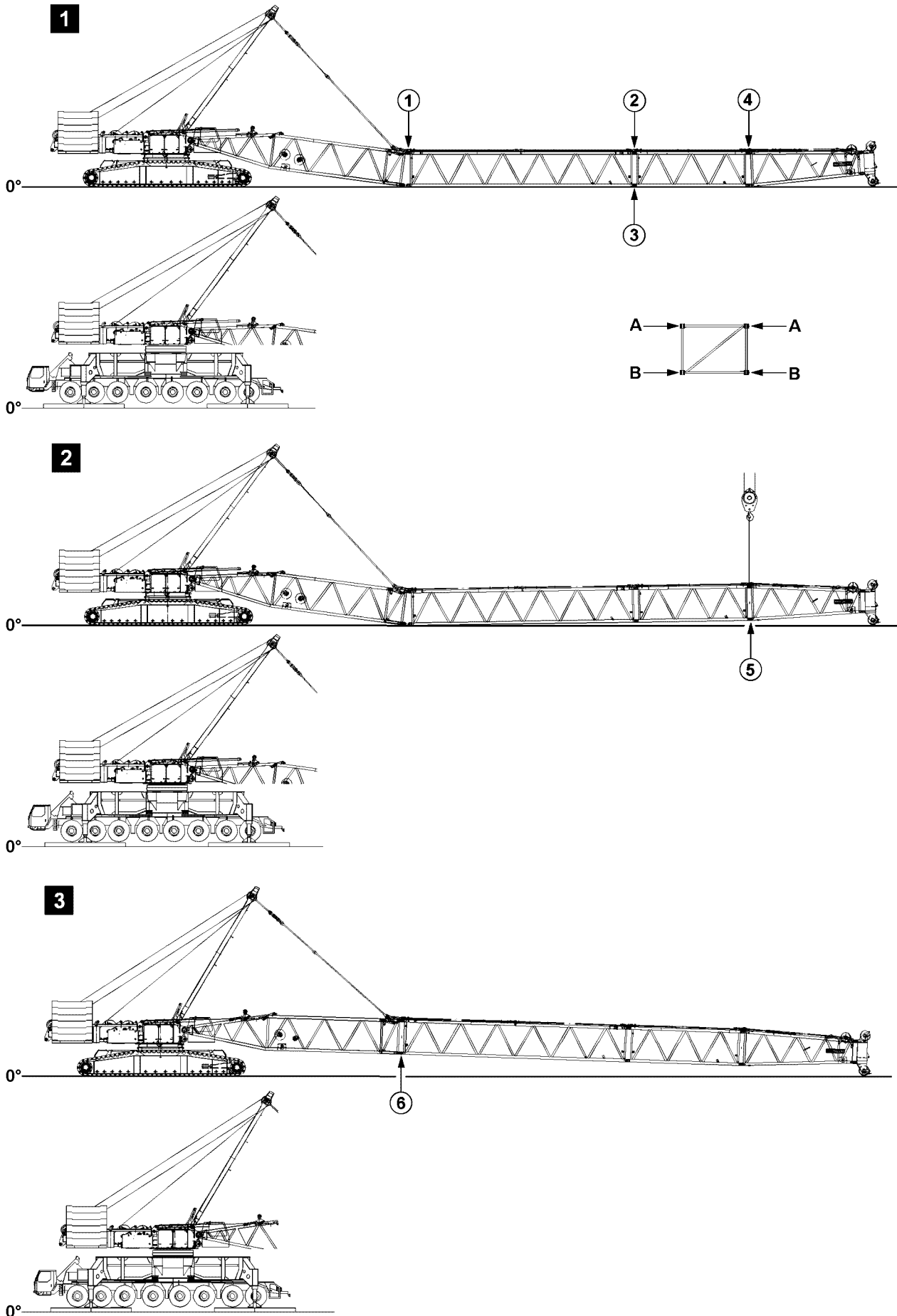

Fig.121633: Example of cranes with a lattice mast boom

LWE/LR 13000-001/19503-01-02/en

16.16 Assembling / disassembling of lattice sections for lattice mast cranes

16.16.1 Assembling lattice sections

The illustrations serve as examples. The illustrations may differ depending on the crane.



WARNING

Danger of fatal injury when assembling booms!

If the pins are not pinned in the given sequence, then lattice sections may suddenly fold down or fall down.

Death, severe bodily injuries, property damage.

▶ Pins must be pinned in the order specified.

- ▶ Pin and secure pins on both sides (level **A**) in point **1**, illustration **1**.
- ▶ Pin and secure pins on both sides (level **A**) in point **2**, illustration **1**.
- ▶ Pin and secure pins on both sides (level **B**) in point **3**, illustration **1**.
- ▶ Pin and secure pins on both sides (level **A**) in point **4**, illustration **1**.
- ▶ Lift the end section with the auxiliary crane, illustration **2**.
- ▶ Pin and secure pins on both sides (level **B**) in point **5**, illustration **2**.
- ▶ Close the boom system with the SA-frame, illustration **3**.
- ▶ Pin and secure pins on both sides (level **B**) in point **6**, illustration **3**.

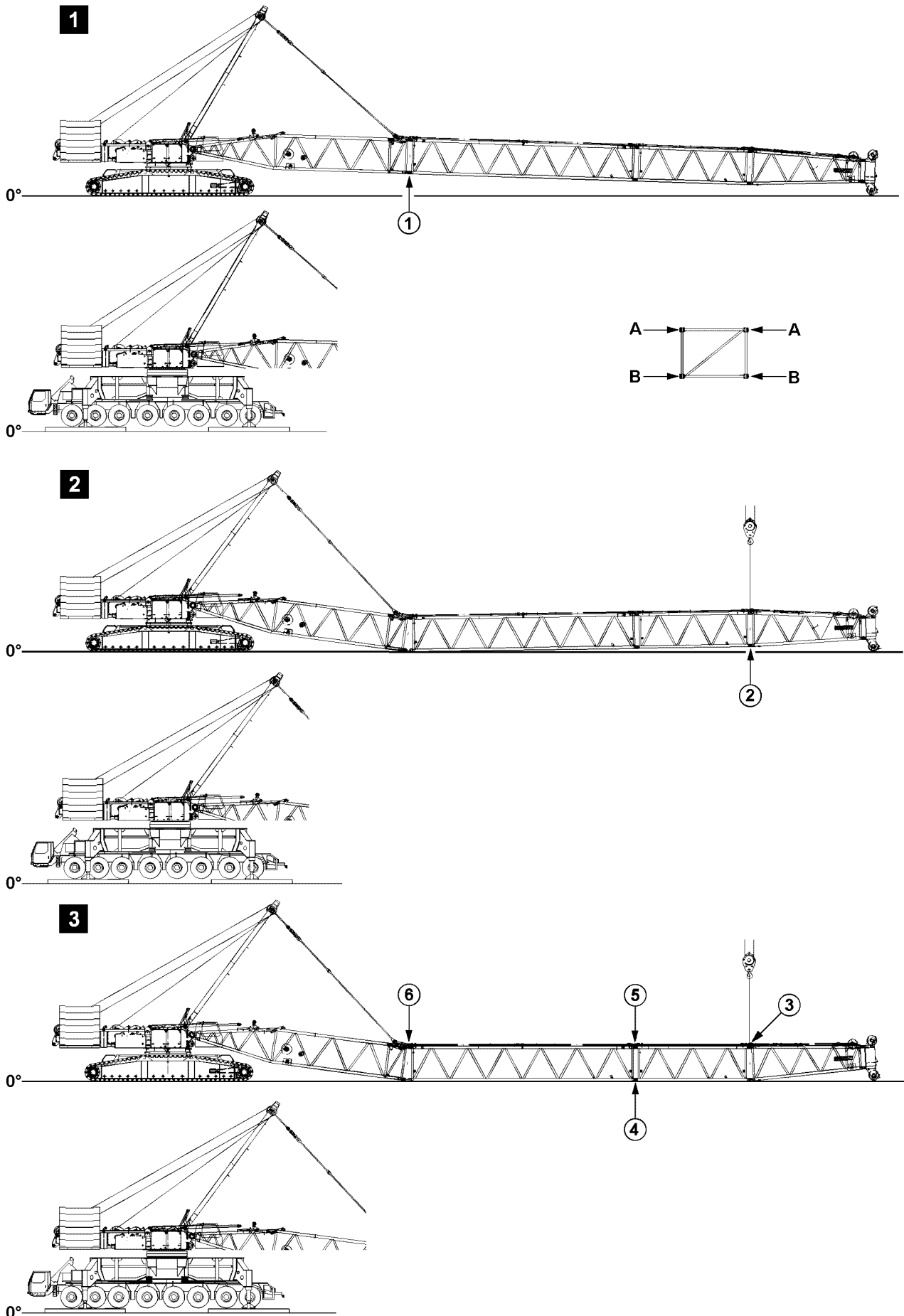

Fig.121634: Example of cranes with a lattice mast boom

LWE/LR 13000-001/19503-01-02/en

16.16.2 Disassembling lattice sections

The illustrations serve as examples. The illustrations may differ depending on the crane.



WARNING

Danger of fatal injury when disassembling booms!

If the pins are not unpinned in the given sequence, then lattice sections may suddenly fold down or fall down.

Death, severe bodily injuries, property damage.

- ▶ Make sure that the SA-frame guying is tensioned before the pins are unpinned in point **1**, see illustration **1**.
 - ▶ Pins must be unpinned in the specified order.
-
- ▶ Luff the boom down until the end section touches the ground slightly, illustration **1**.
 - ▶ Guy the boom with SA-frame, illustration **1**.
 - ▶ Release and unpin the pins on both sides (level **B**) in point **1**, illustration **1**.
 - ▶ Open the boom system with the SA-frame, illustration **2**.
 - ▶ Take the lattice sections down completely, illustration **2**.
 - ▶ Lift the end section with the auxiliary crane, illustration **2**.
 - ▶ Release and unpin the pins on both sides (level **B**) in point **2**, illustration **2**.
 - ▶ Release and unpin the pins on both sides (level **A**) in point **3**, illustration **3**.
 - ▶ Release and unpin the pins on both sides (level **B**) in point **4**, illustration **3**.
 - ▶ Release and unpin the pins on both sides (level **A**) in point **5**, illustration **3**.
 - ▶ Release and unpin the pins on both sides (level **A**) in point **6**, illustration **3**.

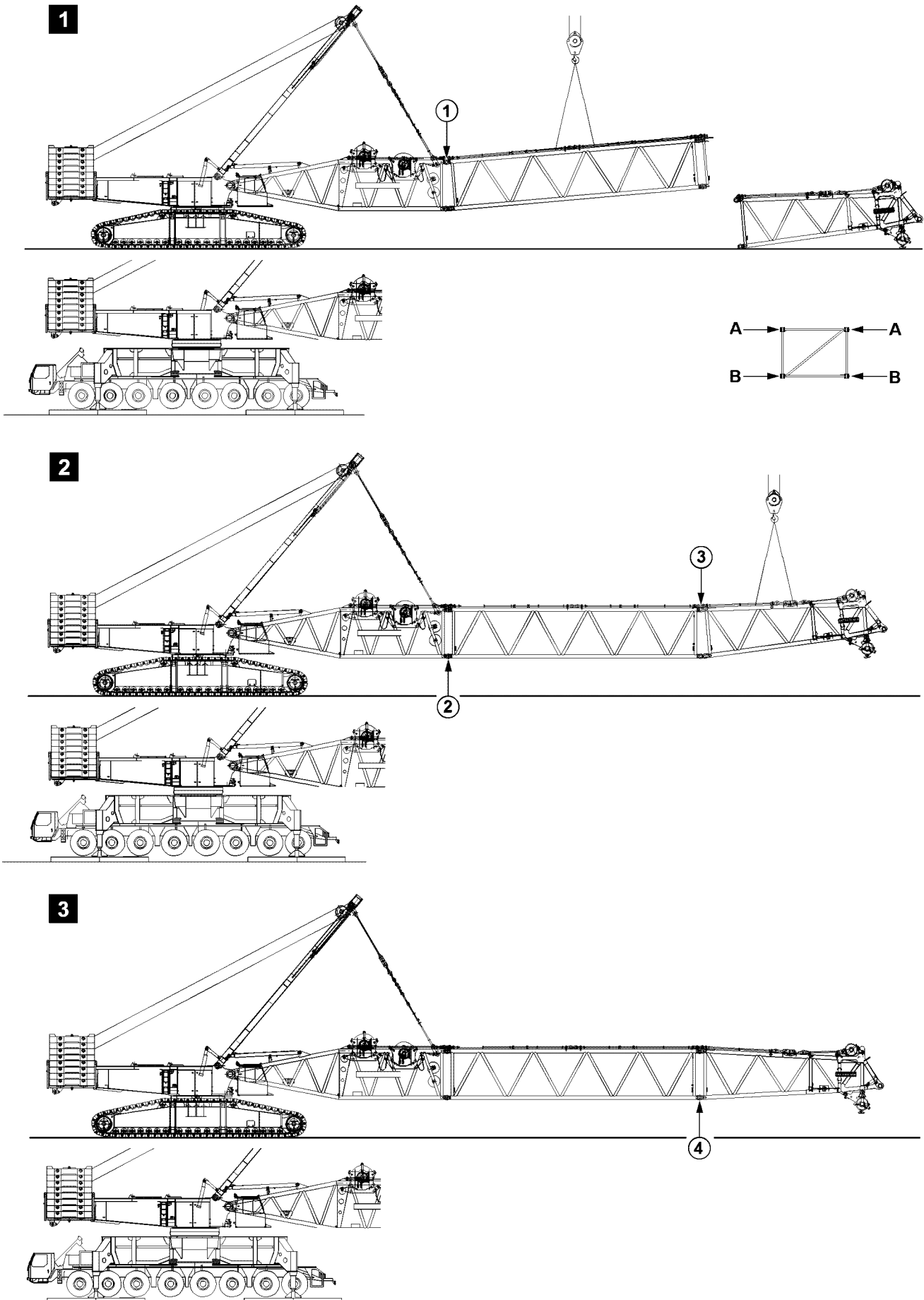

Fig.198182: Example of cranes with a lattice mast boom

LWE/LR 13000-001/19503-01-02/en

16.17 Flying assembly / disassembly of lattice sections

16.17.1 Flying assembly of lattice sections

The illustrations serve as examples. The illustrations may differ depending on the crane.



WARNING

Danger of fatal injury when assembling booms!

If the pins are not pinned in the given sequence, then lattice sections may suddenly fold down or fall down.

Death, severe bodily injuries, property damage.

▶ Pins must be pinned in the order specified.

- ▶ Pin and secure pins on both sides (level **A**) in point **1**, illustration **1**.
- ▶ Pin and secure pins on both sides (level **B**) in point **2**, illustration **2**.
- ▶ Pin and secure pins on both sides (level **A**) in point **3**, illustration **2**.
- ▶ Pin and secure pins on both sides (level **B**) in point **4**, illustration **3**.

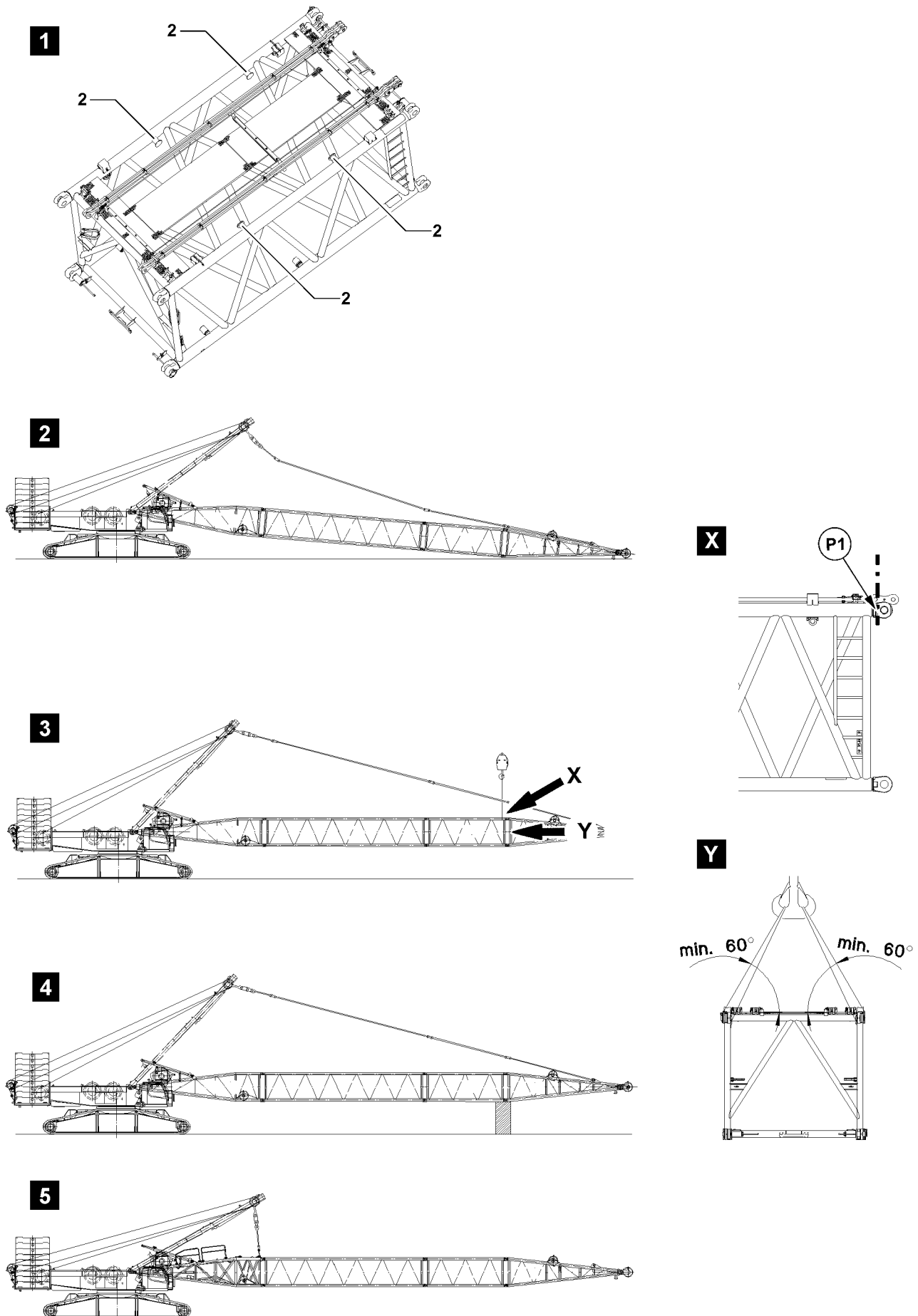

Fig.111448: Guying the pivot section with the SA-frame

LWE/LR 13000-001/19503-01-02/en

16.17.2 Flying disassembly of lattice sections

The illustrations serve as examples. The illustrations may differ depending on the crane.

The flying disassembly of lattice sections can be used on:

- Derrick boom
- Main boom

Make sure that the following prerequisite is met:

- Before guying the pivot section, secure the boom properly to prevent it from falling down.

Guying the pivot section in flying mode with the SA-frame

There are three ways to change the guy point for flying disassembly:

- Take down the boom on the ground.
 - Secure the boom with the auxiliary crane.
 - Support the boom.
- ▶ Take down the boom on the ground, see illustration 2.
or



WARNING

Lattice section incorrectly attached!

If the fastening equipment is attached on the bits **2** when securing the boom, then the bits will be overloaded. The lattice section will be damaged.

The boom can fall down.

Death, severe bodily injuries, property damage.

If an auxiliary crane is used to secure the boom for flying disassembly:

- ▶ Do **not** fasten the lattice section to the bits **2**, see illustration 1.
- ▶ Attach the fastening equipment in the area of point **P1** on both sides on the lattice section, see detail **X**.
- ▶ Make sure that the long fastening equipment is used, so that the angle between the cross-section of the lattice section and guyed fastening equipment is at least 60°, see detail **Y**.

Secure the boom with the auxiliary crane, see illustration 3.

or



WARNING

Falling boom!

If the boom is not properly and securely supported from below, then the boom can fall down.

- ▶ Support the boom properly and safely with suitable material.

Support the boom, see illustration 4.

Result:

- The guy rods can be disassembled.
- ▶ Take down, secure and disassemble the guy rods.
- ▶ Pin and secure the guy rods SA-frame on the pivot section.
- ▶ Tighten the SA-frame guy rods until the boom is in a horizontal position.

Result:

- Pivot section is guyed in flying mode with the SA-frame, see illustration 5.
- The lattice sections can be disassembled in flying mode.

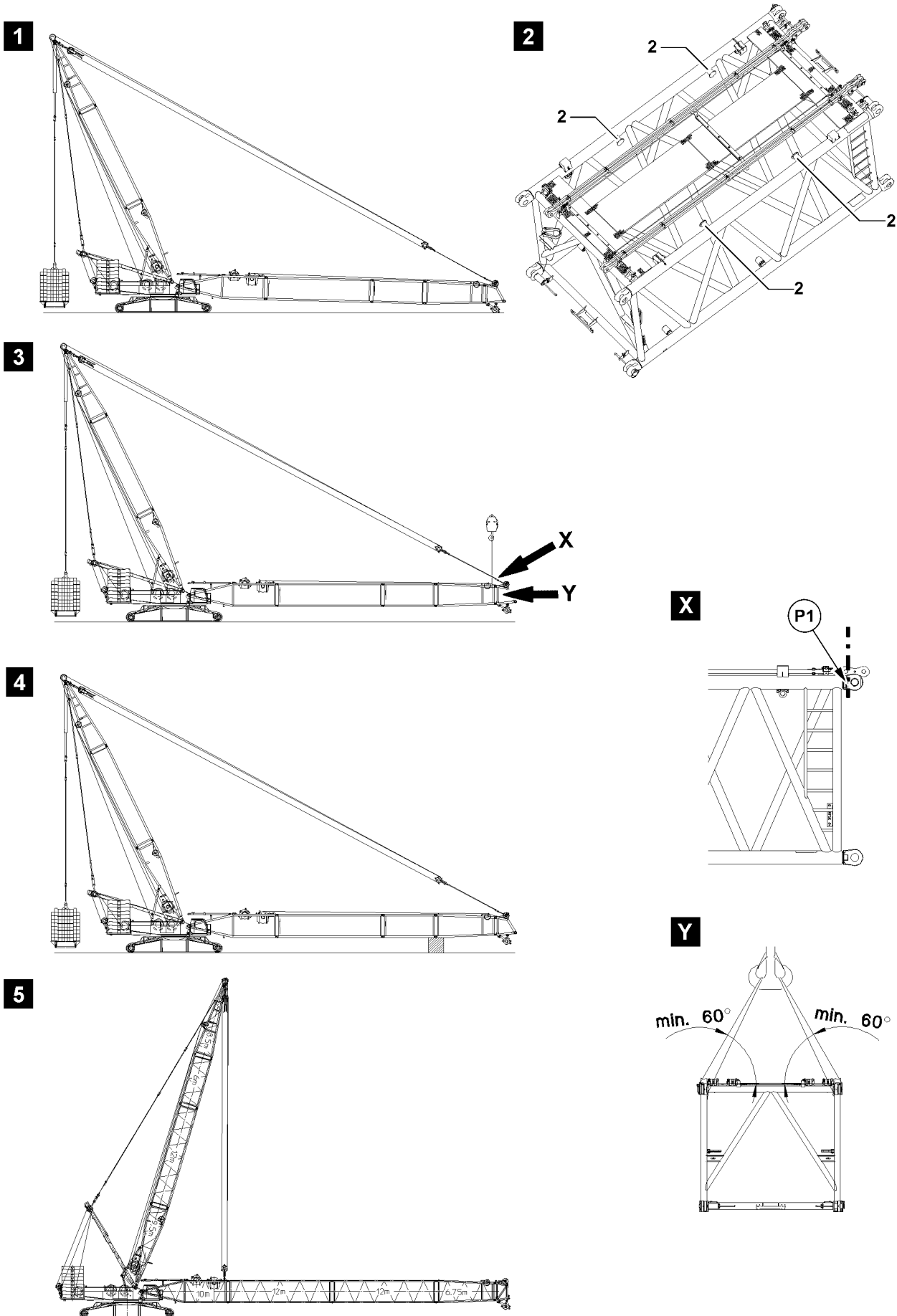

Fig.111449: Guying the pivot section with the derrick boom

LWE/LR 13000-001/19503-01-02/en

Guying the pivot section in flying mode with the derrick boom

There are three ways to change the guy point for flying disassembly:

- Take down the boom on the ground.
 - Secure the boom with the auxiliary crane.
 - Support the boom.
- ▶ Take down the boom on the ground, see illustration 1.
or



WARNING

Lattice section incorrectly attached!

If the fastening equipment is attached on the bitts **2** when securing the boom, then the bitts will be overloaded. The lattice section will be damaged.

The boom can fall down.

Death, severe bodily injuries, property damage.

If the auxiliary crane is used to secure the boom for flying disassembly:

- ▶ Do **not** fasten the lattice section to the bitts **2**, see illustration 2.
- ▶ Attach the fastening equipment in the area of point **P1** on both sides on the lattice section, see detail **X**.
- ▶ Make sure that the long fastening equipment is used, so that the angle between the cross-section of the lattice section and guyed fastening equipment is at least 60°, see detail **Y**.

Secure the boom with the auxiliary crane, see illustration 3.

or



WARNING

Falling boom!

If the boom is not properly supported from below, then the boom can fall down.

- ▶ Support the boom properly and safely with suitable material.

Support the boom, see illustration 4.

Result:

- The guy rods can be disassembled.
- ▶ Take down, secure and disassemble the guy rods.
- ▶ Pin and secure the luffing pulley block on the pivot section.
- ▶ Tighten the control rope until the boom is in a horizontal position.

Result:

- Pivot section is guyed in flying mode with the derrick boom, see illustration 5.
- The lattice sections can be disassembled in flying mode.

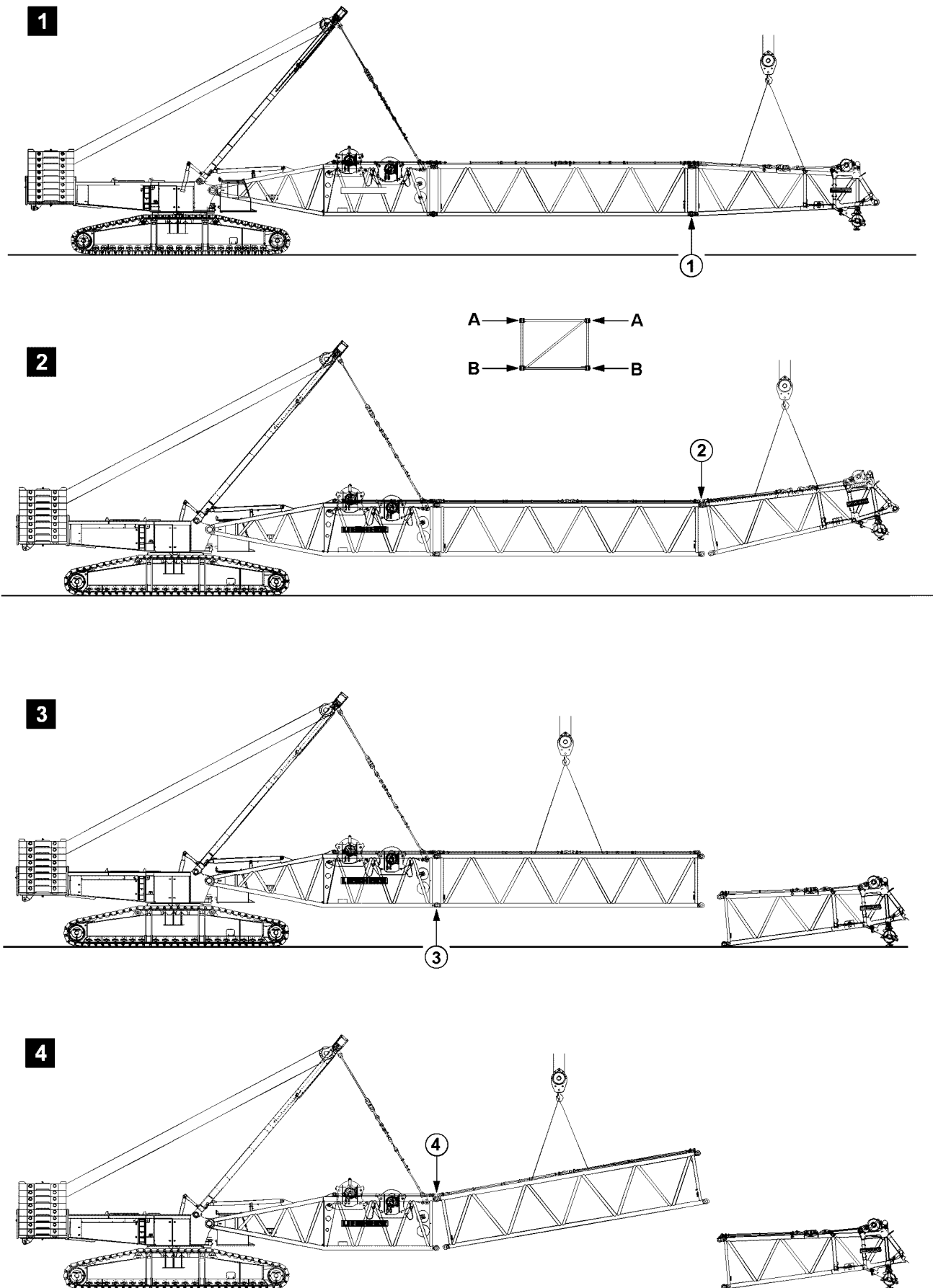

Fig.105511: Example of cranes with a lattice mast boom

Unpinning the lattice components



WARNING

Danger of fatal injury when disassembling booms!

If the pins are not unpinned in the given sequence, then lattice sections may suddenly fold down or fall down.

Death, severe bodily injuries, property damage.

▶ Pins must be unpinned in the specified order.

- ▶ Release and unpin the pins on both sides (level **B**) in point **1**, illustration 1.
- ▶ Release and unpin the pins on both sides (level **A**) in point **2**, illustration 2.
- ▶ Release and unpin the pins on both sides (level **B**) in point **3**, illustration 3.
- ▶ Release and unpin the pins on both sides (level **A**) in point **4**, illustration 4.

16.18 Supporting long lattice mast booms for erection and take-down



Note

- ▶ The illustrations of the crane and lattice mast boom are simplified and are examples and may not match your crane exactly.
- ▶ When working on uneven ground, additional or other substructures may be necessary.

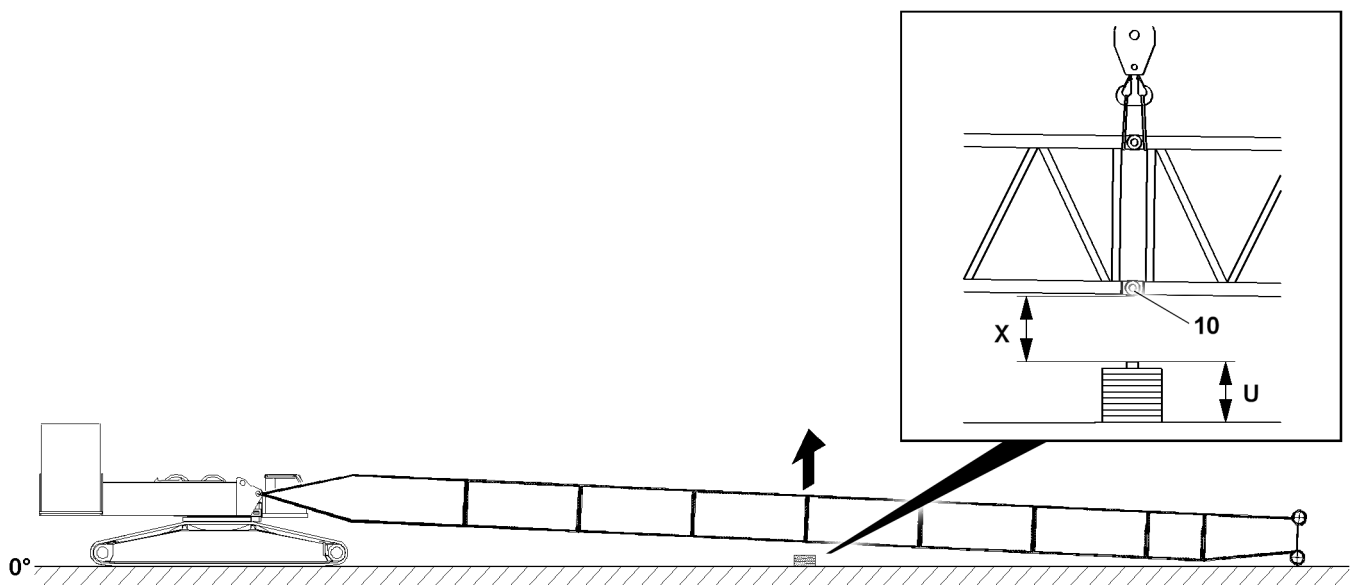

Fig.160362: Example of supporting a long boom system



Note

- ▶ The height **U** of the substructure or dimension **X** is noted in the respective boom assembly chapter, see for example, chapter 5.38 or chapter 5.39.
- ▶ If the height **U** or dimension **X** is not available in the chapter, see the separately supplied drawing „Support assembly drawing“ or the assembly drawing for the concerned boom system.

16.18.1 Supporting lattice mast booms for erection

Support the boom system properly for the closing procedure.

If the lower pins **10** can be inserted during closing:

- ▶ Select the height **U** of the substructure such that the maximum distance according to the dimension **X** is not exceeded.

16.18.2 Supporting lattice mast booms for take-down

For the take-down procedure, the boom system must be supported the same way as for erection.

If the boom system is to be taken down in the same place where it was erected:

- ▶ Take the boom system down in the same place with the same substructure.
- or

If the boom system is to be taken down in another permissible place:

Establish the same conditions for the substructure according to the dimension **X**.

16.19 Assembling / disassembling boom systems for supporting on ascending terrain (assembly / disassembly diagram)



Note

- ▶ The following assembly steps are simplified and are examples and may not match your crane exactly.



WARNING

Danger of fatal injury when assembling / disassembling booms!

If the pins are not pinned / unpinned in the specified sequence, then lattice sections may suddenly fold down or fall down.

Death, severe bodily injuries, property damage.

- ▶ Insert / unpin the pins in the specified sequence, see section „Assembly of lattice sections“.
- ▶ Observe all safety technical notes in section „Assembly / disassembly“.
- ▶ Make sure that there is no personnel in the danger zone.



WARNING

Horizontal movement of the boom!

- ▶ Make sure that there is no personnel in the danger zone.

16.19.1 Assembling the boom systems on ascending terrain

Make sure that the following prerequisites are met:

- An auxiliary crane with sufficient load bearing capacity is available.



Fig.121635: Boom - pivot section installed on the turntable and taken down on the ground

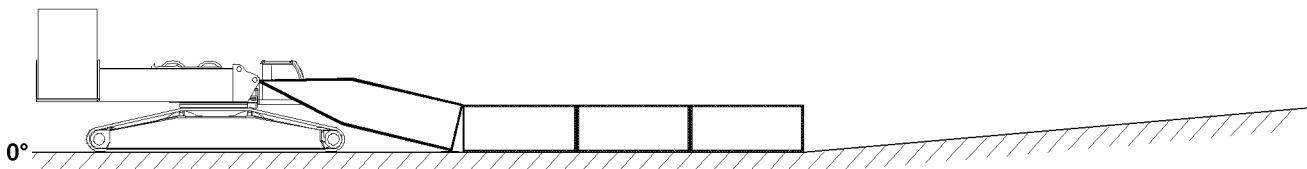

Fig.121636: Boom - intermediate sections installed on the boom - pivot section and taken down on the ground

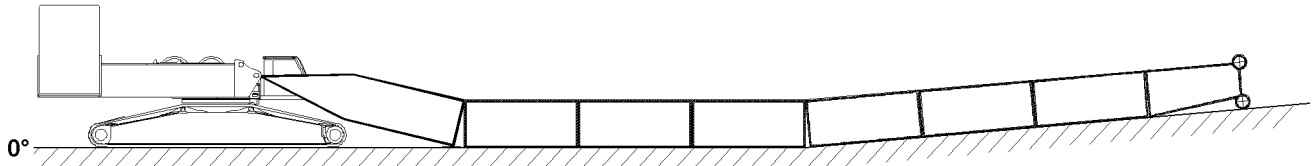

Fig.121637: Boom - intermediate sections installed and taken down on ascending terrain

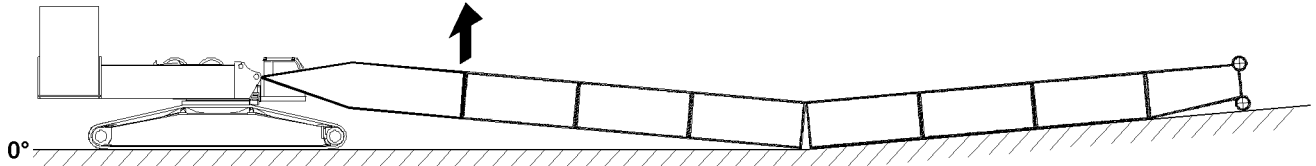

Fig.121638: Lifting and close the boom system in the area of the boom - pivot section

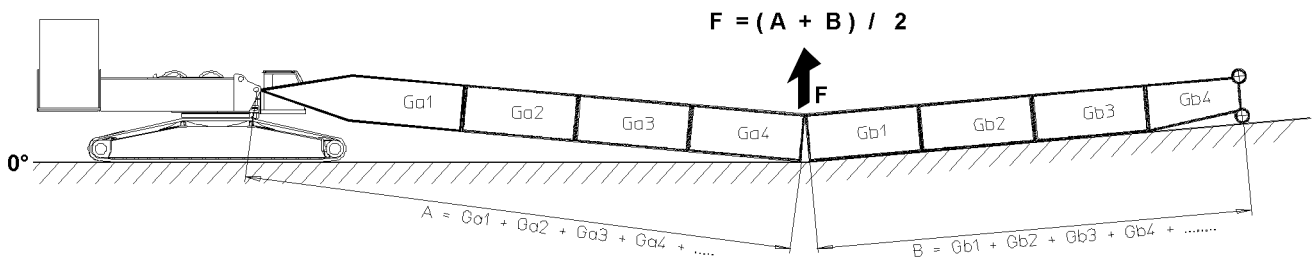

Fig.145512: Calculation of force for the closing procedure of the boom system



Note

- ▶ The abbreviations Ga1, Ga2, ... and Gb1, Gb2, are for the weights of the individual lattice sections.
- ▶ The weights of the lattice sections are noted on the welded-on weight tags on the lattice sections.

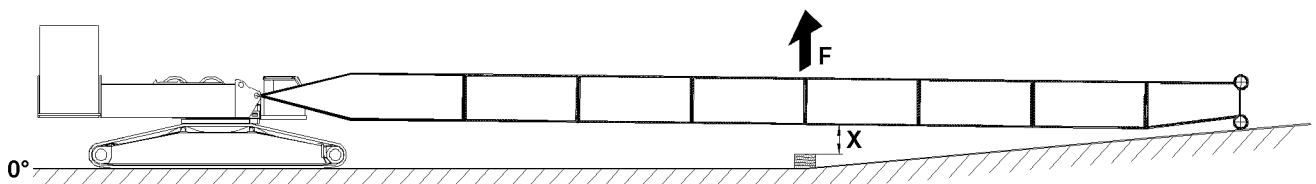

Fig.121639: Lifting and closing the boom system // Supporting the boom system



Note

- ▶ The height of the substructure or the dimension X is noted in the respective boom assembly chapter, see chapter 5.38 or chapter 5.39.
- ▶ If the dimension X is not available in chapter 5.38 or chapter 5.39, see the separately supplied drawing „Support assembly drawing“ or the assembly drawing for the corresponding operating mode.
- ▶ Support the boom system properly after the closing procedure.

16.19.2 Disassembling boom systems on ascending terrain

Make sure that the following prerequisites are met:

- An auxiliary crane with sufficient load bearing capacity is available.

LWE/LR_13000-001/19503-01-02/en

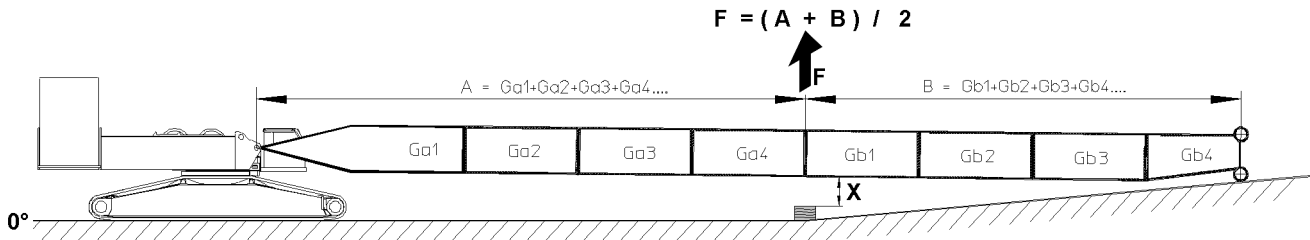

Fig. 145513: Calculation of the force for opening the boom system // Lifting the boom system // Removing the substructure // Opening the boom system



Note

- ▶ The abbreviations Ga1, Ga2, ... and Gb1, Gb2, are for the weights of the individual lattice sections.
- ▶ The weights of the lattice sections are noted on the welded-on weight tags on the lattice sections.

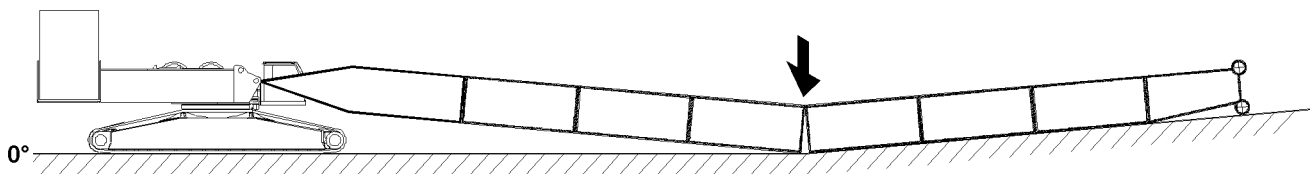

Fig. 121657: Taking the boom system down

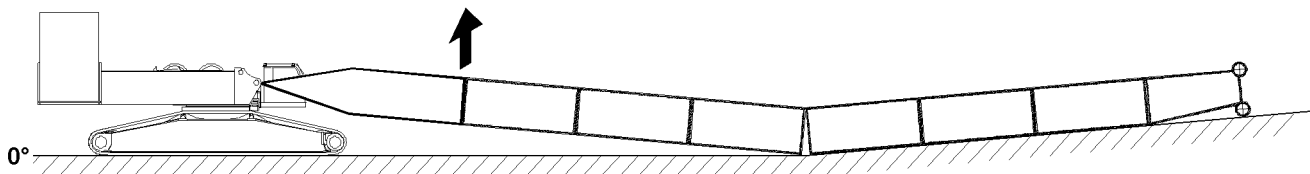

Fig. 121652: Lifting and opening the boom system

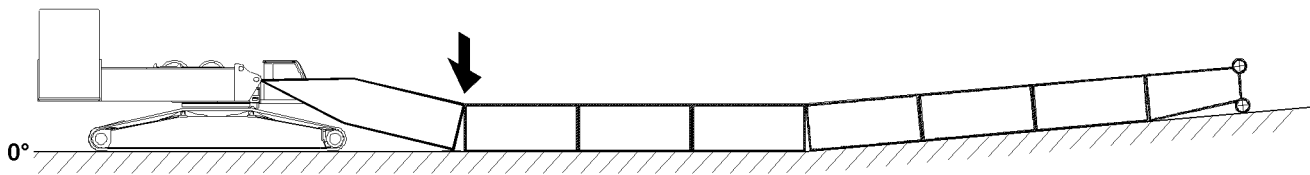

Fig. 121653: Taking the boom system down

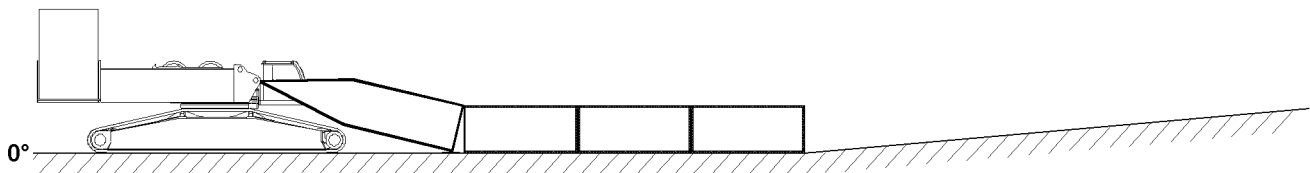

Fig. 121636: Disassembling and removing the boom - intermediate sections with the end section

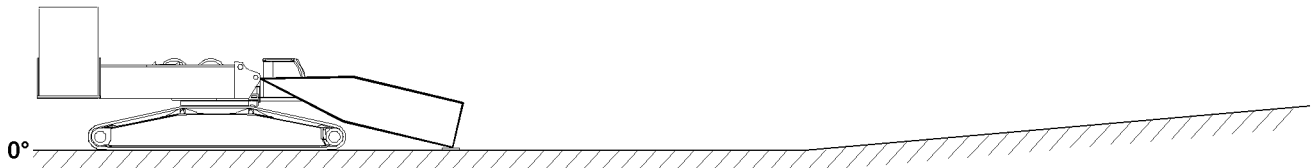

Fig. 121635: Disassembling and removing the boom - intermediate sections to the boom - pivot section

- ▶ Disassemble and remove the boom - pivot section.

16.20 Assembling / disassembling of boom systems for supporting on descending terrain (assembly / disassembly schematic)



Note

- ▶ The following assembly steps are simplified and are examples and may not match your crane exactly.



WARNING

Danger of fatal injury when assembling / disassembling booms!

If the pins are not pinned / unpinned in the specified sequence, then lattice sections may suddenly fold down or fall down.

Death, severe bodily injuries, property damage.

- ▶ Insert / unpin the pins in the specified sequence, see section „Assembly of lattice sections“.
- ▶ Observe all safety technical notes in section „Assembly / disassembly“.
- ▶ Make sure that there is no personnel in the danger zone.

16.20.1 Assembling the boom systems on descending terrain

Make sure that the following prerequisites are met:

- The lattice sections are properly assembled.
- An auxiliary crane with sufficient load bearing capacity is available.

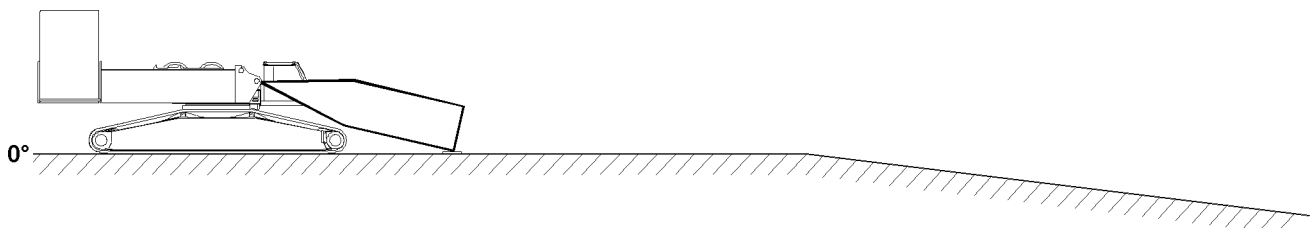

Fig. 121640: Boom - pivot section installed on the turntable and taken down on the ground

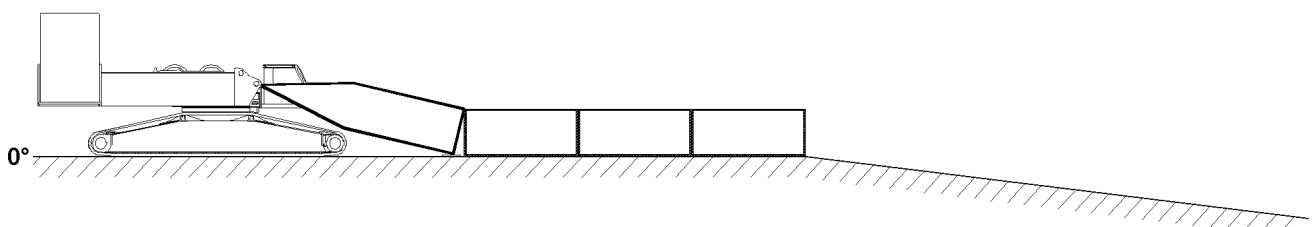

Fig. 121641: Boom - intermediate sections installed on the boom - pivot section and taken down on the ground

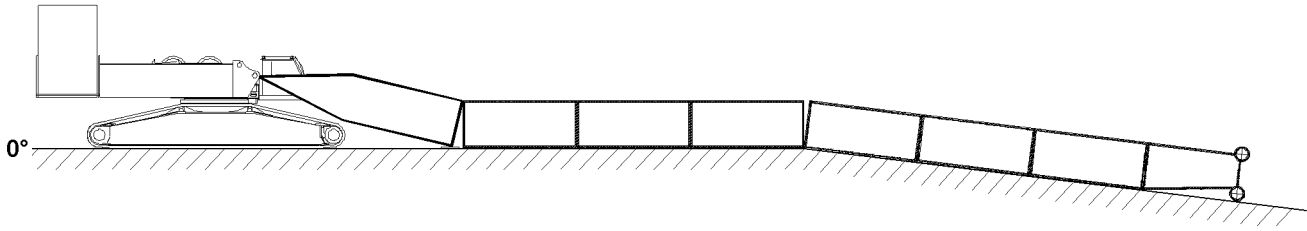

Fig.121642: Boom - intermediate sections installed and taken down on descending terrain

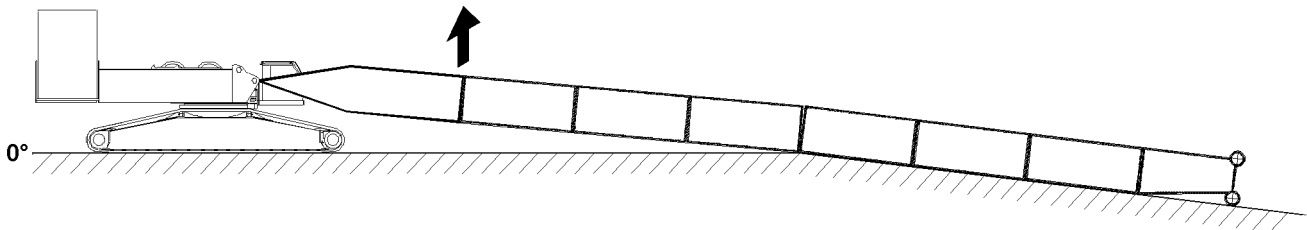

Fig.121643: Lifting and close the boom system in the area of the boom - pivot section

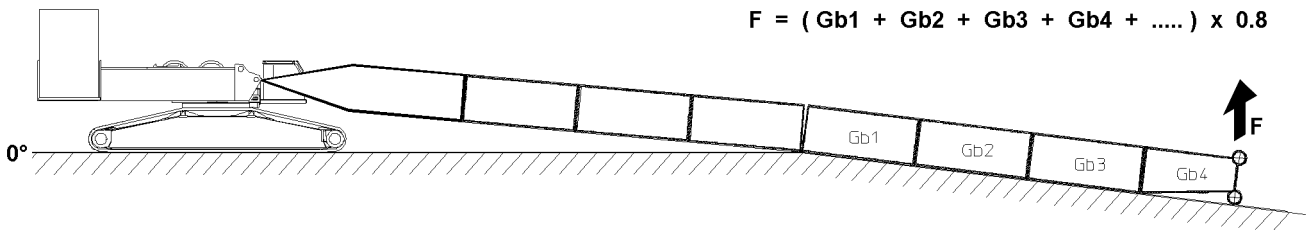

Fig.145514: Calculation of force for the closing procedure of the boom system



Note

- ▶ The abbreviations Gb1, Gb2, ... are for the weights of the individual lattice sections.
- ▶ The weights of the lattice sections are noted on the welded-on weight tags on the lattice sections.

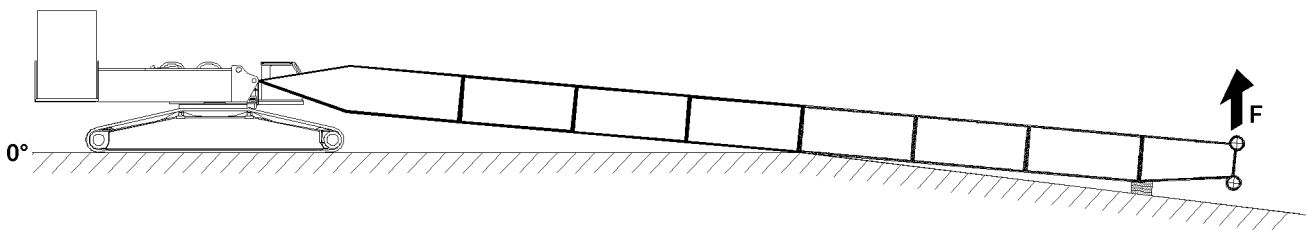

Fig.121644: Lifting and closing the boom system // Supporting the boom system



Note

- ▶ The height of the substructure depends on the lay of the terrain and the resulting incline of the boom system.
- ▶ Support the boom system properly after the closing procedure.

16.20.2 Disassembling boom systems on descending terrain

Make sure that the following prerequisite is met:

- An auxiliary crane with sufficient load bearing capacity is available.

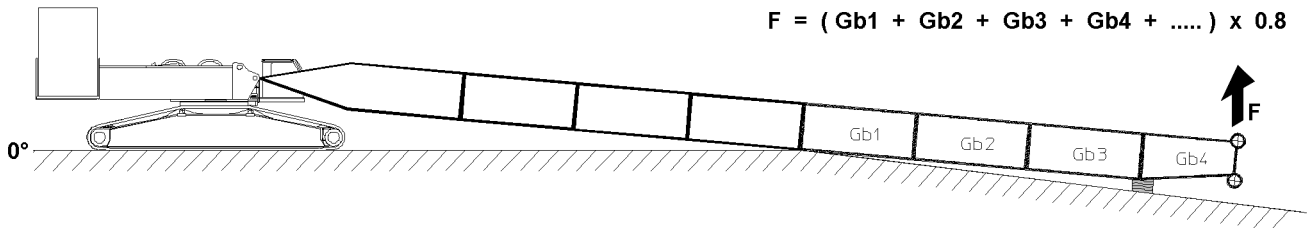

Fig.145515: Calculation of the force for opening the boom system // Lifting the boom system // Removing the substructure // Opening the boom system



Note

- ▶ The abbreviations Gb1, Gb2, ... are for the weights of the individual lattice sections.
- ▶ The weights of the lattice sections are noted on the welded-on weight tags on the lattice sections.

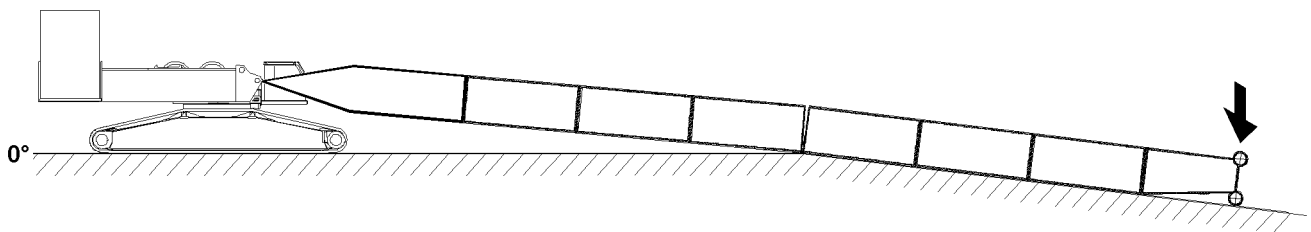

Fig.121658: Taking the boom system down

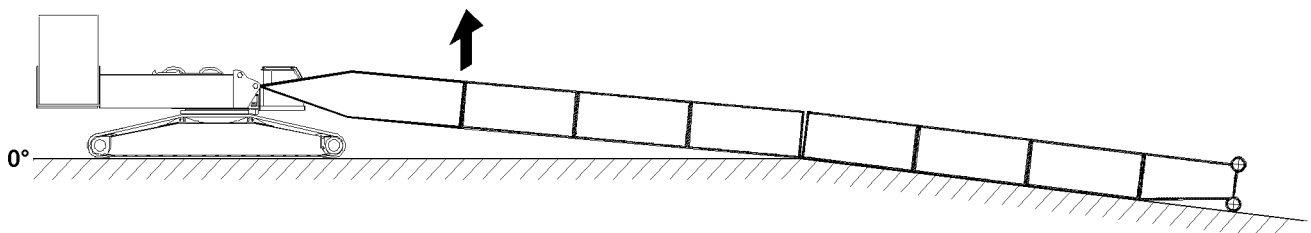

Fig.121655: Lifting and opening the boom system

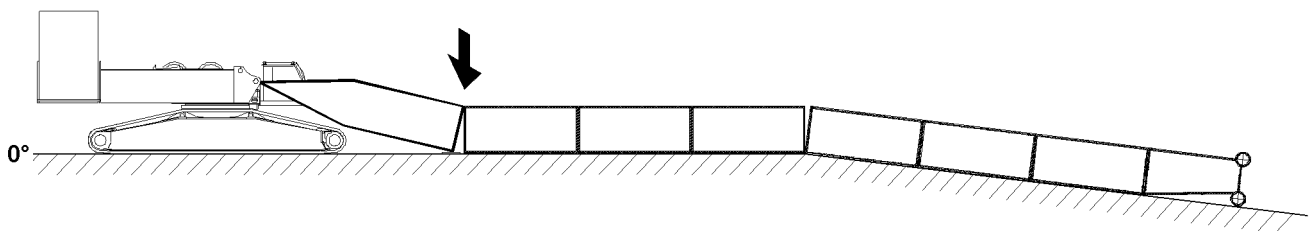

Fig.121656: Taking the boom system down

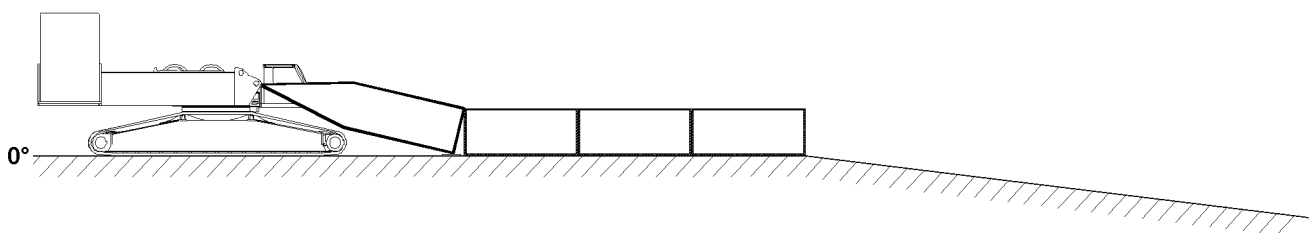

Fig.121641: Disassembling and removing the boom - intermediate sections with the end section

LWE/LR 13000-001/19503-01-02/en

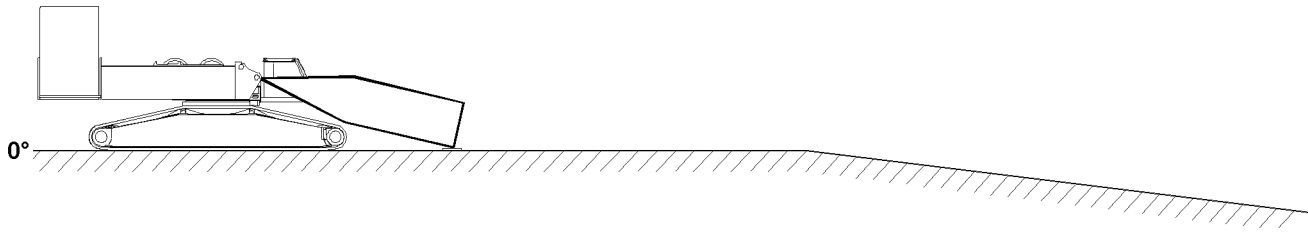

Fig.121640: Disassembling and removing the boom - intermediate sections to the boom - pivot section

- ▶ Disassemble and remove the boom - pivot section.

16.21 Closing the boom system - opening the boom system (via the SA-frame)



Note

- ▶ This section is described as an example.
- ▶ The illustrations in this section are shown as an example.

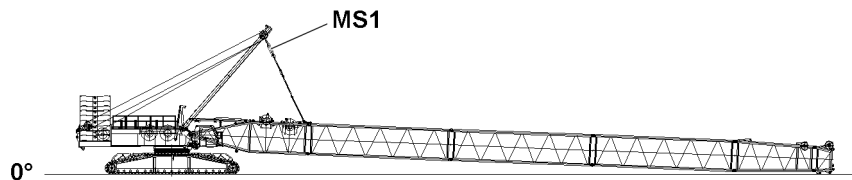

Fig.161332: Test point 1 closing the boom system - opening the boom system



DANGER

Overload of the crane!
Death, severe bodily injuries, property damage.

- ▶ The closing and opening of different boom systems with the SA-frame is only permissible up to certain maximum boom lengths.
- ▶ Make sure that there are no persons on the boom system as well as in the danger zone during the opening and closing procedure.



Note

The actual forces in test point 1 **MS1** - which are used during the closing and opening procedure of the boom system - are displayed on the LICCON monitor. The force determined in test point 1 is generally designated as $F1^{actual}$.

When specifications are available for the force in test point 1 **MS1** on the assembly drawing:

- ▶ Observe the specifications for the force in test point 1 **MS1**.

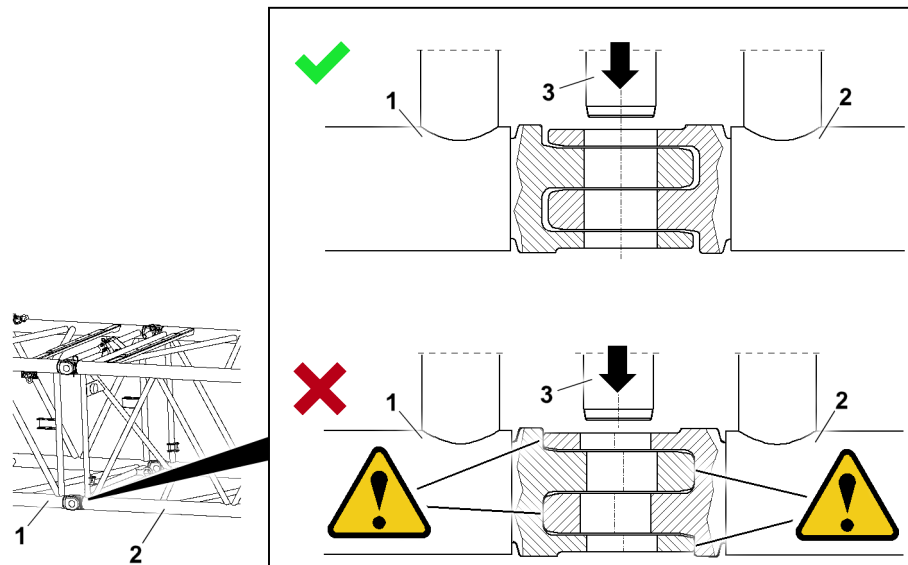

Fig.161335: Alignment of the lattice sections and overloaded pin bores

1 Lattice section 1
2 Lattice section 2

3 Connector pin



DANGER

Overload of the crane!

If when opening and closing too much force is applied in test point 1, the boom system can be overloaded.

Death, severe bodily injuries, property damage.

- ▶ Spool winch 4 up to the maximum when closing the boom system such that the pin bores of the lattice sections align. Take note of the force in test point 1. The noted value is decisive for opening.
- ▶ Do not load or push the connecting forks into each other on the block.
- ▶ When opening, use the noted force from the closing procedure as an orientation.
- ▶ The end section may **not** lift off the ground during the boom system closing and opening procedure, it must lie on the ground.
- ▶ The maximum permissible F1-total force ($F1_{max}$) on the LICCON monitor may not be used as a limit value, as it protects another condition (the completely assembled boom).
- ▶ A maximum force in test point 1 specified in the assembly drawing cannot always be approached. At times, the closing procedure can be carried out with significantly lower forces, for example with light, short booms.



Note

- ▶ Counterweight and central ballast, see the Erection chart depending on the boom length.

16.21.1 Closing the boom system (via the SA-frame)

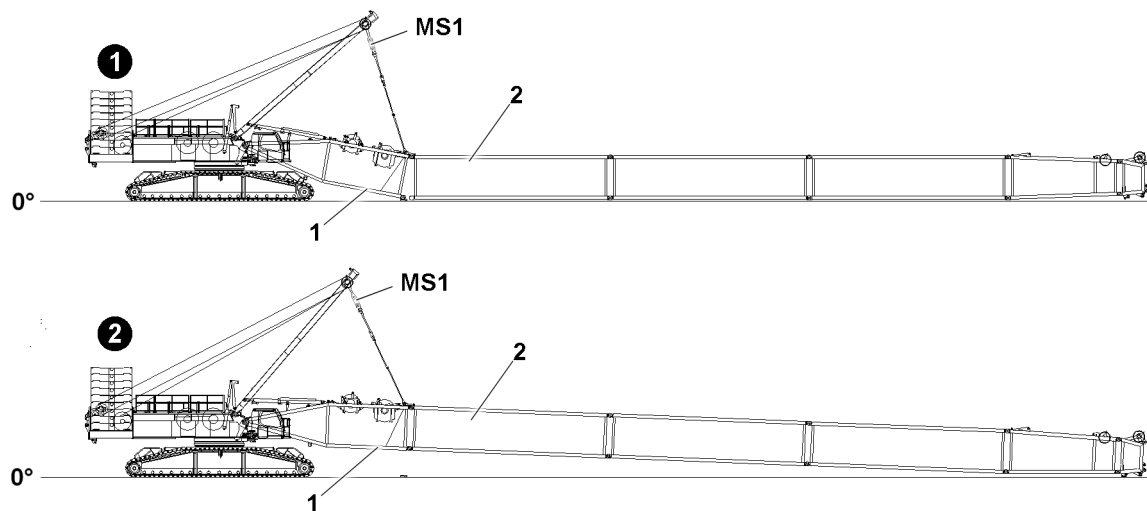

Fig.161384: Example: Boom system with closing

1 Pivot section

2 Intermediate section

Make sure that the following prerequisites are met:

- Counterweight and central ballast positioned according to the assembly drawing.



Note

Noted actual force in test point 1 **MS1** for later disassembly.

- ▶ When unpinning in the same location with the same ACTUAL force in test point 1 **MS1**, pull to release the connector pin.

- ▶ Spool winch 4 up such that the pin bores of the pivot section 1 and the intermediate section 2 align.

When the pin bores align:

- ▶ Take note of the actual force in test point 1 **MS1** displayed on the LICCON monitor.
- ▶ Insert the connector pin on both sides and secure.
- ▶ Spool winch 4 out such that the boom system is relieved.

Result:

- Boom system closed.

16.21.2 Opening the boom system (without derrick boom)

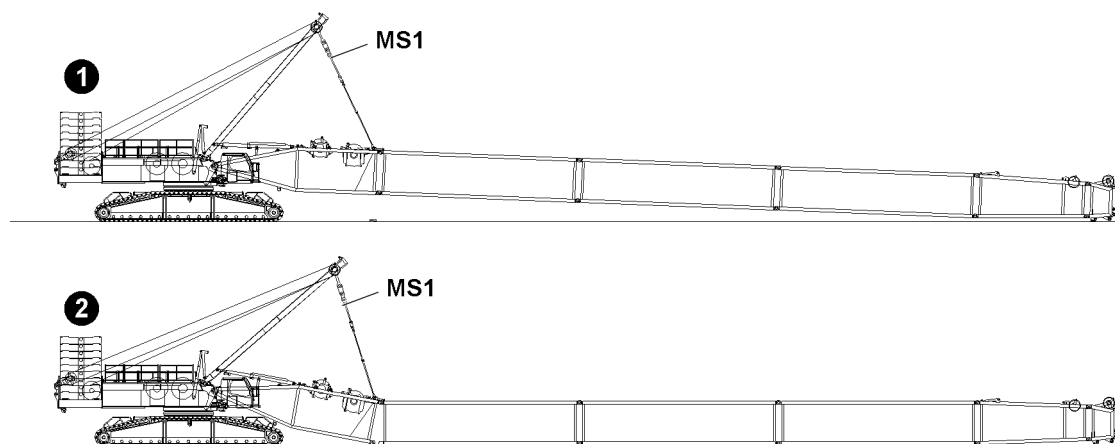

Fig.161385: Example: Opening the boom system

**Note**

- ▶ Use the noted actual force in test point 1 **MS1** to pretension the boom system.
- ▶ Spool winch 4 up until the noted actual force is reached in test point 1 **MS1**.
- ▶ Release and unpin the connector pins on both sides.

NOTICE

Danger of property damage!

When lowering the opened boom system incorrectly, crane components can be damaged.

- ▶ Observe the specifications regarding railings and substructure.
- ▶ Spool winch 4 out and lower the boom system properly.

Result:

- Boom system opened and taken down.

16.22 Closing the boom system - opening the boom system (via the derrick boom)

**Note**

- ▶ This section is described as an example.
- ▶ The illustrations in this section are shown as an example.

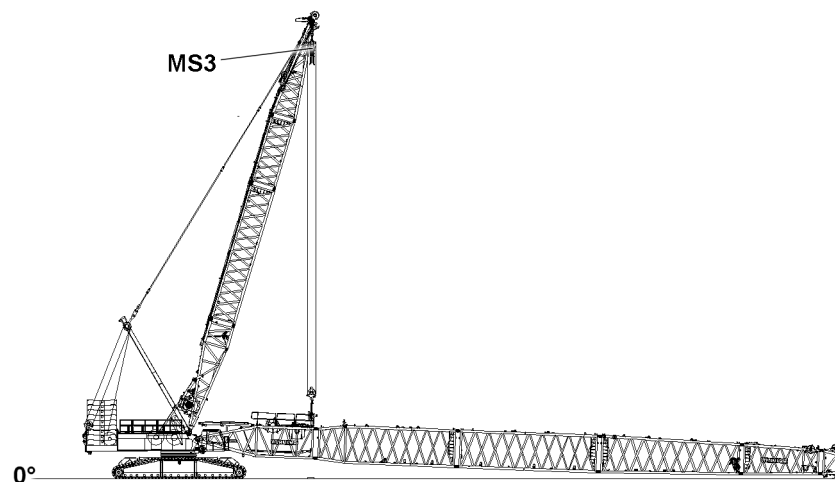

Fig.161378: Test point 3 closing the boom system - opening the boom system

**DANGER**

Overload of the crane!

Death, severe bodily injuries, property damage.

- ▶ The closing and opening of different boom systems with the derrick boom is only permissible up to certain maximum boom lengths.
- ▶ Make sure that there are no persons on the boom system as well as in the danger zone during the opening and closing procedure.

**Note**

The actual forces in test point 3 **MS3** - which are used during the closing and opening procedure of the boom system - are displayed on the LICCON monitor. The force determined in test point 3 is generally designated as $F3^{actual}$.

When specifications are available for the force in test point 3 **MS3** on the assembly drawing:

- ▶ Observe the specifications for the force in test point 3 **MS3**.

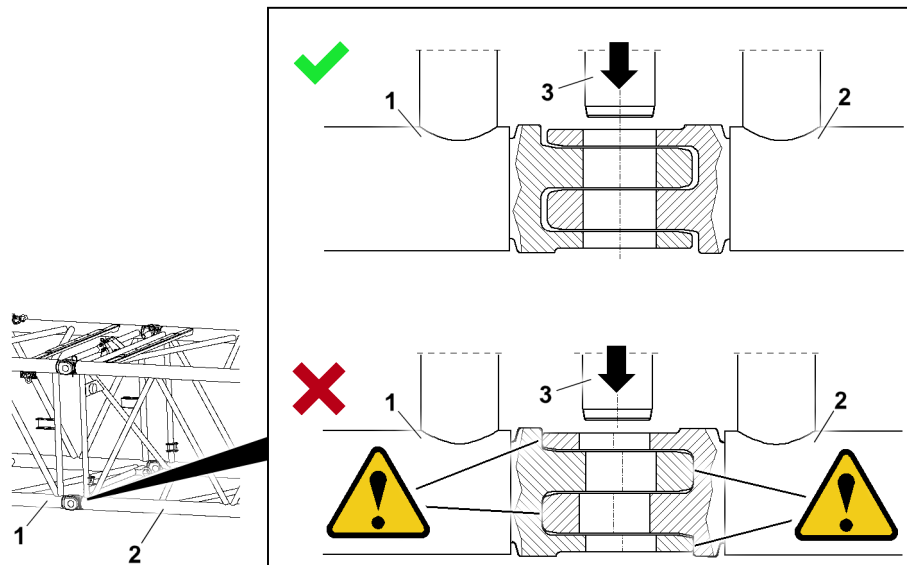

Fig.161335: Alignment of the lattice sections and overloaded pin bores

1 Lattice section 1
2 Lattice section 2

3 Connector pin



DANGER

Overload of the crane!

If when opening and closing too much force is applied in test point 3, the boom system can be overloaded.

Death, severe bodily injuries, property damage.

- ▶ Spool winch 3 up to the maximum when closing the boom system such that the pin bores of the lattice sections align. Take note of the force in test point 3. The noted value is decisive for opening.
- ▶ Do not load or push the connecting forks into each other on the block.
- ▶ When opening, use the noted force from the closing procedure as an orientation.
- ▶ The end section may **not** lift off the ground during the boom system closing and opening procedure, it must be lie on the ground.
- ▶ The maximum permissible F3-total force ($F_{3_{max}}$) on the LICCON monitor may not be used as a limit value, as it protects another condition (the completely assembled boom).
- ▶ The maximum permissible F3-total force ($F_{3_{max}}$) on the LICCON monitor cannot always be approached. At times, the closing procedure can be carried out with significantly lower forces, for example with light, short booms.

16.22.2 Opening the boom system (without derrick boom)

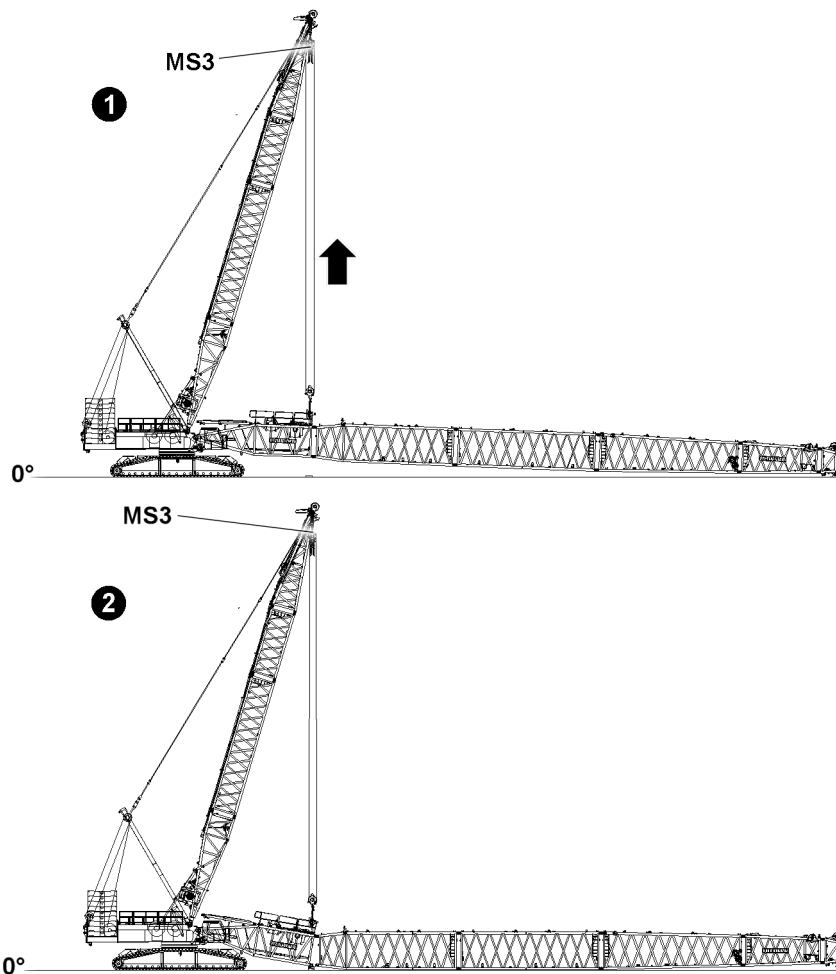

Fig.161382: Example: Opening the boom system



Note

- ▶ Use the noted actual force in test point 3 **MS3** to pretension the boom system.
- ▶ Spool winch 4 up until the noted actual force is reached in test point 3 **MS3**.
- ▶ Release and unpin the connector pins on both sides.

NOTICE

Danger of property damage!

When lowering the opened boom system incorrectly, crane components can be damaged.

- ▶ Observe the specifications regarding railings and substructure.
- ▶ Spool winch 3 out and lower the boom system properly.

Result:

- Boom system opened.

17 Erecting / taking-down



WARNING

The crane can topple over!

Due to an unforeseen occurrence, for example: Sudden strong wind or storm can lead to dangerous operating situations, up to toppling the crane.

Death, severe bodily injuries, property damage.

- ▶ The boom must be able to be taken down at any time with its current equipment, observe the erection and take-down charts. Observe the job planner.
- ▶ The counterweights and / or ballasts required for this must always be in direct vicinity of the crane.
- ▶ The crane operator must ensure that the required counterweight and / or the required ballast is carried along when driving the crane with the equipment in place and that the boom can be placed down at any time.



WARNING

Danger of fatal injury!

- ▶ Incorrectly installed or non-functioning limit switches as well as falling parts (pins, cotter pins, ice etc.) can cause accidents.

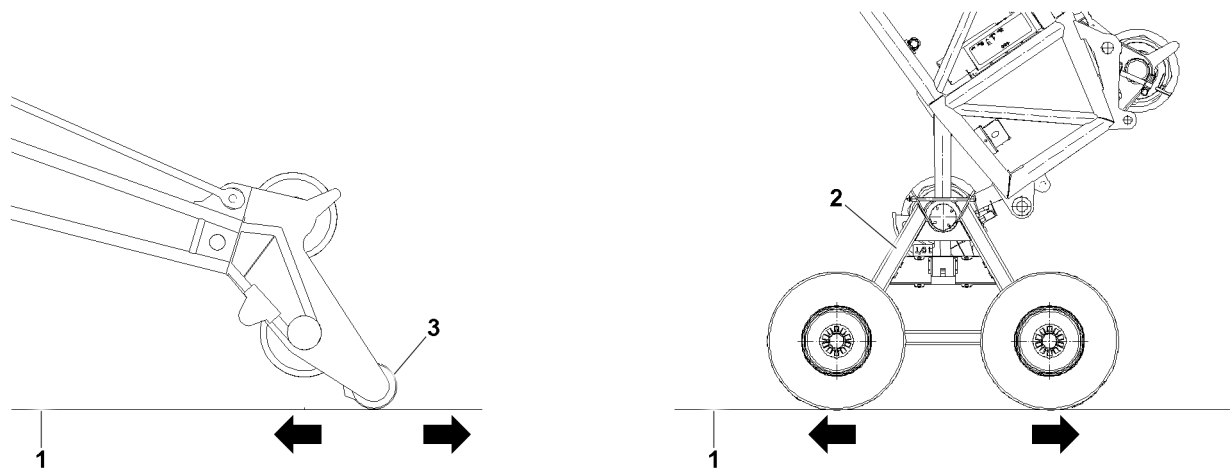

Fig.152357: Roller cart road or lattice head track roller

- | | | |
|------|-------------|---------------------------|
| 1 | 2 | 3 |
| Road | Roller cart | Lattice head track roller |

When erecting or taking down with the aid of a roller cart **2** or a lattice head track roller **3**, make sure that the following prerequisites are met:

- The road **1** is level.
- The road **1** has a sufficient load bearing capacity.
- The road **1** is free of obstacles.
- The road **1** is free of persons.

17.1 Erecting / taking down with mobile cranes

Make sure that the following prerequisites are met:

- The crane is properly supported.
 - The crane is horizontally aligned.
 - The counterweight has been installed on the turntable according to the load chart or the erection / take down charts.
 - In the case of cranes with derrick ballast: The derrick ballast (suspended ballast or ballast trailer ballast) is installed according to the load chart or the erection / take down charts.
 - For cranes with a telescopic boom: The telescopic boom is telescoped in all the way.
 - The boom has been installed according to the load chart and the Crane operating instructions.
 - The hoist rope has been correctly placed in the rope pulleys and prevented from jumping out with the rope retaining pins.
 - All limit switches have been correctly assembled and are fully operational.
 - All pin connections are secured.
 - No persons in the danger zone.
 - No loose parts on the boom or the auxiliary boom.
 - The exposed rope pulleys are free of snow and ice.
 - The boom and its components (limit switches, cable drums, airplane warning light, wind speed sensor etc.) must be kept free of ice and snow.
- Check if all prerequisites have been met.

The roller cart may not be lifted off the ground.

Before the N-head lifts up:

- Unpin the roller cart on the N-head.

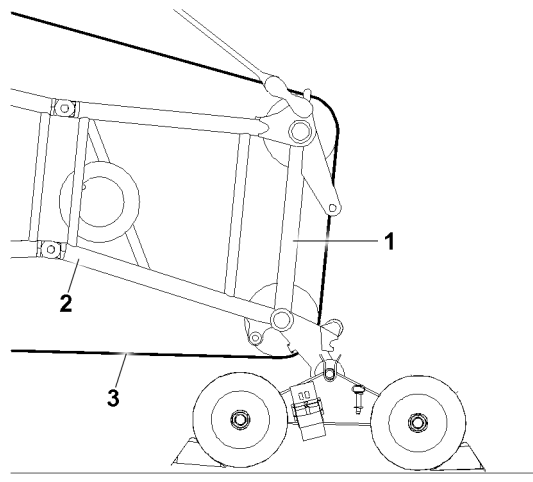

Fig.152358: Securing the hoist rope to the head of the lattice jib

When the luffing lattice jib is erected or taken down **angled**, then the hoist rope must be secured **prior to reeving in** or **after reeving out** the hook block.

Before the hook block is reeved in or after the hook block is reeved out, it is possible that the hoist rope is pulled out of the head of the lattice jib. Therefore the hoist rope must be secured by a hemp rope.



WARNING

Hoist rope not secured!

The hoist rope can run back in the direction of the hoist winch after reeving out or reeving in the hook block.

- Secure the hoist rope with the hemp rope.
- Fasten the hemp rope with Prusik knots to the hoist rope **3**.

- ▶ Fasten both ends of the hemp rope on the corner bar pipe **2** of the head **1** of the lattice jib with tie knots.

17.2 Erecting / taking down with crawler cranes

Make sure that the following prerequisites are met:

- Comply with the maximum permissible incline of the crane specified in the load chart manual.
 - For cranes with a support: The crane is properly supported.
 - For cranes with a support: The crane is horizontally aligned.
 - The counterweight has been installed on the turntable according to the load chart.
 - The central ballast is installed according to the load chart.
 - The counterweight is installed according to the load chart or the erection / take down charts.
 - In the case of cranes with derrick ballast: The derrick ballast (suspended ballast or ballast trailer ballast) is installed according to the load chart or the erection / take down charts.
 - For cranes with a telescopic boom: The telescopic boom is telescoped in all the way.
 - The boom has been installed according to the load chart and the Crane operating instructions.
 - The hoist rope has been correctly placed in the rope pulleys and prevented from jumping out with the rope retaining pins.
 - All limit switches have been correctly assembled and are fully operational.
 - All pin connections are secured.
 - No persons in the danger zone.
 - No loose parts on the boom or the auxiliary boom.
 - The exposed rope pulleys are free of snow and ice.
 - The boom and its components (limit switches, cable drums, airplane warning light, wind speed sensor etc.) must be kept free of ice and snow.
- ▶ Check if all prerequisites have been met.

17.3 Rigging the guy rods on lattice booms on placed down boom system



WARNING

Danger of fatal injury due to damaged guy rods!

If the boom system is placed on the ground or a load bearing substructure in strong wind or longer downtime, the guy rods can be damaged due to wind influence on the boom guying. This wind influenced oscillations can lead to fatigue on the guy rods.

As a result, the guy rods could break or rip off under load - for example when erecting the boom system or in crane operation. The boom system can therefore fall uncontrolled forward onto the ground. Death, severe bodily injuries, property damage.

- ▶ Make sure that the guy rods are taken down completely on the lattice sections and relieved when the boom systems are taken down on the ground.
- ▶ Make sure that freely suspended guy rods are rigged on the lattice boom.
- ▶ Make sure that the upper pulley block is rigged on the lattice boom in Derrick operating modes.
- ▶ Make sure, that the guying on the luffing lattice jib is removed on lattice mast cranes.
- ▶ Make sure that the guy rods are inspected before resuming crane operation and that no damage or cracks are present.
- ▶ Make sure that the maintenance intervals of the guy rods are adhered to.



Note

- ▶ In case of strong wind or longer downtimes of the crane, the boom system must be placed on the ground or on a load bearing substructure.
- ▶ The guying must be relieved and the guy rods must be placed on the transport receptacles.
- ▶ The following illustrations are examples and may not match your crane exactly.

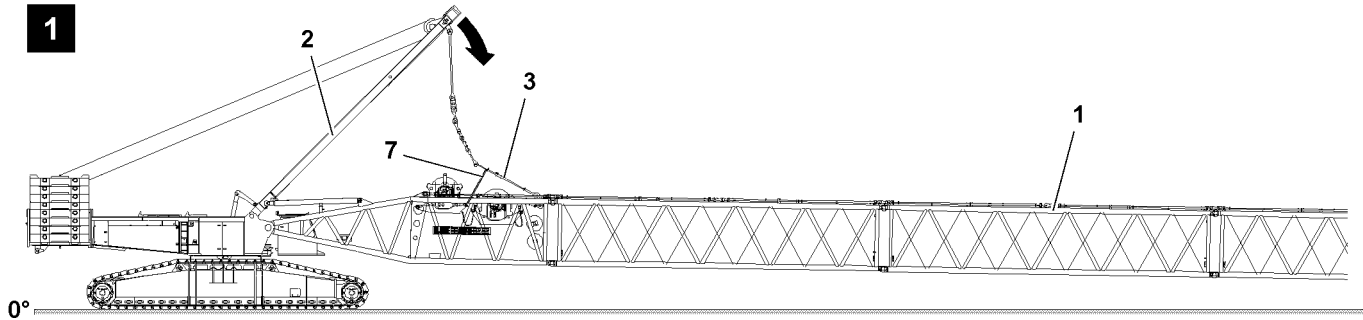

Fig.120722: Guying taken down in transport receptacle and SA-frame guying relieved

- ▶ Take the guy rods down on the lattice sections 1: Luff the SA-frame 2 down to the front until the guying is taken down completely in the transport receptacles on the lattice sections and the SA-frame guying 3 is relieved, see illustration 1.
- ▶ To minimize side oscillation of the SA-frame guying 3 due to wind influence: Rig the SA-frame guying 3 with suitable rigging straps / ropes 7 against the boom, see illustration 1.

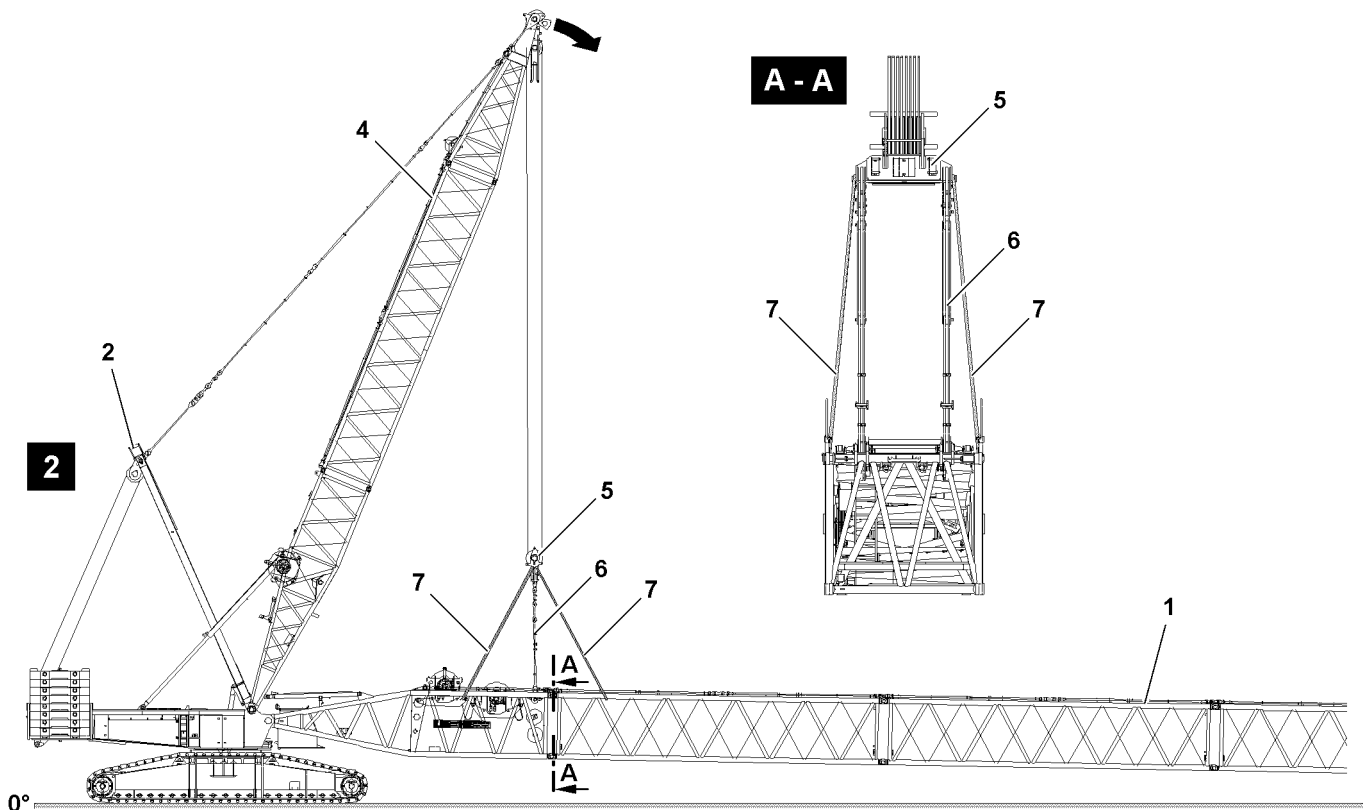

Fig.120771: Guying taken down in the transport receptacle and upper pulley block rigged against the boom

- ▶ Take the boom system down and - if present - release the derrick guying to the derrick ballast.
- ▶ Take the guy rods down on the lattice sections 1: Luff the D-boom 4 down to the front until the main boom guying is taken down completely in the transport receptacles on the lattice sections and the upper pulley block 5 is positioned over the S-pivot section, see illustration 2.
- ▶ To minimize side oscillation of the upper pulley block 5 due to wind influence: Rig the upper pulley block 5 with suitable rigging straps / ropes 7 against the boom, see illustration 2.

For cranes with lattice mast and with luffing lattice jib the following applies:

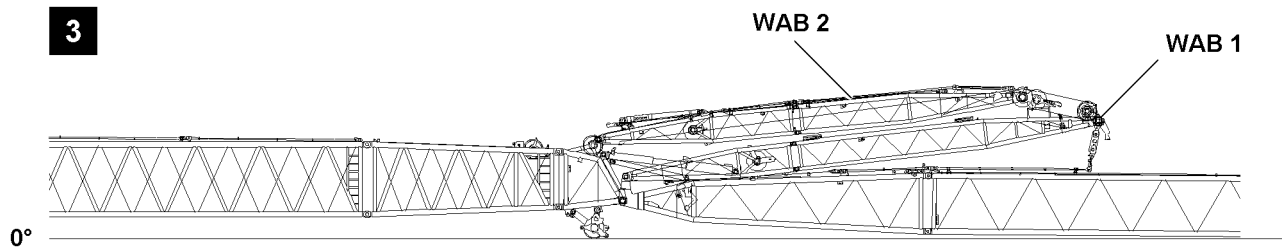

Fig.120821: Guying in the transport receptacle(s) and WA-frames taken down to the front (example crane with lattice mast)



WARNING

Danger of accident when removing the W-guying!

When taking down and removing the guying dangerous situations can arise.

- ▶ Make sure that the danger notes in the respective chapter of the Crane operating instructions are observed.
- ▶ Disassemble the guy rods on the luffing lattice jib and take them down into the transport receptacles.
- ▶ Take the WA-frames (WA-frame 1 **WAB 1** and WA-frame 2 **WAB 2**) down to the front.

For telescopic cranes with luffing lattice jib the following applies:

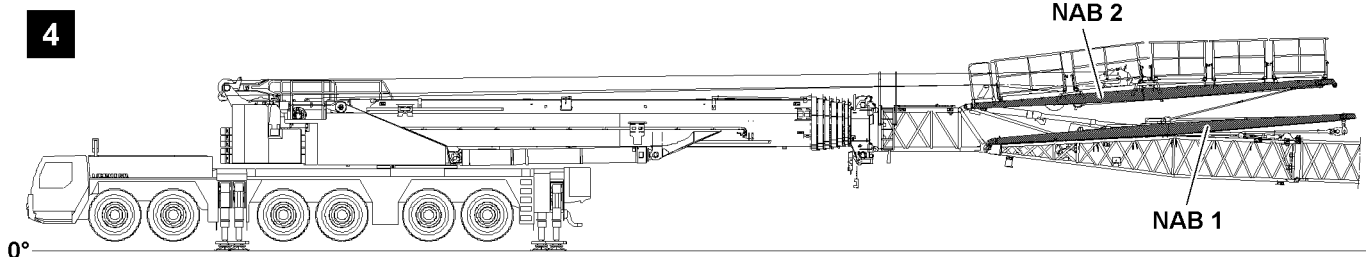

Fig.121261: Guying in the transport receptacle(s) and NA-frames taken down to the front (example telescopic crane)



WARNING

Danger of accident when taking the NA-frames down!

When taking the guy rods as well as the NA-frames down dangerous situations can arise.

- ▶ Make sure that the danger notes in the respective chapter of the Crane operating instructions are observed.
- ▶ Spool the jib control winch out and take the NA-frames down to the front so that the guy rods are relieved.

18 Walking on a boom component



WARNING

Falling from the boom component!

Death, severe bodily injuries.

- ▶ Before working on a boom component, personnel must wear an approved fall arrest system and protective equipment.

**WARNING**

Falling from the boom component!

Operating personnel falling from a boom component due to tripping on objects.

Death, severe bodily injuries.

- ▶ Make sure that there are no objects on the boom component when walking on it.

**WARNING**

Overload of the grating!

Operating personnel falling from the boom component grating if the grating is overloaded due to an impermissible number of personnel.

The grating for the boom components is permitted for the weight of only two people.

Death, severe bodily injuries.

- ▶ Make sure that only the permissible number of personnel can walk on the grating at the same time.

**WARNING**

Impermissible work position for the hydraulic aggregate!

If a hydraulic aggregate is placed on boom components or crane components for assembly purposes, this can cause accident situations.

Operating personnel can fall down from the grating of the boom component if the grating is overloaded by the hydraulic aggregate positioned on it.

The grating for the boom components is permitted for the weight of only two people.

Death, severe bodily injuries, property damage.

- ▶ Make sure that a hydraulic aggregate is never placed on boom components or crane components.
- ▶ The hydraulic aggregate may only be operated on the ground.

5.03 Boom systems

1	Boom components	2
2	Arrangement of intermediate sections and guy rods on the booms / boom systems	2
3	Wire rope auxiliary guying	5
4	Fiber guy rope auxiliary guying	15

1 Boom components



Note

- ▶ For boom components including associated system dimensions, lengths and component weights refer to chapter 1.03.

2 Arrangement of intermediate sections and guy rods on the booms / boom systems



Note

- ▶ The following description is an example and may not exactly match your crane.
- ▶ Lengths, weights and system dimensions of the intermediate sections are examples and may differ from the data on your crane.
- ▶ For exact crane data, and for the arrangement of intermediate sections and guy rods, refer to the respective rod plan.
- ▶ For dimensions and weights of crane components, see chapter 1.03 as well as the weight signs on the corresponding components.



WARNING

The boom can break off!

The arrangement of the intermediate sections on booms or boom systems are based on extensive static calculations.

If the arrangement of the intermediate sections is not observed according to the rod plan, the crane can collapse, the boom can break off or the crane can topple over.

If the arrangement of the guy rods is not observed according to the rod plan, the crane can collapse, the boom can break off or the crane can topple over.

Death, severe bodily injuries, property damage.

- ▶ Only arrange the intermediate sections according to the rod plan.
- ▶ Only arrange the guy rods according to the rod plan.

If auxiliary guying is required for a certain boom length:

- ▶ Only assemble the auxiliary guying according to the rod plan in the position defined in the rod plan.

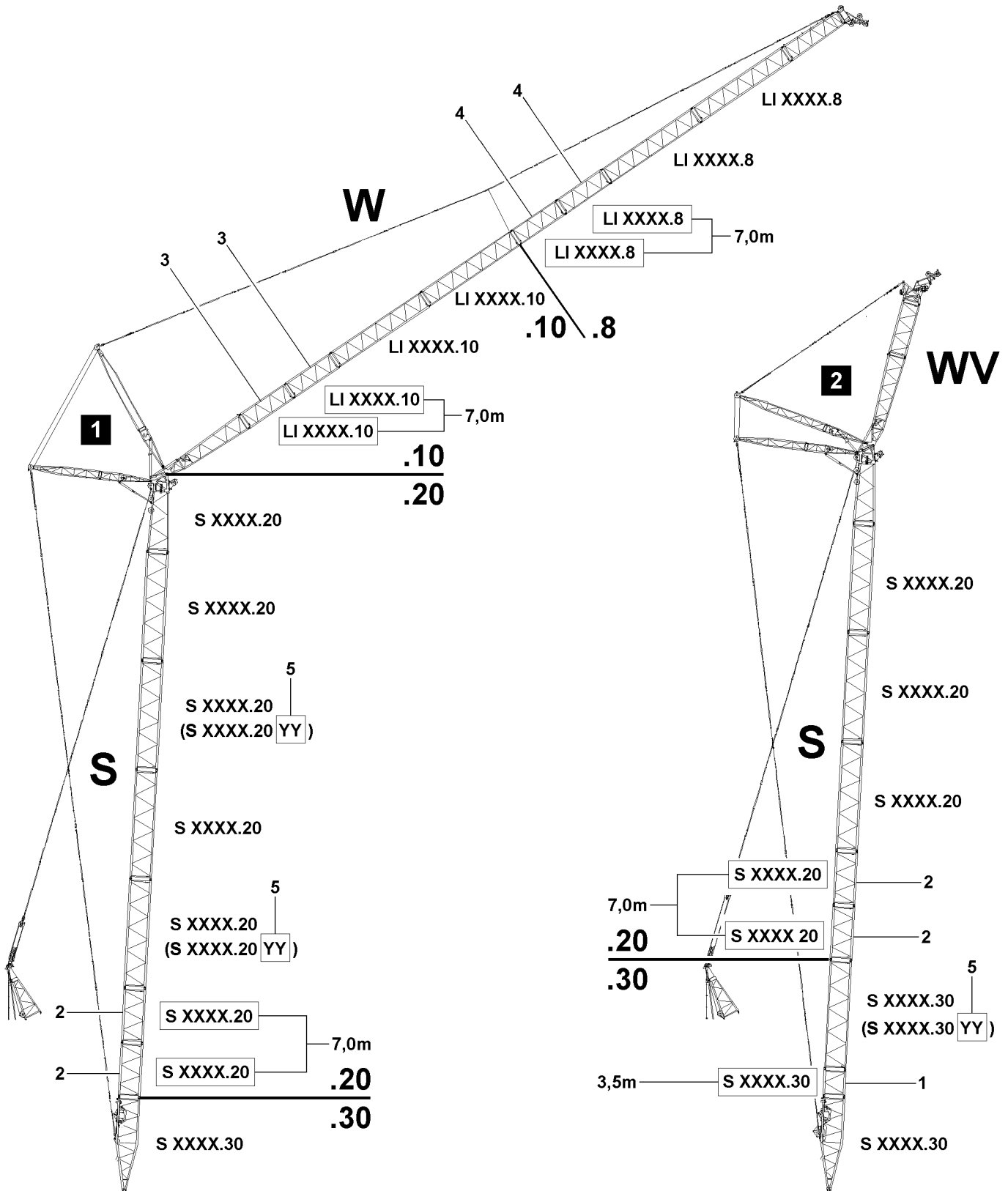

Fig.151885: Arrangement of intermediate sections and the guy rods

LWE/LR 13000-001/19503-01-02/en

System dimensions and assignment				
Position	System		Heavy	Light
1	S XXXX	.30	X	
2	S XXXX	.20		X
3	LI XXXX	.10	X	
4	LI XXXX	.8		X
5	S XXXX	.40 YY	X	

General specifications for the configuration of booms or boom systems:

- With the same system dimension, two short intermediate sections with a length of 3.0 m (3.5 m) are heavier than one single intermediate section with a length of 6.0 m (7.0 m).
- With the same system dimension, two short intermediate sections with a length of 6.0 m (7.0 m) are heavier than one single intermediate section with a length of 12.0 m (14.0 m).
- With the same system dimension, two short intermediate sections with a length of 3.0 m (3.5 m) can be replaced by one single intermediate section with a length of 6.0 m (7.0 m).
- With the same system dimension, two short intermediate sections with a length of 6.0 m (7.0 m) can be replaced by one single intermediate section with a length of 12.0 m (14.0 m).
- For intermediate sections with the same system dimension but different lengths, always install the short intermediate sections on the bottom in the boom, due to their weight, in direction of the slewing ring connection, see illustration 1 and illustration 2.
- The heavier one intermediate section is, the higher is the value of the last two numbers on the system dimension plate.
- Pay attention to the last two numbers following the letter combinations (YY 5) on the system dimension plate and observe them.

2.1 Arrangement of the intermediate sections



WARNING

Danger of accidents due to incorrectly assembled intermediate sections!

Death, severe bodily injuries, property damage.

- ▶ Any arrangement of the intermediate sections other than what is specified in the operating instructions or the rod plans is prohibited.
- ▶ There is the danger that intermediate sections can be mixed up, as they are differently sized and do **not** differ externally.
- ▶ The intermediate sections differ externally only by the welded on plates (.8, .10, .12, .16, .20, .25, .30, .40 YY).
- ▶ When assembling the boom, it must be ensured that the intermediate sections are only arranged and installed according to their description as indicated on the rod plan.
- ▶ Observe and adhere to the additional letter combinations (YY 5) on the system dimension plate of the intermediate sections during assembly of the intermediate sections.



WARNING

Arrangement of the intermediate sections!

If the arrangement of the intermediate sections is not carried out according to the rod plan, then the boom can be overloaded, bend and break off.

Death, severe bodily injuries, property damage.

- ▶ For intermediate sections with the same system dimension but with a different length, the shorter intermediate sections must always be installed on the bottom in the boom, in direction of the slewing ring connection, unless another installation position is specified in the rod plan.
- ▶ Adhere to the specifications in the rod plan in any case.

2.2 Arrangement of the guy rods



WARNING

Danger of accident due to incorrectly assembled guy rods!
Death, severe bodily injuries, property damage.

- ▶ Any arrangement of the guy rods other than what is specified in the operating instructions or the rod plans is prohibited.
- ▶ During assembly of the boom / boom system, only arrange and install the guy rods according to their description in the rod plan.



WARNING

Arrangement of the guy rods!

If the arrangement of the guy rods is not carried out according to the rod plan, then the boom can be overloaded, bend and break off.

Death, severe bodily injuries, property damage.

- ▶ Adhere to the specifications in the rod plan in any case.

3 Wire rope auxiliary guying

The following auxiliary guying variations are assembled:

- The auxiliary guying consists of the fiber guy ropes, see section „Fiber guy rope auxiliary guying“.
- Auxiliary guying is comprised of wire ropes, see section „Auxiliary guying wire ropes“.



Note

- ▶ The following descriptions and illustrations are examples and may not match your crane exactly.
- ▶ For exact crane data refer to the respective rod plan.
- ▶ In the case of questions: Contact Customer Service at Liebherr-Werk Ehingen GmbH.

The auxiliary guying, in regards to safe crane operation - especially for long boom systems - is of vital importance.

The auxiliary guying is a deciding factor in relieving the boom, or the boom system during erection and take-down as well as during crane operation.

Guy ropes with different lengths are used in the different auxiliary guyings.

The assembly of the auxiliary guying between the boom guying and the boom system is implemented using different brackets, cross brackets and connector brackets.



Note

- ▶ The boom lengths, for which an auxiliary guying is required in addition to a boom guying, can be seen in the rod plan.

Depending on the crane type and boom length:

- ▶ Assembly of the auxiliary guying: Remove the standard lugs and install the tension lugs **12**.

**WARNING**

The crane can topple over!

If the auxiliary guying is not installed or not installed on the position specified in the rod plan, then the crane can collapse, the boom can break off or the crane can topple over.

Death, severe bodily injuries, property damage.

- ▶ Only assemble the auxiliary guying in the position specified in the rod plan.
- ▶ Make sure that the auxiliary guying is always completely installed and that all pins are properly pinned and secured.
- ▶ Assemble the auxiliary guying together with the boom guying when the boom / boom system is lying on the ground.
- ▶ **or:**
- ▶ Assemble the auxiliary guying together with the boom guying when the boom / boom system is lying on a load bearing substructure.
- ▶ **or:**
- ▶ Assemble the auxiliary guying together with the boom guying when the boom / boom system is held securely by the auxiliary crane.

3.1 Assembling the auxiliary guying on the main boom variation A

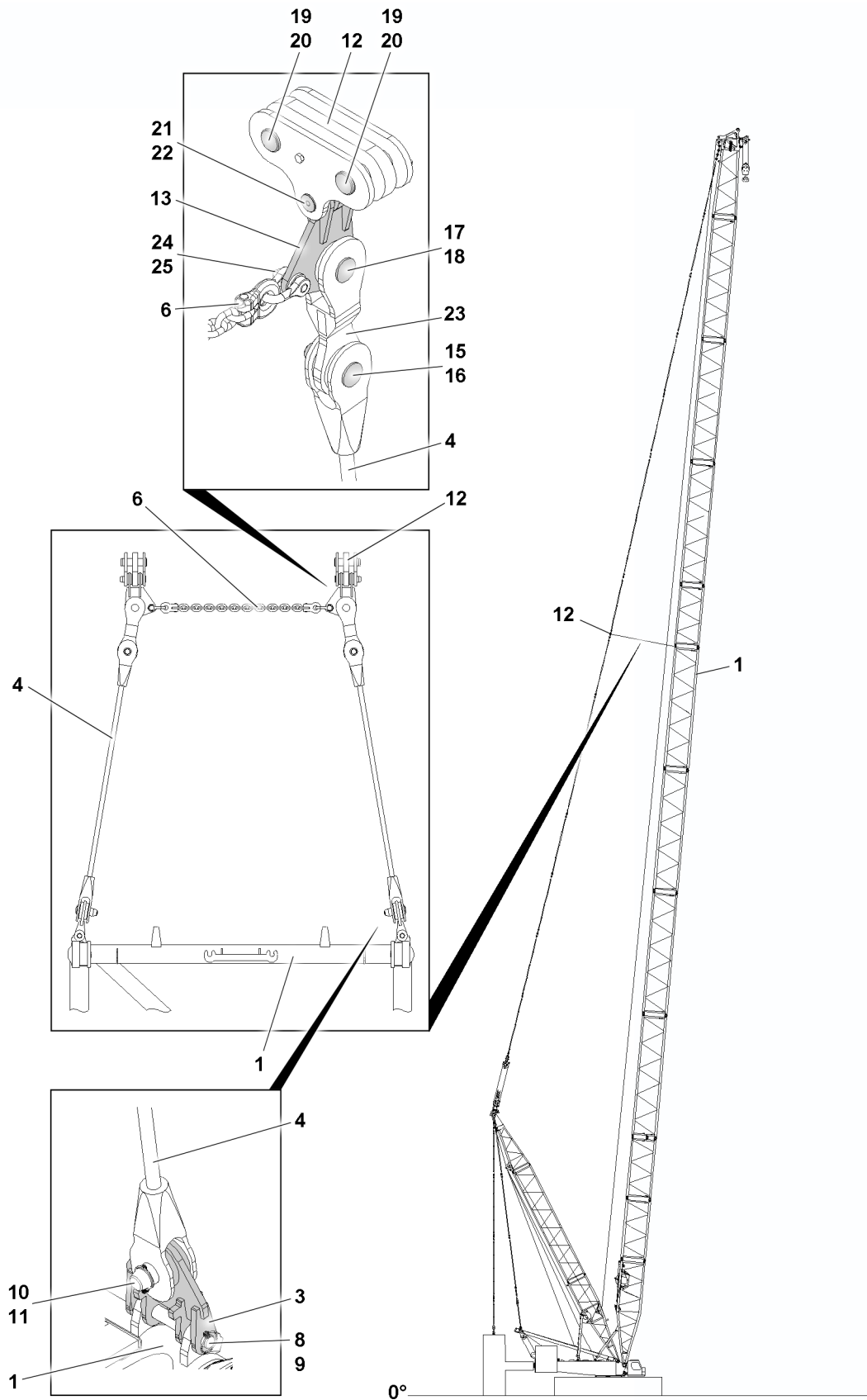

LWE/LR 13000-001/19503-01-02/en

Fig.153507: „Long“ auxiliary guying on the main boom

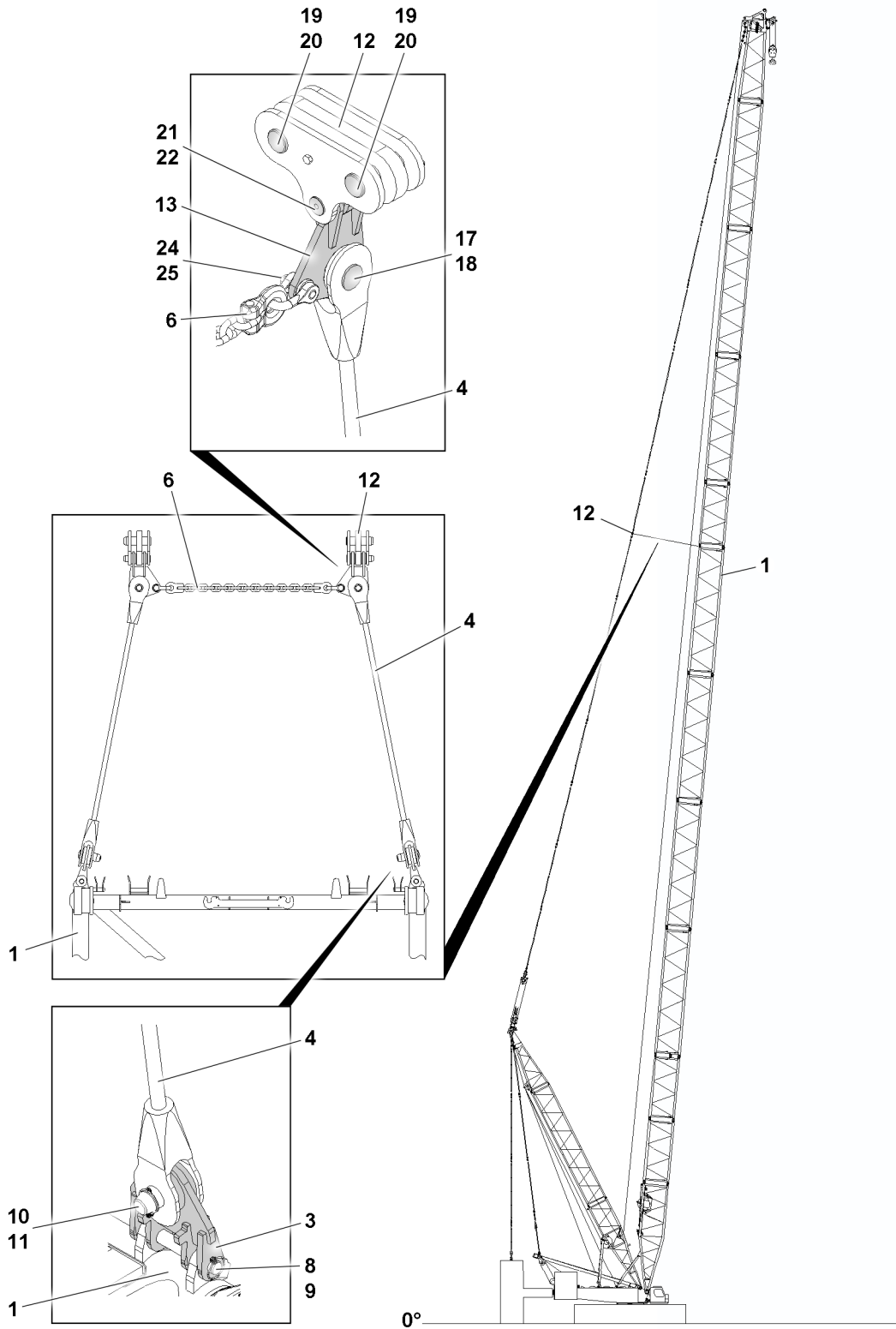

Fig.153603: „Short“ auxiliary guying on the main boom

- | | | | | | |
|----|------------------------------------|----|-------------------|----|-------------------|
| 1 | Intermediate section ¹⁾ | 11 | Retaining element | 19 | Pin |
| 3 | Connector bracket | 12 | Tension lug | 20 | Retaining element |
| 4 | Guy rope ²⁾ | 13 | Cross bracket | 21 | Pin |
| 6 | Chain | 15 | Pin | 22 | Retaining element |
| 8 | Pin | 16 | Retaining element | 23 | Bracket |
| 9 | Retaining element | 17 | Pin | 24 | Shackle |
| 10 | Pin | 18 | Retaining element | 25 | Screw pin |

¹⁾ for the exact designation of the intermediate section: see the rod plan

LWE/LR 13000-001/19503-01-02/en

²⁾ for the exact designation of the guy rope: see the rod plan

The tension lugs **12** must be installed in the boom guying instead of standard lugs. The auxiliary guying is installed on the tension lugs **12**.

Make sure that the following prerequisites are met:

- The standard brackets are have been disassembled in the boom guying.
 - The tension lugs **12** are installed properly on both sides in the boom guying instead of standard lugs.
 - The tension lugs **12** are pinned together properly with pins **19** in the boom guying and secured with a retaining element **20**.
 - The connector bracket **3** is pinned on both sides to the intermediate section **1** with pins **8** and secured with a retaining element **9**.
- ▶ Pin the cross bracket **13** on the tension lug **12**: Insert the pin **21** and secure properly with the retaining element **22**.

In the case of a longer auxiliary guying:

- ▶ Pin the bracket **23** on the cross bracket **13** with a pin **17** and secure properly with the retaining element **18**.
- ▶ Install the guy rope **4**: Pin the guy rope **4** to the bracket **23** with a pin **15** and secure with the retaining element **16**.
- or**

In the case of a shorter auxiliary guying:

Install the guy rope **4**: Pin the guy rope **4** on the cross bracket **13** with a pin **17** and secure properly with the retaining element **18**.

If the guy rope **4** is properly pinned and secured on both sides to the bracket **23** or on both sides to the cross bracket **13**:

- ▶ Pin the guy rope **4** to the connector bracket **3** with a pin **10** and secure with the retaining element **11**.

Install the chain **6** between the cross brackets **13**:

- ▶ Properly install the chain **6** to the left and right on the cross brackets **13** with a shackle **24** and screw pin **25**.



WARNING

The crane can topple over!

If the chain **6** is not assembled in connection with the auxiliary guying, then the boom guying can be damaged, the boom can break off and the crane can topple over.

Death, severe bodily injuries, property damage.

- ▶ Only assemble the auxiliary guying in the position specified in the rod plan.
- ▶ If a chain **6** is specified in the rod plan, then it must always be installed in connection with the auxiliary guying, otherwise the guy rods will be pulled apart.

- ▶ Recheck the proper and complete assembly of the auxiliary guying before erecting the boom / boom system.

3.2 Assembling the auxiliary guying on the main boom variation B

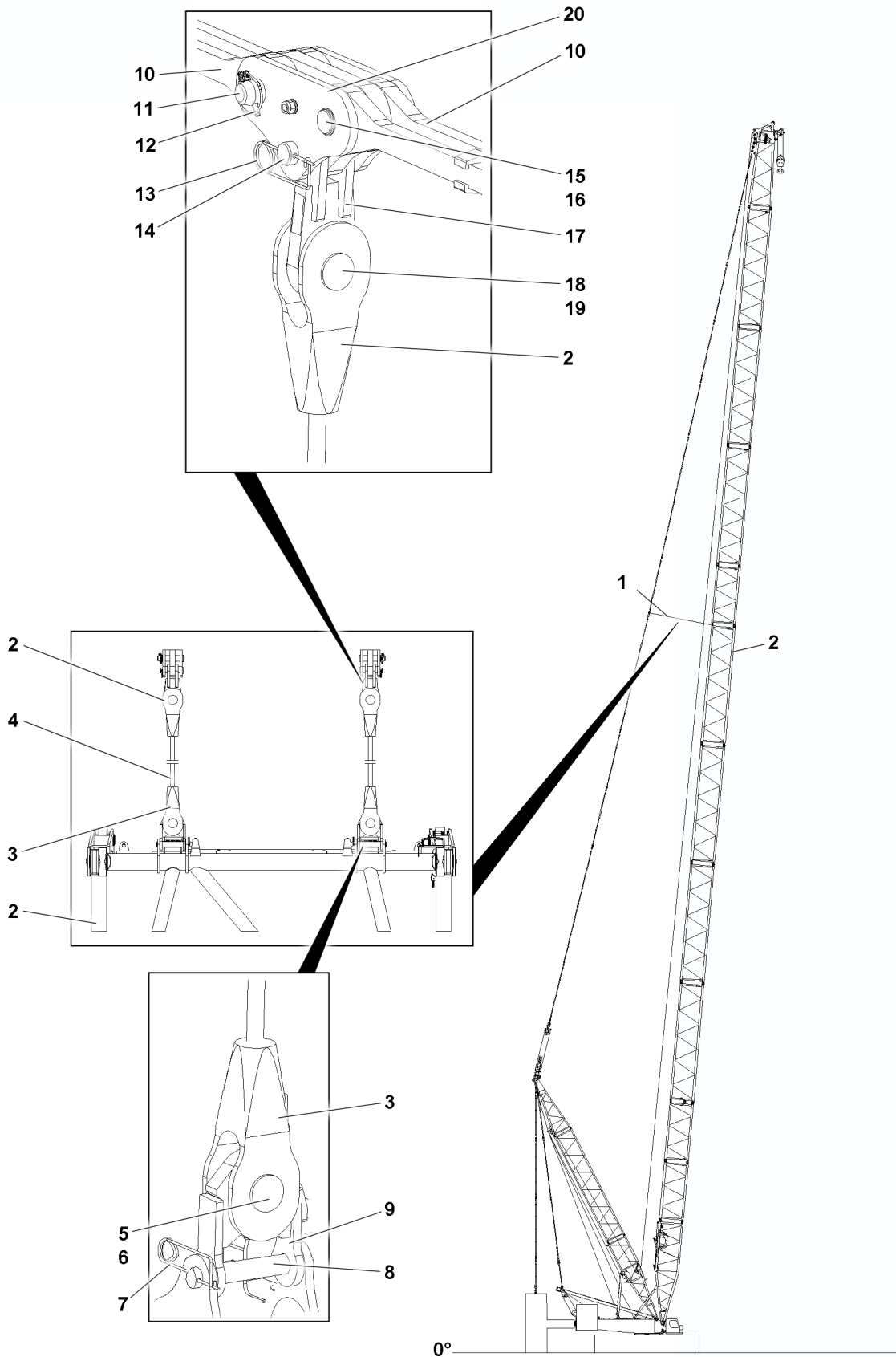

Fig.161359: Auxiliary guying on the main boom variation B

LWE/LR 13000-001/19503-01-02/en

1	Auxiliary guying	8	Pin	15	Pin
2	Intermediate section ¹⁾	9	Connector bracket	16	Retaining element
3	Lower connecting element	10	Guy rods	17	Cross bracket
4	Guy rope ²⁾	11	Pin	18	Pin
5	Pin	12	Retaining element	19	Retaining element
6	Retaining element	13	Retaining element on both sides	20	Tension lug
7	Retaining element	14	Pin		

¹⁾ for the exact designation of the intermediate section: see the rod plan

²⁾ for the exact designation of the guy rope: see the rod plan

The tension lugs **20** must be installed in the boom guying instead of standard lugs. The auxiliary guying is installed on the tension lugs **12**.

Make sure that the following prerequisites are met:

- The standard brackets are have been disassembled in the boom guying.
- The tension lugs **20** are installed properly on both sides in the boom guying instead of standard lugs.
- The tension lugs **20** are pinned with the pin **11** and with the pin **15** in the boom guying and secured with the retaining element **12** and retaining element **16**.
- The connector bracket **9** is pinned on both sides to the intermediate section¹⁾ **2** with pins **8** and secured with a retaining element **7**.
- ▶ Install the guy rope²⁾ **4**: Pin the guy rope²⁾ **4** on the cross bracket **17** with a pin **14** and secure properly with the retaining element **13**.

If the guy rope²⁾ **4** is properly pinned and secured on both sides to the cross bracket **17**:

- ▶ Pin the guy rope²⁾ **4** to the connector bracket **9** with a pin **5** and secure with the retaining element **6**.

Result:

- The auxiliary guying is assembled.



WARNING

The crane can topple over!

If the chain **6** is not assembled in connection with the auxiliary guying, then the boom guying can be damaged, the boom can break off and the crane can topple over.

Death, severe bodily injuries, property damage.

- ▶ Only assemble the auxiliary guying in the position specified in the rod plan.
- ▶ Recheck the proper and complete assembly of the auxiliary guying before erecting the boom / boom system.

3.3 Assembling the auxiliary guying on the W-boom

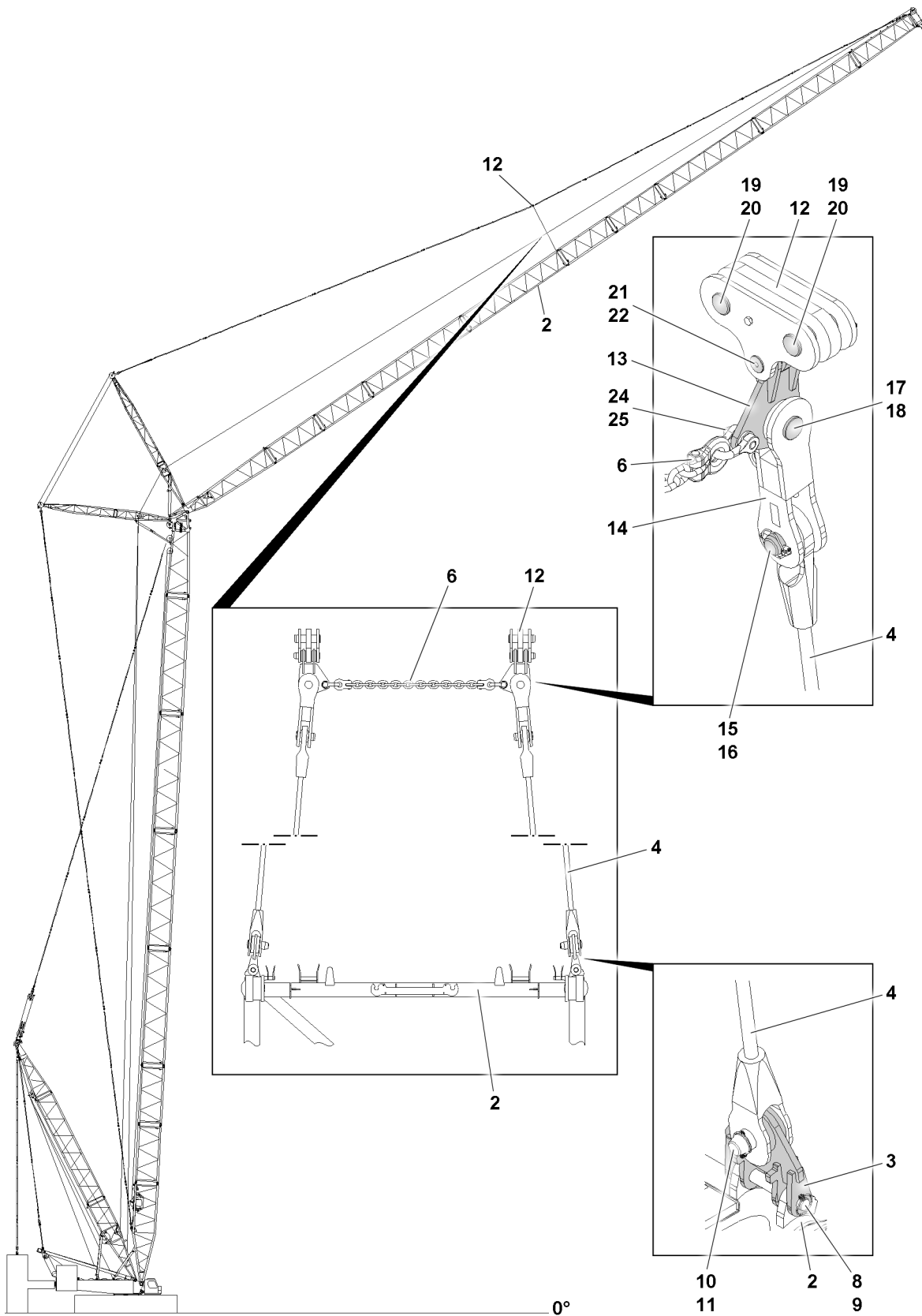

Fig.153508: Auxiliary guying on the W-boom

2 Intermediate section ¹⁾

11 Retaining element

18 Retaining element

For continuation of legend for illustrations, see next page

LWE/LR 13000-001/19503-01-02/en

3	Connector bracket	12	Tension lug	19	Pin
4	Guy rope ²⁾	13	Cross bracket	20	Retaining element
6	Chain	14	Cross bracket	21	Pin
8	Pin	15	Pin	22	Retaining element
9	Retaining element	16	Retaining element	24	Shackle
10	Pin	17	Pin	25	Screw pin

¹⁾ for the exact designation of the intermediate section: see the rod plan

²⁾ for the exact designation of the guy rope: see the rod plan

The tension lugs **12** must be installed in the boom guying instead of standard lugs. The auxiliary guying is installed on the tension lugs **12**.

Make sure that the following prerequisites are met:

- The standard brackets are have been disassembled in the boom guying.
- The tension lugs **12** are installed properly on both sides in the boom guying instead of standard lugs.
- The tension lugs **12** are pinned together properly with pins **19** in the boom guying and secured with a retaining element **20**.
- The connector bracket **3** is pinned on both sides to the intermediate section **2** with pins **8** and secured with a retaining element **9**.
- ▶ Pin the cross bracket **13** on the tension lug **12**: Insert the pin **21** and secure properly with the retaining element **22**.
- ▶ Pin the cross bracket **14** on the cross bracket **13** with a pin **17** and secure properly with the retaining element **18**.
- ▶ Install the guy rope **4**: Pin the guy rope **4** on the cross bracket **14** with a pin **15** and secure with the retaining element **16**.

If the guy rope **4** is properly pinned and secured on both sides to the cross bracket **14**:

- ▶ Pin the guy rope **4** to the connector bracket **3** with a pin **10** and secure with the retaining element **11**.

Install the chain **6** between the cross brackets **13**:

- ▶ Properly install the chain **6** to the left and right on the cross bracket **13** with a shackle **24** and screw pin **25**.



WARNING

The crane can topple over!

If the chain **6** is not assembled in connection with the auxiliary guying, then the boom guying can be damaged, the boom can break off and the crane can topple over.

Death, severe bodily injuries, property damage.

- ▶ Only assemble the auxiliary guying in the position specified in the rod plan.
 - ▶ If a chain **6** is specified in the rod plan, then it must always be installed in connection with the auxiliary guying, otherwise the guy rods will be pulled apart.
-
- ▶ Recheck the proper and complete assembly of the auxiliary guying before erecting the boom / boom system.

Fig.195219

LWE/LR 13000-001/19503-01-02/en

4 Fiber guy rope auxiliary guying

The following auxiliary guying variations are assembled:

- The auxiliary guying consists of the fiber guy ropes, see section „Fiber guy rope auxiliary guying“.
- Auxiliary guying is comprised of wire ropes, see section „Auxiliary guying wire ropes“.



Note

- ▶ The auxiliary guying made of fiber guy ropes are not available for all crane types.
- ▶ The following descriptions and illustrations are examples and may not match your crane exactly.
- ▶ For exact crane data refer to the respective rod plan.
- ▶ In the case of questions: Contact Customer Service at Liebherr-Werk Ehingen GmbH.



WARNING

Impermissible assembly of fiber guy ropes!

The fiber guy ropes can rip.

Death, severe bodily injuries, property damage.

- ▶ Do **not** use buckled, knotted or twisted fiber guy ropes.
- ▶ Do **not** assemble damaged fiber guy ropes.
- ▶ Make sure that the identification of the fiber guy rope on the rod plan and the identification on the individual fiber guy ropes are identical. Identify the fiber guy rope, see chapter 5.01.
- ▶ Make sure that the operating temperature of the fiber guy ropes of -40 °C to $+60\text{ °C}$ is **not** fallen below or exceeded.
- ▶ Check the fiber guy ropes for damage prior to assembly, after disassembly and after exceptional events, see chapter 8.16.
- ▶ Comply with the maintenance intervals, see chapter 7.03.50.
- ▶ Observe the notes regarding the proper transport and storage of the fiber guy ropes, see chapter 2.04.
- ▶ Comply with the instructions for the assembly and disassembly of the fiber guy ropes, see chapter 5.01.
- ▶ Only fasten the fiber guy ropes in the permissible range with belt loops, see chapter 5.01.

The auxiliary guying, in regards to safe crane operation - especially for long boom systems - is of vital importance.

The auxiliary guying is a deciding factor in relieving the boom, or the boom system during erection and take-down as well as during crane operation.

Guy ropes with different lengths are used in the different auxiliary guyings.

The installation of the auxiliary guying between the boom guying and the boom system is implemented using different brackets, cross brackets or connector brackets.



Note

- ▶ The boom lengths, for which an auxiliary guying is required in addition to a boom guying, can be seen in the rod plan.

Depending on the crane type and boom length:

- ▶ Assembly of the auxiliary guying: Remove the standard lugs and install the tension lugs **12**.

**WARNING**

The crane can topple over!

If the auxiliary guying is not installed or not installed on the position specified in the rod plan, then the crane can collapse, the boom can break off or the crane can topple over.

Death, severe bodily injuries, property damage.

- ▶ Only assemble the auxiliary guying in the position specified in the rod plan.
- ▶ Make sure that the auxiliary guying is always completely installed and that all pins are properly pinned and secured.
- ▶ Assemble the auxiliary guying together with the boom guying when the boom / boom system is lying on the ground.
- ▶ **or:**
- ▶ Assemble the auxiliary guying together with the boom guying when the boom / boom system is lying on a load bearing substructure.
- ▶ **or:**
- ▶ Assemble the auxiliary guying together with the boom guying when the boom / boom system is held securely by the auxiliary crane.

4.1 Assembling the auxiliary guying on the main boom

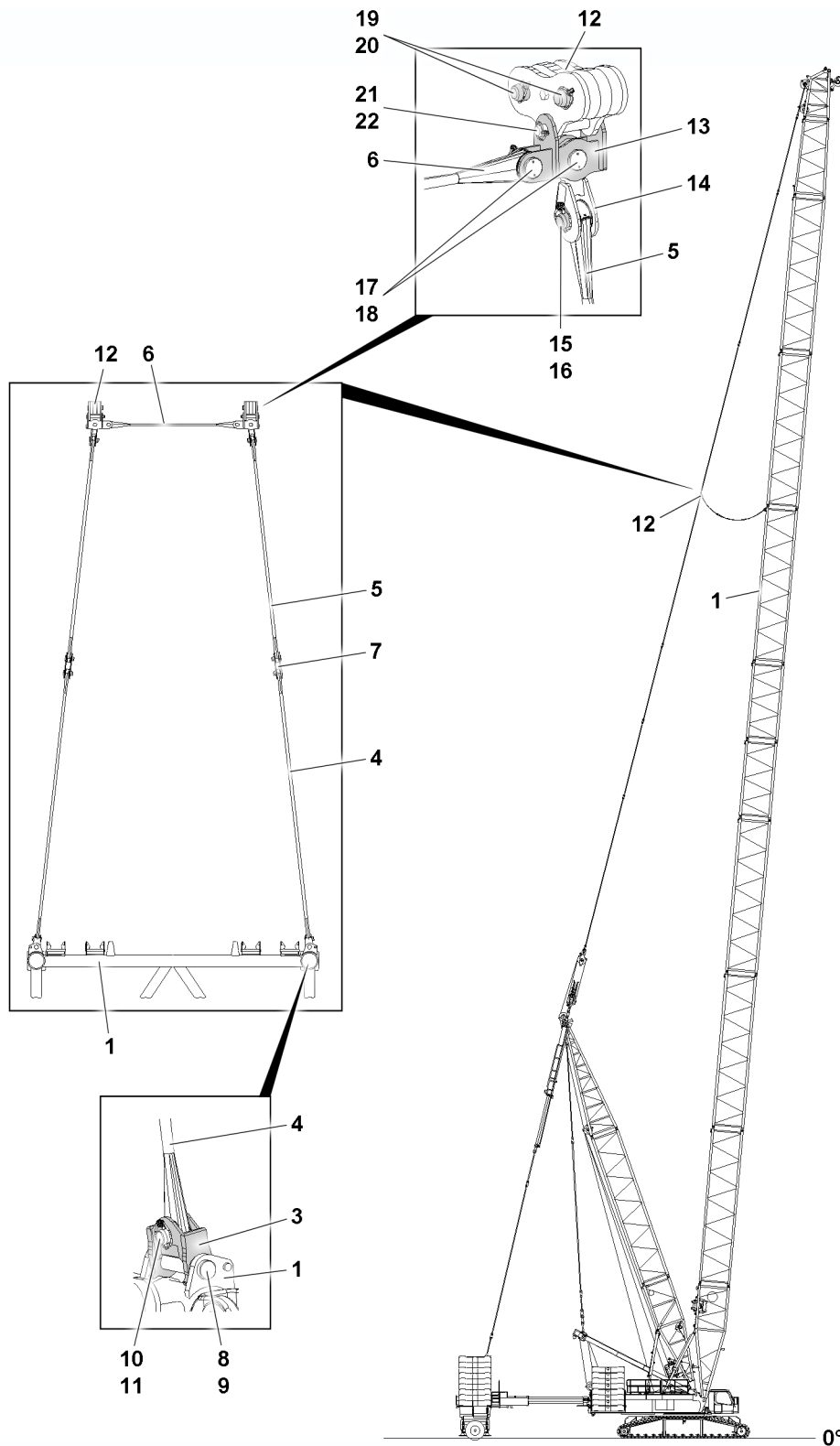

Fig.153504: Auxiliary guying on the main boom

- | | | |
|---|-----------------------------|-----------------------------|
| 1 Intermediate section ¹⁾ | 9 Retaining element | 16 Retaining element |
| 3 Connector bracket | 10 Pin | 17 Pin |
| 4 Fiber guy rope ²⁾ | 11 Retaining element | 18 Retaining element |
| 5 Fiber guy rope ²⁾ | 12 Tension lug | 19 Pin |

For continuation of legend for illustrations, see next page

LWE/LR_13000-001/19503-01-02/en

6	Fiber guy rope ²⁾	13	Cross bracket	20	Retaining element
7	Connector bracket	14	Cross bracket	21	Pin
8	Pin	15	Pin	22	Retaining element

¹⁾ for the exact designation of the intermediate section: See the rod plan

²⁾ for the exact designation of the fiber guy rope: See the rod plan

The tension lugs **12** must be installed in the boom guying instead of standard lugs. The auxiliary guying is installed on the tension lugs **12**.

Make sure that the following prerequisites are met:

- The standard brackets are have been disassembled in the boom guying.
- The tension lugs **12** are installed properly on both sides in the boom guying instead of standard lugs.
- The tension lugs **12** are pinned together properly with pins **19** in the boom guying and secured with a retaining element **20**.
- The connector bracket **3** is pinned on both sides to the intermediate section **1** with pins **9** and secured with a retaining element **8**.
- ▶ Pin the cross bracket **13** on the tension lug **12**: Insert the pin **21** and secure properly with the retaining element **22**.
- ▶ Pin the cross bracket **14** on the cross bracket **13** with a pin **17** and secure properly with the retaining element **18**.
- ▶ Install the guy rope **5**: Pin the guy rope **5** on the cross bracket **14** with a pin **15** and secure with the retaining element **16**.

If the guy rope **5** is properly pinned and secured on both sides to the cross bracket **14**:

- ▶ Properly pin and secure the guy rope **4** with the connector bracket **7** to the guy rope **5**.
- ▶ Pin the guy rope **4** to the connector bracket **3** with a pin **10** and secure with the retaining element **11**.

Install the guy rope **6** between the cross brackets **13**:

- ▶ Pin the guy rope **6** to the left and right on the cross bracket **13** with a pin **17** and secure properly with the retaining element **18**.



WARNING

The crane can topple over!

If the guy rope **6** is not installed in connection with the auxiliary guying, then the boom guying can be damaged, the boom can break off and the crane can topple over.

Death, severe bodily injuries, property damage.

- ▶ Only assemble the auxiliary guying in the position specified in the rod plan.
 - ▶ If a guy rope **6** is specified in the rod plan, then it must always be installed in connection with the auxiliary guying, otherwise the guy rods will be pulled apart.
-
- ▶ Recheck the proper and complete assembly of the auxiliary guying before erecting the boom / boom system.

4.2 Assembling the auxiliary guying on the W-boom

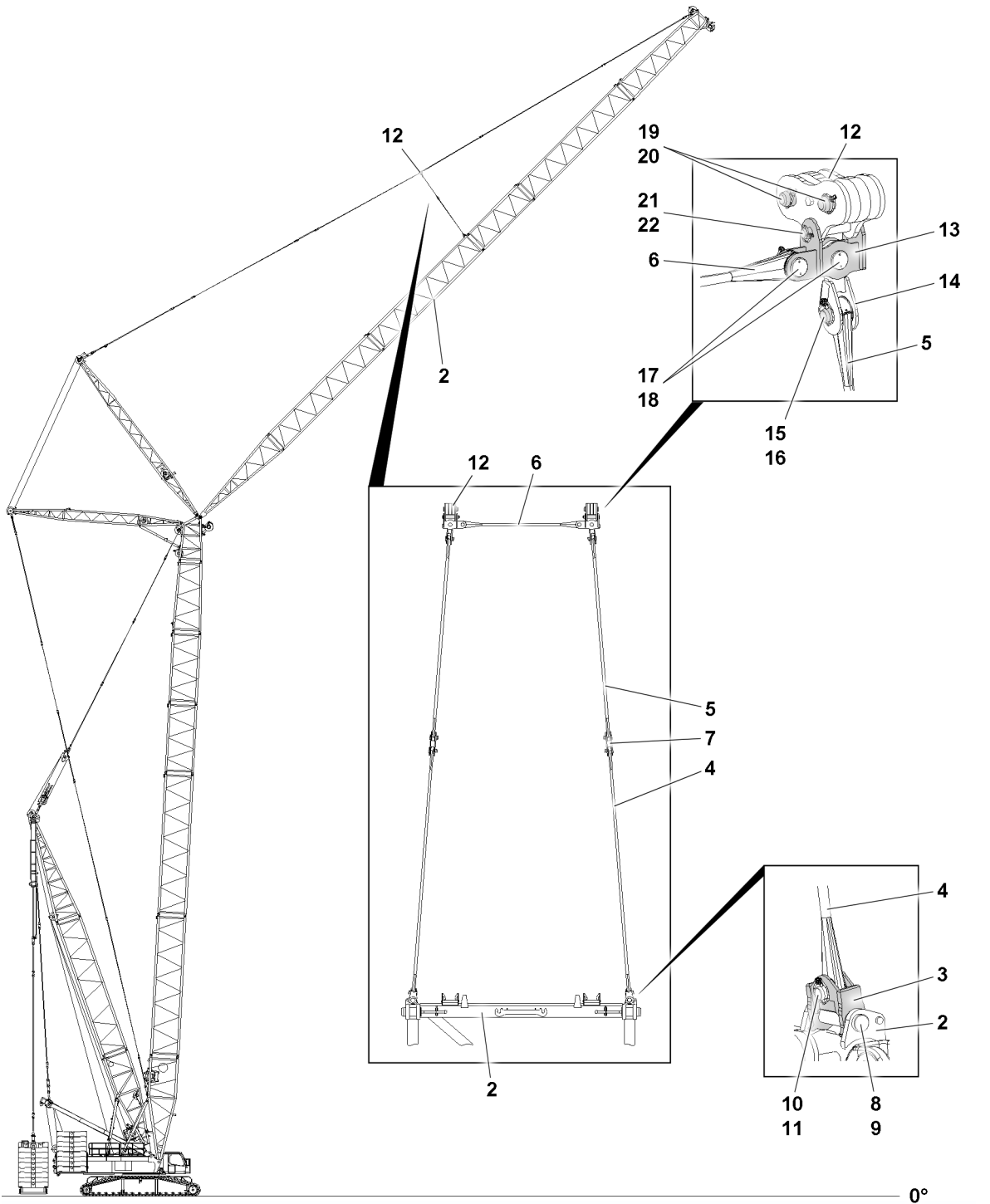

Fig.153505: Auxiliary guying on the W- boom

- | | | |
|---|-----------------------------|-----------------------------|
| 2 Intermediate section ¹⁾ | 9 Retaining element | 16 Retaining element |
| 3 Connector bracket | 10 Pin | 17 Pin |
| 4 Fiber guy rope ²⁾ | 11 Retaining element | 18 Retaining element |
| 5 Fiber guy rope ²⁾ | 12 Tension lug | 19 Pin |
| 6 Fiber guy rope ²⁾ | 13 Cross bracket | 20 Retaining element |
| 7 Connector bracket | 14 Cross bracket | 21 Pin |
| 8 Pin | 15 Pin | 22 Retaining element |

¹⁾ for the exact designation of the intermediate section: See the rod plan

LWE/LR_13000-001/19503-01-02/en

²⁾ for the exact designation of the fiber guy rope: See the rod plan

The tension lugs **12** must be installed in the boom guying instead of standard lugs. The auxiliary guying is installed on the tension lugs **12**.

Make sure that the following prerequisites are met:

- The standard brackets are have been disassembled in the boom guying.
- The tension lugs **12** are installed properly on both sides in the boom guying instead of standard lugs.
- The tension lugs **12** are pinned together properly with pins **19** in the boom guying and secured with a retaining element **20**.
- The connector bracket **3** is pinned on both sides to the intermediate section **1** with pins **9** and secured with a retaining element **8**.
- ▶ Pin the cross bracket **13** on the tension lug **12**: Insert the pin **21** and secure properly with the retaining element **22**.
- ▶ Pin the cross bracket **14** on the cross bracket **13** with a pin **17** and secure properly with the retaining element **18**.
- ▶ Install the guy rope **5**: Pin the guy rope **5** on the cross bracket **14** with a pin **15** and secure with the retaining element **16**.

If the guy rope **5** is properly pinned and secured on both sides to the cross bracket **14**:

- ▶ Properly pin and secure the guy rope **4** with the connector bracket **7** to the guy rope **5**.
- ▶ Pin the guy rope **4** to the connector bracket **3** with a pin **10** and secure with the retaining element **11**.

Install the guy rope **6** between the cross brackets **13**:

- ▶ Pin the guy rope **6** to the left and right on the cross bracket **13** with a pin **17** and secure properly with the retaining element **18**.



WARNING

The crane can topple over!

If the guy rope **6** is not installed in connection with the auxiliary guying, then the boom guying can be damaged, the boom can break off and the crane can topple over.

Death, severe bodily injuries, property damage.

- ▶ Only assemble the auxiliary guying in the position specified in the rod plan.
 - ▶ If a guy rope **6** is specified in the rod plan, then it must always be installed in connection with the auxiliary guying, otherwise the guy rods will be pulled apart.
-
- ▶ Recheck the proper and complete assembly of the auxiliary guying before erecting the boom / boom system.

5.05 D-boom

1	Component overview	3
2	Fastening points for derrick components	5
3	Assembling the D-boom	6
4	Disassembling the D-boom	113
5	Preparing the lattice sections for transport	183

Fig.195219

LWE/LR 13000-001/19503-01-02/en

1 Component overview



Note

- The assembly sections are marked with their own weight.



Note

- For the dimensions and weights, see the Crane operating instructions, chapter 1.03.

Position	Component
1	D-pivot section
2	D-intermediate section 2824.25 12 m
3	D-intermediate section 2824.36 12 m
4	D-intermediate section 2824.36 6 m
5	D-intermediate section 2824.36A 6 m
6	D-end section
7	Winch 3
8	Winch 6
9	S-luffing pulley block
10	Weight

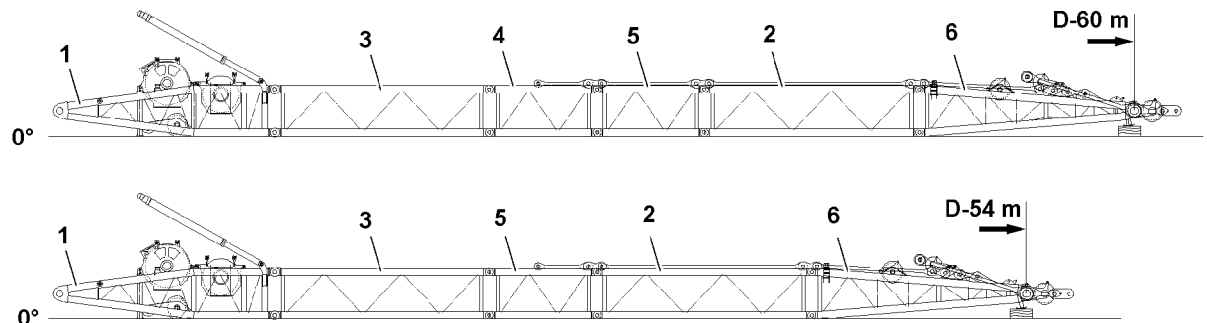

Fig.115647: D-boom system

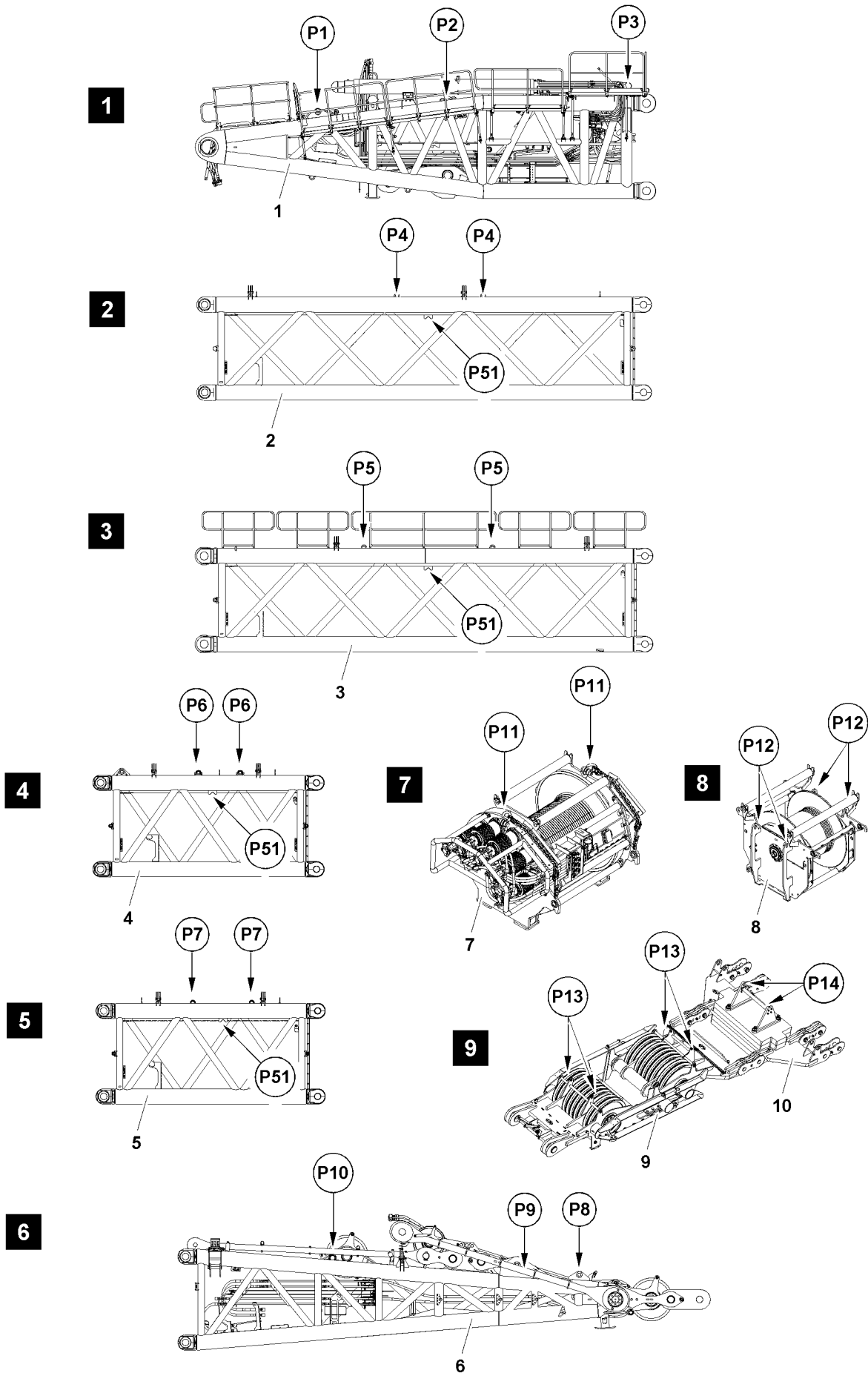

Fig.121997: Position of fastening points

LWE/LR 13000-001/19503-01-02/en

2 Fastening points for derrick components



WARNING

Component incorrectly fastened!

Life-threatening situations can arise due to improper or incorrect fastening of the corresponding components.

Personnel can be severely injured or killed.

- ▶ Fasten the components only in the intended fastening points on both sides.
- ▶ Fastening of components and description of fastening points, see the Crane operating instructions, chapter 5.01.

Fastening points	
P1, P2 and P3	D-pivot section
P4	D-intermediate section 2824.25 12 m
P5	D-intermediate section 2824.36 12 m
P6	D-intermediate section 2824.36 6 m
P7	D-intermediate section 2824.36 A 6 m
P8, P9 and P10	D-end section
P11	Winch 3
P12	Winch 6
P13	S-luffing pulley block
P14	Weight
P50	Cross beam
P51	D-intermediate sections (catch for cross beam)

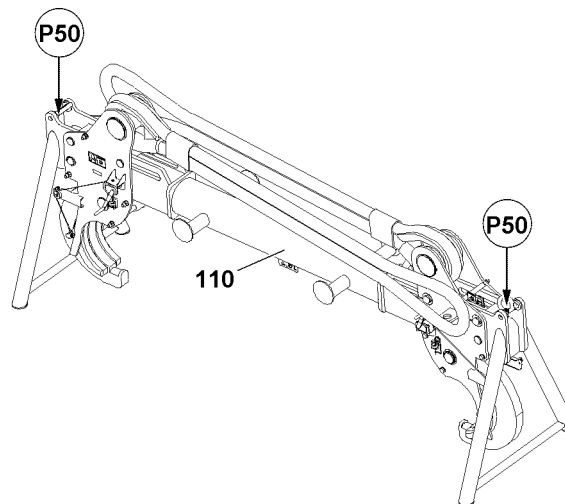

Fig.121996: Position of fastening points

3 Assembling the D-boom



WARNING

Danger of falling!

During assembly / disassembly, inspection and maintenance work, assembly personnel must be secured with appropriate aids to prevent them from falling.

If this is not observed, assembly personnel could fall and be killed or seriously injured.

- ▶ All work at a height, when there is a danger of falling, must be carried out with suitable aids.
- ▶ If aids are not available and work cannot be carried out from the ground, then assembly personnel must secure themselves with the supplied fall arrest system to prevent falling, see the Crane operating instructions, chapter 2.04.
- ▶ If fall protection equipment is available, then it must be used, see the Crane operating instructions, chapter 2.06.
- ▶ When lifting, lowering, swinging crane parts in and out, no persons may remain in the danger zone.
- ▶ When closing or opening boom systems during boom assembly or disassembly, no persons may remain on the boom system or in the danger zone.
- ▶ If railings are present on the components, then they must be brought into the corresponding position and secured for assembly / disassembly work.
- ▶ Only step on the aids, ladders and catwalks with clean shoes.
- ▶ Keep aids, ladders and catwalks free of heavy dirt, snow and ice.
- ▶ During all assembly and disassembly work, maintenance work and inspections, travel or crane operation is prohibited.
- ▶ Remaining on a suspended load is prohibited.
- ▶ Stepping or walking on crane components and lattice sections with an incline of more than 20° is prohibited.
- ▶ For all assembly work, the crane driver of the main crane must be in voice contact with the crane driver / crane drivers of the auxiliary crane / auxiliary cranes.
- ▶ For assembly tasks, the crane driver may only initiate crane movements when the responsible guide has explicitly released the movement.



WARNING

Components not pinned and secured!

If a component is released from the auxiliary crane before being pinned and secured, the component will fall down. Personnel can be severely injured or killed.

- ▶ Do not detach the auxiliary crane until the respective component is pinned and secured.



WARNING

Danger of impact / crushing!

When assembling / disassembling crane components with the auxiliary crane, crane components can start to swing back and forth.

When lifting / lowering and positioning crane components, there is an increased danger of impact / crushing.

Personnel can be caught and thereby injured or killed.

- ▶ Make sure that personnel cannot be caught by components.
- ▶ When working in danger zones: Use aids to protect limbs.
- ▶ Guide components with suitable aids to minimize oscillation.



WARNING

Danger of accident due to interrupted voice and / or visual contact!

If the voice and / or visual contact is interrupted, personnel can be severely injured or killed.

- ▶ Make sure that the crane driver is in constant voice (for example through radio connection) and visual contact with operating and / or assembly personnel during crane or assembly operation.
- ▶ Make sure that the voice and visual contact is not interrupted.
- ▶ If the voice and / or visual contact is interrupted, do not carry out any crane movements or assembly tasks.
- ▶ Re-establish voice and / or visual contact immediately.

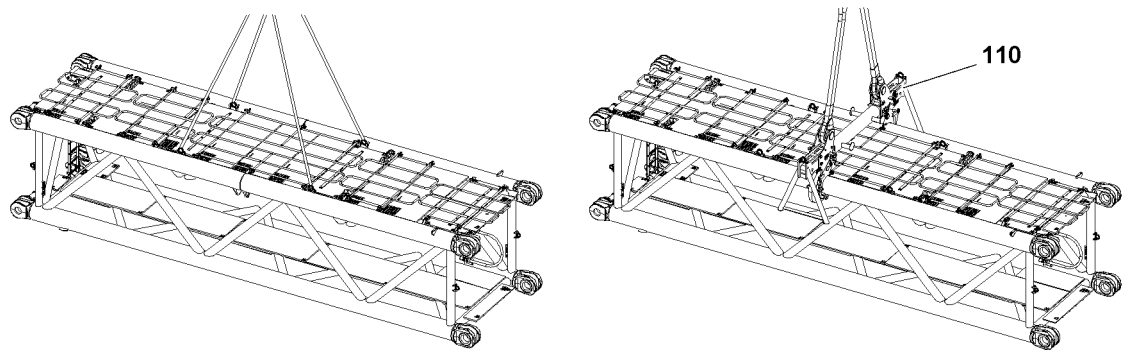

Fig. 121998: Fastening variations



Note

The D-intermediate sections can be raised and assembled differently:

- ▶ Variation 1: with the aid of the usual fastening equipment and assembly eyes on the D-intermediate sections.
- ▶ Variation 2: with the aid of the cross beam **110**, see section „Assembling the D-intermediate sections with the cross beam“.

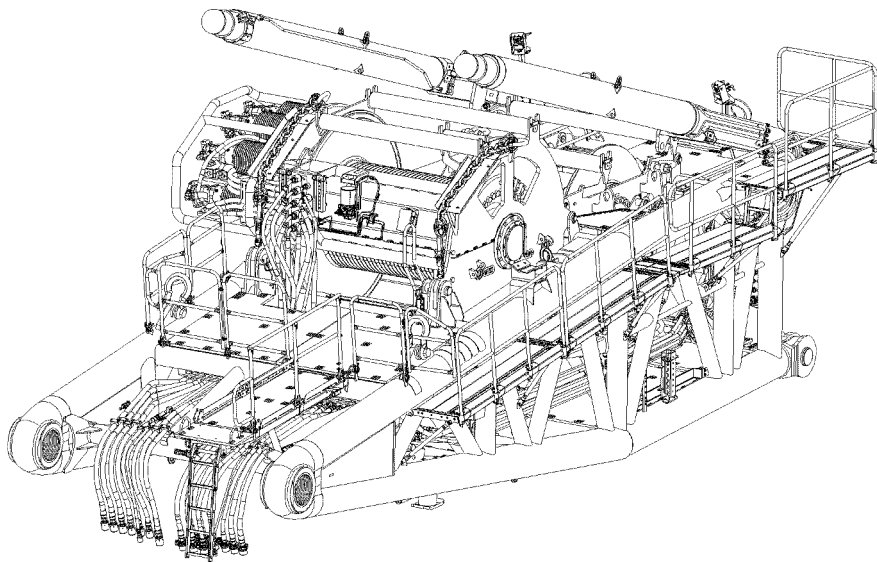

Fig.115649

LWE/LR 13000-001/19503-01-02/en

3.1 Preparing the D-pivot section



WARNING

Danger of falling!

During assembly and disassembly, assembly personnel must be secured with appropriate aids to prevent them from falling.

Even for assembly and disassembly of protective devices there is a danger of falling.

Assembly personnel can fall and be severely injured or killed.

- ▶ Use personal protective equipment.
-

3.1.1 Pulling out the ladder on the D-pivot section



Note

- ▶ Pull the ladder on the D-pivot section out for assembly, see the Crane operating instructions, chapter 2.06.
-

3.1.2 Assembling the railings on the platforms



Note

- ▶ Assemble the railings on the platforms, see the Crane operating instructions, chapter 2.06.
-

3.1.3 Swinging the platforms on the D-pivot section into the operating position



Note

- ▶ Swing the platforms on the D-pivot section into the operating position, see the Crane operating instructions, chapter 2.06.
-

3.1.4 Swinging the railings on the D-pivot section into the operating position



Note

- ▶ Swing the railings on the D-pivot section into the operating position, see the Crane operating instructions, chapter 2.06.
-

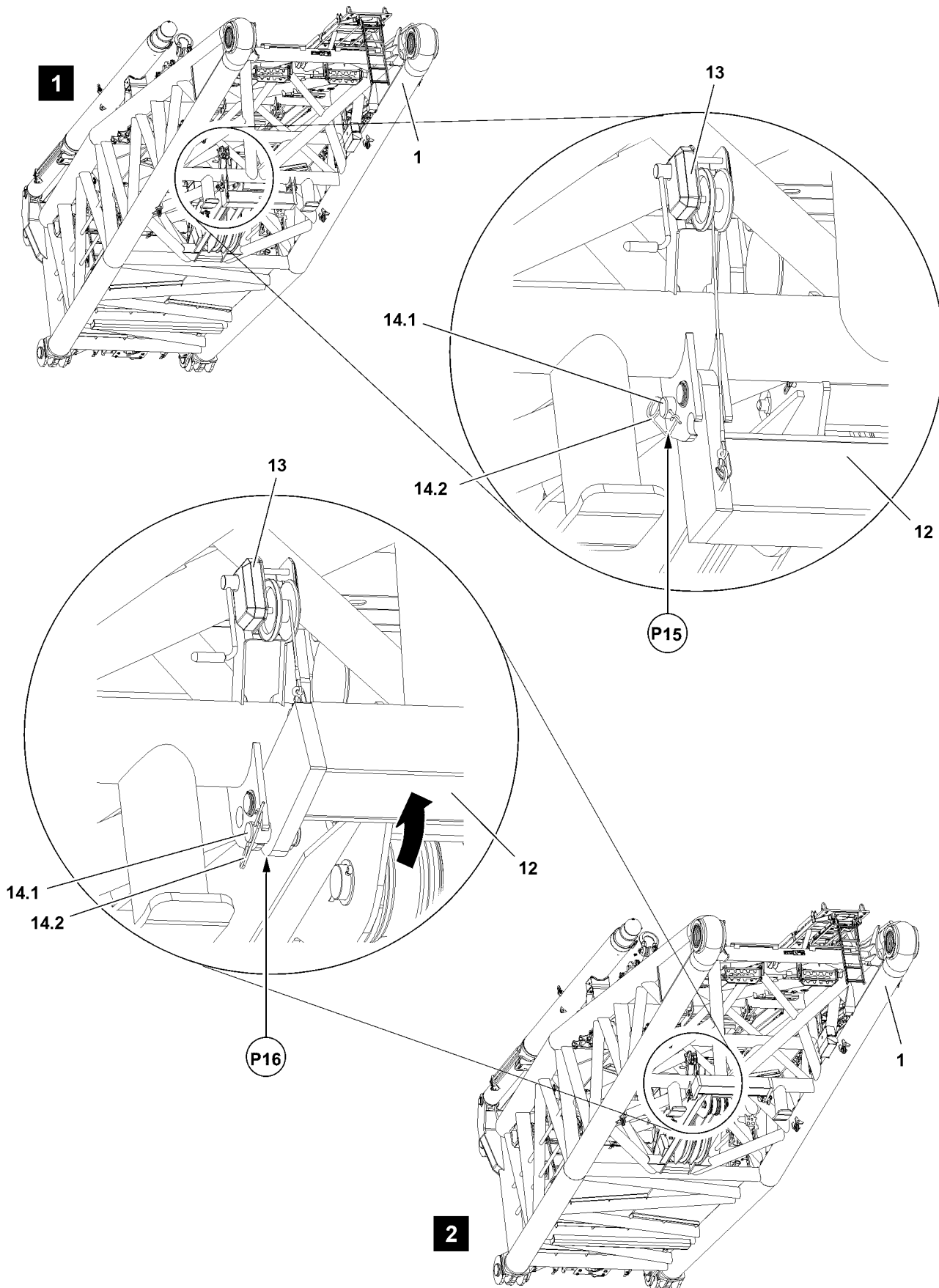

Fig.114355

LWE/LR 13000-001/19503-01-02/en

3.1.5 Folding the transport frame up



WARNING

Damage to the rope!

If the transport frame is not folded up for crane operation, then the hoist rope can scrape and be damaged on the transport frame.

Falling load and property damage can result.

Personnel can be severely injured or killed.

- ▶ Make sure that the transport frame **12** is folded up.
-
- ▶ Release the transport frame **12** on both sides: Remove the spring retainer **14.2** in point **P15** and unpin the pin **14.1**, see illustration 1.
 - ▶ Fold the transport frame **12** up: Actuate the rope winch **13**, see illustration 1.
 - ▶ Secure the transport frame **12** on both sides: Insert the pin **14.1** in point **P16** and secure with the spring retainer **14.2**, see illustration 2.

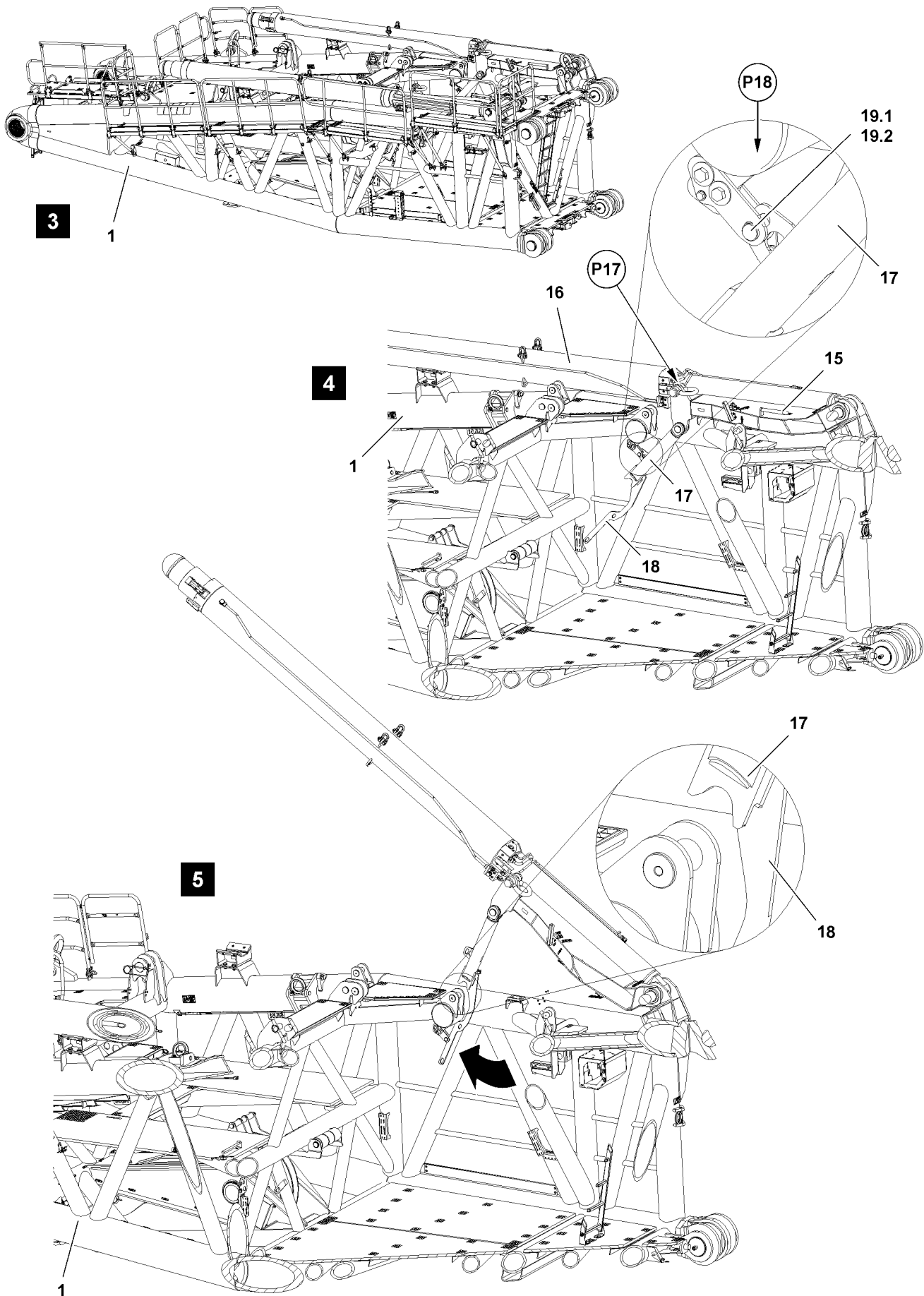

Fig.114367

LWE/LR 13000-001/19503-01-02/en

3.1.6 Erecting the D-relapse retainer

- ▶ Fasten the driver **15** to the auxiliary crane in point **P17**, see illustration **4**.



WARNING

Swinging support!

When releasing the support **17** in point **P18** it can swing forward uncontrolled.

Personnel can be severely injured or killed.

- ▶ Hold the support **17** when unpinning.
 - ▶ Assembly personnel must be to the side of the assembly unit.
-
- ▶ Release the support **17** from the transport position in point **P18**: Remove the spring retainer **19.2** and unpin the pin **19.1**, see illustration **4**.
 - ▶ Erecting the relapse retainer **16**: Pull the driver **15** up with the auxiliary crane, see illustration **5**.
 - ▶ Push the support **17** with the lever **18** to the stop, see illustration **5**.

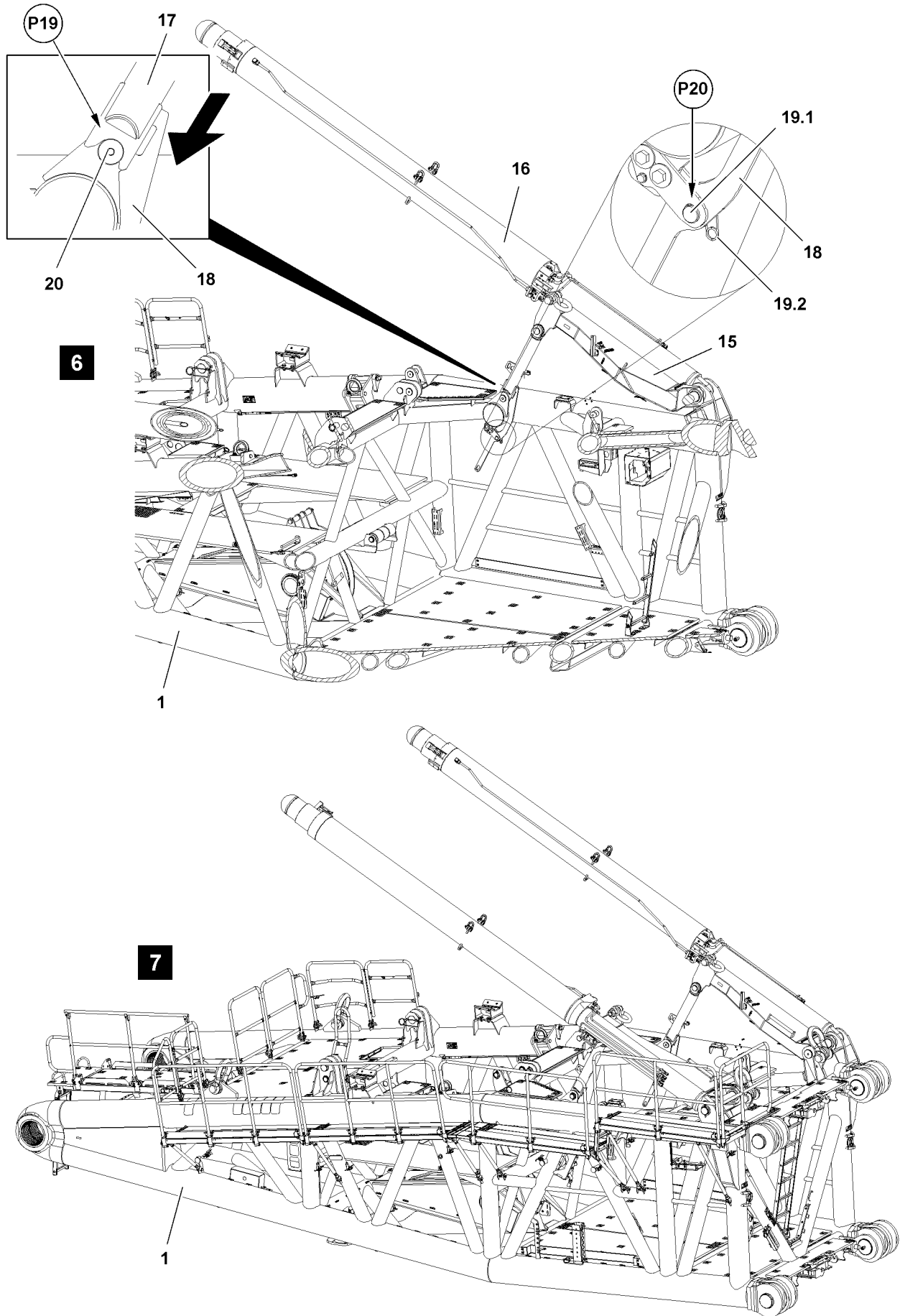

Fig.114368

LWE/LR 13000-001/19503-01-02/en

- ▶ Lower the relapse retainer **16** with the auxiliary crane until the support **17** is lying in the receptacle **20** in point **P19**, see illustration **6**.



WARNING

The pin is not secured!

If the pin **19.1** is not secured, the pin can loosen up by itself during crane operation.

This can cause the crane to topple over.

Personnel can be severely injured or killed.

- ▶ Make sure that pin **19.1** is secured with the spring retainer **19.2**.
-
- ▶ Secure the support **17** in point **P20**: Insert the pin **19.1** and secure with the spring retainer **19.2**, see illustration **6**.
 - ▶ Erecting the second relapse retainer, see illustration **7**.

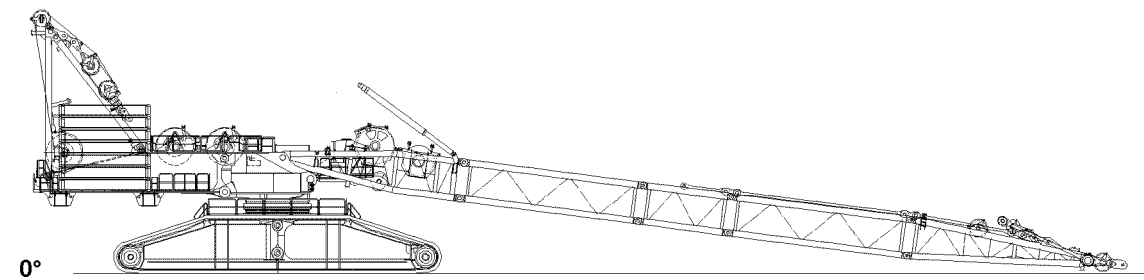
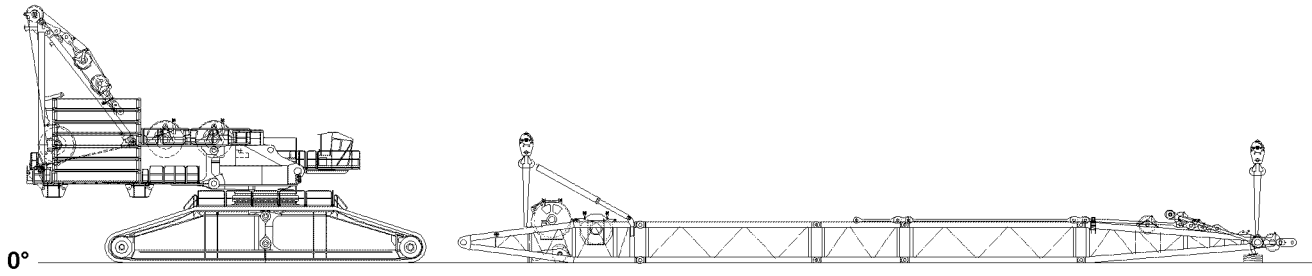
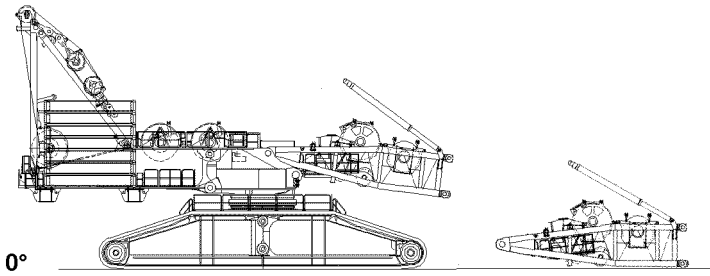
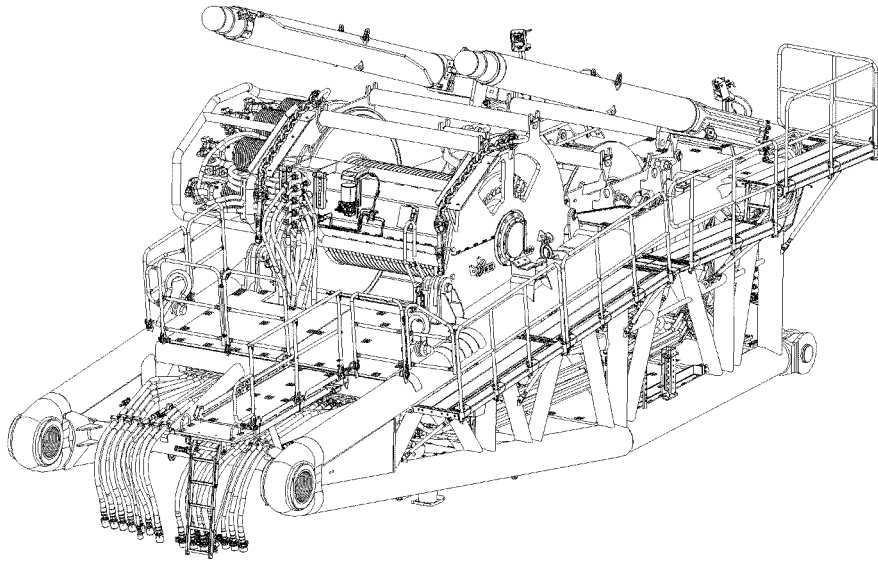

Fig.114366

LWE/LR 13000-001/19503-01-02/en

3.2 Assembling winch 3 and winch 6

NOTICE

Incorrect fastening equipment!

- ▶ For assembly of winch 3 and winch 6, use fastening equipment with a minimum length of 5 m.



Note

- ▶ Winch 3 and winch 6 can be installed directly on the D-pivot section before the D-pivot section is pinned on the turntable, see illustration.
- ▶ Winch 3 and winch 6 can also be installed on the D-pivot section when the D-boom is completely installed and lying on the ground, see illustration.
- ▶ Winch 3 and winch 6 can also be installed on the D-pivot section when the D-boom is completely installed and already pinned on the turntable, see illustration.



Note

- ▶ Assemble the winch 3, see the Crane operating instructions, chapter 3.07.30.



Note

- ▶ Assemble the winch 6, see the Crane operating instructions, chapter 3.07.60.

3.3 Establishing the connections to the winches

Make sure that the following prerequisite is met:

- The winch is properly installed, pinned and secured.

3.3.1 Establishing the hydraulic connections to the winches

The hydraulic connections are established with quick couplings.

When connecting hydraulic lines with quick couplings, make sure that the coupling procedure is carried out correctly.

The matching quick couplings are marked.



WARNING

Pressure in the hydraulic lines!

If the pressure supply is not interrupted before connecting / releasing the hydraulic lines, the hydraulic oil can escape with high pressure.

Death, severe bodily injuries, property damage.

- ▶ Release the pressure in the hydraulic system before connecting / disconnecting: Interrupt the pressure supply and wait a short time.



WARNING

Loss of pressure or leakage!

Incorrectly coupled or self-loosening quick couplings (particularly return lines) can result in serious accidents due to component failure.

Death, severe bodily injuries, property damage.

- ▶ Check that the quick couplings have been properly connected before using the crane.
- ▶ Connect the coupling components (sleeve and connector) and screw together with the knurled nut.
- ▶ Tighten the hydraulic coupling by hand. Turn the knurled nut until it reaches a tangible, fixed stop position.
- ▶ Establish the hydraulic connections to the winches.

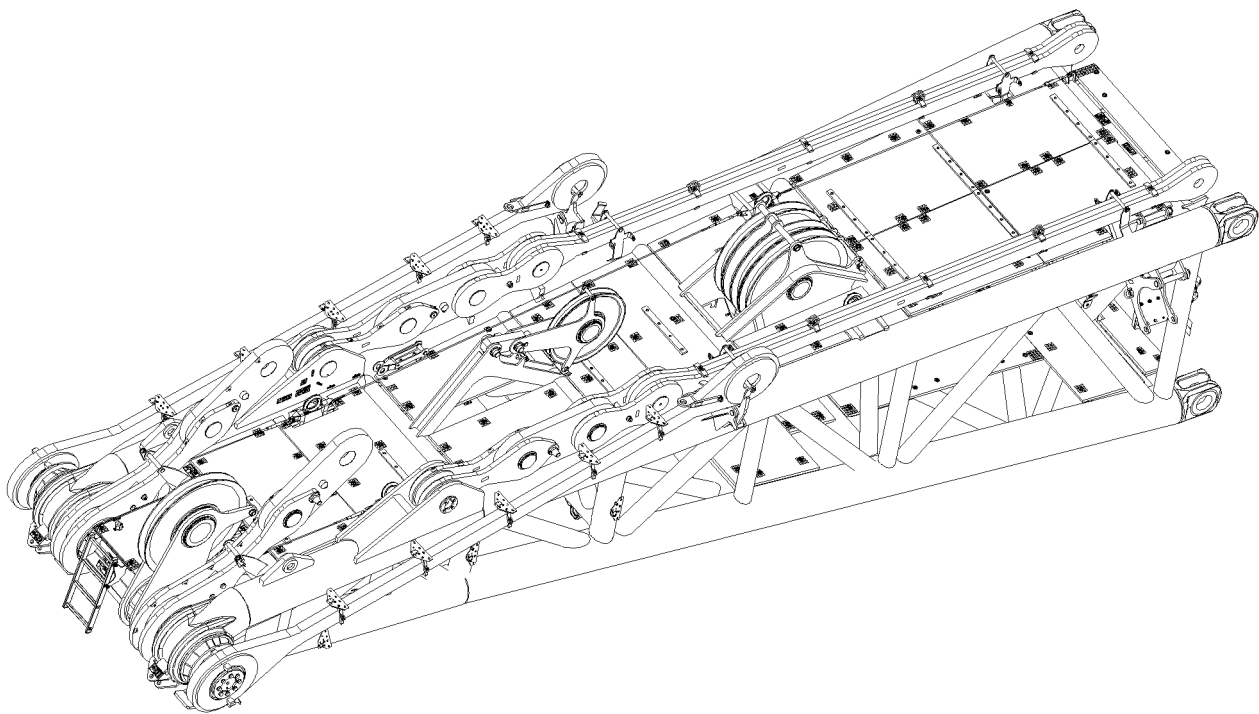

Fig.114374

LWE/LR 13000-001/19503-01-02/en

3.3.2 Establishing the electrical connections to the winches

- ▶ Establish the electrical connections to the winches, see the Electrical wiring diagram.

3.3.3 Establishing the connections for the central lubrication system to the winches

- ▶ Establish the connections for the central lubrication system to the winches.

3.4 Preparing the D-end section



WARNING

Danger of falling!

During assembly and disassembly, personnel must be secured with appropriate aids to prevent them from falling.

Even for assembly and disassembly of protective devices there is a danger of falling.

Assembly personnel can fall and be severely injured or killed.

- ▶ Use personal protective equipment.
-

3.4.1 Folding the ladder on the D-end section



Note

- ▶ Swing the ladder on the D-end section for assembly, see the Crane operating instructions, chapter 2.06.
-

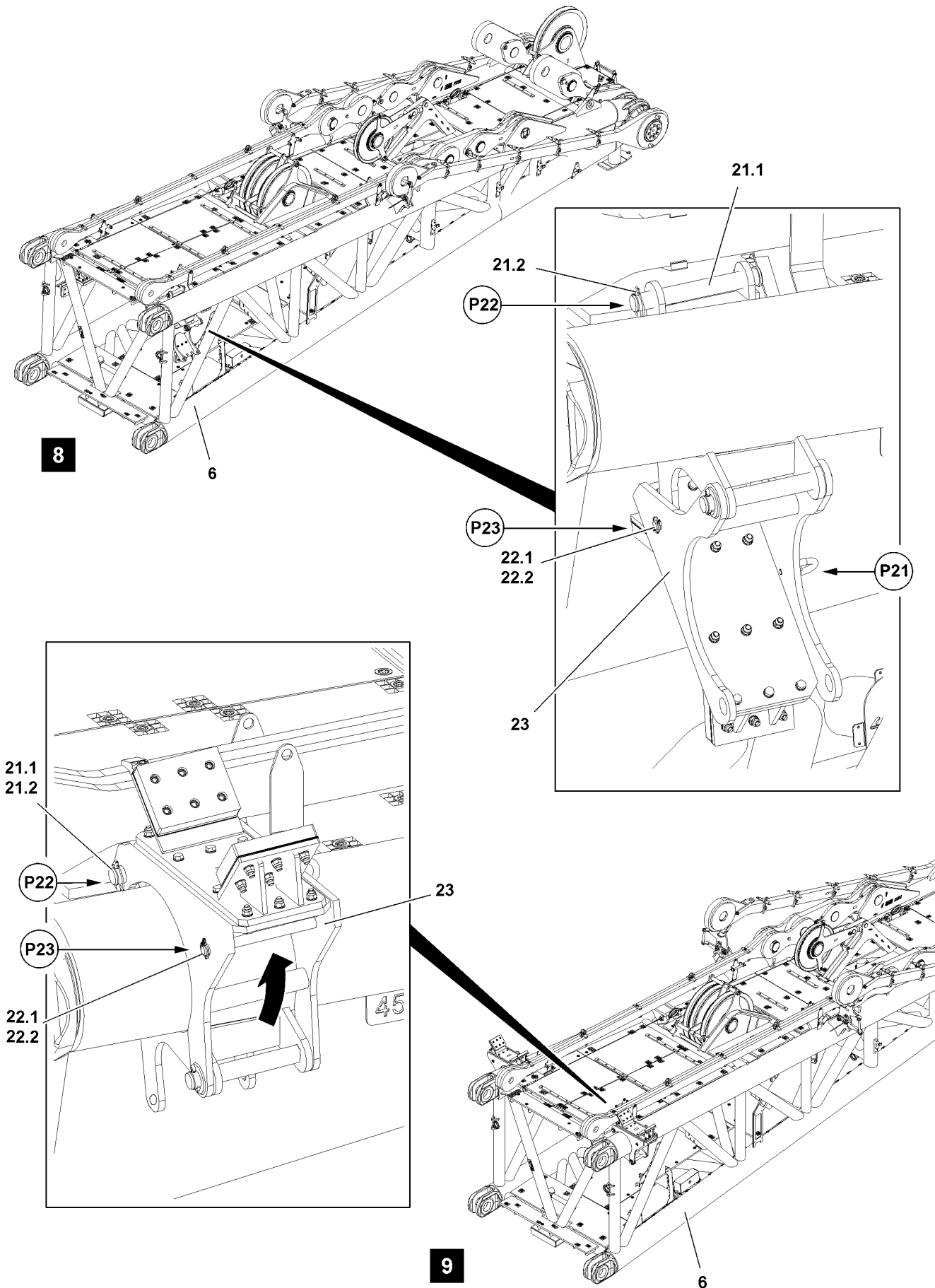

Fig.114373

LWE/LR 13000-001/19503-01-02/en

3.4.2 Folding out the support

- ▶ Fasten the support **23** to the auxiliary crane in point **P21**, see illustration **8**.
- ▶ Release the support **23** from the transport position: Remove the safety locking pin **22.2** in point **P23** and unpin the pin **22.1**, see illustration **8**.
- ▶ Remove the safety locking pin **21.2** in point **P22** and unpin the pin **22.1**, see illustration **8**.



WARNING

Danger of accident when swinging in the support!
When swinging in the support **23**, limbs can be crushed or severed.
Personnel can be severely injured.

- ▶ Make sure that there is no personnel in the danger zone.
 - ▶ Do not reach with your hands into the danger zone.
-
- ▶ Swing the support **23** with the auxiliary crane until it can be pinned in point **P22**, see illustration **9**.



WARNING

The pins can loosen up by themselves!

- ▶ Secure the pin **22.1** immediately after pinning with the safety locking pin **22.2**.
-
- ▶ Secure the support **23** in the operating position: Insert the pin **21.1** in point **P22** and secure with the safety locking pin **21.2**, see illustration **9**.
 - ▶ Insert the pin **22.1** again in point **P23** and secure with a safety locking pin **22.2**, see illustration **9**.
 - ▶ Remove the auxiliary crane.
 - ▶ Fold the second support out.

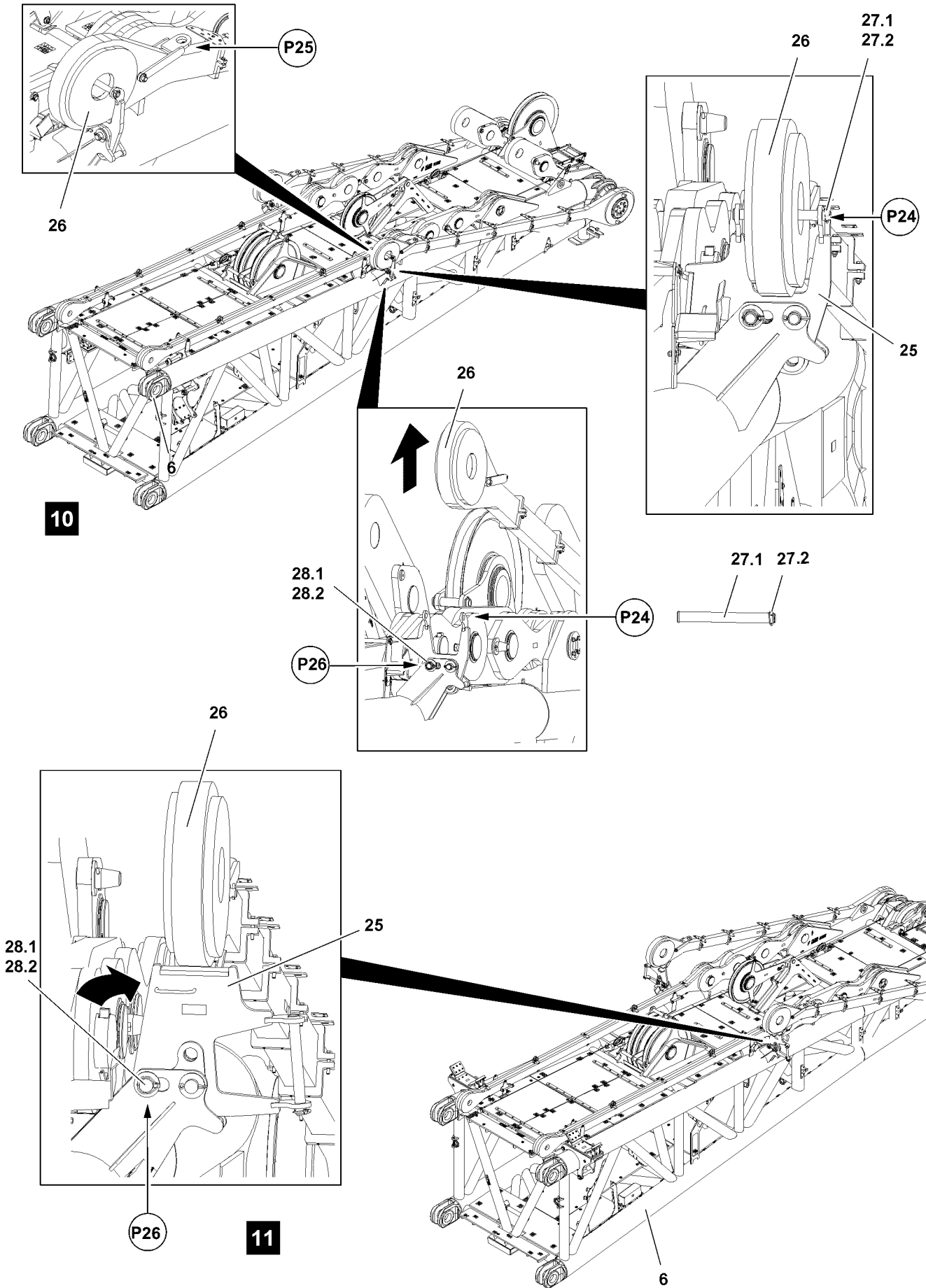

Fig. 114375

LWE/LR 13000-001/19503-01-02/en

3.4.3 Folding the receptacle out

- ▶ Release the rod **26** from the transport position: Remove the safety locking pin **27.2** in point **P24** and unpin the pin **27.1**, see illustration **10**.
- ▶ Fasten the rod **26** to the auxiliary crane in point **P25**, see illustration **10**.
- ▶ Lift the rod **26** with the auxiliary crane.
- ▶ Insert the pin **27.1** again in point **P24** and secure with a safety locking pin **27.2**, see illustration **10**.
- ▶ Release the receptacle **25** from the transport position: Remove the safety locking pin **28.2** in point **P26** and unpin the pin **28.1**, see illustration **10**.



WARNING

Danger of accident when swinging in the receptacle!
When swinging in the receptacle **25**, limbs can be crushed.
Personnel can be severely injured.

- ▶ Do not reach with your hands into the danger zone.
- ▶ Swing the receptacle **25** by hand to the stop.



WARNING

The pins can loosen up by themselves!

- ▶ Secure the pin **28.1** immediately after pinning with the safety locking pin **28.2**.
- ▶ Secure the receptacle **25** in the operating position: Insert the pin **28.1** in point **P26** and secure with the safety locking pin **28.2**, see illustration **11**.
- ▶ Lower the rod **26** with the auxiliary crane to the receptacle **25**, see illustration **11**.
- ▶ Remove the auxiliary crane.
- ▶ Fold the second receptacle out.

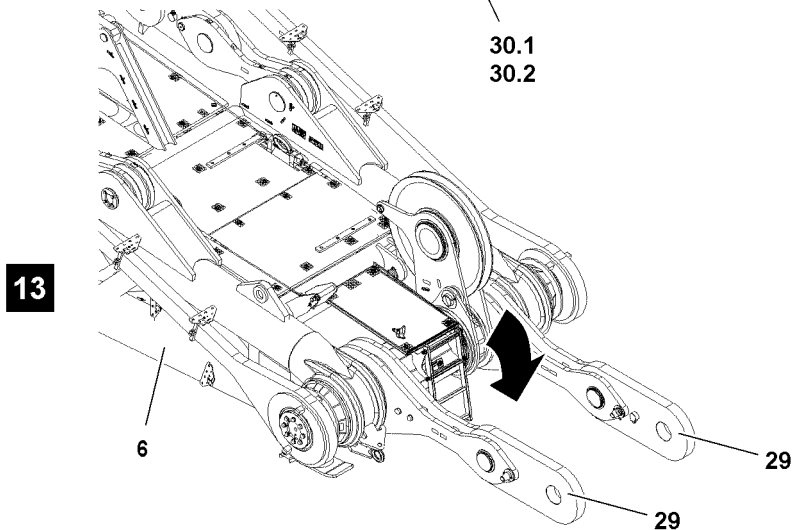
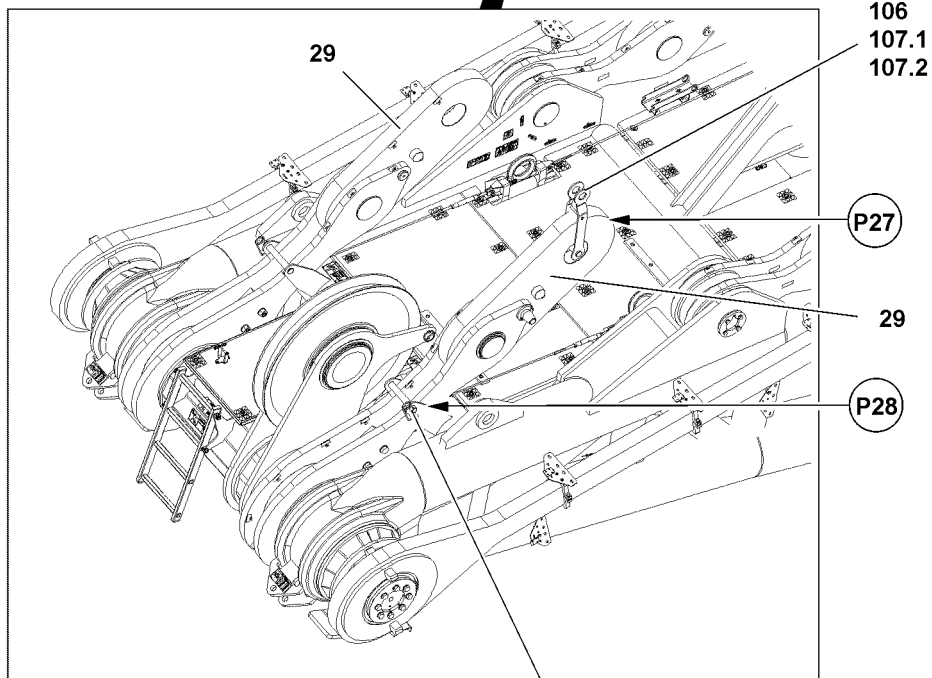
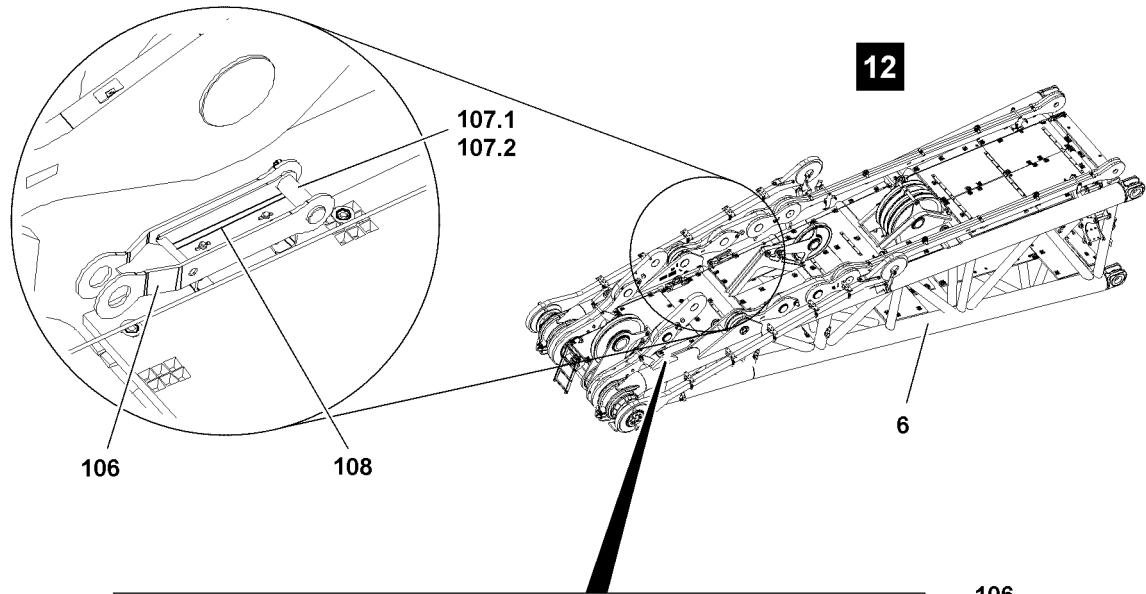

Fig.114376

LWE/LR 13000-001/19503-01-02/en

3.4.4 Swinging the pull test bracket into the operating position

- ▶ Release the pull test bracket **29** from the transport position: Remove the spring retainer **30.2** in point **P28** and unpin the pin **30.1**, see illustration **12**.

NOTICE

Pull test bracket incorrectly attached!

Due to incorrect or improper fastening of the pull test bracket, the pull test bracket can be damaged. Malfunctions of the pull test bracket can be the result.

- ▶ Fasten the pull test bracket **106** only with the bracket to the auxiliary crane.
-
- ▶ Release the bracket **106** from the transport position: Remove the safety locking pin **107.2** and unpin the pin **107.1**, see illustration **12**.
 - ▶ Remove the bracket **106** from the retainer **108**.
 - ▶ Pin the bracket **106** in point **P27** with the pull test bracket **29**: Insert the pin **107.1** and secure with the safety locking pin **107.2**, see illustration **12**.
 - ▶ Fasten the bracket **106** to the auxiliary crane.



WARNING

Danger of accident when swinging in the pull test bracket!

When swinging in the pull test bracket **29**, limbs can be crushed or severed.

Personnel can be severely injured.

- ▶ Make sure that there is no personnel in the danger zone.
 - ▶ Do not reach with your hands into the danger zone.
-
- ▶ Swing the pull test bracket **29** and take it down onto the ground, see illustration **13**.
 - ▶ Remove the auxiliary crane and unpin the bracket **106**.
 - ▶ Fold the second pull test bracket out.

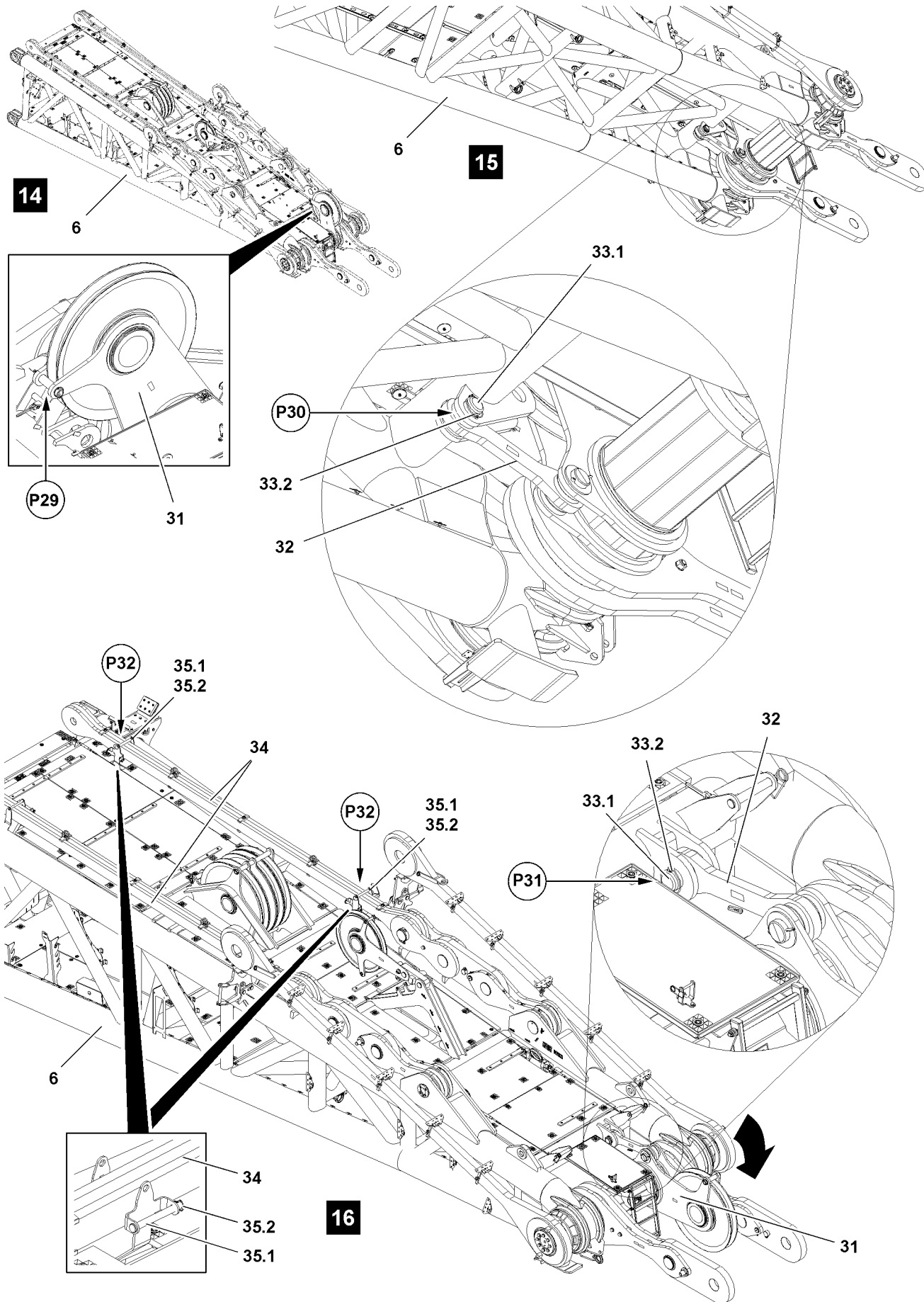

Fig.114377

LWE/LR 13000-001/19503-01-02/en

3.4.5 Swinging the pulley support into the operating position

- ▶ Fasten the pulley support **31** with loops to the auxiliary crane in point **P29**, see illustration **14**.



Note

- ▶ For better accessibility to the bracket **32**, the legs of the D-end section must be supported.
-



WARNING

Swinging bracket!

When releasing the bracket **32** in point **P30**, it can swing downward uncontrolled.

Personnel can be severely injured.

- ▶ Hold the bracket **32** when unpinning.
 - ▶ Assembly personnel must be to the side of the assembly unit.
-



WARNING

Falling pulley support!

When releasing the bracket **32** in point **P30**, the pulley support **31** can fall forward or backward uncontrolled.

Personnel can be severely injured or killed.

- ▶ Make sure that the pulley support **31** is fastened to the auxiliary crane.
-



Note

- ▶ The weight of the bracket **32** is 58 kg.
 - ▶ When unpinning the brackets, a second assembly person must be used to help.
-
- ▶ Release the pulley support **31** from the transport position: Remove the safety locking pin **33.2** in point **P30** and unpin the pin **33.1**, see illustration **15**.

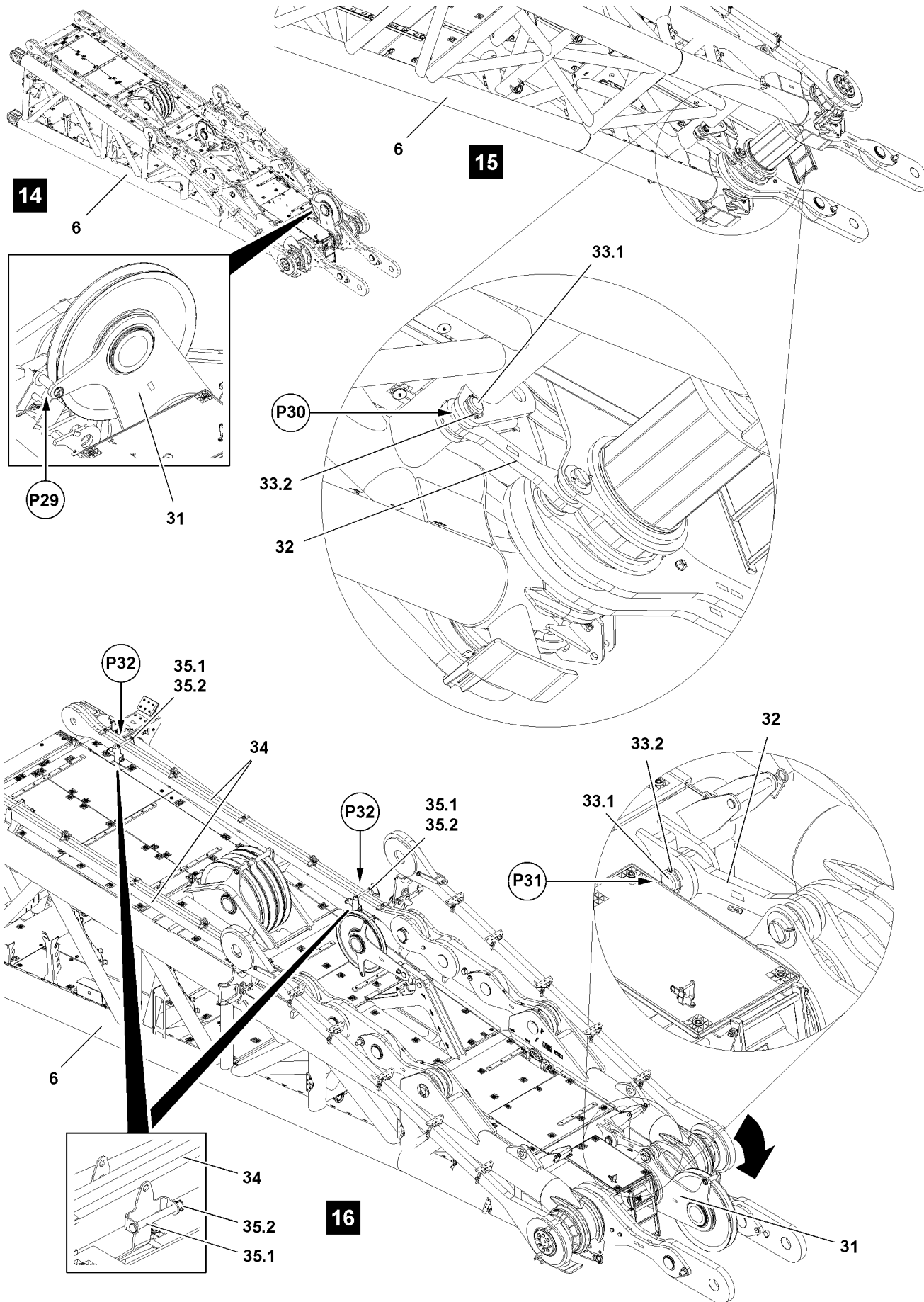

Fig.114377

LWE/LR 13000-001/19503-01-02/en

**WARNING**

Danger of accident when swinging in the pulley support!
When swinging in the pulley support **31**, limbs can be crushed or severed.
Personnel can be severely injured.

- ▶ Make sure that there is no personnel in the danger zone.
 - ▶ Do not reach with your hands into the danger zone.
-
- ▶ Swing the pulley support **31** with the auxiliary crane until the bracket **32** can be pinned in point **P31**, see illustration **16**.

**WARNING**

The pin is not secured!
If the pin **33.1** is not secured, the pin can loosen up by itself during crane operation.
This could result in property damage.

- ▶ Make sure that the pin **33.1** is secured with the safety locking pin **33.2**.
-
- ▶ Secure the pulley support **31** in the operating position: Insert the pin **33.1** in point **P31** and secure with the safety locking pin **33.2**, see illustration **16**.
 - ▶ Remove the auxiliary crane.

3.4.6 Releasing the guy rods

- ▶ Remove the transport retainer for the guy rods **34** in points **P32**: Remove the safety locking pin **35.2** and unpin the pin **35.1**, see illustration **16**.
- ▶ Insert the pin **35.1** in the park position and secure with the safety locking pin **35.2**, see illustration **16**.

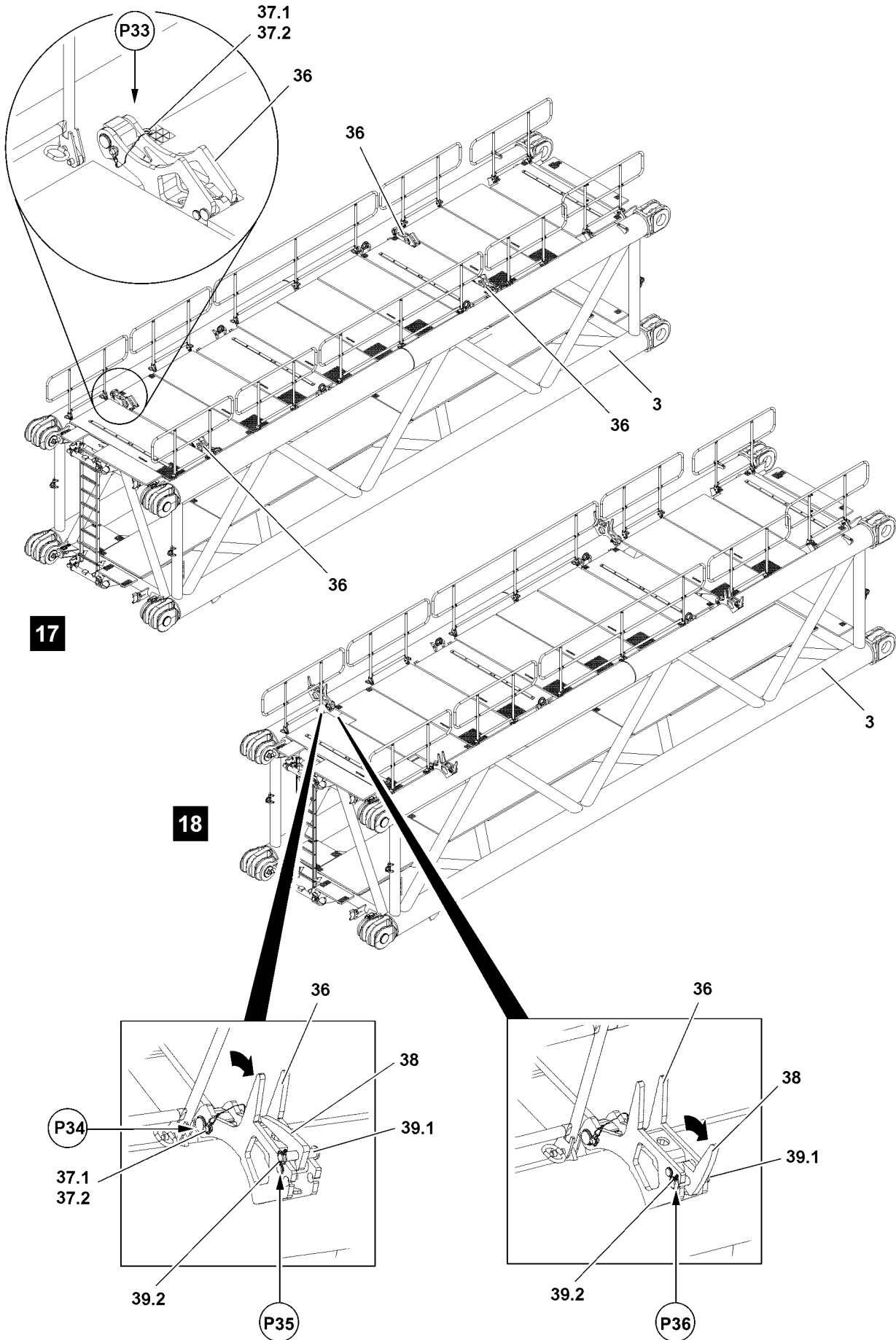

Fig.114380

LWE/LR 13000-001/19503-01-02/en

3.5 Preparing the D-intermediate sections



WARNING

Danger of falling!

During assembly and disassembly, personnel must be secured with appropriate aids to prevent them from falling.

Even for assembly and disassembly of protective devices there is a danger of falling.

Assembly personnel can fall and be severely injured or killed.

- ▶ Use personal protective equipment.

3.5.1 D-intermediate section 2824.36 12 m

Swinging the railing on the D-intermediate section into the operating position



Note

- ▶ Swing the railing on the D-intermediate section into the operating position, see the Crane operating instructions, chapter 2.06.

Swinging the rod receptacles into operating position

- ▶ Release the rod receptacle **36** from the transport position: Remove the safety locking pin **37.2** in point **P33** and unpin the pin **37.1**, see illustration **17**.



WARNING

Danger of accident when swinging in the rod receptacle!

When swinging in the rod receptacle **36**, limbs can be crushed or severed.

Personnel can be severely injured.

- ▶ Do not reach with your hands into the danger zone.
- ▶ Swing the rod receptacle **36** to the stop, see illustration **18**.



WARNING

The pins can loosen up by themselves!

- ▶ Secure the pin **37.1** immediately after pinning with the safety locking pin **37.2**.
- ▶ Secure the rod receptacle **36** in the operating position: Insert the pin **37.1** in point **P34** and secure with the safety locking pin **37.2**, see illustration **18**.
- ▶ Release the latches **38** from the transport position: Remove the safety locking pin **39.2** in point **P35** and unpin the pin **39.1**.
- ▶ Swing the latches **38** to the stop, see illustration **18**.



WARNING

The pins can loosen up by themselves!

- ▶ Secure the pin **39.1** immediately after pinning with the safety locking pin **39.2**.
- ▶ Secure the latches **38** in the operating position: Insert the pin **39.1** in point **P36** and secure with the safety locking pin **39.2**, see illustration **18**.
- ▶ Swing all rod receptacles into the operating position, see illustration **18**.

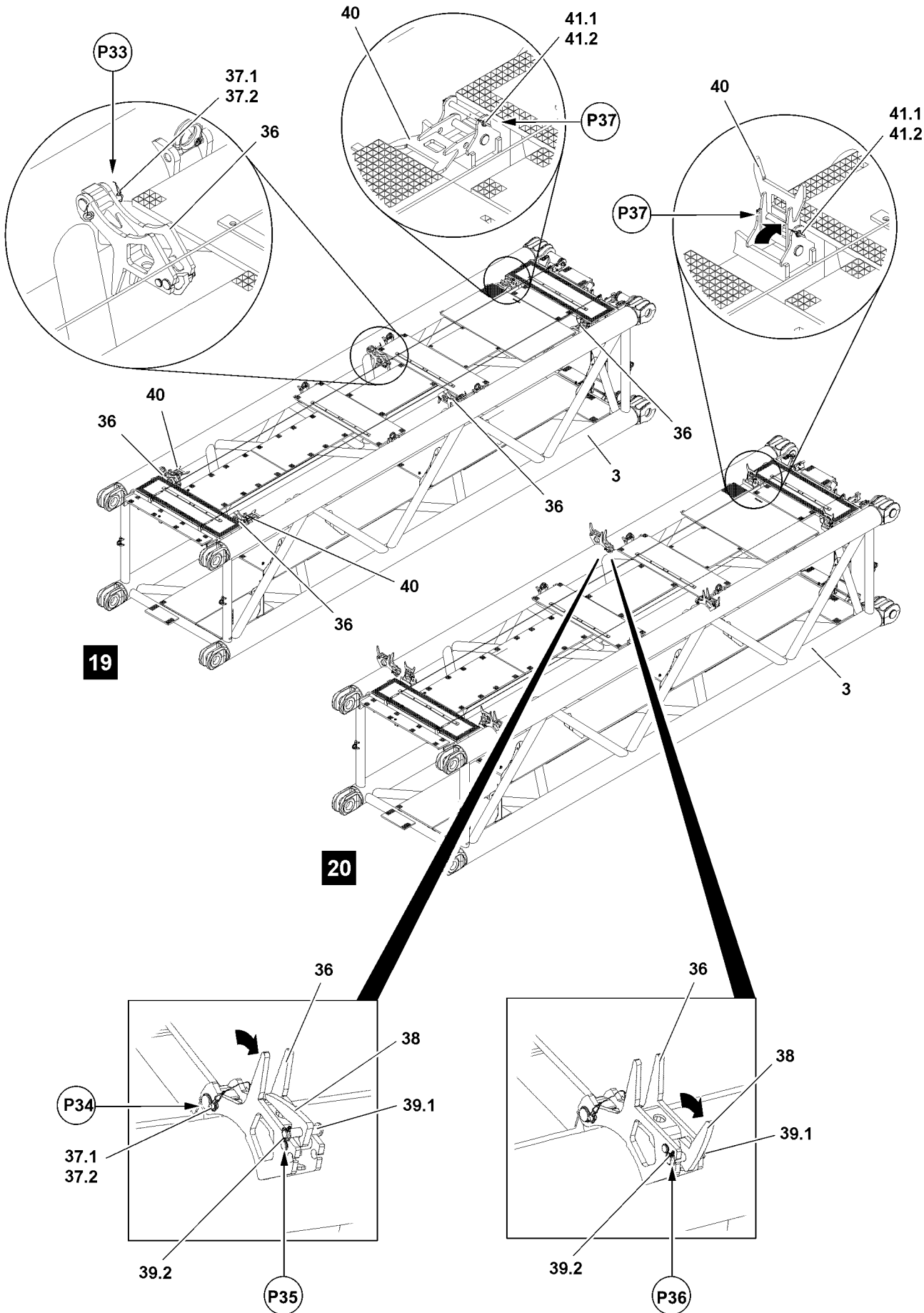

Fig.114381

LWE/LR 13000-001/19503-01-02/en

3.5.2 D-intermediate section 2824.25 12 m

Swinging the rod receptacles into operating position

- ▶ Release the rod receptacle **36** from the transport position: Remove the safety locking pin **37.2** in point **P33** and unpin the pin **37.1**, see illustration **19**.



WARNING

Danger of accident when swinging in the rod receptacle!
When swinging in the rod receptacle **36**, limbs can be crushed or severed.
Personnel can be severely injured.

- ▶ Do not reach with your hands into the danger zone.
- ▶ Swing the rod receptacle **36** to the stop, see illustration **20**.



WARNING

The pins can loosen up by themselves!

- ▶ Secure the pin **37.1** immediately after pinning with the safety locking pin **37.2**.
- ▶ Secure the rod receptacle **36** in the operating position: Insert the pin **37.1** in point **P34** and secure with the safety locking pin **37.2**, see illustration **20**.
- ▶ Release the latches **38** from the transport position: Remove the safety locking pin **39.2** in point **P35** and unpin the pin **39.1**.
- ▶ Swing the latches **38** to the stop, see illustration **20**.



WARNING

The pins can loosen up by themselves!

- ▶ Secure the pin **39.1** immediately after pinning with the safety locking pin **39.2**.
- ▶ Secure the latches **38** in the operating position: Insert the pin **39.1** in point **P36** and secure with the safety locking pin **39.2**, see illustration **20**.
- ▶ Swing all rod receptacles into the operating position, see illustration **20**.

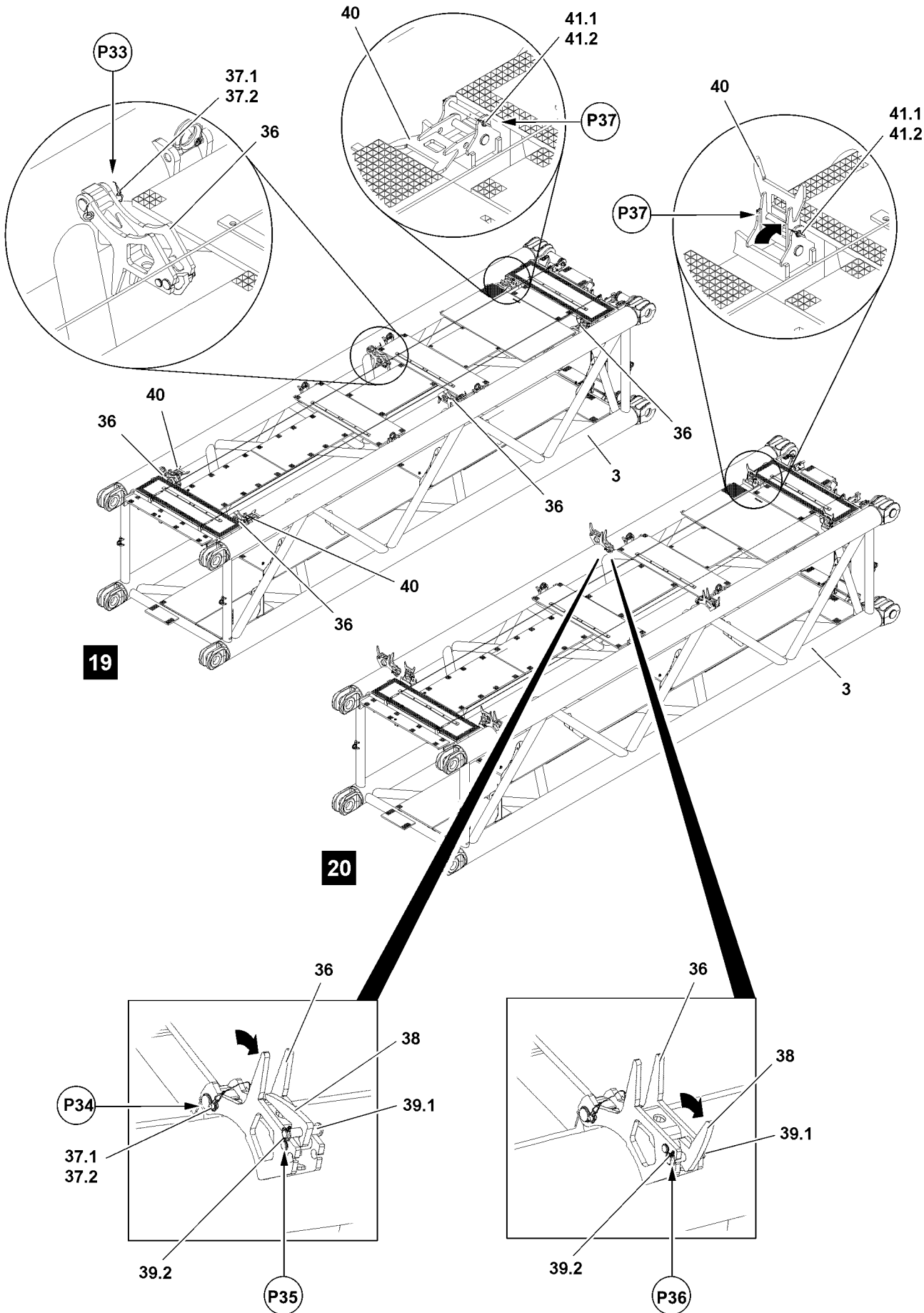

Fig.114381

LWE/LR 13000-001/19503-01-02/en

Swinging the rod receptacles into operating position

- ▶ Release the rod receptacle **40** from the transport position: Remove the safety locking pin **41.2** in point **P37** and unpin the pin **41.1**, see illustration **19**.



WARNING

Danger of accident when swinging in the rod receptacle!
When swinging in the rod receptacle **40**, limbs can be crushed or severed.
Personnel can be severely injured.

- ▶ Do not reach with your hands into the danger zone.
-
- ▶ Swing the rod receptacle **40** up until it can be pinned in point **P37**, see illustration **19**.



WARNING

The pins can loosen up by themselves!

- ▶ Secure the pin **41.1** immediately after pinning with the safety locking pin **41.2**.
-
- ▶ Secure the rod receptacle **40** in the operating position: Insert the pin **41.1** again in point **P37** and secure with a safety locking pin **41.2**, see illustration **20**.
 - ▶ Swing all rod receptacles into the operating position, see illustration **20**.

3.5.3 D-intermediate section 2824.36 6 m and D-intermediate section 2824.36A 6 m



Note

- ▶ The preparation of the intermediate sections with 6 m length is the same as the work steps for the previous described intermediate sections with 12 m length.
-
- ▶ Prepare the required intermediate sections according to the supplied assembly drawings.

21

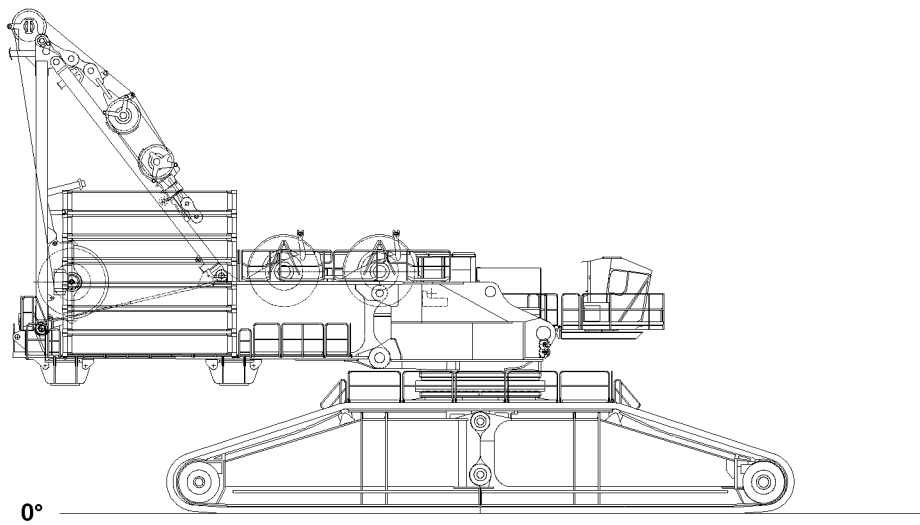

22

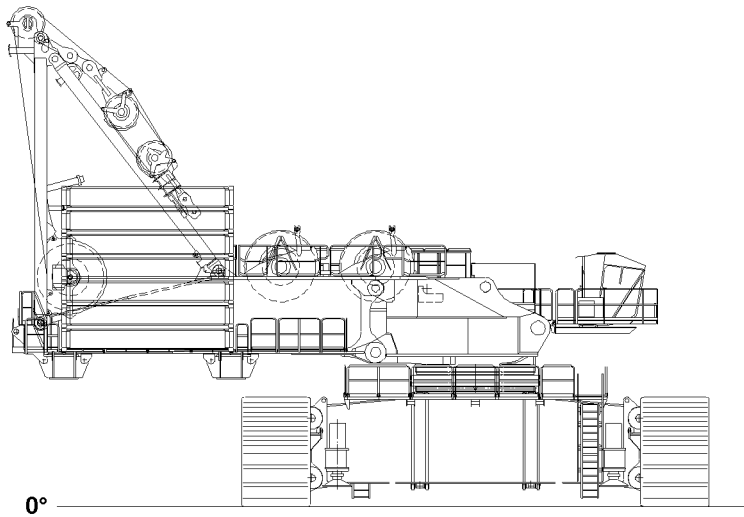

Fig.117571

LWE/LR 13000-001/19503-01-02/en

3.6 Assembling the D-boom in sections

Make sure that the following prerequisites are met:

- The crane is horizontally aligned.
- An auxiliary crane is available.
- An assembly scaffolding / work platform is available.
- The counterweight has been installed on the turntable according to the load chart.
- The LICCON overload protection has been set according to the data in the load chart.
- The LICCON overload protection settings have been compared with the actual set up configuration.
- A main boom is not assembled on the turntable.



Note

- ▶ At assembly, the turntable can be turned along the longitudinal axle of the crawler travel gear or to the side, see illustration **21** and illustration **22**.



DANGER

Danger of fatal injury due falling components!

If the pin connections are not visually inspected, the pins can loosen up by themselves and cause components to fall down.

Personnel can be severely injured or killed.

- ▶ All pins must be secured after assembly with the intended retaining elements. Check visually.
- ▶ The guy rods must be inspected regularly, see the Crane operating instructions, chapter 8.15.



WARNING

Danger of falling!

During assembly and disassembly, assembly personnel must be secured with appropriate aids to prevent them from falling.

Even for assembly and disassembly of protective devices there is a danger of falling.

Assembly personnel can fall and be severely injured or killed.

- ▶ Use personal protective equipment.

Turntable ballast	Central ballast
400 t	0 t
500 t	150 t

21

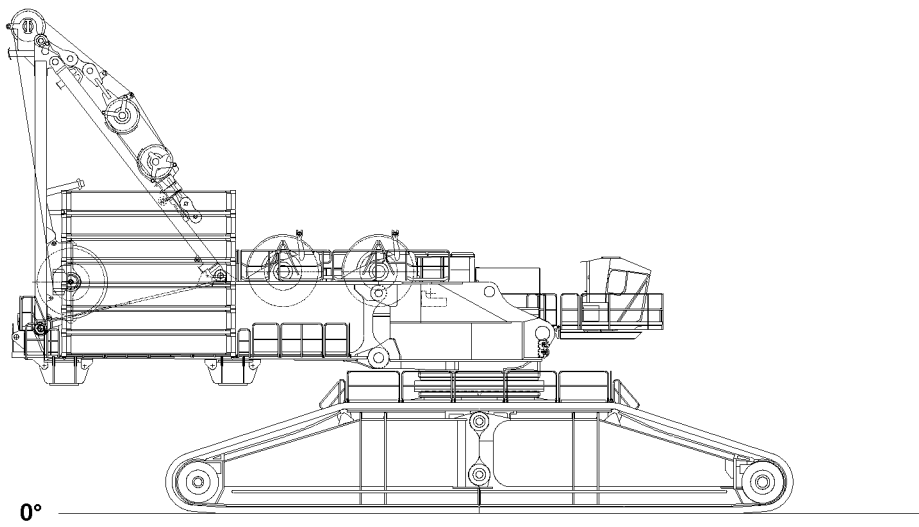

22

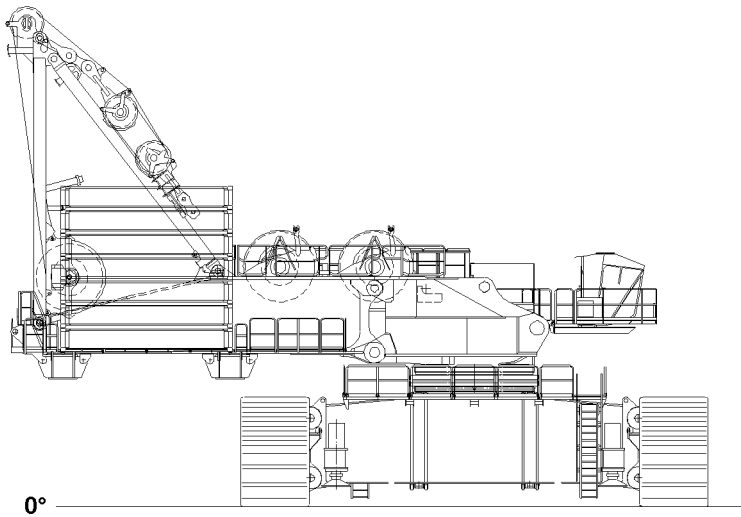

Fig.117571

3.6.1 Activating the assembly operation



WARNING

Activated assembly operation!

When the assembly operation is activated, the LICCON overload protection is deactivated.

In the event of deliberate improper use, the crane could collapse, the D-boom can break off or the crane can topple over.

Personnel can be killed.

This can result in significant property damage.

- ▶ The assembly operation may only be activated by persons who know the effects.
- ▶ Activate the assembly operation only if the crane set up configuration was correctly entered in the LICCON computer system.
- ▶ Observe the erection / take down charts.
- ▶ Crane operation with deactivated LICCON overload protection is strictly prohibited.

-
- ▶ Activate the assembly operation.

Result:

- The LICCON overload protection is deactivated.
- The assembly icon appears on the LICCON monitor.

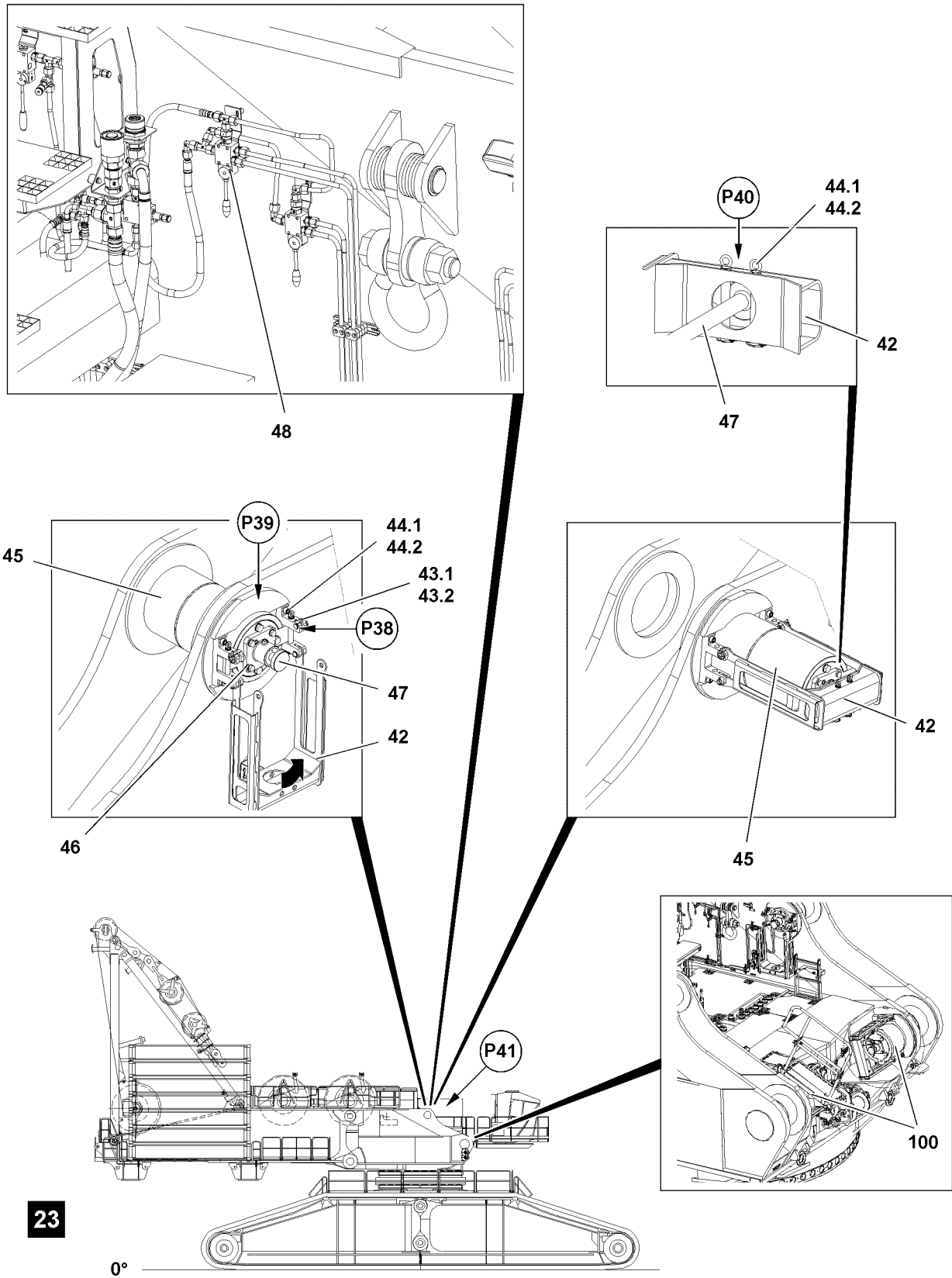

Fig.114383

LWE/LR 13000-001/19503-01-02/en

3.6.2 Pinning the D-pivot section on the turntable

Unpinning the pins for the D-pivot section on the turntable

- ▶ Remove the safety locking pin **43.2** on both sides in point **P38** and unpin the pin **43.1**, see illustration **23**.
- ▶ Fold up the bracket **42** on both sides, insert the pin **43.1** again in point **P38** and secure with the safety locking pin **43.2**, see illustration **23**.
- ▶ Release the pin **45**: Remove the safety locking pin **44.2** on both sides in point **P39** and unpin the pin **44.1**, see illustration **23**.
- ▶ Extend the piston rod **47** of the pin pulling cylinder **46**: Actuate the hand lever **48**.
- ▶ Secure the piston rod **47** of the pin pulling cylinder **46** on the bracket **42** in point **P40**: Insert the pin **44.1** on both sides and secure with the safety locking pin **44.2**, see illustration **23**.
- ▶ Retract the piston rod **47** of the pin pulling cylinder on both sides: Actuate the hand lever **48**.

Result:

- The pin **45** retracts, see illustration **23**.

Unpinning the pins for the S-pivot section on the turntable



Note

- ▶ Unpin the pin **100** for the S-pivot section, see the Crane operating instructions, chapter 5.39.

NOTICE

Collision with pins!

If the pins **100** are not unpinned on the turntable for the S-pivot section, then the D-pivot section and the pins can be damaged when taking them down on the turntable.

This could result in property damage.

- ▶ Make sure that the pins **100** are unpinned on the turntable for the S-pivot section.
- ▶ Unpin the pin **100** for the S-pivot section, see illustration **23**.

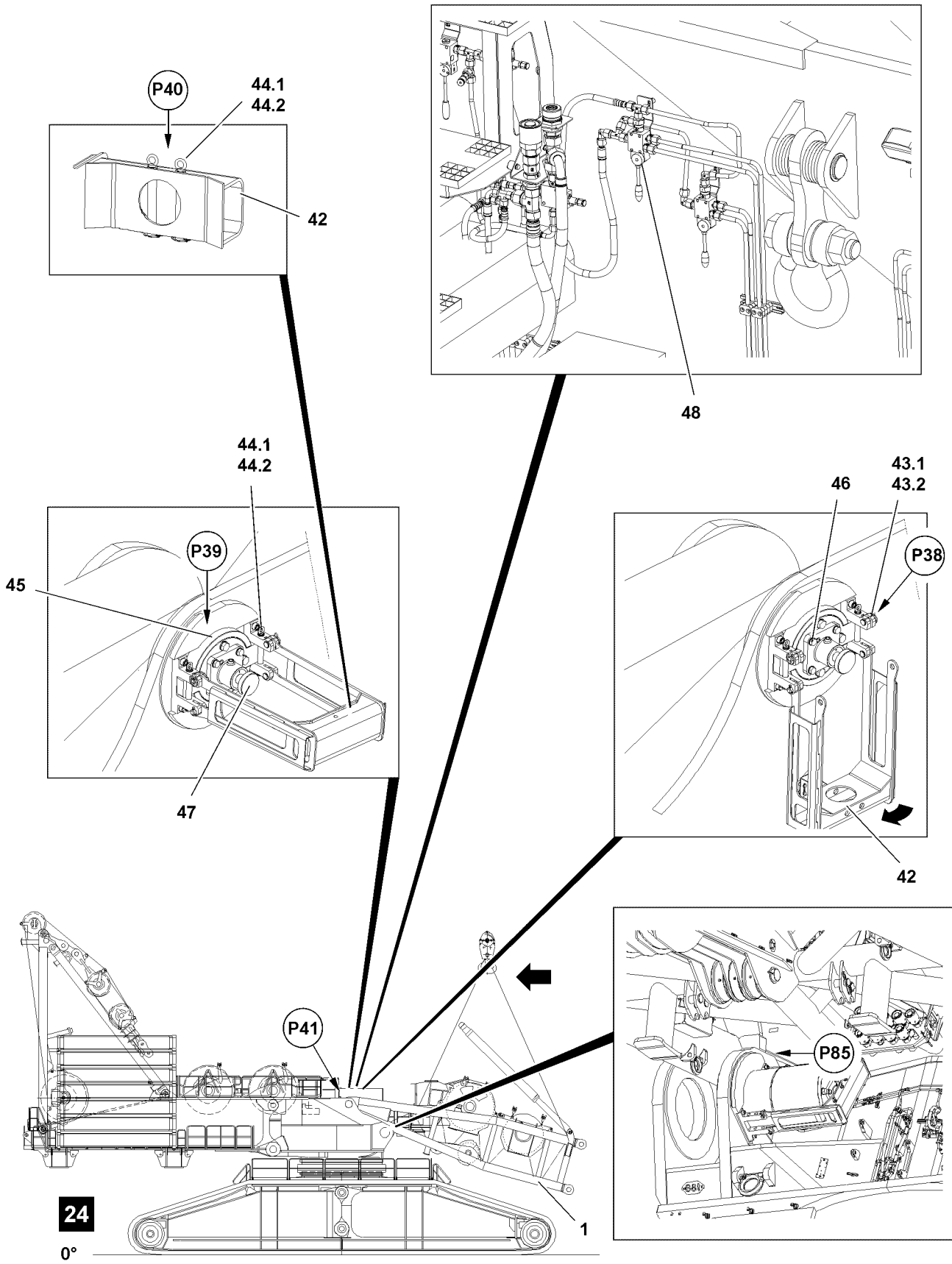

LWE/LR 13000-001/19503-01-02/en

Fig.114398

Pinning the D-pivot section

Make sure that the following prerequisites are met:

- The pins are unpinned for the S-pivot section.
 - The pins are unpinned for the D-pivot section.
- ▶ Fasten the D-pivot section **1** to the fastening points on the auxiliary crane and swing in to the pin points **P41** on the turntable, see illustration **24**.



WARNING

The pin is not secured!

If the pins **45** are not secured, the pins can loosen up by themselves during crane operation. This can cause the crane to topple over.

Personnel can be severely injured or killed.

- ▶ Make sure that the pins **45** are secured after the pin procedure.

When the pin bores on the D-pivot section and on the turntable align:

- ▶ Extend the piston rod **47** of the pin pulling cylinder.
- ▶ Actuate the hand lever **48** until the pins **45** are completely pinned on both sides, see illustration **24**.
- ▶ Secure the pin **45**: Release the pin **44.1** and unpin in point **P40**, then insert the pin **44.1** in point **P39** on both sides and secure with the safety locking pin **44.2**.

When the pins **45** are secured:

- ▶ Carefully lower the D-pivot section **1** with the auxiliary crane on the turntable to the stop in point **P85**, see illustration **24**.
- ▶ Remove the auxiliary crane.
- ▶ Retract the piston rod **47** of the pin pulling cylinder: Actuate the hand lever **48**.



WARNING

Swinging bracket!

When releasing the bracket **42** in point **P38**, it can swing downward uncontrolled.

Personnel can be severely injured.

- ▶ Hold the bracket **42** when unpinning.
 - ▶ Assembly personnel must be to the side of the assembly unit.
- ▶ Remove the safety locking pin **43.2** on both sides in point **P38** and unpin the pin **43.1**.
- ▶ Fold the bracket **42** down, insert the pin **43.1** again on both sides in point **P38** and secure with the safety locking pin **43.2**, see illustration **24**.

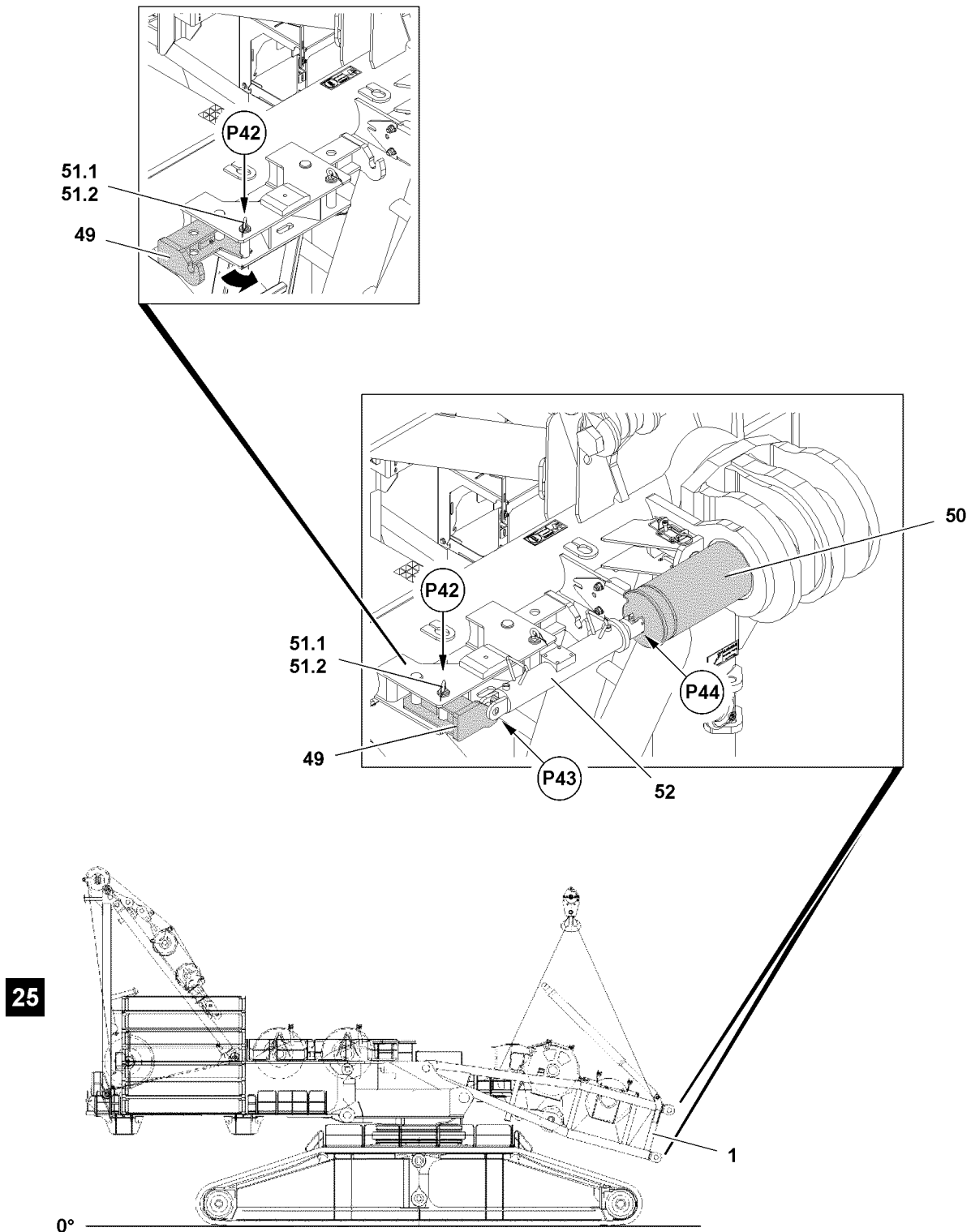

Fig.114384

LWE/LR 13000-001/19503-01-02/en

3.6.3 Pinning the D-intermediate section 2824.36 12 m

Make sure that the following prerequisites are met:

- The D-pivot section is properly installed and secured.
- The pins **50** on the D-pivot section are unpinned.

Establishing the hydraulic connections



Note

- ▶ The hydraulic supply for the pin pulling cylinder is made via the external hydraulic aggregate or the operational engine house.

The hydraulic connections are established with quick couplings.

When connecting hydraulic lines with quick couplings, make sure that the coupling procedure is carried out correctly.

The matching quick couplings are marked.



WARNING

Pressure in the hydraulic lines!

If the pressure supply is not interrupted before connecting / releasing the hydraulic lines, the hydraulic oil can escape with high pressure.

Death, severe bodily injuries, property damage.

- ▶ Release the pressure in the hydraulic system before connecting / disconnecting: Interrupt the pressure supply and wait a short time.



WARNING

Loss of pressure or leakage!

Incorrectly coupled or self-loosening quick couplings (particularly return lines) can result in serious accidents due to component failure.

Death, severe bodily injuries, property damage.

- ▶ Check that the quick couplings have been properly connected before using the crane.

- ▶ Connect the coupling components (sleeve and connector) and screw together with the knurled nut.
- ▶ Tighten the hydraulic coupling by hand. Turn the knurled nut until it reaches a tangible, fixed stop position.
- ▶ Establish the hydraulic connection: Connect the supply lines of the external hydraulic aggregate to the supply lines of the pin pulling cylinder, hydraulic connection **R** and hydraulic connection **P**.

Swinging the folding bracket into the operating position

- ▶ Swing the folding bracket **49** into the operating position: Remove the safety locking pin **51.2** in point **P42** and unpin the pin **51.1** and turn the folding bracket, see illustration **25**.
- ▶ Secure the folding bracket **49** in the operating position: Insert the pin **51.1** in point **P42** and secure with the safety locking pin **51.2**, see illustration **25**.
- ▶ Connect the pin pulling cylinder **52** at the **rear** in point **P43**.
- ▶ Connect the pin pulling cylinder **52** at the **front** in point **P44** with the pin **50**, see illustration **25**.

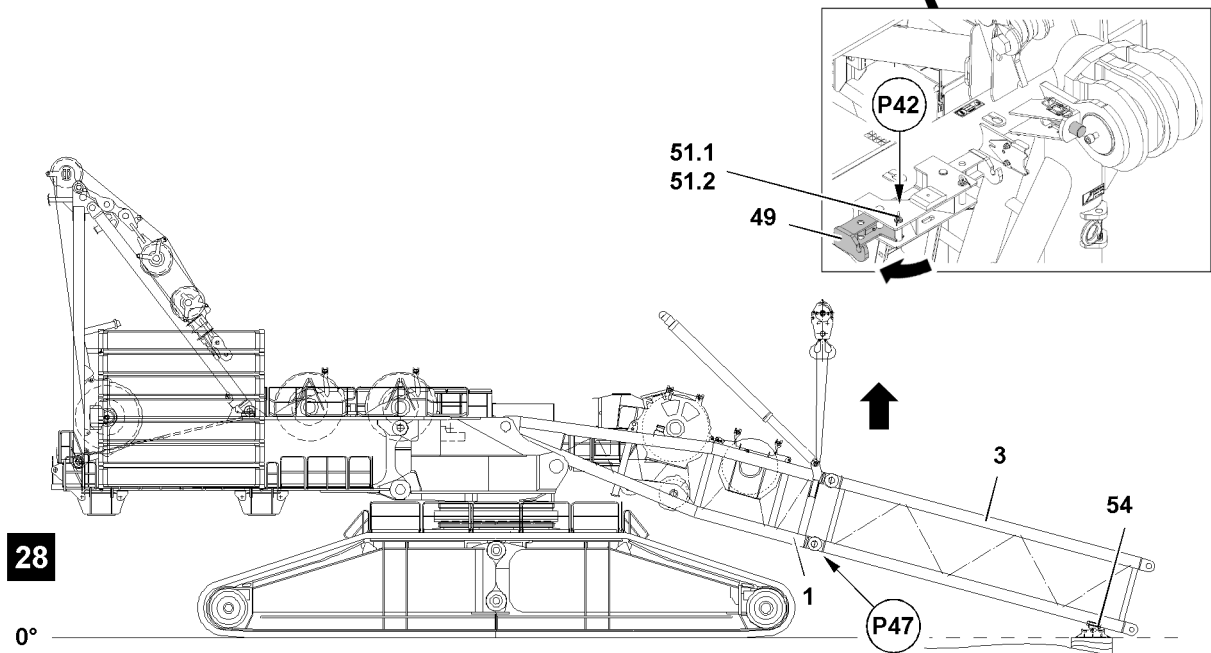
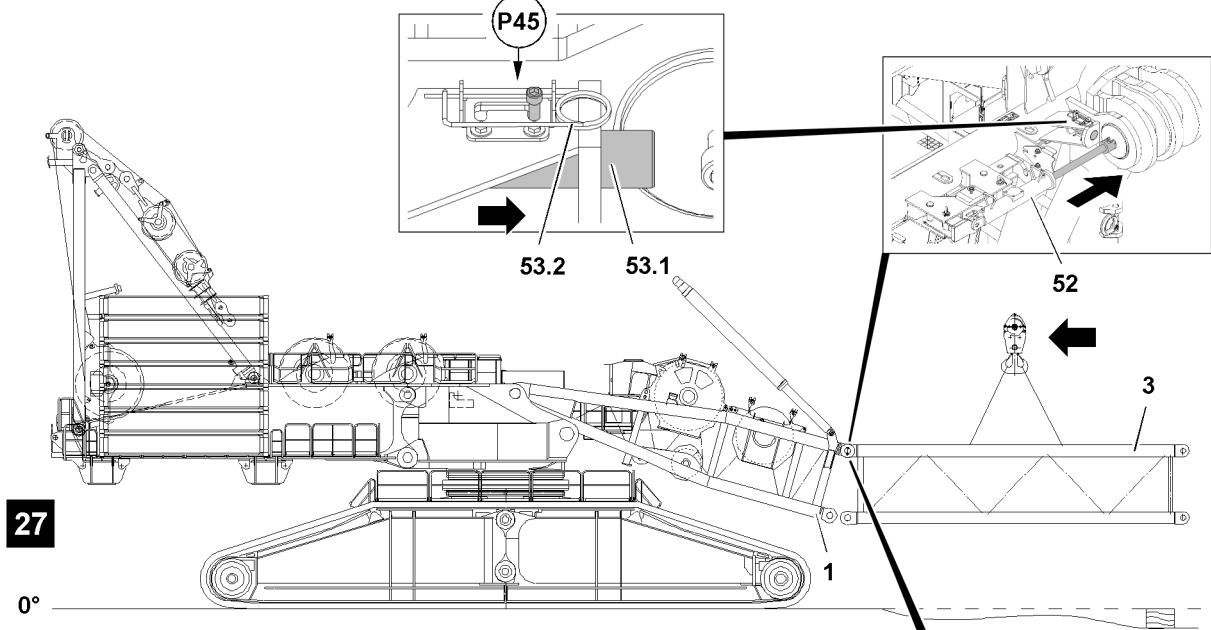
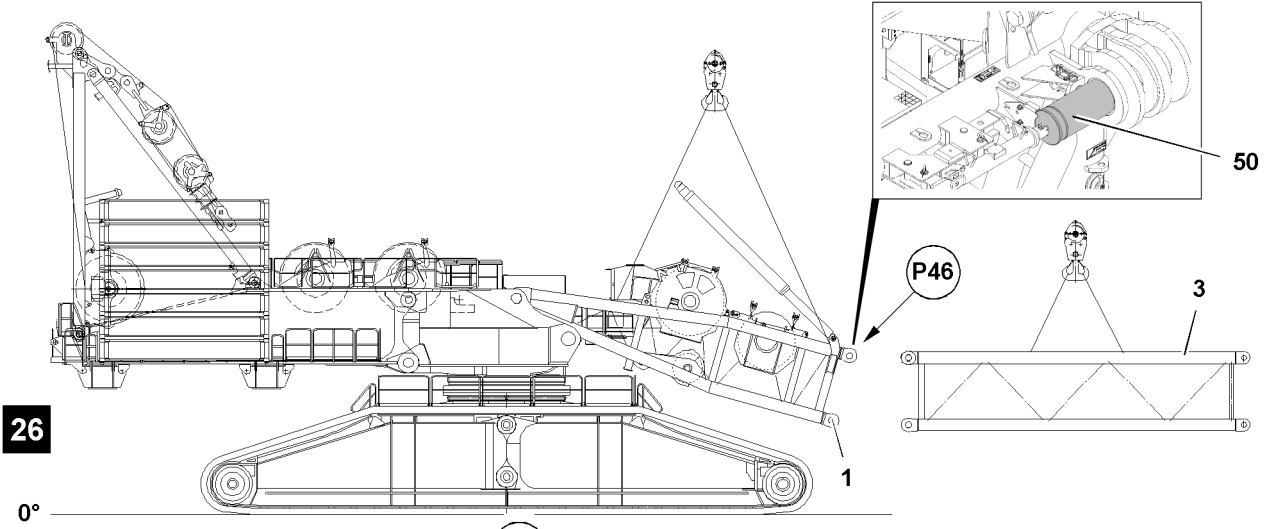

Fig.164536

LWE/LR 13000-001/19503-01-02/en

Pinning the D-intermediate section on top

- ▶ Fasten the D-intermediate section 2824.36 12 m **3** in the fastening points to the auxiliary crane and swing in to the pin points **P46** on the D-pivot section, see illustration **26**.

When the pin bores on the D-pivot section align with those on the D-intermediate section:

- ▶ Insert the pins **50** on **top** on both sides.



WARNING

The pin is not secured!

If the pin **50** is not secured, the pin can loosen up by itself during crane operation.

This can cause the crane to topple over.

Falling load and property damage can result.

Personnel can be severely injured or killed.

- ▶ After pinning, the pin **50** must be secured with the pins **53.1**.

- ▶ Secure the pin **50**: Remove the spring retainer **53.2** and slide the pin **53.1** outward so that the screw engages in point **P45**, see illustration **27**.
- ▶ Secure the pin **53.1**: Attach the spring retainer **53.2**.
- ▶ Remove the pin pulling cylinder **52**.
- ▶ Swing the folding bracket **49** into the transport position: Remove the safety locking pin **51.2** in point **P42** and unpin the pin **51.1** and turn the folding bracket **49**, see illustration **27**.
- ▶ Secure the folding bracket **49** in the transport position: Insert the pin **51.1** in point **P42** and secure with the safety locking pin **51.2**, see illustration **27**.

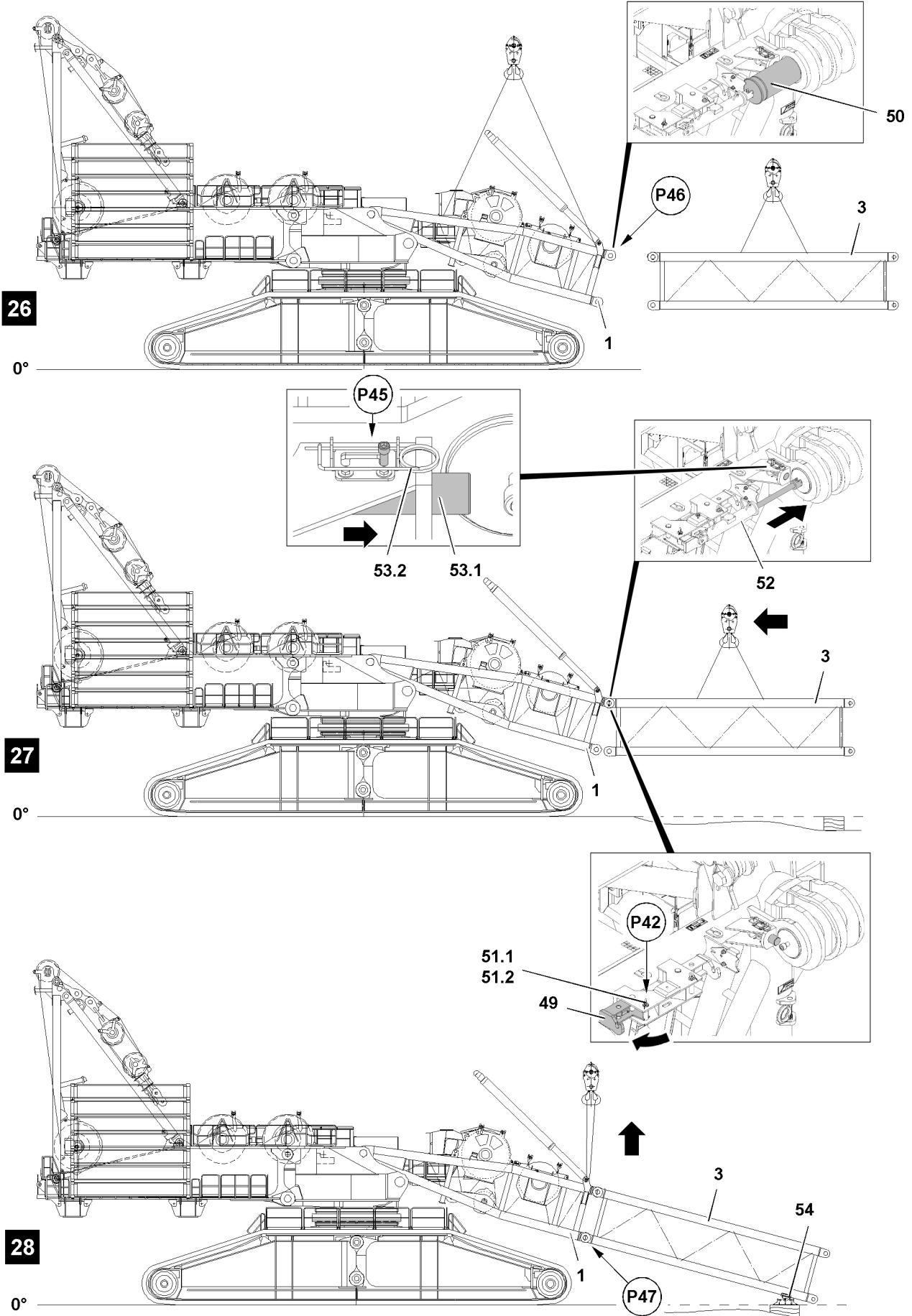

Fig.164536

LWE/LR 13000-001/19503-01-02/en

Pinning the D-intermediate section on the bottom

NOTICE

Damage to the D-intermediate section!

Property damage can occur on the intermediate section by taking the D-intermediate section down on the ground.

- ▶ Do not take the D-intermediate section down directly onto the ground.
- ▶ When taking the D-intermediate section down, use a sufficiently load bearing and large enough substructure.
- ▶ The substructure must be erected at least to the alignment level.

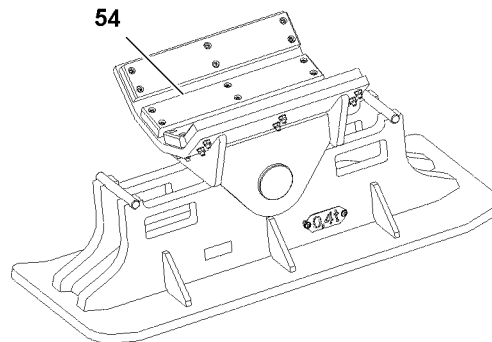

Fig.115648

Substructure: Assembly shoe

- ▶ Take the D-intermediate section 2824.36 12 m **3** down carefully with the auxiliary crane on the substructure **54**, see illustration **28**.
- ▶ Remove the auxiliary crane from the D-intermediate section and fasten to the D-pivot section, see illustration **28**.
- ▶ Erect the auxiliary crane until the pin bores on the D-pivot section and on the D-intermediate section align.



Note

- ▶ The procedure on the pin locations on the **bottom** is the same as the work steps for the previously described pin location on **top**.



WARNING

The pin is not secured!

If the pin **50** is not secured, the pin can loosen up by itself during crane operation.

This can cause the crane to topple over.

Falling load and property damage can result.

Personnel can be severely injured or killed.

- ▶ After pinning, the pin **50** must be secured with the pins **53.1**.
- ▶ Pin and secure the pin **50** on the **bottom** on both sides in point **P47**.
- ▶ Remove the auxiliary crane.

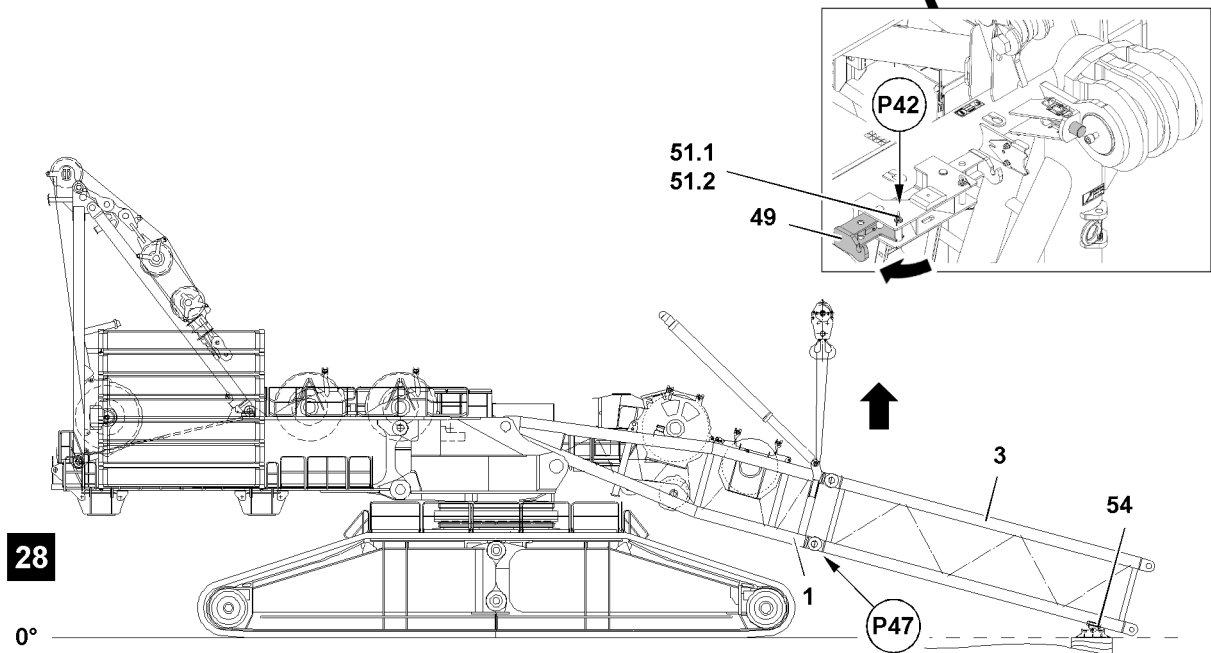
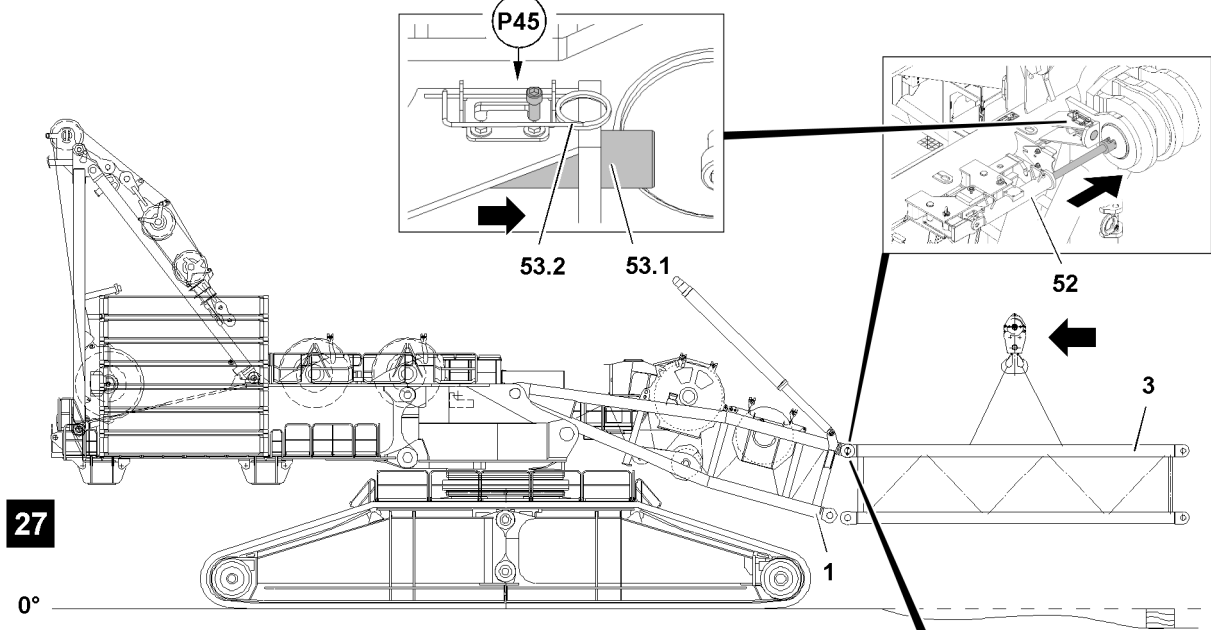
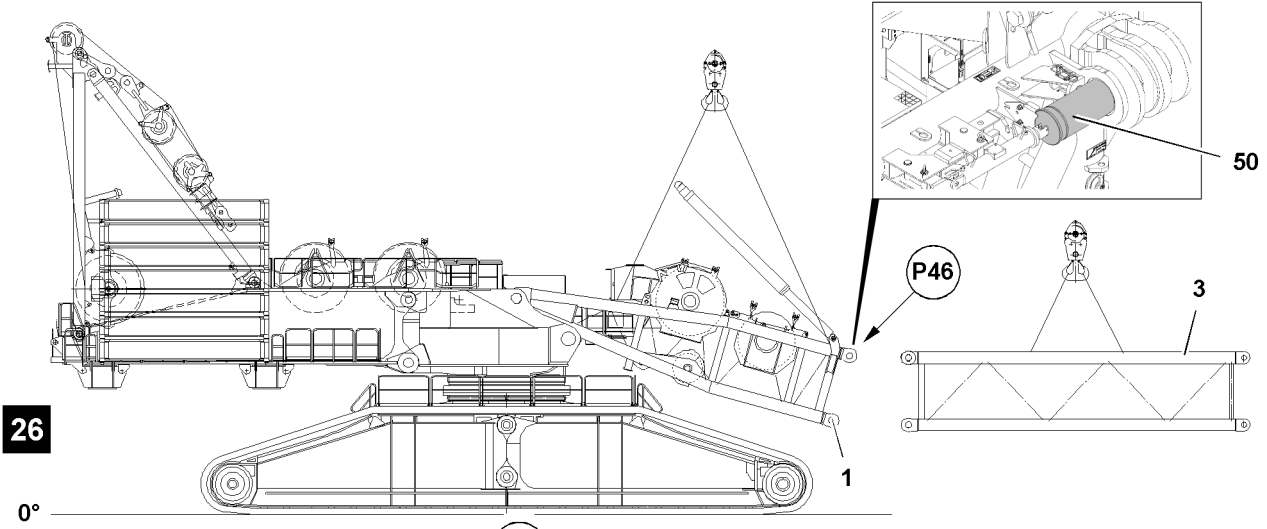

Fig.164536

LWE/LR 13000-001/19503-01-02/en

Assembling the D-intermediate section flying

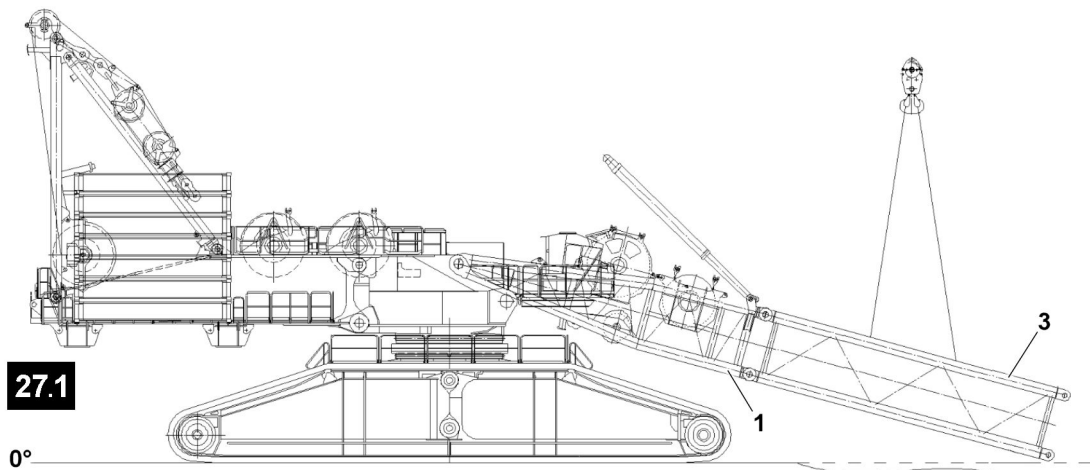

Fig. 164534

- ▶ Fasten the D-intermediate section 2824.36 12 m **3** in the fastening points to the auxiliary crane and swing in to the pin points on the D-pivot section **1**, see illustration **27.1**.



Note

- ▶ The procedure on the pin locations on the **top** and **bottom** is the same as the work steps that are described in the section „Pinning the D-intermediate section on top“.

When the pin bores on the D-pivot section align with those on the D-intermediate section:

- ▶ Insert the pin on the **top** and **bottom** on both sides, see section „Pinning the D-intermediate section on top“.

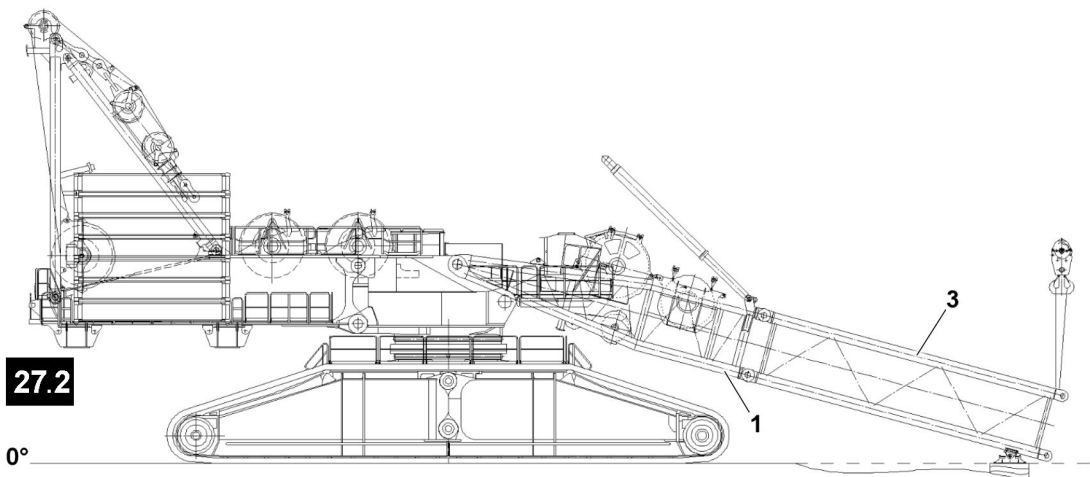

Fig. 164535

- ▶ Move the auxiliary crane, required load 60 t.
- ▶ Lift the D-intermediate section 2824.36 12 m **3** and D-pivot section **1**, see illustration **27.2**.
- ▶ Build up the substructure to at least the erection level, see section „Pinning the D-intermediate section on the bottom“.
- ▶ Take the D-intermediate section 2824.36 12 m **3** and D-pivot section **1** down on the substructure.

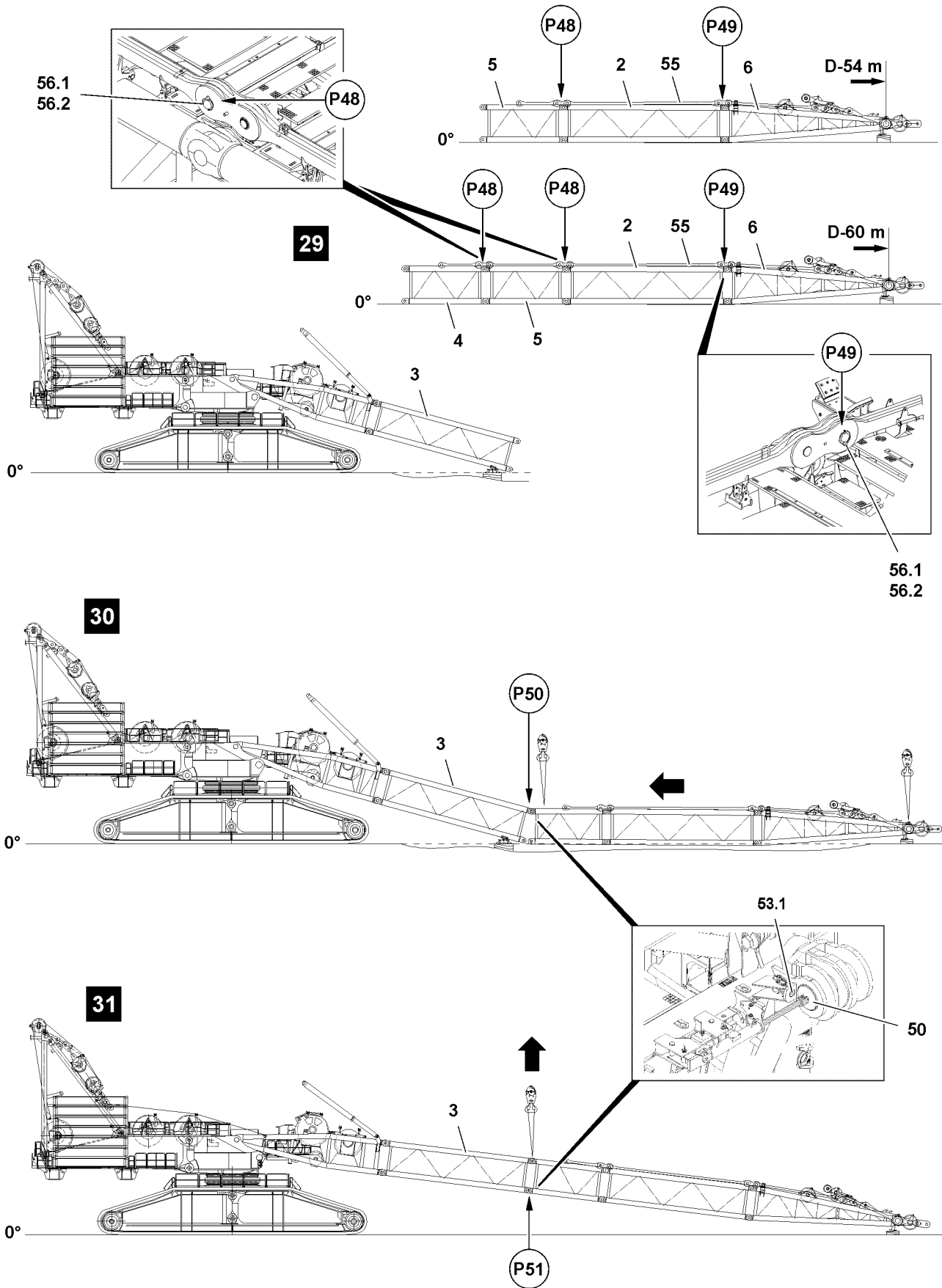

Fig.114386

LWE/LR 13000-001/19503-01-02/en

3.6.4 Assembling the D-boom

Make sure that the following prerequisites are met:

- The D-pivot section and the D-intermediate section are properly installed and secured.
- The D-pivot section and the D-intermediate section are taken down on the substructure.

Pinning the D-end section with the D-intermediate section



Note

- ▶ Always support the D-intermediate sections sufficiently for easier assembly.



Note

- ▶ The procedure in the pin locations is the same as the work steps for the previously described assembly of the D-end section and the D-intermediate section.

- ▶ Assemble the D-intermediate sections according to the separately supplied assembly drawings, see illustration 29.

Assembling the derrick guy rods



WARNING

Neglected inspection and maintenance on guy rods!

If the regular inspection and maintenance of the guy rods is not carried out or is carried out only in irregular intervals, then serious accidents can occur due to existing and unrecognized damage to the guy rods.

Personnel can be severely injured or killed.

- ▶ The guy rods must be checked before every assembly, see the Crane operating instructions, chapter 8.15.



Note

- ▶ The derrick guy rods must be assembled and secured according to the separately supplied assembly drawings. The numbering on the assembly drawings must be identical to the numbering on the guy rods.



Note

- ▶ The pins 56.1 of the derrick guy rods 55 in points P48 may only be pinned from the **inside** to the **outside**.

- ▶ Assemble the derrick guy rods 55 to the required length: Insert the pin 56.1 in points P48 on both sides and secure with the safety locking pin 56.2, see illustration 29.



WARNING

Collision with the pull cylinder!

If the pins on the derrick guy rods are pinned in point P49 from the **inside** to the **outside**, then they can collide later with the pull cylinder.

This could result in property damage.

- ▶ Make sure that the pins are inserted in point P49 from the **outside** to the **inside**.

- ▶ Pin the derrick guy rods 55: Insert the pin 56.1 in point P49 and secure with the safety locking pin 56.2, see illustration 29.

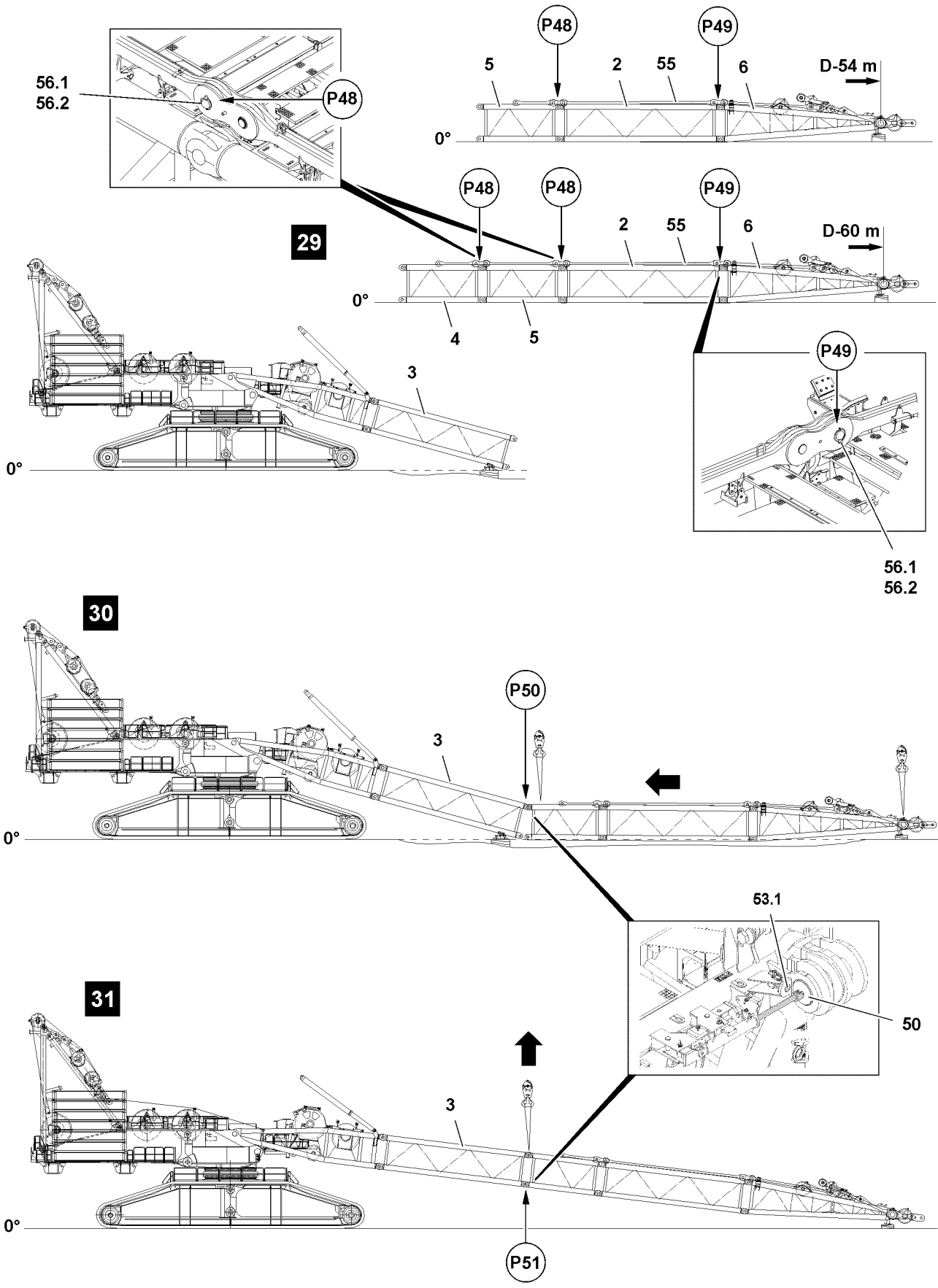

Fig.114386

LWE/LR 13000-001/19503-01-02/en

Pinning the D-boom with the D-intermediate section

- ▶ Connect the derrick boom to the auxiliary crane and align on the D-intermediate section **3**, see illustration **30**.



WARNING

The pin is not secured!

If the pin **50** is not secured, the pin can loosen up by itself during crane operation.

This can cause the crane to topple over.

Falling load and property damage can result.

Personnel can be severely injured or killed.

- ▶ After pinning, the pin **50** must be secured with the pins **53.1**.

When the pin bores on **top** on the D-intermediate section **3** and on the derrick boom align in point **P50**:

- ▶ Insert the pins **50** on both sides and secure with the pin **53.1**, see illustration **30**.
- ▶ Remove the auxiliary crane from the D-boom and fasten to the D-intermediate section **3**, see illustration **31**.
- ▶ Erect the auxiliary crane until the pin bores on the **bottom** on the D-boom and on the D-intermediate section **3** align.
- ▶ Insert the pins **50** on the **bottom** in point **P51** on both sides and secure, see illustration **31**.
- ▶ Remove the auxiliary crane.

32

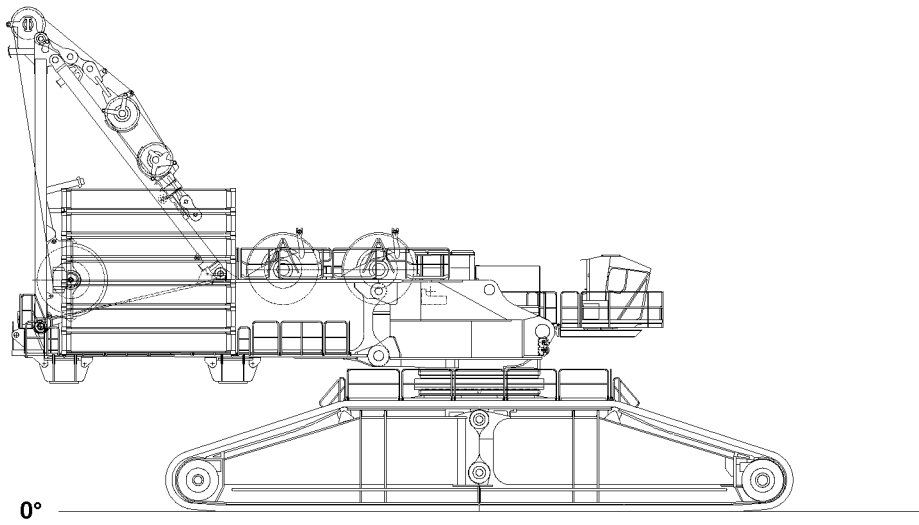

0°

33

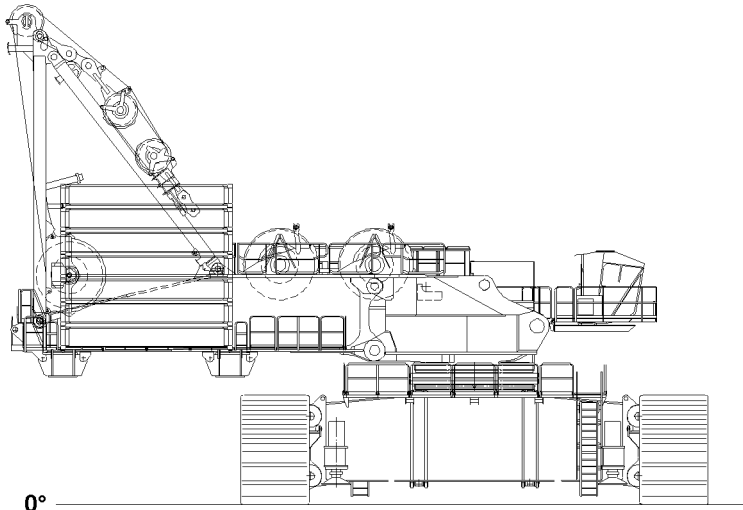

0°

Fig.117572

3.7 Flying assembly of the D-boom

Make sure that the following prerequisites are met:

- The crane is horizontally aligned.
- An auxiliary crane is available.
- An assembly scaffolding / work platform is available.
- The counterweight has been installed on the turntable according to the load chart.
- The LICCON overload protection has been set according to the data in the load chart.
- The LICCON overload protection settings have been compared with the actual set up configuration.
- A main boom is not assembled on the turntable.



Note

- ▶ At assembly, the turntable can be turned along the longitudinal axle of the crawler travel gear or to the side, see illustration **32** and illustration **33**.



DANGER

Danger of fatal injury due falling components!

If the pin connections are not visually inspected, the pins can loosen up by themselves and cause components to fall down.

Personnel can be severely injured or killed.

- ▶ All pins must be secured after assembly with the intended retaining elements. Check visually.
- ▶ The guy rods must be inspected regularly, see the Crane operating instructions, chapter 8.15.



WARNING

Danger of falling!

During assembly and disassembly, assembly personnel must be secured with appropriate aids to prevent them from falling.

Even for assembly and disassembly of protective devices there is a danger of falling.

Assembly personnel can fall and be severely injured or killed.

- ▶ Use personal protective equipment.

Turntable ballast	Central ballast
400 t	0 t
500 t	150 t

32

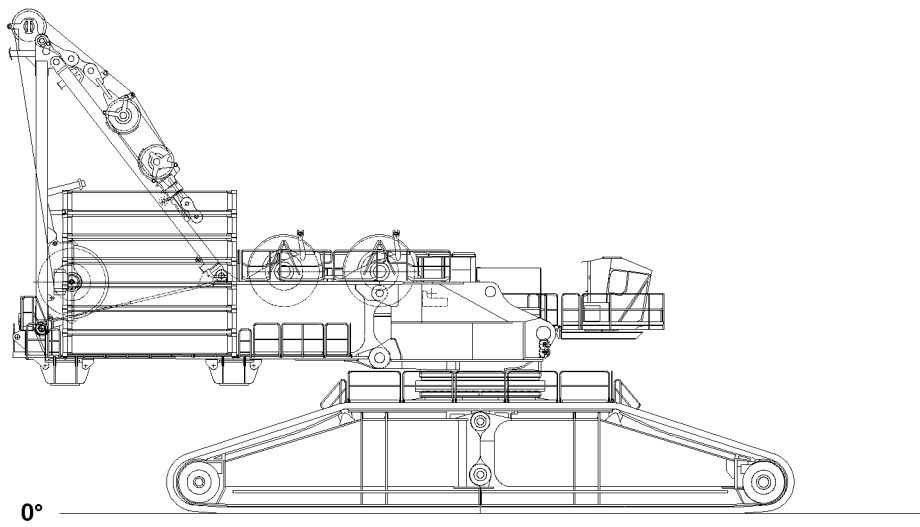

33

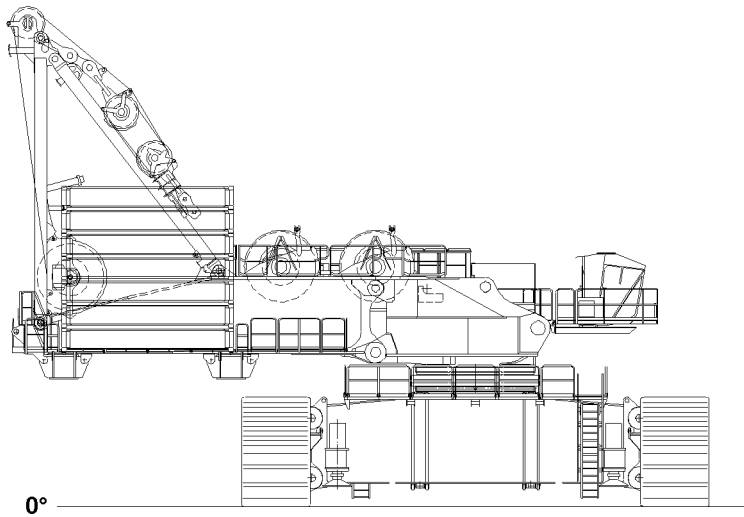

Fig.117572

LWE/LR 13000-001/19503-01-02/en

3.7.1 Activating the assembly operation



WARNING

Activated assembly operation!

When the assembly operation is activated, the LICCON overload protection is deactivated.

In the event of deliberate improper use, the crane could collapse, the D-boom can break off or the crane can topple over.

Personnel can be killed.

This can result in significant property damage.

- ▶ The assembly operation may only be activated by persons who know the effects.
- ▶ Activate the assembly operation only if the crane set up configuration was correctly entered in the LICCON computer system.
- ▶ Observe the erection / take down charts.
- ▶ Crane operation with deactivated LICCON overload protection is strictly prohibited.

-
- ▶ Activate the assembly operation.

Result:

- The LICCON overload protection is deactivated.
- The assembly icon appears on the LICCON monitor.

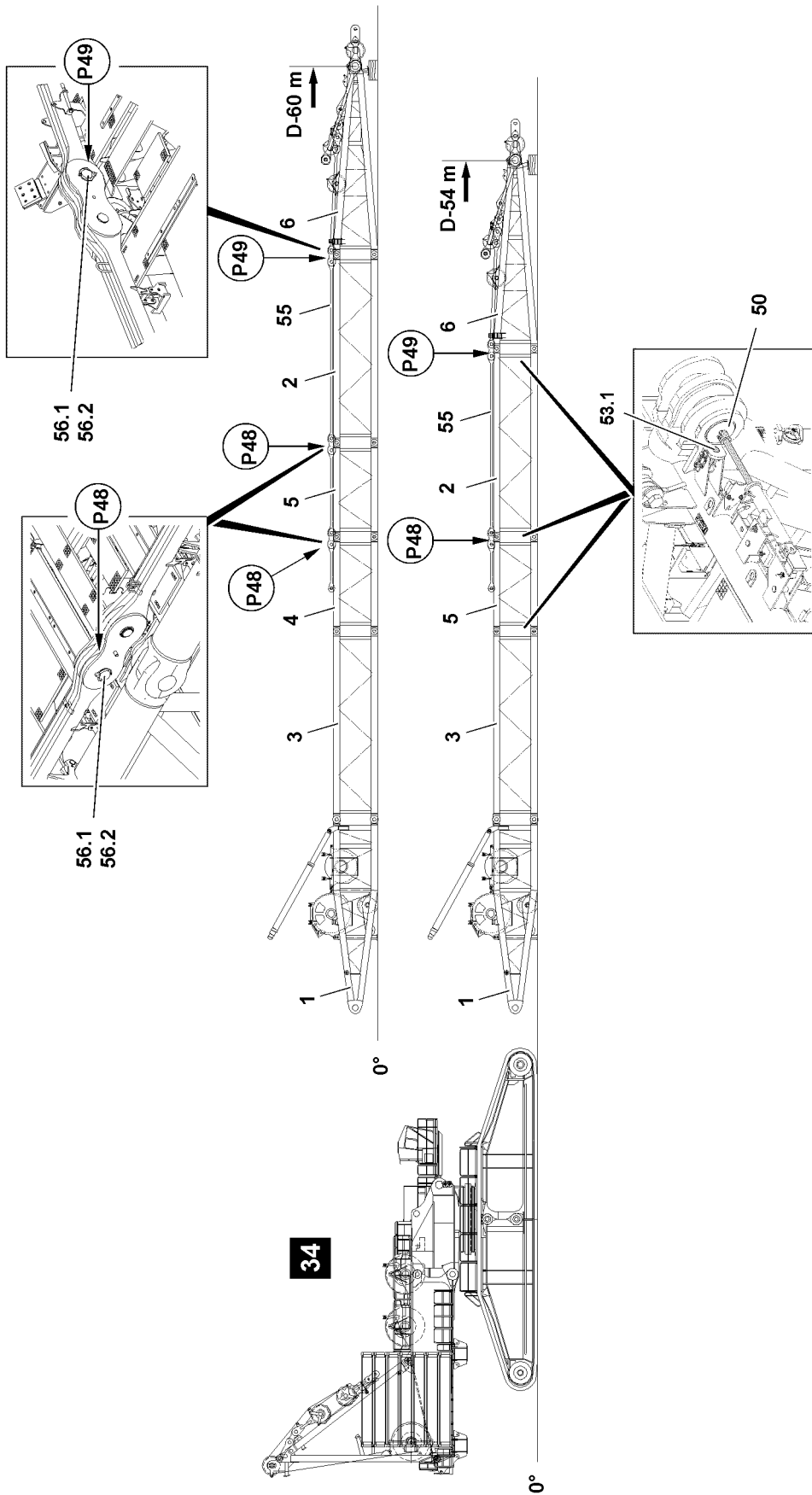

Fig.114388

LWE/LR 13000-001/19503-01-02/en

3.7.2 Assembling the D-boom



Note

- ▶ Always support the D-intermediate sections sufficiently for easier assembly.



Note

- ▶ The procedure in the pin locations is the same as the work steps for the previously described assembly of the D-end section and the D-intermediate section.
- ▶ Assemble the D-intermediate sections according to the separately supplied assembly drawings, see illustration **34**.

3.7.3 Assembling the derrick guy rods



WARNING

Neglected inspection and maintenance on guy rods!

If the regular inspection and maintenance of the guy rods is not carried out or is carried out only in irregular intervals, then serious accidents can occur due to existing and unrecognized damage to the guy rods.

Personnel can be severely injured or killed.

- ▶ The guy rods must be checked before every assembly, see the Crane operating instructions, chapter 8.15.



Note

- ▶ The derrick guy rods must be assembled and secured according to the separately supplied assembly drawings. The numbering on the assembly drawings must be identical to the numbering on the guy rods.



Note

- ▶ The pins **56.1** of the derrick guy rods **55** in points **P48** may only be pinned from the **inside** to the **outside**.
- ▶ Assemble the derrick guy rods **55** to the required length: Insert the pin **56.1** in points **P48** on both sides and secure with the safety locking pin **56.2**, see illustration **34**.



WARNING

Collision with the pull cylinder!

If the pins on the derrick guy rods are pinned in point **P49** from the **inside** to the **outside**, then they can collide later with the pull cylinder.

This could result in property damage.

- ▶ Make sure that the pins are inserted in point **P49** from the **outside** to the **inside**.
- ▶ Pin the derrick guy rods **55**: Insert the pin **56.1** in point **P49** and secure with the safety locking pin **56.2**, see illustration **34**.

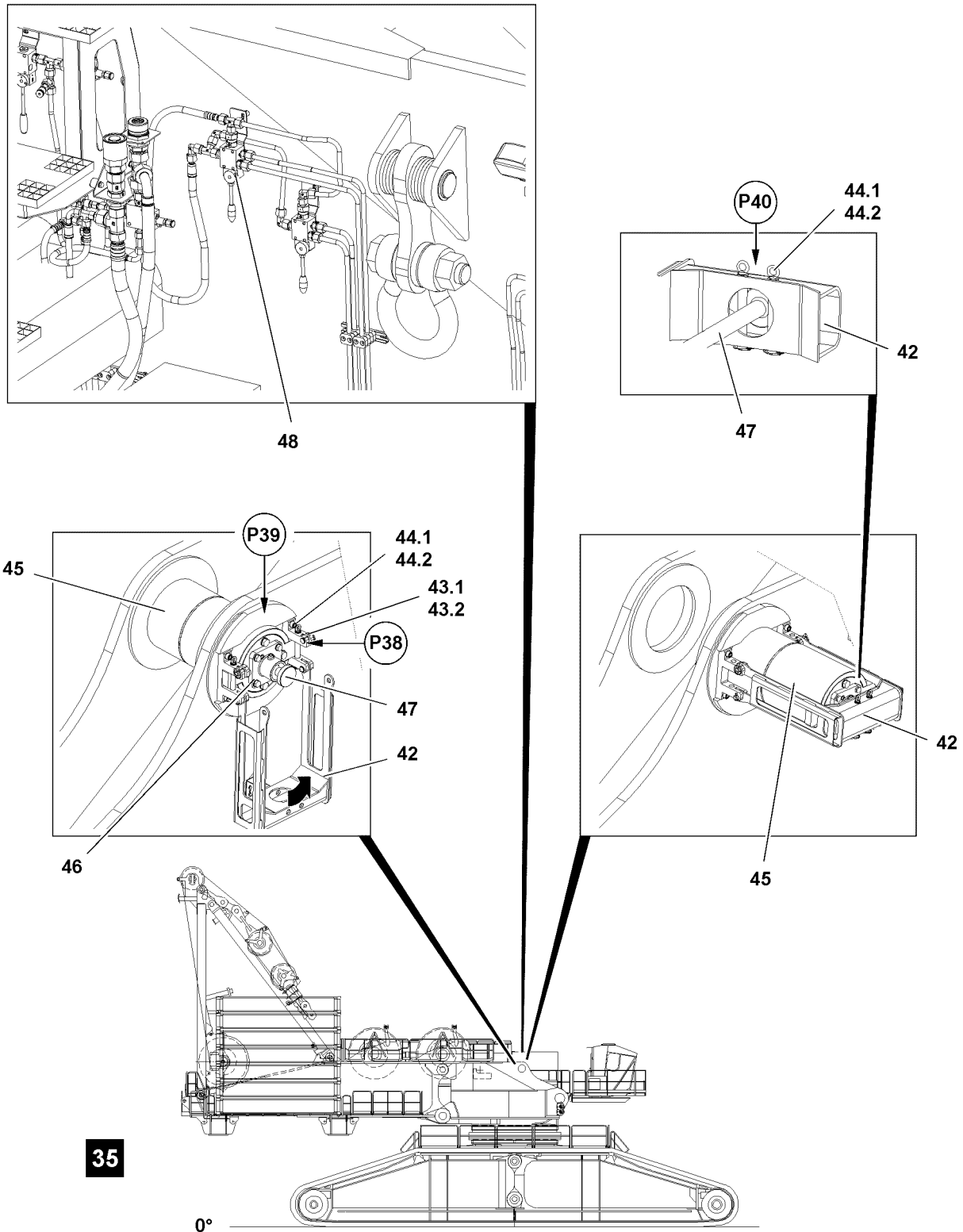

Fig.114389

3.7.4 Pinning the D-boom on the turntable

Unpinning the pins on the turntable.

- ▶ Remove the safety locking pin **43.2** on both sides in point **P38** and unpin the pin **43.1**, see illustration **35**.
- ▶ Fold up the bracket **42** on both sides, insert the pin **43.1** again in point **P38** and secure with the safety locking pin **43.2**, see illustration **35**.
- ▶ Release the pin **45**: Remove the safety locking pin **44.2** on both sides in point **P39** and unpin the pin **44.1**, see illustration **35**.
- ▶ Extend the piston rod **47** of the pin pulling cylinder **46**: Actuate the hand lever **48**.
- ▶ Secure the piston rod **47** of the pin pulling cylinder **46** on the bracket **42** in point **P40**: Insert the pin **44.1** on both sides and secure with the safety locking pin **44.2**, see illustration **35**.
- ▶ Retract the piston rod **47** of the pin pulling cylinder: Actuate the hand lever **48**.

Result:

- The pin **45** retracts, see illustration **35**.

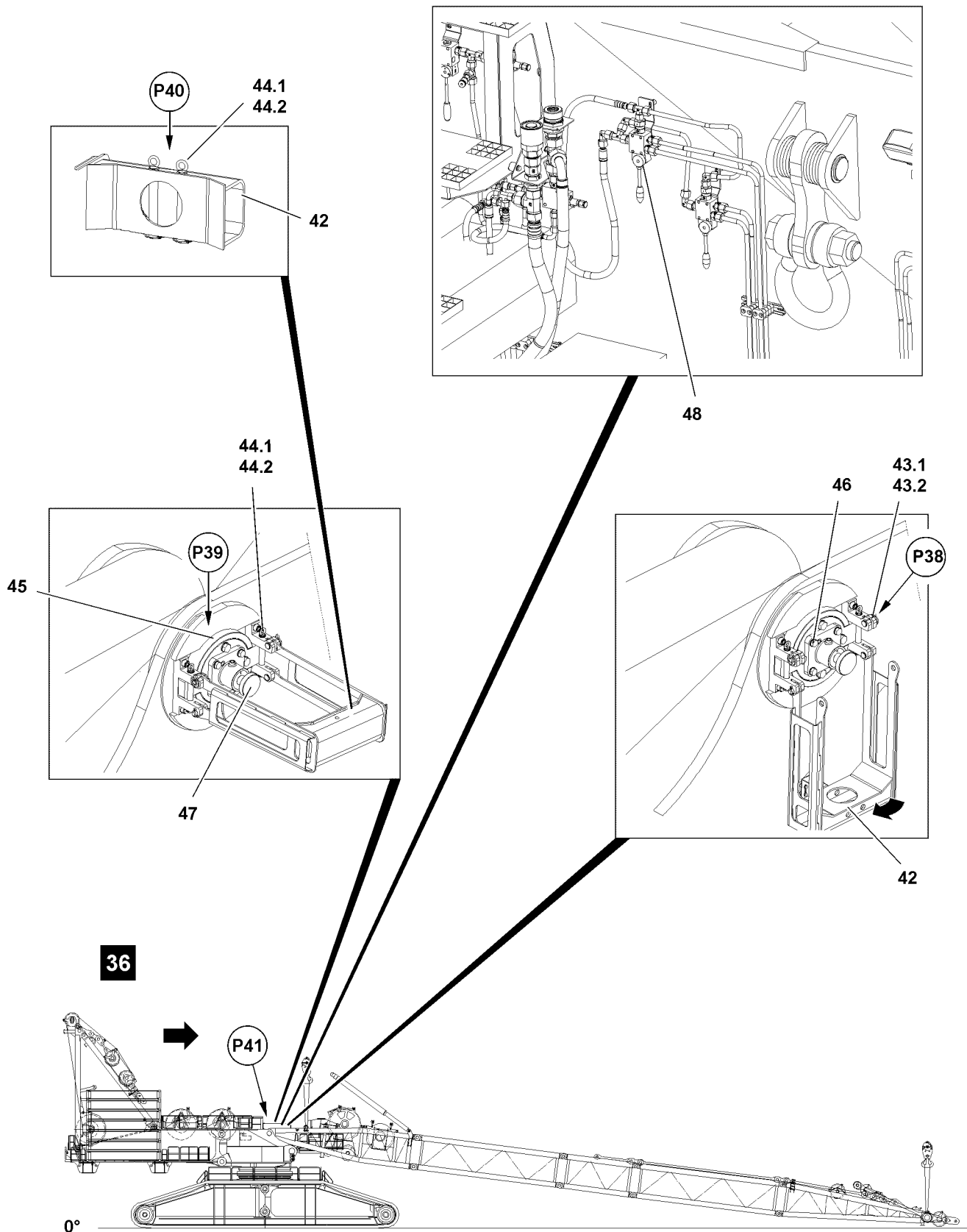

LWE/LR 13000-001/19503-01-02/en

Fig.114399

Pinning the D-pivot section

- ▶ Fasten the D-boom in the fastening points to the auxiliary crane and lift, see illustration **36**.
- ▶ Retract the crane to the pin points **P41** on the D-pivot section, see illustration **36**.



WARNING

The pin is not secured!

If the pins **45** are not secured, the pins can loosen up by themselves during crane operation. This can cause the crane to topple over. Personnel can be severely injured or killed.

- ▶ Make sure that the pins **45** are secured after the pin procedure.

When the pin bores on the D-pivot section and on the turntable align:

- ▶ Extend the piston rod **47** of the pin pulling cylinder.
- ▶ Actuate the hand lever **48** until the pins **45** are completely pinned on both sides, see illustration **36**.
- ▶ Secure the pin **45**: Release the pin **44.1** and unpin in point **P40**, then insert the pin **44.1** in point **P39** on both sides and secure with the safety locking pin **44.2**.
- ▶ Retract the piston rod **47** of the pin pulling cylinder: Actuate the hand lever **38**.



WARNING

Swinging bracket!

When releasing the bracket **42** in point **P38**, it can swing downward uncontrolled. Personnel can be severely injured.

- ▶ Hold the bracket **42** when unpinning.
 - ▶ Assembly personnel must be to the side of the assembly unit.
-
- ▶ Remove the safety locking pin **43.2** on both sides in point **P38** and unpin the pin **43.1**.
 - ▶ Fold the bracket **45** down, insert the pin **43.1** again on both sides in point **P48** and secure with the safety locking pin **43.2**, see illustration **36**.

3.8 Assembling the D-intermediate sections with the cross beam

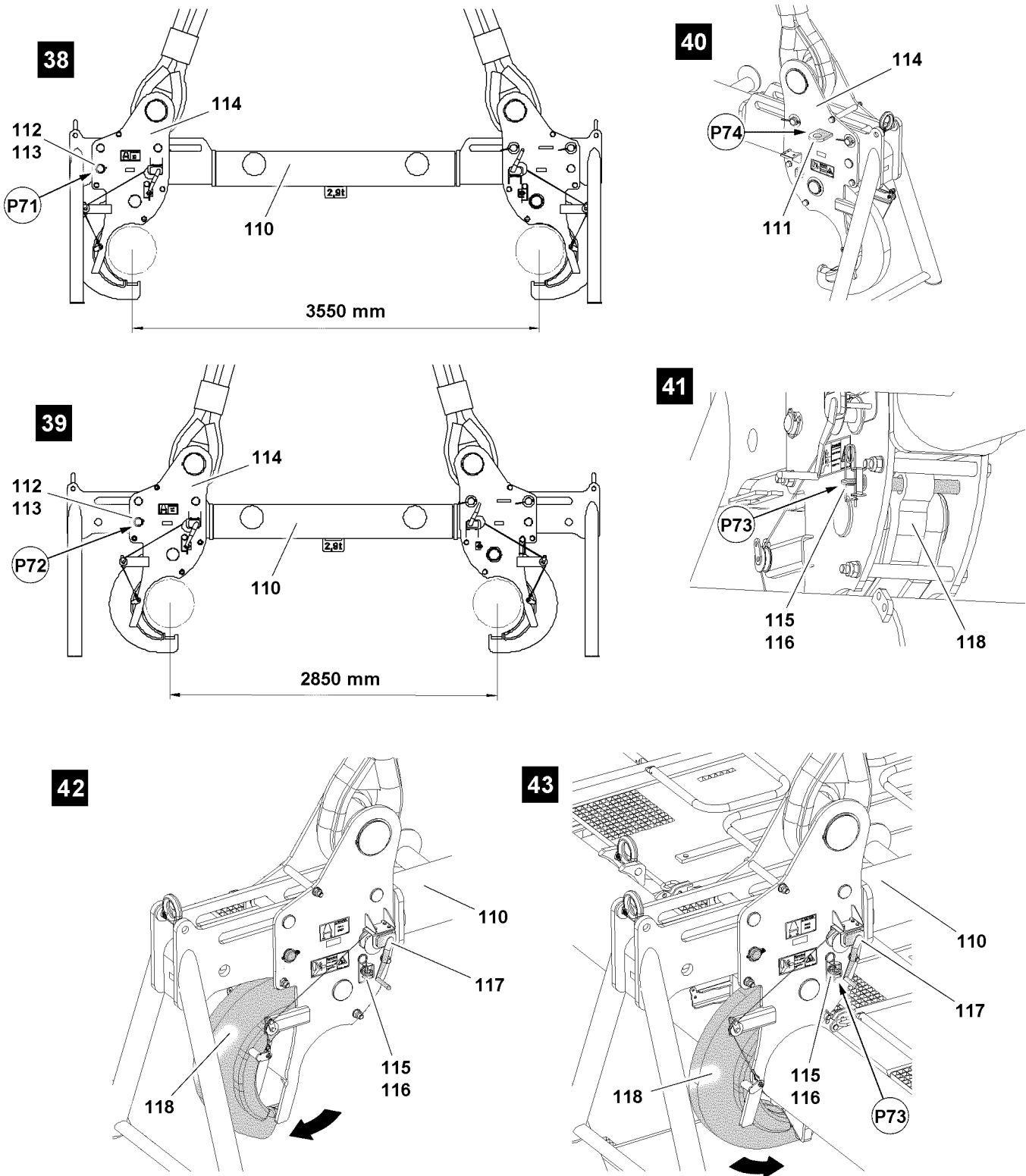

Fig.121999: Assembly condition of cross beam

3.8.1 Cross beam

The cross beam is designed for the assembly of the boom system. During the assembly, the cross beam is used to lift the boom section after every successful assembly of the intermediate section and

LWE/LR 13000-001/19503-01-02/en

to move the assembly shoes forward by one „lattice length“ until the boom section has the required length.

Make sure that the following prerequisites are met:

- An auxiliary crane with sufficient load carrying capacity is available.
- The cross beam is placed safely on the ground.
- The loops on the cross beam are in the transport position.

Preparing the cross beam

The cross beam **110** must be adjusted before assembly depending on the width of the intermediate section, see illustration **38** and illustration **39**.

- ▶ Remove the safety locking pin **112** in point **P71** and unpin the pin **113**, see illustration **38**.
- ▶ Fasten an auxiliary unit with sling to the eyehook **111** in point **P74** of the counter section **114**, see illustration **40**.
- ▶ Slide the counter section **114** with the auxiliary unit until it can be pinned in point **P72**, see illustration **39**.

When the bores align in point **P72**:

- ▶ Insert the pin **113** in point and secure with the safety locking pin **112**, see illustration **39**.

Result:

- The counter section **114** is secured.
- ▶ Slide the second counter section **114**.

Fastening the cross beam to the intermediate section

- ▶ Release the cross beam hook **118**: Remove the spring retainer **116** in point **P73** and unpin the pin **115**, see illustration **41** and illustration **42**.
- ▶ Pull both cross beam hooks **118** up with the manual winch **117**, see illustration **42**.
- ▶ Fasten the cross beam **110** to the auxiliary crane.

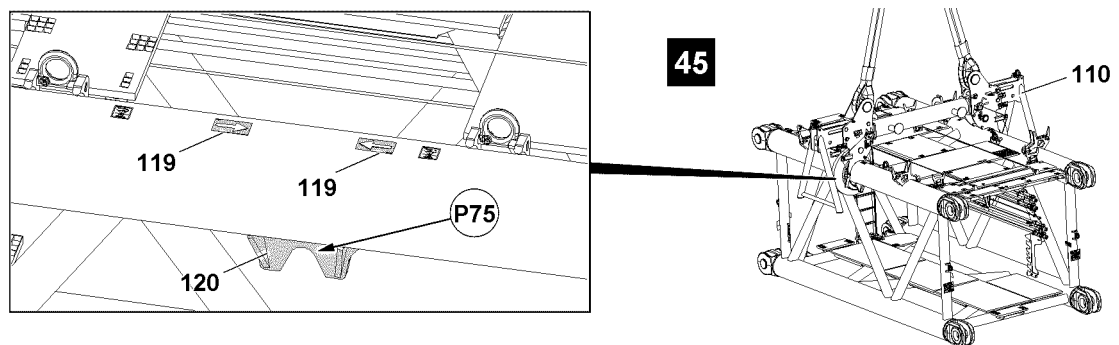

Fig.124406: Position of catches



Note

- ▶ The assembly of the intermediate sections is described based on the example of one intermediate section.



Note

- ▶ The position of the catches **120** on the intermediate section is marked by two arrows **119**, see illustration **45**.

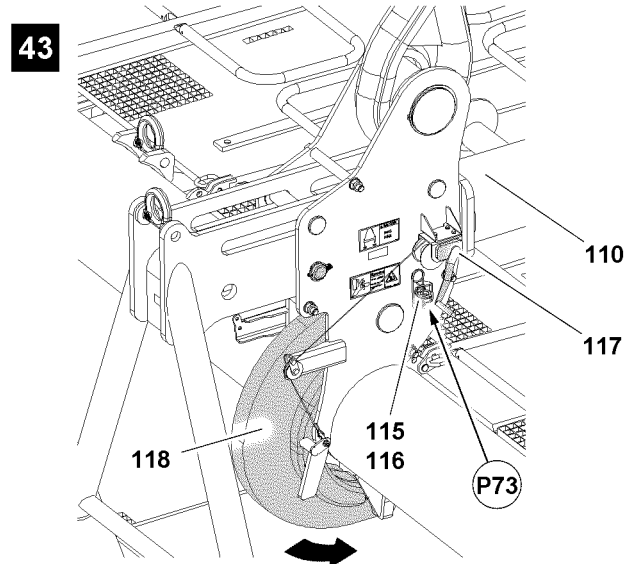
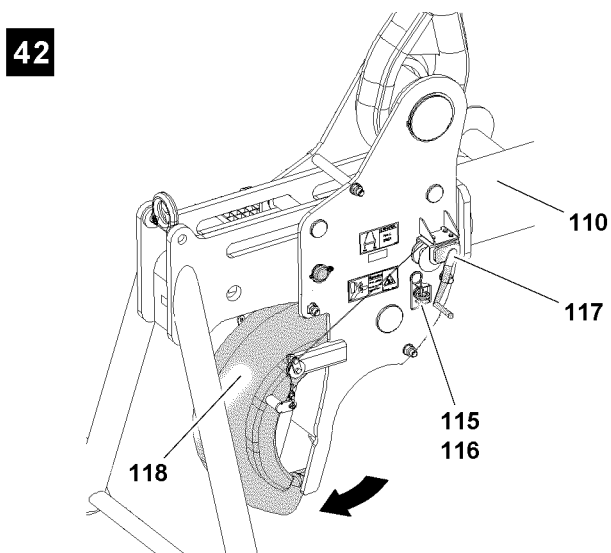
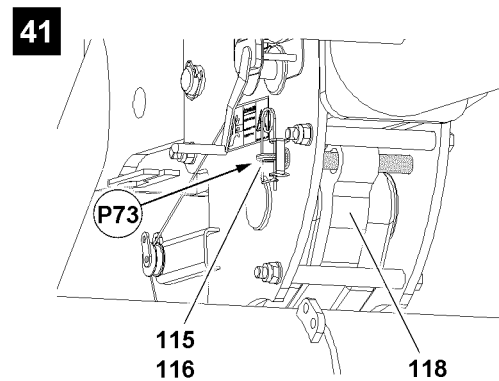
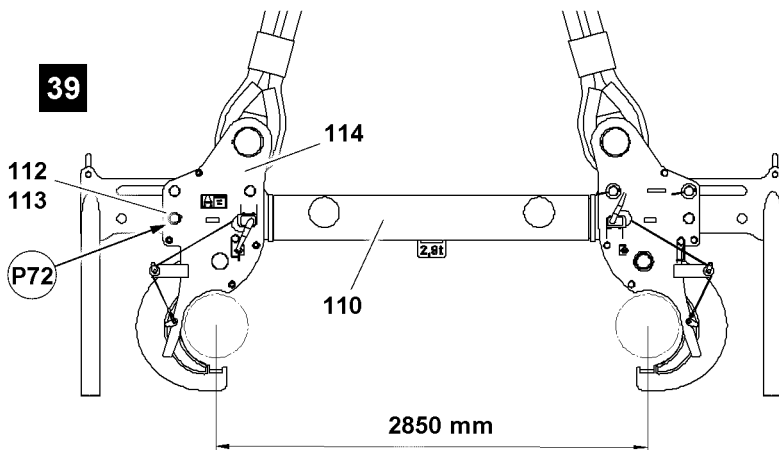
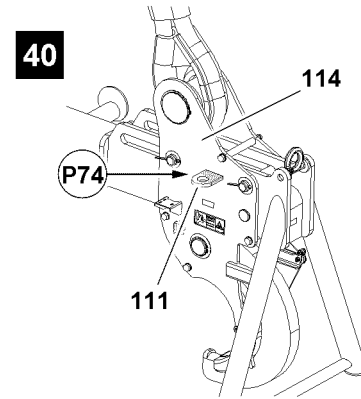
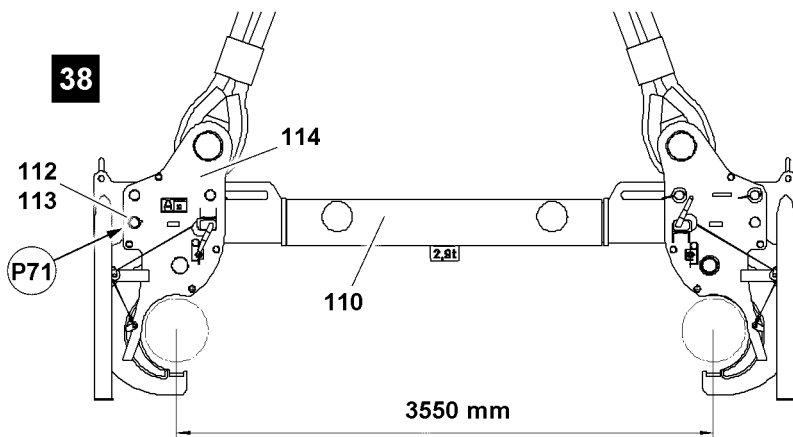

Fig.121999: Assembly condition of cross beam

- ▶ Swing the cross beam 110 with the auxiliary crane to the marked positions on the intermediate section.
- ▶ Set the cross beam 110 with the auxiliary crane on the intermediate section, see illustration 43.
- ▶ Lower the cross beam hook 118 with the manual winch 117 until it can be pinned in point P73, see illustration 43.

**WARNING**

Incorrect fastening!

If the following instructions are not observed, dangerous situations can arise.
Death, severe injuries, property damage.

- ▶ Make sure that the cross beam hooks **118** enter the catches **120**. Visual inspection!
 - ▶ Make sure that the cross beam hooks **118** are secured.
-
- ▶ Secure the cross beam hooks **118**: Insert the pin **115** in point **P73** and secure with the spring retainer **116**, see illustration **41** and illustration **43**.

When the cross beam hooks **118** are entered and secured on the catches **120**:

- ▶ Lift the intermediate section with the cross beam.

3.8.2 Assembling the D-lattice sections with the cross beam

Make sure that the following prerequisites are met:

- The crane is horizontally aligned.
- An auxiliary crane is available.
- An assembly scaffolding / work platform is available.
- The counterweight has been installed on the turntable according to the load chart.
- The D-pivot section **1** and first D-intermediate section **3** are installed on the turntable, see illustration **44**.

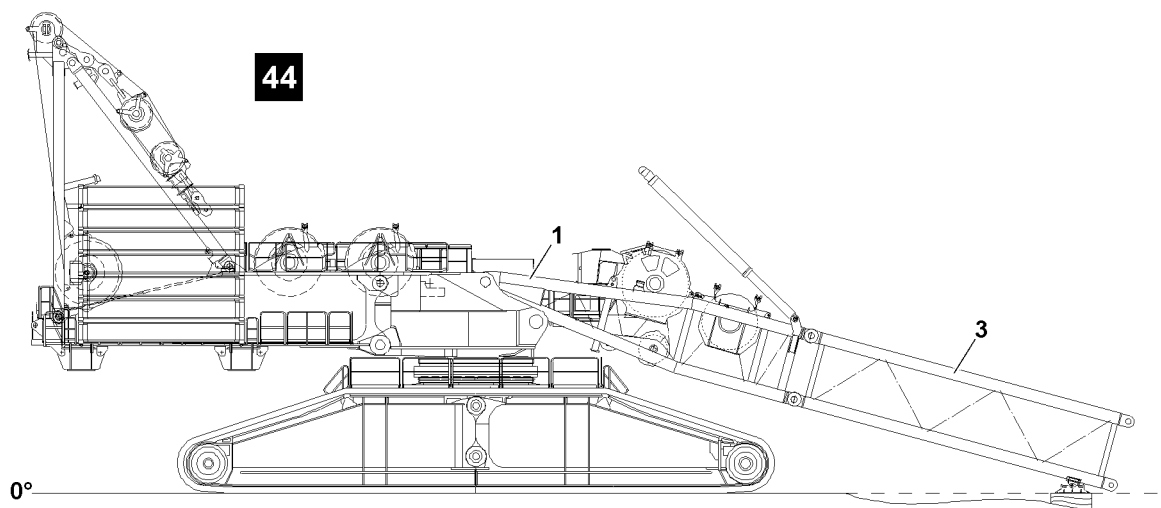

Fig.124407: Assembly of the first D-intermediate section

**WARNING**

Incorrect fastening equipment!

Due to the large installation angle of the first D-intermediate section **3**, dangerous situations can arise during assembly, see illustration **44**.

Death, severe injury, property damage.

- ▶ Make sure that a cross beam is not used at assembly of the first D-intermediate section **3**.
- ▶ For the assembly of the first D-intermediate section **3** use the normal fastening equipment.

**Note**

- ▶ Assembly of the first D-intermediate section **3**, see section „Assembling the D-boom in sections“.

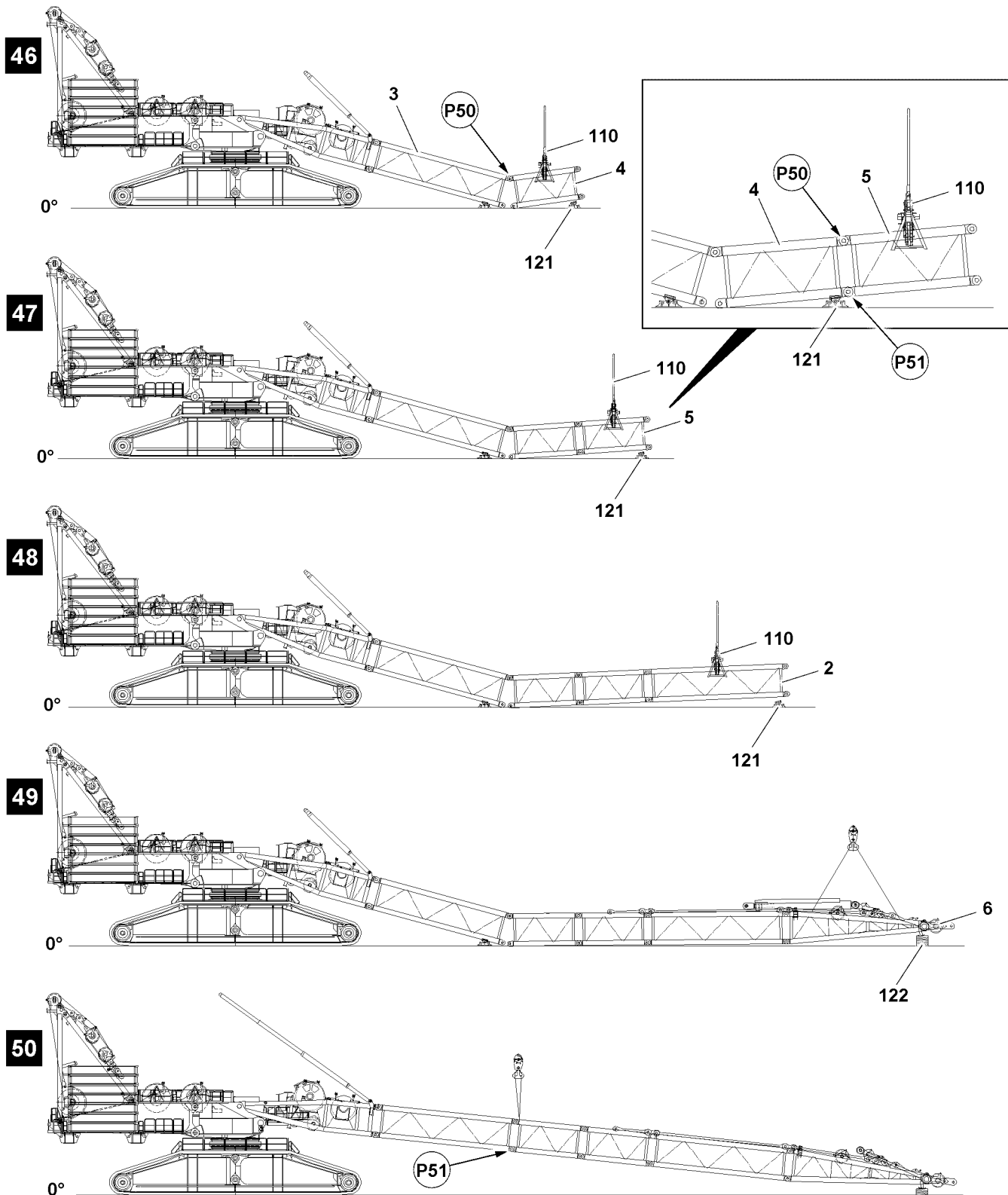

Fig.124409: Assembling the D-intermediate sections with the aid of the cross beam

- Swing the D-intermediate section 4 with the auxiliary crane to the D-intermediate section 3 and align, see illustration 46.

When the pin bores on **top** on the D-intermediate section 3 and D-intermediate section 4 align in point **P50**:

- Insert the pins on both sides and secure with retaining pins, see section „Assembling the D-boom in sections“.

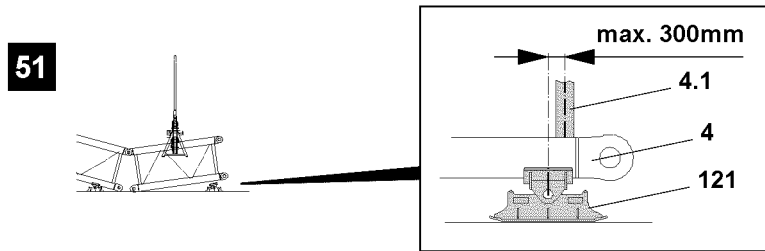

Fig.124408: Position of assembly shoes

NOTICE

Danger of property damage on the intermediate sections!

If the assembly shoes **121** are not placed underneath in the permitted area of the intermediate sections, then the intermediate sections can be overloaded and damaged!

- ▶ Make sure that the assembly shoes are only placed underneath in the permitted area of maximum 300 mm on the corner bar **4.1**, see illustration **51**.
- ▶ The crane operator is responsible for the proper substructure of the intermediate sections with the assembly shoes.

- ▶ Position the assembly shoes **121** in the area of the corner bar **4.1** on the D-intermediate section **4**, see illustration **51** and illustration **46**.
- ▶ Take the D-intermediate section **4** down with the auxiliary crane on the assembly shoes **121**, see illustration **46**.
- ▶ Remove the cross beam **110** with the auxiliary crane: Pull both cross beam hooks up with the manual winch.
- ▶ Fasten the cross beam **110** with the auxiliary crane to the D-intermediate section **5**.
- ▶ Swing the D-intermediate section **5** with the auxiliary crane to the D-intermediate section **4** and align, see illustration **47**.

When the pin bores on **top** on the D-intermediate section **5** and D-intermediate section **4** align in point **P50**:

- ▶ Insert the pins on both sides and secure with retaining pins, see „Assembling the D-boom in sections“.
- ▶ Lower the D-intermediate section **5** with the auxiliary crane until it can be pinned in point **P51**, see illustration **47**.

When the pin bores on the **bottom** on the D-intermediate section **5** and D-intermediate section **4** align in point **P51**:

- ▶ Insert the pins on both sides and secure with retaining pins, see „Assembling the D-boom in sections“.
- ▶ Lift the D-boom system via the cross beam with the auxiliary crane.
- ▶ Remove the assembly shoes **121** under the D-intermediate section **4** and position under the D-intermediate section **5** in the area of the corner bar **4.1**, see illustration **51** and illustration **47**.
- ▶ Take the D-boom system down via the cross beam with the auxiliary crane on the assembly shoes **121**, see illustration **47**.
- ▶ Install the D-intermediate section **2** according to the previously described steps, see illustration **48**
- ▶ Assemble the D-end section **6** with the auxiliary crane, see illustration **49** and section „Assembling the D-boom in sections“.

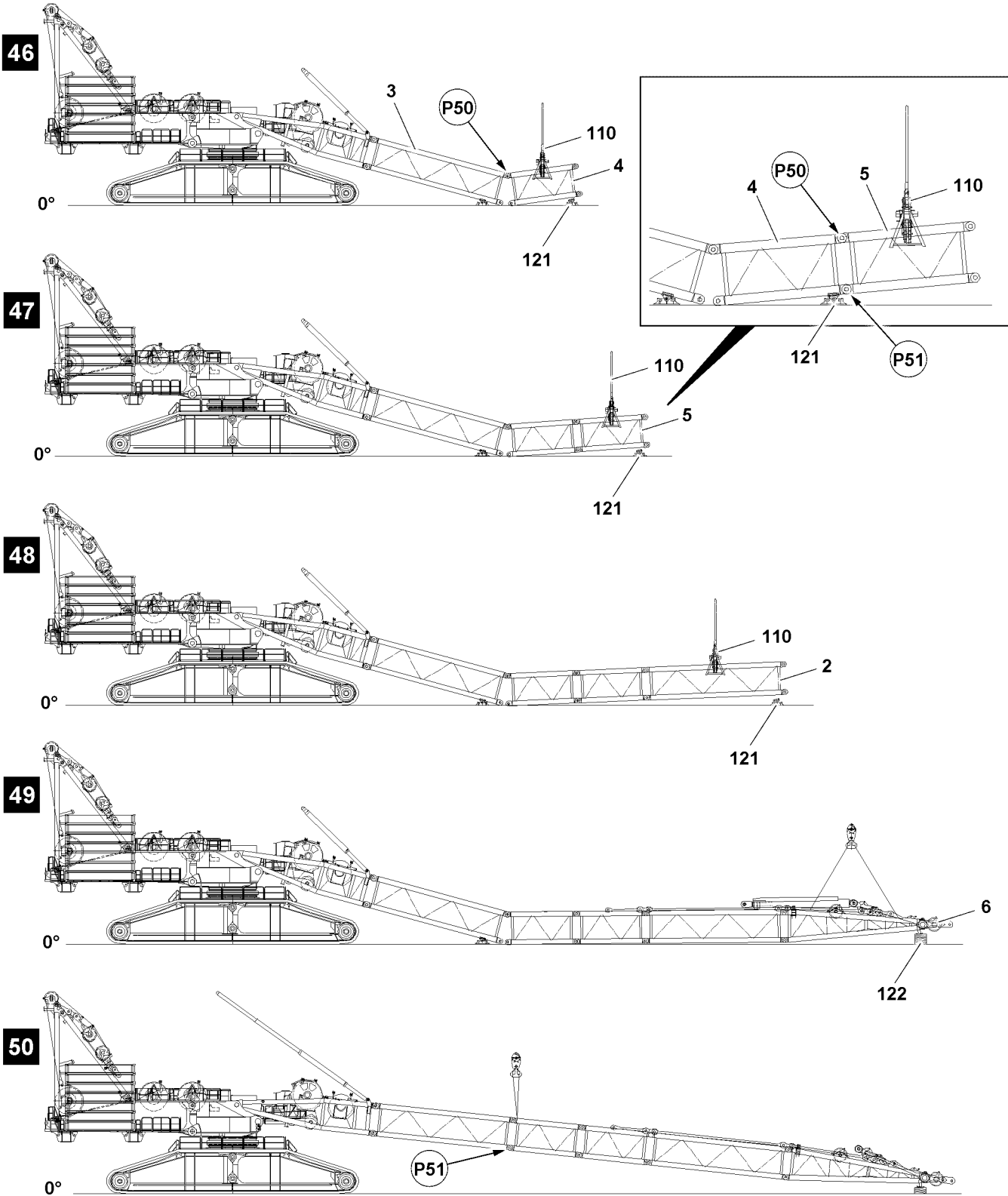

Fig.124409: Assembly of the D-intermediate sections with the aid of the cross beam

LWE/LR 13000-001/19503-01-02/en

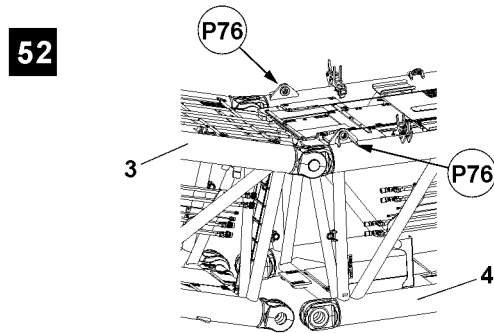

Fig.124410: Close the D-boom system

When the D-boom system is erected:

- ▶ Fasten the auxiliary crane to the D-intermediate section **4** in point **P76**, see illustration **52**.
- ▶ Lift the D-boom system with the auxiliary crane until it can be pinned in point **P51**, see illustration **50**.

When the pin bores on the **bottom** on the D-intermediate section **3** and D-intermediate section **4** align in point **P51**:

- ▶ Insert the pins on both sides and secure with retaining pins, see illustration **50** and section „Assembling the D-boom in sections“.

Result:

- The D-boom system is completely erected.
- ▶ For additional assembly steps, see section „Assembling the D-boom in sections“.

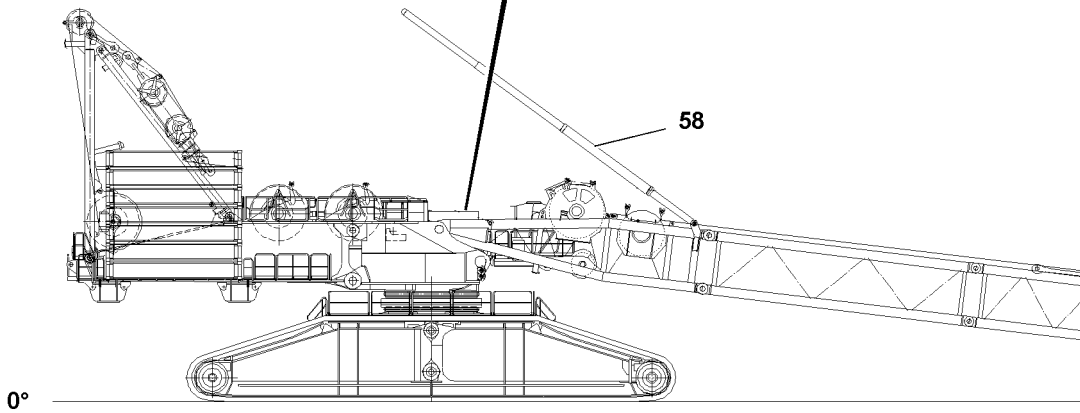
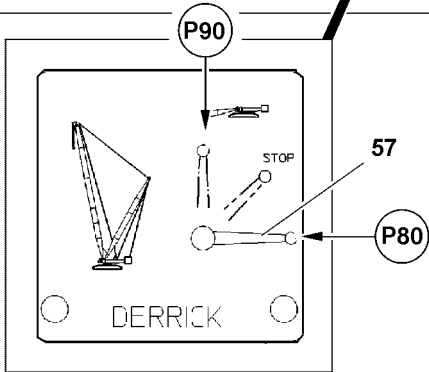
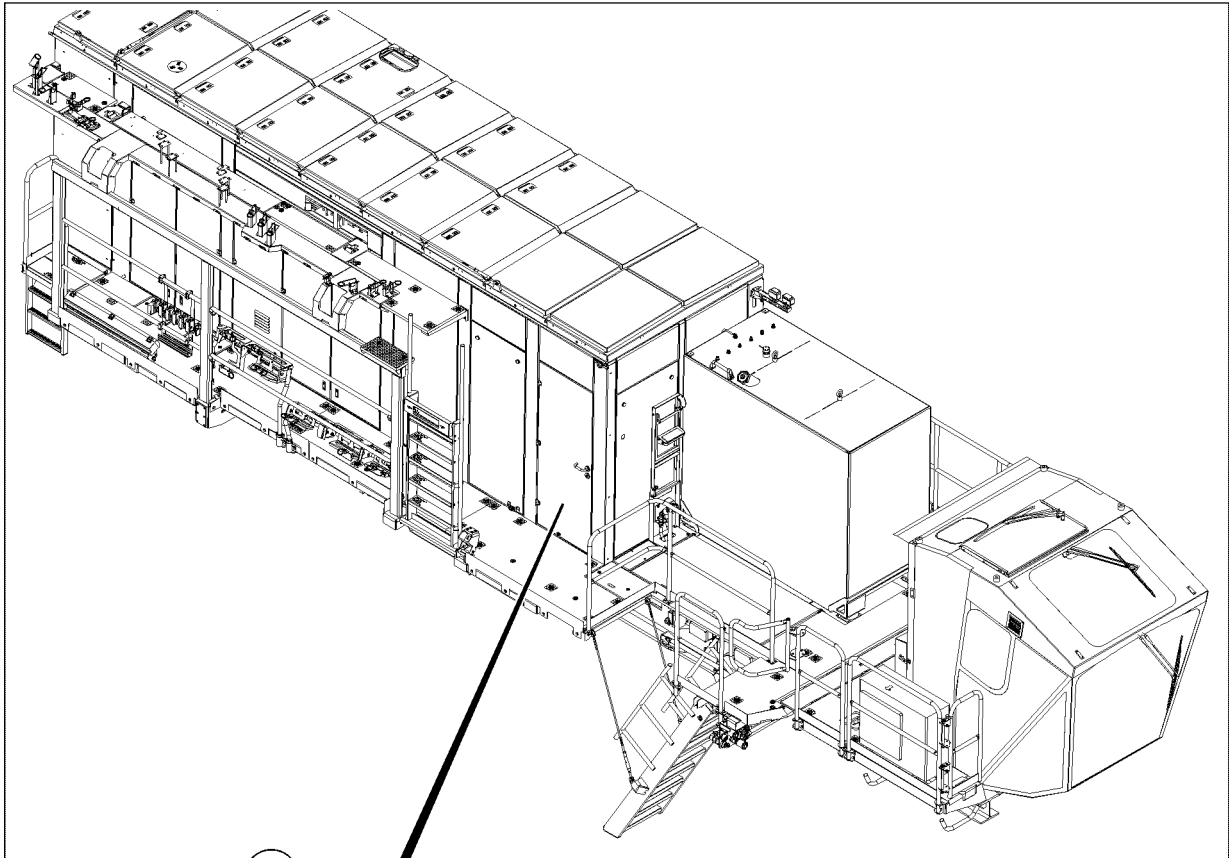

Fig.114390

LWE/LR 13000-001/19503-01-02/en

3.9 Extending the D-relapse cylinder



WARNING

Danger of fatal injury due to the D-boom!

If the D-relapse cylinders are not extended before erecting the D-boom, then the D-boom can fall backward.

Personnel can be severely injured or killed.

- ▶ From a derrick angle of 30°, the D-relapse cylinders must be extended.
- ▶ Before erecting the D-boom, extend the D-relapse cylinders.
- ▶ The ball valve must be secured during crane operation to prevent unintended actuation.

The piston rod on the D-relapse cylinder must be extended by actuating the ball valve **57**.

Ball valve positions	
P80	Crane operation, extend the piston rod
P90	Assembly, retract the piston rod
STOP	The piston rod cannot be retracted / extended

Make sure that the following prerequisite is met:

- All hydraulic connections have been established.

- ▶ Set the ball valve **57** to position **P80**.

Result:

- The piston rods of the D-relapse cylinders **58** extend.



Note

- ▶ The ball valve is secured by closing the door to the engine house and removing the key.

- ▶ Close the door and pull out the key.
- ▶ Hand the key to an authorized person.

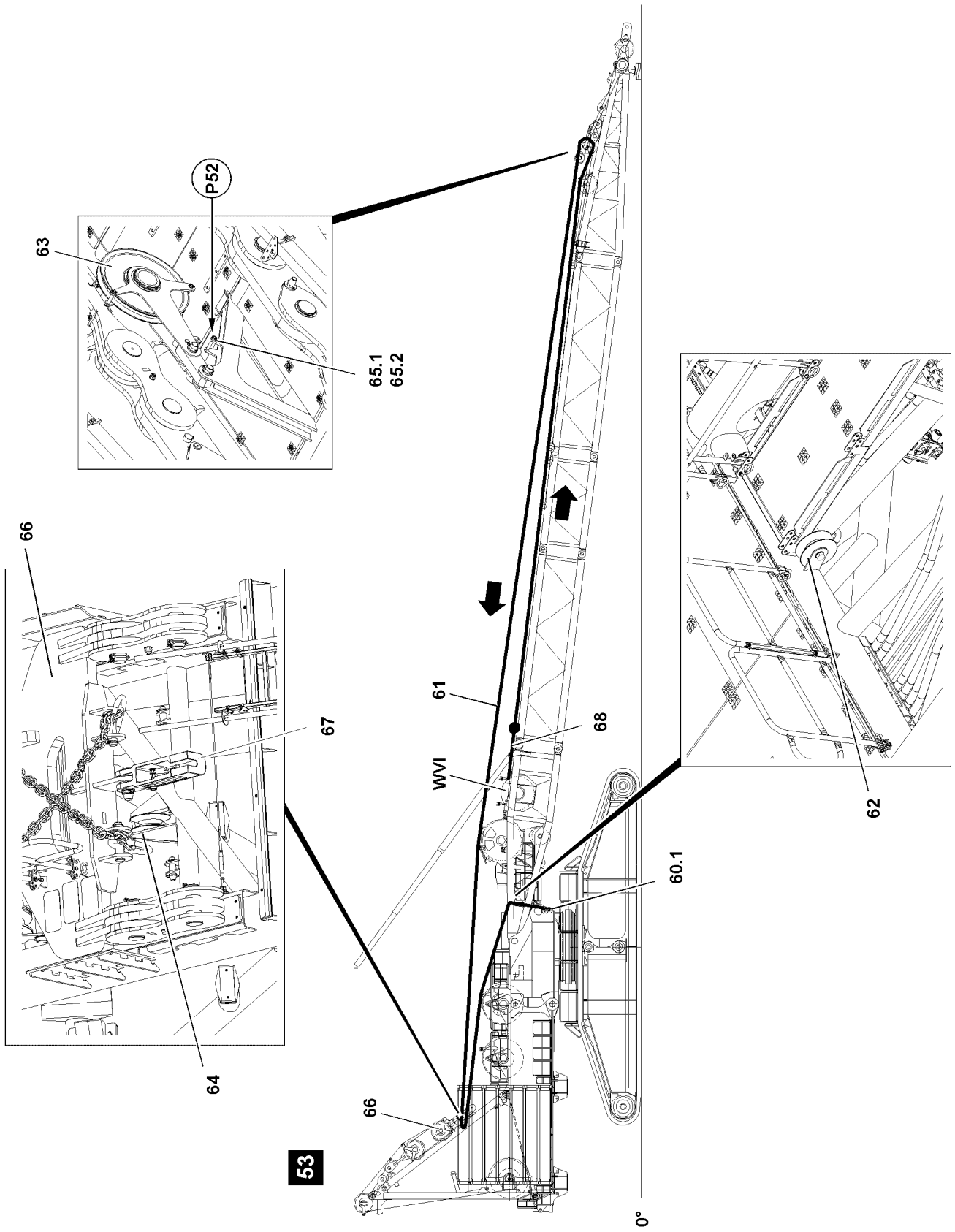

Fig.124411

LWE/LR 13000-001/19503-01-02/en

3.10 Pinning the upper pulley block with the derrick guy rods

3.10.1 Connecting the rope of winch 6 with the upper pulley block

Make sure that the following prerequisite is met:

- The D-boom is completely assembled.
- ▶ Release the change over pulley **63** on the D-end section from the transport position: Remove the safety locking pin **65.2** in point **P52** and unpin the pin **65.1**, see illustration **53**.
- ▶ Lift the change over pulley **63**, insert the pin **65.1** again in point **P52** and secure with safety locking pin **65.2**.



Note

- ▶ Bring the ladder on the A-frame into the operating position, see the Crane operating instructions, chapter 2.06.

Rope run for the assembly rope **61**, see illustration **53**.

- ▶ Guide the assembly rope **61** from the assembly **60.1** winch over the pulley **62** on the D-pivot section, over the pulley **64** on the A-frame and over the change over pulley **63** on the D-end section.
- ▶ Connect the assembly rope **61** with the rope **68** of winch 6.



WARNING

Danger of slack rope formation!

When spooling the rope out, slack rope can form.

- ▶ The rope must be slightly tensioned during the entire pulling procedure.
- ▶ Pull the rope of winch 6 to the upper pulley block on the A-frame: Spool the assembly winch **60.1** up and simultaneously spool winch 6 out.
- ▶ Release the assembly rope **61** on the rope **68** of winch 6 and spool the assembly winch **60.1** up.
- ▶ Connect the rope of winch 6 with the lock **67** on the upper pulley block **66**, see illustration **53**.

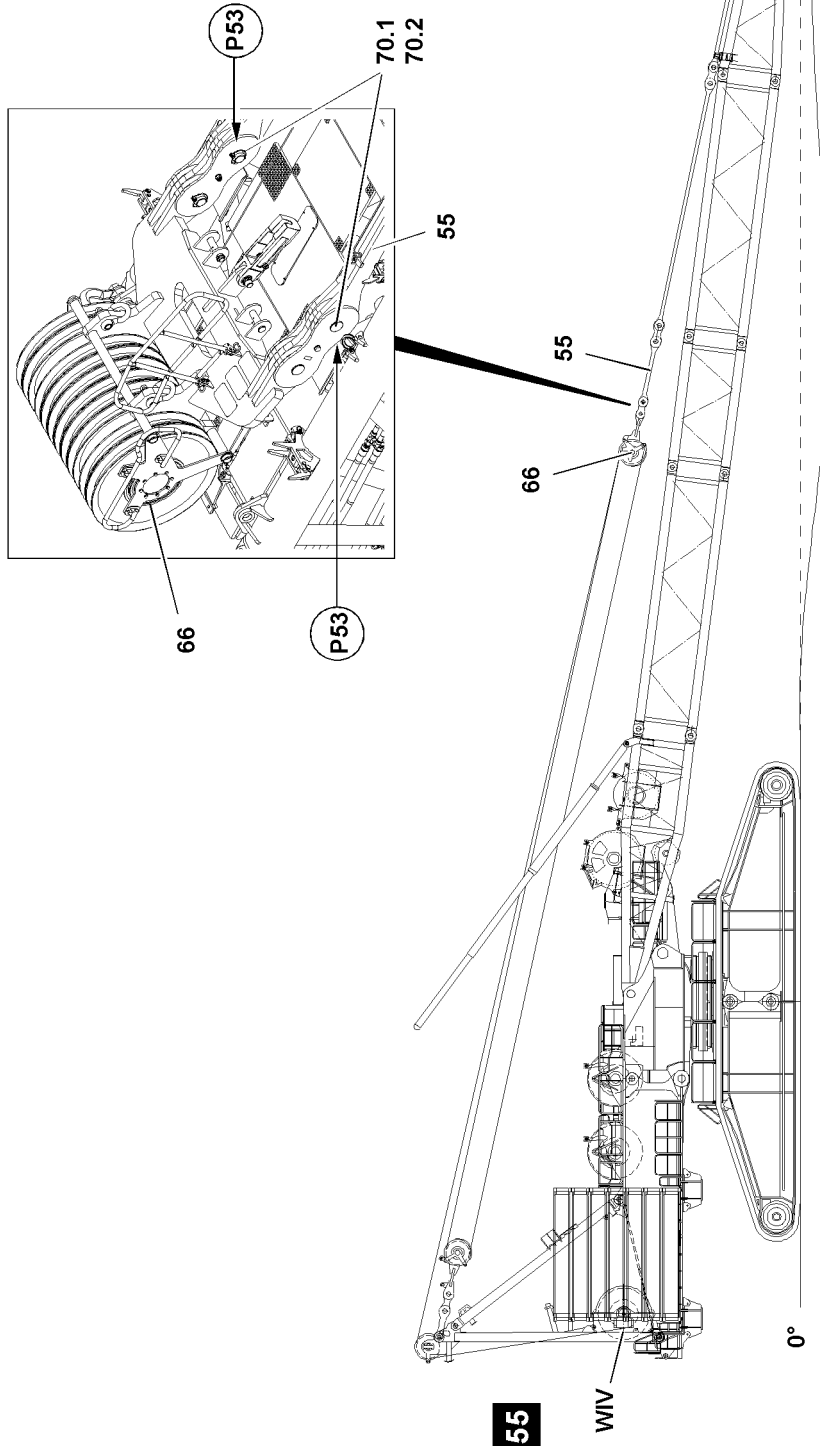
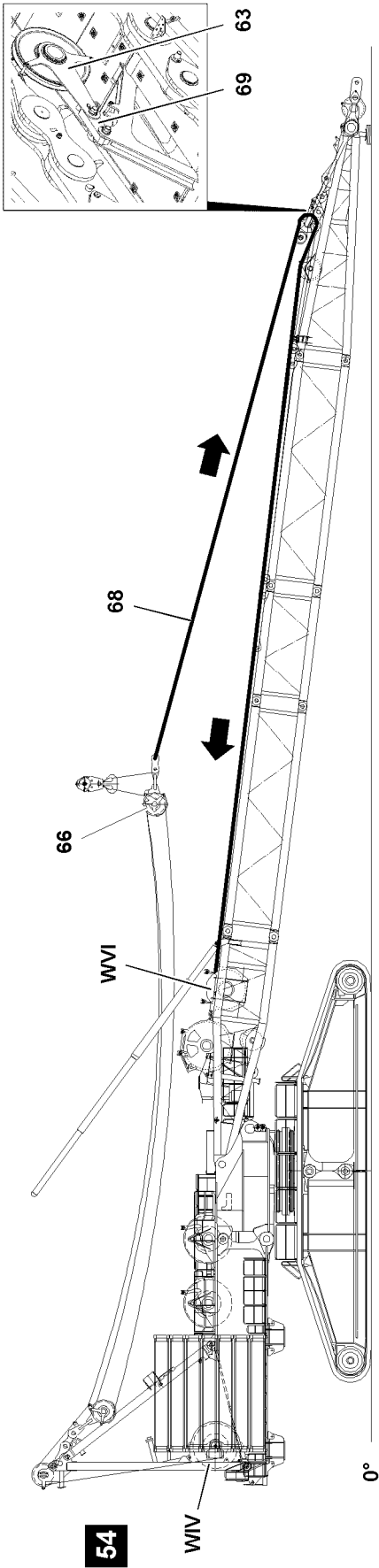

Fig.124412

LWE/LR 13000-001/19503-01-02/en

3.10.2 Getting and pinning the upper pulley block

Make sure that the following prerequisite is met:

- The rope of winch 6 is connected with the upper pulley block.
- ▶ Fasten the upper pulley block **66** to the auxiliary crane, illustration **54**.



WARNING

Danger of slack rope formation!

When spooling the rope out, slack rope can form.

- ▶ The rope must be slightly tensioned during the entire pulling procedure.



WARNING

Property damage!

- ▶ Monitor the rope pull of winch 6 with the pull test bracket **69**.

- ▶ Always use a guide when retracting the upper pulley block.

- ▶ The guide must be in constant acoustic contact with the crane operator of the auxiliary crane.

- ▶ Pull the upper pulley block **66** with the aid of the crane to the derrick guy rods **55**: Spool up winch 6 and simultaneously spool out winch 4, see illustration **54**.



WARNING

The pin is not secured!

If the pins **70.1** are not secured, the pins can loosen up by themselves during crane operation.

This can cause the crane to topple over.

Personnel can be severely injured or killed.

- ▶ Make sure that the pins **70.1** are secured after the pin procedure.

When the pin bores on the upper pulley block **66** and on the derrick guy rods **55** align:

- ▶ Insert the pin **70.1** on both sides and secure with the safety locking pin **70.2**, see illustration **55**.

- ▶ Spool the rope **68** of winch 6 up:



Note

- ▶ Bring the ladder on the A-frame again into the transport position, see the Crane operating instructions, chapter 2.06.

- ▶ Remove the auxiliary crane.

- ▶ Tension the D-adjustment: Spool winch 4 up.

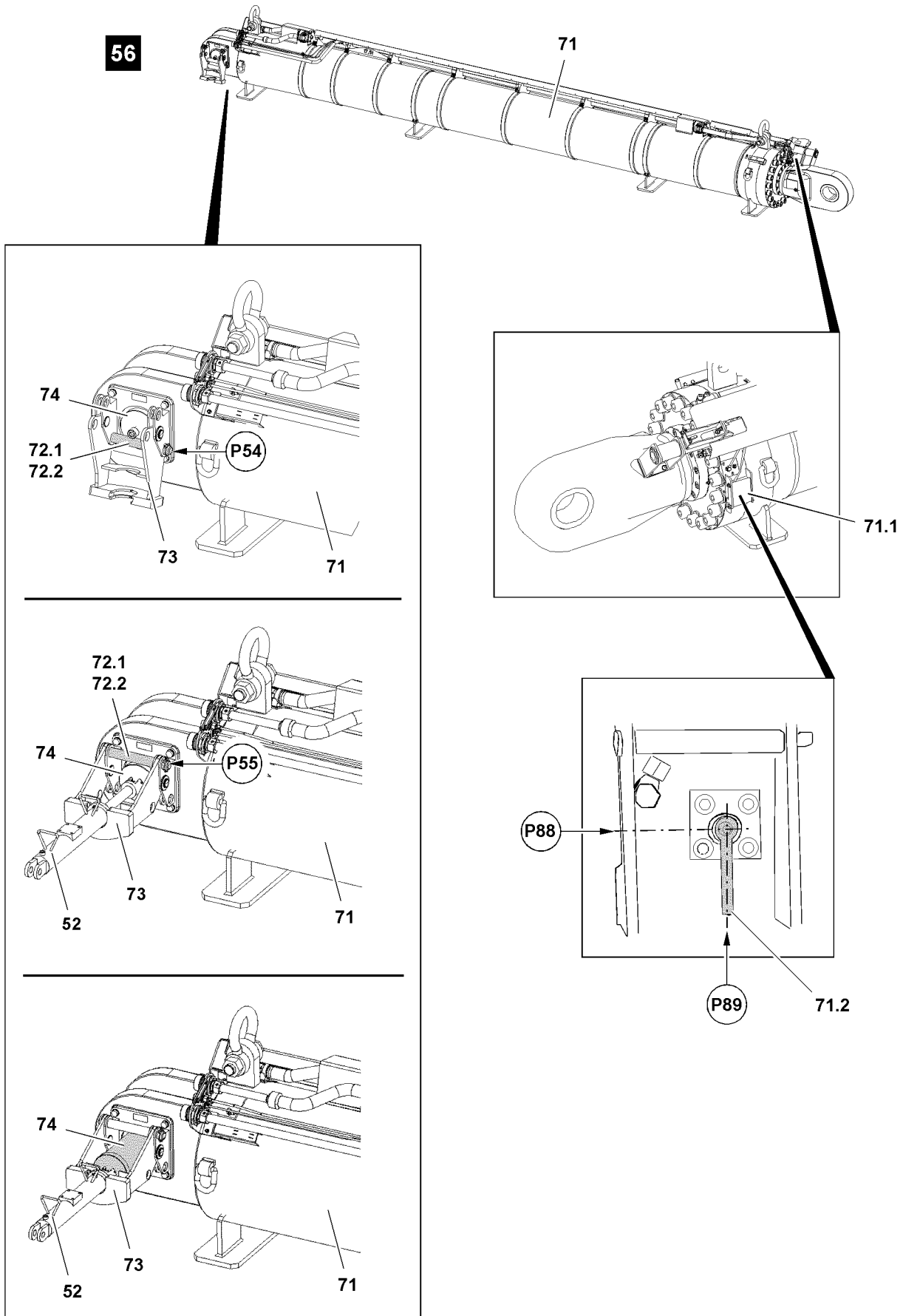

Fig.124413

LWE/LR 13000-001/19503-01-02/en

3.11 Assembling the pull cylinder and ballast rods

3.11.1 Closing the ball valve for the thermo valve



WARNING

The ball valve for the thermo valve is open!

When the ball valve for the thermo valve is open during crane operation with derrick ballast, then the derrick ballast can lower itself uncontrolled. The crane can topple over. Personnel can be severely injured or killed.

- ▶ Close the ball valve **71.2** for the thermo valve.

The ball valve **71.2** is located behind the flap **71.1** on the ballast cylinder.

- ▶ Open the flap **71.1**.
- ▶ Close the thermo valve: Turn the ball valve **71.2** to the position in point **P89**.
- ▶ Close the thermo valves on both ballast cylinders.

3.11.2 Preparing the pull cylinder



WARNING

Swinging support.

When releasing the support **73** it can swing downward uncontrolled.

Personnel can be severely injured.

- ▶ Hold the support **73** when unpinning.
 - ▶ Assembly personnel must be to the side of the assembly unit.
-
- ▶ Release the supports **73** for the pin pulling cylinder **52** in point **P54**: Remove the safety locking pin **72.2** and unpin the pin **72.1**, see illustration **56**.

Result:

- The pin **74** is released.
- ▶ Swing the support **73** up and secure in point **P55**: Insert the pin **72.1** and secure with safety locking pin **72.2**, see illustration **56**.
- ▶ Extend the pin pulling cylinder **52** and connect with the pin **74**.
- ▶ Guide the pin pulling cylinder **52** with the flange into the groove of the support **73**, see illustration **56**.
- ▶ Unpin the pin **74**: Retract the pin pulling cylinder **52**, see illustration **56**.
- ▶ Remove the pin pulling cylinder **52**.

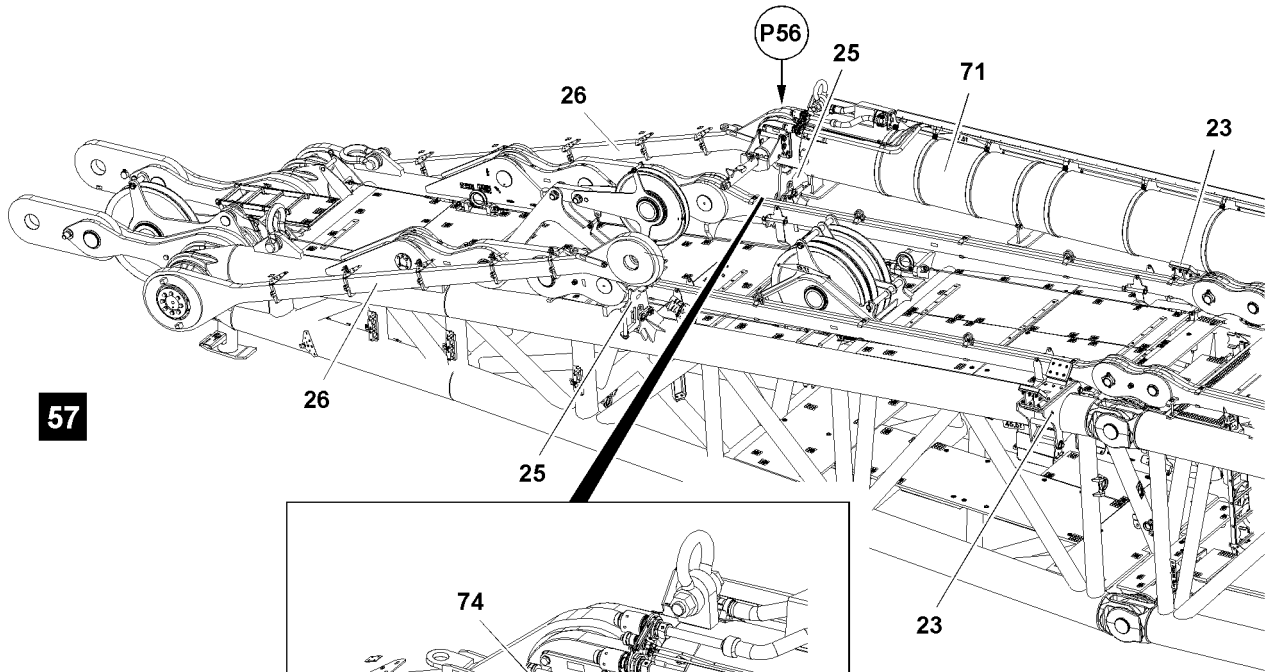

57

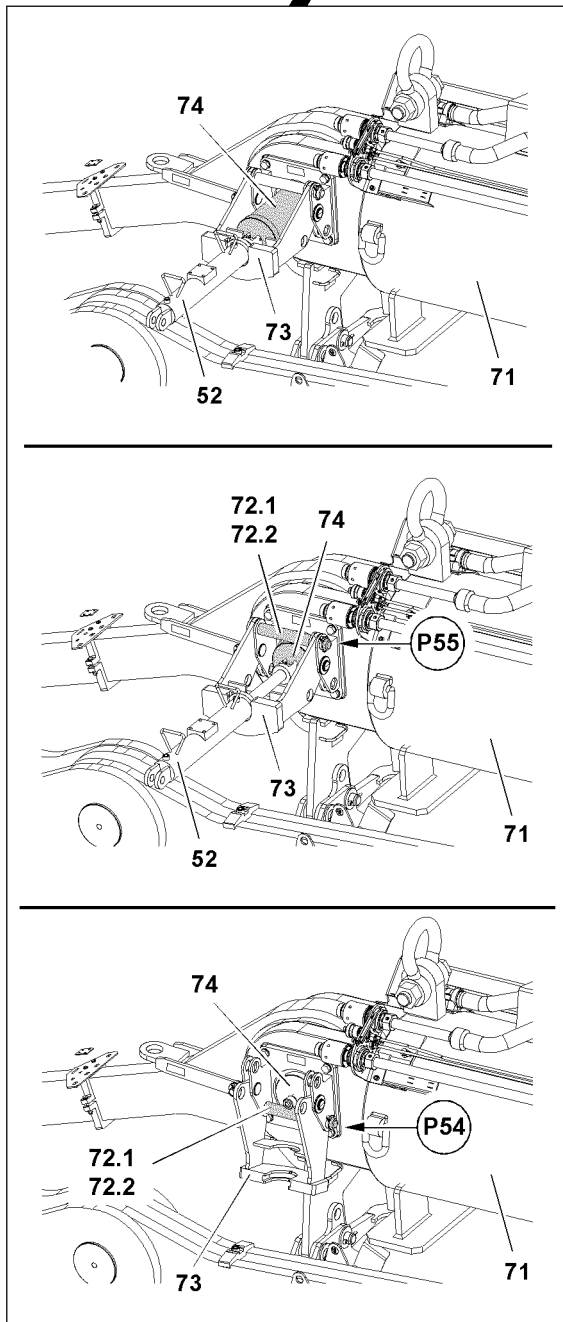

Fig.124414

LWE/LR 13000-001/19503-01-02/en

3.11.3 Pinning the pull cylinder

Make sure that the following prerequisites are met:

- The receptacles **25** and rods **26** are in the operating position.
- The supports **23** are in the operating position.



Note

- ▶ Operating position for receptacles, rods and supports on the D-end section, see section „Preparing the D-end section“.

- ▶ Move the pull cylinder with the auxiliary crane to the pin location in point **P56** and lower onto the supports **23**, see illustration **57**.
- ▶ Connect the pin pulling cylinder **52** with the pin **74**, see illustration **57**.
- ▶ Guide the pin pulling cylinder **52** with the flange into the groove of the support **23**, see illustration **57**.

When the pin bores align in point **P56** on the pull cylinder **71** and on the rod **26**:

- ▶ Extend the pin pulling cylinder.

Result:

- The pin **74** retracts, see illustration **57**.



WARNING

Swinging support!

When releasing the support **73** it can swing downward uncontrolled.

Personnel can be severely injured.

- ▶ Hold the support **73** when unpinning.
- ▶ Assembly personnel must be to the side of the assembly unit.

- ▶ Remove the pin pulling cylinder **52**.
- ▶ Release the support **73** for the pin pulling cylinder in point **P55**: Remove the safety locking pin **72.2** and unpin the pin **72.1**, see illustration **57**.



WARNING

The pin is not secured!

If the pins **74** are not secured, the pins can loosen up by themselves during crane operation.

This can cause the crane to topple over.

Personnel can be severely injured or killed.

- ▶ Make sure that the pins **74** are secured after the pin procedure.

- ▶ Swing the support **73** down and secure in point **P54**: Insert the pin **72.1** and secure with the safety locking pin **72.2**.

Result:

- The pin **74** is secured, see illustration **57**.
- ▶ Remove the auxiliary crane.

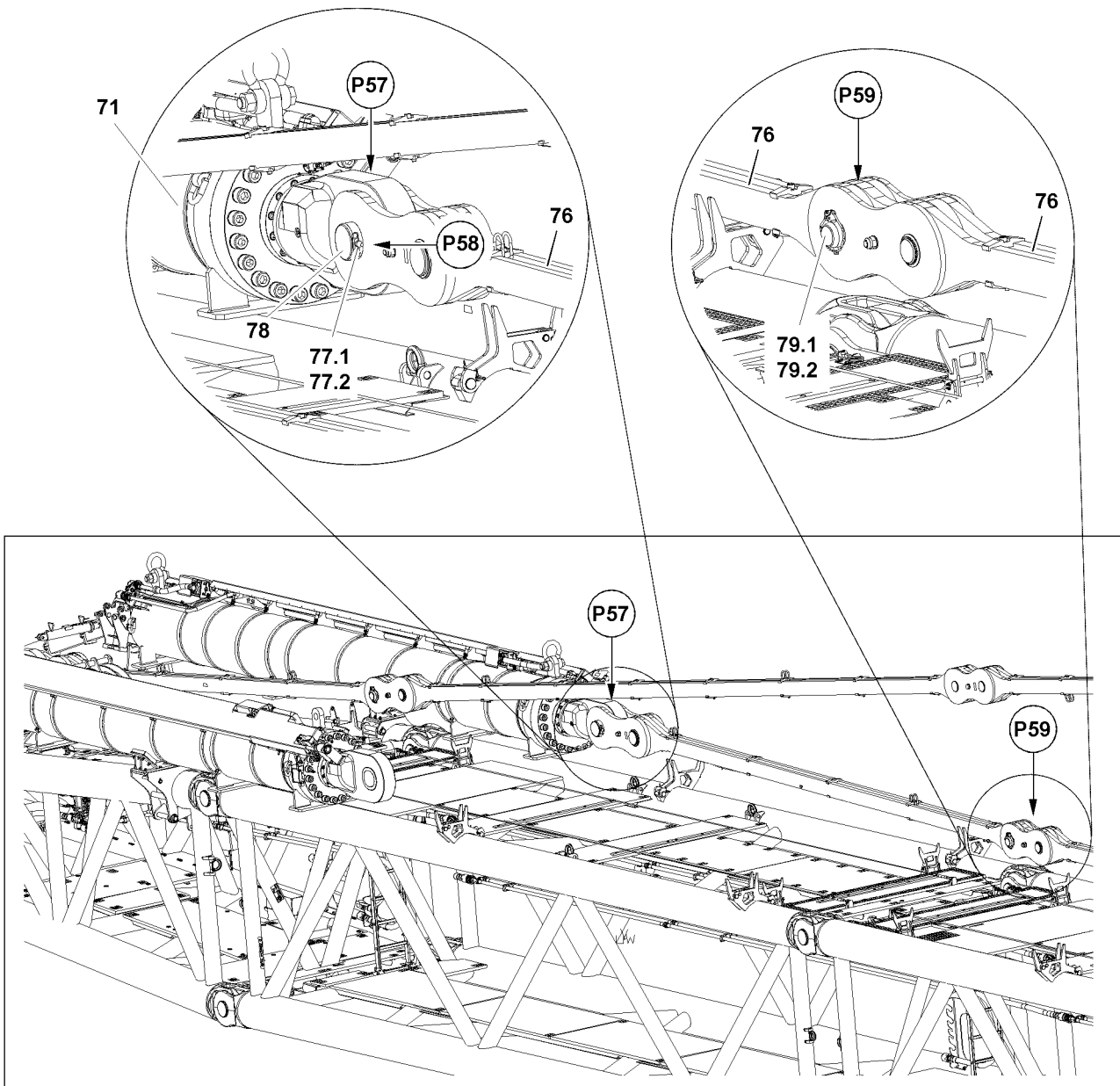

58

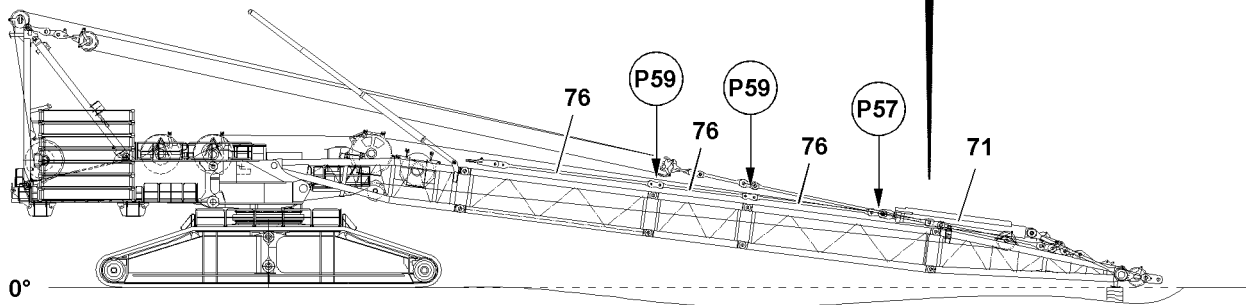

Fig.124415

LWE/LR 13000-001/19503-01-02/en

3.11.4 Pinning the ballast rods



WARNING

Neglected inspection and maintenance on guy rods!

If the regular inspection and maintenance of the guy rods is not carried out or is carried out only in irregular intervals, then serious accidents can occur due to existing and unrecognized damage to the guy rods.

Personnel can be severely injured or killed.

- ▶ The guy rods must be checked before every assembly, see the Crane operating instructions, chapter 8.15.



Note

- ▶ The derrick guy rods must be assembled and secured according to the separately supplied assembly drawings. The numbering on the assembly drawings must be identical to the numbering on the guy rods.



Note

- ▶ The pins **77.1** of the ballast rods **76** in points **P57** may only be pinned from the **outside** to the **inside**, see illustration **58**.



WARNING

The pin is not secured!

If the pins **78** are not secured, the pins can loosen up by themselves during crane operation.

This can cause the crane to topple over.

Personnel can be severely injured or killed.

- ▶ Make sure that the pins **78** are secured after the pin procedure.
- ▶ Pin the ballast rods **76** with the pull cylinder **71**: Insert the pin **78** in point **P57**, insert pin **77.1** in point **P58** and secure with the spring retainer **77.2**, see illustration **58**.



WARNING

The pin is not secured!

If the pins **79.1** are not secured, the pins can loosen up by themselves during crane operation.

This can cause the crane to topple over.

Personnel can be severely injured or killed.

- ▶ Make sure that the pins **79.1** are secured after the pin procedure.
- ▶ Assemble the ballast rods **76** to the required length: Insert the pin **79.1** in points **P59** on both sides and secure with safety locking pin **79.2**, see illustration **58**.

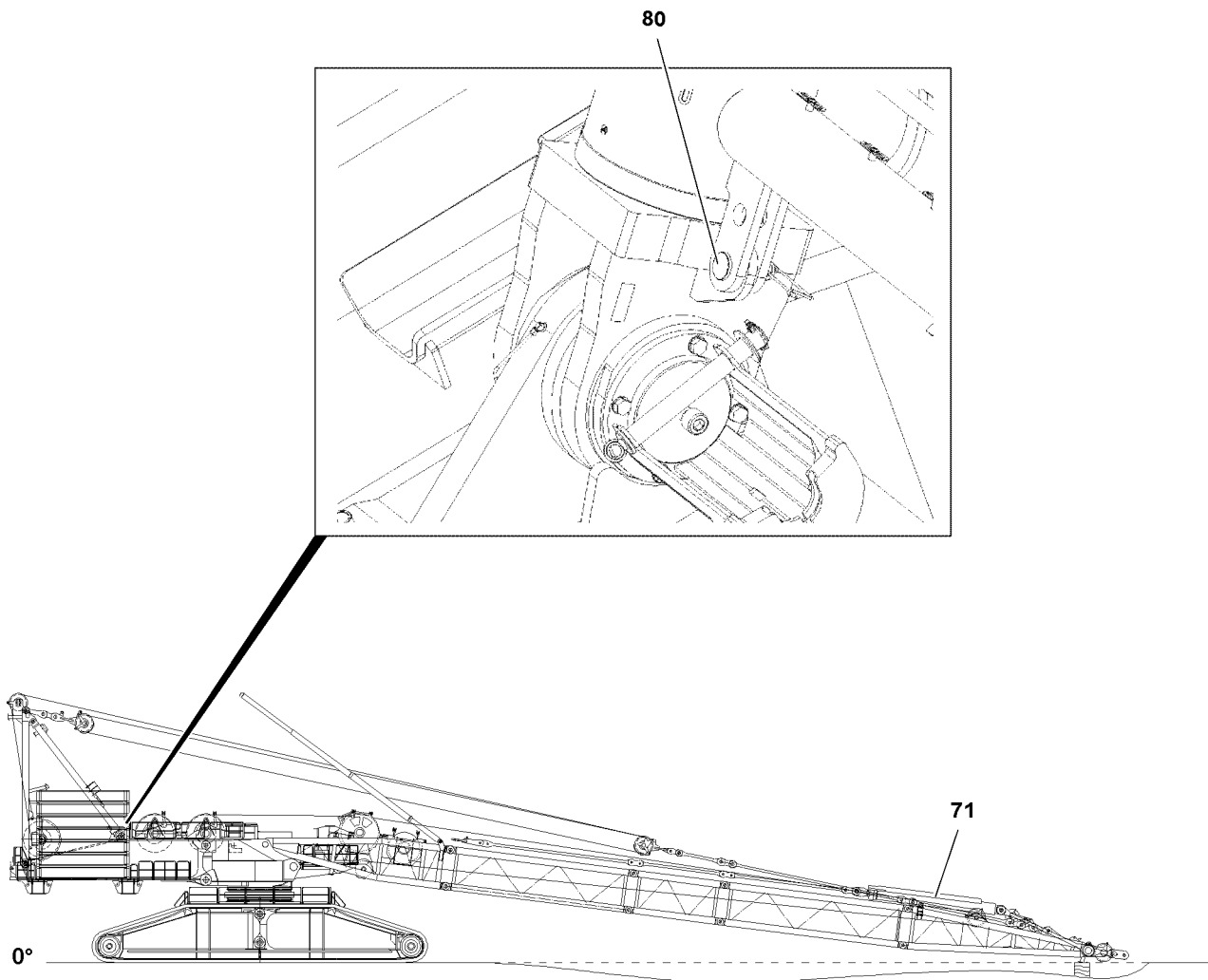

Fig.114395

LWE/LR 13000-001/19503-01-02/en

3.11.5 Establishing the hydraulic connections to the pull cylinders

The hydraulic connections are established with quick couplings.

When connecting hydraulic lines with quick couplings, make sure that the coupling procedure is carried out correctly.

The matching quick couplings are marked.



WARNING

Pressure in the hydraulic lines!

If the pressure supply is not interrupted before connecting / releasing the hydraulic lines, the hydraulic oil can escape with high pressure.

Death, severe bodily injuries, property damage.

- ▶ Release the pressure in the hydraulic system before connecting / disconnecting: Interrupt the pressure supply and wait a short time.



WARNING

Loss of pressure or leakage!

Incorrectly coupled or self-loosening quick couplings (particularly return lines) can result in serious accidents due to component failure.

Death, severe bodily injuries, property damage.

- ▶ Check that the quick couplings have been properly connected before using the crane.
- ▶ Connect the coupling components (sleeve and connector) and screw together with the knurled nut.
- ▶ Tighten the hydraulic coupling by hand. Turn the knurled nut until it reaches a tangible, fixed stop position.

3.12 Releasing the guide pipe



WARNING

Damage to the A-frame!

If the pin **80** on the guide pipe is not unpinned before pulling the derrick up, then the pin connection will be destroyed when the guide pipe extends.

- ▶ Make sure, before pulling up the derrick, that the pin **80** is unpinned.



Note

- ▶ Release the guide pipe, see the Crane operating instructions, chapter 3.05.
- ▶ Release the guide pipe.

59

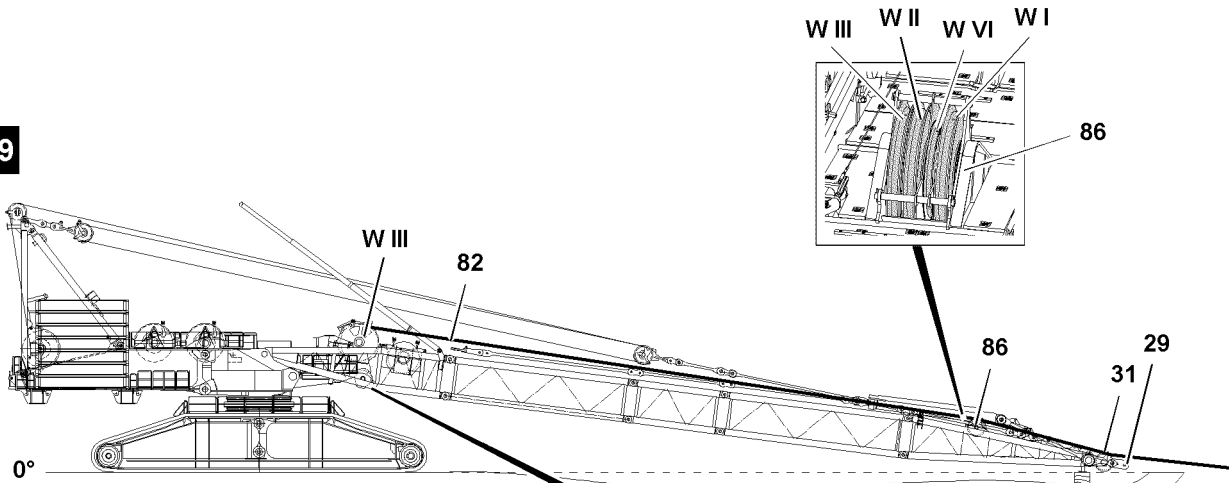

60

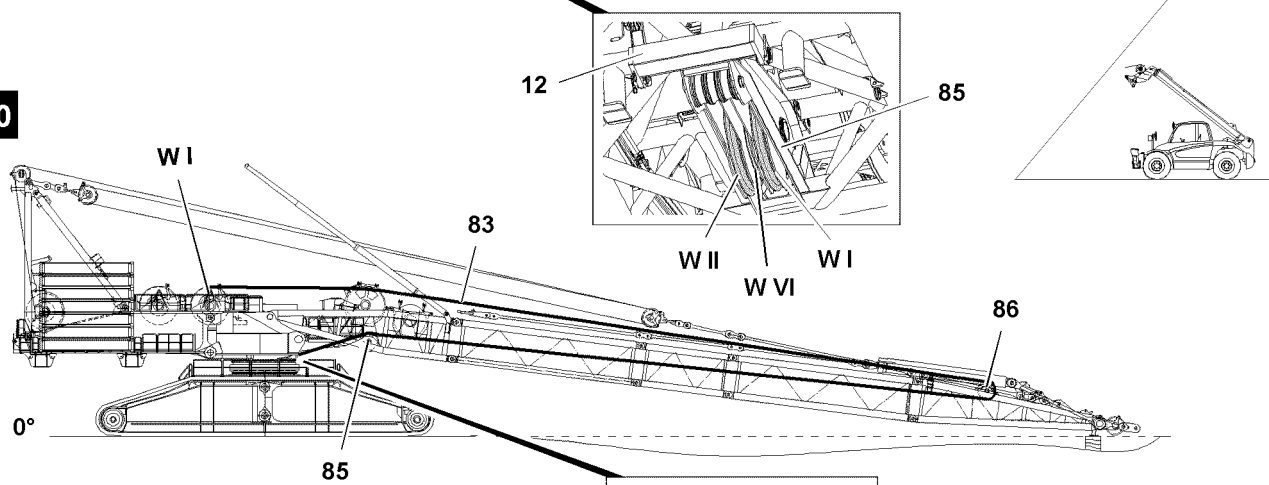

61

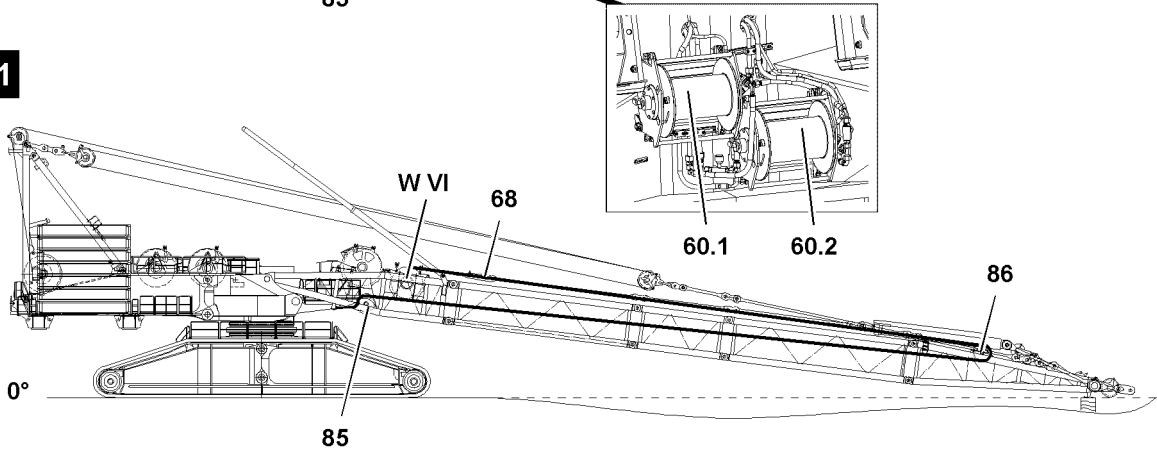

62

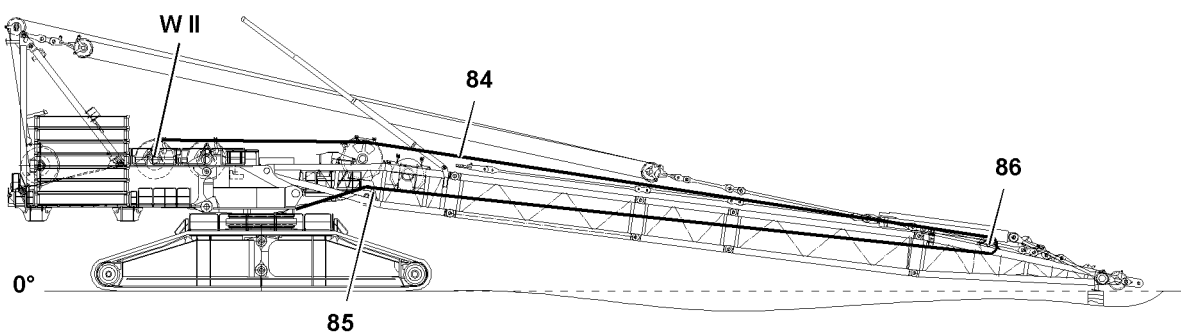

Fig.124416

LWE/LR 13000-001/19503-01-02/en

3.13 Reeving the ropes in



DANGER

General danger note!

If the following conditions are not met before erecting the D-boom, the rope can fall down due to its own weight.

Personnel can be severely injured or killed.

- ▶ Enough hoist rope must be guided over the rope pulleys so that the rope does **not** pull back and fall down when erecting the D-boom.

3.13.1 Reeving the rope of winch 3

Make sure that the following prerequisites are met:

- The pulley support **31** is in the operating position.
- The pull test brackets **29** are in the operating position.



Note

- ▶ Operating position for the pulley support and pull test brackets on the D-end section, see section „Preparing the D-end section“.

NOTICE

Property damage!

Incorrect reeving of the rope on the change over pulleys **86** can cause damage to the crane or break the rope.

- ▶ Reeving the rope on the change over pulleys **86**, see illustration **59** and reeving plans.



Note

- ▶ The driver of the telescopic lift truck must be in constant voice (for example through radio communication) and visual contact with the crane operator.
- ▶ Pull the auxiliary rope of the telescopic lift truck over the rope pulley on the pulley support **31** and on the change over pulleys **86** to winch 3, see illustration **59**.
- ▶ Connect the auxiliary rope with the rope **82** of winch 3.



WARNING

Danger of slack rope formation!

When spooling the rope out, slack rope can form.

- ▶ The rope must be slightly tensioned during the entire pulling procedure.
- ▶ Pull the rope **82** of winch 3 forward to the telescopic lift truck: Spool up the auxiliary winch and simultaneously spool out winch 6, see illustration **59**.
- ▶ Release the auxiliary rope on rope **82** of winch 3 and spool the auxiliary winch up.

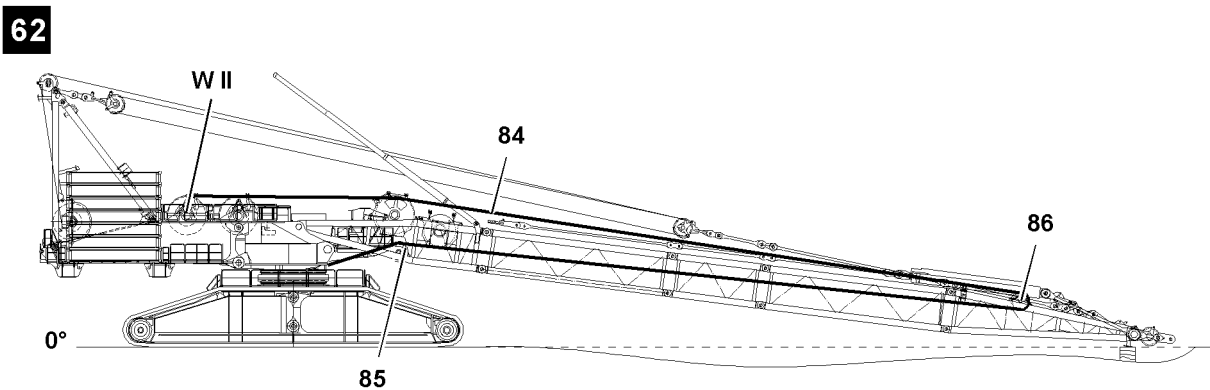
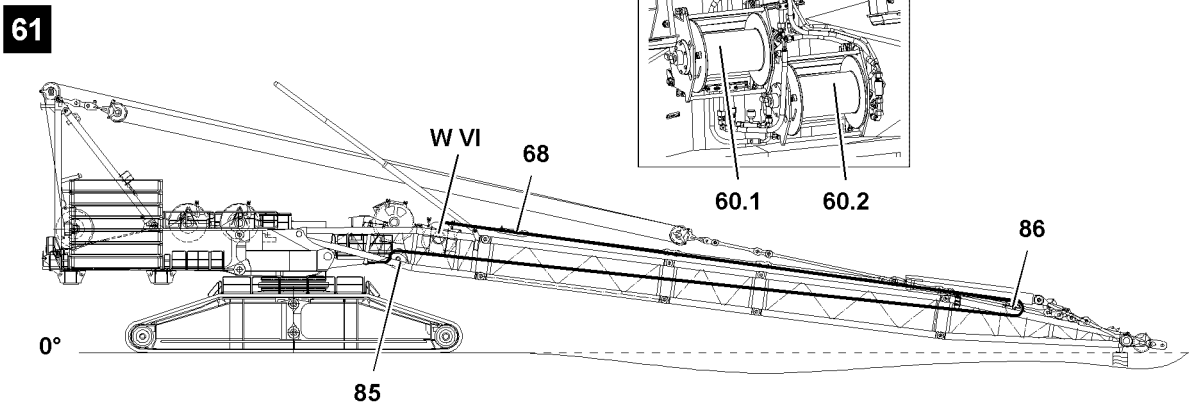
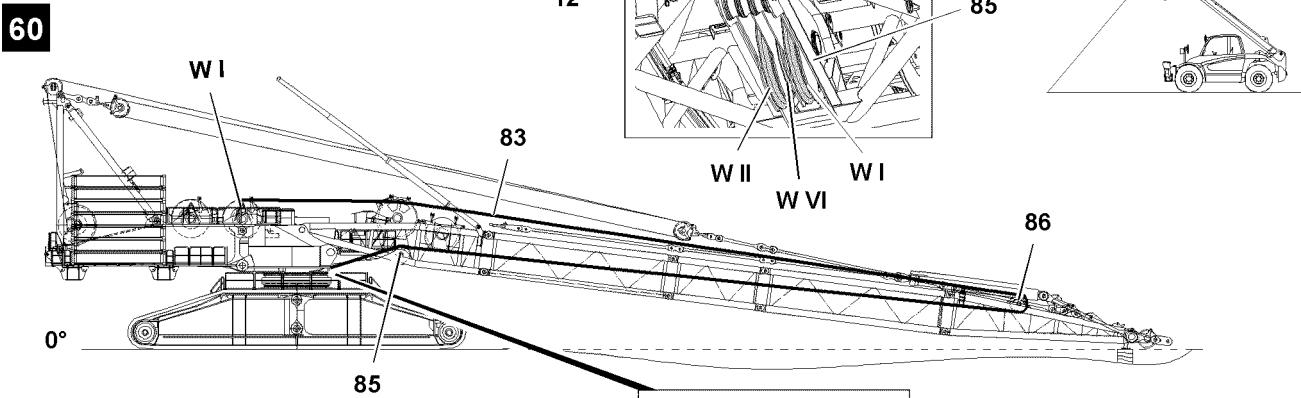
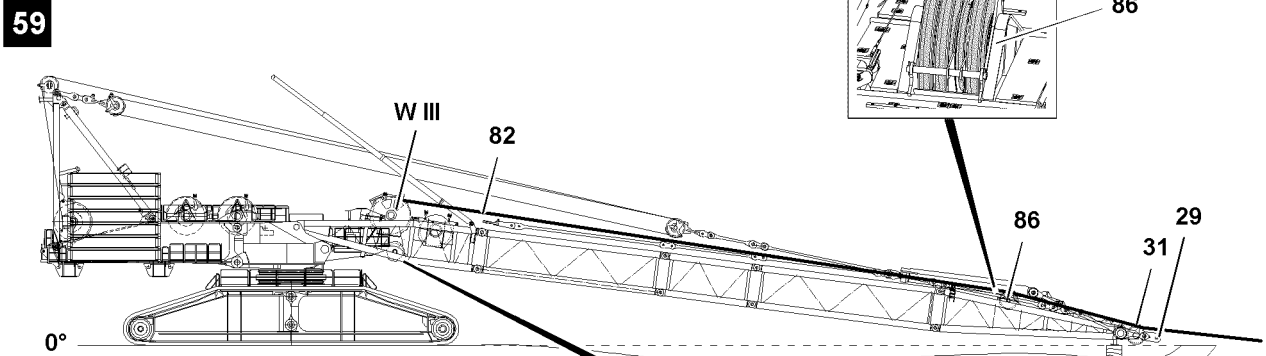

Fig.124416

LWE/LR 13000-001/19503-01-02/en

3.13.2 Reeving the rope of winch 1

Make sure that the following prerequisite is met:

- The transport frame **12** is folded up, see section „Folding the transport frame up“, see illustration **59**.

NOTICE

Property damage!

Incorrect reeving of the rope on the change over pulleys **86** can cause damage to the crane or break the rope.

- ▶ Reeving the rope on the change over pulleys **86**, see illustration **59** and reeving plans.
- ▶ Pull the assembly rope of the assembly winch **60.1** over the rope pulley **85**, over the rope pulley on the change over pulleys **86** and over the guard roller on winch 3, see illustration **60**.
- ▶ Connect the assembly rope of the assembly winch **60.1** with the rope **83** of winch 1.



WARNING

Danger of slack rope formation!

When spooling the rope out, slack rope can form.

- ▶ The rope must be slightly tensioned during the entire pulling procedure.
- ▶ Pull the rope **83** of winch 3 forward to the assembly winch **60.1**: Spool up the assembly winch and simultaneously spool out winch 1, see illustration **60**.



DANGER

General danger note!

If the following conditions are not met before erecting the D-boom, the rope can fall down due to its own weight.

Personnel can be severely injured or killed.

- ▶ Rope **83** from winch 1 must be secured on the assembly winch **60.1**, so that the rope does **not** pull back and fall down due to its own weight when erecting the D-boom.
 - ▶ Secure the rope **83** of winch 3 on the assembly winch **60.1**.
-

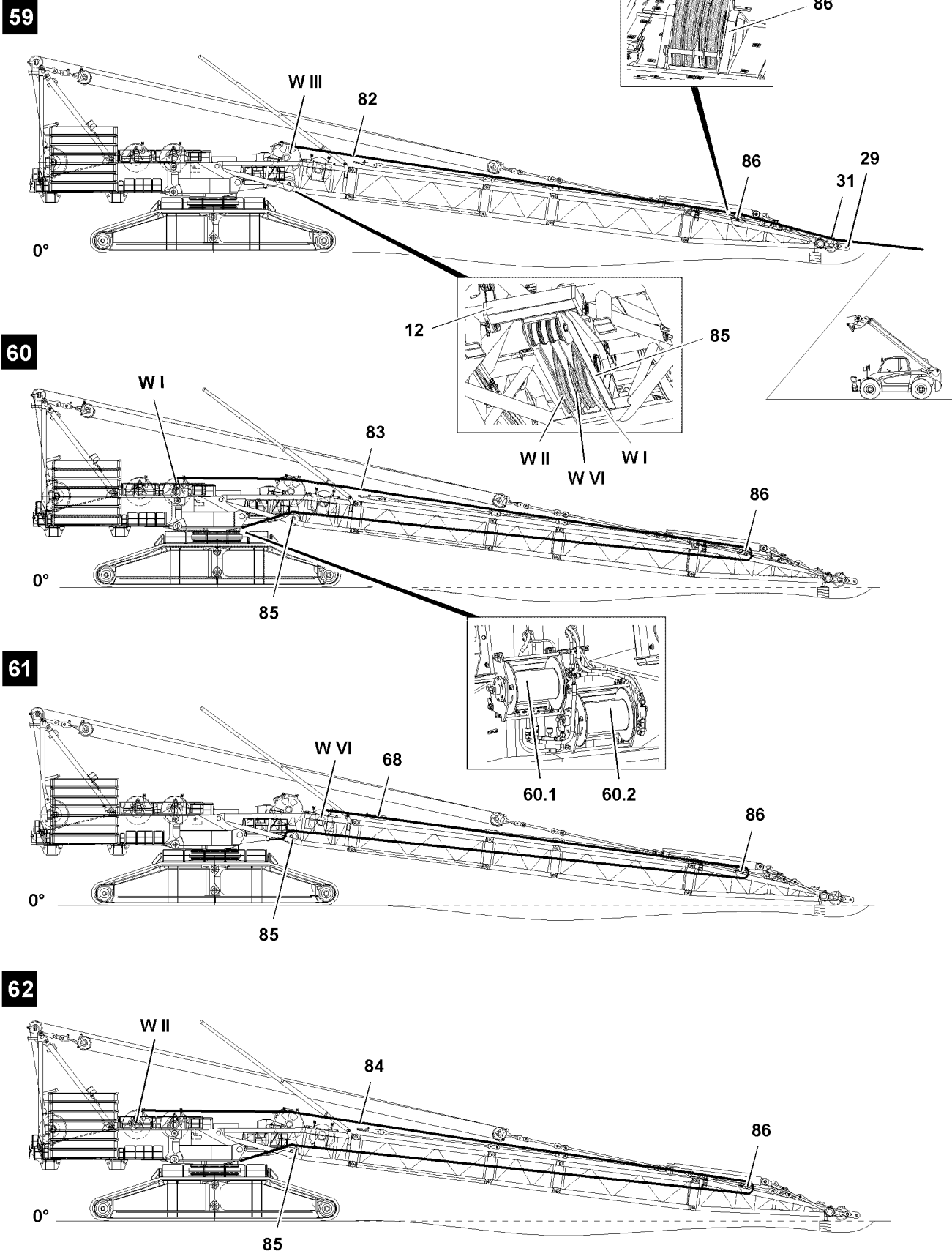

Fig.124416

LWE/LR 13000-001/19503-01-02/en

3.13.3 Reeving the rope of winch 6

NOTICE

Property damage!

Incorrect reeving of the rope on the change over pulleys **86** can cause damage to the crane or break the rope.

- ▶ Reeving the rope on the change over pulleys **86**, see illustration **59** and reeving plans.



Note

- ▶ Reeving the rope **68** of winch 6 is the same as the work steps of the previously described reeving of rope **83** from winch 1.



Note

- ▶ For reeving the rope **68** of winch 6 use the assembly winch **60.2**.
- ▶ Secure the rope **68** of winch 6 with the assembly winch **60.2**, see illustration **61**.
- ▶ Release the rope **68** of winch 6 from the assembly rope and secure on the D-boom, see illustration **61**.

3.13.4 Reeving the rope of winch 2

NOTICE

Property damage!

Incorrect reeving of the rope on the change over pulleys **86** can cause damage to the crane or break the rope.

- ▶ Reeving the rope on the change over pulleys **86**, see illustration **59** and reeving plans.



Note

- ▶ Reeving the rope **84** of winch 2 is the same as the work steps of the previously described reeving of rope **83** from winch 1.



Note

- ▶ For reeving the rope **84** of winch 2 use the assembly winch **60.2**.
- ▶ Reeve the rope **84** of winch 2 with the assembly winch **60.2** and secure on the assembly winch, see illustration **62**.

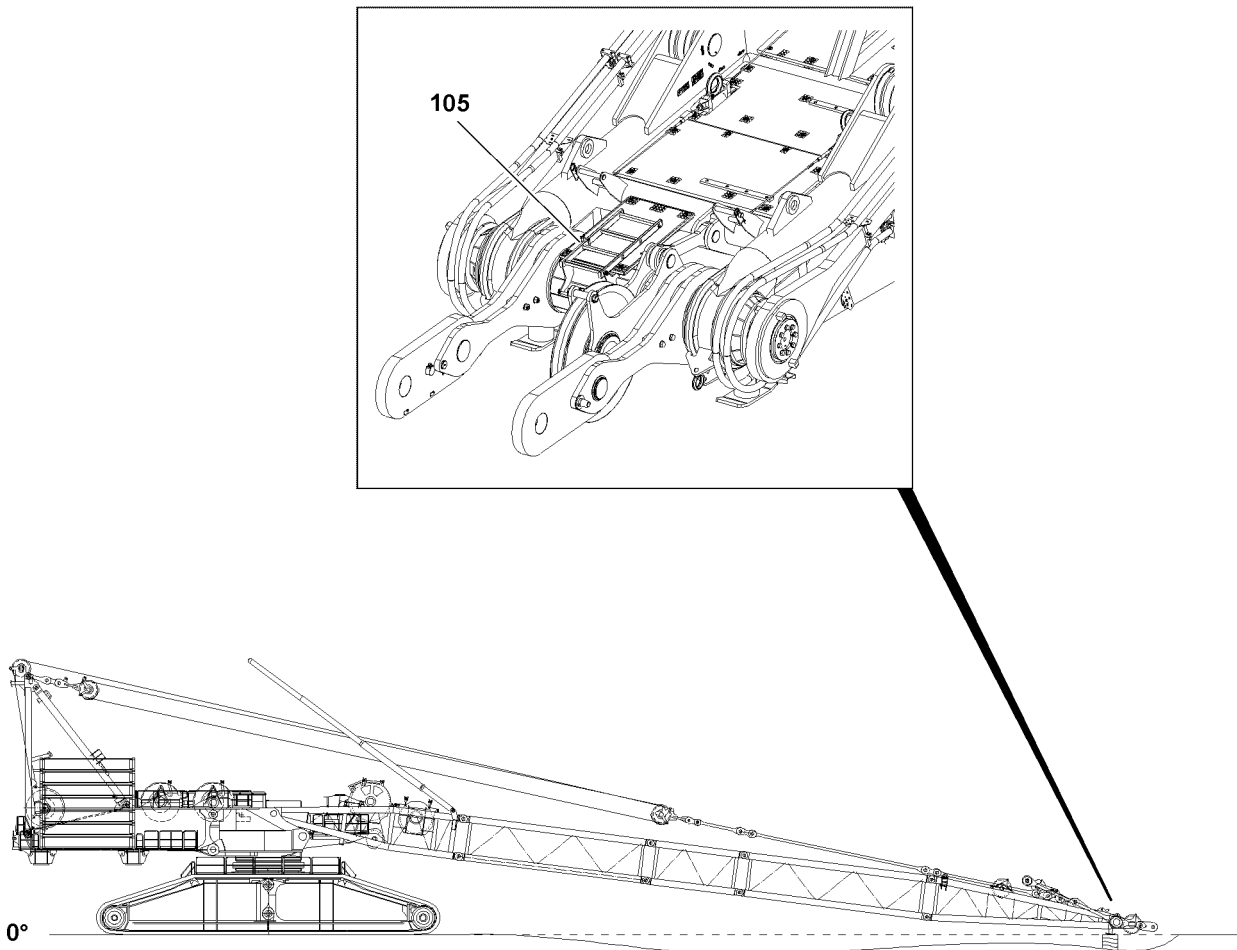

Fig.115605

LWE/LR 13000-001/19503-01-02/en

3.14 Establishing the electrical connections

Make sure that the following prerequisite is met:

- The D-boom is completely assembled.



Note

- ▶ To establish the electrical connections, see the Electric wiring diagram.
- ▶ Establish the electrical connections.
- ▶ Make sure that all electrical connections on the D-boom have been established.

3.15 Establishing the hydraulic connections

The hydraulic connections are established with quick couplings.

When connecting hydraulic lines with quick couplings, make sure that the coupling procedure is carried out correctly.

The matching quick couplings are marked.



WARNING

Pressure in the hydraulic lines!

If the pressure supply is not interrupted before connecting / releasing the hydraulic lines, the hydraulic oil can escape with high pressure.

Death, severe bodily injuries, property damage.

- ▶ Release the pressure in the hydraulic system before connecting / disconnecting: Interrupt the pressure supply and wait a short time.



WARNING

Loss of pressure or leakage!

Incorrectly coupled or self-loosening quick couplings (particularly return lines) can result in serious accidents due to component failure.

Death, severe bodily injuries, property damage.

- ▶ Check that the quick couplings have been properly connected before using the crane.
- ▶ Connect the coupling components (sleeve and connector) and screw together with the knurled nut.
- ▶ Tighten the hydraulic coupling by hand. Turn the knurled nut until it reaches a tangible, fixed stop position.
- ▶ Establish the hydraulic connection to the D-relapse cylinders.

3.16 Folding the ladder on the D-end section



WARNING

Danger of collision!

If the ladder on the D-end section is not brought into the transport position before erecting, then it can collide with other components during crane operation.

This could result in property damage.

- ▶ The ladder on the D-end section must be brought into the transport position before erecting.
- ▶ Bring the ladder **105** into the transport position, see the Crane operating instructions, chapter 2.06.

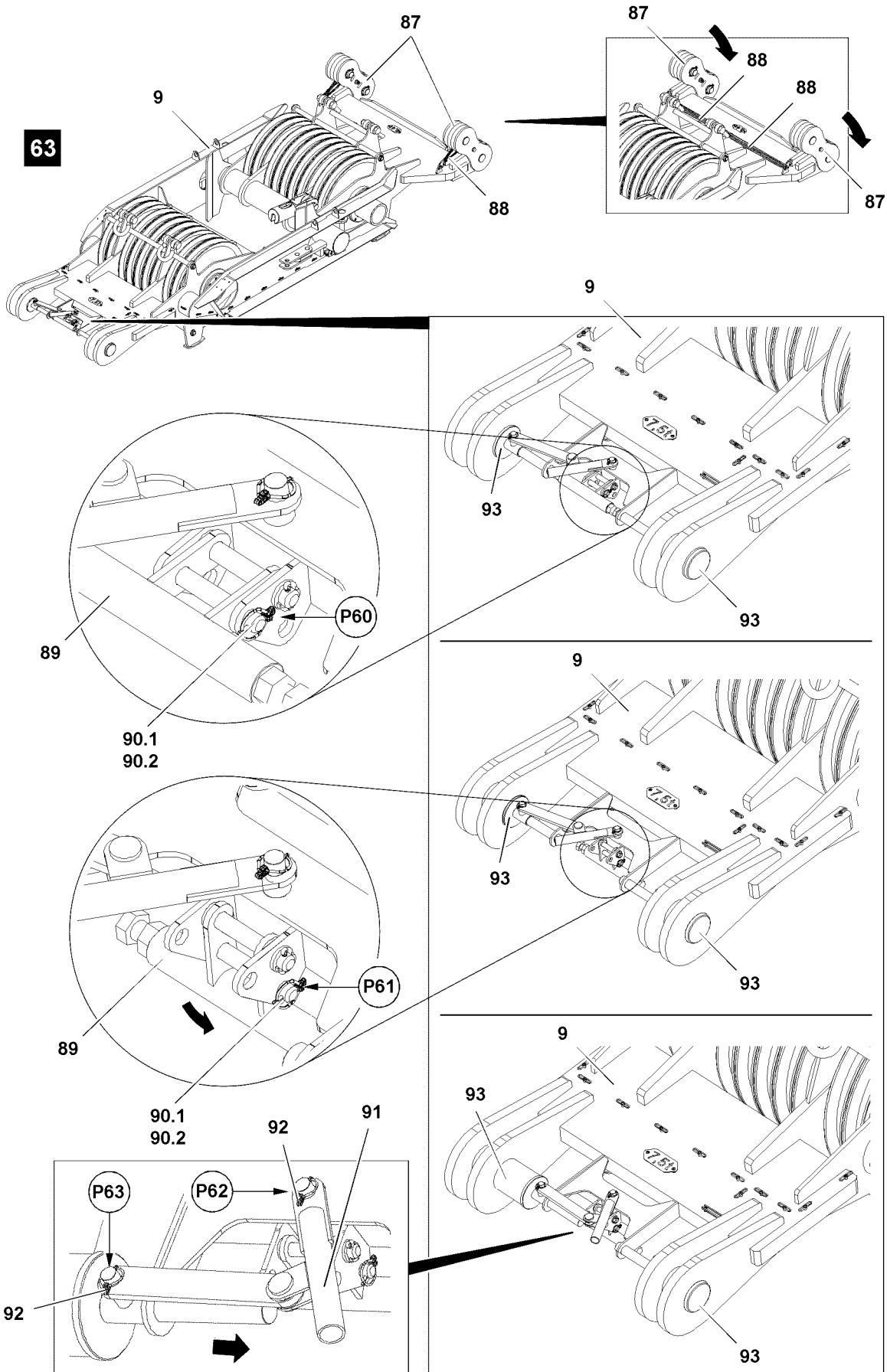

Fig.124417

LWE/LR 13000-001/19503-01-02/en

3.17 Assembling the S-luffing pulley block

3.17.1 Preparing the S-luffing pulley block

Swinging the brackets



WARNING

Danger of accident when swinging in the bracket!
When swinging in the bracket, limbs can be crushed or severed.
Personnel can be severely injured.

- ▶ Make sure that there is no personnel in the danger zone.
 - ▶ Do not reach with your hands into the danger zone.
-
- ▶ Swing the brackets **87** into the operating position: Open the carabiner, remove the round sling **88** and swing the brackets **87** to the rear.
 - ▶ Secure the round sling **88** with the carabiner in the park position, see illustration **63**.

Releasing and unpinning the pin



WARNING

Danger of accident when swinging in the bracket!
When swinging in the bracket, limbs can be crushed.
Personnel can be severely injured.

- ▶ Do not reach with your hands into the danger zone.
-
- ▶ Release the pin **93**: Remove the safety locking pin **90,2** in point **P60** and unpin the pin **90,1**.
 - ▶ Swing the bracket **89** down, see illustration **63**.
 - ▶ Secure the bracket **89** in the park position: Insert the pin **90,1** in point **P61** and secure with the safety locking pin **90,2**, see illustration **63**.



Note

- ▶ To obtain a better level action when actuating the lever **91**, an extension pipe can be used.
-
- ▶ Operate the lever **91**.

Result:

- The pin **93** is unpinned, see illustration **63**.
- ▶ Remove the safety locking pin **92** in point **P62** and in point **P63**, lift and turn the lever **91**.
- ▶ Position the lever **91** inversely on the second pin **93** and secure again in point **P62** and in point **P63**.
- ▶ Unpin the second pin **93**.

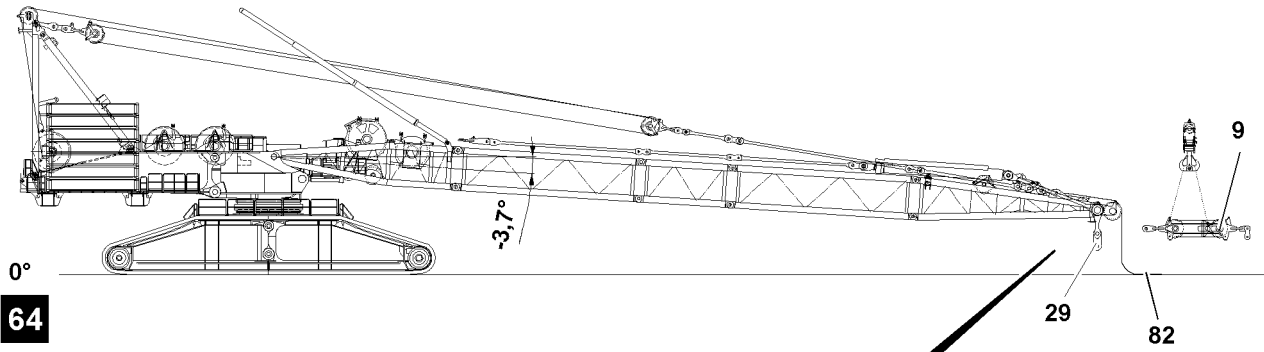

64

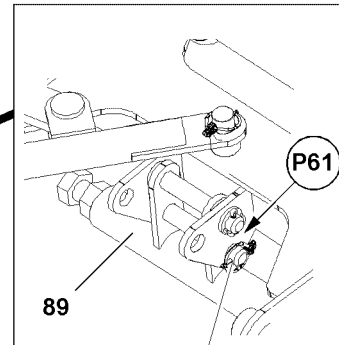
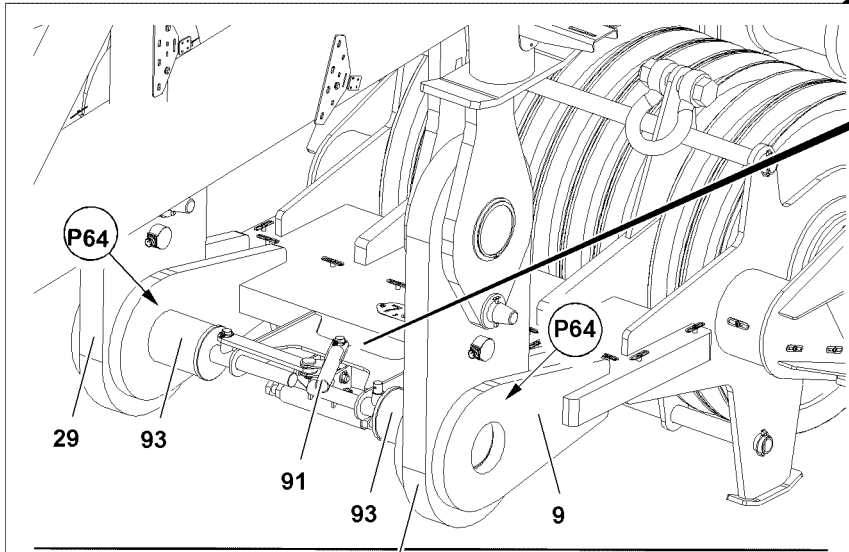

90.1
90.2

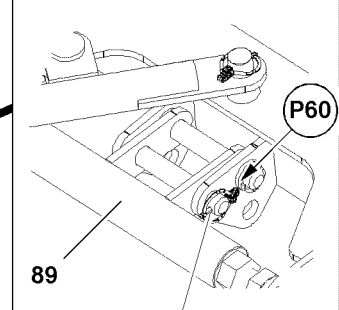
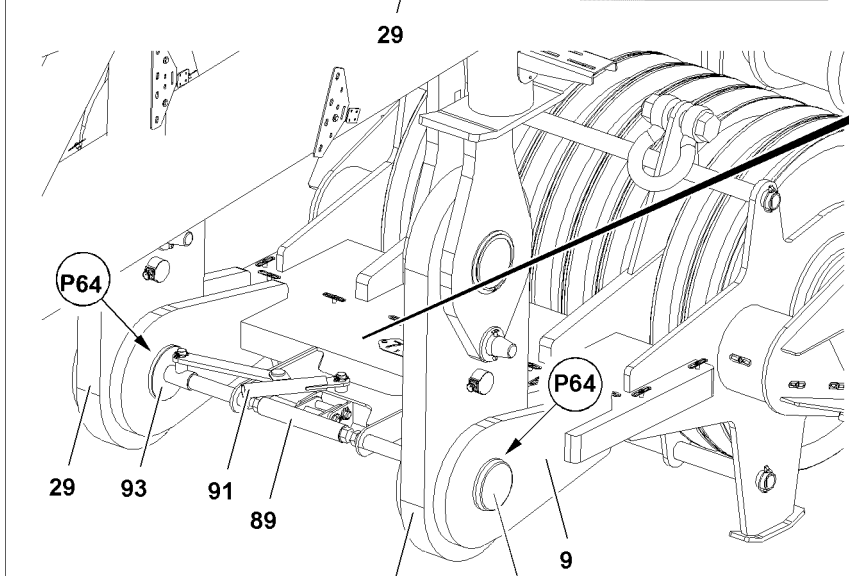

90.1
90.2

65

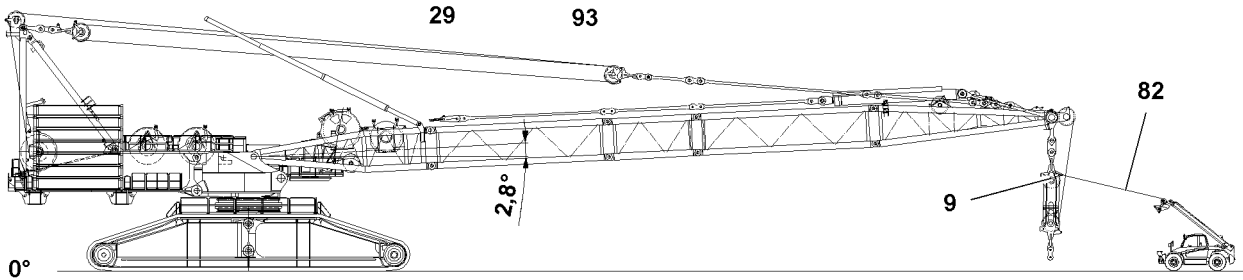

Fig.124418

LWE/LR 13000-001/19503-01-02/en

3.17.2 Pinning the S-luffing pulley block

Make sure that the following prerequisites are met:

- The guide pipes on the A-frame are released, see the Crane operating instructions, chapter 3.05.
- The D-boom is completely assembled and secured.
- All guy rods are installed and secured according to the reeving plans.
- The D-adjustment is tensioned.



WARNING

Overload of the crane!

If the D-boom is lying below the alignment level, then the crane will be overloaded at erection.

- ▶ Support the D-boom to the alignment level or lift it with the auxiliary crane to the alignment level.
- ▶ The D-adjustment may only be used to pull from the alignment level.
- ▶ The rope pull of winch 4 is monitored by the pull test bracket.

- ▶ Erect the D-boom to approx. -3.7° until the pull test brackets **29** are approximately 1.5 m above the ground, see illustration **64**.
- ▶ Fasten the S-luffing pulley block **9** to the auxiliary crane in the fastening points, see section „Fastening points for derrick components“.
- ▶ Move the S-luffing pulley block **9** with the auxiliary crane to the pull test bracket **29** and align with the pin bores in points **P64**.



Note

- ▶ To obtain a better level action when actuating the lever **91**, an extension pipe can be used.

When the pin bores align:

- ▶ Insert the pin **93** with the aid of the lever **91**.
- ▶ Turn the lever **91** over, see section „Releasing und unpinning the pin“.
- ▶ Insert the second pin **93**, see illustration **64**.



WARNING

The pin is not secured!

If the pins are not secured, the pins can loosen up by themselves during crane operation.

This can cause the crane to topple over.

Personnel can be severely injured or killed.

- ▶ Make sure that the pins are secured after the pin procedure.

- ▶ Release the bracket **89**: Remove the safety locking pin **90,2** in point **P61** and unpin the pin **90,1**, see illustration **64**.
- ▶ Swing the bracket **89** up, see illustration **64**.
- ▶ Secure the bracket **89** in the operating position: Insert the pin **90,1** in point **P60** and secure with the safety locking pin **90,2**, see illustration **64**.
- ▶ Erect the D-boom to 2.8° and slowly lower the S-luffing pulley block **9** with the auxiliary crane, see illustration **65**.
- ▶ Remove the auxiliary crane.

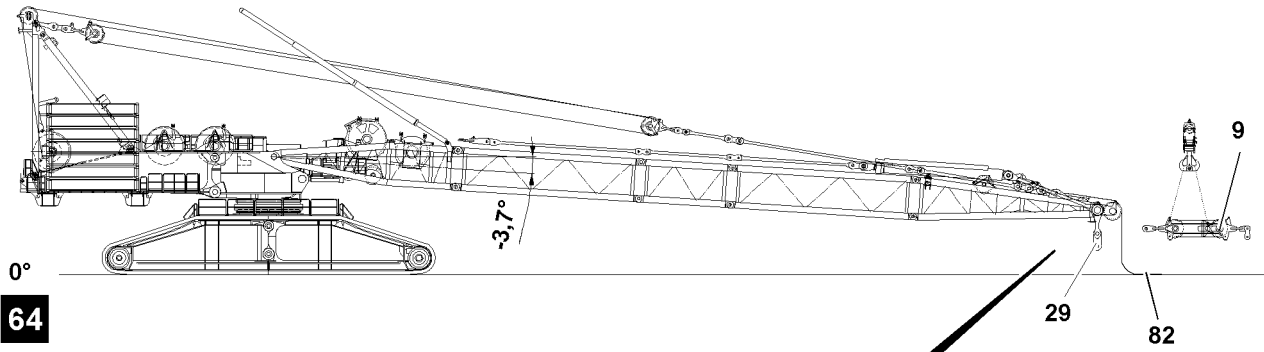

64

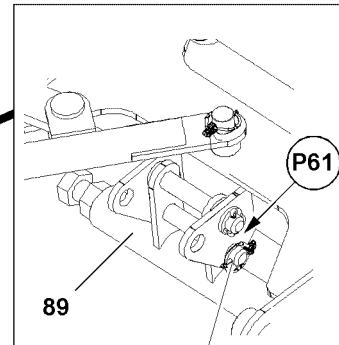
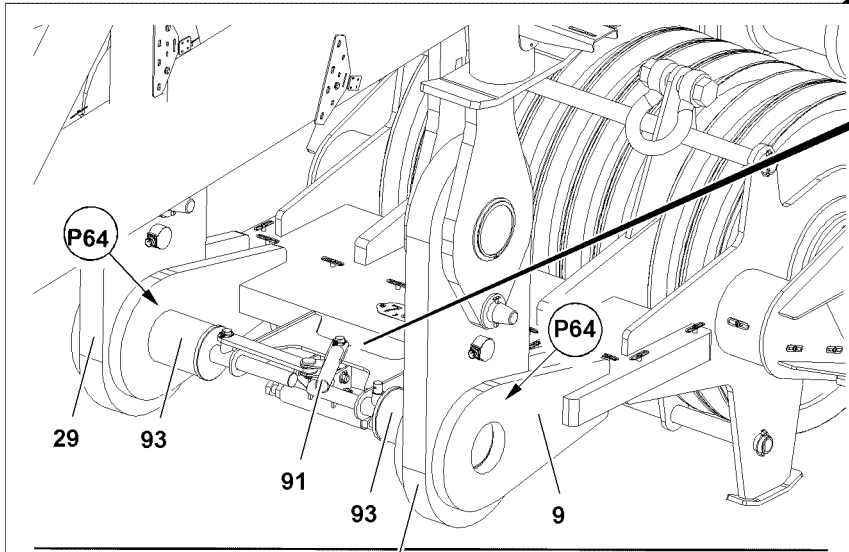

90.1
90.2

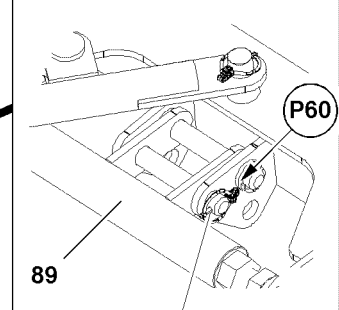
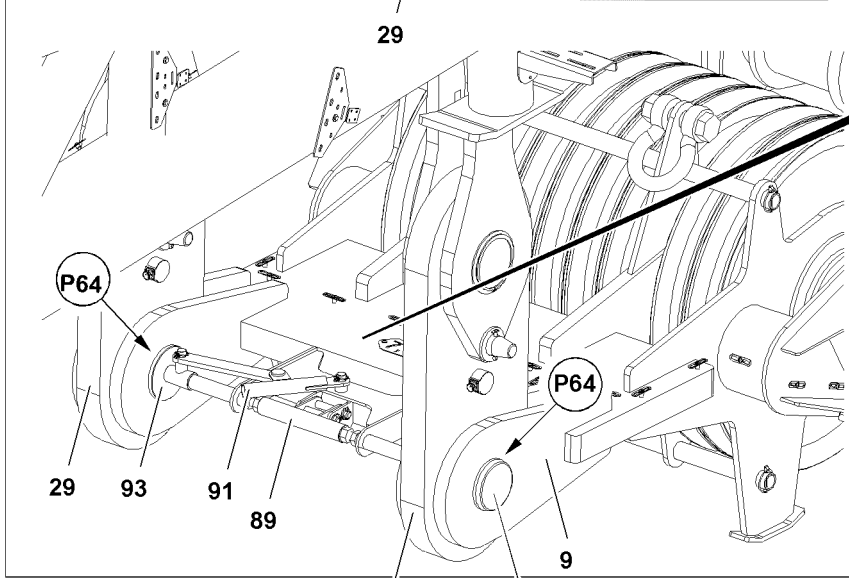

90.1
90.2

65

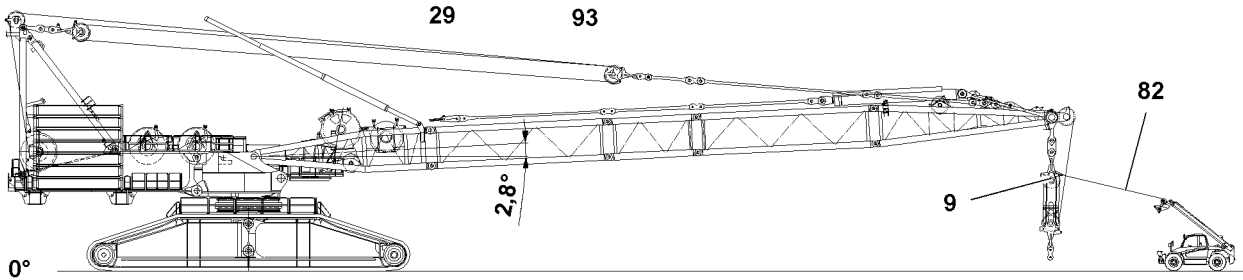

Fig.124418

LWE/LR 13000-001/19503-01-02/en

3.17.3 Reeving the S-luffing pulley block



Note

- ▶ Placing the rope on the S-luffing pulley block, see the Reeving plans.
-



Note

- ▶ The driver of the telescopic lift truck must be in constant acoustic contact with the crane operator.
 - ▶ Pull the auxiliary rope of the telescopic lift truck over the rope pulley on the S-luffing pulley block **9**.
 - ▶ Connect the auxiliary rope of the telescopic lift truck with the rope **82** of winch 3.
-



WARNING

Danger of slack rope formation!

When spooling the rope out, slack rope can form.

- ▶ The rope must be slightly tensioned during the entire pulling procedure.
 - ▶ Reeve the S-luffing pulley block **9**: Spool the auxiliary winch up and simultaneously spool winch 3 out.
 - ▶ Release the auxiliary rope on rope **82** of winch 3 and spool the auxiliary winch up.
 - ▶ Secure the rope **82** of winch 3 with the lock on the S-luffing pulley block **9**.
-

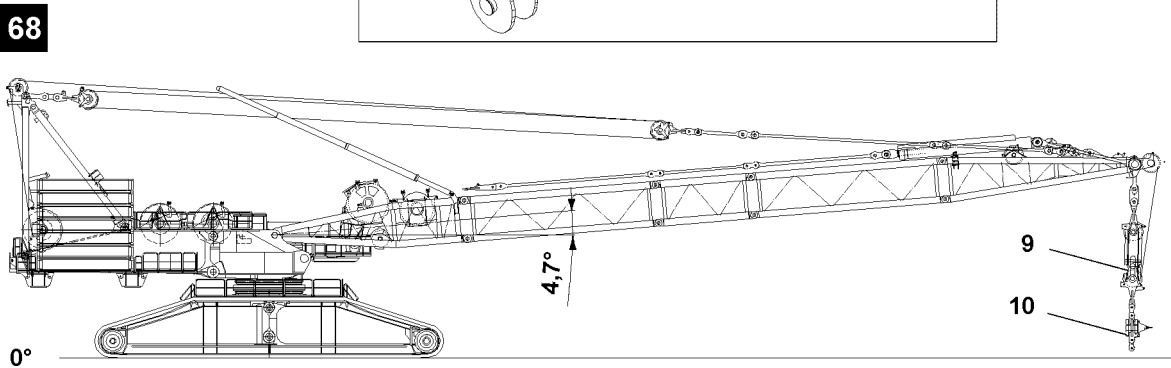
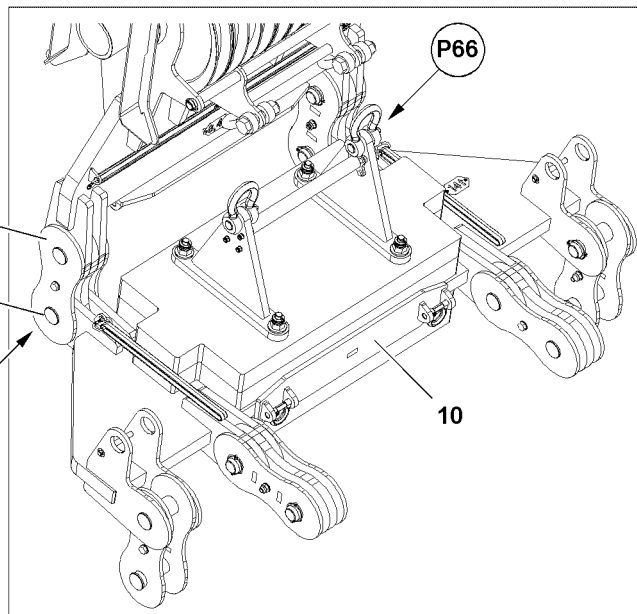
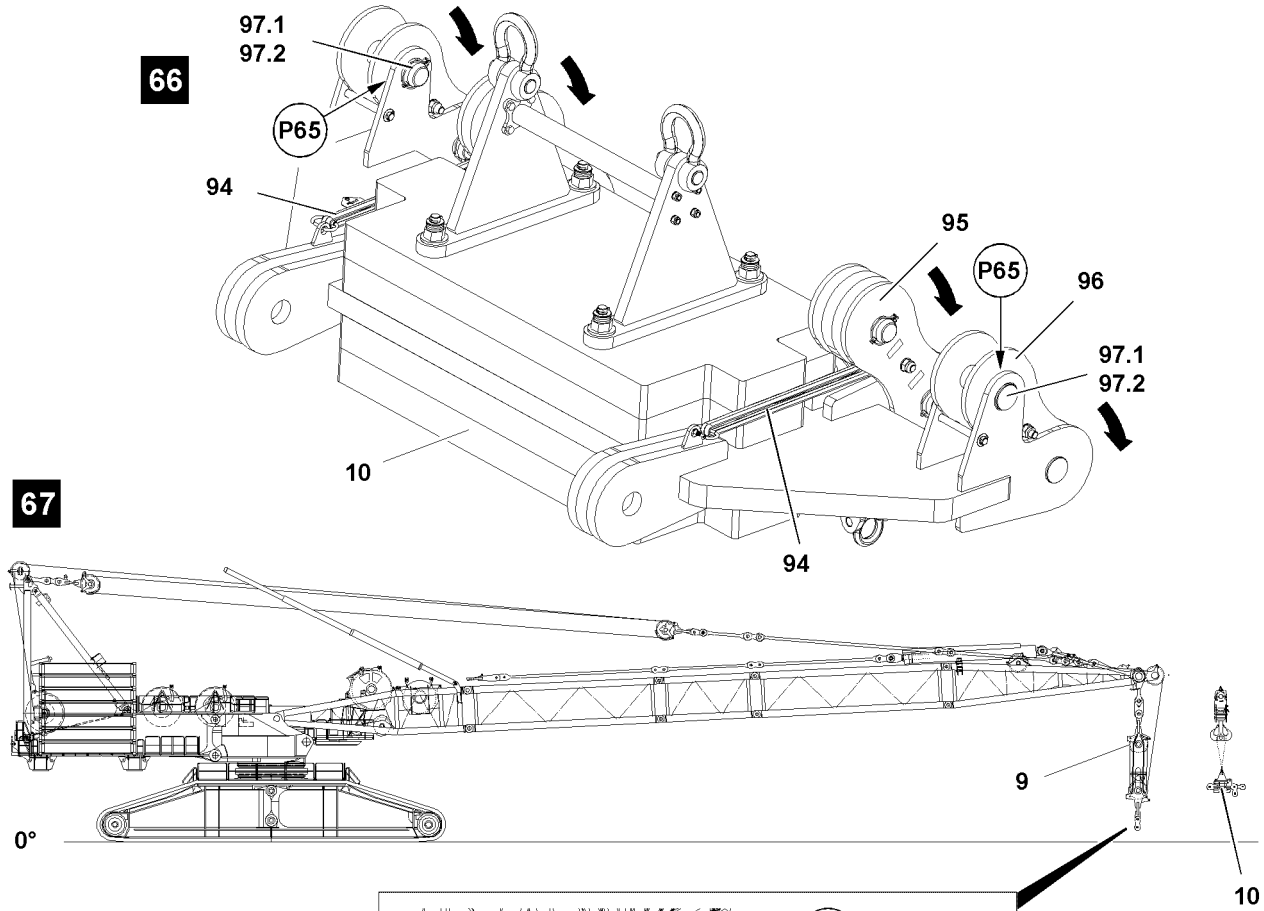

Fig.124419

LWE/LR 13000-001/19503-01-02/en

3.17.4 Assembling the weight

Make sure that the following prerequisites are met:

- The rope of winch 3 is reeved and secured with the lock on the S-luffing pulley block.
- The S-luffing pulley block is completely assembled and secured.

Swinging the brackets



WARNING

Danger of accident when swinging in the bracket!

When swinging in the bracket, limbs can be crushed or severed.

Personnel can be severely injured.

- ▶ Make sure that there is no personnel in the danger zone.
- ▶ Do not reach with your hands into the danger zone.

- ▶ Swing the brackets **95** on both sides into the operating position: Open the carabiner, remove the round sling **94** and swing the brackets **95** to the rear to the stop.
- ▶ Secure the round sling **94** with the carabiner in parking position on the S-luffing pulley block.
- ▶ Release the brackets **96**: Remove the safety locking pin **97,2** on both sides in point **P65** and unpin the pin **97.1**, see illustration **66**.
- ▶ Swing the brackets **96** to the rear.
- ▶ Insert the pin **97.1** again on both sides in point **P65** and secure with the safety locking pin **97,2**.

Pinning the weight

- ▶ Remove the safety locking pin **98,2** on both sides in point **P66** on the S-luffing pulley block **9** and unpin the pin **98.1**.
- ▶ Fasten the weight **10** to the auxiliary crane in the fastening points, see section „Fastening points for derrick components“.
- ▶ Move the weight **10** with the auxiliary crane to the S-luffing pulley block **9** and align with the pin bores in points **P66**, see illustration **67**.



WARNING

The pin is not secured!

If the pins are not secured, the pins can loosen up by themselves during crane operation.

This can cause the crane to topple over.

Personnel can be severely injured or killed.

- ▶ Make sure that the pins **98,1** are secured after the pin procedure.

When the pin bores align:

- ▶ Insert the pin **98,1** on both sides and secure with the safety locking pin **98,2**, see illustration **67**.
- ▶ Erect the D-boom to 4.7° and slowly lower the weight **10** with the auxiliary crane, see illustration **68**.
- ▶ Remove the auxiliary crane.

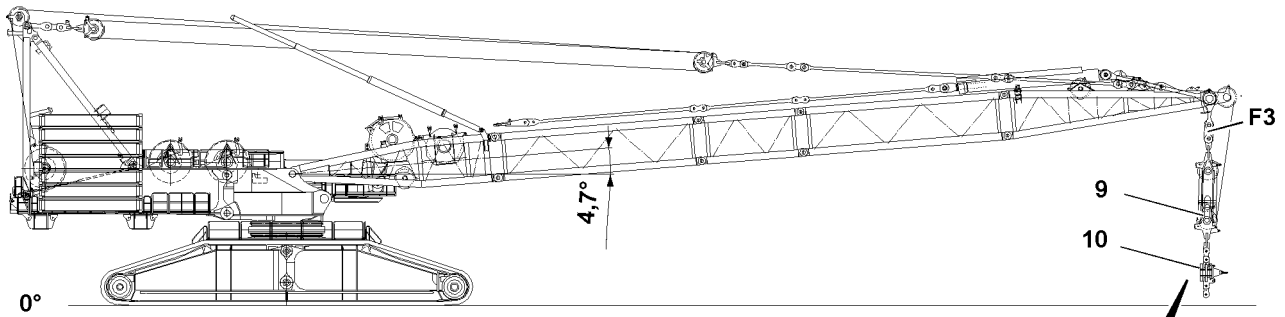

69

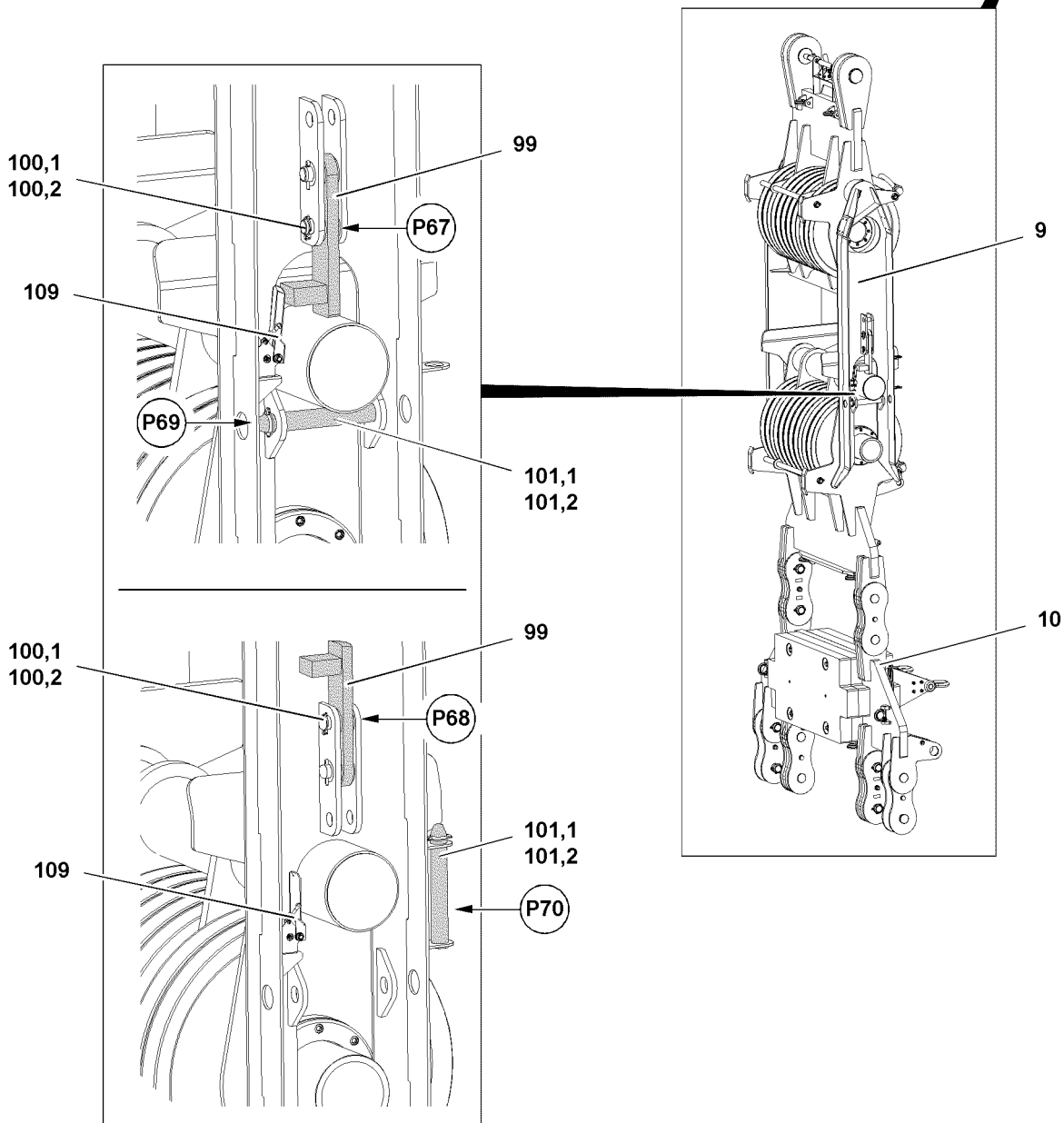

Fig.124420

LWE/LR 13000-001/19503-01-02/en

3.17.5 Releasing the transport retainers of the S-luffing pulley block

Make sure that the following prerequisites are met:

- The S-luffing pulley block is completely assembled and secured with the weight.
- The rope of winch 3 is reeved and secured with the lock on the S-luffing pulley block.



Note

- ▶ If the limit switches are actuated, then the spooling up of winch 3, spooling up as well as spooling out of winch 4 is unbypassably turned off.
 - ▶ It is possible to bypass the limit switch only if the limit switches are unplugged and the dummy plugs is inserted and F3 is less than 8 t.
-
- ▶ Remove the safety locking pin **100.2** on the S-luffing pulley block **9** on both sides in point **P67** and unpin the pin **100.1**, see illustration **69**.
 - ▶ Swing the retaining plate **99** up on both sides.

Result:

- Spooling up winch 3, spooling up as well as spooling out winch 4 is released.
- ▶ Secure the retaining plate **99** on both sides: Insert the pins **100.1** on both sides in point **P68** and secure with a safety locking pin **100.2**, see illustration **69**.
- ▶ Spool winch 3 up until the limit switch **109** turns off further movement of the luffing pulley block.
- ▶ Remove the safety locking pin **101.2** on the S-luffing pulley block **9** on both sides in point **P69** and unpin the pin **101.1**, see illustration **69**.
- ▶ Insert the pin **101.1** in the park position in point **P70** on both sides and secure with the safety locking pin **101.2**, see illustration **69**.

Result:

- The upper and the lower pulley block are held by the control rope.
- ▶ Spool winch 3 out until the limit switch **109** is turned on again.

Result:

- Spooling up winch 3, spooling up as well as spooling out winch 4 is released.

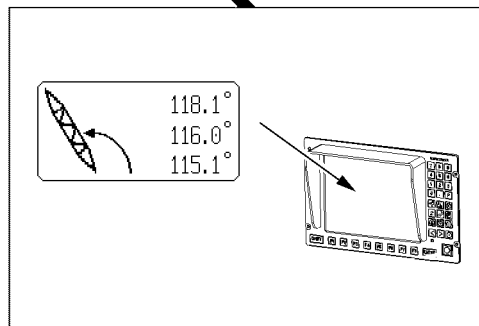
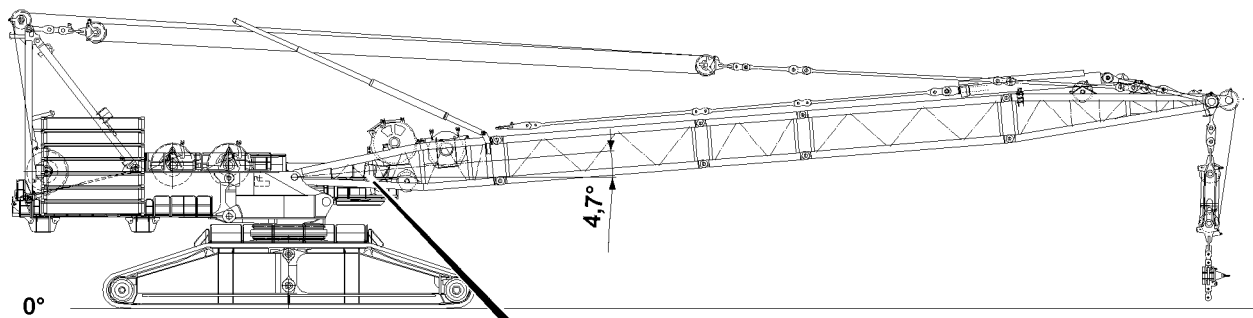

Fig.117573

LWE/LR 13000-001/19503-01-02/en

3.18 Checking the function of the safety equipment



WARNING

Malfunctioning safety equipment!

If the function of the safety equipment is defective, personnel can be severely injured or killed.

- ▶ Crane operation with non-functioning safety equipment is **prohibited**.



Note

- ▶ The function of the individual limit switches must be checked before erection.
- ▶ The function of the limit switch initiators must be checked in the test system, see the Diagnostics manual.



Note

- ▶ If a function check on the limit switches or on the safety equipment does not lead to the desired shut-offs, then the plug connections on the connector boxes or the components itself must be checked.
- ▶ If no visible connection errors or component defects can be found, contact **LIEBHERR** Customer Service.

Make sure that the following prerequisites are met:

- All electrical connections have been established.
- The crane engine is running.
- The corresponding operating mode is set on the LICCON monitor.

3.18.1 Checking the D-boom „Steepest position“ limit switch



Note

- ▶ The limit switch functions have to be checked individually before erection.
- ▶ Cover the limit switch initiators on the D-relapse cylinders individually with a metal plate.

Result:

- The spooling up of the hoist winch turns off.
- The „Derrick boom angle“ icon appears on LICCON monitor 1, see illustration.
- The limit switch is functioning.

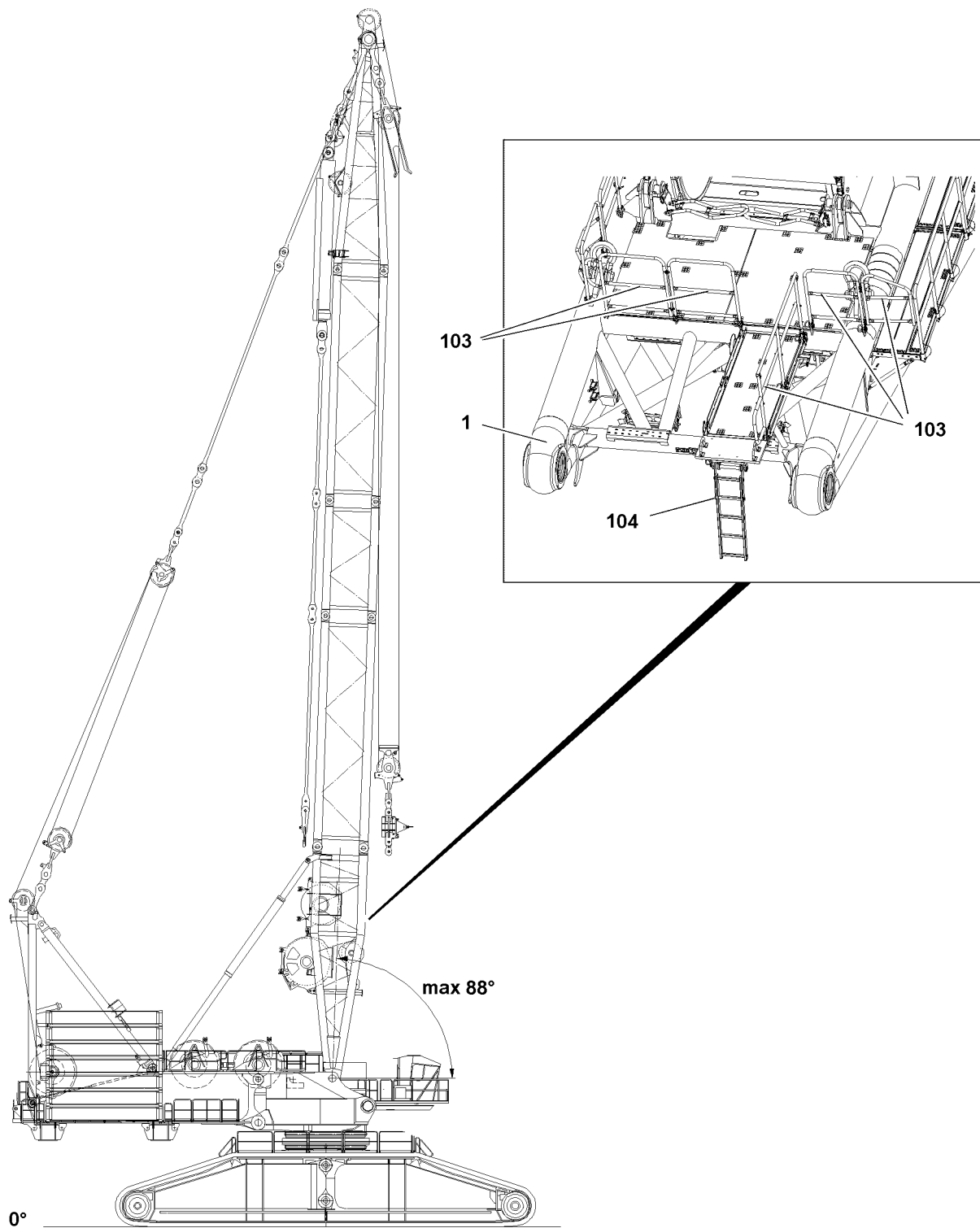

Fig.117574

LWE/LR 13000-001/19503-01-02/en

3.19 Folding the railing on the D-pivot section into the transport position



WARNING

Danger of collision!

If the railings on the D-pivot section are not brought into the transport position before erection, then they can collide with hydraulic lines during erection.

This could result in property damage.

- ▶ The railings on the D-pivot section must be brought into the transport position before erection.
- ▶ Fold the railings **103** into the transport position, see the Crane operating instructions, chapter 2.06.

3.20 Sliding the ladder in on the D-pivot section



WARNING

Danger of collision!

If the ladder on the D-pivot section is not brought into the transport position before erection, then it can collide with hydraulic lines during erection.

This could result in property damage.

- ▶ Make sure to slide the ladder on the D-pivot section in before erection.
- ▶ Slide the ladder **104** in, see the Crane operating instructions, chapter 2.06.

3.21 Erecting the D-boom



WARNING

The crane can topple over!

If the following conditions are not met before erecting the D-boom, the crane can topple over. Personnel can be severely injured or killed.

- ▶ Observe the technical safety instructions, see the Crane operating instructions, chapter 5.01.
- ▶ Extend the D-relapse cylinder before erection.
- ▶ Do not allow slack rope to build up on winch 3.
- ▶ Observe the specifications in the erection and take-down charts.

Make sure that the following prerequisites are met:

- The crane is horizontally aligned.
- All electrical connections have been established.
- All limit switches are functioning.
- The counterweight has been installed on the turntable according to the load chart.
- The pin connections are secured.
- The D-relapse cylinders on the D-pivot section are extended.
- The hoist rope has been correctly inserted in the rope pulleys and is prevented from jumping out with the rope retaining pins.
- The LICCON overload protection has been set according to the data in the load chart.
- The LICCON overload protection settings have been compared with the actual set up configuration.
- The LICCON overload protection is deactivated.
- The assembly icon is visible on the LICCON monitor, see the Crane operating instructions, chapter 4.02 and chapter 4.20.
- No personnel is present in the danger zone.

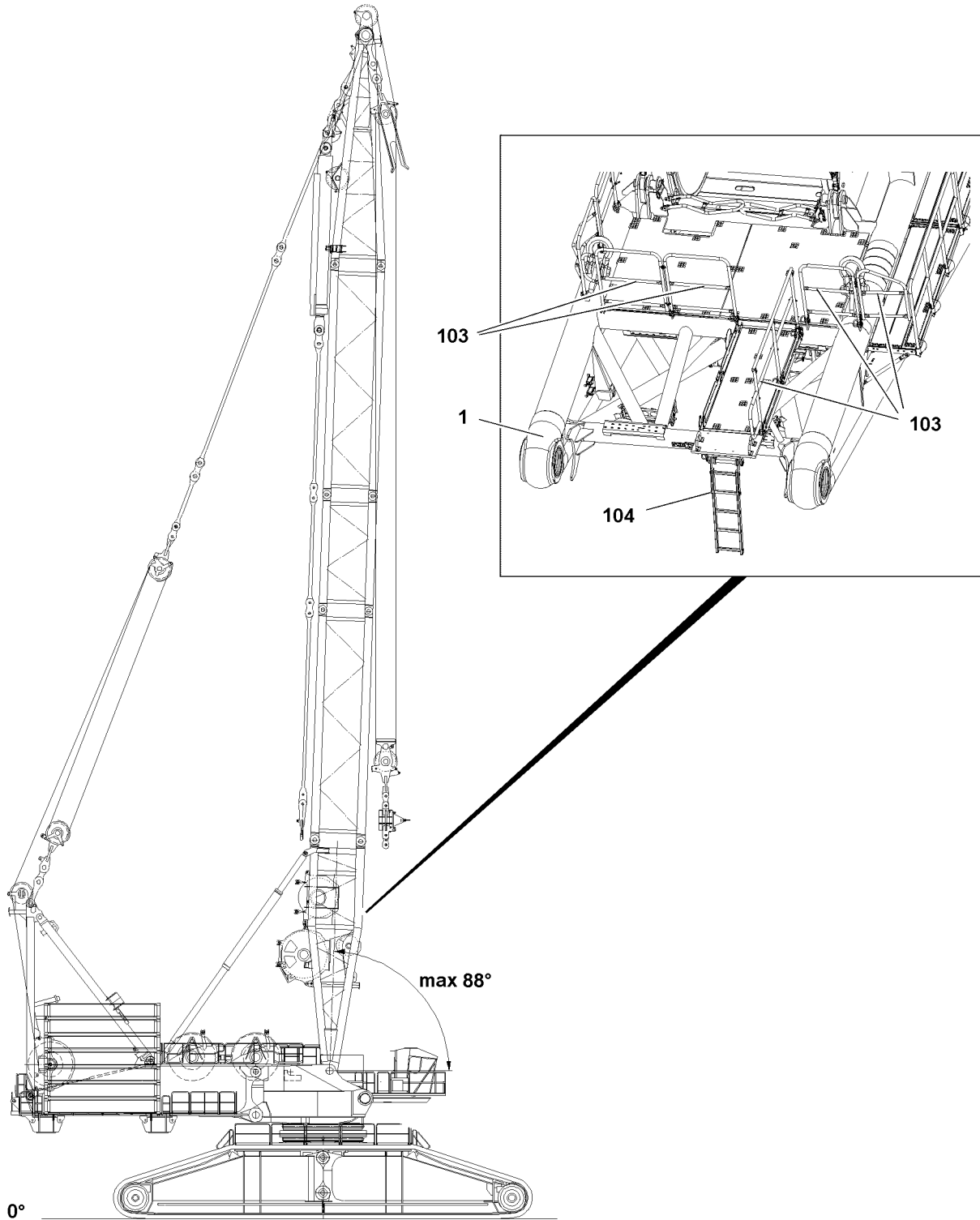

Fig.117574

LWE/LR 13000-001/19503-01-02/en

3.21.1 Erection procedure

Make sure that the following prerequisites are met:

- The D-relapse cylinders are fully extended before erection.
- The control rope of winch 3 is properly reeved on the S-luffing pulley block and properly secured in the rope fixed point.
- The lower pulley block is released.

**Note**

- ▶ During the erection procedure it must be ensured that the D-relapse cylinders engage into the receptacle of the D-relapse retainer.
-

**DANGER**

The crane can topple over!

- ▶ It is prohibited to turn the crane superstructure during the erection procedure.
 - ▶ Do not erect the D-boom further than maximum 88° to the horizontal.
-

**Note**

- ▶ Winch 3 is turned off from a boom angle of 76°.
 - ▶ During the erection procedure, winch 1, winch 2 and the assembly winches must be carried along so that the hoist ropes remain tensioned.
-
- ▶ Actuate winch 4 and erect the D-boom to an angle range of 75° to 85°.

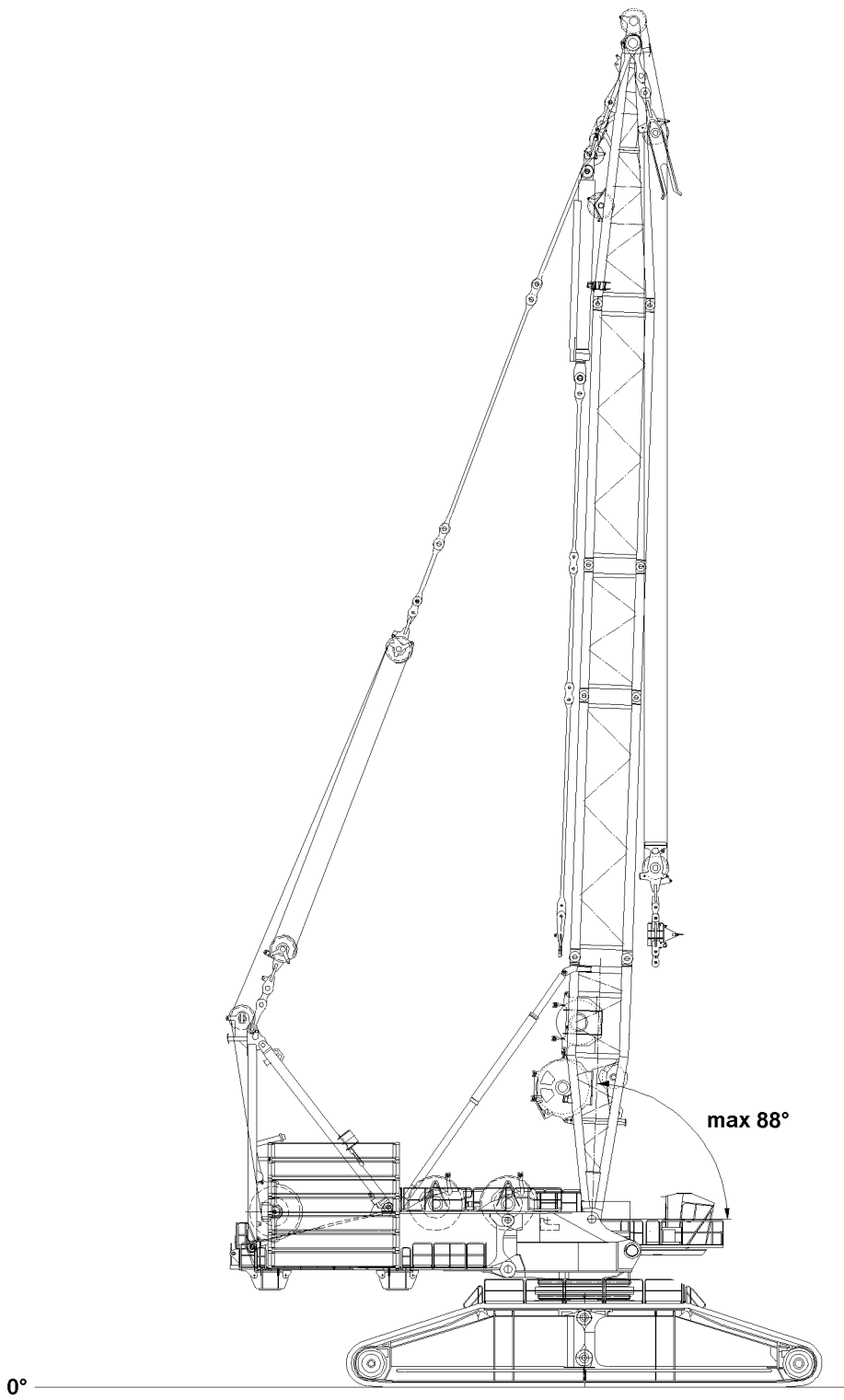

LWE/LR 13000-001/19503-01-02/en

Fig.117576

4 Disassembling the D-boom



WARNING

Danger of falling!

During assembly / disassembly, inspection and maintenance work, assembly personnel must be secured with appropriate aids to prevent them from falling.

If this is not observed, assembly personnel could fall and be killed or seriously injured.

- ▶ All work at a height, when there is a danger of falling, must be carried out with suitable aids.
- ▶ If aids are not available and work cannot be carried out from the ground, then assembly personnel must secure themselves with the supplied fall arrest system to prevent falling, see the Crane operating instructions, chapter 2.04.
- ▶ If fall protection equipment is available, then it must be used, see the Crane operating instructions, chapter 2.06.
- ▶ When lifting, lowering, swinging crane parts in and out, no persons may remain in the danger zone.
- ▶ When closing or opening boom systems during boom assembly or disassembly, no persons may remain on the boom system or in the danger zone.
- ▶ If railings are present on the components, then they must be brought into the corresponding position and secured for assembly / disassembly work.
- ▶ Only step on the aids, ladders and catwalks with clean shoes.
- ▶ Keep aids, ladders and catwalks free of heavy dirt, snow and ice.
- ▶ During all assembly and disassembly work, maintenance work and inspections, travel or crane operation is prohibited.
- ▶ Remaining on a suspended load is prohibited.
- ▶ Stepping or walking on crane components and lattice sections with an incline of more than 20° is prohibited.
- ▶ For all assembly work, the crane driver of the main crane must be in voice contact with the crane driver / crane drivers of the auxiliary crane / auxiliary cranes.
- ▶ For assembly tasks, the crane driver may only initiate crane movements when the responsible guide has explicitly released the movement.

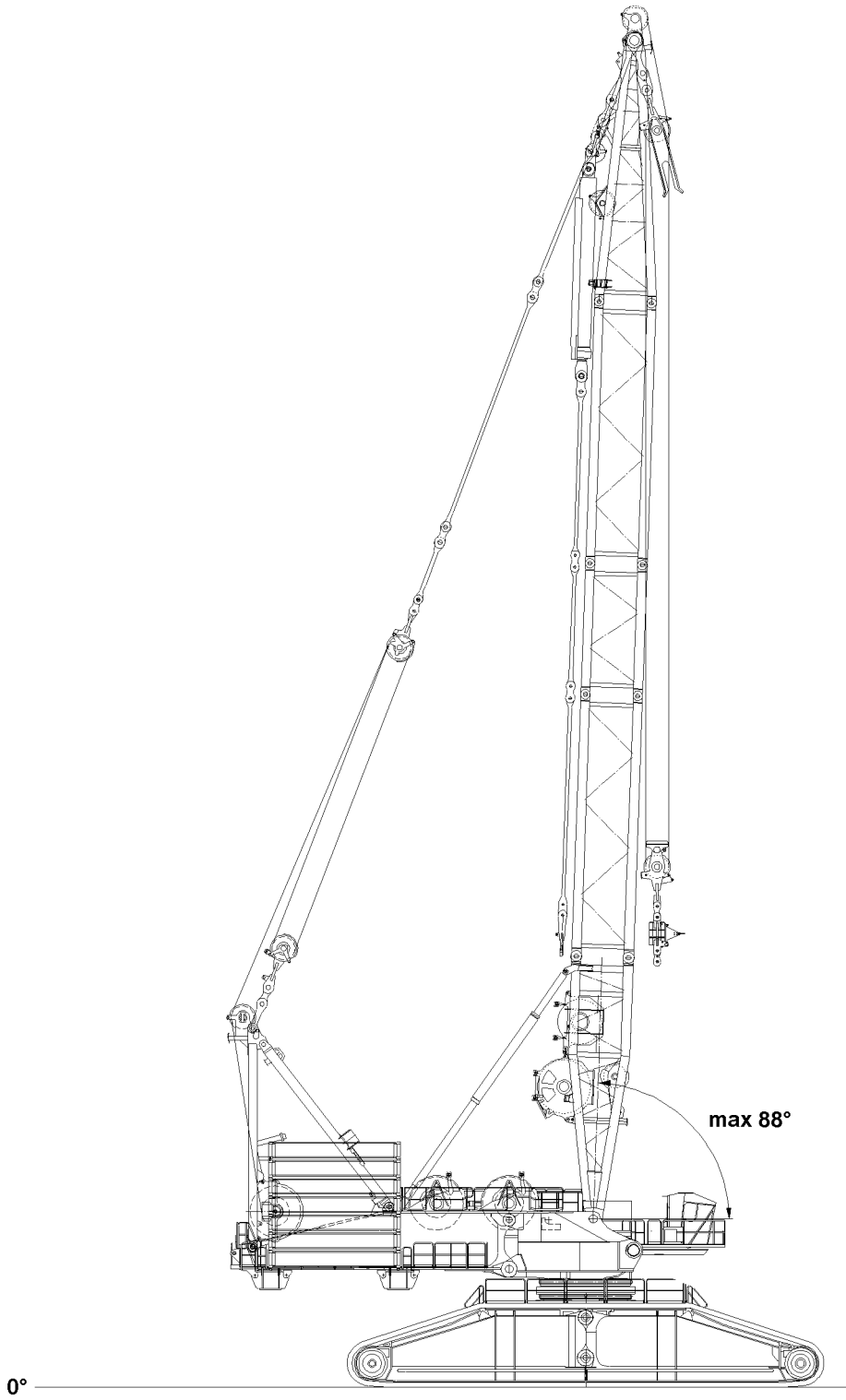

LWE/LR 13000-001/19503-01-02/en

Fig.117576

**WARNING**

Components not pinned and secured!

If a component is released from the auxiliary crane before being pinned and secured, the component will fall down. Personnel can be severely injured or killed.

- ▶ Do not detach the auxiliary crane until the respective component is pinned and secured.

**WARNING**

Danger of impact / crushing!

When assembling / disassembling crane components with the auxiliary crane, crane components can start to swing back and forth.

When lifting / lowering and positioning crane components, there is an increased danger of impact / crushing.

Personnel can be caught and thereby injured or killed.

- ▶ Make sure that personnel cannot be caught by components.
- ▶ When working in danger zones: Use aids to protect limbs.
- ▶ Guide components with suitable aids to minimize oscillation.

**WARNING**

Danger of accident due to interrupted voice and / or visual contact!

If the voice and / or visual contact is interrupted, personnel can be severely injured or killed.

- ▶ Make sure that the crane driver is in constant voice (for example through radio connection) and visual contact with operating and / or assembly personnel during crane or assembly operation.
- ▶ Make sure that the voice and visual contact is not interrupted.
- ▶ If the voice and / or visual contact is interrupted, do not carry out any crane movements or assembly tasks.
- ▶ Re-establish voice and / or visual contact immediately.

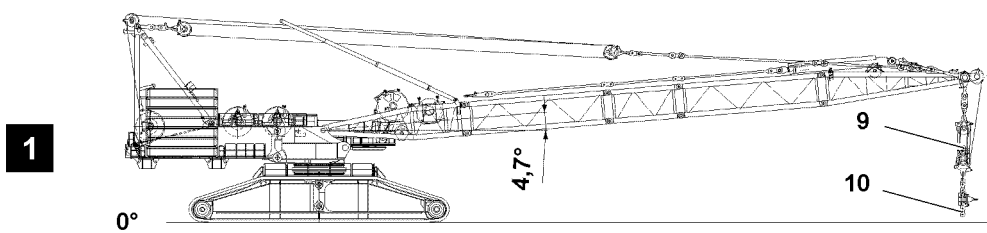
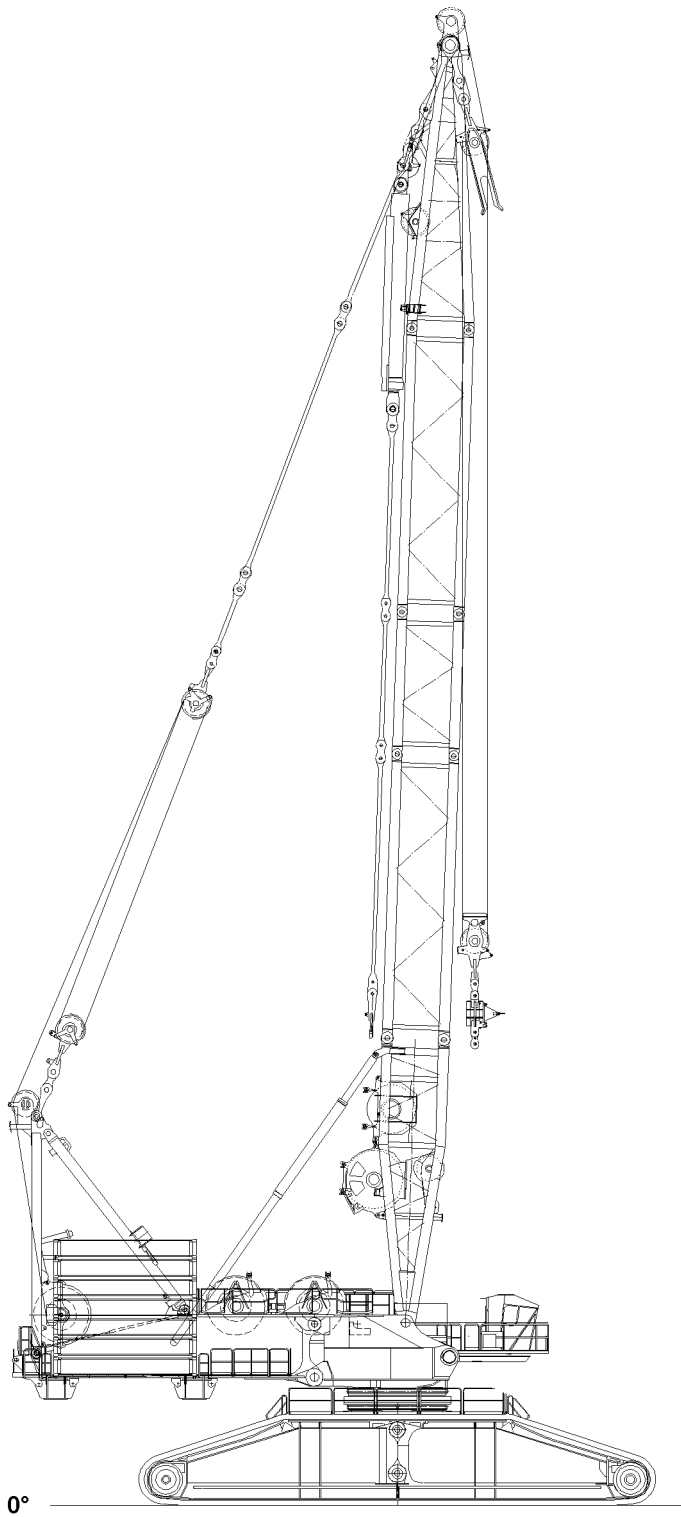

Fig.117575

4.1 Luffing the D-boom down



WARNING

The crane can topple over!

If the following conditions are not met before luffing the D-boom down, the crane can topple over. Personnel can be severely injured or killed.

- ▶ Observe the technical safety instructions, see the Crane operating instructions, chapter 5.01.
- ▶ Observe the specifications in the erection and take-down charts.



Note

- ▶ During disassembly, the turntable can be turned along the longitudinal axle of the crawler travel gear or to the side.

Make sure that the following prerequisites are met:

- The crane is horizontally aligned.
- The S-boom has been removed.
- The LICCON overload protection has been set according to the data in the load chart.
- The LICCON overload protection settings have been compared with the actual set up configuration.
- The LICCON overload protection is deactivated.
- The assembly icon is visible on the LICCON monitor, see the Crane operating instructions, chapter 4.02 and chapter 4.20.
- No personnel is present in the danger zone.

NOTICE

Damage to the S-luffing pulley block!

If the D-boom is luffed down too quickly „to the front“, significant damage can occur on the S-luffing pulley block and on the D-end section.

- ▶ Lower the D-boom carefully to the front.
- ▶ Luff the D-boom down slowly to 4.7° and spool the winch 3 up simultaneously, see illustration 1.

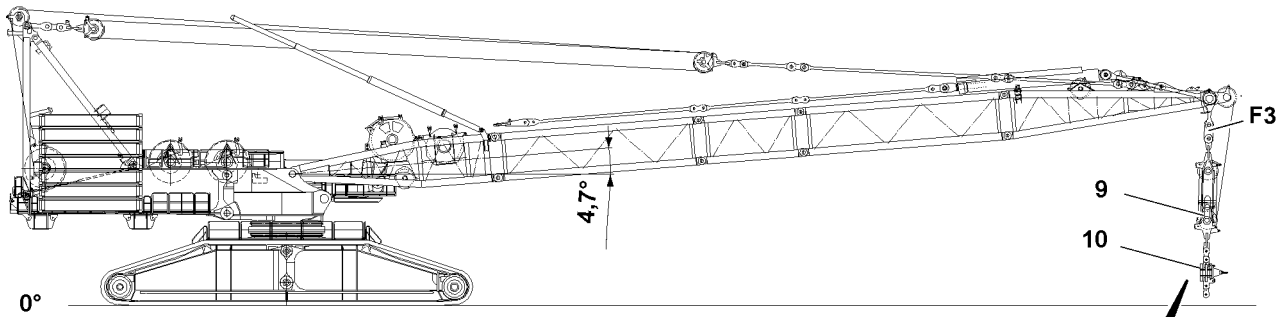

2

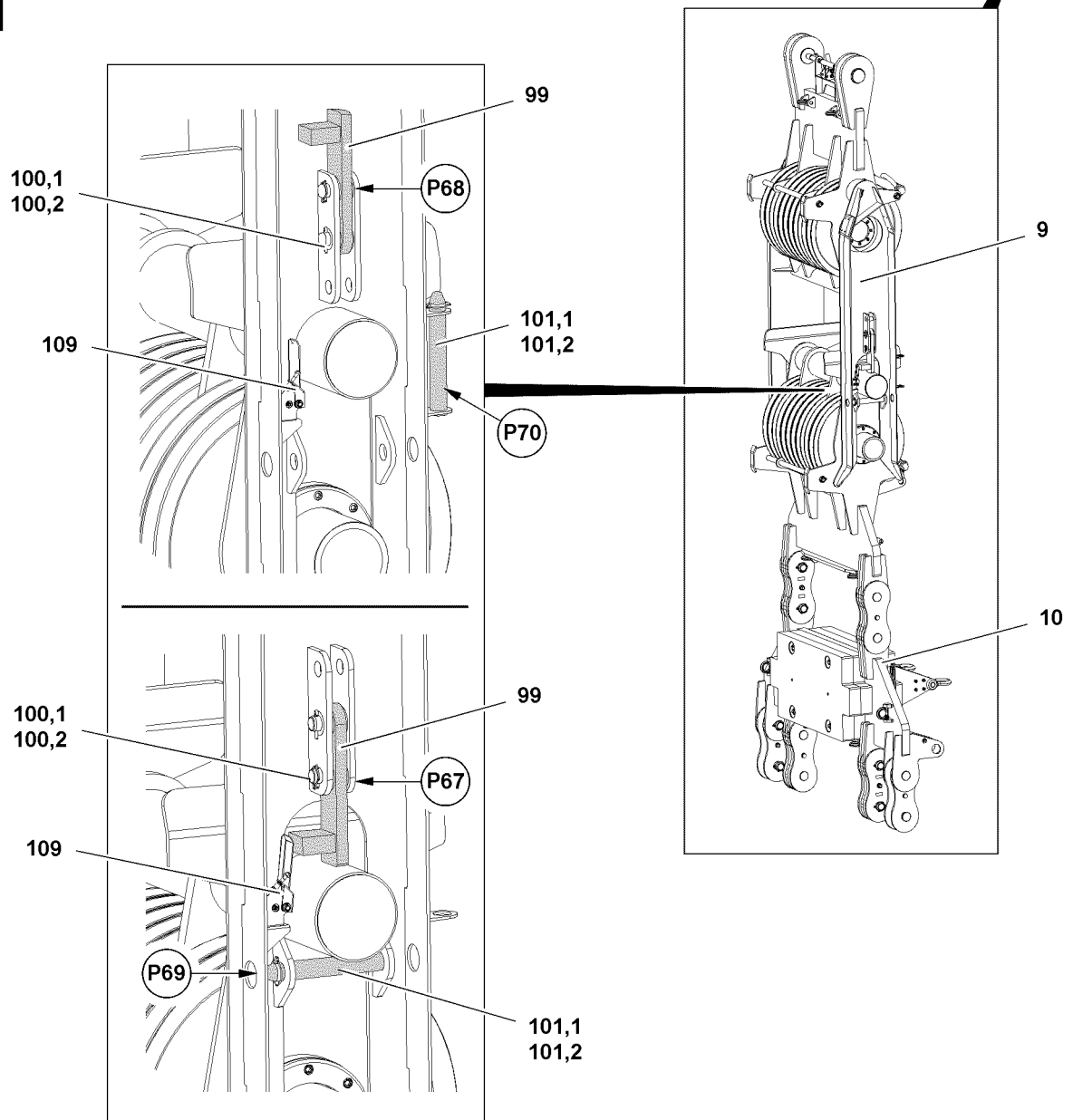

Fig.115620

LWE/LR 13000-001/19503-01-02/en

4.2 Pinning the upper pulley block with the lower pulley block

NOTICE

Danger of property damage on the S-luffing pulley block!

If the D-boom is luffed down too quickly, then significant property damage can occur on the upper as well as the lower pulley block.

- ▶ Always use a guide when connecting the upper and lower pulley block.
- ▶ Carry out all crane movements slowly and with utmost caution.



Note

- ▶ If the limit switches are actuated, then the spooling up of winch 3, spooling up as well as spooling out of winch 4 is unbypassably turned off.
 - ▶ It is possible to bypass the limit switch only if the limit switches are unplugged and the dummy plugs is inserted and F3 is less than 8 t.
-
- ▶ Pull the S-luffing pulley block together until the limit switches **109** turn off further movement of the luffing pulley blocks.

Result:

- The pin **101.1** can be pinned.
- ▶ Remove the safety locking pin **101.2** on both sides in point **P70** and unpin the pin **101.1**, see illustration **2**.
- ▶ Insert the pin **101.1** in the transport position in point **P69** on both sides and secure with the safety locking pin **101.2**, see illustration **2**.
- ▶ Spool winch 3 out until the lower pulley block is lying on the pins **101.1**.
- ▶ Remove the safety locking pin **100.2** on both sides in point **P68** and unpin the pin **100.1**, see illustration **2**.
- ▶ Swing the retaining plate **99** downward on both sides.

Result:

- The limit switches **109** are actuated.
- ▶ Unplug the limit switches **109** and insert dummy plugs.

Result:

- Spooling up winch 3, spooling up as well as spooling out winch 4 is released.
- ▶ Secure the retaining plate **99** on both sides: Insert the pins **100.1** on both sides in point **P67** and secure with a safety locking pin **100.2**, see illustration **2**.

Result:

- The upper pulley block is connected with the lower pulley block.

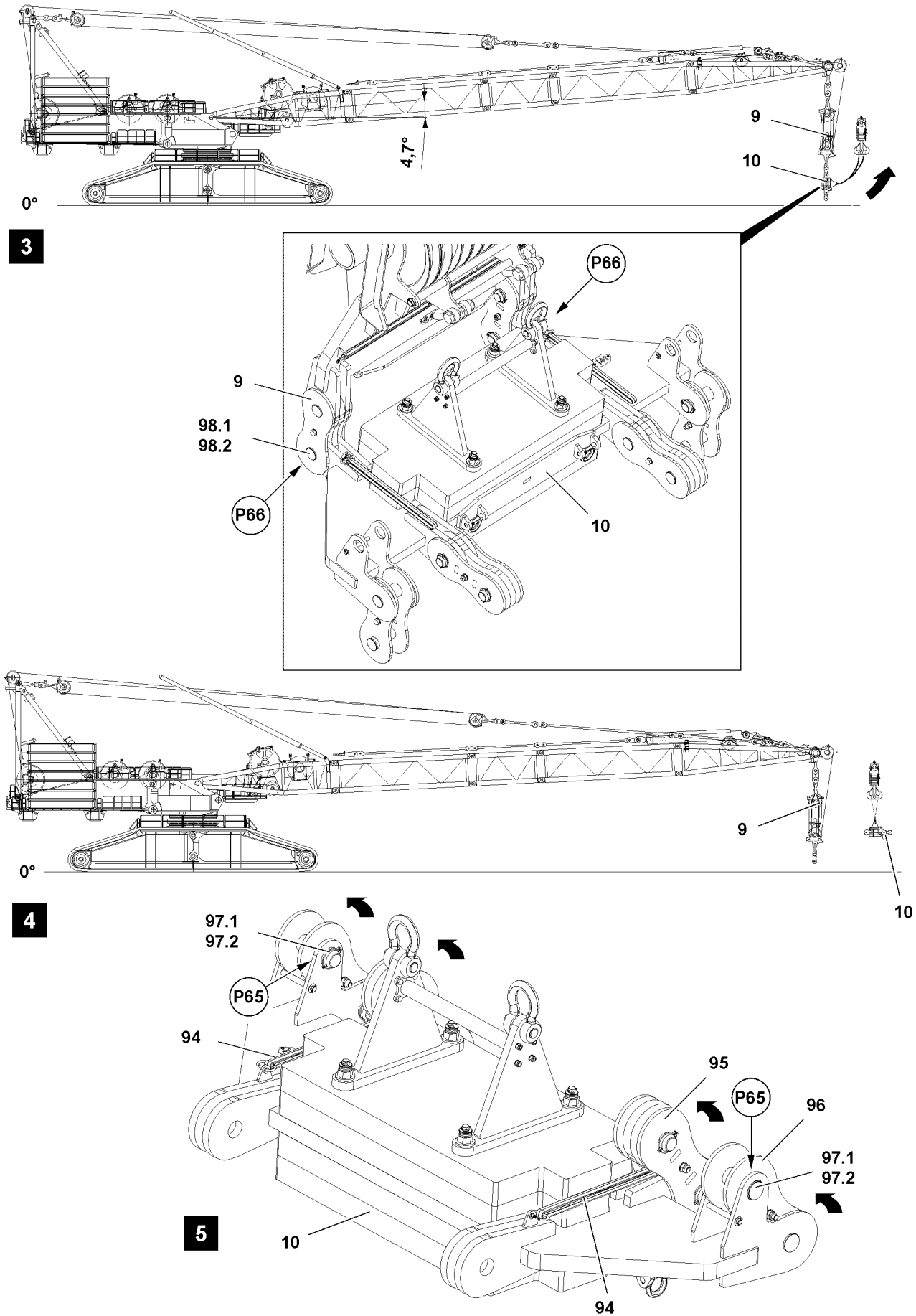

Fig.115621

LWE/LR 13000-001/19503-01-02/en

4.3 Disassembling the weight

Make sure that the following prerequisite is met:

- The upper pulley block is connected with the lower pulley block.

4.3.1 Unpinning the weight

- ▶ Fasten the weight **10** to the auxiliary crane in the fastening points, see section „Fastening points for derrick components“.
- ▶ Slowly pull the weight **10** up with the auxiliary crane, see illustration **3**.



WARNING

Swinging weight!

When releasing the pin connection in point **P66**, the weight **10** can swing forward uncontrolled. Personnel can be severely injured or killed.

- ▶ Make sure that there is no personnel in the danger zone.
 - ▶ Assembly personnel must be to the side of the assembly unit.
 - ▶ Do not reach with your hands into the danger zone.
-
- ▶ Remove the safety locking pin **98,2** on both sides in point **P66** on the S-luffing pulley block **9** and unpin the pin **98.1**.
 - ▶ Remove the weight with the auxiliary crane, see illustration **4**.
 - ▶ Insert the pin **98,1** again on both sides in point **P66** and secure with the safety locking pin **98,2**.

4.3.2 Swinging the brackets



WARNING

Danger of accident when swinging out the bracket!

When swinging out the bracket, limbs can be crushed or severed.

Personnel can be severely injured.

- ▶ Make sure that there is no personnel in the danger zone.
 - ▶ Do not reach with your hands into the danger zone.
-
- ▶ Release the round sling **94** with the carabiner in parking position on the S-luffing pulley block.
 - ▶ Swing the brackets **95** on both sides into the transport position to the stop.
 - ▶ Secure the brackets **95** on both sides with the round sling **94** in the transport position, see illustration **5**.
 - ▶ Remove the safety locking pin **97,2** on both sides and unpin the pin **97.1**.
 - ▶ Swing the brackets **96** upward, see illustration **5**.
 - ▶ Secure the brackets **96** in the transport position: Insert the pins **97.1** on both sides in point **P65** and secure with a safety locking pin **97,2**, see illustration **5**.

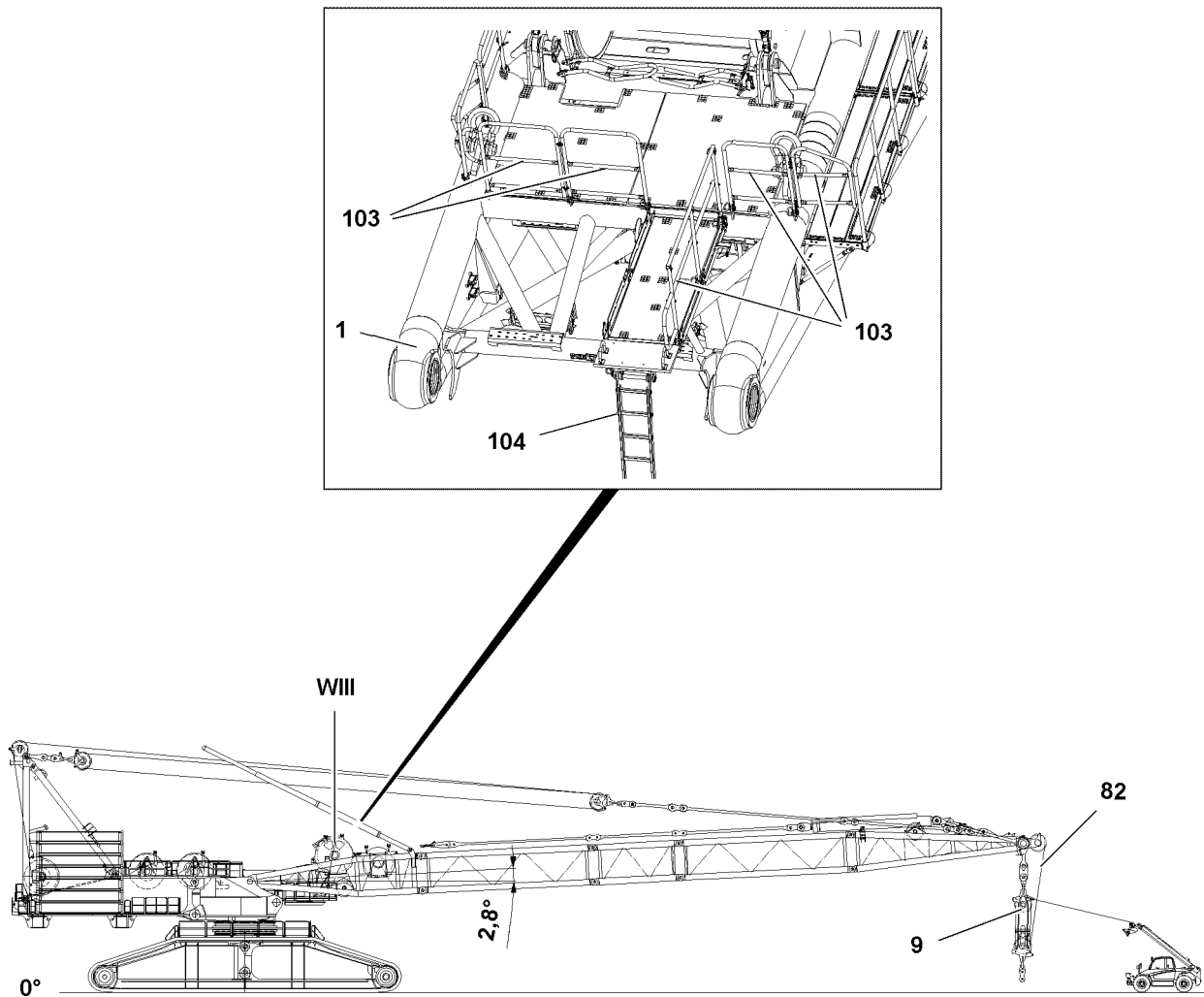

Fig.115622

4.4 Pulling out the ladder on the D-pivot section

- ▶ Luff the D-boom slowly down to 2.8°.



Note

- ▶ Pull the ladder on the D-pivot section out for disassembly, see the Crane operating instructions, chapter 2.06.

- ▶ Pull the ladder out.

4.5 Swinging the railings on the D-pivot section into the operating position



Note

- ▶ Swing the railings on the D-pivot section into the operating position, see the Crane operating instructions, chapter 2.06.

4.6 Reeving the S-luffing pulley block out

Make sure that the following prerequisites are met:

- The weight is disassembled.
- The upper pulley block is connected with the lower pulley block.
- ▶ Remove the rope **82** of winch 3 on the lock on the S-luffing pulley block **9**.
- ▶ Connect the auxiliary rope of the telescopic lift truck with the rope **82** of winch 3.



Note

- ▶ Monitor the rope run during the entire procedure.
- ▶ The driver of the telescopic lift truck must be in constant acoustic contact with the crane operator.



WARNING

Danger of slack rope formation!

When spooling the rope out, slack rope can form.

- ▶ The rope must be slightly tensioned during the entire pulling procedure.
- ▶ Reeve the S-luffing pulley block **9** out: Spool winch 3 up and simultaneously spool the auxiliary winch of the telescopic lift truck out.

When the rope **82** of winch 3 is completely spooled up and secured on winch 3:

- ▶ Spool the auxiliary rope up.

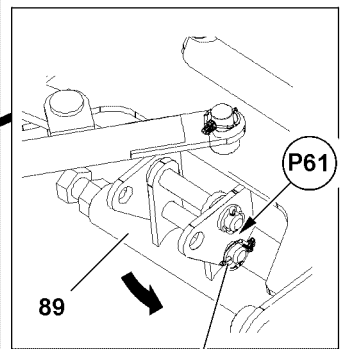
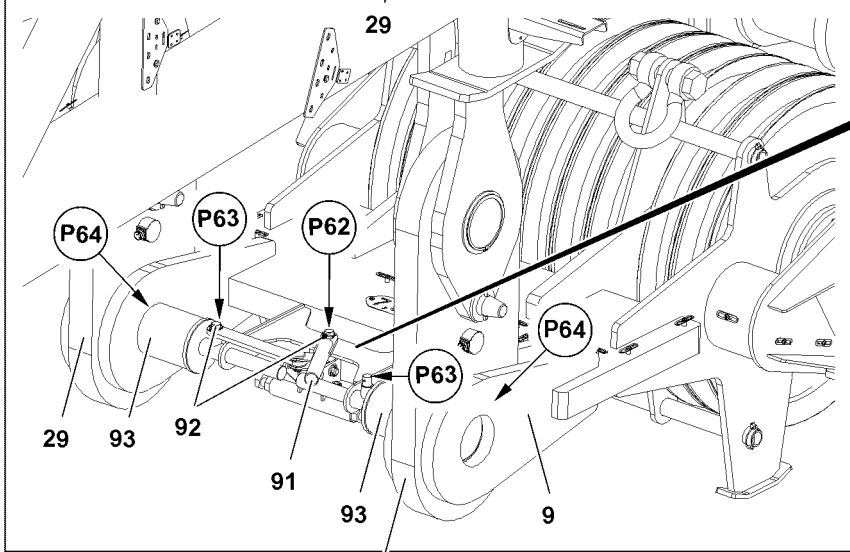
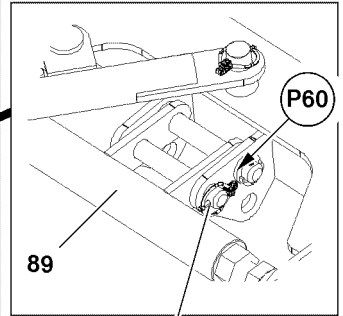
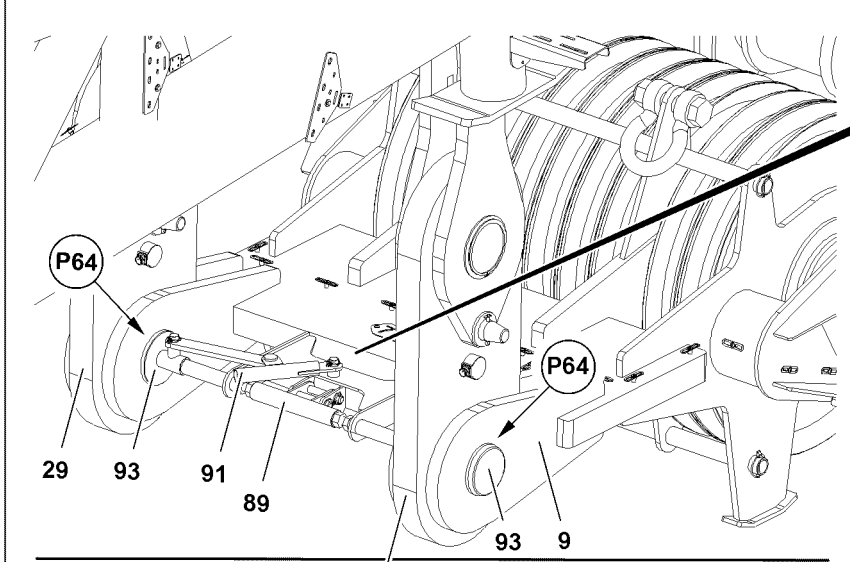
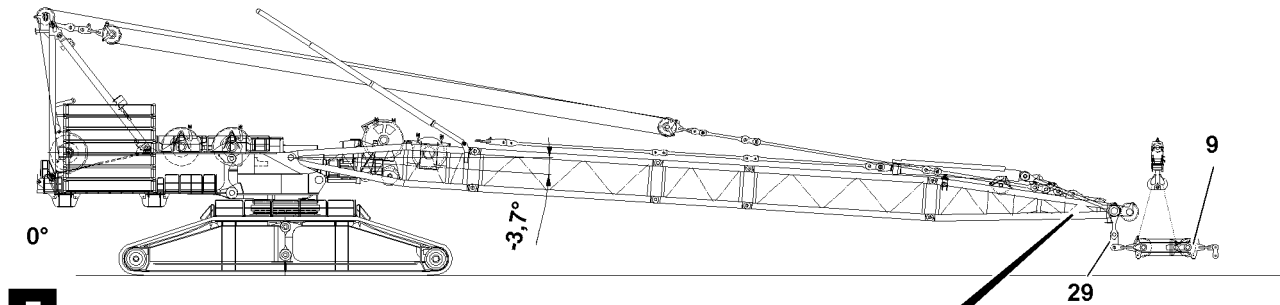
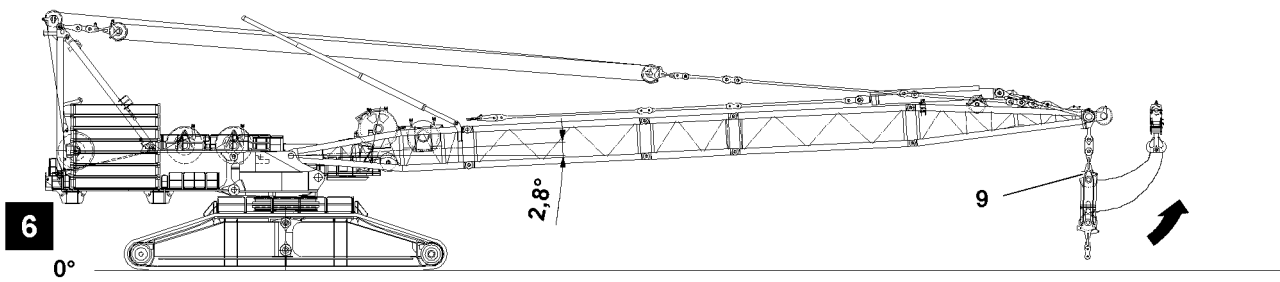

Fig.115623

LWE/LR 13000-001/19503-01-02/en

4.7 Disassembling the S-luffing pulley block

Make sure that the following prerequisite is met:

- The S-luffing pulley block is reeved out.

4.7.1 Unpinning the S-luffing pulley block

- ▶ Fasten the S-luffing pulley block **9** to the auxiliary crane on the fastening points, see section „Fastening points for derrick components“.
- ▶ Slowly pull the S-luffing pulley block **9** up with the auxiliary crane, see illustration **6**.

When the S-luffing pulley block **9** is pulled up:

- ▶ Luff the D-boom down to approx. -3.7° until the pull test brackets **29** are approximately 1.5 m above the ground, see illustration **7**.



WARNING

Danger of accident when swinging in the bracket!
When swinging in the bracket, limbs can be crushed.
Personnel can be severely injured.

- ▶ Do not reach with your hands into the danger zone.

- ▶ Release the pin **93**: Remove the safety locking pin **90,2** in point **P60** and unpin the pin **90,1**.
- ▶ Swing the bracket **89** down, see illustration **7**.
- ▶ Secure the bracket **89** in the park position: Insert the pin **90,1** in point **P61** and secure with the safety locking pin **90,2**, see illustration **7**.



Note

- ▶ To obtain a better level action when actuating the lever **91**, an extension pipe can be used.

- ▶ Operate the lever **91**.

Result:

- The pin **93** is unpinned, see illustration **7**.
- ▶ Remove the safety locking pin **92** in point **P62** and in point **P63**, lift and turn the lever **91**.
- ▶ Position the lever **91** inversely on the second pin **93** and secure again in point **P62** and in point **P63**.
- ▶ Unpin the second pin **93**.

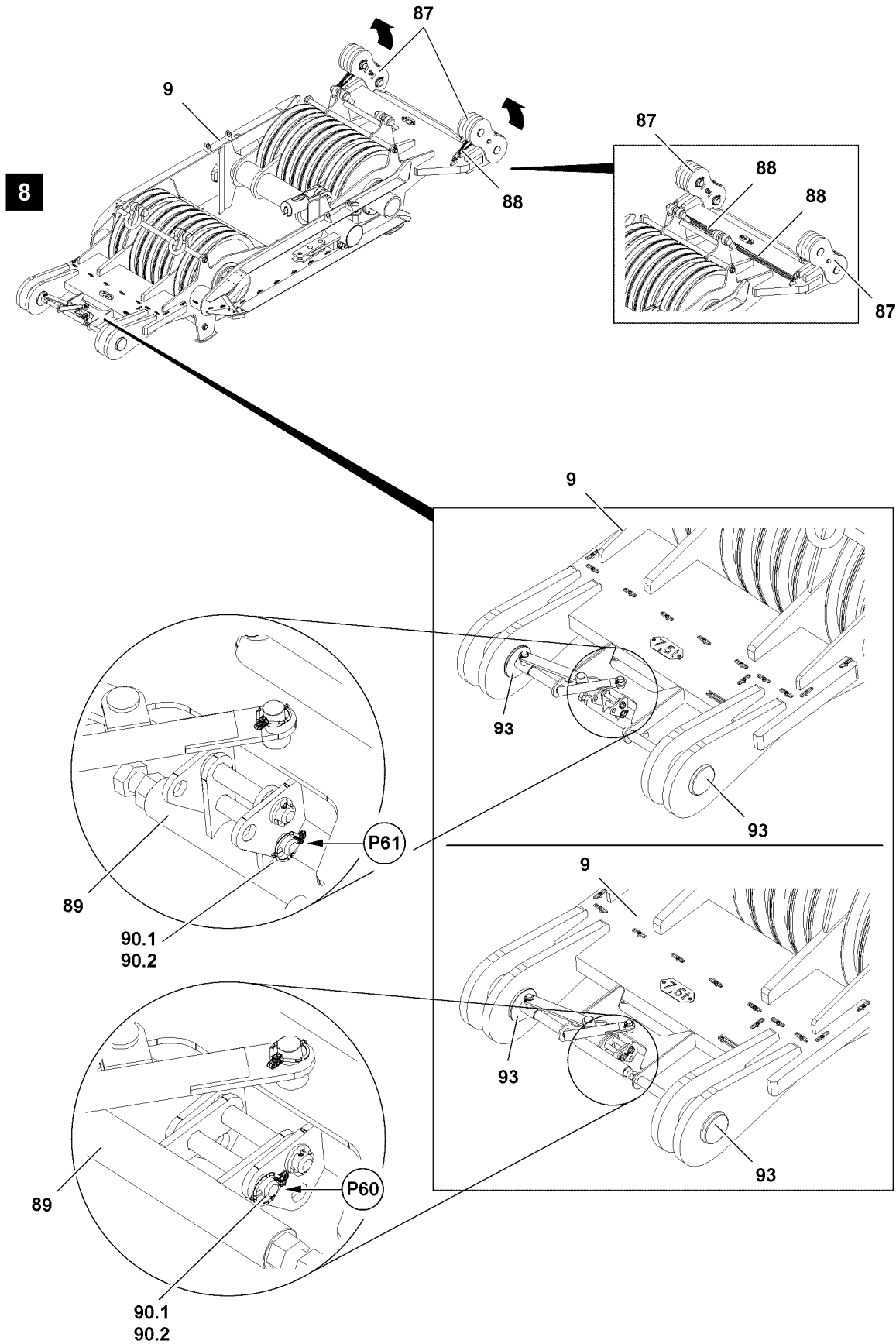

Fig.115624

LWE/LR 13000-001/19503-01-02/en

4.7.2 Securing the pins in the transport position

- ▶ Remove the safety locking pin **90,2** in point **P61** and unpin the pin **90,1**.
- ▶ Swing the bracket **89** up, see illustration **8**.
- ▶ Secure the brackets **89**: Insert the pin **90,1** in point **P60** and secure with the safety locking pin **90,2**, see illustration **8**.

Result:

- The pins **93** are secured.

4.7.3 Swinging the brackets into the transport position



WARNING

Danger of accident when swinging in the bracket!

When swinging in the bracket, limbs can be crushed or severed.

Personnel can be severely injured.

- ▶ Make sure that there is no personnel in the danger zone.
 - ▶ Do not reach with your hands into the danger zone.
-
- ▶ Open the carabiner on both sides and remove the round sling **88** from the park position.
 - ▶ Swing the brackets **87** up on both sides into the transport position to the stop, see illustration **8**.
 - ▶ Secure the brackets **87** on both sides with the round sling **88** in the transport position, see illustration **8**.

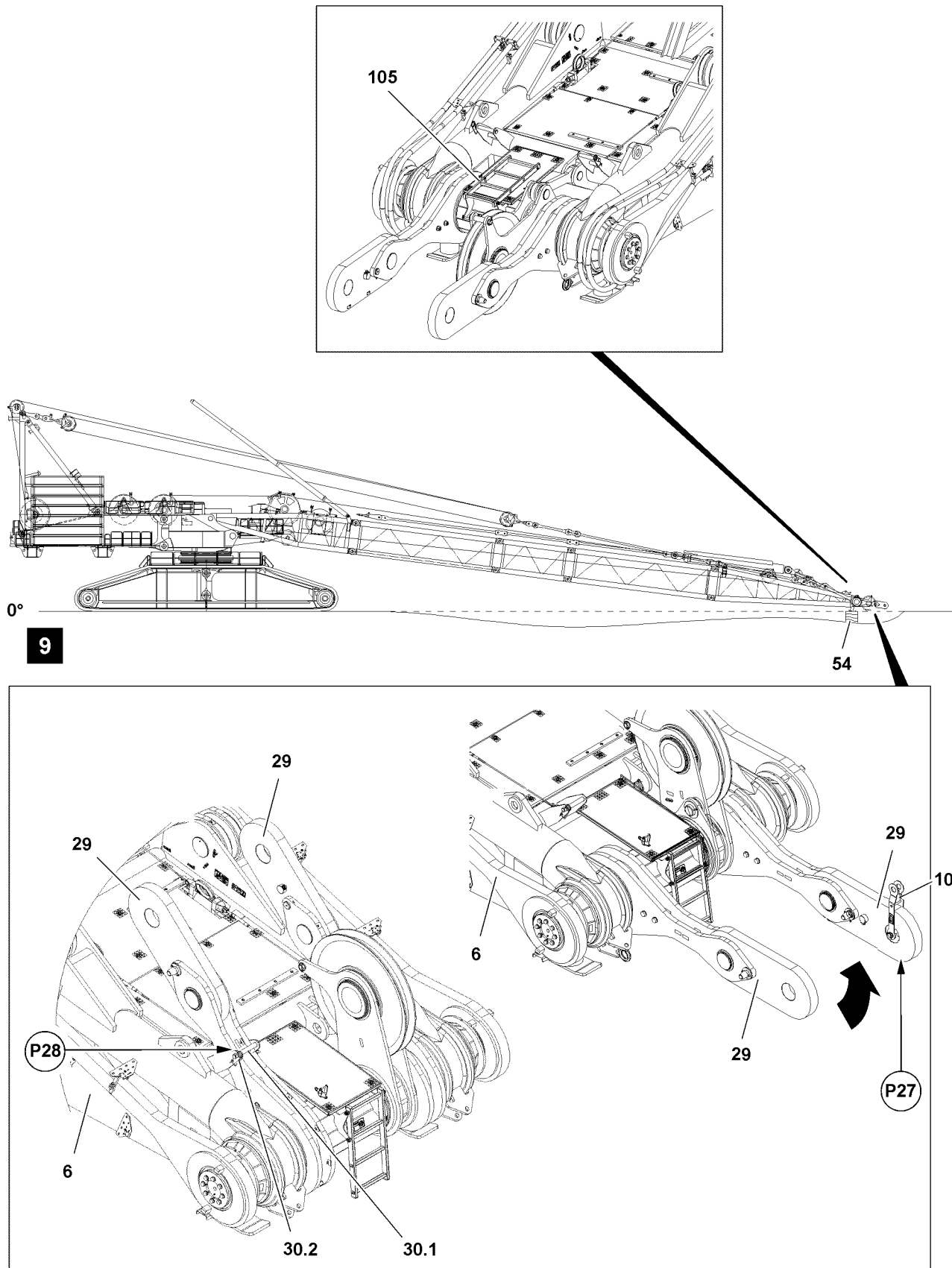

LWE/LR 13000-001/19503-01-02/en

Fig.115625

4.8 Swinging the ladder on the D-end section



WARNING

Overload of the crane!

If the D-boom is lying below the alignment level during placement, then the crane will be overloaded.

- ▶ Build up the substructure **54** to the alignment level.



Note

- ▶ Swing the ladder on the D-end section for disassembly, see the Crane operating instructions, chapter 2.06.

- ▶ Take the D-boom down on the substructure **54**.

4.9 Swinging the pull test bracket into the transport position

- ▶ Remove the spring retainer **30.2** in point **P28** and unpin the pin **30.1**, see illustration **9**.

NOTICE

Pull test bracket incorrectly fastened!

Due to incorrect or improper fastening of the pull test bracket, the pull test bracket can be damaged.

Malfunctions of the pull test bracket can be the result.

- ▶ Fasten the pull test bracket only with the bracket **106** to the auxiliary crane.
- ▶ Release the bracket **106** from the transport position: see section „Swinging the pull test bracket into the operating position“.
- ▶ Remove the bracket **106** from the retainer.
- ▶ Pin the bracket **106** in point **P27** with the pull test bracket **29**: see section „Swinging the pull test bracket into the operating position“, see illustration **9**.
- ▶ Fasten the bracket **106** to the auxiliary crane.



WARNING

Danger of accident when swinging in the pull test bracket!

When swinging in the pull test bracket **29**, limbs can be crushed or severed.

Personnel can be severely injured.

- ▶ Make sure that there is no personnel in the danger zone.
- ▶ Do not reach with your hands into the danger zone.
- ▶ Swing the pull test bracket **29** and take it down in the receptacle, see illustration **9**.
- ▶ Secure the pull test bracket **29**: Insert the pin **30.1** in point **P28** and secure with the spring retainer **30.2**, see illustration **9**.
- ▶ Remove the auxiliary crane and unpin the bracket **106**.
- ▶ Swing the second pull test bracket.

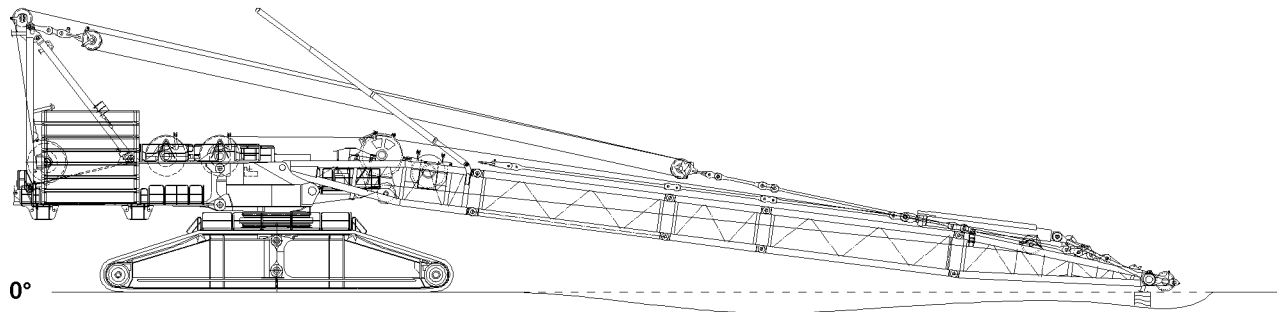

Fig.115626

LWE/LR 13000-001/19503-01-02/en

4.10 Disconnecting the electrical connections

- ▶ Disconnect all electrical connections on the D-boom properly and store the plug and cable properly.

4.11 Disconnecting the hydraulic connections

The hydraulic connections are established with quick couplings.

When disconnecting hydraulic lines with quick couplings, make sure that the uncoupling procedure is carried out correctly.



WARNING

Pressure in the hydraulic lines!

If the pressure supply is not interrupted before connecting / releasing the hydraulic lines, the hydraulic oil can escape with high pressure.

Death, severe bodily injuries, property damage.

- ▶ Release the pressure in the hydraulic system before connecting / disconnecting: Interrupt the pressure supply and wait a short time.
-
- ▶ Release the hydraulic coupling by hand.
 - ▶ Disconnect the hydraulic connection.

10

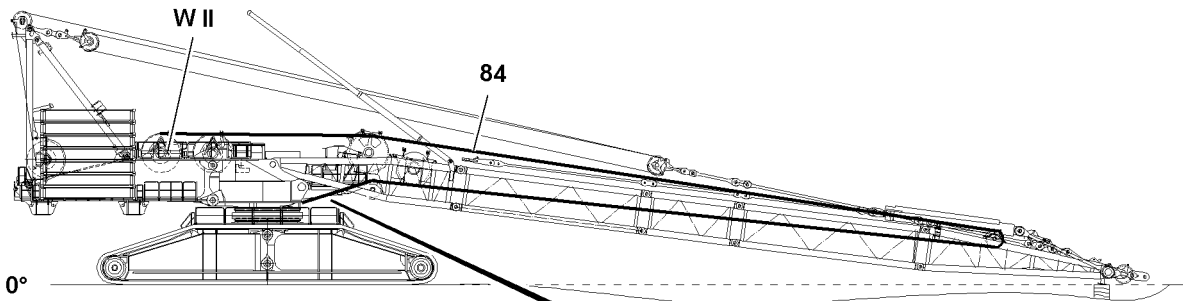

0°

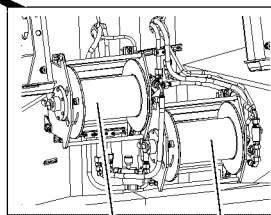

60.1 60.2

11

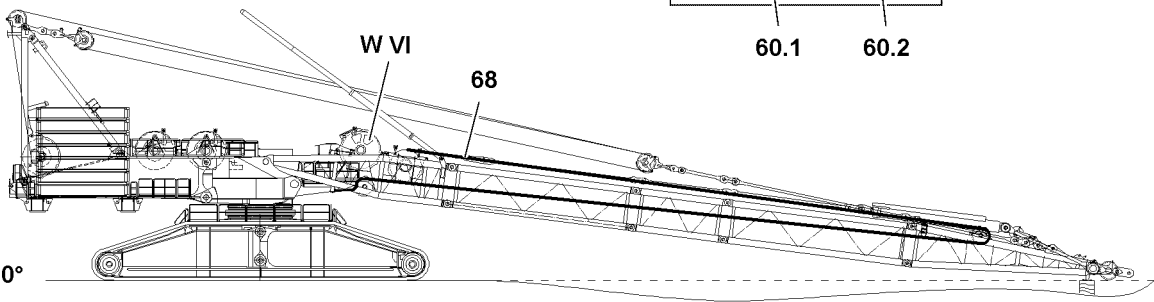

0°

12

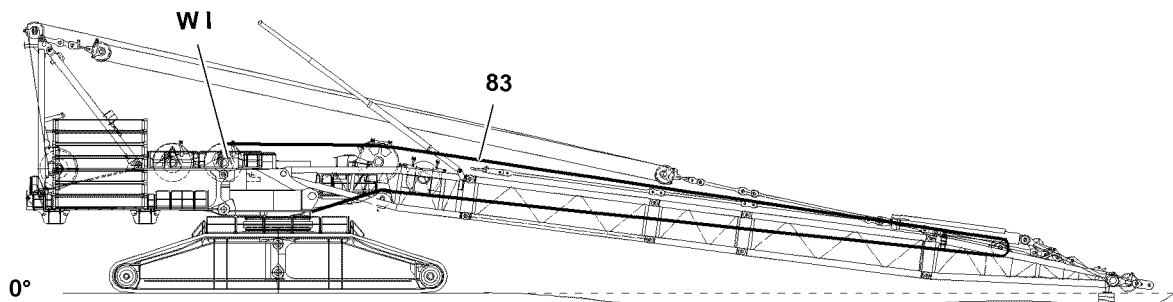

0°

Fig.115627

LWE/LR 13000-001/19503-01-02/en

4.12 Reeving the ropes out

4.12.1 Reeving the rope of winch 2 out

- ▶ Release the rope **84** of winch 2 on the assembly winch **60.2**.
- ▶ Connect the assembly rope of the assembly winch **60.2** with the rope **84** of winch 2.



WARNING

Danger of slack rope formation!

When spooling the rope out, slack rope can form.

- ▶ The rope must be slightly tensioned during the entire pulling procedure.

- ▶ Reeve out the rope **84** of winch 2: Spool winch 2 up and simultaneously spool the assembly winch **60.2** out.
- ▶ Disconnect the assembly rope of the assembly winch **60.2** from the rope **84** of winch 2.

When the rope **84** of winch 2 is completely spooled up and secured on winch 2:

- ▶ Spool the assembly winch **60.2** up, see illustration **10**.

4.12.2 Reeving the rope of winch 6 out

- ▶ Release the rope **68** of winch 6 on the D-boom.
- ▶ Connect the assembly rope of the assembly winch **60.2** with the rope **68** of winch 6.



WARNING

Danger of slack rope formation!

When spooling the rope out, slack rope can form.

- ▶ The rope must be slightly tensioned during the entire pulling procedure.



Note

- ▶ Reeving the rope **68** of winch 6 out is the same as the work steps of the previously described reeving of the rope **84** from winch 2.

When the rope **68** of winch 6 is completely spooled up and secured on winch 6:

- ▶ Spool the assembly winch **60.2** up, see illustration **11**.

4.12.3 Reeving the rope of winch 1 out

- ▶ Release the rope **83** of winch 1 on the assembly winch **60.1**.
- ▶ Connect the assembly rope of the assembly winch **60.1** with the rope **83** of winch 1.



WARNING

Danger of slack rope formation!

When spooling the rope out, slack rope can form.

- ▶ The rope must be slightly tensioned during the entire pulling procedure.



Note

- ▶ Reeving the rope **83** of winch 1 out is the same as the work steps of the previously described reeving of the rope **84** from winch 2.

When the rope **83** of winch 1 is completely spooled up and secured on winch 1:

- ▶ Spool the assembly winch **60.1** up, see illustration **12**.

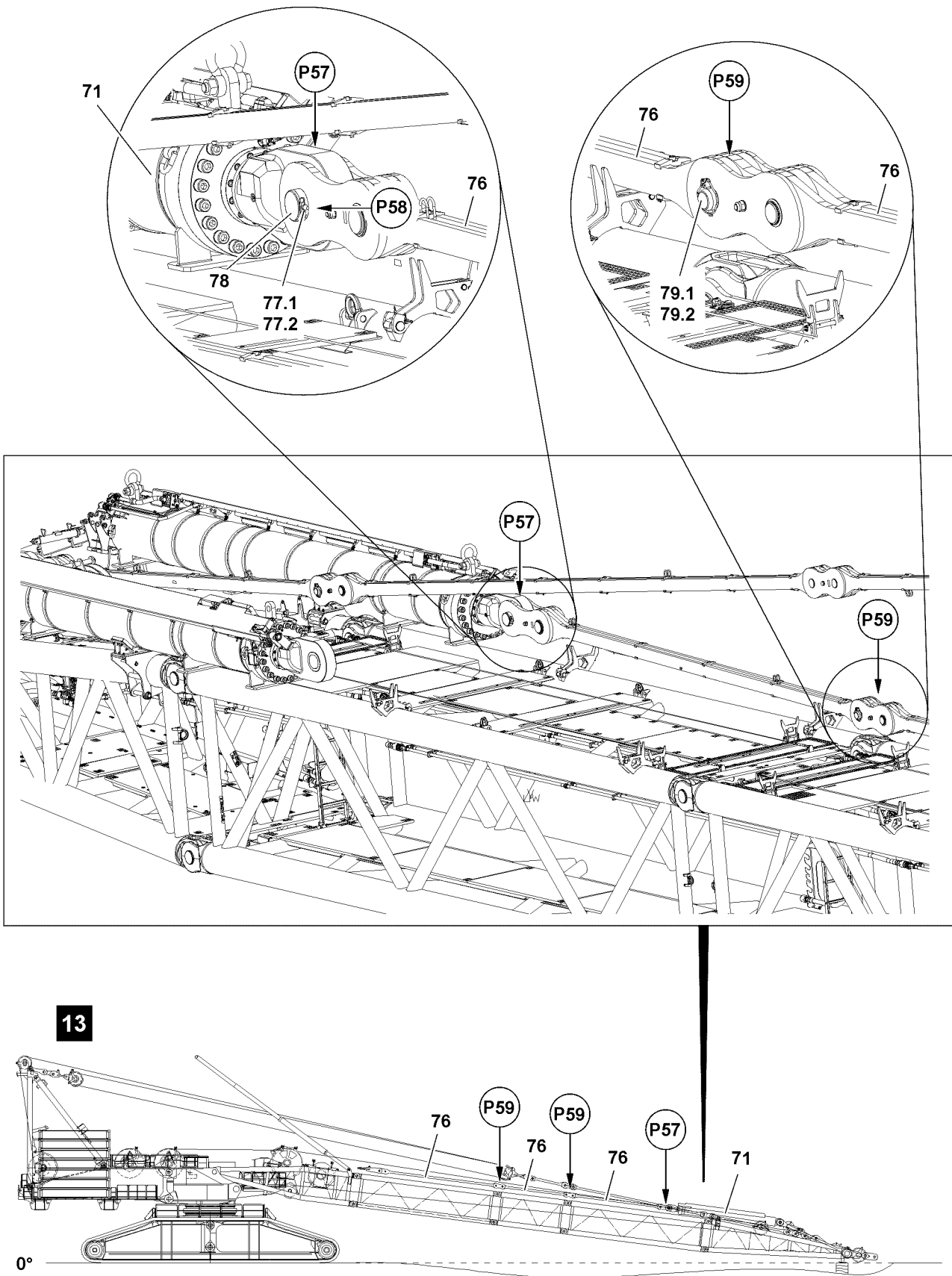

LWE/LR 13000-001/19503-01-02/en

Fig.115628

4.13 Disassembling the ballast rods and pull cylinder

4.13.1 Unpinning the ballast rods



WARNING

Danger of accident during unpinning!

When unpinning the ballast rods **76**, limbs can be crushed or severed.

Personnel can be severely injured.

- ▶ Do not reach with your hands into the danger zone.
-

- ▶ Fasten the ballast rods **76** to the auxiliary crane.
- ▶ Unpin the ballast rods **76** in point **57**: Remove the spring retainer **77.2** and unpin the pin **77.1**.

Result:

- The pin **78** is released.
- ▶ Unpin the pin **78**.
- ▶ Remove the safety locking pin **76.2** in point **P59** and unpin the pin **76.1**, see illustration **13**.
- ▶ Remove the ballast rod **76** with the auxiliary crane.
- ▶ Unpin the ballast rod **76** in points **P59**: Remove the safety locking pin **76.2** and unpin the pin **76.1**, see illustration **13**.
- ▶ Remove the ballast rod **76** with the auxiliary crane.
- ▶ Unpin the ballast rods **76** on both sides and remove with the auxiliary crane.

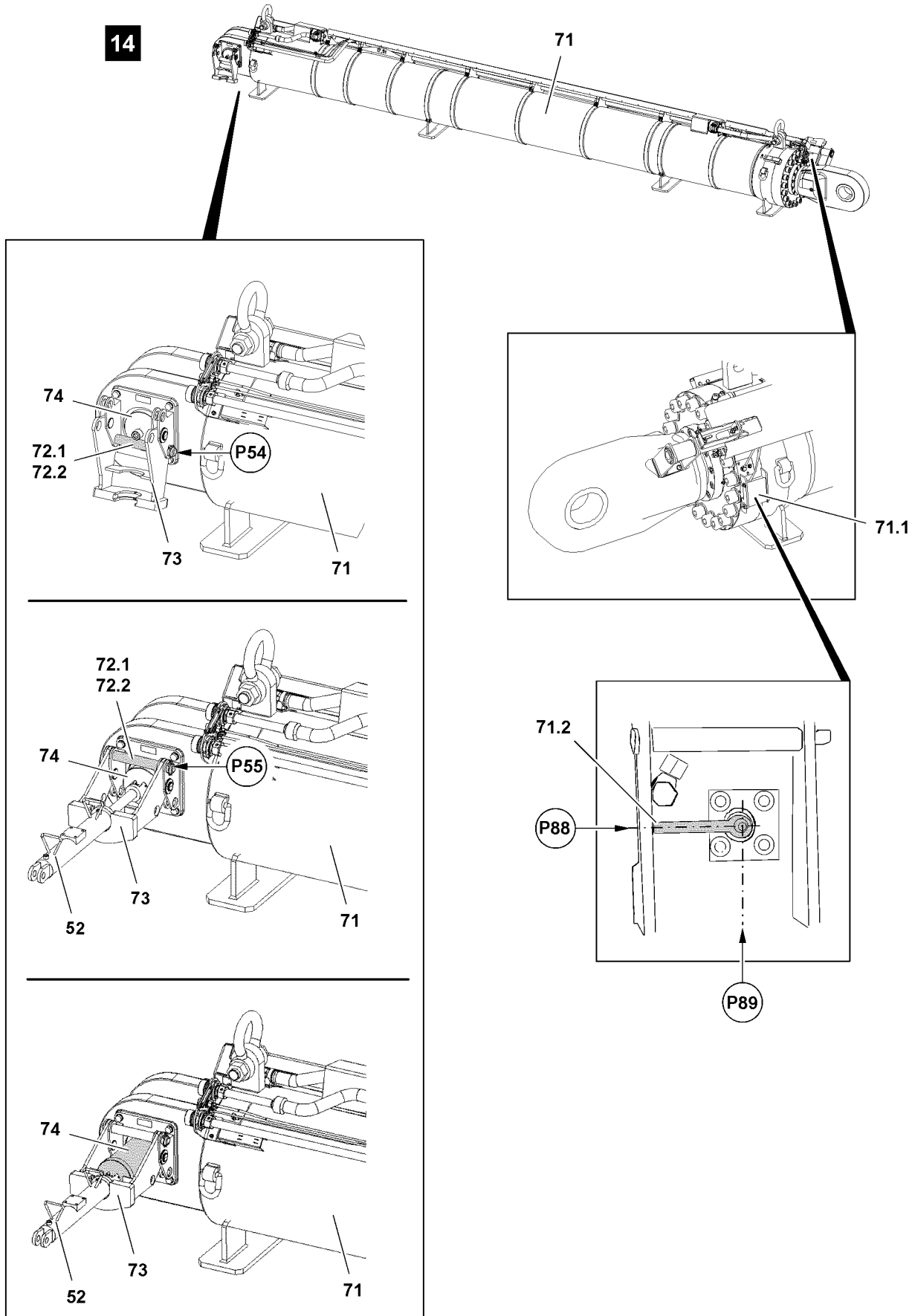

Fig.116525

LWE/LR 13000-001/19503-01-02/en

4.13.2 Removing the pull cylinder

Opening the ball valve for the thermo valve



Note

- ▶ When the ball valve for the thermo valve is closed for transport, then the oil pressure in the ballast cylinder increases in case of large temperature fluctuations. The hydraulic couplings cannot be opened.

The ball valve **71.2** is located behind the flap **71.1** on the ballast cylinder.

- ▶ Open the flap **71.1**.
- ▶ Open the thermo valve: Turn the ball valve **71.2** to the position in point **P88**.
- ▶ Open the thermo valves on both ballast cylinders.

Result:

- The hydraulic couplings can be opened.

Preparing the pull cylinder



WARNING

Swinging support!

When releasing the support **73** it can swing downward uncontrolled.

Personnel can be severely injured.

- ▶ Hold the support **73** when unpinning.
 - ▶ Assembly personnel must be to the side of the assembly unit.
-
- ▶ Release the supports **73** for the pin pulling cylinder **52** in point **P54**: Remove the safety locking pin **72.2** and unpin the pin **72.1**, see illustration **14**.

Result:

- The pin **74** is released.
- ▶ Swing the support **73** up and secure in point **P55**: Insert the pin **72.1** and secure with the safety locking pin **72.2**, see illustration **14**.
- ▶ Extend the pin pulling cylinder **52** and connect with the pin **74**.
- ▶ Guide the pin pulling cylinder **52** with the flange into the groove of the support **73**, see illustration **14**.

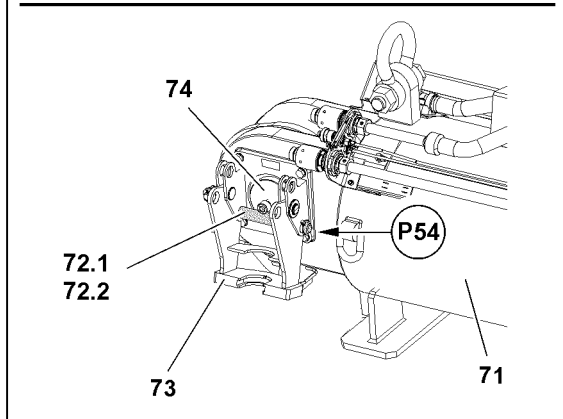
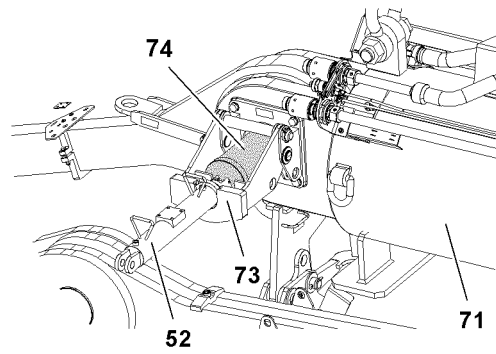
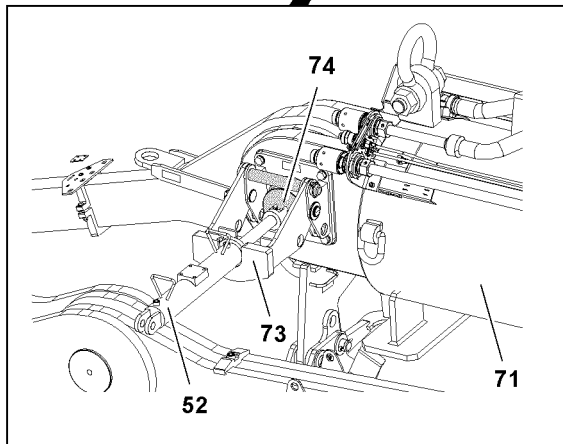
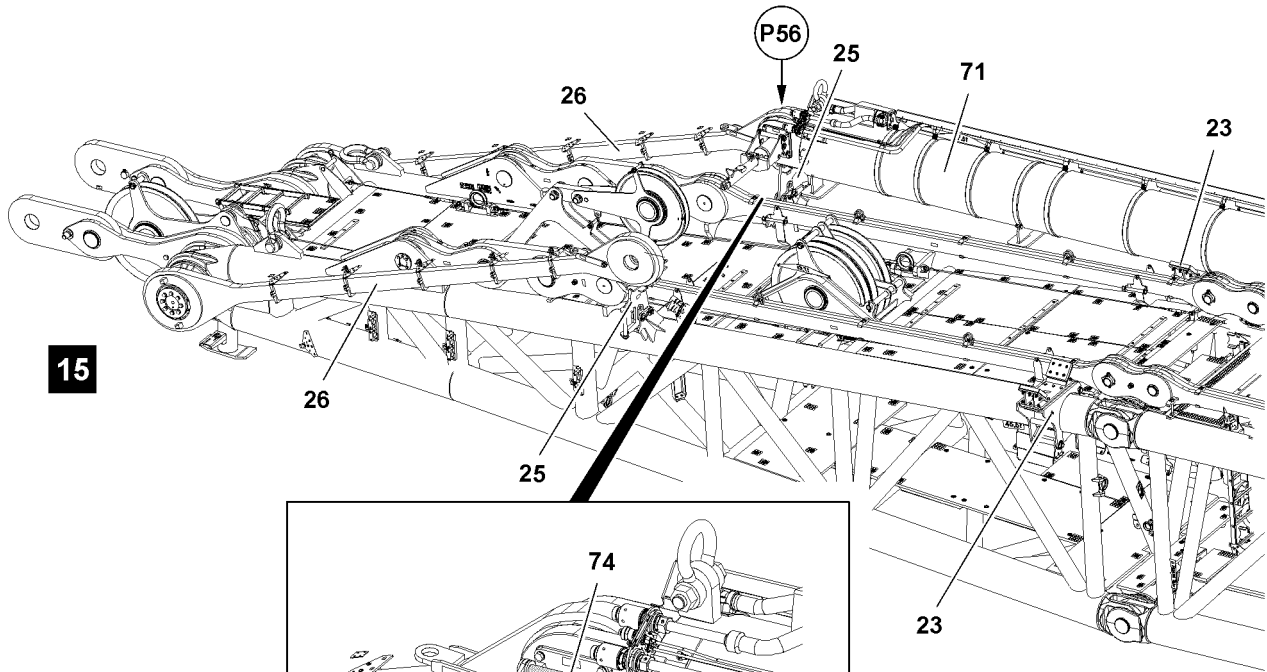

Fig.115630

LWE/LR 13000-001/19503-01-02/en

Disconnecting the hydraulic connections

The hydraulic connections are established with quick couplings.

When disconnecting hydraulic lines with quick couplings, make sure that the uncoupling procedure is carried out correctly.



WARNING

Pressure in the hydraulic lines!

If the pressure supply is not interrupted before connecting / releasing the hydraulic lines, the hydraulic oil can escape with high pressure.

Death, severe bodily injuries, property damage.

- ▶ Release the pressure in the hydraulic system before connecting / disconnecting: Interrupt the pressure supply and wait a short time.
- ▶ Release the hydraulic coupling by hand.
- ▶ Disconnect the hydraulic connection.

Unpinning the pull cylinder

Make sure that the following prerequisites are met:

- The hydraulic connections are disconnected.
- The ballast rods are removed.
- ▶ Fasten the pull cylinder **71** to the auxiliary crane.
- ▶ Unpin the pin **74**: Retract the pin pulling cylinder **52**, see illustration **15**.
- ▶ Remove the pin pulling cylinder **52**.

When the pin is unpinned:

- ▶ Lift the pull cylinder **71** with the auxiliary crane and remove.



Note

- ▶ Carry out the work step „Preparing the pull cylinder“ in reverse order.
- ▶ Insert the pin **74**, fold the bracket **73** and secure the pin **74** in the transport position.

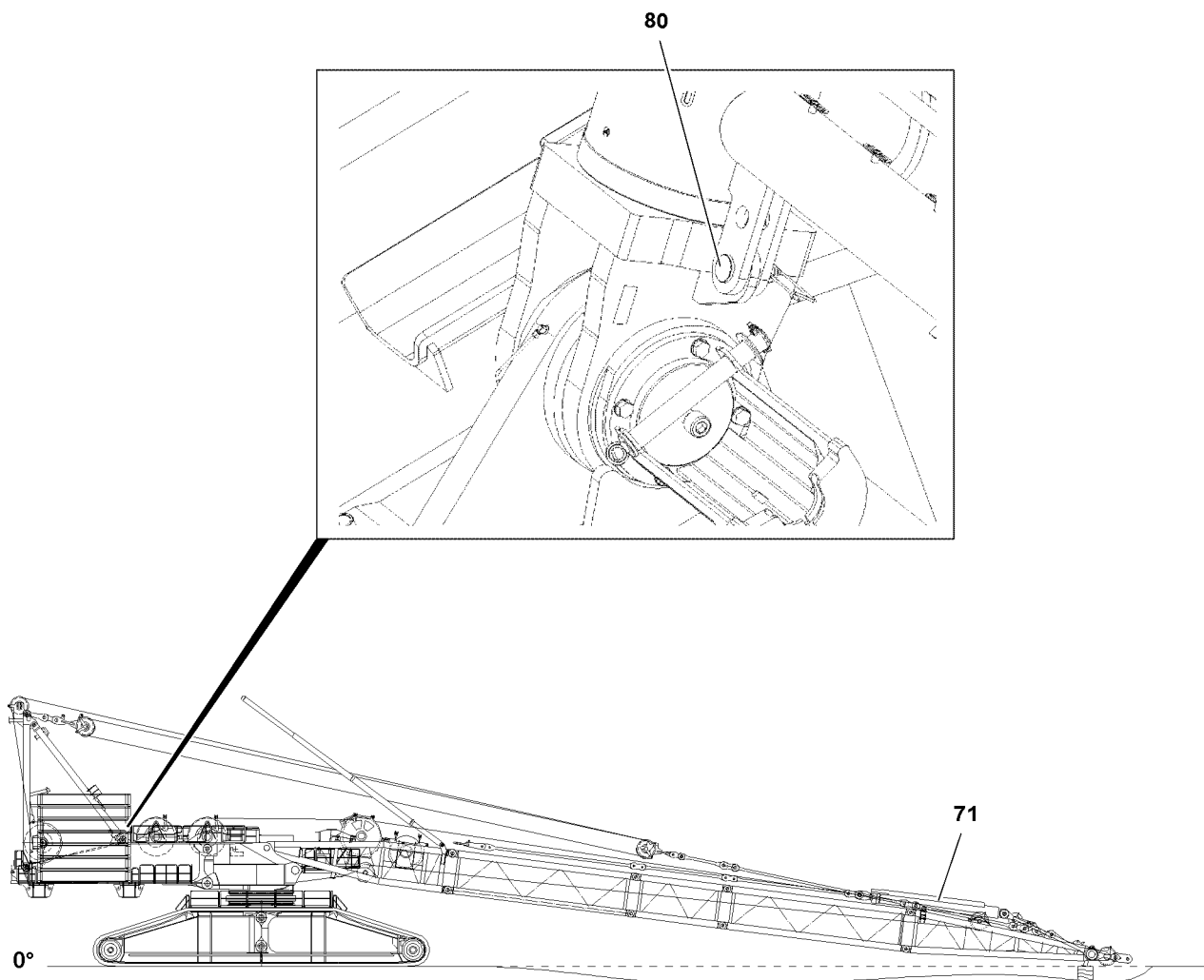

Fig.114395

LWE/LR 13000-001/19503-01-02/en

4.14 Securing the guide pipe



WARNING

The guide pipe drives out by itself!

When the pins **80** are not pinned, then the guide pipes can drive out by themselves at disassembly. Personnel can be severely injured or killed.

- ▶ Make sure that the pins **80** are inserted and secured.
-



Note

- ▶ Secure the guide pipe, see the Crane operating instructions, chapter 3.05.
-

- ▶ Secure the guide pipe.

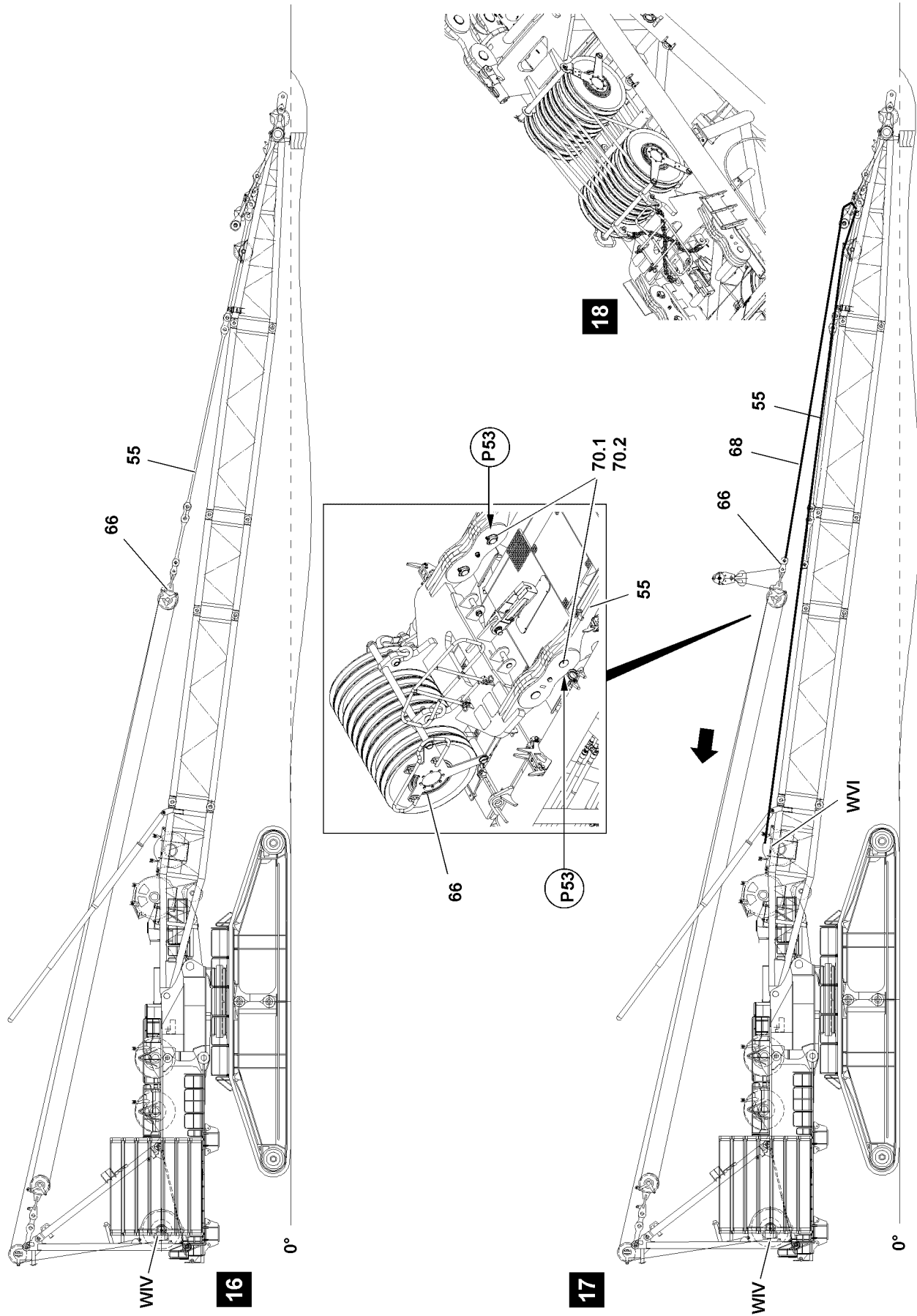

Fig.115631

LWE/LR 13000-001/19503-01-02/en

4.15 Bringing the upper pulley block to the A-frame

4.15.1 Unpinning the upper pulley block

Make sure that the following prerequisite is met:

- The guide pipes are secured on the A-frame.
- ▶ Fasten the upper pulley block **66** to the auxiliary crane.
- ▶ Take the upper pulley block **66** down with the aid of the crane on the D-boom: Spool winch 4 out
- ▶ Unpin the upper pulley block **66**: Release the safety locking pin **70.2** on both sides in point **P53** and unpin the pin **70.1**, see illustration **16**.

4.15.2 Connecting the rope of winch 6 with the upper pulley block



Note

- ▶ Rope run for the assembly rope, see section „Pinning the upper pulley block with the derrick guy rods“.
- ▶ Connect the rope **68** of winch 6 with the upper pulley block **66**.

4.15.3 Getting the upper pulley block



Note

- ▶ Bring the ladder on the A-frame into the operating position, see the Crane operating instructions, chapter 2.06.



WARNING

Danger of slack rope formation!

When spooling the rope out, slack rope can form.

- ▶ The rope must be slightly tensioned during the entire pulling procedure.



WARNING

Property damage!

- ▶ Always use a guide when retracting the upper pulley block.

- ▶ The guide must be in constant acoustic contact with the crane operator of the auxiliary crane.

- ▶ Pull the upper pulley block **66** with the aid of the crane to the A-frame: Spool up winch 4 and simultaneously spool out winch 6, see illustration **17**.
- ▶ Take the upper pulley block **66** down on the A-frame, see illustration **18**.
- ▶ Spool the rope **68** of winch 6 up:



Note

- ▶ Bring the ladder on the A-frame again into the transport position, see the Crane operating instructions, chapter 2.06.

- ▶ Remove the auxiliary crane.

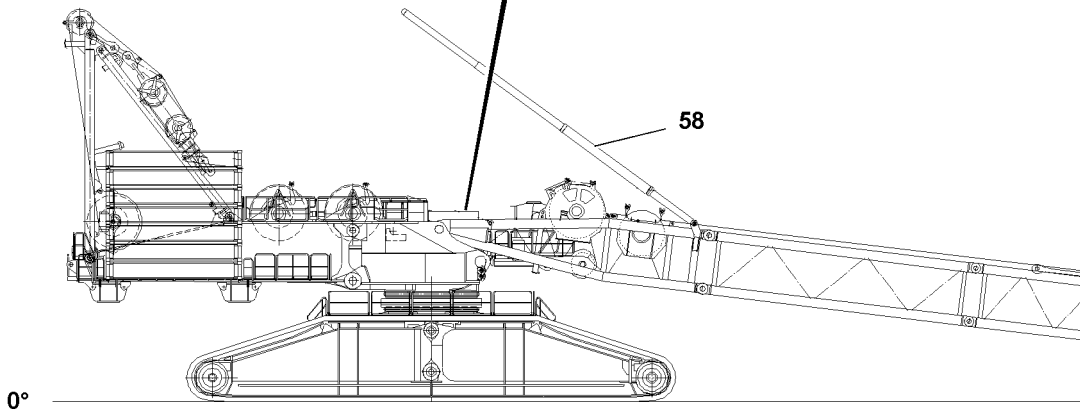
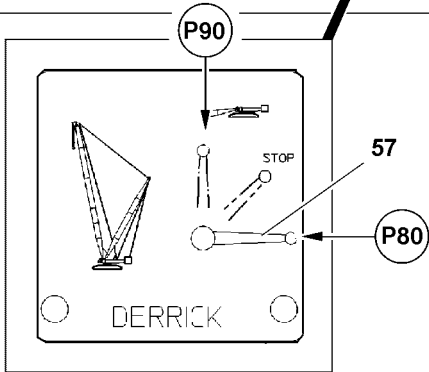
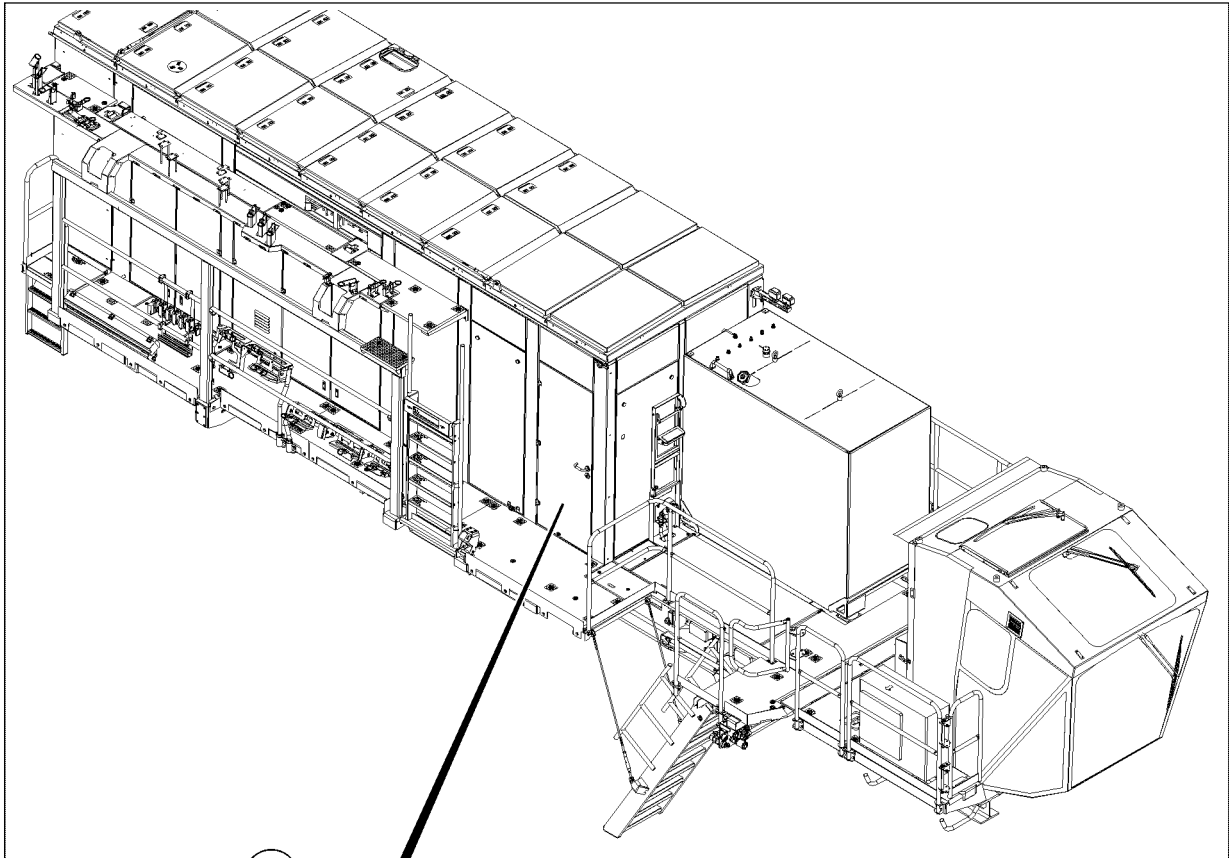

Fig.114390

LWE/LR 13000-001/19503-01-02/en

4.16 Retracting the D-relapse cylinder

The piston rod on the D-relapse cylinder must be retracted by actuating the ball valve **57**.

Ball valve positions	
P80	Crane operation, extend the piston rod
P90	Assembly, retract the piston rod
STOP	The piston rod cannot be retracted / extended

Make sure that the following prerequisite is met:

– All hydraulic connections have been established.

▶ Set the ball valve **57** to position **P90**.

Result:

– The piston rods of the D-relapse cylinders **58** retract.



Note

▶ The ball valve **57** is secured by closing the door to the engine house and removing the key.

▶ Close the door and pull out the key.

▶ Hand the key to an authorized person.

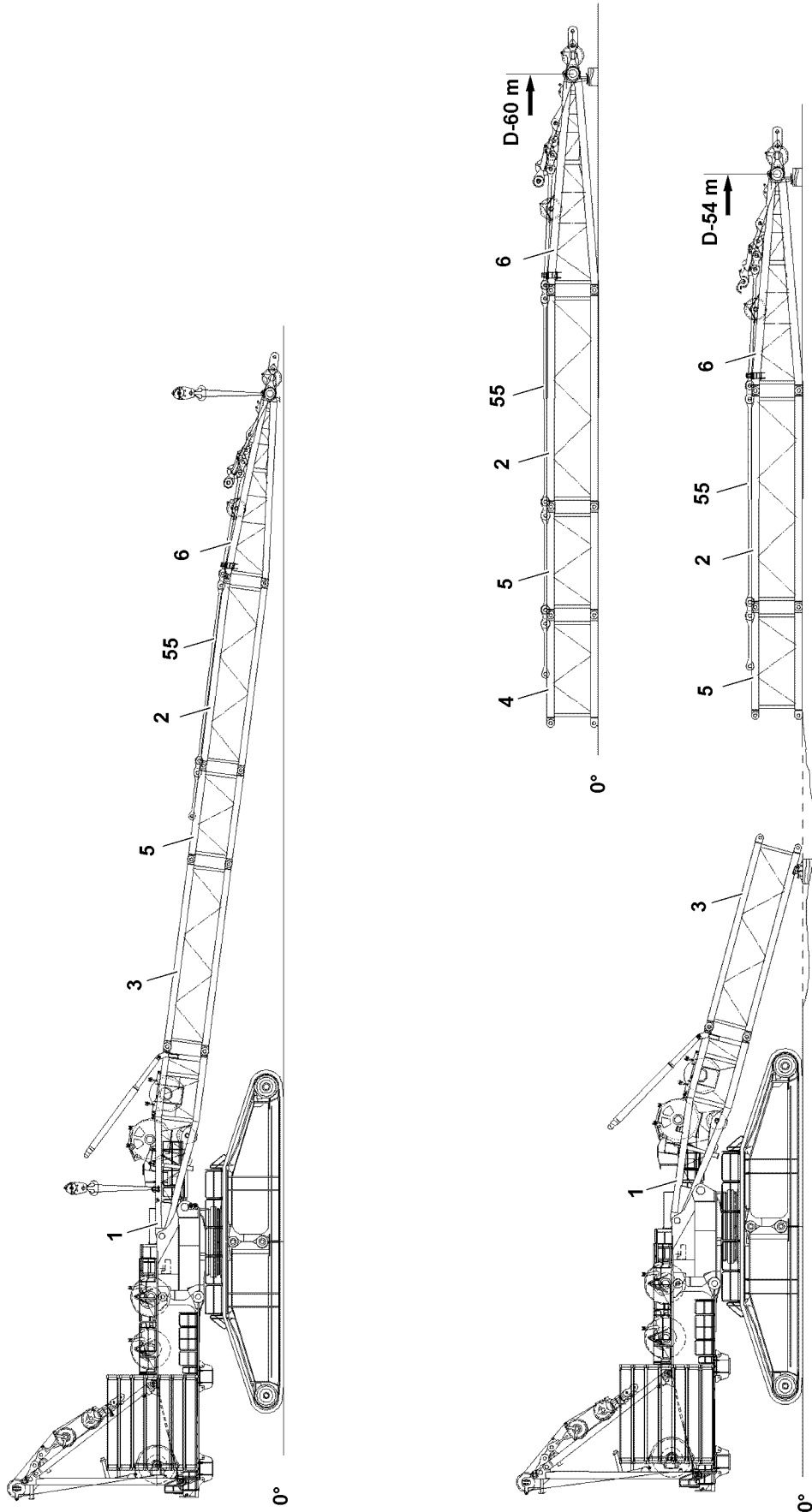

Fig.115636

LWE/LR 13000-001/19503-01-02/en

4.17 Disassembling the D-boom in sections

Make sure that the following prerequisites are met:

- The crane is horizontally aligned.
- An auxiliary crane is available.
- An assembly scaffolding / work platform is available.
- The counterweight has been installed on the turntable according to the load chart.
- The LICCON overload protection has been set according to the data in the load chart.
- The LICCON overload protection settings have been compared with the actual set up configuration.



DANGER

Danger of fatal injury due falling components!

If the pin connections are not visually inspected, the pins can loosen up by themselves and cause components to fall down.

Personnel can be severely injured or killed.

- ▶ All pins must be secured after disassembly with the intended retaining elements, check visually.
- ▶ The guy rods must be inspected regularly, see the Crane operating instructions, chapter 8.15.



WARNING

Danger of falling!

During assembly and disassembly, assembly personnel must be secured with appropriate aids to prevent them from falling.

Even for assembly and disassembly of protective devices there is a danger of falling.

Assembly personnel can fall and be severely injured or killed.

- ▶ Use personal protective equipment.

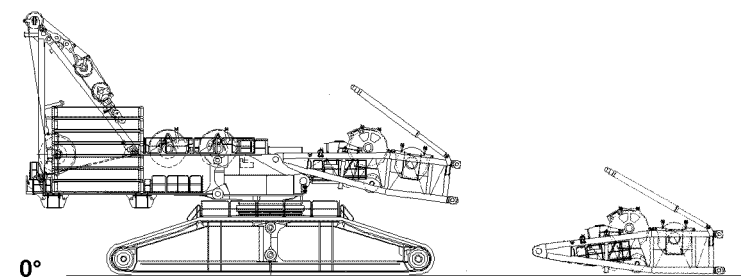
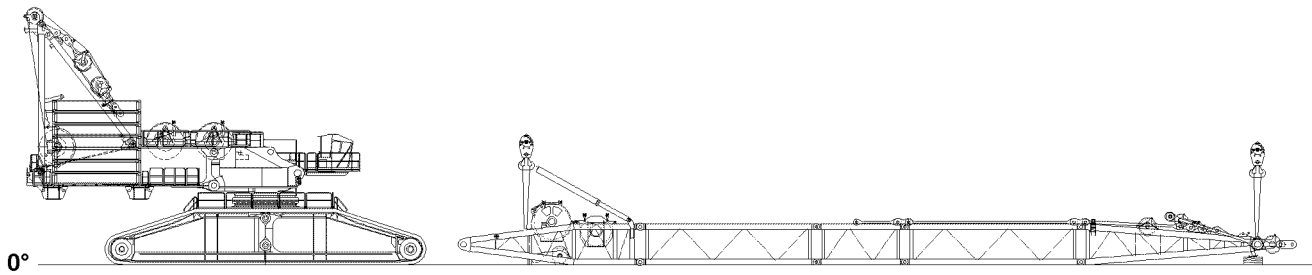
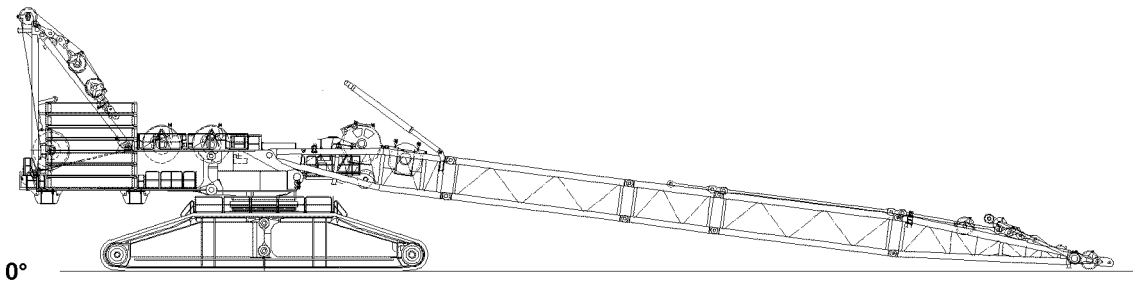
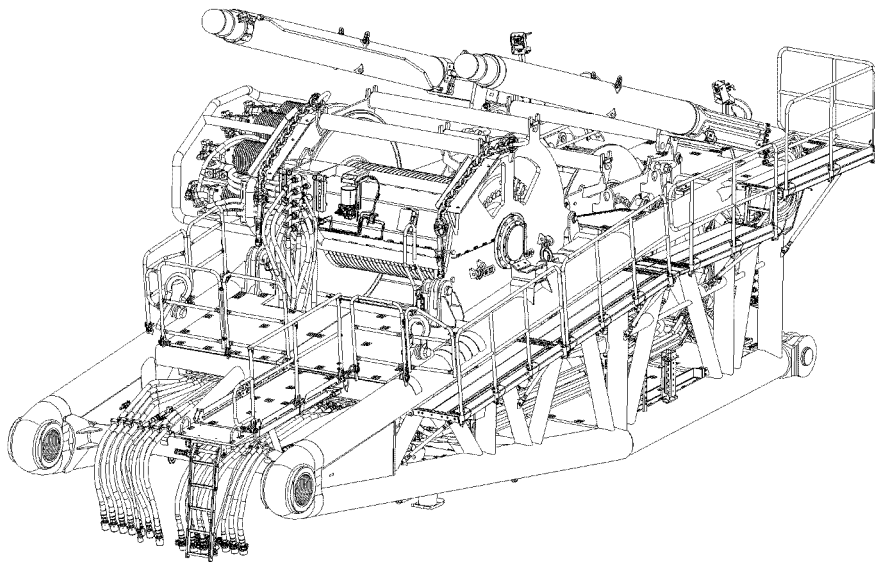

Fig.115650

LWE/LR 13000-001/19503-01-02/en

4.17.1 Disassembling winch 3 and winch 6



Note

- ▶ Winch 3 and winch 6 can be removed directly from the D-pivot section before the D-boom is removed, see illustration.
- ▶ Winch 3 and winch 6 can also be removed from the D-pivot section when the D-boom is removed and laying on the ground, see illustration.
- ▶ Winch 3 and winch 6 can also be removed from the D-pivot section when the D-boom is removed in sections and the D-boom is lying on the ground, see illustration.



WARNING

Danger of falling!

During assembly and disassembly, assembly personnel must be secured with appropriate aids to prevent them from falling.

Even for assembly and disassembly of protective devices there is a danger of falling.

Assembly personnel can fall and be severely injured or killed.

- ▶ Use personal protective equipment.

Disconnecting the electrical connections from the winches

- ▶ Disconnect all electrical connections from the winches properly and store the plug and cable properly.

Disconnecting the hydraulic connections from the winches

The hydraulic connections are established with quick couplings.

When disconnecting hydraulic lines with quick couplings, make sure that the uncoupling procedure is carried out correctly.



WARNING

Pressure in the hydraulic lines!

If the pressure supply is not interrupted before connecting / releasing the hydraulic lines, the hydraulic oil can escape with high pressure.

Death, severe bodily injuries, property damage.

- ▶ Release the pressure in the hydraulic system before connecting / disconnecting: Interrupt the pressure supply and wait a short time.
- ▶ Release the hydraulic coupling by hand.
- ▶ Disconnect the hydraulic connection from the winches.



Note

- ▶ Disassemble winch 3, see the Crane operating instructions, chapter 3.07.30.



Note

- ▶ Disassemble winch 6, see the Crane operating instructions, chapter 3.07.60.
- ▶ Disassembly winch 3 and winch 6.

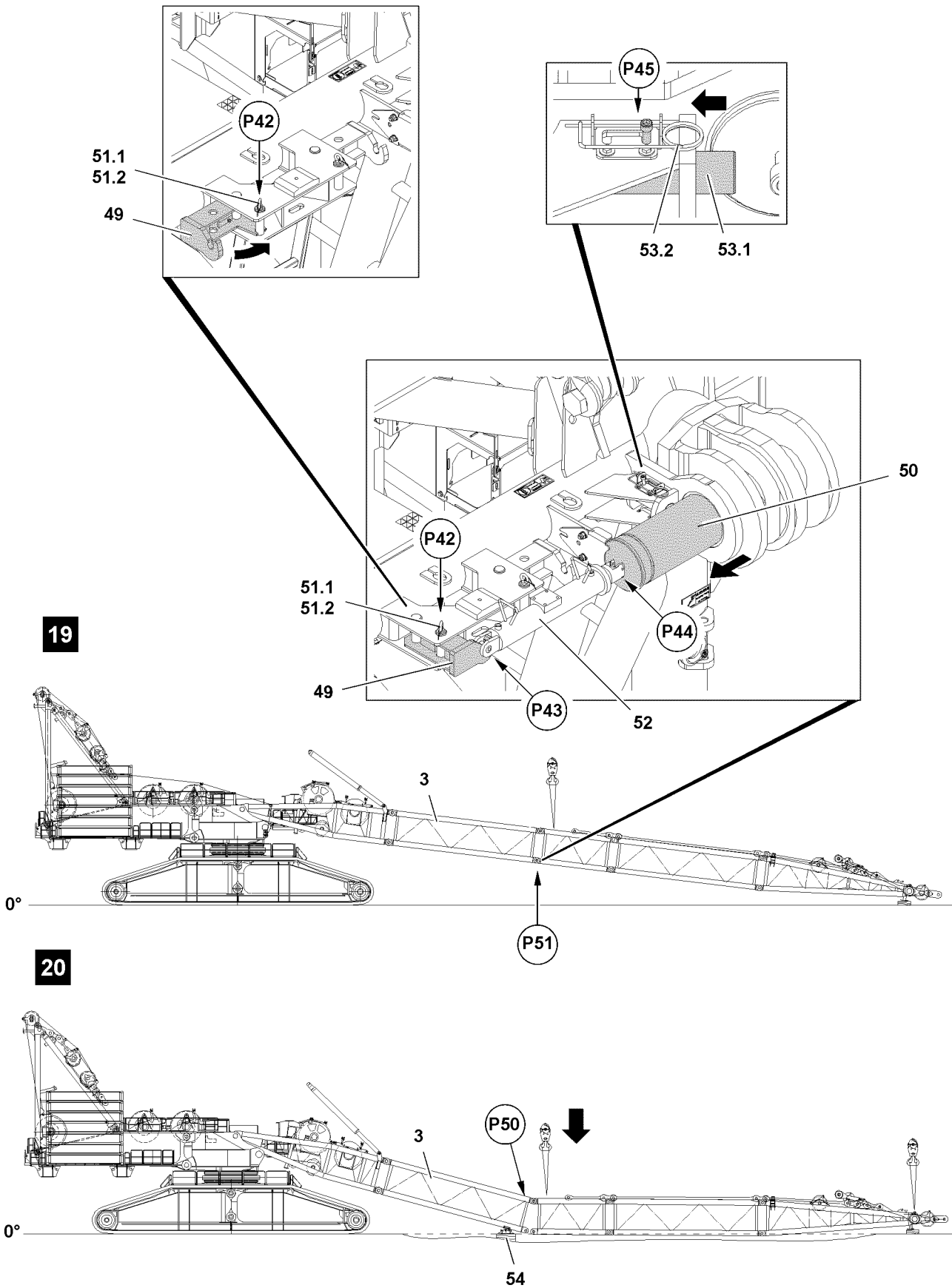

Fig.115632

LWE/LR 13000-001/19503-01-02/en

4.17.2 Disassembling the D-boom

Establishing the hydraulic connections



Note

- ▶ The hydraulic supply for the pin pulling cylinder is made via the external hydraulic aggregate or the operational engine house.

The hydraulic connections are established with quick couplings.

When connecting hydraulic lines with quick couplings, make sure that the coupling procedure is carried out correctly.

The matching quick couplings are marked.



WARNING

Pressure in the hydraulic lines!

If the pressure supply is not interrupted before connecting / releasing the hydraulic lines, the hydraulic oil can escape with high pressure.

Death, severe bodily injuries, property damage.

- ▶ Release the pressure in the hydraulic system before connecting / disconnecting: Interrupt the pressure supply and wait a short time.



WARNING

Loss of pressure or leakage!

Incorrectly coupled or self-loosening quick couplings (particularly return lines) can result in serious accidents due to component failure.

Death, severe bodily injuries, property damage.

- ▶ Check that the quick couplings have been properly connected before using the crane.

- ▶ Connect the coupling components (sleeve and connector) and screw together with the knurled nut.
- ▶ Tighten the hydraulic coupling by hand. Turn the knurled nut until it reaches a tangible, fixed stop position.
- ▶ Establish the hydraulic connection: Connect the supply lines of the external hydraulic aggregate to the supply lines of the pin pulling cylinder, hydraulic connection **R** and hydraulic connection **P**.

Releasing the pin

- ▶ Fasten the D-intermediate section in point **50** to the auxiliary crane.
- ▶ Release the pin **50** in point **P51**: Remove the spring retainer **53.2** and slide the pin **53.1** outward so that the screw engages in point **P45**, see illustration **19**.
- ▶ Secure the pin **53.1**: Attach the spring retainer **53.2**.

Swinging the folding bracket into operating position

- ▶ Swing the folding bracket **49** into the operating position: Remove the safety locking pin **51.2** in point **P42** and unpin the pin **51.1** and turn the folding bracket, see illustration **19**.
- ▶ Secure the folding bracket **49** in the operating position: Insert the pin **51.1** in point **P42** and secure with the safety locking pin **51.2**, see illustration **19**.
- ▶ Connect the pin pulling cylinder **52** at the **rear** in point **P43**.
- ▶ Connect the pin pulling cylinder **52** at the **front** in point **P44** with the pin **50**, see illustration **25**.

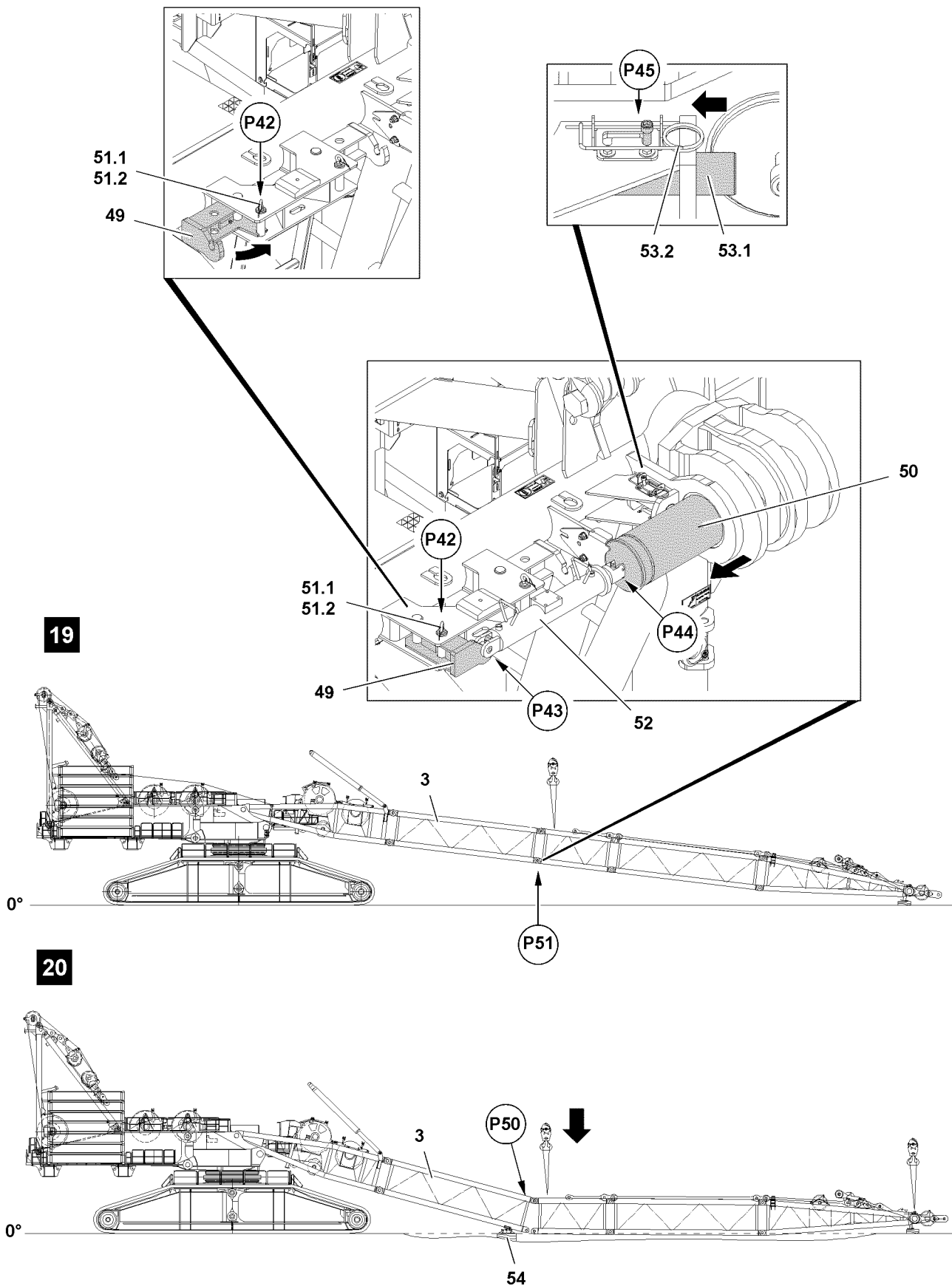

Fig.115632

LWE/LR 13000-001/19503-01-02/en

Unpinning the D-boom from the D-intermediate section

When the D-boom is safely held by the auxiliary crane:

- ▶ Unpin the pin **50** on top on both sides in point **P51**: Retract the pin pulling cylinder **52**.
- ▶ Remove the pin pulling cylinder **52**.

NOTICE

Damage to the D-intermediate section!

Property damage can occur on the intermediate section by taking the D-boom down on the ground.

- ▶ Do not take the D-intermediate section down directly onto the ground.
 - ▶ When taking the D-intermediate section down, use a sufficiently load bearing and large enough substructure.
 - ▶ The substructure must be erected at least to the alignment level.
-

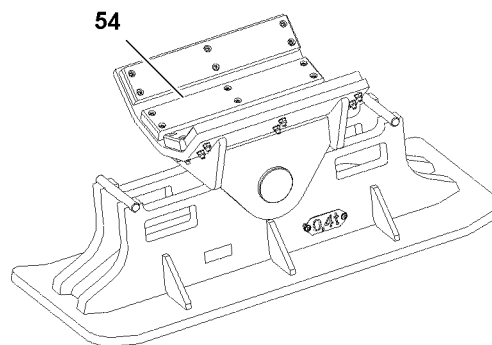

Fig.115648

Substructure: Assembly shoe

- ▶ Take the D-boom down carefully with the auxiliary crane on the substructure **54**, see illustration **20**.



Note

- ▶ The procedure on the pin locations on **top** is the same as the work steps in point **P51** for the previously described pin location on the **bottom**.
-

When the D-boom is lying safely on the substructure:

- ▶ Unpin the pin **50** on both sides in point **P50**: Retract the pin pulling cylinder **52**.
- ▶ Remove the pin pulling cylinder **52**.
- ▶ Fasten the D-end section to the second auxiliary crane.
- ▶ Remove the D-boom with the aid of the cranes.

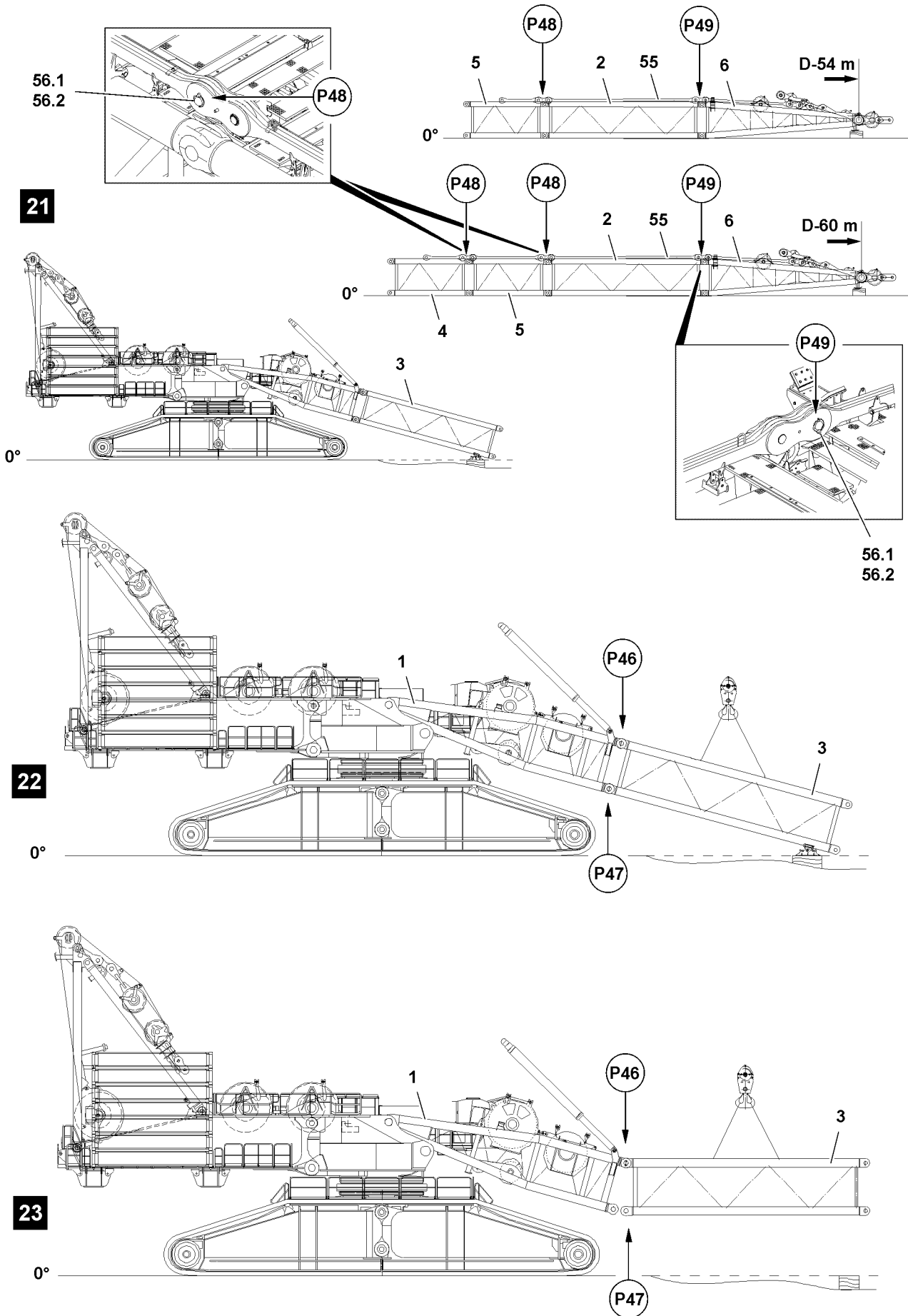

Fig.115633

LWE/LR 13000-001/19503-01-02/en

Disassembling the derrick guy rods



WARNING

Neglected inspection and maintenance on guy rods!

If the regular inspection and maintenance of the guy rods is not carried out or is carried out only in irregular intervals, then serious accidents can occur due to existing and unrecognized damage to the guy rods.

Personnel can be severely injured or killed.

- ▶ The guy rods must be checked before every assembly, see the Crane operating instructions, chapter 8.15.
-
- ▶ Unpin the derrick guy rods **55**: Remove the safety locking pin **56.2** on both sides in points **P48** and unpin the pin **56.1**, see illustration **21**.
 - ▶ Unpin the derrick guy rods **55**: Remove the safety locking pin **56.2** on both sides in points **P49** and unpin the pin **56.1**, see illustration **21**.

Unpinning the D-end section



Note

- ▶ Always support the D-sections sufficiently for easier disassembly.
- ▶ The procedure on the pin locations is the same as the work steps for the previously described unpinning procedure on the D-intermediate section.

- ▶ Unpin the D-end section **6**.

Unpinning the D-intermediate section



Note

- ▶ Always support the D-sections sufficiently for easier disassembly.
- ▶ The procedure on the pin locations is the same as the work steps for the previously described unpinning procedure on the D-intermediate section.

- ▶ Unpin the D-intermediate section **2** and D-intermediate section **5**.

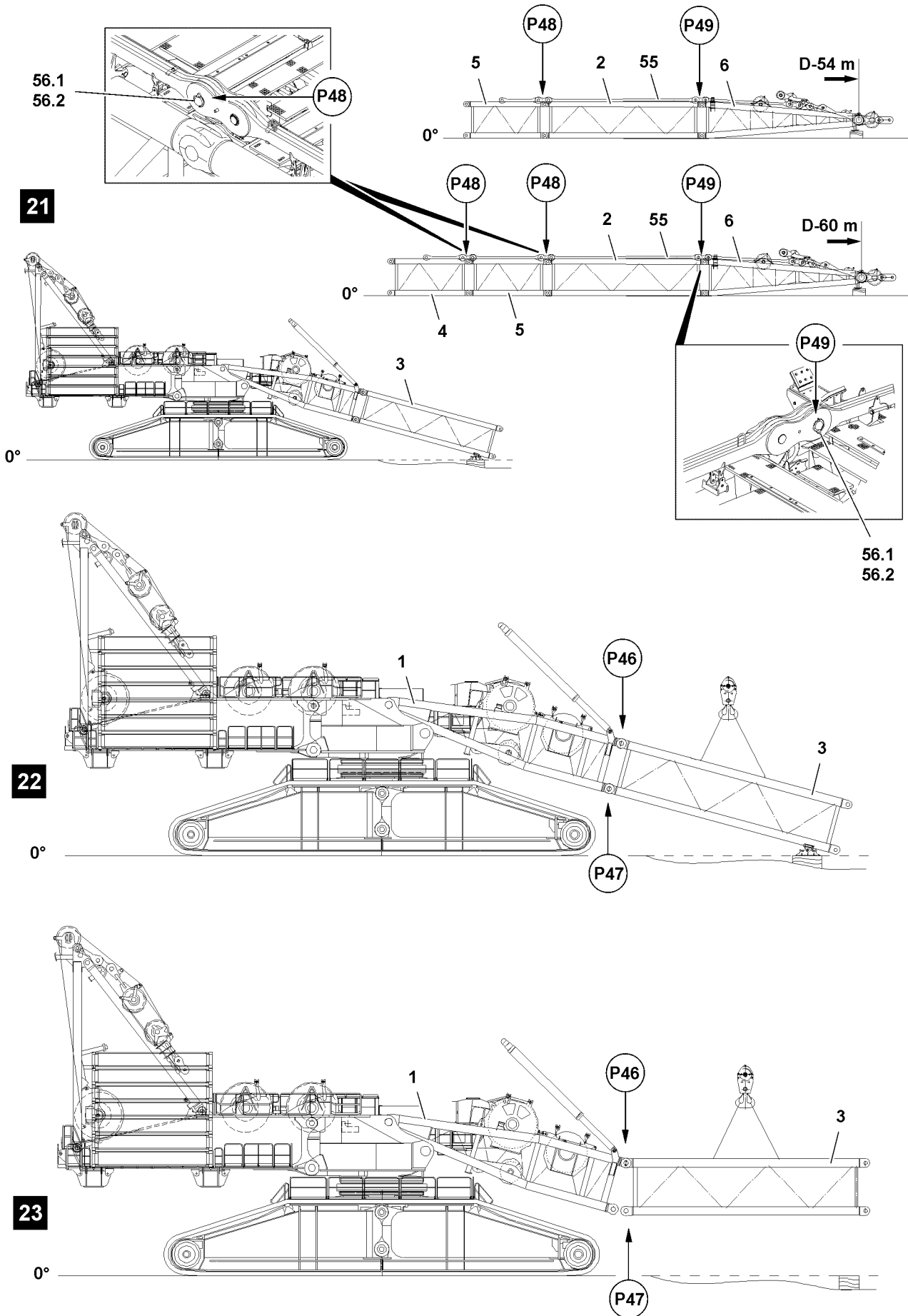

Fig.115633

LWE/LR 13000-001/19503-01-02/en

4.17.3 Unpinning the D-intermediate section 2824.36 12m

Unpinning the D-intermediate section 2824.36 12m on the bottom

- ▶ Fasten the D-intermediate section 2824.36 12m **3** to the auxiliary crane, see illustration.



Note

- ▶ The procedure on the pin locations is the same as the work steps for the previously described unpinning procedure on the D-intermediate section.

-
- ▶ Unpin the D-intermediate section 2824.36 12m **3** on the **bottom**.

Unpinning the D-intermediate section 2824.36 12m on top



Note

- ▶ The procedure on the pin locations is the same as the work steps for the previously described unpinning procedure on the D-intermediate section.

-
- ▶ Unpin the D-intermediate section 2824.36 12m **3** on **top**.
 - ▶ Remove the D-intermediate section 2824.36 12m **3** with the auxiliary crane.

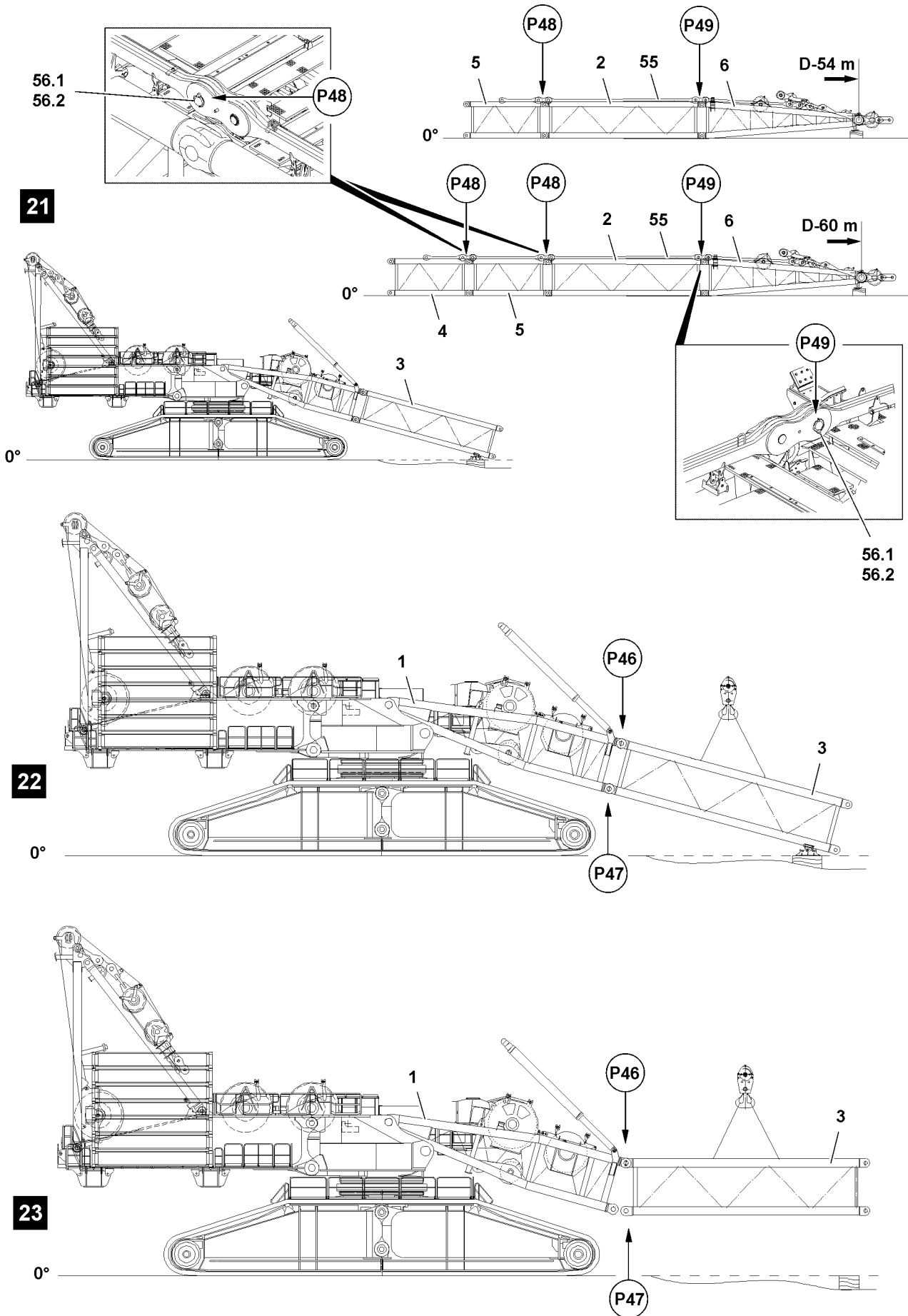

Fig.115633

LWE/LR 13000-001/19503-01-02/en

Disassembling flying the D-intermediate section 2824.36 12m

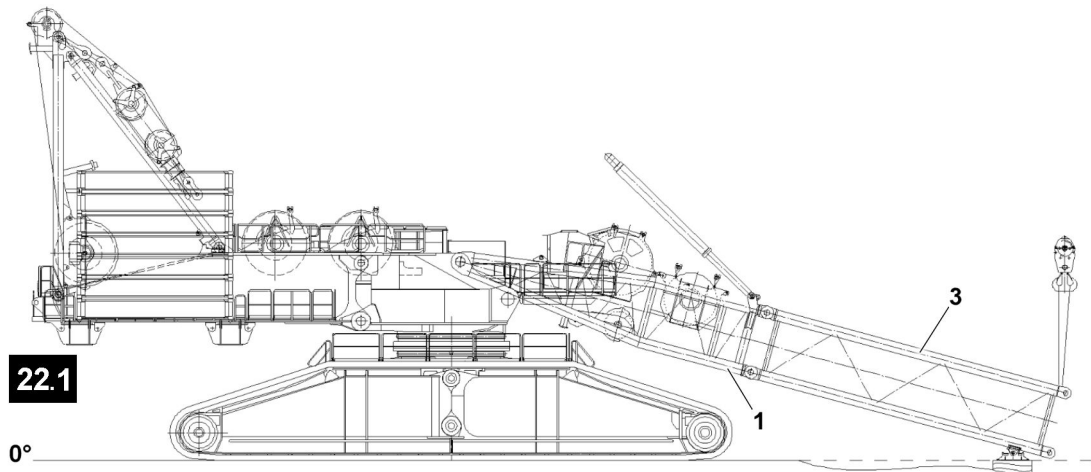

Fig.164537

- ▶ Fasten the D-intermediate section 2824.36 12 m **3** and D-pivot section **1** to the auxiliary crane, required load 60 t.
- ▶ Lift the D-intermediate section 2824.36 12 m **3** and D-pivot section **1**, see illustration **22.1**.
- ▶ Remove the substructure.

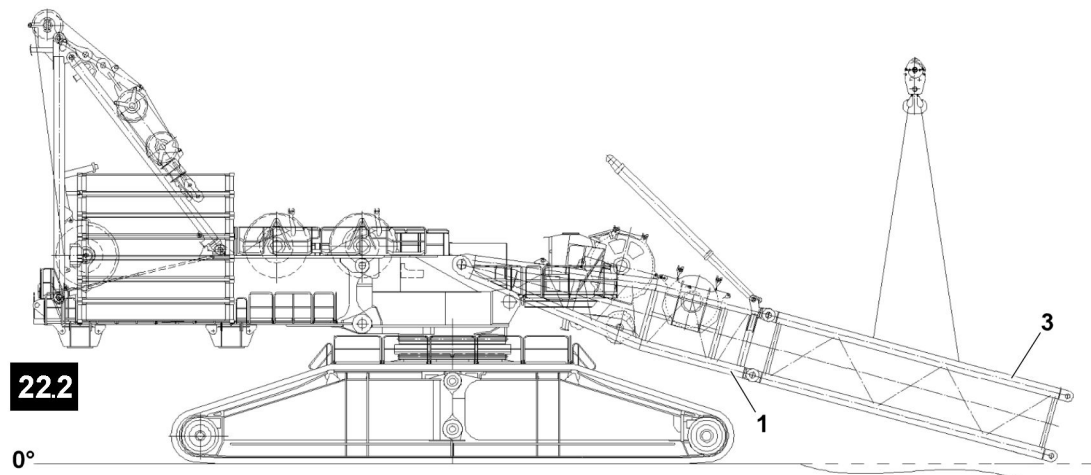

Fig.164538

- ▶ Move the auxiliary crane, see illustration **22.2**.



Note

- ▶ The procedure on the pin locations on the **top** and **bottom** is the same as the work steps that are described in the section „Unpinning the D-boom from the D-intermediate section“.
- ▶ Unpin the pins on **top** and **bottom** on both sides.
- ▶ Remove the D-intermediate section 2824.36 12 m **3**.

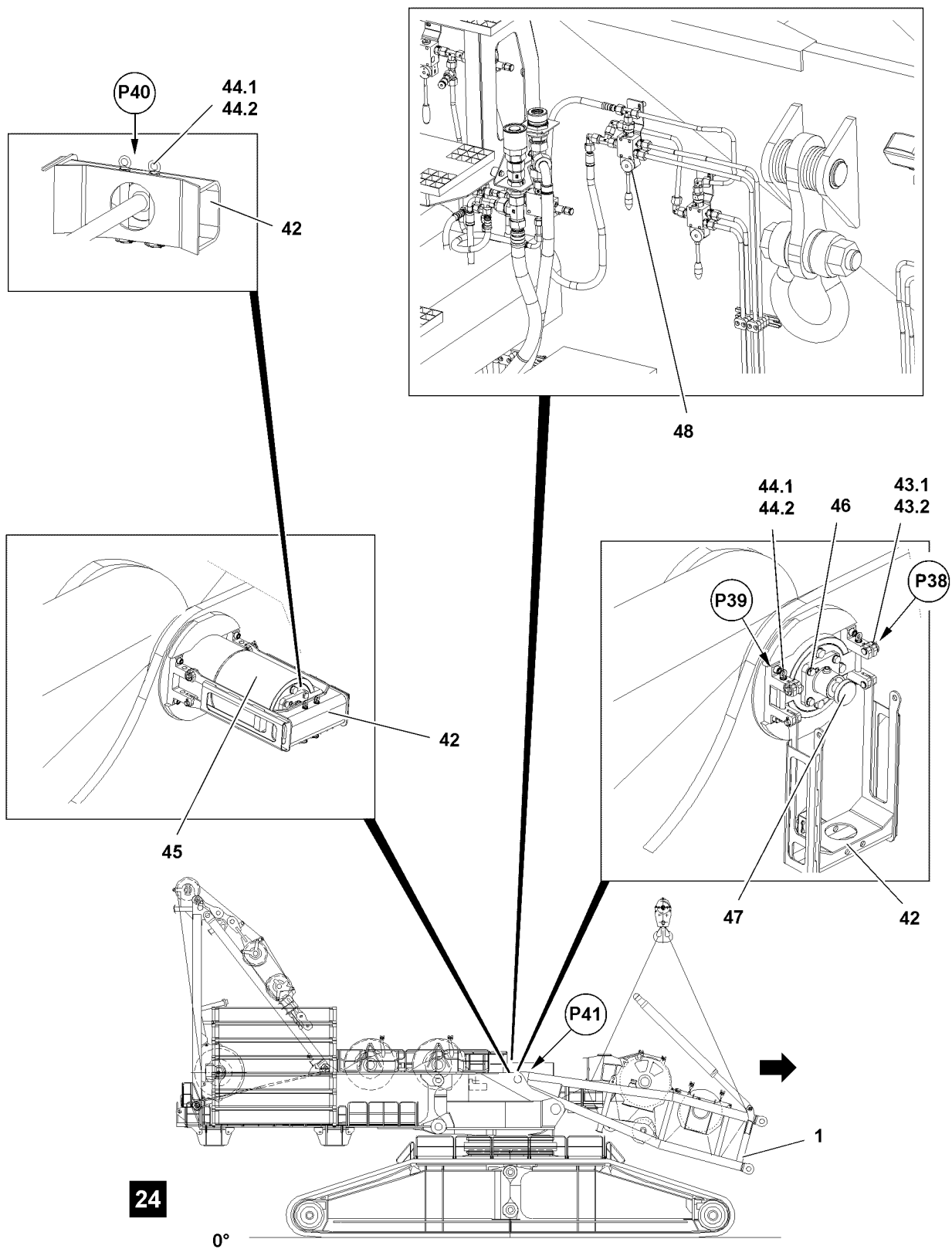

Fig.115634

4.17.4 Unpinning the D-pivot section

Unpinning the D-pivot section on the turntable

- ▶ Fasten the D-pivot section **1** in the fastening points to the auxiliary crane.
- ▶ Remove the safety locking pin **43.2** on both sides in point **P38** and unpin the pin **43.1**.
- ▶ Fold the bracket **42** up, reinsert the pin **43.1** again on both sides in point **P38** and secure with the safety locking pin **43.2**, see illustration **24**.
- ▶ Release the pin **45**: Remove the safety locking pin **44.2** on both sides in point **P39** and unpin the pin **44.1**, see illustration **24**.
- ▶ Extend the piston rod **47** of the pin pulling cylinder: Actuate the hand lever **48**.
- ▶ Secure the piston rod **47** of the pin pulling cylinder **46** on the bracket **42** in point **P40**: Insert the pin **44.1** on both sides and secure with the safety locking pin **44.2**, see illustration **24**.
- ▶ Retract the piston rod **47** of the pin pulling cylinder on both sides: Actuate the hand lever **48**.

Result:

- The pin **45** retracts, see illustration **24**.
- ▶ Lift the D-pivot section **1** with the auxiliary crane and remove.

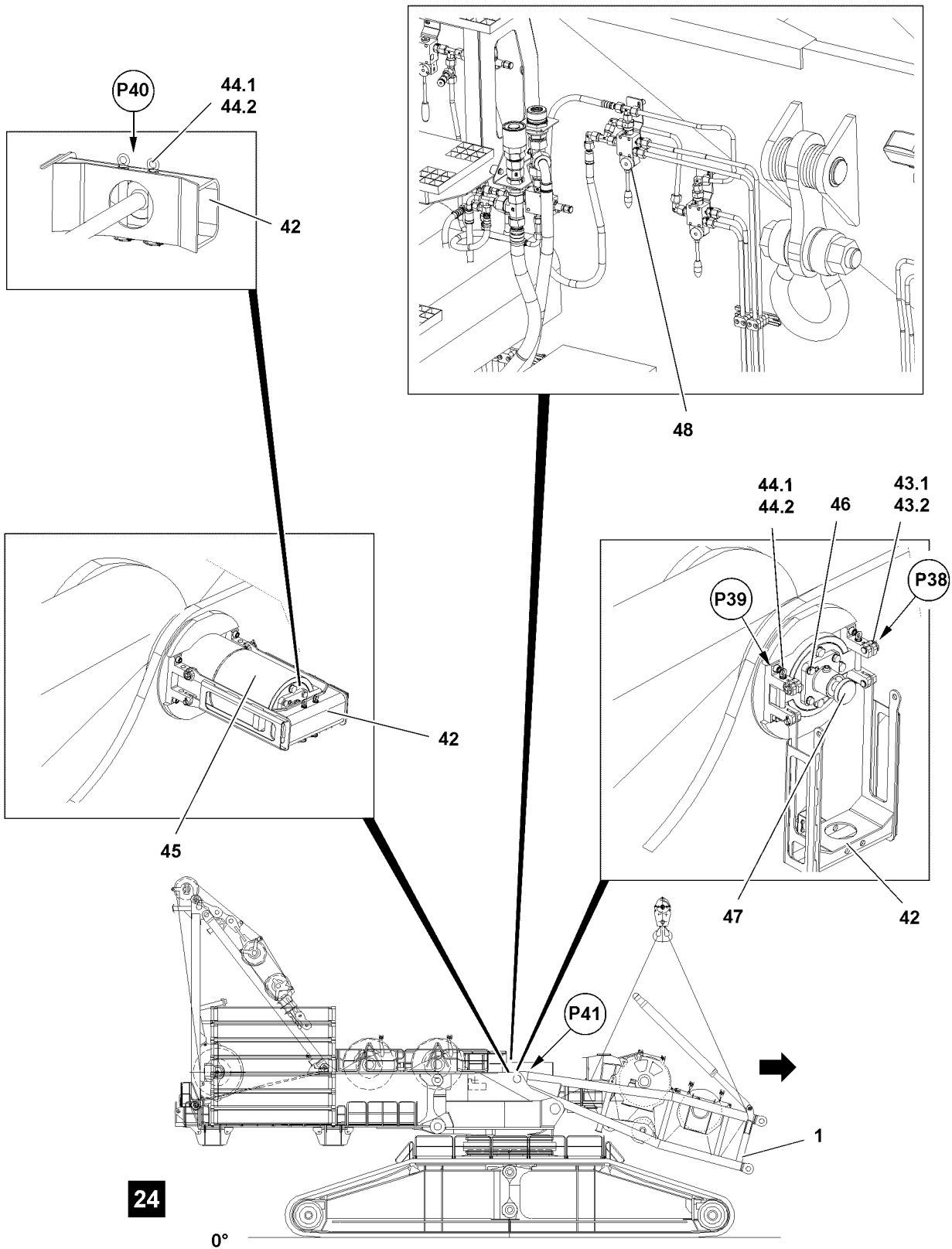

24

0°

Fig.115634

LWE/LR 13000-001/19503-01-02/en

Inserting the pin on the turntable

When the D-pivot section **1** is removed, reinsert the pin **45**:

- ▶ Extend the pin pulling cylinder on both sides: Actuate the hand lever **48**.

Result:

- The piston rod **47** extends and the pin **45** retracts.



WARNING

The pin is not secured!

If the pins **45** are not secured, the pins can loosen up by themselves during transport operation. Personnel can be severely injured or killed.

- ▶ Make sure that the pins **45** are secured after the pin procedure.

- ▶ Secure the pin **45**: Release the pin **44.1** on both sides in point **P40** and unpin, then insert the pin **44.1** in point **P39** on both sides and secure with the safety locking pin **44.2**.
- ▶ Retract the piston rod **47** of the pin pulling cylinder on both sides: Actuate the hand lever **48**.



WARNING

Swinging bracket!

When releasing the bracket **42** in point **P38**, it can swing downward uncontrolled.

Personnel can be severely injured.

- ▶ Hold the bracket **42** when unpinning.
- ▶ Assembly personnel must be to the side of the assembly unit.
- ▶ Remove the safety locking pin **43.2** on both sides in point **P38** and unpin the pin **43.1**.
- ▶ Fold the bracket **42** down, insert the pin **43.1** again on both sides in point **P38** and secure with the safety locking pin **43.2**, see illustration **24**.
- ▶ Retract the piston rod **47** of the pin pulling cylinder: Actuate the hand lever **38**.

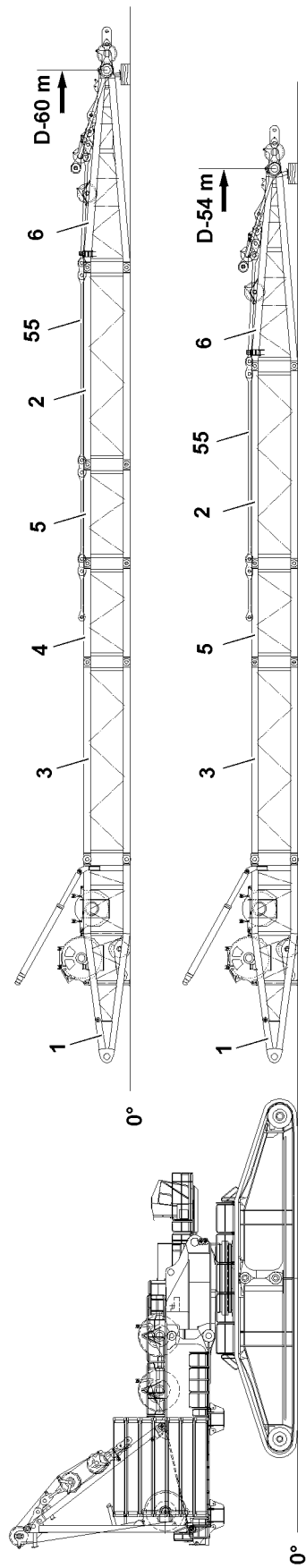
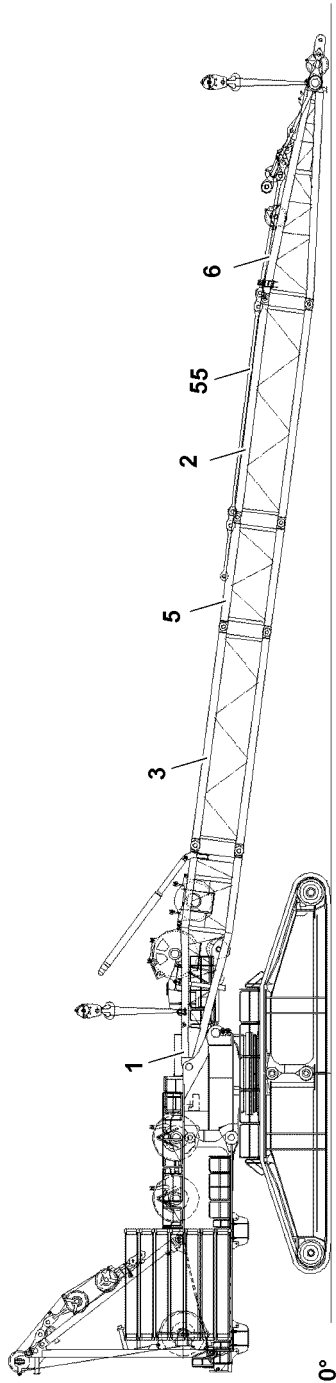

Fig.115635

4.18 Flying disassembly of the D-boom

Make sure that the following prerequisites are met:

- The crane is horizontally aligned.
- An auxiliary crane is available.
- An assembly scaffolding / work platform is available.
- The counterweight has been installed on the turntable according to the load chart.
- The LICCON overload protection has been set according to the data in the load chart.
- The LICCON overload protection settings have been compared with the actual set up configuration.



DANGER

Danger of fatal injury due falling components!

If the pin connections are not visually inspected, the pins can loosen up by themselves and cause components to fall down.

Personnel can be severely injured or killed.

- ▶ All pins must be secured after disassembly with the intended retaining elements, check visually.
- ▶ The guy rods must be inspected regularly, see the Crane operating instructions, chapter 8.15.



WARNING

Danger of falling!

During assembly and disassembly, assembly personnel must be secured with appropriate aids to prevent them from falling.

Even for assembly and disassembly of protective devices there is a danger of falling.

Assembly personnel can fall and be severely injured or killed.

- ▶ Use personal protective equipment.
-

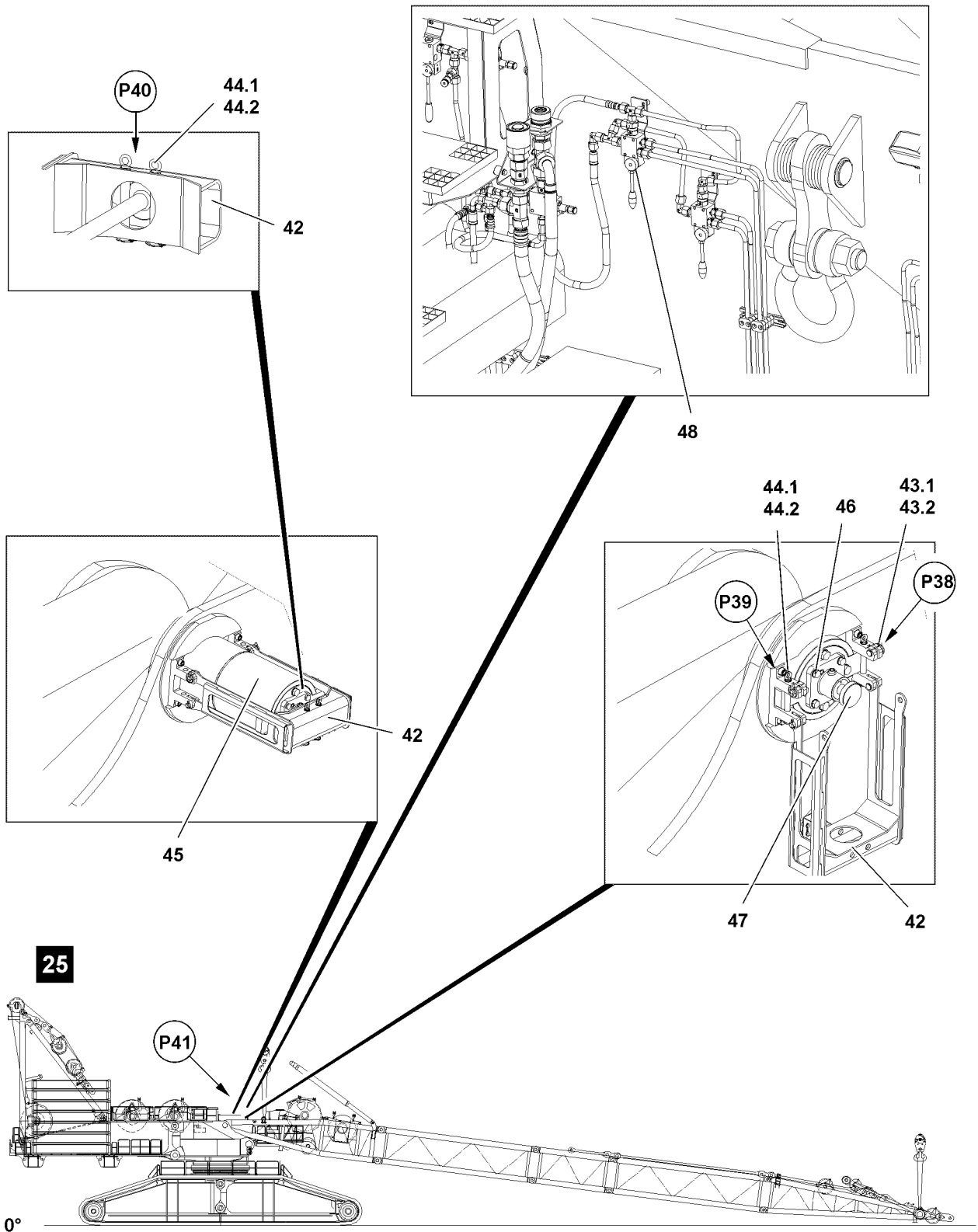

Fig.115637

LWE/LR 13000-001/19503-01-02/en

4.18.1 Unpinning the D-pivot section

Unpinning the D-pivot section on the turntable

Make sure that the following prerequisite is met:

- The hydraulic and electrical connections to the D-boom are disconnected.
- ▶ Fasten the D-boom in the fastening points to the auxiliary crane, see illustration 25.
- ▶ Remove the safety locking pin 43.2 on both sides in point P38 and unpin the pin 43.1.
- ▶ Fold the bracket 42 up, reinsert the pin 43.1 again on both sides in point P38 and secure with the safety locking pin 43.2, see illustration 25.
- ▶ Release the pin 45: Remove the safety locking pin 44.2 on both sides in point P39 and unpin the pin 44.1, see illustration 25.
- ▶ Extend the piston rod 47 of the pin pulling cylinder: Actuate the hand lever 48.
- ▶ Secure the piston rod 47 of the pin pulling cylinder 46 on the bracket 42 in point P40: Insert the pin 44.1 on both sides and secure with the safety locking pin 44.2, see illustration 25.
- ▶ Retract the piston rod 47 of the pin pulling cylinder on both sides: Actuate the hand lever 48.

Result:

- The pin 45 retracts, see illustration 25.
- ▶ Lift the D-boom with the auxiliary crane and remove or extend the crane.

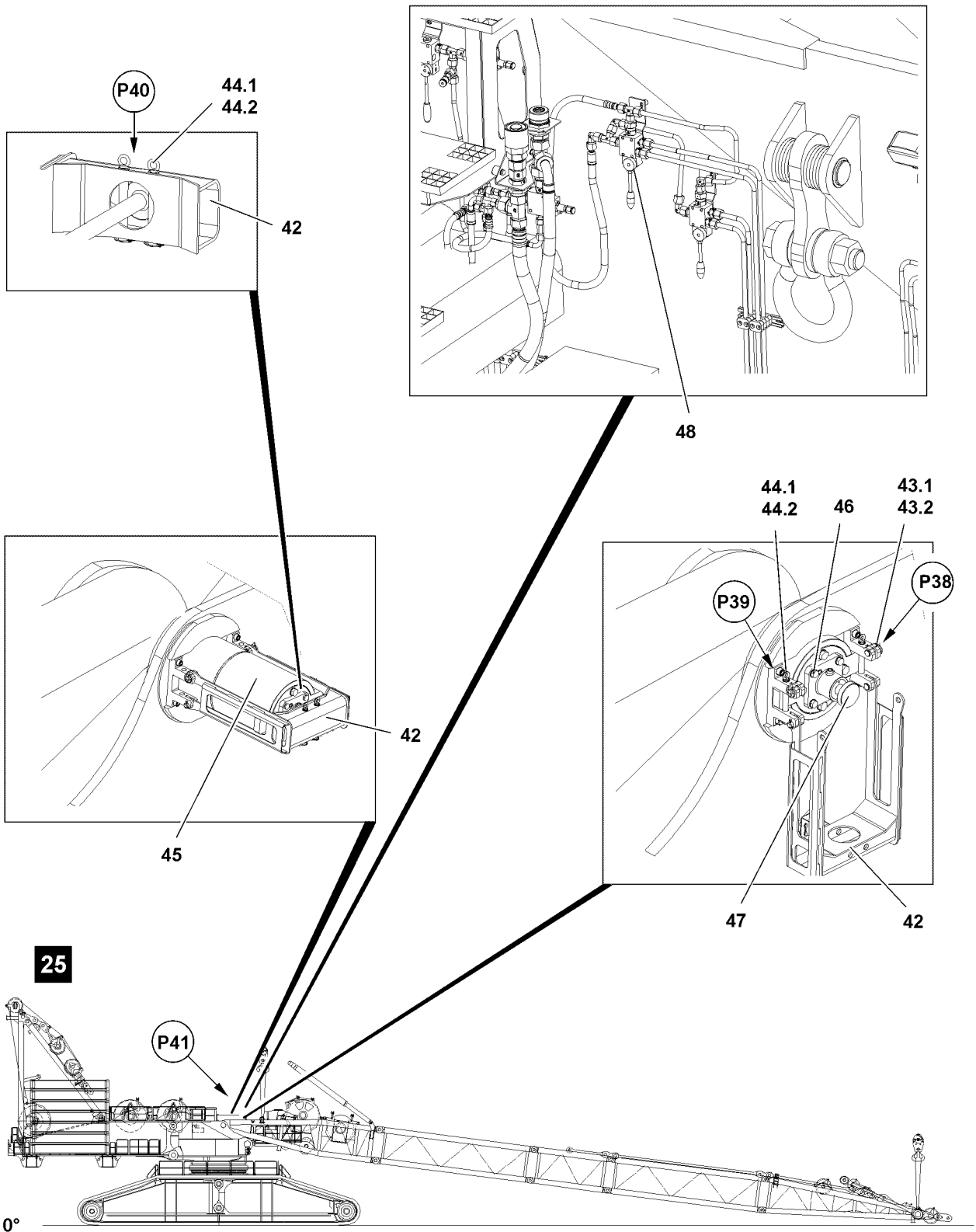

Fig.115637

LWE/LR 13000-001/19503-01-02/en

Inserting the pin on the turntable

When the D-pivot section **1** is removed, reinsert the pin **45**:

- ▶ Extend the pin pulling cylinder on both sides: Actuate the hand lever **48**.

Result:

- The piston rod **47** extends and the pin **45** retracts.



WARNING

The pin is not secured!

If the pins **45** are not secured, the pins can loosen up by themselves during transport operation. Personnel can be severely injured or killed.

- ▶ Make sure that the pins **45** are secured after the pin procedure.

- ▶ Secure the pin **45**: Release the pin **44.1** on both sides in point **P40** and unpin, then insert the pin **44.1** in point **P39** on both sides and secure with the safety locking pin **44.2**.
- ▶ Retract the piston rod **47** of the pin pulling cylinder on both sides: Actuate the hand lever **48**.



WARNING

Swinging bracket!

When releasing the bracket **42** in point **P38**, it can swing downward uncontrolled.

Personnel can be severely injured.

- ▶ Hold the bracket **42** when unpinning.
- ▶ Assembly personnel must be to the side of the assembly unit.
- ▶ Remove the safety locking pin **43.2** on both sides in point **P38** and unpin the pin **43.1**.
- ▶ Fold the bracket **42** down, insert the pin **43.1** again on both sides in point **P38** and secure with the safety locking pin **43.2**, see illustration **25**.

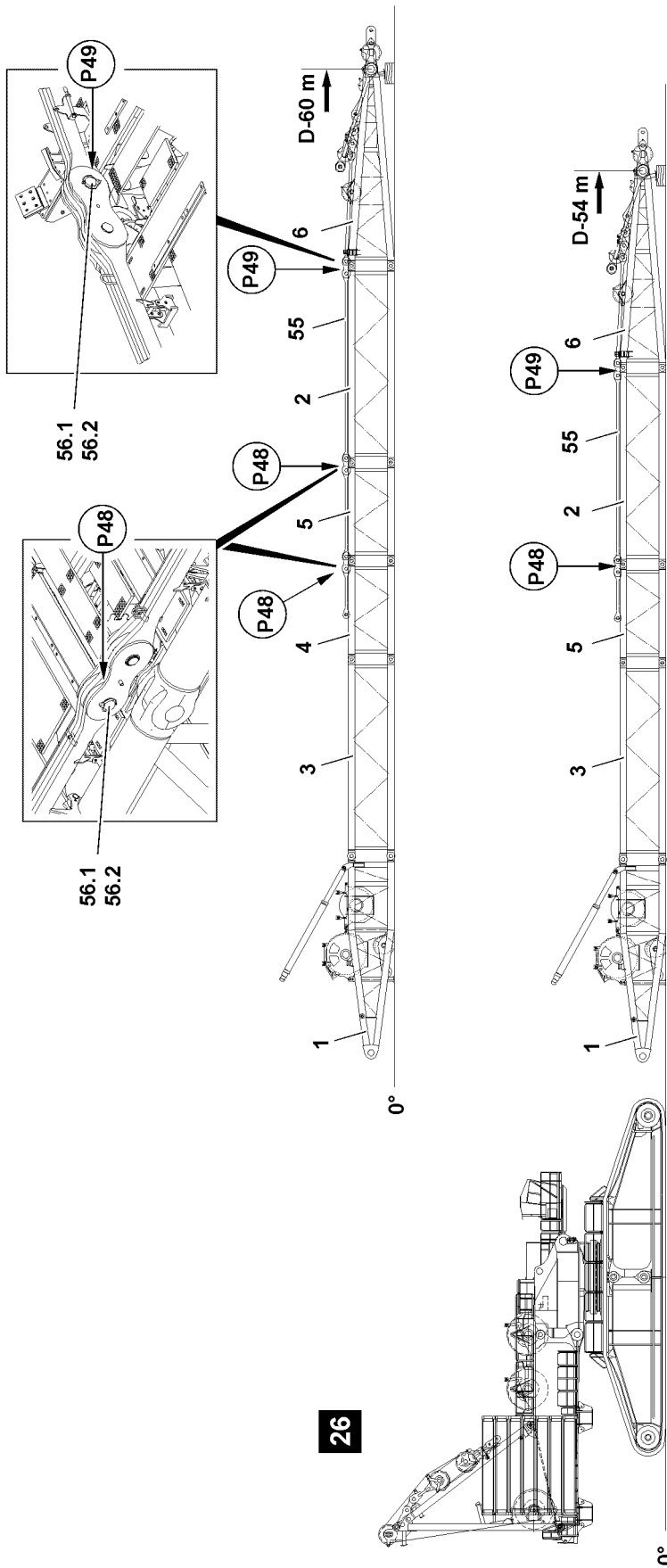

Fig.115638

4.18.2 Disassembling the D-boom



Note

- ▶ Always support the D-intermediate sections sufficiently for easier disassembly.



Note

- ▶ The procedure in the pin locations is the same as the work steps for the previously described disassembly of the D-end section and the D-intermediate section, see section „Disassembling the D-boom in sections“.

Disassembling the derrick guy rods



WARNING

Neglected inspection and maintenance on guy rods!

If the regular inspection and maintenance of the guy rods is not carried out or is carried out only in irregular intervals, then serious accidents can occur due to existing and unrecognized damage to the guy rods.

Personnel can be severely injured or killed.

- ▶ The guy rods must be checked before every assembly, see the Crane operating instructions, chapter 8.15.
- ▶ Unpin the derrick guy rods **55**: Remove the safety locking pin **56.2** on both sides in points **P48** and unpin the pin **56.1**, see illustration **26**.
- ▶ Unpin the derrick guy rods **55**: Remove the safety locking pin **56.2** on both sides in points **P49** and unpin the pin **56.1**, see illustration **26**.

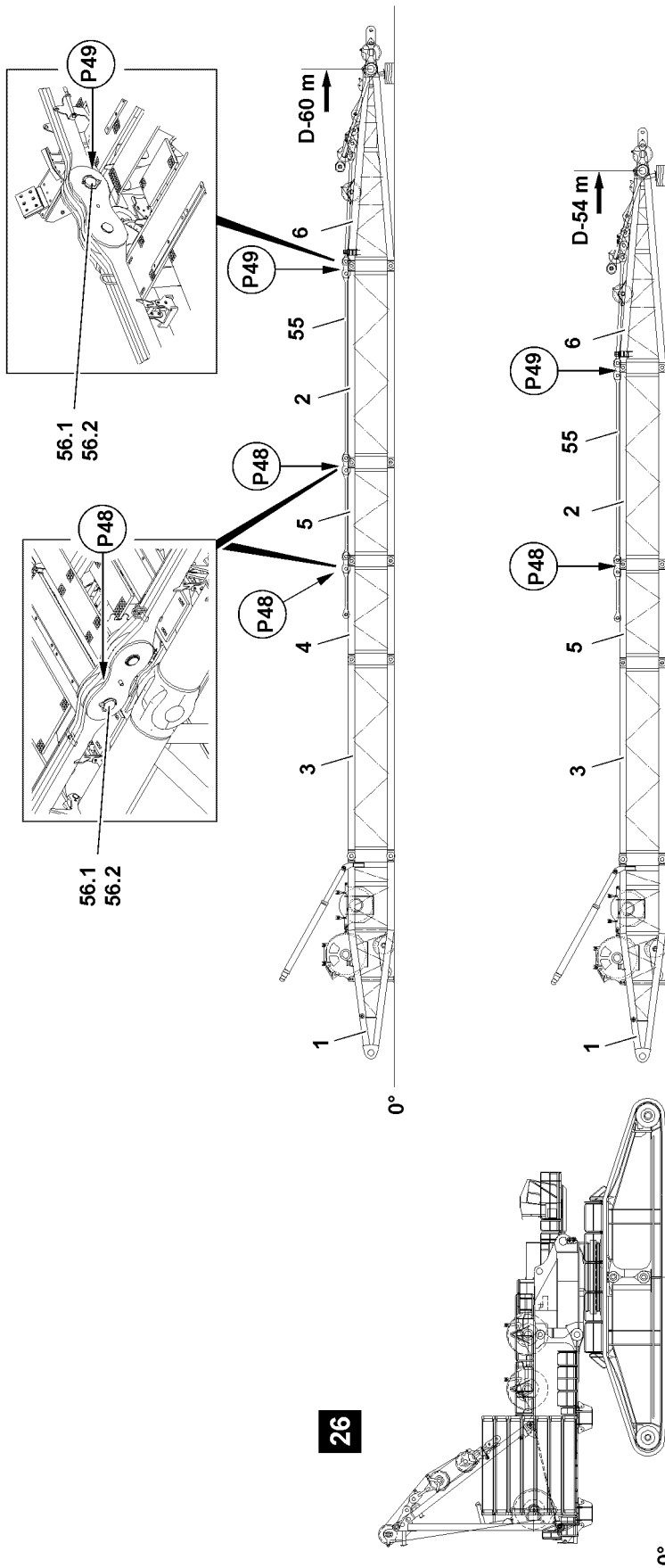

Fig.115638

Unpinning the D-end section

**Note**

- ▶ Always support the D-sections sufficiently for easier disassembly.
 - ▶ The procedure in the pin locations is the same as the work steps for the previously described unpinning procedure on the D-intermediate section, see section „Disassembling the D-boom in sections“.
-

- ▶ Unpin the D-end section **6**.

Unpinning the D-pivot section

**Note**

- ▶ Always support the D-sections sufficiently for easier disassembly.
 - ▶ The procedure in the pin locations is the same as the work steps for the previously described unpinning procedure on the D-intermediate section, see section „Disassembling the D-boom in sections“.
-

- ▶ Unpin the D-pivot section **1**.

Unpinning the D-intermediate section

**Note**

- ▶ Always support the D-sections sufficiently for easier disassembly.
 - ▶ The procedure in the pin locations is the same as the work steps for the previously described unpinning procedure on the D-intermediate section, see section „Disassembling the D-boom in sections“.
-

- ▶ Unpin the D-intermediate section **2** and D-intermediate section **5**.

4.19 Disassembling the D-intermediate sections with the cross beam

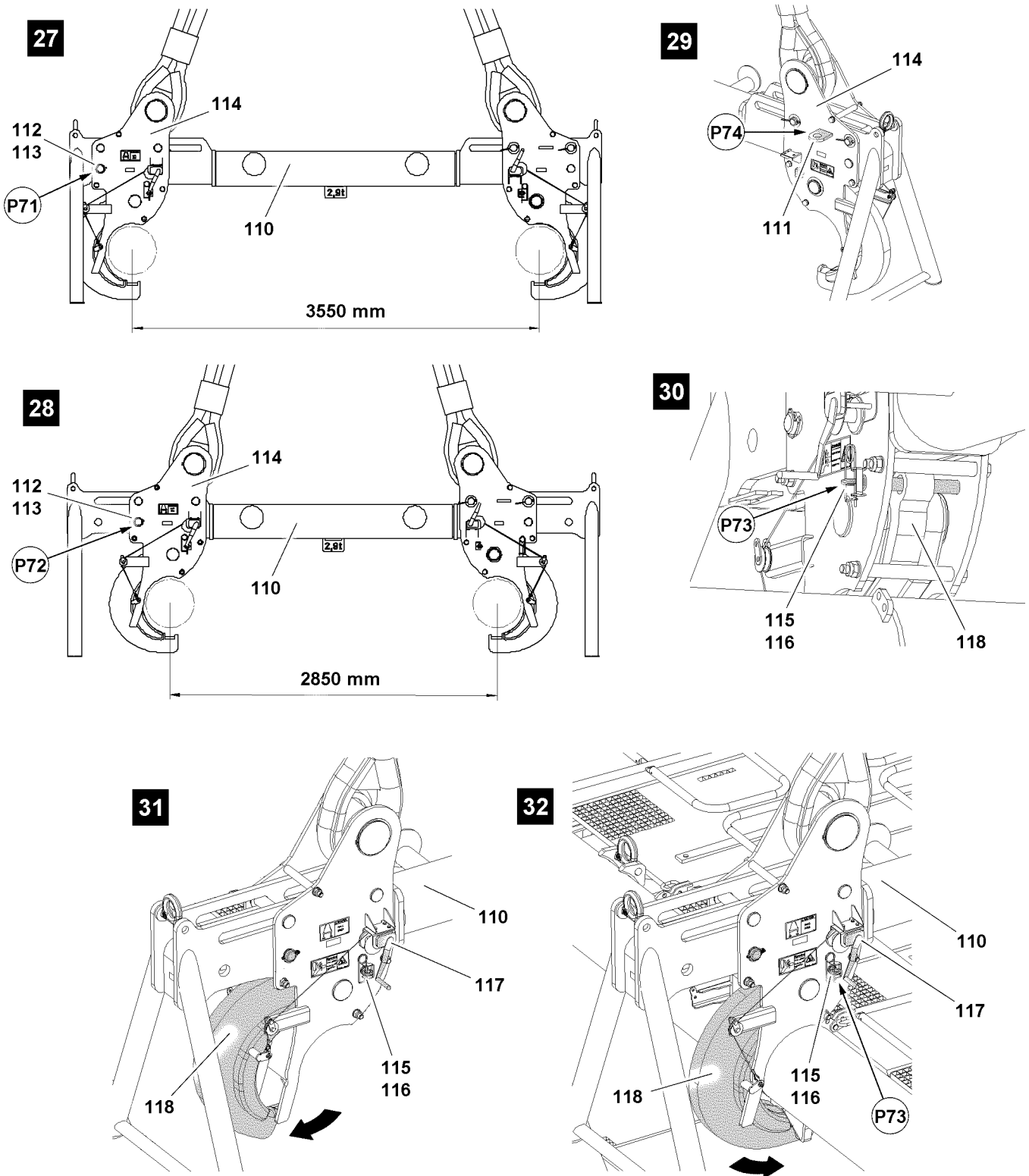

Fig.124433: Assembly condition of cross beam

LWE/LR 13000-001/19503-01-02/en

4.19.1 Cross beam

The cross beam is designed for the assembly and disassembly of the boom system. The cross beam is used during disassembly to lift the boom section and to move the assembly shoes back by one „lattice length“.

Make sure that the following prerequisites are met:

- An auxiliary crane with sufficient load carrying capacity is available.
- The cross beam is placed safely on the ground.
- The loops on the cross beam are in the transport position.

Preparing the cross beam

The cross beam **110** must be adjusted before disassembly depending on the width of the intermediate section, see illustration **27** and illustration **28**.

- ▶ Remove the safety locking pin **112** in point **P71** and unpin the pin **113**, see illustration **27**.
- ▶ Fasten an auxiliary unit with sling to the eyehook **111** in point **P74** of the counter section **114**, see illustration **29**.
- ▶ Slide the counter section **114** with the auxiliary unit until it can be pinned in point **P72**, see illustration **28**.

When the bores align in point **P72**:

- ▶ Insert the pin **113** in point and secure with the safety locking pin **112**, see illustration **28**.

Result:

- The counter section **114** is secured.
- ▶ Slide the second counter section **114**.

Fastening the cross beam to the intermediate section

- ▶ Release the cross beam hook **118**: Remove the spring retainer **116** in point **P73** and unpin the pin **115**, see illustration **30** and illustration **31**.
- ▶ Pull both cross beam hooks **118** up with the manual winch **117**, see illustration **31**.
- ▶ Fasten the cross beam **110** to the auxiliary crane.

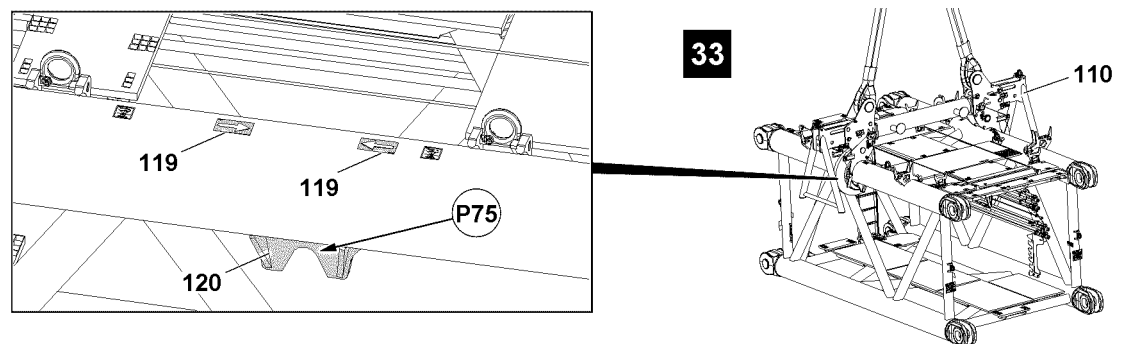

Fig.124434: Position of catches



Note

- ▶ The position of the catches **120** on the intermediate section is marked by two arrows **119**, see illustration **33**.

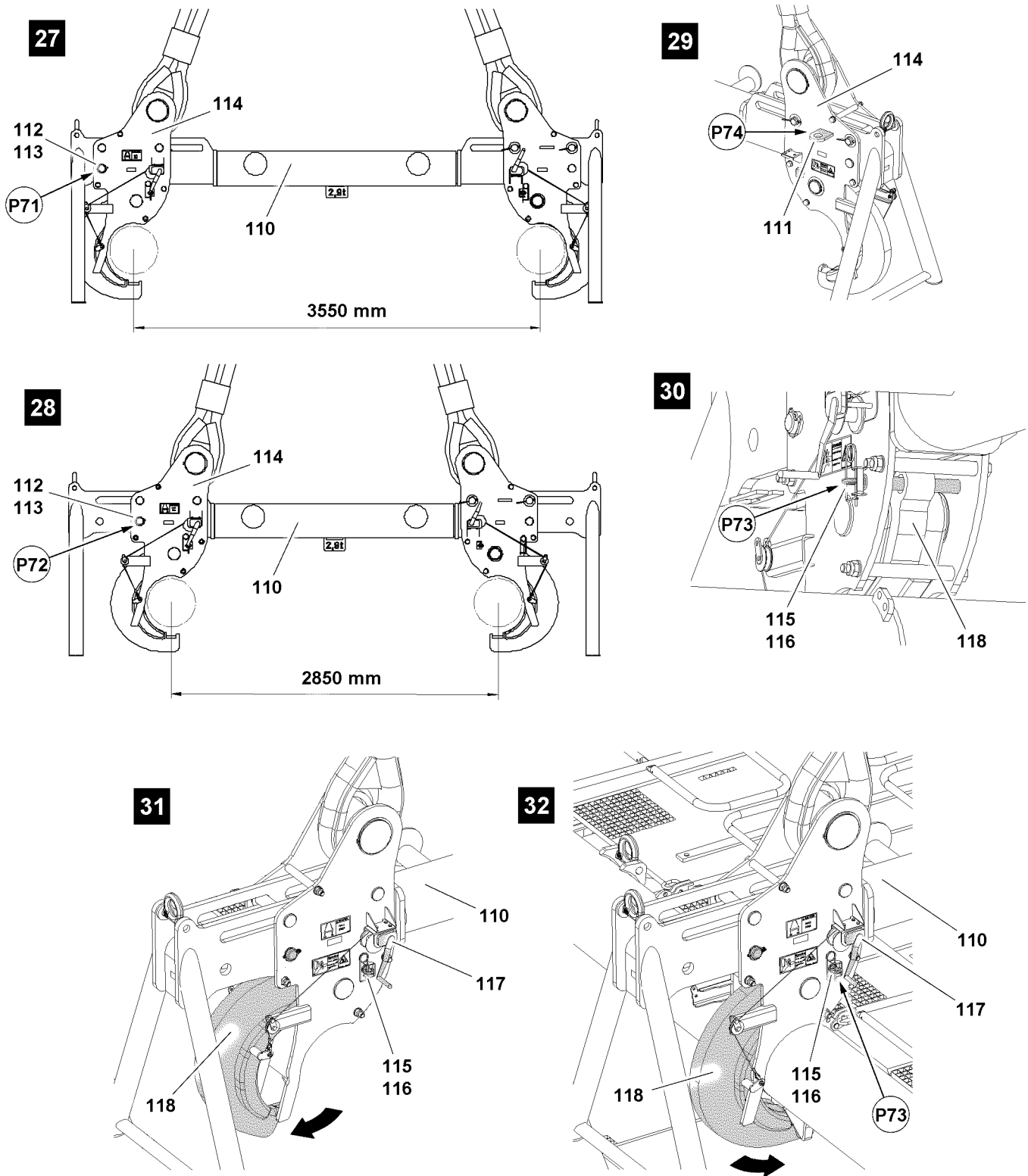

Fig.124433: Assembly condition of cross beam



Note

- ▶ The disassembly of the intermediate sections is described based on the example of one intermediate section.
- ▶ Swing the cross beam **110** with the auxiliary crane to the marked positions on the intermediate section.

- ▶ Set the cross beam **110** with the auxiliary crane on the intermediate section, see illustration **32**.
- ▶ Lower the cross beam hook **118** with the manual winch **117** until it can be pinned in point **P73**, see illustration **32**.



WARNING

Incorrect fastening!

If the following instructions are not observed, dangerous situations can arise.

Death, severe injuries, property damage.

- ▶ Make sure that the cross beam hooks **118** enter the catches **120**. Visual inspection!
 - ▶ Make sure that the cross beam hooks **118** are secured.
-
- ▶ Secure the cross beam hooks **118**: Insert the pin **115** in point **P73** and secure with the spring retainer **116**, see illustration **30** and illustration **32**.

When the cross beam hooks **118** are entered and secured on the catches **120**:

- ▶ Lift the intermediate section with the cross beam.

4.19.2 Disassembling the D-lattice sections with the cross beam

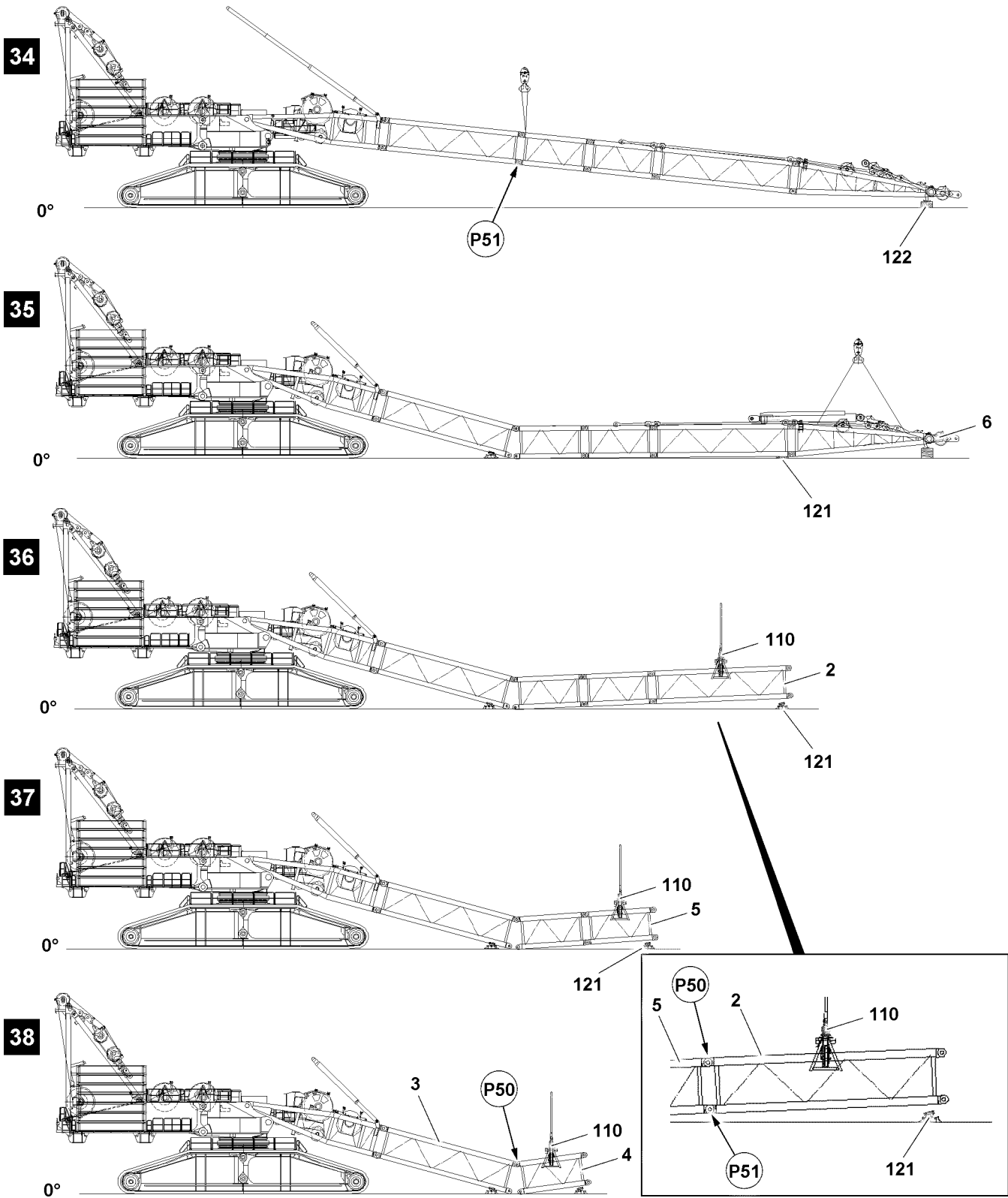

Fig.124429: Disassembling the D-intermediate sections with the aid of the cross beam

LWE/LR 13000-001/19503-01-02/en

Make sure that the following prerequisites are met:

- The crane is horizontally aligned.
- An auxiliary crane is available.
- An assembly scaffolding / work platform is available.
- The counterweight has been installed on the turntable according to the load chart.
- The D-boom system is taken down on the substructure, see illustration 34.

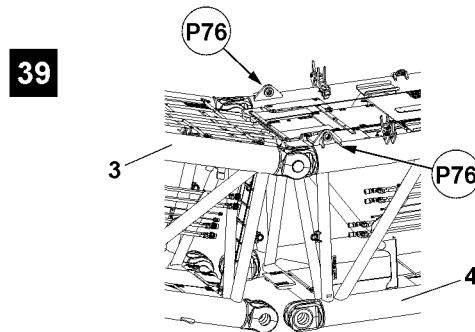

Fig.124430: Opening the D-boom system

- ▶ Fasten the auxiliary crane to the D-intermediate section 4 in point P76, see illustration 39.

When the D-boom system is held by the auxiliary crane:

- ▶ Unpin the pin in point P51 and take the D-boom system down on the assembly shoes, see illustration 34, illustration 35 and section „Disassembling the D-boom in sections“.
- ▶ Disassemble and fasten the D-end section 6 to the auxiliary crane, see illustration 35 and section „Disassembling the D-boom in sections“.
- ▶ Fasten the cross beam 110 with the auxiliary crane on the D-intermediate section 2, see illustration 36.
- ▶ Lift the D-boom system via the cross beam with the auxiliary crane.

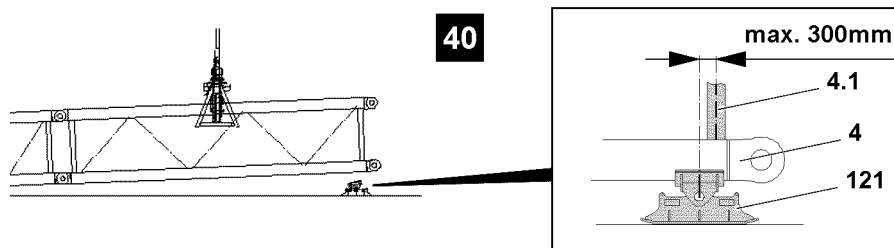

Fig.124431: Position of assembly shoes

NOTICE

Danger of property damage on the intermediate sections!

If the assembly shoes 121 are not placed underneath in the permitted area of the intermediate sections, then the intermediate sections can be overloaded and damaged!

- ▶ Make sure that the assembly shoes are only placed underneath in the permitted area of maximum 300 mm on the corner bar 4.1, see illustration 40.
 - ▶ The crane operator is responsible for the proper substructure of the intermediate sections with the assembly shoes.
-
- ▶ Remove the assembly shoes 121 under the D-intermediate section 2 and position under the D-intermediate section 5 in the area of the corner bar 4.1, see illustration 36, illustration 37 and illustration 40.

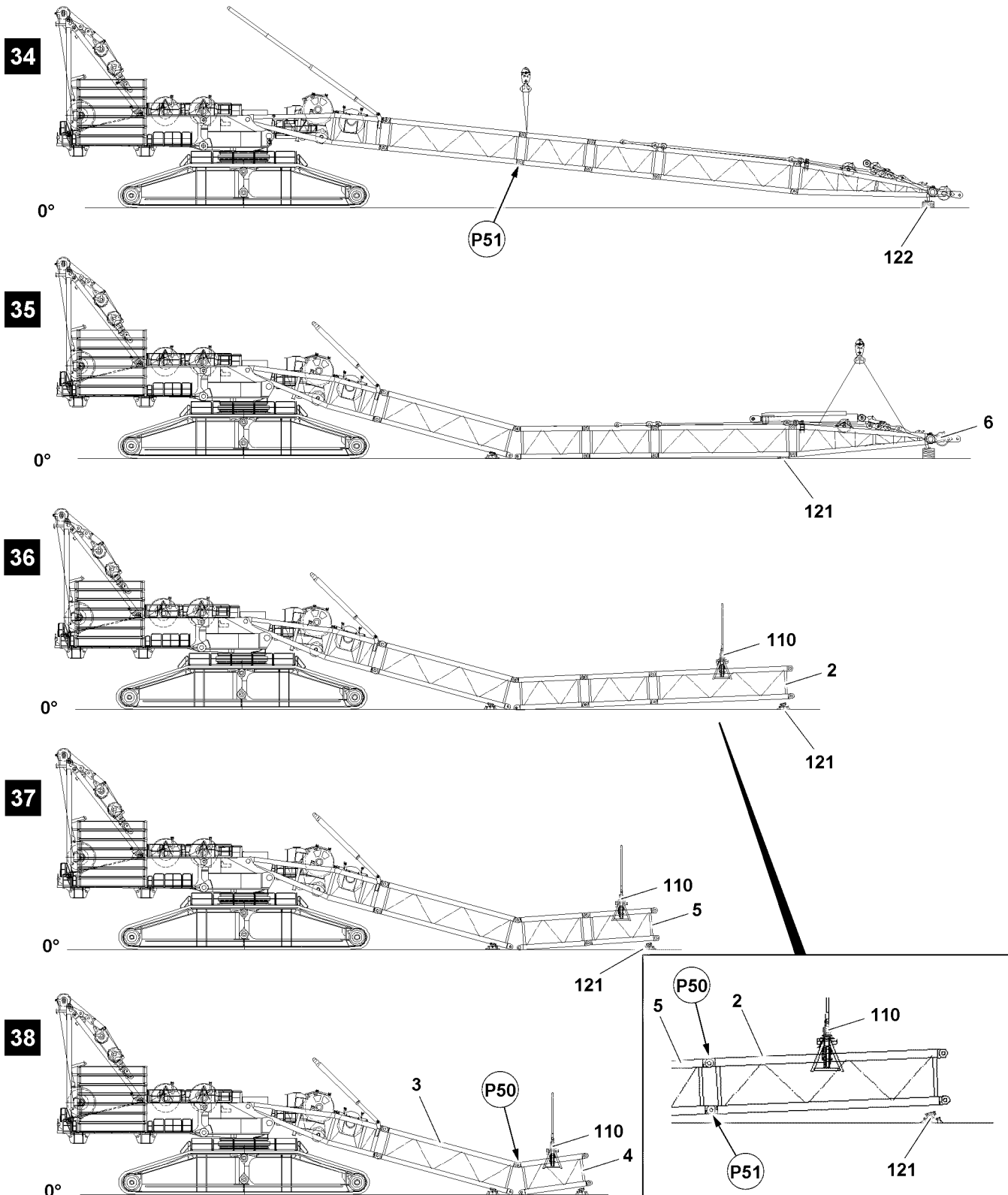

Fig.124429: Disassembling the D-intermediate sections with the aid of the cross beam

- ▶ Take the D-boom system down via the cross beam with the auxiliary crane on the assembly shoes 121, see illustration 37.
- ▶ Unpin the D-intermediate section 2 in point P50 and point P51 and remove, see illustration 37 and section „Disassembling the D-boom in sections“.
- ▶ Remove the D-intermediate section 5 and D-intermediate section 4 according to the previously described steps, see illustration 38.

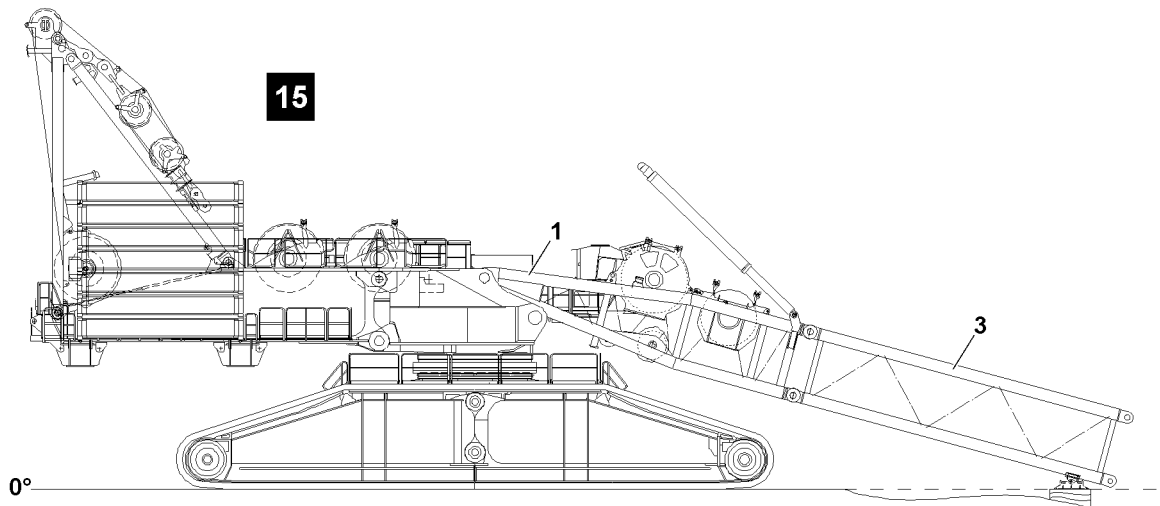

Fig.124432: Disassembly of the first D-intermediate section



WARNING

Incorrect fastening equipment!

Due to the large installation angle of the first D-intermediate section **3**, dangerous situations can arise during disassembly, see illustration **41**.

Death, severe injury, property damage.

- ▶ Make sure that no cross beam is used when disassembling the first D-intermediate section **3**.
- ▶ For the disassembly of the first D-intermediate section **3** use the normal fastening equipment.



Note

- ▶ Disassembly of the first D-intermediate section **3** and D-pivot section **1**, see section „Assembling the D-boom in sections“.

- ▶ Disassemble the D-intermediate section **3**.
- ▶ Disassemble the D-pivot section **1**.

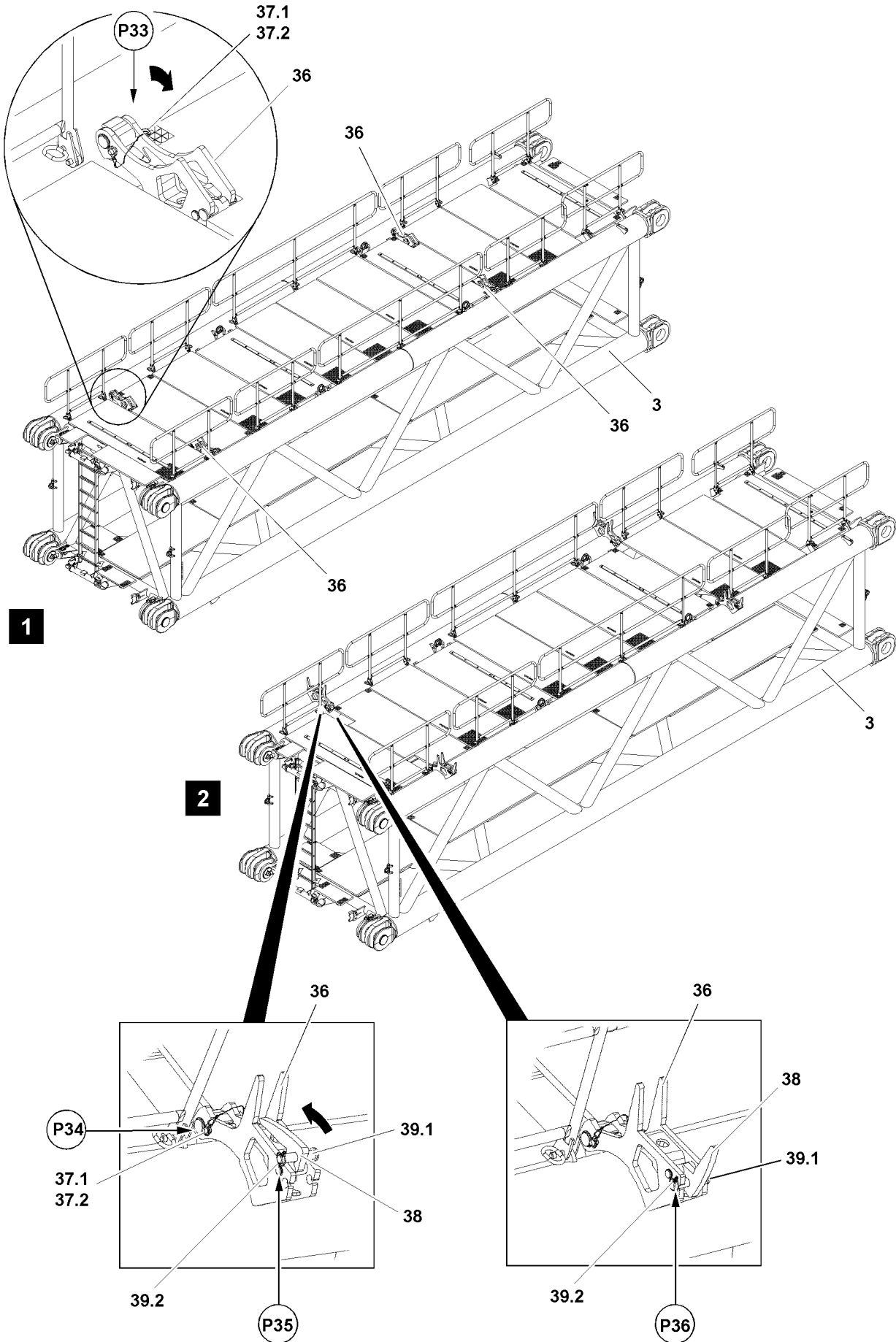

Fig.124421

LWE/LR 13000-001/19503-01-02/en

5 Preparing the lattice sections for transport

5.1 Preparing the D-intermediate section for transport



WARNING

Danger of falling!

During assembly and disassembly, personnel must be secured with appropriate aids to prevent them from falling.

Even for assembly and disassembly of protective devices there is a danger of falling.

Assembly personnel can fall and be severely injured or killed.

- ▶ Use personal protective equipment.

5.1.1 D-intermediate section 2824.36 12m

Swinging the rod receptacles into the transport position

- ▶ Release the latches **38** from the operating position: Remove the safety locking pin **39.2** in point **P36** and unpin the pin **39.1**.
- ▶ Swing the latches **38** to the stop, see illustration **2**.



WARNING

The pins can loosen up by themselves!

- ▶ Secure the pin **39.1** immediately after pinning with the safety locking pin **39.2**.
- ▶ Secure the latches **38** in the transport position: Insert the pin **39.1** in point **P35** and secure with the safety locking pin **39.2**, see illustration **2**.
- ▶ Release the rod receptacle **36** from the operating position: Remove the safety locking pin **37.2** in point **P34** and unpin the pin **37.1**, see illustration **2**.



WARNING

Danger of accident when swinging in the rod receptacle!

When swinging in the rod receptacle **36**, limbs can be crushed or severed.

Personnel can be severely injured.

- ▶ Do not reach with your hands into the danger zone.
- ▶ Swing the rod receptacle **36** to the stop, see illustration **1**.



WARNING

The pins can loosen up by themselves!

- ▶ Secure the pin **37.1** immediately after pinning with the safety locking pin **37.2**.
- ▶ Secure the rod receptacle **36** in the transport position: Insert the pin **37.1** in point **P33** and secure with the safety locking pin **37.2**, see illustration **1**.
- ▶ Swing all rod receptacles into the transport position.

Swinging the railing on the D-intermediate section into the transport position



Note

- ▶ Swing the railings on the D-intermediate section into the transport position, see the Crane operating instructions, chapter 2.06.

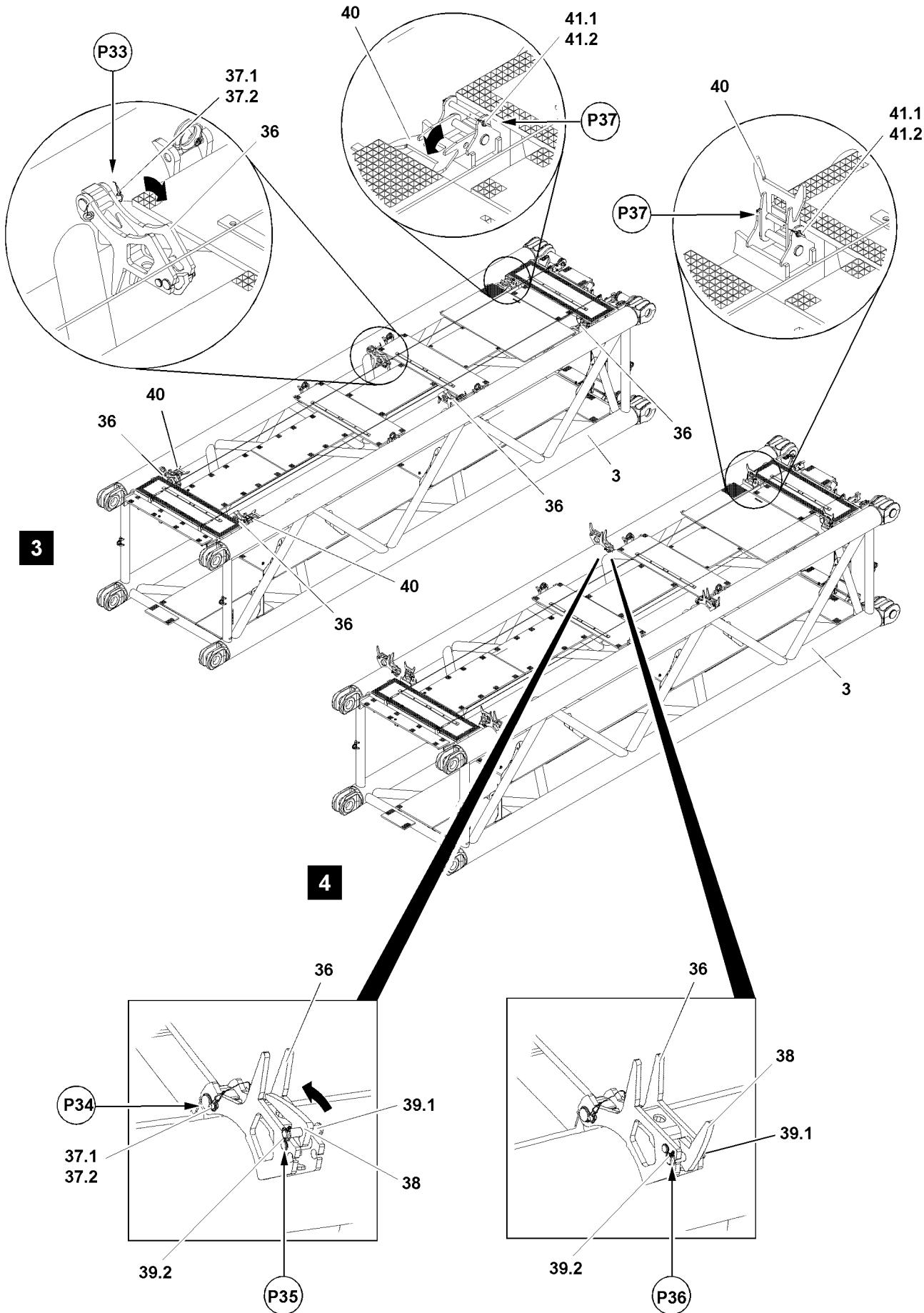

Fig.124422

LWE/LR 13000-001/19503-01-02/en

5.1.2 D-intermediate section 2824.25 12m

Swinging the rod receptacles into the transport position

- ▶ Release the latches **38** from the operating position: Remove the safety locking pin **39.2** in point **P36** and unpin the pin **39.1**.
- ▶ Swing the latches **38** to the stop, see illustration 4.



WARNING

The pins can loosen up by themselves!

- ▶ Secure the pin **39.1** immediately after pinning with the safety locking pin **39.2**.
- ▶ Secure the latches **38** in the transport position: Insert the pin **39.1** in point **P35** and secure with the safety locking pin **39.2**, see illustration 4.
- ▶ Release the rod receptacle **36** from the operating position: Remove the safety locking pin **37.2** in point **P34** and unpin the pin **37.1**, see illustration 4.



WARNING

Danger of accident when swinging in the rod receptacle!

When swinging in the rod receptacle **36**, limbs can be crushed or severed.
Personnel can be severely injured.

- ▶ Do not reach with your hands into the danger zone.
- ▶ Swing the rod receptacle **36** to the stop, see illustration 3.



WARNING

The pins can loosen up by themselves!

- ▶ Secure the pin **37.1** immediately after pinning with the safety locking pin **37.2**.
- ▶ Secure the rod receptacle **36** in the transport position: Insert the pin **37.1** in point **P33** and secure with the safety locking pin **37.2**, see illustration 3.
- ▶ Swing all rod receptacles into the transport position.

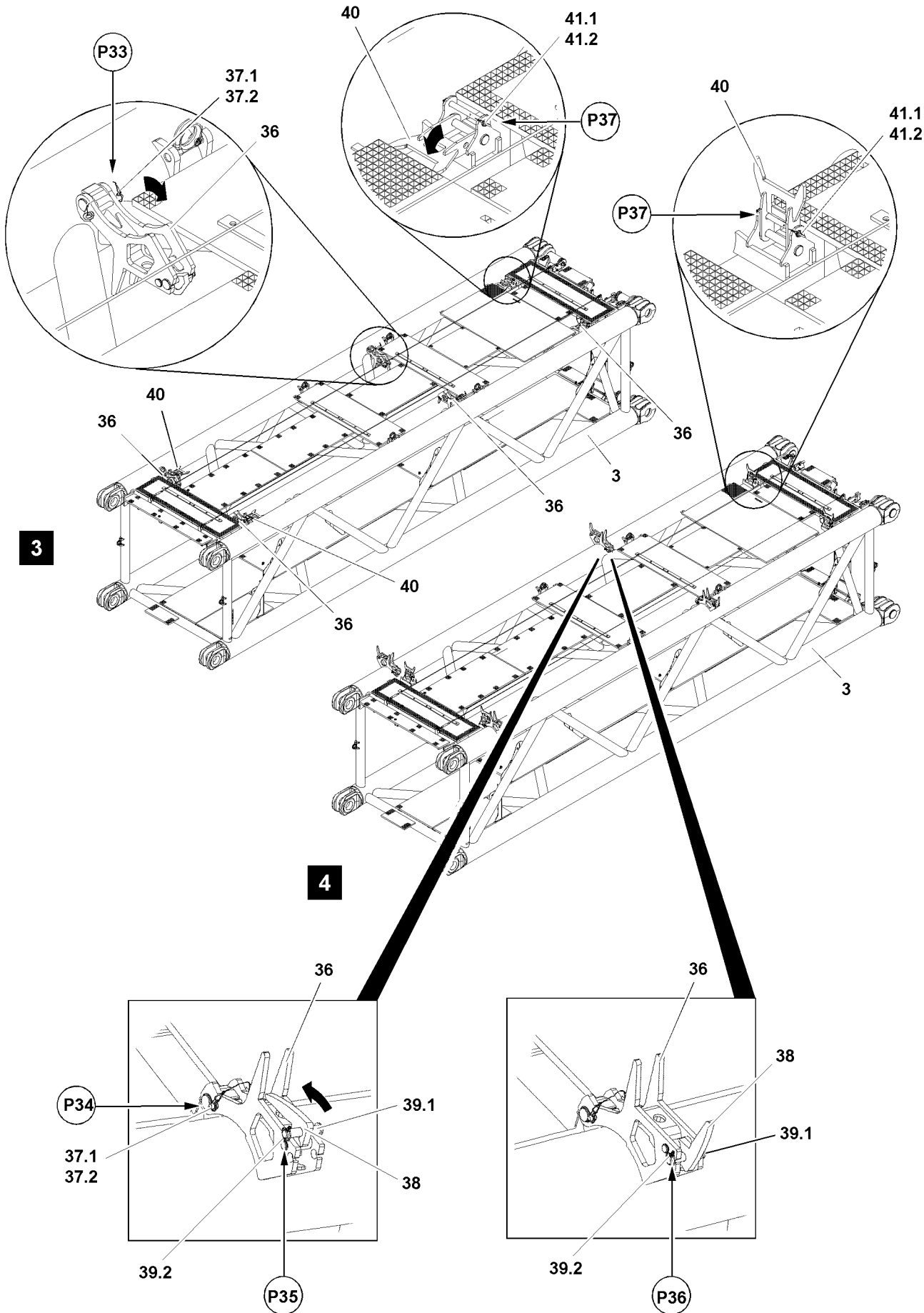

Fig.124422

LWE/LR 13000-001/19503-01-02/en

Swinging the rod receptacles into the transport position

- ▶ Release the rod receptacle **40** from the operating position: Remove the safety locking pin **41.2** in point **P37** and unpin the pin **41.1**, see illustration 4.



WARNING

Danger of accident when swinging in the rod receptacle!
When swinging in the rod receptacle **40**, limbs can be crushed or severed.
Personnel can be severely injured.

- ▶ Do not reach with your hands into the danger zone.
- ▶ Swing the rod receptacle **40** to the stop, see illustration 3.



WARNING

The pins can loosen up by themselves!

- ▶ Secure the pin **41.1** immediately after pinning with the safety locking pin **41.2**.
- ▶ Secure the rod receptacle **40** in the transport position: Insert the pin **41.1** in point **P37** and secure with the safety locking pin **41.2**, see illustration 3.
- ▶ Swing all rod receptacles into the transport position.

5.1.3 D-intermediate section 2824.36 6 m and D-intermediate section 2824.36A 6 m



Note

- ▶ The preparation of the intermediate sections with 6 m length is the same as the work steps for the previous described intermediate sections with 12 m length.
- ▶ Prepare the required intermediate sections for transport.

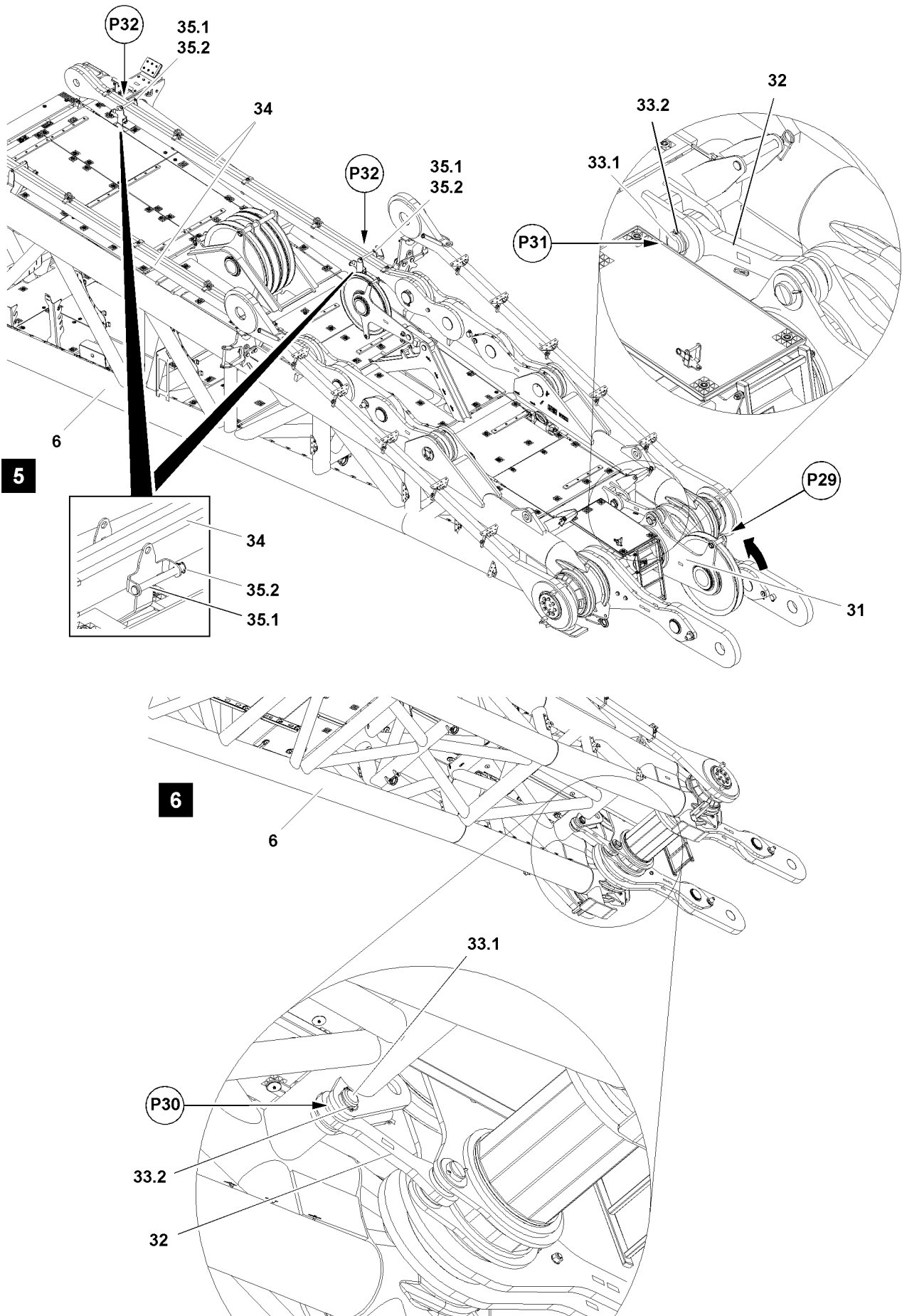

Fig.124423

LWE/LR 13000-001/19503-01-02/en

5.2 Preparing the D-end section for transport



WARNING

Danger of falling!

During assembly and disassembly, assembly personnel must be secured with appropriate aids to prevent them from falling.

Even for assembly and disassembly of protective devices there is a danger of falling.

Assembly personnel can fall and be severely injured or killed.

- ▶ Use personal protective equipment.

5.2.1 Swinging the pulley support into the transport position

- ▶ Fasten the pulley support **31** with loops to the auxiliary crane in point **P29**, see illustration **5**.



WARNING

Swinging bracket!

When releasing the bracket **32** in point **P31**, it can swing downward uncontrolled.

Personnel can be severely injured.

- ▶ Hold the bracket **32** when unpinning.
- ▶ Assembly personnel must be to the side of the assembly unit.



WARNING

Falling pulley support!

When releasing the bracket **32** in point **P31** the pulley support **31** can fall forward uncontrolled.

Personnel can be severely injured or killed.

- ▶ Make sure that the pulley support **31** is fastened to the auxiliary crane.



Note

- ▶ The weight of the bracket **32** is 58 kg.
- ▶ When unpinning the brackets, a second assembly person must be used to help.
- ▶ Release the pulley support **31** from the operating position: Remove the safety locking pin **33.2** in point **P31** and unpin the pin **33.1**, see illustration **5**.

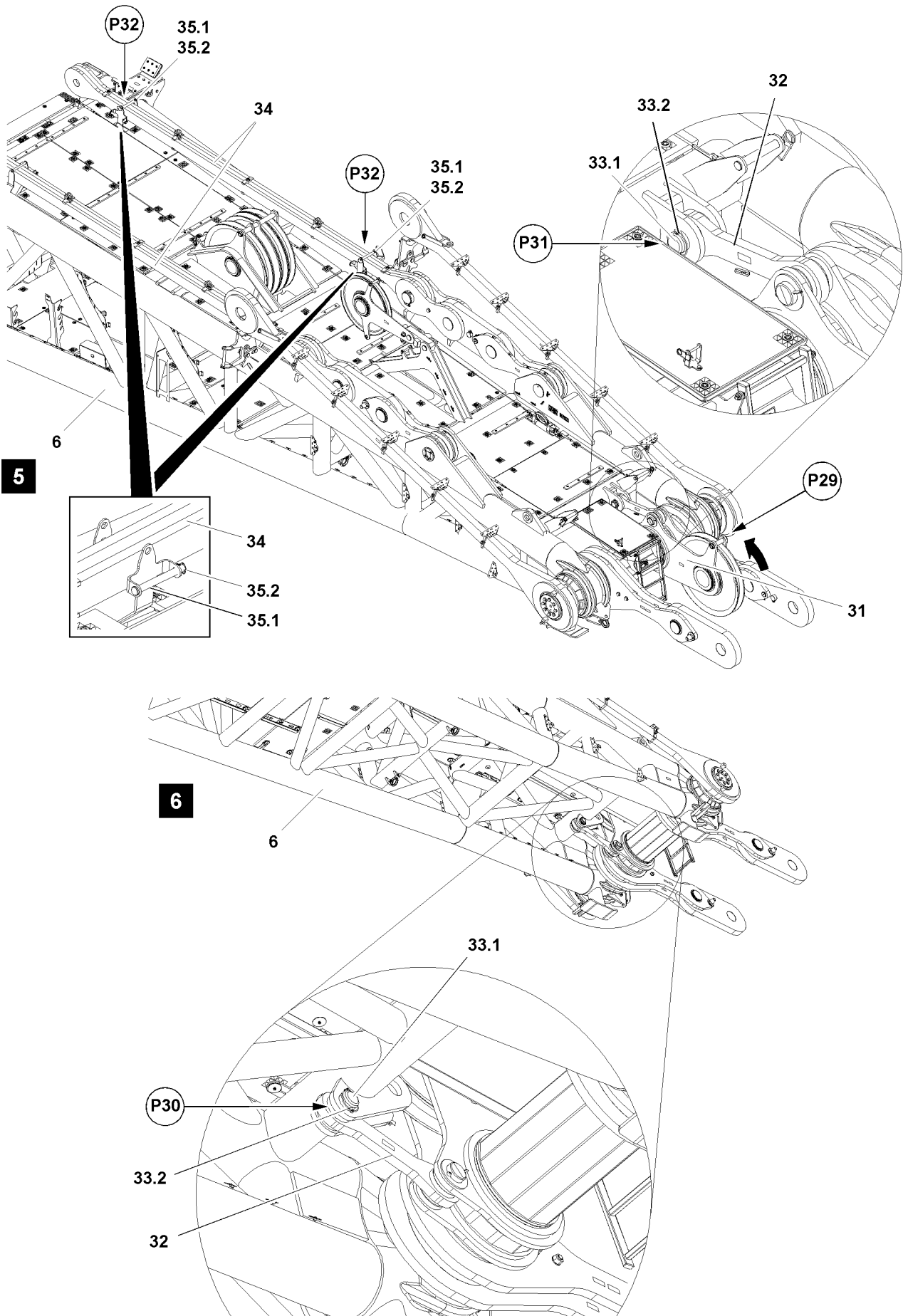

Fig.124423

LWE/LR 13000-001/19503-01-02/en

**WARNING**

Danger of accident when swinging in the pulley support!
When swinging in the pulley support **31**, limbs can be crushed or severed.
Personnel can be severely injured.

- ▶ Make sure that there is no personnel in the danger zone.
 - ▶ Do not reach with your hands into the danger zone.
-
- ▶ Swing the pulley support **31** with the auxiliary crane until the bracket **32** can be pinned in point **P30**, see illustration **6**.

**WARNING**

The pin is not secured!
If the pin **33.1** is not secured, the pin can loosen up by itself during transport operation.
This could result in property damage.

- ▶ Make sure that the pin **33.1** is secured with the safety locking pin **33.2**.
-
- ▶ Secure the pulley support **31** in the transport position: Insert the pin **33.1** in point **P30** and secure with the safety locking pin **33.2**, see illustration **6**.
 - ▶ Remove the auxiliary crane.

5.2.2 Securing the guy rods

- ▶ Remove the safety locking pin **35.2** and unpin the pin **35.1** from the park position, see illustration **5**.
- ▶ Insert the pin **35.1** in points **P32** and secure with the safety locking pin **35.2**, see illustration **5**.

Result:

- The guy rods are secured.

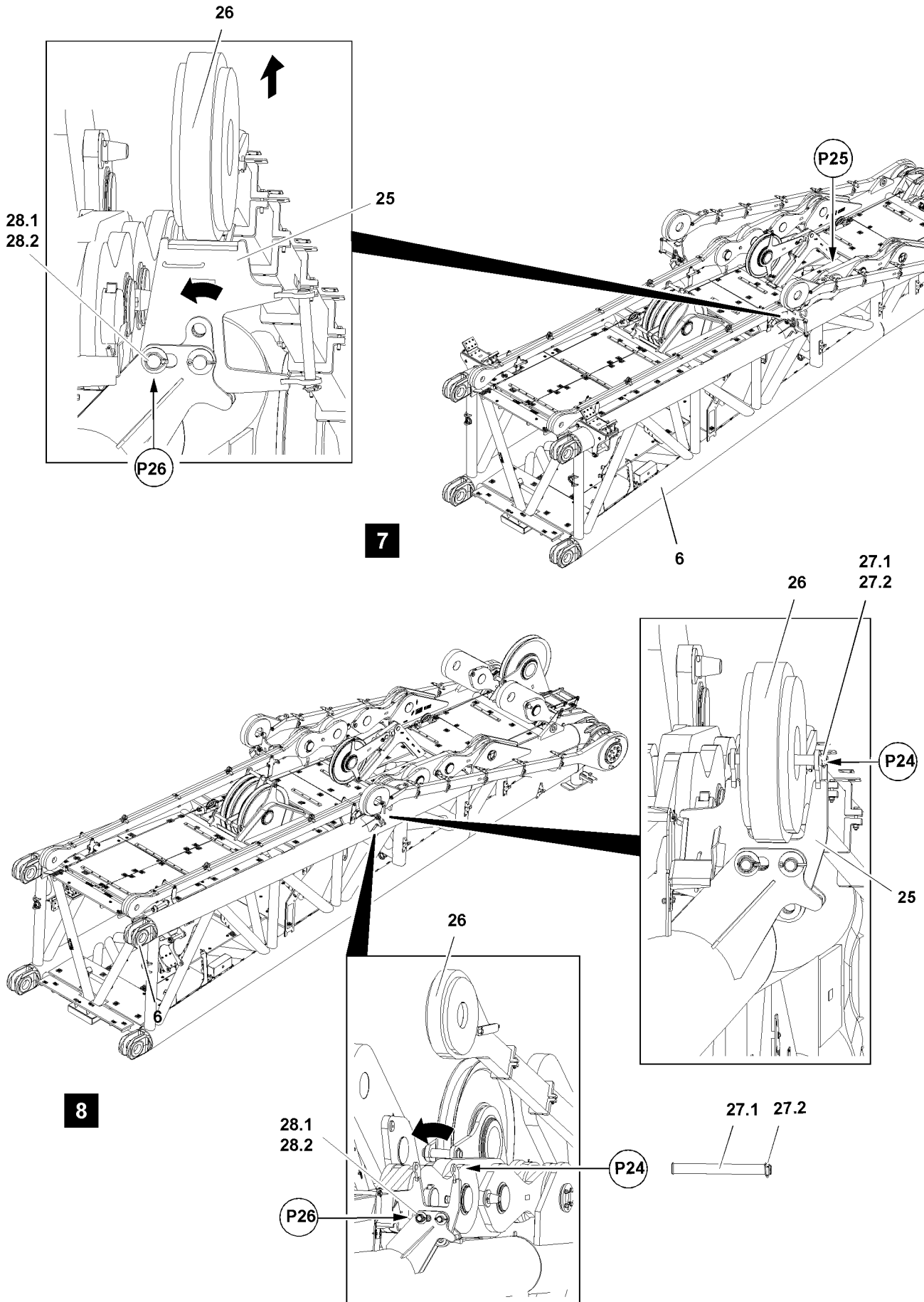

Fig.124424

LWE/LR 13000-001/19503-01-02/en

5.2.3 Folding the receptacle in

- ▶ Fasten the rod **26** to the auxiliary crane in point **P25**, see illustration 7.
- ▶ Lift the rod **26** with the auxiliary crane.
- ▶ Release the receptacle **25** from the operating position: Remove the safety locking pin **28.2** in point **P26** and unpin the pin **28.1**, see illustration 7.



WARNING

Danger of accident when swinging in the receptacle!
When swinging in the receptacle **25**, limbs can be crushed.
Personnel can be severely injured.

- ▶ Do not reach with your hands into the danger zone.

- ▶ Swing the receptacle **25** by hand to the stop.



WARNING

The pins can loosen up by themselves!

- ▶ Secure the pin **28.1** immediately after pinning with the safety locking pin **28.2**.
- ▶ Secure the receptacle **25** in the transport position: Insert the pin **28.1** in point **P26** and secure with the safety locking pin **28.2**, see illustration 8.
- ▶ Lower the rod **26** with the auxiliary crane onto the receptacle **25**, see illustration 7.
- ▶ Remove the auxiliary crane.
- ▶ Secure the rod **26** in the transport position: Insert the pin **27.1** in point **P24** and secure with the safety locking pin **27.2**, see illustration 8.
- ▶ Fold the second receptacle in.

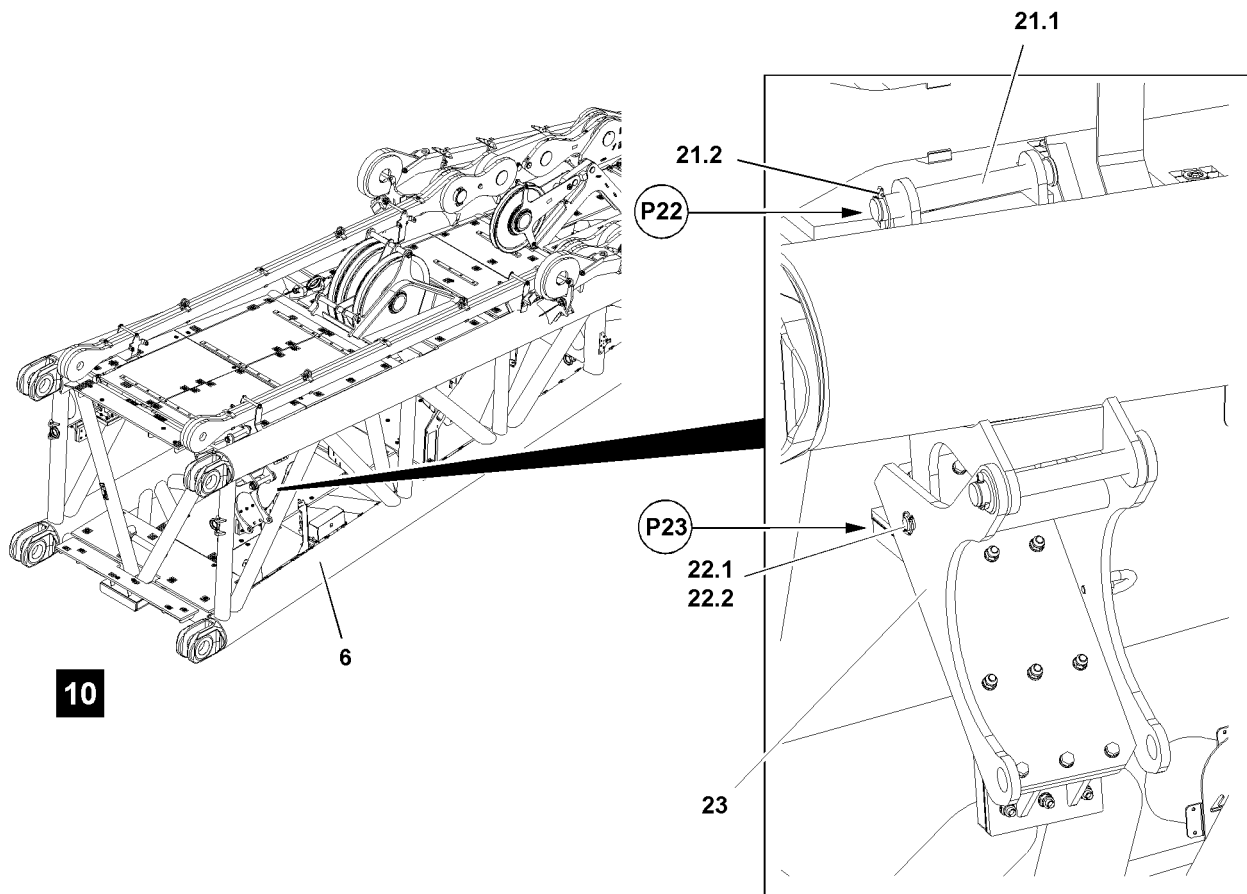
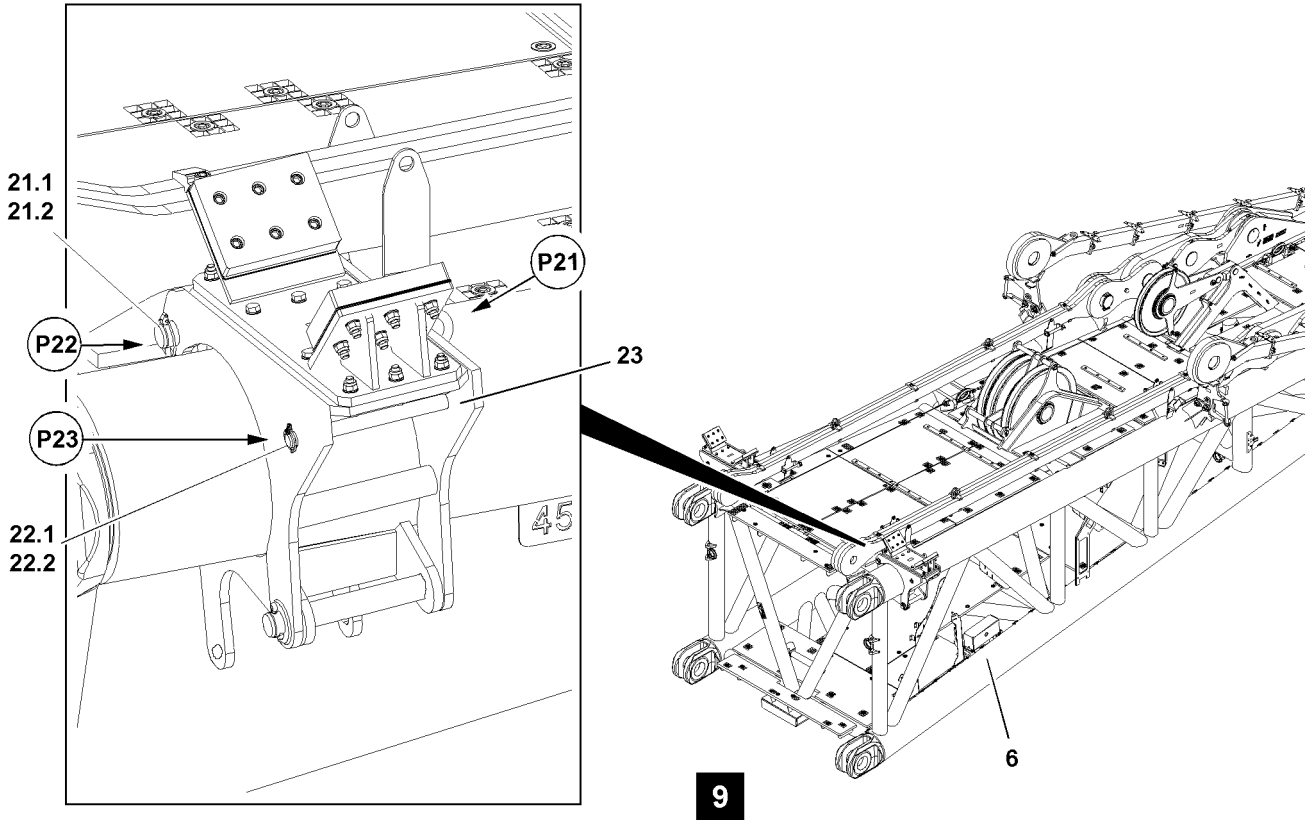

Fig.124425

LWE/LR 13000-001/19503-01-02/en

5.2.4 Folding the support in

- ▶ Fasten the support **23** to the auxiliary crane in point **P21**, see illustration **9**.
- ▶ Release the support **23** from the operating position: Remove the safety locking pin **21.2** in point **P22** and unpin the pin **21.1**, see illustration **9**.
- ▶ Remove the safety locking pin **22.2** in point **P23** and unpin the pin **22.1**, see illustration **9**.



WARNING

Danger of accident when swinging in the support!
When swinging in the support **23**, limbs can be crushed or severed.
Personnel can be severely injured.

- ▶ Make sure that there is no personnel in the danger zone.
 - ▶ Do not reach with your hands into the danger zone.
-
- ▶ Swing the support **23** with the auxiliary crane until it can be pinned in point **P23**, see illustration **10**.



WARNING

The pins can loosen up by themselves!

- ▶ Secure the pin **22.1** immediately after pinning with the safety locking pin **22.2**.
-
- ▶ Secure the support **23** in the transport position: Insert the pin **22.1** in point **P23** and secure with the safety locking pin **22.2**, see illustration **10**.
 - ▶ Insert the pin **21.1** again in point **P22** and secure with a safety locking pin **21.2**, see illustration **10**.
 - ▶ Remove the auxiliary crane.
 - ▶ Fold the second support out.

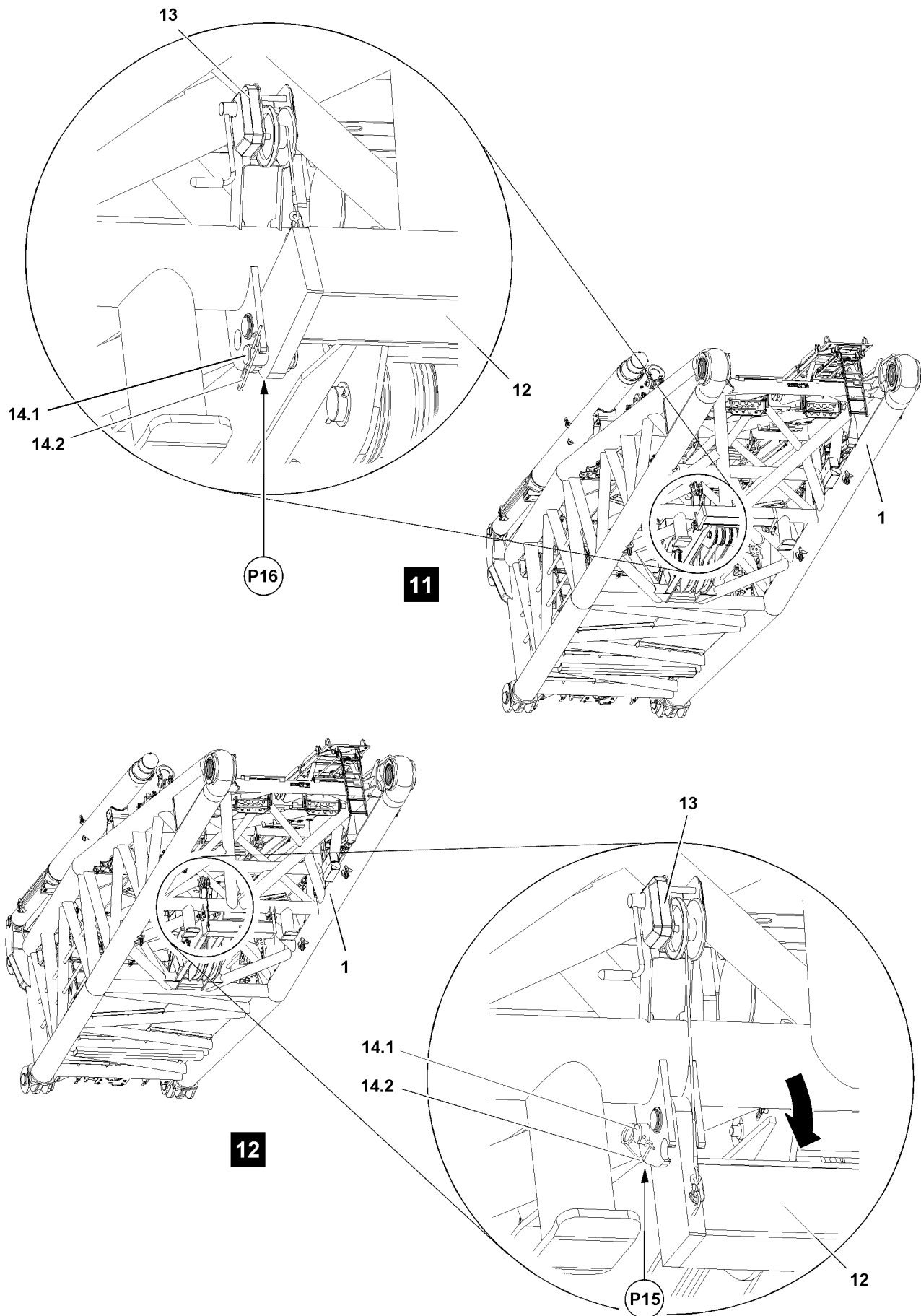

Fig.124426

LWE/LR 13000-001/19503-01-02/en

5.3 Preparing the D-pivot section for transport

5.3.1 Folding the transport frame down

- ▶ Release the transport frame **12** on both sides: Remove the spring retainer **14.2** in point **P16** and unpin the pin **14.1**, see illustration **11**.
- ▶ Fold the transport frame **12** down: Actuate the rope winch **13**, see illustration **12**.
- ▶ Secure the transport frame **12** on both sides: Insert the pin **14.1** in point **P15** and secure with the spring retainer **14.2**, see illustration **12**.

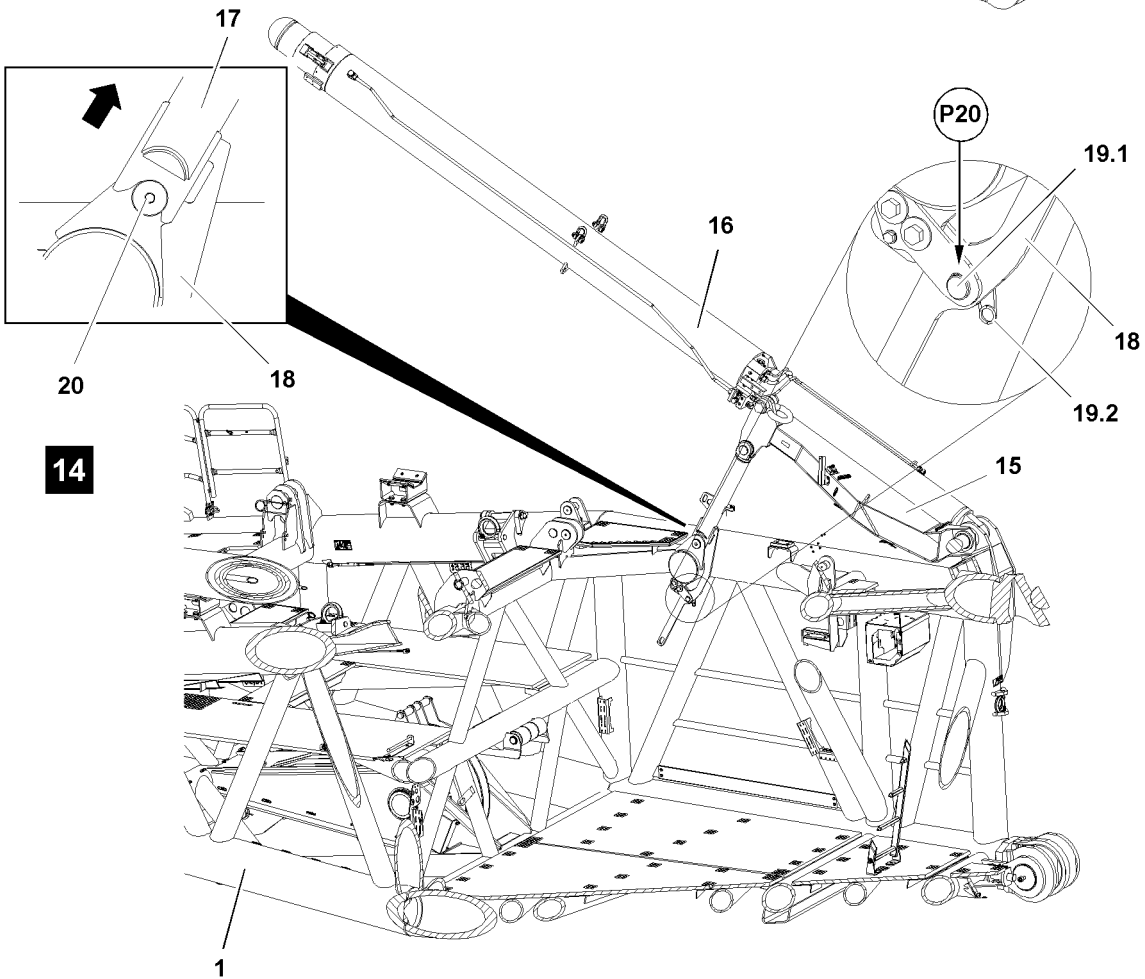
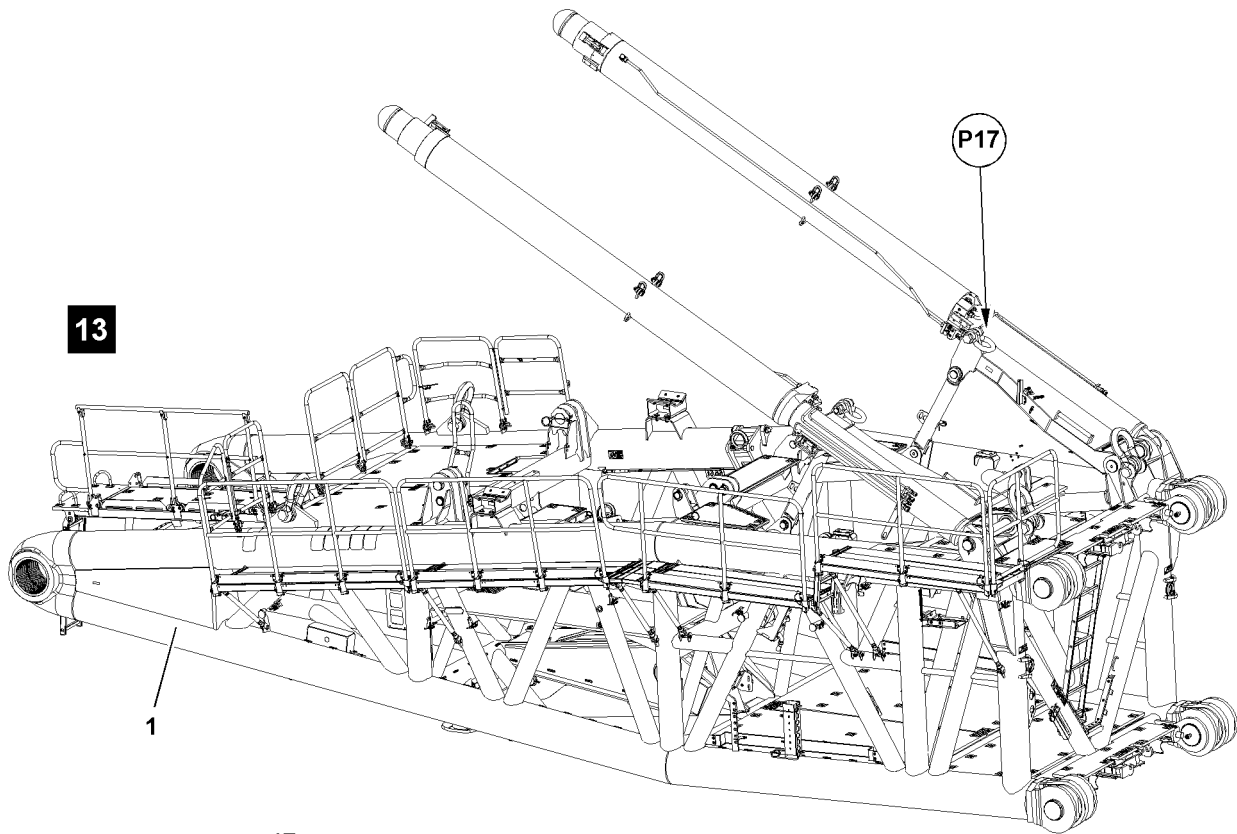

Fig.124427

LWE/LR 13000-001/19503-01-02/en

5.3.2 Taking the relapse retainer down

- ▶ Fasten the driver **15** to the auxiliary crane in point **P17**, see illustration **13**.



WARNING

Swinging support!

When lifting the support **17** it can swing inward uncontrolled.

Personnel can be severely injured or killed.

- ▶ Hold the support **17** when lifting.
 - ▶ Assembly personnel must be to the side of the assembly unit.
-
- ▶ Release the support **17** in point **P20**: Remove the spring retainer **19.2** and unpin the pin **19.1**, see illustration **14**.
 - ▶ Erect the relapse retainer **16** until the support **17** can be disengaged from the receptacle **20**: Lift the driver **15** with the auxiliary crane, see illustration **14**.

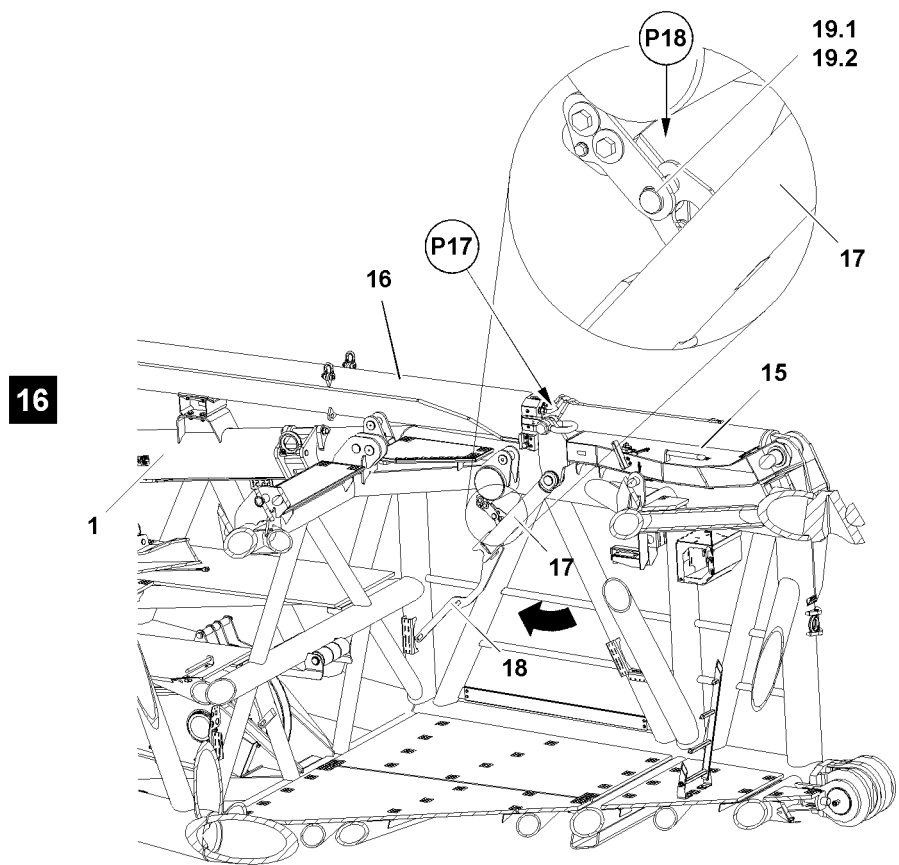
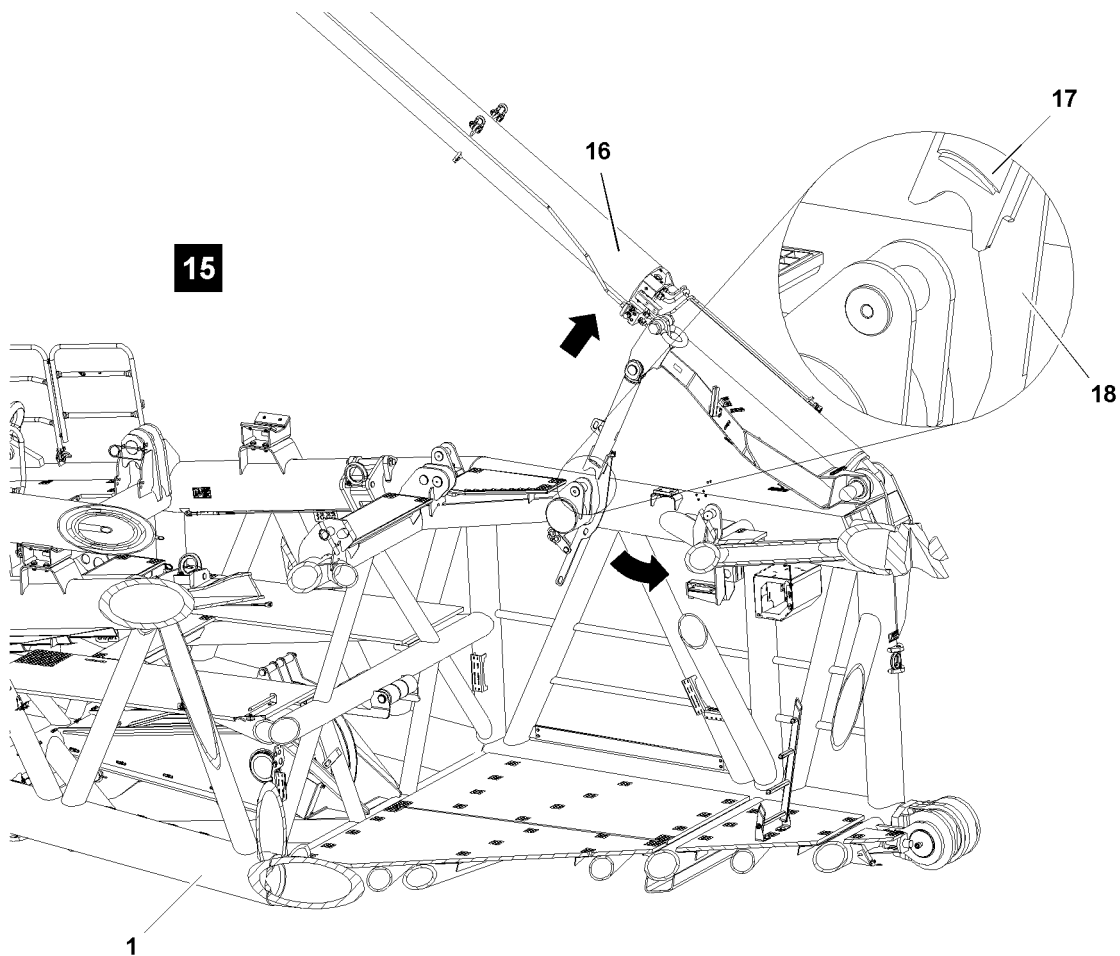

Fig.124428

LWE/LR 13000-001/19503-01-02/en

When the support **17** is disengaged from the receptacle **20**, see illustration **15**:

- ▶ Pull the support **17** with the lever **18** to the inside and take the relapse retainer **16** down with the auxiliary crane, see illustration **16**.
- ▶ Push the support **17** forward with the lever **18** until it can be pinned in point **P18**, see illustration **16**.



WARNING

The pins can loosen up by themselves!

- ▶ Secure the pin **19.1** immediately after pinning with the safety locking pin **19.2**.
- ▶ Secure the support **17** in point **P18**: Insert the pin **19.1** and secure with the spring retainer **19.2**, see illustration **16**.
- ▶ Take the second relapse retainer down.

5.3.3 Disassembling the railings on the platforms



Note

- ▶ Disassemble the railings on the platforms, see the Crane operating instructions, chapter 2.06.

5.3.4 Swinging the platforms on the D-pivot section into the transport position



Note

- ▶ Swing the platforms on the D-pivot section into the transport position, see the Crane operating instructions, chapter 2.06.

5.3.5 Swinging the railing on the D-pivot section into the transport position



Note

- ▶ Swing the railing on the D-pivot section into the transport position, see the Crane operating instructions, chapter 2.06.

5.3.6 Sliding the ladder in on the D-pivot section



Note

- ▶ Push in the ladder on the D-pivot section for assembly, see the Crane operating instructions, chapter 2.06.

Empty page!

LWE/LR 13000-001/19503-01-02/en

5.07 W/WV-lattice jib

1	Component overview	3
2	Fastening points	6
3	Assembling	13
4	Crane operation	65
5	Disassembling	67

Fig.195219

LWE/LR 13000-001/19503-01-02/en

1 Component overview



Note

- ▶ The assembly sections are marked with their own weight.



Note

- ▶ For the dimensions and weights, see the Crane operating instructions, chapter 1.03.

1.1 WA-frame 1 pivot section

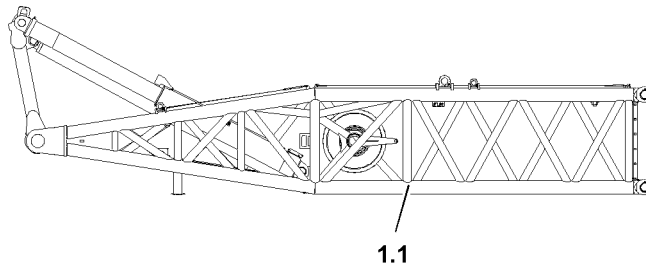

Fig.126403: WA-frame 1 pivot section

Position	Component
1.1	WA-frame 1 pivot section

1.2 WA-frame 1 intermediate section

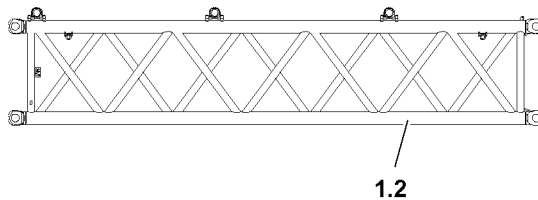

Fig.126466: WA-frame 1 intermediate section

Position	Component
1.2	WA-frame 1 intermediate section

1.3 WA-frame 1, end section

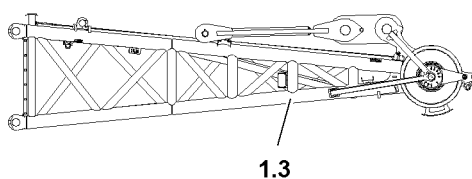

Fig.126467: WA-frame 1, end section

Position	Component
1.3	WA-frame 1, end section

1.4 WA-frame 2 pivot section

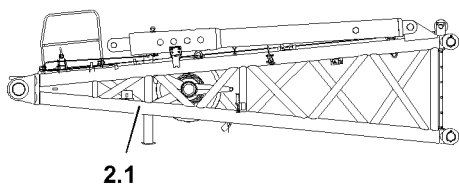

Fig.126468: WA-frame 2 pivot section

Position	Component
2.1	WA-frame 2 pivot section

1.5 WA-frame 2 intermediate section

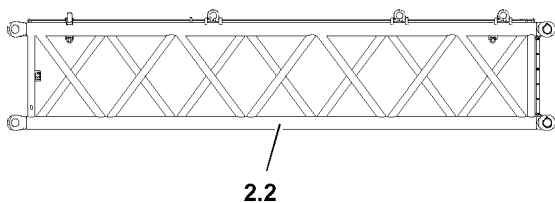

Fig.126469: WA-frame 2 intermediate section

Position	Component
2.2	WA-frame 2 intermediate section

1.6 WA-frame 2 end section

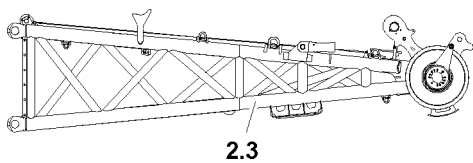

Fig.126470: WA-frame 2 end section

Position	Component
2.3	WA-frame 2 end section

1.7 W-pivot section with swing for WA-frame 2

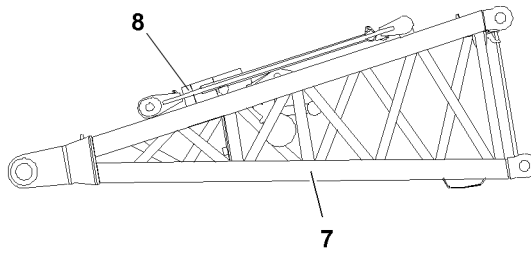

Fig.126471: W-pivot section with swing for WA-frame 2

Position	Component
7	W-pivot section
8	WA-frame 2 swing

1.8 S-/LI-intermediate section 6 m or 12 m

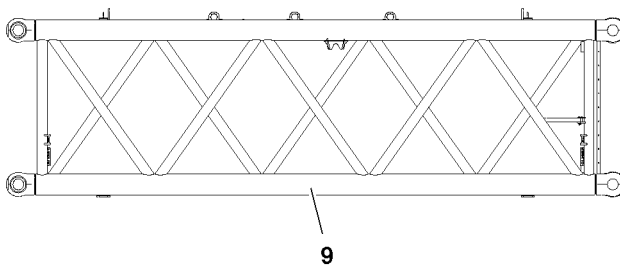

Fig.126472: S-/LI-intermediate section 6 m or 12 m

Position	Component
9	S-/LI-intermediate section 6 m / or 12 m

1.9 SL-reducer section

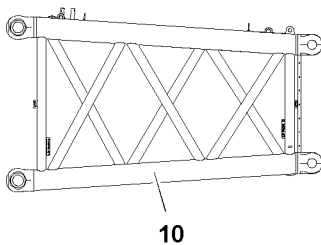

Fig.126473: SL-reducer section

Position	Component
10	SL-reducer section

LWE/LR_13000-001/19503-01-02/en

1.10 L-end section

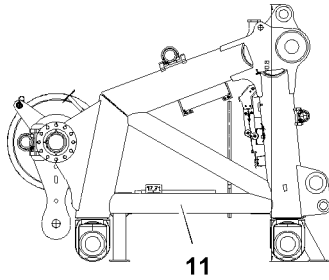

Fig.126474: L-end section

Position	Component
11	L-end section

2 Fastening points



WARNING

Lattice component not properly fastened!

If the lattice component is not properly fastened on the specified fastening positions, then the lattice component can fall down.

Death, severe bodily injuries, property damage.

► Make sure that the fastening equipment is properly fastened in the specified fastening positions.

2.1 Fastening points for WA-frame 1 pivot section

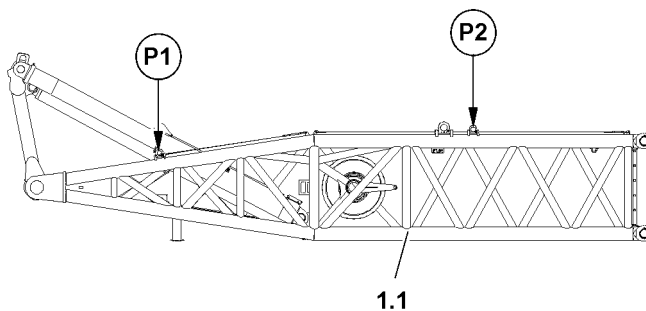

Fig.114993: Fastening points for WA-frame 1 pivot section

Fastening points	Component
P1 and P2	WA-frame 1 pivot section

2.2 Fastening points for WA-frame 1 intermediate section

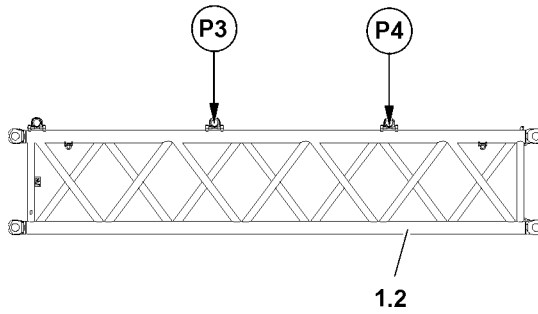

Fig.114994: Fastening points for WA-frame 1 intermediate section

Fastening points	Component
P3 and P4	WA-frame 1 intermediate section

2.3 Fastening points for WA-frame 1 end section

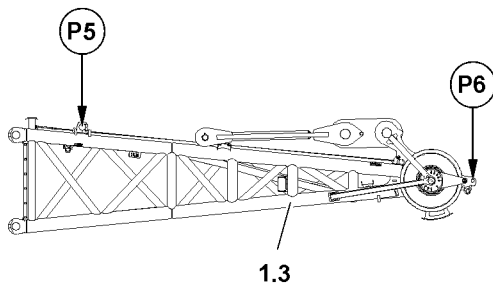

Fig.114995: Fastening points for WA-frame 1 end section

Fastening points	Component
P5 and P6	WA-frame 1, end section

2.4 Fastening points for WA-frame 1 completely installed, long version

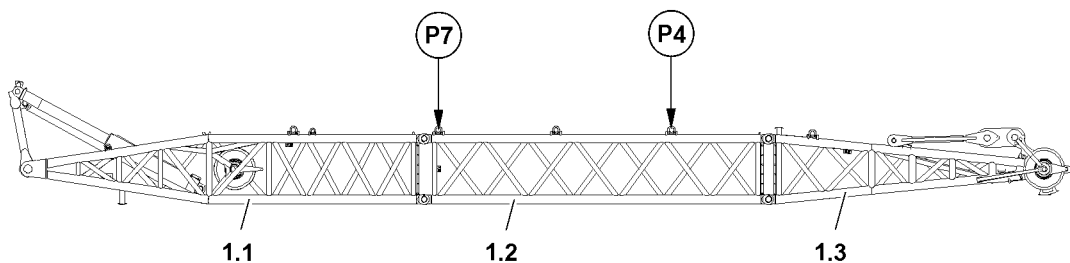

Fig.114996: Fastening points for WA-frame 1 completely installed, long version

Fastening points	Component
P7 and P4	WA-frame 1 completely installed, long version

LWE/LR 13000-001/19503-01-02/en

2.5 Fastening points for WA-frame 1 completely installed, short version

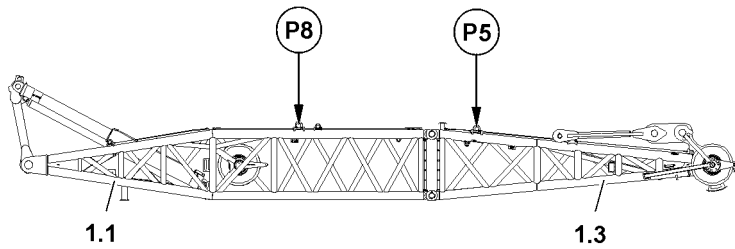

Fig.114997: Fastening points for WA-frame 1 completely installed, short version

Fastening points	Component
P8 and P5	WA-frame 1 completely installed, short version

2.6 Fastening points for WA-frame 2, pivot section

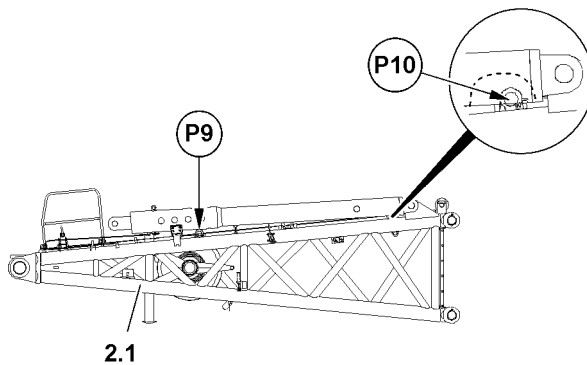

Fig.114998: Fastening points for WA-frame 2, pivot section

Fastening points	Component
P9 and P10	WA-frame 2 pivot section

2.7 Fastening points for WA-frame 2 intermediate section

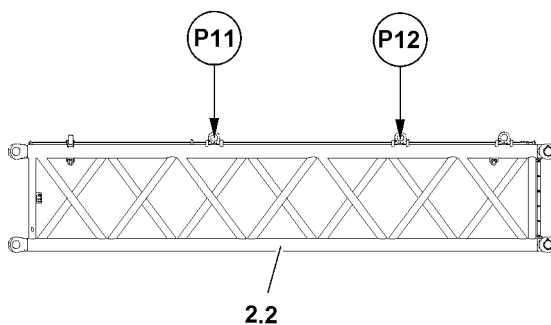

Fig.114999: Fastening points for WA-frame 2 intermediate section

Fastening points	Component
P11 and P12	WA-frame 2 intermediate section

2.8 Fastening points for WA-frame 2, end section

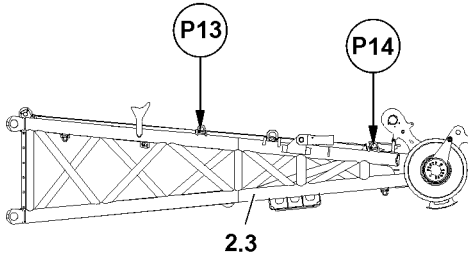

Fig.115000: Fastening points for WA-frame 2, end section

Fastening points	Component
P13 and P14	WA-frame 2 end section

2.9 Fastening points for WA-frame 2 completely installed, long version

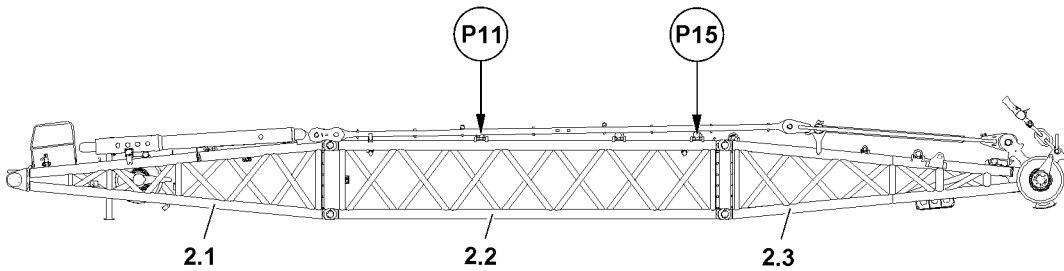

Fig.115783: Fastening points for WA-frame 2 completely installed, long version

Fastening points	Component
P11 and P15	WA-frame 2 completely installed, long version

2.10 Fastening points for WA-frame 2 completely installed, short version

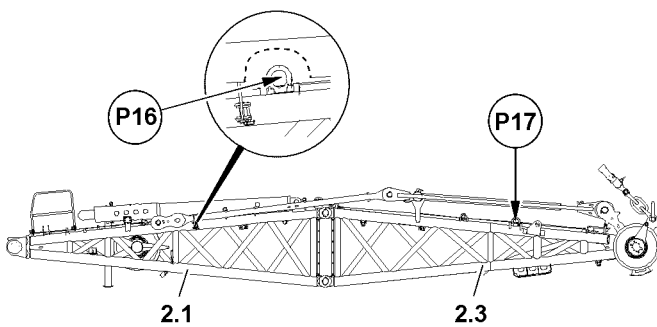

Fig.115784: Fastening points for WA-frame 2 completely installed, short version

LWE/LR_13000-001/19503-01-02/en

Fastening points	Component
P16 and P17	WA-frame 2 completely installed, short version

2.11 Fastening points for transport unit with W-pivot section and swing for WA-frame 2

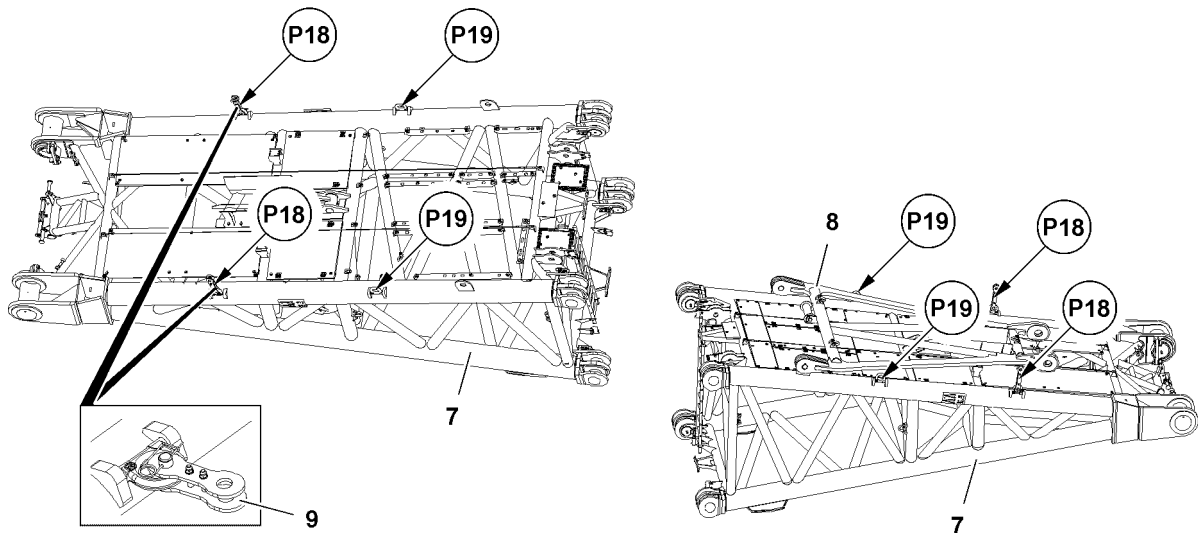

Fig.115785: Fastening points for transport unit with W-pivot section and swing for WA-frame 2

Fastening points	Component
P18' and P19	Transport unit with W-pivot section and swing for WA-frame 2

1) Only in connection with bracket 9

2.12 Fastening points for the S-/LI-intermediate section

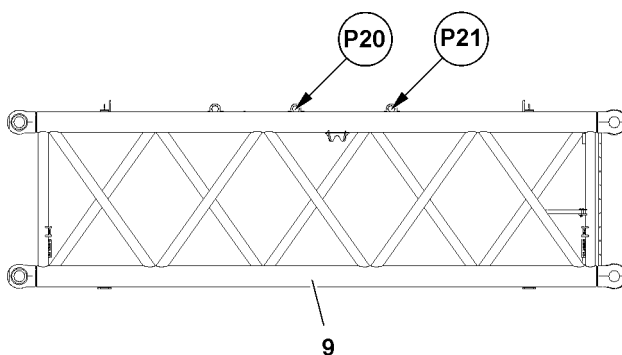

Fig.115791: Fastening points for the S-/LI-intermediate section

Fastening points	Component
P20 and P21	S-/LI-intermediate section

2.13 Fastening points for the SL-reducer section

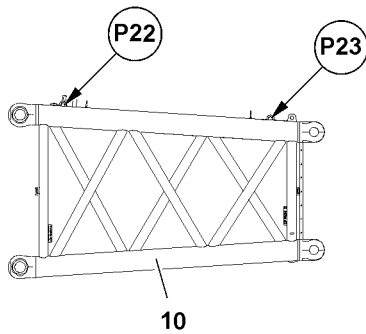

Fig.115793: Fastening points for the SL-reducer section

Fastening points	Component
P22 and P23	SL-reducer section

2.14 L-end section fastening points

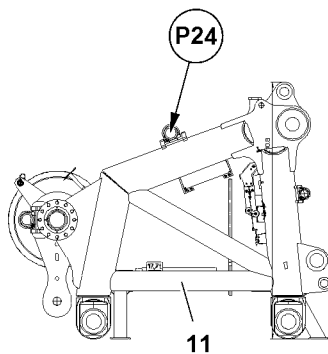

Fig.115792: L-end section fastening points

Fastening points	Component
P24	L-end section

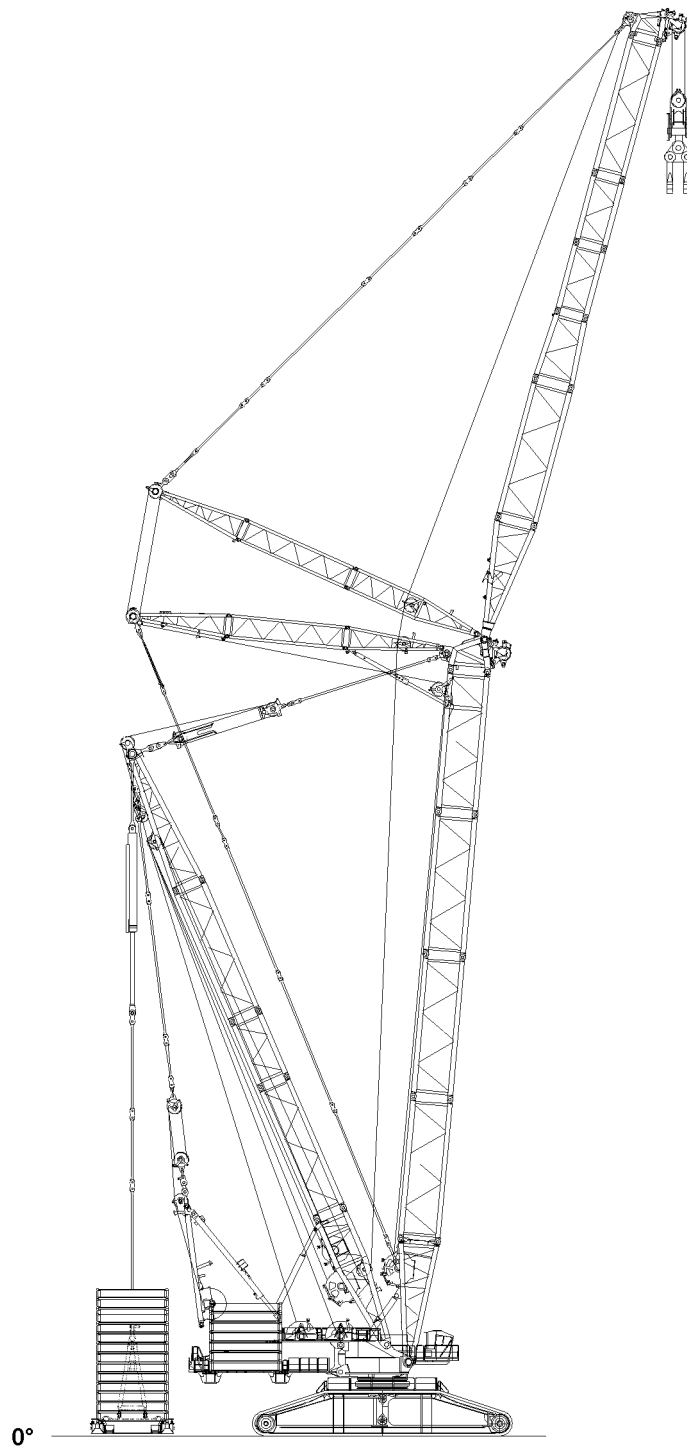

Fig.124461

LWE/LR 13000-001/19503-01-02/en

3 Assembling



WARNING

Danger of falling!

During assembly / disassembly, inspection and maintenance work, assembly personnel must be secured with appropriate aids to prevent them from falling.

Death, severe bodily injuries, property damage.

- ▶ All work at a height, when there is a danger of falling, must be carried out with suitable aids.
- ▶ If aids are not available and work cannot be carried out from the ground, then assembly personnel must secure themselves with the supplied fall arrest system to prevent falling, see the Crane operating instructions, chapter 2.04.
- ▶ If fall protection equipment is available, then it must be used, see the Crane operating instructions, chapter 2.06.
- ▶ When lifting, lowering, swinging crane parts in and out, no persons may remain in the danger zone.
- ▶ If railings are present on the components, then they must be brought into the corresponding position and secured for assembly / disassembly work.
- ▶ Only step on the aids, ladders and catwalks with clean shoes.
- ▶ Keep aids, ladders and catwalks free of heavy dirt, snow, frost and ice.
- ▶ During all assembly and disassembly work, maintenance work and inspections, travel or crane operation is prohibited.
- ▶ Remaining on a suspended load is prohibited.
- ▶ Stepping or walking on crane components and lattice sections with an incline of more than 20° is prohibited.
- ▶ For all assembly work, the crane operator of the main crane must be in voice contact with the crane operator / crane operators of the auxiliary crane / auxiliary cranes.
- ▶ For the assembly / disassembly tasks, the crane operator may only initiate crane movements when the responsible guide has explicitly released the movement.



WARNING

Falling components!

If unsecured or non-supported components are assembled or disassembled, they can fall down.

Death, severe bodily injuries, property damage.

- ▶ During pinning and unpinning of the lattice sections, it is prohibited for anyone to remain **under** or **on** the components as well as within the entire danger zone.
- ▶ Support the boom and components before pinning / unpinning.
- ▶ Pin or unpin both pins positioned horizontally, i.e. **left** and **right!**
- ▶ Secure the pins in the bearing points and in the receptacles.
- ▶ Do not detach the auxiliary crane until the respective component is pinned and secured.
- ▶ It is prohibited to lean a ladder against the component being disassembled.



WARNING

Danger of impact / crushing!

When assembling / disassembling crane components with the auxiliary crane, crane components can start to swing back and forth.

When lifting / lowering and positioning crane components, there is an increased danger of impact / crushing.

Death, severe bodily injuries, property damage.

- ▶ Make sure that personnel cannot be caught by components.
- ▶ Make sure that the crane is horizontally aligned.
- ▶ When working in danger zones: Use aids to protect limbs.
- ▶ Guide components with suitable aids to minimize oscillation.

**WARNING**

Danger of accident!

If no guide is present during assembly work who has voice connection to the crane operator as well as to the drivers of the auxiliary units, then there is a great danger of accident.

Crane movements that are carried out without the approval of the guide can cause accidents.

Death, severe bodily injuries, property damage.

- ▶ For all assembly work, observe the instructions of the guide.
- ▶ Make sure that the danger zone can be seen completely by the crane operator and / or the guide.

**DANGER**

The components can fall down!

If the corresponding component is disengaged from the auxiliary crane before the corresponding component is pinned, then the corresponding component can fall down.

Death, severe bodily injuries, property damage.

- ▶ Do not detach the auxiliary crane until the respective component is pinned and secured.

**WARNING**

The crane can topple over!

Death, severe bodily injuries, property damage.

- ▶ The turntable may not be turned during the assembly of the boom.

Make sure that the following prerequisites are met:

- The crane is placed on ground with a sufficient load bearing capacity.
- The crane is horizontally aligned.
- The main boom (S-/P-) is assembled and aligned horizontally.
- The counterweight is attached to the turntable according to the load chart and taken down on the suspended ballast / ballast trailer.
- The LICCON overload protection has been set according to the data in the load chart.
- All electrical connections have been established.
- The limit switches have been checked for their mechanical function.
- An auxiliary crane is available.

3.1 W-assembly on the main boom (S-/P-)

3.1.1 Exceeding the LICCON overload protection for assembly

**WARNING**

Danger of accident due to the „Exceedance of shut-off limits of the LICCON overload protection“ function!

If the shut off limits of the LICCON overload protection are exceeded, there is no additional protection against crane overload.

Due to erroneous operation or deliberate misuse, the crane could collapse, the boom can break off or the crane can topple over.

Death, severe bodily injuries, property damage.

- ▶ The „Exceeding the shut-off limits of the LICCON overload protection“ function is only permissible in emergencies and for assembly purposes.
 - ▶ The function „Exceeding the shut off limits of the LICCON overload protection“ may only be actuated by persons who know the effects of their actions regarding the function „Exceeding the shut off limits of the LICCON overload protection“.
 - ▶ The „Exceedance of shut off limits of the LICCON overload protection“ function requires the presence of an authorized person and must be performed with utmost caution.
 - ▶ Crane operation with the „Exceedance of shut off limits of the LICCON overload protection“ function activated is prohibited.
- ▶ Exceeding the shut off limits of the LICCON overload protection: Engage assembly operation

Result:

- The shut off limits of the LICCON overload protection are exceeded.
- The assembly icon appears on the LICCON monitor.

**Note**

- ▶ See the Crane operating instructions, chapter 4.02 and chapter 4.20.

3.1.2 WA-frame preassembly

Fig.115787: WA-frame preassembly — Overview

Make sure that the following prerequisites are met:

- The W-pivot section **1.1** is on the ground.
- The connector pins on the W-pivot section **1.1** in points **P25** and points **P26** are completely unpinned.
- An auxiliary crane is available.

**Note**

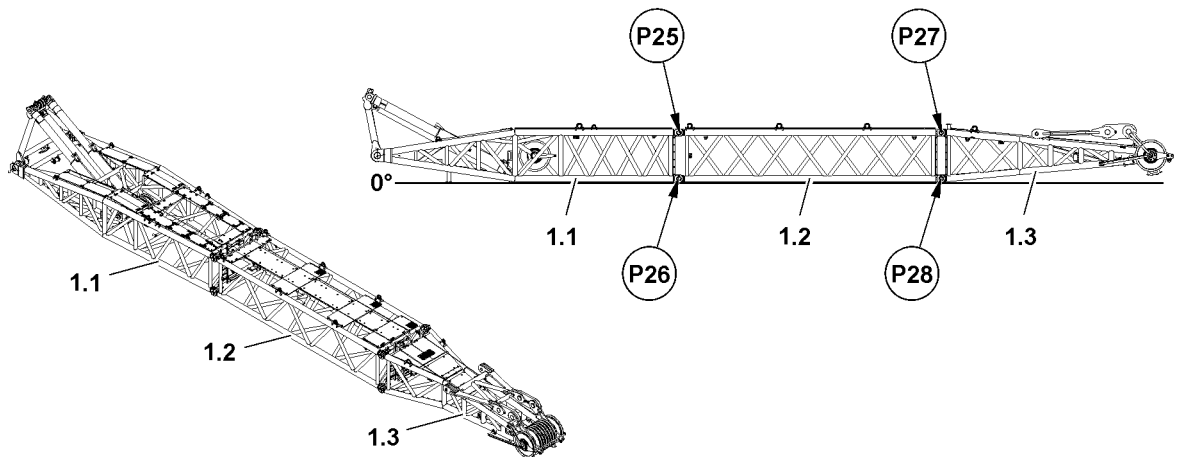
- ▶ The illustrations in this chapter only show the assembly of the WA-frame **1 long version**.
- ▶ The WA-frame **1 long version** or WA-frame **2 long version**, consists of WA-frame pivot section **1.1**, WA-frame intermediate section **1.2** and WA-frame end section **1.3**.
- ▶ The WA-frame **1** or WA-frame **2 short version** consists of a WA-frame pivot section **1.1** and WA-frame end section **1.3**.
- ▶ The assembly and disassembly of the short WA-frames is carried out according to the description for the long WA-frames.
- ▶ The assembly of the WA-frame **2** is carried out according to the description of the WA-frame **1**.

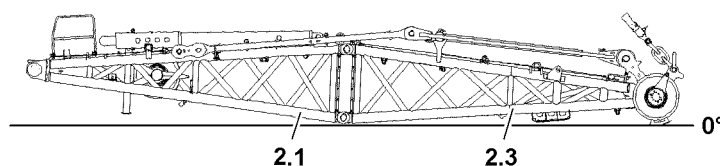

Fig.116131: WA-frame preassembly — WA-frame 2 short version

**WARNING**

General danger notes!

Death, severe bodily injuries, property damage.

- ▶ All pins **12.1** are to be secured after assembly with the intended locking pins **12.2**.

- ▶ Secure the pins **12.1** with locking pins **12.2**.

Result:

- The „upper“ pins **12.1** are completely secured in points **P25**.

- ▶ Lower the WA-frame intermediate section **1.2** with the auxiliary crane until it can be pinned in points **P26**.

When the pin bores on the WA-frame pivot section **1.1** and on the WA-frame intermediate section **1.2** align on the „bottom“:

- ▶ Pin the WA-frame intermediate section **1.2** with the WA-frame pivot section **1.1**: Completely insert the pins **12.1** on the „bottom“ in points **P26** on both sides with the pin pulling device, in the same way as described before.

Result:

- The „lower“ pins **12.1** are completely secured in points **P26**.

- The WA-frame intermediate section **1.2** is completely assembled.

- ▶ Remove the fastening equipment from the WA-frame intermediate section **1.2**.

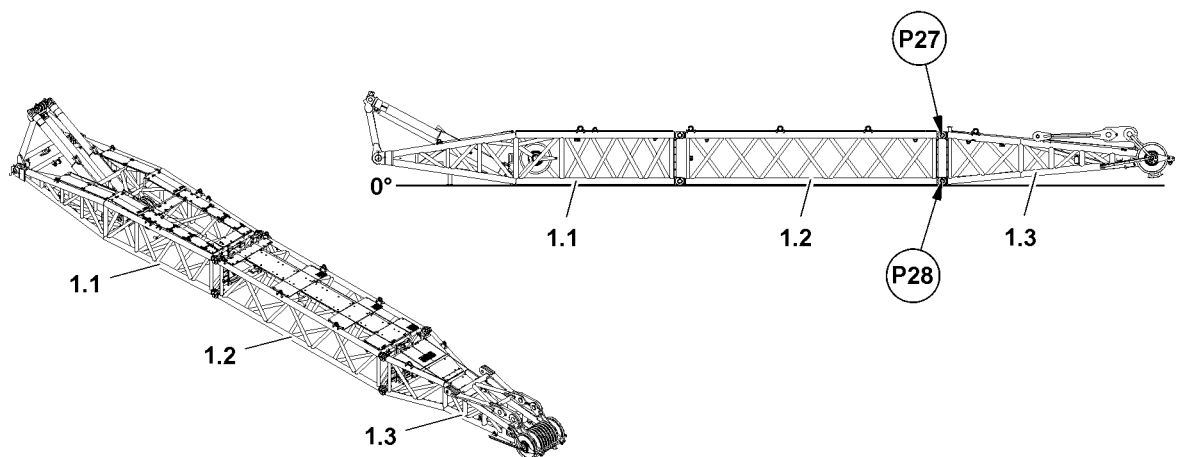

Fig.115789: WA-frame preassembly — Assembling the WA-frame end section on the WA-frame intermediate section

- ▶ Fasten the WA-frame end section **1.3** to the auxiliary crane and align with the WA-frame intermediate section **1.2**.
- ▶ Pin the WA-frame end section **1.3** with the WA-frame intermediate section **1.2** in points **P27** and points **P28**, in the same way as described before.

Result:

- The WA-frame is completely assembled.

3.1.3 Placing the swing

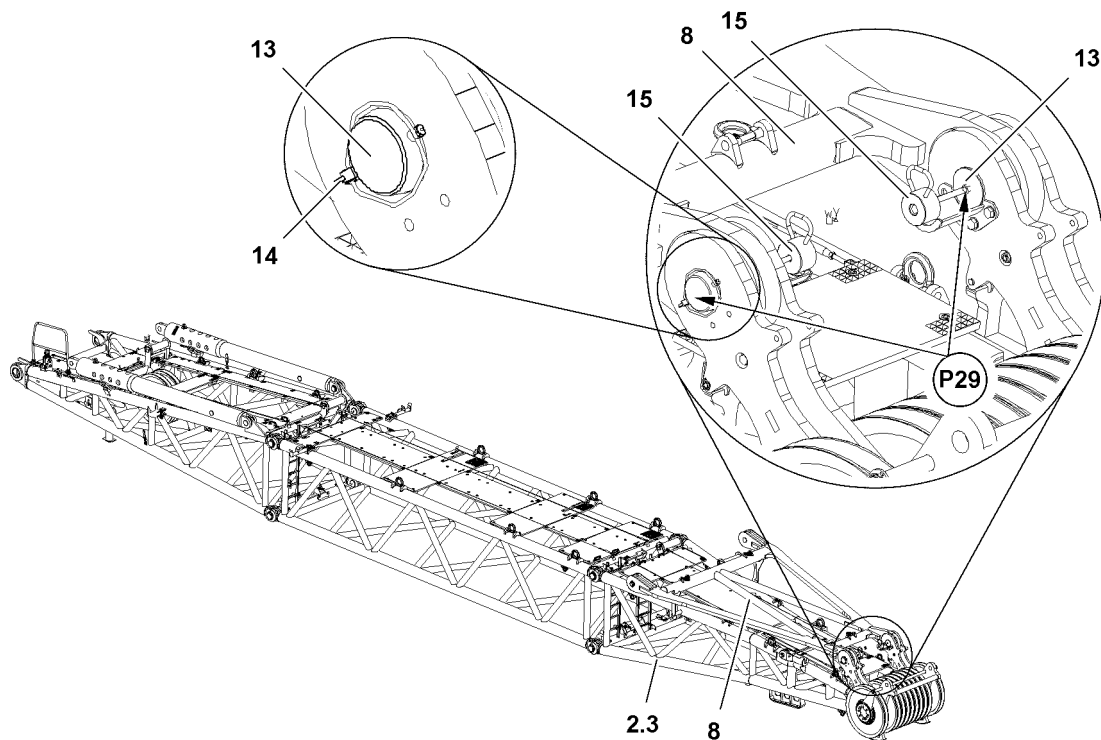

Fig.115794: Placing the swing

Make sure that the following prerequisites are met:

- The WA-frame **2** is completely preassembled.
- The swing **8** is available.
- An auxiliary crane is available.
- ▶ Fasten the swing **8** to the auxiliary crane.
- ▶ Align the swing **8** in the pin bores (points **P29**) of the WA-frame 2 end section **2.3**.

When the pin bores on the swing **8** and on the WA-frame 2 end section **2.3** align:

- ▶ Pin the swing **8** with the WA-frame 2 end section **2.3** on both sides: Insert the connector pins **13** in points **P29** on both sides with the mechanical pin pulling device **15**.



WARNING

General danger notes!

Death, severe bodily injuries, property damage.

- ▶ All connector pins **13** are to be secured after assembly with the intended locking pins **14**.
- ▶ Secure the connector pins **13** on both sides with locking pins **14**.
- ▶ Take the swing **8** down on the WA-frame 2 end section **2.3**.
- ▶ Remove the auxiliary crane.

3.1.4 Assembling the WA-frame 2 guy rods

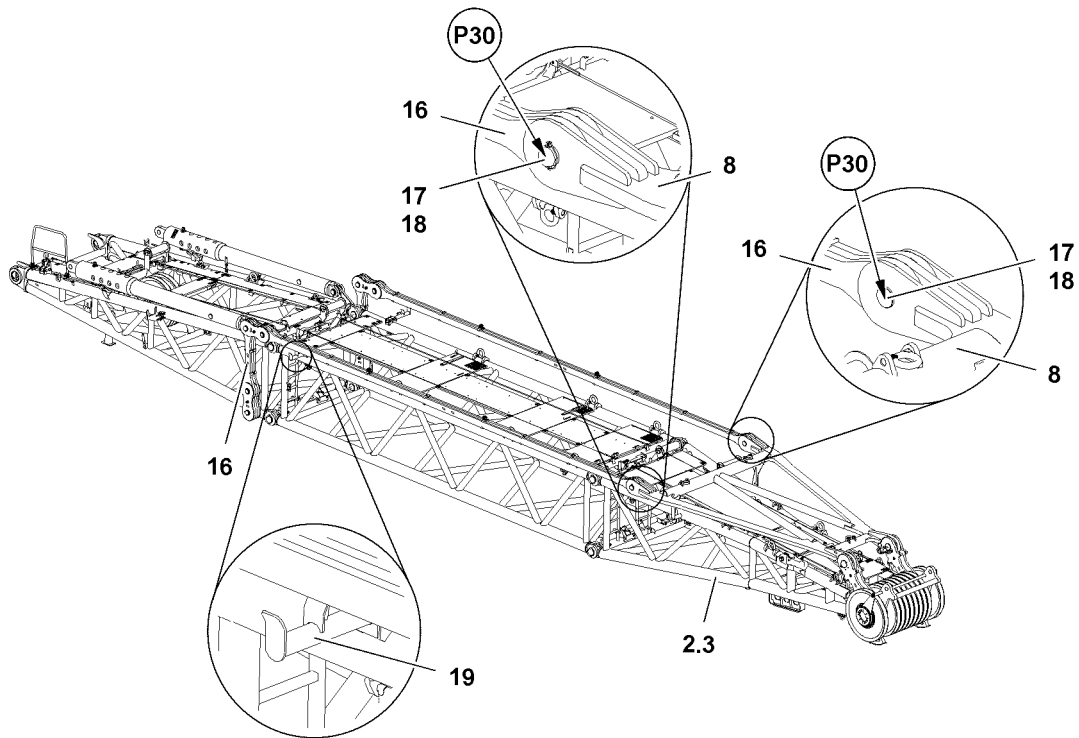

Fig.115795: Assembling the WA-frame 2 guy rods



Note

- ▶ Assembly and retention of the guy rods **16**, see the Rod plans.
- ▶ The numbering on the rod plans must be identical to the numbering on the guy rods **16**.

- ▶ Fasten the guy rod **16** to the auxiliary crane.
- ▶ Lift the guy rod **16** and align in the pin bore (point **30**) of the swing **8**.

When the pin bores for the guy rod **16** and the swing **8** align:

- ▶ Pin the guy rod **16** with the swing: Insert the pin **17** in point **P30** and secure with the locking pin **18**.
- ▶ Take the guy rod **16** down on the retainer **19**.
- ▶ Remove the fastening equipment from the guy rod **16**.
- ▶ Assemble the guy rod **16** on the other side, in the same way as described before.

If additional guy rods **16** must be assembled:

- ▶ Assemble the guy rods **16** in the same way as described before.

3.1.5 Pulling the control rope and the hoist ropes forward to the end section

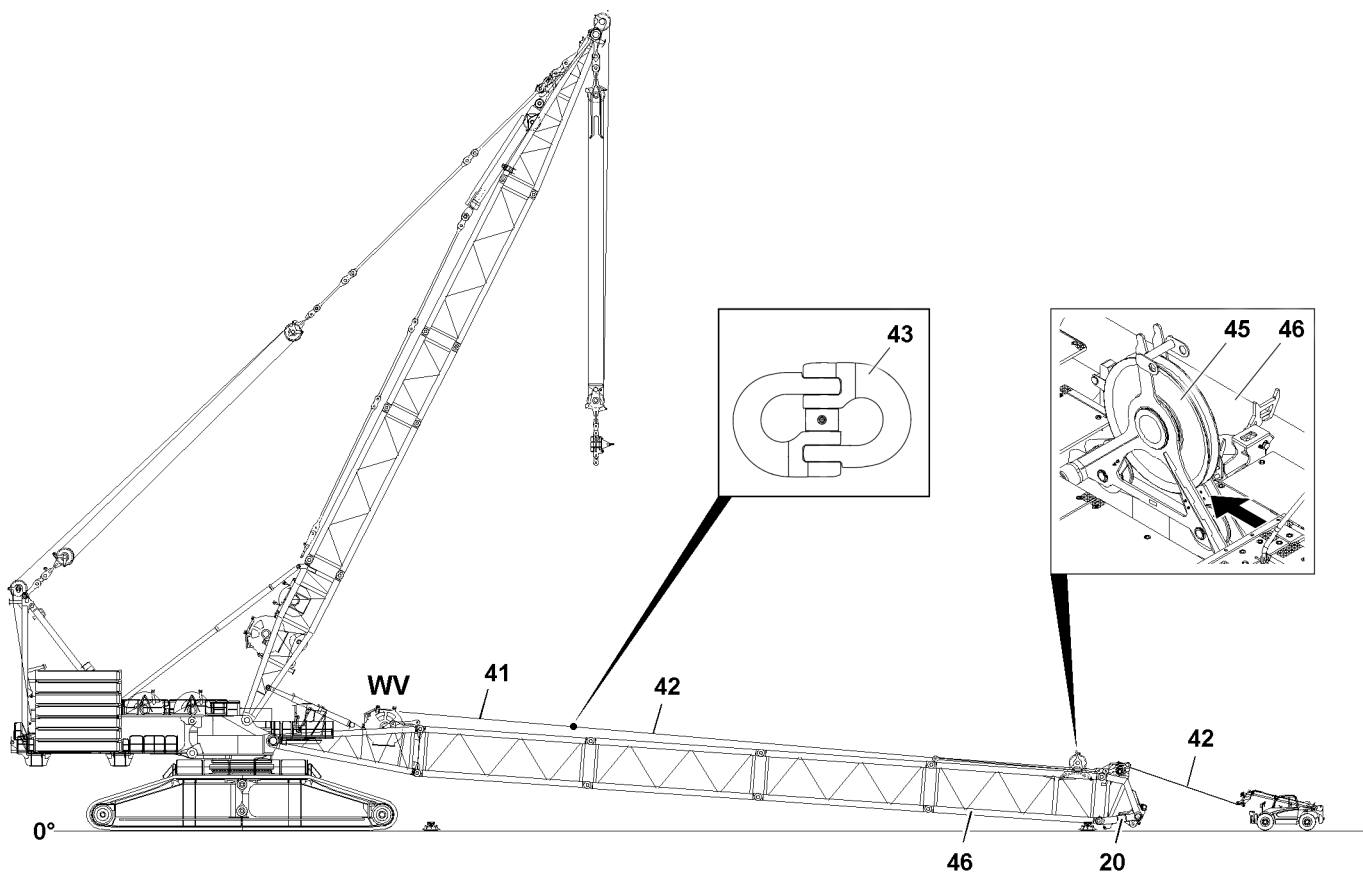

Fig.126475: Pulling the control rope and the hoist ropes forward to the end section

Make sure that the following prerequisite is met:

- A telescopic lift truck is available.



Note

- ▶ The procedure to pull the control rope forward is an example for all ropes that must be pulled forward to the end section **20**.
- ▶ The procedure is an example for all ropes that must be pulled forward to the end section **20**. The hoist ropes are pulled forward in the same way.

The auxiliary rope **42** of the telescopic lift truck is used to pull the control rope **41** forward to the end section.

The auxiliary rope **42** is reeved in opposite to the control rope run.



Note

- ▶ The control rope **41** is reeved in according to the reeving plan.
- ▶ The reeving plan is available separately.

**WARNING**

Danger of accident!

When using **non-approved** connecting links **43** when reeving the hoist rope in / out, the connecting links **43** can rip off suddenly.

Death, severe bodily injuries, property damage.

- ▶ Make sure that only original connecting links are used between the auxiliary winch and the hoist rope.
- ▶ Make sure that the proper pressure stage is set on the auxiliary winch of the telescopic lift truck for the reeving in / out of the respective hoist rope, see the separate operating instructions for the „assembly winch“.
- ▶ Make sure that the connecting links **43** between the auxiliary winch and the hoist rope have a higher load bearing capacity than can be created by the maximum strand pull of the respective auxiliary winch.
- ▶ The strand pull of the auxiliary winches installed on the crane side is **not** identical to the strand pull of the auxiliary winch of the telescopic lift truck.

Connecting link / Description	Load bearing capacity	Use for hoist rope diameter
CW8	2.5 t	38 mm
CWP10	5.0 t	52 mm

- ▶ Guide the auxiliary rope **42** under the change over pulley **45** of the S-adapter **46**.
- ▶ Guide the auxiliary rope **42** over the boom until the end of the rope of winch **5 WV**.

**WARNING**

Danger of crushing due to moving winch **5 WV**!

Death, severe bodily injuries, property damage.

- ▶ Do not actuate winch **5 WV** during the assembly procedure.
- ▶ Connect the auxiliary rope **42** via the connecting link **43** with the control rope **41**.

NOTICE

Slack rope formation!

The control rope **41** can be damaged due to slack rope formation.

This can result in significant property damage.

- ▶ Do not allow slack rope to be formed when spooling out the control rope **41**.
- ▶ Keep the control rope **41** tight when spooling out.

**WARNING**

Danger of accident!

Death, severe bodily injuries, property damage.

- ▶ It is prohibited for anyone to remain in the danger zone of the running rope.
- ▶ A voice connection between the driver of the telescopic lift truck and the crane operator is available.
- ▶ Spool the auxiliary winch of the telescopic lift truck winch up and simultaneously spool winch **5 WV** out until the control rope **41** can be fastened to the end section **20**.
- ▶ Release the connecting link between the auxiliary rope **42** and the control rope **41**.
- ▶ Attach the control rope **41** to the end section **20**.
- ▶ Install the required hoist ropes the same way as described before.

3.1.6 Assembling WA-frame 1 on the end section

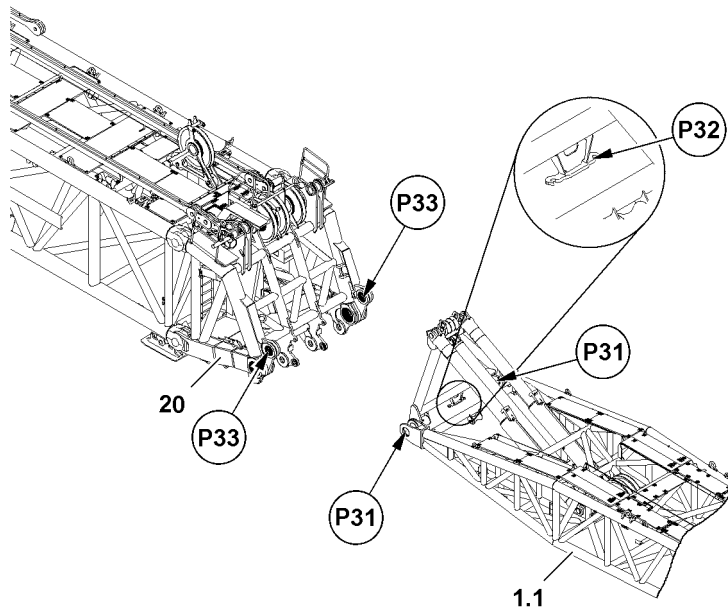

Fig.115796: Assembling WA-frame 1 on the end section — Positioning WA-frame 1

Make sure that the following prerequisites are met:

- The main boom (S-/P-) is completely assembled and is lying on the ground.
 - The required hoist ropes and the control rope have been pulled forward to the end section **20**.
 - The WA-frame is completely preassembled.
 - Both pins on the WA-frame 1 pivot section **1.1** are completely unpinned in points **P31**.
 - An auxiliary crane is available.
- ▶ Fasten the WA-frame **1**, see section „Fastening points“.
 - ▶ Place the pin pulling cylinder in point **P32**.



WARNING

Danger of crushing for people near the load!
Death, severe bodily injuries, property damage.

- ▶ Before lifting the load it must be ensured that there are no persons in the danger zone.
- ▶ It is prohibited to remain in the danger zone.
- ▶ It is prohibited for anyone to be under the load. Maintain a safe distance.
- ▶ Swinging the load is prohibited.
- ▶ Exercise extreme caution when lifting a load.

- ▶ Lift the WA-frame **1** and align with the end section **20** so it can be pinned in points **P33**.

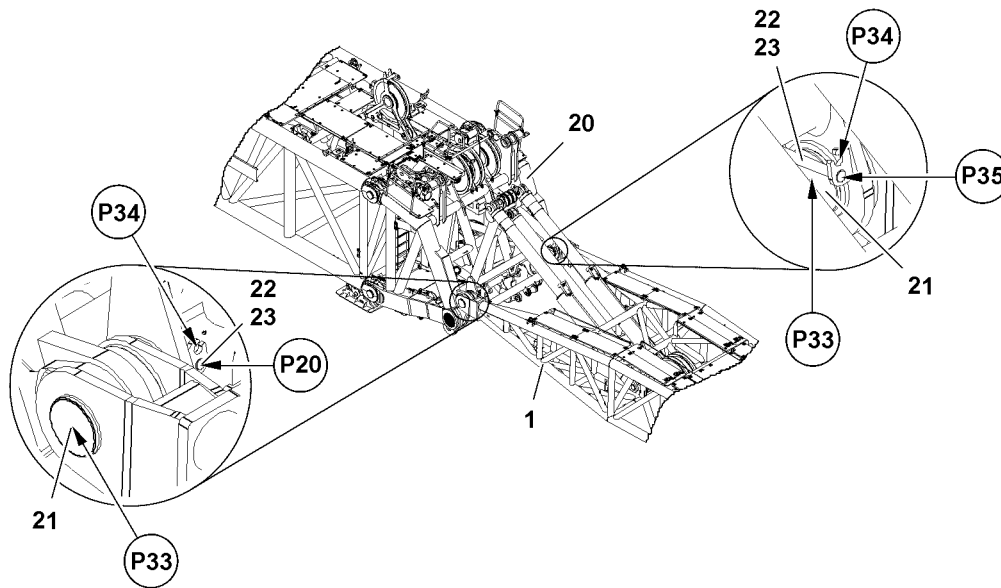

Fig. 115797: Assembling WA-frame 1 on the end section — Pinning procedure

When the pin bores align in points **P33**:

- ▶ Insert the pins **21** completely in points **P33** on both sides with the pin pulling cylinder.
- ▶ Unpin the retaining pins **22** from the park positions **P34**.
- ▶ Secure the pins **21** in the points **P35** with retaining pins **22** and locking pins **23**.
- ▶ Lower the WA-frame **1** onto the ground.
- ▶ Remove the fastening equipment from the WA-frame **1**.

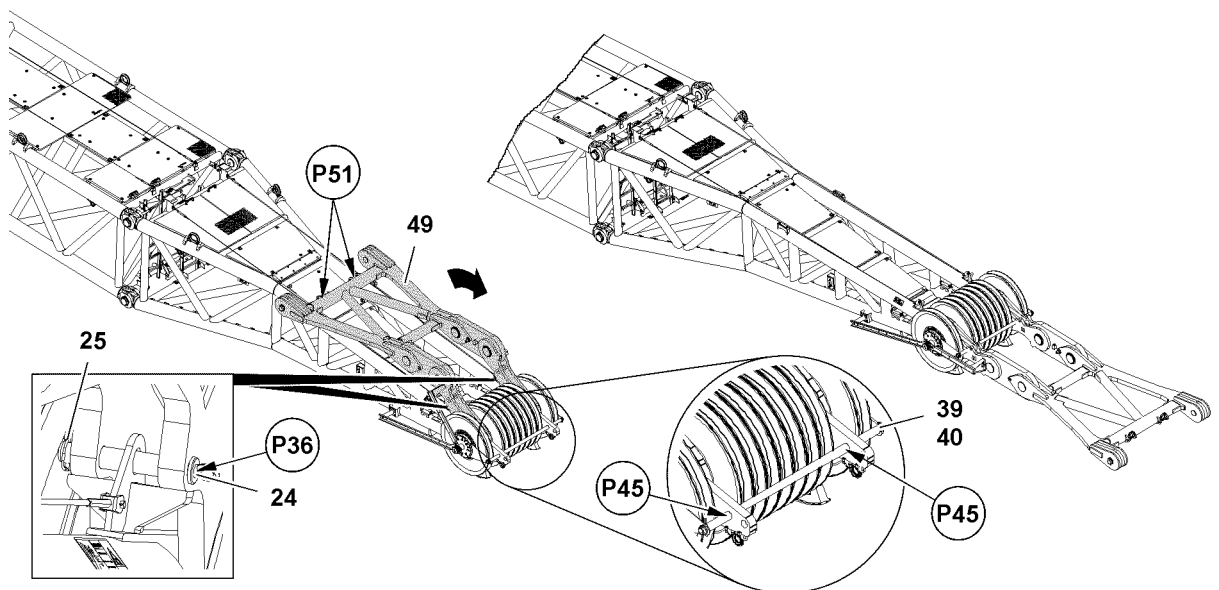

Fig. 115798: Assembling WA-frame 1 on the end section — Swinging the cross beam around

- ▶ Remove the rope retaining pipe **39** in points **P45**.
- ▶ Fasten the cross beam **49** to the auxiliary crane in points **P51**.
- ▶ Unpin the cross beam **49** in the transport position: Release the pins **24** on both sides in points **P36** and unpin.

**WARNING**

Swinging the cross beam **49**!

Death, severe bodily injuries, property damage.

- ▶ It is prohibited to stand in the danger zone during the swing procedure.
- ▶ The cross beam **49** must be swung around with extreme caution.

- ▶ Fold the cross beam **49** with the auxiliary crane from the transport position into the operating position.
- ▶ Insert the pins **24** in points **P36** and secure with locking pins **25**.
- ▶ Pin the rope retaining pipe **39** in points **P45**.

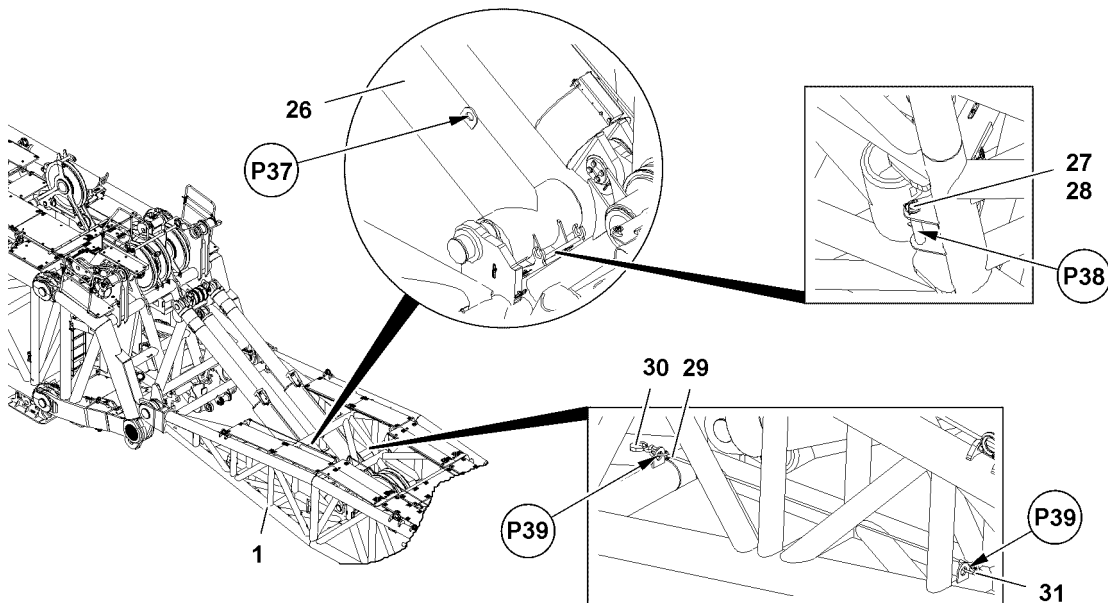

Fig.115799: Assembling WA-frame 1 on the end section — Bringing the W-relapse support into the operating position

- ▶ Fasten the auxiliary crane in point **P37** of the W-relapse support **26**.
- ▶ Lift the W-relapse support **26** with the auxiliary crane until the pin **27** can be unpin.
- ▶ Release the pin **27** in point **P38** and unpin.
- ▶ Lower the W-relapse support **26** onto the ground.
- ▶ Remove the fastening equipment.
- ▶ Release the retaining rope **29** from the park position **P39**.
- ▶ Fasten the retaining rope **29**: Secure the snap hook **31** in point **P38** with the pin **27**.
- ▶ Insert the pin **27** and secure with the locking pin **28**.
- ▶ Connect the retaining rope **29** with the hook **30** in point **P37**.

3.1.7 Assembling WA-frame 2 on the end section

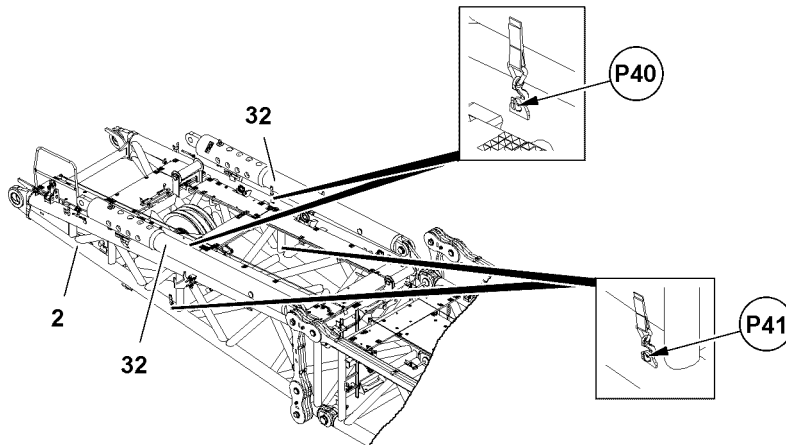

Fig.115800: Assembling WA-frame 2 on the end section — Preparing WA-frame 2

Make sure that the following prerequisites are met:

- The WA-frame 2 is completely preassembled.
- The WA-frame 1 is completely assembled on the end section.
- An auxiliary crane is available.

- ▶ Remove the retaining belts of the WA-frame 2 relapse supports 32 on both sides in points P40 and points P41.

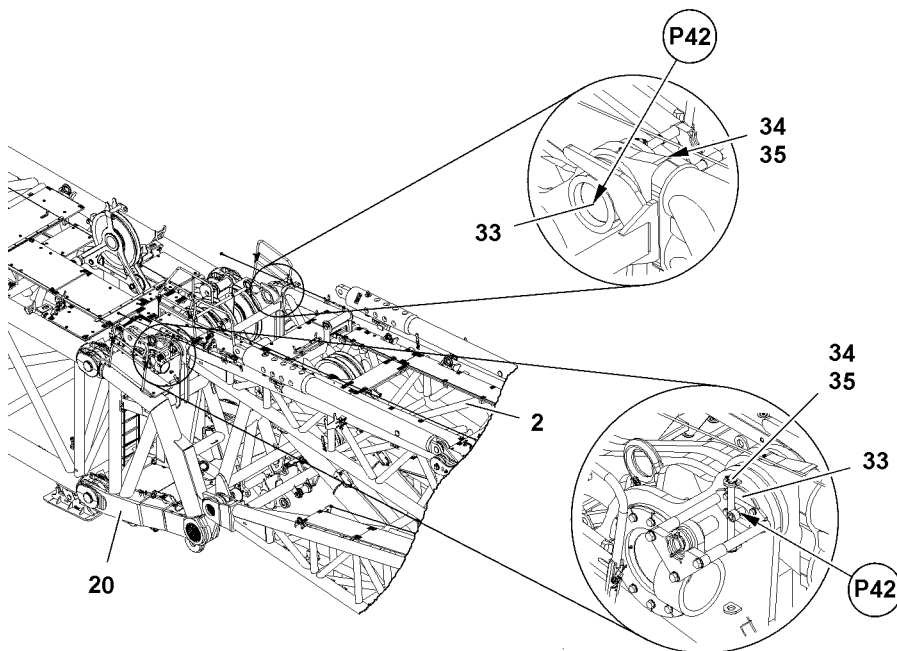

Fig.115801: Assembling WA-frame 2 on the end section — Pinning procedure

- ▶ Fasten the WA-frame 2 to the auxiliary crane, see section „Fastening points“.

**WARNING**

Danger of crushing for people near the load!
Death, severe bodily injuries, property damage.

- ▶ Before lifting the load it must be ensured that there are no persons in the danger zone.
- ▶ It is prohibited to remain in the danger zone.
- ▶ It is prohibited for anyone to be under the load. Maintain a safe distance.
- ▶ Swinging the load is prohibited.
- ▶ Exercise extreme caution when lifting a load.

- ▶ Lift the WA-frame **2** and align with the end section **20** so it can be pinned in points **P42**.

When the pin bores on the end section **20** and WA-frame **2** align in points **P42**:

- ▶ Insert the pins **33** in points **P42** on both sides with the pin pulling device and secure with retaining pins **34** and locking pins **35**.
- ▶ Lower the WA-frame **2** on the WA-frame **1**.
- ▶ Remove the fastening equipment from the WA-frame **2**.

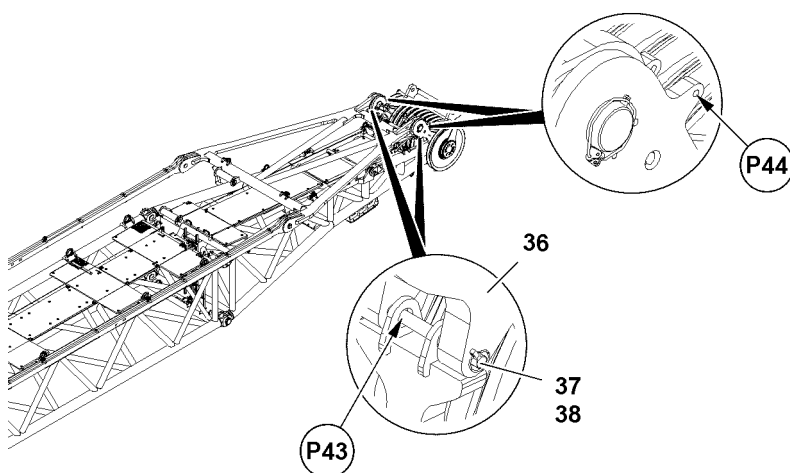

Fig.115802: Assembling WA-frame 2 on the end section — Unpinning the brackets

- ▶ Unpin the bracket **36**: Release the pins **37** on both sides in points **P43** and unpin.
- ▶ Insert the pins **37** in the park positions: Insert the pins **37** on both sides in points **P44** and secure with locking pins **38**.

Empty page!

LWE/LR 13000-001/19503-01-02/en

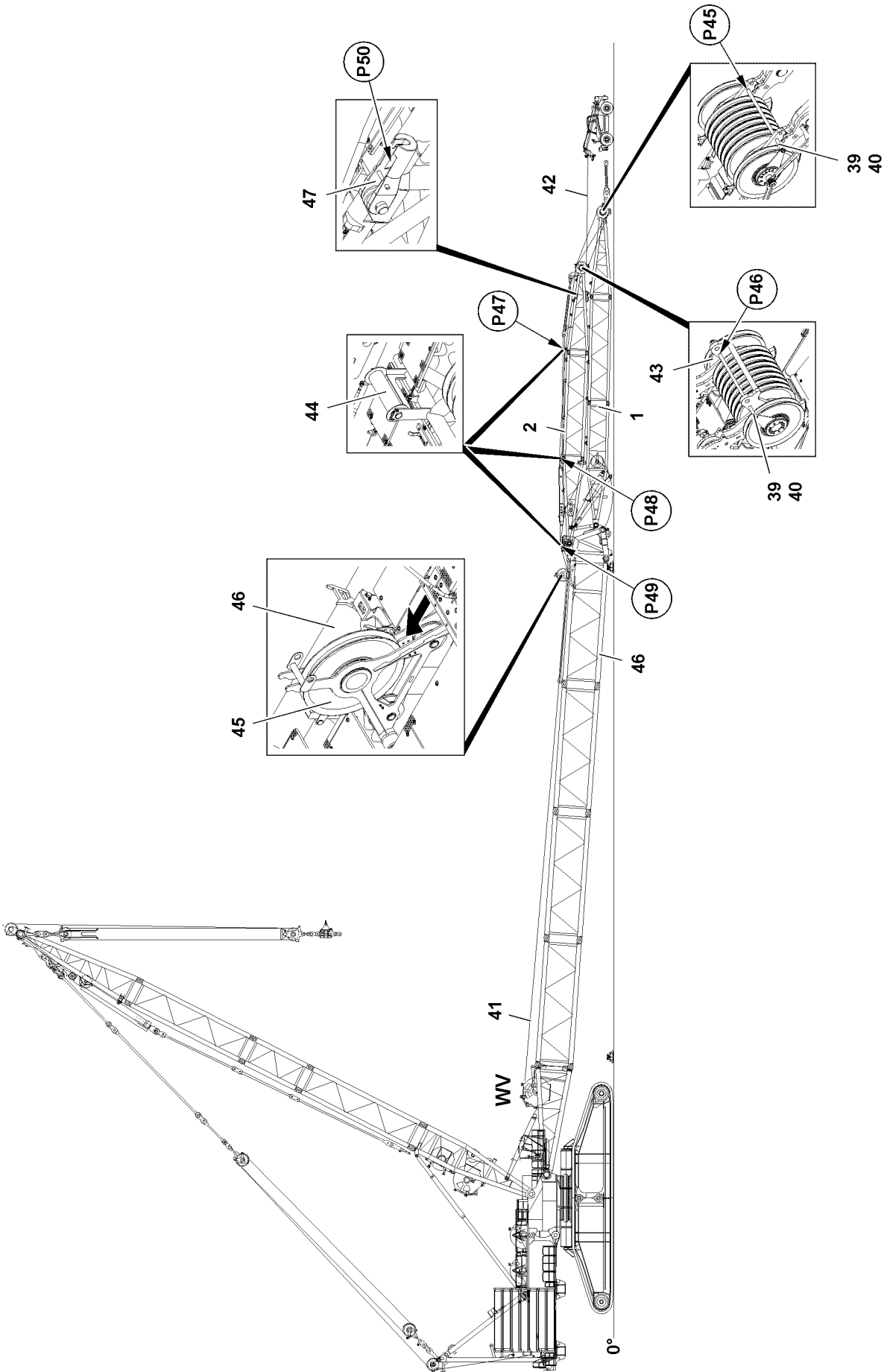

Fig.115803

LWE/LR 13000-001/19503-01-02/en

3.2 Reeving the control rope on the WA-frames

Make sure that the following prerequisites are met:

- The WA-frames are properly installed on the end section.
- A telescopic lift truck is available.
- ▶ Release the rope retaining pipes **39** in point **P45** and point **P46** and remove.



Note

- ▶ The control rope **41** is reeved in according to the reeving plan.
- ▶ The reeving plan is available separately.

The auxiliary rope **42** of the telescopic lift truck is used to pull the control rope **41** over the respective rope pulleys.



WARNING

Danger of accident!

When using **non-approved** connecting links **43** when reeving the hoist rope in / out, the connecting links **43** can rip off suddenly.

Death, severe bodily injuries, property damage.

- ▶ Make sure that only original connecting links are used between the auxiliary winch and the hoist rope.
- ▶ Make sure that the proper pressure stage is set on the auxiliary winch of the telescopic lift truck for the reeving in / out of the respective hoist rope, see the separate operating instructions for the „assembly winch“.
- ▶ Make sure that the connecting links **43** between the auxiliary winch and the hoist rope have a higher load bearing capacity than can be created by the maximum strand pull of the respective auxiliary winch.
- ▶ The strand pull of the auxiliary winches installed on the crane side is **not** identical to the strand pull of the auxiliary winch of the telescopic lift truck.

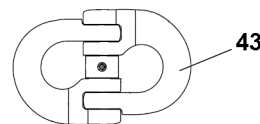

Fig.126476: Connecting link

Connecting link / Description	Load bearing capacity	Use for hoist rope diameter
CW8	2.5 t	38 mm
CWP10	5.0 t	52 mm

The auxiliary rope **42** is reeved in opposite to the control rope run.

- ▶ Pull the auxiliary rope **42** completely into the WA-frame adjustment.
- ▶ Guide the auxiliary rope **42** over the protective rollers **44** in point **P47**, point **P48** and point **P49**.
- ▶ Continue to guide the auxiliary rope **42** until it can be connected with the control rope **41**.



WARNING

Danger of crushing due to moving winch **5 WV**!

Death, severe bodily injuries, property damage.

- ▶ Do not actuate winch **5 WV** during the assembly procedure.
- ▶ Connect the auxiliary rope **42** via the rope lock with the control rope **41**.

LWE/LR 13000-001/19503-01-02/en

NOTICE

Slack rope formation!

The control rope **41** can be damaged due to slack rope formation.

- ▶ Do not allow slack rope to be formed when spooling out the control rope **41**.
- ▶ Keep the control rope **41** tight when spooling out.

**WARNING**

Danger of accident!

Death, severe bodily injuries, property damage.

- ▶ It is prohibited for anyone to remain in the danger zone of the running rope.
 - ▶ A voice connection between the driver of the telescopic lift truck and the crane operator is available.
-
- ▶ Spool the winch of the telescopic lift truck up and simultaneously spool out winch **5 WV** until the control rope **41** is completely reeved in.
 - ▶ Affix the control rope **41** in the rope lock **47** in point **P50**.
 - ▶ Insert the rope retaining pipes **39** in point **P45** and point **P46** and secure with locking pins **40**.

3.3 Erecting the WA-frames

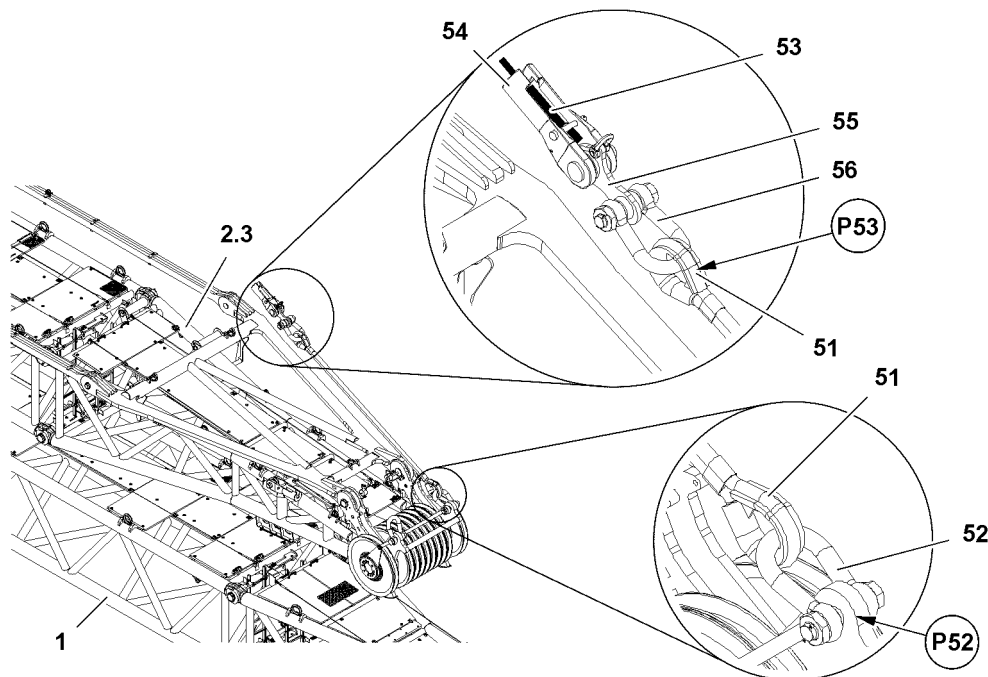

Fig.115804: Erecting the WA-frames — Connecting the hoist rope with WA-frame 2

Make sure that the following prerequisites are met:

- The WA-frame **2** is lying on the WA-frame **1**.
 - The control rope is completely installed.
 - The limit switches were checked for proper function.
 - The pressure of the relapse press was checked.
- ▶ Assemble the fastening rope **51** with the shackle **52** in point **P52** of the WA-frame **2 2.3** end section.
 - ▶ Fasten the hoist rope **53** of winch **1 WI** to the auxiliary crane.
 - ▶ Pull the hoist rope **53** of winch **1 WI** with the auxiliary crane forward to the fastening rope **51** until the connection can be made in point **P53**.
 - ▶ Connect the hoist rope **53** with the fastening rope **51**: Connect the hoist rope **53** via the rope lock **54**, bracket **55** and shackle **56** in point **P53** with the fastening rope **51**.

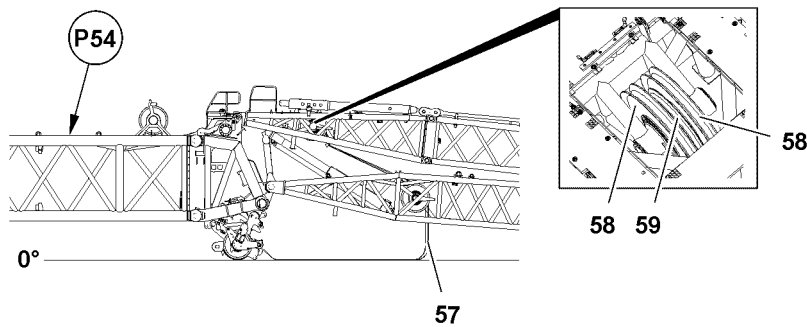

Fig.115805: Erecting the WA-frames — Placing the auxiliary ropes



Note

- ▶ The auxiliary ropes **57** for the hoist ropes of winch 1 and winch 2 must be routed over the outer large rope pulleys **58**.
 - ▶ The auxiliary rope **57** for the hoist rope of winch 6 must be routed over the center small rope pulley **59**.
-
- ▶ Assemble all required auxiliary ropes **57**: Guide the auxiliary ropes **57** over the rope pulleys **58** and rope pulley **59**.
 - ▶ Pull the auxiliary ropes **57** to point **P54**.
 - ▶ Fasten the auxiliary ropes **57** properly in point **P54** and secure them to prevent them from slipping off.

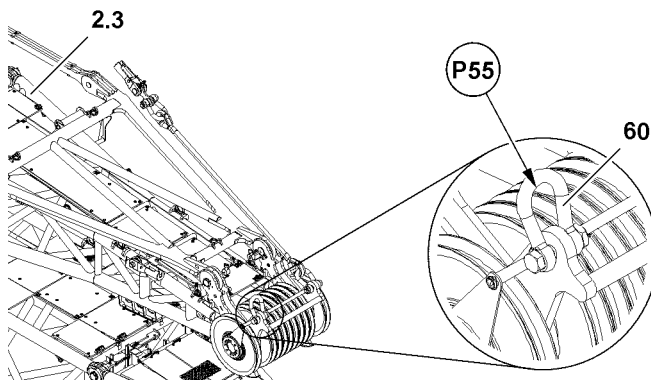

Fig.115806: Erecting the WA-frames — Fastening the auxiliary crane



WARNING

Insufficient load bearing capacity of the auxiliary crane!
Death, severe bodily injuries, property damage.

The crane operator must ensure that the load bearing capacity of the auxiliary crane in the existing boom radius is at least 85 t to be able to lift and securely hold the WA-frame **2**.

- ▶ Make sure that the auxiliary crane can lift a load of at least 85 t.
-
- ▶ Fasten the auxiliary crane with shackle **60** in point **P55** of the WA-frame 2 end section **2.3**.

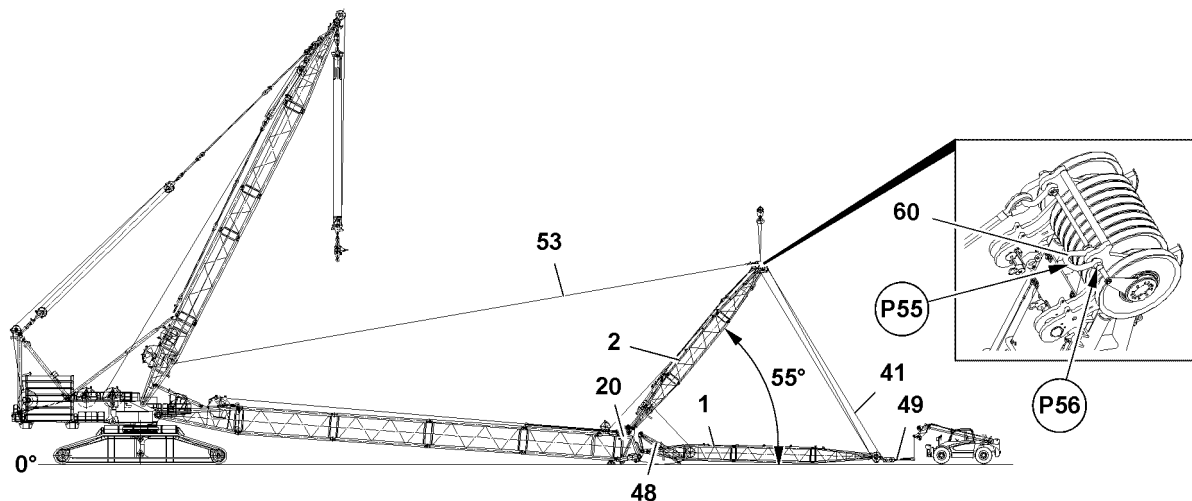

Fig.115807: Erecting the WA-frames — Lifting the WA-frame 2 to 55°

- ▶ Fasten the auxiliary crane on the cross beam and lift.

NOTICE

Slack rope formation!

The control rope **41** can be damaged due to slack rope formation.

This can result in significant property damage.

- ▶ Do not allow slack rope to be formed when spooling out the control rope **41**.
 - ▶ Keep the control rope **41** tight when spooling out.
-
- ▶ Slightly lift the WA-frame **2** while spooling the control rope out.
 - ▶ Lift WA-frame **1** until the cross beam is lifted off the ground.



WARNING

Danger of accident!

Up to an angle of 55°, the WA-frame **2** may only be lifted with an auxiliary crane. The hoist rope **53** may not be subjected to a load.

Death, severe bodily injuries, property damage.

- ▶ Ensure the function of the relapse press **48**: Check the luffing up resistance.
- ▶ It is prohibited to remain in the danger zone. Maintain a safe distance.
- ▶ The spooling procedure must be monitored by a guide.
- ▶ Lift the WA-frame **2** only with the auxiliary crane to approx. 55°.
- ▶ Do not allow slack rope to form on the control winch.



WARNING

Overload of fastening equipment!

During the erection of the WA-frame **2**, a load of no more than maximum 85 t may be lifted, otherwise the fastening points will be overloaded.

Death, severe bodily injuries, property damage.

- ▶ Do not exceed the maximum load of 85 t: Pay attention to the load display.
-
- ▶ Lift the WA-frame **2** with the auxiliary crane to approx. 55° and simultaneously spool the hoist rope **53** up and the control rope **41** out.
 - ▶ Tension the hoist rope **53** until the WA-frame **2** is held by the hoist rope **53**.

**WARNING**

Danger of accident!

If the connector elements are not removed, then they can collide with other crane components during crane operation. The connector elements or other crane components can release and fall down. Death, severe bodily injuries, property damage.

- ▶ Remove the shackle **60** in point **P56**.

- ▶ Remove the auxiliary crane in point **P55**.
- ▶ Fasten the cross beam **49** to the auxiliary crane.
- ▶ Lift the cross beam **49** with the auxiliary crane off the ground.
- ▶ Lift the WA-frame **1** with the control rope **41** until the cross beam **49** can swing freely and does not touch the ground.
- ▶ Lower the cross beam **49** with the auxiliary crane into the vertical position.
- ▶ Remove the auxiliary crane.

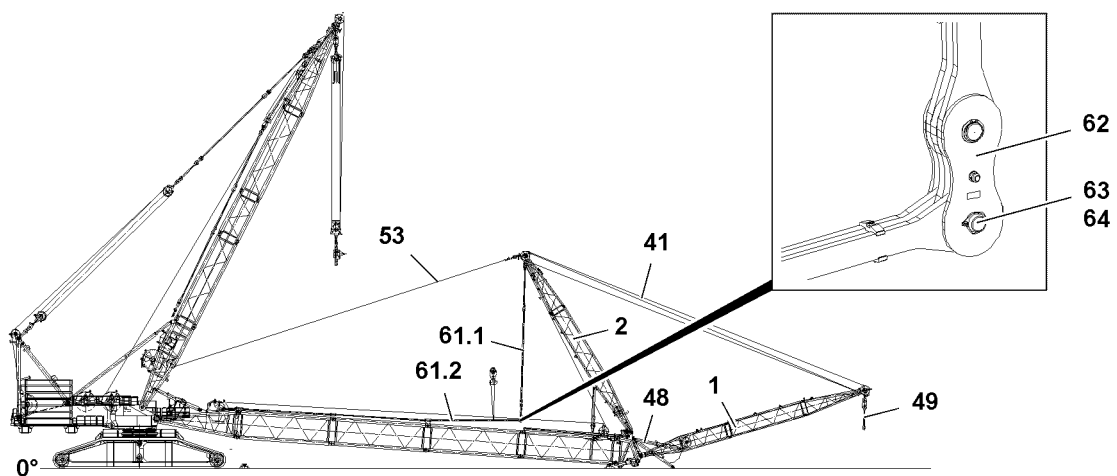

Fig.115808: Erecting the WA-frames — Pinning the guy rods

**WARNING**

Danger of accident!

Death, severe bodily injuries, property damage.

- ▶ Ensure the function of the relapse press **48**: Check the luffing up resistance.
- ▶ It is prohibited to remain in the danger zone. Maintain a safe distance.
- ▶ The spooling procedure must be monitored by a guide.
- ▶ Do not allow slack rope to form on the control winch.
- ▶ Do not exceed the maximum rope pull in the hoist rope.
- ▶ Make sure that the WA-frame **1** remains in a position during the entire erection procedure in which the cross beam **49** is lifted off the ground.

**Note**

- ▶ The guy rods **61.1** are fastened on the WA-frame **2**.
- ▶ The guy rods **61.2** are pinned on the main boom (S-/P-).

The WA-frame **2** is pulled back until the hanging guy rods **61.1** are positioned in such a way that the guy rods **61.2** can be installed. This position is approx. at 120°.

- ▶ Lift the WA-frame **2** by spooling up the hoist rope **53** and simultaneously spooling out the control rope **41** until the guy rods **61.1** can be pinned with the guy rods **61.2**.
- ▶ Fasten the auxiliary crane properly to the guy rods **61.2**.

**WARNING**

Danger of impact / crushing!

When assembling the guy rods **61.2** with the auxiliary crane, they can start to swing back and forth. When lifting / lowering and positioning the guy rods **61.2**, there is an increased danger of impact / crushing.

Death, severe bodily injuries, property damage.

- ▶ Make sure that personnel cannot be caught by the guy rods **61.2**.
- ▶ Maintain a safe distance.

- ▶ Lift the guy rods **61.2**.
- ▶ Pin the guy rods **61.2** with the lug **62**: Insert the pin **63** in point **P57** and secure with the locking pin **64**.
- ▶ Assemble the guy rods **61.2** on the opposite side the same way as described before.

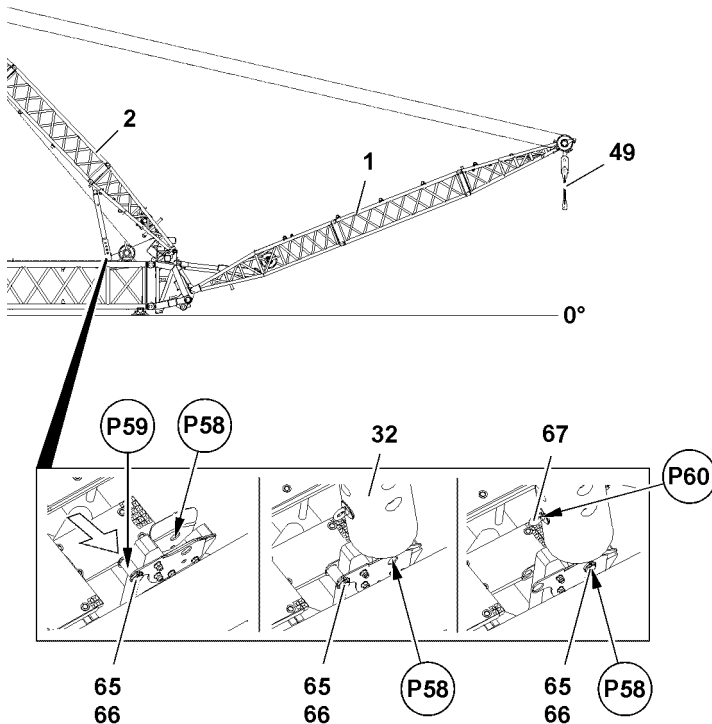

Fig.115809: Erecting the WA-frames — Pinning the WA-frame 2 relapse supports

- ▶ Insert the pins **65** on both sides from the operating position (points **P58**) in the park position (points **P59**) and secure with locking pins **66**.

**WARNING**

Danger of accident!

Death, severe bodily injuries, property damage.

- ▶ Ensure the function of WA-frame 2 **32** relapse supports: Check the luffing up resistance.
- ▶ It is prohibited to remain in the danger zone. Maintain a safe distance.
- ▶ The spooling procedure must be monitored by a guide.
- ▶ Do not allow slack rope to form on the control winch.
- ▶ Make sure that the WA-frame **1** remains in a position during the entire erection procedure in which the cross beam **49** is lifted off the ground.

- ▶ Position the WA-frame 2 **32** relapse supports on the pin points (points **P58**): With the hoist winch, pull the WA-frame **2** back until the pin bores align in the points **P58**.
- ▶ Release and unpin the pins **65** from park position (points **P59**).
- ▶ Pin the WA-frame 2 relapse supports **32** with the S-adaptor **46**: Insert the pins **65** on both sides in points **P58** and secure with locking pins **66**.
- ▶ Release the locking pins **67** on both sides in points **P60** and remove.

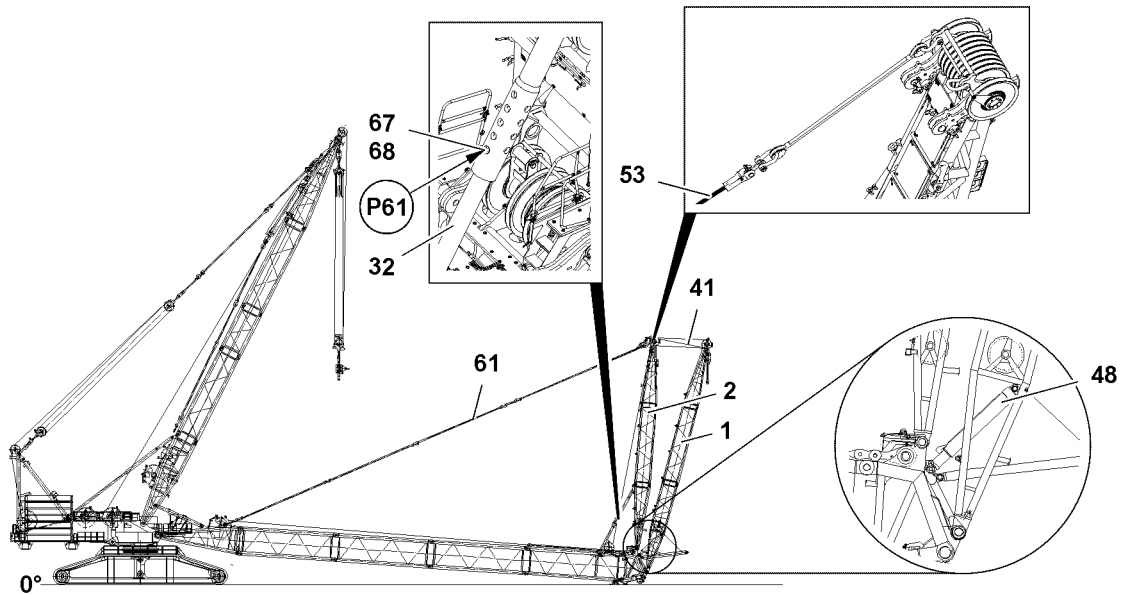

Fig.115810: Erecting the WA-frames — Erecting the WA-frame 1

NOTICE

Damage of the relapse press 48!

Before erecting the WA-frame 1, the electrical connection for the limit switches of the relapse press 48 must be established. If this is **NOT** the case, the WA-frame 1 can be pulled back over the mechanical stop of the relapse press 48, which may damage the relapse press 48.

- ▶ Establish the electrical connection for the limit switches of the relapse press 48.
- ▶ Make sure that the electrical connection for the limit switches of the relapse press 48 is established.
- ▶ Cover the limit switch initiators of the relapse press 48 individually with a metal plate.

Result:

- The icon appears on the LICCON monitor.
- The **spool up function** of the W-control winch turns off.



WARNING

Danger of accident!

Death, severe bodily injuries, property damage.

- ▶ Ensure the function of the relapse press 48: Check the luffing up resistance.
- ▶ Pay attention to the minimum pressure on the relapse press 48.
- ▶ It is prohibited to remain in the danger zone. Maintain a safe distance.
- ▶ The spooling procedure must be monitored by a guide.
- ▶ Erect the WA-frame 1: Spool the control rope 41 up until the WA-frame 1 is pulled against the relapse press 48.
- ▶ Tension the guy rods 61: Spool the hoist rope 53 out until the guy rods 61 are tensioned and simultaneously spool the control rope 41 until the relapse press 48 shuts off.
- ▶ Insert the locking pins 67 on both sides in the maximum possible length of the WA-frame 2 relapse supports 32 in points P61 and secure with locking pins 68.

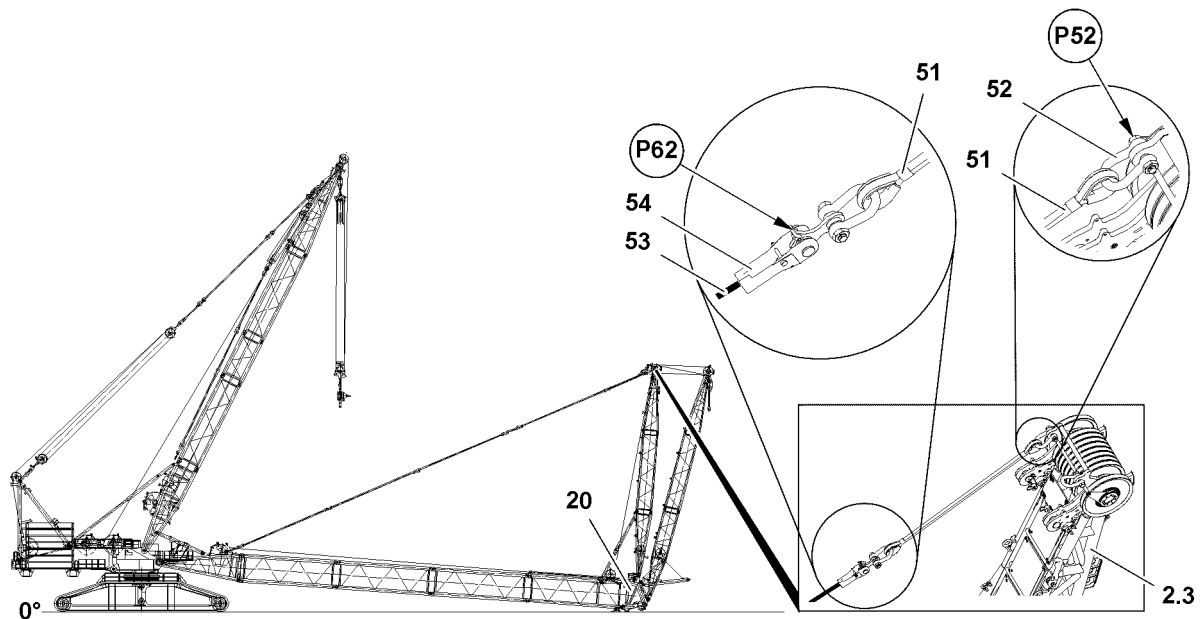

Fig.115811: Erecting the WA-frames — Removing the hoist rope on WA-frame 2

When the hoist rope **53** is no longer tensioned:

- ▶ Fasten the auxiliary crane in point **P62**.



WARNING

Danger of accident!

If the connector elements are not removed, then they can collide with other crane components during crane operation. The connector elements or other crane components can release and fall down. Death, severe bodily injuries, property damage. Crane components can be damaged.

- ▶ Remove all connector elements completely from the WA-frame 2 end section **2.3**.
- ▶ Disconnect the connection between the fastening rope **51** and WA-frame 2 end section **2.3**: Remove the shackle **52** in point **P52**.



WARNING

Danger of accident!

Death, severe bodily injuries, property damage.

- ▶ It is prohibited to remain in the danger zone. Maintain a safe distance.
- ▶ The spooling procedure must be monitored by a guide.
- ▶ Lower the hoist rope **53** with the auxiliary crane and simultaneously spool the hoist winch up until the hoist rope **53** has a length in which it can be taken down on the end section **20**.
- ▶ Take the hoist rope **53** down.
- ▶ Remove the auxiliary crane.
- ▶ Remove the rope lock **54** on the hoist rope **53**.
- ▶ Secure the hoist rope **53** on the end section **20** to prevent it from slipping.

3.4 Assembling the guy rods

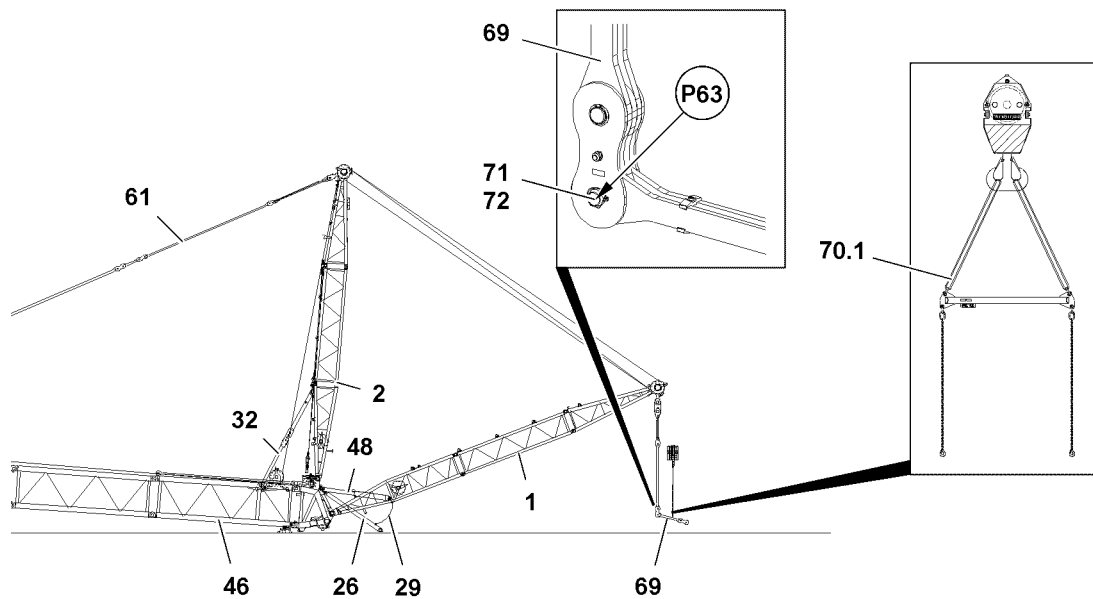

Fig.115812: Assembling the guy rods

Make sure that the following prerequisites are met:

- The guy rods **61** are completely pinned.
- The WA-frame 2 relapse supports **32** are pinned on the S-adapter **46**.
- ▶ Lower the WA-frame **1** until the W-guy rods **69** are close to the ground.
- ▶ Fasten the auxiliary cross beam **70.1** to the auxiliary crane.



Note

- ▶ Check the rod plan for the required W-guy rods **69**.



WARNING

Danger of impact / crushing!

When assembling the W-guy rods **69** with the auxiliary crane, they can start to swing back and forth. When lifting / lowering and positioning the W-guy rods **69**, there is an increased danger of impact / crushing.

Death, severe bodily injuries, property damage.

- ▶ Make sure that personnel cannot be caught by the W-guy rods **69**.
- ▶ Maintain a safe distance.
- ▶ Assemble the W-guy rod pair **69** on the auxiliary cross beam **70.1**.
- ▶ Lift the W-guy rod pair **69** with the auxiliary crane.
- ▶ Pin the W-guy rods **69** with each other: Insert the pins **71** on both sides in points **P63** and secure with locking pins **72**.
- ▶ Lift the WA-frame **1** until the W-guy rods **69** hang vertically: Carry the W-guy rods **69** along with the auxiliary crane so that they do not scrape on the ground when lifting the WA-frame **1**.
- ▶ Assemble additional W-guy rods **69** the same way as described before.
- ▶ Pull up the WA-frame **1** until the relapse press **48** is completely retracted.

Result:

- The W-relapse support **26** is lifted by the retaining rope **29**, which provides more space for the assembly of the W-pivot section **7**.

3.5 Assembling the W-lattice jib

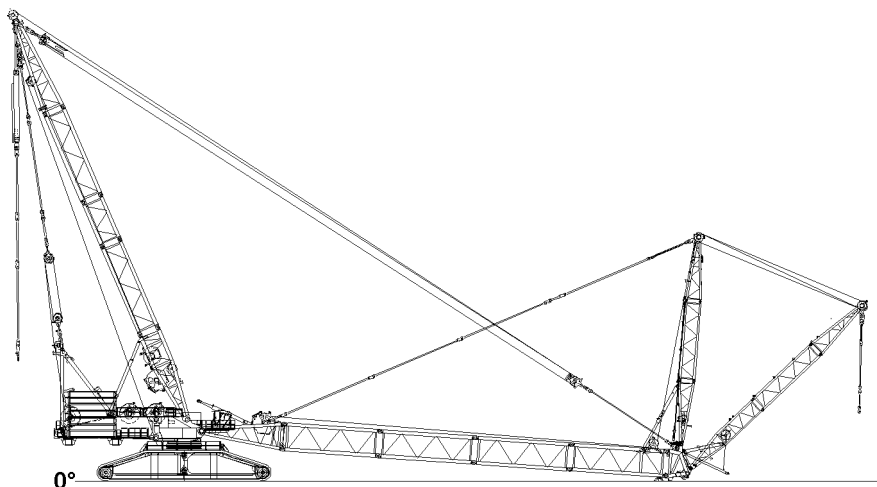

Fig.115813: Assembling the W-lattice jib



WARNING

Danger of crushing for people near the load!

Death, severe bodily injuries, property damage.

- ▶ Before lifting the load it must be ensured that there are no persons in the danger zone.
- ▶ It is prohibited to remain in the danger zone.
- ▶ It is prohibited for anyone to be under the load. Maintain a safe distance.
- ▶ Swinging the load is prohibited.
- ▶ Exercise extreme caution when lifting a load.



DANGER

General danger notes!

- ▶ Support the W-lattice jib during assembly and disassembly with suitable materials.
- ▶ All pins must be secured after assembly.
- ▶ The guy rods must be checked regularly, see the Crane operating instructions, chapter 8.15.



Note

- ▶ During assembly of the W-lattice jib, adhere to the pin sequence, see the Crane operating instructions, chapter 5.01.

3.5.1 Pinning the W-pivot section

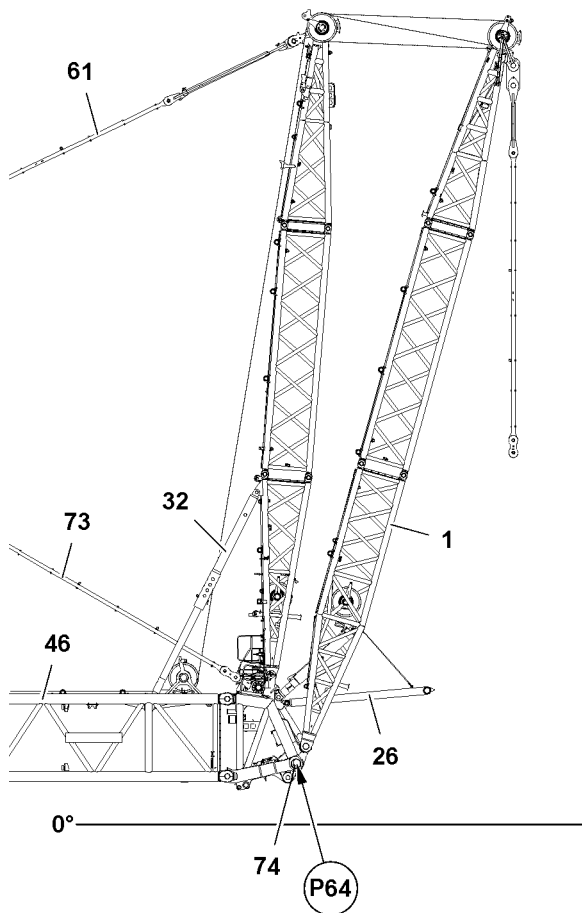

Fig.115814: Pinning the W-pivot section — Lifting the main boom (S-/P-)

Make sure that the following prerequisites are met:

- The main boom control **73** is completely assembled, see the Crane operating instructions, chapter 5.39.
 - The counterweight is installed on the turntable and on the derrick according to the load chart and the erection chart.
 - The suspended ballast has been assembled according to the load chart and the erection chart.
 - The D-boom is in the operating position
 - The guy rods **61** are pinned.
 - The WA-frame **1** is completely erected.
 - The W-relapse support **26** is outside of the assembly range of the W-pivot section.
 - The WA-frame 2 relapse supports **32** are pinned on the S-adapter **46**.
 - The pins **74** on both W-connector points **P64** are unpinned.
 - All retaining elements are removed on both sides on the W-pin points **P64**.
- Erect the main boom (S-/P-) until the W-pin points **P64** are lifted off the ground approx. 1.5 m.

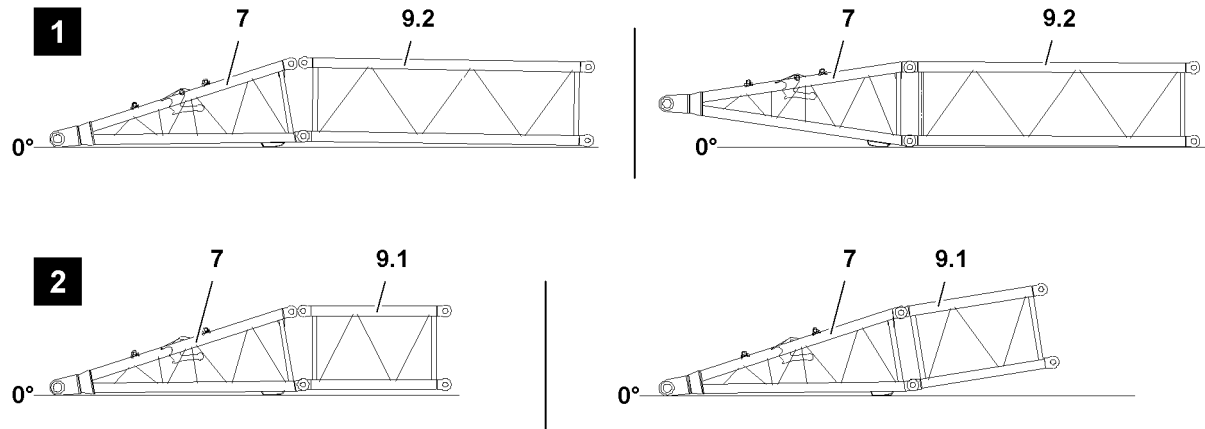

Fig.115816: Pinning the W-pivot section — Assembling the intermediate section on the W-pivot section

It must be differentiated if, after the W-pivot section 7, a 6 m intermediate section 9.1 or a 12 m intermediate section 9.2 is installed. Refer to the rod plan.

If an intermediate section 12 m 9.2 is assembled, the intermediate section 12 m 9.2 is lying on the ground. The W-pivot section 7 is hung on the auxiliary crane and then pinned with the 12 m intermediate section 9.2, see illustration 1.

If a 6 m intermediate section 9.1 is installed, then the W-pivot section 7 is laying on the ground. The 6 m intermediate section 9.1 is hung on the auxiliary crane and then pinned with the W-pivot section 7, see illustration 2.

The pin procedure between the W-pivot section 7 and the intermediate section is identical with the pin procedure of the S-pivot section with a S-intermediate section, see Crane operating instructions, chapter 5.39.



WARNING

Danger of tipping the W-pivot section 7!

If during assembly of the intermediate section 6 m 9.1 with the W-pivot section 7, the W-pivot section 7 is fastened to the auxiliary crane and then assembled on the intermediate section 6 m 9.1, the assembled lattice sections will tip to the side of the W-pivot section 7.

If during assembly of the intermediate section 12 m 9.2 with the W-pivot section 7 the intermediate section 12 m 9.2 is fastened to the auxiliary crane and then the W-pivot section 7 is assembled, the assembled lattice sections will tip to the side of the intermediate section 12 m 9.2.

Death, severe bodily injuries, property damage.

If a 12 m intermediate section 9.2 is required after the W-pivot section 7:

- ▶ Fasten the W-pivot section 7 to the auxiliary crane and align on the lower pin bores of the 12 m intermediate section 9.2 and then pin.
- ▶ Lift the W-pivot section 7 with the auxiliary crane until the „upper“ pin bores align and then pin.

If a 6 m intermediate section 9.1 is required after the W-pivot section 7:

- ▶ Fasten the 6 m intermediate section 9.1 to the auxiliary crane and align on the lower pin bores of the W-pivot section 7 and then pin.
- ▶ Lift the 6 m intermediate section 9.1 with the auxiliary crane until the „upper“ pin bores align and then pin.

- ▶ Assemble the intermediate section on the W-pivot section 7, see the Crane operating instructions, chapter 5.39.

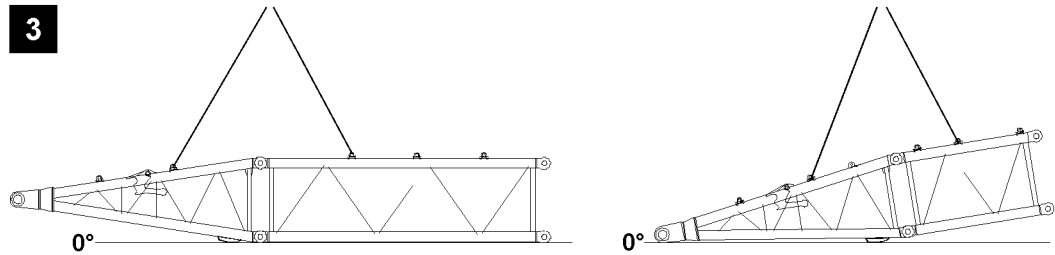

Fig.115818: Pinning the W-pivot section — Fastening points

- ▶ Fasten the W-pivot section 7 with the installed intermediate section 9 to the auxiliary crane, see illustration 3

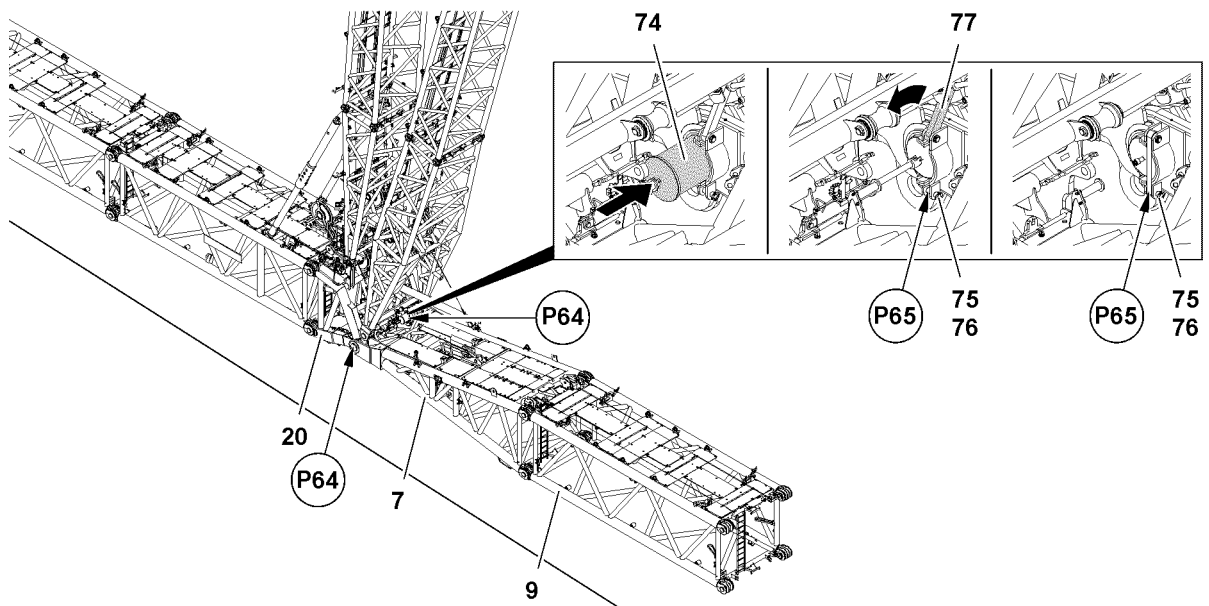

Fig.115817: Pinning the W-pivot section — Pinning procedure

NOTICE

Danger of collision!

The safety latch 77 can be damaged.

- ▶ Make sure that the safety latch 77 is in a position in which it cannot collide while the W-pivot section 7 is positioned.

- ▶ Lift the W-pivot section 7 and the intermediate section 9 and align on the end section 20 so it can be pinned in points P64.

To pin the W-lattice jib with the pin pulling device, see the Crane operating instructions, chapter 5.30.

When the pin bores align in points P64:

- ▶ Insert the pins 74 on both sides completely with the pin pulling cylinder in points P64.
- ▶ Release the retaining pins 75 on both sides in points P65 and unpin.
- ▶ Bring the safety latch 77 in the retaining position P65.
- ▶ Insert the retaining pin 75 and secure with the locking pin 76.

Result:

- The pins 74 are completely secured.

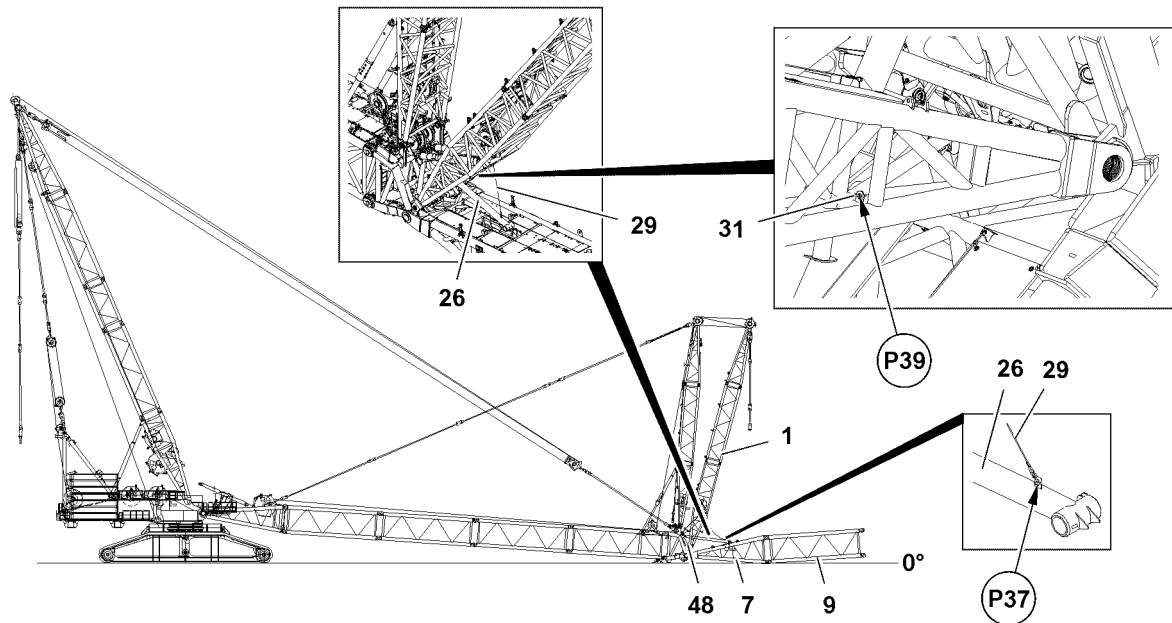

Fig.115819: Pinning the W-pivot section — Fastening the retaining rope in the park position

- ▶ Lower the W-pivot section 7 and intermediate section 9 to the ground.
- ▶ Remove the fastening equipment.
- ▶ Lower the WA-frame 1 until the retaining rope 29 can be removed from the W-relapse support 26.
- ▶ Release the retaining rope 29 on the W-relapse support 26: Remove the hook 30 in point P37.
- ▶ Attach the retaining rope 29 in point P39 with the snap hook 31.

3.5.2 Assembling the W-lattice jib on the W-pivot section

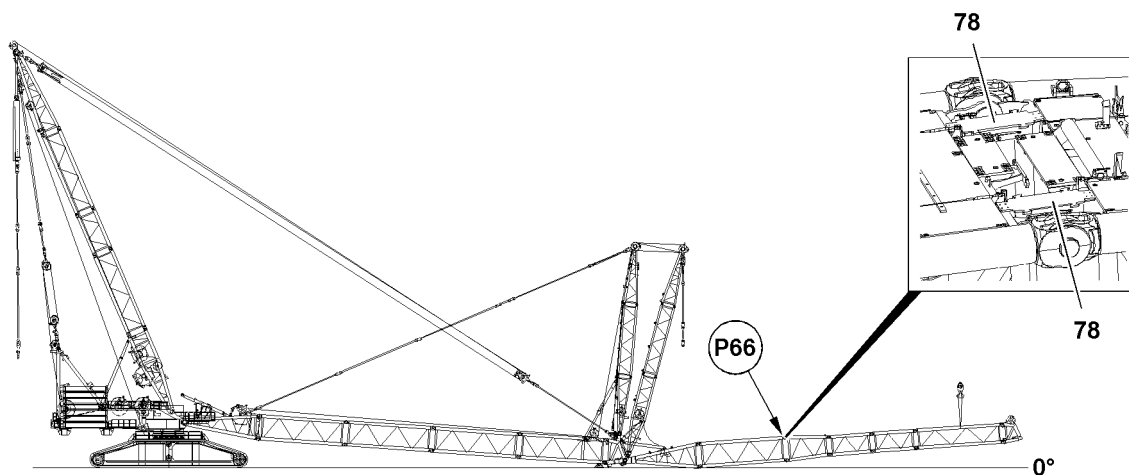

Fig.124455: Assembling the W-lattice jib on the W-pivot section — Assembling the rod receptacles



Note

- ▶ To pin the W-lattice jib with the pin pulling device, see the Crane operating instructions, chapter 5.30.
- ▶ The assembly of the W-lattice jib is the same as the assembly of the main boom (S-/P-), see the Crane operating instructions, chapter 5.39.
- ▶ Refer to the rod plan for the sequence and the number of the individual lattice sections.

**Note**

For assembly of the lattice sections and when lifting the boom system, use the cross beam.

- ▶ For handling of the cross beam, see the Crane operating instructions, chapter 5.39.

NOTICE

Impermissible boom length!

If the boom is lifted with an impermissible boom length with the cross beam, then the last intermediate section can be overloaded when lifting the boom system.

Death, severe injuries, property damage.

- ▶ Make sure that the boom is lifted with the cross beam only up to the permissible boom length, see chart.

Boom system	Permissible boom length
S	132 m
SL	144 m
P	132 m
W	126 m
W2	90 m
W3	108 m

- ▶ Assemble the W-lattice jib to the required length.

NOTICE

Removed rod receptacles **78**!

If the rod receptacles **78** are not installed, the lattice sections and the guy rods will collide. This could result in property damage.

- ▶ Make sure that the rod receptacles **78** are installed.
- ▶ Assemble the rod receptacles **78** on both sides in points **P66**.

3.5.3 Assembling the roller set

- ▶ Fasten the auxiliary crane via the cross beam to the lattice section.

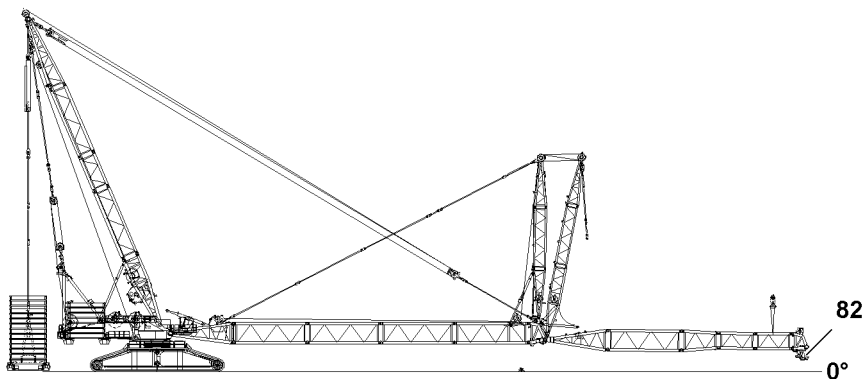

Fig.124457: Assembling the roller set — W-lattice jib up to a length of W- 42 m

When a W-lattice jib up to a length of W- 42 m is assembled:

- ▶ Lift the main boom (S-/P-) to 0° and simultaneously lift the W-lattice jib with the auxiliary crane until the roller set **82** can be assembled.

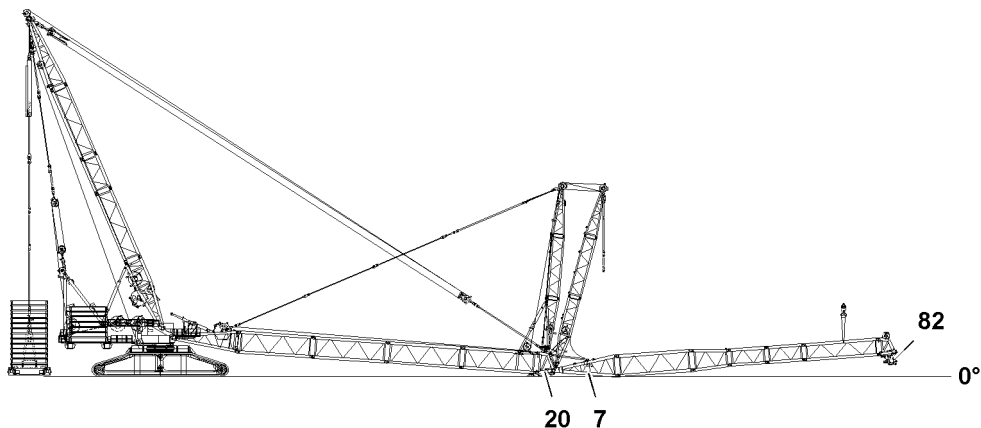

Fig.124456: Assembling the roller set — W-lattice jib larger than W- 42 m

When a W-lattice jib is larger than W- 42 m and the ground is level, then the end section **20** can remain taken down on the ground. However, it must be ensured at any time that the angle between the main boom (S-/P-) and the W-pivot section **7** is not more than maximum 10°.

- ▶ Lift the W-lattice jib with the auxiliary crane until the roller set **82** can be installed.



Note

- ▶ The assembly of the roller sets **82** is described in the Crane operating instructions, chapter 5.14.
- ▶ Assemble the roller set **82**.

3.6 Assembling the placement pins

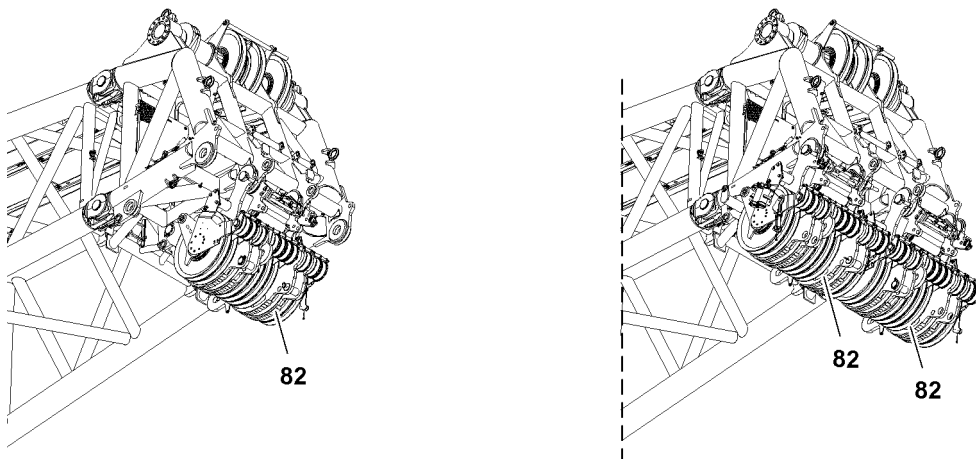

Fig.115825: Assembling the placement pins — L-end section with one roller set and L-end section with two roller sets

Make sure that the following prerequisite is met:

- The roller set **82** / roller sets **82** are completely assembled.

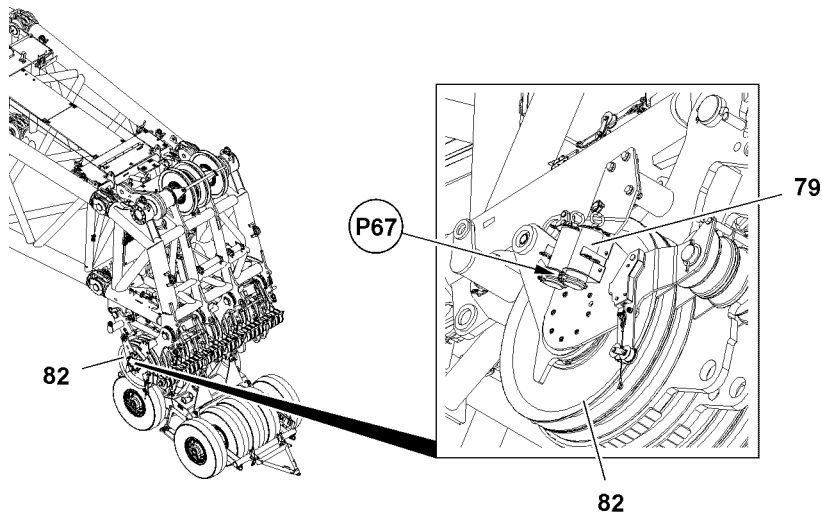

Fig.116105: Assembling the placement pins — Park position of the placement pins

- ▶ Remove the placement pins **79** from the park positions **P67** on the roller set **82**.

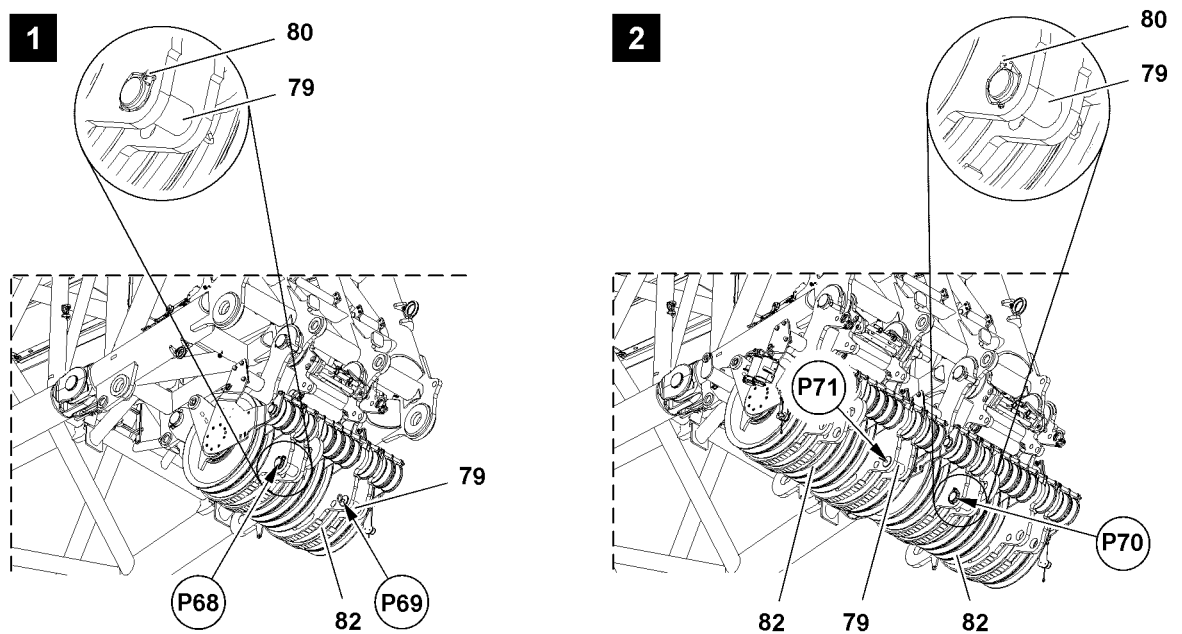

Fig.115830: Assembling the placement pins — Pin procedure



WARNING

Placement pin **79** inserted from the wrong side!

If the placement pins **79** are inserted from the wrong side, the locking pins **80** can be destroyed. The placement pins **79** would be unsecured and could fall down. Death, severe bodily injuries, property damage.

If only one individual roller set **82** is used:

- ▶ Make sure that the placement pins **79** are inserted from the „inside“ to the „outside“, see illustration 1.

If two pulley sets **82** are used:

- ▶ Make sure that the placement pins **79** are inserted from the „outside“ to the „inside“, see illustration 2.

Depending if one roller set **82** or two roller sets **82** are assembled, the placement pins **79** for the support must be pinned on the roller cart **81** in various points.

When one roller set **82** is assembled:

- ▶ Insert the pin in point **P68** and point **P69** and secure with locking pins **80**, see illustration 1.

When two pulley sets **82** are assembled:

- ▶ Insert the pin in point **P70** and point **P71** and secure with locking pins **80**, see illustration 2.

3.7 Assembling the roller cart

3.7.1 Roller cart assembly procedure

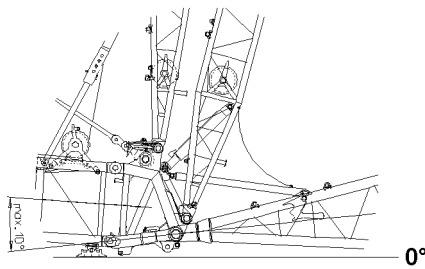

Fig.115822: Assembling the roller cart — Maximum angle between the main boom (S-/P-) and the W-pivot section

NOTICE

Exceeding the maximum angle between the main boom (S-/P-) and the W-pivot section!

If the maximum angle of 10° between the main boom (S-/P-) and the W-pivot section is exceeded, the individual crane components will collide.

This could result in property damage.

- ▶ Make sure that the angle between the main boom (S-/P-) and the W-pivot section is **NEVER** more than 10° .

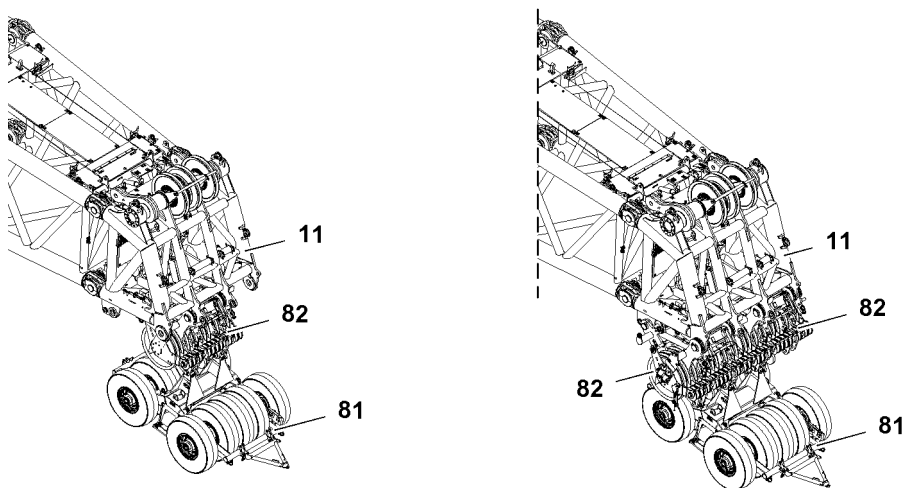

Fig.115826: Assembling the roller cart — Overview

**Note**

- ▶ The placement of the L-end section **11** on the roller cart **81** is the same for one assembled roller set **82** and for two assembled roller sets **82**.
- ▶ On the following illustrations in this section, only the placement of the L-end section **11** for two assembled roller sets **82** is shown. The procedure for one assembled roller set **82** is carried out in the same way.

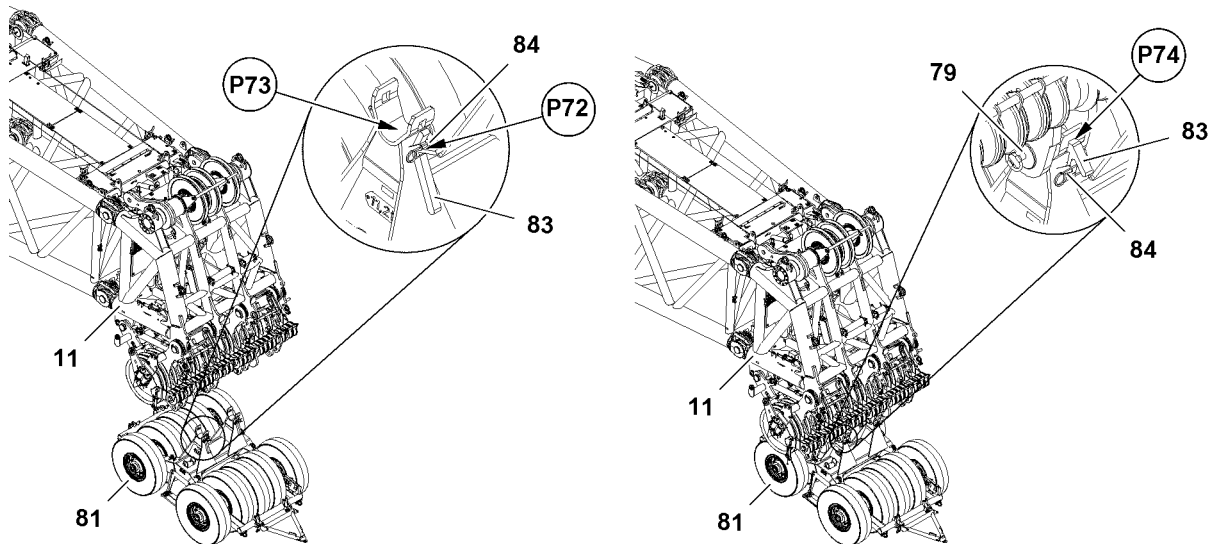

Fig.115827: Assembling the roller cart — Placing the L-end section on the roller cart

Make sure that the following prerequisite is met:

- The retaining plates **83** are in the park position **P72**.
- ▶ Position the roller cart **81** in such a way that the L-end section **11** can be placed on the placement pin **79** in points **P73**.
- ▶ Lower the W-lattice jib with the auxiliary crane until the placement pins **79** are lying on both sides in points **P73**.
- ▶ Remove the retaining plates **83** on both sides from the park positions **P72**.
- ▶ Insert the retaining plates **83** on both sides in points **P74** and secure with spring retainers **84**.
- ▶ Remove the auxiliary crane.

Result:

- The W-lattice jib is lying completely on the roller cart **81**.

3.7.2 Changing the retaining plates during the erection and take down procedure

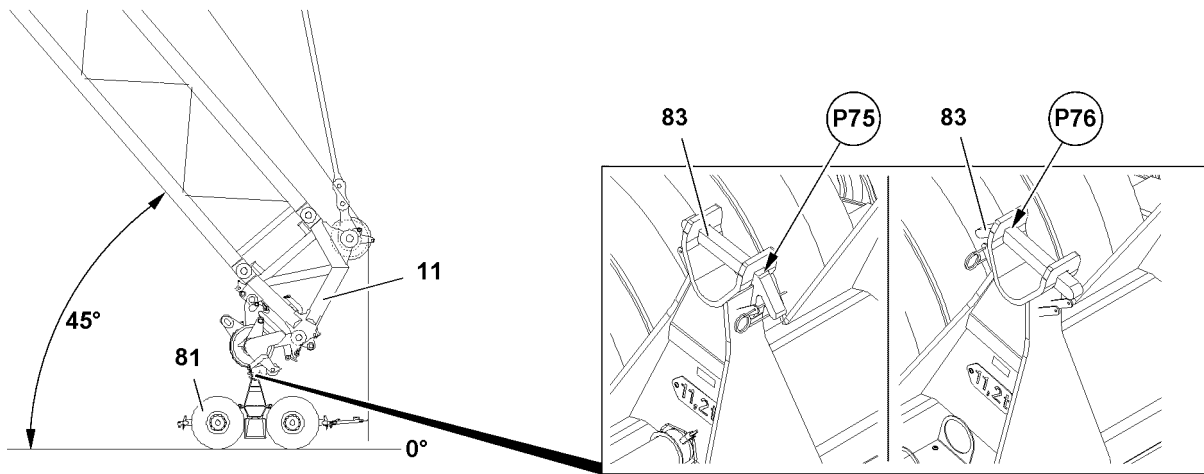

Fig.116104: Changing the retaining plates during the erection and take down procedure



Note

Change the retaining plates **83**!

When the retaining plates **83** are not inserted at an angle of 45° between the W-lattice jib and the ground from the other side, then it is no longer possible subsequently to disassemble the roller cart **81** on the L-end section **11**.

- ▶ Unpin the retaining plates **83** at a W-boom angle of 45° to the ground and reinsert again from the other side and secure.

When the angle between the W-boom and the ground is approx. 45°:

- ▶ Release the retaining plates **83** on both sides in points **P75** and remove.
- ▶ Insert the retaining plates **83** on both sides in points **P76** and secure with spring retainers **84**.

3.8 Assembling the guy rods

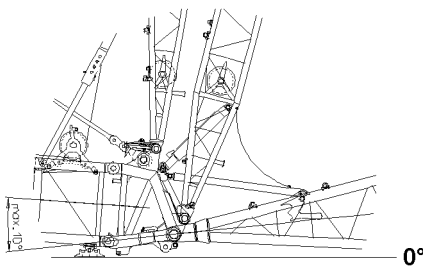

Fig.115822: Assembling the guy rods — Maximum angle between the main boom (S-/P-) and the W-pivot section

NOTICE

Exceeding the maximum angle between the main boom (S-/P-) and the W-pivot section!

If the maximum angle of 10° between the main boom (S-/P-) and the W-pivot section is exceeded, the individual crane components will collide.

This could result in property damage.

- ▶ Make sure that the angle between the main boom (S-/P-) and the W-pivot section is **NEVER** more than 10°.

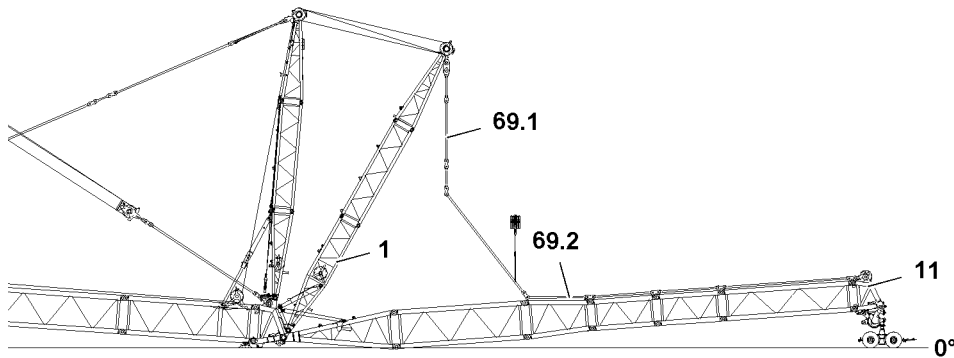

Fig. 115828: Assembling the guy rods — Placing the guy rods and pinning them with each other



Note

- ▶ Assembly of the boom combinations, see the rod plans.
- ▶ Assembly of the W-guy rods **69**, see the rod plans.
- ▶ The numbering on the rod plans must be identical to the numbering on the W-guy rods **69**.



WARNING

Danger of impact / crushing!

When assembling the W-guy rods **69** with the auxiliary crane, they can start to swing back and forth. When lifting / lowering and positioning the W-guy rods **69**, there is an increased danger of impact / crushing.

Death, severe bodily injuries, property damage.

- ▶ Make sure that personnel cannot be caught by the W-guy rods **69**.
- ▶ Maintain a safe distance.

The W-guy rods **69.2** are delivered separately and are not lying on the W-lattice sections. Refer to the rod plan for the sequence and the number of the individual W-guy rods **69.2**.

- ▶ Place the required W-guy rods **69.2** on the W-lattice sections and pin.
- ▶ Pin the W-guy rods **69.2** from the L-end section **11** with the W-guy rods **69.1** from the WA-frame **1** and secure.

3.9 Pulling the hoist ropes in

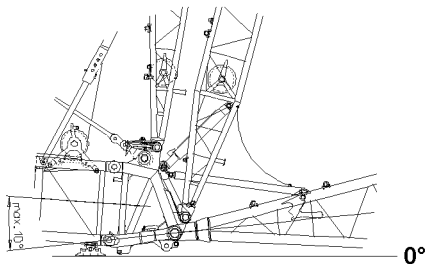

Fig. 115822: Pulling the hoist rope in — Maximum angle between the main boom (S-/P-) and the W-pivot section

NOTICE

Exceeding the maximum angle between the main boom (S-/P-) and the W-pivot section!

If the maximum angle of 10° between the main boom (S-/P-) and the W-pivot section is exceeded, the individual crane components will collide.

This could result in property damage.

- ▶ Make sure that the angle between the main boom (S-/P-) and the W-pivot section is **NEVER** more than 10°.

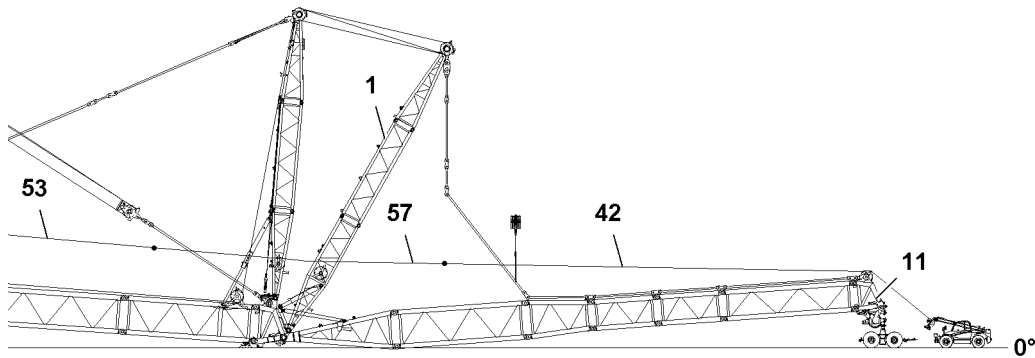

Fig.115829: Pulling the hoist ropes in — Connecting the ropes with each other

- ▶ Erect the WA-frame 1 completely.
- ▶ Connect the hoist rope 53 with the auxiliary ropes 57.
- ▶ Connect the assembly rope 42 of the telescopic lift truck with one of the auxiliary ropes 57.
- ▶ Spool the assembly rope 42 up with the telescopic lift truck.

Result:

- The auxiliary rope 57 and the hoist rope 53 are pulled through between the WA-frames up to the L-end section 11.

If additional hoist ropes 53 are used:

- ▶ Pull the hoist ropes 53 to the L-end section 11 the same way as described before.

3.10 Assembling the auxiliary guying

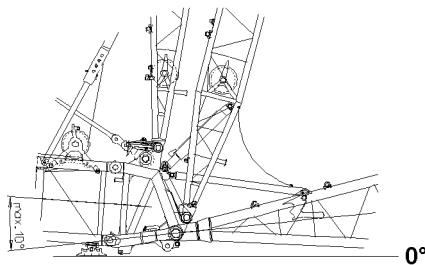

Fig.115822: Assembling the auxiliary guying — Maximum angle between the main boom (S-/P-) and the W-pivot section

NOTICE

Exceeding the maximum angle between the main boom (S-/P-) and the W-pivot section!
If the maximum angle of 10° between the main boom (S-/P-) and the W-pivot section is exceeded, the individual crane components will collide.

This could result in property damage.

- ▶ Make sure that the angle between the main boom (S-/P-) and the W-pivot section is **NEVER** more than 10°.



Note

- ▶ Not every system requires auxiliary guying. Refer to the rod plans if auxiliary guying is required.
- ▶ Assembly of the auxiliary guying, see the rod plans.
- ▶ The numbering on the rod plans must be identical to the numbering on the guy rods.

- ▶ Lower WA-frame 1 until the auxiliary guying can be assembled.
- ▶ Assemble the auxiliary guying.

Empty page!

LWE/LR 13000-001/19503-01-02/en

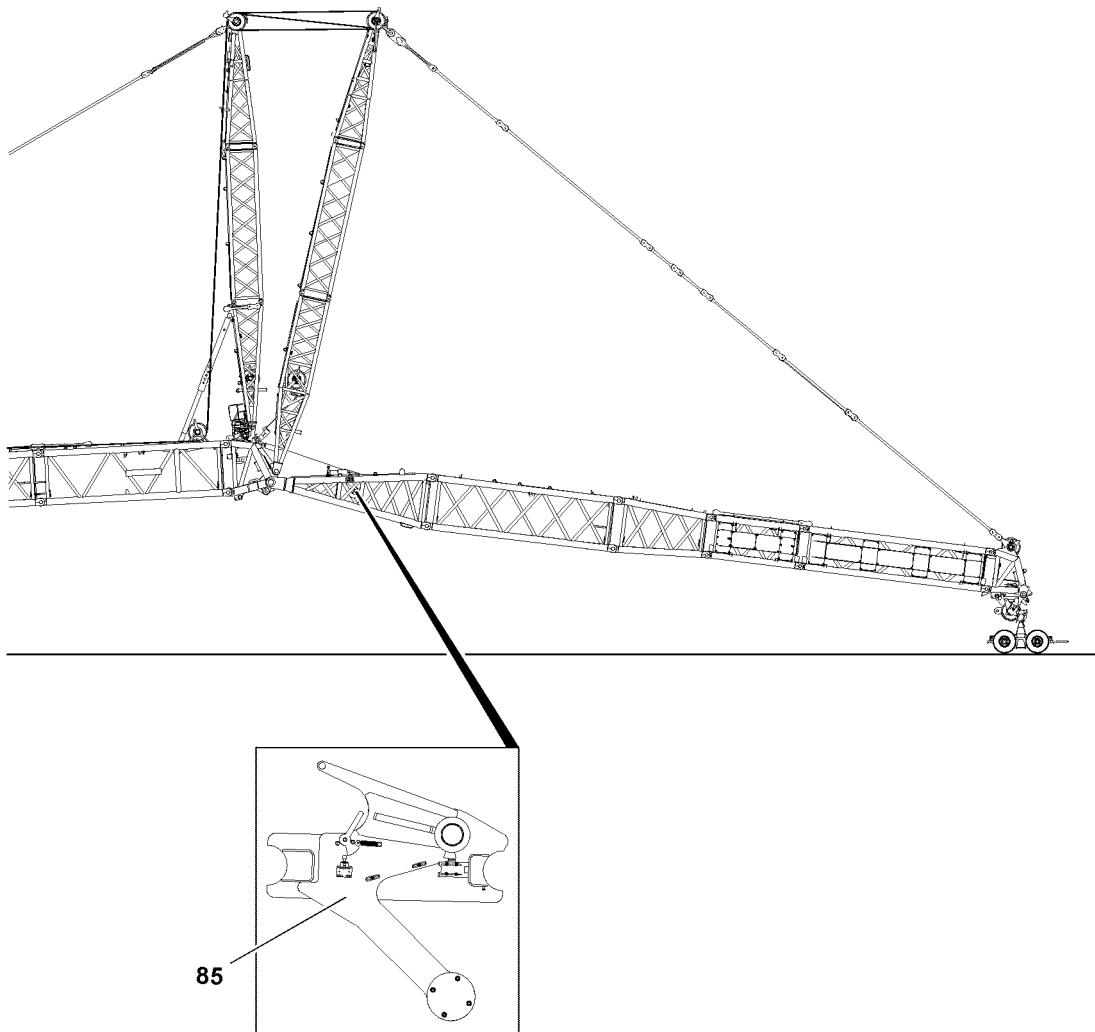

Fig.116101

LWE/LR 13000-001/19503-01-02/en

3.11 Establishing the electrical connections

Make sure that the following prerequisites are met:

- The W-boom is completely assembled.
- The airplane warning light and the wind speed sensor are assembled.

NOTICE

Damage to the electrical connection on the cable drum!

If the electrical connection from the cable drum to the terminal box on the W-pivot section is established first before the connection to the terminal box on the W-connector head, then the electrical connection will be damaged when spooling out the cable drum.

- ▶ First establish the electrical connection from the cable drum on the W-pivot section to the terminal box on the W-end section and then the electrical connection from the terminal box to the cable drum on the W-pivot section.
-



Note

- ▶ To establish the electrical connections on the W-boom, see the Electric wiring diagram.
-

- ▶ Establish the electrical connections.
- ▶ Make sure that all electrical connections on the boom are established.

3.12 Checking the function of the safety equipment

Make sure that the following prerequisites are met:

- All electrical connections have been established.
- The appropriate operating mode is set.

3.12.1 Wind speed sensor*

- ▶ Check the movement and the function of the wind speed sensor.

3.12.2 Airplane warning light*

- ▶ Turn the airplane warning light on and visually check the function.

3.12.3 Oscillation guard



DANGER

Danger of tipping over if the oscillation guard is hard to move!

The mechanical relapse retainer no longer functions if the oscillation guard **85** moves with difficulty. The W-lattice jib can tip backwards uncontrolled and cause the crane to topple over.

- ▶ Crane operation with hard to move oscillation guard **85** is prohibited.
 - ▶ Check the oscillation guard **85** for easy movement.
-

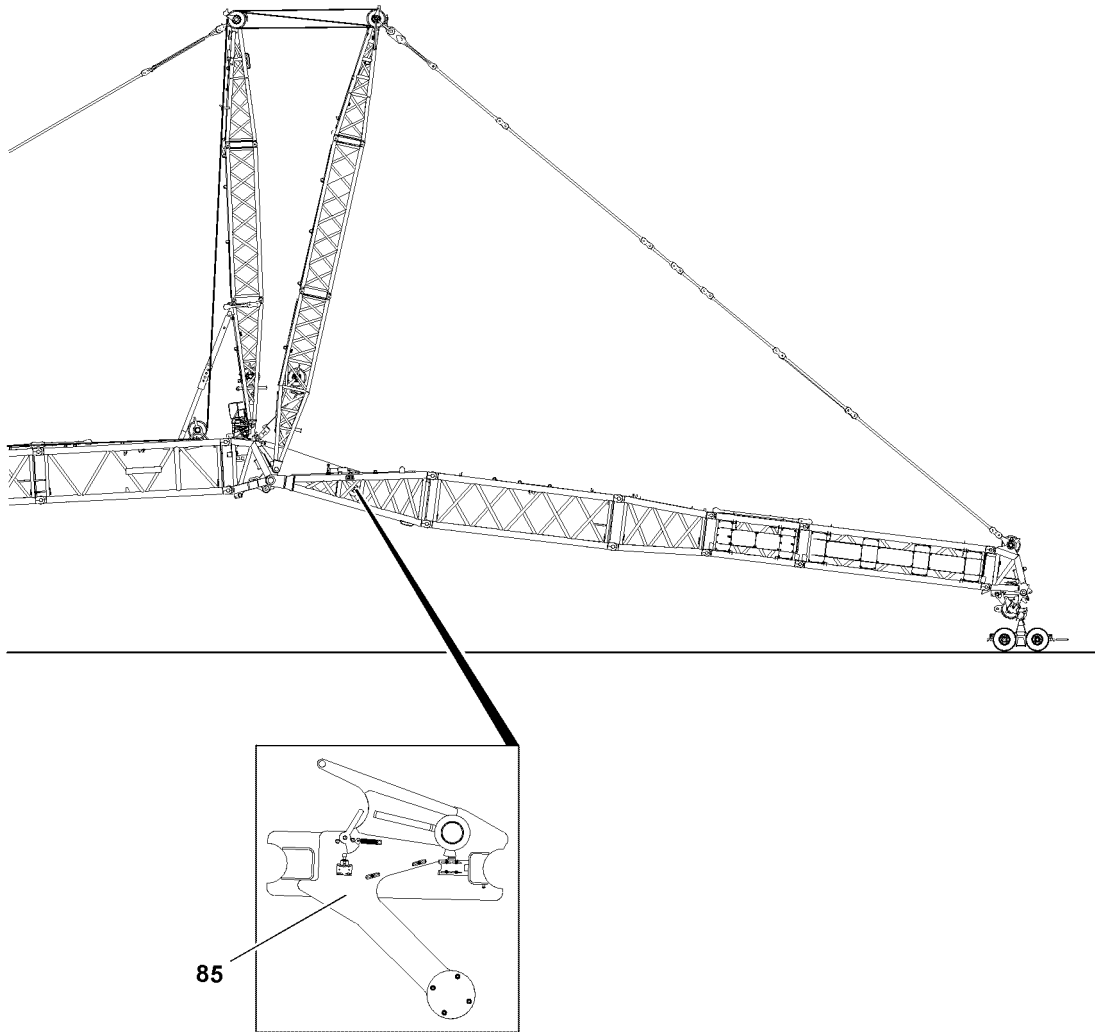

Fig.116101

LWE/LR 13000-001/19503-01-02/en

3.12.4 Limit switch, general



Note

- ▶ The limit switch functions have to be checked individually before erection.
- ▶ The functions of the limit switch initiators must be checked in the test system, see the „Diagnostics“ manual.
- ▶ The limit switch initiators are checked manually as follows.

3.12.5 Hoist limit switch

When replacing or changing the hoist limit switch (HES), the HES must have the correct bus address and the correct software version in order to be recognized again by the bus system (LSB).

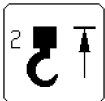

- ▶ Actuate the hoist limit switch manually.

Result:

- The icon appears on the LICCON monitor.
- The **spooling up** of the hoist winch turns off.

3.12.6 Limit switch W-lattice jib, „steepest“ position, relapse cylinder

- ▶ Cover the limit switch initiators individually with a metal plate, see the Crane operating instructions, chapter 8.12.

Result:

- The icon appears on the LICCON monitor.
- The **spool up function** of the W-control winch turns off.

3.12.7 Limit switch W-lattice jib, „lowest“ position, relapse cylinder



- ▶ Cover the „lowest“ position of the limit switch initiators individually with a metal plate, see the Crane operating instructions, chapter 8.12.

Result:

- The icon appears on the LICCON monitor.
- The **spool out function** of the W-control winch turns off.

3.12.8 Limit switch flap in the „steepest“ W-lattice jib position, mechanical relapse support



- ▶ Cover the limit switch initiators individually with a metal plate.

Result:

- The icon appears on the LICCON monitor.
- The **spool up function** of the W-control winch turns off.

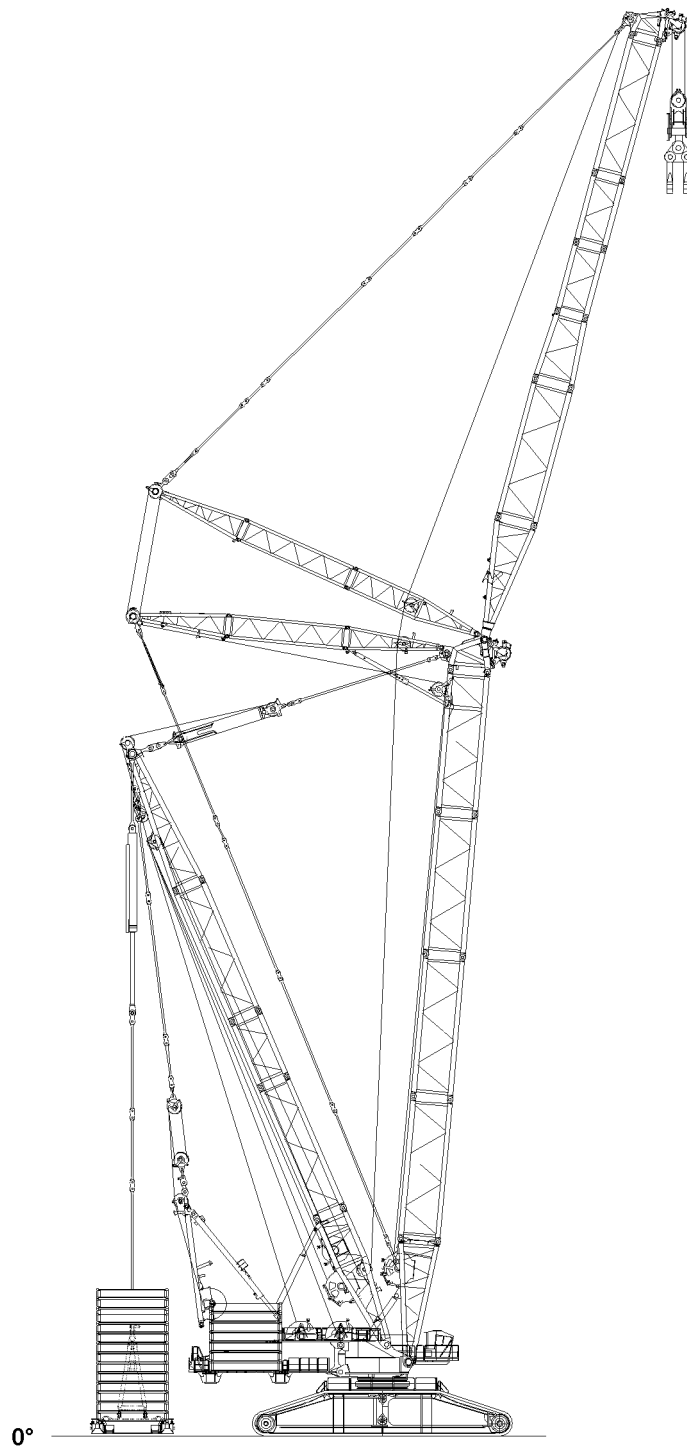

Fig.124461

LWE/LR 13000-001/19503-01-02/en

3.13 Erecting the boom



DANGER

The crane can topple over!

- ▶ It is not permitted to turn the crane during erection.
- ▶ Observe the technical safety instructions, see the Crane operating instructions, chapter 5.01.
- ▶ Observe the specifications in the erection and take-down charts.
- ▶ Extend the relapse cylinder before erection.



DANGER

Tipping lattice jib!

If the easy movement on the pendulum of the mechanical relapse support is not checked before erection or not reestablished, if necessary, then the mechanical relapse support will not engage in the steep lattice jib position. As a result, the lattice jib can tip to the rear.

Death, severe bodily injuries, property damage.

- ▶ Check the easy movement on the pendulum of the mechanical relapse support before erection.
- ▶ If the pendulum does not move easily: Make the pendulum easy to move.



WARNING

The crane can topple over!

If the following conditions are not met before erecting the boom, the crane can topple over.

Death, severe bodily injuries, property damage.

- ▶ The lattice jib must roll on the ground with its entire weight.
- ▶ Spool the lattice jib adjustment out in such that guy rods sag slightly.
- ▶ Do not allow slack rope formation on the control winch.



WARNING

Unutilized guy rods on boom!

If guy rods are on the lattice sections which are not used for operation, then there is a danger of accident.

Death, severe bodily injuries, property damage.

The guy rods will fall down.

The load chart is invalid.

The load display of the LICCON computer system shows an incorrect value.

- ▶ Unutilized guy rods must be removed before erecting the boom.

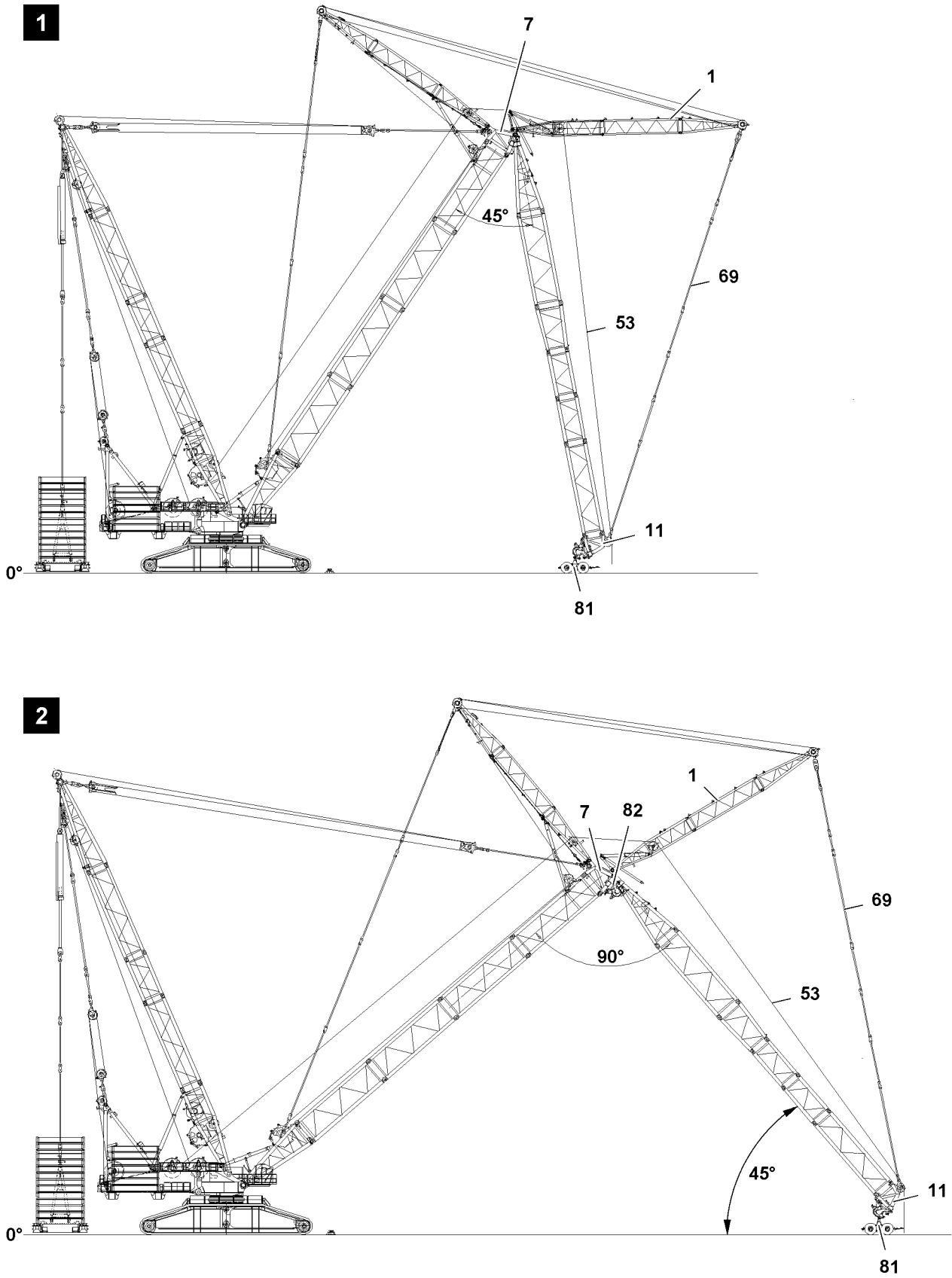

LWE/LR 13000-001/19503-01-02/en

Fig.116102

Make sure that the following prerequisites are met:

- The W-lattice jib is fully assembled.
- The roller cart **81** is assembled on the L-end section **11**.
- No personnel is present in the danger zone.
- The crane is horizontally aligned.
- All electrical connections have been established.
- All limit switches are functioning.
- The counterweight, central ballast and derrick ballast are installed according to the data in the erection and take-down chart / load chart.
- All pin connections are secured.
- The hoist rope **53** has been correctly inserted in the rope pulleys and is prevented from jumping out with the rope retaining pins.
- The hoist rope **53** has been pulled with the respective length over the L-end section **11**.
- There are no loose parts on the boom or the lattice jib.
- The boom, lattice jib and safety equipment are free from snow and ice.
- The LICCON overload protection has been set according to the data in the load chart.
- The LICCON overload protection settings have been compared with the actual set up configuration.
- The assembly icon is visible on the LICCON monitor.



WARNING

Falling hoist rope!

If the hoist rope **53** is not pulled with the respective length over the L-end section **11** before the erection procedure, then it can fall backward due to its own weight.

Death, severe bodily injuries, property damage.

- ▶ Pull the hoist rope **53** before the erection procedure with sufficient length over the L-end section **11** and place on the ground.
- ▶ During erection, walk along with the roller cart and constantly monitor the hoist rope: The hoist rope may not lift off the ground.
- ▶ The hoist rope **53** must be constantly monitored during erection.
- ▶ Do not step into the danger zone.



Note

Change the retaining plates on the roller cart!

When the retaining plates are not inserted at an angle of 45° between the W-lattice jib and the ground from the other side, then it is no longer possible subsequently to disassemble the roller cart **81** on the L-end section **11**.

- ▶ Unpin the retaining plates at a W-boom angle of 45° to the ground and reinsert again from the other side and secure. See section „Changing the retaining plates during the erection and take down procedure“.

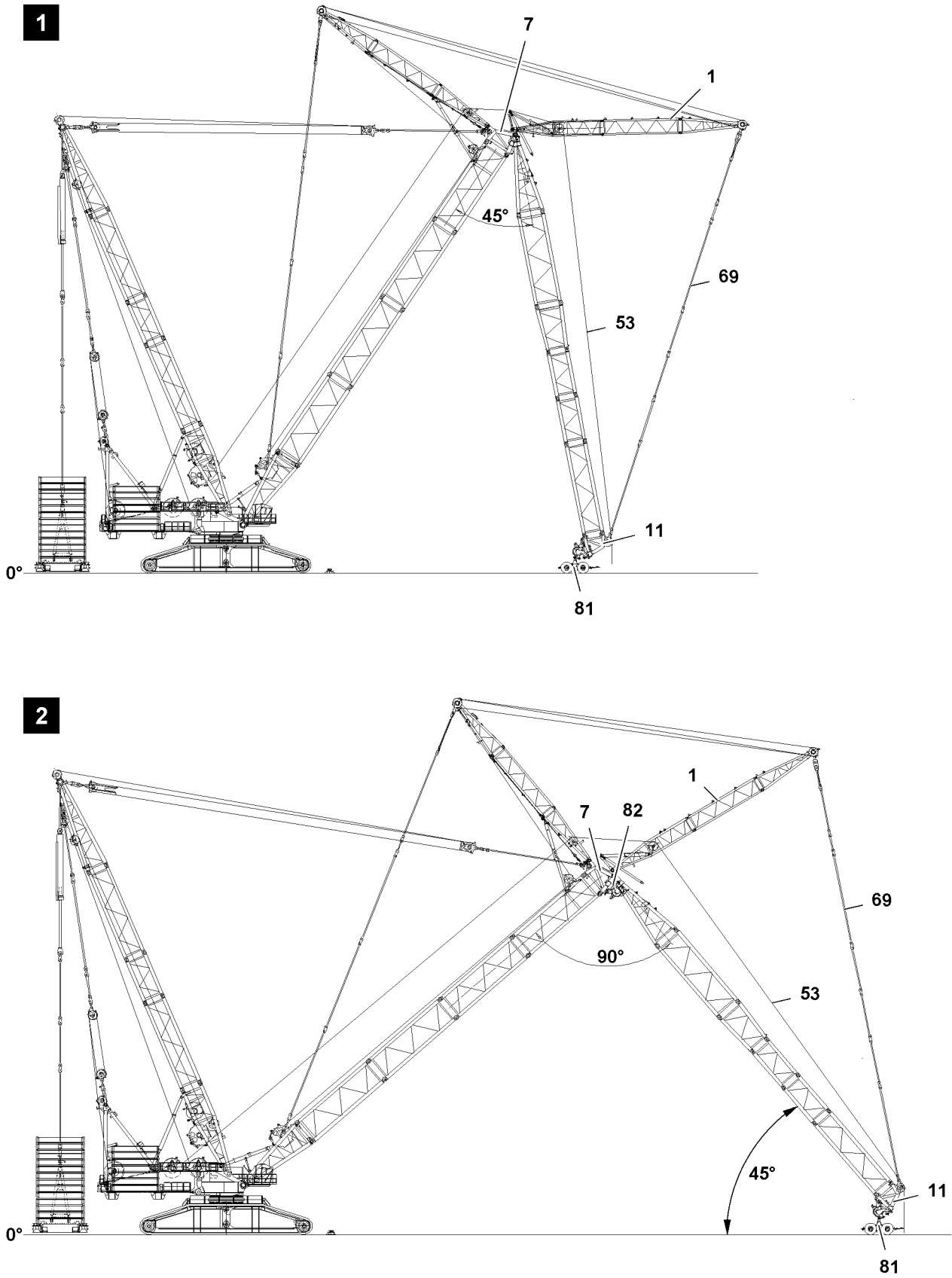

LWE/LR 13000-001/19503-01-02/en

Fig.116102

The procedure differs depending on how the crane is configured.

- Illustration 1: On the main boom end section 7 there is no roller set - switch position „W-lattice jib bottom“ occurs at an angle of approx. 45° between the main boom (S-/P-) and the W-lattice jib.
- Illustration 2: On the main boom end section 7 there is a roller set 82 - switch position „W-lattice jib bottom“ occurs at an angle of approx. 90° between the main boom (S-/P-) and the W-lattice jib.
- The ratio of the lengths of the main boom and the W-lattice jib also have an influence.

The roller cart 81 must absorb the proportional weight of the boom system as long as possible during the erection procedure.

When **NO** roller set 82 is assembled on the main boom end section 7, see illustration 1:

- ▶ Luff up the main boom (S-/P-) and simultaneously spool the W-control winch out to keep the W-lattice jib with the L-end section 11 placed on the roller cart 81 on the ground. Carry out this procedure until **either** the „W-lattice jib bottom“ switch position is reached **or** the main boom has reached its steepest position **or** the L-end section 11 lifts off the ground **or** the WA-frame 1 is in the **bottom** position.

When **ONE** roller set 82 is assembled on the main boom end section 7, see illustration 2:

- ▶ Luff up the main boom (S-/P-) and simultaneously spool the W-control winch out to keep the W-lattice jib with the L-end section 11 placed on the roller cart 81 on the ground. Continue with this process until the main boom (S-/P-) and the W-lattice jib form an angle of approximately 90°, **Switch position W-lattice jib bottom**, or until the L-end section 11 lifts off from the ground first or the WA-frame 1 is in the **bottom** position.
- ▶ Unpin the roller cart 81 on the L-end section 11.

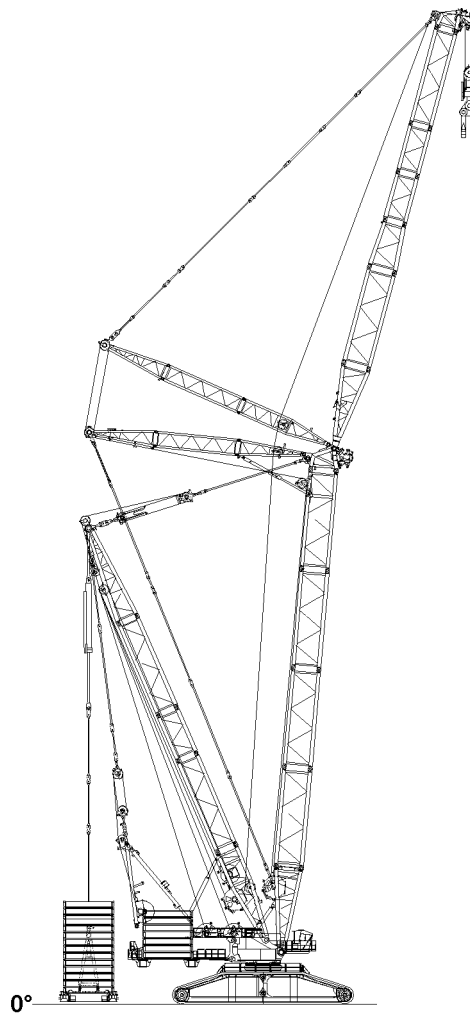
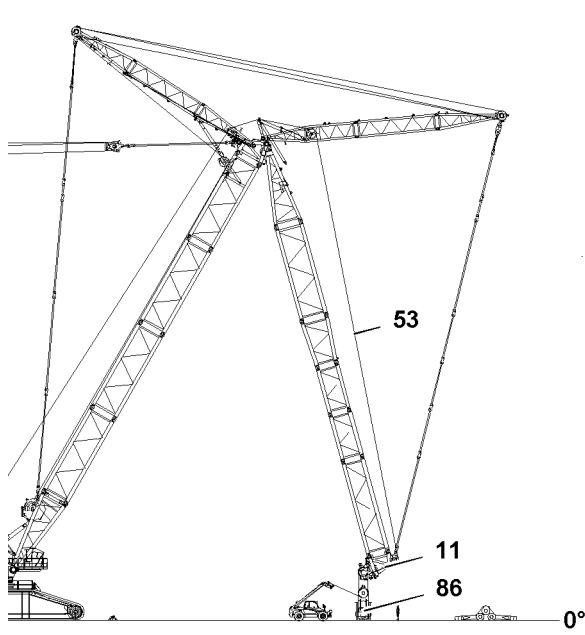
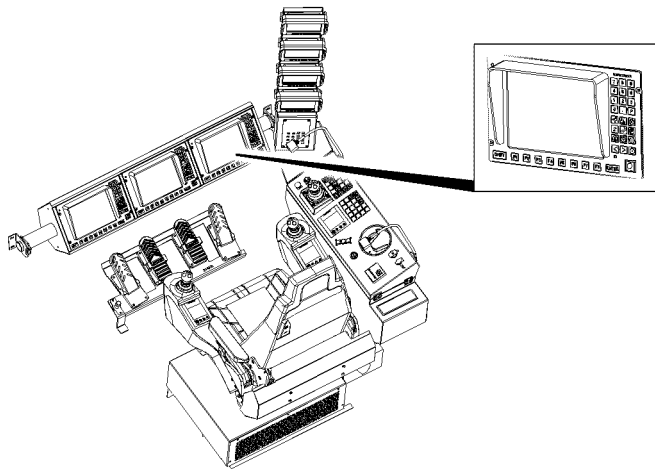

Fig.124464

LWE/LR 13000-001/19503-01-02/en

- ▶ Luff the main boom (S-/P-) up until shortly before the position in which the L-end section **11** lifts off the roller cart.
- ▶ Release and remove the retaining plates on the roller cart.
- ▶ Remove the placement pins on the pulley sets and pin and secure in the respective park positions.
- ▶ Luff the main boom (S-/P-) up until the L-end section **11** is just over the hook block **86**.
- ▶ Reeve in the hook block **86**, see the Crane operating instructions, chapter 4.06.
- ▶ Pin the hook, see the Crane operating instructions, chapter 4.06.
- ▶ Check the actual load on the LICCON monitor.

Problem remedy

The actual load on the LICCON monitor is greater than 0.0 t !

- ▶ Observe the notes for input of hook block weight, see the Crane operating instructions, chapter 4.02.

-
- ▶ Reeve in the hook block **86** properly and secure the hoist rope **53** on the rope fixed point, see Reeving plan.
 - ▶ Attach the hoist limit switch weight.
 - ▶ Enter the weight of the hook block **86** in the LICCON computer system.

NOTICE

Damage to the crane!

- ▶ Luff up the main boom (S-/P-) and simultaneously spool the hoist winch out to prevent the hook block **86** from colliding with the L-end section **11**.
- ▶ Luff up the main boom (S-/P-) to the steepest position (main boom angle 85 ° - upper operating position).



WARNING

The crane can topple over!

In crane operation with exceeded LICCON overload protection, the crane can topple over. Death, severe bodily injuries, property damage.

- ▶ When the lowest operating position of the W-lattice jib is reached, the assembly icon must no longer appear on the LICCON monitor.
- ▶ The boom radii listed in the load chart may not be exceeded or fallen below, even if there is no load on the hook.

If required in the erection and take-down chart:

- ▶ Carry the hook block **86** along with the auxiliary crane.



Note

- ▶ When the lowest operating position of the W-lattice jib is reached, the LICCON overload protection is activated.
- ▶ The maximum load icon displays a load number in „t“ instead of the display „???“.
- ▶ Luff the W-lattice jib up to the lowest operating position.

When the W-lattice jib has reached the lowest operating position:

- ▶ Make sure that the assembly icon on the LICCON monitor turns off.

Result:

- The LICCON overload protection is active.

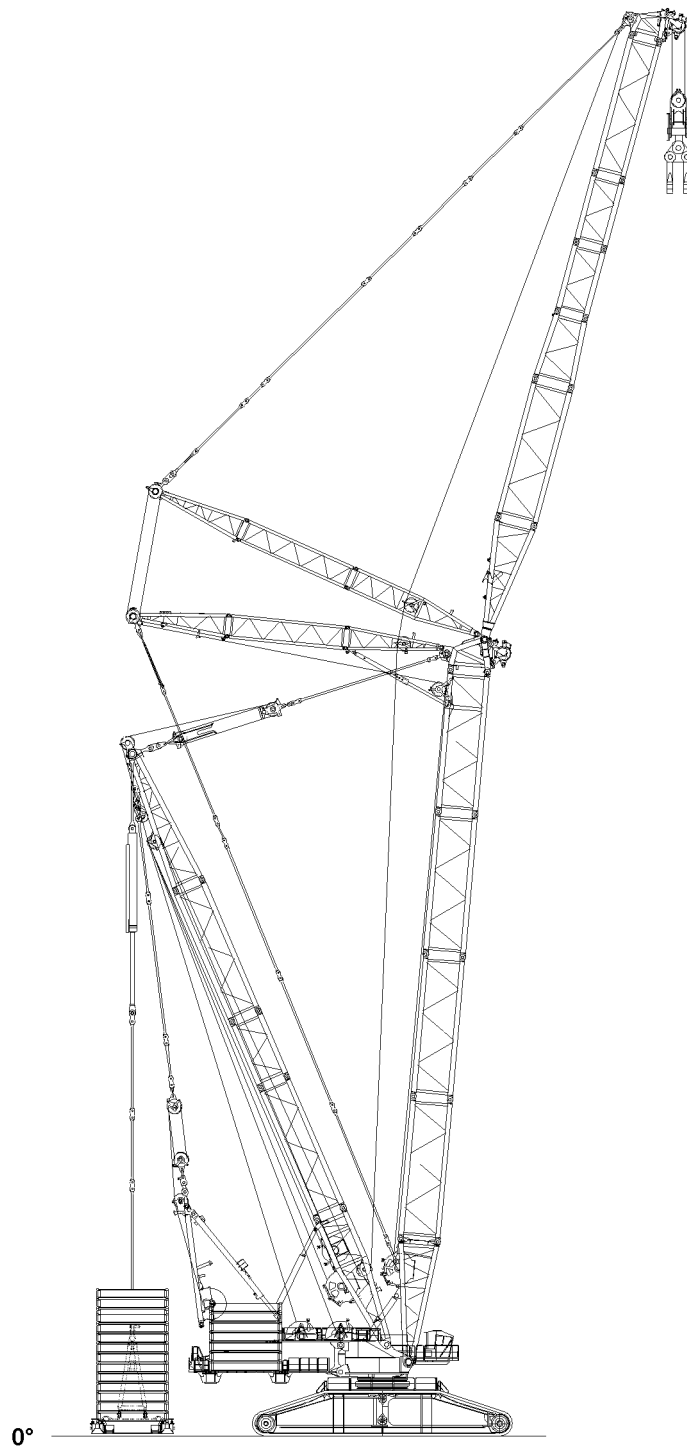

LWE/LR 13000-001/19503-01-02/en

Fig.124461

4 Crane operation



WARNING

The crane can topple over!

During normal crane operation, the crane can be overloaded and topple over if the LICCON overload protection is exceeded.

- ▶ During normal crane operation, make sure that the assembly icon no longer appears on the LICCON monitor.



Note

- ▶ Observe the notes, see the Crane operating instructions, chapter 4.05, Crane operating instructions, chapter 4.08 and Crane operating instructions, chapter 5.01.

Make sure that the following prerequisites are met:

- The LICCON overload protection is active.
- The LICCON overload protection has been set according to the data in the load chart.



WARNING

The crane can topple over!

Death, severe bodily injuries, property damage.

- ▶ Check the horizontal position of the crane before and during operation.
- ▶ If the crane operator leaves the cab, even for a short time, the operating mode setting must be checked and reset if necessary before resuming crane operation.

4.1 Checking the settings

- ▶ Check the function of the overload protection by running against the operating positions on top and bottom.
- ▶ Check the hoist limit switch by running against the hoist limit switch weight.
- ▶ Check the function of the limit switches on the relapse cylinders.

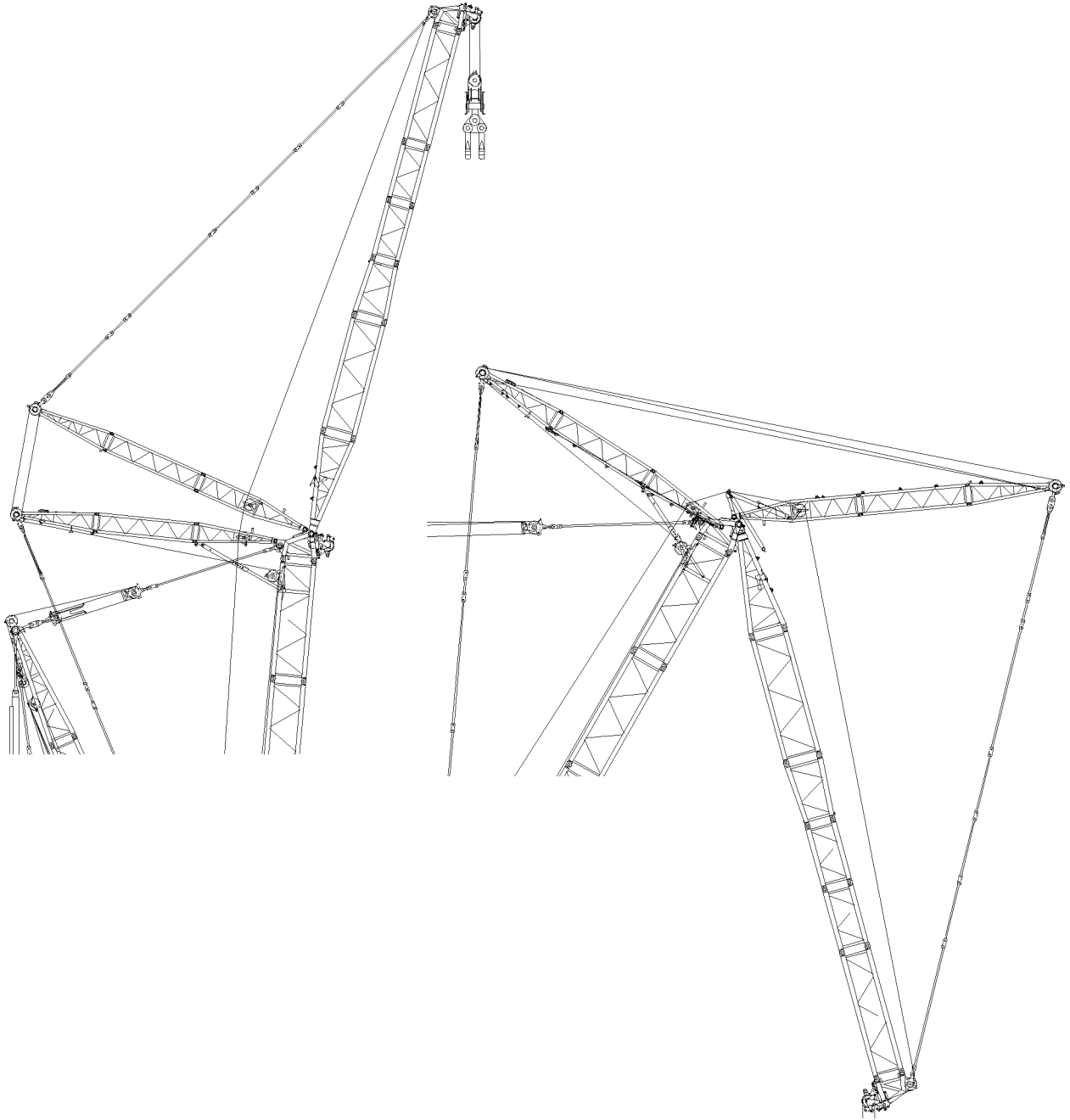

Fig.116106

LWE/LR 13000-001/19503-01-02/en

5 Disassembling



WARNING

Danger of falling!

During assembly / disassembly, inspection and maintenance work, assembly personnel must be secured with appropriate aids to prevent them from falling.

Death, severe bodily injuries, property damage.

- ▶ All work at a height, when there is a danger of falling, must be carried out with suitable aids.
- ▶ If aids are not available and work cannot be carried out from the ground, then assembly personnel must secure themselves with the supplied fall arrest system to prevent falling, see the Crane operating instructions, chapter 2.04.
- ▶ If fall protection equipment is available, then it must be used, see the Crane operating instructions, chapter 2.06.
- ▶ When lifting, lowering, swinging crane parts in and out, no persons may remain in the danger zone.
- ▶ If railings are present on the components, then they must be brought into the corresponding position and secured for assembly / disassembly work.
- ▶ Only step on the aids, ladders and catwalks with clean shoes.
- ▶ Keep aids, ladders and catwalks free of heavy dirt, snow, frost and ice.
- ▶ During all assembly and disassembly work, maintenance work and inspections, travel or crane operation is prohibited.
- ▶ Remaining on a suspended load is prohibited.
- ▶ Stepping or walking on crane components and lattice sections with an incline of more than 20° is prohibited.
- ▶ For all assembly work, the crane operator of the main crane must be in voice contact with the crane operator / crane operators of the auxiliary crane / auxiliary cranes.
- ▶ For the assembly / disassembly tasks, the crane operator may only initiate crane movements when the responsible guide has explicitly released the movement.



WARNING

Falling components!

If unsecured or non-supported components are assembled or disassembled, they can fall down.

Death, severe bodily injuries, property damage.

- ▶ During pinning and unpinning of the lattice sections, it is prohibited for anyone to remain **under** or **on** the components as well as within the entire danger zone.
- ▶ Support the boom and components before pinning / unpinning.
- ▶ Pin or unpin both pins positioned horizontally, i.e. **left** and **right!**
- ▶ Secure the pins in the bearing points and in the receptacles.
- ▶ Do not detach the auxiliary crane until the respective component is pinned and secured.
- ▶ It is prohibited to lean a ladder against the component being disassembled.



WARNING

Danger of impact / crushing!

When assembling / disassembling crane components with the auxiliary crane, crane components can start to swing back and forth.

When lifting / lowering and positioning crane components, there is an increased danger of impact / crushing.

Death, severe bodily injuries, property damage.

- ▶ Make sure that personnel cannot be caught by components.
- ▶ Make sure that the crane is horizontally aligned.
- ▶ When working in danger zones: Use aids to protect limbs.
- ▶ Guide components with suitable aids to minimize oscillation.

**WARNING**

Danger of accident!

If no guide is present during assembly work who has voice connection to the crane operator as well as to the drivers of the auxiliary units, then there is a great danger of accident.

Crane movements that are carried out without the approval of the guide can cause accidents.

Death, severe bodily injuries, property damage.

- ▶ For all assembly work, observe the instructions of the guide.
- ▶ Make sure that the danger zone can be seen completely by the crane operator and / or the guide.

**DANGER**

The components can fall down!

If the corresponding component is disengaged from the auxiliary crane before the corresponding component is pinned, then the corresponding component can fall down.

Death, severe bodily injuries, property damage.

- ▶ Do not detach the auxiliary crane until the respective component is pinned and secured.

**WARNING**

The crane can topple over!

Death, severe bodily injuries, property damage.

- ▶ The turntable may not be turned during the assembly of the boom.

5.1 Taking the boom down

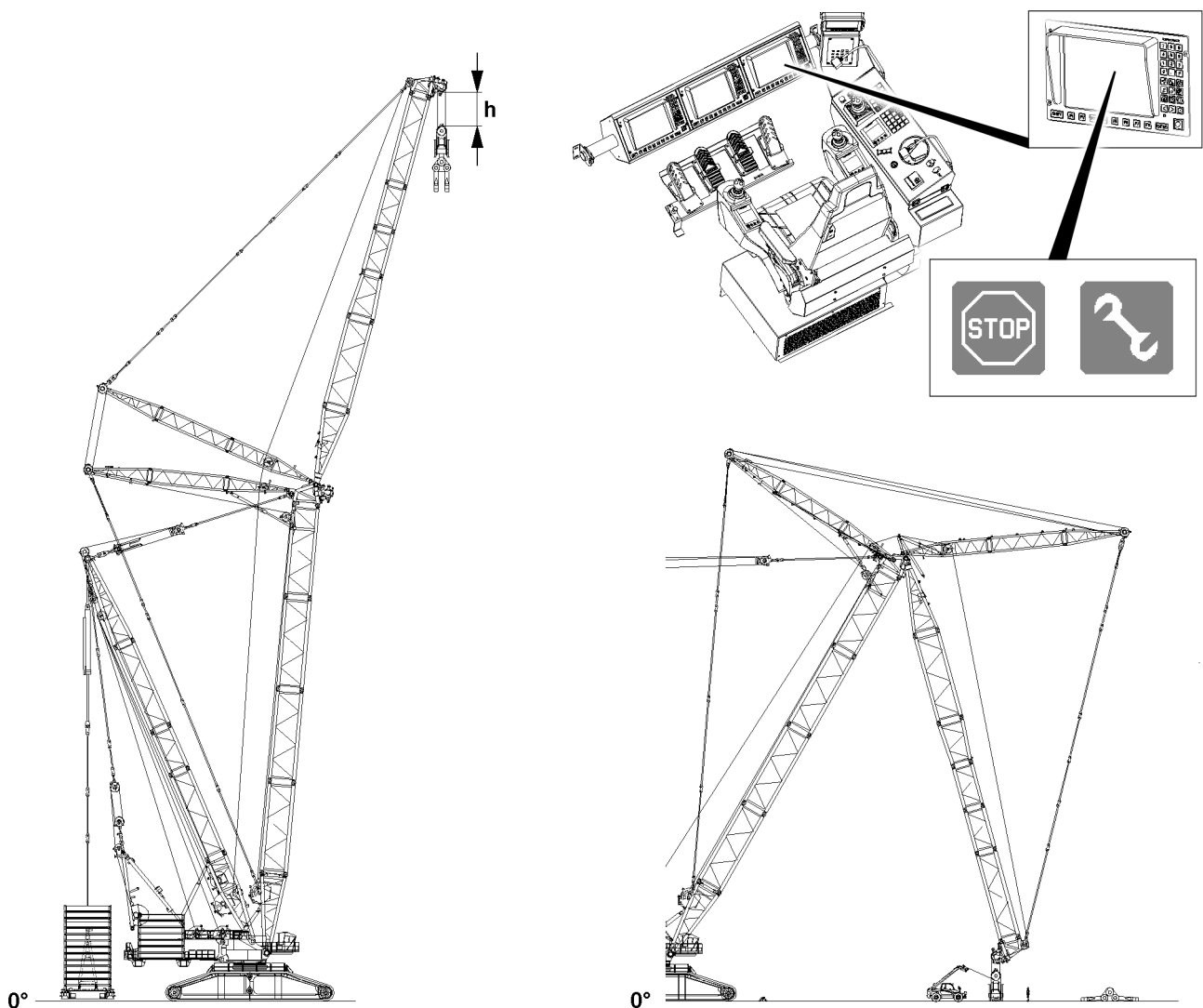

Fig.163433



DANGER

The crane can topple over!

Death, severe bodily injuries, property damage.

- ▶ Observe the technical safety instructions, see the Crane operating instructions, chapter 5.01.
- ▶ Observe the specifications in the erection and take-down charts.

Make sure that the following prerequisite is met:

- The main boom (S-/P-) is in the steepest position (main boom angle 85 ° - observe the upper operating position)
- The hook block / load hook is positioned at a distance **h** of 5 m below the pulley head



Note

- ▶ The luff down movement is turned off as soon as the lowest operating position of the W-lattice jib is reached!
 - ▶ When the lowest operating position of the W-lattice jib is reached, the load display in the maximum load icon turns off and the display „???“ appears instead of the load display.
 - ▶ Alarm functions appear on the crane operating screen.
-
- ▶ Luff the W-lattice jib down to the **lowest** operating position.

Result:

- The luffing movement is turned off.
- The „STOP“ icon appears on the LICCON monitor.

**WARNING**

Danger of accident due to the „Exceedance of shut-off limits of the LICCON overload protection“ function!

If the shut off limits of the LICCON overload protection are exceeded, there is no additional protection against crane overload.

Due to erroneous operation or deliberate misuse, the crane could collapse, the boom can break off or the crane can topple over.

Death, severe bodily injuries, property damage.

- ▶ The „Exceeding the shut-off limits of the LICCON overload protection“ function is only permissible in emergencies and for assembly purposes.
- ▶ The function „Exceeding the shut off limits of the LICCON overload protection“ may only be actuated by persons who know the effects of their actions regarding the function „Exceeding the shut off limits of the LICCON overload protection“.
- ▶ The „Exceedance of shut off limits of the LICCON overload protection“ function requires the presence of an authorized person and must be performed with utmost caution.
- ▶ Crane operation with the „Exceedance of shut off limits of the LICCON overload protection“ function activated is prohibited.

- ▶ Exceeding the shut off limits of the LICCON overload protection: Engage assembly operation

Result:

- The shut off limits of the LICCON overload protection are exceeded.
- The assembly icon appears on the LICCON monitor.

**Note**

- ▶ See the Crane operating instructions, chapter 4.02 and chapter 4.20.

Empty page!

LWE/LR 13000-001/19503-01-02/en

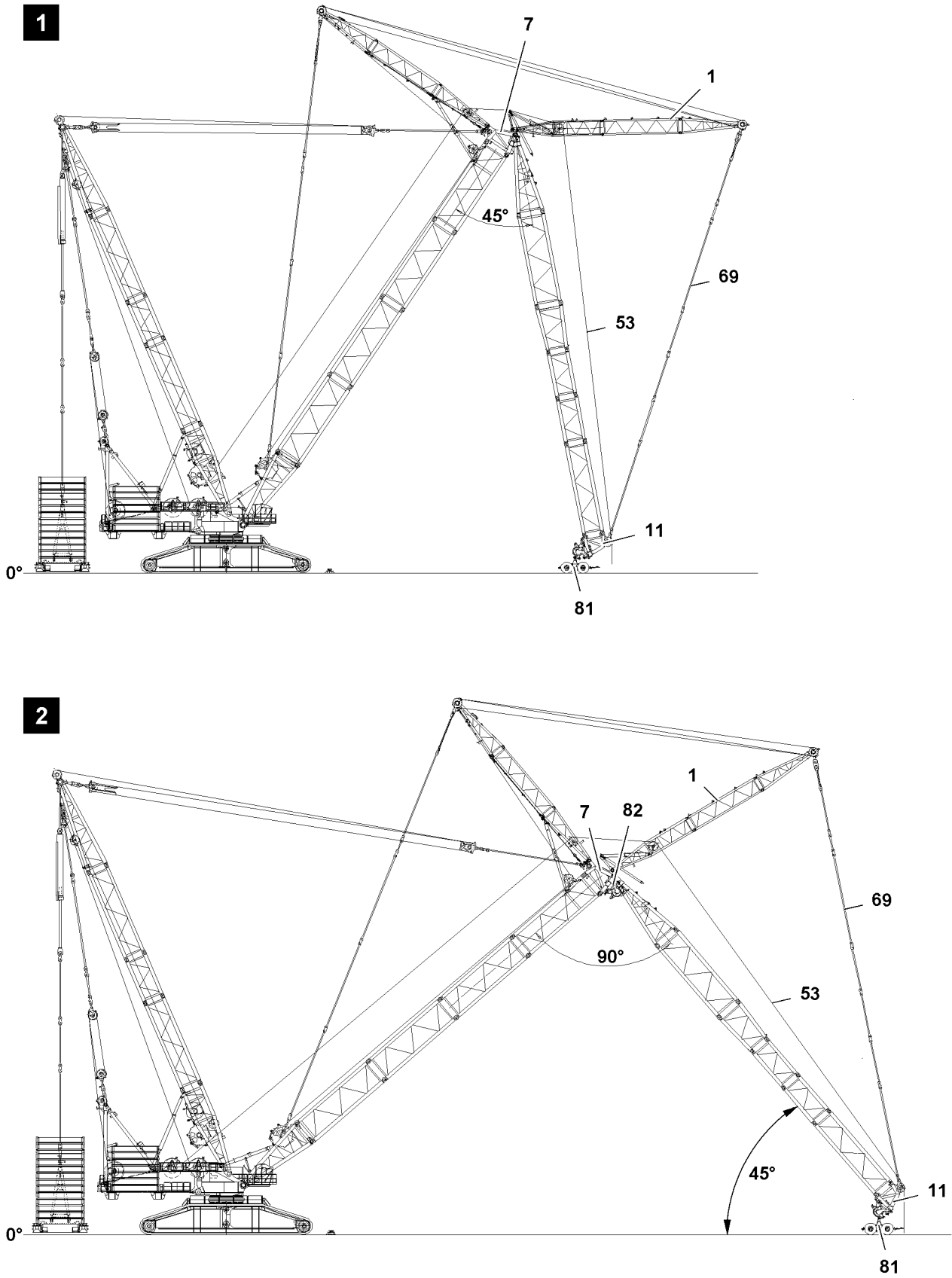

Fig.116102

LWE/LR 13000-001/19503-01-02/en

**Note**

Change the retaining plates on the roller cart!

When the retaining plates are not inserted at an angle of 45° between the W-lattice jib and the ground from the other side, then it is no longer possible subsequently to disassemble the roller cart **81** on the L-end section **11**.

- ▶ Unpin the retaining plates at a W-boom angle of 45° to the ground and reinsert again from the other side and secure. See section „Changing the retaining plates during the erection and take-down procedure“.

The procedure differs depending on how the crane is configured.

- Illustration **1**: On the main boom end section **7** there is no roller set - switch position „W-lattice jib bottom“ occurs at an angle of approx. 45° between the main boom (S-/P-) and the W-lattice jib.
- Illustration **2**: On the main boom end section **7** there is a roller set **82** - switch position „W-lattice jib bottom“ occurs at an angle of approx. 90° between the main boom (S-/P-) and the W-lattice jib.
- The ratio of the lengths of the main boom and the W-lattice jib also have an influence.

The roller cart **81** must absorb the proportional weight of the boom system as early as possible during the take-down procedure.

When **NO** roller set **82** is assembled on the main boom end section **7**, see illustration **1**:

- ▶ Luff down the W-lattice jib until an angle of approximately 45° is reached between the main boom (S-/P-) and the W-lattice jib **or** the hook block touches the ground (only with a short main boom in connection with a long W-lattice jib).

Result:

- The „W-lattice jib bottom“ switch position is reached.
 - The luff down procedure of the W-lattice jib will be ended.
- or**
- The hook block touches the ground.

When **ONE** roller set **82** is assembled on the main boom end section **7**, see illustration **2**:

- ▶ Luff down the W-lattice jib until an angle of approximately 90° is reached between the main boom (S-/P-) and the W-lattice jib.

Result:

- The „W-lattice jib bottom“ switch position is reached.
- The luff down procedure of the W-lattice jib will be ended.

NOTICE

Damage to the crane!

When the hoist rope is not spooled out during the luff down procedure, a collision of the hook block with the L-end section **11** can occur.

This can result in significant property damage.

- ▶ Luff down the main boom (S-/P-) and simultaneously spool the hoist winch out to prevent the hook block from colliding with the L-end section **11**.

When the hook block does not yet touch the ground, but the „W-lattice jib bottom“ switch position is reached:

- ▶ Luff down the main boom (S-/P-) until the hook block touches the ground.
- ▶ Disassemble the hoist limit switch weight and reeve the hook block out.
- ▶ Luff the main boom (S-/P-) or the W-lattice jib down until the placement pins on the roller set **82** / the roller sets **82** can be assembled, see section „Assembling the placement pins“.
- ▶ Place the L-end section **11** on the roller cart **81**.
- ▶ Assemble the L-end section **11** on the roller cart **81**, see section „Roller cart assembly procedure“.

**DANGER**

The crane can topple over!
Death, severe bodily injuries, property damage.

When the roller cart **81** is installed on the L-end section **11** and the W-guy rods **69** are tensioned:

- ▶ Spool the W-lattice jib adjustment out until the W-guy rods **69** sag slightly.

While the main boom (S-/P-) is luffed down:

- ▶ Spool the W-lattice jib adjustment out in such a way that the W-guy rods **69** always sag slightly.
- ▶ The W-lattice jib must roll on the ground with its entire weight.
- ▶ Do not allow slack rope to form on the W-lattice jib adjustment.

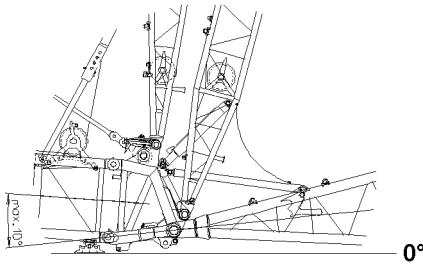

Fig. 115822: Taking the boom down — Maximum angle between the main boom (S-/P-) and the W-pivot section

NOTICE

Exceeding the maximum angle between the main boom (S-/P-) and the W-pivot section!

If the maximum angle of 10° between the main boom (S-/P-) and the W-pivot section is exceeded, the individual crane components will collide.

This could result in property damage.

- ▶ Make sure that the angle between the main boom (S-/P-) and the W-pivot section is **NEVER** more than 10°.

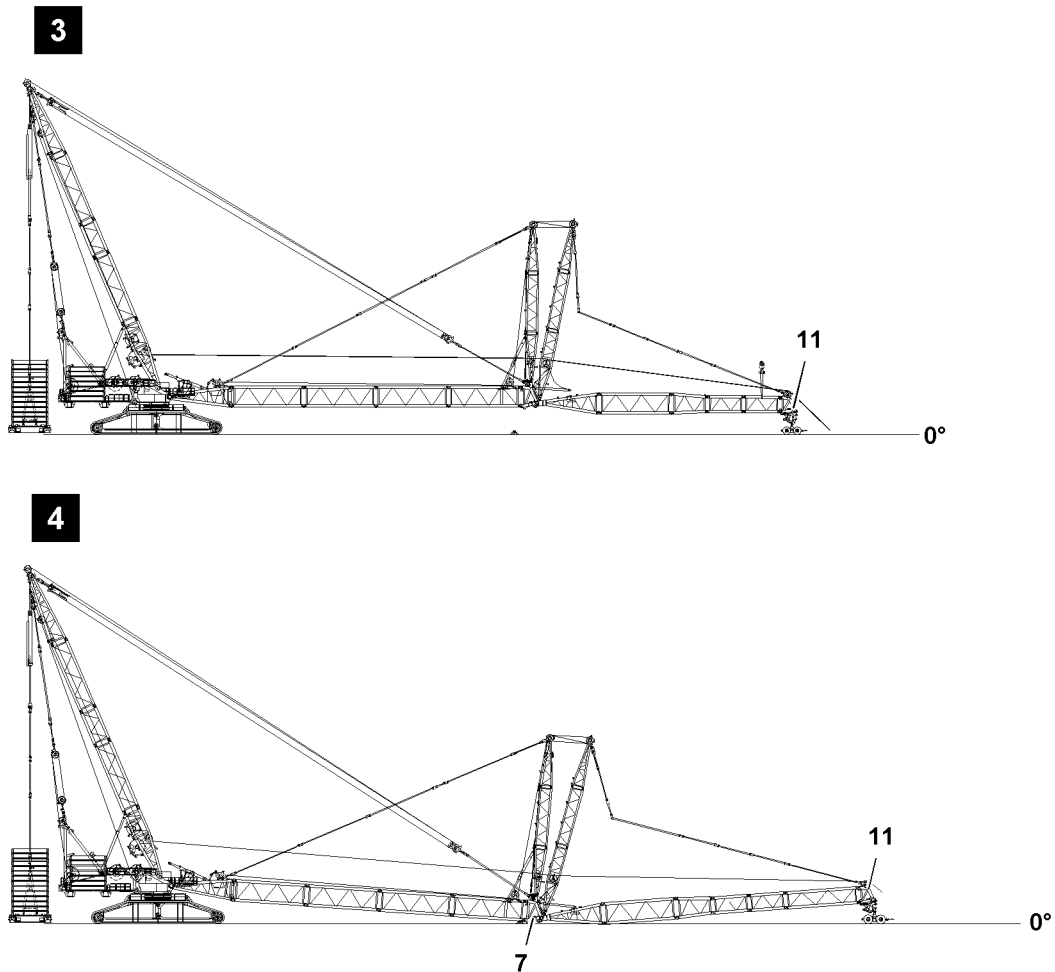

Fig.124458: Taking the boom down — Luffing the main boom (S-/P-) down

When a W-lattice jib up to a length of W- 42 m is assembled:

- ▶ Luff the main boom (S-/P-) down to 0° and at the same time spool the W-lattice jib adjustment up, see illustration 3.

When a W-lattice jib larger than W- 42 m is assembled and the ground is level:

- ▶ Continue to luff the main boom (S-/P-) down and spool the W-lattice jib adjustment up simultaneously until the main boom end section 7 is lying on the substructure on the ground, see illustration 4.



Note

- ▶ To unpin the W-lattice jib with the pin pulling device, see the Crane operating instructions, chapter 5.30.
- ▶ The disassembly of the W-lattice jib is the same as the disassembly of the S-boom, see the Crane operating instructions, chapter 5.39.



Note

- ▶ For the disassembly of the lattice sections and when lifting the boom system, use the cross beam!
- ▶ For handling of the cross beam, see the Crane operating instructions, chapter 5.39.

NOTICE

Impermissible boom length.

If the boom is lifted with an impermissible boom length with the cross beam, then the last intermediate section can be overloaded when lifting the boom system.

Death, severe injuries, property damage.

- ▶ Make sure that the boom is lifted with the cross beam only up to the permissible boom length, see chart.

Boom system	Permissible boom length
S	132 m
SL	144 m
P	132 m
W	126 m
W2	90 m
W3	108 m

- ▶ Fasten the auxiliary crane via the cross beam to the lattice section.

5.2 Disassembling the W-guy rods

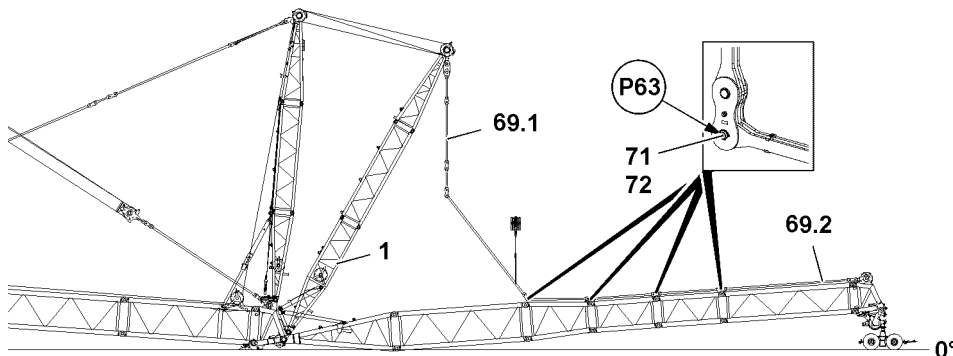

Fig.116111: Disassembling the W-guy rods

- ▶ Relieve the W-guy rods **69** by lowering the WA-frame **1**: Spool the control winch out.
- ▶ Unpin the W-guy rods **69.2** on the W-guy rods **69.1**: Remove the locking pins **72** in points **P63** and unpin the pins **71**.

**WARNING**

Danger of impact / crushing!

When removing the W-guy rods **69** with the auxiliary crane, they can start to swing back and forth! When lifting / lowering and positioning the W-guy rods **69**, there is an increased danger of impact / crushing!

Death, severe bodily injuries, property damage.

- ▶ Make sure that personnel cannot be caught by the W-guy rods **69**!
 - ▶ Maintain a safe distance!
-
- ▶ Remove the disassembled W-guy rods **69** with the auxiliary crane and take them down on the transport vehicle.

5.3 Disassembling the roller cart

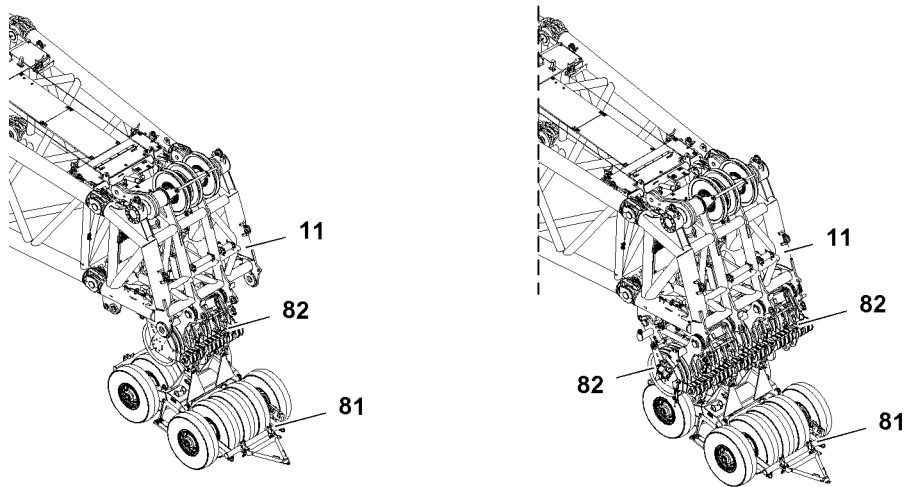

Fig.115826: Disassembling the roller cart — Overview



Note

- ▶ The disassembly of the roller cart **81** on the L-end section **11** is the same for one assembled roller set **82** and for two assembled roller sets **82**!
- ▶ On the following illustrations in this section, only the disassembly of the roller cart **81** for two installed roller sets **82** is shown! The procedure for one assembled roller set **82** is carried out in the same way.

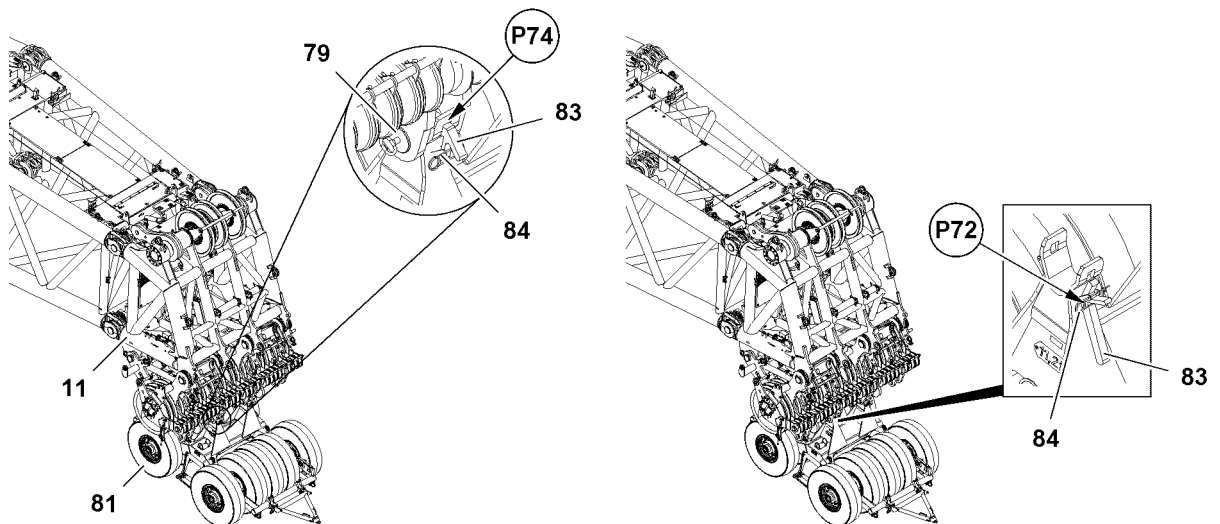

Fig.116109: Removing the roller cart — Removing the retaining plates

- ▶ Release the retaining plates **83** on both sides in points **P74** and remove.
- ▶ Secure the retaining plates **83** on both sides in points **P72** and secure with the spring retainers **84** to prevent them from falling down.

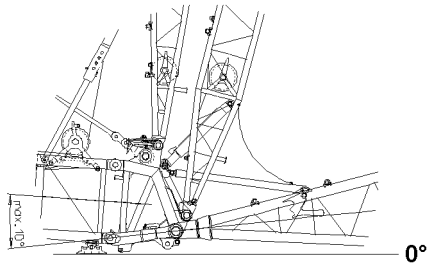

Fig.115822: Disassembling the roller cart — Maximum angle between the main boom (S-/P-) and the W-pivot section

NOTICE

Exceeding the maximum angle between the main boom (S-/P-) and the W-pivot section!
If the maximum angle of 10° between the main boom (S-/P-) and the W-pivot section is exceeded, the individual crane components will collide.
This could result in property damage.

- ▶ Make sure that the angle between the main boom (S-/P-) and the W-pivot section is **NEVER** more than 10°.
-
- ▶ Lift the W-boom with the auxiliary crane and the cross beam until the roller cart **81** can be removed.
 - ▶ Remove the roller cart **81** with the telescopic lift truck.
 - ▶ Take the main boom end section **7** down all the way onto the ground.
 - ▶ Take the L-end section **11** down onto the ground.

5.4 Removing the hoist ropes

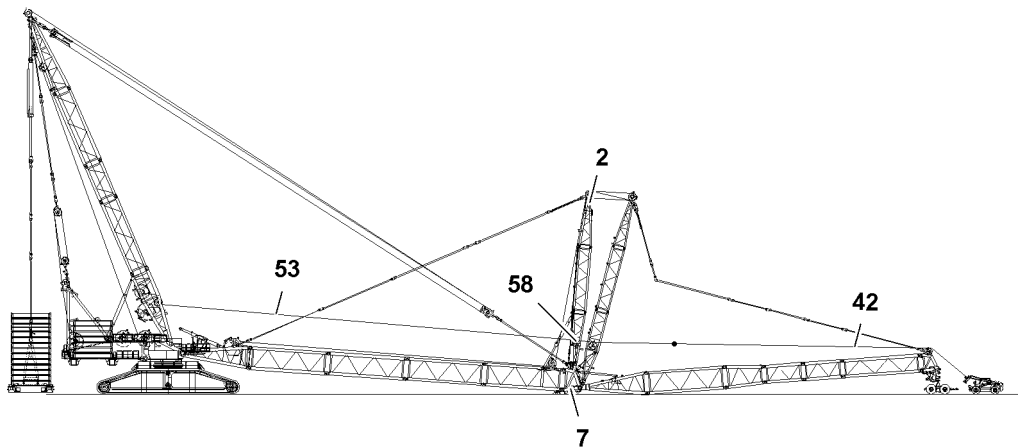

Fig.116110: Removing the hoist ropes

- ▶ Connect the hoist rope **53** with the auxiliary rope **42** of the telescopic lift truck.

**WARNING**

Danger of accident!

When using **non-approved** connecting links **43** when reeving the hoist rope in / out, the connecting links **43** can rip off suddenly.

Death, severe bodily injuries, property damage.

- ▶ Make sure that only original connecting links are used between the auxiliary winch and the hoist rope.
- ▶ Make sure that the proper pressure stage is set on the auxiliary winch of the telescopic lift truck for the reeving in / out of the respective hoist rope, see the separate operating instructions for the „assembly winch“.
- ▶ Make sure that the connecting links **43** between the auxiliary winch and the hoist rope have a higher load bearing capacity than can be created by the maximum strand pull of the respective auxiliary winch.
- ▶ The strand pull of the auxiliary winches installed on the crane side is **not** identical to the strand pull of the auxiliary winch of the telescopic lift truck.

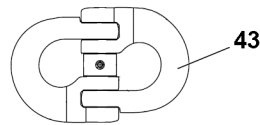

Fig.126476: Connecting link

Connecting link / Description	Load bearing capacity	Use for hoist rope diameter
CW8	2.5 t	38 mm
CWP10	5.0 t	52 mm

**WARNING**

Danger of accident!

Death, severe bodily injuries, property damage.

- ▶ It is prohibited for anyone to remain in the danger zone of the running rope.

NOTICE

Slack rope formation!

The hoist ropes **53** could be damaged by the formation of slack rope.

This can result in significant property damage.

- ▶ Do not allow any slack rope to be formed when spooling up the hoist ropes **53**.
 - ▶ When spooling the hoist ropes **53** up with the telescopic lift truck and its auxiliary winch, hold them taught.
-
- ▶ Slowly spool the hoist rope **53** up and pull it over the rope pulleys **58** that are inside the WA-frames.
 - ▶ Spool the hoist rope **53** up until the end of the rope can be taken down on the main boom end section 7.
 - ▶ Take the hoist rope **53** down.
 - ▶ Disconnect the hoist rope **53** from the auxiliary rope **42**.
 - ▶ Secure the hoist rope **53** to prevent it from falling.
- If additional hoist ropes **53** must be removed:
- ▶ Remove the hoist ropes **53** the same way as described before.

5.5 Disassembling the roller sets

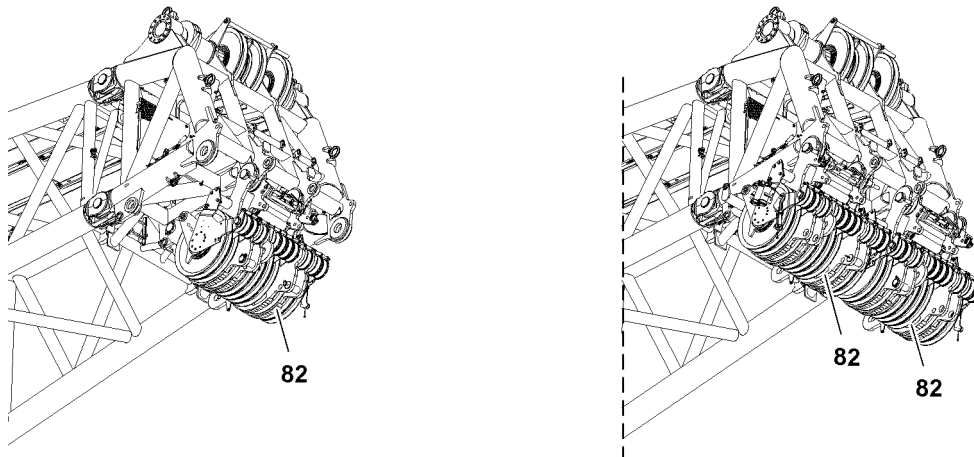

Fig.115825: Disassembling the roller sets



Note

- ▶ The disassembly of the roller sets **82** is described in the Crane operating instructions, chapter 5.14.
- ▶ Disassemble the roller set **82** / roller sets **82**.

5.6 Assembling the retaining rope on the mechanical relapse support

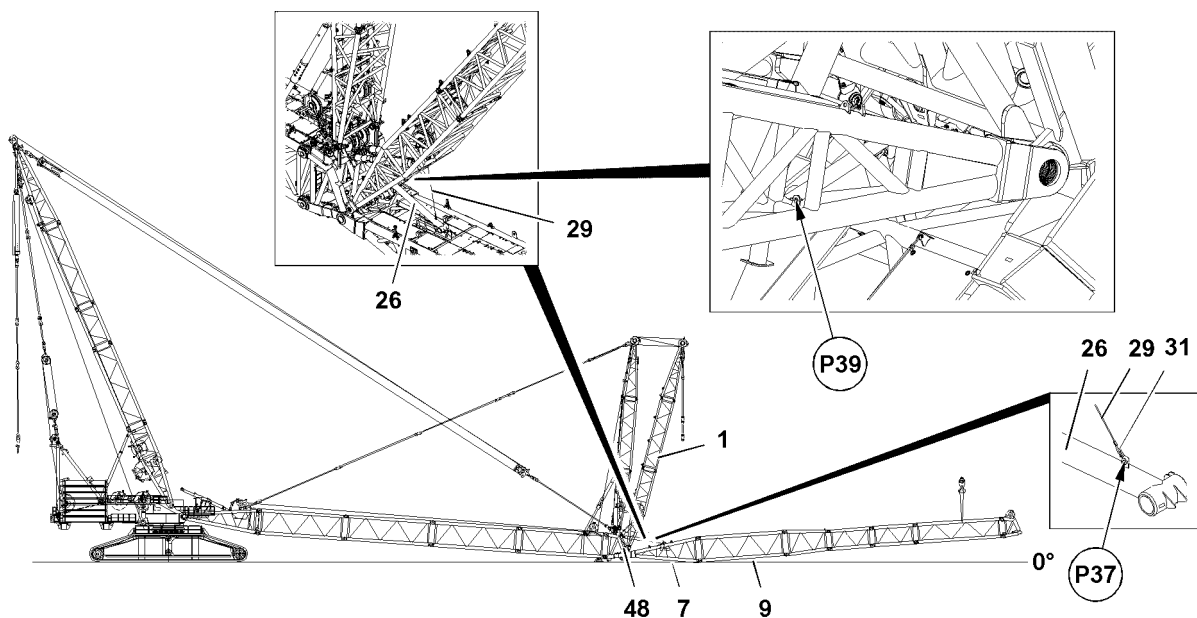

Fig.124459: Assembling the retaining rope on the mechanical relapse support

- ▶ Release the retaining rope **29** in point **P39**.
- ▶ Install the retaining rope **29** in point **P37** of the W-relapse support **26** with snap hooks **31**.
- ▶ Pull up the WA-frame **1** until the relapse press **48** is completely retracted.

Result:

- The W-relapse support **26** is lifted by the retaining rope **29**, which provides more space for the disassembly of the W-pivot section **7**.

5.7 Disassembling the W-lattice jib on the W-pivot section

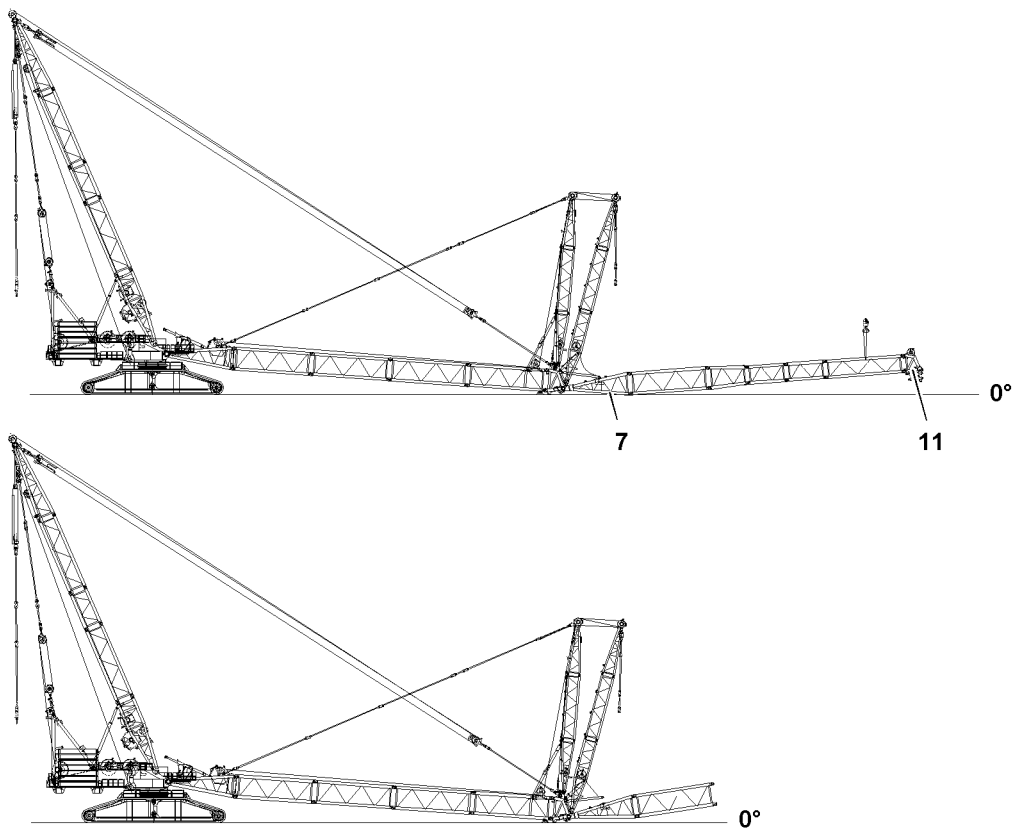

Fig.124460: Disassembling the W-lattice jib on the W-pivot section



Note

- ▶ The W-lattice jib components are unpinned with the pin pulling cylinder, see the Crane operating instructions, chapter 5.30.



DANGER

General danger notes!

- ▶ Support the W-lattice jib during assembly and disassembly with suitable materials.
- ▶ All pins must be secured after assembly.
- ▶ The guy rods must be checked regularly, see the Crane operating instructions, chapter 8.15.
- ▶ Disconnect the electrical connection between the terminal box of the L-end section **11** and the terminal box of the W-pivot section **7**, see the Electric wiring diagram.
- ▶ Unpin the W-lattice sections and disassemble until the W-pivot section **7** remains with one intermediate section, see the Crane operating instructions, chapter 5.39.

5.8 Unpinning the W-pivot section

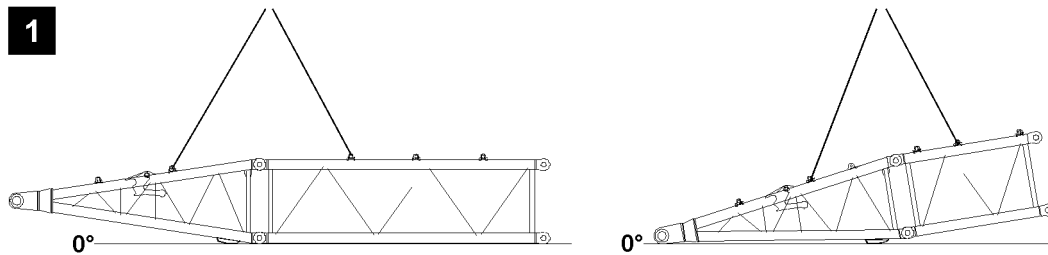

Fig.116115: Unpinning the W-pivot section — Fastening the lattice sections

- ▶ Fasten the W-pivot section **7** with installed intermediate section to the auxiliary crane and lift slightly. For the correct fastening points, see illustration 1.

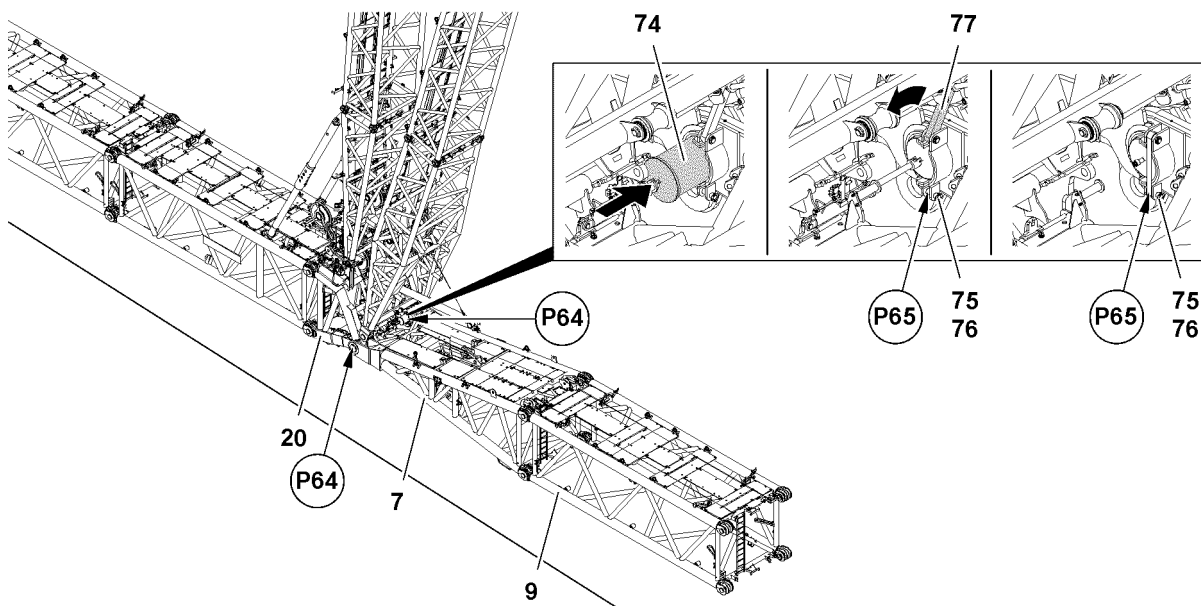

Fig.116114: Unpinning the W-pivot section — Unpinning procedure

- ▶ Erect the main boom (S-/P-) until the W-pin points are lifted off the ground approx. 1.5 m.
- ▶ Release the retaining pins **75** on both sides in points **P65** and unpin.

NOTICE

Danger of collision!

If the safety latch **77** is in a position where a collision occurs, then the safety latch **77** can be damaged.

- ▶ Make sure that the safety latch **77** cannot collide.

- ▶ Fold the safety latch **77** up on both sides.
- ▶ Unpin the W-pivot section **7** on both sides in points **P64** with the pin pulling device.



WARNING

Danger of crushing for people near the load!

Death, severe bodily injuries, property damage.

- ▶ Before lifting the load it must be ensured that there are no persons in the danger zone.
- ▶ It is prohibited to remain in the danger zone.
- ▶ It is prohibited for anyone to be under the load. Maintain a safe distance.
- ▶ Swinging the load is prohibited.
- ▶ Exercise extreme caution when lifting a load.

- ▶ Take the W-pivot section **7** down with the intermediate section on a substructure on the ground and remove the auxiliary crane.
- ▶ Remove the auxiliary crane.
- ▶ Fold the safety latch **77** down on both sides and secure with the retaining pins **75** and locking pins **76**.

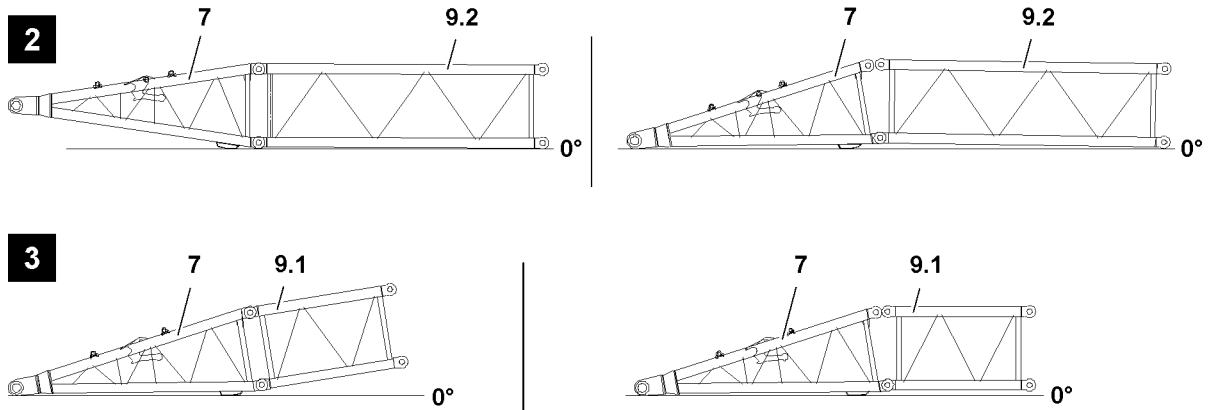

Fig. 116116: Unpinning the W-pivot section — Disassembly sequence

It must be differentiated if, after the W-pivot section **7** an intermediate section 6 m **9.1** or an intermediate section 12 m **9.2** is assembled.

If an intermediate section 12 m **9.2** is disassembled, the intermediate section 12 m **9.2** is lying on the ground. The W-pivot section **7** is fastened to the auxiliary crane. Then the W-pivot section **7** is unpinning on the intermediate section 12 m **9.2** on „top“ and lowered, see illustration **1**.

If a intermediate section 6 m **9.1** is disassembled, then the W-pivot section **7** is lying on the ground. The intermediate section 6 m **9.1** is fastened to the auxiliary crane. Then the intermediate section 6 m **9.1** is unpinning on the W-pivot section **7** on „top“ and lowered, see illustration **2**.

The unpinning procedure between the W-pivot section **7** and the respective intermediate section is identical to the unpinning procedure of the S-pivot section with an S-intermediate section, see the Crane operating instructions, chapter 5.39.



WARNING

Toppling of crane components!

If it is not ensured that the correct lattice component is fastened to the auxiliary crane and the pin is therefore relieved during unpinning, the respective lattice component can fold down.

Death, severe bodily injuries, property damage.

- ▶ Make sure that no uncontrolled folding down of the lattice components is possible.
- ▶ Before lifting the load it must be ensured that there are no persons in the danger zone.
- ▶ It is prohibited to remain in the danger zone.
- ▶ It is prohibited for anyone to be under the load. Maintain a safe distance.
- ▶ Swinging the load is prohibited.
- ▶ Exercise extreme caution when lifting a load.

- ▶ Remove the intermediate section on the W-pivot section.

5.9 Disassembling the W-guy rods

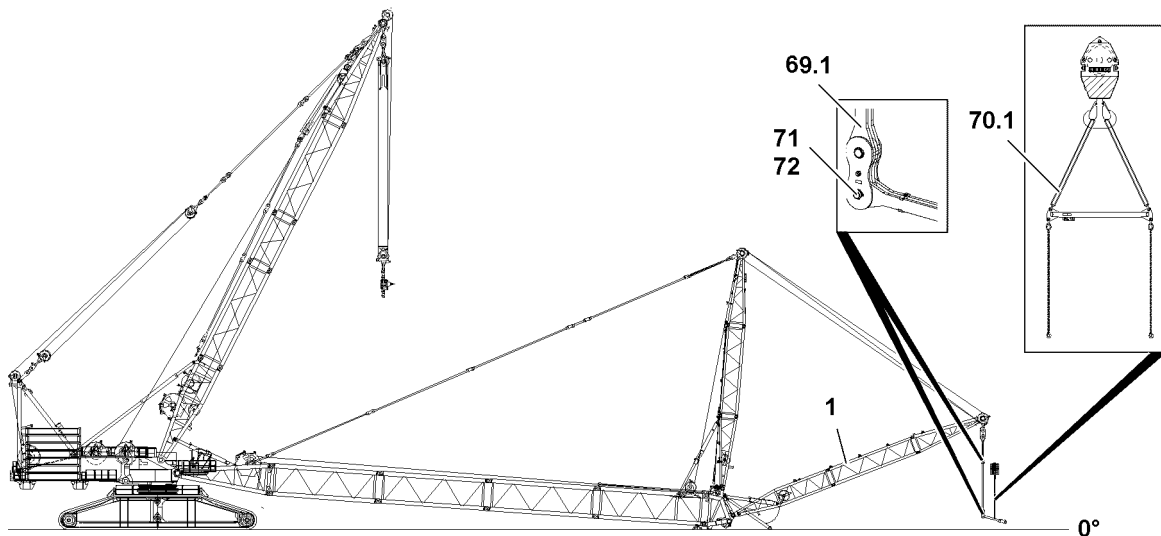

Fig.116117: Disassembling the W-guy rods

- ▶ Lower the WA-frame 1.
- ▶ Connect the cross beam 70.1 to the W-guy rods 69.1.



WARNING

Danger of impact / crushing!

When assembling the W-guy rods 69.1 with the auxiliary crane, they can start to swing back and forth. When lifting / lowering and positioning the W-guy rods 69.1, there is an increased danger of impact / crushing.

Death, severe bodily injuries, property damage.

- ▶ Make sure that personnel cannot be caught by the W-guy rods 69.1.
- ▶ Maintain a safe distance.

- ▶ Lower the WA-frame 1 and lift the cross beam 70.1 until the W-guy rods 69.1 can be taken down horizontally.
- ▶ Remove the locking pin 72 and unpin the pin 71.
- ▶ Take the W-guy rods 69.1 down on the transport vehicle.

If additional W-guy rods 69.1 must be disassembled:

- ▶ Disassemble additional W-guy rods 69.1 the same way as described before.

5.10 Taking down the WA-frames

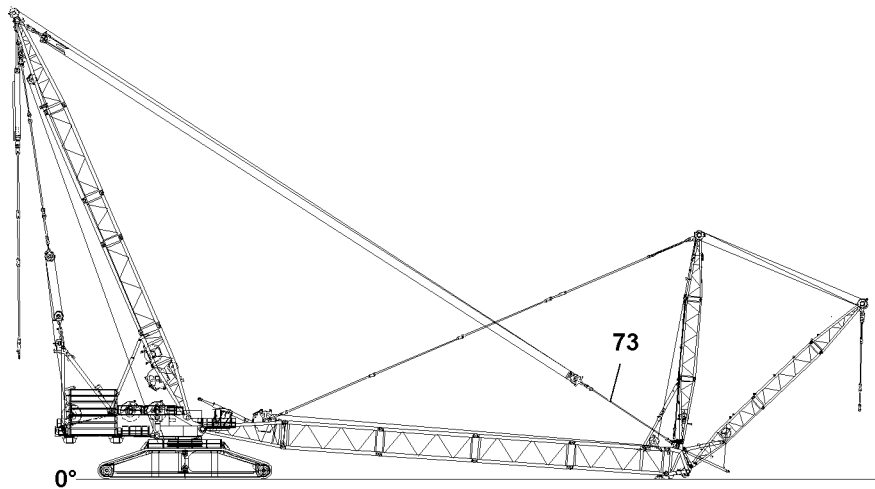

Fig.116118: Taking down the WA-frames — Initial status

Make sure that the following prerequisite is met:

- The main boom control **73** is completely disassembled, see the Crane operating instructions, chapter 5.39.

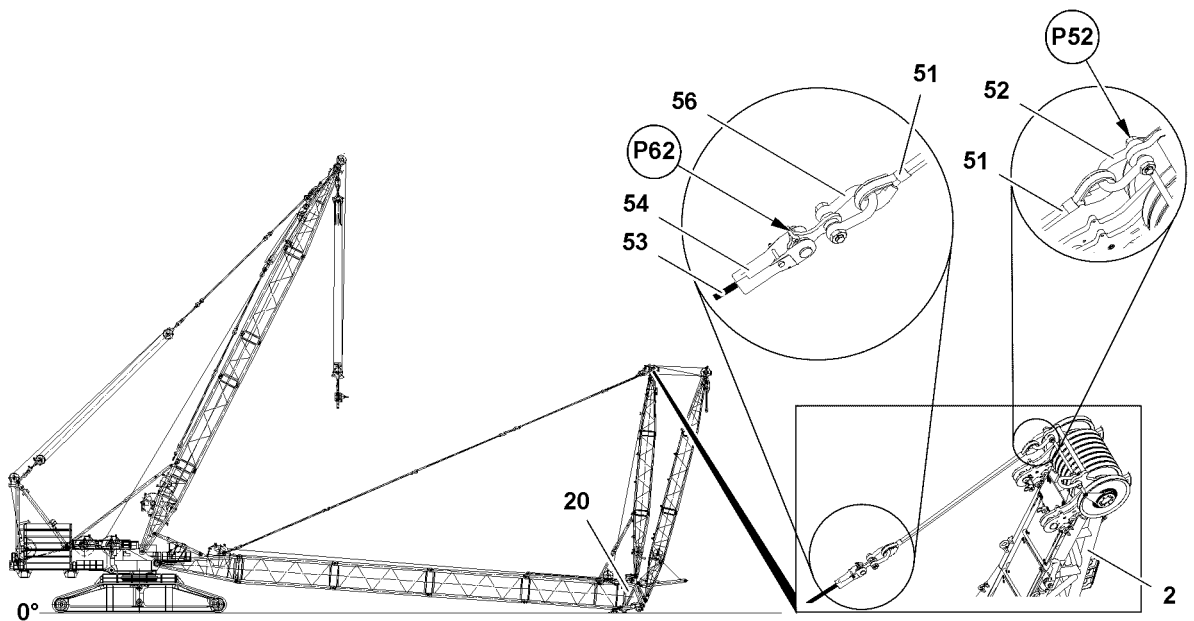

Fig.116119: Taking down the WA-frames — Connecting the hoist rope with WA-frame 2

- ▶ Assemble the rope lock **54** on the hoist rope **53**.
- ▶ Assemble the fastening rope **51** with the shackle **56** and rope lock **54** on the hoist rope **53**.
- ▶ Fasten the auxiliary crane in point **P62**.
- ▶ Lift the hoist rope **53** and fastening rope **51** with the auxiliary crane until the fastening rope **51** can be attached in point **P52**.
- ▶ Fasten the fastening rope **51** with shackle **52** in point **P52** of the WA-frame **2**.

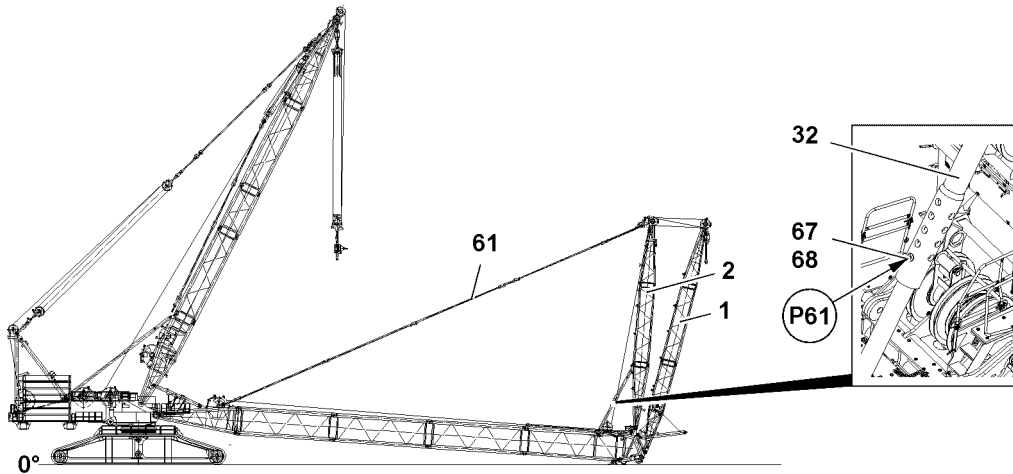

Fig.116120: Taking down the WA-frames — Unpinning the locking pin on the relapse supports



Note

- ▶ The guy rods **61.1** are fastened on the WA-frame **2**.
- ▶ The guy rods **61.2** are pinned on the main boom (S-/P-).



WARNING

Damage to the WA-frame **2**!

If the locking pin **67** is not unpinning on the relapse supports **32** before the WA-frame **2** is pulled back with the hoist rope **53** then the WA-frame **2** can be damaged. The winch **1** WI does not turn off. Death, severe bodily injuries, property damage.

- ▶ Unpin the locking pins **67** on both sides in points **P61** before the WA-frame **2** is pulled back: Remove the spring retainers **68** and unpin the locking pins **67**.

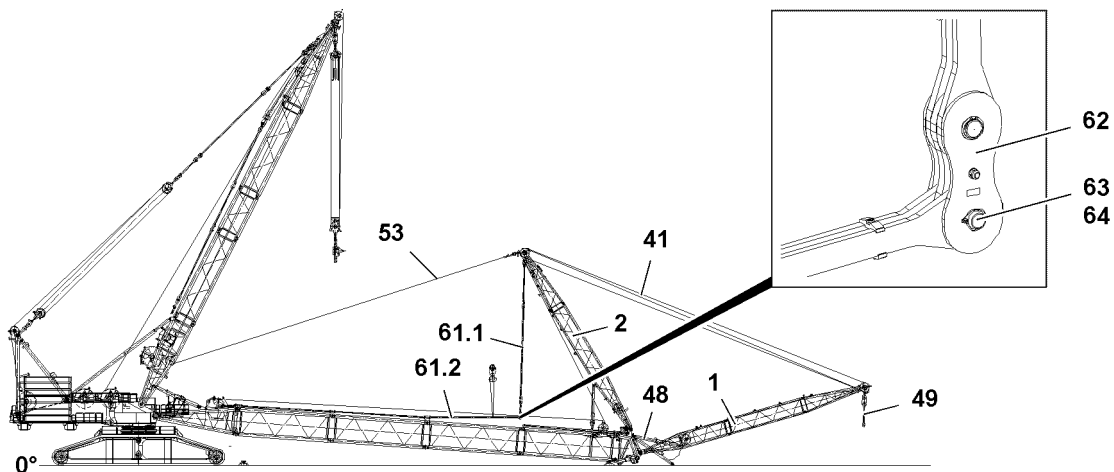

Fig.115808: Taking down the WA-frames — Taking down the main boom guy rods

- ▶ Lower the WA-frame **1** until the cross beam **49** almost touches the ground.

The WA-frame **2** is pulled back until the hanging guy rods **61** are positioned in such a way that they can be disassembled. This position is approx. at 120° .

- ▶ Pull the WA-frame **2** back with the hoist rope **53** until the guy rods **61** can be disassembled.
- ▶ Fasten the auxiliary crane properly to the guy rods **61**.

**WARNING**

Danger of impact / crushing!

When removing the guy rods **61.2** with the auxiliary crane, they can start to swing back and forth!
When lifting / lowering and positioning the guy rods **61.2**, there is an increased danger of impact / crushing.

Death, severe bodily injuries, property damage.

- ▶ Make sure that personnel cannot be caught by the guy rods **61.2**.
 - ▶ Maintain a safe distance.
-
- ▶ Unpin the guy rods **61** on the bracket **62**: Release and unpin the pin **63**.
 - ▶ Lower the guy rods **61** with the auxiliary crane on the lattice sections.
 - ▶ Remove the auxiliary crane.

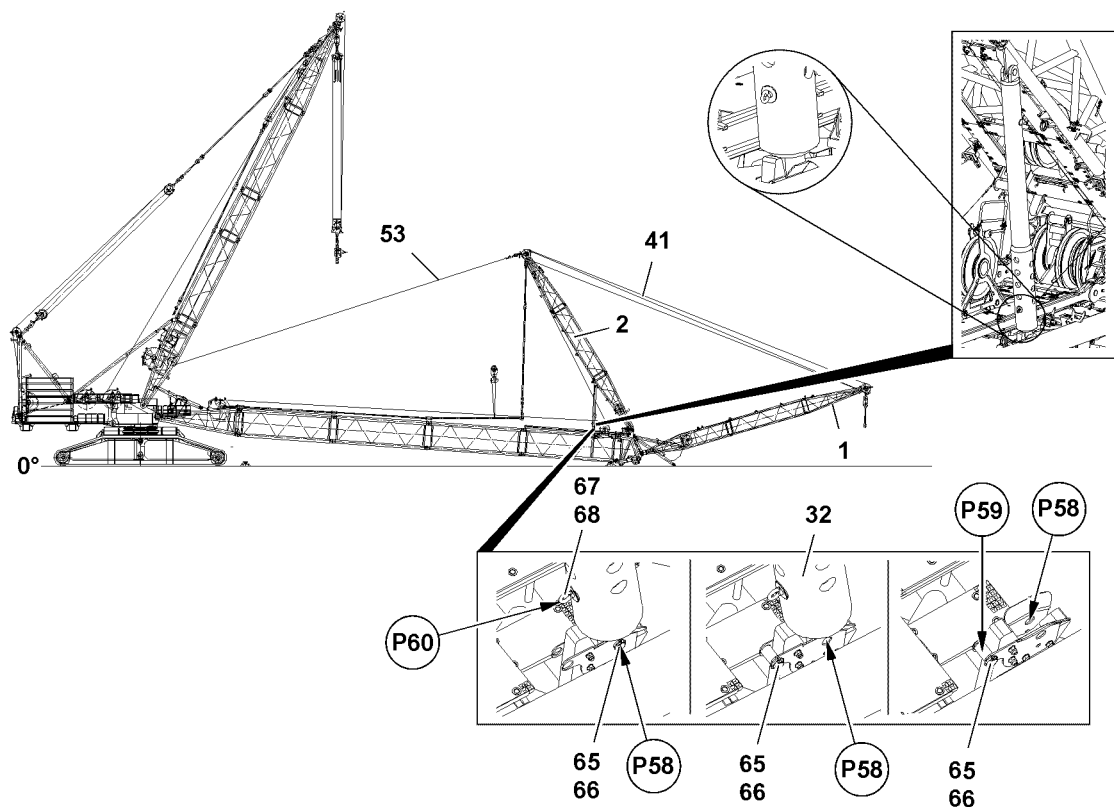

Fig.116121: Taking down the WA-frames — Pinning the relapse support at the minimum length possible

- ▶ Pull the WA-frame **2** back with the hoist rope **53** and simultaneously spool the control rope **41** out until the locking pins **67** can be pinned on both sides T the minimum length possible (transport position).
- ▶ Insert the locking pins **67** on both sides in points **P60** and secure with locking pins **68**.
- ▶ Insert the pins **65** on both sides from the operating position (points **P58**) in the park position (points **P59**) and secure with locking pins **66**.

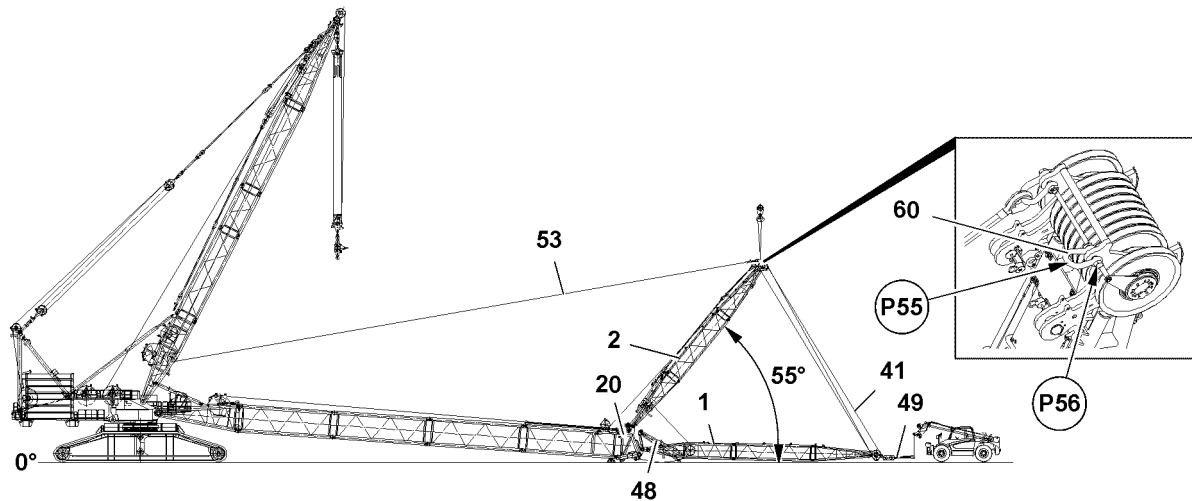

Fig.115807: Taking the WA-frames down — Taking the WA-frames on the ground

The WA-frame **2** is positioned by spooling the control rope **41** up and by spooling the hoist rope **53** out.

- ▶ Bring the WA-frame **2** into a position in which the angle between the WA-frame **2** and the ground is approx. 55° .
- ▶ Fasten the auxiliary crane with shackle **60** in point **P55** of the WA-frame **2** end section **2.3**.



WARNING

Insufficient load bearing capacity of the auxiliary crane!
Death, severe bodily injuries, property damage.

The crane operator must ensure that the load bearing capacity of the auxiliary crane in the existing boom radius is at least 85 t to be able to lift and secure hold the WA-frame **2**.

- ▶ Make sure that the auxiliary crane can lift a load of at least 85 t.
- ▶ Tension the hoist rope **53** of the auxiliary crane slightly until the WA-frame **2** is held by the auxiliary crane.
- ▶ Relieve the hoist rope **53**.



WARNING

Danger of accident!

Up to an angle of 55° , the WA-frame **2** may only be taken down with an auxiliary crane. The hoist rope **53** may not be subjected to a load.

If it is not observed that the hoist rope **53** remains relieved during the take down procedure of the WA-frame **2** then it can be overloaded and break.

Death, severe bodily injuries, property damage.

- ▶ It is prohibited to remain in the danger zone. Maintain a safe distance.
- ▶ The spooling procedure must be monitored by a guide.
- ▶ Do not exceed the maximum rope pull in the hoist rope **53**.
- ▶ Take the WA-frame **2** down from an angle of 55° exclusively with an auxiliary crane.
- ▶ Do not allow slack rope to form on the control winch.



WARNING

Overload of fastening equipment!

During the erection of the WA-frame **2**, a load of no more than maximum 85 t may be lifted, otherwise the fastening points will be overloaded.

Death, severe bodily injuries, property damage.

- ▶ Do not exceed the maximum load of 85 t: Pay attention to the load display.
- ▶ Lower the WA-frame **1** until the cross beam **49** almost touches the ground.
- ▶ Fasten the auxiliary crane to the cross beam **49**.

- ▶ Lift the cross beam **49** until it is horizontal.
- ▶ Continue to lower the WA-frame **1** and cross beam **49** so that they almost touch the ground.

NOTICE

Slack rope formation!

The control rope **41** can be damaged due to slack rope formation.

This can result in significant property damage.

- ▶ Do not allow slack rope to be formed when spooling out the control rope **41**.
- ▶ Keep the control rope **41** tight when spooling out.

- ▶ Lower the WA-frame **2** with the auxiliary crane until it almost is lying on the WA-frame **1**; at the same time, spool the control rope **41** up and spool the hoist rope **53** out.
- ▶ Take the WA-frame **1** down completely on the ground.
- ▶ Take the cross beam **49** down completely on the ground.
- ▶ Remove the auxiliary crane.

NOTICE

Slack rope formation!

The control rope **41** can be damaged due to slack rope formation.

This can result in significant property damage.

- ▶ Do not allow slack rope to be formed when spooling out the control rope **41**.
- ▶ Keep the control rope **41** tight when spooling out.

- ▶ Take the WA-frame **2** all the way down with the auxiliary crane on the WA-frame **1**, spool the control rope **41** up at the same time and spool the hoist rope **53** out.

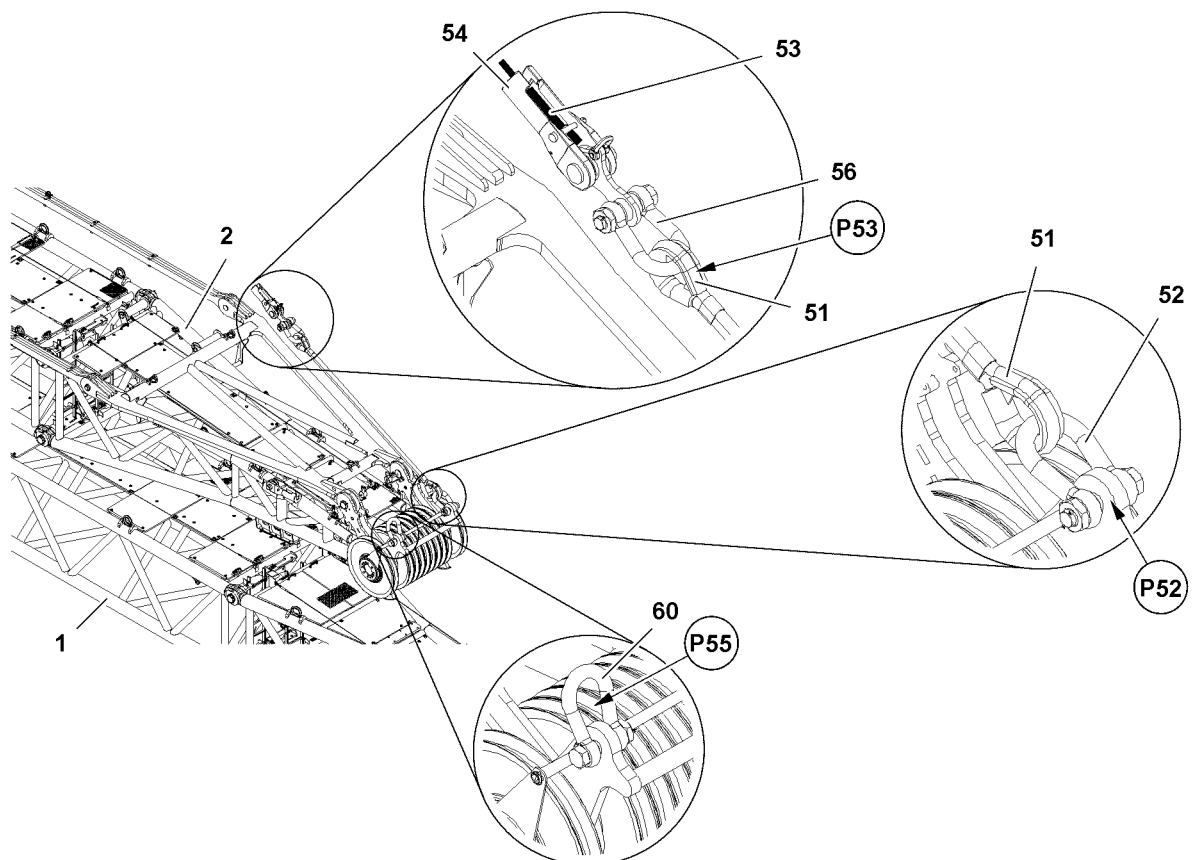

Fig.116122: Taking the WA-frames down — Removing the fastening equipment

When the WA-frame **2** is taken down on the WA-frame **1**:

- ▶ Remove the auxiliary crane in point **P55**.
- ▶ Remove the shackle **60** in point **P55**.

- ▶ Properly remove the fastening rope **51**, shackle **56** in point **P53**, shackle **52** in point **P52** and rope lock **54**.
- ▶ Spool the hoist rope **53** up until it can be taken down on the end section **20**.
- ▶ Take the hoist rope **53** down on the end section **20** and secure it to prevent it from falling down.

Empty page!

LWE/LR 13000-001/19503-01-02/en

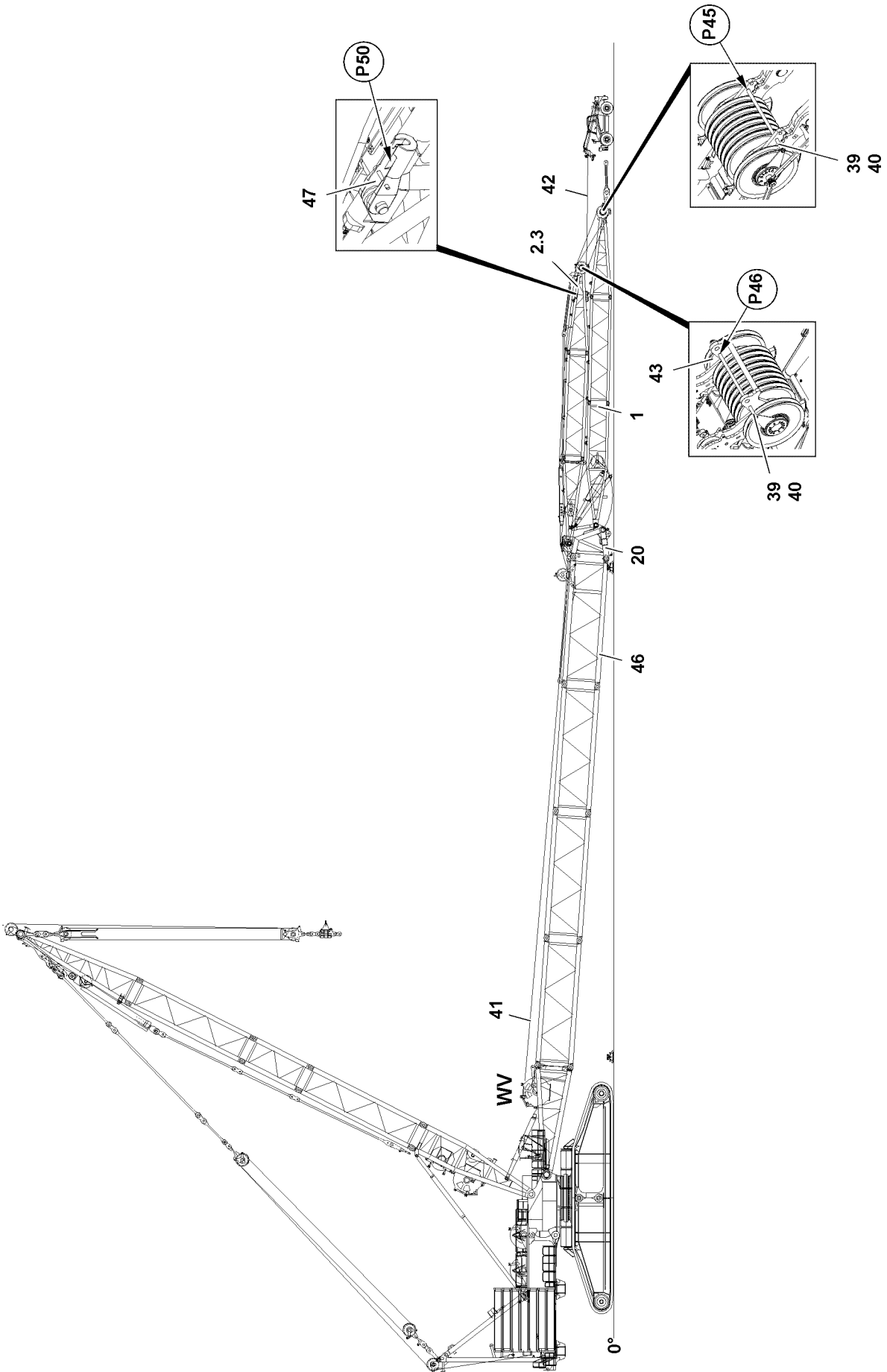

Fig.116123

LWE/LR 13000-001/19503-01-02/en

5.11 Reeving the W-control rope out

Make sure that the following prerequisite is met:

- The control rope **41** is unhooked on the lock **47** in point **P50**.
- ▶ Release the rope retaining pipes **39** in point **P45** and point **P46** and remove.
- ▶ Connect the auxiliary rope **42** of the telescopic lift truck with the control rope **41**.

NOTICE

Slack rope formation!

The control rope **41** can be damaged due to slack rope formation.

- ▶ Do not allow the formation of slack rope when spooling up the control rope **41**.
 - ▶ During the spool up procedure, hold the control rope **41** taut with the auxiliary rope **42** of the telescopic lift truck.
-
- ▶ Spool the control rope **41** up and simultaneously hold the control rope **41** tensioned with the telescopic lift truck.
 - ▶ Spool the control rope **41** up until it can be fastened on the end section **20**.
 - ▶ Release the auxiliary rope **42** on the control rope **41**.
 - ▶ Spool the auxiliary rope **42** of the telescopic lift truck up completely.
 - ▶ Install the rope retaining pipes **39** on the rope pulleys in point **P45** and point **P46**.

5.12 W-disassembly on the main boom (S-/P-)

5.12.1 Disassembling WA-frame 2 on the end section

Make sure that the following prerequisites are met:

- WA-frame **2** is lying completely on WA-frame **1**.
- The control rope is completely spooled up on winch **5**.

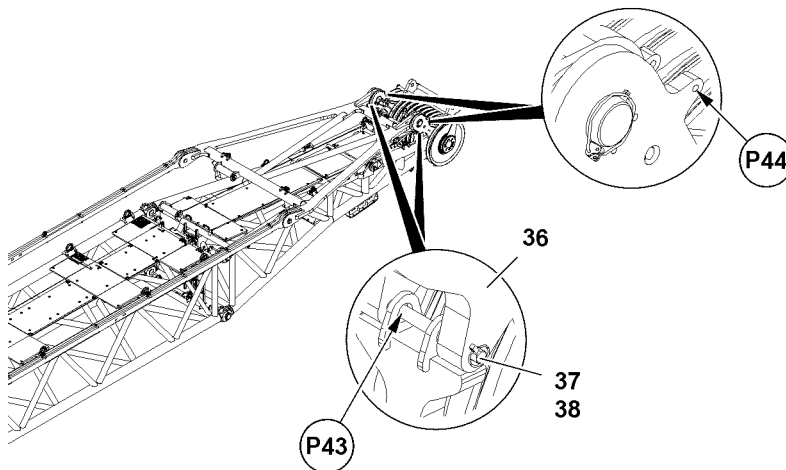

Fig.115802: Disassembling WA-frame 2 on the end section — Unpinning the brackets

- ▶ Unpin the pins **37** from the park positions: Release the pins **37** on both sides in points **P44** and unpin.
- ▶ Pin the brackets **36**: Insert the pins **37** on both sides in points **P43** and secure with locking pins **38**.

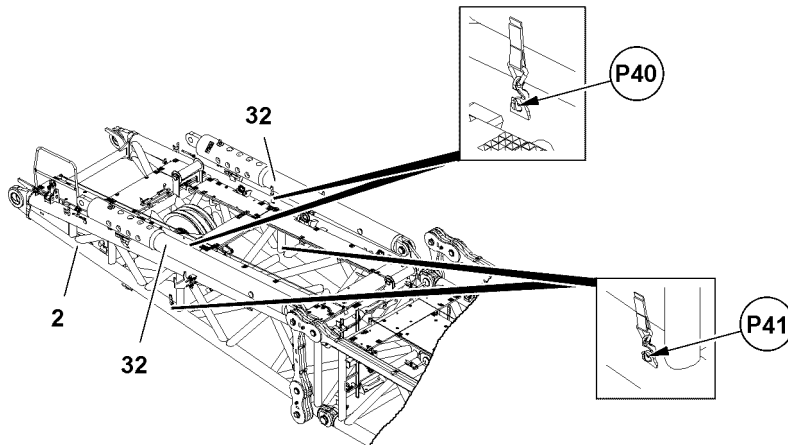

Fig.115800: Disassembling WA-frame 2 on the end section — Fastening the relapse supports

- ▶ Fasten the retaining belts of the WA-frame 2 relapse supports **32** on both sides in points **P40** and points **P41** and tension.

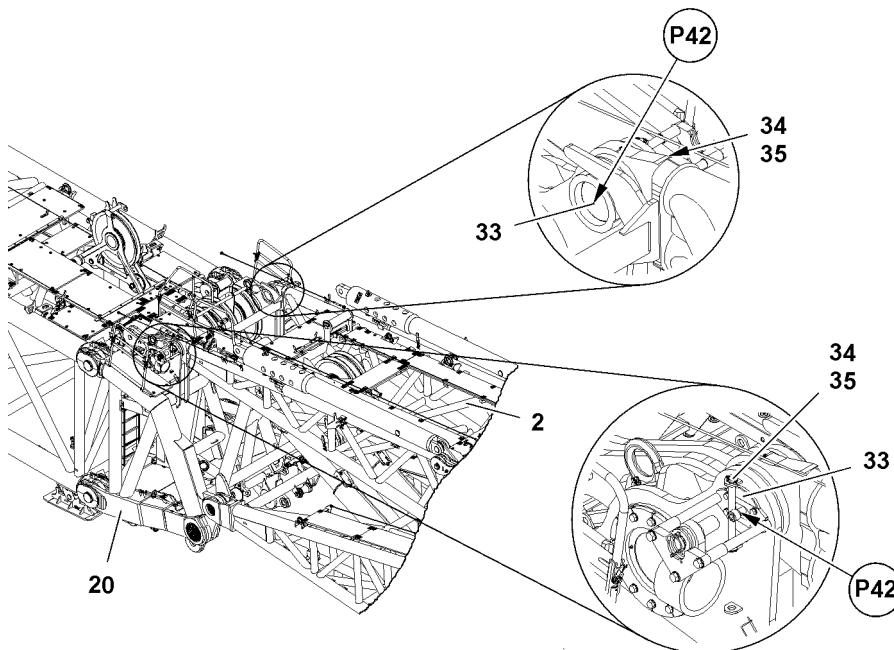

Fig.115801: Disassembling WA-frame 2 on the end section — Unpinning WA-frame 2 on the end section

- ▶ Fasten the WA-frame **2** to the auxiliary crane, see section „Fastening points“.
- ▶ Remove the retaining pins **34** and locking pins **35** on both sides in points **P42**.
- ▶ Unpin the WA-frame **2** on the end section **20**: Unpin the pins **33** completely in points **P42** on both sides with the pin pulling device.



WARNING

Danger of crushing for people near the load!
Death, severe bodily injuries, property damage.

- ▶ Before lifting the load it must be ensured that there are no persons in the danger zone.
- ▶ It is prohibited to remain in the danger zone.
- ▶ It is prohibited for anyone to be under the load. Maintain a safe distance.
- ▶ Swinging the load is prohibited.
- ▶ Exercise extreme caution when lifting a load.

- ▶ Lift the WA-frame 2 and take it down on the ground on a substructure.

5.12.2 Disassembling WA-frame 1 on the end section

Make sure that the following prerequisites are met:

- WA-frame 2 is completely disassembled.

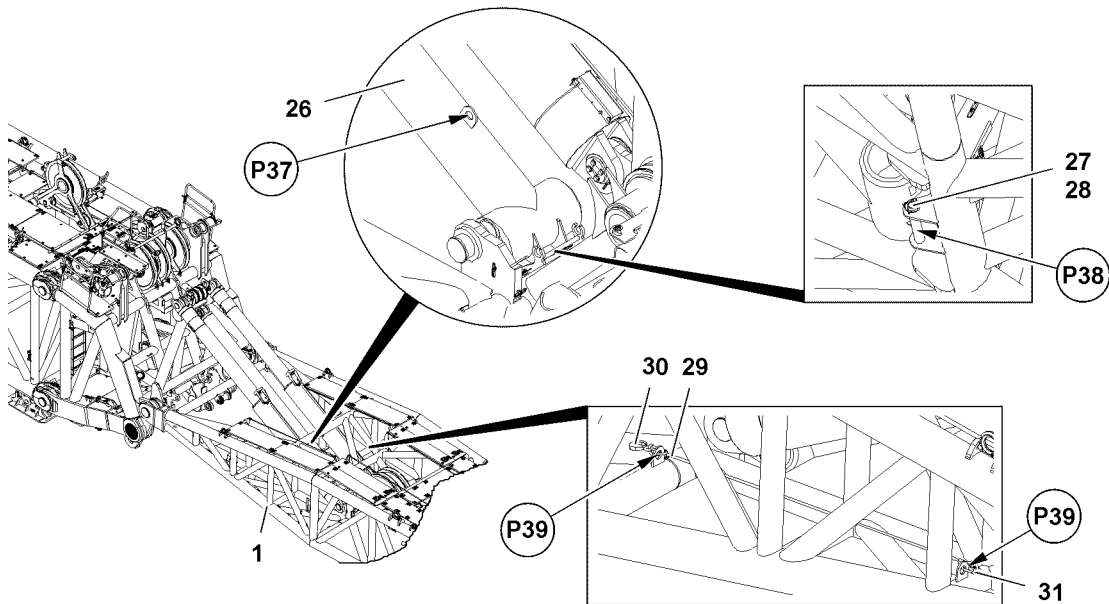

Fig.115799: Disassembling WA-frame 1 on the end section — Assembling the retaining rope in the park position

- ▶ Release the pin 27 in point P38 and unpin.
- ▶ Unhook the retaining rope 29 with the hook 30 in point P37.
- ▶ Install the retaining rope 29 in points P39.
- ▶ Fasten the auxiliary crane in point P37 of the W-relapse support 26.
- ▶ Lift the W-relapse support 26 with the auxiliary crane until the pin 27 can be pinned in point P38 under the W-relapse support 26.
- ▶ Insert the pin 27 in point P38 and secure with the locking pin 28.
- ▶ Lower the W-relapse support 26 until it is lying on the pin 27.

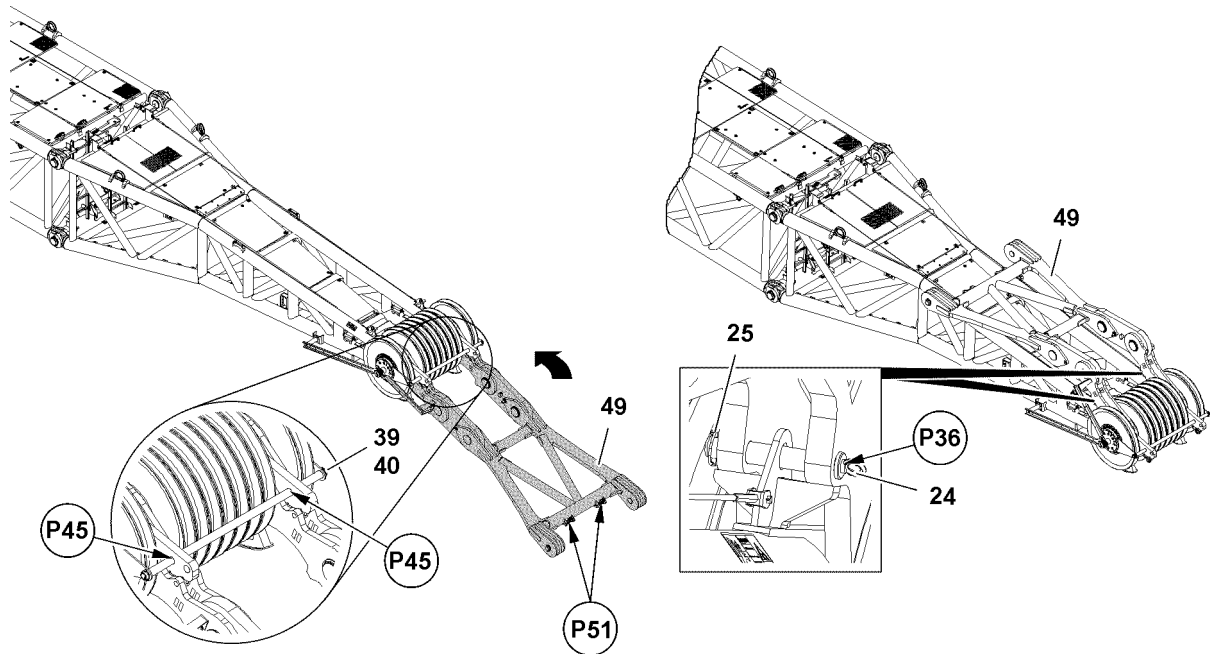

Fig.116124: Disassembling WA-frame 1 on the end section — Folding the cross beam in the transport position

- ▶ Remove the rope retaining pipe **39** in points **P45**.
- ▶ Release the pins **24** on both sides in points **P36** and unpin.
- ▶ Fasten the cross beam **49** in points **P51** to the auxiliary crane.



WARNING

Swinging the cross beam **49**!

Death, severe bodily injuries, property damage.

Fingers, hands and arms can be crushed or severed.

- ▶ It is prohibited to stand in the danger zone during the swing procedure.
- ▶ The cross beam **49** must be swung around with extreme caution.

- ▶ Fold the cross beam **49** with the auxiliary crane from the operating position into the transport position.
- ▶ Pin the cross beam **49** in the transport position: Insert the pins **24** on both sides in points **P36** and secure with locking pins **25**.
- ▶ Remove the auxiliary crane.

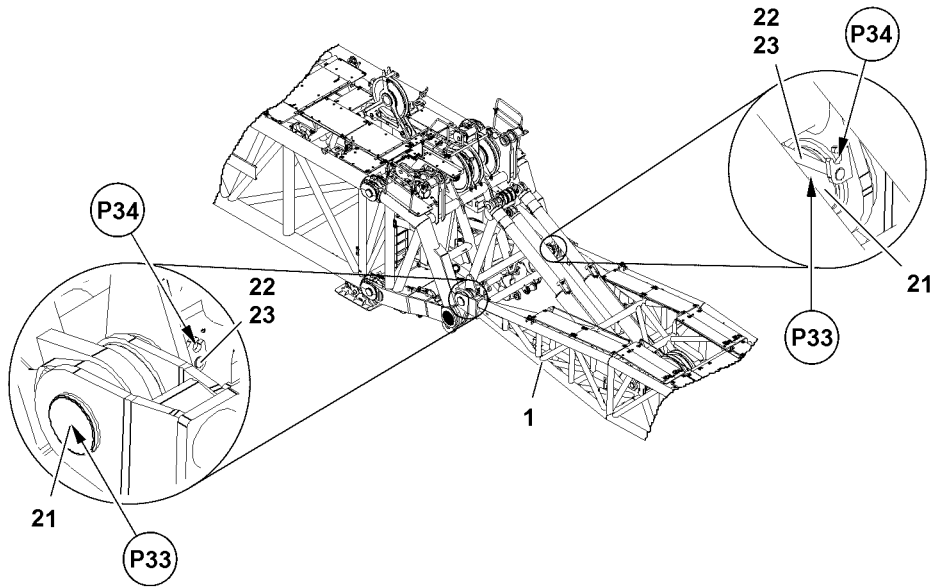

Fig.116125: Disassembling WA-frame 1 on the end section — Unpinning WA-frame 1 on the end section

- ▶ Fasten the auxiliary crane to the WA-frame 1, see section „Fastening points“.
- ▶ Release and remove the retaining pins 22.
- ▶ Insert the retaining pins 22 in the park positions (points P34) and secure with locking pins 23.
- ▶ Unpin the pins 21 completely in points P33 on both sides with the pin pulling cylinder.

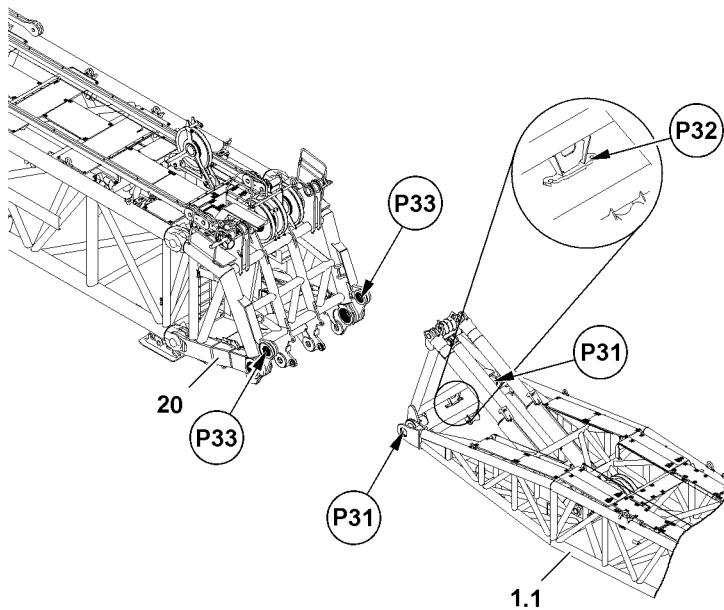

Fig.116126: Disassembling WA-frame 1 on S-end section — Removing WA-frame 1 with the auxiliary crane

**WARNING**

Danger of crushing for people near the load!

Death, severe bodily injuries, property damage.

- ▶ Before lifting the load it must be ensured that there are no persons in the danger zone.
- ▶ It is prohibited to remain in the danger zone.
- ▶ It is prohibited for anyone to be under the load. Maintain a safe distance.
- ▶ Swinging the load is prohibited.
- ▶ Exercise extreme caution when lifting a load.

- ▶ Lift the WA-frame 1 with the auxiliary crane and take it down onto the ground on a substructure.

5.12.3 Disassembling the WA-frame 2 guy rods

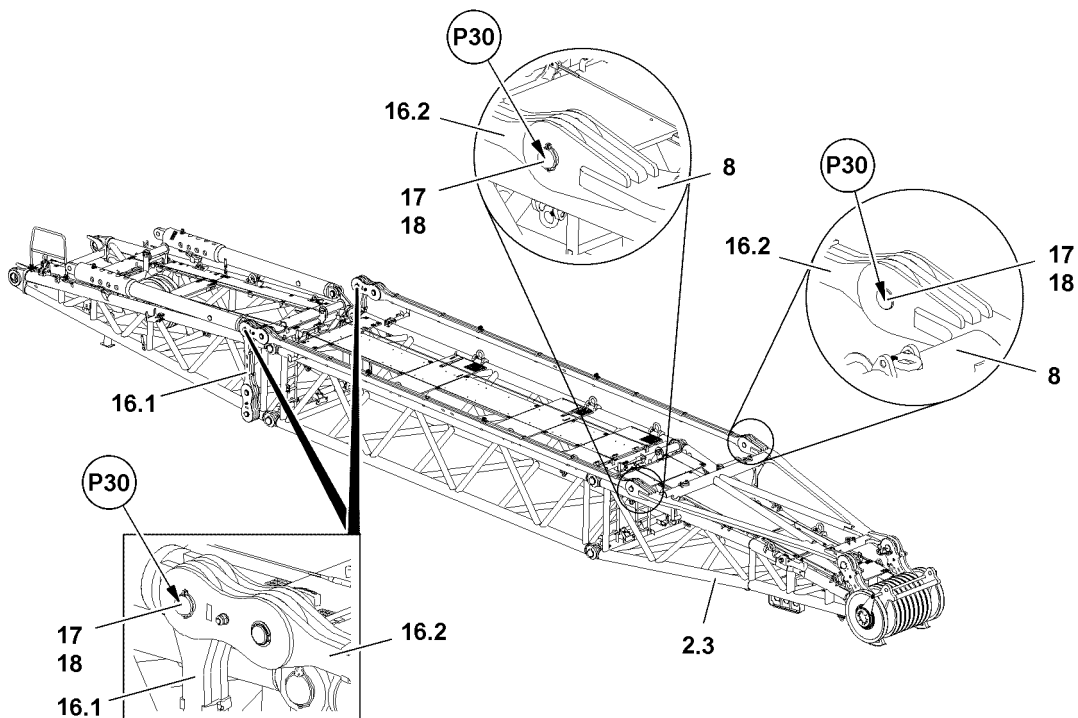

Fig.116127: Disassembling the WA-frame 2 guy rods

- ▶ Fasten the guy rod **16.1** to the auxiliary crane.
- ▶ Unpin the guy rod **16.1**: Release the pin **17** in point **P30** and unpin.
- ▶ Take the guy rod **16.1** down with the auxiliary crane in a suitable location.
- ▶ Remove the auxiliary crane.
- ▶ Remove the guy rod **16.1** on the other side in the same way as described before.

If additional guy rods **16.2** must be disassembled:

- ▶ Remove the guy rods **16.2** in the same way as described before.

5.12.4 Disassembling the swing

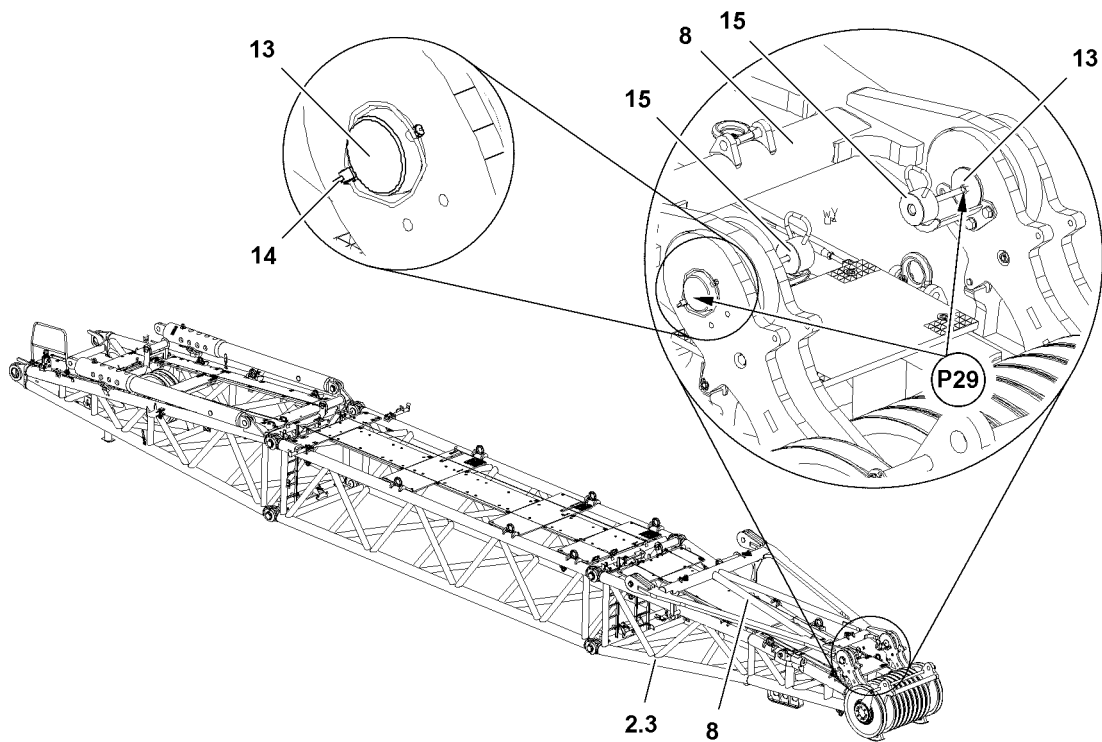

Fig.115794: Disassembling the swing

- ▶ Fasten the swing **8** to the auxiliary crane.
- ▶ Remove the locking pin **14** on both sides.
- ▶ Unpin the swing **8** on the WA-frame 2 end section **2.3**: Unpin the pins **13** in points **P29** on both sides with the mechanical pin pulling device **15**.
- ▶ Lift the swing **8** with the auxiliary crane and take it down in a suitable location.

5.12.5 Disassembling of the WA-frames

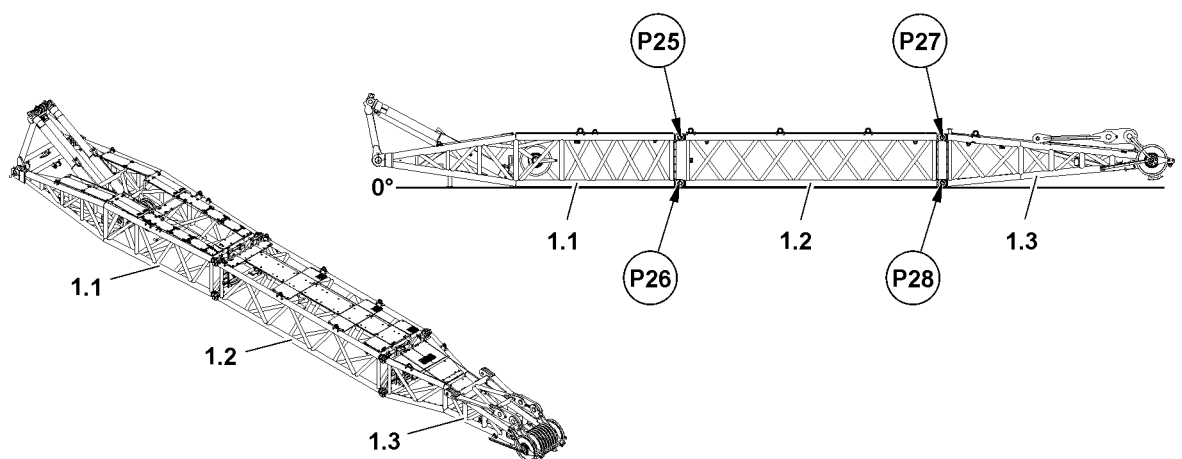

Fig.115787: Disassembling the WA-frames — Overview

**Note**

- ▶ The illustrations in this chapter only show the disassembly of the WA-frame **1 long version**.
- ▶ The WA-frame **1 long version** or WA-frame **2 long version**, consists of WA-frame pivot section **1.1**, WA-frame intermediate section **1.2** and WA-frame end section **1.3**.
- ▶ The short version of the WA-frame **1** and / or WA-frame **2** consists respectively of a WA-frame pivot section **1.1** and WA-frame end section **1.3**.
- ▶ The disassembly of the short WA-frames is carried out according to the description for the long WA-frames.
- ▶ The WA-frame **2** is disassembled according to the description of the WA-frame **1**.

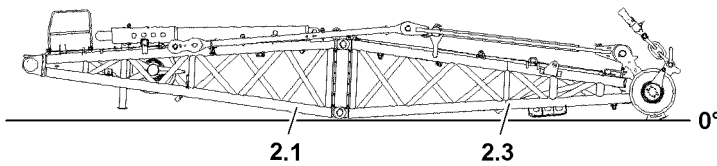

Fig. 116131: Disassembling the WA-frames — WA-frame 2

**Note**

- ▶ The **short version** of the WA-frame **2** is top heavy. To prevent the short version of the WA-frame **2** from tipping over, the WA-frame 2 end section **2.3** is placed on the ground for assembly. The WA-frame 2 pivot section **2.1** is positioned with the auxiliary crane and installed on the WA-frame 2 end section **2.3**.

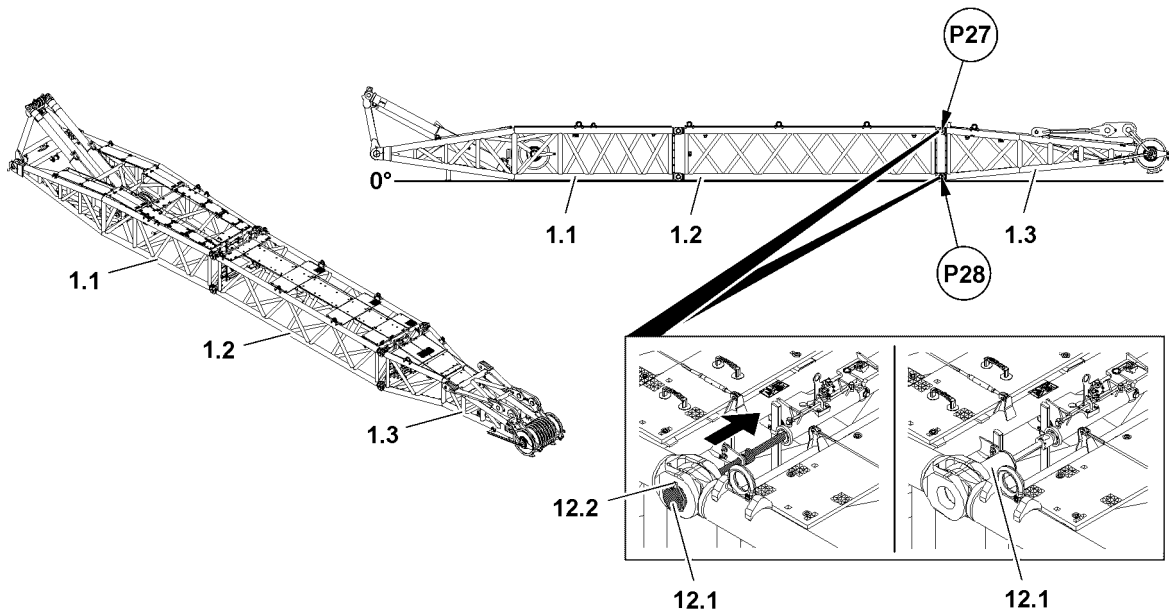

Fig. 116128: Disassembling of the WA-frames — Unpinning the WA-frame end section on the WA-frame intermediate section

- ▶ Fasten the WA-frame end section **1.3** to the auxiliary crane, see section „Fastening points“.
- ▶ Unpin the WA-frame end section **1.3** on the WA-frame intermediate section **1.2**: Release the pins **12.1** on both sides in points **P28** and unpin.
- ▶ Tighten the fastening equipment with the auxiliary crane slightly.

- ▶ Unpin the WA-frame end section **1.3** on the WA-frame intermediate section **1.2**: Release the pins **12.1** on both sides in points **P27** and unpin.
- ▶ Lift the WA-frame end section **1.3** with the auxiliary crane and take it down in a suitable location.
- ▶ Remove the auxiliary crane from the WA-frame end section **1.3**.

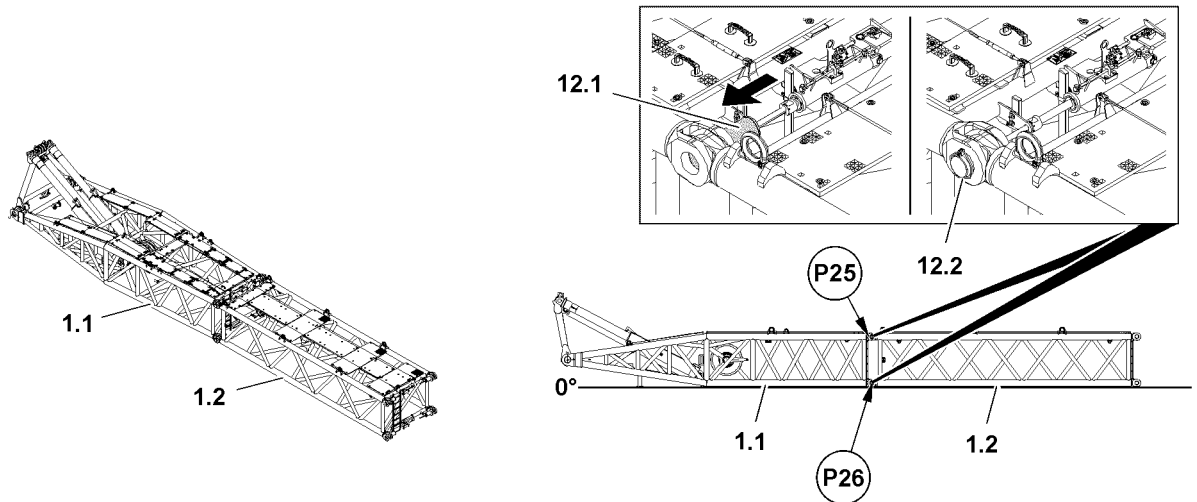

Fig.116129: Disassembling of the WA-frames — Unpinning the WA-frame pivot section on the WA-frame intermediate section

- ▶ Fasten the auxiliary crane to the WA-frame pivot section **1.1**, see section „Fastening points“.
- ▶ Unpin the WA-frame pivot section **1.1** on the WA-frame intermediate section **1.2**: Release the pins **12.1** on both sides in points **P26** and unpin.
- ▶ Tighten the fastening equipment with the auxiliary crane slightly.
- ▶ Unpin the WA-frame pivot section **1.1** on the WA-frame intermediate section **1.2**: Release the pins **12.1** on both sides in points **P25** and unpin.
- ▶ Lift the WA-frame pivot section **1.1** with the auxiliary crane and take it down in a suitable location.
- ▶ Remove the auxiliary crane from the WA-frame pivot section **1.1**.

5.13 Spooling up the hoist ropes and the control rope completely

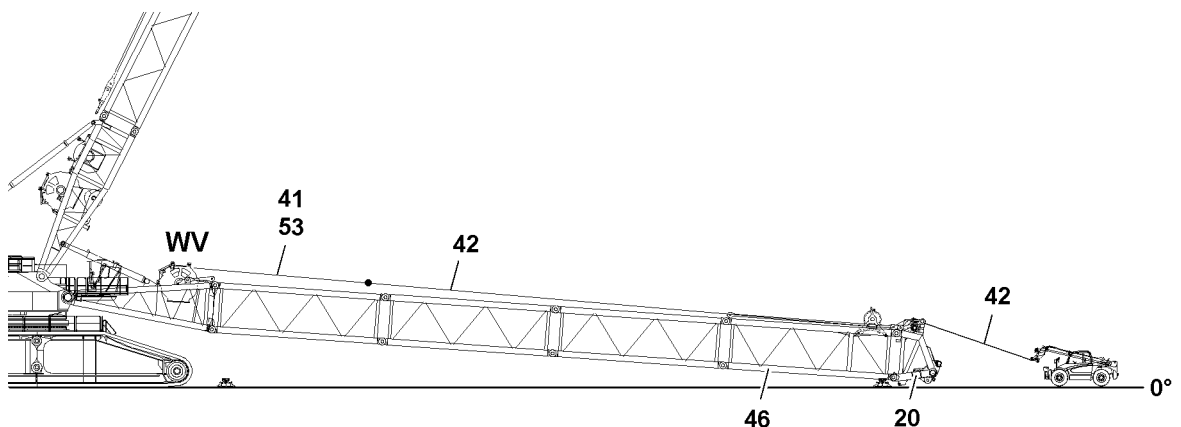

Fig.116130: Spooling up the hoist ropes and the control rope completely

- ▶ Release the hoist rope **53** on the end section **20**.
- ▶ Assemble the hoist rope **53** on the auxiliary rope **42** of the telescopic lift truck.

NOTICE

Slack rope formation!

The control rope **41** can be damaged due to slack rope formation.

This can result in significant property damage.

- ▶ Do not allow slack rope to be formed when spooling out the control rope **41**.
- ▶ Keep the control rope **41** tight when spooling out.

-
- ▶ Spool the hoist rope **53** up completely while the telescopic lift truck tensions the hoist rope **53**.

If additional hoist ropes **53** are secured on the end section **20**:

- ▶ Spool the hoist ropes **53** up completely in the same way as already described.
- ▶ Spool the control rope **41** up in the same way as would have been the case for the hoist rope **53**.

5.07.50 Erecting / taking down the boom system with luffing jib

1	Information about use and the illustrations	2
2	Determining the steepest main boom operating position	2
3	Erecting the boom system with luffing jib	8
4	Taking down the boom system with the luffing jib	15

1 Information about use and the illustrations



Note

How to use this chapter

- ▶ This chapter is a supplement for the operating instructions.



Note

Utilized illustrations

- ▶ The illustrations are exemplary for the erection and take-down procedure.
- ▶ The illustrations do not represent a specific crane.

1.1 Erecting / taking down the boom system angled or stretched

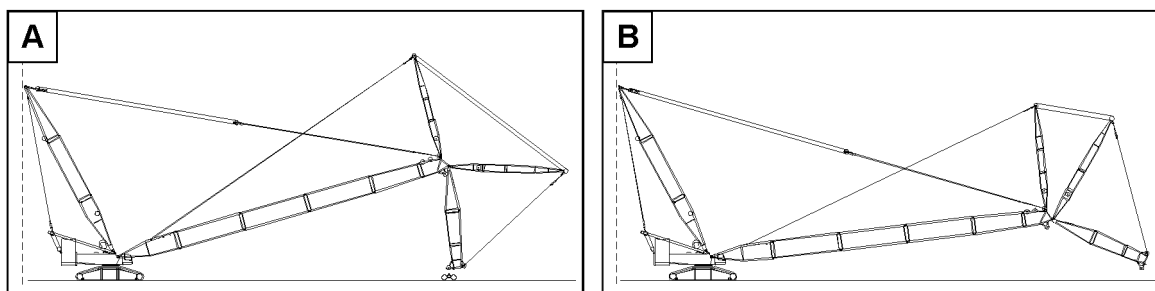

Fig.160426: Example of erecting / taking down the boom system angled or stretched

Variation A

- Example for erecting / taking down the boom system with the luffing jib „angled“. For lifting / positioning, the luffing jib is in the most vertical position possible. In addition, the luffing jib is guided on the roller cart.
- **Note:** This chapter describes how angled erection / take-down takes place. The angled erection / take-down of the boom system with the luffing jib is possible in general.

Variation B

- Example of erecting / taking down the boom system „angled“. For lifting / positioning, the luffing jib is in a relatively horizontal position.
- **Note:** This chapter does **not** describe how stretched erection / take-down takes place. Observe the corresponding description in the operating instructions.



WARNING

The crane can topple over!

If attempting to impermissibly erect or take down a boom system stretched, the crane can be overloaded and topple over.

Death, severe bodily injuries, property damage.

- ▶ Observe the erection and take-down charts.
- ▶ Only erect or take-down the boom systems stretched if explicitly released to do so.
- ▶ In case of doubt, erect or take-down the boom system angled.

2 Determining the steepest main boom operating position

If a specific position is not specified for the set up boom system for erection / take-down, the steepest operating position of the main boom must be known.

**WARNING**

The main boom is in the wrong position!

If the main boom is in the wrong position, the crane can be overloaded during erection / take-down and topple over.

Death, severe bodily injuries, property damage.

- ▶ Before erection / take-down of the boom system, determine the correct position of the boom system.

If there are no explicit specifications regarding the position of the boom system:

- ▶ Determine the steepest operating position of the main boom and approach it at the specified moment.

If there are explicit specifications regarding the position of the boom system, for example in the erection and take-down charts:

- ▶ Approach the positions of the boom system at the specified moment.

Make sure that the following prerequisites are met:

- The set up configuration of the crane and the selected / set load chart match.
- The additional specifications of the erection and take-down charts are observed.
- The additional specifications of the crane documentation including the assembly drawings / assembly plans are observed.

Four different options are described below.

The four options are:

- Curve illustration of the load charts (crane)
- Load chart manual document
- LICCON job planner (PC)
- Curve illustration of the load charts (PC)

2.1 Curve illustration of the load charts (crane)

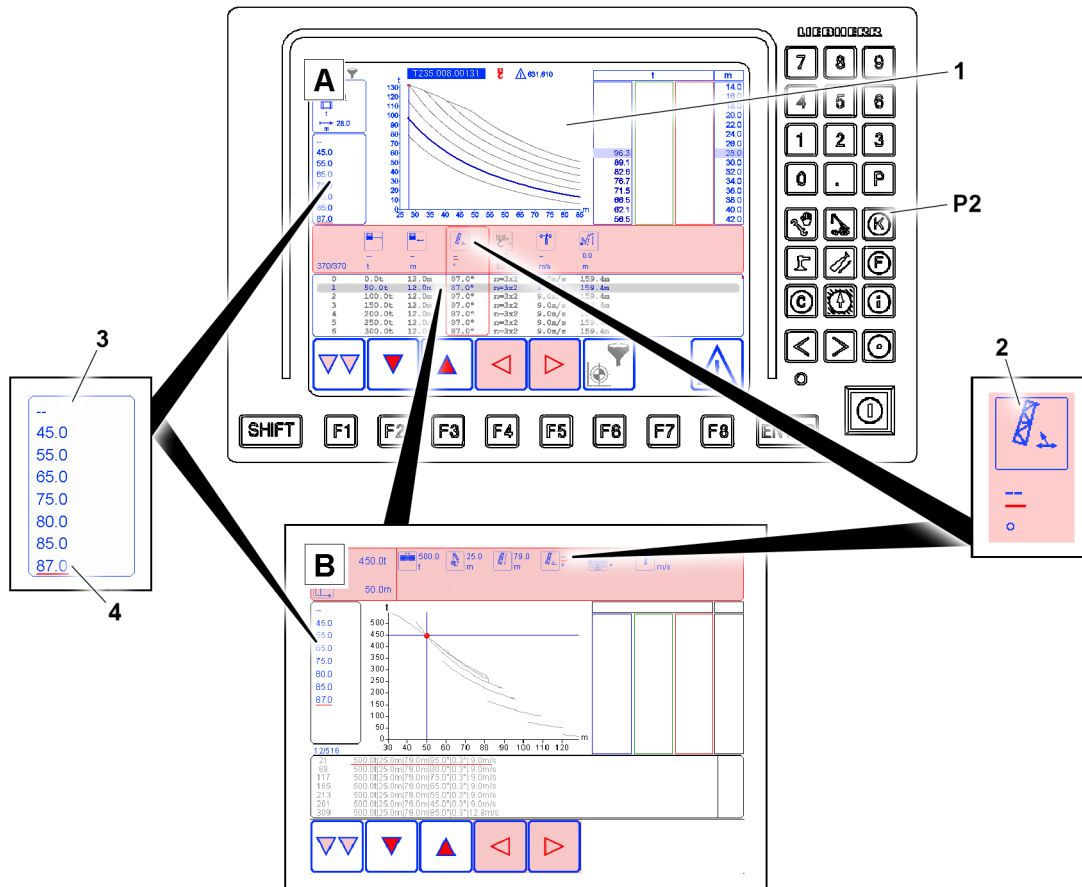

Fig.160418: Example for the curve illustration of load charts on the crane (LICCON monitor)

1 Curve illustration

- Curve illustration of load charts
- **Note:** The curve illustration is called up via a program key **P2** on the right LICCON monitor.
- **Note:** The view of the curve illustration can vary, see variation **A** and variation **B**

2 Main boom angle icon

- Designates the column with the list of the main boom angles
- **Note:** As soon as the main boom angle icon **2** is selected, all main boom angles of the set load charts are displayed in increasing order in the Editing / selection window **3**.

3 Editing / selection window

- If the main boom angle icon **2** is selected, all main boom angles of the set load charts are displayed in increasing order here.

4 Main boom angle

- The largest main boom angle **4** generates the steepest operating position of the main boom. The largest main boom angle is located in the lowest position in the editing / selection window **3**. In the example shown, the 87° main boom angle is underlined.

- ▶ Call up the curve illustration **1** for the set up configuration of the crane.
- ▶ Select the main boom angle icon **2**.
- ▶ Scroll to the very bottom of the editing / selection window **3** to display the largest main boom angle **4** of the set load chart.

Result:

- The largest main boom angle **4** corresponds to the steepest operating position of the main boom.

- Unless the specifications state otherwise, use the steepest determined operating position of the main boom for the erection / take-down of the boom system.

2.2 Load chart manual document

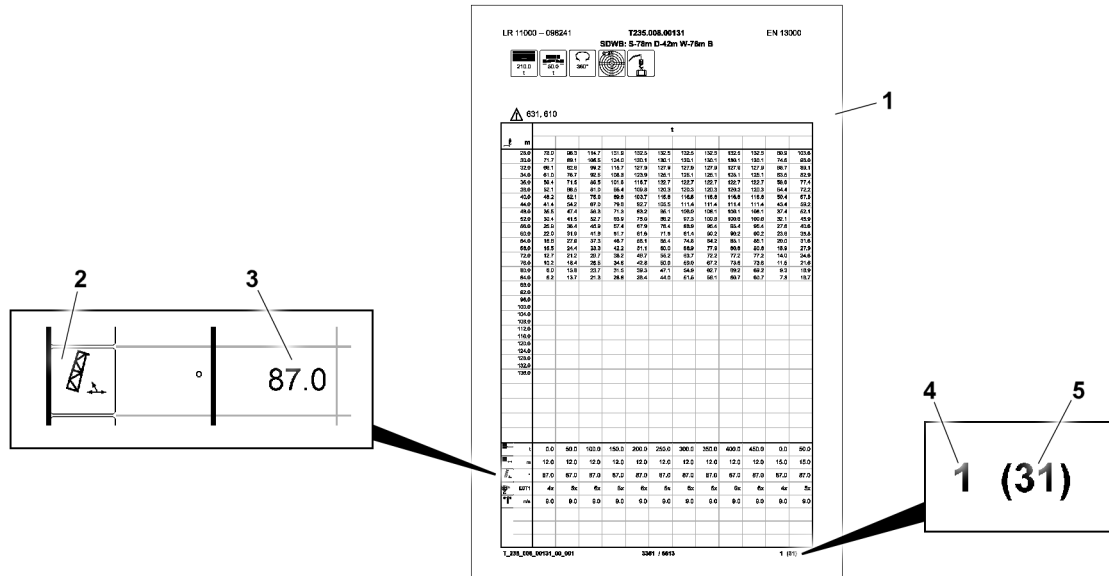

Fig.160411: Example for a load chart in the load chart manual document

1 Load chart

2 Main boom angle icon

- Designates the line with the list of the main boom angles

3 Angle value

- The largest angle value 3 generates the steepest operating position of the main boom. In the example shown, the main boom angle is 87°.

Note: The steepest operating position of the main boom corresponds to the largest angle value 3 in the line. Observe all pages of the respective load chart 1.

4 Page number

- If the load chart is comprised of multiple pages, they are numbered. The page number of the currently displayed page is indicated here.
- **Note:** The example shown shows page 1 of 31 pages.

5 Page number

- Total number of load chart pages.
- **Note:** To determine the steepest permissible operating position of the main boom, observe all pages of the respective load chart.

- ▶ Select the load chart for the crane set up configuration.
- ▶ Determine the highest angle value 3 on all pages of the load chart in the line of the main boom angle icon 2.

Result:

- The largest angle value 3 corresponds to the steepest operating position of the main boom.
- Unless the specifications state otherwise, use the steepest determined operating position of the main boom for the erection / take-down of the boom system.

2.3 LICCON job planner (PC)

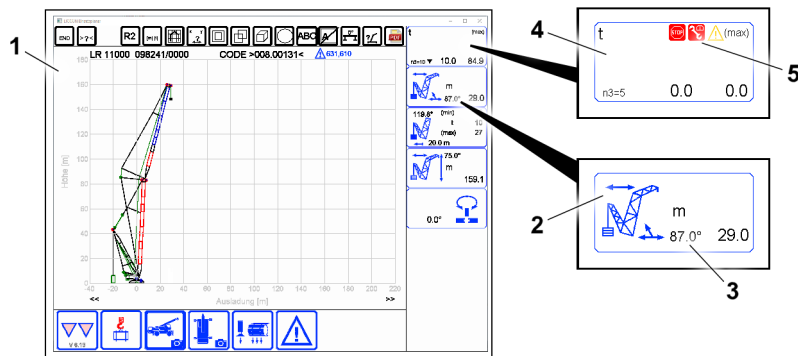

Fig.160416: Example of the LICCON job planner in the Computer (PC)

1 LICCON job planner program

2 Boom radius icon

- Radius boom and main boom angle display

3 Main boom angle

- The largest main boom angle **3** generates the steepest operating position of the main boom. In the example shown, the main boom angle is 87°.
- **Note:** If the LMB function (load torque limiter) is turned off in the LICCON job planner, the main boom positions that are too steep can be simulated. Simulate the steepest operating position of the main boom in the LICCON job planner with active LMB function (load torque limiter).

4 Load icon

- Reeving, maximum load and actual load display.

5 Warning icons

- If a warning event occurs, a warning icon appears. Multiple warning icons can appear at the same time.
- **Note:** Warning icons can also appear in other icons, for example in the case of incorrect ballasting of derrick ballast.



Note

To ensure a valid simulation of the steepest operating position of the main boom, make sure that the corresponding LICCON job planner fulfills all the conditions of the load chart.

- ▶ A valid maximum load appears in the load icon **4**.
- ▶ A warning icon **5** does not appear.

- ▶ Set the set up configuration of the crane in the LICCON job planner.

- ▶ Determine the steepest operating position of the main boom in the load chart through a simulation with the LICCON job planner.

Result:

- The largest main boom angle **3** that can be simulated corresponds to the steepest operating position of the main boom.
- Unless the specifications state otherwise, use the steepest determined operating position of the main boom for the erection / take-down of the boom system.

2.4 Curve illustration of load charts (PC)

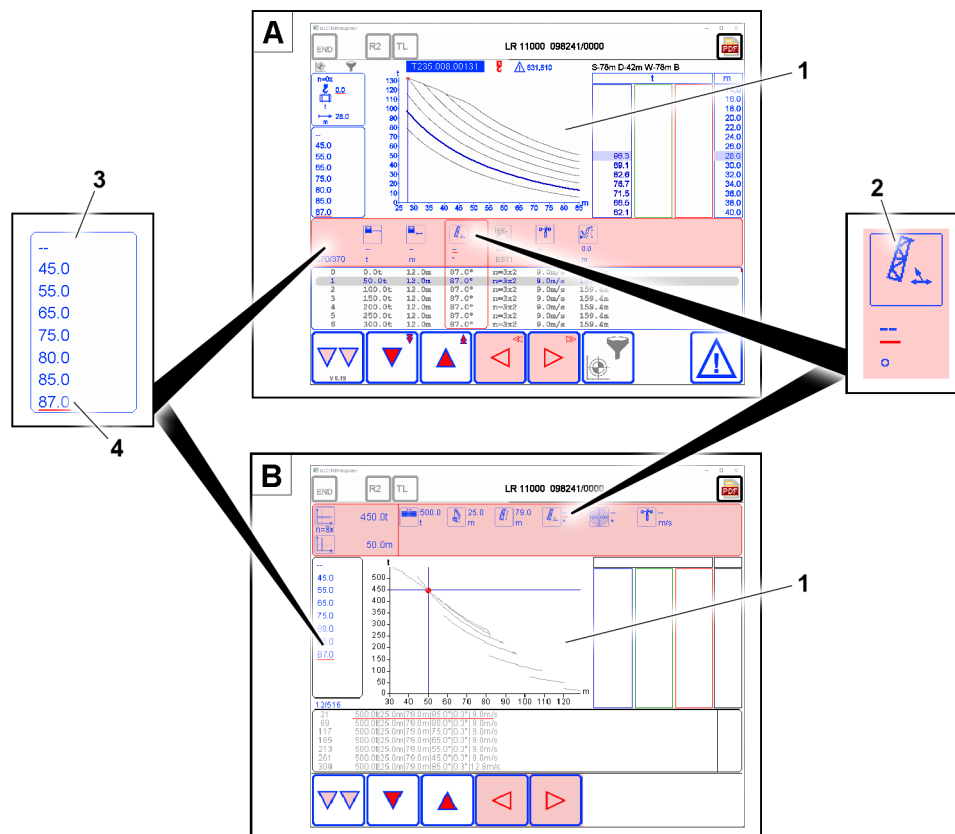

Fig.160456: Example for the curve illustration of load charts on the crane (PC)

1 Curve illustration

- Curve illustration of load charts
- **Note:** The view of the curve illustration can vary, see variation **A** and variation **B**

2 Main boom angle icon

- List of the main boom angles
- **Note:** As soon as the main boom angle icon **2** is selected, all main boom angles of the set load charts are displayed in increasing order in the editing / selection window **3**.

3 Editing / selection window

- If the main boom angle icon **2** is selected, all main boom angles of the set load charts are displayed in increasing order here.

4 Main boom angle

- The largest main boom angle **4** generates the steepest operating position of the main boom. The largest main boom angle is located in the lowest position in the editing / selection window **3**. In the example shown, the 87° main boom angle is underlined.
 - **Note:** Scroll to the very bottom of the editing / selection window **3** to display the largest main boom angle **4** of the set load chart.
- ▶ Set the set up configuration of the crane in the LICCON job planner.
 - ▶ Call up the curve illustration **1**.
 - ▶ Select the main boom angle **2**.
 - ▶ Scroll to the very bottom of the editing / selection window **3** to display the largest main boom angle **4** of the set load chart.

Result:

- The largest main boom angle **4** corresponds to the steepest operating position of the main boom.

- Unless the specifications state otherwise, use the steepest determined operating position of the main boom for the erection / take-down of the boom system.

3 Erecting the boom system with luffing jib

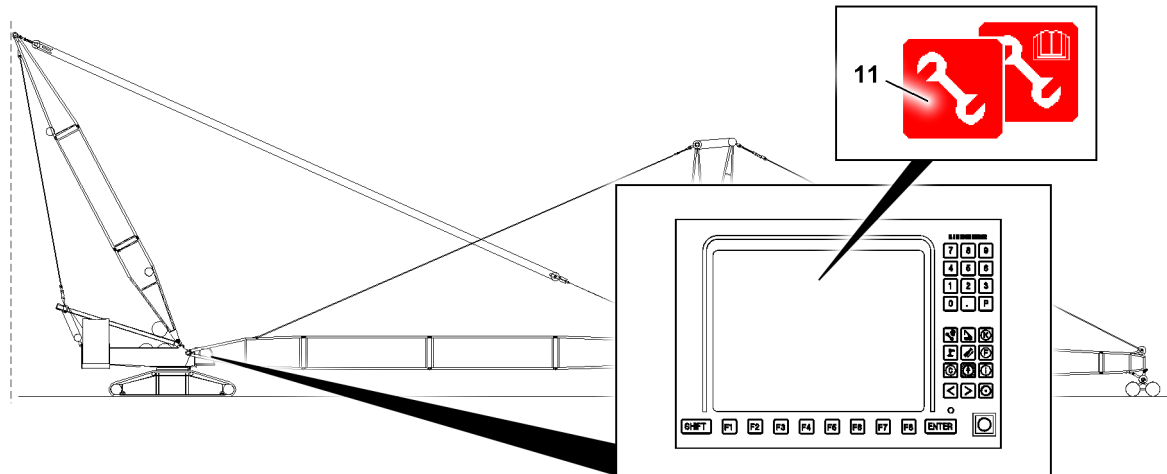

Fig.160419: Assembly operation activated, variations of the assembly icon on the LICCON monitor



Note

The *assembly icon 11* has a small area for additional signs to the top right.

- ▶ A symbolized manual can appear there during erection / take-down procedures.
- ▶ For a detailed description of the variations of the *assembly icon 11*, see chapter 4.02.



WARNING

Impermissible assembly procedures during assembly operation!

If assembly operation is activated, the *assembly icon 11* appears. The LICCON overload protection is bypassed in order to carry out the specified erection / take-down procedures and assembly procedures.

In the case of deviations from the specified sequences, misuse of the function or due to impermissible assembly procedures, the crane can be overloaded and topple over.

Death, severe bodily injuries, property damage.

- ▶ Assembly operation may only be activated by persons who know and can estimate the effects.
- ▶ Activate the assembly operation only when the correct set up configuration was entered in the LICCON computer system.
- ▶ Comply with the specifications, observe the erection / take-down charts.
- ▶ Normal crane operation with activated assembly operation is prohibited, the *assembly icon 11* may not appear.



WARNING

Turning of the crane superstructure when erecting / taking down the boom system!

If the crane superstructure is turned when erecting / taking down the boom system, the crane can be overloaded and topple over.

Death, severe bodily injuries, property damage.

- ▶ It is prohibited to turn the crane superstructure when erecting / taking down the boom system.

**WARNING**

The crane superstructure turns uncontrolled!

If the slewing gear brake is released, then the crane superstructure can turn uncontrolled in strong side wind or in an inclined position.

Death, severe bodily injuries, property damage.

- ▶ Secure the crane superstructure against turning movements when erecting / taking down the boom system.

**WARNING**

Wind speed too high!

If the maximum permissible wind speeds are disregarded, the crane can topple over.

Death, severe bodily injuries, property damage.

- ▶ Observe the specifications regarding the wind speed in the erection and take-down charts.

When there are no specifications regarding the wind speed in the erection and take-down charts:

- ▶ Comply with the specifications regarding the wind speed from the wind out of operation charts.

**WARNING**

Falling hoist rope!

If a hoist rope that is not reeved in is not pulled with the respective length over the luffing jib end section during erection / take-down of the boom system, it can fall backward due to its own weight.

Death, severe bodily injuries, property damage.

- ▶ Pull the rope end out at least 10 m over the luffing jib end section and put it down on the ground.
- ▶ Monitor the behavior of the hoist rope during erection / take-down.

Make sure that the following prerequisites are met:

- The specifications regarding the erection procedure are implemented, the erection / take-down charts are adhered to.
- In the case of boom systems with a minimum hook block weight, the minimum hook block weight is observed.
- The rope end of the hoist rope must be pulled out at least 10 m over the luffing jib end section.
- There are no loose or unnecessary parts on the boom system.
- The boom system and the safety equipment are free of snow, frost and ice.
- The maximum permissible wind speeds are observed.
- Unless the specifications state otherwise, use the steepest operating position of the main boom for the erection / take-down of the boom system. See section „Determining the steepest main boom operating position“.

The steepest operating position of the main boom is individual for every boom system.

- For this individual angle, the place holder MAX^{° TLT/AAT} is used in the following description.

3.1 Information regarding the erection procedure

The set up configuration of the crane and the local conditions influence the erection procedure.

The erection procedure can be divided into two parts:

- The first part of the erection procedure is carried out until the roller cart can be removed with the steepest possible main boom.
- In the second part of the erection procedure, the boom system is lifted out of the roller cart and luffed down into the operating position.
The entire boom weight is carried by the crane.

At the end of the first part of the erection procedure, the boom positions vary according to the set up configuration, see the examples in the following charts.

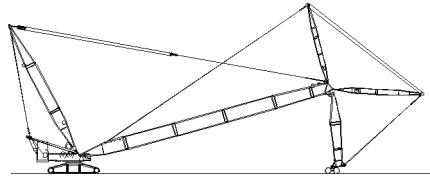
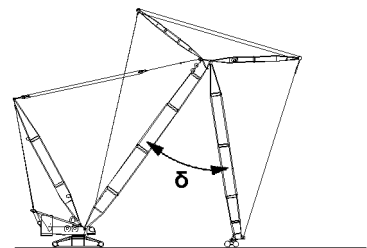
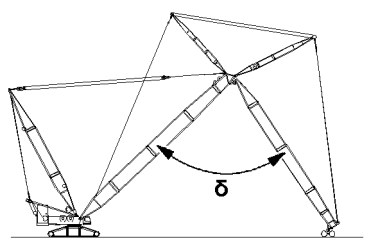
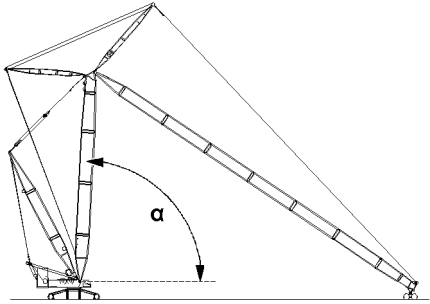
Examples for variations of the boom positions during the erection procedure depending on the set up configuration	
	<p>With an installed roller cart with ground contact, the luffing jib is almost vertical.</p> <p>Note: This is the case, for example, when a relatively shorter luffing jib is installed on a longer main boom.</p>
	<p>With an installed roller cart with ground contact, the luffing jib has reached the „luffing jib bottom“ switch position.</p> <p>Note: Without a roller set on the main boom, the luffing jib reaches the „luffing jib bottom“ switch position with an intermediate angle δ of approx. 45°.</p>
	<p>With an installed roller cart with ground contact, the luffing jib has reached the „luffing jib bottom“ switch position.</p> <p>Note: With a roller set on the main boom, the luffing jib reaches the „luffing jib bottom“ switch position with an intermediate angle δ of approx. 80°.</p>
	<p>With an installed roller cart with ground contact, the main boom has reached the steepest operating position (angle α equal to $\text{MAX}^\circ_{\text{TLT/AAT}}$).</p> <p>Note: This is the case, for example, when a long luffing jib is installed on a short main boom.</p>



WARNING

Impermissible installation of a roller set!

If a roller set is installed impermissibly on the main boom, the intermediate angle δ is too large.

During erection or take down of the boom, the crane can topple over if the intermediate angle δ is too large.

Death, severe bodily injuries, property damage.

► Install a roller set on the main boom only if the boom system with luffing jib is released to do so.

3.2 Carrying out the erection procedure

The erection procedure is carried out with activated assembly operation, the LICCON overload protection is bypassed.

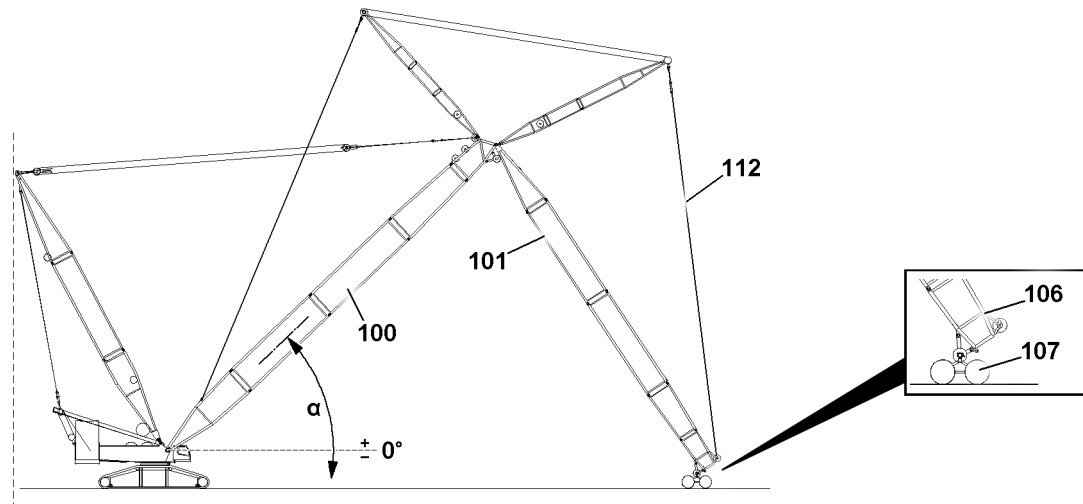

Fig.160375: Carrying out the erection procedure

The roller cart **107** must absorb the proportional weight of the boom system as long as possible during the erection procedure.



WARNING

Overloading of the crane when erecting the boom system!

If the guy rods **112** are tensioned as long as the roller cart **107** must absorb the proportional weight of the boom system, the crane carries too much boom weight. The forces on the boom system become too high.

The crane can be overloaded and topple over.

Death, severe bodily injuries, property damage.

- ▶ When luffing the main boom **100** up, spool the luffing jib control rope out such that the guy rods **112** sag slightly.
- ▶ Do not permit slack rope formation on the luffing jib control rope.

As long as the luffing jib end section **106** can be held on the ground with the roller cart **107**:

- ▶ Luff the main boom **100** up as steep as possible and at the same time spool the luffing jib **101** control rope out so that the guy rods **112** sag slightly.

Result:

One of the following occurs depending on the set up configuration:

- The luffing jib **101** is almost vertical.
- The luffing jib **101** has reached the „luffing jib bottom“ switch position.
- The main boom **100** has reached its steepest operating position (angle α equal to $MAX^{\circ} TL/AAT$).

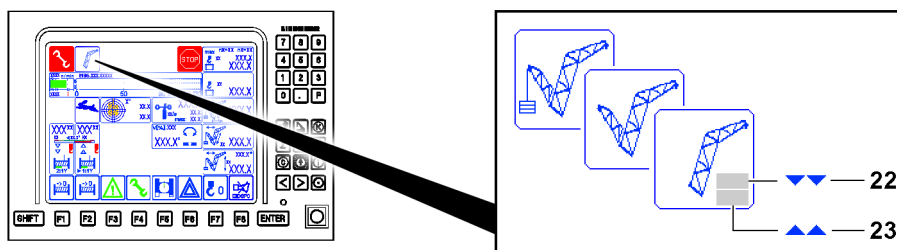

Fig.160420: The „luffing jib bottom“ and „steep main boom“ switch position

**Note**

When the „luffing jib bottom“ switch position blocks a necessary crane movement:

- ▶ Luff the luffing jib up 0.5° until the icon **22** turns off.

When the „steep main boom“ switch position blocks a necessary crane movement:

- ▶ Luff the main boom up 0.5° until the icon **23** turns off.

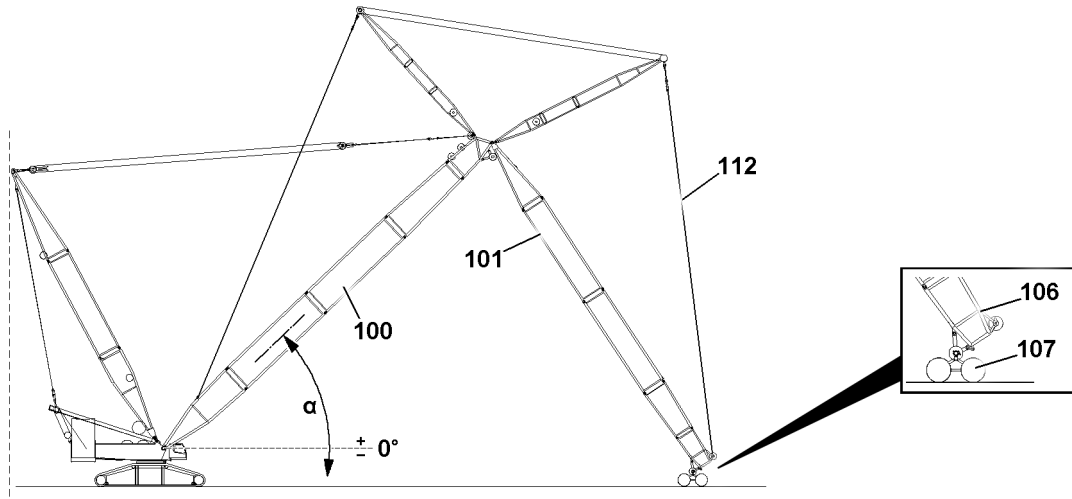

Fig.160375: Carrying out the erection procedure

- ▶ Tighten the guy rods **112**, spool the luffing jib **101** control rope up to do so.
- ▶ Release the roller cart **107** from the luffing jib end section **106**, see chapter 5.15 or 5.61.

**WARNING**

Main boom not in the correct position!

If the main boom **100** is not luffed up as far as possible when lifting the luffing jib **101**, the crane can be overloaded.

Death, severe bodily injuries, property damage.

- ▶ Luff the main boom **100** up as far as possible before the luffing jib **101** is lifted out of the roller cart **107**.

When the main boom **100** is not yet in the steepest operating position:

- ▶ Luff the main boom **100** up until the luffing jib end section **106** lifts up approx. 0.5 m from the roller cart **107**.

or:

If the main boom **100** is already in the steepest operating position (angle α gleich $MAX^\circ_{TLT/AAT}$):

- ▶ Luff the luffing jib **101** up until the luffing jib end section **106** lifts up approx. 0.5 m from the roller cart **107**.

When the luffing jib end section **106** is lifted approx. 0.5 m from the roller cart **107**:

- ▶ Remove the roller cart **107**.
- ▶ Reeve the hook block in and position the hoist limit switch weight, see chapter 4.06 and the separate reeving plans.
- ▶ Position the hook block below the luffing jib end section **106** such that the hoist limit switch is not actuated when the hook block is hanging freely.

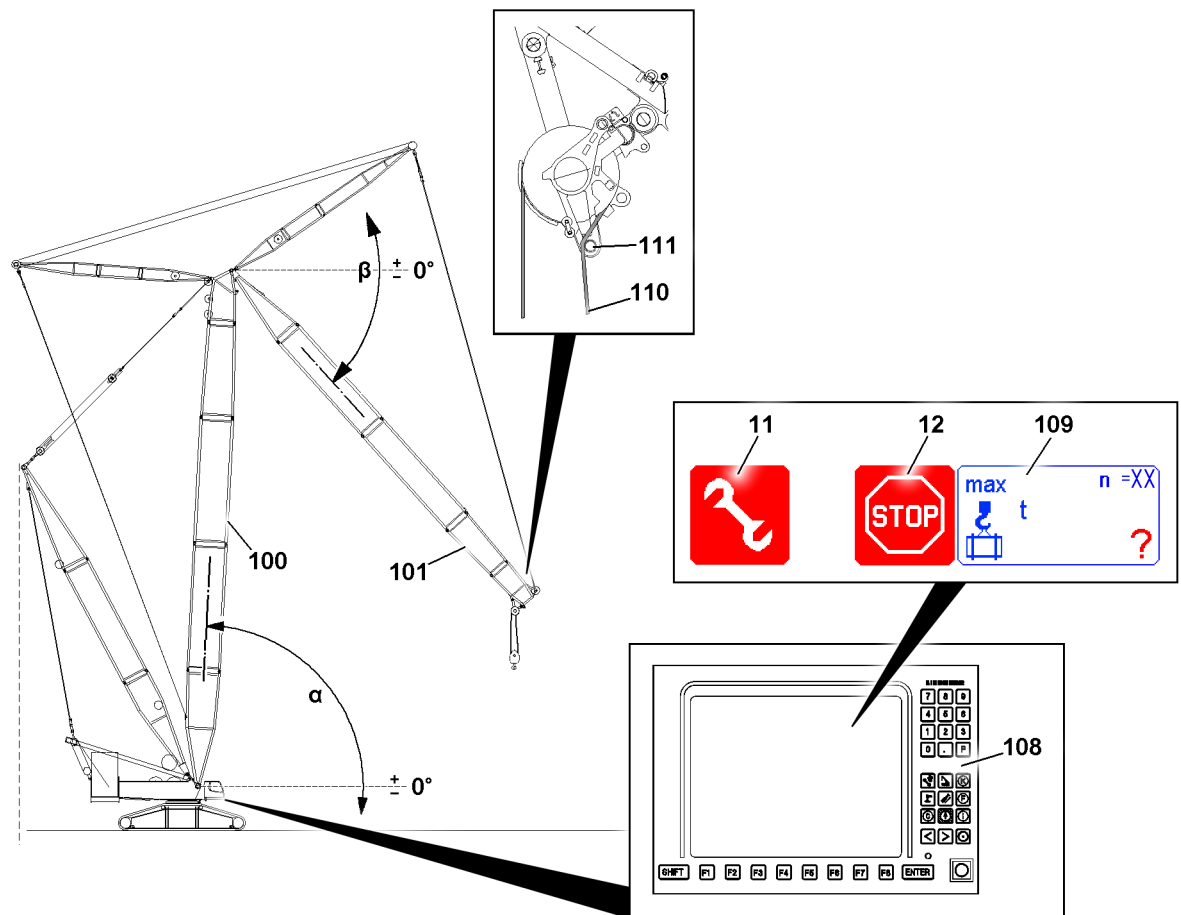

Fig.160422: Carrying out the erection procedure

NOTICE

Damage to the hoist rope!

If the hoist rope **110** is reeved on the hook block and redirected over the small guard rollers **111**, the hoist gear may no longer be driven as long as the hook block hangs free. During spooling up or spooling out, the hoist rope **110** can be damaged.

- ▶ Do not spool the hoist rope **110** up or out with a freely hanging hook block if the luffing jib **101** is luffed down below the horizontal (angle β less than 0°).

When the main boom **100** is not yet in the steepest operating position (angle α equal to $\text{MAX}^\circ_{\text{TLT/AAT}}$):

- ▶ Luff the main boom **100** up to the steepest operating position.



Note

During the erection procedure, the main boom **100** must be at the steepest angle α of $\text{MAX}^\circ_{\text{TLT/AAT}}$ so that the luffing jib **101** can be luffed up securely from below in the range of a load chart. When doing so, the luffing jib **101** may initially not exceed an angle β of 70° . An angle β above 70° is usually only permissible with active monitoring by means of the load chart.

- ▶ A too large boom radius results when the main boom **100** and luffing jib **101** are too flat.
- ▶ A too small boom radius results when the main boom **100** and luffing jib **101** are too steep.

**WARNING**

The crane can tip over!

The crane can tip forward if the boom radius of the boom system is too large.

The crane can tip to the rear if the boom radius of the boom system is too small.

Death, severe bodily injuries, property damage.

- ▶ The boom radii listed in the load chart may not be exceeded or fallen below, even if there is no load on the hook.
- ▶ Assembly operation must be ended when reaching the lowest operating position of the luffing jib **101**. The *Assembly* icon **11** may no longer appear. Also turn the assembly operation off manually.

Only when the main boom **100** is in the steepest operating position (angle α equal to $MAX^{\circ TLT/AAT}$):

- ▶ Luff the luffing jib **101** up to its lowest operating position. When doing so, observe a permissible angle window for the angle β of 0° to 70° .

Problem remedy

Does the *Assembly* icon **11** not turn off on the LICCON monitor **108** even if the luffing jib **101** is luffed up to an angle β of 70° ?

Under some circumstances, the boom system is not in the angle range of the set load chart.

- ▶ Check if the set load chart specifies a target angle for the main boom **100** or the luffing jib **101**.
- ▶ If yes, approach the target angle without an unnecessary increase of the boom radius.
- ▶ When no, check all settings und displays, contact Liebherr Customer Service.

When the luffing jib **101** has reached its lowest operating position:

- ▶ Make sure that the *STOP* icon **12** on the LICCON monitor **108** has turned off.

Result:

- Monitoring by means of the load chart is activated.
- The *Maximum load* icon **109** displays a number instead of a question mark „?“.

Only when the *Assembly* icon **11** continues to be displayed:

- ▶ Turn assembly operation off, see chapter 4.01/4.02.

Result:

- The *Assembly* icon **11** disappears.
- Assembly operation is switched off.

**Note**

When monitoring by means of the load chart is activated:

- ▶ Adapt the additional specifications from the **erection and take-down charts** to the set load charts.
- ▶ In the case of boom systems with a minimum hook block weight, comply with the minimum hook block weight.

4 Taking down the boom system with the luffing jib

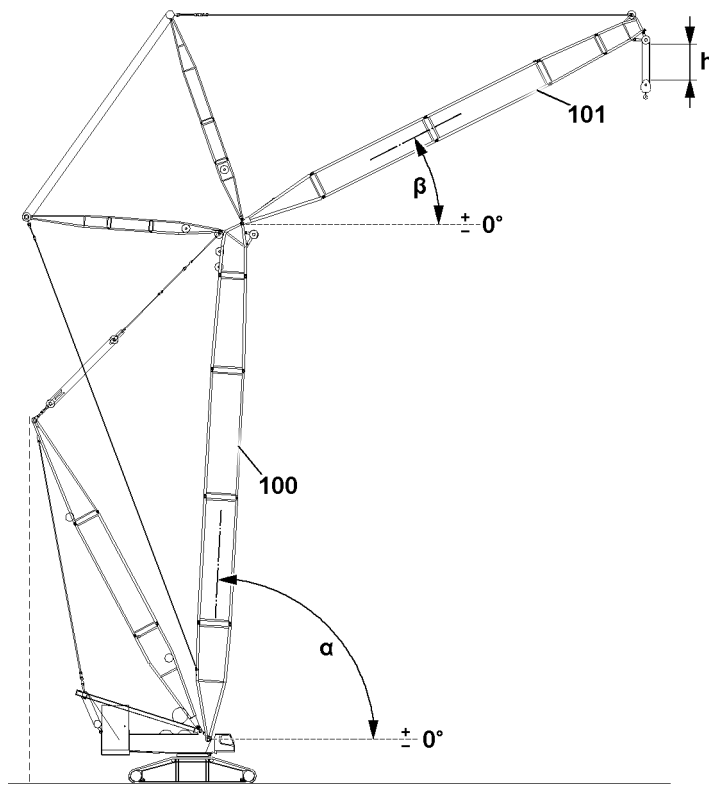

Fig.160393: Carrying out the take-down procedure



WARNING

Impermissible assembly procedures during assembly operation!

If assembly operation is activated, the LICCON overload protection is bypassed. The specified erection / take-down procedures and assembly procedures can be carried out.

In the case of deviations from the specified sequences, misuse of the function or due to impermissible assembly procedures, the crane can be overloaded and topple over.

Death, severe bodily injuries, property damage.

- ▶ Assembly operation may only be activated by persons who know and can estimate the effects.
- ▶ Activate the assembly operation only when the correct set up configuration was entered in the LICCON computer system.
- ▶ Comply with the specifications, observe the erection / take-down charts.
- ▶ Normal crane operation with activated assembly operation is prohibited.



WARNING

The boom system folds backward!

If the minimum hook block weight is not observed, the boom system can tip backwards in steep positions and the crane can topple over.

Death, severe bodily injuries, property damage

- ▶ Observe the minimum hook block weight.



WARNING

The distance between the hook block / load hook and the pulley head is too small!

If the hook block or load hook are too close to the pulley head, a collision can occur during the take-down procedure. Components can be damaged and fall down.

Death, severe bodily injuries, property damage.

- ▶ Ensure sufficient distance between the hook block / load hook and the pulley head.

Make sure that the following prerequisites are met:

- The specifications of the erection / take-down charts are adhered to.
- In the case of boom systems with a minimum hook block weight, the minimum hook block weight is observed.
- The main boom **100** is luffed up to its steepest operating position according to the load chart.
- The luffing jib **101** is luffed down to its lowest operating position according to the load chart.
- The hook block / load hook is positioned at a distance **h** of 5 m below the pulley head.
- The maximum permissible wind speeds are observed.
- Unless the specifications state otherwise, use the steepest operating position of the main boom for the erection / take-down of the boom system. See section „Determining the steepest main boom operating position“.

The steepest operating position of the main boom is individual for every boom system.

- For this individual angle α , the place holder $MAX^{\circ TLT/AAT}$ is used in the following description.



Note

- ▶ Within the load chart, the luff down of the luffing jib **101** is turned off as soon as the lowest operating position of the luffing jib **101** is reached. The lowest limit angle of the load chart is reached.
- ▶ In the lowest operating position, the luffing jib **101** always has a positive angle β .

4.1 Information regarding the take-down procedure

The set up configuration of the crane and the local conditions influence the take-down procedure.

The take-down procedure can be divided into two parts:

- The first part of the take-down procedure is carried out until the roller cart can be removed with the steepest possible main boom.
- During the second part of the take-down procedure, the boom system is taken down completely onto the ground.

At the end of the first part of the take-down procedure, the boom positions vary according to the set up configuration, see the following charts.

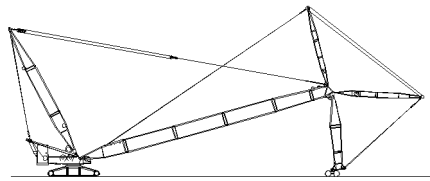
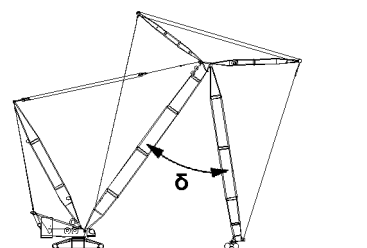
Examples for variations of the boom positions during the take-down procedure depending on the set up configuration	
	<p>When the luffing jib is hanging almost vertically, the main boom is luffed down to the point where the roller cart can be installed.</p> <p>Note: This is the case, for example, when a relatively shorter luffing jib is installed on a longer main boom.</p>
	<p>When the luffing jib is in the „luffing jib bottom“ switch position, the main boom is luffed down to the point where the roller cart can be installed.</p> <p>Note: Without a roller set on the main boom, the luffing jib reaches the „luffing jib bottom“ switch position with an intermediate angle δ of approx. 45°.</p>

Examples for variations of the boom positions during the take-down procedure depending on the set up configuration	
	<p>When the luffing jib is in the „luffing jib bottom“ switch position, the main boom is luffed down to the point where the roller cart can be installed.</p> <p>Note: With a roller set on the main boom, the luffing jib reaches the „luffing jib bottom“ switch position with an intermediate angle δ of approx. 80°.</p>
	<p>With the main boom in the steepest operating position (angle α gleich $MAX^\circ_{TLT/AAT}$) the luffing jib is luffed down to the point where the roller cart can be installed.</p> <p>Note: This is the case, for example, when a long luffing jib is installed on a short main boom.</p>

4.2 Carrying out the take-down procedure

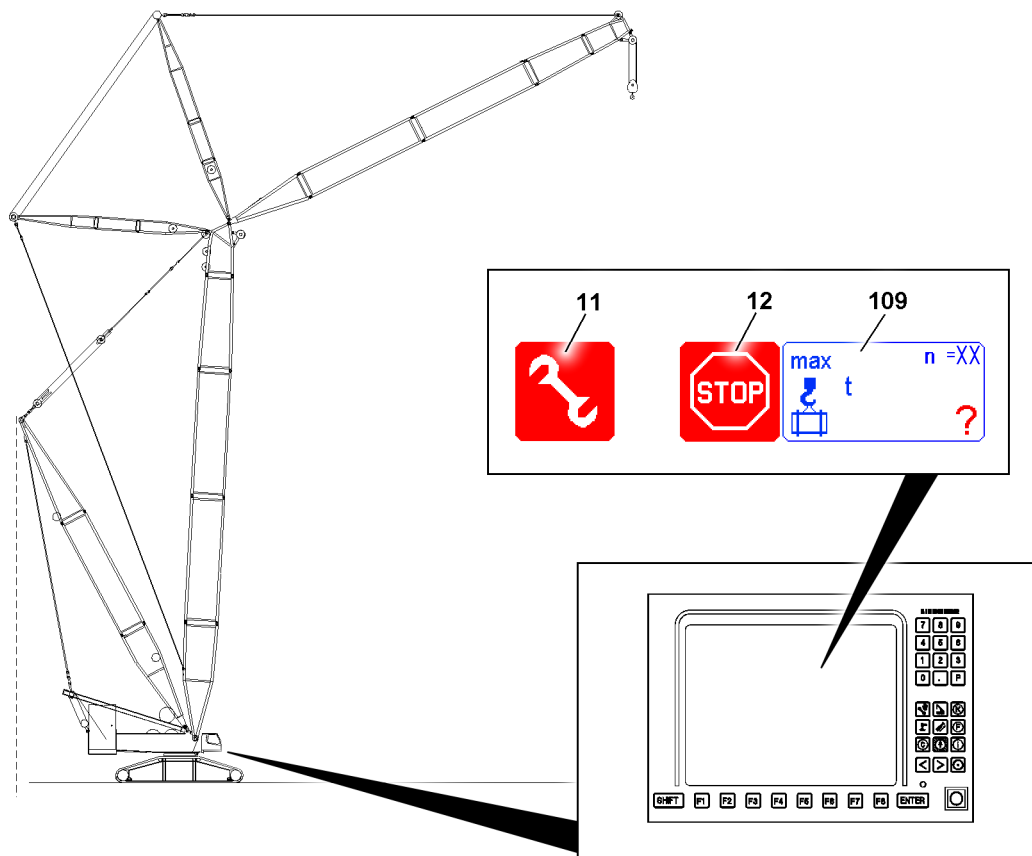

Fig.160454: Carrying out the take-down procedure

LWE/LR 13000-001/19503-01-02/en

**WARNING**

Impermissible assembly procedures during assembly operation!

If assembly operation is activated, the *assembly icon 11* appears. The LICCON overload protection is bypassed in order to carry out the specified erection / take-down procedures and assembly procedures.

In the case of deviations from the specified sequences, misuse of the function or due to impermissible assembly procedures, the crane can be overloaded and topple over.

Death, severe bodily injuries, property damage.

- ▶ Assembly operation may only be activated by persons who know and can estimate the effects.
- ▶ Activate the assembly operation only when the correct set up configuration was entered in the LICCON computer system.
- ▶ Comply with the specifications, observe the erection / take-down charts.
- ▶ Normal crane operation with activated assembly operation is prohibited.

- ▶ Activate assembly operation, see chapter 4.01 / 4.02.

Result:

- The LICCON overload protection is bypassed, the specified erection / take-down procedures and assembly procedures can be carried out.
- The *assembly icon 11* appears on the LICCON monitor.

**Note**

- ▶ If the lower limit angle in the load chart is fallen below, the load value disappears in the *maximum load icon 109* and a question mark appears.
- ▶ Alarm functions appear on the crane operation screen, the *STOP icon 12* appears.

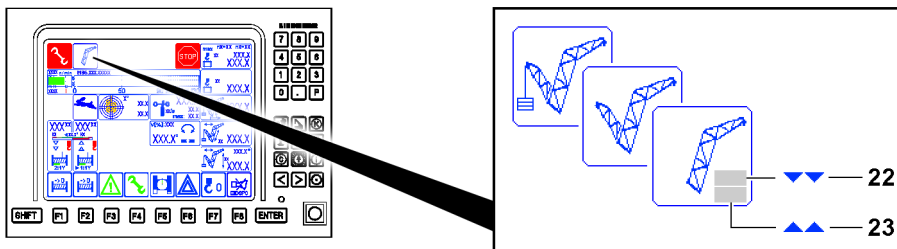

Fig.160420: The „luffing jib bottom“ and „steep main boom“ switch position

**Note**

When the „luffing jib bottom“ switch position blocks a necessary crane movement:

- ▶ Luff the luffing jib up 0.5° until the icon **22** turns off.

When the „steep main boom“ switch position blocks a necessary crane movement:

- ▶ Luff the main boom up 0.5° until the icon **23** turns off.

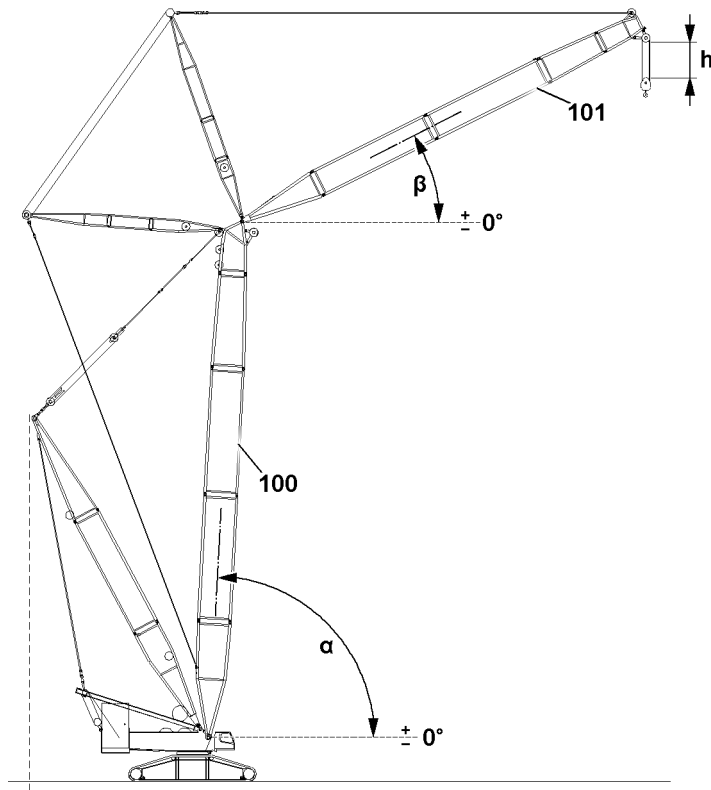

Fig.160393: Carrying out the take-down procedure



WARNING

The main boom is in the wrong position!

If the main boom is in the wrong position, the crane can be overloaded and topple over. Death, severe bodily injuries, property damage.

- ▶ During the take-down procedure, the main boom must remain at a steep angle α of $\text{MAX}^{\circ \text{TLT/AAT}}$, until the luffing jib **101** reaches the „luffing jib bottom“ switch position, or the luffing jib end section can be set down in the roller cart.

Only when the luffing jib **101** is not yet at an angle $\beta \leq 70^{\circ}$:

- ▶ Luff the luffing jib **101** down to an angle β of 70° . Maintain a distance h of 5 m when doing so.

Only when the main boom **100** is not yet in the steepest operating position (angle α equal to $\text{MAX}^{\circ \text{TLT/AAT}}$):

- ▶ Luff the main boom **100** up to the steepest operating position, at the same time hold the luffing jib **101** in the present angle position (angle β) by spooling the luffing jib control rope out.

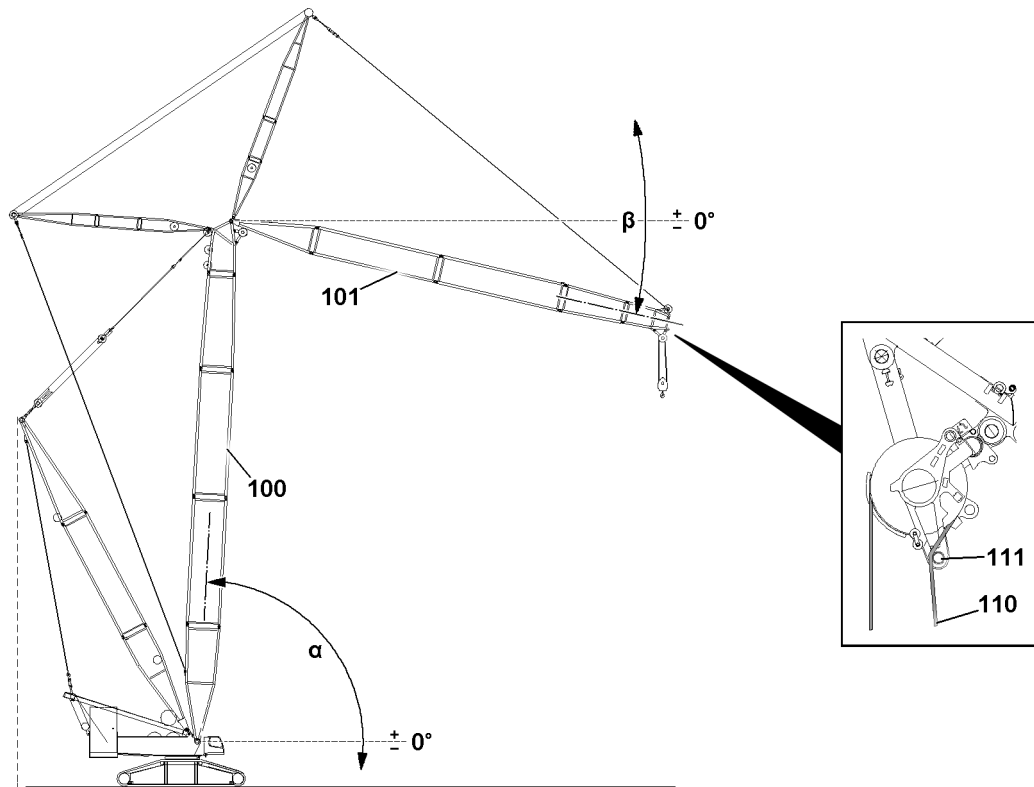

Fig.160385: Carrying out the take-down procedure

NOTICE

Damage to the hoist rope!

If the hoist rope **110** is reeved on the hook block and redirected over the small guard rollers **111**, the hoist gear may no longer be driven as long as the hook block hangs free. During spooling up or spooling out, the hoist rope **110** can be damaged.

- ▶ Do not spool the hoist rope **110** up or out with a freely hanging hook block if the luffing jib **101** is luffed down below the horizontal (angle β less than 0°). Return the luffing jib **101** to the horizontal only to operate the hoist gear.

Only when the main boom **100** is in the steepest operating position (angle α equal to $\text{MAX}^\circ \text{TLT/AAT}$):

- ▶ Luff the luffing jib **101** down until one of the following occurs.

Result:

- The luffing jib **101** has reached the „luffing jib bottom“ switch position.
- The luffing jib **101** can be luffed down until the hook block lies on the floor and the luffing jib end section is located slightly above it.

Only when the luffing jib **101** has reached the „luffing jib bottom“ switch position:

- ▶ Luff the main boom **100** down until one of the following occurs.

Result:

- The luffing jib **101** hangs down almost vertically (angle β at -85°).
- The main boom **100** can be luffed down until the hook block lies on the floor and the luffing jib end section is located slightly above it. The luffing jib **101** does not hang steeper than -85° .

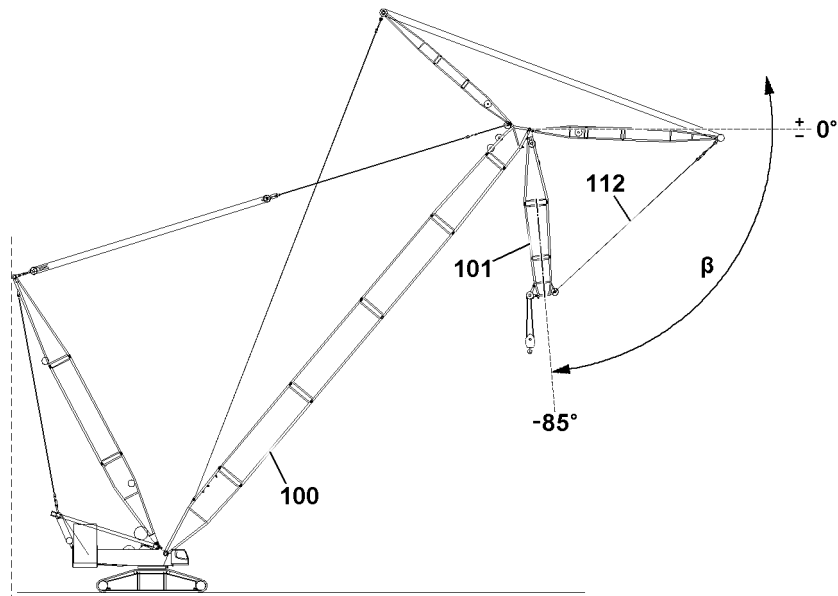

Fig.160382: Carry out the take-down procedure: The luffing jib hangs down almost vertically

Only when the luffing jib **101** hangs down almost vertically (angle β at -85°):

- ▶ Continue to luff the main boom **100** down and keep the luffing jib **101** at an angle β of -85° by spooling the luffing jib control rope up until the hook block touches the ground. When doing so, do not let the guy rods **112** sag.
- ▶ Remove the hoist limit switch weight and reeve out the hook block, see chapter 4.06.



WARNING

Falling hoist rope!

If the hoist rope is not pulled with the respective length over the luffing jib end section after reeving the hook block out, it can fall backward due to its own weight.

Death, severe bodily injuries, property damage.

- ▶ The rope end must be pulled out at least 10 m over the luffing jib end section.
 - ▶ Monitor the behavior of the hoist rope during the take down procedure.
-
- ▶ Pull the rope end out at least 10 m over the luffing jib end section and take it down on the ground.

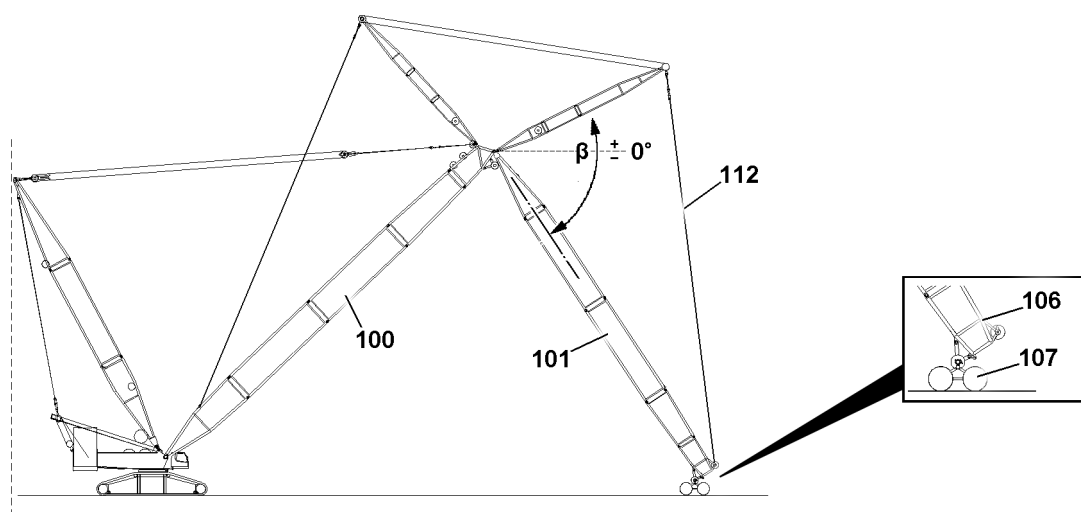

Fig.160391: Carrying out the take-down procedure

NOTICE

Overload of the roller cart!

If a vertically positioned luffing jib **101** is lowered onto the roller cart **107**, the roller cart **107** can be overloaded and collapse.

- ▶ Lower the luffing jib **101** with angle β -85° or smaller on the roller cart **107**.
 - ▶ Do not lower the luffing jib **101** with an angle β of -86° and above onto the roller cart **107**.
-
- ▶ Luff the main boom **100** down until the receptacles on the luffing jib end section **106** touch the receptacles of the roller cart **107**.
 - ▶ Assemble the roller cart **107** on the luffing jib end section **106**, see chapter 5.15 or 5.61.

**WARNING**

Overload of the crane or roller cart when taking the boom system down!

If the guy rods **112** are tensioned, the crane or the roller cart **107** carry too much boom weight. The forces on the boom system or the roller cart **107** become too high.

The crane or roller cart **107** can be overloaded.

Death, severe bodily injuries, property damage.

- ▶ When luffing the main boom down, spool the luffing jib control rope out such that the guy rods **112** sag slightly.
- ▶ Do not permit slack rope formation on the luffing jib control rope.

The roller cart **107** must move away from the crane in the direction of the boom:

- ▶ Continue to luff down the main boom **100** and simultaneously spool the luffing jib control rope out so that the guy rods **112** sag slightly.
- ▶ Luff the main boom **100** down until it is lying on the substructure on the ground.

**WARNING**

Danger of accident!

Personnel in the danger zone can be caught.

Death, severe bodily injuries, property damage.

- ▶ Make sure that no personnel is within the danger zone.
- ▶ Secure the hoist rope with the assembly rope and pull it back slowly over the rope pulleys in the WA-frames and lower it toward the connection point of the main boom **100** and the luffing jib **101**.

- ▶ Take the hoist rope down.

5.10 Boom nose lattice boom

1	Boom nose 120 t	3
2	Assembly	6
3	Erecting the boom	15
4	Operating the crane	15
5	Disassembly	16

Fig.195219

LWE/LR 13000-001/19503-01-02/en

1 Boom nose 120 t



Note

- The installation of the boom nose on the respective end section is only possible when at least one pulley set is installed on the respective end section.

The boom nose 1 is installed on the S- or L-end section.

1.1 Components boom nose

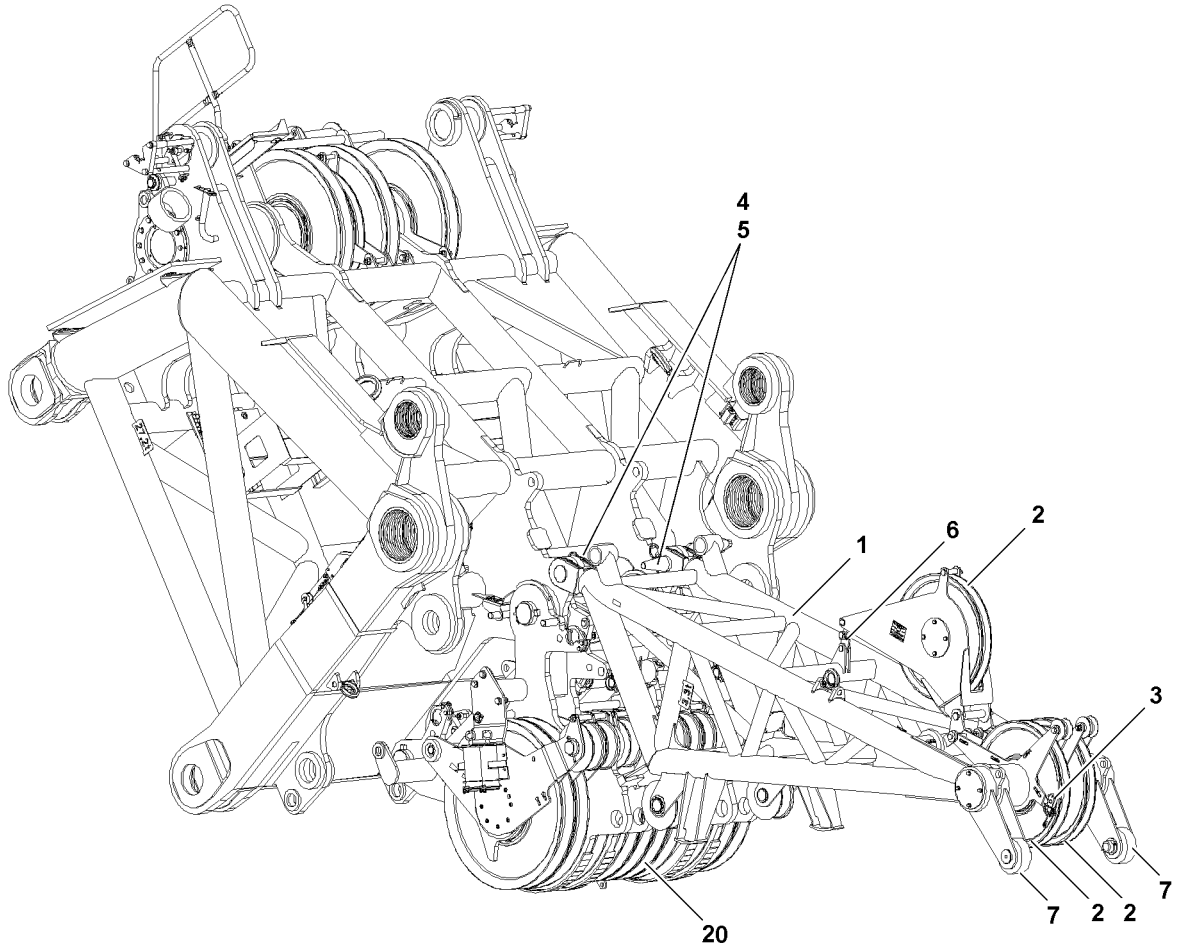

Fig.126401: Components boom nose

Position	Description	Weight
1	Boom nose 120 t	3.3 t
2	Rope pulley	—
3	Hoist limit switch	—
4	Pin	—
5	Spring retainer	—
6	Force test bracket	—

Position	Description	Weight
7	Track roller	—
20	Pulley set	—

1.2 Fastening points

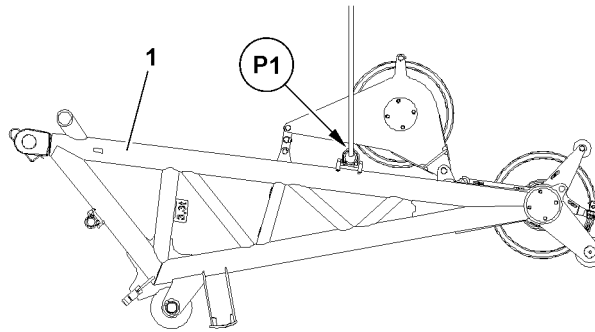

Fig.116183: Fastening points

Fastening points	
P1	For assembly



WARNING

Falling boom nose!

If the boom nose is not properly fastened on the ring brackets, then the boom nose can fall down. Death, severe bodily injuries, property damage.

- Always fasten the boom nose properly.

1.3 Installation possibilities of the boom nose



WARNING

The crane can topple over!

If an individual pulley set is installed off center on the end section, then the crane can be overloaded and topple over.

Death, severe bodily injuries, property damage.

- Install an individual pulley set always centered on the end section.

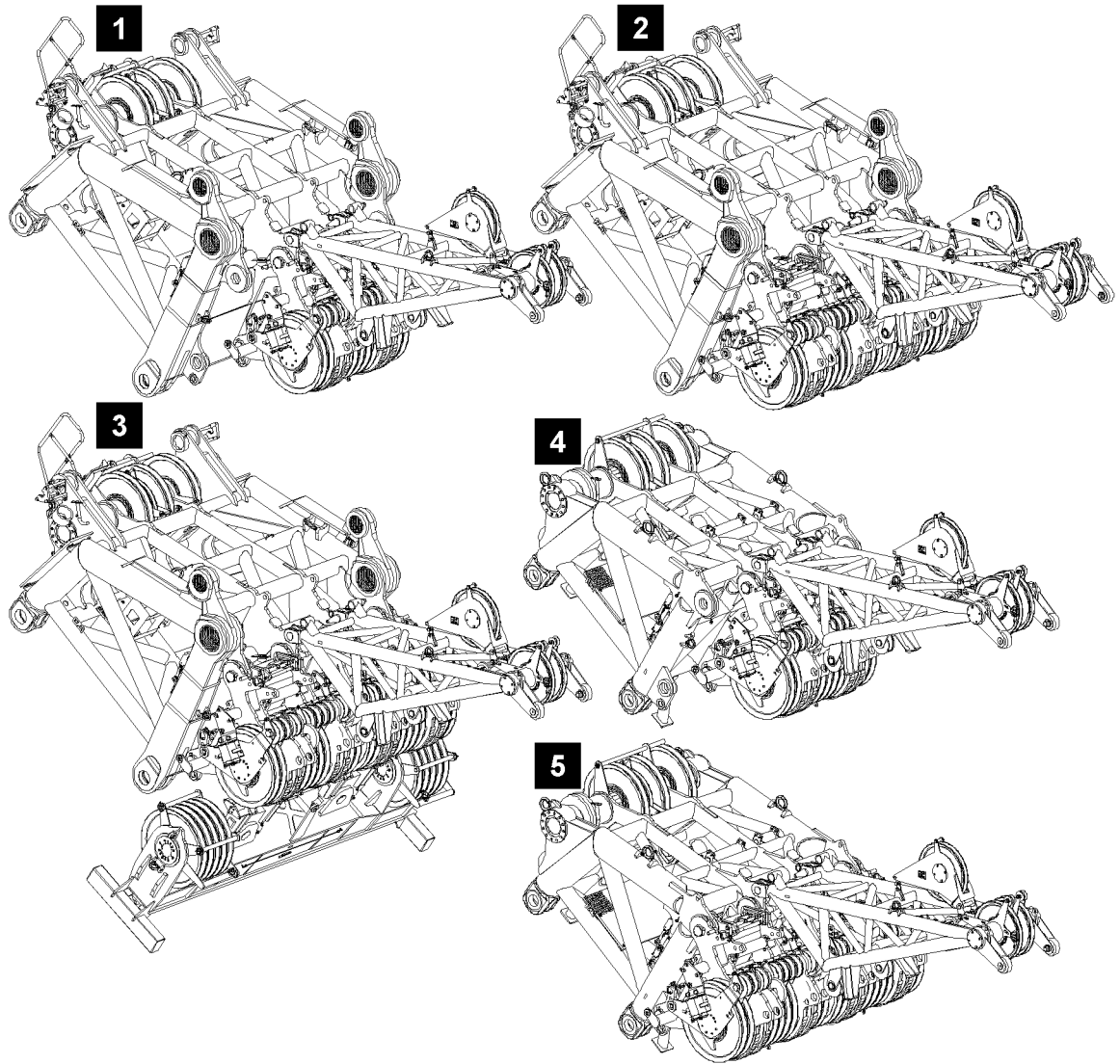

Fig.126402: Installation possibilities of the boom nose

Installation possibilities of the boom nose					
Illustration	End section		Pulley sets		Heavy load device
	S	L	1 ¹⁾	2	
1	X		X		
2	X			X	
3	X			X	X
4		X	X		
5		X		X	

1) Pulley set installed centered on the end section

LWE/LR 13000-001/19503-01-02/en

2 Assembly



WARNING

Danger of falling!

During assembly / disassembly, inspection and maintenance work, assembly personnel must be secured with appropriate aids to prevent them from falling.

Death, severe bodily injuries, property damage.

- ▶ All work aloft, where there is a danger of falling must be carried out with suitable aids.
- ▶ If aids are not available and work cannot be carried out from the ground, then the assembly personnel must secure themselves with the supplied fall arrest system to prevent falling, see Crane operating instructions, chapter 2.04.
- ▶ If fall protection equipment is available, then it must be used, see Crane operating instructions, chapter 2.06.
- ▶ When lifting, lowering, swinging crane parts in and out, no persons may remain in the danger zone.
- ▶ If railings are present on the components, then they must be brought into the corresponding position and secured for assembly / disassembly work!
- ▶ Only step on the aids, ladders and catwalks with clean shoes.
- ▶ Keep aids, ladders and catwalks free of heavy dirt, snow, frost and ice.
- ▶ During all assembly and disassembly work, maintenance work and inspections, travel or crane operation is prohibited.
- ▶ Remaining on a suspended load is prohibited.
- ▶ Stepping or walking on crane components and lattice sections, which have an incline of more than 20° is prohibited.
- ▶ For all assembly work, the crane operator of the main crane must be in voice contact with the crane operator / crane operators of the auxiliary crane / auxiliary cranes.
- ▶ For assembly / disassembly tasks, the crane operator may only initiate crane movements when the responsible guide has explicitly released the movement.



WARNING

Falling components!

If unsecured or non-supported components are assembled or disassembled, they can fall down.

Death, severe bodily injuries, property damage.

- ▶ During pinning and unpinning of the lattice sections, it is prohibited for anyone to remain **under** or **on** the components as well as within the entire danger zone.
- ▶ Support the boom and components before pinning / unpinning.
- ▶ Pin or unpin both pins laying in a horizontal, i.e. **left** and **right**.
- ▶ Secure the pins in the storage locations and in the receptacles.
- ▶ Do not disengage the auxiliary crane until the respective component is pinned and secured.
- ▶ It is prohibited to lean a ladder against the component being disassembled.



WARNING

Danger of impact / crushing!

When installing / removing crane components with the auxiliary crane, crane components can start to swing back and forth.

When lifting / lowering and positioning crane components, there is an increased danger of impacts / crushing.

Death, severe bodily injuries, property damage.

- ▶ Make sure that personnel cannot be caught by components.
- ▶ Make sure that the crane is horizontally aligned.
- ▶ When working in danger zones: Use aids to protect limbs.
- ▶ Guide components with suitable aids to minimize oscillation.

**DANGER**

The components can fall down!

If the corresponding component is disengaged from the auxiliary crane before the corresponding component is pinned, then the corresponding component can fall down.

Death, severe bodily injuries, property damage.

- ▶ Do not disengage the auxiliary crane until the corresponding component is pinned and secured.

**WARNING**

The crane can topple over!

Death, severe bodily injuries, property damage.

- ▶ The turntable may not be turned during the assembly of the boom.

2.1 Exceeding the shut off limits of the LICCON overload protection for assembly operation

**WARNING**

Danger of accident due to function „Exceedance of shut off limits of the LICCON overload protection“! If the shut off limits of the LICCON overload protection are exceeded, there is no additional protection against crane overload.

Due to erroneous operation or deliberate misuse, the crane could collapse, the boom can break off or the crane can topple over.

Death, severe bodily injuries, property damage.

- ▶ The function „Exceedance of shut off limits of the LICCON overload protection“ is only permissible in emergencies and for assembly purposes.
- ▶ The function „Exceeding the shut off limits of the LICCON overload protection“ may only be actuated by persons who know the effects of their actions regarding the function „Exceeding the shut off limits of the LICCON overload protection“.
- ▶ The function „Exceedance of shut off limits of the LICCON overload protection“ requires the presence of an authorized person and must be performed with utmost caution.
- ▶ Crane operation with activated function „Exceedance of shut off limits of the LICCON overload protection“ is prohibited.

- ▶ Exceeding the shut off limits of the LICCON overload protection: Engage assembly operation.

Result:

- The shut off limits of the LICCON overload protection are exceeded.
- The assembly icon appears on the LICCON monitor.

**Note**

- ▶ See Crane operating instructions, chapter 4.02.

2.2 Assembly prerequisites for boom nose(s)

Make sure that the following prerequisites are met:

- The crane is aligned in horizontal direction.
- The boom including the respective end section are installed.
- The central ballast has been installed on the crawler travel gear according to the load chart or the erection and take down chart.
- The counterweight is installed on the turntable according to the load chart or the erection and take down chart.
- The derrick ballast has been installed on the crane according to the load chart or the erection and take down chart.
- The LICCON overload protection has been set according to the data in the load chart.
- The shut off limits of the LICCON overload protection are exceeded.
- The assembly icon is visible on the LICCON monitor.
- An auxiliary crane is available.

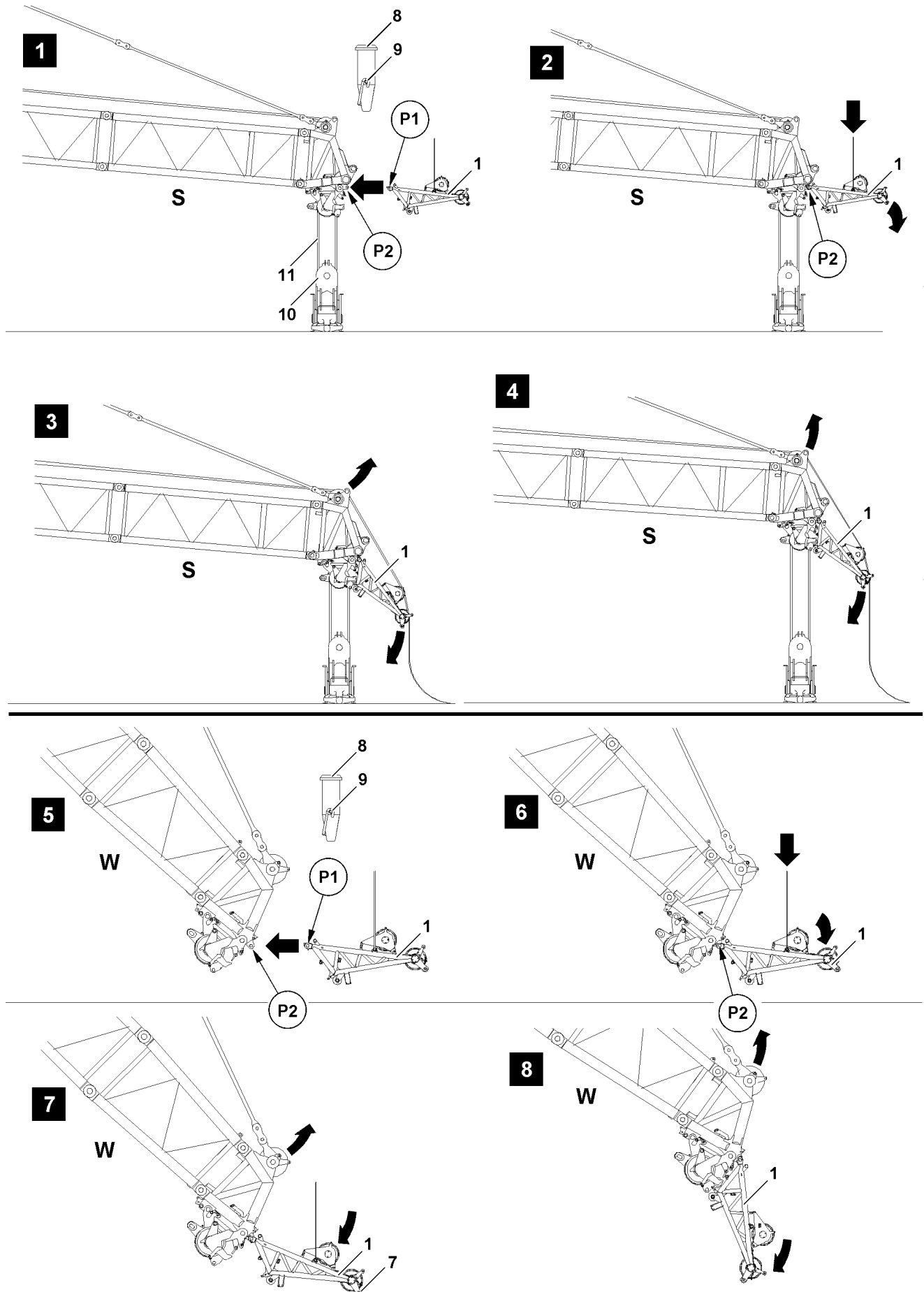

Fig.116187

2.3 Assembly procedure

Make sure that the following prerequisites are met:

- Winch 1 is properly reeved on the pulley set / the pulley sets on the S- or L-end section.
- **SDB / SLDB operation:** The S / SL-boom is lifted off the ground, illustration 1
- **SDWB operation:** The W-boom is lifted off the pulley cart illustration 5
- ▶ Attach the boom nose 1 on the auxiliary crane, see section „Fastening points“.
- ▶ Swing the boom nose in with the auxiliary crane to the pin points on the end section.

When the pin points align:

- ▶ Pin the boom nose on the end section: Insert the pin 4 on the end section at point **P2** on both sides and secure with spring retainer 5.

When the boom nose is properly pinned and secured on the end section:

- ▶ Lower the boom nose 1 with the auxiliary crane until the lower placement surfaces are placed on the pulley set **or** the boom nose is laying on the ground with the track rollers.

When the boom nose is laying on the ground with the track rollers:

- ▶ Erect the boom slowly until the boom nose lifts off the ground.

When the lower placement surfaces of the boom nose are touching on the pulley set / the pulley sets:

- ▶ Pull the hoist rope over the rope pulleys 2 and reeve in the hook block, pay attention to the reeving plan.

2.4 Reeving in the hoist rope with the telescopic lift truck



WARNING

Falling hoist rope!

If the hoist rope is not properly secured with a corresponding length on the boom nose before the erection procedure, then it can fall backward due to its own weight.

Death, severe bodily injuries, property damage.

- ▶ Reeve in the hoist rope with sufficient length on the boom nose before the erection process.
- ▶ The hoist rope must be constantly monitored during erection.
- ▶ Do not step into the danger zone.

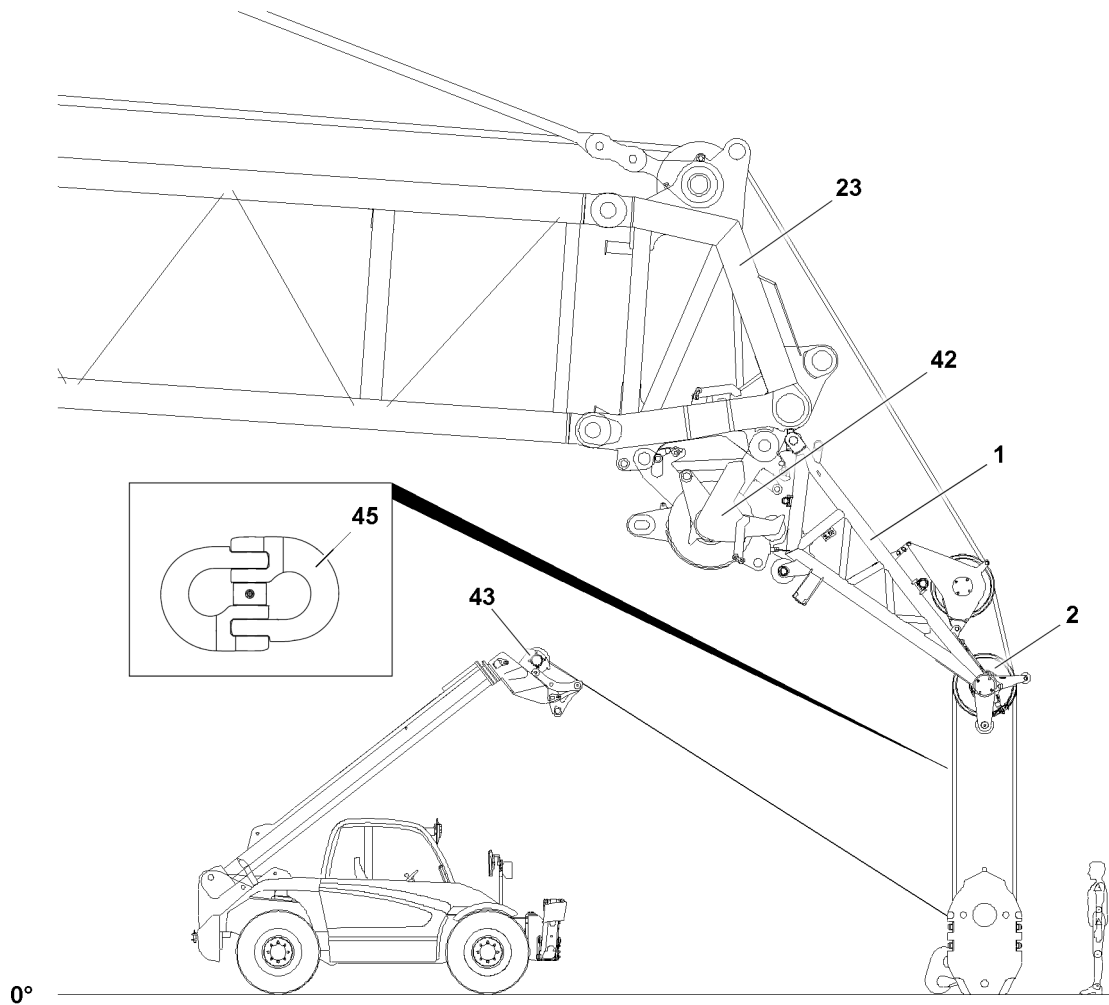

Fig.126400: Reeving in the hook block with the telescopic lift truck



WARNING

Danger of accident!

When using **non-approved** connecting links **45** when reeving in / out the hoist rope, the connecting links **45** can rip off suddenly.

Death, severe bodily injuries, property damage.

- ▶ Make sure than only original connector links are used between the auxiliary winch and the hoist rope.
- ▶ Make sure that the proper pressure stage is set on the auxiliary winch of the telescopic lift truck for the reeving in / out of the respective hoist rope, see the separate operating instructions for the „assembly winch“.
- ▶ Make sure that the connector links **45** between the auxiliary winch and the hoist rope have a higher load capacity than can be created by the maximum strand pull of the respective auxiliary winch.
- ▶ The strand pull of the auxiliary winches installed on the crane side is **not** identical with the strand pull of the auxiliary winch of the telescopic lift truck.

Connecting link / Description	Load capacity	Use for hoist rope diameter
CW8	2.5 t	38 mm
CWP10	5.0 t	52 mm

**Note**

Reeving in the hoist rope with telescopic lift truck.

- ▶ Reeving up to maximum 20-fold can be realized with one rope length on the telescopic lift truck.
- ▶ For higher reeving, reeve in 20-fold first and then the remainder.

Make sure that the following prerequisites are met:

- The pulley set / the pulley sets **42** are properly installed and secured on the S-end section **23**.
- The hook block **44** is properly positioned and aligned under the S-end section **23**.
- The telescopic lift truck is properly positioned under the boom system.

**Note**

- ▶ For the operation of the auxiliary winch **43** on the telescopic lift truck, see the separate Operating instructions of the manufacturer.

- ▶ Spool the rope of the auxiliary winch **43** out.
- ▶ Guide the rope of the auxiliary winch **43** in reverse order to the actual hoist rope reeving through the respective rope pulleys on the hook block **44** and the end section **23**.
- ▶ Fasten the rope of the auxiliary winch **43** properly on the take-in device of the hoist rope by using the connector link **45**.

NOTICE

Danger of slack rope formation!

By spooling the hoist winch out too fast during the reeving procedure, slack rope can form.

- ▶ Make sure that the hoist rope is tensioned during the entire reeving procedure.
- ▶ Reeve in the hoist rope: Spool the auxiliary winch **43** up and simultaneously spool out the hoist rope from the respective winch.

When the hoist rope is properly reeved:

- ▶ Fasten the hoist rope on the rope fixed point, see Crane operating instructions, chapter 4.06 and the separate reeving plan.

2.5 Establishing the electrical connections

NOTICE

Damage to the electrical connection on the cable drum!

If the electrical connection from the cable drum on the S-pivot section to the terminal box on the S-pivot section is established first before the connection to the terminal box on the respective end section, the electrical connection can be damaged when spooling out the cable drum.

- ▶ Establish first the electrical connection from the cable drum in the S-pivot section to the terminal box on the respective end section and then the electrical connection from the terminal box in the S-pivot section to the cable drum in the S-pivot section.
- ▶ Establish the electrical connections from the S-end section to the W-boom properly.

**Note**

- ▶ To establish the electrical connections, use the electrical wiring diagram.

Make sure that the following prerequisites are met:

- The boom / the boom system is completely assembled.
- The airplane warning light and the wind speed sensor are assembled.
- ▶ Establish the electrical connections.
- ▶ Make sure that all electrical connections on the boom are properly established.

2.6 Function check



WARNING

Non-functioning safety equipment!
Death, severe bodily injuries, property damage.

- ▶ Crane operation with non-functioning safety equipment is **prohibited**.



Note

- ▶ The function of the individual limit switches must be checked before erection.
- ▶ The function of the limit switch initiators must be checked in the test system, see Diagnostics manual.



Note

- ▶ If a function check on the limit switches or on the safety equipment does not lead to the desired shut offs, then the plug connections on the terminal boxes or the components itself must be checked.
- ▶ If no visible connection errors or component defects can be found, contact **LIEBHERR** Service.

Make sure that the following prerequisites are met:

- All electrical connections have been made.
- At least one crane engine is running.
- The corresponding operating mode is set on the LICCON monitor.

2.6.1 Checking the wind speed sensor

- ▶ Check the movement and the function of the wind speed sensor.

2.6.2 Checking the airplane warning light

- ▶ Turn the airplane warning light on.
- ▶ Check the function visually.

2.6.3 Checking the hoist limit switch on the pulley head



Note

- ▶ When replacing or changing a hoist limit switch (HES), the corresponding hoist limit switch must have the correct bus address and the correct software version in order to be detected again by the bus system (LSB).

- ▶ Actuate the hoist limit switch manually on the pulley head.

Result:

- The spool up function of the hoist winch turns off.
- The icon „Hoist top“ appears on the LICCON monitor 0.
- The limit switch is functioning.

2.6.4 Checking the limit switch on the S-boom



Note

- ▶ The limit switch functions „steep position“ and „lowest position“ must be checked individually before erection, see Crane operating instructions, chapter 8.12.

- ▶ Check the limit switch actuators.

2.6.5 Checking the limit switch on the W-boom



Note

- ▶ The limit switch functions „steep position“ and „lowest position“ must be checked individually before erection, see Crane operating instructions, chapter 8.12.
-
- ▶ Check the limit switch actuators.

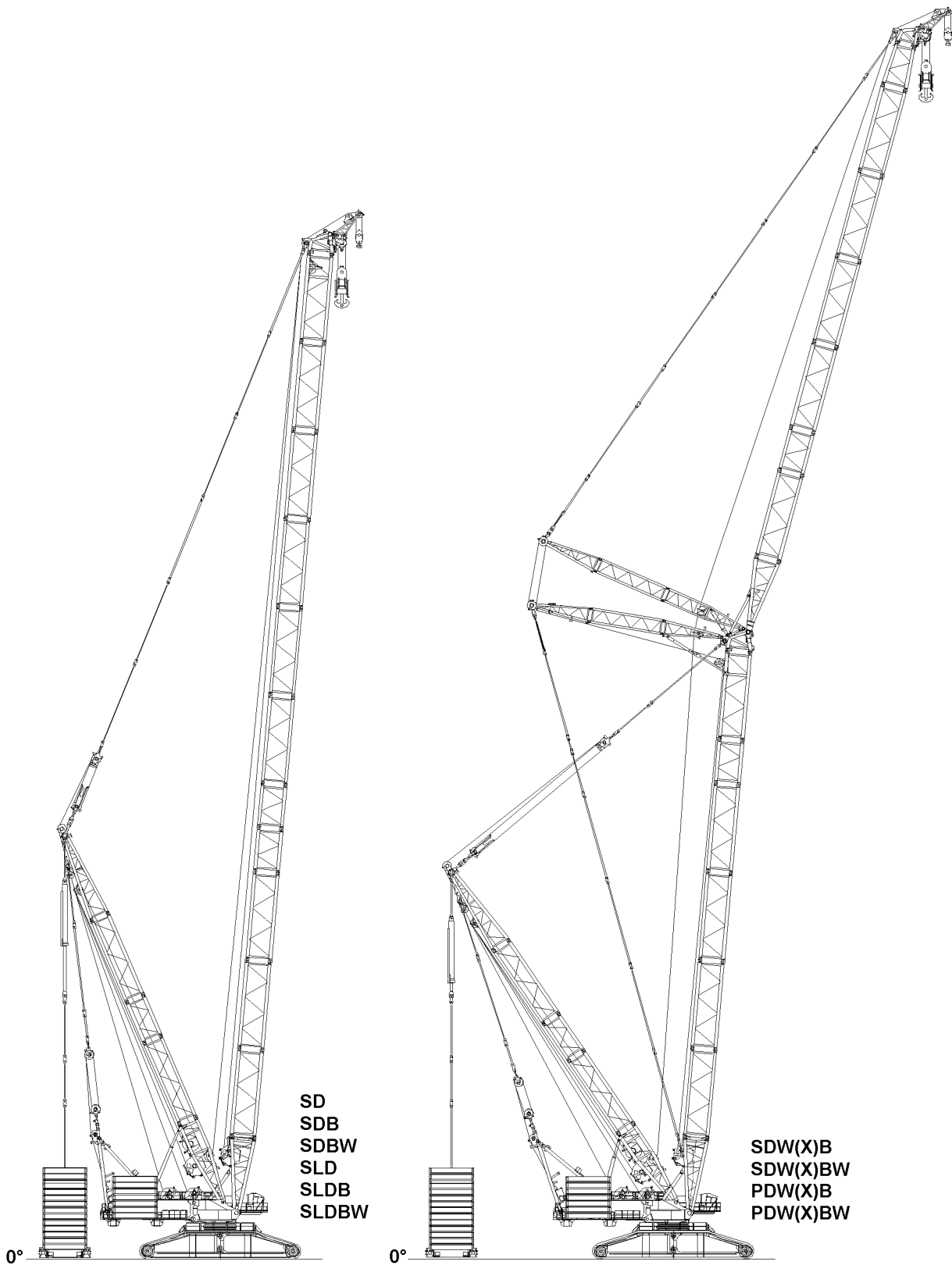

Fig.116185: (X) = Boom variation

LWE/LR 13000-001/19503-01-02/en

3 Erecting the boom



DANGER

The crane can topple over!

If the following conditions are not met before erecting the boom, the crane can topple over. Death, severe bodily injuries, property damage.

- ▶ Observe and adhere to the technical safety instructions, see Crane operating instructions, chapter 5.01.
- ▶ Observe the specifications in the erection and take down charts.
- ▶ Extend the relapse cylinder before erection.

Make sure that the following prerequisites are met:

- The shut off limits of the LICCON overload protection are exceeded.
- The assembly icon is visible on the LICCON monitor.

3.1 Erection



WARNING

The crane can topple over!

In crane operation with exceeded LICCON overload protection, the crane can topple over. Death, severe bodily injuries, property damage.

- ▶ The radii listed in the load chart may not be exceeded or fallen below, even if there is no load on the hook.



Note

- ▶ When the lowest operating position of the boom is reached, the LICCON overload protection is activated.
- ▶ In the maximum load icon appears a load number in „t“ instead of the display „???“.
- ▶ Luff the S-boom up to the lowest operating position.
- ▶ When the boom has reached the lowest operating position: Make sure that the assembly icon on the LICCON monitor turns off.

Result:

- The LICCON overload protection is active.

4 Operating the crane

4.1 Preparing for crane operation



Note

- ▶ Observe the notes, see Crane operating instructions, chapter 4.02, chapter 4.04, chapter 4.05, chapter 4.08 and chapter 5.01.

Make sure that the following prerequisites are met:

- The LICCON overload protection is active.
- The LICCON overload protection has been set according to the data in the load chart.



WARNING

The crane can topple over!

- ▶ Check the horizontal position of the crane before and during operation.
- ▶ If the crane operator leaves the cab, even for a short time, the operating mode setting must be checked and reset if necessary before resuming crane operation.

4.1.1 Checking the settings

- ▶ Check the function of the overload protection by running against the operating positions „on top“ and „bottom“.
- ▶ Check the hoist limit switch by running against the hoist limit switch weight.
- ▶ Check the function of the limit switches „Boom steep“ on the relapse cylinders.
- ▶ Check the function of the force test bracket on the boom nose.

5 Disassembly



WARNING

Danger of falling!

During assembly / disassembly, inspection and maintenance work, assembly personnel must be secured with appropriate aids to prevent them from falling.

Death, severe bodily injuries, property damage.

- ▶ All work aloft, where there is a danger of falling must be carried out with suitable aids.
- ▶ If aids are not available and work cannot be carried out from the ground, then the assembly personnel must secure themselves with the supplied fall arrest system to prevent falling, see Crane operating instructions, chapter 2.04.
- ▶ If fall protection equipment is available, then it must be used, see Crane operating instructions, chapter 2.06.
- ▶ When lifting, lowering, swinging crane parts in and out, no persons may remain in the danger zone.
- ▶ If railings are present on the components, then they must be brought into the corresponding position and secured for assembly / disassembly work!
- ▶ Only step on the aids, ladders and catwalks with clean shoes.
- ▶ Keep aids, ladders and catwalks free of heavy dirt, snow, frost and ice.
- ▶ During all assembly and disassembly work, maintenance work and inspections, travel or crane operation is prohibited.
- ▶ Remaining on a suspended load is prohibited.
- ▶ Stepping or walking on crane components and lattice sections, which have an incline of more than 20° is prohibited.
- ▶ For all assembly work, the crane operator of the main crane must be in voice contact with the crane operator / crane operators of the auxiliary crane / auxiliary cranes.
- ▶ For assembly / disassembly tasks, the crane operator may only initiate crane movements when the responsible guide has explicitly released the movement.



WARNING

Falling components!

If unsecured or non-supported components are assembled or disassembled, they can fall down.

Death, severe bodily injuries, property damage.

- ▶ During pinning and unpinning of the lattice sections, it is prohibited for anyone to remain **under** or **on** the components as well as within the entire danger zone.
- ▶ Support the boom and components before pinning / unpinning.
- ▶ Pin or unpin both pins laying in a horizontal, i.e. **left** and **right**.
- ▶ Secure the pins in the storage locations and in the receptacles.
- ▶ Do not disengage the auxiliary crane until the respective component is pinned and secured.
- ▶ It is prohibited to lean a ladder against the component being disassembled.

**WARNING**

Danger of impact / crushing!

When installing / removing crane components with the auxiliary crane, crane components can start to swing back and forth.

When lifting / lowering and positioning crane components, there is an increased danger of impacts / crushing.

Death, severe bodily injuries, property damage.

- ▶ Make sure that personnel cannot be caught by components.
- ▶ Make sure that the crane is horizontally aligned.
- ▶ When working in danger zones: Use aids to protect limbs.
- ▶ Guide components with suitable aids to minimize oscillation.

**DANGER**

The components can fall down!

Death, severe bodily injuries, property damage.

- ▶ Do not disengage the auxiliary crane until the corresponding component is pinned and secured.

**WARNING**

The crane can topple over!

Death, severe bodily injuries, property damage.

- ▶ The turntable may not be turned during the assembly of the boom.

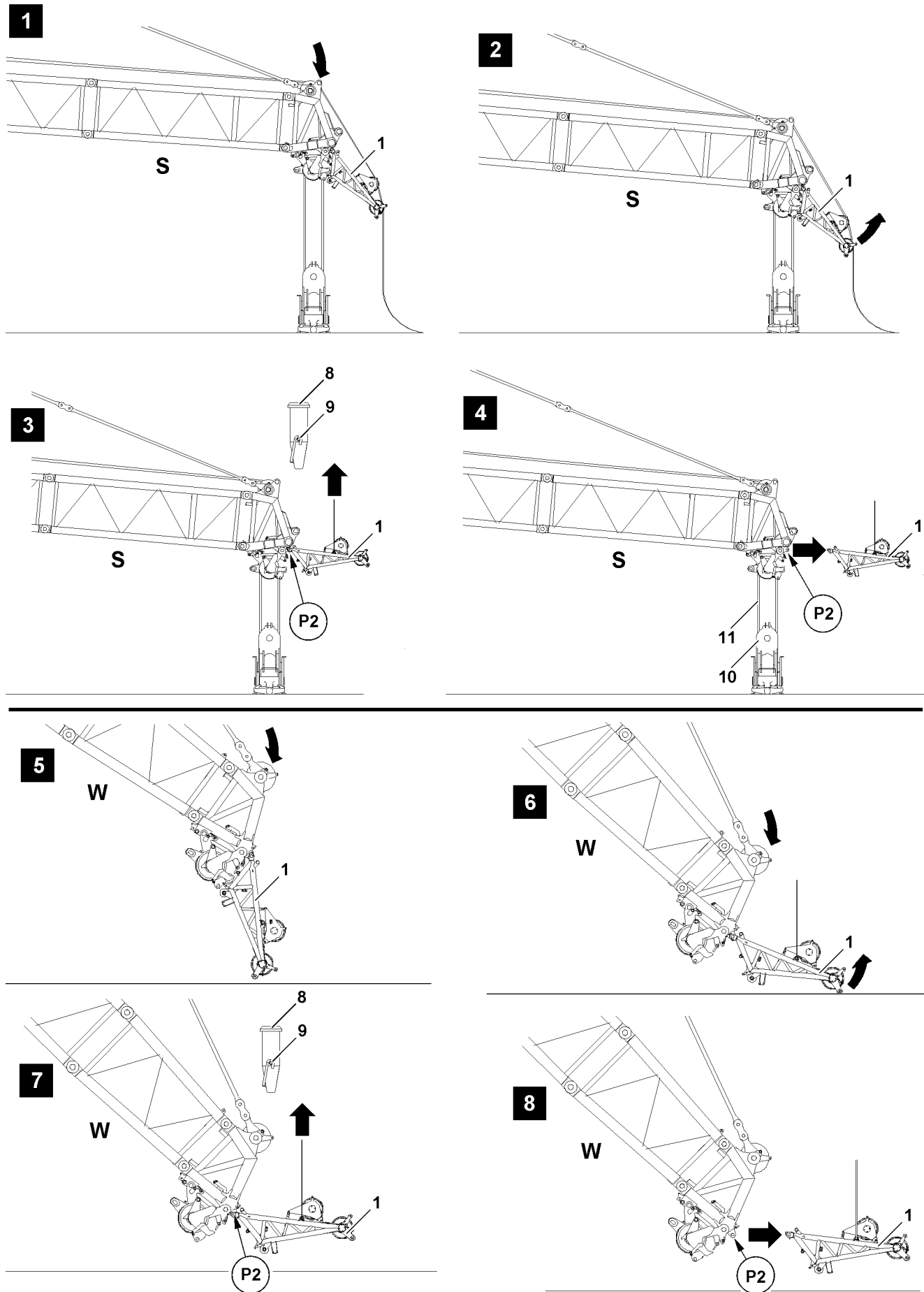

Fig.116301

LWE/LR 13000-001/19503-01-02/en

5.1 Luffing the boom down



DANGER

The crane can topple over!

If the following conditions are not met before taking down the boom, the crane can topple over. Death, severe bodily injuries, property damage.

- ▶ Observe and adhere to the technical safety instructions, see Crane operating instructions, chapter 5.01.
- ▶ Observe the specifications in the erection and take down charts.

NOTICE

Damage of boom components!

Taking down the boom system can lead to a collision between the hook block and the pulley head.

Boom components can be severely damaged.

- ▶ Luff the boom system down at the same time and spool the hoist winch(es) out.



WARNING

The crane can topple over!

If the danger notes for take down of the boom or the boom systems in the following chapters are not observed, then the crane can topple over.

Death, severe bodily injuries, property damage.

Boom nose assembled on the end section:

- ▶ Observe and adhere to the danger notes in the Crane operating instructions, chapter 5.07 and chapter 5.39.
- ▶ Observe and adhere to the Erection and take down charts.
- ▶ Luff down the boom.

5.2 Exceeding the shut off limits of the LICCON overload protection for assembly operation



WARNING

Danger of accident due to function „Exceedance of shut off limits of the LICCON overload protection“! If the shut off limits of the LICCON overload protection are exceeded, there is no additional protection against crane overload.

Due to erroneous operation or deliberate misuse, the crane could collapse, the boom can break off or the crane can topple over.

Death, severe bodily injuries, property damage.

- ▶ The function „Exceedance of shut off limits of the LICCON overload protection“ is only permissible in emergencies and for assembly purposes.
- ▶ The function „Exceeding the shut off limits of the LICCON overload protection“ may only be actuated by persons who know the effects of their actions regarding the function „Exceeding the shut off limits of the LICCON overload protection“.
- ▶ The function „Exceedance of shut off limits of the LICCON overload protection“ requires the presence of an authorized person and must be performed with utmost caution.
- ▶ Crane operation with activated function „Exceedance of shut off limits of the LICCON overload protection“ is prohibited.

- ▶ Exceeding the shut off limits of the LICCON overload protection: Engage assembly operation.

Result:

- The shut off limits of the LICCON overload protection are exceeded.
- The assembly icon appears on the LICCON monitor.



Note

- ▶ See Crane operating instructions, chapter 4.02.

- ▶ Luff the boom down until hook block touches the ground.
- ▶ Remove the hoist limit switch weight and unreeve the hook block.
- ▶ Continue to luff the boom down until the boom nose is just above the ground.

When the boom nose is just above the ground:

- ▶ Remove the hoist rope.

5.3 Disconnecting the electrical connections

NOTICE

Damage to the electrical connections on the cable drum!

If the electrical connection from the cable drum on the S-pivot section to the terminal box on the respective end section is disconnected and spooled up, then the electrical connection from the cable drum to the terminal box on the S-pivot section can be damaged.

- ▶ Disconnect the electrical connection from the cable drum to the terminal box on the S-pivot section first and then the electrical connection from the terminal box to the respective end section.
-
- ▶ Store the cable from the terminal box on the S-pivot section properly.
 - ▶ Spool the cable drum up and secure it to prevent inadvertent spooling out.

5.4 Removing the boom nose

NOTICE

Danger of property damage!

If the W-boom is placed on the ground for disassembly, then the boom system or the boom nose can be damaged.

- ▶ The W-boom may only be placed on the pulley cart when the boom nose is already removed.



Note

- ▶ Observe the description for disassembly of the hoist limit switch weight and the hook block, see Crane operating instructions, chapter 4.06.

NOTICE

The boom nose fork connection can automatically fold out when luffing the boom system down.

If the boom is luffed down at excessive speed, the boom nose can be damaged.

- ▶ Luff the boom down carefully and at slow speed.

Make sure that the following prerequisites are met:

- the hoist rope has been reeved out
- The electrical connections are properly disconnected.

- ▶ Luff the boom down carefully.

When the boom nose is just above the ground:

- ▶ Attach the boom nose **1** on the auxiliary crane, see section „Fastening points“.
- ▶ Tension the fastening equipment.

When the fastening equipment is tensioned:

- ▶ Release the spring retainer **5** and unpin the pin **4** on the end section on both sides.
- ▶ Remove the boom nose with the auxiliary crane and place it down outside the working range.
- ▶ Remove the auxiliary crane from the boom nose.

5.14 Roller set

1	Fastening points	3
2	Boom configuration	5
3	Installing pulley set / pulley sets	7
4	Heavy load device*	25
5	Removing the pulley set / pulley sets	33

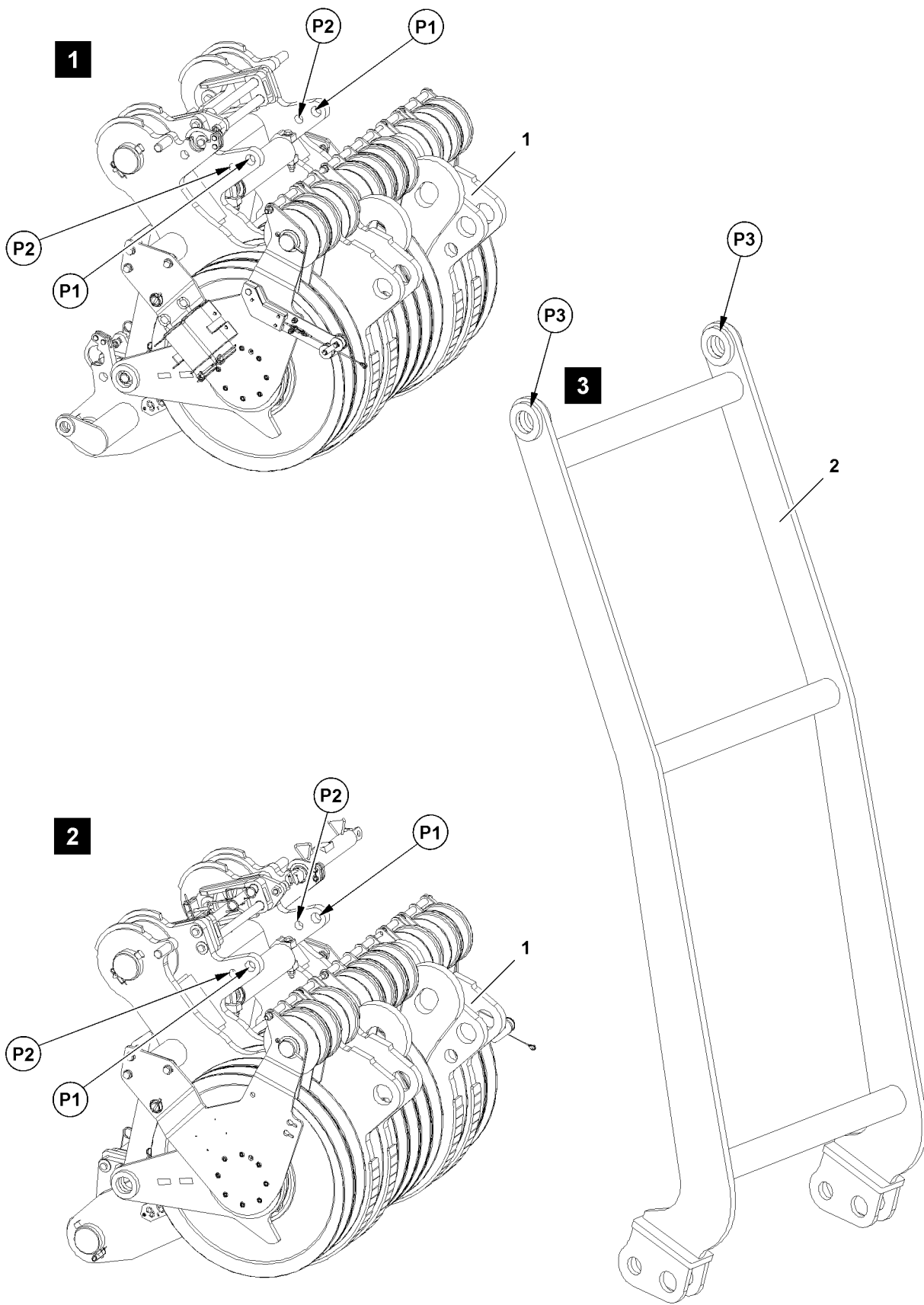

Fig.115912

LWE/LR 13000-001/19503-01-02/en

1 Fastening points

NOTICE

Danger of property damage!

If unsuitable fastening equipment is used for the transport or the assembly of the pulley sets, there is the danger that the fastening points (points **P1** and points **P2**) are distorted and damaged!

The assembly cross bar **2** may then no longer be usable!

- ▶ Make sure that the pulley sets are always properly fastened for transport, for example with shackles.
- ▶ Make sure that only the assembly cross bar **2** is used for the assembly of the pulley sets on the S- or L-end section.

1.1 Fastening points pulley set right, illustration 1

Fastening points	
P1	For loading / unloading procedures
(P1 + P2) ¹⁾	For assembly on the S- or L-end section

1) Only in connection with the assembly cross bar

1.2 Fastening points pulley set left, illustration 2

Fastening points	
P1	For loading / unloading procedures
(P1 + P2) ¹⁾	For assembly on the S- or L-end section

1) Only in connection with the assembly cross bar

1.3 Fastening points assembly cross bar, illustration 3

Fastening points	
P3	For the assembly of the pulley sets on the respective end section

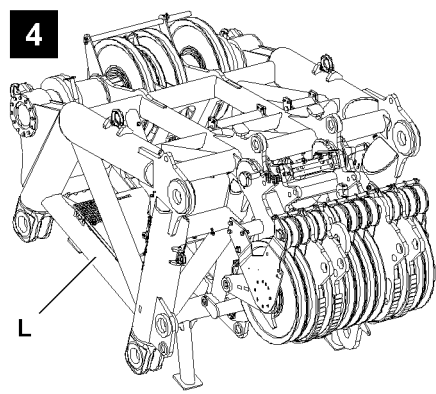
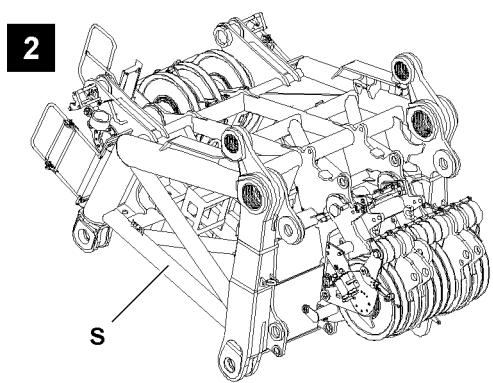
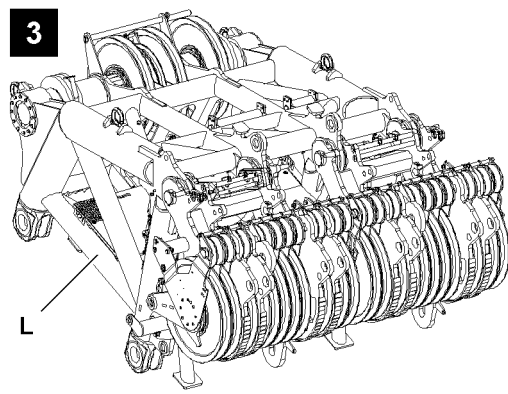
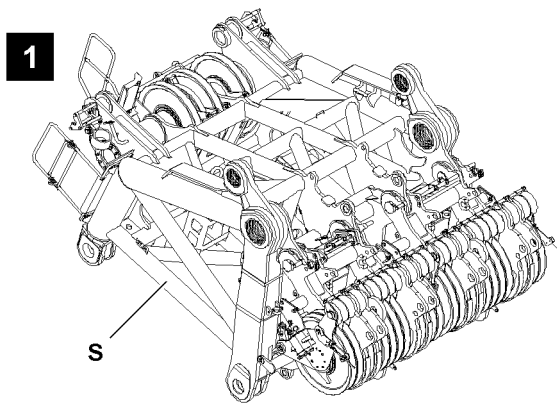

Fig.115909

LWE/LR 13000-001/19503-01-02/en

2 Boom configuration



WARNING

Load capacity reduction!

For the installation of an additional pulley set - in reference to the following operating modes, the value in the load chart is reduced by the own weight of this pulley set!

For the installation of the heavy load device - in reference to the following operating modes, the value in the load chart is reduced by the own weight of the heavy load device!

Personnel can be severely injured or killed!

- ▶ Select the number of pulley sets according to the operating modes.
- ▶ Observe the Erection and take down charts.
- ▶ Observe the load charts.

Boom	Operating modes	Boom head	Number of pulley sets
S without auxiliary boom	SD SDB0 SDB SDBW	S	2
S with auxiliary boom	SDWB SDWBW	S	0
P without auxiliary boom	PDB PDBW	S	2
P with auxiliary boom	PDW3B PDW3BW	S	0
SL	SLD SLDB0 SLDB SLDBW	L	1
W W2 W3	SDWB SDWBW SDW2B PDW3B PDW3BW	L	1

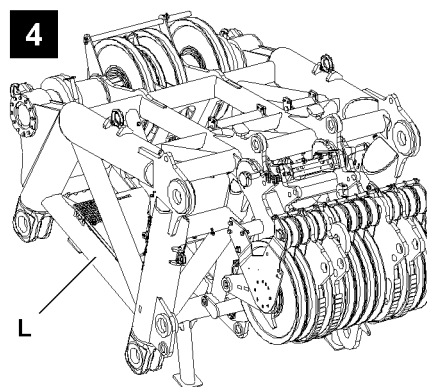
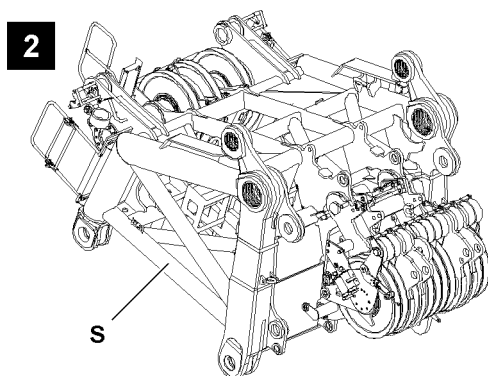
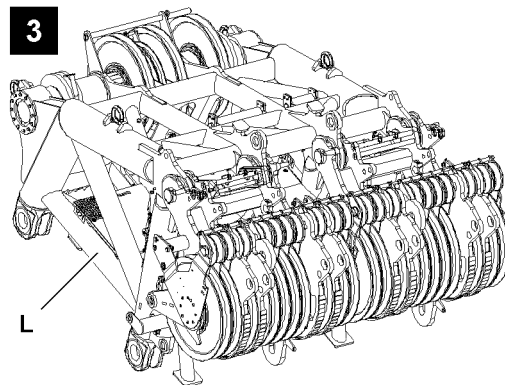
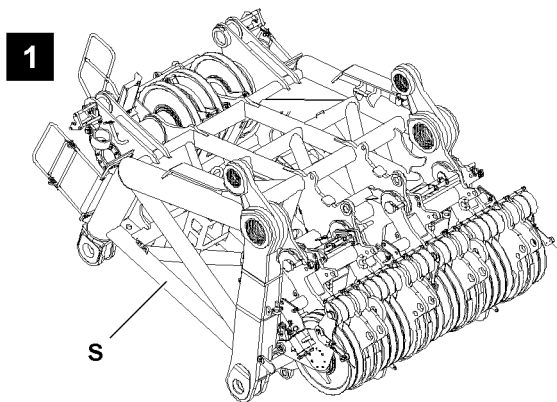

Fig.115909

LWE/LR 13000-001/19503-01-02/en

3 Installing pulley set / pulley sets



Note

- ▶ The assembly of the pulley sets is described on the example of the S-end section!



WARNING

Danger of falling!

During assembly / disassembly, inspection and maintenance work, personnel must be secured with appropriate aids to prevent them from falling!

If this is not observed, assembly personnel could fall and suffer life-threatening or fatal injuries!

- ▶ All work aloft, where there is a danger of falling must be carried out with suitable aids!
- ▶ If aids are not available and work cannot be carried out from the ground, then the assembly personnel must secure themselves with the supplied fall arrest system to prevent falling, see Crane operating instructions, chapter 2.04.
- ▶ If fall protection equipment is available, then it must be used, see Crane operating instructions, chapter 2.06!
- ▶ When lifting, lowering, swinging crane parts in and out, no persons may remain in the danger zone.
- ▶ If railings are present on the components, then they must be brought into the corresponding position and secured for assembly / disassembly work!
- ▶ Only step on the aids, ladders and catwalks with clean shoes!
- ▶ Keep aids, ladders and catwalks free of heavy dirt, snow and ice!
- ▶ During all assembly and disassembly work, maintenance work and inspections, travel or crane operation is prohibited!
- ▶ Remaining on a suspended load is prohibited!
- ▶ Stepping or walking on crane components and lattice sections, which have an incline of more than 20° is prohibited!
- ▶ For all assembly work, the crane operator of the main crane must be in voice contact with the crane operator / crane operators of the auxiliary crane / auxiliary cranes!
- ▶ For assembly / disassembly tasks, the crane operator may only initiate crane movements when the responsible guide has explicitly released the movement!

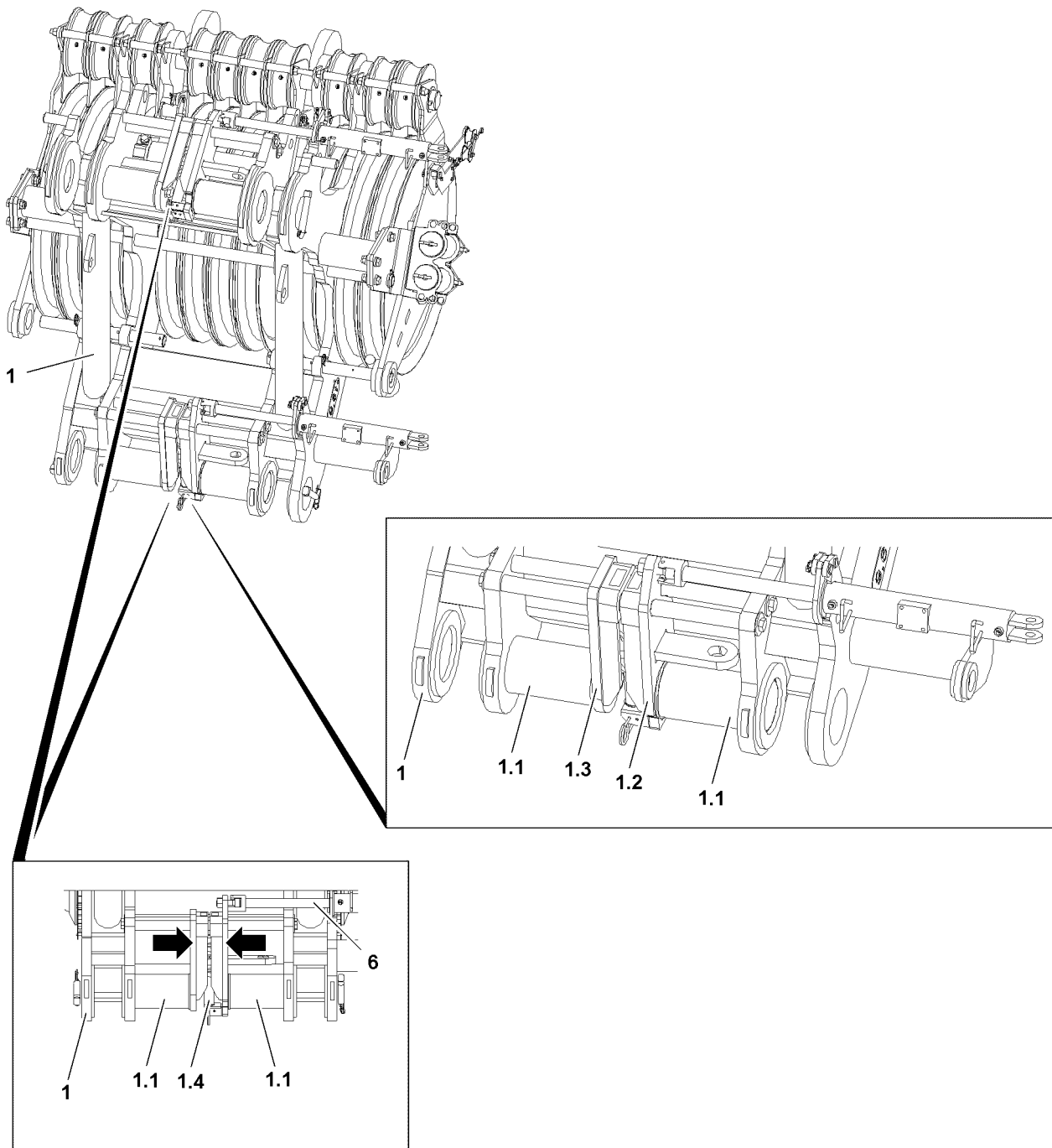

Fig.115913

LWE/LR 13000-001/19503-01-02/en

**WARNING**

Falling pulley sets!

If the pulley sets are not pinned and secured correctly, then they can fall down and fatally injure personnel!

- ▶ Pin or unpin both pins at the same horizontal level, i.e. **left and right!**
- ▶ Do not stand under the pulley sets or within the complete danger zone during the pinning and unpinning procedure of the pulley sets!
- ▶ Safely secure the pins in the bearing points as well as receptacles!
- ▶ It is prohibited to lean the ladder against the component being disassembled!

**WARNING**

Danger of impact / crushing!

When installing / removing crane components with the auxiliary crane, crane components can start to swing back and forth!

When lifting / lowering and positioning crane components, there is an increased danger of impacts / crushing!

Personnel can be caught and severely injured or killed!

- ▶ Make sure that personnel cannot be caught by components.
- ▶ Make sure that the crane is horizontally aligned.
- ▶ When working in danger zones: Use aids to protect limbs.
- ▶ Guide components with suitable aids to minimize oscillation.

**DANGER**

The components can fall down!

If the corresponding components are disengaged from the auxiliary crane before the corresponding component is pinned, the corresponding component can fall down and fatally injure personnel!

- ▶ Do not disengage the auxiliary crane until the corresponding component is pinned and secured.

Make sure that the following prerequisites are met:

- An auxiliary crane with sufficient load carrying capacity is available.
- An assembly scaffolding / a work platform is available.
- The pin pulling devices - slides **1.2** and slides **1.3** - are „moved together“ centered to stop and secured with retaining pins **1.4**.
- The end section are approx. 2.00 mm above the ground.

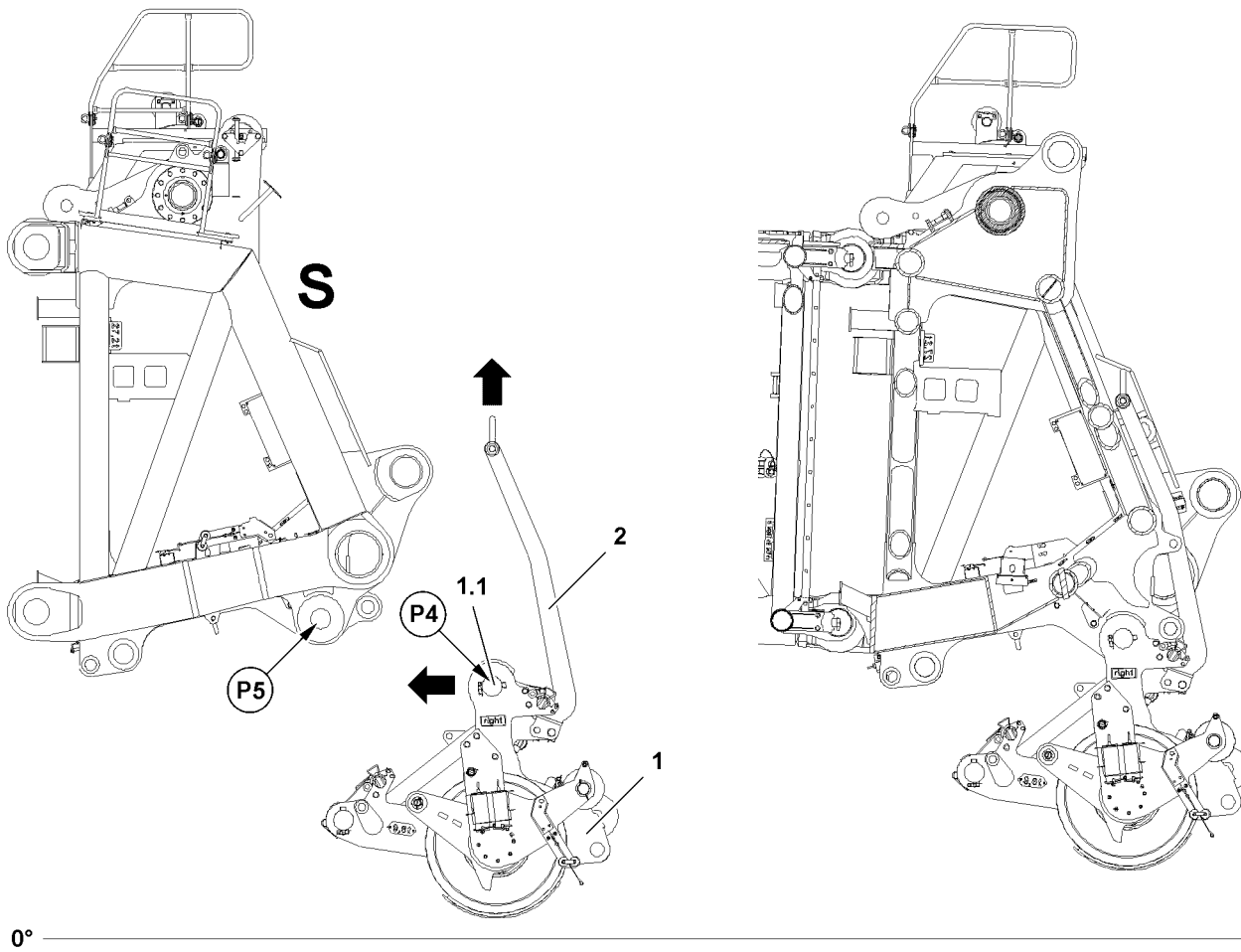
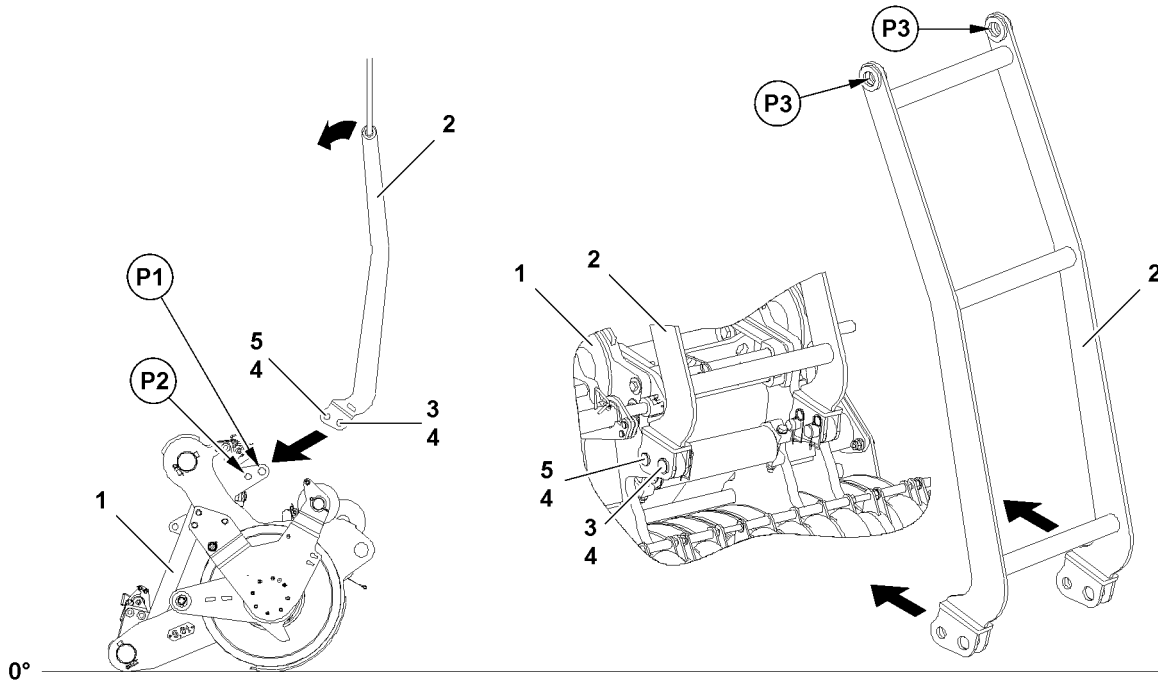

Fig.115910

LWE/LR 13000-001/19503-01-02/en

3.1 Installing the assembly cross bar on the pulley set

Make sure that the following prerequisites are met:

- The pins **3** on the assembly cross bar **2** are unpinned.
- The pins **5** on the assembly cross bar **2** are unpinned.
- ▶ Fasten the assembly cross bar **2** with the auxiliary crane on the fastening points **P3** on the auxiliary crane: Use shackles.

When the assembly cross bar **2** is properly fastened on the auxiliary crane:

- ▶ Lift the assembly cross bar **2** with the auxiliary crane and swing it in to the pin points on the first pulley set.
- ▶ Pin and secure the assembly cross bar **2** on both sides on the pulley set at points, point **P1** and point **P2**: Use pin **3**, pin **5** and safety locking pin **4**.

When the assembly cross bar **2** is properly installed and secured on the pulley set **1**:

- ▶ Install the pulley set with the assembly cross bar on the end section.

3.2 Installing the pulley sets on the end section



Note

- ▶ The S-end section and the L-end section can each be equipped with one or with two pulley sets!
- ▶ Both pulley sets are designed for identical loads!
- ▶ The maximum load capacity of the crane is only possible in connection with both pulley sets and when using the heavy load device, observe the load charts!



WARNING

The crane can topple over!

If the pulley set / pulley sets are improperly assembled, the crane can topple over!

Personnel can be severely injured or killed!

- ▶ Select pulley set / pulley sets according to the operating modes, as specified in the load charts.
- ▶ Observe the Erection and take down charts.
- ▶ Observe the load charts.

NOTICE

Danger of property damage!

If the pulley sets are not installed according to their description on the respective end section, the pulley sets or the end section can be damaged!

- ▶ Pay attention to the description „right“ / „left“ on the pulley sets.
- ▶ The description „right“ / „left“ refers to the direction of view of the crane operator, starting from the crane operator's cab in direction of the boom!

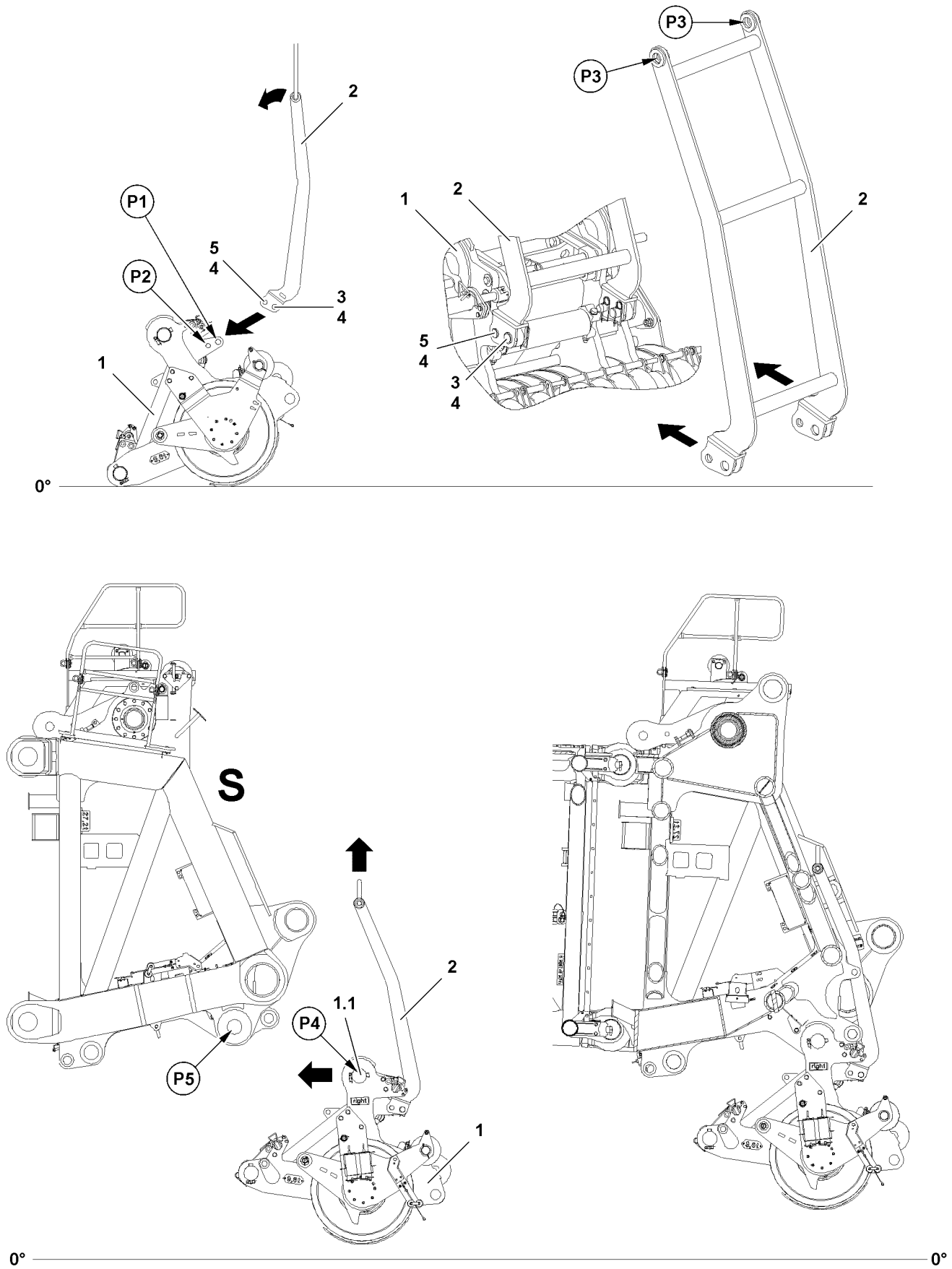

Fig.115910

LWE/LR 13000-001/19503-01-02/en

3.2.1 Installing a pulley set centered on the end section

When installing only one pulley set on the end section, it must be installed centered on the respective end section.



WARNING

Overload of boom system!

If only the pulley set is used and the pulley set is assembled off center of the end section, then the boom system can be overloaded!

Personnel can be severely injured or killed!

If only one pulley set is used:

- ▶ Install the pulley set only on the center pin points of the end section.
-



Note

- ▶ We recommend to use the „right“ pulley set when using only one pulley set on the S- or L-end section, due to the hoist limit switch installation!
-

Make sure that the following prerequisites are met:

- The assembly cross bar **2** is properly installed on the pulley set **1**.
- The retaining pins **1.4** between the slides - slide **1.2** and slide **1.3** - are unpinned.
- The boom head is approx. 2.0 m above the ground.

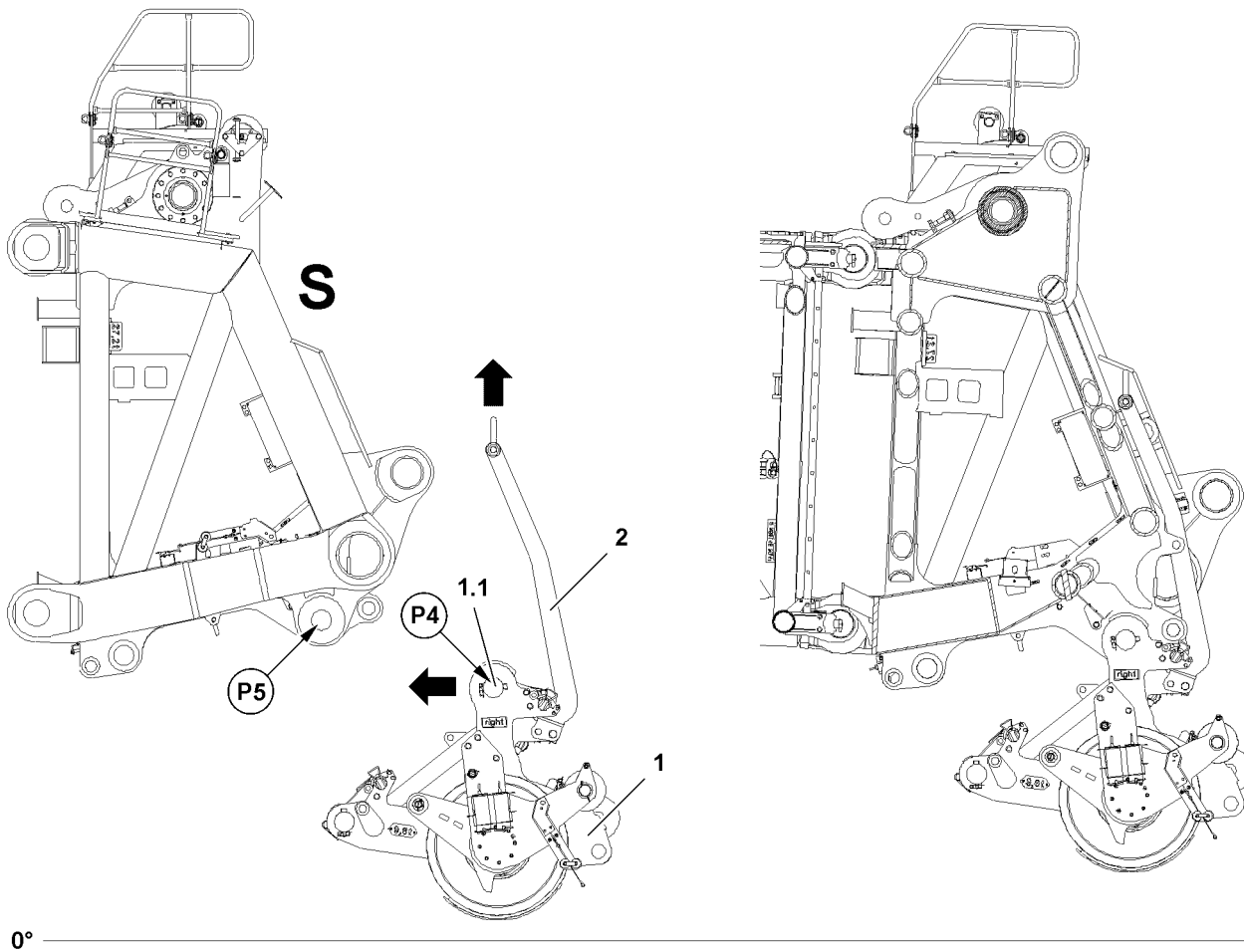
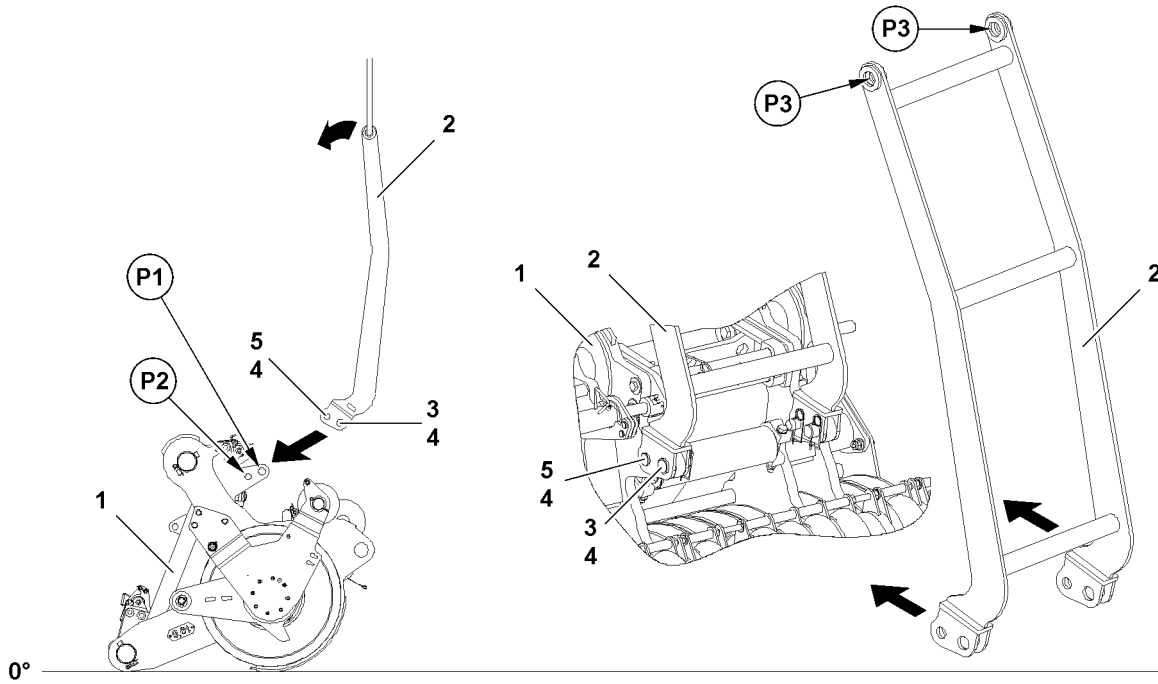

Fig.115910

LWE/LR 13000-001/19503-01-02/en

Pinning the pulley set on top on the end section

- ▶ Lift the pulley set **1** carefully with the auxiliary crane.
- ▶ Position the pulley set **1** under the end section.
- ▶ Lower the pulley set **1** to the ground.

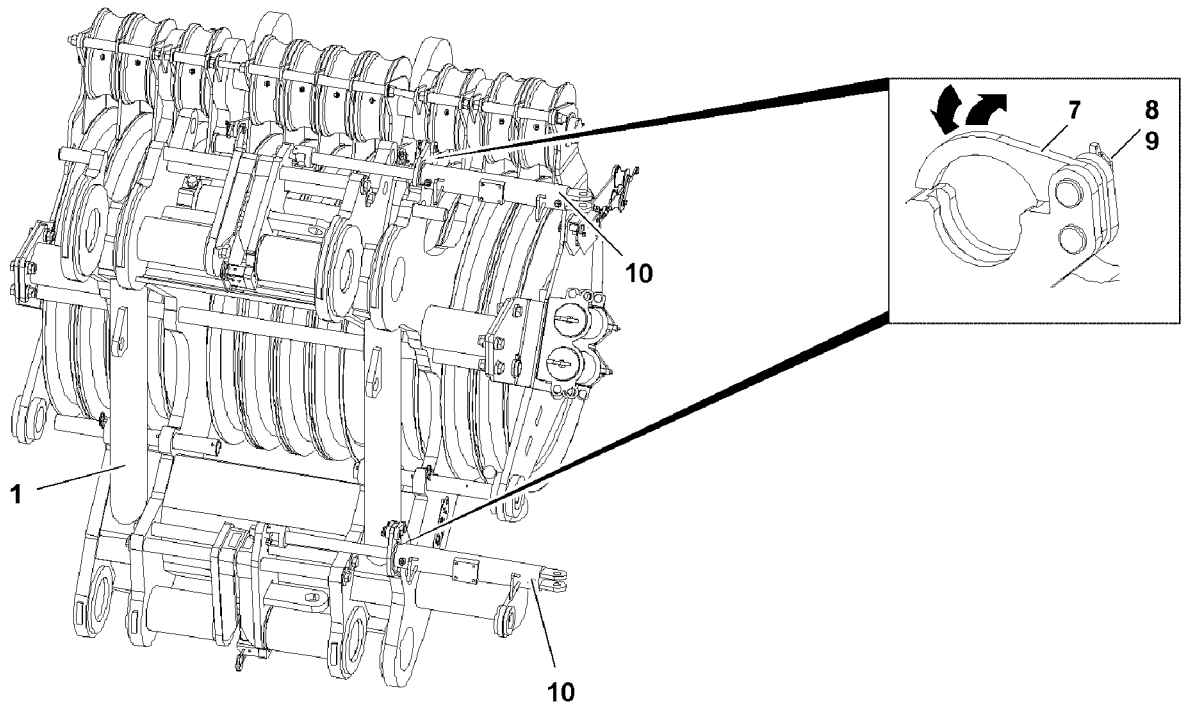

Fig.115916: Place the pin pulling cylinder in the pin pulling device

- ▶ Open the lock **7** on the pin pulling device „on top“ and „bottom“: Remove the safety locking pin **9** and unpin the pin **8**.
- ▶ Set the pin pulling cylinder **10** into the receptacle of the pin pulling device.

When the pin pulling cylinder **10** is properly placed in the pin pulling device:

- ▶ Close the lock **7**, insert the pin **8** and secure with safety locking pin **9**.
- ▶ Lift the pulley set with the auxiliary crane into the pin position on the end section.



WARNING

Falling pulley set!

The pulley set can fall down during installation!

Personnel can be severely injured or killed!

- ▶ Make sure that the fastening equipment on the assembly cross bar remains „tensioned“ during the entire assembly procedure.
- ▶ Do not remove the fastening equipment until after the pulley set is pinned and secured on both sides on the end section.

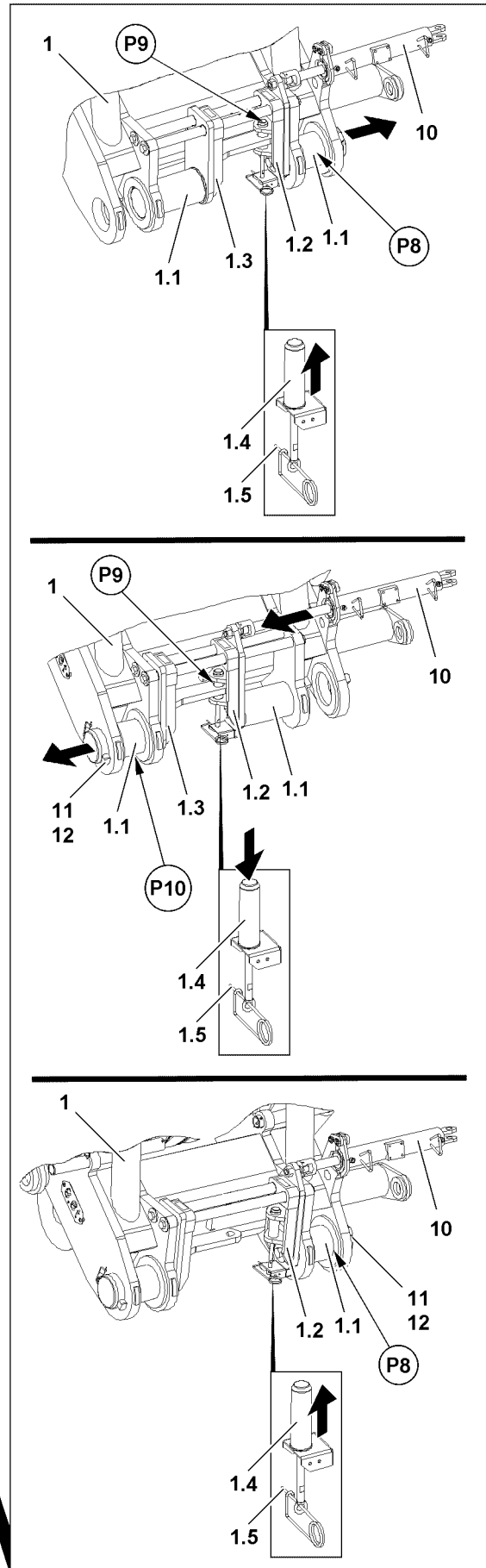
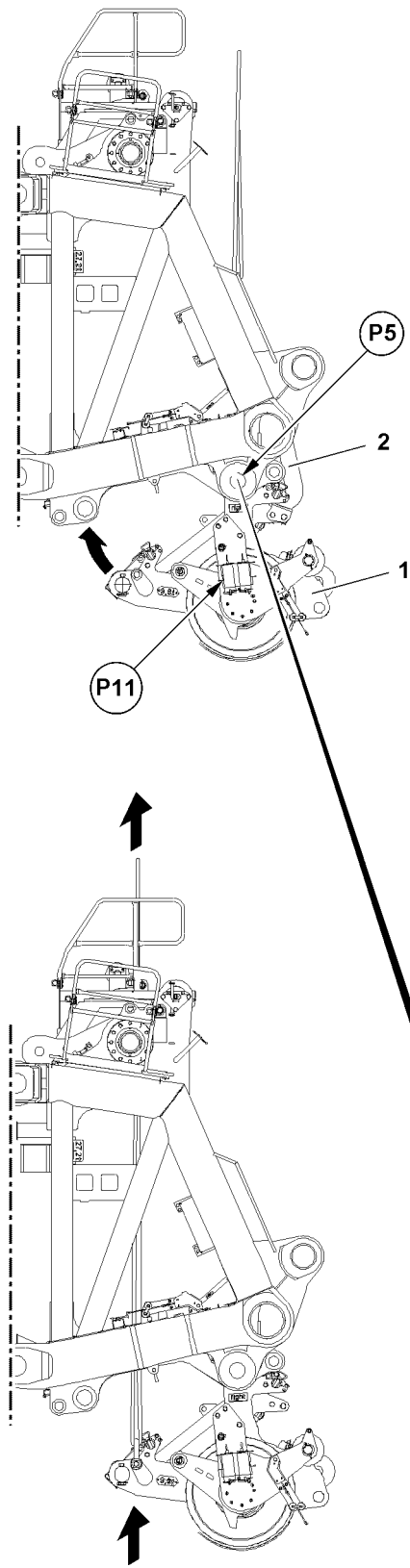

Fig.115942

LWE/LR 13000-001/19503-01-02/en

**WARNING**

Danger of crushing!

When pinning the pulley set on the end section, limbs can be crushed or severed during the sliding movement of the pin pulling device.

Personnel can be severely injured or killed!

- ▶ Make sure that there are no persons within the danger zone during the entire pin procedure.
- ▶ Make sure that no persons reach into the danger zone during the entire pin procedure.
- ▶ Operate at the pin pulling device with utmost caution.

When the pin bores align between the end section and the pulley set:

- ▶ Insert the connector pin on top with the pin pulling device.
- ▶ Move the pin pulling cylinder **10** in.

Result:

- The connector pin **1.1** is inserted at point **P8**.

When the connector pin **1.1** is completely pinned at point **P8**:

- ▶ Pin the slide **1.2** with slide **1.3** at point **P9**: Insert the pin **1.4** and secure with spring retainer **1.5**.

When the slides, slide **1.2** and slide **1.3** are properly pinned and secured at point **P9**:

- ▶ Move the pin pulling cylinder **10** completely out and insert the connector pin **1.1** at point **P10**.

Result:

- The pulley set **1** is pinned at point **P10** on one side on the end section.

- ▶ Secure the connector pin **1.1** at point **P10**: Remove the retaining pin **11** from the parking position at point **P11**.
- ▶ Insert the retaining pin **11** on the connector pin **1.1** at point **P10** and secure with spring retainer **12**.

When the connector pin **1.1** is properly pinned and secured at point **P10**:

- ▶ Release and unpin the pin **1.4**.

When the pin **1.4** is completely unpinned:

- ▶ Move the pin pulling cylinder **10** completely in and insert the connector pin **1.1** at point **P8**.

Result:

- The pulley set **1** is pinned on both sides at point **P5** on the end section.

- ▶ Secure the connector pin **1.1** at point **P8**: Remove the retaining pin **11** from the parking position at point **P11**.
- ▶ Insert the retaining pin **11** on the connector pin **1.1** at point **P8** and secure with spring retainer **12**.
- ▶ Insert the pin **1.4** completely and secure with spring retainer **1.5**.

When the connector pins **1.1** are properly pinned and secured on both sides:

- ▶ Unpin the assembly cross bar **2** on the pulley set.
- ▶ Swing the assembly cross bar **2** out with the auxiliary crane and place it on a suitable support.

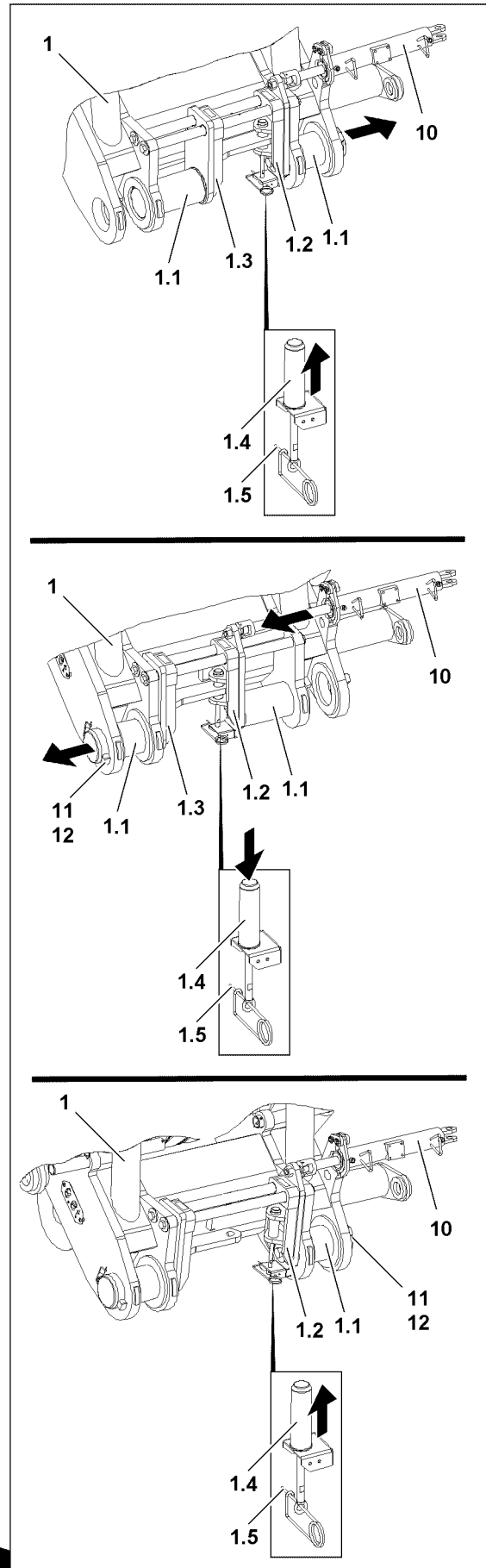
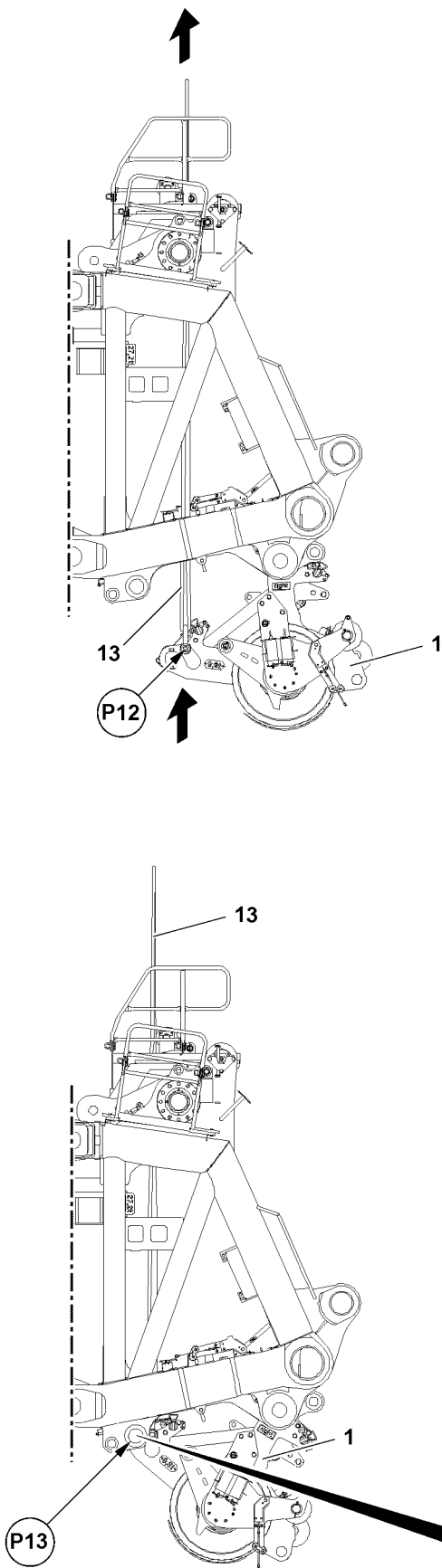

Fig.115943

LWE/LR 13000-001/19503-01-02/en

Pinning the pulley set on the bottom on the end section

To be able to install the pulley set completely on the end section it is necessary that the pulley set **1** is brought into pin position with the auxiliary crane on the end section and „held“ there during the installation. To do so, guide the fastening equipment **13** through the end section to the fastening point **P12**. Lift the pulley set into pin position and pin on both sides. Remove the fastening equipment.



WARNING

Swinging pulley set!

During the installation of the pulley set **1** the pulley set can suddenly swing downward!

Personnel can be severely injured or killed!

- ▶ Make sure that the fastening equipment **13** is properly installed and secured on the fastening point **P12** of the pulley set **1**.
- ▶ Make sure that there are no persons within the swing range of the pulley set **1** during the installation procedure.
- ▶ Make sure that the auxiliary crane does not carry out any movements during the installation procedure on the pulley set **1**.

- ▶ Lower the fastening equipment **13** with the auxiliary crane from top through the end section to the fastening points **P12**.

- ▶ Attach the fastening equipment properly on the fastening point **P12** of the pulley set.

When the pulley set is properly fastened on the auxiliary crane:

- ▶ Lift the pulley set **1** with the auxiliary crane into pin position.

If the pin bores on the pulley set align on point **P13** on both sides:

- ▶ Insert the connector pins **1.1** on both sides, see section „Pinning the pulley set on top on the end section“.

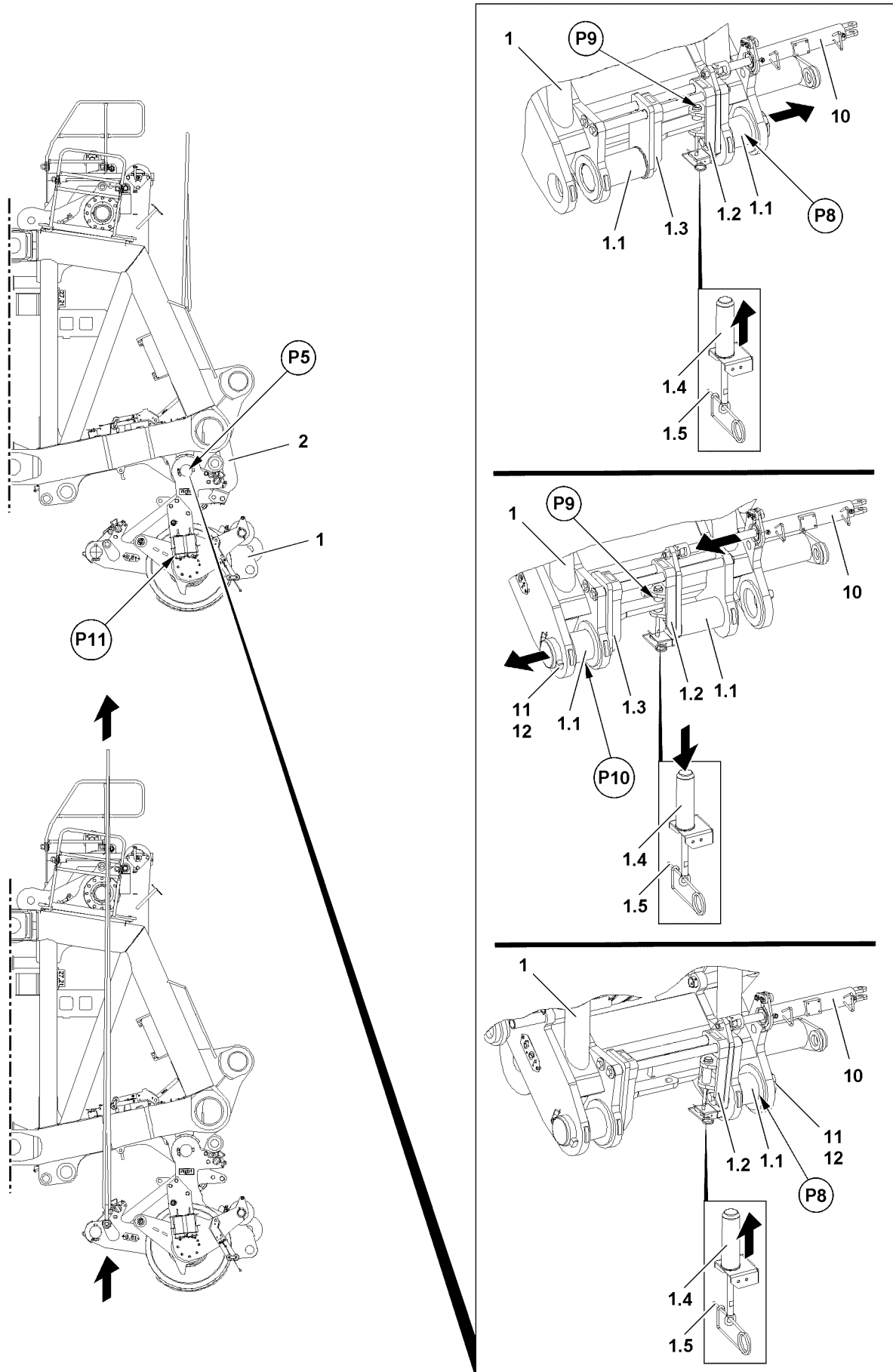

Fig.115944

LWE/LR 13000-001/19503-01-02/en

3.2.2 Installing two pulley sets on the end section



WARNING

Danger of crushing!

When swinging the pulley sets in and pinning them on the end section, limbs can be crushed or severed!

Personnel can be severely injured or killed!

- ▶ Make sure, when swinging the pulley sets in to the pin points, that no persons are within the danger zone.
- ▶ Make sure that there are no persons within the danger zone during the entire pin procedure.
- ▶ Make sure that no persons reach into the danger zone during the entire pin procedure.
- ▶ Operate at the pin pulling device with utmost caution.

Make sure that the following prerequisites are met:

- The assembly cross bar is properly installed on the pulley set.
- The retaining pins **1.4** between the slides - slide **1.2** and slide **1.3** - are unpinned.
- The boom head is approx. 2.0 m above the ground.

Pinning the right pulley set on top on the end section

NOTICE

Danger of property damage!

If the installation position of the pulley sets is not observed, then significant property damage can occur on the pulley sets!

- ▶ Make sure that the pulley sets are always installed on the end section according to their assignment - left / right!
- ▶ Lift the right pulley set with the auxiliary crane in the pin position „on top“ on the end section.



Note

- ▶ The pinning of the pulley set is described in detail in section „Pinning the pulley set on top on the end section“.
- ▶ Pin and secure the right pulley set properly on the end section „on top“.

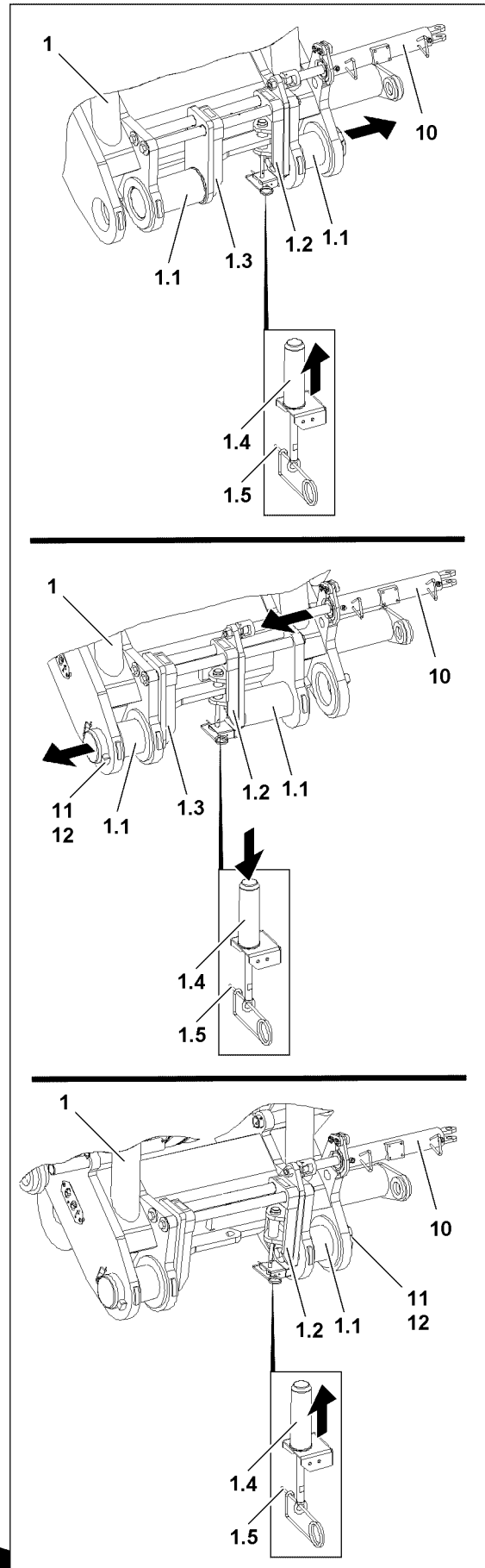
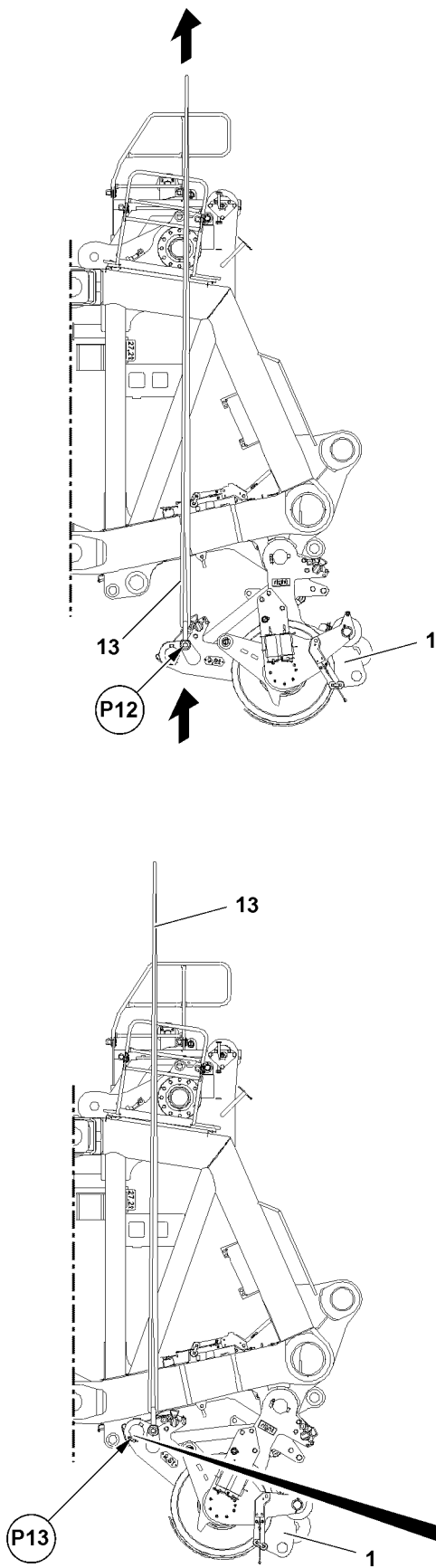

Fig.115945

LWE/LR 13000-001/19503-01-02/en

Pinning the right pulley set on the bottom on the end section

To be able to install the right pulley set completely on the end section it is necessary that the pulley set is brought into required pin position with the auxiliary crane on the end section and „held“ there during the installation.



WARNING

Swinging pulley set!

During the installation of the pulley set the pulley set can suddenly swing downward!
Personnel can be severely injured or killed!

- ▶ Make sure that the fastening equipment is properly installed and secured on the fastening point of the pulley set.
- ▶ Make sure that there are no persons within the swing range of the pulley set during the installation procedure.
- ▶ Make sure that the auxiliary crane does not carry out any movements during the installation procedure on the pulley set.

- ▶ Guide the fastening equipment **13** on the side - past the end section - to the fastening point **P12** on the right pulley set **1**.
- ▶ Attach the fastening equipment **13** properly on the fastening point **P12** of the pulley set.

When the pulley set is properly fastened on the auxiliary crane:

- ▶ Lift the pulley set **1** with the auxiliary crane into pin position.

If the pin bores on the pulley set on the right align on point **P13** on both sides:

- ▶ Insert the connector pins **1.1** on both sides, see section „Pinning the pulley set on top on the end section“.

Pinning the left pulley set on the end section



Note

- ▶ The installation of the left pulley set on the end section is identical with the installation of the right pulley set.
- ▶ Only the procedure of the left pulley set is the mirror image to the right pulley set!
- ▶ Pin and secure the left pulley set properly on the end section, see section „Pinning the right pulley set on the end section on top“ and section „Pinning the right pulley set on the end section on the bottom“.

3.2.3 Establishing the electrical connections

Make sure that the following prerequisites are met:

- The electrical connections to the end section have been established.
- ▶ Establish the electrical connections to the hoist limit switches in the pulley sets according to the electric wiring diagram.

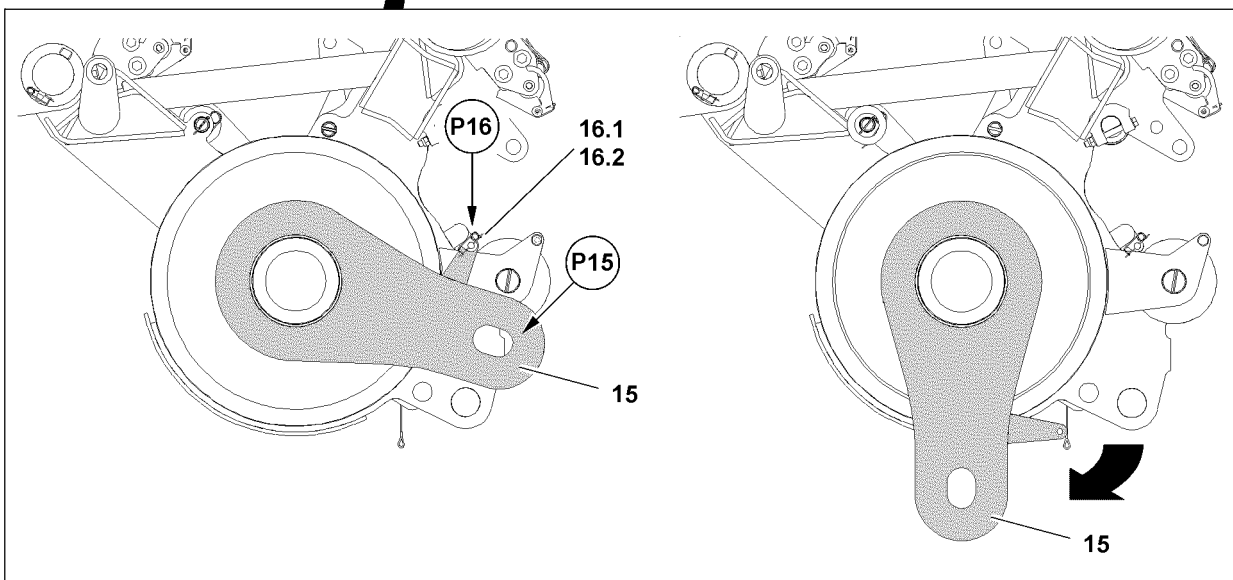
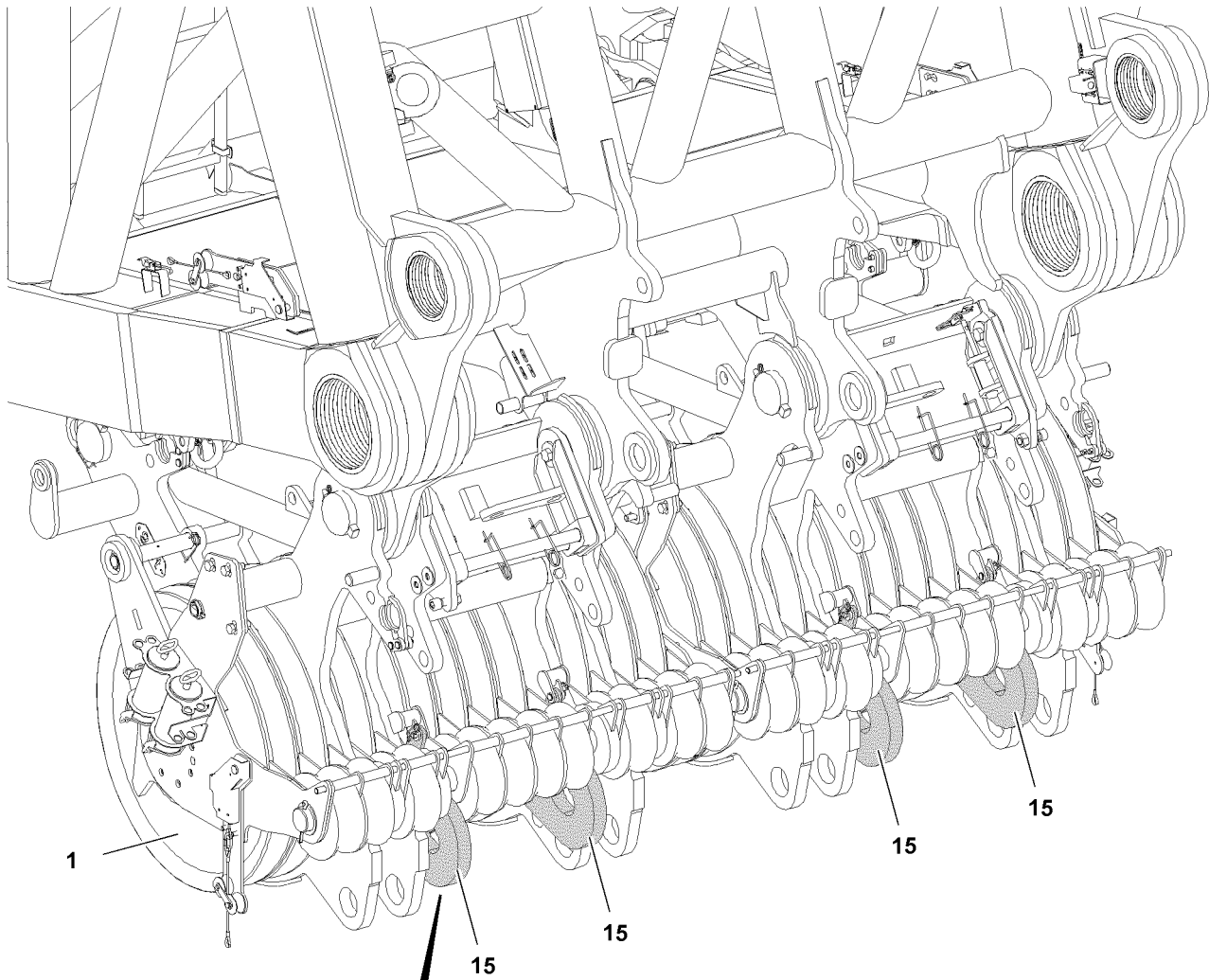

Fig.115682

LWE/LR 13000-001/19503-01-02/en

4 Heavy load device*

4.1 Installing the heavy load device

Make sure that the following prerequisites are met:

- The two pulley sets **1** are properly installed on the S-end section.
- The boom head is approx. 1.0 m above the ground.

4.1.1 Lowering the brackets into assembly position

- ▶ Attach the bracket **15** onto the auxiliary crane at point **P15**.



WARNING

Brackets swings by itself!

The bracket **15** can fall down by itself due to its own weight when it is unpinned!

Personnel can be severely injured!

Fingers and hands can be crushed or severed!

- ▶ Make sure that the bracket **15** is safely held by the auxiliary crane before unpinning at point **P16**!
- ▶ Do not reach into the swing range of the bracket **15**!

-
- ▶ Remove the spring retainer **16.2** at point **P16** and unpin the pin **16.1**.
 - ▶ Swing the bracket **15** downward with the auxiliary crane.
 - ▶ Insert the pin **16.1** again at point **P16** and secure with spring retainer **16.2**.
 - ▶ Remove the auxiliary crane.
 - ▶ Swing all brackets **15** down.

4.1.2 Unpinning the heavy load device

- ▶ Lift the boom to the point where the heavy load device **17** can be lifted into the pulley sets **1**, see illustration **5**.
- ▶ Attach the heavy load device **17** on the points **P17** to the auxiliary crane, see illustration **5**.
- ▶ Lift the heavy load device **17** with the auxiliary crane under the pulley sets **1** and lower it to the ground, see illustration **5**.

NOTICE

Danger of property damage!

If the pins **19** are not unpinned on the points **P18**, the components can be severely damaged when moving the brackets **15** into the cross brackets **18**!

- ▶ Make sure that the pins **19** are unpinned on the points **P18**!

-
- ▶ Remove the safety locking pin **20** on points **P18** and unpin the pin **19**, see illustration **5**.
 - ▶ Carefully lower the boom until it can be pinned on points **P18**.



WARNING

The pin is not secured!

If the pins are not properly secured after assembly, then they can release by themselves during crane operation!

Personnel can be severely injured or killed!

This could result in property damage!

- ▶ Make sure that the pins **19** are inserted completely and secured with safety locking pins **20**!
- ▶ Pin the heavy load device **17** with the brackets **15** on points **P18**: Insert the pin **19** on point **P19** and secure with safety locking pin **20**, see illustration **6**.
- ▶ Insert all pins **19** completely and secure properly.

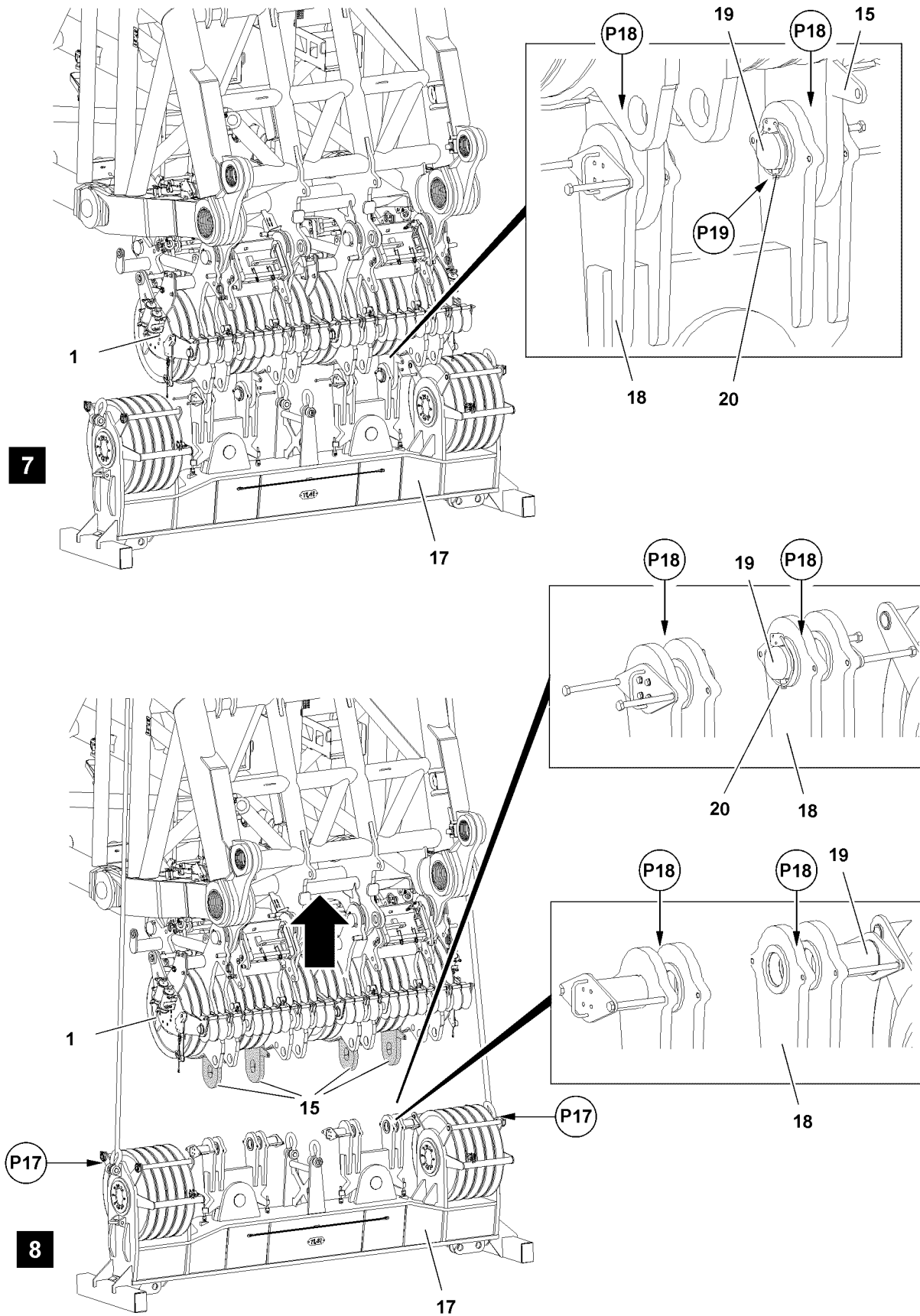

Fig.115685

LWE/LR 13000-001/19503-01-02/en

4.2 Removing the heavy load device

Make sure that the following prerequisites are met:

- An auxiliary crane with sufficient load carrying capacity is available.
- An assembly scaffolding / a work platform is available.
- The hoist rope is unreeved from the heavy load device.
- The heavy load device is on the ground.

4.2.1 Unpinning the heavy load device

- ▶ Unpin the heavy load device **17** on the brackets **15** - points **P18**: Remove the safety locking pin **20** at point **P19** and unpin the pin **19**, see illustration 7.
- ▶ Unpin all pins **19** on the points **P18**.
- ▶ Lift the boom to the point where the heavy load device **17** can be lifted out with the auxiliary crane, see illustration 8.
- ▶ Attach the heavy load device **17** on the auxiliary crane, illustration 8.
- ▶ Lift the heavy load device **17** out with the auxiliary crane and place it on the ground on a suitable location.
- ▶ Insert the pins **19** again at points **P18** and secure with safety locking pins **20**, see illustration 8.

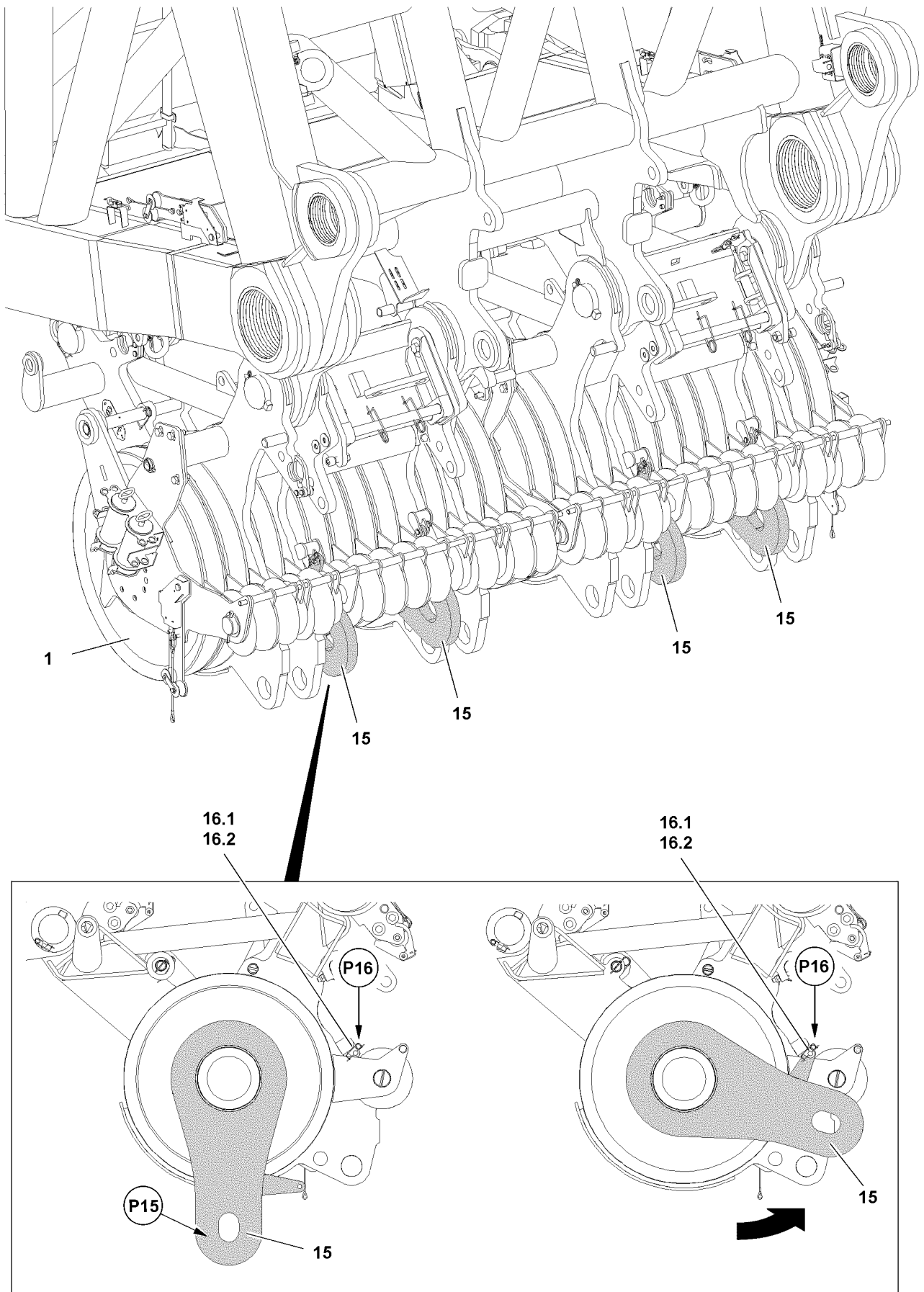

Fig.115686

LWE/LR 13000-001/19503-01-02/en

4.2.2 Swinging the brackets in into park / transport position

- ▶ Remove the spring retainer **16.2** at point **P16** and unpin the pin **16.1**.
- ▶ Attach the bracket **15** onto the auxiliary crane at point **P15**.



WARNING

Brackets swings by itself!

The bracket **15** can fall down by itself due to its own weight during the unpinning procedure!

Personnel can be severely injured!

Fingers and hands can be crushed or severed!

- ▶ Make sure that the bracket **15** is properly pinned and secured at point **P16** before removing the auxiliary crane.
- ▶ Do not reach into the swing range of the bracket **15**!

-
- ▶ Swing the bracket **15** up with the auxiliary crane in park / transport position until the bracket **15** can be pinned at point **P16**.
 - ▶ Insert the pin **16.1** on point **P16** and secure with spring retainer **16.2**.

When the bracket **15** is properly pinned and secured at point **P16**:

- ▶ Remove the auxiliary crane.
- ▶ Swing all brackets **15** up in park / transport position and secure properly.

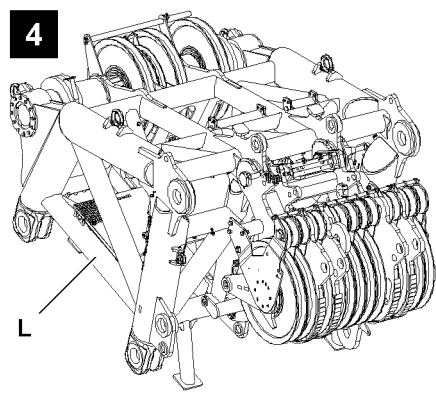
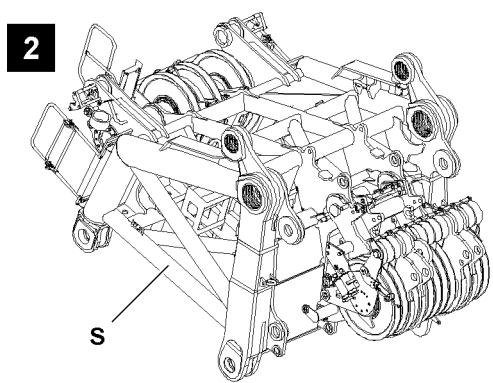
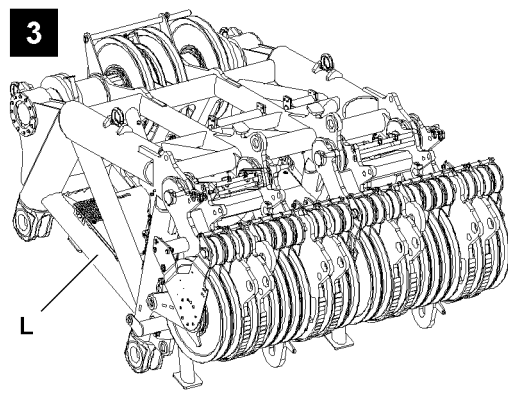
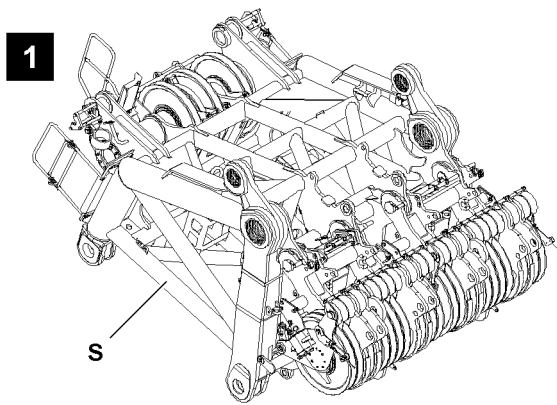

Fig.115909

LWE/LR 13000-001/19503-01-02/en

5 Removing the pulley set / pulley sets



Note

- ▶ The disassembly of the pulley sets is described on the example of the S-end section!



WARNING

Danger of falling!

During assembly / disassembly, inspection and maintenance work, personnel must be secured with appropriate aids to prevent them from falling!

If this is not observed, assembly personnel could fall and suffer life-threatening or fatal injuries!

- ▶ All work aloft, where there is a danger of falling must be carried out with suitable aids!
- ▶ If aids are not available and work cannot be carried out from the ground, then the assembly personnel must secure themselves with the supplied fall arrest system to prevent falling, see Crane operating instructions, chapter 2.04.
- ▶ If fall protection equipment is available, then it must be used, see Crane operating instructions, chapter 2.06!
- ▶ When lifting, lowering, swinging crane parts in and out, no persons may remain in the danger zone.
- ▶ If railings are present on the components, then they must be brought into the corresponding position and secured for assembly / disassembly work!
- ▶ Only step on the aids, ladders and catwalks with clean shoes!
- ▶ Keep aids, ladders and catwalks free of heavy dirt, snow and ice!
- ▶ During all assembly and disassembly work, maintenance work and inspections, travel or crane operation is prohibited!
- ▶ Remaining on a suspended load is prohibited!
- ▶ Stepping or walking on crane components and lattice sections, which have an incline of more than 20° is prohibited!
- ▶ For all assembly work, the crane operator of the main crane must be in voice contact with the crane operator / crane operators of the auxiliary crane / auxiliary cranes!
- ▶ For assembly / disassembly tasks, the crane operator may only initiate crane movements when the responsible guide has explicitly released the movement!

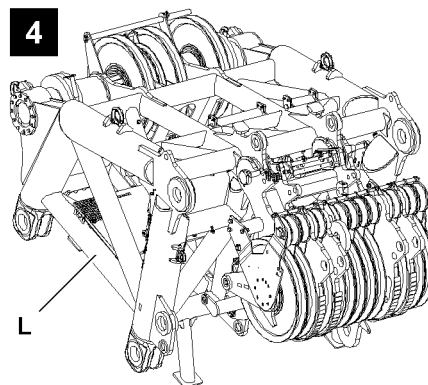
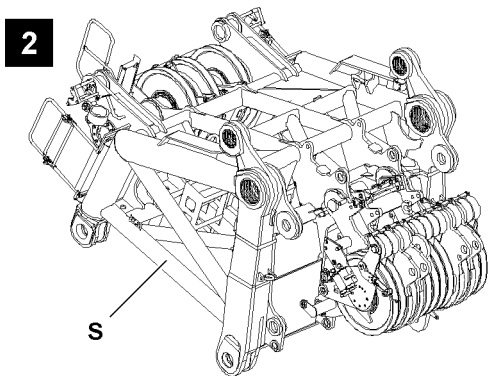
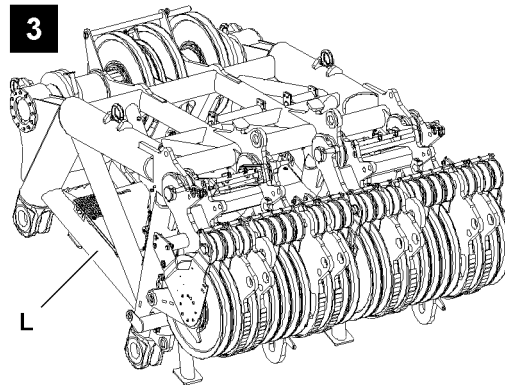
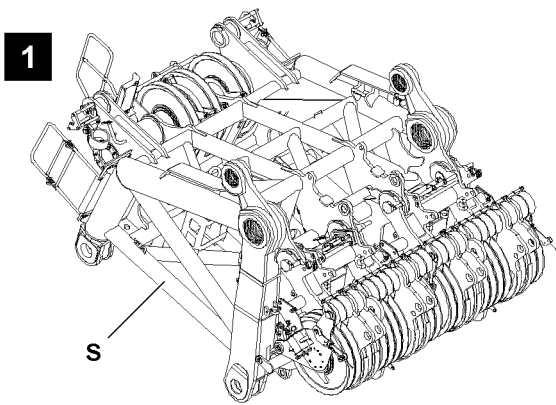

Fig.115909

LWE/LR 13000-001/19503-01-02/en

**WARNING**

Falling pulley sets!

If the pulley sets are not pinned and secured correctly, then they can fall down and fatally injure personnel!

- ▶ Pin or unpin both pins at the same horizontal level, i.e. **left and right!**
- ▶ Do not stand under the pulley sets or within the complete danger zone during the pinning and unpinning procedure of the pulley sets!
- ▶ Safely secure the pins in the bearing points as well as receptacles!
- ▶ It is prohibited to lean the ladder against the component being disassembled!

**WARNING**

Danger of impact / crushing!

When installing / removing crane components with the auxiliary crane, crane components can start to swing back and forth!

When lifting / lowering and positioning crane components, there is an increased danger of impacts / crushing!

Personnel can be caught and severely injured or killed!

- ▶ Make sure that personnel cannot be caught by components.
- ▶ Make sure that the crane is horizontally aligned.
- ▶ When working in danger zones: Use aids to protect limbs.
- ▶ Guide components with suitable aids to minimize oscillation.

**DANGER**

The components can fall down!

If the corresponding components are disengaged from the auxiliary crane before the corresponding component is pinned, the corresponding component can fall down and fatally injure personnel!

- ▶ Do not disengage the auxiliary crane until the corresponding component is pinned and secured.

5.1 Removing the pulley sets on the end section

5.1.1 Disconnecting the electrical connections

NOTICE

Danger of property damage!

If the connection or connector cables are not properly stored after disconnection, then they can be damaged!

- ▶ Always store the connection or connector cables properly on the respective components.
- ▶ Disconnect the electrical connections to the pulley sets.

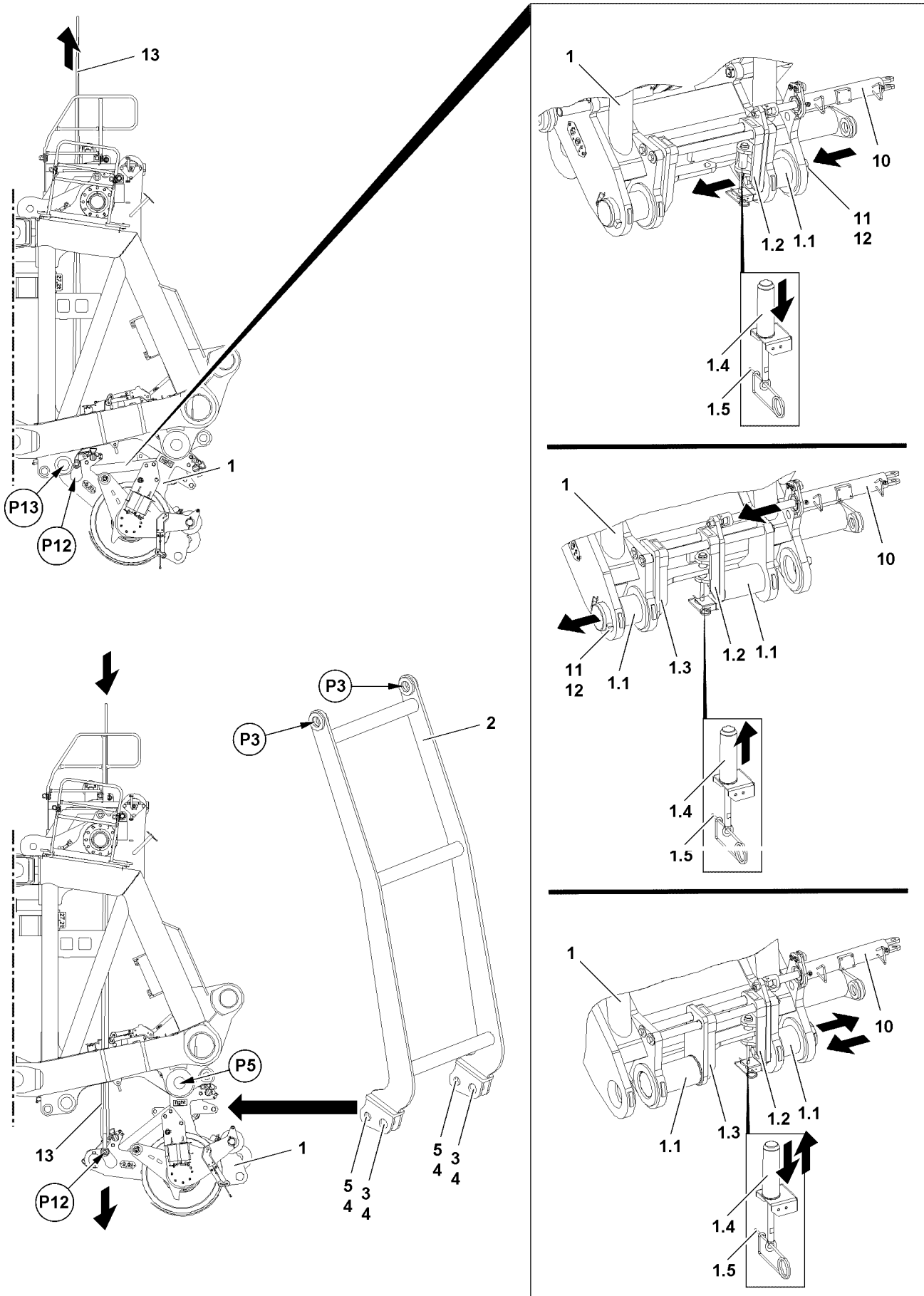

Fig.115946

LWE/LR 13000-001/19503-01-02/en

5.1.2 Removing the pulley set on the end section



Note

- ▶ The removal of the pulley sets is described as an example on one pulley set!

Make sure that the following prerequisites are met:

- The heavy load device is disassembled.
- The brackets of the heavy load device are properly pinned and secured on the respective pulley set.
- The boom head is approx. 2.0 m above the ground.
- The electrical connections from the end section to the pulley set are disconnected.
- The pulley set is fastened properly on the auxiliary crane at point **P12**.
- The fastening equipment **13** between the auxiliary crane and pulley set **1** is on „tension“.

Unpinning the pulley set on the bottom on the end section

At disassembly of the pulley set, it must be „held“ in position by the auxiliary crane until the connector pins are completely unpinned on both sides in the pin level at point **P13**. To do so, guide the fastening equipment **13** to the fastening point **P12**. Tension the fastening equipment, hold the pulley set in position and unpin the connector pins **1.1** on both sides. Lower the pulley set **1** around point **P5**.



WARNING

Swinging pulley set!

During the removal of the pulley set **1** the pulley set can suddenly swing downward!

Personnel can be severely injured or killed!

- ▶ Make sure that the fastening equipment **13** is properly installed and secured on the fastening point **P12** of the pulley set **1**.
- ▶ Make sure that there are no persons within the swing range of the pulley set **1** during the removal procedure.
- ▶ Make sure that the auxiliary crane does not carry out any movements during the removal procedure on the pulley set **1**.

- ▶ Lower the fastening equipment **13** with the auxiliary crane to the fastening point **P12**.



WARNING

Danger of accidents due to angular pull!

If the fastening equipment is not properly fastened at removal of the pulley set / the pulley sets, then the pulley set can swing down by itself!

Personnel can be severely injured or killed!

- ▶ Make sure that the fastening equipment **13** is properly fastened on the fastening point **P12** of the pulley set **1**.
- ▶ Angular pull is **prohibited**.
- ▶ Run of fastening equipment at pulley set removal after center installation of pulley set: Guide the fastening equipment through the end section.
- ▶ Run of fastening equipment at pulley set removal after right / left installation of pulley set: Guide the fastening equipment along the side on the end section in each case.

- ▶ Attach the fastening equipment properly on the fastening point **P12** of the pulley set.

When the pulley set is properly fastened on the auxiliary crane:

- ▶ Tension the fastening equipment **13**.

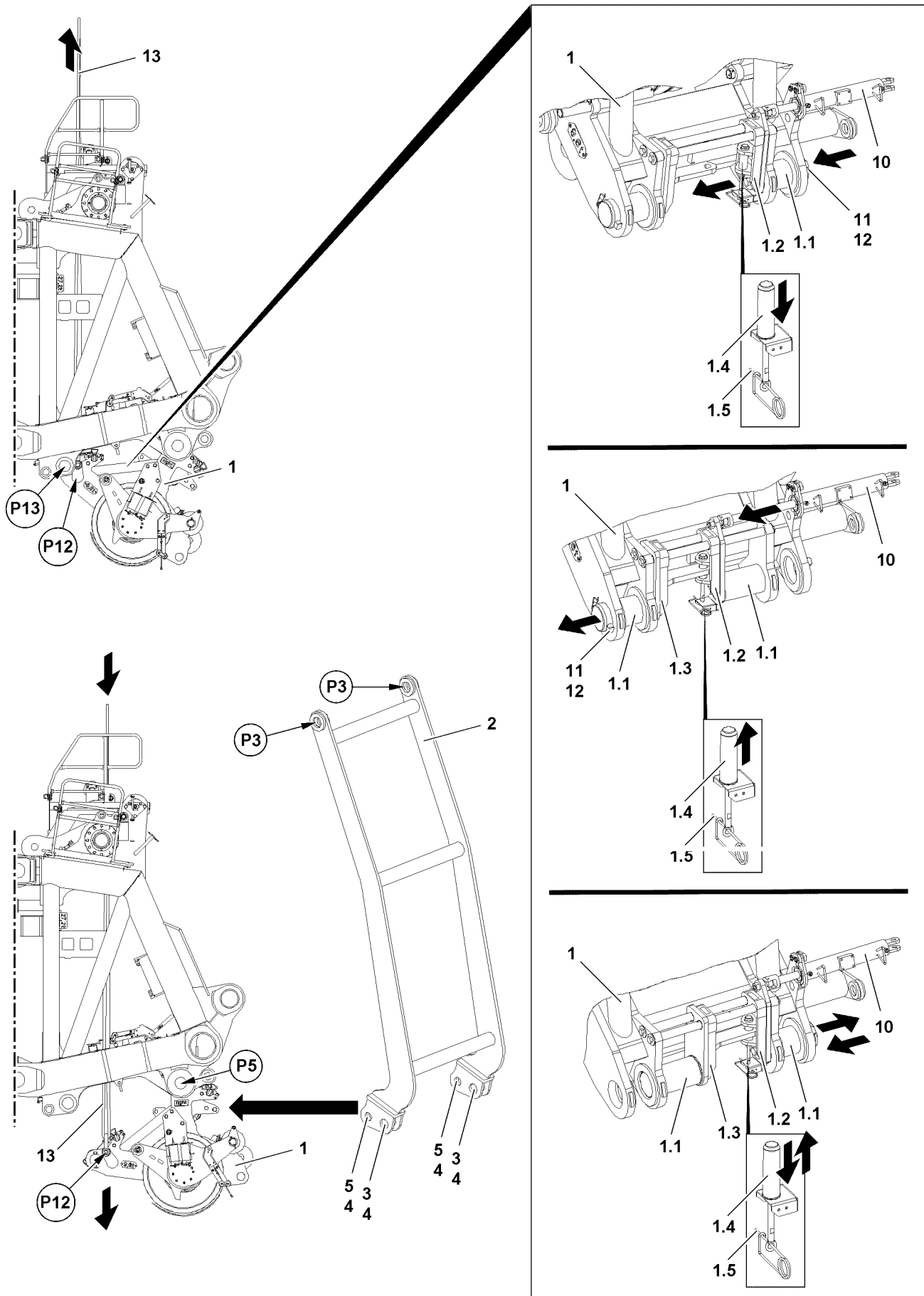

Fig.115946

LWE/LR 13000-001/19503-01-02/en

NOTICE

Danger of property damage!

If the retaining pins **1.4** are not unpinned before removal of the pulley set, then damage can occur in the area of the pin pulling device when moving the pin pulling cylinders out!

- ▶ Make sure, before removal of the respective pulley sets, that the retaining pins **1.4** are completely unpinned.

When the fastening equipment **13** is tensioned:

- ▶ Unpin the connector pins **1.1** on both sides at point **P13**:

When the connector pins **1.1** are fully unpinned on both sides:

- ▶ „Move“ the slide **1.2** and slide **1.3** against the center stop on the pulley set **1** and secure with retaining pins **1.4** to prevent it from moving by itself.
- ▶ Lower the pulley set **1** carefully with the auxiliary crane.

When the pulley set **1** is completely lowered around the pivot point **P5**:

- ▶ Remove the fastening equipment **13** at point **P12**.

Installing the assembly cross bar on the pulley set

Make sure that the following prerequisites are met:

- The pulley set **1** hangs on the pin points **P5** on the end section.
- The fastening equipment is removed on the fastening point **P12**.
- The pins **3** on the assembly cross bar **2** are unpinned.
- The pins **5** on the assembly cross bar **2** are unpinned.
- ▶ Fasten the assembly cross bar **2** with the auxiliary crane on the fastening points **P3** on the auxiliary crane: Use shackles.

When the assembly cross bar **2** is properly fastened on the auxiliary crane:

- ▶ Lift the assembly cross bar **2** with the auxiliary crane and swing it in to the pin points on the pulley set.
- ▶ Pin and secure the assembly cross bar **2** on both sides on the pulley set: Use pin **3**, pin **5** and safety locking pin **4**.

When the assembly cross bar **2** is properly installed and secured on the pulley set **1**:

- ▶ Remove the pulley set **1** with the assembly cross bar **2** on the end section.

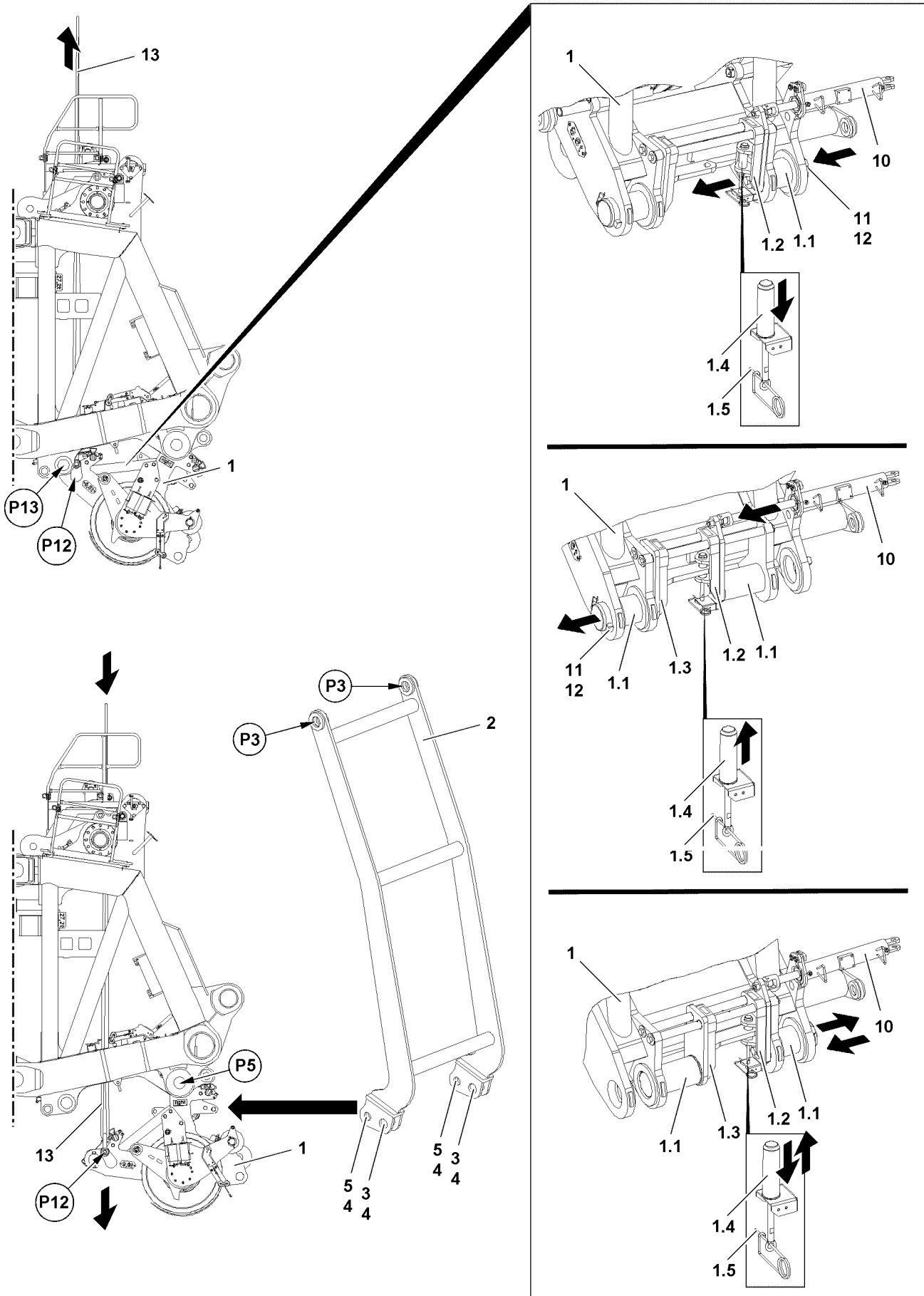

Fig.115946

LWE/LR 13000-001/19503-01-02/en

Unpinning the pulley set on the top on the end section

Make sure that the following prerequisites are met:

- The assembly cross bar **2** is properly pinned and secured on the pulley set **1**.
- The fastening equipment **13** from the auxiliary crane to the assembly cross bar **2** is on „tension“.

- ▶ Unpin the connector pins **1.1** on both sides at point **P5**:

When the connector pins **1.1** are fully unpinned on both sides:

- ▶ „Move“ the slide **1.2** and slide **1.3** against the center stop on the pulley set **1** and secure with retaining pins **1.4** to prevent it from moving by itself.



WARNING

Danger of accident due to pulley sets!

If the pulley sets are not sufficiently secured to prevent them from tipping or toppling over after removal, personnel can be severely injured or killed!

- ▶ Make sure that the pulley sets are sufficiently secured to prevent them from tipping or toppling over.

- ▶ Swing the pulley set **1** out carefully with the auxiliary crane and place it on a suitable support.

When the pulley set **1** is placed on a suitable support:

- ▶ Remove the assembly cross bar **2**.

Empty page!

LWE/LR 13000-001/19503-01-02/en

5.19 Hook blocks

1	Hook blocks	3
2	Radio sending unit for the incline display hook block	3
3	Procedure in case of slack rope	3

Fig.195219

LWE/LR 13000-001/19503-01-02/en

1 Hook blocks



Note

- ▶ For assembly and disassembly of hook blocks, see the separate operating instructions.

2 Radio sending unit for the incline display hook block



Note

- ▶ For the assembly and disassembly of the radio sending unit observe the Crane operating instructions, chapter 5.19.10.

3 Procedure in case of slack rope



Note

- ▶ If the hook block can no longer be lowered due to slack rope formation, then the following steps must be carried out!

3.1 Spooling up loose hoist rope

- ▶ Spool up loose hoist rope between the boom head and the winch carefully onto the winch.



Note

- ▶ A slight rope slack must remain between the boom head and the winch!

3.2 Luffing the boom down

NOTICE

Danger of collision!

When luffing the boom down, the hoist rope length can shorten and pull the hook block against the boom head.

- ▶ Monitor the distance of the hook block to the boom head.

- ▶ Luff the boom down carefully.

Result:

- The hoist rope between the boom head and the winch is tensioned.

3.3 Lowering the hook block

- ▶ Lower the hook block carefully with the hoist gear.

Empty page!

LWE/LR 13000-001/19503-01-02/en

5.19.10 Hook block incline sensors

1	General	2
2	Assembling the radio receiving unit	2
3	Assembling the radio sender unit on the hook block	5
4	Batteries in the radio sender unit	9
5	Radio sender unit and radio receiving unit park position	11

1 General

A radio sender unit and a radio receiving unit belong to the hook block incline sensor. The radio sender unit is located on the hook block. The radio receiving unit is located on the boom and forwards the signal via cable to the crane control.

Every radio sender unit is assigned fixed to a radio receiving unit. If the equipment or individual parts of the equipment must be replaced, the radio sender unit and the radio receiving unit must be left together.

2 Assembling the radio receiving unit

The radio receiving unit is installed on the boom (for example, on the end section or pivot section).



Note

- ▶ The assembly of the radio receiving unit is described in this chapter as an example and may not apply exactly to your crane.
- ▶ The representation of the various mounting positions of the radio receiver are examples and may not apply exactly to your crane.
- ▶ Depending on the crane type and / or equipment, the assembly plate of the radio receiving unit may be constructed with a different design, see variation 1 and variation 2.



Note

- ▶ When using the radio receiving unit, the radio sender unit batteries must be sufficiently charged.



Note

- ▶ The LICCON computer system monitors in parallel operation the incline / incline position of the hook block, see the Crane operating instructions chapter 4.02 and chapter 4.05.



WARNING

Load ripping off!

If the hook block gets into an impermissible incline / incline position in parallel operation of winch 1 and winch 2 (11I2), then the hook block can be overloaded.

Death, severe bodily injuries, property damage.

- ▶ Make sure that the radio receiving unit is properly installed.
- ▶ Make sure that the incline display in the LICCON computer system is constantly monitored during crane operation, see the Crane operating instructions, chapter 4.02.

2.1 Assembly plate Variation 1: Assembling / disassembling the radio receiving unit

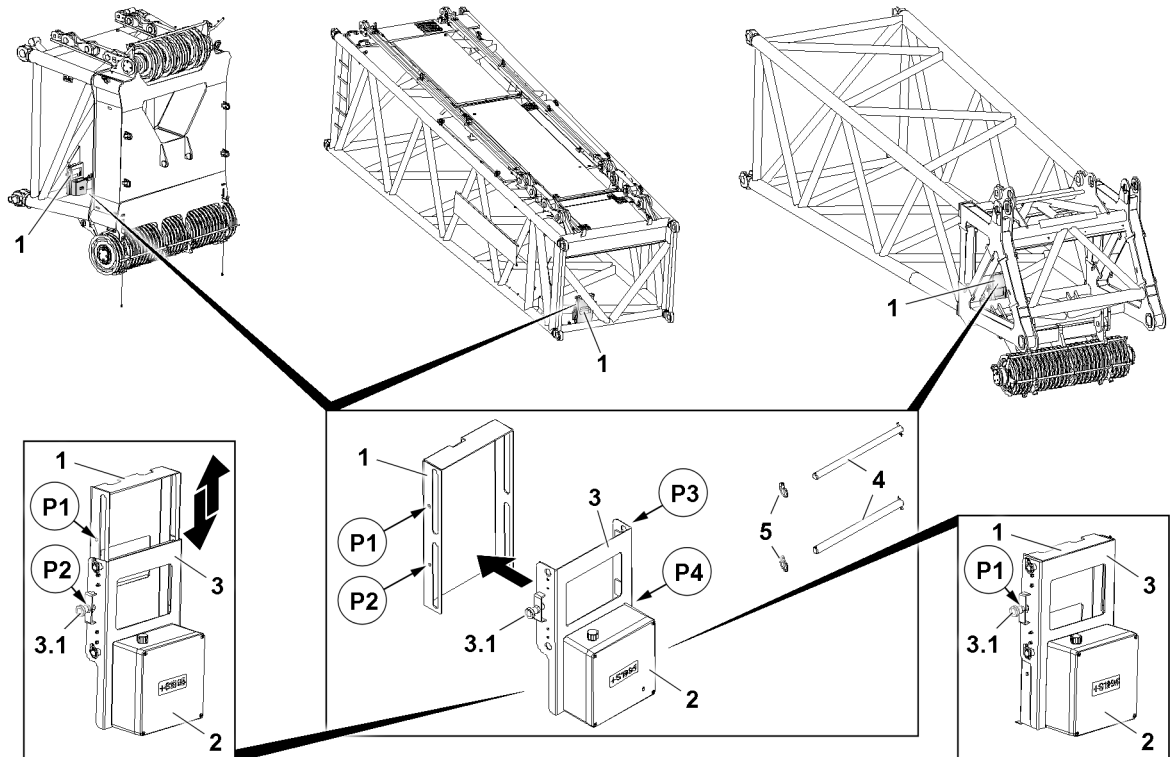

Fig.128140: Assembly plate Variation 1: Assembling the radio receiving unit, examples for the installation positions

Point **P1** = transport position lock

Point **P2** = operating position lock

The radio receiving unit **2** is screwed firmly with the assembly plate **3**.

The assembled assembly plate **3** can be moved and locked twice.

2.1.1 Assembling the radio receiving unit

- ▶ Pull the detent pin **3.1** on the assembly plate **3** and position and hold the radio receiving unit **2** with the assembly plate **3** on the support **1**.

When the assembly plate **3** is properly set on the support **1**:

- ▶ Release the detent pin **3.1** and make sure that the detent pin **3.1** is properly locked in point **P1**.
- ▶ Properly insert the pins **4** in the points (point **P3** and point **P4**) and secure with the retaining element **5**.

Result:

- The radio receiving unit **2** is properly pinned and secured on the support **1**.
- The radio receiving unit **2** is properly locked in the transport position in point **P1**.

When the radio receiving unit **2** is properly pinned and locked:

- ▶ Connect the radio receiving unit **2** electrically, see the Electric wiring diagram.

NOTICE

Damage to the radio receiving unit **2**!

- ▶ Make sure that the radio receiving unit **2**, when handling the respective boom head / lattice section, is always in the transport position.
- ▶ Make sure that the radio receiving unit **2**, when taking down the respective boom head / lattice section on the ground, is always in the transport position.
- ▶ Observe the section „Bringing the radio receiving unit to the transport position from the operating position“.

- ▶ Protect the radio receiving unit **2** from damage.

2.1.2 Bringing the radio receiving unit to the operating position from the transport position

**WARNING**

Interruption of radio connection!

If the radio receiving unit **2** is left in the transport position during crane operation, the radio connection can break off.

- ▶ Make sure that the radio receiving unit **2** is in the operating position during crane operation.

The radio receiving unit **2** must be brought to the operating position before erecting the boom system and locked in point **P2**.

- ▶ Hold the radio receiving unit **2**, pull the detent pin **3.1** and slowly lower the radio receiving unit **2** in the operating position until the detent pin **3.1** engages in point **P2**.

Result:

- The radio receiving unit **2** is in the operating position.

2.1.3 Bringing the radio receiving unit to the transport position from the operating position

The radio receiving unit **2** must be brought to the transport position before disassembling the boom system and locked in point **P1**.

- ▶ Hold the radio receiving unit **2**, pull the detent pin **3.1** and slowly push the radio receiving unit **2** up to the transport position until the detent pin **3.1** engages in point **P1**.

Result:

- The radio receiving unit **2** is in the transport position.

2.1.4 Disassembling the radio receiving unit

- ▶ Disconnect the electrical connection between the terminal box and the radio receiver **2**.
- ▶ Properly store the electrical connection.

When the electrical connection is properly disconnected:

- ▶ Remove the retaining elements **5** on the pins **4**.
- ▶ Hold the radio receiving unit **2** and unpin the pin **4**.
- ▶ Pull the detent pin **3.1** lift the radio receiving unit **2** with the assembly plate **3** from the support **1**.
- ▶ Insert the pin **4** in the assembly plate **3** and secure properly with the retaining elements **5**.

2.2 Assembly plate Variation 2: Assembling the radio receiving unit

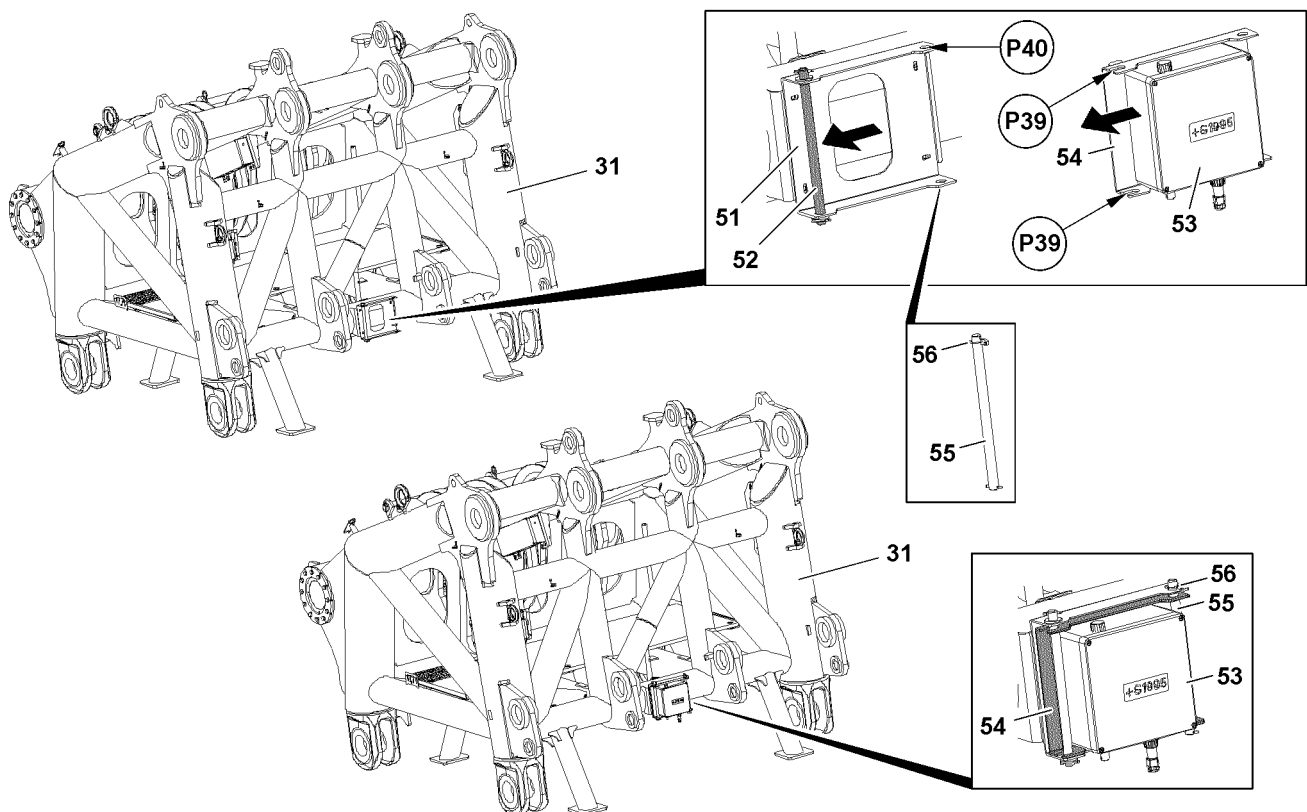

Fig.120089: Assembly plate Variation 2: Assembling the 53 radio receiving unit, examples for the installation position

The radio receiving unit 53 is screwed on the assembly plate 54.

- ▶ Move the assembly plate 54 of the radio receiving unit 53 with the fork connections at point P39 on the axle 52 of the retainer 51.

When the assembly plate 54 of the radio receiving unit 53 is properly in the retainer 51:

- ▶ Insert the pin 55 in point P40 and secure properly with the locking pin 56.
- ▶ Connect the radio receiving unit 53 electrically, see the Electric wiring diagram.

NOTICE

Damage to the radio receiving unit 53!

- ▶ Make sure that the radio receiving unit 53 is not damaged when handling the respective boom head / lattice section.
 - ▶ Make sure that the radio receiving unit 53, when taking down the respective boom head / lattice section on the ground, is not damaged.
-
- ▶ Protect the radio receiving unit 53 from damage.

3 Assembling the radio sender unit on the hook block

So that the inclination of the hook block can be recorded in parallel operation by the crane control, the radio sender unit must be properly assembled on the hook block.

**Note**

- ▶ The assembly of the radio sending unit is described in this chapter as an example and may not apply exactly to your crane.
- ▶ The representation of the various mounting positions of the hook blocks are examples and may not apply exactly to your crane.

**Note**

- ▶ The LICCON computer system monitors in parallel operation the incline / incline position of the hook block, see the Crane operating instructions chapter 4.02 and chapter 4.05.

**WARNING**

Load ripping off!

If the hook block gets into an impermissible incline / incline position in parallel operation of winch 1 and winch 2 (11I2), then the hook block can be overloaded.

Death, severe bodily injuries, property damage.

- ▶ Make sure that the radio sending unit is properly installed on the hook block.
- ▶ Make sure that the installed radio sending unit is facing the crane cab with a freely suspended hook block.
- ▶ Make sure that the incline display in the LICCON computer system is constantly monitored during crane operation, see the Crane operating instructions, chapter 4.02.

3.1 Assembling the radio sender unit on the hook block

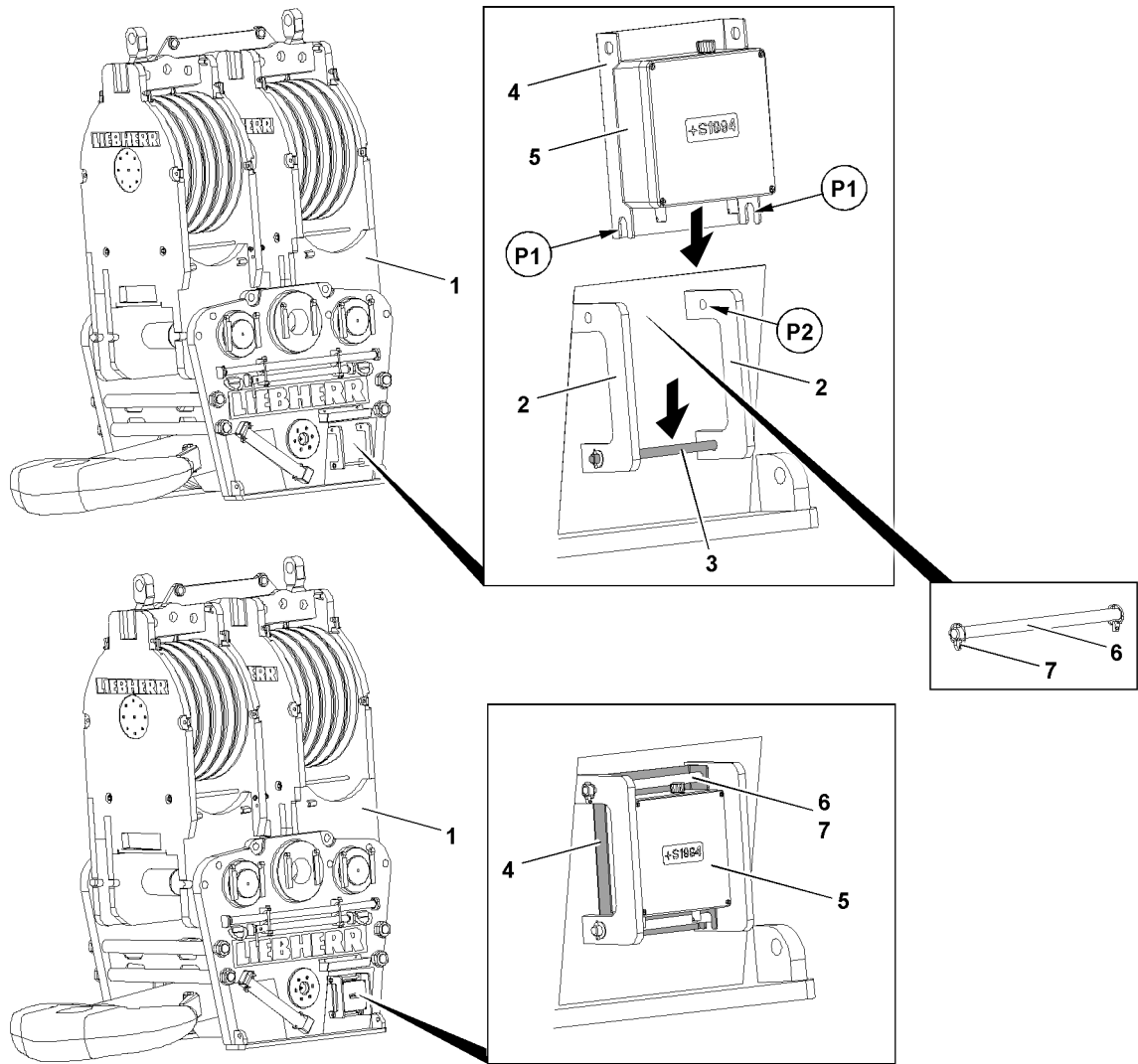

Fig.120141: Assembly of the radio sender unit 5 on the hook block

The installation of the radio sender unit 5 on the respective hook block is required to be able to ensure during parallel operation of winch 1 and winch 2 (1112) via the incline display in the respective winch icons that the hook block does not get into an impermissible incline position.

Make sure that the following prerequisites are met:

- The hook block is placed on the ground.
- The hook block has the required retainer **2** for the assembly of the radio sender unit.
- The side of the hook block on which the radio sender unit **5** is installed is facing the crane cab with a freely suspended hook block.
- The radio sender unit **5** batteries are sufficiently charged.



WARNING

Load ripping off!

If the hook block gets into an impermissible incline position during parallel operation of winch 1 and winch 2 (11I2), then the hook block can be overloaded.

The load can rip off and fall down.

Death, severe bodily injuries, property damage.

- ▶ Make sure that the radio sending unit **5** is properly installed on the hook block.
- ▶ Make sure that the incline display in the LICCON computer system is constantly monitored during crane operation, see the Crane operating instructions, chapter 4.02.



Note

- ▶ The assembly of the radio sender unit **5** on the respective hook block is described as an example.
- ▶ The example assembly of the radio sender unit **5** is identical to the assembly of the radio sender unit **5** on additional hook blocks approved for parallel operation.

The radio sender unit **5** is screwed onto the assembly plate **4**.

- ▶ Retract the assembly plate **4** of the radio sender unit **5** with the fork connections inpoint **P1** on the axle **3** of the retainer **2**.



WARNING

Incorrect orientation of the radio sender unit **5** with the crane.

In the case of incorrect orientation of the radio sender unit **5** with the crane, the incline indicator reacts laterally reversed.

If the incline indicator reacts laterally reversed, there is a danger of accident when spooling the hoist winch up and out.

- ▶ The side of the hook block with the installed radio sender unit **5** must face the crane cab.

When the assembly plate **4** of the radio sender unit **5** is positioned properly in the retainer **2**:

- ▶ Insert the pin **6** inpoint **P2** and secure properly with the locking pin **7**.

NOTICE

Damage to the radio sender unit **5**!

- ▶ Make sure that the radio sender unit **5** is not damaged when handling with the hook block.
- ▶ Protect the radio sender unit **5** from damage.

3.2 Disassembling the radio sender unit on the hook block

Make sure that the following prerequisite is met:

- The hook block is placed on the ground.
- ▶ Release the radio sender unit **5**: Remove the locking pin **7** and unpin the pin **6** in point **P2**.
- ▶ Lift out the radio sender unit **5** and store it properly.
- ▶ Insert the pin **6** again in point **P2** and secure properly with the locking pin **7**.
- ▶ Remove the batteries when the radio sender unit is not used for a longer period of time. Observe the section „Batteries in the radio sender unit“.

4 Batteries in the radio sender unit

Batteries in the radio sender unit:

- check and use during assembly of the radio sender unit
- remove during disassembly of the radio sender unit
- replace if insufficiently charged



Note

- ▶ The representation of the installation position of the radio sender unit is an example and may not apply exactly to your hook block.
- ▶ Depending on the crane type and / or equipment, the radio sender unit may have a different design, see variation 1 and variation 2.
- ▶ The batteries installed in the factory can be used as a model.

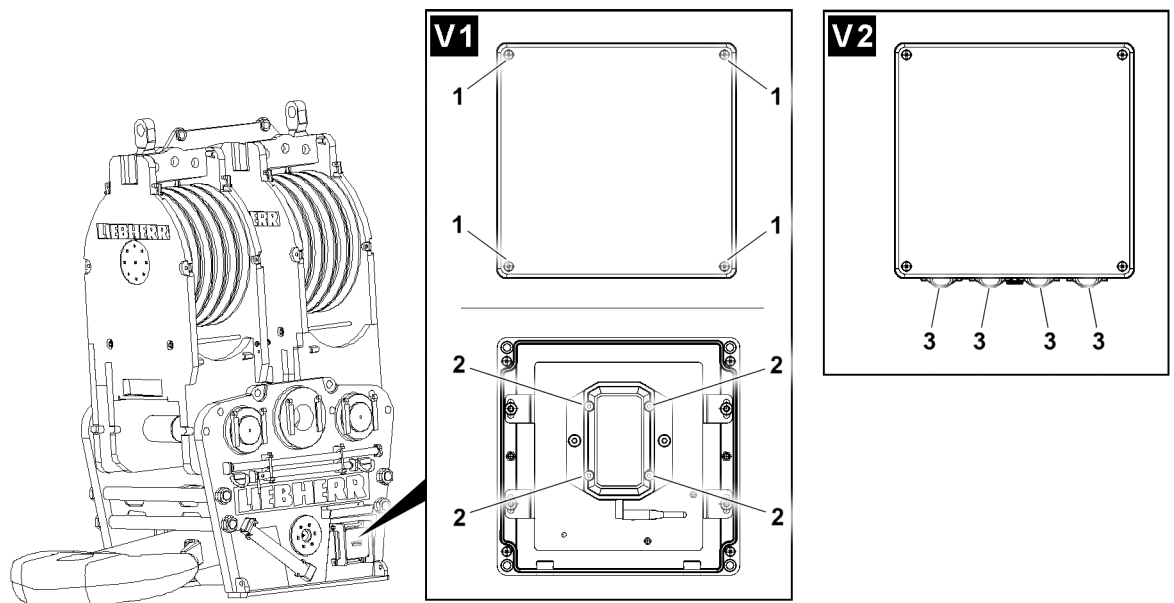

Fig.160474: Removing / replacing batteries in the radio sender unit

V1 Radio sender unit variation 1
1 Screws (terminal box)
2 Screws (housing)

V2 Radio sender unit variation 2
3 Battery compartments

NOTICE

Destruction and failure of the radio sender unit!

If old and new batteries are used together, the batteries can run out.

The performance is limited to the weakest of all batteries in the radio sender unit.

Property damage, failure of the radio incline sensor.

- ▶ Replace all batteries at the same time. Only use new, high-quality batteries.
- ▶ Only use the same type of batteries. The type and manufacturer must be the same.
- ▶ Remove the batteries when the radio sender unit is not used for a longer period of time.
- ▶ Dispose of used batteries properly.

NOTICE

Penetration of water in the radio sender unit!

If the radio sender unit is not closed correctly, water can enter and destroy the radio sender unit.

Property damage, failure of the radio incline sensor.

- ▶ Correctly reclose an open cover.

4.1 Radio sender unit variation 1:



Note

If the wrong screws are loosened, the radio sender unit can move and supply incorrect values.
 ▶ Only release screws **1** and screws **2**.

Radio sender unit variation 1 **V1** must be unscrewed so that the four batteries are accessible.

Suitable batteries:

- Cell size: Type C – LR14 / AM-2 / R14 / UM-2
- Voltage: Alkaline 1.5 V / Lithium 2.9...3.6 V

4.1.1 Open the radio sender unit:

- ▶ Release four screws **1**. Remove the terminal box cover.
- ▶ Release four screws **2**. Remove the housing cover.
- ▶ Take out the batteries.

Result:

- The batteries can be checked, replaced or removed.

4.1.2 Handling the batteries:

When the battery are checked:

- ▶ If one battery is poorly charged, always replace all batteries together.

When the batteries are replaced:

- ▶ Use only suitable batteries.

When battery are removed for a long period of time:

- ▶ Store the batteries properly.

When the batteries are used:

- ▶ Insert the batteries in the right direction.

4.1.3 Close the radio sender unit:

- ▶ Position the housing cover. Tighten the four screws **2** crosswise.
- ▶ Check that the housing cover is positioned correctly.
- ▶ Position the terminal box cover. Tighten the four screws **1** crosswise.
- ▶ Check that the terminal box cover is positioned correctly.

4.2 Radio sender unit variation 2:



Note

- ▶ With radio sender unit variation 2, the state of charge can be read on the LICCON monitor, see chapter 4.02.

Radio sender unit variation 2 **V2** has battery compartments **3** on the bottom that are accessible from the outside.

The four batteries can be replaced without tools. Alkaline primary cells with approx. 16.5 Ah shall be used preferably.

Suitable batteries:

- Cell size: Single cell type D – LR 20
- Voltage: 1.5 Volt
- Capacity: 16.5 Ah (preferably)

4.2.1 Battery compartments open:

- ▶ Screw off the battery compartment **3** cover.

- ▶ Take out the batteries.

Result:

- The batteries can be checked, replaced or removed.

4.2.2 Handling the batteries:

When the battery are checked:

- ▶ If one battery is poorly charged, always replace all batteries together.

When the batteries are replaced:

- ▶ Use only suitable batteries.

When battery are removed for a long period of time:

- ▶ Store the batteries properly.

When the batteries are used:

- ▶ Insert the batteries in the right direction.

4.2.3 Close the battery compartments:

- ▶ Position the battery compartment **3** and screw closed.
- ▶ Check that the cover is positioned correctly on the battery compartment **3**.

5 Radio sender unit and radio receiving unit park position



Note

- ▶ Not available on all crane types.

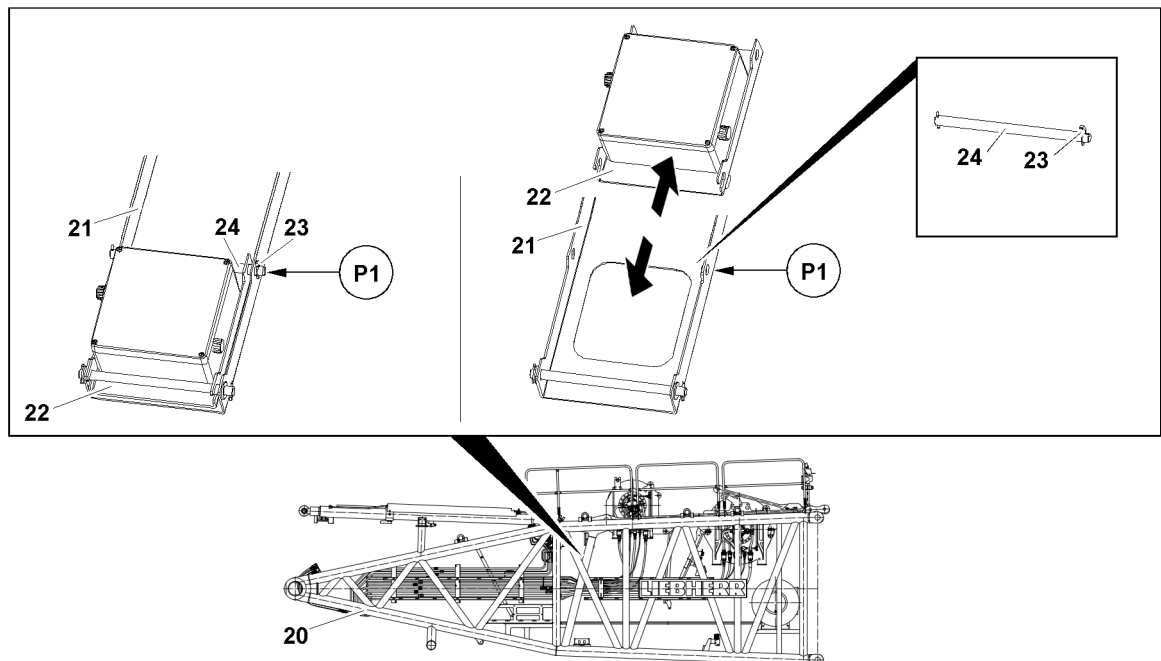

Fig.160475: Radio sender unit and radio receiving unit park position

Usually there are two retainers **21** on the main boom pivot section **20** as park positions. The assembly plates **22** with the radio sender unit and radio receiving unit can be mounted there.

**Note**

- ▶ If there are no park positions on the main boom pivot section **20**, the radio sender unit and radio receiving unit must be stored in another manner.
- ▶ Remove the batteries when the radio sender unit is not used for a longer period of time. Observe the section „Batteries in the radio sender unit“.

5.1 Taking the radio sender unit and radio receiving unit out of the park position

When the assembly plate **22** with the radio sender unit or the radio receiving unit is in one of the retainers **21**:

- ▶ Remove the locking pin **23** in point **P1** and unpin the pin **24**.
- ▶ Pull out the assembly plate **22** with the radio sender unit or the radio receiving unit.
- ▶ Insert the pin **24** again in point **P1** and secure with the locking pin **23**.

5.2 Bringing the radio sender unit and radio receiving unit into the park position

When the assembly plate **22** with the radio sender unit or the radio receiving unit should be parked in one of the retainers **21**:

- ▶ Remove the locking pin **23** in point **P1** and unpin the pin **24**.
- ▶ Push in the assembly plate **22** with the radio sender unit or the radio receiving unit.

When the bores of the retainer **21** and assembly plate **22** align in point **P1**:

- ▶ Insert the pin **24** again and secure with the locking pin **23**.

5.30 Pin pulling device

1	Pin pulling device	2
2	Hydraulic oil level, hydraulic oil, hydraulic oil pressure	6
3	Pinning and unpinning with the pin pulling device	7

1 Pin pulling device

The pin pulling device consists of the hydraulic aggregate and the pin pulling cylinders. The connector pins on the crawler crane and on the lattice sections are pinned and unpinned with these pin pulling cylinders. In doing so the hydraulic aggregate remains on the ground and can be positioned near the pin location, outside of the danger zone.

1.1 Hydraulic aggregate on wheels with „emergency control“ function

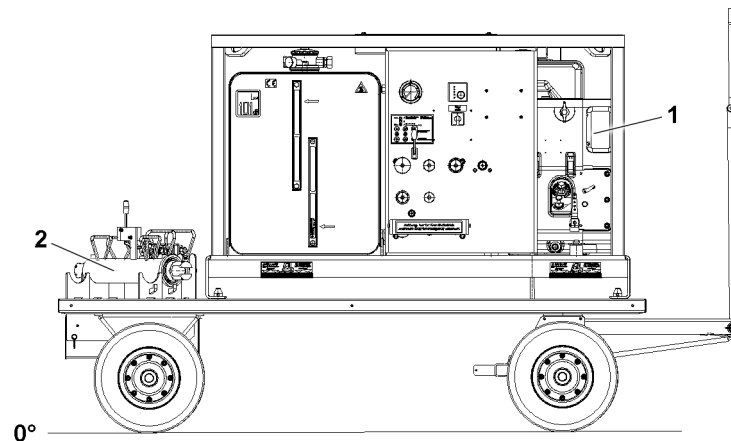

Fig.151398: Hydraulic aggregate on wheels with „emergency control“ function

1 Hydraulic aggregate

2 Pin pulling cylinder

1.2 Hydraulic aggregate on wheels without „emergency control“ function

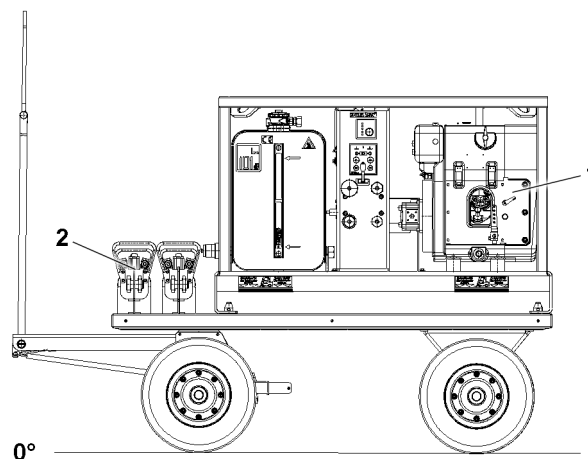

Fig.151399: Hydraulic aggregate on wheels without „emergency control“ function

1 Hydraulic aggregate

2 Pin pulling cylinder

1.5 Pin pulling cylinder

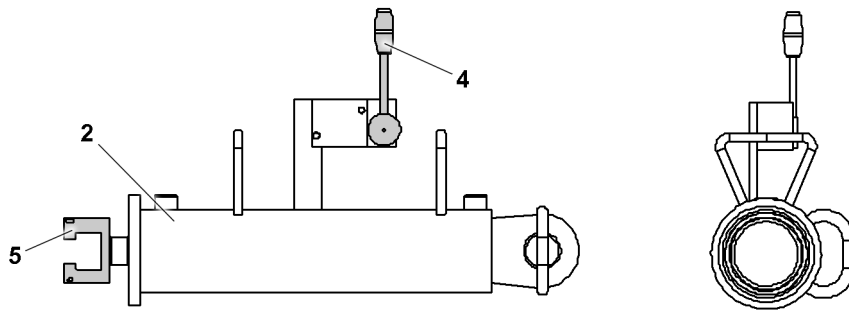

Fig.151408: Pin pulling cylinder

2 Pin pulling cylinder
4 Lever

5 Piston rod head

1.6 Description of the function

1.6.1 Pin pulling cylinder

The pin pulling cylinder has an engaging valve that can set the movement direction of the cylinder.

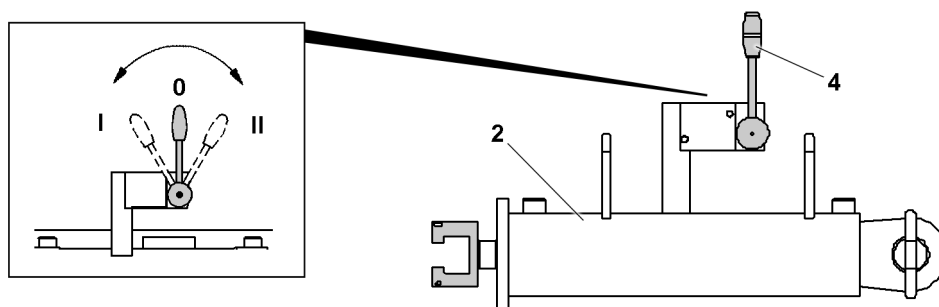

Fig.157045: Pin pulling cylinder

2 Pin pulling cylinder

4 Lever

Lever settings:

- **0 position:** Neutral position.
- **I position:** Extend the piston rod head **5**.
- **II position:** Retract the piston rod head **5**.



Note

- ▶ The weight of the pin pulling cylinder is approx. 25 kg.

1.6.2 Hydraulic aggregate

There are different structural versions of the pin pulling aggregates. In principle, there are two different categories. The hydraulic aggregates that have three setting options, „pressureless“, „low pressure“ and „high pressure“ and those that do not have a switch setting for pressureless circulation, and can only be operated with „low pressure“ and „high pressure“. The hydraulic aggregates are depressurized by switching off the engine. The hoses for connecting the hydraulic aggregate and the pin pulling cylinder can only be connected in a depressurized condition.

**Note**

- ▶ Operate the hydraulic aggregate, see the Operating and maintenance instructions for the hydraulic aggregate.
- ▶ The illustrated hydraulic aggregate is shown as an example and may not exactly match your crane.
- ▶ Lever settings, see the Operating and maintenance instructions for the hydraulic aggregate.

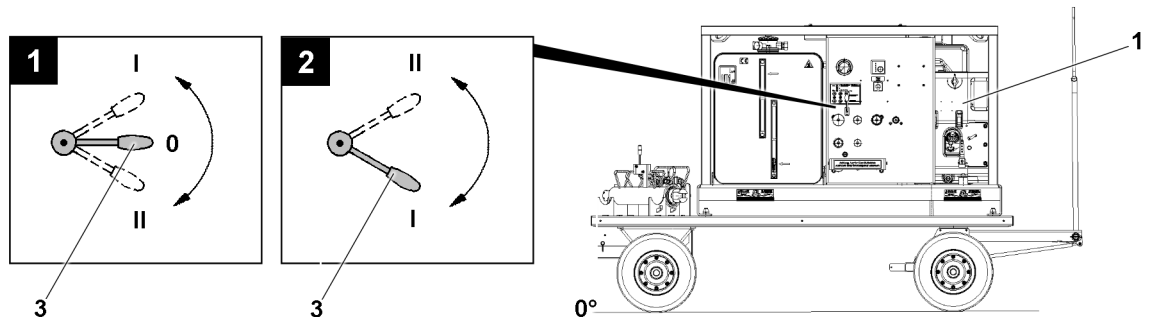

Fig.157047: Hydraulic aggregate

1 Hydraulic aggregate

3 Lever

Lever settings, see illustration 1:

- **0 position:** Neutral position
- **I position:** Low pressure: 30 bar
- **II position:** High pressure: ≥ 210 Bar , not engaging, spring return

Lever settings, see illustration 1:

- **0 position:** Low pressure: 30 Bar , spring centered
- **I position:** High pressure: ≥ 210 Bar , not engaging, spring return
- **II position:** High pressure: ≥ 210 Bar , engaging with lock, only for emergency operation

Lever settings, see illustration 2:

- **I position:** Low pressure: 30 Bar , spring centered
- **II position:** High pressure: ≥ 210 Bar , not engaging, spring return

The **low pressure** setting serves either for positioning the pin pulling cylinder or for pinning / unpinning a „non-tensioned“ pin.

A „tensioned“ pin can also be pulled with the **high pressure** setting.

**Note**

- ▶ Operation with the tele lift truck: The **low pressure** and **high pressure** are set from the tele lift truck.
- ▶ Operation with the tele lift truck, see the Operating and maintenance instructions for the tele lift truck.

**WARNING**

High pressure operation!
Death, severe bodily injuries, property damage.

- ▶ Make sure that when operating the pin pulling cylinder in high pressure operation, no one is located in the danger zone of the pin location, and in particular below or on the parts to be pinned or separated.
- ▶ It is only permitted to control the pin pulling cylinder in high pressure operation by actuating the valve on the hydraulic aggregate.

**WARNING**

Impermissible work position for the hydraulic aggregate!

If a hydraulic aggregate is placed on boom components or crane components for assembly purposes, this can cause accident situations.

Operating personnel can fall down from the grating of the boom component if the grating is overloaded by the hydraulic aggregate positioned on it.

The grating for the boom components is permitted for the weight of only two people.

Death, severe bodily injuries, property damage.

- ▶ Make sure that a hydraulic aggregate is never placed on boom components or crane components.
- ▶ The hydraulic aggregate may only be operated on the ground.

2 Hydraulic oil level, hydraulic oil, hydraulic oil pressure

**Note**

- ▶ The hydraulic oil tank is filled when starting the hydraulic aggregate.
- ▶ Check the hydraulic oil level, see Operating and maintenance instructions for the Hydraulic aggregate.

NOTICE

Emerging hydraulic oil!

When the hydraulic aggregate is changed and / or the operational crane hydraulic is connected, then there is a danger that the hydraulic oil is supplied during the working process into the hydraulic tank circuit and thus forwarded into the hydraulic tank of the hydraulic aggregate.

The forwarded hydraulic oil quantity exceeds the tank volume of the hydraulic aggregate. Hydraulic oil runs over and contaminates the environment.

- ▶ Make sure that the hydraulic aggregate is separated from the hydraulic circuit of the crane before hydraulic components are actuated via the crane hydraulic.
- ▶ Make sure that the work process is started and ended with the same hydraulic aggregate.
- ▶ Make sure that the same amount of hydraulic oil is in the hydraulic oil tank of the hydraulic aggregate before use and after use.

**WARNING**

Loss of pressure or leakage!

Incorrectly coupled or self-loosening quick couplings (particularly return lines) can result in serious accidents due to component failure.

Death, severe bodily injuries, property damage.

- ▶ Check that the quick couplings have been properly connected before using the crane.
- ▶ Connect the coupling components (sleeve and connector) and screw together with the knurled nut.
- ▶ Tighten the hydraulic coupling by hand. Turn the knurled nut until it reaches a tangible, fixed stop position.

**WARNING**

Pressure in the hydraulic lines!

If the pressure supply is not interrupted before connecting / releasing the hydraulic lines, the hydraulic oil can escape with high pressure.

Death, severe bodily injuries, property damage.

- ▶ Release the pressure in the hydraulic system before connecting / disconnecting: Interrupt the pressure supply and wait for a short time.

3 Pinning and unpinning with the pin pulling device



WARNING

Danger to operating personnel!

When pinning / unpinning the pins on the components, components can move uncontrolled. Persons and objects can be caught by moving structural parts and be dragged along.

Death, severe bodily injuries, property damage.

- ▶ It is prohibited for personnel to remain in the entire danger zone!
- ▶ Only stand on fixed components, not on the one to pin / unpin.



DANGER

Danger of accident!

When you disassemble unsecured or unsupported crane parts, they can fall down.

Death, severe bodily injuries, property damage.

- ▶ Never stand under unsecured or unsupported crane parts and unpin the pins.
- ▶ Never unpin the connector pins on unsecured or unsupported booms.
- ▶ Do not stand under the crane parts or within the complete danger zone during the pinning and unpinning procedure.
- ▶ Support the components and boom.
- ▶ Do not lean the ladder against the crane part being disassembled.

Before assembly and disassembly observe the safety instructions:

- Information regarding personal protective equipment. See chapter 2.04.
- Information regarding fall protection equipment. See chapter 2.06.
- Information regarding walking surfaces and stepping surfaces. See chapter 2.07.
- Technical safety instructions for assembly and disassembly. See chapter 5.01.

3.1 Preparatory work

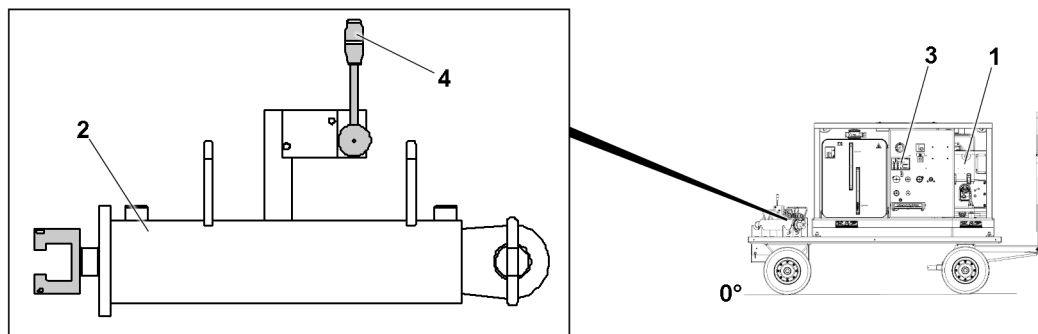

Fig.157052: Hydraulic aggregate with pin pulling cylinder

- | | | | |
|---|----------------------|---|-------|
| 1 | Hydraulic aggregate | 3 | Lever |
| 2 | Pin pulling cylinder | 4 | Lever |



Note

- ▶ Operate the hydraulic aggregate, see the Operating and maintenance instructions for the hydraulic aggregate.
- ▶ The illustrated hydraulic aggregate is shown as an example and may not exactly match your crane.
- ▶ Lever settings, see the Operating and maintenance instructions for the hydraulic aggregate.

Make sure that the following prerequisites are met:

- The pin pulling cylinder 2 are connected to the hydraulic supply.
- The hydraulic aggregate 1 is not yet started.
- The lever 3 is in the **low pressure position** or in the **0 position**.
- The lever 4 is in the **0 position**.

**Note**

- ▶ The weight of the pin pulling cylinder is approx. 25 kg.

**WARNING**

Pin pulling cylinder held manually!

Danger of falling due holding the pin pulling cylinder **2** manually.

- ▶ Use the auxiliary crane to bring the pin pulling cylinder **2** to the correct height.
- ▶ Bring the pin pulling cylinder **2** to the position to be pinned.
or
Use the auxiliary crane to bring the pin pulling cylinder **2** to the correct height.

3.2 Pinning or unpinning pins, pin location variation I

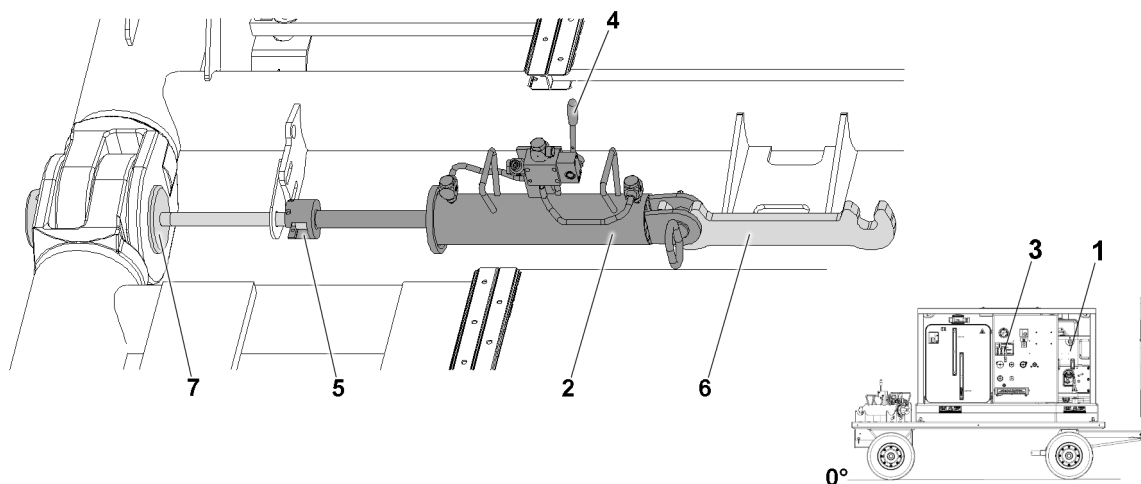

Fig.157048: Pin pulling cylinder

- | | | | |
|---|----------------------|---|-----------------|
| 1 | Hydraulic aggregate | 5 | Piston rod head |
| 2 | Pin pulling cylinder | 6 | Retainer |
| 3 | Lever | 7 | Pin |
| 4 | Lever | | |

**Note**

- ▶ Operate the hydraulic aggregate, see the Operating and maintenance instructions for the hydraulic aggregate.
- ▶ The illustrated hydraulic aggregate is shown as an example and may not exactly match your crane.
- ▶ Lever settings, see the Operating and maintenance instructions for the hydraulic aggregate.

3.2.1 Pinning or unpinning not tensioned pins with low pressure

- ▶ Start the hydraulic aggregate motor on the hydraulic aggregate **1**.
- ▶ Set the engine rpm on the hydraulic aggregate **1**.
- ▶ Set the lever **3** on the hydraulic aggregate **1** to the **low pressure position**, see section „Hydraulic aggregate“.

**WARNING**

Accidental operation of the lever!

Crushing of limbs if the lever **4** is accidentally operated.

- ▶ Make sure that the lever **4** is not accidentally operated.
- ▶ Hold the pin pulling cylinder **2** only by the provided handles.

- ▶ Connect the pin pulling cylinder **2** to the retainer **6** on the component.

To set the pin pulling cylinder stroke, operate the lever **4**:

- ▶ Connect the piston rod head **5** with the screw on the pin **7**.



WARNING

Reaching into the danger zone!

Crushing of limbs when reaching into the danger zone.

- ▶ Hold the pin pulling cylinder **2** only by the provided handles.

When the pin pulling cylinder **2** is positioned securely on the pin location:

- ▶ Operate the lever **4** on the pin pulling cylinder **2**.

Result:

- The pin is pinned or unpinned with **low pressure**.

3.2.2 Pinning or unpinning tensioned pins with high pressure

The pin pulling cylinder **2** is actuated for safety reasons on the hydraulic aggregate **1**!

- ▶ Start the hydraulic aggregate **1**.
- ▶ Set the engine rpm on the hydraulic aggregate **1**.
- ▶ Set the lever **3** on the hydraulic aggregate **1** to the **low pressure position**, see section „Hydraulic aggregate“.



WARNING

Accidental operation of the lever!

Crushing of limbs if the lever **4** is accidentally operated.

- ▶ Make sure that the lever **4** is not accidentally operated.
- ▶ Hold the pin pulling cylinder **2** only by the provided handles.

- ▶ Connect the pin pulling cylinder **2** to the retainer **6** on the component.

To set the pin pulling cylinder stroke, operate the lever **4**:

- ▶ Connect the piston rod head **5** with the screw on the pin **7**.



WARNING

High pressure operation!

Death, severe bodily injuries, property damage.

- ▶ Make sure that when operating the pin pulling cylinder in high pressure operation, no one is located in the danger zone of the pin location, and in particular below or on the parts to be pinned or separated.
- ▶ It is only permitted to control the pin pulling cylinder in high pressure operation by actuating the valve on the hydraulic aggregate.

When the pin pulling cylinder **2** is positioned securely on the pin location:

- ▶ Do not set any movement direction for the pin pulling cylinder **2**, operate the lever **4**.
- ▶ Leave the pin location.

When no one is located in the danger zone:

- ▶ Set the lever **3** on the hydraulic aggregate **1** to **high pressure**, see section „Hydraulic aggregate“.

Result:

- The pin is pinned or unpinned with **high pressure**.

3.3 Pinning or unpinning pins, pin location variation II

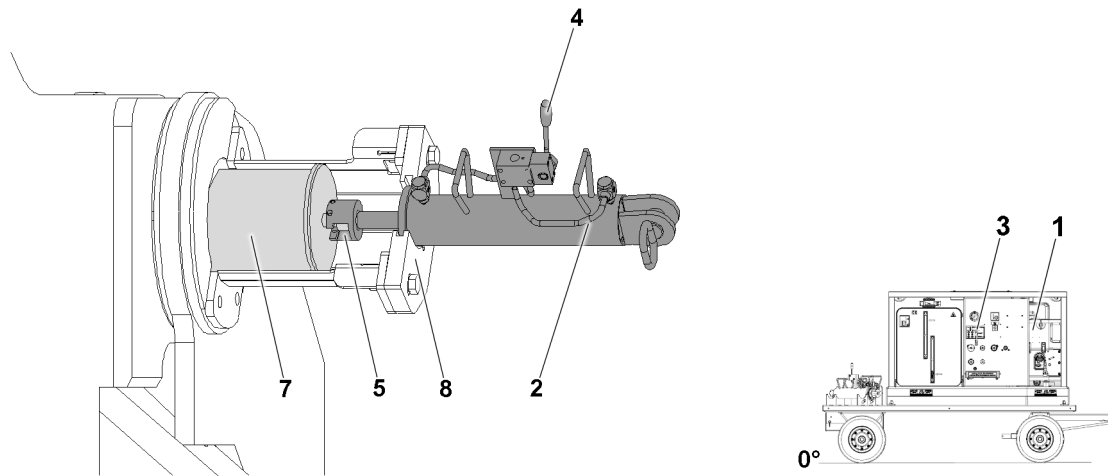

Fig.157049: Pin pulling cylinder

- | | | | |
|---|----------------------|---|-----------------|
| 1 | Hydraulic aggregate | 5 | Piston rod head |
| 2 | Pin pulling cylinder | 7 | Pin |
| 3 | Lever | 8 | Retainer |
| 4 | Lever | | |



Note

- ▶ Operate the hydraulic aggregate, see the Operating and maintenance instructions for the hydraulic aggregate.
- ▶ The illustrated hydraulic aggregate is shown as an example and may not exactly match your crane.
- ▶ Lever settings, see the Operating and maintenance instructions for the hydraulic aggregate.

3.3.1 Pinning or unpinning not tensioned pins with low pressure

- ▶ Start the hydraulic aggregate motor on the hydraulic aggregate 1.
- ▶ Set the engine rpm on the hydraulic aggregate 1.
- ▶ Set the lever 3 on the hydraulic aggregate 1 to the **low pressure position**, see section „Hydraulic aggregate“.



WARNING

Accidental operation of the lever!

Crushing of limbs if the lever 4 is accidentally operated.

- ▶ Make sure that the lever 4 is not accidentally operated.
- ▶ Hold the pin pulling cylinder 2 only by the provided handles.

- ▶ Place the pin pulling cylinder 2 with the collar to the retainer 8 on the component.

To set the pin pulling cylinder stroke, operate the lever 4:

- ▶ Connect the piston rod head 5 with the screw on the pin 7.



WARNING

Reaching into the danger zone!

Crushing of limbs when reaching into the danger zone.

- ▶ Hold the pin pulling cylinder 2 only by the provided handles.

When the pin pulling cylinder 2 is positioned securely on the pin location:

- ▶ Operate the lever 4 on the pin pulling cylinder 2.

Result:

- The pin is pinned or unpinned with **low pressure**.

3.3.2 Pinning or unpinning tensioned pins with high pressure

The pin pulling cylinder **2** is actuated for safety reasons on the hydraulic aggregate **1**!

- ▶ Start the hydraulic aggregate **1**.
- ▶ Set the engine rpm on the hydraulic aggregate **1**.
- ▶ Set the lever **3** on the hydraulic aggregate **1** to the **low pressure position**, see section „Hydraulic aggregate“.

**WARNING**

Accidental operation of the lever!

Crushing of limbs if the lever **4** is accidentally operated.

- ▶ Make sure that the lever **4** is not accidentally operated.
- ▶ Hold the pin pulling cylinder **2** only by the provided handles.

- ▶ Place the pin pulling cylinder **2** with the collar to the retainer **8** on the component.

To set the pin pulling cylinder stroke, operate the lever **4**:

- ▶ Connect the piston rod head **5** with the screw on the pin **7**.

**WARNING**

High pressure operation!

Death, severe bodily injuries, property damage.

- ▶ Make sure that when operating the pin pulling cylinder in high pressure operation, no one is located in the danger zone of the pin location, and in particular below or on the parts to be pinned or separated.
- ▶ It is only permitted to control the pin pulling cylinder in high pressure operation by actuating the valve on the hydraulic aggregate.

When the pin pulling cylinder **2** is positioned securely on the pin location:

- ▶ Do not set any movement direction for the pin pulling cylinder **2**, operate the lever **4**.
- ▶ Leave the pin location.

When no one is located in the danger zone:

- ▶ Set the lever **3** on the hydraulic aggregate **1** to **high pressure**, see section „Hydraulic aggregate“.

Result:

- The pin is pinned or unpinned with **high pressure**.

3.4 Removing the pin pulling cylinder

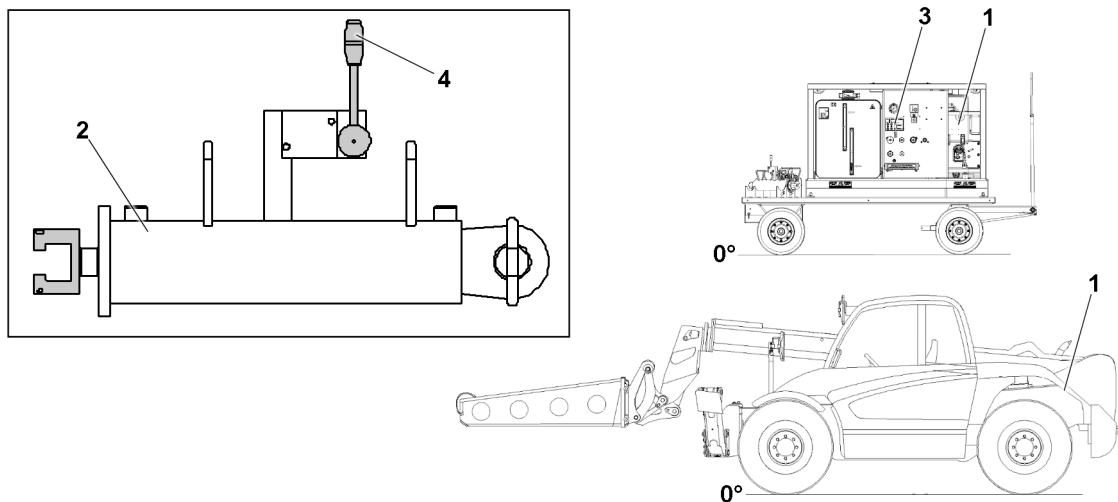

Fig.157050: Hydraulic aggregate with pin pulling cylinder

- | | | | |
|---|---------------------------------------|---|-------|
| 1 | Hydraulic aggregate / tele lift truck | 3 | Lever |
| 2 | Pin pulling cylinder | 4 | Lever |



Note

- ▶ Operate the hydraulic aggregate, see the Operating and maintenance instructions for the hydraulic aggregate.
- ▶ The illustrated hydraulic aggregate is shown as an example and may not exactly match your crane.
- ▶ Lever settings, see the Operating and maintenance instructions for the hydraulic aggregate.

When the pin 7 is successfully pinned or unpinned:

- ▶ Set the lever 3 on the hydraulic aggregate 1 to the **low pressure position** or the **0 position**, see section „Hydraulic aggregate“.
- ▶ Release the pressure in the hydraulic aggregate 1: Turn the hydraulic aggregate motor off.
- ▶ Set the lever 4 on the pin pulling cylinder 2 to the **0 position**.
- ▶ Disconnect the piston rod head 5 from the screw on the pin.
- ▶ Disconnect the pin pulling cylinder 2 from the retainer 6 or retainer 8 on the component.



WARNING

Pin pulling cylinder held manually!

Danger of falling due holding the pin pulling cylinder 2 manually.

- ▶ Carefully lower the pin pulling cylinder 2 to the ground with the auxiliary crane.
-
- ▶ Remove the pin pulling cylinder 2.
 - or**
 - ▶ Carefully lower the pin pulling cylinder 2 to the ground with the auxiliary crane.
 - ▶ Return the pin pulling cylinder 2 to the transport retainer on the hydraulic aggregate 1.
 - ▶ Disassemble the hydraulic hoses and close the connections off with dust caps.

3.5 Operating with the tele lift truck

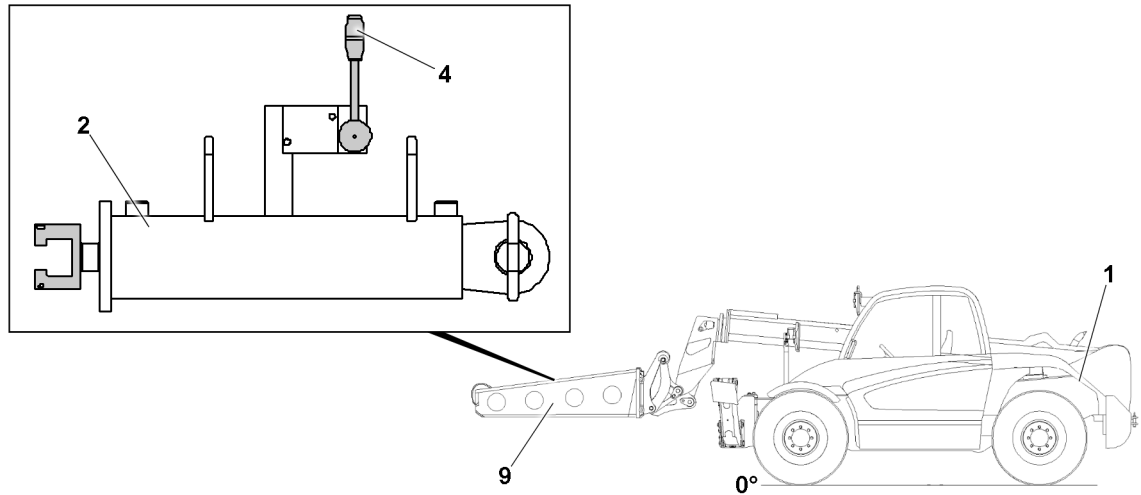

Fig.157051: Tele lift truck hydraulic aggregate

- | | | | |
|---|-------------------------------------|---|--------------|
| 1 | Tele lift truck hydraulic aggregate | 4 | Lever |
| 2 | Pin pulling cylinder | 9 | Assembly arm |



Note

- ▶ Operation with the tele lift truck, see the Operating and maintenance instructions for the tele lift truck.
- ▶ Pinning and unpinning the pin takes place using the same work steps described in the section „Pinning and unpinning with the pin pulling device“.

The pin pulling cylinder can be pulled up or lowered via the rope winch on the assembly arm.

Operation with the tele lift truck: The **low pressure** and **high pressure** are set from the tele lift truck.

Empty page!

LWE/LR 13000-001/19503-01-02/en

5.31 Bluetooth Terminal (BTT)

1	Technical safety instructions	2
2	Description of the function	3
3	BTT operating elements	3
4	BTT system start	6
5	BTT button block	8
6	BTT EMERGENCY OFF switch	9
7	Settings and status displays on the BTT	10
8	Turning the BTT on / off	11
9	Charging the BTT rechargeable battery	13
10	Start menu of the BTT	14
11	<i>Engine operation</i> menu	15
12	<i>Assembly winch</i> menu	22
13	<i>Test system</i> menu	25
14	Measures in case of problems	27
15	Inspection and maintenance	30

1 Technical safety instructions

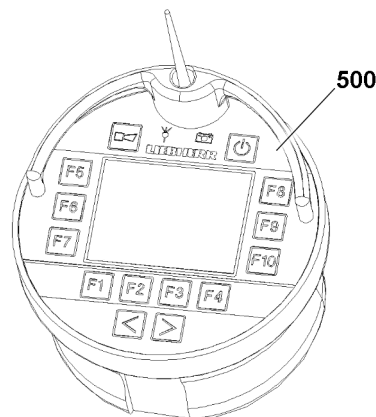

Fig.144547: BTT



Note

- ▶ The Bluetooth Terminal **500** is referred to as BTT in the description.
- ▶ The Bluetooth Basis is referred to as BTB in the description.



WARNING

Danger of accident due to operating error!
Insufficient familiarity and errors in the operation of the crane with the BTT **500** can cause accidents. Personnel can be killed or seriously injured. This could result in property damage.

- ▶ In any case, read the operating instructions completely and carefully.
- ▶ The crane may only be operated if all contents of the operating instructions / crane documentation have been understood and observed.



WARNING

Danger of accident for personnel in the danger zone!
Without a respective advance warning signal, persons in the danger zone of the crane can be surprised by a crane movement and be severely injured or killed.

- ▶ Start crane operation only when no unauthorized persons are in the danger zone.
- ▶ Before initiating a crane movement, give a warning signal (for example, press the *horn* button).

NOTICE

Improper use of the BTT!

Improper use can lead to damage / destruction of the BTT **500**.

- ▶ Protect the BTT from direct sun exposure.
- ▶ Protect the BTT from dirt and moisture.
- ▶ Keep the BTT and the charging cradle clean.
- ▶ Never clean the BTT and the charging cradle with solvents, paint thinners, cleaning fluids or other chemical substances.
- ▶ Maintenance work on the BTT may only be carried out by appropriate qualified personnel.

**Note**

Observe the following information for operation of the BTT **500**:

- ▶ The device number on the data tag of the crane cab and the device number, which is displayed at system start on the BTT-Display must match.
- ▶ The BTT can only be turned on when the EMERGENCY OFF switch on the rear is **not** actuated.
- ▶ The rechargeable battery of the BTT is only charged if the EMERGENCY OFF switch on the rear is **not** actuated when plugging it into the charging cradle.
- ▶ The operation of the BTT must be made with two hands for safety reasons, see section „Key lock on the BTT“.
- ▶ As soon as the reception of the radio signal on the BTT gets worse, the color of the indicator light for the transmission signal changes from green to yellow (weak connection) or red (no connection).
- ▶ The range of the radio signal can fluctuate due to local conditions.
- ▶ If the radio contact between the BTT and the BTB is interrupted or the EMERGENCY OFF switch on the rear of the BTT is actuated, the crane movement stops.

2 Description of the function

The BTT **500** is a combined display / operating element for the crane.

Selected crane functions can be operated with it.

The data exchange is made via the BTB on the crane.

The connection between the BTT **500** and the BTB can also be made wireless as well as via a connector cable.

The BTT **500** is operated by tapping the buttons.

**Note**

- ▶ The illustrations and the icons on the BTT display are only an example and may not match the crane exactly.

With the BTT **500** various menus can be called up, depending on the crane type.

Various crane functions can be selected or preselected, turned on or off, or directly activated in these menus.

The operation of the BTT **500** via the function keys and changeover buttons:

Function keys

- The functions of the function keys is menu dependent. See the respective menu section for an exact description.

Changeover buttons

- The functions of the changeover buttons is menu dependent. See the respective menu section for an exact description.

3 BTT operating elements

Various operating elements are necessary for starting, carrying out and ending BTT operation:

- BTT operating and control instruments
- Crane cab operating and control instruments

3.1 BTT operating and control instruments

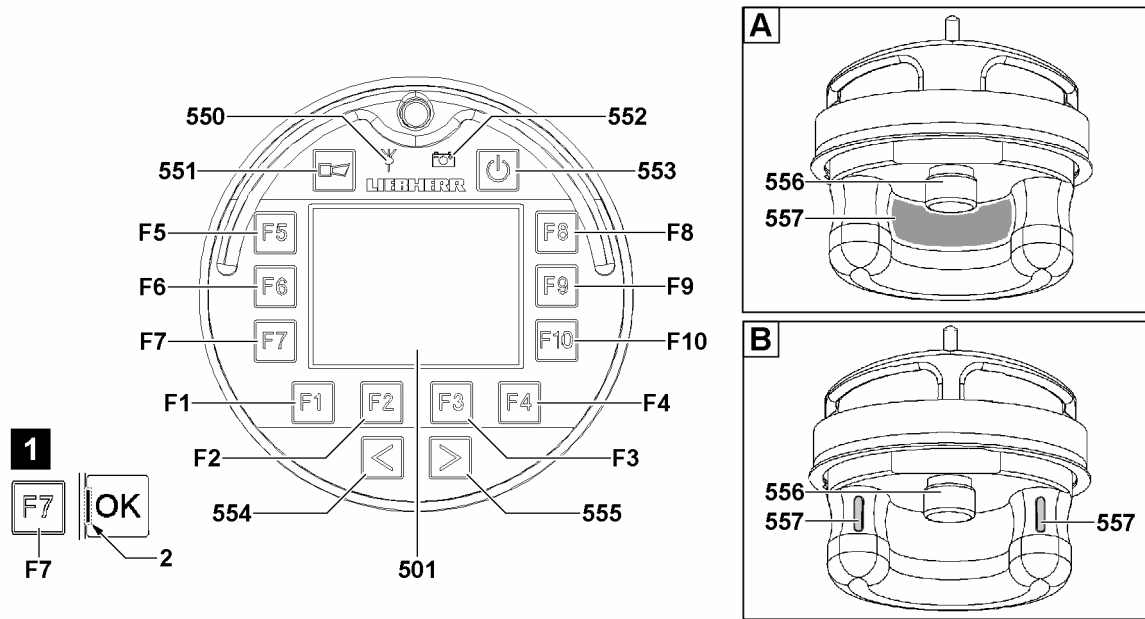

Fig.146319: BTT operating elements

A 2-hand keypad: On the inner surface

B 2-hand keypad: Button on the front side of the curvature



Note

- One of the described BTTs is used depending on the delivery condition of the crane.

501 BTT-Display

550 Transmission signal indicator light

- Indicator light *green*: Transmission signal *good*
- Indicator light *yellow*: Transmission signal *weak*
- Indicator light *red*: Transmission signal *no connection*

551 Horn *button*

- Operate the acoustic signal (horn signal)

552 Rechargeable battery indicator light

- Charge condition of the rechargeable battery on the BTT:
 - Indicator light *green*: Rechargeable battery fully charged
 - Indicator light *yellow*: Rechargeable battery almost discharged
 - Indicator light *red*: Rechargeable battery discharged

553 *On / off* button

- Turn the BTT on / off

554 Change over key

- Function depends on the displayed menu / operating screen

555 Change over key

- Function depends on the displayed menu / operating screen

556 EMERGENCY OFF switch

Note: The EMERGENCY OFF switch **556** is on the underside of the BTT.

557 2-hand keypad

- The area highlighted in gray spans the 2-hand keypad **557**

Note: The 2-hand keypad **557** must be actuated first in order to be able to actuate a movement with the BTT.

F1-F10 Function keys

- The individual function keys **F1-F10** are assigned menu dependent to various functions / icons on the BTT-Display **501**, see the respective menu description.

Note: Not all function keys have to be always assigned.

**Note**

Function keys F1–F10 assignment

- The function keys **F1-F10** are assigned to the individual functions / icons. A small bar **2** marks the respectively assigned function key, see illustration 1: example for the *OK* icon and function key **F7**.

3.2 Crane cab operating and control instruments

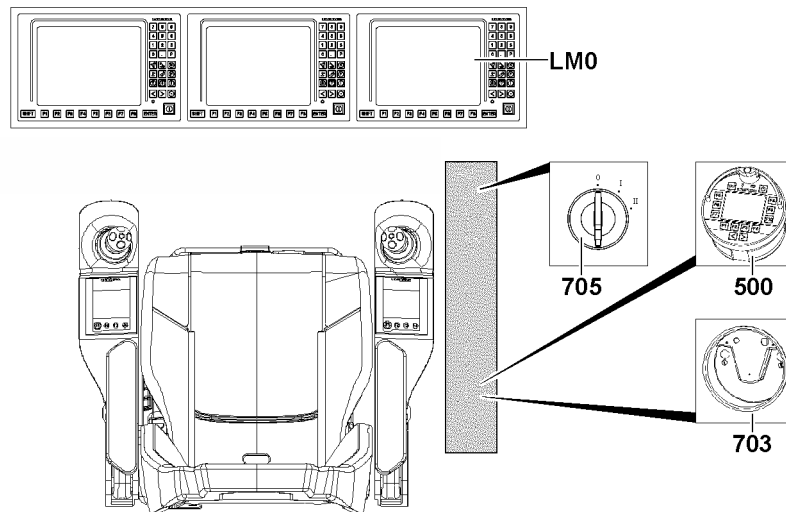

Fig.128016: Crane cab operating and control instruments

705 Crane cab ignition switch

- On the *crane cab* instrument panel

LM0 LICCON monitors

- A total of three LICCON monitors

703 Crane cab charging cradle

- To recharge the rechargeable battery, the BTT **500** must be plugged into the charging cradle **703**
- For the automatic registration of the BTT **500** on the crane, the BTT **500** must be in the charging cradle **703** when the LICCONcomputer system is booted up

**Note**

- For a detailed description of the operating and control instruments in the crane cab, see chapter 4.01.

4 BTT system start

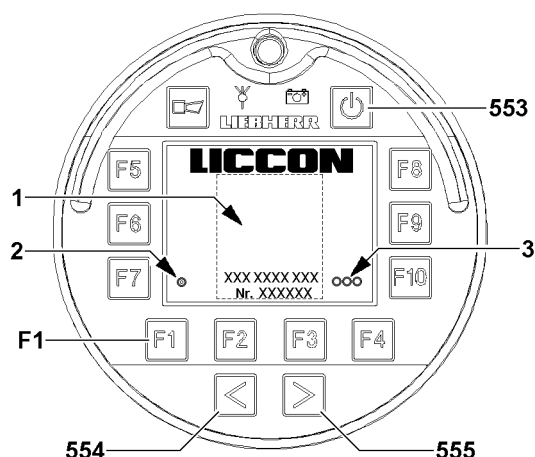

Fig.120691: System start BTT



Note

- ▶ If crane type and crane number **1** do not match with the crane, then a connection from BTT and crane is not possible.

4.1 Connection displays BTT and crane

- 1 Crane type and crane number
- 2 Indicator light
 - *Connection to BTT receiver* status display
 - Yellow / red: not connected
 - Yellow: Transmission signal being established or disconnected
 - Green with a magenta dot: Connection prepared
 - Green: Connection established
 - Red: BTT and BTB are not yet paired (Pairing)
- 3 Indicator light
 - *Code entry* status display:
 - all indicator lights **3** green: Code calibration OK.
 - at least one indicator light **3** red: No code calibration made, code calibration incorrect

4.2 Connecting the BTT automatically with the crane

To be able to control the crane via the BTT a connection must be established between the BTT and the BTB in the crane.

The connection is based on a pairing process and a code calibration.

If the BTT is plugged into the charging cradle when the ignition is turned on, then the link connection is made automatically.

- ▶ Plug the BTT into the charging cradle before turning the ignition on.

4.3 Connecting the BTT manually with the crane

If the BTT is not plugged into the charging cradle when turning the ignition on, then the code calibration must be made by hand.

Make sure that the following prerequisite is met:

- The ignition is turned on.

- ▶ Press the ON / OFF button **553**.

Result:

- The BTT turns on.
- ▶ One after the other, press the change over key **554**, then the change over key **555** and then the function key **F1**.

Result:

- All indicator lights **3** light up green: Code calibration OK.

As soon as the indicator light **2** lights up green:

- ▶ Press any function key on the BTT, for example function key **F1**.

Result:

- The start menu appears.

4.4 Pairing the BTT with the BTB (Pairing process)

A renewal of the Pairing process is only necessary when the indicator light **2** does not change to green at the end, see section „Connection displays BTT and crane“. This is the case, for example, when the BTT is replaced / changed or a change has been made to the crane software version.

To be able to connect the BTT with the crane, the BTT must be paired with the BTB of the crane (Pairing process).

When the pairing process is completed successfully, the indicator light **2** lights up green after system start.

Carry out the pairing process by hand:

- ▶ Plug the turned on BTT into the charging cradle.

Result:

- Various connecting parameters are compared and checked for a match via an infrared interface.



Note

- ▶ If the pairing process does not run successfully, contact your **Liebherr customer service center** or **Liebherr-Werk Ehingen**.

5 BTT button block

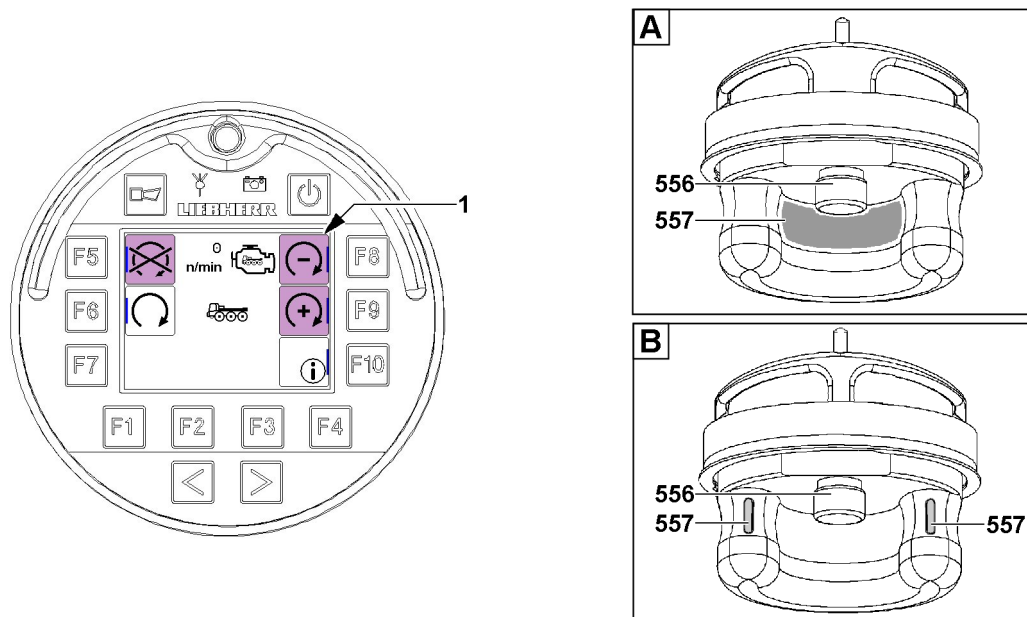

Fig.146320: Example of BTT button block

A 2-hand keypad: On the inner surface

B 2-hand keypad: Button on the front side of the curvature



Note

- ▶ The button block is solely active when the BTT is neither plugged into the charging cradle nor into the radio remote control console* (BTT-E).

To prevent inadvertent crane operation, any functions / crane movements to be carried out on the BTT are secured by a button block. The 2-hand keypad **557** can be activated with the touch of a finger and the button block is released.

5.1 Releasing the button block

Any functions / crane movements to be carried out are only released for execution after releasing the key lock. Released icons are highlighted with the color **purple 1**, see sample illustration.

If the icon is released and the respective function key is pressed, the function / crane movement is carried out.

- ▶ Touch the 2-hand keypad **557** on the rear of the BTT.

Result:

- The button block is eliminated temporarily and the functions / movements are released.



Note

- ▶ The actuation of the 2-hand keypad **557** is stored for 30 seconds. If no movement is actuated within these 30 seconds or if the 2-hand keypad **557** is not actuated, then the button block is activated again and a signal tone sounds.

6 BTT EMERGENCY OFF switch

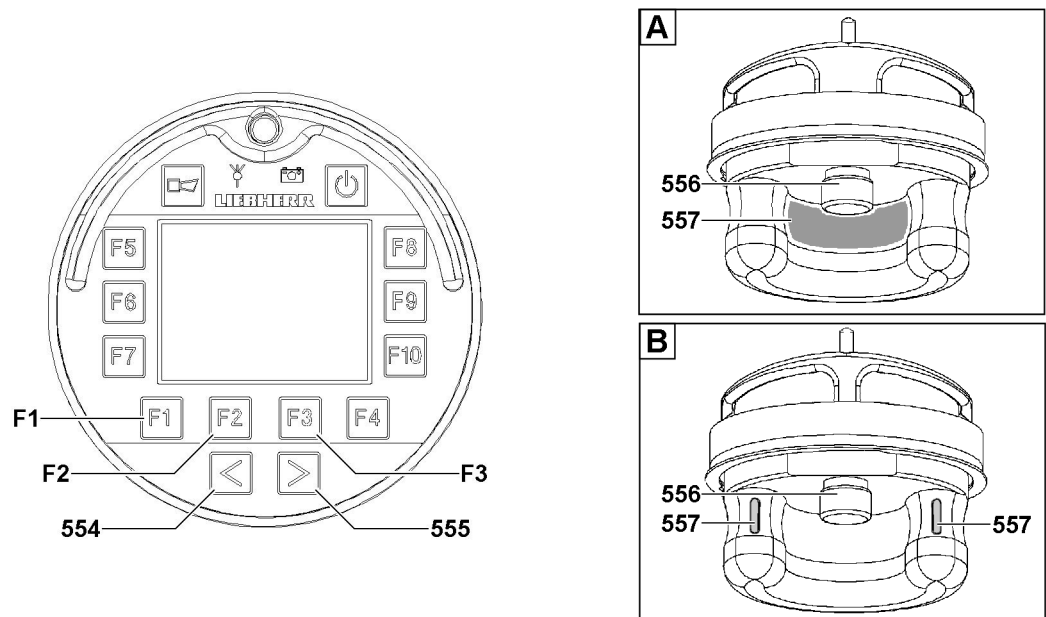

Fig.146321: Resetting the EMERGENCY STOP operating elements

A 2-hand keypad: On the inner surface

B 2-hand keypad: Button on the front side of the curvature

If the EMERGENCY STOP switch was actuated, then the switch must be released and the EMERGENCY STOP must be reset.

6.1 Triggering EMERGENCY STOP on the BTT



WARNING

Crane vibration!

Actuation of the EMERGENCY OFF switch causes the crane movements to shut off abruptly. Abrupt shut off of the crane movement can cause the crane to vibrate.

- ▶ Do not use the EMERGENCY OFF switch in operation.
- ▶ Use the EMERGENCY OFF switch solely in emergency situations.

- ▶ Press the knob of the EMERGENCY OFF switch **556**.

Result:

- Crane movements are shut off.
- Crane engine is shut off.

6.2 Resetting the EMERGENCY STOP on the BTT

Make sure that the following prerequisite is met:

- The EMERGENCY STOP was triggered on the BTT.
- ▶ Release the knob of the EMERGENCY OFF switch **556** by turning it.

Result:

- The system screen appears.
- ▶ Touch the 2-hand keypad **557**.

Carry out code calibration:

- ▶ One after the other, press the change over key **554**, then the change over key **555** and then the function key **F1**.

Result:

- The start menu appears.
- ▶ Call up engine operation: Press the button **F2** or button **F3**.

Result:

- The EMERGENCY STOP is reset.
- The crane engine can be restarted.

7 Settings and status displays on the BTT

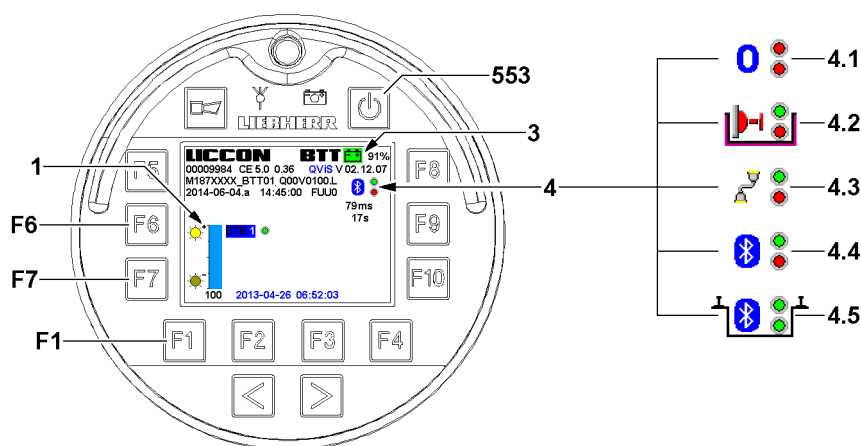

Fig.120694: BTT system screen

Settings can be made and status displays can be read on the BTT system screen.

7.1 Calling up / closing the system screen

Make sure that the following prerequisite is met:

- The start menu is displayed.
- ▶ Select the system screen: Press the *on / off* key **553** briefly (max. 1 second) until the system screen appears.

**Note**

- ▶ If the *on / off* key **553** is pressed too long, the BTT turns off.
- ▶ To switch back to the start menu: Press the function key **F1**.

7.2 Setting the brightness on the BTT-Display

The current setting stage for brightness can be read on the bar diagram 1.

- ▶ BTT-Display brighter: Press the function key **F6**.
- ▶ BTT-Display darker: Press the function key **F7**.

7.3 Determining the exact charge condition of the rechargeable battery

The exact charge condition of the rechargeable battery can be read on the charge condition display 3.

- ▶ Read the charge condition, if necessary recharge the BTT by inserting it in the charging cradle.

7.4 Checking the connection type

The connection type can be read on the connection type display **4**.

- ▶ Read the connection type.

Result:

- **4.1** No connection

- **4.2** Infrared

Note: Appears only when the BTT is plugged in the charging cradle.

- **4.3** Cable

- **4.4** Bluetooth

- **4.5** Bluetooth

Note: Appears only when the BTT is plugged in the radio remote control panel* (BTT-E).



Note

- ▶ If the upper dot of the connection type display **4** is red, then there is no connection to the crane.
- ▶ If the upper dot of the connection type display **4** is green, then there is a connection with the crane.
- ▶ If the lower dot of the connection type display **4** is red, then there is no connection to the BTT.
- ▶ If the lower dot of the connection type display **4** lights up green, then there is a connection to the BTT.

8 Turning the BTT on / off

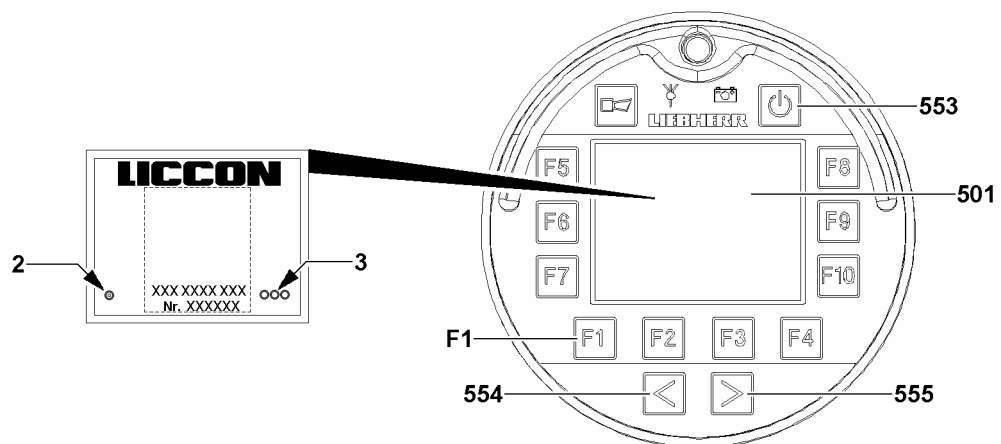

Fig.144544: Turning on / turning off / changing over the BTT operating elements

8.1 Turning on the BTT using the ignition (ignition switch)

Make sure that the following prerequisites are met:

- The BTT is plugged into the respective charging cradle.
- The battery master switch is turned on.
- The ignition is turned off.

- ▶ Turn the ignition on

Result:

- The BTT turns itself on.

- The start screen is shown momentarily on the BTT-Display **501**. As soon as the first menu is shown, the starting phase is completed.

8.2 Turning the BTT off using the ignition (ignition switch)

Make sure that the following prerequisites are met:

- The BTT is plugged into the respective charging cradle.
- The ignition is turned on.
- ▶ Turn the ignition off on the crane

Result:

- The BTT turns itself off.

8.3 Turning the BTT on using the ON / OFF button

Make sure that the following prerequisites are met:

- The BTT is pulled off the charging cradle.
- The BTT is turned off.
- The battery master switch is turned on.
- The ignition is turned off.
- ▶ Turn the ignition on.
- ▶ Turn the BTT on: Press the button **553**.

Result:

- The BTT turns itself on.
- After a short time, the start screen is shown.

Carry out Code calibration:

- ▶ Press the change over key **554**, then the change over key **555** and then the function key **F1**.

Result:

- The indicator light **2** light lights up green with a magenta dot and the indicator lights **3** light up green.
- **Note:** If at least one indicator light **3** lights up red: No code calibration made, code calibration incorrect.
- The connection between the BTT and the receiver is established.
- ▶ Press any function key.

Result:

- The start menu of the *BTT* appears on the BTT .

8.4 Turning the BTT off via the ON / OFF button

Make sure that the following prerequisites are met:

- The BTT is turned on.
- The BTT is pulled off the charging cradle.
- ▶ Turn the BTT off: Press the button **553**.

Result:

- The BTT shuts down and then turns itself off.



Note

- ▶ If the BTT is in the charging cradle when the ignition is turned on, then it cannot be turned off. The system screen appears instead.

9 Charging the BTT rechargeable battery

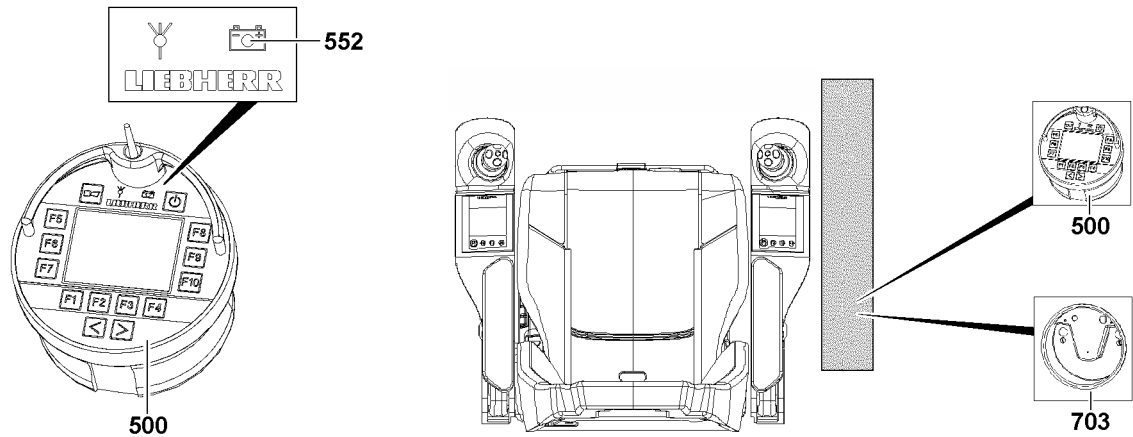

Fig.161667: Charging the BTT rechargeable battery

The rechargeable battery discharges after a long operating duration. As the state of charge of the BTT rechargeable battery decreases, the color of the *rechargeable battery* indicator light **552** changes from green to yellow to red.



WARNING

No transmission signal!

If the state of charge of the BTT rechargeable battery is insufficient, the transmission signal cannot be maintained.

Crane movements / travel movements and the crane engine are turned off in an uncontrolled manner. The crane can no longer be controlled.

- ▶ Continuously check the *rechargeable battery* indicator light **552**.
 - ▶ Make sure the rechargeable battery is charged sufficiently.
-
- ▶ To recharge the rechargeable battery, plug the BTT **500** into the charging cradle **703**.
 - ▶ Determine the exact state of charge of the rechargeable battery, see section „Settings and status displays on the BTT“.

10 Start menu of the BTT

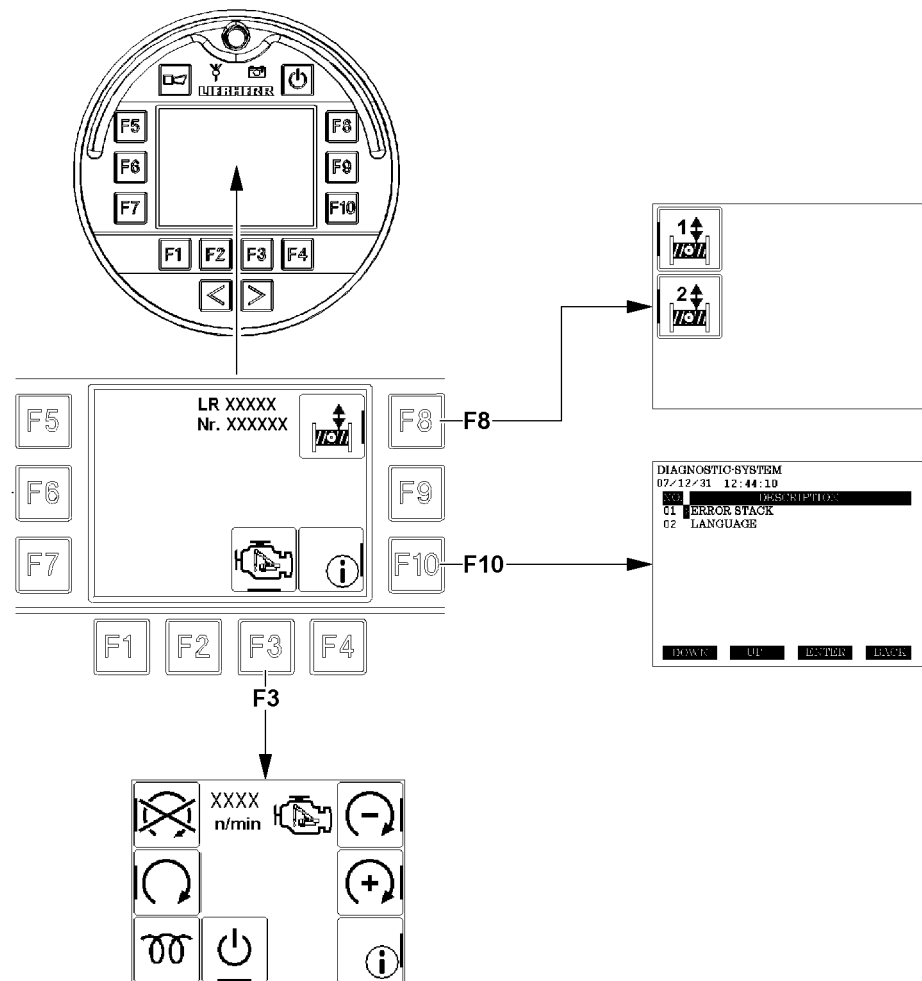

Fig.157723: Start menu of the BTT

F3	Engine operation menu ¹⁾
>> F1	-back to the start menu-
>> F2	Turn the ignition on / off ²⁾
>> F5	Turn the engine off
>> F6	Turn the engine on
>> F8	Decrease the engine rpm
>> F9	Increase the engine rpm
>> F10	Call up the test system

1) Both engines are operated in parallel.

2) Only available in certain situations.

F8	Assembly winch menu
>> F1	-back to the start menu-
>> F2	spool the selected assembly winch out
>> F3	spool the selected assembly winch up
>> F5	Select / deselect assembly winch 1
>> F6	Select / deselect assembly winch 2

F10	Test system
Note: The test system can be called up at any time. If an error message for the LICCON computer system is present, then an error text can be viewed.	

11 Engine operation menu

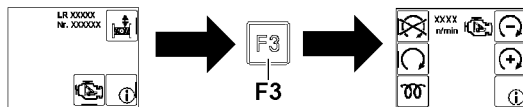

Fig.157724: Switching from the start menu to the engine operation menu



Note

The crane has two engines.

Both engines are operated and monitored in parallel via radio operation.

- ▶ Information is provided separately for both engines on the LICCON monitor, see the Crane operating instructions, chapter 4.02.

11.1 Icons in the Engine operation menu

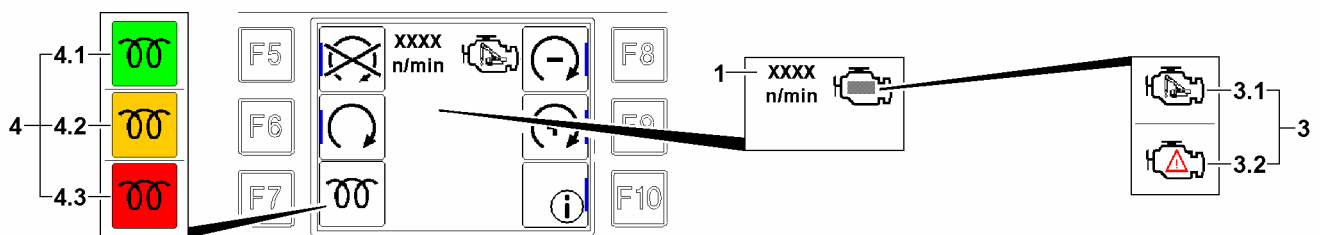

Fig.157685: Icons in the Engine operation menu

- Engine rpm
 - Actual engine rpm
- Engine monitoring
 - 3.1 Engine monitoring reports no problems
 - 3.2 Engine monitoring reports a warning event
 - NOTICE!:** Find the cause immediately and remedy it!
- Monitoring indicator
 - 4.1 Monitoring indicator lights up green: Engine ready to start
 - 4.2 Monitoring indicator lights up yellow: Engine preheating is active
 - 4.3 Monitoring indicator lights up red: Engine not ready to start

11.2 Function keys in the *Engine operation* menu

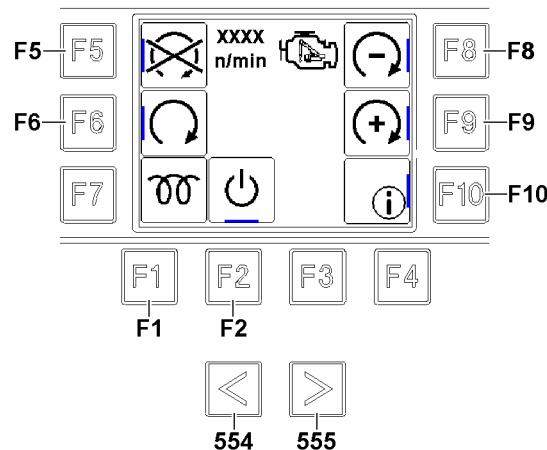

Fig.157686: Function keys in the *Engine operation* menu



Note

- Both engines are operated in parallel via radio operation.



Note

A control release must be issued to control some functions: The corresponding icons must be highlighted in purple.

- The control release is issued by pressing the 2-hand keypad, see section „Release of the button block on the BTT“.

554 Change over key

- Call up *engine* monitoring functions

555 Change over key

- Call up *engine* monitoring functions

F1 Function key

- Back to the start menu or the menu overview

Note: Depends on which level from which the *engine operation* menu was called up

F2 Function key

- Turn the ignition on

Note: Appears only for certain crane types in certain situations.

F5 Function key

- Press long: Turn the engine off
- Press momentarily (less than 0.5 seconds): Reset settings in the *Engine operation* menu

F6 Function key

- Turn the engine on

F8 Function key

- Decrease the engine rpm

Note: The changed engine rpm will remain stored until the next change is made.

F9 Function key

- Increase the engine rpm

Note: The changed engine rpm will remain stored until the next change is made.

F10 Function key

- Call up the *Test system* menu

11.3 Engine monitoring functions

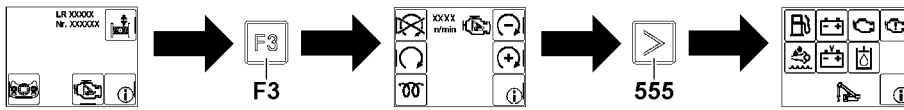

Fig.157725: Switching from the start menu to the engine monitoring functions



WARNING

Messages / warnings for the *engine* monitoring functions ignored!

If messages / warnings for the *engine* monitoring functions are ignored, problems can occur.

If problems are not immediately rectified, the crane can fail and dangerous situations may occur. Personal injury and property damage can result.

- ▶ Remedy the problem immediately.



WARNING

Triggers power reduction or start block of the engine!

If the urea level is too low or if there is a malfunction in the exhaust aftertreatment, then a power reduction or starting block of the engine can be triggered.

The crane operation and travel operation can be limited or disabled.

- ▶ Replenish the Urea level in time.
- ▶ Remedy the faulty function of the exhaust aftertreatment immediately.
- ▶ Observe any valid national / regional regulations and the vehicle configuration.



Note

- ▶ Both engines are monitored in parallel via radio operation.

Messages / warnings of the *engine* monitoring functions can be displayed by:

- Display of warning icons
and / or
- audio warnings
and / or
- Automatic, situation-related switching to the *engine* monitoring functions

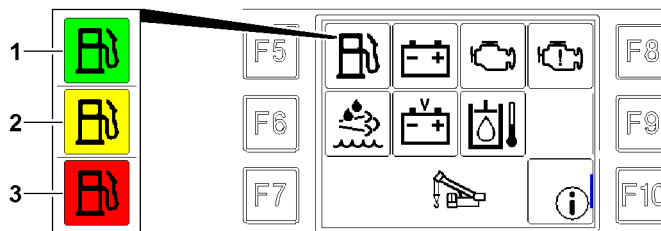

Fig.124801: Example for the colors in the icons

The colors in the icons for the monitoring functions mean:

- If a function is highlighted **green** (example icon 1), then the function is operating correctly.
- If a function is highlighted **yellow** (example icon 2), then the respective function has a problem. An advance warning is active for the *monitoring functions*.
- If a function is highlighted **red** (example icon 3), then the respective function has a problem. A warning is active for the *monitoring functions*.

11.3.1 Function keys in the *Engine* monitoring functions

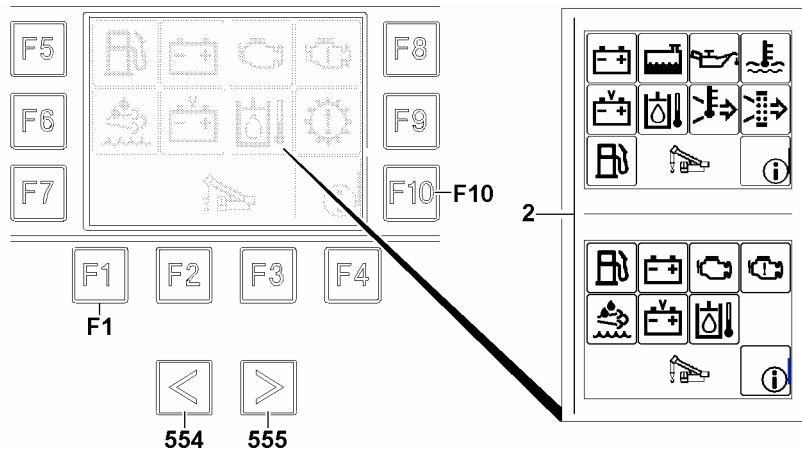

Fig.152713: Function keys in the *Engine* monitoring functions

Depending on the crane type, the depiction of the icons in the *Engine* monitoring function 2 can vary.

- 554** Change over key
 - Call up the *Engine operation* menu
- 555** Change over key
 - Call up the *Engine operation* menu
- F1** Function key
 - Back to the start menu or the menu overview

Note: Depends on which level the *Engine* monitoring functions were called up from
- F10** Function key
 - Call up the *Test system* menu

11.3.2 Icons in the *Engine* monitoring functions





Note

The scope of the monitoring functions depends on the crane type and crane configuration.

- ▶ Not all crane types have all listed monitoring functions.

	Fuel reserve
Green:	Fuel reserve is at the normal fill level, the exact display can be seen on the LICCON monitor
Yellow:	Fuel reserve is short, check the display on the LICCON monitor and add to the fuel reserve if necessary
Red:	Fuel reserve low / depleted / system error NOTICE! Immediately bring the crane to a standstill, turn the engine off and remedy the problem (add to the fuel reserve immediately / remedy the system error). Pay attention to the error message.

 Charge control display (alternator)	
Green:	Charge control OK (engine on)
Red:	Charge control has a problem (engine on) / system error NOTICE! Immediately bring the crane to a standstill, turn the engine off and remedy the problem. Pay attention to the error message.

 Exhaust aftertreatment ¹⁾	
Green:	Exhaust aftertreatment OK
Yellow / red:	Malfunction Exhaust aftertreatment or Urea level too low / system error NOTICE! Add urea or remedy the erroneous function of the exhaust aftertreatment. Under some circumstances a power reduction or start block of the engine ²⁾ is triggered, pay attention to the error message.

1) Valid only for engines equipped with an SCR system with exhaust aftertreatment.

2) The type and scope of a power reduction of the engine depends on the respectively valid national / regional regulations and the vehicle configuration. Under some circumstances, the engine starting procedure may not be possible (starting block).

 Collective warning	
Green:	No warning messages present
Generally at yellow or red:	A warning is present / system error NOTICE! Determine the cause with the error message or in the LICCON monitor and observe the following description.
Yellow:	Air intake opening / air filter dirty NOTICE! Turn the engine off immediately and remedy the problem, pay attention to the error message.
Red:	Engine oil pressure too low or too high NOTICE! Turn the engine off immediately and remedy the problem, pay attention to the error message.
Red:	Engine oil level too low or too high NOTICE! Call up engine oil level display in the LICCON monitor and match the engine oil according to the display, see chapter 4.02. Pay attention to the error message.
Red:	Coolant level too low NOTICE! Turn the engine off and add coolant, see chapter 7.04 or chapter 7.05. Pay attention to the error message.
Red:	Coolant temperature too high NOTICE! Bring the coolant temperature into a permissible range, turn the engine off if necessary. Pay attention to the error message.
Red:	Charge air temperature too high NOTICE! Bring the charge air temperature into a permissible range, turn the engine off if necessary. Pay attention to the error message.

 Urea tank / exhaust aftertreatment ¹⁾	
Green:	Urea reserve sufficient
Yellow:	The urea reserve is low or erroneous function of exhaust aftertreatment Advance warning! Add urea or remedy the erroneous function of the exhaust aftertreatment. Pay attention to the error message.
Red:	Urea level too low or erroneous function of exhaust aftertreatment system / system error NOTICE! Add urea or remedy the erroneous function of the exhaust aftertreatment. Under some circumstances a power reduction or start block of the engine ²⁾ is triggered, pay attention to the error message.

1) Valid only for engines equipped with an SCR system with exhaust aftertreatment.

2) The type and scope of a power reduction of the engine depends on the respectively valid national / regional regulations and the vehicle configuration. Under some circumstances, the engine starting procedure may not be possible (starting block).

 Battery voltage	
Green:	Battery voltage OK
Red:	Overvoltage / undervoltage in on-board power supply / system error NOTICE! Immediately bring the crane to a standstill, turn the engine off and remedy the problem. Pay attention to the error message.

 Hydraulic oil ³⁾	
Green:	Leak oil filter, return filter ³⁾ and charge pressure filter ³⁾ OK (engine on) / hydraulic oil temperature ³⁾ OK / hydraulic oil level ³⁾ OK
Red:	Leak oil filter, return filter ³⁾ and / or charge pressure filter ³⁾ dirty (engine on) / hydraulic oil temperature ³⁾ too high / hydraulic oil level ³⁾ too low / system error NOTICE! Immediately bring the crane to a standstill, turn the engine off and remedy the problem. Pay attention to the error message.

3) Only present for certain crane types.

 Hydraulic oil temperature	
Green:	Hydraulic oil temperature OK
Red:	Hydraulic oil temperature too high / system error NOTICE! Immediately bring the crane to a standstill, turn the engine off and remedy the problem. Pay attention to the error message.

 Hydraulic oil level	
Green:	Hydraulic oil level OK
Red:	Hydraulic oil level too low / system error NOTICE! Immediately bring the crane to a standstill, turn the engine off and remedy the problem. Pay attention to the error message.

 Transmission	
Green:	Transmission OK
Yellow / red:	Problem in transmission / system error NOTICE! Immediately bring the crane to a standstill, turn the engine off and remedy the problem. Pay attention to the error message.

 Coolant level	
Green:	Coolant level OK
Red:	Insufficient coolant / system error NOTICE! Immediately bring the crane to a standstill, turn the engine off and remedy the problem. Pay attention to the error message.

 Engine oil pressure	
Green:	Engine oil pressure OK (engine on)
Red:	Engine oil pressure too low (engine on) / system error NOTICE! Immediately bring the crane to a standstill, turn the engine off and remedy the problem. Pay attention to the error message.

 Coolant temperature	
Green:	Coolant temperature OK
Red:	Coolant temperature too high / system error NOTICE! Immediately bring the crane to a standstill, turn the engine off and remedy the problem. Pay attention to the error message.

 Charge air temperature	
Green:	Charge air temperature OK
Red:	Charge air temperature too high / system error NOTICE! Immediately bring the crane to a standstill, turn the engine off and remedy the problem. Pay attention to the error message.

 Engine air filter	
Green:	Air filter OK (engine on)
Yellow / red	Air filter dirty (engine on) / system error NOTICE! Immediately bring the crane to a standstill, turn the engine off and remedy the problem. Pay attention to the error message.

 Information field	
B / E:	If a <i>B (operating error)</i> or <i>E (system error)</i> appears in the information field, then at least one error message is present. Call up and evaluate the error message by pressing function key F10 on the BTT, see also the Diagnostics Manual.

12 Assembly winch menu

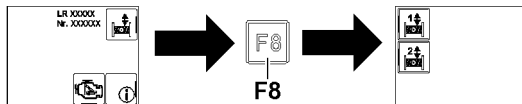

Fig.157726: Switching from the start menu to the Assembly winch menu

12.1 Function keys in the *Assembly winch* menu

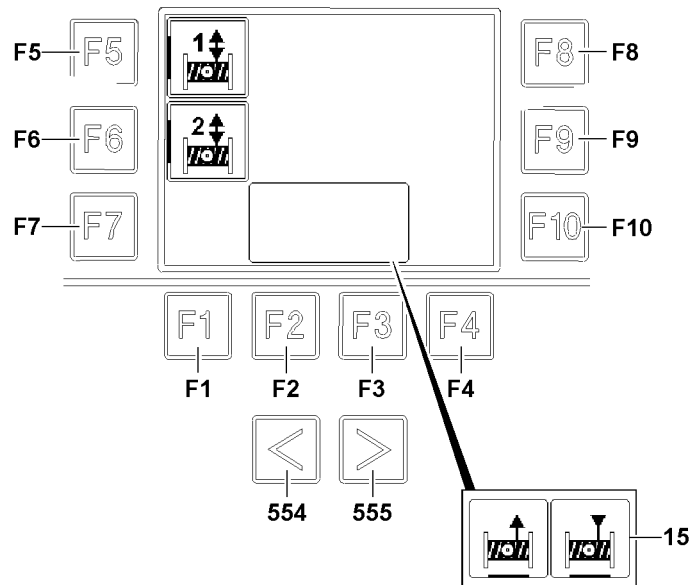

Fig.157690: Function keys in the *Assembly winch* menu

- 554** Change over key
 - Call up the *Engine operation* menu
- 555** Change over key
 - Call up the *Engine operation* menu
- F1** Function key
 - Back to the start menu
- F2** Function key
 - spool the selected assembly winch out
- F3** Function key
 - spool the selected assembly winch up
- F5** Function key
 - Select / deselect assembly winch 1
 - After selection, the operating icons **15** appear additionally
- F6** Function key
 - Select / deselect assembly winch 2
 - After selection, the operating icons **15** appear additionally
- F7** Function key
 - -No function-
- F8** Function key
 - -No function-
- F9** Function key
 - -No function-
- F10** Function key
 - -No function-

12.2 Spool assembly winch 1 out / up

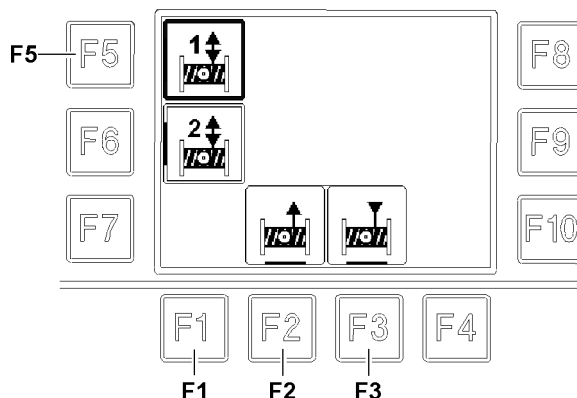

Fig.157691: Spool assembly winch 1 out / up

- **Selection / deselection of spooling the assembly winch 1 out / up:**
 - Press the function key **F5**.
 - **Result:** When the selection has been made, the border on the icon on the right of function key **F5** is bold. The icons above the function key **F2** and function key **F3** appear.
- **Control release:**
 - The control release is issued by pressing the 2-hand keypad, see section „BTT button block“.
 - After the control release is provided, the icons over the function key **F2** and function key **F3** are highlighted in purple.



Note

- ▶ To control the functions, a control release must be issued: The corresponding icons must be highlighted in purple.

- **Spool assembly winch 1 out:**
 - Press the function key **F2**.
- **Spool assembly winch 1 up:**
 - Press the function key **F3**.
- **Exit the menu:**
 - Press the function key **F1**.

12.3 Spool assembly winch 2 out / up

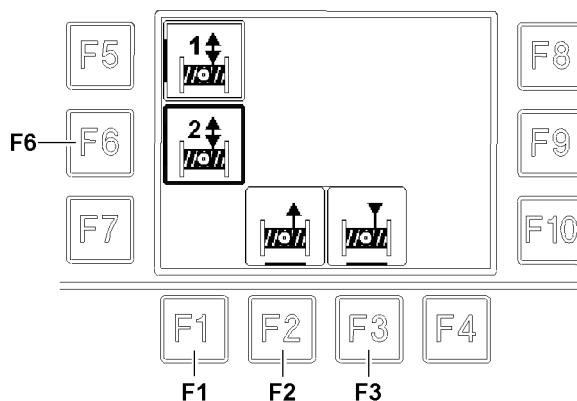

Fig.157692: Spooling assembly winch 2 out / up

- **Selection / deselection of spooling the assembly winch 2 out / up:**
 - Press the function key **F6**.
 - **Result:** When the selection has been made, the border on the icon on the right of function key **F6** is bold. The icons above the function key **F2** and function key **F3** appear.
- **Control release:**
 - The control release is issued by pressing the 2-hand keypad, see section „BTT button block“.
 - After the control release is provided, the icons over the function key **F2** and function key **F3** are highlighted in purple.

**Note**

- ▶ To control the functions, a control release must be issued: The corresponding icons must be highlighted in purple.

- **Spool assembly winch 2 out:**
 - Press the function key **F2**.
- **Spool assembly winch 2 up:**
 - Press the function key **F3**.
- **Exit the menu:**
 - Press the function key **F1**.

13 Test system menu

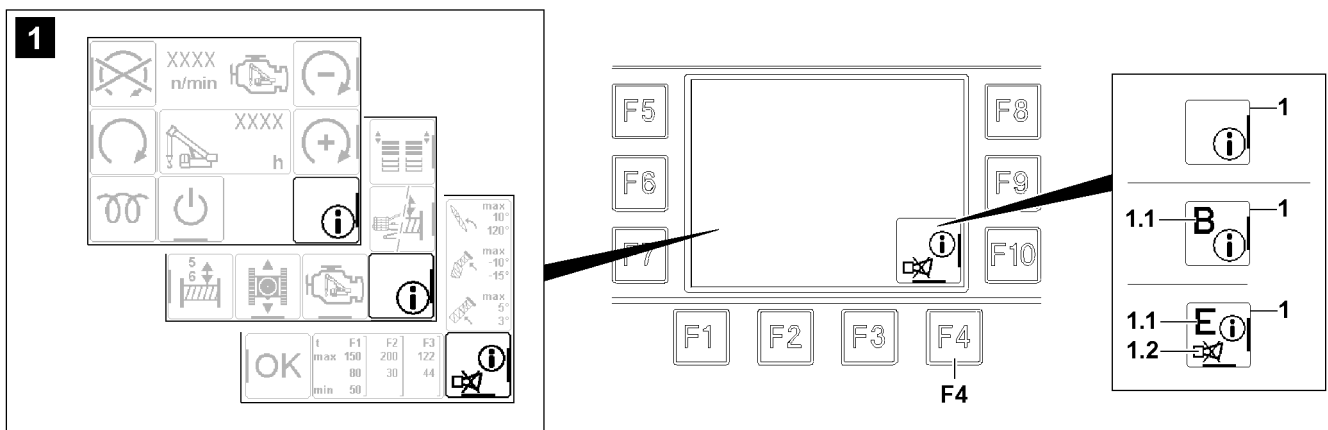

Fig.155092: Example for screen displays with test system icon

The test system is always active in the background.

The *test system* icon 1 appears in the selected screen displays, see the example in illustration 1.

In the *test system* icon 1, the following additional displays can appear:

- **1.1 Error message display**
 - An operating error (B) or system error (S) has occurred
- **1.2 Horn display**
 - Selected *acoustic warning signals* of the BTT can be shut off
 - Press the function key **F4** to turn off the disengageable *acoustic warning signal* of the BTT.
 - **Note:** Not every acoustic warning signal of the BTT can be shut off.

13.1 Operating interface from the *Test system* menu

If necessary, the operating interface from the *Test system* menu can be shown from all screen displays with the *Test system* icon displayed.

13.1.1 Show the operating interface from the *Test system* menu

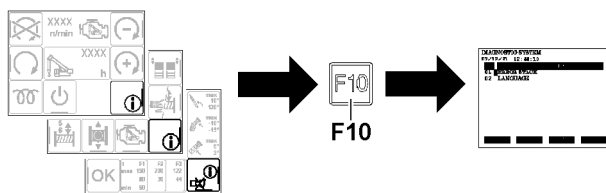

Fig.155093: Show the operating interface from the *Test system* menu

- Press the function key **F10** when the *Test system* icon is displayed.
 - The operating interface from the *Test system* menu is shown.

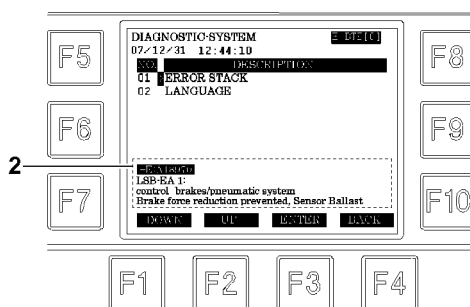

Fig.153739: Operating interface from the *Test system* menu

If an error message occurs during BTT operation, an error text **2** with an error number and description is displayed in the test system.



Note

- ▶ In certain situations, automatic switching to the test system takes place.



Note

- ▶ For a detailed description of the test system, see the Diagnostics Manual.

13.1.2 Hide operating interface from the *Test system* menu

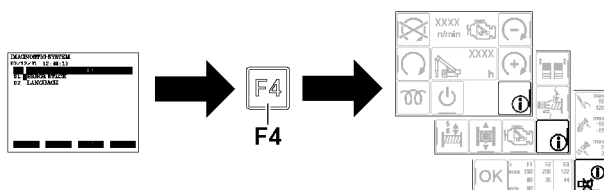

Fig.155094: Hide operating interface from the *Test system* menu

- 1) Press the function key **F4** until the *Test system* menu is hidden.
- Press the function key **F4** as often as necessary when the operating interface is displayed from the *Test system* menu.
 - The operating interface from the *Test system* menu is hidden.

14 Measures in case of problems

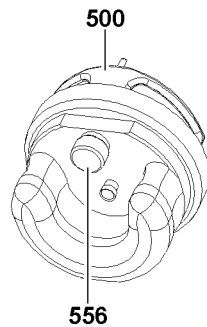

Fig.155515: Carrying out an emergency stop during radio operation



WARNING

Danger of accident!

- ▶ If location of the crane operator changes, then crane operation via BTT must be interrupted. Deactivate the BTT - no crane movement may be possible via the function keys.
- ▶ Never take the BTT down unsupervised.
- ▶ In case of an emergency, in case of all problems in the working range of the crane or in case of a technical defect of the BTT, take the system out of operation immediately by actuating the emergency stop switch **556** on the rear of the BTT **500**.

14.1 An error message appears

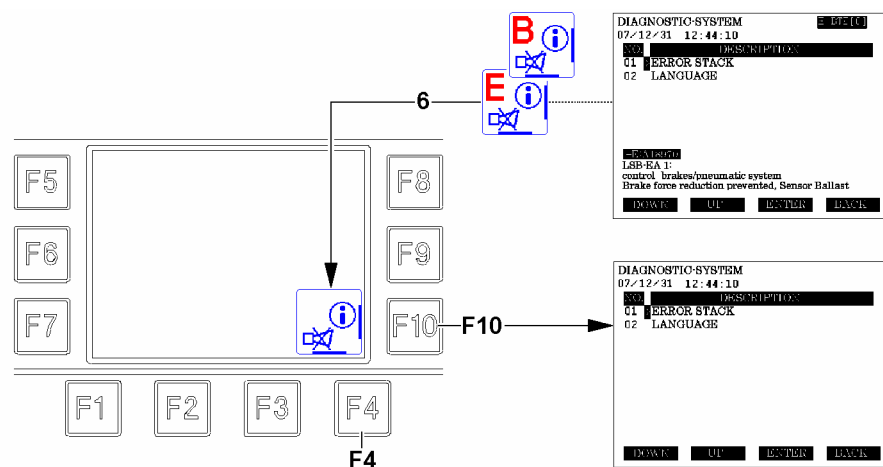

Fig.144608: Error message is issued

If an event occurs that leads to the display of an error message, a „B“ or „E“ is displayed on the *test system* icon **6**, see illustration.



WARNING

Danger of accident!

If the displayed errors in the *test system* icon **6** are ignored, there is a danger of accident.

- ▶ Take the crane out of operation and remedy the cause of the error.
- ▶ Do not put the crane back into operation before the cause of the error has been remedied.
- ▶ Press the function key **F4**.

Result:

- Acoustic warning signal of the BTT, which can be shut off in case of operating / system errors is shut off.

**Note**

- ▶ In the case of some errors, the acoustic warning signal of the BTT can be turned off after a waiting period (up to six seconds).

- ▶ Press the function key **F10**.

Result:

- The *Test system* program (error determination screen) is called up.

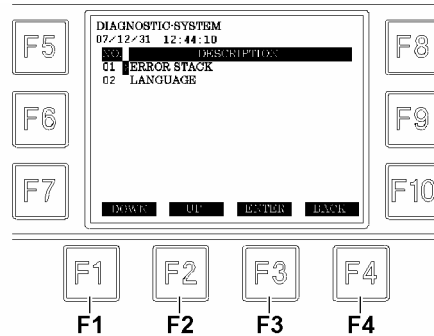

Fig.144609: Function keys in the Test system program

Cursor down:

- ▶ Press the function key **F1**.

Cursor up:

- ▶ Press the function key **F2**.

Select:

- ▶ Press the function key **F3**.

Back:

- ▶ Press the function key **F4**.

**Note**

- ▶ For detailed description, see the Diagnostics Manual.

14.2 The BTT display remains dark

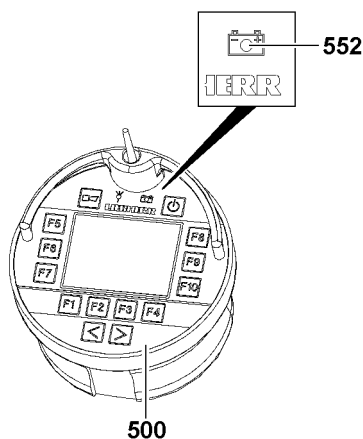

Fig.155516: Rechargeable battery / state of charge indicator light

**Note**

- ▶ The *rechargeable battery* indicator light **552** shows the state of charge of the BTT **500**.

If the *rechargeable battery* indicator light **552** does not light up after turning on the BTT **500**:

- ▶ Plug the BTT **500** into the charging cradle and charge it.

If the *rechargeable battery* indicator light **552** does not light up after inserting the BTT **500** in the charging cradle:

- ▶ Contact Liebherr Service to determine the cause of the problem and the further procedure.

14.3 If the radio connection is faulty

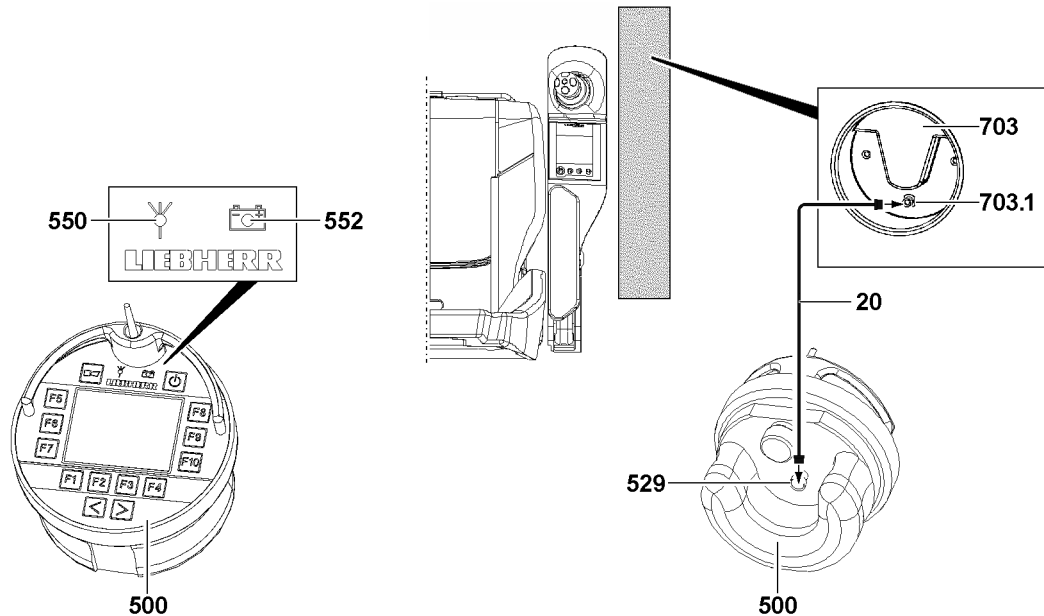

Fig.161668: Bypassing the radio connection

If the radio connection to the BTT **500** is faulty or interrupted (the *Transmission signal* indicator light **550** lights up red), then it can be bypassed with the line **20**, see section „Bypassing the radio connection“.

The radio connection to the BTT **500** can become faulty or interrupted due to the following:

- By electric / electronic interference signals and / or obstacles (such as interference signals from a close-by radio transmitter and / or walls).
- The radio module on the BTT **500** or on the BTB is defective.
- The rechargeable battery in the BTT **500** is discharged.
- Due to bad selection of the placement location by the operator.

14.3.1 Bypassing the radio connection

Make sure that the following prerequisites are met:

- The line **20** to bypass the radio connection is available.
- The BTT **500** is turned on.
- The caps on the plug connection **703.1** and the plug connection **529** have been removed.

- ▶ Screw the line **20** in the charging cradle **703** onto the plug connection **703.1**.
- ▶ Screw the line **20** on the BTT **500** onto the plug connection **529**.

Result:

- The radio connection is bypassed.



Note

If the radio connection cannot be bypassed, even though the BTT is connected via the line **20** with the charging cradle **703** then there is an error.

- ▶ Contact Liebherr Service to determine the cause of the problem and the further procedure.

15 Inspection and maintenance

15.1 Inspecting the BTT



WARNING

BTT malfunctions!

BTT malfunctions can cause accidents.

Personnel can be killed or seriously injured.

This could result in property damage.

▶ Check the BTT for functionality before starting crane operation.

▶ Before starting crane operation, run through all crane movements individually without a load.

15.2 BTT maintenance instructions

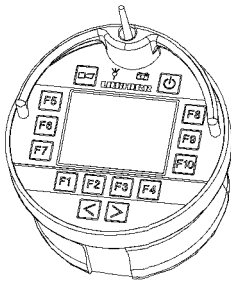

Fig.155518: BTT

- Protect the BTT from direct sun exposure.
- Protect the BTT from dirt and moisture.
- Never clean the BTT using a water jet or steam jet cleaner.
- Never clean the BTT with solvents, paint thinners, cleaning fluids or other chemical substances.



WARNING

Danger of accident!

▶ Never work with a defective BTT.

▶ The repair of a defective BTT may only be made by expert personnel, and only by using original spare parts from Liebherr-Werk Ehingen.

▶ If this is not observed, the **license for the BTT becomes invalid** and the required operational safety is no longer ensured.

▶ If this is not done, warranty claims will be void.

– In case of a technical defect, shut down the BTT every time until the problem has been rectified.

▶ Turn the BTT off.

▶ Have the BTT repaired properly in case of a defect.

5.36 Derrick ballast - suspended ballast

1	Description of suspended ballast	3
2	Component overview - Derrick ballast	5
3	Component overview Derrick ballast pallet	7
4	Lifting heights of derrick ballast	9
5	Installing the suspended ballast	13
6	Crane operation with derrick ballast	67
7	Crawler operation with derrick ballast	97
8	Disassembling the derrick ballast	99

1 Description of suspended ballast

The derrick ballast radius R required according to the load chart is set by adjusting the derrick boom.

The following radii are possible as derrick ballast radius R:

- R 21 m
- R 25 m
- R 30 m

The suspended ballast is described in general as derrick ballast. The fixed compensation weight which is installed on the turntable is generally referred to as the counterweight.

The derrick boom angle, the derrick ballast, weight and utilization are shown on the LICCON monitors.

After assembly on the ground, the derrick ballast is raised for crane operation with the pull cylinders **2** in the derrick guying **1**.



Note

- ▶ For crane operation with derrick ballast, see Crane operating instructions, chapter 4.02.
-

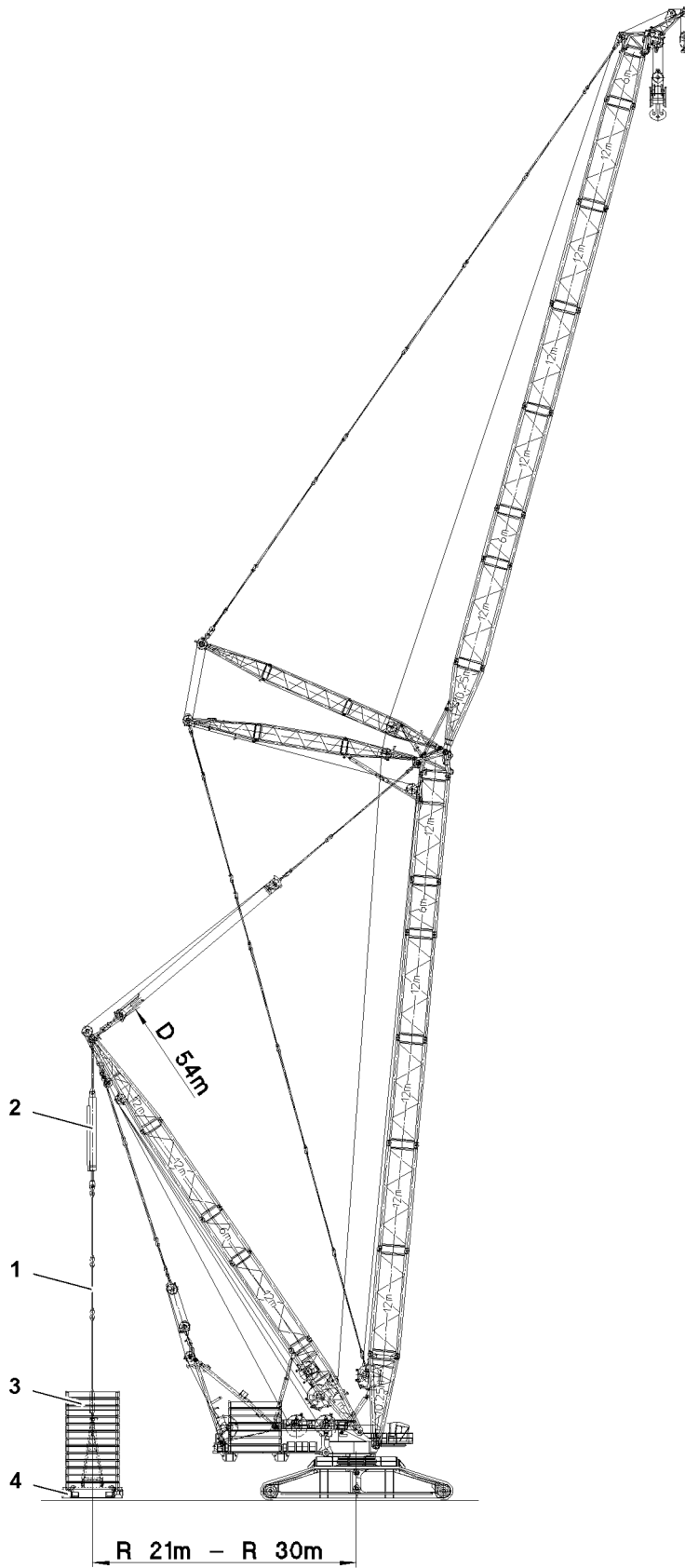

Fig.115861

LWE/LR 13000-001/19503-01-02/en

2 Component overview - Derrick ballast

The components for crane operation with derrick ballast are in the following chart:

Position	Component
1	D-guying
2	Pull cylinder A and pull cylinder B
3	Derrick ballast plates
4	Derrick ballast pallet

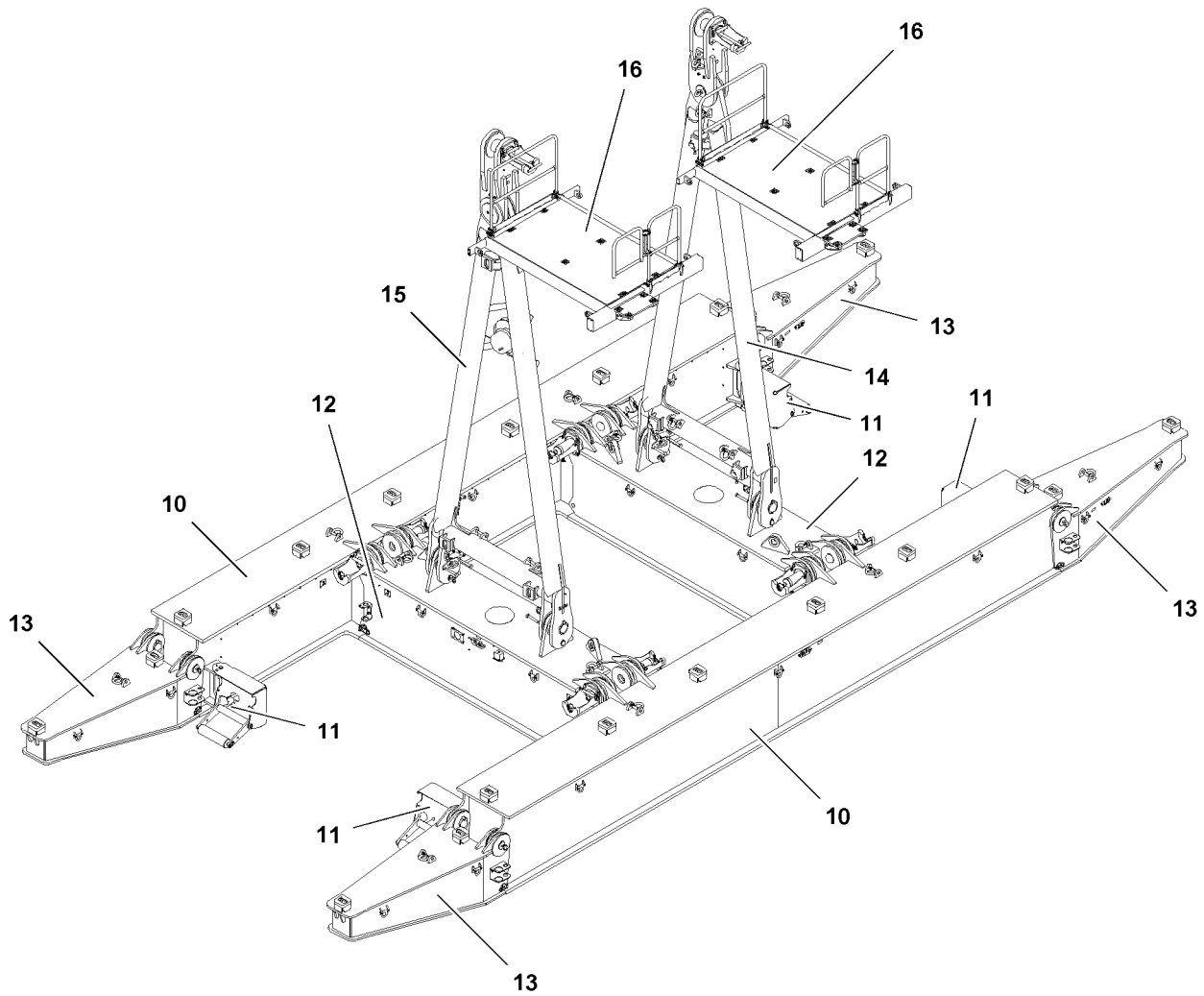

Fig.116164

3 Component overview Derrick ballast pallet

The components for the derrick ballast pallet are in the following chart:

Position	Component
10	Cross carrier
11	Switch unit
12	Connector carrier
13	Bracket ballast placement
14	Right frame
15	Left frame
16	Platform

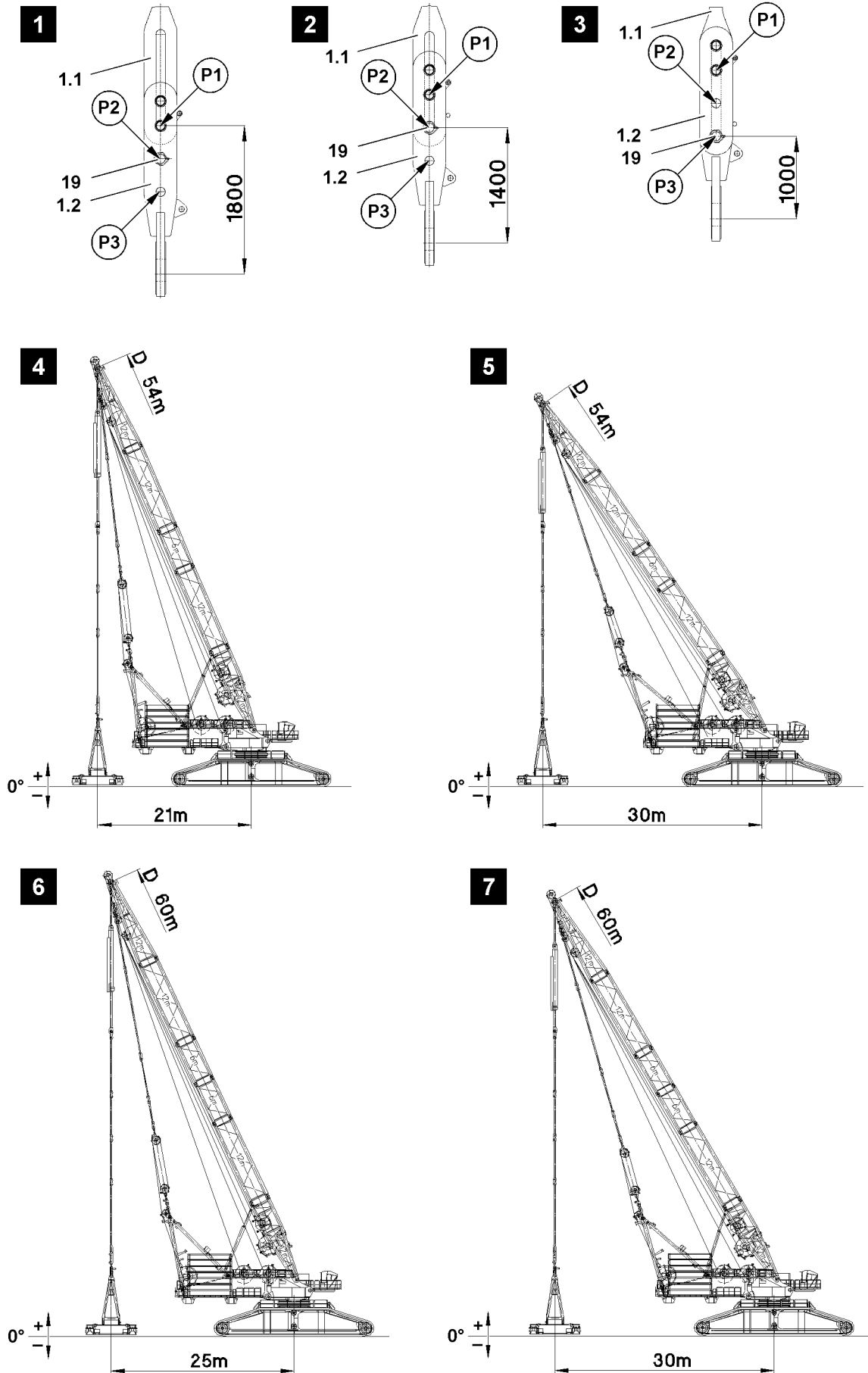

Fig.116523

LWE/LR 13000-001/19503-01-02/en

4 Lifting heights of derrick ballast



Note

- ▶ The length of the D-guy rods **1.1** can be checked by changing the cross bar **1.2** in the slot of the D-buy rod (pinned length).
- ▶ The charts in this section contain the lifting heights for the derrick ballast, which can be obtained with the pull cylinders depending on the pinned lengths on the D-guy rods **1.1**.
- ▶ With the fixed pin on point **P1** a length of 1800 mm is reached, see illustration **1**.
- ▶ With the pin **19** pinned on point **P2** a length of 1400 mm is reached, see illustration **2**.
- ▶ With the pin **19** pinned on point **P3** a length of 1000 mm is reached, see illustration **3**.

4.1 Lifting heights for derrick 54 m

With the 54 m derrick, the following radii are possible:

- R 21 m , see illustration **4**
- R 30 m , see illustration **5**

Lifting heights	Pinned length		
Derrick 54 m Ballast radius 21 m	1,800 mm	1400 mm	1000 mm
Above base	5,978 mm	6378 mm	6778 mm
Below base	-1122 mm	-722 mm	-322 mm

Lifting heights	Pinned length		
Derrick 54 m Ballast radius 30 m	1,800 mm	1400 mm	1000 mm
Above base	1,042 mm	1442 mm	1842 mm
Below base	-6058 mm	-5658 mm	-5258 mm

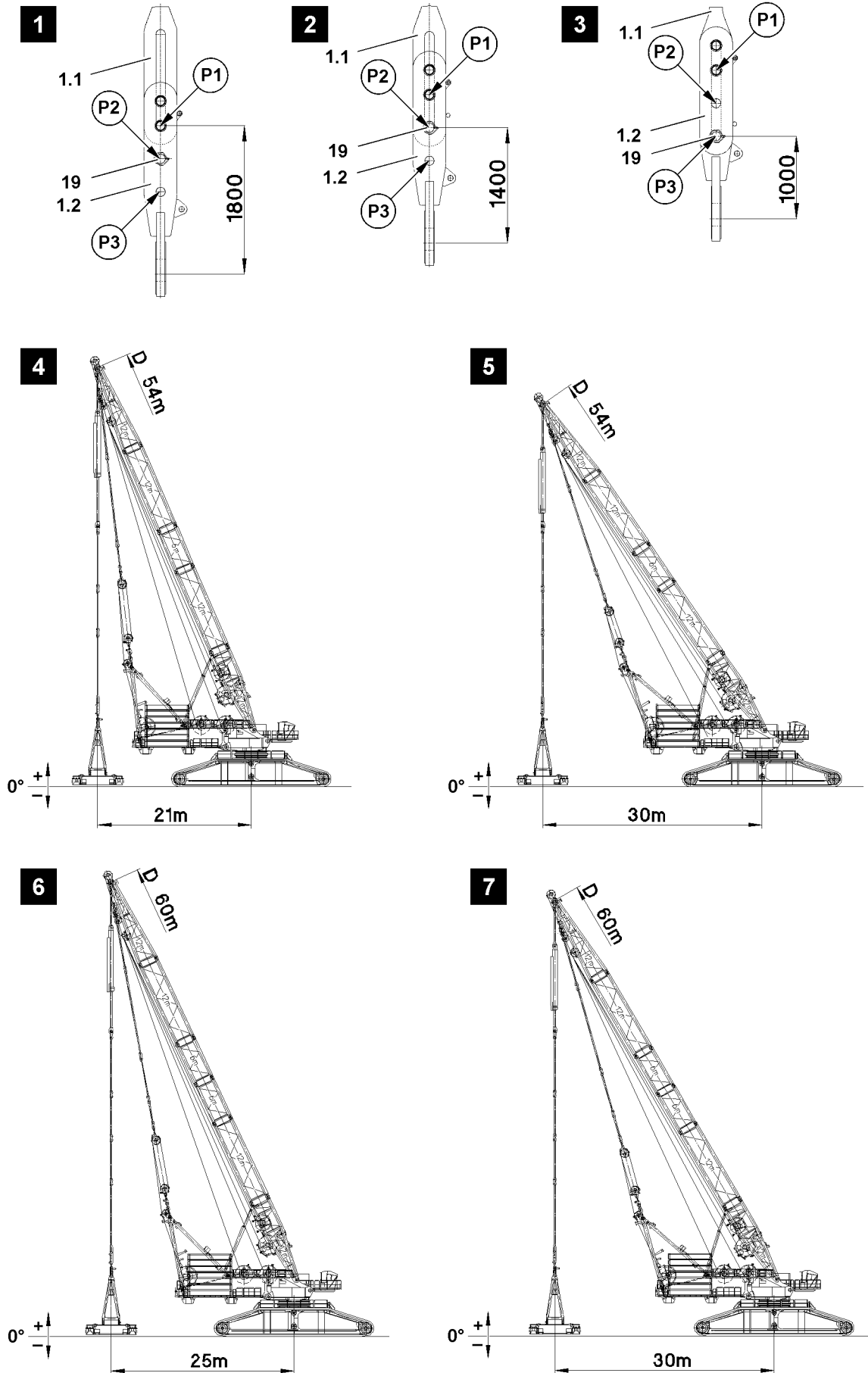

Fig.116523

LWE/LR 13000-001/19503-01-02/en

4.2 Lifting heights for derrick 60 m

With the 54 m derrick, the following radii are possible:

- R 25 m , see illustration 6
- R 30 m , see illustration 7

Lifting heights	Pinned length		
Derrick 60 m Ballast radius 25 m	1,800 mm	1400 mm	1000 mm
Above base	4,760 mm	5160 mm	5560 mm
Below base	-2340 mm	-1940 mm	-1540 mm

Lifting heights	Pinned length		
Derrick 60 m Ballast radius 30 m	1,800 mm	1400 mm	1000 mm
Above base	2,136 mm	2536 mm	2936 mm
Below base	-4964 mm	-4564 mm	-4164 mm

Fig.195219

LWE/LR 13000-001/19503-01-02/en

5 Installing the suspended ballast



WARNING

Danger of falling!

During assembly / disassembly, inspection and maintenance work, assembly personnel must be secured with appropriate aids to prevent them from falling!

If this is not observed, assembly personnel could fall and suffer life-threatening or fatal injuries!

- ▶ All work aloft, where there is a danger of falling must be carried out with suitable aids!
- ▶ If aids are not available and work cannot be carried out from the ground, then the assembly personnel must secure themselves with the supplied fall arrest system to prevent falling, see Crane operating instructions, chapter 2.04.
- ▶ If fall protection equipment is available, then it must be used, see Crane operating instructions, chapter 2.06!
- ▶ When lifting, lowering, swinging crane parts in and out, no persons may remain in the danger zone.
- ▶ If railings are present on the components, then they must be brought into the corresponding position and secured for assembly / disassembly work!
- ▶ Only step on the aids, ladders and catwalks with clean shoes!
- ▶ Keep aids, ladders and catwalks free of heavy dirt, snow and ice!
- ▶ During all assembly and disassembly work, maintenance work and inspections, travel or crane operation is prohibited!
- ▶ Remaining on a suspended load is prohibited!
- ▶ Stepping or walking on crane components and lattice sections, which have an incline of more than 20° is prohibited!
- ▶ For all assembly work, the crane operator of the main crane must be in voice contact with the crane operator / crane operators of the auxiliary crane / auxiliary cranes!
- ▶ For assembly / disassembly tasks, the crane operator may only initiate crane movements when the responsible guide has explicitly released the movement!



WARNING

Danger of impact / crushing!

When installing / removing crane components with the auxiliary crane, crane components can start to swing back and forth!

When lifting / lowering and positioning crane components, there is an increased danger of impacts / crushing!

Personnel can be caught and severely injured or killed!

- ▶ Make sure that personnel cannot be caught by components!
- ▶ When working in danger zones: Use aids to protect limbs!
- ▶ Guide components with suitable aids to minimize oscillation!



WARNING

Incorrect handling of the fastening equipment!

If fastening equipment cannot be attached correctly and if it is not secured sufficiently to prevent it from loosening up, loads can fall down. Personnel can be severely injured or killed!

- ▶ Make sure that the fastening equipment is correctly attached on the fastening points and that it is secured sufficiently to prevent it from loosening up!



WARNING

The components can fall down!

If the corresponding components are disengaged from the auxiliary crane before the corresponding component is pinned, the corresponding component can fall down and fatally injure personnel!

- ▶ Do not disengage the auxiliary crane until the corresponding component is pinned and secured!

Make sure that the following prerequisites are met:

- The crane is aligned in horizontal direction.
- The maximum ground unevenness for the placement surface of the derrick ballast is $\pm 1^\circ$
- The boom and the derrick are installed on the turntable.

- The derrick is erected.
- The counterweight has been installed on the turntable according to the load chart.
- The LICCON overload protection has been set according to the data in the load chart or the erection and take down charts.
- An auxiliary crane is available.

5.1 Hydraulic connections to the pin pulling cylinder



Note

- ▶ The hydraulic supply for the pin pulling cylinder is made via the external hydraulic aggregate!
- ▶ Hydraulic connection of the pin pulling device, see Crane operating instructions, chapter 5.30!

Make sure that the following prerequisite is met:

- The external hydraulic aggregate is operational.

5.1.1 Establishing the hydraulic connections to the pin pulling cylinder

When connecting hydraulic lines with quick-release couplings, make sure that the coupling procedure is carried out correctly.



WARNING

Pressure in the hydraulic lines!

If the pressure supply is not interrupted before connecting / releasing the hydraulic lines, the hydraulic oil can escape with high pressure!

Personnel can be severely injured or killed!

- ▶ Release the pressure in the hydraulic system before connecting / disconnecting: Interrupt the pressure supply and wait for a short time!
- ▶ Connect the coupling components (sleeve and connector) and screw together with the hand-tightened nut.
- ▶ Make sure that the description on the connections matches.
- ▶ Tighten the hydraulic couplings by hand. Rotate the hand-tightened nut until it reaches a tangible, fixed stop position.
- ▶ Establish the hydraulic connection to the pin pulling cylinder.

5.1.2 Disconnecting the hydraulic connections to the pin pulling cylinder

When releasing hydraulic lines with quick couplings, make sure that the coupling procedure is carried out correctly.



WARNING

Pressure in the hydraulic lines!

If the pressure supply is not interrupted before connecting / releasing the hydraulic lines, the hydraulic oil can escape with high pressure!

Personnel can be severely injured or killed!

- ▶ Release the pressure in the hydraulic system before connecting / disconnecting: Interrupt the pressure supply and wait for a short time!
- ▶ Make sure that the hydraulic system pressure has been relieved.
- ▶ Unscrew and separate the coupling components (sleeve and connector) with the hand-tightened nut.
- ▶ Disconnect the hydraulic connection to the pin pulling cylinder.
- ▶ Install dust caps on the quick couplings.

Empty page!

LWE/LR 13000-001/19503-01-02/en

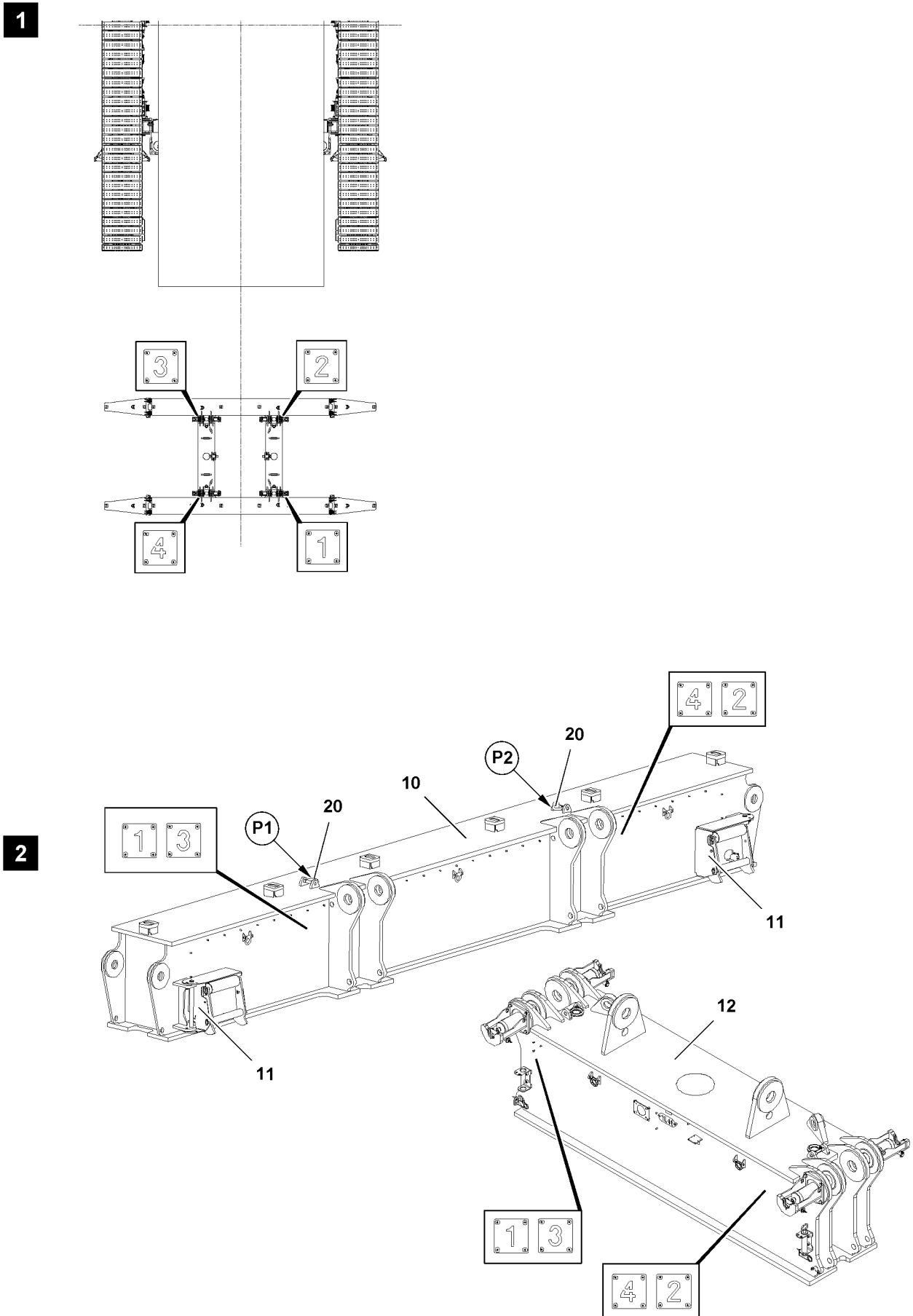

Fig.116165

LWE/LR 13000-001/19503-01-02/en

5.2 Installing the cross carrier and connector carrier



WARNING

Assembly personnel is not secured!

Assembly personnel can fall and be severely injured or killed!

- ▶ Secure assembly personnel with suitable aids to prevent them from falling!
- ▶ Use personal protective equipment!



WARNING

Danger of crushing!

During assembly, hands can be crushed or even severed due to swing movements of the components!

- ▶ Make sure that the components do not swing back and forth during assembly!

5.2.1 Alignment of derrick ballast pallet

Make sure that the following prerequisites are met:

- The switch units **11** is folded in and secured.



Note

- ▶ The cross carriers **10** and connector carriers **12** are identified with numbers, see illustrations!
- ▶ With the aid of these number, you can align the derrick ballast pallet in reference to the crane, see illustration **1**.
- ▶ The cross carriers **10** and connector carriers **12** can be pinned together near the crane and positioned with an auxiliary crane under the D-guy rods of the derrick boom.

5.2.2 Positioning the first cross carrier



Note

- ▶ The weight of the cross carrier is 18 t.
- ▶ The selection of the assembly location is important to keep the transport paths for aligning the derrick ballast pallet to a minimum.
- ▶ The cross carriers **10** and connector carriers **12** are identified with numbers, see illustrations!
- ▶ Attach the cross carrier **10** on the auxiliary crane: Attach the fastening equipment on the ring brackets **20**, point **P1** and on point **P2**, see illustration **2**.
- ▶ Set the cross carrier **10** on a level surface.
- ▶ Remove the fastening equipment from the cross carrier.

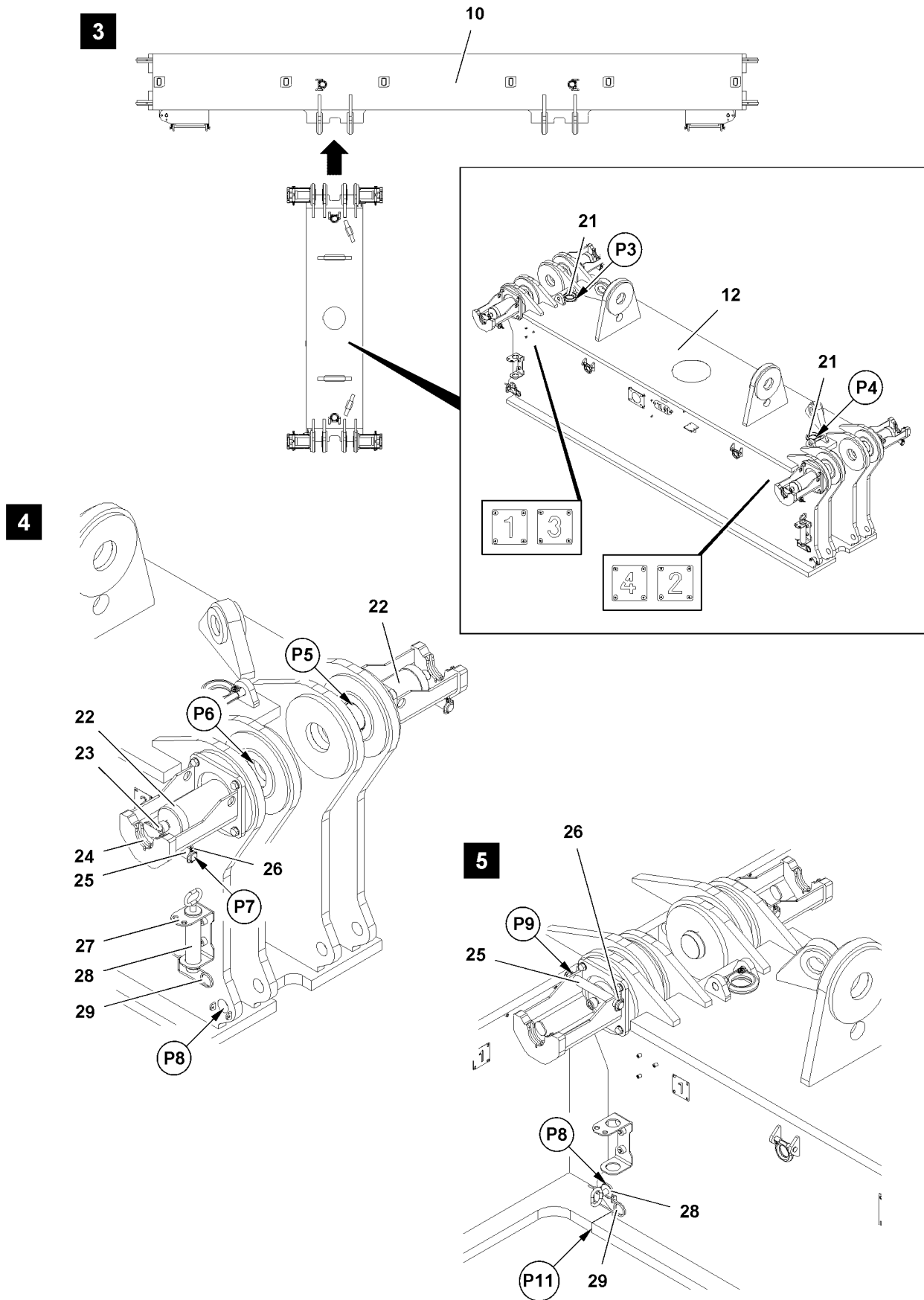

Fig.116166

LWE/LR 13000-001/19503-01-02/en

5.2.3 Installing the connector carriers

Make sure that the following prerequisites are met:

- The first cross carrier is standing on a level surface and is positioned for assembly.

5.2.4 Positioning the first connector carrier on the cross carrier



Note

- ▶ The weight of the connector carrier is 11.4 t.
 - ▶ The cross carriers **10** and connector carriers **12** are identified with numbers, see illustration **3!**
 - ▶ The numbers on the cross carrier **10** and on the connector carrier **12** must match!
-
- ▶ Attach the connector carrier **12** onto the auxiliary crane: Attach the fastening equipment on the ring bracket **21**, point **P3** and on point **P4**, see illustration **3**.

NOTICE

Pin inserted!

If the pins **22** are pinned when positioning the connector carrier **12** on the cross carrier **10**, components can be severely damaged.

- ▶ Make sure that the pins **22** are unpinned on the connector carrier **12** before positioning, point **P5** and point **P6**, see illustration **4**.
 - ▶ Make sure that the pins **22** are unpinned on the connector carrier **12** before positioning on the cross carrier **10**.
-
- ▶ Make sure that the pins **22** are unpinned.
 - ▶ Make sure that the pin **22** and the spring retainer **29** are pinned and secured in the retainer **27**.



WARNING

Danger of crushing!

When positioning the connector carrier **12** on the cross carrier **10** there is an increased danger of accidents due to crushing.

Personnel can be severely injured or killed.

- ▶ It is prohibited for anyone to remain between the connector carrier **12** and the cross carrier **10**.
 - ▶ Observe the crane movements diligently!
 - ▶ It is prohibited to remain in the slewing range of the auxiliary crane.
 - ▶ Crane operator and guide must maintain visual contact.
-
- ▶ Lift the connector carrier **12** with the auxiliary crane.
 - ▶ Remove the fastening equipment from the cross carrier **10**.

You can freely select the sequence in which the connector carriers are pinned on the cross carriers.

With the numbers on the pin points you can ensure that the connector carrier is pinned on the correct side on the correct cross carrier.

- ▶ Position the connector carrier **12** on the pin points of the cross carrier **10**.
- ▶ Make sure that the numbers on the pin points match.
- ▶ Move the connector carrier **12** in on the cross carrier **10** until the pin bores align.

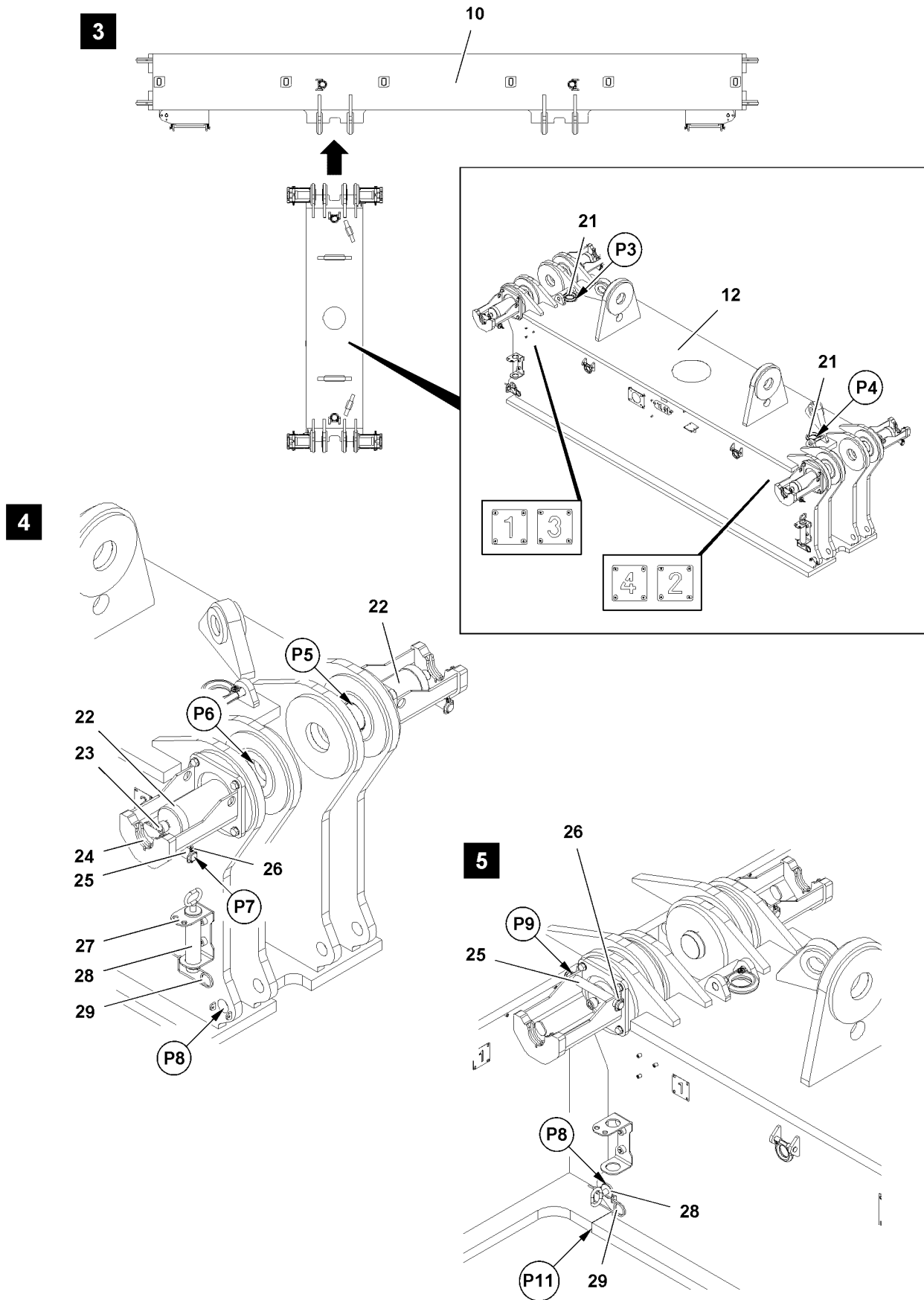

Fig.116166

LWE/LR 13000-001/19503-01-02/en

5.2.5 Pinning the first connector carrier on the cross carrier

Make sure that the following prerequisites are met:

- The hydraulic connection to the pin pulling cylinder is established, see section „Establishing the hydraulic connection to the pin pulling cylinder“
- The pin bores of cross carrier and connector carrier align.



Note

- ▶ Every connector carrier is pinned on both sides with pins **22** on the cross carrier.
- ▶ Every connector carrier is pinned on one side with pin **28** on the cross carrier.
- ▶ The pin points for the pins **22** on the connector carrier are on point **P5** and point **P6**.
- ▶ The pin point for the pin **28** on the connector carrier is on point **P8**.

- ▶ Attach the pin pulling cylinder on the auxiliary crane.
- ▶ Hang in the pin pulling cylinder on the screw **23** and retainer **24**.
- ▶ Move the pin pulling cylinder out.

Result:

- The pin **22** is inserted.

When the pin **22** is inserted to the stop:

- ▶ Unhook the pin pulling cylinder on the screw **23** and remove from the retainer **24**.
- ▶ Move the pin pulling cylinder in.



WARNING

The pin is not secured!

If the pins **22** are not secured, the pins **22** can loosen up by themselves during crane operation. The crane can topple over, personnel can be severely injured or killed.

- ▶ Secure the pin **22** with retaining pin **25**.

- ▶ Unpin retaining pins **25**: Remove the locking pin **26** and unpin the retaining pin **25** on point **P7**.
- ▶ Secure the pin **22**: Insert the retaining pin **25** on point **P9** and secure with locking pin **26**, see illustration **5**.

Result:

- The pin **22** is inserted and secured.

- ▶ Make sure that the connector carrier is placed completely on the cross carrier on point **P11**.
- ▶ Unpin the pin **28**: Remove the spring retainer **29** and unpin the pin **28** from the retainer **27**.
- ▶ Insert the pin **28** on point **P8** and secure with spring retainer **29**.

Result:

- The pin **28** is inserted and secured.

- ▶ Make sure that the pins **22** are pinned and secured at point **P5** and point **P6**.
- ▶ Make sure that the pin **22** is pinned and secured at point **P8**.

Result:

- The connector carrier is pinned on the cross carrier.

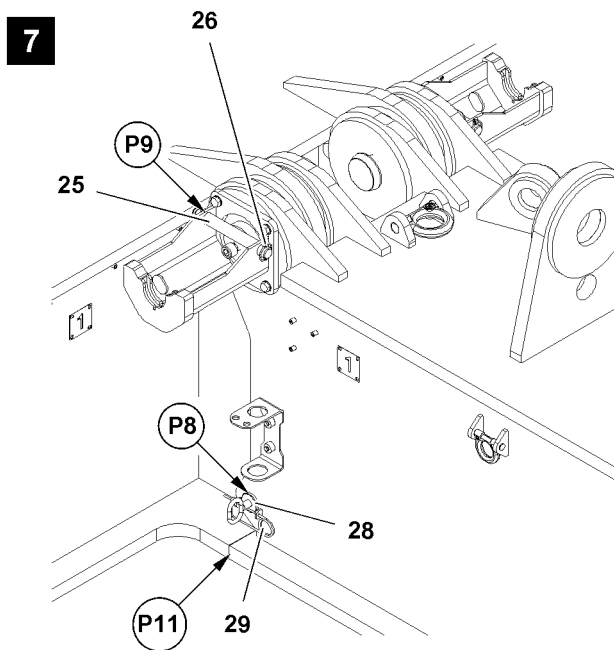
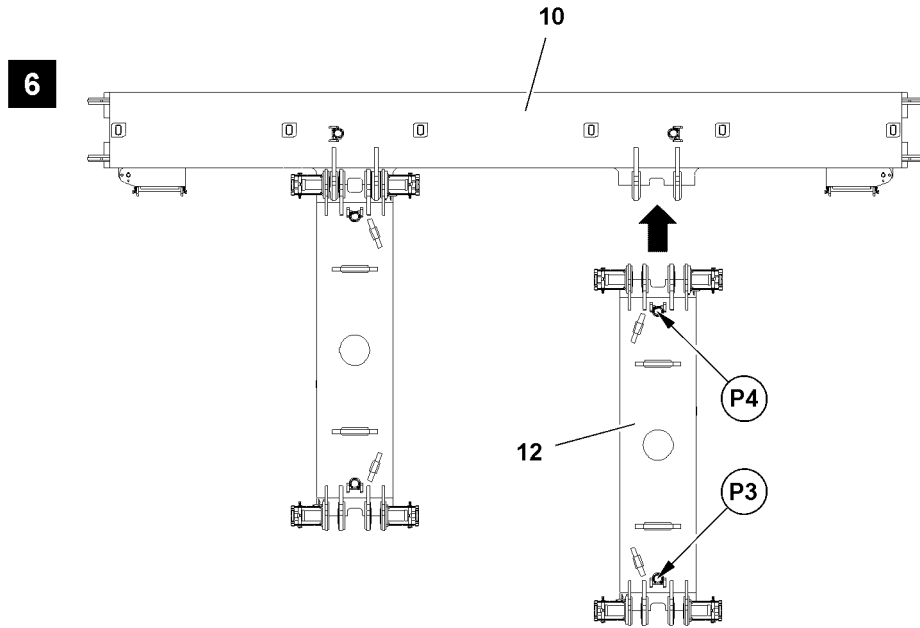

Fig.116167

LWE/LR 13000-001/19503-01-02/en

5.2.6 Pinning the second connector carrier on the cross carrier

Make sure that the following prerequisite is met:

- The first connector carrier is pinned on the cross carrier.



WARNING

Danger of crushing!

When positioning the connector carrier **12** on the cross carrier **10** there is an increased danger of accidents due to crushing.

Personnel can be severely injured or killed.

- ▶ It is prohibited for anyone to remain between the connector carrier **12** and the cross carrier **10**.
- ▶ Observe the crane movements diligently.
- ▶ It is prohibited to remain in the slewing range of the auxiliary crane.
- ▶ Crane operator and guide must maintain visual contact.



Note

- ▶ The second connector carrier must be positioned the same way as the first connector carrier, see section „Positioning the first connector carrier on the cross carrier“.
 - ▶ The second connector carrier must be pinned with the cross carrier the same way as the first connector carrier, see section „Pinning the first connector carrier on the cross carrier“.
-
- ▶ Pin the second connector carrier on the cross carrier.
 - ▶ Make sure that the pins **22** are pinned and secured at point **P5** and point **P6**.
 - ▶ Make sure that the pin **22** is pinned and secured at point **P8**.

Result:

- The connector carrier is pinned on the cross carrier.

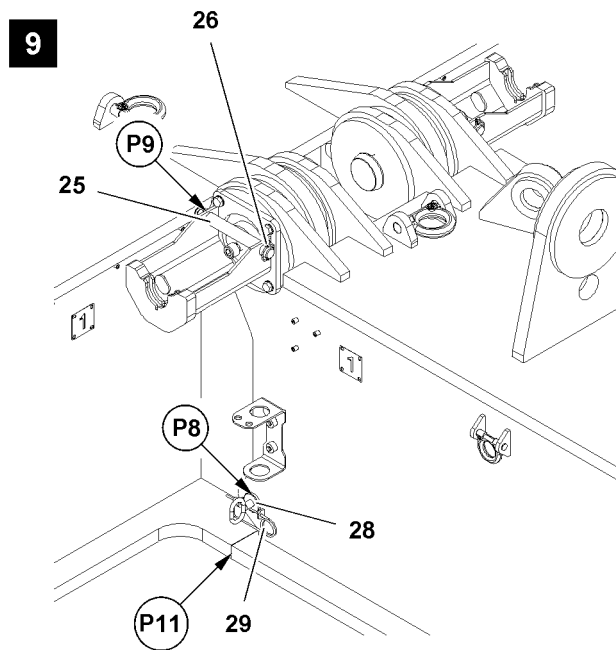
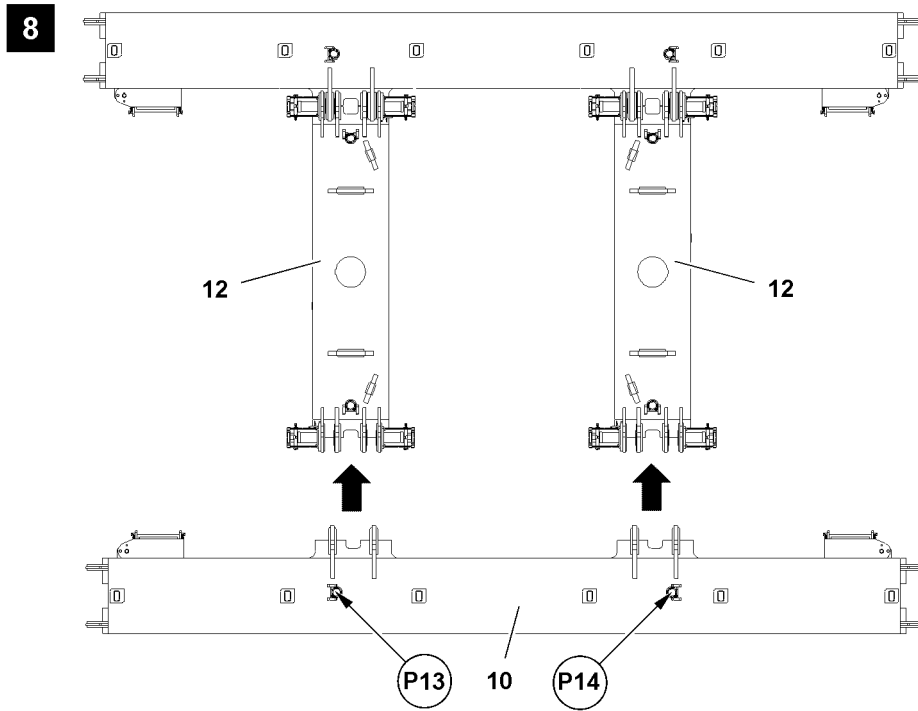

Fig.116168

LWE/LR 13000-001/19503-01-02/en

5.2.7 Installing the second cross carrier on the connector carriers



WARNING

Danger of crushing!

When positioning the second cross carrier **10** on the connector carrier **12** there is an increased danger of accidents due to crushing.

Personnel can be severely injured or killed.

- ▶ It is prohibited for anyone to remain between the connector carriers **12** and the second cross carrier **10**.
- ▶ Observe the crane movements diligently.
- ▶ It is prohibited to remain in the slewing range of the auxiliary crane.
- ▶ Crane operator and guide must maintain visual contact.

Make sure that the following prerequisite is met:

- Both connector carriers **12** are installed on the first cross carrier.
- ▶ Attach the second cross carrier **10** on the auxiliary crane, point **P13** and point **P14**.
- ▶ Lift the cross carrier **10** and position on the pin points until the pin bores align.



Note

- ▶ The connector carriers must be pinned the same way with the second cross carrier as described in section „Pinning the first connector carrier on the cross carrier“ and in section „Pinning the second connector carrier on the cross carrier“.

- ▶ Pin the cross carrier **10** on both connector carriers **12**.
- ▶ Make sure that the pins **22** are pinned and secured at point **P5** and point **P6**.
- ▶ Make sure that the pin **22** is pinned and secured at point **P8**.

Result:

- The second cross carrier is installed on both connector carriers.

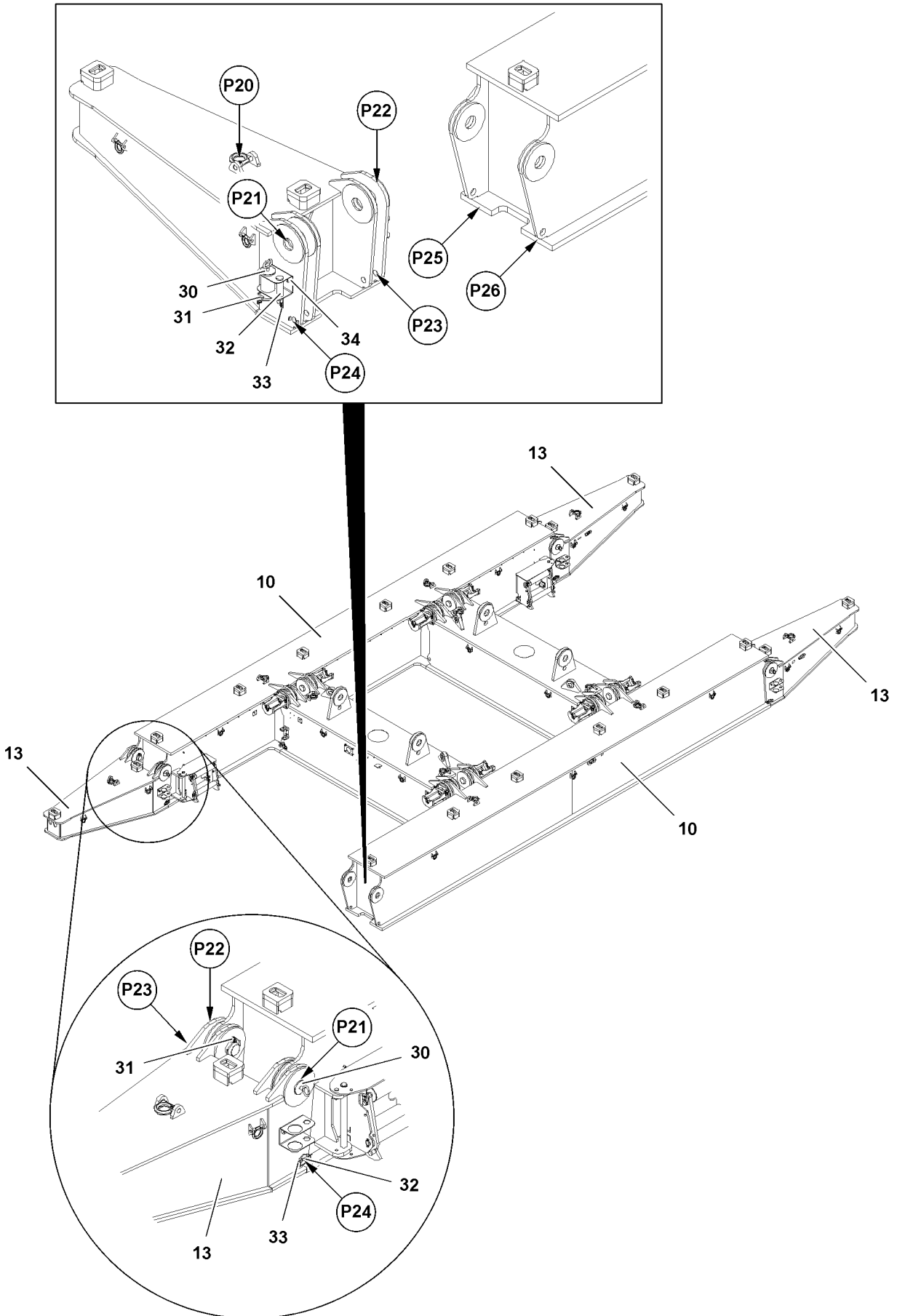

Fig.116169

LWE/LR 13000-001/19503-01-02/en

5.3 Installing the brackets



Note

- ▶ The brackets **13** are installed when the derrick ballast plates are placed in five stacks.
- ▶ Without brackets **13** the number of stacks with derrick ballast plates is limited to three.

You can freely select the sequence in which the brackets **13** are pinned on the cross carriers **10**. The brackets are identical and can be interchanged.

This section describes as an example how a bracket **13** is pinned on the cross carrier **10**. The installation of the other brackets is made in the same way.



Note

- ▶ The weight of the bracket is 2.2 t.

- ▶ Hang the bracket **13** onto the auxiliary crane, point **P20**.
- ▶ Make sure that pin **30** and pin **32** are secured in the retainer **34**.
- ▶ Lift the brackets **13** on the pin positions on the cross carrier **10** until the pin bores align.
- ▶ Remove the pin **30** and locking pin **31** from the retainer **34**.
- ▶ Pin the brackets **13** on the cross carriers **10**: Insert the pin **30** on point **P21** and point **P22** and secure with locking pins **31**.
- ▶ Remove the pin **32** and spring retainer **33** from the retainer **34**.
- ▶ Pin the brackets **13** on the cross carriers **10**: Insert the pin **32** on point **P23** and point **P24** and secure with spring retainers **33**.
- ▶ Make sure that every pin is inserted and secured.
- ▶ Remove the fastening ropes on the bracket **13**.

Result:

- The bracket **13** is installed.
- ▶ The additional three brackets **13** are installed on the cross carriers **10**.

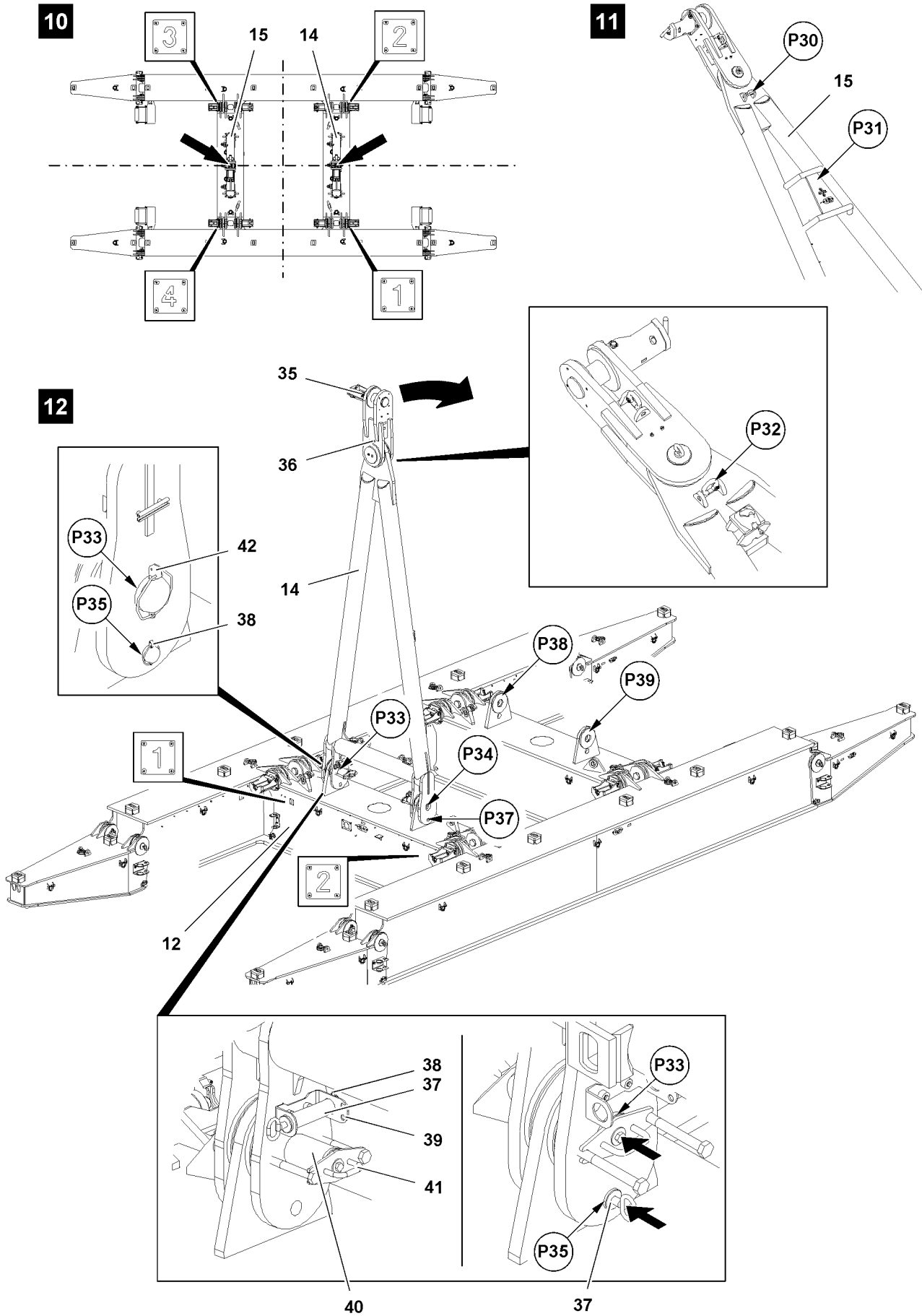

Fig.116170

LWE/LR 13000-001/19503-01-02/en

5.4 Installing the frames



WARNING

Danger of crushing!

When positioning the frames, there is an increased danger of accidents due to crushing! Personnel can be severely injured or killed!

- ▶ It is prohibited for anyone to remain between the connector carriers and the frames!
- ▶ Observe the crane movements diligently!
- ▶ It is prohibited to remain in the slewing range of the auxiliary crane!
- ▶ Crane operator and guide must maintain visual contact!



Note

- ▶ The right frame **14** must be installed on the connector carrier between the assembly point **1** and the assembly point **2**, see illustration **10**.
- ▶ You can recognize the right frame **14** because there are no attachments on the pipes.
- ▶ The left frame **15** must be installed on the connector carrier between the assembly points **4** and **3**, see illustration **10**.
- ▶ You can recognize the left frame **15** by the fact that a retainer for the cable drum is welded on the pipes, point **P31**, see illustration **11**.

Make sure that the following prerequisite is met:

- The center points of the connector carriers must be aligned for the assembly to the D-guy rods, see arrows illustration **10**.

5.4.1 Installing the right frame

Pinning the frame on the connector carrier



Note

- ▶ The weight of a frame with cross bracket is 3.9 t.

The pinning devices **35** on the cross brackets must be on the side of the assembly point **1** and assembly point **4**.

- ▶ Hang the frame **14** onto the auxiliary crane, point **P32**, see illustration **12**.
- ▶ Lift the frame **14** until it hangs vertically.
- ▶ Position the frame **14** over the pin points on the connector carrier **12**.
- ▶ Unpin the pin **40** on point **P33** and on point **P34**: Remove the locking pin **42** and unpin the pin **40**.
- ▶ Lift the frame **14** on the pin points of the connector carrier **12** until the pin bores align.
- ▶ Insert the pin **40** on point **P33** and point **P34** and secure with locking pin **42**.



WARNING

Frame is unsecured!

When the retaining pins are not pinned, then the frame falls over after the fastening equipment is removed.

- ▶ Secure the frame **14** with retaining pins **37** on point **P35** and point **P37**.
- ▶ Remove retaining pins **37** from the retainer **39**: Remove the locking pin **38** and unpin the retaining pin **37**.
- ▶ Insert the retaining pin **37** on point **P35** and point **P37** and secure with locking pin **38**.
- ▶ Make sure that retaining pins **37** are inserted and secured.
- ▶ Lower the frame **14** with the auxiliary crane until the frame **14** inclines to the inside, see illustration.

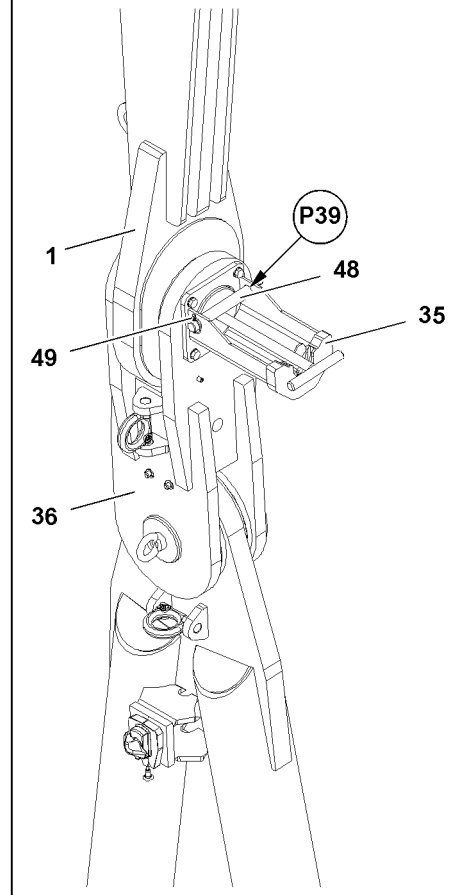
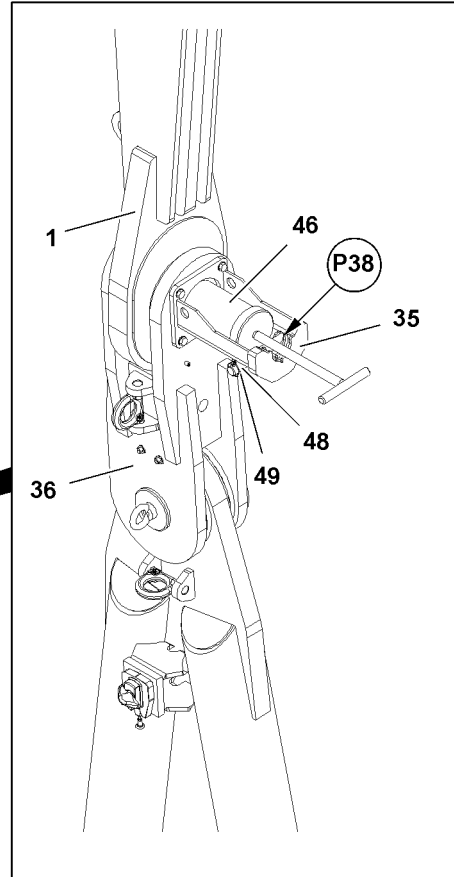
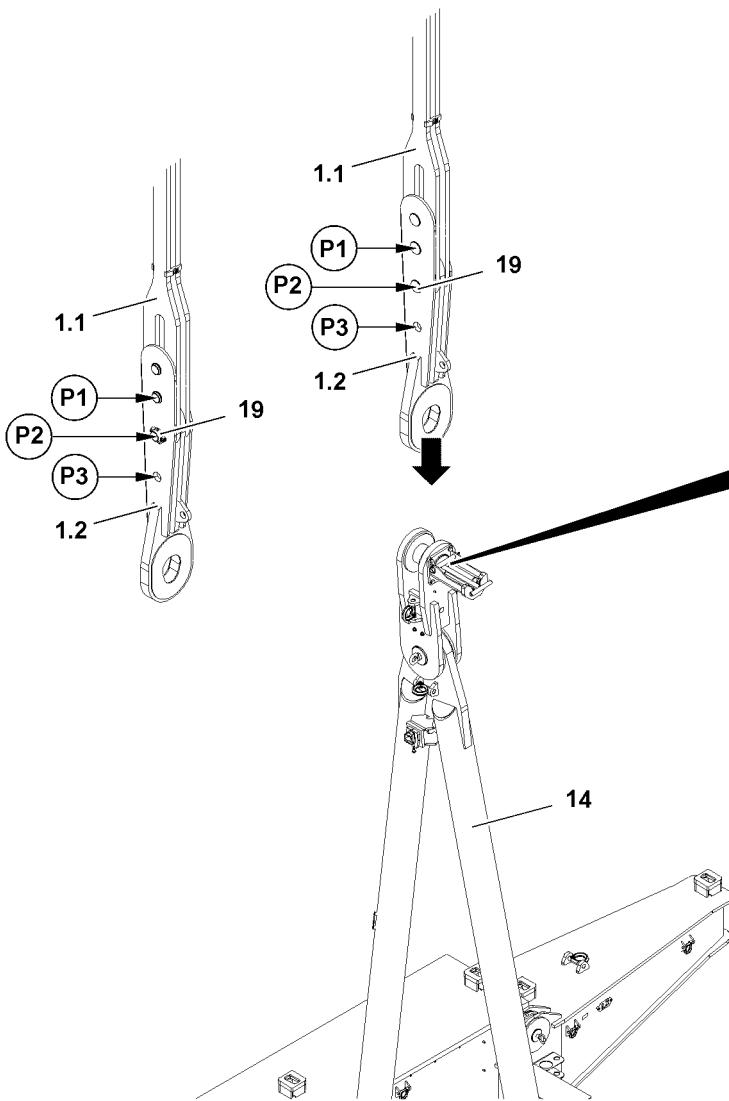

Fig.116171

LWE/LR 13000-001/19503-01-02/en

Setting the cross bracket to lifting heights



WARNING

Assembly personnel is not secured!

Assembly personnel can fall and be severely injured or killed!

- ▶ Secure assembly personnel with suitable aids to prevent them from falling!
- ▶ Use personal protective equipment!



Note

- ▶ The possible lifting heights for the derrick ballast and the assignment to the pinned lengths on the D-guy rods is noted in section „Lifting heights of derrick ballast“.

Make sure that the following prerequisites are met:

- The pins **19** are inserted and secured with locking pins.
- A work platform is available.
- An auxiliary crane is available.

You only have to carry out this assembly procedure if you need another lifting height for the derrick ballast.

Position the work platform in such a way that the cross bracket **1.2** can be unpinned.

- ▶ Make sure that you are secured by your personal protective equipment.
- ▶ Secure the cross bracket **1.2** with the auxiliary crane.
- ▶ Tension the fastening equipment until the cross bracket **1.2** can be unpinned.
- ▶ Unpin the cross bracket **1.2** on the D-guy rod **1.1**: Remove the locking pin and unpin the pin **19**.

The pin points for the pin **19** are shown depending on the respective pinned length in section „Lifting heights of derrick ballast“.

- ▶ Lift or lower the cross bracket **1.2** with the auxiliary crane to the required length until the pin bores align.
- ▶ Pin the cross bracket **1.2** on the D-guy rod **1.1**: Insert the pin **19** and secure with locking pin.
- ▶ Make sure that the pin location is pinned and the pin **19** is secured.

Result:

- The right cross bracket is set for the required lifting heights.

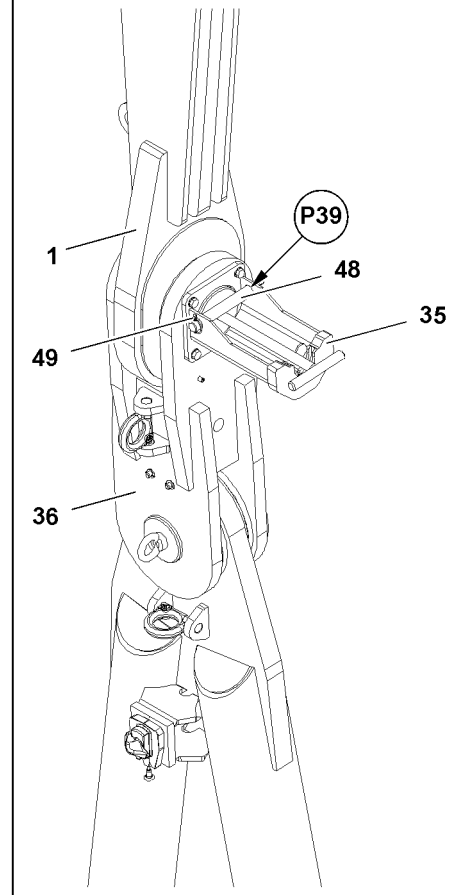
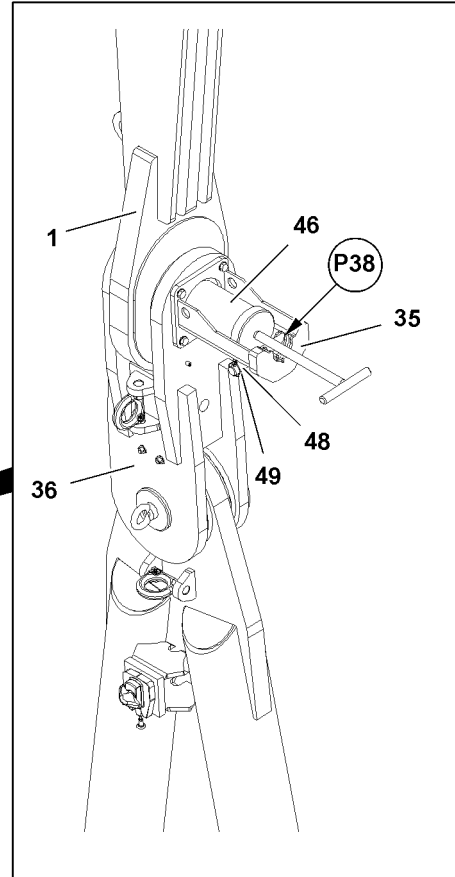
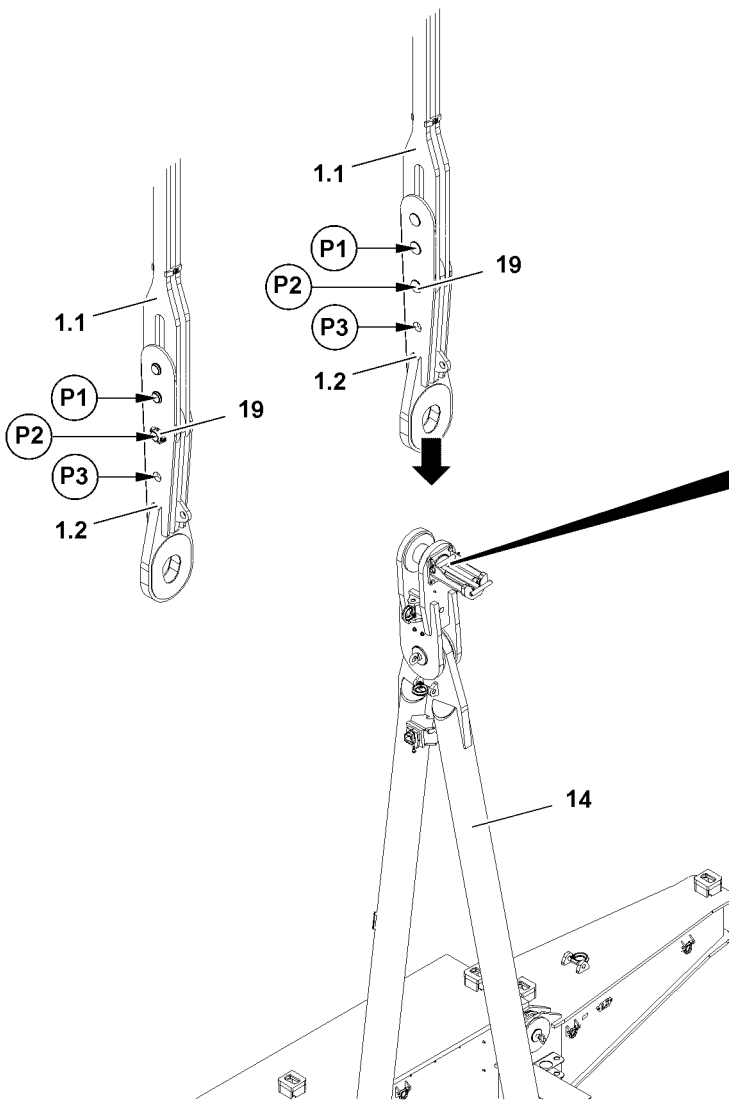

Fig.116171

LWE/LR 13000-001/19503-01-02/en

Pinning the D-guy rods on the frame



WARNING

Assembly personnel is not secured!

Assembly personnel can fall and be severely injured or killed!

- ▶ Secure assembly personnel with suitable aids to prevent them from falling!
- ▶ Use personal protective equipment!



WARNING

D-guy rods pinned one-sided!

Both D-guy rods must be pinned and secured, otherwise the derrick ballast pallet can tip over. Personnel can be severely injured or killed.

- ▶ Make sure that the right frame **14** and the left frame are pinned with the D-guy rods **1**.

Make sure that the following prerequisites are met:

- The cross brackets is set to the required lifting heights.
- The pin **46** is inserted and secured.
- A work platform is available.

Position the work platform in such a way that the pin **46** can be pinned on the pinning device **35**.

- ▶ Make sure that you are secured by your personal protective equipment.
- ▶ Release the pin **46**: Remove the locking pin **49** and unpin the retaining pin **48**.
- ▶ Insert the retaining pin **48** on point **P38** and secure with locking pin **49**.
- ▶ Unpin the pin **46**.
- ▶ Lower the D-guy rods **1** by extending the piston rods on the pull cylinder into the cross bracket **36** until the pin bores align.
- ▶ Inserting the pin **46**
- ▶ Remove the locking pin **49** and unpin the retaining pin **48** on point **P38**.
- ▶ Secure the pin **46**: Insert the retaining pin **48** on point **P39** and secure with locking pin **49**.
- ▶ Remove the fastening equipment on the frame.
- ▶ Make sure that the pin location is pinned and the pin is secured.

Result:

- The right frame is installed and pinned with the D-guy rods.

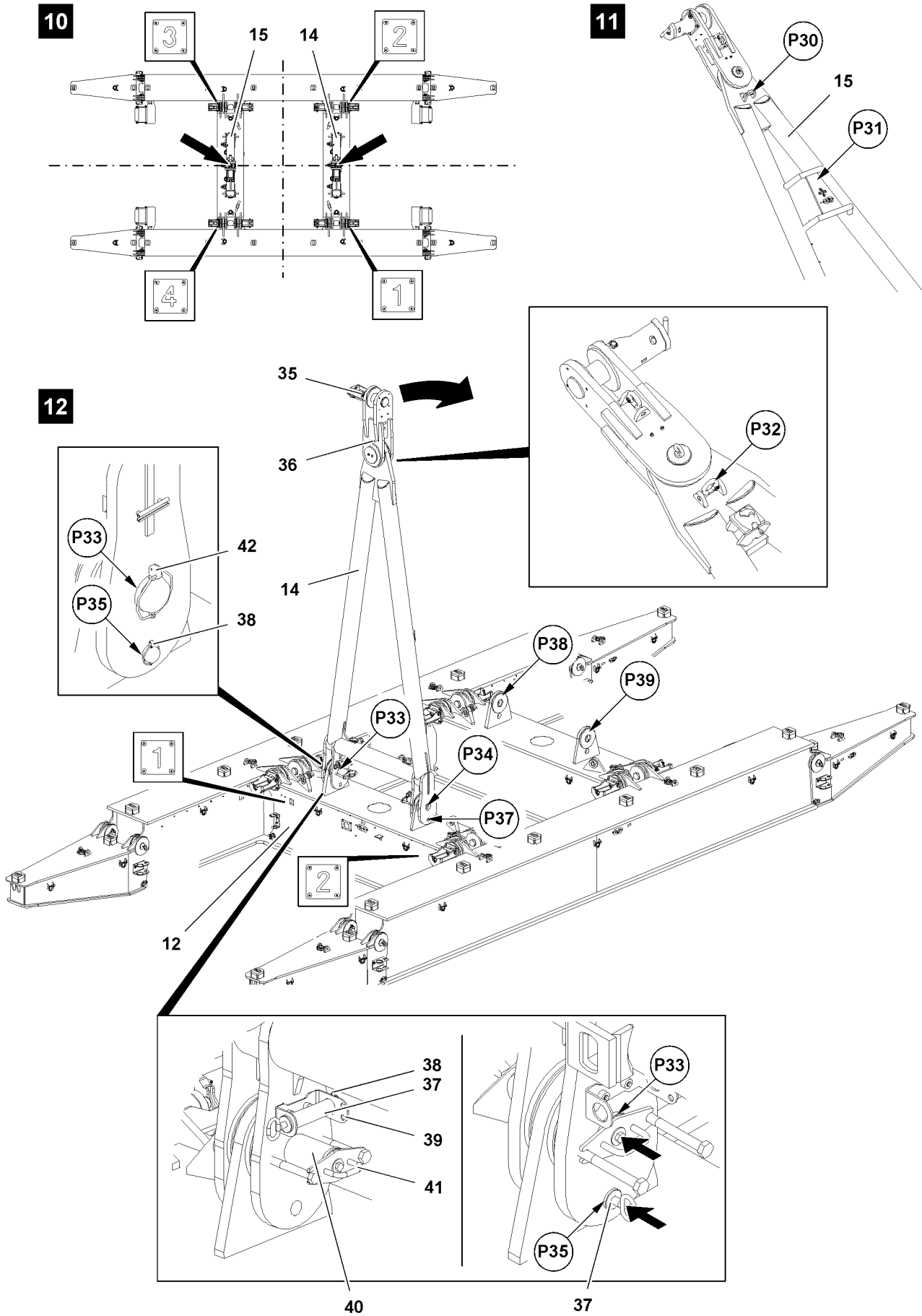

Fig.116170

LWE/LR 13000-001/19503-01-02/en

5.4.2 Installing the left frame



WARNING

Assembly personnel is not secured!

Assembly personnel can fall and be severely injured or killed!

- ▶ Secure assembly personnel with suitable aids to prevent them from falling!
- ▶ Use personal protective equipment!



WARNING

D-guy rods pinned one-sided!

Both D-guy rods must be pinned and secured, otherwise the derrick ballast pallet can tip over. Personnel can be severely injured or killed.

- ▶ Make sure that the right frame and the left frame are pinned with the D-guy rods.

Make sure that the following prerequisite is met:

- The right frame is installed and pinned with the D-guy rods.

- ▶ Hang the frame **15** onto the auxiliary crane, point **P30**, see illustration **11**.
- ▶ Lift the frame **15** until it hangs vertically.
- ▶ Position the frame **15** over the pin locations point **P38** and point **P39** on the connector carrier **12**.



Note

- ▶ The left frame must be pinned the same way with the connector carriers as described in section „Pinning the frame on the connector carrier“.
- ▶ The left cross bracket must be set the same way to the required lifting heights as described in section „Setting the cross bracket to lifting heights“.
- ▶ The left frame must be pinned the same way with the D-guy rods as described in section „Pinning the D-guy rods on the frame“.

- ▶ Make sure that the pin location are pinned and the pin is secured.

Result:

- The left frame is installed and pinned with the D-guy rods.

5.5 Establishing the electrical connection from the suspended ballast to the turntable



Note

- ▶ Establish the electrical connections from the suspended ballast to the turntable, see Electric wiring diagram.
- ▶ The cable drum for the electrical connection is located on the left frame.

- ▶ Establish the electrical connections.

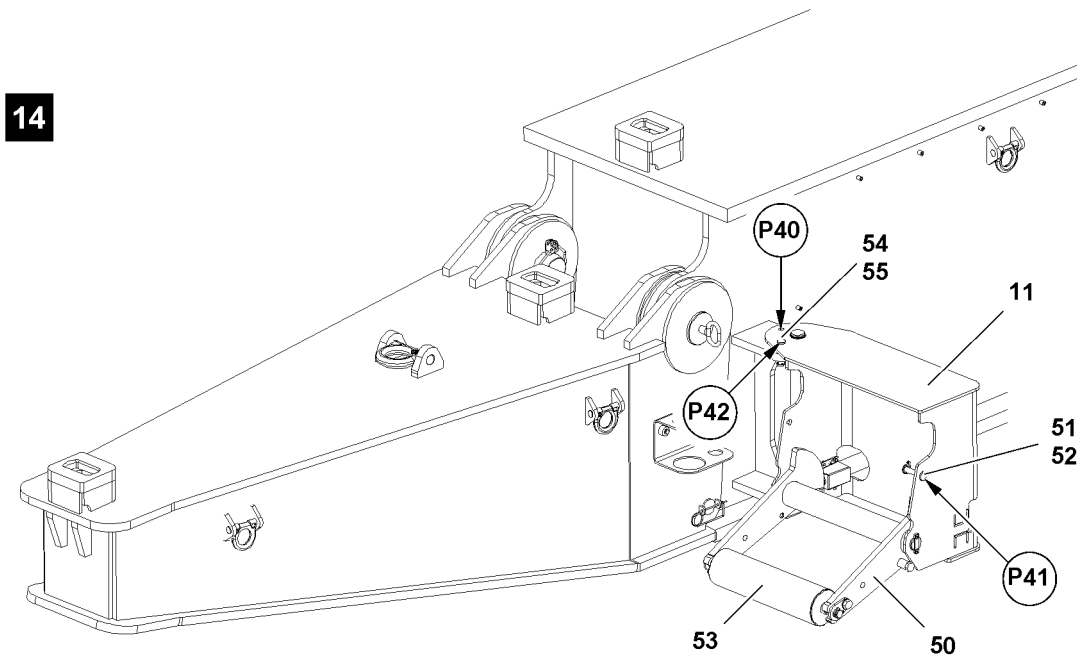
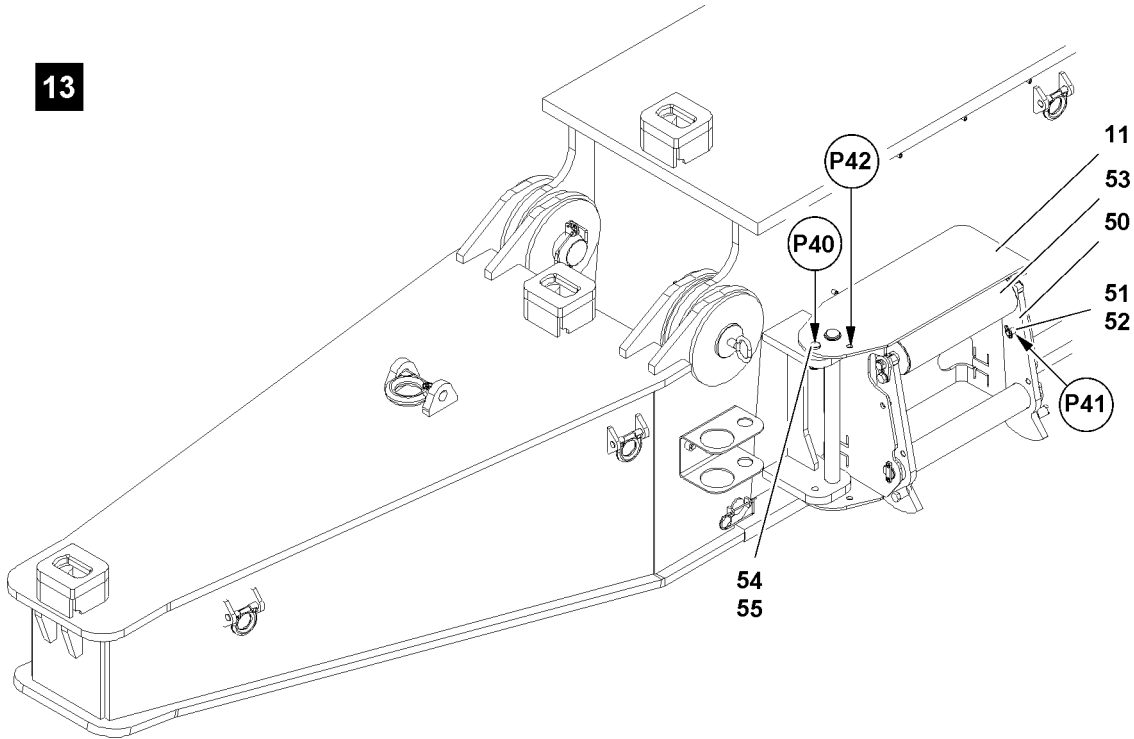

Fig.116175

LWE/LR 13000-001/19503-01-02/en

5.6 Folding the switch units out

Make sure that the following prerequisite is met:

- The frames are installed.



Note

- ▶ The weight of the switch unit is 0.15 t.

This section describes by example how a switch unit is folded out. The additional switch units must be folded out the same way.

When folded in, the switch unit **11** is pinned on point **P40** and on point **P41**, see illustration **13**.

When folded out, the switch unit **11** is pinned on point **P42** and on point **P41**, see illustration **14**.

- ▶ Release the switch unit **11**: Remove the locking pin **54** on point **P40** and unpin the pin **55**, see illustration **13**.
- ▶ Fold the switch unit **11** out.
- ▶ Secure the switch unit **11**: Insert the pin **55** on point **P42** and secure with locking pin **54**, see illustration **14**.



CAUTION

Danger of crushing!

When the ground contact roller **53** is released, the ground contact roller **53** can fold down with the retainer **50**. Hands and other body parts can be crushed.

- ▶ Make sure that the ground contact roller **53** is folded down in a controlled manner.

- ▶ Release the retainer **50**: Remove the locking pin **51** on point **P41** and unpin the pin **52**.
- ▶ Fold the ground contact roller **53** down.
- ▶ Secure the pin **52**: Insert the pin **52** on point **P40** and secure with locking pin **51**.

Result:

- The switch unit **11** is folded out and secured.

- ▶ Fold the remaining switch units **11** out.

Result:

- The four switch units **11** are folded out and secured.

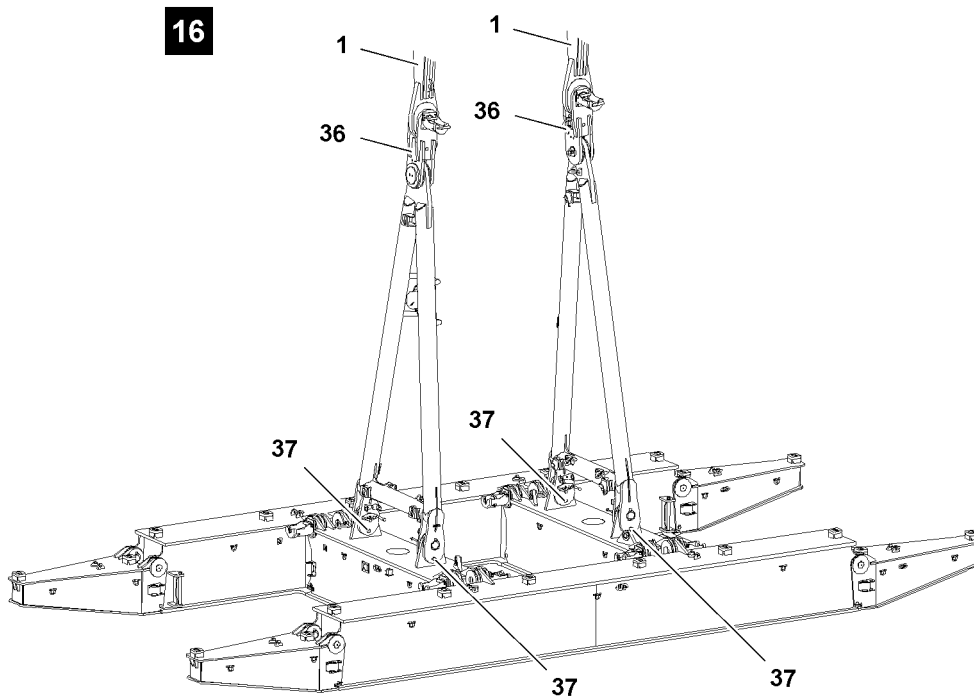
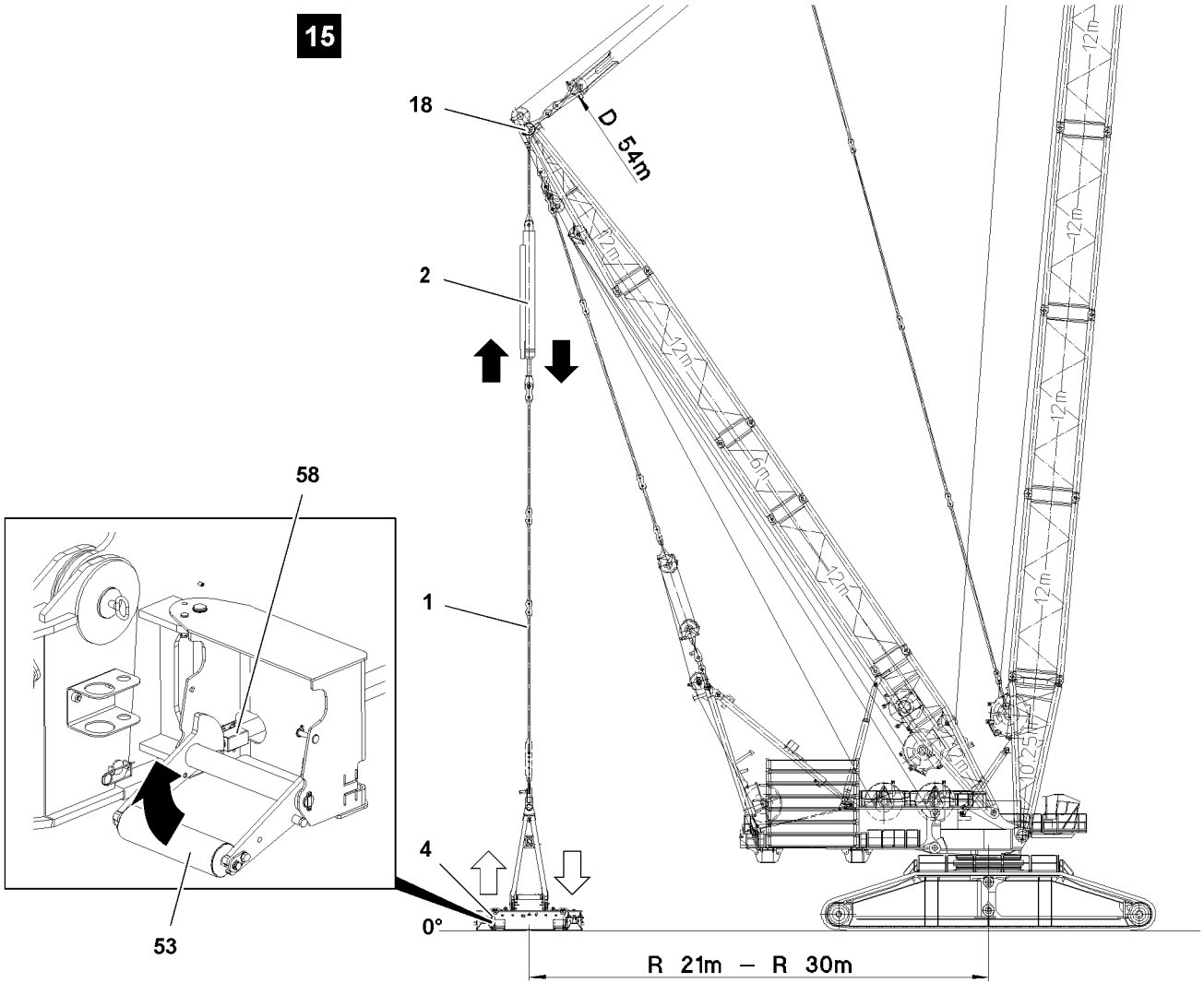

Fig.116176

LWE/LR 13000-001/19503-01-02/en

5.7 Aligning the derrick ballast pallet vertically



WARNING

Derrick ballast pallet not aligned!

When the derrick ballast plates are placed as long as the derrick ballast pallet is not vertically to the guy rods, the boom system can be overloaded. Personnel can be severely injured or killed.

- ▶ Lift the derrick ballast pallet before ballasting and set it down vertically.



WARNING

Maximum value for ground unevenness exceeded!

When the ground unevenness exceeds the maximum value, then the crane can topple over.

Personnel can be severely injured or killed.

- ▶ Make sure that the value for the ground unevenness is no more than maximum $\pm 1^\circ$.

Make sure that the following prerequisites are met:

- The frames are installed and secured with four retaining pins **37**, see illustration **16**
- The D-guy rods **1** are pinned and secured on the cross brackets **36**.
- The derrick boom is set to the required radius.
- The electrical connection between the derrick ballast pallet and the turntable has been established.

5.7.1 Lifting the derrick ballast pallet off the ground



WARNING

Uncontrolled oscillation of the derrick ballast pallet!

If the Derrick ballast pallet is raised, it can start to swing back and forth.

Personnel can be severely injured or killed.

- ▶ It is prohibited to remain within the danger zone.
 - ▶ Secure the derrick ballast pallet with auxiliary ropes.
-
- ▶ Lift the empty derrick ballast pallet **4** with the pull cylinders **2** until the ground contact rollers **53** hang down freely.

Result:

- The ground contact switches **58** can be tested for function.

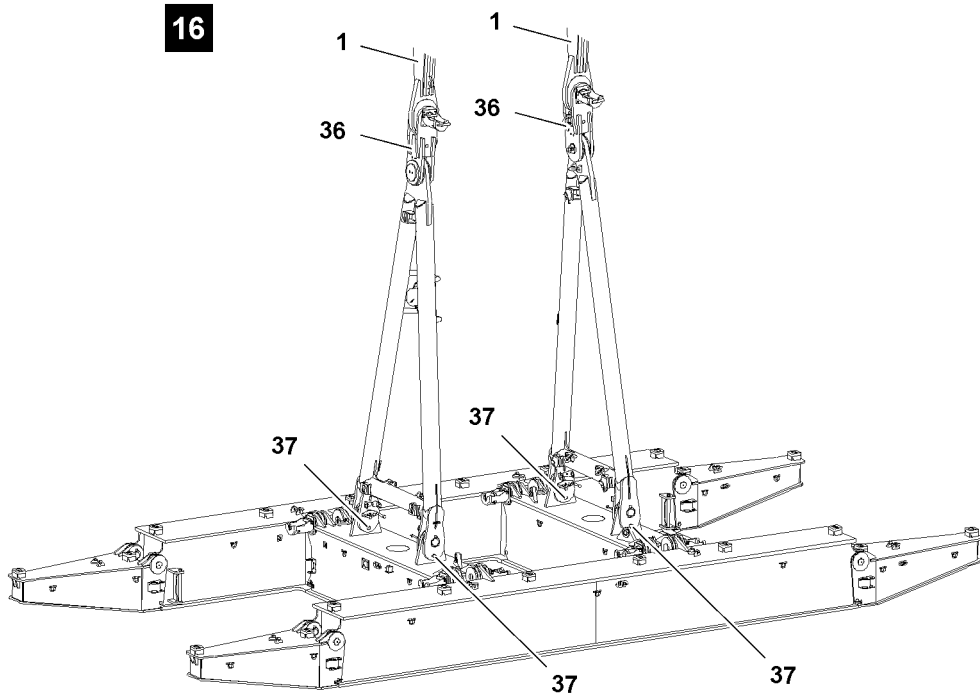
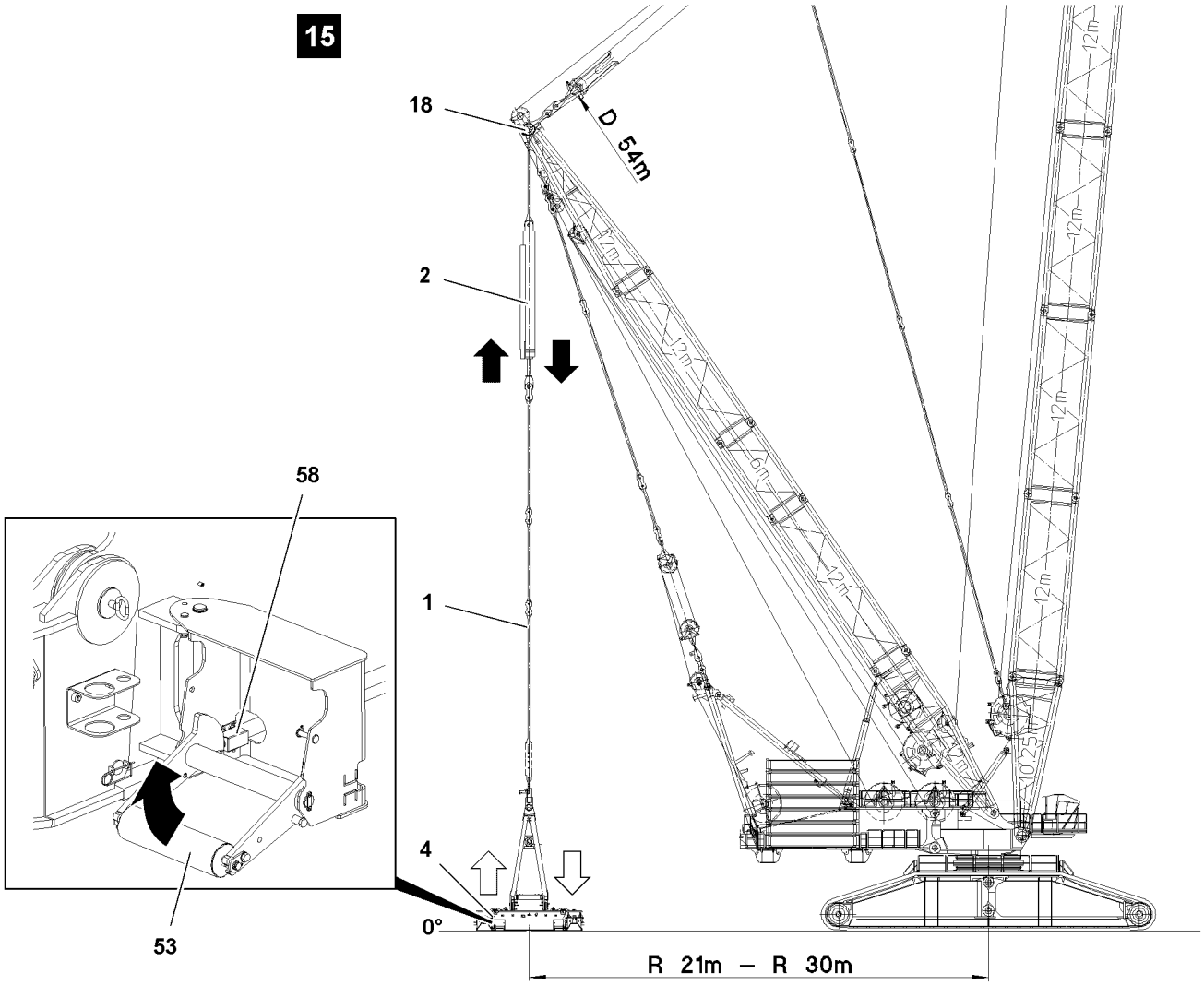

Fig.116176

LWE/LR 13000-001/19503-01-02/en

5.7.2 Function check of ground contact switch

Make sure that the following prerequisites are met:

- The cable drum cable is plugged in on the turntable.
- The ground contact rollers **53** must move easily.



WARNING

Defective ground contact roller!

When the ground contact rollers are **NOT** functioning, then the crane movements do **NOT** turn off when the derrick ballast pallet touches the ground. The crane can topple over. Personnel can be severely injured or killed.

- ▶ At ground contact, at least one ground contact switch **58** must be actuated.
- ▶ Check the ground contact rollers **53** for function.

- ▶ Manually lift the ground contact roller **53**.

Result:

- The ground contact switch **58** is actuated.
- On the LICCON monitor appears the icon „Derrick ballast has ground contact“, see Crane operating instructions, chapter 4.02.

- ▶ Check every individual ground contact roller **53** for function.

Result:

- The derrick ballast pallet **4** can be set on the ground.

5.7.3 Setting the derrick ballast pallet on the ground

- ▶ Make sure that the derrick ballast pallet **4** does not oscillate.
- ▶ Lower the empty derrick ballast pallet **4** with the pull cylinders **2** until the derrick ballast pallet **4** is standing completely on the ground and the D-guy rods **1** are relieved.

Result:

- The empty derrick ballast pallet **4** is standing exactly vertically under the derrick head **18**.

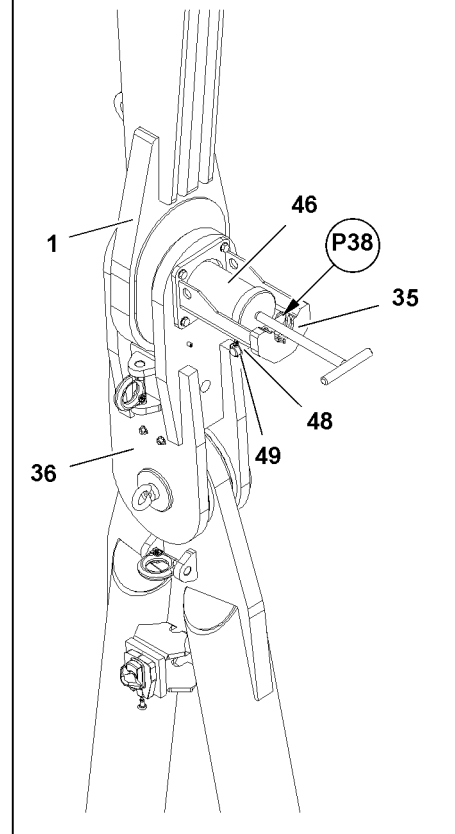
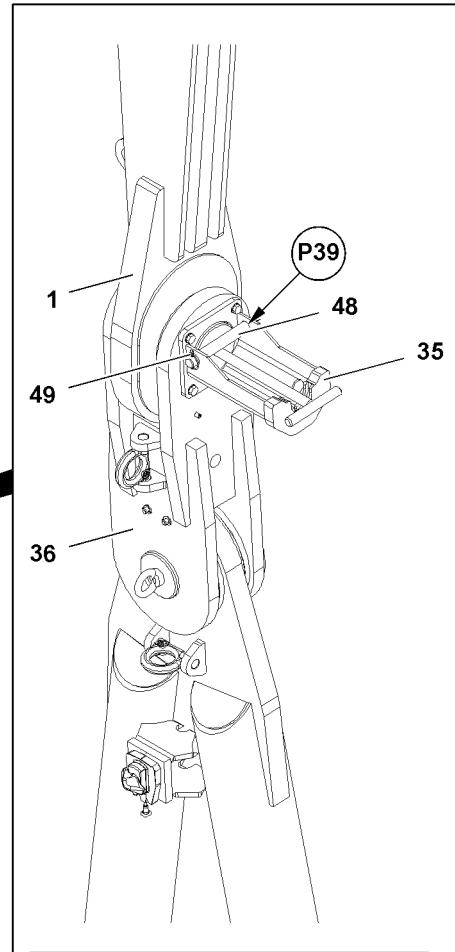
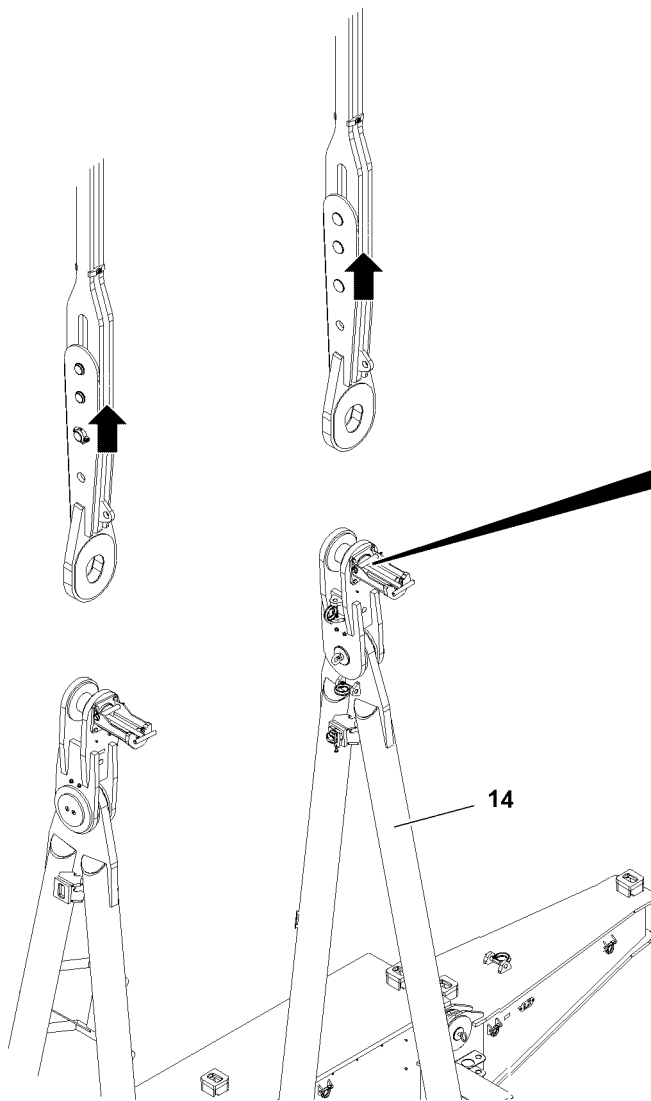

Fig.116177

LWE/LR 13000-001/19503-01-02/en

5.8 Unpinning the D-guy rods on the frames



WARNING

Assembly personnel is not secured!

Assembly personnel can fall and be severely injured or killed.

- ▶ Secure assembly personnel with suitable aids to prevent them from falling.
- ▶ Use personal protective equipment.

Make sure that the following prerequisite is met:

- The pins **46** are inserted and secured.
- A work platform is available.

Position the work platform in such a way that the pin **46** can be unpinned on the pinning device **35**.

- ▶ Make sure that you are secured by your personal protective equipment.
- ▶ Release the pin **46**: Remove the locking pin **49** and unpin the retaining pin **48**.
- ▶ Insert the retaining pin **48** on point **P38** and secure with locking pin **49**.
- ▶ Unpin the pin **46**.
- ▶ Lift the D-guy rods **1** by retracting the piston rods on the pull cylinder from the cross bracket **20** until sufficient room is available for ballasting.
- ▶ Inserting the pin **46**
- ▶ Remove the locking pin **49** and unpin the retaining pin **48** on point **P38**.
- ▶ Secure the pin **46**: Insert the retaining pin **48** on point **P39** and secure with locking pin **49**.
- ▶ Make sure that the pin location is pinned and secured.

Result:

- The D-guy rods are unpinned on the first frame.
- The second D-guy rods can be unpinned.
- ▶ Position the work platform for access to the second frame.
- ▶ On the second frame: Unpin the D-guy rods **1** on the cross brackets **36**.

When the D-guy rods are unpinned and pulled up:

- ▶ Insert pins **46** and secure with retaining pins **48**.
- ▶ Make sure that the pin location is pinned and secured.

Result:

- The derrick ballast pallet can be ballasted.

Fig.195219

LWE/LR 13000-001/19503-01-02/en

5.9 Ballasting the derrick ballast pallet



DANGER

Danger of impact and crushing!

Due to presence near the derrick ballast assembly, there is an increased danger of impact and crushing when the derrick plates are „moved in“.

- ▶ Exercise extreme caution when lifting the derrick ballast.
- ▶ Make sure that **NO** persons are underneath the suspended derrick ballast.
- ▶ Extreme caution is needed when lowering the derrick ballast plates. Danger of crushing people in the immediate area of the derrick ballast being lowered.



WARNING

Derrick ballast too low / too high!

If the placed derrick ballast deviates from the specifications in the load charts or the erection and take down chart, then the crane can be damaged or topple over.

Personnel can be severely injured or killed.

- ▶ Make sure that the derrick ballast is placed according to the specifications in the load chart or the erection and take down chart.



WARNING

Damaged derrick ballast plates!

Damage on the derrick ballast plates can cause the fastening equipment to release.

Derrick ballast plates can fall down.

Personnel can be severely injured or killed.

- ▶ Do not use damaged derrick ballast plates and replace them immediately.



WARNING

Overload of fastening points for derrick ballast plates!

If more than the permissible number of derrick ballast plates are lifted together, then the fastening points can be overloaded.

Derrick ballast plates and components can fall down.

Personnel can be severely injured or killed.

- ▶ Attach no more than maximum „two“ derrick ballast plates per lift.

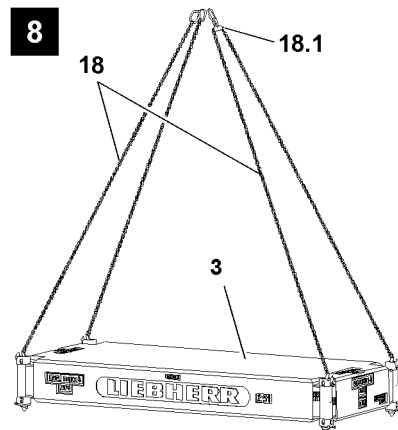
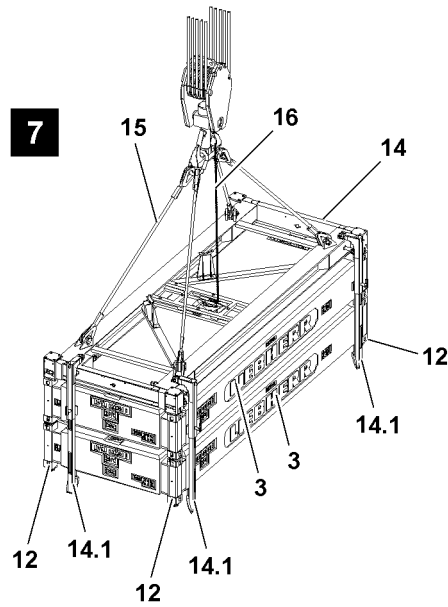
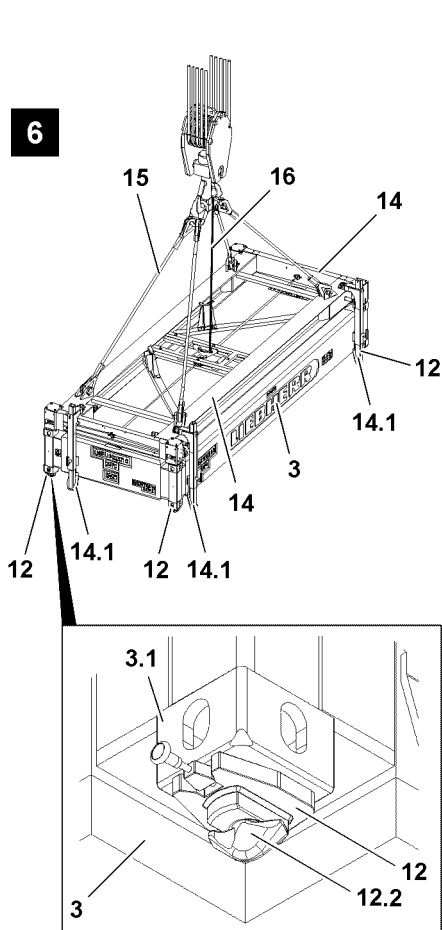
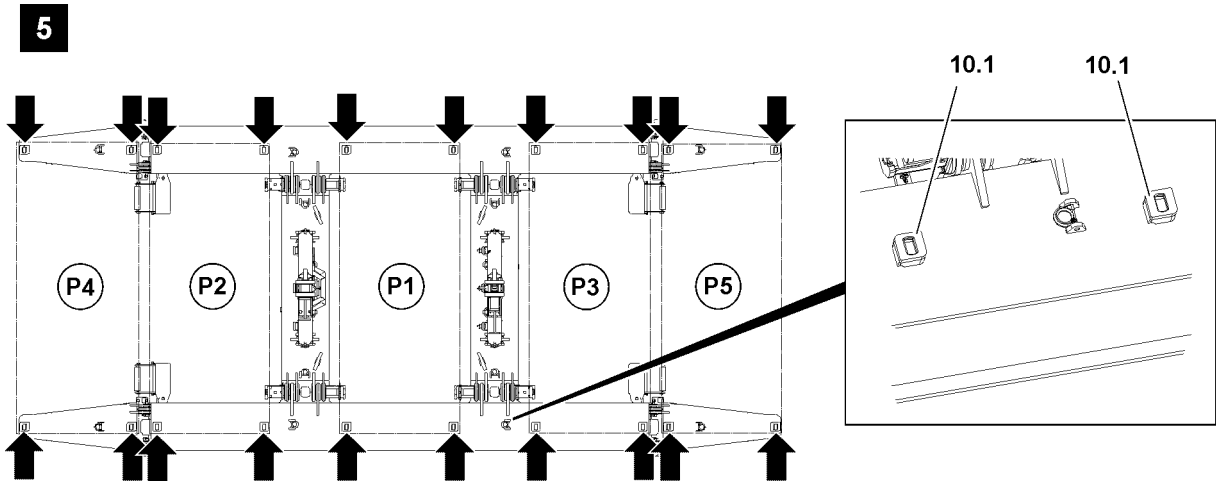

Fig.116172

LWE/LR 13000-001/19503-01-02/en

5.9.1 Placing the derrick ballast plates

The derrick ballast plates can be ballasted or placed with the following devices or fastening equipment:

1. Container spreader **14**, see illustration **6** and illustration **7**
2. With a chain suspension **18** at least 6 m long with balancer **18.1**, see illustration **8**.



WARNING

Danger of accidents due to overload!

If more than the permissible **two** derrick ballast plates are fastened on the container spreader **14**, the derrick ballast plates can fall down and the container spreader can be significantly damaged.

If more than **one** derrick ballast plate is fastened on the chain suspension **18**, then the chain suspension can rip off and the derrick ballast plates can fall down.

Personnel can be severely injured or killed.

- ▶ Make sure that no more than maximum **two** derrick ballast plates are fastened on the container spreader **14**.
 - ▶ Make sure that no more than maximum **one** derrick ballast plate is are fastened on the chain suspension **18**.
-



WARNING

Danger of accident due to damaged derrick ballast plates!

If damaged derrick ballast plates are used for ballasting, they can break off or parts can fall down.

Personnel can be severely injured or killed.

- ▶ Replace damaged derrick ballast plates immediately.
 - ▶ Continued use of damaged derrick ballast plates is prohibited.
-

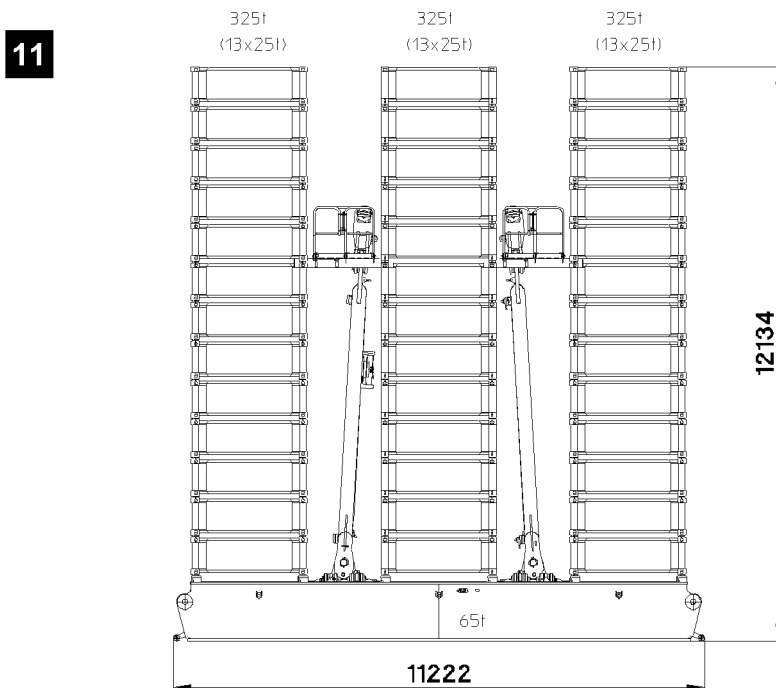
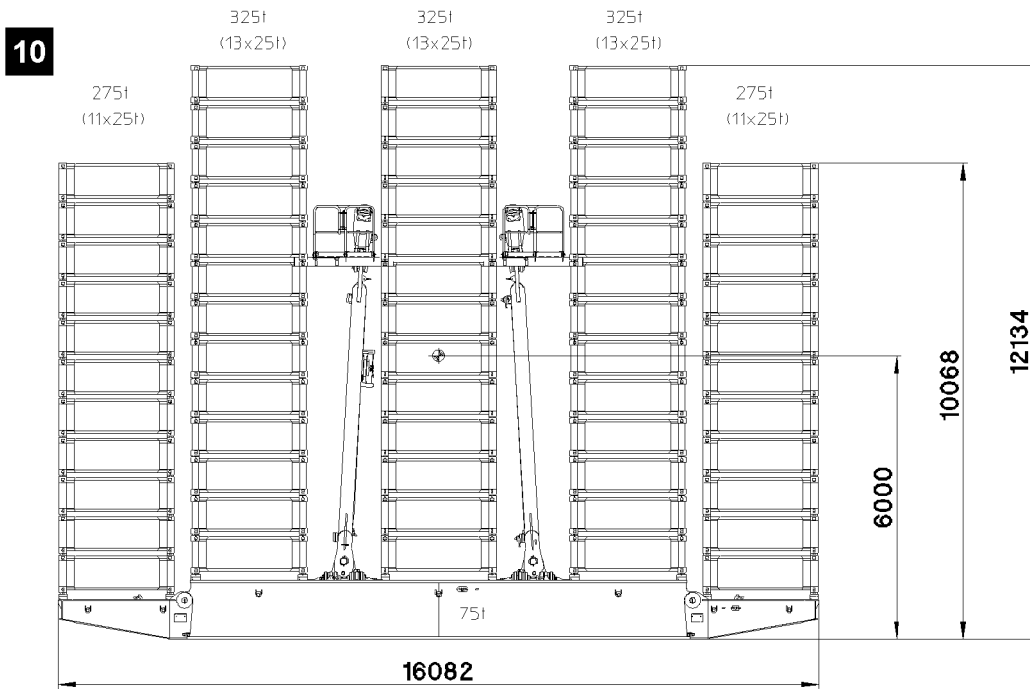
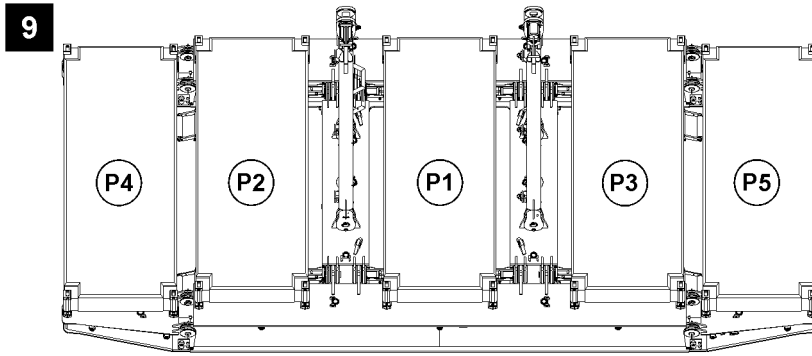

Fig.116178

LWE/LR 13000-001/19503-01-02/en

**WARNING**

The crane can topple over!

If the placed derrick ballast deviates from the specifications in the load chart or the erection and take down chart, then the crane can be damaged or topple over.

Personnel can be severely injured or killed.

- ▶ Place the derrick ballast according to the specifications in the load chart or the erection and take down chart.

**WARNING**

The crane can topple over!

If more than 50 t are placed with one lift on the derrick ballast pallet or on the derrick ballast plates or if the derrick ballast is placed asymmetrically, then the crane can topple over.

Personnel can be severely injured or killed.

- ▶ At the beginning of the ballasting procedure, place one individual derrick ballast plate on each stack **P**.
- ▶ Alternately place up to a maximum of 50 t counterweight assemblies symmetrically on the ballast stacks.
- ▶ The total center of gravity of the derrick ballast may be no more than maximum 6500 mm above the placement surface, in the example 6000 mm, see illustration **10**.
- ▶ Maximum 13 derrick ballast plates may be stacked on each other.

When the brackets are installed (5 ballast stacks):

- ▶ The maximum permissible derrick ballast is 1600 t.
- ▶ Maximum 1525 t may be placed on the derrick ballast pallet.
- ▶ For ballasting, a weight difference between the stacks on the right side (stack **P3** and stack **P5**) and the stacks on the left side (stack **P2** and stack **P4**) of more than 100 t is prohibited.

When the brackets are NOT installed (3 ballast stacks):

- ▶ The maximum permissible derrick ballast is 1040 t.
- ▶ Maximum 975 t may be placed on the derrick ballast pallet.
- ▶ During subsequent ballasting, a weight difference between the right stack **P3** and the left stack **P2** of more than 100 t is prohibited.

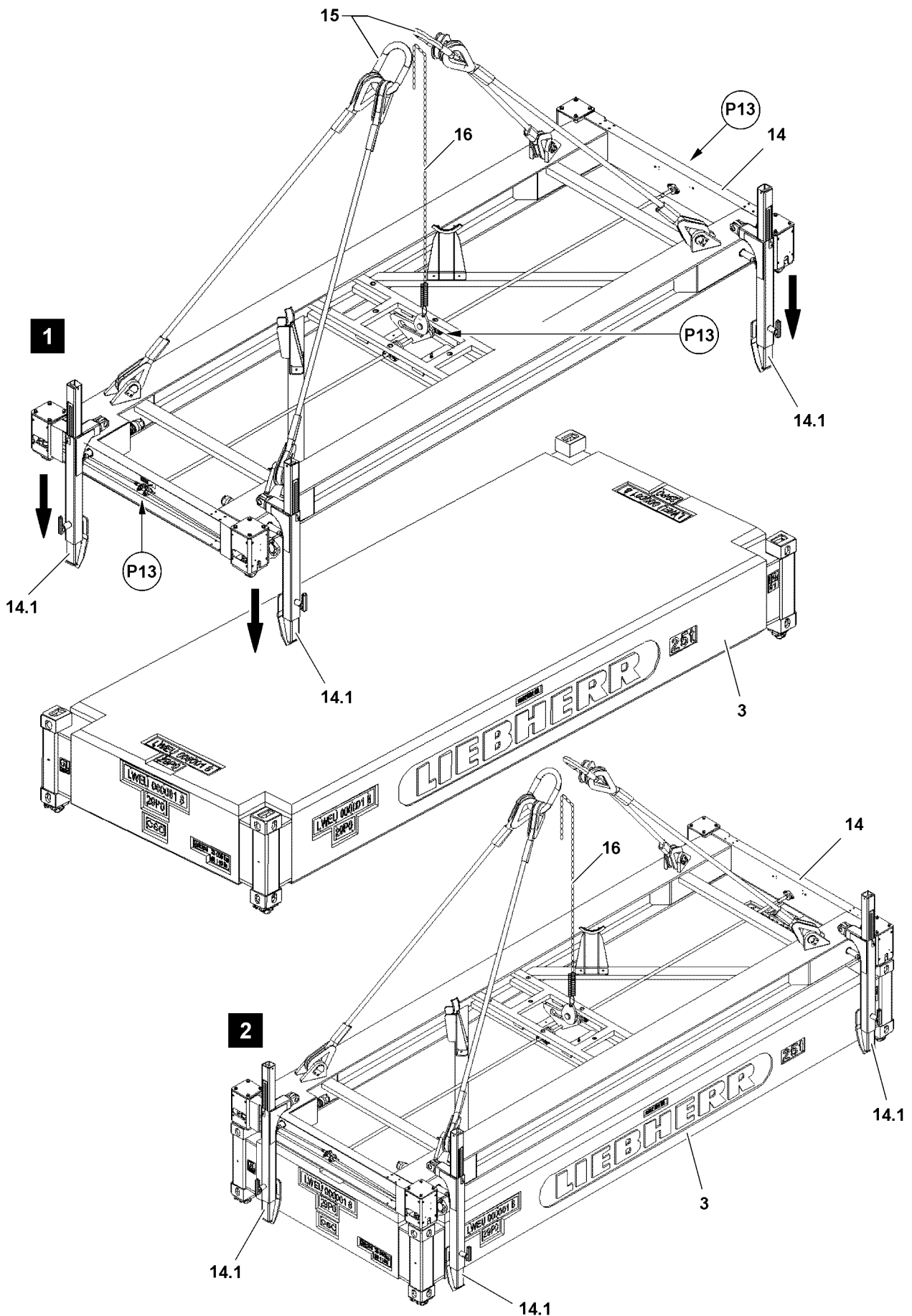

Fig.114754

LWE/LR 13000-001/19503-01-02/en

Use of container spreader



WARNING

Danger of accident!

If the container spreader operating instructions are not observed, personnel can be severely injured or killed.

Property damage on the crane can occur.

- ▶ Before operation of the container spreader, the assembly personnel must read and observe the separately supplied container spreader Operating instructions.



Note

- ▶ The strut guides **14.1** serve as guide stops on the derrick ballast plates **3** and can be telescoped depending on application.
 - ▶ The height of the derrick ballast plate **3** is 800 mm.
 - ▶ For adjustment of strut guide **14.1**, see separately supplied Container spreader Operating instructions.
- ▶ Set the strut guide **14.1** to the height of the derrick ballast plate.



Note

- ▶ For adjustment of spring load lock **16**, see separately supplied Container spreader Operating instructions.
- ▶ Fasten the fastening ropes **15** of the container spreader **14** and the chain of the spring load lock **16** on the hook of the auxiliary crane.

For a visual check, **red** and **green** color marks are provided to recognize the respective locking position in the slewing range of the axle lever on the respective front side and on the locking rocker, see points **P13** illustration **1**.



Note

- ▶ Make sure, before setting the container spreader **14** on the derrick ballast plate **3**, that a corresponding locking position is selected.
- ▶ Set the container spreader **14** with the auxiliary crane on the derrick ballast plate **3**.



Note

- ▶ Observe the function and warning notes for the Self-lock fixture lock, see separately supplied Container spreader Operating instructions.
- ▶ The locking procedure is carried out fully automatic by the Self-lock fixture lock.

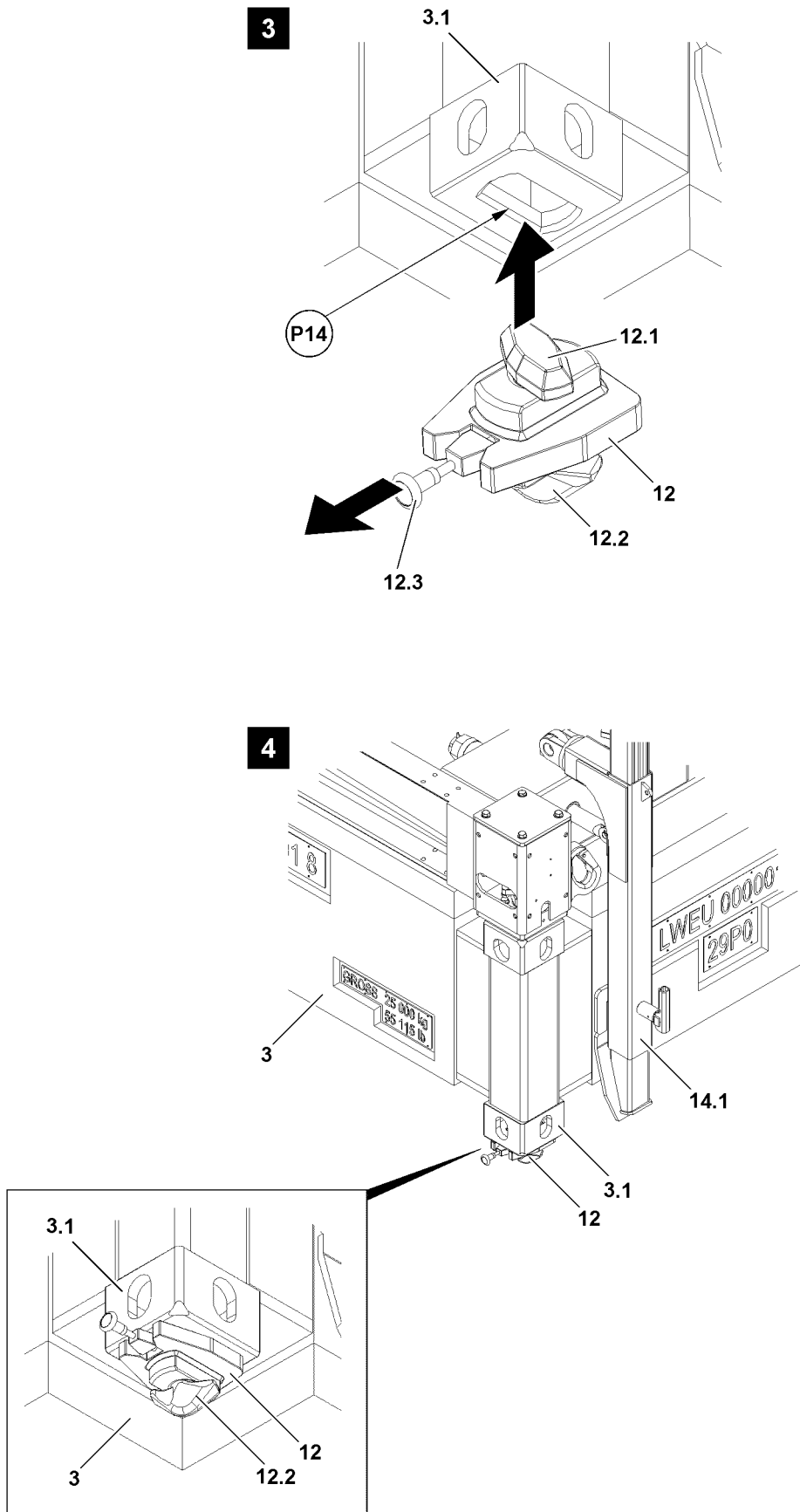

LWE/LR 13000-001/19503-01-02/en

Fig.116385

Installing the Twistlock on the derrick ballast plate

Make sure that the following prerequisites are met:

- The empty derrick ballast pallet is placed vertically under the derrick head.
 - The frames are separated from the D-guy rods.
 - The D-guy rods are pulled up.
 - The container spreader is set and locked on the first derrick ballast plate **3**.
- ▶ Lift the derrick ballast plate **3** with the auxiliary crane off the ground.

Result:

- The Twistlock **12** can be inserted from below into the container corner fittings **3.1**.
- ▶ Unlock the Twistlock **12**: Pull the release **12.3** and hold it pulled until the locking cone **12.1** has turned by 90°.

Result:

- The Twistlock **12** can be inserted in the container corner fitting **3.1**.



Note

- ▶ Pay attention to the installation position of the Twistlock.
 - ▶ Make sure that the Twistlock **12** is inserted with the flat locking cone **12.1** upward into the container corner fitting **3.1**.
-
- ▶ Guide the Twistlock **12** at point **P14** into the container corner fitting **3.1** of the derrick ballast plate **3**.
 - ▶ Activate the locking mechanism of the Twistlock **12**: Slowly let the release **12.3** return to its original position.

Result:

- The locking cone **12.1** turns and locks the Twistlock **12** with the container corner fitting **3.1**.
- ▶ Insert the Twistlocks **12** in the remaining container corner fittings **3.1** of the derrick ballast plate **3** and lock.

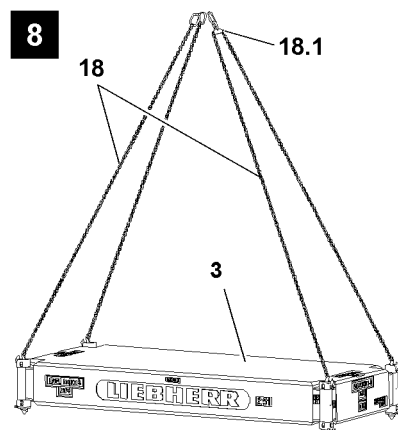
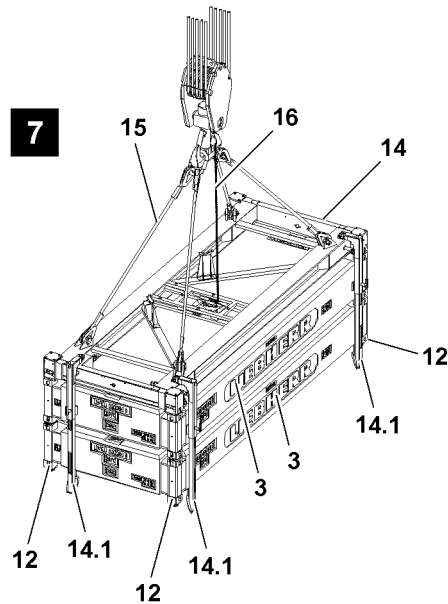
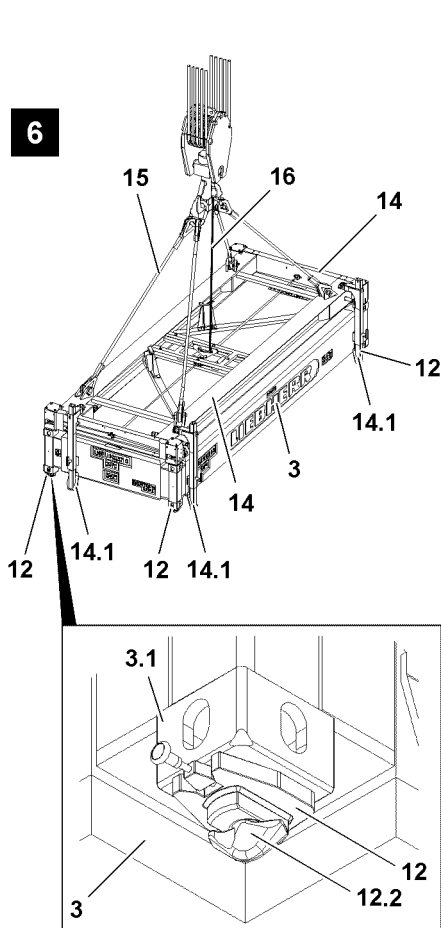
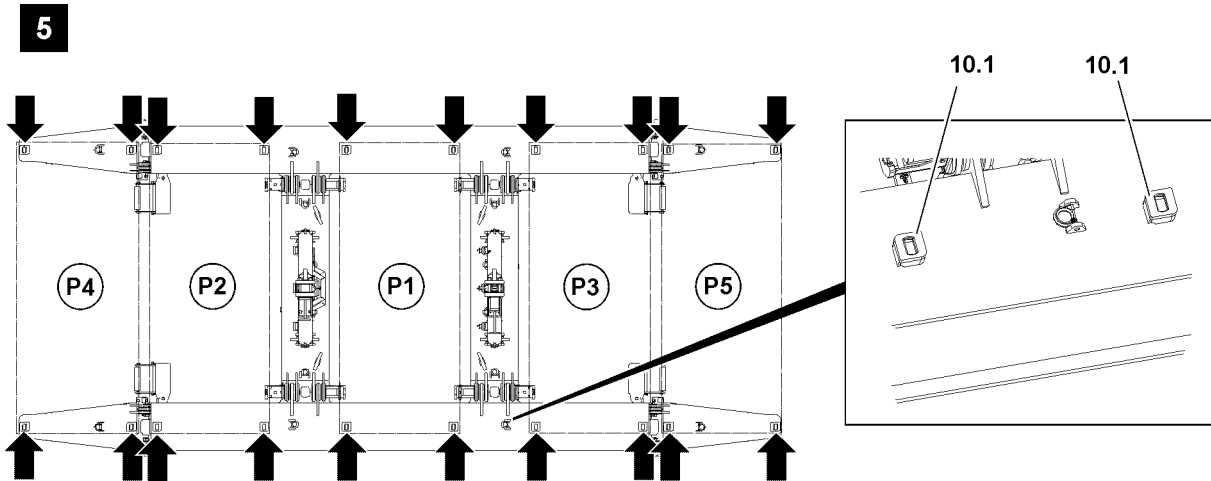

Fig.116172

LWE/LR 13000-001/19503-01-02/en

Placing the first derrick ballast plate on the derrick ballast pallet

Make sure that the following prerequisites are met:

- The Twistlocks **12** are properly guided from below and locked in all container corner fittings **3.1** of the first derrick ballast plate, see illustration **6**.
 - The container spreader operating instructions were read and understood.
 - The telescope pipes of the strut guides **14.1** on the container spreader are moved in, see container spreader Operating instructions.
 - The brackets are installed: Five ballast stacks are placed.
 - The brackets are **NOT** installed: Three ballast stacks are placed.
- ▶ Swing the first derrick ballast plate **3** with the auxiliary crane in to the derrick ballast pallet.



Note

- ▶ The locks **12.2** of Twistlocks **12** lock by themselves when the derrick ballast plate is set correctly set on the base **10.1**.
 - ▶ Positions of the base **10.1**, see illustration **5**.
-
- ▶ Align the derrick ballast plate **3** and place it on a stack **P** of the derrick ballast pallet, see illustration **5**.
 - ▶ Ballast the derrick ballast plates **3** until a derrick ballast plate is laying on each stack.



WARNING

Falling derrick ballast plates!

If the derrick ballast plates are not checked before removing the container spreader to ensure that they are locked properly, the derrick ballast plates can fall down.

Personnel can be severely injured or killed.

- ▶ Make sure that the derrick ballast plate is properly locked on all four locking points.

When the derrick ballast plate is properly locked on all four locking points:

- ▶ Remove the container spreader **16**.
- or**
- ▶ Remove the chain suspension **18**.

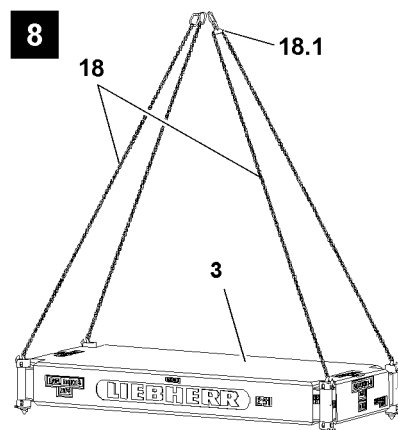
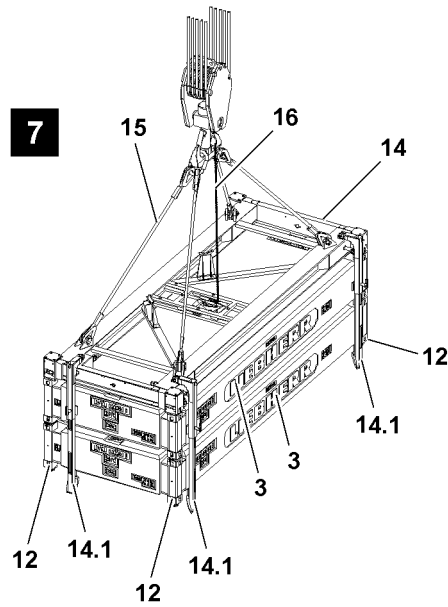
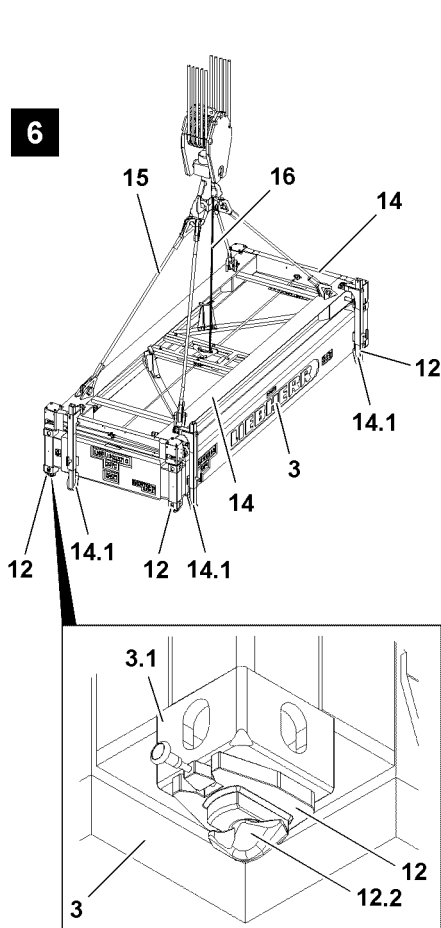
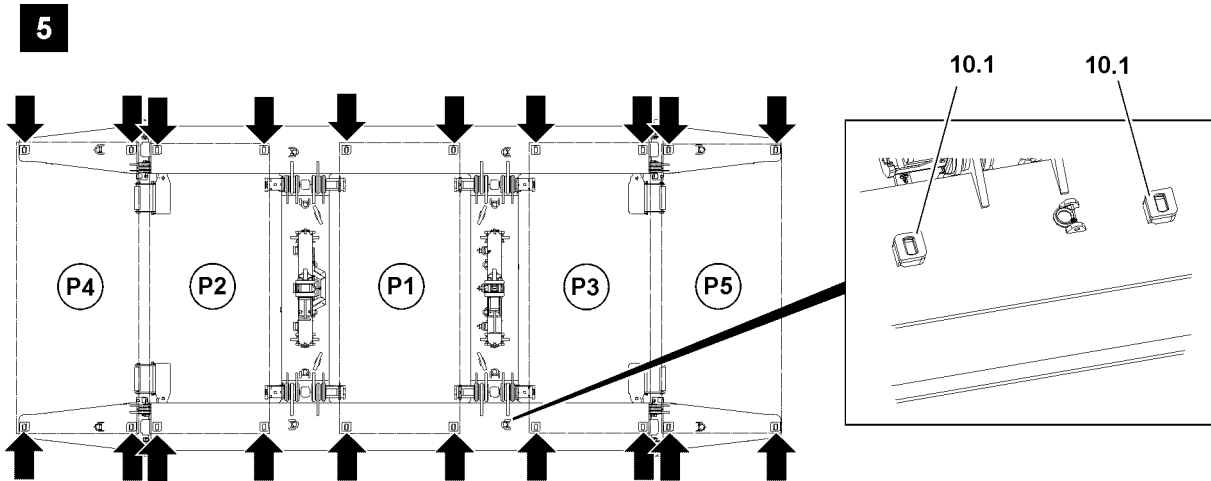

Fig.116172

LWE/LR 13000-001/19503-01-02/en

Placing additional derrick ballast plates

Make sure that the following prerequisite is met:

- **Ballasting with container spreader:**
 - For ballasting of two derrick ballast plates: Pull the strut guide out to the required length, see container spreader operating instructions.



Note

- ▶ The derrick ballast plates **3** are marked with their own weights.
- ▶ The installation of additional derrick ballast plates is made according to the working steps of the first derrick ballast plate **3**, see section „Placing the first derrick ballast plate on the derrick ballast pallet“.

-
- ▶ Ballast the derrick ballast plates **3** until **eight** derrick ballast plates are laying on each stack.

Result:

- The platforms can be installed.

5.9.2 Assembling the platforms

You can freely select the sequence in which the platforms **1** are installed. The platforms **1** are identical and can be interchanged.

Described in this section, as an example, is the swing procedure of the railings into operating position and the placement of the platform on the derrick ballast plates. The installation of the other platform is made in the same way.



Note

- ▶ The weight of the platform is 0.4 t.

Make sure that the following prerequisite is met:

- Eight derrick ballast plates have been placed on each ballast stack.
- A work platform is available.

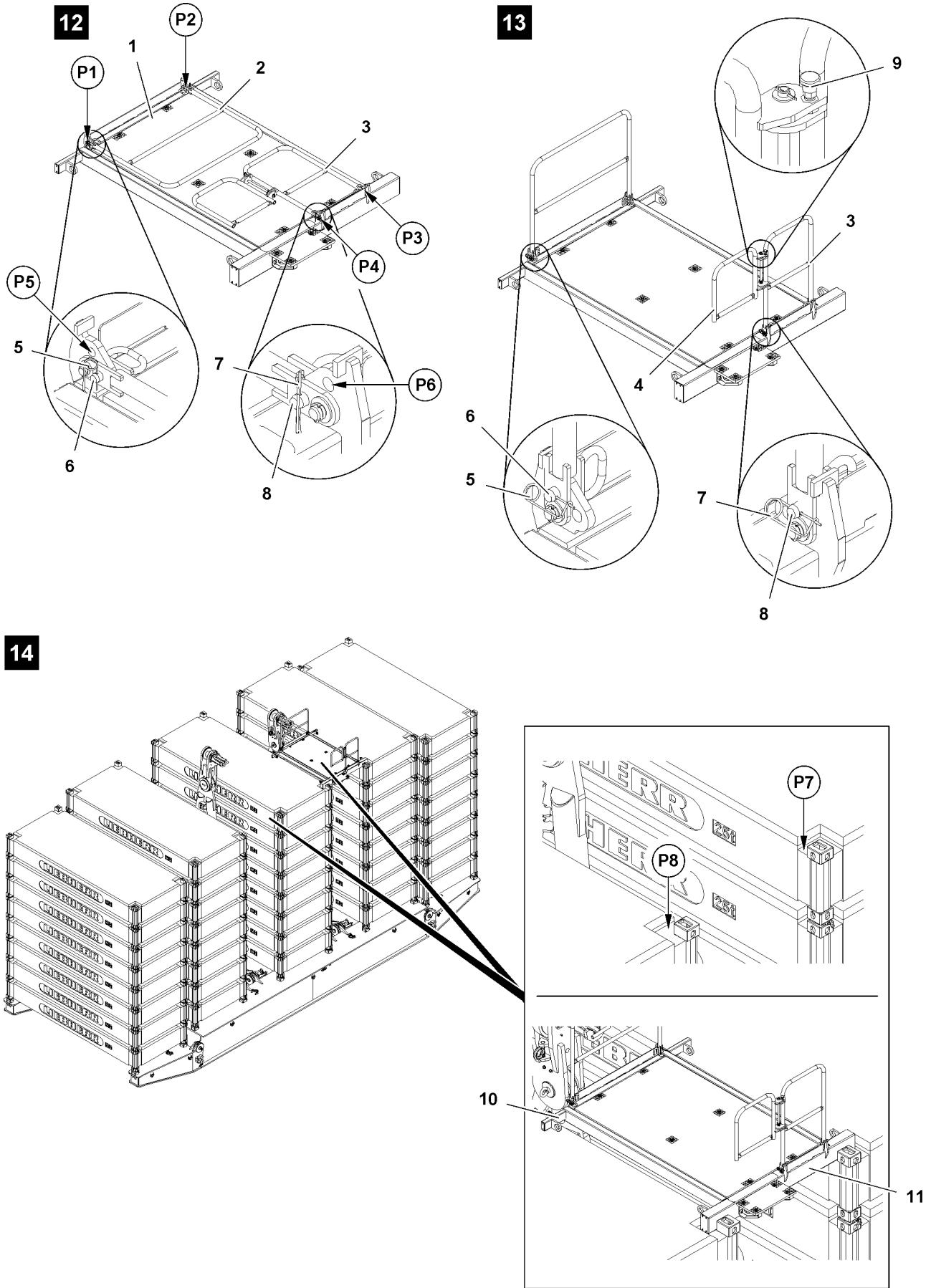

Fig.116173

LWE/LR 13000-001/19503-01-02/en

Swinging the railing (rear) into operating position



Note

- ▶ The railing (rear) consists of two parts. The door **4** is released and locked with the detent pin **9**, see illustration **13**.
 - ▶ After releasing, the door **4** returns automatically into its initial position.
-
- ▶ Release the railing **3** on point **P4**: Remove the spring retainer **7** and unpin the pin **8**, see illustration **12**.
 - ▶ Release the railing **3** on point **P3**: Remove the spring retainer **7** and unpin the pin **8**.



WARNING

Danger of crushed limbs!

When swinging the railing **3**, fingers and hands can be crushed.

- ▶ Do not reach with your hands into the danger zone.
-
- ▶ Swing the railing **3** upward.
 - ▶ Secure the railing **3** on point **P4**: Insert the pin **8** on point **P6** and secure with spring retainer **7**, see illustration **13**.
 - ▶ Secure the railing **3** on point **P3**: Insert the pin **8** on point **P6** and secure with spring retainer **7**.

Result:

- The railing (rear) is secured in operating position.

Swinging the railing (front) into operating position

- ▶ Release the railing **2** on point **P1**: Remove the spring retainer **5** and unpin the pin **6**, see illustration **12**.
- ▶ Release the railing **2** on point **P2**: Remove the spring retainer **5** and unpin the pin **6**.



WARNING

Danger of crushed limbs!

When swinging the railings, fingers and hands can be crushed!

- ▶ Do not reach with your hands into the danger zone!
-
- ▶ Swing the railing upward.
 - ▶ Secure the railing **2** on point **P1**: Insert the pin **6** on point **P5** and secure with spring retainer **5**, see illustration **13**.
 - ▶ Secure the railing **2** on point **P2**: Insert the pin **6** on point **P5** and secure with spring retainer **5**.

Result:

- The railing (front) is secured in operating position.

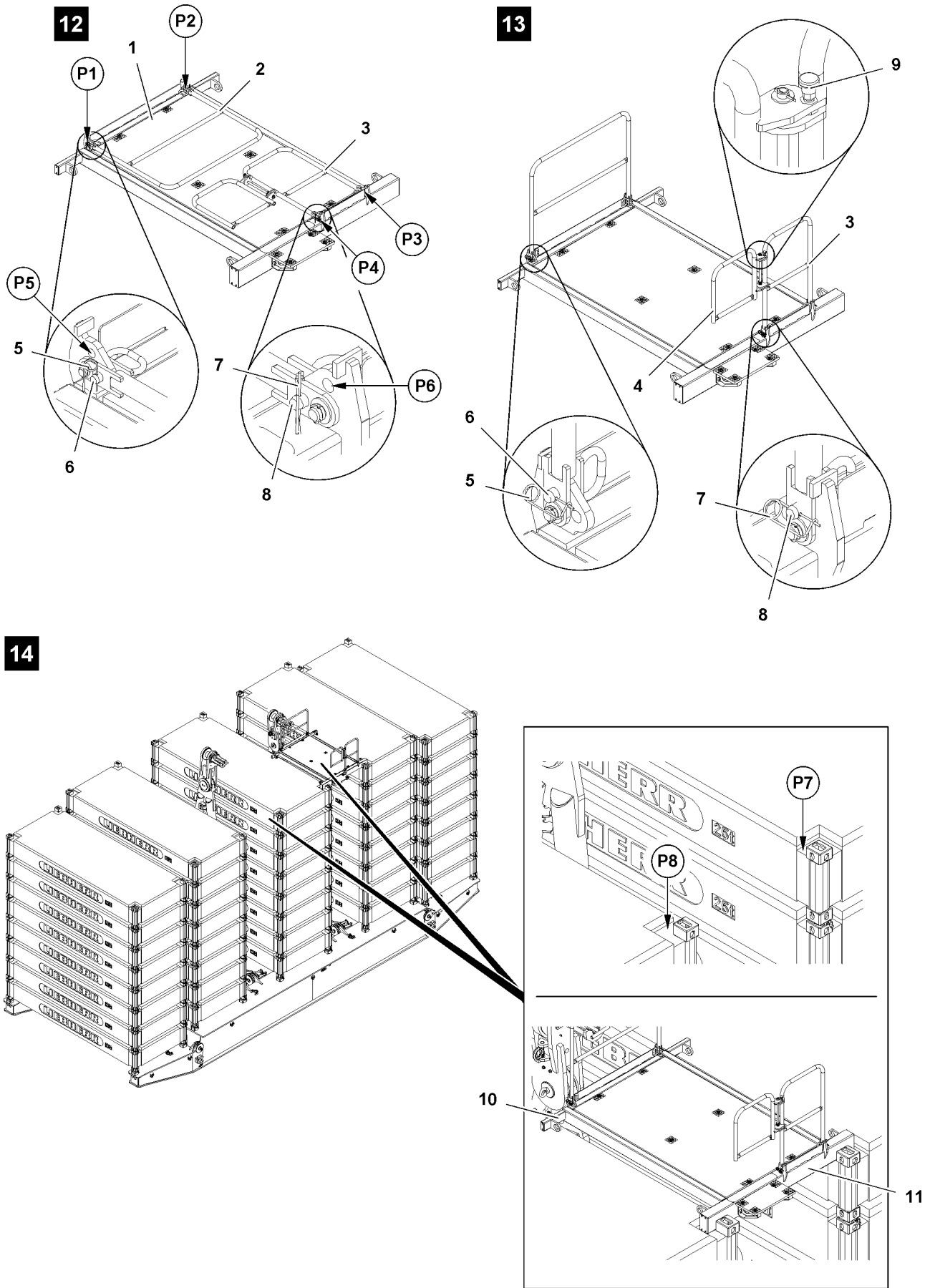

Fig.116173

Setting the platforms on the derrick ballast plates



WARNING

Assembly personnel is not secured!

Assembly personnel can fall and be severely injured or killed.

- ▶ Secure assembly personnel with suitable aids to prevent them from falling.
- ▶ Use personal protective equipment.



WARNING

Danger of crushing!

During assembly, hands can be crushed or even severed due to swing movements of the components!

- ▶ Make sure that the components do not swing back and forth during assembly!

Make sure that the following prerequisites are met:

- The railing (rear) and railing (front) are swung into operating position and secured.
- A work platform is available.

- ▶ Fasten the platform **1** on the auxiliary crane.

Position the work platform in such a way that you can set the platforms in the derrick ballast plates.

- ▶ Set the rectangular pipe **11** on point **P7** and on point **P8** into the derrick ballast plates, see illustration **14**.

Result:

- The rectangular pipe **10** is laying on both ends on the derrick ballast plates.

Second platform: Swing the railing (rear) and the railing (front) into operating position.

When the railing (rear) and railing (front) of the second platform are swung into operating position and secured:

- ▶ Set the second platform on the derrick ballast plates.

Result:

- When both platforms are set, then the remaining derrick ballast plates can be placed.

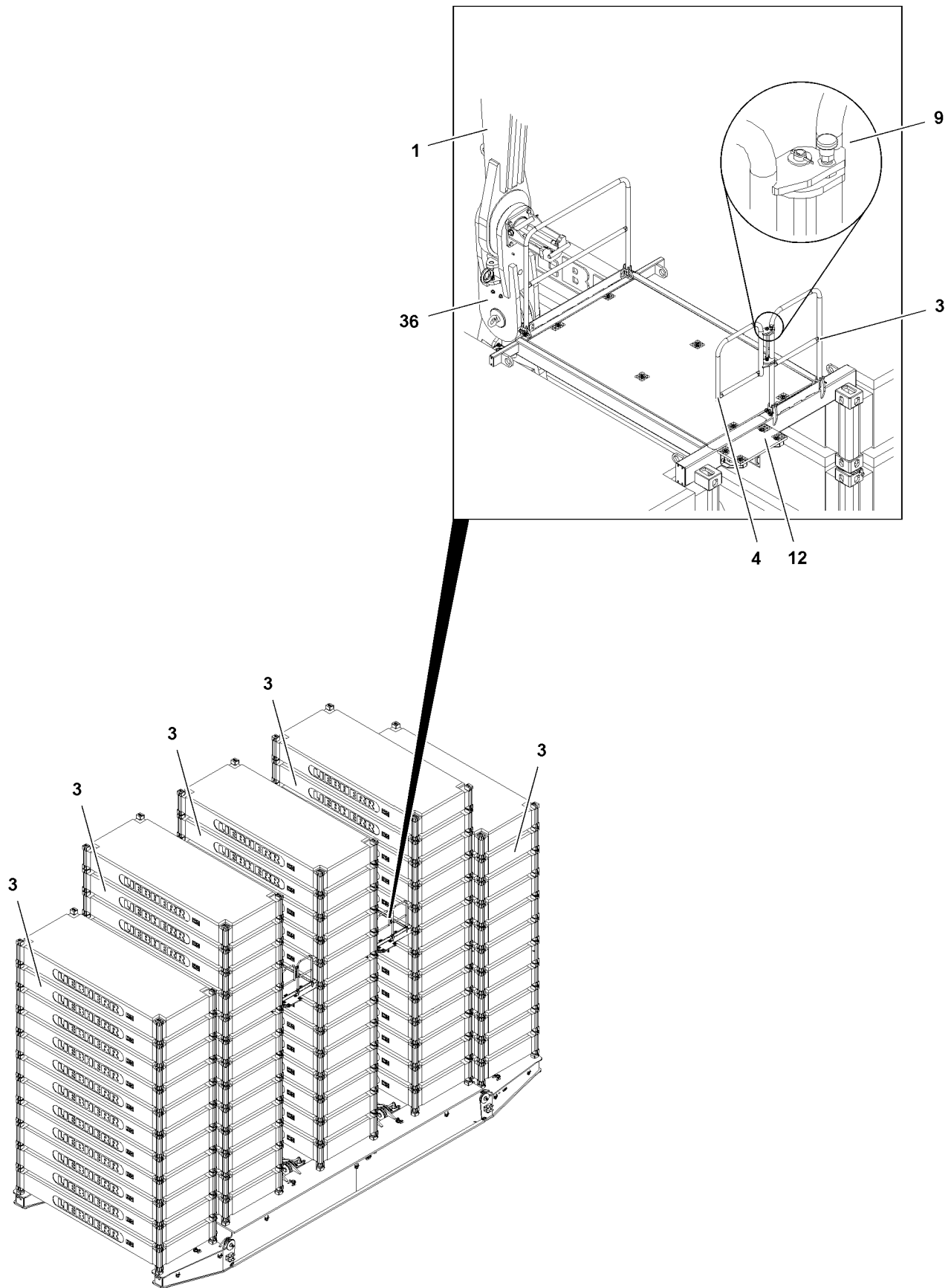

Fig.116174

LWE/LR 13000-001/19503-01-02/en

5.9.3 Placing the remaining derrick ballast plates

Make sure that the following prerequisites are met:

- Both platforms are set on the derrick ballast plates.



WARNING

Danger of crushing!

During assembly, hands can be crushed or even severed due to swing movements of the components!

- ▶ Make sure that the components do not swing back and forth during assembly!
-

NOTICE

Oscillating derrick ballast plates!

When the derrick ballast plates swing back and forth during placement, the platforms can be damaged.

- ▶ Make sure that the derrick ballast plates do **NOT** swing back and forth during placement.
 - ▶ Make sure that the platforms are **NOT** damaged during ballasting.
-
- ▶ Place the remaining derrick ballast plates **3** the same way as described in section „Placing the derrick ballast plates“.

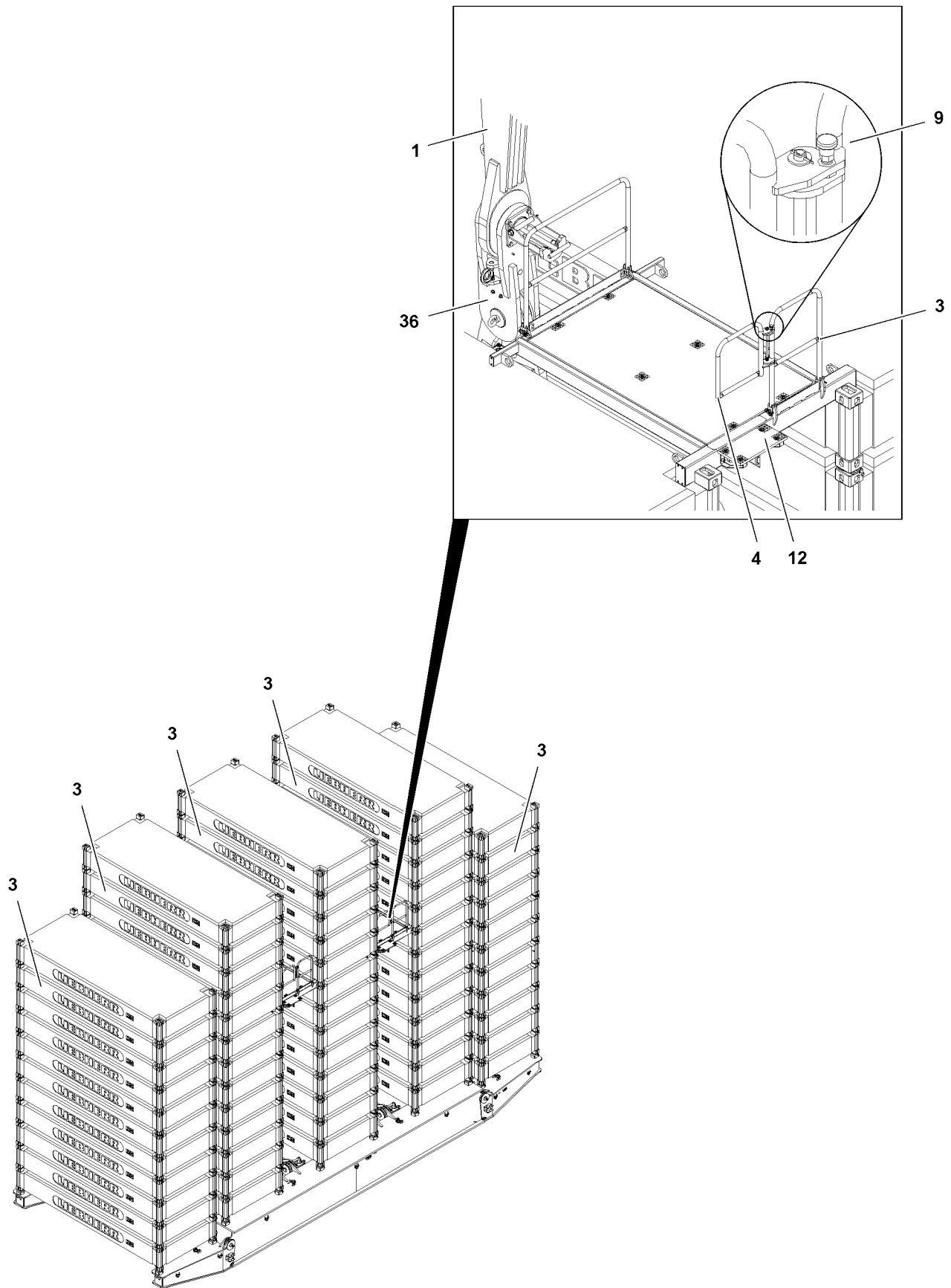

Fig.116174

LWE/LR 13000-001/19503-01-02/en

5.9.4 Pinning the D-guy rods on the derrick ballast pallet



WARNING

Assembly personnel is not secured!

Assembly personnel can fall and be severely injured or killed.

- ▶ Secure assembly personnel with suitable aids to prevent them from falling.
- ▶ Use personal protective equipment.



WARNING

D-guy rods pinned one-sided!

Both D-guy rods must be pinned and secured, otherwise the derrick ballast pallet can tip over. Personnel can be severely injured or killed.

- ▶ Make sure that the right frame and the left frame are pinned with the D-guy rods.

Make sure that the following prerequisites are met:

- The derrick ballast pallet is ballasted completely, see load chart or erection and take down chart.
- A work platform is available.



Note

- ▶ The step 12 on the outside of the platform allows access.

Position the work platform in such a way that you have safe access to the first platform.

- ▶ Make sure that you are secured by your personal protective equipment.
- ▶ Pull the detent pin 9 and swing the door 4 in.
- ▶ Step on the platform.
- ▶ Swing the door 4 outward and let the detent pin 9 engage.

Result:

- The D-guy rods can be pinned from the platform with the cross brackets.

Pin the D-guy rods on the cross brackets the same way as in section „Pinning the D-guy rods on the frame“.

- ▶ On the first frame: Pin the D-guy rods 1 on the cross brackets 36.
- ▶ Make sure that the pin location is pinned and secured.

Result:

- The D-guy rods are pinned on the first frame.
- The second D-guy rods can be pinned.
- ▶ Position the work platform for access to the second platform.
- ▶ Step on the second platform.
- ▶ Pin the D-guy rods 1 on the cross brackets 36.

Result:

- Both D-guy rods are pinned on the frames of the derrick ballast pallet.

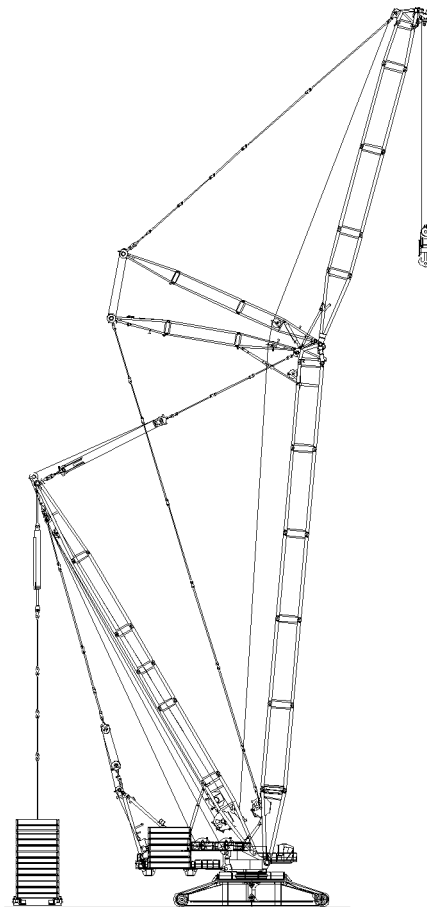
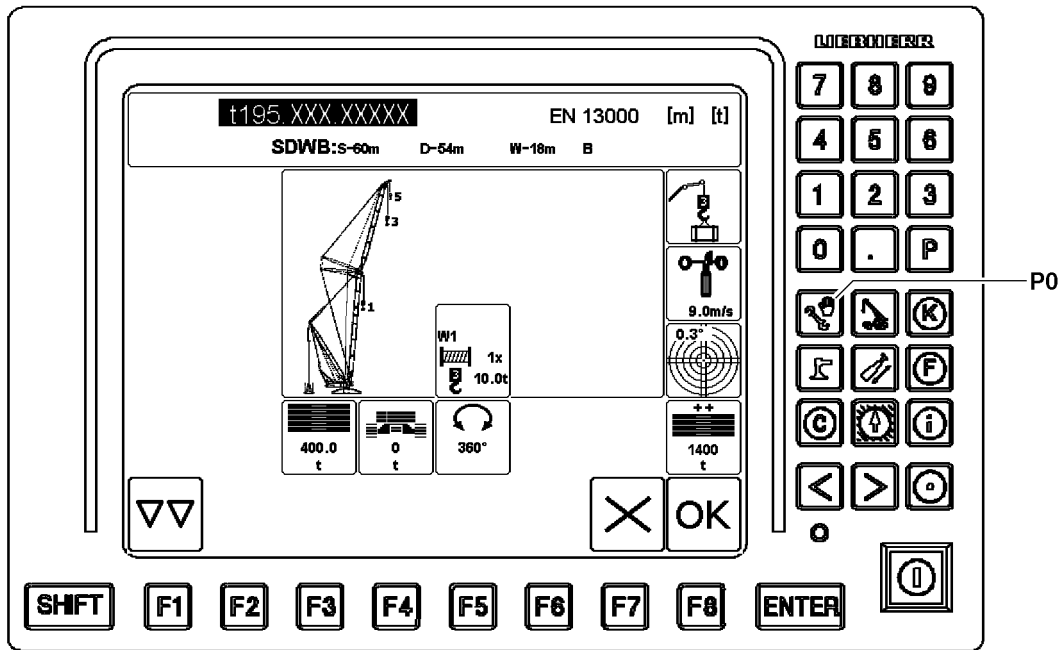

Fig.116047

LWE/LR 13000-001/19503-01-02/en

6 Crane operation with derrick ballast

During crane operation with derrick ballast the required maximum / minimum load can be actively influenced.

This is made possible by increasing or reducing the derrick ballast. Depending on the situation, this procedure is also possible under load.



Note

- ▶ The suspended ballast and ballast trailer are generally referred to as the **derrick ballast**.
- ▶ The fixed compensation weight which is installed on the turntable is generally referred to as the **counterweight**.
- ▶ Additional personnel to carry out crane operation is generally referred to as **guide**.

6.1 Checking the settings in the LICCON overload protection

Make sure that the following prerequisites are met:

- The derrick ballast is placed according to the load chart.
- The actual placed derrick ballast has been entered and confirmed in the Set up program, see Crane operating instructions, chapter 4.02.
- The derrick boom is in operating position.



WARNING

Incorrectly set overload protection!

If the actual set up configuration of the crane deviates from the entries and settings in the Set up program, then the overload protection is not correctly set.

An incorrectly set overload protection calculates the actual load incorrectly and transmits faulty display values.

The crane can be overloaded unnoticed and topple over.

This could result in serious accidents.

- ▶ The entries and settings in the set up program must match the actual set up configuration of the crane.



Note

- ▶ Set the LICCON overload protection in the set up program, see Crane operating instructions, chapter 4.02.

- ▶ Press the program key **P0**.

Result:

- The Set up program is called up.
- ▶ In the monitor display of the Set up program check if the LICCON overload protection is set according to the data in the load chart and the actual set up configuration of the crane, see example illustration.

LM

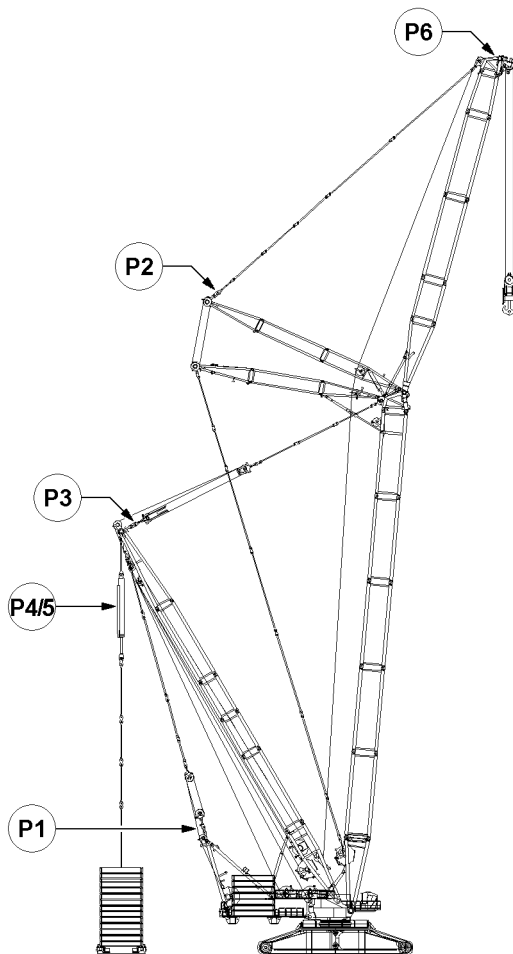
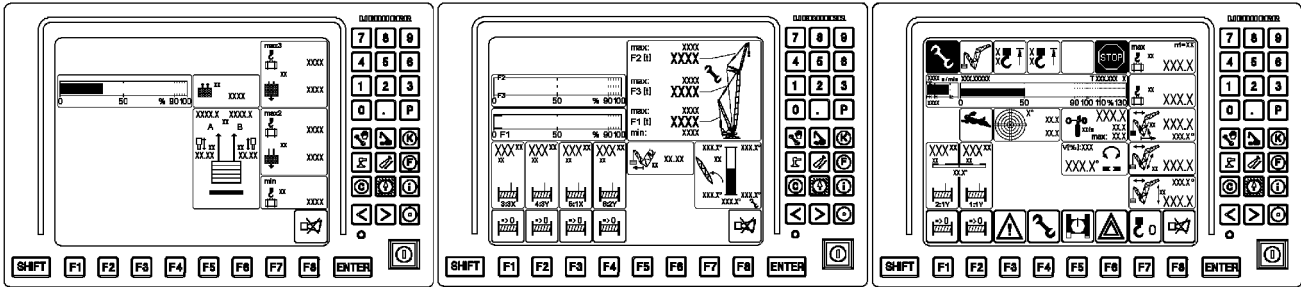

Fig.116050

LWE/LR 13000-001/19503-01-02/en

6.2 F-load display for operating modes with derrick ballast

Assignment of test points for operating modes with derrick ballast:

- Force in the guying between A-frame and derrick head:
 - Test point 1 on point **P1** = force F1
 - The display is made in the F-load display in the center LICCON monitor **LM**.
- Force in the guying between WA-frame and accessory head:
 - Test point 2 on point **P2** = force F2
 - The display is made in the F-load display in the center LICCON monitor **LM**.
Note: Only for respective boom system.
- Force in the guying between main boom head and derrick head:
 - Test point 3 on point **P3** = force F3
 - The display is made in the F-load display in the center LICCON monitor **LM**.
- Force in the guying between derrick ballast and derrick head:
 - Test point 4/5 on point **P4/5** = force F4/5
 - The display is made in the display of the derrick ballast in the left LICCON monitor **LM**.
- Force on the pressure test bracket boom nose:
 - Test point 6 on point **P6** = force F6
 - The display is made in the actual load display in the right LICCON monitor **LM**.
Note: Only with existing boom nose.



Note

- ▶ For detailed description of the displays for crane operation with derrick ballast, see Crane operating instructions, chapter 4.02.



WARNING

Overloading / toppling of the crane!

If the permissible values of the F-load display are exceeded / fallen below, then the crane can be overloaded.

This could result in serious accidents.

- ▶ Adhere to the permissible values of the F-load display.



Note

The values of the F-load display depend on the set up configuration of the crane and the crane geometry.

The values of the F-load display change continuously when the crane is moved.

- ▶ Monitor the F-load display continuously.

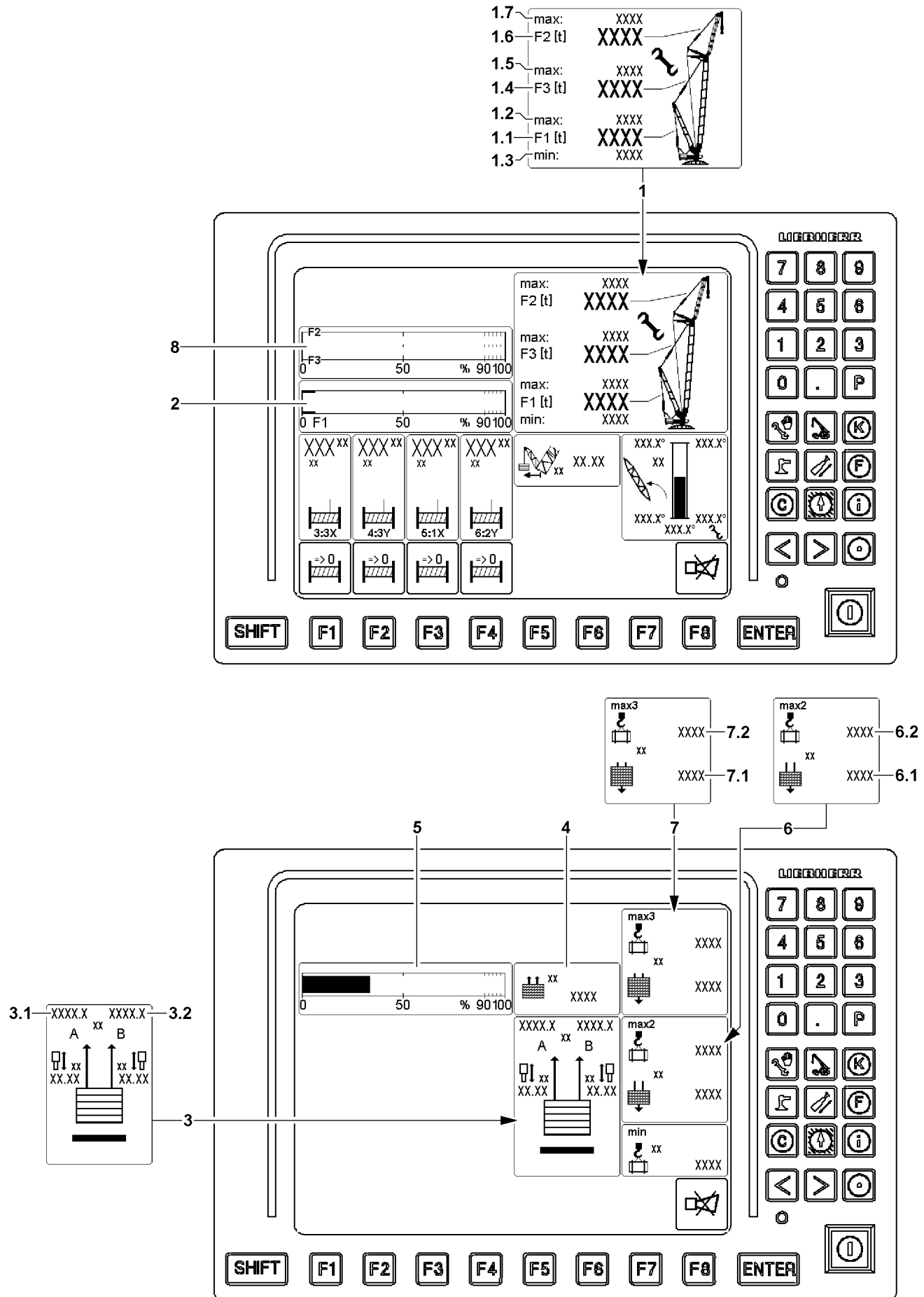

Fig.116048

LWE/LR 13000-001/19503-01-02/en

6.2.1 Force F1 (test point 1)

The force F1 (test point 1) is determined in the guying between the A-frame and the derrick head and displayed in the LICCON monitor as operating force $F1_{\text{actual}}$.

Display values of force F1 (test point 1) in the F-load display **1**:

- F1-actual value ($F1_{\text{actual}}$) **1.1** = operating force $F1_{\text{actual}}$
- F1-maximum ($F1_{\text{max}}$) **1.2** = F1 maximum force
- F1-minimum ($F1_{\text{min}}$) **1.3** = F1 minimum force

Composition of the F1-utilization bar **2**:

- Ratio of operating force $F1_{\text{actual}}$ to F1 maximum force

6.2.2 Force F2 (test point 2) and force F3 (test point 3)

The force F2 (test point 2) is determined between the WA-frame and the accessory head and displayed in the LICCON monitor as operating force $F2_{\text{actual}}$. A display is made only with the respective boom system.

The force F3 (test point 3) is determined between the main boom head and the derrick head and displayed in the LICCON monitor as operating force $F3_{\text{actual}}$.

Display values of force F2 (test point 2) in the F-load display **1**:

- F2-actual value ($F2_{\text{actual}}$) **1.6** = operating force $F2_{\text{actual}}$
- F2-maximum ($F2_{\text{max}}$) **1.7** = F2 maximum force

Display values of force F3 (test point 3) in the F-load display **1**:

- F3-actual values ($F3_{\text{actual}}$) **1.4** = operating force $F3_{\text{actual}}$
- F3-maximum ($F3_{\text{max}}$) **1.5** = F3 maximum force

Composition of the F2 / F3-utilization bar **8**:

- Ratio of operating force $F2_{\text{actual}}$ to F2 maximum force
- Ratio of operating force $F3_{\text{actual}}$ to F3 maximum force
- The F2/F3-utilization bars **8** appear only in assembly operation

In crane operation, the display values are displayed clearly for information. A special monitoring does not occur.

In assembly operation the display values are monitored. The limit values may not be exceeded.

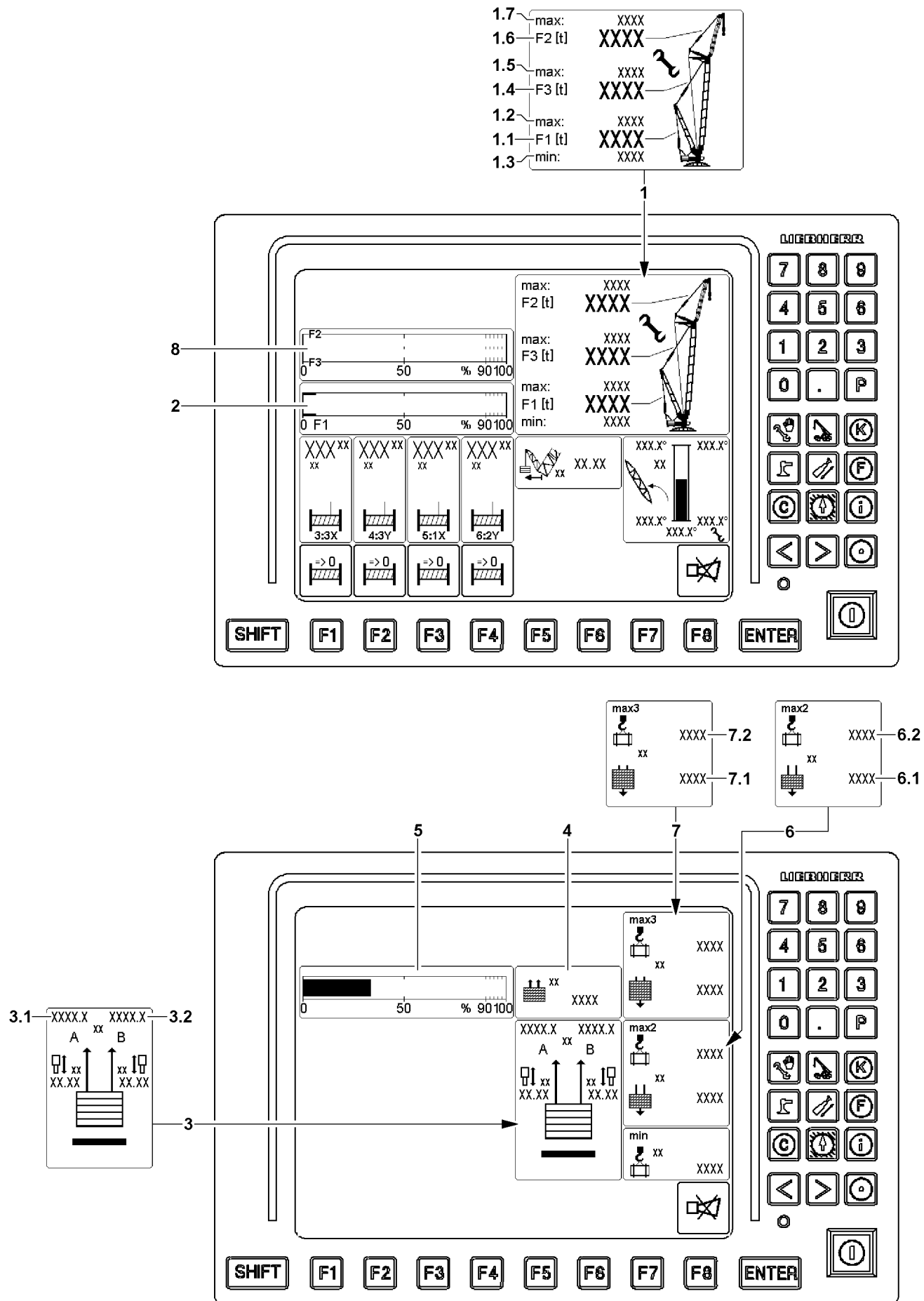

Fig.116048

LWE/LR 13000-001/19503-01-02/en

6.2.3 Force F4/5 (test point 4/5)

The forces F4/5 (test point 4/5) are effective in the guy rods from the derrick ballast to the derrick head.

The existing forces in the guy rods are calculated from four pressure sensors, which are installed on the pull cylinders.

Test points guying A (left) are:

- Test point 4A = pressure sensor ring surface left (force F4A)
- Test point 5A = pressure sensor piston surface left (force F5A)

Test points guying B (right) are:

- Test point 4B = pressure sensor ring surface right (force F4B)
- Test point 5B = pressure sensor piston surface right (force F5B)

Display values of force F4/5 (test point 4/5) in icon Guying derrick ballast **3**:

- Force in the guying A **3.1**
- Force in the guying B **3.2**

Display values derrick ballast:

- Currently pulled derrick ballast = BA_{pulled} **4**
- Current utilization of derrick ballast = Utilization bar derrick ballast **5**
- Currently placed derrick ballast = BA_{placed} **6.1**

From the sum of guying A **3.1** and guying B **3.2** is the pulled derrick ballast BA_{pulled} **4** calculated.

If the ballast still has ground contact, then only that part of the ballast is displayed which is pulled up by the guying. The remaining part is laying on the ground.

Composition of utilization bar derrick ballast **5**:

- Ratio of pulled derrick ballast (BA_{pulled} **4**) to placed derrick ballast (BA_{placed} **6.1**)

Additional displays:

- Icon „Load max2“ **6** (see section „Utilization conditions“)
- Currently placed derrick ballast = BA_{placed} (Input value in set up program) **6.1**
- Possible load with currently placed derrick ballast = $Load_{\text{max2}}$ **6.2**
- Icon „Load max3“ **7** (see section „Utilization conditions“)
- Maximum derrick ballast according to load chart = BA_{max} **7.1** (Highest value in Set up program)
- Possible load with maximum derrick ballast according to load chart = $Load_{\text{max3}}$ **7.2**

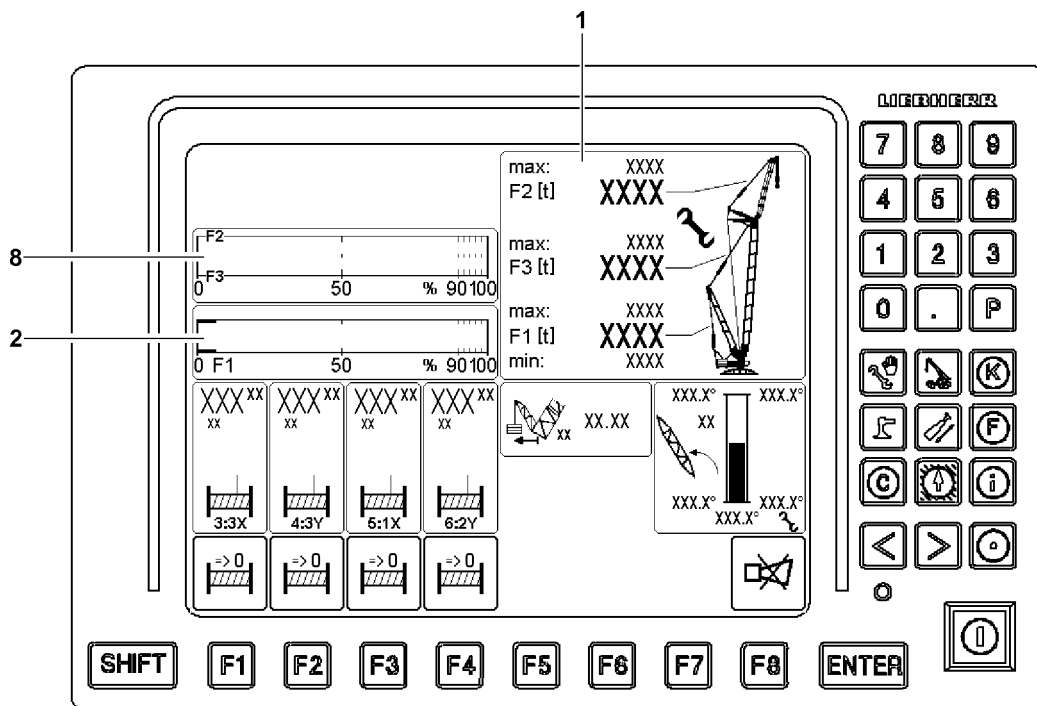
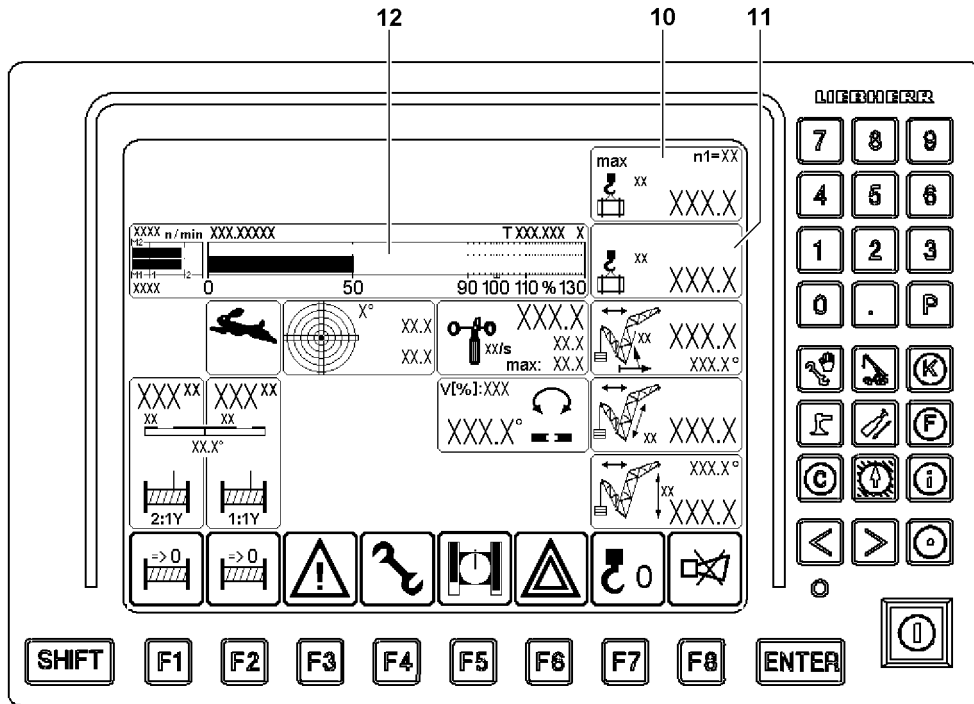

Fig.116051

LWE/LR 13000-001/19503-01-02/en

6.3 Monitoring of crane utilization in operating modes with derrick ballast



WARNING

Incorrect display values!

If the display values do not increase correspondingly when lifting known weights, an erroneous display value may be present.

If the crane is operated with erroneous display values, then the crane can be overloaded.

This could result in serious accidents.

- ▶ When lifting the hook block off the ground check if the display value for the actual load increases correspondingly.
- ▶ When lifting the derrick ballast off the ground check if the display value for the pulled derrick ballast (BA_{pulled}) increases correspondingly.
- ▶ When lifting the load off the ground check if the display value for the actual load increases correspondingly.

In operating modes with derrick ballast the monitoring of the crane utilization includes, among others:

1. Monitoring of load torque
Via icon „Maximum load“ **10**, icon „Actual load“ **11** and the „bar diagram utilization“ **12**.
2. Utilization conditions
Support the crane driver with additional display values.
3. Monitor the F-load display **1**.
Supported by the F1-utilization bar **2** and possibly the F2/F3-utilization bar **8**.

6.3.1 Monitoring of load torque

It monitors the „maximum load according to the load chart and reeving“.

In crane operation, the actual load is compared with the maximum load which may be lifted in the current crane configuration. The display of the values is made in the icon „Maximum load“ **10** and in icon „actual load“ **11**. The current percentage utilization is displayed as „bar diagram utilization“ **12** in the right LICCON monitor.

The color of the utilization bar in the „bar diagram utilization“ **12** also displays the crane utilization:

- Utilization bar blue / green (below 90 %): Utilization in permissible range
- Utilization bar yellow (90 % to 100 %): Advance warning! - Utilization just before impermissible range
- Utilization bar red (above 100 %): Warning! - Utilization in impermissible range



Note

- ▶ Procedure for optimum utilization of „maximum load according to load chart and reeving“, see section „Utilization conditions“.

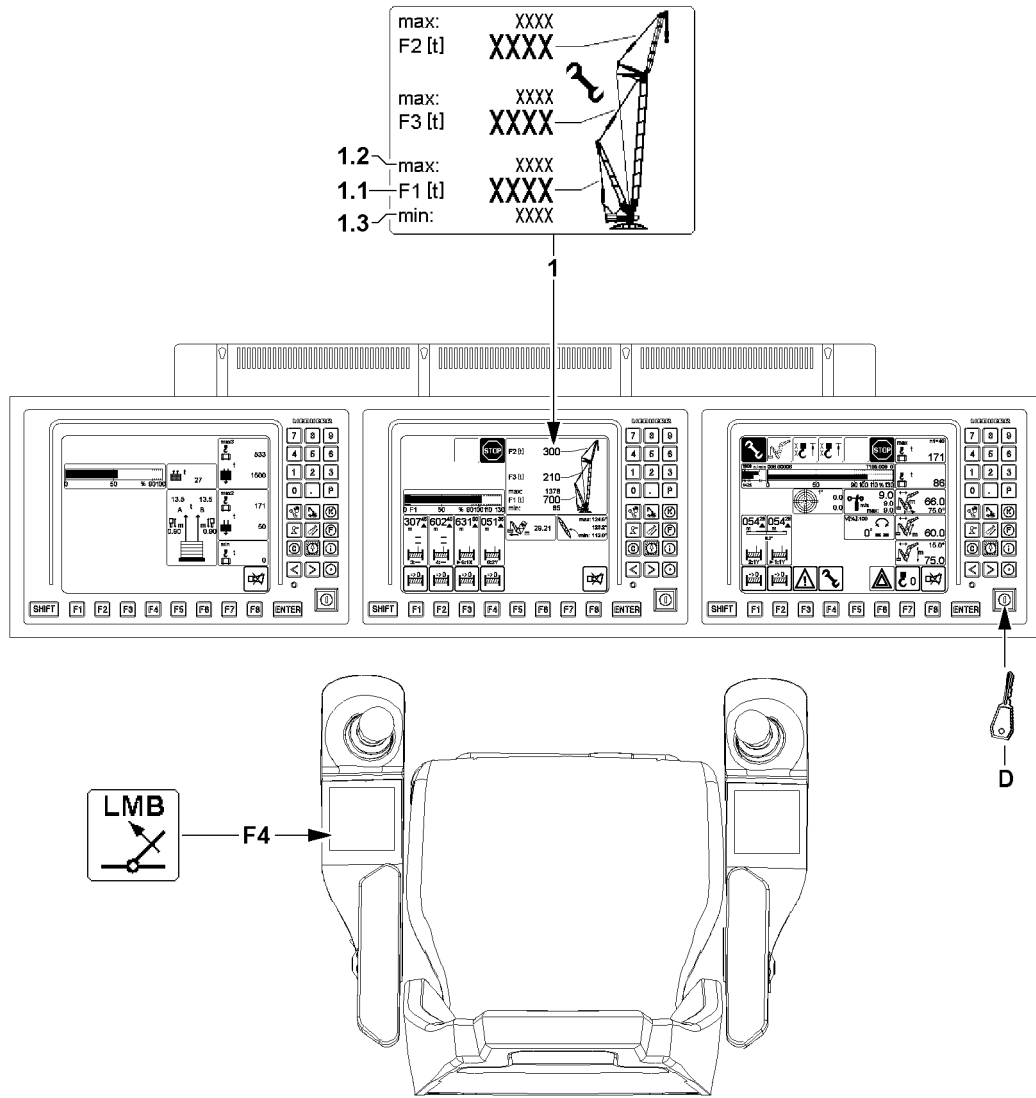

Fig.116049

**WARNING**

Access into the functionality of the LICCON overload protection!

If the functionality of the LICCON overload protection is accessed by pressing the key **F4** (luffing in with suspended load) or the set up key **D**, then the LICCON overload protection is entirely deactivated, bypassed or limited.

It is possible to exceed several shut off limits of the LICCON overload protection simultaneously or one after the other.

It is possible to carry out crane movements, which are not monitored by the LICCON overload protection.

Without the LICCON overload protection, no additional protection against overload of the crane via the crane control is present.

This could result in serious accidents.

- ▶ When accessing the functionality of the LICCON overload protection, take into account that the LICCON overload protection is deactivated totally or limited.
- ▶ When accessing the functionality of the LICCON overload protection, the chapters 4.20 and 7.15 in the Crane operating instructions must be observed.

**WARNING**

Assembly with turned on set up key!

When the set up key **D** is turned on, the shut off limits of the LICCON overload protection can be exceeded.

In the event of deliberate improper use, the crane could collapse, the boom can break off or the crane can topple over.

This could result in serious accidents.

- ▶ The set up key **D** may only be actuated when chapters 4.20 and 7.15 in the Crane operating instructions are observed.
- ▶ The set up key **D** may only be actuated by persons who know the effects of a bypass.
- ▶ When the set up key **D** is turned on, only load moment reducing crane movements may be carried out until a permissible operating and load range.
- ▶ Press the set up key **D** only when the set up configuration was correctly entered into the LICCON computer system.
- ▶ The set up key **D** must be turned off immediately after reaching the permissible load range.
- ▶ The crane operator carries complete and sole responsibility for his actions if the LICCON overload protection is exceeded.
- ▶ Crane operation with the set up key **D** turned on is strictly prohibited.

**Note**

- ▶ The maximum permissible load moment can be exceeded with the set up key **D**, see Crane operating instructions, chapter 4.20.

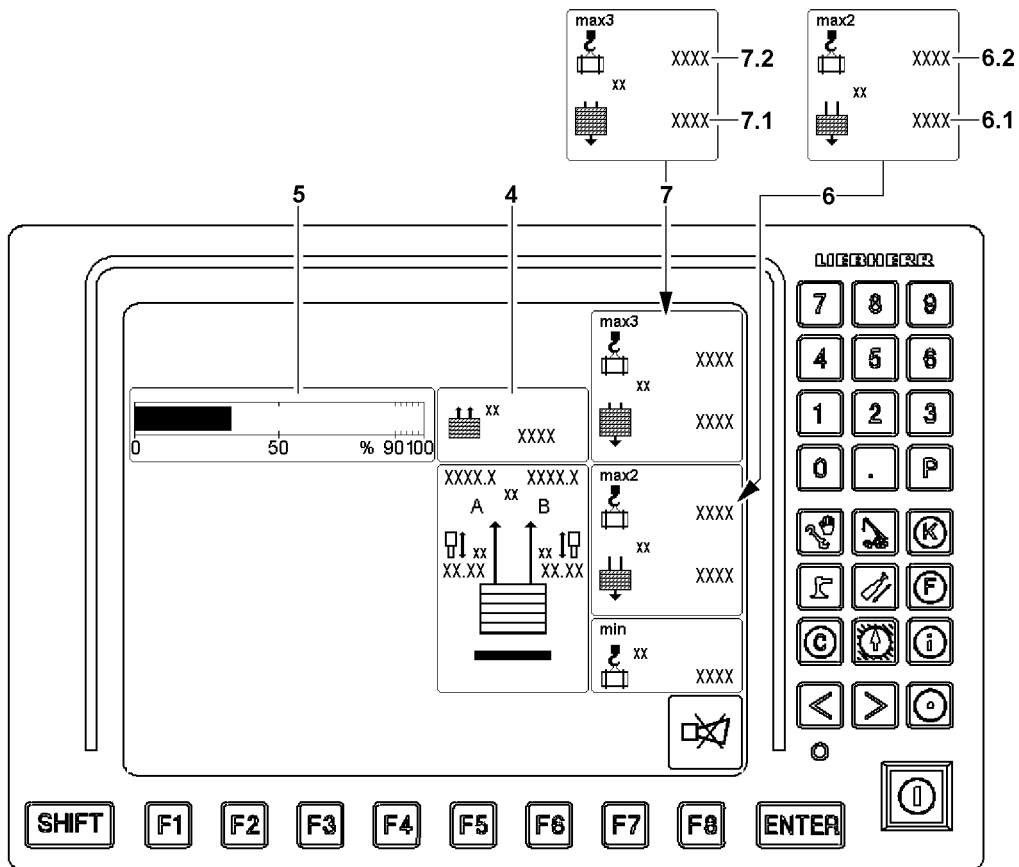
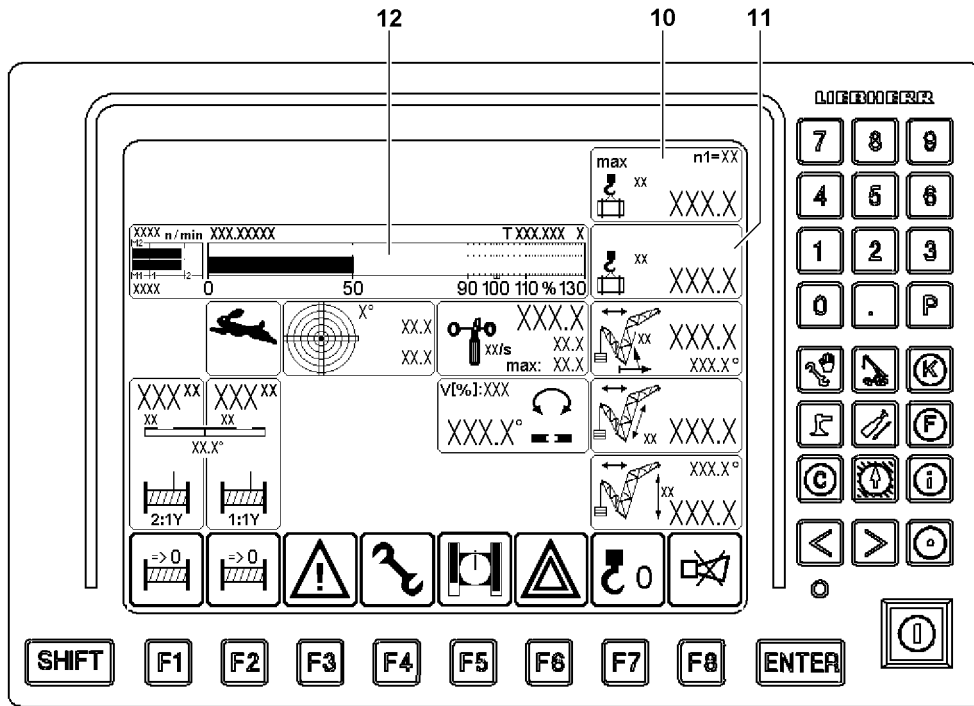

Fig.116052

LWE/LR 13000-001/19503-01-02/en

6.3.2 Utilization conditions

The current percentage utilization of the crane is displayed as „bar diagram utilization“ **10** in the right LICCON monitor.

Additional displays:

- **6** Icon „Load max2“
 - Currently placed derrick ballast = BA_{placed} (Input value in set up program) **6.1**
 - Possible load with currently placed derrick ballast = $\text{Load}_{\text{max2}}$ **6.2**
- **7** Icon „Load max3“
 - Maximum derrick ballast according to load chart = BA_{max} **7.1** (Highest value in Set up program)
 - Possible load with maximum derrick ballast according to load chart = $\text{Load}_{\text{max3}}$ **7.2**

Maximum load, right LICCON monitor:

- The maximum load in the current operating condition is reached when the utilization bar shows 100 % in the „bar diagram utilization“ **12**.
This is the case when the „utilization of the crane according to the load chart and reeving“ reaches 100 % (Values in icon „Maximum load“ **10** and in icon „actual“ **11** are equal).
When the „Maximum load“ **10** is smaller or the same as the $\text{load}_{\text{max2}}$ **6.2**, then an increase might possibly be obtained:
 - By increasing the pulled derrick ballast BA_{pulled} **4**, if the utilization bar derrick ballast **5** is not yet at 100 % (derrick ballast not suspended).
 - By increasing the derrick ballast when the BA_{placed} **6.1** is smaller than BA_{max} **7.1**
 - By changing the derrick ballast radius within the permissible range, see load chart manual or LICCON job planner.

max2-load, icon „load max2“ **6**:

- The highest possible load in current operating condition „**max2-load**“ is reached when in the „bar diagram utilization“ **12** 100 % is shown **and** the utilization bar derrick ballast **5** is at 100 % (Derrick ballast is completely lifted off the ground).
This is the case when the value in icon „Actual load“ **11** is the same as the $\text{load}_{\text{max2}}$ **6.2**.
When the $\text{load}_{\text{max2}}$ **6.2** is smaller or the same as the $\text{load}_{\text{max3}}$ **7.2**, then an increase might possibly be obtained:
 - By increasing the derrick ballast by loading additional ballast plates (increase BA_{placed} **6.1** to BA_{max} **7.1**)

max3-load, icon „load max3“ **7**:

- The highest possible load at the maximum derrick ballast in current operating condition „**max3-load**“ is reached when in the „bar diagram utilization“ **12** 100 % is shown **and** the utilization bar derrick ballast **5** is at 100 % (Derrick ballast according to load chart is placed and is completely lifted off the ground).
This is the case when the value in icon „Actual load“ **11** is the same as the $\text{load}_{\text{max3}}$ **7.2**.
- The maximum derrick ballast according to the load chart is placed and completely pulled.
Further increase of the derrick ballast is impermissible.

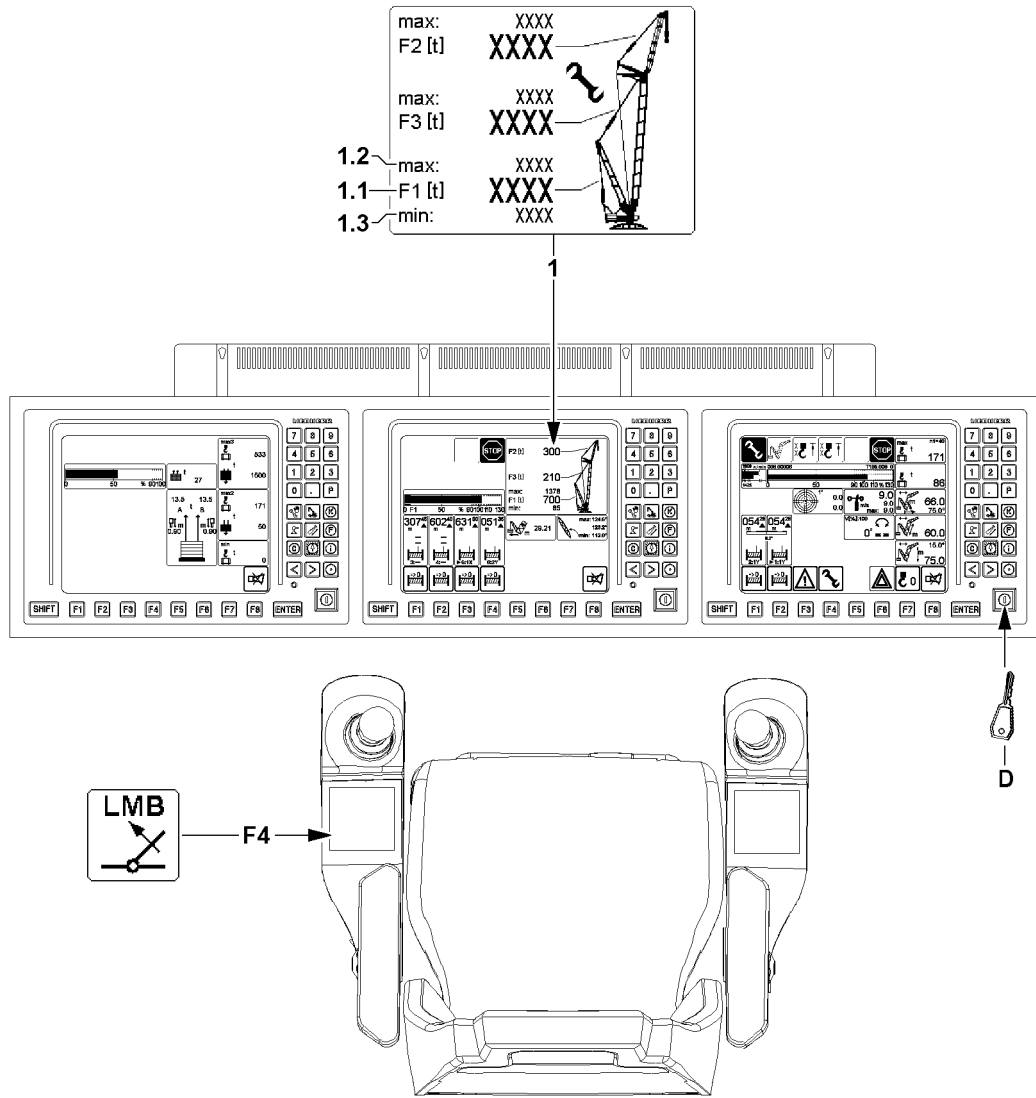

Fig.116049

6.3.3 Monitoring of F1-maximum force

Display values of force F1 (test point 1) in the F-load display **1**:

- Operating force $F1_{\text{actual}} = F1\text{-actual value } (F1_{\text{actual}})$ **1.1**
- F1-maximum force = F1-maximum ($F1_{\text{max}}$) **1.2**
- F1-minimum force = F1-minimum ($F1_{\text{min}}$) **1.3**

The display values of force F1 (test point 1) are displayed permanently in the LICCON monitor. At F1-actual value ($F1_{\text{actual}}$) **1.1** larger F1-maximum ($F1_{\text{max}}$) **1.2** a shut off of all load moment increasing movements occurs.



WARNING

Access into the functionality of the LICCON overload protection!

If the functionality of the LICCON overload protection is accessed by pressing the key **F4** (luffing in with suspended load) or the set up key **D**, then the LICCON overload protection is entirely deactivated, bypassed or limited.

It is possible to exceed several shut off limits of the LICCON overload protection simultaneously or one after the other.

It is possible to carry out crane movements, which are not monitored by the LICCON overload protection.

Without the LICCON overload protection, no additional protection against overload of the crane via the crane control is present.

This could result in serious accidents.

- ▶ When accessing the functionality of the LICCON overload protection, take into account that the LICCON overload protection is deactivated totally or limited.
- ▶ When accessing the functionality of the LICCON overload protection, the chapters 4.20 and 7.15 in the Crane operating instructions must be observed.



Note

The limit value for the F1-maximum force depends not only from the set up configuration and the crane geometry, but also from the pulled derrick ballast.

- ▶ If the pulled derrick ballast is larger, then the limit value for the F1-minimum force is generally reduced.
- ▶ If the pulled derrick ballast is smaller, then the limit value for the F1-maximum force is generally increased.



Note

By actuating the set up key **D** the limit value for the F1-maximum force can be exceeded by a few tons. This makes it possible to reset a crane movement, which has caused the shut off.

- ▶ Reset triggered shut off by reverse crane movement.

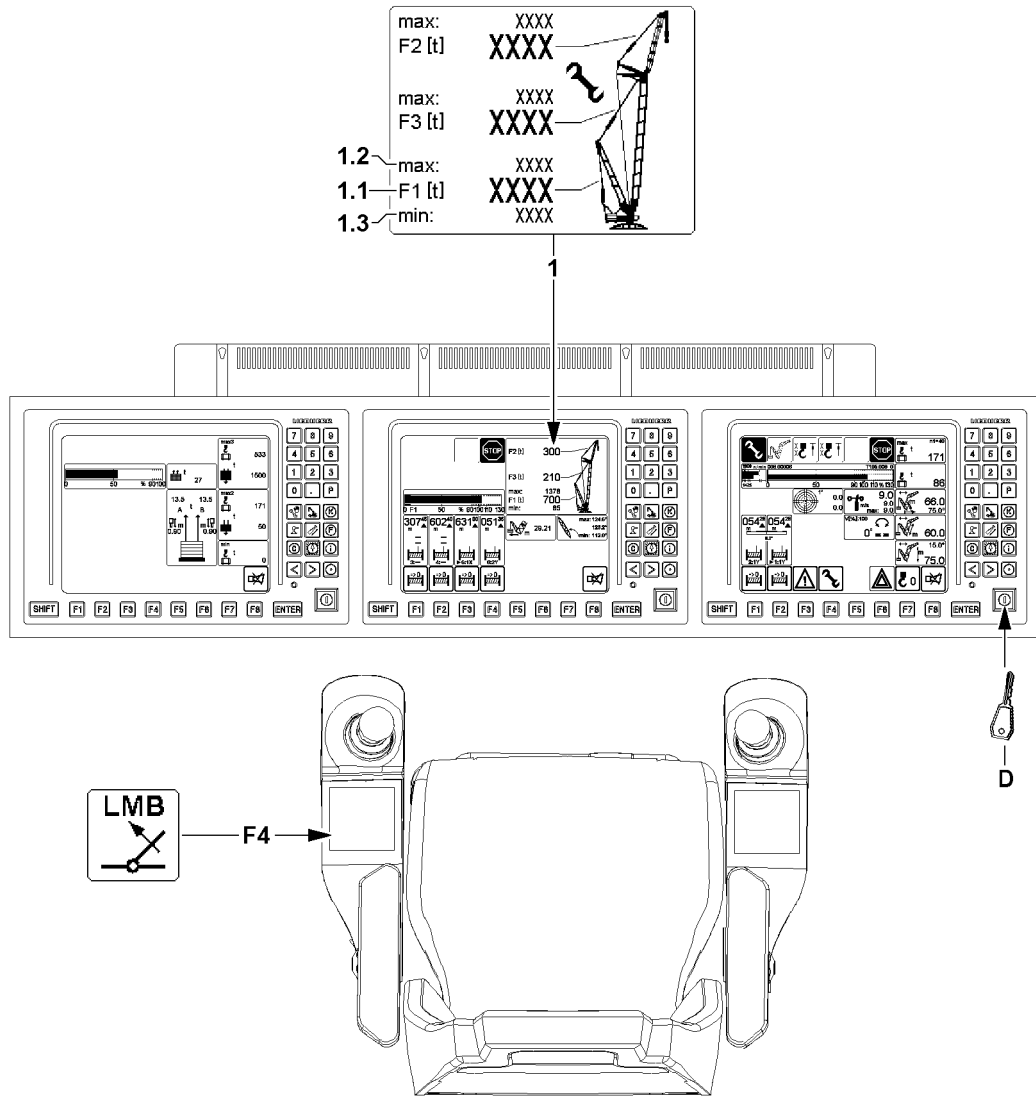

Fig.116049

6.3.4 Monitoring of F1-minimum force

Display values of force F1 (test point 1) in the F-load display 1:

- Operating force $F1_{\text{actual}} = F1\text{-actual value (}F1_{\text{actual}}\text{)}$ **1.1**
- F1-maximum force = F1-maximum ($F1_{\text{max}}$) **1.2**
- F1-minimum force = F1-minimum ($F1_{\text{min}}$) **1.3**



WARNING

Uncontrolled movements of the boom system!

If the guying between the A-frame and the derrick head (test point 1) becomes powerless, then this can lead to uncontrolled movements of the boom system.

This could result in serious accidents.

- ▶ The guying between the A-frame and the derrick head (test point 1) may never be without power.
- ▶ Relieve the guying between the derrick head and the derrick ballast to the point where the F1-actual value ($F1_{\text{actual}}$) **1.1** is larger than the F1-minimum ($F1_{\text{min}}$) **1.3**.



WARNING

Access into the functionality of the LICCON overload protection!

If the functionality of the LICCON overload protection is accessed by pressing the key **F4** (luffing in with suspended load) or the set up key **D**, then the LICCON overload protection is entirely deactivated, bypassed or limited.

It is possible to exceed several shut off limits of the LICCON overload protection simultaneously or one after the other.

It is possible to carry out crane movements, which are not monitored by the LICCON overload protection.

Without the LICCON overload protection, no additional protection against overload of the crane via the crane control is present.

This could result in serious accidents.

- ▶ When accessing the functionality of the LICCON overload protection, take into account that the LICCON overload protection is deactivated totally or limited.
- ▶ When accessing the functionality of the LICCON overload protection, the chapters 4.20 and 7.15 in the Crane operating instructions must be observed.



Note

By actuating the set up key **D** the limit value for the F1-minimum force can be fallen below by a few tons. This makes it possible to reset a crane movement, which has caused the shut off.

- ▶ Reset triggered shut off by reverse crane movement.

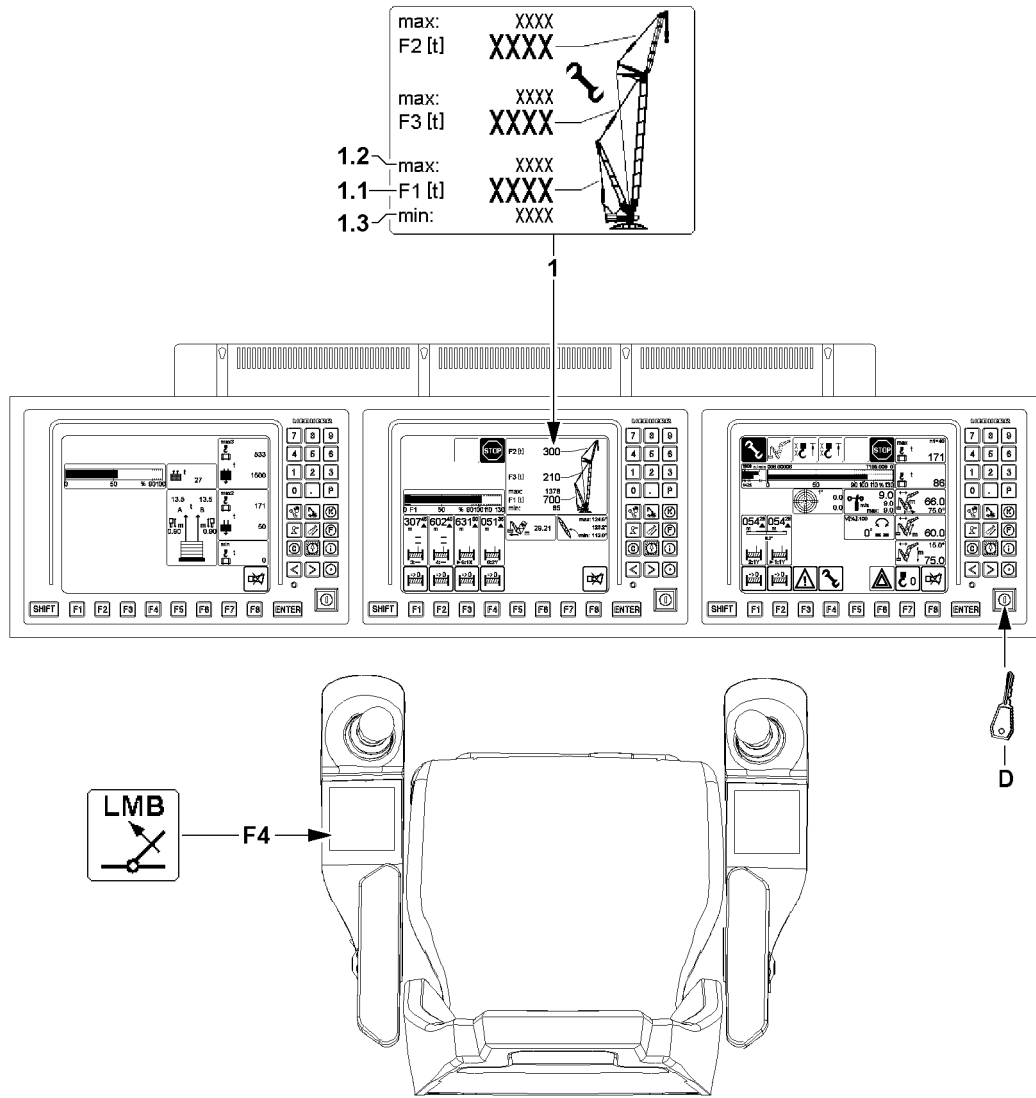

Fig.116049

**WARNING**

Autonomous movement of the boom system at increase of load torque!

If the F1-minimum force is fallen below, the guying between the A-frame and the derrick head can become powerless.

If the guying between the A-frame and the derrick head is powerless and the „Derrick ballast is on the ground“ at the same the derrick ballast can suddenly lift off the ground due to increase of the load torque.

As a result, the boom system can move suddenly forward. Strong oscillating movements of the derrick ballast and load can be the result.

The crane can be overloaded and severe accidents can be the result.

- ▶ Hold the F1-actual value ($F1_{\text{actual}}$) **1.1** above the F1-minimum ($F1_{\text{min}}$) **1.3**.
- ▶ It is prohibited to fall below the F1-minimum force.

**WARNING**

Autonomous movement of the boom system at decrease of load torque!

If the F1-minimum force is fallen below, the guying between the A-frame and the derrick head can become powerless.

If the guying between the A-frame and the derrick head is powerless and the „Derrick ballast is suspended“ at the same the derrick ballast can suddenly lift off the ground due to decrease of the load torque.

As a result, the boom system can move suddenly backward. As a result, the relapse cylinders can be pressed on block, be overloaded and damaged. Strong oscillating movements of the derrick ballast and load can be the result.

The crane can be overloaded and severe accidents can be the result.

- ▶ Hold the F1-actual value ($F1_{\text{actual}}$) **1.1** above the F1-minimum ($F1_{\text{min}}$) **1.3**.
- ▶ It is prohibited to fall below the F1-minimum force.

The following applies:

- After a shut off due to falling below the F1-minimum ($F1_{\text{min}}$) **1.3** the F1-actual value ($F1_{\text{actual}}$) **1.1** must be increased by a crane movement. If the derrick ballast is suspended, this can be achieved by setting down the ballast.
- When taking up the load, the guying between the derrick ballast and the derrick head must be relieved to the point where the F1-actual value ($F1_{\text{actual}}$) **1.1** is larger than the F1-minimum ($F1_{\text{min}}$) **1.3**.
- When increasing the load torque, and the limit value F1-minimum ($F1_{\text{min}}$) **1.3** is fallen below, an already set down derrick ballast can loose contact with the ground and lift off.
- When decreasing the load torque, and the limit value F1-minimum ($F1_{\text{min}}$) **1.3** is fallen below, an already „suspended derrick ballast“ can set down on the ground.
- If the set up key **D** is already pressed and the F1 force continues to drop below the minimum force $F1_{\text{min}}$ which was reduced by the set up key **D**, the $F1_{\text{min}}$ shut off can no longer be passed.

Limitations from 50 % pulled derrick ballast

If more than 50 % of the set derrick ballast is being pulled (utilization bar derrick ballast **5** larger than 50 %) and the F1-minimum ($F1_{\text{min}}$) **1.3** is fallen below at the same time, all crane movements that increase load torque are turned off.

Limitations from 90 % pulled derrick ballast

If more than 90 % of the set derrick ballast is being pulled (utilization bar derrick ballast **5** larger than 90 %) and the F1-minimum ($F1_{\text{min}}$) **1.3** is fallen below at the same time, all crane movements that increase load torque and all crane movements that decrease load torque are turned off. This also turns the „spooling out“ movement of the winch off.

6.4 Monitoring of pull cylinders on block position

The pull cylinders (also called ballast lift cylinders) of the derrick ballast are equipped with length sensors and limit switches for monitoring.

In crane operation, the monitoring of the pull cylinders on block position is always active. If there is the danger of a block position, then only that direction of the pull cylinders can be moved which improves the condition. The other direction is unbyypassably blocked. As long as the length sensors and the limit switches function correctly, the pull cylinders cannot get into a block position.



WARNING

Problem at monitoring of pull cylinders!

If the length sensors or limit switches are defective or missing, then the monitoring of the pull cylinders is not active.

Without monitoring, the pull cylinders can be moved without restriction, as a result, a block position is possible.

At a block position, the pressure measurements of the pull cylinders become inexact and the values are incorrectly calculated.

The overload protection calculates the actual load incorrectly and transmits faulty display values.

The crane can be overloaded and topple over.

This could result in serious accidents.

- ▶ Observe the display values and possible error messages.
- ▶ If length sensors or limit switches are defective or missing, monitor the pull cylinders manually.

The following applies:

- The display values of the pull cylinders must function and be plausible.

6.5 Monitoring the lateral incline of the ballast pallet

The ballast pallet is equipped with an incline sensor for monitoring.

The monitoring to $\pm 2.5^\circ$ lateral incline of the ballast pallet is always active. If a lateral incline of $\pm 2.5^\circ$ is reached, then only those directions of the pull cylinders can be moved which improve the condition. The other directions are unbyypassably blocked. The ballast can be set down for that reason only to a maximum incline of the terrain of 2.5° .



WARNING

Defective incline sensor!

If an incline sensor is defective or missing, the monitoring of the lateral incline of the suspended ballast is not active.

The pull cylinders can be moved without restriction and the derrick ballast can be overturned as a result.

This could result in serious accidents.

- ▶ Observe the display values and possible error messages.
- ▶ If an incline sensor is defective, monitor the lateral incline of the derrick ballast manually.

The following applies:

- The display values of the lateral incline of the derrick ballast must function and be plausible.

6.6 Differential force monitoring for derrick ballast-guying

In operating modes with derrick ballast the forces of the derrick ballast guyings A and B are displayed in the LICCON monitor.



WARNING

Danger of accident!

If the forces in the derrick ballast guyings A and B are too high, then this can lead to an overload of the crane. Components can fail and severe accidents can be the result.

- ▶ Load the derrick ballast guyings A and B evenly.

After reaching the specified limit value of the difference force threshold, the displays of the pulled ballast of pull cylinder A and B blink and become red, the function ballast up / down is stopped. The difference force must be lowered again.

If the difference of the forces of the derrick ballast guyings A and B exceeds the limit value, then this can have various causes:

- Flexing of the turntable.
- The ground under the derrick ballast is uneven.
- The crane is leaning to one side.
- The derrick ballast has been loaded one-sided.
- The force measurement in one guying is incorrect.

The crane driver must recognize the correct cause and take countermeasures:

- The error, which caused the one-sided force, must be remedied.
- If sensor values are implausible: Stop crane operation and find the cause and remedy it.

6.6.1 Bypassing the shut off of the function ballast up / down

- The following measures are permitted providing the ground is only slightly uneven: Control the individual pull cylinders in such a way that the difference between the forces becomes smaller. Ensure that the derrick ballast is not tilted at an inadmissible angle with respect to the crane, otherwise the derrick ballast guide and attachments will be damaged.

- ▶ Carry out the following: Press the set up button **D**.

Result:

- The shut off of the function ballast up / down is bypassed.
- On the left LICCON monitor appears an assembly icon.
- ▶ Press the button Ballast up or down **and** the stop button on the desired side at the same time, see section „Lifting / setting down / equalizing the derrick ballast“.

Problem remedy

The display of the entire pulled ballast is shown blinking red. An LMB-Stop was triggered. All crane functions were stopped.

The crane driver has moved the pull cylinders into the incorrect direction and further exceeded the limit value for the difference force threshold.

- ▶ Move the pull cylinders again into the correct (other) direction and align the ballast in such a way that the displays of the pulled ballast of pull cylinder A and B are again in the permissible range.

- ▶ Press the set up button again.

Result:

- The shut off of the function ballast up / down is bypassed again.
- All other crane functions are still suppressed.
- ▶ Move the pull cylinders into the correct direction.



DANGER

Overload of crane!

If the pull cylinders are moved into the incorrect direction after a new bypass of the function ballast up / down, the crane will be overloaded.

This could result in serious accidents.

- ▶ Monitor the display values and move the pull cylinders in the correct direction (values of pull cylinder A and B become closer).
- ▶ If unsure: Contact Liebherr Service.
- ▶ Find the error and remedy it which caused the shut off of the function „Ballast up / down“.

6.7 Carrying out crane movements



Note

- ▶ For an overview of the displays in the LICCON monitors, see Crane operating instructions, chapter 4.02.

**WARNING**

Incorrect display values!

If the display values do not increase correspondingly when lifting known weights, an erroneous display value may be present.

If the crane is operated with erroneous display values, then the crane can be overloaded.

This could result in serious accidents.

- ▶ When lifting the hook block off the ground check if the display value for the actual load increases correspondingly.
- ▶ When lifting the derrick ballast off the ground check if the display value for the pulled derrick ballast BA_{pulled} increases correspondingly.
- ▶ When lifting the load off the ground check if the display value for the actual load increases correspondingly.

**WARNING**

The crane can topple over!

The jerky execution or braking of turning maneuvers can cause the load or suspended ballast to swing.

If the load and / or the suspended ballast collides with obstacles then the crane can be damaged or impeded.

Oscillating movements, damage or impediments can cause the crane to topple over.

This could result in serious accidents.

- ▶ Initiate or slow down crane movements with load and / or suspended derrick ballast extremely sensitively.
- ▶ There may be no persons and / or objects within the working range / danger zone of the crane.
- ▶ During crane operation additional personnel (guide) must monitor and secure the working range / danger zone of the crane from a safe position.

**WARNING**

Danger of accident due to unsafe ground!

If the crane is operated on insufficient ground, there is a danger of accidents.

- ▶ The ground in the entire working area of the crane must be level and of sufficient load carrying capacity, in order to be able to securely accept the encountered surface pressures.
- ▶ Before setting down the load or the derrick ballast, the crane operator must make sure that the intended placement surface is suitable. A safe set down of load and derrick ballast must be ensured.

**WARNING**

Uncontrolled movements of the boom system!

If the guying between the A-frame and the derrick head (test point 1) becomes powerless, then this can lead to uncontrolled movements of the boom system.

This could result in serious accidents.

- ▶ The guying between the A-frame and the derrick head (test point 1) may never be without power.

**WARNING**

Danger of accidents due to angular pull!

Due to angular pull of load or derrick ballast impermissible side forces are directed into the crane. Impermissible side forces can cause failure of components or a dangerous change of the center of gravity of crane and / or load, among others.

Crane and load can be severely damaged and topple over.

This could result in serious accidents.

- ▶ Before taking on a load or the derrick ballast, make sure that the derrick ballast, the center of rotation of the turntable and the load are on one line.

Make sure that the following prerequisites are met:

- The test points must be checked before crane operation for functionality.
- The weight of the load to be lifted must be known.
- The placement surface of the derrick ballast must be level, horizontal and of sufficient load bearing capacity.
- The placement surface of the derrick ballast must be able to safely take on the surface pressure.
- There may be no obstacles within the slewing range of the crane, the derrick ballast and the load.
- Additional personnel is instructed to monitor and secure the working range / danger zone of the crane from a safe distance.
- A permanent acoustic / visual connection between the crane operator and the additional personnel is available.
- The lifted derrick ballast is monitored by a guide or the crane operator.

The following applies:

- When taking up the load, the guying between the derrick ballast and the derrick head must be relieved so that the operating force $F_{1_{\text{actual}}}$ is larger than the limit value for the F1-minimum force.
- Before taking up the load or the derrick ballast, make sure that the following components are on one line:
 - the load
 - the center of rotation of the turntable
 - the derrick ballast

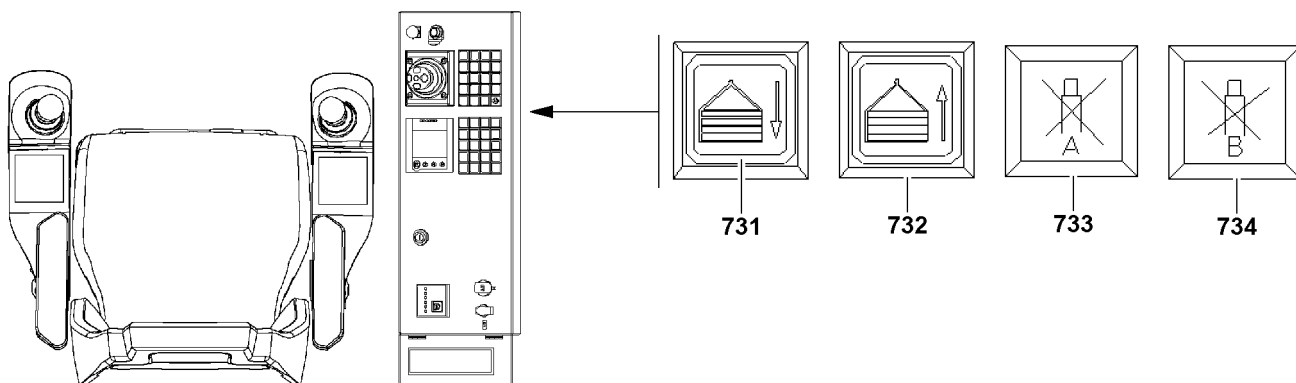
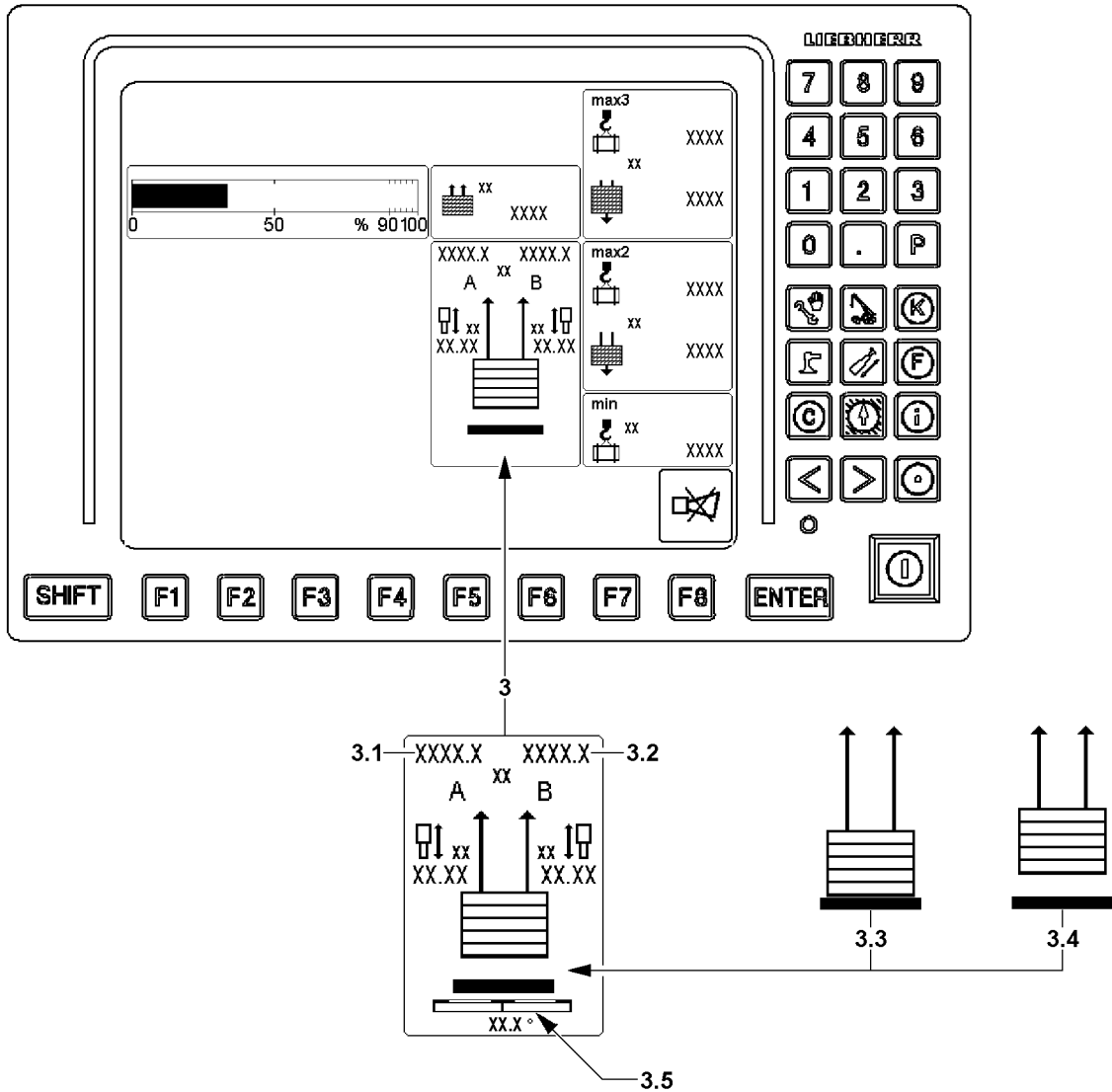





Fig.116054

LWE/LR 13000-001/19503-01-02/en

6.7.1 Operating element of derrick ballast

The operating elements for the derrick ballast are located in the right instrument panel of the crane operator's cab.

Position	Button	Function	Description
731	 Button Lower derrick ballast	Off	Releasing the button interrupts the movement
		On	Pressing and holding the button lowers the derrick ballast
732	 Button Lift derrick ballast	Off	Releasing the button interrupts the movement
		On	Pressing and holding the button lifts the derrick ballast
733	 Button block derrick ballast - pull cylinder A	Off	Releasing the button releases the pull cylinder A on the derrick ballast
		On	Pressing and holding the button blocks the pull cylinder A on the derrick ballast
734	 Button block derrick ballast - pull cylinder B	Off	Releasing the button releases the pull cylinder B on the derrick ballast
		On	Pressing and holding the button blocks the pull cylinder B on the derrick ballast

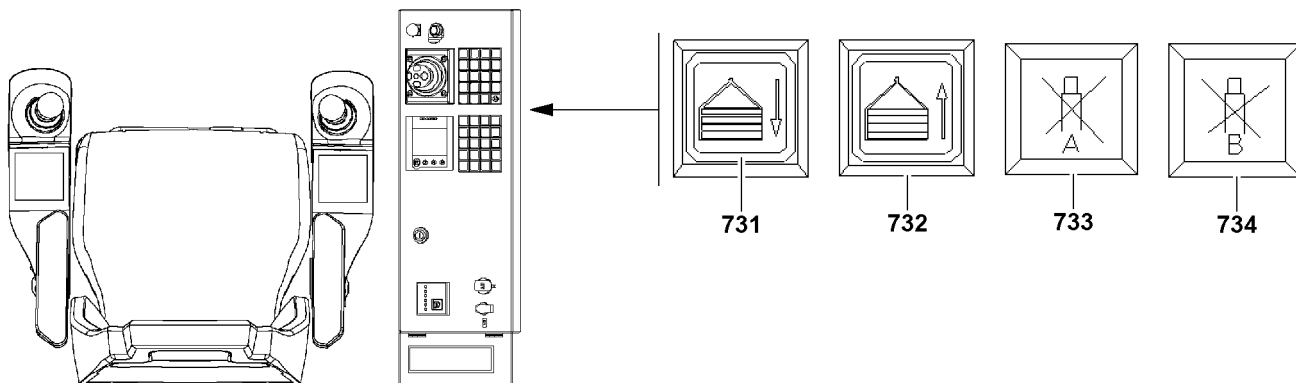
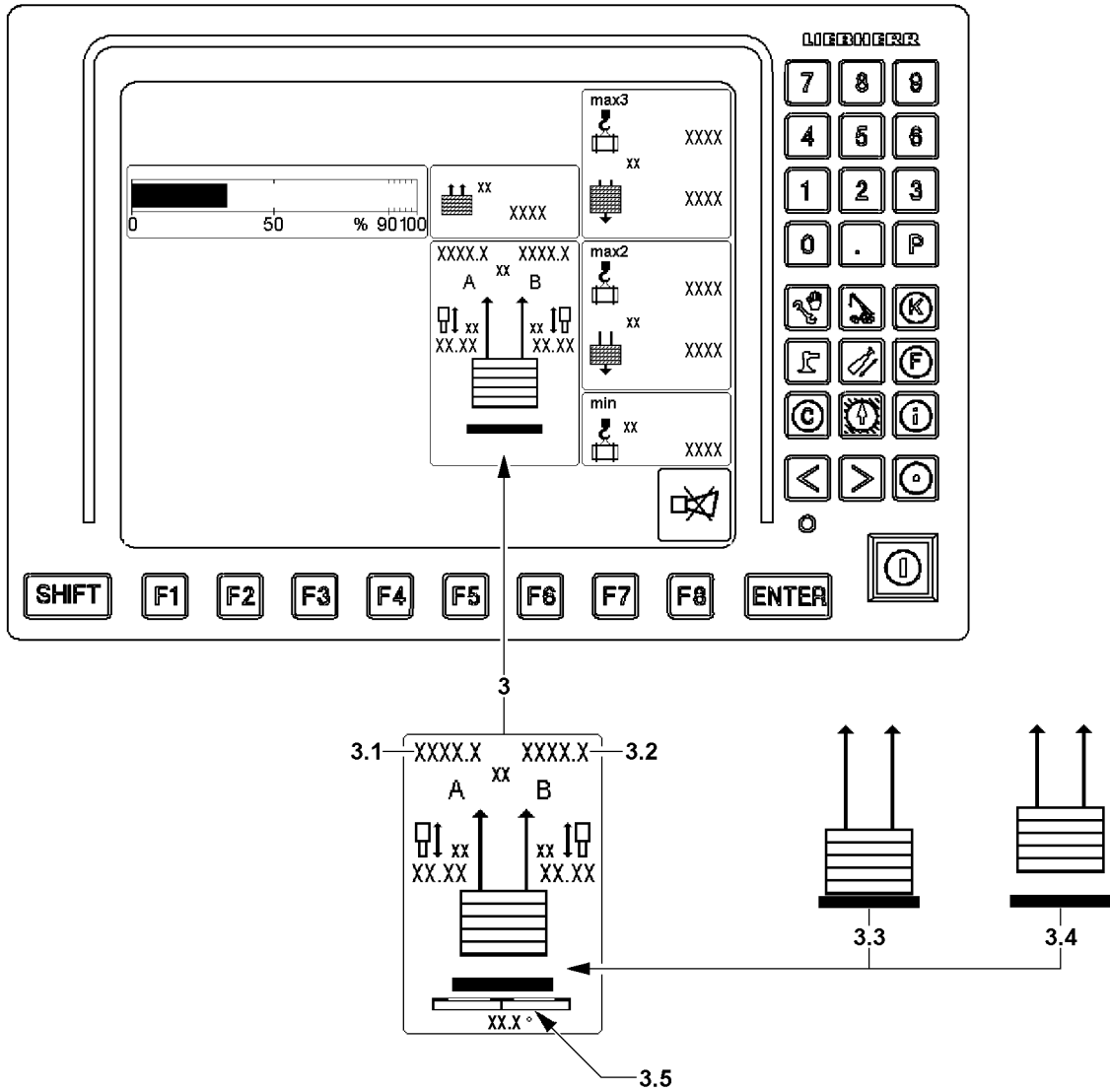

Fig.116054

LWE/LR 13000-001/19503-01-02/en

6.7.2 Lifting / setting down / equalizing the derrick ballast



WARNING

The crane can topple over!

If the derrick ballast is lifted past the maximum permissible 250 mm off the ground, then the crane can be topple over to the rear of the load rips off.

Death, severe bodily injuries, property damage.

- ▶ Do not lift the derrick ballast by more than 250 mm off the ground.
- ▶ The ground in the entire working area of the crane, including the derrick ballast and the load, must be even and of sufficient load bearing capacity in order to be able to securely accept the encountered surface pressures and weight loads.



WARNING

Danger of accident!

The placement surface for the ballast pallet must be level, horizontal and of sufficient load bearing capacity, otherwise the ballast pallet can tip over.

This could result in serious accidents.

- ▶ Check the incline of the crane during the set down procedure.
- ▶ Check the incline of the ballast pallet with the incline display **3.5**.
- ▶ Monitor the difference forces (guying A **3.1** to guying B **3.2**).
- ▶ It is strictly prohibited for anyone to stand under the ballast pallet or within the entire danger zone during the set down procedure.

Make sure that the following prerequisites are met:

- A guide or crane driver must monitor the lifting and setting down of the derrick ballast and the load.
- The placement surface of the derrick ballast must be level, horizontal and of sufficient load bearing capacity.

Lifting / setting down the derrick ballast

The lifting and set down of the derrick ballast is monitored by the LICCON computer system. Normally the crane operator does not have to do anything. However, if corrective measures or preventative measures should be necessary, observe the following section „Equalizing the derrick ballast“.

- ▶ Lift the derrick ballast: Press the button **732**.

Result:

- The piston rods of the pull cylinders move in together.
- The ballast pallet loses all ground contact:
The ground contact switches are no longer actuated, icon „Derrick ballast lifted off“ **3.4** appears.
The crane movements „turning the turntable“ and „driving the crawler“ are released.

- ▶ Lower the derrick ballast: Press the button **731**.

Result:

- The piston rods of the pull cylinders move out together.
- When the ballast pallet touches the ground:
The ground contact switches are actuated, icon „Derrick ballast has ground contact“ **3.3** appears.
The crane movements „turning the turntable“ and „driving the crawler“ are blocked.

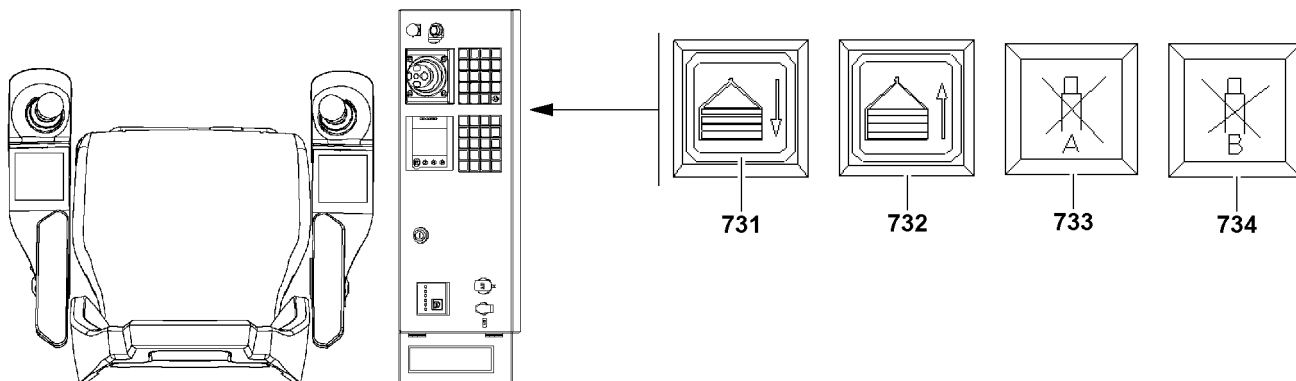
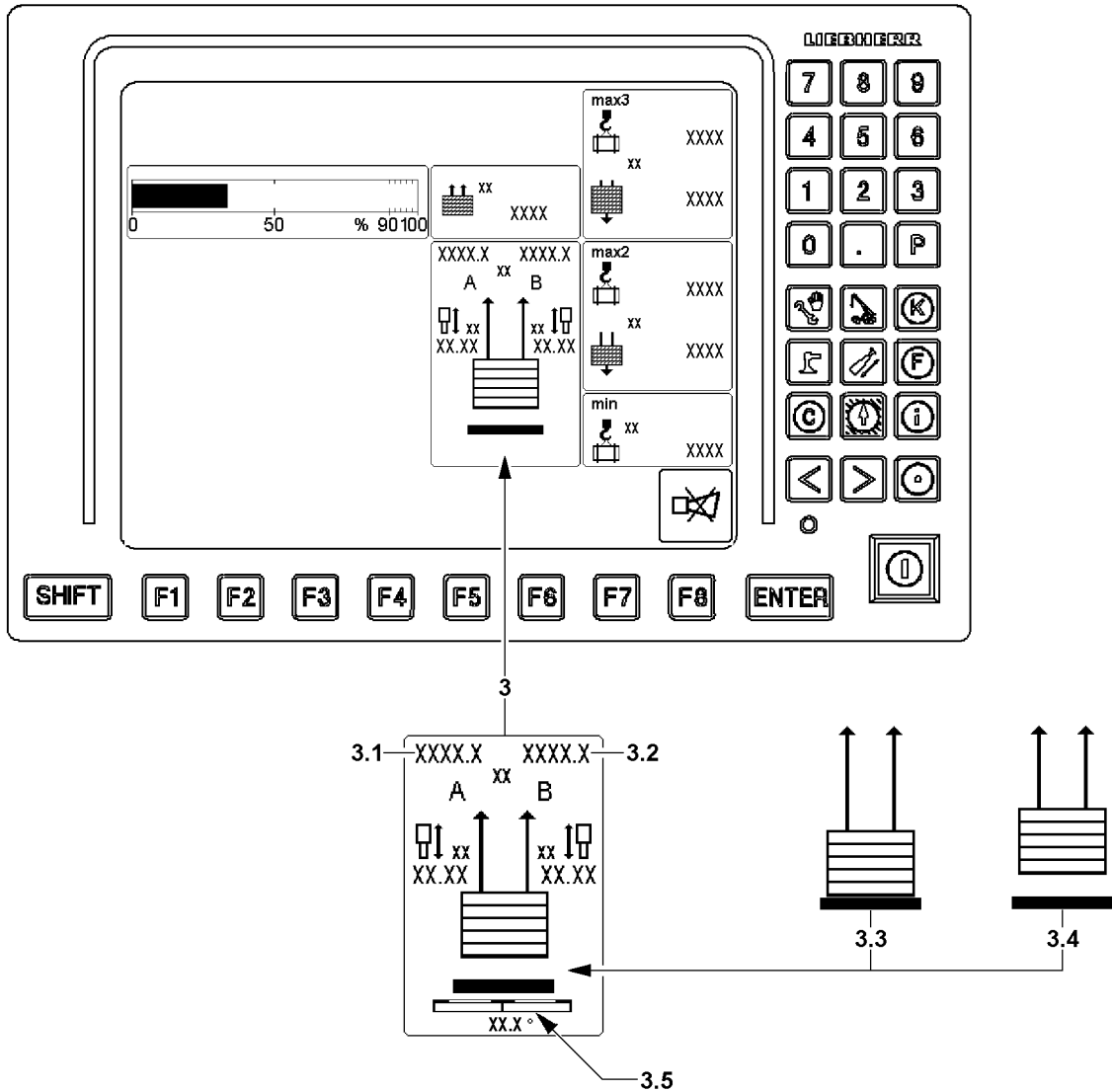

Fig.116054

LWE/LR 13000-001/19503-01-02/en

Equalizing the derrick ballast

If a limit value in the difference force monitoring (Ratio of guying A **3.1** to guying B **3.2**) or the incline display **3.5** is exceeded, the derrick ballast must be equalized.

- ▶ Block the pull cylinder (A) when lifting: Press button **732** and button **733**.

Result:

- The piston rod of the pull cylinder (A) stops.
- The piston rod of pull cylinder (B) moves in.
- Side (B) of the derrick ballast lifts up.

- ▶ Block the pull cylinder (B) when lifting: Press button **732** and button **734**.

Result:

- The piston rod of the pull cylinder (B) stops.
- The piston rod of pull cylinder (A) moves in.
- Side (A) of the derrick ballast lifts up.

- ▶ Block the pull cylinder (A) when lowering: Press button **731** and button **733**.

Result:

- The piston rod of the pull cylinder (A) stops.
- The piston rod of pull cylinder (B) moves out.
- Side (B) of the derrick ballast lowers.

- ▶ Block the pull cylinder (B) when lowering: Press button **731** and button **734**.

Result:

- The piston rod of the pull cylinder (B) stops.
- The piston rod of pull cylinder (A) moves out.
- Side (A) of the derrick ballast lowers.

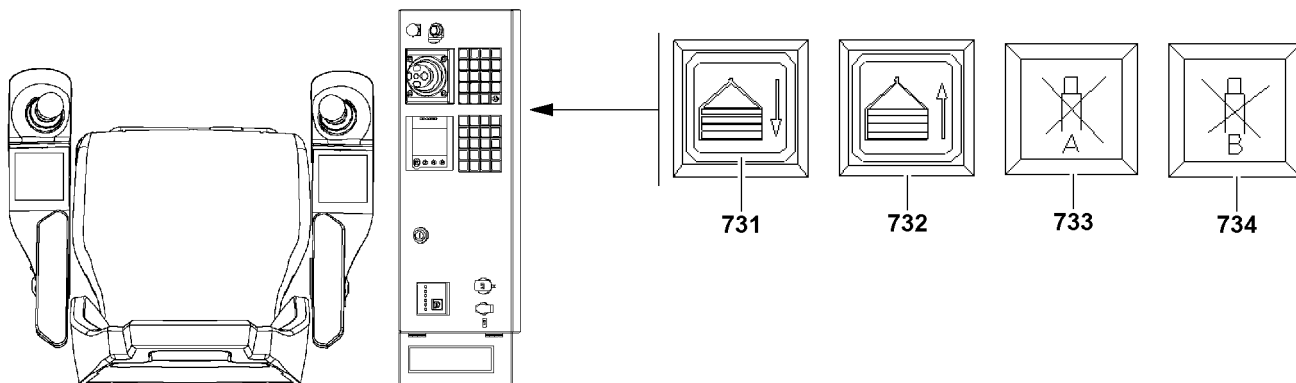
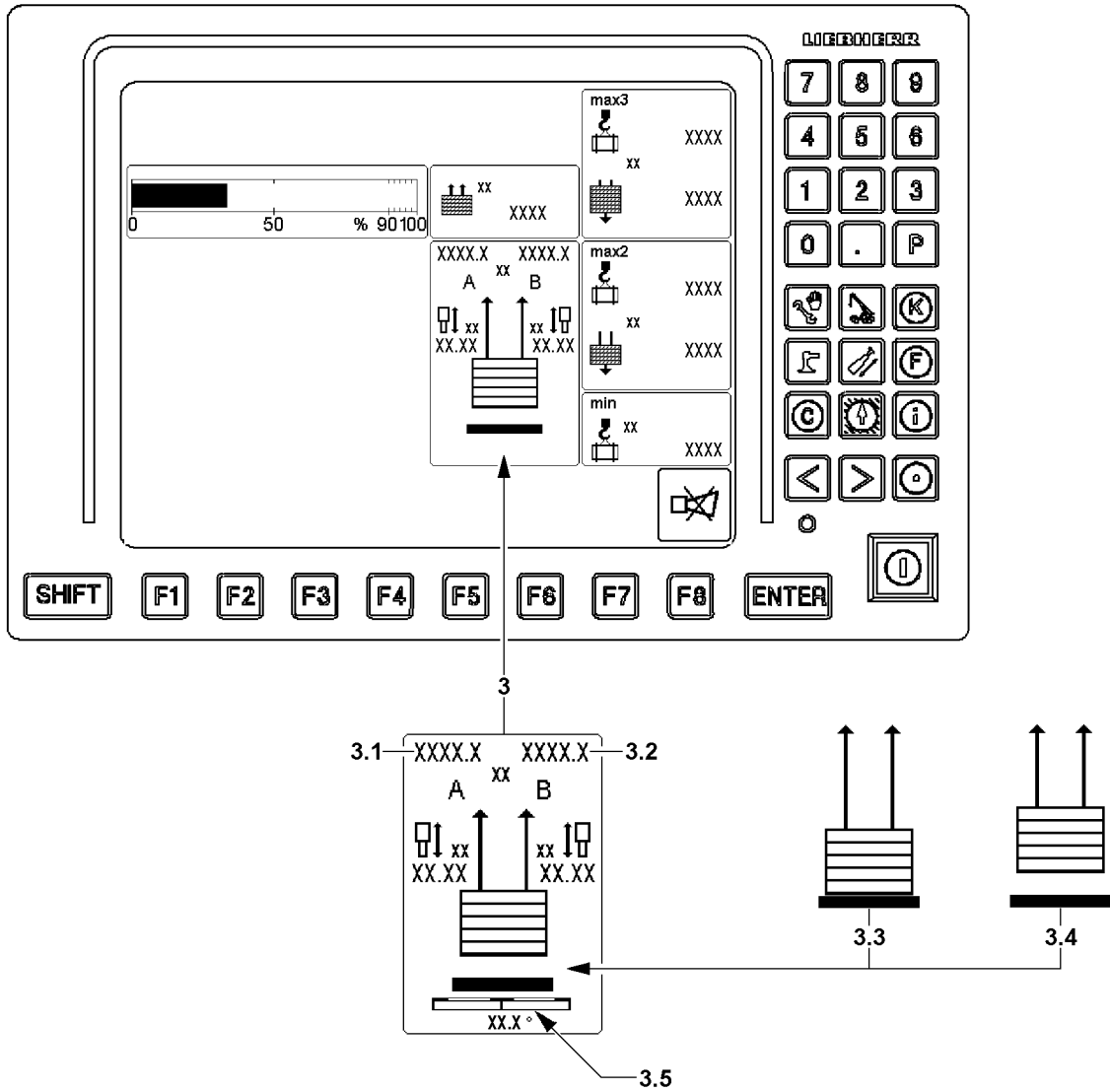

Fig.116054

LWE/LR 13000-001/19503-01-02/en

7 Crawler operation with derrick ballast



Note

- ▶ Driving the crawler crane, see Crane operating instructions, chapter 4.10.
- ▶ Release for driving the crawler takes place when all 4 ground contact rollers are no longer in contact with the ground.

7.1 Driving the crawler

Driving with suspended derrick ballast.



WARNING

Danger of accident!

If the specifications from the Crane operating instructions, chapter 4.10 are not observed, there is a danger of accident.

If the suspended load or the suspended derrick ballast starts to swing too much, then the crane operator can lose control over the crane.

If the following prerequisites are not observed, the crane can topple over!

This could result in serious accidents.

- ▶ Observe the specifications in the Crane operating instructions, chapter 4.10.
- ▶ Do not exceed the maximum permissible driving speed of the crawler.
- ▶ Avoid jerky driving movements.
- ▶ The attached load and suspended derrick ballast must be secured to prevent it from swinging. If oscillating movements should occur, set the load / derrick ballast as fast as possible down on the ground. Hereby pay attention to the limit values of the load moment display and the F-load display.
- ▶ Steering the crawler with suspended load and / or installed derrick ballast is prohibited.
- ▶ Uphill or downhill travel is prohibited.

Make sure that the following prerequisites are met:

- Observe the specifications in the Crane operating instructions, chapter 4.10.
- Pay special attention to the limitations for crawler operation with derrick ballast.
- The ground is suitable for crawler operation with derrick ballast.
- The ground can safely take on the resulting surface pressure.
- The derrick ballast has been lifted off the ground.
- The icon „Derrick ballast lifted off“ 3.4 appears in the LICCON monitor.
- The derrick ballast is horizontally aligned (observe the incline display 3.5).

Fig.195219

LWE/LR 13000-001/19503-01-02/en

8 Disassembling the derrick ballast



WARNING

Danger of falling!

During assembly / disassembly, inspection and maintenance work, assembly personnel must be secured with appropriate aids to prevent them from falling!

If this is not observed, assembly personnel could fall and suffer life-threatening or fatal injuries!

- ▶ All work aloft, where there is a danger of falling must be carried out with suitable aids!
- ▶ If aids are not available and work cannot be carried out from the ground, then the assembly personnel must secure themselves with the supplied fall arrest system to prevent falling, see Crane operating instructions, chapter 2.04.
- ▶ If fall protection equipment is available, then it must be used, see Crane operating instructions, chapter 2.06!
- ▶ When lifting, lowering, swinging crane parts in and out, no persons may remain in the danger zone.
- ▶ If railings are present on the components, then they must be brought into the corresponding position and secured for assembly / disassembly work!
- ▶ Only step on the aids, ladders and catwalks with clean shoes!
- ▶ Keep aids, ladders and catwalks free of heavy dirt, snow and ice!
- ▶ During all assembly and disassembly work, maintenance work and inspections, travel or crane operation is prohibited!
- ▶ Remaining on a suspended load is prohibited!
- ▶ Stepping or walking on crane components and lattice sections, which have an incline of more than 20° is prohibited!
- ▶ For all assembly work, the crane operator of the main crane must be in voice contact with the crane operator / crane operators of the auxiliary crane / auxiliary cranes!
- ▶ For assembly / disassembly tasks, the crane operator may only initiate crane movements when the responsible guide has explicitly released the movement!



WARNING

Falling components!

At assembly / disassembly, the components and counterweight plates can fall down!

Personnel can be severely injured or killed!

- ▶ Make sure that no persons or objects are within the danger zone!



WARNING

Incorrect handling of the fastening equipment!

If fastening equipment cannot be attached correctly and if it is not secured sufficiently to prevent it from loosening up, loads can fall down. Personnel can be severely injured or killed!

- ▶ Make sure that the fastening equipment is correctly attached on the fastening points and that it is secured sufficiently to prevent it from loosening up!



WARNING

Danger of impact / crushing!

When installing / removing crane components with the auxiliary crane, crane components can start to swing back and forth.

When lifting / lowering and positioning crane components, there is an increased danger of impacts / crushing!

Personnel can be caught and severely injured or killed.

- ▶ Make sure that there are no persons between the components which are to be assembled / disassembled!
- ▶ Make sure that personnel cannot be caught by components.
- ▶ When working in danger zones: Use aids to protect limbs.
- ▶ Guide components with suitable aids to minimize oscillation.

Make sure that the following prerequisites are met:

- The crane is aligned in horizontal direction.

- The placement location is level and of sufficient load carrying capacity.
- The maximum ground unevenness for the placement surface of the derrick ballast is $\pm 1^\circ$
- The counterweight has been installed on the turntable according to the load chart.
- The LICCON overload protection has been set according to the data in the load chart or the erection and take down charts.
- An auxiliary crane is available.

Empty page!

LWE/LR 13000-001/19503-01-02/en

8.1 Securing the frames to prevent them from folding down

Make sure that the following prerequisite is met:

- The derrick ballast is standing on the ground.



WARNING

Frames are unsecured!

When the retaining pins **37** are **NOT** pinned, then the frame **14** and the frame **15** fall over after the D-guy rods are unpinned. Personnel can be severely injured or killed.

- ▶ Secure the frame **14** and frame **15** on both pin locations with retaining pins **37**.

Before you unpin the D-guy rods, you have to secure the frames to prevent them from folding down.

- ▶ Secure the frame **14** and frame **15** on both sides with retaining pins **37**, see illustration **2**.
- ▶ Secure the retaining pins **37** with locking pins.

8.2 Disconnecting the electrical connection



WARNING

Assembly personnel is not secured!

Assembly personnel can fall and be severely injured or killed.

- ▶ Secure assembly personnel with suitable aids to prevent them from falling.
- ▶ Use personal protective equipment.



Note

- ▶ Disconnect the electrical connections between the derrick ballast and the turntable, see Electric wiring diagram!
- ▶ Disconnect the electrical connections between the derrick ballast and the turntable and store the plug and cable properly.

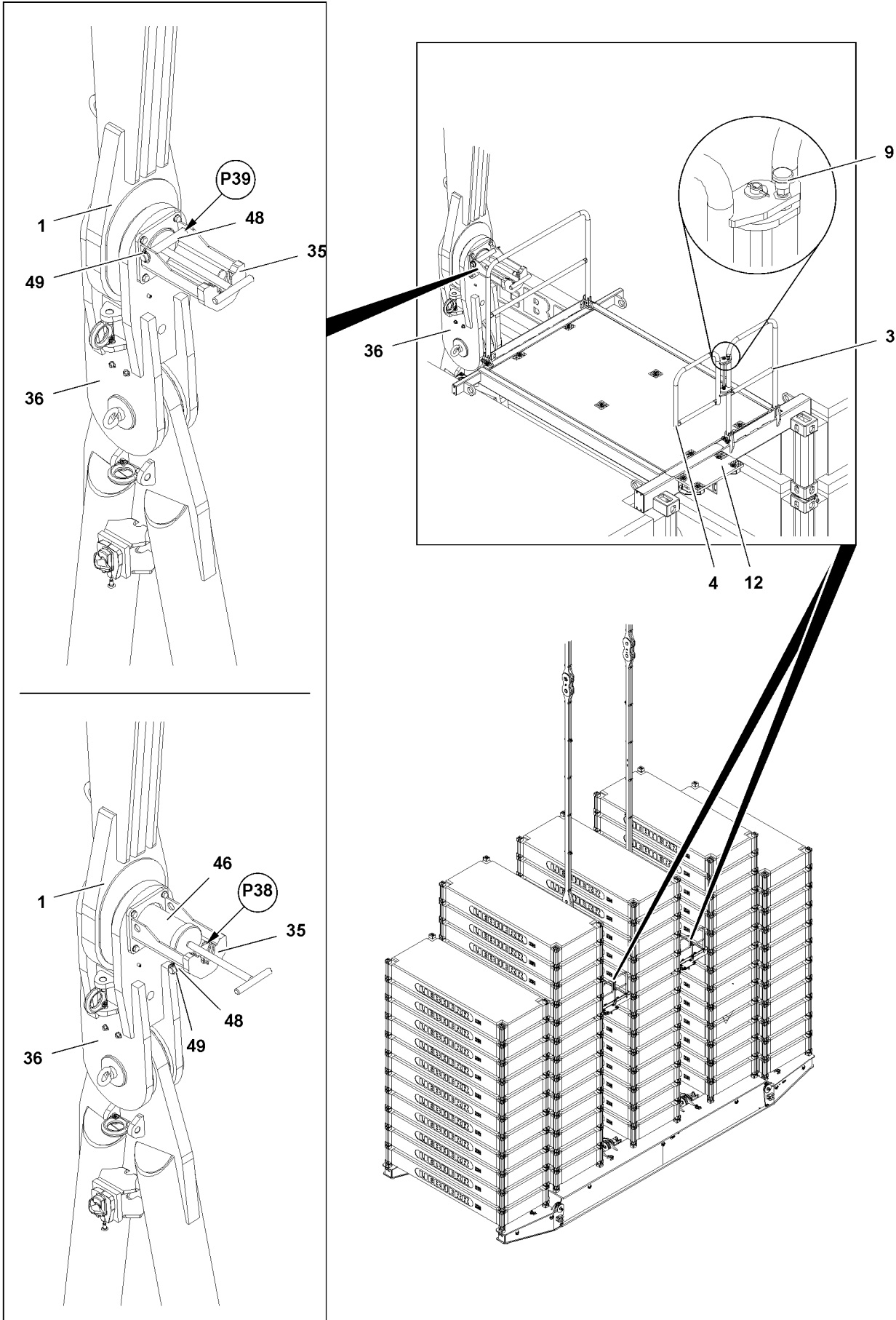

Fig.116179

LWE/LR 13000-001/19503-01-02/en

8.3 Unpinning the derrick ballast pallet on the D-guy rods



WARNING

Assembly personnel is not secured!

Assembly personnel can fall and be severely injured or killed.

- ▶ Secure assembly personnel with suitable aids to prevent them from falling.
- ▶ Use personal protective equipment.

Make sure that the following prerequisites are met:

- The frames are secured to prevent them from folding down.
- The derrick ballast pallet is standing on the ground and the D-guy rods are completely relieved.
- A work platform is available.



Note

- ▶ The step 12 on the outside of the platform allows access.

Position the work platform in such a way that you have safe access to the first platform.

- ▶ Make sure that you are secured by your personal protective equipment.
- ▶ Pull the detent pin 9 and swing the door 4 in.
- ▶ Step on the platform.
- ▶ Swing the door 4 outward and let the detent pin 9 engage.

Result:

- The D-guy rods 1 can be unpinned from the platform on the cross brackets 36.
- ▶ Release the pin 46: Remove the locking pin 49 and unpin the retaining pin 48 on point P39.
- ▶ Insert the retaining pin 48 on point P38 and secure with locking pin 49.
- ▶ Unpin the pin 46.
- ▶ Lift the D-guy rods 1 by retracting the piston rods on the pull cylinder from the cross bracket 36 until sufficient room is available for ballasting down.
- ▶ Insert the pins 46.
- ▶ Remove the locking pin 49 and unpin the retaining pin 48 on point P38.
- ▶ Secure the pin 46: Insert the retaining pin 48 on point P39 and secure with locking pin 49.
- ▶ Make sure that the pin location is pinned and secured.

Result:

- The D-guy rods are unpinned on the first frame.
- The second D-guy rods can be unpinned.
- ▶ Position the work platform for access to the second platform.
- ▶ On the second frame: Unpin the D-guy rods 1 on the cross brackets 36.
- ▶ Insert pins 46 and secure with retaining pins 48.
- ▶ Make sure that the pin location is pinned and secured.

Result:

- The derrick ballast pallet can be ballasted down.

Fig.195219

LWE/LR 13000-001/19503-01-02/en

8.4 Ballasting the derrick ballast pallet down



DANGER

Danger of impact and crushing!

Due to presence near the derrick ballast assembly, there is an increased danger of impact and crushing when the derrick plates are „moved in“.

- ▶ Exercise extreme caution when lifting the derrick ballast.
- ▶ Make sure that persons are **NOT** underneath the suspended derrick ballast.
- ▶ Exercise extreme caution when lowering the derrick ballast. Danger of crushing people in the immediate area of the derrick ballast being lowered.



WARNING

Derrick ballast too low / too high!

If the placed derrick ballast deviates from the specifications in the load charts or the erection and take down chart, then the crane can be damaged or topple over.

Personnel can be severely injured or killed.

- ▶ Make sure that the derrick ballast is placed according to the load chart or the erection and take down chart.



WARNING

Damaged derrick ballast plates!

Damage on the derrick ballast plates can cause the fastening equipment to release.

Derrick ballast plates can fall down.

Personnel can be severely injured or killed.

- ▶ Do not use damaged derrick ballast plates and replace them immediately.



WARNING

Overload of fastening points for derrick ballast plates!

If more than the permissible number of derrick ballast plates are lifted together, then the fastening points can be overloaded.

Derrick ballast plates and components can fall down.

Personnel can be severely injured or killed.

- ▶ Attach no more than maximum „two“ derrick ballast plates per lift.

Make sure that the following prerequisite is met:

- Work equipment or other aids to work aloft are available.

5

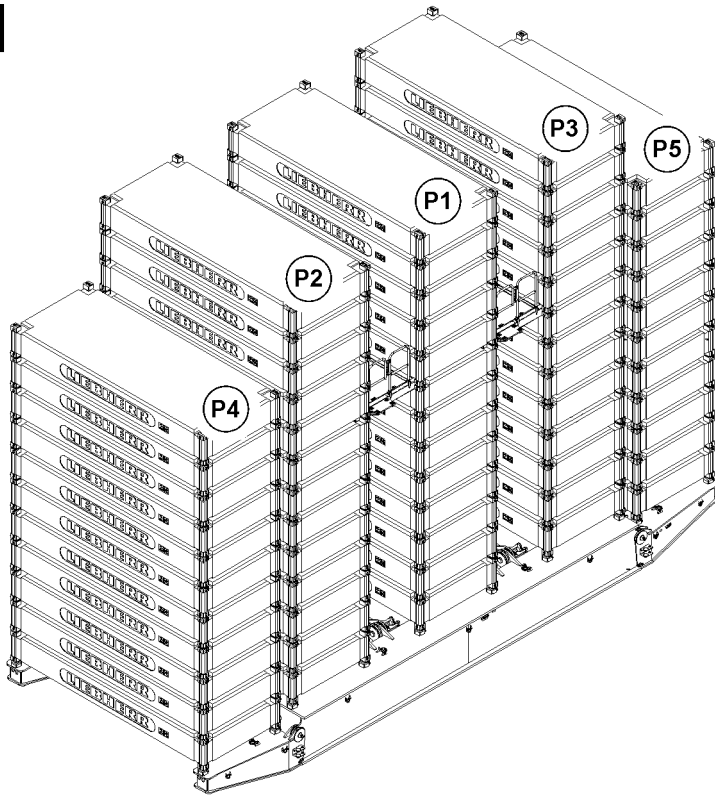

6

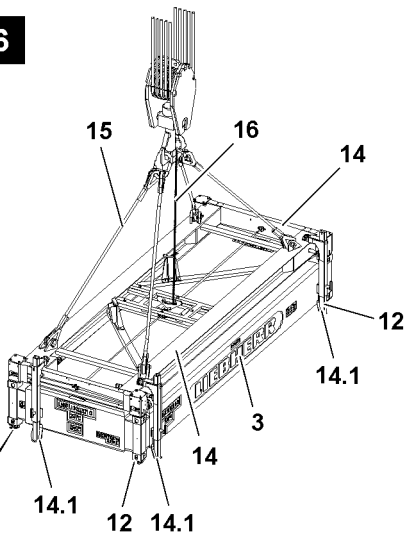

7

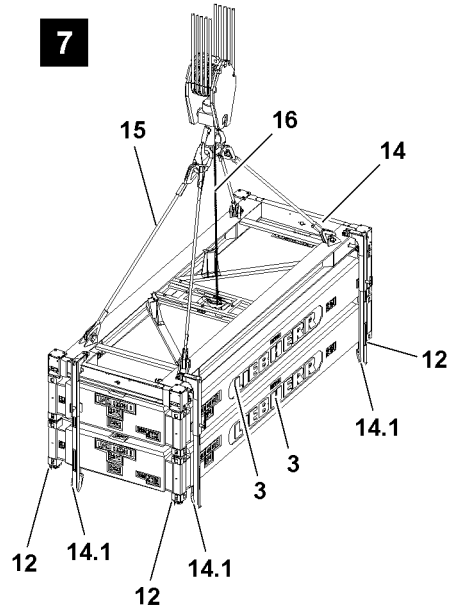

8

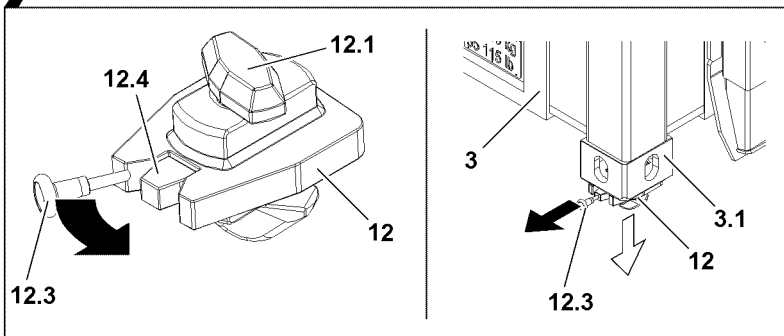
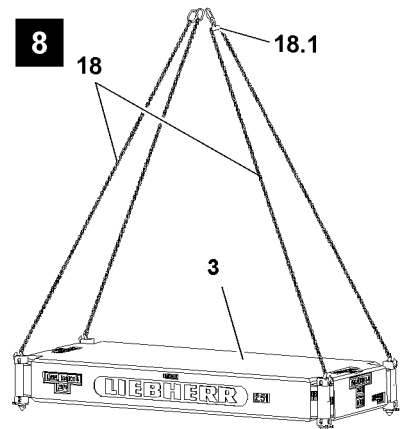

Fig.116376

LWE/LR 13000-001/19503-01-02/en

8.4.1 Lifting the derrick ballast plates off

The derrick ballast plates can be ballasted down or lifted off with the following devices or fastening equipment:

1. Container spreader **14**, see illustration **6** and illustration **7**
2. With a chain suspension **18** at least 6 m long with balancer **18.1**, see illustration **8**.



WARNING

Danger of accidents due to overload!

If more than the permissible **two** derrick ballast plates are fastened on the container spreader **14**, the derrick ballast plates can fall down and the container spreader can be significantly damaged.

If more than **one** derrick ballast plate is fastened on the chain suspension **18**, then the chain suspension can rip off and the derrick ballast plates can fall down.

Personnel can be severely injured or killed.

- ▶ Make sure that no more than maximum **two** derrick ballast plates are fastened on the container spreader **14**.
- ▶ Make sure that no more than maximum **one** derrick ballast plate is are fastened on the chain suspension **18**.



WARNING

The crane can topple over!

If more than 50 t are lifted off with one lift from the derrick ballast plates or from the derrick ballast pallet or if the derrick ballast is ballasted down asymmetrically, then the crane can topple over.

Personnel can be severely injured or killed.

- ▶ Alternately lift off a maximum of 50 t counterweight assemblies symmetrically from the ballast stacks.

When the brackets are installed (5 ballast stacks):

- ▶ For ballasting down, a weight difference between the stacks on the right side (stack **P3** and stack **P5**) and the stacks on the left side (stack **P2** and stack **P4**) of more than 100 t is prohibited.

When the brackets are NOT installed (3 ballast stacks):

- ▶ During subsequent ballasting down, a weight difference between the right stack **P3** and the left stack **P2** of more than 100 t is prohibited.



Note

- ▶ The derrick ballast plates **3** are marked with their own weights.

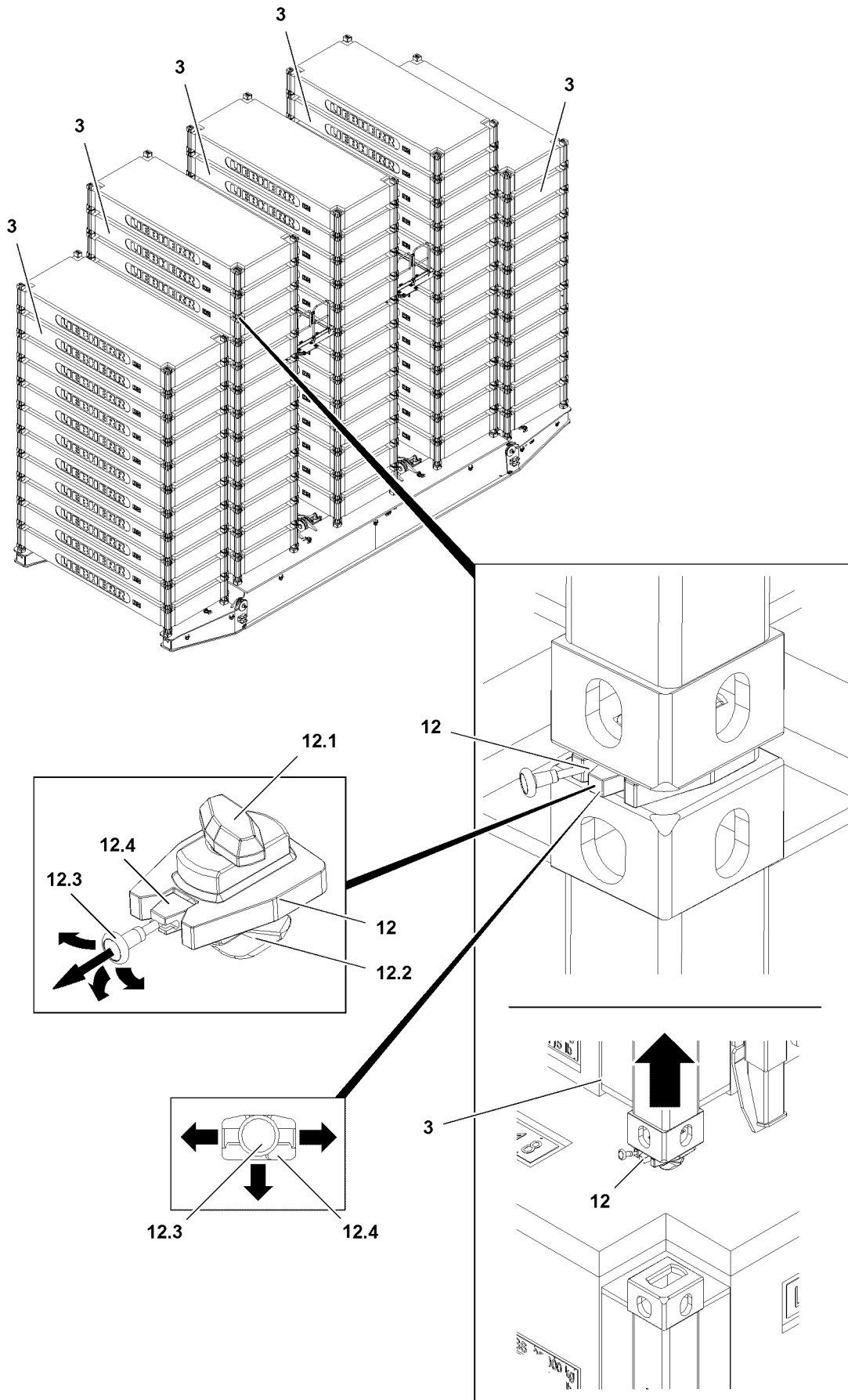

Fig.116379

LWE/LR 13000-001/19503-01-02/en

Unlocking the Twistlocks



WARNING

Danger of falling!

If the derrick ballast pallet or one of the ballast stacks must be accessed by assembly personnel, the assembly personnel can fall down.

Personnel can be severely injured or killed.

- ▶ Walking or stepping on the derrick ballast pallet and / or the ballast stack without personal protective equipment (fall protection equipment) is explicitly prohibited.
- ▶ Use personal protective equipment!
- ▶ Use a work platform.



Note

When the derrick ballast plates are lifted off the ballast stacks **individually**:

- ▶ Always unlock only the uppermost derrick ballast plate on the ballast stack.

When the derrick ballast plates in **assembly** (maximum two derrick ballast plates together) are lifted off the ballast stacks:

- ▶ Always unlock only the every second derrick ballast plate on the ballast stack.
- ▶ Unlock maximum **one** row of derrick ballast plates or derrick ballast assemblies for ballasting down.
- ▶ Position the work platform.
- ▶ Unlock the Twistlock **12**: Pull the release **12.3** and engage it either to the left, to the right or downward into the bracket **12.4**.

Result:

- The lock **12.2** turns, the Twistlock is unlocked.

NOTICE

Danger of property damage!

If the following notes are not observed, the derrick ballast plate **3** and Twistlock **12** can be damaged.

- ▶ Make sure that every one of the four Twistlocks **12** is unlocked before the derrick ballast plate or the derrick ballast assembly is lifted.

- ▶ Unlock all four Twistlocks **12** between the derrick ballast plates.

Result:

- Twistlocks **12** are unlocked and the derrick ballast plate or the derrick ballast assembly can be lifted off.

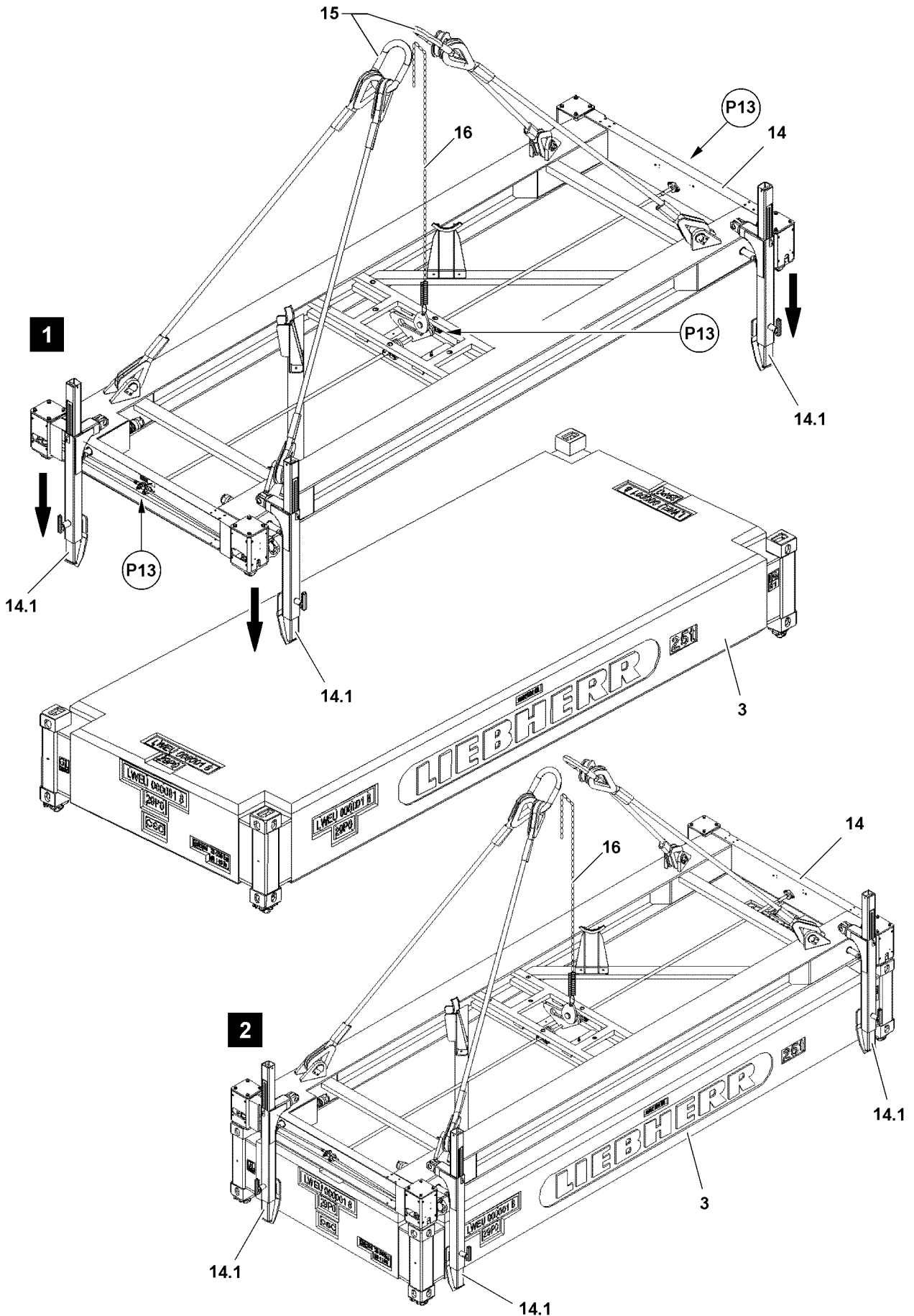

Fig.114754

LWE/LR 13000-001/19503-01-02/en

Use of container spreader



WARNING

Danger of accident!

If the container spreader operating instructions are not observed, personnel can be severely injured or killed.

Property damage on the crane can occur.

- ▶ Before operation of the container spreader, the assembly personnel must read and observe the separately supplied container spreader Operating instructions.



Note

- ▶ The strut guides **14.1** serve as guide stops on the derrick ballast plates **3** and can be telescoped depending on application.
 - ▶ The height of the derrick ballast plate **3** is 800 mm.
 - ▶ For adjustment of strut guide **14.1**, see separately supplied Container spreader Operating instructions.
- ▶ Set the strut guide **14.1** to the height of the derrick ballast plate.



Note

- ▶ For adjustment of spring load lock **16**, see separately supplied Container spreader Operating instructions.
- ▶ Fasten the fastening ropes **15** of the container spreader **14** and the chain of the spring load lock **16** on the hook of the auxiliary crane.

For a visual check, **red** and **green** color marks are provided to recognize the respective locking position in the slewing range of the axle lever on the respective front side and on the locking rocker, see points **P13** illustration **1**.



Note

- ▶ Make sure, before setting the container spreader **14** on the derrick ballast plate **3**, that a corresponding locking position is selected.
- ▶ Set the container spreader **14** with the auxiliary crane on the derrick ballast plate **3**.



Note

- ▶ Observe the function and warning notes for the Self-lock fixture lock, see separately supplied Container spreader Operating instructions.
- ▶ The locking procedure is carried out fully automatic by the Self-lock fixture lock.

5

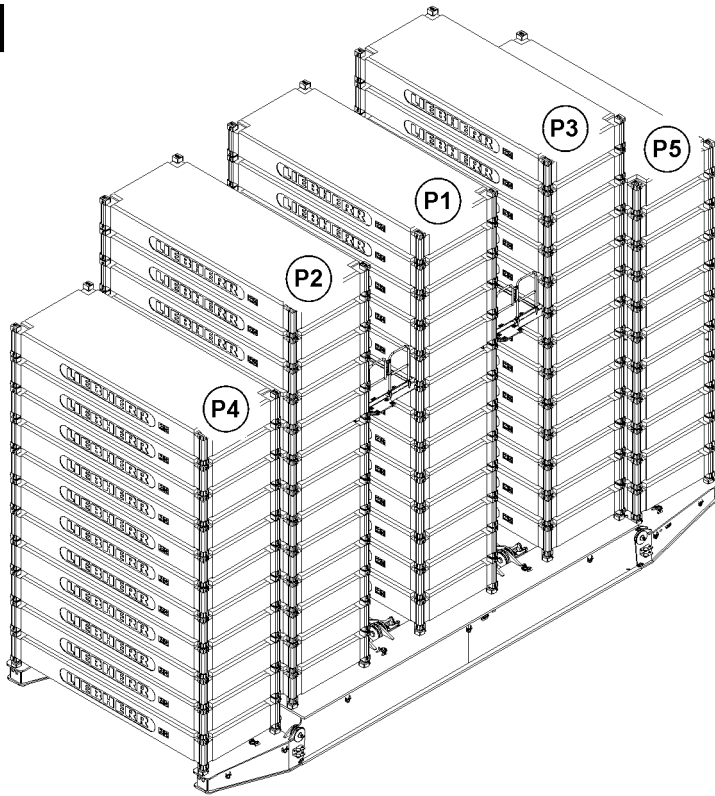

6

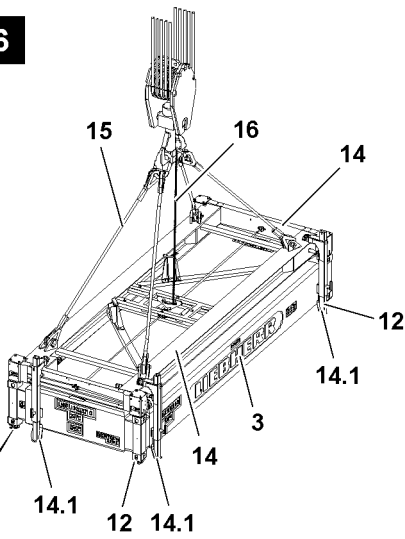

7

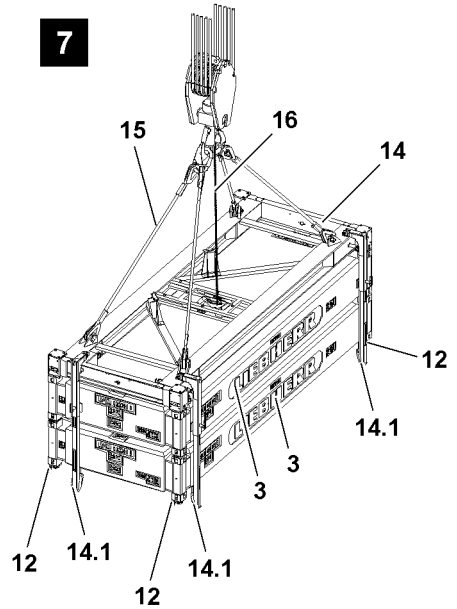

8

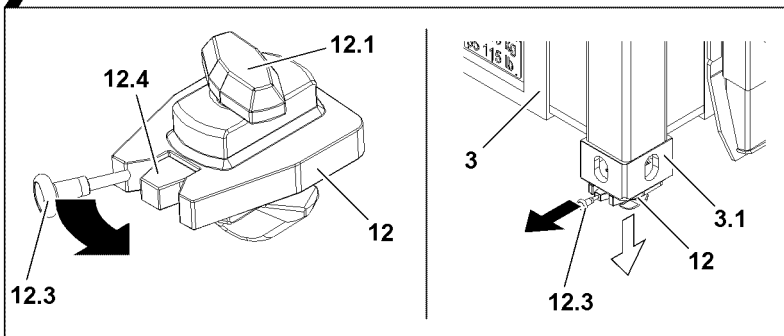
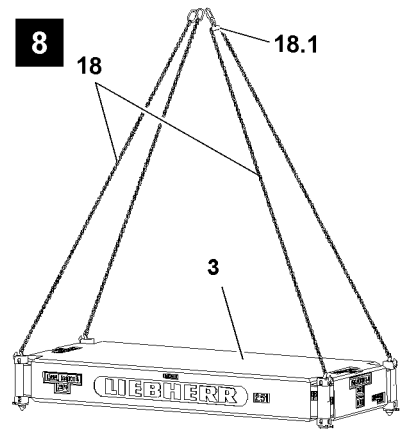

Fig.116376

LWE/LR 13000-001/19503-01-02/en

Lifting the derrick ballast plates from the ballast stacks



WARNING

Danger of falling!

If the derrick ballast pallet or one of the ballast stacks must be accessed by assembly personnel, the assembly personnel can fall down.

Personnel can be severely injured or killed.

- ▶ Walking or stepping on the derrick ballast pallet and / or the ballast stack without personal protective equipment (fall protection equipment) is explicitly prohibited.
- ▶ Use a work platform.

Make sure that the following prerequisites are met:

- The required Twistlocks are unlocked.
- Make sure that the telescope pipes of the strut guides **14.1** on the container spreader have the correct length, see container spreader Operating instructions.
- The container spreader operating instructions were read and understood.

NOTICE

Danger of property damage!

- ▶ Make sure that the strut guides are moved in to the point where they do not protrude past the contour of the derrick ballast plate / the derrick ballast assembly.



Note

- ▶ The lock between the derrick ballast plate(s) and the container spreader can be locked / unlocked via a kinematical-mechanical locking mechanism, see container spreader operating instructions.

NOTICE

Danger of property damage!

If the following notes are not observed, the derrick ballast plates and the Twistlocks can be damaged!

- ▶ Make sure that all four Twistlocks are unlocked before the individual derrick ballast plates or a derrick ballast assembly is lifted off.

When the Twistlocks are unlocked:

- ▶ Take on the first derrick ballast assembly **3** with the container spreader **14**, lift off and swing out.
or
Take on the first derrick ballast plate **3** individually with the chain suspension **18**, lift off and swing out.
- ▶ Lower the derrick ballast assembly **3** or derrick ballast plate **3** until the derrick ballast plates **3** are just above the ground.

Result:

- The Twistlocks can be disassembled.

5

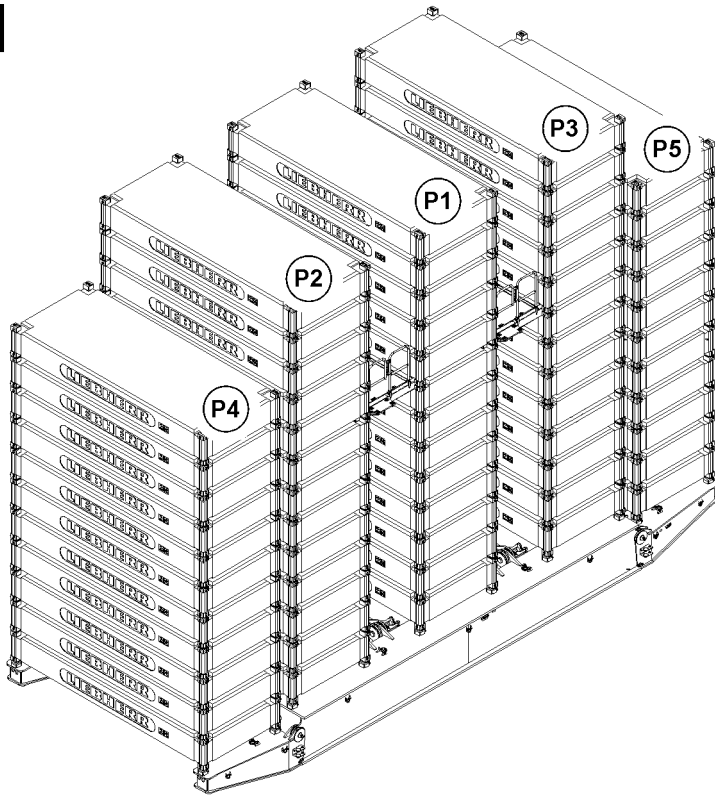

6

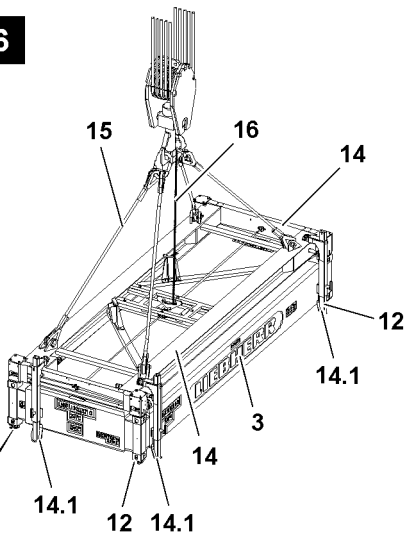

7

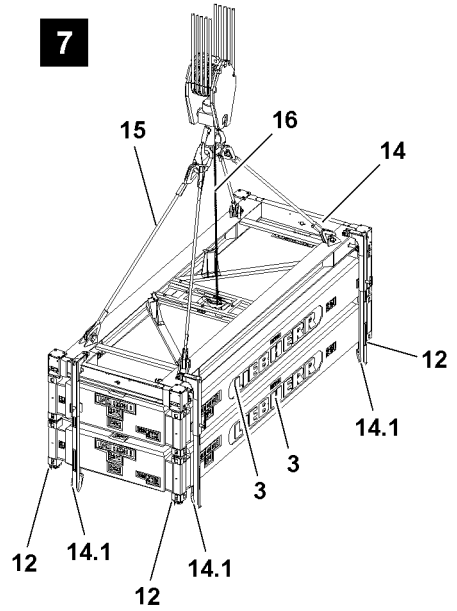

8

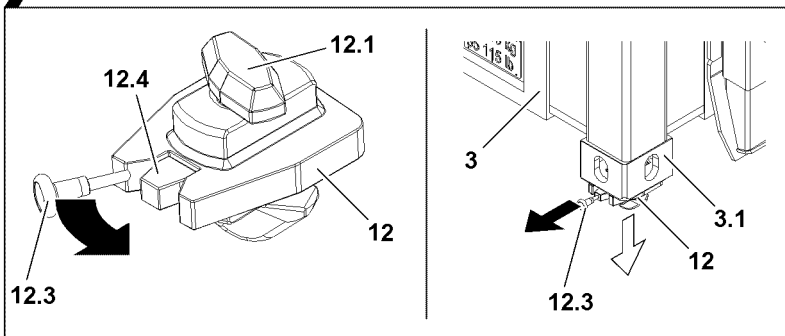
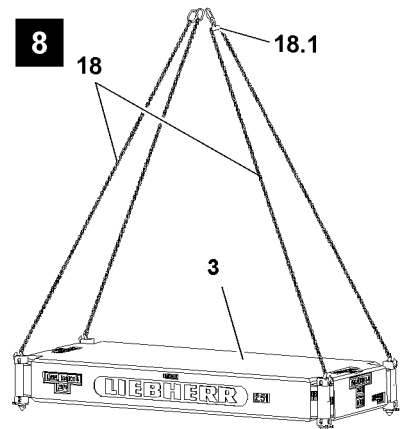

Fig.116376

LWE/LR 13000-001/19503-01-02/en

Removing the Twistlock on the counterweight plate(s)

Make sure that the following prerequisite is met:

- The lifted off derrick ballast plate / the derrick ballast assembly **3** is just above the ground.



WARNING

Falling Twistlock!

When unlocking the Twistlock, it can fall down!

Personnel can be severely injured!

- ▶ Secure the Twistlock before unlocking to prevent it from falling.

-
- ▶ Unlock the Twistlock **12**: Release the release **12.3** from the bracket **12.4**, pull and hold.
 - ▶ Take the Twistlock downward from the container corner fitting **3.1**.
 - ▶ Activate the locking mechanism of the Twistlock **12** again: Slowly let the release **12.3** return to its original position.
 - ▶ Place the Twistlock **12** into a suitable transport container.
 - ▶ Place the derrick ballast plates down.
 - ▶ Remove the container spreader.

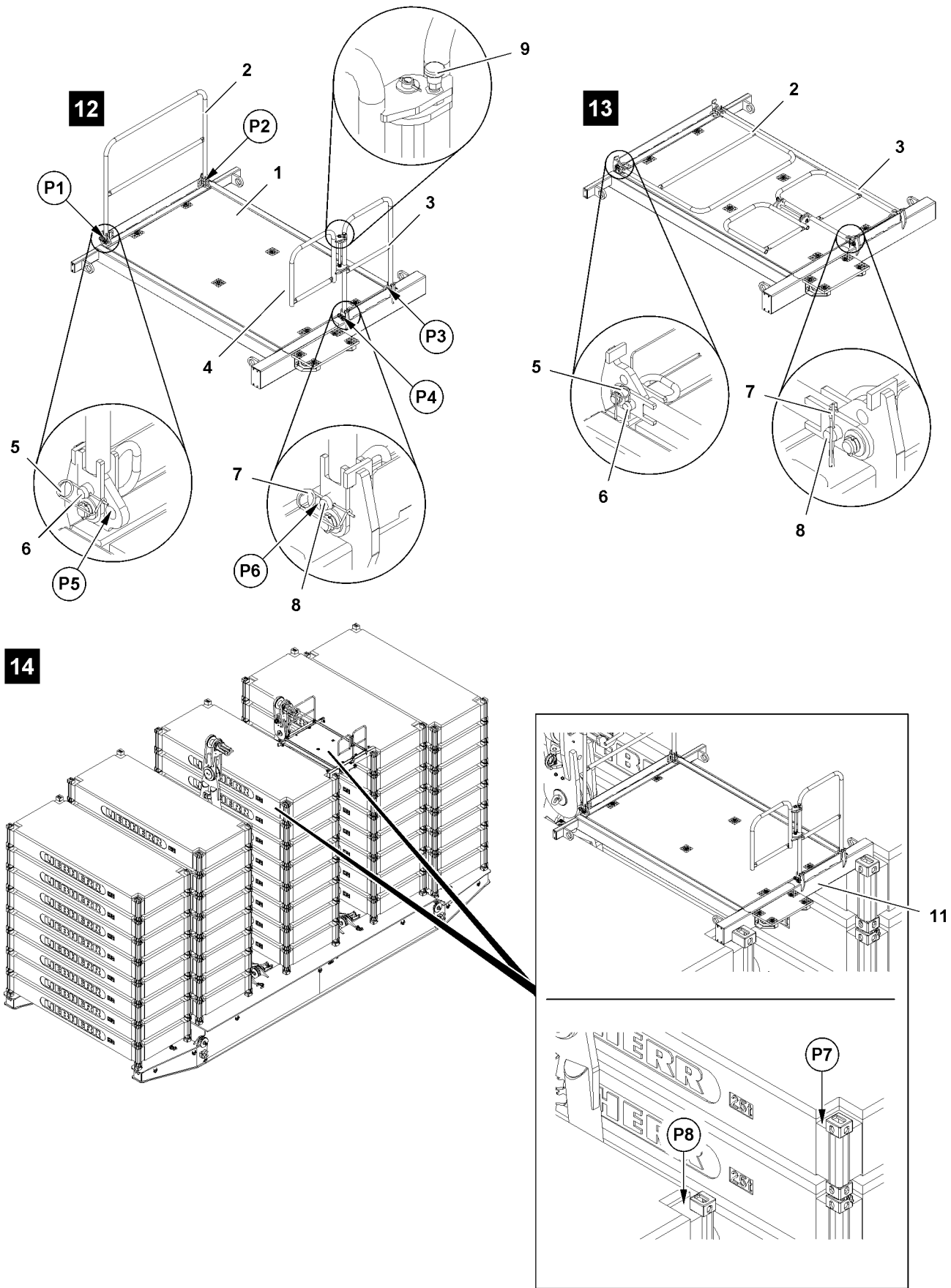

Fig.116377

LWE/LR 13000-001/19503-01-02/en

8.5 Disassembling the platforms

You can freely select the sequence in which the platforms **1** are removed.

This section described, by example, how a platform is lifted off the derrick ballast plates and how the railings are swung into transport position. The removal of the other platform is made in the same way.



Note

- ▶ The weight of the platform is 0.4 t.

Make sure that the following prerequisite is met:

- An auxiliary crane is available.

8.5.1 Lifting the platforms off from the derrick ballast plates



WARNING

Assembly personnel is not secured!

Assembly personnel can fall and be severely injured or killed.

- ▶ Secure assembly personnel with suitable aids to prevent them from falling.
- ▶ Use personal protective equipment.



WARNING

Danger of crushing!

During disassembly, hands can be crushed or even severed due to swing movements of the components!

- ▶ Make sure that the components do not swing back and forth during disassembly.

Make sure that the following prerequisites are met:

- Eight derrick ballast plates are still laying on each ballast stack.
- The railing (rear) and railing (front) are in operating position and are secured.
- A work platform is available.

Position the work platform in such a way that you can remove the platforms from the derrick ballast plates.

- ▶ Fasten the platform **1** on the auxiliary crane.
- ▶ Lift the rectangular pipe **11** on point **P7** and on point **P8** from the derrick ballast plates, see illustration **14**.

Result:

- The platform **1** can be removed.

When the work platform is positioned under the second platform:

- ▶ Remove the second platform from the derrick ballast plate.

Result:

- When both platforms are removed, then the remaining derrick ballast plates can be lifted off.

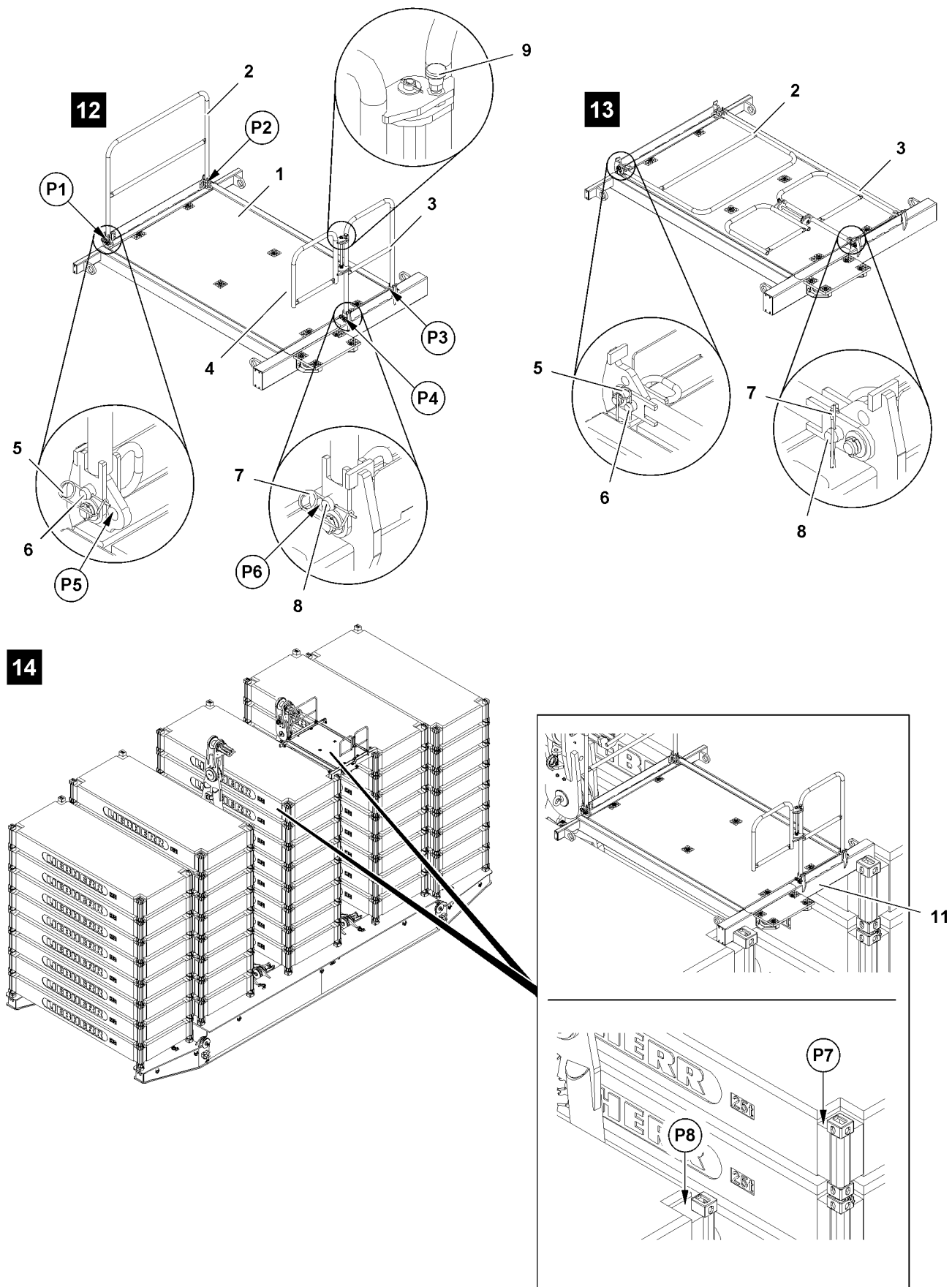

Fig.116377

LWE/LR 13000-001/19503-01-02/en

8.5.2 Swinging the railing (rear) into transport position

Make sure that the following prerequisite is met:

- The platform is placed down on the ground.



Note

- ▶ The railing (rear) consists of two parts. The door **4** can be released and locked with the detent pin **9**.
 - ▶ After releasing, the door **4** returns automatically into its initial position.
-
- ▶ Release the railing **3** on point **P3**: Remove the spring retainer **7** and unpin the pin **8**, see illustration **12**.
 - ▶ Release the railing **3** on point **P4**: Remove the spring retainer **7** and unpin the pin **8**.



WARNING

Danger of crushed limbs!

When swinging the railing **3**, fingers and hands can be crushed.

- ▶ Do not reach with your hands into the danger zone.
-
- ▶ Swing the railing **3** downward.
 - ▶ Secure the railing **3** on point **P4**: Insert the pin **8** and secure with spring retainer **7**, see illustration **13**.
 - ▶ Secure the railing **3** on point **P3**: Insert the pin **8** and secure with spring retainer **7**.

Result:

- The railing (rear) is secured in operating position.

8.5.3 Swinging the railings (front) into transport position

Make sure that the following prerequisite is met:

- The platform is placed down on the ground.

- ▶ Release the railing **2** on point **P1**: Remove the spring retainer **5** and unpin the pin **6**, see illustration **12**.
- ▶ Release the railing **2** on point **P2**: Remove the spring retainer **5** and unpin the pin **6**.



WARNING

Danger of crushed limbs!

When swinging the railings, fingers and hands can be crushed!

- ▶ Do not reach with your hands into the danger zone!
-
- ▶ Swing the railing **2** upward.
 - ▶ Secure the railing **2** on point **P2**: Insert the pin **6** and secure with spring retainer **5**, see illustration **13**.
 - ▶ Secure the railing **2** on point: Insert the pin **6** and secure with spring retainer **5**.

Result:

- The railing (front) is secured in operating position.

5

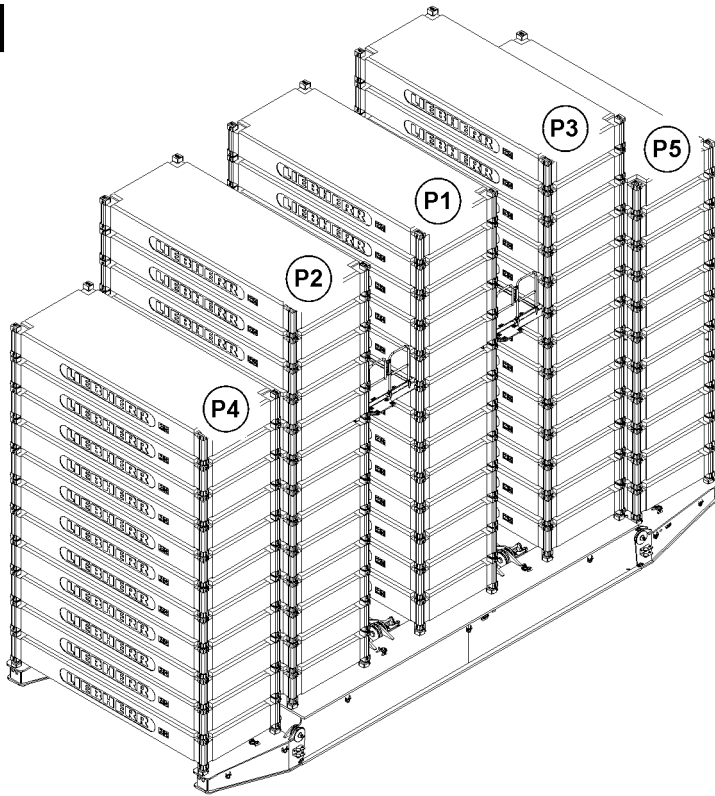

6

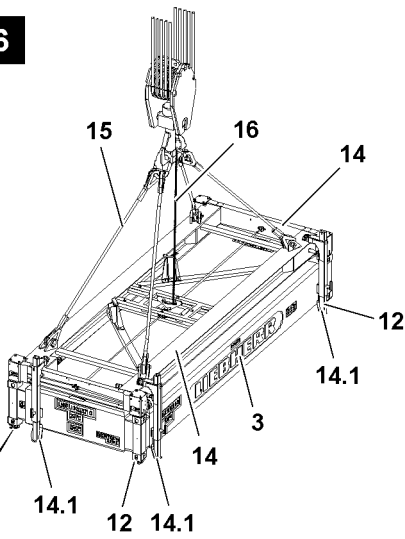

7

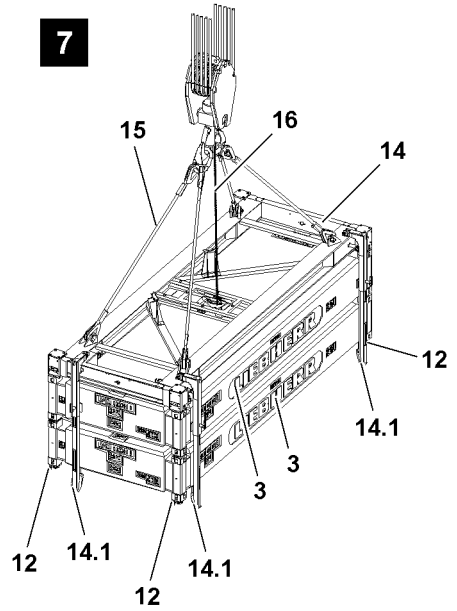

8

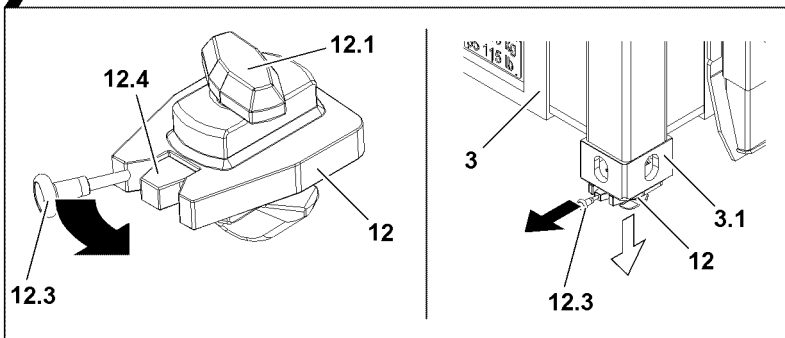
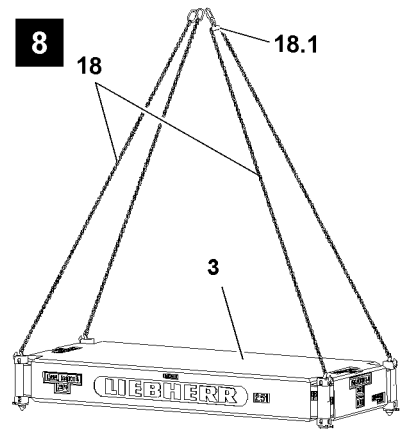

Fig.116376

LWE/LR 13000-001/19503-01-02/en

8.6 Lifting the remaining derrick ballast plates off

Make sure that the following prerequisite is met:

- Both platforms are removed on the derrick ballast plates.
- ▶ Lift the remaining derrick ballast plates off the same way as described in section „Lifting the derrick ballast plates off“.

15

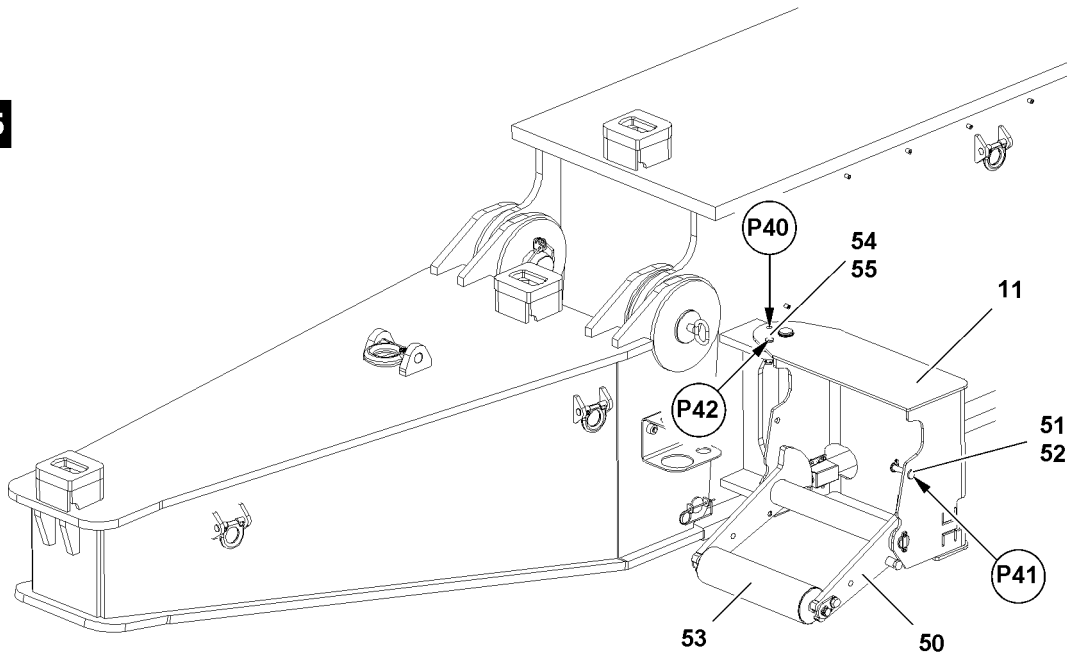

16

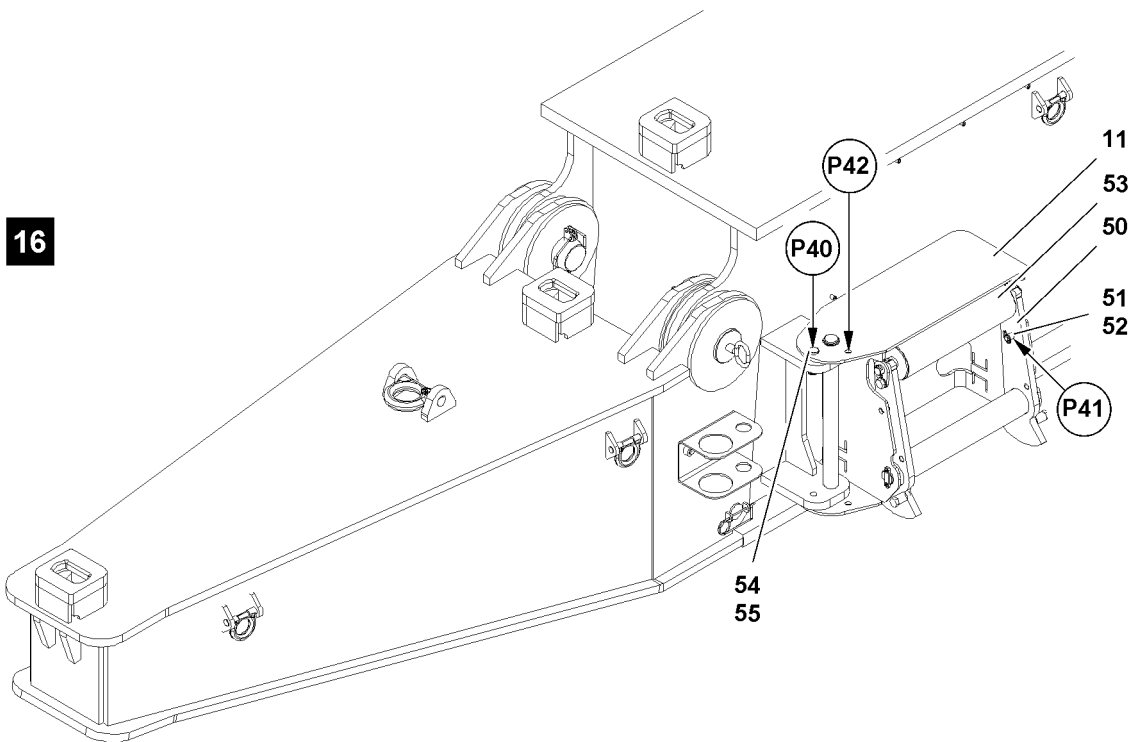

Fig.116380

LWE/LR 13000-001/19503-01-02/en

8.7 Folding the switch units in

Make sure that the following prerequisite is met:

- The derrick ballast pallet is ballasted down.



Note

- ▶ The weight of the switch unit is 0.15 t.

This section describes by example how a switch unit is folded in. The additional switch units must be folded in the same way.

When folded out, the switch unit **11** is pinned on point **P42**, see illustration **15**.

When folded in, the switch unit **11** is pinned on point **P40** and on point **P41**, see illustration **16**.

- ▶ Remove the locking pin **51** on point **P41** and unpin the pin **52**.



CAUTION

Danger of crushing!

When the ground contact roller **53** is released, the ground contact roller **53** can fold down with the retainer **50**. Hands and other body parts can be crushed.

- ▶ Make sure that the ground contact roller **53** is folded down in a controlled manner.

- ▶ Fold the ground contact roller **53** up until the pin bores align.
- ▶ Secure the retainer **50**: Insert the pin **52** on point **P41** and secure with locking pin **51**.
- ▶ Release the switch unit **11**: Remove the locking pin **54** on point **P42** and unpin the pin **55**.
- ▶ Fold the switch unit **11** in.
- ▶ Secure the switch unit **11**: Insert the pin **55** on point **P40** and secure with locking pin **54**.

Result:

- The switch unit **11** is folded in and secured.
- ▶ Fold the remaining switch units **11** in.

Result:

- The four switch units **11** are folded in and secured.

Fig.195219

LWE/LR 13000-001/19503-01-02/en

8.8 Removing the derrick ballast pallet

8.8.1 Hydraulic connections to the pin pulling cylinder



Note

- ▶ The hydraulic supply for the pin pulling cylinder is made via the external hydraulic aggregate!
- ▶ Hydraulic connection of the pin pulling device, see Crane operating instructions, chapter 5.30!

Make sure that the following prerequisite is met:

- The external hydraulic aggregate is operational.

Establishing the hydraulic connections to the pin pulling cylinder

When connecting hydraulic lines with quick-release couplings, make sure that the coupling procedure is carried out correctly.



WARNING

Pressure in the hydraulic lines!

If the pressure supply is not interrupted before connecting / releasing the hydraulic lines, the hydraulic oil can escape with high pressure!

Personnel can be severely injured or killed!

- ▶ Release the pressure in the hydraulic system before connecting / disconnecting: Interrupt the pressure supply and wait for a short time!
- ▶ Connect the coupling components (sleeve and connector) and screw together with the hand-tightened nut.
- ▶ Make sure that the description on the connections matches.
- ▶ Tighten the hydraulic couplings by hand. Rotate the hand-tightened nut until it reaches a tangible, fixed stop position.
- ▶ Establish the hydraulic connection to the pin pulling cylinder.

Disconnecting the hydraulic connections to the pin pulling cylinder

When releasing hydraulic lines with quick couplings, make sure that the coupling procedure is carried out correctly.



WARNING

Pressure in the hydraulic lines!

If the pressure supply is not interrupted before connecting / releasing the hydraulic lines, the hydraulic oil can escape with high pressure!

Personnel can be severely injured or killed!

- ▶ Release the pressure in the hydraulic system before connecting / disconnecting: Interrupt the pressure supply and wait for a short time!
- ▶ Make sure that the hydraulic system pressure has been relieved.
- ▶ Unscrew and separate the coupling components (sleeve and connector) with the hand-tightened nut.
- ▶ Disconnect the hydraulic connection to the pin pulling cylinder.
- ▶ Install dust caps on the quick couplings.

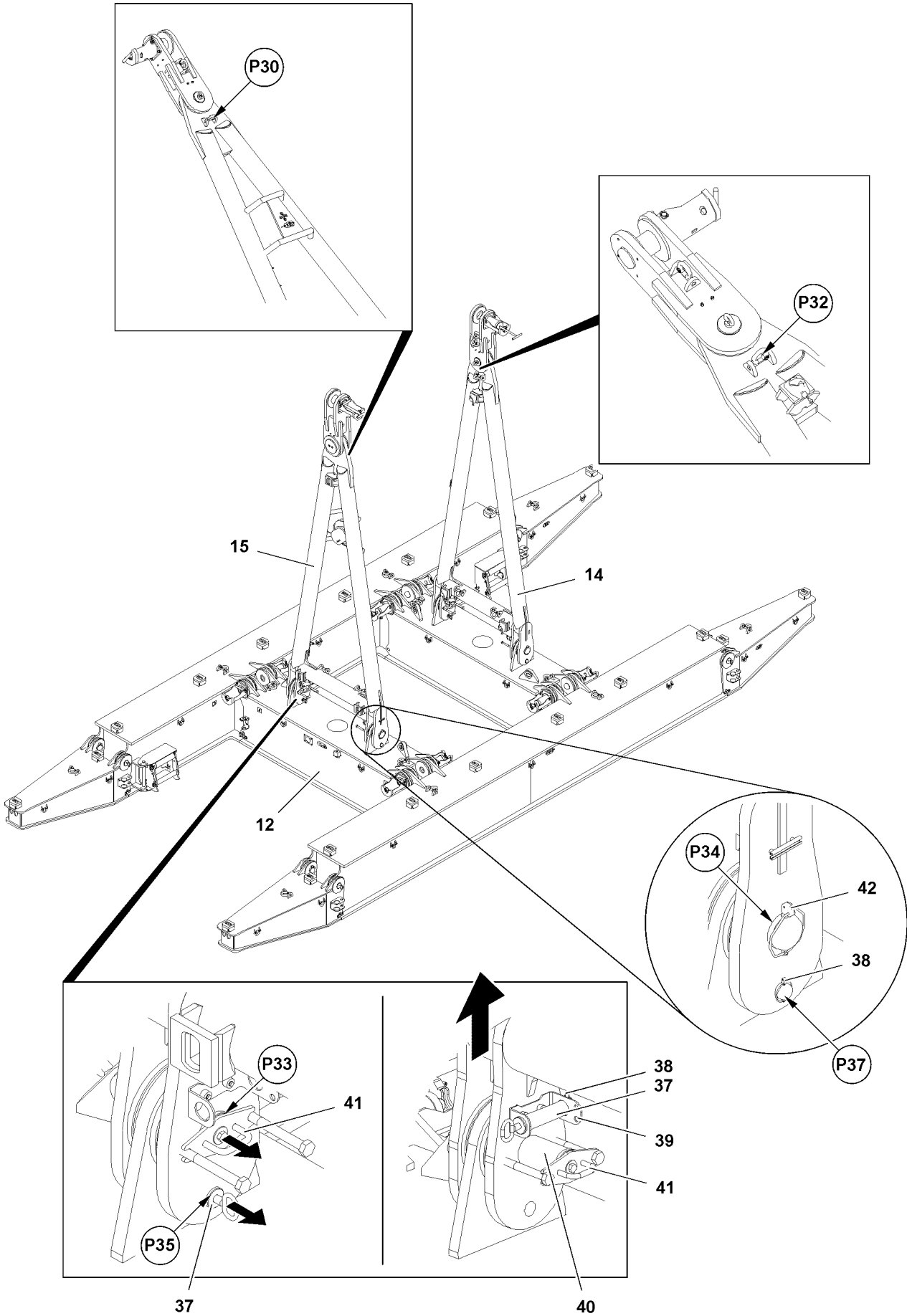

Fig.116382

LWE/LR 13000-001/19503-01-02/en

8.8.2 Removing the frames

You can freely select the sequence in which the frames on the cross carriers are removed.

In this section is described, by example, how the left frame **15** is unpinned on the connector carrier **12**. The removal of the right frame **14** is made in the same way.

- ▶ Hang the frame **14** onto the auxiliary crane, point **P30**.
- ▶ Tension the fastening equipment until the frame **15** is secured to prevent it from folding down.
- ▶ Unpin the frame **15** on point **P35** and on point **P37**: Remove the locking pin **38** and unpin the retaining pin **37**.
- ▶ Insert the retaining pin **37** in the retainer **39** and secure with locking pin **38**.

You can unpin the pin **40** with the aid of the handle **41**.

- ▶ Unpin the frame **15** on point **P33** and on point **P34**: Remove the locking pin **42** and unpin the pin **40** to the point where that the frame **14** can be lifted.
- ▶ Lift the frame **15** with the auxiliary crane until the pins **40** can be unpinned without restrictions.
- ▶ Insert both pins **40** on point **P33** and point **P34** and secure with locking pin **42**.
- ▶ Place the frame **15** down and remove the fastening equipment.

Result:

- The right frame **14** can be removed.
- ▶ Hang the right frame **14** onto the auxiliary crane, point **P32**.

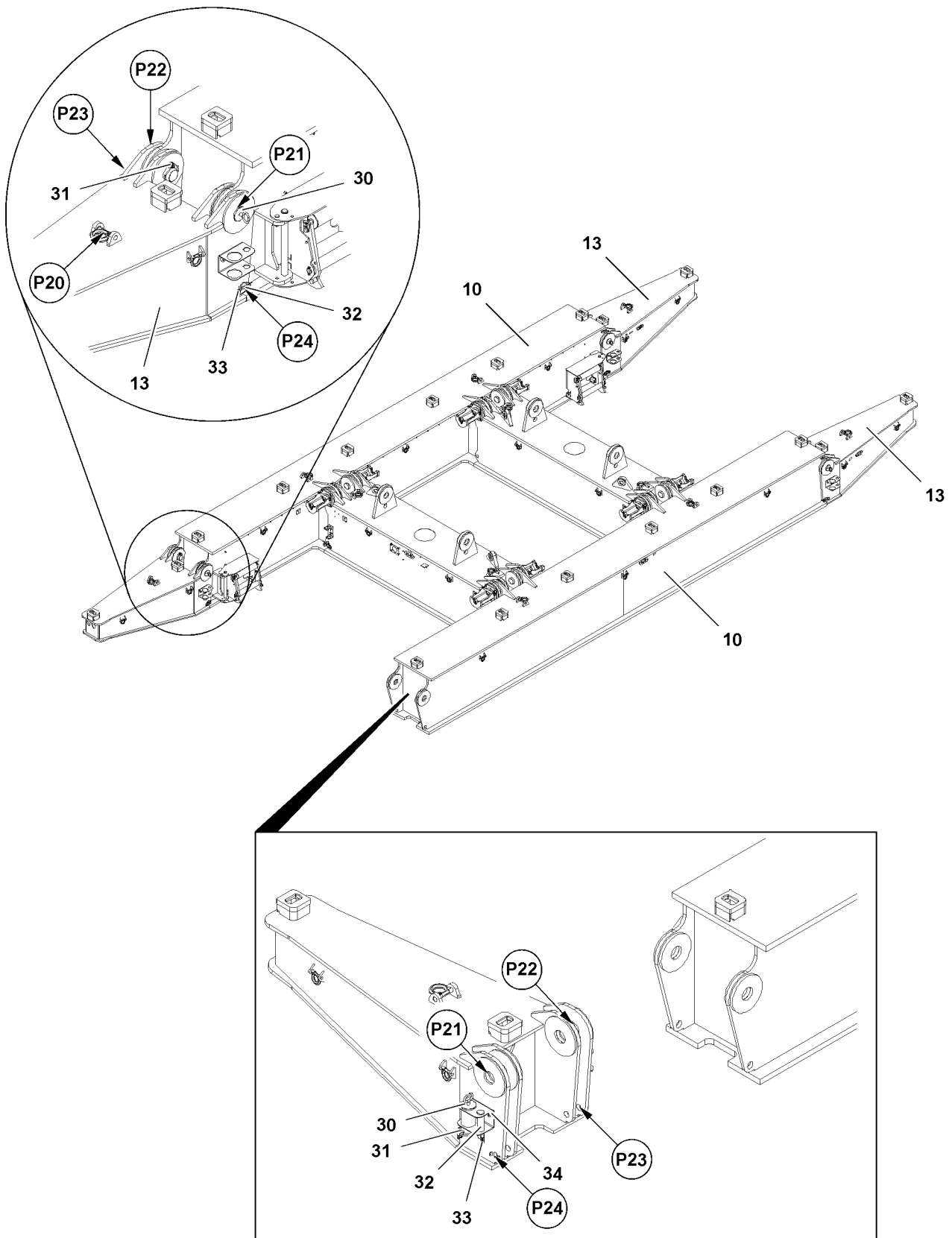

Fig.116381

LWE/LR 13000-001/19503-01-02/en

8.8.3 Removing the brackets

Make sure that the following prerequisite is met:

- The brackets **13** are removed.

You can freely select the sequence in which the brackets **13** are uninned on the cross carriers **10**.

This section describes as an example how a bracket **13** is uninned on the cross carrier **10**. The removal of the other brackets is made in the same way.



Note

- ▶ The weight of the bracket is 2.2 t.
-

- ▶ Hang the bracket **13** onto the auxiliary crane, point **P20**.
- ▶ Unpin the brackets **13** on the cross carriers **10**: Remove the spring retainers **33** and unpin the pin **32** at point **P23** and point **P24**.
- ▶ Insert the pins **32** in the retainer **34** and secure with spring retainer **33**.
- ▶ Unpin the brackets **13** on the cross carriers **10**: Remove the locking pin **31** and unpin the pin **30** on point **P21** and point **P22**.
- ▶ Insert the pins **30** in the retainer **34** and secure with spring retainer **31**.
- ▶ Remove the bracket **13** with the auxiliary crane.

Result:

- The bracket **13** is removed.
- ▶ Remove the additional three brackets **13** on the cross carriers **10**.
- ▶ Make sure that pin **30** and pin **32** are inserted and secured in the retainer **34**.

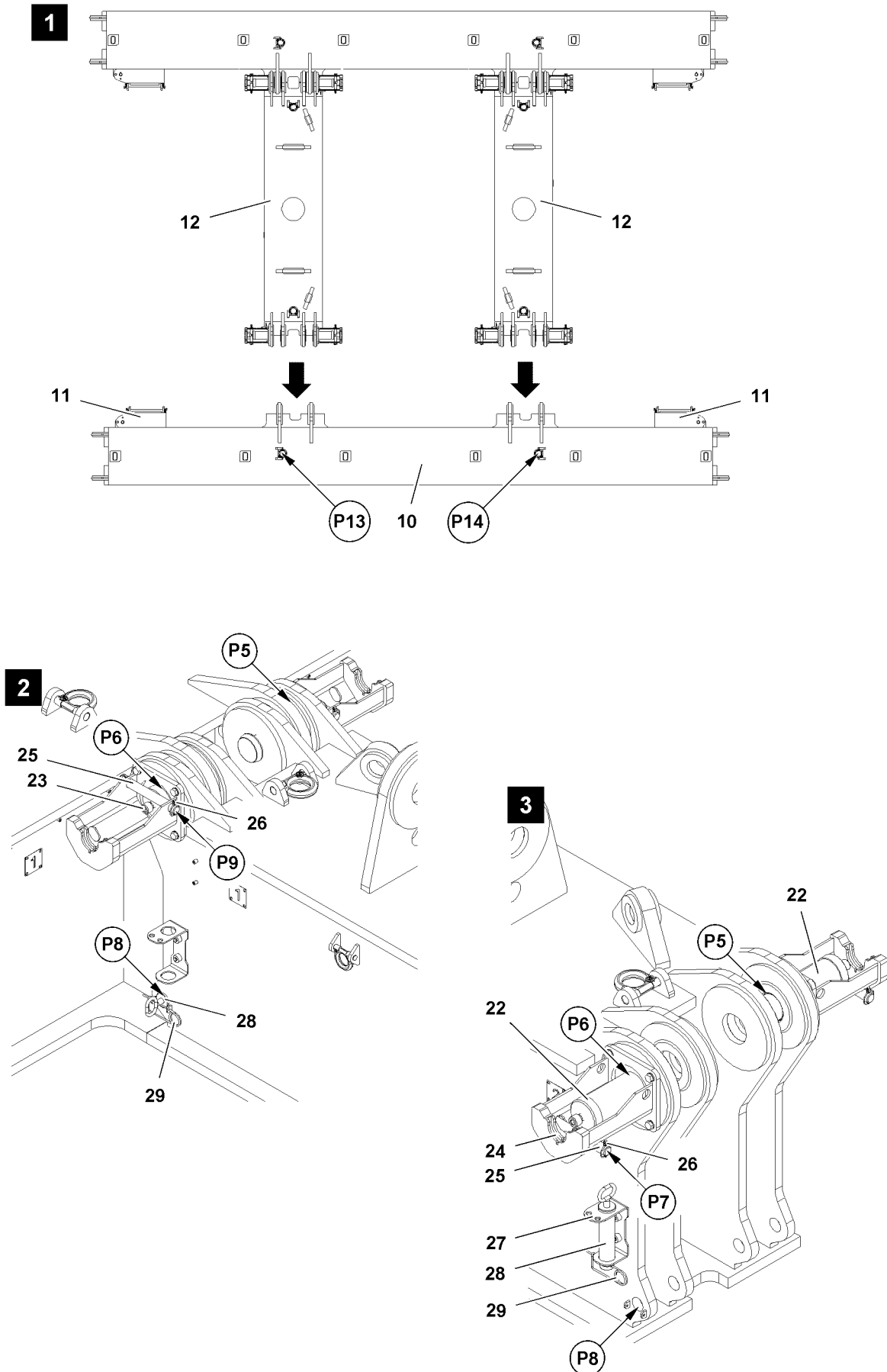

Fig.116383

LWE/LR 13000-001/19503-01-02/en

8.8.4 Removing the cross carrier and connector carrier



WARNING

Danger of crushing!

When removing the first cross carrier **10** from the connector carriers **12** there is an increased danger of accidents due to crushing.

Personnel can be severely injured or killed.

- ▶ It is prohibited for anyone to remain between the connector carriers **12** and the cross carrier **10**.
 - ▶ Observe the crane movements diligently.
 - ▶ It is prohibited to remain in the slewing range of the auxiliary crane.
 - ▶ Crane operator and guide must maintain visual contact.
-

Make sure that the following prerequisites are met:

- The frames are removed.
- The brackets are removed.
- The switch units **11** are folded in and secured.
- An auxiliary crane is on hand.

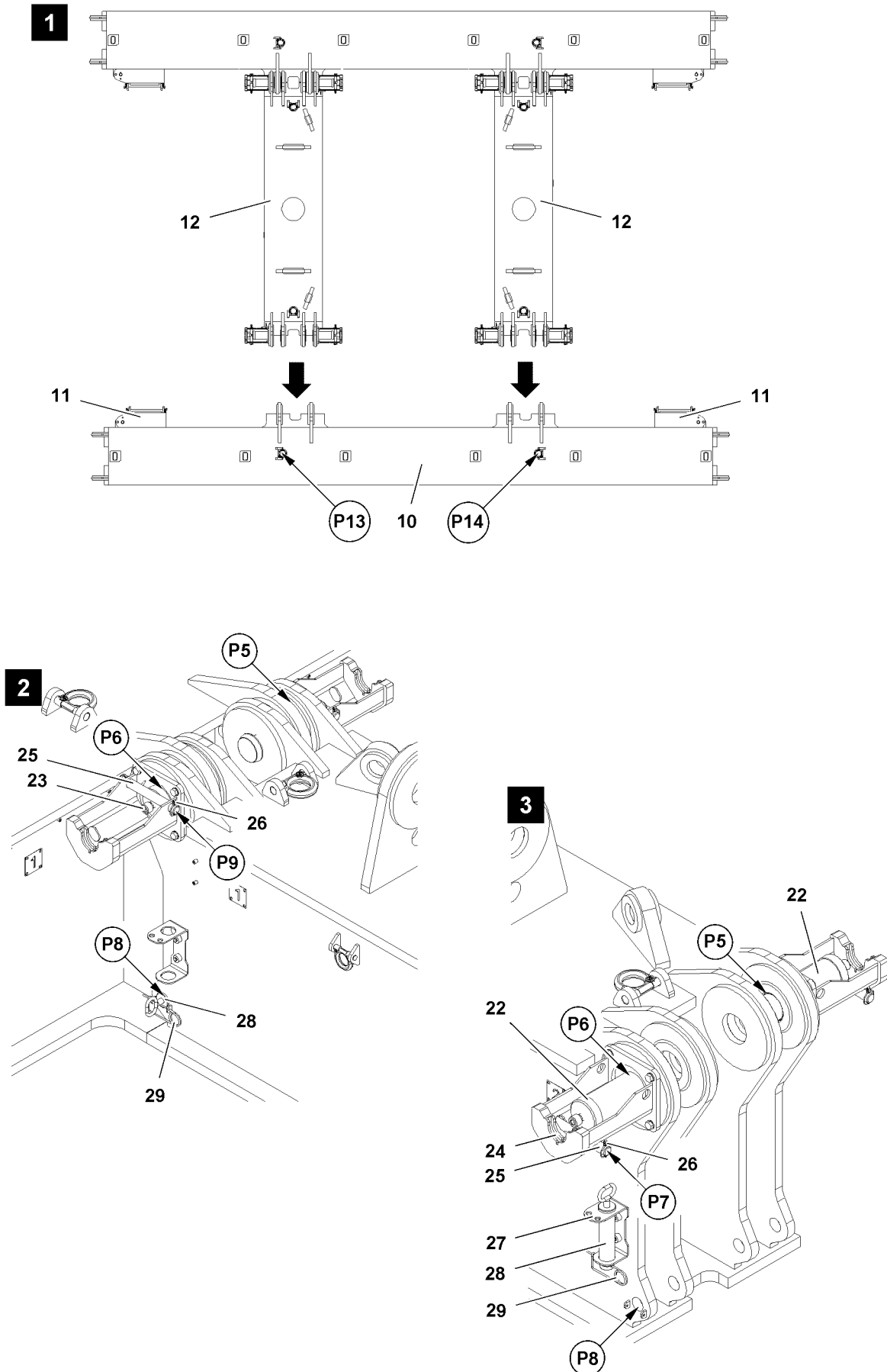

Fig.116383

LWE/LR 13000-001/19503-01-02/en

Unpinning the first connector carrier on the cross carrier

Make sure that the following prerequisite is met:

- The hydraulic connection to the pin pulling cylinder is established, see section „Establishing the hydraulic connection to the pin pulling cylinder“



Note

- ▶ The pin points for the pins **22** on the connector carrier are on point **P5** and point **P6**.
- ▶ The pin point for the pin **28** on the connector carrier is on point **P8**.

- ▶ Unpin pin **25** on point **P8**: Remove the locking pin **29** and unpin the pin **25**.
- ▶ Insert the pin **25** in the retainer **27** and secure with locking pin **29**.

The following describes how a pin **22** is unpinned. The procedure for the second pin **22** is the same.

- ▶ Release the pin **22** on point **P5** and on point **P6**: Remove the locking pin **26** on point **P9** and unpin the retaining pin **25**.
- ▶ Insert the retaining pin **25** on point **P7** and secure with locking pin **26**.
- ▶ Attach the pin pulling cylinder on the auxiliary crane.
- ▶ Move the pin pulling cylinder out and hang on the screw **23** and in the retainer **24**.
- ▶ Move the pin pulling cylinder in.

Result:

- The pin **22** is unpinned.

When the pin **22** is unpinned to the stop:

- ▶ Unhook the pin pulling cylinder on the screw **23** and remove from the retainer **24**.
- ▶ Unpin the second pin **22** with the pin pulling cylinder.



WARNING

Pins unpinned and unsecured!

If the pins **22** are not secured, then the pins **22** can loosen up by themselves during transport. Personnel can be severely injured or killed.

- ▶ Insert the pins **22** after removal.
- ▶ Secure the pin **22** with retaining pin **25**.

- ▶ Attach the first cross carrier **10** on the auxiliary crane, point **P13** and point **P14**, see illustration **1**.
- ▶ Lift the first cross carrier **10** and move it carefully out from the pin points.

When the first cross carrier is removed from the connector carriers:

- ▶ Remove the locking pin **26** and unpin the retaining pin **25** on the retainer **24**.
- ▶ Pin the pin **22** with the pin pulling cylinder on point **P5** and on point **P6**.
- ▶ Secure the pin **22**: Insert the retaining pin **25** on point **P9** and secure with locking pin **26**.

Result:

- The first cross carrier is removed.

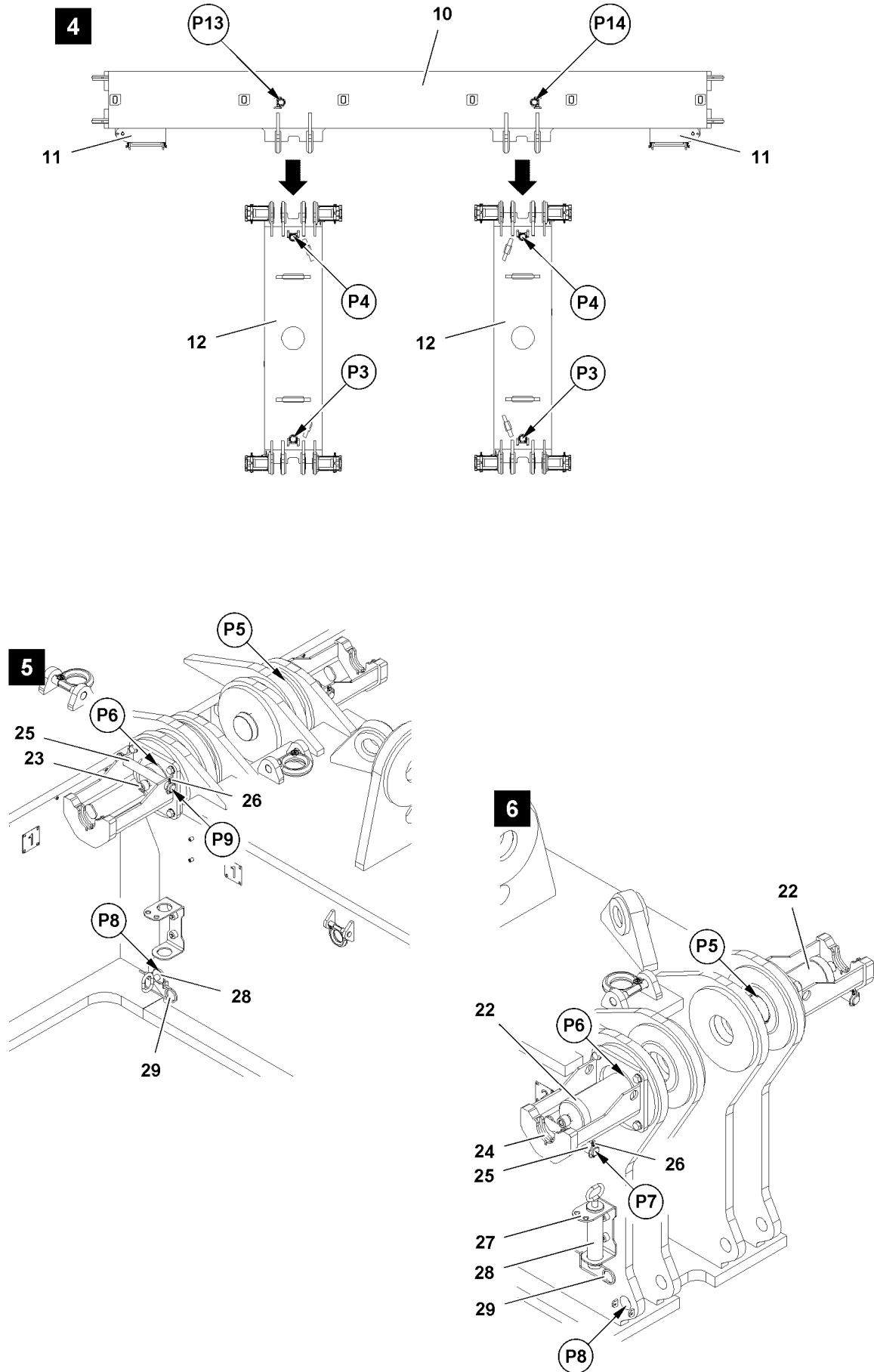

Fig.116384

LWE/LR 13000-001/19503-01-02/en

Unpinning the connector carrier on the cross carrier



WARNING

Danger of crushing!

When removing the connector carrier **12** from the cross carrier **10** there is an increased danger of accidents due to crushing.

Personnel can be severely injured or killed.

- ▶ It is prohibited for anyone to remain between the connector carriers **12** and the cross carrier **10**.
 - ▶ Observe the crane movements diligently.
 - ▶ It is prohibited to remain in the slewing range of the auxiliary crane.
 - ▶ Crane operator and guide must maintain visual contact.
-

Make sure that the following prerequisite is met:

- The first cross carrier has been removed.

You can freely select the sequence in which the connector carriers **12** are removed.



Note

- ▶ The connector carriers must be unpinned the same way on the cross carrier as described in section „Unpinning the first connector carrier on the cross carrier“.
 - ▶ The fastening points on the connector carriers **12** are on point **P3** and point **P4**.
-
- ▶ Unpin and remove the first cross carrier **10**.
 - ▶ Unpin and remove the second cross carrier **10**.
 - ▶ Make sure that pins **22** are inserted and secured after removal.
 - ▶ Make sure that pins **28** are inserted and secured in the retainer **27** after removal.

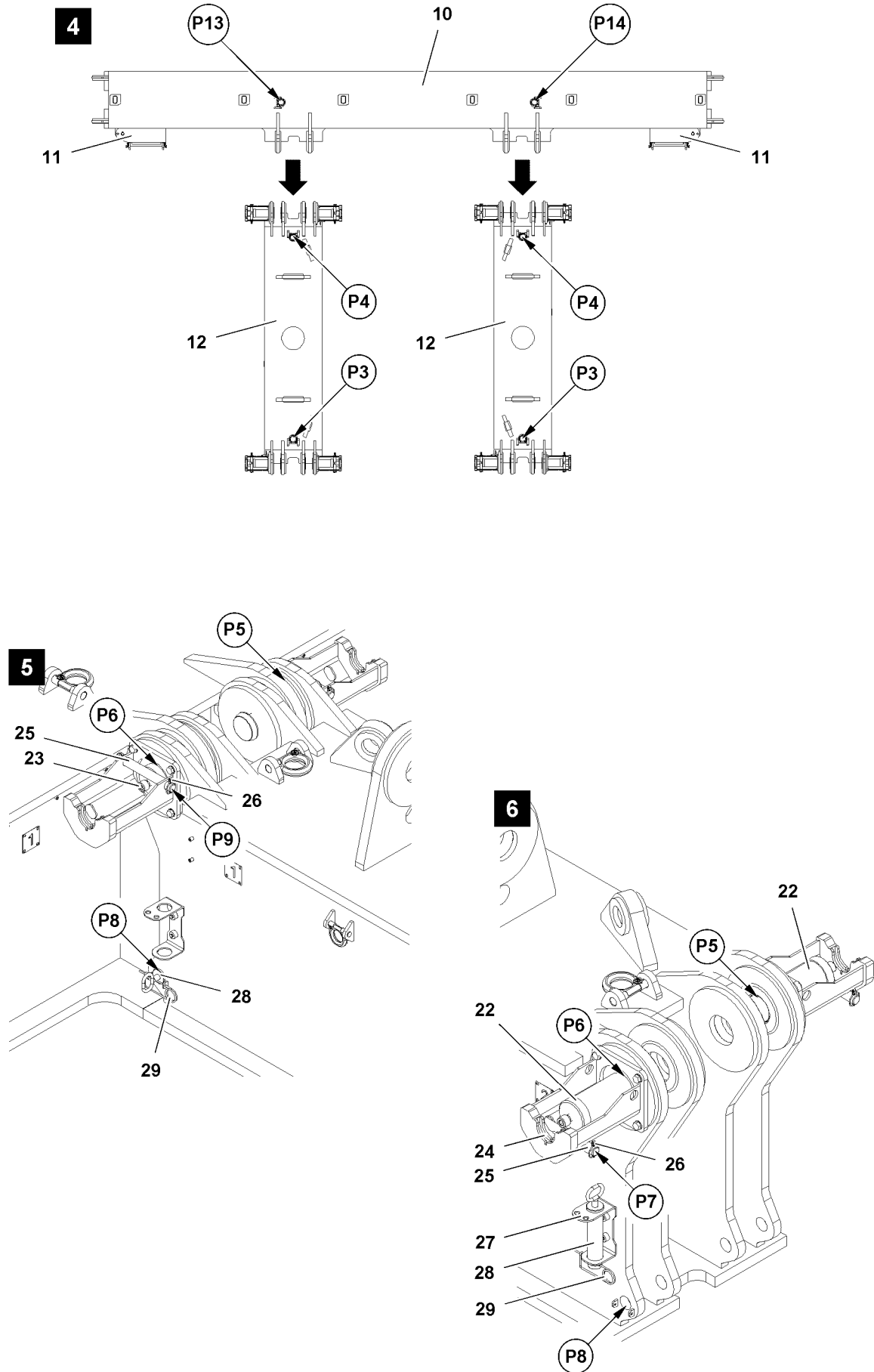

Fig.116384

LWE/LR 13000-001/19503-01-02/en

Removing the cross carrier

Make sure that the following prerequisites are met:

- The connector carriers **12** are removed.
- The switch units **11** are folded in and secured.



Note

▶ The fastening points on the cross carriers **10** are on point **P13** and point **P14**.

-
- ▶ Attach the cross carrier **10** on the auxiliary crane.
 - ▶ Remove the cross carrier **10**.

Result:

- The derrick ballast pallet is removed.

Empty page!

LWE/LR 13000-001/19503-01-02/en

5.39 LD/SLD/SD-boom combination

1	Component overview S-pivot section	3
2	Fastening points	5
3	Assembling the SD/SLD-boom	12
4	Assembling the SD/SLD-boom in „flying“ mode	61
5	Preassembling the SD/SLD-boom on the ground and installing it on the crane	67
6	Assembling the boom with the substructure	67
7	Assembling the roller sets on the boom head	71
8	Performing the function checks	71
9	Erecting the boom	75
10	Installing the central ballast	85
11	Installing the derrick ballast	85
12	Operating the crane	87
13	Disassembling the SD/SLD-boom	87

Fig.195219

LWE/LR 13000-001/19503-01-02/en

1 Component overview S-pivot section

Position	Component	Weight
1	S-pivot section	44.65 t
2	Relapse support	2.23 t
3	Rods WA-frame I	0.82 t
4	Railings	—
5	Bracket	—
	S-pivot section complete	47.70 t



Note

- For the remaining boom sections, such as S-intermediate sections, S-adapter, SL-reducer section and the S- or L-end section, see chapter 1.03.

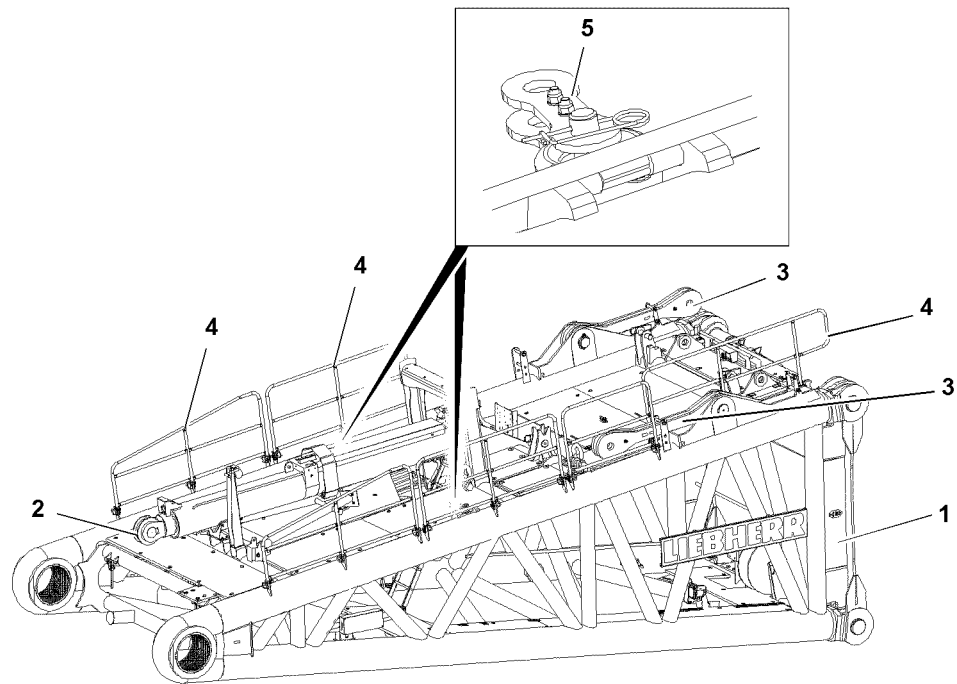

Fig.124435

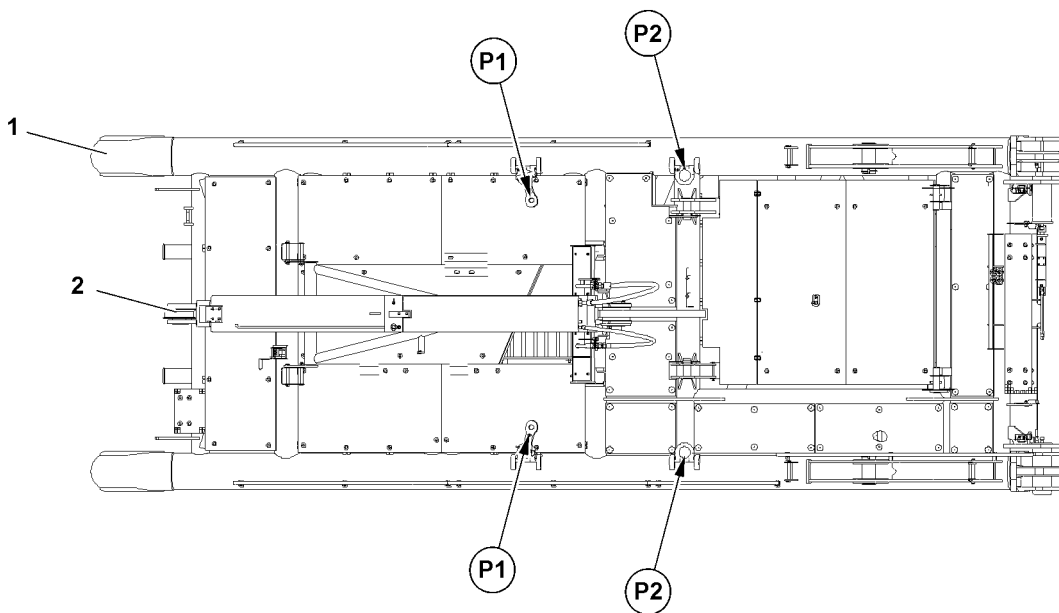
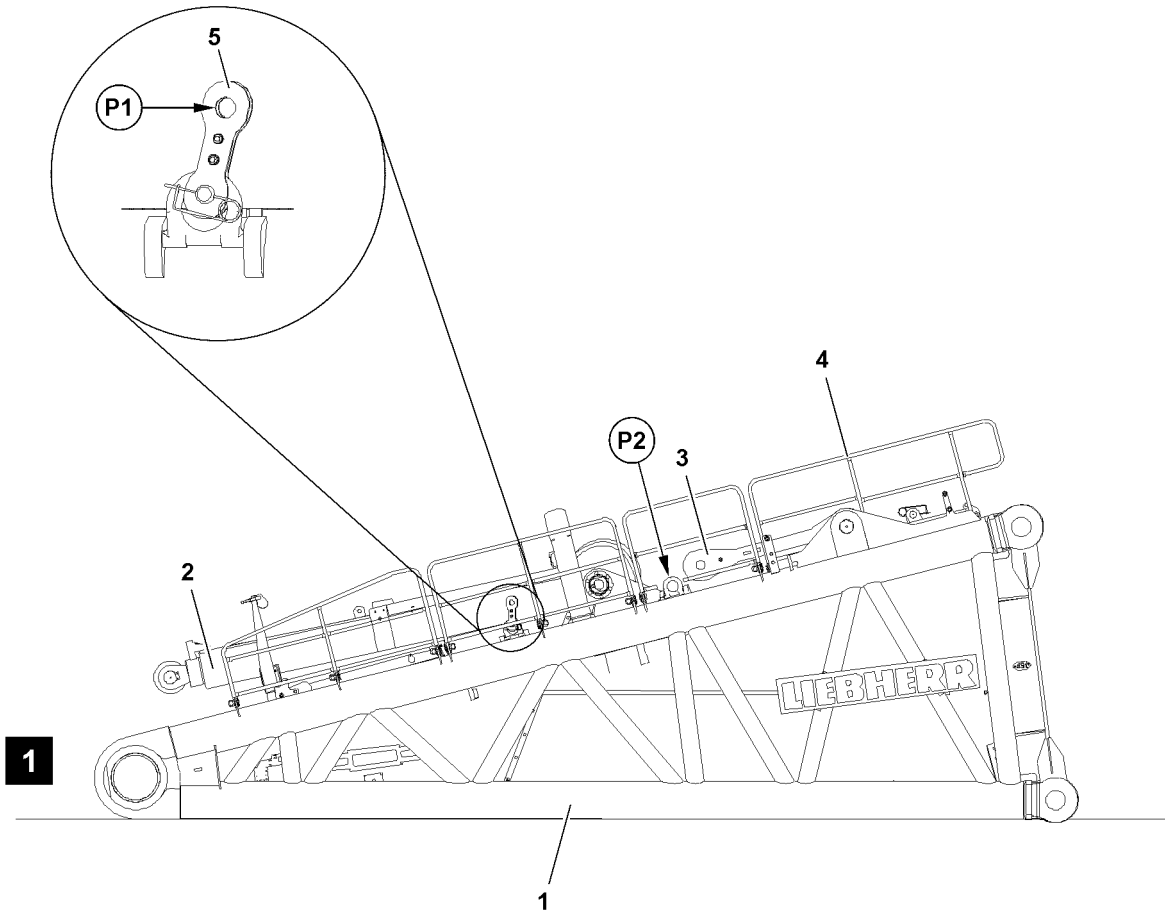

Fig.115220

LWE/LR 13000-001/19503-01-02/en

2 Fastening points

2.1 Fastening points - cross beam

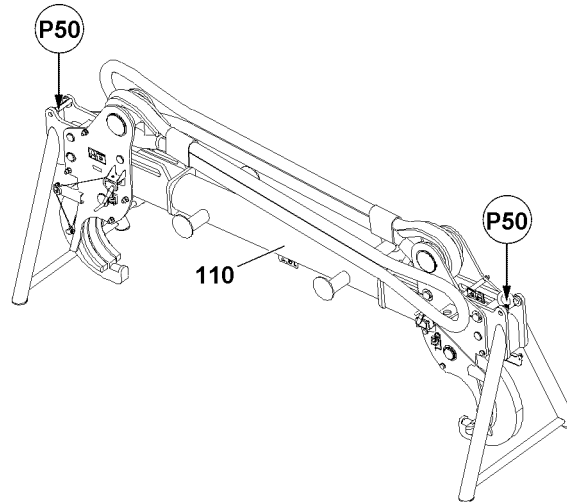

Fig.121996

Fastening points	
P50	For cross beam

2.2 Fastening points S-pivot section

Fastening points	
P1 ¹⁾ + P2	For S-pivot section without winch V

1) Only in connection with bracket 5



DANGER

Falling S-pivot section!

If the S-pivot section with installed winch 5 is lifted or transported on the fastening points (point **P1** and point **P2**) the fastening points (ring brackets) will rip off.

The S-pivot section falls down.

Personnel can be severely injured or killed.

This can result in increased property damage.

- ▶ On the fastening points (point **P1** and point **P2**) the S-pivot section may only be fastened **without** winch 5.
- ▶ Fastening and transporting the S-pivot section with installed winch 5 is **prohibited**.

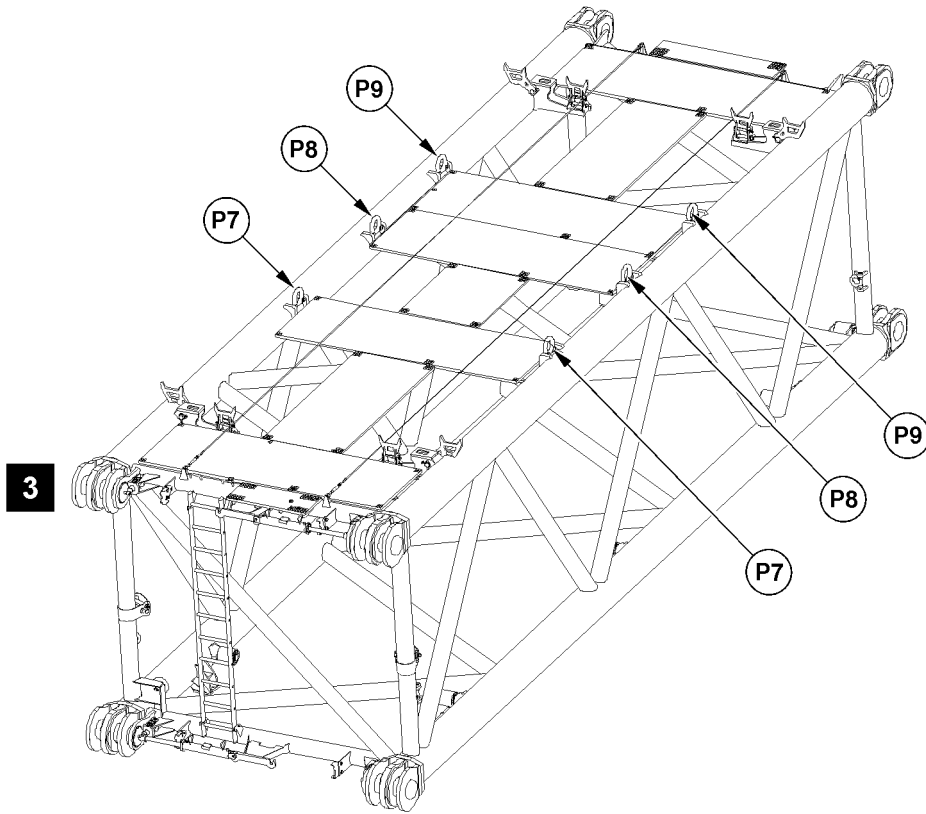
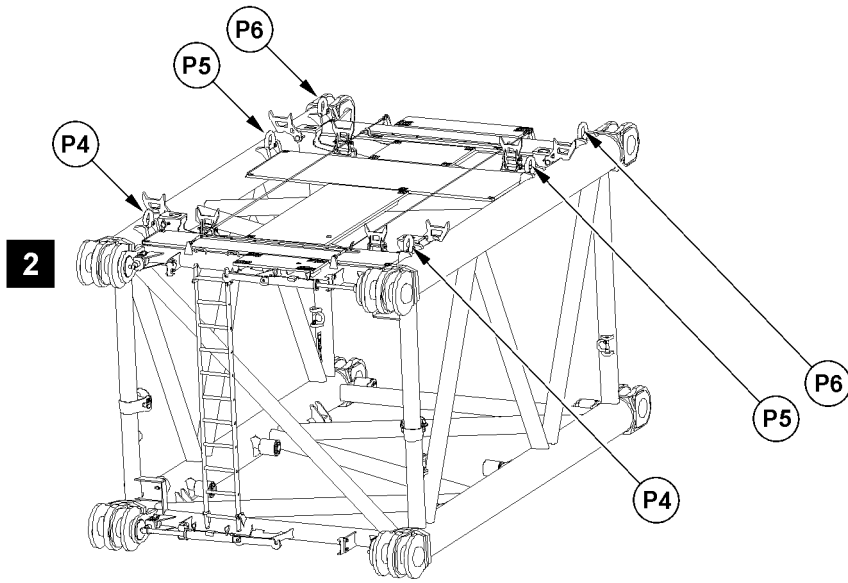

Fig.115225

LWE/LR 13000-001/19503-01-02/en

2.3 Fastening points S-intermediate section 6 m



Note

- ▶ For the combination of the various boom systems, refer to the Rod plan and chapter 5.03.

Fastening points	
P4 + P5	For assembly of the S-intermediate section 6 m
P4 + P6	For combined transport of S-intermediate section and LI-intermediate section



WARNING

Falling S-intermediate section!

If the S-intermediate section is not properly fastened on the ring brackets, then the S-intermediate section can fall down.

Personnel can be severely injured or killed.

This can result in increased property damage.

- ▶ On the ring brackets - points **P4** and points **P5** - the S-intermediate section may only be fastened in individual transport.

2.4 Fastening points S-intermediate sections 12 m



Note

- ▶ The S-intermediate sections are available in various system dimensions.
- ▶ For the combination of the various boom systems, refer to the Rod plan and chapter 5.03.

Fastening points	
P7 + P8	For assembly of the S-intermediate sections 12 m
P7 + P9	For combined transport of S-intermediate section and LI-intermediate section



WARNING

Falling S-intermediate section!

If the S-intermediate section is not properly fastened on the ring brackets, then the S-intermediate section can fall down.

Personnel can be severely injured or killed.

This can result in increased property damage.

- ▶ On the ring brackets - points **P7** and points **P8** - the S-intermediate section may only be fastened in individual transport.

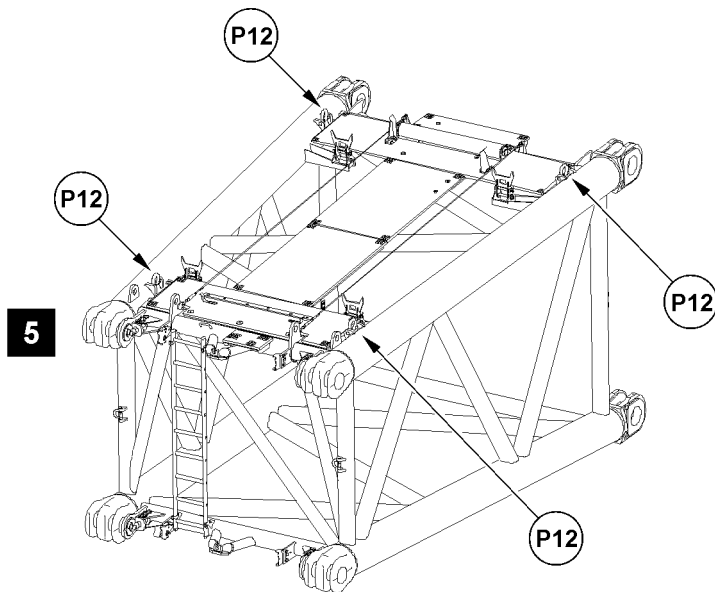
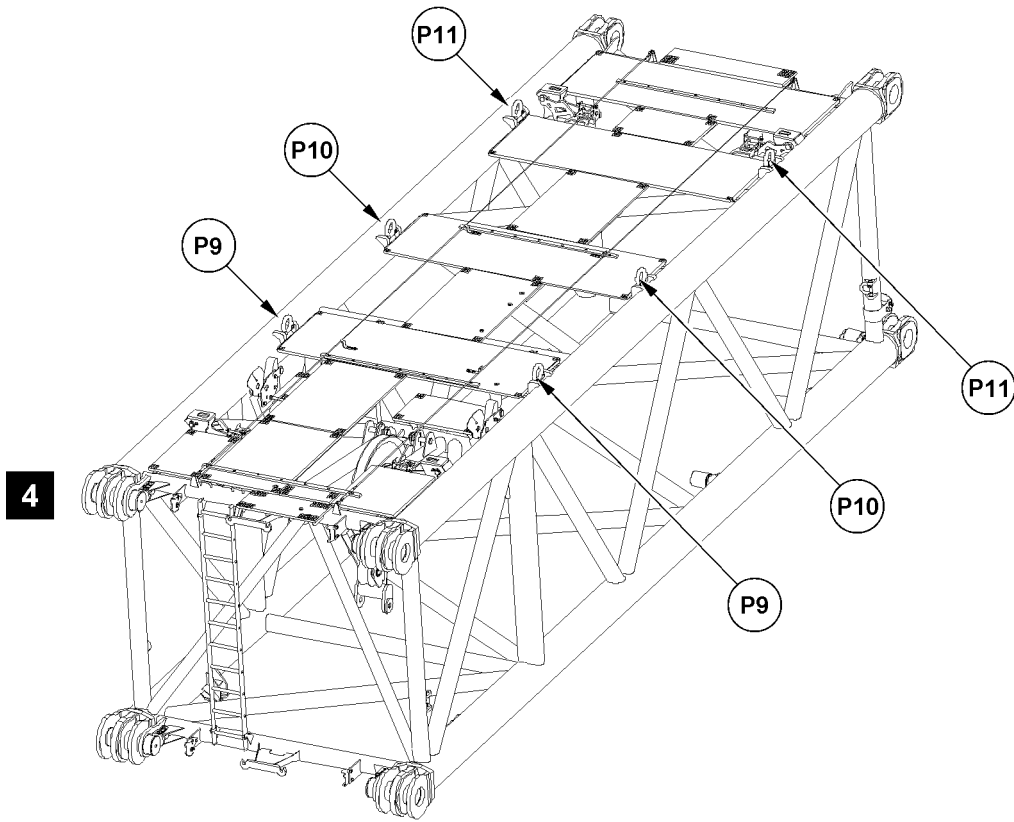

Fig.115226

LWE/LR 13000-001/19503-01-02/en

2.5 Fastening points S-adapter



Note

- For the combination of the various boom systems, refer to the Rod plan and chapter 5.03.

Fastening points	
P9 + P10	For assembly of the S-adapter
P9 + P11	For combined transport of the S-adapter and LI-intermediate section



WARNING

Falling S-adapter!

If the S-adapter is not properly fastened on the ring brackets, then the S-adapter can fall down. Personnel can be severely injured or killed.

This can result in increased property damage.

- On the ring brackets - points **P9** and points **P10** - the S-adapter may only be fastened in individual transport.

2.6 Fastening points SL-reducer section 6 m



Note

- For the combination of the various boom systems, refer to the Rod plan and chapter 5.03.

Fastening points	
P12	For the SL-reducer section 6 m



WARNING

Falling SL-reducer section!

If the SL-reducer section is not properly fastened on the ring brackets, then the SL-reducer section can fall down.

Personnel can be severely injured or killed.

This can result in increased property damage.

- Always fasten the SL-reducer section properly on the ring brackets - points **P12**.

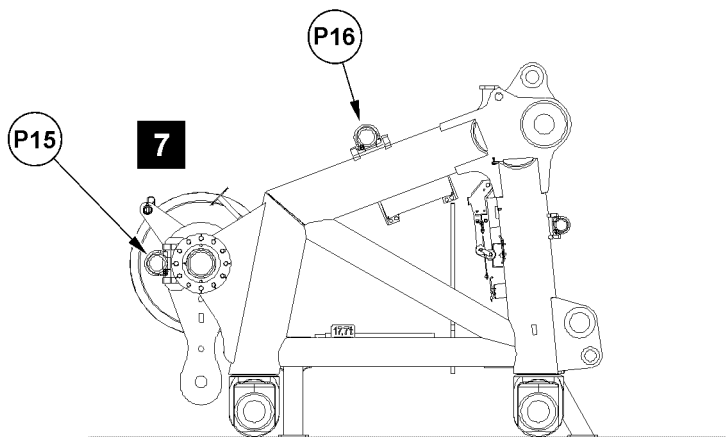
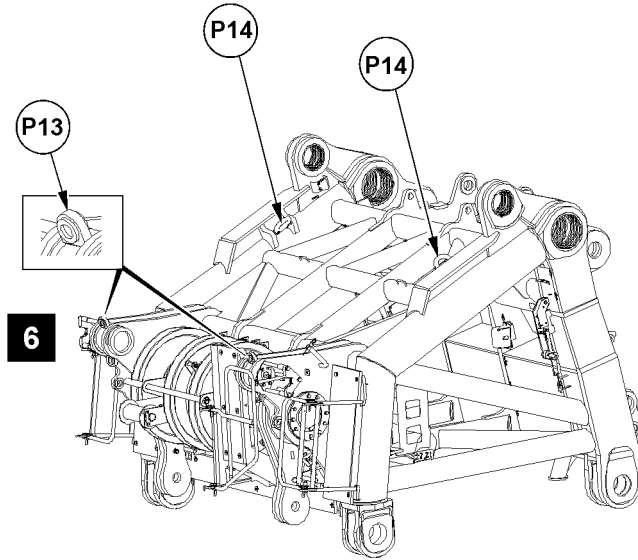

Fig.115227

LWE/LR 13000-001/19503-01-02/en

2.7 Fastening points S-end section



Note

► For the combination of the various boom systems, refer to the Rod plan and chapter 5.03.

Fastening points	
P13	For assembly of the S-end section
P13 + P14	For lifting and turning with two auxiliary cranes



WARNING

Falling S-end section!

If the S-end section is not properly fastened, the S-end section can fall down.

Personnel can be severely injured or killed.

This can result in increased property damage.

► Always fasten the S-end section properly.

2.8 Fastening points L-end section



Note

► For the combination of the various boom systems, refer to the Rod plan and chapter 5.03.

Fastening points	
P15	For assembly of the L-end section
P15 + P16	For lifting and turning with two auxiliary cranes



WARNING

Falling L-end section!

If the L-end section is not properly fastened, the L-end section can fall down.

Personnel can be severely injured or killed.

This can result in increased property damage.

► Always fasten the L-end section properly.

3 Assembling the SD/SLD-boom



WARNING

Danger of falling!

During assembly / disassembly, inspection and maintenance work, assembly personnel must be secured with appropriate aids to prevent them from falling. If this is not observed, assembly personnel could fall and suffer life-threatening or fatal injuries.

- ▶ All work aloft, where there is a danger of falling must be carried out with suitable aids.
- ▶ If aids are not available and work cannot be carried out from the ground, then the assembly personnel must secure themselves with the supplied fall arrest system to prevent falling, see chapter 2.04.
- ▶ If fall protection equipment is available, then it must be used, see chapter 2.06.
- ▶ When lifting, lowering, swinging crane parts in and out, no persons may remain in the danger zone.
- ▶ When closing or opening boom systems during boom assembly or disassembly, no persons may remain on the boom system or in the danger zone.
- ▶ If railings are present on the components, then they must be brought into the corresponding position and secured for assembly / disassembly work.
- ▶ Only step on the aids, ladders and catwalks with clean shoes.
- ▶ Keep aids, ladders and catwalks free of heavy dirt, snow and ice.
- ▶ During all assembly and disassembly work, maintenance work and inspections, travel or crane operation is prohibited.
- ▶ Remaining on a suspended load is prohibited.
- ▶ Stepping or walking on crane components and lattice sections, which have an incline of more than 20° is prohibited.
- ▶ For all assembly work, the crane driver of the main crane must be in voice contact with the crane driver / crane drivers of the auxiliary crane / auxiliary cranes.
- ▶ For assembly tasks, the crane driver may only initiate crane movements when the responsible guide has explicitly released the movement.



WARNING

The lattice sections can fall down!

If the lattice sections are not pinned and secured correctly, then they can fall down and fatally injure personnel.

- ▶ Pin or unpin both pins at the same horizontal level, i.e. **left and right**.
- ▶ Do not stand under the lattice sections or within the entire danger zone during the pinning and unpinning procedure of the boom.
- ▶ Safely secure the pins in the storage locations as well as in the receptacles.
- ▶ It is prohibited to lean the auxiliary ladder against the component being disassembled.



Note

- ▶ The assembly is described on the example of the S-boom.
- ▶ For the combination of the boom lattice sections, observe and adhere to the Rod plan and chapter 5.03.



WARNING

Danger of accident due to interrupted voice and / or visual contact!

If the voice and / or visual contact is interrupted, personnel can be severely injured or killed.

- ▶ Make sure that the crane driver is in constant voice (for example through radio connection) and visual contact with the operating and / or assembly personnel during crane or assembly operation.
- ▶ Make sure that the voice and visual contact is not interrupted.
- ▶ If the voice and / or visual contact is interrupted, carry out no crane movements or assembly tasks.
- ▶ Re-establish voice and / or visual contact immediately.

**WARNING**

Danger of impact / crushing!

When installing / removing crane components with the auxiliary crane, crane components can start to swing back and forth.

When lifting / lowering and positioning crane components, there is an increased danger of impacts / crushing.

Personnel can be caught and severely injured or killed.

- ▶ Make sure that personnel cannot be caught by components.
- ▶ Make sure that the crane is horizontally aligned.
- ▶ When working in danger zones: Use aids to protect limbs.
- ▶ Guide components with suitable aids to minimize oscillation.

**DANGER**

The components can fall down!

If the corresponding components are disengaged from the auxiliary crane before the corresponding component is pinned, the corresponding component can fall down and fatally injure personnel.

- ▶ Do not disengage the auxiliary crane until the corresponding component is pinned and secured.

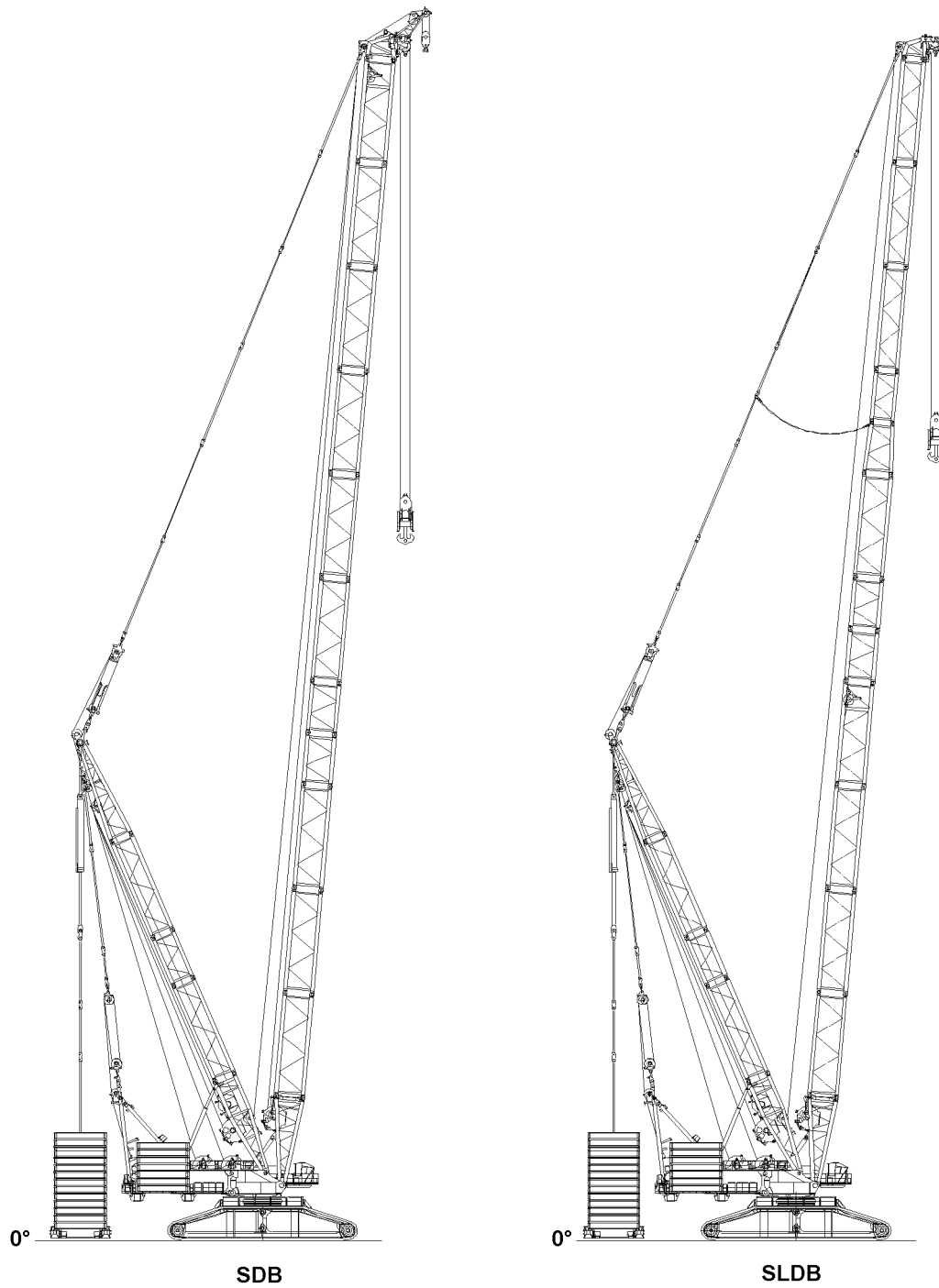

Fig.115221

LWE/LR 13000-001/19503-01-02/en

Make sure that the following prerequisites are met:

- The ground is able to safely take on the entire operating weight of the crane including the load to be lifted.
- The crane is horizontally aligned.
- Two auxiliary cranes with sufficient load capacity are available.
- A forklift or telescopic lift truck are available.
- An assembly scaffolding / work platform is available.
- Winch 1 and winch 2 are properly installed and secured on the turntable.
- The A-frame properly installed and secured on the turntable.
- The central ballast has been installed on the crawler travel gear according to the load chart or the erection and take-down charts.
- The counterweight has been installed on the turntable according to the load chart or the erection and take-down charts.
- The D-boom is completely assembled and erected on the turntable, see chapter 5.05.
- The LICCON overload protection has been set according to the data in the load chart.

3.1 Turning the turntable into assembly position



WARNING

The crane can topple over!

If the following conditions are not met before turning the turntable - **without** assembled S-boom, the crane can topple over.

Personnel can be severely injured or killed.

- ▶ Observe the data in the erection and take down charts.
 - ▶ Observe the data in the load charts.
-
- ▶ Turn the turntable in lengthwise direction of the crawler travel gear.

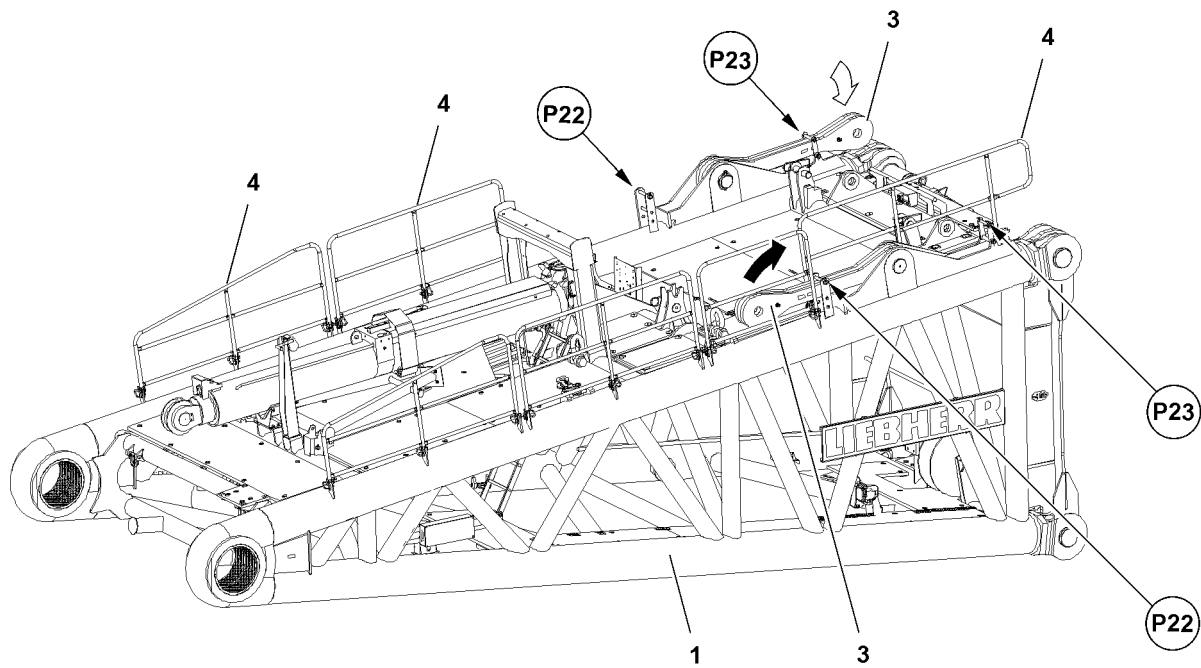

Fig.115236

3.2 Bringing the railing and rods into operating position

3.2.1 Swinging the railing on the S-pivot section into operating position



WARNING

Danger of falling!

At assembly and disassembly of the railings **4**, the assembly personnel can fall down and be severely injured or killed.

- ▶ The assembly personnel must secure themselves for assembly / disassembly of railings **4** and protective devices with an approved fall arrest system to prevent them from falling.
- ▶ For assembly and disassembly work, maintenance and inspection work on the S-pivot section, all railings and the protective devices must be assembled and secured.

Make sure that the following prerequisites are met:

- The ground is able to safely take on the weight of the S-pivot section.
- The S-pivot section is laying completely on the ground.
- ▶ For the assembly / disassembly of railings and protective devices, see chapter 2.06.

3.2.2 Bringing the rods for WA-frame 2 guying into the operating position

Make sure that the following prerequisites are met:

- The retaining elements of the rod **3** have been removed at point **P22** (transport receptacle) and point **23** (operating position).



WARNING

Danger due to guy rod!

During the assembly procedure of the rod **3**, it can swing down by itself due to incorrect fastening of the fastening equipment.

Personnel can be severely injured or killed.

- ▶ Attach the fastening equipment properly on the rod **3**.
- ▶ Lift the rod with the auxiliary crane from the transport receptacle and lower it around the pivot point into operating position.

When the rod is in operating position:

- ▶ Remove the auxiliary crane.

Secure the rod **23** in operating position:

- ▶ Insert and secure the pin at point **P23**.
- ▶ Reinsert and secure the pin in the transport receptacle at point **P22**.
- ▶ Bringing the second rod into operating position.

3.3 Exceeding the shut off limits of the LICCON overload protection for assembly operation



WARNING

Danger of accident due to function „Exceedance of shut off limits of the LICCON overload protection“! If the shut off limits of the LICCON overload protection are exceeded, there is no additional protection against crane overload.

Due to erroneous operation or deliberate misuse, the crane could collapse, the boom can break off or the crane can topple over.

Personnel can be severely injured or killed.

- ▶ The function „Exceedance of shut off limits of the LICCON overload protection“ is only permissible in emergencies and for assembly purposes.
- ▶ The function „Exceeding the shut off limits of the LICCON overload protection“ may only be actuated by persons who know the effects of their actions regarding the function „Exceeding the shut off limits of the LICCON overload protection“.
- ▶ The function „Exceedance of shut off limits of the LICCON overload protection“ requires the presence of an authorized person and must be performed with utmost caution.
- ▶ Crane operation with activated function „Exceedance of shut off limits of the LICCON overload protection“ is prohibited.

- ▶ Exceeding the shut off limits of the LICCON overload protection: Engage assembly operation

Result:

- The shut off limits of the LICCON overload protection are exceeded.
- The assembly icon appears on the LICCON monitor.



Note

- ▶ See chapter 4.02 and chapter 4.20.

3.4 Cross beam

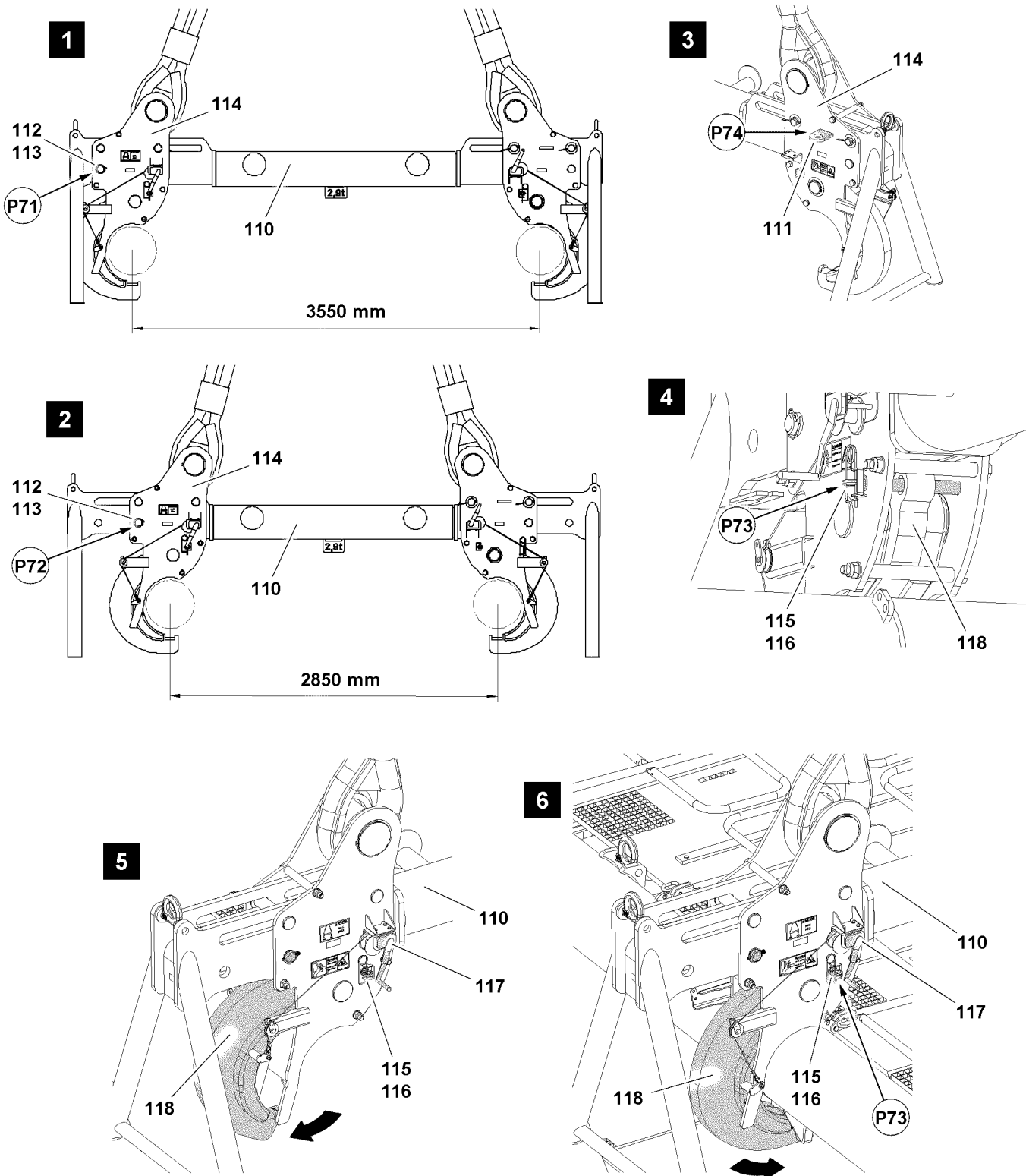

Fig.124436: Assembly condition of cross beam

The cross beam is designed for the assembly of the boom system. During the assembly, the cross beam is used to lift the boom section after every successful assembly of the intermediate section and to move the assembly shoes forward by one „lattice length“ until the boom section has the required length.

Make sure that the following prerequisites are met:

- An auxiliary crane with sufficient load carrying capacity is available.
- The cross beam is placed safely on the ground.
- The loops on the cross beam are in transport position.

3.4.1 Preparing the cross beam

The cross beam **110** must be adjusted before assembly depending on the width of the intermediate section, see illustration **1** and illustration **2**.

- ▶ Remove the safety locking pin **112** at point **P71** and unpin the pin **113**, see illustration **1**.
- ▶ Fasten an auxiliary unit with sling on eyehook **111** at point **P74** of the counter section **114**, see illustration **3**.
- ▶ Slide the counter section **114** with the auxiliary unit until it can be pinned on point **P72**, see illustration **2**.

When the bores align at point **P72**:

- ▶ Insert the pin **113** on point and secure with the safety locking pin **112**, see illustration **2**.

Result:

- The counter section **114** is secured.
- ▶ Slide the second counter section **114**.

3.4.2 Fastening the cross beam on the intermediate section

- ▶ Release the cross beam hook **118**: Remove the spring retainer **116** at point **P73** and unpin the pin **115**, see illustration **4** and illustration **5**.
- ▶ Pull both cross beam hooks **118** up with the manual winch **117**, see illustration **5**.
- ▶ Fasten the cross beam **110** on the auxiliary crane.

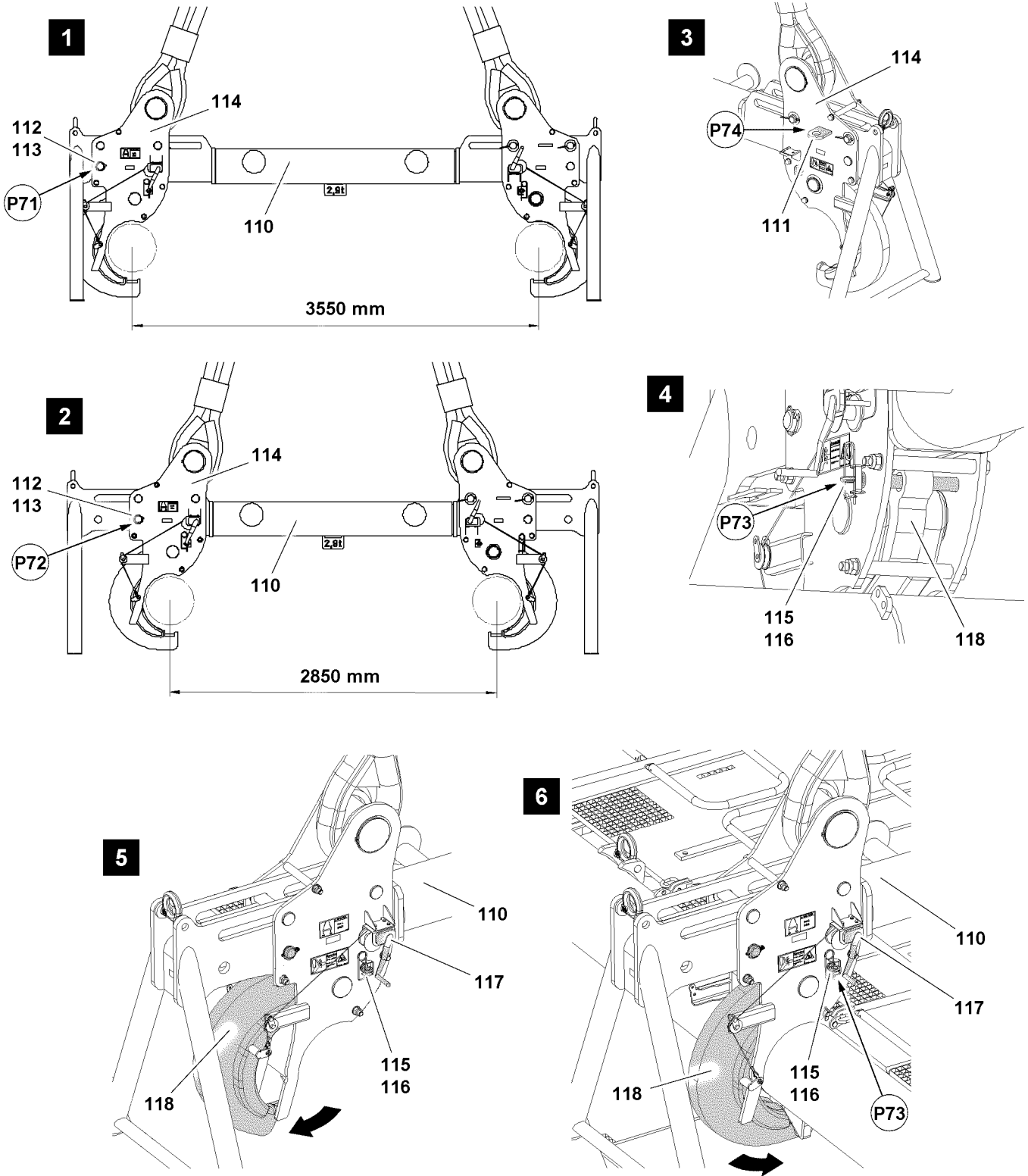

Fig.124436: Assembly condition of cross beam

LWE/LR 13000-001/19503-01-02/en

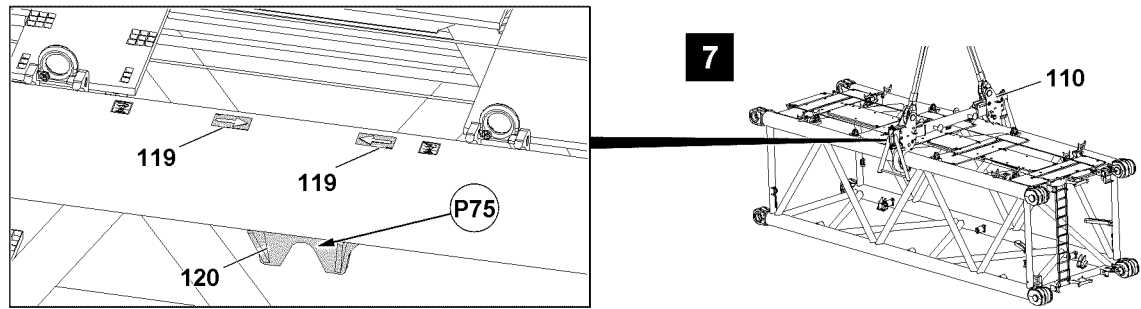

Fig.124437: Position of catches



Note

- ▶ The assembly of the intermediate sections is described on the example of one intermediate section.



Note

- ▶ The position of the catches **120** on the intermediate section is marked by two arrows **119**, see illustration 7.
- ▶ Swing the cross beam **110** with the auxiliary crane to the marked positions on the intermediate section.
- ▶ Set the cross beam **110** with the auxiliary crane on the intermediate section, see illustration 6.
- ▶ Lower the cross beam hook **118** with the manual winch **117** until it can be pinned on point **P73**, see illustration 6.



WARNING

Incorrect fastening!

If the following instructions are not observed, dangerous situations can arise.
Death, severe injuries, property damage.

- ▶ Make sure that the cross beam hooks **118** enter in the catches **120**. Visual check!
- ▶ Make sure that the cross beam hooks **118** are secured.
- ▶ Secure the cross beam hooks **118**: Insert the pin **115** at point **P73** and secure with spring retainer **116**, see illustration 4 and illustration 6.

When the cross beam hooks **118** are entered and secured on the catches **120**:

- ▶ Lift the intermediate section with the cross beam.

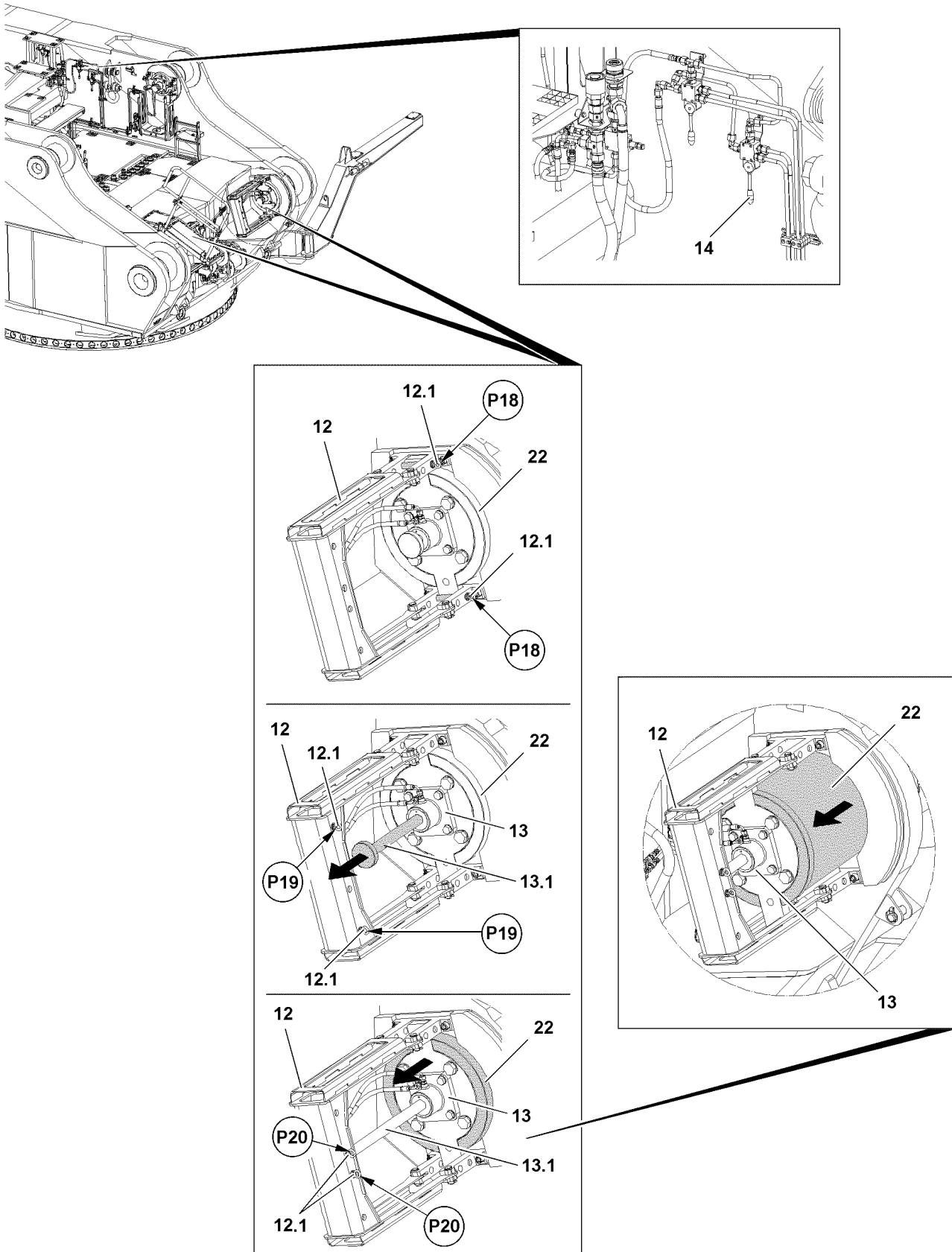

Fig.115224

LWE/LR 13000-001/19503-01-02/en

3.5 Unpinning the S-connector pins on the turntable



Note

- ▶ The pin pulling cylinders **13** are integrated on this crane into the S-connector pins **22**.
- ▶ Unpinning and pinning of the S-connector pins **22** can be done only in connection with the pin pulling device installed on the crane.

Make sure that the following prerequisites are met:

- The derrick boom is properly pinned and secured to the turntable.
- The derrick boom is erected to 88°.
- The pin pulling devices **12** are installed on the pin points.
- At least one crane engine is running.

3.5.1 Unpinning the S-connector pins

In transport condition, the S-connector pins **22** are pinned on the turntable and secured with the retaining pins **12.1**.



WARNING

Danger of crushing!

When unpinning or pinning the S-connector pins **22**, there is a danger of crushing. Limbs can be crushed or severed.

- ▶ During the unpinning or pinning procedure, make sure that no persons are within the danger zone.
- ▶ Do not reach into the danger zone of the pin pulling device and the connector pins.

- ▶ Release and unpin the retaining pins **12.1** on the points **P18** of the pin pulling device.
- ▶ Insert and secure the retaining pins **12.1** on points **P19** of the pin pulling device **12** (parking position).
- ▶ Extend the piston rod **13.1** of the pin pulling cylinder: Actuate the hand lever **14** until the piston rods **13.1** on both pin pulling cylinders **13** are completely extended.

When the piston rods **13.1** for the pin pulling cylinders are completely extended on both sides:

- ▶ Unpin the retaining pin **12.1** from the parking position at point **P19** and insert and secure in locking position, points **P20** on both sides.

Result:

- The piston rods **13.1** of the pin pulling cylinders **13** are locked with the pressure / pull plate in the pin pulling device.
- ▶ Actuate the hand lever **14**.

Result:

- The S-connector pins **22** are unpinned on both sides by the pin pulling cylinder **13**.

NOTICE

Danger of property damage!

When swinging the S-pivot section in to the pin points on the turntable, the S-connector pins **22** or the S-pivot section can be damaged.

- ▶ Make sure that the S-connector pins are completely unpinned before assembly of the S-pivot section.

When the connector pins are completely unpinned:

- ▶ Assemble the S-pivot section on the turntable.

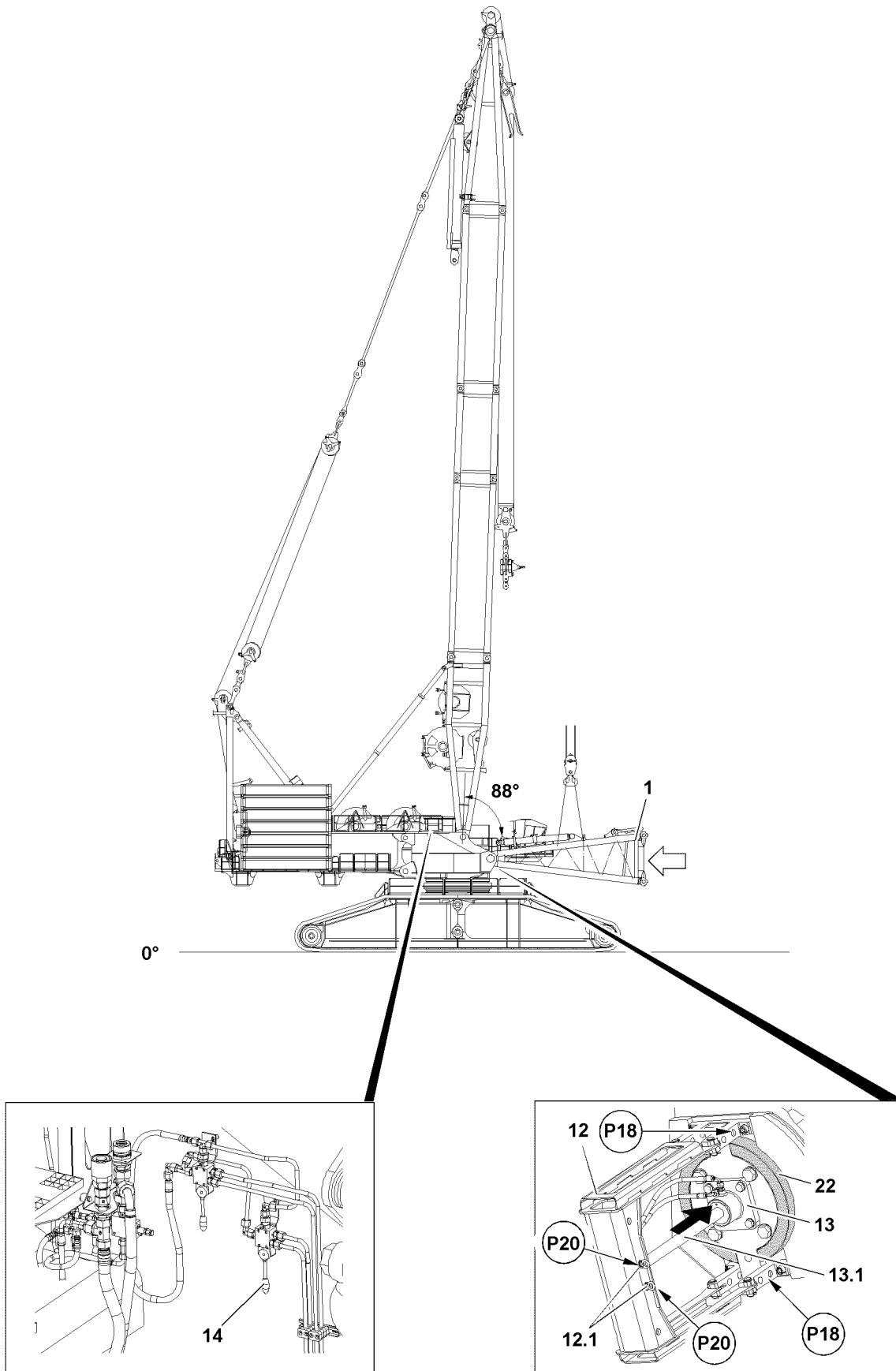

Fig.124438

LWE/LR 13000-001/19503-01-02/en

3.6 Assembling the S-pivot section on the turntable



Note

- ▶ Assemble the boom combinations according to the supplied Rod plans.
- ▶ For the combination of the boom systems, observe chapter 5.03.

NOTICE

Danger of property damage!

When placing the assembled S-pivot section down, the S-pivot section or the turntable can be damaged.

- ▶ Lower the S-pivot section **1** after assembly on the turntable on the supplied assembly shoes **15** and pin it with them.

For operating mode with central ballast:

- ▶ Preassemble the boom system completely on the ground.
- ▶ Lift the boom system with the derrick and move with the crane, see section „Installing the preassembled boom on the turntable“.



WARNING

The crane can topple over!

If the specifications listed below are not observed, the crane can collapse, the boom can break off or the crane can topple over.

Personnel can be severely injured or killed.

- ▶ The instructions in chapter 5.03 must be observed and adhered to.
- ▶ All pins are to be secured after assembly with the intended retaining elements.
- ▶ The guy rods must be inspected regularly, see chapter 8.15.

Make sure that the following prerequisites are met:

- The S-connector pins **22** are completely unpinned.
- Winch **5 WV** is **not** installed on the S-pivot section.



Note

- ▶ Select the fastening points on the S-pivot section **1** in such a way that the S-pivot section **1** hangs horizontally on the auxiliary crane at assembly. See section „Fastening points“.

- ▶ Attach the S-pivot section **1** on the auxiliary crane.
- ▶ Swing the S-pivot section **1** in with the auxiliary crane to the pin points on the turntable.



DANGER

Falling S-pivot section!

Due to non-secured or insufficiently secured S-connector pins **22**, the S-pivot section **1** can fall down. Personnel can be severely injured or killed.

- ▶ Secure the S-connector pins **22** between the S-pivot section **1** and the turntable after the pinning procedure immediately with the retaining pins **12.1**.

- ▶ Insert the S-connector pins **22** on both sides with the pin pulling cylinder **13**: Actuate the hand lever **14** until the S-connector pins **22** are completely pinned on both sides.

When the S-connector pins **22** are completely pinned on both sides:

- ▶ Secure the S-connector pins **22**: Unpin the retaining pins **12.1** on the pin pulling device **12** on points **P20** and insert on points **P18** and secure.

Result:

- The S-pivot section **1** is pinned and secured on the turntable.

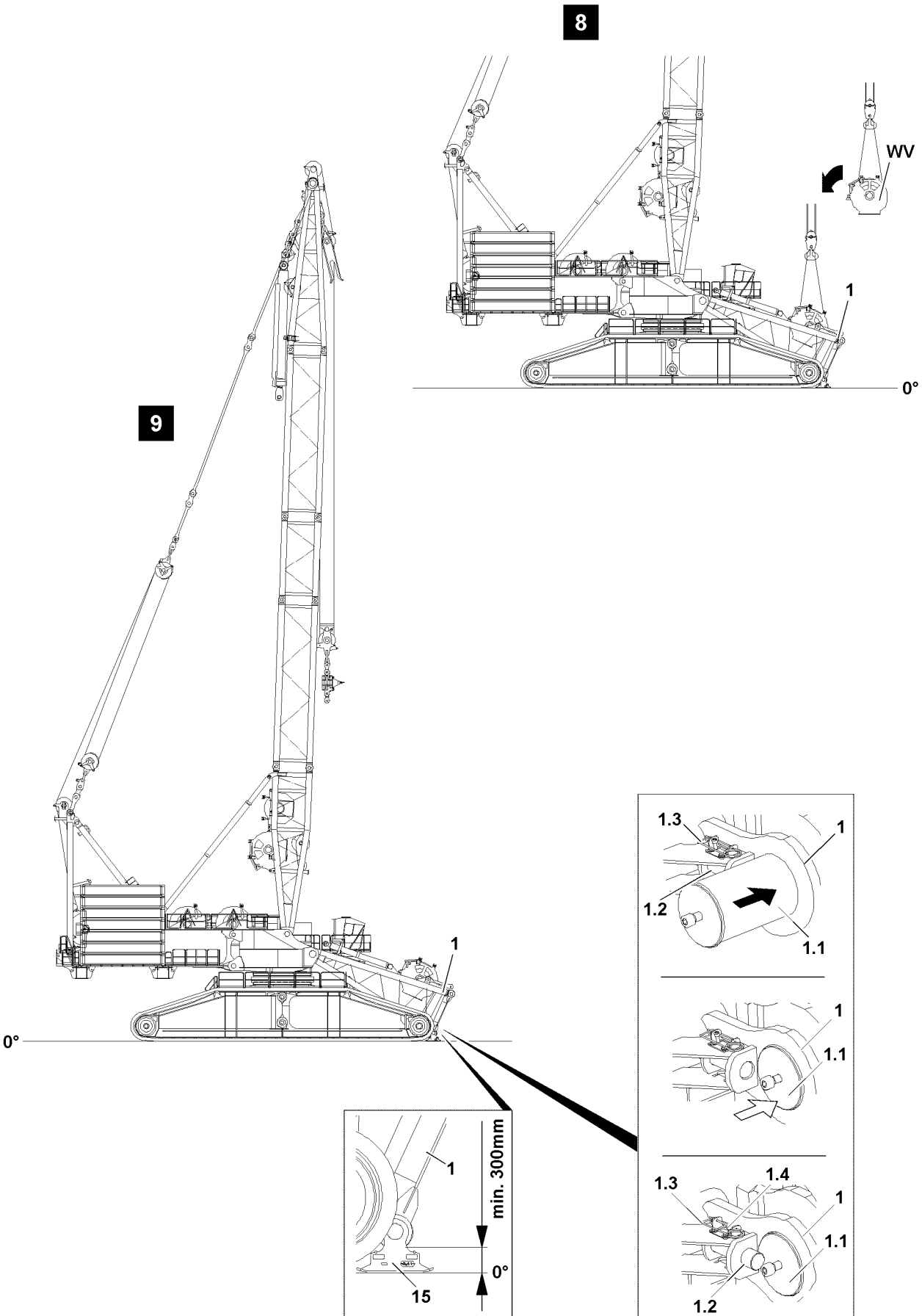

Fig.124439

LWE/LR 13000-001/19503-01-02/en

NOTICE

Danger of property damage!

When placing the assembled S-pivot section down, the S-pivot section or the turntable can be damaged.

- ▶ Lower the S-pivot section **1** after assembly on the turntable on the supplied assembly shoes **15** and pin it with them.

For operating mode with central ballast:

- ▶ Preassemble the boom system completely on the ground.
- ▶ Lift the boom system with the derrick and move with the crane, see section „Installing the preassembled boom on the turntable“.

The assembly shoes **15** have each two receptacles on the side, which are used for the transport of the assembly shoes with a standard fork of a forklift or telescopic lift truck.

- ▶ Move the fork into the receptacles on the assembly shoes **15**.
- ▶ Take the assembly shoes up with the forklift and position on the pin points on the S-pivot section **1** „on the bottom“.

When the assembly shoes **15** are positioned on the S-pivot section on both sides:

- ▶ Lower the S-pivot section **1** carefully and at slow speed.

**Note**

- ▶ After assembly the S-pivot section **1** must be at least 300 mm above the alignment level (0°), see illustration **9**.

- ▶ Lower the S-pivot section **1** to the assembly shoes **15**, see illustration **9**.
- ▶ Pin the assembly shoes **15** with the lower connector pins **1.1** of the S-pivot section **1** on the S-pivot section: Insert the connector pin **1.1** and secure with retaining pin **1.2**, see illustration **9**.
- ▶ Lower the S-pivot section **1** completely on the assembly shoes **15**.

When the S-pivot section **1** is placed on the assembly shoes **15**:

- ▶ Remove the auxiliary crane.

3.7 Assembly of winch 5 (WV) on the S-pivot section

**Note**

- ▶ The assembly of winch 5 is described in detail in chapter 3.07.50. see illustration **8**.

3.8 Establishing the electric and hydraulic connections on the S-pivot section

3.8.1 Establishing the electrical connections

NOTICE

Danger of damage of electrical connections!

If the electrical connection between the terminal box and the S-pivot section and the cable drum in the S-pivot section is established before the boom end section is installed and electrically connected, then the electric connection can be damaged.

- ▶ Make sure that the electric connection between the terminal box in the S-pivot section and the cable drum in the S-pivot section is only established **after** assembly and the connection of the electric wiring for the boom end section.

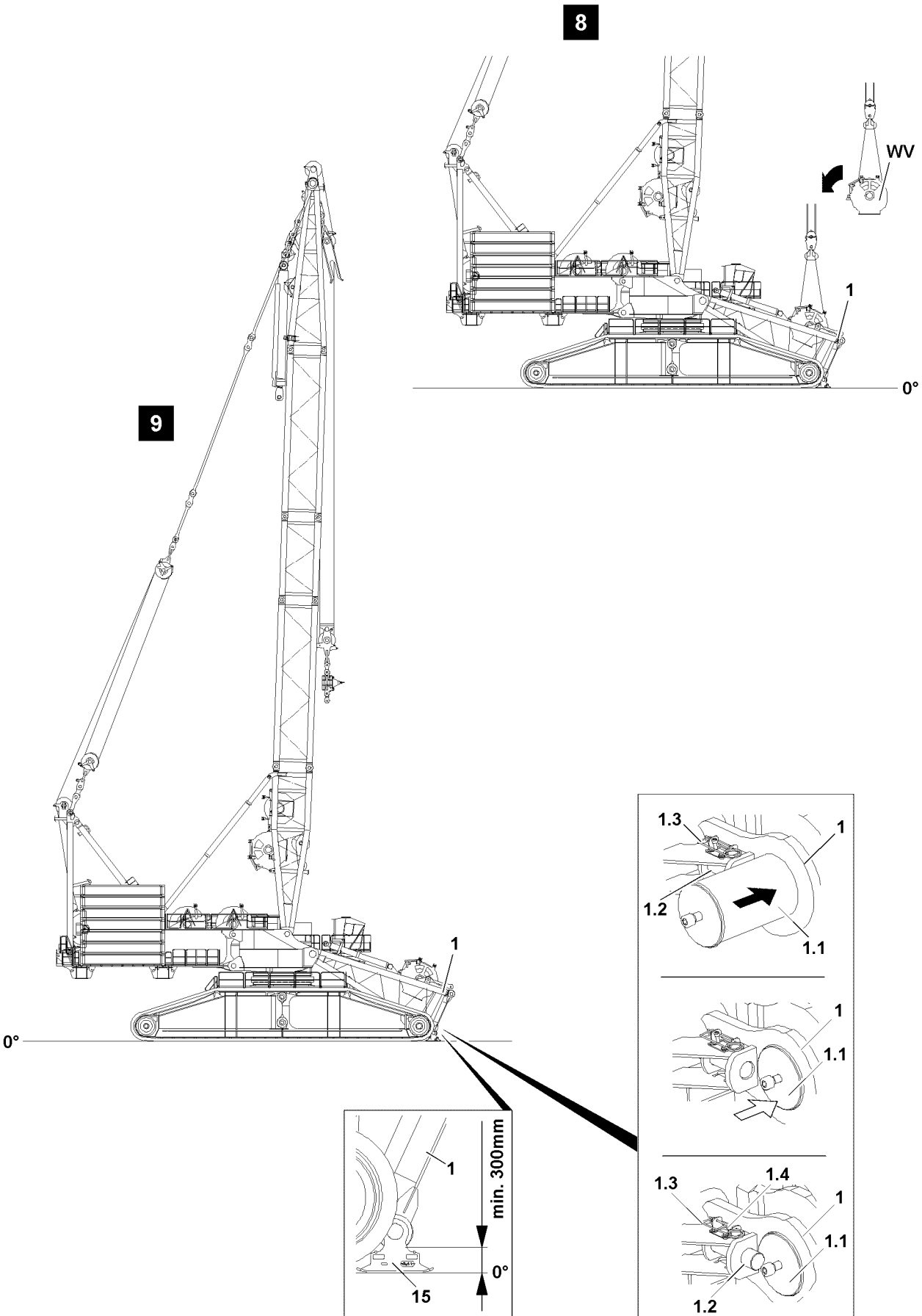

Fig.124439

LWE/LR 13000-001/19503-01-02/en

**Note**

- ▶ To establish the electrical connections on the S-pivot section: Use the Electrical wiring diagram.

Make sure that the following prerequisites are met:

- The S-pivot section is completely assembled and placed on the substructure.
- ▶ Establish the electrical connections.
- ▶ Make sure that all electrical connections to the S-pivot section have been established.

**WARNING**

Malfunction if dummy plugs are not installed!

If the dummy plugs on the non-required electrical connections are not installed, then malfunctions or functional limitations can occur on the crane.

- ▶ Make sure that all non-required electrical connections, which have a dummy plug are closed off with dummy plugs.
- ▶ Pay attention to the Electrical wiring diagram.
- ▶ As a rule, close off on-required electrical connections (for example for accessories which cannot be installed) with the respective dummy plugs.

NOTICE

Property damage due to dirt and / or corrosion!

If non-required electrical connections are not closed off with the respective protective caps, then dirt and / or corrosion can damage the electrical connections.

This could result in malfunctions.

- ▶ Make sure that all non-required electrical connections are always closed off properly.
- ▶ Pay attention to the Electrical wiring diagram.
- ▶ Close electrical connections, which have no dummy plugs, properly off with the corresponding protective caps.

3.8.2 Establishing the hydraulic connections

When connecting and releasing hydraulic lines with quick couplings, make sure that the coupling procedure is carried out correctly.

**DANGER**

Danger of accident due to loss of pressure or leakage!

Incorrectly coupled or self-loosening quick couplings (particularly return lines) can result in serious accidents due to component failure.

- ▶ Check that the quick couplings have been properly connected before using the crane.

**Note**

- ▶ To connect or release the hydraulic lines with quick couplings, see chapter 5.01.
- ▶ Release the pressure in the hydraulic system before connecting or disconnecting. Turn the engine off and wait for short time.
- ▶ Assembling coupling components (sleeve and connector) by using knurled nut.
- ▶ Connect coupling components.

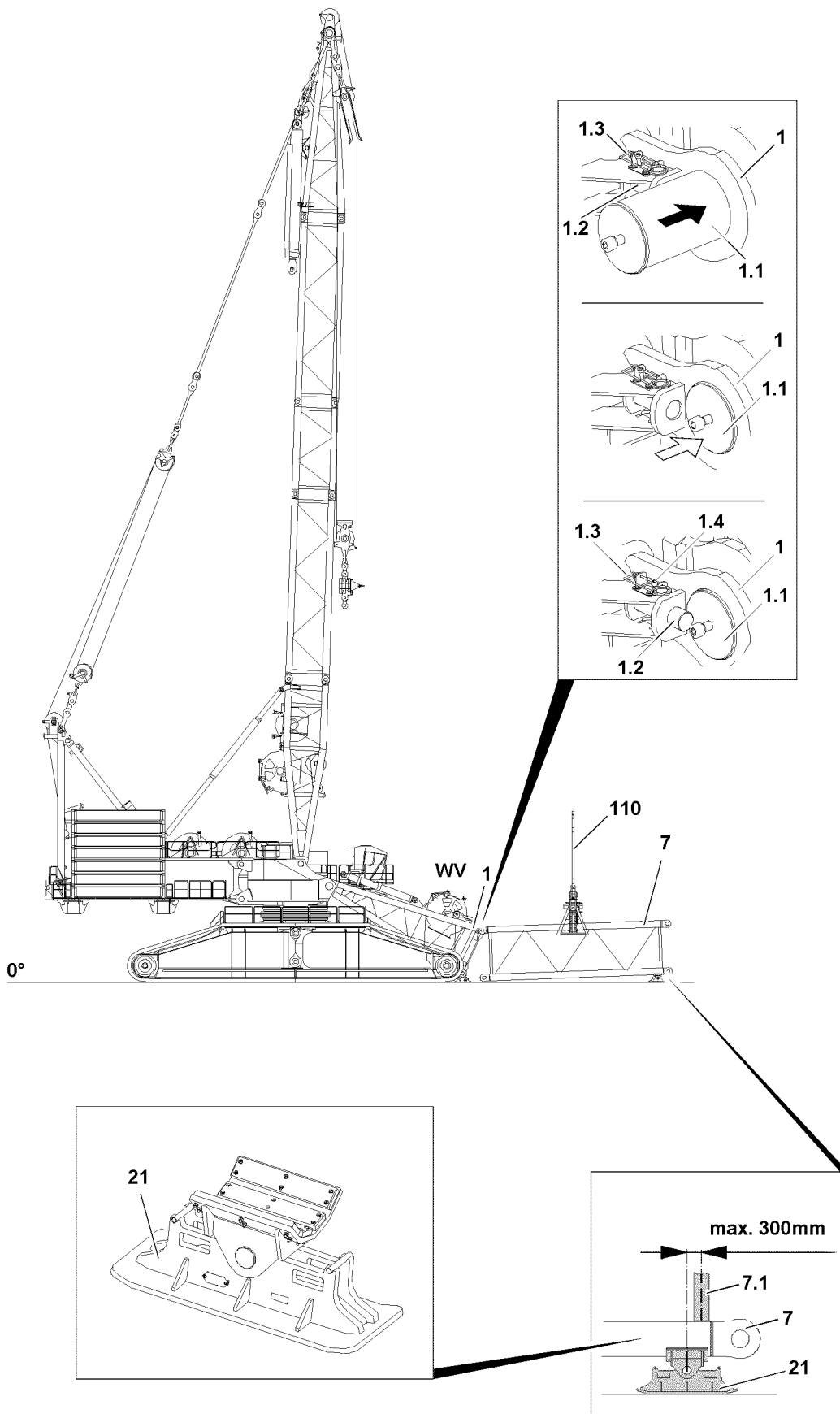

Fig.124440

LWE/LR 13000-001/19503-01-02/en

3.9 Assembling the S-intermediate section on the S-pivot section

Make sure that the following prerequisites are met:

- The S-pivot section **1** is properly pinned and secured on the turntable.
- The S-pivot section **1** is properly placed on the assembly shoes.
- Winch **5 WV** is properly installed on the S-pivot section **1** (if only winch **5 WV** is required for the upcoming crane operation).
- The connector pins **1.1** on the S-pivot section **1** are fully unpinned.
- The auxiliary crane is removed.



Note

- ▶ The S-intermediate section **7** is pinned with the pin pulling cylinders on the S-pivot section **1**, see chapter 5.30.
- ▶ The S-intermediate sections **7** are pinned with the pin pulling cylinders, see chapter 5.30.
- ▶ For easier assembly / disassembly of the S-intermediate sections, the last installed intermediate section must always be supported with the supplied assembly shoes **15**.



WARNING

General danger notes!

- ▶ All connector pins **1.1** are to be secured after assembly with the intended retaining pins **1.2**.



Note

- ▶ For fastening of boom sections, observe and adhere to section „Fastening points“.

- ▶ Fasten the first S-intermediate section **7** via the cross beam **110** on the auxiliary crane and align on the S-pivot section **1**.

When the pin bores on the S-pivot section **1** and on the S-intermediate section **7** align on „on top“.

- ▶ Insert the connector pins **1.1** with the pin pulling cylinders on both sides to the stop.
- ▶ Secure the connector pin **1.1**: Remove the spring retainer **1.3** on the bracket.
- ▶ Unpin the retaining pin **1.2**: Guide the cylinder screw **1.4** in the bracket to the end stop and lock on the side.

Result:

- The connector pin **1.1** is secured by the retaining pin **1.2**.
- ▶ Secure the cylinder screw **1.4** in this „position“ with spring retainer **1.3**.

Result:

- The retaining pin **1.2** is secured by the spring retainer **1.3**.
- The connector pin **1.1** is secured in „pinned“ position by the retaining pin **1.2**.

NOTICE

Danger of property damage on the intermediate sections!

If the assembly shoes **21** are not placed underneath in the permitted area of the intermediate sections, then the intermediate sections can be overloaded and damaged.

- ▶ Make sure that the assembly shoes **21** are only placed underneath in the permitted area of maximum 300 mm on the corner bar **7.1**.
- ▶ The crane operator is responsible for the proper substructure of the intermediate sections with the assembly shoes **21**.

After the first S-intermediate section **7** is pinned and secured on the S-pivot section **1**.

Place the assembly shoes **21** in the area of the corner bar **7.1** on the S-intermediate section **7**.

- ▶ Place the S-intermediate section **7** on the assembly shoes **21**.
- ▶ Remove the auxiliary crane with the cross beam **110**.

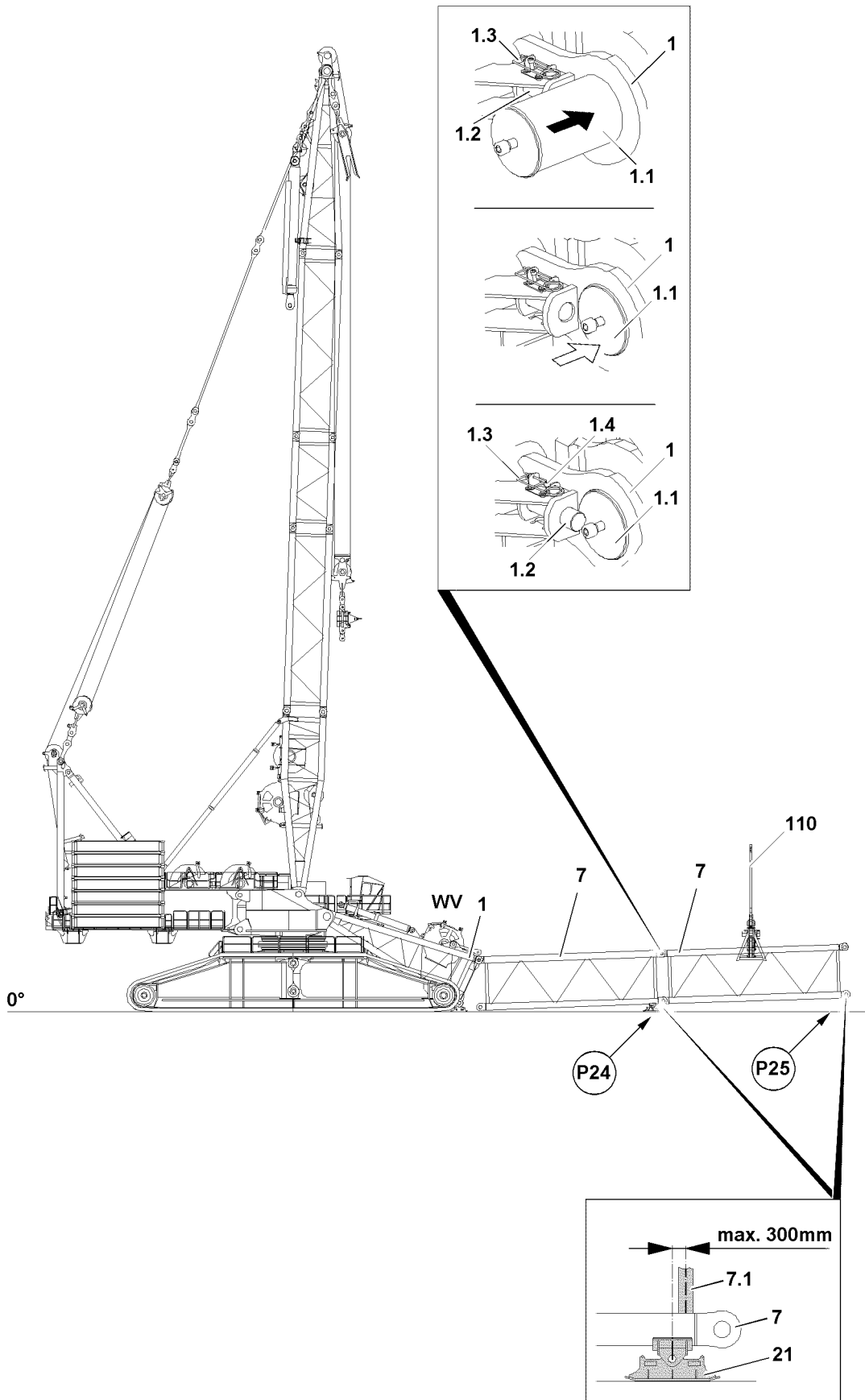

Fig.124441

LWE/LR 13000-001/19503-01-02/en

3.10 Installing the S-intermediate sections

Make sure that the following prerequisites are met:

- The connector pins on the first S-intermediate section **7** - in direction of the expansion of the boom system - are completely unpinned.
- The first S-intermediate section **7** is laying properly on the assembly shoes **21**.
- The brackets of the cross beam are set to the S-boom system.
- A forklift or telescopic lift truck are available.



WARNING

The crane can topple over!

If the rod plans and the data in chapter 5.03 are not observed, this can cause the crane to collapse, the boom to break off or the crane to topple over.

Personnel can be severely injured or killed.

- ▶ The combination of the various boom systems must be taken from the Rod plan and it must be adhered to.
- ▶ The instructions in chapter 5.03 must be observed and adhered to.

When the connector pins **1.1** on the first S-intermediate section **7** are fully unpinned:

- ▶ Fasten the second S-intermediate section **7** on the auxiliary crane via the cross beam and swing in to the pin points on the first S-intermediate section **7**.

When the pin bores between the first and the second S-intermediate section **7** align „on top“ and „on the bottom“:

- ▶ Insert the connector pins **1.1** „on top“ with the pin pulling cylinders on both sides to the stop and secure.

When the connector pins **1.1** „on top“ are fully pinned to the stop and secured on both sides:

- ▶ Insert the connector pins **1.1** „on the bottom“ with the pin pulling cylinders on both sides to the stop and secure.
- ▶ Lift the boom system with the auxiliary crane via the cross beam until the assembly shoes **21** are „free“ at point **P24**.

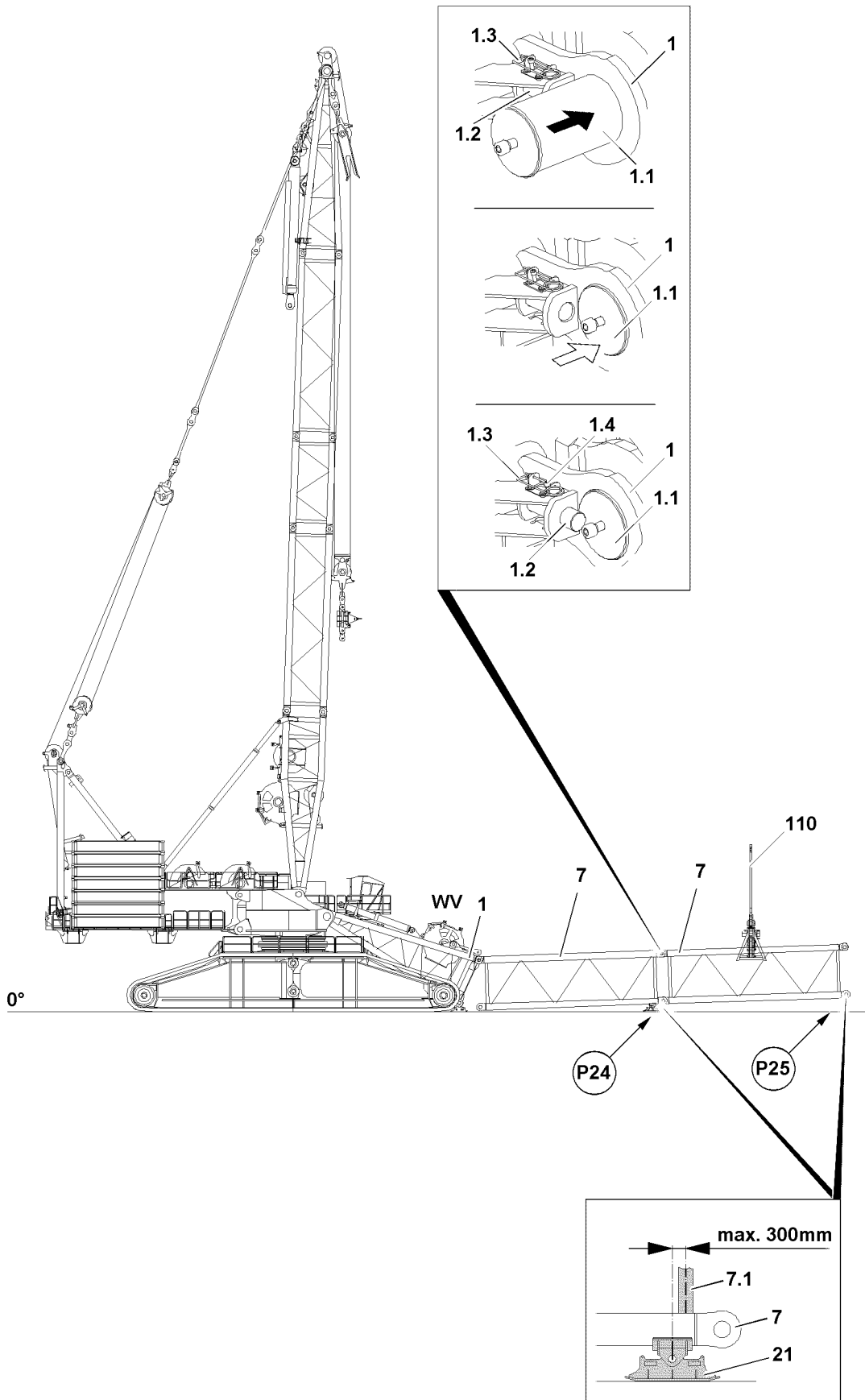

Fig.124441

LWE/LR 13000-001/19503-01-02/en

NOTICE

Danger of property damage on the intermediate sections!

If the assembly shoes **21** are not placed underneath in the permitted area of the intermediate sections, then the intermediate sections can be overloaded and damaged.

- ▶ Make sure that the assembly shoes **21** are only placed underneath in the permitted area of maximum 300 mm on the corner bar **7.1**.
- ▶ The crane operator is responsible for the proper substructure of the intermediate sections with the assembly shoes **21**.

- ▶ Remove the assembly shoes on the first S-intermediate section **7** at point **P24** and install in the area of the front corner bar on the second S-intermediate section **7** at point **P25**.
- ▶ Place the second S-intermediate section **7** completely on the assembly shoes.

When the boom system is placed on the assembly shoes **21**:

- ▶ Remove the auxiliary crane with the cross beam **110**.

NOTICE

Impermissible boom length!

If the boom is lifted with impermissible boom length with the cross beam, then the last intermediate section can be overloaded when lifting the boom system.

Death, severe injuries, property damage.

- ▶ Make sure that the boom is lifted with the cross beam only up to the permissible boom length, see chart.

Boom system	Permissible boom length
S	132 m
SL	144 m
P	132 m
W	126 m
W2	90 m
W3	108 m

- ▶ Assemble all S-intermediate sections according to the previously described steps.

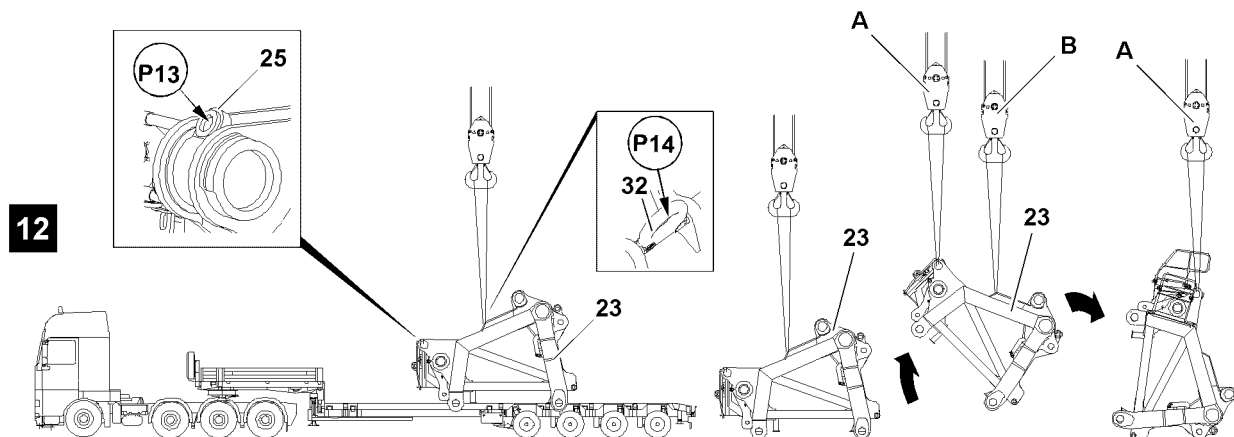
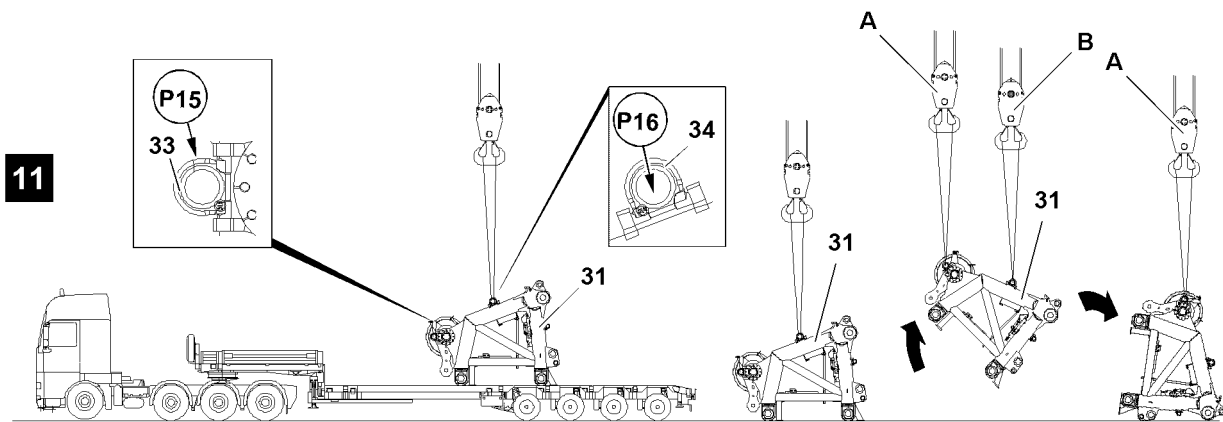
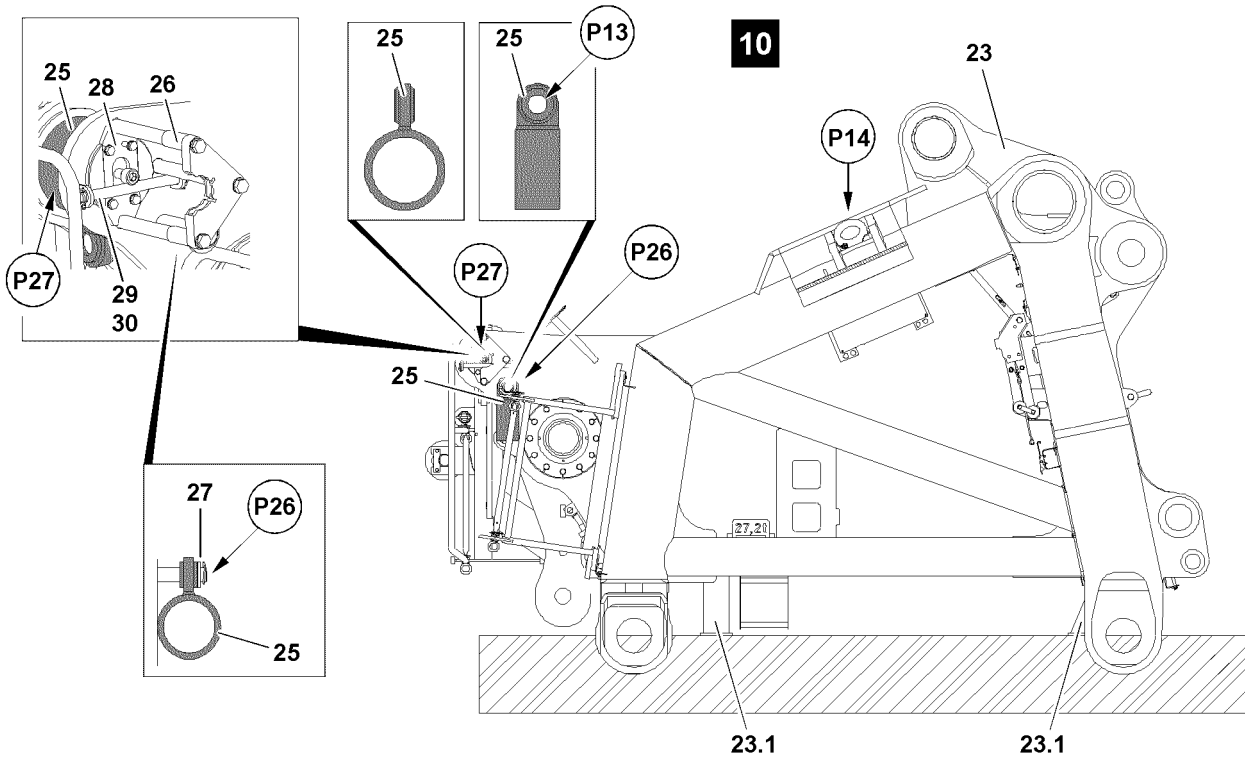

Fig.124443

LWE/LR 13000-001/19503-01-02/en

3.11 Assembling the S-end section / L-end section

3.11.1 Lifting the end section from the flatbed trailer

Make sure that the following prerequisites are met:

- The transport retainers are removed on the respective end section.
- There are no roller sets on the respective end section.
- The ground is able to safely take on the weight of the respective end section.

To fasten the end sections, use the inner accesses and platforms on the end sections.



WARNING

Danger of falling!

When fastening the end sections, assembly personnel can fall down.

Personnel can be severely injured or killed.

- ▶ To fasten the end section, the assembly personnel must use the existing accesses, hand holds and platforms.

- ▶ Fasten the L-end section **31** on both sides on the eyes **34** of the fastening points **P16** on the auxiliary crane, see illustration **11**.

or

- Fasten the S-end section **23** on both sides on the eyes **32** of the fastening points **P14** on the auxiliary crane, see illustration **12**.

When the required end section is properly fastened on the auxiliary crane:

- ▶ Carefully lift the end section with the auxiliary crane from the transport vehicle and remove the transport vehicle.
- ▶ Lower the end section to the ground.

When the end section is properly laying on the ground:

- ▶ Bring the railing into operating position (for S-end section).

3.11.2 Preparing the S-end section for installation

Swinging the railing on the S-end section into operating position



WARNING

Danger of falling!

At assembly and disassembly of the railings, the assembly personnel can fall down and be severely injured or killed.

- ▶ The assembly personnel must secure themselves for assembly / disassembly of railings and protective devices with an approved fall arrest system to prevent them from falling.
- ▶ For assembly and disassembly work, maintenance and inspection work on the S-end section, all railings and the protective devices must be assembled and secured.

Make sure that the following prerequisite is met:

- The S-end section is laying completely on the ground or on a substructure.
- ▶ For the assembly / disassembly of railings and protective devices, see chapter 2.06.

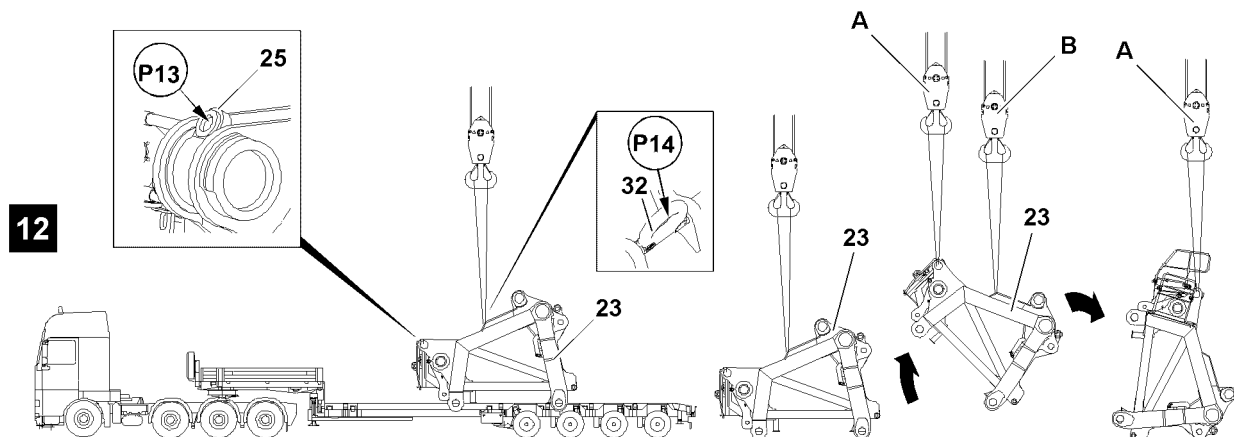
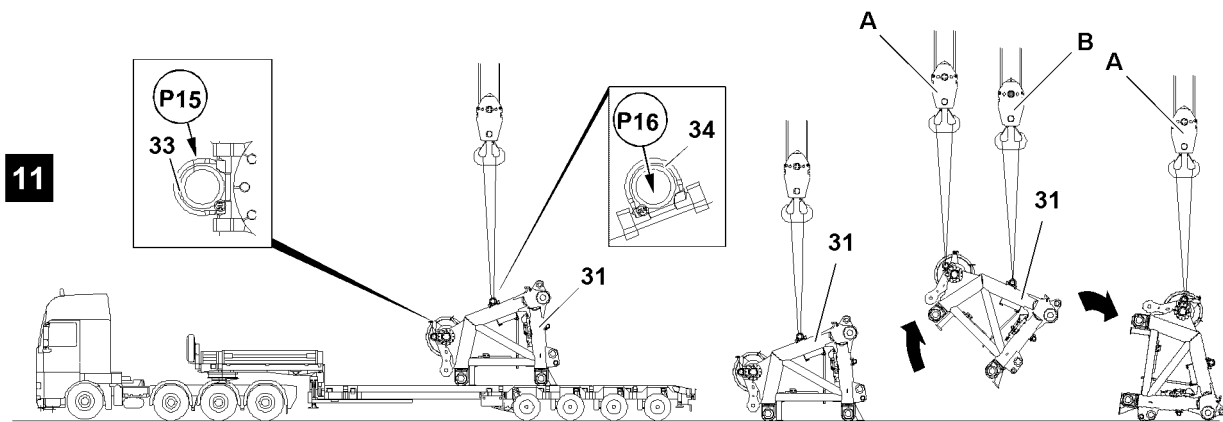
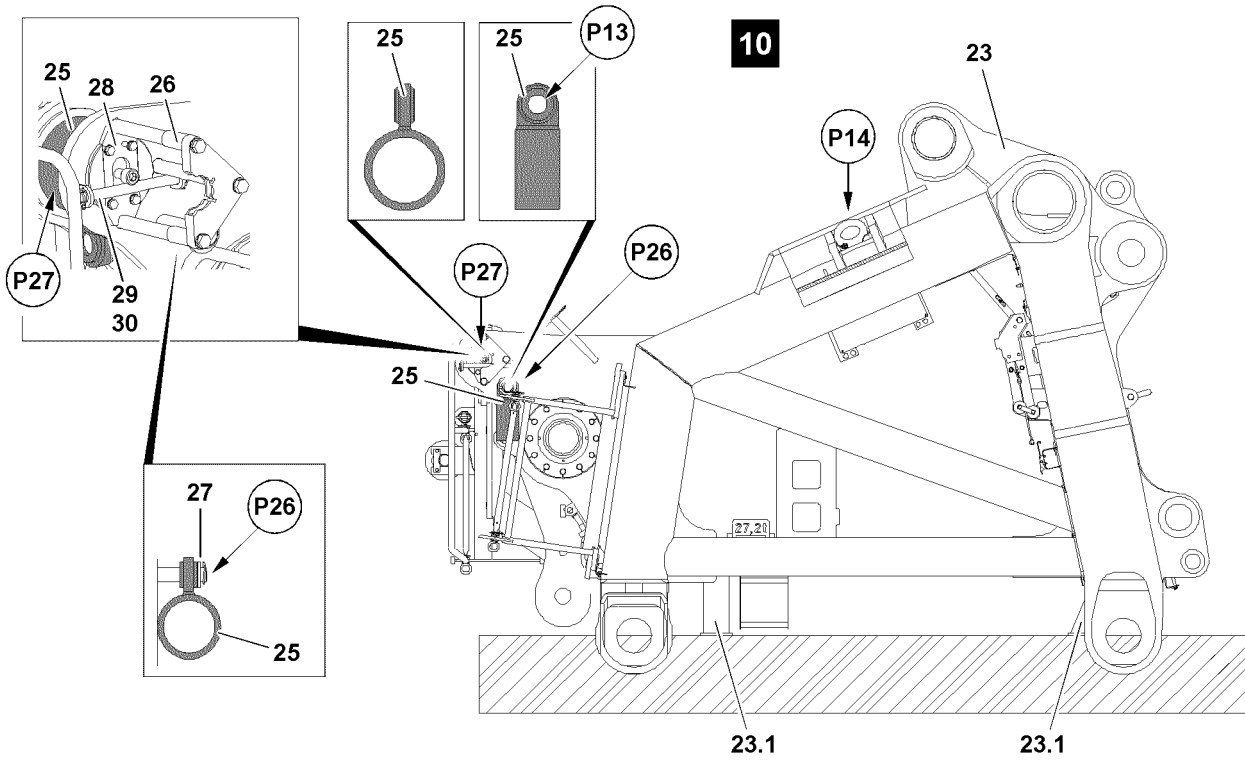

Fig.124443

LWE/LR 13000-001/19503-01-02/en

Installing the brackets for the assembly of the S-end section on the boom

Make sure that the following prerequisites are met:

- The S-end section **23** is horizontally aligned.
 - The railings on the S-end section **23** are in operating position.
 - A platform or a work platform is available.
- ▶ Release the bracket **25** in the parking position **P26**: Remove the safety locking pin **27** at point **P26**, see illustration **10**.



Note

- ▶ The own weight of the bracket **25** is approx. 35 kg.



WARNING

Falling bracket!

The bracket **25** can fall down at assembly.

Personnel can be severely injured or killed.

- ▶ Fasten the bracket **25** properly on the auxiliary crane and lift it out of the parking position.
- ▶ Lift the bracket **25** with the auxiliary crane from the parking position **P26**, see illustration **10**.
- ▶ Place the bracket **25** on a suitable substructure on the ground.

Before pinning the bracket **25** in assembly position **P27**, unpin the connector pins **28**.

- ▶ Remove the safety locking pin **30** and unpin the retaining pin **29**.

Result:

- The connector pin **28** is released.
- ▶ Place the pin pulling cylinder in the pin pulling device **26** and unpin the connector pins **28**.
- ▶ Fasten the bracket **25** on point **P13** with the auxiliary crane, see illustration **10**.
- ▶ Swing the bracket **25** with the auxiliary crane in to the pin point **P27**.
- ▶ Align the bracket **25** and pin with the pin pulling cylinder on pin point **P27**.

When the connector pin **28** is completely pinned:

- ▶ Insert the retaining pin **29** and secure properly with safety locking pin **30**.

Result:

- The first bracket **25** is pinned and secured in assembly position **P27**.



Note

- ▶ The assembly of the second bracket **25** is identical with the assembly of the first bracket **25**.

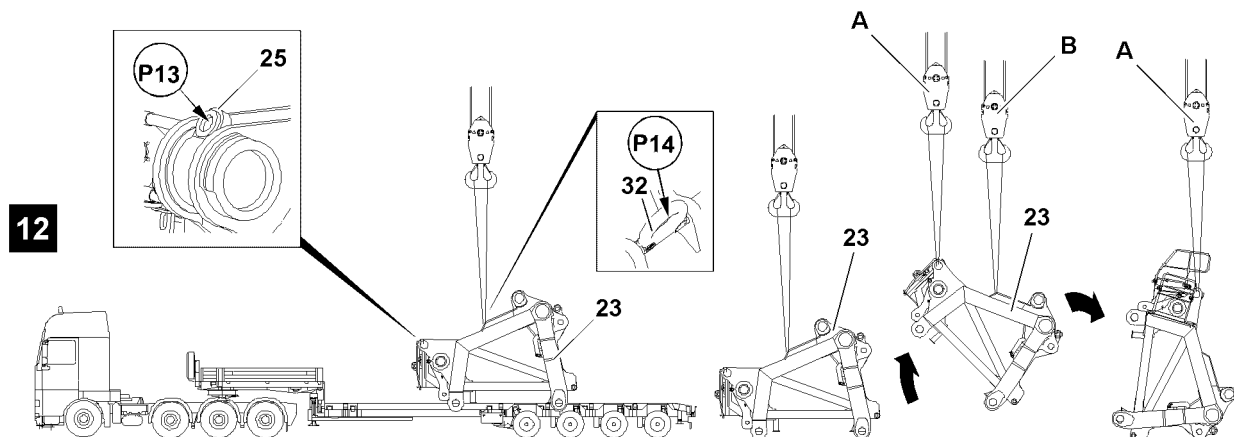
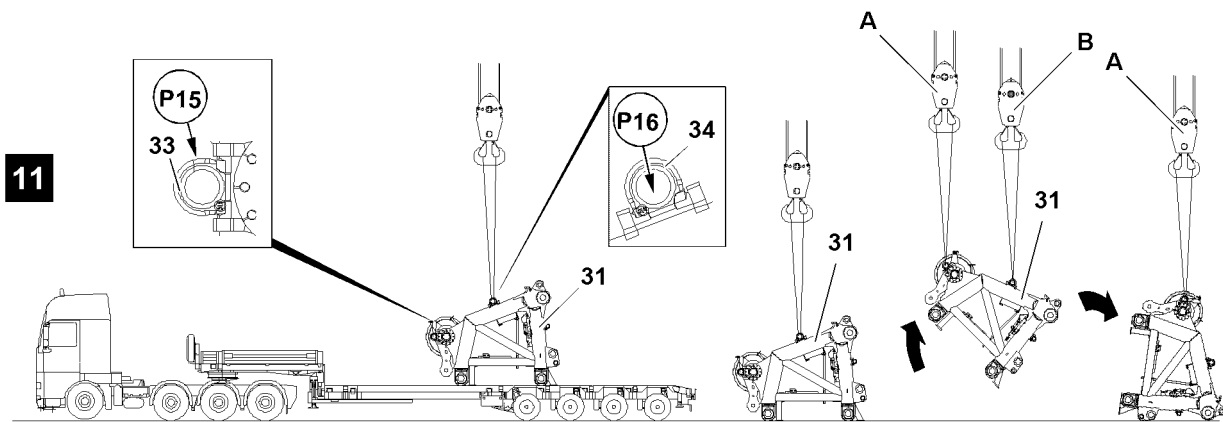
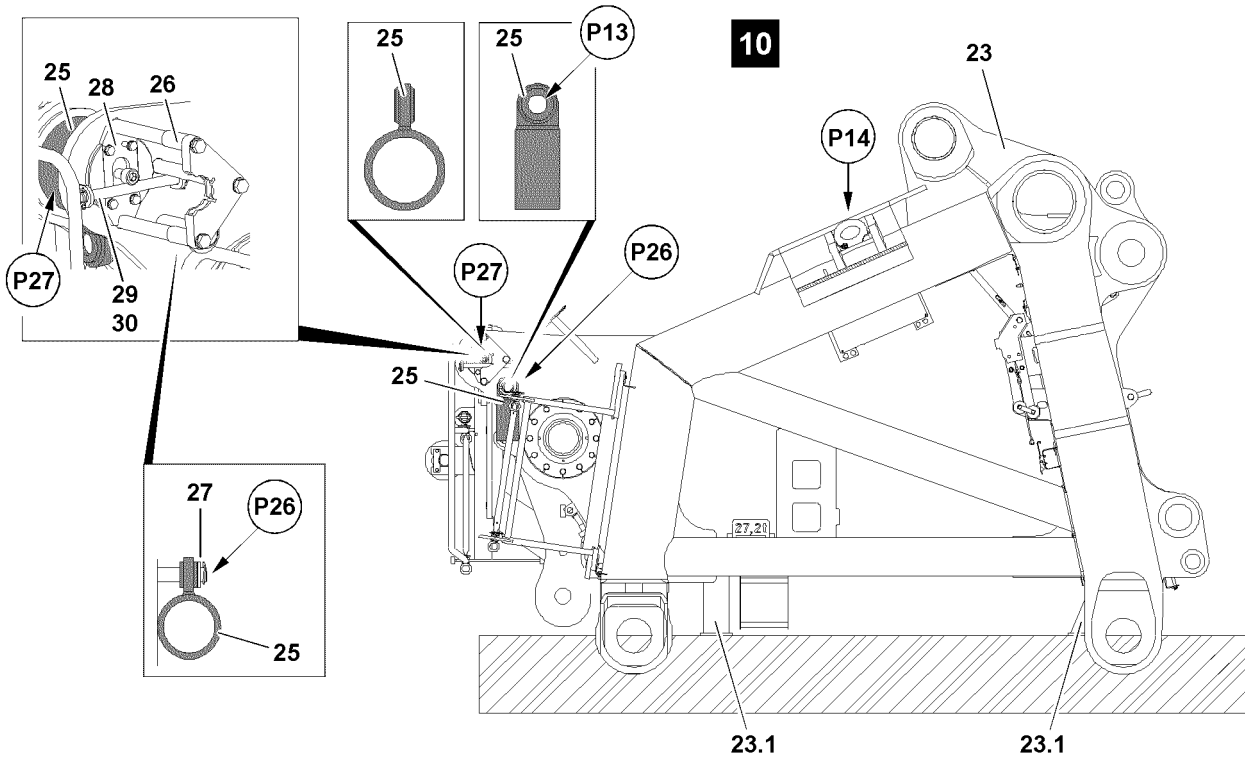

Fig.124443

LWE/LR 13000-001/19503-01-02/en

3.11.3 Turning the S-/L-end section into assembly position

The S-end section and the L-end section must be turned before assembly on the boom with two auxiliary cranes from the transport position into the assembly position.

Make sure that the following prerequisites are met:

- The brackets **25** are properly installed and secured on the S-end section **23**.
- **No** roller sets are on the end sections.



Note

- ▶ The turning procedure of the S- and L-end section is identical.



WARNING

Danger of falling for assembly personnel!

When fastening the end sections on the auxiliary cranes, the assembly personnel can fall down. Personnel can be severely injured or killed.

S-end section:

- ▶ You must use a work platform to install the fastening equipment on the fastening points **P13**.
- ▶ When fastening the fastening equipment on the fastening points **P14** use the installed platforms in the end section.

L-end section:

- ▶ Install the fastening equipment properly on the fastening points **P15**.
- ▶ When fastening the fastening equipment on the fastening points **P16** use the installed platforms in the end section.

Illustration 11:

- ▶ Fasten the L-end section **31** with the auxiliary crane **A** on the fastening points **33** at point **P15** on both sides.
 - ▶ In addition, fasten the L-end section **31** with the auxiliary crane **B** on the fastening points **34** at point **P16** on both sides.
- or**

Illustration 12:

- ▶ Fasten the S-end section **23** with the auxiliary crane **A** on the fastening points **25** at point **P13** on both sides.
- ▶ In addition, fasten the S-end section **23** with the auxiliary crane **B** on the fastening points **32** at point **P14** on both sides.

Result:

- The required end section is fastened on the auxiliary crane **A** and auxiliary crane **B**.

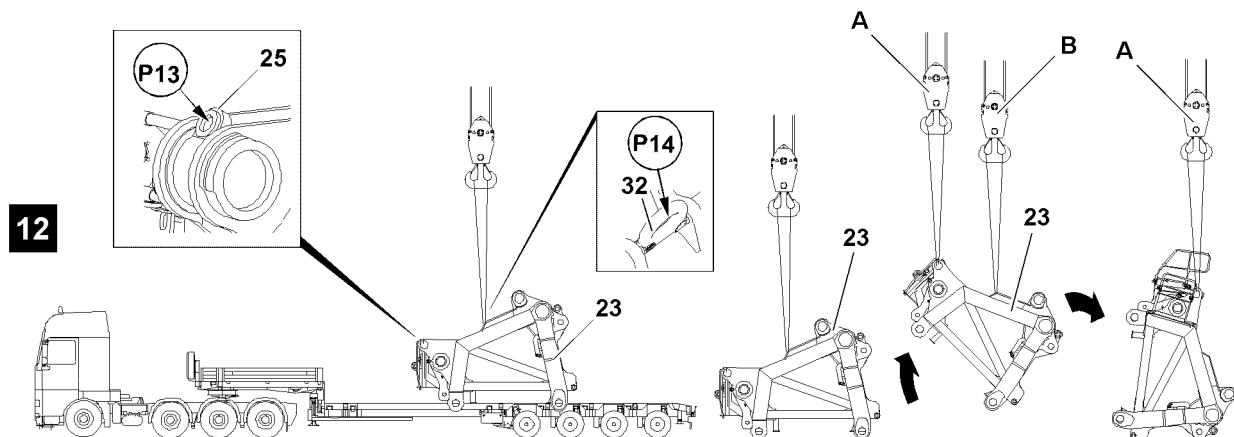
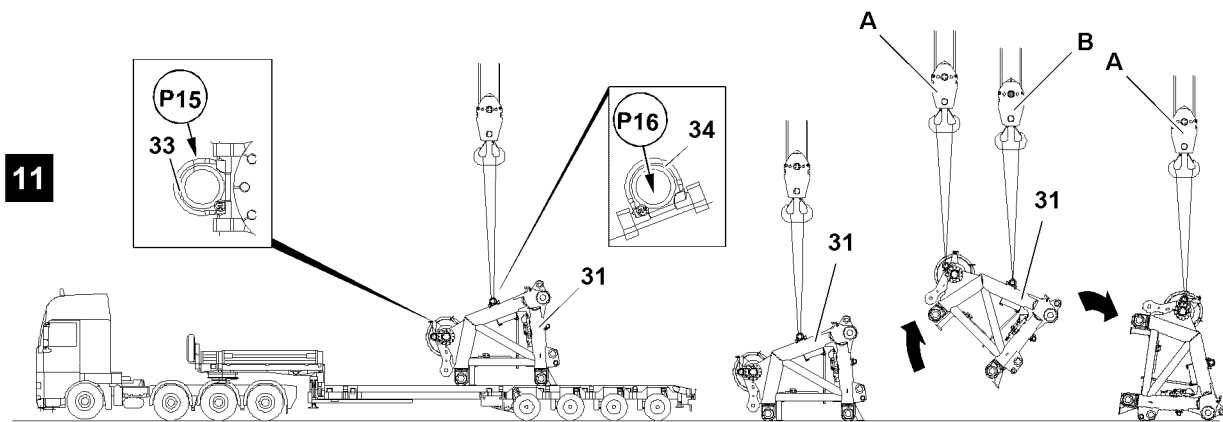
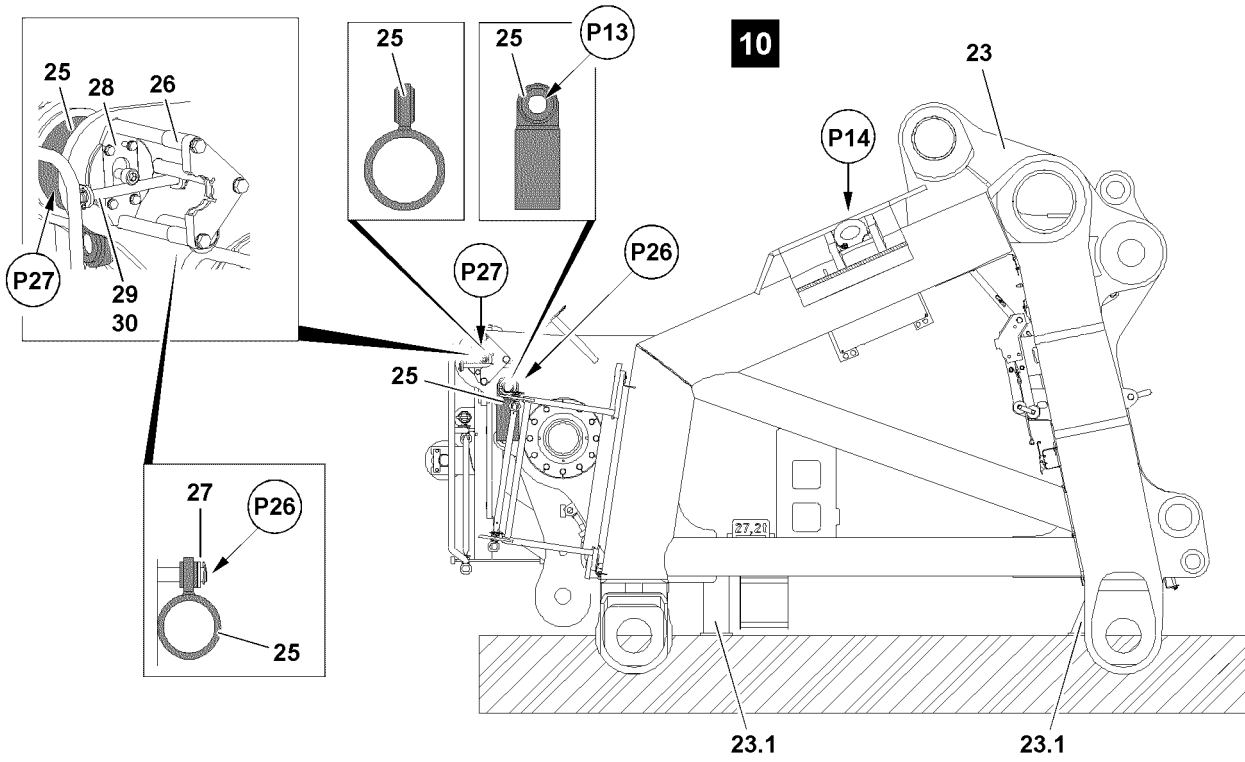

Fig.124443

LWE/LR 13000-001/19503-01-02/en

**WARNING**

Danger due to end section!

While turning the required end section, persons can be caught and severely injured or killed.

- ▶ Make sure that there are no persons within the danger zone of the auxiliary cranes and in the danger zone of the turning end section.
- ▶ The crane drivers of both auxiliary cranes as well as the guide are in voice contact with each other.

- ▶ Turn the end section with the auxiliary cranes, auxiliary crane **A** and auxiliary crane **B** into assembly position, see illustration **12**.

**WARNING**

Danger of falling!

When removing the fastening equipment on the fastening points, point **P14** (S-end section) or point **P16** (L-end section), the assembly personnel can fall down.

Personnel can be severely injured or killed.

- ▶ Set the end section on the ground to avoid oscillation of the end section.
- ▶ Remove the fastening equipment on the fastening points, point **P14** (S-end section) or point **P16** (L-end section) by using a work platform.

When the respective end section is turned in assembly position:

- ▶ Set the end section carefully and with low speed on the ground to avoid oscillation of the end section.

**WARNING**

Tipping end section!

When the fastening equipment is removed on the fastening points, point **P13** (S-end section) or point **P15** (L-end section), the end section can tip over.

Personnel can be severely injured or killed.

- ▶ Make sure that the fastening equipment is between the fastening points, point **P13** (S-end section) or point **P15** (L-end section) is tensioned with the auxiliary crane.
- ▶ The fastening equipment on the fastening points, point **P13** (S-end section) or point **P15** (L-end section) may not be removed.

When the end section is seated on the ground:

- ▶ Disengage the fastening equipment on the fastening points, point **P14** (S-end section) or point **P16** (L-end section).
- ▶ Remove the auxiliary crane **B**.

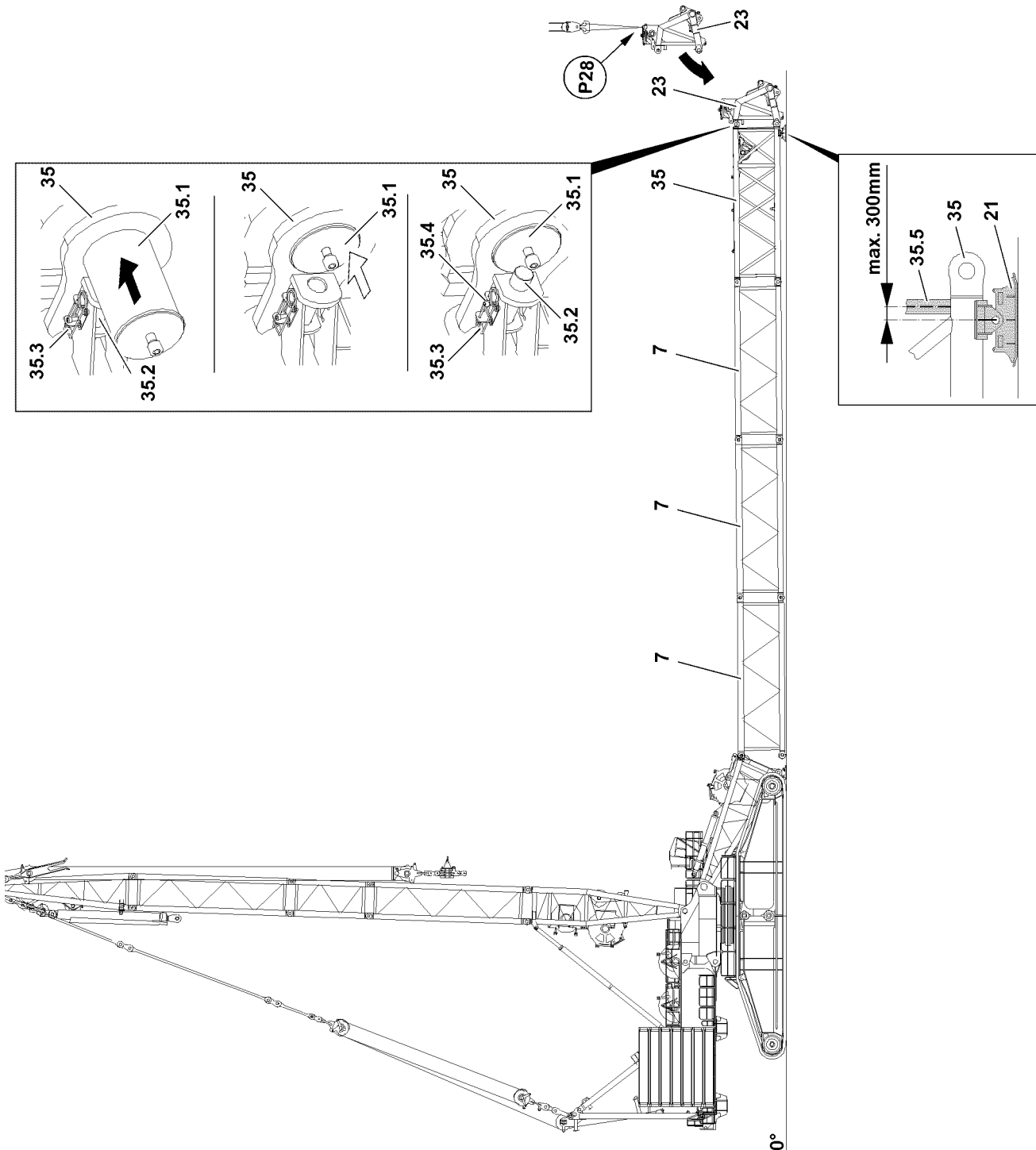

Fig.115833

LWE/LR 13000-001/19503-01-02/en

3.12 Assembling the end section on the boom



Note

- ▶ The installation of the end section on the boom is described on the example of the S-end section.
- ▶ The installation of the L-end section is identical to the installation of the S-end section.

Make sure that the following prerequisites are met:

- The installed boom system is properly placed on the S-adapter **35** on the assembly shoes **21**.
- The connector pins **35.1** on the S-adapter **35** are fully unpinned.
- The fastening equipment on the fastening points **P28** of the S-end section **23** is tensioned.

When the connector pins **35.1** on the S-adapter are fully unpinned:

- ▶ Swing the S-end section **23** with the auxiliary crane in to the pin points on the S-adapter **35**.

When the pin bores between the S-end section and the S-adapter align „on top“ and „on the bottom“:

- ▶ Insert the connector pins **35.1** „on top“ with the pin pulling cylinders on both sides to the stop and secure.

When the connector pins **35.1** „on top“ are fully pinned to the stop and secured on both sides:

- ▶ Insert the connector pins **35.1** „on the bottom“ with the pin pulling cylinders on both sides to the stop and secure.

When the connector pins **35.1** „on top“ and „bottom“ are properly pinned and secured with the retaining pins **35.2**:

- ▶ Remove the auxiliary crane.

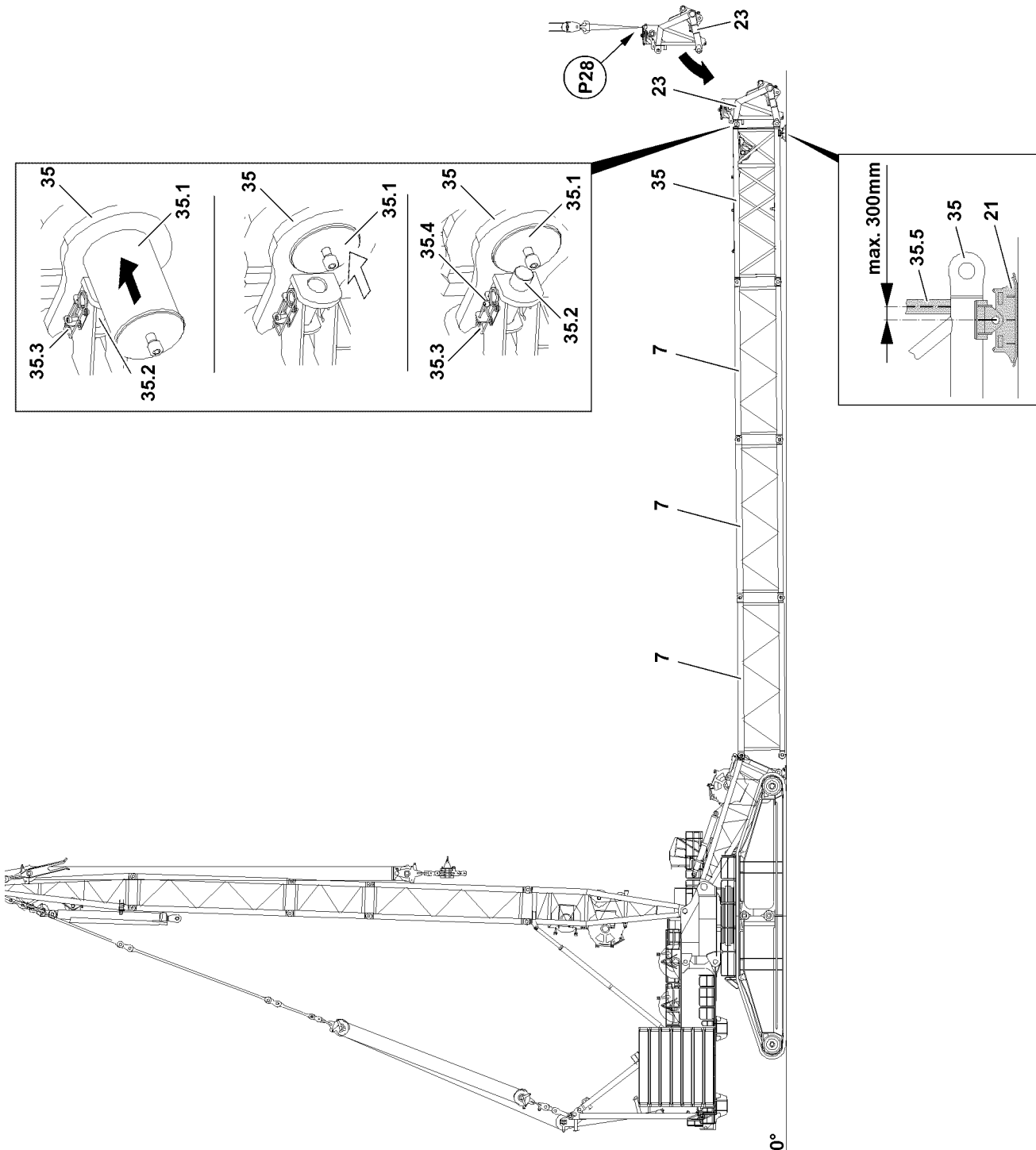

Fig.115833

LWE/LR 13000-001/19503-01-02/en

3.13 Establishing the electrical connections on the boom end section

Make sure that the following prerequisites are met:

- The S-intermediate sections are properly assembled and secured on the ground.
- The boom end section is properly assembled and secured.
- The electrical connections to the boom end section have been established.
- The airplane warning light, wind speed sensor and all sensors are properly installed and secured on the boom end section.
- The hoist limit switches are properly installed and secured on the pulley head / pulley heads.

NOTICE

Danger of damage of electrical connections!

If the electrical connection from the cable drum on the S-pivot section to the terminal box on the S-pivot section is established first before the connection to the terminal box on the boom end section, the electrical connection can be damaged when spooling out the cable drum.

- ▶ Establish first the electrical connection from the cable drum in the S-pivot section to the terminal box on the boom end section and then the electrical connection from the terminal box in the S-pivot section to the cable drum.
-



Note

- ▶ To establish the electrical connections on the S-boom: Use the Electrical wiring diagram.
-

- ▶ Establish the electrical connections.
 - ▶ Make sure that all electrical connections on the boom are established.
-



WARNING

Malfunction if dummy plugs are not installed!

If the dummy plugs on the non-required electrical connections are not installed, then malfunctions or functional limitations can occur on the crane.

- ▶ Make sure that all non-required electrical connections, which have a dummy plug are closed off with dummy plugs.
 - ▶ Pay attention to the Electrical wiring diagram.
-
- ▶ As a rule, close off on-required electrical connections (for example for accessories which cannot be installed) with the respective dummy plugs.
-

NOTICE

Property damage due to dirt and / or corrosion!

If non-required electrical connections are not closed off with the respective protective caps, then dirt and / or corrosion can damage the electrical connections.

This could result in malfunctions.

- ▶ Make sure that all non-required electrical connections are always closed off properly.
 - ▶ Pay attention to the Electrical wiring diagram.
-
- ▶ Close electrical connections, which have no dummy plugs, properly off with the corresponding protective caps.
-

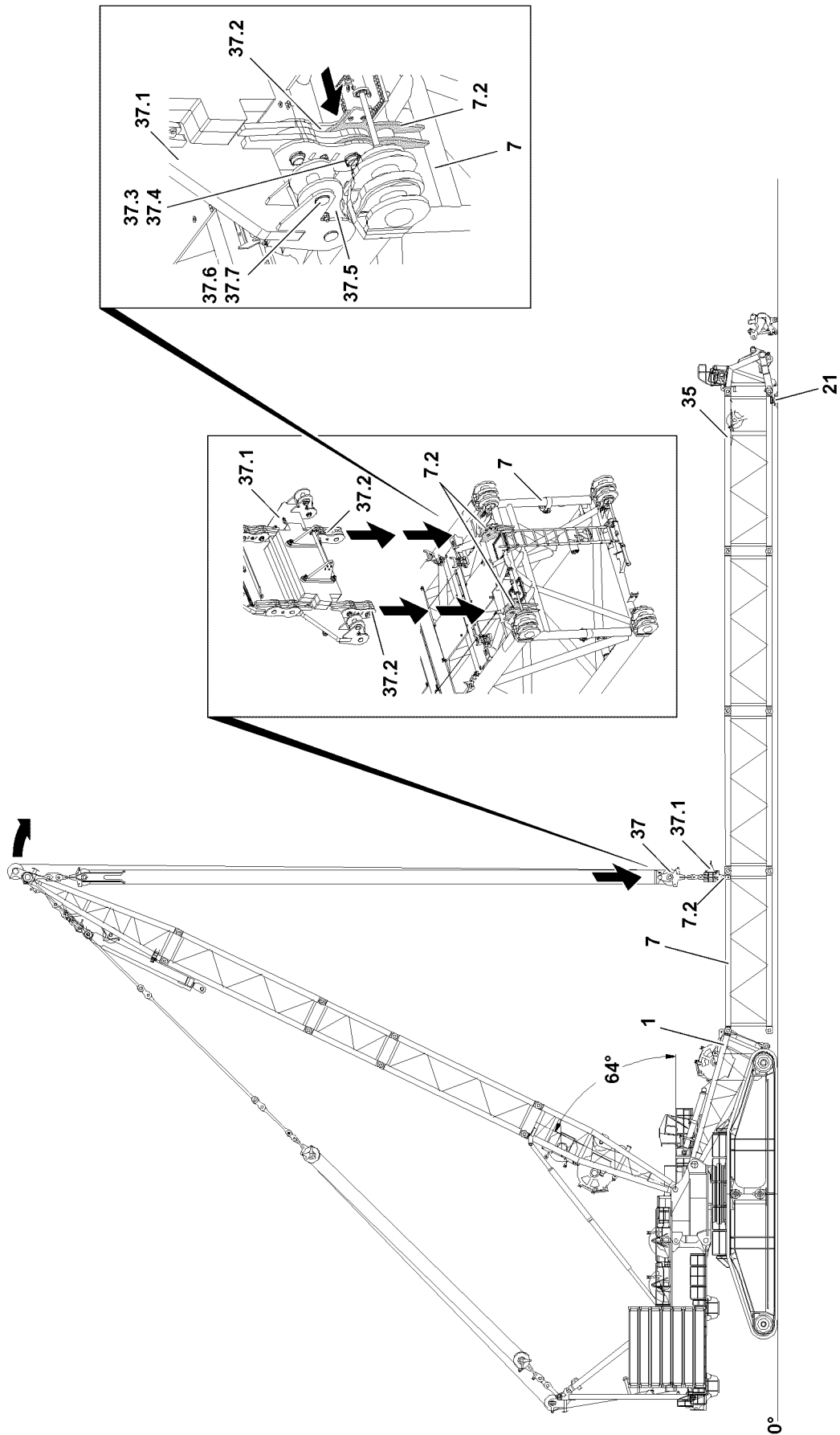

Fig.115835

LWE/LR 13000-001/19503-01-02/en

3.14 Pinning the upper pulley block on the S-intermediate section

To be able to „close“ the S-boom combination after assembly, it may be necessary that the D-boom is luffed down forward to approx. 64°. Then the upper pulley block **37** must be lowered with the brackets **37.2** of the assembly weight **37.1** until it can be pinned on the S-intermediate section **7**.



Note

- ▶ Luff the D-boom forward only to the point where the upper pulley block **37** „stands“ vertically above the pin points **7.2** on the S-intermediate section **7**.

Make sure that the following prerequisites are met:

- The S-intermediate section **7** is properly pinned and secured on the S-pivot section **1** „on top“.
 - The S-pivot section **1** is placed on the assembly shoes.
 - The S- or L-end section is properly installed and secured on the boom.
 - The S-adapter is laying on the assembly shoes.
 - The auxiliary crane is removed.
- ▶ Luff the D-boom down to the front to approx. 64°.
 - ▶ Lower the upper pulley block **37** until the brackets **37.2** of the assembly weight **37.1** hang over the pin points **7.2** of the S-intermediate section **7**.
 - ▶ Remove the safety locking pin **37.4** on the brackets **37.2** and unpin the pin **37.3**.

When the pins **37.3** are fully unpinned on both sides:

- ▶ Continue to lower the upper pulley block **37** until the pin bores of the brackets **37.2** align on the pin points **7.2**.

When the pin bores align:

- ▶ Insert the pin **37.3** on both sides completely and secure with safety locking pin **37.4**.

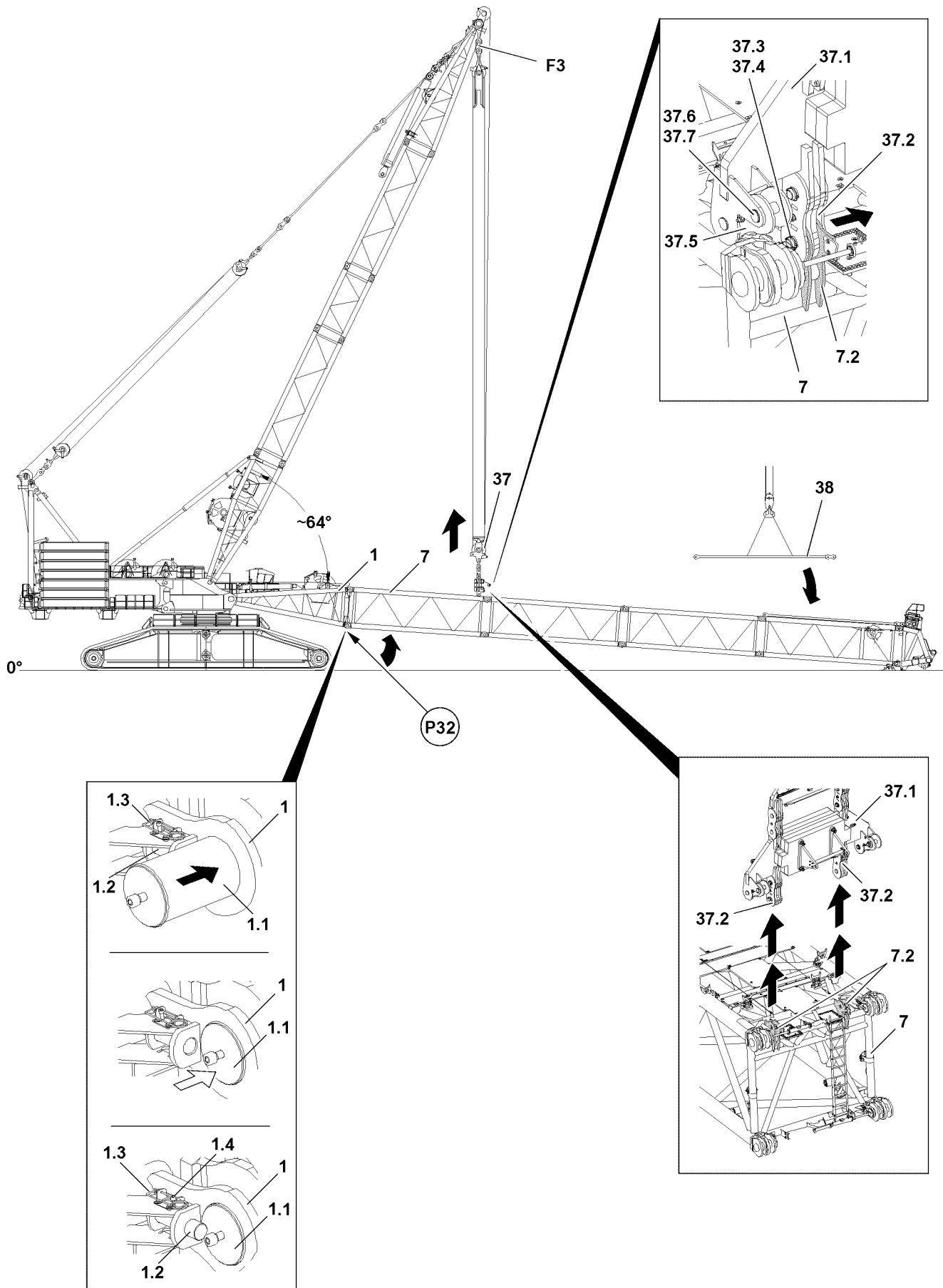

Fig.115836

LWE/LR 13000-001/19503-01-02/en

3.15 Closing the boom system



WARNING

The crane can topple over!

If the following conditions are not met, the crane can topple over or be significantly damaged. Personnel can be severely injured or killed.

- ▶ During the „closing procedure“ of the boom system, the maximum permissible F3-total force of **300 t** on test point 3 **MS3** may **not** be exceeded.
- ▶ The end section of the corresponding SL/S-boom combination may **not** lift off the ground during the „closing procedure“.
- ▶ Make sure that there are no persons on the boom system as well as in the danger zone during the closing procedure.



Note

- ▶ The actual forces on test point 3 **F3** (MS3) - which are used during the closing procedure of the S-boom system - are displayed on LICCON monitor 1.
- ▶ Note the actual forces of test point 3 **F3** (MS3) and keep it ready for the disassembly of the S-boom system.
- ▶ At boom disassembly, pretension the control rope of winch 3 until the noted (assembly) actual forces of test point 3 **F3** (MS3) on the LICCON monitor are reached, so that the connector pins of the S-intermediate sections can be uninned.

When the SL-/S-boom combination is assembled to the desired length:

- ▶ Lift the S-boom section with the upper pulley block **37** until the pin bores „on the bottom“ align at point **P32**.
- ▶ Insert connector pin **1.1** „on the bottom“ and secure with retaining pin **1.2**.



WARNING

Danger of fatal injury due to folding down of boom!

By unpinning the upper pulley block **37** on the S-intermediate section **7**, the boom can suddenly fold down if the boom is not properly pinned and secured at point **P32** „on the bottom“.

Personnel can be severely injured or killed.

- ▶ It is prohibited for anyone to remain under the raised boom combination during the pinning / unpinning procedure.
- ▶ Unpin the upper pulley block **37** on the S-intermediate section **7** only when it is ensured that the S-pivot section **1** is properly pinned and secured „on top“ and „bottom“ with the S-intermediate section **7**.

When the S-boom is „closed“:

- ▶ Unpin the bracket **37.2** of the assembly weight **37.1** on the S-intermediate section **7**: Release and unpin the pins **37.3** on both sides.

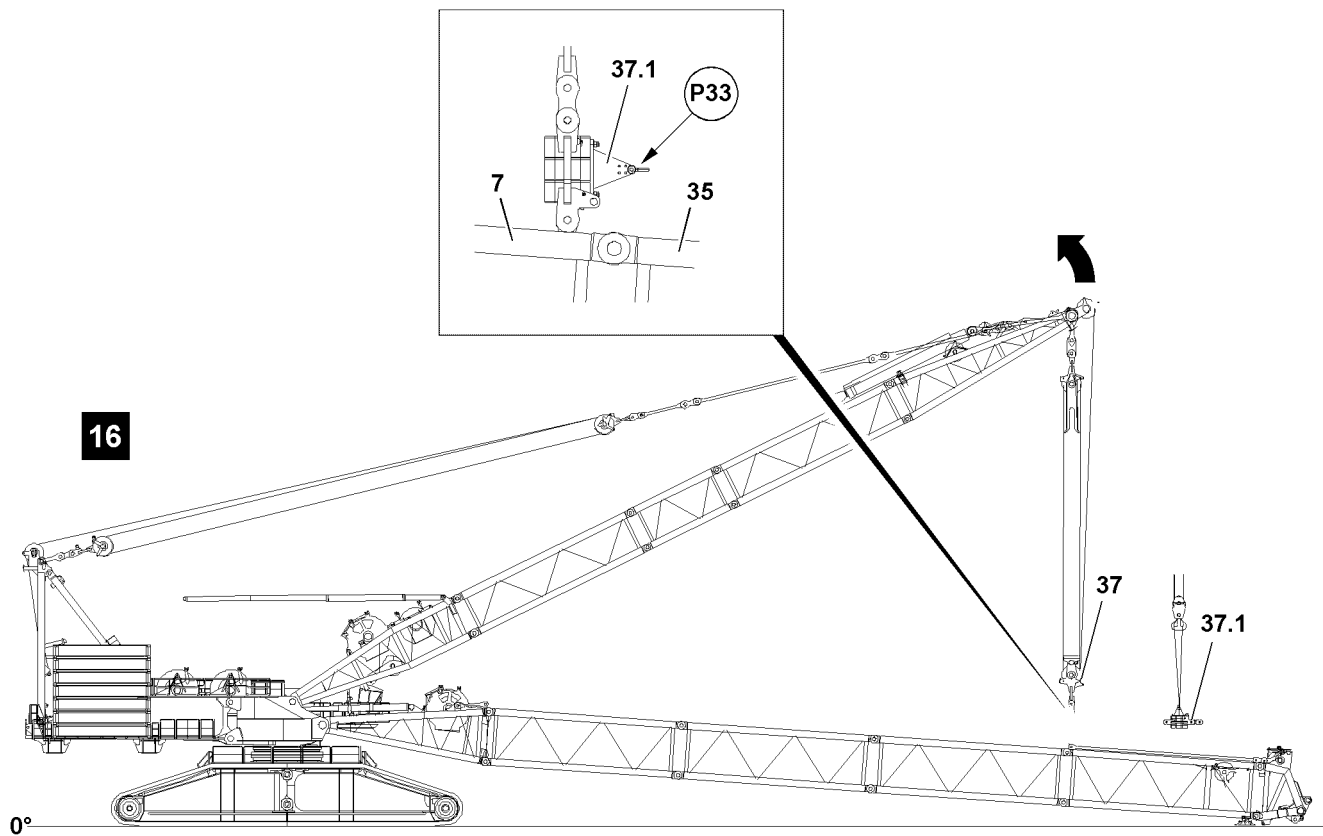
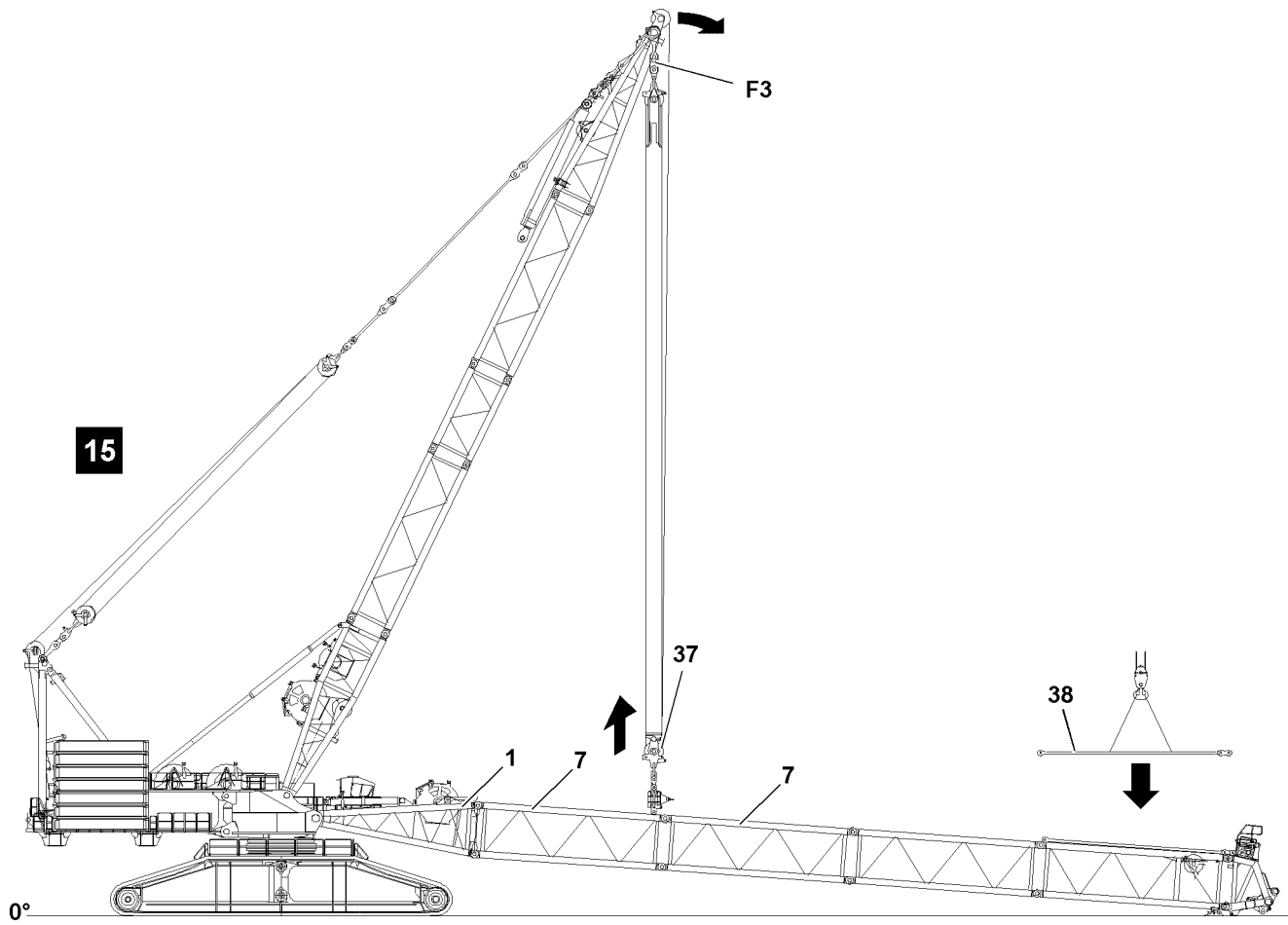

Fig.124444

LWE/LR 13000-001/19503-01-02/en

3.16 Assembling the guy rods



WARNING

Neglected inspection and maintenance on guy rods!

If the regular inspection and maintenance of the guy rods is not carried out or only in irregular intervals, then severe accidents can occur due to existing and not recognized damage on the guy rods. Personnel can be severely injured or killed.

- ▶ The guy rods must be checked before every assembly, see also chapter 8.15.



Note

- ▶ The guy rods must be assembled and secured according to the rod plans. The numbering on the rod plans must be identical to the numbering on the guy rods.

Make sure that the following prerequisites are met:

- The S-boom is completely assembled.
 - The S-relapse cylinder is in the transport receptacle.
 - All lattice sections are properly pinned with each other.
 - All pin connections are secured.
 - The assembly weight **37.1** of the upper pulley block **37** is unpinned on the S-intermediate section **7**.
- ▶ Lift the upper pulley block **37**.



WARNING

Incorrectly installed guy rods!

Due to an incorrect combination of guy rods, severe accidents, up to toppling the crane, can occur. Personnel can be severely injured or killed.

- ▶ Make sure that the guy rods are always assembled and installed according to the Rod plan.
- ▶ Place the guy rods **38** with the auxiliary crane according to the data in the Rod plan on the rod receptacles on the S-intermediate sections, see illustration **15**.

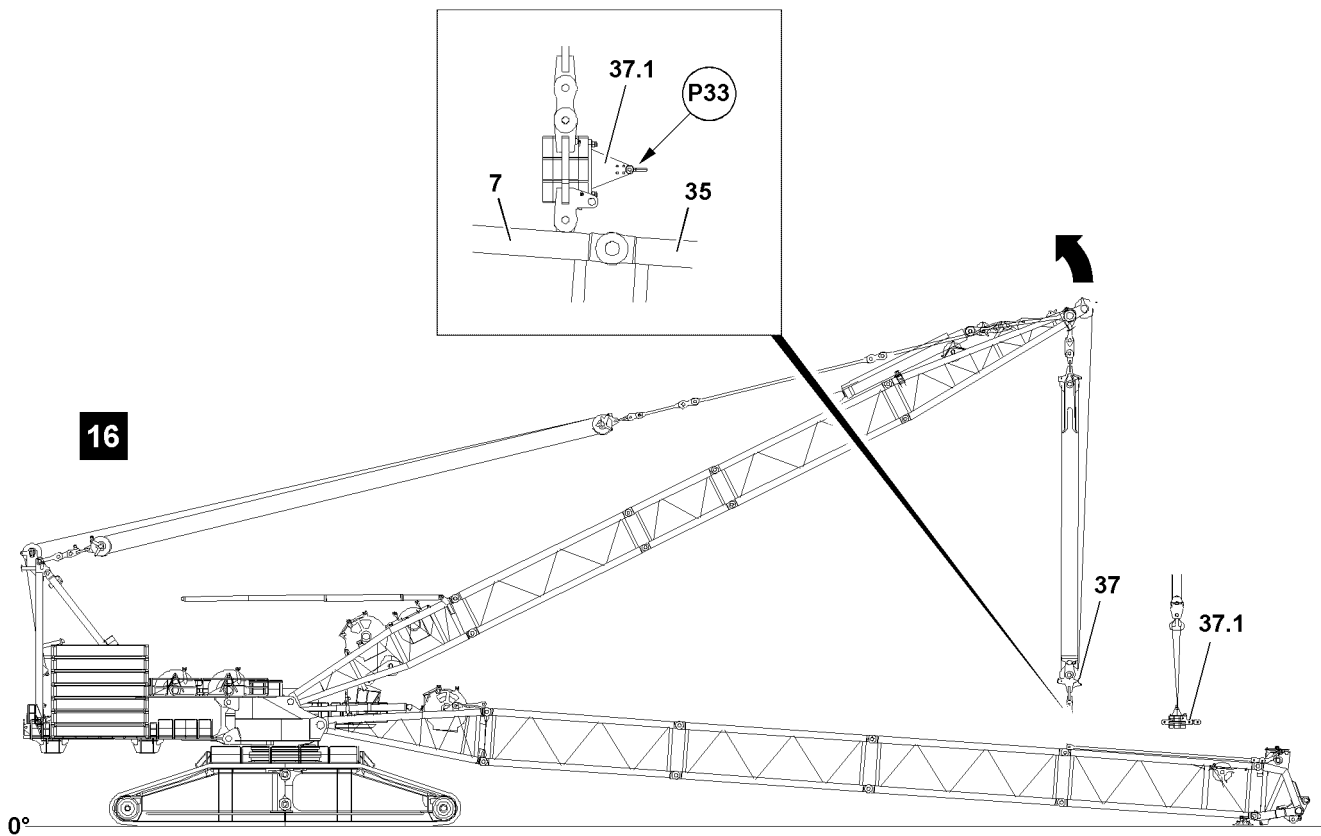
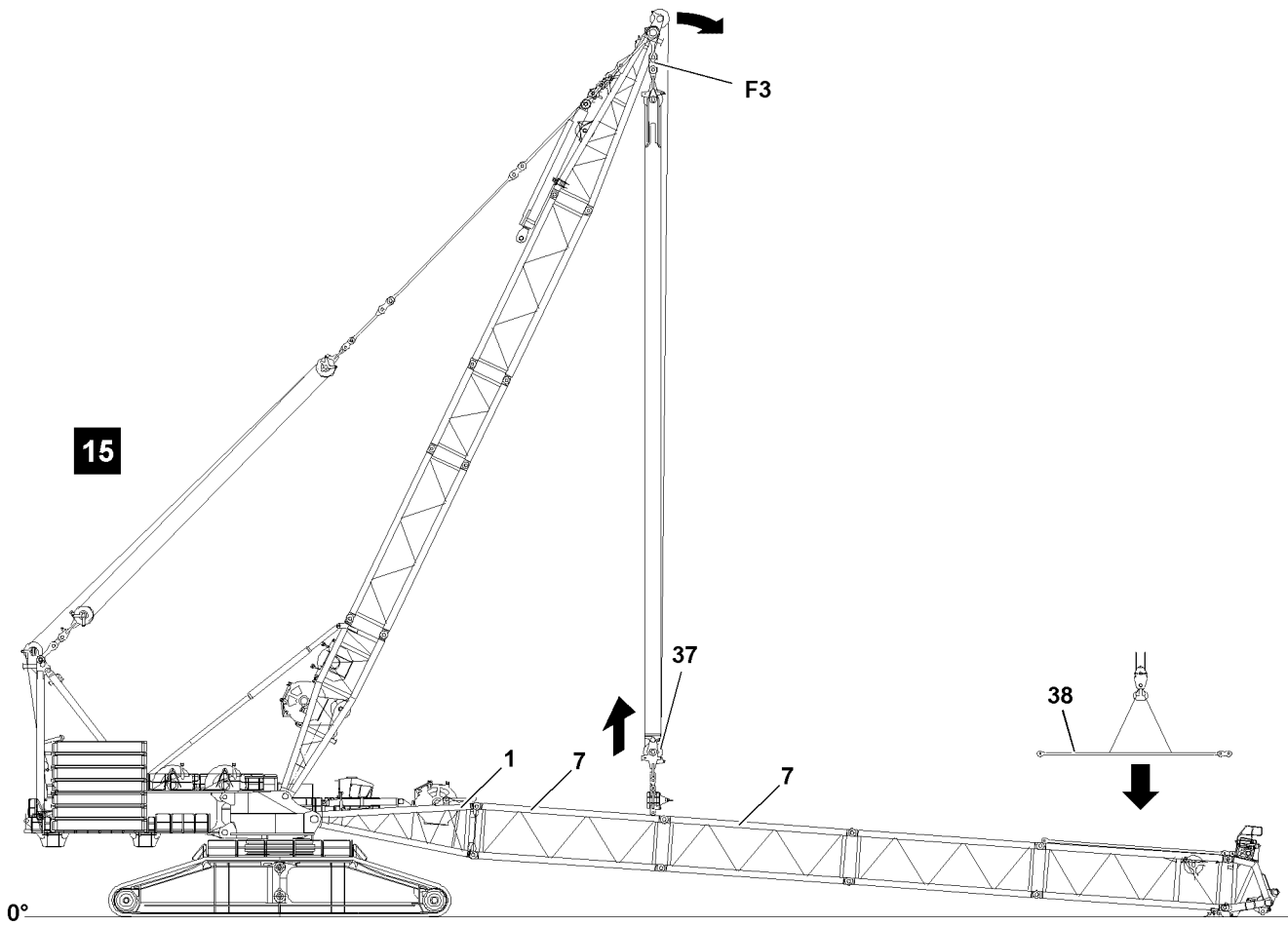

Fig.124444

LWE/LR 13000-001/19503-01-02/en

NOTICE

Danger of property damage!

If the pins of the guy rods are not pinned from the „inside“ to the „outside“, the hoist rope can scrape on the pins and be damaged.

- ▶ Always insert the pins of the guy rods from the „inside“ to the „outside“.
- ▶ Pay attention to the Rod plan.

- ▶ Pin the guy rods: Insert the pins from the inside to the outside and secure the pins properly with safety locking pins.

**Note**

- ▶ The guy rods of the S-intermediate sections are pinned and secured together starting from the lugs **23.1** on the fixed point of the S-end section.

NOTICE

Danger of property damage!

When luffing the D-boom down, the upper pulley block **37** can run with the assembly weight **37.1** on the S-boom system and damage the boom.

This could result in high property damage.

- ▶ Make sure that the assembly weight **37.1** does not run on the S-boom when luffing down the D-boom.
- ▶ Make sure, when luffing down the D-boom, that there is always sufficient distance between the S-boom and the assembly weight **37.1**.

When all required guy rods are properly placed and secured on the rod receptacles of the S-intermediate sections:

- ▶ Unpin the assembly weight on the upper pulley block: Luff the D-boom down carefully to the front.
- ▶ Lower the upper pulley block **37** until the fastening points **P33** on the assembly weight **37.1** are easily accessible.
- ▶ Fasten the assembly weight **37.1** properly on the fastening points **P33** on the auxiliary crane, see illustration **16**.
- ▶ Lift the assembly weight **37.1** with the auxiliary crane to the horizontal.

When the assembly weight **37.1** hangs horizontally on the auxiliary crane:

- ▶ Release and unpin the pin **39** between the assembly weight **37.1** and the upper pulley block **37**.
- ▶ Swing the assembly weight **37.1** out with the auxiliary crane and place it on a suitable substructure.
- ▶ Luff the D-boom down until the upper pulley block **37** is over the guy rods to be pinned.

Problem remedy

The D-boom cannot be luffed down further?

You luffed the D-boom down to the mandatory system shut off.

- ▶ Move the D-boom into the opposite direction from the shut off.

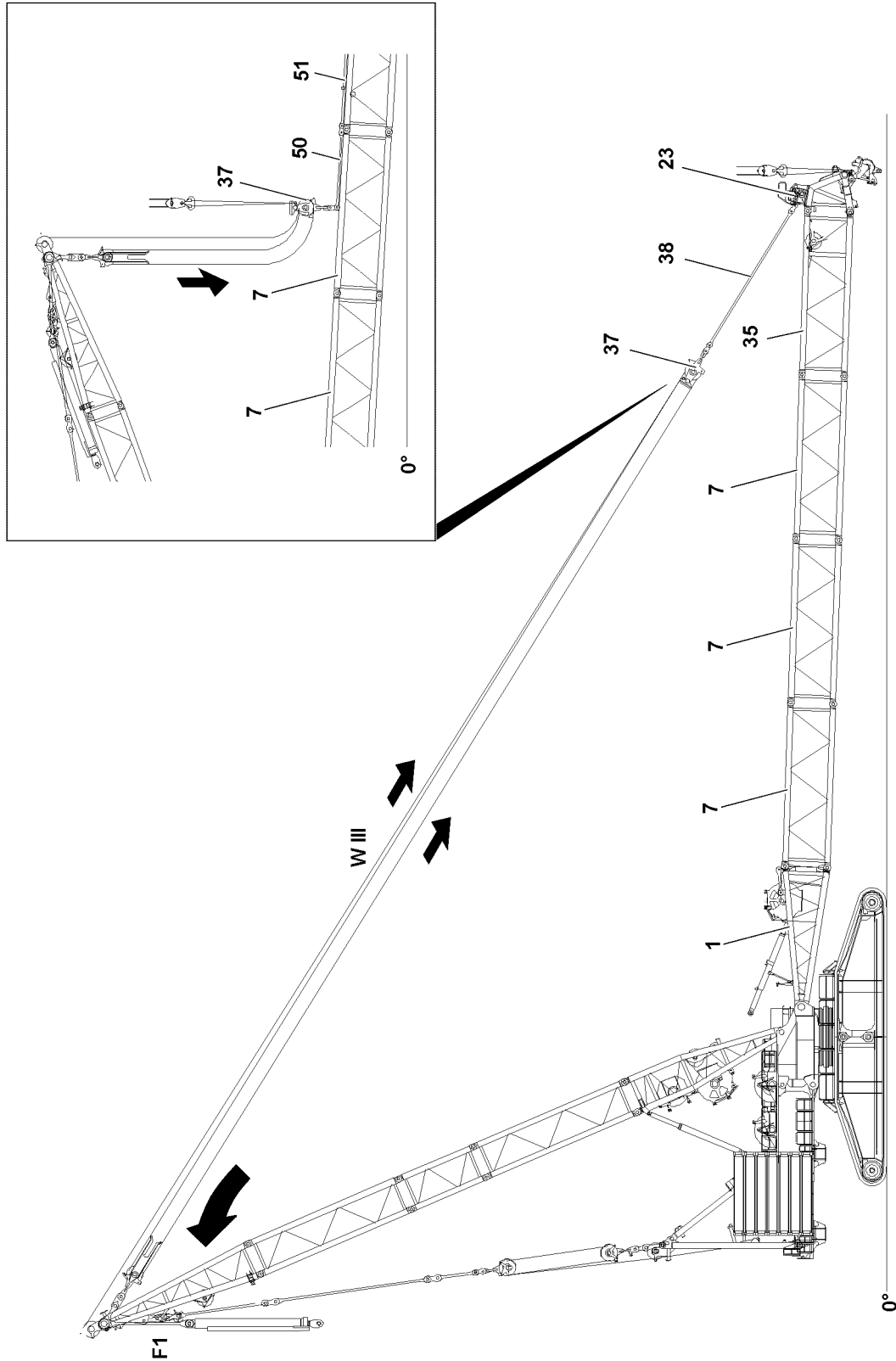

Fig.115889

LWE/LR 13000-001/19503-01-02/en

- ▶ Luff the D-boom slightly up.

**Note**

- ▶ On boom length over 60 m , the upper pulley block **37** must be positioned with the auxiliary crane over the guy rods in such a way that the guy rods can be safely pinned on the upper pulley block **37**.
- ▶ Pin and secure the guy rods with the upper pulley block **37**: Insert the pin from the inside to the outside and secure with safety locking pin.

**Note**

- ▶ The S-boom must remain on the ground when erecting the D-boom and may **not** be pulled up along.

When the guy rods are properly pinned and secured with the upper pulley block **37**:

- ▶ Erect the D-boom to operating position and at the same time, spool out winch 3 **WIII**.

**Note**

- ▶ When erecting the D-boom, pay attention to the minimum force **F1** on test point 1.
- ▶ To avoid a shut-off of the LMB during the erection procedure on the D-boom, do not fall below the minimum force **F1** on test point 1.

When the D-boom has reached the operating position:

- ▶ Tension the guying carefully between the D-boom and the S-boom head **23**.

When the guying is tensioned:

- ▶ Carefully and at slow speed lift the S-boom off the ground.
- ▶ Luff the S-boom up until the roller set / the roller sets can be installed on the S-end section.

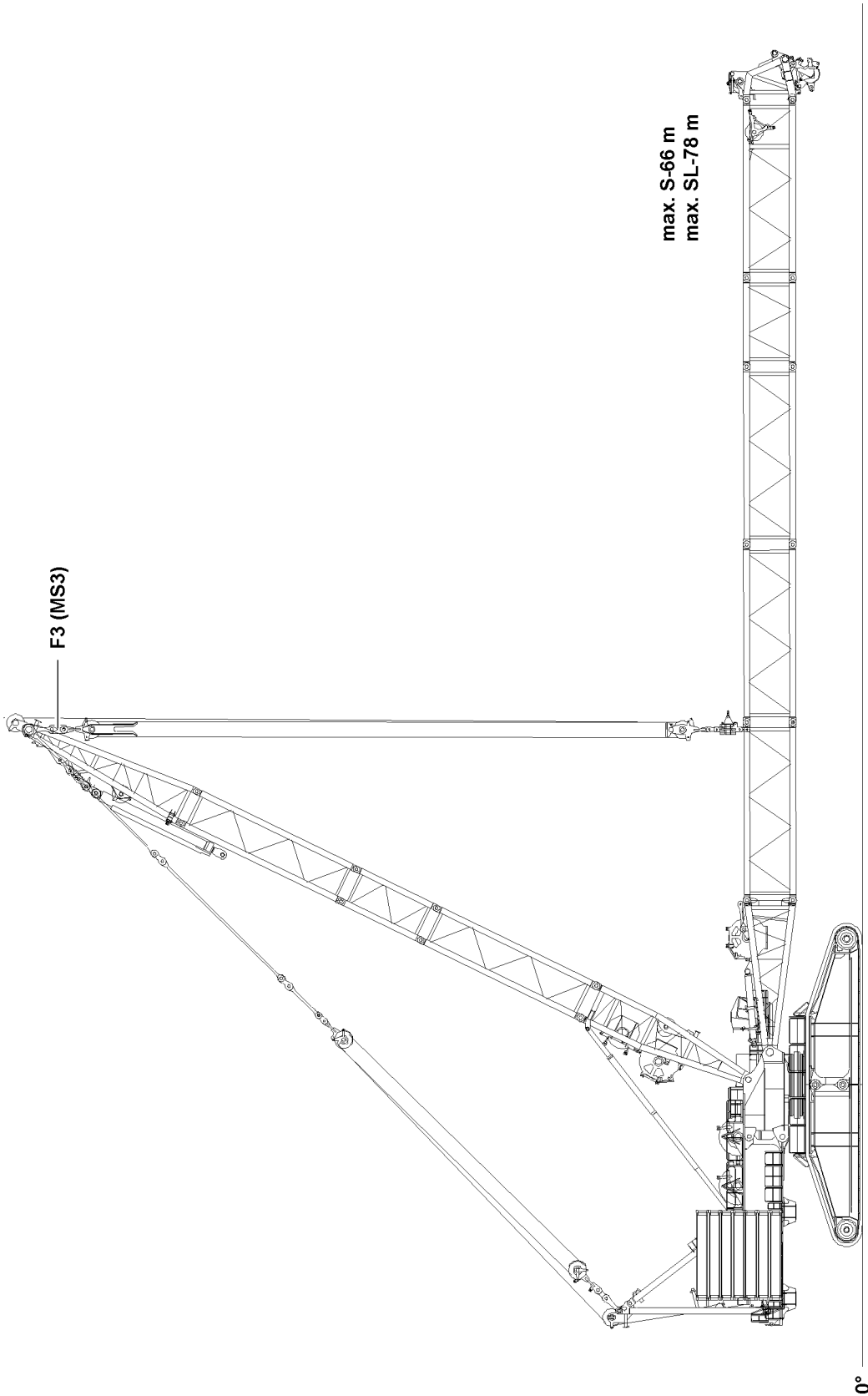

Fig.115838

LWE/LR 13000-001/19503-01-02/en

4 Assembling the SD/SLD-boom in „flying“ mode

If spatial prerequisites on the job site are limited for the assembly of the S-boom, or if they are limited by buildings or similar, then the S-boom can be assembled in „flying“ mode.



WARNING

General danger notes!

- ▶ All pins are to be secured after assembly with the intended retaining elements.



WARNING

The crane can topple over!

If the following conditions are not met, the crane can topple over or be significantly damaged.

Personnel can be severely injured or killed.

- ▶ For the „flying“ boom assembly, the maximum permissible total force on the test point 3 may **not** be exceeded. The „actual force“ is shown on LICCON monitor 1.
- ▶ The „flying mode“ boom assembly is only permissible to certain system lengths.
- ▶ The maximum permissible system lengths may **not** be exceeded, refer to the following chart.



Note

- ▶ Weights of the individual lattice sections, the respective guy rods as well as the roller sets, see chapter 1.03.

Maximum permissible system lengths for a maximum total force F3 (MS3) of 500 t				
Boom system	Maximum system length	Equipment	DB _{min} ¹⁾	Illustration
SL(D)	78.0 m	- with head -1 roller set - S- and WA-frame 2 guy rods to SL-78m	400 t	
S(D)	66.0 m	- with head - 2 roller sets - S- and WA-frame 2 guy rods to S-66m	400 t	

1) This counterweight must be at least installed on the turntable for „flying assembly“.

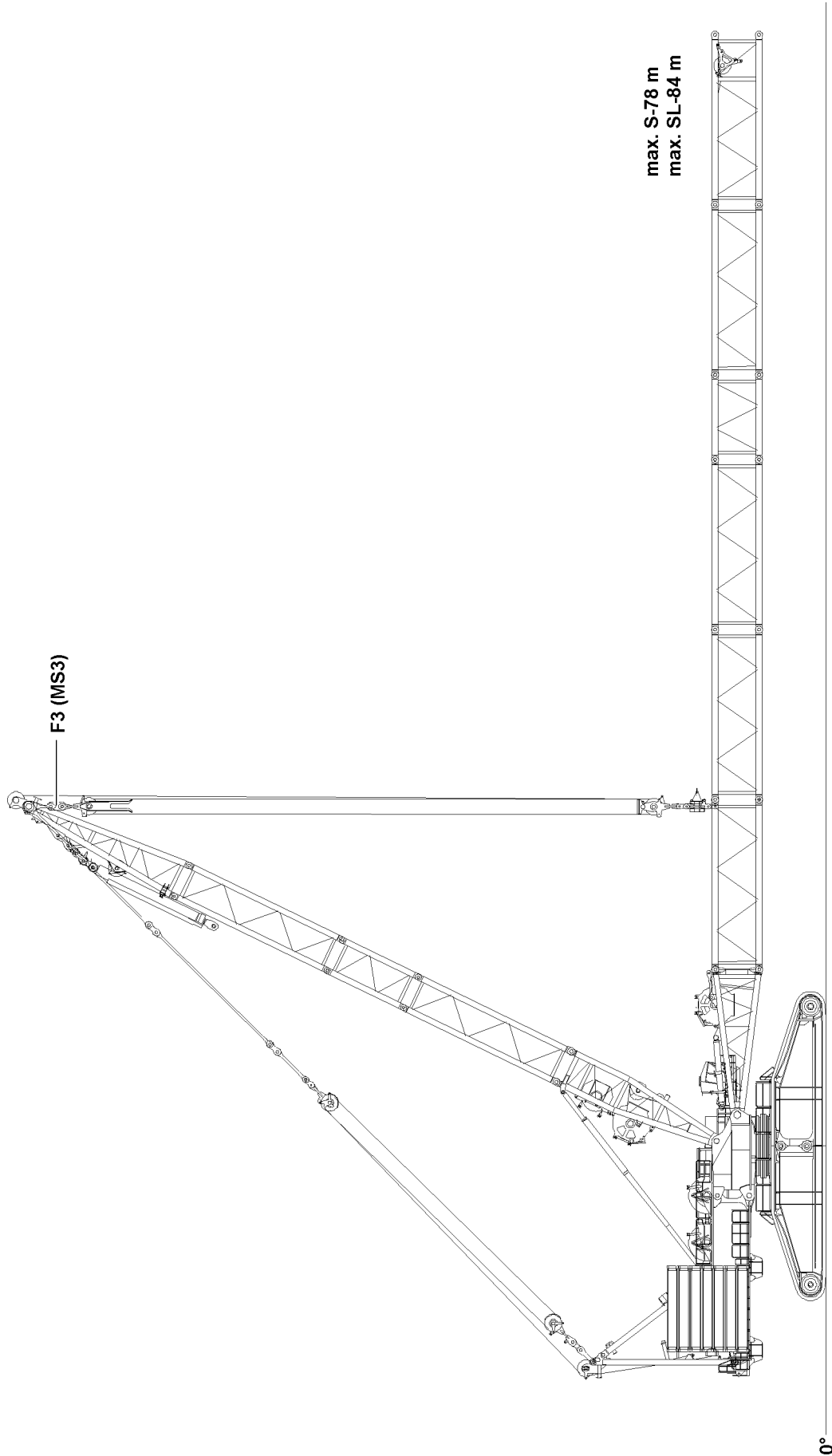

Fig.115890

LWE/LR 13000-001/19503-01-02/en

Maximum permissible system lengths for a maximum total force F3 (MS3) of 500 t				
Boom system	Maximum system length	Equipment	DB _{min} ¹⁾	Illustration
SL(D)	84.0 m	- without head - S- and WA-frame 2 guy rods to SL-84m	400 t	
S(D)	78.0 m	- without head - S- and WA-frame 2 guy rods to SL-78m	400 t	

1) This counterweight must be at least installed on the turntable for „flying assembly“.

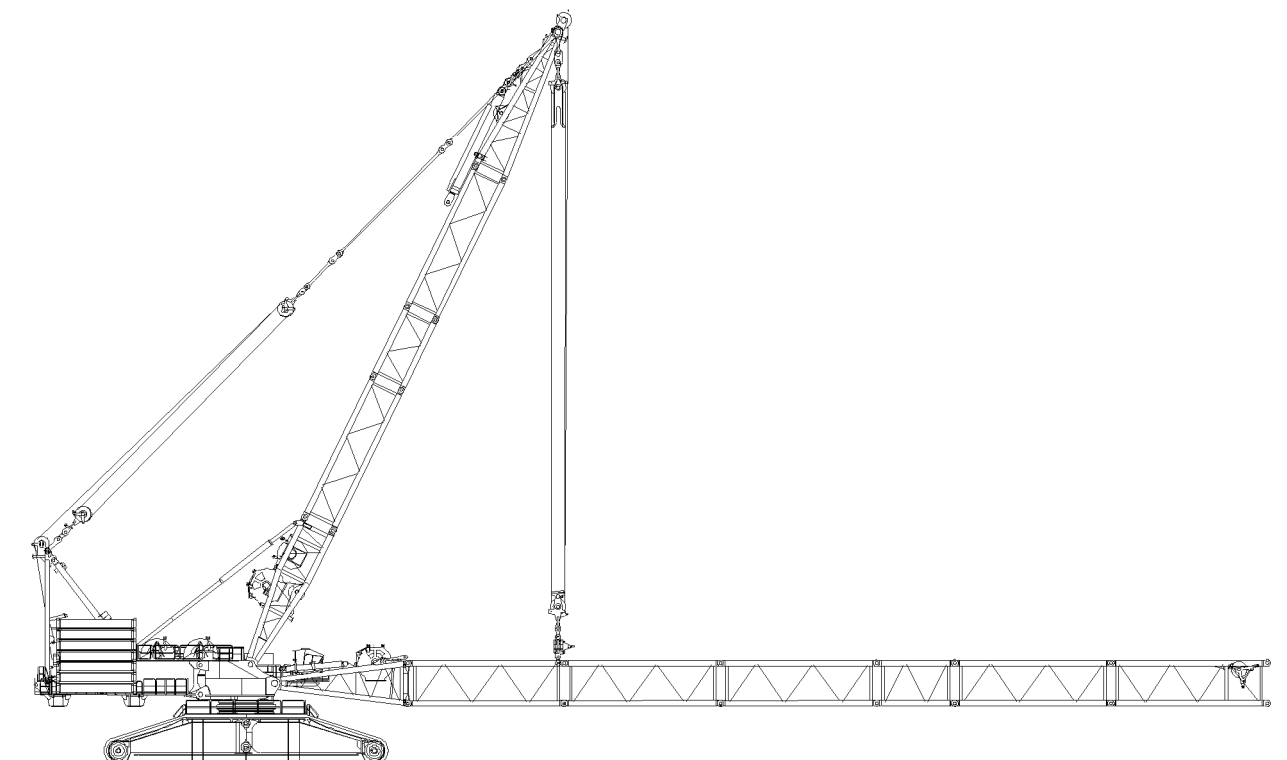
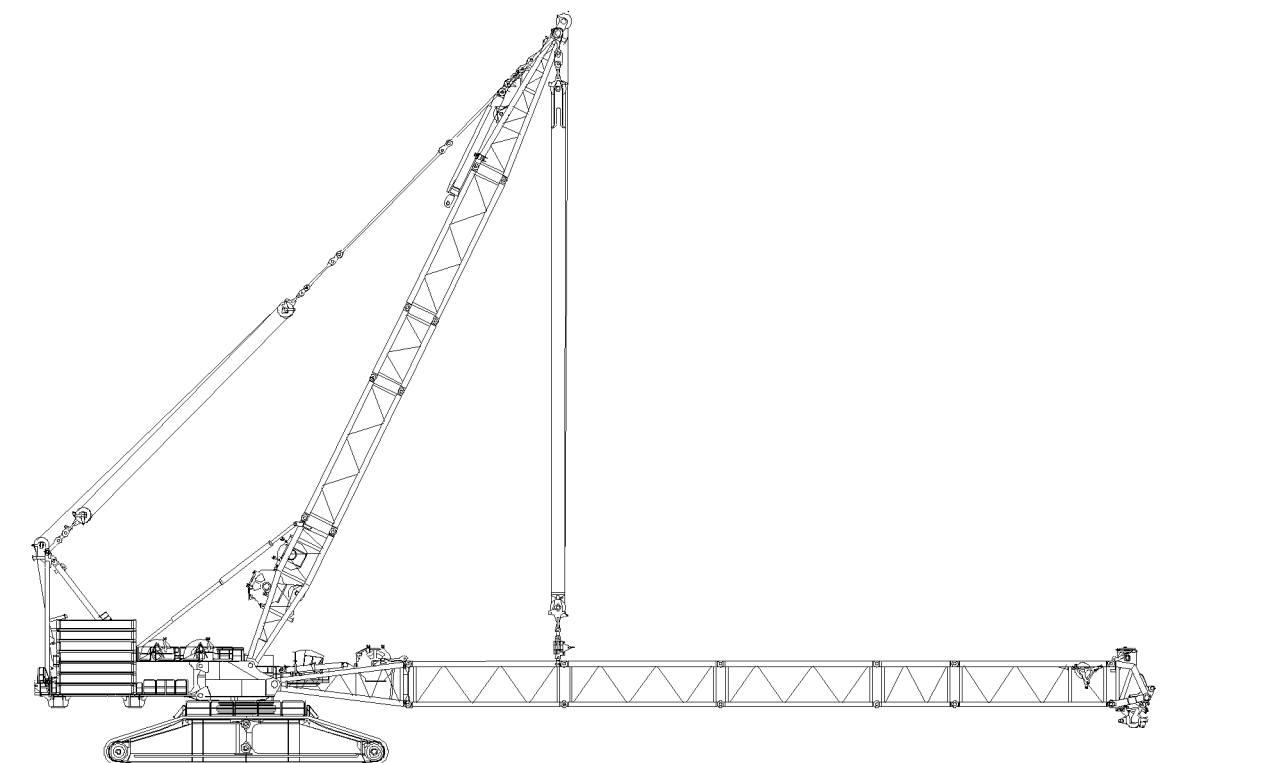

Fig.115839

LWE/LR 13000-001/19503-01-02/en

4.1 S-intermediate sections „flying“ assembly

In „flying“ assembly, the intermediate sections can be pinned and secured with the auxiliary crane individually or as a preassembled unit on the tensioned S-intermediate section.



WARNING

Impermissible boom lengths!

If impermissible boom lengths are installed on the crane, significant property damage can occur on the crane.

Personnel can be severely injured or killed.

- ▶ The maximum permissible boom / system lengths for the „flying assembly“ may not be exceeded.
- ▶ The specifications in the erection and take-down charts as well as the load charts must be observed.

Make sure that the following prerequisites are met:

- The S-pivot section is pinned and secured on the turntable.
- The S-boom system is guyed horizontally with the first S-intermediate section.
- A minimum of 400 t counterweight is placed on the turntable.
- Two auxiliary cranes with sufficient load capacity are available.



WARNING

Falling components!

If unsecured components are installed or removed, they can fall down.

Personnel can be severely injured or killed.

- ▶ During pinning and unpinning of the intermediate sections, it is prohibited for anyone to remain **under** or **on** the components as well as within the entire danger zone.
- ▶ Make sure that all crane components and intermediate sections are properly secured before unpinning.
- ▶ Secure the pins in the storage locations and in the receptacles.
- ▶ It is prohibited to lean a auxiliary ladder against the crane section which is being disassembled.

- ▶ Attach the S-intermediate sections or preassembled boom unit on the auxiliary crane.

- ▶ Lift the S-intermediate sections or the preassembled boom unit with the auxiliary crane and position on the guyed S-intermediate section.

When the pin points between the S-intermediate section and on the S-intermediate section to be assembled **or** the preassembled boom unit align „on top“ and „bottom“:

- ▶ Pin the connector pins „on top“ and „bottom“ on both sides and secure with retaining pins, see section „Installing the S-intermediate sections“.

When the connector pins between the guyed S-intermediate section and on the S-intermediate section to be assembled **or** the preassembled boom unit are properly pinned and secured „on top“ and „bottom“:

- ▶ Hold the boom with the auxiliary crane in position.

When the boom is safely held by the auxiliary crane:

- ▶ Carefully lower the upper pulley block until the brackets are relieved.
- ▶ Release and unpin the brackets on the assembly weight.



Note

- ▶ Assembly of guy rods, see section „Assembling the guy rods“.

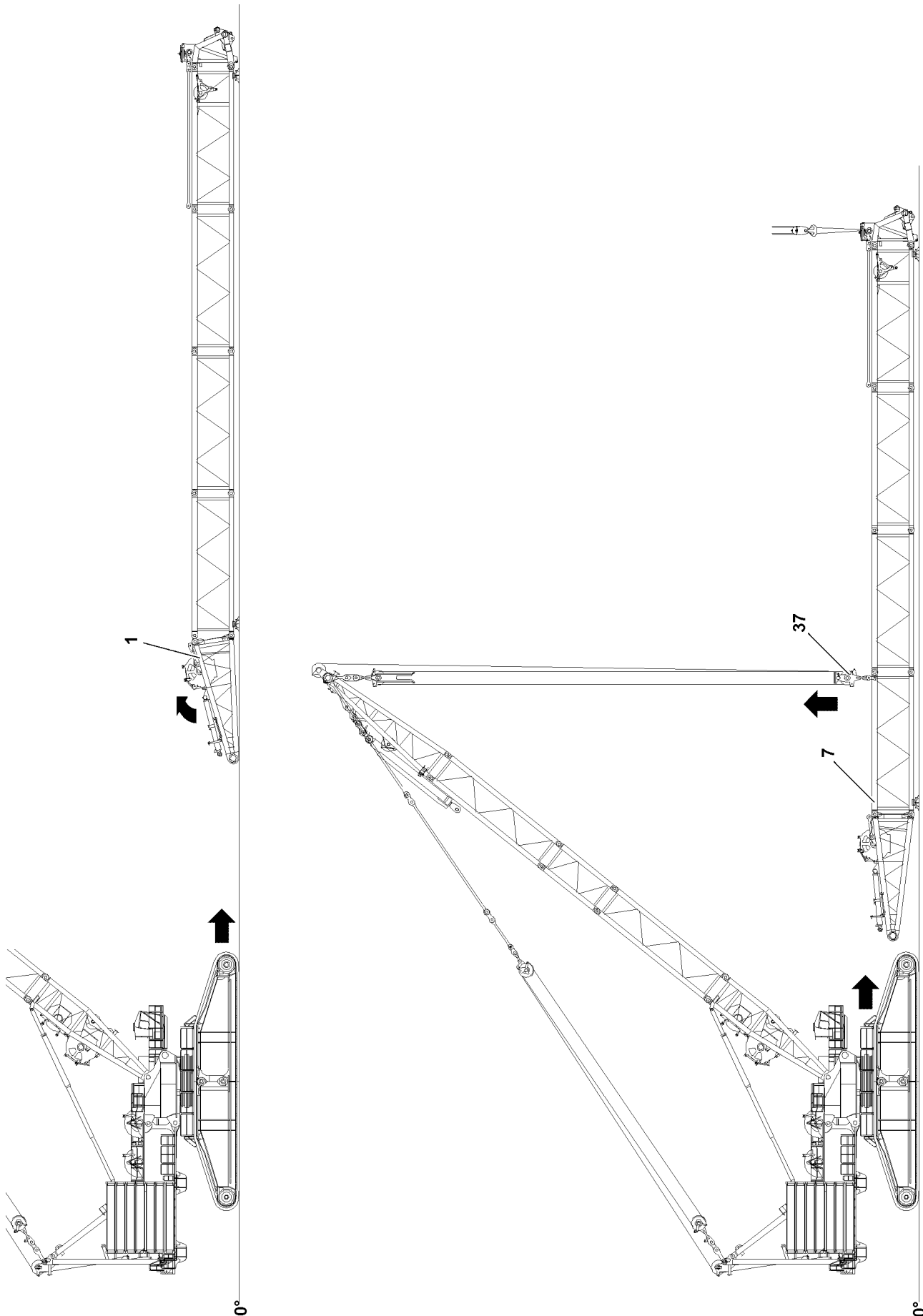

Fig. 115888

LWE/LR 13000-001/19503-01-02/en

5 Preassembling the SD/SLD-boom on the ground and installing it on the crane

NOTICE

Danger of property damage!

With the central ballast installed, if the boom sections - starting from the S-pivot section - are individually installed on the turntable, then severe property damage on the central ballast or on the boom system can be the result.

- ▶ Make sure, with assembled central ballast, that the boom is preassembled on the ground and then installed on the turntable.

5.1 Preassembling the SD/SLD-boom on the ground

Make sure that the following prerequisites are met:

- The ground is level.
- The ground is able to safely take on the weight of the entire boom.
- The connector pins for the assembly of the S-boom on the turntable are completely unpinned.



WARNING

Danger due to tipping boom!

During the boom assembly on the ground, the boom can tip over in direction of the S-pivot section. Personnel can be severely injured or killed.

- ▶ Make sure that the boom system is assembled on the assembly shoes.
- ▶ Make sure that the upper pinning of the S-pivot section is connected only after the assembly of the boom.

- ▶ Assemble the S-boom properly.

When the S-boom is completely assembled on the ground and all pin connections are properly secured:

- ▶ Lift the S-boom with the D-boom and auxiliary crane in to the pin points on the turntable.
- or
- ▶ Lift the S-boom with the D-boom and move the crane until the pin points between the S-pivot section and the turntable align.
- ▶ Pin and secure the S-boom properly on the turntable.



Note

- ▶ Assembly of guy rods, see section „Assembling the guy rods“.

6 Assembling the boom with the substructure

If the assembly conditions for the assembly of the boom system are restricted due to the terrain on the jobsite, then it is possible to install the SL-boom with a substructure 1.



WARNING

General danger notes!

- ▶ All pins are to be secured after assembly with the intended retaining elements.
- ▶ The guy rods must be inspected regularly, see chapter 8.15.
- ▶ Secure the boom with the substructure or auxiliary crane, see chapter 5.01.
- ▶ It is prohibited for anyone to remain under the booms or within the complete danger zone during the pinning and unpinning procedure of the lattice section.

NOTICE

Property damage!

If the pins of the guy rods are not pinned from the „inside“ to the „outside“, the hoist rope can scrape on the pins and be damaged.

- ▶ Always insert the pins of the guy rods from the „inside“ to the „outside“, see Rod plan.

**WARNING**

The crane can topple over!

Death, severe bodily injuries, property damage.

- ▶ For boom assembly / disassembly with the substructure, observe chapter 5.01.
- ▶ The „actual force“ on test point **F3** is shown on LICCON monitor 1.
- ▶ Observe the assembly conditions, see chapter 3.06.
- ▶ The specifications in the erection and take-down charts as well as the load charts must be observed.
- ▶ For the itemization of the lattice sections refer to the Rod plan.

NOTICE

Overload of the SL-boom!

If the SL-boom is not supported before the erection procedure, then the boom will be overloaded during the erection procedure.

The boom system will be damaged.

- ▶ Always support the SL-boom from a length of more than 138 m.
- ▶ Make sure that the dimension **X** for the maximum permissible deflection of the boom system is never exceeded.
- ▶ Support the SL-boom with suitable materials with sufficient load carrying capacity in the marked area, see illustration.

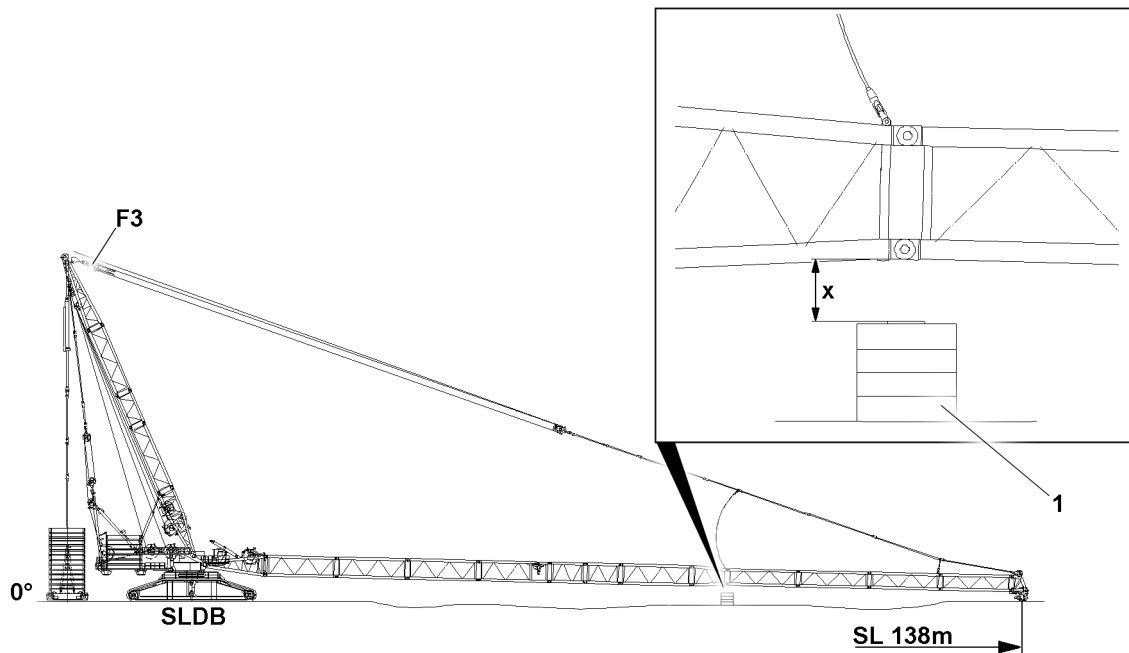

Fig.145059: Assembling the SL-boom with the substructure

The SL-boom must be preassembled at a suitable location.

Swing the preassembled SL-boom with the auxiliary crane(s) in to the turntable, pin and secure.

- ▶ Preassemble the SL-boom.

**WARNING**

Danger of accident due to boom system!

Death, severe bodily injuries, property damage.

- ▶ Make sure that no persons are within the danger zone of the crane and the boom system to be assembled.

- ▶ Swing the preassembled SL-boom with the auxiliary crane (s) to the turntable.
- ▶ Pin and secure the SL-boom with the S-pivot section on the turntable, see section „Assembling the S-pivot section on the turntable“.

When the boom system is properly installed with the S-pivot section on the turntable:

- ▶ Support the boom system properly before placing it on the ground.

Operating mode	Support from length	Dimension X ¹⁾
SL	138 m	1.3 m

1) = maximum permissible deflection of the boom system

- ▶ Lower the SL-boom on the ground.

**Note**

- ▶ Assembly of guy rods, see section „Assembling the guy rods“.

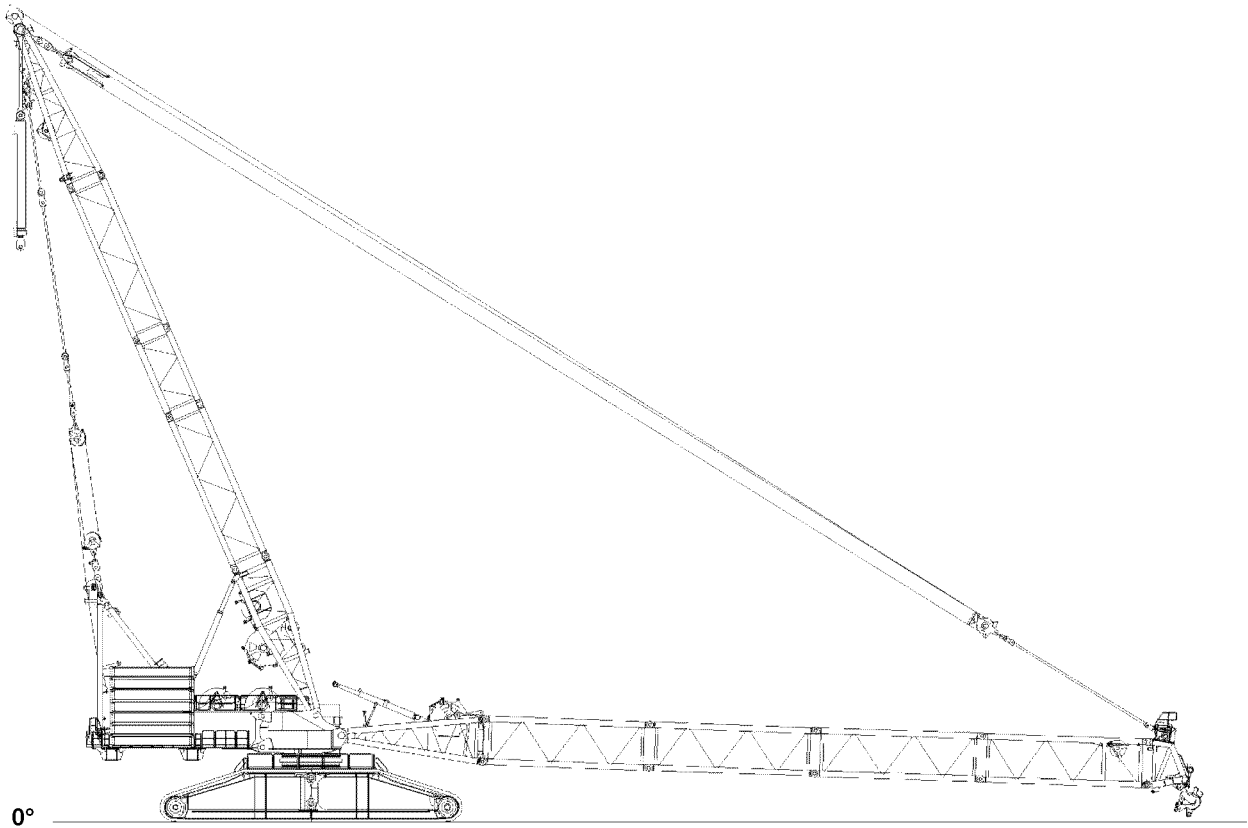

0°

Fig. 124445

LWE/LR 13000-001/19503-01-02/en

7 Assembling the roller sets on the boom head

7.1 Assembling the roller sets



Note

- ▶ The assembly of the roller sets is described in chapter 5.14.

When the roller set / the roller sets are properly installed on the boom head:

- ▶ Route the hoist limit switch from the end section forward on the roller set / the roller sets.

8 Performing the function checks



WARNING

Non-functioning safety equipment!

If the function of the safety equipment is defective, personnel can be severely injured or killed.

- ▶ Crane operation with non-functioning safety equipment is **prohibited**.



Note

- ▶ The function of the individual limit switches must be checked before erection of the boom system.
- ▶ The function of the limit switch initiators must be checked in the test system, see Diagnostics manual.



Note

- ▶ If a function check on the limit switches or on the safety equipment does not lead to the desired shut offs, then the plug connections on the connector boxes or the components itself must be checked. If no visible connection errors or component defects can be found, contact Liebherr Service.

Make sure that the following prerequisites are met:

- All electrical connections have been made.
- At least one crane engine is running.
- The corresponding operating mode is set on the LICCON monitor.
- The actuator levers of the limit switches have been checked for easy movement and are lubricated.

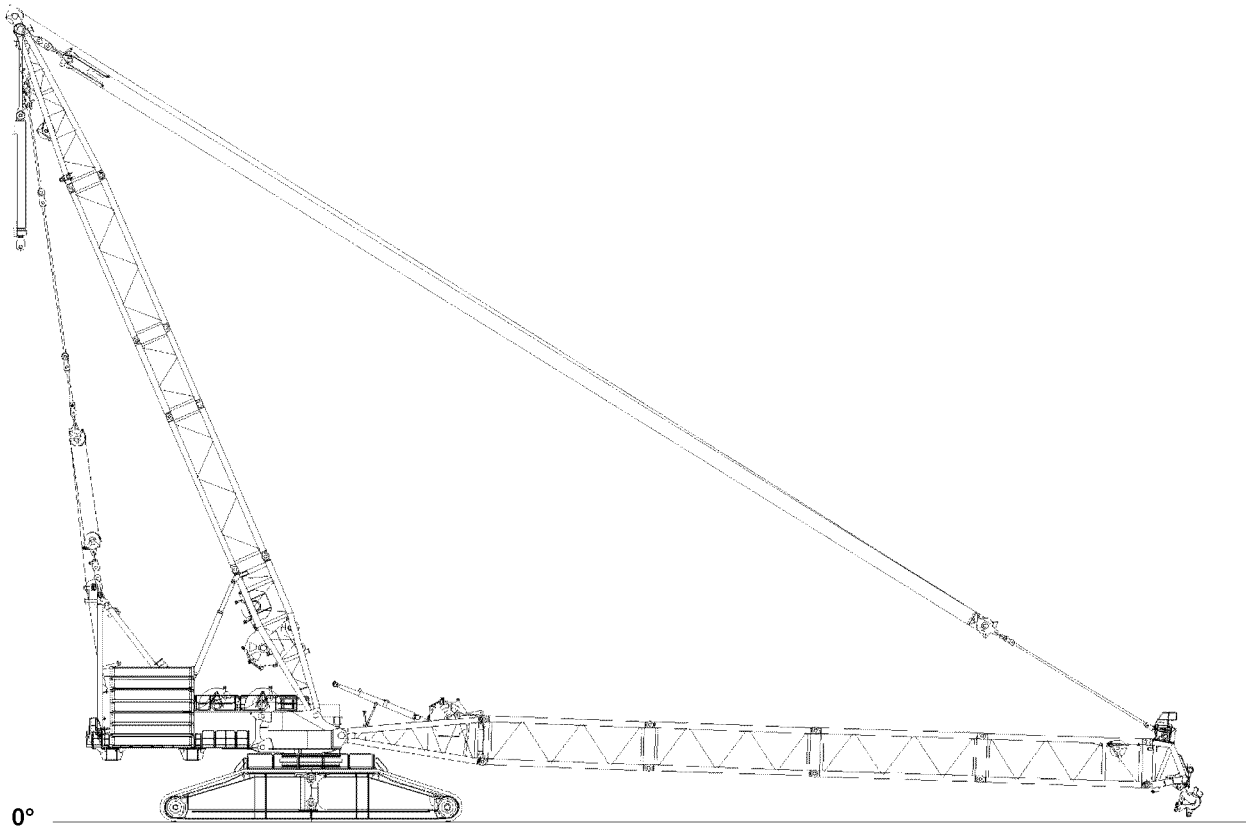

Fig. 124445

8.1 Wind speed sensor

- ▶ Check the movement and the function of the wind speed sensor.

8.2 Airplane warning light

- ▶ Turn the airplane warning light on, see chapter 4.01.
- ▶ Check the function visually.

8.3 Hoist limit switch

- ▶ Actuate the hoist limit switch manually on the pulley head.

Result:

- The hoist winch turns off in upward movement.
- The hoist top icon on the LICCON monitor 0 blinks.
- The hoist limit switch is functioning.

8.4 Checking the limit switch D-boom „Steepest position“



Note

- ▶ The limit switch functions have to be checked individually before erection.

- ▶ Cover the limit switch initiators on the D-relapse cylinders individually with a metal plate.

Result:

- The limit switch is actuated manually.
- The spool up function of winch 4 (control winch) turns off.
- The icon „Boom limitation“ appears on the LICCON monitor 0.

8.5 Checking the limit switch main boom „steepest position“



Note

- ▶ The limit switch functions have to be checked individually before erection.

- ▶ Cover the limit switch initiators on the relapse cylinders of the main boom individually with a metal plate.

Result:

- The limit switch is actuated manually.
- The spool up function of winch 3 turns off.
- The icon „Boom limitation“ appears on the LICCON monitor 0.

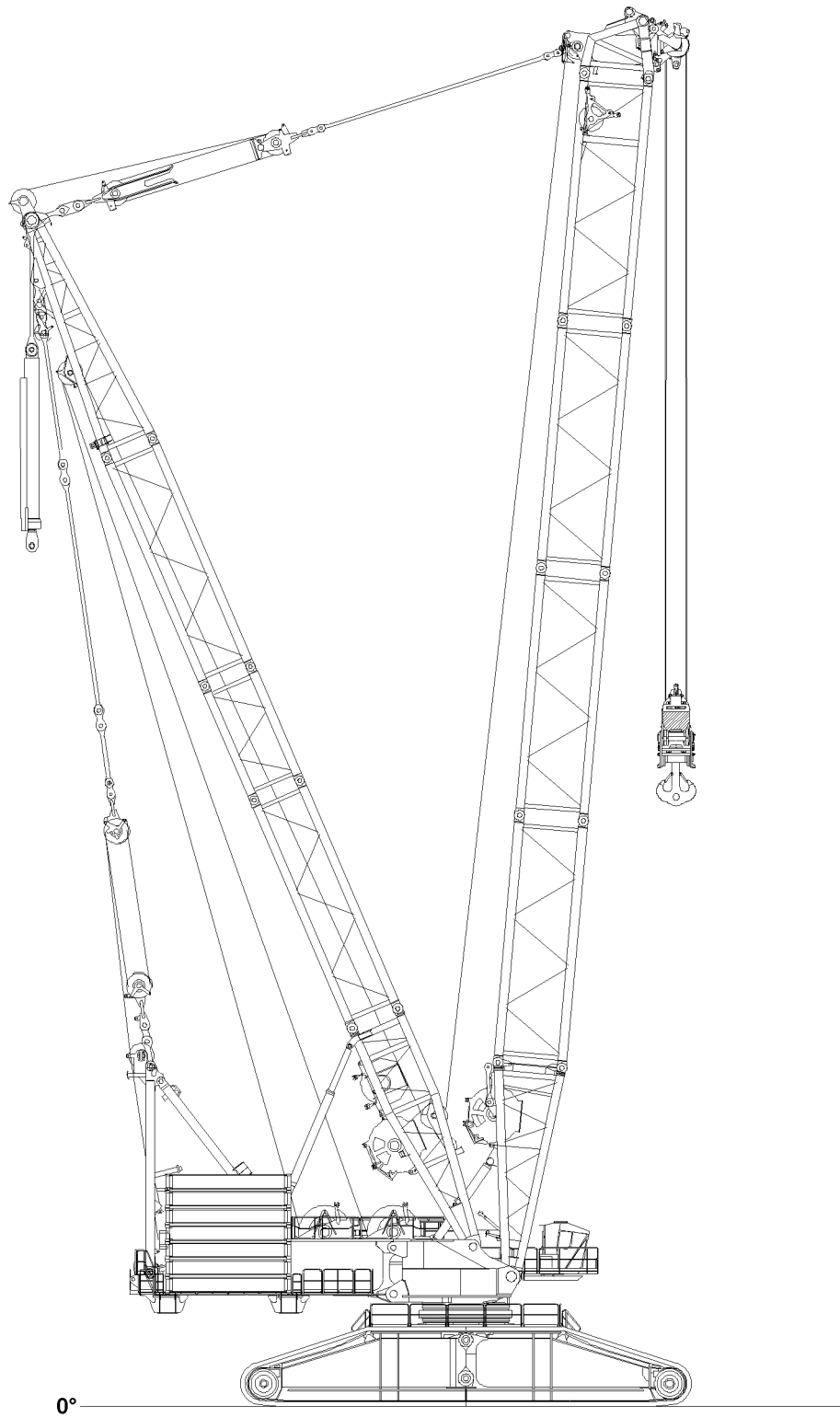

LWE/LR 13000-001/19503-01-02/en

Fig.115841

9 Erecting the boom



WARNING

The crane can topple over!

In crane operation with deactivated LICCON overload protection, the crane can topple over. Personnel can be severely injured or killed.

- ▶ The radii listed in the load chart may not be exceeded or fallen below, even if there is no load on the hook.

If required in the erection and take down chart:

- ▶ Carry the hook block along with the auxiliary crane.



WARNING

The crane can topple over!

If the following conditions are not met before erecting the boom, the crane can topple over. Personnel can be severely injured or killed.

- ▶ Observe the technical safety instructions, see chapter 5.01.
- ▶ Make sure that the relapse cylinder of the main boom is completely extended before erection of the boom combination.
- ▶ Do not allow slack rope formation on the control winch.

Make sure that the following prerequisites are met:

- The crane is horizontally aligned.
- The guy rods are properly assembled.
- The D-boom is in the operating position.
- All electrical connections have been made.
- All hydraulic connections have been made.
- All limit switches are functioning.
- The function checks were carried out properly.
- The counterweight has been installed on the turntable according to the erection and take-down charts.
- The central ballast (if required) is installed according to the erection and take-down charts on the crane chassis.
- All pin connections are secured.
- The hoist rope has been correctly placed in the rope pulleys and is prevented from jumping out with the rope retaining pins.
- There are no loose parts on the boom.
- The boom is free of snow and ice.
- The LICCON overload protection has been set according to the data in the load chart.
- The load weighing was carried out on the boom and the hook block weight has been entered on the LICCON monitor, see chapter 4.02.
- The LICCON overload protection settings have been compared with the actual set up configuration.
- The LICCON overload protection is deactivated.
- The assembly icon is visible on the LICCON monitor.
- No persons are present in the danger zone.

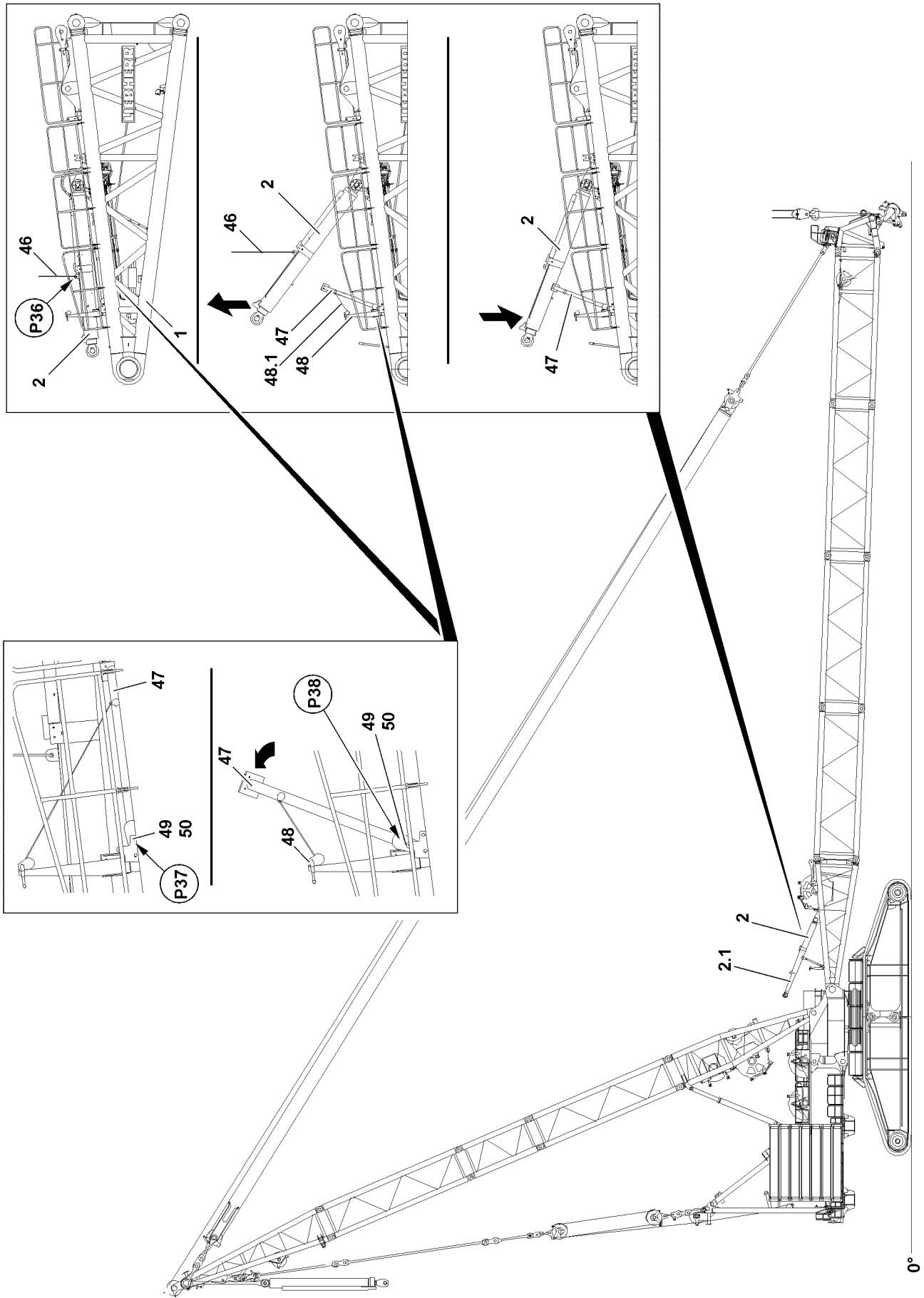

Fig.115892

LWE/LR 13000-001/19503-01-02/en

9.1 Bringing the S-relapse cylinders into the operating position

- ▶ Release the support **47** in transport position: Remove the safety locking pin **50** at point **P37** and unpin the retaining pin **49**.
- ▶ Attach the S-relapse cylinder **2** with the fastening equipment **46** on the fastening point **P36** on the auxiliary crane.

When the S-relapse cylinder **2** is properly fastened on the auxiliary crane:

- ▶ Lift the S-relapse cylinder **2** with the auxiliary crane.
- ▶ Bring the support **47** with the auxiliary winch **48** into the operating position.

When the support **47** is in operating position:

- ▶ Insert the retaining pin **49** on both sides at point **P38** and secure with safety locking pin **50**.
- ▶ Place the S-relapse cylinder **2** on the support **47**.

When the S-relapse cylinder **2** is completely placed on the prism of the support **47**:

- ▶ Remove the auxiliary crane.

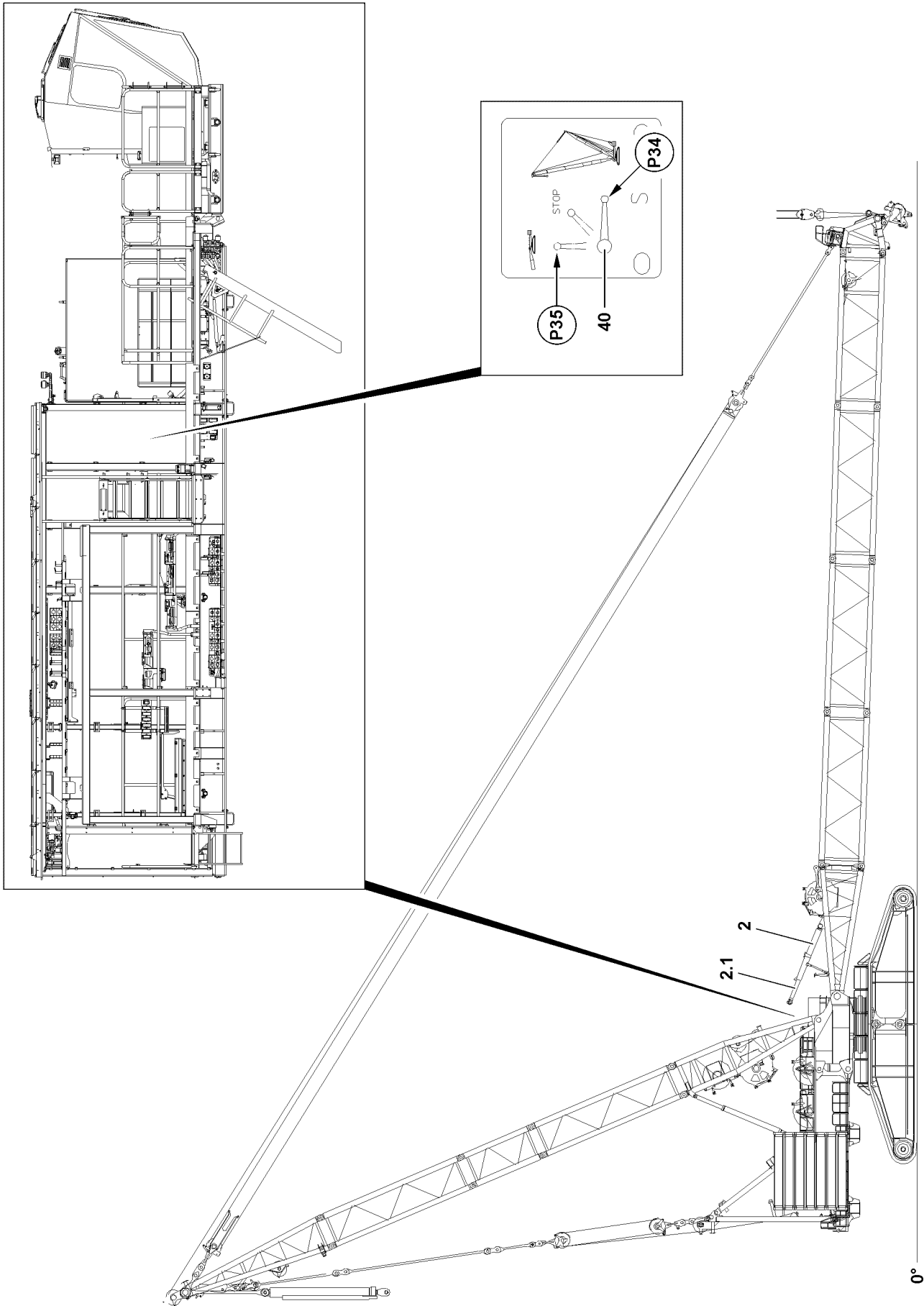

Fig.115842

LWE/LR 13000-001/19503-01-02/en

9.2 Extending the S-relapse cylinder on the S-pivot section



Note

- ▶ If the S-relapse cylinder is not extended in time, then the D-boom cannot be luffed up or down due to the block position of the limit switches on the S-relapse cylinder.



WARNING

The crane can topple over!

If the relapse cylinder for the main boom is not moved out before erecting the boom, then the boom can fall to the rear during erection or in crane operation and the crane can topple over.

Personnel can be severely injured or killed.

- ▶ Extend the S-relapse cylinder **2** before erecting the main boom.
- ▶ Secure the ball valve **40** during crane operation to prevent inadvertent actuation.

Ball valve positions	
Position (P)	Function
34	Crane operation, extend the piston rod
35	Assembly, retract the piston rod
STOP	The piston rod cannot be retracted / extended

Make sure that the following prerequisites are met:

- The hydraulic connections to the S-pivot section are properly established.
- At least one crane engine is running.

- ▶ Set the ball valve **40** to position **P34**.

Result:

- The piston rod of the S-relapse cylinder **2** extends.



Note

- ▶ The ball valve **40** is secured by closing the door to the engine house and removing the key.

When the piston rod of the S-relapse cylinder **2** is fully extended:

- ▶ Close the door and pull the key.
- ▶ Hand the key to an authorized person.

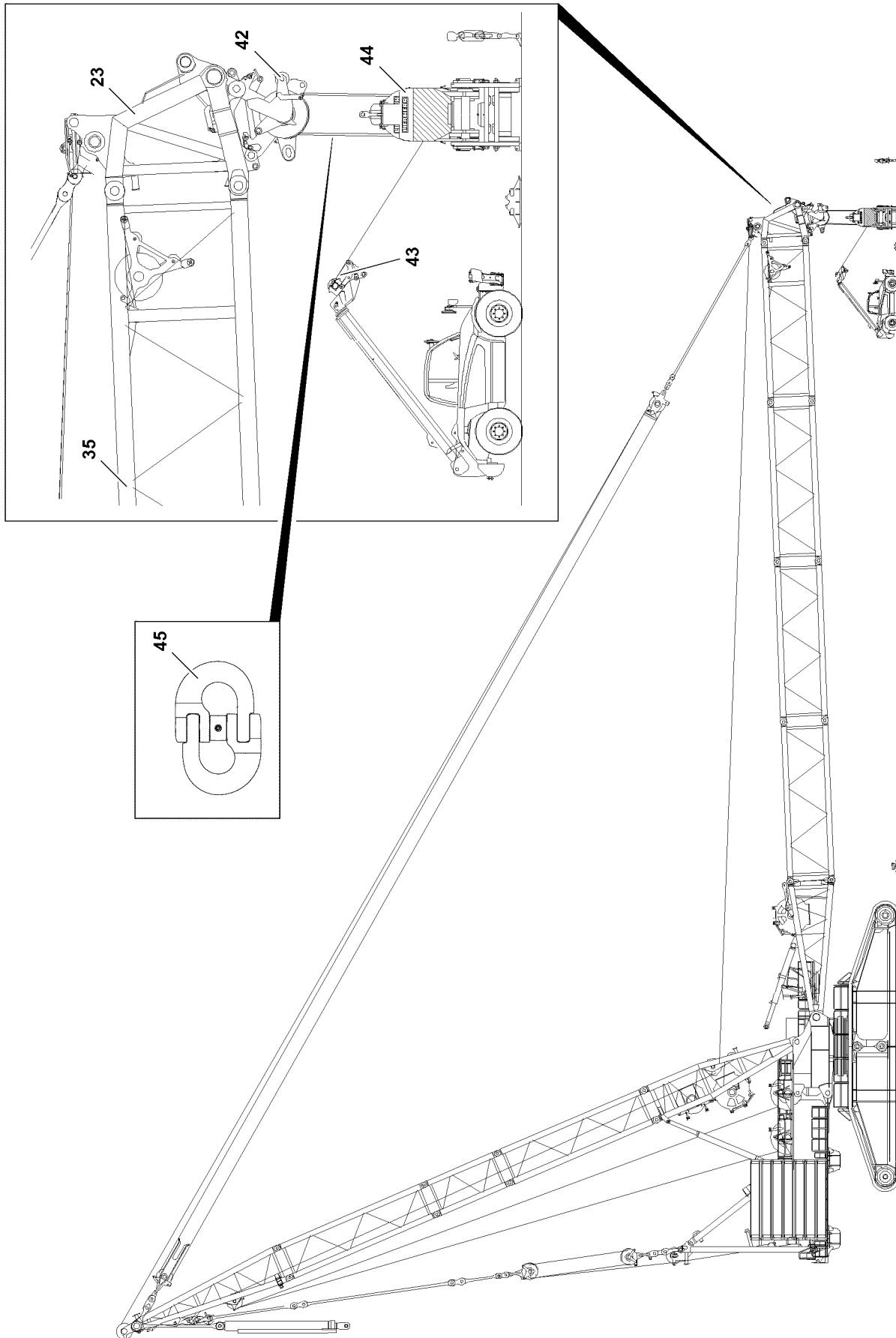

Fig.115843

LWE/LR 13000-001/19503-01-02/en

9.3 Erection procedure



DANGER

The crane can topple over!

- ▶ It is prohibited to turn the crane superstructure while erecting the boom.
- ▶ Adhere to the specifications in the erection and take down charts.

Make sure that the following prerequisite is met:

- The load weighing was carried out on the boom and the hook block weight has been entered on the LICCON monitor, see chapter 4.02.

9.3.1 Reeving in the hook block with the telescopic lift truck



WARNING

Danger of accident!

When using **non-approved** connecting links **45** when reeving in / out the hoist rope, the connecting links **45** can rip off suddenly.

Death, severe bodily injuries, property damage.

- ▶ Make sure that only original connecting links are used between the auxiliary winch and the hoist rope.
- ▶ Make sure that the proper pressure stage is set on the auxiliary winch of the telescopic lift truck for the reeving in / out of the respective hoist rope, see the separate operating instructions for the „assembly winch“.
- ▶ Make sure that the connecting links **45** between the auxiliary winch and the hoist rope have a higher load bearing capacity than can be created by the maximum strand pull of the respective auxiliary winch.
- ▶ The strand pull of the auxiliary winches installed on the crane side is **not** identical with the strand pull of the auxiliary winch of the telescopic lift truck.

Connecting link / Description	Load carrying capacity	Use for hoist rope diameter
CW8	2.5 t	38 mm
CWP10	5.0 t	52 mm



Note

Reeving in the hoist rope with telescopic lift truck.

- ▶ Reeving up to maximum 20-fold can be realized with one rope length on the telescopic lift truck.
- ▶ For higher reeving, reeve in 20-fold first and then the remainder.

Make sure that the following prerequisites are met:

- The roller set / roller sets **42** are properly installed and secured on the S-end section **23**.
- The hook block **44** is properly positioned and aligned under the S-end section **23**.
- The telescopic lift truck is properly positioned under the boom system.

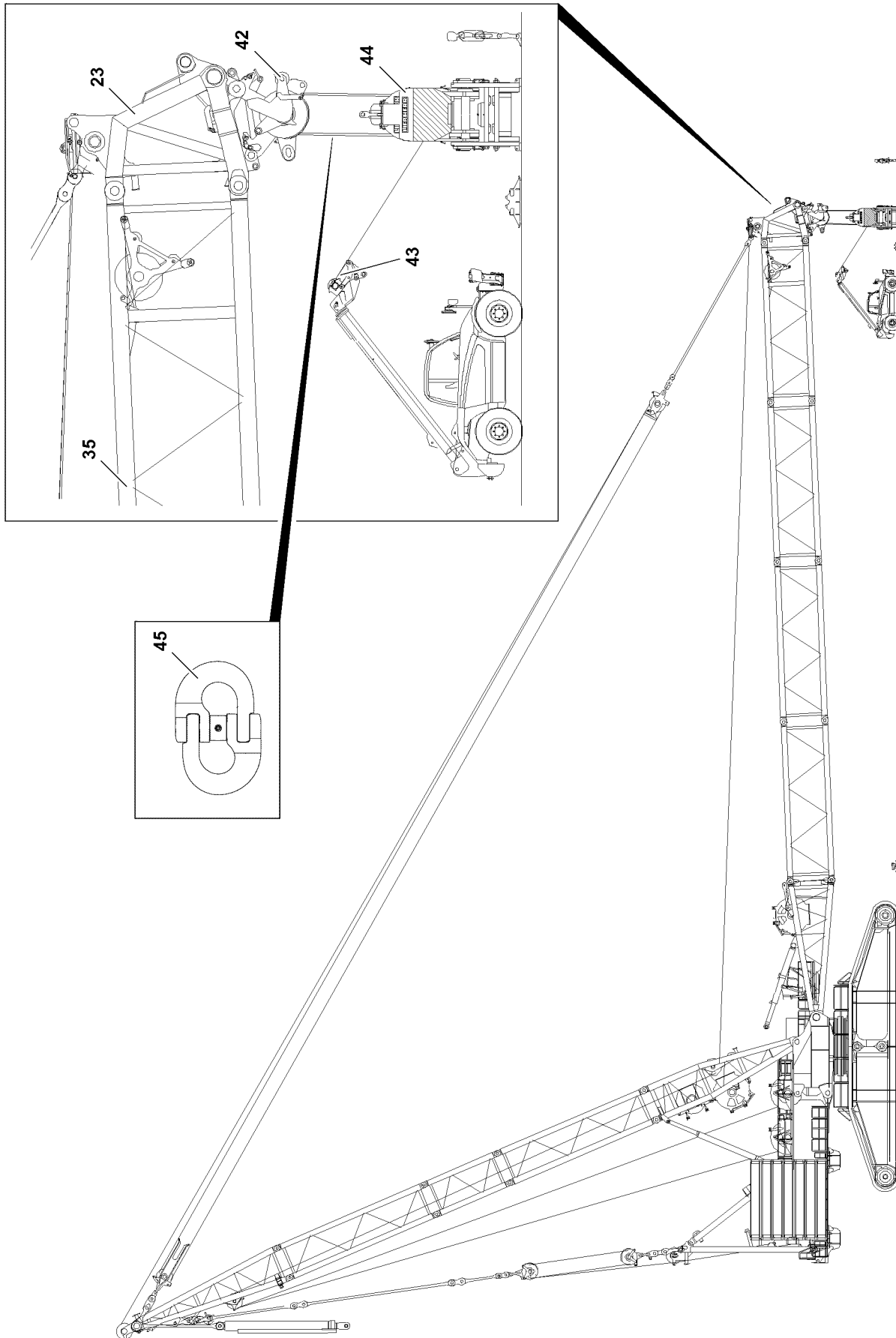

Fig.115843

LWE/LR 13000-001/19503-01-02/en

**Note**

- ▶ For the operation of the auxiliary winch **43** on the telescopic lift truck, see the separate Operating instructions of the manufacturer.
-
- ▶ Spool the rope of the auxiliary winch **43** out.
 - ▶ Guide the rope of the auxiliary winch **43** in reverse order to the actual hoist rope reeving through the respective rope pulleys on the hook block **44** and the end section **23**.
 - ▶ Fasten the rope of the auxiliary winch **43** properly on the take-in device of the hoist rope by using the connecting link **45**.

NOTICE

Danger of slack rope formation!

By spooling the hoist winch out too fast during the reeving procedure, slack rope can form.

- ▶ Make sure that the hoist rope is tensioned during the entire reeving procedure.
-
- ▶ Reeve in the hoist rope: Spool the auxiliary winch **43** up and simultaneously spool out the hoist rope from the respective winch.

When the hoist rope is properly reeved:

- ▶ Fasten the hoist rope on the rope fixed point, see chapter 4.06 and the separate reeving plan.

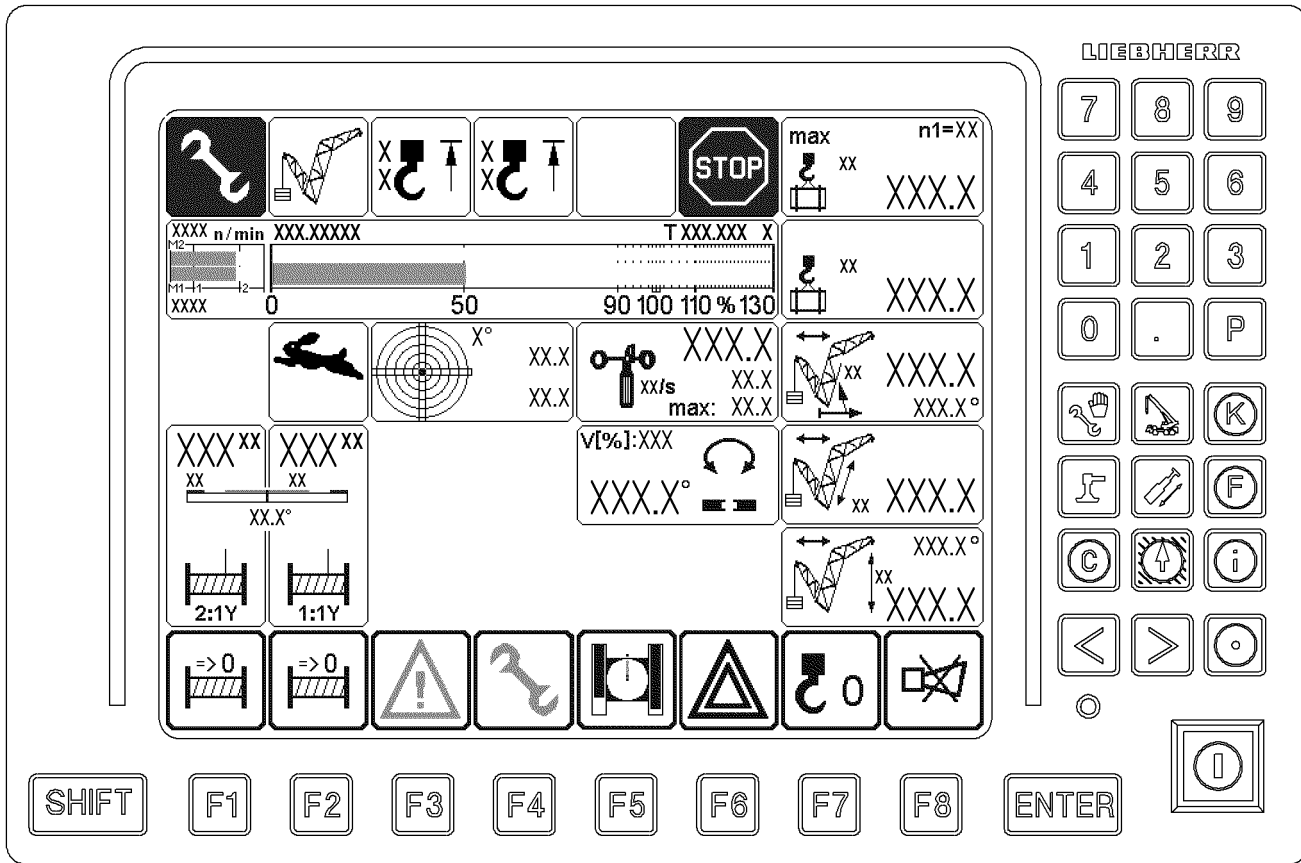

Fig.115840

9.3.2 Erecting the main boom



WARNING

The crane can topple over!

In crane operation with deactivated LICCON overload protection, the crane can topple over.

There is then no additional protection against crane overload.

Personnel can be severely injured or killed.

- ▶ The radii listed in the load chart may not be exceeded or fallen below, even if there is no load on the hook.
- ▶ Crane operation with deactivated LICCON overload protection is prohibited.



Note

- ▶ When the lowest operating position of the boom is reached, the LICCON overload protection is activated.
- ▶ In the maximum load icon appears a load number in „t“ instead of the display „???“.
- ▶ Luff the S-boom up to the lowest operating position.

When the S-boom has reached the lowest operating position:

- ▶ Make sure that the assembly icon on the LICCON monitor turns off.

Result:

- The LICCON overload protection is active.

10 Installing the central ballast

If a central ballast according to the load chart is required for the planned crane operation, then install the central ballast, see chapter 3.03.



WARNING

The crane can topple over!

If no central ballast is installed on the crane, the crane can topple over.

Personnel can be severely injured or killed.

- ▶ Make sure that the central ballast according to the load chart is installed for the planned crane operation.

11 Installing the derrick ballast

If a derrick ballast according to the load chart is required for the planned crane operation, then install the derrick ballast, see chapter 5.36.



WARNING

The crane can topple over!

If no derrick ballast is installed on the crane, the crane can topple over.

Personnel can be severely injured or killed.

- ▶ Make sure that the derrick ballast according to the load chart is installed for the planned crane operation.

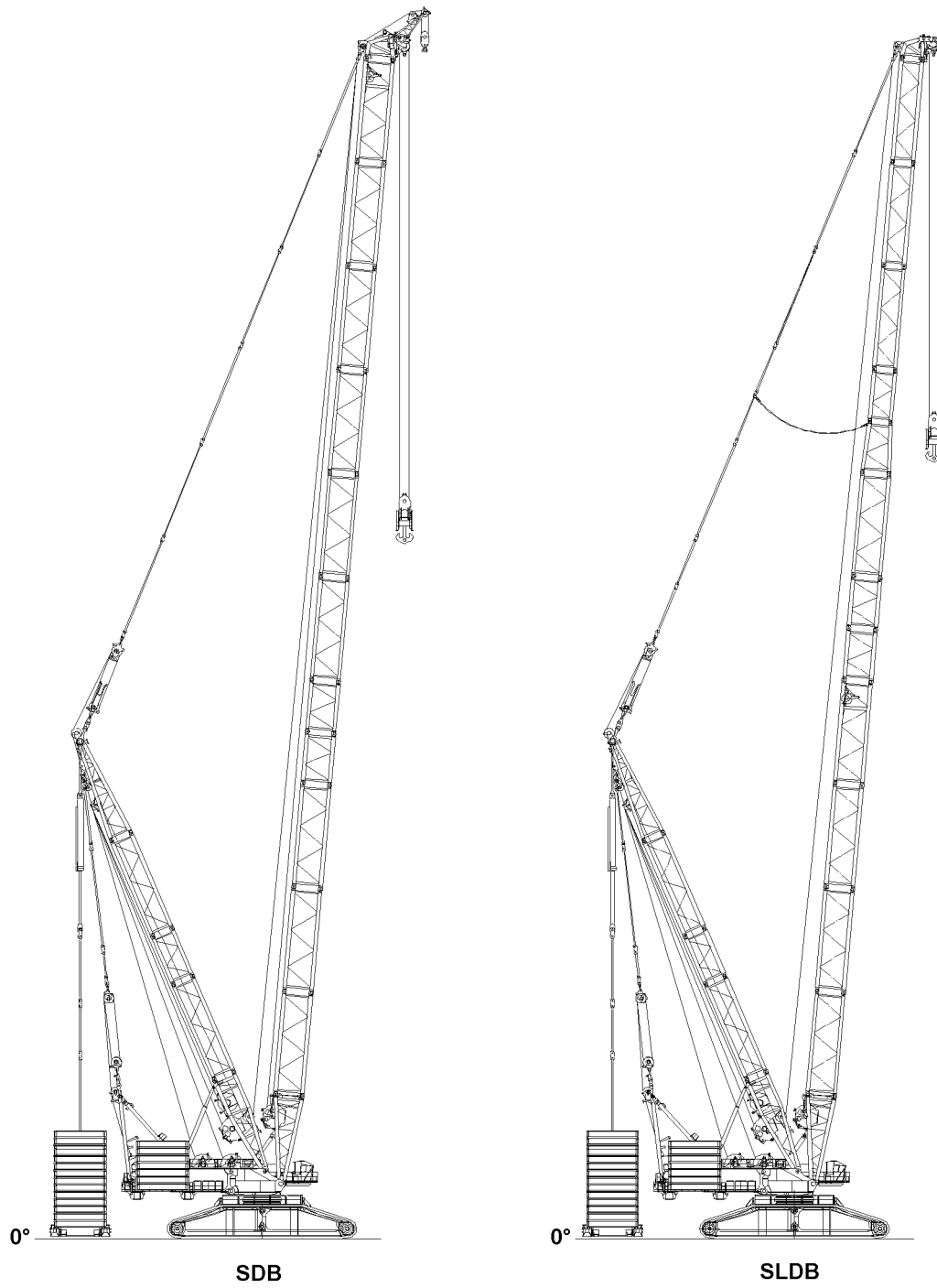

Fig.115221

12 Operating the crane

12.1 Preparing for crane operation



Note

- ▶ Observe the notes, see chapter 4.02, chapter 4.04, chapter 4.05, chapter 4.08 and chapter 5.01.

Make sure that the following prerequisites are met:

- The LICCON overload protection is active.
- The LICCON overload protection has been set according to the data in the load chart.



WARNING

The crane can topple over!

- ▶ Check the horizontal position of the crane before and during operation.
- ▶ If the crane operator leaves the cab, even for a short time, the operating mode setting must be checked and reset if necessary before resuming crane operation.

12.1.1 Checking the settings

- ▶ Check the function of the overload protection by running against the operating positions „on top“ and „bottom“.
- ▶ Check the hoist limit switch by running against the hoist limit switch weight.
- ▶ Check the function of the limit switches „Boom steep“ on the relapse cylinders.

13 Disassembling the SD/SLD-boom



WARNING

Danger of falling!

During assembly / disassembly, inspection and maintenance work, assembly personnel must be secured with appropriate aids to prevent them from falling. If this is not observed, assembly personnel could fall and suffer life-threatening or fatal injuries.

- ▶ All work aloft, where there is a danger of falling must be carried out with suitable aids.
- ▶ If aids are not available and work cannot be carried out from the ground, then the assembly personnel must secure themselves with the supplied fall arrest system to prevent falling, see chapter 2.04.
- ▶ If fall protection equipment is available, then it must be used, see chapter 2.06.
- ▶ When lifting, lowering, swinging crane parts in and out, no persons may remain in the danger zone.
- ▶ When closing or opening boom systems during boom assembly or disassembly, no persons may remain on the boom system or in the danger zone.
- ▶ If railings are present on the components, then they must be brought into the corresponding position and secured for assembly / disassembly work.
- ▶ Only step on the aids, ladders and catwalks with clean shoes.
- ▶ Keep aids, ladders and catwalks free of heavy dirt, snow and ice.
- ▶ During all assembly and disassembly work, maintenance work and inspections, travel or crane operation is prohibited.
- ▶ Remaining on a suspended load is prohibited.
- ▶ Stepping or walking on crane components and lattice sections, which have an incline of more than 20° is prohibited.
- ▶ For all assembly work, the crane driver of the main crane must be in voice contact with the crane driver / crane drivers of the auxiliary crane / auxiliary cranes.
- ▶ For assembly tasks, the crane driver may only initiate crane movements when the responsible guide has explicitly released the movement.

**WARNING**

The lattice sections can fall down!

If the lattice sections are not pinned and secured correctly, then they can fall down and fatally injure personnel.

- ▶ Pin or unpin both pins at the same horizontal level, i.e. **left and right**.
- ▶ Do not stand under the lattice sections or within the entire danger zone during the pinning and unpinning procedure of the boom.
- ▶ Safely secure the pins in the storage locations as well as in the receptacles.
- ▶ It is prohibited to lean the auxiliary ladder against the component being disassembled.

**Note**

- ▶ The disassembly is described on the example of the S-boom.
- ▶ For the combination of the boom lattice sections, observe and adhere to the Rod plan and chapter 5.03.

**WARNING**

Danger of impact / crushing!

When installing / removing crane components with the auxiliary crane, crane components can start to swing back and forth.

When lifting / lowering and positioning crane components, there is an increased danger of impacts / crushing.

Personnel can be caught and severely injured or killed.

- ▶ Make sure that personnel cannot be caught by components.
- ▶ Make sure that the crane is horizontally aligned.
- ▶ When working in danger zones: Use aids to protect limbs.
- ▶ Guide components with suitable aids to minimize oscillation.

**DANGER**

The components can fall down!

If the corresponding components are disengaged from the auxiliary crane before the corresponding component is pinned, the corresponding component can fall down and fatally injure personnel.

- ▶ Do not disengage the auxiliary crane until the corresponding component is pinned and secured.

Empty page!

LWE/LR 13000-001/19503-01-02/en

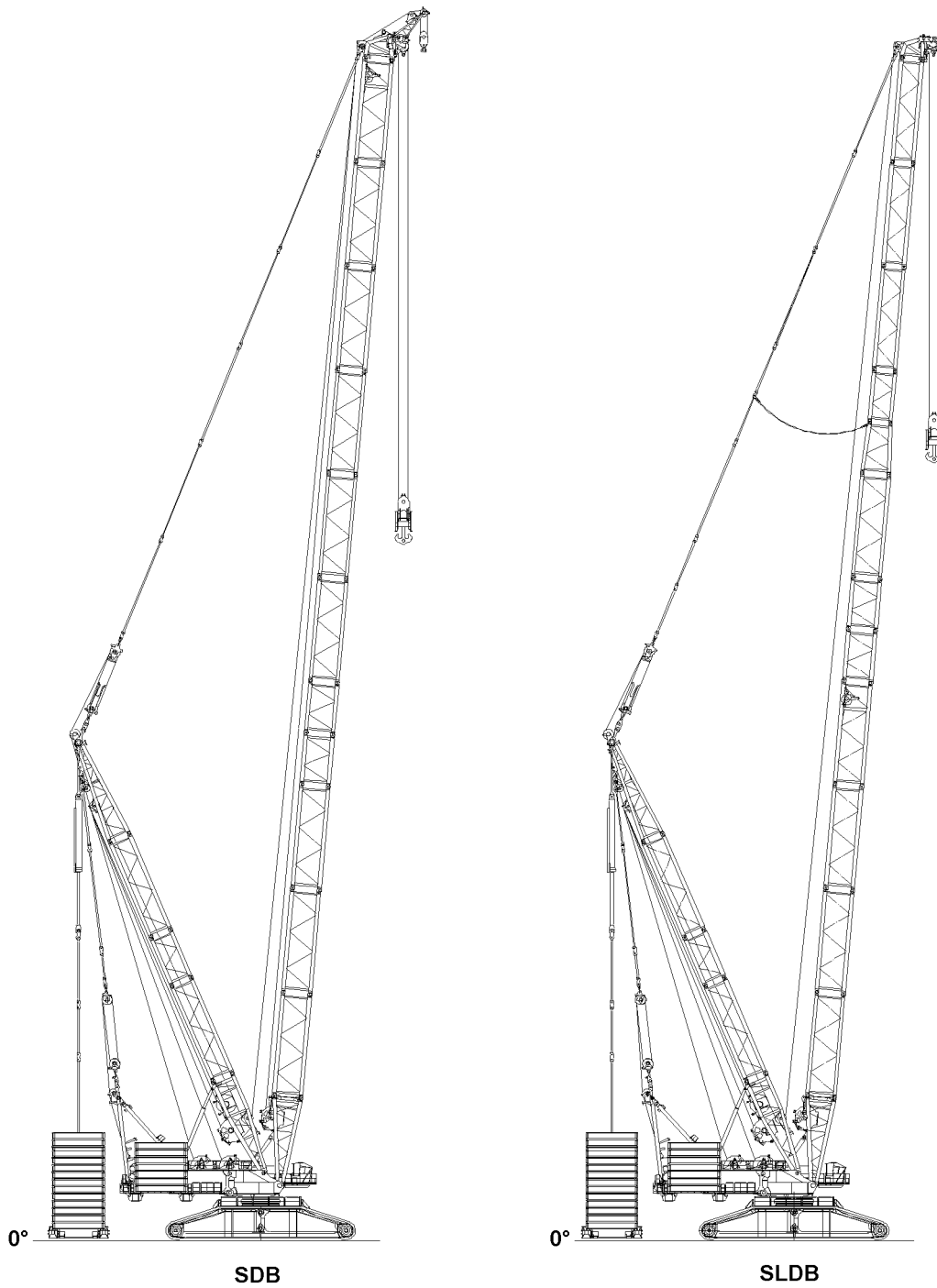

Fig.115221

LWE/LR 13000-001/19503-01-02/en

13.1 Disassembling the derrick ballast



WARNING

The crane can topple over!

If no derrick ballast is installed on the crane, the crane can topple over.

Personnel can be severely injured or killed.

- ▶ Observe the Erection and take down charts.
 - ▶ If a derrick ballast is required for taking down the boom system, then leave the derrick ballast on the crane.
-

When no derrick ballast is required for taking down the boom system:

- ▶ Disassemble the derrick ballast, see chapter 5.36.

13.2 Disassembling the central ballast



WARNING

The crane can topple over!

If no central ballast is installed on the crane, the crane can topple over.

Personnel can be severely injured or killed.

- ▶ Observe the Erection and take down charts.
 - ▶ If a central ballast is required for taking down the boom system, then leave the central ballast on the crane.
-

When no central ballast is required for taking down the boom system:

- ▶ Disassemble the central ballast, see chapter 3.03.

13.3 Turning the turntable to the disassembly position



WARNING

The crane can topple over!

If the following conditions are not met before turning the turntable, then the crane can topple over.

Personnel can be severely injured or killed.

- ▶ Observe the specifications in the erection and take down charts.
 - ▶ Observe the data in the load charts.
-

- ▶ Turn the turntable in lengthwise direction of the crawler travel gear.

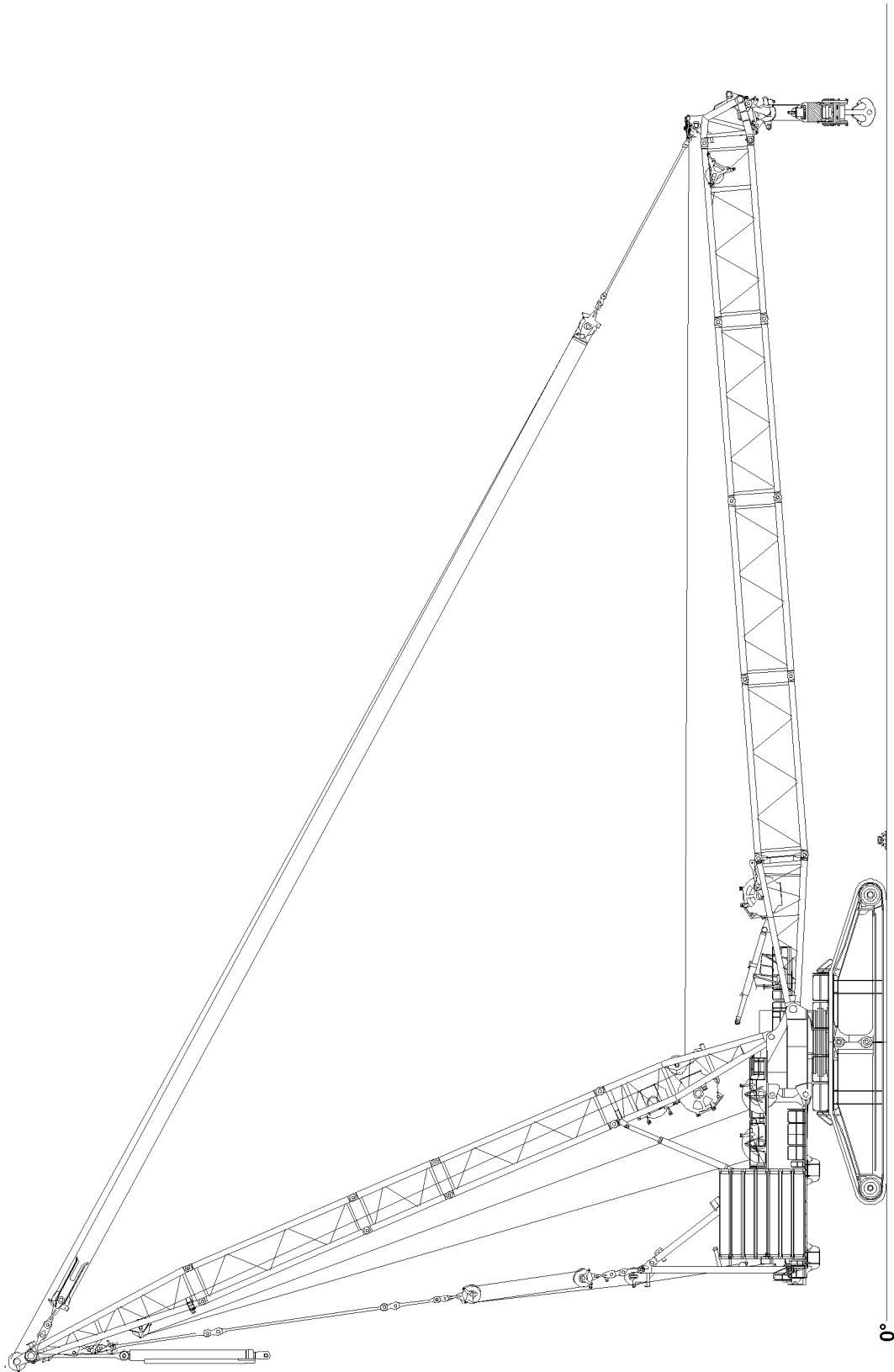

Fig.115893

LWE/LR 13000-001/19503-01-02/en

13.4 Luffing the main boom down and unreeving the hoist rope



WARNING

The crane can topple over!

If the following conditions are not met before taking down the main boom, the crane can topple over. Personnel can be severely injured or killed.

- ▶ Observe the technical safety instructions, see chapter 5.01.
- ▶ Observe the specifications in the erection and take down charts.

NOTICE

Damage of boom components!

Taking down the boom system can lead to a collision between the hook block and the pulley head. Boom components can be severely damaged.

- ▶ Luff the boom system down at the same time and spool the hoist winch out.
- ▶ When luffing the boom system down, the D-boom must remain in operating position until the S-end section is laying on the ground or is safely held by an auxiliary crane.



Note

- ▶ The luff down movement is turned off as soon as the lowest operating position of the main boom is reached.
- ▶ When the lowest operating position of the main boom is reached, the load display in the maximum load icon turns off and instead of the load display appears the display „???“.
- ▶ In the crane operating screen appear alarm functions.

- ▶ Luff the boom down to the **lowest** operating position.

Result:

- The luff down movement is turned off.
- The „STOP“ icon appears on the LICCON monitor.
- The horn icon appears on the LICCON monitor.



WARNING

Danger of accident due to function „Exceedance of shut off limits of the LICCON overload protection“! If the shut off limits of the LICCON overload protection are exceeded, there is no additional protection against crane overload.

Due to erroneous operation or deliberate misuse, the crane could collapse, the boom can break off or the crane can topple over.

Personnel can be severely injured or killed.

- ▶ The function „Exceedance of shut off limits of the LICCON overload protection“ is only permissible in emergencies and for assembly purposes.
- ▶ The function „Exceeding the shut off limits of the LICCON overload protection“ may only be actuated by persons who know the effects of their actions regarding the function „Exceeding the shut off limits of the LICCON overload protection“.
- ▶ The function „Exceedance of shut off limits of the LICCON overload protection“ requires the presence of an authorized person and must be performed with utmost caution.
- ▶ Crane operation with activated function „Exceedance of shut off limits of the LICCON overload protection“ is prohibited.

- ▶ Exceeding the shut off limits of the LICCON overload protection: Engage assembly operation.

Result:

- The shut off limits of the LICCON overload protection are exceeded.
- The assembly icon appears on the LICCON monitor.



Note

- ▶ See chapter 4.02 and chapter 4.20.

- ▶ At the same time, spool the hoist winch out and luff the boom system down until the hook block touches the ground.
- ▶ Remove the hoist limit switch weight and reeve the hook block out.
- ▶ Remove the hook block with the auxiliary crane.

When the hook block is removed under the boom head:

- ▶ Continue to luff the boom system down until the roller set / the roller sets are just above the ground.



WARNING

Spooling up of hoist rope!

By spooling the hoist rope up, personnel can be severely injured or killed.

- ▶ All rope retaining pins / pipes on the boom system are removed.
- ▶ Slowly spool up the hoist rope over the rope pulleys back to the winch.
- ▶ No one may be present in the danger zone.

- ▶ Connect the hoist rope with the auxiliary rope of the telescopic lift truck.



WARNING

Danger of accident!

When using **non-approved** connecting links **45** when reeving in / out the hoist rope, the connecting links **45** can rip off suddenly.

Death, severe bodily injuries, property damage.

- ▶ Make sure that only original connecting links are used between the auxiliary winch and the hoist rope.
- ▶ Make sure that the proper pressure stage is set on the auxiliary winch of the telescopic lift truck for the reeving in / out of the respective hoist rope, see the separate operating instructions for the „assembly winch“.
- ▶ Make sure that the connecting links **45** between the auxiliary winch and the hoist rope have a higher load bearing capacity than can be created by the maximum strand pull of the respective auxiliary winch.
- ▶ The strand pull of the auxiliary winches installed on the crane side is **not** identical with the strand pull of the auxiliary winch of the telescopic lift truck.

Connecting link / Description	Load carrying capacity	Use for hoist rope diameter
CW8	2.5 t	38 mm
CWP10	5.0 t	52 mm



WARNING

Danger of accident!

Death, severe bodily injuries, property damage.

- ▶ It is prohibited for anyone to remain in the danger zone of the running rope.



WARNING

Slack rope formation!

The hoist ropes could be damaged by the formation of slack rope.

This could result in high property damage.

- ▶ Do not allow any slack rope to be formed when spooling up the hoist ropes.
- ▶ When spooling the hoist ropes up with the telescopic lift truck and its auxiliary winch, hold them taught.
- ▶ A voice connection between the driver of the telescopic lift truck and the crane operator is available.

NOTICE

Overspooled winch!

If the hoist rope is pulled under the winch when spooling up, then the adjustment of the cam limit switch can change.

A new adjustment by **Liebherr Service** is required.

- ▶ Stop the winch in time, with sufficient rope reserve.
 - ▶ Do not overspool the winch.
-
- ▶ Carefully spool up the hoist rope at a low speed while spooling out the auxiliary winch.
 - ▶ Stop the hoist rope with sufficient rope reserve before the hoist winch.

13.5 Retracting the S-relapse cylinder and placing it down in transport position

Make sure that the following prerequisite is met:

- At least one crane engine is running.
- The support **47** is pinned and secured in operating position with retaining pins **49**.
- The S-relapse cylinder **2** is laying on the support.

- ▶ Move the S-relapse cylinder **2** in: Actuate the ball valve **40** in the engine house.

When the S-relapse cylinder is completely retracted:

- ▶ Attach the S-relapse cylinder **2** with the fastening equipment **46** on the fastening point **P36** on the auxiliary crane.



WARNING

Danger of accident!

When unpinning the support **47** it can fold down by itself.

Personnel can be severely injured or killed.

- ▶ Make sure that the support **47** is safely held by the rope **48.1** of the hand winch **48** before unpinning.

- ▶ Lift the S-relapse cylinder from the support **47**.

When the S-relapse cylinder is lifted off the support:

- ▶ Spool the hand winch **48** up until the rope **48.1** is tensioned:
- ▶ Release the support **47**: Remove the safety locking pin **50** at point **P38** and unpin the retaining pin **49**.
- ▶ Lower the support **47** with the hand winch **48** into transport position.

When the support **47** is in transport position:

- ▶ Insert the retaining pin **49** on both sides at point **P37** and secure with safety locking pin **50**.
- ▶ Lower the S-relapse cylinder **2** with the auxiliary crane into transport position.

When the S-relapse cylinder **2** is completely placed on the prism of the transport receptacle:

- ▶ Remove the auxiliary crane.

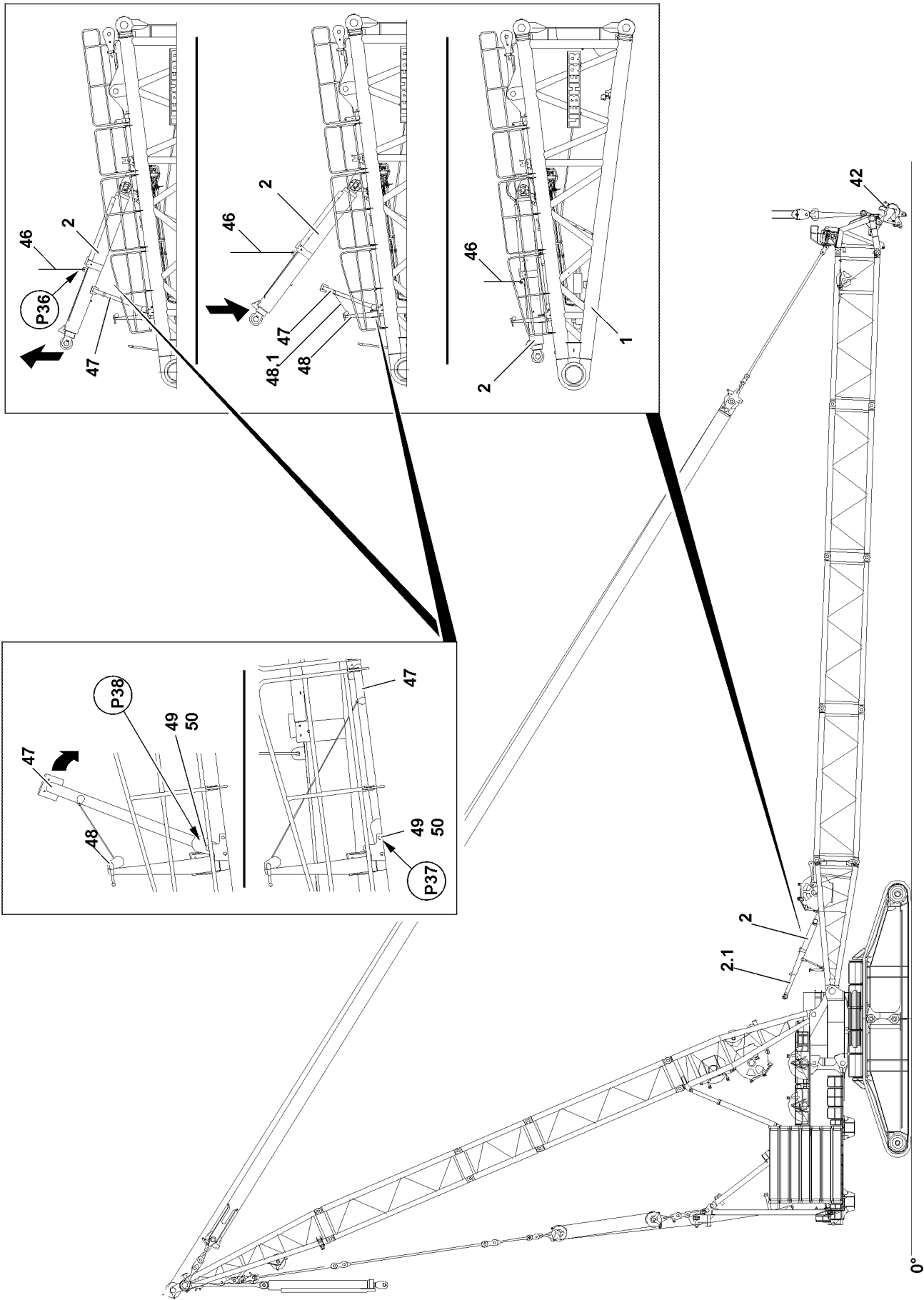

Fig.115895

LWE/LR 13000-001/19503-01-02/en

13.6 Disassembly of the roller sets on the boom head

NOTICE

Danger of property damage!

During the disassembly of the roller sets **42** the electrical connections to the hoist limit switches can be damaged.

- ▶ Remove the hoist limit switches on the roller sets.
-
- ▶ Before disassembly of the roller sets **42**, route the hoist limit switches from the roller sets back to the end section.
-



Note

- ▶ The disassembly of the roller sets is described in chapter 5.14.
-

13.7 Disconnecting the electrical connections on the boom end section

Make sure that the following prerequisite is met:

- The main boom is placed on the ground or is safely held by the auxiliary crane.
-

NOTICE

Damage to cable drum or cable!

If the cable of the cable drum is not properly spooled up on the cable drum after unplugging the S-end section, then the cable drum or the cable can be significantly damaged.

- ▶ Spool the cable drum up after unplugging.
-
- ▶ Spool the cable drum up and secure it to prevent inadvertent spooling out.
 - ▶ Disconnect the electrical connections and store the plugs and cables properly.
-

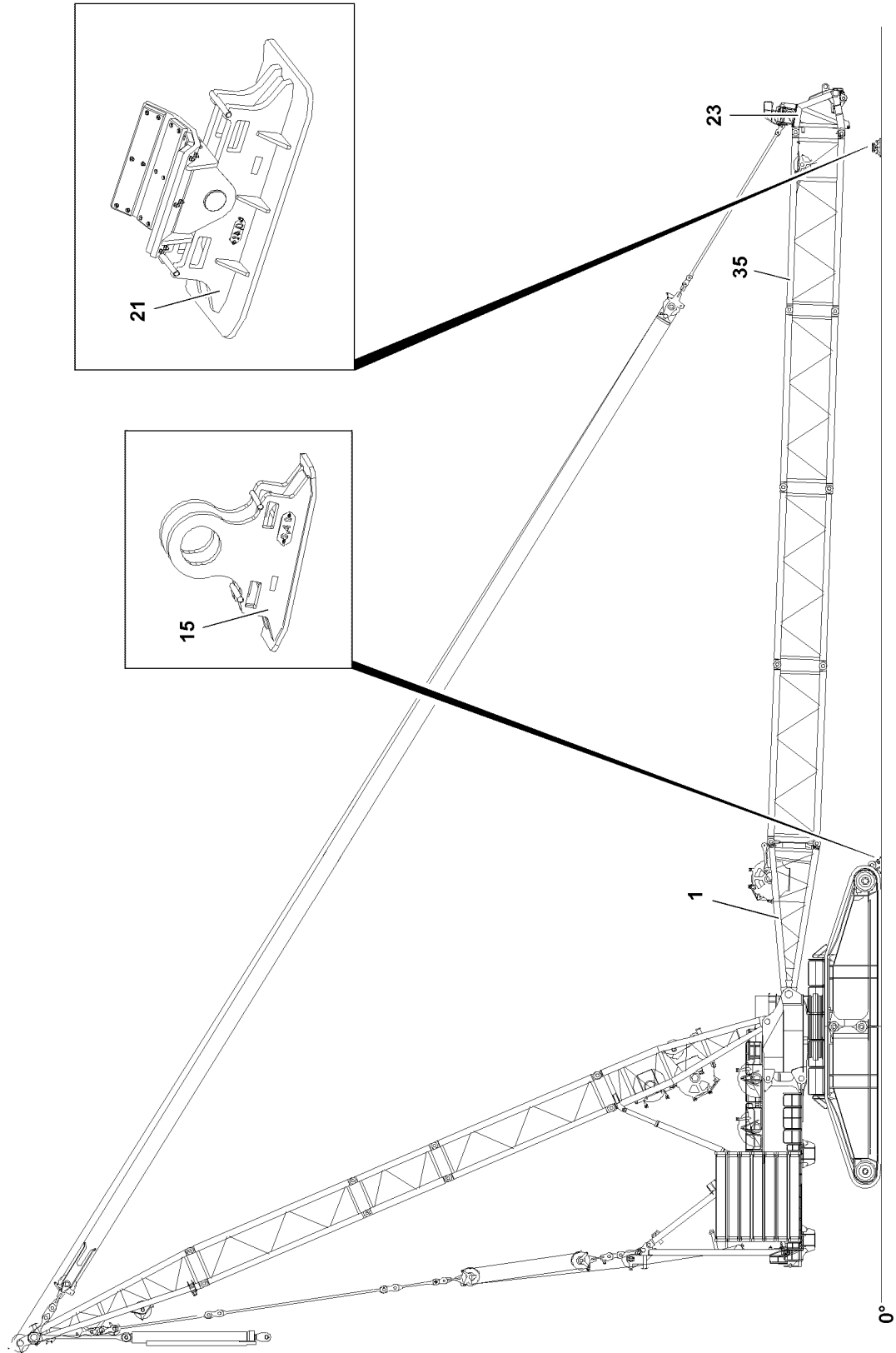

Fig.115894

LWE/LR 13000-001/19503-01-02/en

13.8 Placing the boom on the assembly shoes

Make sure that the following prerequisites are met:

- The hook block is reeved out and removed.
- The hoist rope is properly spooled up.
- The roller set / roller sets are properly removed.

NOTICE

Danger of property damage on the intermediate sections!

If the assembly shoes **21** are not placed underneath in the permitted area of the intermediate sections, then the intermediate sections can be overloaded and damaged.

- ▶ Make sure that the assembly shoes **21** are only placed underneath in the permitted area of maximum 300 mm on the corner bar.
 - ▶ The crane operator is responsible for the proper substructure of the intermediate sections with the assembly shoes **21**.
-
- ▶ Position the assembly shoes **21** properly under the boom system.

When the assembly shoes are positioned properly under the boom system:

- ▶ Lower the boom slowly and with slow speed on the assembly shoes **21**.

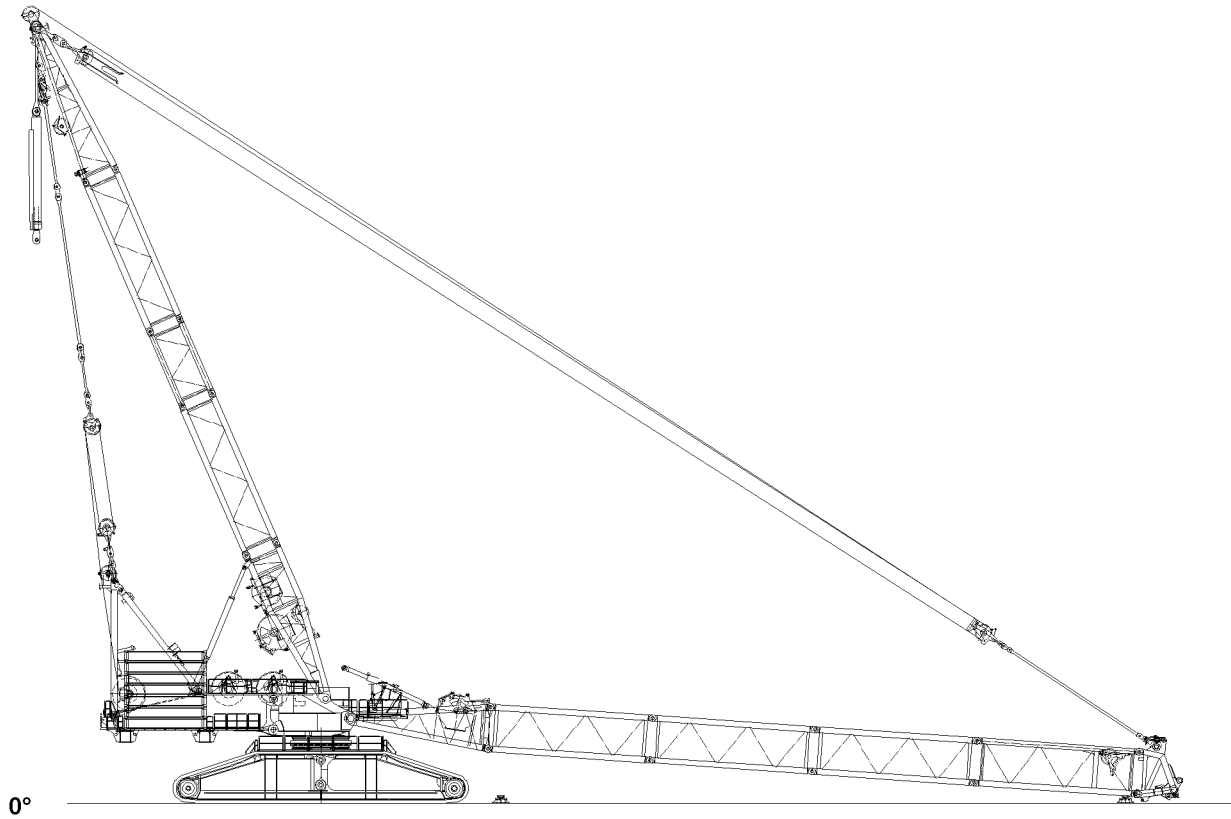

0°

Fig.124447

LWE/LR 13000-001/19503-01-02/en

13.9 Disconnecting the electric and hydraulic connections on the S-pivot section

13.9.1 Disconnecting the electrical connections

NOTICE

Damage to cable drum or cable!

If the cable of the cable drum is not properly spooled up on the cable drum after unplugging the S-end section, then the cable drum or the cable can be significantly damaged.

▶ Spool the cable drum up after unplugging.

-
- ▶ Spool the cable drum up and secure it to prevent inadvertent spooling out.
 - ▶ Disconnect the electrical connections and store the plugs and cables properly.

13.9.2 Disconnecting the hydraulic connections

When connecting and releasing hydraulic lines with quick couplings, make sure that the coupling procedure is carried out correctly.



DANGER

Danger of accident due to loss of pressure or leakage!

Incorrectly coupled or self-loosening quick couplings (particularly return lines) can result in serious accidents due to component failure.

▶ Check that the quick couplings have been properly connected before using the crane.



Note

▶ To connect or release the hydraulic lines with quick couplings, see chapter 5.01.

-
- ▶ Release the pressure in the hydraulic system before connecting or disconnecting. Turn the engine off and wait for short time.
 - ▶ Assembling coupling components (sleeve and connector) by using knurled nut.
 - ▶ Connect coupling components.

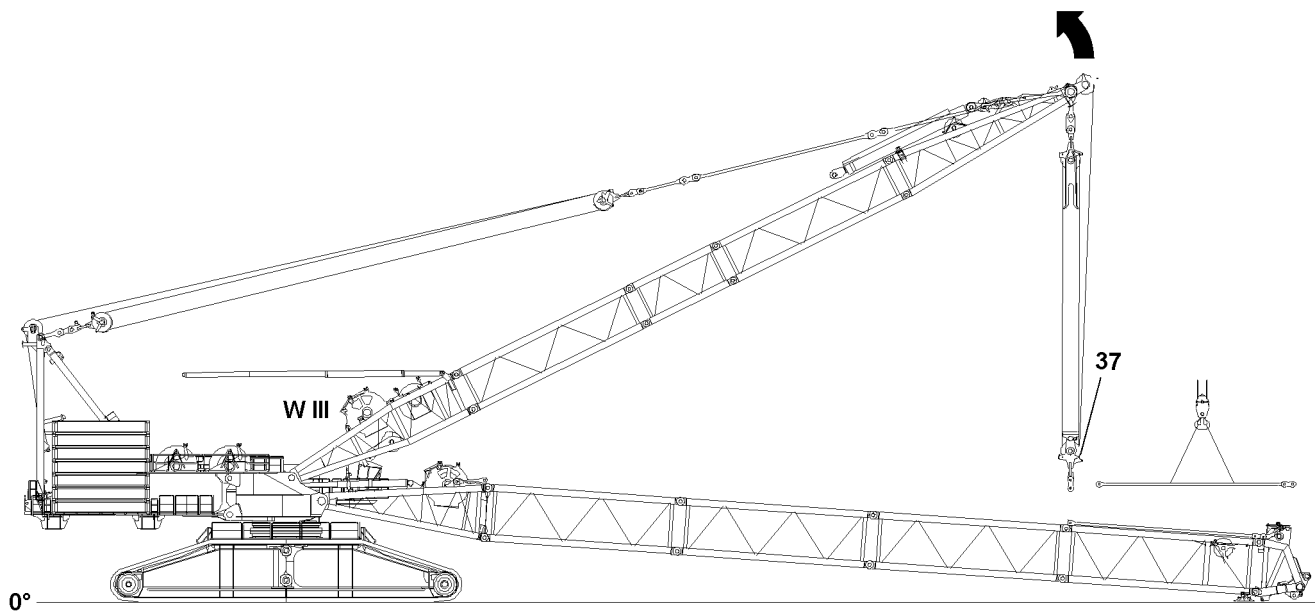

Fig.115896

13.10 Disassembling the guy rods

NOTICE

Slack rope formation!

The control rope can become damaged due to slack rope formation.

- ▶ When placing the guy rods down into the transport receptacles, don't let the ropes slacken up.
-

- ▶ Relieve the guying: Luff the D-boom down to the front until the guy rods are placed in the rod receptacles of the lattice sections.

When the guy rods are in the rod receptacles of the lattice sections:

- ▶ Stop the luff down movement of the D-boom.
- ▶ Carefully spool out winch 3 **WIII** until the guying is relieved.

When the guying is relieved:

- ▶ Disassemble the auxiliary guying (if present on the boom).
- ▶ Unpin the upper pulley block **37** on the S-guy rods.
- ▶ Disconnect the guy rods: Remove the safety locking pin and unpin the pin.

When the guy rods are unpinned:

- ▶ Fasten the guy rods individually on the auxiliary crane and lift off from the lattice sections.
 - ▶ Place the guy rods with the auxiliary crane on a suitable substructure.
-

NOTICE

Damage to lattice sections!

- ▶ Do not pull the upper pulley block **37** over the intermediate sections, rather guide them with the auxiliary crane.
 - ▶ Make sure when erecting the D-boom, that the upper pulley block **37** is not pulled against the D-end section.
-

When all guy rods are removed from the lattice sections:

- ▶ Erect the D-boom and spool up winch 3 **WIII** at the same time.

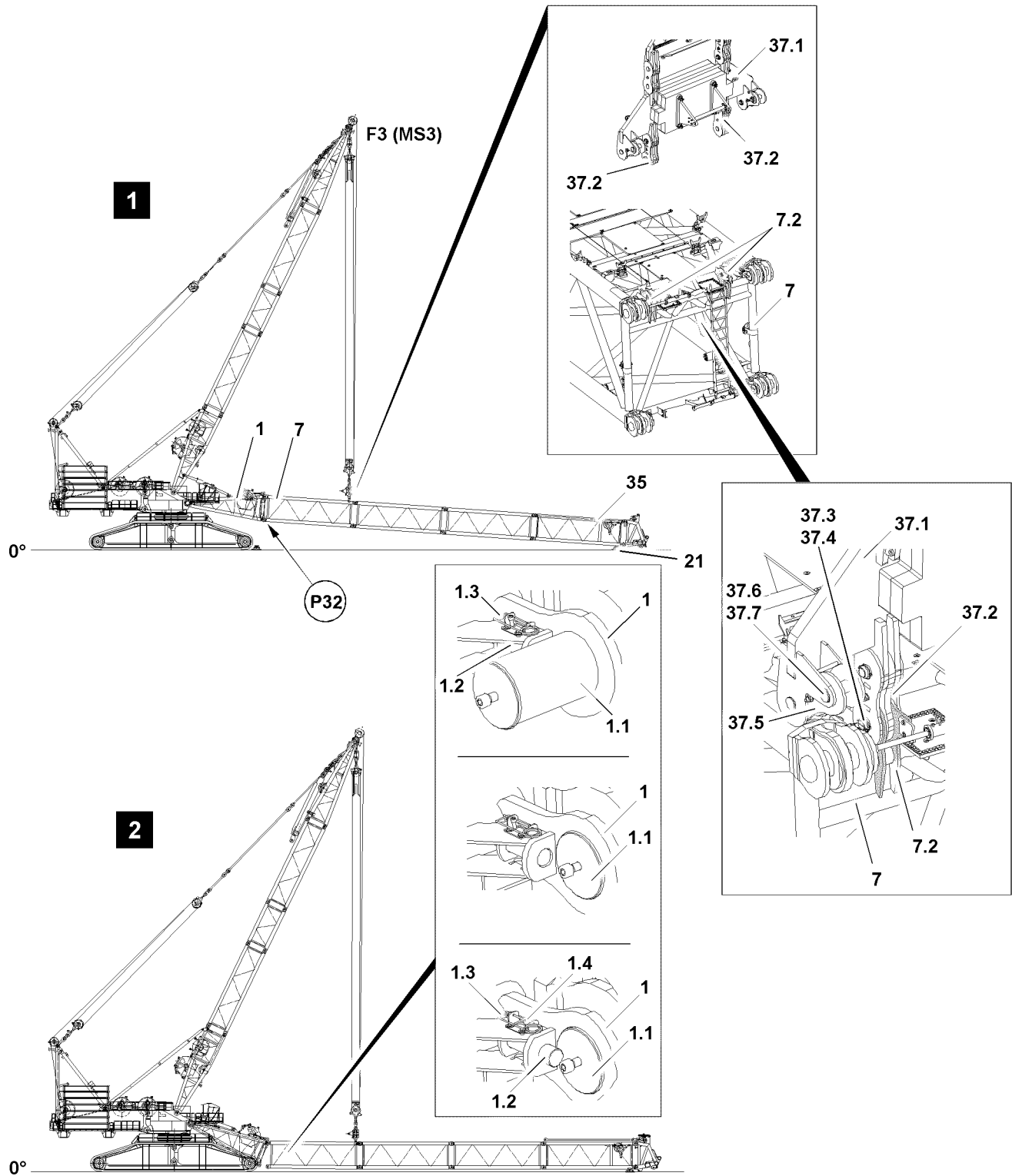

Fig.124448

LWE/LR 13000-001/19503-01-02/en

13.11 Opening the boom system



WARNING

The boom can suddenly fold down!

If the following conditions are not met before disassembling the boom, the boom can fold down. Personnel can be severely injured or killed.

- ▶ Place the S-boom for disassembly on the assembly shoes.
- ▶ During pinning and unpinning of the lattice sections, it is prohibited for anyone to remain **under** or **on** the components as well as within the entire danger zone.

Make sure that the following prerequisites are met:

- All electrical and hydraulic connections have been disconnected.
- The radio receiver is properly removed on the end section.
- The auxiliary guying is disassembled.
- The guy rods have been removed.
- The guy rods have been removed from the lattice sections.
- ▶ Lower the upper pulley block **37** until the brackets on the upper pulley block are over the pin points **7.2** on the S-intermediate section **7**.
- ▶ Swing the assembly weight **37.1** in with the auxiliary crane to the upper pulley block **37**, see illustration **1**.
- ▶ Pin the assembly weight **37.1** on the upper pulley block **37** and secure.
- ▶ Pin and secure the assembly weight **37.1** with the brackets **37.2** on the pin points **7.2** of the S-intermediate section **7**: Use the pin **37.3** and safety locking pin **37.4**, see illustration **1**.



WARNING

The crane can topple over!

If the following conditions are not met, the crane can topple over or be significantly damaged. Personnel can be severely injured or killed.

- ▶ The maximum permissible total force on test point 3 **F3** (MS3) may **not** be exceeded.
- ▶ Lifting and opening the respective boom is only permissible by observing the maximum permissible boom lengths and total forces.



Note

- ▶ The actual forces on test point 3 **F3** (MS3) are shown on LICCON monitor 1.
- ▶ Tension the guying on the test points at disassembly with the same forces as for assembly.
- ▶ For this, refer the ACTUAL forces measured and recorded on the test points during the assembly.
- ▶ The pins can be pulled easier and the pins and lugs are therefore not damaged.



Note

- ▶ Unpin the intermediate sections with the pin pulling device, see chapter 5.30.

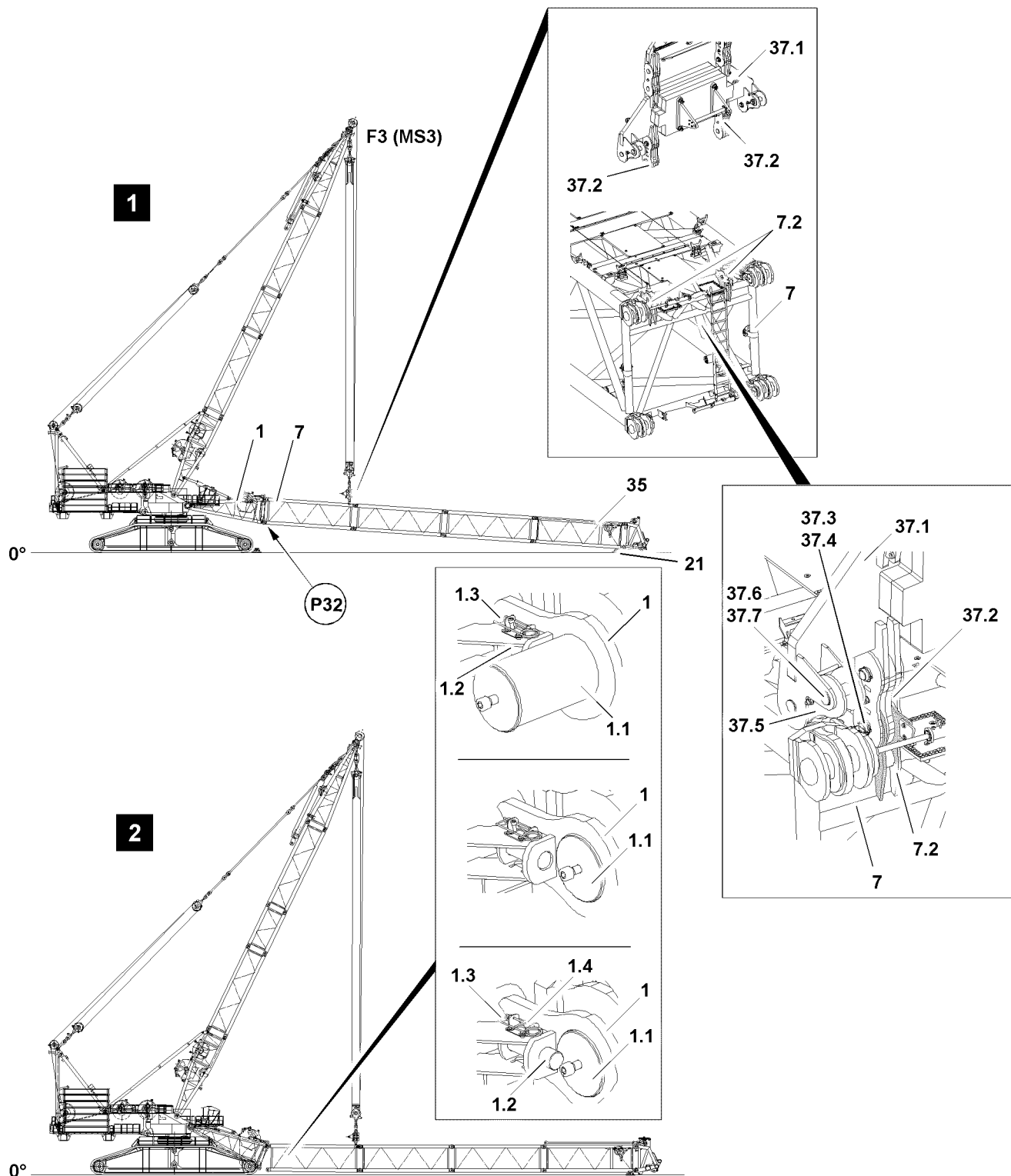

Fig.124448

NOTICE

Danger of property damage!

If the maximum permissible total forces are not observed when lifting the boom system for disassembly, then crane components can be severely damaged.

- ▶ Reassemble long booms to the required length for flying disassembly.
- ▶ Do not exceed the maximum permissible total forces.

- ▶ Tension the main boom by spooling up winch 3.

When the main boom is safely held by the winch 3:

- ▶ Open the S-boom system: Unpin the connector pin **1.1** at point **P32** on both sides: Release and unpin the connector pins **1.1**, see illustration **2**.

NOTICE

Danger of property damage!

When lowering the S-boom system, crane components can be damaged.

- ▶ Make sure that the S-pivot section **1** is not lowered directly on the ground.
- ▶ Pin the S-pivot section **1** when opening the S-boom system with the assembly shoes **15**.

When the connector pins **1.1** are completely unpinned at point **P32**:

- ▶ Carefully lower the S-boom system on the ground and from a respective height, pin the assembly shoes **15** on the S-pivot section **1**.
- ▶ Lower the S-pivot section **1** completely, see illustration **2**.

When the S-pivot section is laying on the assembly shoes **15**:

- ▶ Unpin the assembly weight **37.1** on the pin points **7.2** of the S-intermediate section: Release and unpin the pin **37.3**.
- ▶ Lift the upper pulley block.

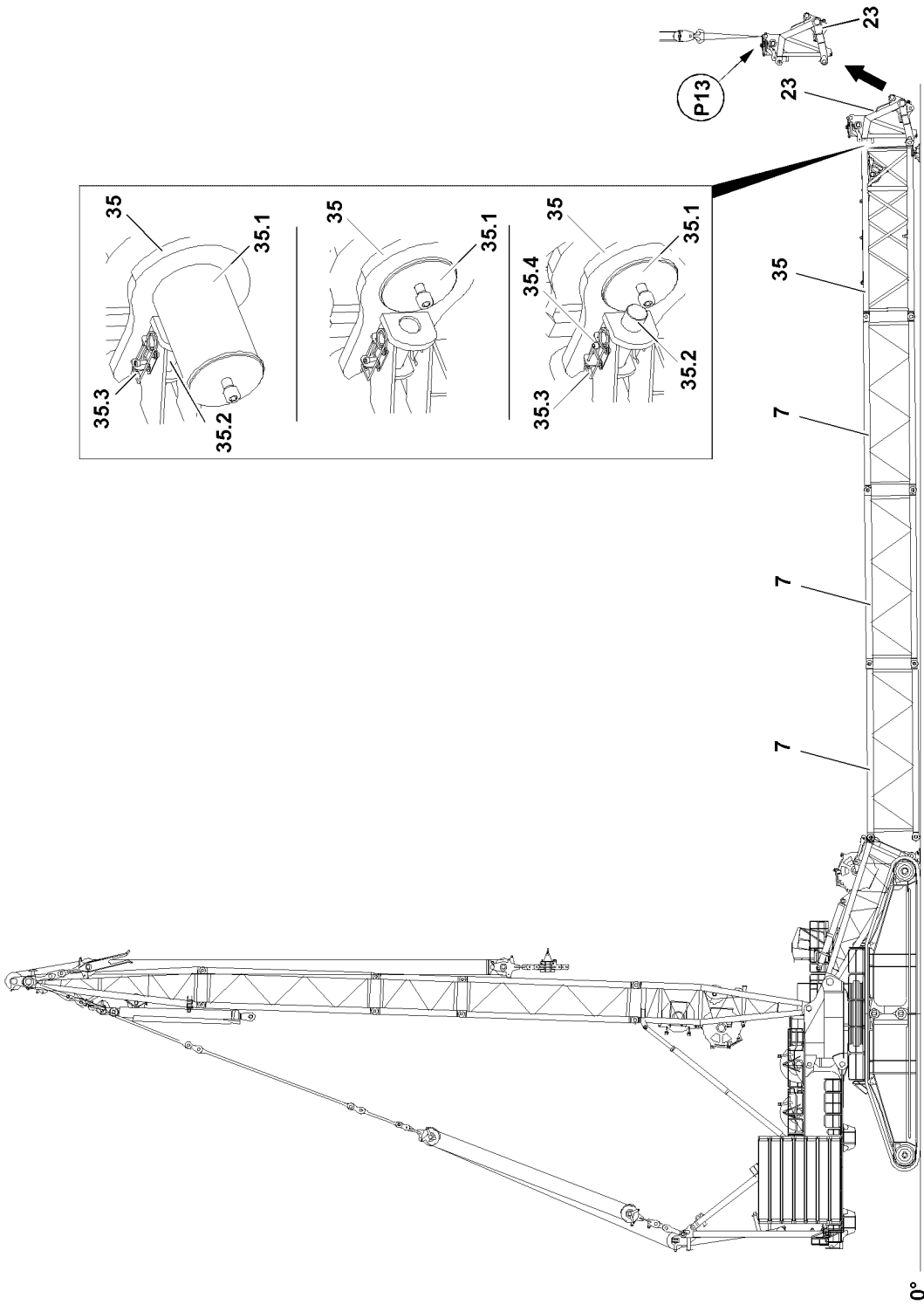

Fig.124449

LWE/LR 13000-001/19503-01-02/en

13.12 Removing the S-end section

13.12.1 Removing the S-end section



Note

- ▶ The removal of the end section on the boom is described on the example of the S-end section.
- ▶ The removal of the L-end section is identical to the removal of the S-end section.



WARNING

Danger of falling for assembly personnel!

When fastening the end sections on the auxiliary cranes, the assembly personnel can fall down. Personnel can be severely injured or killed.

S-end section:

- ▶ You must use a work platform to install the fastening equipment on the fastening points **P13**.
- ▶ When fastening the fastening equipment on the fastening points **P14** use the installed platforms in the end section.

L-end section:

- ▶ Install the fastening equipment properly on the fastening points **P15**.
- ▶ When fastening the fastening equipment on the fastening points **P16** use the installed platforms in the end section.

Make sure that the following prerequisites are met:

- The electrical connections on the S-end section have been removed.
- The S-end section **23** is properly fastened on the auxiliary crane at point **P13**.
- The fastening equipment is tensioned.
- ▶ Remove the spring retainer **35.3** on both sides „on top“ and „bottom“.
- ▶ Insert the retaining pins **35.2**: Guide the cylinder screw **35.3** in the bracket to the end stop and lock on the side.

When the S-end section **23** is safely held by the auxiliary crane:

- ▶ Unpin the connector pins **35.1** on both sides „on top“ and „bottom“.
- ▶ Remove the S-end section **23** with the auxiliary crane and place it on the ground.

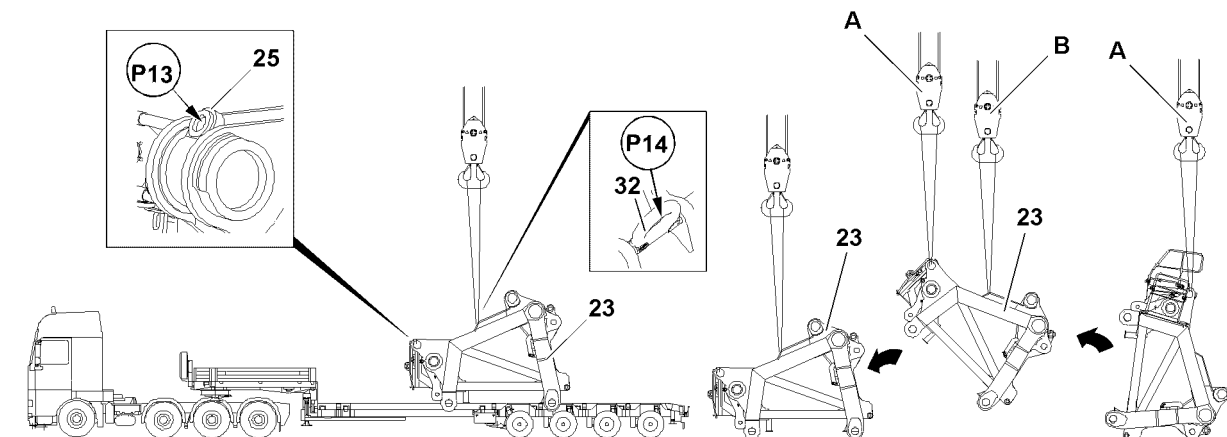
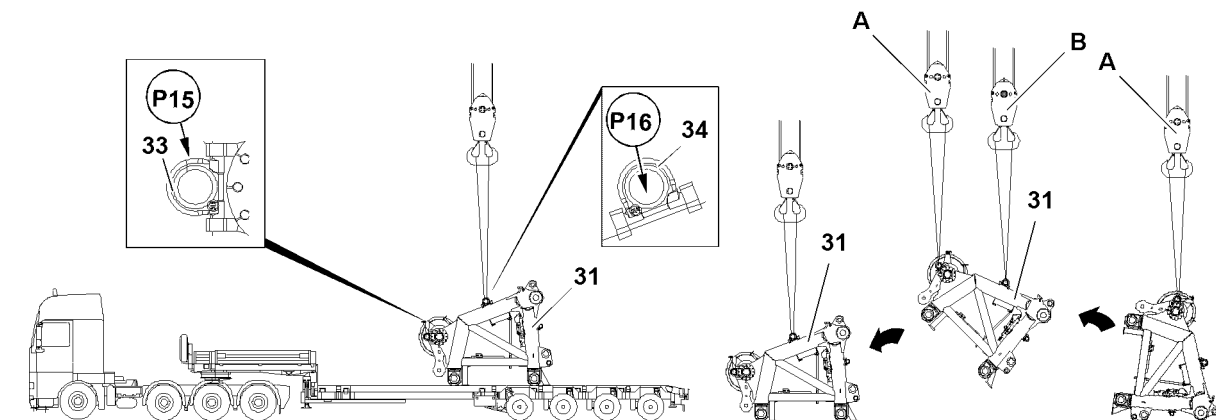
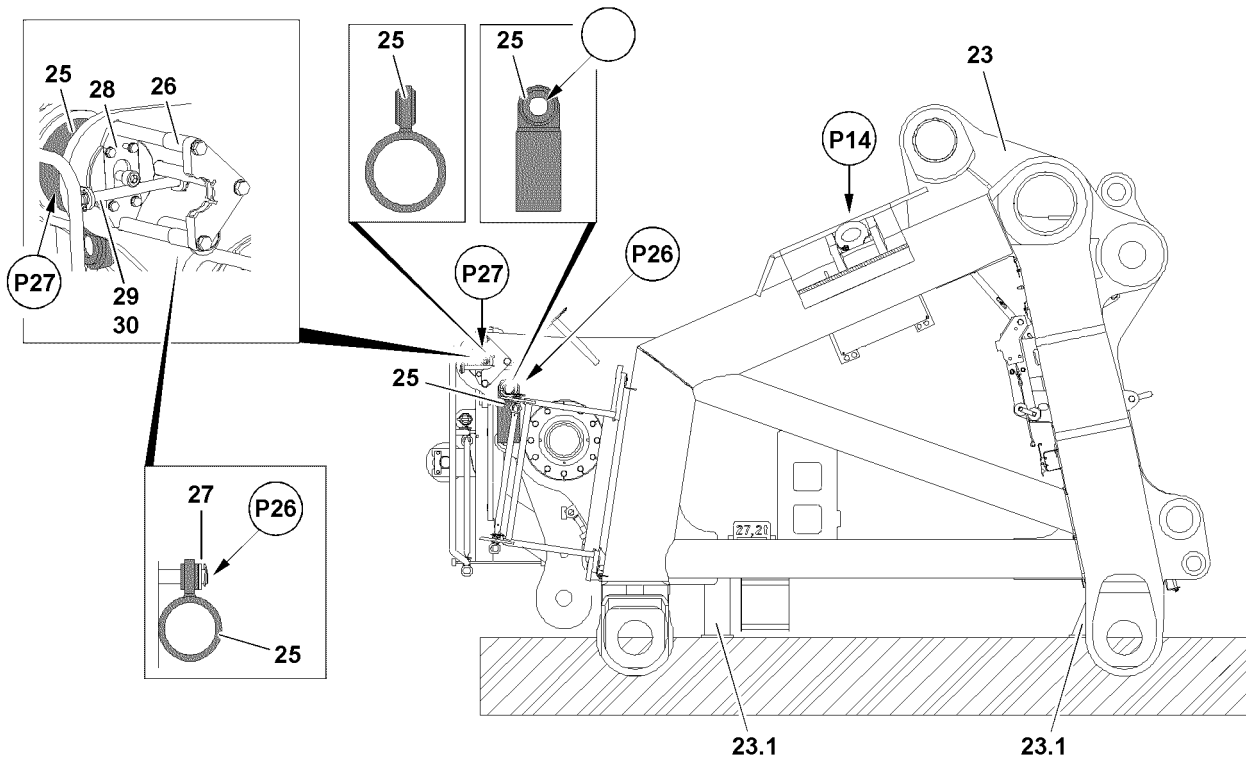

Fig.124450

LWE/LR 13000-001/19503-01-02/en

13.12.2 Turning the S-end section from assembly position into transport position



Note

- ▶ The turning procedure of the S- and L-end section is identical.



WARNING

Danger of falling!

At assembly and disassembly of the railings, the assembly personnel can fall down and be severely injured or killed.

- ▶ The assembly personnel must secure themselves for assembly / disassembly of railings and protective devices with an approved fall arrest system to prevent them from falling.
- ▶ For assembly and disassembly work, maintenance and inspection work on the S-end section, all railings and the protective devices must be assembled and secured.



WARNING

Danger due to end section!

While turning the required end section, persons can be caught and severely injured or killed.

- ▶ Make sure that there are no persons within the danger zone of the auxiliary cranes and in the danger zone of the turning end section.
- ▶ The crane drivers of both auxiliary cranes as well as the guide are in voice contact with each other.



WARNING

Tipping end section!

When the fastening equipment is removed on the fastening points, point **P13** (S-end section) or point **P15** (L-end section), the end section can tip over.

Personnel can be severely injured or killed.

- ▶ Make sure that the fastening equipment is between the fastening points, point **P13** (S-end section) or point **P15** (L-end section) is tensioned with the auxiliary crane.
- ▶ The fastening equipment on the fastening points, point **P13** (S-end section) or point **P15** (L-end section) may not be removed.



Note

- ▶ Carry out the turning procedure from the assembly position into transport position in reverse order as from transport position into assembly position, see „Turning the S-/L-end section into assembly position“.

- ▶ Remove the railings (only for S-end section), see chapter 2.06.
- ▶ Turn the S-end section from assembly position into transport position, see section „Turning the S-/L-end section into assembly position“.
- ▶ Place the S-end section on the flatbed trailer and fasten, see section „Lifting the end section from the flatbed trailer“.
- ▶ Remove the brackets for the assembly of the S-end section on the boom, see section „Installing the brackets for the assembly of the S-end section on the boom“.

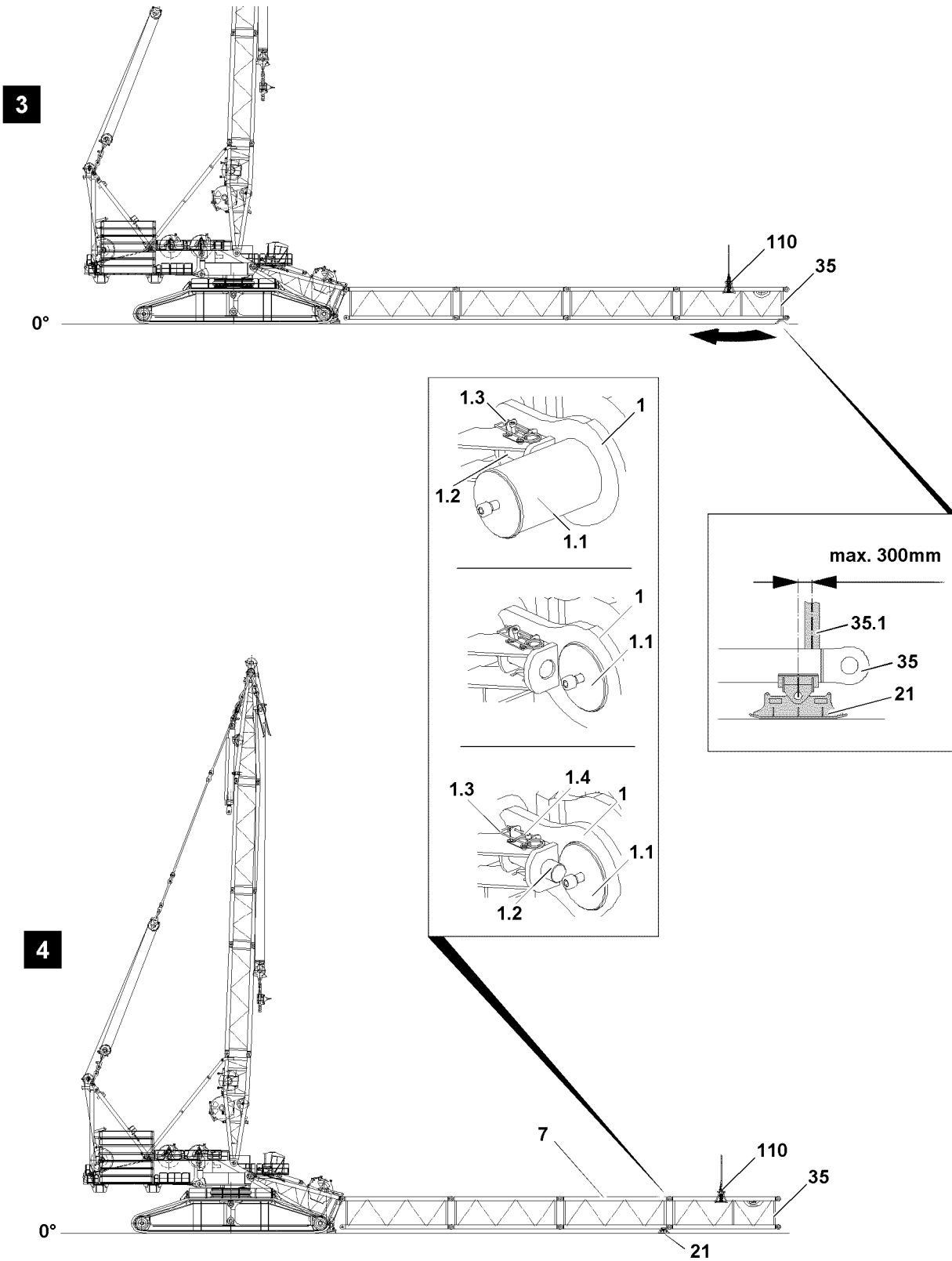

Fig.124451

LWE/LR 13000-001/19503-01-02/en

13.13 Disassembling the S-intermediate sections

Make sure that the following prerequisites are met:

- The crane is horizontally aligned.
- An auxiliary crane is available.
- An assembly scaffolding / work platform is available.
- The S-boom system is placed on the assemble shoes, see illustration 3.

NOTICE

Impermissible boom length!

If the boom is lifted with impermissible boom length with the cross beam, then the last intermediate section can be overloaded when lifting the boom system.

Death, severe injuries, property damage.

- ▶ Make sure that the boom is lifted with the cross beam only up to the permissible boom length, see chart.

Boom system	Permissible boom length
S	132 m
SL	144 m
P	132 m
W	126 m
W2	90 m
W3	108 m

- ▶ Fasten the cross beam **110** with the auxiliary crane on S-adapter **35**, see illustration 3.
- ▶ Lift the S-boom system via the cross beam with the auxiliary crane.

NOTICE

Danger of property damage on the intermediate sections!

If the assembly shoes **21** are not placed underneath in the permitted area of the intermediate sections, then the intermediate sections can be overloaded and damaged!

- ▶ Make sure that the assembly shoes are only placed underneath in the permitted area of maximum 300 mm on the corner bar **35.1**, see illustration 3 and illustration 4.
- ▶ The crane operator is responsible for the proper substructure of the intermediate sections with the assembly shoes.

- ▶ Remove the assembly shoes **21** under the S-adapter **35** and position under the S-intermediate section **7** in the area of the corner bar, see illustration 3 and illustration 4.
- ▶ Place the S-boom system down via the cross beam with the auxiliary crane on the assembly shoes **21**, see illustration 4.



Note

- ▶ The S-intermediate sections are pinned with the pin pulling cylinders, see chapter 5.30.
- ▶ Release the retaining pins **1.2** on both sides „on top“ and „bottom“: Remove the spring retainer **1.3**.
- ▶ Insert the retaining pins **1.2**: Guide the cylinder screw **1.3** in the bracket to the end stop and lock on the side.
- ▶ Unpin the connector pin **1.1**.
- ▶ Remove the S-adapter **35**.
- ▶ Remove all S-intermediate sections **7** according to the previously described steps.

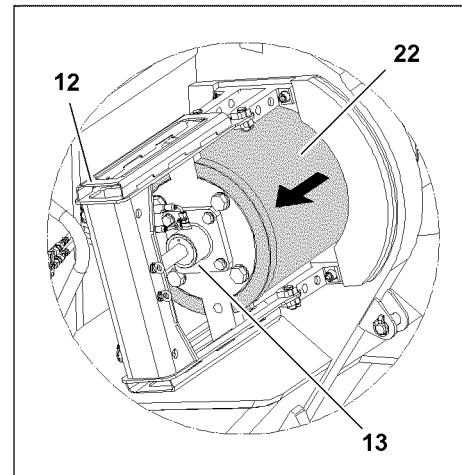
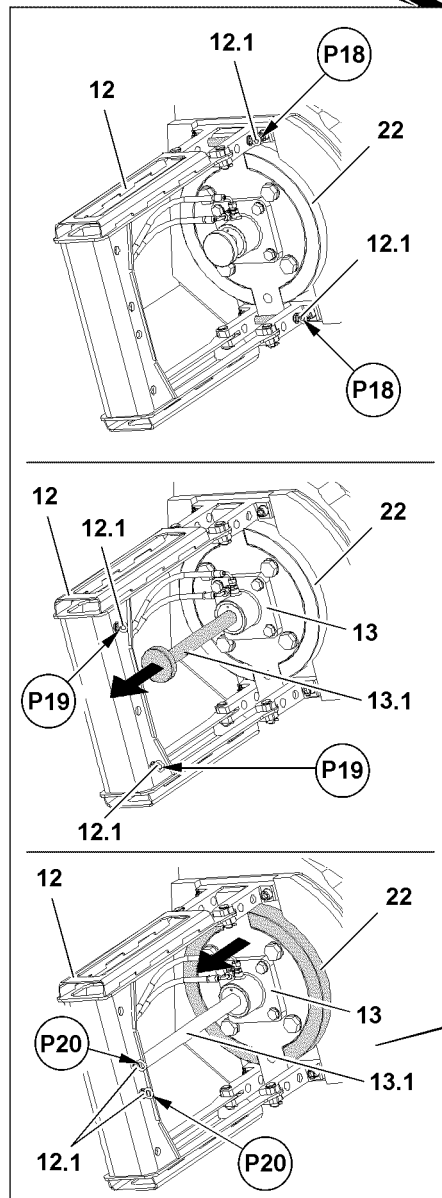
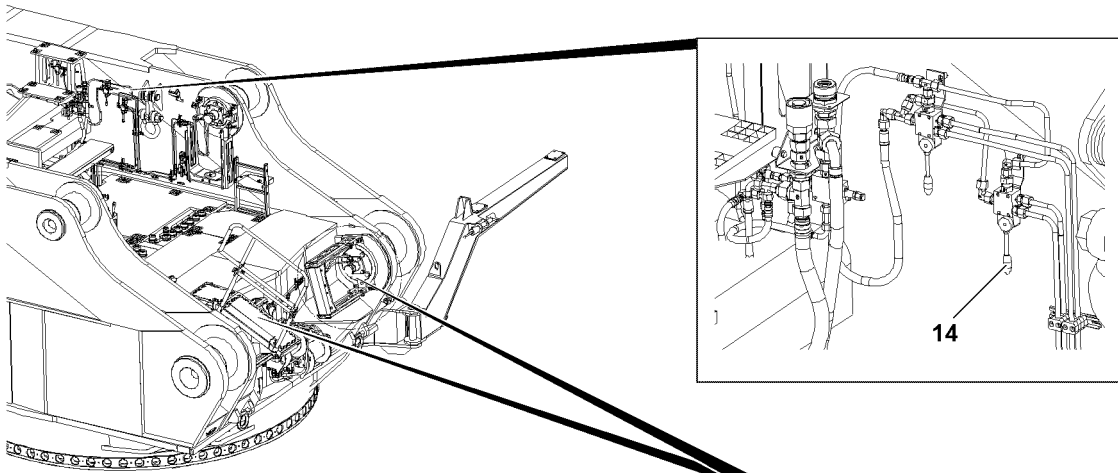

Fig.115224

LWE/LR 13000-001/19503-01-02/en

13.14 Disassembling winch 5 on the S-pivot section



Note

- ▶ The disassembly of winch 5 is described in chapter 3.07.50.

13.15 Unpinning the S-pivot section on the turntable



WARNING

General danger note!

- ▶ Insert and secure all pins after disassembly in the intended transport receptacles.

Make sure that the following prerequisites are met:

- The D-boom is erected to the point where the S-pivot section can be disassembled without obstructions.
- Winch 5 is properly removed.
- The installation location of winch 5 on the S-pivot sections is properly closed and secured with the catwalk.
- At least one crane engine is running.



Note

- ▶ Select the fastening points on the S-pivot section in such a way that the S-pivot section hangs horizontally on the auxiliary crane at disassembly. See section „Fastening points“.

- ▶ Attach the S-pivot section **1** properly on the auxiliary crane.
- ▶ Lift the S-pivot section **1** with the auxiliary crane to the horizontal.



WARNING

Falling S-pivot section!

- ▶ Make sure that the S-pivot section **1** is safely held by the auxiliary crane before unpinning the S-connector pins **22**.



Note

- ▶ The unpinning of the S-pivot section on the turntable is described in detail in section: „Unpinning the S-connector pins on the turntable“.

When the S-pivot section is horizontally aligned and safely held by the auxiliary crane:

- ▶ Unpin the S-connector pins **22** on the turntable.

NOTICE

Damage of the turntable and the S-pivot section **1**!

- ▶ Slowly swing the S-pivot section **1** out with the auxiliary crane and at low speed on the turntable.
- ▶ Before placing it on the ground, support the S-pivot section **1**.

When the S-connector pins **22** on the S-pivot section **1** are fully unpinned on both sides:

- ▶ Swing the S-pivot section **1** out on the turntable with the auxiliary crane and place it down.
- ▶ Remove the auxiliary crane.



Note

- ▶ Disassemble the D-boom, see chapter 5.05.

When the S-pivot section **1** is removed on the turntable:

- ▶ Fully insert and secure the S-connector pins **22** again.

Empty page!

LWE/LR 13000-001/19503-01-02/en

5.44 PD-boom combination

1	Components	3
2	Fastening points	4
3	Assembling the PD-boom	11
4	Erecting the boom	59
5	Operating the crane	67
6	Disassembling the PD-boom	69

Fig.195219

LWE/LR 13000-001/19503-01-02/en

1 Components

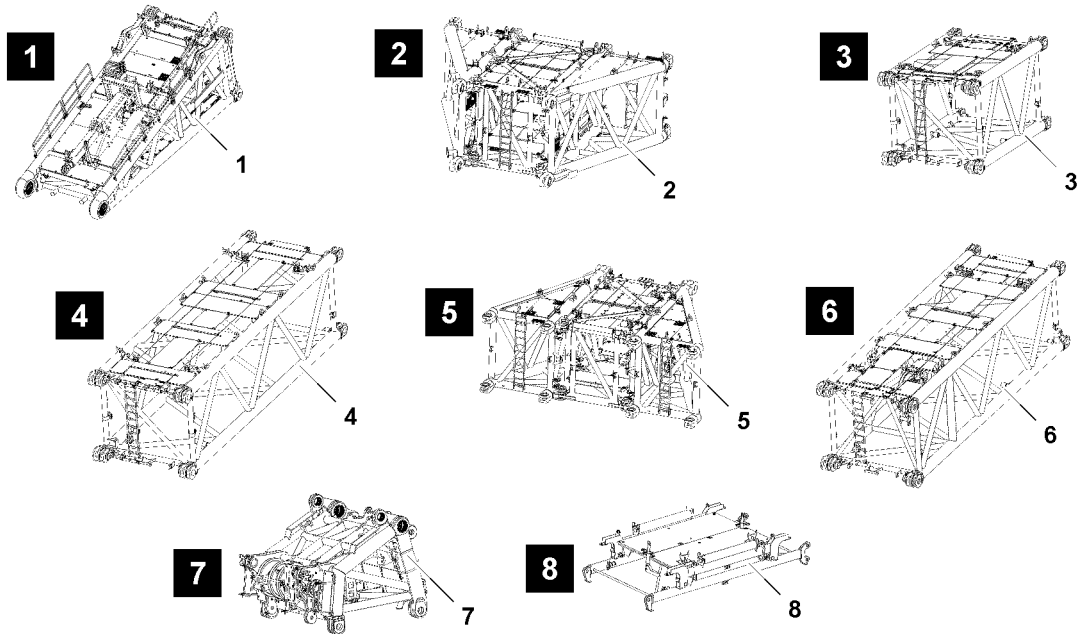

Fig.124452: Component — overview

Position	Component	Illustration
1	S-pivot section	Illustration 1
2	Lower P-adapter	Illustration 2
2.1	Right lattice section	Illustration 2
2.2	Center lattice section	Illustration 2
2.3	Left lattice section	Illustration 2
3	Intermediate section 6 m	Illustration 3
4	Intermediate section 12 m	Illustration 4
5	Upper P-adapter	Illustration 5
5.1	Right lattice section	Illustration 5
5.2	Center lattice section	Illustration 5
5.3	Left lattice section	Illustration 5
6	S-adapter	Illustration 6
7	S-end section	Illustration 7
8	Bridge	Illustration 8

LWE/LR 13000-001/19503-01-02/en

2 Fastening points



WARNING

Lattice component not properly fastened!

If the lattice component is not properly fastened on the specified fastening positions, then the lattice component can fall down.

Personnel can be severely injured or killed.

This can result in increased property damage.

- ▶ Make sure that the fastening equipment is properly fastened in the specified fastening positions.
- ▶ The lattice component may only be fastened in the specified fastening positions if transported individually.

2.1 S-pivot section fastening points

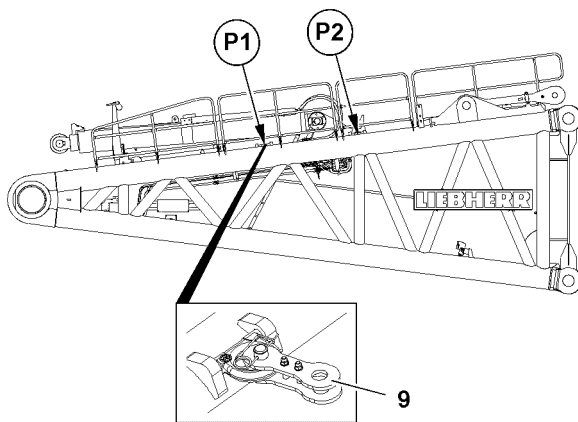

Fig.115420: S-pivot section fastening points

Fastening points	
P1 ¹⁾ and P2	S-pivot section WITHOUT winch 5

1) Only in connection with bracket 9



DANGER

Falling S-pivot section!

If the S-pivot section with installed winch 5 is lifted or transported on the fastening points (point **P1** and point **P2**) the fastening points (ring brackets) will rip off.

The S-pivot section falls down.

Personnel can be severely injured or killed.

This can result in increased property damage.

- ▶ On the fastening points (point **P1** and point **P2**) the S-pivot section may only be fastened **without** winch 5.
- ▶ Fastening and transporting the S-pivot section with installed winch 5 is **prohibited**.

2.2 Fastening points lower P-adapter, left and right lattice section

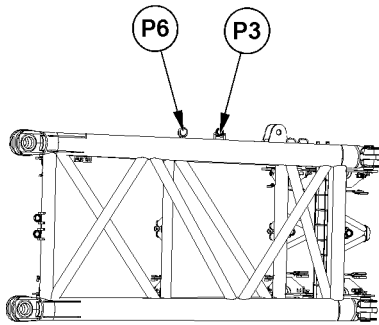

Fig.115421: Fastening points lower P-adapter, left and right lattice section

Fastening points	
P3 and P6	Lower P-adapter, left and right lattice section

2.3 Fastening points lower P-adapter, center lattice section

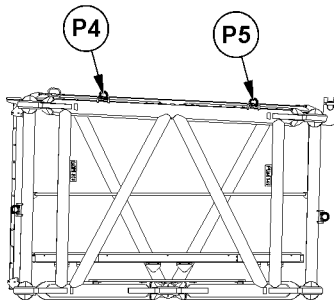

Fig.115423: Fastening points lower P-adapter, center lattice section

Fastening points	
P4 and P5	Lower P-adapter, center lattice section

LWE/LR 13000-001/19503-01-02/en

2.4 Fastening points lower P-adapter preassembled

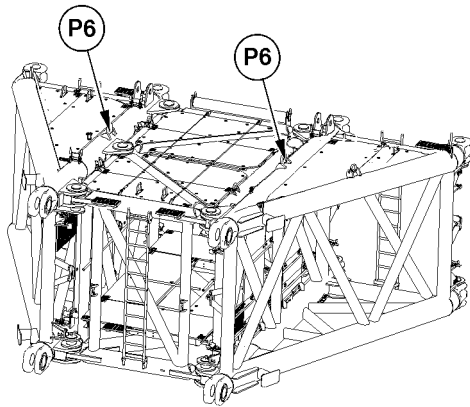

Fig.115422: Fastening points lower P-adapter preassembled

Fastening points	
P6	Lower P-adapter preassembled

2.5 Fastening points intermediate section 6 m

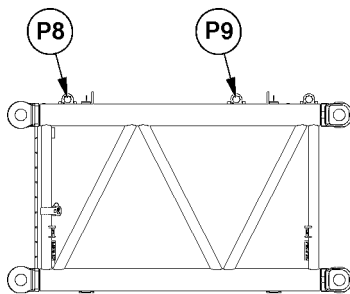

Fig.115424: Fastening points S-intermediate section 6 m

Fastening points	
P8 and P9	S-intermediate section 6 m

2.6 Fastening points intermediate section 12 m

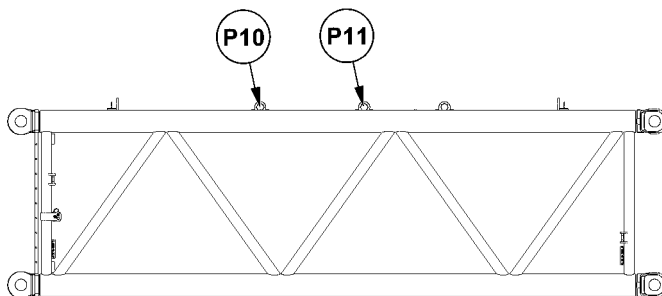

Fig.115425: Fastening points S-intermediate section 12 m

Fastening points	
P8 and P9	S-intermediate section 12 m

2.7 Fastening points upper P-adapter, left and right lattice section

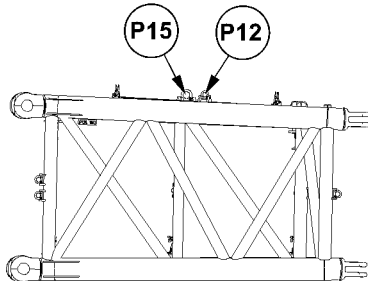

Fig.115426: Fastening points upper P-adapter, left and right lattice section

Fastening points	
P12 and P15	Upper P-adapter, left and right lattice section

2.8 Fastening points upper P-adapter, center lattice section

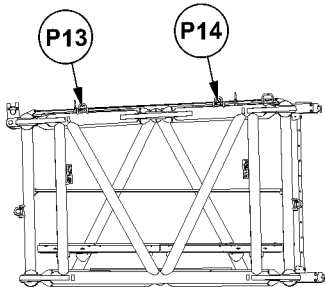

Fig.115427: Fastening points upper P-adapter, center lattice section

Fastening points	
P13 and P14	Upper P-adapter, center lattice section

2.9 Fastening points upper P-adapter preassembled

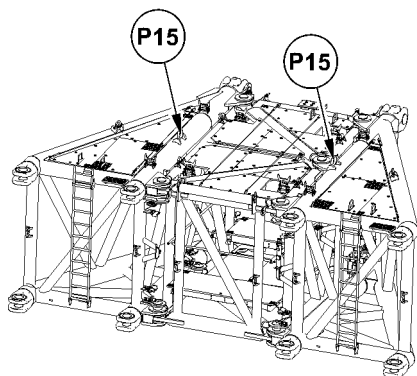

Fig.115428: Fastening points upper P-adapter preassembled

Fastening points	
P15	Upper P-adapter preassembled

2.10 Fastening points S-adapter

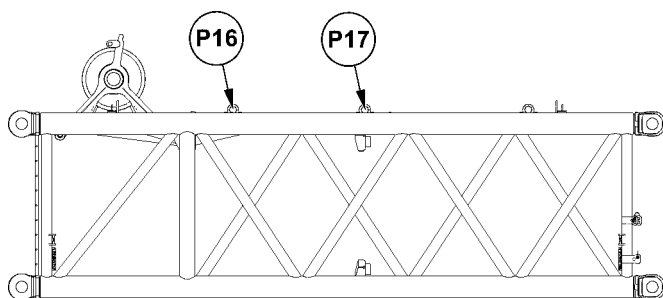

Fig.115429: Fastening points S-adapter

Fastening points	
P16 and P17	S-adapter

2.11 S-end section fastening points

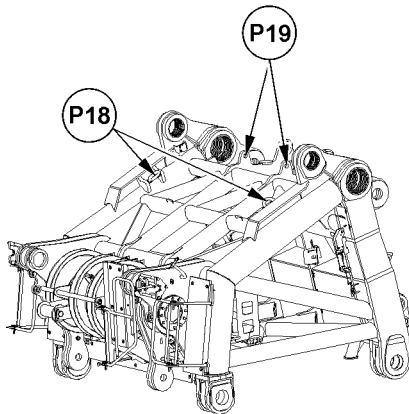

Fig.115430: S-end section fastening points

Fastening points	
P18	S-end section WITHOUT roller set
P19	S-end section WITH one roller set or two roller sets

2.12 Fastening points bridge

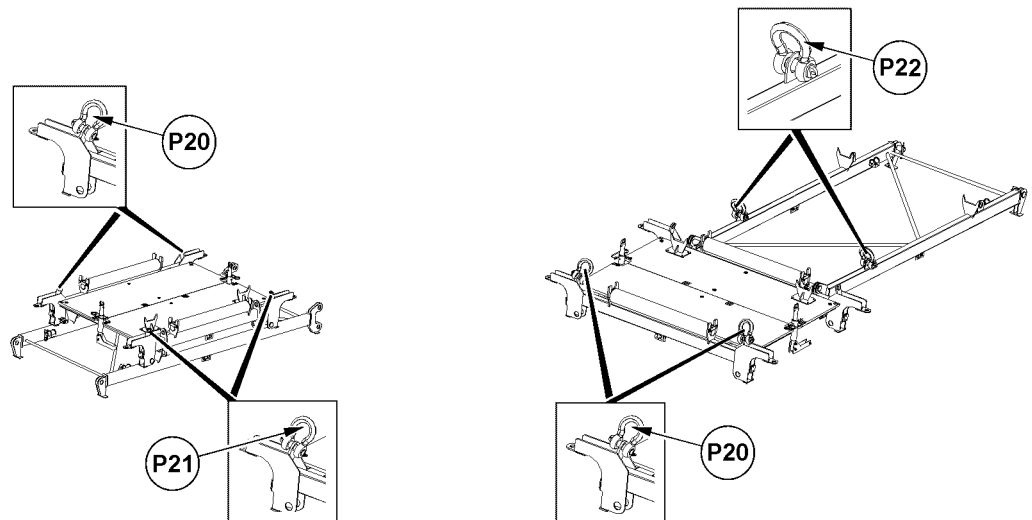
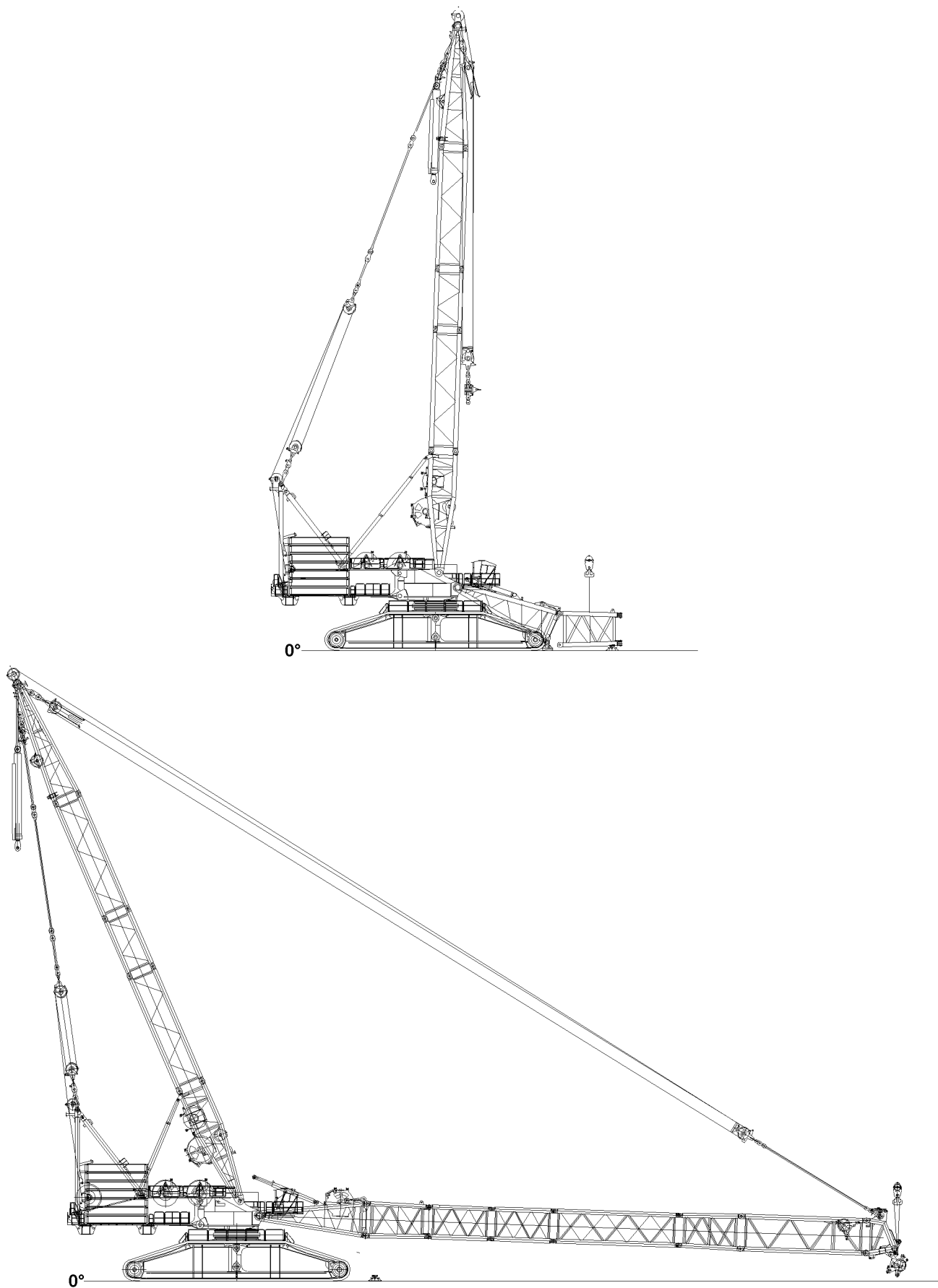

Fig.115431: Fastening points bridge

Fastening points	
P20 and P21	Bridge in transport position
P20 and P22	Bridge in operating position

LWE/LR_13000-001/19503-01-02/en



LWE/LR 13000-001/19503-01-02/en

Fig.114637: Assembling the PD-boom

3 Assembling the PD-boom



WARNING

Danger of falling!

During assembly / disassembly, inspection and maintenance work, assembly personnel must be secured with appropriate aids to prevent them from falling. If this is not observed, assembly personnel could fall and be killed or seriously injured.

- ▶ All work at a height, when there is a danger of falling, must be carried out with suitable aids.
- ▶ If aids are not available and work cannot be carried out from the ground, then assembly personnel must secure themselves with the supplied fall arrest system to prevent falling, see the Crane operating instructions, chapter 2.04.
- ▶ If fall protection equipment is available, then it must be used, see the Crane operating instructions, chapter 2.06.
- ▶ When lifting, lowering, swinging crane parts in and out, no persons may remain in the danger zone.
- ▶ When closing or opening boom systems during boom assembly or disassembly, no persons may remain on the boom system or in the danger zone.
- ▶ If railings are present on the components, then they must be brought into the corresponding position and secured for assembly / disassembly work.
- ▶ Only step on the aids, ladders and catwalks with clean shoes.
- ▶ Keep aids, ladders and catwalks free of heavy dirt, snow and ice.
- ▶ During all assembly and disassembly work, maintenance work and inspections, travel or crane operation is prohibited.
- ▶ Remaining on a suspended load is prohibited.
- ▶ Stepping or walking on crane components and lattice sections with an incline of more than 20° is prohibited.
- ▶ For all assembly work, the crane driver of the main crane must be in voice contact with the crane driver / crane drivers of the auxiliary crane / auxiliary cranes.
- ▶ For assembly tasks, the crane driver may only initiate crane movements when the responsible guide has explicitly released the movement.



WARNING

The lattice sections can fall down!

If the lattice sections are not pinned and secured correctly, then they can fall „down“ and severely injure or kill personnel.

- ▶ Insert or unpin both pins on the same horizontal level, i.e. **left and right**.
- ▶ Do not stand under the lattice sections or within the entire danger zone during the pinning and unpinning procedure of the boom.
- ▶ Safely secure the pins in the storage locations as well as in the receptacles.
- ▶ It is prohibited to lean the ladder against the component being disassembled.



WARNING

Danger of impact / crushing!

When assembling / disassembling crane components with the auxiliary crane, crane components can start to swing back and forth.

When lifting / lowering and positioning crane components, there is an increased danger of impact / crushing.

Personnel can be caught and thereby injured or killed.

- ▶ Make sure that personnel cannot be caught by components.
- ▶ Make sure that the crane is horizontally aligned.
- ▶ When working in danger zones: Use aids to protect limbs.
- ▶ Guide components with suitable aids to minimize oscillation.

**WARNING**

Danger of accident!

If no guide is present during assembly work who has voice connection to the crane operator as well as to the drivers of the auxiliary units, then there is a great danger of accident.

Crane movements that are carried out without the approval of the guide can cause accidents.

Personnel can be severely injured or killed.

This can result in significant property damage.

- ▶ For all assembly work, observe the instructions of the guide.
- ▶ Make sure that the danger zone can be seen completely by the crane operator and / or the guide.

**DANGER**

The components can fall down!

If the corresponding components are disengaged from the auxiliary crane before the corresponding component is pinned, the corresponding component can fall down and fatally injure personnel.

- ▶ Do not detach the auxiliary crane until the respective component is pinned and secured.

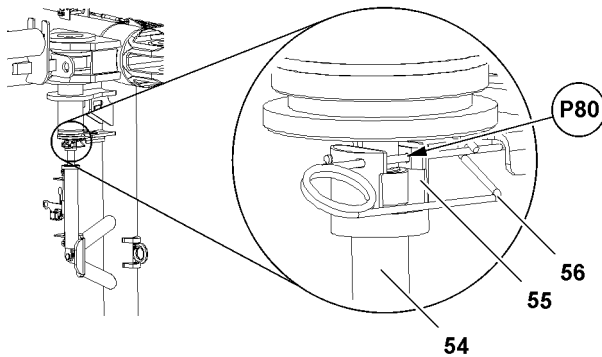

Fig.117040

**WARNING**

Unsecured pin pulling cylinder **54**!

When the claw **55** of the pin pulling cylinder **54** is not secured by a spring retainer **56**, then the pin pulling cylinder **54** can fall down.

Personnel can be severely injured or killed.

- ▶ Make sure that the claw **55** of the pin pulling cylinder **54** is secured in point **P80** by a spring retainer **56**.

Make sure that the following prerequisites are met:

- The ground is able to safely take on the entire operating weight of the crane including the load to be lifted.
- The crane is horizontally aligned.
- Two auxiliary cranes with sufficient load capacity are available.
- A forklift or telescopic lift truck are available.
- An assembly scaffolding / work platform is available.
- Winch 1 and winch 2 are properly installed and secured on the turntable.
- The A-frame is properly installed and secured on the turntable.
- The central ballast has been installed on the crawler travel gear according to the load chart or the erection and take-down charts.
- The counterweight has been installed on the turntable according to the load chart or the erection and take-down charts.
- The D-boom is completely assembled and erected on the turntable, see the Crane operating instructions, chapter 5.05.
- The LICCON overload protection has been set according to the data in the load chart.

3.1 Turning the turntable into the assembly position



WARNING

The crane can topple over!

If the following conditions are not met before turning the turntable - **without** an installed PD-boom, the crane can topple over!

Personnel can be severely injured or killed.

- ▶ Observe the data in the erection and take-down charts.
- ▶ Observe the data in the load charts.

- ▶ Turn the turntable in the lengthwise direction of the crawler travel gear.

3.2 Preparations on the S-pivot section

3.2.1 Swinging the railing on the S-pivot section into the operating position

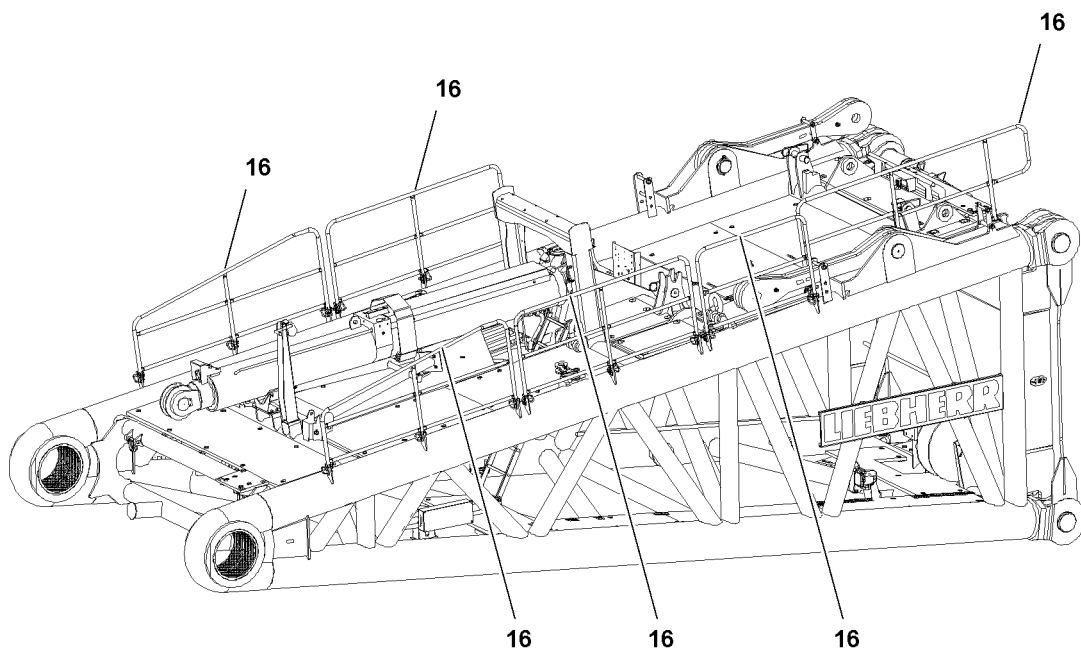

Fig.114608: Swinging the railing on the S-pivot section into the operating position



WARNING

Danger of falling!

During assembly and disassembly of the railings **16**, assembly personnel can fall down and be severely injured or killed.

- ▶ Assembly personnel must secure themselves for assembly / disassembly of railings **16**, using protective devices with an approved fall arrest system to prevent them from falling.
- ▶ For assembly and disassembly work, maintenance and inspection work on the S-pivot section, all railings and the protective devices must be assembled and secured.

Make sure that the following prerequisites are met:

- The ground is able to safely take on the weight of the S-pivot section.
- The S-pivot section is lying completely on the ground.

- ▶ For assembly / disassembly of railings and protective devices, see the Crane operating instructions, chapter 2.06.

3.2.2 Assembling the grating



WARNING

Disassembled or incompletely assembled grating!

If the grating is not assembled or incompletely assembled when winch 5 is missing, then personnel can fall and be severely injured or killed.

- ▶ For the non-assembled winch 5 on the S-pivot section: Assemble the grating.
- ▶ The grating may only be accessed when it is pinned and secured in the operating position, check visually.



WARNING

Grating swinging down!

Gratings that swing down by themselves can cause severe face or head injuries for assembly personnel!

Personnel can be severely injured or killed.

- ▶ For safety reasons, assemble the gratings always with two persons.



Note

- ▶ For assembly / disassembly of the gratings, see the Crane operating instructions, chapter 2.06.

3.3 Exceeding the shut-off limits of the LICCON overload protection for assembly operation

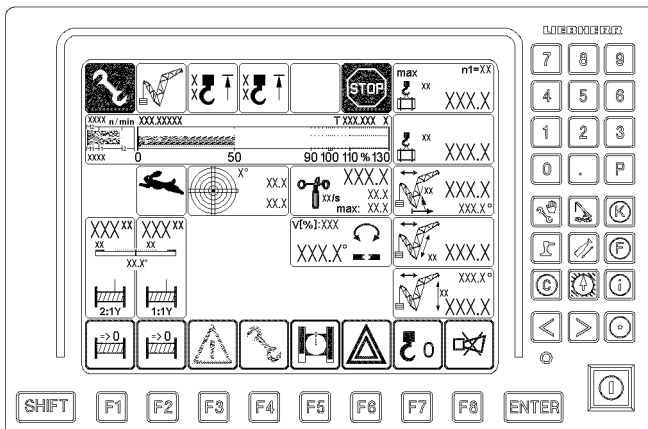

Fig.114636: Exceeding the shut-off limits of the LICCON overload protection for assembly operation

**WARNING**

Danger of accident due to the „Exceedance of shut-off limits of the LICCON overload protection“ function!

If the shut off limits of the LICCON overload protection are exceeded, there is no additional protection against crane overload.

Due to erroneous operation or deliberate misuse, the crane could collapse, the boom can break off or the crane can topple over.

Personnel can be severely injured or killed.

- ▶ The „Exceeding the shut-off limits of the LICCON overload protection“ function is only permissible in emergencies and for assembly purposes.
- ▶ The function „Exceeding the shut off limits of the LICCON overload protection“ may only be actuated by persons who know the effects of their actions regarding the function „Exceeding the shut off limits of the LICCON overload protection“.
- ▶ The „Exceedance of shut off limits of the LICCON overload protection“ function requires the presence of an authorized person and must be performed with utmost caution.
- ▶ Crane operation with the „Exceedance of shut off limits of the LICCON overload protection“ function activated is prohibited.

-
- ▶ Exceeding the shut off limits of the LICCON overload protection: Engage assembly operation

Result:

- The shut off limits of the LICCON overload protection are exceeded.
- The assembly icon appears on the LICCON monitor.

**Note**

- ▶ See the Crane operating instructions, chapter 4.02 and chapter 4.20.

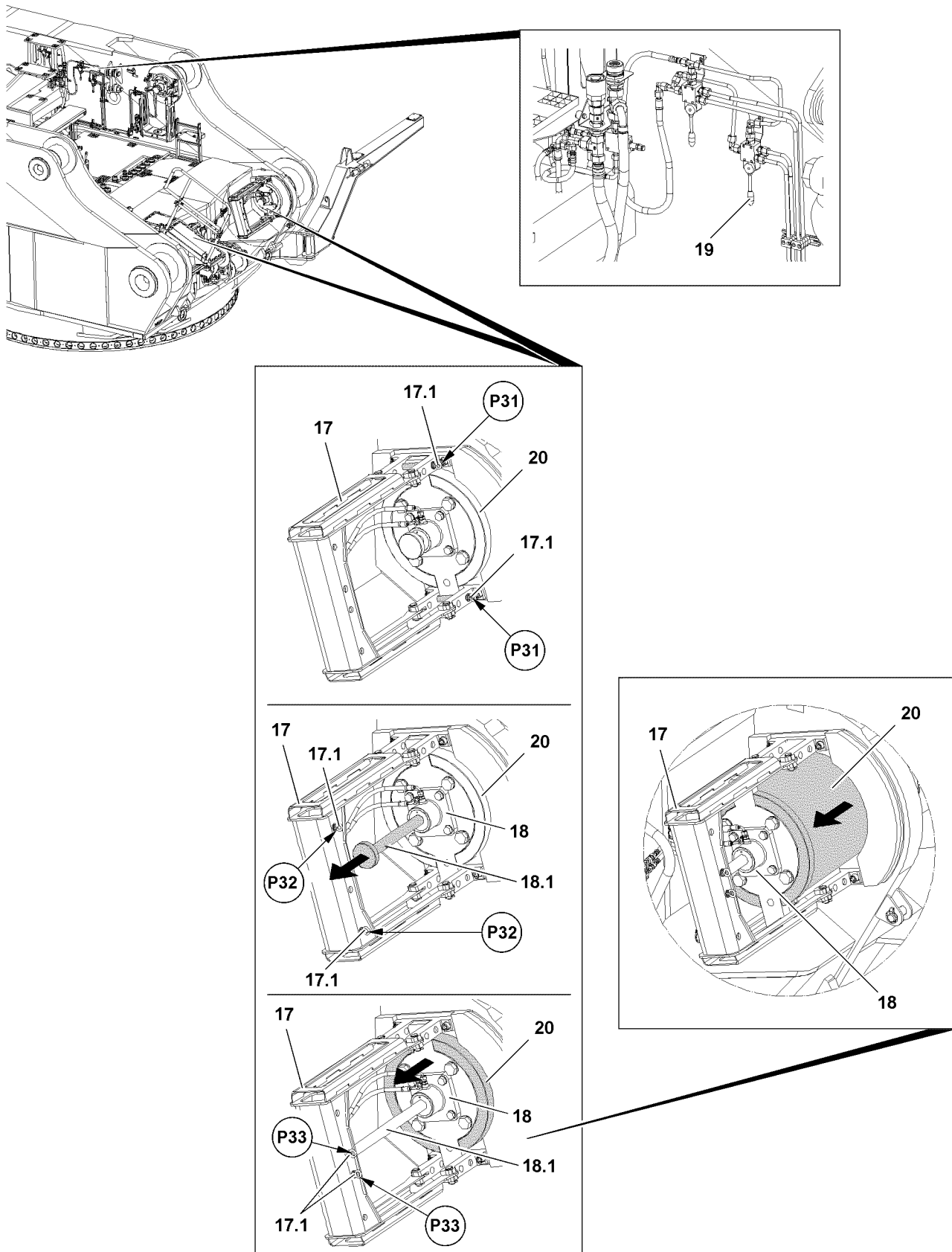

Fig.114610: Unpinning the S-connector pins on the turntable

LWE/LR 13000-001/19503-01-02/en

3.4 Unpinning the S-connector pins on the turntable



Note

- ▶ The pin pulling cylinders **18** are integrated into the S-connector pins **20** on this crane.
- ▶ The unpinning and pinning of the S-connector pins **20** can be done only in connection with the pin pulling device **17** installed on the crane.
- ▶ In the transport condition, the S-connector pins **20** are pinned on the turntable and secured with the retaining pins **17.1** in points **P31**.

Make sure that the following prerequisites are met:

- The derrick boom is properly pinned and secured to the turntable.
- The derrick boom is erected to 88°.
- The pin pulling devices **17** are installed in the pin points.
- At least one crane engine is running.



WARNING

Danger of crushing!

When unpinning or pinning the S-connector pins **20**, there is a danger of crushing! Limbs can be crushed or severed.

- ▶ During the unpinning or pinning procedure, make sure that no persons are in the danger zone.
- ▶ Do not reach into the danger zone of the pin pulling device **17** and the S-connector pins **20**.
- ▶ Release and unpin the retaining pins **17.1** in the points **P31** of the pin pulling device **17**.
- ▶ Insert and secure the retaining pins **17.1** in points **P32** of the pin pulling device **17** (park position).
- ▶ Extend the piston rod **18.1** of the pin pulling cylinder **18**: Actuate the hand lever **19** until the piston rods **18.1** on both pin pulling cylinders **18** are completely extended.

When the piston rods **18.1** for the pin pulling cylinders **18** are completely extended on both sides:

- ▶ Unpin the retaining pin **17.1** from the park position in points **P32** and insert and secure in the locking position in points **P33** on both sides.

Result:

- The piston rods **18.1** of the pin pulling cylinders **18** are locked with the pressure / pull plate in the pin pulling device **17**.
- ▶ Actuate the hand lever **19**.

Result:

- The S-connector pins **20** are unpinned on both sides by the pin pulling cylinder **18**.

NOTICE

Danger of property damage!

When swinging the S-pivot section **1** in to the pin points on the turntable, the S-connector pins **20** or the S-pivot section **1** can be damaged.

- ▶ Make sure that the S-connector pins **20** are completely unpinned before assembly of the S-pivot section **1**.

When the connector pins **20** are completely unpinned:

- ▶ Assemble the S-pivot section **1** on the turntable.

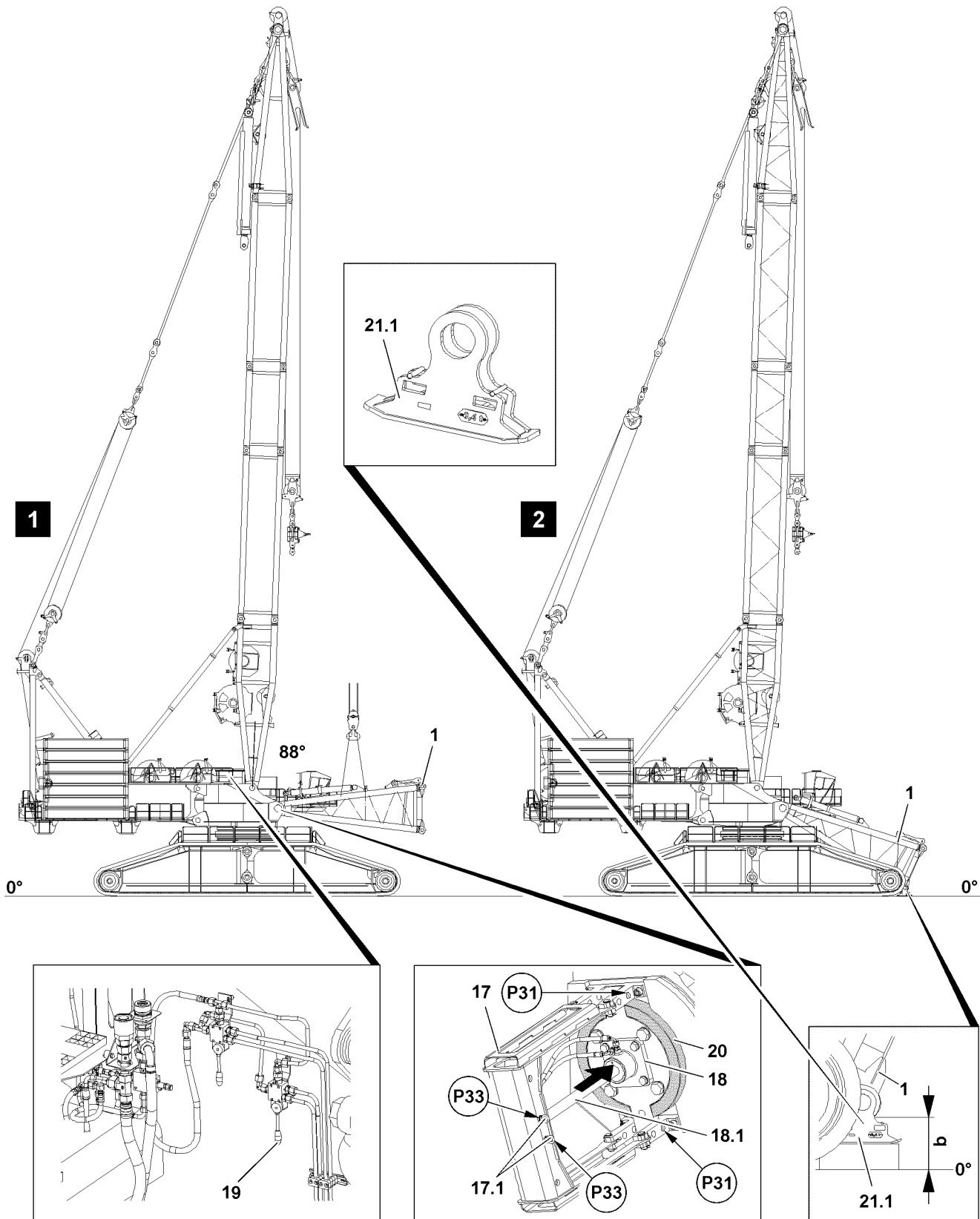

Fig.114611: Assembling the S-pivot section on the turntable

3.5 Assembling the S-pivot section on the turntable



Note

- ▶ Assemble the boom combinations according to the supplied Rod plans.
- ▶ For the combination of the boom systems, observe the Crane operating instructions, chapter 5.03.

NOTICE

Danger of property damage!

When taking the assembled S-pivot section **1** down, the S-pivot section **1** or the turntable can be damaged.

- ▶ Lower the S-pivot section **1** after assembly on the turntable on the supplied assembly shoes **21.1** and pin it with them.



WARNING

The crane can topple over!

If the specifications listed below are not observed, the crane can collapse, the boom can break off or the crane can topple over.

Personnel can be severely injured or killed.

- ▶ Observe and adhere to the instructions in the Crane operating instructions, chapter 5.03.
- ▶ Secure all pins after assembly with the intended retaining elements.
- ▶ Inspect the guy rods regularly, see the Crane operating instructions, chapter 8.15.

Make sure that the following prerequisites are met:

- The S-connector pins **20** are completely unpinned.
- Winch **5 WV** is **not** installed on the S-pivot section.



Note

- ▶ Select the fastening points on the S-pivot section **1** in such a way that the S-pivot section **1** hangs horizontally on the auxiliary crane during assembly. See section „Fastening points“.

- ▶ Fasten the S-pivot section **1** to the auxiliary crane.
- ▶ Swing the S-pivot section **1** in with the auxiliary crane to the pin points on the turntable.



DANGER

Falling S-pivot section!

Due to non-secured or insufficiently secured S-connector pins **20**, the S-pivot section **1** can fall down! Personnel can be severely injured or killed.

- ▶ Secure the S-connector pins **20** between the S-pivot section **1** and the turntable after the pinning procedure immediately with the retaining pins **17.1**.

- ▶ Insert the S-connector pins **20** on both sides with the pin pulling cylinder **18**: Actuate the hand lever **19** until the S-connector pins **20** are completely pinned on both sides.

When the S-connector pins **20** are completely pinned on both sides:

- ▶ Secure the S-connector pin **20**: Unpin the retaining pins **17.1** on the pin pulling device **17** in points **P33** and insert in points **P31** and secure.

Result:

- The S-pivot section **1** is pinned and secured on the turntable.

NOTICE

Danger of property damage!

When taking the assembled S-pivot section **1** down, the S-pivot section **1** or the turntable can be damaged.

- ▶ Lower the S-pivot section **1** after assembly on the turntable on the supplied assembly shoes **21.1** and pin it with them.

The assembly shoes **21.1** each have two receptacles on the side, which are used for the transport of the assembly shoes **21.1** with a standard fork of a forklift or telescopic lift truck.

- ▶ Move the fork into the receptacles on the assembly shoes **21.1**.
- ▶ Pick up the assembly shoes **21.1** with the forklift and position them under the pin points **P34** on the S-pivot section **1** on the „bottom“.

When the assembly shoes **21.1** are positioned under the S-pivot section **1** on both sides:

- ▶ Lower the S-pivot section **1** carefully and at a slow speed on the assembly shoes **21.1** can be pinned.

**Note**

- ▶ After assembly the S-pivot section **1** must be positioned at a distance **b** of at least 550 mm above the alignment level (0°).

- ▶ Pin the assembly shoes **21.1** with the lower connector pins **1.1** of the S-pivot section **1** in points **P34**: Insert the connector pin **1.1** and secure with the retaining pin **1.2**.
- ▶ Lower the S-pivot section **1** completely onto the assembly shoes **21.1**.

When the S-pivot section **1** is taken down on the assembly shoes **21.1**:

- ▶ Remove the auxiliary crane.

3.6 Unpinning the connector pins on the S-pivot section

NOTICE

Danger of property damage!

During assembly of the boom lattice sections, the pin connections can be severely damaged.

This can result in significant property damage.

- ▶ Before assembly of the lattice sections, make sure that all connector pins are completely unpinned.
- ▶ To unpin the connector pins, use the pin pulling cylinder, see the Crane operating instructions, chapter 5.30.

3.7 Establishing the electric and hydraulic connections on the S-pivot section

3.7.1 Establishing the electrical connections

NOTICE

Damage to the electrical connections!

If the electrical connection between the terminal box and the S-pivot section and the cable drum in the S-pivot section is established before the boom end section is installed and electrically connected, then the electric connection can be damaged.

- ▶ Make sure that the electric connection between the terminal box in the S-pivot section and the cable drum in the S-pivot section is only established **after** assembly and the connection of the electric wiring for the boom end section.

**Note**

- ▶ To establish the electrical connections on the S-pivot section: Use the wiring diagram.

Make sure that the following prerequisites are met:

- The S-pivot section is completely assembled and taken down on the substructure.
- ▶ Establish the electrical connections.
- ▶ Make sure that all electrical connections to the S-pivot section have been established.



WARNING

Malfunction if dummy plugs are not installed!

If the dummy plugs on the non-required electrical connections are not installed, then malfunctions or functional limitations can occur on the crane.

- ▶ Make sure that all non-required electrical connections, which have a dummy plug, are closed off with dummy plugs.
 - ▶ Pay attention to the Electrical wiring diagram.
-
- ▶ As a rule, close off on-required electrical connections (for example for accessories which cannot be installed) with the respective dummy plugs.

NOTICE

Property damage due to dirt and / or corrosion!

If unnecessary electrical connections are not closed off with the respective protective caps, then dirt and / or corrosion can damage the electrical connections.

This could result in malfunctions.

- ▶ Make sure that all non-required electrical connections are always closed off properly.
 - ▶ Pay attention to the Electrical wiring diagram.
-
- ▶ Close off electrical connections, which do not have any dummy plugs, properly with the corresponding protective caps.

3.7.2 Establishing the hydraulic connections

When connecting and releasing hydraulic lines with quick couplings, make sure that the coupling procedure is carried out correctly.



DANGER

Danger of accident due to loss of pressure or leakage!

Incorrectly coupled or self-loosening quick couplings (particularly return lines) can result in serious accidents due to component failure.

- ▶ Check that the quick couplings have been properly connected before using the crane.



Note

- ▶ To connect or release the hydraulic lines with quick couplings, see the Crane operating instructions, chapter 5.01.
-
- ▶ Release the pressure in the hydraulic system before connecting or disconnecting. Turn the engine off and wait a short time.
 - ▶ Bolting the coupling components (sleeve and connector) by using the knurled nut.
 - ▶ Connect the coupling components.

3.8 Assembling the boom



Note

- ▶ Observe the arrangement of the intermediate sections of the boom system, see the Crane operating instructions, chapter 5.03.



WARNING

The crane can topple over!

Personnel can be severely injured or killed.

- ▶ The turntable may not be turned during the assembly of the boom.

**WARNING**

Danger of accident!

If the following instructions are not observed, personnel can be severely injured or killed.

- ▶ For assembly of the boom combinations, the rod plan must be observed and adhered to.
- ▶ Depending on the condition of the ground, the boom and the lattice sections must be supported for boom assembly.
- ▶ Observe the technical safety instructions, see the Crane operating instructions, chapter 5.01.

**WARNING**

General danger notes!

Personnel can be severely injured or killed.

- ▶ Support the main boom during assembly / disassembly with suitable materials.
- ▶ All pins must be secured after assembly with the intended retaining elements.
- ▶ The guy rods must be checked regularly, see the Crane operating instructions, chapter 8.15.
- ▶ Secure the boom with the substructure or auxiliary crane, see the Crane operating instructions, chapter 5.01.
- ▶ It is prohibited for anyone to remain under the booms in the entire danger zone during the pinning and unpinning procedure of the lattice sections.

**Note**

- ▶ For weights of lattice sections with placed guy rods, see the Crane operating instructions, chapter 1.03.
- ▶ The lattice sections are pinned with the pin pulling device, see the Crane operating instructions, chapter 5.30.

Make sure that the following prerequisites are met:

- The ground is able to safely take on the entire operating weight of the crane including the load to be lifted.
- The crane is horizontally aligned.
- Two auxiliary cranes with sufficient load capacity are available.
- The telescopic lift truck is available.
- An assembly scaffolding / work platform is available.
- The winches - winch 1 and winch 2 - are properly installed and secured on the turntable.
- The A-frame is properly installed and secured on the turntable.
- The central ballast has been installed on the crawler travel gear according to the load chart or the erection and take-down charts.
- The counterweight has been installed on the turntable according to the load chart or the erection and take-down charts.
- The D-boom is completely assembled and erected on the turntable, see the Crane operating instructions, chapter 5.05.
- The LICCON overload protection has been set according to the data in the load chart.

3.8.1 Preassembling the P-adapter

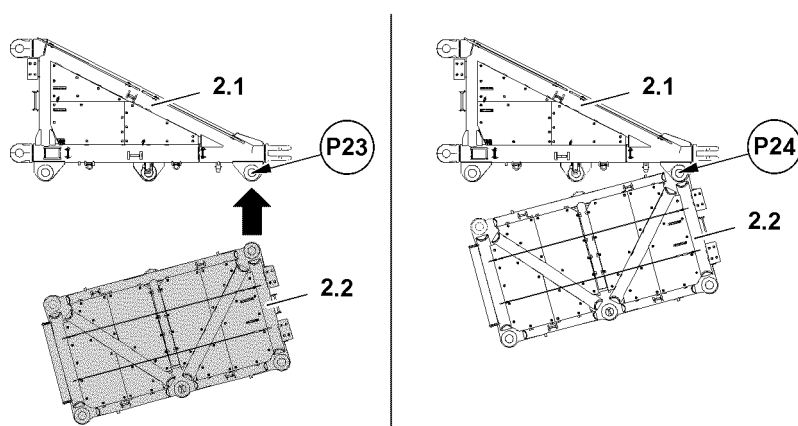

Fig.115432: Preassembling the P-adapter — positioning the center lattice section



Note

- ▶ The assembly / disassembly of the lower P-adapter and the upper P-adapter are identical. The assembly / disassembly is described based on the example of the lower P-adapter.

Make sure that the following prerequisites are met:

- The right lattice section **2.1** is on a level surface.
- Sufficient space is available to assemble the P-adapter completely.
- An auxiliary crane is available.
- All connector pins are unpinned and secured with the respective retaining elements.
- ▶ Fasten the auxiliary crane to the center lattice section **2.2**, see section „Fastening points“.
- ▶ Assemble the pin pulling device in the upper pin point **P23**.
- ▶ Position the center lattice section **2.2** in such a way that it can be pinned in point **P24**.

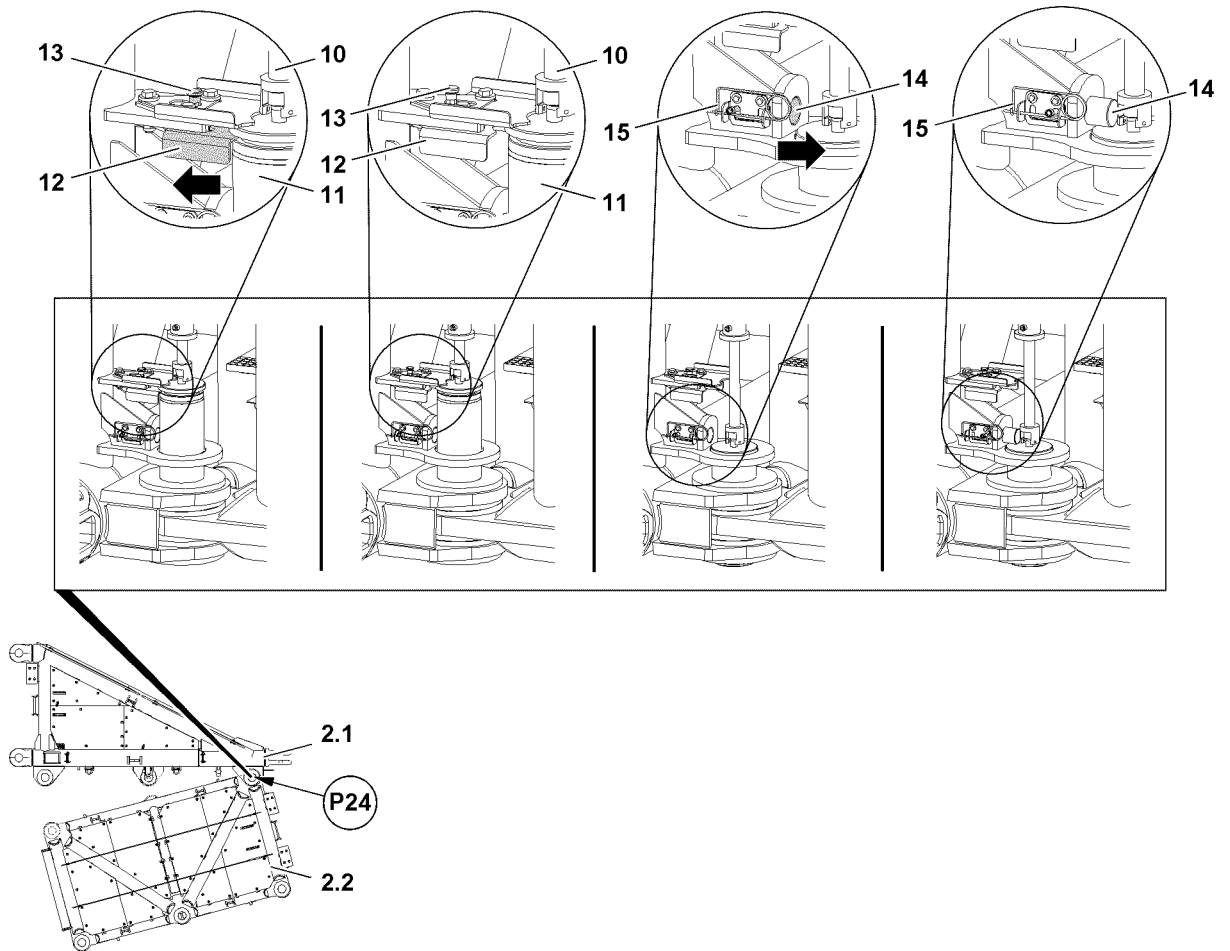

Fig.115436: Preassembling the P-adapter — Pin procedure and retaining procedure



Note

- ▶ The pinning or unpinning is carried out with the pin pulling device, see the Crane operating instructions, chapter 5.30.
- ▶ Pin the center lattice section 2.2 with the right lattice section 2.1: Insert the pin 11 on top in point P24 completely with the pin pulling device 10.



WARNING

General danger notes!

Personnel can be severely injured or killed.

- ▶ Secure all pins after the pinning procedure with the intended retaining elements.
- ▶ Release the retaining pin 14: Remove the spring retainer 15 on the bracket.
- ▶ Secure the pin 11 with the retaining pin 14. Guide the cylinder screw inside the bracket to the end stop.
- ▶ Secure the cylinder screw in this position with the spring retainer 15.

Result:

- The retaining pin 14 is secured by the spring retainer 15.
- The upper pin 11 is completely secured in point P24.
- ▶ Assemble the pin pulling device in the lower pin point P24.

**WARNING**

Premature removal of the sliding retainer **12**!

When the sliding retainer **12** is pulled back without having secured the pin **11** with the pin pulling device **10**, then the pin **11** falls down.

Personnel can be severely injured or killed.

- ▶ Make sure that the lower pin **11** is secured by the pin pulling device **10**.

There is a sliding retainer **12** on the lower pins **11** that keeps the pin **11** in position when it is unpinned. It must be pushed back after the pin **11** is held by the pin pulling device **10**.

When the pin **11** is held by the pin pulling device **10**:

- ▶ Remove the sliding retainer **12** on the pin **11**: Unpin the detent pin **13**, pull the sliding retainer **12** back and engage the detent pin **13**.
- ▶ Pin the center lattice section **2.2** with the right lattice section **2.1**: Insert the pin **11** on the bottom in point **P24** completely with the pin pulling device **10**.

**WARNING**

General danger notes!

Personnel can be severely injured or killed.

- ▶ Secure all pins after the pinning procedure with the intended retaining elements.
- ▶ Release the retaining pin **14**: Remove the spring retainer **15** on the bracket.
- ▶ Secure the lower pin **11** with retaining pin **14**: Guide the cylinder screw inside the bracket to the end stop.
- ▶ Secure the cylinder screw in this position with the spring retainer **15**.

Result:

- The retaining pin **14** is secured by the spring retainer **15**.
- The lower pin **11** is completely secured in point **P24**.

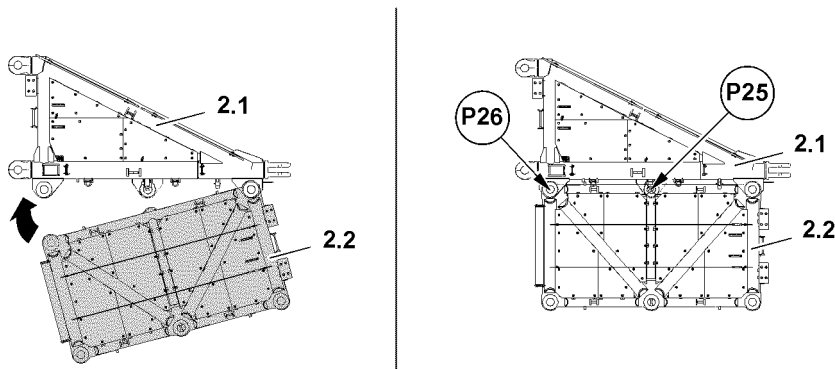

Fig. 115433: Preassembling the P-adaptor — Pinning the center lattice section with the right lattice section

- ▶ Swing the center lattice section in completely so that it can be pinned in point **P25** and point **P26**.
- ▶ Insert the pin in point **P25** on top and secure the same way as described above.
- ▶ Insert the pins **P26** in point each on top and bottom and secure the same way as was described before.

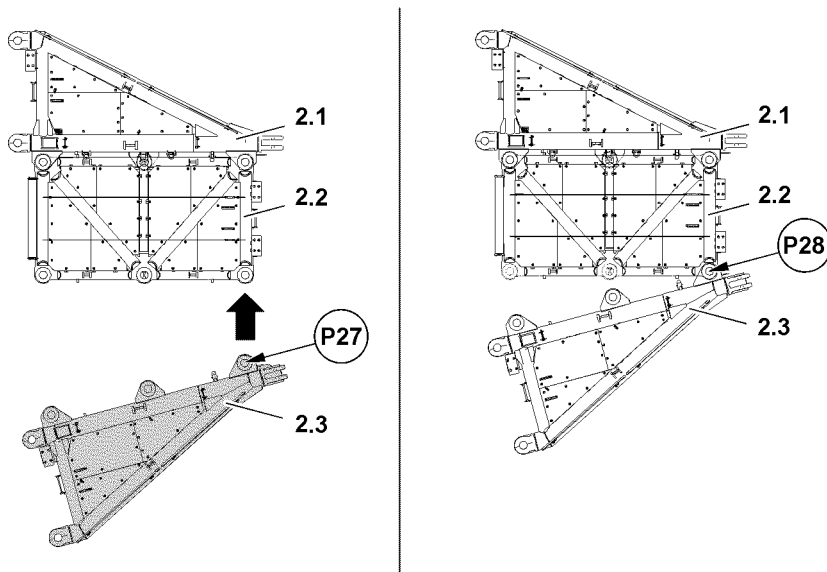

Fig.115434: Preassembling the P-adapter — Pinning the left lattice section with the center lattice section

- ▶ Fasten the auxiliary crane to the left lattice section **2.3**, see section „Fastening points“.
- ▶ Assemble the pin pulling device in the upper pin point **P27**.
- ▶ Position the left lattice section **2.3** in such a way that it can be pinned in point **P28**.
- ▶ Insert the pins **P28** in point each on top and bottom and secure the same way as was described before.

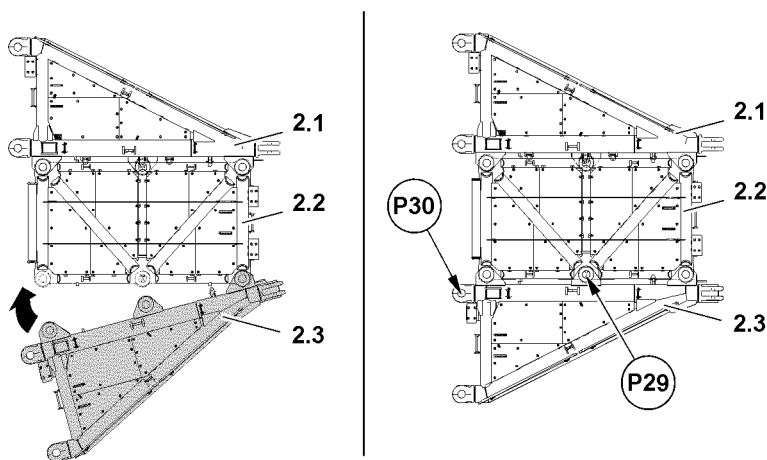

Fig.115435: Preassembling the P-adapter — Pinning the left lattice section with the center lattice section

- ▶ Swing the left lattice section **2.3** in completely so that it can be pinned in point **P29** and point **P30**.
- ▶ Insert the pin in point **P29** on top and secure the same way as described above.
- ▶ Insert the pins **P30** in point each on top and bottom and secure the same way as was described before.

Result:

- The P-adapter is completely preassembled.
- ▶ Carry out the procedure the same way as was described before for the second P-adapter.

3.8.2 Assembling the lower P-adapter on the S-pivot section

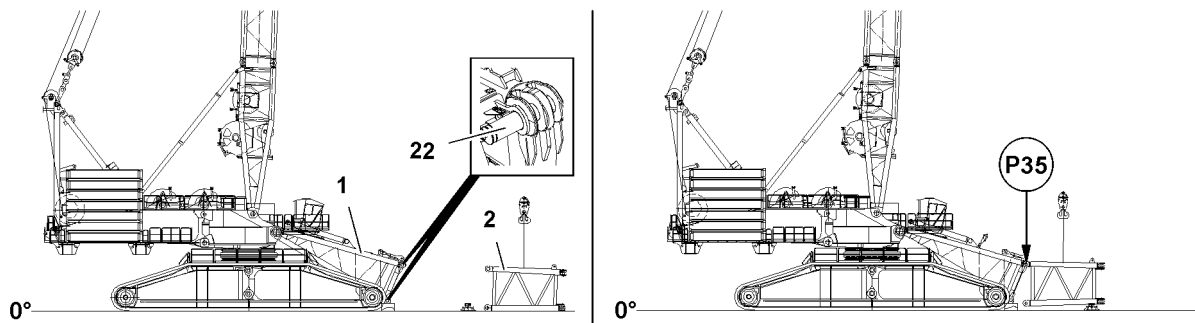

Fig.115437: Assembling the lower P-adapter on the S-pivot section - Positioning

Make sure that the following prerequisites are met:

- The derrick boom is erected to 88°.
- The pins **22** on the S-pivot section **1** are fully unpinned.
- The S-pivot section **1** is properly taken down at a height of at least 550 mm.



Note

- ▶ The pinning or unpinning is carried out with the pin pulling device, see the Crane operating instructions, chapter 5.30!
- ▶ Fasten the lower P-adapter **2** to the auxiliary crane, see section „Fastening points“.
- ▶ Lift and position the lower P-adapter **2** in such a way that it can be pinned on both sides in points **P35**.

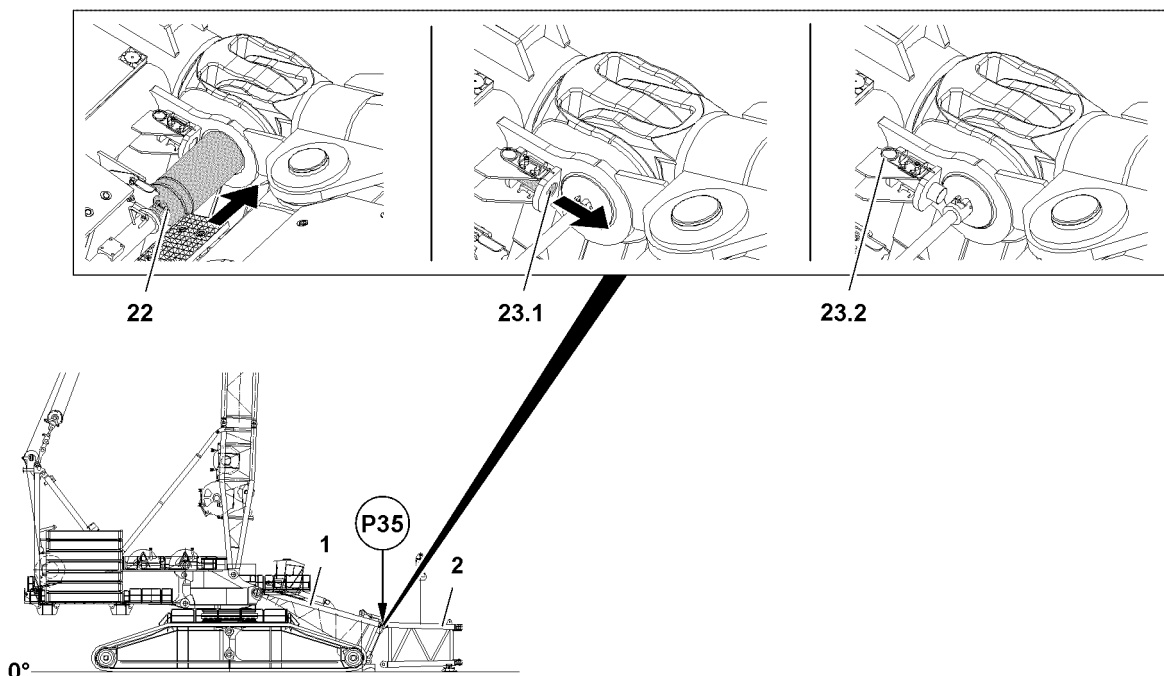

Fig.115438: Assembling the lower P-adapter on the S-pivot section - Pinning procedure

**WARNING**

General danger notes!

Personnel can be severely injured or killed.

- ▶ Secure all pins **22** after the pinning procedure with the intended retaining elements (pin **23.1**, spring retainer **23.2**).
- ▶ Pin the lower P-adapter **2** with the S-pivot section **1**: Insert the pin **22** on both sides in points **P35** with the pin pulling device.
- ▶ Release the pin **23.1**.
- ▶ Slide the pin **23.1** out to the stop and lock the screw in place downward.
- ▶ Secure the pin **23.1** with the spring retainers **23.2**.

Result:

- The upper pins **22** are secured.

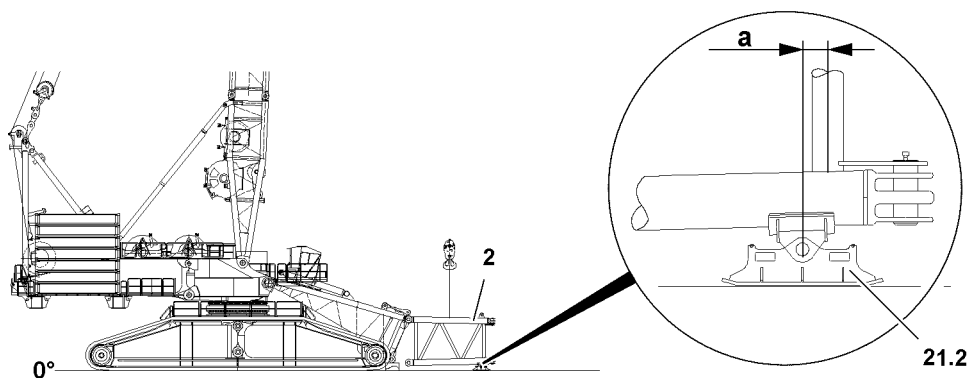

Fig.115439: Assembling the lower P-adapter on the S-pivot section - Positioning the assembly shoe

**Note**

- ▶ If the assembly shoes **21.2** are not placed under the lower P-adapter **2** then it is not possible to assemble the Li-intermediate sections.

**WARNING**

Incorrect position of the assembly shoes **21.2**!

If the assembly shoes **21.2** are not placed underneath in the permitted area of the lattice sections, then the lattice sections can be overloaded and damaged.

An accident can occur during crane operation due to a damaged or previously overloaded lattice section!

The distance **a** may not be more than 300 mm.

Personnel can be severely injured or killed.

- ▶ Make sure that the distance **a** is not more than 300 mm.
- ▶ The crane operator is responsible for the proper substructure of the assembly shoes **21.2** on the intermediate sections.
- ▶ Lower the lower P-adapter **2** until it is lying stable on the assembly shoes **21.2**.

3.8.3 Changing the boom: Turning the Li-intermediate sections

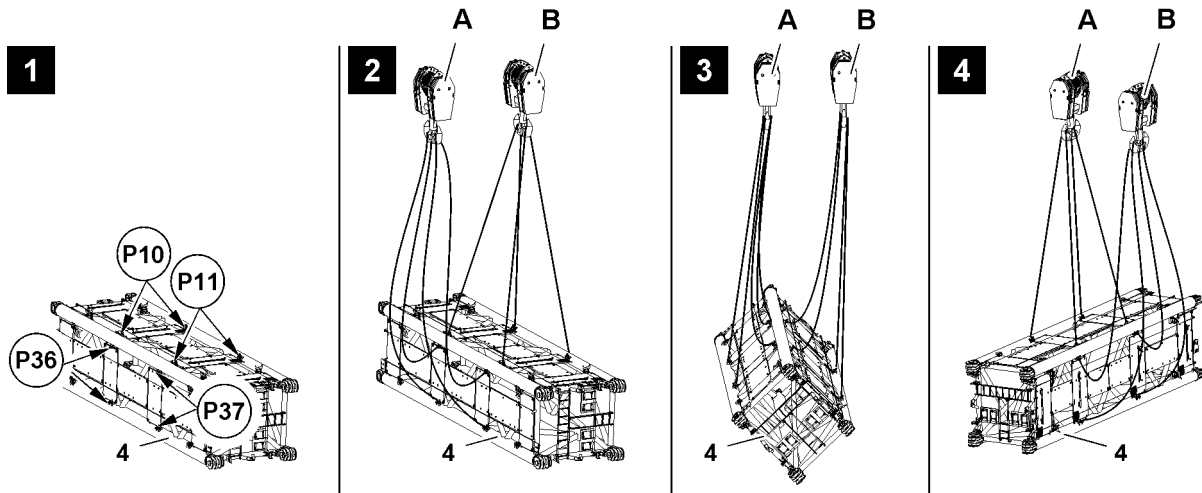

Fig.114603: Changing the boom: Turning the Li-intermediate sections

This section applies only if the Li-intermediate sections 4 were used previously in another boom system.

The Li-intermediate sections 4 must be turned for use in the P-boom system.

Make sure that the following prerequisite is met:

- Two auxiliary cranes with sufficient load carrying capacity are available.



Note

- ▶ For fastening of the crane / boom sections, observe and adhere to section „Fastening points“!



WARNING

Turning at an excessive height!

In case of an accident, personnel can be severely injured or killed.

- ▶ Make sure that there are no persons in the danger zone.
- ▶ Turn the Li-intermediate sections 4 as close as possible to the ground without them touching the ground.

- ▶ Fasten the first Li-intermediate section 4 to both auxiliary cranes: Fasten the auxiliary crane A in points P36 and points P37 and fasten the auxiliary crane B in points P10 and points P11, see illustration 1.

- ▶ Relieve the fastening equipment completely from the auxiliary crane A, see illustration 2.

When the fastening equipment is completely relieved from the auxiliary crane A:

- ▶ Lift the Li-intermediate section 4 with the auxiliary crane B, see illustration 2.
- ▶ Turn the Li-intermediate section 4 90°: Lift the Li-intermediate section 4 slowly with the auxiliary crane A and lower simultaneously with the auxiliary crane B until the Li-intermediate section 4 is lifted completely by the auxiliary crane A, see illustration 3 and illustration 4.
- ▶ Relieve the fastening equipment completely to the auxiliary crane B.

When the fastening equipment is completely relieved on the auxiliary crane B:

- ▶ Place the Li-intermediate section 4 with the auxiliary crane A on the ground.
- ▶ Remove the fastening equipment from the auxiliary crane B in points P10 and points P11.
- ▶ Remove the fastening equipment from the auxiliary crane A in points P36 and points P37.
- ▶ Carry out the procedure the same way as was described before for all required Li-intermediate sections.

3.8.4 Assembling the Li-intermediate sections on the P-adapter

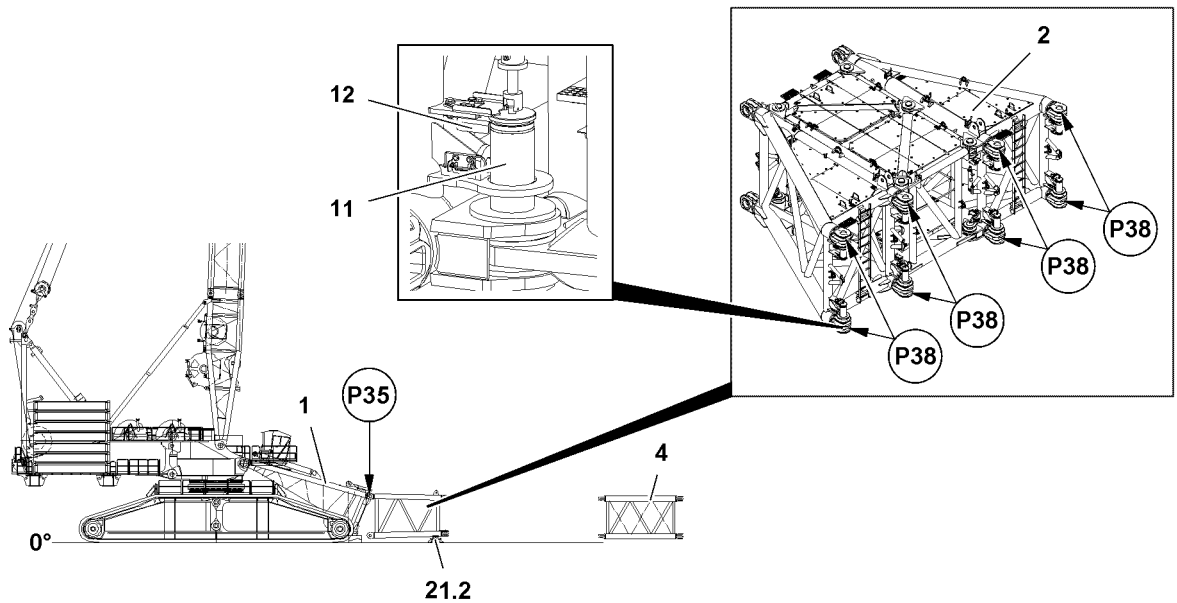

Fig.115440: Assembling the Li-intermediate sections on the P-adapter - Pin points

Make sure that the following prerequisites are met:

- The lower P-adapter **2** is properly pinned and secured in point **P35** of the S-pivot section **1**.
- The lower P-adapter **2** is properly taken down on the assembly shoes **21.2**.
- The eight pins **11** in the points **P38** of the lower P-adapter **2** are completely unpinned.
- The lower positioned pins **11** of the lower P-adapter **2** are secured by the sliding retainer **12** to prevent them from slipping out.
- The folding brackets on the lower P-adapter are folded down.
- The fastening equipment on the lower P-adapter **2** has been removed.
- The Li-intermediate sections **4** are taken down in such a way that they can be pinned without further turning.
- Two auxiliary cranes are provided.

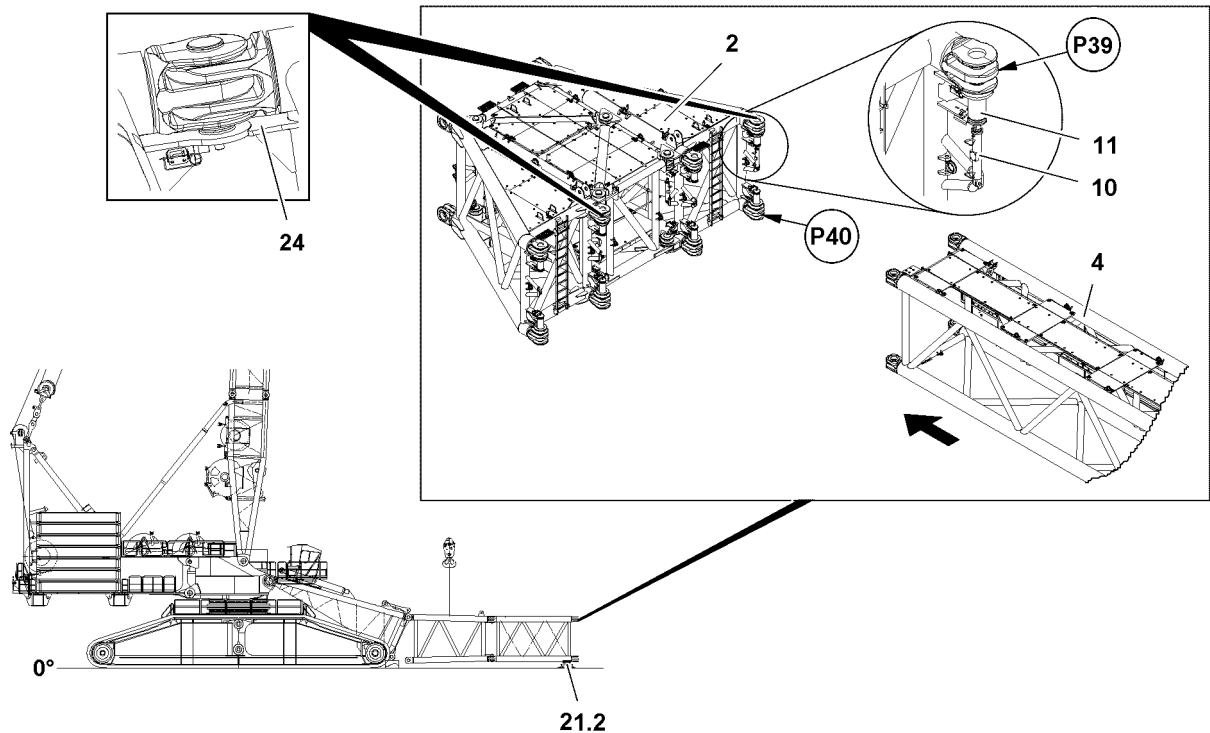

Fig.114604: Assembling the Li-intermediate sections on the P-adapter - Positioning procedure



Note

- ▶ The assembly is described for the left Li-intermediate section 4!
- ▶ The combination of the various boom systems must be taken from the rod plan and must be adhered to!



Note

- ▶ The Li-intermediate sections 4 are pinned with the pin pulling device 10 on the lower P-adapter 2 and the additional Li-intermediate sections 4, see the Crane operating instructions, chapter 5.30!
- ▶ For easier assembly / disassembly of the Li-intermediate sections 4, the last installed Li-intermediate section 4 must always be supported with the supplied assembly shoes 21.2!

The Li-intermediate sections 4 must be each pinned and secured on both sides of the lower P-adapter 2.

Position the respective Li-intermediate section 4 first on the side on which the pre-centering 24 is located.

The pin pulling cylinder 10 is installed on the upper pin location before installation of the Li-intermediate section 4.

- ▶ Lift the Li-intermediate section 4 with the auxiliary crane.
- ▶ Align and position the Li-intermediate section 4 with the pre-centering 24 on the lower P-adapter 2 so that it can be pinned in point P39 and point P40.

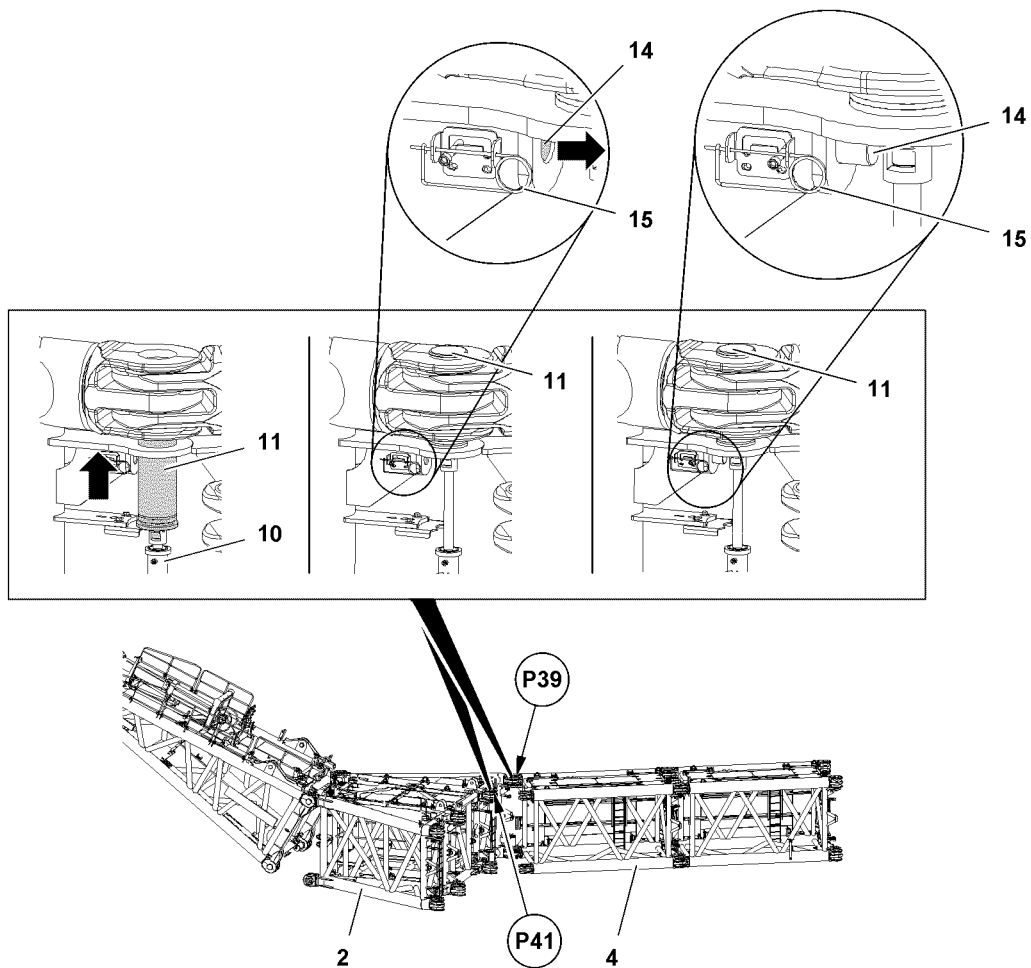

Fig.114614: Assembling the Li-intermediate sections on the P-adapter - Pinning procedure on top

When the pin bores on the lower P-adapter 2 and on the Li-intermediate section 4 align in point P39 and point P40:

- ▶ Pin the lower P-adapter 2 with the Li-intermediate section 4: Insert the pin 11 with the pin pulling device 10 in point P39 to the stop.



WARNING

General danger notes!
Personnel can be severely injured or killed.

- ▶ Secure all pins 11 after the pinning procedure with the intended retaining elements (retaining pin 14, spring retainer 15).
- ▶ Release the retaining pin 14: Remove the spring retainer 15 on the bracket.
- ▶ Secure the pin 11 with the retaining pin 14. Guide the cylinder screw inside the bracket to the end stop.
- ▶ Secure the cylinder screw in this position with the spring retainer 15.

Result:

- The retaining pin 14 is secured by the spring retainer 15.
- The pin 11 is completely secured in point P39.

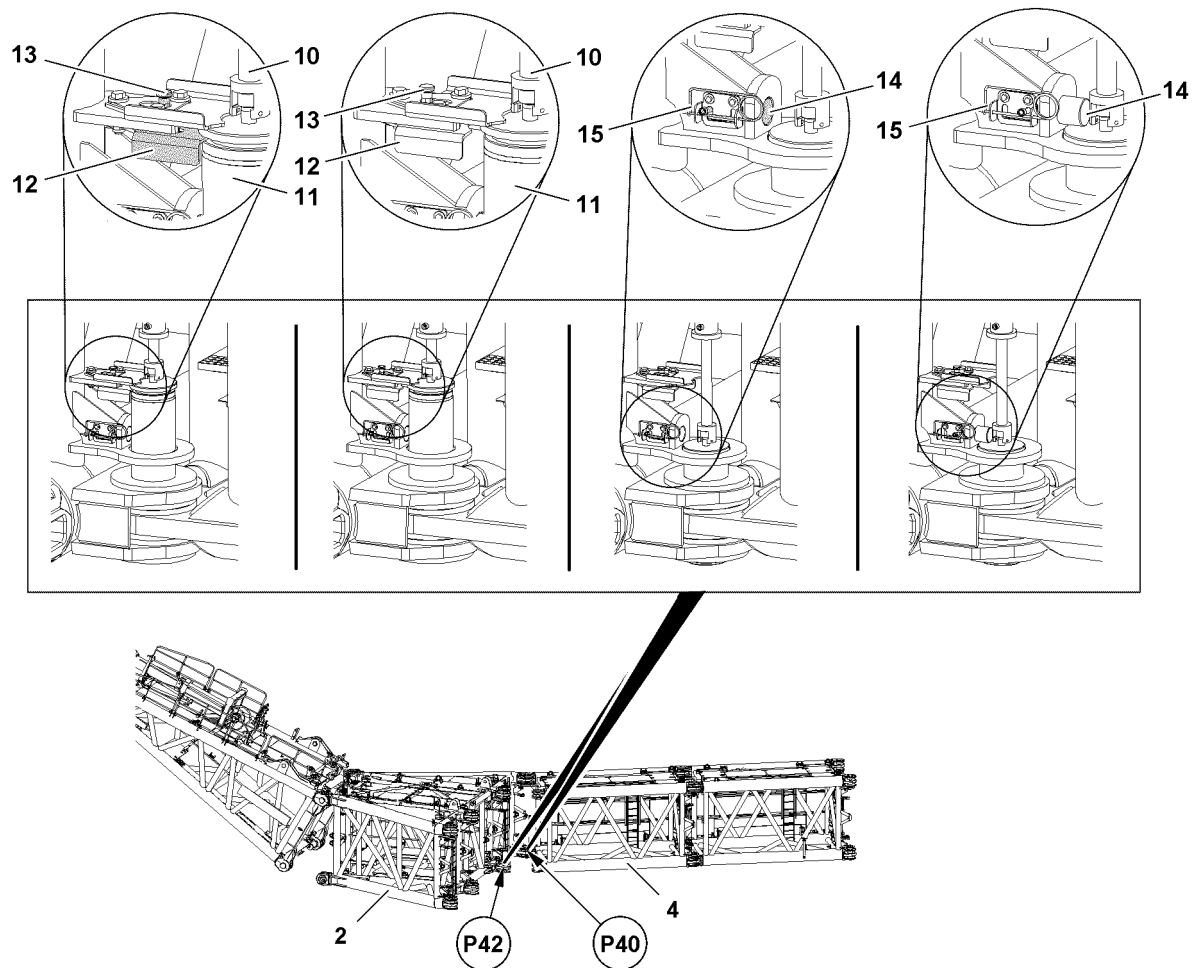

Fig.114605: Assembling the Li-intermediate sections on the P-adapter - Pinning procedure on the bottom

- ▶ Assemble the pin pulling device in the lower pin point **P40**.



WARNING

Premature removal of the sliding retainer **12**!

When the sliding retainer **12** is pulled back without having secured the pin **11** with the pin pulling device **10**, then the pin **11** falls down.

Personnel can be severely injured or killed.

- ▶ Make sure that the lower pin **11** is secured by the pin pulling device **10**.

There is a sliding retainer **12** on the lower pins **11** that keeps the pin **11** in position when it is unpinned. It must be pushed back after the pin **11** is held by the pin pulling device **10**.

When the pin **11** is held by the pin pulling device **10**:

- ▶ Remove the sliding retainer **12** on the pin **11**: Unpin the detent pin **13**, pull the sliding retainer **12** back and engage the detent pin **13**.
- ▶ Pin the Li-intermediate section **4** with the lower P-adapter **2**: Insert the pin **11** in point **P40** with the pin pulling device **10**.



WARNING

General danger notes!

Personnel can be severely injured or killed.

- ▶ Secure all pins **11** after the pinning procedure with the intended retaining elements (retaining pin **14**, spring retainer **15**).
- ▶ Release the retaining pin **14**: Remove the spring retainer **15** on the bracket.

- ▶ Secure the lower pin **11** with retaining pin **14**: Guide the cylinder screw inside the bracket to the end stop.
- ▶ Secure the cylinder screw in this position with the spring retainer **15**.

Result:

- The retaining pin **14** is secured by the spring retainer **15**.
- The pin **11** is completely secured in point **P40**.
- ▶ Fold the Li-intermediate section in so that it can be pinned in point **P41** and point **P42**.
- ▶ Repeat the pinning procedure in point **P41** the same way as described before in point **P39**.
- ▶ Repeat the pinning procedure in point **P42** the same way as described before in point **P40**.
- ▶ Remove the auxiliary crane.
- ▶ Place the assembly shoes properly under the Li-intermediate section **4**, see section „Changing the assembly shoes at assembly“.

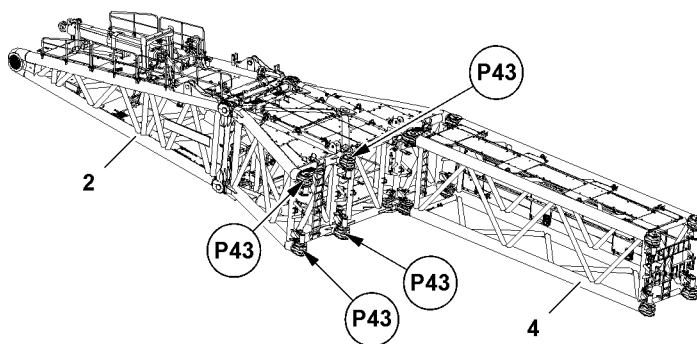

Fig.114615: Assembling the Li-intermediate sections on the P-adaptor - Pin points for the second section leg

**WARNING**

The crane can topple over!

If the rod plans and the data in the Crane operating instructions, chapter 5.03 are not observed, this can cause the crane to collapse, the boom to break off or the crane to topple over.

Personnel can be severely injured or killed.

- ▶ The combination of the various boom systems must be taken from the rod plan and must be adhered to.
- ▶ Observe and adhere to the instructions in the Crane operating instructions, chapter 5.03.

- ▶ Assemble the Li-intermediate section **4** in points **P43** of the lower P-adaptor **2** the same way as described before.

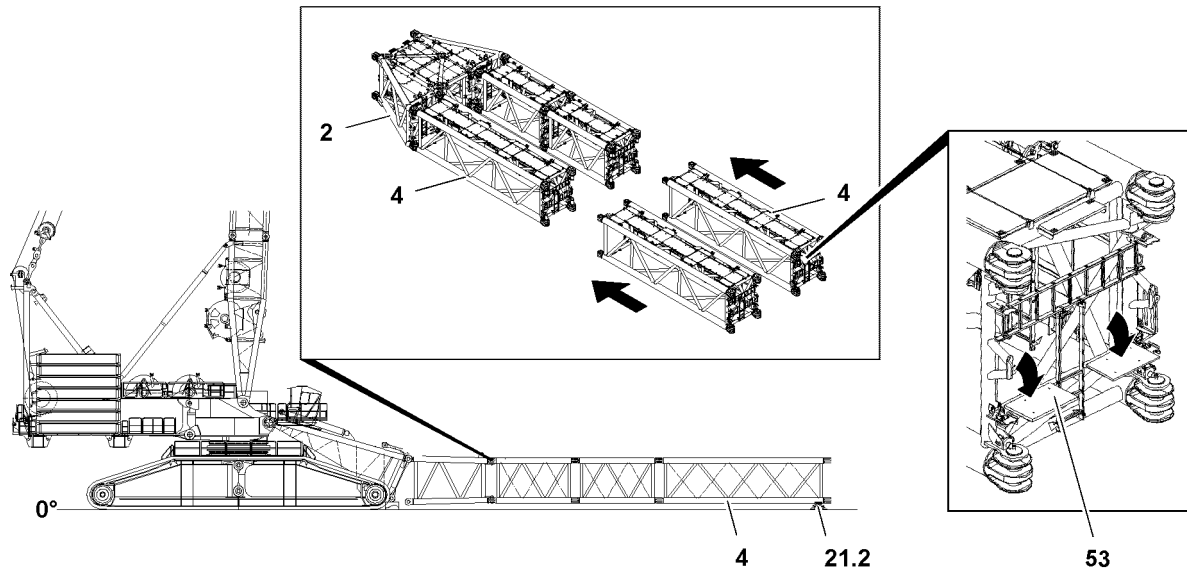

Fig.114606: Assembling the Li-intermediate sections on the P-adapter - Assembly of additional Li-intermediate sections

Depending on the system length, a different number of Li-intermediate sections **4** is used.

Refer to the rod plan for the number and sequence of the Li-intermediate sections **4**.

The assembly between the Li-intermediate sections **4** is identical with the previously described assembly between the lower P-adapter **2** and an Li-intermediate section **4**.

To be able to reach the upper pin points easier, use the folding brackets **53**.



WARNING

Changing the assembly shoes **21**!

If the assembly shoes **21** are not changed over under the last assembled Li-intermediate section **4**, the Li-intermediate sections **4** can be overloaded and damaged.

An accident can occur during crane operation due to a damaged or previously overloaded lattice section!

Personnel can be severely injured or killed.

- ▶ Place the assembly shoes **21** properly under the last assembled Li-intermediate section **4**, see section „Changing the assembly shoes at assembly“.
- ▶ Assemble the parallel section of the boom system to the required length.

3.8.5 Changing the assembly shoes at assembly

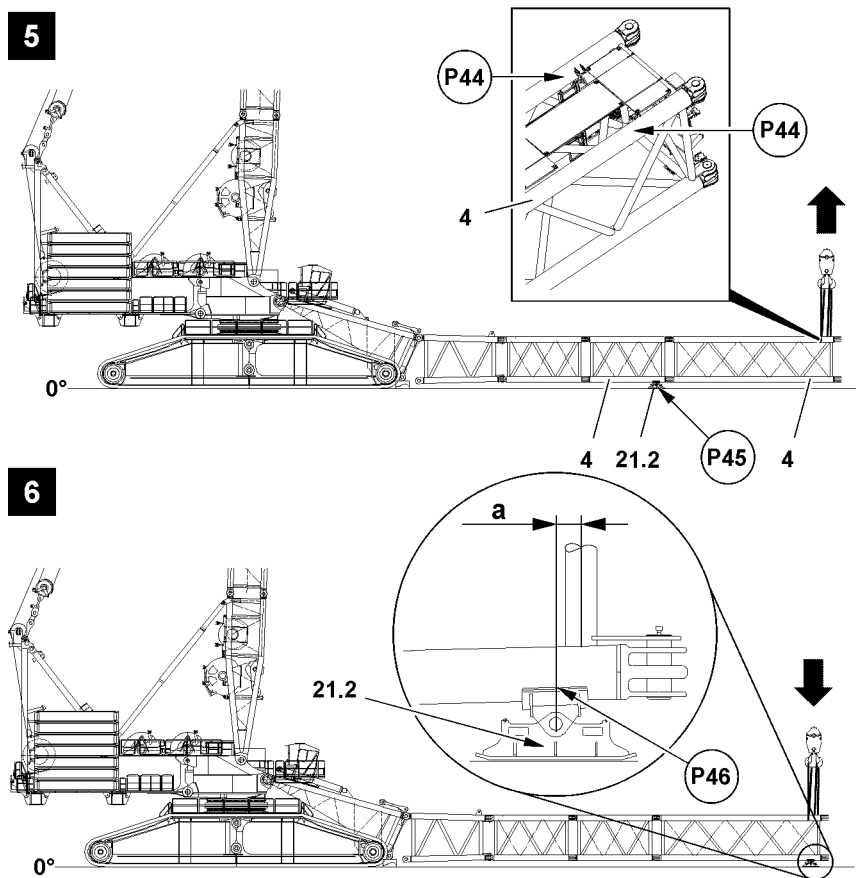

Fig.114607: Changing the assembly shoes at assembly

Make sure that the following prerequisites are met:

- The respective Li-intermediate section **4** is completely assembled.
- The fastening equipment has been removed.
- An auxiliary crane is available.



Note

- ▶ Changing the assembly shoes **21.2** is identical for each Li-intermediate section **4**. The change procedure is described based on the example of one Li-intermediate section **4**!

- ▶ Fasten the fastening equipment properly in points **P44**: Use the fastening equipment to place a loop on the bars on the left and right.
- ▶ Lift the lattice section leg with the auxiliary crane, see illustration **5**.

Result:

- The assembly shoes **21.2** in point **P45** are not loaded and can be offset.
- ▶ Remove the assembly shoes **21.2** in point **P45**.

**WARNING**

Incorrect position of the assembly shoes **21.2**!

If the assembly shoes **21.2** are not placed underneath in the permitted area of the Li-intermediate sections **4**, then the Li-intermediate sections **4** can be overloaded and damaged.

An accident can occur during crane operation due to a damaged or previously overloaded lattice section.

The distance **a** may not be more than 300 mm.

Personnel can be severely injured or killed.

- ▶ Make sure that the distance **a** is not more than 300 mm.
 - ▶ The crane operator is responsible for the proper substructure of the assembly shoes **21.2** on the Li-intermediate sections **4**.
-
- ▶ Position the assembly shoes **21.2** in such a way in point **P46** that the distance **a** is no more than 300 mm.
 - ▶ Lower the lattice section leg with the auxiliary crane until the last Li-intermediate section **4** is properly lying on the assembly shoes **21.2**, see illustration **6**.

3.8.6 Assembling the upper P-adapter on the Li-intermediate sections

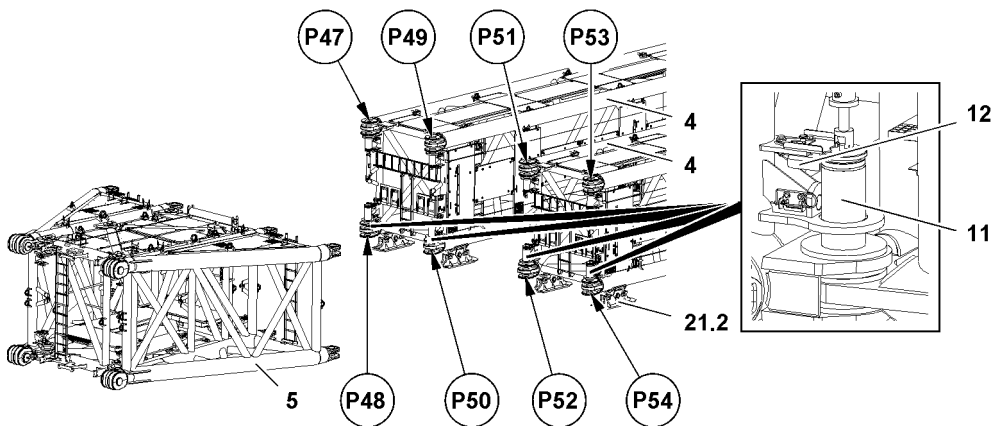

Fig.114616: Assembling the upper P-adapter on the Li-intermediate sections - Pin points

Make sure that the following prerequisites are met:

- The upper P-adapter **5** is completely preassembled.
- The parallel section of the P-boom is assembled to the desired length.
- The assembly shoes **21.2** are properly supported under the Li-intermediate sections **4**.
- The connector pins **11** are completely unpinned in point **P47**, point **P48**, point **P49**, point **P50**, point **P51**, point **P52**, point **P53**, point **P54** of the Li-intermediate sections **4**.
- The lower positioned connector pins **11** of the Li-intermediate sections **4** are secured by the sliding retainer **12** to prevent them from slipping out.
- A second auxiliary crane with sufficient load carrying capacity is available.

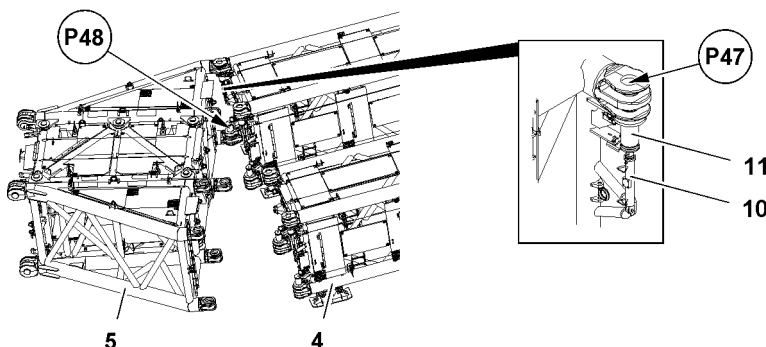

Fig.114617: Assembling the upper P-adapter on the Li-intermediate sections — Positioning procedure

**Note**

- ▶ The pinning or unpinning is carried out with the pin pulling device **10**, see the Crane operating instructions, chapter 5.30!

The upper P-adapter **5** must be pinned and secured on both Li-intermediate sections **4**.

The upper P-adapter **5** must be pinned and secured on both sides on the respective Li-intermediate section **4**.

The pin pulling cylinder **10** is installed before installation of the upper P-adapter **5** in point **P47**.

- ▶ Fasten the upper P-adapter **5** to the auxiliary crane, see section „Fastening points“.
- ▶ Lift and position the upper P-adapter **5** in such a way that it can be pinned in point **P47** and point **P48**.

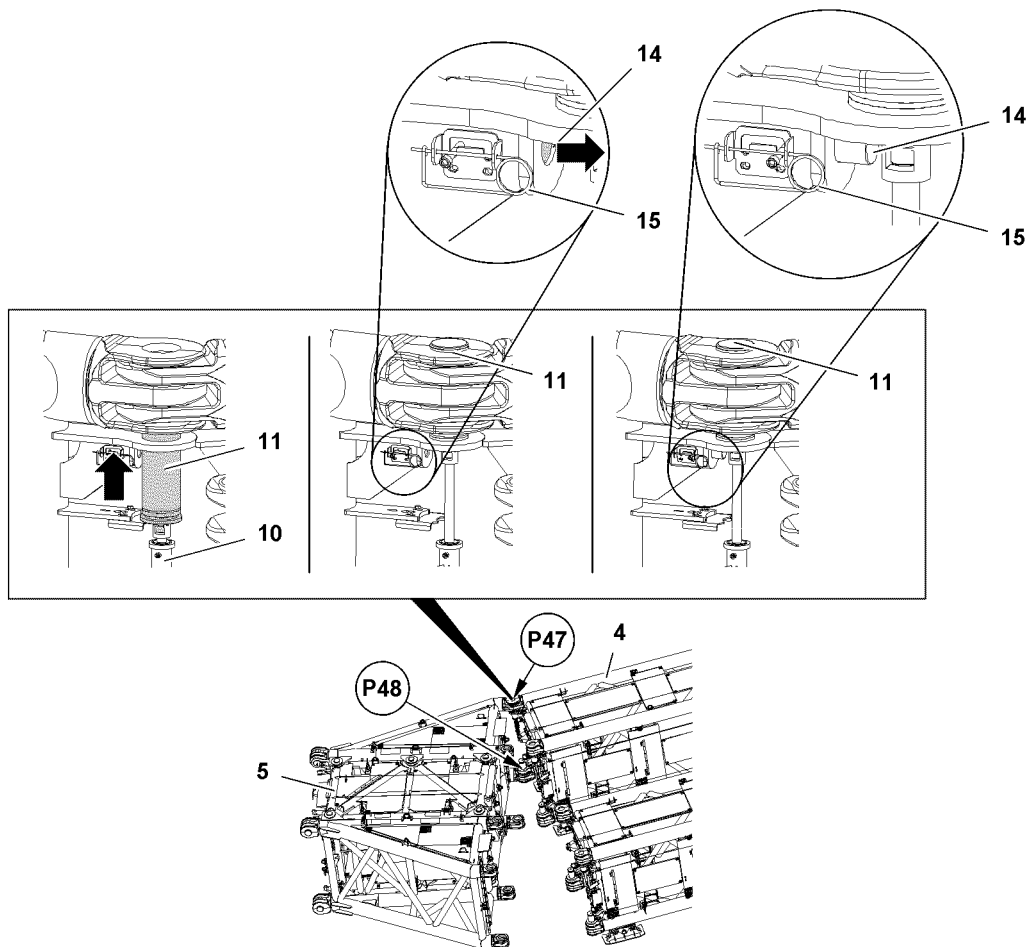

Fig.114618: Assembling the upper P-adapter on the Li-intermediate sections - Pinning procedure on top

When the pin bores on the upper P-adapter **5** and on the Li-intermediate section **4** align in point **P47** and point **P48**:

- ▶ Pin the upper P-adapter **5** with the Li-intermediate section **4**: Insert the pin **11** with the pin pulling device **10** in point **P47** to the stop.

**WARNING**

General danger notes!

Personnel can be severely injured or killed.

- ▶ Secure all pins **11** after the pinning procedure with the intended retaining elements (retaining pin **14**, spring retainer **15**).

- ▶ Release the retaining pin **14**: Remove the spring retainer **15** on the bracket.
- ▶ Secure the pin **11** with the retaining pin **14**. Guide the cylinder screw inside the bracket to the end stop.
- ▶ Secure the cylinder screw in this position with the spring retainer **15**.

Result:

- The retaining pin **14** is secured by the spring retainer **15**.
- The pin **11** is completely secured in point **P47**.

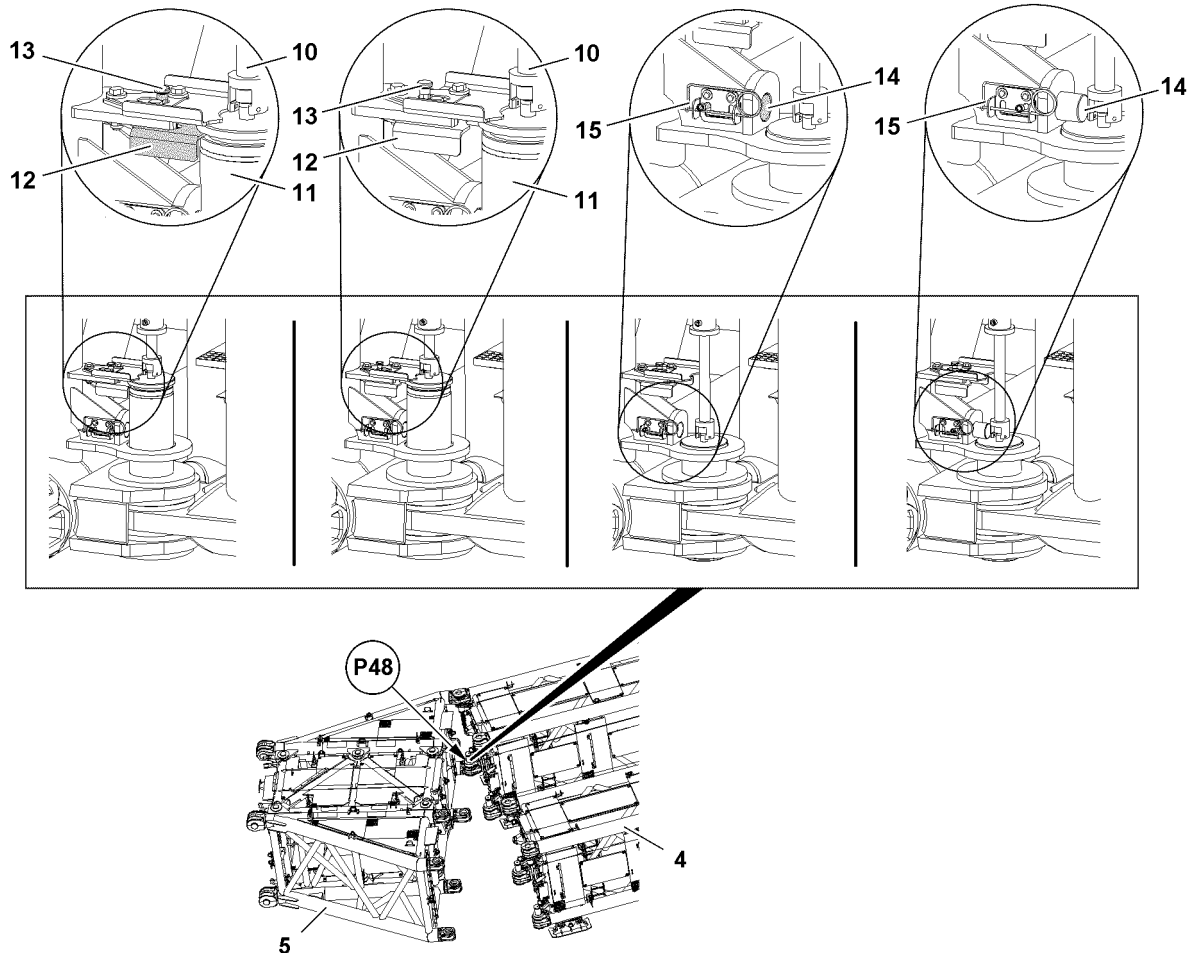

Fig.114619: Assembling the upper P-adapter on the Li-intermediate sections - Pinning procedure on the bottom

- ▶ Assemble the pin pulling device in the lower pin point.



WARNING

Premature removal of the sliding retainer **12**!

When the sliding retainer **12** is pulled back without having secured the pin **11** with the pin pulling device **10**, then the pin **11** falls down.

Personnel can be severely injured or killed.

- ▶ Make sure that the lower pin **11** is secured by the pin pulling device **10**.

There is a sliding retainer **12** on the lower pins **11** that keeps the pin **11** in position when it is unpinned. It must be pushed back after the pin **11** is held by the pin pulling device **10**.

When the pin **11** is held by the pin pulling device **10**:

- ▶ Remove the sliding retainer **12** on the pin **11**: Unpin the detent pin **13**, pull the sliding retainer **12** back and engage the detent pin **13**.

- ▶ Pin the upper P-adapter **5** with the Li-intermediate section **4**: Insert the pin **11** in point **P48** with the pin pulling device **10**.

**WARNING**

General danger notes!

Personnel can be severely injured or killed.

- ▶ Secure all pins **11** after the pinning procedure with the intended retaining elements (retaining pin **14**, spring retainer **15**).
- ▶ Release the retaining pin **14**: Remove the spring retainer **15** on the bracket.
- ▶ Secure the pin **11** with the retaining pin **14**: Guide the cylinder screw inside the bracket to the end stop.
- ▶ Secure the cylinder screw in this position with the spring retainer **15**.

Result:

- The retaining pin **14** is secured by the spring retainer **15**.
- The pin **11** is completely secured in point **P48**.

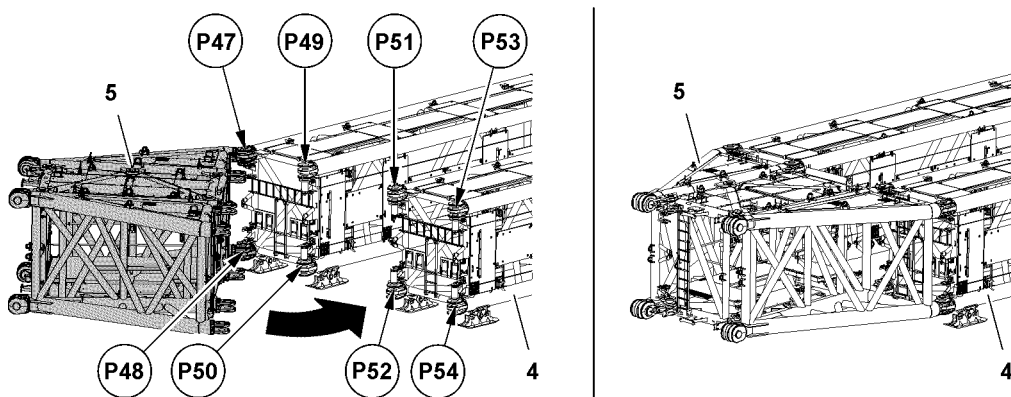

Fig.114620: Assembling the upper P-adapter on the Li-intermediate sections - Assembling the upper P-adapter completely

**WARNING**

Death or severe injury due to impact on the 16 t eyehooks!

Property damage.

- ▶ Place the 20 t loop around both upper corner bars and fasten with 35 t fastening ropes to the auxiliary crane.

To be able to fold in the upper P-adapter, the free Li-section leg is lifted and positioned with the second auxiliary crane by slinging it.

**WARNING**

Death or severe injury during positioning of the upper P-adapter **5**!

- ▶ Make sure that there is no personnel in the danger zone.
- ▶ Fold the upper P-adapter **5** in so that it can be pinned in point **P49**, point **P50**, point **P51**, point **P52**, point **P53**, point **P54**.
- ▶ Repeat the pinning procedure in point **P49**, point **P51**, point **P53** the same way as was described before in point **P47**.
- ▶ Repeat the pinning procedure in point **P50**, point **P52**, point **P54** the same way as was described before in point **P48**.
- ▶ Remove the auxiliary crane.

3.8.7 Assembling the S-intermediate sections / S-adapter / S-end section on the upper P-adapter

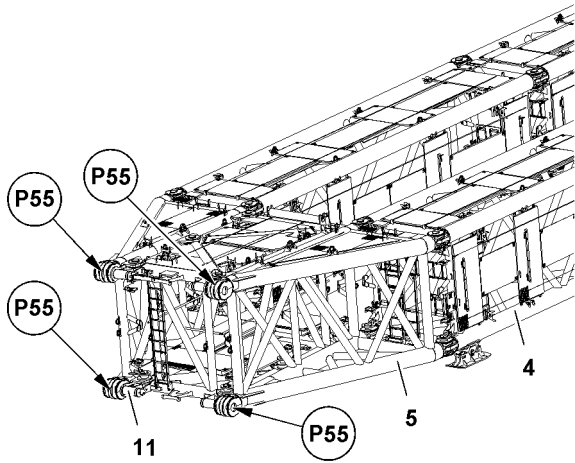

Fig.114621: Assembling the S-intermediate sections / S-adapter / S-end section on the upper P-adapter — Pin points

Make sure that the following prerequisites are met:

- The upper P-adapter **5** is completely installed on the Li-intermediate sections **4**.
- The pins **11** in the points **P55** are completely unpinned.

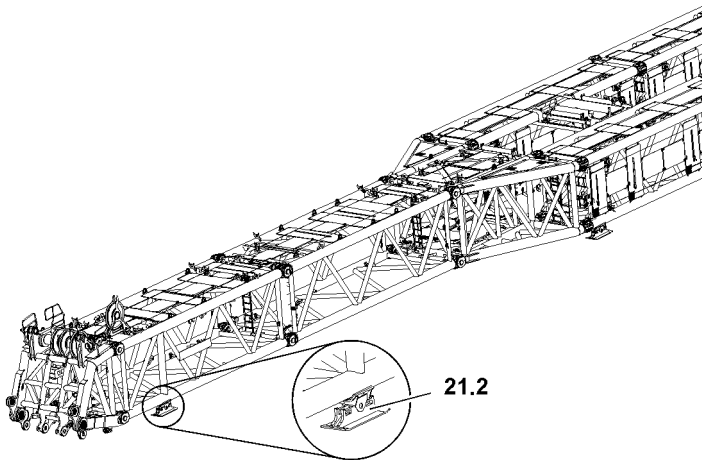

Fig.114622: Assembling the S-intermediate sections / S-adapter / S-end section on the upper P-adapter — Changing the assembly shoes



WARNING

The crane can topple over!

If the rod plans and the data in the Crane operating instructions, chapter 5.03 are not observed, this can cause the crane to collapse, the boom to break off or the crane to topple over.

Personnel can be severely injured or killed.

- ▶ The combination of the various boom systems must be taken from the rod plan and must be adhered to.
- ▶ Observe and adhere to the instructions in the Crane operating instructions, chapter 5.03.

**WARNING**

Changing the assembly shoes **21.2!**

If the assembly shoes **21.2** are not changed over under the last assembled S-intermediate section, the S-intermediate sections can be overloaded and damaged.

An accident can occur during crane operation due to a damaged or previously overloaded lattice section!

Personnel can be severely injured or killed.

- ▶ Place the assembly shoes **21.2** properly under the last assembled S-intermediate section, see section „Changing the assembly shoes at assembly“.

**Note**

- ▶ The assembly of the S-intermediate sections, the S-adapter and the S-end section is described in detail in the Crane operating instructions, chapter 5.39. The described assembly from the S-pivot section on is an example. Carry out the assembly of the S-boom section leg the same way, starting from the upper P-adapter.

**Note**

For assembly of the lattice sections and when lifting the boom system, use the cross beam!

- ▶ For handling of the cross beam, see the Crane operating instructions, chapter 5.39.

NOTICE

Impermissible boom length!

If the boom is lifted with an impermissible boom length with the cross beam, then the last intermediate section can be overloaded when lifting the boom system.

Death, severe injuries, property damage.

- ▶ Make sure that the boom is lifted with the cross beam only up to the permissible boom length, see chart.

Boom system	Permissible boom length
S	132 m
SL	144 m
P	132 m
W	126 m
W2	90 m
W3	108 m

- ▶ Assembling the S-boom section, see the Crane operating instructions, chapter 5.39.

3.8.8 Assembling the frame

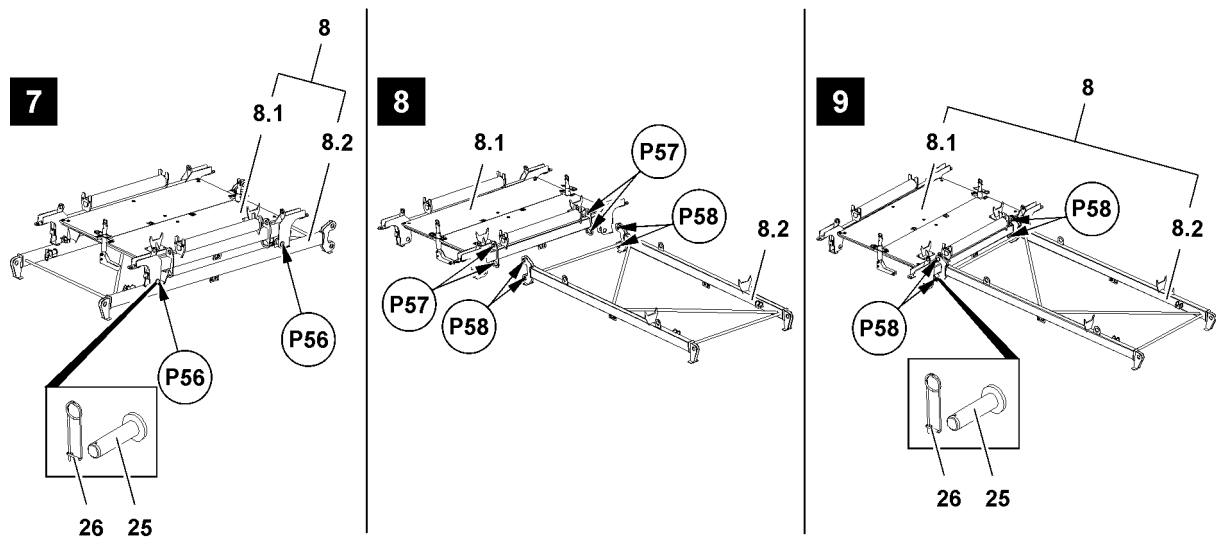

Fig.114623: Assembling the frame - Preassembling the frame



Note

- ▶ With an assembled derrick boom of 54 m , the frame must be installed to properly take the S-guy rods down.

Make sure that the following prerequisites are met:

- The upper P-adapter is completely installed on both Li-intermediate sections.
- The frame **8** is in the transport condition, see illustration 7.
- ▶ Release the pins **25** and spring retainers **26** in points **P56**.
- ▶ Remove the pins **25** and spring retainers **26** on the opposite side.
- ▶ Fasten the frame components **8.1** to the auxiliary crane and lift, see section „Fastening points of the lattice sections“.
- ▶ Position the frame components **8.1** in such a way that points **P57** and points **P58** align.

When points **P57** and points **P58** align:

- ▶ Pin the frame components **8.1** with the frame components **8.2** : Insert the pins **25** in points **P58** and secure with the spring retainer **26**, see illustration 9.

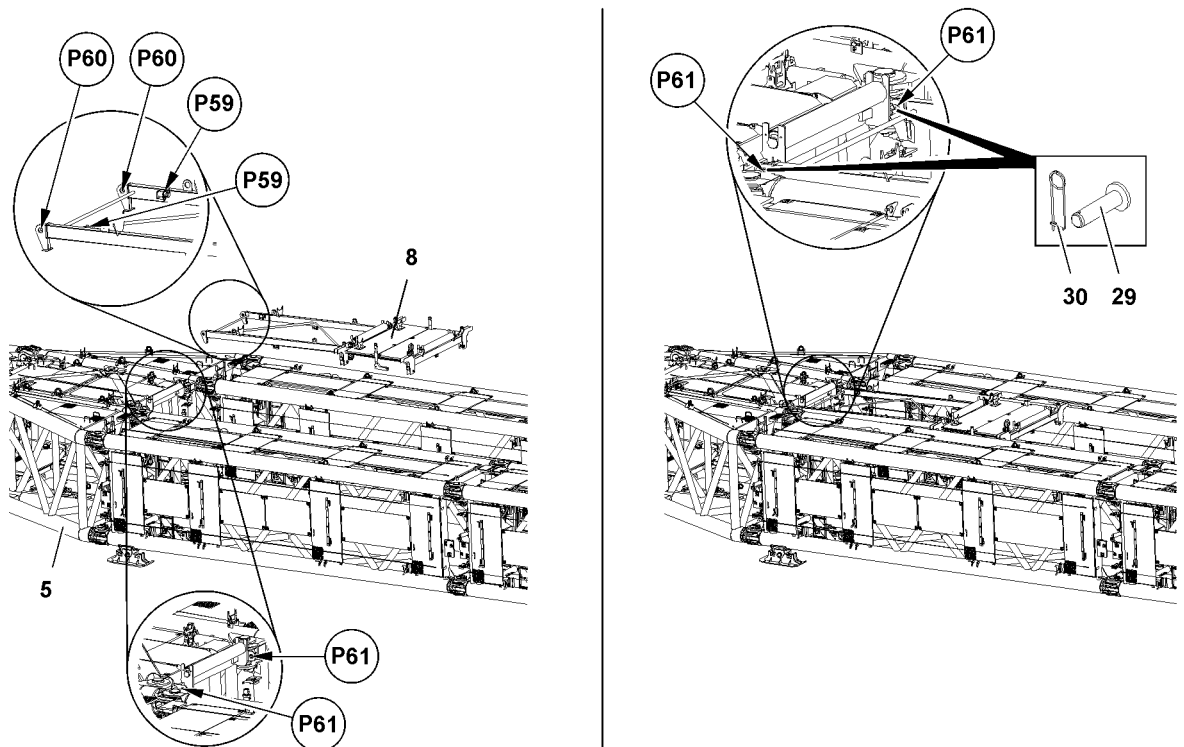

Fig. 114624: Assembling the frame - Pinning the frame with the upper P-adapter

- ▶ Unpin the pins **29** on both sides in points **P59**.
- ▶ Fasten the frame **8** to the auxiliary crane and lift, see section „Fastening points of the lattice sections“.
- ▶ Position the frame **8** in such a way that points **P60** and points **P61** align.

When points **P60** and points **P61** align:

- ▶ Pin the frame **8** on the upper P-adapter **5**: Insert the pins **29** in points **P61** on both sides and secure with the spring retainer **30**.

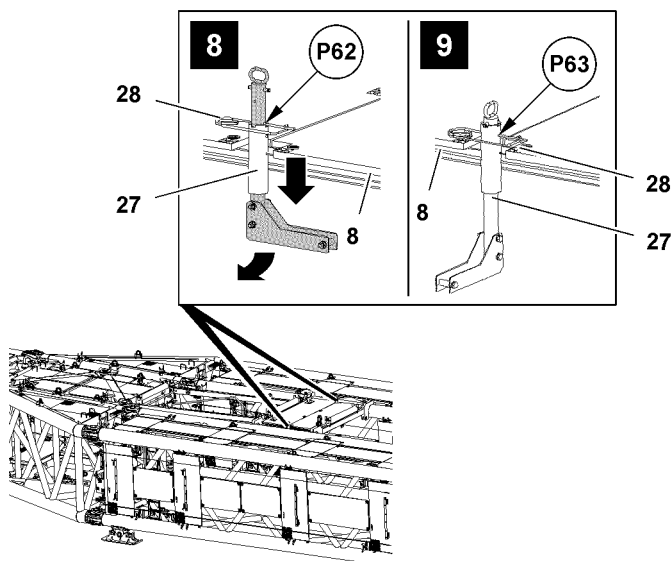

Fig. 114625: Assembling the frame - Closing the lock

The frame **8** must be secured after placing it on **both** lattice section legs. To do so, the lock **27** must be brought from transport position (illustration **8**) into the operating position (illustration **9**). This procedure is described on an example of one side.

- ▶ Remove the spring retainer **28** in point **P62**.
- ▶ Lower the lock **27** and turn 90° until the bores align in point **P63**.

When the bores align in point **P63**:

- ▶ Secure the lock **27** with the spring retainer **28** in point **P63**.
- ▶ Bring the opposite side of the frame **8** into the operating position, the same way as described before.

Result:

- The lock **27** is in the operating position.
- The frame **8** is secured to prevent it from slipping.

3.8.9 Establishing the electrical connections to the boom end section

Make sure that the following prerequisites are met:

- The S-intermediate sections are properly assembled and secured on the ground.
- The boom end section is properly assembled and secured.

NOTICE

Damage to the electrical connections!

If the electrical connection from the cable drum in the S-pivot section to the terminal box on the S-pivot section is established first before the connection to the terminal box on the boom end section, then the electrical connection will be damaged when spooling out the cable drum.

- ▶ Establish first the electrical connection from the cable drum in the S-pivot section to the terminal box on the boom end section and then the electrical connection from the terminal box in the S-pivot section to the cable drum in the S-pivot section.
-



Note

- ▶ To establish the electrical connections on the S-boom: Use the wiring diagram.
-

- ▶ Establish the electrical connections.
 - ▶ Make sure that all electrical connections on the boom are established.
-



WARNING

Malfunction if dummy plugs are not installed!

If the dummy plugs on the non-required electrical connections are not installed, then malfunctions or functional limitations can occur on the crane.

- ▶ Make sure that all non-required electrical connections, which have a dummy plug, are closed off with dummy plugs.
 - ▶ Pay attention to the Electrical wiring diagram.
-
- ▶ As a rule, close off on-required electrical connections (for example for accessories which cannot be installed) with the respective dummy plugs.
-

NOTICE

Property damage due to dirt and / or corrosion!

If unnecessary electrical connections are not closed off with the respective protective caps, then dirt and / or corrosion can damage the electrical connections.

This could result in malfunctions.

- ▶ Make sure that all non-required electrical connections are always closed off properly.
 - ▶ Pay attention to the Electrical wiring diagram.
-
- ▶ Close off electrical connections, which do not have any dummy plugs, properly with the corresponding protective caps.
-

3.8.10 Pinning the upper pulley block on the P-adapter

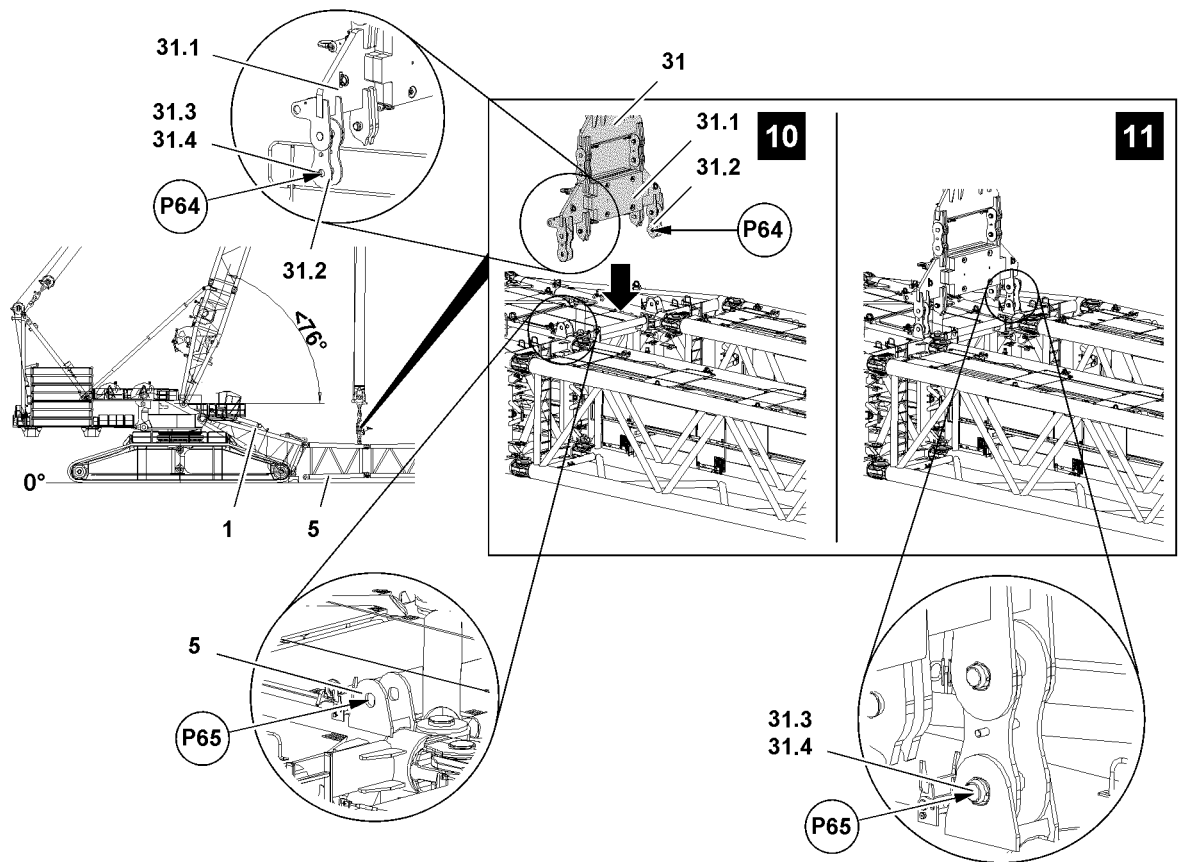

Fig.114626: Pinning the upper pulley block on the P-adapter



WARNING

Death or severe injury if the angle of the derrick boom is set too large!
Property damage.

- ▶ Keep the angle of the derrick boom smaller than 76°.

To be able to „close“ the P-boom combination after assembly, it may be necessary that the D-boom is luffed down forward to less than 76°, so that the winch rope does not collide with the derrick boom. Then the upper pulley block **31** must be lowered until it can be pinned with the brackets **31.2** of the assembly weight **31.1** on the P-adapter **5**.



Note

- ▶ Luff the D-boom forward only to the point where the upper pulley block **31** is „positioned“ vertically above the pin points **P65** on the P-adapter!

Make sure that the following prerequisites are met:

- The P-adapter **5** is properly pinned and secured on the S-pivot section **1** on „top“.
- The S-pivot section is taken down on the assembly shoes **1**.
- The S-end section is properly installed and secured on the boom.
- The S-adapter is lying on the assembly shoes.
- The auxiliary crane is removed.

- ▶ Luff the D-boom down to the front to less than 76°.
- ▶ Lower the upper pulley block **31** until the brackets **31.2** of the assembly weight **31.1** hang over the pin points **P65** of the P-adapter **5**, see illustration **10**.
- ▶ Remove the safety locking pins **31.4** on both sides in points **P64** and unpin the pins **31.3**.

When the pins **31.3** are fully unpinned on both sides:

- ▶ Continue to lower the upper pulley block **31** until the pin bores (point **P64**) of the brackets **31.2** align in the pin points **P65**.

When the pin bores align:

- ▶ Insert the pins **31.3** completely on both sides and secure with safety locking pins **31.4**, see illustration **11**.

3.8.11 Closing the boom system



WARNING

The crane can topple over!

If the following conditions are not met, the crane can topple over or be significantly damaged. Personnel can be severely injured or killed.

- ▶ During the „closing procedure“ of the boom system, the maximum permissible F3-total force of **400 t** in test point 3 may **not** be exceeded. Pay attention to the display of test point 3 on LICCON monitor 1, see the Crane operating instructions, chapter 4.02.
- ▶ During the „closing procedure“ of the P-boom system, the maximum permissible length of the boom of **132 t** may **not** be exceeded.
- ▶ The S-end section of the S-boom may **not** lift off the ground during „closure“!
- ▶ Make sure that there are no persons on the boom system as well as in the danger zone during the closing procedure.



Note

- ▶ The actual forces on test point 3 - which are used during the closing procedure of the P-boom system - are displayed on LICCON monitor 1!
- ▶ Note the actual forces of test point 3 and keep it ready for the disassembly of the P-boom system!
- ▶ For boom disassembly, pretension the control rope of winch 3 until the actual force of test point 3 noted on assembly is reached on the LICCON monitor. The connector pins between the S-pivot section and P-adapter can only then be unpinned!

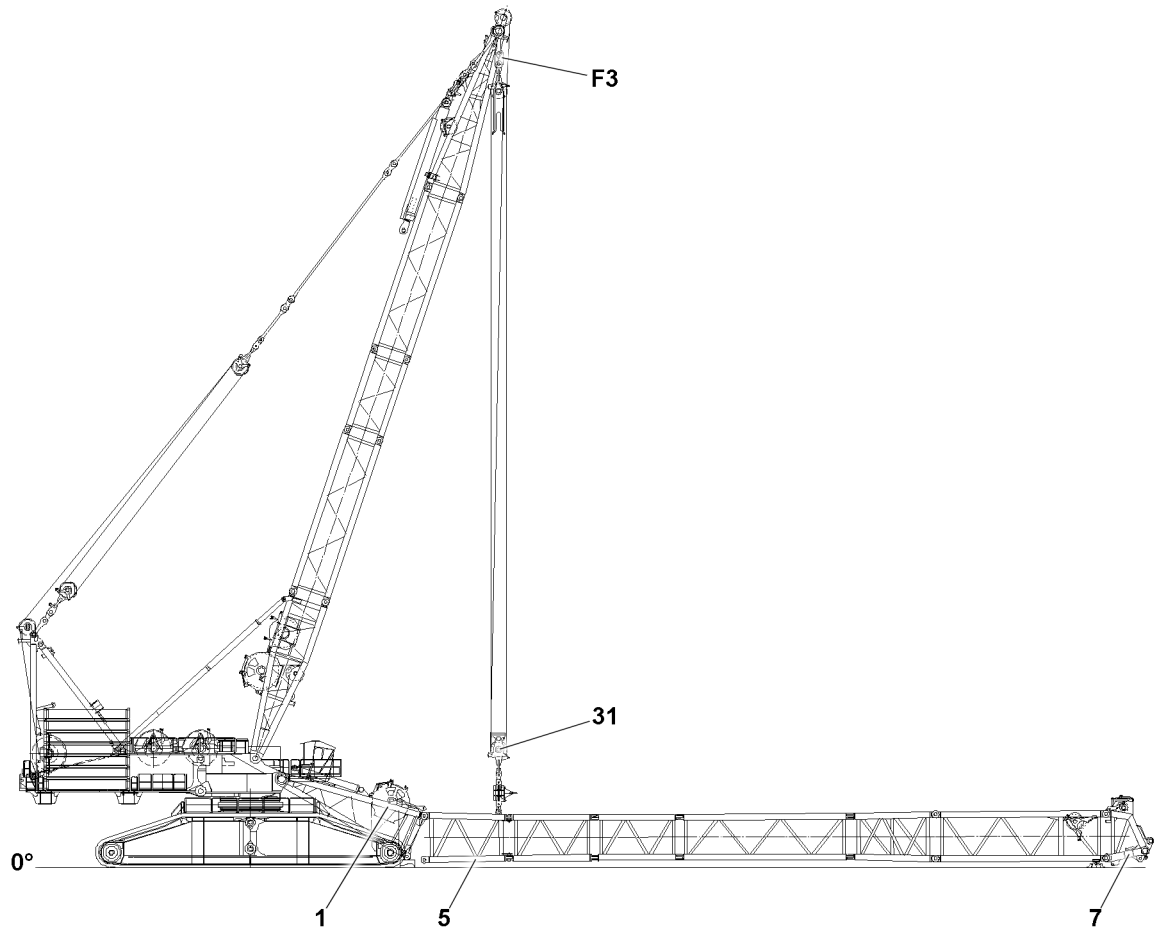

Fig.145058: Opening the boom system

- | | | | |
|---|-----------------|----|--------------------|
| 1 | S-pivot section | 7 | S-end section |
| 5 | P-adapter | 31 | Upper pulley block |

When the upper pulley block **31** is completely assembled in points **P65**:

- ▶ Lift the P-boom section with the upper pulley block **31** until the pin bores align in point **P66**.
- ▶ Insert the pin **1.1**.
- ▶ Bring the pin **1.2** in retaining position and secure with the spring retainer **1.3**.

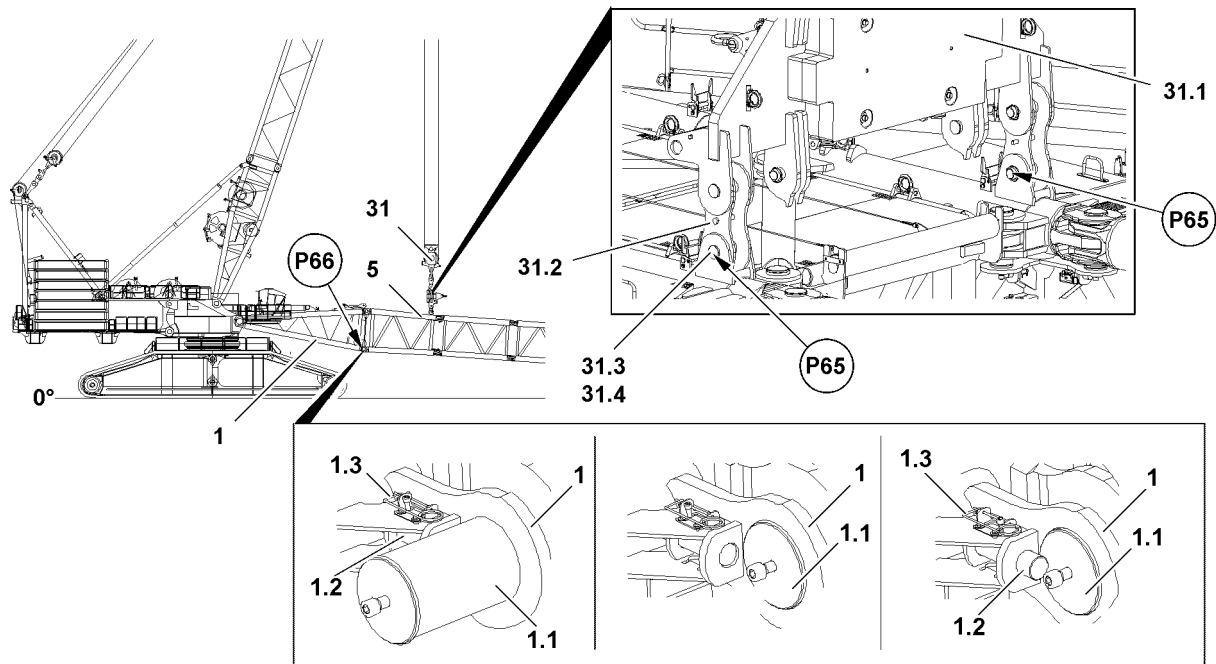

Fig.114627: Closing the boom system



WARNING

Danger of fatal injury due to folding down of boom!

If the boom is not properly pinned and secured in point **P66**, then the boom can suddenly fold down when unpinning the upper pulley block **31** on the P-adapter **5**.

Personnel can be severely injured or killed.

- ▶ It is prohibited for anyone to remain under the raised boom combination during the pinning / unpinning procedure.
- ▶ Unpin the upper pulley block **31** on the P-adapter **5** only when it is ensured that the S-pivot section **1** is properly pinned and secured on „top“ and „bottom“ with the P-adapter **5**.

When the P-boom is pinned completely with the S-pivot section **1**:

- ▶ Unpin the brackets **31.2** of the assembly weight **31.1** on the P-adapter **5**: Release the pins **31.3** on both sides in points **P65** and unpin.
- ▶ Lift the upper pulley block **31** and remove.

3.8.12 Assembling the guy rods

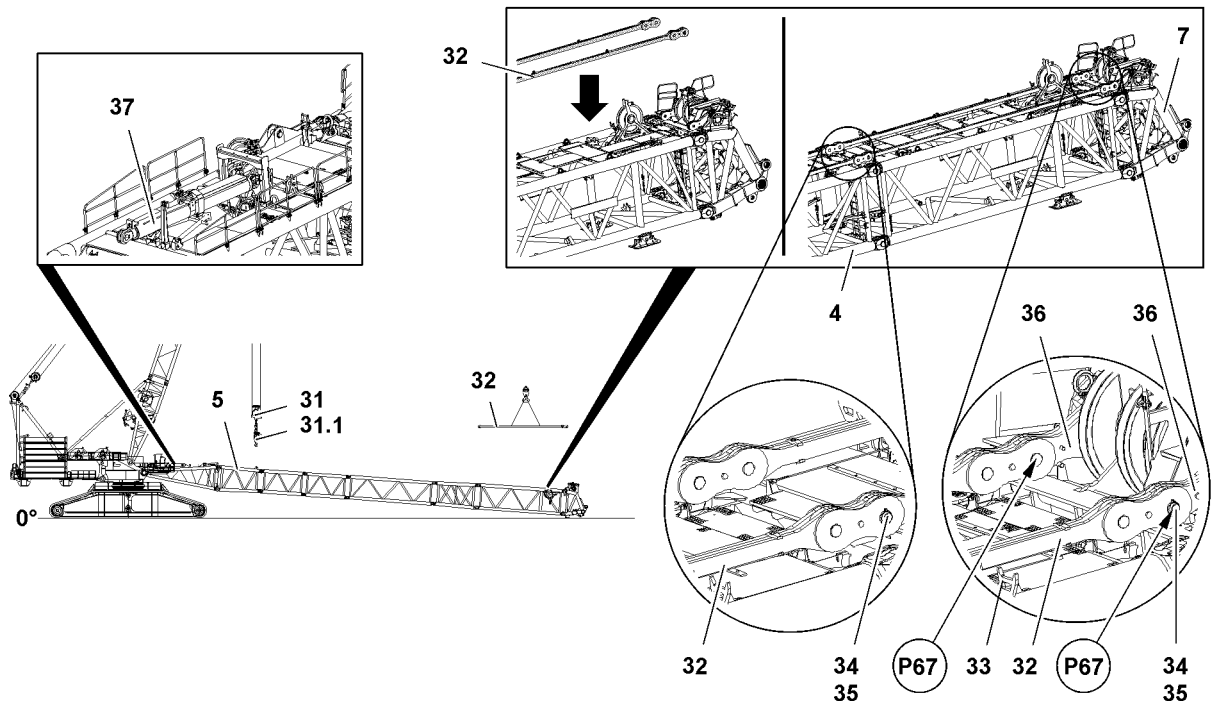

Fig.114628: Assembling the guy rods



WARNING

Failure to perform inspection and maintenance on the guy rods **32**!

If the regular inspection and maintenance of the guy rods **32** is not carried out or only at irregular intervals, then severe accidents can occur due to existing and not recognized damage to the guy rods **32**. Personnel can be severely injured or killed.

- ▶ The guy rods **32** must be checked before every assembly, see the Crane operating instructions, chapter 8.15.



Note

- ▶ The guy rods **32** must be installed and secured according to the separately supplied rod plans. The numbering on the rod plans must be identical to the numbering on the guy rods **32**!

Make sure that the following prerequisites are met:

- The P-boom is completely assembled.
- The S-relapse cylinder **37** is in the transport receptacle.
- All lattice sections are properly pinned with each other.
- All pin connections are secured.
- The assembly weight **31.1** of the upper pulley block **31** is unpinned on the P-adapter **5**.



WARNING

Incorrectly installed guy rods **32**!

Due to an incorrect combination of guy rods **32**, severe accidents, up to toppling the crane, can occur. Personnel can be severely injured or killed.

- ▶ Make sure that the guy rods **32** are always assembled and installed according to the Rod plan.



Note

- ▶ The guy rods **32** of the S-intermediate sections **4** are pinned and secured with each other starting from the brackets **36** in points **P67** of the S-end section **7**!
- ▶ Position the guy rods **32** with the auxiliary crane in such a way that it can be pinned in points **P67**.

NOTICE

Danger of property damage!

If the pins **34** of the guy rods **32** are not pinned from the „inside“ to the „outside“, the hoist rope can scrape on the pins **34** and be damaged.

- ▶ Always insert the guy rod **32** pins **34** from the „inside“ to the „outside“.
- ▶ Pay attention to the Rod plan.

- ▶ Pin the guy rods **32** on the S-end section **7**: Insert the pins **34** in the points **P67** and secure with safety locking pins **35**.
- ▶ Take additional guy rods **32** down with the auxiliary crane according to the data in the Rod plan on the rod receptacles **33** on the S-intermediate sections **4**.
- ▶ Pin the guy rods **32**: Insert the pins **34** from the „inside“ to the „outside“ and secure the pins **34** properly with safety locking pins **35**.
- ▶ Repeat the procedure with additional required guy rods **32** the same way as described before.

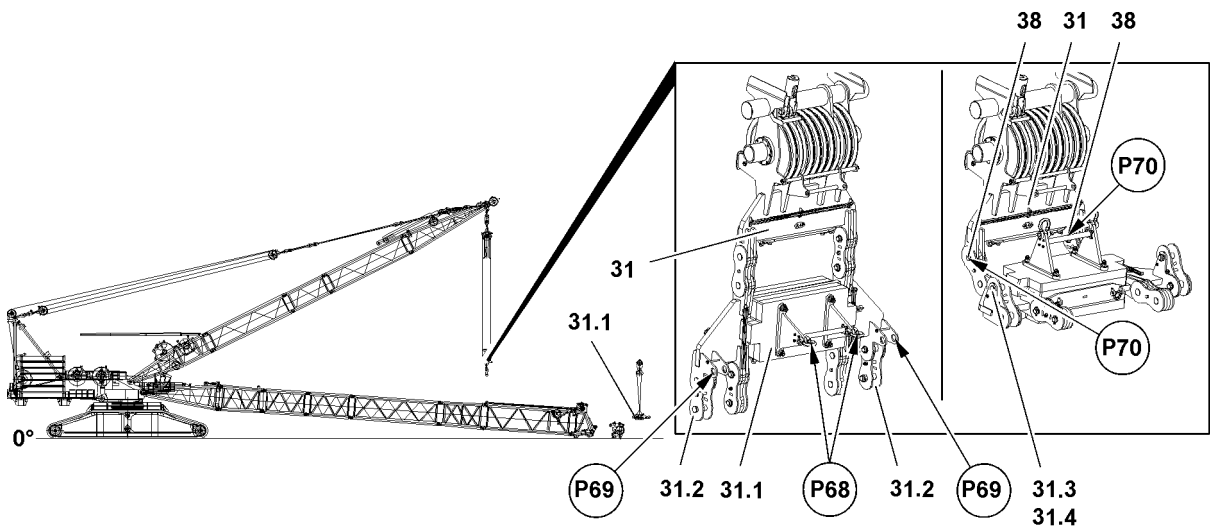

Fig.114629: Assembling the guy rods - Disassembling the assembly weight

NOTICE

Danger of property damage!

When luffing the D-boom down, the assembly weight **31.1** of the upper pulley block **31** can collide with the P-boom system and damage the boom.

This can result in significant property damage.

- ▶ Make sure that the assembly weight **31.1** does not run on the P-boom when luffing down the D-boom.
- ▶ Make sure, when luffing down the D-boom, that there is always sufficient distance between the P-boom and the assembly weight **31.1**.

When all required guy rods are properly placed and secured on the rod receptacles of the S-intermediate sections:

- ▶ Luff the D-boom down carefully to the front.
- ▶ Lower the upper pulley block **31** until the fastening points **P68** in the assembly weight **31.1** are easily accessible.
- ▶ Fasten the assembly weight **31.1** properly to the auxiliary crane in the fastening points **P68**.
- ▶ Lift the assembly weight **31.1** with the auxiliary crane to the horizontal.

When the assembly weight **31.1** hangs horizontally on the auxiliary crane:

- ▶ Fold in the brackets **31.2** on both sides.
- ▶ Insert the pins **31.3** in the points **P69** and secure with safety locking pins **31.4**.

Result:

- The brackets **31.2** are in the transport position.

- ▶ Release and unpin the pins **38** between the assembly weight **31.1** and the upper pulley block **31** on both sides in points **P70**.
- ▶ Swing the assembly weight **31.1** out with the auxiliary crane and take it down on a suitable sub-structure.

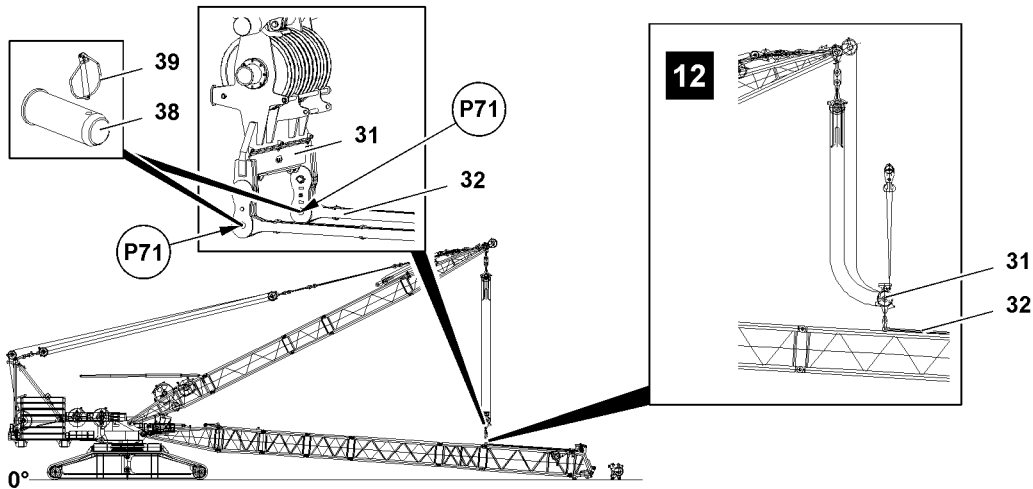

Fig.114630: Assembling the guy rods - Pinning the upper pulley block with the guy rods

- ▶ Luff the D-boom down until the upper pulley block **31** is over the guy rods **32** to be pinned.

Problem remedy

Can the D-boom not be luffed down further?

You luffed the D-boom down to the mandatory system shut-off.

- ▶ Extend the D-boom in the opposite direction from the shut-off.
- ▶ Luff the D-boom slightly up.



Note

- ▶ On boom length over 60 m , the upper pulley block **31** must be positioned with the auxiliary crane over the guy rods **32** in such a way that the guy rods **32** can be safely pinned on the upper pulley block **31**, see illustration **12**.
- ▶ Pin and secure the guy rods **32** with the upper pulley block **31**: Insert the pins **38** in points **P71** from the „inside“ to the „outside“ and secure with the safety locking pin **39**.

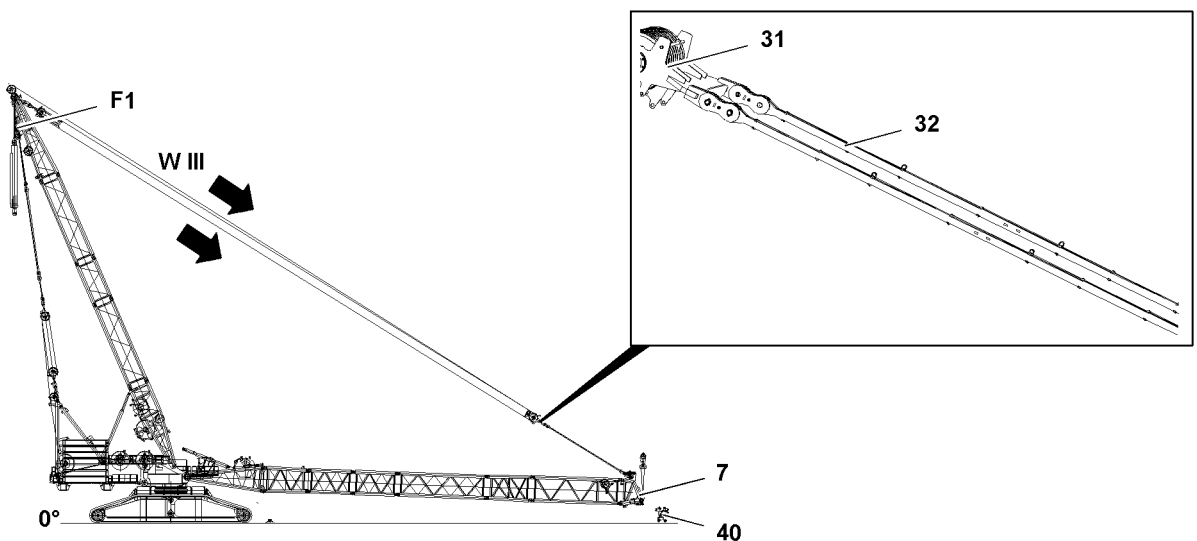

Fig.114631: Assembling the guy rods - Tensioning procedure

LWE/LR 13000-001/19503-01-02/en

**Note**

- ▶ The P-boom must remain on the ground when erecting the D-boom and may **not** be pulled up.

When the guy rods **32** are properly pinned and secured with the upper pulley block **31**:

- ▶ Erect the D-boom to operating position and at the same time, spool out winch 3 **WIII**.

**Note**

- ▶ When erecting the D-boom, pay attention to the minimum force **F1** in test point 1.
- ▶ To avoid a shut-off during the erection procedure of the P-boom, do not fall below the minimum force **F1** in test point 1. From a derrick boom angle of 76°, the minimum force **F1** in test point 1 must be at least 100 t.

When the D-boom has reached the operating position:

- ▶ Tension the guying carefully between the D-boom and the S-end section **7**.

When the guying is tensioned:

- ▶ Lift the P-boom off the ground carefully and at slow speed.
- ▶ Luff the P-boom up until the roller set / roller sets can be installed on the S-end section **7**.

3.8.13 Assembling the roller sets

**Note**

- ▶ The assembly of the roller sets is described in the Crane operating instructions, chapter 5.14.

When the roller set / roller sets are properly installed on the end section:

- ▶ Route the hoist limit switch from the end section forward on the roller set / roller sets, pay attention and adhere to the Electrical wiring diagram.

3.8.14 Establishing the electrical connections on the boom end section

Make sure that the following prerequisites are met:

- The S-intermediate sections are properly assembled and secured on the ground.
- The boom end section is properly assembled and secured.
- The electrical connections to the boom end section have been established.
- The airplane warning light, wind speed sensor and all sensors are properly installed and secured on the boom end section.
- The hoist limit switches are properly installed and secured on the pulley head / pulley heads.

NOTICE

Damage to the electrical connections!

If the electrical connection from the cable drum on the S-pivot section to the terminal box on the S-pivot section is established first before the connection to the terminal box on the boom end section, the electrical connection can be damaged when spooling out the cable drum.

- ▶ Establish first the electrical connection from the cable drum in the S-pivot section to the terminal box on the boom end section and then the electrical connection from the terminal box in the S-pivot section to the cable drum.

**Note**

- ▶ To establish the electrical connections on the S-boom: Use the wiring diagram.
- ▶ Establish the electrical connections.
- ▶ Make sure that all electrical connections on the boom are established.

**WARNING**

Malfunction if dummy plugs are not installed!

If the dummy plugs on the non-required electrical connections are not installed, then malfunctions or functional limitations can occur on the crane.

- ▶ Make sure that all non-required electrical connections, which have a dummy plug, are closed off with dummy plugs.
- ▶ Pay attention to the Electrical wiring diagram.

- ▶ As a rule, close off on-required electrical connections (for example for accessories which cannot be installed) with the respective dummy plugs.

NOTICE

Property damage due to dirt and / or corrosion!

If unnecessary electrical connections are not closed off with the respective protective caps, then dirt and / or corrosion can damage the electrical connections.

This could result in malfunctions.

- ▶ Make sure that all non-required electrical connections are always closed off properly.
- ▶ Pay attention to the Electrical wiring diagram.

- ▶ Close off electrical connections, which do not have any dummy plugs, properly with the corresponding protective caps.

3.9 Assembling the central ballast

If a central ballast according to the load chart is required for the planned crane operation, then assemble the central ballast, see the Crane operating instructions, chapter 3.03.

**WARNING**

The crane can topple over!

If no central ballast is installed on the crane, the crane can topple over.

Personnel can be severely injured or killed.

- ▶ Make sure that the central ballast is installed according to the load chart for the planned crane operation.

3.10 Assembling the suspended ballast

If a derrick ballast is required according to the load chart for the planned crane operation, then assemble the derrick ballast, see the Crane operating instructions, chapter 5.36.

**WARNING**

The crane can topple over!

If no derrick ballast is installed on the crane, the crane can topple over.

Personnel can be severely injured or killed.

- ▶ Make sure that the derrick ballast is installed according to the load chart for the planned crane operation.

3.11 Performing the function check

**WARNING**

Malfunctioning safety equipment!

If the function of the safety equipment is defective, personnel can be severely injured or killed.

- ▶ Crane operation with non-functioning safety equipment is **prohibited**.

**Note**

- ▶ The function of the individual limit switches must be checked before erection of the boom system.
- ▶ The function of the limit switch initiators must be checked in the test system, see the Diagnostics manual.

**Note**

- ▶ If a function check on the limit switches or on the safety equipment does not lead to the desired shut-offs, then the plug connections on the connector boxes or the components itself must be checked. If no visible connection errors or component defects can be found, contact Liebherr Service.

Make sure that the following prerequisites are met:

- All electrical connections have been established.
- The crane engine is running.
- The corresponding operating mode is set on the LICCON monitor.
- The actuator levers of the limit switches have been checked for easy movement and are lubricated.

3.11.1 Wind speed sensor

- ▶ Check the movement and the function of the wind speed sensor.

3.11.2 Airplane warning light

- ▶ Turn the airplane warning light on, see the Crane operating instructions, chapter 4.01.
- ▶ Check the function visually.

3.11.3 Hoist limit switch

- ▶ Actuate the hoist limit switch manually on the pulley head.

Result:

- The hoist winch turns off in the lifting direction.
- The hoist top icon blinks on LICCON monitor 0.

3.11.4 Checking the D-boom „Steepest position“ limit switch

**Note**

- ▶ The limit switch functions have to be checked individually before erection.

- ▶ Cover the limit switch initiators on the D-relapse cylinders individually with a metal plate.

Result:

- The limit switch is actuated manually.
- The spool up function of winch 4 (control winch) turns off.
- The „Boom limitation“ icon appears on LICCON monitor 0.

3.11.5 Checking the limit switch main boom „steep position“

**Note**

- ▶ The limit switch functions have to be checked individually before erection.

- ▶ Cover the limit switch initiators on the relapse cylinders of the main boom individually with a metal plate.

Result:

- The limit switch is actuated manually.
- The spool up function of winch 3 turns off.
- The „Boom limitation“ icon appears on LICCON monitor 0.

Empty page!

LWE/LR 13000-001/19503-01-02/en

Fig.195219

LWE/LR 13000-001/19503-01-02/en

4 Erecting the boom



WARNING

The crane can topple over!

The crane can topple over during crane operation with a deactivated LICCON overload protection. Personnel can be severely injured or killed.

- ▶ The boom radii listed in the load chart may not be exceeded or fallen below, even if there is no load on the hook.

If required in the erection and take down chart:

- ▶ Carry the hook block along with the auxiliary crane.



WARNING

The crane can topple over!

If the following conditions are not met before erecting the boom, the crane can topple over.

Personnel can be severely injured or killed.

- ▶ Observe the technical safety instructions, see the Crane operating instructions, chapter 5.01.
- ▶ Make sure that the relapse cylinder of the main boom is completely extended before erection of the boom combination.
- ▶ Do not allow slack rope formation on the control winch.

Make sure that the following prerequisites are met:

- The crane is horizontally aligned.
- The guy rods are properly assembled.
- The D-boom is in the operating position
- All electrical connections have been established.
- All hydraulic connections have been established.
- All limit switches are functioning.
- The function checks were carried out properly.
- The counterweight has been installed on the turntable according to the erection and take-down charts.
- The central ballast (if required) is installed according to the erection and take-down charts on the crane chassis.
- All pin connections are secured.
- The hoist rope has been correctly inserted in the rope pulleys and is prevented from jumping out with the rope retaining pins.
- There are no loose parts on the boom.
- The boom is free of snow and ice.
- The LICCON overload protection has been set according to the data in the load chart.
- The load weighing was carried out on the boom and the hook block weight has been entered on the LICCON monitor, see the Crane operating instructions, chapter 4.02.
- The LICCON overload protection settings have been compared with the actual set up configuration.
- The LICCON overload protection is deactivated.
- The assembly icon is visible on the LICCON monitor.
- No personnel is present in the danger zone.

4.1 Bringing the S-relapse cylinders into the operating position

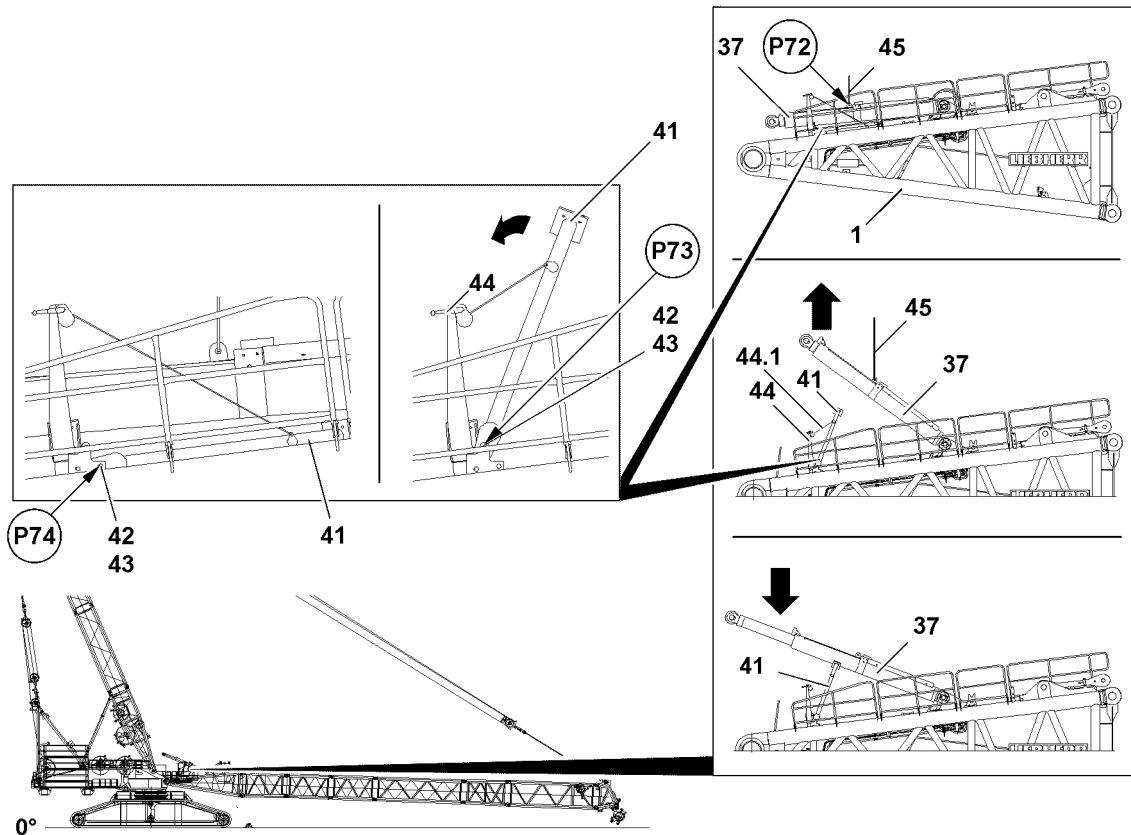

Fig.114632: Bringing the S-relapse cylinders into the operating position

- ▶ Release the support **41** in the transport position: Remove the safety locking pin **43** in point **P74** and unpin the retaining pin **42**.
- ▶ Fasten the S-relapse cylinder **37** with the fastening equipment **45** in the fastening point **P72** to the auxiliary crane.

When the S-relapse cylinder **37** is properly fastened to the auxiliary crane:

- ▶ Lift the S-relapse cylinder **37** with the auxiliary crane.
- ▶ Bring the support **41** with the auxiliary winch **44** into the operating position.

When the support **41** is in the operating position:

- ▶ Insert the retaining pin **42** on both sides in point **P73** and secure with safety locking pin **43**.
- ▶ Take the S-relapse cylinder **37** down on the prism of the support **41**.

When the S-relapse cylinder **37** is completely taken down on the prism of the support **41**:

- ▶ Remove the auxiliary crane.

4.2 Extending the S-relapse cylinder on the S-pivot section

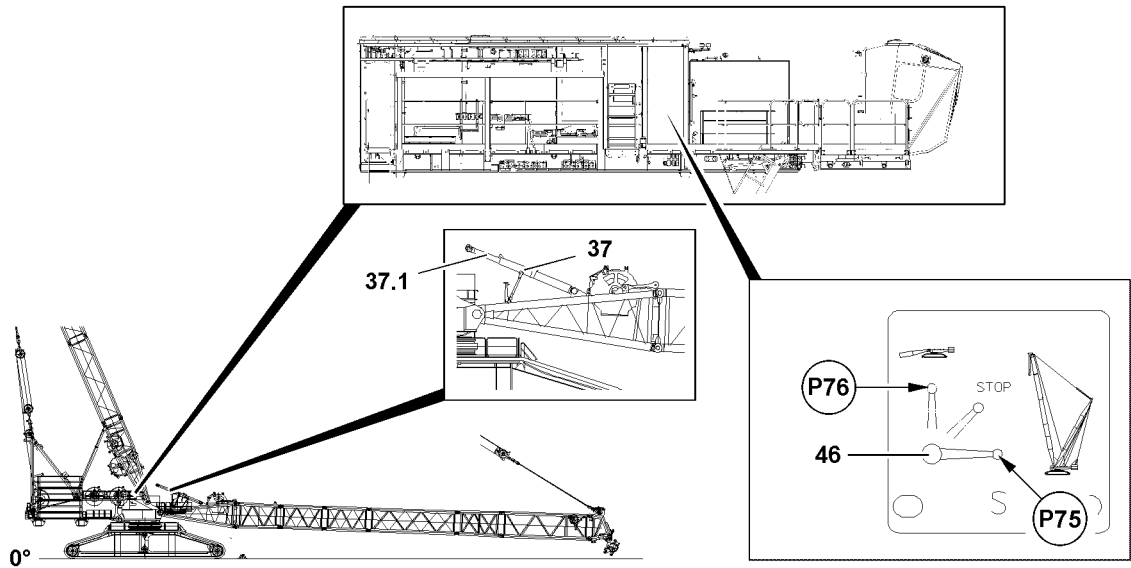

Fig.114634: Extending the S-relapse cylinder on the S-pivot section



Note

- ▶ If the S-relapse cylinder **37** is not extended in time, then the D-boom cannot be luffed up or down due to the block position of the limit switches on the S-relapse cylinder **37**.



WARNING

The crane can topple over!

If the S-relapse cylinder **37** for the main boom is not extended before erecting the boom, then the boom can fall to the rear during erection or crane operation and the crane can topple over. Personnel can be severely injured or killed.

- ▶ Extend the S-relapse cylinder **37** before erecting the main boom.
- ▶ Secure the ball valve **46** during crane operation to prevent inadvertent actuation.

Ball valve positions	
Position (P)	Function
75	Crane operation, extend the piston rod
76	Assembly, retract the piston rod
STOP	The piston rod cannot be retracted / extended

Make sure that the following prerequisites are met:

- The hydraulic connections to the S-pivot section are properly established.
- At least one crane engine is running.

- ▶ Set the ball valve **46** to position **P75**.

Result:

- The piston rod **37.1** of the S-relapse cylinder **37** extends.



Note

- ▶ The ball valve **46** is secured by closing the door to the engine house and removing the key.

LWE/LR 13000-001/19503-01-02/en

When the piston rod **37.1** of the relapse cylinder **37** is fully extended:

- ▶ Close the door and pull out the key.
- ▶ Hand the key to an authorized person.

4.3 Erection procedure



DANGER

The crane can topple over!

- ▶ It is prohibited to turn the crane superstructure while erecting the boom.
- ▶ Adhere to the specifications in the erection and take-down charts.

Make sure that the following prerequisite is met:

- The relapse press is in the operating position and is extended.
- The load weighing was carried out on the boom and the hook block weight has been entered on the LICCON monitor, see the Crane operating instructions, chapter 4.02.

4.3.1 Reeving in the hook block with the telescopic lift truck

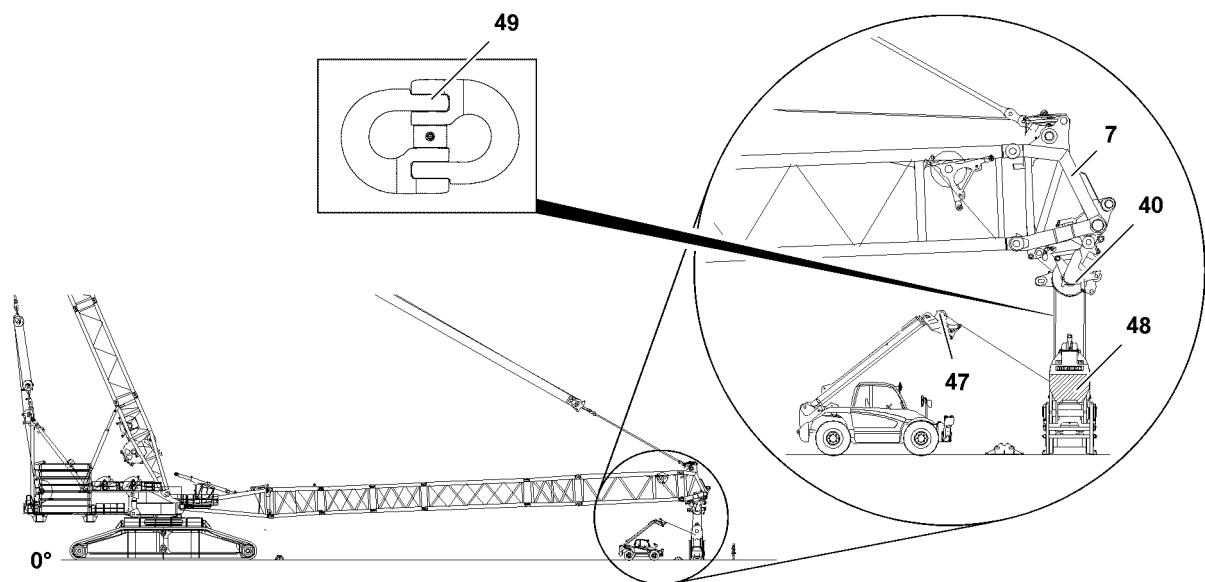

Fig.114635: Reeving in the hook block with the telescopic lift truck



WARNING

Danger of accident!

When using **non-approved** connecting links **49** when reeving the hoist rope in / out, the connecting links **49** can rip off suddenly.

Death, severe bodily injuries, property damage.

- ▶ Make sure that only original connecting links are used between the auxiliary winch and the hoist rope.
- ▶ Make sure that the proper pressure stage is set on the auxiliary winch of the telescopic lift truck for the reeving in / out of the respective hoist rope, see the separate operating instructions for the „assembly winch“.
- ▶ Make sure that the connecting links **49** between the auxiliary winch and the hoist rope have a higher load bearing capacity than can be created by the maximum strand pull of the respective auxiliary winch.
- ▶ The strand pull of the auxiliary winches installed on the crane side is **not** identical to the strand pull of the auxiliary winch of the telescopic lift truck.

Connecting link / Description	Load bearing capacity	Use for hoist rope diameter
CW8	2.5 t	38 mm
CWP10	5.0 t	52 mm

**Note**

Reeving in the hoist rope with telescopic lift truck!

- ▶ Reeving up to maximum 20-fold can be realized with one rope length on the telescopic lift truck.
- ▶ For a higher number of reeving, reeve in 20 times first and then the remainder.

Make sure that the following prerequisites are met:

- The roller set / roller sets **40** are properly installed and secured on the S-end section **7**.
- The hook block **48** is properly positioned and aligned without the hook under the S-end section **7**.
- The telescopic lift truck is properly positioned under the boom system.

**Note**

- ▶ For the operation of the auxiliary winch **47** on the telescopic lift truck, see the separate Operating instructions of the manufacturer.

- ▶ Spool the rope of the auxiliary winch **47** out.
- ▶ Guide the rope of the auxiliary winch **47** in the reverse direction to the actual hoist rope reeving through the respective rope pulleys on the hook block **48** and those of the end section **7**, see separate Reeving plan.
- ▶ Fasten the rope of the auxiliary winch **47** properly to the pull in device of the hoist rope by using the connecting link **49**.

NOTICE

Danger of slack rope formation!

Slack rope can form if the hoist winch is spooled out too fast during the reeving procedure.

- ▶ Make sure that the hoist rope is tensioned during the entire reeving procedure.
- ▶ Reeve the hoist rope in: Spool the auxiliary winch **47** up and simultaneously spool out the hoist rope from the respective winch.

When the hoist rope is properly reeved:

- ▶ Fasten the hoist rope in the rope fixed point, see the Crane operating instructions, chapter 4.06 and the separate reeving plan.

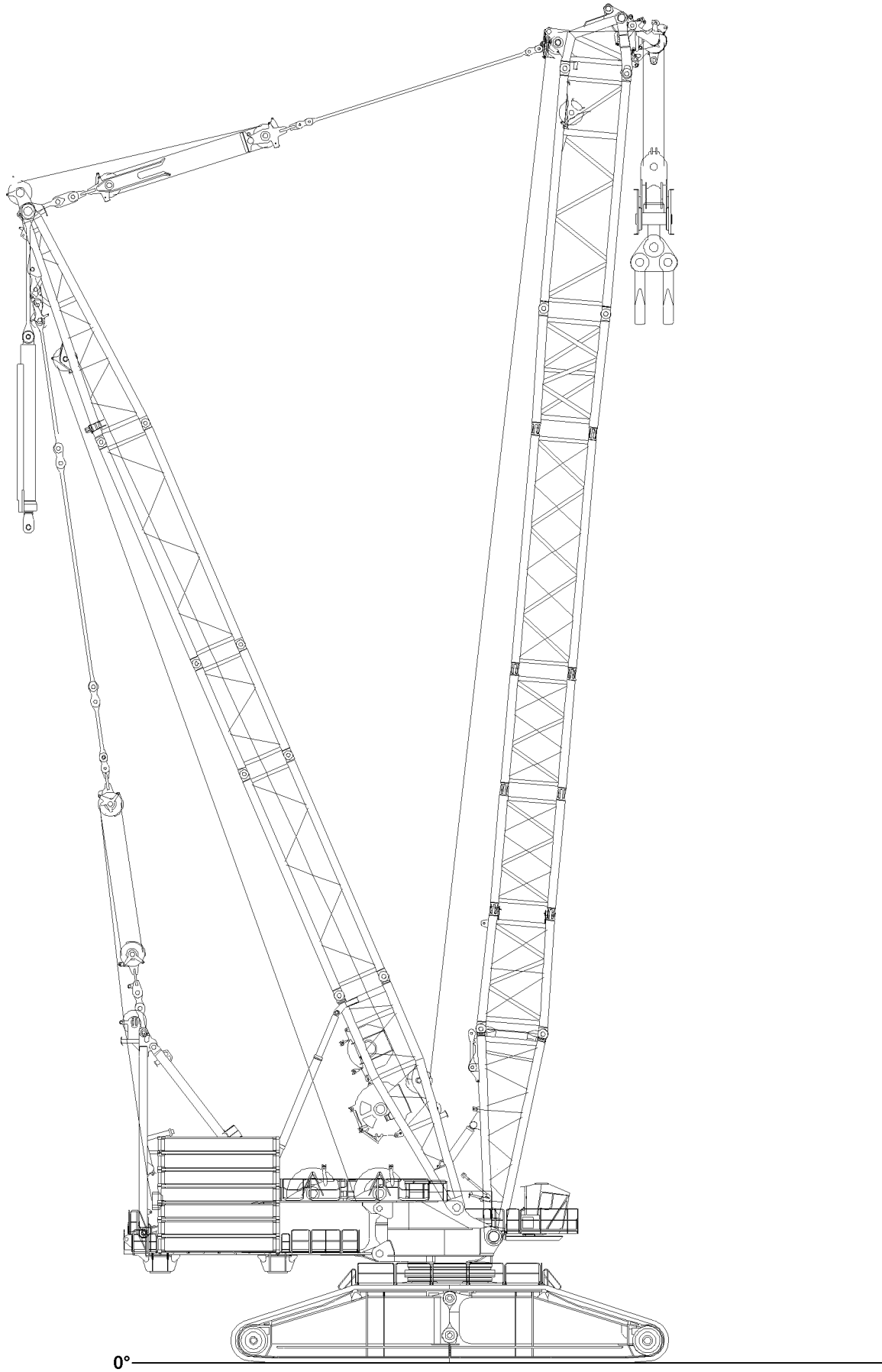

LWE/LR 13000-001/19503-01-02/en

Fig.114633: Erecting the main boom

4.3.2 Erecting the main boom

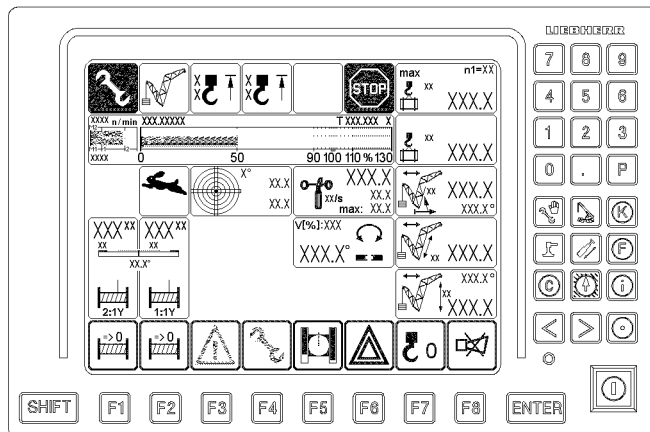

Fig.114636: Erecting the main boom - LICCON overload protection



WARNING

The crane can topple over!

The crane can topple over during crane operation with a deactivated LICCON overload protection. There is then no additional protection against crane overload.

Personnel can be severely injured or killed.

- ▶ The boom radii listed in the load chart may not be exceeded or fallen below, even if there is no load on the hook.
- ▶ Crane operation with deactivated LICCON overload protection is prohibited.



Note

- ▶ When the lowest operating position of the boom is reached, the LICCON overload protection is activated.
- ▶ The maximum load icon displays a load number in „t“ instead of the display „???“.
- ▶ Luff the P-boom up to the lowest operating position.

When the P-boom has reached the lowest operating position:

- ▶ Make sure that the assembly icon on the LICCON monitor turns off.

Result:

- The LICCON overload protection is active.

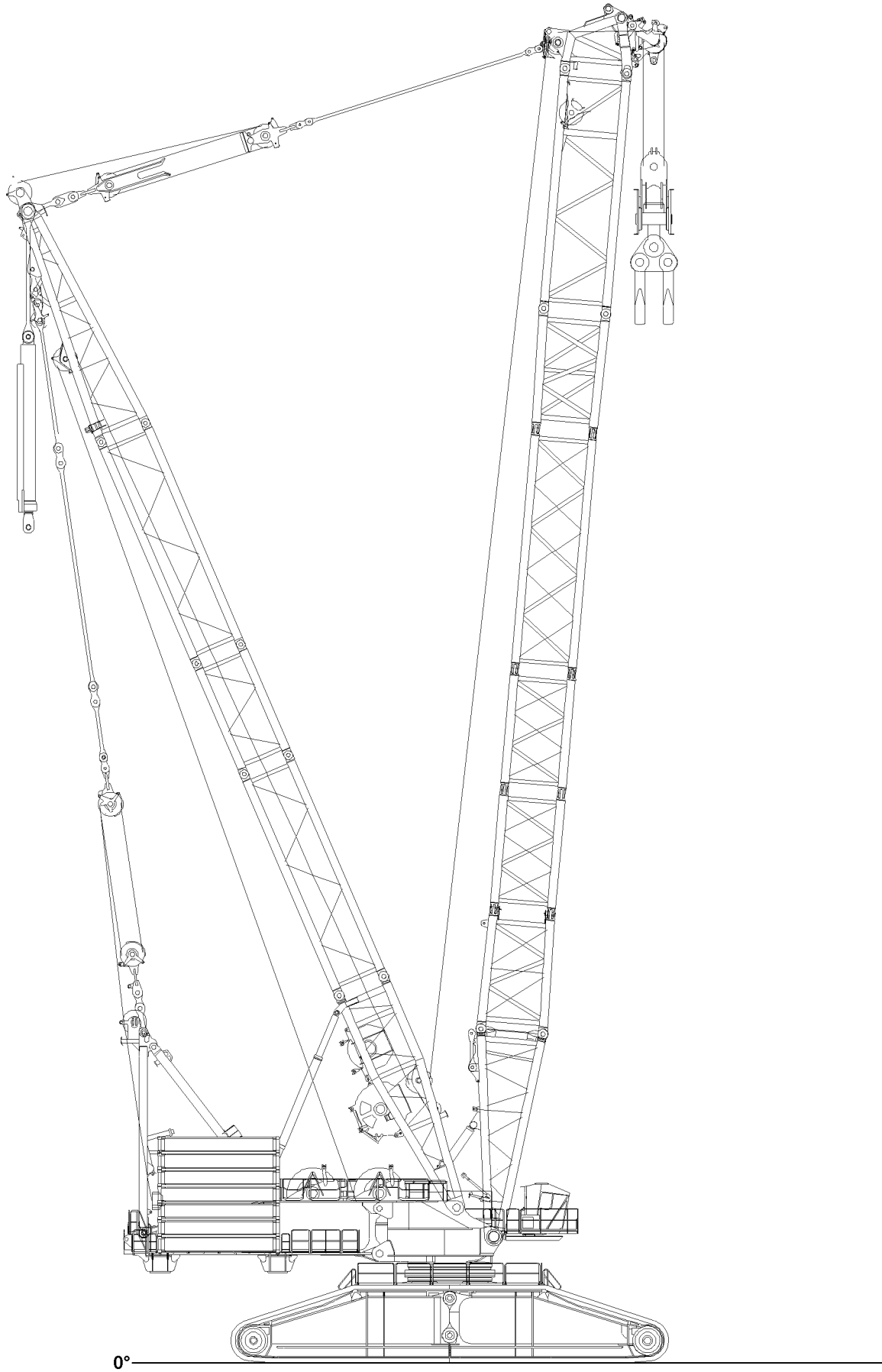

LWE/LR 13000-001/19503-01-02/en

Fig.114633: Operating the crane

5 Operating the crane

5.1 Preparing for crane operation

**Note**

- ▶ Observe the notes, see the Crane operating instructions, chapter 4.02, chapter 4.05, chapter 4.08 and chapter 5.01!

Make sure that the following prerequisites are met:

- The LICCON overload protection is active.
- The LICCON overload protection has been set according to the data in the load chart.

**WARNING**

The crane can topple over!

Personnel can be severely injured or killed.

- ▶ Check the horizontal position of the crane before and during crane operation.
- ▶ If the crane operator leaves the cab, even for a short time, the operating mode setting must be checked and reset if necessary before resuming crane operation.

5.1.1 Checking the settings

- ▶ Check the function of the overload protection by running against the operating positions „on top“ and „bottom“.
- ▶ Check the hoist limit switch by running against the hoist limit switch weight.
- ▶ Check the function of the „Boom steep“ limit switches on the relapse cylinders of the main boom.

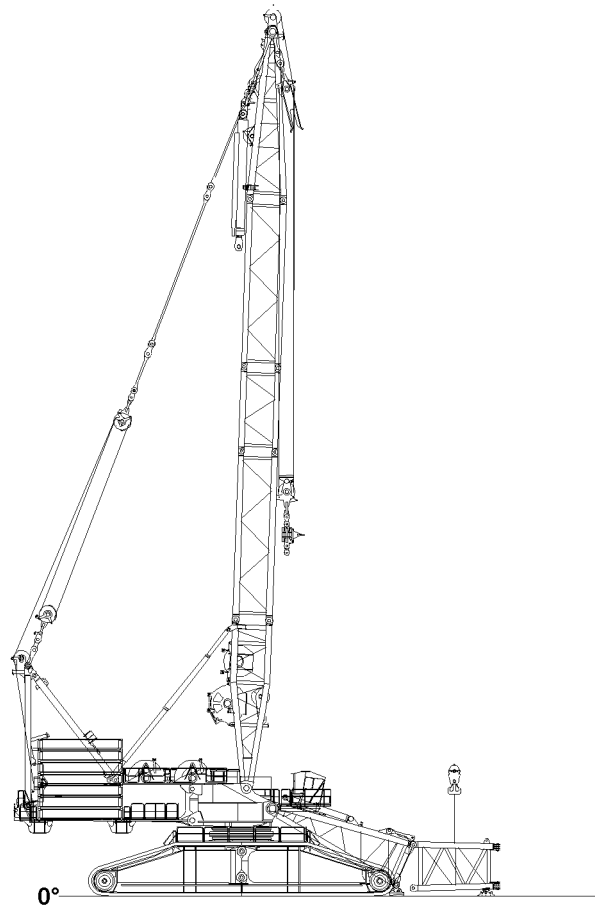
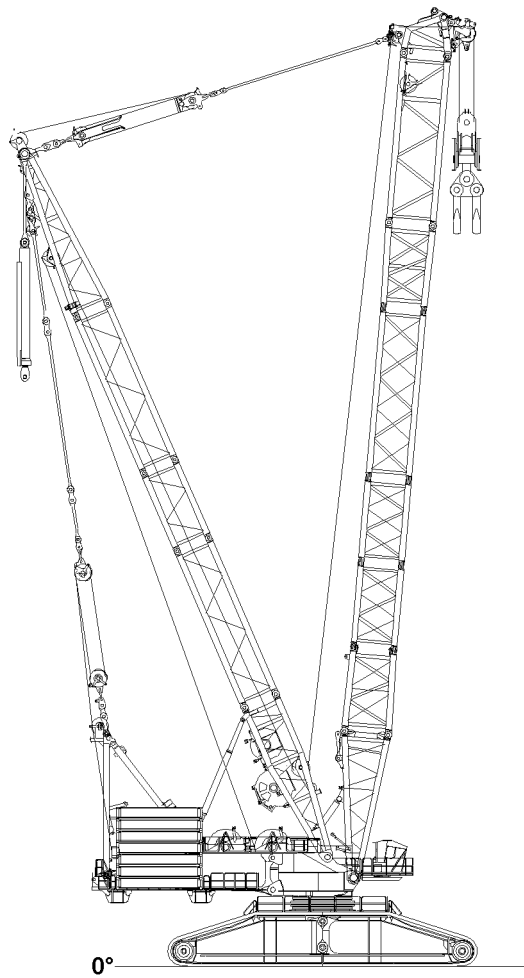

Fig.114638: Disassembling the PD-boom

LWE/LR 13000-001/19503-01-02/en

6 Disassembling the PD-boom



Note

- ▶ For the combination of the boom lattice sections, observe and adhere to the Rod plan and the Crane operating instructions, chapter 5.03.



WARNING

Danger of falling!

During assembly / disassembly, inspection and maintenance work, assembly personnel must be secured with appropriate aids to prevent them from falling! If this is not observed, assembly personnel could fall and be killed or seriously injured.

- ▶ All work at a height, when there is a danger of falling, must be carried out with suitable aids.
- ▶ If aids are not available and work cannot be carried out from the ground, then assembly personnel must secure themselves with the supplied fall arrest system to prevent falling, see the Crane operating instructions, chapter 2.04.
- ▶ If fall protection equipment is available, then it must be used, see the Crane operating instructions, chapter 2.06.
- ▶ When lifting, lowering, swinging crane parts in and out, no persons may remain in the danger zone.
- ▶ When closing or opening boom systems during boom assembly or disassembly, no persons may remain on the boom system or in the danger zone.
- ▶ If railings are present on the components, then they must be brought into the corresponding position and secured for assembly / disassembly work.
- ▶ Only step on the aids, ladders and catwalks with clean shoes.
- ▶ Keep aids, ladders and catwalks free of heavy dirt, snow and ice.
- ▶ During all assembly and disassembly work, maintenance work and inspections, travel or crane operation is prohibited.
- ▶ Remaining on a suspended load is prohibited.
- ▶ Stepping or walking on crane components and lattice sections with an incline of more than 20° is prohibited.
- ▶ For all assembly work, the crane driver of the main crane must be in voice contact with the crane driver / crane drivers of the auxiliary crane / auxiliary cranes.
- ▶ For assembly tasks, the crane driver may only initiate crane movements when the responsible guide has explicitly released the movement.



WARNING

The lattice sections can fall down!

If the lattice sections are not pinned and secured correctly, then they can fall down and fatally injure personnel.

- ▶ Insert or unpin both pins on the same horizontal level, i.e. **left and right**.
- ▶ Do not stand under the lattice sections or within the entire danger zone during the pinning and unpinning procedure of the boom.
- ▶ Safely secure the pins in the storage locations as well as in the receptacles.
- ▶ It is prohibited to lean the ladder against the component being disassembled.



WARNING

Danger of impact / crushing!

When assembling / disassembling crane components with the auxiliary crane, crane components can start to swing back and forth.

When lifting / lowering and positioning crane components, there is an increased danger of impact / crushing.

Personnel can be caught and thereby injured or killed.

- ▶ Make sure that personnel cannot be caught by components.
- ▶ Make sure that the crane is horizontally aligned.
- ▶ When working in danger zones: Use aids to protect limbs.
- ▶ Guide components with suitable aids to minimize oscillation.

**DANGER**

The components can fall down!

If the corresponding components are disengaged from the auxiliary crane before the corresponding component is pinned, the corresponding component can fall down and fatally injure personnel.

- ▶ Do not detach the auxiliary crane until the respective component is pinned and secured.

6.1 Disassembling the derrick ballast

**WARNING**

The crane can topple over!

If no derrick ballast is installed on the crane, the crane can topple over.

Personnel can be severely injured or killed.

- ▶ Observe the erection and take-down charts.
- ▶ If a derrick ballast is required for taking down the boom system, then leave the derrick ballast on the crane.

When derrick ballast is not required for taking down the boom system:

- ▶ Disassemble the derrick ballast, see the Crane operating instructions, chapter 5.36.

6.2 Disassembling the central ballast

**WARNING**

The crane can topple over!

If no central ballast is installed on the crane, the crane can topple over.

Personnel can be severely injured or killed.

- ▶ Observe the erection and take-down charts.
- ▶ If a central ballast is required for taking down the boom system, then leave the central ballast on the crane.

When central ballast is not required for taking down the boom system:

- ▶ Disassemble the central ballast, see the Crane operating instructions, chapter 3.03.

6.3 Turning the turntable into the disassembly position

**WARNING**

The crane can topple over!

If the following conditions are not met before turning the turntable, then the crane can topple over.

Personnel can be severely injured or killed.

- ▶ Observe the data in the erection and take-down charts.
- ▶ Observe the data in the load charts.

- ▶ Turn the turntable in the lengthwise direction of the crawler travel gear.

6.4 Luffing the main boom down and unreeving the hoist rope

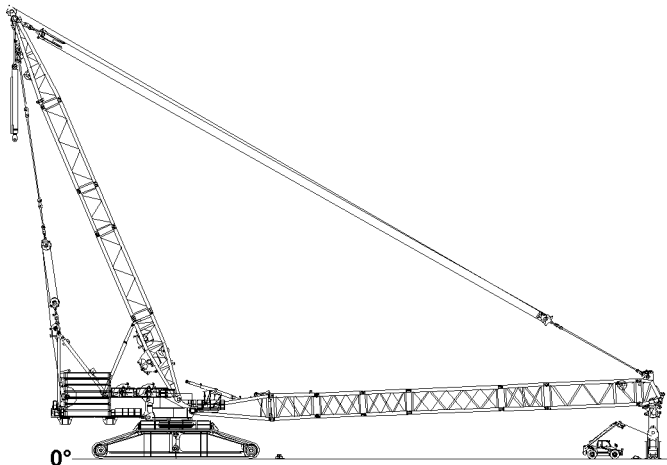

Fig.114639: Luffing the main boom down and unreeving the hoist rope - Taking the main boom down



WARNING

The crane can topple over!

If the following conditions are not met before taking down the main boom, the crane can topple over. Personnel can be severely injured or killed.

- ▶ Observe the technical safety instructions, see the Crane operating instructions, chapter 5.01.
- ▶ Observe the specifications in the erection and take-down charts.

NOTICE

Damage to the boom components!

Taking down the boom system can lead to a collision between the hook block and the pulley head. The boom components can be severely damaged.

- ▶ Luff the boom system down and spool the hoist winch out at the same time.
- ▶ When luffing the boom system down, the D-boom must remain in the operating position until the S-end section is lying on the ground or is safely held by an auxiliary crane.



Note

- ▶ The luff down movement is turned off as soon as the lowest operating position of the main boom is reached.
 - ▶ When the lowest operating position of the main boom is reached, the load display in the maximum load icon turns off and instead of the load display appears the display „???”.
 - ▶ Alarm functions appear on the crane operating screen.
- ▶ Luff the boom down to the **lowest** operating position.

Result:

- The luffing movement is turned off.
- The „STOP“ icon appears on the LICCON monitor.
- The horn icon appears on the LICCON monitor.

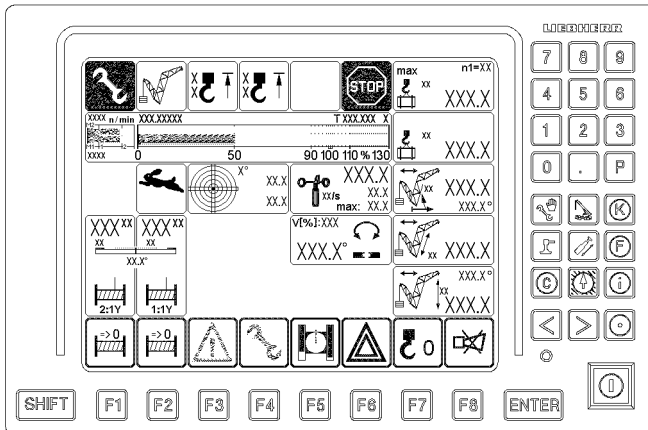

Fig.114636: Luffing the main boom down and unreeving the hoist rope - LICCON overload protection



WARNING

Danger of accident due to the „Exceedance of shut-off limits of the LICCON overload protection“ function!

If the shut off limits of the LICCON overload protection are exceeded, there is no additional protection against crane overload.

Due to erroneous operation or deliberate misuse, the crane could collapse, the boom can break off or the crane can topple over.

Personnel can be severely injured or killed.

- ▶ The „Exceeding the shut-off limits of the LICCON overload protection“ function is only permissible in emergencies and for assembly purposes.
- ▶ The function „Exceeding the shut off limits of the LICCON overload protection“ may only be actuated by persons who know the effects of their actions regarding the function „Exceeding the shut off limits of the LICCON overload protection“.
- ▶ The „Exceedance of shut off limits of the LICCON overload protection“ function requires the presence of an authorized person and must be performed with utmost caution.
- ▶ Crane operation with the „Exceedance of shut off limits of the LICCON overload protection“ function activated is prohibited.

- ▶ Exceeding the shut off limits of the LICCON overload protection: Engage assembly operation

Result:

- The shut off limits of the LICCON overload protection are exceeded.
- The assembly icon appears on the LICCON monitor.



Note

- ▶ See the Crane operating instructions, chapter 4.02 and chapter 4.20.

- ▶ At the same time, spool the hoist winch out and luff the boom system down until the hook block touches the ground.
- ▶ Disassemble the hoist limit switch weight and reeve the hook block out.
- ▶ Remove the hook block with the auxiliary crane.

When the hook block is removed under the boom head:

- ▶ Continue to luff the boom system down until the roller set / roller sets are just above the ground.



WARNING

Spooling up of the hoist rope!

By spooling the hoist rope up, personnel can be severely injured or killed.

- ▶ All rope retaining pins / pipes on the boom system are removed.
- ▶ Slowly spool up the hoist rope over the rope pulleys back to the winch.
- ▶ Make sure that no personnel is in the danger zone!

- ▶ Connect the hoist rope with the auxiliary rope of the telescopic lift truck.

**WARNING**

Danger of accident!

When using **non-approved** connecting links **49** when reeving the hoist rope in / out, the connecting links **49** can rip off suddenly.

Death, severe bodily injuries, property damage.

- ▶ Make sure that only original connecting links are used between the auxiliary winch and the hoist rope.
- ▶ Make sure that the proper pressure stage is set on the auxiliary winch of the telescopic lift truck for the reeving in / out of the respective hoist rope, see the separate operating instructions for the „assembly winch“.
- ▶ Make sure that the connecting links **49** between the auxiliary winch and the hoist rope have a higher load bearing capacity than can be created by the maximum strand pull of the respective auxiliary winch.
- ▶ The strand pull of the auxiliary winches installed on the crane side is **not** identical to the strand pull of the auxiliary winch of the telescopic lift truck.

Connecting link / Description	Load bearing capacity	Use for hoist rope diameter
CW8	2.5 t	38 mm
CWP10	5.0 t	52 mm

**WARNING**

Danger of accident!

Death, severe bodily injuries, property damage.

- ▶ It is prohibited for anyone to remain in the danger zone of the running rope.

**WARNING**

Slack rope formation!

The hoist ropes could be damaged by the formation of slack rope.

This can result in significant property damage.

- ▶ Do not allow any slack rope to be formed when spooling up the hoist ropes.
- ▶ When spooling the hoist ropes up with the telescopic lift truck and its auxiliary winch, hold them taught.
- ▶ A voice connection between the driver of the telescopic lift truck and the crane operator is available.

NOTICE

Overspooled winch!

If the hoist rope is pulled under the winch when spooling up, then the adjustment of the cam limit switch can change.

A new adjustment by **Liebherr Customer Service** is required.

- ▶ Stop the winch in time, with sufficient rope reserve.
- ▶ Do not overspool the winch.
- ▶ Carefully spool up the hoist rope at a low speed while spooling out the auxiliary winch.
- ▶ Stop the hoist rope with sufficient rope reserve before the hoist winch.

6.5 Retracting the S-relapse cylinder and taking it down in the transport position

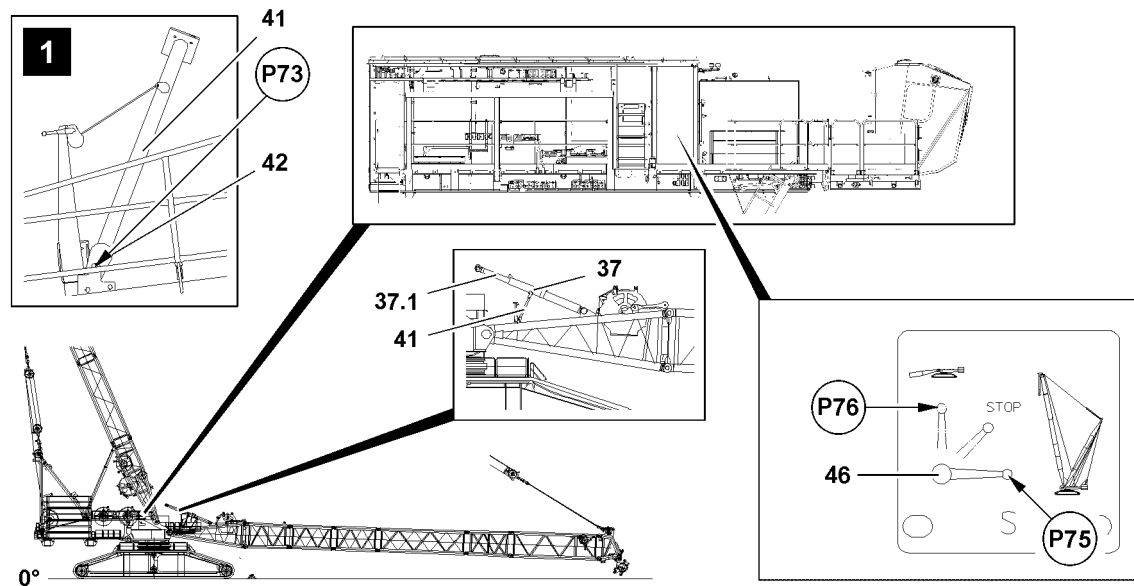

Fig. 114642: Retracting the S-relapse cylinder and taking it down in the transport position - Retracting the piston rod

Ball valve positions	
Position (P)	Function
75	Crane operation, extend the piston rod
76	Assembly, retract the piston rod
STOP	The piston rod cannot be retracted / extended

Make sure that the following prerequisite is met:

- At least one crane engine is running.
- The support **41** is pinned and secured in the operating position in point **P73** with pin **42**, see illustration **1**.
- The S-relapse cylinder **37** is lying on the support **41**.
- ▶ Set the ball valve **46** to position **P76**.

Result:

- The piston rod **37.1** of the S-relapse cylinder **37** retracts.

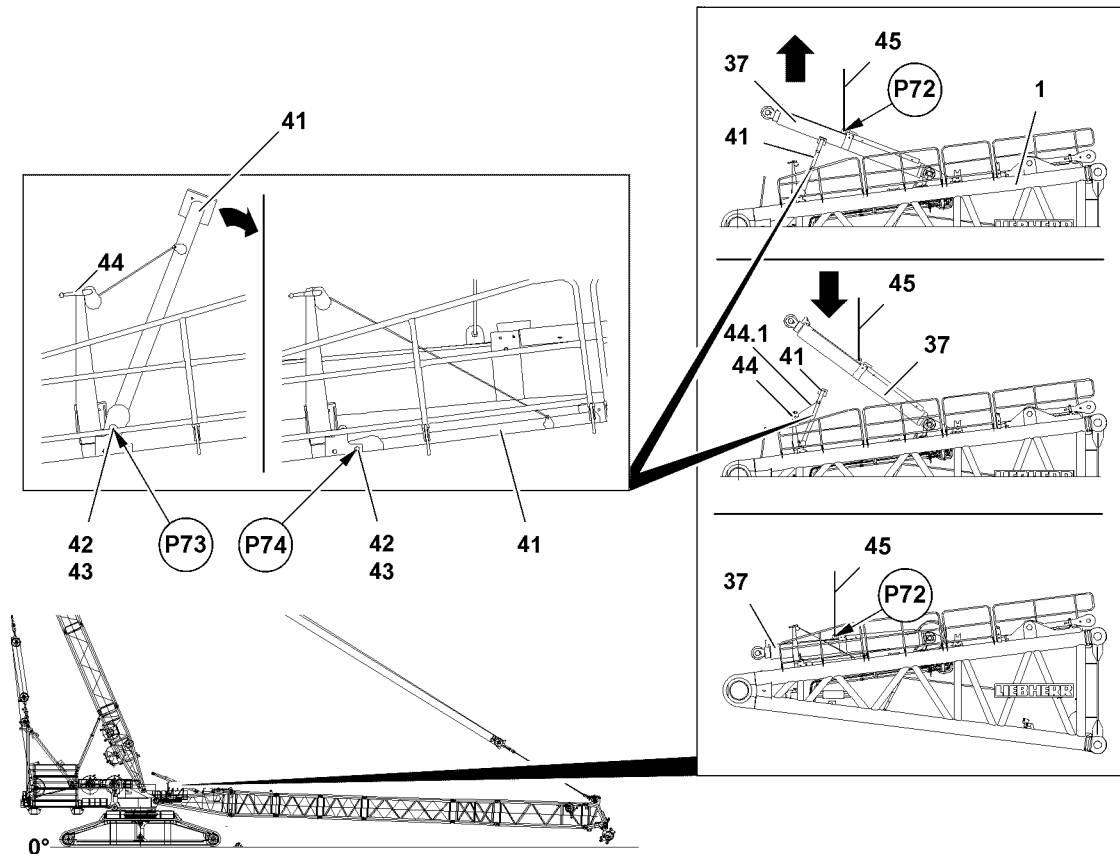

Fig.114641: Retracting the S-relapse cylinder and taking it down in the transport position — Taking the S-relapse cylinder down in the transport position

When the S-relapse cylinder **37** is completely retracted:

- ▶ Fasten the S-relapse cylinder **37** with the fastening equipment **45** in the fastening point **P72** to the auxiliary crane.



WARNING

Danger of accident!

When unpinning the support **41** it can fold down by itself.

Personnel can be severely injured or killed.

- ▶ Make sure that the support **41** is safely held by the rope **44.1** of the hand winch **44** before unpinning.

- ▶ Lift the S-relapse cylinder **37** from the support **41**.

When the S-relapse cylinder **37** is lifted off the support **41**:

- ▶ Spool the hand winch **44** up until the rope **44.1** is tensioned.
- ▶ Release the support **41**: Remove the safety locking pin **43** in point **P73** and unpin the pin **42**.
- ▶ Lower the support **41** with the hand winch **44** into the transport position.

When the support **41** is in the transport position:

- ▶ Insert the pins **42** on both sides in point **P74** and secure with the safety locking pin **43**.
- ▶ Lower the S-relapse cylinder **37** with the auxiliary crane into the transport position.

When the S-relapse cylinder **37** is completely taken down on the prism of the transport receptacle:

- ▶ Remove the auxiliary crane.

6.6 Disassembling the roller sets on the boom head

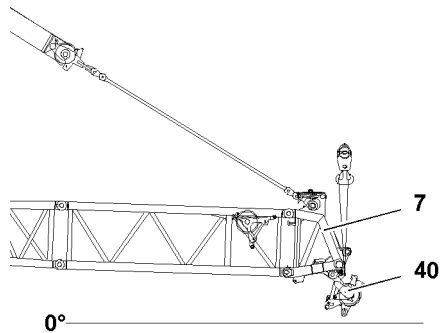

Fig.114643: Disassembling the roller sets on the boom head

NOTICE

Danger of property damage!

During the disassembly of the roller sets **40** the electrical connections to the hoist limit switches can be damaged.

► Remove the hoist limit switches on the roller sets **40**.

► Before disassembly of the roller sets **40**, route the hoist limit switches from the roller sets **40** back to the end section **7**.



Note

► The disassembly of the roller sets **40** is described in the Crane operating instructions, chapter 5.14.

6.7 Taking the boom down on the assembly shoes

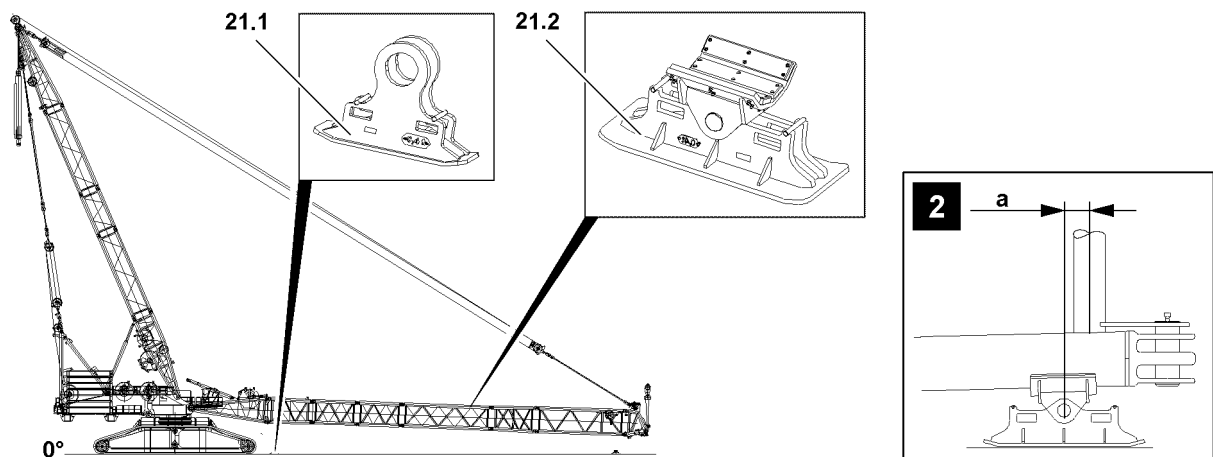

Fig.114644: Taking the boom down on the assembly shoes

Make sure that the following prerequisites are met:

- The hook block is reeved out and removed.
- The hoist rope is properly spooled up.
- The roller set / roller sets are properly removed.

**WARNING**

Incorrect position of the assembly shoes **21.2**!

If the assembly shoes **21.2** are not placed underneath in the permitted area of the lattice sections, then the lattice sections can be overloaded and damaged.

An accident can occur during crane operation due to a damaged or previously overloaded lattice section.

The distance **a** may not be more than 300 mm, see illustration 2.

Personnel can be severely injured or killed.

- ▶ Make sure that the distance **a** is not more than 300 mm.
- ▶ The crane operator is responsible for the proper substructure of the assembly shoes **21.2** on the intermediate sections.

- ▶ Position the assembly shoes **21.2** properly under the boom system.

When the assembly shoes **21.2** are positioned properly under the boom system:

- ▶ Lower the boom slowly and with slow speed onto the assembly shoes **21.2**.

6.8 Disconnecting the electrical connections from the boom head

Make sure that the following prerequisite is met:

- The main boom is taken down on the ground or is safely held by the auxiliary crane.

NOTICE

Damage to the cable drum or cable!

If the cable of the cable drum is not properly spooled up on the cable drum after unplugging the S-end section, then the cable drum or the cable can be significantly damaged.

- ▶ Spool the cable drum up after unplugging.
- ▶ Spool the cable drum up and secure it to prevent inadvertent spooling out.
- ▶ Disconnect the electrical connections and store the plugs and cables properly.
- ▶ Disassemble and store the wind speed sensor and airplane warning light properly.

6.9 Disassembling the guy rods

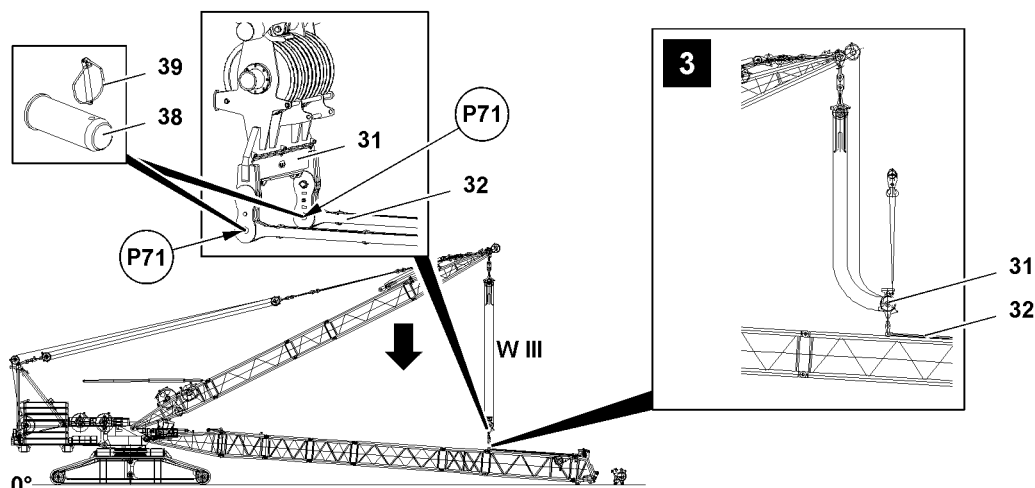

Fig.114645: Disassembling the guy rods - Unpinning the upper pulley block

NOTICE

Slack rope formation!

The control rope can be damaged due to slack rope formation.

- ▶ When taking the guy rods **32** down onto the transport receptacles, do not permit slack rope to form.

Make sure that the following prerequisite is met:

- The P-boom is taken down properly on the assembly shoes.
- ▶ Relieve the guying: Luff the D-boom down to the front until the guy rods **32** are taken down in the rod receptacles of the lattice sections.

When the guy rods **32** are in the rod receptacles of the lattice sections:

- ▶ Stop the luff down movement of the D-boom.
- ▶ Carefully spool out winch 3 **WIII** until the guying is relieved.

When the guying is relieved:

- ▶ Disassemble the auxiliary guying (if present on the boom).

NOTICE

Swinging upper pulley block **31**!

If the upper pulley block **31** is not secured with the auxiliary crane on boom lengths of more than 60 m, then it will swing back, see illustration **3**

The lattice sections and the upper pulley block **31** can be damaged.

This can result in increased property damage.

When booms with a length of more than 60 m are disassembled:

- ▶ Secure the upper pulley block **31** before disassembly with the auxiliary crane.
- ▶ Do not pull the upper pulley block **31** over the intermediate sections, rather carry them along with the auxiliary crane.

- ▶ Unpin the upper pulley block **31** on the guy rods **32**: Release the pin **38** in points **P71** and unpin.

When booms with a length of more than 60 m are disassembled:

- ▶ Guide the upper pulley block **31** back carefully with the auxiliary crane.

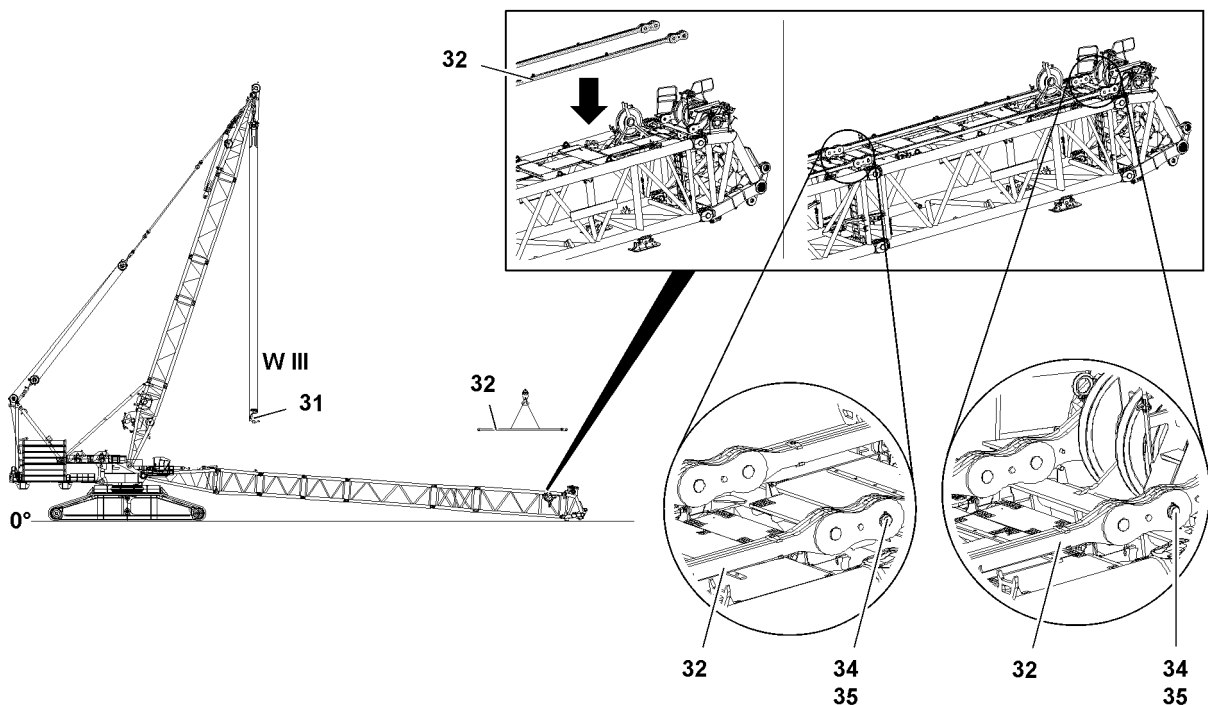

Fig.114646: Disassembling the guy rods - Unpinning the guy rods

- ▶ Unpin the guy rods **32** from each other: Remove the safety locking pin **35** and unpin the pin **34**.
- ▶ Repeat the procedure the same way for all additional guy rods **32**.

When all guy rods **32** are unpinned:

- ▶ Fasten the guy rods **32** individually to the auxiliary crane and lift off from the lattice sections.
- ▶ Take the guy rods **32** down with the auxiliary crane onto a suitable substructure.

NOTICE

Collision between the upper pulley block **31** and D-end section!

- ▶ Make sure when erecting the D-boom, that the upper pulley block **31** is not pulled against the D-end section.

When all guy rods **32** are removed from the lattice sections:

- ▶ Erect the D-boom and spool up winch **3** **WIII** at the same time.

6.10 Disassembling the lattice sections of the boom

6.10.1 Opening the boom system

**WARNING**

The boom can suddenly fold down!

If the following conditions are not met before disassembling the boom, the boom can fold down!

Personnel can be severely injured or killed.

- ▶ Take the P-boom down for disassembly on the assembly shoes.
- ▶ During pinning and unpinning of the lattice sections, it is prohibited for anyone to remain **under or on** the components as well as within the entire danger zone.

Make sure that the following prerequisites are met:

- All electrical and hydraulic connections have been disconnected.
- The auxiliary guying is disassembled.
- The guy rods have been removed.
- The guy rods have been removed from the lattice sections.

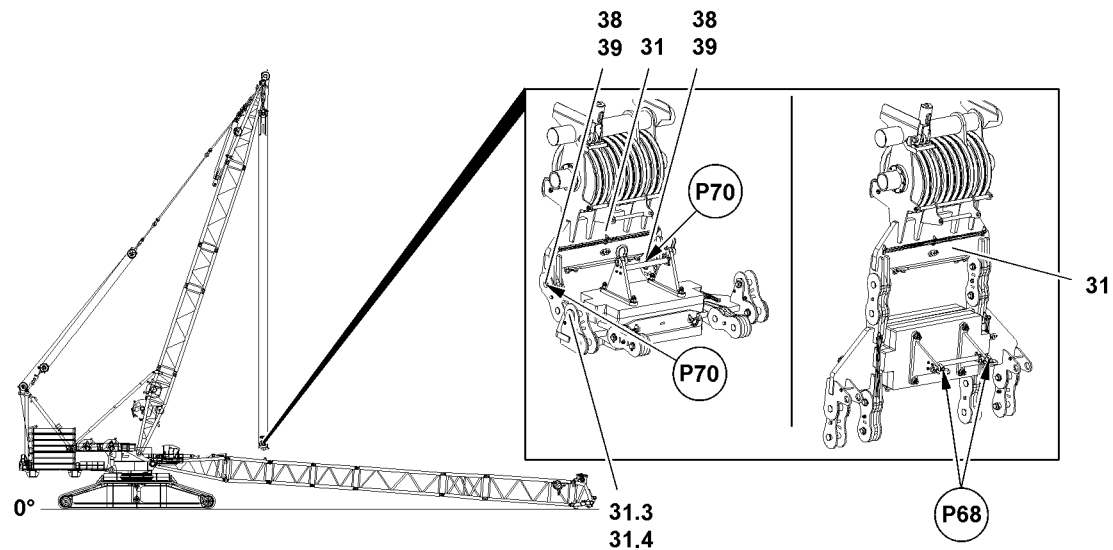

Fig.114647: Opening the boom system - Assembling the assembly weight

- ▶ Lower the upper pulley block **31** until the assembly weight **31.1** can be installed.
- ▶ Fasten the assembly weight **31.1** to the auxiliary crane in the points **P68** and lift.
- ▶ Swing the assembly weight **31.1** with the auxiliary crane in to the upper pulley block **31**.
- ▶ Pin the assembly weight **31.1** with the upper pulley block **31**: Insert the pins **38** on both sides in points **P70** and secure with the safety locking pins **39**.

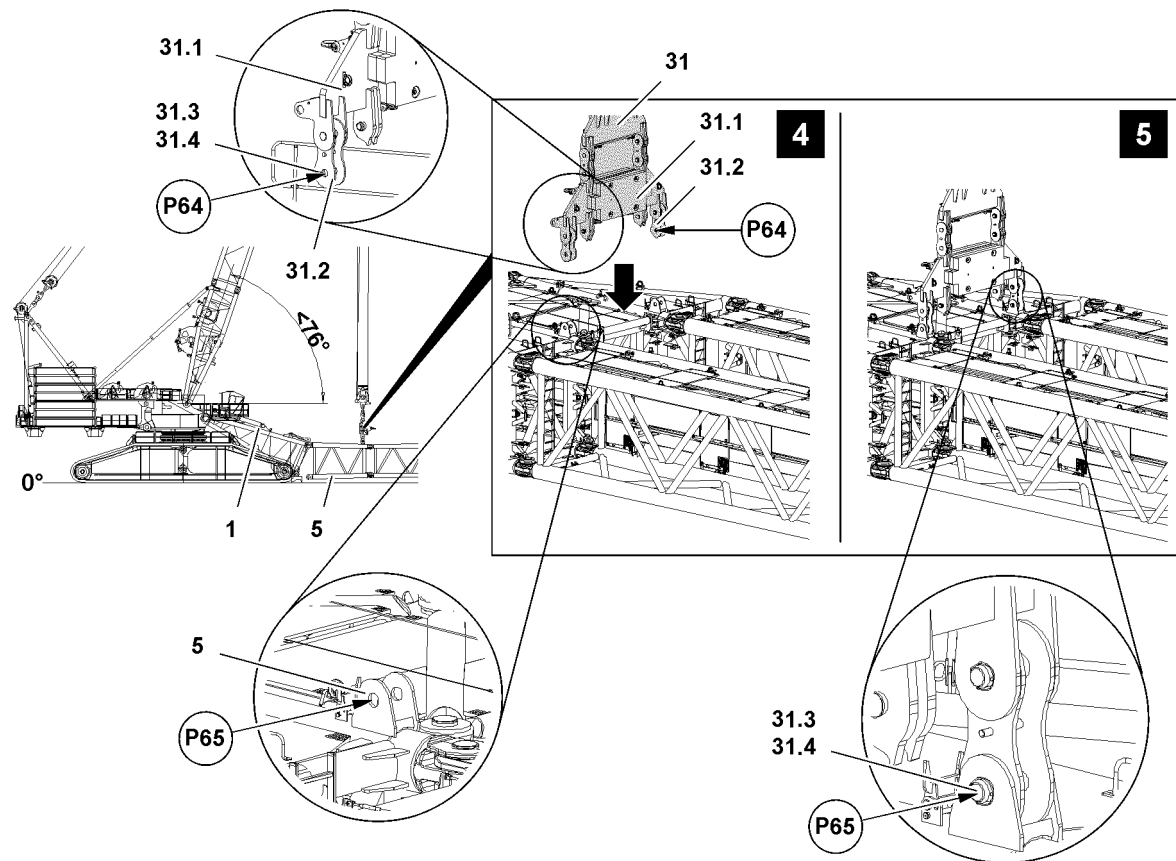

Fig.114648: Opening the boom system - Pinning the upper pulley block with the lower P-adapter

- ▶ Position the upper pulley block **31** in such a way that the brackets **31.2** of the assembly weight **31.1** hang over the pin points **P65** of the P-adapter **5**, see illustration **4**.
- ▶ Remove the safety locking pins **31.4** on both sides in points **P64** and unpin the pins **31.3**.

When the pins **31.3** are completely unpinned on both sides in points **P64**:

- ▶ Continue to lower the upper pulley block **31** until the pin bores (point **P64**) of the brackets **31.2** align in the pin points **P65**.

When the pin bores align:

- ▶ Insert the pins **31.3** completely on both sides and secure with safety locking pins **31.4**, see illustration **5**.

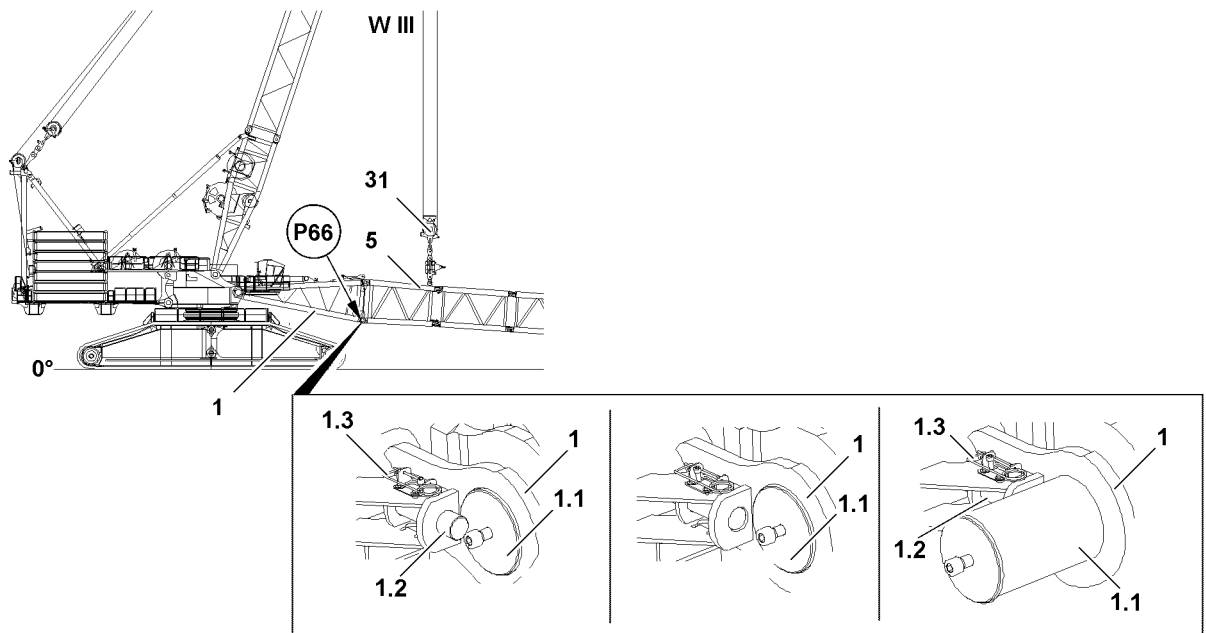

Fig.114649: Opening the boom system - Unpinning the lower P-adapter on the S-pivot section



WARNING

Overload of the crane!

If the following conditions are not met, the crane can topple over or be significantly damaged. Personnel can be severely injured or killed.

- ▶ When „opening“ the boom system, the maximum permissible F3-total force of **400 t** in test point 3 may **not** be exceeded. Pay attention to the display of test point 3 on LICCON monitor 1, see the Crane operating instructions, chapter 4.02.
- ▶ When „closing“ the P-boom system, the maximum permissible length of the boom of **132 t** may **not** be exceeded.
- ▶ Lifting and opening the respective boom is only permissible by observing the maximum permissible boom lengths and total forces.
- ▶ Make sure that there are no persons on the boom system as well as in the danger zone when „opening“.



Note

- ▶ The actual forces on test point 3 **F3** (MS3) are shown on LICCON monitor 1.
- ▶ Tension the guying in the test points at disassembly with the same forces as for assembly.
- ▶ For this, refer the **ACTUAL** forces measured and recorded in the test points during assembly.
- ▶ The pins **1.1** will therefore be easier to pull and the pins **1.1** and lugs will not be damaged.



Note

- ▶ Unpin the intermediate sections with the pin pulling device, see the Crane operating instructions, chapter 5.30.

- ▶ Tension the main boom by spooling up winch 3 **WIII**.

When the main boom is safely held by the winch 3 **WIII**:

- ▶ Open the P-boom system: Release the connector pins **1.1** on both sides: Remove spring retainer **1.3** and unpin the pin **1.2**.
- ▶ Unpin the pins **1.1** on both sides in points **P66** with the pin pulling device.

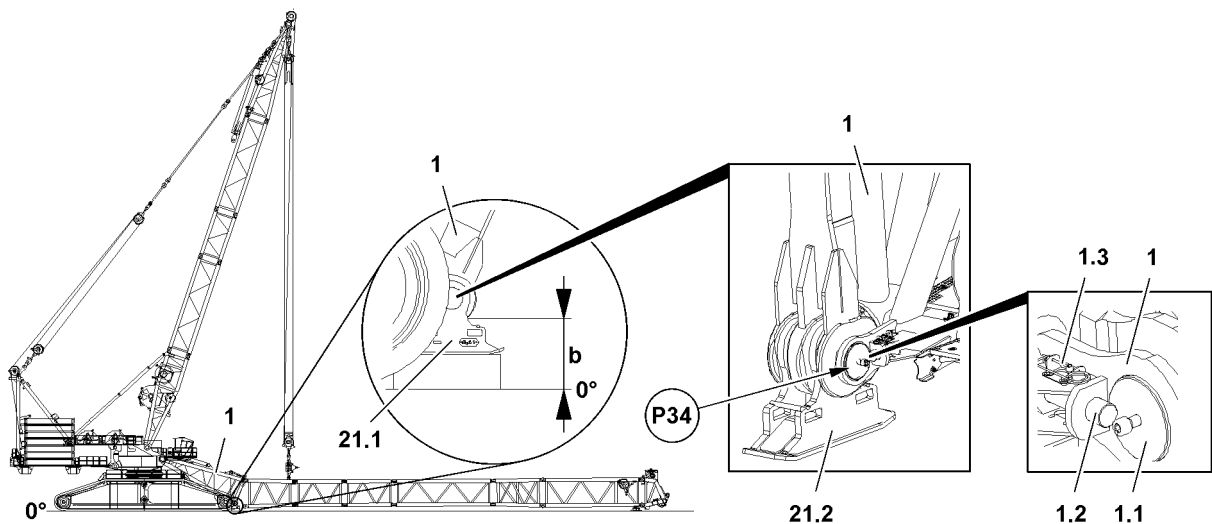

Fig.114650: Opening the boom system - Assembling the assembly shoes

NOTICE

Danger of property damage!

When lowering the P-boom system, crane components can be damaged.

- ▶ Make sure that the S-pivot section **1** is not lowered directly onto the ground.
- ▶ Pin the S-pivot section **1** when opening the P-boom system with the assembly shoes **21.1**.



Note

- ▶ After the take down procedure the S-pivot section **1** must be positioned with a distance **b** of at least 550 mm above the alignment level (0°).

When the pins **1.1** are completely unpinned in point **P34** :

- ▶ Lower the P-boom system carefully to a height where the assembly shoes **21.1** can be pinned on the S-pivot section **1**.
- ▶ Pin the assembly shoes **21.1** on both sides with the S-pivot section **1**: Insert the pin **1.1** on both sides in the points and secure with retaining elements (pin **1.2** and spring retainer **1.3**).
- ▶ Lower the S-pivot section **1** completely.

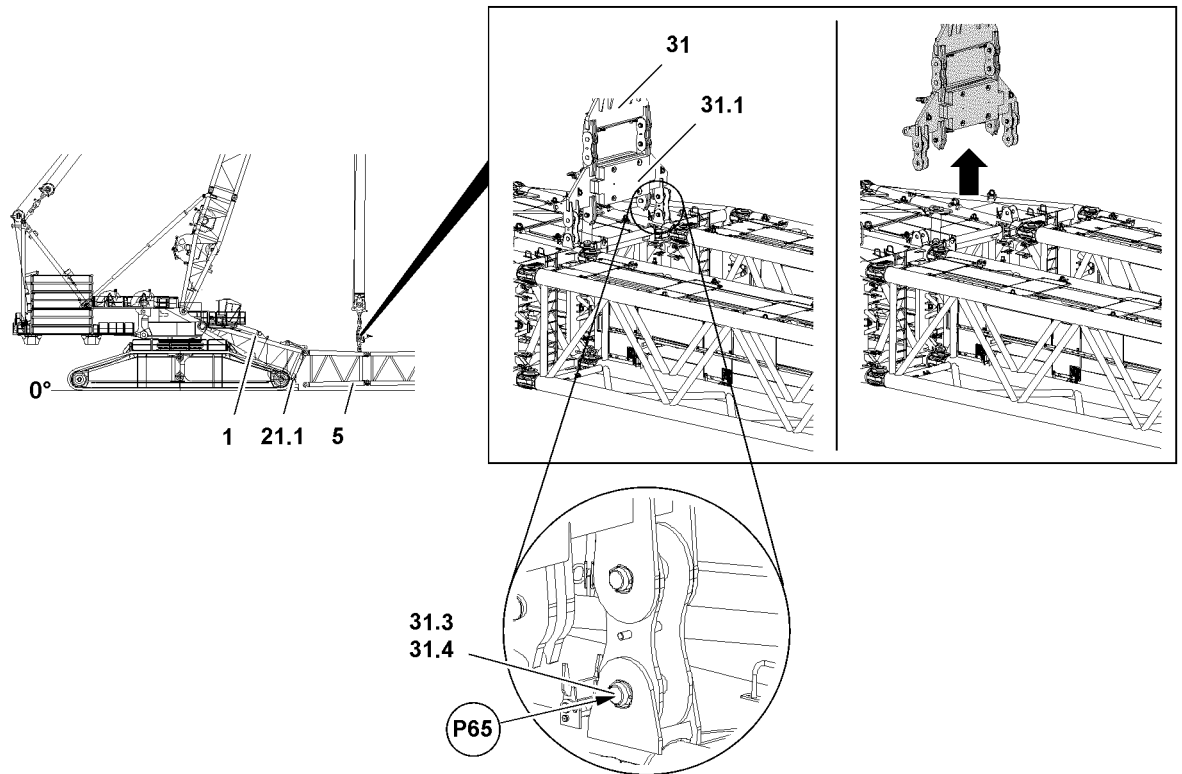

Fig.117003: Opening the boom system - Disassembling the assembly weight on the lower P-adapter

When the S-pivot section **1** is lying on the assembly shoes **21.1**:

- ▶ Unpin the assembly weight **31.1** on the P-adapter **5**: Remove the safety locking pin **31.4** in point **P65** and unpin the pin **31.3**.
- ▶ Lift the upper pulley block **31**.
- ▶ Disconnect the electrical connections between the boom end section and the S-pivot section properly.

6.10.2 Disassembling the S-end section / S-adapter / S-intermediate sections on the upper P-adapter

Make sure that the following prerequisites are met:

- The PD-boom system is open and properly taken down on the assembly shoes.
- The upper pulley block is disassembled and lifted on the P-adapter.
- The guy rods are completely disassembled and removed from the lattice sections.
- A second auxiliary crane with sufficient load carrying capacity is available.
- A forklift or telescopic lift truck are available.

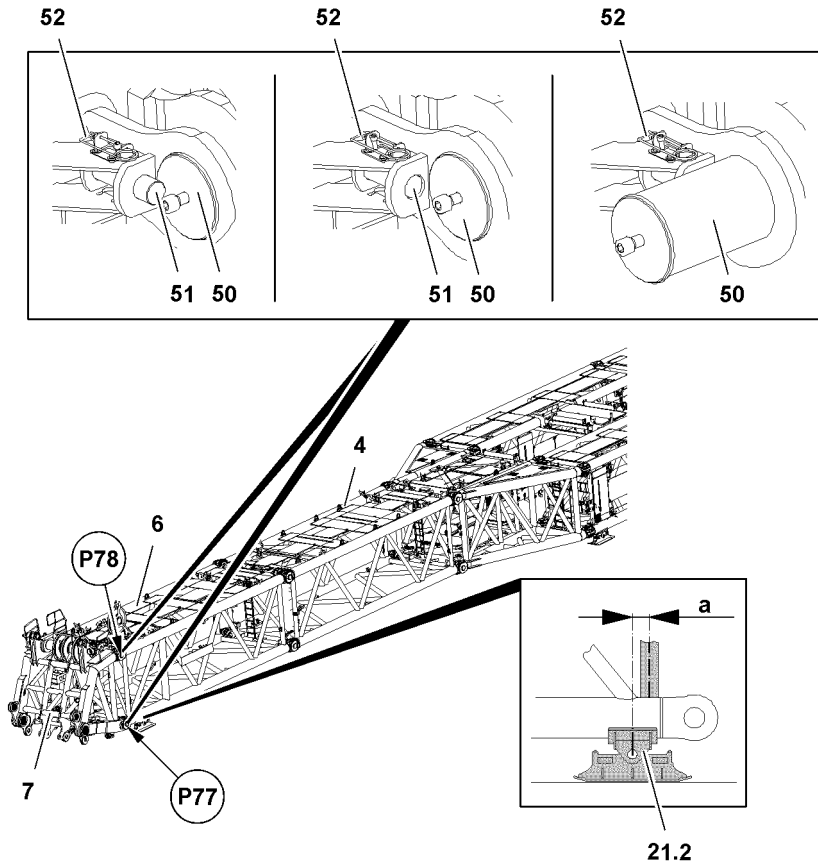

Fig.117004: Disassembling the S-end section / S-adapter / S-intermediate sections on the upper P-adapter



Note

► The disassembly of the single strand of the P-boom system is shown as an example on the disassembly of the S-end section 7. The disassembly of the S-adapter 6 and the S-intermediate sections 4 is performed the same way. For the respective fastening points, refer to section „Fastening points“.



Note

For the disassembly of the lattice sections and when lifting the boom system, use the cross beam!
 ► For handling of the cross beam, see the Crane operating instructions, chapter 5.39.

NOTICE

Impermissible boom length!

If the boom is lifted with an impermissible boom length with the cross beam, then the last intermediate section can be overloaded when lifting the boom system.

Death, severe injuries, property damage.

► Make sure that the boom is lifted with the cross beam only up to the permissible boom length, see chart.

Boom system	Permissible boom length
S	132 m
SL	144 m
P	132 m

LWE/LR_13000-001/19503-01-02/en

Boom system	Permissible boom length
W	126 m
W2	90 m
W3	108 m

**WARNING**

Death or severe injury due to failure of changing the assembly shoes **21.2!**

Property damage.

- ▶ Place the assembly shoes **21.2** properly under the lattice section, which is lying in front of the one which is to be disassembled, see section „Changing the assembly shoes at disassembly“.
 - ▶ Adhere to the maximum distance **a** of 300 mm.
-
- ▶ Fasten the S-end section **7** to the auxiliary crane.

**WARNING**

Death or severe injury due to incorrect unpinning sequence!

Property damage.

- ▶ Unpin the S-end section **7** first on the „bottom“ and then on „top“.
-
- ▶ Unpin the S-end section **7** on the S-adapter **6**: Remove the retaining elements (spring retainer **52** and pin **51**) on both sides in points **P77** and unpin the pin **50** on both sides with the pin pulling device.
 - ▶ Unpin the S-end section **7** on the S-adapter: Remove the retaining elements (spring retainer **52** and pin **51**) on both sides in points **P78** and unpin the pin **50** on both sides with the pin pulling device.

**Note**

- ▶ For the rotation of the S-end section **7** refer to the Crane operating instructions, chapter 5.39 in section „Turning the S-/L -end section into assembly position“.
-
- ▶ Remove the S-end section **7** with the auxiliary crane and take it down in a suitable location.

6.10.3 Disassembling the frame

Make sure that the following prerequisite is met:

- The guy rods are completely disassembled and removed from the lattice sections.

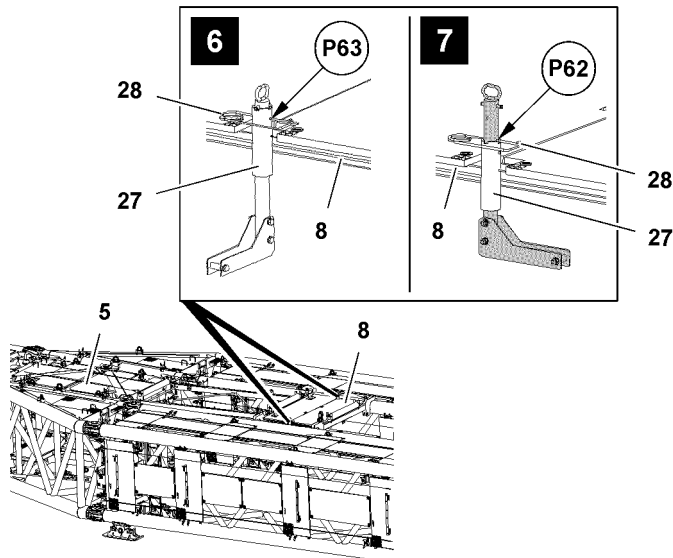

Fig.117005: Disassembling the frame - Opening the lock

- ▶ Fasten the frame **8** to the auxiliary crane, see section „Fastening points of the lattice sections“.

Before the frame **8** of the upper P-adapter **5** can be lifted off, the lock **27** must be brought from the operating position (illustration **6**) into the transport position (illustration **7**). This procedure is described on an example of one side.

- ▶ Remove the spring retainer **28** in point **P63**.
- ▶ Turn the lock **27** 90° until the bores align in point **P62**.

When the bores align in point **P62**:

- ▶ Secure the lock **27** with the spring retainer **28** in point **P62**.
- ▶ Bring the opposite side of the frame **8** into the transport position, the same way as described before.

Result:

- The lock **27** is in the transport position.

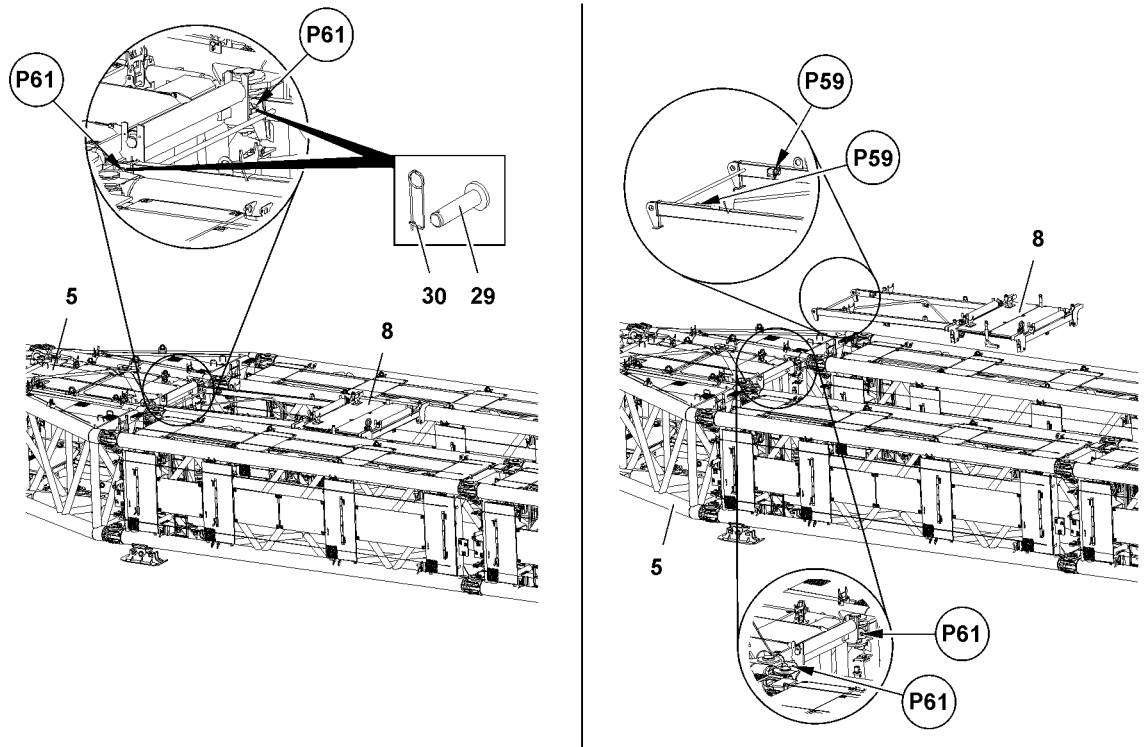

Fig.117006: Disassembling the frame - Unpinning the frame on the upper P-adapter



WARNING

Death or severe injuries due to the frame **8** folding down!
Property damage.

- ▶ Before unpinning, secure the frame **8** with the auxiliary crane to prevent it from folding down.

To be able to unpin the pins **29**, the pins **29** must be relieved.

- ▶ Tension the fastening equipment slightly with the auxiliary crane until the pins **29** can be uninned.

When the pins **29** are relieved and can be moved freely:

- ▶ Unpin the frame **8** on the upper P-adapter **5**: Remove the safety spring **30** on both sides and unpin the pins **29** in points **P61**.
- ▶ Insert the pin **29** in the park position **P59**: Insert the pins **29** in the points **P59** and secure with safety springs **30**.
- ▶ Remove the frame **8** with the auxiliary crane and take it down in a suitable location.

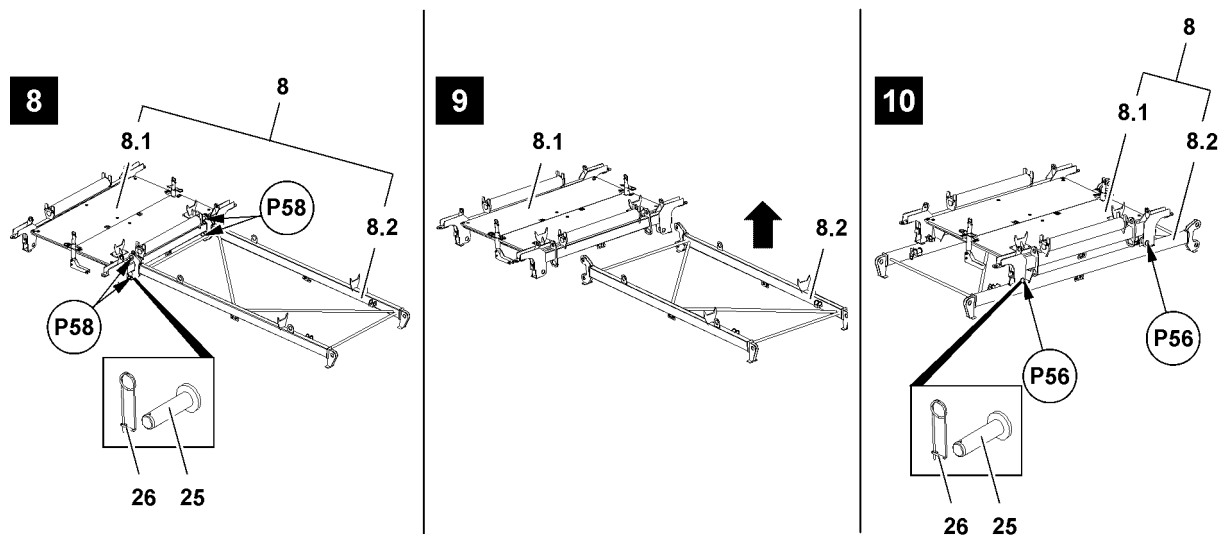

Fig.117007: Disassembling the frame - Establishing transport position

- ▶ Unpin the frame components **8.2** on the frame components **8.1**: Remove the safety springs **26** and unpin the pin **25** in points **P58**, see illustration **8**.
- ▶ Fasten the frame components **8.1** to the auxiliary crane, see section „Fastening points of the lattice sections“.
- ▶ Lift the frame components **8.1** with the auxiliary crane and position it in such a way that it can be pinned in points **P56**, see illustration **10**.
- ▶ Pin the frame components **8.1** with the frame components **8.2** : Insert the pins **25** in the points **P56** and secure with safety springs **26**.
- ▶ Insert the pins **25** on the opposite side and secure with safety springs **26**.

Result:

- ▷ The frame **8** is now in the transport position, see illustration **10**.
- ▶ Take the frame **8** down with the auxiliary crane in a suitable location.

6.10.4 Disassembling the upper P-adapter on the Li-intermediate sections

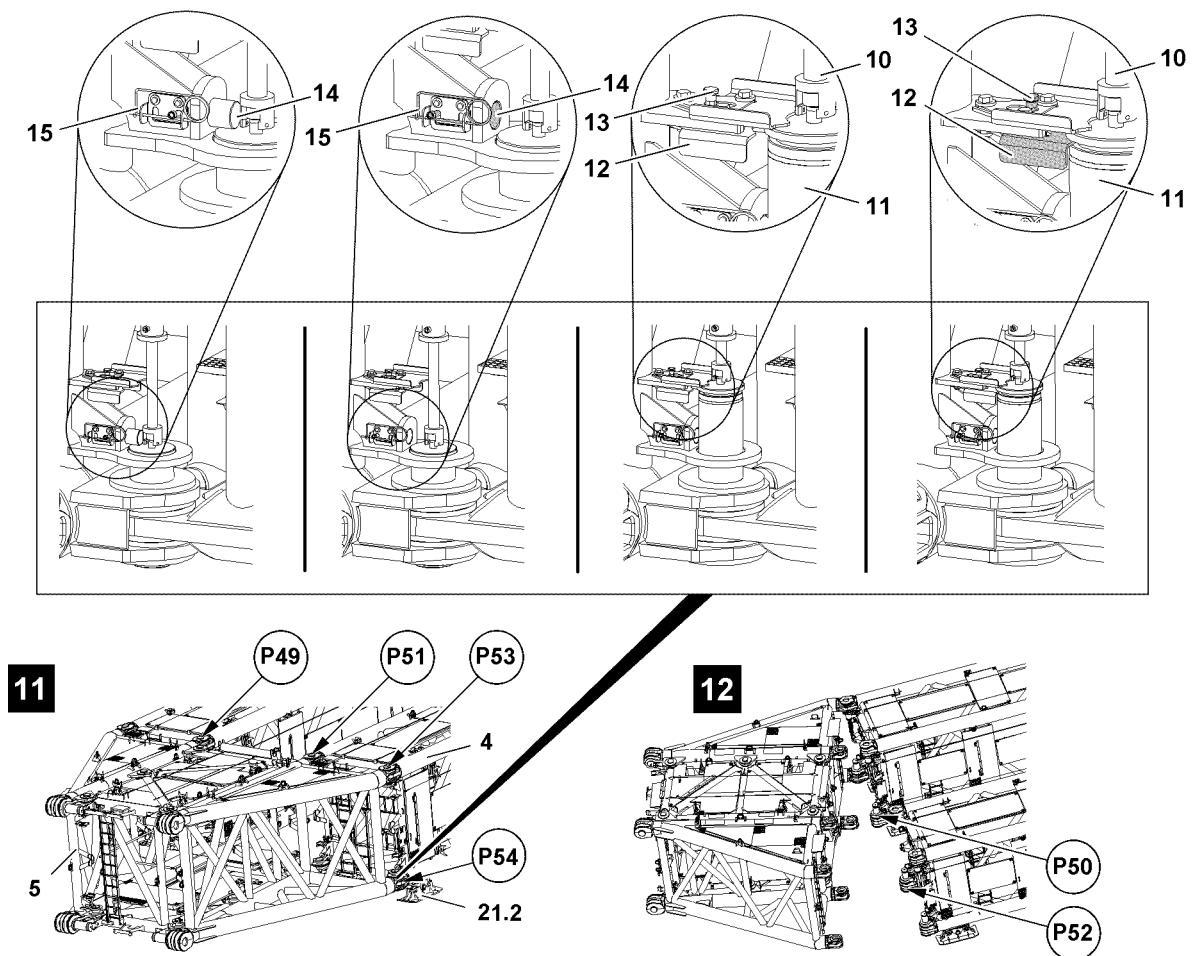

Fig.117008: Disassembling the upper P-adapter on the Li-intermediate sections - Unpinning procedure

Make sure that the following prerequisite is met:

- The frame is completely disassembled on the upper P-adapter 5.
- The two strands between the Li-intermediate sections 4 are each lying properly on the assembly shoes 21.2, see illustration 11
- ▶ Fasten the auxiliary crane to the upper P-adapter 5, see section „Fastening points of the lattice sections“.
- ▶ Unpin the upper P-adapter 5 on the Li-intermediate section 4: Remove the retaining elements (pin 14 and safety spring 15) and unpin the pin 11 with the pin pulling device in point P54.



WARNING

Death or severe injury due to unsecured pins!

- ▶ Before removing the pin pulling device, secure the pins with sliding retainer.

There is a sliding retainer 12 on the lower pins 11 that keeps the pin 11 in position when it is unpinned. It must be engaged in the pin 11 to hold the pin 11.

When the pin 11 is held by the sliding retainer 12:

- ▶ Remove the pin pulling device.
- ▶ Repeat the procedure for the lower pins 11 in point P52 and point P50, see illustration 12.
- ▶ Unpin the upper P-adapter 5 on the Li-intermediate sections 4: Remove the retaining elements (pin 14 and sliding retainer 12) and unpin the pin 11 with the pin pulling device in point P49, point P51 and point P53.

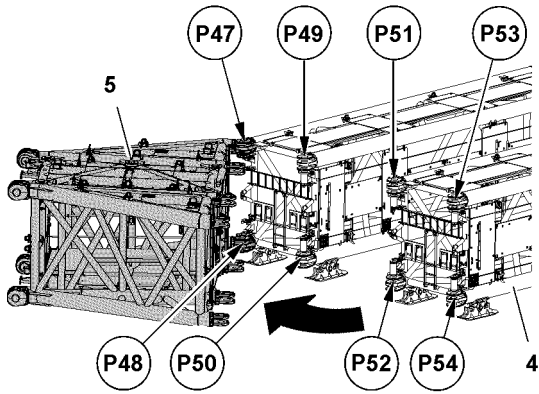

Fig.117009: Disassembling the upper P-adapter on the Li-intermediate sections - Disassembling the upper P-adapter completely on the Li-intermediate sections

- ▶ Swing the upper P-adapter **5** up with the auxiliary crane.
- ▶ Repeat the unpinning procedure in point **P47** the same way as described before in point **P49**.
- ▶ Repeat the unpinning procedure in point **P48** the same way as described before in point **P54**.
- ▶ Remove the upper P-adapter **5** with the auxiliary crane and take it down in a suitable location.

6.10.5 Changing the assembly shoes at disassembly

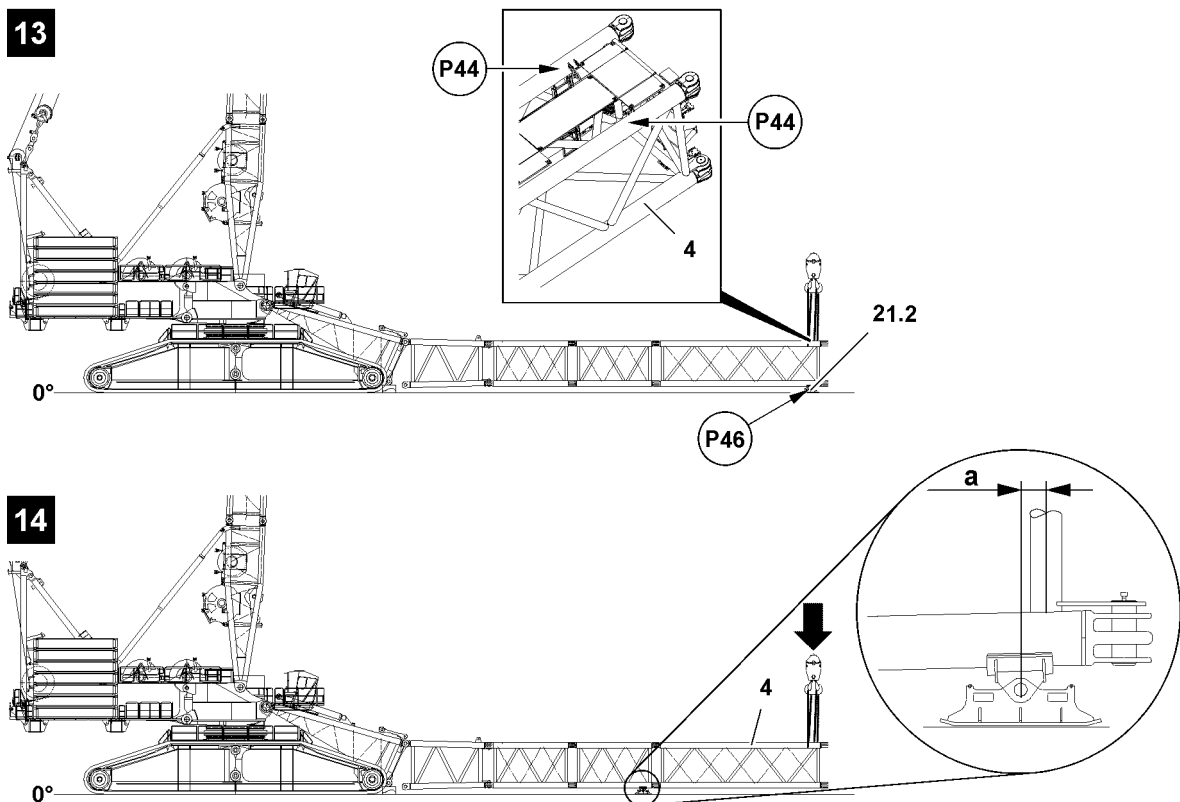

Fig.117010: Changing the assembly shoes at disassembly

Make sure that the following prerequisites are met:

- The respective Li-intermediate section **4** is taken down on the assembly shoes **21.2**.
- An auxiliary crane is available.



Note

- ▶ Changing the assembly shoes **21.2** is identical for each Li-intermediate section **4**. The change procedure is described based on the example of one Li-intermediate section **4**.

- ▶ Fasten the fastening equipment properly in points **P44**: Use the fastening equipment to place a loop on the bars on the left and right.
- ▶ Lift the lattice section leg with the auxiliary crane, see illustration **13**.

Result:

- The assembly shoes **21.2** in point **P46** are not loaded and can be offset.
- ▶ Remove the assembly shoes **21.2** in point **P46**.

**WARNING**

Incorrect position of the assembly shoes **21.2**!

If the assembly shoes **21.2** are not placed underneath in the permitted area of the Li-intermediate sections **4**, then the Li-intermediate sections **4** can be overloaded and damaged.

An accident can occur during crane operation due to a damaged or previously overloaded lattice section.

The distance **a** may not be more than 300 mm, see illustration **14**!

Personnel can be severely injured or killed.

- ▶ Make sure that the distance **a** is not more than 300 mm.
- ▶ The crane operator is responsible for the proper substructure of the assembly shoes **21.2** on the Li-intermediate sections **4**.

- ▶ Position the assembly shoes **21.2** in such a way in point **a** that the distance is not more than 300 mm, see illustration **14**.
- ▶ Lower the lattice section leg with the auxiliary crane, see illustration **14**.
- ▶ Remove the lattice section.

6.10.6 Disassembling the Li-intermediate sections

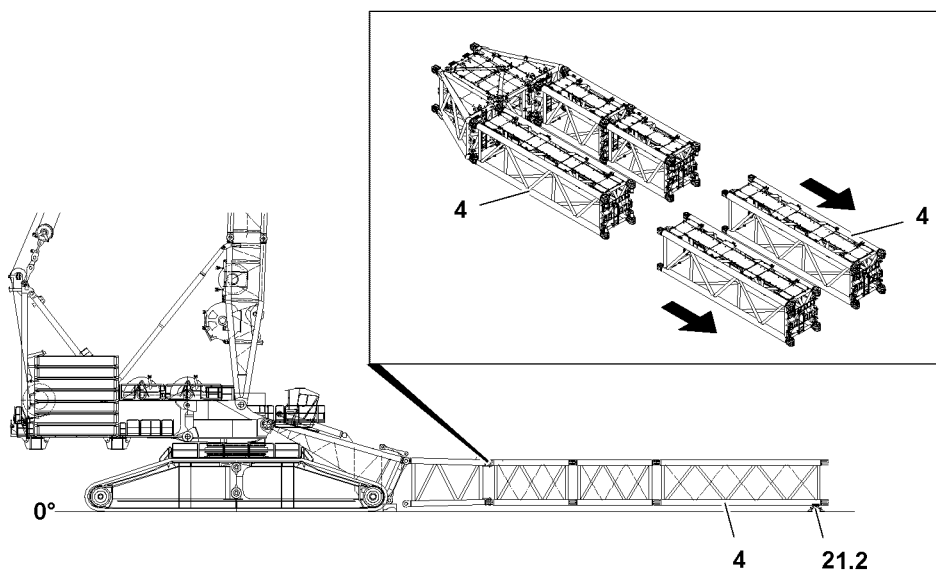

Fig.117011: Disassembling the Li-intermediate sections

Make sure that the following prerequisites are met:

- The respective Li-intermediate section **4** is taken down on the assembly shoes **21.2**.
- An auxiliary crane is available.

**Note**

- ▶ The disassembly of the Li-intermediate sections **4** is identical for each Li-intermediate section **4**. The disassembly procedure is described based on the example of one Li-intermediate section **4**.
- ▶ Fasten the Li-intermediate section **4** to the auxiliary crane.
- ▶ Change the assembly shoes **21.2**, see section „Changing the assembly shoes at disassembly“.

- ▶ Unpin the Li-intermediate section 4 on the Li-intermediate section 4, see the unpinning procedure in section „Disassembling the upper P-adapter on the Li-intermediate sections“.
- ▶ Remove the Li-intermediate section 4 with the auxiliary crane.
- ▶ Turn the Li-intermediate section 4 90° in the transport position, see section „Changing the boom: Turning the Li-intermediate sections“.
- ▶ Take the Li-intermediate section 4 down in a suitable location.
- ▶ Repeat the procedure for all Li-intermediate sections 4 in the same way.

6.10.7 Disassembling the lower P-adapter on the S-pivot section

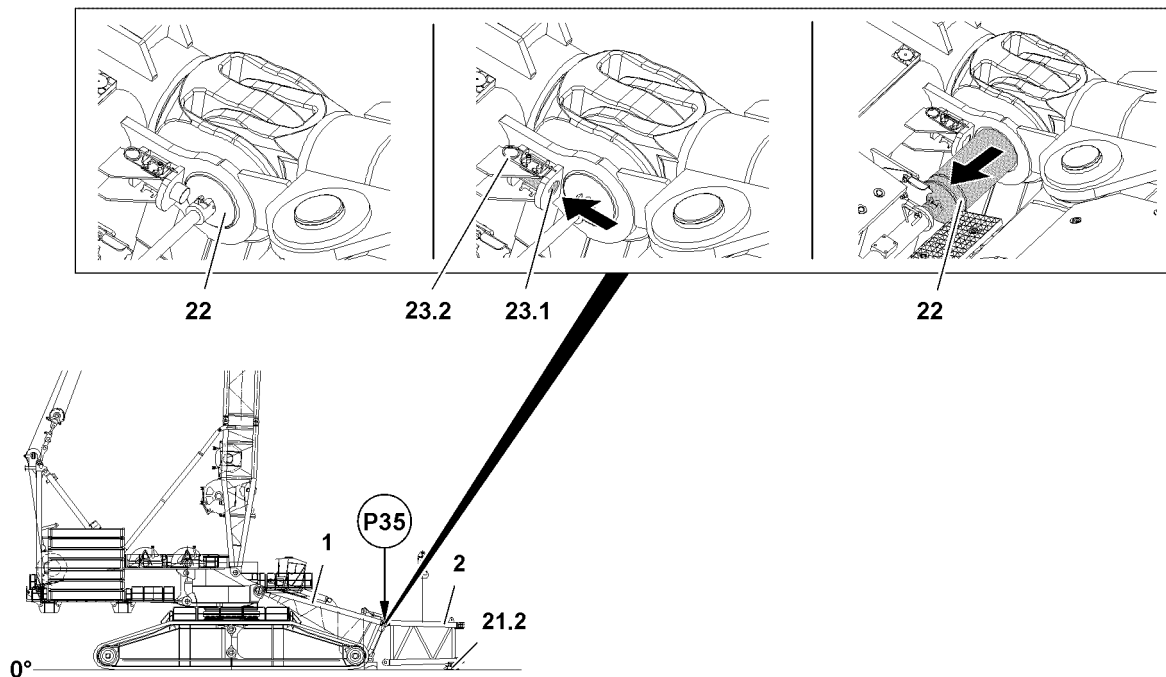

Fig.117012: Disassembling the lower P-adapter on the S-pivot section

Make sure that the following prerequisites are met:

- The lower P-adapter 2 is taken down properly on the assembly shoes 21.2.
 - An auxiliary crane is available.
 - All Li-intermediate sections are disassembled.
- ▶ Fasten the lower P-adapter 2 to the auxiliary crane, see section „Fastening points“.
 - ▶ Tension the fastening equipment slightly until the lower P-adapter 2 can no longer fall down.
 - ▶ Unpin the lower P-adapter 2 on the S-pivot section 1: Remove the retaining elements (spring retainer 23.2 and pin 23.1) and unpin the pin 22 with the pin pulling device in points P35.
 - ▶ Remove the lower P-adapter P35 with the auxiliary crane.

Empty page!

LWE/LR 13000-001/19503-01-02/en

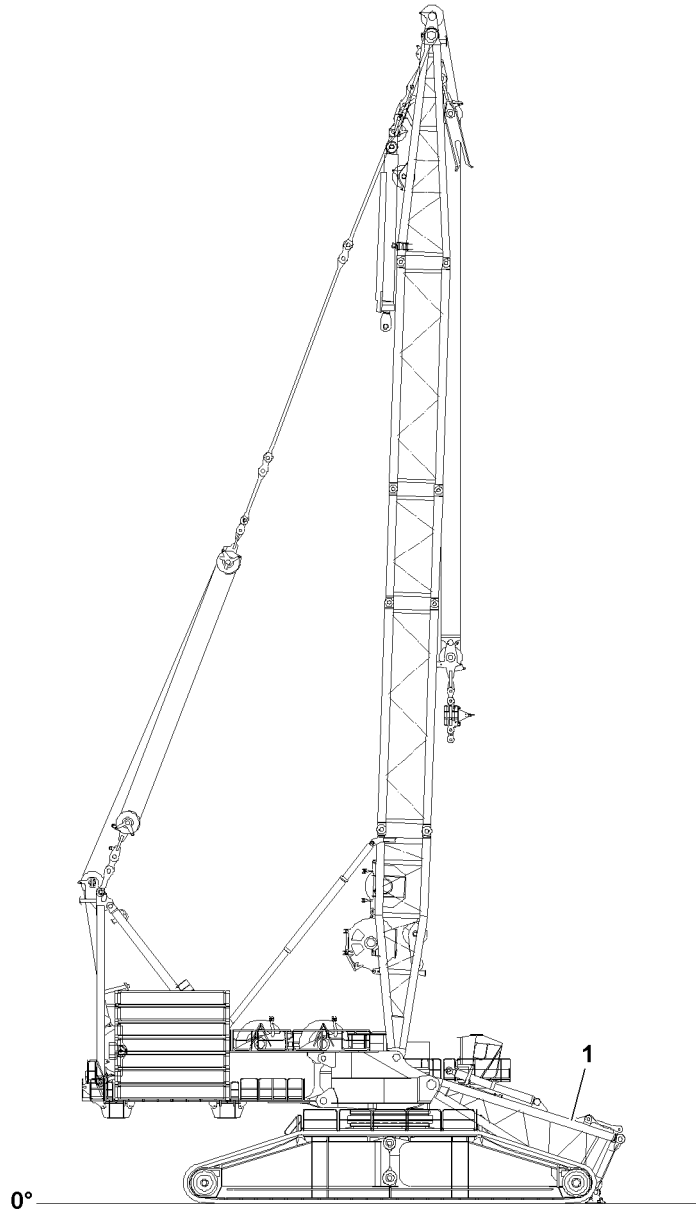

LWE/LR 13000-001/19503-01-02/en

Fig.124453

6.11 Disconnecting the electrical connections from the S-pivot section

Make sure that the following prerequisite is met:

- The main boom is taken down on the ground or is safely held by the auxiliary crane.

NOTICE

Damage to the cable drum or cable!

If the cable of the cable drum is not properly spooled up on the cable drum after unplugging the S-end section, then the cable drum or the cable can be significantly damaged.

- ▶ Spool the cable drum up after unplugging.
-
- ▶ Spool the cable drum up and secure it to prevent inadvertent spooling out.
 - ▶ Disconnect the electrical connections and store the plugs and cables properly.
 - ▶ Disassemble and store the wind speed sensor and airplane warning light properly.

6.12 Disconnecting the hydraulic connections

When connecting and releasing hydraulic lines with quick couplings, make sure that the coupling procedure is carried out correctly.



DANGER

Danger of accident due to loss of pressure or leakage!

Incorrectly coupled or self-loosening quick couplings (particularly return lines) can result in serious accidents due to component failure!

- ▶ Check that the quick couplings have been properly connected before using the crane!
-



Note

- ▶ To connect or release the hydraulic lines with quick couplings, see the Crane operating instructions, chapter 5.01!
-
- ▶ Release the pressure in the hydraulic system before connecting or disconnecting. Turn the engine off and wait a short time.
 - ▶ Bolting the coupling components (sleeve and connector) by using the knurled nut.
 - ▶ Connect the coupling components.

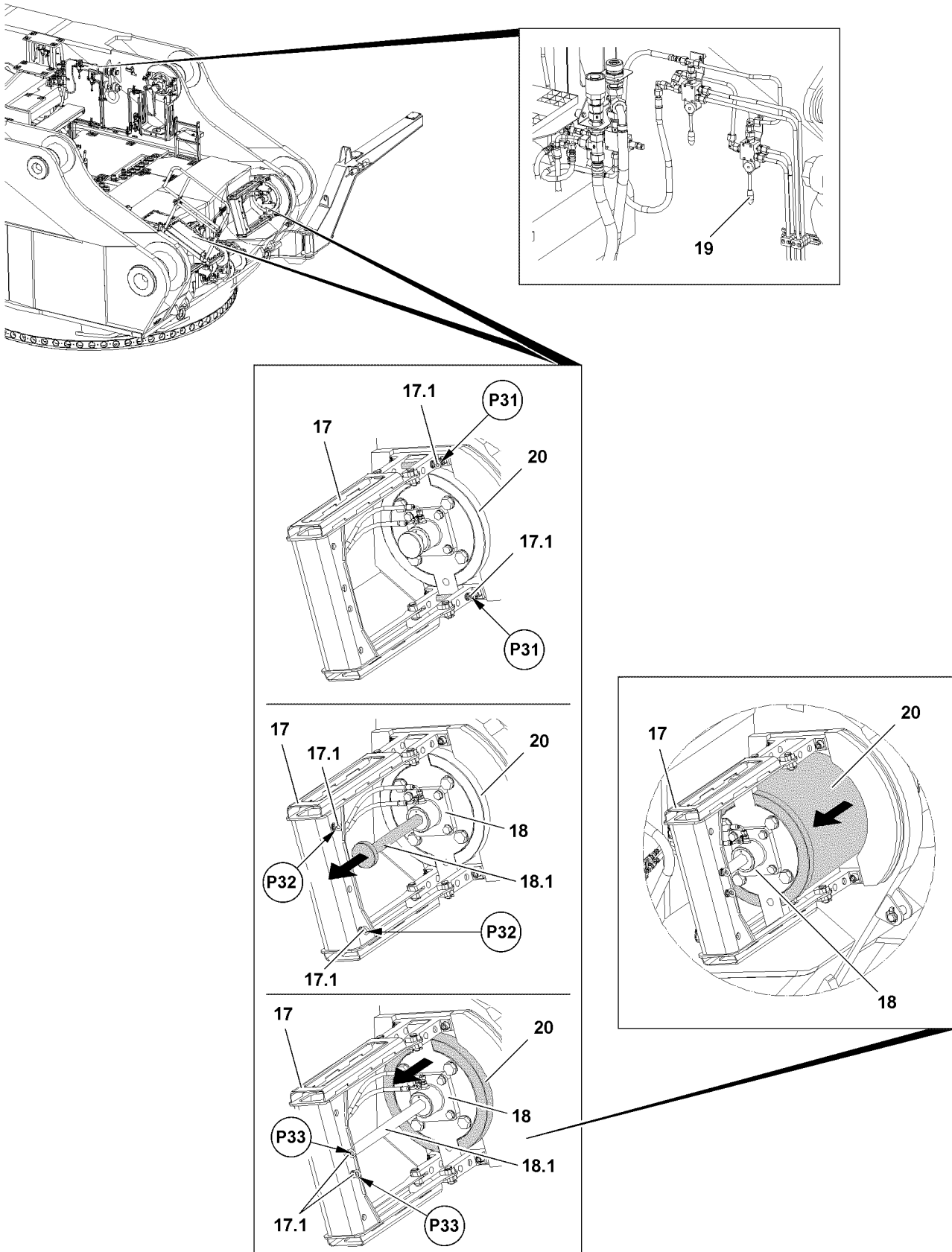

Fig.114610: Unpinning the S-pivot section on the turntable

6.13 Disassembling the S-pivot section on the turntable



WARNING

General danger note!

- ▶ Insert and secure all pins after disassembly in the intended transport receptacles.

Make sure that the following prerequisites are met:

- The hydraulic connections to the S-pivot section are properly disconnected.
- The hydraulic connections on the S-pivot sections are properly closed off with caps.
- The electrical connections to the S-pivot section are properly disconnected.
- The electrical connections are properly closed off with dummy plugs (see the Electrical wiring diagram).
- The D-boom is erected to the point where the S-pivot section can be disassembled without obstructions.
- The installation location of winch 5 on the S-pivot sections is properly closed and secured with the catwalk.
- At least one crane engine is running.
- An auxiliary crane with sufficient load bearing capacity is available.



Note

- ▶ Select the fastening points on the S-pivot section in such a way that the S-pivot section hangs horizontally on the auxiliary crane during disassembly. See section „Fastening points“.

- ▶ Fasten the S-pivot section **1** properly to the auxiliary crane.
- ▶ Lift the S-pivot section **1** with the auxiliary crane to the horizontal.



WARNING

Falling S-pivot section!

- ▶ Make sure that the S-pivot section **1** is safely held by the auxiliary crane before unpinning the S-connector pins **20**.



Note

- ▶ The unpinning of the S-pivot section on the turntable is described in detail in section: „Unpinning the S-connector pins on the turntable“.

When the S-pivot section is horizontally aligned and safely held by the auxiliary crane:

- ▶ Unpin the S-connector pins **20** on the turntable.

NOTICE

Damage to the turntable and the S-pivot section **1**!

- ▶ Slowly swing the S-pivot section **1** out with the auxiliary crane and at low speed on the turntable.
- ▶ Before taking it down on the ground, support the S-pivot section **1**.

When the S-connector pins **20** on the S-pivot section **1** are fully unpinned on both sides:

- ▶ Swing the S-pivot section **1** out on the turntable with the auxiliary crane and take it down.
- ▶ Remove the auxiliary crane.



Note

- ▶ Disassemble the D-boom, see the Crane operating instructions, chapter 5.05.

When the S-pivot section **1** is disassembled on the turntable:

- ▶ Fully insert and secure the S-connector pins **22** again.

Empty page!

LWE/LR 13000-001/19503-01-02/en

5.61 Roller cart

1 Pulley cart

3

LWE/LR 13000-001/19503-01-02/en

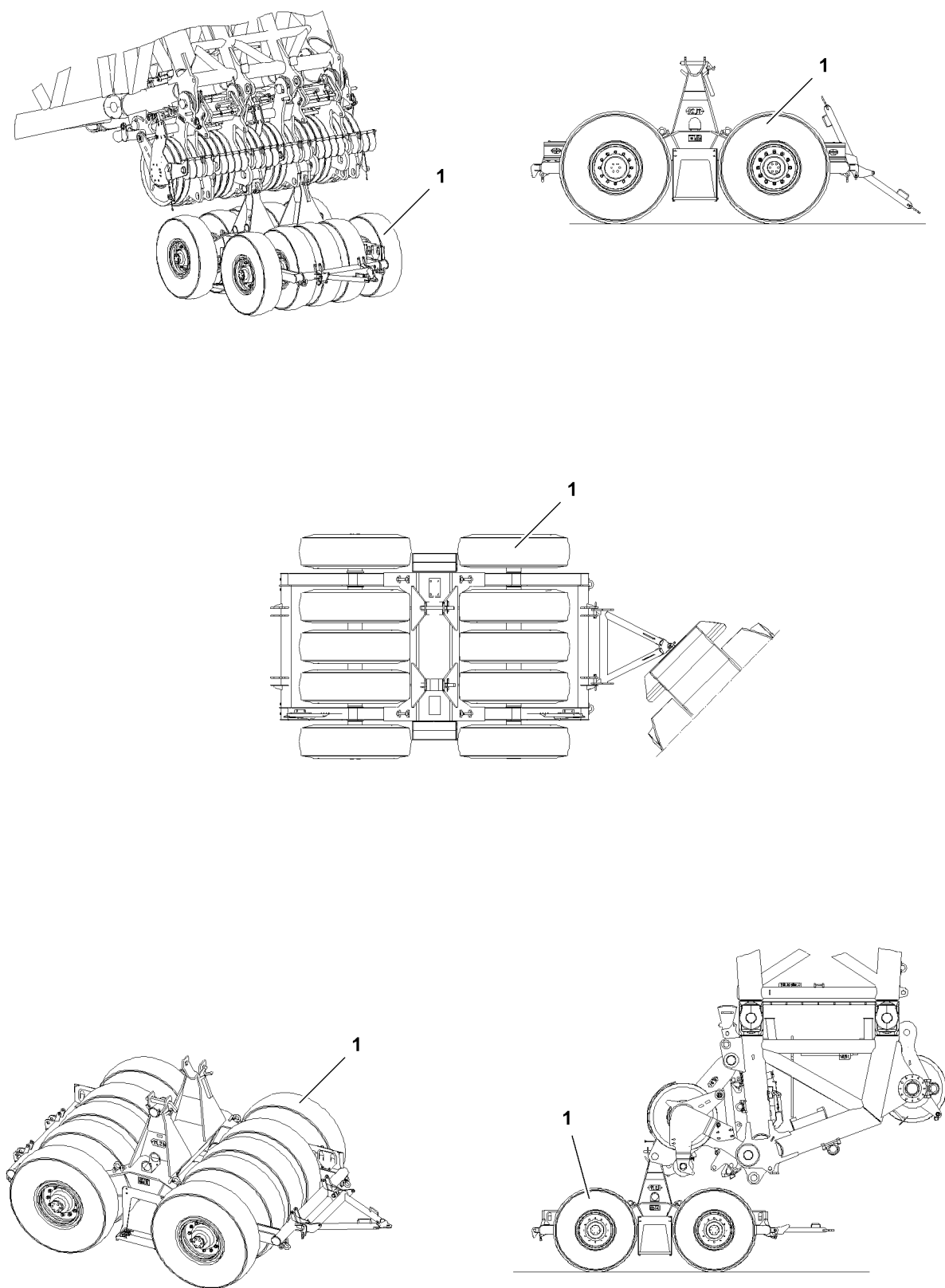

Fig.116302

LWE/LR 13000-001/19503-01-02/en

1 Pulley cart

**Note**

- ▶ The assembly, use and disassembly of the pulley cart **1** is described in the Crane operating instructions, chapter 5.07!

Empty page!

LWE/LR 13000-001/19503-01-02/en

5.62 Assembly shoes

1 Assembly shoes

3

LWE/LR 13000-001/19503-01-02/en

Fig.195219

LWE/LR 13000-001/19503-01-02/en

1 Assembly shoes

**Note**

- ▶ During assembly / disassembly of the S-boom system, the W-boom system and the P-boom system the assembly shoes **1** must be offset to avoid overload of the intermediate sections **3**.
- ▶ The change of the assembly shoes **1** is described on the example of the S-boom and is made the same way for boom assembly / disassembly of the P-boom system and the W-boom system.

**WARNING**

Incorrect position of the assembly shoes **1**!

If the assembly shoes **1** are not placed underneath in the permitted area of the intermediate sections **3**, then the intermediate sections **3** can be overloaded and damaged.

An accident can occur during crane operation due to a damaged or previously overloaded intermediate sections **3**.

Personnel can be severely injured or killed.

- ▶ Make sure that the assembly shoes **1** are placed underneath between the arrow marks **2**.
- ▶ The crane operator is responsible for the proper support of the assembly shoes **1** on the intermediate sections **3**.

1.1 Changing the assembly shoes at assembly

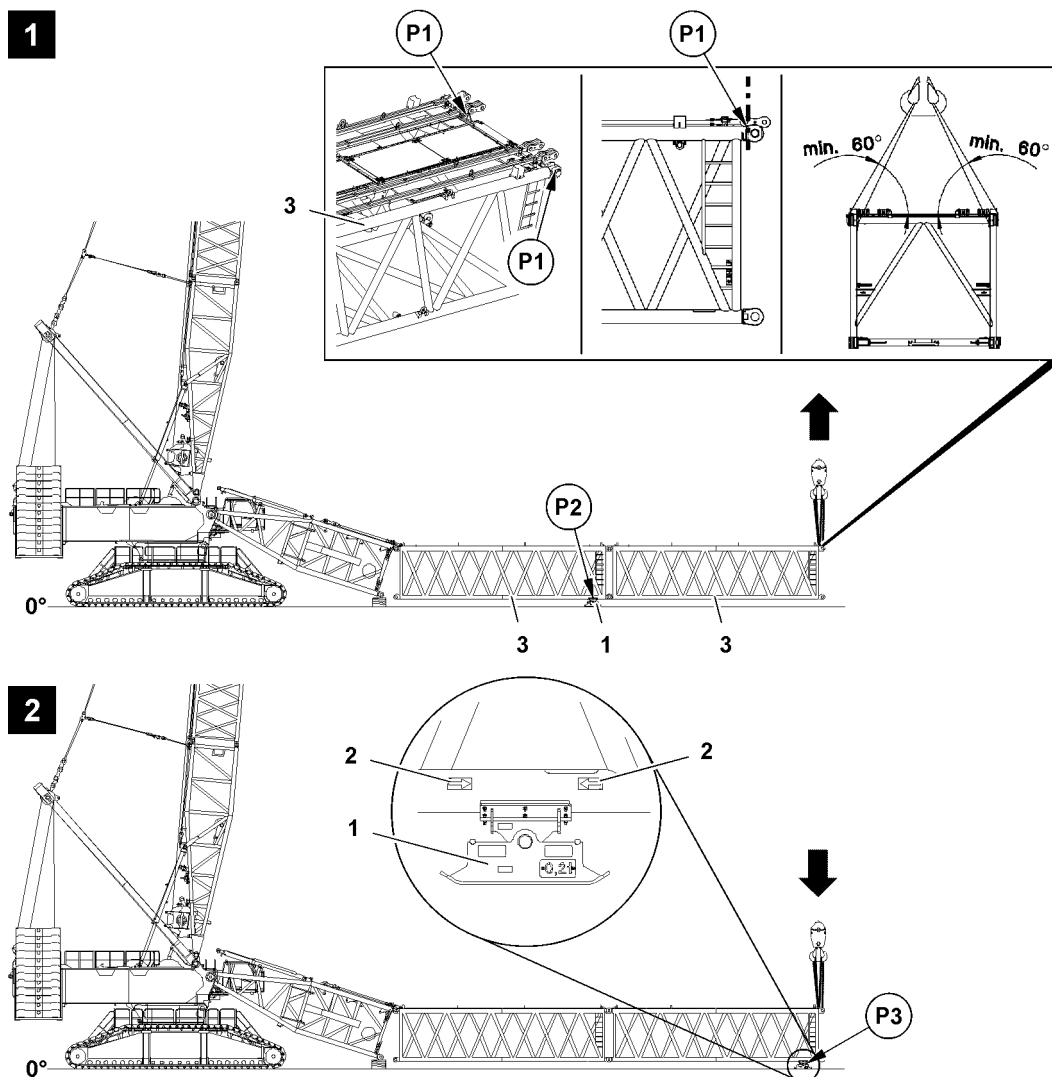

Fig.120304: Change the assembly shoes at assembly

Make sure that the following prerequisites are met:

- The respective intermediate section **3** is completely assembled.
- The fastening equipment has been removed.
- An auxiliary crane is available.



Note

- Changing the assembly shoes **1** is identical for each intermediate section **3**. The change procedure is described as an example for one intermediate section **3**.

- Fasten the intermediate section **3** on the points **P1**.



WARNING

Overload of lattice sections!

Personnel can be severely injured or killed.

Significant property damage can result.

If the lattice section leg is lifted higher than necessary, the lattice sections can be overloaded.

At a later point in time an accident can occur.

- Lift the lattice section leg only as high until the assembly shoes can be moved freely.
- Lift the lattice section leg with the auxiliary crane, see illustration **1**.

Result:

- The assembly shoes **1** on point **P2** are not subjected to a load and can be changed over.
- ▶ Remove the assembly shoes **1** on point **P2**, see illustration 1.
- ▶ Support the assembly shoes **1** on point **P3** so that they are between the arrow marks **2**, see illustration 2.
- ▶ Lower the lattice section leg with the auxiliary crane until the intermediate section **3** is properly laying on the assembly shoes **1**, see illustration 2.
- ▶ Repeat the procedure the same way for additional intermediate sections **3**.

1.2 Changing the assembly shoes at disassembly

Fig. 120305

Make sure that the following prerequisites are met:

- The respective intermediate section is laying on the assembly shoes.
- An auxiliary crane is available.

**Note**

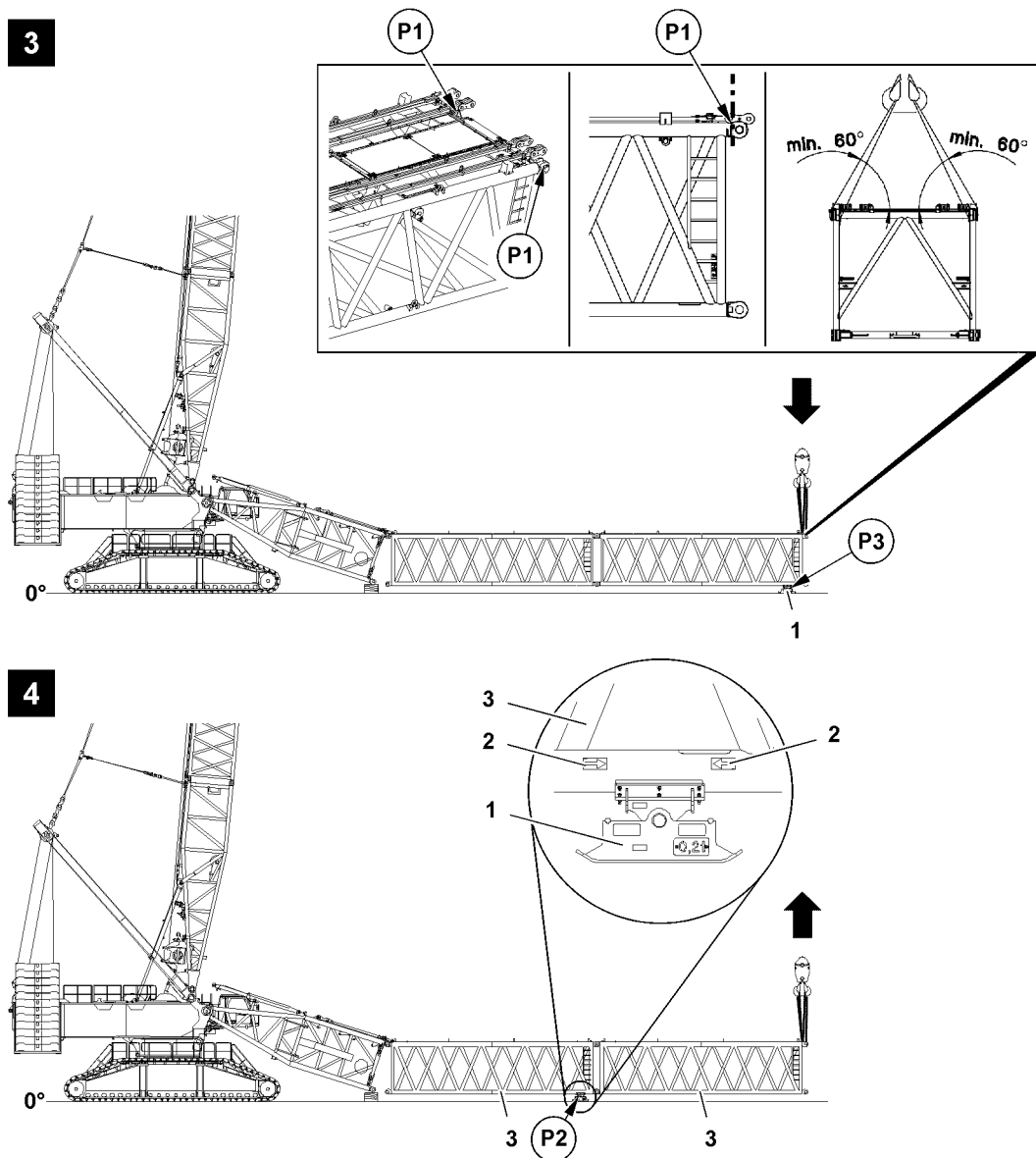
- ▶ Changing the assembly shoes **1** is identical for each intermediate section **3**. The change procedure is described as an example for one intermediate section **3**.

- ▶ Fasten the intermediate section **3** on the points **P1**.

**WARNING**

Overload of lattice sections!

Personnel can be severely injured or killed.

Significant property damage can result.

If the lattice section leg is lifted higher than necessary, the lattice sections can be overloaded.

At a later point in time an accident can occur.

- ▶ Lift the lattice section leg only as high until the assembly shoes can be moved freely.

- ▶ Lift the lattice section leg with the auxiliary crane, see illustration **3**.

Result:

- The assembly shoes **1** on point **P3** are not subjected to a load and can be changed over.

- ▶ Remove the assembly shoes **1** on point **P3**, see illustration **3**.
- ▶ Support the assembly shoes **1** on point **P2** so that they are between the arrow marks **2**, see illustration **4**.
- ▶ Lower the lattice section leg with the auxiliary crane.
- ▶ Remove the front intermediate section **3**.
- ▶ Repeat the procedure the same way for additional intermediate sections **3**.

6 Auxiliary equipment

LWE/LR 13000-001/19503-01-02/en

LWE/LR 13000-001/19503-01-02/en

6.02 Crane operator's cab heater / engine preheating / air conditioning system

1 Heating the crane cab

3

LWE/LR 13000-001/19503-01-02/en

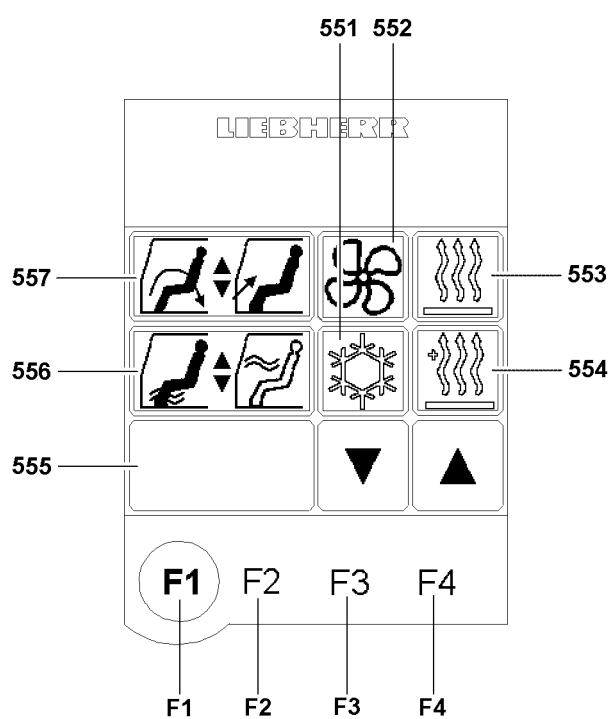

Fig.107379

1 Heating the crane cab

The cab can be heated with three independent types of heat:

- Engine-dependent heater.
- Engine-independent auxiliary heater with engine pre-heating, at ambient temperatures of up to -40 °C, WEBASTO; Thermo 90 ST*.
- Engine-independent auxiliary heater for cab preheating, at ambient temperatures of less than -40 °C, WEBASTO; DBW 2020*.

The individual heat adjustment (both for engine-dependent as well as the engine-independent auxiliary heater*) are made solely via the „Air conditioning settings“ menu on the touch display.

NOTICE

Risk of damage in the electrical / electronic component area when carrying out electrical welding work on the crane!

- ▶ Disconnect the negative and positive cables from the batteries and place the positive cable on the vehicle ground!
-

2 The „Air conditioning settings“ menu

2.1 General

The „Air conditioning settings“ menu is accessed - with the ignition turned on - by pressing the function key **F1** on the touch display.



Note

- ▶ The „Air conditioning settings“ menu is faded out automatically after 30 sec. if no settings are changed during this time.

If the crane ignition is turned off, the LICCON computer system as well as the touch display also turn themselves off. The settings made in the „Air conditioning settings“ menu are retained.



Note

- ▶ If the auxiliary heater has been programmed, the settings are saved when the ignition is turned „OFF“.
-

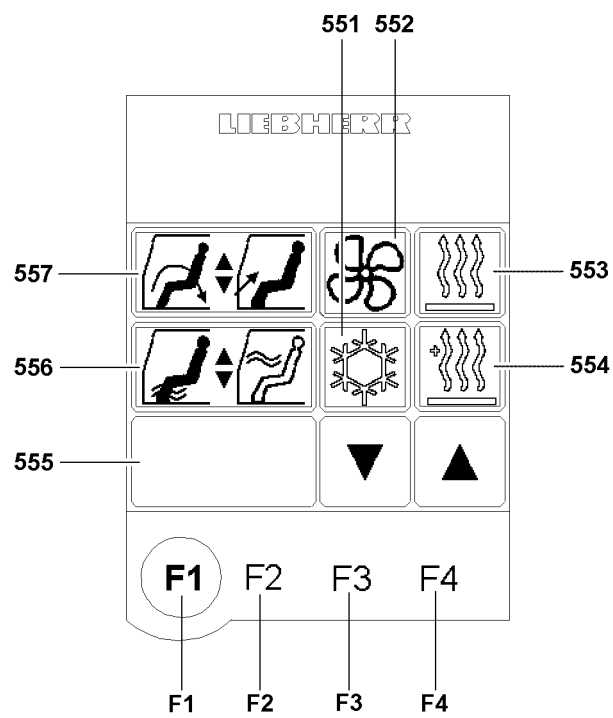

Fig.107379

2.2 Operating the touch display

On the touch display, all functions are available for making and operating all heating, ventilation and air conditioning settings and for programming the auxiliary heater on the crane:

- **557** Circulating air / fresh air
 - Function selection
- **556** Air distribution „upper“ / „lower“
 - Function selection
- **555** Status display
 - Display function

The status indicator **555** contains the following depending on the function that is selected:

- The adjustment rates between the head and floorboard area for circulating air / fresh air
- The adjustment rates for air distribution
- The temperature setting in manual heating mode
- The temperature setting in AUTOMATIC heating mode
- Air conditioning on - „ON“
- Air conditioning off - „OFF“
- The programming display for the auxiliary heater
- **551** Air conditioning system
 - Function selection
- **552** Fan / blower
 - Function selection
- **553** Heater
 - Function selection
- **554** Auxiliary heater
 - Function selection

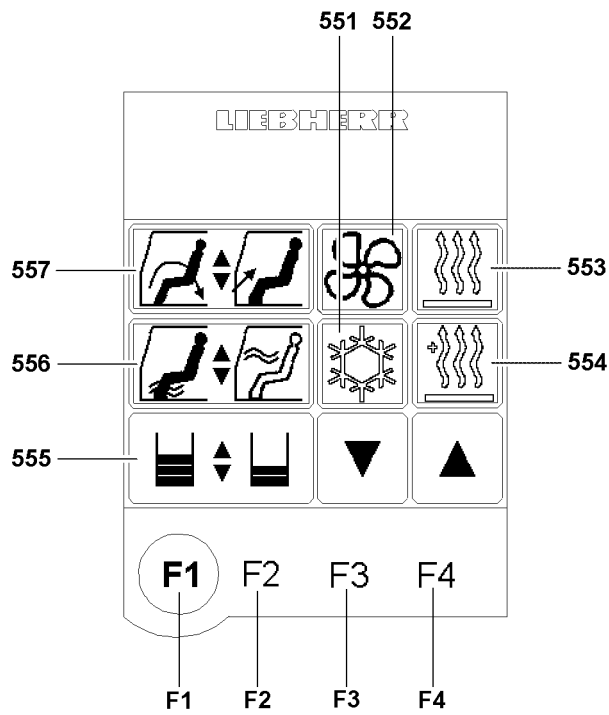

Fig.107380











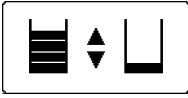

LWE/LR 13000-001/19503-01-02/en

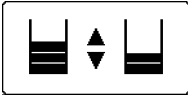
2.3 Adjusting the circulating air / fresh air

The „circulating air / fresh air“ function is selected by „touching“ the icon **557** on the left touch display.

The adjustment rate is displayed in the Status display **555** as a double bar display for „circulating air“ and „fresh air“.

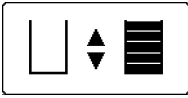
The adjustment rate between „circulating air / fresh air“ is changed with the function key **F3** and the function key **F4**.

Adjustment rates for circulating air / fresh air			
Status display	Circulating air	Fresh air	Icon display
	5	0	 <i>Fresh air „OFF“</i>
	4	1	
	3	2	
	2	3	
	1	4	
	0	5	 <i>Circulating air „OFF“</i>

- ▶ Select „circulating air / fresh air“ **557** function by „touching“.

Result:

- The „circulating air / fresh air“ icon is surrounded with a black border.
- The current adjustment rate is displayed in the Status display **555** as a double bar display for „circulating air“ and „fresh air“.

- ▶ Press the function key **F3**.

Result:

- The „proportion of circulating air“ is reduced and the „proportion of fresh air“ increases at the same time.

- ▶ Press the function key **F4**.

Result:

- The „proportion of fresh air“ is reduced and the „proportion of circulating air“ increases at the same time.

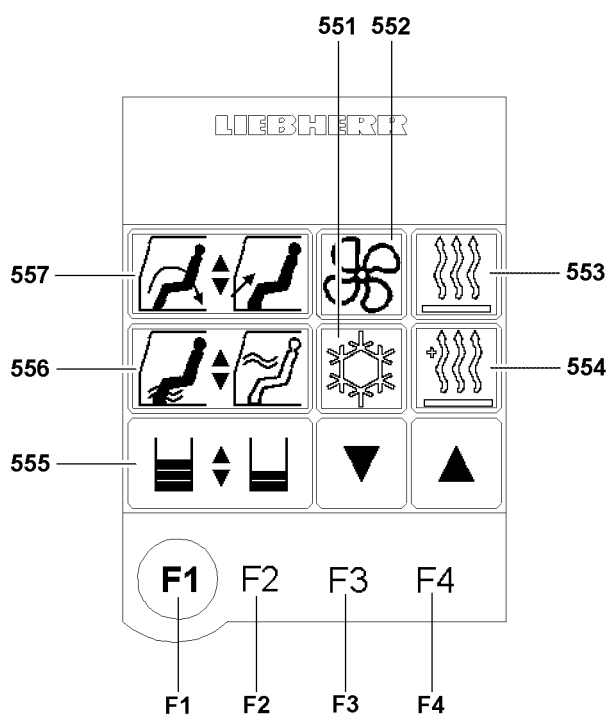

Fig.107380

2.4 Adjusting the „lower“ / „upper“ air distribution

The „lower“ / „upper“ air distribution function is selected by „touching“ the icon **556** on the left touch display.

The adjustment ratio is displayed in the Status display **555** - as a double bar display - for the „lower“ and „upper“ air distribution.

The „lower“ and „upper“ adjustment rate is changed with the function key **F3** and the function key **F4**.

Air distribution adjustment rates			
Status display	„lower“	„upper“	Icon display
	5	0	 <i>upper „OFF“</i>
	4	1	
	3	2	
	2	3	
	1	4	
	0	5	 <i>lower „OFF“</i>

- ▶ Select Air distribution „upper / lower“ **556** function by „touching“.

Result:

- The „lower / upper“ air distribution icon is surrounded with a black border.
- The current adjustment rate is displayed in the Status display **555** - as a double bar display - for „lower“ and „upper“.

- ▶ Press the function key **F3**.

Result:

- The proportion of „lower“ air is reduced; while the proportion of „upper“ air increases at the same time.

- ▶ Press the function key **F4**.

Result:

- The proportion of „upper air“ is reduced, while the proportion of „lower air“ increases at the same time.

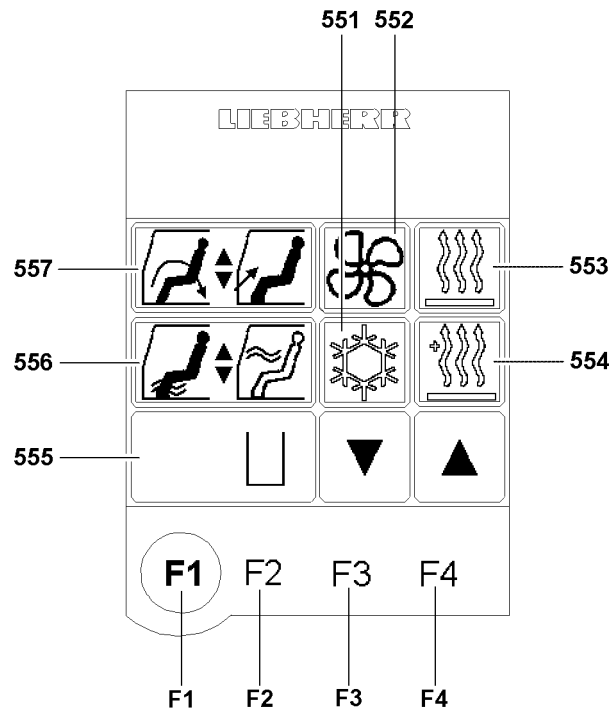

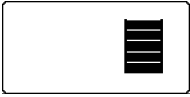

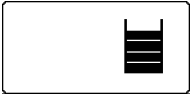

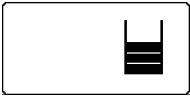







Fig.107381

2.5 Fan / blower adjustment

The „fan / blower“ function is selected by „touching“ the icon **552** on the left touch display.

The current „fan“ / „blower setting“ is shown as a bar display in the Status display **555**.

The „fan“ / „blower setting“ is reduced with the function key **F3** and increased with the function key **F4**.

„Fan“ / „blower setting“		
Status display	Stage	Icon display
	5	
	4	
	3	
	2	
	1	
	0	 <i>Fan „OFF“</i>

- ▶ Select „fan / blower **552**“ by „touching“.

Result:

- The „fan / blower“ icon is surrounded with a black border.
- In „fan“ / „blower stage“ appears as a bar display in the Status display **555**.

- ▶ Press the function key **F3**.

Result:

- The „fan“ / „blower stage“ is reduced.

- ▶ Press the function key **F4**.

Result:

- The „fan“ / „blower stage“ is increased.

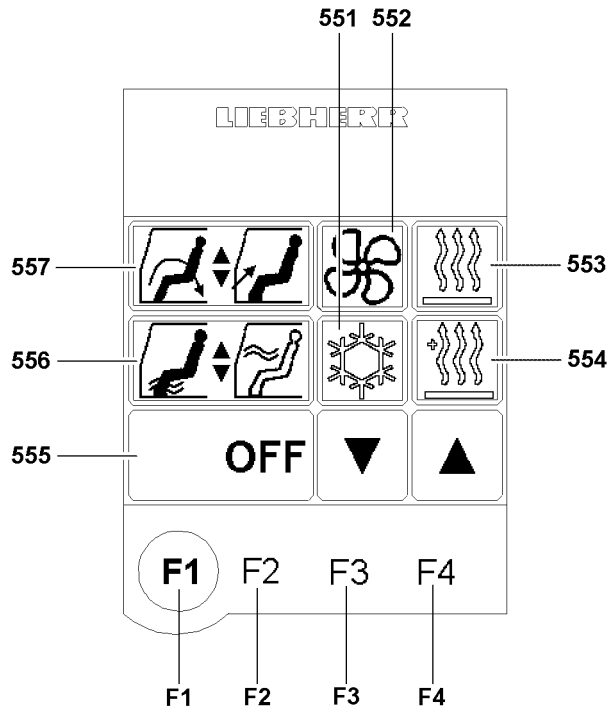

Fig.107382

LWE/LR 13000-001/19503-01-02/en

2.6 Operating the air conditioning system

The „Air conditioning system“ function is selected by „touching“ the icon **551** on the left touch display.





The status of the air conditioning system is displayed in the Status display **555**.

The „Air conditioning system“ is turned off with the function key **F3** („OFF“) and turned with the function key **F4** („ON“).



Note

- ▶ The air conditioning system turns itself on automatically if the „AUTO“ heating mode is activated.

Air conditioning system		
Status display	State	Icon display
	„OFF“	
	„ON“	

Make sure that the following preconditions are met before starting up the air conditioning system:

- The air intake opening for circulating air operation is clear.
- All windows and the cab door are closed.
- The circulating air / fresh air adjustment rate is 5:0.
- ▶ Select „Air conditioning system **551**“ function by „touching“.

Result:

- The „Air conditioning system“ icon is surrounded with a black border.
- The switch status of the air conditioning system appears in the status display **555**.

- ▶ Press the function key **F3**.

Result:

- The air conditioning system is turned off.

- ▶ Press the function key **F4**.

Result:

- The air conditioning system is turned on.
- ▶ Open or close the air vents as desired.
- ▶ Open the appropriate air vent for upward air distribution.
- ▶ Turn the fan / blower on.
- ▶ Select heater and change into „MANUAL“ heating mode.
- ▶ Set the temperature stage.
- or**
- ▶ Select heater and change into „AUTO“ heating mode.
- ▶ Set the temperature in [°C] or [°F].

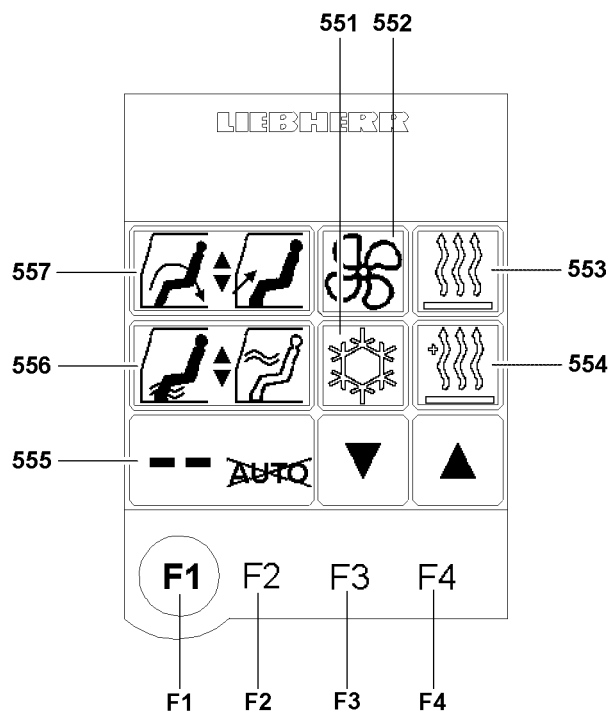

Fig.107383

LWE/LR 13000-001/19503-01-02/en

2.7 Turning the heater on

2.7.1 General

The „heater“ function is selected by „touching“ the icon **553** on the left touch display.

The heater status is displayed in the Status display **555**.

The temperature is regulated in „MANUAL“ heating mode via the function key **F3** („reduce“ temperature) and function key **F4** („increase“ temperature).

Function key **F2** is used to switch from „MANUAL“ heating mode to „AUTO“ heating mode and vice versa.

2.7.2 Manual heating mode

In „MANUAL“ heating mode, the temperature stages - from stage 1 to stage 16 - are available to the crane operator for temperature adjustment.







With the function key **F3**, the temperature stages can be reduced from stage 16 in increments until „heater OFF“.

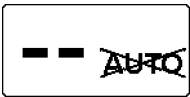

Note

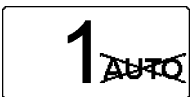
- ▶ If the status „heater OFF“ is reached, the heater does not operate.
- ▶ The crane cab is **not** heated.

Press the function key **F4** to leave the „OFF“ status and to increase the temperature stages incrementally from stage 1 to maximum stage 16.

Heating mode „MANUAL“			
Status display	State	Stage	Icon display
	„OFF“	--	 Heater „OFF“
	„ON“	1	
	„ON“	16	

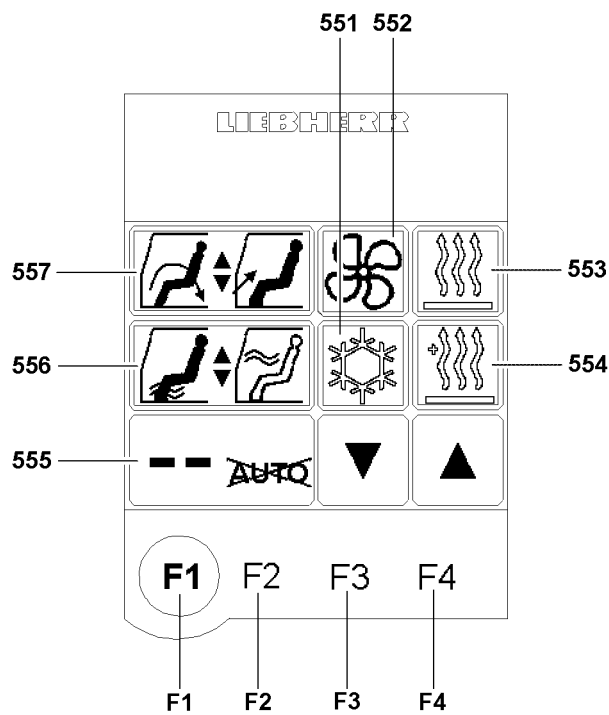

Fig.107383

LWE/LR 13000-001/19503-01-02/en

- ▶ Select „heater **553**“ function by „touching“.

Result:

- The „Heater“ icon is surrounded with a black border.
- In the status display **555** appears the current status of the „Heater“.

- ▶ Press the function key **F2**.

Result:

- Switch from heating mode „AUTO“ to heating mode „MANUAL“.

- ▶ Press the function key **F3**.

Result:

- The „temperature stages“ are reduced incrementally by one stage.
- The amount of heat supplied into the cab is reduced accordingly.

- ▶ Press the function key **F4**.

Result:

- The „temperature stages“ are increased incrementally by one stage.
- The amount of heat supplied into the cab is increased.

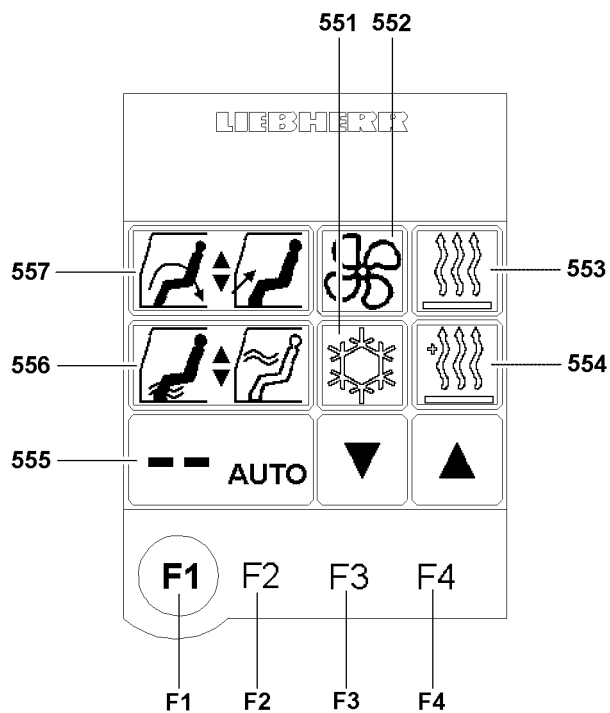

Fig.107401

2.7.3 AUTO heating mode

If heating mode „AUTO“ is selected, the air conditioning system is automatically enabled.



Note

- ▶ The blower / fan stage is automatically regulated in the „AUTO“ heating mode, whereby the maximum blower / fan stage is available, which was set before manually.

In „AUTO“ heating mode, the crane operator can adjust the temperature infinitely variable.







By pressing the function key **F3**, the temperature is reduced steplessly from maximum value to minimum value and if the function key **F3** is pressed again, the heater is turned off.

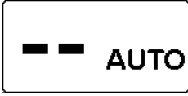

Note

- ▶ If a status „Heat OFF“ has been reached, the heater does **not** operate but the cab can continue to be cooled.
- ▶ The crane cab is **not** heated.

Leave the „OFF“ state by pressing the function key **F4** and the temperature can be increased infinitely variable from minimum value to maximum value.

Heating mode „AUTO“			
Status display	State	Temperature in [°C] or [°F]	Icon display
	„OFF“	—	 <i>Heater „OFF“</i>
 <i>Minimum value</i>	„ON“	15	
 <i>Maximum value</i>	„ON“	30	

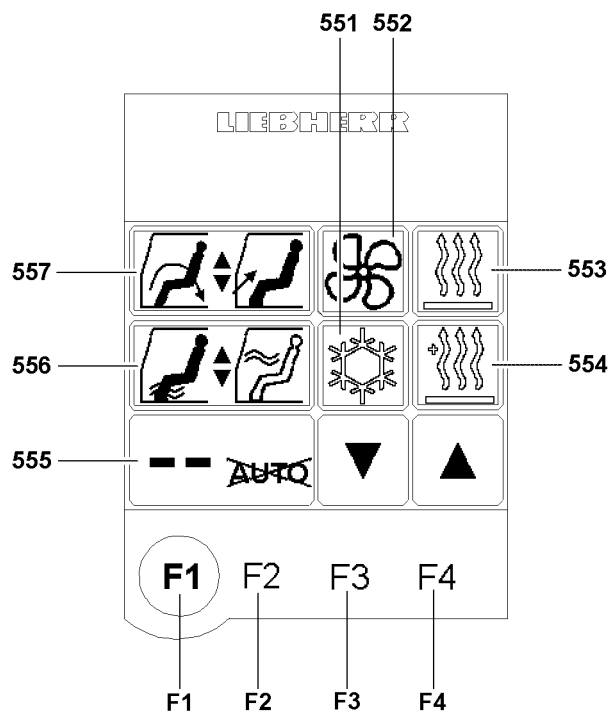

Fig.107383

LWE/LR 13000-001/19503-01-02/en

- ▶ Select „heater **553**“ function by „touching“.

Result:

- The „Heater“ icon is surrounded with a black border.
- In the status display **555** appears the current status of the „Heater“.

- ▶ Press the function key **F2**.

Result:

- Change from heating mode „MANUAL“ to heating mode „AUTO“.

- ▶ Press the function key **F3**.

Result:

- The „temperature setting“ is reduced in stages in steps of 1 °C.
- The amount of heat that is led to the cab is controlled according to the current temperature setting.

- ▶ Press the function key **F4**.

Result:

- The „temperature setting“ is increased in stages in steps of 1 °C.
- The amount of heat that is led to the cab is controlled according to the current temperature setting.

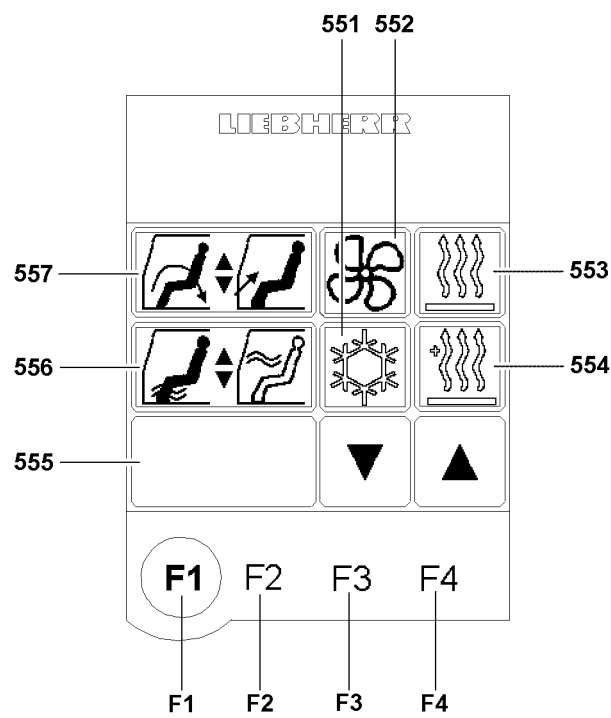

Fig.107379

LWE/LR 13000-001/19503-01-02/en

2.8 Procedure for fogged windows

2.8.1 General

A certain sequence of adjustments must be followed to clear the windows quickly in order to use the crane.

The settings can be made manually or semi-automatically.

2.8.2 Manual adjustments in the „Air conditioning settings“ menu

- ▶ Set air distribution **556** to maximum level „upwards“ - level 5.
- ▶ Open the air vents.
- ▶ Set circulating air **557** to maximum level - level 5.
- ▶ Set fan / blower **552** to maximum level - level 5.
- ▶ Set Air conditioning system **551** to „ON“.
- ▶ Set heater **553** to maximum possible level in „manual“ heating mode.
- ▶ If the crane engine is cold, add the auxiliary heater **554**, if required.

2.8.3 Making adjustments semi-automatically in the „Air conditioning settings“ menu

- ▶ Set heater **553** to „AUTO“ heating mode.
- ▶ Set air distribution **556** to maximum level „upwards“ - level 5.
- ▶ Open the air vents.
- ▶ If the crane engine is cold, add the auxiliary heater **554**, if required.



Note

- ▶ The other functions are automatically added by the system.
-

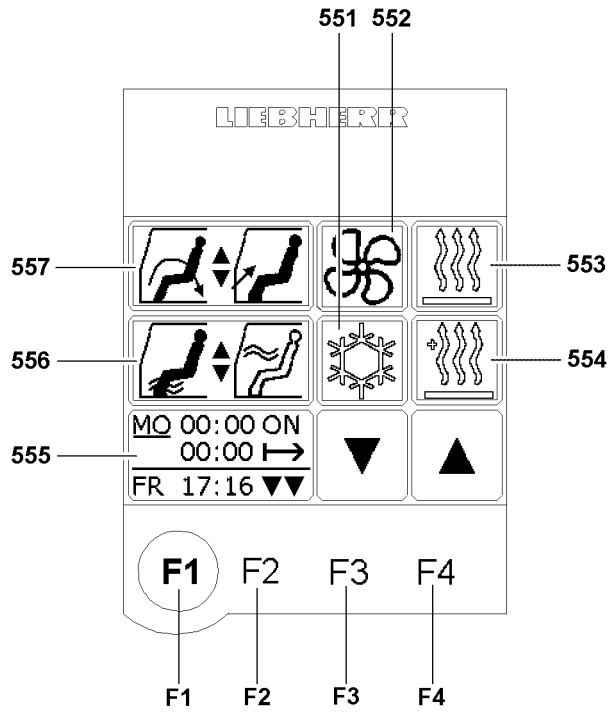

Fig.107385

LWE/LR 13000-001/19503-01-02/en

2.9 Operating the engine-independent auxiliary heater

The engine-independent auxiliary heater is used to heat the crane cab when the engine is turned off and to provide additional heat at low ambient temperatures if the engine-dependent heater is not sufficient.

At ambient temperatures of below $-20\text{ }^{\circ}\text{C}$, the crane engine must be pre-heated by the engine-independent auxiliary heater. In this case, the crane cab does not have to be heated too.



Note

- ▶ In summer, run the auxiliary heating once a month for approx. 15 to 20 minutes.

Carry out maintenance work on the auxiliary heater according to the supplied manufacturer's operating instructions.

2.9.1 General

NOTICE

Damage of auxiliary heater!

- ▶ Fill all units with sufficient service fluids for winter operation, as specified in the lubricant chart!



DANGER

Risk of poisoning and suffocation in enclosed areas!

- ▶ Operate the engine-independent auxiliary heater in enclosed areas such as garages or workshops only if a exhaust emission suction is present, even in „programming mode“.



DANGER

Risk of explosion!

In areas where combustible fumes or dust could form, such as in the vicinity of storage areas for fuel, coal, wood dust or grain storage or similar and in the vicinity of filling stations or tank depots, there is a risk of explosion.

- ▶ Turn the auxiliary heater off.

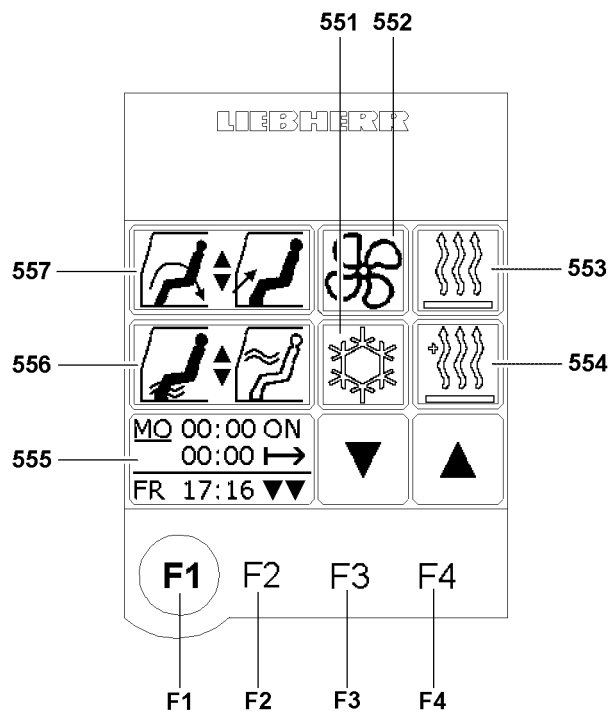

Fig.107385

2.9.2 Turning the engine-independent auxiliary heater on manually

The engine-independent auxiliary heater can be turned on manually in driving or crane operation. The auxiliary heater, icon **554**, must be selected and turned on.



If the auxiliary heater is in the „OFF“ state, pressing function key **F4** once adds the cab auxiliary heater.

Pressing the function key **F4** again turns engine preheating auxiliary heater on.



Note

- ▶ If the auxiliary heater is turned on for engine pre-heating, then the crane cab is **not** heated.

Manual auxiliary heater			
Status display	Function key F4	Function key F3	Icon display
<div style="border: 1px solid black; padding: 2px;"> MO 06:45 ON 00:30 → <hr/> FR 17:16 OFF </div>	▲ (F4)	---	 Auxiliary heater „OFF“
<div style="border: 1px solid black; padding: 2px;"> MO 06:45 ON 00:30 → <hr/> FR 17:16 ON </div>	▲ (F4)	▼ (F3)	 Auxiliary heater - cab „ON“
<div style="border: 1px solid black; padding: 2px;"> MO 06:45 ON 00:30 → <hr/> FR 17:16 ON[≈] </div>	▲ (F4)	▼ (F3)	 Auxiliary heater - engine pre-heating „ON“

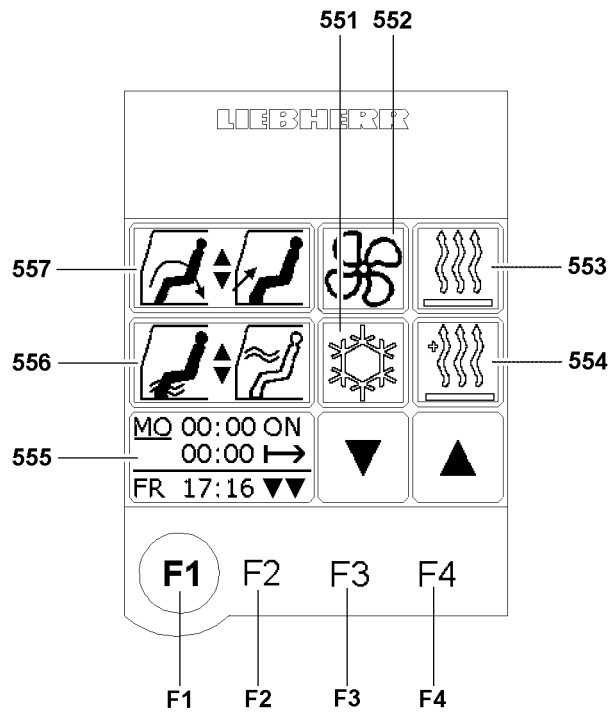

Fig.107385

LWE/LR 13000-001/19503-01-02/en

Adding the auxiliary heater

- ▶ Select heat **553** and set the required temperature via function key **F3** or function key **F4** (see section entitled „Turning the heater on“).



Note

- ▶ The temperature adjustment via function key **F3** or function key **F4** is only needed to heat the crane cab!
- ▶ Select auxiliary heater **554** and press function key **F3** or function key **F4** until the required setting is displayed in the status display **555** (see chart).

Result:

- The auxiliary heater is added.
- The crane cab or the engine is heated, depending on the setting.



Note

- ▶ When the crane cab is „warm“ and the engine is at the operating temperature, turn the auxiliary heater off.
- ▶ This increases the service life of the auxiliary heater!

Turning the auxiliary heater off

- ▶ Select auxiliary heater **554** and press the function key **F3** until the status display **555** shows the setting auxiliary heater „OFF“ (**OFF**).

Result:

- The auxiliary heater is turned off.
- An afterrun is carried out each time the auxiliary heater is turned off.
- ▶ Turn the battery master switch off if the crane is temporarily not being used.

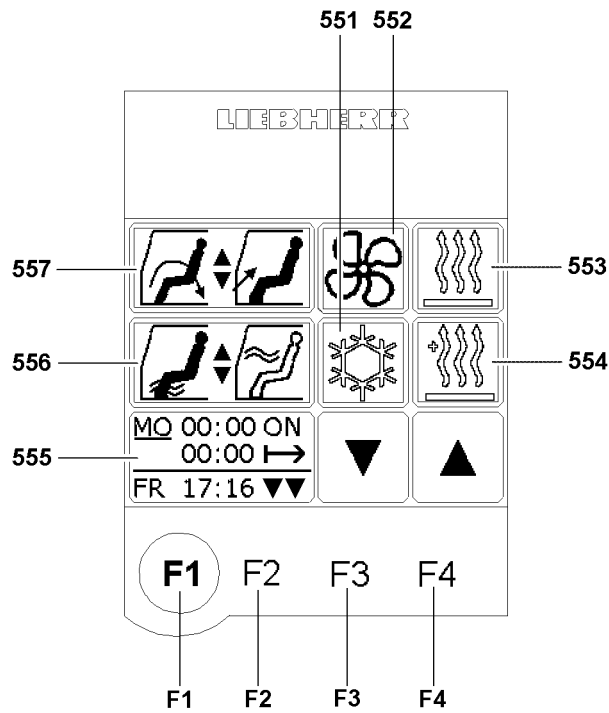

Fig.107385

LWE/LR 13000-001/19503-01-02/en

2.9.3 Turning the engine-independent auxiliary heater on in programming mode

The engine-independent auxiliary heater to heat the cab or to preheat the engine can be programmed a **maximum** of one week in advance.



Note

- It is advisable to restrict the auxiliary heater programming to two days, since there is a risk that the battery discharge extremely quickly at freezing temperatures.

Auxiliary heater programmed			
Status display	Function key F4	Function key F3	Icon display
		---	 Auxiliary heater „OFF“
			 Auxiliary heater - cab
	---		 Auxiliary heater - engine preheating

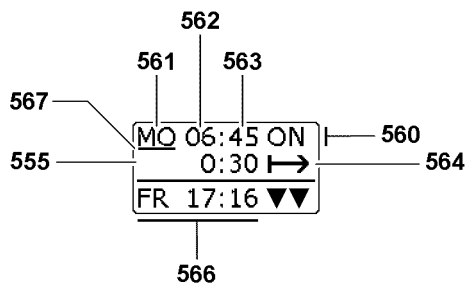
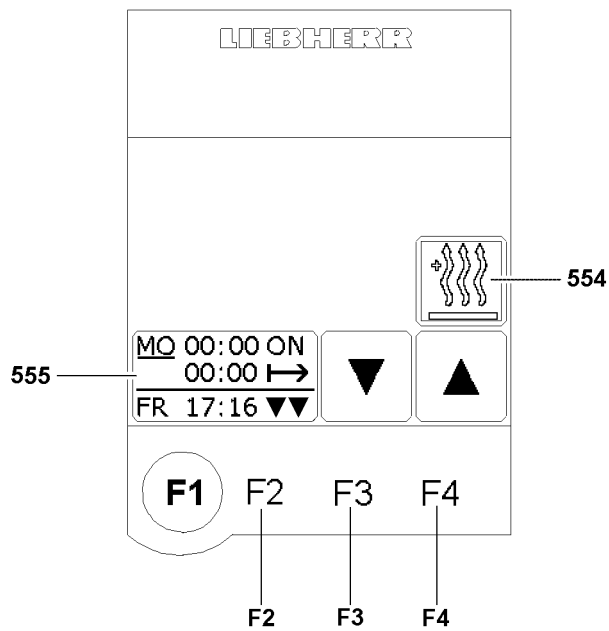
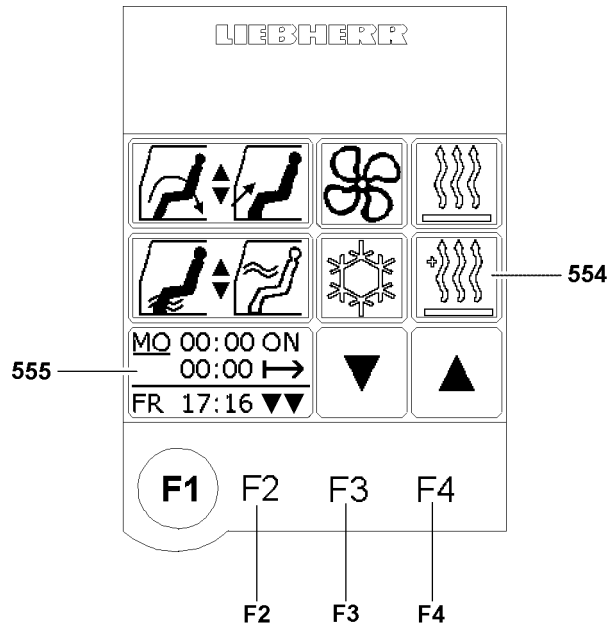

Fig.107384

LWE/LR 13000-001/19503-01-02/en

Programming the auxiliary heater

In order to access auxiliary heater programming mode, press the function key **F4** until the status display shows the „clock“ (programming mode for cab heater), or the „clock with wave“ (programming mode for engine preheating), fig. 1.

The status display **555** shows the current day of the week with the time **566**. The time in the status display **555** is coupled to the „real-time clock“ in the test system.



Note

- ▶ The procedure for programming the auxiliary heater - to heat the crane cab or to preheat the engine - is identical in both cases.

Make sure that the following preconditions are met **before** the auxiliary heater is programmed:

- The required temperature of the heater has been set.
 - The fan / blower is set to stage 0 („OFF“).
 - The required programming mode, cabin heater („clock“) or engine preheating („clock with wave“) has been selected.
- ▶ Press the function key **F2**.

Result:

- The auxiliary heater programming interface is displayed, fig. 2.
- In the status display **555** appears the cursor **567** under the modifiable input value.



Note

- ▶ The cursor **567** is positioned to day programming **560** by default.

- ▶ Press the function key **F4** and select the required day of the week **561** (**ascending** order).
- or**
- ▶ Press the function key **F3** and select the required day of the week **561** (**descending** order).

Result:

- The selected day of the week is „set“.
- ▶ Press the function key **F2**.

Result:

- The cursor **567** changes from day programming **561** to hour programming **560**.
- ▶ Press the function key **F4** and select the desired hour **562** (**ascending** order).
- or**
- ▶ Press the function key **F3** and select the desired hour **562** (**descending** order).

Result:

- The selected hour is „set“.
- ▶ Press the function key **F2**.

Result:

- The cursor **567** changes from hour programming **562** to minute programming **563**.
- ▶ Press the function key **F4** and select the desired minute **563** (**ascending** order).
- or**
- ▶ Press the function key **F3** and select the desired minute **563** (**descending** order).

Result:

- The selected minute is „set“.
- ▶ Press the function key **F2**.

Result:

- The cursor **567** changes from minute programming **563** to turn on duration **564**.
- ▶ Press the function key **F4** and select the desired turn on duration **564** (ascending).
or
Press the function key **F3** and select the desired turn on duration **564** (descending).

Result:

- The selected turn on duration **564** is „set“.

**Note**

- ▶ The turn on duration **564** of the auxiliary heater is restricted to a maximum of **0:55 minutes!**
- ▶ The cursor **567** automatically changes to the minutes setting for the turn on duration **564**.
- ▶ The turn on duration **564** can only be changed in 5 minute increments.

- ▶ Press the function key **F2**.

Result:

- The cursor **567** changes from turn on duration **564** to day programming **560**.
- The auxiliary heater programming is complete.
- ▶ Select the auxiliary heater **554** by „touching“.

Result:

- The programmed settings are taken over.
- The „Air conditioning settings“ menu is displayed.
- The auxiliary heater starts to operate when the programmed turn on time for heater operation is reached and turns the heater operation off again when the selected turn on duration has expired.
- In automatic regulation, the auxiliary heater operates according to the „manual“ or „AUTO“ heat setting.

**Note**

- ▶ The auxiliary heater programming must be manually reset to „zero“ after programmed heating has taken place. Otherwise, the auxiliary heater is automatically turned on according to the programming.

Resetting the auxiliary heater programming

To reset the auxiliary heater programming, proceed as described in „Programming the auxiliary heater“.

- ▶ Reset the values in the status display **555** to „zero“.

Result:

- The programming is turned off.

**Note**

- ▶ The programming can be modified manually or turned off altogether at any time.

2.10 Bleeding the heating system

When draining the engine coolant, the contents of the heating system will also be drained because the engine and heater operate as one circuit. When refilling the system, it should be carefully bled.

- ▶ Add coolant via the expansion tank of the engine cooling system according to the lubricant chart.
- ▶ Start the engine as described in Chapter 3.04.
- ▶ Set the heater to „warm“.
- ▶ Check the expansion tank for air bubbles.

Result:

- The engine is bled as soon as no more air bubbles rise.

When no more air bubbles rise in the expansion tank:

- ▶ Set the heater to „cold“.

Result:

- The heating circuit will be vented.
- ▶ Check the expansion tank for air bubbles.

Result:

- The heating circuit is vented as soon as no more air bubbles rise.

Empty page!

LWE/LR 13000-001/19503-01-02/en

6.50 Customer-specific special equipment

1 Load handling equipment LMZ- 1250 t

3

LWE/LR 13000-001/19503-01-02/en

Fig.195219

LWE/LR 13000-001/19503-01-02/en

1 Load handling equipment LMZ- 1250 t

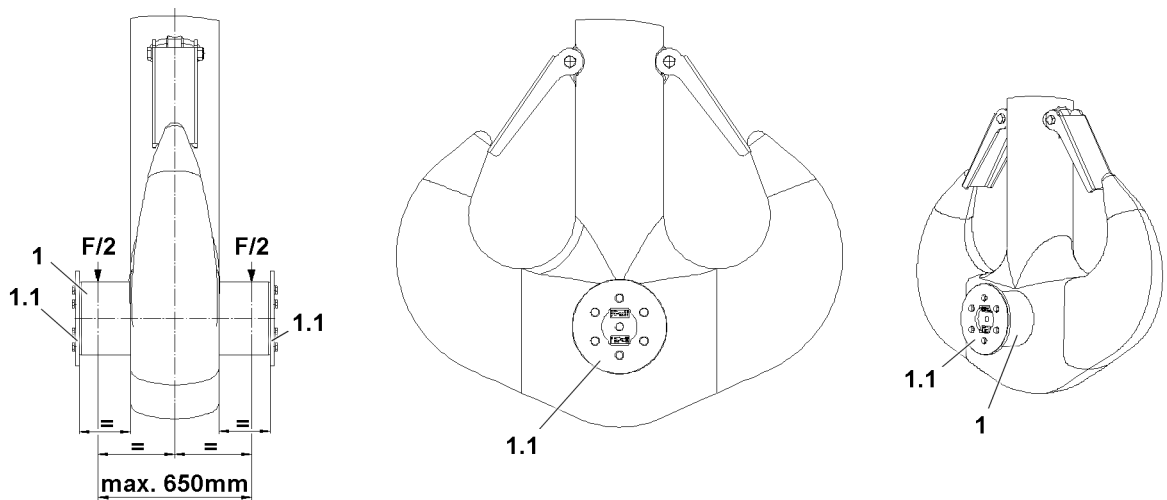

Fig.126001: Load handling equipment LMZ- 1250 t



WARNING

Falling down of the load!

If the load handling equipment **1** is not properly installed on the centric bore on the double hook, the load can fall down.

If the load handling equipment **1** is not aligned symmetrically with respect to the center of the hook, the load can fall down.

If the load is not fastened symmetrically on the load handling equipment **1**, the load handling equipment **1** can move, which overloads the load handling equipment **1**, and the load can fall down.

Death, severe bodily injuries, property damage.

- ▶ Make sure that the load handling equipment **1** is properly installed on the centric bore on the double hook.
- ▶ Make sure that the load handling equipment **1** is properly secured with the side covers **1.1**.
- ▶ Make sure that the load handling equipment **1** is aligned symmetrically with respect to the center of the hook.
- ▶ Make sure that the force transmission on the load handling equipment **1** always takes place symmetrically (respectively $F/2$) and at a permissible distance of **maximum** 650 mm.
- ▶ Make sure that the load handling equipment **1** cannot slip in the centric bore on the double hook under load.
- ▶ Make sure that the fastening equipment on the load handling equipment **1** cannot slip when under load.

Empty page!

LWE/LR 13000-001/19503-01-02/en

7 Maintenance and service

LWE/LR 13000-001/19503-01-02/en

LWE/LR 13000-001/19503-01-02/en

7.01 Maintenance and service - General

1	Safety	2
2	Warranty and coverage	7
3	Liebherr Customer Service	7
4	Taking an oil sample	8
5	Taking care of the crane	8
6	Storage	14
7	Recommendation for safe disposal	15

1 Safety



WARNING

Maintenance instructions **not** adhered to!

Death, severe injury, increased wear and failure of components.

- ▶ Observe the following listed safety instructions and the generally applicable safety rules.
- ▶ Adhere to the maintenance intervals.
- ▶ Carry out only applicable maintenance tasks.
- ▶ Repair and maintenance tasks are to be carried out carefully.
- ▶ For aggregates and components: Follow the operating instructions of the manufacturer.

1.1 Personnel



WARNING

Personnel requirements **not** adhered to!

Improper maintenance. Death, severe bodily injuries, property damage.

- ▶ Adhere to the areas of responsibility and personnel requirements.
- ▶ Comply with the personnel requirements within the scope of the respective maintenance tasks.
- ▶ Have the repair tasks performed exclusively by authorized and trained service personnel.
- ▶ Make sure that only authorized persons are in the danger zone.

The operator commissions maintenance personnel and authorized and trained service personnel according to the maintenance and inspection schedule.

1.1.1 Maintenance technician

The maintenance technician has the following responsibilities:

- The maintenance technician is responsible for the crane maintenance assigned to him according to the maintenance and inspection schedule and to guarantee safe and satisfactory operation. Maintenance personnel carries out all required maintenance work in compliance with the manufacturer's maintenance and inspection schedule and within the framework of a systematic procedure for creating a safe working environment.
- The maintenance technician shall have read and understood the operating instructions and the maintenance instructions.
- The maintenance technician wears the personal protective equipment necessary for the respective work procedure in accordance with the operating instructions and national regulations.
- The maintenance technician shall not make any alterations or repairs to the crane that exceed his technical knowledge (welding, for example) without consulting with the manufacturer and receiving written approval.
- The maintenance technician uses only original spare parts from Liebherr-Werk Ehingen GmbH.
- The maintenance technician contacts his supervisors when the information in the operating instructions or maintenance instructions is not sufficient.

1.1.2 Authorized and trained service technician

The service technician has the following responsibilities:

- He is responsible for carrying out the assigned crane maintenance and repairs to guarantee safe and satisfactory operation. The technician carries out all required maintenance work in compliance with the manufacturer's maintenance and inspection schedule and within the framework of a systematic procedure for creating a safe working environment.
- The technician wears the personal protective equipment necessary for the respective work procedure in accordance with the operating instructions and national regulations.
- The technician only carries out work for which he was authorized and trained to carry out by Liebherr-Werk Ehingen GmbH or a Liebherr service point.

1.2 Description of intervals and tasks



Note

- ▶ Fill quantities and designations of service fluids and lubricants are specified in the Service fill.

The maintenance intervals and scope of maintenance are described in several chapters.

For crane maintenance, observe the following chapters:

- Crane operating instructions, chapter 7.02: Maintenance intervals - Crane chassis ¹⁾
- Crane operating instructions, chapter 7.02.50: Maintenance intervals Ballast trailer*¹⁾
- Crane operating instructions, chapter 7.03: Maintenance intervals - Crane superstructure ¹⁾
- Crane operating instructions, chapter 7.03.50: Maintenance intervals - Crane boom ¹⁾
- Crane operating instructions, chapter 7.04: Maintenance instructions - Crane chassis ²⁾
- Crane operating instructions, chapter 7.04.50: Ballast trailer maintenance instructions ²⁾
- Crane operating instructions, chapter 7.05: Maintenance instructions - Crane superstructure ²⁾
- Crane operating instructions, chapter 7.05.50: Crane boom maintenance instructions ²⁾
- Crane operating instructions, chapter 7.06: Fill quantities, lubrication plan
- Crane operating instructions, chapter 7.07: Service fluids and lubricants

¹⁾ These chapters contain a list of maintenance intervals for all maintenance tasks.

²⁾ For aggregates, observe and adhere additionally to the instructions of the manufacturer.

1.3 Maintenance intervals

Use the following rules for interval determination:

- Carry out maintenance and inspection tasks on the crane chassis after reaching the specified driven mileage, operating hours or calendar intervals. The interval that occurs first is the deciding factor.
- Carry out maintenance and inspection tasks on the crane superstructure after reaching the specified operating hours or calendar intervals. The interval that occurs first is the deciding factor.
- The maintenance intervals complement each other. If a higher interval is coming up, then carry out the tasks according to the lower interval also.

1.4 Securing against start up



WARNING

Impermissible travel or crane operation during maintenance or repair tasks!

Death, severe injury, severe property damage.

- ▶ Make sure that travel and crane operation is not possible during maintenance and repair tasks.
- ▶ Show clearly with signs that maintenance or repair tasks are being carried out on the mobile crane.
- ▶ Use signs which show without a doubt that it travel operation and crane operation are prohibited.
- ▶ Adhere to the national regulations regarding tagging on mobile crane and signs.
- ▶ Turn the engine on the crane superstructure and the crane chassis off.
- ▶ Apply the „parking brake crane chassis“.

If possible:

- ▶ Lock the driver's cab and the crane cab.
- ▶ Hand the ignition key from the crane superstructure and the crane chassis to an authorized person.

1.5 Securing against falls



WARNING

Personnel is **not** secured against falls!

During maintenance tasks on the crane superstructure or boom, personnel must be secured with appropriate safety measures to prevent them from falling. If this is **not** observed, working personnel can fall and be killed or severely injured.

- ▶ For all tasks on the crane where there is a danger of falling, take suitable safety measures.
- ▶ The crane superstructure or the boom may **not** be accessed without suitable aids.
- ▶ Suitable aids are, for example: Lifting platforms, scaffoldings, ladders, assembly platforms, auxiliary crane.
- ▶ If railings are present on the crane superstructure, then they must be swung into operating position and secured for all tasks. See the Crane operating instructions, chapter 2.06.
- ▶ Only step on such aids with clean shoes.
- ▶ Keep aids clean, free of snow and ice.
- ▶ If tasks cannot be carried out using these aids or from the ground, then the maintenance personnel must be protected from falling using approved fall arrest systems. See the Crane operating instructions, chapter 2.04.
- ▶ It is prohibited to step on the driver's cab or cab roof and specially marked surfaces. See the Crane operating instructions, chapter 2.05



WARNING

Dirty slip-resistant mats!

Fall

- ▶ Keep slip-resistant mats clean and free of snow and ice!
- ▶ Only step on slip-resistant mats with clean shoes!
- ▶ Replace or renew missing or damaged slip-resistant mats!

1.6 Preventing fires



WARNING

Excess fuel, excess oil in engine compartment during operation!

Death, severe injury, fire damage.

- ▶ Check the diesel engine after repairs and Service tasks but also in regular intervals for leaking oil and fuel.
- ▶ Fix the leaks. Replace damaged components.
- ▶ Do **not** spill service fluids.



WARNING

Disregard of general safety regulations during tasks on the fuel system or on the electrical system!

Severe burns, fire damage.

- ▶ Disconnect the battery from the power supply.
- ▶ Do **not** smoke.
- ▶ Do **not** work near open flames.
- ▶ Keep a functioning fire extinguisher ready.

**WARNING**

Sound insulation mats are contaminated with fuel, engine oil, gear oil, hydraulic oil or solvents!
The sound insulation mats can ignite. Severe burns, fire damage.

- ▶ Remove any polluted sound insulation mats **immediately** and **replace immediately** with **Original Liebherr spare parts**.

If there are sound insulation mats in the chassis near the starter:

- ▶ **Immediately remove** any sound insulation mats located in an area of 0.5 m around the starter and **do not replace them**

If there are sound insulation mats in the superstructure in the engine compartment flap:

- ▶ **Immediately remove** the sound insulation mats and **do not replace them**.
- ▶ Also observe and adhere to the section „Sound insulation mats“.

1.7 Protecting against burns

**WARNING**

Hot surfaces!
Severe burns.

- ▶ Let any components to be maintained or inspected cool off.
- ▶ Let hot components cool off.
- ▶ Avoid contact with hands and skin.
- ▶ Wear personal protective equipment and suitable protective gloves.

**WARNING**

Hot service fluids!
Severe burns.

- ▶ Let hot service fluids cool off.
- ▶ Avoid contact with hands, skin and eyes.
- ▶ Wear safety goggles.
- ▶ Wear personal protective equipment and suitable protective gloves.

**WARNING**

Electric short circuit!
Severe burns.

- ▶ Prevent short circuits in the electrical system, especially on the battery.
- ▶ Replace or change missing or defective protective insulation.

1.8 Protecting from scalding

**WARNING**

The cooling system is pressurized!
When the coolant reservoir is opened, hot coolant can escape explosively.
Severe scalding.

When the engine is warm:

- ▶ Do **not** open the cover of the coolant reservoir.
- ▶ To protect face, hands and arms from hot steam of hot coolant, cover the cap with a large rag when opening.

1.9 Rotating parts



WARNING

Rotating parts, ignition system on running engine!
The cooler fan can turn on suddenly.
Death, severe injury.

- ▶ Proceed especially careful.
- ▶ Do **not** reach into rotating parts.
- ▶ Never reach into the cooler fan when the engine is hot.

1.10 Using permissible service fluids

NOTICE

Impermissible service fluid added!
Destruction of components. Failure of the crane.

- ▶ Only add the service fluid that is specified on the sign on the respective service fluid container.
- ▶ Keep the service fluid absolutely pure.

1.11 Protecting against the hazards of service fluids



WARNING

Contact with service fluids!
Health risk.

- ▶ Make sure that personnel are aware of first aid measures.
- ▶ Use personal protective equipment depending on the service fluid.
- ▶ Observe and adhere to the safety data sheets of the service fluid manufacturer.



WARNING

Impermissible handling of service fluids!
Environmental risk.

- ▶ Make sure that the service fluids are **not** released in the environment.
- ▶ Immediately collect spilled service fluids using suitable material.
- ▶ Observe and adhere to the safety data sheets of the service fluid manufacturer.

1.12 Replacing damaged crane components



WARNING

Damaged crane components **not** replaced!
Death, severe injury, failure of components.

- ▶ Service the crane components according to the data in the maintenance intervals, the maintenance guidelines and the chart for service fluids and lubricants.
- ▶ Replace damaged crane components immediately.

1.13 After replacement of components

Type of oil, see data tag and supplied „Service fill“.

The following instructions must be observed when replacing components such as the engine, transmission or axle:

**WARNING**

Maintenance of a replaced component **not** carried out!

- ▶ Before start up, be sure to refill with the correct type of oil to the center of the minimum / maximum mark.
- ▶ Carry out first maintenance. See chapter „Maintenance intervals“.
- ▶ Adhere to regular maintenance intervals.
- ▶ Follow the break-in instructions. See the Crane operating instructions, chapter 2.02.

1.14 Tire size

When changing certain tire sizes, the mobile crane must be modified.

Contact Liebherr customer service to change the following tire sizes:

- From 385/95 R 25 to 445/95 R 25
- From 385/95 R 25 to 525/80 R 25
- From 445/95 R 25 to 385/95 R 25
- From 525/80 R 25 to 385/95 R 25

2 Warranty and coverage

NOTICE

Maintenance intervals and maintenance guidelines **not** adhered to, impermissible lubricants used!
Damage, failure of crane components.

The warranty for the respective crane component is voided.

- ▶ Service the crane components according to the data in the maintenance intervals, the maintenance guidelines and the chart for service fluids and lubricants.

NOTICE

Use of **non**-original Liebherr spare parts and **non**-original Liebherr service fluids!

In the event that replacement parts are used that are **not** original Liebherr replacement parts and **not** original Liebherr service fluids and lubricants, Liebherr-Werk Ehingen GmbH excludes all liability for system functionality as well as for the parts.

- ▶ Use only original Liebherr spare parts.

**Note**

- ▶ Original Liebherr replacement parts have been tested for crane operation and may be used without risking safety.

The buyer is entitled to warranty or coverage only:

- When only original Liebherr spare parts are used.
- When Liebherr service fluids and Liebherr lubricants are used for the Liebherr crane.

3 Liebherr Customer Service

Liebherr mobile cranes, whether truck-mounted, mobile or crawler cranes - are technically advanced products, which prove their worth daily even under tough conditions.

The high technical standards of these cranes provide functional security, resistance to failure and ease of maintenance.

Liebherr is continuously developing the drive and control components. The combination of well proven units and modern manufacturing methods produces cranes that are safe to operate and easy to maintain.

Several hundred cranes are built every year for the international market, supported by international service.

Liebherr's „After Sales Service“ plays an important role at Liebherr in ensuring operational readiness and high crane availability.

With Liebherr, Service begins when the crane is handed over. Your crane operators will be professionally trained in line with their level of knowledge and we devote much time to this.

We also train your workshop staff in all crane-specific matters, because we know that they can deal with more than just minor repairs themselves. Often there are specialists who can quickly and reliably carry out crane repairs.

We have special service advisers available who will solve any problems you may have. This phone contact saves time and money. You should take advantage of it as soon as possible.

Our service technicians are specialists with years of experience, who can be deployed from local support points. Naturally these experts have specialized knowledge and special tools.

But before you call these specialists, it is worth making use of the facilities for getting advice mentioned above.

4 Taking an oil sample



Note

- ▶ Liebherr recommends taking oil samples for the gears, engines and hydraulic system in regular intervals.
- ▶ Based on the trend analysis of the oil analysis results, changes can be determined in the lubricity of the oil and increased component wear.



WARNING

Tasks on components and operating fluids at operating temperature!

Burns.

- ▶ Carry out all tasks with utmost caution.
- ▶ Wear protective clothing.

Make sure that the following prerequisites are met:

- Oil has a normal operating temperature.
- ▶ Always take oil in the same location.
- ▶ Take oil always according to the same method.
- ▶ Do **not** take oil right after an oil change.
- ▶ Do **not** take oil immediately after larger amounts of oil have been added.



Note

Recommendation:

- ▶ Fill oil into original laboratory sample containers.
- ▶ Fill oil exclusively in a clean and dry sample container.

5 Taking care of the crane

5.1 Washing the crane

In order to ensure a consistent surface quality, the crane must be washed regularly. See the maintenance intervals, chapter 7.02, chapter 7.03, chapter 7.03.50. Clean the crane in particular after contact with highly corrosive materials or highly adherent contaminants.

Highly adherent contaminants are:

- Residual road salt
- Oils, grease and fuel
- Insect remains
- Rust film
- Tar splashes, concrete splatter

Check the crane for corrosion and paint damage. See the maintenance intervals, chapter 7.02, chapter 7.03chapter 7.03.50. If detected, have corrosion and paint damage removed by authorized and trained service personnel.

NOTICE

Impermissible cleaning agent!
Damage to the surface.

- ▶ Do not use aggressive cleaning agents.
- ▶ Do not use scouring cleaning agents.
- ▶ Do not use a phosphate based cleaner.
- ▶ Do not solvents or cleaning agents that contain solvents.
- ▶ Only use cleaning agents with a pH value that is less than / equal to 12.
- ▶ Make sure that the cleaning agent and water ratio of 3% is not exceeded.
- ▶ Rinse with clear water (not salt water).

Make sure that the following prerequisites are met:

- The crane is switched off and secured against unauthorized start up.
- The crane has cooled down.
- The battery master switch is turned off.

5.1.1 High pressure cleaner

The water jet of a circular jet nozzle can cause damage to the tires or parts of the travel gear that cannot be seen exteriorly.

NOTICE

High pressure cleaner with circular jet nozzle used!
Damaged components could fail unexpectedly.

- ▶ Do not use a high pressure cleaner with a circular jet nozzle.
- ▶ Replace damaged components.



CAUTION

Hot steam and water pressure!
Burns.

- ▶ Wear personal protective equipment.

Do **not** expose the following components to a water jet:

- Inside of the driver's cab and cab
- Electric motor
- Electrical plug connections, line drums and power distributor
- Control units
- Transmitter
- Relay circuit boards and fuse circuit boards
- Hydraulic block
- Intake manifolds for combustion air
- Seals
- Bellows
- Gear shafts
- Retracted sliding beams
- Sealing lips on slewing ring connections
- Radial shaft sealing rings on winches
- Slewing gears

- Hoist rope, control rope, assembly rope
- Piston rods
- Slip-resistant mats
- Signs
- Overflow container on the equipment
- Generator
- Lighting
- Wind speed sensor / airplane warning light
- Bearing on the rope pulleys
- Carrier rollers
- Swivel joints
- Pin points
- Head camera inclusive of the transmitter and receiver unit
- Hand pump on the folding jib

The crane can be cleaned with the high pressure cleaner. The water pressure, minimum distance and water temperature are specified in the following chart:

Washing painted surfaces		
Water pressure	Minimum distance	Water temperature
maximum 150 bar	30 cm to 40 cm	60 °C

Adjusting the high pressure cleaner

Washing surfaces covered with film		
Water pressure	Minimum distance	Water temperature
maximum 150 bar	80 cm	60 °C

Adjusting the high pressure cleaner

Washing surfaces protected against corrosion with Carlofon 81		
Water pressure	Minimum distance	Water temperature
maximum 30 bar	30 cm to 40 cm	40 °C

Adjusting the high pressure cleaner

Clean electrical systems, cables, cable harnesses and sound insulation mats with low pressure.

- ▶ Before cleaning, cover all openings.
- ▶ Wash the crane and equipment with a high pressure cleaner.
- ▶ Lubricate the crane and equipment.



Note

Environmental pollution!

- ▶ Dispose of auxiliary and cleaning materials contaminated with oil according to national and international regulations and directives.
- ▶ Only direct cleaning water through the oil separator of the drainage system.

5.1.2 Exhaust system

NOTICE

Ingress of water, steam or cleaning substances into the AGN-module!

Sensors and electrics for the exhaust aftertreatment can be destroyed, the coating of the catalytic converter can be washed off.

- ▶ Before cleaning, let the AGN system cool down (surface temperature 50 °C).
- ▶ Before cleaning, cover all openings.
- ▶ Make sure that **no** fluids and **no** dirt gets into the tailpipe opening of the AGN module.
- ▶ During cleaning, maintain a sufficient distance from the tailpipe opening.

5.1.3 Sound insulation mats

NOTICE

Improper cleaning (tools or cleaning methods)!

Sound insulation mats can be destroyed or damaged.

- ▶ Remove severe contamination with suitable tools, for example with soft plastic scrapers.
- ▶ Do **not** use tools with sharp edges.
- ▶ Use high pressure cleaners **exclusively** with extreme caution and with a sufficient distance to the sound insulation mats and with low water pressure.
- ▶ Do **not** use solvents for cleaning.

If sound insulation mats are contaminated with fuel, engine oil, gear oil, hydraulic oil or solvents:

- ▶ Observe and adhere to the section „Preventing fires“.

5.1.4 Slip-resistant mats



WARNING

Heavily worn slip-resistant mats!

People can slip and fall down from the crane.

- ▶ Replace heavily worn slip-resistant mats.
 - ▶ Do **not** wax slip-resistant mats.
-
- ▶ Before every access: Check the slip-resistant mats for slip resistance and cleanliness.
 - ▶ If dirty: Clean the slip-resistant mats with a brush with hard plastic bristles.
 - ▶ For cleaning the surfaces, use commercially available cleaners.
 - ▶ Flush with water.

5.1.5 Driver's cab and crane cab



Note

- ▶ The steering wheel, center console, instrument panel cover, floor covering and dirty upholstery in the driver's cab and the crane cab should only be cleaned with warm water mixed with dishwashing detergent.
- ▶ Keep the driver's cab and crane cab free from trash.

5.1.6 Ladders

- ▶ Remove any dirt on the ladders.
- ▶ Make sure that the grooves on the rungs are free of dirt.

5.2 Protecting the crane against corrosion

NOTICE

Aggressive environmental conditions!
Crane components can corrode and be damaged.
▶ Protecting the crane against corrosion

The corrosion protection agent **Carlofon 81** must be reapplied regularly according to wear. See the maintenance intervals, chapter 7.02, chapter 7.03 chapter 7.03.50.

The corrosion protection agent **Metacorin 822** must be reapplied regularly according to wear on the mechanically machined, blank surfaces. See the maintenance intervals, chapter 7.02, chapter 7.03 chapter 7.03.50.

The corrosion protection agent **Liebherr Cylinder Protect** must be reapplied regularly on the chrome-plated piston rods. See the maintenance intervals, chapter 7.02, chapter 7.03 chapter 7.03.50.



WARNING

Improper corrosion protection!
Injury to the respiratory system, suffocation.
▶ Wear a respirator mask.

NOTICE

Improper corrosion protection!
Damage to the crane.

- ▶ Make sure that crane corrosion protection is carried out only by authorized and trained service personnel.
- ▶ Make sure that the inspection and reconditioning intervals are not exceeded.

Make sure that the following prerequisites are met:

- A sufficient quantity of corrosion protection agent is available.
- Appropriate tools and aids are available.
- The crane is switched off and secured against unauthorized start up.
- The crane has cooled down.
- The battery master switch is turned off.
- Protective equipment is worn.

5.2.1 Crane

- ▶ Wash the crane thoroughly with a high pressure cleaner.
- ▶ Let the crane dry.

If corrosion or paint damage is found:

- ▶ Remove the corrosion and paint damage.

The following surfaces must be masked prior to corrosion protection:

- Walking surfaces and stepping surfaces
- Vents on brake valves and control valves
- Vents and drains on electrical equipment
- Mechanically machined, blank surfaces
- Piston rods



WARNING

Walking surfaces and stepping surfaces **not** masked!
Personnel can slip and fall down.

- ▶ Mask walking surfaces and stepping surfaces prior to corrosion protection.

- ▶ All surfaces that should **not** be corrosion protected should be masked.
- ▶ Protect the crane against corrosion with **Carlofon 81**.
- ▶ Remove the masking.

5.4 Protecting the crane against corrosion for shutdown



Note

- ▶ Before shutting down the crane, contact the Service department at Liebherr-Werk Ehingen GmbH.

6 Storage

If the conditions in this section are observed, the crane can be stored as long as necessary.

6.1 Storage conditions

- ▶ Store the crane in a dry hall.

6.2 Decommissioning

Make sure that the following prerequisites are met:

- The crane is carefully washed.
- Corrosion and paint damage on the crane have been removed.
- Worn or damaged components have been replaced.

In the case of cranes with the battery master switch in the chassis and superstructure, both battery master switches must be turned off.

- ▶ Turn the battery master switch off.

In the case of cranes with a superstructure engine and a chassis engine, the batteries in the chassis and superstructure must be removed.

- ▶ Remove the batteries properly.

6.3 Maintenance

In the case of cranes with a fuel tank in the chassis and superstructure, both fuel tanks must be filled.

- ▶ Fill up the fuel tank completely.
- ▶ Apply approved lubricants in all lube points.
- ▶ Replace all operating fluids.
- ▶ Check the crane for leaking fluids.

If fluids are leaking from the crane:

- ▶ fix the leak.

In the case of cranes with a superstructure engine and a chassis engine, both engines must be started once a month.

- ▶ Start the engine once a month.

The specified maintenance interval must be observed even if the crane is in storage.

- ▶ Service the crane according to the maintenance interval.

6.4 Returning to service

NOTICE

Impermissible start up!

Damage to the crane.

- ▶ Make sure that the crane is supplied with approved lubricants.
- ▶ Make sure that the oil levels are correct.
- ▶ Only operate the crane in a perfect condition.

In the case of cranes with a superstructure engine and a chassis engine, the batteries must be installed in the chassis and superstructure.

- ▶ Install the batteries properly.
- ▶ Turn on the battery master switch.
- ▶ Put the crane in operation.

7 Recommendation for safe disposal

7.1 Service fluids and lubricants



WARNING

Service fluids and lubricants are dangerous waste products!

- ▶ Dispose of service fluids and lubricants separately.
- ▶ Service fluids and lubricants may **not** be disposed of in the ground, bodies of waters, wastewater systems, sewers or in the groundwater.
- ▶ Dispose of service fluids and lubricants in an environmentally safe manner.
- ▶ When disposing of service fluids and lubricants, observe and follow the applicable regulations of the responsible authorities.
- ▶ Observe and adhere to the safety data sheets of the service fluid manufacturer and the lubricant manufacturer.

Service fluids and lubricants are:

- Fuels
- Coolant
- Urea
- Engine oils, gear oils
- Hydraulic fluids
- Brake fluids
- Window washer concentrate
- Greases

7.2 Batteries



WARNING

Batteries contain harmful substances!

- ▶ Do **not** dispose of batteries in regular household trash.
- ▶ Collect batteries separately and send them for environmentally safe disposal.
- ▶ Leave batteries at a qualified workshop or at a licensed collection points for used batteries.

7.3 Prevention of improper machine use

After the end of its service life, the crane must be made unusable by cutting the load bearing crane structures, and in particular the steel structures. This can be done by means of flame cutting.

After the machine's service life has ended:

- ▶ Make the machine unusable.

7.4 Disposing of the machine

The crane owner is responsible for disposal.

- ▶ Separate the metals.

If the counterweights are made of concrete:

- ▶ Brake the steel parts out of the counterweight. Dispose of the concrete or recycle it.

Rope pulleys and bearing shoes in the boom are made out of PA6.

Due to the markings on the plastic parts, it is possible to dispose of them properly.

- ▶ Separate the plastic parts.
- ▶ Separate the remaining parts (for example, rubber, glass).
- ▶ Sort all parts.
- ▶ Take all parts to a licensed collection point for reusable materials and send them for recycling.

7.01.10 Service system

1	Description	2
2	Safety instructions	2
3	Calling up the service system	2
4	<i>Service system</i> operating interface	3
5	<i>Service system</i> function key line	6
6	Checking the maintenance status	6
7	Resetting the maintenance status	7

1 Description

The service system is only available for certain cranes.

The service system is a function of the BSE test system.

For further functions of the BSE test system, see the Diagnostics manual.

2 Safety instructions

Observe and comply with chapter 2.04, chapter 2.06, chapter 2.07.

Observe and comply with chapter 7.01.

NOTICE

Maintenance intervals of the engine manufacturer **not** observed!

The engine could be damaged, property damage.

- ▶ Make sure that the maintenance intervals of the engine manufacturer are adhered to.
- ▶ Reset the performed maintenance intervals in the service system.

3 Calling up the service system

Make sure that the following prerequisite is met:

- The *Crane operation* program is visible on the LICCON monitor.

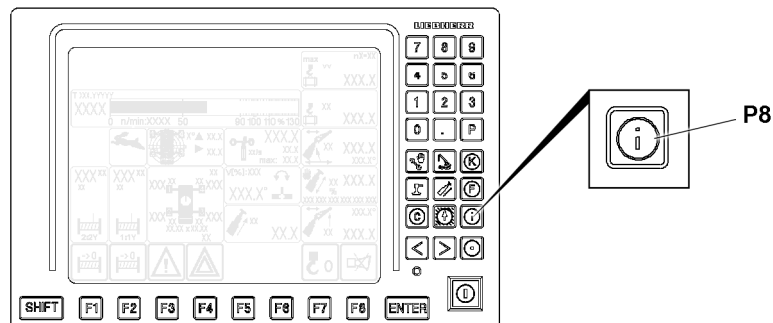

Fig.152484: Crane operation program

- ▶ Press the program key **P8**.

Result:

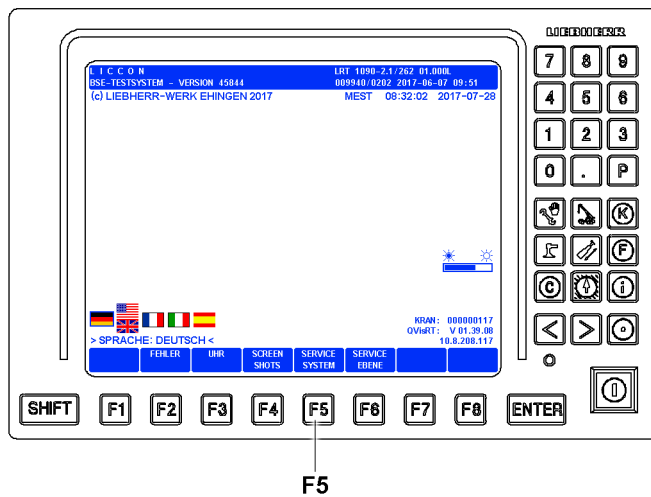

Fig.147628: BSE test system, start screen

– The BSE test system start screen is visible on the LICCON monitor.

▶ Press the function key **F5**.

Result:

– The service system operating interface is visible on the LICCON monitor.

4 Service system operating interface

4.1 Total operating hours

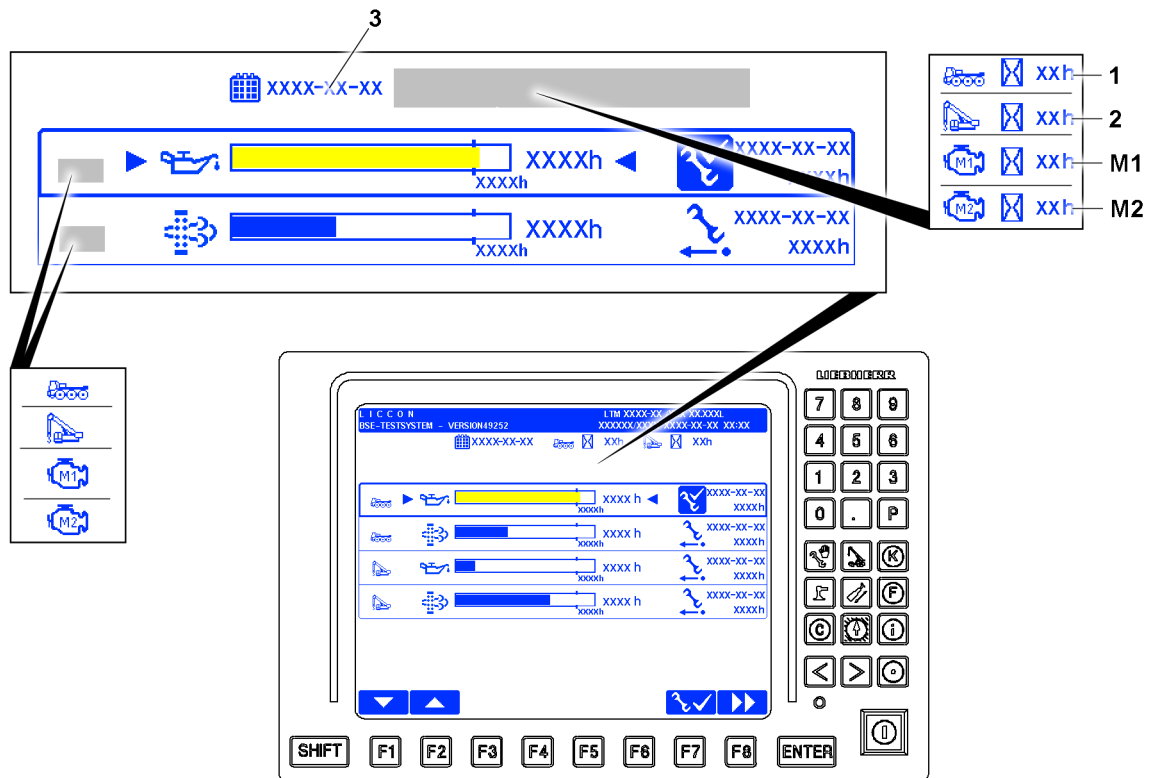

Fig.152481: Service system operating interface

LWE/LR 13000-001/19503-01-02/en

Depending on the crane type, there are different displays for the total operating hours:

- 1 Crane chassis total operating hours
 - Only available for certain cranes.
- 2 Crane superstructure total operating hours
 - Only available for certain cranes.
- M1 Crane engine total operating hours (engine 1)
 - Only available for certain cranes.
- M2 Crane engine total operating hours (engine 2)
 - Only available for certain cranes.
- 3 Current date (year-month-day)

4.2 Maintenance status

When maintenance is due, the bar in the respective bar diagram turns yellow.

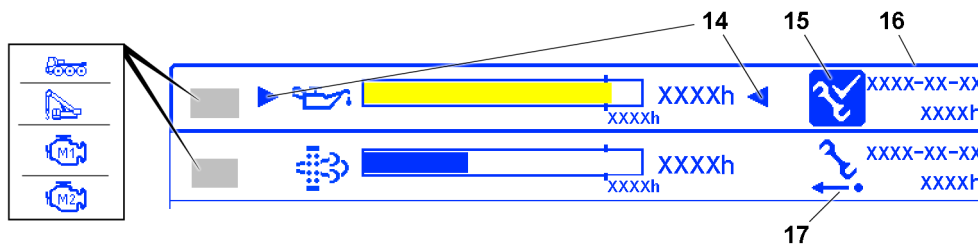

Fig.152482: Maintenance status, selected

The selected maintenance status is marked with the following elements:

- 14 Arrow
- 15 Selected maintenance status icon
- 16 Frame

The **unselected** maintenance status is marked with the following element:

- 17 Maintenance status not selected icon

4.3 Only available for a diesel engine: Determining the total operating hours for the diesel engine

Only for mobile cranes with a shared diesel engine for the crane chassis and crane superstructure.

Diesel engine ¹ total operating hours (example)	
Crane chassis total operating hours 1	2680 h
+ crane superstructure total operating hours 2	+ 2260 h
Total operating hours of the diesel engine	= 4940 h

1) Only concerns cranes with a diesel engine and separate crane superstructure and crane chassis operating hour meter

- ▶ Add the crane chassis total operating hours 1 and the crane superstructure total operating hours 2.

4.4 Crane chassis diesel engine maintenance status



Note

- ▶ Only available for certain cranes

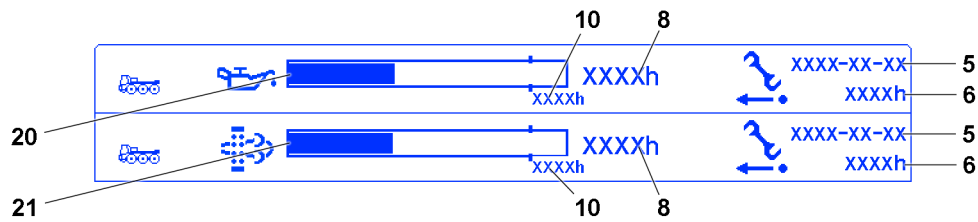

Fig.152554: Crane chassis diesel engine maintenance status

- | | | | |
|---|---|----|---|
| 5 | Date of last maintenance (year-month-day) | 10 | Maintenance interval in hours |
| 6 | Interval hours at the last maintenance | 20 | Engine oil maintenance status bar diagram (crane chassis diesel engine) |
| 8 | Lapsed interval hours | 21 | Diesel particle filter maintenance status bar diagram (crane chassis diesel engine) |

4.5 Crane superstructure diesel engine maintenance status



Note

► Only available for certain cranes

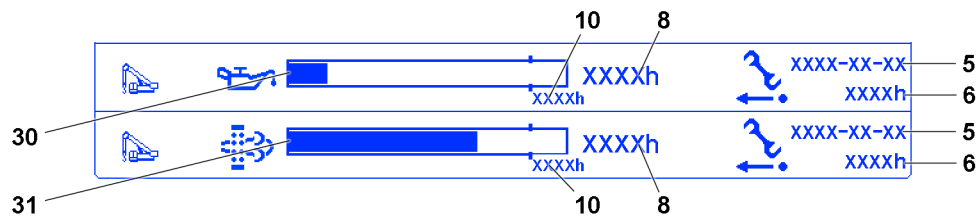

Fig.152555: Crane superstructure diesel engine maintenance status

- | | | | |
|---|---|----|--|
| 5 | Date of last maintenance (year-month-day) | 10 | Maintenance interval in hours |
| 6 | Interval hours at the last maintenance | 30 | Engine oil maintenance status bar diagram (crane superstructure diesel engine) |
| 8 | Lapsed interval hours | 31 | Diesel particle filter maintenance status bar diagram (crane superstructure diesel engine) |

4.6 Crane engine maintenance status (engine 1)



Note

► Only available for certain cranes

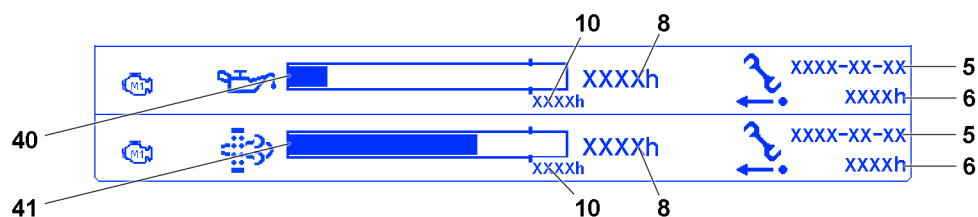

Fig.152589: Crane engine maintenance status

- | | | | |
|---|---|----|-------------------------------|
| 5 | Date of last maintenance (year-month-day) | 10 | Maintenance interval in hours |
|---|---|----|-------------------------------|

For continuation of legend for illustrations, see next page

LWE/LR_13000-001/19503-01-02/en

6	Interval hours at the last maintenance	40	Engine oil maintenance status bar diagram (engine 1)
8	Lapsed interval hours	41	Diesel particle filter maintenance status bar diagram (engine 1)

4.7 Crane engine maintenance status (engine 2)



Note

► Only available for certain cranes

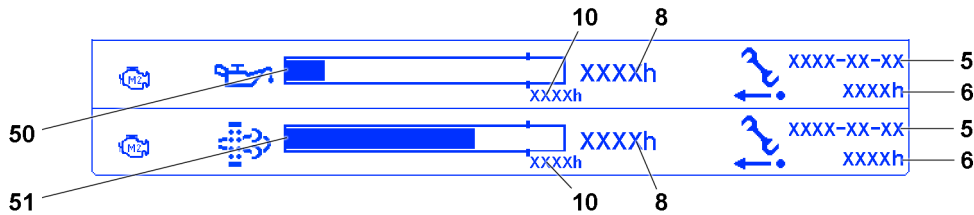

Fig.152588: Crane engine maintenance status

5	Date of last maintenance (year-month-day)	10	Maintenance interval in hours
6	Interval hours at the last maintenance	50	Engine oil maintenance status bar diagram (engine 2)
8	Lapsed interval hours	51	Diesel particle filter maintenance status bar diagram (engine 2)

5 Service system function key line

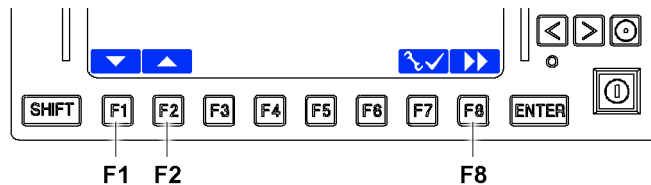

Fig.148511: Service system operating interface

The function key line consists of function keys **F1** to **F8** and the function key icon line above it.

- F1** Function key
 - Navigation in the *service system operating interface*: change downward
- F2** Function key
 - Navigation in the *service system operating interface*: change upward
- F8** Function key
 - Call up the *BSE test system* start screen.

6 Checking the maintenance status

When a bar diagram is displayed in yellow:

- Carry out the maintenance activities for the due maintenance interval.

When maintenance has been carried out completely:

- Reset the maintenance status for the due maintenance interval, see section „Resetting the maintenance status“.

7 Resetting the maintenance status

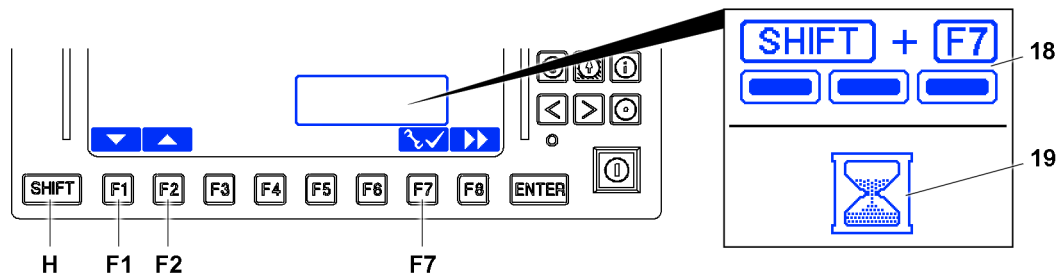

Fig.152483: Resetting the maintenance status

7.1 Resetting the engine oil maintenance status

Make sure that the following prerequisite is met:

- The diesel engine is turned off.

- ▶ Use the function key **F1** and function key **F2** to select the maintenance status that must be reset.

Result:

- The selected maintenance status is marked visually, see section „Maintenance status“.

- ▶ Press the SHIFT key **H** and function key **F7** simultaneously and hold.

Result:

- The display **18** is visible.

- ▶ Hold the SHIFT key **H** and the function key **F7** until the display **19** is displayed.
- ▶ Wait until the display **19** is hidden.

Result:

- The selected maintenance status is reset.
- The elapsed interval hours are taken over from the interval hours of the last maintenance.
- The date is updated.

7.2 Resetting the diesel particle filter maintenance status

Make sure that the following prerequisite is met:

- The diesel engine is turned off.

The maintenance interval for the diesel particle filter (DPF) can only be reset with a daily code.

The icon over the function key **F7** for resetting the maintenance interval for the diesel particle filter (DPF) appears only when entering the daily code.

- ▶ For registered customers: Call up the daily code at www.myliebherr.com.

or

Request the daily code from Customer Service at Liebherr-Werk Ehingen GmbH.

- ▶ Enter the daily code on the service level in the *BSE test system*, see the Diagnostics manual.
- ▶ Use the function key **F1** and function key **F2** to select the maintenance status that must be reset.

Result:

- The maintenance status is marked visually, see section „Maintenance status“.

- ▶ Press the SHIFT key **H** and function key **F7** simultaneously and hold.

Result:

- The display **18** is visible.

- ▶ Hold the SHIFT key **H** and the function key **F7** until the display **19** is displayed.
- ▶ Wait until the display **19** is hidden.

Result:

- The selected maintenance status is reset.

- The elapsed interval hours are taken over from the interval hours of the last maintenance.
- The date is updated.

7.02 Maintenance intervals - Crawler chassis

1 Maintenance and inspection schedule

2

LWE/LR 13000-001/19503-01-02/en

1 Maintenance and inspection schedule



Note

- ▶ Carry out maintenance work after reaching the specified operating hours or calendar intervals. The interval that occurs first is the deciding factor.
- ▶ The maintenance intervals complement each other. If a higher interval is coming up, then carry out the work according to the lower interval also.
- ▶ The operating hour meter of the crawler travel gear is the determining factor for the operator hour intervals.
- ▶ The „crawler travel gear“ operating hour meter* is located in the control cabinet.

First maintenance after	Operating hour intervals			Calendar intervals			Work to be carried out	O.K.
	10 h	100 h	1000 h	Daily	Weekly	Annually		
Safety systems								
						X	Personal protective equipment Follow the instructions of the manufacturer	<input type="checkbox"/>
						X	Height rescue system Follow the instructions of the manufacturer	
Fall protection equipment								
						X	Check protection points	<input type="checkbox"/>
						X	Check safety ropes	
						X	Check the ladders for technically immaculate condition	
						X	Check railings, steps and pedestals for safe function	
						X	Check catwalks and gratings for safe function	
Crane surface								
					X		Check accessible surfaces for cleanliness	<input type="checkbox"/>
						X	Check accessible surfaces for completeness and slip resistance	
						X	Check labels for completeness and legibility	
Rigging and fastening points								
				X ²⁾			Check the condition and mounting	<input type="checkbox"/>
						X	Check for continued suitability by an expert	

LWE/LR 13000-001/19503-01-02/en

First maintenance after	Operating hour intervals			Calendar intervals			Work to be carried out	O.K.
	10 h	100 h	1000 h	Daily	Weekly	Annually		
Travel gear								□
			X			X	Check the oil level	
			X			X	Checking for leaks	
	X						Grease the sprocket bearing if it is not lubricated via the central lubrication system	
		X					Check the tightness of the mounting screws	
		500 h					Check the gear oil via an oil analysis	
250 h			1000 h			Every 4 years	Change the gear oil	
Crawler carrier								□
		X					Check track rollers, carrier rollers with oil lubrication for leaks	
	X						Grease the track rollers, carrier rollers if they are not lubricated via the central lubrication system	
	X				Every 4 weeks		Check the wear on the roll-off surfaces of the track rollers / carrier rollers, replace the track rollers / carrier rollers if necessary	
	X				Every 4 weeks		Check for wear on the glide rails	
						X	Grease the guide rails on the sliding section	
						X	Lubricate the consoles	
					Every 4 weeks		Lubricate the connector pins between crawler carrier and crawler center section or crawler carrier and cross carriers	

First maintenance after	Operating hour intervals			Calendar intervals			Work to be carried out	O.K.
	10 h	100 h	1000 h	Daily	Weekly	Annually		
Crawler chain								<input type="checkbox"/>
		X					Check the connector pin retainer	
		X					Check for damage	
	X				Every 4 weeks		Check the chain tension, retension the crawler chain if necessary	
	X						Check the wear on the bores of the outrigger pads, replace the outrigger pads if necessary	
	X						Check the wear on the connector pins of the outrigger pads, replace the pins if necessary	
	X				Every 4 weeks		Check the wear on the roll-off surfaces of the outrigger pads / track rollers, replace the outrigger pads if necessary	
					Every 4 weeks		Check the wear on the sprocket wheels and the transport cams of the outrigger pads	
Assembly support								<input type="checkbox"/>
					X		Check the hydraulic cylinder for leaks	
						X	Check the support beam for ease of movement and grease	
						X	Lubricate the bearing points of the support beams	
						X	Check the sight gauge, adjust if necessary	
Crane support								<input type="checkbox"/>
					X		Check the hydraulic cylinder for leaks	
						X	Check the support beam for ease of movement and grease	
						X	Lubricate the struts	
						X	Lubricate the mounting pins on the struts	
						X	Lubricate the support plate bearing	
Concrete ballast plates / concrete catwalks (central ballast) (only LR1500)								
				X			Check for damage	
						X ⁴⁾	Have an authorized inspector check that the fastening points are fit tightly and for continued suitability	

First maintenance after	Operating hour intervals			Calendar intervals			Work to be carried out	O.K.
	10 h	100 h	1000 h	Daily	Weekly	Annually		
Pin connections								<input type="checkbox"/>
					Every 2 months ³⁾		Check the retainer of the pin connections	
					Every 2 months ³⁾		Check the pins and / or connection elements for damage, visual inspection	
					Every 2 months ³⁾		Check the retaining elements for damage, visual inspection	
Rotary connection								<input type="checkbox"/>
			X				Lubricate (grease lubrication)	
Hydraulic cylinder								<input type="checkbox"/>
					X		Checking for leaks	
Hydraulic hose lines								<input type="checkbox"/>
				X			Check for leaks and damage	
						X	Have safe working condition checked by an expert	
Central lubrication system								<input type="checkbox"/>
					Every 6 months ¹⁾		Carry out intermediate lubrication (in case of a central lubrication system with the control unit).	
		X					Checking the function	
	8 h			X			Check the lubricant level	

¹⁾ if the crane is not moved: Every 3 months

²⁾ before every start up: Perform a visual inspection

³⁾ also for cranes used for a long period of time

⁴⁾ and at each assembly / disassembly

Empty page!

LWE/LR 13000-001/19503-01-02/en

7.03 Maintenance intervals - Crane superstructure

1 Maintenance and inspection schedule

2

LWE/LR 13000-001/19503-01-02/en

1 Maintenance and inspection schedule



Note

- ▶ Carry out maintenance work after reaching the specified operating hours or calendar intervals. The interval that occurs first is the deciding factor!
- ▶ The maintenance intervals complement each other. If a higher interval is coming up, then also carry out the work according to the lower interval!

First maintenance after	Operating hour intervals			Calendar intervals			Work to be carried out	O.K.
	250 h	500 h	1000 h	Daily	Weekly	Annually		
Safety systems								<input type="checkbox"/>
						X	Personal protective equipment Follow the instructions of the manufacturer	
						X	Height rescue system Follow the instructions of the manufacturer	
Fall protection equipment								<input type="checkbox"/>
						X	Check protection points	
						X	Check safety ropes	
						X	Check the ladders for technically immaculate condition	
						X	Lubricating the ladders	
						X	Check railings, steps and pedestals for safe function	
						X	Check catwalks and gratings for safe function	
Crane surface								<input type="checkbox"/>
					X		Check accessible surfaces for cleanliness	
						X	Check accessible surfaces for completeness and slip resistance	
						X	Check labels for completeness and legibility	
Rigging and fastening points								<input type="checkbox"/>
				X ²⁾			Check the condition and mounting	
						X	Check for continued suitability by an authorized inspector, inspection expert	
Load handling equipment and assembly aids								<input type="checkbox"/>
				X ²⁾			Check for cracks, damage, wear and distortion	
						X	Check for continued suitability by an authorized inspector, inspection expert	

First maintenance after	Operating hour intervals			Calendar intervals			Work to be carried out	O.K.
	250 h	500 h	1000 h	Daily	Weekly	Annually		
Fastening equipment and load securing devices								<input type="checkbox"/>
				X ²⁾			Observe and adhere to the manufacturer's instructions	
				X ²⁾			Check the grommets and cable laid fastening rope for damage, operational safety, proper identification. Take-down criteria, see chapter 8.01	
						X	Have the fastening equipment checked by an authorized person, authorized inspector	
Fire extinguishing system								<input type="checkbox"/>
						X	Carry out a visual inspection of the system For all other maintenance tasks, observe the instructions of the fire extinguishing system manufacturer	
						Every 5 years	Replace trigger elements and extinguisher tank	

First maintenance after	Operating hour intervals			Calendar intervals			Work to be carried out	O.K.
	250 h	500 h	1000 h	Daily	Weekly	Annually		
Diesel engine								□
					X		Visual inspection (leaks, contamination, damage)	
				X			Check the oil level on the LICCON monitor	
		X					Checking the oil level with the dipstick	
			X ^{14) 15)}				Change the engine oil, replace the oil filter and oil separator filter insert	
			Or when displayed in the service system*: The interval and be reduced depending on the individual load duty cycle					
			X				Check the ribbed V-belt	
			X				Check the condition of the belt drive, replace if required	
			Every 5000 h			Every 5 years	Replace the belt drive	
100 h			X				Check the condition and fastening of the intake and exhaust system and check for leaks	
			X				Check the engine mount and diesel engine brackets for tight seating	
			every 10000 h			X	Check the heat flange	
			every 10000 h				Replace the heat flange	
			X				Check the valve clearance	
			X				Check the engine control unit mount, sensors, actuators, cable holders and plugs for damage	
Cooling system								□
				X			Checking the coolant level	
					X		Check the cooling system for leaks	
						X	Check the concentration of the anti-freeze in the coolant	
			Every 6000 h			Every 4 years	Change the coolant	

First maintenance after	Operating hour intervals			Calendar intervals			Work to be carried out	O.K.	
	250 h	500 h	1000 h	Daily	Weekly	Annually			
Fuel system									
					X		Check the lubrication oil system and fuel system for leaks	□	
			X				Check the condition and mounting of the fuel system		
100 h			X				Draining the sediment in the fuel tank		
					X		Check fuel preliminary filter, drain water if necessary		
			X				Servicing the fuel preliminary filter		
			X				Replace the fuel fine filter		
Urea system									
						X	Check the filter strainer in the tank fitting of the urea tank, replace if necessary	□	
Exhaust system*									
				X			Visual inspection: Check the exhaust system for leaks and damage	□	
			X				Check the profile clamps		
			Every 5000 h				Replace the diesel particle filter*		
			Or when displayed in the service system*						
						X	Visual inspection: Check the lines and electronic plug		
Air filter system									
					X		If present: Clean the dust discharge valve	□	
						X ¹³⁾	Replace the air filter main element		
						X	If present: Replace the air filter safety element		
Pump distributor gear									
				X			Checking for leaks	□	
					X		Checking the oil level with the dipstick		
200 h			2000 h			X	Change the gear oil		
Central lubrication system									
					Every 6 months ¹⁾		Activate intermediate lubrication	□	
		X					Check the function		
					X		Check the fill level in the grease container		

First maintenance after	Operating hour intervals			Calendar intervals			Work to be carried out	O.K.
	250 h	500 h	1000 h	Daily	Weekly	Annually		
Slewing ring connection								□
	X						Lubricate the gear ring and the slewing gear pinion	
						X ¹⁾	Lubricate the slewing ring connection	
250 h			1500 h			X	Check the tightness of the mounting screws	
						X	Check the tilt play	
Slewing gear								□
250 h			X			X	Check the tightness of the mounting screws	
				X			Checking for leaks	
					X		Checking the oil level with the dipstick	
250 h			4000 h			Every 4 years	Change the gear oil	
Slewing gear brakes								□
				X			Checking for leaks	
						X	Check the function	
Press on pulleys of rope winches								□
	X					X	Grease the guides	

First maintenance after	Operating hour intervals			Calendar intervals			Work to be carried out	O.K.
	250 h	500 h	1000 h	Daily	Weekly	Annually		
Winches								□
250 h			X			X	Check the tightness of the mounting screws	
				X			Check for damage and distortion	
				X			Checking for leaks	
					X ⁶⁾		Checking the oil level with the dipstick	
		X					Recommendation: Check the gear oil (oil analysis)	
250 h			3000 h			Every 3 years	Change the gear oil	
			1500 h ⁴⁾			X ⁴⁾	If grease fittings are available for the lubricatable winch bearings: Lubricate the space between the V-ring / winch bearing	
			200 h			X	When winches with a gear ring drive are present: Check the condition of the tooth flanks; the determining factor is operating hours of the winch	
						X	Check the remaining theoretical service life by an authorized inspector	
						Every 4 years	Check of the remaining theoretical service life by an inspection expert	
Winch brakes								□
			X			X	Checking for leaks	
			X			X	Check the function	
Hydraulic system								□
				X			Check the oil level on the LICCON monitor	
					X		If present: Check the oil level on the fuel level display of the hydraulic oil tank	
					X		Checking for leaks	
250 h		X				X	Replace the pressure filter element	
250 h		X				X	Replace the return filter inserts	
250 h		X				X	Replace the breather and vent filter	
500 h			X			X	Check the hydraulic oil: Take an oil sample and have it checked by the oil supplier (required degree of purity: 20/18/15)	
		X ⁴⁾				X ⁴⁾	Have the pretension pressure of the hydro reservoir (nitrogen) checked by authorized and trained service personnel	

First maintenance after	Operating hour intervals			Calendar intervals			Work to be carried out	O.K.
	250 h	500 h	1000 h	Daily	Weekly	Annually		
Hydraulic cylinder								
					X		Check for leaks	□
					Every 3 months <small>5), 6)</small>		Lubricate the bearings	
Hydraulic hose lines								
				X			Check for leaks and damage	□
						X	Check for a safe condition by an authorized inspector, inspection expert	
Compressed air system								
					X		Checking for leaks	□
					X		Check operating pressure	
					X		Check shut off pressure	
					X		Automatic drain valve: Check the function	
					X		Draining water from the compressed air tank	
						X	Replace air dryer granular cartridges	
						X	Clean the air dryer preliminary filter	
Relapse supports								
					Every 3 months <small>5), 6)</small>		Lubricate the bearings	□
X ^{2), 6)}							Check the oscillation guard for easy movement	
Relapse cylinder								
X ^{2), 6)}					X		Check for leaks	□
					Every 3 months <small>5), 6)</small>		Lubricate the bearings	
X ^{2), 6)}		X				X	Have the pretension pressure (nitrogen) checked by an authorized and trained service technician	
X ^{2), 6)}		X				X	Check the oil quantity	

First maintenance after	Operating hour intervals			Calendar intervals			Work to be carried out	O.K.
	250 h	500 h	1000 h	Daily	Weekly	Annually		
A-frame								
		X					Lubricate the bearing	<input type="checkbox"/>
X ^{2), 6)}						X	Check the lever for the limit switch on the A-frame 3 for easy movement and reset of spring	
X ^{2), 6)}						X	Check the rods with guide rail on A-frame 2 and A-frame 3 for easy movement and distortion	
Pneumatic springs								
X ^{2), 5), 6)}		X				X	Check the function	<input type="checkbox"/>
Concrete ballast plates (ballast container) (only LR 13000)								
				X			Check for damage	<input type="checkbox"/>
						Every 5 years	have checked by the licensing agency	
Rope pulleys								
					X ^{5), 6)}		Check the groove base for cleanliness	<input type="checkbox"/>
			X	X		X	Check for wear, damage, cracks and easy movement	
			3000 h			Every 3 years	Lubricate the bearings	
Carrier rollers								
				X ²⁾			Check for damage and distortion	<input type="checkbox"/>
			X	X		X	Check for wear, damage and easy movement	
			X			X	Check the tightness of the mounting screws	
Bearings								
						X	Check the retaining elements	<input type="checkbox"/>
Pin connections								
					Every 2 months ¹⁰⁾		Check the retainer of the pin connections	<input type="checkbox"/>
					Every 2 months ¹⁰⁾		Check the pins and / or connection elements for damage, visual inspection	
					Every 2 months ¹⁰⁾		Checking the retaining elements for damage, visual inspection	
Window washing system								
				X			Check the fill level of the window washing fluid	<input type="checkbox"/>

LWE/LR 13000-001/19503-01-02/en

First maintenance after	Operating hour intervals			Calendar intervals			Work to be carried out	O.K.
	250 h	500 h	1000 h	Daily	Weekly	Annually		
Emergency control								□
						X	Check the function	
Overload protection								□
				X			Check the function	
		X				X	Length sensor: Check the function	
		X				X	Check the length sensor rope for damage	
Remote diagnostics device								□
						X	Check the function	
						X	Check the validity of the SIM card	
Electrical system								□
						X	Check the bulbs, fuses, lines and cable connections	
					Every 6 months ³⁾		Check the batteries	
Heating-air conditioning device								□
					Every 4 weeks		Operate the climate control system for 15 min and check the function	
						X	Replace the filter insert	
Cab auxiliary heater*, Engine preheating auxiliary heater*								□
				X			Check the fill level of the fuel container	
				X			Check the fill level in the expansion tank	
					Every 4 weeks ⁸⁾		operate and check the function for 15 min with the engine cold and the highest fan stage	
					X ⁹⁾		operate and burn-off the burner for 15 min with the engine cold and the highest fan stage	
						X ¹²⁾	Have the water heater checked by an authorized and trained service technician	
						Every 2 years	Have the fluid in the heating system replaced by an authorized and trained service technician	
			3000 h				Have the burner of the heating system replaced by an authorized and trained service technician	
						Every 10 years	Have the heat exchanger of the heater replaced by an authorized and trained service technician	

First maintenance after	Operating hour intervals			Calendar intervals			Work to be carried out	O.K.
	250 h	500 h	1000 h	Daily	Weekly	Annually		
Air heater auxiliary heater*								<input type="checkbox"/>
					Every 4 weeks ⁸⁾		operate and check the function for 15 min with the highest fan stage	
					X ⁹⁾		operate and free-burn the burner for 15 min with the highest fan stage	
						X ¹²⁾	Have the air heater checked by an authorized and trained service technician	
			3000 h				Have the burner of the heating system replaced by an authorized and trained service technician	
						Every 10 years	Have the heat exchanger of the heater replaced by an authorized and trained service technician	
Drive assembly air conditioning system*								<input type="checkbox"/>
	X	X		X	X		Maintenance activities, see the separate equipment manufacturer's operating instructions	
Crane cab								<input type="checkbox"/>
				X			Instrument panels: Check the function	
				X			Indicator lights: Check the function	
		X				X	Sliding or incline device: Checking the function	
		X				X	Lubricate the bearings of the sliding or incline device	
Suspended ballast								<input type="checkbox"/>
						X	Check the fall protection equipment	
						X	Check the frame, suspension and guide section for distortion and cracks	
Crane superstructure								<input type="checkbox"/>
					X ¹¹⁾		Wash the crane superstructure	
						Every 6 months ¹¹⁾	Check the crane superstructure for corrosion and paint damage	

First maintenance after	Operating hour intervals			Calendar intervals			Work to be carried out	O.K.
	250 h	500 h	1000 h	Daily	Weekly	Annually		
Crane superstructure, protected against corrosion								□
						Every 6 months	Check the corrosion protection for wear, and if necessary reapply protection	
						Every 2 months	Check the corrosion protection on mechanically machined, blank surfaces for wear and reapply the corrosion protection if necessary	
						Every 3 months	Check the corrosion protection on the chrome-plated piston rods for wear, and if necessary reapply the corrosion protection	

- 1) if the crane is not moved: every 3 months
- 2) before every start up: Performing a visual inspection
- 3) in hot climate zones: every month
- 4) observe the crane superstructure maintenance instructions, chapter 7.05
- 5) and as necessary
- 6) and during assembly
- 7) in Great Britain: every 6 months
- 8) outside of the heating period
- 9) during the heating period
- 10) also for cranes used for a long period of time
- 11) each time after the crane is used if possible
- 12) before and after every heating period
- 13) or if the maintenance display activates, or error message
- 14) the interval is reduced in the case of alternative oil specifications, see the see separate engine manufacturer's operating instructions
- 15) the interval depends on the sulfur content in the permissible fuel for the respective emissions level, see the see separate engine manufacturer's operating instructions

7.03.50 Maintenance intervals - Crane boom

1 Maintenance and inspection schedule

3

LWE/LR 13000-001/19503-01-02/en

Fig.195219

LWE/LR 13000-001/19503-01-02/en

1 Maintenance and inspection schedule



Note

- ▶ Carry out maintenance work after reaching the specified operating hours or calendar intervals. The interval that occurs first is the deciding factor!
- ▶ The maintenance intervals complement each other. If a higher interval is coming up, then also carry out the work according to the lower interval!

First maintenance after	Operating hour intervals			Calendar intervals			Work to be carried out	O.K.
	250 h	500 h	1000 h	Daily	Weekly	Annually		
Safety systems								
						X	Personal protective equipment Follow the instructions of the manufacturer	□
						X	Height rescue system Follow the instructions of the manufacturer	
Fall protection equipment								
						X	Check protection points	□
						X	Check safety ropes	
						X	Check the ladders for technically immaculate condition	
						X	Check railings, steps and pedestals for safe function	
						X	Check catwalks and gratings for safe function	
Crane boom surface								
					X		Check accessible surfaces for cleanliness	□
						X	Check accessible surfaces for completeness and slip resistance	
						X	Check labels for completeness and legibility	
Rigging and fastening points								
				X ²⁾			Check the condition and mounting	□
						X	Check for continued suitability by an authorized inspector, inspection expert	
Load handling equipment and assembly aids								
				X ²⁾			Check for cracks, damage, wear and distortion	□
						X	Check for continued suitability by an authorized inspector, inspection expert	

LWE/LR 13000-001/19503-01-02/en

First maintenance after	Operating hour intervals			Calendar intervals			Work to be carried out	O.K.
	250 h	500 h	1000 h	Daily	Weekly	Annually		
Fastening equipment and load securing devices								<input type="checkbox"/>
				X ²⁾			Observe and adhere to the manufacturer's instructions	
Lattice sections								<input type="checkbox"/>
						X	Check for cracks, damage and distortion	
						X	Check protection points	
						X	Check safety ropes	
						X	Check railings and pedestals for safe function	
						X	Check catwalks and gratings for safe function	
X ⁶⁾						X	Grease the lube points of lattice sections	
Guy rods								<input type="checkbox"/>
						X	Check for cracks, damage and distortion by an authorized person	
						Every 4 years	Check cracks, damage and distortion by an authorized inspector	
						X	Checking the retaining elements	
						X	Check labels for completeness and legibility	
X ⁶⁾						X	Lubricate the lube points of guy rods	
Fiber guy ropes								<input type="checkbox"/>
				X			Check the rope, grommet and rope end connection for damage and distortion	
					X		Check rope for dirt. If necessary, wash or spray the rope with clean water. After cleaning: Dry the rope in the air at approx. 20 °C.	
					X ⁷⁾		Check the thimble and rope end connection, see chapter 8.16	
					X ⁷⁾		Check the rope layers, see chapter 8.16	
					X ⁷⁾		Check the rope for buckles, see chapter 8.16	
						X	Check the rope for kinks, see chapter 8.16	

First maintenance after	Operating hour intervals			Calendar intervals			Work to be carried out	O.K.
	250 h	500 h	1000 h	Daily	Weekly	Annually		
Relapse supports								
					Every 3 months ^{5), 6)}		Lubricate the bearings	☐
X ^{2), 6)}							Check the oscillation guard for easy movement	
Relapse cylinder								
X ^{2), 6)}					X		Check for leaks	☐
					Every 3 months ^{5), 6)}		Lubricate the bearings	
X ^{2), 6)}		X				X	Check pretension pressure (nitrogen)	
X ^{2), 6)}		X				X	Check the oil quantity	
Hydraulic hose lines								
				X			Check for leaks and damage	☐
						X	Check for a safe condition by an authorized inspector, inspection expert	
Hydraulic cylinder								
					X		Check for leaks	☐
					Every 3 months ^{5), 6)}		Lubricate the bearings	
Hydraulic pressure accumulator (nitrogen)								
		X ⁴⁾				X ⁴⁾	Check pretension pressures	☐
Rope pulleys								
					X ^{5), 6)}		Check the groove base for cleanliness	☐
			X	X		X	Check for wear, damage, cracks and easy movement	
			3000 h			Every 3 years	Lubricate the bearings	
Carrier rollers								
				X ²⁾			Check for damage and distortion	☐
			X			X	Check for wear, damage and easy movement	
			X			X	Check the tightness of the mounting screws	

First maintenance after	Operating hour intervals			Calendar intervals			Work to be carried out	O.K.
	250 h	500 h	1000 h	Daily	Weekly	Annually		
Auxiliary guying								<input type="checkbox"/>
						X ⁶⁾	Check the rope connection between the guy point and the lattice section	
						X ⁶⁾	Check for cracks, damage and distortion	
Pin connections								<input type="checkbox"/>
					Every 2 months ⁸⁾		Check the retainer of the pin connections	
					Every 2 months ⁸⁾		Check the pins and / or connection elements for damage, visual inspection	
					Every 2 months ⁸⁾		Checking the retaining elements for damage, visual inspection	
Crane ropes								<input type="checkbox"/>
				X			Check the rope and rope end connection for damage and distortion	
					Monthly ⁵⁾		Check, grease by expert personnel	
						X	Check by an authorized inspector	
						Every 4 years	Check by an inspection expert	

First maintenance after	Operating hour intervals			Calendar intervals			Work to be carried out	O.K.
	250 h	500 h	1000 h	Daily	Weekly	Annually		
Hook blocks								
				X ³⁾			Check of the load hook for distortion, wear, damage and cracks by the crane operator	□
			X	X		X	Check rope pulleys for distortion, wear, damage and cracks	
			3000 h			Every 3 years	Lubricate rope pulley bearings	
	100 h				Every 3 months ⁵⁾		Lubricate pressure bearings	
	100 h				Every 3 months ⁵⁾		Lubricate radial bushing	
	100 h				Every 3 months ⁵⁾		Lubricate suspension of hook beam	
					Every 6 months ⁵⁾		Replace batteries on incline sensor	
						X	Load hook: Check the distance (y)	
						X	Check of the load hook for distortion, wear, damage and cracks by an authorized person	
						Every 4 years	Check of the load hook for distortion, wear, damage and cracks by an inspection expert	

²⁾ before every start up: Perform a visual inspection

³⁾ before starting crane operation: Perform a visual inspection

⁴⁾ observe the crane superstructure maintenance instructions, chapter 7.05

⁵⁾ and as necessary

⁶⁾ and during assembly

⁷⁾ before assembly and before disassembly

⁸⁾ also for cranes used for a long period of time

Empty page!

LWE/LR 13000-001/19503-01-02/en

7.04 Maintenance instructions - Crane chassis

1	Servicing the travel gear	3
2	Servicing the central lubrication system of the crawler carrier	11
3	Servicing the track chain	19
4	Ladders	33

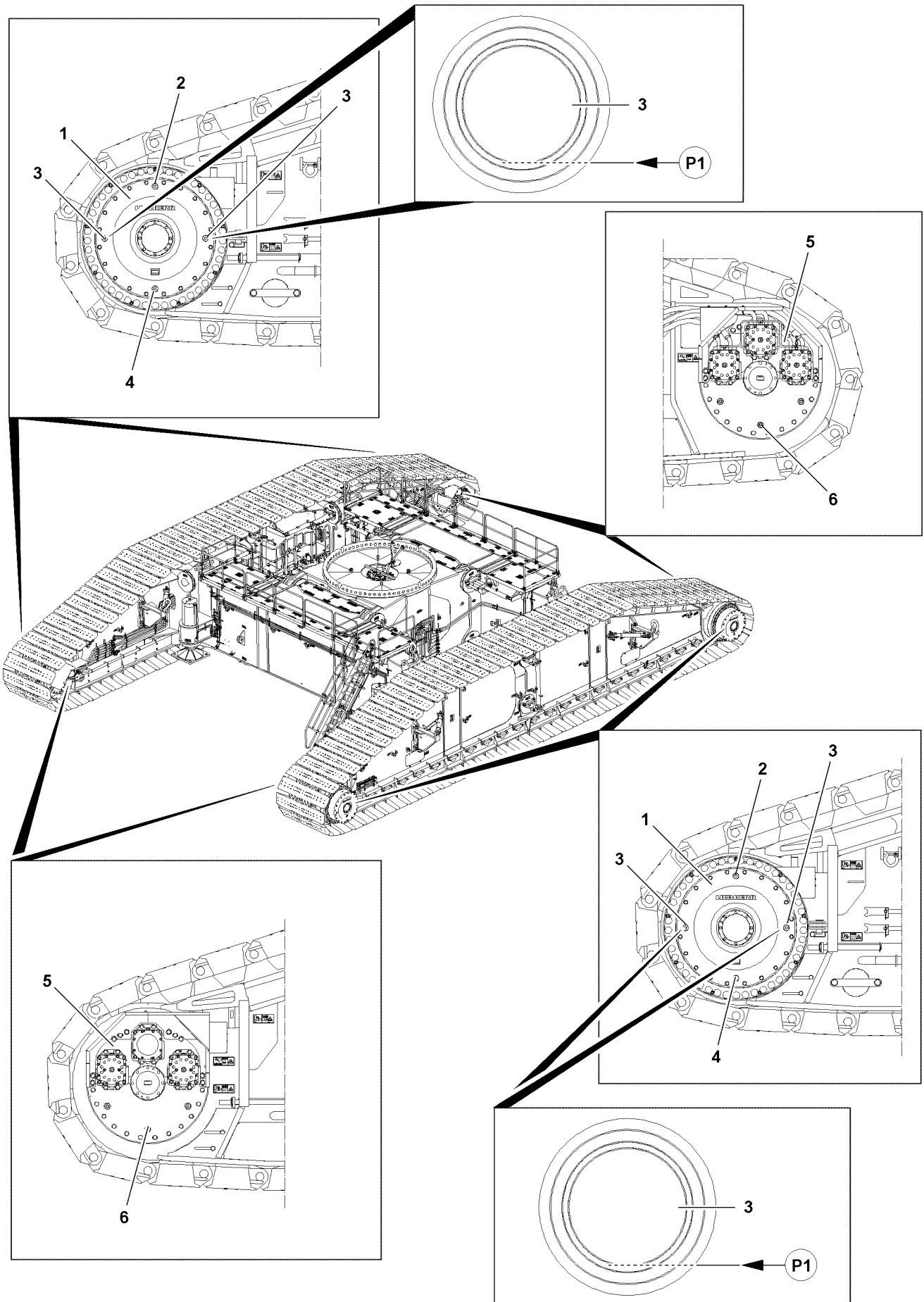

Fig.116369

LWE/LR 13000-001/19503-01-02/en

1 Servicing the travel gear



Note

- ▶ Use service items and lubricants according to the chart, see Crane operating instructions, chapter 7.07.
- ▶ Observe the maintenance intervals, see Crane operating instructions, chapter 7.02.

The travel gear consists of:

- 1 Planetary gear
- 5 Spur gear



WARNING

Danger of burns during maintenance and inspection work!

Severe burns can result due to the travel gear and oils at operating temperatures.

- ▶ Avoid direct body contact with heated components and service fluids.

NOTICE

Dirt in travel gear!

If any dirt gets inside of the travel gear, gear damage can occur.

- ▶ Make sure that no dirt gets into the inside of the travel gear during maintenance work.

The following maintenance ports are on the planetary gear 1:

- 2 Oil filler port
- 3 Oil level plug, oil level port, oil filler port
- 4 Oil drain plug, oil drain port

The following maintenance port is on the spur gear 5:

- 6 Oil drain plug, oil drain port



Note

- ▶ The planetary gear 1 and the spur gear 5 have separate oil chambers, which are connected with an „overflow“.
- ▶ The oil level check for both gears is made on the planetary gear 1.
- ▶ The oil is added for both gears on the oil level ports 3 on the planetary gear 1.

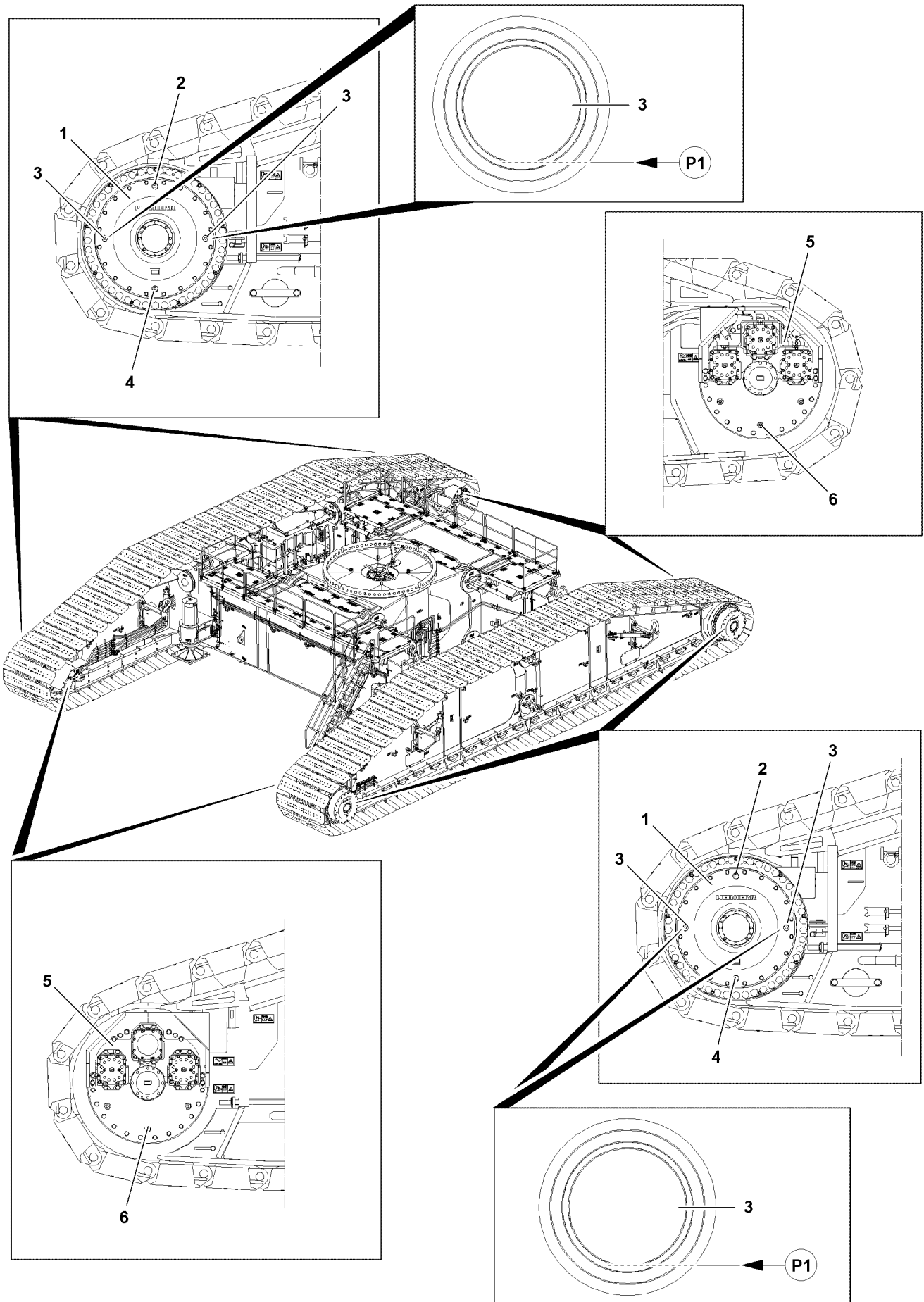

Fig.116369

LWE/LR 13000-001/19503-01-02/en

1.1 Checking for leaks

- ▶ Check visually to ensure that the travel gears do not leak.

1.2 Checking the oil level

NOTICE

Damage to the travel gear!

If seals are used repeatedly, it can result in loss of oil.

Due to loss of oil, the travel gears can wear significantly and / or be damaged.

- ▶ Use the seals on the maintenance ports only once.
-

NOTICE

Varying oil level in the travel gear!

Depending on the position of the gears in the planetary gear, the oil level in the entire travel gear can vary slightly.

When opening the oil level plug(s) on the planetary gear, oil can emerge despite correct fill quantity.

- ▶ However, the fill height must be at least on the height of the point **P1**.
 - ▶ If any oil emerged during the oil level check, replace the same amount.
-

Make sure that the following prerequisites are met:

- The crane is in horizontal position.
 - The travel gear is at a standstill.
-



Note

- ▶ To ensure a reliable oil level check, it must be ensured that the travel gears have been at a standstill for at least two minutes. This ensures that the oil has returned to the oil chamber completely.
 - ▶ Carefully open the oil level port **3** on the planetary gear **1**.
-

NOTICE

Insufficient oil fill quantity!

If the oil level drops below the minimum fill level on point **P1**, the travel gears can be damaged.

- ▶ Add gear oil until the oil level is again on the fill level on point **P1**.
-

If gear oil must be added:

- ▶ Add oil on the oil filler port **2**.

or

Add oil on the oil level plug, oil level port or oil filler port **3**.

- ▶ If the oil level is on the minimum fill level on point **P1**, then the oil level on the travel gear is OK.
- ▶ Close the maintenance ports tightly.

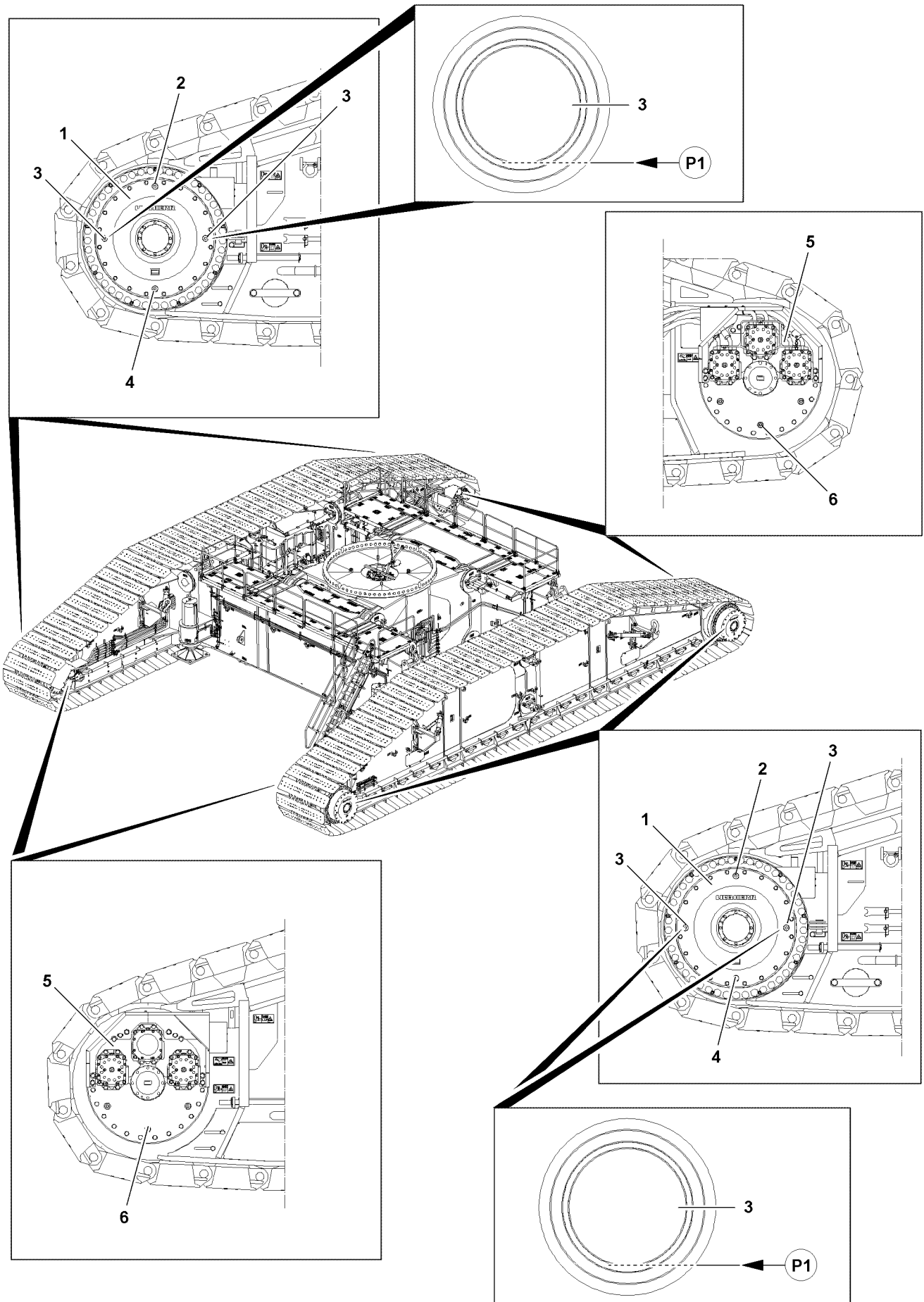

Fig.116369

LWE/LR 13000-001/19503-01-02/en

1.3 Changing the oil

NOTICE

Damage to the travel gear!

If seals are used repeatedly, it can result in loss of oil.

Due to loss of oil, the travel gears can wear significantly and / or be damaged.

- ▶ Use the seals on the maintenance ports only once.

1.3.1 Changing the oil on the travel gear

Make sure that the following prerequisites are met:

- The crane is in horizontal position.
- The travel gear must be at a standstill.
- The travel gear is at operating temperature.
- A container to catch the used oil is available.



Note

- ▶ When selecting the container to catch the used oil, make sure that the container is sufficiently sized to be able to catch all the used oil.
- ▶ The fill quantities of the travel gear are listed in the Service fill list.

- ▶ Remove the oil filler plug **2** on the planetary gear **1**.
- ▶ Remove the oil drain plug **4** on the planetary gear **1** and drain the oil into a suitable container.



Note

- ▶ Allow the planetary gear **1** to empty completely.

When the planetary gear **1** is fully drained:

- ▶ Clean the oil drain plug **4** and the sealing surface.
- ▶ Close off the oil drain port **4** tightly.
- ▶ Remove the oil drain plug **6** on the spur gear **5** and drain the oil into a suitable container.



Note

- ▶ Allow the spur gear **5** to empty completely.

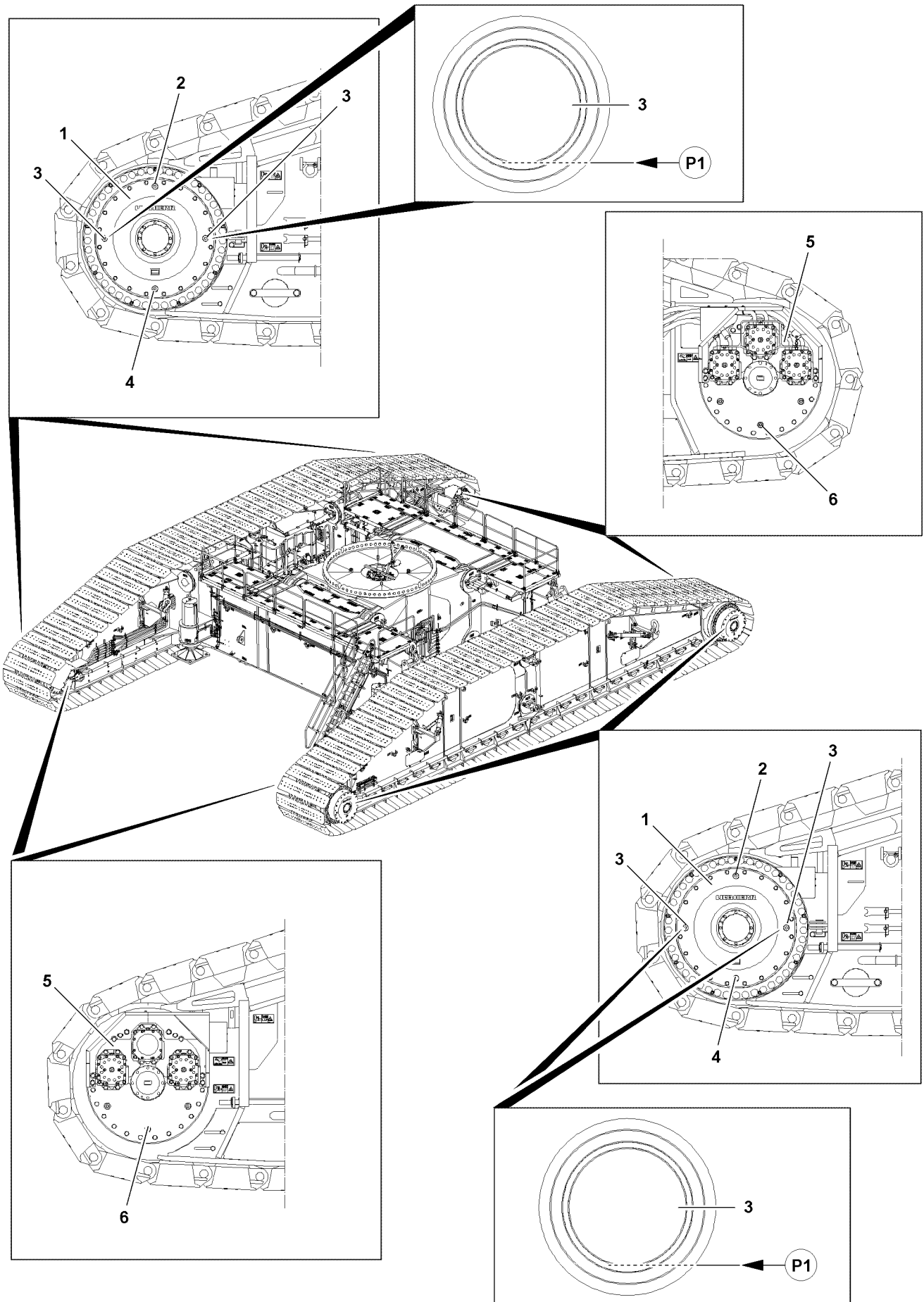

Fig.116369

LWE/LR 13000-001/19503-01-02/en

When the spur gear **5** is fully drained:

- ▶ Clean the oil drain plug **6** and the sealing surface.
- ▶ Close off the oil drain port **6** tightly.

When the oil drain ports on the planetary and the spur gear are properly closed:

- ▶ Add oil on the oil filler port **2** of the planetary gear until it „stands“ at the height of the fill level on point **P1** of the oil level port **3** or until it starts to run over.

NOTICE

Danger of property damage!

If the oil filler ports are closed immediately after adding the gear oil, then it cannot be ensured that the required oil quantity is in the travel gear and that the oil has distributed evenly in the planetary gear **1** and in the spur gear **5**.

The travel gear (spur and planetary gear) can be severely damaged.

This could result in high property damage.

- ▶ After adding the gear oil, wait a few minutes until the gear oil has distributed via the overflow also in the spur gear **5**. If necessary, add oil on the planetary gear **1** until it starts to overflow on the oil level plug **3**.

-
- ▶ Clean the sealing surfaces on the oil level plug / oil level port **3**.
 - ▶ Close off the oil level plug / oil level port **3** tightly.
 - ▶ Close off the oil fill port **2** tightly on the planetary gear **1**.

2 Servicing the central lubrication system of the crawler carrier



Note

- ▶ The illustrations in this chapter are examples and may not apply exactly to your crane.
- ▶ Use service items and lubricants according to the chart, see Crane operating instructions, chapter 7.07 and the separate Service fill list.
- ▶ Observe the maintenance intervals, see Crane operating instructions, chapter 7.02.

If the crane is driven via the crawler travel gear, then the central lubrication systems for the crawler carrier turn on automatically and supply all grease points with the correct amount of grease.

NOTICE

Insufficient lubrication!

The lubrication film is removed over time due to environmental influences.

Due to insufficient lubrication, the crawler carriers are exposed to significant wear and can be damaged.

- ▶ If the crawler carriers are not moved for a period of more than three months, then it must be lubricated every quarter, possibly with an external grease pump.



Note

- ▶ When putting the crane back into service after an extended downtime, check the central lubrication system for function.
- ▶ When working on the central lubrication system, observe utmost cleanliness.
- ▶ On the left crawler carrier **1**, there is a grease pump on each crawler carrier half, crawler carrier half, left front **1.1** and crawler carrier half, left rear **1.2**.
- ▶ On the right crawler carrier **2**, there is a grease pump on each crawler carrier half, crawler carrier half, right front **2.1** and crawler carrier half, right rear **2.2**.

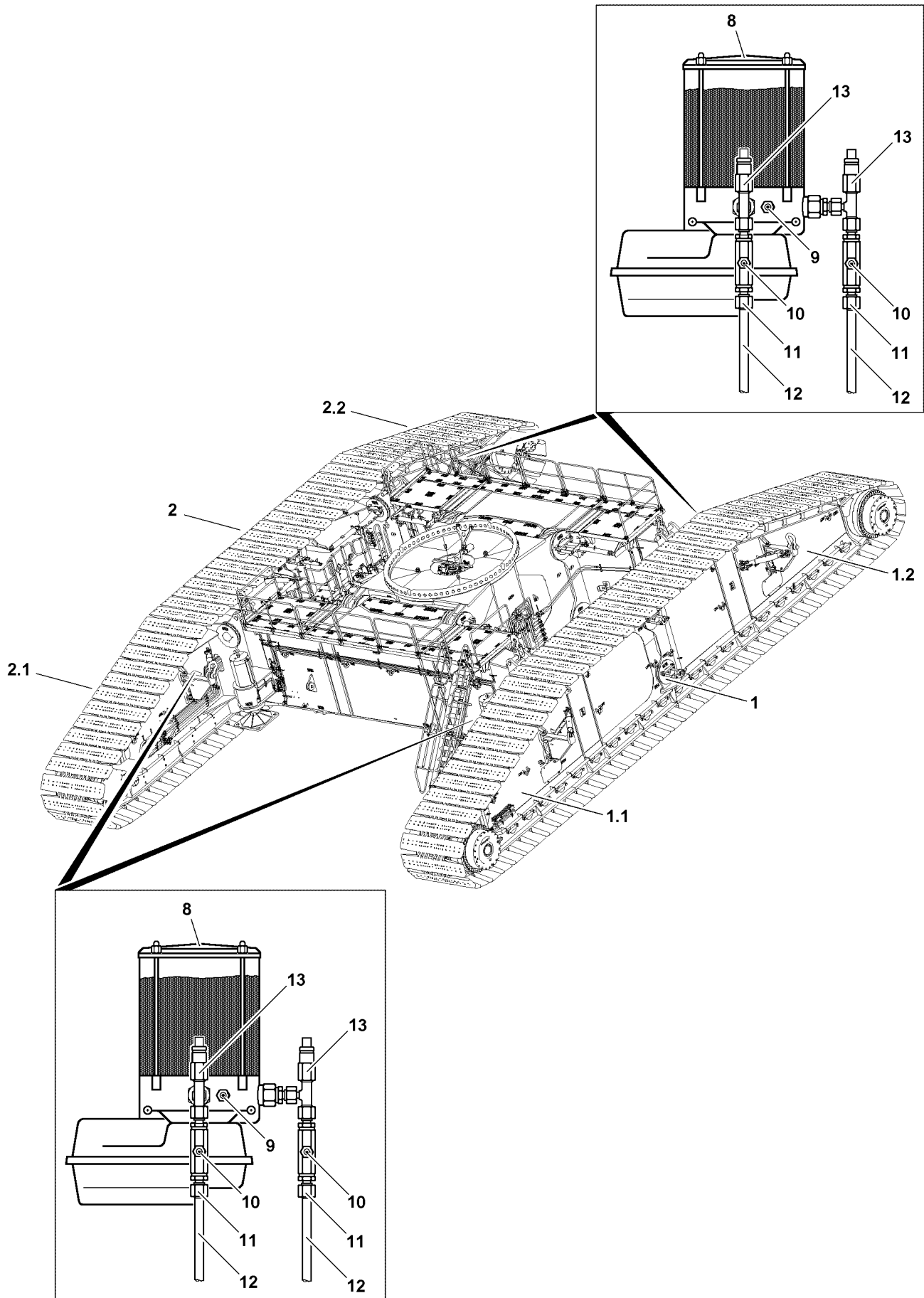

Fig.116364

LWE/LR 13000-001/19503-01-02/en

The following maintenance relevant components are located on the grease pumps:

- 8** Grease container
- 9** Grease fitting
 - Filling the grease container
- 10** Grease fitting
 - Fill the lube lines.
- 11** Main line connection
- 12** Main line
- 13** Pressure relief valve

2.1 Filling the grease container

NOTICE

Insufficient lubrication!

In case of insufficient lubrication, the grease lubrication points can run dry.

This could result in high property damage.

- ▶ Make sure that always sufficient grease is in the grease containers **8** of the central lubrication systems.
 - ▶ Do not deplete the grease container **8**.
-



Note

- ▶ If the grease container **8** is empty, the central lubrication system must be bled.
 - ▶ Fill the grease container **8** with an external grease pump via the grease fitting **9**.
-

2.2 Bleeding the central lubrication system

NOTICE

Insufficient lubrication!

If there is air in the grease pump, lubrication points can run dry.

- ▶ Bleed the central lubrication system carefully.

The central lubrication system of the crawler travel gear can be bled two ways:

- By actuation of the grease pump by simulating the crawler operation.
- By separate actuation of the grease pump with the aid of the electric wiring diagram.

2.2.1 Bleeding by simulating crawler operation



WARNING

Crane can start to drive unintentionally!

If the foot rocker in the crane operator's cab is pressed down too far while bleeding the grease pump, then the crawler travel gear can start to move.

The crane can start to drive and catch personnel.

Death, severe bodily injuries, property damage.

- ▶ Actuate the foot rocker carefully while bleeding the grease pump.
- ▶ Watch the emergence of grease from the grease pump from a safe position.

- ▶ Fill the grease container **8** with an external grease pump via the grease fitting **9**.
- ▶ Fill the main lines **12** with an external grease pump via the grease fittings **10** until grease free of air bubbles emerges on all grease points.



Note

- ▶ Carry out the bleeding procedure individually for each main line connection **11**.
- ▶ Every crawler carrier half has a separate grease pump.

- ▶ Unscrew the main line **12** from the main line connection **11**.
- ▶ Start at least one crane engine.
- ▶ Select crawler operation.
- ▶ Actuate the foot rocker / manual control lever of the crawler carrier of the grease pump which is being bled only so far that the track chain does not start to move.

Result:

- The grease pumps starts to supply.
- The acoustic signal crawler operation sounds.
- ▶ Actuate the foot rocker / manual control lever only until grease free of air bubbles emerges on the main line connection **11**.
- ▶ Reconnect the main line **12**.
- ▶ Actuate the foot rocker / manual control lever again until grease emerges again on at least one of the grease points in the bled lubrication circuit.

2.2.2 Bleeding via separate actuation of the grease pump



Note

- ▶ Work on the electrical system of the crane may only be carried out by authorized and trained expert personnel.

Make sure that the following prerequisite is met:

- The separate electric wiring diagram of the crane is available.
- ▶ Fill the grease container **8** with an external grease pump via the grease fitting **9**.
- ▶ Fill the main lines **12** with an external grease pump via the grease fittings **10** until grease free of air bubbles emerges on all grease points.



Note

- ▶ The bleeding procedure must be carried out individually for every main line connection **11**.
- ▶ Every crawler carrier half has a separate grease pump.

- ▶ Unscrew the main line **12** from the main line connection **11**.
- ▶ Actuate the grease pump separately, see electric wiring diagram for the crane.

Result:

- The grease pump starts to supply.
- ▶ Actuate the grease pump until grease free of air bubbles emerges on the main line connection **11**.
- ▶ Reconnect the main line **12**.
- ▶ Actuate the grease pump again until grease emerges again on at least one of the grease points in the bled lubrication circuit.

2.3 Bleeding repaired lubrication lines

NOTICE

Insufficient lubrication!

If there is air in the lubrication lines, lubrication points can run dry.

This could result in high property damage.

- ▶ If the lubrication lines are repaired or replaced, make sure that they are completely filled with grease.
- ▶ Fill lubrication lines completely with grease before installation.
- ▶ Check repaired lubrication lines for function and leaks.

2.4 Intermediate lubrication of crawler carriers

- ▶ Fill the main line **12** with an external grease pump via the grease fitting **10** until grease free of air bubbles emerges on all grease points.
- or**
- ▶ Actuate the foot rocker / manual control lever in crawler operation until the grease pump starts to supply, but the track chain does not yet start to move. Continue actuation until grease emerges on all lube points.

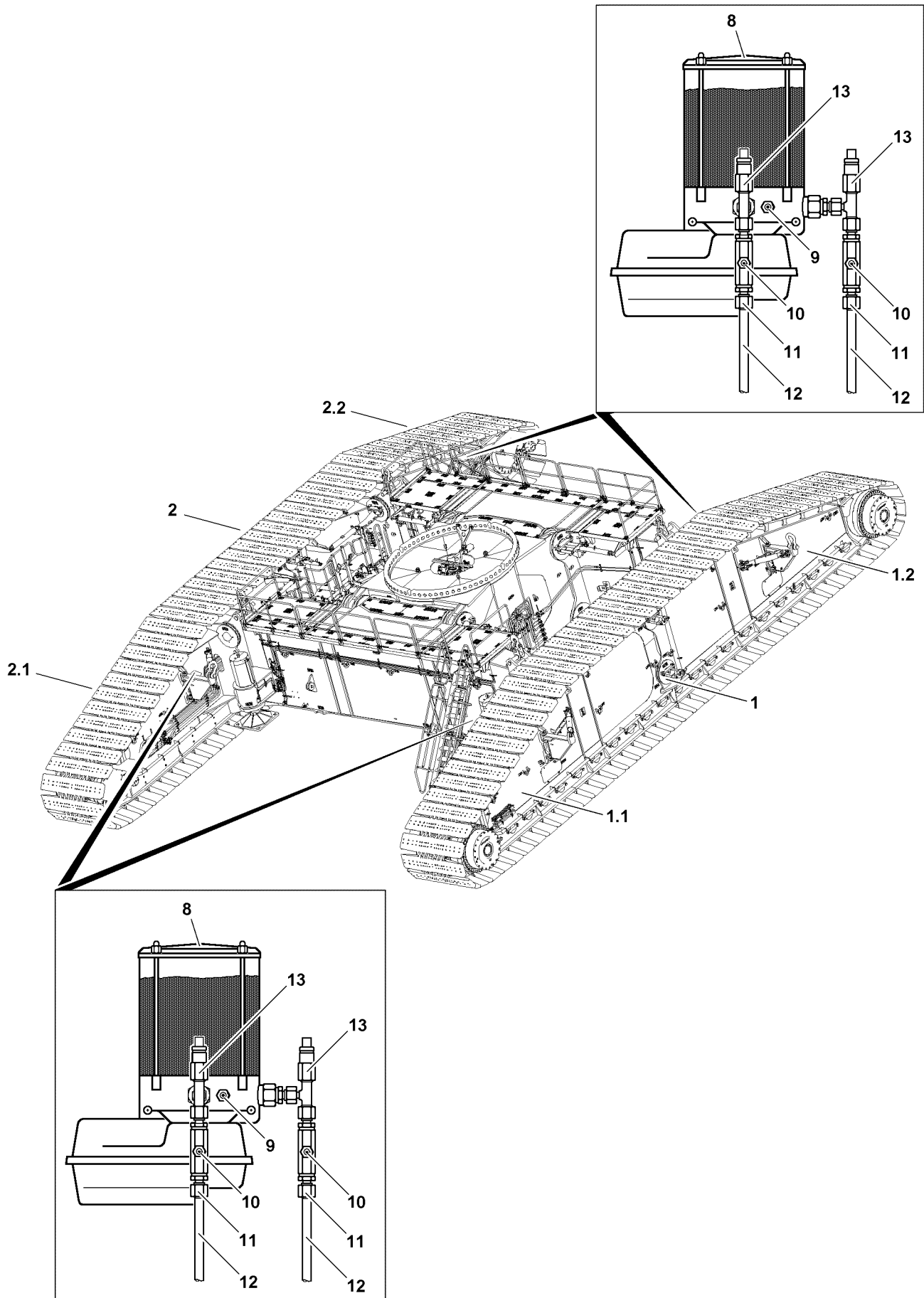

Fig.116364

LWE/LR 13000-001/19503-01-02/en

2.5 Troubleshooting on the central lubrication system

Problem	Cause	Remedy
The grease pump does not work	Electrical line interrupted, grease pump defective.	Fix or replace the electrical line, replace the grease pump
Grease pump operates, but does not deliver	Air cushion in delivery piston, minimum fill level fallen below, grease pump element defective	Bleed grease pump, fill reservoir, replace grease pump element
No grease collar on all lube points	Grease pump does not work, system blocked	See „Grease pump does not work“ or „Grease emerges via pressure relief valve“
No grease collar on several lube points	Supply lines to secondary distributors broken or leaking, screw connections leaking	Replace lines, tighten or replace screw connections
No grease collar on one lube point	Associated lube line broken or leaking, screw connection leaking	Replace line, tighten or replace screw fitting
Grease pump speed reduced	High system pressure, low ambient temperature	Check the system / bearing points, if no damage is found: grease intermediately once or twice, if necessary ¹⁾
Grease escapes at the pressure relief valve	System pressure too high, distributor blocked, system blocked, defective valve spring on pressure relief valve	Check system, replace distributor, repair blocked / seized bearing point, replace pressure relief valve

1) See section „Intermediate lubrication of crawler carriers“.



Note

► If a problem cannot be remedied, contact the Service Dept. at Liebherr-Werk Ehingen.

3 Servicing the track chain



Note

► The illustrations in this chapter are examples and may not apply exactly to your crane.

In crawler operation, the components of the crawler travel gear are subject to wear caused by operation.

In order to continuously guarantee safe and effective crane operation, components must be checked at the specified maintenance intervals and replaced if necessary, see the Crane operating instructions, chapter 7.02.

**WARNING**

Maintenance interval exceeded!

Failure to observe the specified maintenance intervals can lead to increased crane failure time as well as to damage on the crawler travel gear.

Death, severe bodily injuries, property damage.

- ▶ Make sure that the maintenance intervals in the Crane operating instructions chapter 7.02 are observed.
- ▶ The crane operator is responsible for complying with the maintenance intervals, properly performing the specified maintenance tasks as well as initiating the corresponding measures as a result of the inspection results.

3.1 Tensioning the track chain

The track chain must be retensioned at the latest when three track pads **2** at point **P2** are laying flat on the glide rails **1.1** on the crawler carrier **1**.

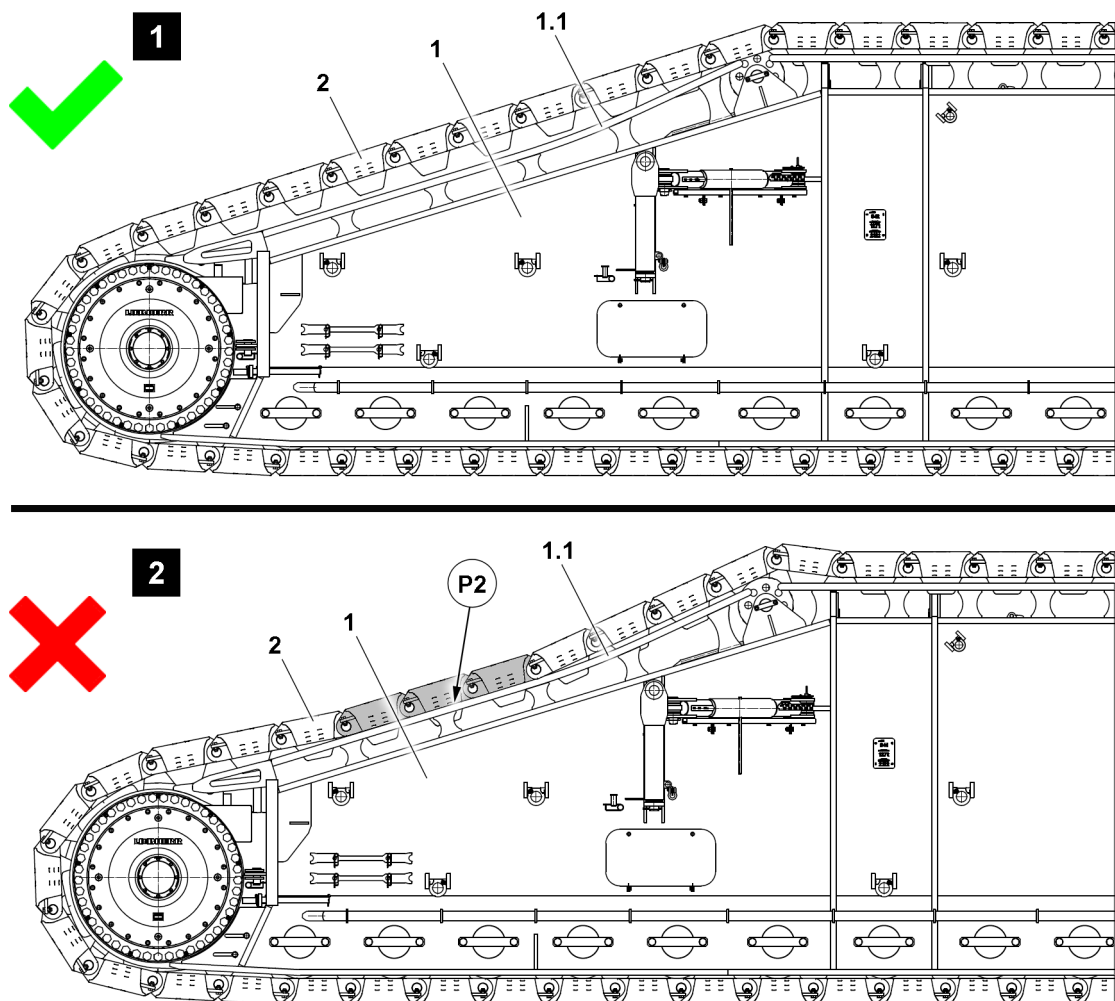

Fig.128243: Chain tension OK, illustration 1 // Track chain too slack, illustration 2

NOTICE

Damage to the track chain and the crawler carrier!

If the chain tension is not checked within the specified maintenance intervals, the track chain or the steel structure of the crawler carrier can be damaged.

- ▶ Observe and adhere to the maintenance intervals, see the Crane operating instructions, chapter 7.02.
- ▶ If **three** of the track pads **2** of the track chain lie flat on the glide rails **1.1** on the crawler carrier **1** (see point **P2**), then the track chain must be retensioned **immediately**.

The following applies in the case of crawler carriers **1** without glide rails **1.1** or with worn glide rails **1.1**:

- ▶ Make sure that the track pad cams never come into contact with the base steel structure of the crawler carrier. Always retension the track chain early on.

The following applies:

- ▶ The crane driver bears full responsibility for damage resulting from a non-tensioned track chain.
-

NOTICE

Glide rails worn!

If the glide rails on the crawler carriers are worn to the extent that the remaining material can be deformed or could break under the weight of the track chain, this could result in capital property damage to the crawler travel gear.

- ▶ Retension the track chain early on.
 - ▶ Make sure that worn glide rails are replaced early on, please contact Customer Service at LIEBHERR-Werk Ehingen GmbH.
-

**Note**

- ▶ By extending the tension cylinder integrated in the crawler carrier **14** the sliding section **17** of the crawler carrier is moved in the direction of the arrow.
 - ▶ The chain tension is held by spacer plates **16**.
-

NOTICE

Foreign matter in track chains!

Foreign matter in the track chains and on the travel drive can cause damage.

- ▶ Before tensioning the track chains, check the track chains and the travel drives for foreign particles, such as rocks, and clean them, if necessary.

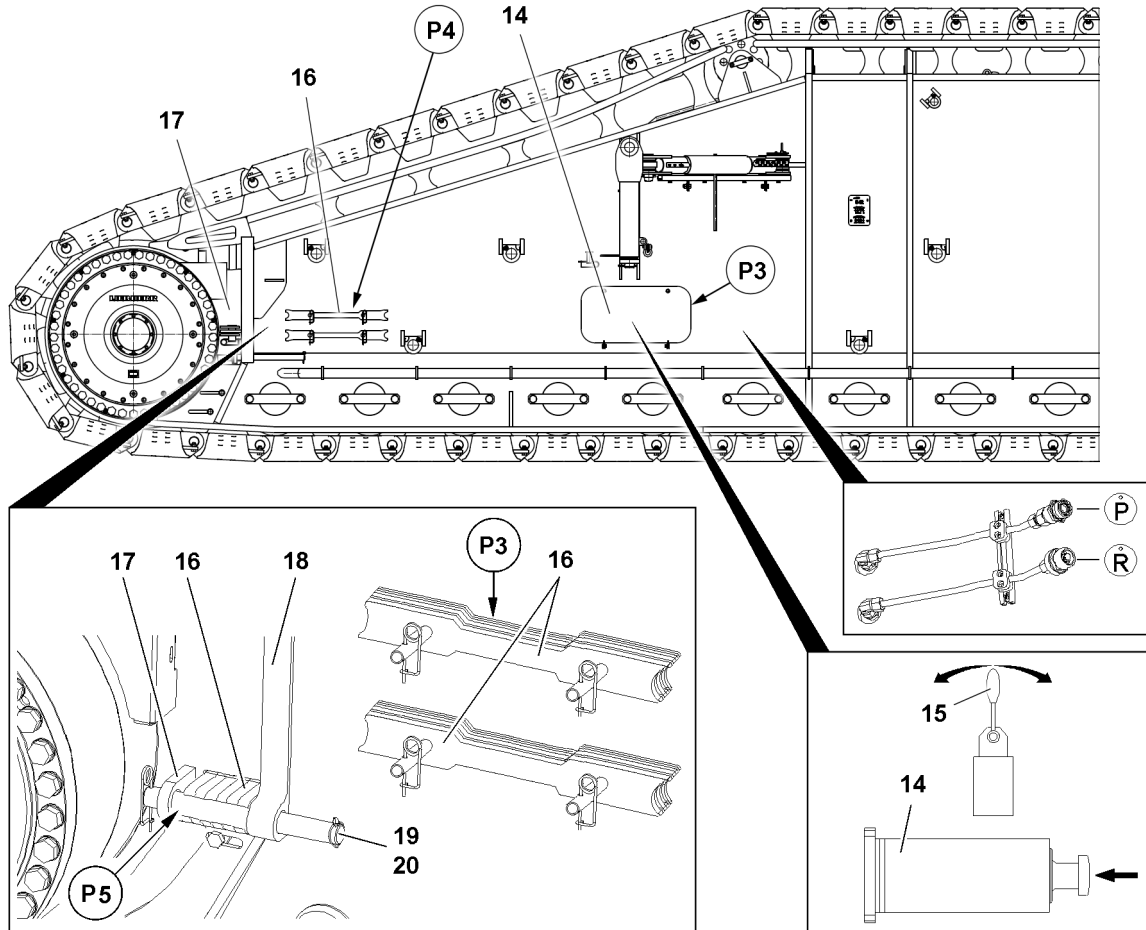

Fig.127107: Tensioning the track chain

Make sure that the following prerequisites are met:

- The crane is in horizontal position.
- The hydraulic aggregate is available.

3.2 Hydraulic connection tension cylinder

When hydraulic lines are connected / disconnected using quick-release couplings, please ensure that the coupling procedure is being performed correctly.

**WARNING**

Pressure in the hydraulic lines!

If the pressure supply is not interrupted before connecting / releasing the hydraulic lines, the hydraulic oil can escape with high pressure.

Death, severe bodily injuries, property damage.

- ▶ Release the pressure in the hydraulic lines before connecting / disconnecting: Interrupt the pressure supply and wait for a short time.

**WARNING**

Loss of pressure or leakage!

Incorrectly coupled or self-loosening quick couplings (particularly return lines) can result in serious accidents due to component failure.

- ▶ Check that the quick-release couplings have been properly connected before starting the tension procedure.

3.2.1 Establishing the hydraulic connection

- ▶ Connect the quick-release coupling components (sleeve and connector) and screw together with the hand-tightened nut.
- ▶ Tighten the quick couplings by hand: Rotate the hand-tightened nut until it reaches a tangible, fixed stop position.
- ▶ Establishing the hydraulic connections to the tension cylinder **14**: Connect the supply lines of the external hydraulic aggregate on the supply lines of the crawler carrier, hydraulic connection **P** and hydraulic connection **R**, see the Hydraulic diagram.
- ▶ Add the pressure supply.

3.2.2 Disconnecting the hydraulic connection

When the tension procedure has been completed:

- ▶ Interrupt the pressure supply.
- ▶ Disconnect the coupling parts (sleeve and connector).
- ▶ Install dust caps on the quick couplings.
- ▶ Close the maintenance hatch on point **P3**.

3.3 Carrying out the tension procedure

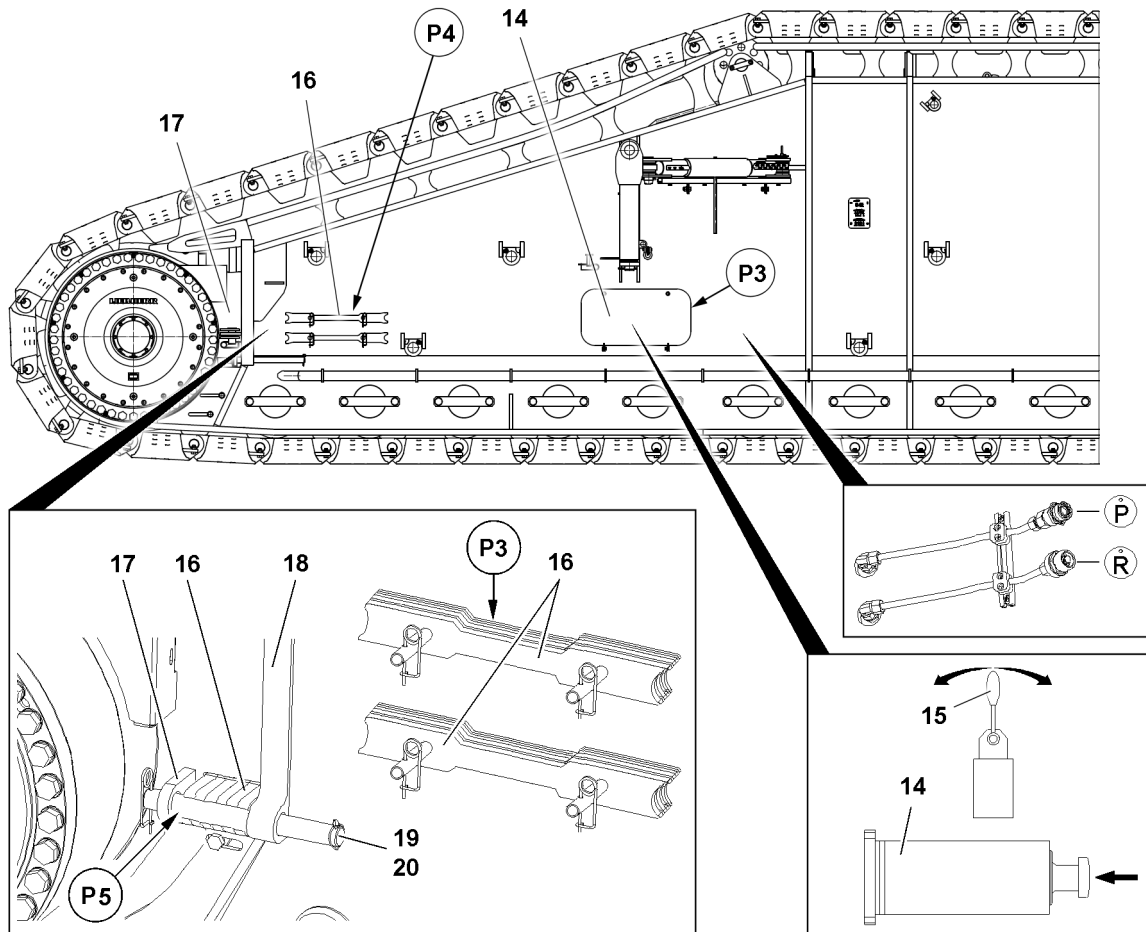

Fig.127107

Make sure that the following prerequisites are met:

- The hydraulic connections from the external hydraulic aggregate to the connections of the tension cylinder have been established.
- The maintenance flap / service flap at point **P3** is open

NOTICE

Damage to the crawler carrier!

Since the sprocket does not turn along by itself during the tension procedure of the track chain, the travel drive must be actuated for a short time again on the sliding section.

If this is not observed, severe property damage can occur on the sprocket or the travel drive.

- ▶ When tensioning the track chain, the travel drive must always be actuated for a short time on the sliding section side of the crawler carrier to correctly engage the sprocket on the cams of the track chain.

- ▶ Extend the tension cylinder **14** by actuating the hand lever **15**.

Result:

- The crawler chain is tensioned.

NOTICE

Component wear due to **insufficient** chain tension!

If the track chain sags too much after the tension procedure, the track pads of the track chain as well as the glide rails **1.1** can wear significantly in travel operation.

- ▶ Make sure that the track chain always has sufficient tension.

NOTICE

Component wear due to **high** chain tension!

If the track chain is tensioned too much after the tension procedure, the pin connections can wear significantly.

In addition, the pitch on the sprocket changes, which also can lead to significant wear or significant damage on the sprocket.

- ▶ Make sure that the track chain is not tensioned too much.

- ▶ Remove the spacer plates **16** from the transport receptacle on point **P4**.
- ▶ On point **P5**, insert as many spacer plates **16** as fit into the gap between the sliding section **17.1** and the crawler carrier **18**.
- ▶ Secure the spacer plates **16** with pin **19** and spring retainer **20**.

**WARNING**

Danger of crushing!

When releasing the tension cylinder **14**, body parts, such as: Fingers, hands and arms can be crushed or severed.

- ▶ When relieving the tension cylinder **14**, any work on the crawler carrier is prohibited.
- ▶ Relieve the tension cylinder **14** by actuating the hand lever **15**.
- ▶ After the tension procedure, drive the crawler back and forth about two crawler lengths in operating mode „Straight forward travel“.

Result:

- The tension of the track chain is reduced.
- ▶ Check the distance of the track chain to the steel construction of the crawler carrier again at point **P2**.

**Note**

- ▶ If necessary, repeat the tension procedure of the track chain and insert additional spacer plates **16**.
- ▶ If the lift on the tension cylinder **14** is no longer sufficient to tension the track chain, then trained expert personnel must remove one track pad.
- ▶ Release the pressure from the hydraulic supply lines.
- ▶ Disconnect the hydraulic supply lines on the hydraulic connection **P** and hydraulic connection **R**.

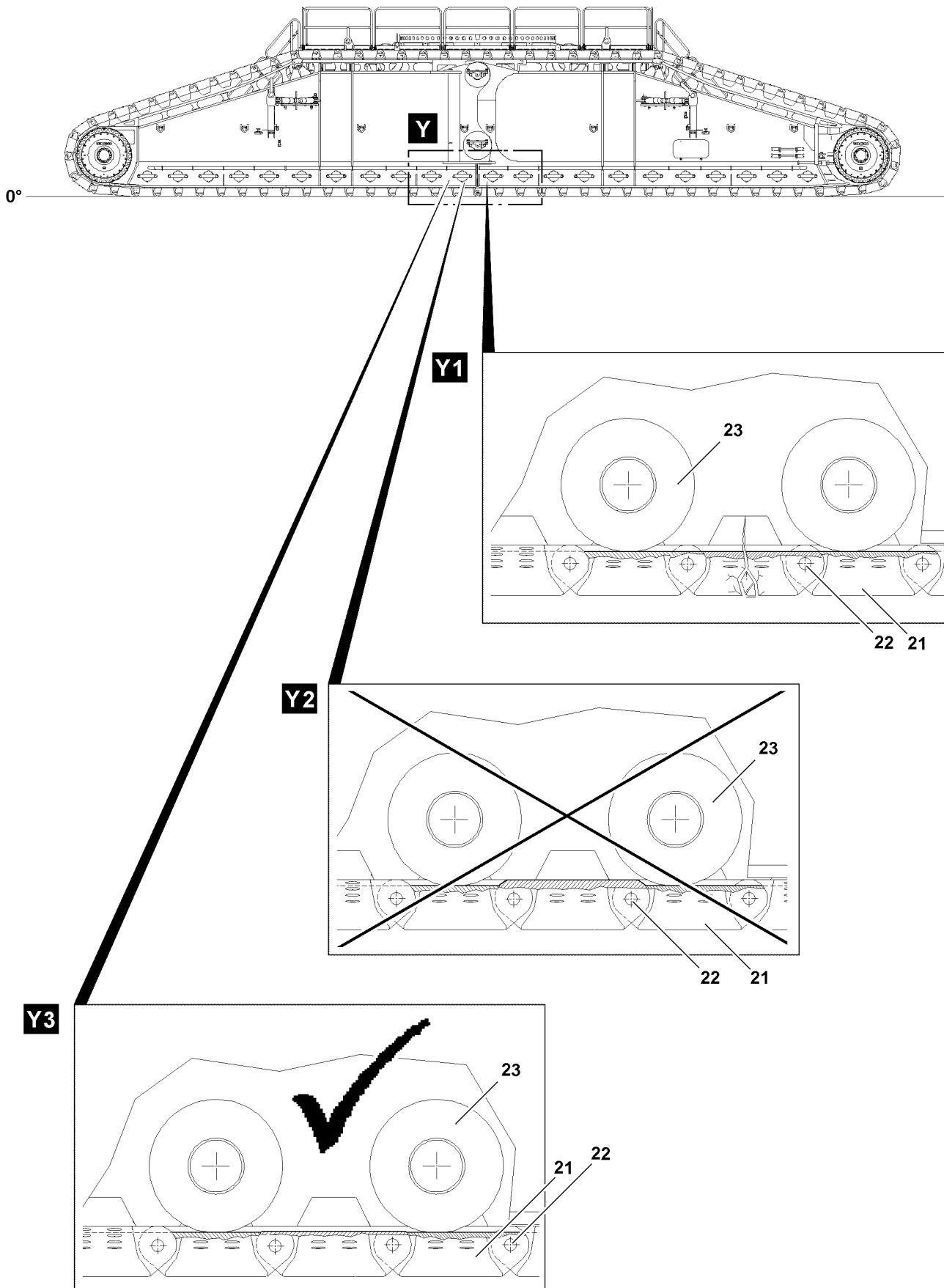

Fig.116366

LWE/LR 13000-001/19503-01-02/en

3.4 Checking wear on the track chain



WARNING

Track chain can be ripped off!

If the wear limit on the track pads **21**, pins **22** or track rollers **23** is exceeded, then the track chain can break off during crawler operation.

The crane can topple over.

Death, severe bodily injuries, property damage.

- ▶ Random checks of the track pads **21**, pins **22** and track rollers **23** must be carried out within the specified intervals.
- ▶ During the random inspection of the track rollers, the first and last track roller on the crawler carrier must be included in the inspection.
- ▶ If a wear limit on the component is reached, then the component must be replaced or remachined.

NOTICE

Significant wear of crawler travel gear!

If an individual track pad **21** must be replaced then it may not be replaced with a track pad **21** that shows a much lower degree of wear.

Significant height differences between the individual track pads **21**, see illustration **Y2**, lead to an increased mechanical stress on the track pads **21** and the track rollers **23** of the crawler carrier.

- ▶ Replace a defective track pad **21** with a track pad **21** that shows a similar degree of wear, see illustration **Y3**.



Note

- ▶ Due to the break-in period of the components toward each other, a larger stretch of the track chains occurs on a new crawler travel gear. For that reason, it may be necessary to remove a track pad **21** earlier to be able to tension the track chain correctly.

The wear of the track pad **21**, bolts **22** and track rollers **23** depends a various factors:

- Length of travel route
- Frequency of driving in curves
- Friction ratios track pad **21** - ground
- Evenness of the ground
- Type of ground
- Load bearing capacity of the ground / base
- Position of the total center of gravity
- Load on the hook
- Placed ballast on the crane

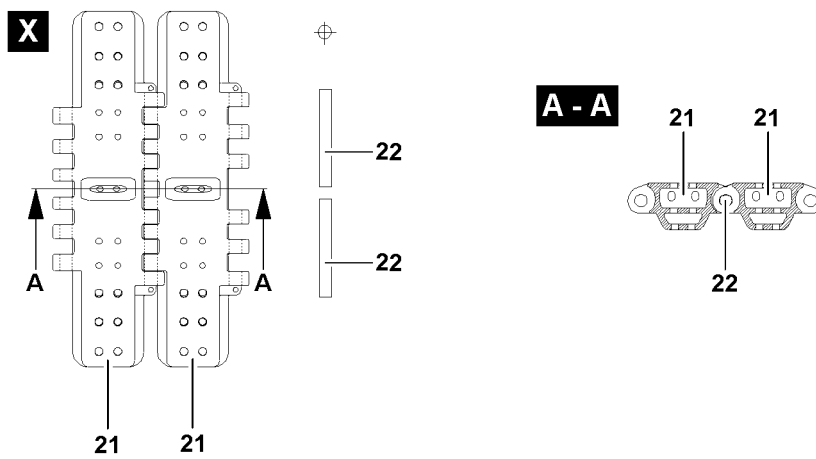
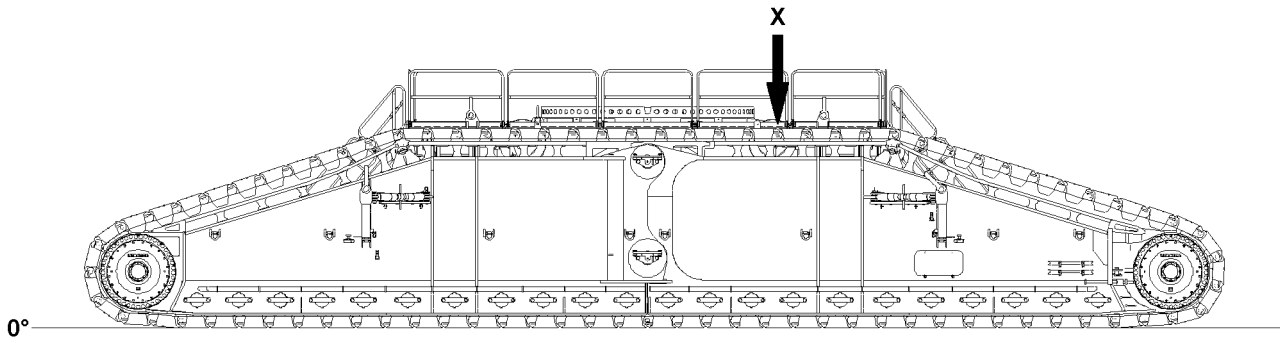

Fig.116367

LWE/LR 13000-001/19503-01-02/en

3.4.1 Checking the wear on the connections of the track pads

NOTICE

Damage to the sprocket!

If the wear limit on the connections to the track pads is reached, it can lead to increased wear on the sprocket and on the transporting lugs of the track pads due to excessive chain stretch.

Expensive and extensive repairs can result.

- ▶ The random inspection of the pin diameter must be made within the specified intervals.
- ▶ If one pin **22** falls below the minimum permissible dimension, then it must be replaced with a new pin **22**.
- ▶ The random inspection of the bore diameter must be made within the specified intervals.
- ▶ If the bore diameter exceeds the maximum permissible dimension, then the track pad **21** must be replaced.

The track pads **21** of the crawler track are connected by bolts **22**.

Wear limit bore for the track pad	
Initial diameter	83 mm
Maximum permissible upper limit	86 mm

Wear limit bolt	
Initial diameter	80 mm
Maximum permissible minimum dimension	78 mm

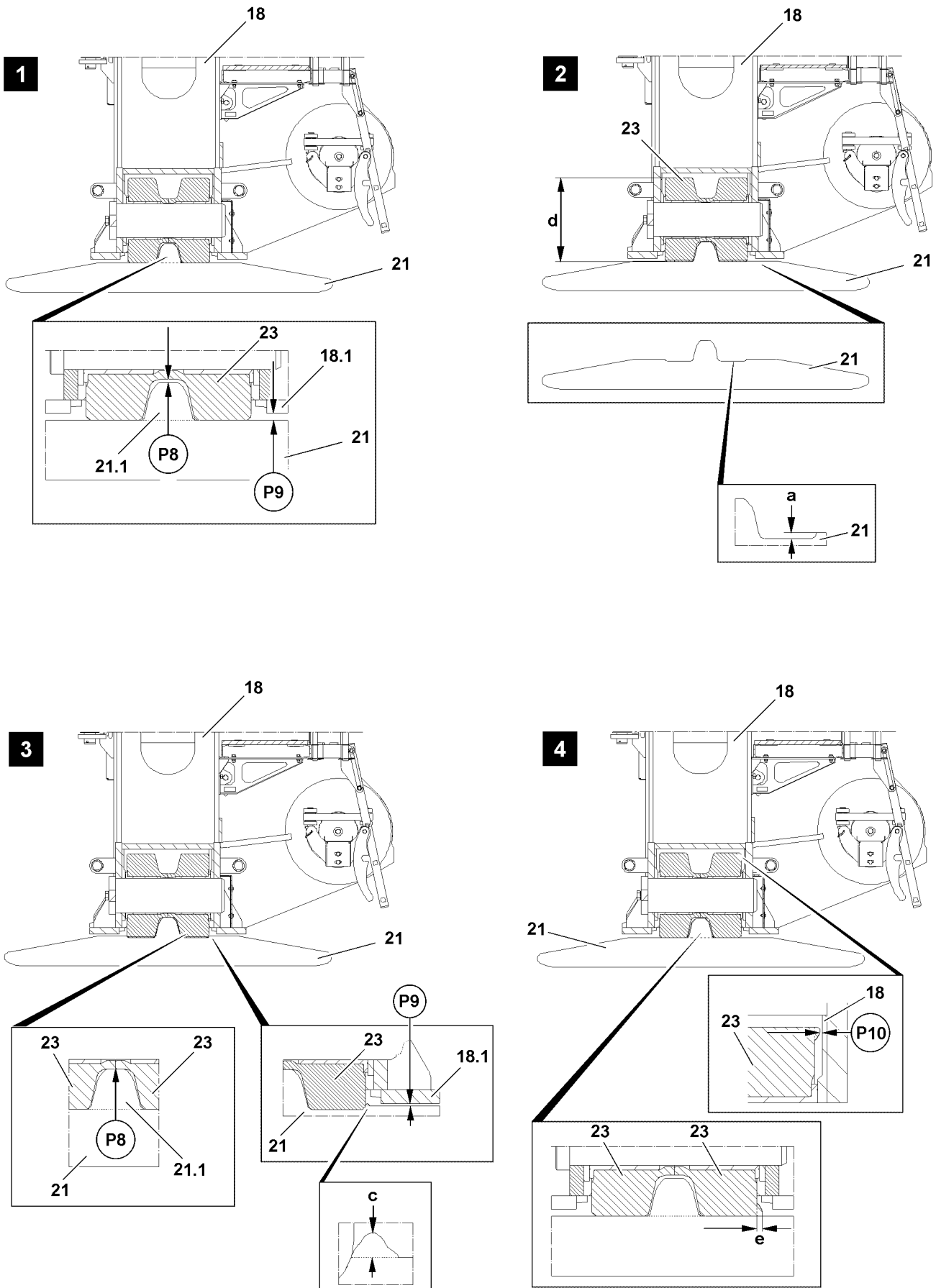

Fig.116368

LWE/LR 13000-001/19503-01-02/en

3.4.2 Checking the wear on the roll off surfaces of the track pads / track rollers

NOTICE

Destruction of track pad!

If a track pad **21** is not fixed or replaced after reaching the wear limit, then the track pad **21** will be destroyed and can cause damage to the crawler carrier **18**.

This could result in high property damage.

- ▶ Fix or replace the track pad **21** after reaching the wear limit.
-

NOTICE

Failure of track rollers!

If the track rollers **23** are not replaced after reaching the wear limit, then they can fail and cause damage to the crawler carrier **18** and track pad **21**.

This could result in high property damage.

- ▶ Replace track rollers **23** after reaching the wear limit.
-

NOTICE

Increased wear!

If the bulges on the track pads **21** and the track pads **23** become too large, see illustration **3** and illustration **4**, then it results in increased wear on the crawler travel gear.

This could result in high property damage.

- ▶ Grind off / remove bulges in time.
-

If the wear limits are not adhered to, the minimum distances are fallen below:

- On point **P8** between the transport lugs **21.1** and track rollers **23**
 - On point **P9** between the track pad **21** and base belt **18.1**
 - On point **P10** between the track rollers **23** and crawler carrier **18**
-

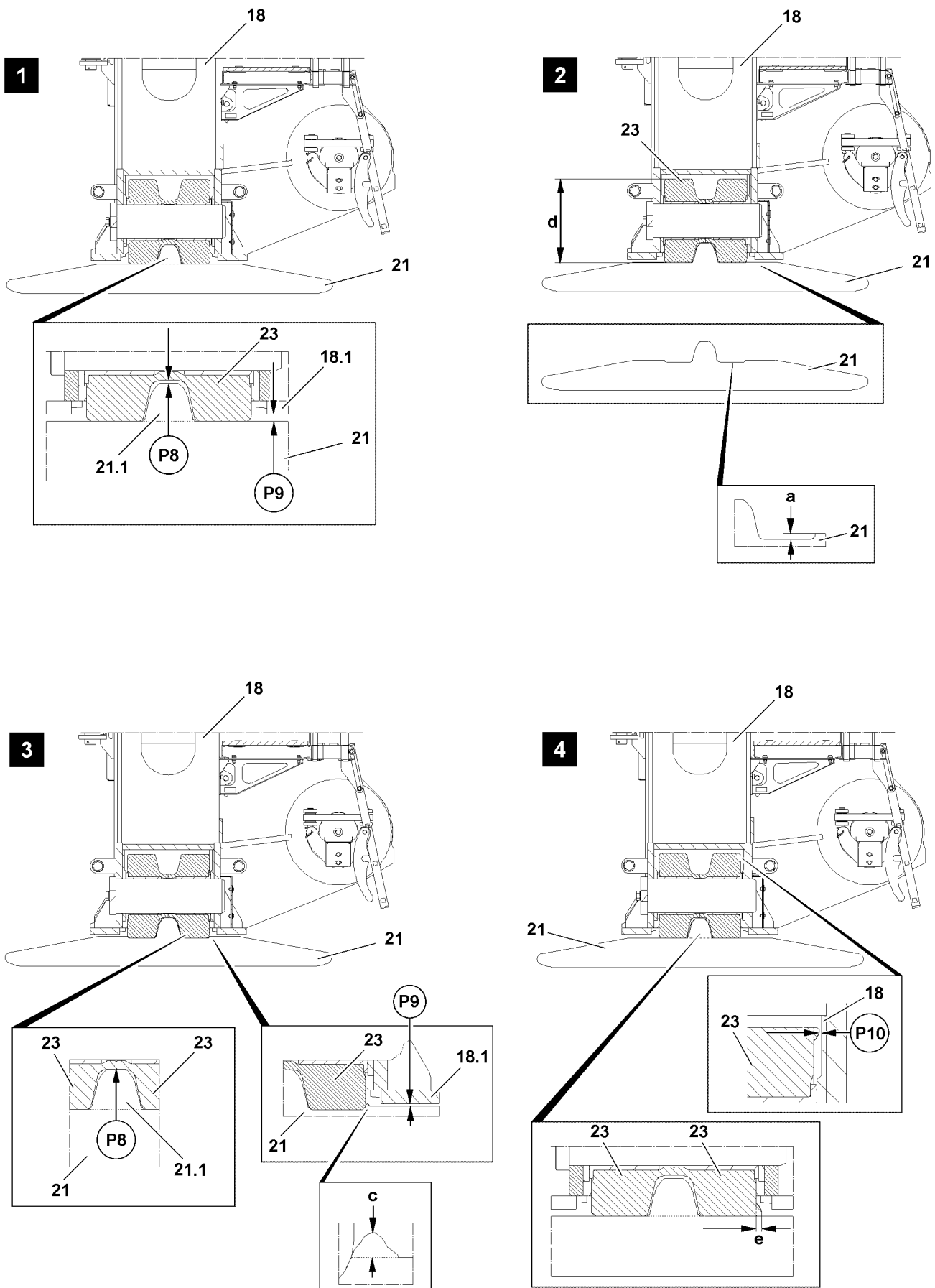

Fig.116368

LWE/LR 13000-001/19503-01-02/en

Wear limit track pad	
Maximum permissible run in depth a	8 mm
Maximum permissible bulge c	1)

Wear limit track roller	
Initial diameter	620 mm
Permissible minimum diameter d (measured in the center of the running surface)	616 mm
Maximum permissible bulge e	3 mm ²⁾

1) As soon as the bulge scrapes on the base belt of the crawler carrier, **grind bulge off**.

2) Valid for all track systems: If the bulge is larger than 3 mm , **grind the bulge off**.



WARNING

Danger of injury due to improper procedure!

- ▶ All work on the track chains must be carried out by trained expert personnel.



Note

- ▶ Track pads that have reached the maximum run in depth, or whose running surface is heavily worn, can be repaired by repair welds according to welding guideline or repair instructions of **LIEBHERR-Werk Ehingen GmbH**.
- ▶ Damage on sprocket and track pads - caused by operational wear - can be repaired by repair welds according to welding guidelines or repair instructions of **LIEBHERR-Werk Ehingen GmbH**.
- ▶ Please contact the Service Dept. at **LIEBHERR-Werk Ehingen GmbH**.
- ▶ Replace worn track rollers **23**.
- ▶ Grind off excessive bulges, see illustration **3** and illustration **4**.

4 Ladders



Note

- ▶ The following listed ladders are examples and may not match your crane exactly.



WARNING

Danger of falling!

If the following safety notes are **not** observed, personnel can fall down.

Death, severe bodily injuries, property damage.

- ▶ Observe and adhere to the installation and safety guidelines for ladders.
- ▶ Observe and adhere to the safety signs on the ladders.
- ▶ Install and secure the ladders properly.
- ▶ Do **not** use damaged ladders and replace them immediately.
- ▶ Repair the ladder exclusively through authorized service facilities.

4.1 Lubricating ladders

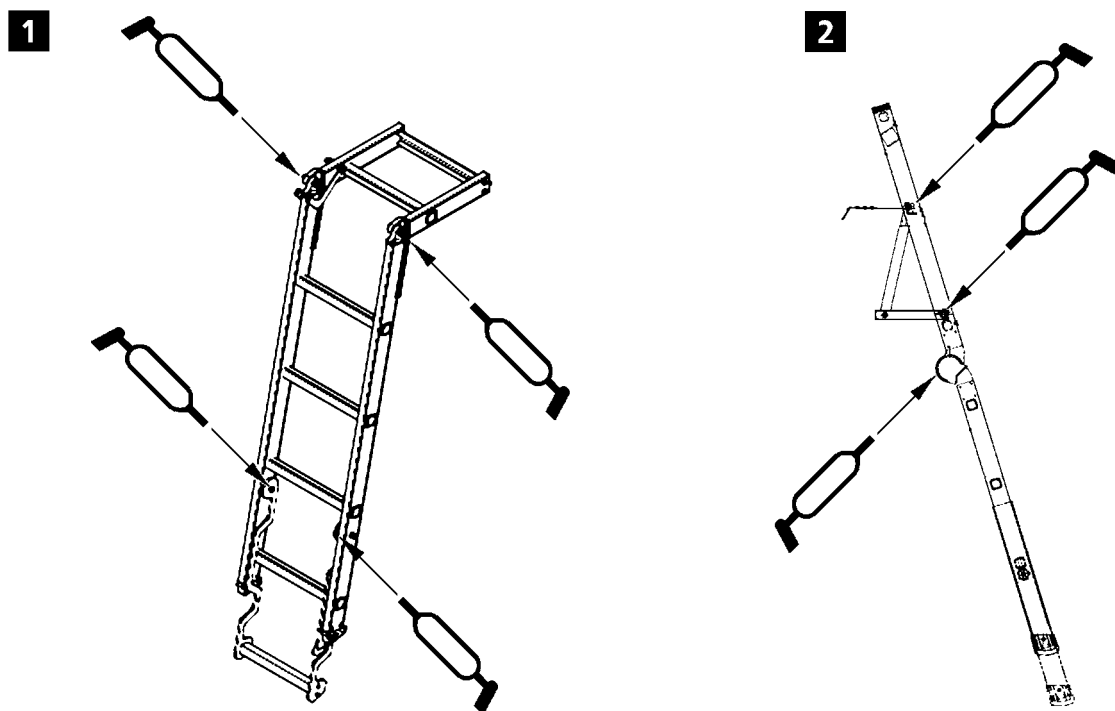

Fig.109766

- ▶ Grease joints and pivot points on the ladders regularly and check them for easy movement, see illustration 1 and illustration 2.
- ▶ Repairs and maintenance work on the ladder must be made by expert personnel.

7.05 Maintenance instructions - Crane superstructure

1	Crane engine	3
2	Pump distributor gear	9
3	Hydraulic system	11
4	Fuel system	17
5	Slewing ring connection	21
6	Central lubrication system	25
7	Winches 1, 2, 3, 4, 5	41
8	Winch 6	47
9	Air dryer of the pressurized air system	49
10	Electrical system - Lighting	49

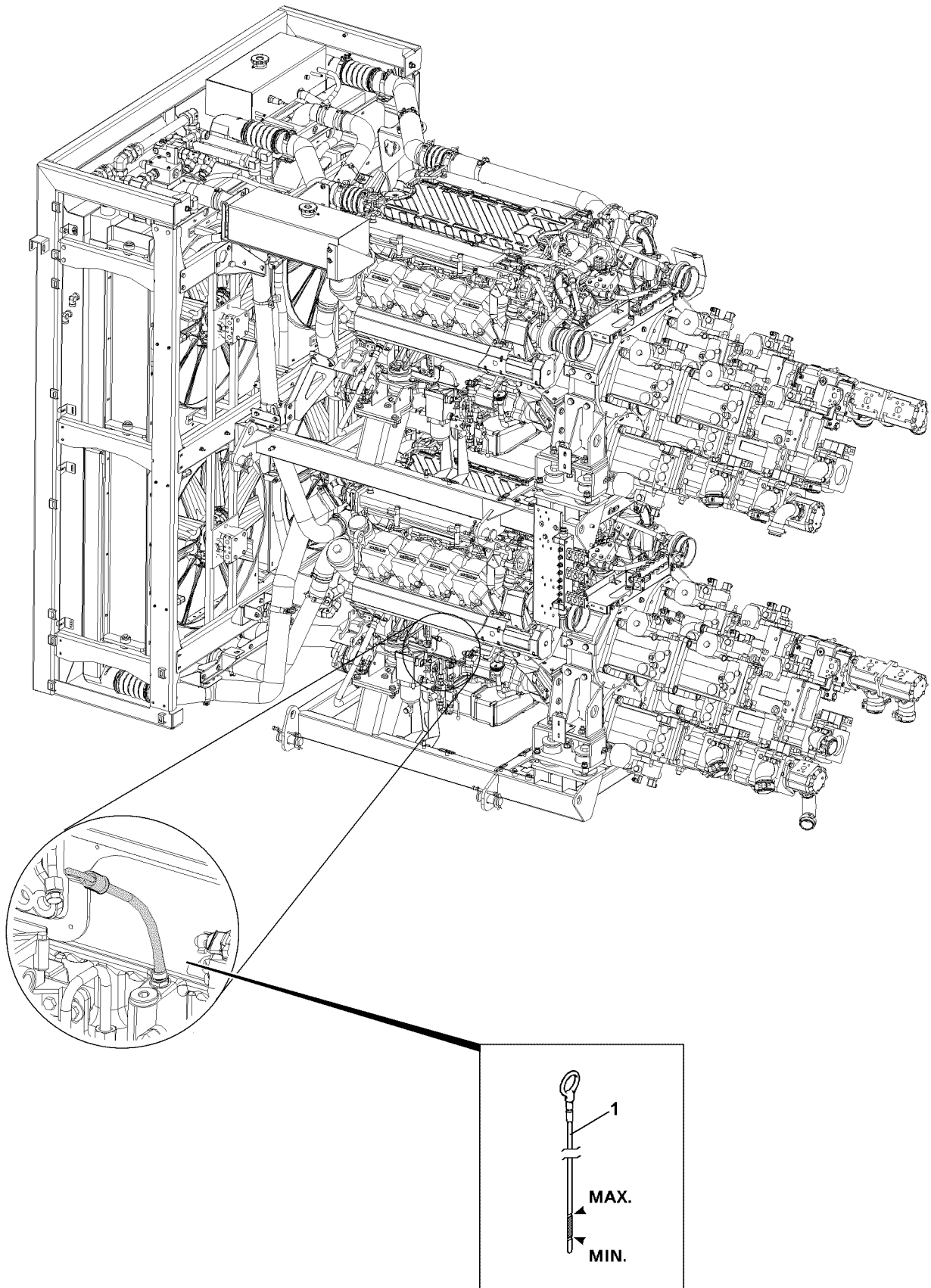

Fig.115661

LWE/LR 13000-001/19503-01-02/en

1 Crane engine



Note

- ▶ The crane LR 13000 has two identical engines and is therefore only explained on one engine unit!

Never step on fuel lines during maintenance or repair work in the engine area!



DANGER

Danger of fire!

- ▶ Make sure that the engine area is kept free of diesel fuel!
- ▶ Extreme cleanliness is vital, particularly during filter changes and bleeding. Wipe up any spilled fuel!
- ▶ When replacing the filter, it is recommended to place down cleaning rags before removing the filter in order to absorb fuel!



WARNING

Danger of burns during maintenance and inspection work!

Severe burns can result due to the engine and oils at operating temperatures!

- ▶ Avoid direct body contact to heated components and fluids!

1.1 Engine oil

1.1.1 Checking the oil level

Make sure that the following prerequisites are met:

- The crane is in horizontal position.
- The engine is turned off and the oil has collected in the oil pan.
- ▶ Remove the dipstick **1** and wipe it off.
- ▶ Reinsert the dipstick **1** and pull it out again.

The oil level must be between the min. and max. marks on the dipstick **1**.

- ▶ Check the oil level.

NOTICE

Risk of damaging the engine!

If the oil level has dropped below the minimum mark, add engine oil according to the lubrication chart until the oil level is between the minimum and maximum marks!

- ▶ Add engine oil and check again!

- ▶ Reinsert the dipstick **1**.

1.1.2 Changing the oil

Refer to the separate operating instructions for „LIEBHERR Diesel engines“.

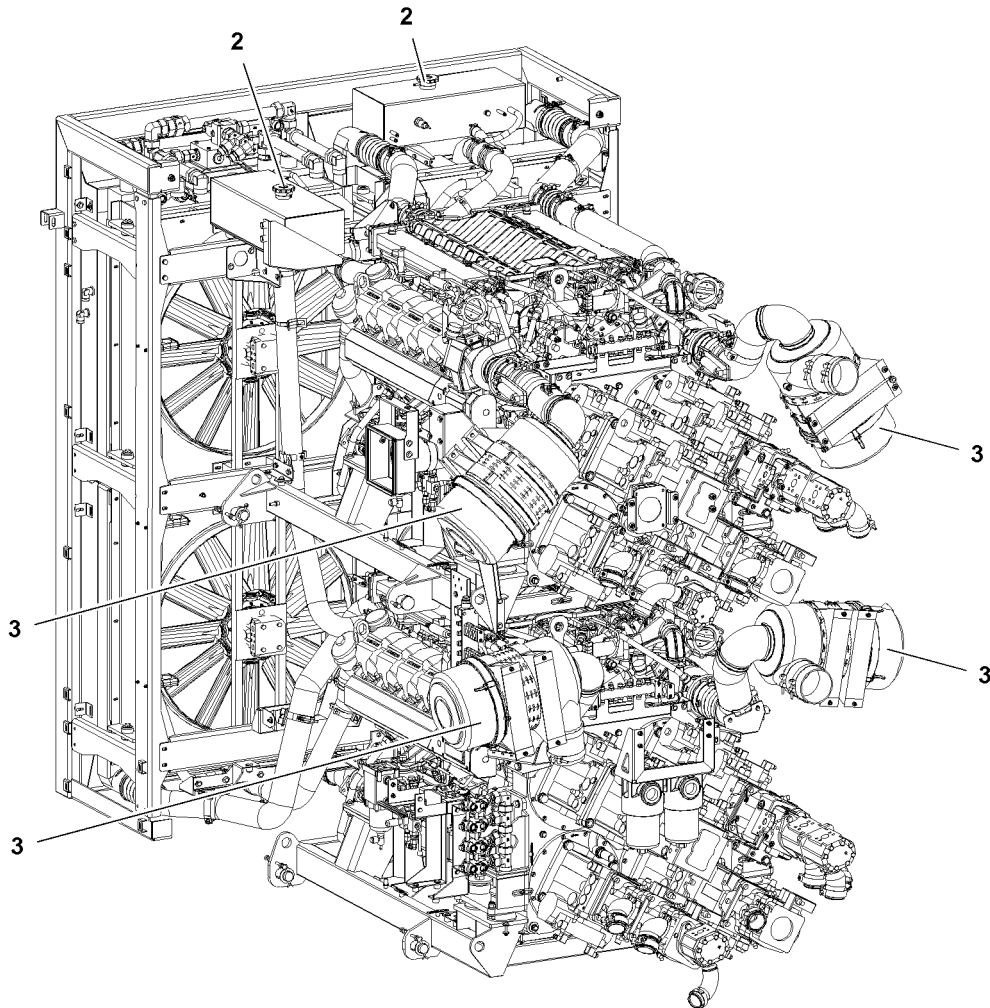
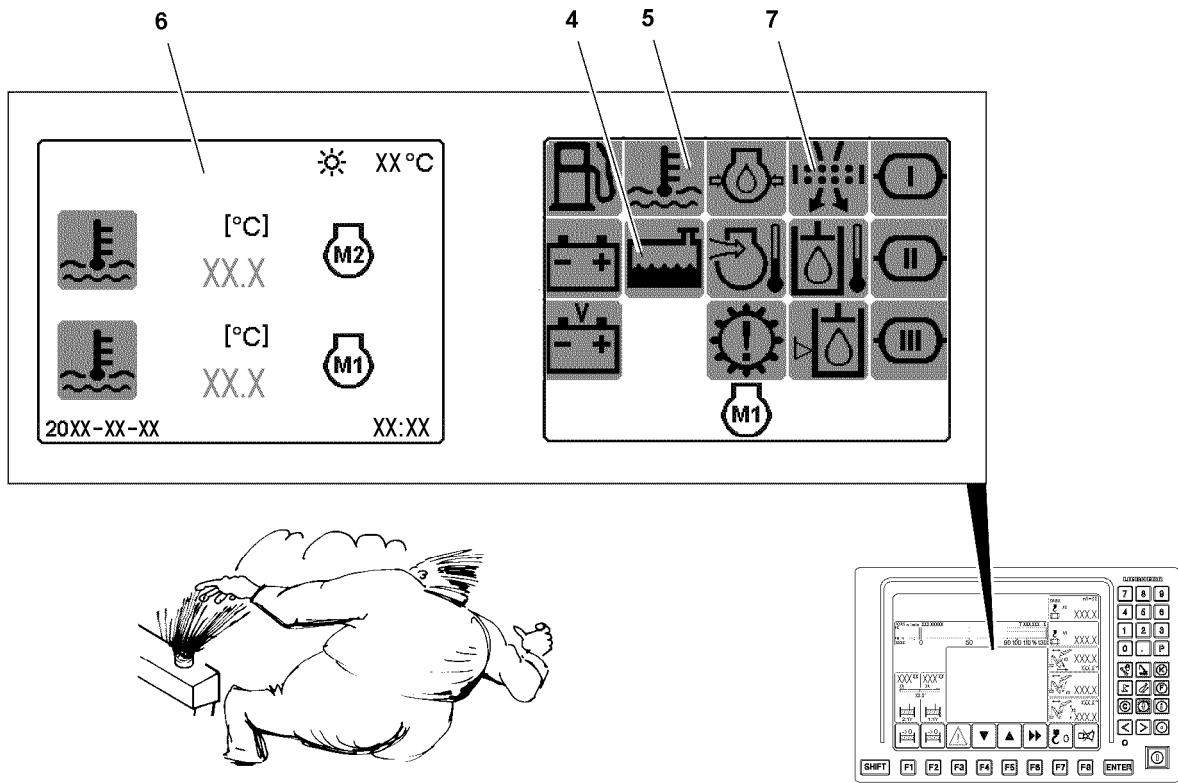

Fig.115662

LWE/LR 13000-001/19503-01-02/en

1.2 Engine coolant

The coolant level is monitored by the LICCON computer system. If the coolant level is too low the „Coolant level too low“ **4 red** icon appears on the LICCON monitor.

The coolant temperature is monitored by the LICCON computer system. If the coolant temperature is too high, the icon „Coolant temperature“ **5 red** appears on the LICCON monitor.

The exact coolant temperature of the crane engine can also be read in the individual control display **6** on the LICCON monitor, see Crane operating instructions, chapter 4.02.



WARNING

Danger of skin burns!

▶ Check the coolant only when the engine is cold!

- ▶ Turn the cap **2** on the filler neck of the water cooler expansion tank to the first notch.
- ▶ Release excess pressure.
- ▶ Remove the cap **2**.
- ▶ Check the coolant level.

Add coolant as specified in the lubrication chart only on the filler neck of the water cooler expansion tank.

▶ Add coolant to overflow level if necessary.

1.3 Air filter

The air filter **3** is monitored by the LICCON computer system. If the vacuum increases in the intake line due to dirty filter units, the „Air filter contaminated“ **7 red** icon is displayed on the LICCON monitor.

If the „Air filter contaminated“ **7** icon appears:

▶ Clean or replace filter insert.

1.4 Diesel particle filter*



DANGER

Danger of igniting the diesel particle filter*!

▶ The diesel particle filter* may only be regenerated under the supervision of operating personnel!

Carry out the operation and maintenance of the diesel particle filter* according to the separate operating instructions of the diesel particle filter* manufacturer.

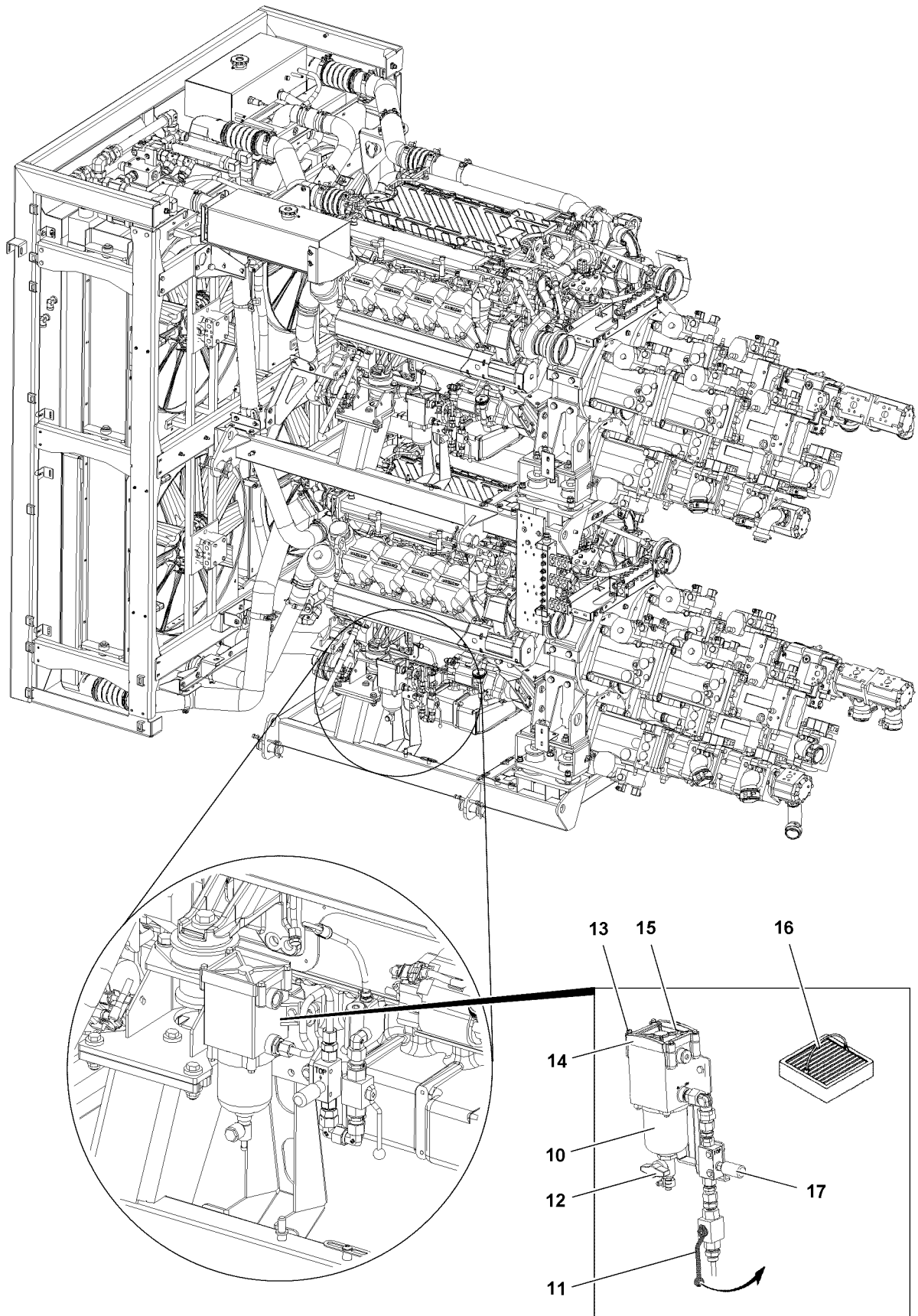

Fig.115663

LWE/LR 13000-001/19503-01-02/en

1.5 Fuel preliminary filter



DANGER

Danger of fire and explosion!

- ▶ Do not smoke!
- ▶ Avoid open flames!
- ▶ Work only when the engine is turned off!
- ▶ Maintain extreme cleanliness during all work!

1.5.1 Draining the fuel preliminary filter



WARNING

Danger of burns during maintenance and inspection work!

Severe burns can result due to the engine at operating temperature!

- ▶ Avoid direct body contact to heated components!



Note

- ▶ The water separator **10** on the fuel pre-filter must be drained at regular intervals!

- ▶ Turn the engine off.
- ▶ Place a catch basin under the water separator.
- ▶ Close the ball valve **11**.
- ▶ Open the drain valve **12** and drain water until fuel emerges.
- ▶ Close the drain valve **12**.
- ▶ Open the ball valve **11**.
- ▶ Remove the catch basin and dispose of the fluid.

1.5.2 Cleaning the filter strainer

- ▶ Turn the engine off.
- ▶ Place a catch basin under the fuel preliminary filter.
- ▶ Close the ball valve **11**.
- ▶ Open the drain valve **12** until no more fuel emerges.
- ▶ Remove the catch basin and dispose of the fluid.
- ▶ Remove the screws **13** and remove the cover **14**.
- ▶ Remove the filter strainer **16** and clean it properly.
- ▶ Insert the cleaned filter strainer **16** properly.
- ▶ Install the cover **14** with seals properly.
- ▶ Properly tighten the screws **13**.
- ▶ Open the ball valve **11**.
- ▶ Open the breather screw **15**.
- ▶ Operate the hand pump **17** and properly bleed the fuel filter.
- ▶ Properly tighten the breather screw **15**.
- ▶ Start the engine and check the fuel preliminary filter for leaks.

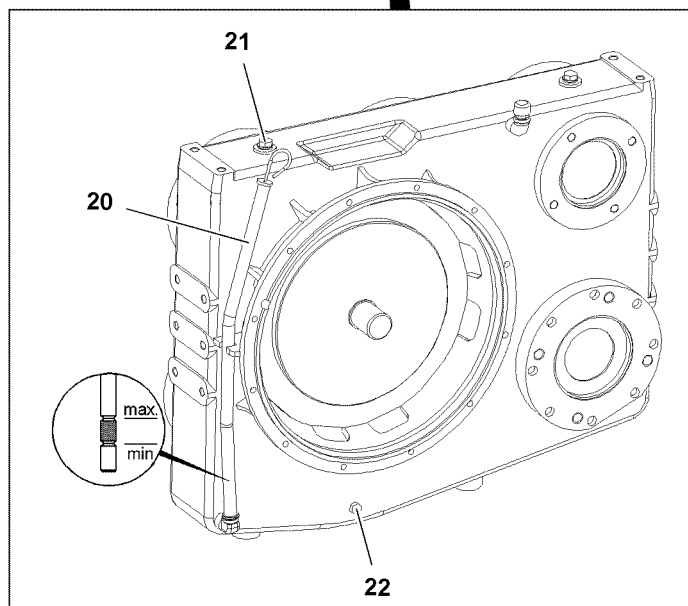
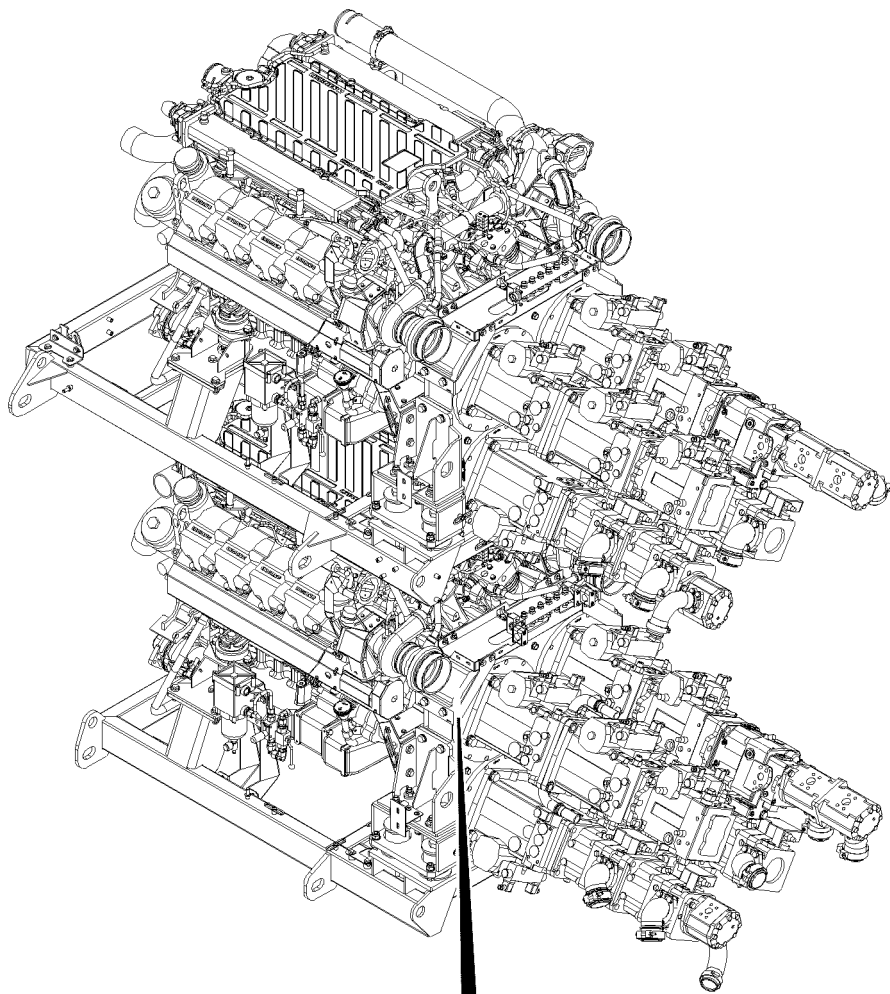

Fig.115664

2 Pump distributor gear



WARNING

Danger of burns during maintenance and inspection work!
Severe burns can result due to the gears and oils at operating temperatures!

- ▶ Avoid direct body contact to heated components and fluids!

NOTICE

Dirt in travel gear!
If any dirt gets into the inside of the gear, gear damage can occur!

- ▶ Make sure that no dirt gets into the inside of the gear during maintenance work!

2.1 Checking the oil level

Make sure that the following prerequisite is met:

- The crane is in horizontal position.
- ▶ Remove the dipstick **20** and wipe it off.
- ▶ Reinsert the dipstick **20** and pull it out again.

The oil level must be between the min. and max. marks on the dipstick **20**.

- ▶ Check the oil level.

NOTICE

Danger of gear damage!
If the oil level has dropped below the minimum mark, add engine oil as specified in the lubrication chart until the oil level is between the minimum and maximum marks!

- ▶ Add oil and check again!

- ▶ Reinsert the dipstick **20**.

2.2 Changing the oil

Make sure that the following prerequisites are met:

- The crane is in horizontal position.
- The gear is warm.
- ▶ Remove the oil filler plug **21**.
- ▶ Remove the oil drain plug **22** and drain the oil.
- ▶ Install the oil drain plug **22** with new seal and tighten.
- ▶ Add oil as specified in the lubrication chart on the oil filler plug **21** until the oil level is between the min. and max. marks on the dipstick **20**.
- ▶ Install the oil filler plug **21** with new seal.
- ▶ Check the oil level.

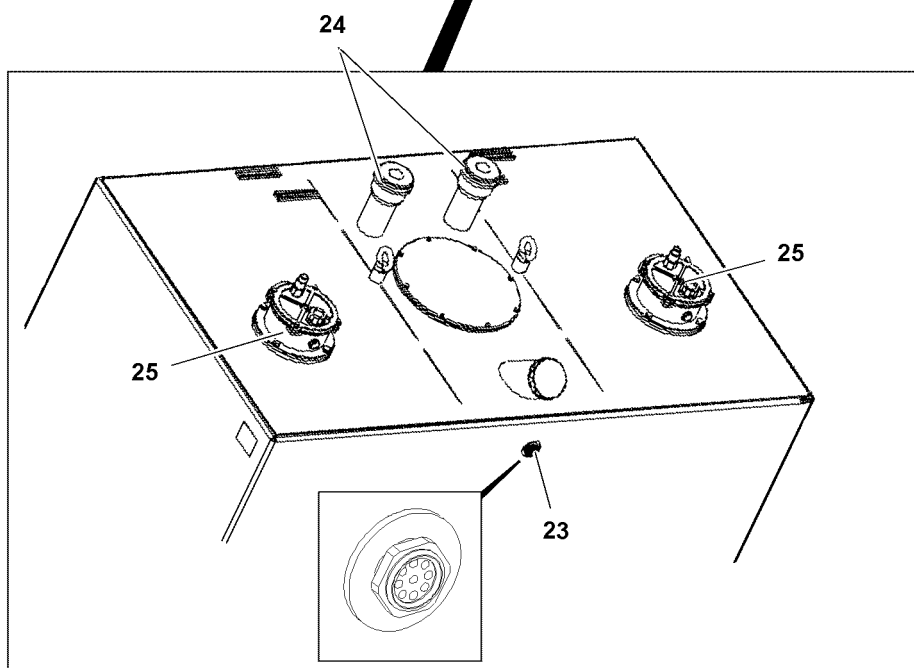
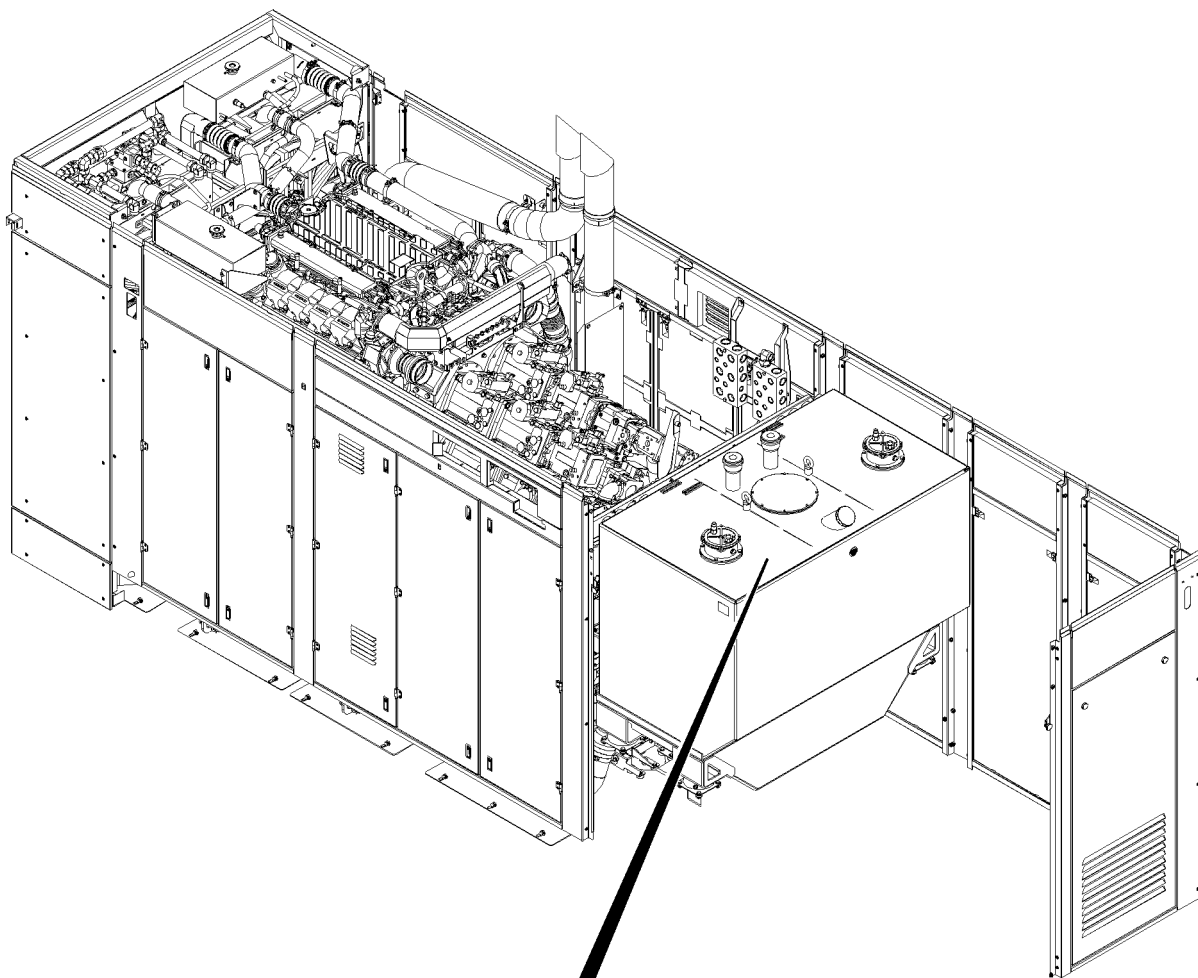

Fig.115665

LWE/LR 13000-001/19503-01-02/en

3 Hydraulic system



DANGER

Danger of fire and explosion!

- ▶ Do not smoke! Avoid open flames!
- ▶ Work only when the engine is turned off!
- ▶ Maintain extreme cleanliness during all work!

3.1 Hydraulic tank

3.1.1 Checking the oil level

Make sure that the following prerequisites are met:

- The crane is in horizontal position.
- All hydraulic cylinders are fully retracted.

The oil level must be in the center of the oil level sight gauge **23**.

- ▶ Check the oil level on the oil level sight gauge **23** of the hydraulic oil tank.

Problem remedy

No oil is visible in the oil level sight gauge **23**?

- ▶ Add oil as specified in the lubrication chart with a fine-mesh strainer until the oil level is visible in the center of the oil level sight gauge **23**.

3.1.2 Checking the vent / breather filter

- ▶ Open the cover with the turn lock.
- ▶ Check the filter **24** for impurities (visual inspection).

In the event of heavy contamination:

- ▶ Replace the filter **24**.
- ▶ Close the cover with the turn lock again.

3.1.3 Return filter

The return filter **25** is equipped with a maintenance indicator. If the red mark is visible when the oil is at operating temperature, then the filter insert must be replaced.

- ▶ Remove the filter cover.
- ▶ Remove the filter insert.
- ▶ Rinse out the filter housing.
- ▶ Clean sealing surface on the cover and the filter housing.
- ▶ Insert a new filter insert.
- ▶ Lubricate the rubber seal ring in the cover with oil.
- ▶ Replace the filter cover and tighten.
- ▶ Start the engine and check the filter for leaks.
- ▶ Check the oil level and add oil if necessary.

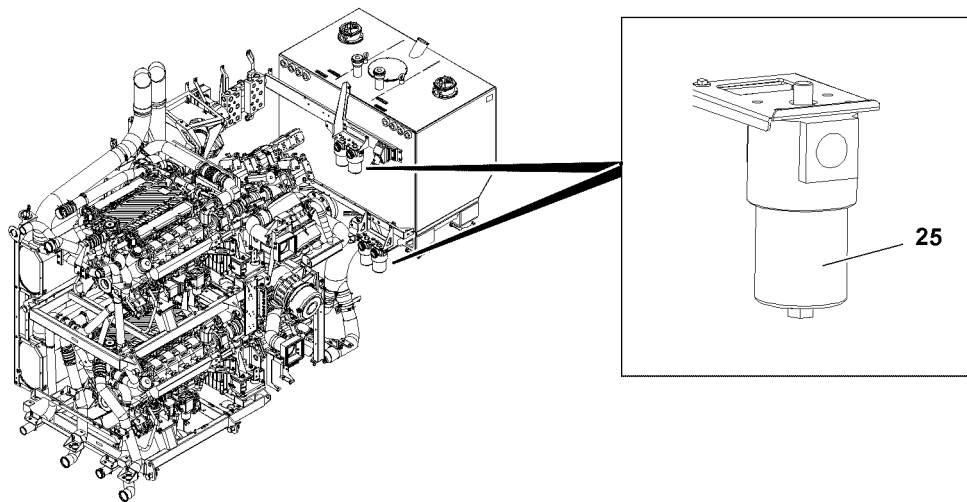

Fig. 115666

3.2 Pressure filters in the crane hydraulic

The pressure filter **26** is equipped with a maintenance indicator. If the red bar indicator is visible when the oil is at operating temperature, then the filter cartridge must be replaced.

- ▶ Turn the engine off.
- ▶ Release the filter cartridge and collect any escaping oil in a suitable container.
- ▶ Remove and dispose of the filter cartridge.
- ▶ Clean the sealing surface on the filter bracket.
- ▶ Lubricate the rubber seal ring on the new oil filter cartridge with oil.
- ▶ Install a new filter cartridge and tighten.
- ▶ Start the engine and check for leaks.
- ▶ Slowly run through all crane movements.

Result:

- This bleeds the hydraulic system.
- ▶ Check the oil level again and add oil if necessary.

3.3 Diaphragm reservoirs

Various diaphragm reservoirs are installed in the hydraulic system. The pretension pressures are specified in the hydraulic circuit diagram as well as on the individual diaphragm reservoirs. The pretension pressure must be measured separately in each diaphragm reservoir.

NOTICE

Risk of damaging the hydraulic system!

If the outside temperature fluctuates considerably, e.g. after transport to extremely hot or cold countries or in countries with considerable differences between the summer and winter temperatures, the accumulator pressures may change!

- ▶ Check the accumulator pressures and correct if necessary!
-

**DANGER**

Risk of explosion!

The pressure in the nitrogen cylinder must be less than the maximum permissible operating pressure of the accumulator or the pressure gauge. Otherwise install a pressure reducer between the cylinder and the filling device!

- ▶ The diaphragm reservoir must be relieved on the fluid side!
- ▶ Do not use air or oxygen to fill the diaphragm reservoir!

- ▶ Turn the engine off.

Result:

- The diaphragm reservoir is relieved on the fluid side.

The pretension pressure in the hydraulic reservoirs may only be checked by an expert with appropriate training and equipment. In addition, the national regulations for pressurized container inspections must also be observed.

- ▶ Check the pretension pressure with a testing and filling device and correct, if necessary.

3.4 Hydraulic hose lines

The hydraulic hose lines must be checked according to ISO 9927-1 by an **experienced technician** or **expert mechanic**, as required, depending on the duration of use and the operating conditions, but at least once a year.

Experienced technicians are persons who:

- possess sufficient knowledge about cranes due to their professional background and experience.
- are familiar with the relevant settings to detect any abnormal deviations from the nominal condition.
- have undergone special training.

Expert mechanics are mechanics, who:

- are experienced in the design, construction or maintenance of cranes.
- possess sufficient knowledge about the relevant settings and standards.
- are fully equipped to perform inspections.
- are able to assess the safety status of the crane.
- can decide which action needs to be taken to ensure the crane can continue to be operated safely.

**Note**

- ▶ The applicable national regulations must also be complied with!

3.4.1 Checking the hydraulic hoses within area of responsibility of the German employer's liability insurance associations

At least once a year, an **expert** must inspect the hydraulic hoses to ensure they are in operationally safe condition. The crane must be inspected by an **authorized inspector** every four years from the day it was first licensed. After the 12th year of operation, the crane must be inspected by the authorized inspector annually.

The **expert** or **authorized inspector** must document the fact that the hydraulic hoses can continue to be used in the crane!

An expert is someone:

- whose technical training and experience means that he has adequate knowledge in the field of hydraulic hoses and hose systems.
- who is familiar with the relevant occupational health and safety regulations.
- who is familiar with the relevant accident prevention guidelines.
- who is familiar with the directives and generally accepted technical regulations (e.g. DIN standards, VDE regulations, technical regulations of other EU member states or other countries that have signed the European Economic Community agreement).
- who can properly assess whether hydraulic hoses and hose systems are deemed safe in accordance with the guidelines and regulations stated above.

Authorized inspector(s) is / are:

- an authorized expert employed by the technical supervisory authorities.
- in Hamburg this is the Amt für Arbeitsschutz (office for occupational health and safety).
- in Hessen these are the technical supervisory offices.
- an authorized expert appointed by the professional associations.

3.4.2 Examples of possible defects in hose lines**DANGER**

Risk of fire or accident!

If problems are discovered during inspections, then they must be remedied immediately or suitable measures are to be taken. Failure to do this can result in serious injury to persons, death or damage to property!

► Remedy problems or take suitable measures!

- Damage to the outer layer as far as the intermediate later (e.g. chafing, cuts and cracks).
- Outer layer brittleness (crack formation of the hose material).
- Deformation that differs from the natural shape of the hose or hose line, in depressurized as well as in pressurized condition or in bends, for example layer separation, bubbling, crushing or kinking.
- Leaks.
- Failure to follow installation instructions.
- Damage or deformation of hose fittings that inhibit the function and strength of the fitting or the hose / fitting connection.
- Hose slipping out of fitting.
- Fitting corrosion that inhibits function and strength.
- Storage time or usage period exceeded.

3.4.3 Maintenance of hose lines

- We recommend to check all hoses, hose lines and screw fittings daily, but at least every two weeks for leaks and externally recognizable signs of damage.
- Damaged parts must be replaced immediately! Oil spray can lead to injuries and fires!
- Hydraulic lines and hoses may not be repaired!
- Hoses that have already been used as a part of a hose line may not be reinstalled in hose lines.
- Always use Original Liebherr spare parts when replacing hoses and hose lines.
- Always ensure that the hoses are routed free of torsion. If high pressure hoses are being used, attach the screws of the half clamps or full flange at both ends of hose and then tighten.
- When using high pressure hoses with a bent fitting, tighten the end with the bent fitting first when tightening the flanges, then the end with the straight fitting.
- Any mounting clamps in the hose center may be attached and tightened only thereafter.
- Route the hoses in such a way that chafing with other hoses or other structures is prevented. Maintain a minimum clearance of approximately $\frac{1}{2}$ the outer diameter of the hose to other parts. The clearance may never be less than 10 to 15 mm.

3.4.4 Replacing the hose lines**DANGER**

Risk of fire or accident!

Failure to replace the hose lines at appropriate intervals can cause serious injury to persons, death or damage to property!

► Replace hose lines according to appropriate intervals!

This must be documented in the crane's log book by the **expert** or the **authorized inspector**.

The service life of a hose line may not exceed six years, including a storage period of a maximum of two years (pay attention to the manufacturing date on the hoses). The duration of use can also be defined by the **expert** or **authorized inspector** in accordance with existing test and empirical data in the individual application areas, taking the usage conditions into consideration.

Empty page!

LWE/LR 13000-001/19503-01-02/en

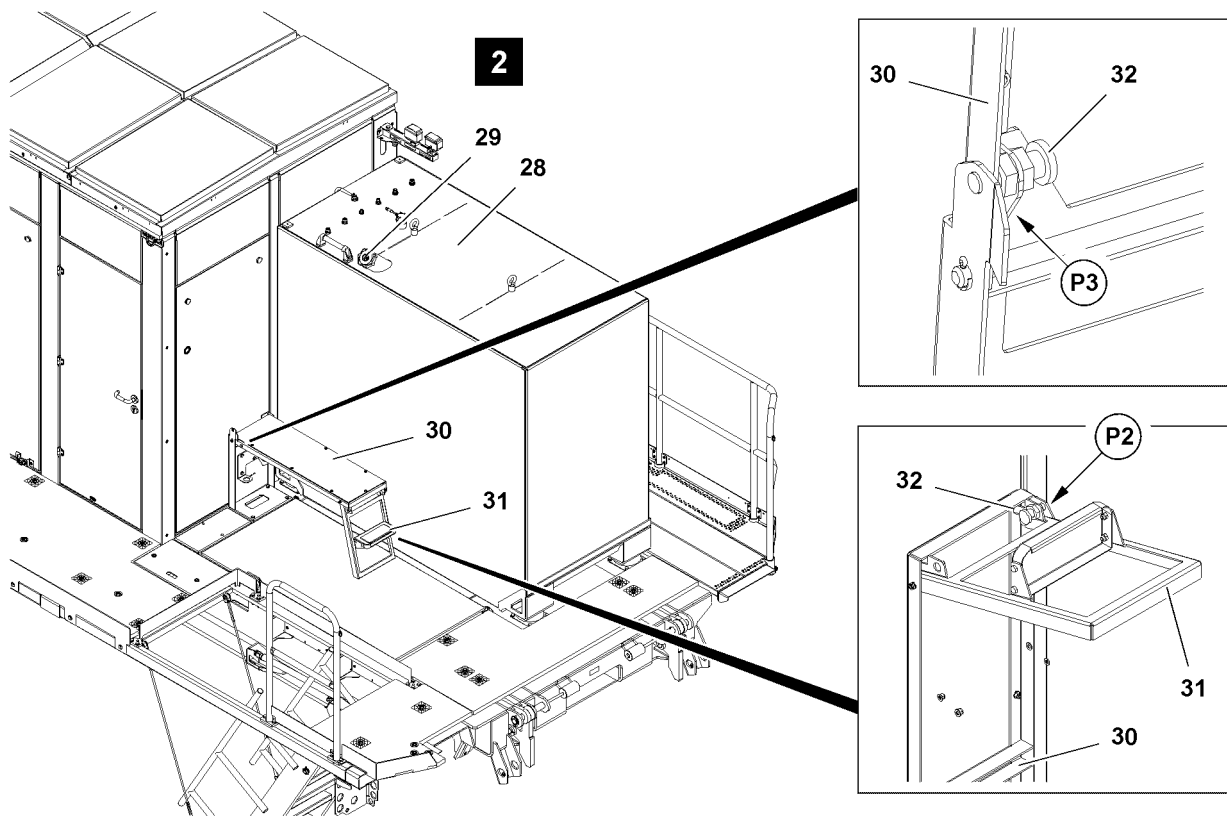
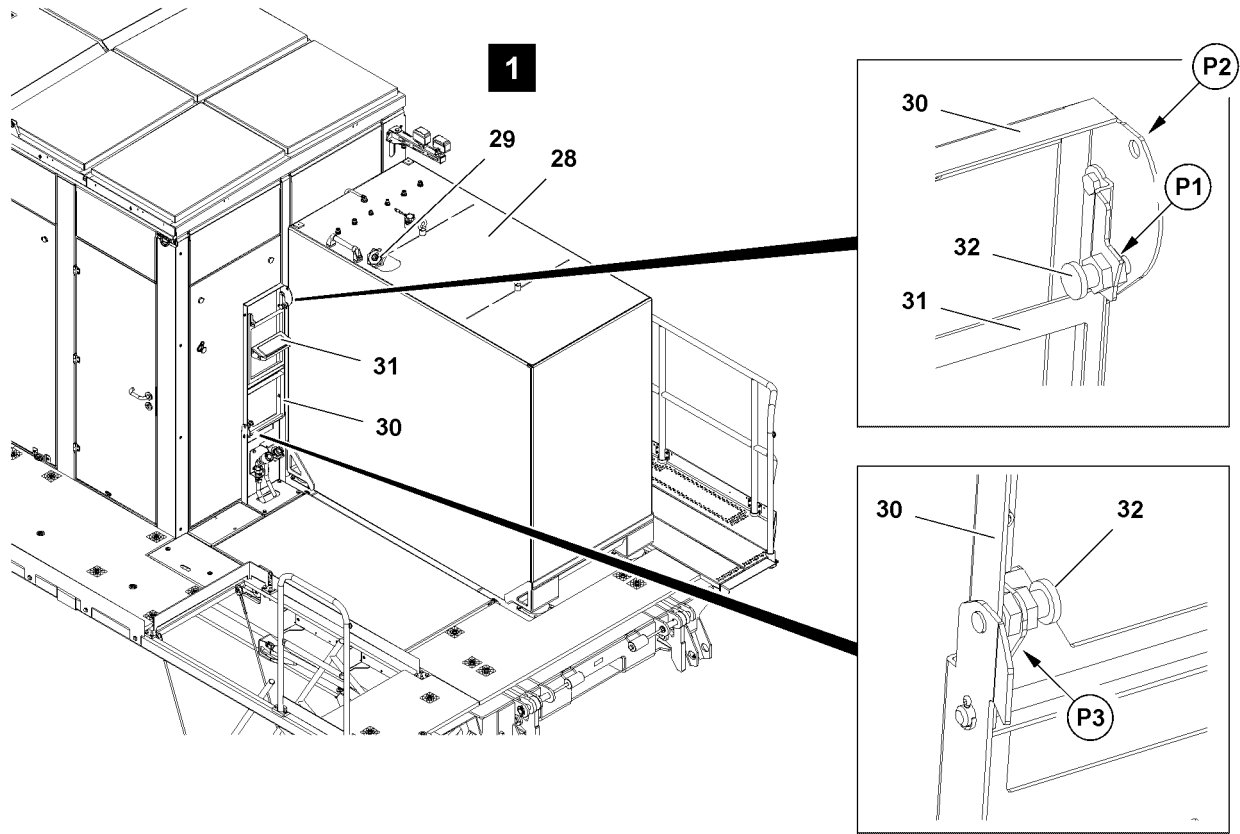

Fig.115667

LWE/LR 13000-001/19503-01-02/en

4 Fuel system



DANGER

Danger of fire and explosion!

- ▶ Do not smoke!
- ▶ Avoid open flames!
- ▶ Work only when the engine is turned off!
- ▶ Maintain extreme cleanliness during all work!

4.1 Swinging the folding step

- ▶ Pull the spring latch **32** at point **P1**, see illustration 1.



WARNING

Folding access step!

When folding the access step **31** out, fingers and hands can be crushed!

- ▶ Do not reach with your hands into the danger zone!
-
- ▶ Fold the access step **31** up until the access step engages with the spring latch **32** at point **P2**, see illustration 2.



WARNING

Folding access step!

The folding step **30** can fold down by itself due to its own weight when it is unlocked at point **P3**!

Personnel can be severely injured!

Fingers and hands can be crushed!

- ▶ When unlocking the folding step **30** at point **P3**, the folding step must be held!
 - ▶ Do not reach with your hands into the danger zone!
-
- ▶ Pull the spring latch at point **P3**.
 - ▶ Slowly swing the folding step **30** down and set it on the platform, see illustration 2.

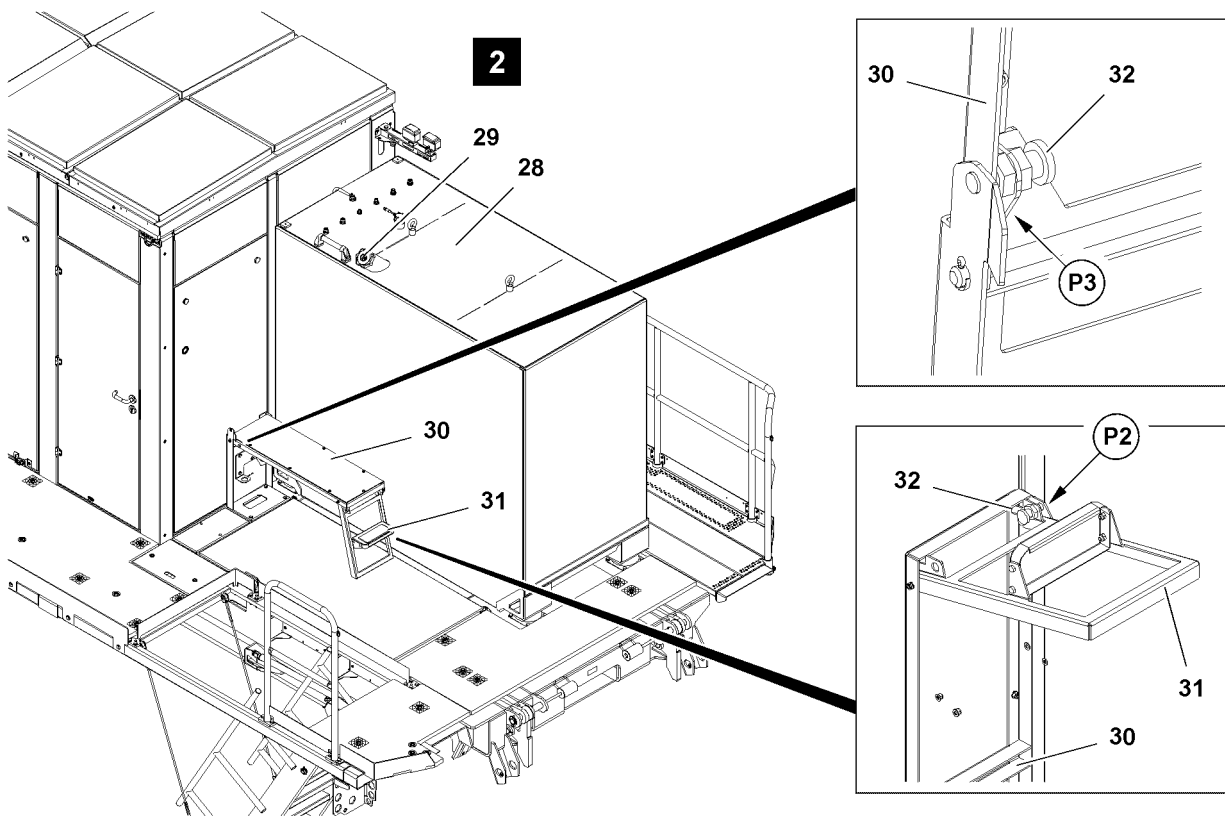
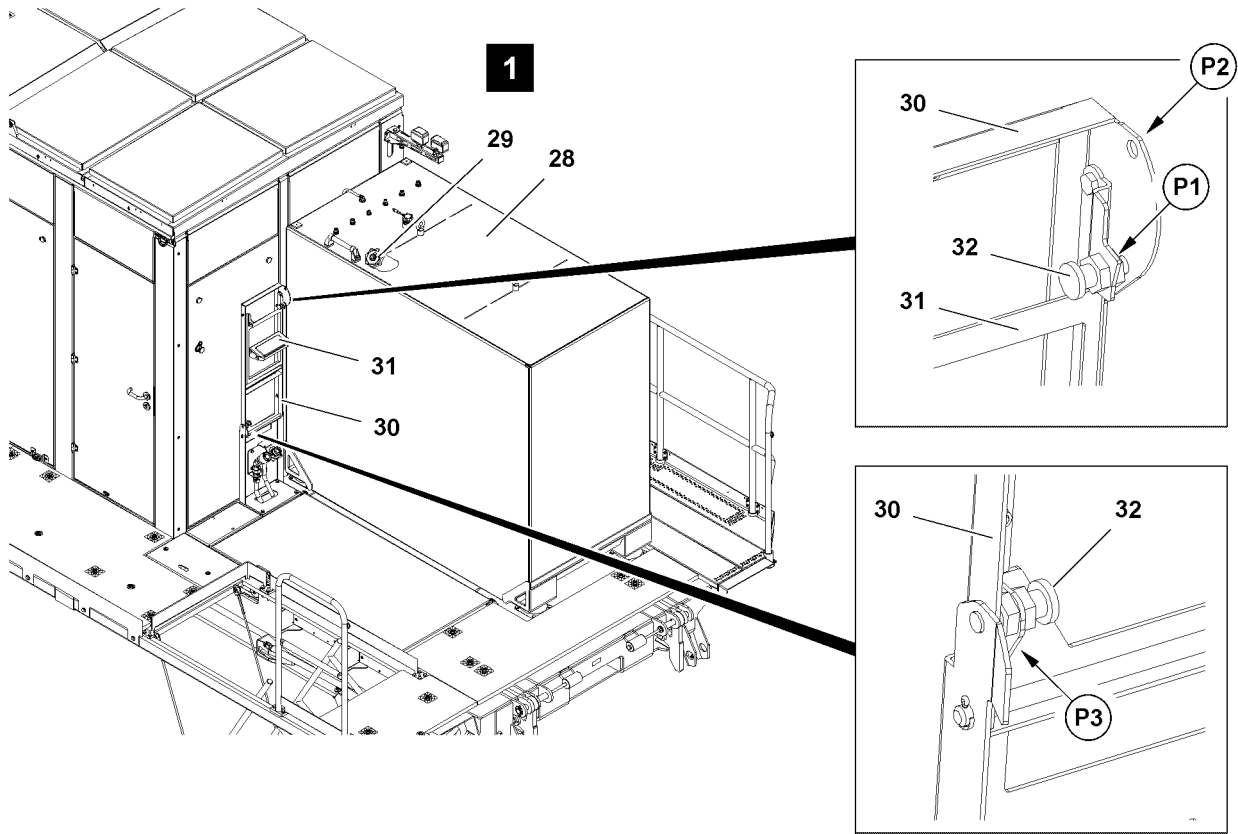

Fig.115667

LWE/LR 13000-001/19503-01-02/en

4.2 Refueling

Make sure that the following prerequisites are met:

- The crane is in horizontal position.
- The engine and the ignition are turned off.



Note

- ▶ Also observe the danger notes in the Crane operating instructions, chapter 7.01!
-
- ▶ Step on the folding step **30**.
 - ▶ Open the tank cover **29**.
 - ▶ Insert the fuel nozzle in the filler neck.
 - ▶ Refuel the fuel tank **28** with fuel.
 - ▶ After the refueling procedure: Take the fuel nozzle from the filler neck.
 - ▶ Close the tank cover **29** and step down from the folding step.

4.3 Swinging the folding step

- ▶ Fold the folding step **30** up slowly until the folding step engages automatically with the spring latch at point **P3**, see illustration **2**.



WARNING

Folding step!

If the folding step **30** is not secured when folding it in, then the folding step can fold down by itself due to its own weight!

Personnel can be severely injured!

- ▶ Make sure that the spring latch is engaged at point **P3**!



WARNING

Folding access step!

When unlocking the access step **31** at point **P2** the access step folds down by itself due to its own weight!

Personnel can be severely injured!

Fingers and hands can be crushed!

- ▶ When unlocking the access step **31** at point **P2**, the access step must be held!
- ▶ Do not reach with your hands into the danger zone!

- ▶ Pull the spring latch **32** at point **P2**.
- ▶ Swing the access step **31** down until the access step engages with the spring latch **32** at point **P1**, see illustration **1**.

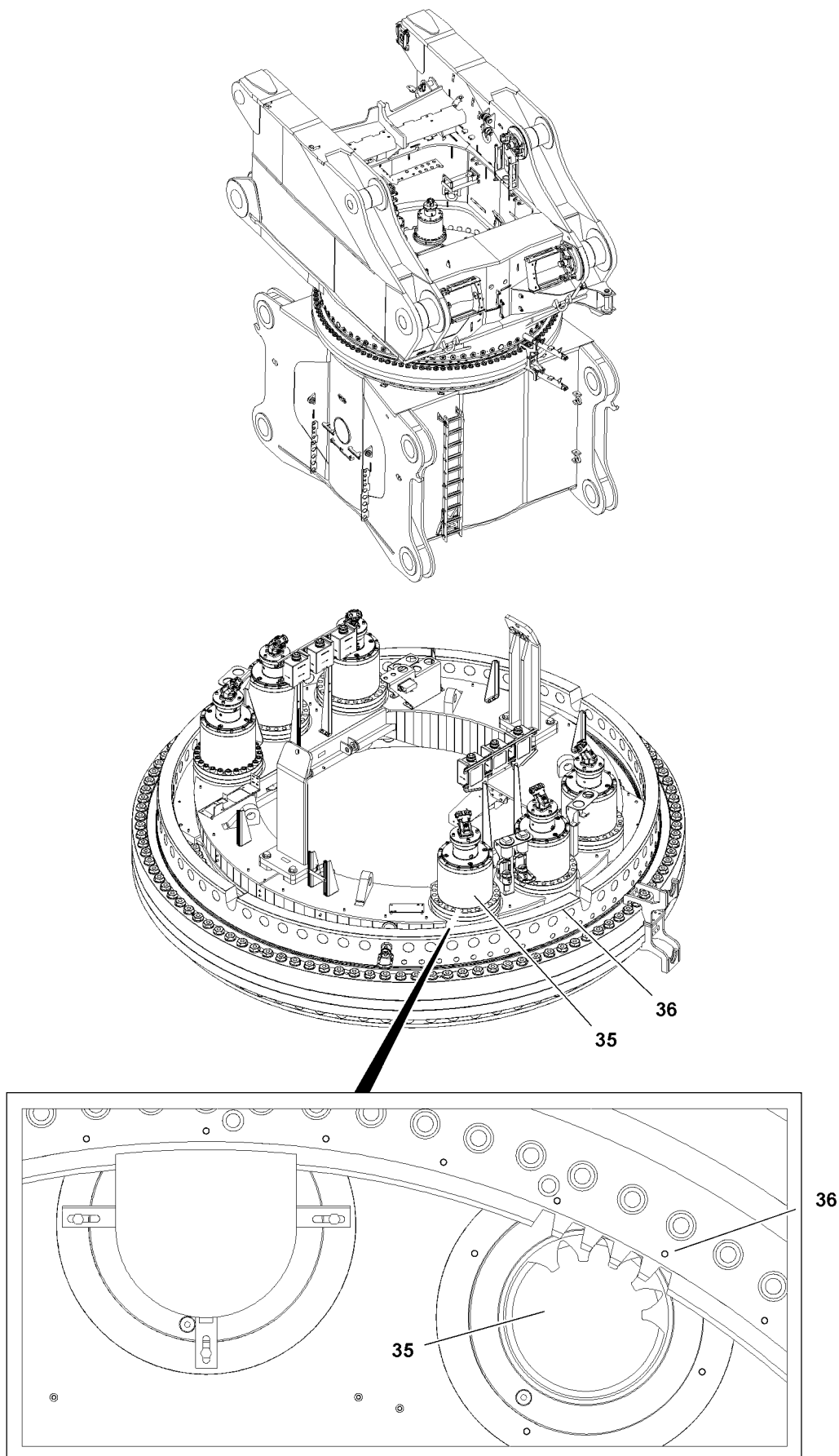

Fig.115668

LWE/LR 13000-001/19503-01-02/en

5 Slewing ring connection

5.1 Lubricate the slewing ring connection

Make sure that the following prerequisites are met:

- The crane is in horizontal position.
- The engine and the ignition are turned off.

Before and after long breaks in operation, especially before and after a possible winter break, carry out the lubrication procedure with special care to ensure the best possible corrosion protection.

If the crane has not been moved for more than 3 months, then it must be lubricated every 3 months with an external grease pump until grease emerges from all grease points, see also section of „Central lubrication system“. Then the relevant crane movement must be repeated several times and the lubrication procedure must be carried out again.

- ▶ Lubricate the slewing ring connection.

5.2 Lubricating the gear ring and the slewing gear pinion

Before and after extended breaks in service, grease the gear ring **36** and the slewing gear pinion **35** to ensure the best possible protection from corrosion.

- ▶ Grease the gear ring **36** and the slewing gear pinion **35** externally.

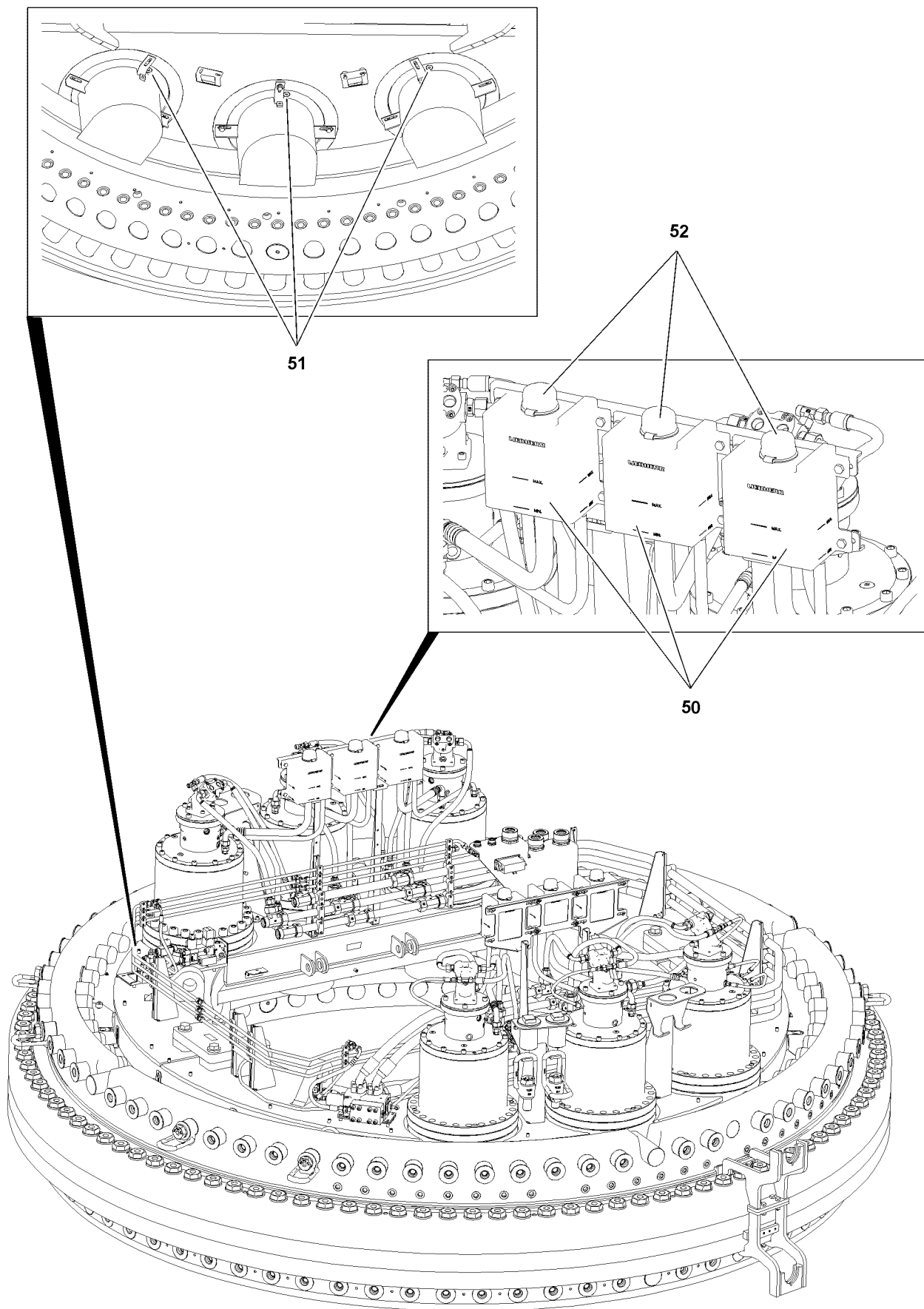

Fig.115678

LWE/LR 13000-001/19503-01-02/en

5.3 Slewing gear



WARNING

Danger of burns during maintenance and inspection work!
Severe burns can result due to the gears and oils at operating temperatures!

- ▶ Avoid direct body contact to heated components and fluids!

NOTICE

Dirt in travel gear!
If any dirt gets into the inside of the gear, gear damage can occur!

- ▶ Make sure that no dirt gets into the inside of the gear during maintenance work!

5.3.1 Checking the oil level

Make sure that the following prerequisites are met:

- The crane is in horizontal position.
- The engine and the ignition are turned off.

NOTICE

Danger of gear damage!
If the oil level has dropped below the lower mark, add oil as specified in the lubrication chart until the oil level is between the two marks!

- ▶ Add oil and check again!

The oil is visually checked on the oil tank **50**.

The oil must be between the two marks „**MIN**“ and „**MAX**“.

- ▶ Check the oil level.

5.3.2 Changing the oil

Make sure that the following prerequisites are met:

- The crane is in horizontal position.
- The gear is warm.
- ▶ Open the container over **52**.
- ▶ Remove the oil drain plug **51** with the seal ring and drain the oil.
- ▶ Clean the oil drain plug **51** and sealing surface on the housing.
- ▶ Install the oil drain plug **51** with new seal ring and tighten.
- ▶ Add oil according to the lubrication chart on the container **50** until the oil is between the two marks.
- ▶ Close the container cover **52**.
- ▶ Check the oil level again.

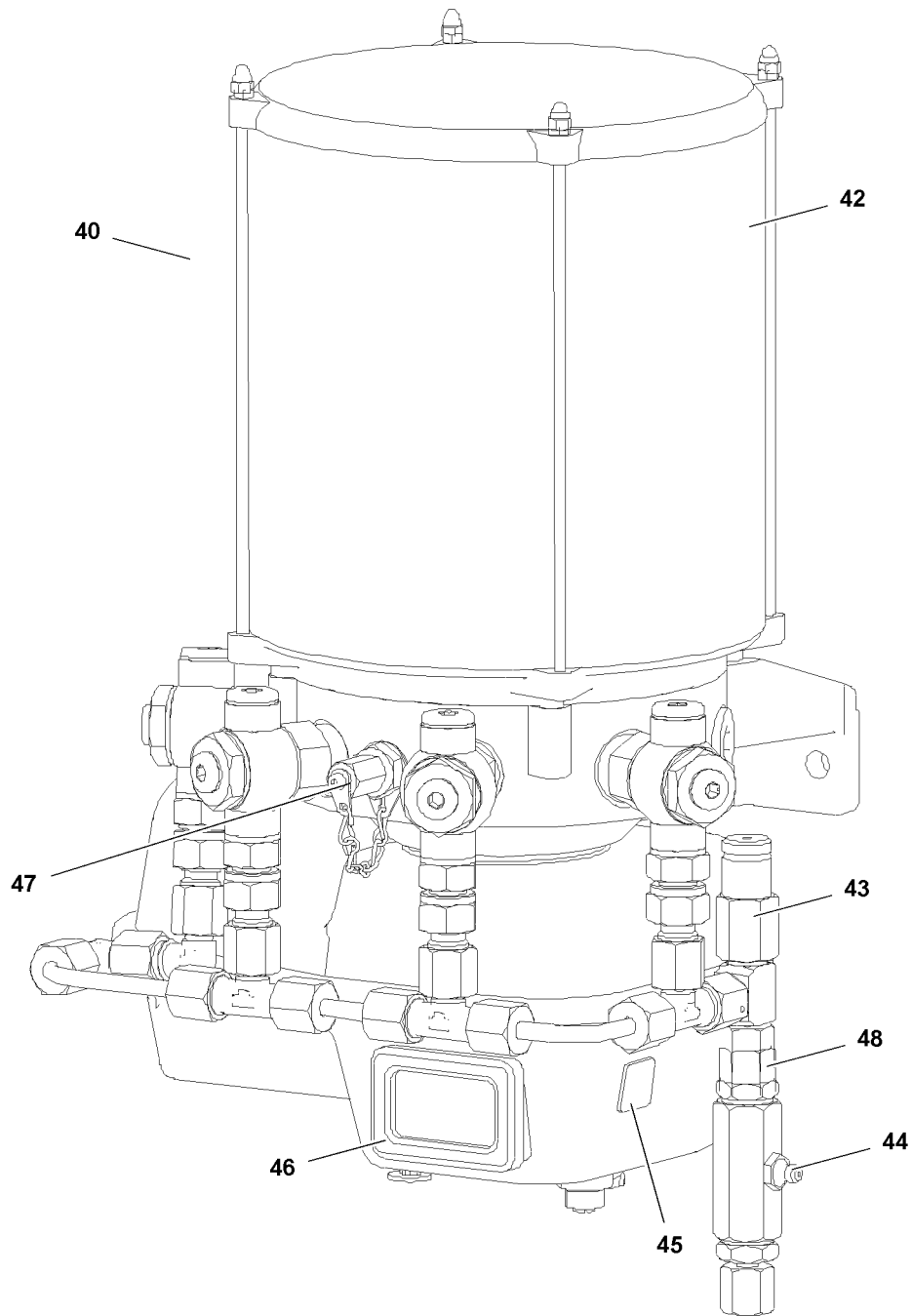

Fig.115669

6 Central lubrication system

NOTICE

Dirty lubricant!

If the crane is not moved for longer than 3 months, then contaminants adhere to the lubricant! Components are exposed to increased wear!

If the crane has not been moved for longer than three months:

- ▶ Lubricate the grease fitting with an external grease pump until lubricant emerges on the sealing lips!
- ▶ Repeat crane movements several times and carry out the lubrication procedure again!



Note

- ▶ Cleaning is permitted in washing bays or with high pressure cleaners!



Note

- ▶ The lubrication and break period is set in the factory!



WARNING

Danger of burns during maintenance and inspection work!

Severe burns can result due to the components at operating temperature!

- ▶ Avoid direct body contact to heated components!



Note

- ▶ Maintain extreme cleanliness during all work!

NOTICE

Danger of property damage!

If the factory set settings on the control unit of the central lubrication system are changed, crane components or parts can be significantly damaged due to insufficient lubrication!

This could result in high repair costs!

- ▶ Do not change factory set settings on the control unit of the central lubrication system yourself.
- ▶ If the central lubrication system is replaced with a central lubrication system of the same type, take over the settings of the control unit.

6.1 Winch 1

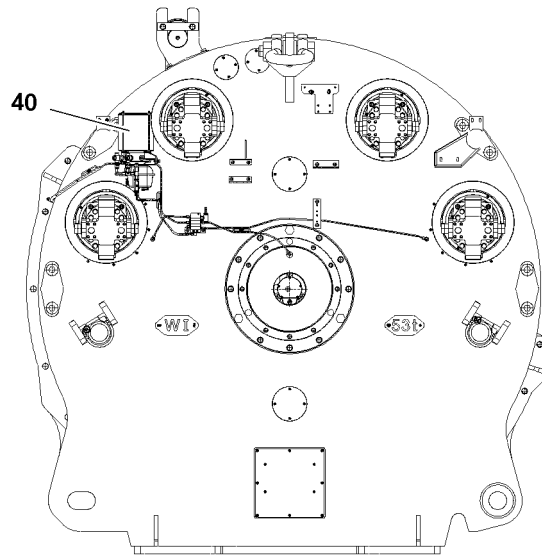

Fig. 115670

Winch 1 is equipped with a central lubrication system **40**. All grease points are automatically supplied with the correct amount of grease.

6.2 Winch 2

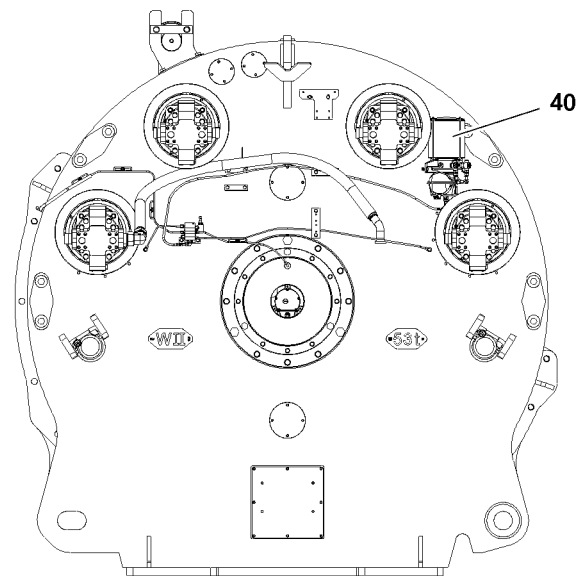

Fig.115671

Winch 2 is equipped with a central lubrication system **40**. All grease points are automatically supplied with the correct amount of grease.

6.3 Winch 3 and winch 6

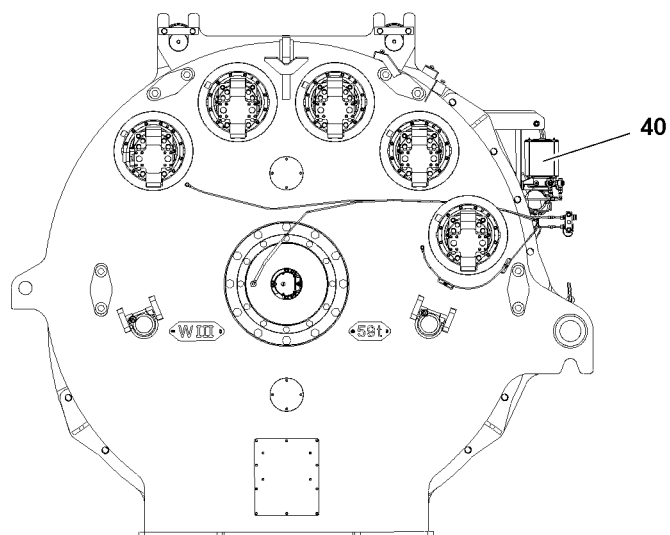

Fig.115672

Winch 3 is equipped with a central lubrication system **40**. All grease points are automatically supplied with the correct amount of grease.

**Note**

- Winch 6 does not have its own central lubrication system and is supplied by winch 3!

6.4 Winch 4

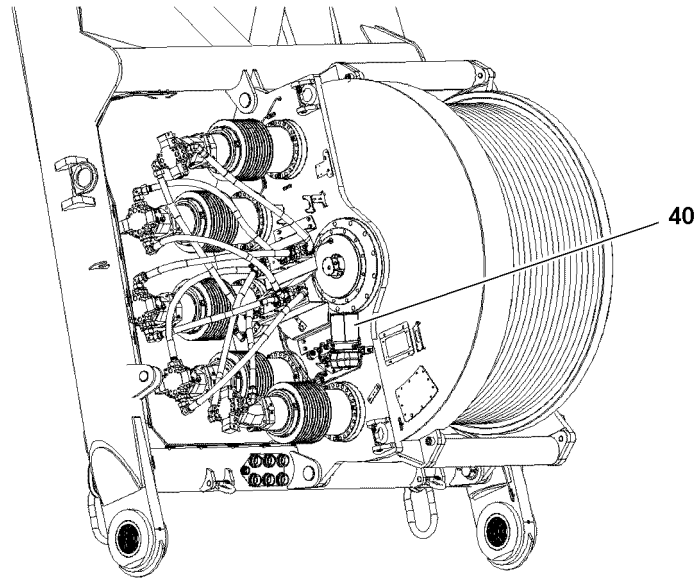

Fig.115673

Winch 4 is equipped with a central lubrication system **40**. All grease points are automatically supplied with the correct amount of grease.

6.5 Winch 5

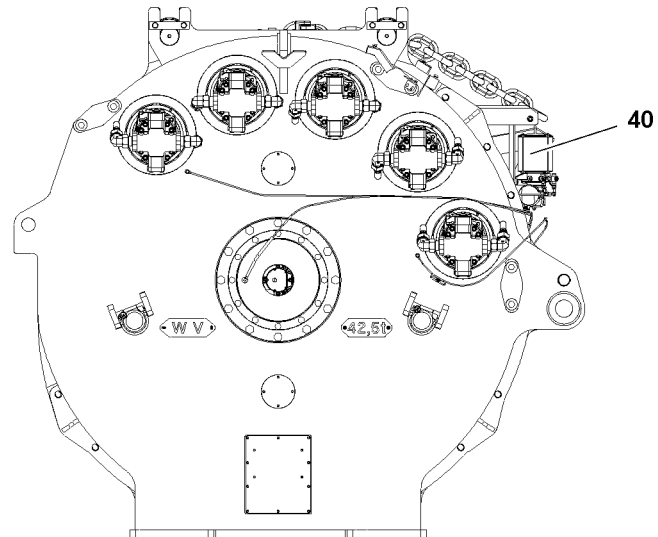

Fig.115674

Winch 5 is equipped with a central lubrication system **40**. All grease points are automatically supplied with the correct amount of grease.

6.6 Turntable frame - rear section

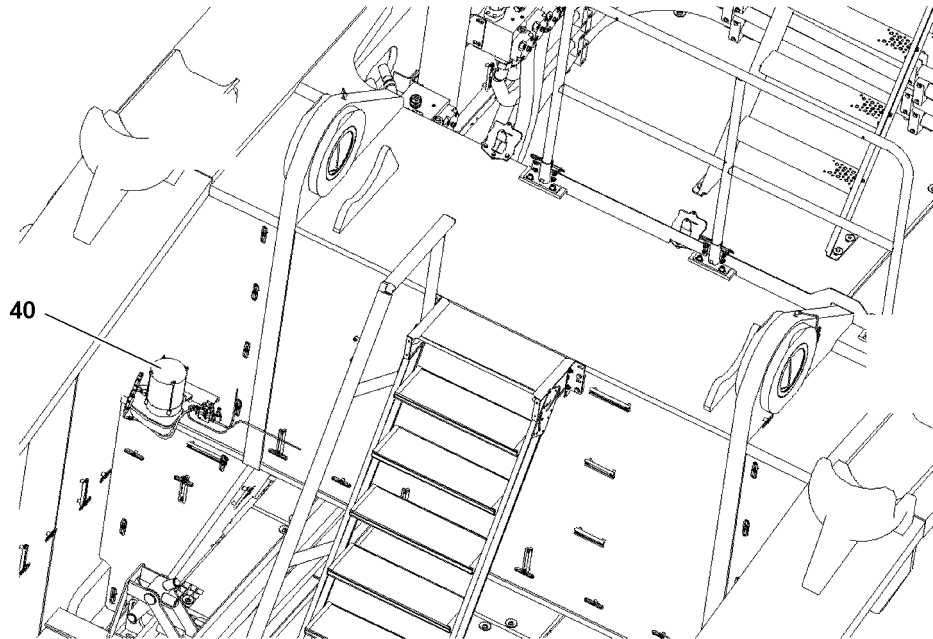

Fig. 115675

The rear section of the turntable frame is equipped with a central lubrication system **40**. All greasing points are automatically supplied with the correct amount of grease.

6.7 Turntable frame, front section

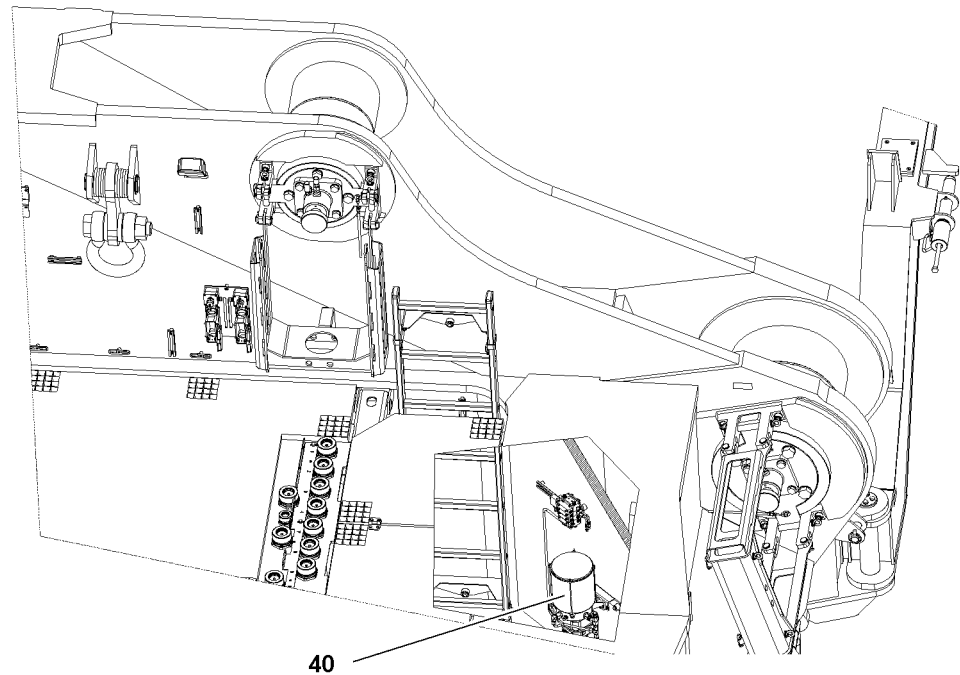

Fig.115676

The front section of the turntable frame is equipped with a central lubrication system **40**. All grease points are automatically supplied with the correct amount of grease.

6.8 Slewing ring connection

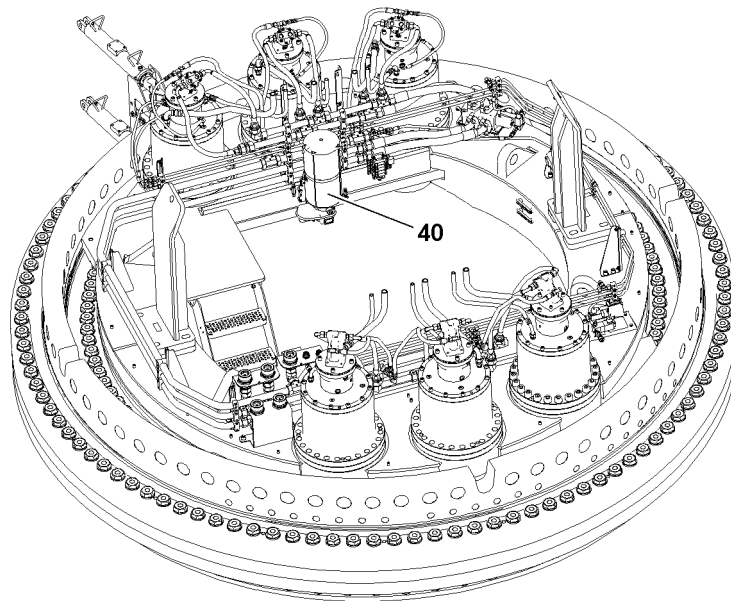

Fig. 115677

The slewing ring connection is equipped with a central lubrication system **40**. All grease points are automatically supplied with the correct amount of grease.

Empty page!

LWE/LR 13000-001/19503-01-02/en

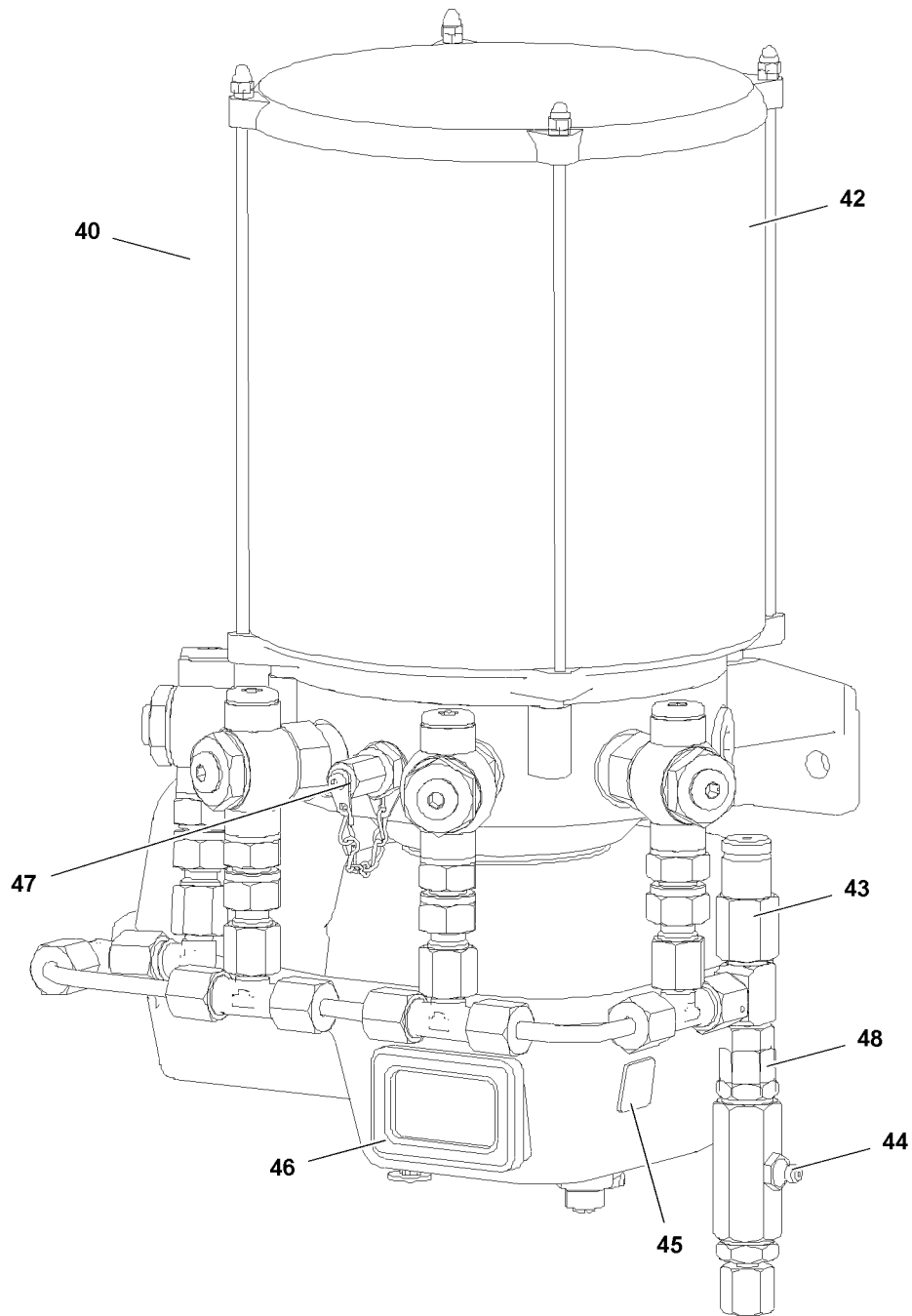

Fig.115669

6.9 Servicing the central lubrication system

6.9.1 Indicator lights of the central lubrication system

**Note**

- ▶ Indicator lights of central lubrication system, see Crane operating instructions, chapter 4.01.

6.9.2 Checking the function of the central lubrication system

- ▶ Check functional readiness: Turn on the engine ignition.

Result:

- When turning the ignition on: The green LED and the red LED at the control **46** light up for approx. 2 s.
- The control **46** is operational.
- ▶ When the control is operational: Start the engine.
- ▶ Trigger 2 or 3 grease pulses using the push button **45**.

Result:

- Grease emerges on the lube points.
- If the system is blocked but the electric pump is properly functioning, the grease emerges through the pressure relief valve **43**.

6.9.3 Carrying out an intermediate lubrication

An intermediate lubrication is made in the following cases:

- After washing the crane
- After a repair
- ▶ With ignition turned on: Press the push button **45** on the engine protection housing of the grease pump.

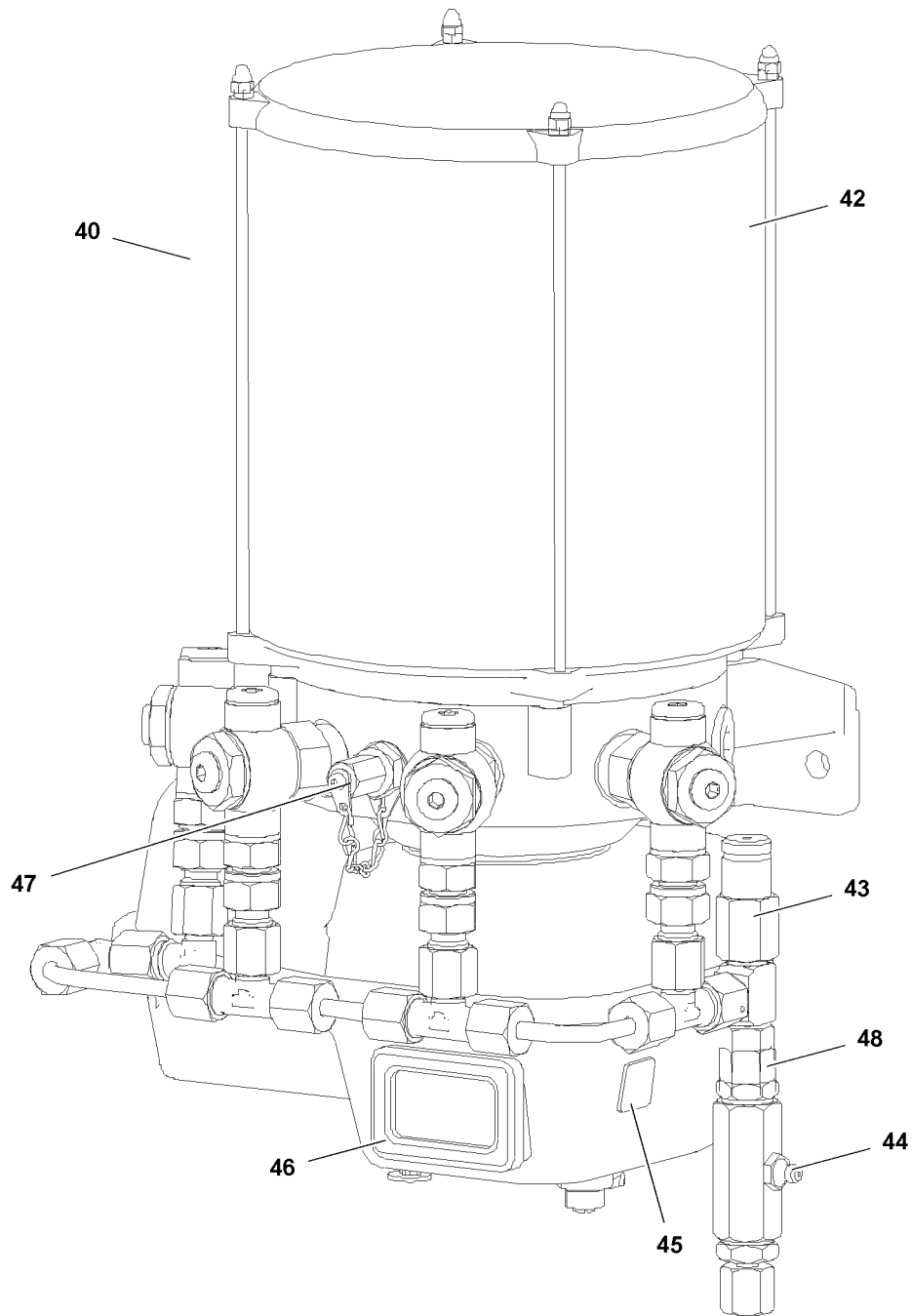

Fig.115669

6.9.4 Filling the grease container of the central lubrication system

NOTICE

Insufficient lubrication!

If there is not enough grease in the container, components will be damaged or worn!

- ▶ There must always be sufficient grease in the grease container **42**!
 - ▶ Observe utmost cleanliness when filling the grease container **42**!
-

- ▶ Fill the grease container **42** with a grease pump via the grease fitting **47** on the central lubrication pump.

6.9.5 Bleeding the central lubrication system

If the grease container **42** has been emptied, then it may be necessary to bleed the central lubrication system.

- ▶ Fill the grease container **42**.
- ▶ Unscrew the main line from the grease pump outlet **48**.
- ▶ Trigger additional lubricating pulses until there are no more air bubbles in the emerging grease at the grease pump outlet **48**.
- ▶ Reconnect the main line.
- ▶ Trigger an additional lubricating process.

6.9.6 Filling the lubrication lines

NOTICE

Risk of damage due to insufficient lubrication!

The lubrication lines must be refilled after any repair on components, which are lubricated with grease.

If this is not observed, the component may run dry!

- ▶ Sufficient grease must be available in the grease lines after every repair on greased components!
 - ▶ Observe utmost cleanliness when filling the grease lines!
-

- ▶ Add grease with an external grease pump via the grease fitting **44**.

or

With the ignition turned on, press the push button **45** on the engine protection housing of the grease pump.

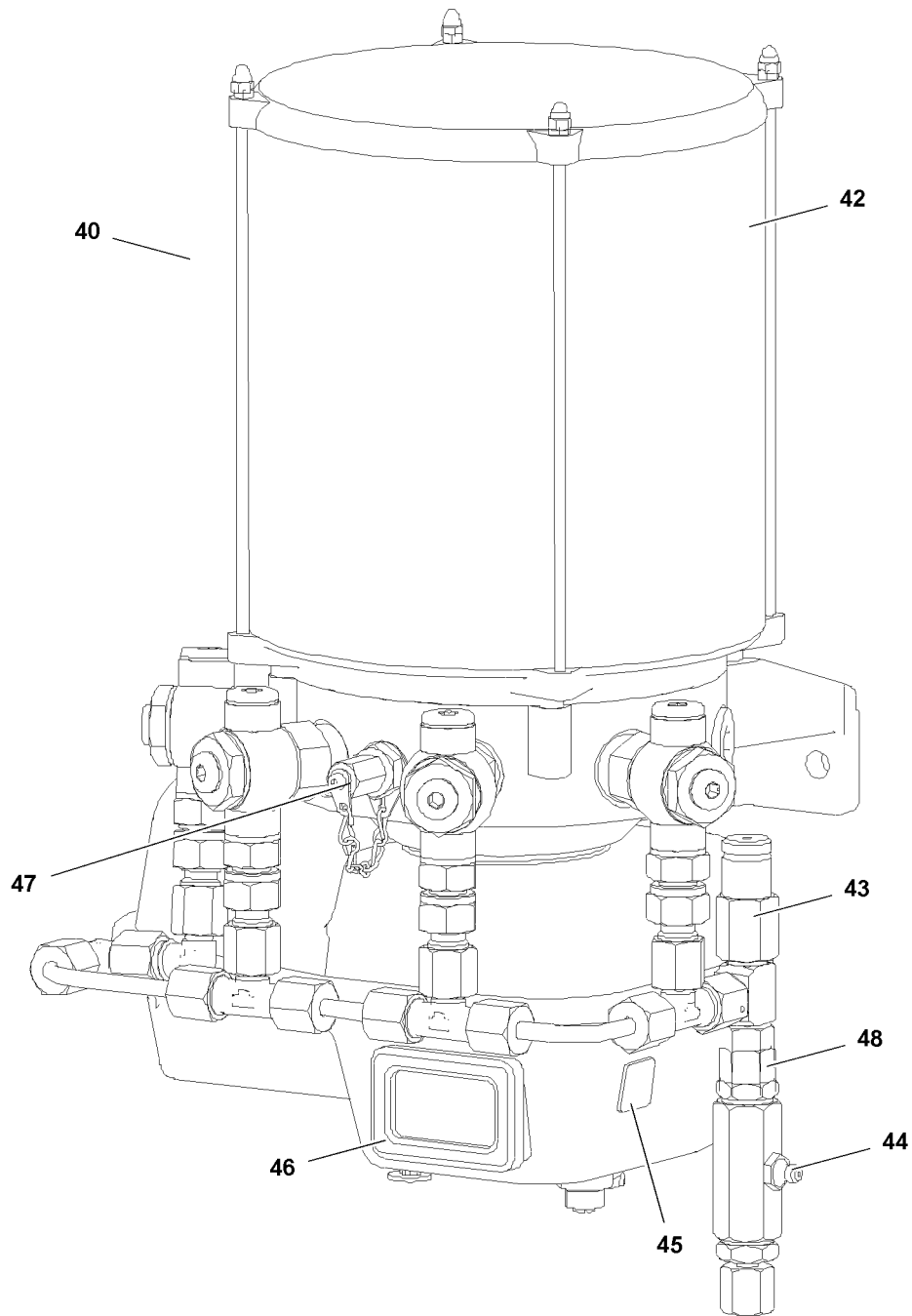

Fig.115669

6.10 Troubleshooting on the central lubrication system

Problem	Cause	Remedy
The grease pump does not work	Integrated electronic control defective, electrical line interrupted, grease pump defective	Replace lower part of motor protection housing, replace electrical line, replace grease pump
Grease pump operates, but does not deliver	Air cushion in delivery piston, minimum fill level fallen below, grease pump element defective	Bleed grease pump, fill reservoir, replace grease pump element
No grease collar on all lube points	Grease pump not operating, interval time too high or cycle time too short, system blocked	See „Grease pump not operating“, reduce interval time or increase number of cycles, refer to „Grease emerges on pressure relief valve“.
No grease collar on several lube points	Supply lines to secondary distributors broken or leaking, screw connections leaking	Replace lines, tighten or replace screw connections
No grease collar on one lube point	Associated lube line broken or leaking, screw connection leaking	Replace line, tighten or replace screw fitting
Grease pump speed reduced	High system pressure, low ambient temperature	Check system / bearing points, no damage: Grease intermediately once or twice, if necessary
Grease escapes at the pressure relief valve	System pressure too high, progressive distributor blocked, system blocked, defective valve spring	Check system, replace distributor, repair blocked / seized bearing point, replace pressure relief valve
The red LED blinks very fast	Error CPU / memory	Consult Liebherr Service
The red LED and the indicator light blink fast	Error in the monitoring period from cycle start	The proximity switch is defective, consult Liebherr Service

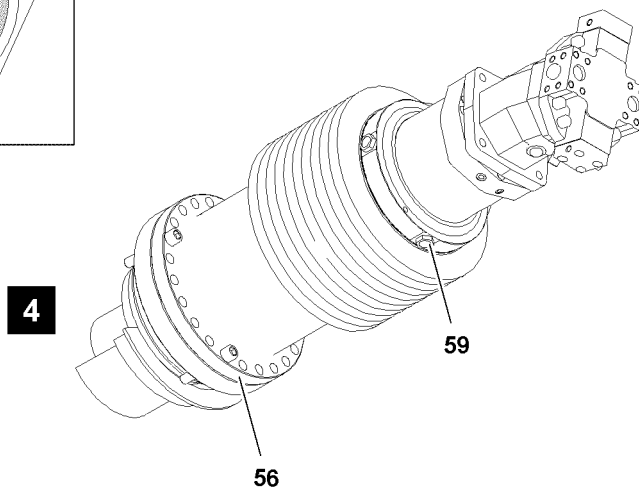
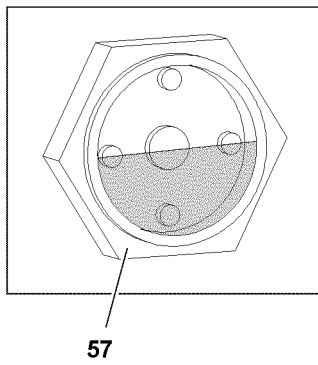
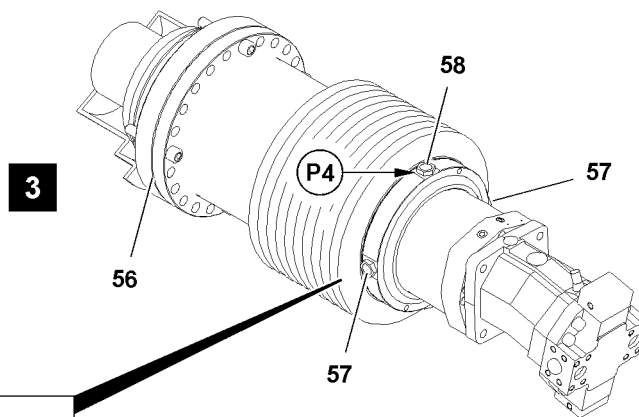
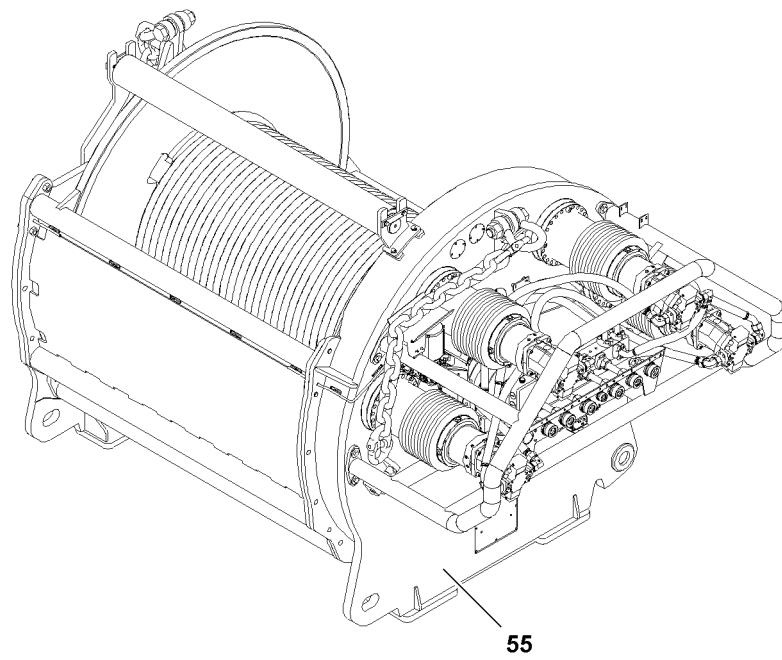

Fig.115680

LWE/LR 13000-001/19503-01-02/en

7 Winches 1, 2, 3, 4, 5

7.1 Checking the oil level

Make sure that the following prerequisites are met:

- The hoist gear is inactive.
- The crane is in horizontal position.



WARNING

Danger of burns during maintenance and inspection work!

Severe burns can result due to the gears and oils at operating temperatures!

- ▶ Avoid direct body contact to heated components and fluids!

NOTICE

Dirt in travel gear!

If any dirt gets into the inside of the gear, gear damage can occur!

- ▶ Make sure that no dirt gets into the inside of the gear during maintenance work!



Note

- ▶ Carrying out the oil level check and the oil change is identical for all winches and is described on the example of one winch!

NOTICE

Danger of gear damage!

If the oil level has dropped below the minimum mark, add oil according to the lubrication chart!

- ▶ Check the oil level!

The oil level must be to the center of the sight gauge **57**, see illustration **3**.

- ▶ Check the oil level.

7.2 Changing the oil

- ▶ Remove the bleeder fitting **58**, see illustration **3**.
- ▶ Remove the oil drain plug **59** with seal ring and drain the oil into a suitable container, see illustration **4**.
- ▶ Install the oil drain plug **59** with new seal ring and tighten.
- ▶ Add oil according to the lubrication chart on the oil filler port at point **P4** to the minimum mark, see illustration **3**.
- ▶ Screw in and tighten the breather fitting **58**.
- ▶ Check the oil level.

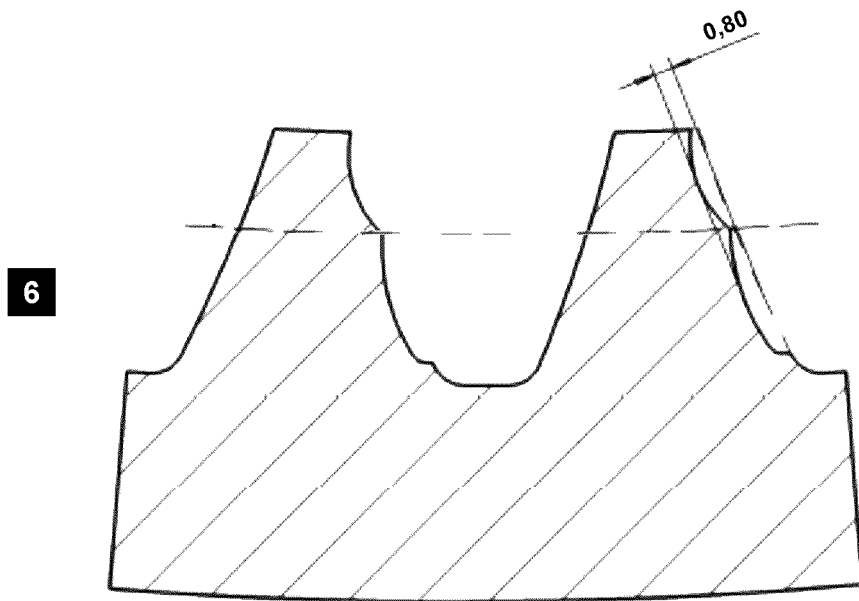
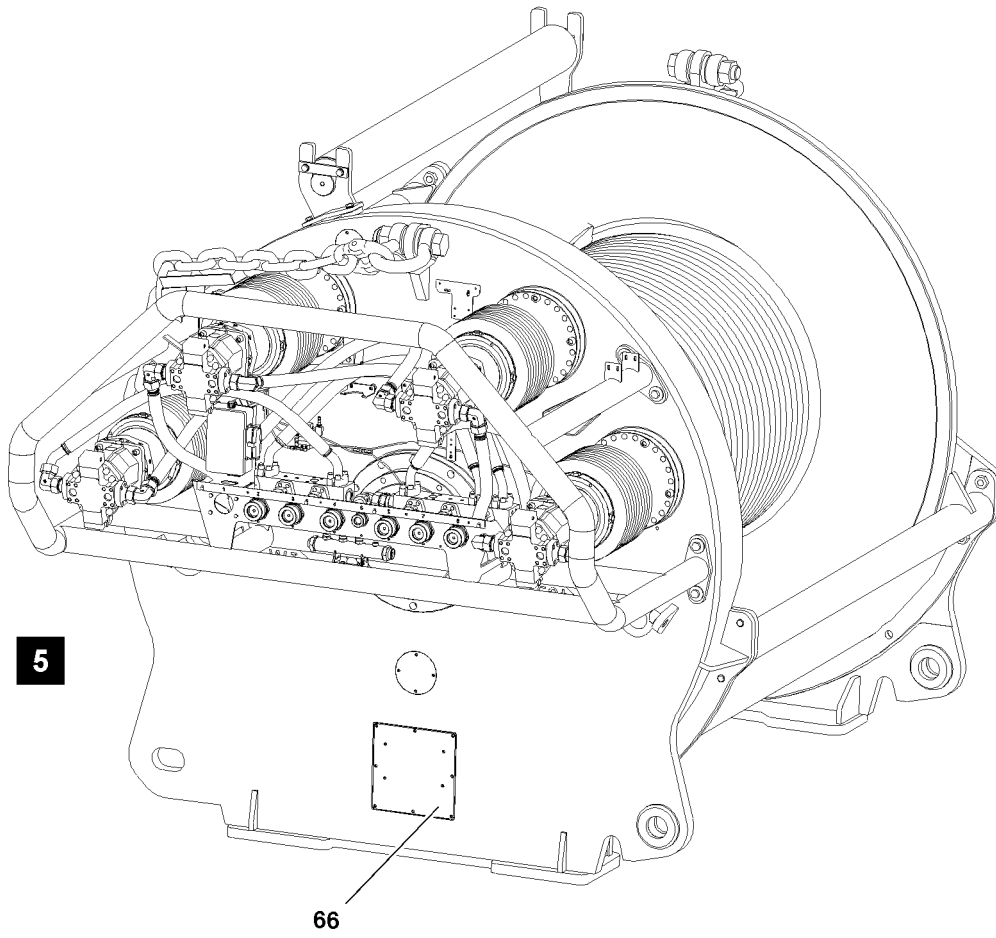

Fig.115683

7.3 Inspection of drive pinion and the gear rings

On the rope winches, on the drive side in the lower area is a maintenance opening **66** to carry out inspection tasks, see illustration **5**.



Note

- ▶ Carrying out inspections is identical for all winches and is described on the example of one winch!

Make sure that the following prerequisites are met:

- The hoist gear is inactive.
- The crane engine is turned off.

7.3.1 Checking the grease quantity



Note

- ▶ The grease discharged by the central lubrication system is collected in the grease chamber in the area of the gear ring.
- ▶ The grease chamber only had to be cleaned if the grease emerges in this area uncontrolled!

- ▶ Remove the maintenance opening **66**, see illustration **5**.

NOTICE

Risk of damage due to insufficient lubrication!

If there is not enough grease on the tooth flanks of the gear ring, components will be damaged or worn!

- ▶ Make sure that after cleaning there is a sufficient amount of grease on the tooth flanks of the gear ring!

- ▶ Collect excess grease.

NOTICE

Danger of gear ring damage!

If the following notes are not observed, the gear ring or the drive pinion can be damaged!

- ▶ Make sure that no dirt or foreign particles get in the area of the tooth flanks during inspection work!
- ▶ Make sure, after completing the inspection work, that the maintenance opening **66** is closed again!

- ▶ Close the maintenance opening **66**, see illustration **5**.

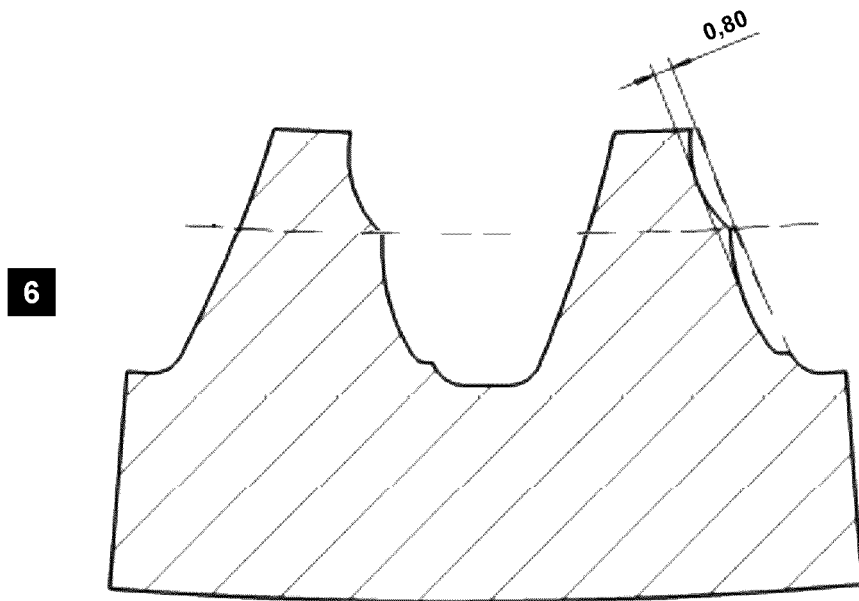
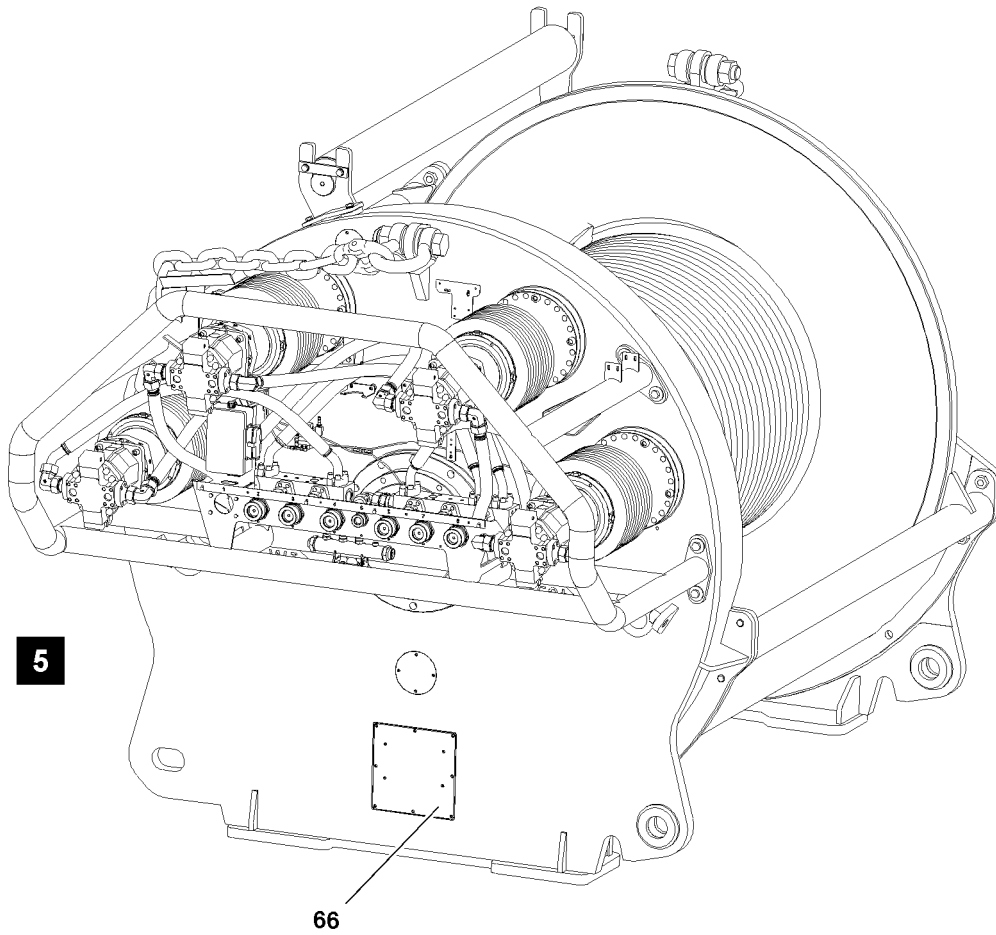

Fig.115683

7.3.2 Checking the tooth flanks on the gear ring

- ▶ Remove the maintenance opening **66**, see illustration **5**.
- ▶ Clean at least two or more teeth on the gear ring with a grease solvent and a cleaning cloth until a blank tooth surface is visible.

NOTICE

Wear on tooth flanks!

- ▶ In case of wear of more than 0.8 mm on the deepest point of the tooth flank consult Liebherr Service immediately, see illustration **6**!
-
- ▶ Check the tooth flanks of the gear ring for wear and other irregularities.

NOTICE

Tooth wear on drive pinions!

If any damage on the tooth flanks of the gear ring is found, then the tooth flanks of the drive pinion must be checked immediately via the opening on the inside of the end plate!

- ▶ Check the tooth flanks of the drive pinion!

NOTICE

Risk of damage due to insufficient lubrication!

If there is not enough grease on the tooth flanks of the gear ring, components will be damaged or worn!

- ▶ Make sure that after inspection there is a sufficient amount of grease on the tooth flanks of the gear ring!
-
- ▶ Lubricate the tooth flanks of the gear ring again with grease.

NOTICE

Danger of gear ring damage!

If the following notes are not observed, the gear ring or the drive pinion can be damaged!

- ▶ Make sure that no dirt or foreign particles get in the area of the tooth flanks during inspection work!
- ▶ Make sure, after completing the inspection work, that the maintenance opening **66** is closed again!

NOTICE

Danger due to corrosion!

Strong corrosion can lead to significant wear on the gear ring!

- ▶ Check for entering water and strong corrosion!
-
- ▶ Close the maintenance opening **66**, see illustration **5**.

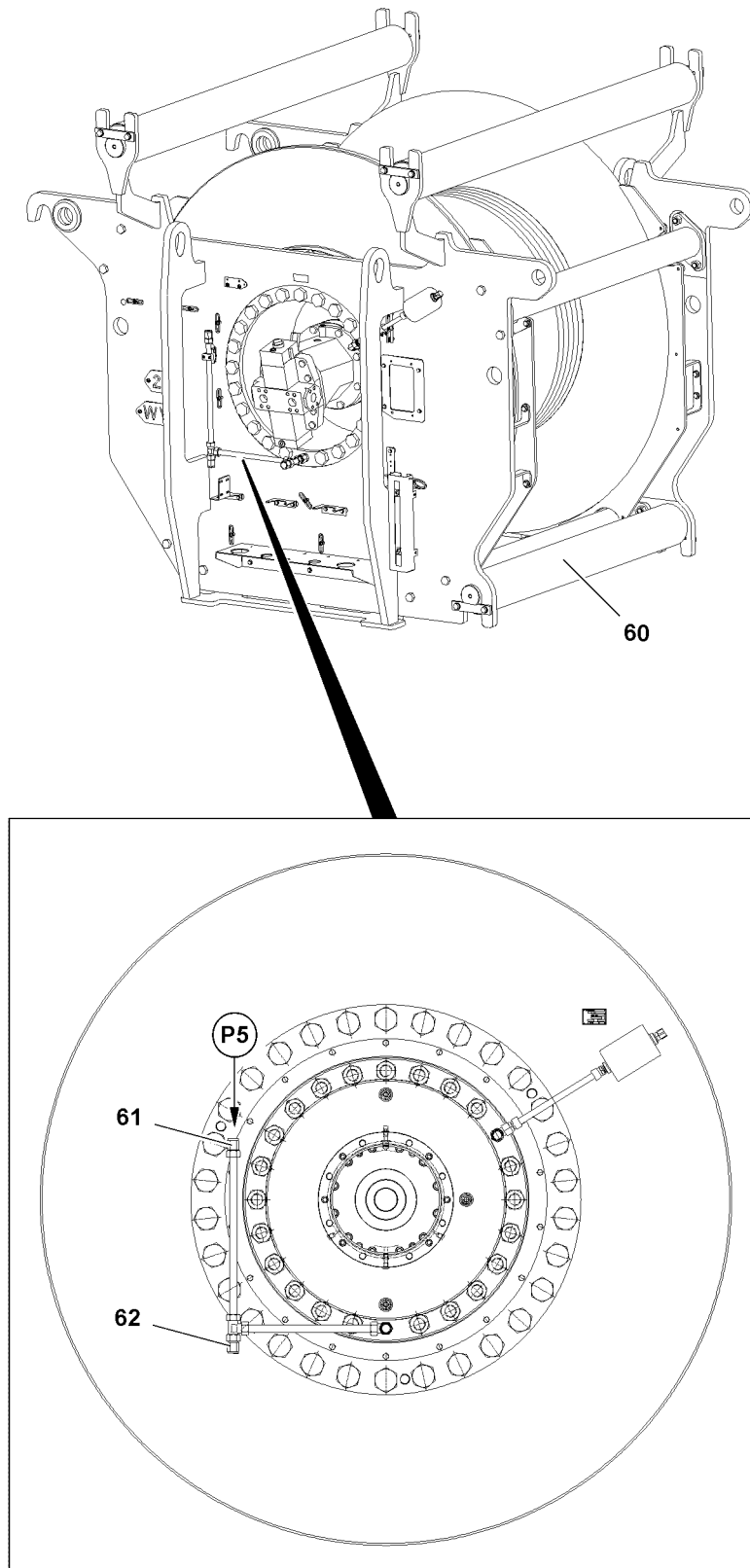

Fig.115681

8 Winch 6

8.1 Checking the oil level

Make sure that the following prerequisites are met:

- The hoist gear is inactive.
- The crane is in horizontal position.



WARNING

Danger of burns during maintenance and inspection work!
Severe burns can result due to the gears and oils at operating temperatures!

- ▶ Avoid direct body contact to heated components and fluids!
-

NOTICE

Dirt in travel gear!

If any dirt gets into the inside of the gear, gear damage can occur!

- ▶ Make sure that no dirt gets into the inside of the gear during maintenance work!
-



CAUTION

Danger of gear damage!

If the oil level has dropped below the minimum mark, add oil according to the lubrication chart!

- ▶ Check the oil level!
-

- ▶ Remove the dipstick **61** and wipe it off.
- ▶ Reinsert the dipstick **61** and pull it out again.

The oil level must be between the min. and max. marks on the dipstick **61**.

- ▶ Check the oil level.

8.2 Changing the oil

- ▶ Remove the dipstick **61** and wipe it off.
- ▶ Remove the oil drain plug **62** with seal ring and drain the oil into a suitable container.
- ▶ Install the oil drain plug **62** with new seal ring and tighten.
- ▶ Add oil according to the lubrication chart on the oil filler port at point **P5**.
- ▶ Reinsert the dipstick **61** and pull it out again.
- ▶ Check the oil level.

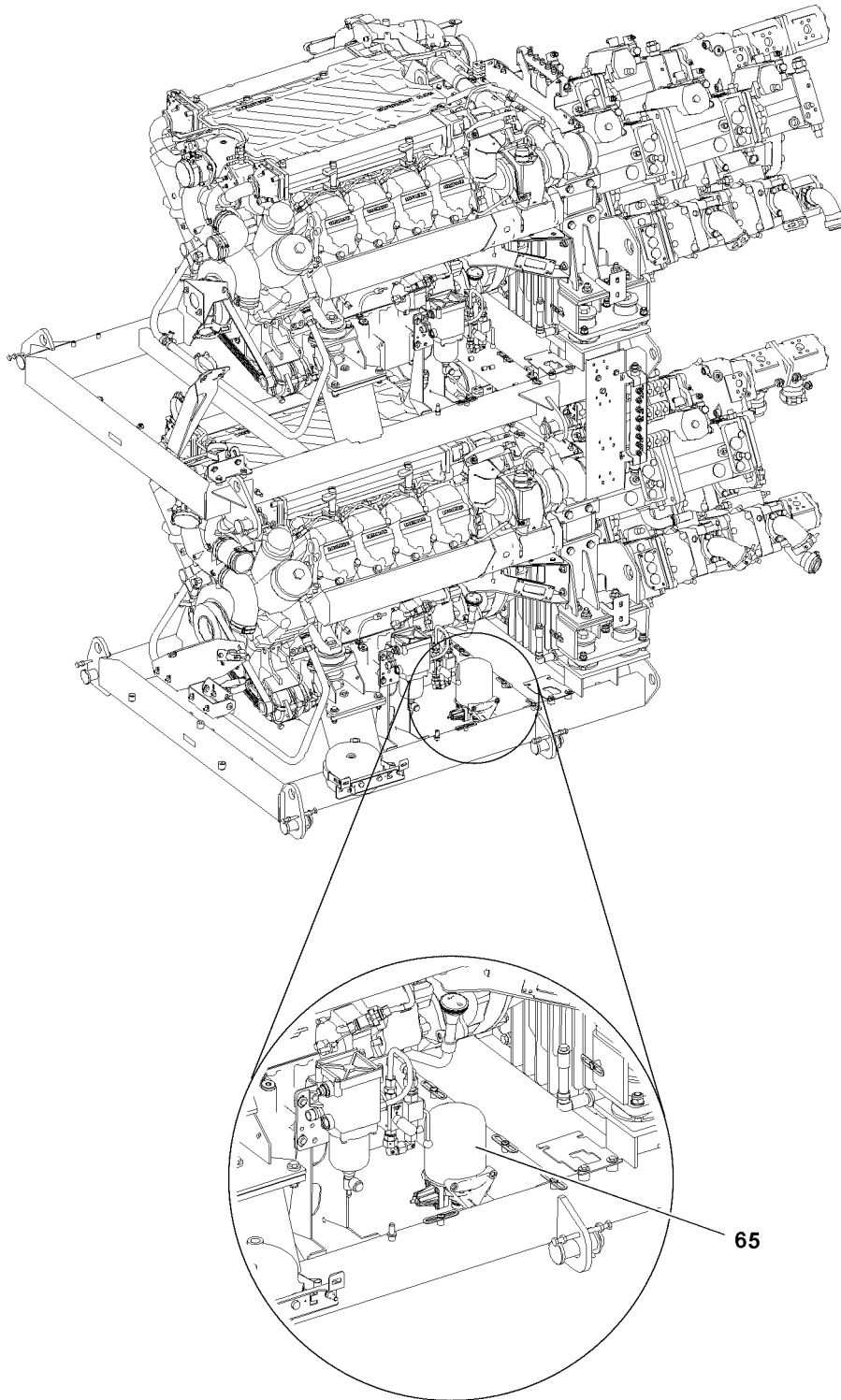

Fig.115679

9 Air dryer of the pressurized air system

9.1 Replacing the granular cartridge



WARNING

Danger of burns during maintenance and inspection work!
Severe burns can result due to the engine at operating temperature!

- ▶ Avoid direct body contact to heated components!



WARNING

Risk of accident due to pretensioned granular cartridge!
The granular cartridge **65** is under spring tension!

- ▶ Caution when replacing the granular cartridge **65**!
- ▶ Replace the granular cartridge **65** once per year.

10 Electrical system - Lighting

The maintenance of the electrical system is essentially limited to replacing defective fuses and bulbs and maintaining the batteries.

NOTICE

Damage to electrical system!
Never short circuit defective fuses with wire or similar items!

- ▶ Always replace defective fuses with fuses of the same amperage!
- ▶ If there is a repeat problem with the same fuse, check the electrical system!

10.1 Battery maintenance



DANGER

Danger of fatal injury!

- ▶ Always disconnect the batteries from the power circuits when working on the electrical system of the crane and during all welding work!
- ▶ Keep batteries dry and clean.
- ▶ Do not bring oil, grease, fuel or solvents into contact with the battery casting compound.
- ▶ Release dirty terminals, clean and grease them with an acid-free and acid-resistant grease.
- ▶ Check the acid levels in batteries at least once a year. In summer and in hot climate zones, check it at least twice a year.
- ▶ On conventional batteries, check electrolyte level at regular intervals and add distilled water to the specified „max mark“, if necessary.

When adding distilled water:

- ▶ Measure the acid concentration only after 30 minutes. The acid temperature for measuring should be + 20 °C if possible.

Proceed as follows when checking the battery charge:

Specific weight	Charge condition
1.28/1.23*	Well charged
1.20/1.16*	Semi-charged, recharge
1.12/1.08*	Discharged, recharge immediately

* in tropical countries

Reduced battery performance requires greater power requirements.

- ▶ Ensure that batteries are well charged, particularly during the colder months.

10.2 Mixing battery acid

- ▶ Ensure that work area is well ventilated.



DANGER

Risk of explosion!

- ▶ When mixing battery acid, always pour distilled water into the container first, then the concentrated sulphuric acid!
- ▶ Observe this order, otherwise explosions and spattering can occur!
- ▶ Stir the mixture with an acid-proof stick (glass or plastic).

Desired acid concentration kg/l	1.23	1.24	1.25	1.26	1.27	1.28
Volume ratio of concentrated sulphuric acid (96 %) to distilled water	1:3.8	1:3.6	1:3.4	1:3.2	1:3.0	1:2.8

When adding the battery acid, the acid level should be 15 mm above the top edge of the battery plates and the temperature of the acid should be approximately 15 °C.

- ▶ Add battery acid to battery.

Wait approximately 20 minutes before connecting the battery. By that time, it will be balanced out.

- ▶ Connect the battery after approximately 20 minutes.

10.3 Removing and recharging the battery



WARNING

Danger of injuries!

- ▶ Do not place tools on batteries and keep open flames away!

10.3.1 Removing the battery

Make sure that the following prerequisites are met:

- The engine is turned off.
- All electrical users are turned off.

NOTICE

Damage to alternator!

- ▶ Do not disconnect batteries unless the engine has been turned off!
- ▶ Carry out work in well ventilated rooms and avoid sparks.
- ▶ Disconnect the negative terminal first (ground cable), then the positive terminal.
- ▶ Remove the battery.

- ▶ Avoid spark formation caused by electrostatic charge. To avoid this, touch the ground support point in the driver's cab.
- ▶ Do not tilt or shake the battery.

10.3.2 Recharging the battery

NOTICE

Damage to battery!

- ▶ Recharge only with direct current, the strength of which does not exceed 1/10 of the battery capacity!
-

Recharging example: A battery with 170 Ah should be charged with a maximum charging current of 17.0 A.

- ▶ Frozen batteries must be thawed out before charging.
- ▶ Remove all plugs before charging.
- ▶ Provide ventilation during charging (risk of oxyhydrogen gas explosion!).
- ▶ Connect the battery to a battery charger (positive to positive and negative to negative).
- ▶ Turn on the battery charger after connecting the battery.

Stop charging immediately if:

- The acid temperature exceeds 55 °C (casing more than warm to the touch).
 - The battery starts to give off gas.
 - The acid concentration or the charging voltage has not changed for 2 hours.
- ▶ Turn the battery charger off after charging, then remove the connector cables individually from battery and battery charger.

10.3.3 Installing the battery

- ▶ Reinstall the battery tightly in the vehicle.
- ▶ Avoid spark formation caused by electrostatic charge. To avoid this, touch the ground support point in the driver's cab.
- ▶ Connect the positive terminal to the battery first, then the negative terminal (ground cable).
- ▶ Check that the terminals are tightly seated (low transfer resistance).
- ▶ Grease the terminals and terminal posts with acid-free and acid-resistant grease (use corrosion protection even for modern maintenance-free batteries).

Empty page!

LWE/LR 13000-001/19503-01-02/en

7.05.50 Maintenance instructions - Crane boom

1	Lattice mast boom	3
2	Rope pulleys and guide pulleys	4
3	Crane ropes	4

Fig.195219

LWE/LR 13000-001/19503-01-02/en

1 Lattice mast boom



WARNING

Danger of falling!
Death, severe injuries.

- ▶ For all work on the crane where there is a danger of falling, suitable safety measures must be taken, see Crane operating instructions, chapter 2.06.



Note

- ▶ The following illustration is an example and may not exactly match to your crane.

1.1 Lubricating the pin bores on the lattice sections and guy rods

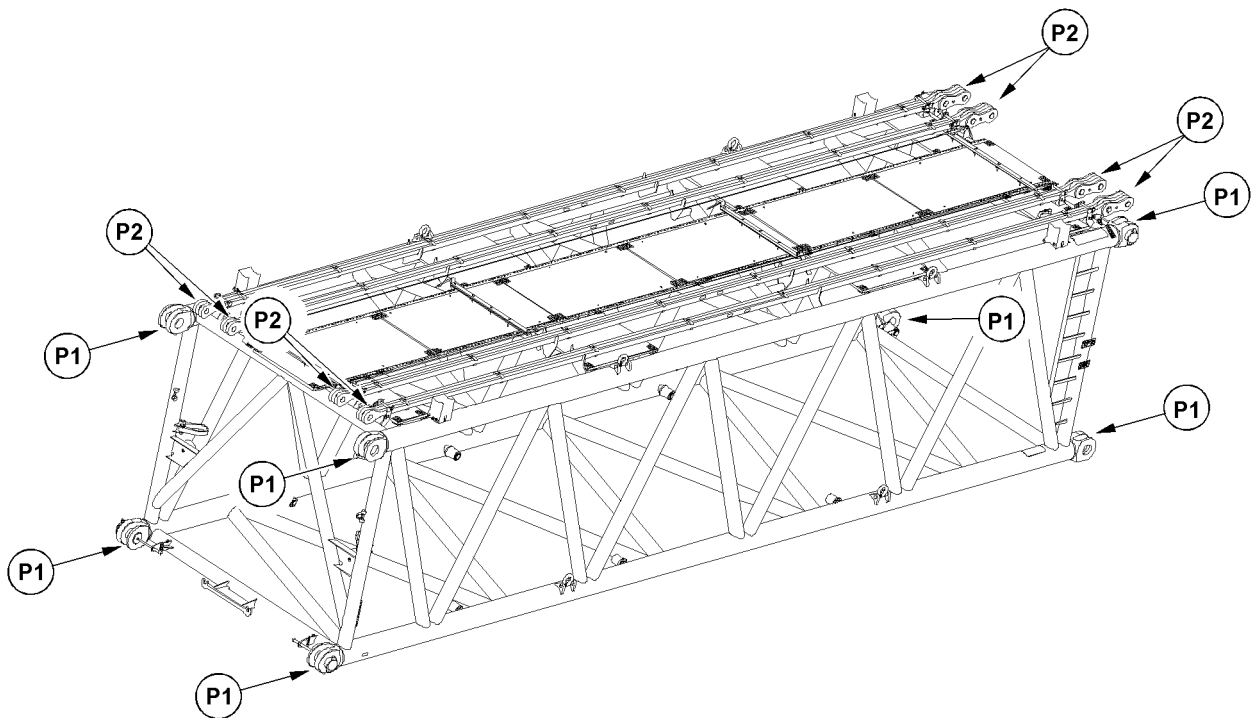

Fig.123861: Lube points on boom lattice sections and guy rods



Note

- ▶ For the pin bores on the lattice sections (points **P1**) and the guy rods (points **P2**), use special grease as lubricant. See Service fill and Crane operating instructions, chapter 7.07.
- ▶ Apply the grease on the pin bores over the entire circumference.
- ▶ The lubrication of the pin bores on the boom lattice sections and the guy rods is made before assembly or after disassembly.

Make sure that the following prerequisites are met:

- The lattice sections are not installed on the crane.
- The lattice sections are playing on a load bearing support on the ground.
- ▶ Grease the pin bores on the boom lattice sections and the guy rods.

2 Rope pulleys and guide pulleys

2.1 Check bearings for easy movement

Stiff or blocked rope pulleys or compensation pulleys wear rapidly and unevenly and cause serious rope abrasion.

Ineffective compensation pulleys can lead to irregular rope tension.

- ▶ Check the rope pulleys for proper movement in their bearings.

When rope pulleys are **not** easily moveable in their bearings:

- ▶ Fix the bearings.

2.2 Checking for mechanical damage

Ropes can cause mechanical damage, such as stress marks.

- ▶ Check guide pulleys and rope pulleys for mechanical damage.

3 Crane ropes

3.1 Personal protective equipment



WARNING

Injury due to wires and skin irritation due to lubricant!

- ▶ When working with ropes, always wear work gloves.



WARNING

Injuries if protective equipment is **not** worn!

- ▶ Wear hard hat, safety shoes and safety glasses.

3.2 Safe and problem-free operation



WARNING

Wear, overload, incorrect use, damage, improper maintenance!

Failure of ropes. Death, severe injuries, property damage.

- ▶ Prevent failure of ropes: Observe and adhere to the following notes.

Carry out the following measures to ensure safe and problem-free rope operation.

- Service ropes and rope end connections regularly according to the maintenance intervals.
- Check ropes and rope end connections regularly according to the inspection intervals.
- When it is determined that the ropes should be withdrawn from service, do **not** continue to use them further.
- Exclude contact of rope with components except rope drive elements.
- Exclude contact of rope with structural parts, power lines or other objects within the surrounding area.
- Avoid corrosive and chemical surroundings.
- Avoid excessive soiling.
- Avoid excessive heat influence.
- Ensure proper condition of all elements of rope drive.
- Ensure proper spooling formation on the rope drum.
- Use the entire rope length of hoist ropes.
- Avoid slack rope formation on the drum.
- Do **not** bring outer twists into the rope.
- Avoid shock relief of the rope, such as sudden set down of the load.

- Avoid **non-permissible** angular pull, for example by pulling the load at an angle.

3.3 Temperature operating limits

Adhere the temperature operating limits for steel ropes. The determining factors are wire material, lubricant, rope end connections. See Manufacturer's specifications.

3.4 Qualification Maintenance personnel

Make sure that the following prerequisites are met:

- The maintenance personnel is trained and instructed in maintenance tasks.
- The maintenance personnel is assigned (authorized) for the maintenance by the crane operator.

3.5 Damage on rope

Rope removal criteria: If severe damage reduces the operational safety, then the rope can reach the removal criteria.

This section provides an overview for possible damage on the rope. For clearer illustration, the distortions on the illustrations are exaggerated.

The displayed ropes show a condition, which is far above the removal criteria.

Damage on the rope causes uneven load distribution in the affected areas.

Damage on the rope is most often localized.

Typical examples for damage, which can be recognized during maintenance work:

- Broken strands
- Wire breaks
- Reduction of rope diameter
- Localized increase of rope diameter
- Corrosion
- Flattenings
- Corkscrew-like distortion
- Basket formation
- Protruding, distorted inlay or braiding
- Loop formation
- Kinking, rope loops (grommets) pulled closed
- Buckles
- Influence of heat or electrical voltage, such as arcing

3.5.1 Broken strands

A strand consists of several individual wires.

When a complete braid is broken, then the rope must be taken down.

3.5.2 Broken wire

Externally visible broken wires are the result of wear caused by operation.

Additional types of broken wires:

- Broken wire in the inside of the rope
- Broken wire in the strand valleys
- Broken wire on a rope connection

A broken wire does not endanger the safety of the rope.

3.5.3 Reduction of rope diameter

The rope diameter changes due to abrasion, settling and external influences.

Abrasion of cover wires of outer strands of rope due to frictional contact. Especially in those areas where ropes are in contact with the rope pulleys during start up or slow down of the load.

Wear is increased by lack of or incorrect lubrication and the effect of dust.

Abrasion reduces the tensile strength of steel ropes because the cross section of the steel is reduced.

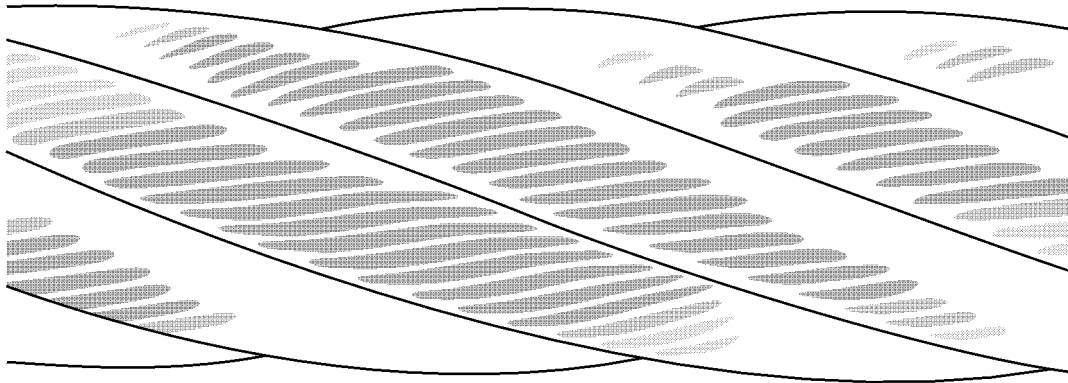

Fig.121001: External abrasion on the rope

When the rope diameter is reduced, the rope must be checked by **expert personnel for crane rope inspection**.

3.5.4 Localized increase of rope diameter

An increase, which occurs over a longer area of the rope can be caused by absorption of moisture in the fiber insert or due to corrosion in the inside of the rope.

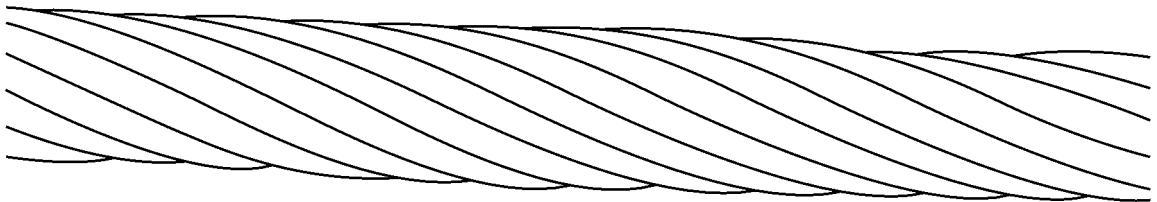

Fig.120992: Increase of rope diameter

When a localized increase of the rope diameter is present, then the rope must be checked by **expert personnel for crane rope inspection**.

3.5.5 Corrosion

Corrosion occurs due to insufficient lubrication, in maritime climates and in an atmosphere polluted by industrial fumes.

External corrosion is indicated by a rough wire surface. A superficial rust film can be wiped off.

Significant corrosion reduces the strength and elasticity of the rope due to the reduction of the rope diameter.

Inner corrosion is hard to detect.

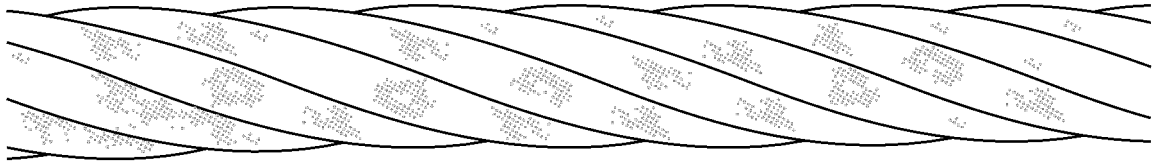

Fig.120994: External corrosion

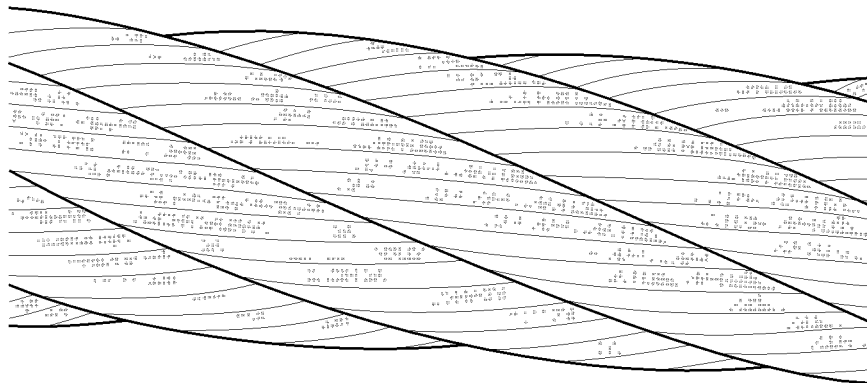

Fig.120995: Magnification of external corrosion for better depiction

When significant corrosion is present, the rope must be checked by **expert personnel for crane rope inspection**.

3.5.6 Flattening

Flattening occurs when the rope runs through the rope pulleys. In this area the rope wears quicker. Corrosion occurs faster on retaining ropes and guy ropes.

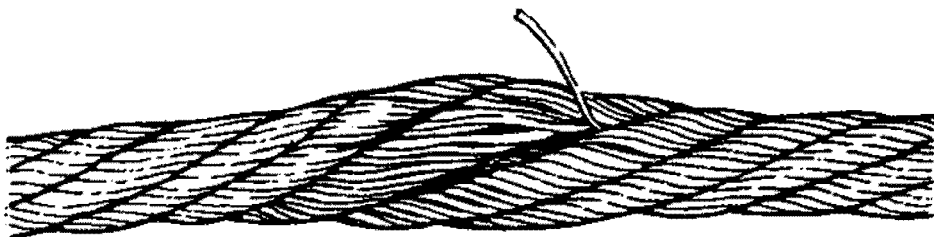

Fig.120997: Localized limited flattening, which leads to broken wires (single layer rope)

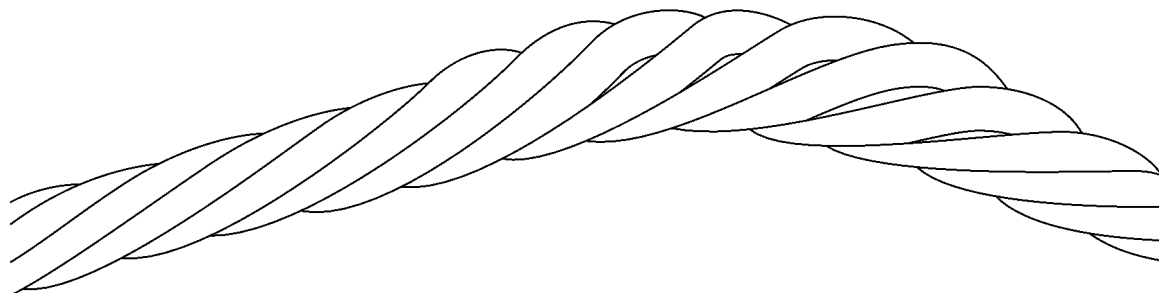

Fig.120996: Flattenings on multi layer spoolings

When flattening is present, the rope must be checked by **expert personnel for crane rope inspection**.

3.5.7 Corkscrew-like distortion

Distortion where the rope is in the form of a corkscrew along its longitudinal axis.

Corkscrew-like distortion causes rope wear, broken wires and bearing damage on rope pulleys.



Fig.120988: Corkscrew-like distortion

When corkscrew-like distortion is present, the rope must be checked by **expert personnel for crane rope inspection**.

3.5.8 Basket formation

This distortion occurs due to different layers between the outer strand layers and the inside of the rope.

Causes for basket formation are high angular pull angles during the run over the rope pulleys and run-in rope pulleys. Even load distribution over the entire cross section is not possible.

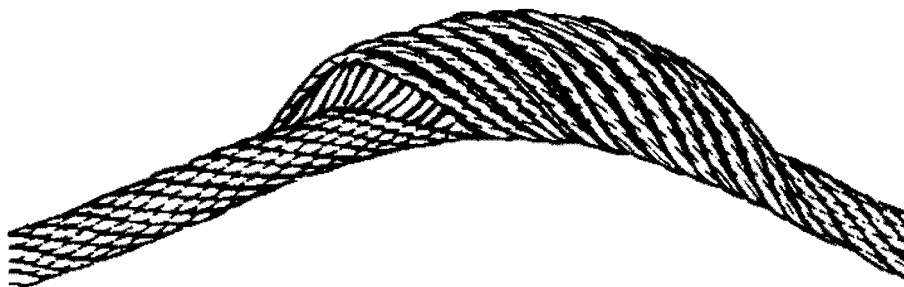

Fig.120989: Basket formation

When basket formation is present, then the rope must be taken down.

3.5.9 Protruding, distorted inlay, braiding

This distortion is a special form of basket formation: The insert or the core of the rope protrudes between the external braids or an external braid protrudes from the rope banding.

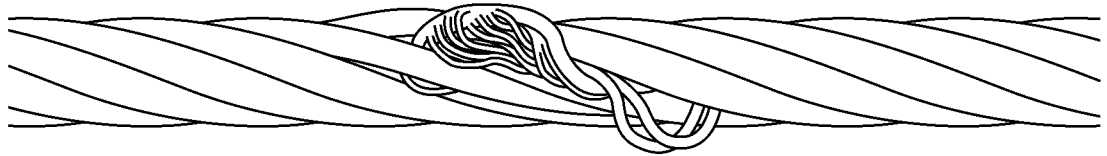

Fig.120990: Protrusion of an insert (rope single layer)



Fig.120991: Distorted or protruding strand

When the insert or a strand protrudes or is distorted, place the rope down. Have **expert personnel for crane rope inspection** check if the rope area with the distortion can be removed.

3.5.10 Loop formation

At loop formation individual wires protrude from the rope banding, when no broken wire ends can be seen.

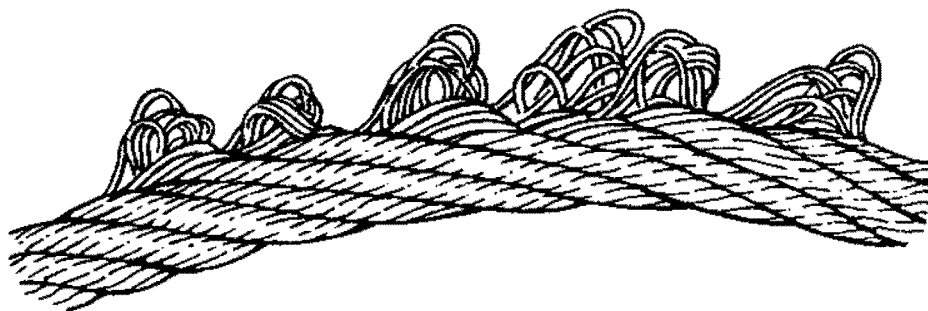

Fig.120993: Emergence of individual wires

When loop formation is present, take the rope down.

3.5.11 Kinking, rope loops (grommets) pulled closed

Deformation, where a loop has formed in the rope, without the possibility to rotate around its own axis during a load. The rope is subjected to more wear.

The rope is deformed. The strength remains only in part.

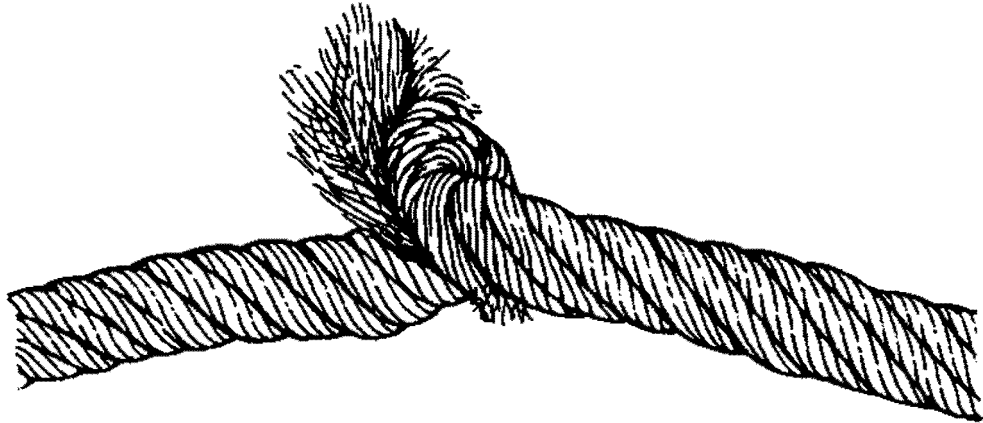

Fig.120998: Severe kinking or knots

When kinking or rope loops are present, place the rope down.

3.5.12 Buckles

Buckles are angular deformations. The rope was damaged due to external influences. Strong deformations of the rope cause stronger wear.

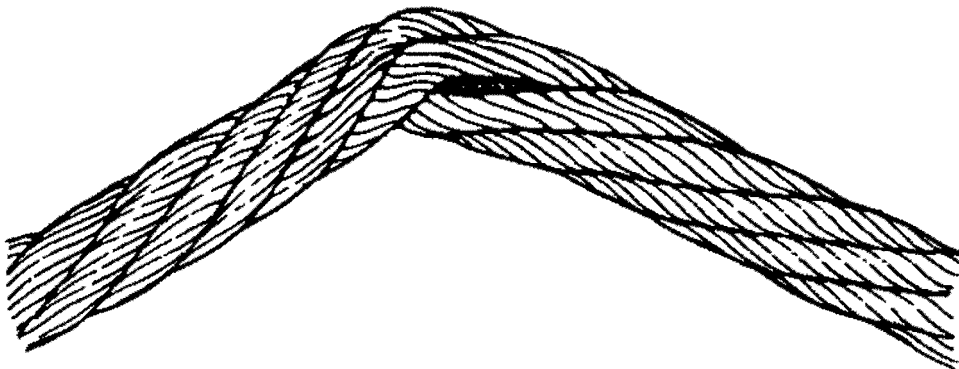

Fig.120999: Severe buckle

When buckles are present, take the rope down.

3.5.13 Effects of heat, arcs

Damage caused to the rope by welding work, for example.

Unusual heat impact is visible by tempering colors and loss of lubricant.

When heat impact has occurred on the rope, then the rope must be taken down.

3.6 Checking the ropes



WARNING

Operation with damaged rope!
Failure of rope. Death, severe injury, property damage.

When damage, wear and deformations are present:

- ▶ Have **expert personnel for crane rope inspection** determine if the rope has to be taken down.

The following sections describe the tasks for **daily visual inspection**.

The crane operator can carry out a daily visual inspection if he is sufficiently trained in the tasks and considered to be able to do so.

3.6.1 Intervals

Intervals and situations where the daily visual inspection must be made:

- Daily, before starting to work
- In case of change of the reeving of the crane rope due to
 - Transport
 - New reeving
 - Removal and installation

3.6.2 Areas

The rope must be checked over the entire length.

The following areas must be checked with special diligence:

- Rope end connections
- Safety coils and fixed point on the winch
- Areas of the rope which run through the hook block
- Areas of the rope which run over the rope pulleys or laying on the rope pulleys
- Areas of the rope which are spooled on the winch, especially cross over areas
- Areas of the rope which are laying above the compensation pulleys
- Areas of the rope which are subjected to abrasion due to external components
- All areas of the rope which are subjected to temperatures above 60°C

3.6.3 Documentation of rope condition

Every visible change of the wire rope must be documented in the crane records.

3.6.4 Checking the lubrication



WARNING

Missing lubrication!

Functional problems. Inner and outer corrosion.

- ▶ Lubricate the rope regularly.
- ▶ Make sure that the rope is lubricated all around.
- ▶ Select manual or automatic lubrication procedures.

The lubrication must be checked at least once a **month**.

When the rope shows signs of drying out:

- ▶ Lubricate the rope, see section „Lubricating the rope“.

3.6.5 Check for wear and distortion

- ▶ Check all visible parts of the rope for wear and distortion.
- ▶ Check the rope end connections and fixed points especially carefully for wear, damage, cracks and distortion.
- ▶ Check pressed together rope end connection for slipping and traces on the rope.



Note

- ▶ The maximum permissible number for broken wires over a certain rope length may not be exceeded.
- ▶ Determine the maximum permissible number of broken wires, see Crane operating instructions, chapter 8.04.
- ▶ Check the rope end connection and rope area near the rope end connection for broken wires.

When broken wires are present on the rope:

- ▶ Remove the broken wire, see section „Removing broken wires“.

When broken wires or damage is present on the rope end connection:

- ▶ Document visible changes of the rope condition.
- ▶ Have the rope checked by **expert personnel for crane rope inspection**.

When the rope can be shortened without reducing the operational safety:

- ▶ Shorten the rope, see section „Shortening the rope“.

3.6.6 Checking the rope drive for spooling problems

Lacking pretension of the rope on the winch can cause spooling problems in multi layer spooling.

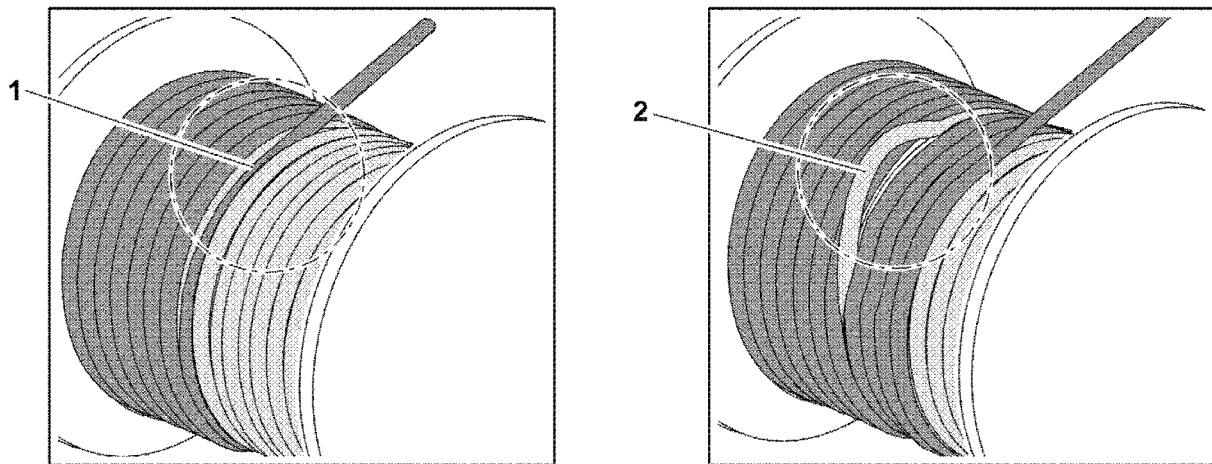

Fig.120967: Possible spooling problems on the rope winch

- 1** Cutting into the lower rope layers **2** Loop formation in the lower rope layers

- ▶ Check the spooling behavior of rope on the rope winch for cutting into the lower rope layers **1**.
- ▶ Check the spooling behavior of rope on the rope winch for loop formation in the lower rope layers **2**.

When spooling defects are found:

- ▶ Renew the pretension, see section „Renewing the pretension of hoist ropes“.
- ▶ Document visible changes of the rope condition.
- ▶ Have the rope checked by **expert personnel for crane rope inspection**.

3.6.7 Checking the position

- ▶ Check the correct position of the rope on the rope pulleys.

When the rope is **not** correctly laying on the rope pulley:

- ▶ Have the rope and rope pulley checked by **expert personnel for crane rope inspection**.

3.6.8 Checking for corrosion

A superficial „rust film“ can be wiped off.

- ▶ Do **not** clean the rope with solvents or cleaners.
- ▶ Clean the rope solely with a wire hand brush.
- ▶ Check rope for corrosion.

When the rope shows a rough surface:

- ▶ Document visible changes of the rope condition and have the rope checked by **expert personnel for crane rope inspection**.

- If there is any uncertainty regarding the condition of the rope:
- ▶ Place the rope down or contact Liebherr Service.

3.6.9 Checking for flattenings

In the cross over area of the spooled up rope layers on the winch the rope is stressed more. The rope can be flattened as a result.

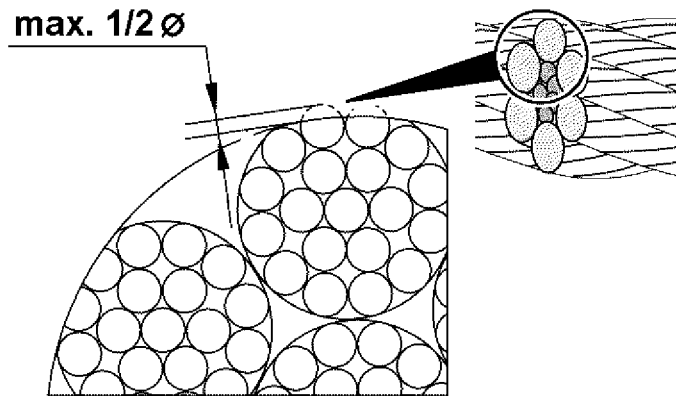

Fig.120966: Maximum flattening of wires on the outer strands

- ▶ Check the rope in the ascent zones of the rope spooling on the winch for flattenings.

When the outer braids are flattened more than half of the wire diameter:

- ▶ Document visible changes of the rope condition.
- ▶ Have the rope inspected by **expert personnel for crane rope inspection** or place the rope down.

When the rope can be shortened without reducing the operational safety:

- ▶ Shorten the rope on the rope drum fixed point, see section „Shortening the rope“.

3.7 Checking the control rope for distortions

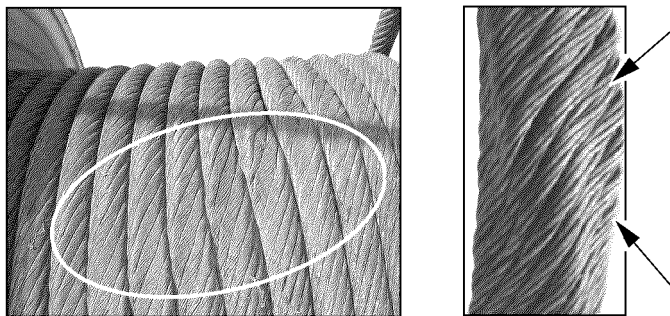

Fig.114002: Distortion on control ropes

- ▶ Check the first rope layer of the control rope for crushed areas and distortions.

When distortions are present:

- ▶ Have the rope checked by **expert personnel for crane rope inspection**.

3.8 Lubricating the rope



WARNING

Missing lubrication!

Functional problems. Inner and outer corrosion.

- ▶ Lubricate the rope regularly.
- ▶ Make sure that the rope is lubricated all around.
- ▶ Select manual or automatic lubrication procedures.

NOTICE

Too much or incorrect lubricant!

Excessive soiling. Wear on rope, on rope pulley and on winch. Recognition of take down criteria is impeded.

- ▶ Use lubricant, which is compatible with the rope and the original lubricant.

- ▶ Do **not** clean the rope with solvents or cleaners.
- ▶ Clean the rope solely with a wire hand brush.

Areas, which must be lubricated especially well are bending zones on winch and rope pulleys.

- ▶ Lubricate the rope.

3.9 Removing broken wires

NOTICE

Broken wires!

Damage of other components in crane operation, for example rope pulleys and compensation pulleys.

- ▶ Remove broken wires.

Make sure that the following prerequisite is met:

- Suitable pliers are on hand.

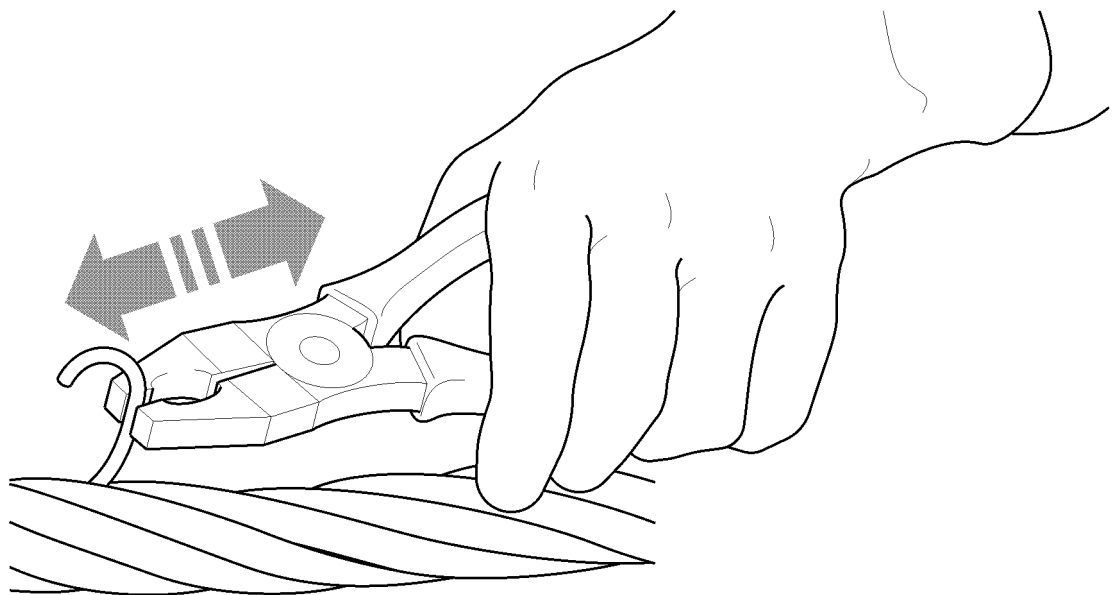

Fig.120979: Remove broken wire

- ▶ Grasp the wire on the upper end with pliers. Bend the wire back and forth until the wire breaks off in the braid valley.

The position of a broken wire is important for subsequent inspection. Individual broken wires are counted and are recorded later in the evaluation for withdrawal from service.

- ▶ Document the position of the broken wires in the crane record. Inspection checklist, see chapter 8.04.

3.10 Turning an extremely rotation-resistant hoist rope out



WARNING

Damage of rope due to incorrect procedure!

- ▶ Use extreme caution for the following procedures.
- ▶ Observe the following instructions exactly.

The cause for the turn-in of the hook block can have various reasons.

Check the crane for the following peculiarities:

- Scrub marks: Are hoist rope scrub marks present on the crane components? If scrub marks are present, check the hoist rope run and correct it.
- Rope pulleys: Did the groove diameter become too small?
 - Groove diameter dimensional stability must be present.
 - If this is not the case, the rope pulley must be replaced.
- Rope lubrication: Has the hoist rope been sufficiently lubricated? If the rope surface is dry, the hoist rope must be re-lubricated.

If the crane does not display other peculiarities, the hoist rope must be spun out.

The following sections describe two methods of how to spin out the hoist rope. The methods must be applied in the described sequence.

3.10.1 Spinning out with single strand reeving

- ▶ Reeve in the single strand hoist rope.
- ▶ Extend the boom to the maximal boom length and hook height.
- ▶ Lower hooks to approximately 1 m above the ground and allow the hoist rope to spin out.
- ▶ With an empty hook block, carry out one complete hoist cycle.
- ▶ Lower the hook again to approximately 1 m above the ground and allow the hoist rope to spin out again.
- ▶ Reeve the number of strands of hoist rope carefully and spin free where the twisting of the hook block is largest.
- ▶ Distribute the spin out to the entire rope length: Run at least two entire hoist cycles at maximum boom length and hook height.



Note

When the hook block continues to turn in:

- ▶ Spin the rope out, see section „Spinning out by turning the hook block out“.

3.10.2 Spinning out by turning out the hook block

Make sure that the following prerequisite is met:

- The hook block is reeved with the number of strands where the twisting is the largest.
 - ▶ Extend the boom completely and lower the hook block.
 - ▶ Attach a load of approximately 10 % of the nominal rope pull on the hook block.

Before lifting the load, a helper must rotate the twisted hook block to a straight position by hand until the rope strands no longer touch each other.

- ▶ Continue to turn the hook block by one entire turn.

Result:

- The rope strands touch again.

NOTICE

The hook block turns back under load in a straight position!

When the hook block turns back in a straight position:

- ▶ Release the hook block.
-
- ▶ Hold the hook block in the prescribed position until the load lifts off the ground.
 - ▶ Move the load until approximately 15 m before the uppermost hook position of the completely extended boom.
 - ▶ Lower load and set it down.

3.11 Renewing the pretension of hoist ropes

**WARNING**

Lacking pretension of the rope on the winch!

Excessive rope wear in the lower spooling layers, gap formation, rope cutting in.

When the lower rope layers on the winch are hardly used or **not**:

- ▶ Renew the pretension in the entire rope regularly.

Make sure that the following prerequisites are met:

- A reeving is selected where the entire rope length can be spooled.
- Clean spooling pattern on the drum at spooling.

**Note**

Recommendation!

- ▶ The rope application is the most economical when the entire rope length is utilized.

When only a part of the rope length is used for a longer period of time:

- ▶ Use a proportionally shorter rope.
-
- ▶ Spool the rope out until three safety coils.
 - ▶ Spool the rope up with a rope tensile force of 10 % of the maximum rope tensile force.

3.12 Shortening the rope

**WARNING**

Distortions and mechanical damage!

Operational safety significantly disturbed, uneven load distribution within the rope.

- ▶ Have the manufacturer check if the distorted and damaged area can be severed.

Visible form changes often occur localized or in short rope sections.

When a safe operation of the rope is ensured, a distorted and damaged area can be severed.

To shorten the rope there are different prerequisites:

- Rope shows flattenings
- Broken wires occur solely within the area of the rope end connection, the remaining rope is undamaged

**DANGER**

Minimum number of remaining coils on the winch fallen below!

Rope releases or rips off, falling load. Death, severe injury, property damage.

- ▶ Make sure, after shortening the rope that **at least three remaining coils** remain on the winch in all working positions of the crane.

Make sure that the following prerequisite is met:

- The rope was shortened by authorized and trained expert personnel.

Multi layer spooling: When the rope on the fixed point on the winch is shortened by half the winch diameter, then the service life of the rope increases significantly.

Empty page!

LWE/LR 13000-001/19503-01-02/en

7.06 Fill quantities, lubrication chart

1	Fill quantities	3
2	Lubrication schedule	4

Fig.195219

LWE/LR 13000-001/19503-01-02/en

1 Fill quantities



WARNING

Handling poisonous operating fluids and lubricants!
Poisoning, severe health damage.

When operating fluids are to be used, stored and disposed of:

- ▶ Observe and follow the printed instructions on the original containers.
- ▶ Store operating fluids exclusively in the closed original container.
- ▶ Keep children away from operating fluids. Keep operating fluids away from children.
- ▶ Dispose of operating items and lubricants in an environmentally safe manner.

NOTICE

Damage on aggregates due to impermissible additives!

- ▶ Make sure that **no** impermissible additives are added to the operating fluids.



Note

- ▶ Fill quantities and descriptions of service items and lubricants are specified in the Service fill.
- ▶ Fill the crane chassis, crane superstructure and equipment with the respective operating fluids.
- ▶ The specified fill quantities (change quantities) are orientation values. The marks on the dipsticks, inspection ports and sight gauges are decisive for filling.
- ▶ The equipment depends on the purchased scope of delivery.

On mobile cranes with truck chassis:

- ▶ Observe the maintenance intervals and maintenance notes of the truck chassis manufacturer.

NOTICE

Danger of property damage!

- ▶ Do **not** mix different oil products!
- ▶ Do **not** mix synthetic oils with mineral oils!
- ▶ Adhere to the data in the Service fill!

1.1 Diesel engine

- ▶ Check the engine oil. See Maintenance intervals and maintenance instructions.
- ▶ Adhere to the operating instructions of the engine manufacturer.

1.2 Coolant system

NOTICE

Property damage due to impermissible coolant!

- ▶ Do **not** mix different coolant products.
- ▶ Do **not** thin Liebherr-Fertig-Mix (Liebherr Ready Made Mix).

When adding coolant:

- ▶ Use exclusively the same coolant.

Coolants contain corrosion inhibitor - antifreeze fluid.

Add coolant only on the filler neck. See Service fill.



Note

If the coolant is changed:

- ▶ Contact the Service Dept. at Liebherr-Werk Ehingen GmbH for procedure.
- ▶ Empty the cooling system completely and flush.

In exceptional cases, the coolant can be supplemented with different coolants.

**Note**

Supplementing the coolant with different coolants:

- ▶ Contact the Service Dept. at Liebherr-Werk Ehingen GmbH for procedure.
- ▶ Check the coolant level. See Maintenance intervals and maintenance instructions.

1.3 Transmission

- ▶ Check the gear oil. See Maintenance intervals and maintenance instructions.

1.4 Hydraulic system

**Note**

- ▶ The oil level must be in the center of the hydraulic oil level sight gauge at 20 °C oil temperature.

At lower hydraulic oil temperature:

- ▶ Warm up the hydraulic oil.

At higher hydraulic oil temperature:

- ▶ Cool off the hydraulic oil.
- ▶ Retract all hydraulic cylinders completely, for example luffing cylinder, telescoping cylinder.

On vehicles with level regulation:

- ▶ Lower the vehicle completely with the level regulation.

- ▶ Check the hydraulic oil. See Maintenance intervals and maintenance instructions.

2 Lubrication schedule

**Note**

- ▶ Grease the crane chassis, crane superstructure and equipment with the respective lubricants. See Service fill.
- ▶ The equipment depends on the purchased scope of delivery.

On mobile cranes with truck chassis:

- ▶ Observe the maintenance intervals and maintenance notes of the truck chassis manufacturer.

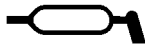

Fig.107729

**Note**

- ▶ Lube points are marked with a symbol.

7.07 Operating fluids and lubricants

1	Specified service fluids and lubricants for Liebherr cranes	3
---	---	---

Fig.195219

LWE/LR 13000-001/19503-01-02/en

1 Specified service fluids and lubricants for Liebherr cranes

Information about the service fluids and lubricants that are approved for a mobile crane from Liebherr-Werk Ehingen GmbH can be found online at <https://lubricants.liebherr.com>.



Note

► Observe and adhere to the specifications and notes in the safety data sheets.

No.	Crane components	Ambient temperature for driving and crane operation	
		-20 °C to +50 °C	-40 °C to +30 °C
1.1	Diesel engine with Exhaust aftertreatment	LWE Id. No.: 11100934 Liebherr Motoroil 5W-30 low ash or: LWE Id. No.: 10663796 Liebherr Motoroil 10W-40 low ash LH-00-ENG _{LA} Observe the instructions of the engine manufacturer	LWE Id. No.: 11100934 Liebherr Motoroil 5W-30 low ash or: LWE Id. No.: 10663796 Liebherr Motoroil 10W-40 low ash LH-00-ENG _{LA} Observe the instructions of the engine manufacturer below -20 °C with pre-heating
		Note: To improve the cold start ability of the diesel engine at an ambient temperature below -10 °C we recommend the use of Liebherr Motoroil 5W-30 low ash, LWE Id. no.: 11100934	
	Cummins B 6.7 with Exhaust aftertreatment	LWE Id. No.: 10663796 Liebherr Motoroil 10W-40 low ash CES 20081 and 5W-40 or CES 20081 and 10W-40	CES 20081 and 0W-40
		Note: To improve the cold start ability of the Cummins diesel engine at an ambient temperature below -10°C, we recommend the use of engine oil according to CES 20081 and SAE viscosity grade 5W-40	
Note: For alternative oil specifications, see the separate engine manufacturer's operating instructions.			

No.	Crane components	Ambient temperature for driving and crane operation	
		-20 °C to +50 °C	-40 °C to +30 °C
1.2	Diesel engine without Exhaust aftertreatment	LWE Id. No.: 10871536 Liebherr Motoroil 5W-30 or: LWE Id. No.: 861005308 Liebherr Motoroil 10W-40 LH-00-ENG Observe the instructions of the engine manufacturer	LWE Id. No.: 10871536 Liebherr Motoroil 5W-30 or: LWE Id. No.: 861005308 Liebherr Motoroil 10W-40 LH-00-ENG Observe the instructions of the engine manufacturer below -20 °C with pre-heating
	Note: To improve the cold start ability of the diesel engine at an ambient temperature below -10 °C , we recommend the use of Liebherr Motoroil 5W-30, LWE-Id no.: 10871536		
	Cummins B 6.7 without Exhaust aftertreatment	LWE Id. No.: 10663796 Liebherr Motoroil 10W-40 low ash CES 20078 and 5W-40 or CES 20078 and 10W-40	CES 20078 and 0W-40
Note: To improve the cold start ability of the Cummins diesel engine at an ambient temperature below -10°C, we recommend the use of engine oil according to CES 20081 and SAE viscosity grade 5W-40			
Note: For alternative oil specifications, see the separate engine manufacturer's operating instructions.			
2	Drive axle with differentials, planetary gear and installed distributor gear	LWE Id. No.: 861901008 Liebherr Gear Hypoid 90 EP SAE 90 and API GL 5	LWE Id. No.: 10425142 Liebherr Syntogear Plus 75W-90 SAE 75W-90 and API GL 5
3	Axle drive ZF DK-7	LWE Id. No.: 861901008 Liebherr Gear Hypoid 90 EP ZF TE-ML 05	LWE Id. No.: 10425142 Liebherr Syntogear Plus 75W-90 ZF TE-ML 05
4.1	Vehicle distributor gear KESSLER VG 1800, VG 2400, VG 2550, VG 2600, VG 2700, VG 3750, VG 3751 W 3750, W 3751	LWE Id. No.: 861901008 Liebherr Gear Hypoid 90 EP SAE 90 and API GL 5	LWE Id. No.: 10425142 Liebherr Syntogear Plus 75W-90 SAE 75W-90 and API GL 5

No.	Crane components	Ambient temperature for driving and crane operation	
		-20 °C to +50 °C	-40 °C to +30 °C
4.2	Vehicle distributor gear with PTO for crane drive KESSLER VG 2700 with PTO VG 3751 with PTO	LWE Id. No.: 10425142 Liebherr Syntogear Plus 75W-90 SAE 75W-90 and API GL 5	LWE Id. No.: 10425142 Liebherr Syntogear Plus 75W-90 SAE 75W-90 and API GL 5
4.3	Vehicle distributor gear ZF Passau, STEYR PUCH VG 1200, VG 1600, VG 2000, VG 3800	LWE Id. No.: 861901008 Liebherr Gear Hypoid 90 EP ZF TE-ML 19	LWE Id. No.: 10425142 Liebherr Syntogear Plus 75W-90 ZF TE-ML 19
5	Miter gear for crane drive	LWE Id. No.: 10425142 Liebherr Syntogear Plus 75W-90 SAE 75W-90 and API GL 5	LWE Id. No.: 10425142 Liebherr Syntogear Plus 75W-90 SAE 75W-90 and API GL 5
6	Displacement gear (drop box) ZF Passau, STEYR PUCH	LWE Id. No.: 861901008 Liebherr Gear Hypoid 90 EP ZF TE-ML 19	LWE Id. No.: 10425142 Liebherr Syntogear Plus 75W-90 ZF TE-ML 19
7.1	Pump distributor gear filled with mineral gear oil	LWE Id. No.: 861901008 Liebherr Gear Hypoid 90 EP SAE 90 and API GL 5	LWE Id. No.: 10425142 Liebherr Syntogear Plus 75W-90 SAE 75W-90 and API GL 5
7.2	Pump distributor gear filled with synthetic gear oil	LWE Id. No.: 861901208 Liebherr Gear PG 220 CLP PG 220, DIN 51517-3 WARNING: May not be mixed with other oils!	LWE Id. No.: 10664125 Liebherr Gear PG 150 CLP PG 150, DIN 51517-3 WARNING: May not be mixed with other oils!
7.3	Pump distributor gear LTC 1055-3.1	LWE Id. No.: 10425142 Liebherr Syntogear Plus 75W-90 SAE 75W-90 and API GL 5	LWE Id. No.: 10425142 Liebherr Syntogear Plus 75W-90 SAE 75W-90 and API GL 5
8.1	Powershift transmission ZF torque converter WG 120, WG 150, WG 180, WG 181, WG 200, WG 201	LWE Id. No.: 861005308 Liebherr Motoroil 10W-40 ZF TE-ML 03	LWE Id. No.: 861900608 Liebherr Hydraulic-Gear ATF ZF TE-ML 03 below -20 °C run until warm according to the operating instructions

LWE/LR 13000-001/19503-01-02/en

No.	Crane components	Ambient temperature for driving and crane operation	
		-20 °C to +50 °C	-40 °C to +30 °C
8.2	Powershift transmission ZF torque converter WG 251* ZF ERGOPOWER WG 210, WG 260, WG 310 * also for ambient temperatures above -10 °C	LWE Id. No.: 861900608 Liebherr Hydraulic-Gear ATF ZF TE-ML 03	LWE Id. No.: 861900608 Liebherr Hydraulic-Gear ATF ZF TE-ML 03 below -20 °C run until warm according to the operating in- structions
9	Powershift transmission CLARK	LWE Id. No.: 861005308 Liebherr Motoroil 10W-40 SAE 10W-40 and ACEA E4	LWE Id. No.: 861900608 Liebherr Hydraulic-Gear ATF ATF Dexron II D and ALLI- SON C4 below -20 °C run until warm according to the operating in- structions
10	Displacement gear (drop box) ALLISON	LWE Id. No.: 861005308 Liebherr Motoroil 10W-40 SAE 10W-40 and API CF, ACEA E4	LWE Id. No.: 861900608 Liebherr Hydraulic-Gear ATF ALLISON C4 below -20 °C run until warm according to the operating in- structions
11.1	Automatic transmission ALLISON CLBT 740, CLBT 750, CLBT 754, CLBT 755 HT 755, HD 4560	LWE Id. No.: 861900608 Liebherr Hydraulic-Gear ATF ALLISON C4	LWE Id. No.: 861903708 CASTROL Transynd ALLISON C4 below -20 °C run until warm according to the operating in- structions
11.2	Automatic transmission ZF	LWE Id. No.: 861900608 Liebherr Hydraulic-Gear ATF ZF TE-ML 14	LWE Id. No.: 861900608 Liebherr Hydraulic-Gear ATF ZF TE-ML 14 below -20 °C run until warm according to the operating in- structions
12.1	Automatic transmission ZF AS-Tronic ZF TC-Tronic (basic gear) ZF TC-Tronic HD (basic gear)	LWE Id. No.: 10218305 ZF-Ecofluid M ZF TE-ML 02	LWE Id. No.: 10218305 ZF-Ecofluid M ZF TE-ML 02 below -20 °C preheat the gear according to the operating in- structions

No.	Crane components	Ambient temperature for driving and crane operation	
		-20 °C to +50 °C	-40 °C to +30 °C
12.2	Automatic transmission ZF TraXon ZF TraXon Torque (basic gear)	LWE Id. No.: 10218305 ZF-Ecofluid M ZF TE-ML 02	LWE Id. No.: 10218305 ZF-Ecofluid M ZF TE-ML 02 below -20 °C preheat the gear according to the operating instructions
13.1	Torque converter coupling ZF TC HD	LWE Id. No.: 10218305 ZF-Ecofluid M ZF TE-ML 02	LWE Id. No.: 10218305 ZF-Ecofluid M ZF TE-ML 02 below -20 °C preheat the gear according to the operating instructions
13.2	Torque converter coupling ZF TC 2	LWE Id. No.: 861900608 Liebherr Hydraulic-Gear ATF ZF TE-ML 14	LWE Id. No.: 861900608 Liebherr Hydraulic-Gear ATF ZF TE-ML 14
14	Transmission ZF ECO-Split	LWE Id. No.: 10218305 ZF-Ecofluid M ZF TE-ML 02	LWE Id. No.: 10218305 ZF-Ecofluid M ZF TE-ML 02
15	Slewing gear	LWE Id. No.: 861901208 Liebherr Gear PG 220 CLP PG 220, DIN 51517-3 WARNING: May not be mixed with other oils!	LWE Id. No.: 861901208 Liebherr Gear PG 220 CLP PG 220, DIN 51517-3 WARNING: May not be mixed with other oils!
16.1	Rope winch	LWE Id. No.: 861901208 Liebherr Gear PG 220 CLP PG 220, DIN 51517-3 WARNING: May not be mixed with other oils!	LWE Id. No.: 861901208 Liebherr Gear PG 220 CLP PG 220, DIN 51517-3 WARNING: May not be mixed with other oils!
16.2	Rope winch (tooth flanks) LR 13000	LWE Id. No.: 11000948 Liebherr Universal grease 9900 KPF2N-25, DIN 51502	LWE Id. No.: 11000948 Liebherr Universal grease 9900 KPF2N-25, DIN 51502
17	Winch of Telescopic boom guying	LWE Id. No.: 861901208 Liebherr Gear PG 220 CLP PG 220, DIN 51517-3 WARNING: May not be mixed with other oils!	LWE Id. No.: 861901208 Liebherr Gear PG 220 CLP PG 220, DIN 51517-3 WARNING: May not be mixed with other oils!
18.1	Crane hydraulics Crane chassis and crane superstructure Observe exceptions, see 18.2	LWE Id. No.: 861903508 Liebherr Hydraulic 37	LWE Id. No.: 10293807 Liebherr Hydraulic Plus Arctic

LWE/LR 13000-001/19503-01-02/en

No.	Crane components	Ambient temperature for driving and crane operation	
		-20 °C to +50 °C	-40 °C to +30 °C
18.2	Crane hydraulics Crane chassis and crane superstructure LTM 11200-9.1 LTR 11200 LR-crane und LG-crane with LIC-CON 2 control LTC 1055-3.1	LWE Id. No.: 10293807 Liebherr Hydraulic Plus Arctic	LWE Id. No.: 10293807 Liebherr Hydraulic Plus Arctic
19	Brake system if hydraulically actuated	LWE Id. No.: 861000108 DOT 4 SAE J 1703e	LWE Id. No.: 861000108 DOT 4 SAE J 1703e
20	Clutch actuator	LWE Id. No.: 861000108 DOT 4 SAE J 1703e	LWE Id. No.: 861000108 DOT 4 SAE J 1703e
21	King pin bearing Gear shaft if not maintenance-free	LWE Id. No.: 861301308 Liebherr Special grease 9610 Plus KP2K-20, DIN 51502	LWE Id. No.: 10296825 Liebherr Universal grease Arctic KPFHC1N-60, DIN 51502
22.1	Glide and roller bearing roller bearing joint	LWE Id. No.: 861301308 Liebherr Special grease 9610 Plus KP2K-20, DIN 51502	LWE Id. No.: 10296825 Liebherr Universal grease Arctic KPFHC1N-60, DIN 51502
22.2	Rope pulley bearing	LWE Id. No.: 10296825 Liebherr Universal grease Arctic KPFHC1N-60, DIN 51502	LWE Id. No.: 10296825 Liebherr Universal grease Arctic KPFHC1N-60, DIN 51502
23	Central lubrication system	LWE Id. No.: 861301308 Liebherr Special grease 9610 Plus KP2K-20, DIN 51502	LWE Id. No.: 10296825 Liebherr Universal grease Arctic KPFHC1N-60, DIN 51502
24.1	Slewing ring connection Roller bearing	LWE Id. No.: 861301308 Liebherr Special grease 9610 Plus KP2K-20, DIN 51502	LWE Id. No.: 10296825 Liebherr Universal grease Arctic KPFHC1N-60, DIN 51502
24.2	Slewing ring connection LR 13000	LWE Id. No.: 11000948 Liebherr Universal grease 9900 KPF2N-25, DIN 51502	LWE Id. No.: 10296825 Liebherr Universal grease Arctic KPFHC1N-60, DIN 51502

No.	Crane components	Ambient temperature for driving and crane operation	
		-20 °C to +50 °C	-40 °C to +30 °C
25.1	Support plate with equalization	LWE Id. No.: 10877698 Loctite LB 8104 Silicone oil base WARNING: Do not use oils with another base!	LWE Id. No.: 10877698 Loctite LB 8104 Silicone oil base WARNING: Do not use oils with another base!
25.2	Sliding shoes for cab guidance on vehicle frame LTC 1045-3.1 LTC 1050-3.1	LWE Id. No.: 861303608 Liebherr Telescope grease 9613 Plus KP2K-30, DIN 51502	LWE Id. No.: 861303608 Liebherr Telescope grease 9613 Plus KP2K-30, DIN 51502
26	Sliding beam Plastic glide bearing Beam for track adjustment	LWE Id. No.: 861303608 Liebherr Telescope grease 9613 Plus KP2K-30, DIN 51502	LWE Id. No.: 861303608 Liebherr Telescope grease 9613 Plus KP2K-30, DIN 51502
27.1	Telescopic boom Lower shell outer slide bearing Plastic glide bearing or corner guide top Cylinder guide in telescope end section Lock pocket in telescope end section (only for Telematik)	LWE Id. No.: 861303608 Liebherr Telescope grease 9613 Plus KP2K-30, DIN 51502	LWE Id. No.: 861303608 Liebherr Telescope grease 9613 Plus KP2K-30, DIN 51502
27.2	Telescopic boom LTC 1045-3.1 LTC 1050-3.1 Lower shell outer slide bearing Plastic glide bearing or corner guide top Cylinder guide in telescope end section Lock pocket in telescope end section (only for Telematik)	LWE Id. No.: 11651459 Bechem Berulub TCG 1 V	LWE Id. No.: 11651459 Bechem Berulub TCG 1 V
27.3	Telescopic boom LTM 1050-3.1 Lower shell outer slide bearing Plastic glide bearing or corner guide top Cylinder guide in telescope end section Lock pocket in telescope end section (only for Telematik)	LWE Id. No.: 10878154 Liebherr Sliding Paste TB 1	LWE Id. No.: 10878154 Liebherr Sliding Paste TB 1

LWE/LR 13000-001/19503-01-02/en

No.	Crane components	Ambient temperature for driving and crane operation	
		-20 °C to +50 °C	-40 °C to +30 °C
28	Boom lock	LWE Id. No.: 861301308 Liebherr Special grease 9610 Plus KP2K-20, DIN 51502	LWE Id. No.: 10296825 Liebherr Universal grease Arctic KPFHC1N-60, DIN 51502
29	Gear ring rotary connection Slewing gear drive pinion	LWE Id. No.: 861007708 Liebherr RHS-Fluid OGPF 0 S-20, DIN 51502	LWE Id. No.: 861007708 Liebherr RHS-Fluid OGPF 0 S-20, DIN 51502
		or LWE Id. No.: 861301508 Liebherr gear protection RHY OGPF 2 S-30, DIN 51502	or LWE Id. No.: 861301508 Liebherr gear protection RHY OGPF 2 S-30, DIN 51502
30	Running rope	LWE Id. No.: 10173371 Liebherr WR-Lube SC Adhesive grease	LWE Id. No.: 10173371 Liebherr WR-Lube SC Adhesive grease
		or LWE Id. No.: 10174262 Liebherr WR-Lube SC Adhesive grease	or LWE Id. No.: 10174262 Liebherr WR-Lube SC Adhesive grease
31	Radiator fluid Diesel engine and heating system	LWE Id. No.: 10871121 Liebherr Antifreeze OS Mix Pre-mixed corrosion inhibitor / antifreeze WARNING: May not be diluted and / or mixed with other corrosion inhibitors / anti-freeze!	LWE Id. No.: 10871121 Liebherr Antifreeze OS Mix Pre-mixed corrosion inhibitor / antifreeze WARNING: May not be diluted and / or mixed with other corrosion inhibitors / anti-freeze!
32.1	Crawler crane travel gear	see data tag	see data tag
32.2	Crawler crane with telescopic boom travel gear	see data tag	see data tag
33	Recovery winch	See the data tag and manufacturer's specifications	See the data tag and manufacturer's specifications
34	Recovery winch rope	See the manufacturer's specifications	See the manufacturer's specifications
35	Steering uncoupling LTC 1045-3.1 LTC 1050-3.1	LWE Id. No.: 10800345 Teflon Spray	LWE Id. No.: 10800345 Teflon Spray
36	Pin connections	LWE Id. No.: 11000948 Liebherr Universal grease 9900 KPF2N-25, DIN 51502	LWE Id. No.: 11000948 Liebherr Universal grease 9900 KPF2N-25, DIN 51502

LWE/LR 13000-001/19503-01-02/en

Empty page!

LWE/LR 13000-001/19503-01-02/en

8 Inspections of cranes

LWE/LR 13000-001/19503-01-02/en

LWE/LR 13000-001/19503-01-02/en

8.01 Periodic crane inspections

1	General information	2
2	Inspecting load bearing crane structures, especially steel structures	4
3	Inspecting the locking system of the telescopic boom	79
4	Inspection of the screws in the adjustment plates	81
5	Checking the safety ropes and anchor points	82
6	Inspecting the load handling equipment and assembly aids	84
7	Inspecting of fastening equipment	84
8	Inspecting the diaphragm reservoir	85
9	Inspecting the relapse cylinders	85
10	Inspecting the rope pulleys	86
11	Inspecting the carrier rollers	87
12	Inspecting the extension conditions of sliding beams	88
13	Inspecting the function of the overload protection	88
14	Inspecting the pin connections	89
15	Inspecting the slewing ring connection	89
16	Inspecting the mounting of the load bearing equipment	90
17	Inspecting the tele extension with eccentric, illustration 1	91
18	Inspecting the change over pulleys, illustration 2	92
19	Inspecting the oil and fuel tanks	92

1 General information

This crane was tested at the manufacturer's facilities prior to shipment in accordance with the valid ISO, FEM and DIN Standards and DGUV 52 (DGUV 309-001).

The safety level achieved during initial start up may not be attainable during operation.

Examples of the root cause of such deviations include; e.g., wear and tear, corrosion, effects of external forces, changes in the environment and changes to the mode of operation.

The operator is responsible for taking the necessary steps to ensure that the level of safety is maintained.

Periodic inspections are regulated nationally in the BetrSichV.

The crane operator is therefore obligated to have the crane inspected by an **authorized inspector**, at intervals depending on the operational conditions but at least once per year, from the first day of vehicle registration.

Certain conditions of use require however shorter inspection intervals or tests.

Conditions of use, the shorter inspection intervals or inspections between the regular inspections require:

- High utilization of the crane and / or a greater number of load cycles.
- Ramming work and pulling work, see chapter 4.08.
- Operation at low temperatures, see chapter 2.08.
- Lifting of personnel, see chapter 2.04.
- Situations during which the crane was exposed to sudden loads.

When equipment parts from other cranes are used: Make sure that the inspections and inspection intervals are observed also for the replaced equipment parts.

The operator specifies an authorized inspector and assigns him to perform the tests and maintenance required nationally and by Liebherr-Werk Ehingen GmbH to ensure further, safe and reliable crane operation:

- Carry out the inspection tasks required by Liebherr-Werk Ehingen GmbH.
- Additional national inspection intervals must be monitored by the crane operator.

Every 4 operating years, in the 13th Operating year and thereafter at least annually, from the first day of vehicle registration, the crane must be inspected by an **inspection expert**.

Periodic inspection are principally a visual inspection, where the inspector appraises the condition of the crane and its components.



WARNING

There is danger of weakening the supporting components when major changes or repairs are made to the crane!

- ▶ In this case, the operator must have the crane reinspected by an inspection expert before putting it back in service!

In addition, all respective local and national regulations apply.

Authorized inspector

Authorized inspectors are those persons who through their professional training, their professional experience and their recent professional activity have the necessary knowledge for the inspection of work equipment.

Authorized inspector for pressure containers

Authorized inspectors for pressure containers are authorized inspectors who additionally:

- Have relevant technical professional training.
- Have at least one year of experience with the manufacture, assembly, operation or maintenance of the equipment or components to be inspected in accordance with BetrSichV.
- Keep their knowledge about pressure-related hazards up to date by participating in training or instruction, in particular with regard to the following topics:
 - Design and manufacturing processes

- Equipment and safeguarding concepts
- Assembly, installation and operation / use
- Intended use
- Risk assessment
- Inspections, inspection periods, inspection procedures including assessment of the results
- Relevant influences and damage symptoms found in practice

Inspection expert

Inspection experts are authorized inspectors who also:

- Have completed training as an engineer or have equivalent knowledge and experience in the subject area with which their activities are involved.
- Have at least three years of experience in the design, construction, maintenance or inspection of cranes, of which at least half a year were involved in the inspection activities of an inspection expert.
- Possess sufficient knowledge of the relevant regulations and rules.
- Have the necessary facilities for inspection and documentation.
- Keep their professional knowledge up to date.

To ensure the high safety standard of the crane, it is recommended, no later than the 12th year, in the 20th year, in the 26th year and then every 4 years, to have the crane undergo a **general inspection** by an **inspection expert**. At that time, in addition to the usual scope of inspection, all load carrying parts of the crane - the complete steel structure with all welding seams as well as all components and connecting devices - are to be subjected to a complete visual inspection. The following procedural notes for repeat inspections are to be observed for that.

The purpose of the inspections is to avoid accidents by detecting deficiencies early on. Any deficiencies found by the inspector must be documented, corrected and subsequently reinspected.

For safe crane operation, important components must be inspected for their percentage of utilization or their reusability. Based on this inspection a statement can be made about the suitability of the components for further operation.

A number of important examples of items that are particularly important during the periodic crane inspections are listed below. We wish to advise that the **authorized inspectors** or **inspection experts** take sole responsibility for the crane inspections that they carry out.



Note

- ▶ The inspection may not be solely limited to the following positions shown in the sample component illustrations. Rather the **entire** crane structure must be subjected to a careful inspection!

A checklist is provided in the Crane operating instructions, chapter 8.90, to assist the inspector during the periodic inspections of Liebherr mobile and crawler cranes.

If the inspector has any questions they should be directed through the Service Department of Liebherr-Werk Ehingen GmbH to the technical departments.



WARNING

Danger of accident!

- ▶ Adhere to the following inspection guidelines and intervals.

2 Inspecting load bearing crane structures, especially steel structures

2.1 Basic principles and procedure



DANGER

Danger of fatal injury!

The crane structures, particularly steel constructions, have to be checked by an **authorized inspector** or **inspection expert** at least once a year. If this is not the case, they could fail and cause fatal injury or seriously damage the crane!

- ▶ Crane structures, particularly steel constructions must be checked by an **authorized inspector** or an **inspection expert** at least once a year!
- ▶ Shorten the inspection intervals when the crane is subjected to above-average load spectrums, for example during handling operation or frequently erecting long boom systems.
- ▶ When the crane was subjected to excessive operating loads; e.g., due to an unusual impact, the crane structure, especially the steel structures must be inspected immediately!

Crane structures, especially steel structures, such as booms, turntables, chassis, support equipment (e.g., sliding beams or folding outriggers) must be carefully inspected, at the very least during the annual recommended crane inspections. Inspect welding seams especially through an intensive visual inspection.

If paint damage with corrosion (rust) is found on load carrying parts of the crane structure, especially on telescopic booms, lattice booms, lattice jibs, pull rods etc., then the rust must be removed, primed and painted.

In the case of an electrolyte process, such as corrosion in combination with water, atomic hydrogen is created, which leads to hydrogen induced corrosion with resulting cracks in high tensile fine grain construction steel.

If disassembly and assembly work on the crane is required to carry out the inspections, then they must be carried out by taking the manufacturer's data into account or in coordination with the crane manufacturer.

We would like to point out that the framework of mobile cranes is designed for a limited number of stress work cycles. This also determines the utilization or service life of the framework. The service life is not determined solely by the number of stress cycles. It also depends on the loads (load spectrum) applied during the time in operation.

Liebherr mobile and crawler cranes are designed for specific characteristics and movements, such as constant deployment of drive forces, only occasional operation and load conditions according to EN 13000.

Liebherr mobile and crawler cranes are designed for assembly operation and, according to grouping in class A1 according to ISO 4301-1, they can only take on a limited number of work cycles ($N = 63000$) with a collective class $Q_1 = \text{light}$ ($k_p = 0.125$).

Example of a load collective according to grouping in collective class $Q_1 = \text{light}$ ($k_p = 0.125$).

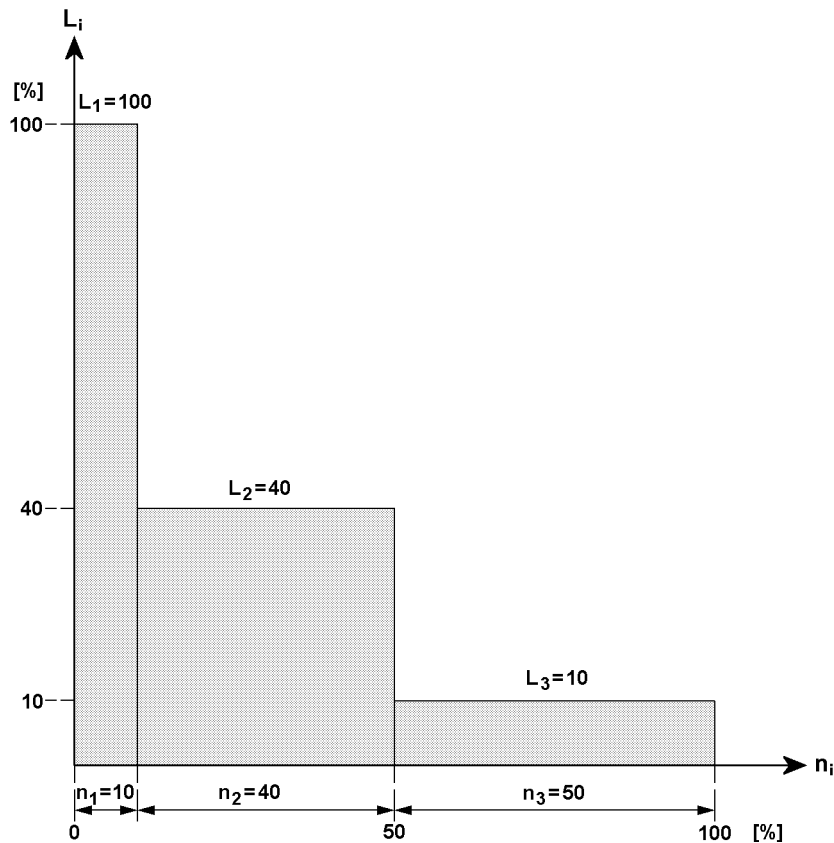

Fig.104716

L_i: Load proportion in relation to maximum load [%] **n_i:** Load cycles in relation to maximum number [%]

**Note**

- ▶ The service life of Liebherr mobile and crawler cranes can be drastically reduced, for example when used in magnet, grapple or handling operations!
- ▶ Repeated inspection of crane structure, especially the steel structure and the welding seams must then be carried out in shorter intervals than specified.

For that reason, the steel structures and the welding joints must be subjected to a visual intensive inspection by the **authorized inspector** or **inspection expert** during the specified periodic inspections.

If any damage, such as cracks or suspicion of cracks, are apparent on any part of the steel structure, the total extent of the damage must be determined by qualified specialists using appropriate material testing methods, such as magnetic crack detection, ultrasound or x-rays. Thereafter, the qualified personnel must determine whether or not the damaged area can be repaired by welding or by other means.

The following diagrams are samples of the load-bearing welding structures. The welding joints or seams or steel structural zones that require inspection may be present more than once and in various forms. The joints or zones must be inspected all around at the locations identified by arrows.

**Note**

- ▶ The scope and extent of all inspections remain the sole responsibility of the inspectors!
- ▶ The scope and results of tests should be documented to permit reproducibility. This documentation forms part of the crane records and should be safely stored during the entire service life of the crane!
- ▶ The following diagrams are provided to assist the inspector. The illustrations are only examples and are not necessarily 100 % complete!

2.2 Repair welding

Defects such as cracks or permanent deformations on load-bearing steel components must be immediately reported to Customer Service at **Liebherr-Werk Ebingen GmbH**.

The defect must immediately be appraised by an inspection expert according to standard welding technology rules. The inspection expert must immediately ascertain if the crane can continue to be safely operated due to danger of accident until a repair welding is performed.

Repair welding may solely be made in consultation and under the guidance of Customer Service at **Liebherr-Werk Ebingen GmbH** by authorized and trained expert personnel.



WARNING

Repair welding **not** according to regulations!
Death, severe bodily injuries, property damage.

- ▶ Contact Customer Service at **Liebherr-Werk Ebingen GmbH**.
 - ▶ Coordinate the procedure for repair welding with **Liebherr-Werk Ebingen GmbH**.
-



Note

Exclusion of liability!

In the case of repair welding that were not carried out by personnel from **Liebherr-Werk Ebingen GmbH** or by authorized personnel from **Liebherr-Werk Ebingen GmbH**, **Liebherr-Werk Ebingen GmbH** excludes all liability for system functionality as well as for the parts.

- ▶ Have repair welding carried out solely by personnel of **Liebherr-Werk Ebingen GmbH** or by personnel authorized by **Liebherr-Werk Ebingen GmbH**.
-

2.3 Examples of test points

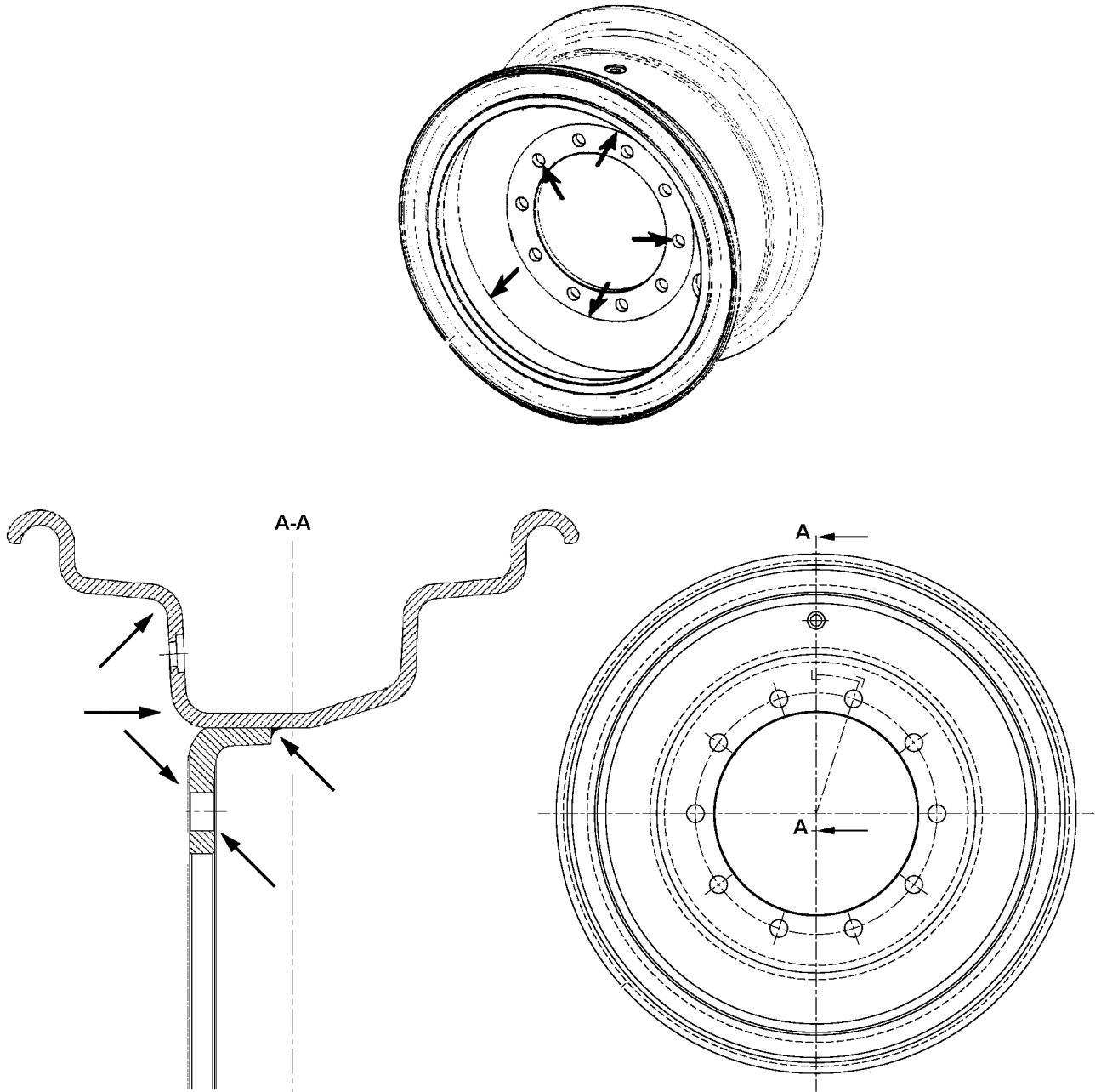

Fig.118052: Example of a 1-part disk wheel

LWE/LR 13000-001/19503-01-02/en

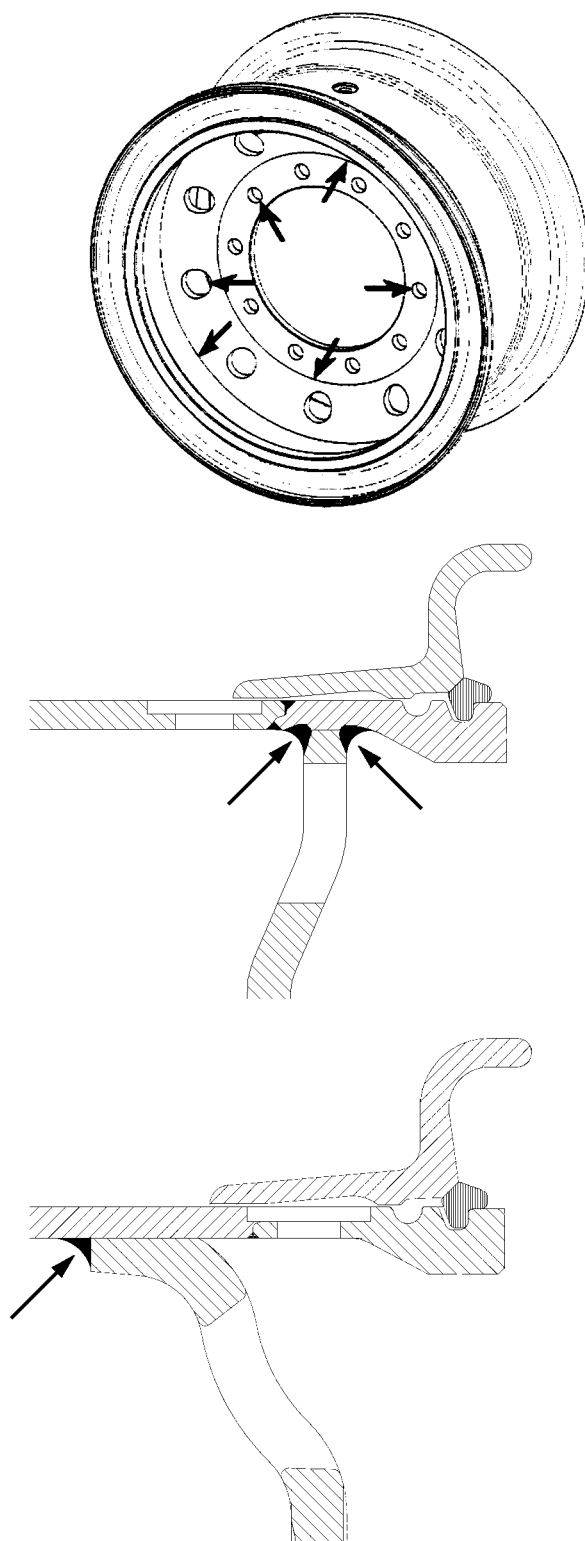
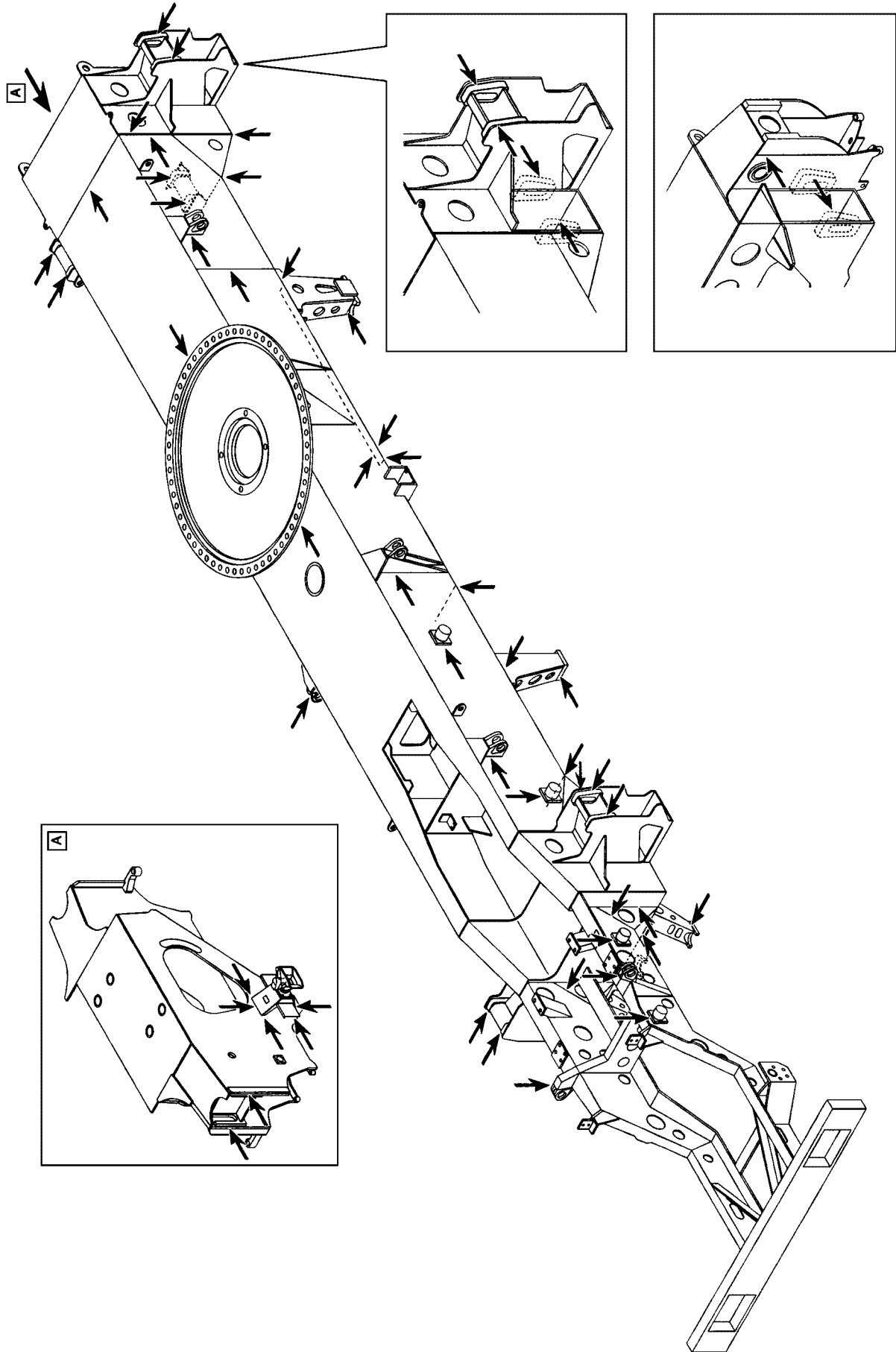

Fig.118053: Example of a 3-part disk wheel



LWE/LR 13000-001/19503-01-02/en

Fig.185046: Example of a vehicle frame

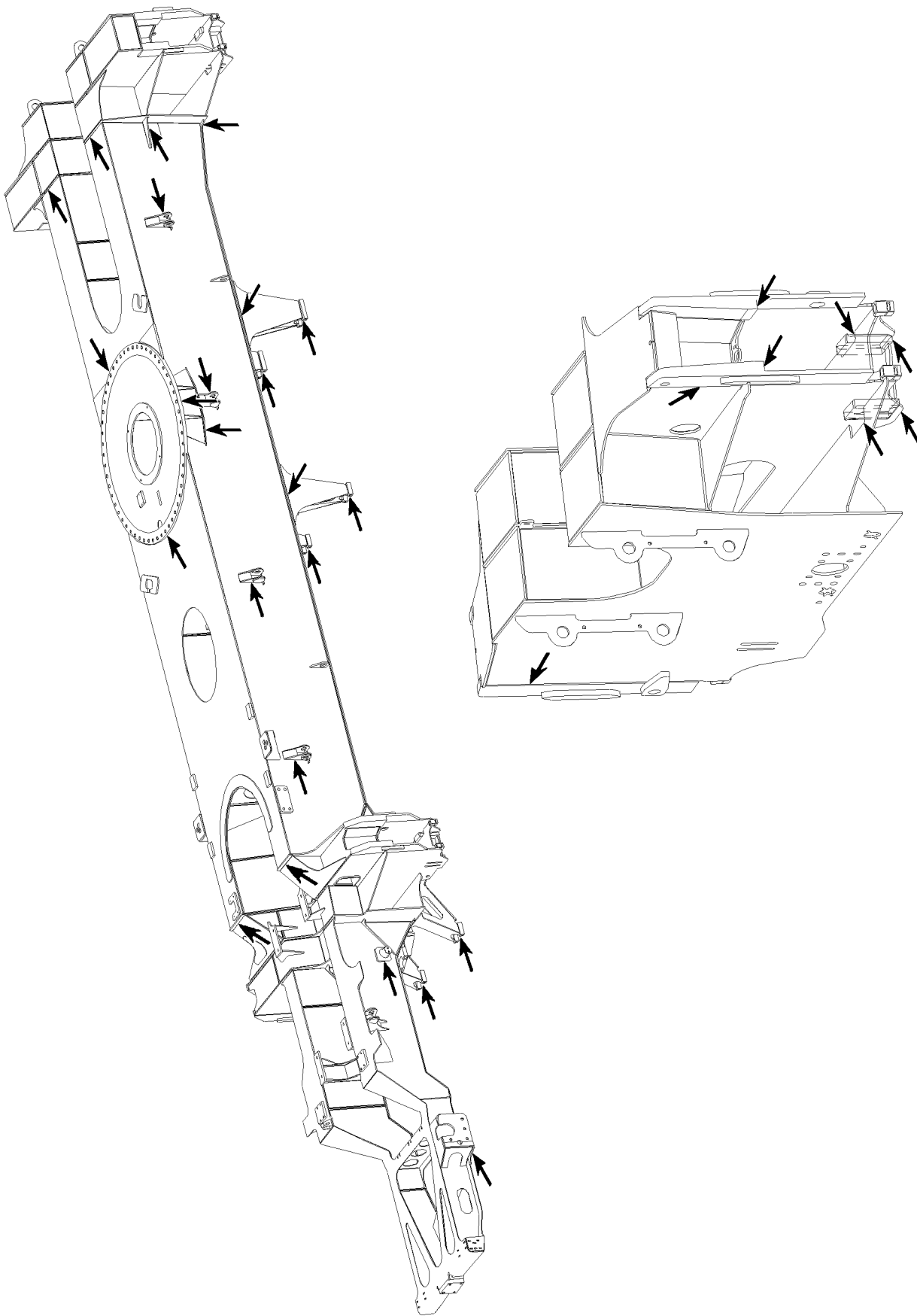
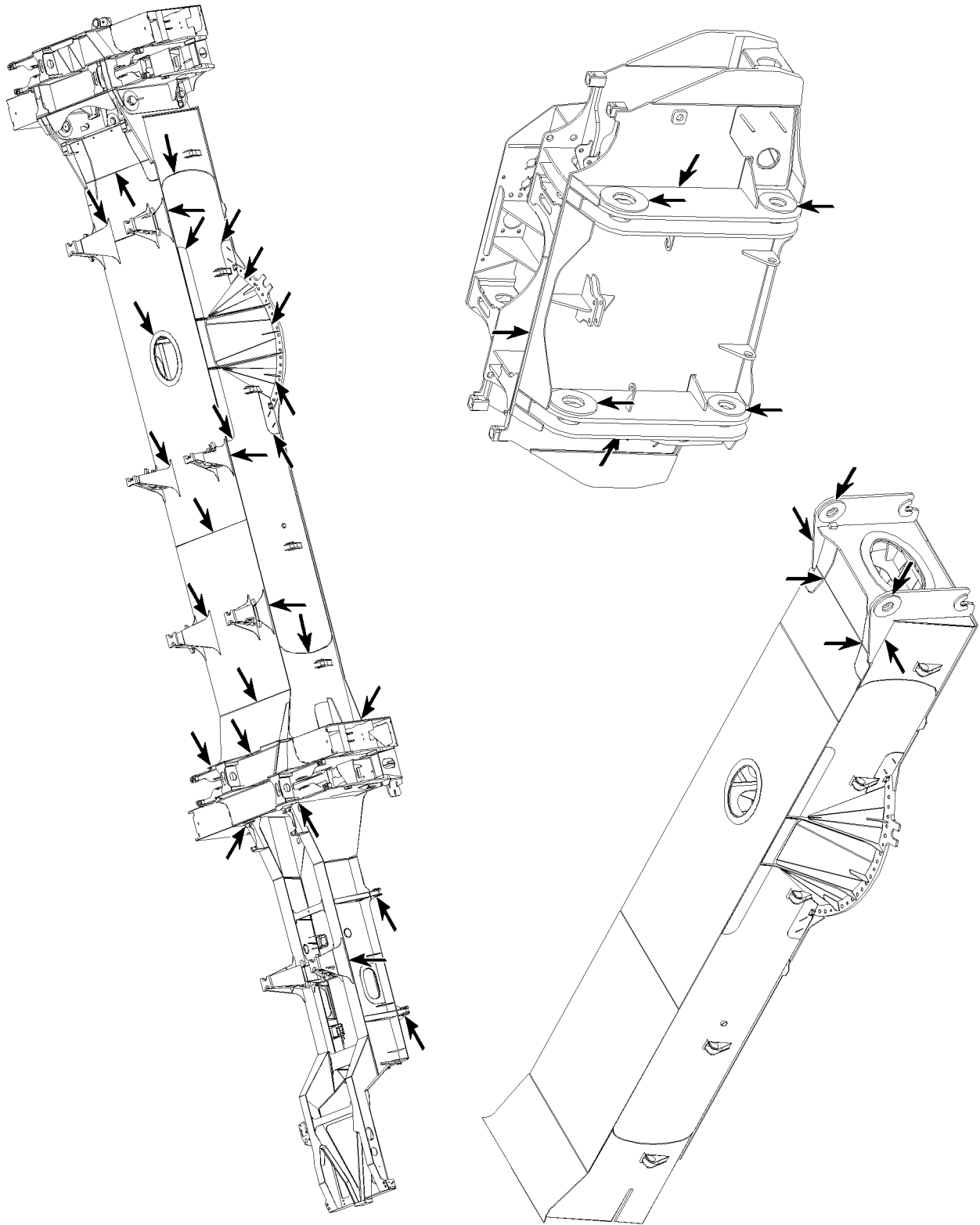

Fig.105702: Example of a vehicle frame

LWE/LR 13000-001/19503-01-02/en



LWE/LR 13000-001/19503-01-02/en

Fig.105719: Example of a vehicle frame

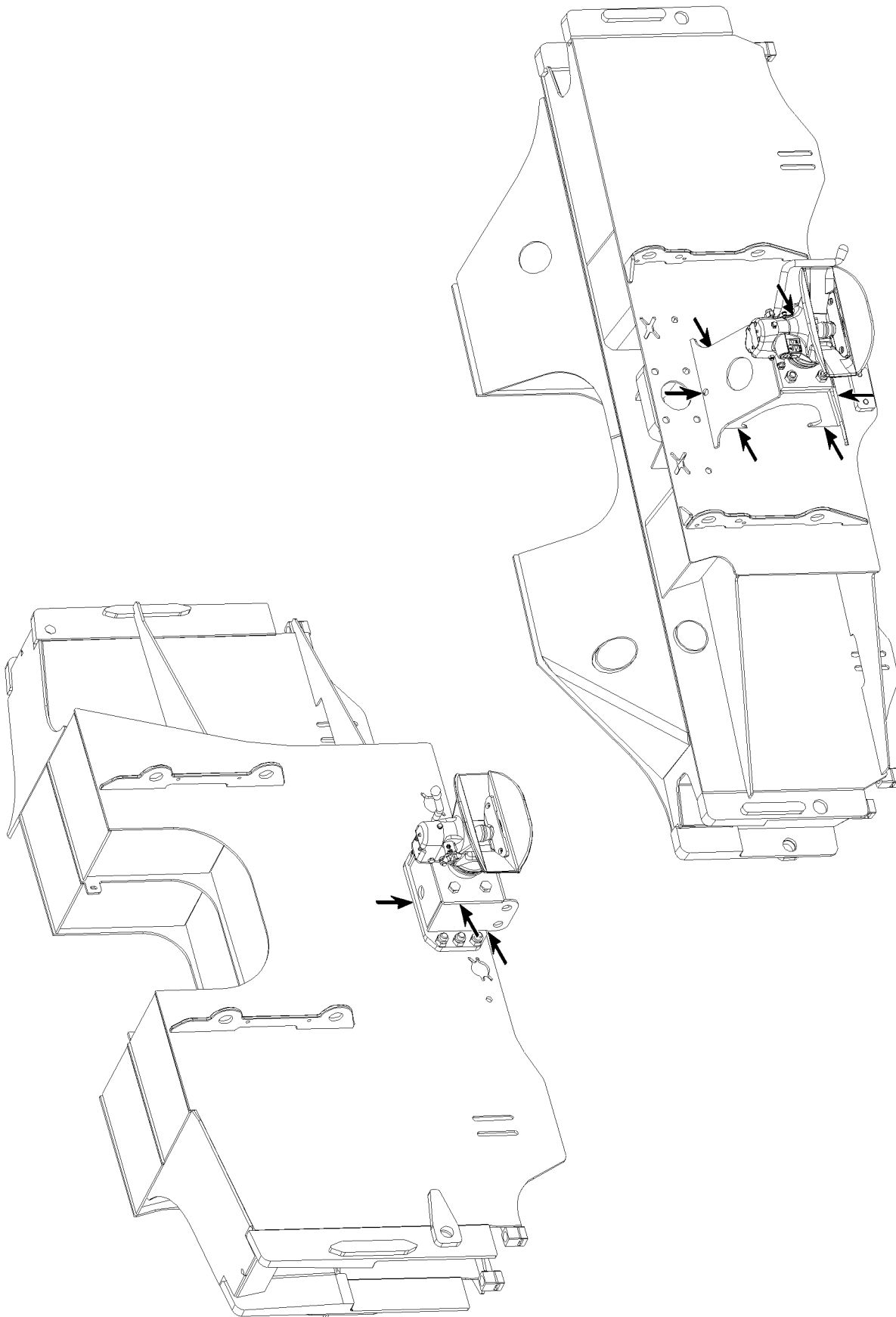
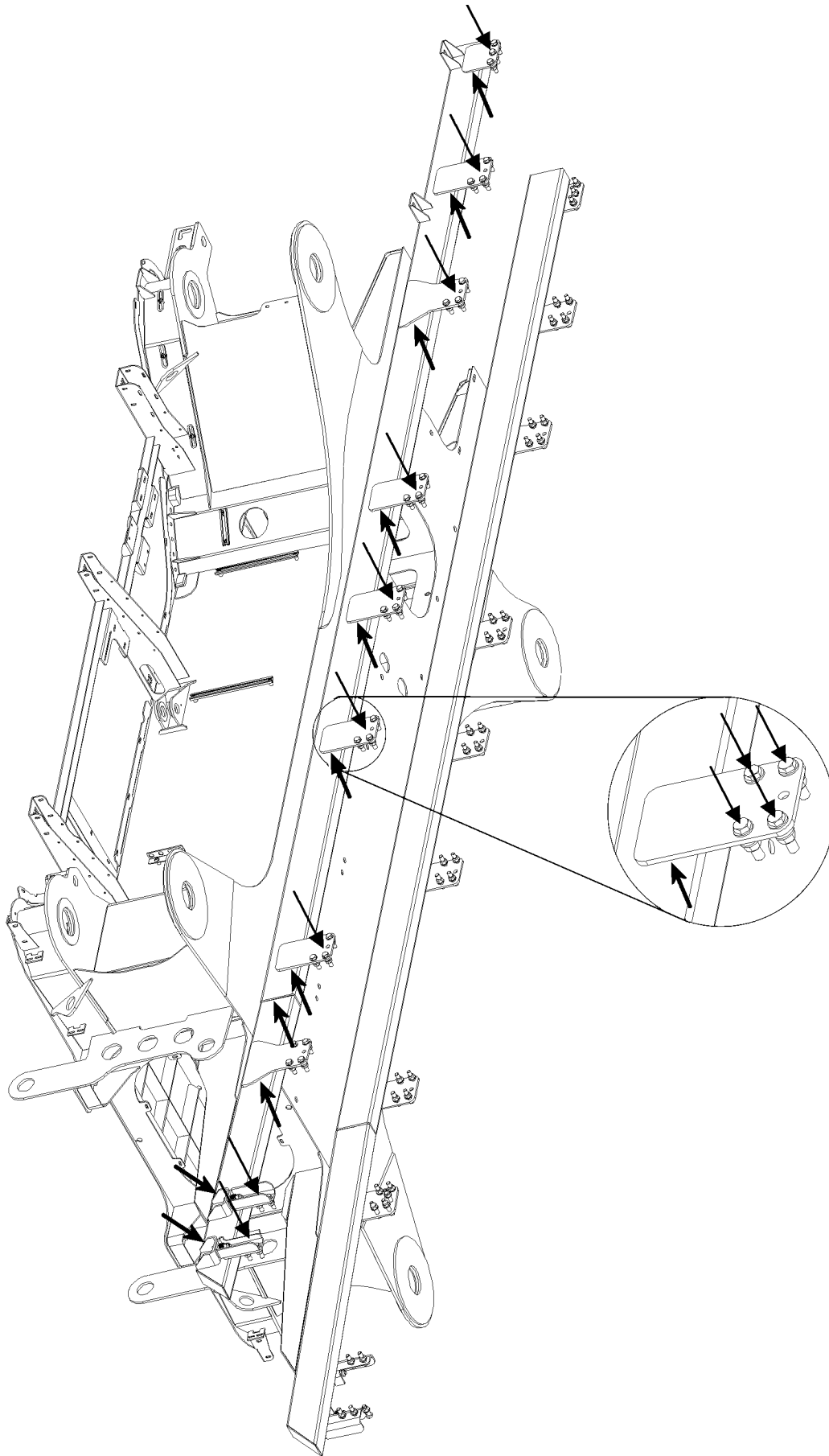

Fig.105687: Example of tow coupling



LWE/LR 13000-001/19503-01-02/en

Fig.113940: Example of an intermediate frame

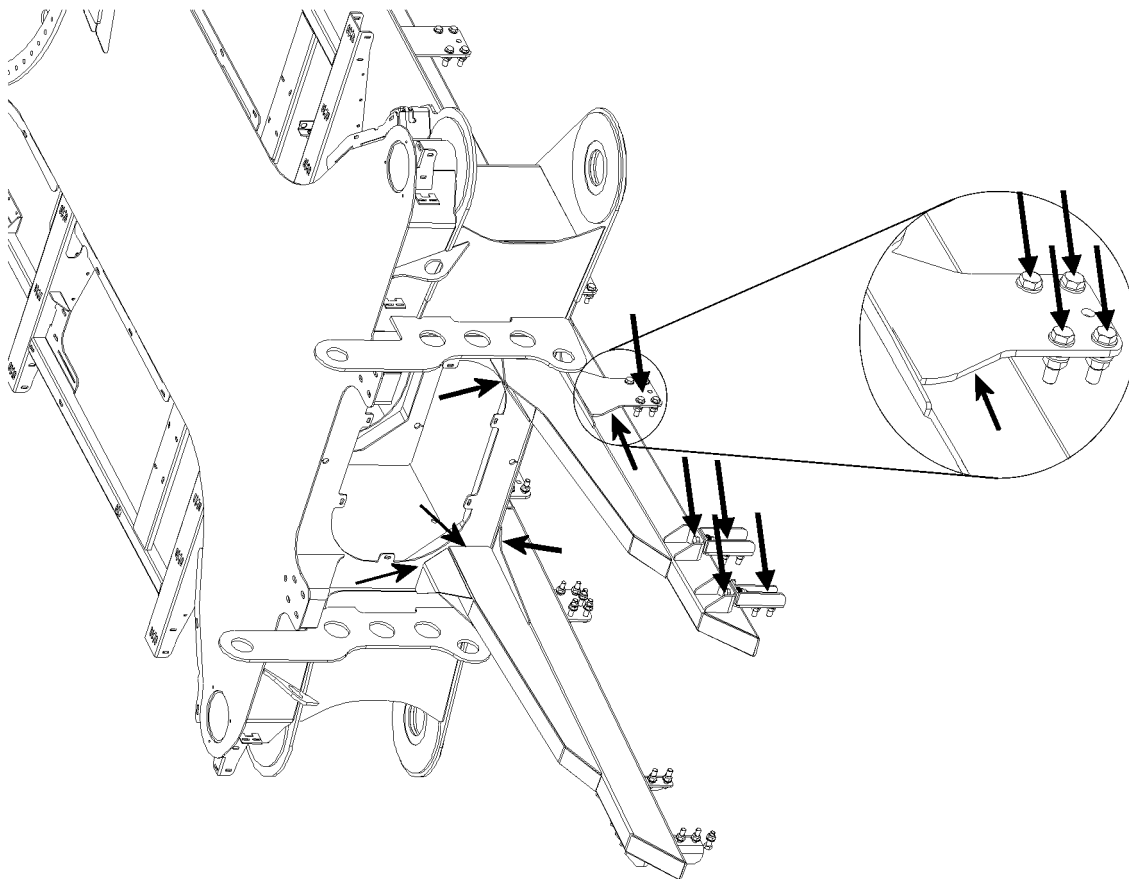
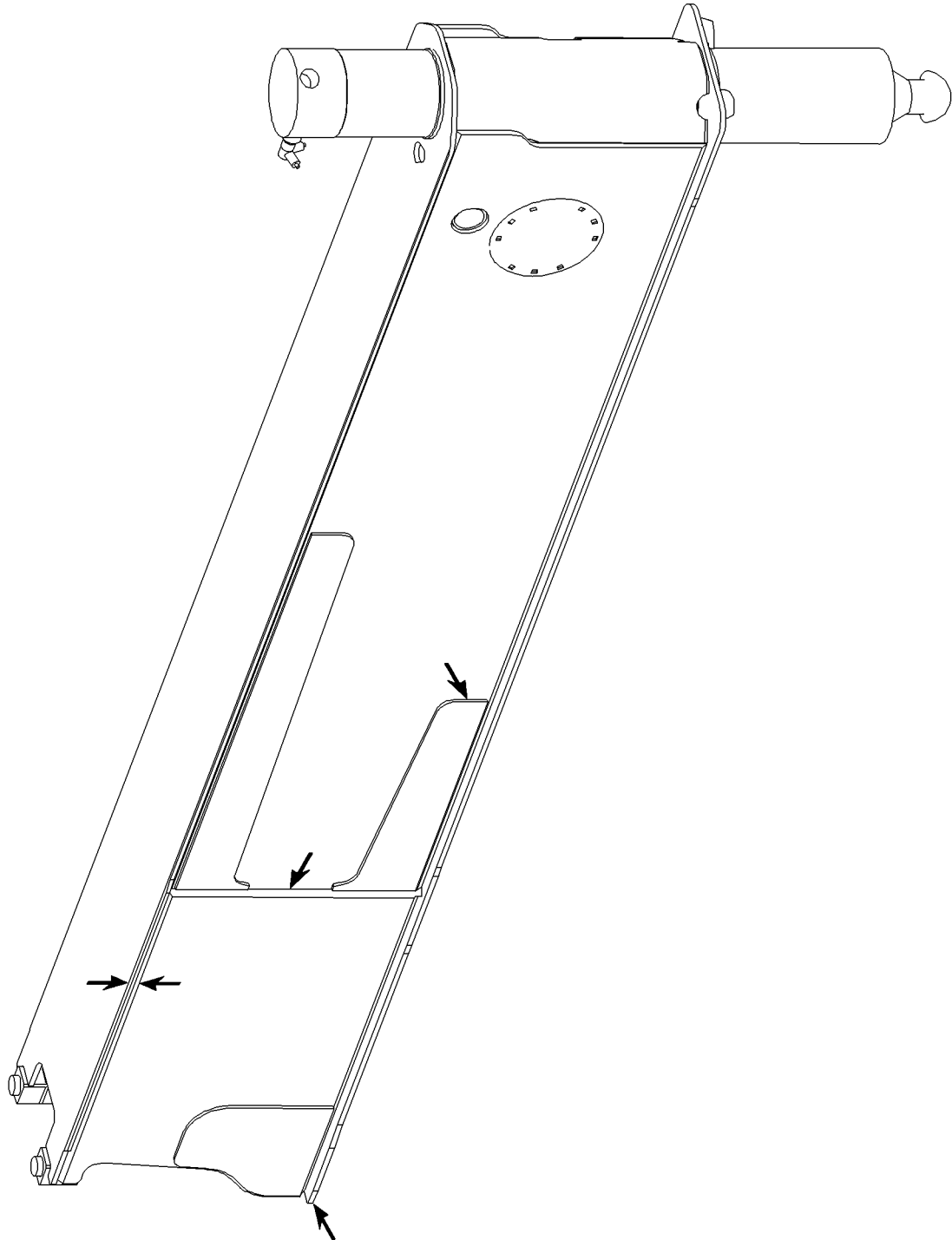

Fig.114000: Example of an intermediate frame



LWE/LR 13000-001/19503-01-02/en

Fig.105698: Example of a sliding beam

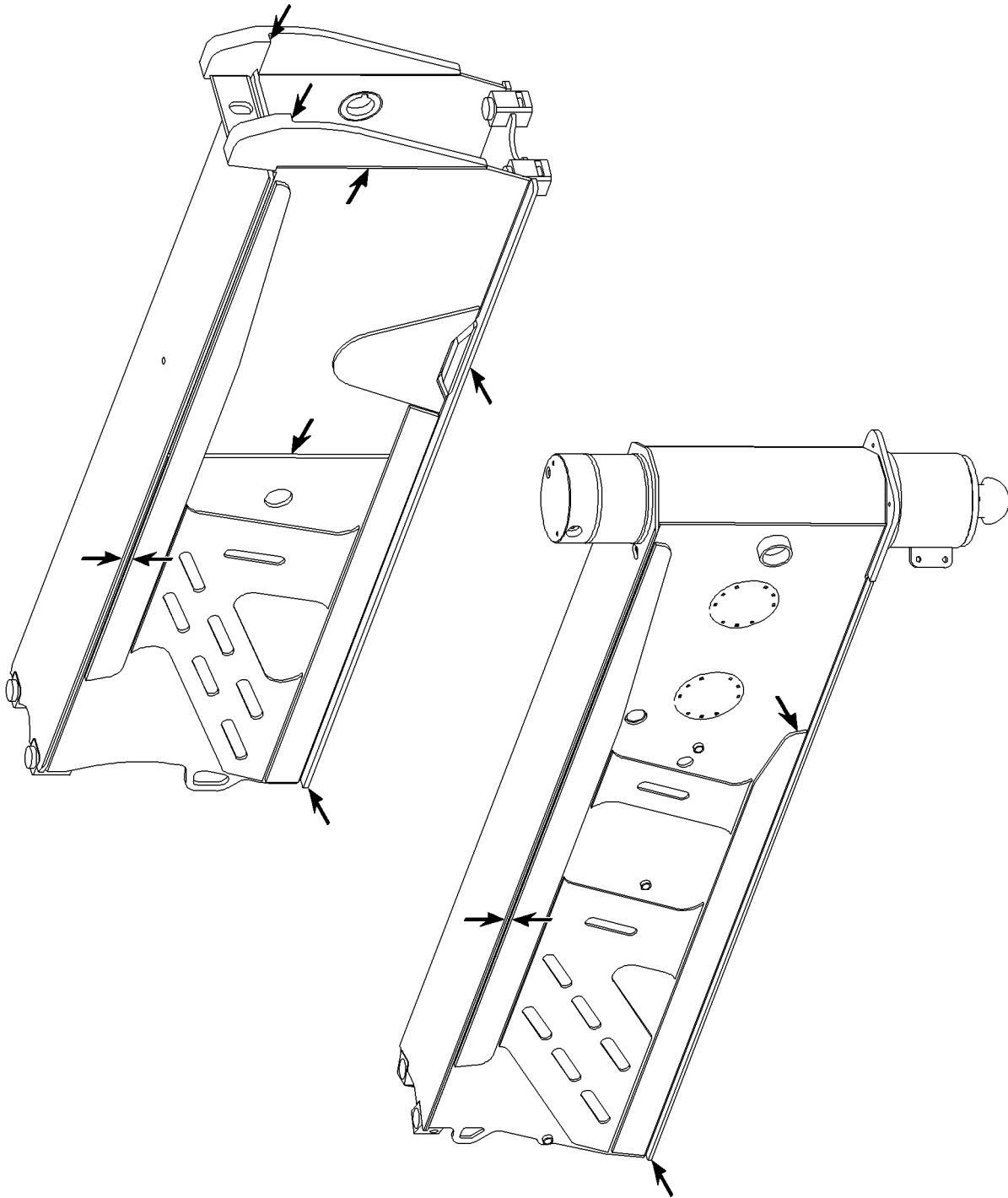
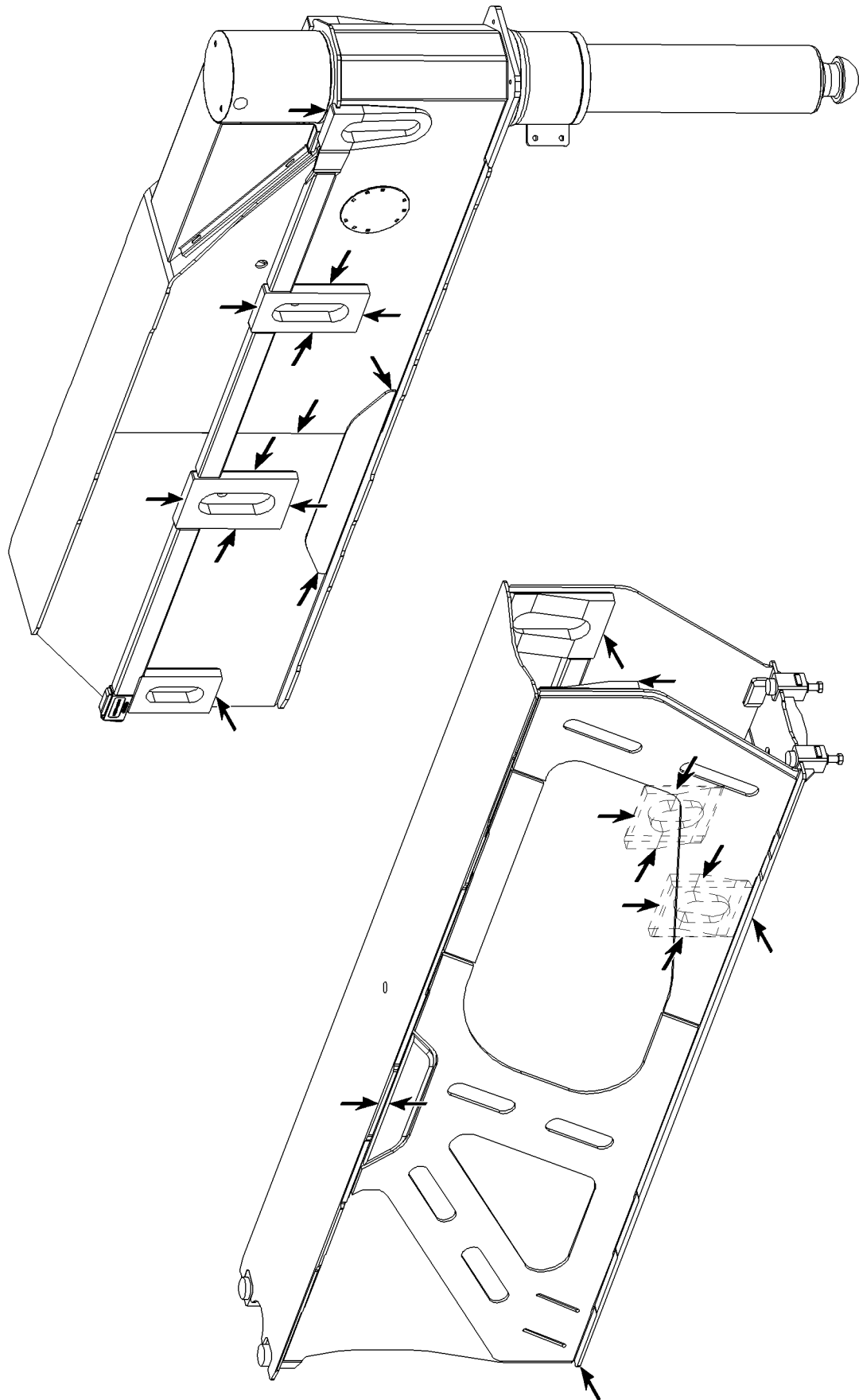

Fig.105717: Example of a sliding beam

LWE/LR 13000-001/19503-01-02/en



LWE/LR 13000-001/19503-01-02/en

Fig.105718: Example of a sliding beam

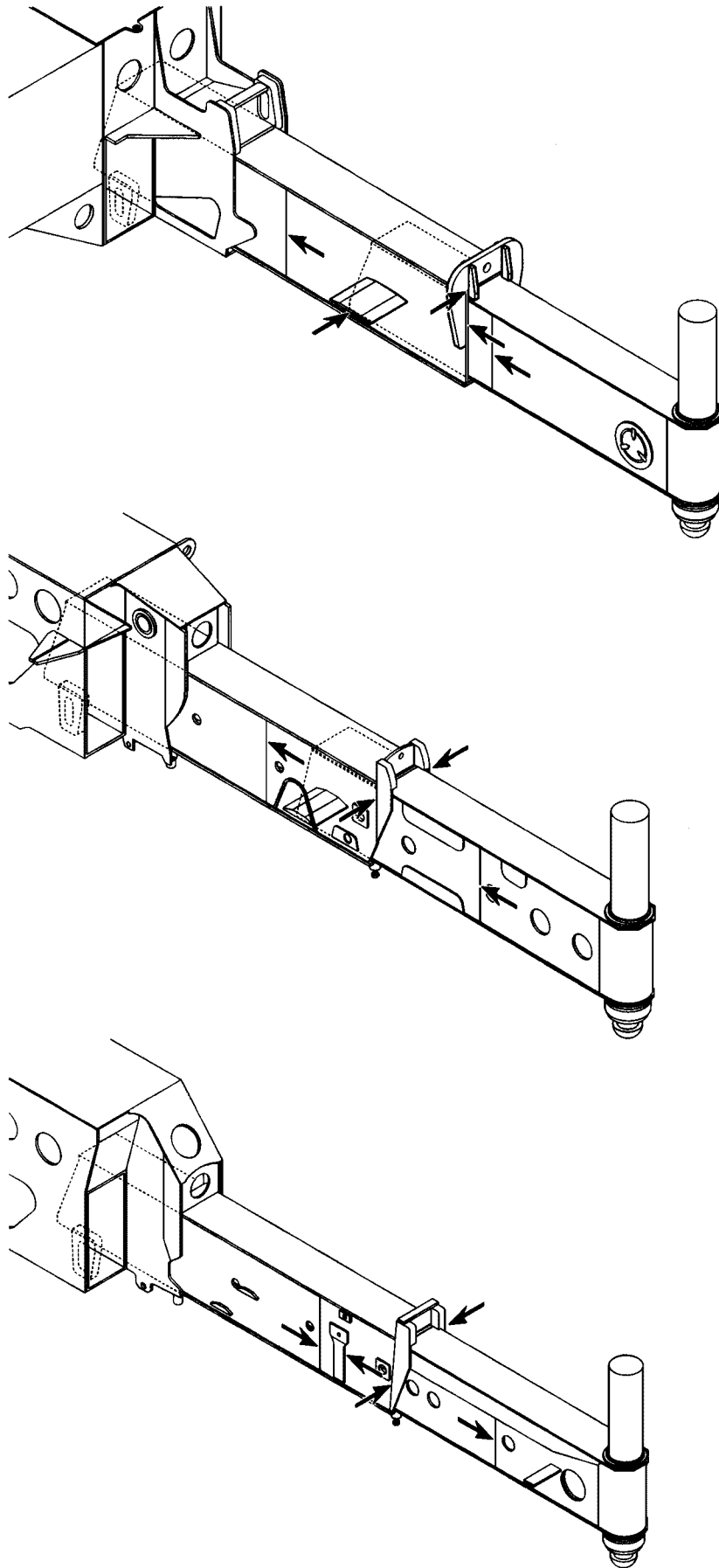
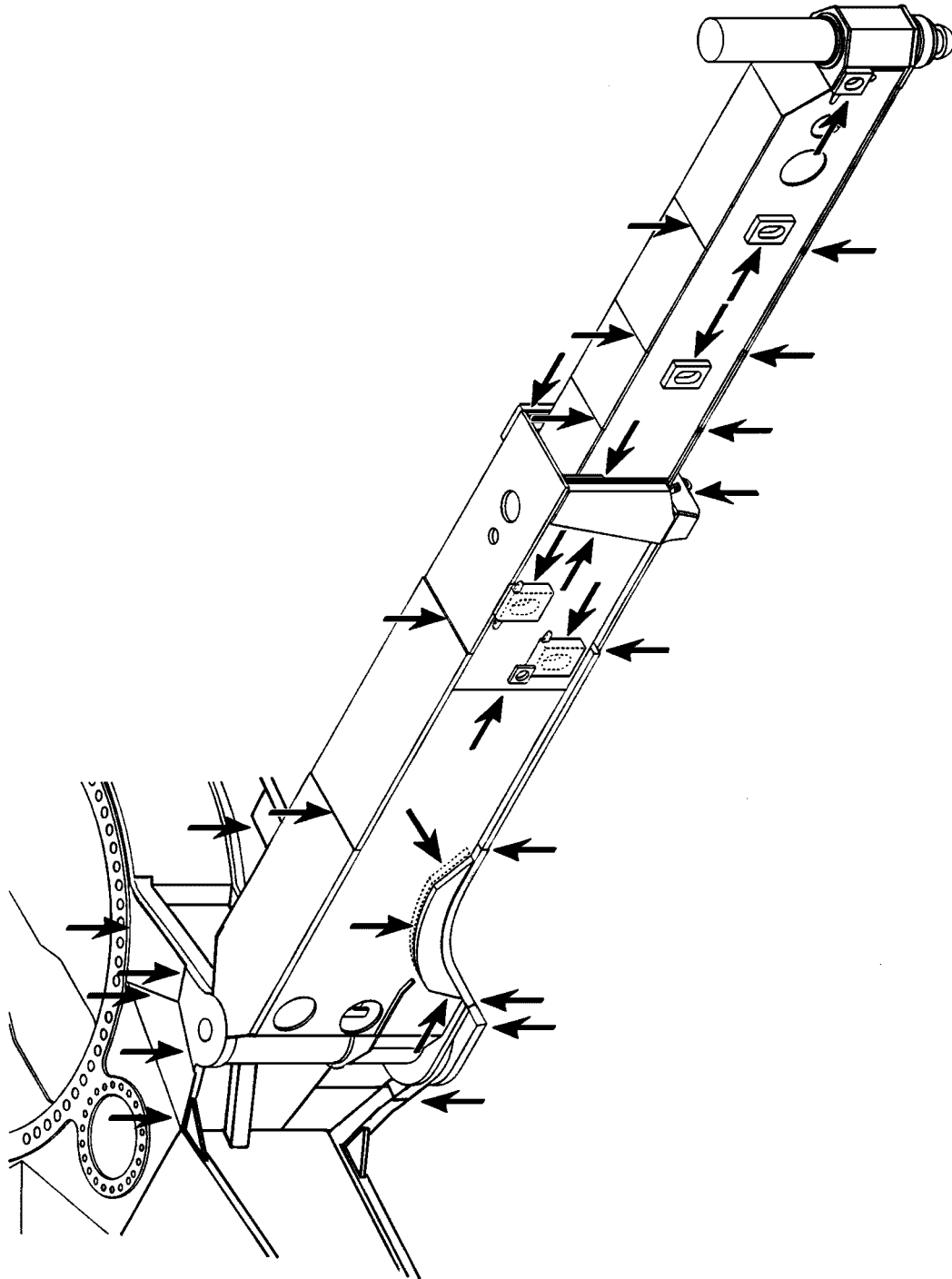

Fig.185047: Example of a sliding beam

LWE/LR 13000-001/19503-01-02/en



LWE/LR 13000-001/19503-01-02/en

Fig.185060: Example of a swinging sliding beam

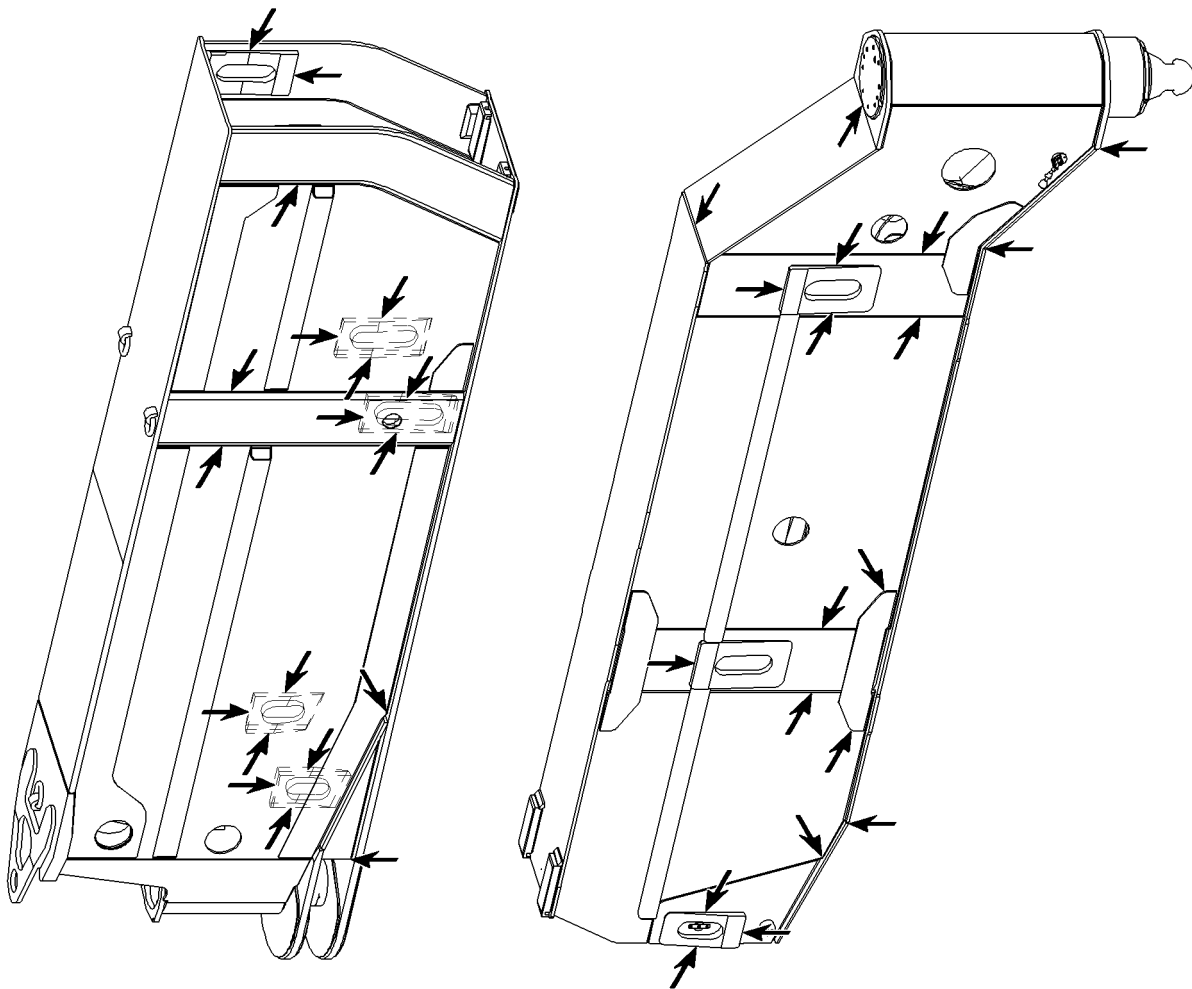
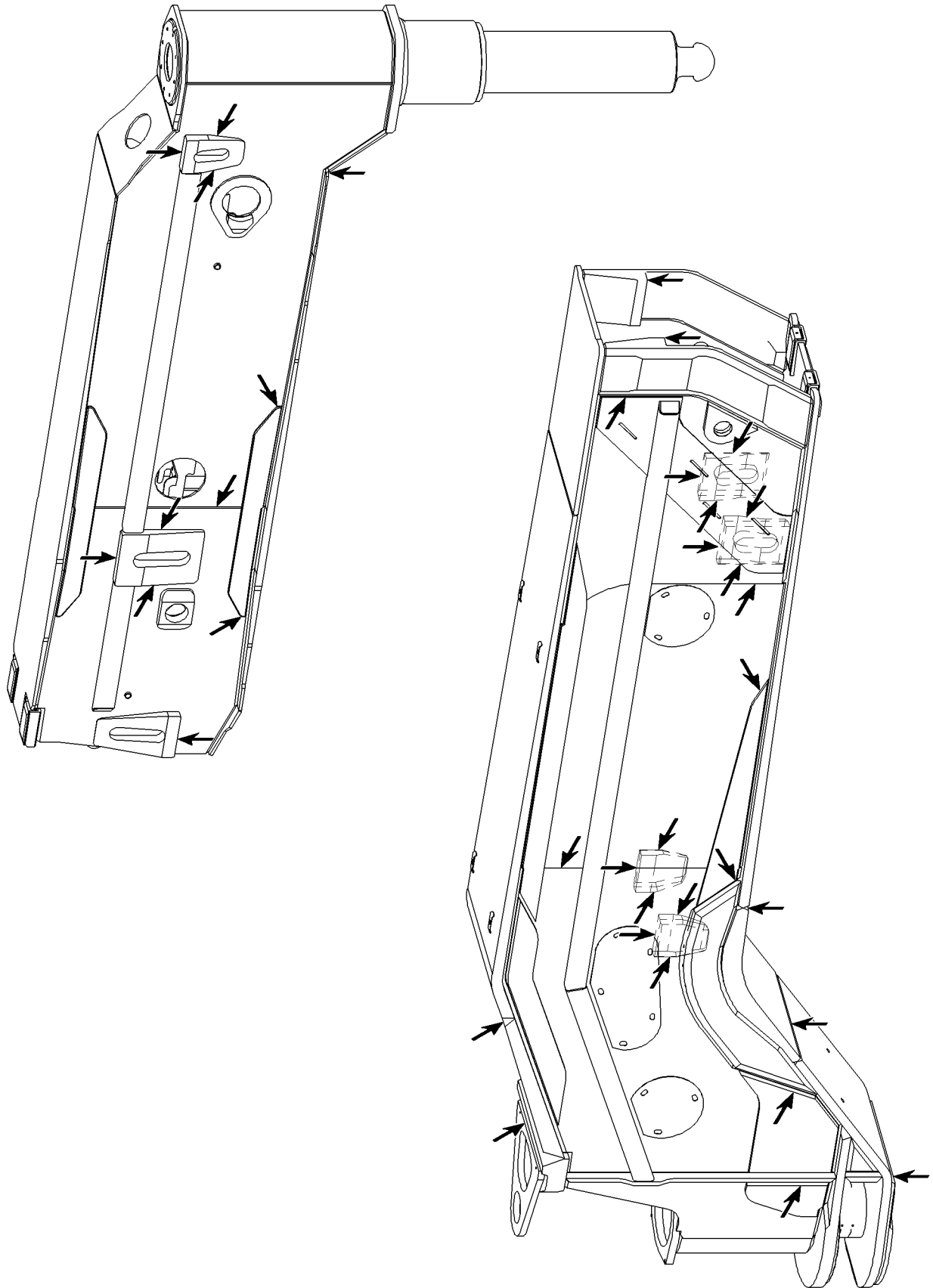

Fig.105690: Example of a swinging sliding beam



LWE/LR 13000-001/19503-01-02/en

Fig.105704: Example of a swinging sliding beam

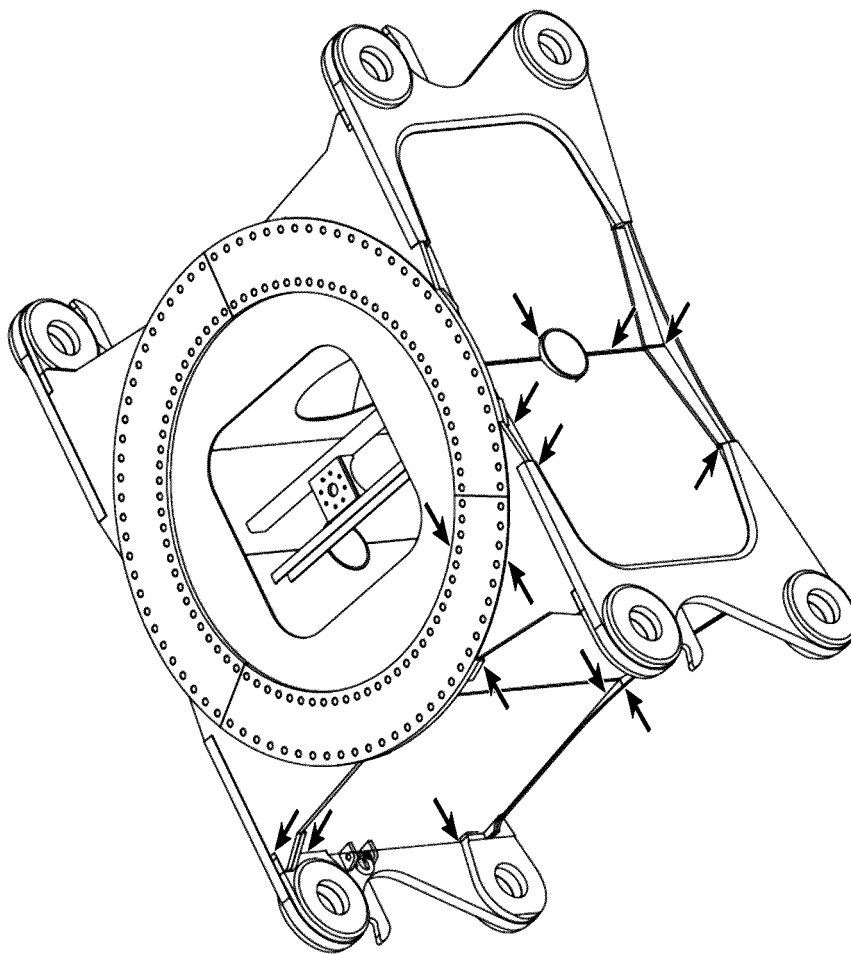
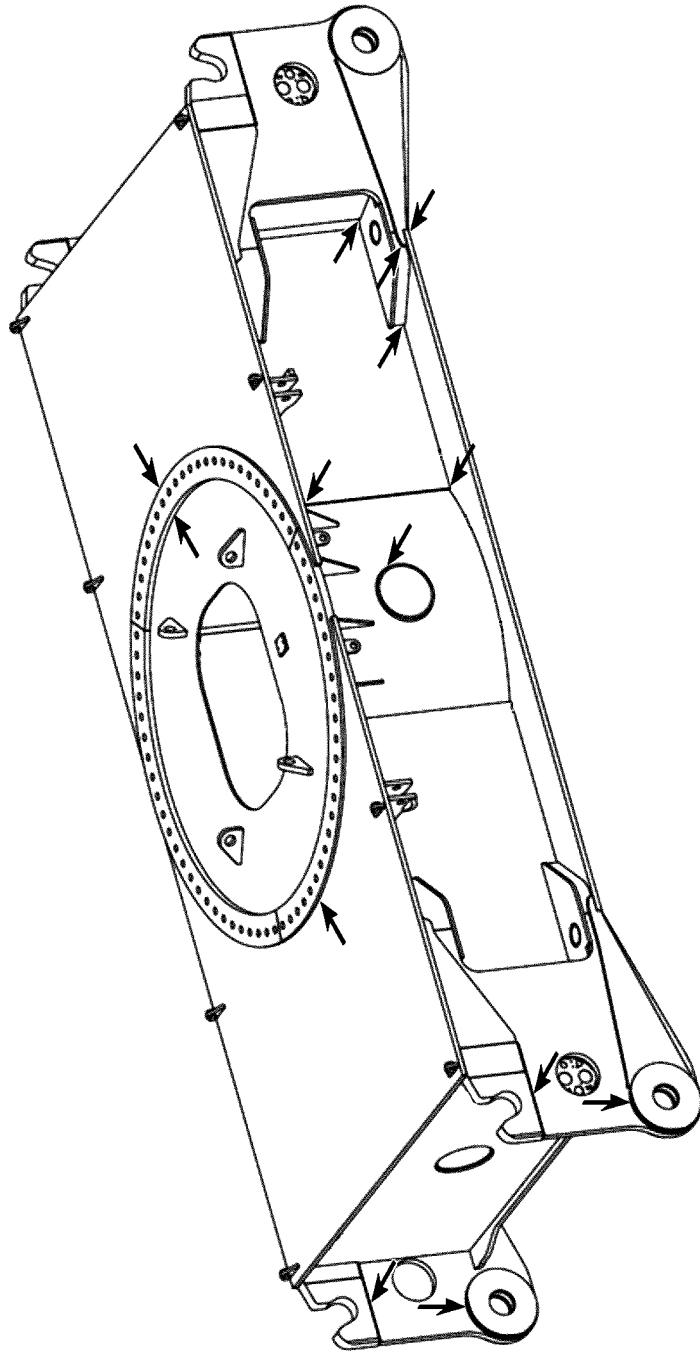

Fig.105725: Example of a crawler center section

LWE/LR 13000-001/19503-01-02/en



LWE/LR 13000-001/19503-01-02/en

Fig.105726: Example of a crawler center section

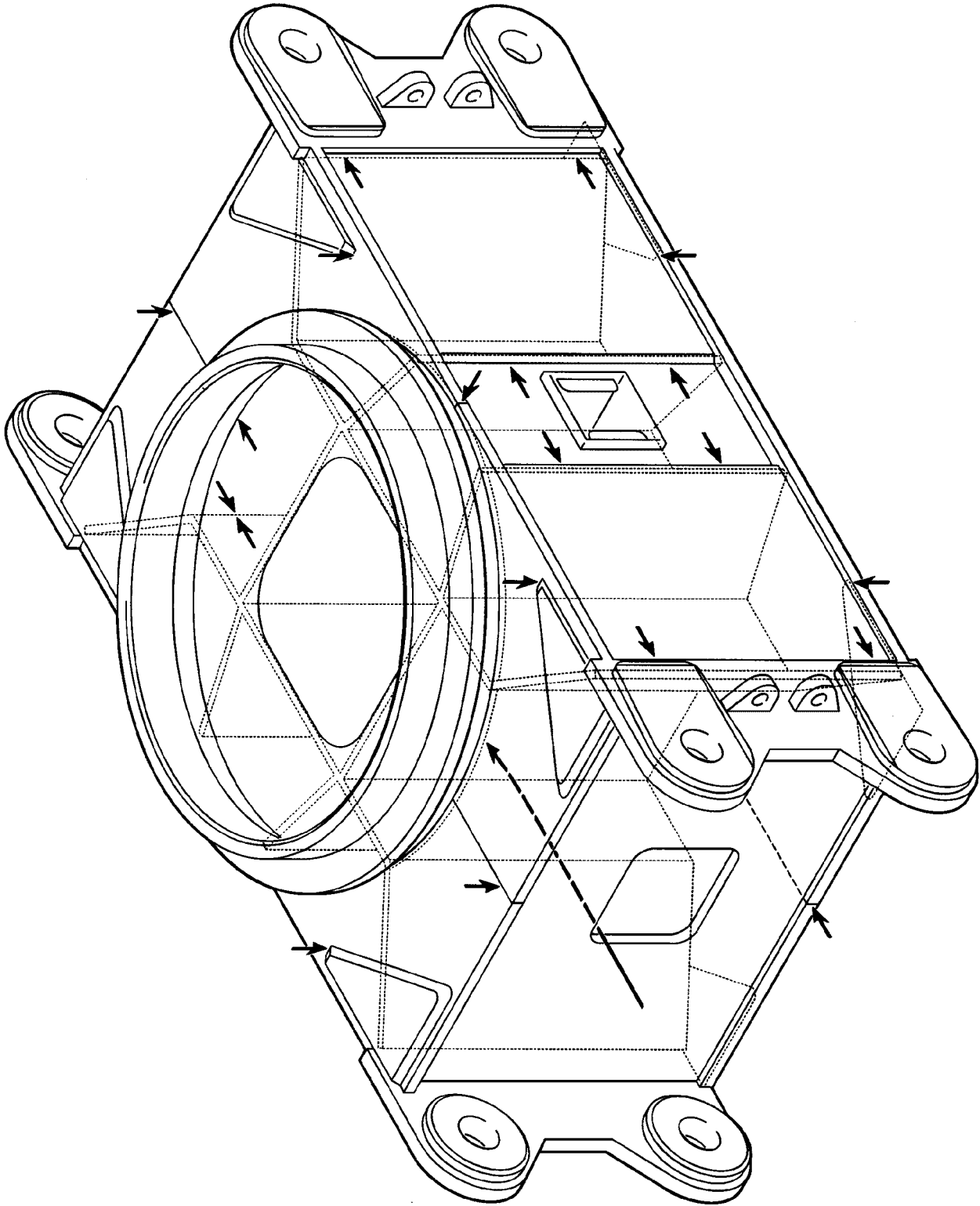
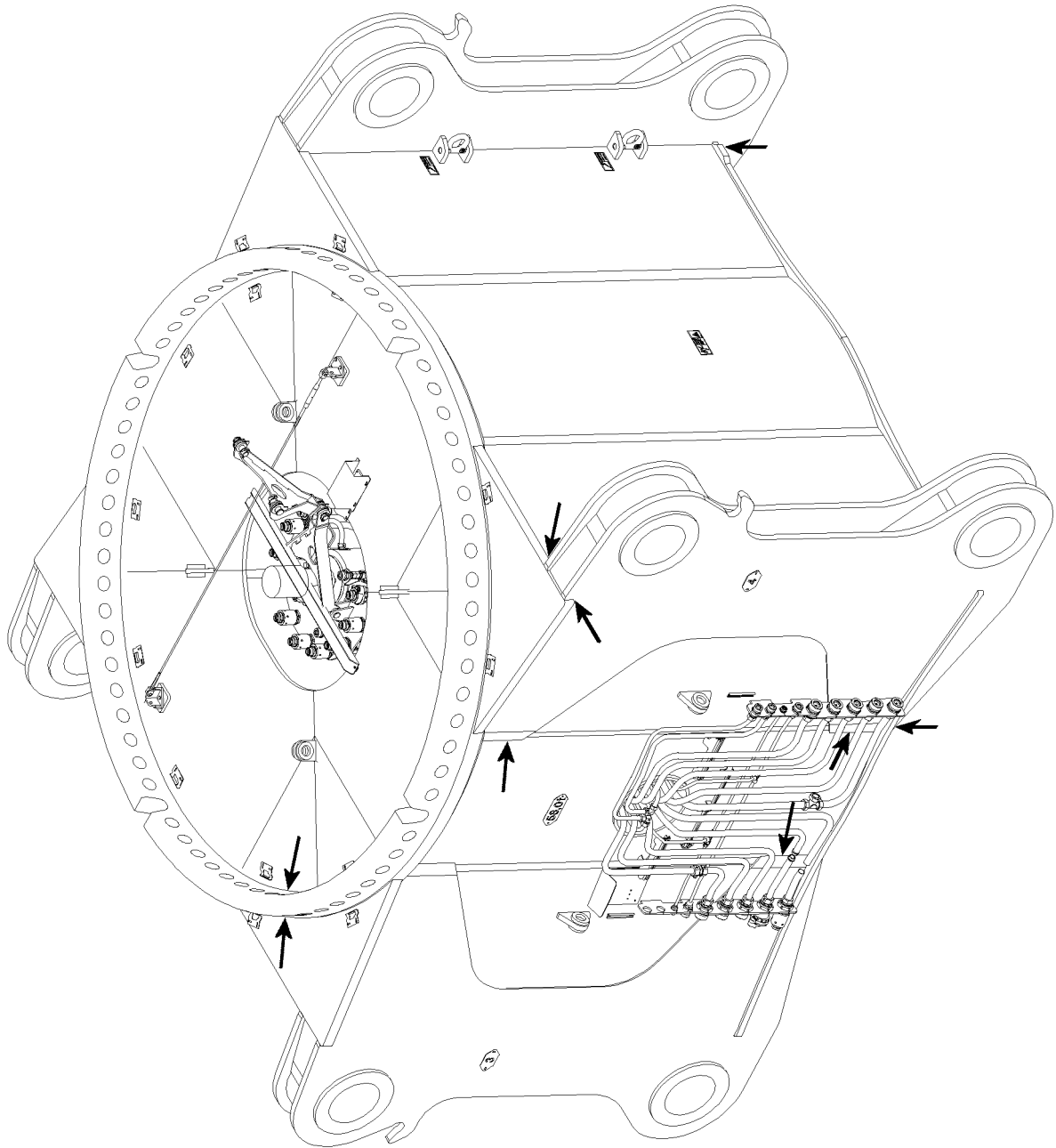

Fig.187347: Example of a crawler center section

LWE/LR 13000-001/19503-01-02/en



LWE/LR 13000-001/19503-01-02/en

Fig.115920: Example of a crawler center section

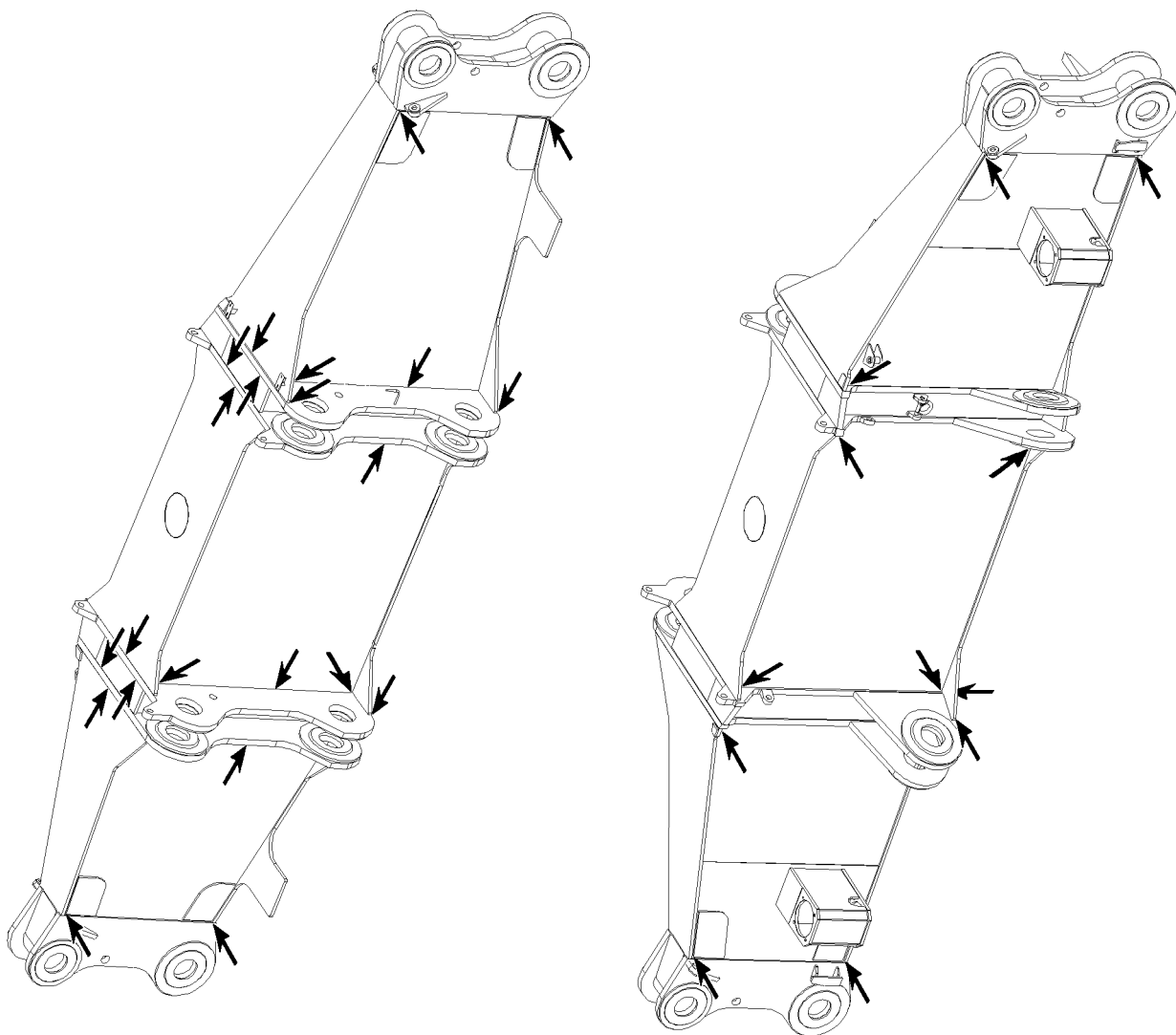
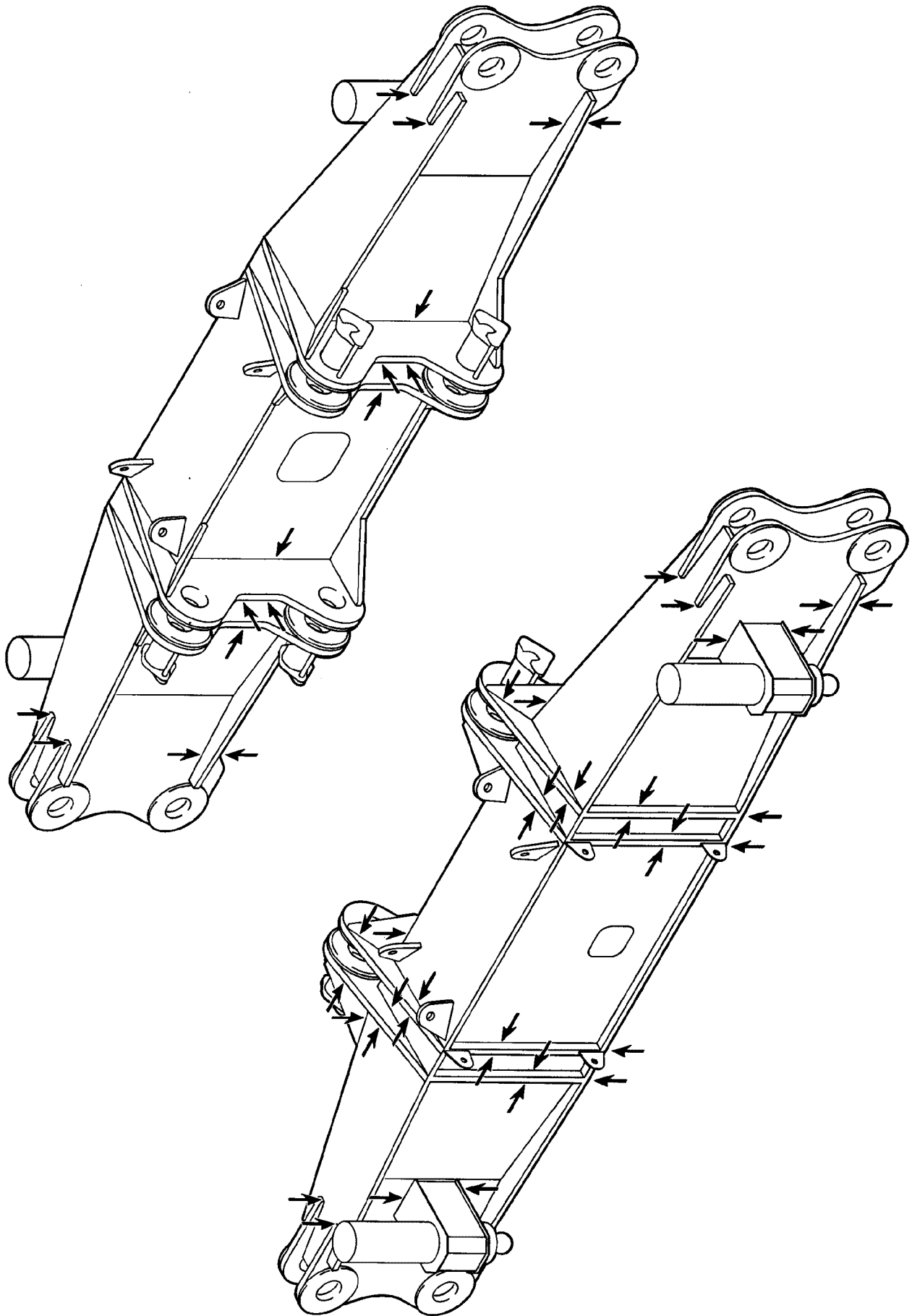

Fig.105727: Example of a cross carrier



LWE/LR 13000-001/19503-01-02/en

Fig.187348: Example of a cross carrier

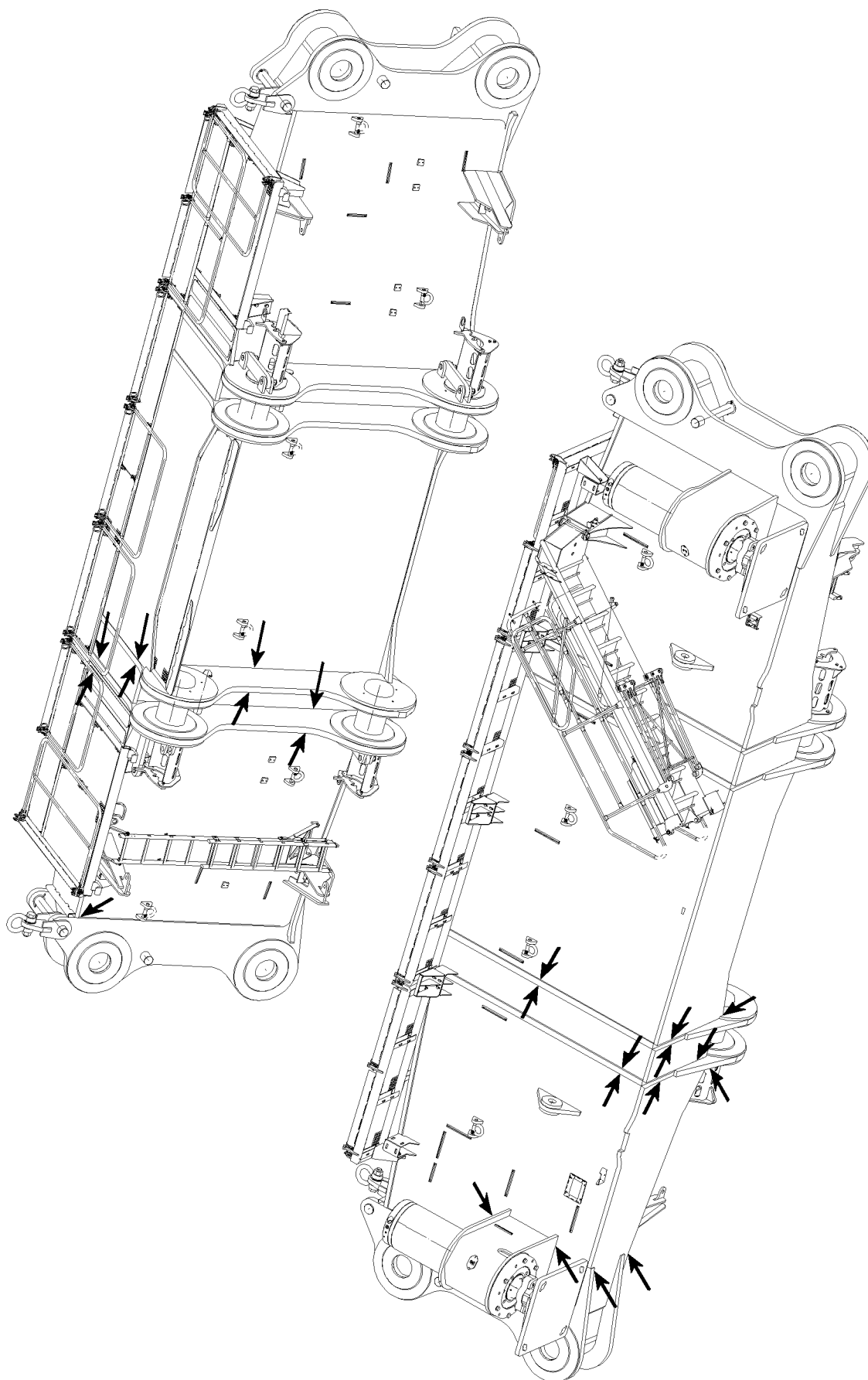
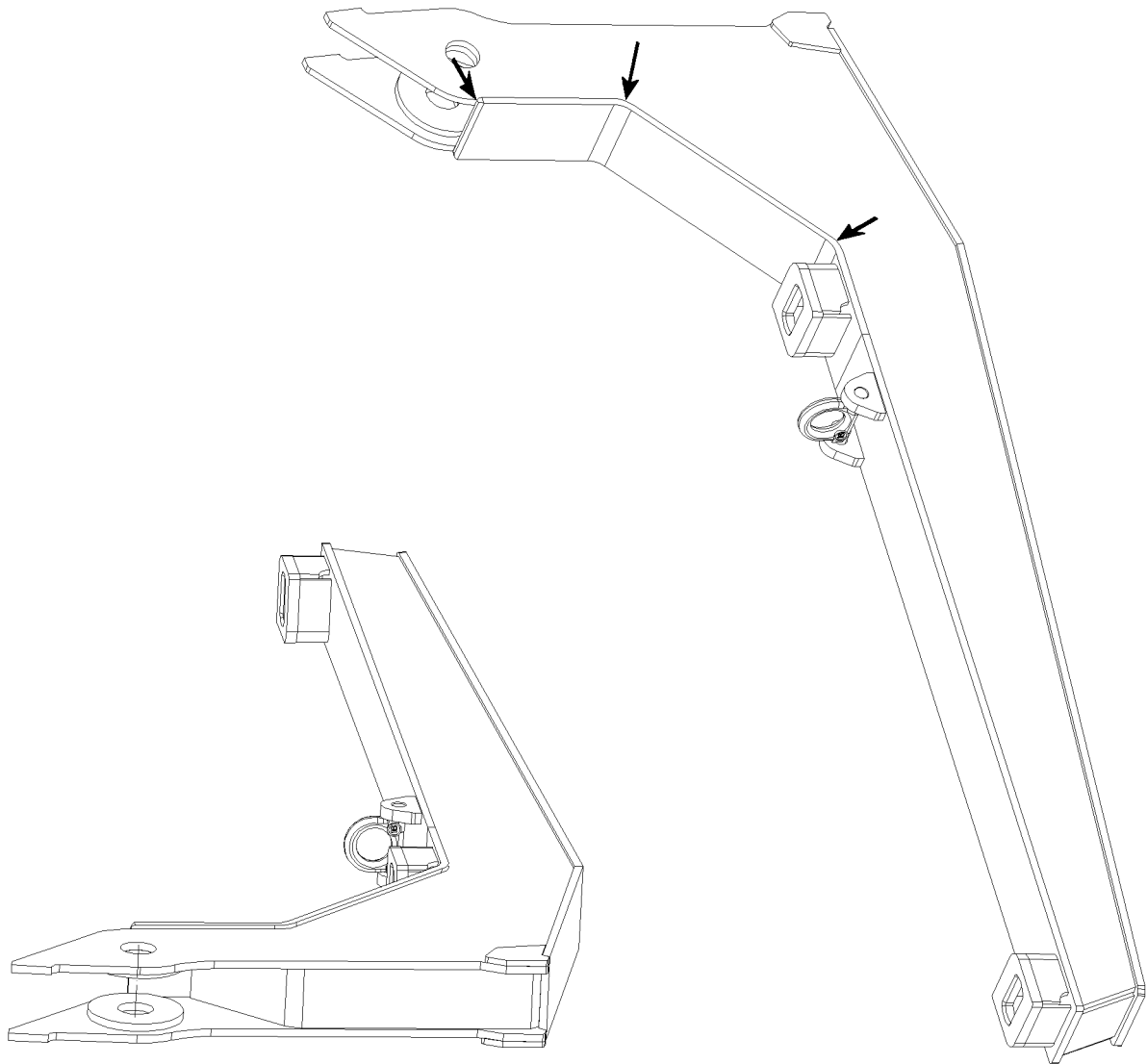

Fig.115921: Example of a cross carrier

LWE/LR 13000-001/19503-01-02/en



LWE/LR 13000-001/19503-01-02/en

Fig.115919: Example of carrier for central ballast

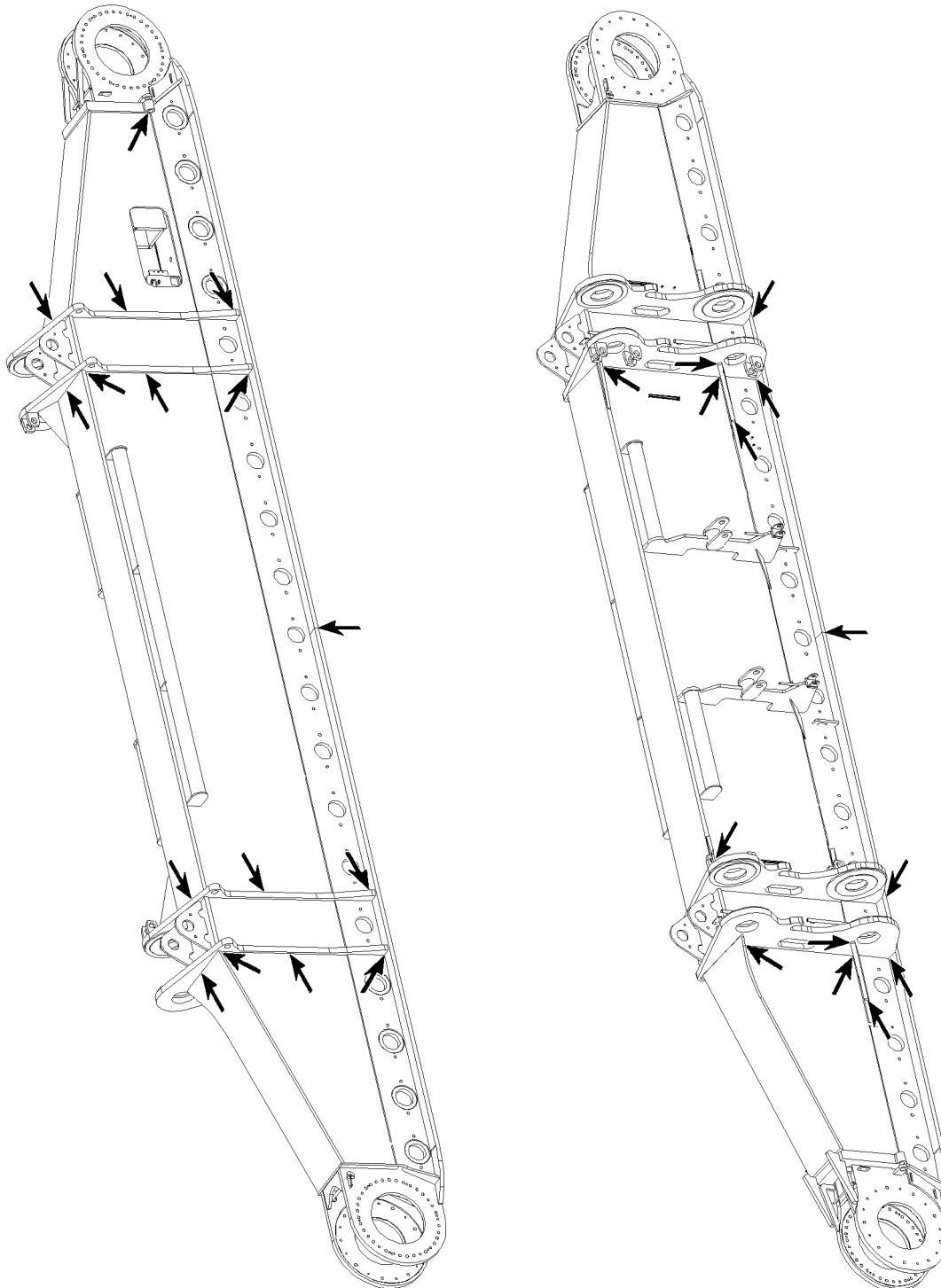
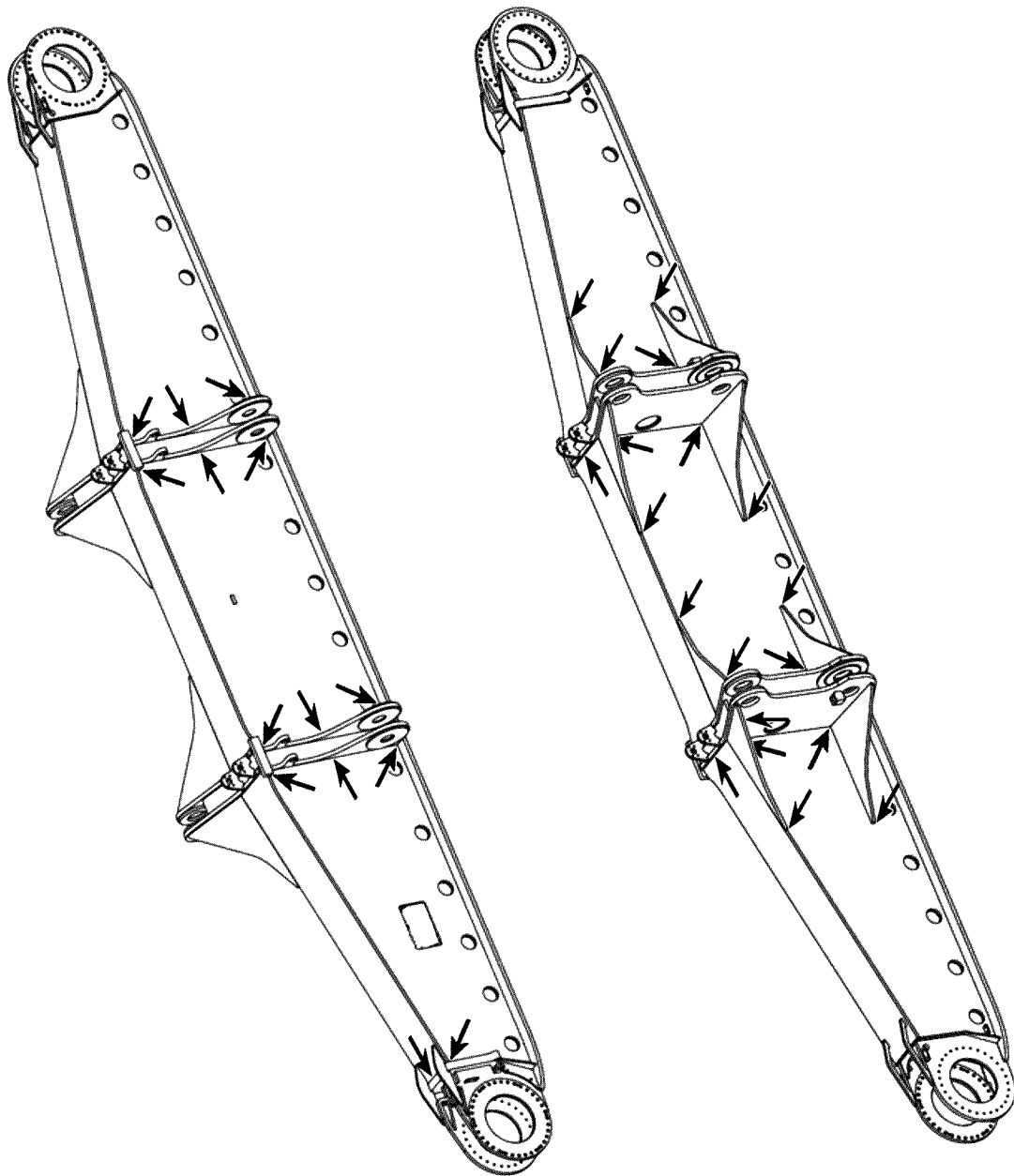

Fig.105728: Example of a crawler carrier



LWE/LR 13000-001/19503-01-02/en

Fig.105729: Example of a crawler carrier

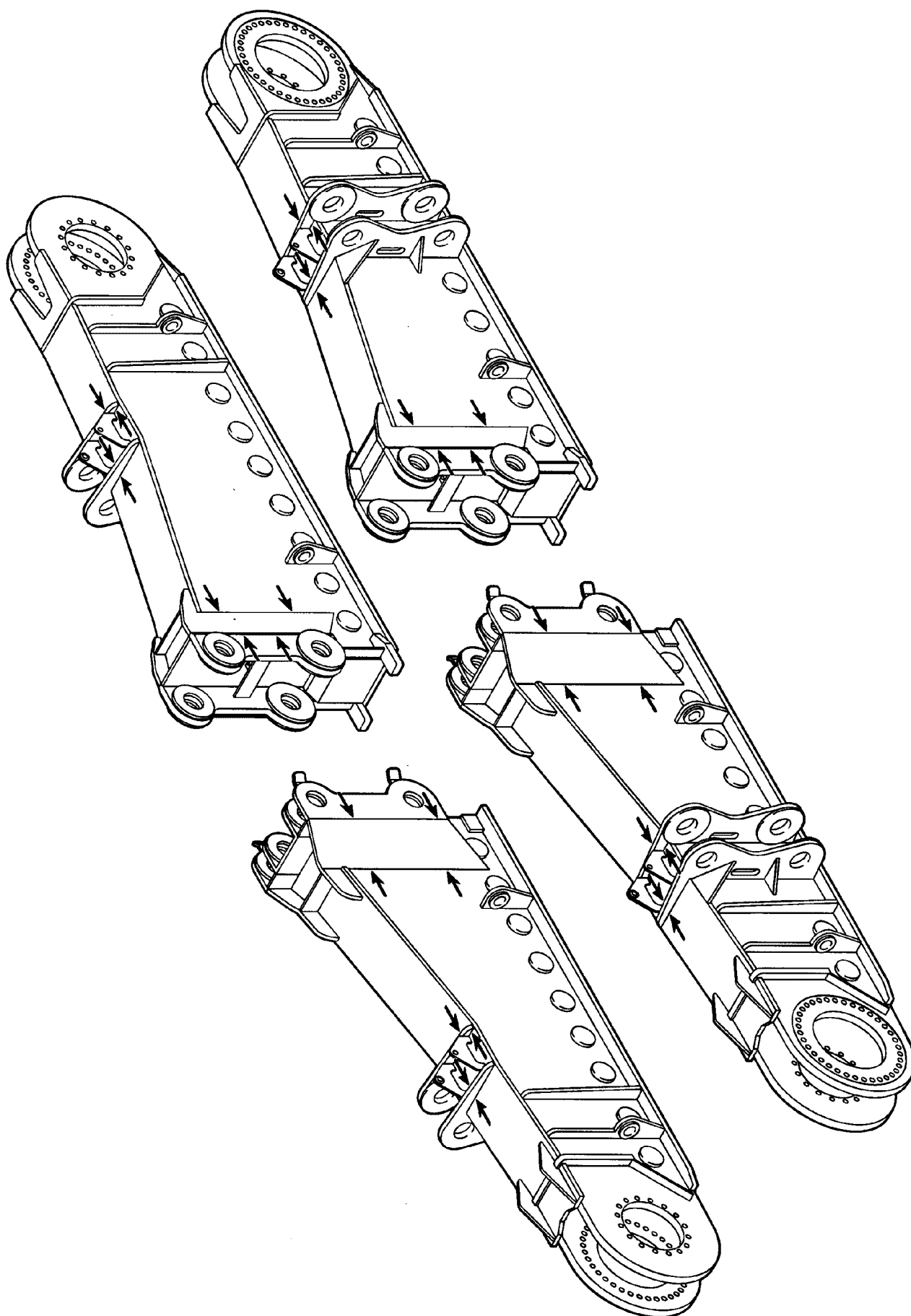
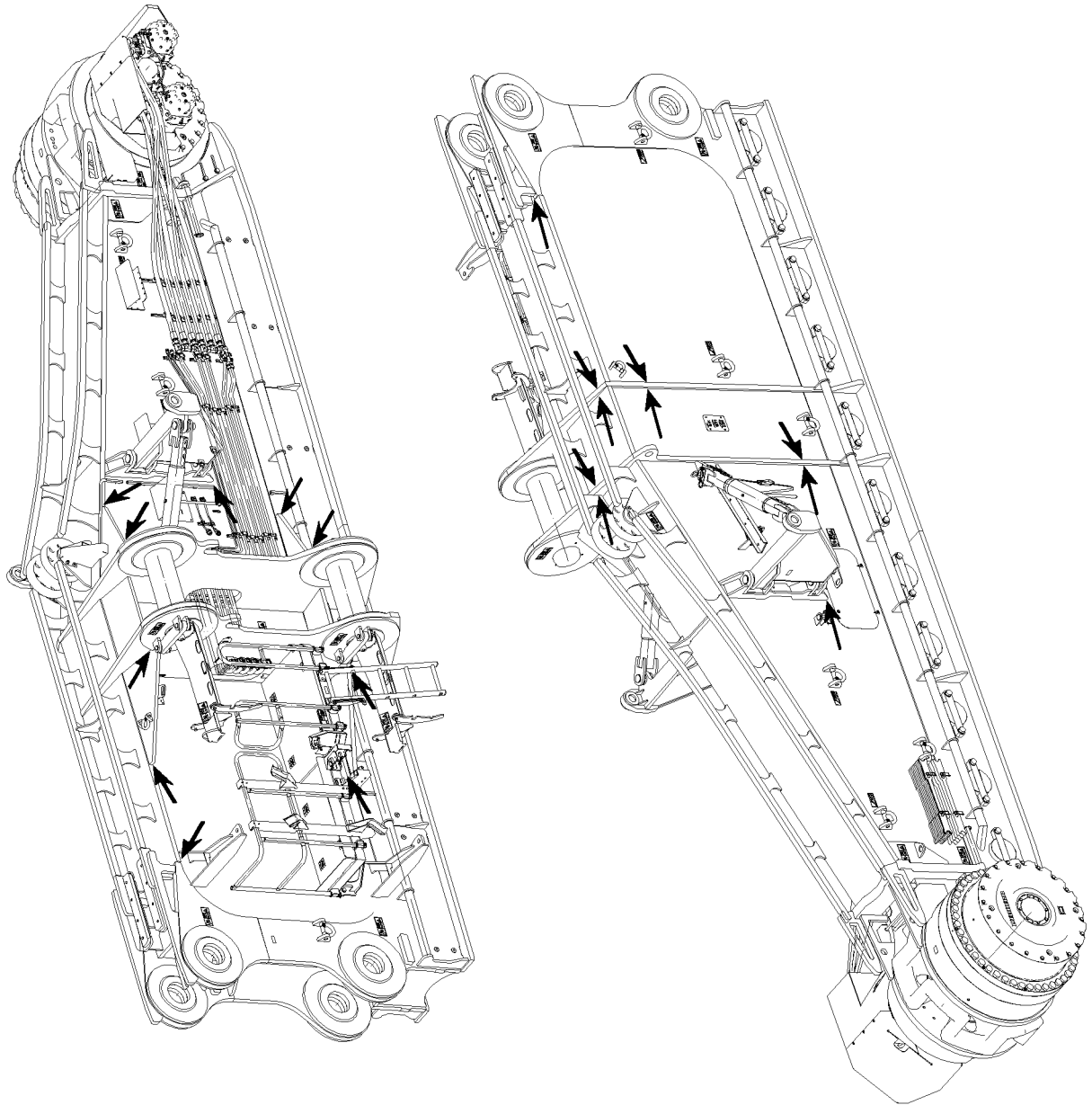

Fig.187349: Example of a crawler carrier



LWE/LR 13000-001/19503-01-02/en

Fig.115917: Example of a crawler carrier

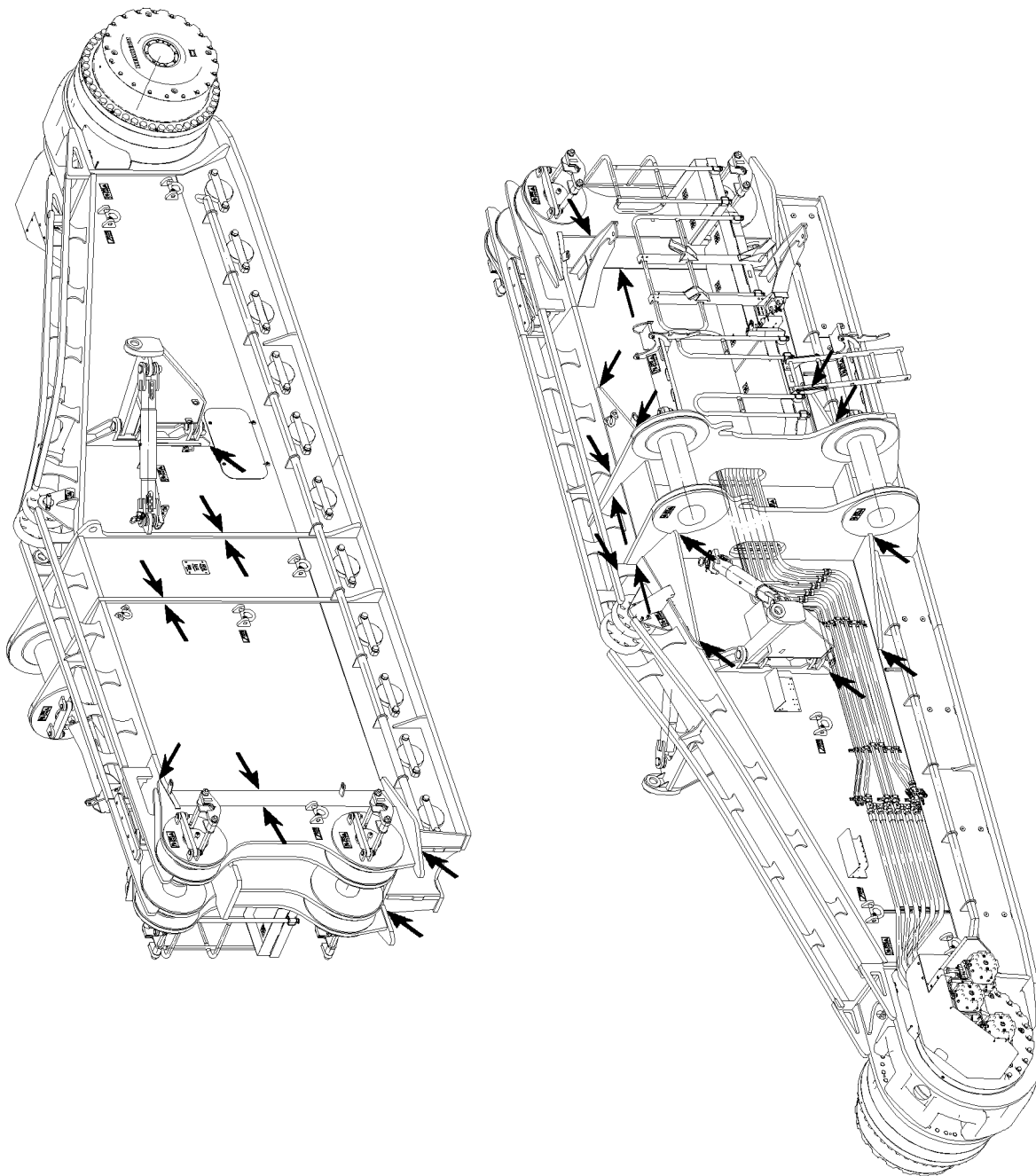
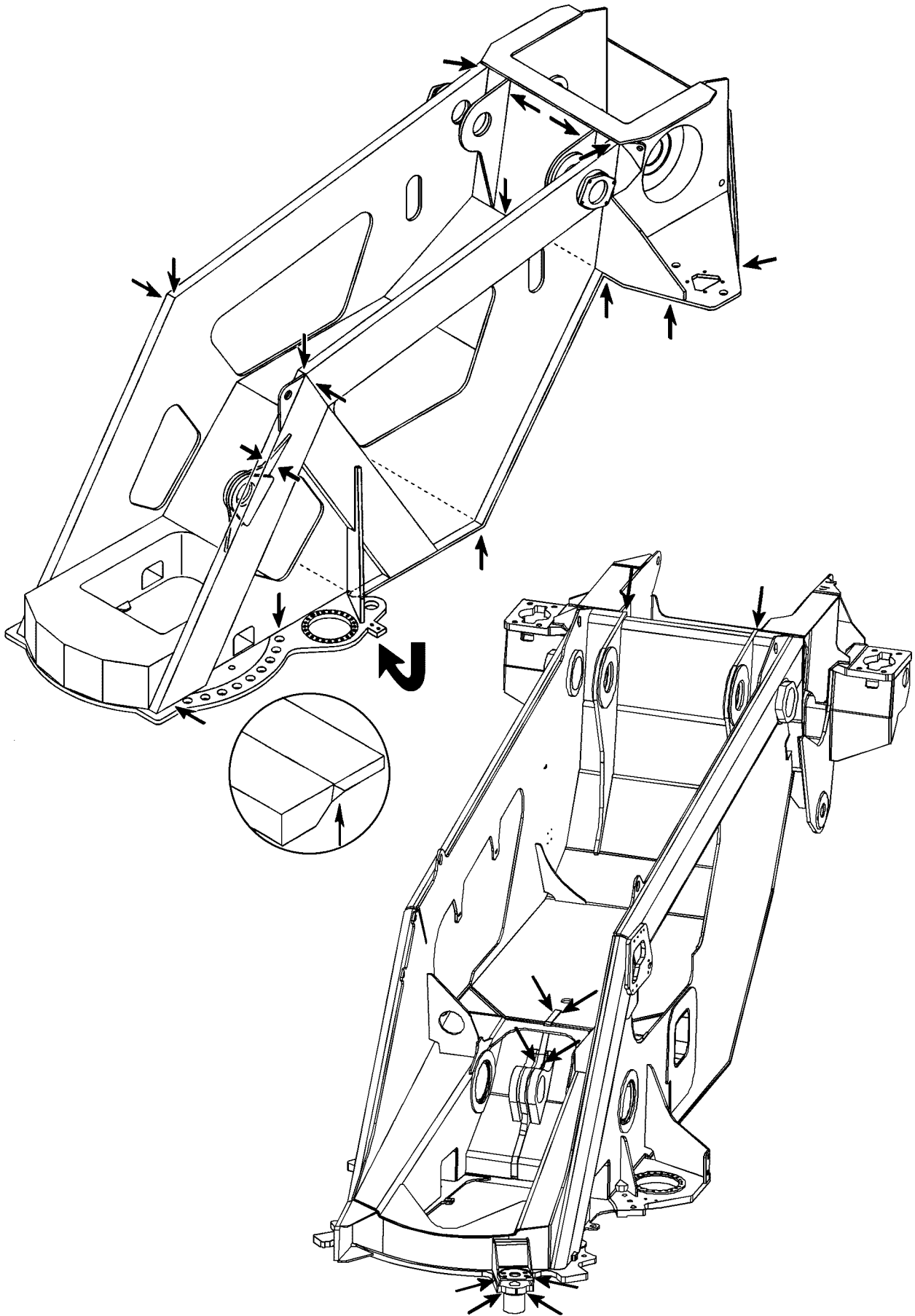

Fig.115918: Example of a crawler carrier



LWE/LR 13000-001/19503-01-02/en

Fig.185048: Example of a turntable frame

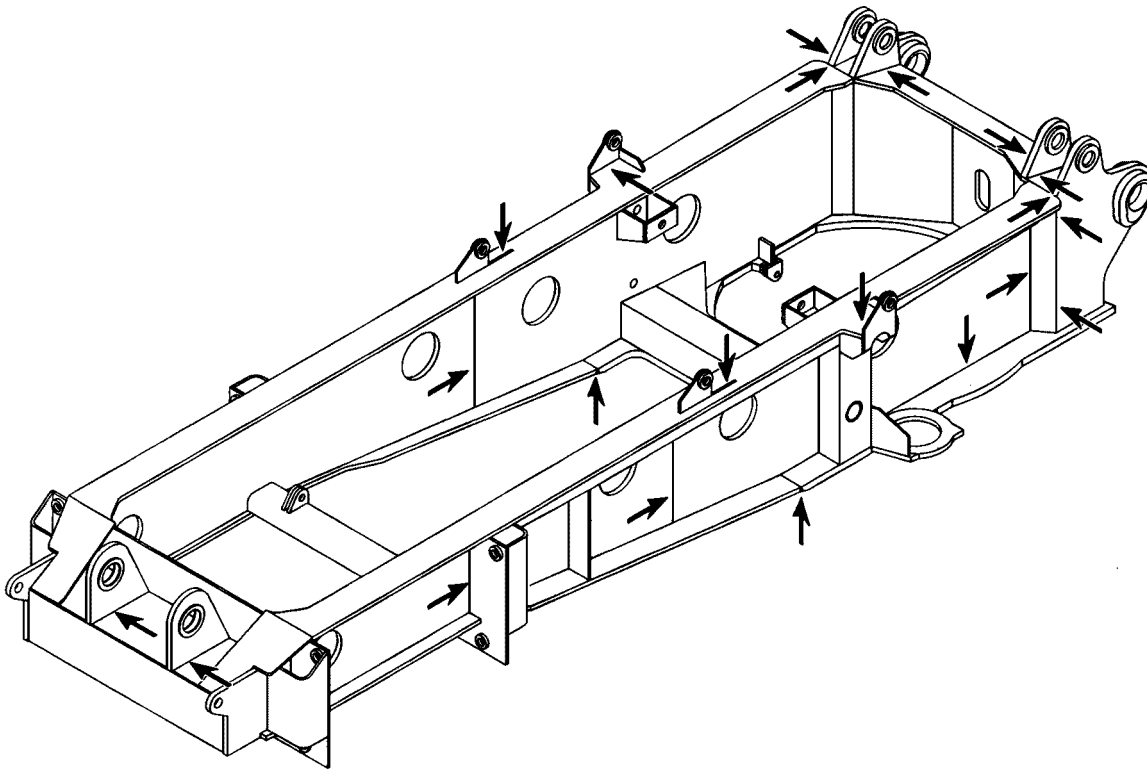

Fig.185049: Example of a turntable frame

LWE/LR 13000-001/19503-01-02/en

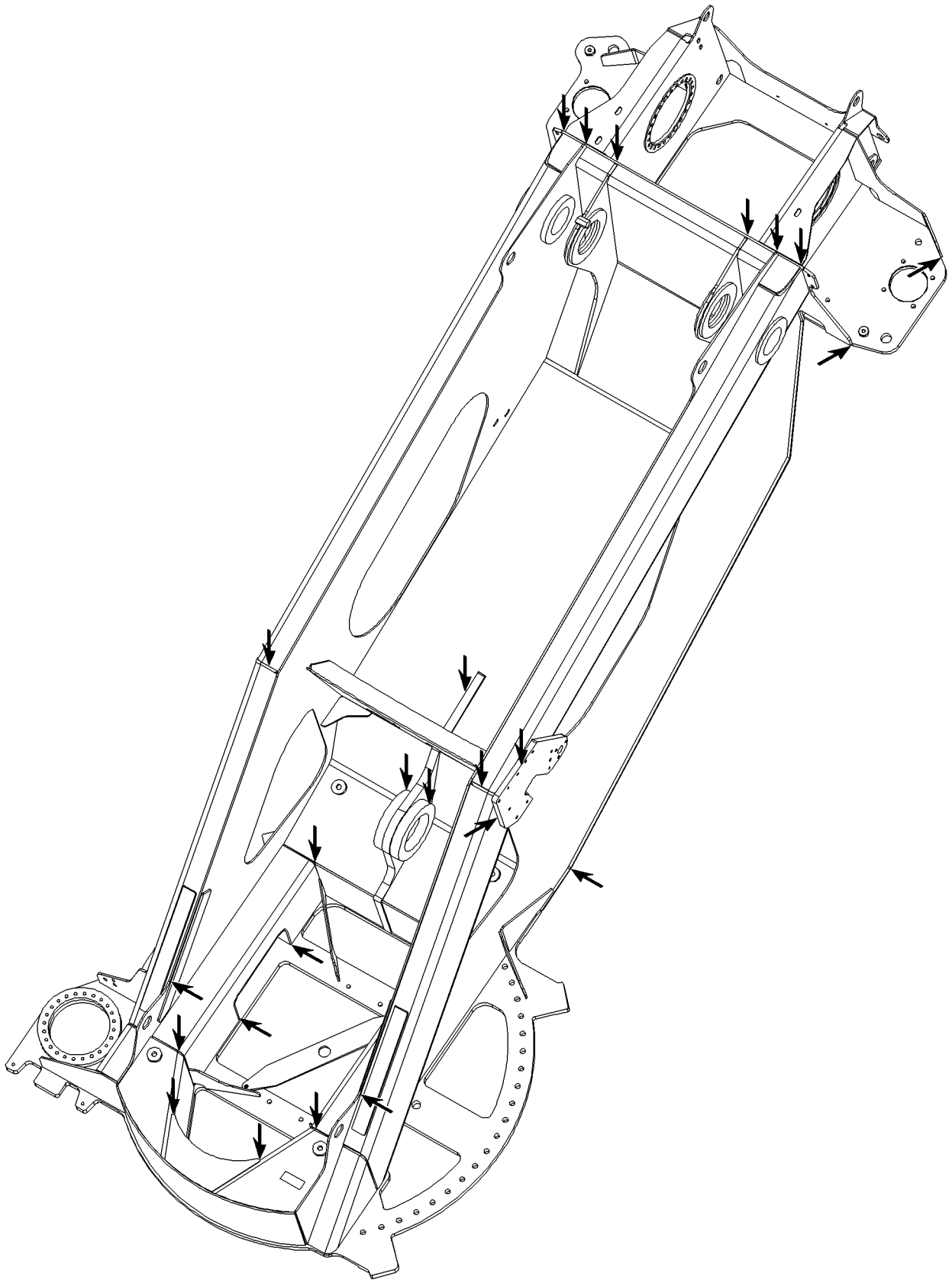

Fig.105700: Example of a turntable frame

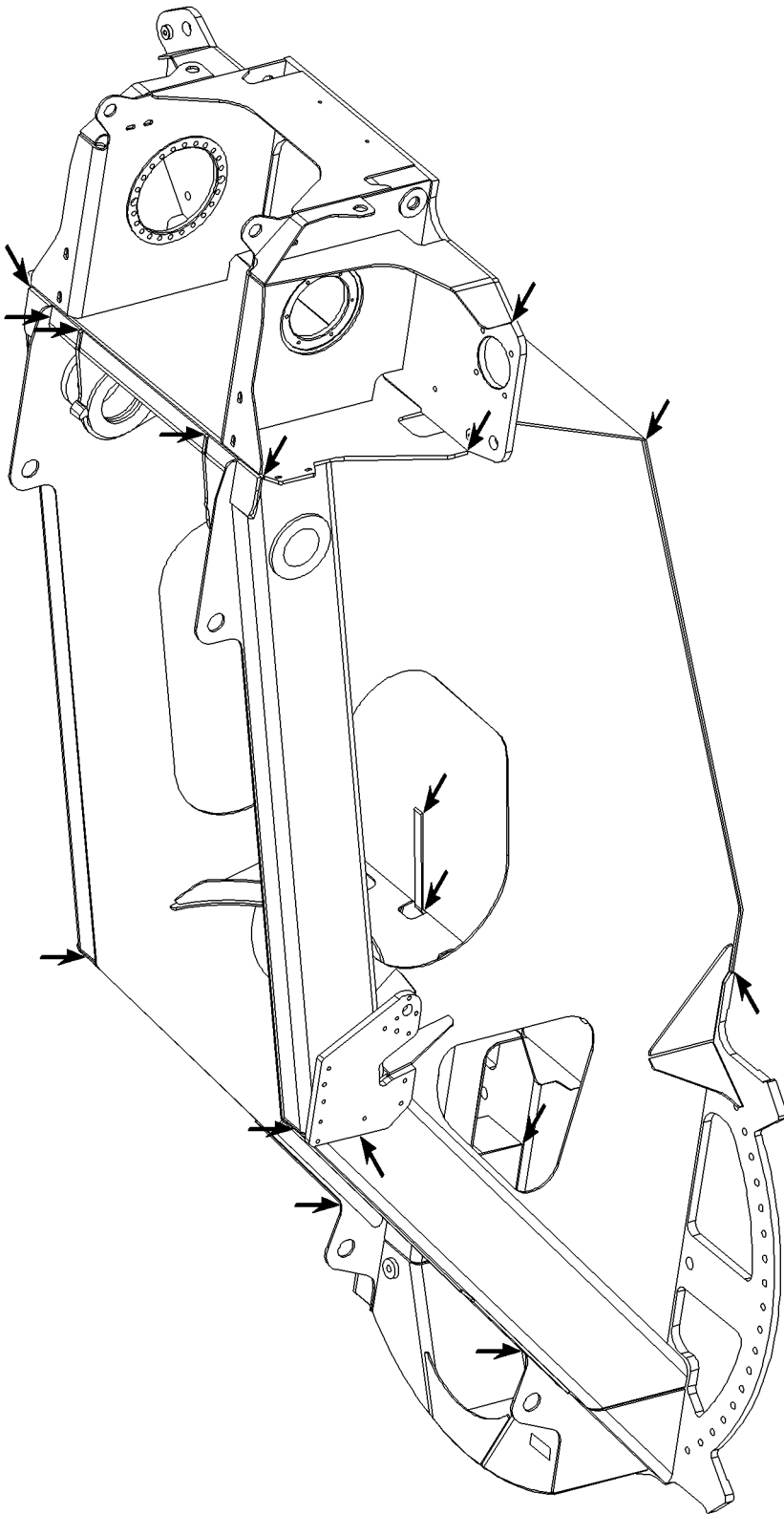
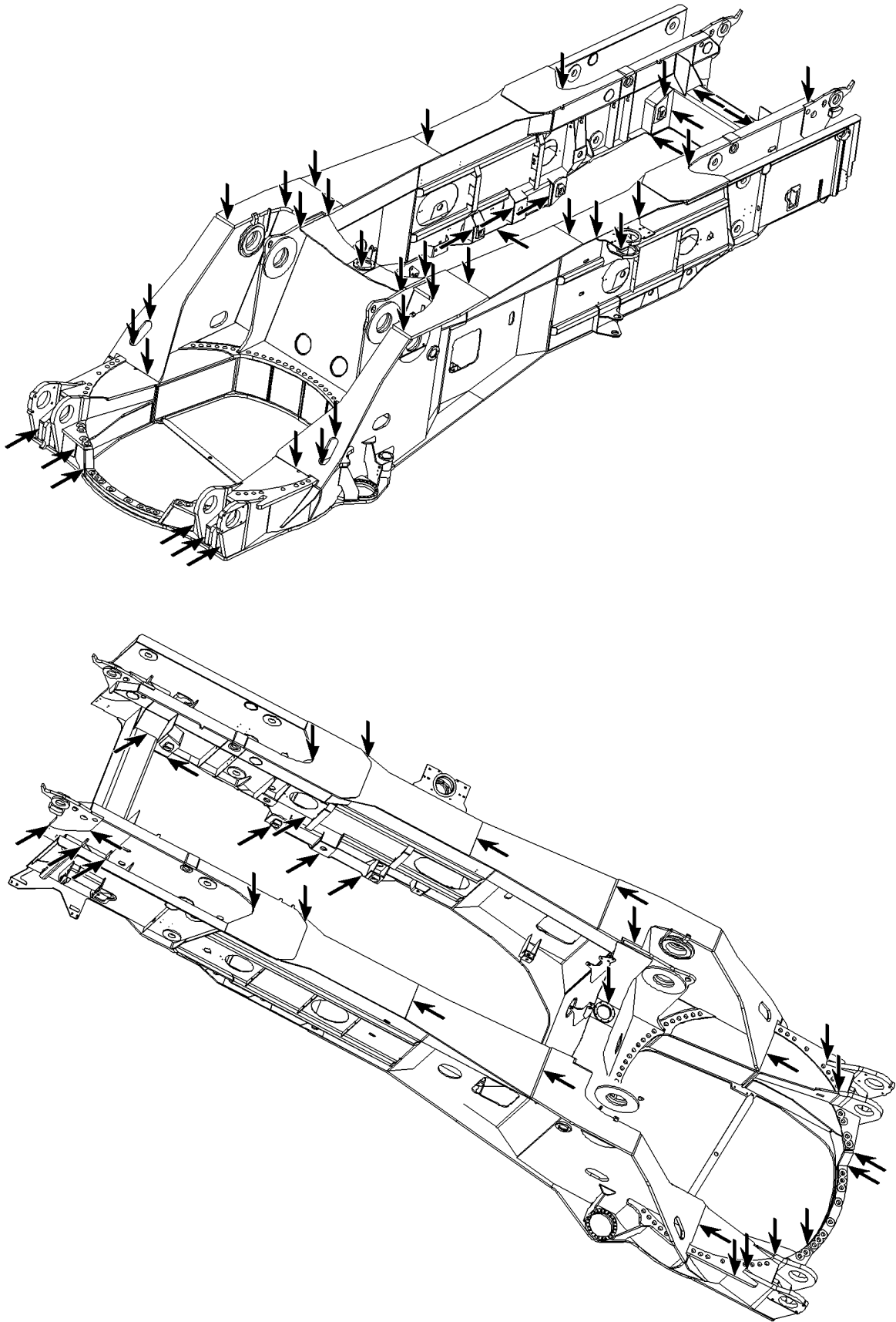

Fig.105701: Example of a turntable frame



LWE/LR 13000-001/19503-01-02/en

Fig.105706: Example of a turntable frame

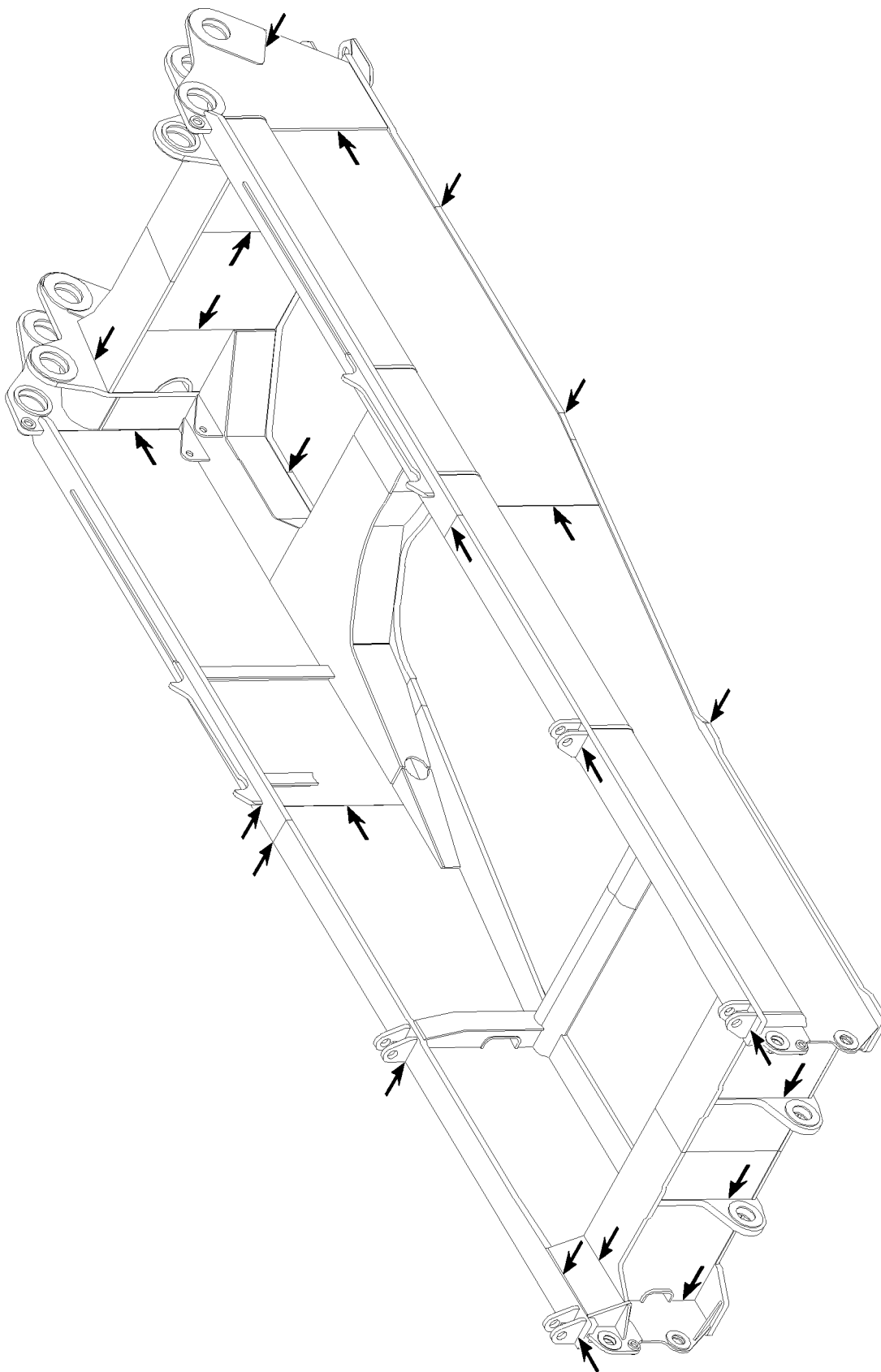
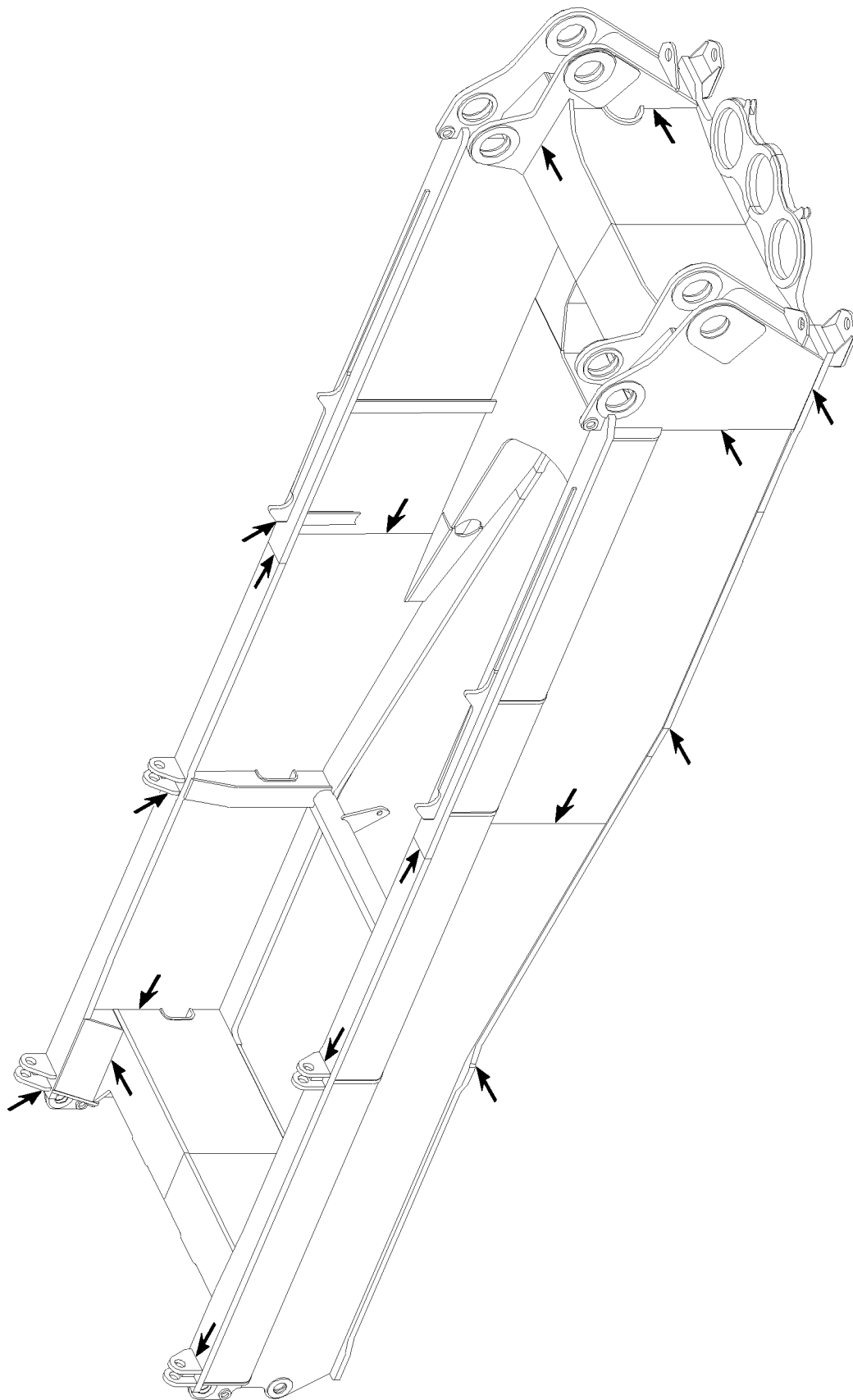

Fig.105694: Example of a turntable frame

LWE/LR 13000-001/19503-01-02/en



LWE/LR 13000-001/19503-01-02/en

Fig.105695: Example of a turntable frame

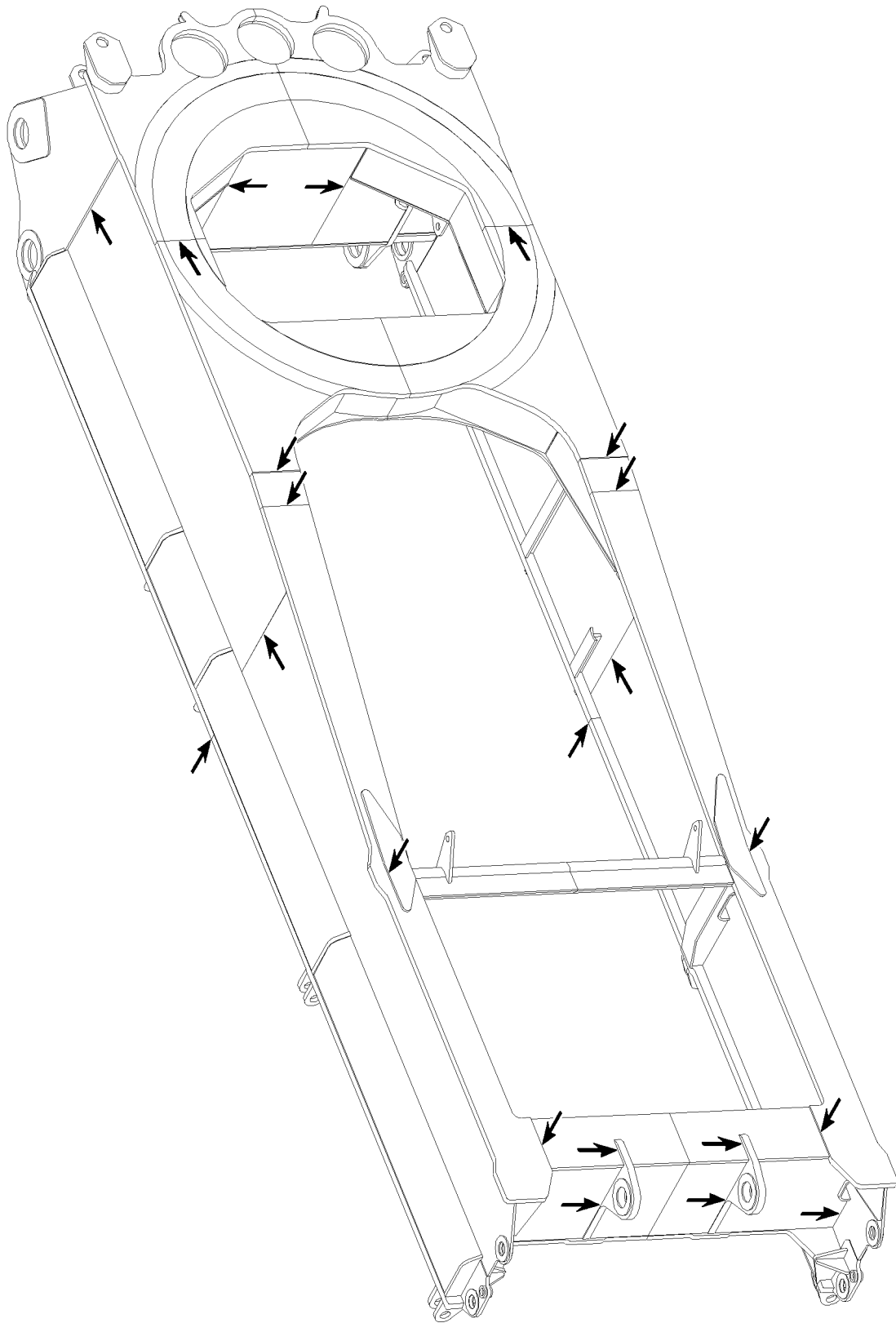
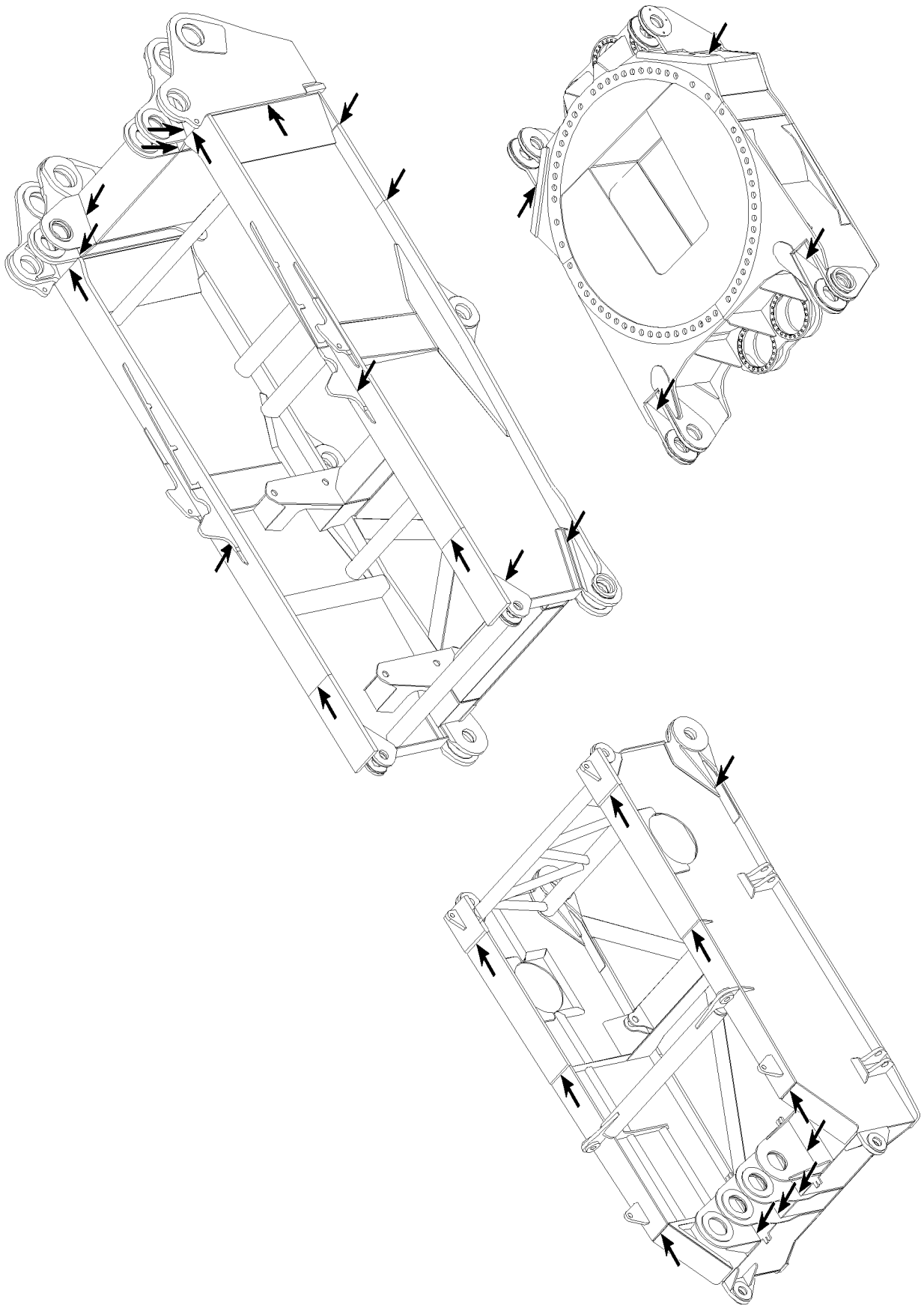

Fig.105696: Example of a turntable frame

LWE/LR 13000-001/19503-01-02/en



LWE/LR 13000-001/19503-01-02/en

Fig.105691: Example of a turntable frame

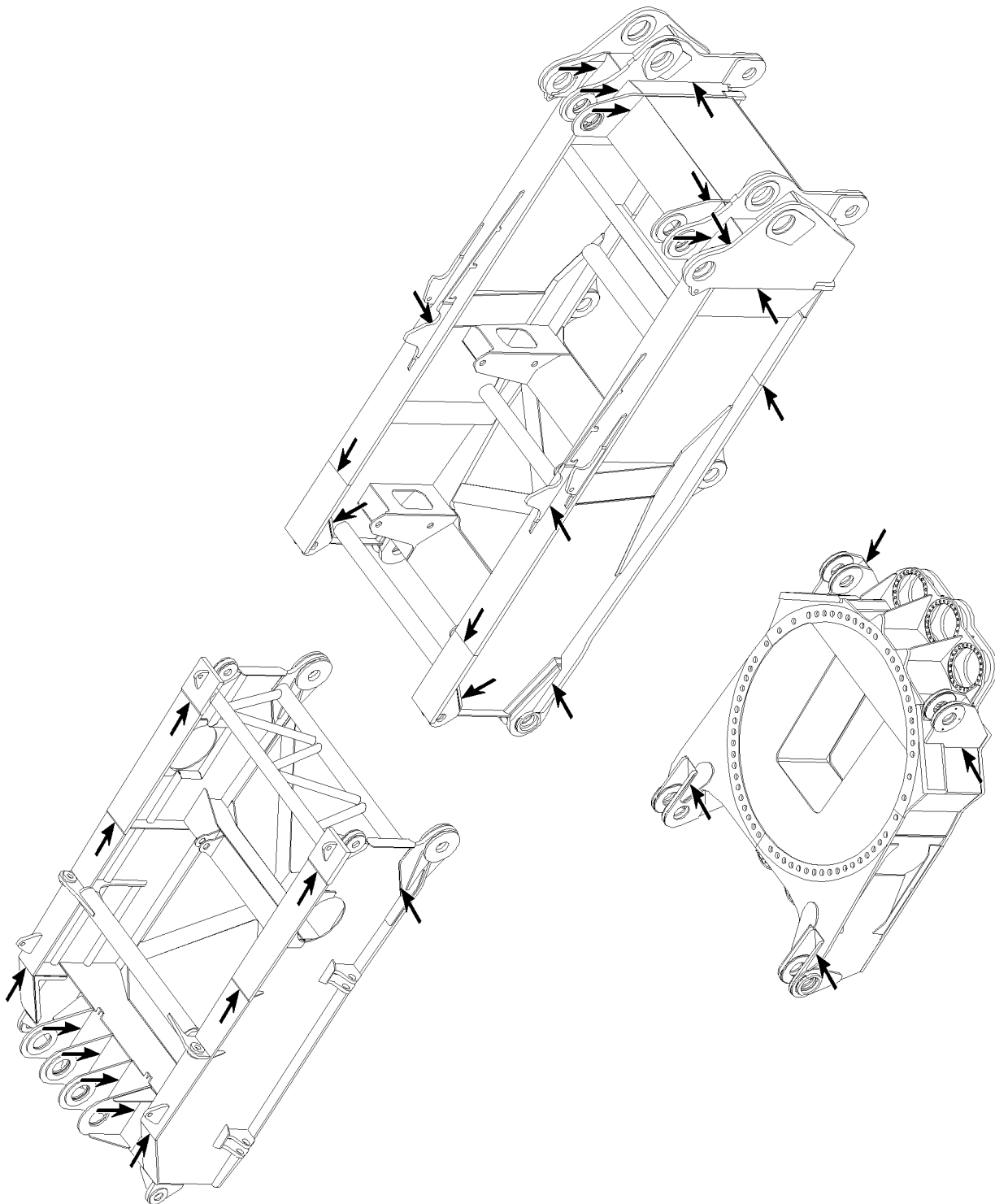
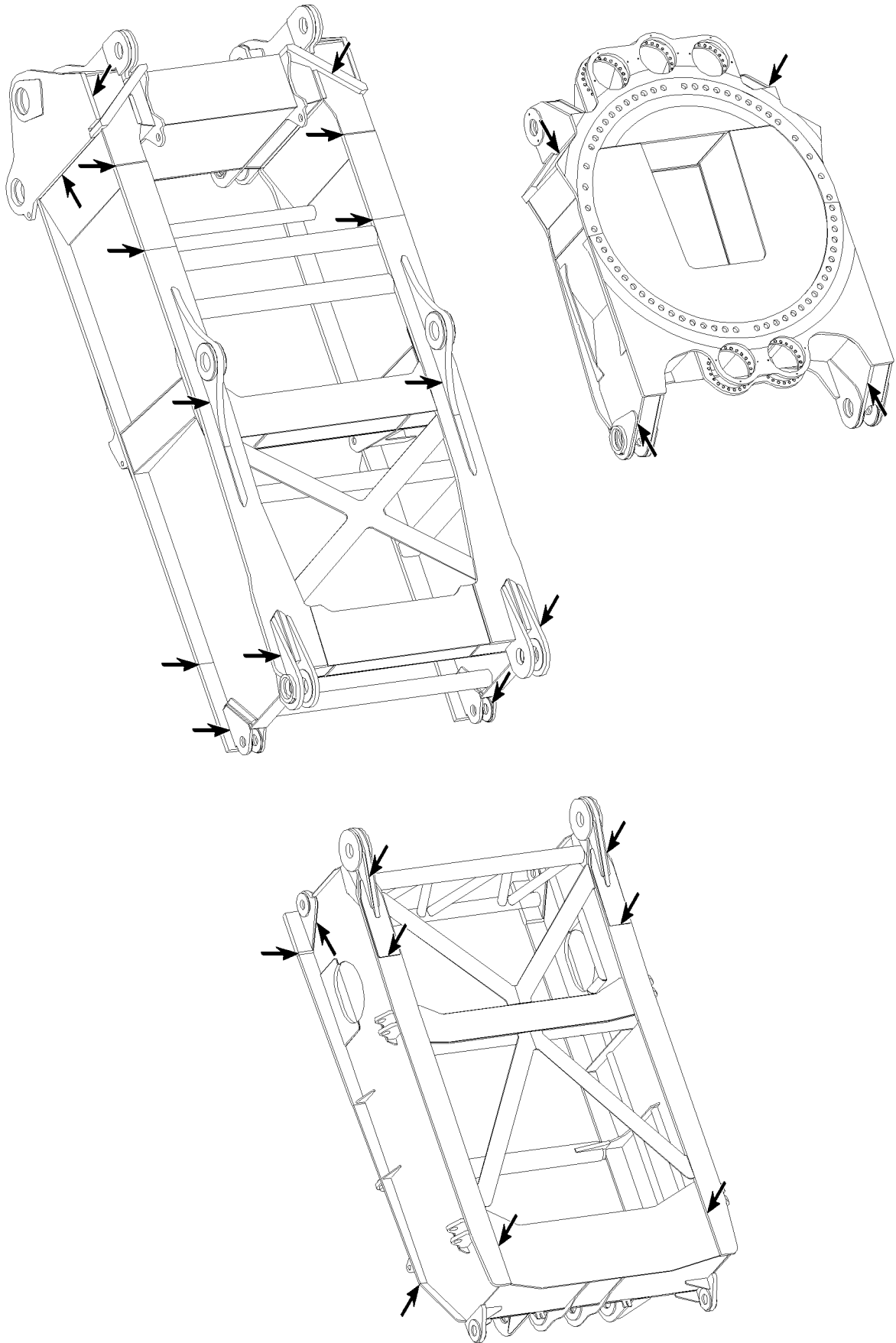

Fig.105692: Example of a turntable frame



LWE/LR 13000-001/19503-01-02/en

Fig.105693: Example of a turntable frame

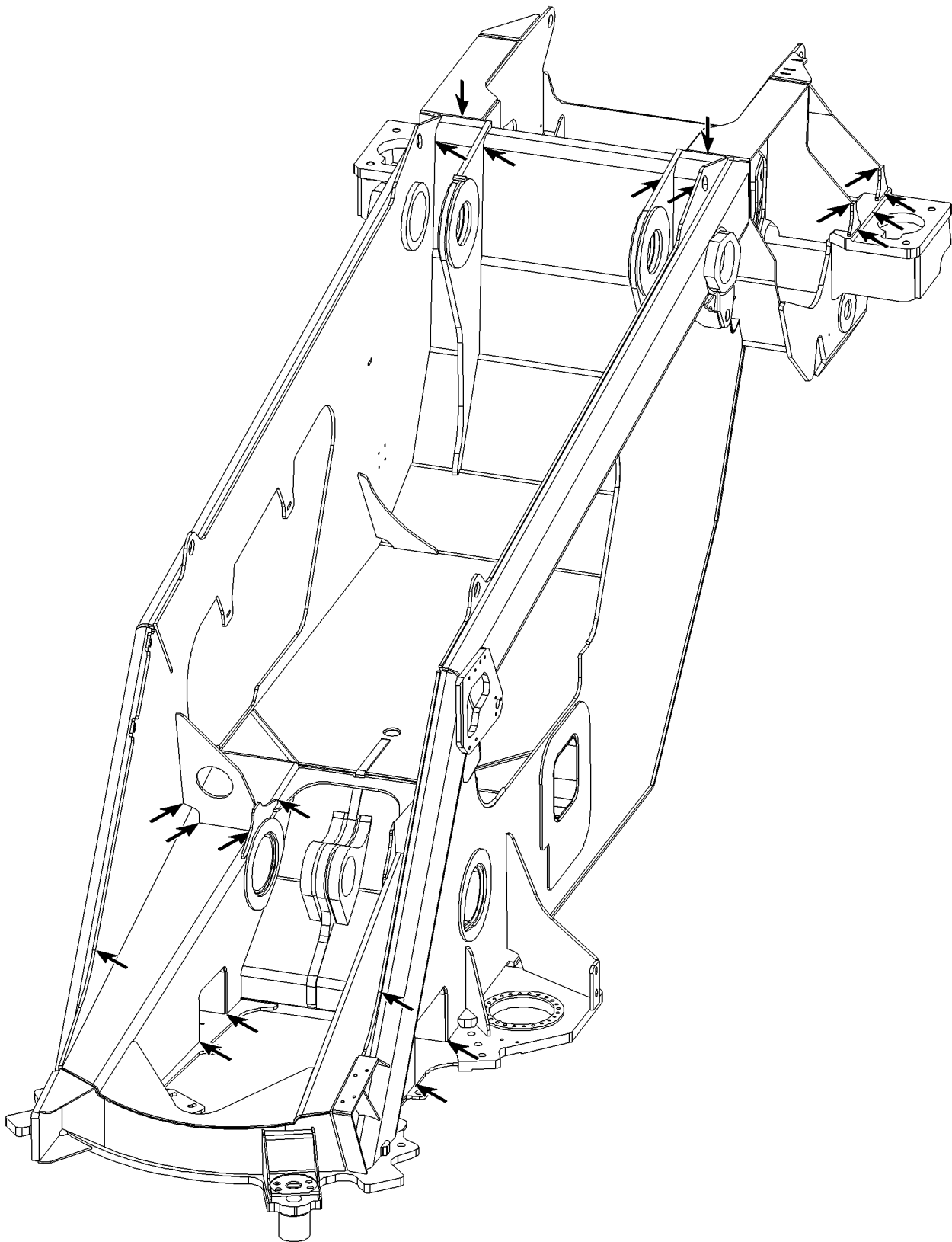
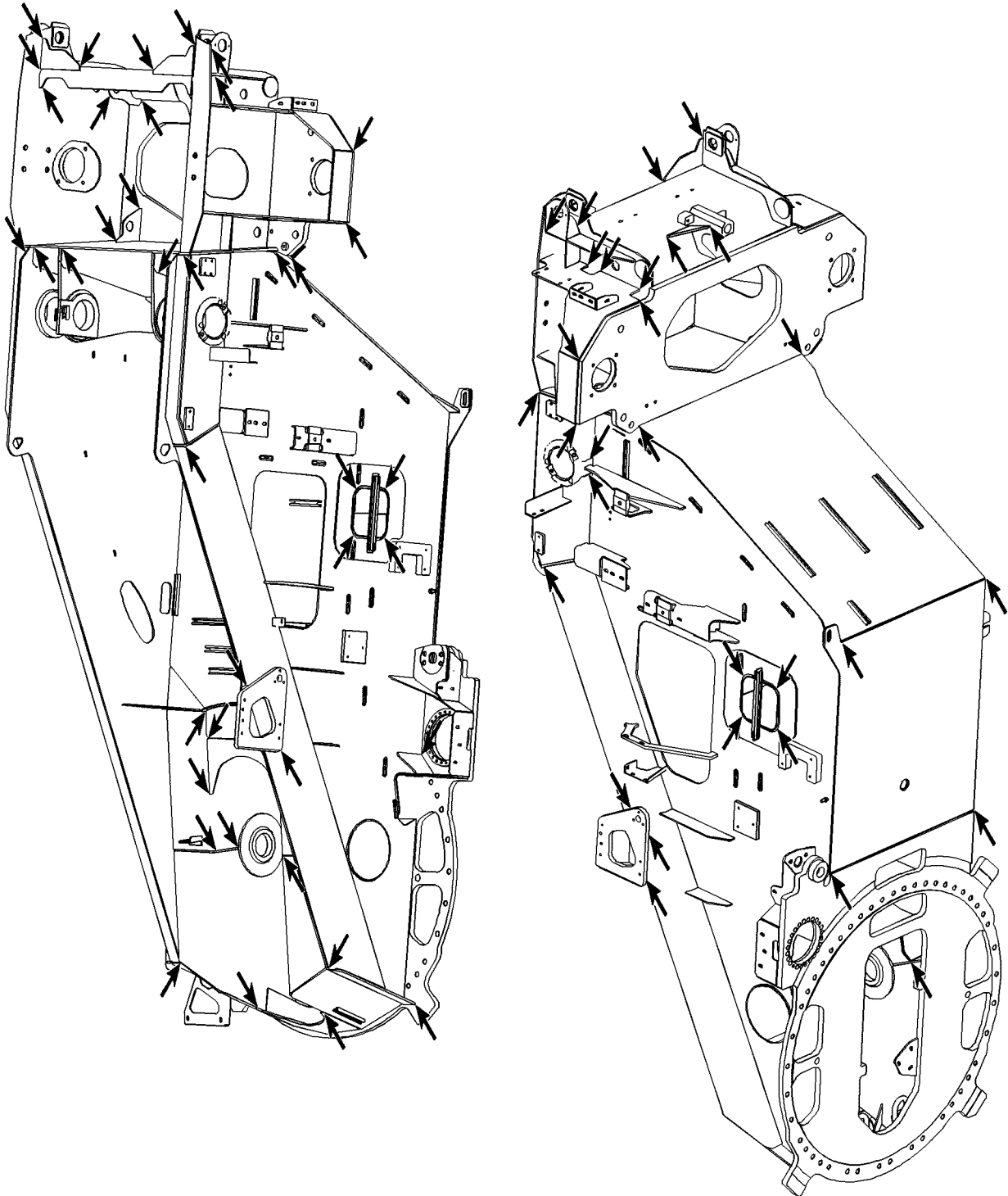

Fig.105722: Example of a turntable frame



LWE/LR 13000-001/19503-01-02/en

Fig.105932: Example of a turntable frame

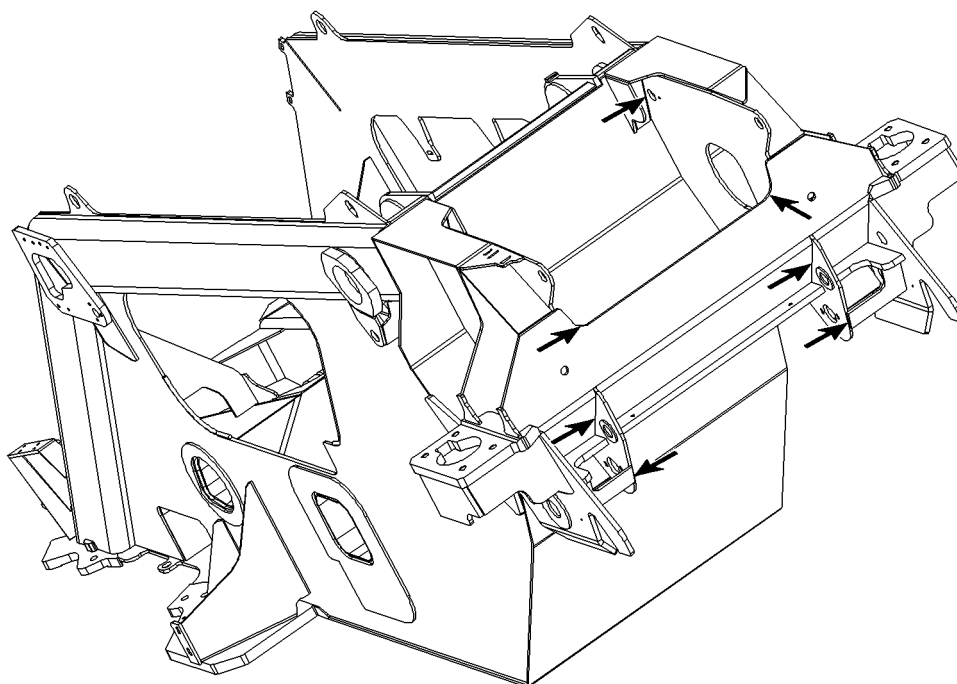
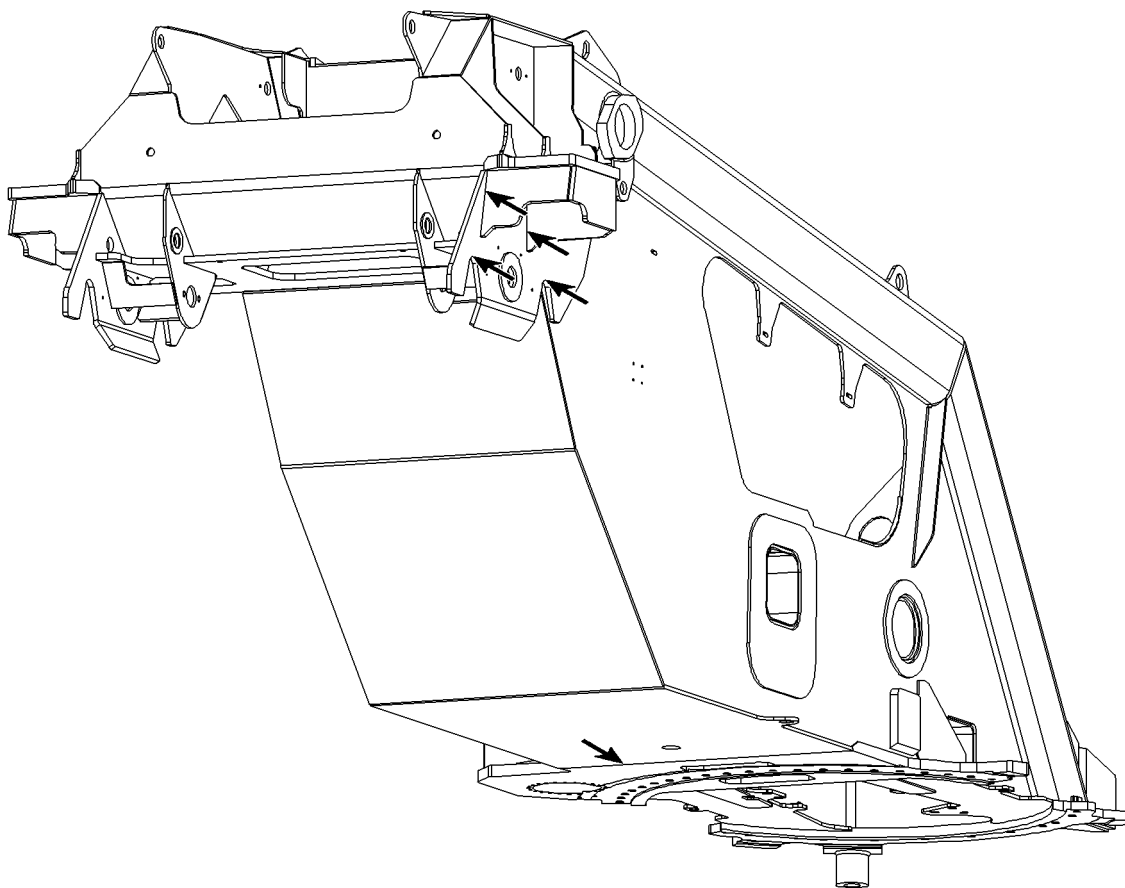
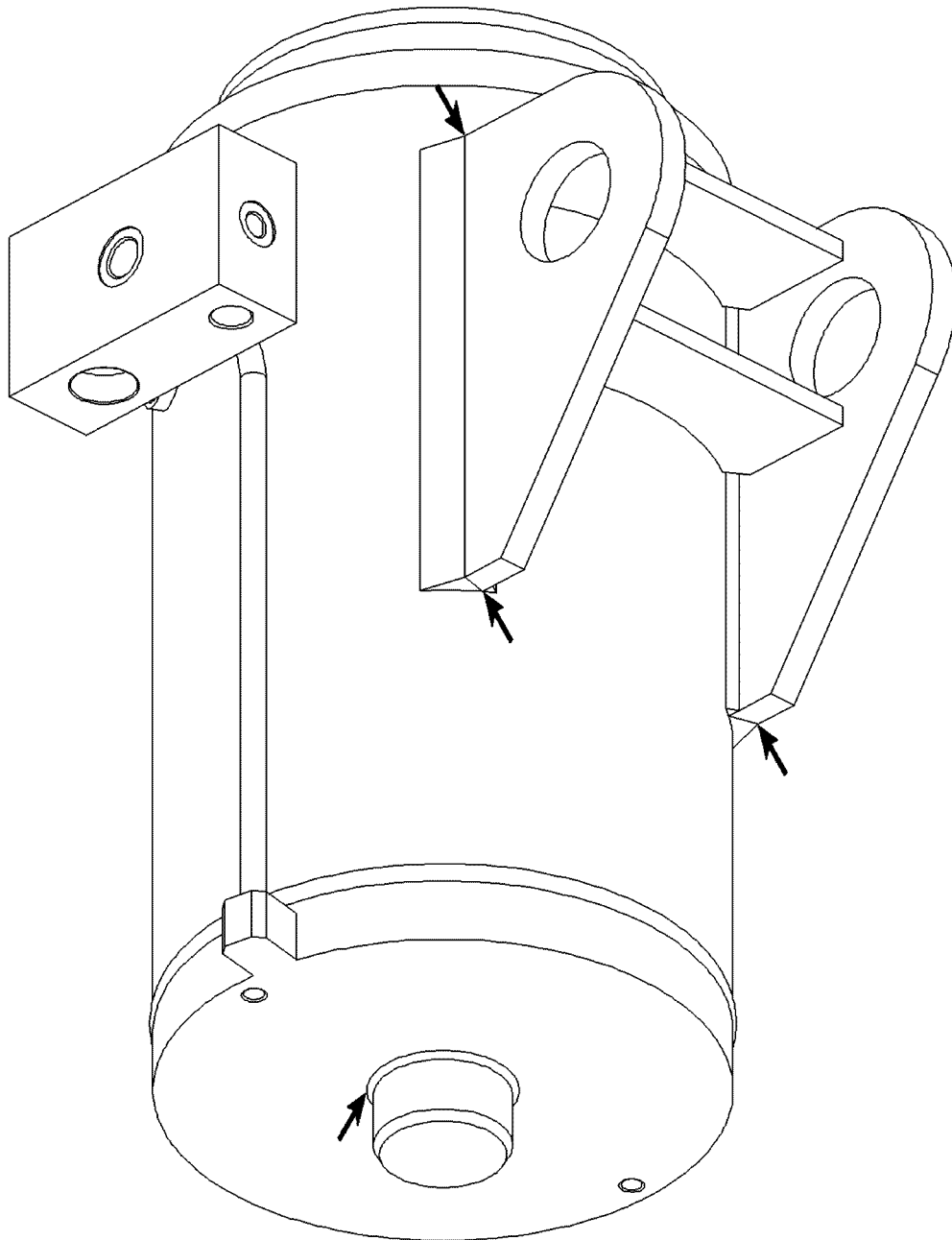

Fig.105723: Example of a turntable frame



LWE/LR 13000-001/19503-01-02/en

Fig.105801: Example of a ballast cylinder

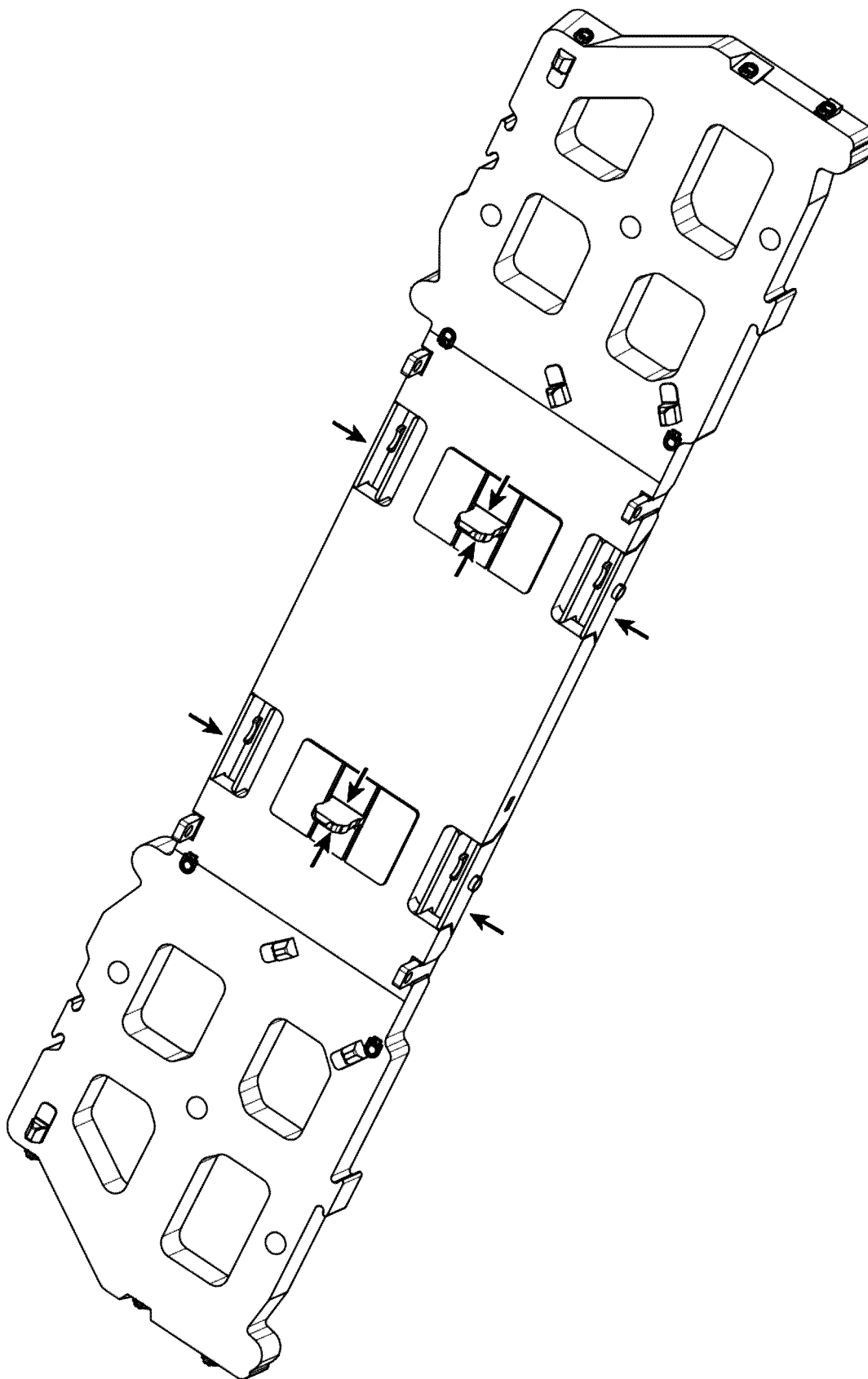
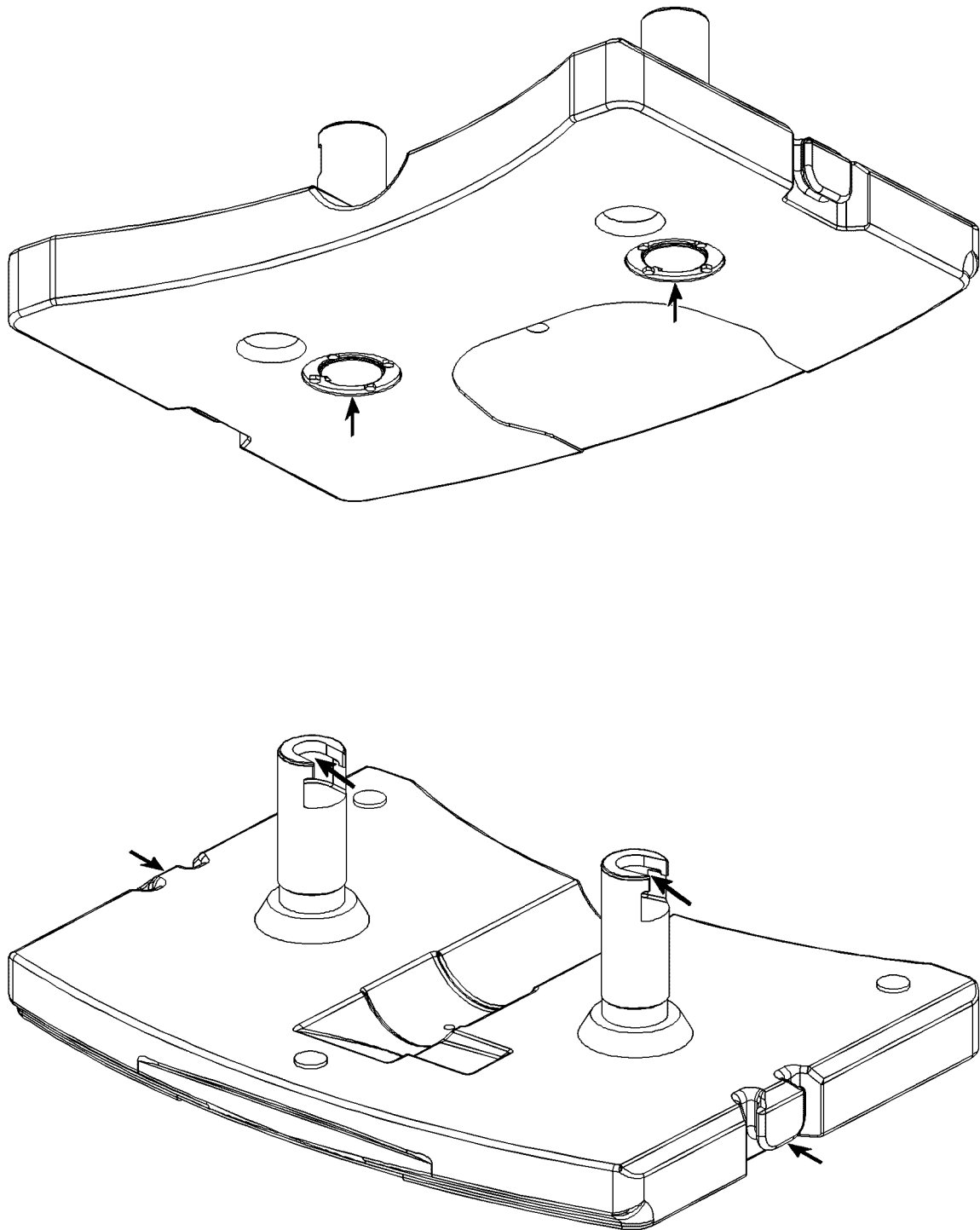

Fig.105705: Example of mounting plate

LWE/LR 13000-001/19503-01-02/en



LWE/LR 13000-001/19503-01-02/en

Fig.105807: Example of base plate

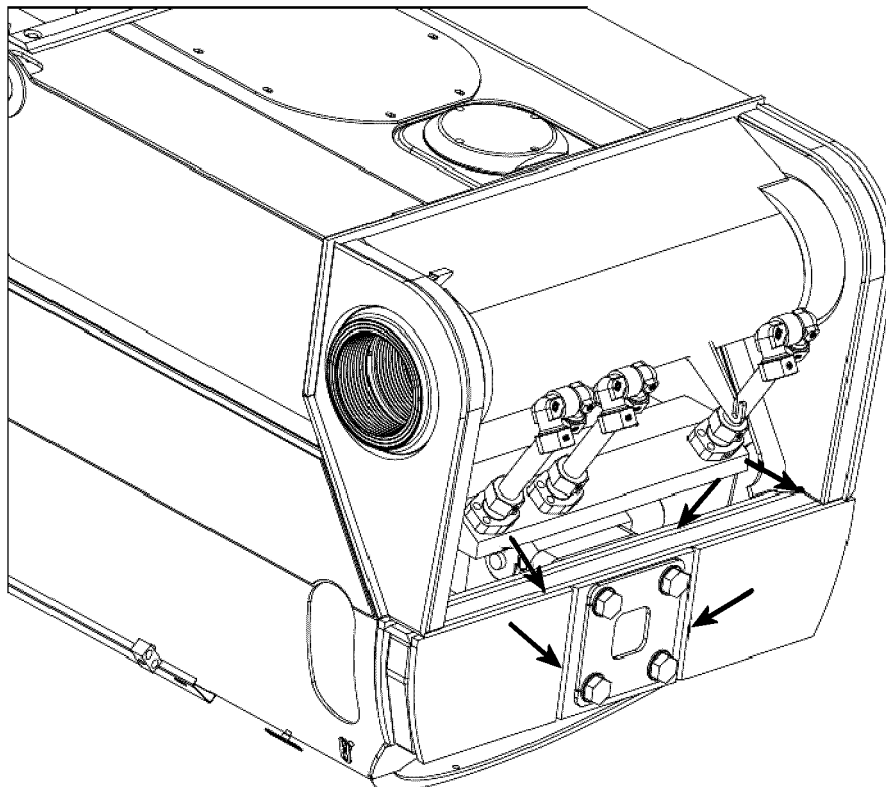
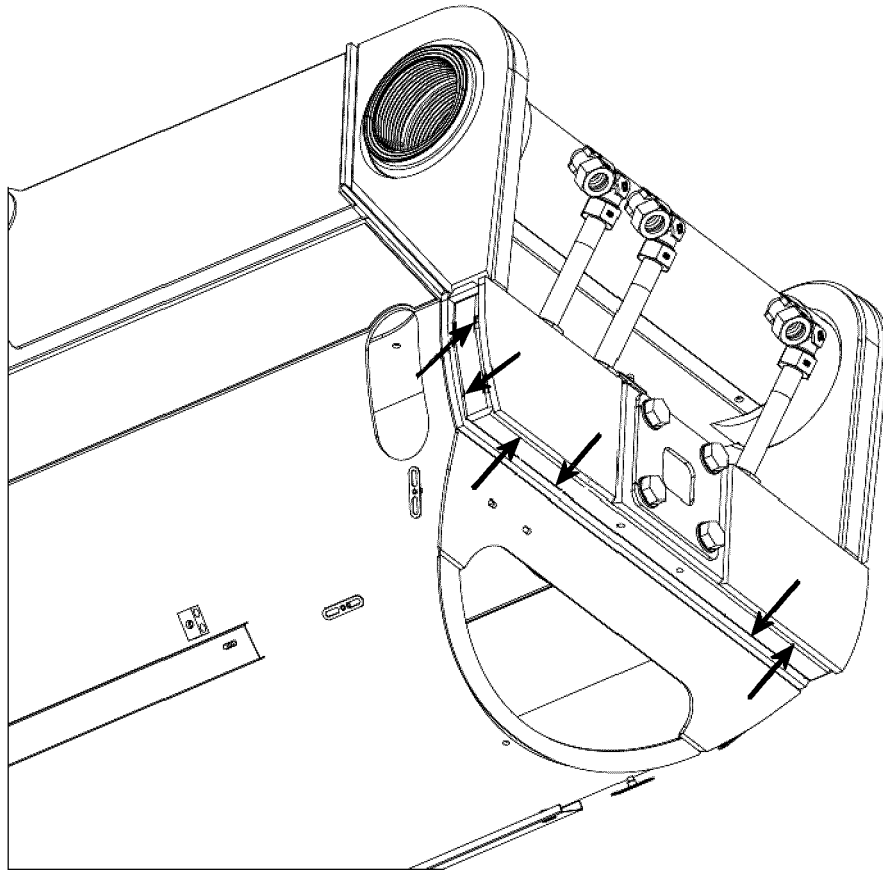
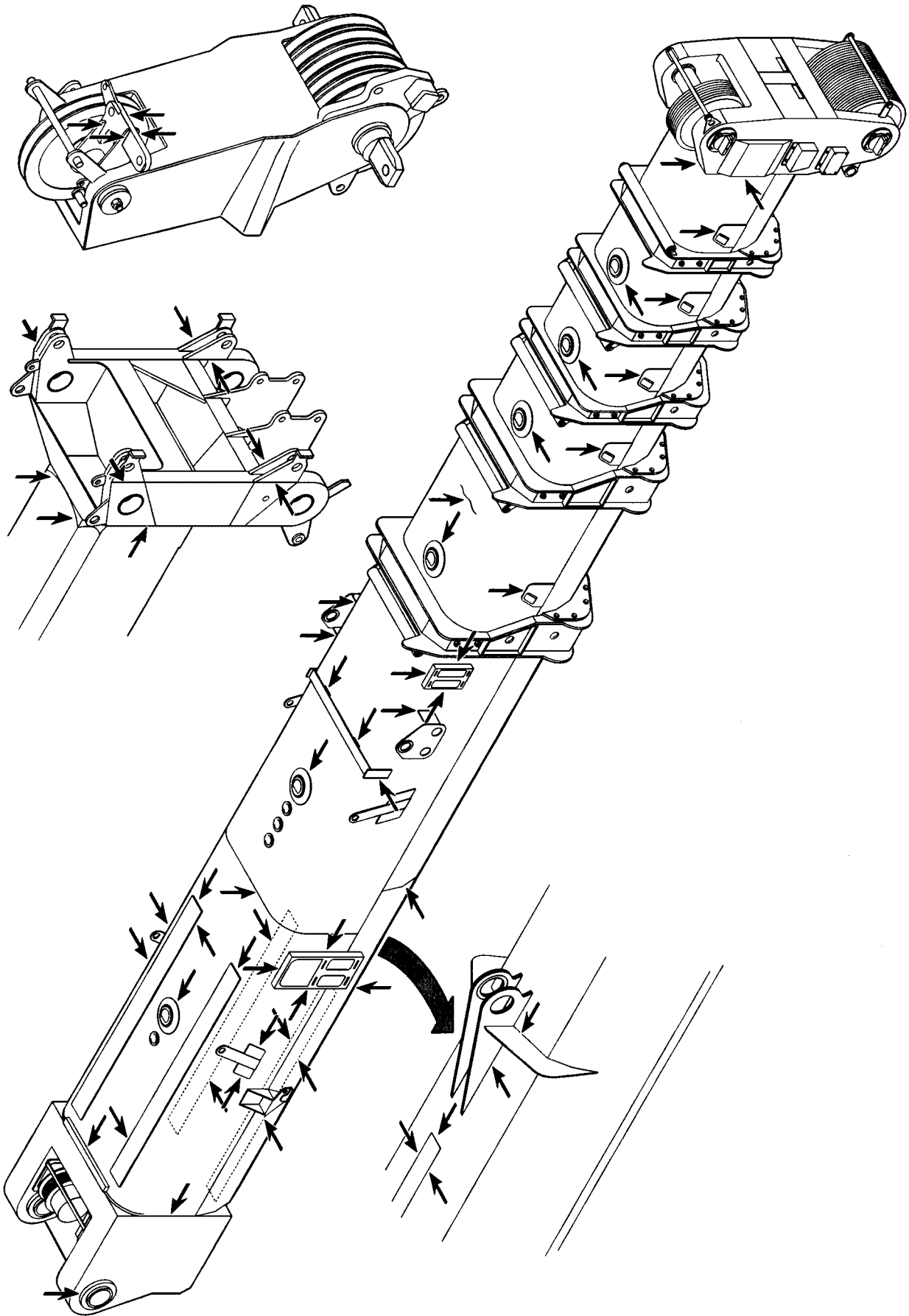

Fig.120273: Example of pivot section

LWE/LR 13000-001/19503-01-02/en



LWE/LR 13000-001/19503-01-02/en

Fig.185050: Example of a telescopic boom

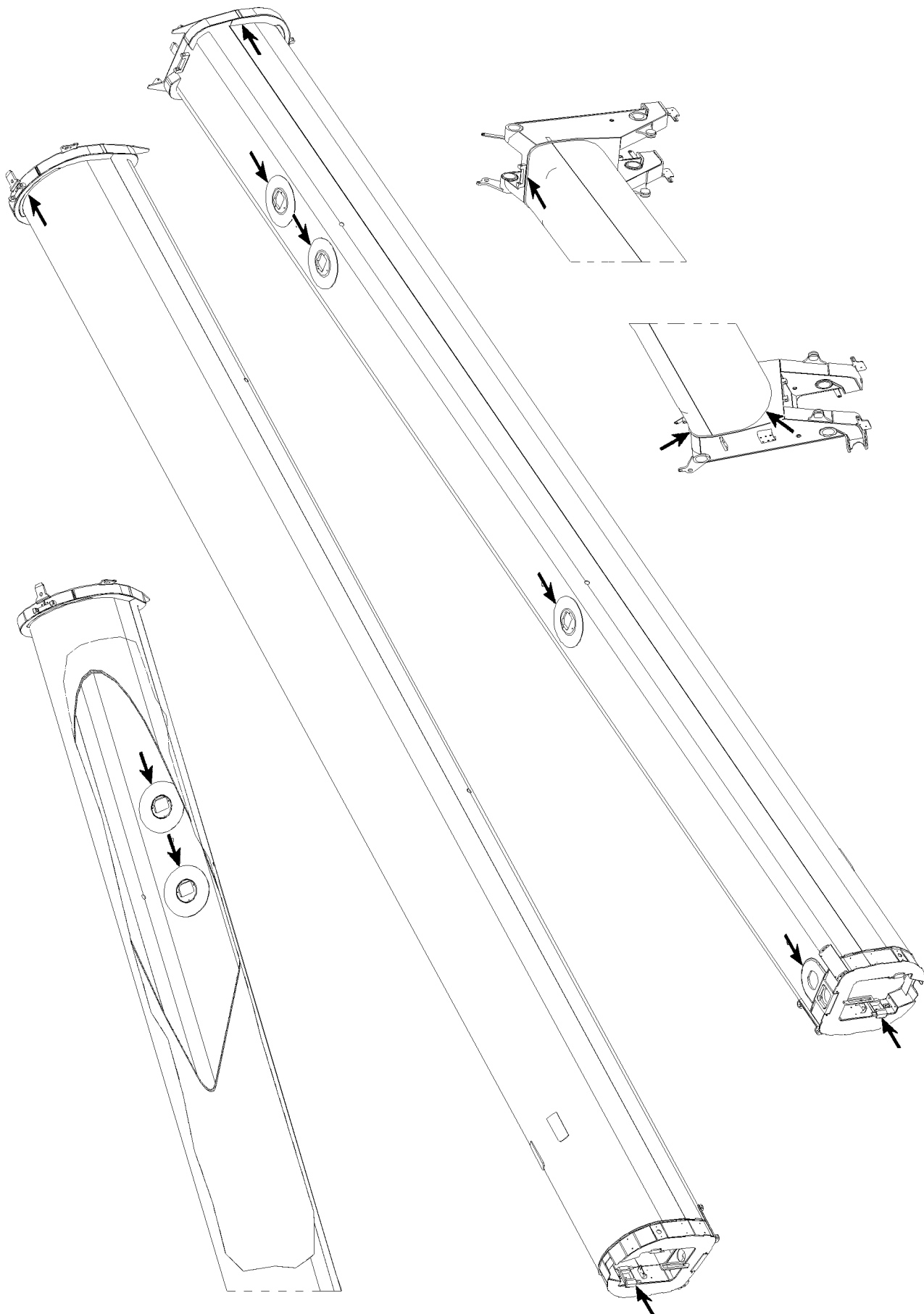

Fig.105710: Example of a telescopic boom

LWE/LR 13000-001/19503-01-02/en

LWE/LR 13000-001/19503-01-02/en

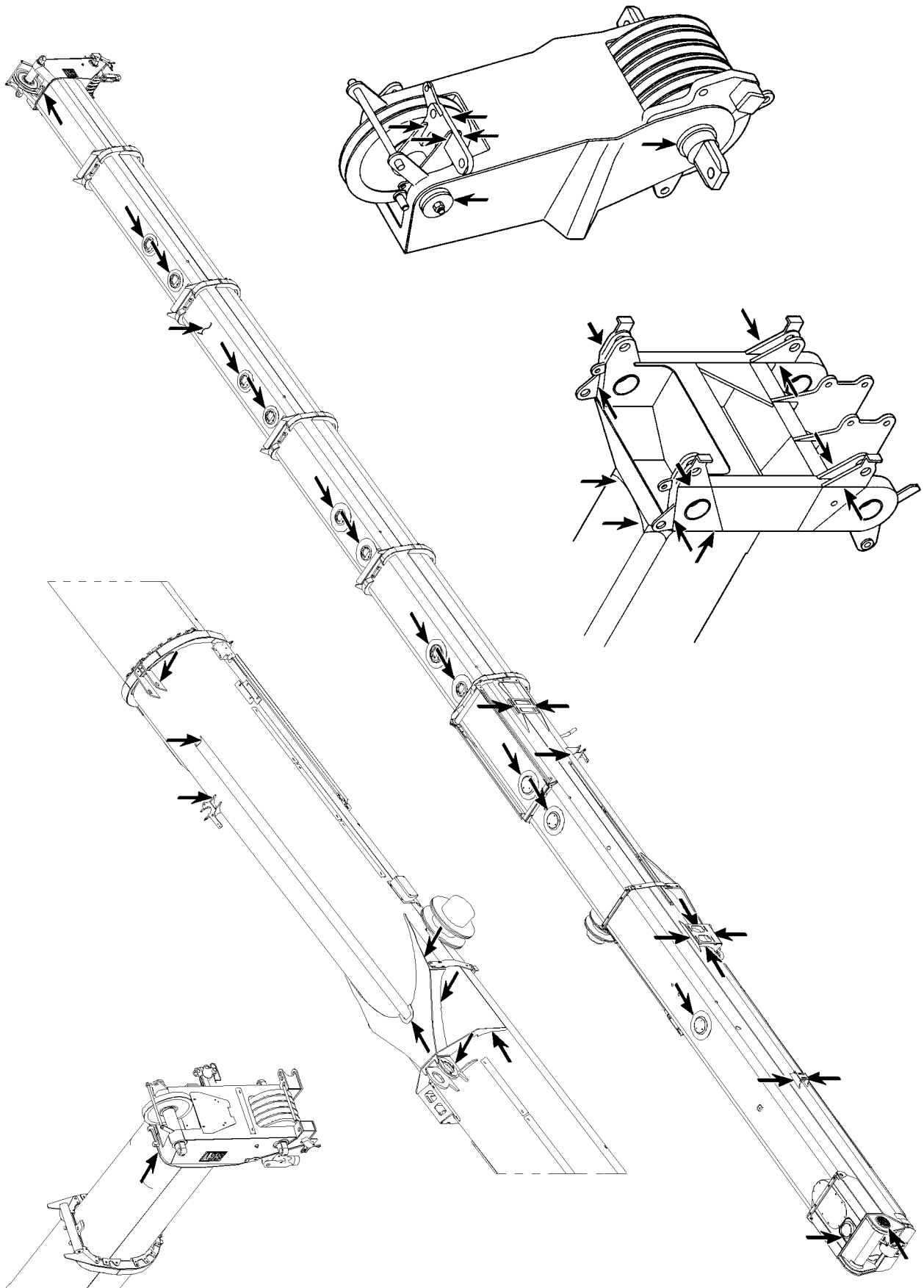

Fig.105711: Example of a telescopic boom

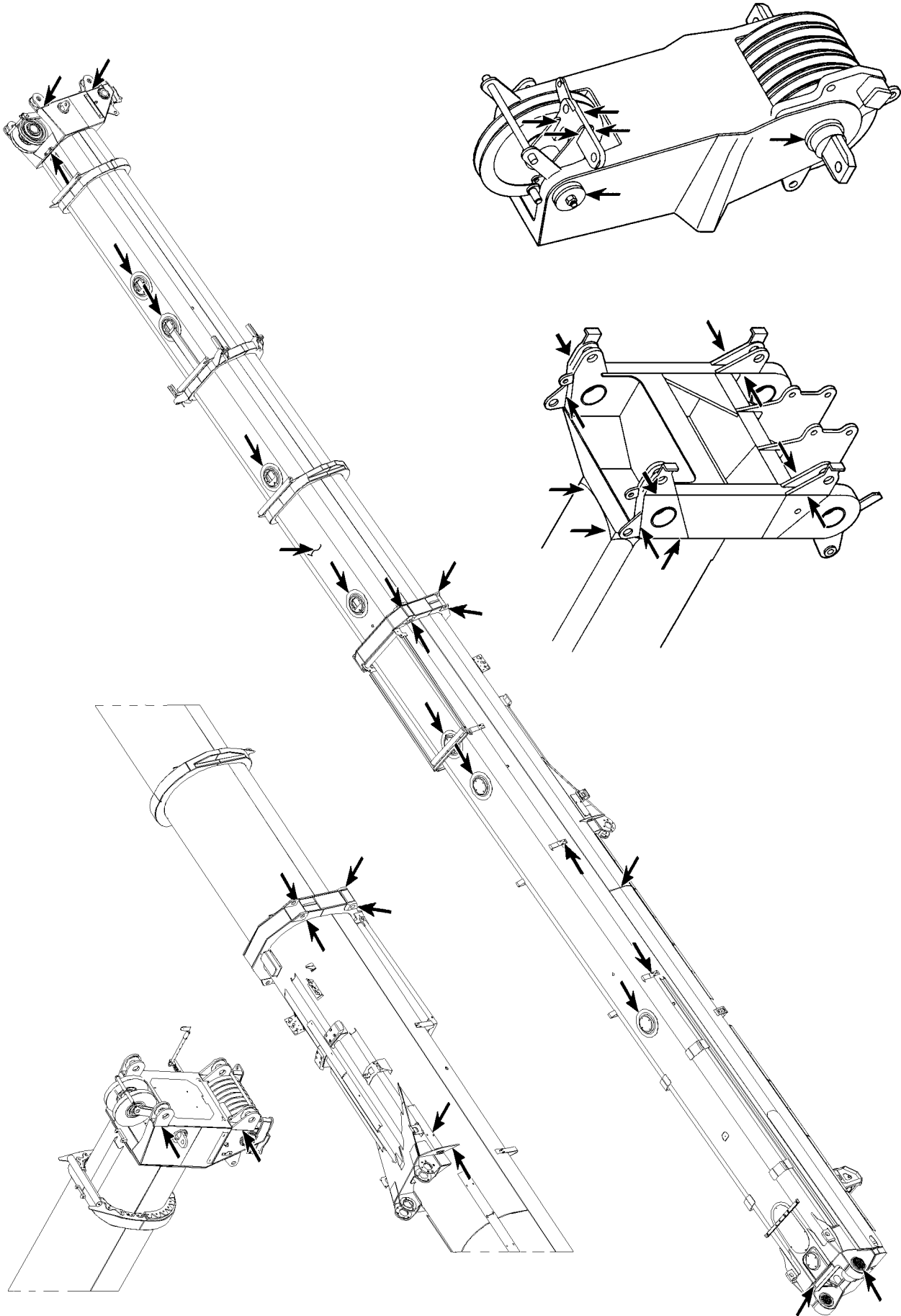
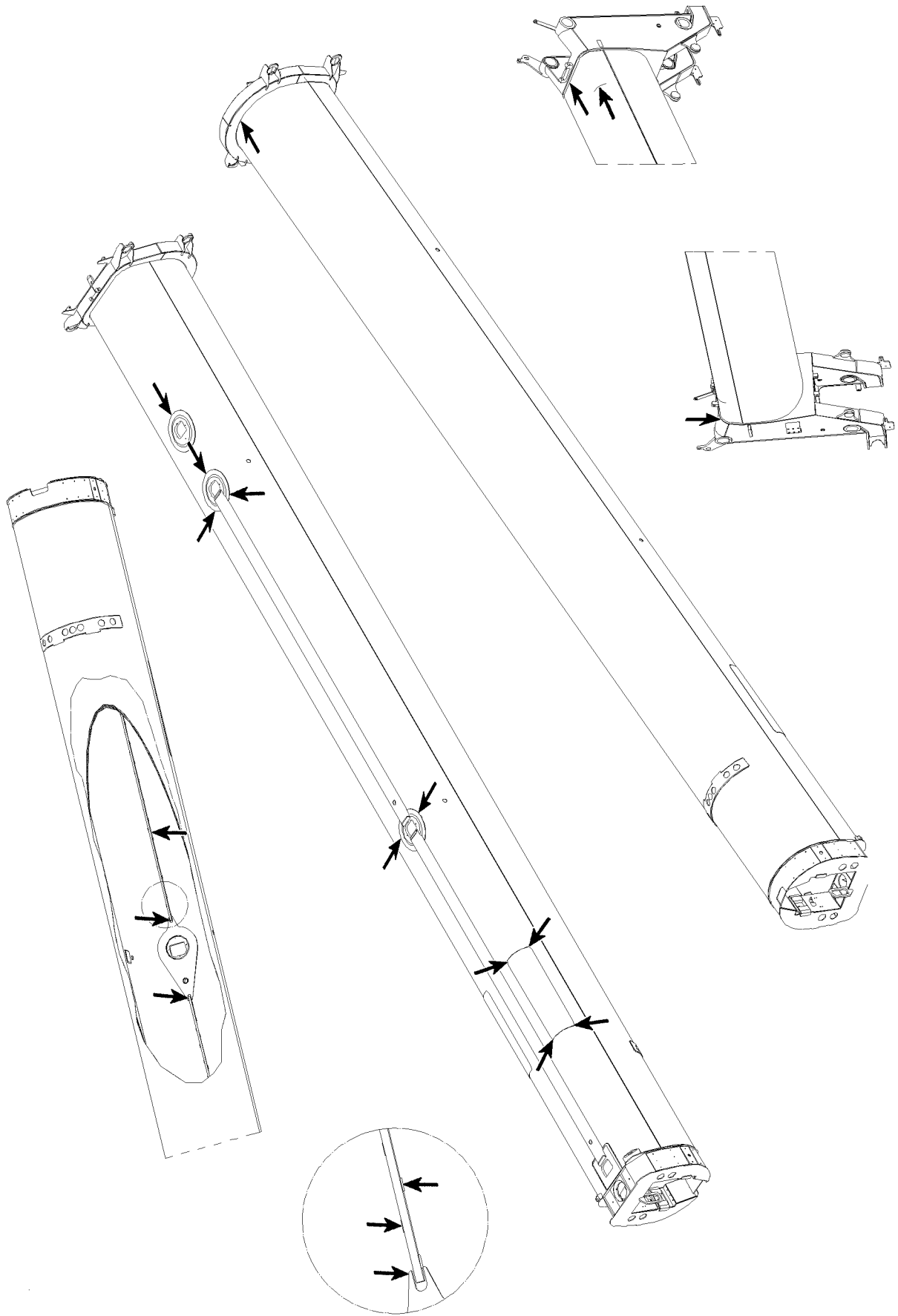

Fig.105720: Example of a telescopic boom

LWE/LR 13000-001/19503-01-02/en



LWE/LR 13000-001/19503-01-02/en

Fig.105721: Example of a telescopic boom

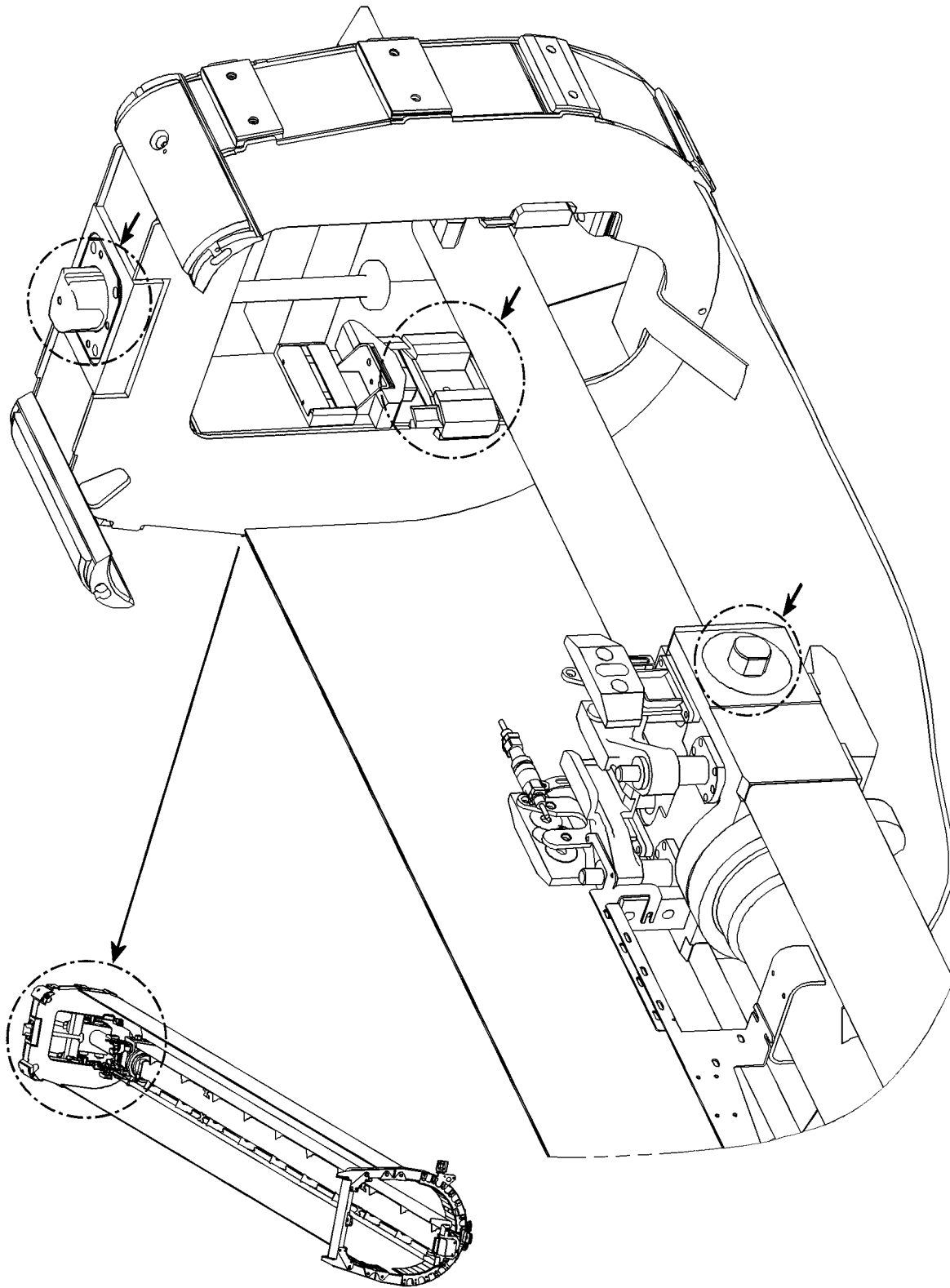

LWE/LR 13000-001/19503-01-02/en

Fig.105891: Example of push out mechanics telescopic boom

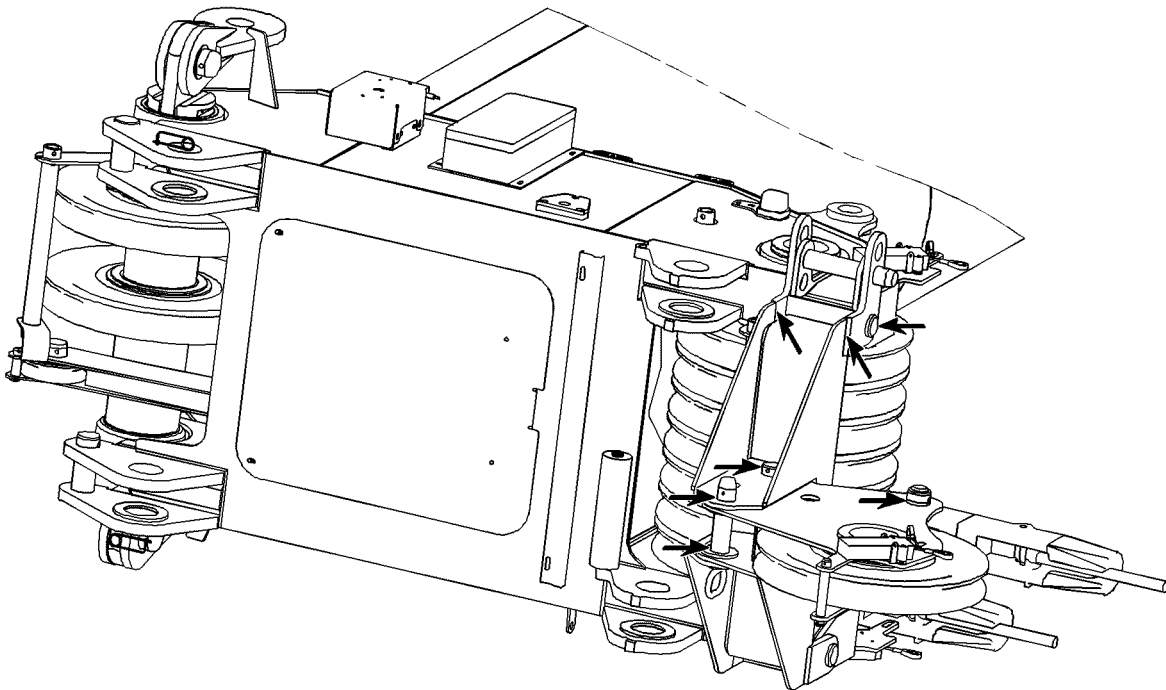
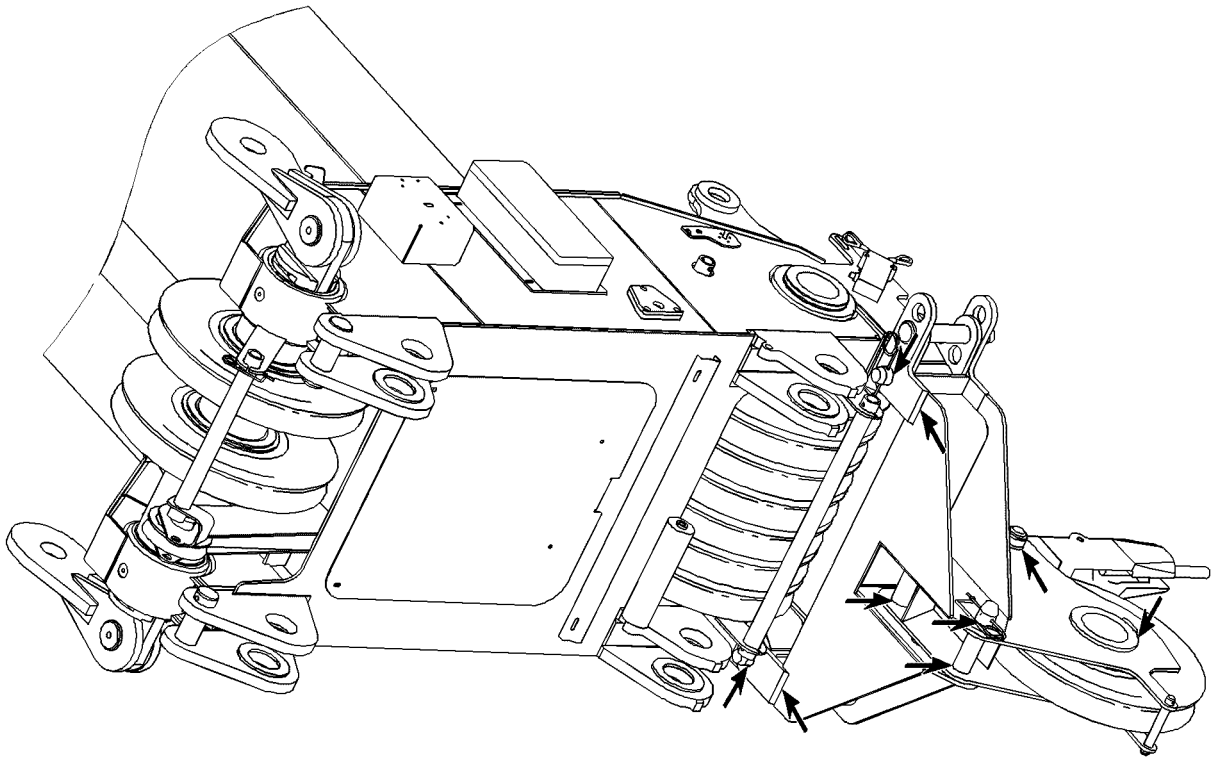

LWE/LR 13000-001/19503-01-02/en

Fig.105892: Example of boom nose

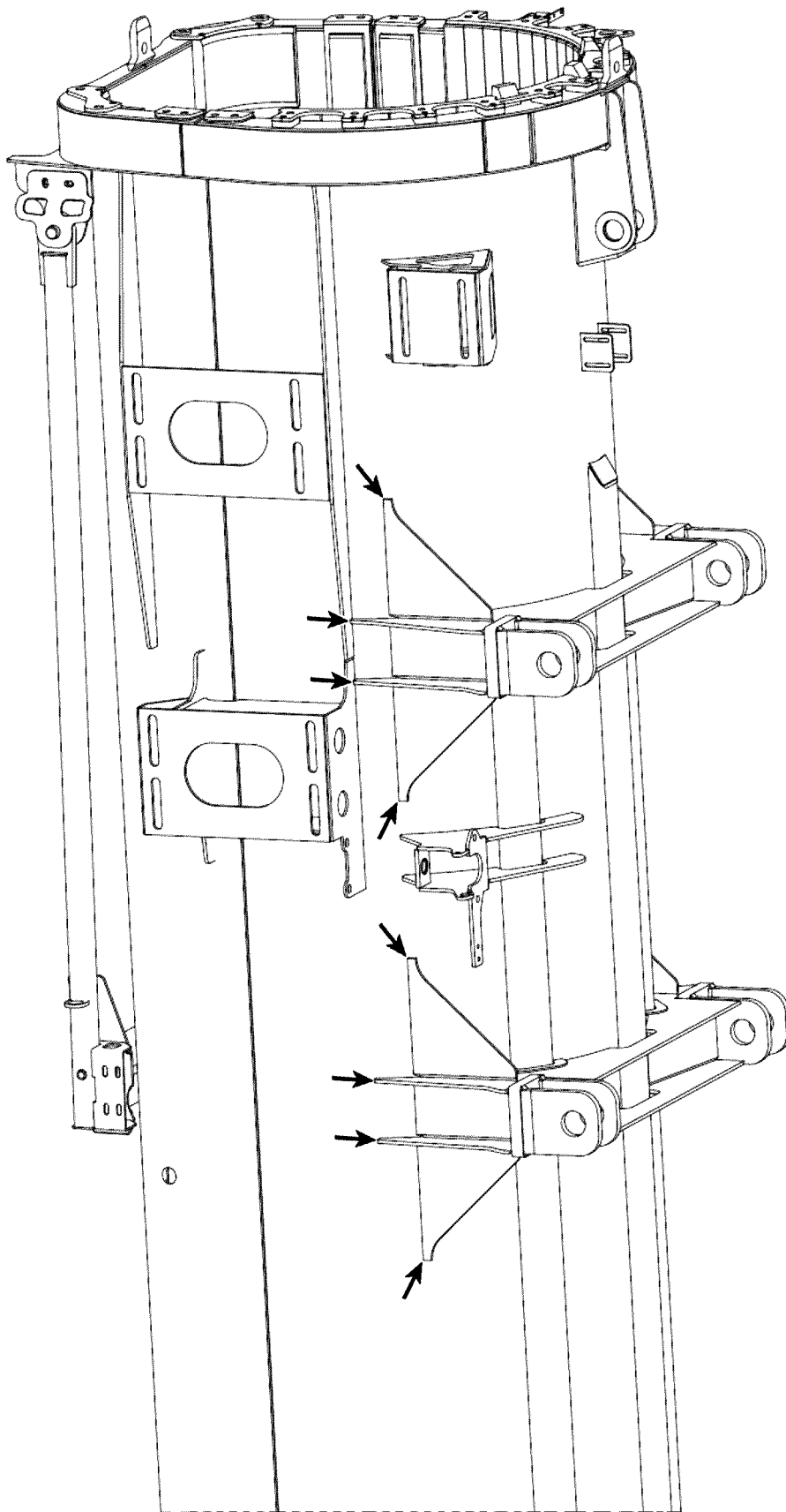

LWE/LR 13000-001/19503-01-02/en

Fig.105689: Example of dolly console

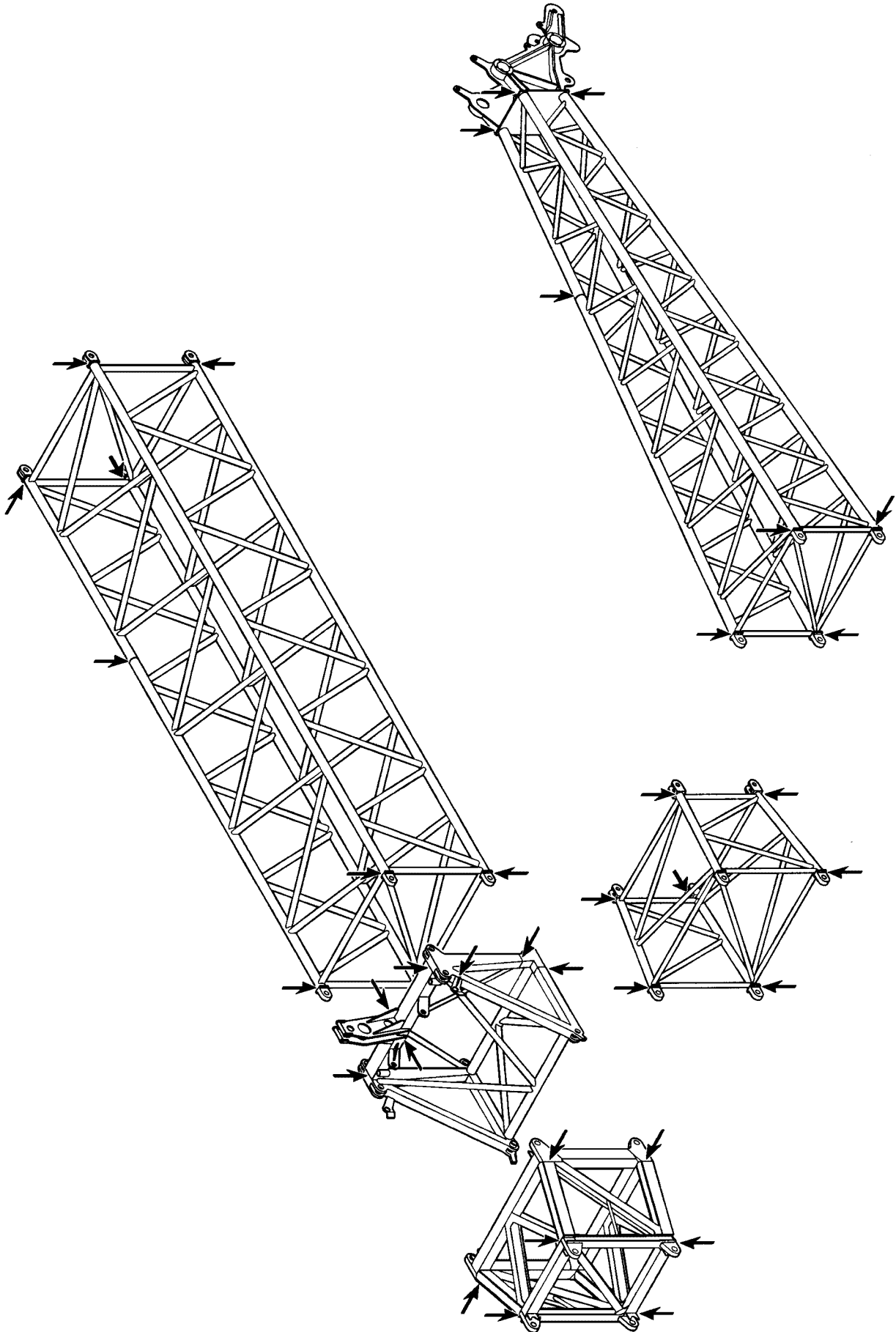

LWE/LR 13000-001/19503-01-02/en

Fig.185051: Example of lattice jib

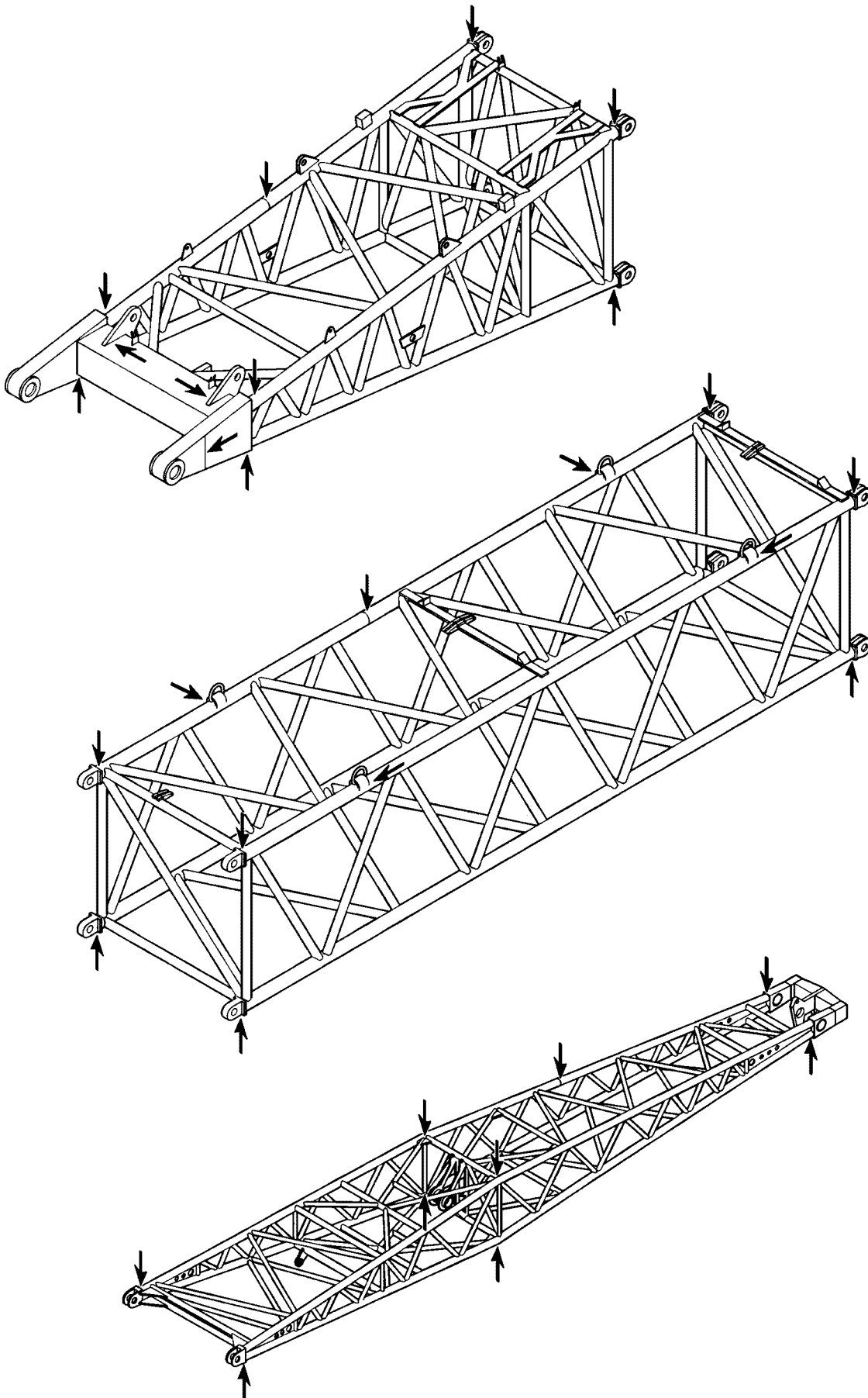
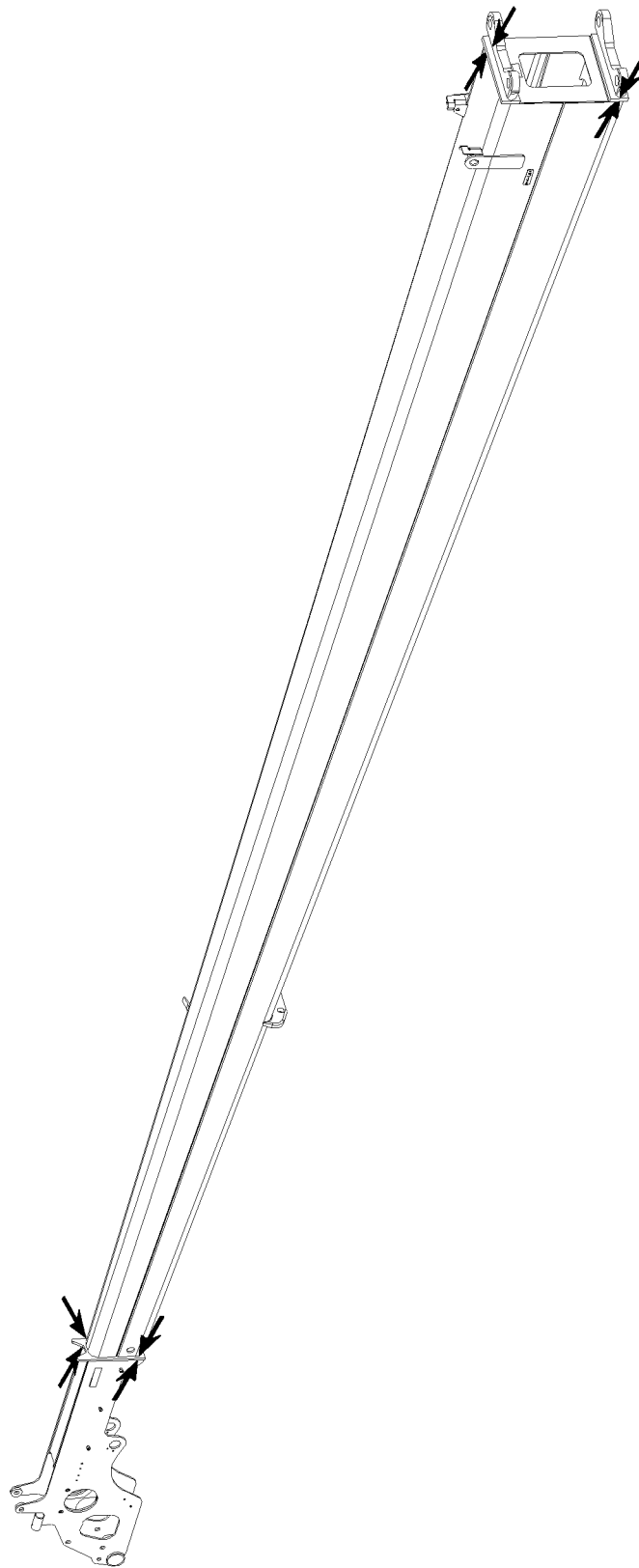

Fig.185052: Example of NA / WA-frame

LWE/LR 13000-001/19503-01-02/en



LWE/LR 13000-001/19503-01-02/en

Fig.105713: Example of an end section

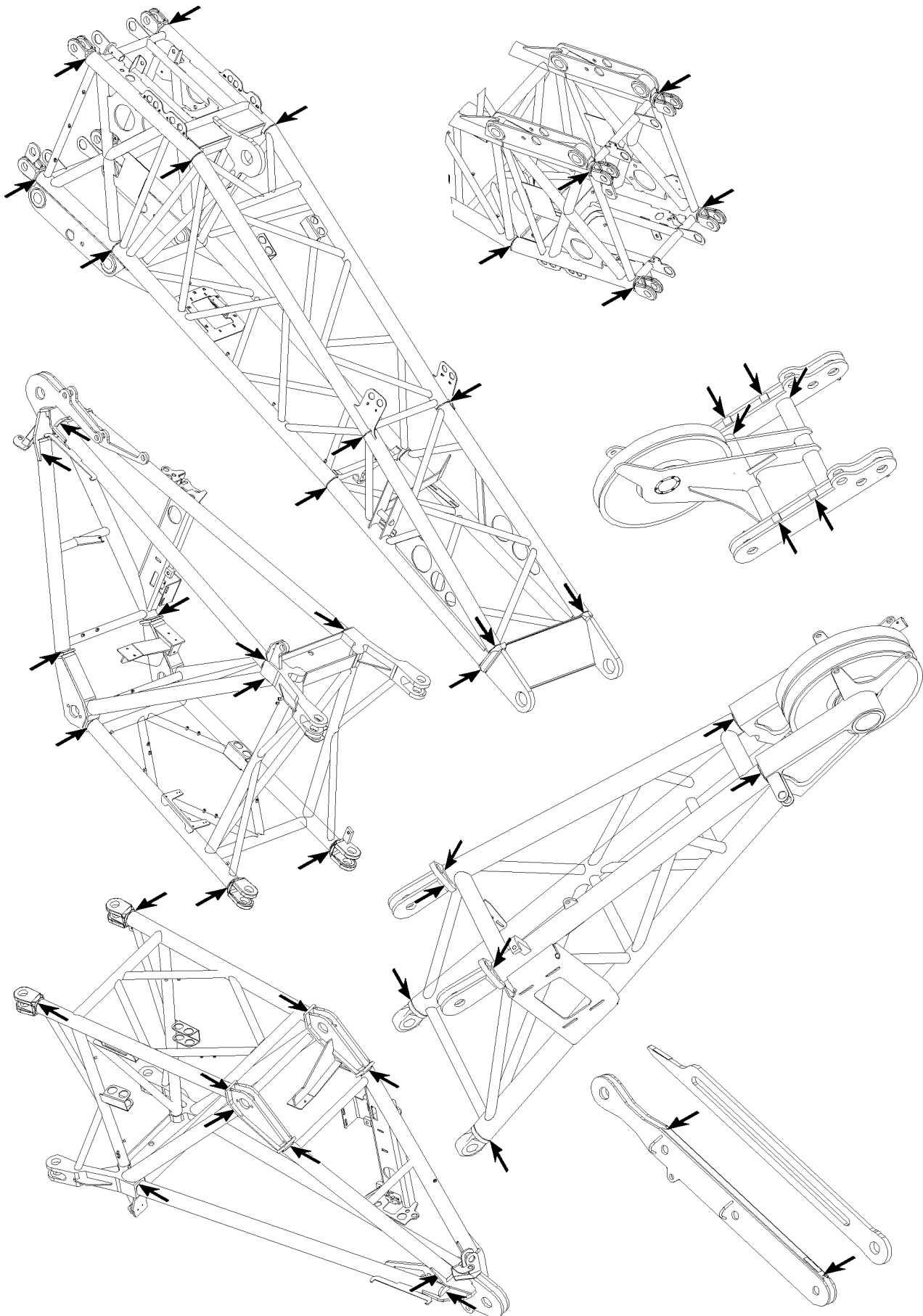
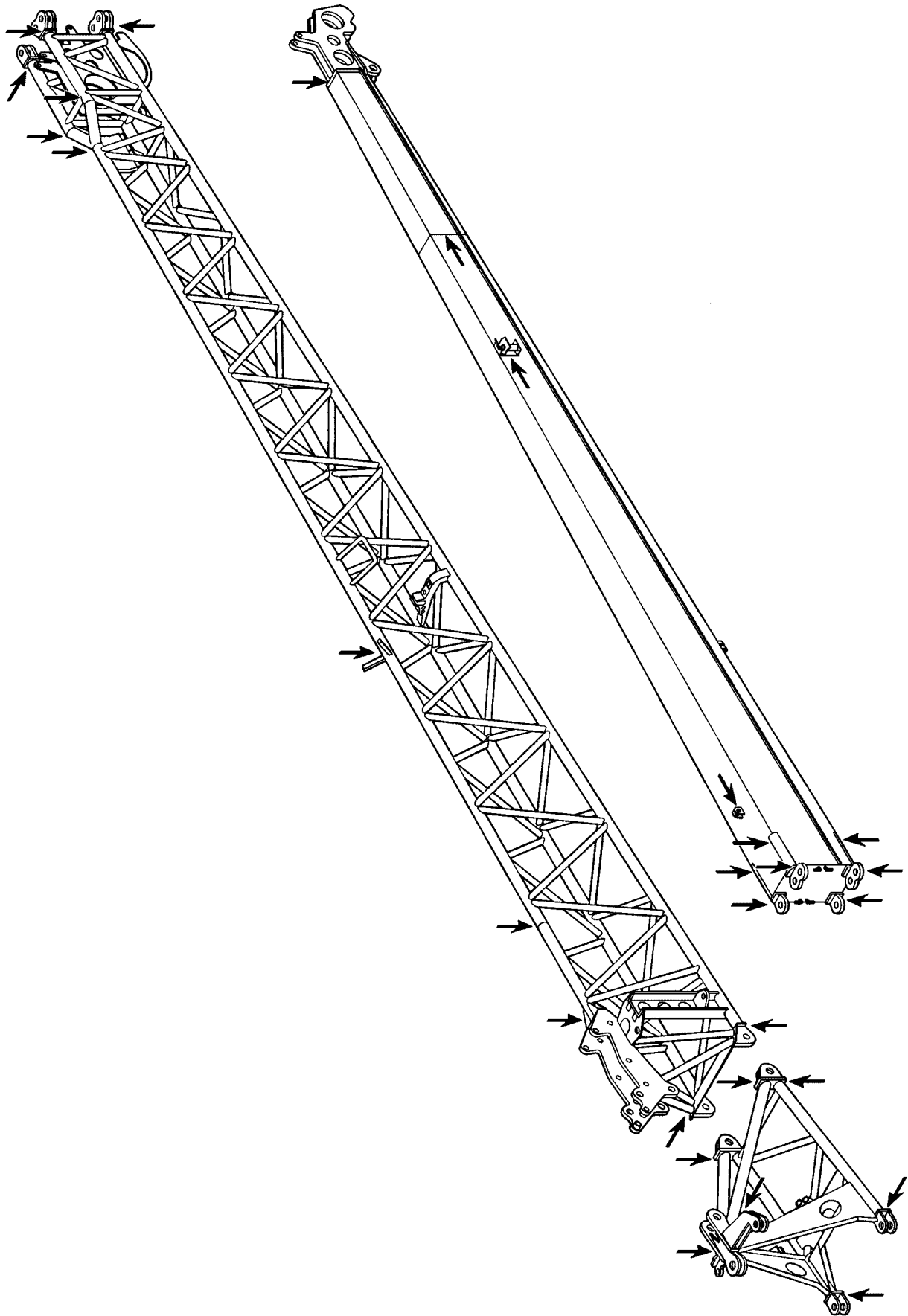

Fig.105836: Example of pivot section, adapter and boom nose

LWE/LR 13000-001/19503-01-02/en



LWE/LR 13000-001/19503-01-02/en

Fig.185058: Example of a folding jib

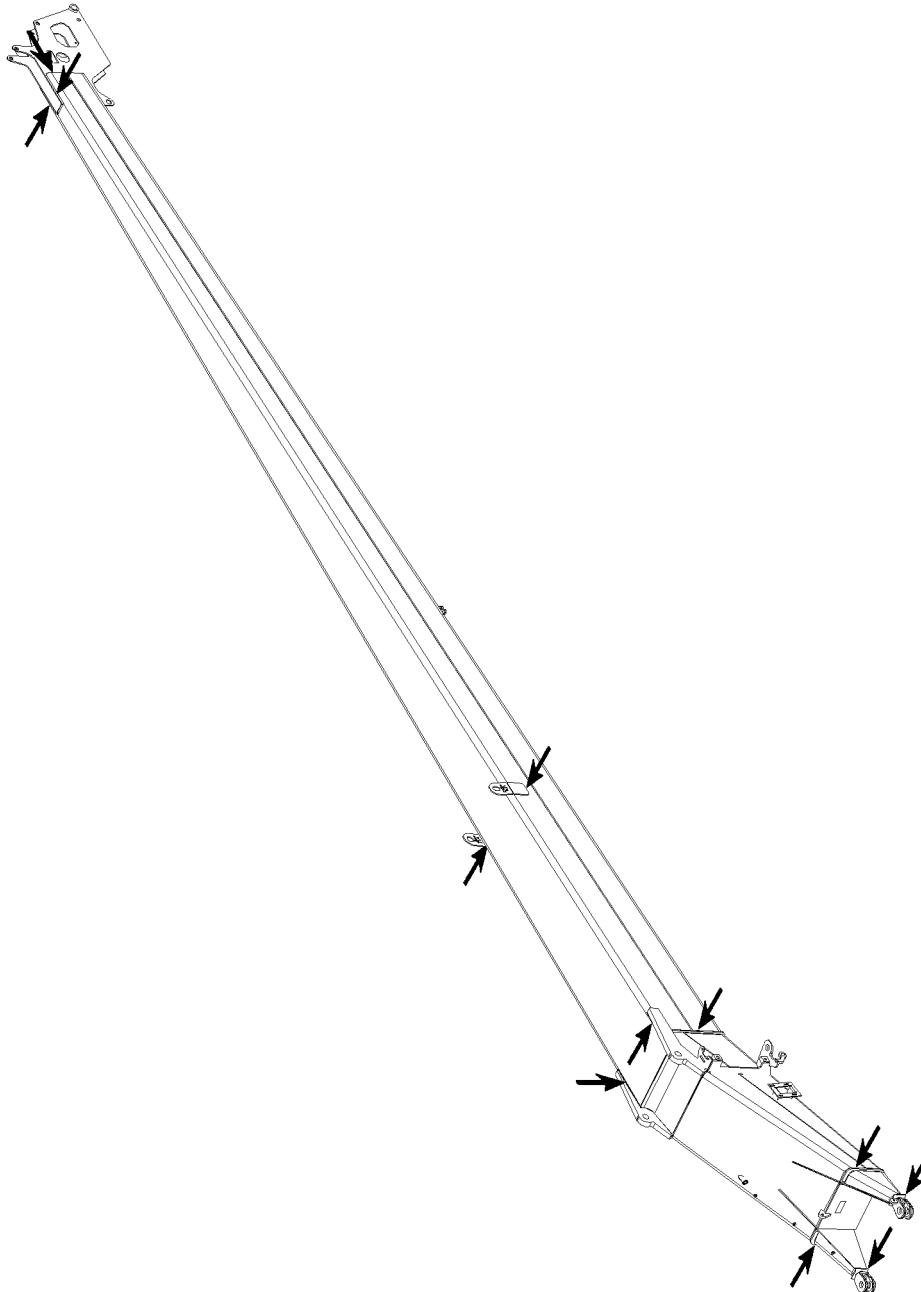
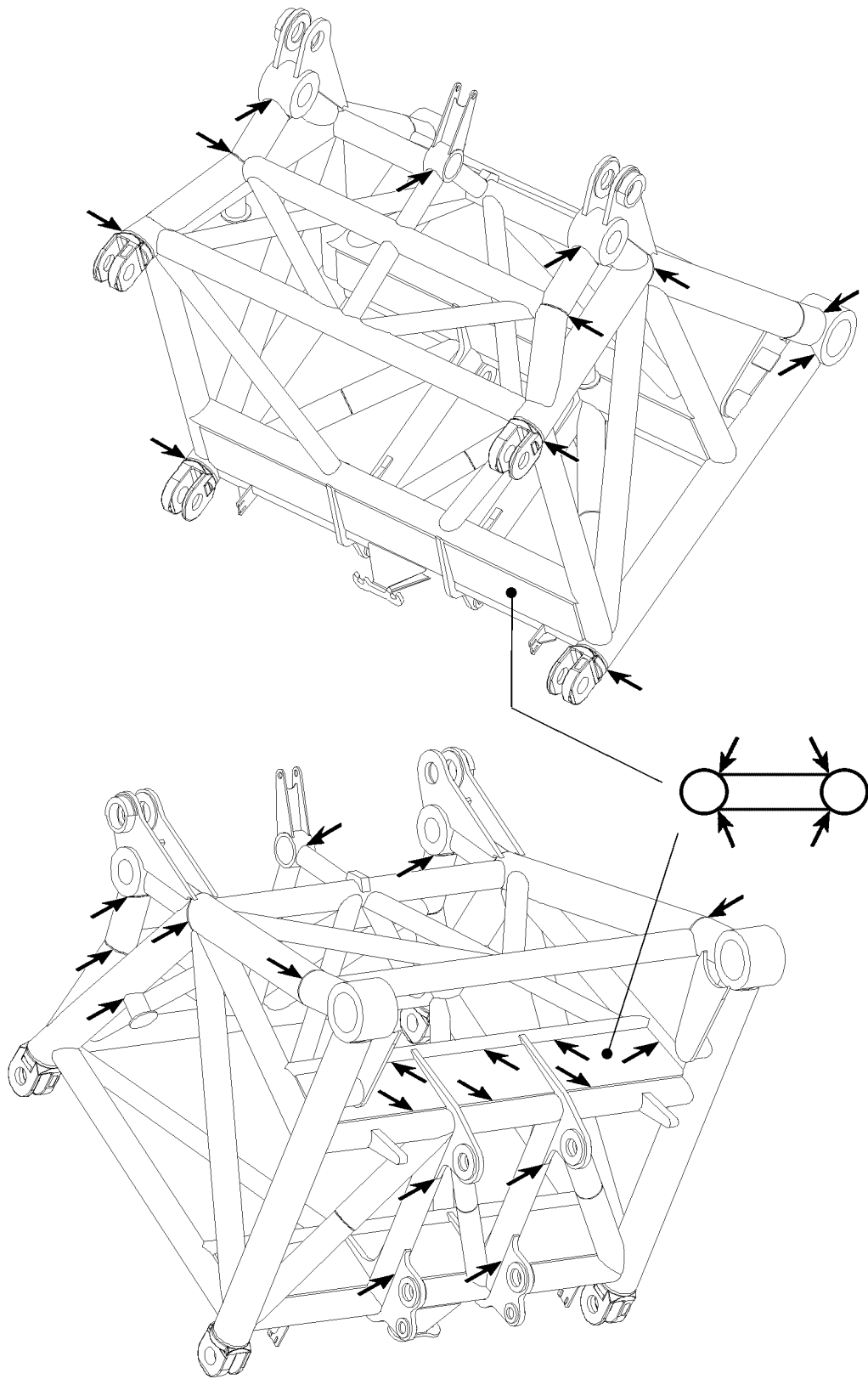

Fig.105697: Example of a folding jib

LWE/LR 13000-001/19503-01-02/en



LWE/LR 13000-001/19503-01-02/en

Fig.105732: Example of W-connector head

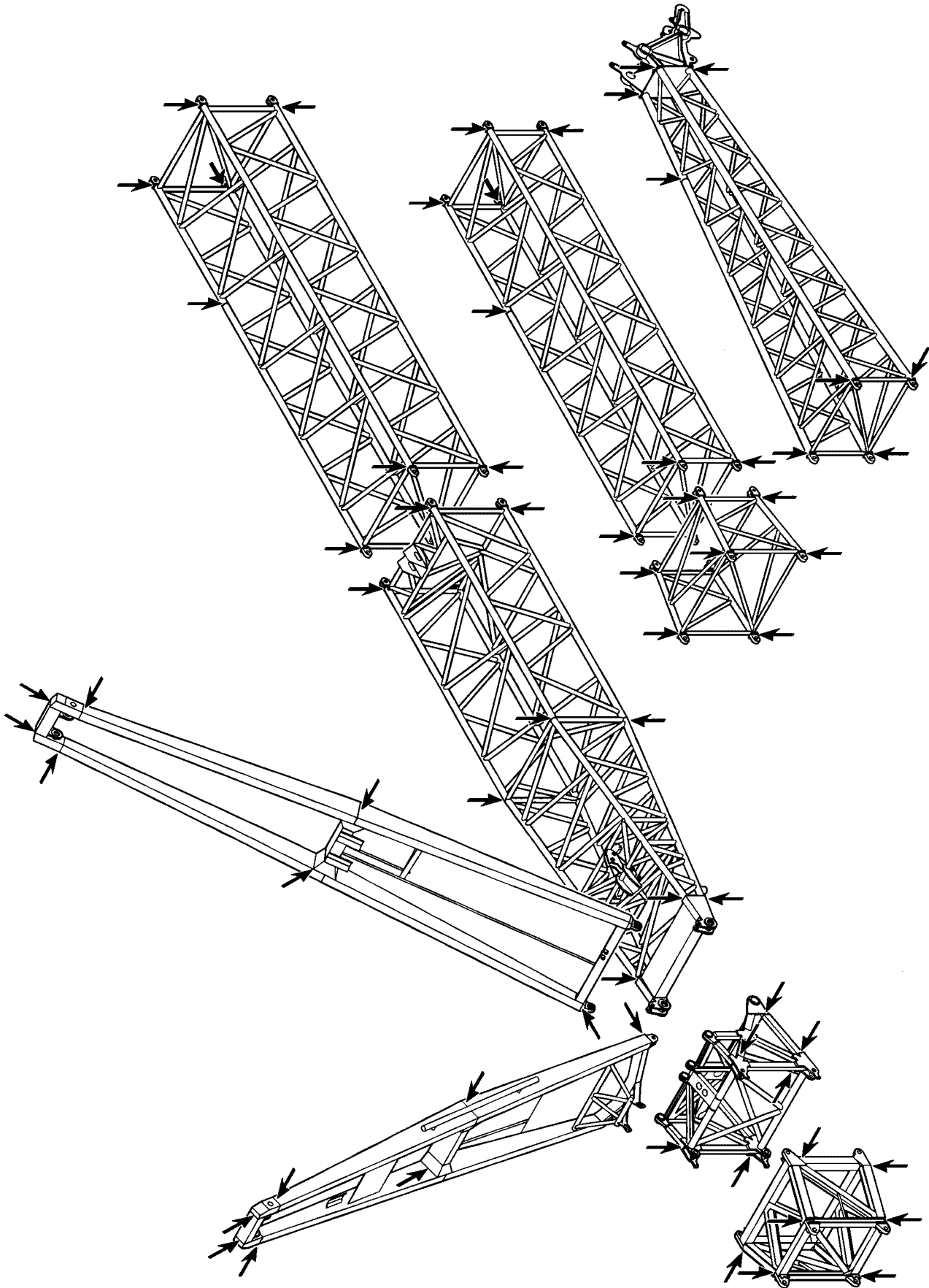
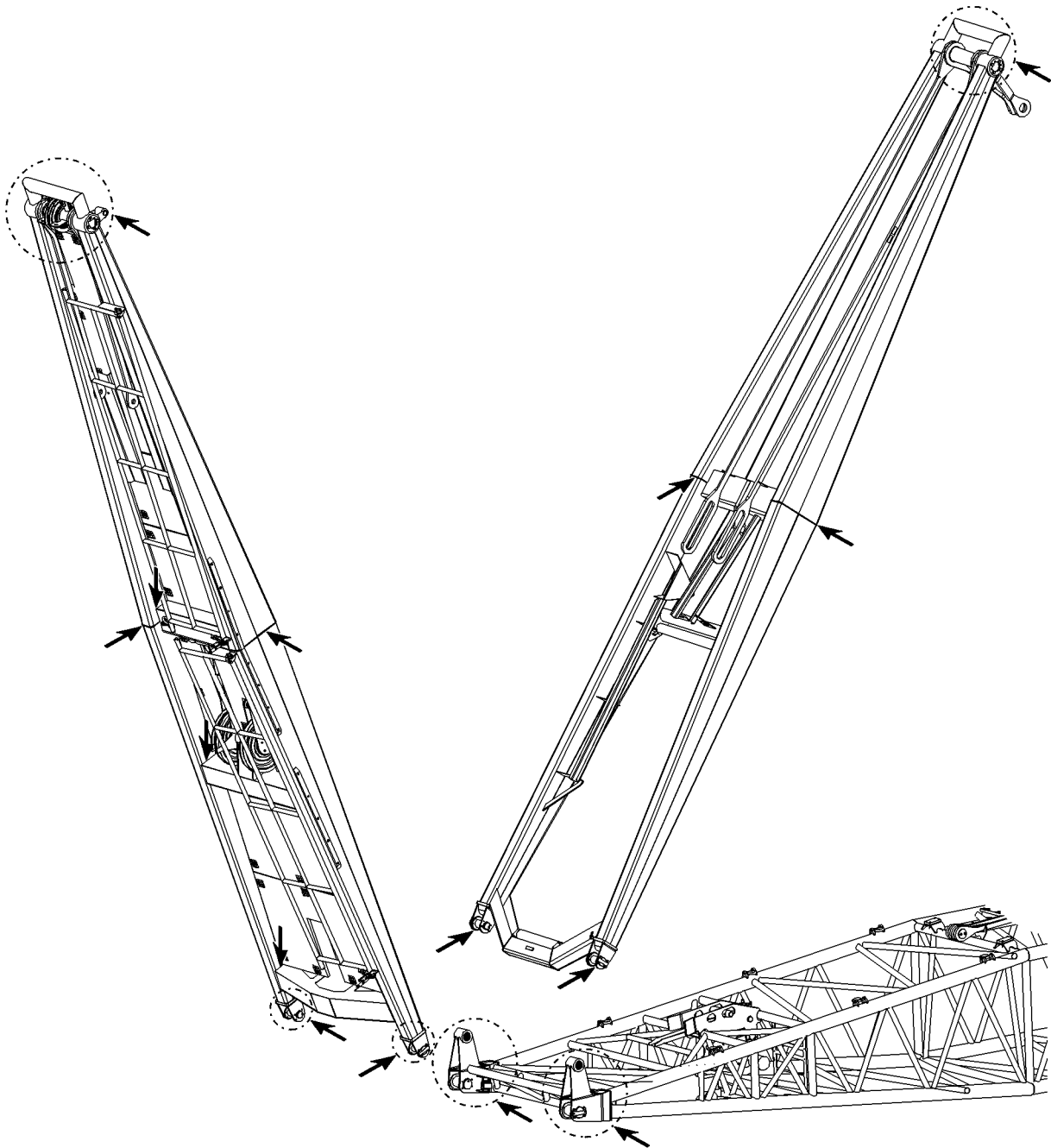

Fig.185053: Example of assembly unit with lattice jib

LWE/LR 13000-001/19503-01-02/en



LWE/LR 13000-001/19503-01-02/en

Fig.105838: Example of NA frames

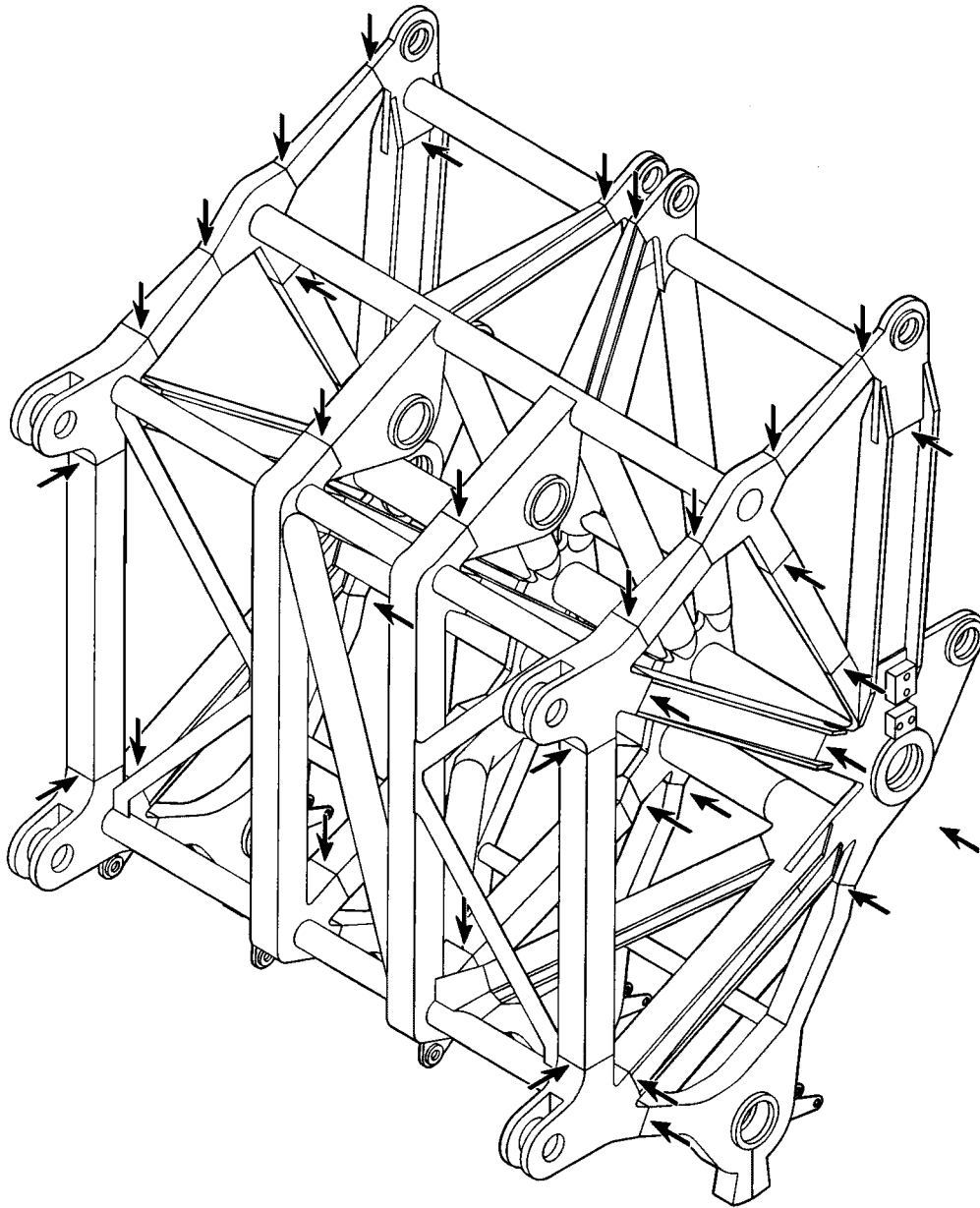

Fig.185054: Example of pulley head

LWE/LR 13000-001/19503-01-02/en

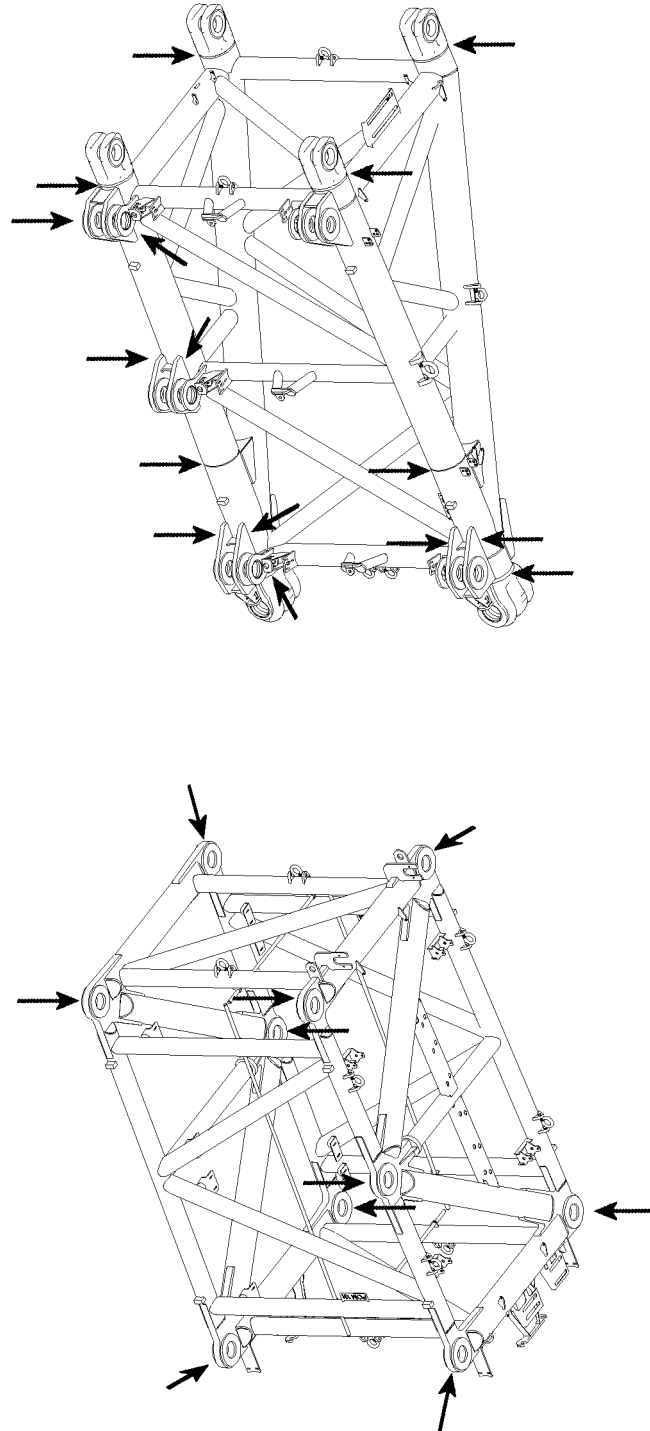

Fig.116609: Example of P-adapter

LWE/LR 13000-001/19503-01-02/en

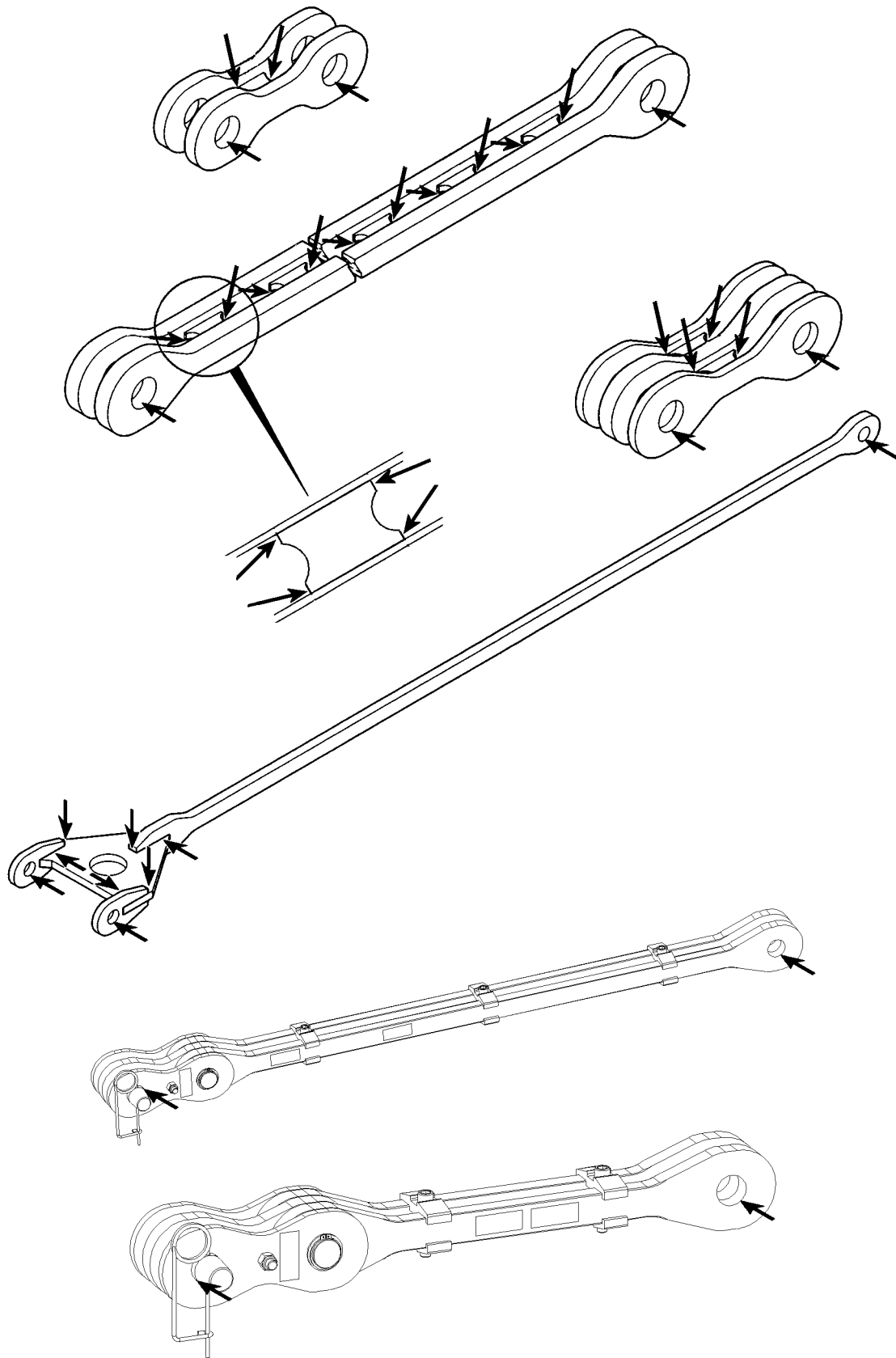
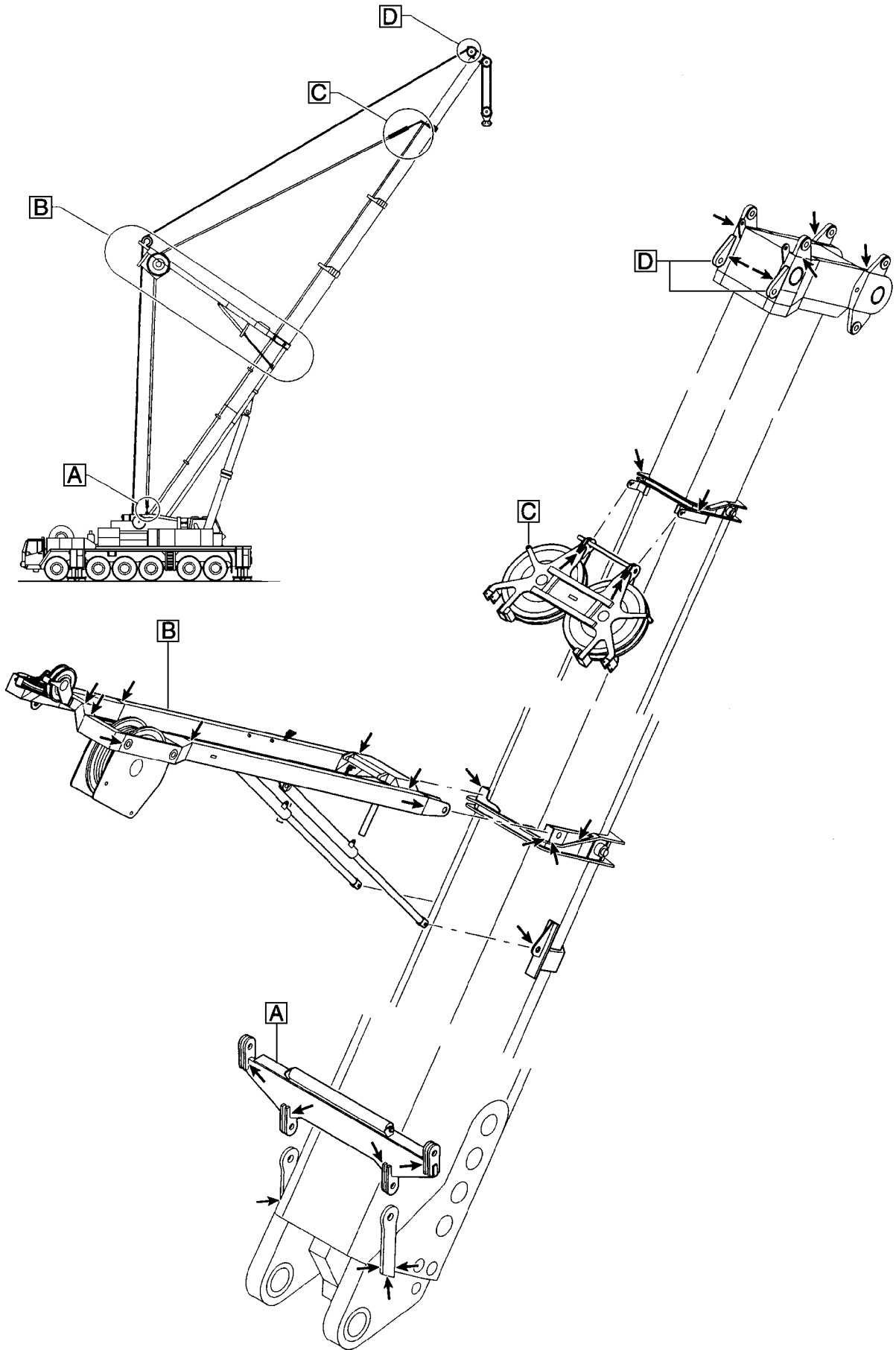

Fig.154111: Example of guy rods



LWE/LR 13000-001/19503-01-02/en

Fig.185059: Example of TA-guying

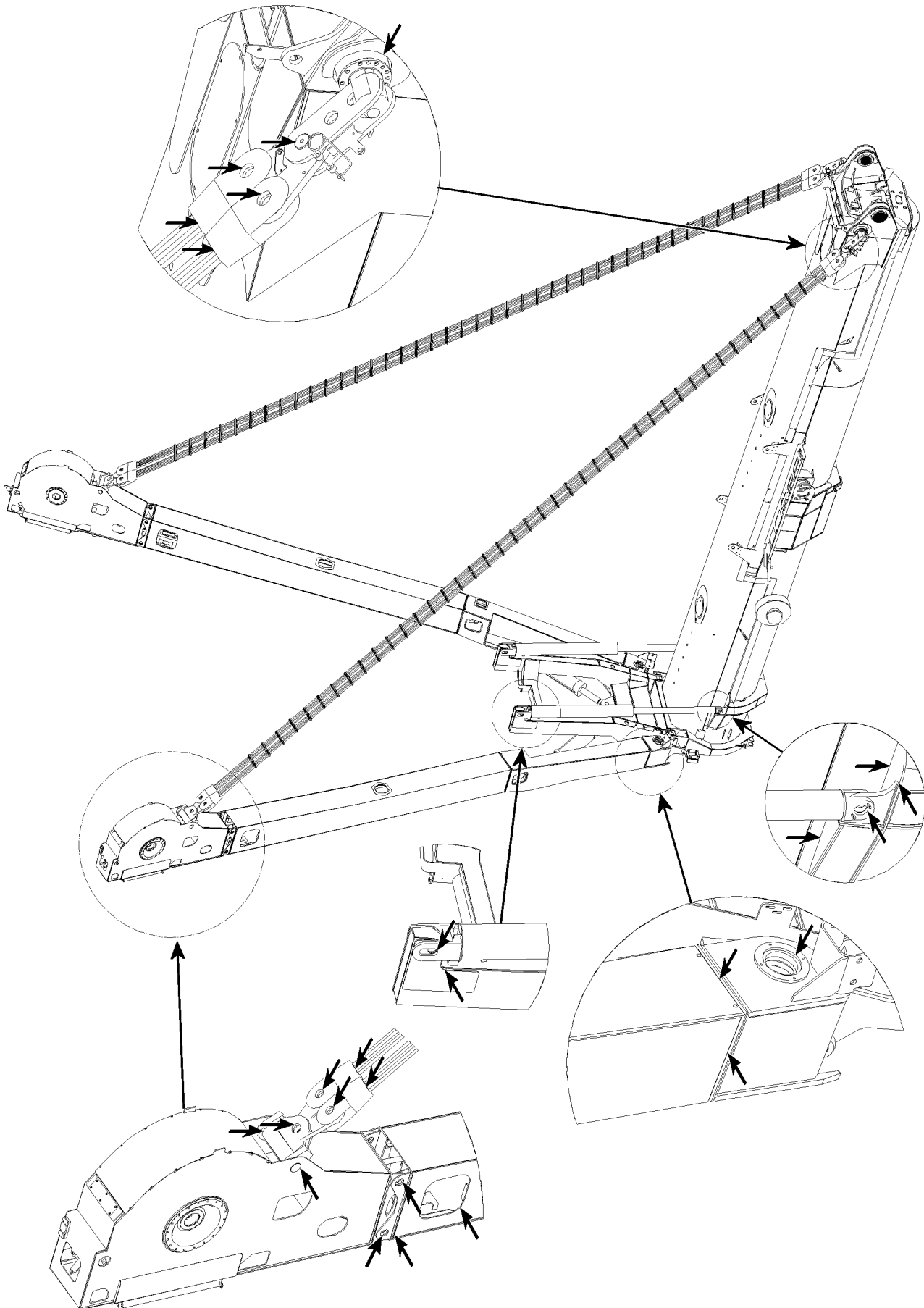
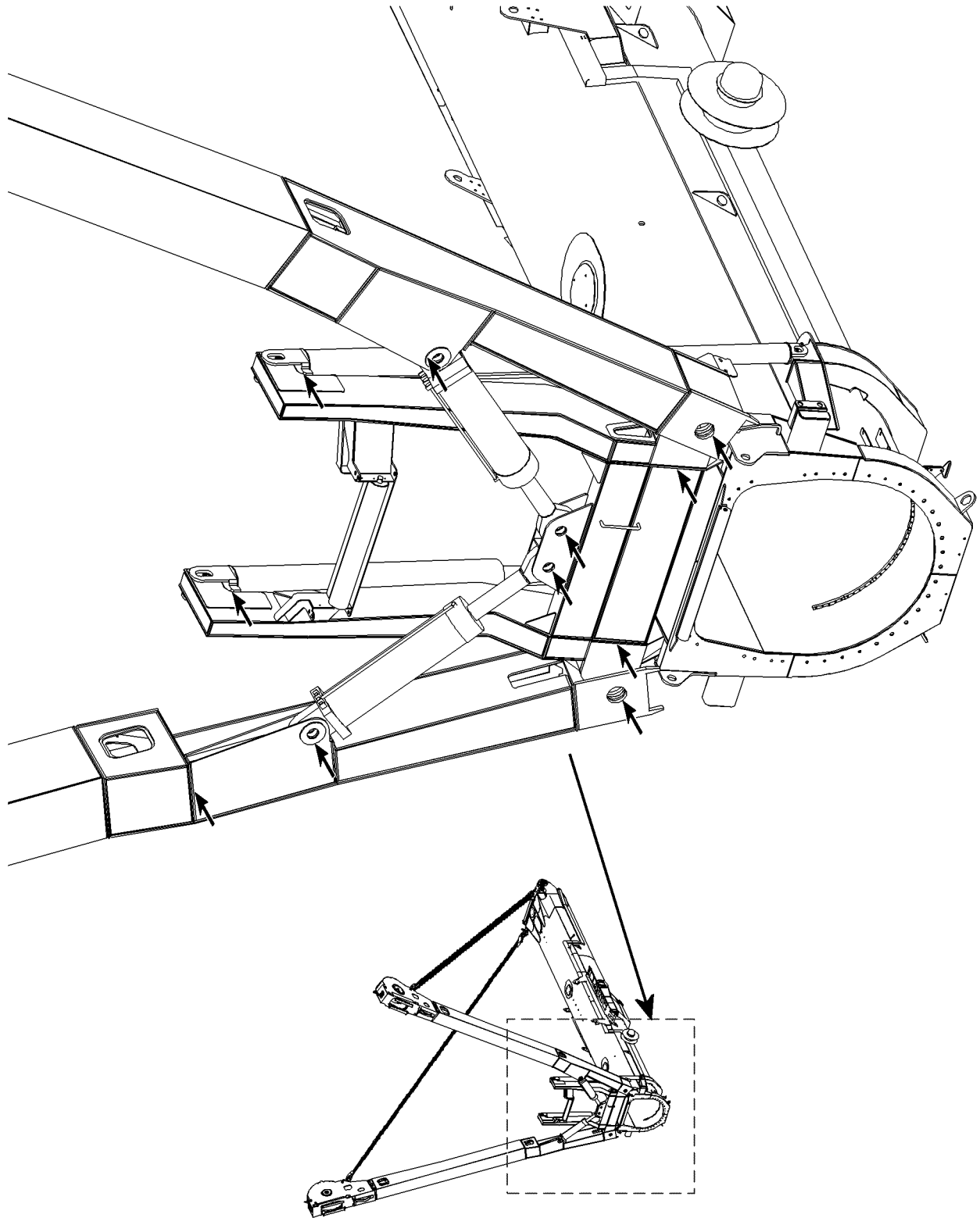

Fig.105707: Example of TY-guying

LWE/LR 13000-001/19503-01-02/en



LWE/LR 13000-001/19503-01-02/en

Fig.105708: Example of TY-guying

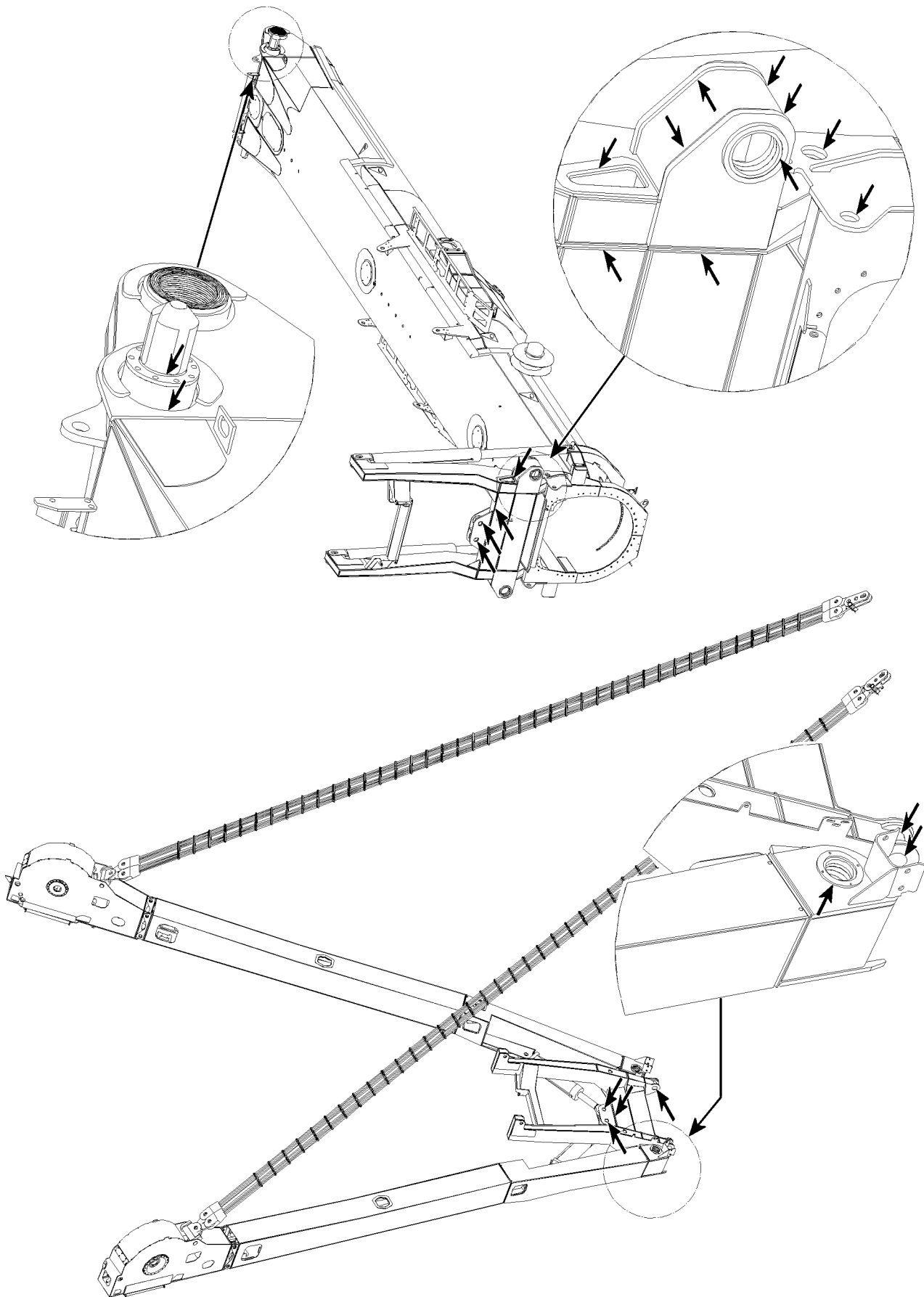

Fig.105709: Example of TY-guying

LWE/LR 13000-001/19503-01-02/en

2.4 Rigging points and fastening points

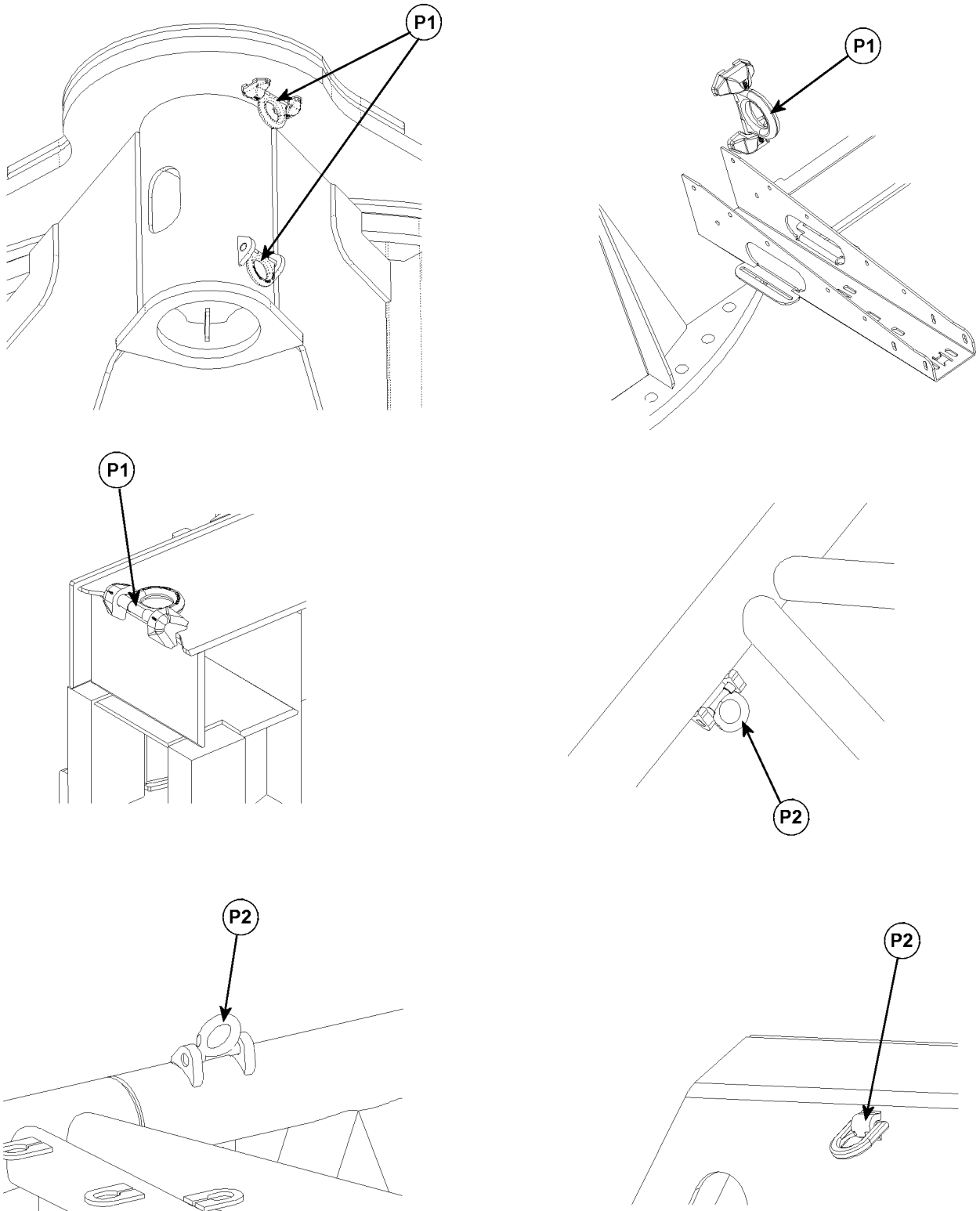

Fig.121160: Examples of rigging points and fastening points

P1 Rigging points

P2 Fastening points

LWE/LR 13000-001/19503-01-02/en

**WARNING**

Unsafe rigging point or fastening point!

The mobile crane or component can rip free and fall down.

When a rigging point or fastening point is not safe for operation:

- ▶ Have the rigging point or fastening point replaced by authorized and trained expert personnel.
- ▶ Avoid damage on the rigging device due to a sharp-edged load.

Make sure that the following damage does **not** occur:

- Crushing points
- Shearing points
- Catch points
- Impact points

Inspection criteria:

- Completeness of the rigging point.
- Distortion of carrying parts.
- Mechanical damage such as severe nicks.
- Changes in diameter due to wear.
- Significant corrosion (pitting).
- Cracks on carrying parts.
- Cracks or other damage on the welding seam.

Check the rigging points **P1** and fastening points **P2** before every start up and at regular intervals.

2.5 Inspecting the lattice sections

**Note**

- ▶ The illustration is only an example and is valid for all lattice sections!
- ▶ Check all diagonal and frame pipe connections!
- ▶ Check all bores of the fork - finger connections!

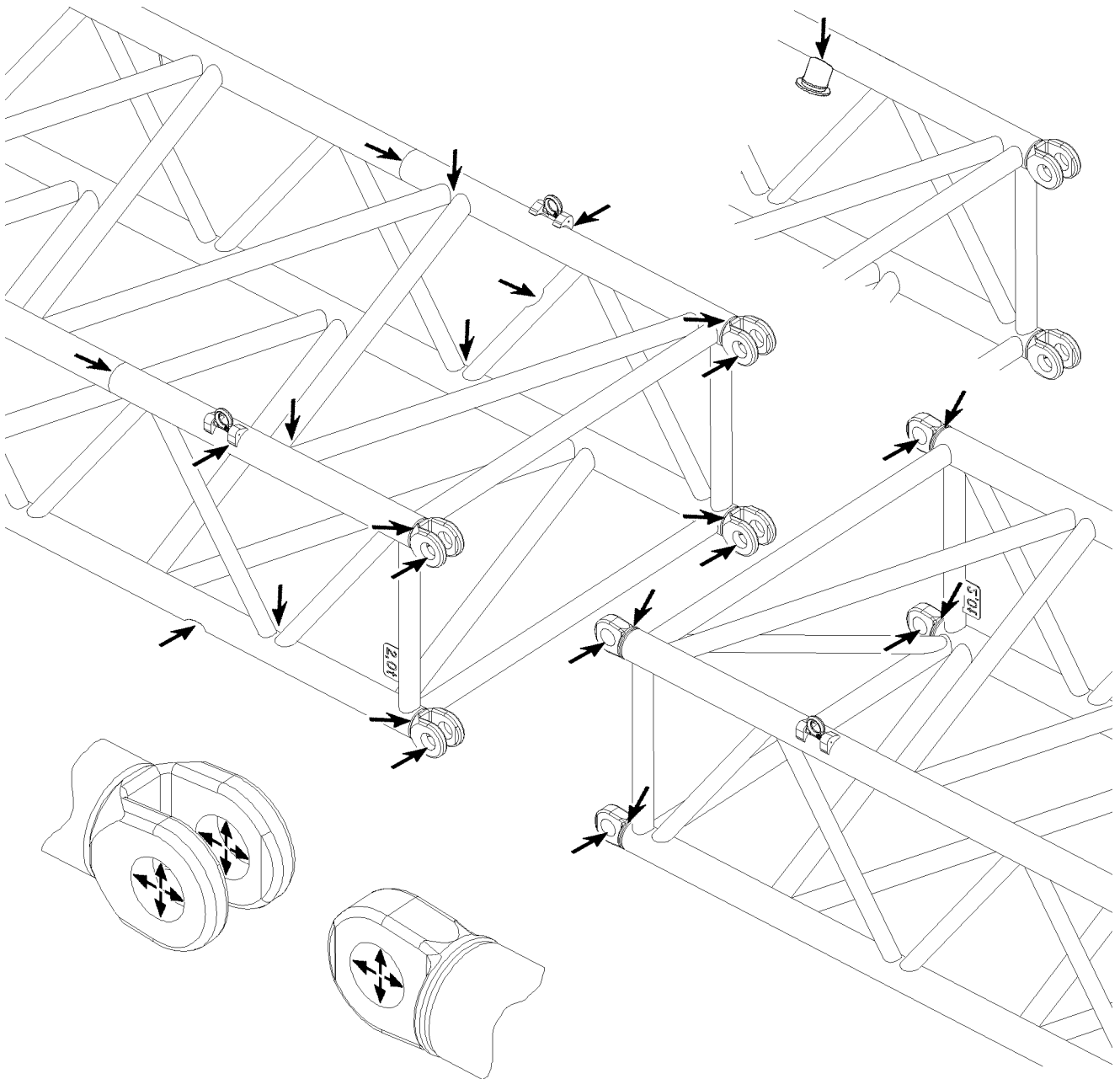

Fig.121023: Example of lattice sections

3 Inspecting the locking system of the telescopic boom

3.1 For cranes with pneumatic boom locking system

- For inspection of function, see chapter 8.11.
- For inspection of pin wear pattern, see chapter 8.11.
- For inspection of wear, see chapter 8.11.
- For inspection of safety control, see chapter 8.11.

3.2 For cranes with the Telematik telescopic boom system

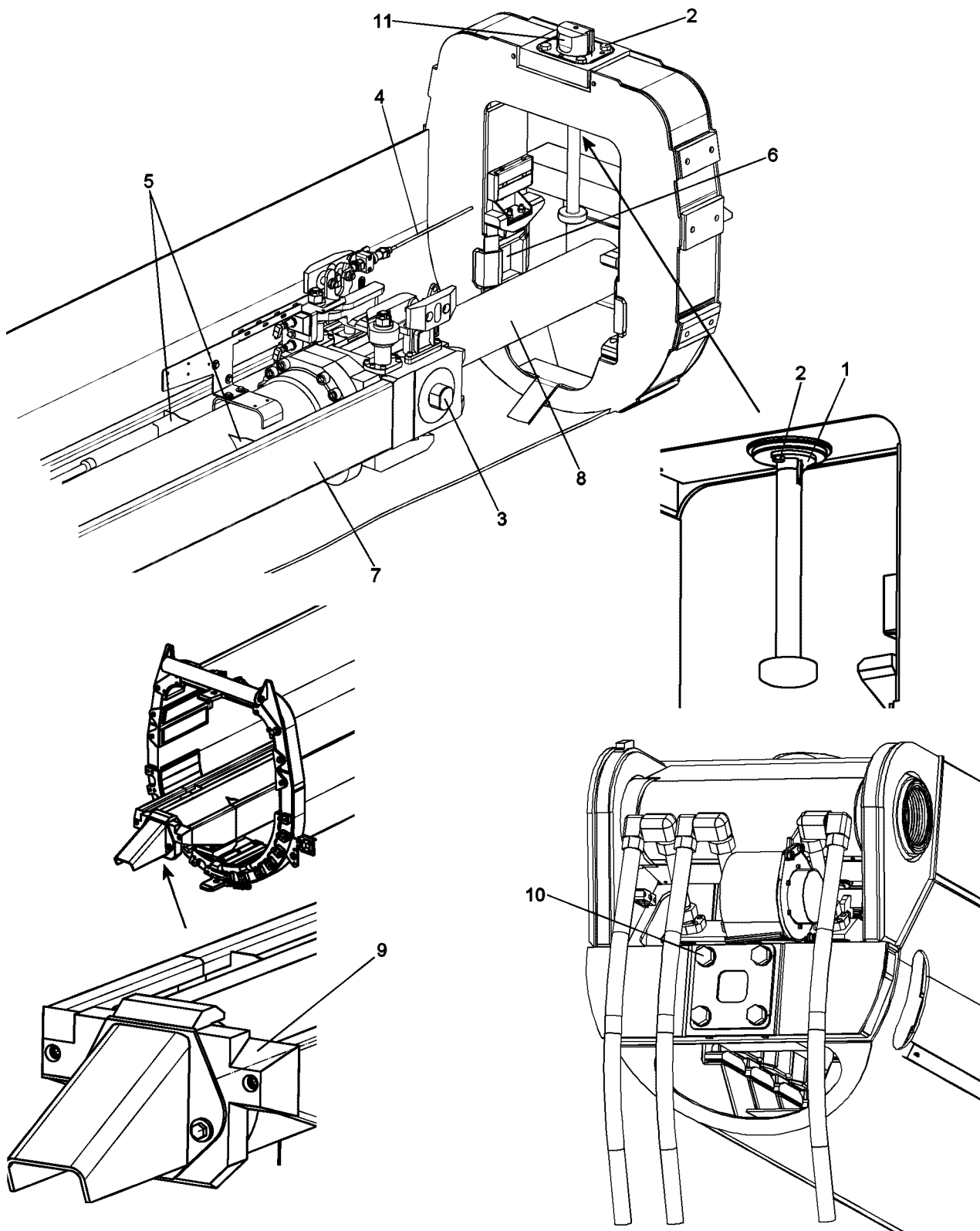

Fig.109286

- Inspection of the pull knob safety **1** and all mounting screws **2** for tight seating
- Inspection of twist guards for cylinder pinning **3** and telescopic boom pinning **11**
- Inspection of the length sensor rope **4** for damage
- Inspection of the cylinder barrel in the area of all welding seams **5** for crack formation
- Inspection of the locking pockets **6** for damage

- Grease the guide rail **7**
- In case of leakage: Inspection of the piston rod **8** for grooves
- Inspection of the wear pattern on the cylinder pinning **3** and the telescopic boom pinning **11**
- Inspection of guide rail **7** for distortion of contour
- Inspection of plastic guide **9** on the cylinder bottom for damage
- Inspection of all mounting screws **10** on the push out cylinder for tight seating

4 Inspection of the screws in the adjustment plates

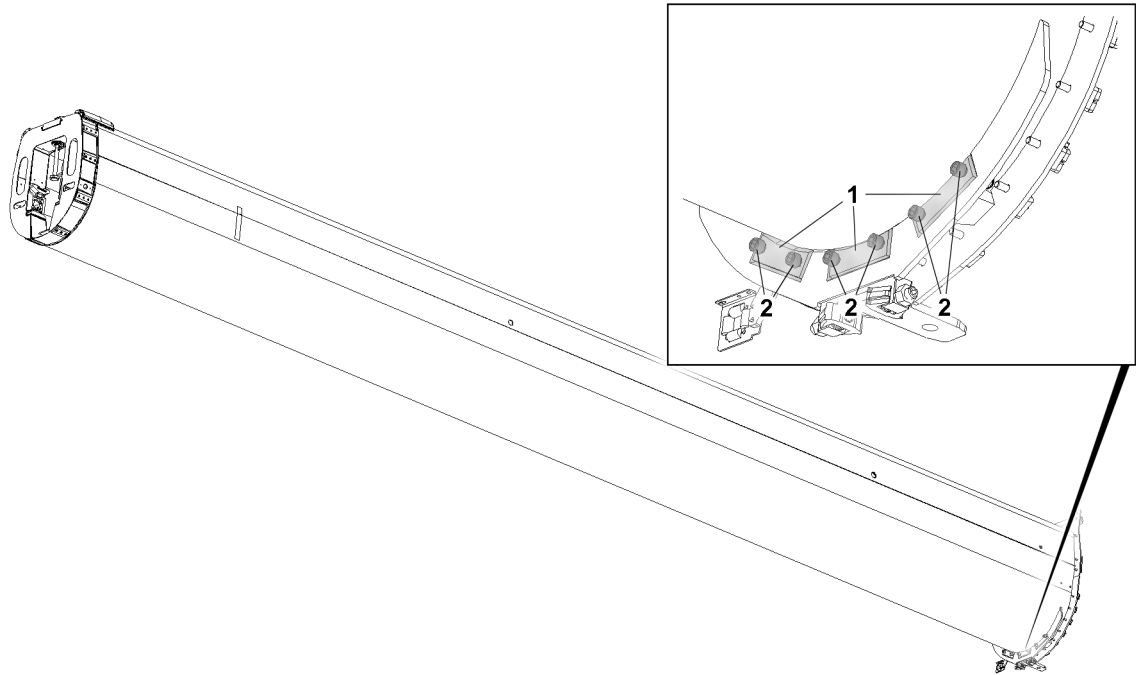

Fig.156447: Exemplary illustration of the adjustment plates on the telescope

The adjustment plates **1** are **not** installed for all crane types.

Check that screws **2** in the adjustment plates **1** are firmly tightened according to the maintenance intervals.

5 Checking the safety ropes and anchor points

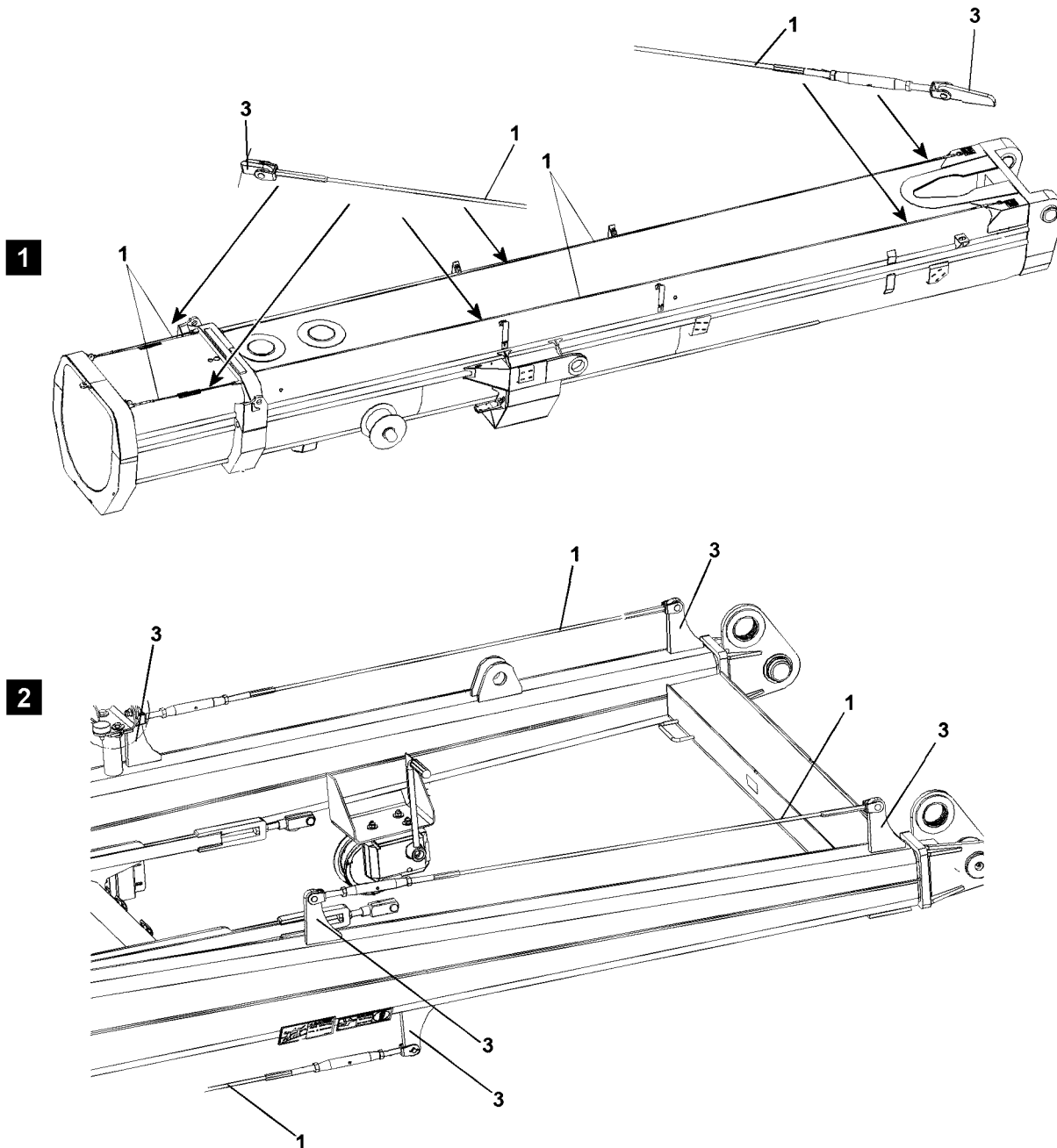

Fig.127130



WARNING

Danger of falls due to damaged safety ropes or anchor points!

The safety ropes **1** and anchor points **3** must be checked **at least once a year** by an **authorized inspector** for safety and damage!

If any defects are found on the safety ropes **1** or anchor points **3** during the inspections, then the safety ropes **1** or anchor points **3** must be replaced immediately by authorized and trained specialists! If this is not observed, assembly personnel could be killed or fatally injured during a fall!

- ▶ The rope pretension on the safety ropes must be 800 N !
- ▶ Have damaged safety ropes **1** or anchor points **3** replaced immediately by trained expert personnel!



Note

Document the inspections in writing!

- ▶ The scope and results of tests should be documented to permit reproducibility. This documentation forms part of the crane records and should be safely stored during the entire service life of the crane.

5.1 Checking of rope pretension on telescopic booms, illustration 1

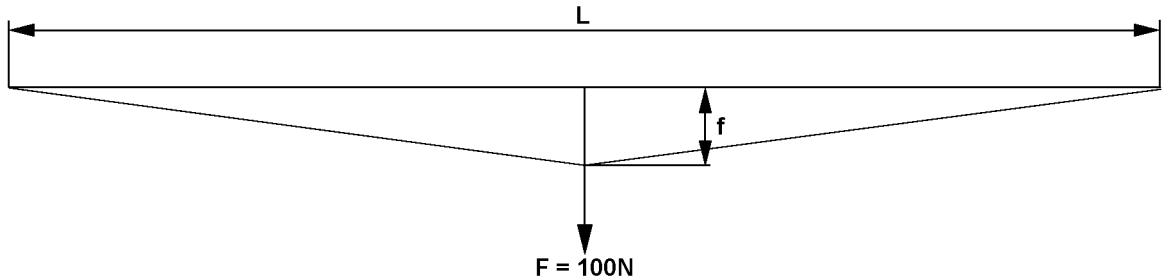

Fig.112738

The rope pretension must be 800 N. This can be checked with the aid of a spring balance, which is pulled centered on the safety rope. If the specified deflection (f) depending on the rope length (L) according to the following charts results for the raised load $F = 100$ N then the rope pretension of 800 N is set correctly.

Rope pretension is 800 N if:					
Rope length (L)	1.0 m	1.5 m	2.0 m	2.5 m	3.5 m
Deflection (f)	15 mm	25 mm	30 mm	40 mm	55 mm

Rope pretension is 800 N if:					
Rope length (L)	5.5 m	7.5 m	9.5 m	11.5 m	13.5 m
Deflection (f)	85 mm	115 mm	145 mm	180 mm	215 mm

5.2 Inspecting the rope pretension on lattice sections, illustration 2

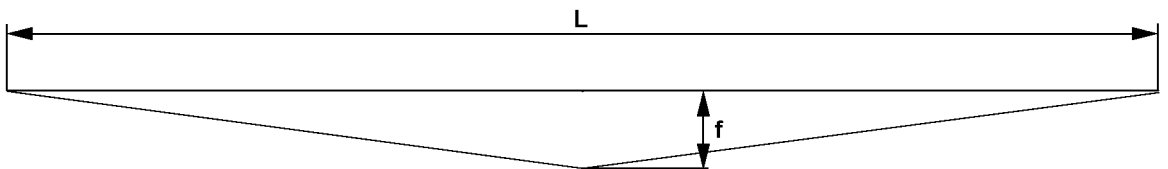

Fig.117747

The rope pretension is 800 N , if a sag (f) according to the chart is present on the safety rope according to the rope length (L).

Rope pretension is 800 N if:					
Rope length (L)	1.0 m	1.5 m	2.0 m	2.5 m	3.5 m
Deflection (f)	0	1 mm	2 mm	3 mm	6 mm

LWE/LR 13000-001/19503-01-02/en

Rope pretension is 800 N if:					
Rope length (L)	5.5 m	7.5 m	9.5 m	11.5 m	13.5 m
Deflection (f)	15 mm	28 mm	45 mm	66 mm	90 mm

6 Inspecting the load handling equipment and assembly aids



WARNING

Load handling equipment and / or assembly aids **not** inspected!

Death, severe bodily injuries, property damage.

- ▶ Inspect load handling equipment and / or assembly aids at least once a year.

The recurring inspection of the load handling equipment and / or assembly aids must be carried out once a year.

The inspections of load handling equipment and / or assembly aids must be recorded.

The welding seams must be subjected to a visual inspection.

Check load handling equipment and assembly aids for:

- Damage
- Wear
- Cracks

Replace damaged, worn or ripped load handling equipment and assembly aids immediately.

Repairs on load handling equipment and assembly aids may solely be made in consultation and under the instructions of the Customer Service at **Liebherr-Werk Ehingen GmbH** by authorized and trained expert personnel.



Note

- ▶ Document the scope of the inspection and the results in writing and comprehensibly.
- ▶ Save the documentation as a part of the crane records for the entire service life of the crane.

7 Inspecting of fastening equipment



WARNING

Fastening equipment **not** inspected!

Death, severe bodily injuries, property damage.

- ▶ Check the fastening equipment at least once a year.

The inspections of the fastening equipment must be recorded.

The welding seams must be subjected to a visual inspection.

Inspect the fastening equipment according to the specifications of the corresponding regulations and standards.

Replace damaged, worn or ripped fastening equipment immediately.



Note

- ▶ Document the scope of the inspection and the results in writing and comprehensibly.
- ▶ Save the documentation as a part of the crane records for the entire service life of the crane.

7.1 Grommets and cable laid fastening rope

Observe and comply with the manufacturer's operating instructions.



WARNING

Damaged grommets and cable laid fastening rope used!

The fastening ropes can fail. The load can fall down.

- ▶ Do **not** use grommets and cable laid fastening rope with a corresponding number of wire breaks.
- ▶ Do **not** use grommets and cable laid fastening rope with a corresponding amount of damage.

Do **not** use grommets and cable laid fastening rope if there is one of the following numbers of wire breaks:

- Wire breaks of more than 10 wires along a length of 3D
- Wire breaks of more than 15 wires along a length of 6D
- Wire breaks of more than 40 wires along a length of 30D

Do **not** use grommets and cable laid fastening rope in the case of the following damage:

- Strong rope distortion
- Rotary distortion
- Kinks, bends, basket formation
- Corrosion
- Corrosion of the zinc coating
- Opening of the splice
- Loosening or opening of the rope bond
- Displacement of the rope bond from its original position
- Lack of identification

8 Inspecting the diaphragm reservoir



Note

- ▶ The national regulations for pressurized container inspection must be observed!

The inspection of the diaphragm reservoir for specified gas pressure must be carried out by an **authorized inspector**, see chapter 7.04 and chapter 7.05.

9 Inspecting the relapse cylinders



WARNING

Fatal accidents due to defective relapse cylinders!

Loss of oil or corrosion can damage the relapse cylinders!

Safe crane operation is no longer ensured!

- ▶ Crane operation with defective relapse cylinders is prohibited!

9.1 Pressure testing the relapse cylinders

The relapse cylinders must be inspected annually by an **authorized inspector**. The purpose of the inspections is to avoid accidents by detecting deficiencies early on.

9.2 Checking the gas pressure and oil fill before start up



WARNING

Fatal accidents due to defective relapse cylinders!
Loss of oil or corrosion can damage the relapse cylinders!
Safe crane operation is no longer ensured!

- ▶ Before every start up: Carry out a visual inspection for leaks, damage and corrosion on the relapse cylinders.
- ▶ If any defects are found, the relapse cylinders must be inspected by the cylinder manufacturer!

The gas pressure and the oil fill must be checked by an **authorized inspector** for pressure containers.

9.3 Inspecting the safety controls on the relapse cylinders

Inspecting the interlocking system or limit switches on the relapse cylinders and the boom A-frames, see chapter 8.12.

10 Inspecting the rope pulleys

10.1 Checking for damage and cracks



DANGER

Danger of accident in case of damage or cracks!

- ▶ Replace rope pulley immediately!

Check the entire rope pulley assemblies for damage and cracks once a year.

If rope pulleys are subjected to any impacts (e.g., with buildings) or are otherwise overloaded, they must be visually inspected for damage or cracks immediately.

10.2 Checking the groove diameter

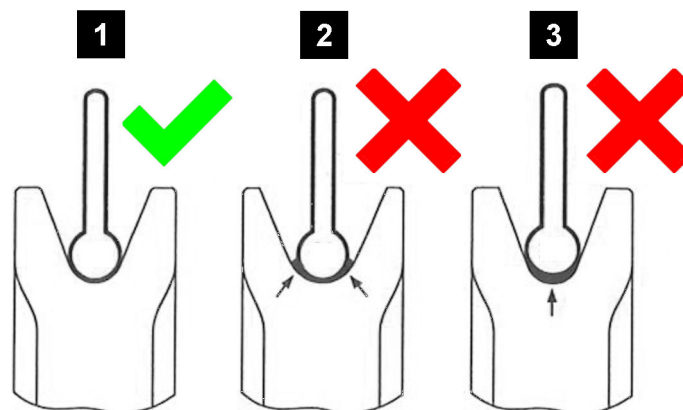

Fig.154258: Checking the groove diameter

- | | |
|---|-------------------------------------|
| <p>1 Groove diameter ok</p> <p>2 Groove diameter too wide</p> | <p>3 Groove diameter too narrow</p> |
|---|-------------------------------------|

NOTICE

Worn rope pulleys!

The functionality and service life of the rope is reduced. Damage on rope.

- ▶ Before placing the rope, check the groove diameter of rope pulleys.

Visible wear on rope pulleys:

- Reduced groove diameter
- Negative impressions of the rope profile in the groove

Make sure that the following tools are available:

- Groove caliper

Make sure that the following prerequisites are met:

- All components to be inspected are cleaned.
- The rope does **not** obstruct the inspection of the components.



Note

- ▶ The actual groove diameter **must** be larger than the actual diameter of the rope!

The groove diameter of rope pulleys and winches must be at least 6 % larger than the nominal rope diameter.

Check the rope pulleys with a groove caliper for wear. When wear exists on the rope grooves: Repair or replace the rope pulleys.

11 Inspecting the carrier rollers

11.1 Performing a visual inspection



DANGER

Damaged carrier rollers!

Breakage and falling components. Death, severe bodily injuries, property damage.

- ▶ Carry out a visual inspection according to the maintenance intervals.
- ▶ Replace the carrier roller immediately.

The visual inspection must be carried out according to the following criteria:

- Wear
- Damage
- Cracks

Visible wear on carrier rollers:

- Negative imprints of the rope profile on the circumference of the carrier rollers
- Lead-in tracks

11.2 Checking the depth of the lead-in tracks



DANGER

Worn carrier rollers!

Breakage and falling components. Damage to ropes. Death, severe bodily injuries, property damage.

- ▶ Check the depth of the lead-in tracks.
- ▶ Replace worn carrier rollers immediately.

Make sure that the following prerequisites are met:

- All components to be inspected are cleaned.
- The rope does **not** obstruct the inspection of the components.

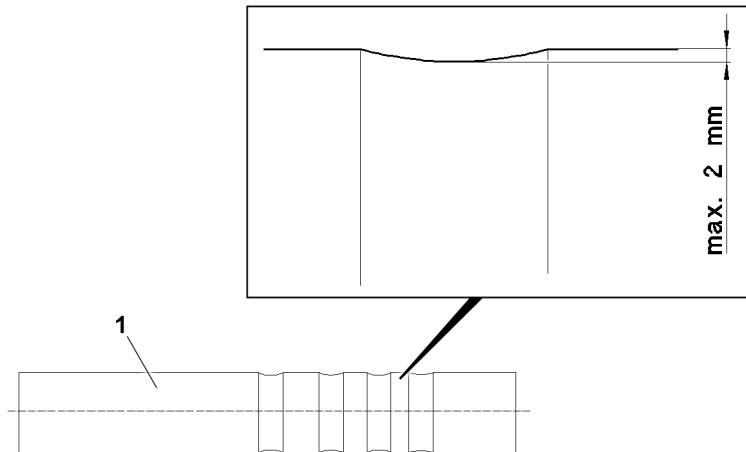

Fig.124864: Permissible depth of the lead-in tracks

1 Carrier roller

The depth of the lead-in tracks may be maximum 2 mm.

11.3 Checking the bearings for easy movement

Stiff or blocked carrier rollers wear unevenly and cause serious rope abrasion.

Ineffective carrier rollers can lead to irregular rope tension.

Tasks to check the carrier rollers:

- Check the carrier rollers for proper movement in their bearings.
- When carrier rollers are **not** easily moveable in their bearings: Fix the bearings.

11.4 Checking the tightening torque

The tightening torque of screws must be checked according to maintenance interval.

12 Inspecting the extension conditions of sliding beams

The extension conditions of the sliding beams must be inspected annually by an **authorized inspector**.

Check the extension conditions on every sliding beam:

- Check if the position 0 % of the LICCON display matches the actual condition of the sliding beam.
- Check if the position 100 % of the LICCON display matches the actual condition of the sliding beam.

13 Inspecting the function of the overload protection

Position the longest boom at minimum and maximum radius: Check the load indicator, using the hook block as a test load.

The display reading may not deviate by more than 10 % off the true load value at these two extreme positions.

Measure the indicated radius for the longest boom at its minimum radius and at a boom angle of 45°.

The display readings may not deviate more than 10 % from the measured boom radius.

14 Inspecting the pin connections



WARNING

Pin connections **not** inspected!
 Death, severe bodily injuries, property damage.
 ▶ Check the pin connections at least once a year.

The periodic inspection of all pin connections must be carried out once a year.

The inspections of the pin connection must be recorded.

Check the pin connections for:

- Properly secured pin connections
- Damage to the pins and / or connector elements
- Damage to the retaining elements

Replace damaged pins immediately.

Immediately replace damaged, bent or broken retaining elements.

Only replace damaged pins with identical pins.

Only replace damaged retaining elements with identical retaining elements.



Note

- ▶ Document the scope of the inspection and the results in writing and comprehensibly.
- ▶ Save the documentation as a part of the crane records for the entire service life of the crane.

15 Inspecting the slewing ring connection

15.1 Checking the tilt play

The wear of the slewing ring connection is determined by measuring the tilt play with the ring installed.

The permissible tilt play depends on the type of slewing ring connection.



WARNING

The tilt play of the slewing ring connection is too large!
 If the permissible tilt play is exceeded, then safe crane operation is **no** longer possible.
 Death, severe bodily injuries, property damage.

When the permissible tilt play is exceeded:

- ▶ Replace the slewing ring connection.

The determination of the tilt play must be carried out according to the **test instructions** of **Liebherr-Werk Ehingen GmbH**.

Request the test instructions and permissible tilt play: Contact Liebherr Service.

16 Inspecting the mounting of the load bearing equipment

16.1 Checking the tightness of the mounting screws

The mounting screws must be checked for a tight fit during the annual crane inspection.

The mounting screws are pre-stressed at the factory, so that no loosening of the screw connections will occur during normal crane operation.

The screw connection may become overloaded and the mounting screws may be permanently stretched if the crane is overloaded or if the load is pulled free. The mounting screws must be checked immediately for a tight fit after an overload.

Check the tightening torque of the mounting screws of load bearing equipment for a tight fit:

- Slewing ring connection
- Winches
- Slewing gears
- Transmission
- Trailer coupling

If a mounting screw can be tightened, then the mounting screw is loose. Follow the instructions in section „Checking the mounting screws for damage“.

16.2 Checking the mounting screws for damage

Completely unscrew the loose mounting screws and check in detail for damage.

Completely unscrew the adjacent mounting screws and check in detail for damage.

Replace the mounting screw if any of the following damage is present:

- The mounting screw is stretched by more than 2 % (in relation to its original length).
- Cracks, permanent deformation or other damage is visible on the mounting screw.
- The mounting screw is uneven.
- There is pitting.
- The thread is hard to move.

If there is **no** damage, reuse the checked mounting screws (expansion screws) a maximum of two times.

17 Inspecting the tele extension with eccentric, illustration 1

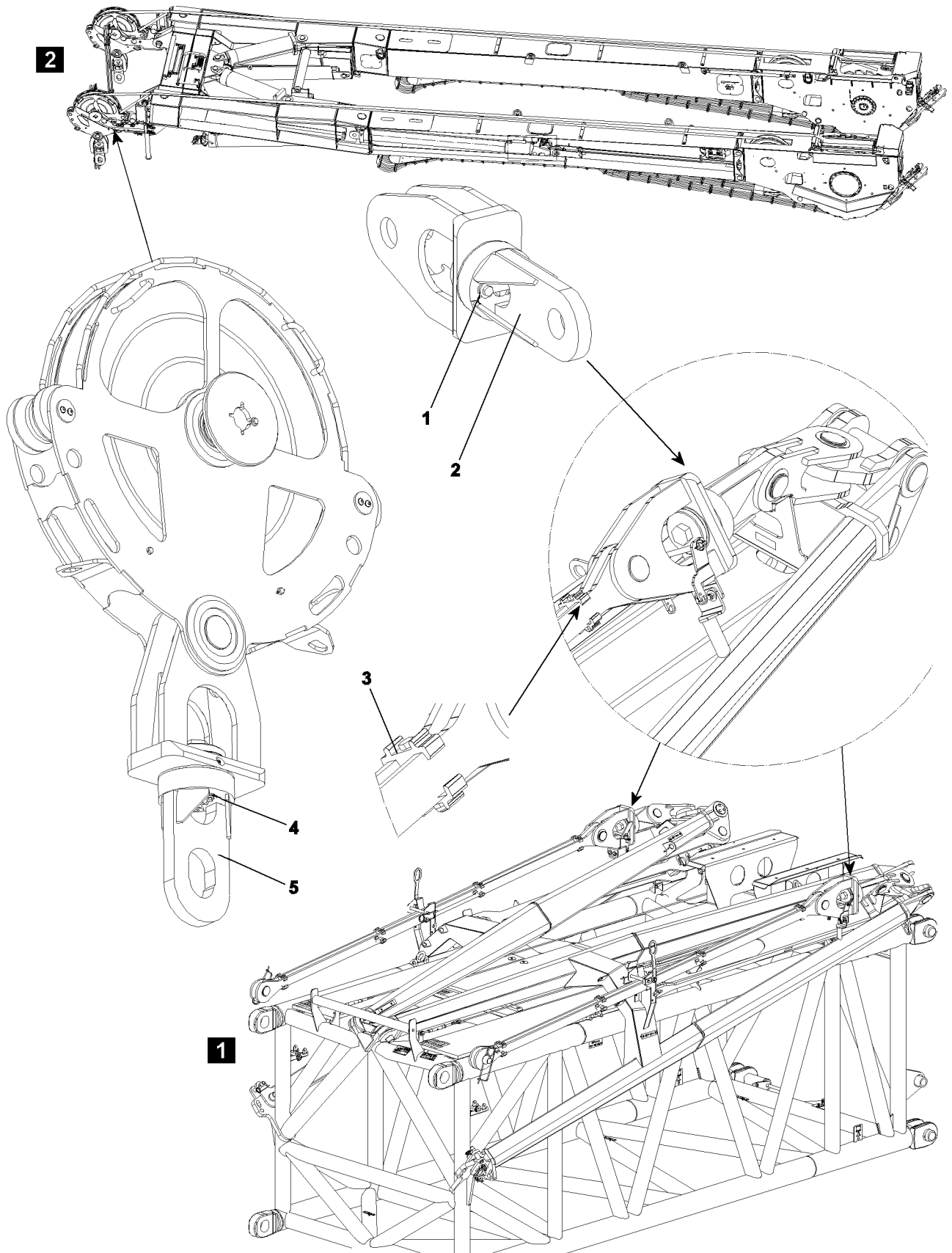

LWE/LR 13000-001/19503-01-02/en

Fig.109096

- Inspection of anti-rotation device **1** for damage and loose screw connection.
- Inspection of swivel **2** for easy turnability.
- Inspection of all clamps **3** for damage and function.

18 Inspecting the change over pulleys, illustration 2

- Inspection of anti-rotation device **4** for damage and loose screw connection.
- Inspection of swivel **5** for easy turnability.

19 Inspecting the oil and fuel tanks

Visually check the oil and fuel tanks at least once a year for leaks and safe mounting.

Repairs may only be carried out by authorized and trained specialists.

Improper repairs; e.g., welding, hard or soft soldering is not permitted, particularly if the Service department at Liebherr-Werk Ehingen GmbH has not been consulted!

8.03 Inspecting of winches

1	Inspecting the hoist and retracting winches	3
2	Inspection of the auxiliary reeving winch, recovery winch and spare wheel winch	5
3	Monitoring the winches	5

Fig.195219

LWE/LR 13000-001/19503-01-02/en

1 Inspecting the hoist and retracting winches

The hoist and retracting winches are designed in sealed planetary gear version. These gears are sized for long service life and the drive shafts and gears are designed for endurance.

Even though the hoist and retracting winches are designed for long life, an external visual inspection is not adequate, since their life can be significantly affected by bad maintenance (insufficient oil), using oil that does not meet specification requirements, defective seals, improper operation or overloading.

The annual inspection must therefore be carried out by an **expert** in accordance with the following specification.

The winches must be inspected by an **authorized inspector** every four years after the initial license.

Within the territorial validity of the BGV D6, after the 10th year in operation, counted from the first day of initial license, when the theoretical service life is not over, the winches must be checked annually by an **authorized inspector**.

1.1 Checking the groove diameter



WARNING

Worn winches!

Damage of flanged disks, high rope wear, operational problems. Broken rope, falling load.

- ▶ Before placing the rope, check the groove diameter of winches.

Visible wear on winches:

- Reduced groove diameter.
- Mechanical damage, for example scrub marks or scouring on flanged disks

Make sure that the following tools are available:

- Groove caliber

Make sure that the following prerequisites are met:

- All components to be inspected are cleaned.
- The rope does **not** obstruct the inspection of the components.



Note

- ▶ The groove radius may **not** be smaller than the actual diameter of the rope.

The groove diameter of rope pulleys and winches must be at least 6 % larger than the nominal rope diameter.

Check winches with a groove caliber for wear. When wear is present: Fix the winch or replace.

1.2 Inspection intervals

At least once a year, see Crane operating instructions, chapter 7.03.

1.3 Checking the oil level

Check the oil level with the dipstick.

For hoist and retracting winches **without** a dipstick, we recommend that the oil is drained and the amount compared to the specified oil quantity.

1.4 Evaluating oil color

Assume that the oil has been overheated if it is black and / or a burnt oil smell is detected. Change the oil.

1.5 Checking for solid foreign substances

In general, the oil must be analyzed by a qualified laboratory.

For simple testing, the following procedure can be used:

- Drip the used oil on a specified filter fleece.
- Visual inspection with a magnifying glass may reveal coarse particles.
- If coarse particles are found: Have the components of the oil analyzed by a qualified laboratory.

NOTICE

Danger of property damage!

- ▶ Repairs may only be carried out by an authorized and trained expert personnel.
 - ▶ Replace damaged parts and change the gear oil.
-

1.6 Visual inspection for leaks

The gears must be checked for leaks, since oil losses - in addition to polluting the environment - can lead to gear failure.

1.7 Checking the gear brakes

Check the brakes each time the gears are inspected.



WARNING

Condition of gear and brakes incorrectly transmission evaluated!

The load can fall down, death, property damage.

- ▶ Only qualified personnel with specialized knowledge may be used to evaluate gears and brakes.
-

In order to do so, proceed as follows:

- Make sure that the hoist rope is sufficiently pretensioned, in particular in the lower layer of the winch. See chapter 4.08.
- Attach a load, which creates the maximum rope pull in the uppermost layer of the coil with 1 strand, and raise it just off the ground by luffing it up.
- Block the winch brake:
 - For cranes with LICCON 1: „Release the winch brake“ by unplugging the valve plug from the valve.
 - For cranes with LICCON 2: By activating the setting program for blocking the winch brake.
- Activate the winch in the lowering direction.

The brake may **not** slip during the test, which means that the winch may **not** turn.



WARNING

The brake slips and the winch turns!

The load can fall down, death, property damage.

- ▶ Stop crane operation.
 - ▶ Contact Customer Service at Liebherr-Werk Ehingen GmbH.
-

1.8 Documenting the completed inspection

The results of the annual inspections and maintenance work, including the steps taken, must be documented by the competent or authorized inspector, including attachments from the inspection labs and qualified service companies if applicable.

This documentation must be filed in the crane inspection log under the heading "Periodic inspections".

2 Inspection of the auxiliary reeving winch, recovery winch and spare wheel winch

The inspection of the auxiliary reeving winch, recovery winch and spare wheel winch regarding scope and content is made according to the manufacturer's instructions.

- Check the auxiliary reeving winch, recovery winch and spare wheel winch according to the manufacturer's instructions.
- Request data about the service life of the auxiliary reeving winch, recovery winch and spare wheel winch from the respective manufacturer.

3 Monitoring the winches

3.1 Theoretical service life

The designer of your crane used a theoretical total operating time when designing and sizing the winches. This resulted in the theoretical service life of the equipment.

The winches of your crane are classified according to ISO 4301/1 as follows:

Winches	Classification
Power train group:	M3
Load spectrum:	L1
Load spectrum factor Km:	0.125
Theoretical service life D:	3200 h



Note

- ▶ The „theoretic service life“ is not equal to the real (true) service life of a winch!

The actual service life of the winch is affected by many additional outside factors; for example:

- Overloads caused by unapproved use of the crane.
- Inadequate maintenance: Oil is not changed in a timely manner
- Improper operation:
 - Extreme acceleration or deceleration of the load
 - Load falling into the ropes
- Maintenance errors:
 - Using the wrong type of oil
 - Too much or too little oil
 - Contamination during oil change
- Assembly errors during repair and maintenance
- **Undetected** leaks
- Incorrectly set safety equipment
- Hidden damage from accidents
- Extreme environmental conditions:
 - Low or high temperatures
 - Aggressive atmosphere
 - Dust and dirt

3.2 Used proportion of the theoretical service life

The crane operator is obligated to carry out an inspection of the crane at least once a year.

At this time, the actually used part of the theoretical service life must also be calculated. If necessary, the crane operator must contract an authorized inspector.

For the determination of the used part of the theoretical service life, the actual operating conditions (load spectrum) and the hoist gear operating hours for each inspection interval are to be determined. The operator is responsible for the documentation in the crane inspection log.

3.2.1 Determining the operating conditions (load spectrum)

The load spectrum of the crane is divided into groups, please refer to ISO 4301/1.

Select one of the following load spectrums and record it in the crane inspection log for the respective inspection interval based on the actual operating conditions. A more precise determination of the load spectrum is permissible.

Load spectrum class: Light L1

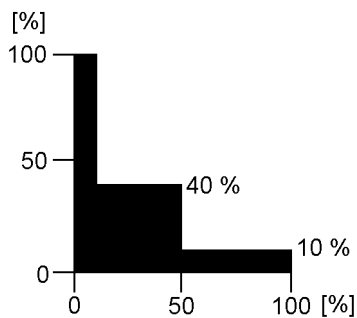

Fig.195234: Graphic illustration Load spectrum L1

Definition:

Power train or parts thereof are subjected to maximum stress only in exceptional cases, but normally only operate at very light loads.

Operating time rates:

- 10 % of the time at maximum load (dead load and 1/1 working load)
- 40 % of the time with dead load and 1/3 working load
- 50 % of the time only with dead load

Factor of load spectrum:

$K_m = 0.125$



Note

- Load spectrum L1 with load spectrum factor $K_m = 0.125$ is normally applied to cranes used for assembly operations!

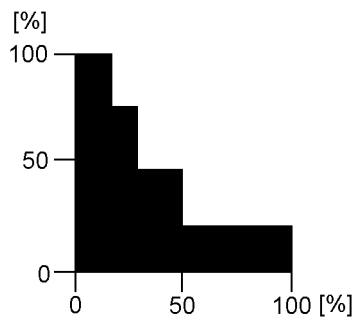
Load spectrum class: Medium L2*Fig.195235: Graphic illustration Load spectrum L2***Definition:**

Power train or parts thereof are subjected to maximum load relatively often, but normally only operate at light load.

Operating time rates:

- 1/6 of the time at maximum load (dead load and 1/1 working load)
- 1/6 of the time with dead load and 2/3 working load
- 1/6 of the time with dead load and 1/3 working load
- 50 % of the time only with dead load

Factor of load spectrum:

$$K_m = 0.25$$

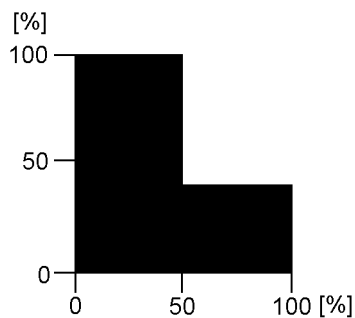
Load spectrum class: Heavy L3*Fig.195236: Graphic illustration Load spectrum L3***Definition:**

Power train or parts thereof are frequently subjected to maximum load and normally operate at medium load.

Operating time rates:

- 50 % of the time at maximum load (dead load and 1/1 working load)
- 50 % of the time only with dead load

Factor of load spectrum:

$$K_m = 0.5$$

Load spectrum class: Very heavy L4

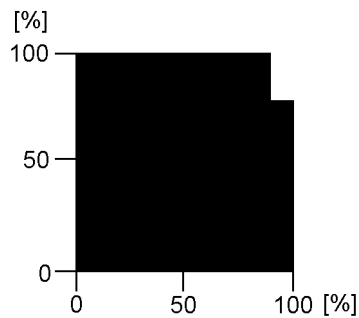

Fig.195237: Graphic illustration Load spectrum L4

Definition:

Power train or parts thereof are regularly subjected to near maximum loads.

Operating time rates:

- 90 % of the time at maximum load (dead load and 1/1 working load)
- 10 % of the time only with dead load

Factor of load spectrum:

$K_m = 1$

3.2.2 Determining the effective operating hours T_i

The effective operating hours calculated as follows must be entered into the crane inspection log for the respective inspection interval.

There are four different scenarios:

1. Operating hour meter installed on every winch.
If an operating hour meter is installed on every winch in your crane, the effective operating hours T_i can be read directly during each inspection.
2. Operating hour meter installed for the overall crane drive.
The winch proportion of the total superstructure operating hours must be estimated.
For cranes used in assembly operations, the operating time for the hoist winches can be estimated generally at 20 % of the total operating hours of the superstructure.
3. One operating hour meter is used for both the crane engine and the crane drive.
The winch proportion of the total crane operating hours must be estimated.
For cranes used in assembly operations, the operating time for the superstructure can be estimated at 60 % of the total operating hours of the crane. If the hoist winch proportion is estimated at 20 % of the superstructure operating hours (see previous item), then the result in relation to the **total** operating hours of the crane is: 12 %.
4. No operating hour meter is available.
In this case, the operator must estimate and document the actual operating hours of the winch.
The approximate percentages stated above normally apply to main hoist winches. For auxiliary hoist winches or boom control winches, the proportion of the total operating hours can be significantly less and should therefore be estimated by the operator.

3.2.3 Determining the used proportion of the theoretical service life

For an inspection interval i (max. 1 year), the actually used proportion S_i of the theoretical Service life is derived from the formula:

$$S_i = \frac{K_{m_i}}{K_m} \times T_i$$

Fig.195230

Abbreviation	Explanation
S_i	Used proportion of the theoretical service life.
K_m	Load spectrum factor that was used to calculate the winch rates. This factor is provided in the Operating instructions.
K_{m_i}	Load spectrum factor for inspection interval i according to section „Determining the operating conditions“.
T_i	Effective operating hours for inspection interval i according to section „Determining the effective operating hours T_i “.

The actually used proportion is subtracted from the remaining theoretical service life D_i after each inspection interval (see example).

If the remaining theoretical service life is not long enough to cover the next projected operating period, a general overhaul of the winch is required.

If the theoretical service life D has been reached (see section on „Theoretical service life“), then the winch may only be operated after conducting a general overhaul.

A general overhaul of the winch is required not later than 10 years after start up.

The general overhaul must be arranged by the operator and carried out by the manufacturer or the manufacturer's authorized representatives and must be documented in the inspection log. After the general overhaul, the manufacturer or the manufacturer's authorized representative will define a new theoretical service life D .

When the design life has not been reached after 10 years, continued operation of the winch without a general overhaul is acceptable, when the crane's authorized inspector has confirmed the accuracy of the actual service life calculation by signing the crane inspection log at each authorized inspection interval.

In such a case, the authorized crane inspector must thoroughly inspect the winch. This comprises at least:

- External visual inspection (leaks damage, deformation, etc.).
- Oil check, especially for metal residues.
- Load test at minimum and maximum rope pull and at maximum possible speed in both cases. At least one layer must be spooled up. Pay particular attention to any unusual noises during this load test.

The authorized crane inspector must confirm this inspection in the crane inspection log and must make a statement regarding suitability of the winch for continued operation. The next inspection must take place before the end of the 12th operating year and annually thereafter.

3.3 Example

According to the manufacturer's operating instructions, a crane with a separate operating hour meter for the travel drive and the crane drive is classified as follows:

- Power train group: M3
- Load spectrum: Light L1
- Factor of load spectrum: $K_m = 0.125$
- Theoretical service life: $D = 3200$ h

Actual usage proportion S of the theoretical service life is calculated using the individual inspection intervals as follows:

3.3.1 First inspection (first year)

The crane was used for assembly work during the past year:

Load spectrum L1, in other words $Km_1 = 0.125$.

The superstructure operating hour meter indicates 800 h. The winch was operated about 20 % of the time; i.e. $T_1 = 160$ h.

The actual usage proportion S of the theoretical service life at the time of the first inspection is therefore:

$$S_1 = \frac{0,125}{0,125} \times 160 \text{ h} = 160 \text{ h}$$

Fig.195231

Remaining theoretical service life:

$$D_1 = 3200 \text{ h} - 160 \text{ h} = 3040 \text{ h}$$

The above values are recorded in the crane inspection log.

3.3.2 Second inspection (second year)

The crane was used at a harbor for unloading work:

Load spectrum L3, in other words $Km_2 = 0.5$.

The superstructure operating hour meter indicates 2000 h ; i.e., this means that during this period: 2000 h – 800 h = 1200 h (800 h were used during the first year of operation)

The winch was operated about 40 % of the time; i.e. $T_2 = 480$ h.

The actual usage proportion S_2 of the theoretical service life at the time of the second inspection is therefore:

$$S_2 = \frac{0,5}{0,125} \times 480 \text{ h} = 1920 \text{ h}$$

Fig.195232

Remaining theoretical service life:

$$D_2 = 3040 \text{ h} - 1920 \text{ h} = 1120 \text{ h}$$

3.3.3 Third inspection (third year)

The crane was used for assembly work and occasionally at a harbor for unloading work:

Load spectrum L2, in other words $Km_3 = 0.25$.

The superstructure operating hour meter indicates 3000 h ; i.e., this means that during this period: 3000 h – 2000 h = 1000 h (2000 h were used during the first two years of operation)

The winch was operated about 30 % of the time; i.e. $T_3 = 300$ h.

The actual usage proportion S_3 of the theoretical service life at the time of the third inspection is therefore:

$$S_3 = \frac{0,25}{0,125} \times 300 \text{ h} = 600 \text{ h}$$

Fig.195233

Remaining theoretical service life:

$$D_3 = 1120 \text{ h} - 600 \text{ h} = 520 \text{ h}$$

3.4 Chart for determining the theoretically remaining service life

Chart 1 includes an example.

The remaining theoretical service life is to be documented in chart 2.

Chart to determine the remaining theoretical service life of winch No. 1 (Main hoist winch)

Crane type: LTM 1050
 Fabrication No.: 0010 540 08
 Put in service: 12345
 Serial number of winch according to data tag: 0815
 Last general overhaul performed on:
 Configuration data of winch (see Operating Manual):
 Drive gear group: M 3
 Load collective: L 1
 Factor of load collective Km: 0.125
 Theoretical service life D: 3200 hrs.

S_i = Used part of theoretical service life since last inspection
 D_i = Remaining theoretical service life
 D_{i-1} = Remaining theoretical service life after previous inspection
 Km = Factor of load collective, which was taken for calculation of winch.
 Km_i = Factor of load collective in inspection interval i
 T_i = Effective operating hours in inspection interval i

(*) In the following pages, carry over the last line from the previous page.

Inspection interval No. (max. annually)	Date of initial service data of inspection	Operating conditions since last inspection (load collective)	Factor of load collective	Total crane operating hours	Operating hours of super-structure	Operating hours of super-structure since last inspection	Operating hours of winch	Operating hours of winch since last inspection T_i	Used part of theoretical service life $D_i = \frac{S_i}{Km_i} \times T_i$	Remaining theoretical service life $D_i = D_{i-1} - S_i$	Name of inspector	Signature	Remarks	Name of expert	Signature
(*) 0	10.06.90	-	-	-	0	0	0	0	0	3200					
1	05.06.91	L1	0,125	-	800	800	-	160 (20% of 800)	160	3040	Müller				
2	20.05.92	L3	0,5	-	2000	1200	-	480 (40% of 1200)	1920	1120	Huber				
3	18.05.93	L2	0,25	-	3000	1000	-	300 (30% of 1000)	600	520	Mair				
4															

CAUTION: Perform general overhaul at least once every 10 years! In case of deviation, see guidelines in this chapter.
 General overhaul last performed on :

LWE/LR 13000-001/19503-01-02/en

Chart to determine the remaining theoretical service life of winch No.

- Crane type:
 - Fabrication No.:
 - Put in service:
 - Serial number of winch according to data tag:
 - Last general overhaul performed on:
 - Configuration data of winch (see Operating Manual): M.....
 - Drive gear group: L.....
 - Load collective:
 - Factor of load collective Km:
 - Theoretical service life D:
- S_i = Used part of theoretical service life since last inspection
 D_i = Remaining theoretical service life
 D_{i-1} = Remaining theoretical service life after previous inspection
 Km = Factor of load collective, which was taken for calculation of winch.
 This factor is to be taken from the Operating Manual
 Km_i = Factor of load collective in inspection interval i
 T_i = Effective operating hours in inspection interval i
- *) In the following pages, carry over the last line from the previous page.

Inspection interval No. (max. annually)	Date of initial service data of inspection	Operating conditions since last inspection (load collective)	Factor of load collective	Total crane operating hours	Operating hours of super-structure	Operating hours of super-structure since last inspection	Operating hours of winch	Operating hours of winch since last inspection T_i	Used part of theoretical service life D_i : $\frac{Km_i}{Km} \times T_i$	Remaining theoretical service life $D_i = D_{i-1} - S_i$	Name of inspector	Signature	Remarks	Name of expert	Signature
i			Km_i	[h]	[h]	[h]	[h]	[h]	[h]	[h]					
(*)															

CAUTION: Perform general overhaul at least once every 10 years! In case of deviation, see guidelines in this chapter.

General overhaul last performed on :

Fig.121552-en: Table 2

8.04 Inspection of crane wire ropes

1	Crane ropes	3
2	Importance of inspection	3
3	Personal protective equipment	3
4	Qualification Inspection personnel	3
5	Unscheduled inspection	3
6	Intervals	4
7	Areas	4
8	Documenting inspection results	5
9	Wire ropes and rope end connections	5
10	Degree of severity	8
11	Abbreviations Rope diameter	8
12	Distortions and mechanical damage	8
13	Removal criteria Overview	8
14	Checking for broken strands	10
15	Determining the number of broken wires	10
16	Checking the rope end connection	15
17	Checking of rope diameter	15
18	Corrosion	18
19	Corkscrew-like distortion	20
20	Basket formation	21
21	Protruding, distorted insert or strand	22
22	Loop formation	23
23	Kinking or rope loops pulled closed	24
24	Buckles	25
25	Effects of heat, arcs	26
26	Combined degree of severity	26
27	Flattenings	26
28	Current checklist	29

Fig.195219

LWE/LR 13000-001/19503-01-02/en

1 Crane ropes

This chapter applies, for example, for the following crane ropes:

- Hoist ropes
- Control ropes for the boom system
- Control ropes of the telescopic boom with rope mechanism: Pull-out ropes and return ropes
- Guy ropes for boom system

2 Importance of inspection

Rope removal criteria: If severe damage reduces the operational safety, then the rope has reached the removal criteria.

The importance of regular inspections is demonstrated by:

- Evaluation of operational safety of ropes
- Determination of rope removal criteria
- Determination of next inspection

3 Personal protective equipment



WARNING

Wires and lubricant!

Severe injury and skin irritation.

- ▶ When working with ropes, always wear work gloves.



WARNING

Protective equipment **not** worn!

Severe injuries.

- ▶ Wear hard hat, safety shoes and safety glasses.

4 Qualification Inspection personnel

Make sure that the following prerequisites are met:

- Inspection personnel are **expert personnel for crane rope inspection**.
- **Expert personnel for crane rope inspection:**
 - Are trained in the inspection of crane ropes according to **DIN ISO 4309** and have practical experience in the evaluation of rope removal criteria.
 - Have practical experience in the evaluation of rope removal criteria according to **DIN ISO 4309**.
- The inspection personnel is assigned (authorized) for the maintenance by the crane operator.

5 Unscheduled inspection

In the following situations the rope must be inspected:

- After unusual strain
- If non visible damage is suspected
- When a rope or the rope end connection is damaged
- When the rope has been placed again after disassembly
- When the rope has been out of service for longer than three months

6 Intervals

Intervals for crane inspection:

- according to determination by **expert personnel for crane rope inspection**
- or **at least once a year**



Note

- ▶ Shortening the inspection interval: The older a rope is the more frequently will wire breaks occur.

Determining factors for determination of inspection intervals are:

- Legal regulations in the country where the crane is operated
- Climate conditions under which the rope drive is utilized
- Power train group
- Results of previous inspections on current or comparable machine and under comparable operating conditions
- Frequency and type of use of a rope
- Service life of rope

7 Areas



WARNING

Broken wires and distortions on ropes in cross over areas!

Rope performance can be greatly reduced. Rope breakage. Death, severe injuries, property damage.

- ▶ Check rope cross over areas especially diligently.

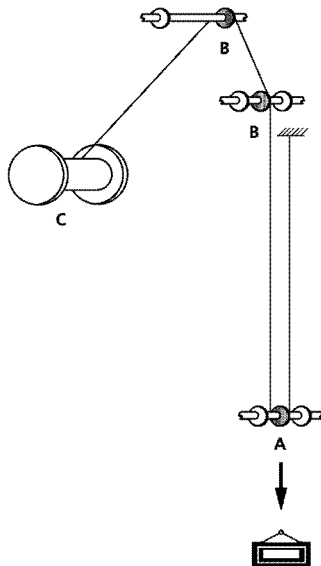

Fig.120969: Important inspection areas for multi layer spooled up ropes

- | | |
|--|---|
| <p>A Rope sections, which run in the area of the load rise into the lower rope pulleys (the load is raised here).</p> <p>B Rope intake on the first rope pulley in the area of the load rise</p> | <p>C Rope sections, which are subjected in the cross over areas to the strongest effects (maximum deflection angle).</p> |
|--|---|

The rope must be checked over the entire length.

The following areas must be checked with special care:

- Rope end connections
- Safety coils and fixed point on the winch
- Areas of the rope which run through the hook block.
- Areas of the rope that run over the rope pulleys or lay on the rope pulleys.
- Areas of the rope that are spooled on the winch, especially cross over areas.
- Areas of the rope which are laying above the compensation pulleys.
- Areas of the rope which are subjected to abrasion due to external components.
- All areas of the rope that are subjected to temperatures above 60 °C.

8 Documenting inspection results



Note

- ▶ Document the results of the inspections in an inspection checklist.
- ▶ Form for an inspection checklist, see section „Current checklist“.

9 Wire ropes and rope end connections



WARNING

Wire rope with impermissible rope end connection!

The wire rope can fail. The load can fall down.

Death, severe bodily injuries, property damage.

- ▶ Select the permissible rope type for the respective application.
- ▶ Select the permissible rope end connection for the respective rope type.
- ▶ Observe and adhere to the warning display on the lock.

Wire rope application	Rope type
Hoist rope	Rotation-resistant rope
Guy rope or control rope	Non-rotation resistant rope
Auxiliary rope or assembly rope	Non-rotation resistant rope

Rope type depending on the application

The type of rope that is selected determines the corresponding rope end connections.

9.1 Rotation-resistant ropes with rope end connections

Use rotation-resistant ropes as **hoist ropes**.

Rotation-resistant ropes are special ropes that produce extremely little torque and twisting at the rope end connection when they are under strain.

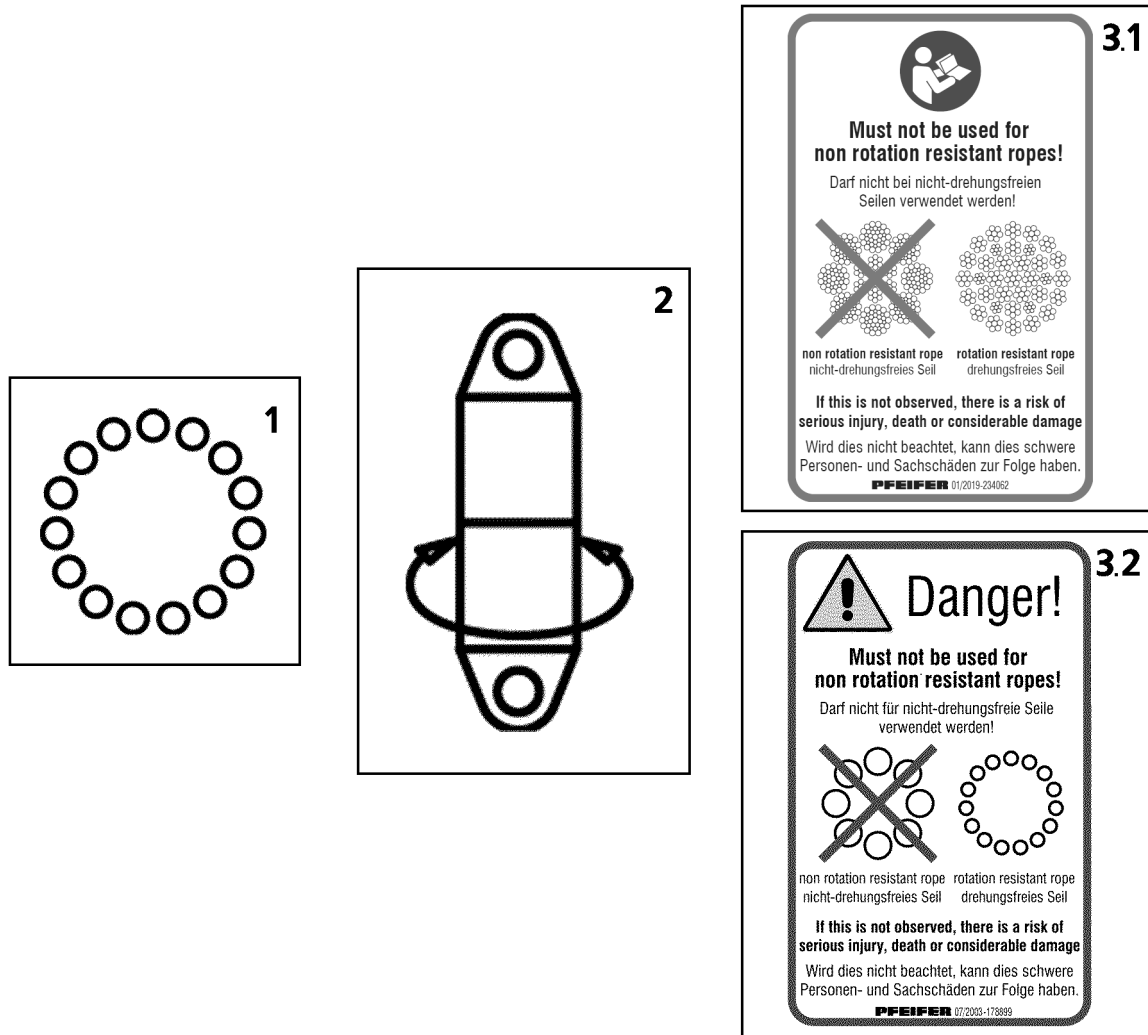

Fig.154083: Symbols for rotation-resistant ropes with rope end connections

- | | | | |
|---|-------------------------------------|-----|--|
| 1 | Rotation-resistant rope symbol | 3.1 | Variation 1: Warning display on the PFEIFER lock |
| 2 | Rotating rope end connection symbol | 3.2 | Variation 2: Warning display on the PFEIFER lock |

Typical rotation-resistant rope structures are wire ropes with 15 to 18 outer strands. Rotation-resistant ropes are symbolically depicted with 15 outer strands (circles), see illustration 1.

9.1.1 Non-rotating rope end connection



Note

- ▶ In the case of a rotation-resistant ropes, Liebherr recommends the use of a lock **without** a swivel or a wedge lock. This can reduce the stress on the hoist ropes.

9.1.2 Rotating rope end connection



Note

- ▶ In the case of rotation-resistant ropes, Liebherr recommends **not** using a lock **with** a swivel and **not** to use a twist compensator / swivel.

To reduce a problematic turning behavior, the following rope end connections can be used in an individual case and after consultation with Liebherr customer service:

- Lock **with** swivel

- Twist compensator / swivel

9.2 Non-twisting ropes with rope end connections



WARNING

Wire rope with impermissible rope end connection!

The wire rope can fail. The load can fall down.

Death, severe bodily injuries, property damage.

- ▶ Use a lock **without** a swivel or a wedge lock.
- ▶ **Never** use a lock **with** a swivel with non-twisting rope.
- ▶ **Never** use a twist compensator / swivel with a non-twisting rope.

Use non-twisting ropes as **guy ropes** or **control ropes**, **auxiliary ropes** or **assembly ropes**.

Non-twisting ropes generate high torque levels on the rope end connection under strain. For this reason, the rope ends must be protected from twisting using an appropriate rope end connection to prevent the wire rope from unscrewing under strain.

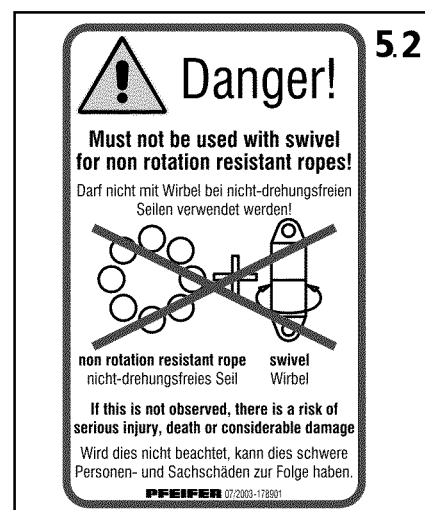
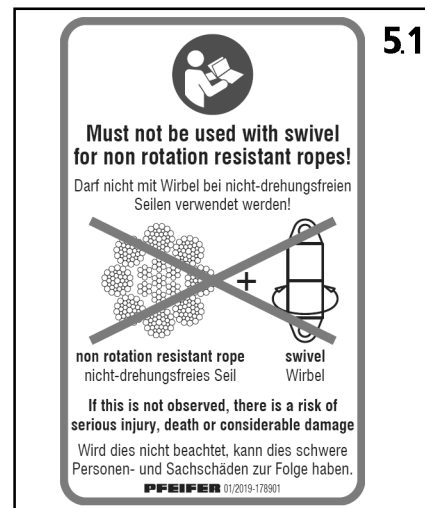
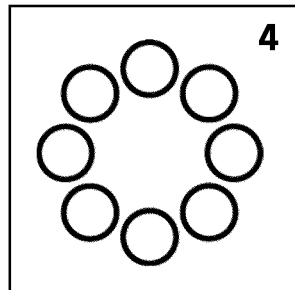

Fig.154084: Symbols for non-twisting ropes with rope end connections

4 Non-twisting rope symbol

5.2 Variation 2: Warning display on the PFEIFER lock / wedge lock

5.1 Variation 1: Warning display on the PFEIFER lock / wedge lock

Typical non-twisting rope structures are wire ropes with eight or ten outer strands. Non-twisting ropes are symbolically depicted with eight outer strands (circles), see illustration 4.

Only use non-twisting ropes with the following **non-twisting** rope end connections:

- Lock **without** swivel
- Wedge lock

A non-rotating rope end connection is also the mounting of the rope on the fixed point of the winch drum.

10 Degree of severity

The deciding factor for the removal criteria is which removal criteria are present and to which degree they occur.

When various removal criteria are **not** present to a full degree, then the removal criteria must be evaluated as a total entity. For every individual removal criteria a degree of severity must be determined (percentage value).

For a certain rope section the sum of individual degrees of severity results in a **combined degree of severity**, see section „Combined degree of severity“.

When the combined degree of severity is more than 100 %, then the rope must be taken down.

11 Abbreviations Rope diameter

Abbreviations	Description
Rope nominal diameter d	Rope diameter, identification of rope
Reference diameter d_{ref}	Measured rope diameter of a straight rope section, directly after placing the rope
6d	Length of 6-fold rope nominal diameter
30d	Length of 30-fold rope nominal diameter

Abbreviations Rope diameter

12 Distortions and mechanical damage



WARNING

Distortions and mechanical damage!

Operational safety significantly disturbed, uneven load distribution within the rope.

- ▶ Have the manufacturer check if the distorted and damaged area can be severed.

Visible form changes often occur localized or in short rope sections.

When a safe operation of the rope is ensured, a distorted and damaged area can be severed.

13 Removal criteria Overview

The following chart provides an overview between removal criteria and the respective method for inspection. The degree is described, when the removal criteria is reached.

The removal criteria is described in detail in the subsequent sections.

**Note**

When the rope for parallel operation has reached the removal criteria:

- ▶ Often, both ropes must be replaced. The new rope has a larger diameter and other elongation characteristics.

Removal criteria	Degree for removal criteria	Inspection method
Broken strands	One strand is broken	Visual check
Broken wires on ropes, which run over rope pulleys and are spooled in multiple layers	Maximum number of broken wires reached, see Section Determining the number of broken wires	Count
Broken wire in the strand valleys	Two or more broken wires in strand valleys, on the contact points of two neighboring strands within an angular length (corresponds approx. to 6d)	Count
Broken wires in the area of the rope end connection	Two or more broken wires, according to decision of expert personnel for crane rope inspection	Visual inspection, test with marlin spike
Broken wire nests	On occurrence	Visual check
Reduction rope diameter at even diameter reduction	Maximum reduction of rope diameter reached	Measurement, calculation
Localized increase of rope diameter	Maximum increase of rope diameter reached	Measurement
Significant corrosion	Surface of rope is significantly affected or rust film emerges, according to decision of expert personnel for crane rope inspection	Visual check
Corkscrew-like distortion	Maximum permissible distortion reached	Measurement, calculation
Basket formation	On occurrence	Visual check
Wires or bunches of wires protruding from the rope	On occurrence, if more than one wire protrudes from the rope	Visual check
Flattenings	Larger than half of the diameter of the outer strand, according to decision of expert personnel for crane rope inspection	Visual check
Loop formation	Loops on several wires	Visual check
Kinking or remaining distortion	On occurrence	Visual check
Buckles or contusions	On occurrence, according to decision of expert personnel for crane rope inspection	Visual check

Removal criteria	Degree for removal criteria	Inspection method
Heat influence, electric voltage	Bluish discoloration, broken or melted wires	Visual check
Damage on rope end connections: Material cracks, deformation, wear, corrosion, traces of slipping between the locking clamp and rope	According to decision of expert personnel for crane rope inspection	Visual inspection
Combined degree of severity	Degree of severity 100 % or above, according to decision of expert personnel for crane rope inspection	Calculation of individual degrees of severity

Removal criteria Overview

14 Checking for broken strands

A strand consists of several individual wires.

If a complete strand is broken:

- ▶ Take the rope down.

15 Determining the number of broken wires

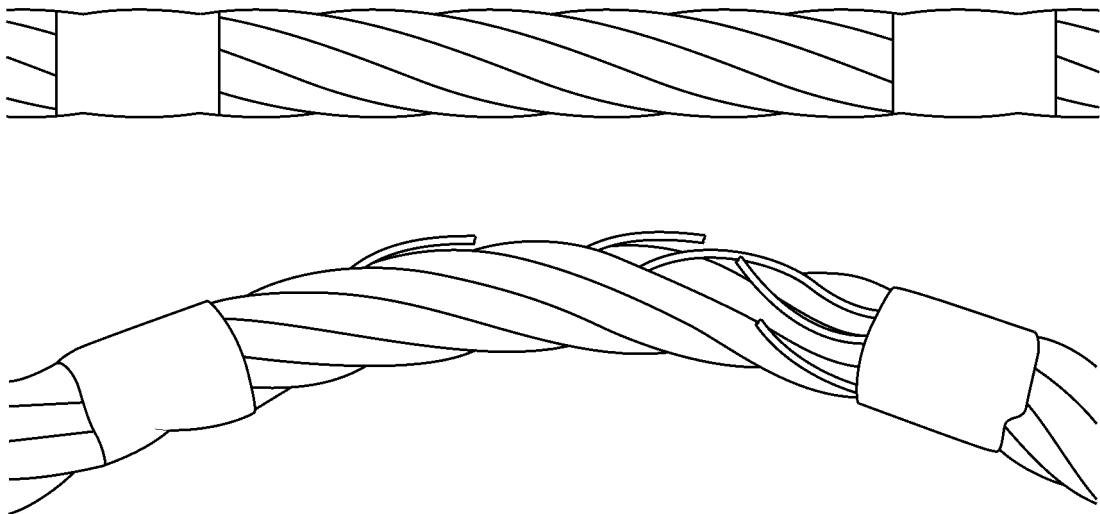

Fig.120980: Determine broken wires by bending

By bending the rope, broken wires can be recognized better.

Make sure that the following prerequisites are met:

- The rope is clean.
- Inspection checklist is on hand.

15.1 Scattered occurring broken wires

The following different rope types each have their own chart for the permissible number of broken wires:

- Single layer and parallel roped ropes

- Rotation resistant ropes

The charts in this section are valid exclusively for **scattered occurring broken wires**.

15.1.1 Wire break increase rate

The wire break increase rate is an increase of broken wires, which can skyrocket with increasing use of the rope.

- ▶ Include the inspection checklists for the previous inspection and use it to draw a conclusion for the wire break rate increase.

15.1.2 Single layer and parallel roped ropes

Rope category number RCN	Total number of load carrying wires in the outer strand layer of rope ¹ n	Number of visible outer wire breaks ²					
		Rope sections, which run over steel pulleys and / or wind up on a single layer spooling drum (coincidental distribution of broken wires)				Rope sections, which wind up on a multi layer drum ³	
		Class M1 to M4, or class unknown ⁴				All classes	
		Lang lay		Even lay		Lang lay and even lay	
		Over a length of 6d ⁵	Over a length of 30d ⁵	Over a length of 6d ⁵	Over a length of 30d ⁵	Over a length of 6d ⁵	Over a length of 30d ⁵
01	$n \leq 50$	2	4	1	2	4	8
02	$51 \leq n \leq 75$	3	6	2	3	6	12
03	$76 \leq n \leq 100$	4	8	2	4	8	16
04	$101 \leq n \leq 120$	5	10	2	5	10	20
05	$121 \leq n \leq 140$	6	11	3	6	12	22
06	$141 \leq n \leq 160$	6	13	3	6	12	26
07	$161 \leq n \leq 180$	7	14	4	7	14	28
08	$181 \leq n \leq 200$	8	16	4	8	16	32
09	$201 \leq n \leq 220$	9	18	4	9	18	36
10	$221 \leq n \leq 240$	10	19	5	10	20	38
11	$241 \leq n \leq 260$	10	21	5	10	20	42
12	$261 \leq n \leq 280$	11	22	6	11	22	44

Rope category number RCN	Total number of load carrying wires in the outer strand layer of rope ¹ n	Number of visible outer wire breaks ²					
		Rope sections, which run over steel pulleys and / or wind up on a single layer spooling drum (coincidental distribution of broken wires)				Rope sections, which wind up on a multi layer drum ³	
		Class M1 to M4, or class unknown ⁴				All classes	
		Lang lay		Even lay		Lang lay and even lay	
		Over a length of 6d ⁵	Over a length of 30d ⁵	Over a length of 6d ⁵	Over a length of 30d ⁵	Over a length of 6d ⁵	Over a length of 30d ⁵
13	281 ≤ n ≤ 300	12	24	6	12	24	48
	n > 300	0.04 x n	0.08 x n	0.02 x n	0.04 x n	0.08 x n	0.16 x n

Note: Ropes with outer strands in the Seale type, number of wires per strand 19 or less (for example 6 × 19 Seale), are classified in this chart as two lines over the line, which would be defined due to the number of load carrying wires in the outer strands.

Number of visible broken wires (reached or exceeded) for removal criteria is reached, for **single-layer** and **parallel roped** ropes according to **DIN ISO 4309**

- 1) For the purpose of this international standard, fill wires are not considered to be load carrying wires and are not included in the value for n.
- 2) A broken wire has two ends (counted as one wire).
- 3) The values apply for damage in the cross over areas and the layers of coils due to deflection angles (not for rope sections, which run only over rope pulleys and do not spool up on the winch).
- 4) For ropes on drive gears of groups M5 to M8 twice the number of broken wires listed can be used.
- 5) d = Rope nominal diameter

- ▶ Check the rope over the entire length for visible broken wires.

When visible broken wires are scattered present:

- ▶ On the point of a broken wire, mark the rope sections on a length of 30d in both directions.
- ▶ Count visible broken wires in the marked rope sections and record them.
- ▶ Take the RCN (Rope category number) from the manufacturer's documentation of the rope.

When the make for single layer and parallel roped ropes is **not** listed in the chart:

- ▶ Determine the total number of load carrying wires in the rope: Add all wires in the strands of the outer layer, do **not** count fill wires.
- ▶ Compare the number of broken wires of each marked rope section 30d with the number of broken wires in the chart.

When the number of visible broken wires is smaller than listed in the chart:

- ▶ Within the rope section with the most broken wires: Mark the rope section with the most broken wires on a length of 6d.
- ▶ Count visible broken wires in the marked rope sections 6d and record them.
- ▶ Compare the number of broken wires of the marked rope section with the number of broken wires in the chart.

When the number of visible broken wires is equal to or larger than that listed in the chart:

- ▶ Take the rope down.
- ▶ Enter the results in the inspection checklist.

15.1.3 Rotation resistant ropes

Rope category number RCN	Total number of load carrying wires in the outer strands of rope ¹ n	Number of visible outer wire breaks ²			
		Rope sections, which run over steel pulleys and / or wind up on a single layer spooling drum (coincidental distribution of broken wires)		Rope sections, which wind up on a multi layer drum ³	
		Over a length of 6d ⁴	Over a length of 30d ⁴	Over a length of 6d ⁴	Over a length of 30d ⁴
21	4 strands n ≤ 100	2	4	2	4
22	3 or 4 strands n ≥ 100	2	4	4	8
	At least 11 strands in the outer layer				
23-1	71 ≤ n ≤ 100	2	4	4	8
23-2	101 ≤ n ≤ 120	3	5	5	10
23-3	121 ≤ n ≤ 140	3	5	6	11
24	141 ≤ n ≤ 160	3	6	6	13
25	161 ≤ n ≤ 180	4	7	7	14
26	181 ≤ n ≤ 200	4	8	8	16
27	201 ≤ n ≤ 220	4	9	9	18
28	221 ≤ n ≤ 240	5	10	10	19
29	241 ≤ n ≤ 260	5	10	10	21
30	261 ≤ n ≤ 280	6	11	11	22
31	281 ≤ n ≤ 300	6	12	12	24
	n > 300	6	12	12	24

Note: Ropes with outer strands in Seale type, number of wires in each strand 19 or less (for example 18 × 19 Seale - WSC), are classified in this chart as two lines over the line, which would be defined due to the number of load carrying wires in the outer strands.

*Number of visible broken wires (reached or exceeded) is achieved in the rope removal criteria, for **rotation-resistant** ropes according to **DIN ISO 4309***

- 1) For the purpose of this international standard, fill wires are not considered to be load carrying wires and are not included in the value for n.
- 2) A broken wire has two ends (counted as one wire).
- 3) The values apply for damage in the cross over areas and the layers of coils due to deflection angles (not for rope sections, which run only over rope pulleys and do not spool up on the drum).
- 4) d = Rope nominal diameter

- ▶ Check the rope over the entire length for visible broken wires.

When visible broken wires are scattered present:

- ▶ On the point of a broken wire, mark the rope sections on a length of 30d in both directions.
- ▶ Count visible broken wires in the marked rope sections and record them.
- ▶ Take the RCN (Rope category number) from the manufacturer's documentation of the rope.

When the make for rotation-resistant ropes is **not** listed in the chart:

- ▶ Determine the total number of load carrying wires in the rope: Add all wires in the strands of the outer layer, do **not** count fill wires.

- ▶ Compare the number of broken wires of each marked rope section 30d with the number of broken wires in the chart.

When the number of visible broken wires is smaller than listed in the chart:

- ▶ Within the rope section with the most broken wires: Mark the rope section with the most broken wires on a length of 6d.
- ▶ Count visible broken wires in the marked rope sections 6d and record them.
- ▶ Compare the number of broken wires of the marked rope section with the number of broken wires in the chart.

When the number of visible broken wires is equal to or larger than that listed in the chart:

- ▶ Take the rope down.
- ▶ Enter the results in the inspection checklist.

15.2 Broken wire in the strand valleys

The broken wires in these areas point to the fact that the condition in the inside of the rope is deteriorating.

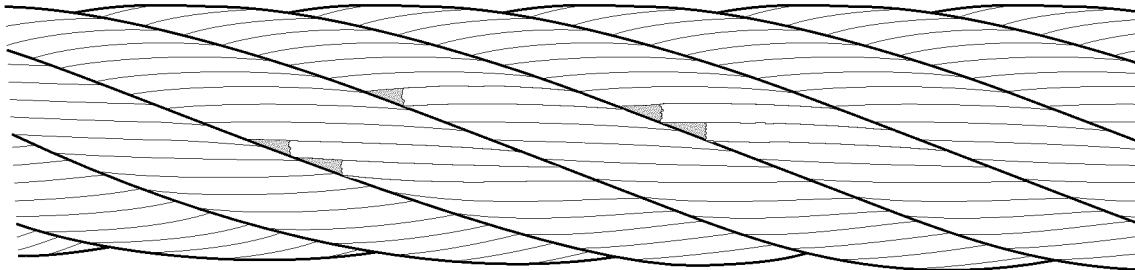

Fig.121005: Broken wire in the strand valleys

When two or more broken wires occur within a 6d long rope section:

- ▶ Take the rope down.

15.3 Broken wires on rope end connections

- ▶ Check the area near the rope end connections and carefully check for broken wires.

Loose wires are a sign of broken wires in the rope end connection.

- ▶ Use a marlin spike to check for loose wires.

When broken wires are near a rope end connection and two or more wires are affected:

- ▶ Take the rope down.

or

When the remaining rope lengths fulfil the minimum number of remaining coils in all operating positions:

- ▶ Shorten the rope, see chapter 7.05.50.
- ▶ Attach the rope end connection.

15.4 Broken wires in rope sections, which are not spooled up on the winch

When the broken wires are concentrated on one or two strands, the removal criteria can be present at fewer broken wires as noted in the chart (rope section in the length of 6d).

- ▶ Have the rope removal criteria determined by **expert personnel for crane rope inspection**.

15.5 Broken wire nests

When broken wires are very close to each other or when the broken wires are concentrated on one strand, then the rope must be taken down, even at fewer broken wires than noted in the chart (rope section 6d).

- ▶ Have the rope removal criteria determined by **expert personnel for crane rope inspection**.

16 Checking the rope end connection

The removal criteria are evaluated by the **expert personnel for crane rope inspection**.

Check for broken wires, see section „Broken wires on rope end connections“.

16.1 Pressed rope end connection

Example of a pressed rope end connection: Locking clamp.

- ▶ Check the rope end connections for signs of possible slipping between the locking clamp and the wire rope.
- ▶ Check the rope end connections for material cracks.
- ▶ Check rope end connections for corrosion, deformation and wear.

16.2 Enlarged rope end connection

Example of an enlarged rope end connection: Locking cast sleeve.

- ▶ If present: Remove the beam.
- ▶ Check rope end connections for corrosion, deformation and wear.

If the rope connection is on a flat rope:

- ▶ Check the cone setting, see chapter 8.04.10.

16.3 Detachable rope end connection

Example of a detachable rope end connection: Wedge lock.

- ▶ Check that the rope end connections are fit tightly and correctly installed.
- ▶ Check the wire rope inside and at the outlet of the rope end connection. Check the rope according to the removal criteria in this chapter.

17 Checking of rope diameter

17.1 Even reduction of rope diameter



WARNING

Spooling problems due to reduced rope diameter!

- ▶ Take the rope down even when the removal criteria according to **DIN ISO 4309** has not yet been reached.

The values in this section do **not** apply for rope sections, which were damaged in cross over areas due to multi layer spooling on a winch.

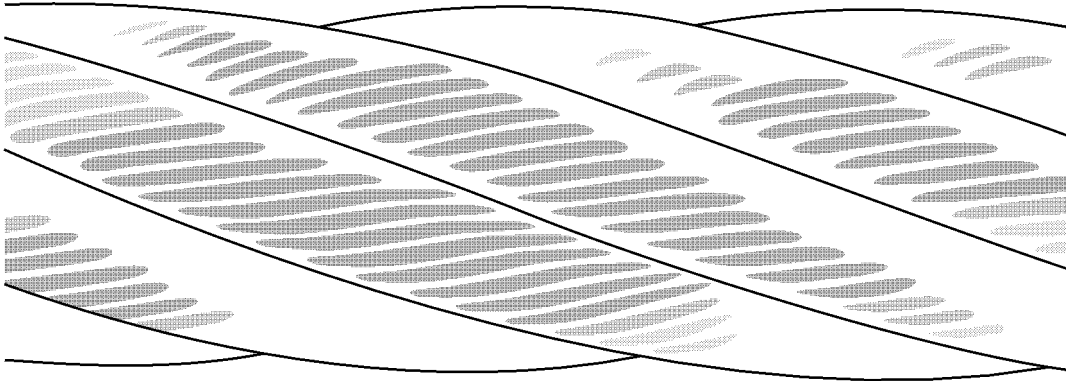

Fig.121001: External abrasion on the rope

The rope diameter changes due to abrasion, settling and external influences.

Abrasion of cover wires of outer strands of rope due to frictional contact. Especially in those areas where ropes are in contact with the rope pulleys during start up or slow down of the load.

Wear is increased by lack of or incorrect lubrication and the effect of dust.

Abrasion reduces the tensile strength of steel ropes because the cross section of the steel is reduced.

Additional possible causes for reduction of rope diameter:

- Wear in the inside of the rope
- Wear of fiber insert
- Breakage of a steel insert
- Broken inner strands

This section is valid solely for the following ropes:

- Ropes, which wind up on single layer winches
- Ropes, which run through a steel rope pulley

$$d_v = \frac{d_{\text{ref}} - d_m}{d} \times 100 \%$$

Fig.121372: Formula Reduction of rope diameter

d_v = even reduction of rope diameter

d_{ref} = rope diameter, which was determined before placement

d_m = measured rope diameter

d = rope nominal diameter: Take value from inspection checklist

The following chart applies exclusively for ropes, which wind up on single layer winches and / or run through a steel rope pulley.

Rope type	Even reduction of diameter d_v (in percentages of rope nominal diameter d)	Classification of degree of severity	
		Description	%
	Less than 6 %	—	0
Single layer rope with fiber insert	6 % and above, but less than 7 %	Light	20
	7 % and above, but less than 8 %	Medium	40
	8 % and above, but less than 9 %	High	60
	9 % and above, but less than 10 %	Very high	80
	10 % and above	Rope removal criteria	100

Rope type	Even reduction of diameter d_v (in percentages of rope nominal diameter d)	Classification of degree of severity	
		Description	%
Single layer rope with steel insert or parallel roped rope	Less than 3.5 %	—	0
	3.5 % and above, but less than 4.5 %	Light	20
	4.5 % and above, but less than 5.5 %	Medium	40
	5.5 % and above, but less than 6.5 %	High	60
	6.5 % and above, but less than 7.5 %	Very high	80
	7.5 % and above	Rope removal criteria	100
Rotation-resistant rope	Less than 1 %	—	0
	1 % and above, but less than 2 %	Light	20
	2 % and above, but less than 3 %	Medium	40
	3 % and above, but less than 4 %	High	60
	4 % and above, but less than 5 %	Very high	80
	5 % and above	Rope removal criteria	100

Degree of severity and removal criteria depending on rope type and even diameter reduction according to DIN ISO 4309

The medium value from the smallest and the largest measured diameter results in the value for d_m .

- ▶ Measure rope diameter on several locations and calculate measured diameter d_m .
- ▶ Calculate even reduction d_v of rope diameter with formula.
- ▶ Read the degree of severity in the chart, depending on the rope type.
- ▶ Document the degree of severity in the inspection checklist.

When the degree of severity has reached 100 %:

- ▶ Take the rope down.

17.2 Localized reduction of rope diameter

Localized reductions of rope diameter point to the fact that a rope insert may have failed, for example.

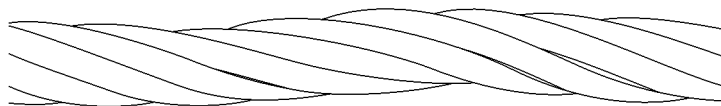

Fig. 120983: Localized reduction of rope diameter

- ▶ Check the rope for localized reduction of rope diameter.

When a localized reduction of the rope diameter is found:

- ▶ Take the rope down.

17.3 Localized increases of rope diameter

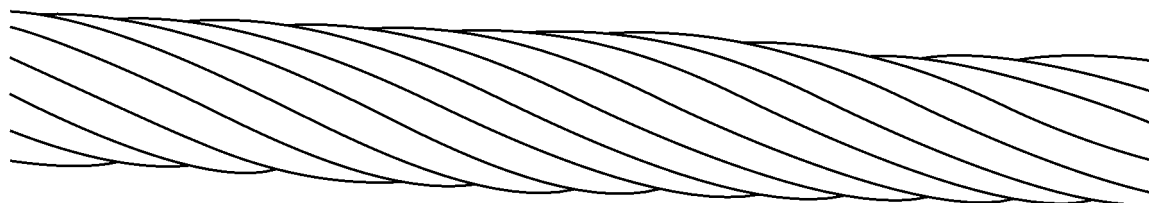

Fig.120992: Localized increase of rope diameter

An increase over a longer area of the rope can be caused by absorption of moisture in the fiber insert or due to corrosion in the inside of the rope.

Rope insert	Maximum increase of rope diameter during operation
Steel	5 %
Fiber	10 %

- ▶ Check the rope for increases in rope diameter.

When the increases exceed the maximum values:

- ▶ Take the rope down.

18 Corrosion

Corrosion occurs due to insufficient lubrication, in maritime climates and in an atmosphere polluted by industrial fumes.

External corrosion is indicated by a rough wire surface. A superficial rust film can be wiped off.

Significant corrosion reduces the strength and elasticity of the rope due to the reduction of the rope diameter.

Inner corrosion is hard to detect.

Do **not** use solvents to clean the rope.

Make sure that the following prerequisite is met:

- Rope is cleaned (wiped and brushed).

18.1 External corrosion

The various types of corrosion are classified and noted with the classification for removal criteria in percentages:

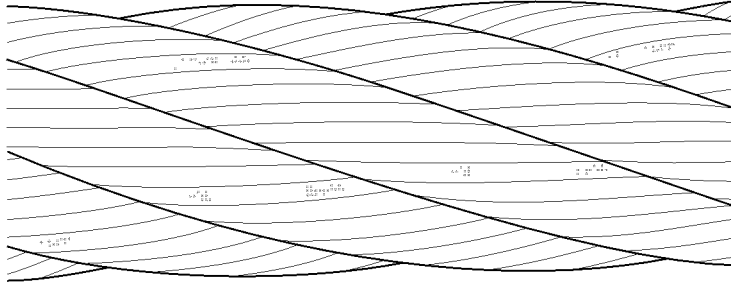

Fig.120984: Surface light corrosion: Classification 0 % of removal criteria

Superficial light corrosion (rust film) can be wiped off.

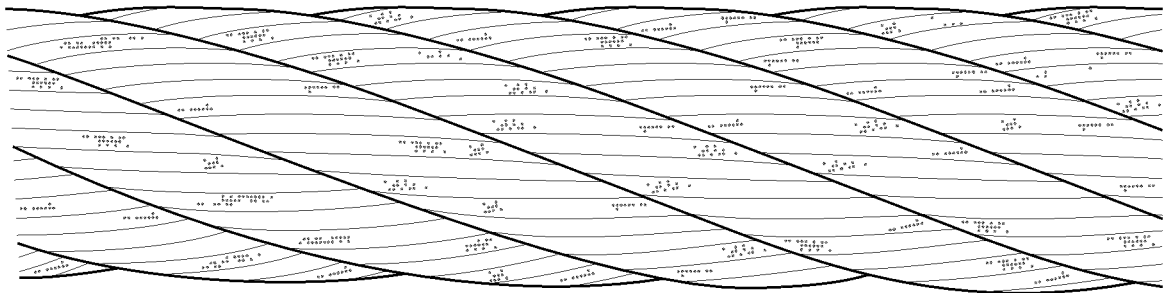

Fig.120985: Surface feels rough: Classification 20 % of removal criteria

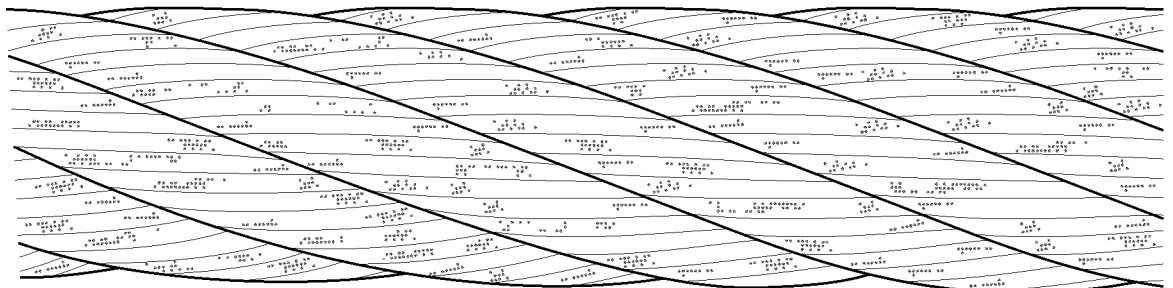

Fig.120986: Surface feels very rough: Classification 60 % of removal criteria

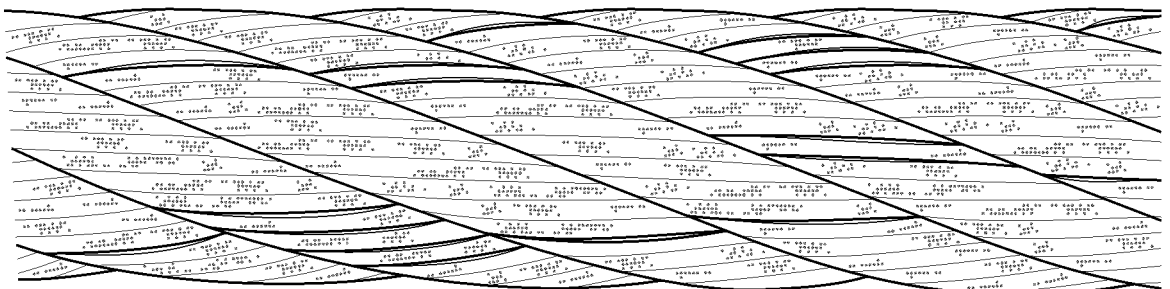

Fig.120987: Surface very decayed, spaces between individual wires can be easily recognized: Classification 100 % of removal criteria

When 100 % of removal criteria is reached:

- ▶ Take the rope down.

18.2 Internal corrosion

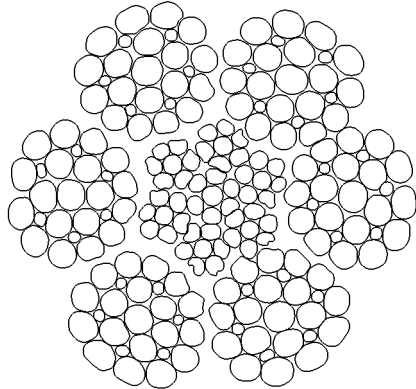

Fig.120982: Corrosion in the inside of the rope

Internal corrosion is present when clearly visible corrosion particles migrate between the valleys of the outer strands: Classification 100 % removal criteria.

When internal corrosion is found:

- ▶ Have the rope removal criteria evaluated by **expert personnel for crane rope inspection** or take the rope down.

18.3 Friction corrosion

Friction corrosion occurs as a type of brown powder, which migrates from the inside of the rope to the outside: Classification 100 % of removal criteria.

- ▶ Check the rope diligently for friction corrosion.

If friction corrosion is found:

- ▶ Have the rope removal criteria evaluated by **expert personnel for crane rope inspection** or take the rope down.

19 Corkscrew-like distortion



Fig.120988: Corkscrew-like distortion

Distortion where the rope is in the form of a corkscrew along its longitudinal axis.

Effects of corkscrew-like distortion:

- Irregular rope drive
- Rope wear
- Broken wire
- Bearing damage on rope pulleys

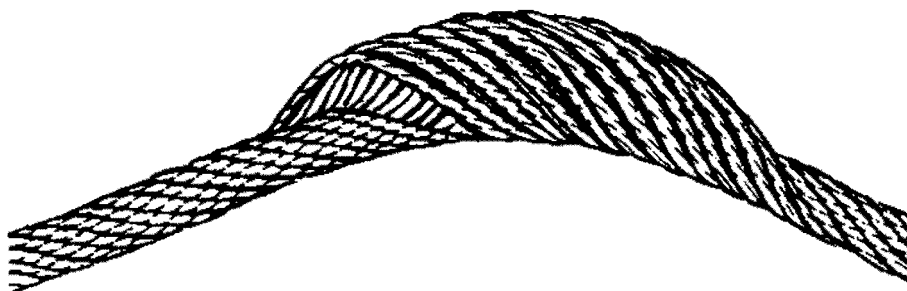

Fig.120989: Basket formation

- ▶ Check the entire rope for basket formation.

When basket formation is present:

- ▶ Take the rope down.

21 Protruding, distorted insert or strand

This distortion is a special form of basket formation. The insert or the core of the rope protrudes between the outer strands or an outer strand protrudes from the rope banding.

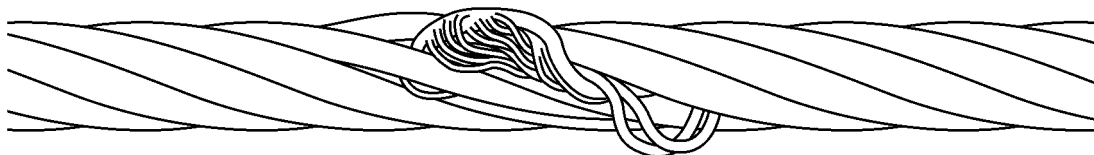

Fig.120990: Protrusion of an insert (rope single layer)



Fig.120991: Distorted or protruding strand

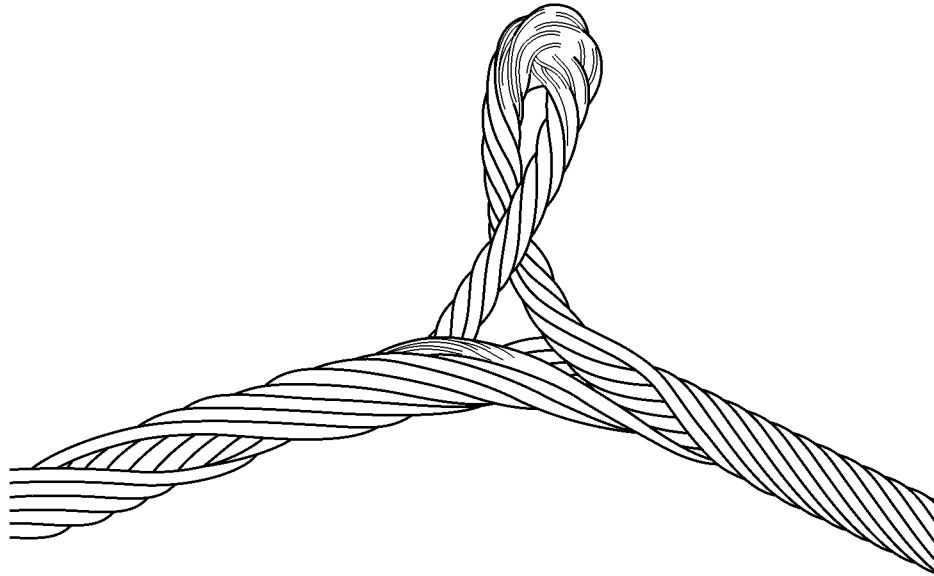

Fig.121373: Protrusion of rope insert on rotation-resistant rope

When the insert or a strand protrudes or is distorted, take the rope down. Have authorized inspector for crane rope inspection check if the rope area with the distortion can be removed.

- ▶ Check the entire rope for protruding, distorted insert or strand.

When protruding, distorted insert or braid is present:

- ▶ Take the rope down.
- ▶ Have **expert personnel for crane rope inspection** check if the rope area with the distortion can be removed.

22 Loop formation

At loop formation individual or several wires protrude from the rope and bulge upward (bird-caging).

These areas are most often on the opposite side of the rope pulley groove.

Make sure that the following prerequisite is met:

- There are **no** broken wire ends present.

If only a core wire of the rope insert protrudes through the outer strands, then the rope does not have to be taken down when:

- The wire can be removed.
- The wire does not disturb other elements of the rope drive.

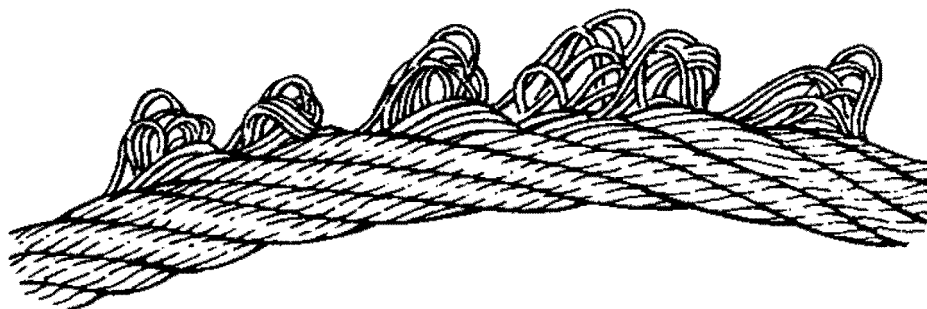

Fig.120993: Emergence of individual wires

- ▶ Check rope for loop formation.

When solely a core wire protrudes:

- ▶ Remove the core wire.

When several wires are affected from the loop formation:

- ▶ Take the rope down.

23 Kinking or rope loops pulled closed

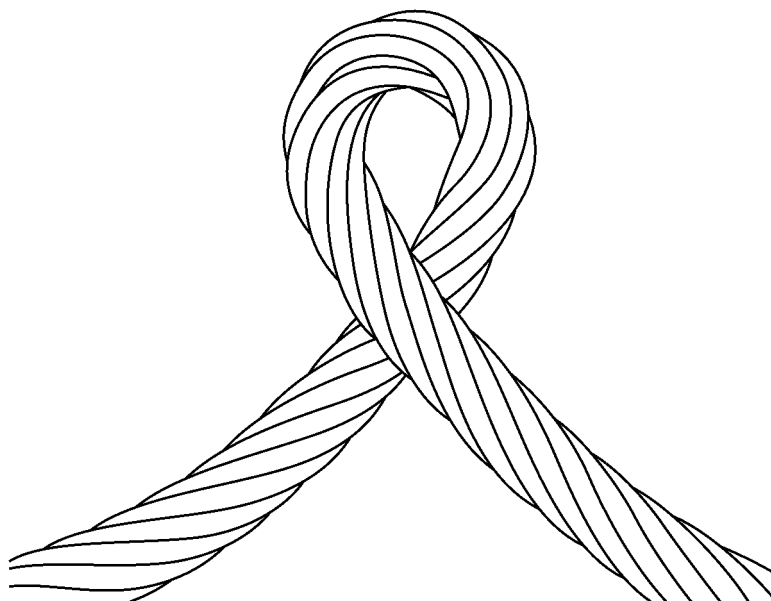

Fig.121007: Kinking or rope loop pulled closed

At this deformation a loop has formed in the rope, without the possibility to rotate around its own axis during a load. The rope is subjected to significant wear.

The rope is significantly distorted. The strength remains only in part.

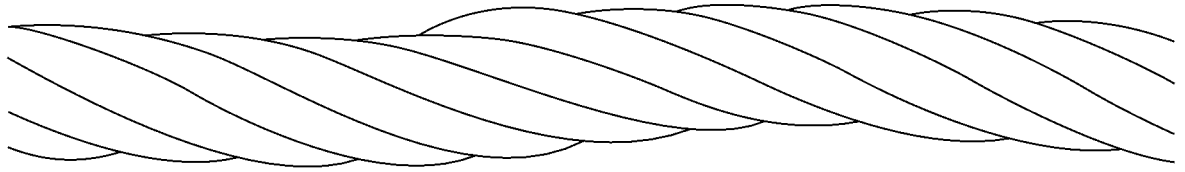

Fig.121002: Positive Kinking

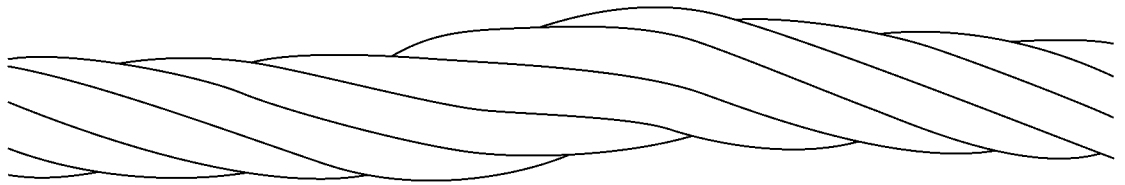

Fig.121003: Negative Kinking

- ▶ Check the rope for kinking or rope loops pulled closed.

When kinking or rope loops pulled closed occur:

- ▶ Take the rope down.

24 Buckles

Buckles are angular deformations. The rope was damaged due to external influences. Strong deformations of the rope cause stronger wear.

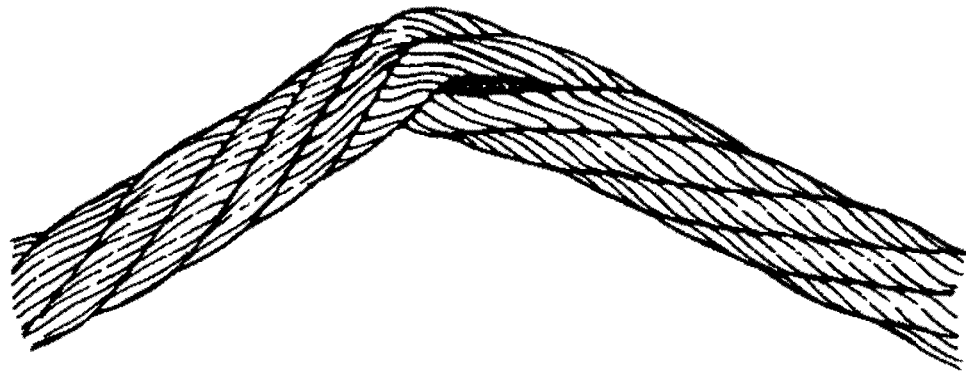

Fig.120999: Severe buckle

A buckle is a serious matter if a fold is visible on the underside of the rope.

When buckles are present:

- ▶ Have the rope inspected by **expert personnel for crane rope inspection**.

When a distortion and degree of severity permits further operation:

- ▶ Shorten the inspection interval.

When the removal criteria is reached:

- ▶ Take the rope down.

25 Effects of heat, arcs

Damage caused to the rope by welding work, for example.

Exceptional thermal effect is visible through tempering colors, the loss of lubricant and by localized melting of wires.

When thermal effect has occurred on the rope:

- ▶ Take the rope down.

26 Combined degree of severity



Note

- ▶ For a method to determine the effect of a combined degree of severity and damage to the rope, see **DIN ISO 4309**.

When the condition of the rope deteriorates, then often a combination of various causes occurs.

To determine the degree of severity, the **expert personnel for crane rope inspection** must:

- take different damage within a rope section into account
- evaluate the entire effect of the damage and the distortions
- decide about the operational safety of the rope
- evaluate if inspection intervals must be adjusted
- decide if the rope must be taken down

When the combined degree of severity is more than 100 %, then the rope must be taken down.

27 Flattenings

Effects of flattenings on the rope:

- Rope sections with flattenings, which move **over the rope pulleys** tend to higher wear and a higher number of broken wires.
- Rope pulleys can be damaged.
- Flattenings on **stationary ropes** (guy ropes boom) promote quicker corrosion, especially in the areas where the outer strands have opened.

Flattened rope sections must be checked in shorter intervals for broken wires and corrosion.

27.1 Shorting the intervals

- ▶ Check the entire rope for flattenings.

When flattenings are present on stationary ropes:

- ▶ Shorten the intervals for rope inspection.

When it is **not** possible to shorten the intervals for the rope inspection:

- ▶ Take the rope down.

27.2 Improper mechanical damage

An improper mechanical damage occurs, for example, when the rope is trapped.

- ▶ Take the rope down immediately or shorten it, see chapter 7.05.50.

27.3 Operational transverse pressure

Operational transverse pressure causes flattenings, for example in the incline range of multi layer spooling.

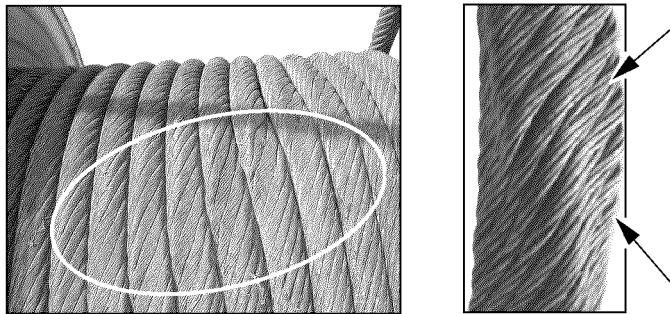

Fig.114002: Flattenings

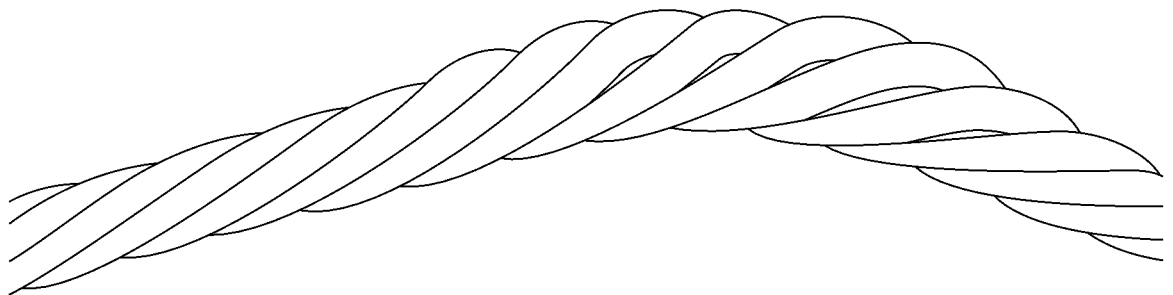

Fig.120996: Flattenings on multi layer windings

- ▶ Check the first rope layer of the winches for crushed areas and distortions.

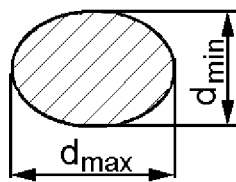

Fig.121006: Largest and smallest diameter on the distortion area

$$V = \frac{d_{\max} - d_{\min}}{d} \times 100 \%$$

Fig.121374: Formula to calculate the distortion

V Rope distortion in percentages

d_{max} Largest diameter of distortion area

d Rope nominal diameter

x

d_{min} Smallest diameter of distortion area

n

When distortions are present:

- ▶ Determine the number of broken wires See section „Determining the number of broken wires“.

When the number of permissible broken wires is exceeded:

- ▶ Take the rope down.
- ▶ Calculate the distortion V with the formula and document it in the inspection checklist.

When distortion V is larger than 5 %:

- ▶ Check the rope before every assembly and erection procedure.

When distortion V is larger than 10 %:

- ▶ Document the degree of severity of 50 % in the inspection checklist.

When distortion V is larger than 20 %:

- ▶ The degree of severity of 100 % is reached: Take the rope down.

8.05 Inspection of load hooks

1	Safety instructions	2
2	Inspection intervals	2
3	Checking the load hook	2

1 Safety instructions



WARNING

The load hook did **not** pass the inspection!
The load hook can rip. The fastened load can fall down.
Death, severe bodily injuries, property damage.

If the load hook did **not** pass the inspection:

- ▶ Replace the load hook with the hook nut.
- ▶ Contact Customer Service at Liebherr-Werk Ehingen GmbH.



WARNING

Incorrect remedy of defects!

The load hook can rip. The fastened load can fall down.
Death, severe bodily injuries, property damage.

- ▶ Have defects remedied by authorized, trained expert personnel.



WARNING

Welds on the load hook!

The load hook can rip. The fastened load can fall down.
Death, severe bodily injuries, property damage.

- ▶ Do **not** weld the load hook, to repair defects, for example.

2 Inspection intervals

To detect defects in time and avoid accidents, observe the following instructions:

- Have the load hook checked as required, however **at least once a year** by an authorized inspector.
- Observe the national regulations concerning the inspection of load hooks.

3 Checking the load hook

The following points must be documented in the crane inspection log:

- Performance of the inspections
- Defects and damage
- Measures for remedying the defects and damage

3.1 Checking the load hook for distortion

3.1.1 Hook shaft

If distortion is visible on the hook shaft:

- ▶ Replace the load hook with the hook nut.

3.1.2 Hook jaw

Identifying the manufacturing method

Depending on the moment at which a load hook is delivered, the manufacturing method must be found in the various documentation:

- ▶ Manufacturing method, see the technical data in the load hook documentation.
or
Manufacturing method, see the certificate of the load hook manufacturer in the crane inspection log.

Checking the expansion of the hook jaw

The manufacturing method differs by the maximum permissible expansion of the hook jaw, see the following charts:

Load hook manufacturing method	Hook shape	Maximum permissible expansion of the hook jaw in reference to the respective initial dimension
Cast	Double hook	3 %
Forged	Double hook	10 %
Forged	Single hook	10 %

Hook jaw: Dependency between the manufacturing method and maximum permissible expansion

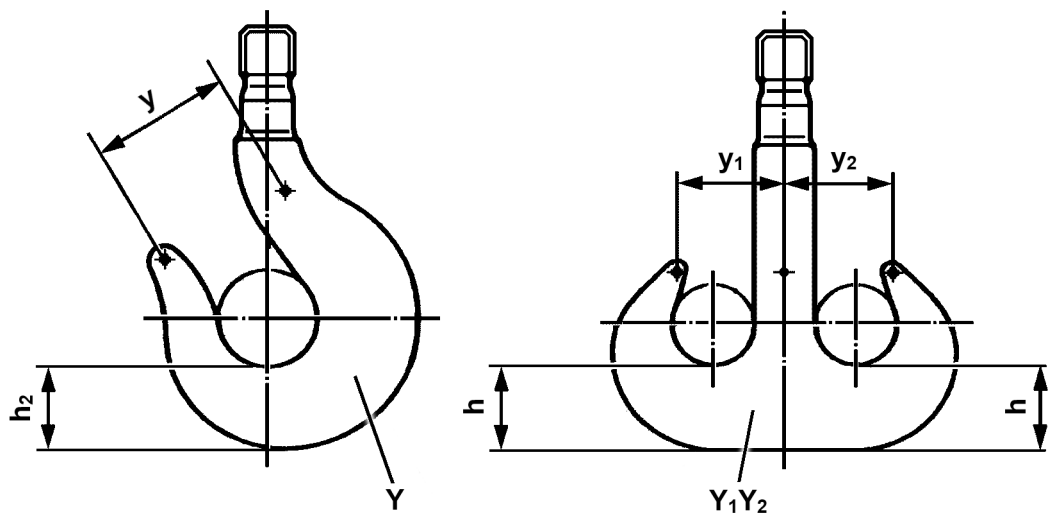

Fig. 149076: Description of the measured distances on the load hook

The initial dimensions are indicated on the load hook, see chapter 2.05.10:

- Single hook: Initial dimension Y
- Double hook: Initial dimension Y_1Y_2
- ▶ Single hook: Distance y between the punch marks.
- ▶ Double hook: Measure the distance y_1 and distance y_2 between the punch marks.

When the available expansion of the hook jaw is larger than the maximum permissible expansion:

- ▶ Replace the load hook with the hook nut.

3.2 Checking the load hook for surface cracks

Make sure that the following prerequisites are met:

- Distortion is present.

Inspection is required in all points where distortion is present, mainly on the hook jaw.

If it is **not** possible to check the installed load hook:

- ▶ Remove the load hook: Contact Customer Service at Liebherr-Werk Ehingen GmbH.
- ▶ Prior to the inspection: Put the surfaces into a state in which surface cracks can be detected correctly.
- ▶ Check the load hook for surface cracks using a suitable procedure.

An authorized inspector must decide if the surface cracks can be repaired.

When the surface cracks have been repaired:

- ▶ Check if the load hook dimensions lie within the permissible tolerances. Contact Customer Service at Liebherr-Werk Ehingen GmbH.

When the surface cracks are **not** permissible:

- ▶ Replace the load hook with the hook nut.

3.3 Checking the hook body for wear

3.3.1 Hook base

The wear on the hook base may be maximum 5 % in reference to the respective initial dimension:

- Single hook: Initial dimension h_2
- Double hook: Initial dimensions h

The respective initial dimensions are provided in the following chart:

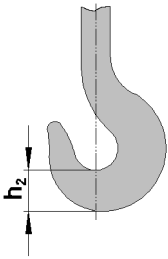
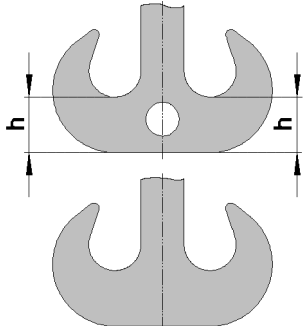
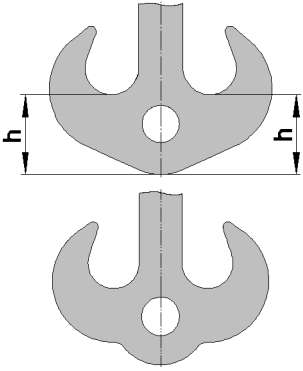
Hook number	Single hook	Double hook, shape A	Double hook, shape B
	h_2	h	h
			
4	67 mm	—	—
5	75 mm	—	—
6	85 mm	75 mm	—
8	95 mm	85 mm	—
10	106 mm	95 mm	130 mm
12	118 mm	106 mm	150 mm
16	132 mm	118 mm	174 mm
20	150 mm	132 mm	196 mm
25	170 mm	150 mm	218 mm
32	—	170 mm	242 mm
40	—	190 mm	271 mm
50	—	212 mm	308 mm
63	—	236 mm	353 mm
80	—	265 mm	399 mm
100	—	300 mm	449 mm
125	—	335 mm	500 mm
160	—	375 mm	530 mm

Hook number	Single hook	Double hook, shape A	Double hook, shape B
	h_2	h	h
200	—	425 mm	600 mm
250	—	475 mm	670 mm
320	—	530 mm	—
400	—	600 mm	—

Initial dimensions for wear on the hook base, single hooks and double hooks

- ▶ Single hook: Measure the ACTUAL dimension h_2 .
- ▶ Double hook: Measure the ACTUAL dimension h .
- ▶ Determine the initial dimension depending on the hook shape with the chart.

When the wear on the hook base is 5 % greater than the initial dimension:

- ▶ Replace the load hook with the hook nut.

3.3.2 Surfaces

Surfaces with wear must be connected smoothly with the adjacent surfaces.

- ▶ Check surfaces with wear for sharp edges, grooves or other surface errors.

An authorized inspector must decide if the surface errors can be repaired.

When the surface errors have been repaired:

- ▶ Check if the load hook dimensions lie within the permissible tolerances. Contact Customer Service at Liebherr-Werk Ehingen GmbH.

When the wear is **not** permissible:

- ▶ Replace the load hook with the hook nut.

3.4 Checking the double hook for damage

Visible damage indicate **improper** fastening of the load.

Relevant areas for the inspection:

- Lower area on the hook shaft
- On every hook: Transition area from the hook shaft to the hook jaw

- ▶ Check the load hook for visual damage.

An authorized inspector must decide if the damage can be repaired.

When the damage has been repaired:

- ▶ Check if the load hook dimensions lie within the permissible tolerances. Contact Customer Service at Liebherr-Werk Ehingen GmbH.

When the damage is **not** permissible:

- ▶ Replace the load hook with the hook nut.

3.5 Checking the load hook for corrosion

Depending on the overall condition of the load hook, an inspection expert must decide if the hook thread must be checked for corrosion nicks.

If the hook thread must be checked:

- ▶ Determine the Liebherr ID no. and manufacturer of the load hook, see chapter 2.05.10.
- ▶ Request the assembly instructions for the load hook: Contact Customer Service at Liebherr-Werk Ehingen GmbH.
- ▶ Remove the load hook: Contact Customer Service at Liebherr-Werk Ehingen GmbH.
- ▶ Disassemble the hook nut according to the manufacturer's assembly instructions.
- ▶ Check the hook thread, hook nut and machined surfaces on the hook shaft for corrosion.

An inspection expert must decide if the corrosion nicks can be repaired.

When the corrosion nicks have been repaired:

- ▶ Check if the dimensions of the hook thread and the hook shaft lie within the permissible tolerances.
Contact Customer Service at Liebherr-Werk Ehingen GmbH.

If an **impermissible** axial play is suspected on the hook nut:

- ▶ Contact Customer Service at Liebherr-Werk Ehingen GmbH.

When the corrosion is **not** permissible:

- ▶ Replace the load hook with the hook nut.

If the load hook passed the inspection:

- ▶ Follow the instructions in the section „Assembling the hook nut“.

3.6 Assembling the hook nut

Make sure that the following prerequisites are met:

- The hook shaft, hook thread and hook nut fulfill all test criteria.
- The axial bearing is free of damage and turns easily.

If the axial bearing does **not** turn easily:

- ▶ Clean the axial bearing and replace the lubricant.

or

Replace the axial bearing.

If the axial bearing is damaged:

- ▶ Replace the axial bearing.

Before the assembly of the hook nut: Corrosion protection must be applied between the thread sides.

- ▶ Grease the threads of the hook nut.
- ▶ Assemble the hook nut according to the manufacturer's assembly instructions.

The type of sealing after assembly must correspond to the sealing before the inspection.

- ▶ Seal the transition between the hook thread and the hook nut thread.
- ▶ Install the load hook.

3.7 Checking the retaining elements

- ▶ Check if the anti-rotation device of the hook nut (axle retainer) is tightened.
- ▶ Check if the anti-rotation device of the hook nut functions.
- ▶ Check the function of the hook guard.

If the retaining element did **not** pass the inspection:

- ▶ Contact Customer Service at Liebherr-Werk Ehingen GmbH.

8.06 Inspection of hydraulic hose lines

1	Safety guidelines	3
2	Inspection intervals	3
3	Checking the end of the service life	3
4	Inspecting the hydraulic hose lines for damage	4
5	Inspecting the hydraulic hose lines for leaks	5
6	Documenting the inspection	5
7	Replacing hydraulic hose lines	5

Fig.195219

LWE/LR 13000-001/19503-01-02/en

1 Safety guidelines



WARNING

Damaged and leaky hydraulic hose lines!
Fire, accidents, death, severe injury, property damage.

If leaky areas are found:

- ▶ Have these leaky areas inspected immediately by authorized and trained expert personnel and remedied.

If damage is found:

- ▶ Have the hydraulic hose lines replaced exclusively by authorized and trained expert personnel.

If it is determined that the service life is over:

- ▶ Have the hydraulic hose lines replaced exclusively by authorized and trained expert personnel.

Make sure that the following prerequisite is met:

- A **competent person for hydraulic hose lines** inspects the hydraulic hose lines.

A **competent person for hydraulic hose lines** has the following knowledge:

- Knowledge and experience in hydraulic and mechanics
- Knowledge of all requirements regarding valid standards:
 - ISO 8331
 - ISO 2230
 - ISO 1402
 - ISO/TR
 - EN 853 to EN 857
 - National regulations
- **or:** Knowledge of all requirements regarding the valid German standards, for example:
 - DIN 20066:202-10
 - BGR 237 Feb 2008, BG-Regulation

2 Inspection intervals

The inspection of hydraulic hose lines must be carried out in the following intervals:

- when the crane is **up to 10 years** old, at least one inspection every twelve months
- when the crane is **older than 10 years**, at least one inspection every six months

3 Checking the end of the service life

Hydraulic hose lines have a limited service life.

When hydraulic hose lines are properly stored, installed and used, then the manufacturer guarantees a service life of at least 10 years.

The life expectancy of hydraulic hose lines can deviate significantly from the noted service life of hydraulic hose lines.



Note

Special case: Active rear axle steering!

- ▶ The life expectancy of hydraulic hose lines is six years, including a storage period of maximum two years.

The life expectancy of a hydraulic hose line depends on various factors:

- Environmental influences, for example: Temperature, humidity, corrosive air
- Use

- Working cycles
- Number of bending cycles
- Friction
- Fluid

The following factors reduce the life expectancy significantly:

- Heat
- Repeated bending under pressure

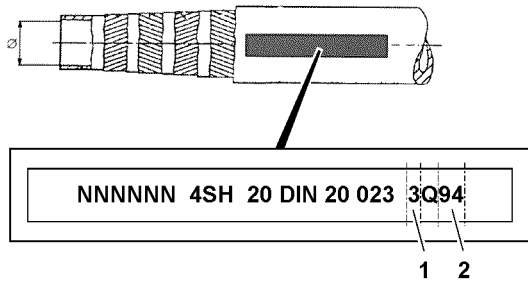

Fig.120159: Example for identification of hydraulic hose lines

The manufacturing date is marked on the fixtures or fittings.

- ▶ Read the quarter **1** of manufacture.
- ▶ Read the year **2** of manufacture.

When the life expectancy of a hydraulic hose line has been exceeded, then a **competent person** can decide **not** to replace the hydraulic hose line. Document the decisions, see section „Documenting the inspection“.

When the end of the service life is determined:

- ▶ Have the hydraulic hose lines replaced exclusively by authorized and trained expert personnel.

4 Inspecting the hydraulic hose lines for damage

Hydraulic hose lines must be replaced when one of the following damage is present:

- Damage on outer surface, such as chafe marks, cuts and cracks
- Brittleness due to aging of outer layer (cracks)
- Distortion, such as splitting of hose layers, bubbles, crushed areas, kinks, rotational stress
- Leakages
- Damage or distortion of hose fixtures or hose fitting (seal is endangered)
- Movement between hose and hose line, hose working itself loose from the fixture or the fitting
- Requirements for installation **not** observed
- Corrosion of fixture or fitting (solidness or function of fitting is endangered)

When the hydraulic hose line is **not** completely accessible:

- ▶ Remove the hydraulic hose line.

When the hydraulic hose line is protected with a protective hose:

- ▶ Check the hose protection for abrasion. Abrasion on a hose protective hose can indicate abrasion on the hydraulic hose line.
- ▶ Check hydraulic hose lines for distortion in pressureless and pressurized status and during bending.

When the hydraulic hose line is slightly damaged, then a **competent person** can decide **not** to replace the hydraulic hose line. Document the decisions, see section „Documenting the inspection“.

If damage is found:

- ▶ Have the hydraulic hose lines replaced exclusively by authorized and trained expert personnel.

5 Inspecting the hydraulic hose lines for leaks

- ▶ Check the crane for escaped hydraulic oil.
- ▶ Check the crane for leaks by visually checking the ground under the crane.

When the hydraulic system leaks:

- ▶ Have these leaks inspected immediately by authorized and trained expert personnel and remedied.
or
Contact Liebherr Service.

6 Documenting the inspection

Make sure that the following prerequisite is met:

- A **competent person for hydraulic hose lines** documents noticeable observations.

The following data about hydraulic hose lines is documented:

- Installation location
- Condition
- Date
- Time
- ▶ Document noticeable observations comprehensibly.

When the life expectancy of a hydraulic hose line has been exceeded or if the hydraulic hose line is slightly damaged, then a **competent person** can decide **not** to replace the hydraulic hose line.

When the hydraulic hose line is **not** replaced:

- ▶ Document decisions and replacements comprehensibly.
- ▶ Document the date for the next inspection comprehensibly.

7 Replacing hydraulic hose lines

To ensure maximum safety, sealing and service life, the following guidelines apply for replacement of hydraulic hose lines.



WARNING

Impermissible spare parts!

Death, severe injury, property damage.

- ▶ Do **not** use repaired or used hydraulic hose lines.
- ▶ Use exclusively Original Liebherr spare parts.
- ▶ Use exclusively hydraulic hose lines according to manufacturer's specification (including fixtures, rubber piece goods and manufacturing process).

NOTICE

Routing of hydraulic hose lines changed!

Abrasion. Incorrect bending radius. Stress. Shortened service life.

- ▶ Keep the routing of hydraulic hose lines.
- ▶ Inspect the hydraulic hose lines according to intervals.
- ▶ Adhere to the hose bending radii according to the manufacturer's specifications.
- ▶ Ensure the routing of hydraulic hose lines according to manufacturer's specifications (pressureless and pressurized condition).
- ▶ Ensure the distance between lines and structures.

If necessary:

- ▶ Check moving parts in the area of hydraulic hose lines.

When the hydraulic hose line is installed in straight direction:

- ▶ Ensure a sag of the hose.
- ▶ Avoid mechanical tension and twisting of the hose during installation.
- ▶ Fasten the hydraulic hose line according to manufacturer's specification.
- ▶ Do not cross hydraulic hose lines for high pressure and low pressure.
- ▶ Keep hydraulic hose lines away from hot components.

When hydraulic hose lines are in a surrounding with high temperatures:

- ▶ Install protective insulation according to manufacturer's specifications.

8.12 Inspection of safety controls on the relapse supports

1 S-boom relapse retainer

3

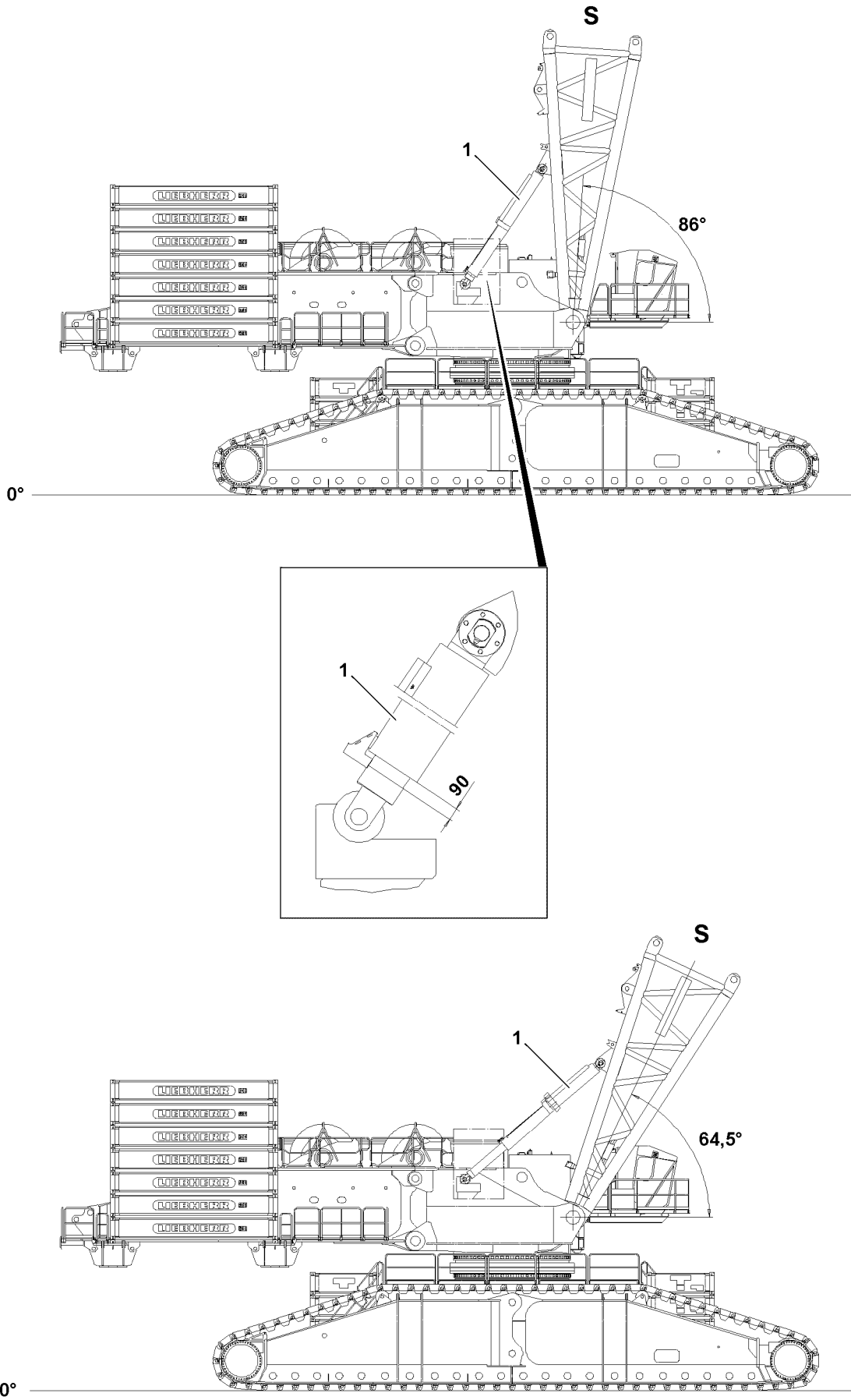

Fig.116303

LWE/LR 13000-001/19503-01-02/en

1 S-boom relapse retainer

A hydraulic cylinder 1 prevents the S-boom from falling backward.

In the steepest boom position, the luffing up movement is turned off by activating the limit switches on the cylinder.

Icon appears on the LICCON monitor.

1.1 Checking the limit switch actuators for function

Cover limit switch actuators on the S-relapse cylinder individually with a metal plate.

- The S-boom movement „luff up“ must turn off.
- The icon must appear on the LICCON monitor.

	Boom angle	Cylinder length
Cylinder extended	64.5 °	6437 mm
Steepest position	85 °	5076 mm
Electric switch position	86 °	5007 mm
Block position	87 °	4937 mm

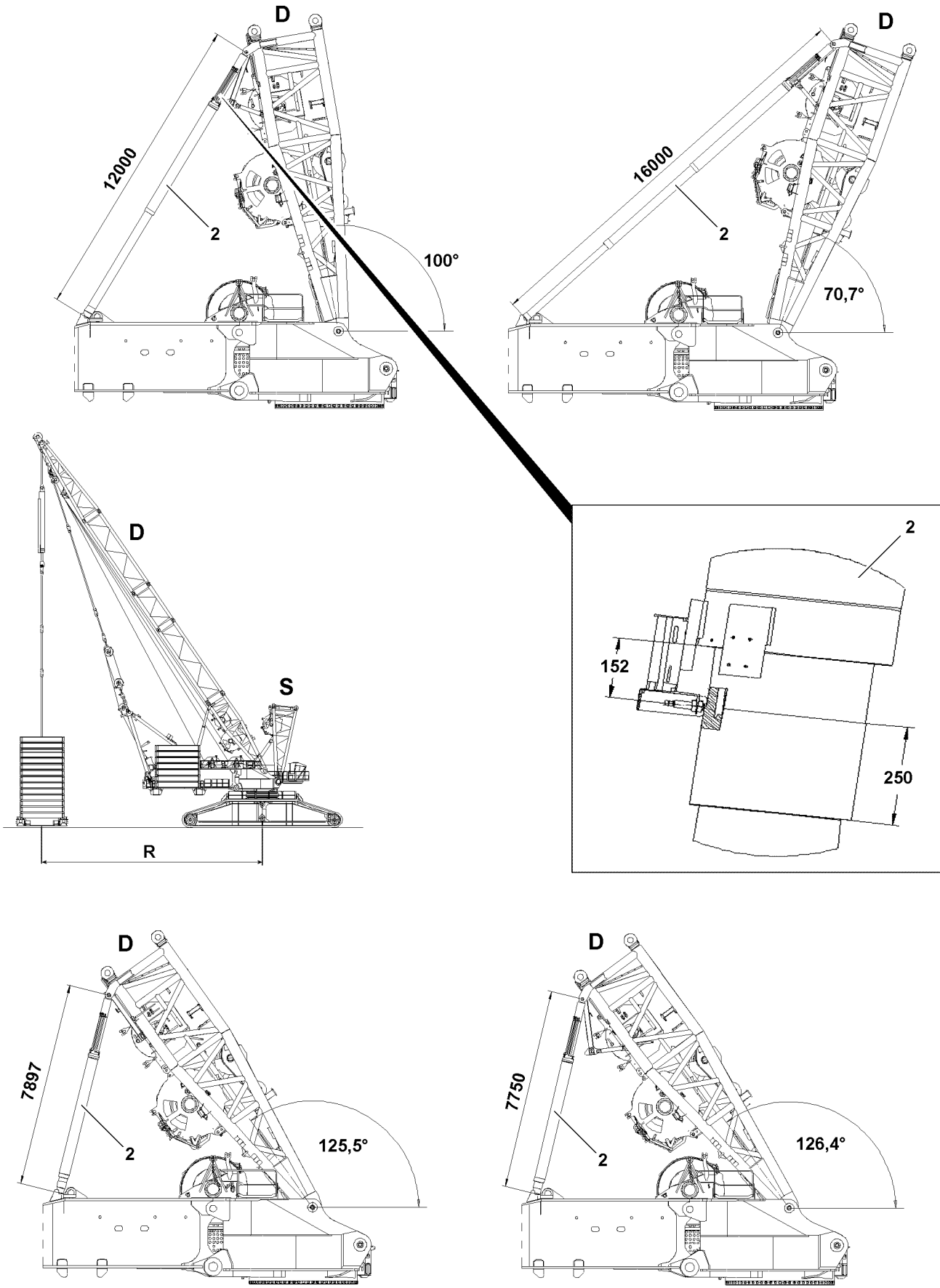

Fig.116304

LWE/LR 13000-001/19503-01-02/en

2 Derrick relapse retainer

Two hydraulic cylinders **2** prevent the derrick boom from falling backward.

- If the limit switches on the cylinders are actuated, the winch 4 „spool up“ movement is shut off.
- The icon appears on the LICCON monitor.

2.1 Checking the limit switch actuators for function

Cover limit switch actuators individually on the D-relapse cylinder **2** with a metal plate.

- The D-boom „luffing up“ movement must turn off.
- The icon must appear on the LICCON monitor.

	Swing radius R		Derrick Boom angle	Cylinder length
	D- 60 m	D- 54 m		
Stage II extended	10.0 m	9.0 m	100.0°	12000 mm
Stage I and stage II extended	-20.1 m	-18.2 m	70.7°	16000 mm
Electric switch position	34.5 m	31.0 m	125.5°	7897 mm
Block position	35.3 m	31.7 m	126.4°	7750 mm

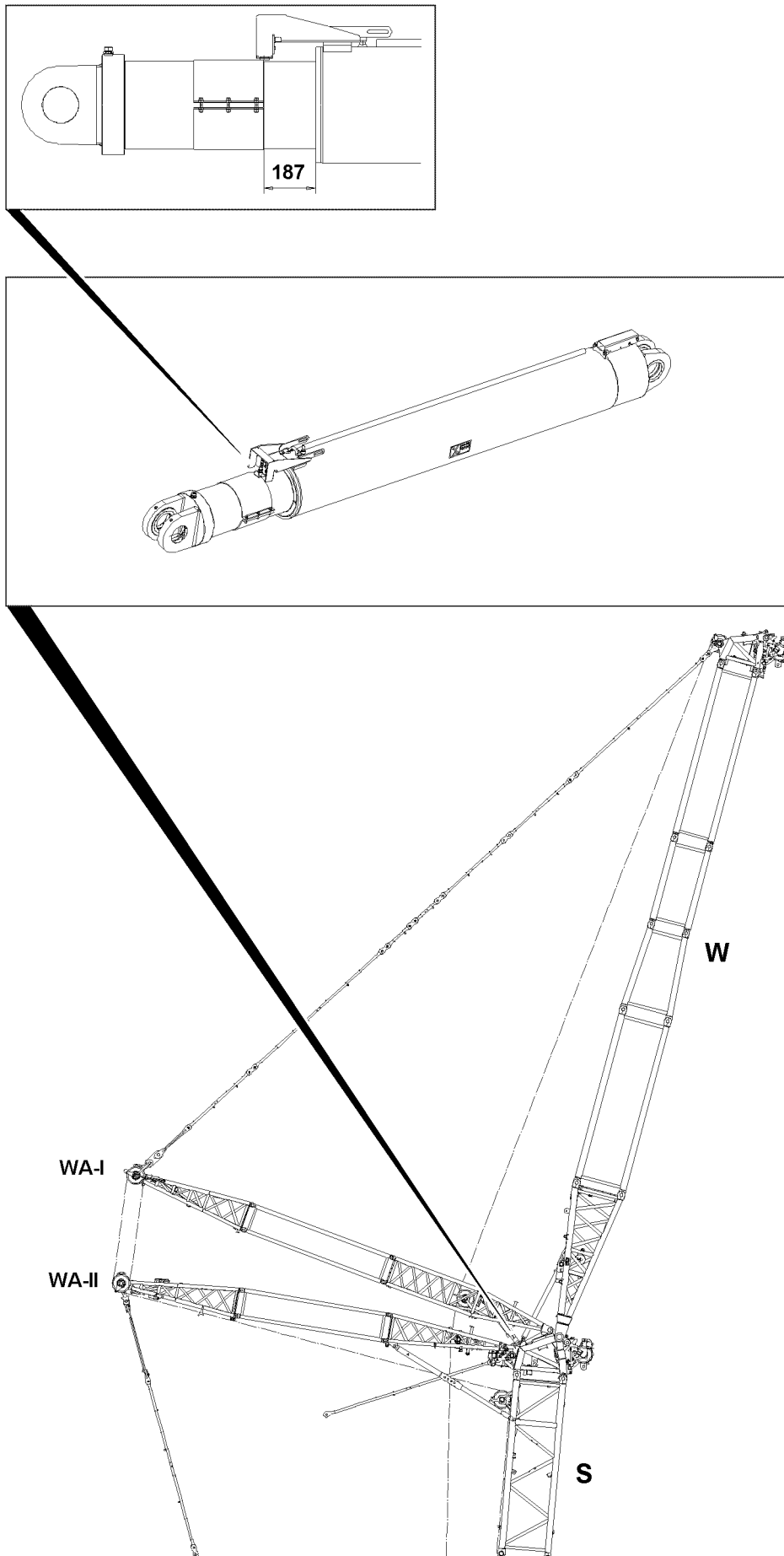

Fig.116305

LWE/LR 13000-001/19503-01-02/en

3 W-lattice jib

3.1 Checking the limit switch actuators for function

Cover the limit switch actuators on the W-relapse cylinder individually with a metal plate.

- The W-control winch „spool up“ movement must turn off.
- The icon must appear on the LICCON monitor.

3.2 Checking the limit switch actuators on switch point „steepest position“

Before erecting the boom, check the function of the limit switch actuators in installed condition. Pull up both WA-frames to the specified dimension (see illustration) until the switch contact opens.

- The W-control winch „spool up“ movement must turn off.
- The icon must appear on the LICCON monitor.

After successful test, reset the WA-frames to set up configuration, see Crane operation instructions, chapter 5.07.

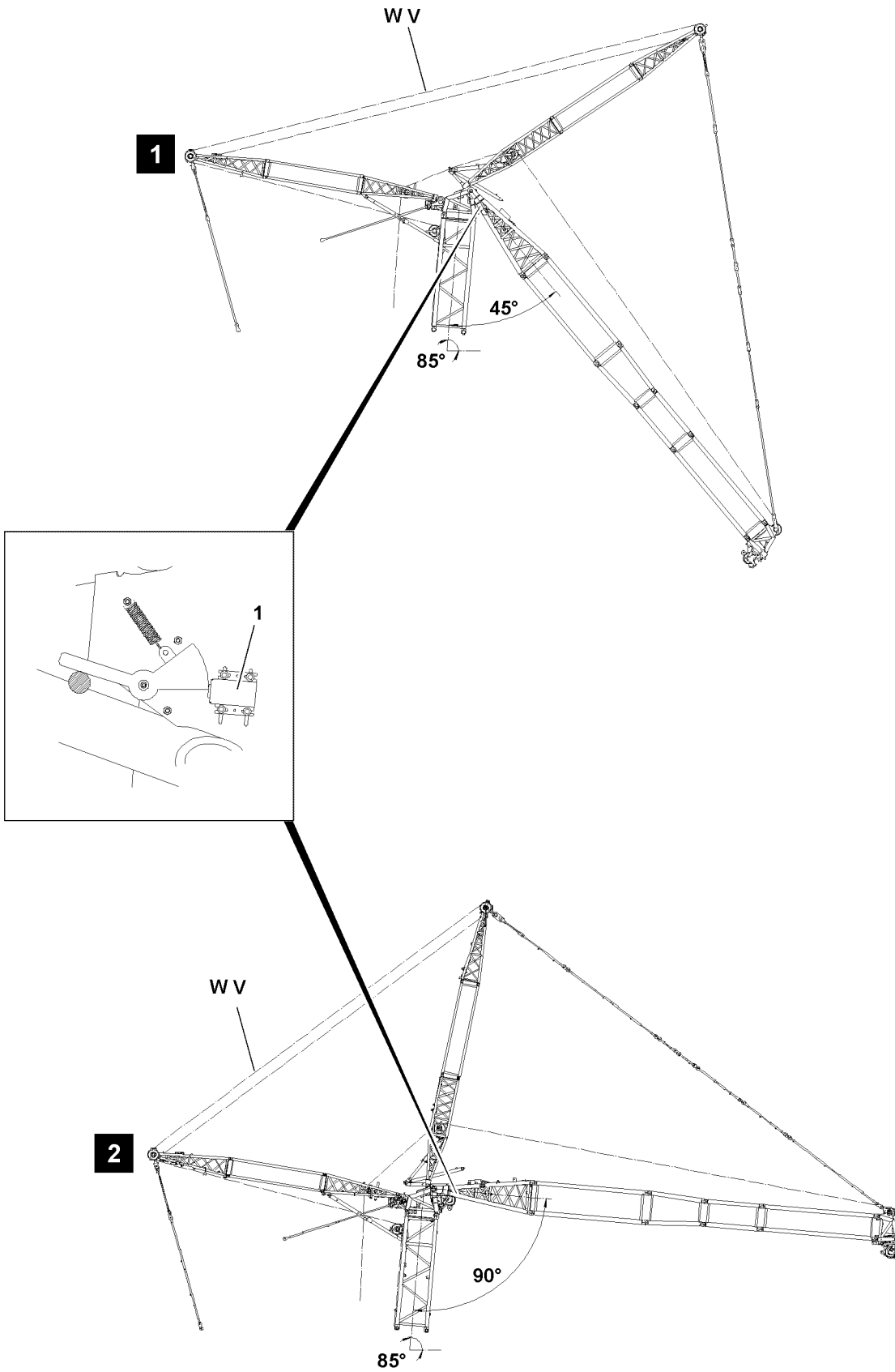

Fig.116306

LWE/LR 13000-001/19503-01-02/en

3.3 W-lattice jib „bottom“

Cover the limit switch actuators individually with a metal plate.

- The movement of the W-control winch winch 5 **W V**) „spool out“ must turn off.
- The icon must appear on the LICCON monitor.

3.3.1 Checking the limit switch actuators for function (S-end section without pulley set)

- Switch position „luffing jib bottom“, approx. 45°. Limit switch (actuator), see illustration 1.

3.3.2 Checking the limit switch actuators for function (S-end section with pulley set)

- Switch position „luffing jib bottom“, approx. 90° limit switch (actuator), see illustration 2.

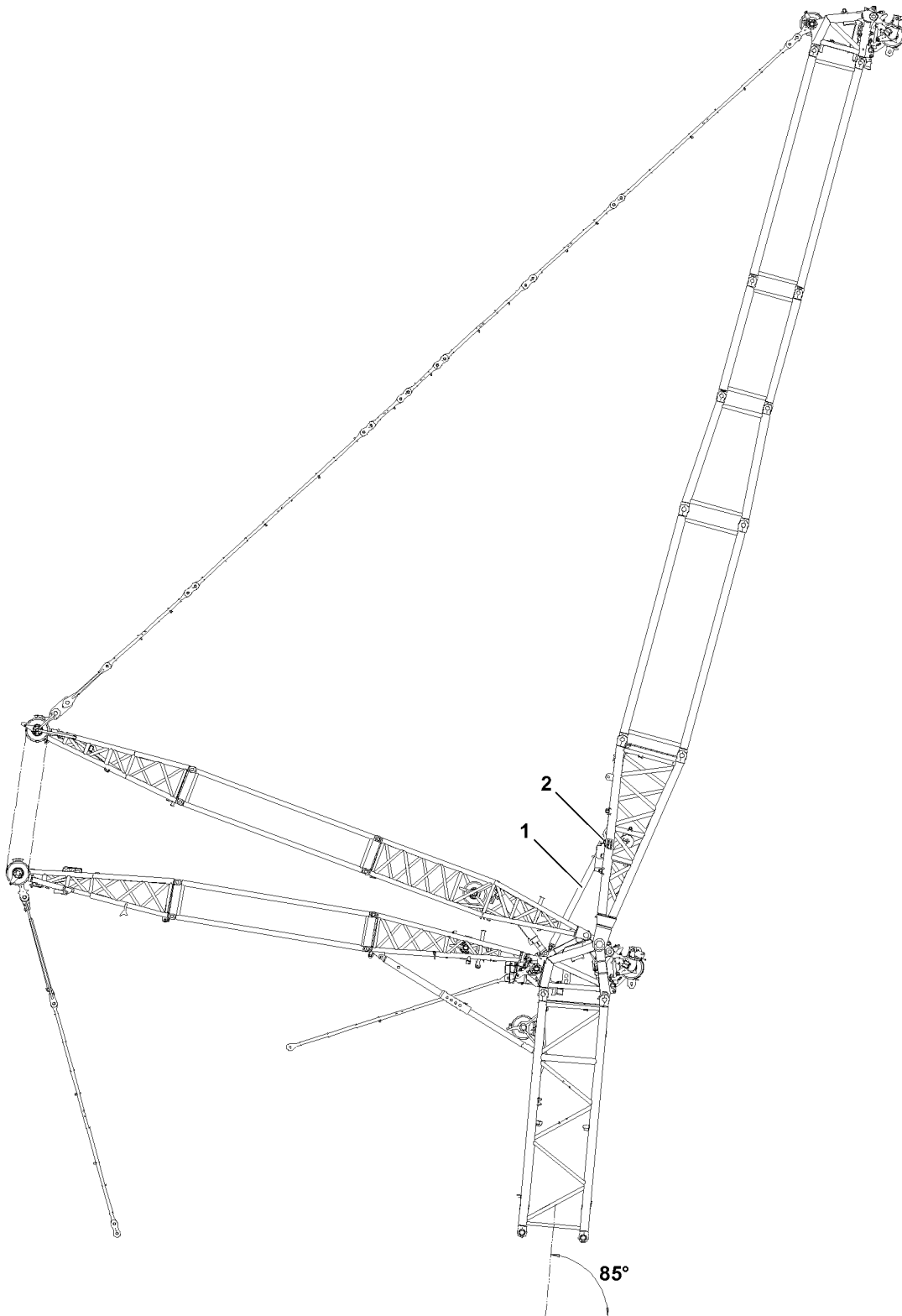

Fig.116323

LWE/LR 13000-001/19503-01-02/en

3.4 Function check of limit switch acutators on the mechanical relapse retainer - flap

- 1 Mechanical relapse support
- Flap 2 (oscillating guard for mechanical relapse support)

In addition to the relapse cylinders, the W-lattice jib is also secured by a mechanical relapse support 1, which engages in steepest lattice jib position into the flap 2 of the oscillation guard. The luffing up movement of the W-lattice jib is turned off by the actuated limit switches on the oscillation guard.



DANGER

Danger of tipping over if the oscillation guard is hard to move!

If the flap 2 is hard to move, the mechanical relapse retainer will no longer function!

The W-lattice jib can tip backwards uncontrolled and cause the crane to topple over!

Personnel can be severely injured or killed!

- ▶ Before erecting the boom system, the flap 2 must be checked for easy movement over the entire swing range.
- ▶ Make sure that the easy movement of the flap 2 is ensured before every crane application.
- ▶ Crane operation with hard to move flap 2 is prohibited.

Depending on the angle of the W-lattice jib, the position of the flap changes due to the pendulum weight.

3.4.1 Flap can be pushed open

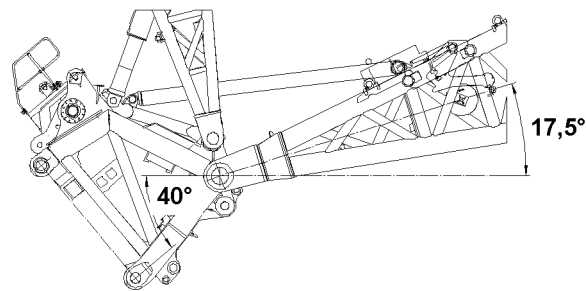

Fig.116307: Flap can be pushed open

3.4.2 Flap can be pushed closed

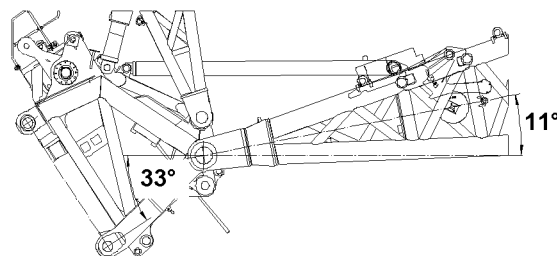

Fig.116308: Flap can be pushed closed

3.4.3 Flap swings in at stop

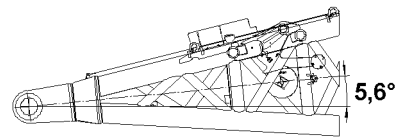

Fig.116321: Flap swings in at stop

3.4.4 Flap swings out to stop

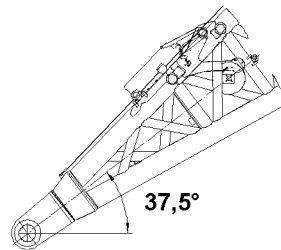

Fig.116322: Flap swings out to stop

Empty page!

LWE/LR 13000-001/19503-01-02/en

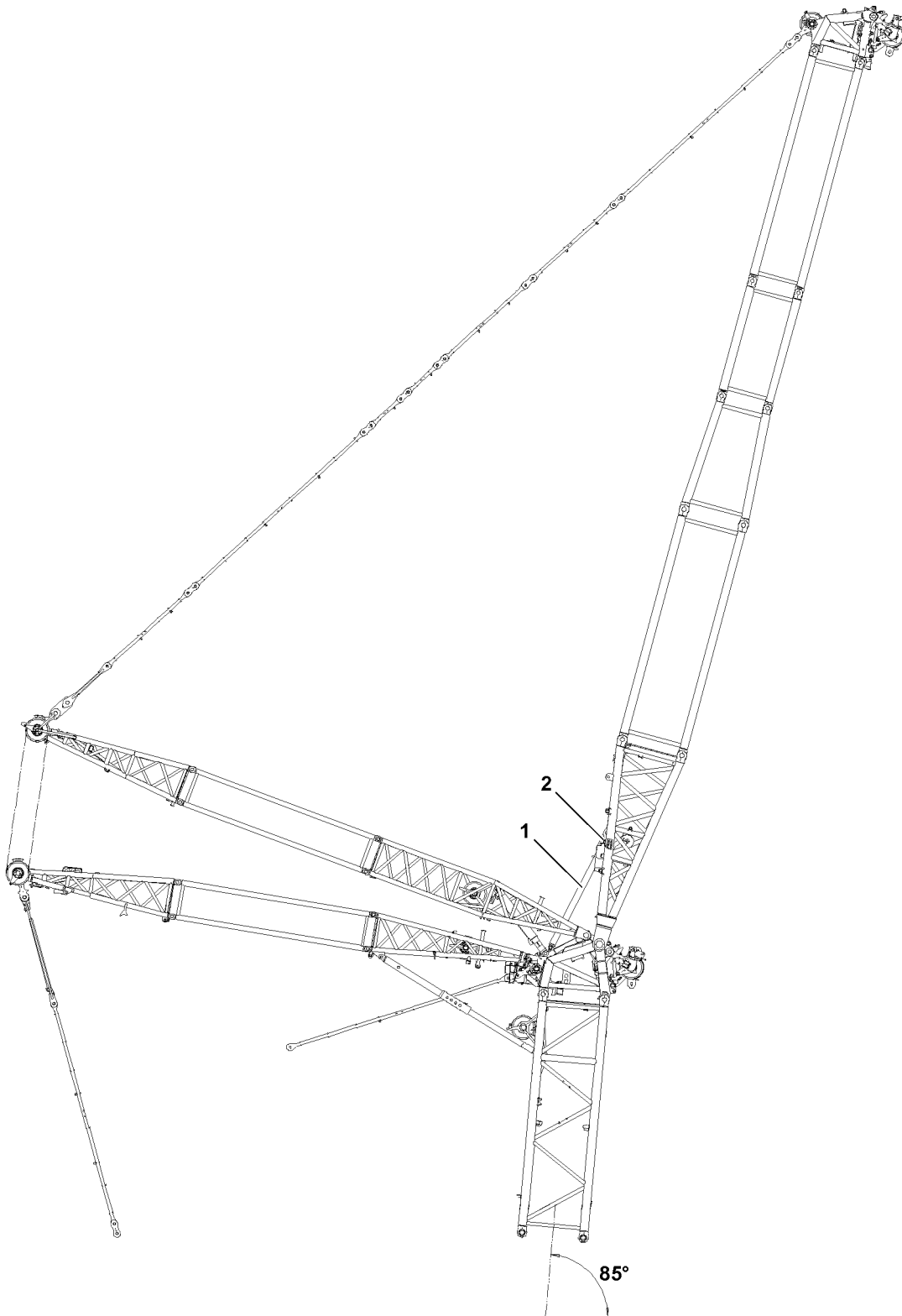

Fig.116323

LWE/LR 13000-001/19503-01-02/en

3.5 Collision of mechanical relapse support with flap

**DANGER**

Risk of collision!

At an angle between the main boom and the W-lattice jib of 20.7° , the mechanical relapse support collides with the flap 2.

The W-lattice jib can tip backwards uncontrolled and cause the crane to topple over!

Personnel can be severely injured or killed!

- ▶ Make sure that no collision will occur between the relapse support and the flap.
- ▶ Perform a visual inspection.

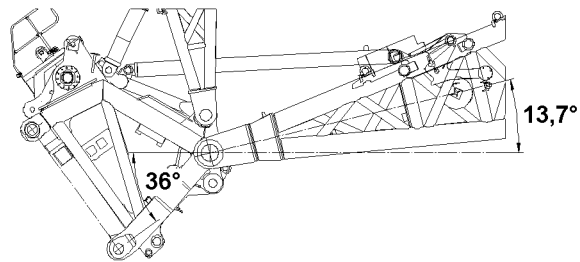

Fig.116320: Flap on collision

Empty page!

LWE/LR 13000-001/19503-01-02/en

8.14 Inspection of accumulator pressure in relapse cylinder

1	Checking the accumulator pressure in the relapse cylinder	2
2	Checking the accumulator pressure in the W-relapse cylinder, W-boom on the ground	3
3	Checking the accumulator pressure in the W-relapse cylinder, W-boom luffed up	4

1 Checking the accumulator pressure in the relapse cylinder

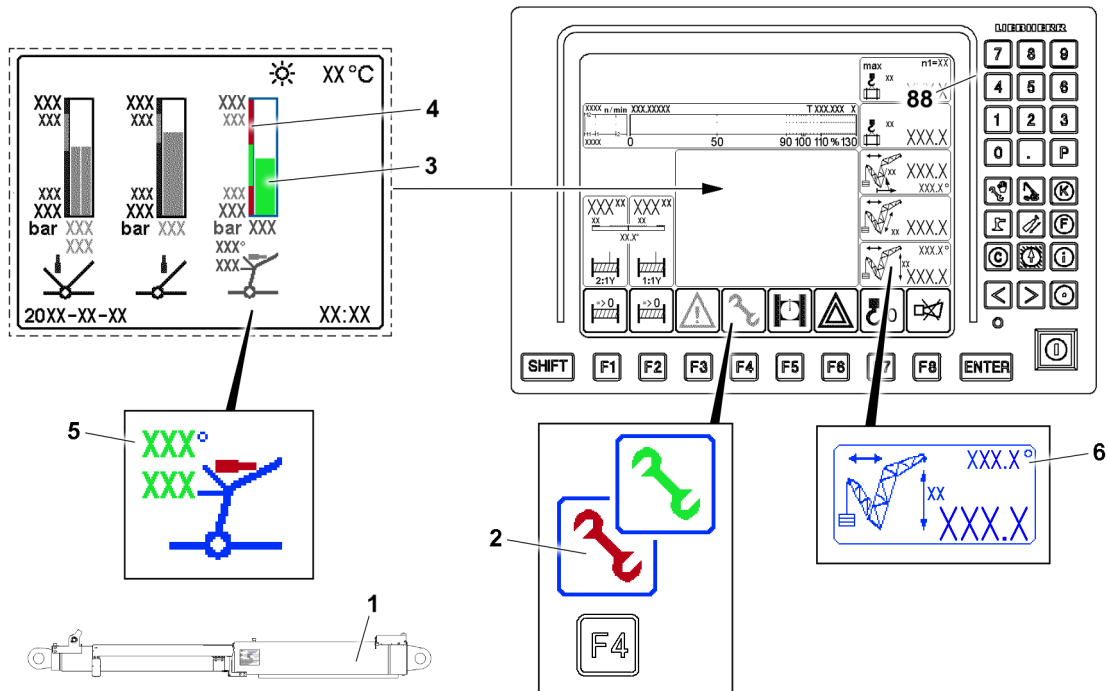

Fig.164539: Crane operating screen

- | | | | |
|---|-----------------------------|---|--|
| 1 | W-relapse cylinder | 4 | Pressure display scale (ideal pressure range, min / max. pressure range) |
| 2 | Warning icon | 5 | WA-frame 1 angle (γ) |
| 3 | Actual pressure bar display | 6 | W-boom angle (β) |

Before and during crane operation, the accumulator pressure in the W-relapse cylinder must be checked on the crane operating screen of the LICCON monitor, see chapter 4.02.

The actual pressure shown must match the nominal pressure in the chart.

The specified nominal pressure depends on the ambient temperature.

For a detailed description of the icons and displays, refer to chapter 4.02.



Note

- The maximum permissible difference between the actual and the nominal pressure is maximum ± 5 bar.

When the W-relapse cylinder accumulator pressure is within a **permissible** range:

- The warning icon **2** is **green**.
- The actual pressure bar display **3** is **green**.

When the W-relapse cylinder accumulator pressure is within an **impermissible** range:

- The warning icon **2** is **red**.
- The actual pressure bar display **3** is **red**.
- An error message is output.



Note

- If the actual pressure is within an impermissible range, contact Liebherr Customer Service.

2 Checking the accumulator pressure in the W-relapse cylinder, W-boom on the ground

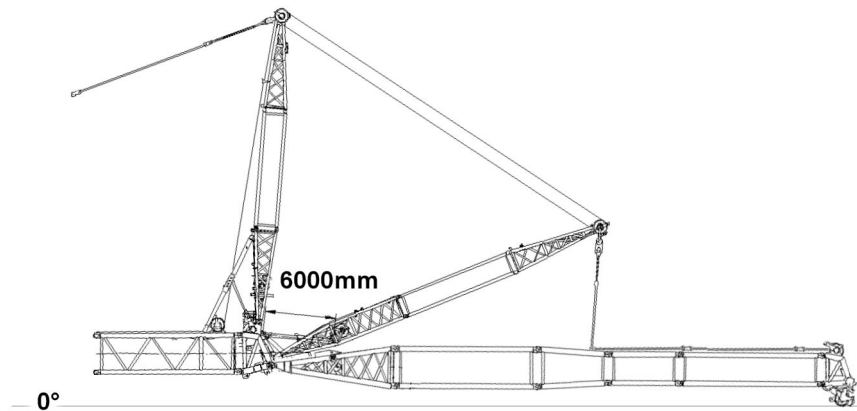

Fig.164541: W-relapse cylinder in the test position, W-boom on the ground

Make sure that the following prerequisites are met:

- The W-boom is assembled.
- The main boom is lying on the ground.
- The WA-frame 1 is taken down.
- The relapse cylinder is lifted off the W-connection head.
- The LICCON monitor displays the crane operation program.
- W-operation is set.

	Cylinder length W	Stroke
W-relapse cylinder extended all the way	6000 mm	2200 mm

W-relapse cylinder in the test position

W-relapse cylinder					
Ambient temperature	-40 °C	-20 °C	0 °C	20 °C	40 °C
Nominal pressure	141.9 bar	154.1 bar	166.3 bar	178.5 bar	190.7 bar

Nominal pressure depending on the ambient temperature for the W-relapse cylinder

- ▶ Display the „Checking the accumulator pressure in the relapse cylinder“ field: Press the function key F4.
- ▶ Make sure that the actual pressure bar display lies in the permissible pressure range.
- ▶ Make sure that the actual pressure bar display is green.
- ▶ Make sure that actual pressure is the same as the nominal pressure, observe the pressure table for the W-relapse cylinder.

3 Checking the accumulator pressure in the W-relapse cylinder, W-boom luffed up

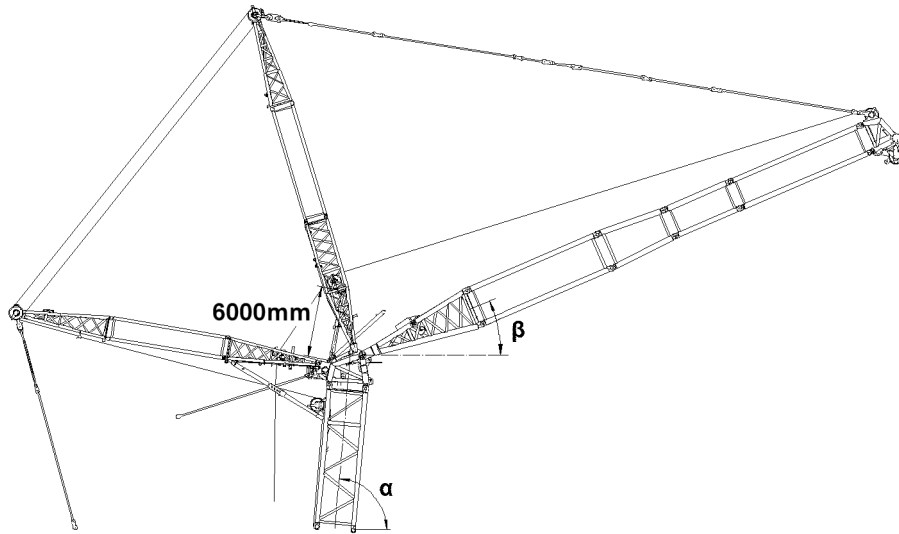

Fig.164540: W-relapse cylinder in the test position, W-boom luffed up

Make sure that the following prerequisites are met:

- The W-boom is luffed up.
- The LICCON monitor displays the crane operation program.
- W-operation is set.

	Cylinder length W	Stroke	Angle	
			α	β
W-relapse cylinder extended all the way	6000 mm	2200 mm	85°	23°

W-relapse cylinder in the test position

α = Angle between the horizontal and the main boom

β = Angle between the horizontal and the luffing jib

W-relapse cylinder					
Ambient temperature	-40 °C	-20 °C	0 °C	20 °C	40 °C
Nominal pressure	141.9 bar	154.1 bar	166.3 bar	178.5 bar	190.7 bar

Nominal pressure depending on the ambient temperature for the W-relapse cylinder

- ▶ Set the main boom and the W-boom to the angle specified in the chart, see the illustration and chart „W-W-relapse cylinder in the test position“.
- ▶ Display the „Checking the accumulator pressure in the relapse cylinder“ field: Press the function key F4.
- ▶ Make sure that the actual pressure bar display lies in the permissible pressure range.
- ▶ Make sure that the actual pressure bar display is green.
- ▶ Make sure that actual pressure is the same as the nominal pressure, observe the pressure table for the W-relapse cylinder.

8.15 Inspection of guy rods

1	Safety guidelines	3
2	Inspection intervals	3
3	Checking the guy rods	3

Fig.195219

LWE/LR 13000-001/19503-01-02/en

1 Safety guidelines



WARNING

Damaged guy rods!

Accident. Death, severe injury, property damage.

- ▶ Crane operation with damaged guy rods **1** is prohibited.
- ▶ Replace damaged guy rods **1**.

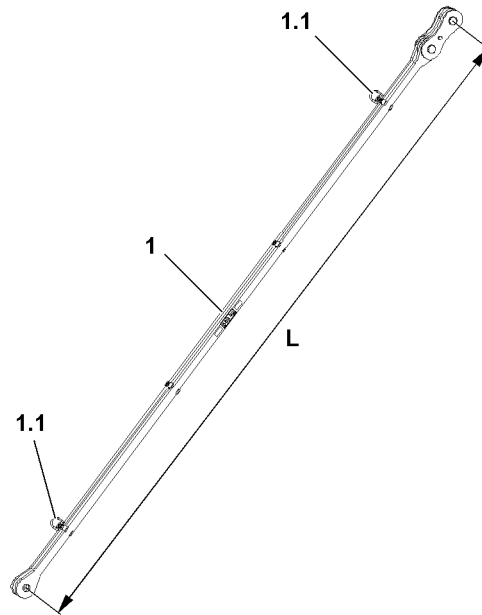

Fig.123845: Guy rod

Make sure that the following prerequisites are met:

- **Authorized and trained expert personnel** checks the guy rods **1**.
- A checklist for documentation of the inspection is on hand

2 Inspection intervals

The inspection of the guy rods **1** must be carried out in the following intervals:

- One inspection of the guy rods every 12 months by an expert.
- One inspection of the guy rods every four years by an authorized inspector.

After a load rip-off or overload of the crane:

- immediate inspection of guy rods by an expert

3 Checking the guy rods

3.1 Inspection



Note

- ▶ All inspections of the guy rods **1** must be documented.

The guy rods must be inspected in removed condition.

**WARNING**

The guy rods **1** can be ripped off!

If a damaged guy rod **1** is used further, it can rip off in crane operation.

Death, severe injury, property damage.

- ▶ Crane operation with damaged guy rods is prohibited.
- ▶ Repairs on guy rods **1** (for example: through welding) are prohibited.
- ▶ Replace damaged guy rods immediately.
- ▶ If one of the following stated damage is found, then the guy rods **1** may no longer be used.

3.2 Cracks and dents

- ▶ Check the guy rods **1** thoroughly through a visual inspection for cracks and dents.

Problem remedy

Damage to guy rods is not clearly evidenced through a visual inspection?

- ▶ Check the respective areas of the guy rods thoroughly, for example with a magnetic particle test.
- ▶ If damage is found: Replace the guy rods **1** immediately.

3.3 Elongation

**Note**

- ▶ The initial dimension **L** of the guy rods **1** refers to the bore spacing of the pin bores.
- ▶ The initial dimension **L** of the guy rods **1** is listed in the separate rod plan.
- ▶ Check the elongation of the guy rods **1** by measuring the guy rods.

**WARNING**

The guy rods can be ripped off!

The permissible elongation of the guy rods **1** may be a maximum of 0.2 %, for example 14 mm , at an initial dimension **L** of 7000 mm.

Death, severe injury, property damage.

- ▶ If the maximum permissible elongation is reached or exceeded: Replace the guy rods **1** immediately.
- ▶ If an elongation of the guy rods of more / equal to 0.2 % of the initial dimension **L** is proven: Replace the guy rods **1** immediately.

3.4 Wear

- ▶ Check the bores, pins and pin retainers for signs of wear.
- ▶ If respective wear is present in the stated areas: Replace the guy rods **1** immediately.

3.5 Ductile deformation

- ▶ If a guy rod **1** shows any ductile deformation: Replace the guy rod **1** immediately.

3.6 Paint / coating

- ▶ The guy rods **1** must be checked for paint damage or corrosion.
- ▶ If damage is present on the paint finish / coating: Repair the paint / coating of the guy rods **1** expertly.

NOTICE

Danger of property damage!

- ▶ Never store guy rods **1** in or near aggressive media, for example: Seawater.
- ▶ Always store the guy rods **1** properly and outside of aggressive media.

3.7 Fastening points

- ▶ Check the fastening points **1.1** of the guy rods **1** for damage.
- ▶ Replace damaged fastening points **1.1**.

Empty page!

LWE/LR 13000-001/19503-01-02/en

8.17 Inspection of ladders

1	Safety instructions	3
2	Inspection intervals	3
3	Inspecting the ladders	3
4	Inspection sheet and check list	3

Fig.195219

LWE/LR 13000-001/19503-01-02/en

1 Safety instructions



WARNING

Damaged ladders!
Accident. Death, severe injury, property damage.

If damage is found:

- ▶ Have ladders repaired by authorized and trained expert personnel.

If it is determined that the ladder cannot be repaired:

- ▶ Scrap the ladder immediately.

Make sure that the following prerequisite is met:

- **Authorized and trained expert personnel** inspects the ladders.

The authorized and trained expert personnel has the following expertise:

- Knowledge, experience and abilities in repairing ladders
- Is familiar with the necessary prerequisites as determined by the contractor for the inspection of ladders
- Has the knowledge about the type, scope and intervals for the required inspections as determined by the contractor

2 Inspection intervals

The inspection of ladders must be carried out in the following intervals:

- The contractor determines the **required** intervals
- But there must be at least one inspection every **12 months**

Intervals depend on:

- Operating conditions
- Frequency of use
- Operational demands during use
- Frequency and severity of defects found during previous inspections

3 Inspecting the ladders

Make sure that the following prerequisites are met:

- Ladder inspection sheets are on hand. For blank form, see section „Inspection form for the inspection of ladders and steps“.
- Check lists are on hand. For a blank form, see section „Check list for the inspection of ladders and steps“.
- ▶ For every ladder and every step: Enter the data in the ladder inspection form.
or
Get the ladder inspection form for ladders or steps.
- ▶ Check the ladders and steps according to the check list and document the results.
- ▶ Collect the ladder inspection forms and check lists in the crane documentation.

4 Inspection sheet and check list

A sample inspection form and check list for the inspection of ladders and steps are shown below.

4.1 Inspection form for the inspection of ladders and steps

Ladder inspection form	
Inventory no. of the ladder / step	
Location / installation location	
Ladder type	Multi-purpose ladder
	Stepladder
	Leaning ladder
	Leaning ladder with transition
	Vertical ladder
	Vertical ladder with transition aid
	Platform ladder
	Step
	Other
Ladder material	Aluminum
	Plastic
	Steel
	Stainless steel
Number of rungs / steps	
Ladder length / ladder shortened to	
Manufacturer / dealer	
Article / type number	
Date of purchase	
Date of selection	
Name of authorized inspector	
Next inspection	

Inspection form for the inspection of ladders and steps

Fig.151627-en

4.2 Check list for the inspection of ladders and steps

Ensure the recording of the systematic inspection of ladders and steps:

- Summarize the following checklist for an inspection book.

LWE/LR_13000-001/19503-01-02/en

Inspection criteria	1. Inspection		2. Inspection		3. Inspection		4. Inspection		5. Inspection	
	Yes	No	Yes	No	Yes	No	Yes	No	Yes	No
1. Operating instructions (decal on the ladder) Present and legible	<input type="checkbox"/>	<input type="checkbox"/>	<input type="checkbox"/>	<input type="checkbox"/>	<input type="checkbox"/>	<input type="checkbox"/>	<input type="checkbox"/>	<input type="checkbox"/>	<input type="checkbox"/>	<input type="checkbox"/>
2. Beams and rungs / stringers and steps Loose connections Damage, cracks, breaks, wear Dents, kinks Exposed fibers of glass-fiber reinforced plastic Paint / glaze significantly damaged (if applicable) Tie rod loose or damaged (if applicable) Platform loose or damaged (if applicable)	<input type="checkbox"/>	<input type="checkbox"/>	<input type="checkbox"/>	<input type="checkbox"/>	<input type="checkbox"/>	<input type="checkbox"/>	<input type="checkbox"/>	<input type="checkbox"/>	<input type="checkbox"/>	<input type="checkbox"/>
3. Ladder locks (if applicable) Belts, chains, bracing damaged Hinge spreader damaged	<input type="checkbox"/>	<input type="checkbox"/>	<input type="checkbox"/>	<input type="checkbox"/>	<input type="checkbox"/>	<input type="checkbox"/>	<input type="checkbox"/>	<input type="checkbox"/>	<input type="checkbox"/>	<input type="checkbox"/>
4. Fixtures Hinges, articulations, locks damaged or loose Sliding parts are well lubricated Locking elements do not engage	<input type="checkbox"/>	<input type="checkbox"/>	<input type="checkbox"/>	<input type="checkbox"/>	<input type="checkbox"/>	<input type="checkbox"/>	<input type="checkbox"/>	<input type="checkbox"/>	<input type="checkbox"/>	<input type="checkbox"/>
5. Feet and accessories Feet, tips, caps missing or damaged Cross beam, feet extension defective	<input type="checkbox"/>	<input type="checkbox"/>	<input type="checkbox"/>	<input type="checkbox"/>	<input type="checkbox"/>	<input type="checkbox"/>	<input type="checkbox"/>	<input type="checkbox"/>	<input type="checkbox"/>	<input type="checkbox"/>
6. Other defects	<input type="checkbox"/>	<input type="checkbox"/>	<input type="checkbox"/>	<input type="checkbox"/>	<input type="checkbox"/>	<input type="checkbox"/>	<input type="checkbox"/>	<input type="checkbox"/>	<input type="checkbox"/>	<input type="checkbox"/>
Result of the inspection The ladder is OK and can be used The ladder may only be used after it is repaired The ladder must be replaced DATE, SIGNATURE	<input type="checkbox"/>	<input type="checkbox"/>	<input type="checkbox"/>	<input type="checkbox"/>	<input type="checkbox"/>	<input type="checkbox"/>	<input type="checkbox"/>	<input type="checkbox"/>	<input type="checkbox"/>	<input type="checkbox"/>
Sent for repair to: DATE, SIGNATURE										
Repair / ladder replaced: DATE, SIGNATURE										

Fig.14994-en

8.20 Country-specific content

1 Country-specific content

2

LWE/LR 13000-001/19503-01-02/en

1 Country-specific content

**Note**

Chapter 8.20 has country-specific content

If supplementary content is available, it is described in the respective language.

- ▶ Observe the operating instructions in the language version of the country of use.

8.90 Inspection chart for cranes

1 Inspection chart for recurring inspections of Liebherr cranes

3

LWE/LR 13000-001/19503-01-02/en

Fig.195219

LWE/LR 13000-001/19503-01-02/en

1 Inspection chart for recurring inspections of Liebherr cranes

The following is a checklist to assist the inspector during the periodic inspections of Liebherr mobile and crawler cranes.

Company:	Inspector:
Crane manufacturer: Liebherr	Crane type:
Serial number:	Stock number:
Year of construction:	Date:
Inspector's signature for No. 1 to 22:	

1. inspection category: Crane document						
Component to be inspected	A	B	C	D	E	Comments
Crane inspection log						
Operating and installation instructions						
Crane control log						
Load chart manual						
Job planner						

2. inspection category: Signs / identification						
Component to be inspected	A	B	C	D	E	Comments
Factory tag						
Load data						
Operating instruction label						
Prohibition and command signs						
Other safety signs						

3. inspection category: Travel gear ¹						
Component to be inspected	A	B	C	D	E	Comments
Frame ²						
Supports ³						
Axles						
Wheels						
Tires						
Storage						
Transmission						
Universal drive shaft						
Leaf springs / springs						
Shock absorbers						

LWE/LR 13000-001/19503-01-02/en

3. inspection category: Travel gear ¹						
Component to be inspected	A	B	C	D	E	Comments
Steering						
Brakes						
Hydraulic axle suspension						

4. inspection category: Chassis ¹						
Component to be inspected	A	B	C	D	E	Comments
Coverings						
Accessible surfaces						
Counterweight holders ²						
Towing devices						
Accesses, ladders						
Holding devices, handles						
Platforms, railings						
Retainer for hook block ²						
Boom support ²						

5. inspection category: Chassis - driver's cab ¹						
Component to be inspected	A	B	C	D	E	Comments
Doors						
Windows / windshields						
Window wiper						
Mirrors						
Seat						
Heater						
Ventilation						
Sound absorber						
Trip recorder						
First aid kit						
Spare bulbs						
Hazard warning triangle						
Safety vest						

6. inspection category: Chassis - drive ¹						
Component to be inspected	A	B	C	D	E	Comments
Combustion engine						
Exhaust system						
Fuel tank						

6. inspection category: Chassis - drive ¹						
Component to be inspected	A	B	C	D	E	Comments
Urea tank						
Fuel container						
Filter						
Sound absorber						
Engine mount						
Oil levels						
Fuel lines						
Urea lines						
Fuel lines						

7. inspection category: Chassis - hydraulics ¹						
Component to be inspected	A	B	C	D	E	Comments
Oil container						
Filter with maintenance indicator						
Pumps						
Motors						
Valves						
Lines						
Hoses						
Cylinders						
Pressure limiting valves						

8. inspection category: Chassis - compressed air system ¹						
Component to be inspected	A	B	C	D	E	Comments
Compressor						
Filter						
Air tanks						
Valves						
Lines						
Hoses						
Cylinders						

9. inspection category: Chassis - electrical system ¹						
Component to be inspected	A	B	C	D	E	Comments
Motors						
Generators						
Battery						

LWE/LR 13000-001/19503-01-02/en

9. inspection category: Chassis - electrical system ¹						
Component to be inspected	A	B	C	D	E	Comments
Switches / buttons						
Lines						
Fuses						
Resistors						
Lighting						
Brake lights						
Blinkers						
Tail lights						
Working lights						
Signaling systems						
Indicator lights						
Battery switch						
Limit switches: Transmission, steering, drive train						
Support pressure indicator ²						

10. inspection category: Chassis - control systems ¹						
Component to be inspected	A	B	C	D	E	Comments
Engine regulation						
Transmission						
Couplings						
Circuits						
Brakes						
Steering						
Control displays						
Engine shut off line						
Control of supports ²						
Axle suspension						
Crane leveling						
Rear axle steering						

11. inspection category: Superstructure						
Component to be inspected	A	B	C	D	E	Comments
Frame						
Coverings						
Treads						
Storage						

11. inspection category: Superstructure						
Component to be inspected	A	B	C	D	E	Comments
Counterweights						
Relapse retainer						
Slewing ring connection: Tilt play						
Slewing ring connection: Mounting screws						
Slewing ring connection: Gears						
Slewing gear: Mounting screws						
Slewing gear: Gears						

12. inspection category: Superstructure - crane operator's cab						
Component to be inspected	A	B	C	D	E	Comments
Doors						
Windows / windshields						
Window wiper						
Mirrors						
Seat						
Heater						
Ventilation						
Muffler						
Joystick for working functions						
Gear shifts						
Retainer: Crushing / shear locations						

13. inspection category: Superstructure - Retaining and protection devices						
Component to be inspected	A	B	C	D	E	Comments
Accesses, ladders						
Handles						
Coverings						
Covers						
Hatches						
Treads						

14. inspection category: Superstructure - drive train						
Component to be inspected	A	B	C	D	E	Comments
Combustion engine						
Exhaust system						
Fuel tank						
Urea tank						

LWE/LR 13000-001/19503-01-02/en

14. inspection category: Superstructure - drive train						
Component to be inspected	A	B	C	D	E	Comments
Fuel container						
Filter						
Sound absorber						
Engine mount						
Fuel lines						
Urea lines						
Fuel lines						

15. inspection category: Superstructure - hydraulic system						
Component to be inspected	A	B	C	D	E	Comments
Oil container						
Filter						
Pumps						
Motors						
Valves						
Lines						
Hoses						
Cylinders						
Pressure limiting valves						
Lowering brake valves						
Brake control: Hoist gear						
Brake control: Slewing gear						

16. inspection category: Superstructure - electrical system						
Component to be inspected	A	B	C	D	E	Comments
Motors						
Generators						
Batteries						
Switches / buttons						
Lines						
Fuses						
Resistors						
Lighting						
Signal lights						

17. inspection category: Superstructure - control systems						
Component to be inspected	A	B	C	D	E	Comments
Engine regulation						
Transmission						
Flexible couplings						
Circuits						
Engine shut off line						
Control displays						

18. inspection category: Superstructure - rope drives						
Component to be inspected	A	B	C	D	E	Comments
Winch 1 ³						
Winch 2 ³						
Winch 3 ³						
Winch 4 ³						
Winch 5 ³						
Winch 6C ³						
Winch 6 ³						
Assembly winches ³						
Rope pulleys						
Rope end connection						
Rope for winch 1						
Rope for winch 2						
Rope for winch 3						
Rope for winch 4						
Rope for winch 5						
Rope for winch 6C						
Rope for winch 6						
Rope for assembly winches						
Guy ropes						

19. inspection category: Superstructure - hook						
Component to be inspected	A	B	C	D	E	Comments
Pulleys						
Rope guards on pulleys						
Axle support						
Load hook						
Load hook mounting						
Hook retention						

LWE/LR 13000-001/19503-01-02/en

20. inspection category: Superstructure - safety and switch systems						
Component to be inspected	A	B	C	D	E	Comments
Hoist emergency limit switch I						
Hoist emergency limit switch II						
Lowering emergency limit switch I						
Lowering emergency limit switch II						
Boom emergency limit switch I						
Boom emergency limit switch II						
Luffing jib: Boom limit switch I						
Luffing jib: Boom limit switch II						
Load torque limiter						
Angle indicator: Boom						
Angle indicator: Luffing jib						
Angle indicator: Slewing gear						
Safety equipment: Control						
Working range limitation						
Pressure sensor						
Speed sensor						
Wind sensor						
Sliding beam monitoring						
Support pressure indicator						
Incline indicator						
Length indicator: Boom radius, boom length						
Emergency off system						
Engine stop						

21. inspection category: Boom						
Component to be inspected	A	B	C	D	E	Comments
Weld structure						
Rope pulleys						
Change over pulleys feed mechanism						
Luffing cylinder						
Telescoping cylinder						
Boom extension ropes						
Boom retraction ropes						
Boom bearings						
Boom pinning						
Guy rods						
Guy ropes						

21. inspection category: Boom						
Component to be inspected	A	B	C	D	E	Comments
Control ropes						
Guide ropes						
Safety ropes						
Relapse cylinders						
Pin connections						

22. inspection category: Equipment						
Component to be inspected	A	B	C	D	E	Comments
Weld structure						
Rope pulleys						
Relapse cylinder						
Relapse support						
Oscillation guard						
A-frame bearings						
Pinning of components						
Guy rods with pinning						
Rods with guide rail on A-frame 2 and A-frame 3						
All limit switches with switch mechanism						
Pin connections						

Inspection chart for periodic inspections of Liebherr mobile and crawler cranes

Inspection criteria:

- A = Present / complete
- B = Condition / maintenance
- C = Function
- D = Repair / replace
- E = Re-inspection required

Evaluation:

- Satisfactory = x
- Unsatisfactory = -
- Not required = 0

Comments:

- ¹ Inspection of the crane carrier vehicle road worthiness is also fulfilled if it has already been certified by the road traffic department certification authority. For cranes that are not certified for use on public roads, an expert or authorized inspector must conduct the required tests to validate the vehicle's road worthiness.
- ² These inspections must be carried out by an authorized inspector even if it has passed the road traffic department test and is certified.
- ³ Inspection of the winches with respect to the actually used proportion of their service life.

Empty page!

LWE/LR 13000-001/19503-01-02/en

90 Appendix

LWE/LR 13000-001/19503-01-02/en

LWE/LR 13000-001/19503-01-02/en

90.01 Preface to the appendix

1 Foreword

3

LWE/LR 13000-001/19503-01-02/en

Fig.195219

LWE/LR 13000-001/19503-01-02/en

1 Foreword

This crane may only be used in a flawless technical condition and according to its mission as well as with constant awareness of safety and dangers. Any problems, which could affect safety, must be fixed immediately.



Note

- ▶ Modifications on the crane may only be made with written approval by Liebherr-Werk Ehingen GmbH.

1.1 Change to the operating instructions

Changes to the operating instructions are received in the form of chapters. The chapter to be replaced must be removed from the operating instructions and replaced with the new chapter in the same location.

When you receive a change to the operating instructions:

- ▶ Remove the chapter to be replaced from the operating instructions.
- ▶ File the new chapter in the same location in the operating instructions.
- ▶ Destroy the replaced chapter.
- ▶ Fill out the change confirmation form in chapter 90.05 of the operating instructions.

1.2 Update to the operating instructions

Updates to the operating instructions, which you receive in the circular as Customer information, must be filed in the operating instructions in chapter 90.05.



Fig. 113870: Customer information decal

When you receive an update to the operating instructions:

- ▶ Attach the decals **1**, which are enclosed in the customer information to the footer of the respective chapter. See the following example.



Note

Example: Update to the operating instructions!

If there is an update that concerns the operating instructions, chapter 2.04:

- ▶ Attach the decal **1** in the footer of chapter 2.04.
- ▶ File the update in chapter 90.05 of the operating instructions.
- ▶ Fill out the update confirmation form in chapter 90.05 of the operating instructions.

Empty page!

LWE/LR 13000-001/19503-01-02/en

90.05 Update confirmation

1	Change confirmation form	3
2	Update confirmation	3
3	Customer information	4

Fig.195219

LWE/LR 13000-001/19503-01-02/en

3 Customer information

Index

1

11952500 – California Proposition 65 Label **2.05 - 2**

3

3-point support **2.04.10 - 25**

7

7725039 – Warning of high voltage **2.05 - 2**

772564008 – Slewing range **2.05 - 3**

772580408 – Limitation of maximum travel speed **2.05 - 3**

9

9402377 – Fastening point / lifting point **2.05 - 11**

9412158 – Reading the operating instructions **2.05 - 7**

97001802 – Falling platform **2.05 - 41**

97003109 – Accessing the step ladder **2.05 - 18**

97003110 – Folding the step ladder in and out **2.05 - 18**

97003112 – Maximum suspended load **2.05 - 25**

97004046 – Safety harness, maximum two persons **2.05 - 7**

97006167 – Identifying the support base **2.05 - 19, 2.05 - 19**

97008514 – Warning of head injuries **2.05 - 19**

97009799 – Data logger **2.05 - 20**

97011336 - Transport weights of the components **2.05 - 41**

97011689 – Danger of crushing **2.05 - 22**

97011690 – Overload of cab is prohibited **2.05 - 22**

97012095 – Maximum load **2.05 - 20**

97012737 – Danger of accident **2.05 - 24**

97012949 – Maximum load **2.05 - 20**

97016304 – Refueling **2.05 - 22**

97016392 – Crushing danger for feet **2.05 - 23**

97016911 – Danger of collision **2.05 - 36**

97017585 – Falling telescopic boom during disassembly / assembly **2.05 - 8**

97018351 – Falling telescopic boom during transport! **2.05 - 8**

97018564 – Falling telescopic boom during transport! **2.05 - 8**

97023034 – Disassembling **2.05 - 24**

97027147 – Overloading of the combi box is prohibited **2.05 - 9**

97033982 – Assembling / disassembling the Derrick pivot section **2.05 - 30**

97036732 – Access via 3-point support **2.05 - 24**

97036733 – Fastening point **2.05 - 9**

97036734 – Rigging point **2.05 - 39**

97036735 – Fastening point for lattice section **2.05 - 13**

97036736 – Fastening point for lattice sections **2.05 - 14**

97036917 – Maximum suspended load **2.05 - 25**

97037383 – Urea **2.05 - 26**

97037625 – Suspended load Fastening points / rigging points **2.05 - 11**

97037871 – Fastening points for lattice sections **2.05 - 15**

97037952 – Warning of fatal electric shock **2.05 - 26**

97038442 – Fastening point for lattice section **2.05 - 14**

97038452 – Fastening point for lattice sections **2.05 - 14**

97038454 – Fastening point for lattice sections **2.05 - 15**

97039035 – Suspended load Assembly unit **2.05 - 17**

97039753 – Danger of stumbling **2.05 - 35**

97041305 – Overload of components **2.05 - 27**

97042730 – Falling luffing cylinder **2.05 - 26**

97042797 – Overload of components **2.05 - 27**

97046488 – Corrosion inhibitor - antifreeze fluids **2.05 - 23**

97047810 – Pinning brackets **2.05 - 27**

97053409 – Entanglement hazard during winch operation **2.05 - 21**

97053410 – Fastening equipment **2.05 - 15**

97057097 – Fastening point to turn the component **2.05 - 16**

97057524 – Fastening point for assembly of lattice sections **2.05 - 16**

97057767 – Fastening points for lattice sections **2.05 - 16**

97059339 – Suspended load Derrick pivot section **2.05 - 17**

97068370 – Closing the cab door **2.05 - 21**

97068839 - Transport weights of the components / fastening length of the fastening equipment **2.05 - 42**

97069053 – Storage boxes open **2.05 - 21**

97070905 – Disassembling the auxiliary jib (boom nose) **2.05 - 28**

9707704 – Driving with the outrigger pad **2.05 - 29**

97077304 – Positioning the outrigger pad **2.05 - 28**

97094940 – Spark catcher **2.05 - 40**

97095312 – Suspended load and fastening points for counterweight frame **2.05 - 18**

97096132 – Fastening points for N-assembly unit **2.05 - 13**

97097951 – Counterweight **2.05 - 30**

97100047 – Retaining pins for erection rack **2.05 - 31**

97100629 – Connector pins for erection rack / guy rods **2.05 - 31**

97106824 – Installing the N-assembly unit **2.05 - 12**

97107101 – Unlocking the telescopic boom locking pin **2.05 - 32**

97107199 – Do not unlock the telescopic boom locking pin **2.05 - 32**

97124295 – Load stop **2.05 - 4**
 97127242 – Assembly aid **2.05 - 5**
 97128894 – Counterweight and counterweight radius **2.05 - 32**
 97131530 – Reduced crawler crane track width **2.05 - 33**
 97133617 – Hydraulic connection **2.05 - 6**
 97137170 – Luffing cylinder and counterweight collision **2.05 - 4**
 97140080 – Assembling the fixed lattice jib **2.05 - 12**
 971494208 – Limitation of maximum travel speed **2.05 - 33**
 97151252 – Hoist device **2.05 - 6**
 971539808 – Warning notice for unpinning the auxiliary boom on the pulley head **2.05 - 34**
 971539908 – Warning notice for unlocking the auxiliary boom **2.05 - 34**
 973974408 – Transport weights of the components **2.05 - 41**
 973974608 – Transport weights of the components **2.05 - 41**
 976624808 – Fastening the load **2.05 - 43**
 977055908 – Fastening point for swingable sliding beam **2.05 - 33**
 978673908 – Warning of suspended load **2.05 - 35**
 978674008 – Access for unauthorized personnel prohibited **2.05 - 35**
 978674108 – Warning of crushing danger **2.05 - 36**
 978674308 – Radio remote control **2.05 - 36**
 978674408 – Danger of burns to hands **2.05 - 37**
 978674508 – Warning of rotating parts **2.05 - 37**
 978674608 – Crushing danger for hands **2.05 - 37**
 978674808 – Personal protective equipment **2.05 - 38**
 978674908 – Accessing the area is prohibited **2.05 - 38**
 978675008 – Access prohibited **2.05 - 38**
 978687408 – Rigging point **2.05 - 39**
 978867108 – Warning of fatal electric shock **2.05 - 39**
 979383308 – Oil change **2.05 - 40**
 979561108 – Counterweight **2.05 - 40**

A

Abbreviations Rope diameter **8.04 - 8**
 Accelerating, changing the load **2.04 - 33**
 Accepting the entries and settings **4.02 - 57**
 Accepting the entries and settings of the operating mode category **4.02 - 34**
 Access for LTR 1060 and LTR 1100 **2.04 - 26**
 Access for LTR 1220 **2.04 - 27**
 Access for LTR cranes **2.04 - 25**
 Accessing the lattice sections or booms **2.04 - 20**
 Accessing via the front step **2.04 - 25**
 Access ladder on the cross carrier **2.06 - 15**
 Access to the crane cab below the cab door **2.04 - 22**

Access to the crane cab in front of the crane cab **2.04 - 23**
 Access via an extendable step from the rear **2.04 - 24**
 Acoustic / visual warnings outside the crane operator's cab **4.20 - 15**
 Acoustic / visual warnings within the crane operator's cab **4.20 - 13**
 Acoustic and optical warning devices **4.04 - 11**
 Acoustic and optical warning signals **4.02 - 3**
 Acoustic warning on LICCON monitor 0 **4.02 - 109**
 Acoustic warning on LICCON monitor 1 **4.02 - 183**
 Acoustic warning on LICCON monitor 2 **4.02 - 197**
 Acoustic warning priority **4.02 - 109, 4.02 - 183, 4.02 - 197**
 Activating normal speed **4.10 - 28**
 Activating the assembly operation **5.05 - 39, 5.05 - 59**
 Activating the bypass at assembly and disassembly **5.01 - 38**
 Activating the bypass at crawler assembly and crawler disassembly **5.01 - 37**
 Actual load **4.02 - 3**
 Actual load (current load) / net load **4.02 - 83**
 Actual load display **4.08 - 15**
 Actuating the slewing gear brake with the pedal **4.05 - 55**
 Actuation of winches and / or crane movements during assembly / disassembly **5.01 - 39**
 Adapting the consoles to the crane operator **4.03 - 25**
 Adapting to the wind speed **4.05 - 23**
 Adding the auxiliary heater **6.02 - 29**
 Adding the vibration sensor for the slewing gear **4.05 - 15**
 Adding the vibration sensor winch 1 **4.05 - 13**
 Additional controls for certain crawler cranes **5.01 - 10**
 Additional controls for cranes on tires on the front and supported on the rear **5.01 - 9**
 Additional controls for cranes supported on the front and on tires on the rear **5.01 - 10**
 Additional controls for cranes with a derrick boom **5.01 - 10**
 Additional controls for cranes with crane support **5.01 - 9**
 Additional controls for cranes with luffing auxiliary boom / accessories **5.01 - 10**
 Additional controls for freestanding crane operation (on tires) **5.01 - 10**
 Additional emergency operating modes **4.02 - 112**
 Additional notes **0.01 - 3**
 Additional risks **2.04 - 86**
 Additional work **4.06 - 31**
 Adjusting the circulating air / fresh air **6.02 - 7**
 Adjusting the consoles **4.03 - 23**
 Adjusting the crane operator's seat **4.03 - 21**
 Adjusting the reeving **4.08 - 14**
 Adjusting the „lower“ / „upper“ air distribution **6.02 - 9**

- Adjusting winch 1 and winch 2 **4.05 - 25**
- A-frame **1.03 - 9**
- A-frame assembly **3.05 - 1**
- After a possible lightning strike to the crane **2.04 - 54**
- After replacement of components **7.01 - 6**
- Aids for work at a height **2.04 - 18**
- Air dryer of the pressurized air system **7.05 - 49**
- Air filter **7.05 - 5**
- Airplane warning light **5.39 - 73, 5.44 - 56**
- Airplane warning light * **5.07 - 53**
- Alarm functions **4.02 - 93**
- Alarm functions of LICCON monitor 1 **4.02 - 181**
- Aligning the crane **2.04 - 48**
- Aligning the crawler center section with the cross carriers in the horizontal direction **3.01.20 - 27**
- Aligning the derrick ballast pallet vertically **5.36 - 39**
- Aligning the turntable for disassembly **3.02 - 81**
- Alignment of derrick ballast pallet **5.36 - 17**
- Ambient temperature **0.01 - 9**
- An error message appears **5.31 - 27**
- Angle adjustment on the fixed lattice jib with mechanical adjustment **5.01 - 48**
- Angle sensors **4.04 - 18**
- Angular pull **4.08 - 11**
- Applying the parking brake **4.05 - 53**
- Areas **7.05.50 - 11, 8.04 - 4**
- Areas of responsibility for crane transport on floating devices **2.25 - 3**
- Areas of responsibility for operating conditions **2.25 - 2**
- Armrests **4.03 - 25**
- Arrangement of intermediate sections and guy rods on the booms / boom systems **5.03 - 2**
- Arrangement of the guy rods **5.03 - 5**
- Arrangement of the intermediate sections **5.03 - 4**
- Assembling **5.07 - 13**
- Assembling / disassembling **5.01 - 29**
- Assembling / disassembling boom systems for supporting on ascending terrain (assembly / disassembly diagram) **5.01 - 78**
- Assembling / disassembling of boom systems for supporting on descending terrain (assembly / disassembly schematic) **5.01 - 81**
- Assembling / disassembling of hydraulic lines **5.01 - 36**
- Assembling / disassembling of lattice sections for lattice mast cranes **5.01 - 67**
- Assembling / disassembling the adapter on the wedge lock **4.06 - 32**
- Assembling / disassembling the booms **5.01 - 40**
- Assembling / disassembling the counterweight **5.01 - 39**
- Assembling / disassembling the crane components **2.08 - 6**
- Assembling / disassembling the electrical lines **5.01 - 35**
- Assembling / disassembling the lattice sections on telescopic cranes with a luffing lattice jib **5.01 - 48**
- Assembling / disassembling the lattice sections on telescopic cranes with an auxiliary boom, with an auxiliary crane **5.01 - 59**
- Assembling / disassembling the lattice sections on telescopic cranes with an auxiliary boom, without an auxiliary crane **5.01 - 63**
- Assembling / disassembling the wedge lock **4.06 - 23**
- Assembling crawler carrier halves and track chain **3.01.10 - 1**
- Assembling lattice sections **5.01 - 67**
- Assembling the adapter on the wedge lock **4.06 - 33**
- Assembling the A-frame **3.05 - 7**
- Assembling the A-frame on the turntable **3.02 - 75**
- Assembling the auxiliary guying **5.07 - 50**
- Assembling the auxiliary guying on the main boom **5.03 - 17**
- Assembling the auxiliary guying on the main boom variation A **5.03 - 7**
- Assembling the auxiliary guying on the main boom variation B **5.03 - 10**
- Assembling the auxiliary guying on the W-boom **5.03 - 12, 5.03 - 19**
- Assembling the boom **5.44 - 22**
- Assembling the boom systems on ascending terrain **5.01 - 78**
- Assembling the boom systems on descending terrain **5.01 - 81**
- Assembling the boom with the substructure **5.39 - 67**
- Assembling the brackets on the carriers **4.07 - 9**
- Assembling the carrier for the counterweight on the turntable **3.02 - 75**
- Assembling the carriers on the turntable **4.07 - 9**
- Assembling the catwalks **3.01.20 - 25**
- Assembling the catwalks and railings on the engine house **3.02 - 59**
- Assembling the central ballast **3.02 - 15, 5.44 - 55**
- Assembling the central ballast mounting **3.03 - 7**
- Assembling the counterweight frame **4.07 - 7**
- Assembling the counterweight on the turntable **3.02 - 75**
- Assembling the crawler carrier **3.01.10 - 7**
- Assembling the crawler carrier on the cross carrier **3.01.30 - 3**
- Assembling the crawler carrier on the preassembled crawler center section **3.01.30 - 1**
- Assembling the crawler chain **3.01.10 - 27**
- Assembling the crawler chain on the crawler carrier **3.01.10 - 33**
- Assembling the cross beam without wheels **2.04.10 - 16**
- Assembling the cross beam with wheels **2.04.10 - 16**
- Assembling the cross carrier on the crawler center section **3.01.20 - 1, 3.01.20 - 5**
- Assembling the D-boom **5.05 - 6, 5.05 - 53, 5.05 - 61**
- Assembling the D-boom in sections **5.05 - 37**
- Assembling the derrick guy rods **5.05 - 53, 5.05 - 61**
- Assembling the D-intermediate section flying **5.05 - 51**

Assembling the D-intermediate sections with the cross beam **5.05 - 66**
Assembling the D-lattice sections with the cross beam **5.05 - 69**
Assembling the end section on the boom **5.39 - 47**
Assembling the engine house on the turntable **3.02 - 61**
Assembling the first bracket on the carrier (ground assembly) **4.07 - 9**
Assembling the first carrier on the turntable frame **4.07 - 13**
Assembling the first crawler carrier **3.01.30 - 5**
Assembling the first cross carrier **3.01.20 - 9**
Assembling the fixed lattice jib on the TF-adapter **5.01 - 45**
Assembling the frame **5.44 - 44**
Assembling the grating **5.44 - 14**
Assembling the guy rods **5.07 - 37, 5.07 - 48, 5.39 - 55, 5.44 - 51**
Assembling the hook nut **8.05 - 6**
Assembling the ladder **2.04.10 - 14, 2.06 - 93**
Assembling the lattice sections on a luffing lattice jib **5.01 - 55**
Assembling the lattice sections on an auxiliary boom with an auxiliary crane **5.01 - 59**
Assembling the lattice sections on an auxiliary boom without an auxiliary crane **5.01 - 63**
Assembling the Li-intermediate sections on the P-adapter **5.44 - 31**
Assembling the load hook * **4.06 - 16**
Assembling the lower P-adapter on the S-pivot section **5.44 - 28**
Assembling the PD-boom **5.44 - 11**
Assembling the pin pulling cylinder **3.05 - 15, 3.05 - 25, 3.05 - 43, 3.05 - 45**
Assembling the placement pins **5.07 - 44**
Assembling the platform **2.06 - 95**
Assembling the platform ladder **2.04.10 - 16**
Assembling the platforms **5.36 - 57**
Assembling the platforms on the turntable frame rear section **2.06 - 51**
Assembling the pull cylinder and ballast rods **5.05 - 81**
Assembling the radio receiving unit **5.19.10 - 2, 5.19.10 - 3**
Assembling the radio sender unit on the hook block **5.19.10 - 5, 5.19.10 - 7**
Assembling the railing on the catwalk in the operating position **2.06 - 55**
Assembling the railing on the platforms **2.06 - 89**
Assembling the railing on the turntable **3.05 - 23, 3.05 - 53**
Assembling the railings on the platforms **5.05 - 9**
Assembling the retaining rope on the mechanical relapse support **5.07 - 80**
Assembling the roller cart **5.07 - 46**
Assembling the roller ring connection **3.01.30 - 23**
Assembling the roller set **5.07 - 43**
Assembling the roller sets **5.39 - 71, 5.44 - 54**

Assembling the roller sets on the boom head **5.39 - 71**
Assembling the SD/SLD-boom **5.39 - 12**
Assembling the SD/SLD-boom in „flying“ mode **5.39 - 61**
Assembling the second bracket on the carrier **4.07 - 9**
Assembling the second carrier on the turntable frame **4.07 - 17**
Assembling the second crawler carrier **3.01.30 - 16**
Assembling the second cross carrier **3.01.20 - 21**
Assembling the S-end section / L-end section **5.39 - 39**
Assembling the S-intermediate section on the S-pivot section **5.39 - 33**
Assembling the S-intermediate sections / S-adapter / S-end section on the upper P-adapter **5.44 - 42**
Assembling the S-luffing pulley block **5.05 - 97**
Assembling the S-pivot section on the turntable **5.39 - 27, 5.44 - 19**
Assembling the suspended ballast **5.44 - 55**
Assembling the transport lugs for the assembly of the engine house with one auxiliary crane **3.02 - 57**
Assembling the transport lugs for the assembly of the engine house with two auxiliary cranes **3.02 - 55**
Assembling the turntable **3.02 - 11**
Assembling the upper P-adapter on the Li-intermediate sections **5.44 - 38**
Assembling the WA-frame 2 guy rods **5.07 - 19**
Assembling the wedge lock **4.06 - 30**
Assembling the weight **5.05 - 103**
Assembling the winch **3.07.50 - 5**
Assembling the W-lattice jib **5.07 - 38**
Assembling the W-lattice jib on the W-pivot section **5.07 - 42**
Assembling WA-frame 1 on the end section **5.07 - 22**
Assembling WA-frame 2 on the end section **5.07 - 25**
Assembling winch 1 **3.07.10 - 7**
Assembling winch 2 **3.07.20 - 7**
Assembling winch 3 **3.07.30 - 7**
Assembling winch 3 and winch 6 **5.05 - 17**
Assembling winch 5 **3.07.50 - 7**
Assembling winch 6 **3.07.60 - 7**
Assembly **5.10 - 6**
Assembly / disassembly procedures **4.20 - 5**
Assembly aid **2.05 - 5**
Assembly conditions **3.06 - 1**
Assembly configurations on the crawler carrier **3.06 - 3**
Assembly drawings **5.01 - 31**
Assembly of A-frame **4.07 - 17**
Assembly of winch 5 (WV) on the S-pivot section **5.39 - 29**
Assembly plate Variation 1: Assembling / disassembling the radio receiving unit **5.19.10 - 3**
Assembly plate Variation 2: Assembling the radio receiving unit **5.19.10 - 5**
Assembly prerequisites for boom nose(s) **5.10 - 7**
Assembly procedure **5.10 - 9**

Assembly rope **1.03 - 35**
 Assembly shoe for boom **1.03 - 33**
 Assembly shoe for S-pivot section **1.03 - 33**
 Assembly shoe for the roller set, end section **1.03 - 33**
 Assembly shoes **5.62 - 1, 5.62 - 3**
 Assembly winch **1.02 - 3, 1.03 - 11**
 Assembly winch menu **5.31 - 22**
 Assigning the fixed accessory **4.02 - 69**
 Assigning the hoist winch (normal operation of hoist winch) **4.02 - 59**
 Assigning the hoist winch (parallel operation of hoist winches) **4.02 - 61**
 Assigning the reeving (normal operation of hoist winch) **4.02 - 63**
 Assigning the reeving (parallel operation of hoist winch) **4.02 - 65**
 Attaching and removing the load hook * **4.06 - 15**
 Attaching the container spreader on the auxiliary crane **3.03 - 11, 3.03 - 19**
 Attaching the fastening equipment on the engine house **3.02 - 91**
 Attaching the hoist limit switch weight **4.06 - 19, 4.06 - 22**
 Authorized and trained service technician **7.01 - 2**
 AUTO heating mode **6.02 - 19**
 Automatic regeneration of the diesel particle filter **4.03 - 14**
 Auxiliary boom / accessory limit signs **4.02 - 97**
 Auxiliary equipment **1.02 - 5, 2.08 - 2**
 Auxiliary guying **5.01 - 13**

B

Ballast automatic * **4.02 - 171**
 Ballasting additional counterweight plates **4.07 - 29**
 Ballasting sequence **4.07 - 27**
 Ballasting the counterweight plates **4.07 - 25**
 Ballasting the derrick ballast pallet **5.36 - 45**
 Ballasting the derrick ballast pallet down **5.36 - 107**
 Ballast trailer * **4.02 - 190**
 Ballast trailer emergency operation **4.02 - 195**
 Ball locking pin **5.01 - 27**
 Basic principles and procedure **8.01 - 4**
 Basic requirements **2.25 - 2**
 Basket formation **7.05.50 - 8, 8.04 - 21**
 Batteries **7.01 - 15**
 Batteries in the radio sender unit **5.19.10 - 9**
 Battery compartments open: **5.19.10 - 10**
 Battery maintenance **7.05 - 49**
 Battery voltage individual control display **4.02 - 125**
 Before starting to work **2.04 - 74**
 Bitt fastening point **5.01 - 33**
 Bleeding by simulating crawler operation **7.04 - 15**
 Bleeding repaired lubrication lines **7.04 - 17**
 Bleeding the central lubrication system **7.04 - 15, 7.05 - 37**
 Bleeding the heating system **6.02 - 34**

Bleeding via separate actuation of the grease pump **7.04 - 17**
 Block position of the relapse cylinders when setting down the load **5.01 - 11**
 Bluetooth Terminal (BTT) **5.31 - 1**
 Boom components **5.03 - 2**
 Boom configuration **5.14 - 5**
 Boom length **4.02 - 89**
 Boom limitation **4.02 - 93**
 Boom nose **1.03 - 15**
 Boom nose 120t **5.10 - 3**
 Boom nose lattice boom **5.10 - 1**
 Boom on the ground function **4.02 - 181**
 Boom radius **4.02 - 87**
 Boom system component overview **1.01 - 4**
 Boom system dimensions and weights **1.03 - 13**
 Boom systems **1.02 - 5, 5.03 - 1**
 Boom systems / boom combinations **1.02 - 5**
 Bracket **1.03 - 25**
 Breaking away fixed loads **4.08 - 13**
 Brief description **4.08 - 22**
 Bringing platforms, gratings, ladders and railings into the operating position **3.02 - 31**
 Bringing the bracket for the engine house into the operating position **3.02 - 27, 3.02 - 31**
 Bringing the bracket for the engine house on the turntable frame rear section into the transport position **3.02 - 113**
 Bringing the cross beam into the operating position **2.04.10 - 15**
 Bringing the cross beam into the transport position **2.04.10 - 15**
 Bringing the deflector on the engine house into operating position **3.02 - 57**
 Bringing the deflector on the engine house into transport position **3.02 - 99**
 Bringing the folding bracket into operating position **3.02 - 69**
 Bringing the folding bracket into transport position **3.02 - 87**
 Bringing the folding step on the access ladder into operating position **3.02 - 69**
 Bringing the folding step on the access ladder into transport position **3.02 - 87**
 Bringing the leaning ladder into the transport position **2.04.10 - 19**
 Bringing the radio receiving unit to the operating position from the transport position **5.19.10 - 4**
 Bringing the radio receiving unit to the transport position from the operating position **5.19.10 - 4**
 Bringing the radio sender unit and radio receiving unit into the park position **5.19.10 - 12**
 Bringing the railing and rods into operating position **5.39 - 17**
 Bringing the railings on the carriers into operating position **4.07 - 9**
 Bringing the railings on the carriers into transport position **4.07 - 49**

Bringing the rods for WA-frame 2 guying into the operating position **5.39 - 17**
Bringing the sliding section into the transport position **3.01.10 - 63**
Bringing the S-relapse cylinders into the operating position **5.39 - 77, 5.44 - 60**
Bringing the stairs into the transport position **3.02 - 93**
Bringing the step into operating position and removing the fastening equipment on the engine house **3.02 - 67**
Bringing the stepladder into the transport position **2.04.10 - 20**
Bringing the upper catwalk into operating position **3.02 - 67**
Bringing the upper catwalk on the engine house into assembly position **3.02 - 59, 3.02 - 89**
Bringing the upper pulley block to the A-frame **5.05 - 143**
Broken strands **7.05.50 - 5**
Broken wire **7.05.50 - 5**
Broken wire in the strand valleys **8.04 - 14**
Broken wire nests **8.04 - 15**
Broken wires in rope sections, which are not spooled up on the winch **8.04 - 14**
Broken wires on rope end connections **8.04 - 14**
BTT button block **5.31 - 8**
BTT EMERGENCY OFF switch **5.31 - 9**
BTT maintenance instructions **5.31 - 30**
BTT operating and control instruments **5.31 - 4**
BTT operating elements **5.31 - 3**
BTT system start **5.31 - 6**
Buckles **7.05.50 - 10, 8.04 - 25**
Bypassing at assembly / disassembly **5.01 - 37**
Bypassing at assembly and disassembly **5.01 - 38**
Bypassing at crawler assembly / disassembly **5.01 - 37**
Bypassing the difference force monitoring of derrick ballast guying **4.02 - 112**
Bypassing the hoist top shut-off **4.20 - 49, 5.01 - 15**
Bypassing the LICCON overload protection **5.01 - 14**
Bypassing the overload protection **5.01 - 13**
Bypassing the PAT overload protection **5.01 - 15**
Bypassing the radio connection **5.31 - 29**
Bypassing the shut off of the function ballast up / down **5.36 - 87**
Bypass of hoist limit switch **4.02 - 112**
Bypass of overload protection **4.04 - 5**
Bypass of overload protection: Emergency situation (according to EN 13000:2010) **4.04 - 6**
Bypass of overload protection: Failure of overload protection (according to EN 13000:2010) **4.04 - 6**
Bypass of overload protection: Failure of the overload protection **4.04 - 5**

C

Cab attachment parts **4.01 - 3**
Cab equipment **4.01 - 3**

Cab operating units overview **4.01 - 9**
Calculating the required length of transitions on uphill / downhill slopes **4.10 - 4**
Calculation example **4.10 - 5**
Calculation examples **2.04 - 43**
California Proposition 65 **0.01 - 1**
Calling up / closing the system screen **5.31 - 10**
Calling up / masking / switching the crane operation monitoring functions **4.02 - 116**
Calling up / masking the crane operation monitoring functions **4.02 - 117**
Calling up and checking the monitoring functions of the LICCON computer system **4.03 - 5**
Calling up the diesel particle filter load condition **4.03 - 13**
Calling up the service system **7.01.10 - 2**
Camera monitoring **4.01 - 21**
Camera monitoring control unit **4.01 - 21**
Camera monitoring monitors **4.01 - 23**
Carrier central ballast **1.03 - 7**
Carrying out an intermediate lubrication **7.05 - 35**
Carrying out crane movements **5.36 - 87**
Carrying out erection procedures **4.20 - 57**
Carrying out take down procedures **4.20 - 59**
Carrying out the assembly procedures **4.20 - 61**
Carrying out the erection / take down procedures **4.20 - 53**
Carrying out the erection procedure **5.07.50 - 10**
Carrying out the take-down procedure **5.07.50 - 17**
Carrying out the tension procedure **7.04 - 24**
Catwalk crawler travel gear **1.03 - 7**
CE marking **0.01 - 5**
Center of gravity display on the LICCON monitor **4.10 - 7**
Center of gravity of the counterweight **2.05 - 44**
Central ballast **1.02 - 2, 3.03 - 1**
Central ballast plate **1.03 - 7**
Central lubrication system **7.05 - 25**
Change confirmation form **90.05 - 3**
Change to the operating instructions **90.01 - 3**
Changing and saving settings **4.02 - 215**
Changing over regulation Parallel operation winch 1 and winch 2 **4.05 - 30**
Changing over winch 1 and winch 2 parallel operation regulation **4.02 - 194**
Changing the assembly shoes at assembly **5.44 - 37, 5.62 - 4**
Changing the assembly shoes at disassembly **5.44 - 90, 5.62 - 5**
Changing the boom: Turning the Li-intermediate sections **5.44 - 30**
Changing the oil **7.04 - 7, 7.05 - 3, 7.05 - 9, 7.05 - 23, 7.05 - 41, 7.05 - 47**
Changing the oil on the travel gear **7.04 - 7**
Changing the retaining plates during the erection and take down procedure **5.07 - 48**
Changing the set up configuration **4.03 - 39**
Changing the travel direction **4.10 - 30**

- Charge air temperature individual control display **4.02 - 126**
- Charging the BTT rechargeable battery **5.31 - 13**
- Chart for determining the theoretically remaining service life **8.03 - 11**
- Check bearings for easy movement **7.05.50 - 4**
- Check for wear and distortion **7.05.50 - 11**
- Checking before start up **4.03 - 2**
- Checking for broken strands **8.04 - 10**
- Checking for corrosion **7.05.50 - 12**
- Checking for damage and cracks **8.01 - 86**
- Checking for flattenings **7.05.50 - 13**
- Checking for leaks **7.04 - 5**
- Checking for mechanical damage **7.05.50 - 4**
- Checking for solid foreign substances **8.03 - 4**
- Checking of rope diameter **8.04 - 15**
- Checking of rope pretension on telescopic booms, illustration 1 **8.01 - 83**
- Checking the accumulator pressure in the relapse cylinder **8.14 - 2**
- Checking the accumulator pressure in the W-relapse cylinder, W-boom luffed up **8.14 - 4**
- Checking the accumulator pressure in the W-relapse cylinder, W-boom on the ground **8.14 - 3**
- Checking the airplane warning light **5.10 - 12**
- Checking the battery voltage **4.03 - 9**
- Checking the battery voltage on the batteries **4.03 - 9**
- Checking the battery voltage on the LICCON monitor **4.03 - 9**
- Checking the bearings for easy movement **8.01 - 88**
- Checking the center of gravity display on the LICCON monitor **4.03 - 10**
- Checking the central lubrication system **4.03 - 4**
- Checking the connection type **5.31 - 11**
- Checking the control rope for distortions **7.05.50 - 13**
- Checking the coolant level **4.03 - 4**
- Checking the crane **2.04 - 54**
- Checking the D-boom „Steepest position“ limit switch **5.05 - 107, 5.44 - 56**
- Checking the depth of the lead-in tracks **8.01 - 87**
- Checking the diesel particle filter load condition (DPF) **4.03 - 7**
- Checking the display for the incline in the LICCON monitor **4.03 - 12**
- Checking the display for the surface pressure on the LICCON monitor **4.03 - 10**
- Checking the double hook for damage **8.05 - 5**
- Checking the end of the service life **8.06 - 3**
- Checking the engine oil level **4.03 - 7**
- Checking the engine oil levels **4.03 - 3**
- Checking the expansion of the hook jaw **8.05 - 3**
- Checking the filter for the hydraulic tank **4.03 - 4**
- Checking the fuel level **4.03 - 6**
- Checking the function of the central lubrication system **7.05 - 35**
- Checking the function of the safety equipment **5.05 - 107, 5.07 - 53**
- Checking the gas pressure and oil fill before start up **8.01 - 86**
- Checking the gear brakes **8.03 - 4**
- Checking the general condition of the crane **4.03 - 3**
- Checking the grease quantity **7.05 - 43**
- Checking the groove diameter **8.01 - 86, 8.03 - 3**
- Checking the guy rods **8.15 - 3**
- Checking the HATZ-DIESEL generator **4.03 - 5**
- Checking the hoist limit switch on the pulley head **5.10 - 12**
- Checking the hook body for wear **8.05 - 4**
- Checking the horn **4.03 - 30**
- Checking the hydraulic hoses within area of responsibility of the German employer's liability insurance associations **7.05 - 13**
- Checking the hydraulic oil level **4.03 - 8**
- Checking the hydraulic tank **4.03 - 4**
- Checking the labeling **5.01 - 2**
- Checking the limit switch actuators for function **8.12 - 3, 8.12 - 5, 8.12 - 7**
- Checking the limit switch actuators for function (S-end section without pulley set) **8.12 - 9**
- Checking the limit switch actuators for function (S-end section with pulley set) **8.12 - 9**
- Checking the limit switch actuators on switch point „steepest position“ **8.12 - 7**
- Checking the limit switch D-boom „Steepest position“ **5.39 - 73**
- Checking the limit switch main boom „steepest position“ **5.39 - 73**
- Checking the limit switch main boom „steep position“ **5.44 - 56**
- Checking the limit switch on the S-boom **5.10 - 12**
- Checking the limit switch on the W-boom **5.10 - 13**
- Checking the load hook **8.05 - 2**
- Checking the load hook for corrosion **8.05 - 5**
- Checking the load hook for distortion **8.05 - 2**
- Checking the load hook for surface cracks **8.05 - 3**
- Checking the lubrication **7.05.50 - 11**
- Checking the maintenance status **7.01.10 - 6**
- Checking the monitoring functions on the LICCON monitor **4.03 - 44**
- Checking the mounting screws for damage **8.01 - 90**
- Checking the oil level in the hydraulic tank **4.03 - 4**
- Checking the operating and control instruments after starting **4.03 - 43**
- Checking the position **7.05.50 - 12**
- Checking the retaining elements **5.01 - 21, 8.05 - 6**
- Checking the rope drive for spooling problems **7.05.50 - 12**
- Checking the rope end connection **8.04 - 15**
- Checking the ropes **7.05.50 - 10**
- Checking the safety measures **2.04 - 49**
- Checking the safety ropes and anchor points **2.06 - 7, 8.01 - 82**
- Checking the settings **5.07 - 65, 5.10 - 16, 5.39 - 87, 5.44 - 67**
- Checking the settings in the LICCON overload protection **5.36 - 67**
- Checking the steel structures **5.01 - 2**
- Checking the tightening torque **8.01 - 88**

Checking the tightness of the mounting screws **8.01 - 90**
 Checking the tilt play **8.01 - 89**
 Checking the tooth flanks on the gear ring **7.05 - 45**
 Checking the urea reserve **4.03 - 6**
 Checking the vent / breather filter **7.05 - 11**
 Checking the wear on the connections of the track pads **7.04 - 29**
 Checking the wear on the roll off surfaces of the track pads / track rollers **7.04 - 31**
 Checking the winch oil level **4.03 - 3**
 Checking the window cleaning fluid **4.03 - 4**
 Checking the wind speed sensor **5.10 - 12**
 Checking wear on the track chain **7.04 - 27**
 Check list for the inspection of ladders and steps **8.17 - 4**
 Checks before starting to work with the crane **4.08 - 4**
 Chemicals **2.04 - 3**
 Cleaning the filter strainer **7.05 - 7**
 Cleaning the roller ring connection **3.01.30 - 25**
 Close the battery compartments: **5.19.10 - 11**
 Close the radio sender unit: **5.19.10 - 10**
 Closing the ball valve for the thermo valve **5.05 - 81**
 Closing the boom system **5.39 - 53, 5.44 - 48**
 Closing the boom system (via the derrick boom) **5.01 - 89**
 Closing the boom system (via the SA-frame) **5.01 - 86**
 Closing the boom system - opening the boom system (via the derrick boom) **5.01 - 87**
 Closing the boom system - opening the boom system (via the SA-frame) **5.01 - 84**
 Closing the end section **5.01 - 42**
 Closing the fixed lattice jib **5.01 - 47**
 Closing the turntable frame rear section on the turntable frame front section **3.02 - 45**
 Collision of mechanical relapse support with flap **8.12 - 15**
 Combined degree of severity **8.04 - 26**
 Combining the crawler carrier front section and the crawler carrier rear section **3.01.10 - 19**
 Comparison **4.02 - 3**
 Complete crawler carrier **1.03 - 5**
 Complete crawler carrier fastening points **3.01.10 - 5**
 Component fastening points **3.01.20 - 3**
 Component overview - Derrick ballast **5.36 - 5**
 Component overview Derrick ballast pallet **5.36 - 7**
 Component overview S-pivot section **5.39 - 3**
 Components **5.44 - 3**
 Components boom nose **5.10 - 3**
 Components of counterweight **4.07 - 3**
 Components of counterweight frame **4.07 - 3**
 Components of the crawler carrier **3.01.10 - 3**
 Components of the crawler carrier front section **3.01.10 - 3**
 Components of the crawler carrier rear section **3.01.10 - 3**

Components of transport frame / engine house / crane operator's cab **3.02 - 3**
 Components of turntable frame, rear section **3.02 - 3**
 Connecting / closing the crawler chain **3.01.10 - 41**
 Connecting and climbing up the leaning ladder **2.04.10 - 33**
 Connecting the BTT automatically with the crane **5.31 - 6**
 Connecting the BTT manually with the crane **5.31 - 6**
 Connecting the crawler carrier to the cross carrier **3.01.30 - 7**
 Connecting the cross carrier to the crawler center section **3.01.20 - 9, 3.01.20 - 21**
 Connecting the hoist rope **4.06 - 16**
 Connecting the hoist rope to the rope lock **4.06 - 10, 4.06 - 13**
 Connecting the hydraulic and electrical connections to the rotary connection **3.02 - 29**
 Connecting the hydraulic supply lines **3.02 - 107**
 Connecting the hydraulic supply lines for assembly **3.02 - 33**
 Connecting the ladder (small) to the turntable frame rear section **2.06 - 65**
 Connecting the ladder to the A-frame in the operating position **2.06 - 75**
 Connecting the rope of winch 6 with the upper pulley block **5.05 - 77, 5.05 - 143**
 Connecting the supply **4.03 - 35**
 Connection displays BTT and crane **5.31 - 6**
 Connector carrier **1.03 - 25**
 Control bore auxiliary function * **4.06 - 27**
 Control cabinet **4.01 - 7**
 Control measures before crane operation **5.01 - 8**
 Control platform overview **4.01 - 9**
 Control release **4.04 - 17**
 Control ropes **1.03 - 34**
 Conversion chart **0.01 - 11**
 Conversion chart for wind force **2.04 - 57**
 Coolant system **7.06 - 3**
 Coolant temperature individual control display **4.02 - 125**
 Corkscrew-like distortion **7.05.50 - 8, 8.04 - 20**
 Corrosion **7.05.50 - 6, 8.04 - 18**
 Cotter pin **5.01 - 22**
 Counterweight **1.02 - 3, 4.07 - 1**
 Counterweight and / or ballast **2.04 - 77**
 Counterweight frame **1.03 - 11**
 Country-specific content **8.20 - 1, 8.20 - 2**
 Cracks and dents **8.15 - 4**
 Crane **2.04 - 86, 7.01 - 12**
 Crane and crane components **2.04 - 30**
 Crane and crane component transport **3.80 - 1**
 Crane cab **1.02 - 3, 1.03 - 11, 2.04 - 21**
 Crane cab operating and control instruments **5.31 - 5**
 Crane cab with incline adjustment **2.04 - 28**
 Crane cab with securing bracket **2.04 - 28**
 Crane chassis diesel engine maintenance status **7.01.10 - 4**
 Crane control **1.02 - 3**

Crane documentation **0.01 - 3**
Crane engine **7.05 - 3**
Crane engine maintenance status (engine 1) **7.01.10 - 5**
Crane engine maintenance status (engine 2) **7.01.10 - 6**
Crane geometry and load information **4.02 - 79**
Crane incline **4.02 - 141**
Crane in operation **2.04 - 5**
Crane on floating body **2.25 - 1**
Crane operation **2.04 - 74, 2.08 - 7, 4.05 - 1, 4.08 - 18, 5.07 - 65**
Crane operation in case of thunderstorms **2.04 - 53**
Crane operation monitoring functions **4.02 - 113**
Crane operation with a load **2.04 - 75**
Crane operation with derrick ballast **5.36 - 67**
Crane operator's cab heater / engine preheating / air conditioning system **6.02 - 1**
Crane operator's cab work station **4.03 - 21**
Crane operator responsibilities **2.04 - 33**
Crane out of service **2.04 - 6**
Crane rope pretension **4.08 - 20**
Crane ropes **7.05.50 - 4, 8.04 - 3**
Crane speeds **1.03 - 34**
Crane superstructure **1.02 - 2**
Crane superstructure diesel engine maintenance status **7.01.10 - 5**
Crane surface pressure **1.03 - 33**
Cranes with a telescopic boom **2.08 - 6, 2.08 - 7**
Cranes with cam limit switch **5.01 - 3**
Cranes with lattice mast boom **2.08 - 5, 2.08 - 7**
Cranes with winch speed sensor **5.01 - 3**
Crane transport on floating devices **2.25 - 3**
Crane types with an electronic engine oil level display **4.03 - 3**
Crane types without an electronic engine oil level display **4.03 - 3**
Crawler carrier fastening points **3.01.10 - 5**
Crawler carrier front section fastening points **3.01.10 - 5**
Crawler carrier halves, front **1.03 - 3**
Crawler carrier halves, rear **1.03 - 3**
Crawler carrier halves installed **1.03 - 5**
Crawler carrier rear section fastening points **3.01.10 - 5**
Crawler center section **1.03 - 5**
Crawler chain **1.03 - 3**
Crawler operation with derrick ballast **5.36 - 97**
Crawler travel gear **1.01 - 3, 1.02 - 2, 1.02 - 2**
Creeper gear or very slow movement **2.04 - 65**
Cross beam **5.05 - 66, 5.05 - 175, 5.39 - 20**
Cross beams for platform ladder **2.04.10 - 15**
Cross carrier **1.03 - 25**
Cross carrier, front **1.03 - 5**
Cross carrier, rear **1.03 - 5**
Current checklist **8.04 - 29**
Curve illustration of load charts (PC) **5.07.50 - 7**
Curve illustration of the load charts (crane) **5.07.50 - 4**

Curve illustration program **4.02 - 197**
Customer information **90.05 - 4**
Customer-specific special equipment **6.50 - 1**
Cylinders **7.01 - 13**

D

Damage on rope **7.05.50 - 5**
Danger of crushing **4.08 - 19**
Danger of falling **4.08 - 19**
Dangers on the crane **2.04 - 3**
Danger zone of crane **2.04 - 5**
Data logger **0.01 - 2**
Data tag **0.01 - 5**
D-boom **5.05 - 1**
Deactivating the bypass at crawler assembly and crawler disassembly **5.01 - 37**
Decommissioning **7.01 - 14**
Definition of directional data for crawler cranes **0.01 - 10**
Definition of directional data for mobile cranes **0.01 - 10**
Degree of severity **8.04 - 8**
D-end section 12.0m **1.03 - 23**
Derrick ballast **4.02 - 187**
Derrick ballast boom radius display **4.02 - 171**
Derrick ballast guying difference force monitoring shut-off **4.02 - 194**
Derrick ballast - suspended ballast **2.04 - 78, 5.36 - 1**
Derrick ballast utilization display **4.02 - 188**
Derrick boom angle indicator **4.02 - 171**
Derrick relapse retainer **8.12 - 5**
Descending from lattice sections or booms **2.04 - 20**
Description **1.03.10 - 2, 7.01.10 - 2**
Description of acoustic / visual warnings **4.20 - 11**
Description of intervals and tasks **7.01 - 3**
Description of suspended ballast **5.36 - 3**
Description of the function **5.30 - 4, 5.31 - 3**
Description using the example LR 1600-2, SL3F **4.08 - 22**
Destruction of a glass pane **2.04 - 29**
Detachable rope end connection **8.04 - 15**
Detaching the hoist rope **4.06 - 11, 4.06 - 14, 4.06 - 17**
Detent pin **5.01 - 25**
Determining the auxiliary boom / accessory variation **4.02 - 28**
Determining the effective operating hours Ti **8.03 - 8**
Determining the exact charge condition of the rechargeable battery **5.31 - 10**
Determining the main boom variation **4.02 - 21**
Determining the number of broken wires **8.04 - 10**
Determining the operating conditions (load spectrum) **8.03 - 6**
Determining the steepest main boom operating position **5.07.50 - 2**
Determining the used proportion of the theoretical service life **8.03 - 8**
Diaphragm reservoirs **7.05 - 12**

Diesel engine **7.06 - 3**
Diesel engine exhaust emissions **2.04 - 3**
Diesel particle filter (DPF) * **4.03 - 13**
Diesel particle filter * **7.05 - 5**
Diesel particle filter individual control display **4.02 - 124**
Diesel particle filter load conditions **4.03 - 14**
Differential force monitoring for derrick ballast-guying **5.36 - 86**
Dimensions and weights **1.03 - 3**
Dimensions and weights crawler crane chassis **1.03 - 3**
D-intermediate section 12.0m **1.03 - 21, 1.03 - 23**
D-intermediate section 2824.25 12m **5.05 - 185**
D-intermediate section 2824.25 12 m **5.05 - 33**
D-intermediate section 2824.36 12m **5.05 - 183**
D-intermediate section 2824.36 12 m **5.05 - 31**
D-intermediate section 2824.36 6 m and D-intermediate section 2824.36A 6 m **5.05 - 35, 5.05 - 187**
D-intermediate section 6.0m **1.03 - 21, 1.03 - 21**
Disabling automatic regeneration of the diesel particle filter **4.03 - 15**
Disassembling **5.07 - 67**
Disassembling / lifting the counterweight plates off **4.07 - 33**
Disassembling boom systems on ascending terrain **5.01 - 79**
Disassembling boom systems on descending terrain **5.01 - 82**
Disassembling flying the D-intermediate section 2824.36 12m **5.05 - 159**
Disassembling lattice sections **5.01 - 69**
Disassembling of the WA-frames **5.07 - 99**
Disassembling platforms, gratings, ladders and railings on the turntable frame rear section and bringing them into the transport position **3.02 - 113**
Disassembling the adapter on the wedge lock **4.06 - 33**
Disassembling the A-frame **3.05 - 33**
Disassembling the A-frame on the turntable **3.02 - 77**
Disassembling the ballast rods and pull cylinder **5.05 - 135**
Disassembling the brackets on the carriers **4.07 - 49**
Disassembling the carriers for the counterweight on the turntable **3.02 - 77**
Disassembling the carriers on the turntable **4.07 - 43**
Disassembling the catwalks **3.01.20 - 31**
Disassembling the catwalks and railings on the engine house **3.02 - 99**
Disassembling the central ballast **3.02 - 127, 5.39 - 91, 5.44 - 70**
Disassembling the central ballast mounting **3.03 - 25**
Disassembling the counterweight frame **4.07 - 41**
Disassembling the counterweight on the turntable **3.02 - 77**
Disassembling the crane operator's cab on the engine house **3.02 - 101**
Disassembling the crawler carrier on the cross carrier **3.01.30 - 39**

Disassembling the crawler carriers **3.01.10 - 47**
Disassembling the crawler chain **3.01.10 - 65**
Disassembling the crawler chain into chain segments **3.01.10 - 65**
Disassembling the crawler chain on the crawler carrier **3.01.10 - 49**
Disassembling the cross carrier on the crawler center section **3.01.20 - 29**
Disassembling the D-boom **5.05 - 113, 5.05 - 151, 5.05 - 171**
Disassembling the D-boom in sections **5.05 - 147**
Disassembling the derrick ballast **5.36 - 99, 5.39 - 91, 5.44 - 70**
Disassembling the derrick guy rods **5.05 - 155, 5.05 - 171**
Disassembling the D-intermediate sections with the cross beam **5.05 - 174**
Disassembling the D-lattice sections with the cross beam **5.05 - 178**
Disassembling the engine house on the turntable **3.02 - 95**
Disassembling the first bracket on the carrier **4.07 - 49**
Disassembling the first carrier on the turntable frame **4.07 - 43**
Disassembling the first crawler carrier **3.01.30 - 51**
Disassembling the first cross carrier **3.01.20 - 33**
Disassembling the frame **5.44 - 85**
Disassembling the guy rods **5.39 - 105, 5.44 - 77**
Disassembling the ladder **2.06 - 99**
Disassembling the lattice sections of the boom **5.44 - 79**
Disassembling the lattice sections on a luffing lattice jib **5.01 - 57**
Disassembling the lattice sections on an auxiliary boom with an auxiliary crane **5.01 - 61**
Disassembling the lattice sections on an auxiliary boom without an auxiliary crane **5.01 - 65**
Disassembling the Li-intermediate sections **5.44 - 91**
Disassembling the lower P-adapter on the S-pivot section **5.44 - 92**
Disassembling the PD-boom **5.44 - 69**
Disassembling the pin pulling cylinder **3.05 - 23, 3.05 - 25, 3.05 - 43, 3.05 - 53**
Disassembling the platform **2.06 - 97**
Disassembling the platforms **5.36 - 119**
Disassembling the platforms on the turntable frame rear section **2.06 - 53**
Disassembling the radio receiving unit **5.19.10 - 4**
Disassembling the radio sender unit on the hook block **5.19.10 - 8**
Disassembling the railing on the catwalk in the transport position **2.06 - 57**
Disassembling the railing on the platforms **2.06 - 89**
Disassembling the railings on the platforms **5.05 - 201**
Disassembling the roller cart **5.07 - 77**
Disassembling the roller ring connection **3.01.30 - 33**
Disassembling the roller sets **5.07 - 80**

Disassembling the roller sets on the boom head **5.44 - 76**
 Disassembling the SD/SLD-boom **5.39 - 87**
 Disassembling the second bracket on the carrier **4.07 - 49**
 Disassembling the second carrier on the turntable frame **4.07 - 47**
 Disassembling the second crawler carrier **3.01.30 - 58**
 Disassembling the second cross carrier **3.01.20 - 41**
 Disassembling the S-end section / S-adapter / S-intermediate sections on the upper P-adapter **5.44 - 83**
 Disassembling the S-intermediate sections **5.39 - 115**
 Disassembling the S-luffing pulley block **5.05 - 125**
 Disassembling the S-pivot section on the turntable **5.44 - 97**
 Disassembling the swing **5.07 - 99**
 Disassembling the transport frame on the engine house **3.02 - 51**
 Disassembling the transport lugs and storing them on the base frame of the engine house **3.02 - 99**
 Disassembling the turntable **3.02 - 79**
 Disassembling the turntable frame front section on the crawler travel gear **3.02 - 119**
 Disassembling the turntable frame rear section on the turntable frame front section **3.02 - 109**
 Disassembling the upper P-adapter on the Li-intermediate sections **5.44 - 89**
 Disassembling the WA-frame 2 guy rods **5.07 - 98**
 Disassembling the wedge lock **4.06 - 34**
 Disassembling the weight **5.05 - 121**
 Disassembling the W-guy rods **5.07 - 76, 5.07 - 84**
 Disassembling the winch **3.07.50 - 17**
 Disassembling the W-lattice jib on the W-pivot section **5.07 - 81**
 Disassembling WA-frame 1 on the end section **5.07 - 95**
 Disassembling WA-frame 2 on the end section **5.07 - 93**
 Disassembling winch 3 and winch 6 **5.05 - 149**
 Disassembling winch 5 **3.07.50 - 21**
 Disassembling winch 5 on the S-pivot section **5.39 - 117**
 Disassembly **5.10 - 16**
 Disassembly of the roller sets on the boom head **5.39 - 99**
 Disassembly sequence of the counterweight **4.07 - 35**
 Disconnecting the connections for the central lubrication system from the winch **3.07.50 - 19**
 Disconnecting the connections for the central lubrication system to the winch **3.07.10 - 17, 3.07.20 - 17, 3.07.30 - 17, 3.07.60 - 17**
 Disconnecting the connections from the winch **3.07.50 - 19**
 Disconnecting the connections from winch 4 **3.05 - 37**

Disconnecting the connections of the central lubrication system from winch 4 **3.05 - 37**
 Disconnecting the connections to the winch **3.07.10 - 17, 3.07.20 - 17, 3.07.30 - 17, 3.07.60 - 17**
 Disconnecting the crawler carrier rear section and the crawler carrier front section **3.01.10 - 75**
 Disconnecting the crawler chain **3.01.10 - 55**
 Disconnecting the electrical connection **5.36 - 103**
 Disconnecting the electrical connections **3.02 - 115, 5.05 - 131, 5.10 - 20, 5.14 - 35, 5.39 - 103**
 Disconnecting the electrical connections between the engine house and the crane operator's cab **3.02 - 99**
 Disconnecting the electrical connections between the turntable frame rear section and the turntable frame front section **3.02 - 105**
 Disconnecting the electrical connections from the boom head **5.44 - 77**
 Disconnecting the electrical connections from the crawler carriers **3.01.30 - 39**
 Disconnecting the electrical connections from the engine house to the turntable **3.02 - 85**
 Disconnecting the electrical connections from the S-pivot section **5.44 - 95**
 Disconnecting the electrical connections from the winch **3.07.50 - 19**
 Disconnecting the electrical connections from the winches **5.05 - 149**
 Disconnecting the electrical connections from winch 4 **3.05 - 37**
 Disconnecting the electrical connections on the boom end section **5.39 - 99**
 Disconnecting the electrical connections to the winch **3.07.10 - 17, 3.07.20 - 17, 3.07.30 - 17, 3.07.60 - 17**
 Disconnecting the electric and hydraulic connections on the S-pivot section **5.39 - 103**
 Disconnecting the hydraulic and electrical connections **3.02 - 83**
 Disconnecting the hydraulic connection **7.04 - 23**
 Disconnecting the hydraulic connections **3.02 - 115, 5.05 - 131, 5.05 - 139, 5.39 - 103, 5.44 - 95**
 Disconnecting the hydraulic connections between the engine house and the turntable **3.02 - 83**
 Disconnecting the hydraulic connections from the crawler carriers **3.01.30 - 41**
 Disconnecting the hydraulic connections from the cross carrier **3.01.30 - 19**
 Disconnecting the hydraulic connections from the cross carrier and crawler center section **3.01.20 - 39, 3.01.20 - 43**
 Disconnecting the hydraulic connections from the tension cylinder **3.01.10 - 53**
 Disconnecting the hydraulic connections from the turntable frame rear section to the turntable frame front section **3.02 - 105**

Disconnecting the hydraulic connections from the winch **3.07.50 - 19**
 Disconnecting the hydraulic connections from the winches **5.05 - 149**
 Disconnecting the hydraulic connections from winch 4 **3.05 - 37**
 Disconnecting the hydraulic connections to the pin pulling cylinder **5.36 - 14, 5.36 - 127**
 Disconnecting the hydraulic connections to the winch **3.07.10 - 17, 3.07.20 - 17, 3.07.30 - 17, 3.07.60 - 17**
 Disconnect the crawler carrier on the cross carrier **3.01.30 - 57**
 Disconnect the hydraulic and electrical connections on the rotary connection **3.02 - 115**
 Dismantling the platform ladder **2.04.10 - 18**
 Display for the incline on the LICCON monitor **4.10 - 10**
 Displaying the settings window **4.02 - 213**
 Display of auxiliary functions **4.02 - 139**
 Displays on the LICCON monitor **4.10 - 6**
 Disposal **4.06 - 35**
 Disposing of the machine **7.01 - 15**
 Distortions and mechanical damage **8.04 - 8**
 Distribution of the surface pressure **4.10 - 11**
 Documentation of rope condition **7.05.50 - 11**
 Documenting inspection results **8.04 - 5**
 Documenting the completed inspection **8.03 - 4**
 Documenting the inspection **8.06 - 5**
 D-pivot section complete 12.0m **1.03 - 21**
 Draining the fuel preliminary filter **7.05 - 7**
 Drive **1.02 - 2**
 Driver's cab and crane cab **7.01 - 11**
 Drive the crawler **4.10 - 29**
 Driving / swinging in the specified direction **2.04 - 67**
 Driving from the crane cab **4.10 - 1**
 Driving on side inclines **4.10 - 18**
 Driving the crane: Load chart available **4.10 - 13**
 Driving the crane: No load chart is available **4.10 - 15**
 Driving the crawler **5.36 - 97**
 Driving the crawler crane **4.10 - 19**
 Driving the crawler forward and backward **4.10 - 31**
 Driving the outrigger pad in the cross direction over a cavity with a crawler crane **1.03.10 - 32**
 Driving the outrigger pad in the cross direction with a crawler crane **1.03.10 - 28, 1.03.10 - 31**
 Driving uphill / downhill **4.10 - 16**
 Driving uphill / downhill by adjusting the angle of the boom system **4.10 - 17**
 Driving with a load on the hook and / or derrick ballast **4.10 - 14**
 Driving with an extremely reduced load **2.04 - 73**
 Driving with a reduced load **2.04 - 73**
 Driving with a trailer **2.04 - 73**
 Driving without a load on the hook and without derrick ballast **4.10 - 15**
 Ductile deformation **8.15 - 4**

E

Editing the speed reduction **4.02 - 213**
 Effects of heat, arcs **7.05.50 - 10, 8.04 - 26**
 Electrical system **1.02 - 4**
 Electrical system - Lighting **7.05 - 49**
 Elongation **8.15 - 4**
 Emergency crane cab exit **2.04 - 8**
 Emergency equipment **4.01 - 5**
 Emergency exit - driver's cab **2.04 - 8**
 Emergency exit through an open door **2.04 - 8**
 Emergency exit through the open cab door **2.04 - 9**
 Emergency exit through the open front window **2.04 - 9**
 Emergency exit through the roof window with emergency release **2.04 - 10**
 Emergency exit through the side window with emergency release **2.04 - 12**
 Emergency hammer * **2.04 - 29**
 Emergency release on the window handle **2.04 - 10**
 Emergency situations **4.20 - 6**
 Emergency stop (quick stop) **2.04 - 65**
 EMERGENCY STOP switch / EMERGENCY OFF switch **4.04 - 17**
 Endangering air traffic **2.04 - 6**
 Ending crane operation **2.04 - 82**
 Ending operation, no longer follow my instructions **2.04 - 65**
 Engine **1.02 - 2**
 Engine coolant **7.05 - 5**
 Engine house **1.03 - 11, 1.03 - 11**
 Engine house with crane operator's cab fastening points **3.02 - 7**
 Engine monitoring functions **5.31 - 17**
 Engine oil **7.05 - 3**
 Engine oil level display, variation 1 **4.03 - 8**
 Engine oil level display, variation 2 **4.03 - 8**
 Engine oil level individual control display **4.02 - 124**
 Engine oil pressure individual control display **4.02 - 126**
 Engine operation menu **5.31 - 15**
 Engine preheating **2.08 - 4**
 Engine rpm **4.05 - 7**
 Engine type D 9508 A7-03 **1.02 - 3**
 Engine type D 9508 A7-04 **1.02 - 3**
 Engine type D 9508 A7-05 **1.02 - 2, 1.02 - 3**
 Enlarged rope end connection **8.04 - 15**
 Entering / changing the maximum permissible surface pressure **4.03 - 11**
 Entering the hook block weight **4.02 - 67**
 Entering the maximum permissible surface pressure **4.10 - 9**
 Environmental / component temperature below -20°C **2.08 - 3**
 Equalizing the derrick ballast **5.36 - 95**
 Equipment **5.01 - 2**
 Equipment and spare parts **0.01 - 9**
 Equipment in engine house **4.01 - 7**
 Erecting / taking-down **5.01 - 91**

- Erecting / taking down the boom system angled or stretched **5.07.50 - 2**
- Erecting / taking down the boom system with luffing jib **5.07.50 - 1**
- Erecting / taking down with crawler cranes **5.01 - 93**
- Erecting / taking down with mobile cranes **5.01 - 92**
- Erecting the A-frame **3.05 - 11**
- Erecting the boom **5.07 - 57, 5.10 - 15, 5.39 - 75, 5.44 - 59**
- Erecting the boom system with luffing jib **5.07.50 - 8**
- Erecting the D-boom **5.05 - 109**
- Erecting the D-relapse retainer **5.05 - 13**
- Erecting the main boom **5.39 - 85, 5.44 - 65**
- Erecting the WA-frames **5.07 - 30**
- Erection **5.10 - 15**
- Erection procedure **5.05 - 111, 5.39 - 81, 5.44 - 62**
- Error messages **4.02 - 3**
- Error messages by the LICCON computer system **4.04 - 11**
- Establishing the connections for the central lubrication system to the winch **3.07.10 - 13, 3.07.20 - 13, 3.07.30 - 13, 3.07.50 - 15, 3.07.60 - 13**
- Establishing the connections for the central lubrication system to the winches **5.05 - 19**
- Establishing the connections of the central lubrication system to winch 4 **3.05 - 31**
- Establishing the connections to the winches **5.05 - 17**
- Establishing the connections to winch 4 **3.05 - 31**
- Establishing the electrical connection from the suspended ballast to the turntable **5.36 - 35**
- Establishing the electrical connections between the engine house and the crane operator's cab **3.02 - 53**
- Establishing the electrical connections between the turntable frame front section and the turntable frame rear section **3.02 - 49**
- Establishing the electrical connections from the engine house to the turntable **3.02 - 73**
- Establishing the electrical connections on the boom end section **5.39 - 49, 5.44 - 54**
- Establishing the electrical connections to the boom end section **5.44 - 46**
- Establishing the electrical connections to the crawler carriers **3.01.30 - 21**
- Establishing the electrical connections to the winch **3.07.50 - 15**
- Establishing the electrical connections to the winches **5.05 - 19**
- Establishing the electrical connections to winch 4 **3.05 - 31**
- Establishing the electric and hydraulic connections on the S-pivot section **5.39 - 29, 5.44 - 21**
- Establishing the hydraulic and electrical connections **3.02 - 71**
- Establishing the hydraulic connection **7.04 - 23**
- Establishing the hydraulic connections **3.02 - 29, 5.05 - 45, 5.05 - 95, 5.05 - 151, 5.39 - 31, 5.44 - 22**
- Establishing the hydraulic connections from the engine house to the installation circuit **3.02 - 33, 3.02 - 107**
- Establishing the hydraulic connections from the engine house to the turntable **3.02 - 71**
- Establishing the hydraulic connections from the external hydraulic aggregate to the assembly circuit **3.02 - 33, 3.02 - 107**
- Establishing the hydraulic connections from the turntable frame rear section to the turntable frame front section **3.02 - 49**
- Establishing the hydraulic connections to the crawler carriers **3.01.30 - 21**
- Establishing the hydraulic connections to the cross carrier **3.01.20 - 11, 3.01.30 - 43**
- Establishing the hydraulic connections to the cross carrier and crawler center section **3.01.20 - 23**
- Establishing the hydraulic connections to the pull cylinders **5.05 - 87**
- Establishing the hydraulic connections to the tension cylinder **3.01.10 - 35, 3.01.10 - 49**
- Establishing the hydraulic connections to the winch **3.07.10 - 13, 3.07.20 - 13, 3.07.30 - 13, 3.07.50 - 15, 3.07.60 - 13**
- Establishing the hydraulic connections to the winches **5.05 - 17**
- Establishing the hydraulic connections to winch 4 **3.05 - 31**
- EU Declaration of Conformity **0.01 - 5**
- Evaluating oil color **8.03 - 3**
- Even reduction of rope diameter **8.04 - 15**
- Example **8.03 - 9**
- Example of crane on crawler with derrick boom, suspended ballast and long (main) boom system **2.04 - 45**
- Example of crane on crawler with derrick boom, suspended ballast and short (main) boom system **2.04 - 45**
- Example of crane on supports **2.04 - 46**
- Examples for the distribution of surface pressure **4.10 - 11**
- Examples of possible defects in hose lines **7.05 - 14**
- Examples of test points **8.01 - 7**
- Examples of the load bearing capacity of the ground **2.04 - 43**
- Exceeding the LICCON overload protection for assembly **5.07 - 14**
- Exceeding the shut-off limits of the LICCON overload protection **4.02 - 111**
- Exceeding the shut off limits of the LICCON overload protection for assembly operation **5.10 - 7, 5.10 - 19, 5.39 - 19**
- Exceeding the shut-off limits of the LICCON overload protection for assembly operation **5.44 - 14**
- Exhaust system **7.01 - 11**
- Exhaust system cleaning procedure **4.03 - 18**
- Extendible step * for cranes on tires **2.04 - 21**
- Extending the assembly support **3.01.30 - 45**

Extending the assembly supports **3.01.20 - 19, 3.01.20 - 23**
Extending the boom **2.04 - 71**
Extending the D-relapse cylinder **5.05 - 75**
Extending the S-relapse cylinder on the S-pivot section **5.39 - 79, 5.44 - 61**
Extend the sliding section on the crawler carrier front section **3.01.10 - 37**
Extension ladder **2.04.10 - 24**
Extension ladder on crawler center section **2.06 - 11**
Extension ladder on the cross carrier **2.06 - 31**
External corrosion **8.04 - 18**
Eyehook fastening points **5.01 - 32**

F

F1-display bar **4.02 - 169**
F2/F3-display bar **4.02 - 169**
Failure of components **4.20 - 6**
Failure of sensor / limit switch **4.02 - 101**
Failure of the overload protection **4.04 - 5**
Falling below the minimum value of the F-load display in crane operation **4.20 - 45**
Fall protection equipment and ladders on the crane chassis **2.06 - 9**
Fall protection equipment and ladders on the crane superstructure **2.06 - 43**
Fall protection equipment and ladders on the D-boom **2.06 - 83**
Fall protection equipment and ladders on the S-boom **2.06 - 131**
Fall protection equipment on the crane **2.06 - 1**
Fan / blower adjustment **6.02 - 11**
Fastening **2.04 - 33**
Fastening device **2.04 - 86**
Fastening multiple outrigger pads with a chain **1.03.10 - 7**
Fastening multiple outrigger pads with a round sling **1.03.10 - 6**
Fastening of guy rods **5.01 - 35**
Fastening point for end section **2.05 - 17**
Fastening points, turntable frame - rear section **3.02 - 5**
Fastening points A-frame - assembly **3.05 - 3, 3.05 - 5**
Fastening points assembly cross bar, illustration 3 **5.14 - 3**
Fastening points bracket **4.07 - 5**
Fastening points bridge **5.44 - 9**
Fastening points carrier **4.07 - 5**
Fastening points Carrier with bracket **4.07 - 5**
Fastening points Counterweight plate **4.07 - 5**
Fastening points - crane operator's cab **3.02 - 5**
Fastening points - cross beam **5.39 - 5**
Fastening points for derrick components **5.05 - 5**
Fastening points for the S-/LI-intermediate section **5.07 - 10**
Fastening points for the SL-reducer section **5.07 - 11**

Fastening points for transport unit with W-pivot section and swing for WA-frame 2 **5.07 - 10**
Fastening points for WA-frame 1 completely installed, long version **5.07 - 7**
Fastening points for WA-frame 1 completely installed, short version **5.07 - 8**
Fastening points for WA-frame 1 end section **5.07 - 7**
Fastening points for WA-frame 1 intermediate section **5.07 - 7**
Fastening points for WA-frame 1 pivot section **5.07 - 6**
Fastening points for WA-frame 2, end section **5.07 - 9**
Fastening points for WA-frame 2, pivot section **5.07 - 8**
Fastening points for WA-frame 2 completely installed, long version **5.07 - 9**
Fastening points for WA-frame 2 completely installed, short version **5.07 - 9**
Fastening points for WA-frame 2 intermediate section **5.07 - 8**
Fastening points for winch 1 **3.07.10 - 3**
Fastening points for winch 2 **3.07.20 - 3**
Fastening points for winch 3 **3.07.30 - 3**
Fastening points for winch 5 **3.07.50 - 3**
Fastening points for winch 6 **3.07.60 - 3**
Fastening points intermediate section 12m **5.44 - 6**
Fastening points intermediate section 6m **5.44 - 6**
Fastening points L-end section **5.39 - 11**
Fastening points lower P-adapter, center lattice section **5.44 - 5**
Fastening points lower P-adapter, left and right lattice section **5.44 - 5**
Fastening points lower P-adapter preassembled **5.44 - 6**
Fastening points pulley set left, illustration 2 **5.14 - 3**
Fastening points pulley set right, illustration 1 **5.14 - 3**
Fastening points S-adapter **5.39 - 9, 5.44 - 8**
Fastening points S-end section **5.39 - 11**
Fastening points S-intermediate section 6m **5.39 - 7**
Fastening points S-intermediate sections 12m **5.39 - 7**
Fastening points SL-reducer section 6m **5.39 - 9**
Fastening points S-pivot section **5.39 - 5**
Fastening points - transport frame **3.02 - 5**
Fastening points upper P-adapter, center lattice section **5.44 - 7**
Fastening points upper P-adapter, left and right lattice section **5.44 - 7**
Fastening points upper P-adapter preassembled **5.44 - 8**
Fastening positions for assembly / disassembly of the lattice jib **5.01 - 41**
Fastening the A-frame to the auxiliary cranes **3.05 - 17, 3.05 - 39**
Fastening the crawler carrier to the auxiliary crane **3.01.30 - 5, 3.01.30 - 51**

- Fastening the cross beam on the intermediate section **5.39 - 21**
- Fastening the cross beam to the intermediate section **5.05 - 67, 5.05 - 175**
- Fastening the engine house with one auxiliary crane **3.02 - 7**
- Fastening the engine house with two auxiliary cranes **3.02 - 7**
- Fastening the fiber guy ropes **5.01 - 7**
- Fastening the individual outrigger pad **1.03.10 - 5**
- Fastening the ladder on the A-frame in the transport position **2.06 - 79**
- Fastening the lattice sections **5.01 - 31, 5.01 - 34**
- Fastening the load **4.08 - 7**
- Fastening the load hook * **4.06 - 16**
- Fastening the multiple outrigger pads **1.03.10 - 6**
- Fastening the outrigger pad **1.03.10 - 5**
- Fastening the turntable frame rear section to the auxiliary crane **3.02 - 107**
- Fiber guy rope auxiliary guying **5.03 - 15**
- Fiber guy ropes **2.04 - 31, 5.01 - 4**
- Filling the grease container **7.04 - 13**
- Filling the grease container of the central lubrication system **7.05 - 37**
- Filling the lubrication lines **7.05 - 37**
- Filling the window washer system **4.03 - 29**
- Fill quantities **7.06 - 3**
- Fill quantities, lubrication chart **7.06 - 1**
- First aid measures after rescue **2.04 - 21**
- First inspection (first year) **8.03 - 10**
- Flap can be pushed closed **8.12 - 11**
- Flap can be pushed open **8.12 - 11**
- Flap swings in at stop **8.12 - 12**
- Flap swings out to stop **8.12 - 12**
- Flattening **7.05.50 - 7**
- Flattenings **8.04 - 26**
- F-load display **4.02 - 165**
- F-load display for operating modes with derrick ballast **5.36 - 69**
- Floating device **2.25 - 2**
- Floating device, not supported **2.25 - 3**
- Floating device, supported **2.25 - 3**
- Flying assembly / disassembly of lattice sections **5.01 - 71**
- Flying assembly of lattice sections **5.01 - 71**
- Flying assembly of the D-boom **5.05 - 57**
- Flying disassembly of lattice sections **5.01 - 73**
- Flying disassembly of the D-boom **5.05 - 165**
- Folding cross beam **2.04.10 - 15**
- Folding out the support **5.05 - 21**
- Folding the ladder on the D-end section **5.05 - 19, 5.05 - 95**
- Folding the ladder on the turntable frame front section into the transport position **2.06 - 47**
- Folding the ladder on the turntable frame front section out into the operating position **2.06 - 45**
- Folding the ladder on the turntable frame rear section into the transport position **2.06 - 61**
- Folding the ladder on the turntable frame rear section out into the operating position **2.06 - 59**
- Folding the platforms down **2.06 - 101**
- Folding the platforms up **2.06 - 91**
- Folding the railing on the D-pivot section into the transport position **5.05 - 109**
- Folding the receptacle in **5.05 - 193**
- Folding the receptacle out **5.05 - 23**
- Folding the support in **5.05 - 195**
- Folding the switch units in **5.36 - 125**
- Folding the switch units out **5.36 - 37**
- Folding the transport frame down **5.05 - 197**
- Folding the transport frame up **5.05 - 11**
- Force distribution when driving on pressure distributor plates **4.10 - 23**
- Force F1 (test point 1) **5.36 - 71**
- Force F2 (test point 2) and force F3 (test point 3) **5.36 - 71**
- Force F4/5 (test point 4/5) **5.36 - 73**
- For cranes with pneumatic boom locking system **8.01 - 79**
- For cranes with the Telematik telescopic boom system **8.01 - 80**
- Foreword **90.01 - 3**
- Frame **1.02 - 2, 1.03 - 25**
- Friction corrosion **8.04 - 20**
- Fuel preliminary filter **7.05 - 7**
- Fuel reserve individual control display **4.02 - 123**
- Fuel system **7.05 - 17**
- Function check **5.10 - 12**
- Function check of ground contact switch **5.36 - 41**
- Function check of limit switch actuators on the mechanical relapse retainer - flap **8.12 - 11**
- Function key assignment TE3 **4.01 - 53**
- Function key line in the Set up program **4.02 - 14**
- Function key line in the Working range limitation program **4.02 - 207**
- Function keys in the Assembly winch menu **5.31 - 23**
- Function keys in the Engine monitoring functions **5.31 - 18**
- Function keys in the Engine operation menu **5.31 - 16**
- Further procedure **5.01 - 50**
- ## G
- Gas pressure spring emergency release **2.04 - 11**
- General controls before crane operation **5.01 - 9**
- General information **8.01 - 2**
- General notes for assembly **4.06 - 26**
- General notes regarding the acoustic / optical warnings to the crane surrounding area **4.20 - 9**
- Getting and pinning the upper pulley block **5.05 - 79**
- Getting the upper pulley block **5.05 - 143**
- Giving a warning signal **4.05 - 5**
- Gravity actuated relapse retainer **4.04 - 18**
- Grommets and cable laid fastening rope **5.01 - 39, 8.01 - 85**
- Grounding for potential equalization **2.04 - 50**

Grounding the crane **2.04 - 51**
Grounding the load **2.04 - 51**
Guiding crane structures, lattice sections or crane components **5.01 - 31**
Guiding the load **4.08 - 18**
Guiding the Twistlock in **3.03 - 13**
Guying the pivot section in flying mode with the derrick boom **5.01 - 75**
Guying the pivot section in flying mode with the SA-frame **5.01 - 73**
Guy rods **5.01 - 12**
Guy rods for telescopic cranes with luffing lattice jib **5.01 - 12**
Guy rod transport retainer during assembly **5.01 - 48**
Guy rod transport retainer during disassembly **5.01 - 50**
Guy ropes **1.03 - 35**

H

Handling the batteries: **5.19.10 - 10, 5.19.10 - 11**
Hand signals **2.04 - 64**
Hand signals for guidance **2.04 - 64**
Hard hat **2.04 - 17**
Hearing protection **2.04 - 18**
Heated crane components **2.04 - 5**
Heating the crane cab **6.02 - 3**
Heavy load device * **5.14 - 25**
Heavy load system for the roller set **1.03 - 17**
Height-dependent wind speed **2.04 - 58**
Height rescue system **2.04 - 16**
Hide operating interface from the Test system menu **5.31 - 26**
Hiding the settings window **4.02 - 216**
High pressure cleaner **7.01 - 9**
Hinged ladders **2.04.10 - 19**
Hoist gear, hoist rope **2.04 - 79**
Hoist limit
switch **4.02 - 103, 5.07 - 55, 5.39 - 73, 5.44 - 56**
Hoist limit switch „Hoist top“ **4.04 - 11**
Hoist rope length **4.08 - 15**
Hoist ropes **1.03 - 34**
Holding the luffing lattice jib **5.01 - 45**
Hook base **8.05 - 4**
Hook block incline sensors **5.19.10 - 1**
Hook blocks **5.19 - 1, 5.19 - 3**
Hook jaw **8.05 - 2**
Hook shaft **8.05 - 2**
Horizontally aligning the hook block **4.05 - 23**
Horizontal movements **2.04 - 67**
Horn warning
sound **4.02 - 109, 4.02 - 183, 4.02 - 197**
Hydraulic aggregate **5.30 - 4**
Hydraulic aggregate on crawlers **5.30 - 3**
Hydraulic aggregate on wheels without „emergency control“ function **5.30 - 2**
Hydraulic aggregate on wheels with „emergency control“ function **5.30 - 2**
Hydraulically adjustable auxiliary boom **2.04 - 79**

Hydraulic assembly support **1.02 - 5**
Hydraulic circuit 1 hydraulic oil temperature individual control display **4.02 - 126**
Hydraulic circuit 2 hydraulic oil temperature individual control display **4.02 - 126**
Hydraulic connections to the pin pulling cylinder **3.01.30 - 9, 3.01.30 - 47, 3.05 - 9, 3.05 - 35, 5.36 - 14, 5.36 - 127**
Hydraulic connection tension cylinder **7.04 - 22**
Hydraulic hose lines **7.05 - 13**
Hydraulic oil, diesel fuel, operating fluids **2.04 - 5**
Hydraulic oil level, hydraulic oil, hydraulic oil pressure **5.30 - 6**
Hydraulic oil level individual control display **4.02 - 125**
Hydraulic safety valves **4.04 - 18**
Hydraulic system **7.05 - 11, 7.06 - 4**
Hydraulic tank **7.05 - 11**

I

Icons in the Engine monitoring functions **5.31 - 18**
Icons in the Engine operation menu **5.31 - 15**
Identification of sliding beam **2.05 - 42**
Identification of track width retracted **2.05 - 43**
Identifications on auxiliary weights **2.05.10 - 5**
Identifications on auxiliary weights at delivery **2.05.10 - 5**
Identifications on auxiliary weights for re-order **2.05.10 - 6**
Identifications on single hook or double hook **2.05.10 - 4**
Identifications on the hook block or load hook **2.05.10 - 3**
Identifying the fiber guy rope **5.01 - 5**
Identifying the manufacturing method **8.05 - 2**
If the radio connection is faulty **5.31 - 29**
Impact protection **5.01 - 18**
Importance of inspection **8.04 - 3**
Improper mechanical damage **8.04 - 26**
Improvement of force ratio in the guying of the boom system **4.20 - 63**
Increased corrosion **2.25 - 4**
Increasing the hook block weight **2.08 - 7, 4.08 - 24**
Increasing the reeving number **4.08 - 24**
Indicator lights and operating buttons **4.01 - 11**
Indicator lights of the central lubrication system **7.05 - 35**
Indicator lights on the BKE **4.01 - 15**
Information about use and the illustrations **5.07.50 - 2**
Information regarding the erection procedure **5.07.50 - 9**
Information regarding the take-down procedure **5.07.50 - 16**
Inserting and unpinning the collar pins **5.01 - 17**
Inserting and unpinning the double cone pins horizontally **5.01 - 17**

Inserting and unpinning the double cone pins vertically **5.01 - 18**
 Inserting the connector pins on the Quick Connection **3.02 - 25**
 Inserting the pin on the turntable **5.05 - 163, 5.05 - 169**
 Inspecting before start up **2.04 - 84**
 Inspecting load bearing crane structures, especially steel structures **8.01 - 4**
 Inspecting of fastening equipment **8.01 - 84**
 Inspecting of winches **8.03 - 1**
 Inspecting the BTT **5.31 - 30**
 Inspecting the carrier rollers **8.01 - 87**
 Inspecting the change over pulleys, illustration 2 **8.01 - 92**
 Inspecting the diaphragm reservoir **8.01 - 85**
 Inspecting the extension conditions of sliding beams **8.01 - 88**
 Inspecting the function of the overload protection **8.01 - 88**
 Inspecting the hoist and retracting winches **8.03 - 3**
 Inspecting the hydraulic hose lines for damage **8.06 - 4**
 Inspecting the hydraulic hose lines for leaks **8.06 - 5**
 Inspecting the ladders **8.17 - 3**
 Inspecting the lattice sections **8.01 - 78**
 Inspecting the load handling equipment and assembly aids **8.01 - 84**
 Inspecting the locking system of the telescopic boom **8.01 - 79**
 Inspecting the mounting of the load bearing equipment **8.01 - 90**
 Inspecting the oil and fuel tanks **8.01 - 92**
 Inspecting the pin connections **8.01 - 89**
 Inspecting the relapse cylinders **8.01 - 85**
 Inspecting the rope pretension on lattice sections, illustration 2 **8.01 - 83**
 Inspecting the rope pulleys **8.01 - 86**
 Inspecting the safety controls on the relapse cylinders **8.01 - 86**
 Inspecting the slewing ring connection **8.01 - 89**
 Inspecting the tele extension with eccentric, illustration 1 **8.01 - 91**
 Inspection **8.15 - 3**
 Inspection and maintenance **5.31 - 30**
 Inspection chart for cranes **8.90 - 1**
 Inspection chart for recurring inspections of Liebherr cranes **8.90 - 3**
 Inspection form for the inspection of ladders and steps **8.17 - 4**
 Inspection intervals **8.03 - 3, 8.05 - 2, 8.06 - 3, 8.15 - 3, 8.17 - 3**
 Inspection of accumulator pressure in relapse cylinder **8.14 - 1**
 Inspection of crane wire ropes **8.04 - 1**
 Inspection of drive pinion and the gear rings **7.05 - 43**
 Inspection of guy rods **8.15 - 1**
 Inspection of hydraulic hose lines **8.06 - 1**

Inspection of ladders **8.17 - 1**
 Inspection of load hooks **8.05 - 1**
 Inspection of safety controls on the relapse supports **8.12 - 1**
 Inspection of the auxiliary reeving winch, recovery winch and spare wheel winch **8.03 - 5**
 Inspection of the screws in the adjustment plates **8.01 - 81**
 Inspection sheet and check list **8.17 - 3**
 Installation possibilities of the boom nose **5.10 - 4**
 Installing a pulley set centered on the end section **5.14 - 13**
 Installing pulley set / pulley sets **5.14 - 7**
 Installing the A-frame **4.07 - 17**
 Installing the assembly cross bar on the pulley set **5.14 - 11, 5.14 - 39**
 Installing the battery **7.05 - 51**
 Installing the brackets **5.36 - 27**
 Installing the brackets for the assembly of the S-end section on the boom **5.39 - 41**
 Installing the central ballast **3.03 - 5, 5.39 - 85**
 Installing the connector carriers **5.36 - 19**
 Installing the counterweight **4.07 - 19**
 Installing the crane operator's cab on the engine house **3.02 - 53**
 Installing the crawler carrier on the preassembled crawler center section **3.01.10 - 47**
 Installing the cross carrier and connector carrier **5.36 - 17**
 Installing the derrick ballast **5.39 - 85**
 Installing the frames **5.36 - 29**
 Installing the heavy load device **5.14 - 25**
 Installing the left frame **5.36 - 35**
 Installing the pulley sets on the end section **5.14 - 11**
 Installing the right frame **5.36 - 29**
 Installing the second cross carrier on the connector carriers **5.36 - 25**
 Installing the S-intermediate sections **5.39 - 35**
 Installing the suspended ballast **5.36 - 13**
 Installing the transport frame on the engine house **3.02 - 103**
 Installing the transport lugs on the base frame of the engine house **3.02 - 55**
 Installing the turntable frame front section on the crawler travel gear **3.02 - 17**
 Installing the turntable frame rear section on the turntable frame front section **3.02 - 33**
 Installing the Twistlock on the counterweight plate **4.07 - 23**
 Installing the Twistlock on the derrick ballast plate **5.36 - 53**
 Installing the winch **3.07.10 - 5, 3.07.20 - 5, 3.07.30 - 5, 3.07.60 - 5**
 Installing the winches **3.02 - 49**
 Installing two pulley sets on the end section **5.14 - 21**
 Instructions for proper handling **5.01 - 6**
 Instructions for resuming crane movement **4.20 - 17**
 Instrument panel **4.01 - 11**

Intended use **0.01 - 6, 2.04 - 82, 2.04 - 84, 2.04.10 - 2, 2.25 - 2**
Interfaces **4.01 - 5**
Interior equipment **4.01 - 5**
Intermediate lubrication of crawler carriers **7.04 - 17**
Intermediate section WA-frame I **1.03 - 27**
Intermediate section WA-frame II **1.03 - 29**
Internal corrosion **8.04 - 20**
Interrupting crane operation **2.04 - 79**
Intervals **7.05.50 - 11, 8.04 - 4**
Invalid chart name **4.02 - 25**

J

Job planning **2.03 - 1**

K

Key button Boom on the ground **4.20 - 61**
Kinking, rope loops (grommets) pulled closed **7.05.50 - 9**
Kinking or rope loops pulled closed **8.04 - 24**

L

Labeling of the load carriers **2.05.10 - 1**
Ladder (small) on the turntable frame rear section **2.06 - 65**
Ladder access **2.04.10 - 25**
Ladder categories **2.04.10 - 2**
Ladder inspection **2.04.10 - 12**
Ladder on the A-frame **2.06 - 75**
Ladder on the crawler carrier **2.06 - 39**
Ladder on the D-end section **2.06 - 123**
Ladder on the D-pivot section **2.06 - 85**
Ladder on the turntable frame front section **2.06 - 45**
Ladder on the turntable frame rear section **2.06 - 59**
Ladders **2.04.10 - 1, 7.01 - 11, 7.04 - 33**
Ladder safeguards **2.04.10 - 25**
Latch **5.01 - 26**
Lattice mast boom **7.05.50 - 3**
Lattice sections **2.04 - 30**
Lattice section with walking surfaces and stepping surfaces **5.01 - 19**
Laying the chain segments out and pinning **3.01.10 - 27**
LD/SLD/SD-boom combination **5.39 - 1**
Lead and lead compounds **2.04 - 4**
Legal prerequisites **2.04 - 83**
L-end section **1.03 - 19, 5.07 - 6**
L-end section fastening points **5.07 - 11**
Leveling instrument in the Bluetooth™ Terminal (BTT) **4.04 - 9**
Leveling instruments **4.04 - 9**
Leveling instruments in the LICCON monitor **4.04 - 9**
LICCON computer system **4.02 - 1, 4.04 - 3, 4.05 - 3**
LICCON computer system monitors **4.01 - 21**
LICCON job planner **2.04 - 44**

LICCON job planner (PC) **5.07.50 - 6**
LICCON monitor 0 **4.02 - 4**
LICCON Monitor 0 special functions **4.02 - 111**
LICCON Monitor 0 winch display **4.02 - 151**
LICCON monitor 1 **4.02 - 5**
LICCON Monitor 1 winch display **4.02 - 173**
LICCON monitor 2 **4.02 - 5**
LICCON Monitor 2 special functions **4.02 - 194**
LICCON monitors at system start **4.02 - 4**
LICCON overload protection emergency operation (according to EN 13000:2010) **4.02 - 112**
LICCON overload safety device **4.04 - 3**
Liebherr Customer Service **7.01 - 7**
Lifting / lowering a load with even speed **2.04 - 66**
Lifting / setting down / equalizing the derrick ballast **5.36 - 93**
Lifting / setting down the derrick ballast **5.36 - 93**
Lifting a load with two cranes **2.04 - 61**
Lifting and lowering **4.05 - 17**
Lifting category **4.02 - 57**
Lifting heights for derrick 54m **5.36 - 9**
Lifting heights for derrick 60m **5.36 - 11**
Lifting heights of derrick ballast **5.36 - 9**
Lifting of personnel **2.04 - 82**
Lifting slowly **2.04 - 66**
Lifting the boom **2.04 - 70**
Lifting the boom and lower the load at the same time **2.04 - 72**
Lifting the central ballast plate **3.03 - 21**
Lifting the counterweight plates from the counterweight stacks **4.07 - 37**
Lifting the crawler carrier front section from the flatbed trailer **3.01.10 - 9**
Lifting the crawler carrier rear section from the flatbed trailer **3.01.10 - 13**
Lifting the derrick ballast pallet off the ground **5.36 - 39**
Lifting the derrick ballast plates from the ballast stacks **5.36 - 115**
Lifting the derrick ballast plates off **5.36 - 109**
Lifting the end section from the flatbed trailer **5.39 - 39**
Lifting the engine house with the auxiliary crane from the brackets **3.02 - 95**
Lifting the load **4.08 - 11, 4.08 - 16**
Lifting the platforms off from the derrick ballast plates **5.36 - 119**
Lifting the remaining derrick ballast plates off **5.36 - 123**
Lifting the turntable frame front section from the roller ring connection on the crawler travel gear **3.02 - 125**
Lifting winch 1 from the flatbed trailer **3.07.10 - 7**
Lifting winch 2 from the flatbed trailer **3.07.20 - 7**
Lifting winch 3 from the flatbed trailer **3.07.30 - 7**
Lifting winch 5 from the flatbed trailer **3.07.50 - 9**
Lifting winch 6 from the flatbed trailer **3.07.60 - 7**
Lifting with auxiliary winch **2.04 - 70**
Lifting with main winch **2.04 - 70**
Light and / or heavy work **2.04.10 - 25**

Lightning: Protective measures for the crane and load **2.04 - 54**

LI-intermediate section

12.0m **1.03 - 17, 1.03 - 17, 1.03 - 19**

LI-intermediate section 6.0m **1.03 - 17**

Limitations from 50 % pulled derrick ballast **5.36 - 85**

Limitations from 90 % pulled derrick ballast **5.36 - 85**

Limit switch, general **5.07 - 55**

Limit switch Boom system **4.04 - 19**

Limit switch flap in the „steepest“ W-lattice jib position, mechanical relapse support **5.07 - 55**

Limit switch winch spooled out **4.04 - 13**

Limit switch W-lattice jib, „lowest“ position, relapse cylinder **5.07 - 55**

Limit switch W-lattice jib, „steepest“ position, relapse cylinder **5.07 - 55**

Load bearing crane structures **2.08 - 7**

Load burdens on the ground on cranes on crawlers **2.04 - 42**

Load burdens on the ground on cranes on supports **2.04 - 42**

Load chart manual document **5.07.50 - 5**

Load handling equipment **1.03 - 33**

Load handling equipment LMZ-1250t **6.50 - 3**

Loading the crawler center section on the transport vehicle **3.01.20 - 45**

Loading the preassembled lattice jib **5.01 - 48**

Load max **4.02 - 187**

Load max2 **4.02 - 187**

Load max3 **4.02 - 187**

Loads on the ground **1.03.10 - 3**

Loads on the ground due to crane operation **2.04 - 42**

Load spectrum class: Heavy L3 **8.03 - 7**

Load spectrum class: Light L1 **8.03 - 6**

Load spectrum class: Medium L2 **8.03 - 7**

Load spectrum class: Very heavy L4 **8.03 - 8**

Load weighing **4.08 - 14**

Load weighing and load display **4.08 - 13**

Localized increase of rope diameter **7.05.50 - 6**

Localized increases of rope diameter **8.04 - 18**

Localized reduction of rope diameter **8.04 - 17**

Locking pin **5.01 - 24**

Locking the engine rpm **4.05 - 7**

Long guy rods **5.01 - 12**

Loop formation **7.05.50 - 9, 8.04 - 23**

Lowering slowly **2.04 - 67**

Lowering the boom **2.04 - 71**

Lowering the boom and lift the load at the same time **2.04 - 72**

Lowering the brackets into assembly position **5.14 - 25**

Lowering the hook block **4.06 - 11, 4.06 - 14, 5.19 - 3**

Lowering the load **4.08 - 17**

Lowering the load hook **4.06 - 17**

Lowering the load while stationary **2.04 - 67**

L-shaped rope lock **4.06 - 3**

Lubricate the slewing ring connection **7.05 - 21**

Lubricating ladders **7.04 - 34**

Lubricating the gear ring and the slewing gear pinion **7.05 - 21**

Lubricating the pin bores on the lattice sections and guy rods **7.05.50 - 3**

Lubricating the rope **7.05.50 - 14**

Lubrication schedule **7.06 - 4**

Luffing **4.05 - 43**

Luffing the boom down **5.10 - 19, 5.19 - 3**

Luffing the D-boom down **5.05 - 117**

Luffing the derrick boom **4.05 - 47**

Luffing the derrick boom down **4.05 - 47**

Luffing the derrick boom up **4.05 - 47**

Luffing the luffing jib **4.05 - 49**

Luffing the luffing jib down **4.05 - 49**

Luffing the luffing jib up **4.05 - 49**

Luffing the main boom **4.05 - 45**

Luffing the main boom down **4.05 - 45**

Luffing the main boom down and unreeving the hoist rope **5.39 - 93, 5.44 - 71**

Luffing the main boom up **4.05 - 45**

Luff in with suspended load **4.20 - 35**

M

Machine related movements **2.04 - 70**

Main boom limit signs **4.02 - 93**

Maintenance **2.08 - 7, 7.01 - 14**

Maintenance and inspection schedule **7.02 - 2, 7.03 - 2, 7.03.50 - 3**

Maintenance and service - General **7.01 - 1**

Maintenance instructions - Crane boom **7.05.50 - 1**

Maintenance instructions - Crane chassis **7.04 - 1**

Maintenance instructions - Crane superstructure **7.05 - 1**

Maintenance intervals **7.01 - 3**

Maintenance intervals - Crane boom **7.03.50 - 1**

Maintenance intervals - Crane superstructure **7.03 - 1**

Maintenance intervals - Crawler chassis **7.02 - 1**

Maintenance of hose lines **7.05 - 14**

Maintenance status **7.01.10 - 4**

Maintenance technician **7.01 - 2**

Making adjustments semi-automatically in the „Air conditioning settings“ menu **6.02 - 23**

Manual adjustments in the „Air conditioning settings“ menu **6.02 - 23**

Manual heating mode **6.02 - 15**

Manual rope winches **5.01 - 11**

Manufacturer **0.01 - 1**

Master switch / pedal sensor speed reduction **4.02 - 209**

Master switch assignment MS1 **4.01 - 29**

Master switch assignment MS2 **4.01 - 39**

Master switch assignment MS3 **4.01 - 53**

Master switch functions **4.05 - 5**

Master switch MS2 functions **4.01 - 39**

Maximum climbing ability **4.10 - 16**

Maximum liftable derrick ballast **4.02 - 193**

Maximum load **4.02 - 81**

Maximum load according to the load chart and reeving **4.02 - 3**
 Maximum sound power level **2.05 - 30**
 Measurement of wind speed **2.04 - 56**
 Measures in case of problems **5.31 - 27**
 Minimum rope coils **5.01 - 3**
 Minimum rope reeving / minimum hook block weight **2.05 - 45**
 Minimum value F3-load display during erection of the derrick boom fallen below **4.20 - 63**
 Minimum values or maximum values of F-load display reached **4.20 - 63**
 Mixing battery acid **7.05 - 50**
 Mobile cranes **2.04 - 32**
 Monitored auxiliary functions **4.02 - 139**
 Monitoring of crane utilization in operating modes with derrick ballast **5.36 - 75**
 Monitoring of F1-maximum force **5.36 - 81**
 Monitoring of F1-minimum force **5.36 - 83**
 Monitoring of load torque **5.36 - 75**
 Monitoring of pull cylinders on block position **5.36 - 85**
 Monitoring the lateral incline of the ballast pallet **5.36 - 86**
 Monitoring the surface pressure and center of gravity **4.02 - 133**
 Monitoring the winches **8.03 - 5**
 Movement on the crane **2.04 - 7**
 Move the cab to the horizontal position. **4.03 - 27**
 Moving away from me **2.04 - 68**
 Moving both track chains **2.04 - 68**
 Moving one crawler chain **2.04 - 69**
 Moving toward me **2.04 - 68**
 Multi-purpose ladder with height adjustment **2.04.10 - 21**

N

Negative longitudinal inclination **4.10 - 17**
 Noise emission **1.03 - 33**
 No load chart is available **4.02 - 111**
 Nominal dimensions when assembling the wedge lock **4.06 - 26**
 Non-intended use **0.01 - 6, 2.25 - 2**
 Non-rotating rope end connection **8.04 - 6**
 Non-twisting ropes with rope end connections **8.04 - 7**
 Note of sliding beam weight **2.05 - 44**
 Note regarding the signs **2.05 - 2**
 Numeric F-load display **4.02 - 165**

O

Obligations of the crane operator **2.04 - 35**
 Occurrence of an advance warning **4.02 - 105, 4.02 - 181**
 Occurrence of a shut-off in the working range limitation **4.02 - 207**
 One-part hoist limit switch weight **4.06 - 21**

Only available for a diesel engine: Determining the total operating hours for the diesel engine **7.01.10 - 4**
 Opening / closing cab doors and cab windows **4.03 - 30**
 Opening and closing the parking brake slewing gear **4.05 - 53**
 Opening the ball valve for the thermo valve **5.05 - 137**
 Opening the boom system **5.39 - 107, 5.44 - 79**
 Opening the boom system (without derrick boom) **5.01 - 86, 5.01 - 90**
 Opening the end section **5.01 - 44**
 Open the radio sender unit: **5.19.10 - 10**
 Operating and control unit (BKE) **4.01 - 15**
 Operating and monitoring instruments on the crane superstructure **4.01 - 1**
 Operating buttons on the BKE, standard assignment **4.01 - 16**
 Operating buttons on the BKE for release actuati-
 ons **4.01 - 19**
 Operating condition of crane **4.20 - 7**
 Operating conditions **2.25 - 2**
 Operating console overview **4.01 - 15**
 Operating element of derrick ballast **5.36 - 91**
 Operating element on LICCON monitor 0 **4.02 - 7**
 Operating element on LICCON monitor 1 **4.02 - 9**
 Operating element on LICCON monitor 2 **4.02 - 10**
 Operating elements for crawler operation **4.10 - 24**
 Operating elements for special cases at operation of
 the LICCON overload protection **4.20 - 3**
 Operating elements in the Set up program **4.02 - 13**
 Operating elements on the LICCON moni-
 tors **4.02 - 6**
 Operating elements with master switch / pedal sensor
 speed reduction **4.02 - 209**
 Operating fluids and lubricants **7.07 - 1**
 Operating interface **4.02 - 201**
 Operating interface from the Test system
 menu **5.31 - 25**
 Operating interface in the settings window for master
 switch / pedal sensor speed reduction **4.02 - 211**
 Operating sequence 1 **4.01.10 - 3**
 Operating sequence 2 **4.01.10 - 4**
 Operating the air conditioning system **6.02 - 13**
 Operating the crane **5.10 - 15, 5.39 - 87, 5.44 - 67**
 Operating the engine-independent auxiliary heater
6.02 - 25
 Operating the fast settings **4.02 - 213**
 Operating the function using the touch func-
 tion **4.01.10 - 3**
 Operating the function with the F-keys **4.01.10 - 2**
 Operating the touch display **6.02 - 5**
 Operating the window washer system **4.03 - 29**
 Operating the window wipers **4.03 - 29**
 Operating variations **4.01.10 - 2**
 Operating with telescopic boom and auxiliary
 boom **4.08 - 4**
 Operating with the tele lift truck **5.30 - 13**
 Operational transverse pressure **8.04 - 27**

Optimizing measures for the travel route **4.10 - 4**
 Optional equipment and functions **0.01 - 10**
 Order of the displays in the crane operation monitoring functions **4.02 - 115**
 Oscillation guard **5.07 - 53**
 Other operating elements **4.02 - 160**
 Outtrigger pad LWE ID number 914618608 **1.03.10 - 23**
 Outtrigger pad LWE ID number 914786508 **1.03.10 - 8**
 Outtrigger pad LWE ID number 914786808 **1.03.10 - 10**
 Outtrigger pad LWE ID number 914861908 **1.03.10 - 9**
 Outtrigger pad LWE ID number 915236308 **1.03.10 - 11**
 Outtrigger pad LWE ID number 915236408/915464608 **1.03.10 - 12**
 Outtrigger pad LWE ID number 915696408 **1.03.10 - 24**
 Outtrigger pad LWE ID number 918339808 **1.03.10 - 26**
 Outtrigger pad LWE ID number 919427108 **1.03.10 - 29**
 Outtrigger pad LWE ID number 919663108 **1.03.10 - 15**
 Outtrigger pad LWE ID number 919663508 **1.03.10 - 17**
 Outtrigger pad LWE ID number 919663608 **1.03.10 - 19**
 Outtrigger pad LWE ID number 919663708 **1.03.10 - 21**
 Outtrigger pads **1.03.10 - 1**
 Overlapping of working ranges of several cranes **2.04 - 63**
 Overload protection **4.02 - 2**
 Overview Load chart **4.20 - 18**
 Overview of acoustic / optical warnings **4.20 - 9**
 Overview of monitoring function icons **4.02 - 118**
 Overview of the individual control displays **4.02 - 122**
 Overview of the retaining elements **5.01 - 21**

P

P-adapter bottom center **1.03 - 31**
 P-adapter bottom left **1.03 - 31**
 P-adapter bottom right **1.03 - 31**
 P-adapter top center **1.03 - 31**
 P-adapter top left **1.03 - 31**
 P-adapter top right **1.03 - 31**
 Paint / coating **8.15 - 4**
 Pairing the BTT with the BTB (Pairing process) **5.31 - 7**
 Parallel operation: Spooling the hoist winches out **4.05 - 29**
 Parallel operation: Spooling the hoist winches up **4.05 - 29**
 Parallel operation: Spooling the hoist winches up and out **4.05 - 27**

PD-boom combination **5.44 - 1**
 PDW3B/PDB– boom **1.01 - 10**
 Pedal carrier **4.01 - 25, 4.10 - 24**
 Performing a visual inspection **4.03 - 3, 8.01 - 87**
 Performing the function check **5.44 - 55**
 Performing the function checks **5.39 - 71**
 Periodic crane inspections **8.01 - 1**
 Permissible counterweight / permissible central ballast **3.06 - 3**
 Permissible load configurations **1.03.10 - 3**
 Permissible support pressures on the outrigger pad [A-B-C] **2.05 - 29**
 Permissible support pressures on the outrigger pad [A-B-C-D] **2.05 - 29**
 Personal protective equipment **2.04 - 12, 2.06 - 3, 7.05.50 - 4, 8.04 - 3**
 Personnel **7.01 - 2**
 Personnel and qualification **2.04 - 85**
 Picking up and lowering overhead loads **4.08 - 24**
 Picking up the fastening equipment **4.08 - 21**
 Pin connections **5.01 - 16**
 Pinning and securing the connector pins on the turntable frame front section **3.02 - 117**
 Pinning and securing the inner connector pins **3.01.10 - 21**
 Pinning and securing the outer connector pins **3.01.10 - 25**
 Pinning and unpinning with the pin pulling device **5.30 - 7**
 Pinning or unpinning not tensioned pins with low pressure **5.30 - 8, 5.30 - 10**
 Pinning or unpinning pins, pin location variation I **5.30 - 8**
 Pinning or unpinning pins, pin location variation II **5.30 - 10**
 Pinning or unpinning tensioned pins with high pressure **5.30 - 9, 5.30 - 11**
 Pinning the ballast rods **5.05 - 85**
 Pinning the connector pins, lower left **3.02 - 45**
 Pinning the connector pins, lower right **3.02 - 45**
 Pinning the connector pins, upper left **3.02 - 47**
 Pinning the connector pins, upper right **3.02 - 47**
 Pinning the crawler carrier front section with the crawler carrier rear section **3.01.10 - 21**
 Pinning the crawler carrier to the cross carrier **3.01.30 - 13**
 Pinning the cross carrier to the crawler center section **3.01.20 - 15, 3.01.20 - 23**
 Pinning the D-boom on the turntable **5.05 - 63**
 Pinning the D-boom with the D-intermediate section **5.05 - 55**
 Pinning the D-end section with the D-intermediate section **5.05 - 53**
 Pinning the D-guy rods on the derrick ballast pallet **5.36 - 65**
 Pinning the D-guy rods on the frame **5.36 - 33**
 Pinning the D-intermediate section 2824.36 12 m **5.05 - 45**

Pinning the D-intermediate section on the bottom **5.05 - 49**
Pinning the D-intermediate section on top **5.05 - 47**
Pinning the D-pivot section **5.05 - 43, 5.05 - 65**
Pinning the D-pivot section on the turntable **5.05 - 41**
Pinning the first connector carrier on the cross carrier **5.36 - 21**
Pinning the frame on the connector carrier **5.36 - 29**
Pinning the frame with the turntable **3.05 - 19**
Pinning the left pulley set on the end section **5.14 - 23**
Pinning the pull cylinder **5.05 - 83**
Pinning the pulley set on the bottom on the end section **5.14 - 19**
Pinning the pulley set on top on the end section **5.14 - 15**
Pinning the Quick-Connection by hand **3.01.30 - 29**
Pinning the Quick-Connection with the pin pulling device **3.01.30 - 31**
Pinning the right pulley set on the bottom on the end section **5.14 - 23**
Pinning the right pulley set on top on the end section **5.14 - 21**
Pinning the roller ring connection on the crawler center section **3.01.30 - 29**
Pinning the rotary connection with drawbar of the roller ring connection **3.01.30 - 27**
Pinning the second connector carrier on the cross carrier **5.36 - 23**
Pinning the S-luffing pulley block **5.05 - 99**
Pinning the support with the turntable **3.05 - 25**
Pinning the turntable frame front section with the Quick-Connection on the crawler travel gear **3.02 - 23**
Pinning the turntable frame rear section on the turntable frame front section **3.02 - 43**
Pinning the upper pulley block on the P-adapter **5.44 - 47**
Pinning the upper pulley block on the S-intermediate section **5.39 - 51**
Pinning the upper pulley block with the derrick guy rods **5.05 - 77**
Pinning the upper pulley block with the lower pulley block **5.05 - 119**
Pinning the weight **5.05 - 103**
Pinning the W-pivot section **5.07 - 39**
Pinning winch 1 **3.07.10 - 11**
Pinning winch 2 **3.07.20 - 11**
Pinning winch 3 **3.07.30 - 11**
Pinning winch 5 **3.07.50 - 13**
Pinning winch 6 **3.07.60 - 11**
Pin pulling cylinder **5.30 - 4, 5.30 - 4**
Pin pulling device **1.02 - 5, 5.30 - 1, 5.30 - 2**
Pin transport position **5.01 - 20**
Placement width **1.03.10 - 3**
Placing additional derrick ballast plates **5.36 - 57**
Placing a shorter crane rope **4.08 - 21**
Placing the boom on the assembly shoes **5.39 - 101**

Placing the central ballast plate down, without Twist-lock **3.03 - 23**
Placing the central ballast plate down, with Twist-lock **3.03 - 23**
Placing the central ballast plates **3.03 - 9**
Placing the derrick ballast plates **5.36 - 47**
Placing the first counterweight plate per side on the counterweight frame **4.07 - 29**
Placing the first derrick ballast plate on the derrick ballast pallet **5.36 - 55**
Placing the hoist rope or the control rope **5.01 - 2**
Placing the remaining derrick ballast plates **5.36 - 63**
Placing the swing **5.07 - 18**
Planning Crane operation **2.03 - 3**
Platform ladder **2.04.10 - 16**
Platforms on the D-pivot section **2.06 - 91**
Platforms on the turntable frame rear section **2.06 - 51**
Pneumatic springs **5.01 - 11**
Positioning crawler track chain on the crawler carrier front section **3.01.10 - 39**
Positioning the access ladder and the extension ladder in the operating position **3.01.20 - 25**
Positioning the access ladder and the extension ladder in the transport position **3.01.20 - 31**
Positioning the connecting forks for pinning **5.01 - 19**
Positioning the crawler chain on the crawler carrier rear section **3.01.10 - 33**
Positioning the first connector carrier on the cross carrier **5.36 - 19**
Positioning the first cross carrier **5.36 - 17**
Positioning the support plate off-center on the outrigger pad lying on the complete surface **1.03.10 - 16, 1.03.10 - 18, 1.03.10 - 20, 1.03.10 - 22**
Positioning the support plate off-center on the outrigger pad over a cavity **1.03.10 - 16, 1.03.10 - 18, 1.03.10 - 20, 1.03.10 - 22**
Positioning winch 1 **3.07.10 - 9**
Positioning winch 2 **3.07.20 - 9**
Positioning winch 3 **3.07.30 - 9**
Positioning winch 5 **3.07.50 - 11**
Positioning winch 6 **3.07.60 - 9**
Positive longitudinal incline **4.10 - 17**
Possible weighing errors **4.08 - 14**
Power aggregate / supply **4.01 - 7**
Power-save mode and Stand-by mode in the LIC-CON computer system **4.02 - 219**
Preassembling the P-adapter **5.44 - 24**
Preassembling the SD/SLD-boom on the ground **5.39 - 67**
Preassembling the SD/SLD-boom on the ground and installing it on the crane **5.39 - 67**
Preface **0.01 - 1**
Preface to the appendix **90.01 - 1**
Preheating the hydraulic oil **2.08 - 4**
Preheating the hydraulic oil with Hydraulic oil preheating * **4.03 - 37**

Preheating time **2.08 - 3**
 Preparations on the S-pivot section **5.44 - 13**
 Preparatory work **5.30 - 7**
 Preparing for crane driving **4.10 - 11**
 Preparing for crane operation **5.10 - 15, 5.39 - 87, 5.44 - 67**
 Preparing the crawler carrier for assembly **3.01.30 - 5**
 Preparing the crawler carrier for disassembly **3.01.30 - 45**
 Preparing the cross beam **5.05 - 67, 5.05 - 175, 5.39 - 21**
 Preparing the D-end section **5.05 - 19**
 Preparing the D-end section for transport **5.05 - 189**
 Preparing the D-intermediate section for transport **5.05 - 183**
 Preparing the D-intermediate sections **5.05 - 31**
 Preparing the D-pivot section **5.05 - 9**
 Preparing the D-pivot section for transport **5.05 - 197**
 Preparing the engine house for assembly on the turntable **3.02 - 51**
 Preparing the engine house for disassembly on the turntable **3.02 - 83**
 Preparing the hook block **4.06 - 9, 4.06 - 13**
 Preparing the lattice sections for transport **5.05 - 183**
 Preparing the pull cylinder **5.05 - 81, 5.05 - 137**
 Preparing the S-end section for installation **5.39 - 39**
 Preparing the S-luffing pulley block **5.05 - 97**
 Preparing the turntable for the assembly of the carriers **4.07 - 11**
 Preparing the turntable frame rear section for assembly **3.02 - 31**
 Preparing the turntable frame rear section for disassembly **3.02 - 105**
 Prerequisites **2.04 - 85**
 Prerequisites for crane equipment and accessories **2.04 - 83**
 Prerequisites for driving the crane (crawler operation) **4.10 - 2**
 Prerequisites for driving uphill / downhill without adjusting the angle of the boom system **4.10 - 18**
 Prerequisites for lifting of personnel **2.04 - 83**
 Prerequisites for operation with lifting cage (cherry picker) **2.04 - 84**
 Preselection of slewing speed **4.05 - 59**
 Pressed rope end connection **8.04 - 15**
 Pressure filters in the crane hydraulic **7.05 - 12**
 Pressure monitoring in the relapse cylinders **4.04 - 15**
 Pressure testing the relapse cylinders **8.01 - 85**
 Pretensioning the hoist rope with pretensioning bal-
 last with two hook operation **4.08 - 24**
 Preventing fires **7.01 - 4**
 Prevention of improper machine use **7.01 - 15**
 Procedure for fogged windows **6.02 - 23**
 Procedure for shut-off of crane movement **4.20 - 1**
 Procedure for special cases at operation of the LIC-
 CON overload protection **4.20 - 31**
 Procedure in case of slack rope **5.19 - 3**

Product description **1.02 - 1**
 Programming the auxiliary heater **6.02 - 33**
 Protecting against burns **7.01 - 5**
 Protecting against the hazards of service fluids **7.01 - 6**
 Protecting from scalding **7.01 - 5**
 Protecting the crane against corrosion **7.01 - 12**
 Protecting the crane against corrosion for shut-
 down **7.01 - 14**
 Protecting the crane against corrosion for sto-
 rage **7.01 - 13**
 Protective gloves **2.04 - 17**
 Protruding, distorted inlay, braiding **7.05.50 - 9**
 Protruding, distorted insert or strand **8.04 - 22**
 PSAG, rescue equipment and tools **2.04 - 85**
 Pull cylinder **1.03 - 23**
 Pulley cart **5.61 - 3**
 Pulley head height **4.02 - 91**
 Pulling out the ladder on the D-pivot sec-
 tion **5.05 - 9, 5.05 - 123**
 Pulling out the ladder on the D-pivot section into the
 operating position **2.06 - 85**
 Pulling the control rope and the hoist ropes forward to
 the end section **5.07 - 20**
 Pulling the hoist ropes in **5.07 - 49**
 Pump distributor gear **7.05 - 9**

Q

Qualification Inspection personnel **8.04 - 3**
 Qualification Maintenance personnel **7.05.50 - 5**
 Quick test Crane geometry **4.04 - 3**
 Quick test EMERGENCY STOP switch / EMER-
 GENCY OFF switch **4.04 - 17**
 Quick test Hoist limit switch **4.04 - 11**
 Quick test Leveling instrument **4.04 - 9**
 Quick test Limit switch winch **4.04 - 15**
 Quick test Overload protection **4.04 - 3**
 Quick test Wind speed sensor **4.04 - 13**

R

Radio sender unit and radio receiving unit park posi-
 tion **5.19.10 - 11**
 Radio sender unit variation 1: **5.19.10 - 10**
 Radio sender unit variation 2: **5.19.10 - 10**
 Radio sending unit for the incline display hook
 block **5.19 - 3**
 Railing 2 **2.06 - 103, 2.06 - 121**
 Railing 3 **2.06 - 105, 2.06 - 119**
 Railing 4 **2.06 - 107, 2.06 - 117**
 Railing 5 **2.06 - 109, 2.06 - 115**
 Railing 6 **2.06 - 111, 2.06 - 113**
 Railing on the A-frame **2.06 - 73**
 Railing on the catwalk **2.06 - 89**
 Railing on the D-intermediate section **2.06 - 127**
 Railing on the D-pivot section **2.06 - 103**
 Railing on the turntable frame front section **2.06 - 49**

Railings on crawler center section with cross carriers **2.06 - 35**
Railings on the carriers for the counterweight **2.06 - 69**
Railings on the S-end section **2.06 - 137**
Railings on the S-pivot section **2.06 - 133**
Railings on the turntable frame rear section **2.06 - 55, 2.06 - 63**
Ram work or pulling sheet piles **4.08 - 19**
Rapid gear **4.02 - 113**
Rear of turntable attachment parts **4.01 - 3**
Recharging the battery **7.05 - 51**
Recommendation for safe disposal **7.01 - 15**
Reducing rope pull **2.08 - 6**
Reducing rope unwinding **4.08 - 21**
Reducing the maximum load **2.08 - 7**
Reducing the maximum permissible wind speed * **4.02 - 145**
Reduction of rope diameter **7.05.50 - 5**
Reeving in / reeving out the hook block, rope end connection in the standard version **4.06 - 8**
Reeving in / reeving out the hook block, rope end connection with L-shaped rope lock **4.06 - 11**
Reeving in the hoist rope **4.06 - 5**
Reeving in the hoist rope with the assembly winch **4.06 - 6**
Reeving in the hoist rope with the telescopic lift truck **5.10 - 9**
Reeving in the hook block with the telescopic lift truck **5.39 - 81, 5.44 - 62**
Reeving plans **4.15 - 1, 4.15 - 3**
Reeving the control rope on the WA-frames **5.07 - 29**
Reeving the hook block in **4.06 - 9, 4.06 - 12**
Reeving the hook block out **4.06 - 10, 4.06 - 14**
Reeving the rope of winch 1 **5.05 - 91**
Reeving the rope of winch 1 out **5.05 - 133**
Reeving the rope of winch 2 **5.05 - 93**
Reeving the rope of winch 2 out **5.05 - 133**
Reeving the rope of winch 3 **5.05 - 89**
Reeving the rope of winch 6 **5.05 - 93**
Reeving the rope of winch 6 out **5.05 - 133**
Reeving the ropes in **5.05 - 89**
Reeving the ropes out **5.05 - 133**
Reeving the S-luffing pulley block **5.05 - 101**
Reeving the S-luffing pulley block out **5.05 - 123**
Reeving the W-control rope out **5.07 - 93**
Reference texts **4.02 - 74**
Refueling **7.05 - 19**
Regenerating at a standstill of the diesel particle filter **4.03 - 16**
Relapse cylinder / erection cylinder monitoring **4.02 - 129**
Relapse cylinders **5.01 - 11**
Release and unpin the outer connector pins **3.01.10 - 69**
Releasing and unpinning the connector pins on the „turntable top“ **3.02 - 35, 3.02 - 109**
Releasing and unpinning the connector pins „turntable bottom“ **3.02 - 39, 3.02 - 110**

Releasing and unpinning the inner connector pins **3.01.10 - 73**
Releasing and unpinning the pin **5.05 - 97**
Releasing the button block **5.31 - 8**
Releasing the engine rpm lock **4.05 - 7**
Releasing the frame on the turntable **3.05 - 45**
Releasing the guide pipe **3.05 - 27, 5.05 - 87**
Releasing the guy rods **5.05 - 29**
Releasing the parking brake **4.05 - 53**
Releasing the pin **5.05 - 151**
Releasing the pins on the Quick-Connection **3.01.30 - 35**
Releasing the transport retainers of the S-luffing pulley block **5.05 - 105**
Relieving the crawler chain **3.01.10 - 51**
Removal criteria Overview **8.04 - 8**
Removal of A-frame **4.07 - 39**
Removing and recharging the battery **7.05 - 50**
Removing broken wires **7.05.50 - 14**
Removing the A-frame **3.05 - 55, 4.07 - 39**
Removing the auxiliary crane **3.05 - 29**
Removing the battery **7.05 - 50**
Removing the boom nose **5.10 - 20**
Removing the brackets **5.36 - 131**
Removing the central ballast **3.03 - 15**
Removing the central ballast plates **3.03 - 17**
Removing the counterweight **4.07 - 31**
Removing the crawler chain from the crawler carrier front section **3.01.10 - 57**
Removing the crawler chain from the crawler carrier rear section **3.01.10 - 59**
Removing the cross carrier **5.36 - 139**
Removing the cross carrier and connector carrier **5.36 - 133**
Removing the derrick ballast pallet **5.36 - 127**
Removing the first central ballast plate **3.03 - 21**
Removing the frames **5.36 - 129**
Removing the heavy load device **5.14 - 29**
Removing the hoist limit switch weight **4.06 - 20, 4.06 - 23**
Removing the hoist ropes **5.07 - 78**
Removing the load hook * **4.06 - 17**
Removing the pin pulling cylinder **5.30 - 12**
Removing the pull cylinder **5.05 - 137**
Removing the pulley set / pulley sets **5.14 - 33**
Removing the pulley set on the end section **5.14 - 37**
Removing the pulley sets on the end section **5.14 - 35**
Removing the railing from the turntable **3.05 - 47**
Removing the railing on the turntable **3.05 - 15**
Removing the roller ring connection from the crawler center section **3.01.30 - 39**
Removing the second and third central ballast plate **3.03 - 23**
Removing the S-end section **5.39 - 111, 5.39 - 111**
Removing the transport lugs on the base frame of the engine house **3.02 - 99**
Removing the Twistlock on the counterweight plate(s) **4.07 - 39, 5.36 - 117**

Removing the winch **3.07.10 - 15, 3.07.20 - 15, 3.07.30 - 15, 3.07.60 - 15**
 Removing the winches **3.02 - 105**
 Removing the work platform **2.06 - 67**
 Removing winch 1 **3.07.10 - 19**
 Removing winch 1 **3.07.10 - 19**
 Removing winch 2 **3.07.20 - 19**
 Removing winch 2 **3.07.20 - 19**
 Removing winch 3 **3.07.30 - 19**
 Removing winch 3 **3.07.30 - 19**
 Removing winch 5 **3.07.50 - 21**
 Removing winch 6 **3.07.60 - 19**
 Removing winch 6 **3.07.60 - 19**
 Renewing the pretension of hoist ropes **7.05.50 - 16**
 Repair welding **8.01 - 6**
 Replacing damaged crane components **7.01 - 6**
 Replacing hydraulic hose lines **8.06 - 5**
 Replacing safety ropes subjected to a fall **2.06 - 7**
 Replacing the granular cartridge **7.05 - 49**
 Replacing the hose lines **7.05 - 14**
 Rescue **2.04 - 86**
 Rescuing the assembly personnel **2.04 - 21**
 Resetting the auxiliary heater programming **6.02 - 34**
 Resetting the diesel particle filter maintenance status **7.01.10 - 7**
 Resetting the EMERGENCY STOP on the BTT **5.31 - 9**
 Resetting the engine oil maintenance status **7.01.10 - 7**
 Resetting the maintenance status **7.01.10 - 7**
 Respiratory protection **2.04 - 18**
 Responsibility when using or reselling the crane **0.01 - 9**
 Restoring hoist rope pretension **4.08 - 22**
 Resuming crane operation **2.04 - 82**
 Retaining clips **5.01 - 28**
 Retaining elements **5.01 - 21**
 Retracting the assembly support **3.01.30 - 17**
 Retracting the assembly supports **3.01.20 - 33**
 Retracting the assembly supports and supporting the crawler center section **3.01.20 - 33**
 Retracting the boom **2.04 - 71**
 Retracting the D-relapse cylinder **5.05 - 145**
 Retracting the S-relapse cylinder and placing it down in transport position **5.39 - 97**
 Retracting the S-relapse cylinder and taking it down in the transport position **5.44 - 74**
 Retrofitting old ladders **2.04.10 - 3**
 Return filter **7.05 - 11**
 Returning to service **7.01 - 14**
 Rigging plans **3.80 - 3**
 Rigging points and fastening points **8.01 - 77**
 Rigging the guy rods on lattice booms on placed down boom system **5.01 - 93**
 Rods **1.03 - 33**
 Roller cart **5.61 - 1**
 Roller cart assembly procedure **5.07 - 46**
 Roller cart W **1.03 - 29**

Roller ring connection components **3.02 - 3**
 Roller ring connection with quick connection (QC) **1.03 - 7**
 Roller set **1.03 - 17, 5.14 - 1**
 Rope end connections **4.06 - 2**
 Rope lock (standard version) **4.06 - 3**
 Rope pulleys **5.01 - 2**
 Rope pulleys and guide pulleys **7.05.50 - 4**
 Rope pulleys and hydraulic cylinders **2.08 - 8**
 Rope reeving **4.06 - 1, 4.06 - 35**
 Ropes **1.03 - 34, 5.01 - 2**
 Rotating parts **7.01 - 6**
 Rotating rope end connection **8.04 - 6**
 Rotation resistant ropes **8.04 - 13**
 Rotation-resistant ropes with rope end connections **8.04 - 5**

S

S-/LI-intermediate section 6m or 12m **5.07 - 5**
 S-adapter 12.0m **1.03 - 15**
 Safe and problem-free operation **7.05.50 - 4**
 Sa-
 fety **1.03.10 - 2, 2.08 - 2, 3.80 - 3, 4.06 - 24, 7.01 - 2**
 Safety and warning display **0.01 - 2**
 Safety equipment **0.01 - 9, 1.02 - 4, 4.04 - 1**
 Safety goggles **2.04 - 18**
 Safety guidelines **8.06 - 3, 8.15 - 3**
 Safety harness with height safety equipment **2.04 - 14**
 Safety instructi-
 ons **2.04.10 - 2, 4.08 - 3, 7.01.10 - 2, 8.05 - 2, 8.17 - 3**
 Safety instructions in case of an external power supply **2.04 - 50**
 Safety locking pin **5.01 - 23**
 Safety of crane transport on floating devices **2.25 - 3**
 Safety rope **2.06 - 5**
 Safety ropes as fall protection equipment **2.06 - 5**
 Safety shoes **2.04 - 17**
 Safety signs **2.04.10 - 3**
 Safety systems on the crane **4.04 - 9**
 S-boom relapse retainer **8.12 - 3**
 Scattered occurring broken wires **8.04 - 10**
 Screen display in the Set up program **4.02 - 12**
 SD/SDB0– boom **1.01 - 4**
 SDB/SDWB– boom **1.01 - 6**
 SDW2B/SLDB– boom **1.01 - 8**
 SDWVB– boom **1.01 - 12**
 Second inspection (second year) **8.03 - 10**
 Securing against falls **7.01 - 4**
 Securing against start up **7.01 - 3**
 Securing personnel on shut off crane **2.04 - 84**
 Securing persons to prevent them from falling **2.04 - 19**
 Securing the frames to prevent them from folding down **5.36 - 103**
 Securing the guide pipe **3.05 - 41, 5.05 - 141**
 Securing the guy rods **5.05 - 191**

Securing the pins in the transport position **5.05 - 127**
Securing the pins on the Quick-Connection **3.01.30 - 31**
Selecting and deselecting touch functions **4.01 - 27**
Selecting derrick ballast settings **4.02 - 33**
Selecting the abbreviation for the boom system **4.02 - 20**
Selecting the auxiliary boom / accessory **4.02 - 27**
Selecting the auxiliary boom / accessory for the first variation (V1) **4.02 - 29**
Selecting the auxiliary boom / accessory for the second variation (V2) **4.02 - 32**
Selecting the derrick boom **4.02 - 25**
Selecting the environmental / mechanical influence category **4.02 - 37**
Selecting the fast setting **4.02 - 215**
Selecting the function on the touch display **4.10 - 26**
Selecting the lifting category **4.02 - 58**
Selecting the location **2.04 - 35**
Selecting the main boom for the first variation (V1) **4.02 - 22**
Selecting the main boom for the second variation (V2) **4.02 - 24**
Selecting the operating mode category **4.02 - 19**
Selecting the program category **4.02 - 37**
Selecting the set up completion category **4.02 - 37**
Selecting the travel speed **4.10 - 27**
Select the function using the touch function and then operate using the F-keys **4.01.10 - 3**
S-end section **1.03 - 15**
S-end section fastening points **5.44 - 9**
Service fluids and lubricants **7.01 - 15**
Service system **7.01.10 - 1**
Service system function key line **7.01.10 - 6**
Service system operating interface **7.01.10 - 3**
Servicing the central lubrication system **7.05 - 35**
Servicing the central lubrication system of the crawler carrier **7.04 - 11**
Servicing the track chain **7.04 - 19**
Servicing the travel gear **7.04 - 3**
Servo oil pressure monitoring in the winches **4.04 - 15**
Settings and status displays on the BTT **5.31 - 10**
Setting the brightness on the BTT-Display **5.31 - 10**
Setting the central ballast **4.02 - 41**
Setting the central ballast: Specified settings distances **4.02 - 41**
Setting the central ballast: Stepless settings distances **4.02 - 42**
Setting the counterweight **4.02 - 53**
Setting the counterweight: Specified settings distances **4.02 - 53**
Setting the counterweight: Stepless settings distances **4.02 - 54**
Setting the crane chassis **4.02 - 38**
Setting the cross bracket to lifting heights **5.36 - 31**
Setting the derrick ballast pallet on the ground **5.36 - 41**
Setting the derrick ballast radius **4.02 - 40**

Setting the derrick ballast weight **4.02 - 51**
Setting the engine house on the brackets with the auxiliary crane and pinning it **3.02 - 61**
Setting the first central ballast plate **3.03 - 13**
Setting the incline range **4.02 - 45**
Setting the incline range: Specified settings distances **4.02 - 45**
Setting the incline range: Stepless settings distances **4.02 - 46**
Setting the load position **4.02 - 49**
Setting the master switch speed reduction **4.03 - 39**
Setting the operating mode via chart name (chart number) **4.02 - 17**
Setting the operating mode via the function keys **4.02 - 19**
Setting the platforms on the derrick ballast plates **5.36 - 61**
Setting the project chart **4.02 - 48**
Setting the roller ring connection on the crawler center section **3.01.30 - 25**
Setting the second and third central ballast plate **3.03 - 13**
Setting the set up configuration in general **4.02 - 15**
Setting the set up functions **4.02 - 35**
Setting the slewing range **4.02 - 44**
Setting the turntable frame front section on the crawler travel gear **3.02 - 17**
Setting the wind speed **4.02 - 56**
Setting up parallel operation **4.05 - 21**
Setting up the work platform **2.06 - 67**
Set up program **4.02 - 11**
Shortening the rope **7.05.50 - 16**
Short horn warning sound **4.02 - 109, 4.02 - 183, 4.02 - 197**
Shorting the intervals **8.04 - 26**
Showing the horizontal distance **2.04 - 69**
Showing the vertical distance **2.04 - 66**
Show the operating interface from the Test system menu **5.31 - 26**
Shut-off difference force monitoring of derrick ballast guying **4.20 - 28**
Shut-off due to error message **4.20 - 28**
Shut off hoist top **4.20 - 26**
Shut-off luffing the auxiliary boom / accessory up / down **4.20 - 21**
Shut-off luffing the derrick boom up / down **4.20 - 26**
Shut-off luffing the main boom up / down **4.20 - 20**
Shut off maximum / minimum value F-load display **4.20 - 23**
Shut off maximum value F1 in crane operation **4.20 - 23**
Shut off minimum value F1 in crane operation **4.20 - 24**
Shut-off of crane movement **4.20 - 18**
Shut-off overload **4.20 - 19**
Shut-off parallel operation winch 1 and winch 2 **4.20 - 27**
Shut-off spooling the winch up / out **4.20 - 25**

Shutting off the crane movement **4.02 - 107, 4.02 - 181**
 Side window **2.04 - 29**
 Signs **2.05 - 2**
 Signs on the crane **2.05 - 1**
 Single layer and parallel roped ropes **8.04 - 11**
 Single strand height safety equipment **2.04 - 16**
 S-intermediate section
 12.0m **1.03 - 13, 1.03 - 13, 1.03 - 15, 1.03 - 15**
 S-intermediate section 6.0m **1.03 - 13**
 S-intermediate sections „flying“ assembly **5.39 - 65**
 Slewing gear **1.02 - 3, 7.05 - 23**
 Slewing gear brake **4.10 - 25**
 Slewing range **4.02 - 147**
 Slewing ring connection **7.05 - 21, 7.05 - 32**
 Sliding the ladder in on the D-pivot section **5.05 - 109, 5.05 - 201**
 Sliding the ladder on the D-pivot section into the transport position **2.06 - 87**
 Slip-resistant mats **7.01 - 11**
 Slopes and excavations **2.04 - 39**
 SL-reducer 6.0m **1.03 - 15**
 SL-reducer section **5.07 - 5**
 S-luffing pulley block **1.03 - 23**
 Sound insulation mats **7.01 - 11**
 Special cases at operation of the LICCON overload protection **4.20 - 5**
 Special operating conditions **4.20 - 5**
 Specified service fluids and lubricants for Liebherr cranes **7.07 - 3**
 Spinning out by turning out the hook block **7.05.50 - 15**
 Spinning out with single strand reeving **7.05.50 - 15**
 S-pivot section 10.25m **1.03 - 13**
 S-pivot section before installation of winch 5 **3.07.50 - 7**
 S-pivot section fastening points **5.44 - 4**
 Split pin **5.01 - 22**
 Spool assembly winch 1 out / up **5.31 - 24**
 Spool assembly winch 2 out / up **5.31 - 24**
 Spooling the assembly winches up constantly and parallel **4.05 - 39**
 Spooling the assembly winch out **4.05 - 33**
 Spooling the assembly winch up **4.05 - 35**
 Spooling the assembly winch up and out **4.05 - 33**
 Spooling the assembly winch up constantly **4.05 - 37**
 Spooling the hoist winches up and out **4.05 - 19**
 Spooling the hoist winch out **4.05 - 19**
 Spooling the hoist winch up **4.05 - 21**
 Spooling up loose hoist rope **5.19 - 3**
 Spooling up the hoist ropes and the control rope completely **5.07 - 101**
 Spring retainer **5.01 - 24**
 Stacking the outrigger pads **1.03.10 - 7**
 Stand-by mode **4.02 - 223**
 Starting and turning off the engine **4.03 - 41**
 Starting operation, follow my instructions **2.04 - 64**
 Starting out with a strong side wind **4.05 - 55**
 Starting the engines individually **4.03 - 43**

Starting the engines together **4.03 - 43**
 Starting the LICCON computer system (before engine start) **4.03 - 38**
 Starting the LICCON computer system parallel to the engine **4.03 - 48**
 Starting the program **4.02 - 201**
 Starting to drive **2.04 - 72**
 Starting up the LICCON computer system and the touch displays **4.01 - 27**
 Start menu of the BTT **5.31 - 14**
 Start up and shut down of crane **4.03 - 1**
 Stationary stability **2.04.10 - 3**
 Steering ability **4.10 - 13**
 Steering the crane **4.10 - 33**
 Steering the crawler travel gear to the left **4.10 - 33**
 Steering the crawler travel gear to the right **4.10 - 34**
 Stop (normal stop) **2.04 - 64**
 Stopping the mobile crane **2.04 - 73**
 Stopping the slewing movement with a strong side wind **4.05 - 55**
 Storage **7.01 - 14**
 Storage conditions **7.01 - 14**
 Structure of the operating mode category **4.02 - 16**
 Suitable distribution of the surface pressure **4.10 - 12**
 Supplied cross beam **2.04.10 - 14**
 Supplied fall arrest system **2.04 - 13**
 Supplied fire extinguisher **2.04 - 19**
 Supply via external feed / power aggregate **4.03 - 33**
 Support **2.04 - 46**
 Supporting lattice mast booms for erection **5.01 - 77**
 Supporting lattice mast booms for take-down **5.01 - 78**
 Supporting long lattice mast booms for erection and take-down **5.01 - 77**
 Supporting the crane **2.04 - 47, 2.08 - 4**
 Supporting the crane with a variable support **2.04 - 47**
 Support plates **2.04 - 46**
 Surface pressure: Center of gravity in the front **4.10 - 12**
 Surface pressure: Center of gravity in the middle **4.10 - 11**
 Surface pressure: Center of gravity in the rear **4.10 - 12**
 Surface pressure display on the LICCON monitor **4.10 - 8**
 Surface pressures and force distribution when driving the crane **4.10 - 21**
 Surface pressures in case of wind load on the boom **4.10 - 22**
 Surfaces **8.05 - 5**
 Suspended ballast * **4.02 - 189**
 Suspended ballast pallet **1.03 - 25**
 Suspended load fastening point **2.05 - 10, 2.05 - 10, 2.05 - 11**
 Swinging the access ladder on the cross carrier into the operating position **2.06 - 15**
 Swinging the access ladder on the cross carrier into the transport position **2.06 - 23**

Swinging the brackets **5.05 - 97, 5.05 - 103, 5.05 - 121**
Swinging the brackets in into park / transport position **5.14 - 31**
Swinging the brackets into the transport position **5.05 - 127**
Swinging the extension ladder on the crawler center section in position of assembly / disassembly **2.06 - 11**
Swinging the extension ladder on the crawler center section into the vertical position **2.06 - 13**
Swinging the extension ladder on the cross carrier in position for assembly / disassembly **2.06 - 31**
Swinging the extension ladder on the cross carrier into the vertical position **2.06 - 33**
Swinging the folding bracket into operating position **5.05 - 151**
Swinging the folding bracket into the operating position **5.05 - 45**
Swinging the folding step **7.05 - 17, 7.05 - 19**
Swinging the ladder on the crawler carrier into position for assembly / disassembly **2.06 - 39**
Swinging the ladder on the crawler carrier into the transport position **2.06 - 41**
Swinging the ladder on the D-end section **5.05 - 129**
Swinging the ladder on the D-end section into the operating position **2.06 - 123**
Swinging the ladder on the D-end section into the transport position **2.06 - 125**
Swinging the platforms on the D-pivot section into the operating position **2.06 - 91, 2.06 - 97, 5.05 - 9**
Swinging the platforms on the D-pivot section into the transport position **5.05 - 201**
Swinging the pulley support into the operating position **5.05 - 27**
Swinging the pulley support into the transport position **5.05 - 189**
Swinging the pull test bracket into the operating position **5.05 - 25**
Swinging the pull test bracket into the transport position **5.05 - 129**
Swinging the railing (front) into operating position **5.36 - 59**
Swinging the railing (on top) and (rear) into the operating position **2.06 - 55**
Swinging the railing (on top) and (rear) into the transport position **2.06 - 57**
Swinging the railing (on top) into the operating position **2.06 - 55**
Swinging the railing (on top) into the transport position **2.06 - 57**
Swinging the railing (rear) into operating position **5.36 - 59**
Swinging the railing (rear) into the operating position **2.06 - 55**
Swinging the railing (rear) into the transport position **2.06 - 57**
Swinging the railing (rear) into transport position **5.36 - 121**

Swinging the railing on the A-frame into the operating position **2.06 - 73**
Swinging the railing on the A-frame into the transport position **2.06 - 73**
Swinging the railing on the D-intermediate section into the operating position **2.06 - 127, 5.05 - 31**
Swinging the railing on the D-intermediate section into the transport position **2.06 - 129, 5.05 - 183**
Swinging the railing on the D-pivot section into the transport position **5.05 - 201**
Swinging the railing on the S-end section into operating position **5.39 - 39**
Swinging the railing on the S-end section into the operating position **2.06 - 137**
Swinging the railing on the S-end section into the transport position **2.06 - 139**
Swinging the railing on the S-pivot section into operating position **5.39 - 17**
Swinging the railing on the S-pivot section into the operating position **2.06 - 133, 5.44 - 13**
Swinging the railing on the S-pivot section into the transport position **2.06 - 135**
Swinging the railing on the turntable frame front section into the operating position **2.06 - 49**
Swinging the railing on the turntable frame front section into the transport position **2.06 - 49**
Swinging the railing on the turntable frame rear section into the operating position **2.06 - 55, 2.06 - 63**
Swinging the railing on the turntable frame rear section into the transport position **2.06 - 57, 2.06 - 63**
Swinging the railings (front) into transport position **5.36 - 121**
Swinging the railings into the operating position **2.06 - 69, 2.06 - 103, 3.01.20 - 27**
Swinging the railings into the transport position **2.06 - 71, 2.06 - 113, 3.01.20 - 29**
Swinging the railings on the crawler center section with cross carriers into the operating position **2.06 - 35**
Swinging the railings on the crawler center section with cross carriers into the transport position **2.06 - 37**
Swinging the railings on the D-pivot section into the operating position **5.05 - 9, 5.05 - 123**
Swinging the rod receptacles into operating position **5.05 - 31, 5.05 - 33, 5.05 - 35**
Swinging the rod receptacles into the transport position **5.05 - 183, 5.05 - 185, 5.05 - 187**
Swinging the turntable frame rear section to the turntable frame front section **3.02 - 41**
Switch for crawler operation **4.10 - 25**
Switching the crane operation monitoring functions **4.02 - 117**
Switching the slewing gear to freewheeling **4.05 - 57**
Symbols from 2018 **2.04.10 - 9**
Symbols until the end of 2017 **2.04.10 - 4**
System start of the LICCON computer system **4.02 - 4, 4.03 - 38**

T

- Taking an oil sample **7.01 - 8**
- Taking care of the crane **7.01 - 8**
- Taking down the boom system with the luffing jib **5.07.50 - 15**
- Taking down the WA-frames **5.07 - 85**
- Taking on a load **4.08 - 7**
- Taking on a load with cross beam **4.08 - 9**
- Taking over the entries and settings from the Set up program **4.02 - 72**
- Taking over the entries and settings of the lifting category **4.02 - 72**
- Taking over the set up configuration that was previously set **4.03 - 39**
- Taking the boom down **5.07 - 69**
- Taking the boom down on the assembly shoes **5.44 - 76**
- Taking the lattice jib down into the roller cart **5.01 - 42**
- Taking the radio sender unit and radio receiving unit out of the park position **5.19.10 - 12**
- Taking the relapse retainer down **5.05 - 199**
- TE1 boom and equipment assignment **4.01 - 31**
- TE1 Function key assignment **4.01 - 29**
- TE1 main menu: Functions and assignment **4.01 - 30**
- TE1 Touch functions **4.01 - 30**
- TE1 winch assignment **4.01 - 31**
- TE1 „Block winch“ menu (right touch display) **4.01 - 35**
- TE1 „Block winch“ menu assignment **4.01 - 35**
- TE1 „Block winch“ menu function key assignment **4.01 - 35**
- TE1 „Block winch“ menu touch functions **4.01 - 35**
- TE2 assignment slewing gear **4.01 - 41**
- TE2 Function key assignment **4.01 - 39**
- TE2 main menu: Functions and assignment **4.01 - 40**
- TE2 Menu: „Climate control settings“ (Left touch display) **4.01 - 43**
- TE2 Menu: „Hydraulic oil preheating / diesel particle filter“ (left touch display) **4.01 - 51**
- TE2 Touch functions **4.01 - 40**
- TE2 winch assignment **4.01 - 40**
- TE2 „Climate control settings“ menu assignment **4.01 - 44**
- TE2 „Climate control settings“ menu function key assignment **4.01 - 43**
- TE2 „Climate control settings“ menu touch functions **4.01 - 43**
- TE2 „floodlight“ menu (left touch display) **4.01 - 47**
- TE2 „floodlight“ menu assignment **4.01 - 47**
- TE2 „floodlight“ menu function key assignment **4.01 - 47**
- TE2 „floodlight“ menu touch functions **4.01 - 47**
- TE2 „Hydraulic oil preheating / diesel particle filter“ menu assignment **4.01 - 51**
- TE2 „Hydraulic oil preheating / diesel particle filter“ menu function key assignment **4.01 - 51**
- TE2 „Hydraulic oil preheating / diesel particle filter“ menu touch functions **4.01 - 51**
- TE3 boom and equipment assignment **4.01 - 55**
- TE3 main menu: Functions and assignment **4.01 - 54**
- TE3 touch functions **4.01 - 54**
- TE3 winch assignment **4.01 - 55**
- Technical data **1.03 - 1**
- Technical outrigger pad data for cranes with a lattice mast boom **1.03.10 - 23**
- Technical safety instructions **2.04 - 1, 5.31 - 2**
- Technical safety instructions for assembly and disassembly **5.01 - 1**
- Technical track pad data for cranes with a telescopic boom **1.03.10 - 8**
- Tele lift truck hydraulic aggregate **5.30 - 3**
- Telescopic boom **4.08 - 21**
- Telescopic boom distortion because of sunshine on one side **4.08 - 5**
- Telescoping crane movement **4.08 - 5**
- Temperature operating limits **7.05.50 - 5**
- Tensioning the crawler chain **3.01.10 - 43**
- Tensioning the track chain **7.04 - 20**
- Terminology **1.01 - 1**
- Terms and abbreviations **2.04 - 84**
- Test brackets (force test boxes) **4.04 - 18**
- Test system menu **5.31 - 25**
- The BTT display remains dark **5.31 - 28**
- The Crane operation program on LICCON monitor 0 **4.02 - 77**
- The Crane operation program on LICCON monitor 1 **4.02 - 163**
- The Crane operation program on LICCON monitor 2 **4.02 - 185**
- The function key line of LICCON monitor 0 **4.02 - 157**
- The function key line of LICCON monitor 1 **4.02 - 179**
- Theoretical service life **8.03 - 5**
- The Power-Save mode **4.02 - 219**
- The „Air conditioning settings“ menu **6.02 - 3**
- Third inspection (third year) **8.03 - 10**
- Three-part multi-purpose ladder **2.04.10 - 21**
- Tilting the cab upward **4.03 - 27**
- Tilting the crane cab * **4.03 - 27**
- Tipping the A-frame **3.05 - 21, 3.05 - 49**
- Tire size **7.01 - 7**
- To exceed the maximum permissible load moment. **4.20 - 37**
- To exceed the maximum value of the F-load display in crane operation. **4.20 - 41**
- Total operating hours **7.01.10 - 3**
- Touch display **4.01.10 - 2**
- Touch display menu operation **4.01.10 - 1**
- Touch display overview **4.01 - 9**
- Touch displays **4.01 - 27**
- Touch functions **4.01 - 27**
- Traffic endangerment and environmental damage **2.04 - 6**

Transfer (between two cranes or two hooks) **2.04 - 69**
Transferring the crawler carrier **3.01.10 - 61**
Transferring the crawler carrier from the crawler chain to the substructure **3.01.10 - 61**
Transferring the crawler carrier from the substructure to the crawler chain **3.01.10 - 31**
Transmission **7.06 - 4**
Transport **2.04 - 30**
Transporting the hook block **4.08 - 9**
Travel gear / hydraulic motors / track rollers **4.10 - 6**
Travel operation **2.04 - 72**
Travel power **1.02 - 2**
Travel route **4.10 - 3**
Triggering EMERGENCY STOP on the BTT **5.31 - 9**
Troubleshooting on the central lubrication system **7.04 - 19, 7.05 - 39**
Turning **4.05 - 51**
Turning / driving in reverse **2.04 - 73**
Turning an extremely rotation-resistant hoist rope out **7.05.50 - 15**
Turning crawler operation rapid gear on / off **4.10 - 28**
Turning hydraulic oil preheating * on **4.03 - 37**
Turning normal travel crawler operation on / off **4.10 - 27**
Turning off „Power Plus“ rapid gear **4.05 - 11**
Turning on the BTT using the ignition (ignition switch) **5.31 - 11**
Turning on „Power Plus“ rapid gear **4.05 - 9**
Turning parallel travel crawler operation on / off **4.10 - 31**
Turning the auxiliary heater off **6.02 - 29**
Turning the BTT off using the ignition (ignition switch) **5.31 - 12**
Turning the BTT off via the ON / OFF button **5.31 - 12**
Turning the BTT on / off **5.31 - 11**
Turning the BTT on using the ON / OFF button **5.31 - 12**
Turning the crane superstructure **4.05 - 59, 4.05 - 59**
Turning the crane superstructure to the left **4.05 - 61**
Turning the crane superstructure to the right **4.05 - 61**
Turning the crawler travel gear on the spot to the left **4.10 - 34**
Turning the crawler travel gear on the spot to the right **4.10 - 35**
Turning the engine-independent auxiliary heater on in programming mode **6.02 - 31**
Turning the engine-independent auxiliary heater on manually **6.02 - 27**
Turning the engine off **4.03 - 47**
Turning the engine off in the event of danger **4.03 - 47**
Turning the engines off individually **4.03 - 47**
Turning the engines off together **4.03 - 47**
Turning the heater on **6.02 - 15**
Turning the hydraulic oil preheating on **2.08 - 4**

Turning the S-/L-end section into assembly position **5.39 - 43**
Turning the S-end section from assembly position into transport position **5.39 - 113**
Turning the supply off **4.03 - 35**
Turning the turntable into assembly position **5.39 - 15**
Turning the turntable into the assembly position **5.44 - 13**
Turning the turntable into the disassembly position **5.44 - 70**
Turning the turntable to the disassembly position **5.39 - 91**
Turning the vibration sensor for the slewing gear off **4.05 - 15**
Turning the vibration sensor winch 1 off **4.05 - 15**
Turntable **1.01 - 3**
Turntable assembly **3.02 - 1**
Turntable components **3.02 - 3**
Turntable dimensions and weights **1.03 - 9**
Turntable frame **1.02 - 2**
Turntable frame, front section **7.05 - 31**
Turntable frame components, front section **3.02 - 3**
Turntable frame front **1.03 - 9**
Turntable frame front section fastening points **3.02 - 5**
Turntable frame rear **1.03 - 9**
Turntable frame - rear section **7.05 - 30**
Two-part hoist limit switch weight **4.06 - 18**
Two strand height safety equipment **2.04 - 16**

U

Unhooking the ladder (small) on the turntable frame rear section **2.06 - 65**
Unloading and supporting the crawler center section **3.01.20 - 7**
Unlocking the Twistlocks **5.36 - 111**
Unpinning the ballast rods **5.05 - 135**
Unpinning the connector carrier on the cross carrier **5.36 - 137**
Unpinning the connector pin **3.02 - 123**
Unpinning the connector pins on the S-pivot section **5.44 - 21**
Unpinning the crawler carrier front section and the crawler carrier rear section **3.01.10 - 69**
Unpinning the crawler carrier on the cross carrier **3.01.30 - 51**
Unpinning the cross carrier on the crawler center section **3.01.20 - 35, 3.01.20 - 41**
Unpinning the D-boom from the D-intermediate section **5.05 - 153**
Unpinning the D-end section **5.05 - 155, 5.05 - 173**
Unpinning the derrick ballast pallet on the D-guy rods **5.36 - 105**
Unpinning the D-guy rods on the frames **5.36 - 43**
Unpinning the D-intermediate section **5.05 - 155, 5.05 - 173**
Unpinning the D-intermediate section 2824.36 12m **5.05 - 157**

Unpinning the D-intermediate section 2824.36 12m on the bottom **5.05 - 157**
 Unpinning the D-intermediate section 2824.36 12m on top **5.05 - 157**
 Unpinning the D-pivot section **5.05 - 161, 5.05 - 167, 5.05 - 173**
 Unpinning the D-pivot section on the turntable **5.05 - 161, 5.05 - 167**
 Unpinning the drawbar for the roller ring connection on the rotary connection **3.01.30 - 39**
 Unpinning the first connector carrier on the cross carrier **5.36 - 135**
 Unpinning the frame on the turntable **3.05 - 51**
 Unpinning the heavy load device **5.14 - 27, 5.14 - 29**
 Unpinning the lattice components **5.01 - 77**
 Unpinning the pins for the D-pivot section on the turntable **5.05 - 41**
 Unpinning the pins for the S-pivot section on the turntable **5.05 - 41**
 Unpinning the pins on the Quick-Connection by hand **3.01.30 - 35**
 Unpinning the pins on the Quick-Connection with the pin pulling device **3.01.30 - 37**
 Unpinning the pins on the turntable. **5.05 - 63**
 Unpinning the pull cylinder **5.05 - 139**
 Unpinning the pulley set on the bottom on the end section **5.14 - 37**
 Unpinning the pulley set on the top on the end section **5.14 - 41**
 Unpinning the roller ring connection on the crawler center section **3.01.30 - 35**
 Unpinning the S-connector pins **5.39 - 25**
 Unpinning the S-connector pins on the turntable **5.39 - 25, 5.44 - 17**
 Unpinning the S-luffing pulley block **5.05 - 125**
 Unpinning the S-pivot section on the turntable **5.39 - 117**
 Unpinning the support on the turntable **3.05 - 43**
 Unpinning the turntable frame front section with the Quick Connection on the crawler travel gear **3.02 - 119**
 Unpinning the upper pulley block **5.05 - 143**
 Unpinning the weight **5.05 - 121**
 Unpinning the W-pivot section **5.07 - 82**
 Unpinning winch 1 **3.07.10 - 19**
 Unpinning winch 2 **3.07.20 - 19**
 Unpinning winch 3 **3.07.30 - 19**
 Unpinning winch 5 **3.07.50 - 21**
 Unpinning winch 6 **3.07.60 - 19**
 Unscheduled inspection **8.04 - 3**
 Update confirmation **90.05 - 1, 90.05 - 3**
 Update to the operating instructions **90.01 - 3**
 Urea tank individual control displays **4.02 - 123**
 Used proportion of the theoretical service life **8.03 - 5**
 Use of container spreader **4.07 - 21, 5.36 - 51, 5.36 - 113**
 User guidelines **2.04.10 - 12**
 Using a hinged ladder as a leaning ladder **2.04.10 - 19**

Using a hinged ladders as a stepladder **2.04.10 - 20**
 Using a wedge lock **4.06 - 33**
 Using permissible service fluids **7.01 - 6**
 Using the Leaning ladder **2.04.10 - 28**
 Using the leaning ladder as a transition **2.04.10 - 31**
 Using the leaning ladder without the conical end section **2.04.10 - 29**
 Using the platform ladder **2.04.10 - 36**
 Using the stepladder **2.04.10 - 26**
 Using the three-part multi-purpose ladder as a leaning ladder **2.04.10 - 22**
 Using the three-part multi-purpose ladder as a stepladder **2.04.10 - 23**
 Using the vertical ladder with transition aid **2.04.10 - 35**
 Utilization bar diagram **4.02 - 85**
 Utilization conditions **5.36 - 79**

V

Vehicle height **2.05 - 3**
 Vertical movements **2.04 - 66**
 Vibrations **1.03 - 34**
 Vibration sensor **4.05 - 13**
 Vibration sensor slewing gear **4.05 - 15**
 Vibration sensor winches **4.05 - 13**
 Visual check for damage **4.08 - 4**
 Visual inspection for leaks **8.03 - 4**

W

W/WV-lattice jib **5.07 - 1**
 WA-frame 1, end section **5.07 - 3**
 WA-frame 1 intermediate section **5.07 - 3**
 WA-frame 1 pivot section **5.07 - 3**
 WA-frame 2 end section **5.07 - 4**
 WA-frame 2 intermediate section **5.07 - 4**
 WA-frame 2 pivot section **5.07 - 4**
 WA-frame I end section **1.03 - 27**
 WA-frame II end section **1.03 - 29**
 WA-frame II pivot section **1.03 - 29**
 WA-frame I pivot section **1.03 - 27**
 WA-frame preassembly **5.07 - 15**
 Walking on a boom component **5.01 - 95**
 Walking on lattice sections or booms **2.04 - 20**
 Walking on the telescopic boom **2.04 - 20**
 Warning apparel **2.04 - 18**
 Warranty and coverage **7.01 - 7**
 Washing the crane **7.01 - 8**
 W-assembly on the main boom (S-/P-) **5.07 - 14**
 W-disassembly on the main boom (S-/P-) **5.07 - 93**
 Wear **8.15 - 4**
 Wedge lock **4.06 - 5**
 Wedge lock with a bore for a clamp **4.06 - 27**
 Wedge lock without a bore for a clamp **4.06 - 28**
 Weights **5.01 - 12**
 Welding work on the load **2.04 - 86**
 While working with the crane **2.04 - 74**
 Winch 1 **1.02 - 4, 1.03 - 9, 3.07.10 - 3, 7.05 - 26**

Winch 1 assembly **3.07.10 - 1**
Winch 2 **3.07.20 - 3**
Winch 2 **1.02 - 4, 1.03 - 9, 7.05 - 27**
Winch 2 assembly **3.07.20 - 1**
Winch 3 **1.02 - 4, 1.03 - 21, 3.07.30 - 3**
Winch 3 and winch 6 **7.05 - 27**
Winch 3 assembly **3.07.30 - 1**
Winch 4 **1.02 - 4, 7.05 - 28**
Winch 5 **1.02 - 4, 1.03 - 13, 3.07.50 - 3, 7.05 - 29**
Winch 5 assembly **3.07.50 - 1**
Winch 6 **1.02 - 4, 1.03 - 21, 3.07.60 - 3, 7.05 - 47**
Winch 6 assembly **3.07.60 - 1**
Winches **1.02 - 4**
Winches 1, 2, 3, 4, 5 **7.05 - 41**
Winch influences **2.04 - 54**
Wind influences during crane operation **2.04 - 60**
Wind influences during erection and take-down **2.04 - 59**
Wind influences for „Crane out of operation“ **2.04 - 61**
Window wiper / window washer system **4.03 - 29**
Wind speed **4.02 - 143**
Wind speed, wind gust speed and wind direction **2.04 - 56**
Wind speed charts for a variable support **2.04 - 55**
Wind speed sensor **4.04 - 13, 5.39 - 72, 5.44 - 56**
Wind speed sensor * **5.07 - 53**
Winter operation **2.08 - 3**
Wire break increase rate **8.04 - 11**
Wire rope auxiliary guying **5.03 - 5**
Wire ropes **4.06 - 2**
Wire ropes and rope end connections **4.06 - 2, 8.04 - 5**
W-lattice jib **8.12 - 7**
W-lattice jib „bottom“ **8.12 - 9**
Working in low temperatures **2.08 - 1**
Working in the vicinity of overhead electrical lines **4.08 - 19**
Working in the vicinity of transmitters **2.04 - 52**
Working on lattice sections or booms **2.04 - 20**
Working on the crane superstructure or boom **2.04 - 34**
Working on the telescopic boom head and / or auxiliary boom **2.04 - 19**
Working range limitation program **4.02 - 201**
Working with a high rope pull **4.08 - 21**
Working with a load **4.08 - 1**
Work platform on the turntable frame rear section **2.06 - 67**
W-pivot section 10.25m **1.03 - 27**
W-pivot section with swing for WA-frame 2 **5.07 - 5**

”
„Power Plus“ rapid gear **4.05 - 9**

LWE/LR 13000-001/19503-01-02/en

LWE/LR 13000-001/19503-01-02/en