

LIEBHERR

Crawler crane with lattice mast

LR 1600/2

LR 1600-2-008

Operating instructions

BAL No.: 18109-09-02

Serial No.	
Date	

ORIGINAL OPERATING MANUAL

The operating manual is part of the crane!

It must always be available within reach!

The regulations for crane operation must be observed!

Liebherr-Werk Ebingen GmbH

Postfach 1361

D-89582 Ebingen / Donau

+49 (0) 7391 502-0

+49 (0) 7391 502-3399

info.lwe@liebherr.com

www.liebherr.com

Preface

Manufacturer

Liebherr - Werk Ehingen GmbH
Postfach 1361
D-89582 Ehingen / Donau
+49 (0) 7391 502-0
+49 (0) 7391 502-3399
info.lwe@liebherr.com
www.liebherr.com

General

This crane was built according to the state of technology and recognized safety technical regulations. Despite that, dangers to body and life for the user and / or third persons or damage to the crane and / or other material assets can occur.

This crane may only be used:

- In impeccable technical condition.
- For destined use.
- By trained personnel, which acts in a safety and danger conscious way.
- When no safety relevant problems are present.
- When no modifications were made on the crane.

Any problems, which could affect safety must be fixed immediately.

Modifications on the crane may only be made with written approval by Liebherr-Werk Ehingen GmbH.

Data logger

This crane is equipped with a data recording device. Among others, the following data is recorded:



- Date and time of day.
- Entered set up configuration of the crane.
- Actual load.
- Percentage of utilization of the crane.
- Boom radius (working radius).
- Main boom angle, luffing jib angle.
- Total telescopic boom length, length of each telescopic section.
- Every actuation of bypass devices.

The recorded data can be read with a respective software.

Safety and warning display

The safety and warning display is directed to all persons who work with the crane.

The terms **DANGER**, **WARNING**, **CAUTION** and **NOTICE** used in the crane documentation are intended to point out certain rules of conduct to all persons working with the crane.

Warn- ing signs	Signal word	Explanation
	DANGER	Designates a dangerous situation which will lead to death or serious injury if it is not prevented. ¹⁾
	WARNING	Designates a dangerous situation, which can lead to death or serious injury if it is not prevented. ¹⁾
	CAUTION	Designates a dangerous situation, which can lead to slight or medium-grade injuries if it is not prevented. ¹⁾
	NOTICE	Designates a dangerous situation, which can lead to property damage if it is not prevented.

¹⁾ This could also result in property damage.

Additional notes

The term **Note** is used in the crane documentation to make all persons working with the crane aware of useful information and tips.

Sign	Signal word	Explanation
	Note	Designates useful information and tips.

Crane documentation

The crane documentation is comprised of:

- All supplied documents on paper and in digital form.
- All supplied programs and applications.
- All subsequently supplied information, updates and addenda for the crane documentation.

The crane documentation:

- Makes it possible for you to operate the crane safely.
- Supports you to utilize the permissible application possibilities of the crane.
- Provides you with information about the functionality of important components and systems.



Note

Terminology in the crane documentation.

Certain expressions are used in the crane documentation.

- ▶ In order to avoid misunderstandings, the same expressions should always be used.

Translations from the German version of the crane documentation: The crane documentation has been translated to be best of one's knowledge. Liebherr-Werk Ehingen GmbH assumes no liability for translation errors. The German version of the crane documentation is solely applicable for factual accuracy. If you find any errors or if any misunderstandings arise when reading the crane documentation, please contact Liebherr-Werk Ehingen GmbH immediately.

**WARNING**

Danger of accident due to incorrect operation of the crane!

Incorrect operation of the crane can lead to accidents!

Personnel can be killed or seriously injured!

This could result in property damage!

- ▶ Only authorized and trained expert personnel are permitted to work on the crane.
- ▶ The crane documentation is part of the crane and must be accessible on the crane.
- ▶ The crane documentation and on-site regulations and specifications (such as accident prevention regulations) must be observed.

Using the crane documentation:

- **Makes it easier** to become familiar with the crane.
- **Avoids** problems due to improper operation.

Observing the crane documentation:

- **Increases** reliability in use.
- **Extends** the service life of the crane.
- **Minimizes** repair costs and downtime.

Place the crane documentation accessible in the driver's cab or in the crane cab.

**WARNING**

Outdated version of crane documentation!

If subsequently supplied information, updates and addenda to the crane documentation are not observed and added, there is a danger of accidents!

Personnel can be killed or seriously injured!

This could result in property damage!

- ▶ Observe and add all subsequently supplied information, updates and addenda for the crane documentation.
- ▶ Make sure that all affected persons always know and understand the latest version of the crane documentation.

**WARNING**

Crane documentation is not understood!

If parts of the crane documentation are not understood and the tasks are carried out on or with the crane, then there is a danger of accidents!

Personnel can be killed or seriously injured!

This could result in property damage!

- ▶ Clear up open questions regarding the crane documentation with Liebherr Service before carrying out the respective task.

This documentation may not be reproduced or duplicated, distributed or used for purposes of competition, neither in part nor in excerpts. All rights are expressly reserved in accordance with copyright laws.

All accident prevention guidelines, operating instructions, load charts etc. are based on destined use of the crane.

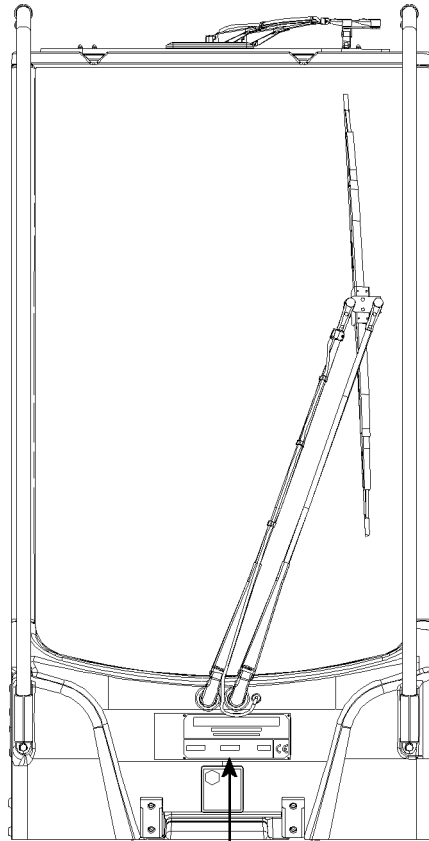

1

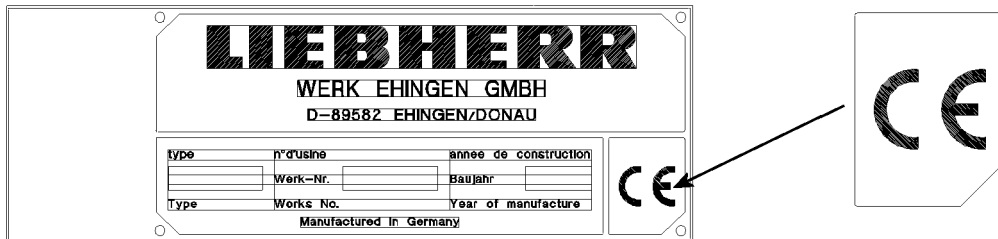

2



Fig.110001

LWE/LR 1600-2-008/18109-09-02/en

CE marking

The CE marking is a mark according to EU laws:

- Cranes with CE-marking according to the European machinery directive 2006/42/EC and the EN 13000! Data tag Crane with CE-marking, see illustration 1.
- Cranes that are operated outside the respective area of application of the European machinery directive do not require a CE marking. Data tag Crane without CE marking, see illustration 2.
- It is prohibited to market and operate cranes without CE marking, which do not meet the product-specific regulations valid in Europe, when a CE marking is specified for the country.
- It is prohibited to operate cranes with a tipping load utilization of 85 % within the European Union or in countries that only permit a lower tipping load utilization! The national regulations apply. These cranes may not have a CE marking!

Destined use

The destined use of the crane consists solely in vertical lifting and lowering of free and non-adhered loads, whose weight and center of gravity are known.

To do so, a hook or hook block approved by Liebherr must be reeved on the hoist rope and it may only be operated within the permissible crane configurations.

Driving with the crane, with or without an attached load is only permissible if a corresponding driving or load chart is available. The set up configurations intended for it and the safety conditions must be observed according to the corresponding crane documentation.

Any other use or any other exceeding utilization is **not** destined use.

Destined use also includes the adherence of the required safety guidelines, conditions, prerequisites, set up conditions and working steps in the crane documentation (for example: Operating instructions, load charts, erection and take down charts, job planner).

The manufacturer is **not** liable for damages, which are caused by non-destined use or improper use of the crane. Any associated risk it is carried solely by the owner, the operator and the user of the crane.

Non-destined use

Non-destined use is:

- Working outside the permissible set up configurations according to the load chart.
- Working outside the permissible boom radii and slewing ranges according to the load chart.
- Selecting load charts, which do not correspond to the actual set up configuration.
- Selection of a set up configuration via code or via manual entry, which does not correspond to the actual set up configuration.
- Working with bypassed / deactivated safety equipment, for example bypassed load torque limiter or with bypassed hoist limit switch.
- Increasing the boom radius of the lifted load after a LMB shut off, for example by diagonally pulling the load.
- Using the support pressure display as information in order to utilize the crane up to the tipping limit!
- Use of equipment parts which are not approved for the crane.
- Operation of the crane in an area exposed to explosion hazards.
- Using the crane at sports and recreational events, especially for "Bungee" jumps and / or "Dinner in the sky".
- On-road driving in non-permissible travel condition (axle load, dimension).
- Driving with the equipment in place in a non-permissible travel condition.
- Pushing, pulling or lifting loads with the level control, the sliding beams or the support cylinders.
- Pushing, pulling or lifting loads by actuating the slewing gear, the luffing gear or the telescoping gear.
- Ripping stuck objects loose with the crane.
- Utilizing the crane for a longer period of time for material handling tasks.
- Releasing the crane suddenly (grapple or dumping operation).
- Utilizing the crane when the weight of the load, which is suspended on the crane is changed, for example by filling a container suspended on the load hook, except:

- The load torque limiter was checked before for function with a known load.
- The crane cab is occupied.
- The crane is operational.
- The container size is selected in such a way that an overload of the crane with full load is eliminated within the valid used load chart.

The crane may **not** be used for:

- Attaching a stuck load for which the weight and center of gravity are not known and which is released only by flame cutting, for example.
- Letting persons drive along outside the driver's cab.
- Transporting personnel in the crane cab while driving.
- Transporting personnel with the load handling equipment and on the load.
- Transporting of persons with work baskets (cherry pickers), if the national regulations of the responsible work safety organization are not observed.
- Transporting loads and objects on the crane chassis.
- Transporting loads and objects on the crane superstructure.
- Transporting loads and objects on the boom lattice sections and / or the crane boom.
- Two hook operation without auxiliary equipment.
- Extended material handling operation.
- Crane operation on a barge if the conditions are not determined and the written release by **Liebherr Werk Ehingen GmbH** is not present.

The crane documentation must be read and used by all persons who are involved in use, operation, assembly and maintenance of the crane.

Ambient temperature

The crane is designed for an ambient temperature of -20 °C to +50 °C.

If the ambient temperature is lower than -20 °C the crane must be modified with „auxiliary equipment for working at low temperatures“.



WARNING

Working at low temperatures without the corresponding auxiliary equipment!
The crane components can be damaged and fail. The load can rip off.
Death or severe bodily injuries.

If the crane is operated at an ambient temperature lower than -20 °C:

- ▶ Make sure that the crane is equipped with the corresponding „auxiliary equipment for working at low temperatures“. Observe and adhere to the Crane operating instructions, chapter 2.08.
- ▶ Use the operating fluids for the corresponding ambient temperature in time. Observe and adhere to the Crane operating instructions, chapter 7.07.

Safety equipment

Special attention must be paid to the safety equipment built into the crane. The safety equipment must constantly be checked for functionality. The crane may not be operated if the safety equipment are not working or not working correctly.



Note

Your motto must always be:

- ▶ **Safety first!**

The crane has been built in accordance with the applicable travel operation and driving regulations and has been approved by the relevant authorities.

Equipment and spare parts



WARNING

Danger to life if original equipment parts are **not** used!

If the crane is operated with equipment parts, which are **not** original, then the crane can fail and cause fatal accidents!

Crane components can be damaged!

- ▶ Operate the crane only with original equipment parts!
- ▶ Crane operation with equipment parts, which do **not** belong to the crane is prohibited!
- ▶ If there is any doubt about the origin of equipment parts, contact Liebherr Service!



WARNING

The crane permit and the manufacturer's warranty will become void!

If any original installed parts are modified, manipulated or replaced (e.g. removal of parts, installation of non-original Liebherr parts), both the crane permit and the manufacturer's warranty will become void.

- ▶ Leave installed original parts unchanged!
- ▶ Do not remove installed original parts!
- ▶ Use only Original Liebherr spare parts!
- ▶ If there is any doubt about the origin of spare parts, contact Liebherr Service!

For ordering equipment and spare parts, always keep the crane number handy and provide it.

Definition of directional data for mobile cranes

Driving forwards: Driving with the driver's cab on the front.

Driving in reverse: Driving with the taillights of the crane chassis on the front.

Front, rear, right, left in the **driver's cab** refer to the crane chassis. The driver's cab is always in the front.

Front, rear, right, left in the **crane cab** refer to the crane superstructure. Front is always in direction of the placed down boom.

0° turning angle of the crane superstructure: The boom points in the longitudinal direction to the rear past the rear of the vehicle.

180° turning angle of the crane superstructure: The boom points in the longitudinal direction to the front past the driver's cab.

Definition of directional data for crawler cranes

Driving forward driving forward from the view of the crane operator seated in the crane cab. Turntable in 0° or 180° position.

Driving reverse driving backward from the view of the crane operator seated in the crane cab. Turntable in 0° or 180° position.

Front, rear, right, left always orient themselves on the **crawler track** from the position of the chain tension devices. The chain tension devices on the crawler track are always on the front.

Front, rear, right, left refer to the direction of view of the crane operator seated in the **crane cab**. Front is always in direction of the placed down boom.

Optional equipment and functions

The equipment marked with * and the functions are optionally available and are **not** part of the standard crane (optional equipment).

Conversion chart

	Initial unit	Multiplication factor	Target unit
Length	mm	0.03937	in
	in	25.4000	mm
	mm	0.00328	ft
	ft	304.8	mm
	cm	0.39370	in
	in	2.5400	cm
	cm	0.0328	ft
	ft	30.48	cm
	m	39.37	in
	in	0.0254	m
	m	3.281	ft
	ft	0.3048	m
	km	0.62137	mile
	mile	1.6093	km
Surface	cm ²	0.155	in ²
	in ²	6.4516	cm ²
	m²	10.764	ft²
	ft²	0.0929	m²
Volume	cm ³	0.06102	in ³
	in ³	16.387	cm ³
	m ³	35.3147	ft ³
	ft ³	0.0283	m ³
	l	0.001	m ³
	m ³	1000	l
	l	61.024	in ³
	in ³	0.016387	l
	l	0.0353	ft ³
	ft ³	28.32	l
	l	0.264178	US. liq. gal
	US. liq. gal	3.7853265	l

	Initial unit	Multiplication factor	Target unit
Mass (weight)	kg	2.20462	lb
	lb	0.45359	kg
	t	2204.62	lb
	lb	0.0004536	t
	t	1.1023	short ton US (tn. sh.)
	short ton US (tn. sh.)	0.90718	t
	t	0.45359	kip
	kip	2.20462	t
Mass / length	kg/m	0.055998	lb/in
	lb/in	17.857781	kg/m
	kg/m	0.67197	lb/ft
	lb/ft	1.48816	kg/m
Force	N	0.2248	lbf
	lbf	4.4483986	N
	kN	224.809	lbf
	lbf	0.0044483986	kN
Turning moment	Nm	8.85075	lbf·in
	lbf·in	0.112984	Nm
	Nm	0.73756	lbf·ft
	lbf·ft	1.3559	Nm
Performance	HP (DIN HP)	0.7355	kW
	kW	1.3596	HP (DIN HP)
Speed	m/s	39.37	in/s
	in/s	0.0254	m/s
	m/s	3.28084	ft/s
	ft/s	0.3048	m/s
	km/h	0.62137	mph (mi/h)
	mph (mi/h)	1.60935	km/h
	m/s	2.2369	mph (mi/h)
	mph (mi/h)	0.44704	m/s

	Initial unit	Multiplication factor	Target unit
Pressure	kPa (kN/m ²)	0.01	bar
	bar	100	kPa (kN/m ²)
	bar	14.5038	psi
	psi	0.06895	bar
	kPa (kN/m²)	0.145038	psi
	psi	6.894759	kPa (kN/m²)
	N/cm ²	1.450377	psi
	psi	0.6894759	N/cm ²
	N/m ²	0.000145038	psi
	psi	6894.759	N/m ²
	t/m ²	204.81	lbs/ft ²
	lbs/ft ²	0.0048828	t/m ²
Load-related surface	m ² /t	0.004882	ft ² /lbs
	ft ² /lb	204.81	m ² /t
Temperature	°C	([°C] · 1.8) + 32	°F
	°F	([°F] - 32) / 1.8	°C

Conversion chart

Contents

1 Description of crane

1.01 Terminology	1
1 Component overview crawler travel gear	3
2 Component overview turntable	4
3 Boom component overview	5
4 Winch component overview	6
5 Component overview derrick ballast	6
6 Ground connection	7
7 S // SL // SL(HS) // SL9-boom combinations	8
8 SLF // SL3F // SL8F3-boom combinations	10
9 SDBW/B // SLDB/BW // SL2DBW/B-boom combinations	12
10 SW // SWF-boom combinations	14
11 SDWBW/B // SDWVB/BW-boom combinations	16
12 SL2DFB/BW // SL4DFB/BW // SL5DFB/B-boom combinations	18
13 SL10DFB/B2 // SL11DB/B2-boom combinations	20
14 SL13DFB/B2 // SL14DB/B2-boom combinations	22
15 HSDBW/B // HSLDB/BW // HSL2DBW/B-boom combinations	24
16 HSDWBW/B // HSDWVB/BW-boom combinations	26
17 HSL2DFB/BW // HSL4DFB/BW-boom combinations	28
1.02 Product description	1
1 Crawler travel gear	3
2 Crane superstructure	3
1.03 Technical data	1
1 Dimensions and weights	3
2 Load handling equipment	20
3 Ground pressure	20
4 Noise emission	20
5 Vibrations	21
6 Crane speeds	21
7 Ropes	21

2 Safety

2.03 Job planning	1
1 Planning Crane operation	3
2.04 General safety technical guidelines	1
1 Dangers on the crane	3
2 Danger zone of crane	4
3 Traffic endangerment and environmental damage	5
4 Endangering air traffic	5
5 Movement on the crane	6
6 Emergency exit	6
7 Personal protective equipment	8
8 Securing persons to prevent them from falling	14

9	Rescuing the assembly personnel	16
10	Crane cab	17
11	Transport	21
12	Fastening	22
13	Heated crane components	22
14	Crane operator responsibilities	22
15	Selecting the location	24
16	Slopes and excavations	28
17	Loads on the ground due to crane operation	31
18	Support	35
19	Aligning the crane	37
20	Checking the safety measures	38
21	Safety guidelines in case of external power supply	39
22	Grounding	39
23	Working in the vicinity of transmitters	41
24	Crane operation in case of thunderstorms	42
25	Wind influences	43
26	Lifting a load with two cranes	49
27	Working ranges of several cranes overlap	51
28	Hand signals for guidance	52
29	Travel operation	60
30	Crane operation	62
31	Lifting of personnel	68
32	Securing personnel on shut off crane	70
33	Welding work on the load	72
2.04.10 Ladders		1
1	Safety guidelines	3
2	Safety signs	3
3	Ladder inspection	8
4	User guidelines	8
5	Ladder access	9
2.05 Signs on the crane		1
1	Signs	3
2.05.10 Labeling of load lifting equipment		1
1	Identifications on the hook block or load hook	3
2	Identifications on single hook or double hook	4
3	Identifications on auxiliary weights	5
2.06 Antifall guards on the crane		1
1	Personal protective equipment	3
2	Fall protection equipment on the crane chassis	5
3	Fall protection equipment on the crane operator's cab	9
4	Fall protection equipment on the crane superstructure	11
5	Fall protection equipment on the counterweight brackets	13
6	Fall protection equipment on the turntable extension	15
7	Fall protection equipment on the pivot sections and lattice mast boom	19
2.08 Working in low temperatures		1
1	Auxiliary equipment	3

2	Ambient temperatures below -20 °C	3
3	Maintenance	7
2.15 General safety technical notes for operation with ballast trailer		1
1	Safety guidelines	3
2	Inspecting tires and disk wheels	4
2.25 Crane on floating device		1
1	Non-destined use	3
2	Destined use	3
3	Floating device	3
4	Operating conditions	3
5	Crane transport on floating devices	4
6	Increased corrosion	5

3 Crane assembly

3.01 Crawler carrier assembly		1
1	Component overview crawler travel gear	3
2	Dimensions and weights	3
3	Installing the assembly supports	5
4	Assembly / disassembly of the crawler carriers with the auxiliary crane	11
5	Assembly / disassembly of the crawler carriers with SA-frame	27
6	Disassembling the assembly support	49
3.02 Turntable assembly		1
1	Turntable with Quick Connection*	3
2	Installing the turntable	7
3	Removing the turntable	11
3.03 Central ballast		1
1	Components	3
2	Central ballast combinations	5
3	Permissible central ballast assemblies	5
4	Installing the central ballast	7
5	Removing the central ballast	19
3.04 Mechanical auxiliary support		1
1	Installing the mechanical auxiliary support	3
3.05 Assembly of SA bracket		1
1	Component overview SA-frame	3
2	Attachment points SA-frame	3
3	Assemble SA-frame	5
4	Disassemble SA-frame	13
3.06 Assembly conditions		1
1	Assembly conditions for operation on crawlers	3
3.07 Assembly hoist winches		1
1	Component overview	3
2	Dimensions and weights	3
3	Assembling winch 1	5
4	Removing winch 1	13

4 Operation of crane superstructure

4.01 Operating and control instruments on the crane superstructure	1
1 Operating and monitoring instruments	3
2 Equipment in the cab	3
3 Operating units in the cab	7
4 Control units crane chassis	31
4.02 LICCON computer system	1
1 General	3
2 LICCON computer system boot up	7
3 Operating mode preselection on the LICCON computer system	7
4 Operating elements of the LICCON computer system on monitor 0	11
5 The set up program	15
6 The winch - pulley head assignment screen	39
7 The Crane operation program on monitor 0	59
8 Operating elements of the LICCON computer system on monitor 1	135
9 The Crane operation program on monitor 1	137
10 The Control parameter program	181
11 The Support program	189
12 The Working range limitation program*	205
13 The Engine monitoring program	209
14 LICCON computer system in stand-by mode	217
4.03 Crane start up and taking the crane out of service	1
1 Power supply for the crane*	3
2 Checks before start up	7
3 Work station - Crane operator's cab	15
4 Starting and stopping the engine	25
5 LICCON computer system after engine start	35
6 Load weighing and load display	41
4.04 Safety equipment	1
1 General	3
2 Quick test Crane geometry	3
3 Quick test Overload protection	3
4 LICCON computer system	3
5 Safety devices on the crane	9
4.05 Crane operation	1
1 LICCON computer system	3
2 Winch and master switch assignment to operating modes	3
3 Carrying out crane movements	5
4.06 Rope reeving	1
1 Wire ropes and rope end connections	3
2 Reeving in the hoist rope	5
3 Reeving the hook block in and out	8
4 Reeving in / reeving out the hook block, L-shaped rope end connection (LR 11000 only)	11
5 Attaching and removing the load hook*	16
6 Attaching / removing the hoist limit switch weight	19

7	Assembling / disassembling the wedge lock	21
8	Rope reeving	22
4.07 Counterweight		1
1	Component overview	3
2	Fastening points	4
3	Permissible counterweight assemblies	5
4	Installing the counterweight	6
5	Disassembling the counterweight	15
4.07.10 Turntable extension		1
1	Component overview	3
2	Fastening points	4
3	Permissible counterweight assemblies	5
4	Assembling the turntable extension	6
5	Disassembling the turntable extension	14
4.08 Working with a load		1
1	Safety guidelines	3
2	Checks before starting to work with the crane	4
3	Crane movement - Telescoping	5
4	Taking on a load	7
5	Crane operation	13
6	Crane rope pretension	15
4.10 Driving from the crane operator's cab		1
1	Prerequisites for driving / moving crawler cranes (crawler operation)	3
2	Driving with a load and / or Derrick ballast	8
3	Driving without a load and without derrick ballast	9
4	Driving uphill / downhill	11
5	Driving the crawler crane	21
4.20 Procedure for shut off of crane movements		1
1	General	3
2	Instructions for resuming crane movements for cranes with CE mark	7
3	Instructions for resuming crane movements for cranes without CE mark	55

5 Equipment

5.01 Safety technical notes for assembly and disassembly		1
1	Rope pulleys	3
2	Ropes	3
3	Control measures	4
4	Relapse cylinder	6
5	Pneumatic springs	7
6	Manual rope winches	7
7	Weights	7
8	Guy rods	8
9	Auxiliary guying	8
10	Bypassing the overload protection	9
11	Bypassing the hoist top shut-off	11
12	Pin connections	11
13	Retaining elements	14

14	Assembling / disassembling	22
15	Erecting / taking down	67
5.02 SA-frame		1
1	SA-frame	3
5.03 Boom systems		1
1	Boom components	3
2	Arrangement of intermediate sections on the boom	3
3	Auxiliary guying	7
5.05 D-boom		1
1	Components overview	3
2	Fastening points	3
3	Assembly D-boom	5
4	Disassembly D-boom	33
5.07 SW/SDW boom combination		1
1	Component overview W-boom system	3
2	Fastening points W-transport units	3
3	Assembling the W-boom system	5
4	Operating the crane	35
5	Disassembling the W-boom system	37
5.08 WV-lattice jib		1
1	Overview WV-lattice jib	3
2	Assembling the WV-boom system	5
3	Operating the crane	17
4	Disassembling the WV-boom system	19
5.10 Boom nose		1
1	Overview of boom nose components	3
2	Assembling the 36 t boom nose on the SW-end section	5
3	Erecting / taking down the boom	11
4	Crane operation	13
5	Disassembling the 36 t boom nose	15
5.13 SLF-boom combination		1
1	Component overview	3
2	Fastening points	3
3	Assembling the auxiliary jib	4
4	Operating the crane	31
5	Disassembling the auxiliary jib	33
5.13.20 SLF boom combination- fiber guy ropes		1
1	Component overview	3
2	Fastening points for the F-jib	5
3	Assembling the F-jib	9
4	Establishing the electrical connections	43
5	Checking the function of the safety equipment	44
6	Erecting the boom	45
7	Operating the crane	46
8	Disassembling the F-jib	47

5.14	Roller set	1
1	W-connector head components	3
2	SW-end section and roller set components	3
3	Combinations of boom heads / end sections with roller sets	4
4	Assembling / disassembling the roller set	5
5.17	SWF-boom combination	1
1	Component overview	3
2	Assembling SWF-boom	5
3	Operating the crane	21
4	Disassembling the SWF-booms	23
5.19	Hook blocks	1
1	Procedure in case of slack rope	3
2	Hook block overview	5
3	Installing a double hook block for single operation	7
4	Installing a double hook block for parallel operation	17
5	Single hook blocks	29
5.30	Pin pulling device	1
1	Pin pulling device	3
2	Hydraulic oil level	3
3	Pin pulling device	4
4	Pinning and unpinning the pin with pin pulling cylinder 2	6
5	Pinning and unpinning the pin with pin pulling cylinder 3	7
5.35.10	Derrick ballast - ballast trailer	1
1	Component description and general notes	3
2	Assembling the ballast trailer	9
3	Setting the ballast trailer radii	35
4	Steering programs	37
5	Driving with the ballast trailer	57
6	Crane operation with derrick ballast	71
7	Removing the ballast trailer	91
8	Emergency operation with a defective CPU	109
9	Maintenance intervals / maintenance instructions for the ballast trailer	117
5.36.10	Derrick ballast - suspended ballast	1
1	Component overview of suspended ballast	3
2	Fastening points	4
3	Derrick ballast radii and standing levels	7
4	Derrick ballast radii and standing levels - standard crane	11
5	Derrick ballast radii and standing levels - narrow track crane	14
6	Assembling	19
7	Assembling the suspended ballast guide*	20
8	Assembling the suspended ballast pallet	31
9	Ballasting the suspended ballast pallet	38
10	Function check before lifting the derrick ballast	41
11	Lifting and lowering the derrick ballast using the pull cylinders	42
12	Crane operation with derrick ballast	44
13	Crawler operation with derrick ballast	56
14	Disassembly	57

15	Setting down the suspended ballast pallet	58
16	Removing the ballast plates	59
17	Disassembling the suspended ballast pallet	61
18	Disassembling the suspended ballast guide*	67
5.38 S/SL-boom		1
1	Component overview	3
2	Fastening points	3
3	Assembling the S/SL boom	6
4	Operating the crane	41
5	Disassembling the S/SL boom	42
5.39 LD/SLD/SD-boom combination		1
1	Component overview	3
2	Fastening points	3
3	Assembling the SLD / SD-boom	6
4	Operating the crane	57
5	Disassembling the SLD / SD-boom	57
5.42 HS auxiliary jib		1
1	Auxiliary jib „HS“	3
2	Installing the auxiliary jib „HS“ on the SL-boom	5
3	Erecting the SL-boom	15
4	Operating the crane	21
5	Removing the auxiliary jib „HS“	23
5.61 Pulley cart		1
1	Overview components pulley cart	3
2	Installing / removing the pulley cart	5

6 Additional equipment

6.02 Heater / engine preheating / Air conditioning system Crane operator's cab		1
1	Heating the crane cab	3
2	Menu „Climate control settings“	3
6.05 Emergency take-down		1
1	Emergency operation	3
2	Emergency operation with assembly plate Variation 1 (V1)	9
3	Emergency operation of slewing gear(s) with assembly plate Variation 1 (V1)	15
4	Emergency operation with assembly plate(s) Variation 2 (V2)	19
5	Emergency operation slewing gear(s) with assembly plate(s) Variation 2 (V2)	29
6	Emergency operation of winch 4 (W IV) on the LR1600/2 and LR1600/2-W	33
7	Ending emergency operation	37

7 Service and maintenance

7.01 Maintenance and service - General		1
1	Technical safety instructions	3
2	Warranty and coverage	7
3	Liebherr Service	8
4	Taking an oil sample	8
5	Cleaning	9

6	Disposal	10
7.02	Maintenance intervals Crawler chassis	1
1	Maintenance and inspection schedule	3
7.02.50	Maintenance intervals ballast trailer	1
1	Maintenance and inspection schedule	3
7.03	Maintenance intervals - Crane superstructure	1
1	Maintenance and inspection schedule	3
7.03.50	Maintenance intervals - Crane boom	1
1	Maintenance and inspection schedule	3
7.04	Maintenance guidelines - Crane chassis	1
1	Servicing the travel gear	3
2	Servicing the central lubrication system of the crawler carrier	11
3	Servicing the track chain	17
4	Ladders	29
7.04.50	Ballast trailer maintenance instructions	1
1	Maintenance	3
2	Ballast trailer tires	3
3	Hydraulic hose lines	3
4	Slewing gear	3
5	Central lubrication system	5
6	Wheel drive	6
7.05	Maintenance guidelines - Crane superstructure	1
1	Crane engine	3
2	Pump distributor gear	9
3	Hydraulic system	11
4	Slewing ring connection	17
5	Central lubrication system	19
6	Hoist gear 1 to 6, illustration 1	29
7	Assembly winch, illustration 2	31
8	Slewing gear	33
9	Air dryer of the compressed air system of the crane superstructure	35
10	Electrical system - Lighting	35
7.05.50	Maintenance guidelines - Crane boom	1
1	Lattice mast boom	3
2	Rope pulleys and guide pulleys	4
3	Crane ropes	4
7.06	Fill quantities, lubrication schedule	1
1	Fill quantities	3
2	Lubrication schedule	7
7.07	Service fluids and lubricants	1
1	Specified service fluids and lubricants for Liebherr cranes	3
7.15	Procedure in case of problems	1
1	Procedure to follow in case of a problem	3

2	Carrying out error diagnostics	9
3	Measures in clear problem cases	15
4	Measures for defective components	21

8 Inspections of cranes

8.01	Periodic crane inspections	1
1	General information	3
2	Inspection of carrying crane structures, especially steel structures	4
3	Inspection of locking system of telescopic boom	79
4	Inspection of safety ropes and anchor points	81
5	Inspection of load handling equipment and assembly aids	83
6	Inspection of fastening equipment	84
7	Inspection of diaphragm reservoir	84
8	Inspection of relapse cylinders	84
9	Inspection of rope pulleys	85
10	Inspection of carrier rollers	85
11	Inspection of extension conditions of sliding beams	87
12	Inspection of the function of the overload protection	87
13	Inspecting the pin connections	87
14	Inspection of slewing ring connection	87
15	Inspection of the mounting of the load bearing equipment	88
16	Inspection of the tele extension with eccentric, illustration 1	89
17	Inspection of change over pulleys, illustration 2	90
18	Inspection of the oil and fuel tanks	90
8.03	Inspection of winches	1
1	Inspecting the hoist and retracting winches	3
2	Inspection of the auxiliary reeving winch, recovery winch and spare wheel winch	4
3	Monitoring the winches	5
8.04	Inspection of crane wire ropes	1
1	Crane ropes	3
2	Importance of inspection	3
3	Personal protective equipment	3
4	Qualification Inspection personnel	3
5	Unscheduled inspection	3
6	Intervals	4
7	Areas	4
8	Documenting inspection results	5
9	Wire ropes and rope end connections	5
10	Degree of severity	7
11	Abbreviations Rope diameter	7
12	Distortions and mechanical damage	8
13	Removal criteria Overview	8
14	Checking for broken strands	9
15	Determining the number of broken wires	9
16	Checking the rope end connection	14
17	Checking of rope diameter	14
18	Corrosion	17
19	Corkscrew-like distortion	19
20	Basket formation	20

21	Protruding, distorted insert or strand	21
22	Loop formation	22
23	Kinking or rope loops pulled closed	23
24	Buckles	24
25	Effects of heat, arcs	25
26	Combined degree of severity	25
27	Flattenings	25
28	Current checklist	28

8.05	Inspection of load hooks	1
------	--------------------------	---

1	Safety guidelines	3
2	Inspection intervals	3
3	Inspecting and monitoring the load hook	3

8.06	Inspection of hydraulic hose lines	1
------	------------------------------------	---

1	Safety guidelines	3
2	Inspection intervals	3
3	Checking the end of the service life	3
4	Inspecting the hydraulic hose lines for damage	4
5	Inspecting the hydraulic hose lines for leaks	5
6	Documenting the inspection	5
7	Replacing hydraulic hose lines	5

8.12	Inspection of safety switching on the relapse supports	1
------	--	---

1	S-boom relapse retainer	3
2	Derrick relapse retainer	5
3	W-lattice jib	7

8.14	Inspection of accumulator pressure in anti-tilt cylinder	1
------	--	---

1	Checking jib stop cylinder pressure	3
---	-------------------------------------	---

8.15	Inspection of guy rods	1
------	------------------------	---

1	Safety guidelines	3
2	Inspection intervals	3
3	Checking the guy rods	3

8.16	Inspection of fiber guy ropes	1
------	-------------------------------	---

1	Safety guidelines	3
2	Inspection intervals	4
3	Inspecting the fiber guy ropes	4

8.17	Inspection of ladders	1
------	-----------------------	---

1	Safety guidelines	3
2	Inspection intervals	3
3	Inspecting ladders	3
4	Inspection sheet and check list	3

8.90	Inspection chart for cranes	1
------	-----------------------------	---

1	Inspection chart for recurring inspections of Liebherr cranes	3
---	---	---

90 Attachment

90.01	Foreword to attachment	1
-------	------------------------	---

1	Foreword	3
---	----------	---

90.05 Update confirmation	1
1 Change confirmation form	3
2 Update confirmation	3
3 Customer information	4

1 Description of crane

LWE/LR 1600-2-008/18109-09-02/en

LWE/LR 1600-2-008/18109-09-02/en

1.01 Terminology

1	Component overview crawler travel gear	3
2	Component overview turntable	4
3	Boom component overview	5
4	Winch component overview	6
5	Component overview derrick ballast	6
6	Ground connection	7
7	S // SL // SL(HS) // SL9-boom combinations	8
8	SLF // SL3F // SL8F3-boom combinations	10
9	SDBW/B // SLDB/BW // SL2DBW/B-boom combinations	12
10	SW // SWF-boom combinations	14
11	SDWBW/B // SDWVB/BW-boom combinations	16
12	SL2DFB/BW // SL4DFB/BW // SL5DFB/B-boom combinations	18
13	SL10DFB/B2 // SL11DB/B2-boom combinations	20
14	SL13DFB/B2 // SL14DB/B2-boom combinations	22
15	HSDWBW/B // HSLDB/BW // HSL2DBW/B-boom combinations	24
16	HSDWBW/B // HSDWVB/BW-boom combinations	26
17	HSL2DFB/BW // HSL4DFB/BW-boom combinations	28

Fig.195219

LWE/LR 1600-2-008/18109-09-02/en

1 Component overview crawler travel gear

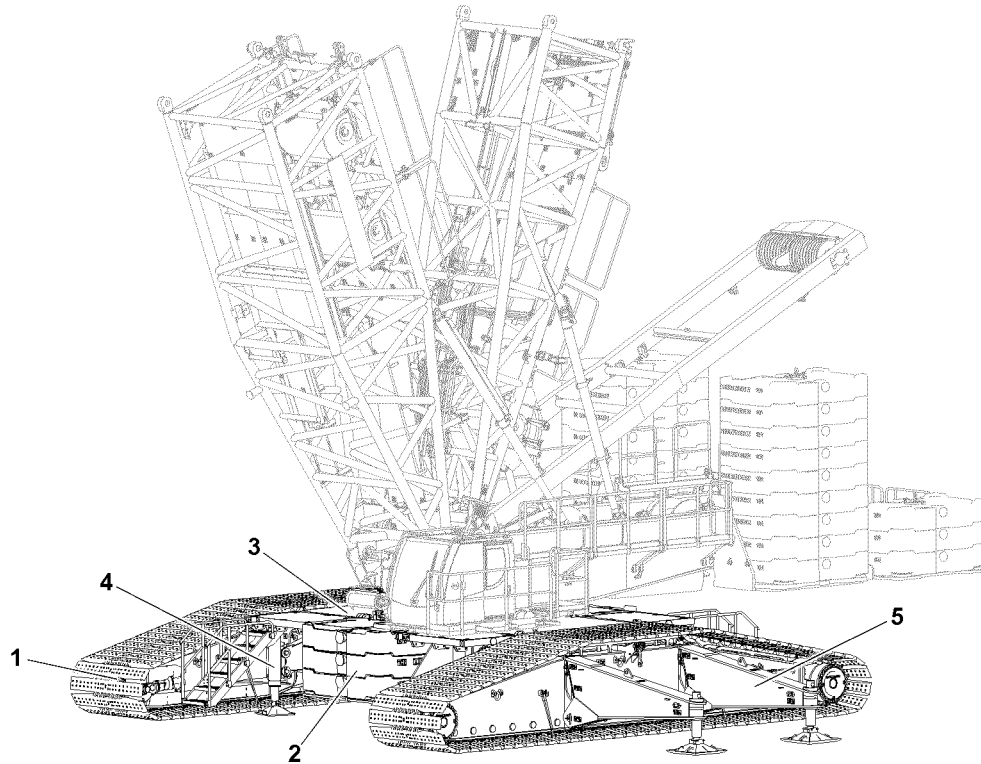

Fig.147687: Component overview crawler travel gear

- | | | | |
|---|------------------------|---|-------------------------------|
| 1 | Crawler carrier | 4 | Hydraulic assembly supports |
| 2 | Central ballast | 5 | Mechanical auxiliary supports |
| 3 | Crawler center section | | |

2 Component overview turntable

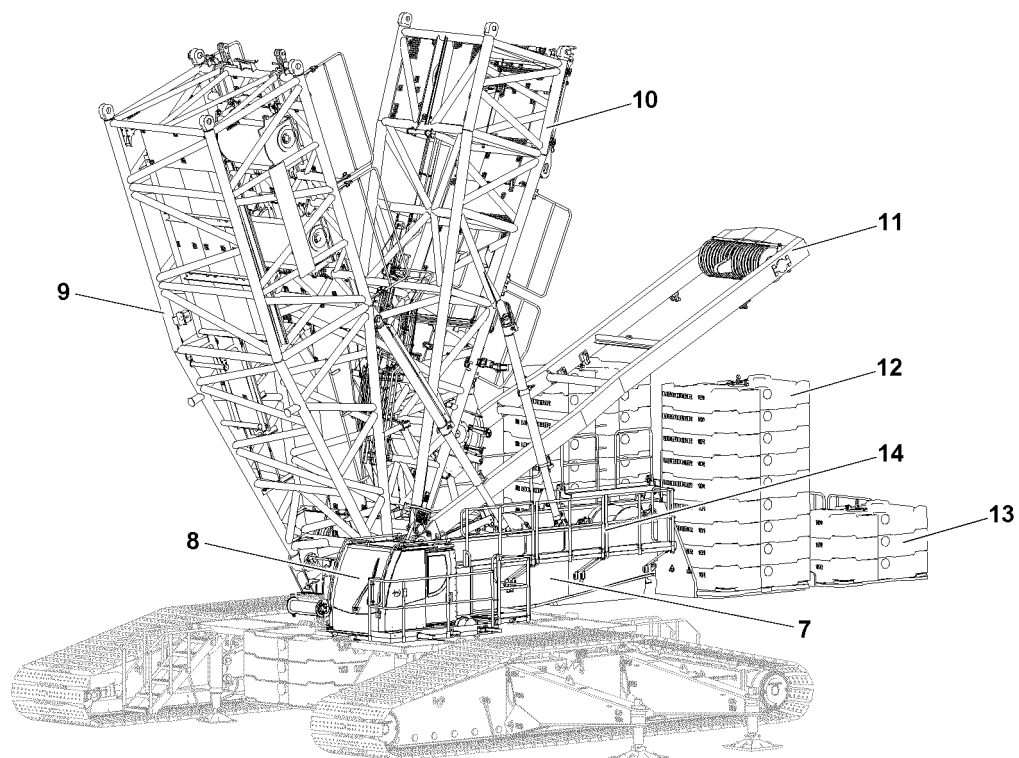

Fig.147688: Component overview turntable

- | | | | |
|-----------|----------------------|-----------|--|
| 7 | Turntable | 11 | SA-frame |
| 8 | Crane operator's cab | 12 | Counterweight |
| 9 | S-pivot section | 13 | Turntable extension with counterweight |
| 10 | D-pivot section | 14 | Turntable catwalks and railing |

3 Boom component overview

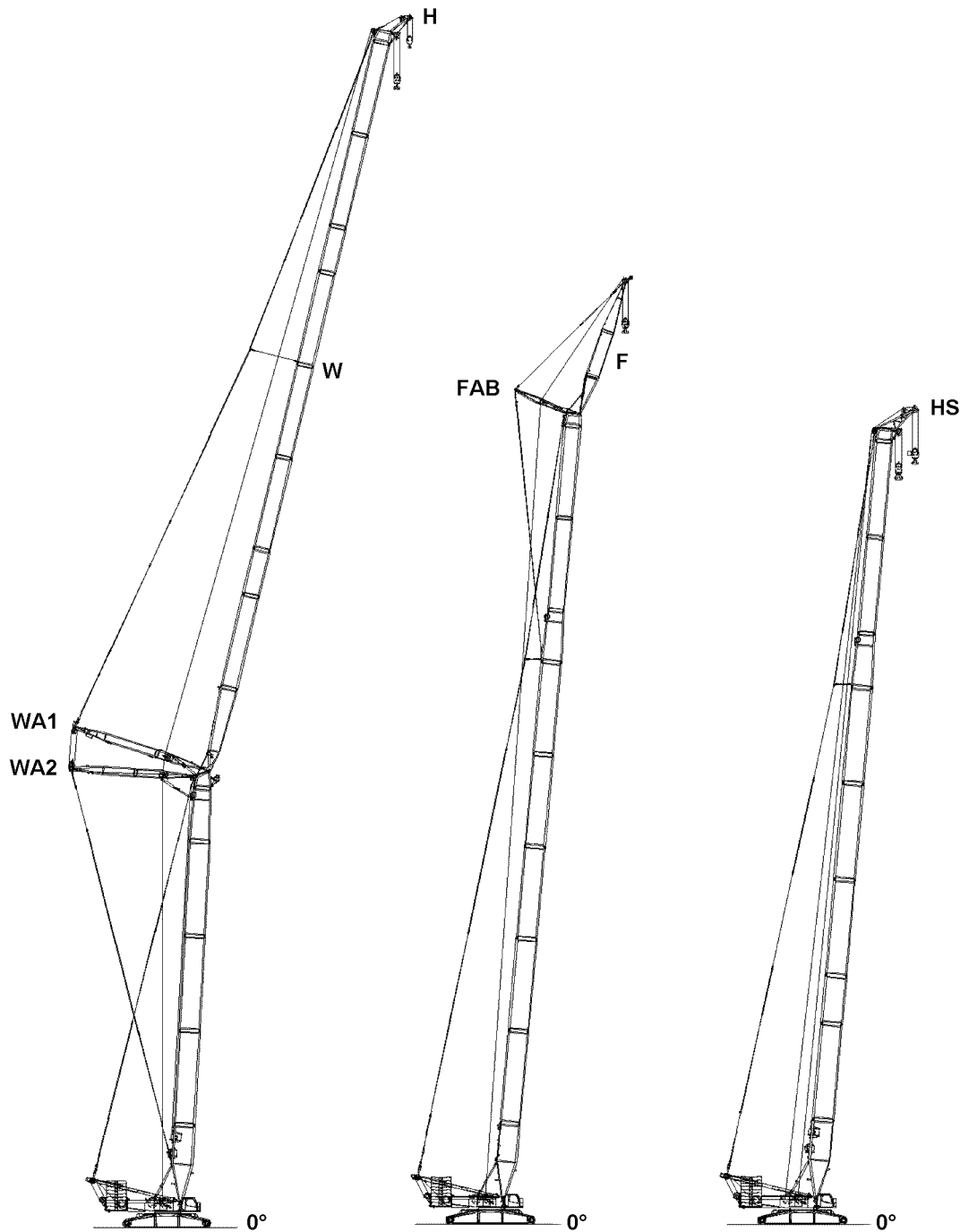

Fig.147691: Boom component overview

WA1 WA-frame 1
WA2 WA-frame 2
W Luffing lattice jib
H Boom nose

HS Auxiliary jib
FAB F-guying frame
F Fixed lattice jib

4 Winch component overview

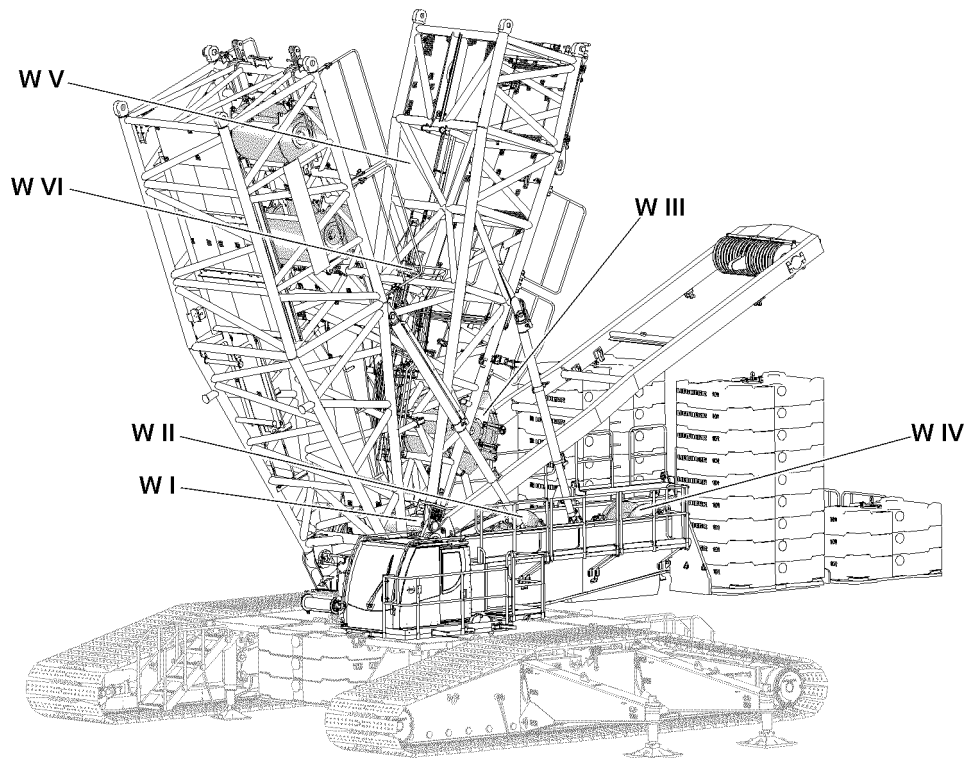

Fig.147689: Winch component overview

W I Winch 1
W II Winch 2
W III Winch 3

W IV Winch 4
W V Winch 5
W VI Winch 6

5 Component overview derrick ballast

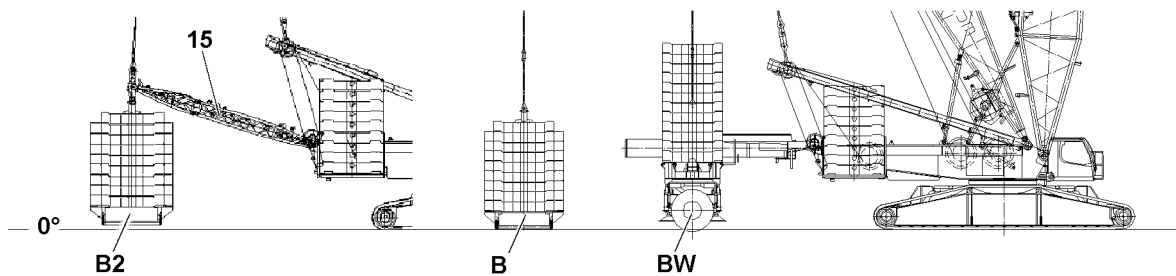

Fig.147690: Component overview derrick ballast

15 Suspended ballast guide

B2 Derrick ballast - suspended ballast with mechanical suspended ballast guide

B Derrick ballast - suspended ballast

BW Ballast trailer



Note

► The ballast trailer **BW** and the suspended ballast **B** are generally referred to as the **derrick ballast**.

6 Ground connection

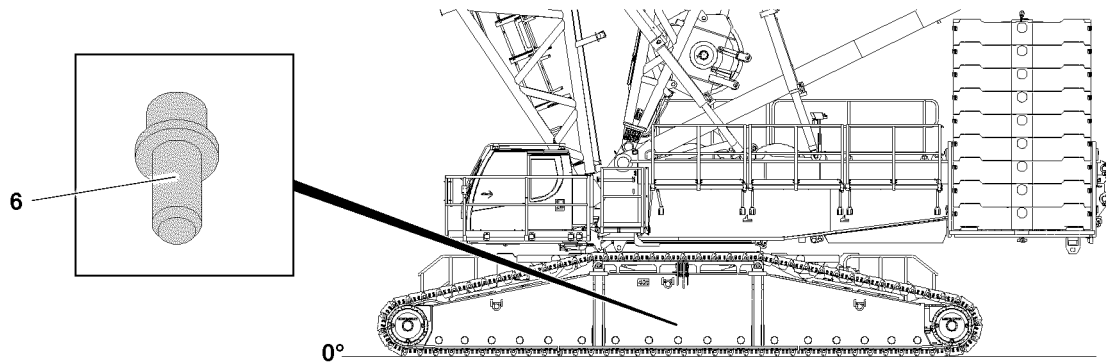

Fig.147692: Ground connection

6 Ground connection



Note

Ground the crane:

- Observe and adhere to the instructions in chapter 2.04.

7 S // SL // SL(HS) // SL9-boom combinations

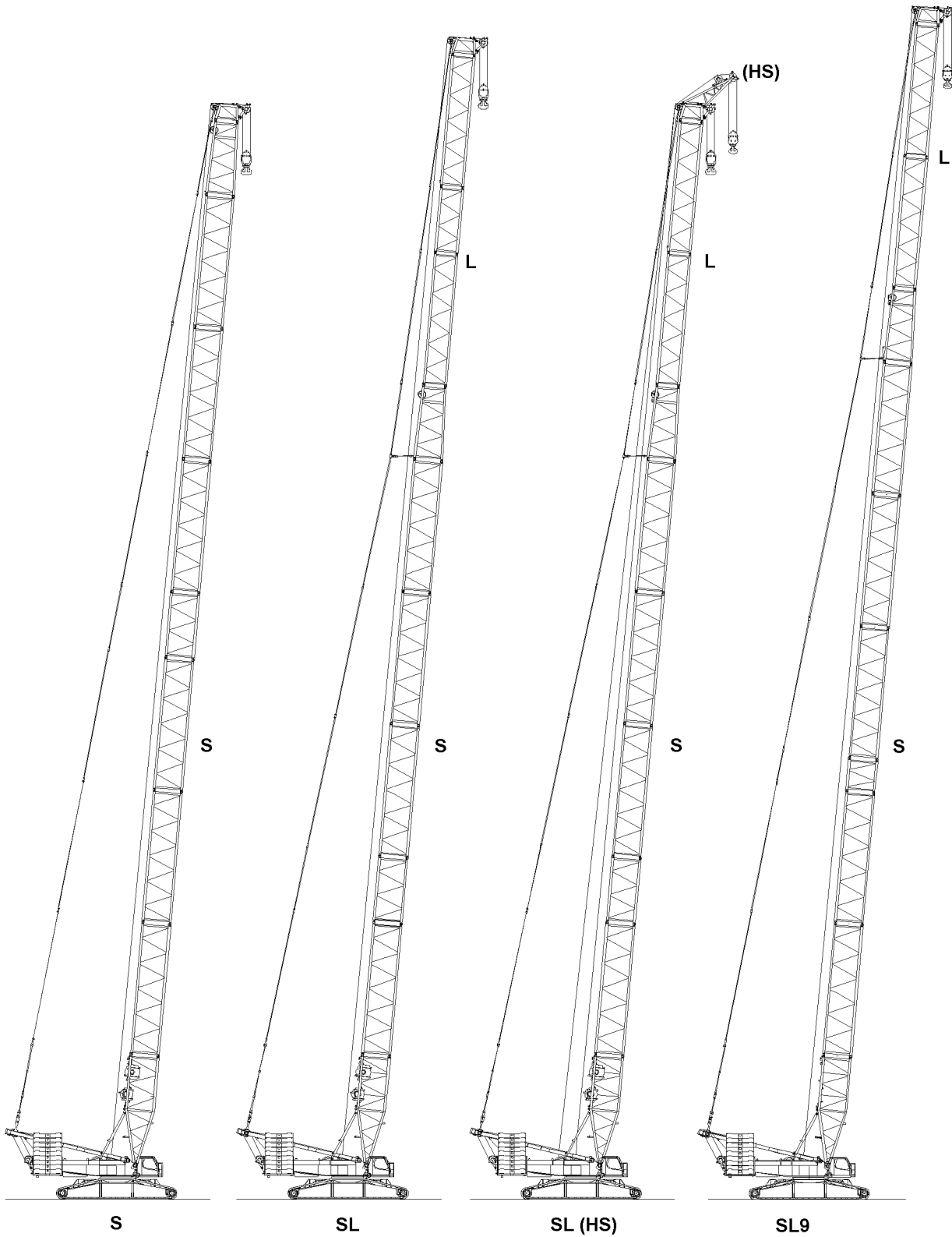

Fig.147694: S // SL // SL(HS) // SL9

LWE/LR 1600-2-008/18109-09-02/en

**WARNING**

The crane can topple over!

- ▶ Make sure that all boom systems are installed only according to the respective assembly chapters and the associated rod plans.
- ▶ Make sure that danger notes for assembly and for crane operation are observed and adhered to.
- ▶ The use of the following boom illustrations for assembly purposes is prohibited.

-
- S** Main boom
 - Heavy-duty version
 - SL** Main boom
 - Heavy-duty version, supplemented on top with light lattice sections **L**
 - SL9** Main boom
 - Heavy-duty version, supplemented on top with light lattice sections **L**
 - **SL9** Variation
 - HS** Auxiliary jib
 - Auxiliary jib with own load chart

8 SLF // SL3F // SL8F3-boom combinations

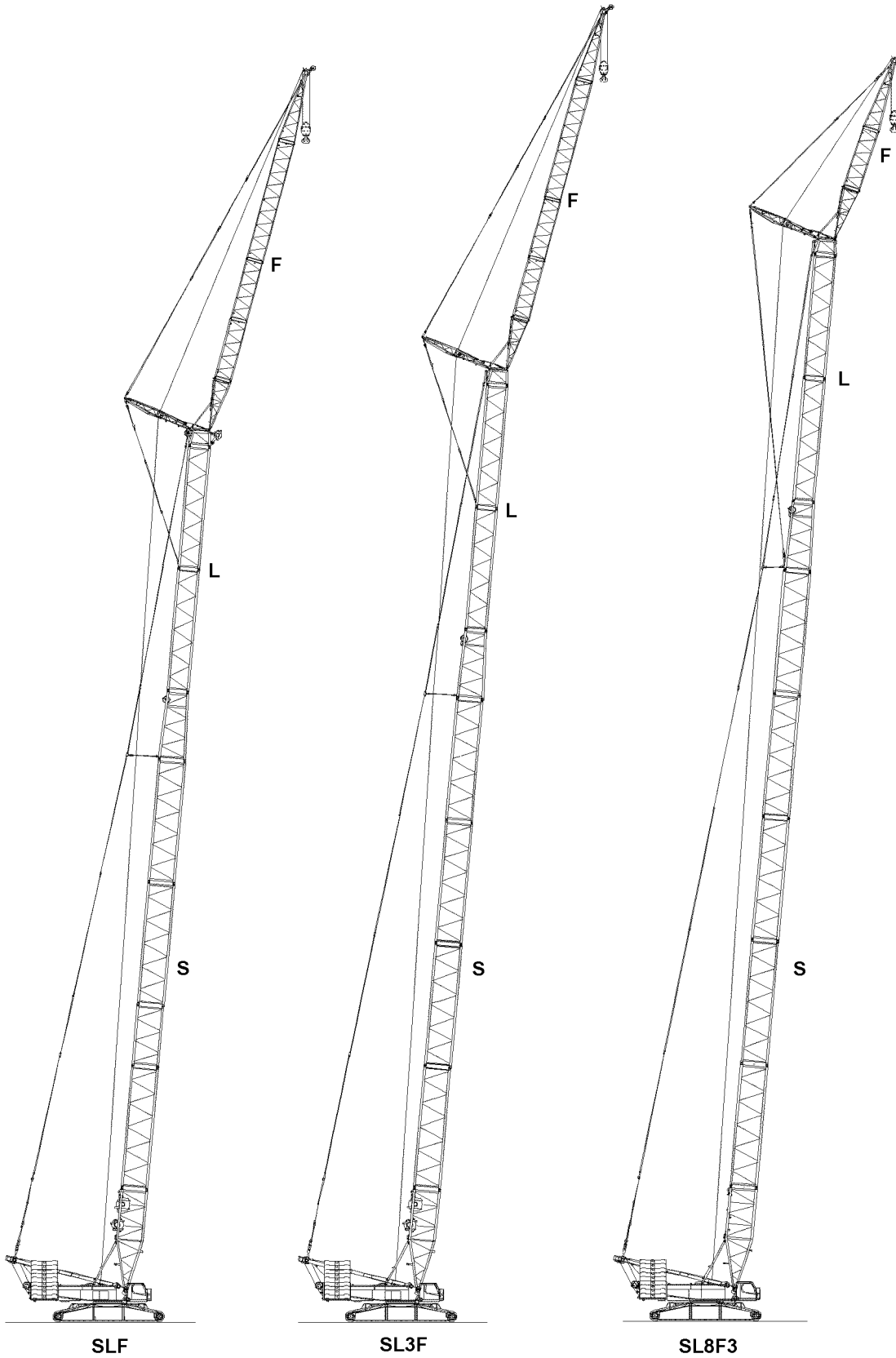

Fig.147693: SLF // SL3F // SL8F3

LWE/LR 1600-2-008/18109-09-02/en

**WARNING**

The crane can topple over!

- ▶ Make sure that all boom systems are installed only according to the respective assembly chapters and the associated rod plans.
- ▶ Make sure that danger notes for assembly and for crane operation are observed and adhered to.
- ▶ The use of the following boom illustrations for assembly purposes is prohibited.

S Main boom

- Heavy-duty version

SL Main boom

- Heavy-duty version, supplemented on top with light lattice sections **L**

SL3 Main boom

- Heavy-duty version, supplemented on top with light lattice sections **L**
- **SL3** Variation

SL8 Main boom

- Heavy-duty version, supplemented on top with light lattice sections **L**
- **SL8** Variation

F Fixed jib

- Light version

F3 Fixed jib

- With fiber guy ropes and auxiliary lugs

9 SDBW/B // SLDB/BW // SL2DBW/B-boom combinations

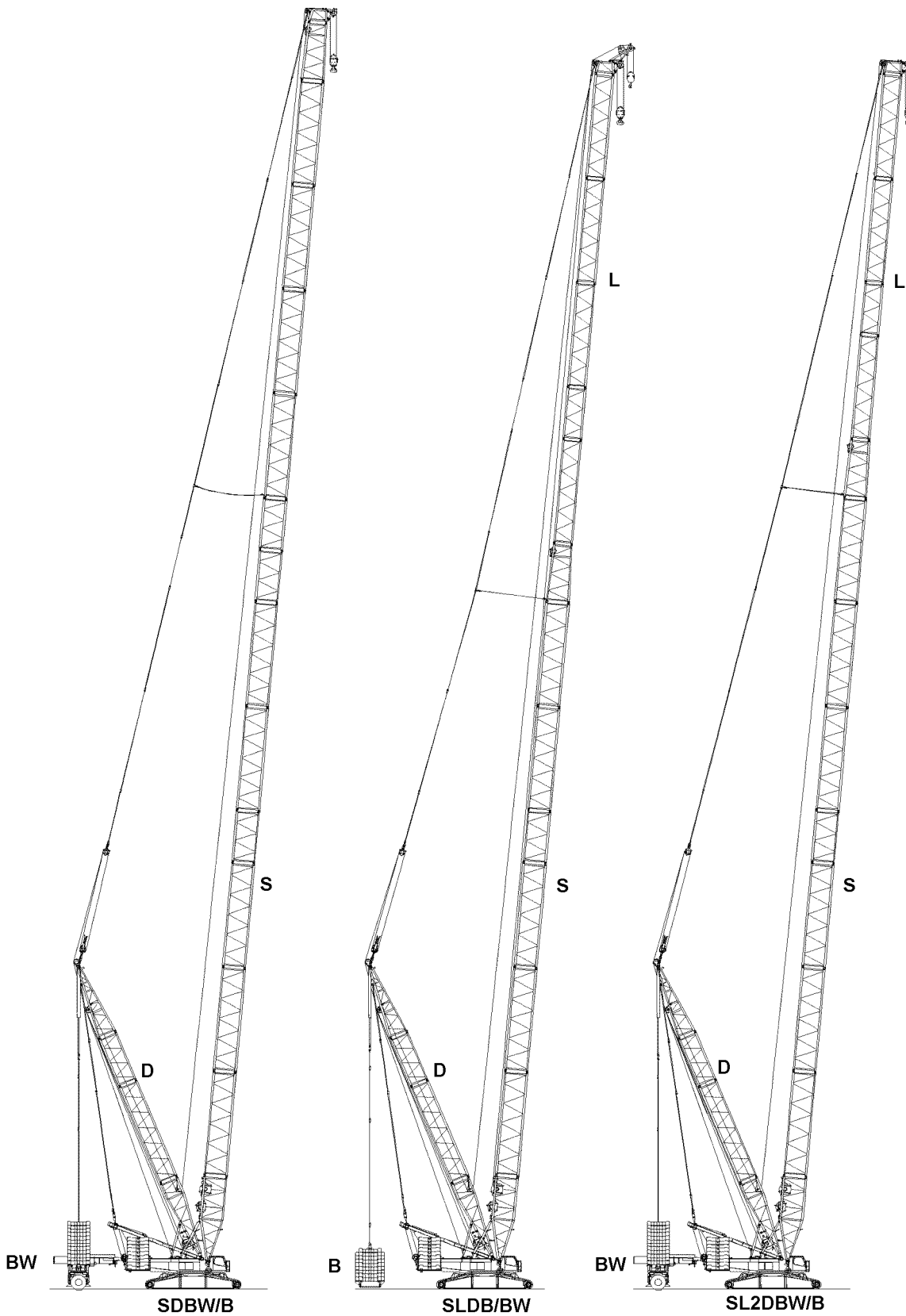

Fig.147695: SDBW/B // SLDB/BW // SL2DBW/B

LWE/LR 1600-2-008/18109-09-02/en

**WARNING**

The crane can topple over!

- ▶ Make sure that all boom systems are installed only according to the respective assembly chapters and the associated rod plans.
- ▶ Make sure that danger notes for assembly and for crane operation are observed and adhered to.
- ▶ The use of the following boom illustrations for assembly purposes is prohibited.

- S** Main boom
 - Heavy-duty version
- SL** Main boom
 - Heavy-duty version, supplemented on top with light lattice sections **L**
- SL2** Main boom
 - Heavy-duty version, supplemented on top with light lattice sections **L**
 - **SL2** Variation
- D** Derrick boom
 - Alone as assembly device or in connection with SD or SLD
- B** Suspended ballast
 - Derrick ballast
- BW** Ballast trailer
 - Derrick ballast

10 SW // SWF-boom combinations

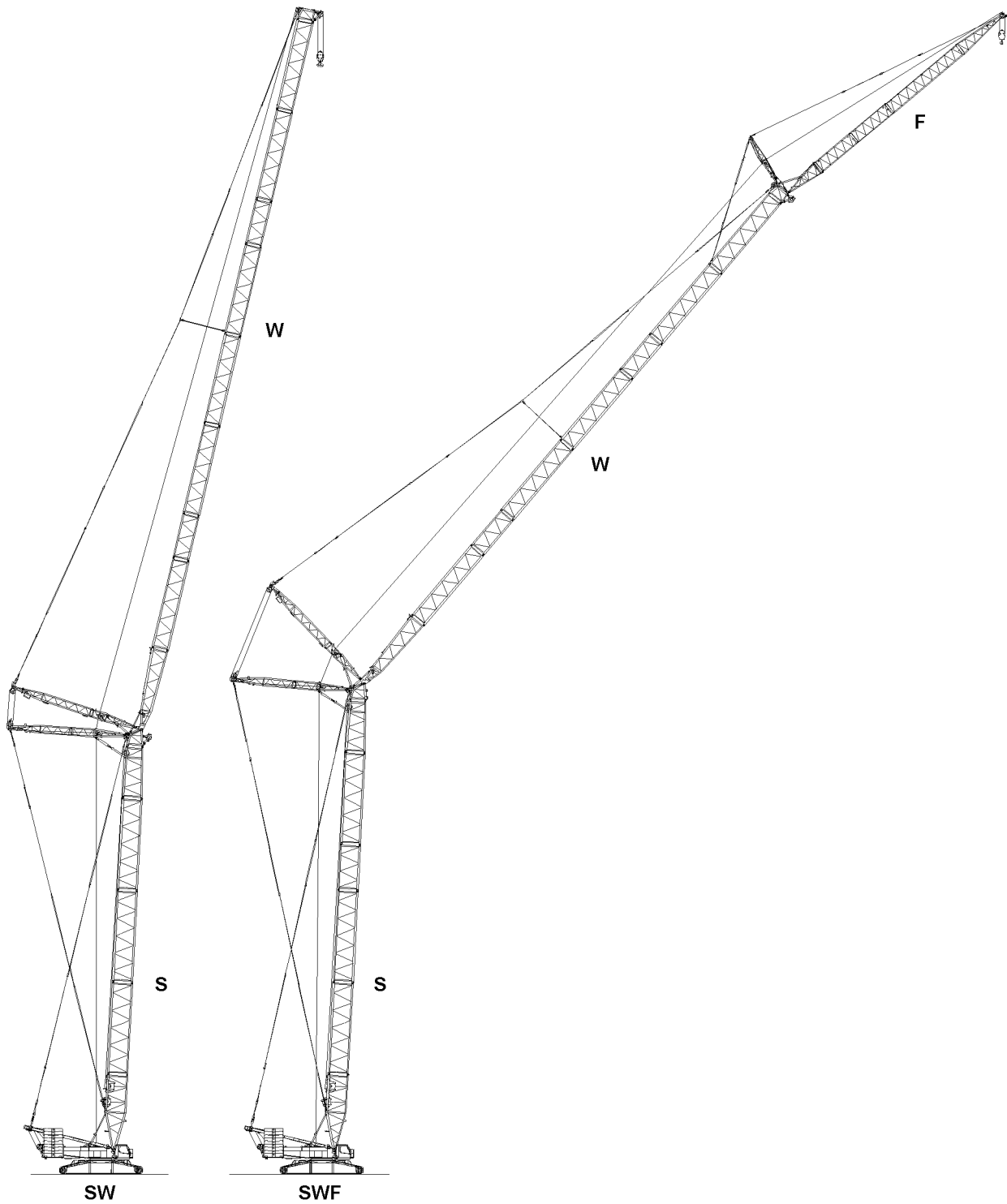

Fig.147696: SW // SWF

LWE/LR 1600-2-008/18109-09-02/en

**WARNING**

The crane can topple over!

- ▶ Make sure that all boom systems are installed only according to the respective assembly chapters and the associated rod plans.
- ▶ Make sure that danger notes for assembly and for crane operation are observed and adhered to.
- ▶ The use of the following boom illustrations for assembly purposes is prohibited.

- S** Main boom
 - Heavy-duty version
- W** Luffing jib
 - Heavy-duty version
- F** Fixed jib
 - Light version

11 SDWBW/B // SDWVB/BW-boom combinations

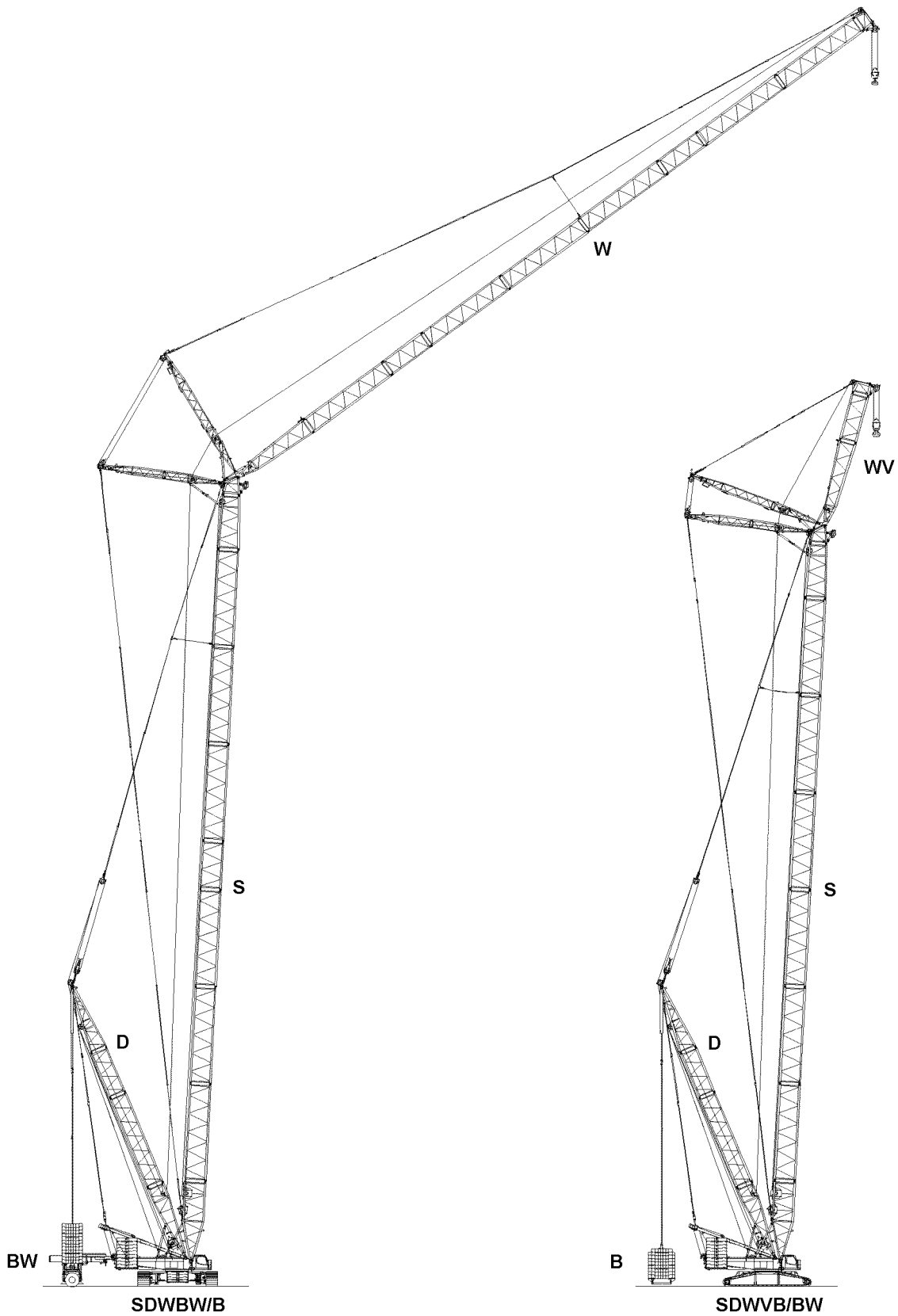

Fig.147697: SDWBW/B // SDWVB/BW

LWE/LR 1600-2-008/18109-09-02/en

**WARNING**

The crane can topple over!

- ▶ Make sure that all boom systems are installed only according to the respective assembly chapters and the associated rod plans.
- ▶ Make sure that danger notes for assembly and for crane operation are observed and adhered to.
- ▶ The use of the following boom illustrations for assembly purposes is prohibited.

- S** Main boom
 - Heavy-duty version
- D** Derrick boom
 - Alone as assembly device or in connection with SD or SLD
- W** Luffing jib
 - Heavy-duty version
- V** Fixed jib
 - Heavy-duty version
- B** Suspended ballast
 - Derrick ballast
- BW** Ballast trailer
 - Derrick ballast

12 SL2DFB/BW // SL4DFB/BW // SL5DFBW/B-boom combinations

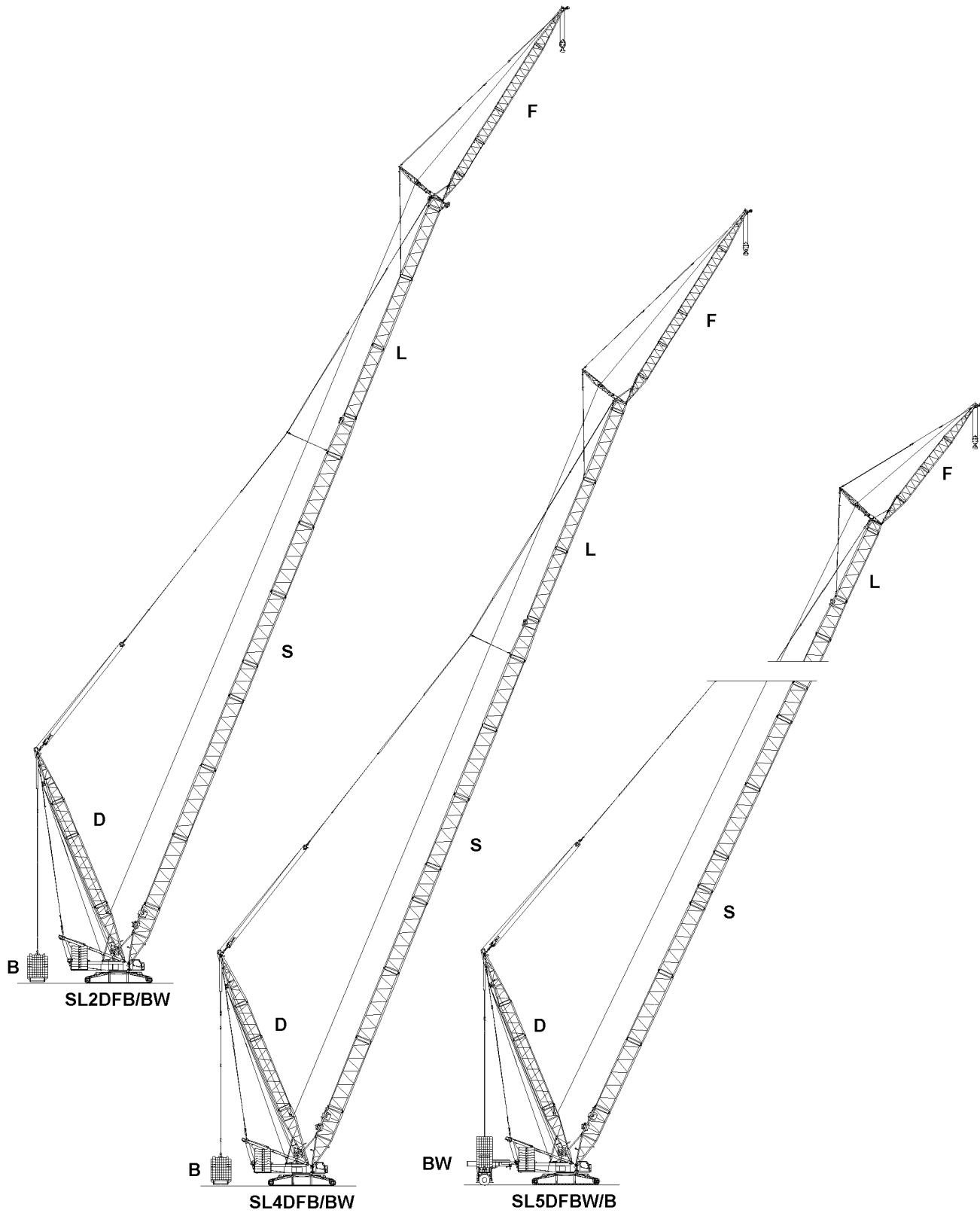

Fig.147698: SL2DFB/BW // SL4DFB/BW // SL5DFBW/B

LWE/LR 1600-2-008/18109-09-02/en

**WARNING**

The crane can topple over!

- ▶ Make sure that all boom systems are installed only according to the respective assembly chapters and the associated rod plans.
- ▶ Make sure that danger notes for assembly and for crane operation are observed and adhered to.
- ▶ The use of the following boom illustrations for assembly purposes is prohibited.

SL Main boom

- Heavy-duty version, supplemented on top with light lattice sections **L**

Main boom variations SL:

- **SL2** Main boom
- **SL4** Main boom
- **SL5** Main boom

D Derrick boom

- Alone as assembly device or in connection with SD or SLD

F Fixed jib

- Light version

B Suspended ballast

- Derrick ballast

BW Ballast trailer

- Derrick ballast

13 SL10DFB/B2 // SL11DB/B2- boom combinations

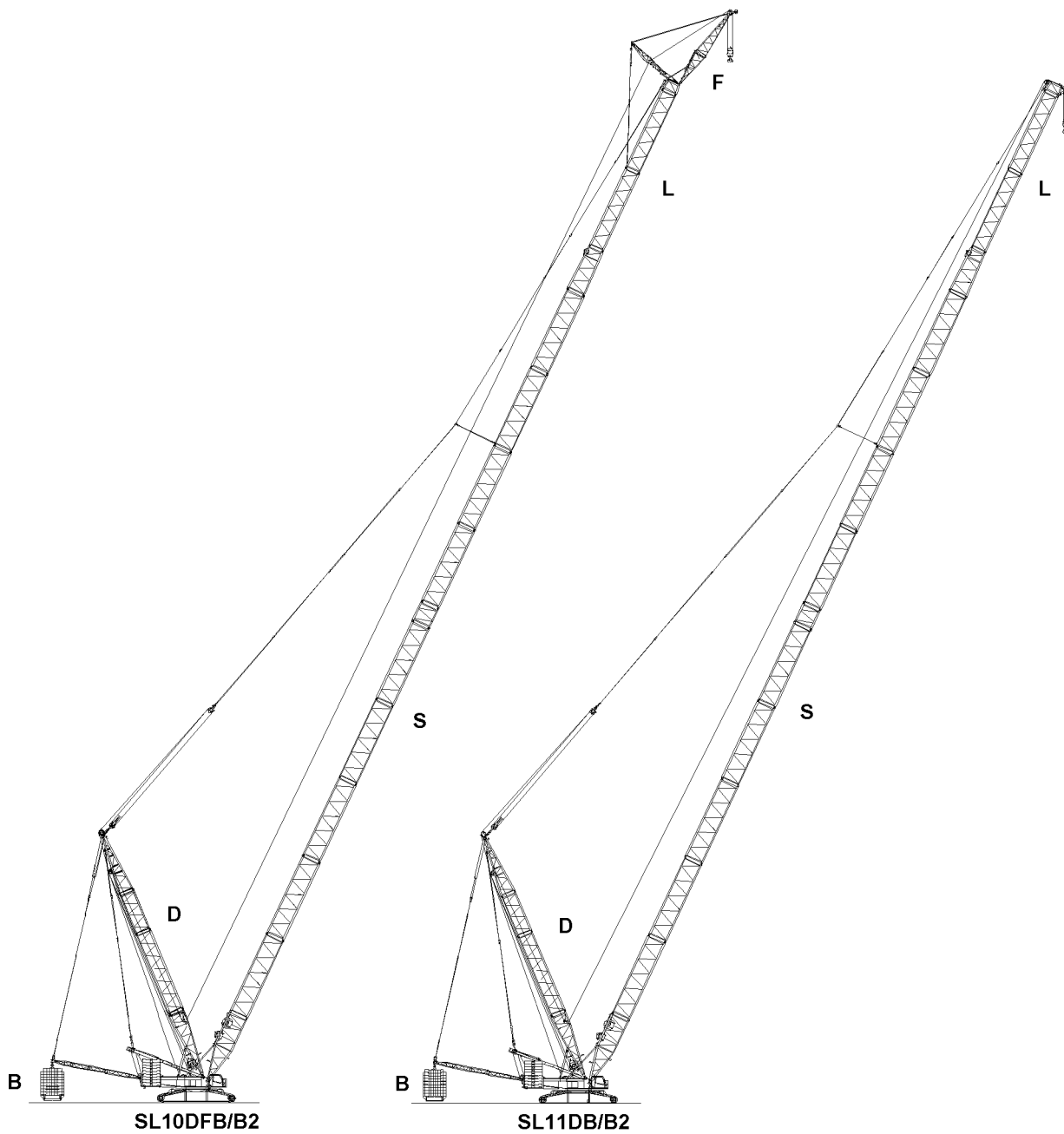

Fig.147699: SL10DFB/B2 // SL11DB/B2

LWE/LR 1600-2-008/18109-09-02/en

**WARNING**

The crane can topple over!

- ▶ Make sure that all boom systems are installed only according to the respective assembly chapters and the associated rod plans.
- ▶ Make sure that danger notes for assembly and for crane operation are observed and adhered to.
- ▶ The use of the following boom illustrations for assembly purposes is prohibited.

SL Main boom

- Heavy-duty version, supplemented on top with light lattice sections **L**

Main boom variations SL:

- **SL10** Main boom
- **SL11** Main boom

D Derrick boom

- Alone as assembly device or in connection with SD or SLD

F Fixed jib

- Light version

B Suspended ballast

- Derrick ballast

BW Ballast trailer

- Derrick ballast

14 SL13DFB/B2 // SL14DB/B2-boom combinations

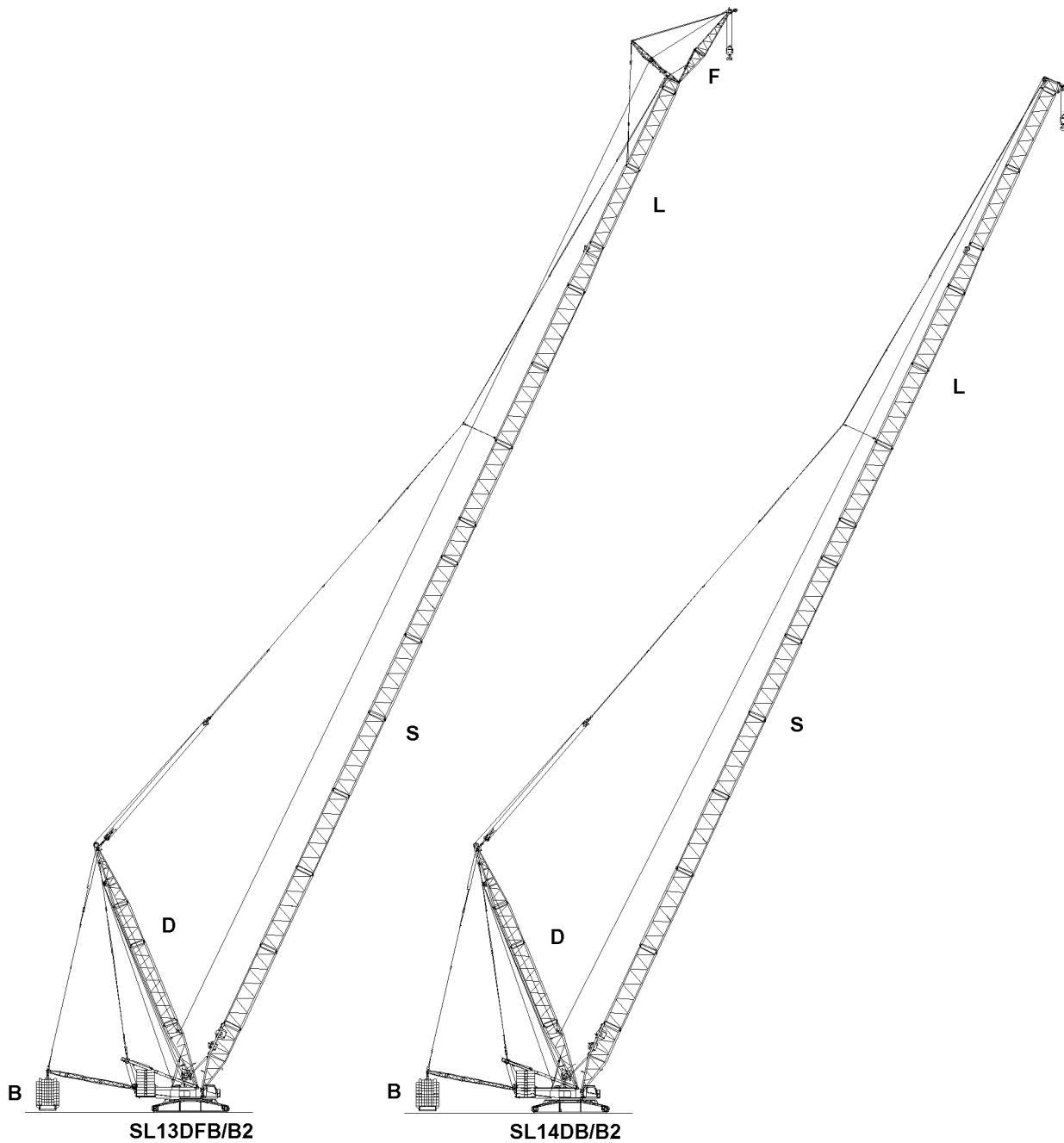

Fig.147700: SL13DFB/B2 // SL14DB/B2

LWE/LR 1600-2-008/18109-09-02/en

**WARNING**

The crane can topple over!

- ▶ Make sure that all boom systems are installed only according to the respective assembly chapters and the associated rod plans.
- ▶ Make sure that danger notes for assembly and for crane operation are observed and adhered to.
- ▶ The use of the following boom illustrations for assembly purposes is prohibited.

SL Main boom

- Heavy-duty version, supplemented on top with light lattice sections **L**

Main boom variations SL:

- **SL13** Main boom
- **SL14** Main boom

D Derrick boom

- Alone as assembly device or in connection with SD or SLD

F Fixed jib

- Light version

B Suspended ballast

- Derrick ballast

BW Ballast trailer

- Derrick ballast

15 HSDBW/B // HSLDB/BW // HSL2DBW/B-boom combinations

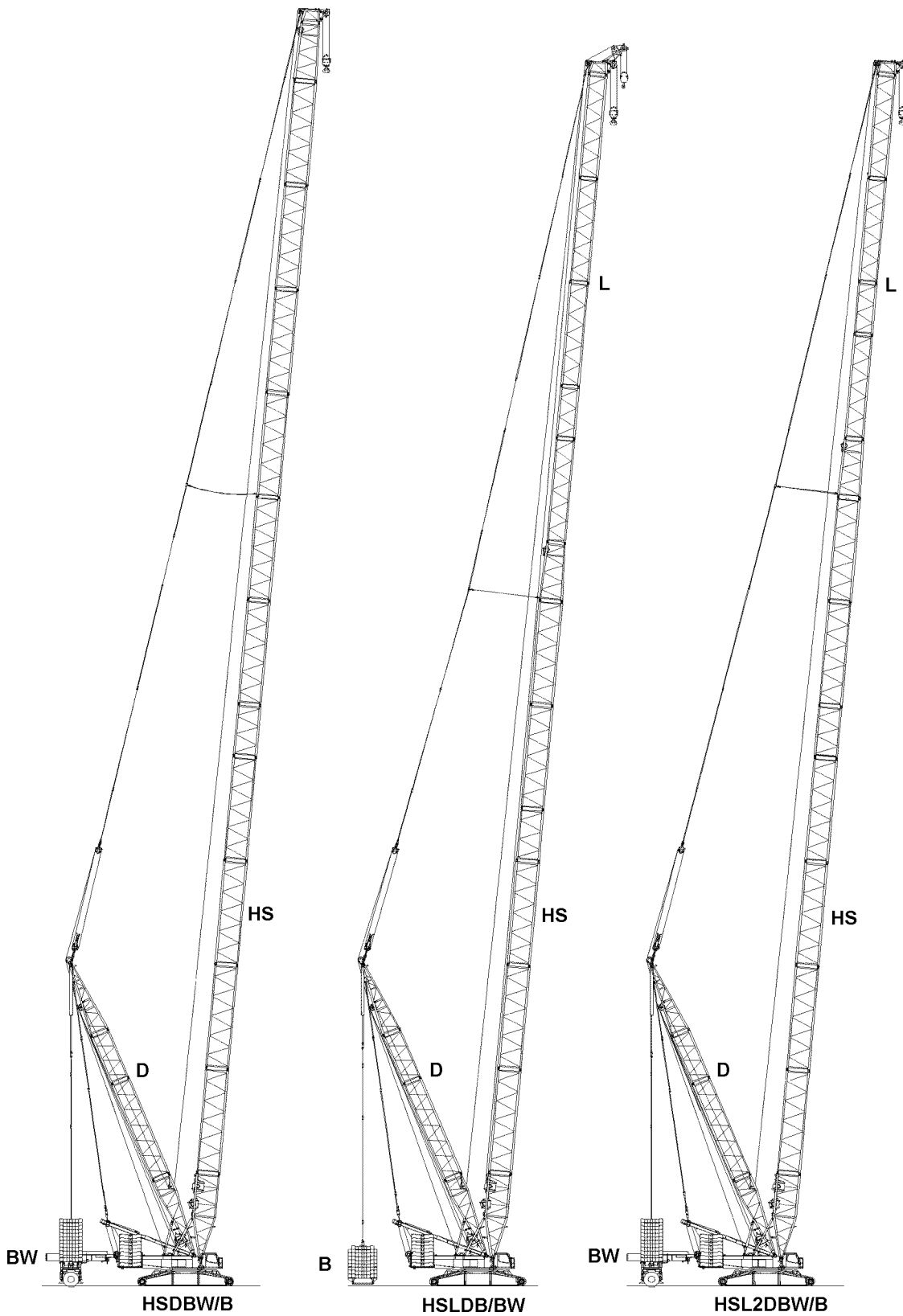

Fig.147703: HSDBW/B // HSLDB/BW // HSL2DBW/B

LWE/LR 1600-2-008/18109-09-02/en

**WARNING**

The crane can topple over!

- ▶ Make sure that all boom systems are installed only according to the respective assembly chapters and the associated rod plans.
- ▶ Make sure that danger notes for assembly and for crane operation are observed and adhered to.
- ▶ The use of the following boom illustrations for assembly purposes is prohibited.

HS Main boom

- Heavy duty version

HSL Main boom

- Heavy duty version, supplemented on top with light lattice sections **L**

HSL2 Main boom

- Heavy duty version, supplemented on top with light lattice sections **L**
- **HSL2** Variation

D Derrick boom

- Alone as assembly device or in connection with HSD or HSLD

B Suspended ballast

- Derrick ballast

BW Ballast trailer

- Derrick ballast

16 HSDWBW/B // HSDWVB/BW-boom combinations

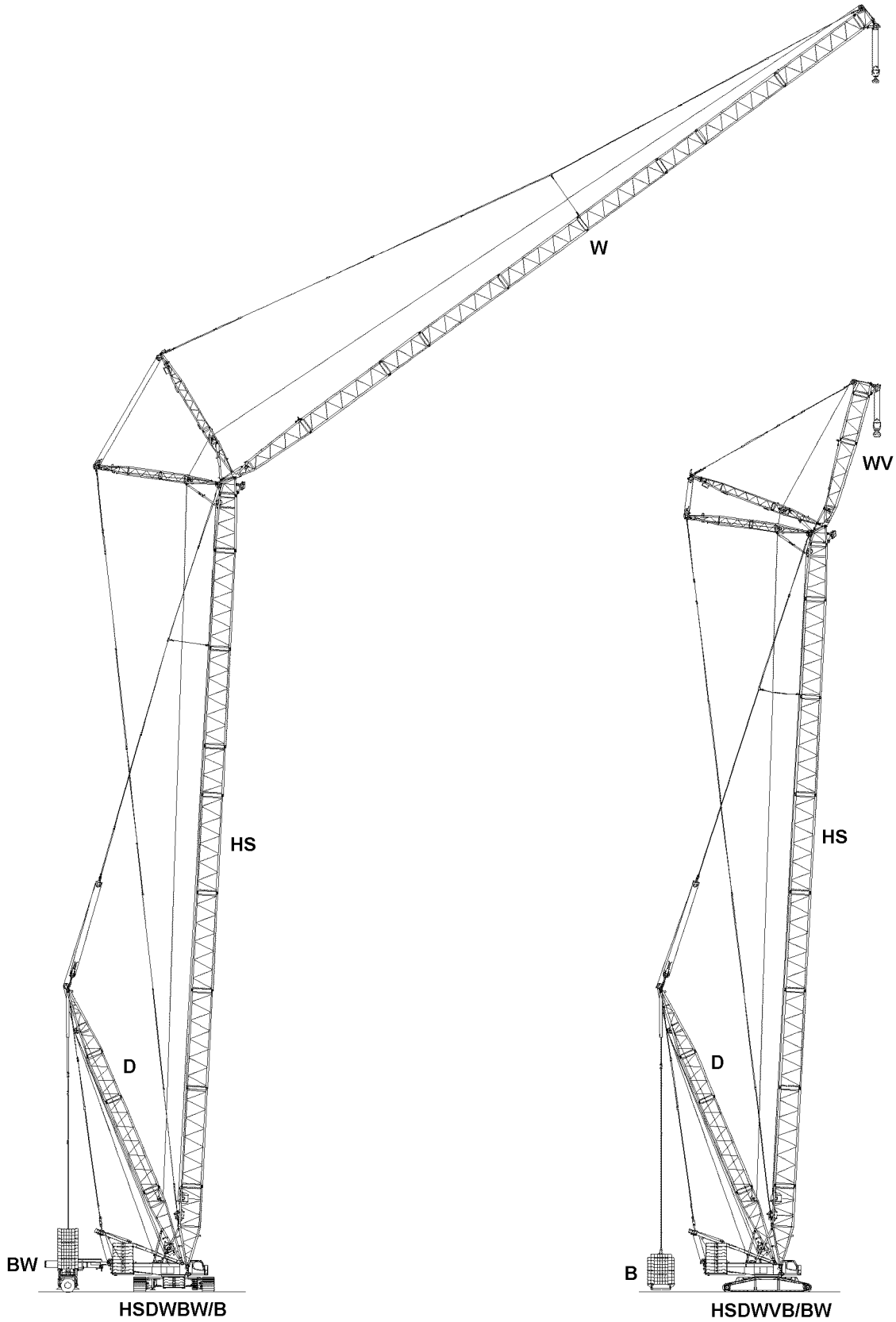

Fig.147701: HSDWBW/B // HSDWVB/BW

LWE/LR 1600-2-008/18109-09-02/en

**WARNING**

The crane can topple over!

- ▶ Make sure that all boom systems are installed only according to the respective assembly chapters and the associated rod plans.
- ▶ Make sure that danger notes for assembly and for crane operation are observed and adhered to.
- ▶ The use of the following boom illustrations for assembly purposes is prohibited.

- HS** Main boom
 - Heavy duty version
- D** Derrick boom
 - Alone as assembly device or in connection with HSD or HSLD
- W** Luffing jib
 - Heavy-duty version
- V** Fixed jib
 - Heavy-duty version
- B** Suspended ballast
 - Derrick ballast
- BW** Ballast trailer
 - Derrick ballast

17 HSL2DFB/BW // HSL4DFB/BW-boom combinations

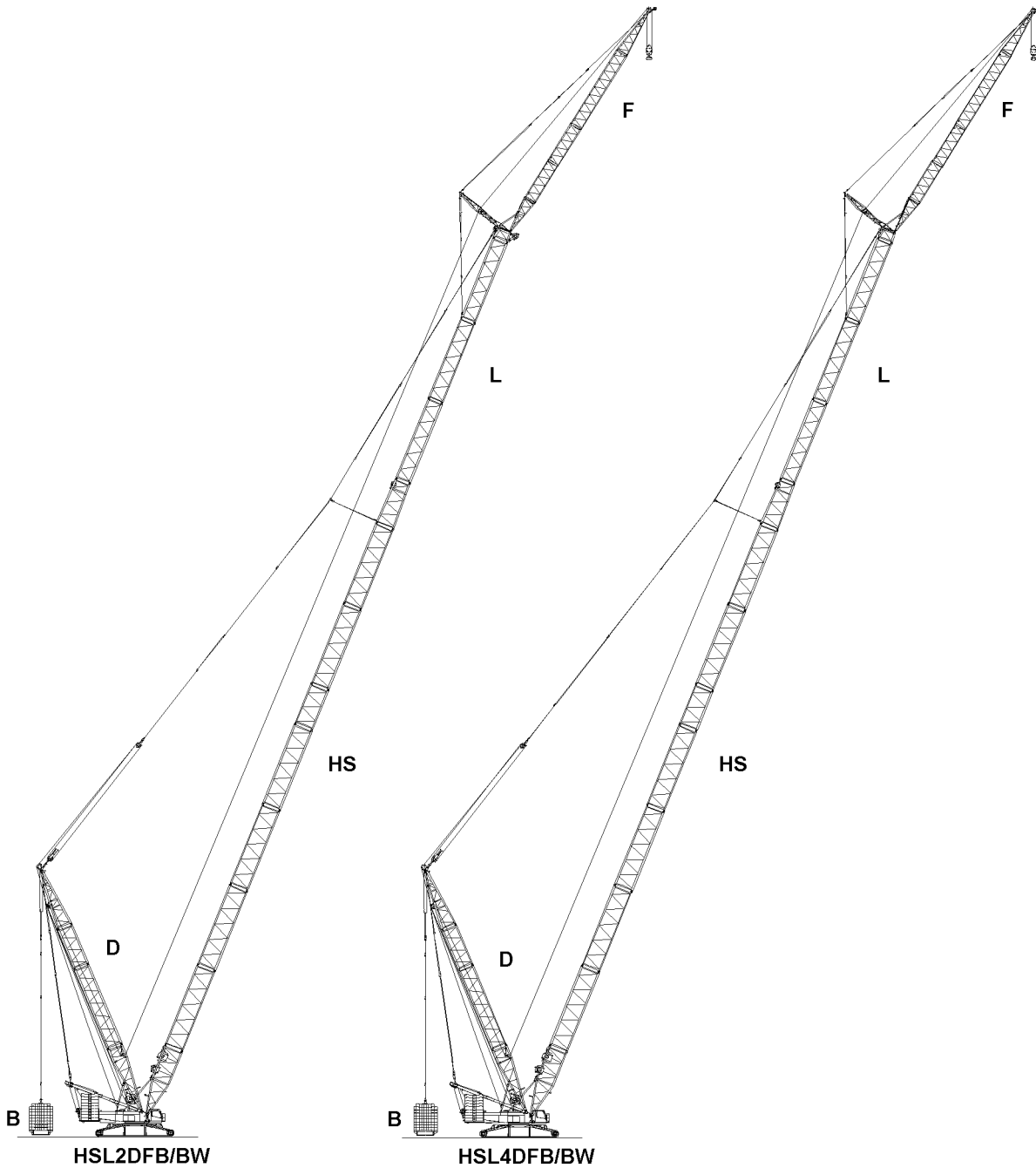

Fig.147702: HSL2DFB/BW // HSL4DFB/BW

LWE/LR 1600-2-008/18109-09-02/en

**WARNING**

The crane can topple over!

- ▶ Make sure that all boom systems are installed only according to the respective assembly chapters and the associated rod plans.
- ▶ Make sure that danger notes for assembly and for crane operation are observed and adhered to.
- ▶ The use of the following boom illustrations for assembly purposes is prohibited.

HSL Main boom

- Heavy duty version, supplemented on top with light lattice sections **L**

Main boom variations HSL:

- **HSL2** Main boom
- **HSL4** Main boom

D Derrick boom

- Alone as assembly device or in connection with HSD or HSLD

F Fixed jib

- Light version

B Suspended ballast

- Derrick ballast

BW Ballast trailer

- Derrick ballast

Empty page!

LWE/LR 1600-2-008/18109-09-02/en

1.02 Product description

1	Crawler travel gear	3
2	Crane superstructure	3

Fig.195219

LWE/LR 1600-2-008/18109-09-02/en

1 Crawler travel gear

1.1 Frame

In-house manufactured, distortion-resistant welded structure made from high-strength, close-grained structural steel.

The crawler carriers can be removed and can be installed / removed by the crane itself.

1.2 Tracks

Maintenance free, dirt protected crawler track with flat track pads.

Pad width: 1.5 m

Track width: 8.4 m

1.3 Drive

Hydraulic travel drives with planetary gears.

The crawler chains can be controlled independently and in the opposite direction.

There is no preferred travel direction.

1.4 Travel power

Stepless speed from 0 km/h to 1.09 km/h.

2 Crane superstructure

2.1 Frame

In-house manufactured, distortion-resistant welded structure made from high-strength, close-grained structural steel.

Connection to crawler travel gear via 3-row roller rotary connection, slewable by 360°.

2.2 Diesel engine

- Number of cylinders: 6
- Make: LIEBHERR
- Water cooled



Note

- ▶ Depending on one of the respective crane configurations, one of the following engine types is installed on the crane, see also separate Diesel engine operating instructions!

2.2.1 Engine type D 846 A7

Performance: 370 KW at 1900 rpm

Maximum torque: 2355 Nm at 1500 rpm.

2.2.2 Engine type D 856 A7 SCR

Performance: 390 KW at 1900 rpm
Maximum torque: 2503 Nm at 1350 rpm.

2.3 Crane drive

Hydraulic via pump distributor gear with four axial piston pumps with power regulation, closed oil circuits.

Axial piston pumps in open circuit for luffing and telescoping.

2.4 Crane control

Servo control with electronic synchronous run device, energy recycling when lowering the load.

All movements are carried out independently of each other via joysticks.

2.5 Winches

Two winches as hoist and intake gear hydraulically driven via axial piston pumps and planetary gears.

Disk brakes spring loaded and hydraulically vented.

2.6 Slewing gear

Hydraulically driven via axial piston pumps and planetary gears.

Disk brakes spring loaded and hydraulically vented.

Slewing speed steplessly regulated from 0 rpm to 0.95 rpm.

2.7 Crane operator's cab

Steel plate design with safety glass, can be swung out to the side and inclined to the rear with operating and control instruments.

2.8 Counterweight

190.0 t , consists of: Two consoles 2 x 5.0 t and 18 counterweight plates with each 10.0 t.

2.9 Safety systems

LICCON overload system, hoist limitation, electronic incline display, safety valves against pipe and hose bursts.

2.10 Electrical system

24 Volt direct current, 2 batteries with 143 Ah each.

1.03 Technical data

1	Dimensions and weights	3
2	Load handling equipment	20
3	Ground pressure	20
4	Noise emission	20
5	Vibrations	21
6	Crane speeds	21
7	Ropes	21

Fig.195219

LWE/LR 1600-2-008/18109-09-02/en

1 Dimensions and weights

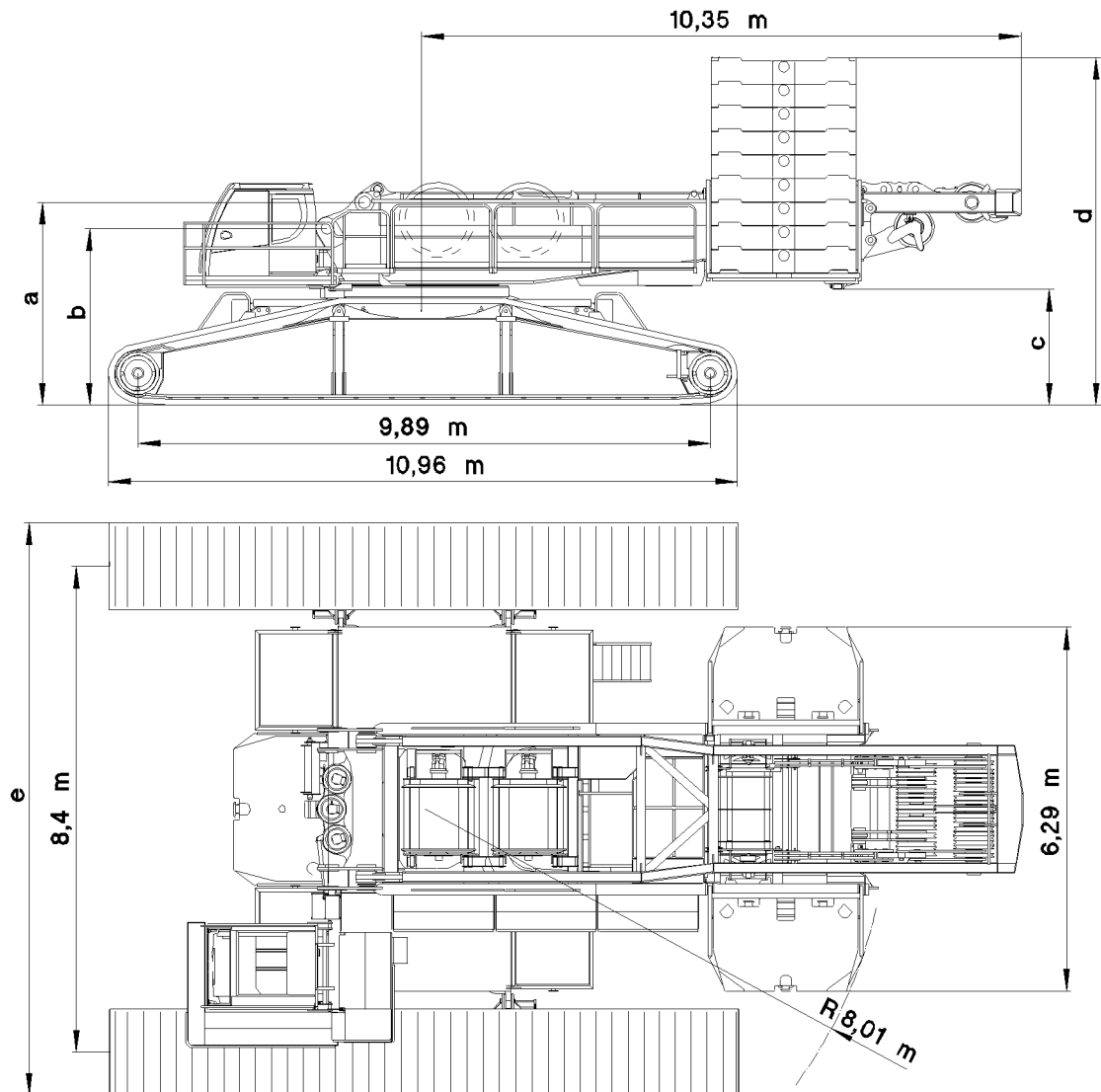

Fig.126805



Note

- ▶ The following listed weights are reference values and may not match your crane exactly.
- ▶ The illustrations of crane components / crane parts are examples and may not apply exactly to your crane.



WARNING

Danger of accidents when handling crane components / crane parts!

- ▶ Make sure that the actual weight is known before fastening crane components / crane parts.
- ▶ Check the weight label on the crane components / crane parts.
- ▶ Fasten crane components / crane parts only with approved and sufficiently load bearing fastening equipment.
- ▶ Make sure that crane components / crane parts are fastened only on the intended fastening points.

1.1 Lengths of crawler track with superstructure

Component	a	b	c	d
Crawler track with Quick Connection	3.8 m	3.4 m	2.3 m	6.3 m
Crawler track without Quick Connection	3.5 m	3.1 m	2.0 m	6.0 m

Component	Track pad width	e
Crawler travel gear	1.5 m	9.9 m
Crawler travel gear	2.0 m	10.4 m

1.2 Crawler carrier

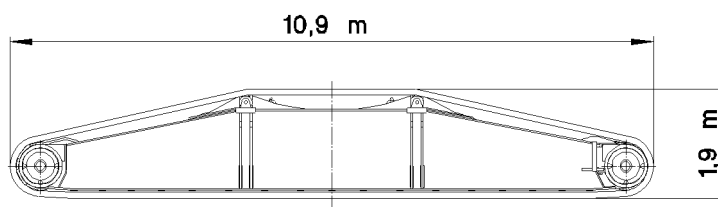

Fig.119973: Crawler carrier

Component	Track pad width	Weight	Width
Crawler carrier with two travel drives	1.5 m	35.0 t	1.8 m
Crawler carrier with two travel drives	2.0 m	38.0 t	2.0 m

1.3 Mechanical auxiliary support

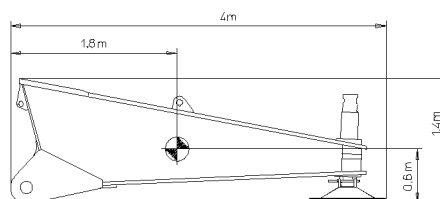

Fig.119974: Mechanical auxiliary support

Component	Weight	Width
Mechanical auxiliary support	2.3 t	0.9 m

1.4 Crawler center section

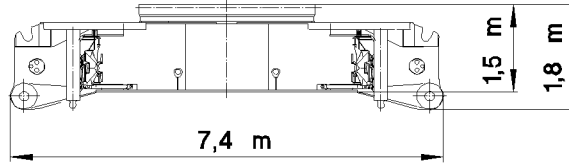

Fig.119975: Crawler center section

Component	Weight	Width
Crawler center section	27.5 t	3.0 m

1.5 Turntable with Quick Connection

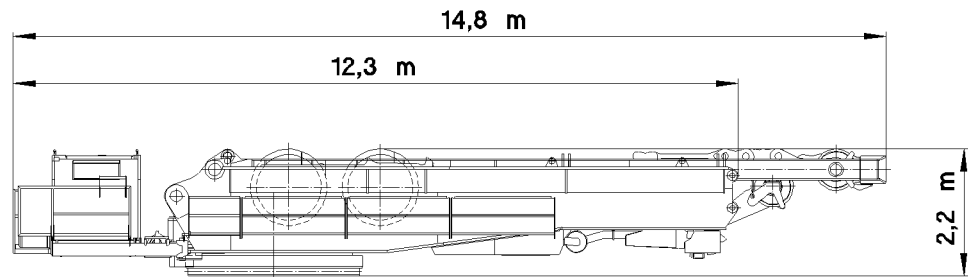

Fig.119976: Turntable with Quick Connection

For the weight data of assembly connections the following is valid:

- Including 3 slewing gears
- Winches including ropes
- SA-frame with pulley set

Component	Weight	Width
Turntable with winch 1, winch 2 and winch 4 and SA-frame	64.5 t	3.0 m
Turntable with winch 1, winch 2, without winch 4, and SA-frame	47.5 t	3.0 m

LWE/LR 1600-2-008/18109-09-02/en

1.6 Turntable with crawler center section

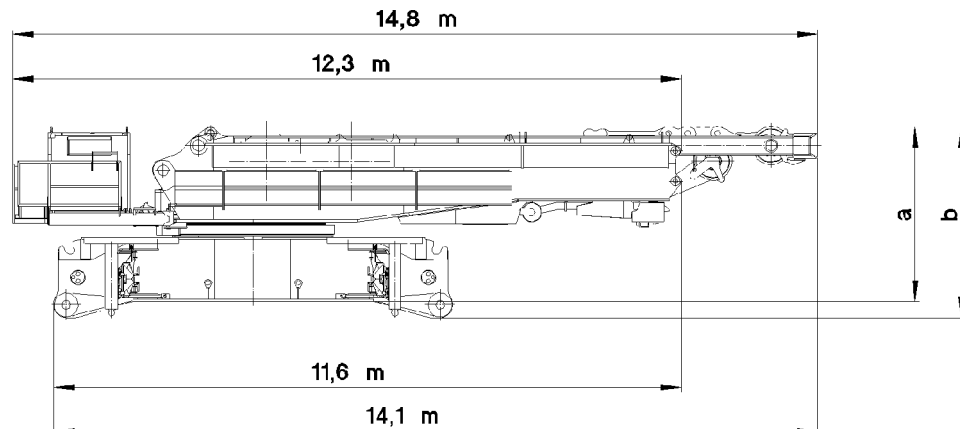

Fig.119977: Turntable with crawler center section

For the weight data of assembly connections is valid on principle:

- Including 3 slewing gears
- Winches including ropes
- SA-frame with pulley set

Component	Weight	Width
Turntable with SA-frame and winch 4 with rope With crawler center section and assembly support Without winch 1 and winch 2	75.1 t	3.0 m
Turntable without SA-frame With crawler center section and assembly support Without winch 1, winch 2 and winch IV	57.6 t	3.0 m

Component	a	b
Turntable, crawler center section without Quick connection	3.2 m	3.5 m
Turntable, crawler center section with Quick connection	3.5 m	3.8 m

1.7 SA-frame

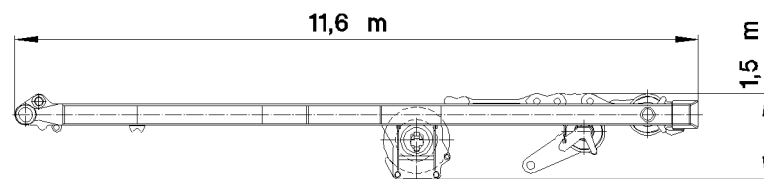

Fig.119978: SA-frame

Component	Weight	Width
SA-bracket with winch 4 including rope and pulley set.	17.0 t	2.7 m

1.8 Winch 1

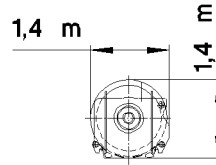

Fig.119979: Winch 1

Component	Weight	Width
Winch 1 with rope	7.5 t	2.0 m

1.9 Winch 2

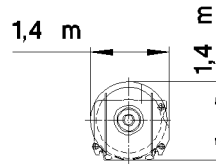

Fig.119980: Winch 2

Component	Weight	Width
Winch 2 with rope	7.5 t	2.0 m

1.10 Central ballast bracket

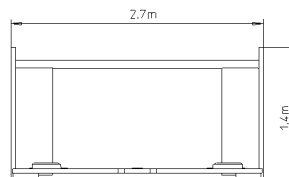

Fig.120039: Central ballast bracket

Component	Weight	Width
Central ballast bracket	2.5 t	2.0 m

LWE/LR 1600-2-008/18109-09-02/en

1.11 Counterweight bracket

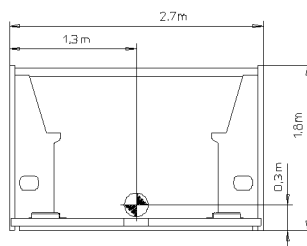

Fig.120040: Counterweight bracket

Component	Weight	Width
Counterweight bracket	5.0 t	1.8 m

1.12 Ballast plate for central ballast / counterweight / derrick ballast

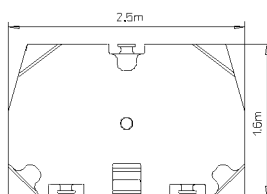

Fig.120041: Ballast plate for central ballast / counterweight / derrick ballast



Note

► The ballast plates are used as central ballast, counterweight and as derrick ballast.

Component	Weight	Thickness
Ballast plate	10.0 t	0.5 m
Ballast plate	7.5 t	0.4 m

1.13 S-pivot section 10 m

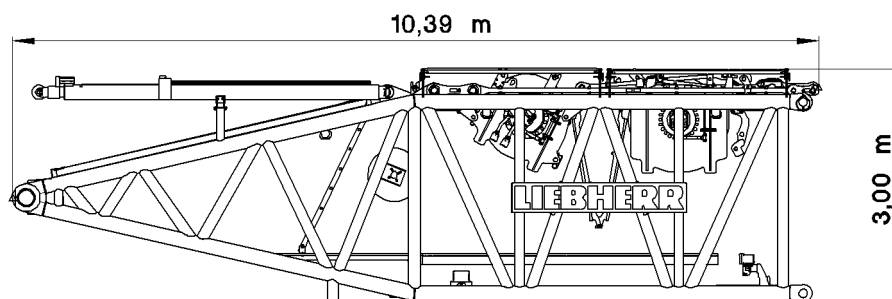

Fig.120042: S-pivot section 10 m

Component	Weight	Width
S-pivot section complete ¹⁾	25.5 t	3.0 m
S-pivot section complete ²⁾	26.5 t	3.0 m

- 1) Winch 6 with rope (rope diameter 25 mm)
- 2) Winch 6 with rope (rope diameter 28 mm)

1.14 S-intermediate section 3 m

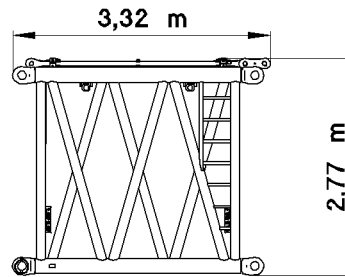

Fig.120043: S-intermediate section 3 m

Component	Weight	Width
S-intermediate section 3 m 2825.25	3.0 t	3.0 m

1.15 S-intermediate section 6 m

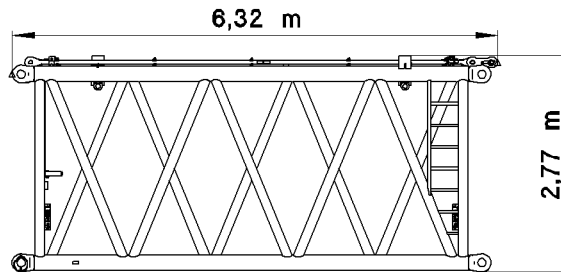

Fig.120044: S-intermediate section 6 m

Component	Weight	Width
S-intermediate section 6 m 2825.25	5.3 t	3.0 m
S-intermediate section 6 m 2825.20	4.6 t	
S-intermediate section 6 m 2825.16	4.4 t	

LWE/LR 1600-2-008/18109-09-02/en

1.16 S-intermediate section 12 m

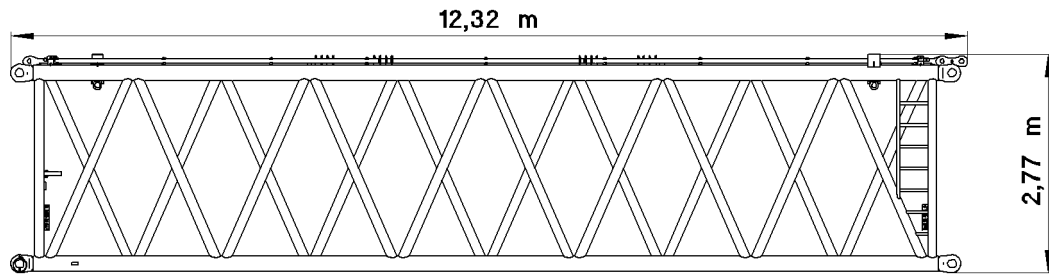

Fig.120045: S-intermediate section 12 m

Component	Weight	Width
S-intermediate section 12 m 2825.45	11.1 t	3.0 m
S-intermediate section 12 m 2825.25	9.2 t	
S-intermediate section 12 m 2825.20	8.3 t	
S-intermediate section 12 m 2825.20 FLM	9.3 t	
S-intermediate section 12 m , 2825.16Z	7.7 t	
S-intermediate section 12 m 2825.16	7.7 t	

1.17 SL-reducer section 6.75 m

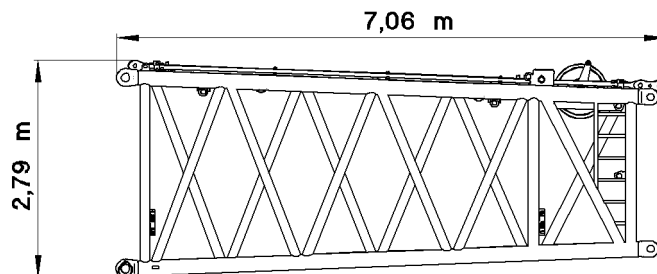

Fig.120046: SL-reducer section 6.75 m

Component	Weight	Width
SL-reducer section with S-guy rods	5.0 t	3.0 m

1.18 LI-intermediate section 6 m

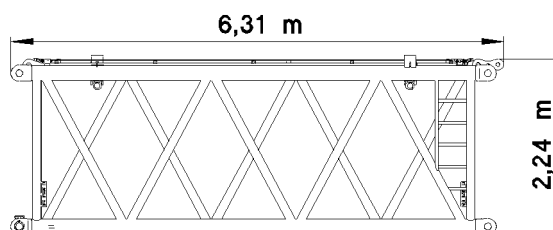

Fig.120048: LI-intermediate section 6 m

Component	Weight	Width
LI-intermediate section 6 m , 2420.12	3.0 t	2.6 m
LI-intermediate section 6 m , 2420.10	2.8 t	

1.19 LI-intermediate section 12 m

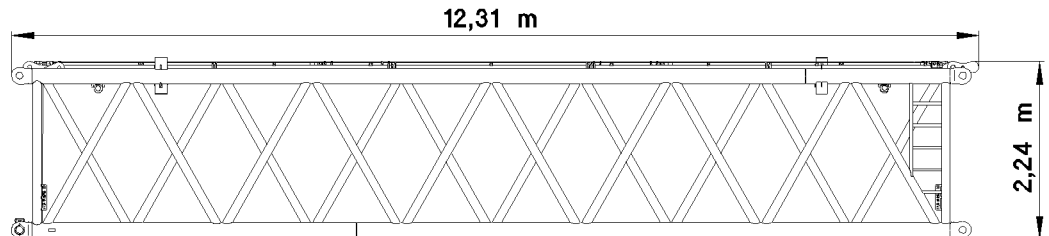

Fig.120047: LI-intermediate section 12 m

Component	Weight	Width
LI-intermediate section 12 m , 2420.12	5.2 t	2.6 m
LI-intermediate section 12 m , 2420.10Z	4.9 t	
LI-intermediate section 12 m , 2420.10	4.7 t	
LI-intermediate section 12 m , 2420.09F	5.1 t	

1.20 SW-end section

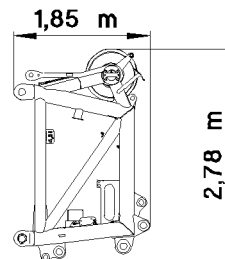

Fig.120049: SW-end section

Component	Weight	Width
SW-end section	4.5 t	2.7 m

1.21 F-connector head

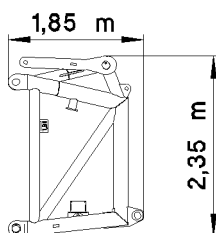

Fig.120050: F-connector head

Component	Weight	Width
F-connector head	1.9 t	2.7 m

1.22 Boom nose

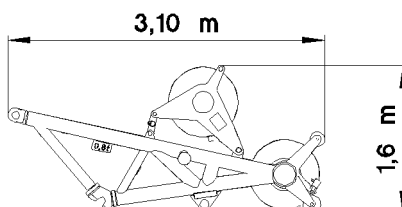

Fig.120051: Boom nose

Component	Weight	Width
Boom nose	0.9 t	1.5 m

1.23 Pulley set 300 t

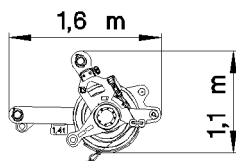

Fig.120052: Pulley set 300 t

Component	Weight	Width
Pulley set 300 t	1.4 t	1.3 m

1.24 Pulley set 320 t

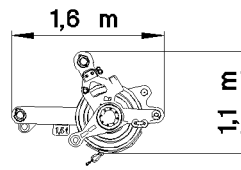

Fig.120053: Pulley set 320 t

Component	Weight	Width
Pulley set 320 t	1.5 t	1.4 m

1.25 Pulley cart

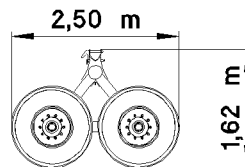

Fig.120054: Pulley cart

Component	Weight	Width
Pulley cart	1.5 t	1.8 m

1.26 F-assembly unit

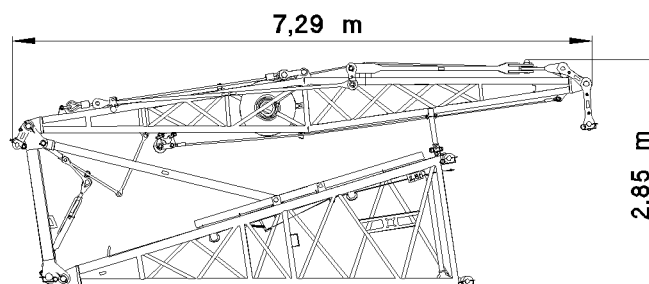

Fig.120055: F-assembly unit

Component	Weight	Width
Assembly unit	2.7 t	2.8 m

1.27 F-intermediate section 6 m , 1916.06

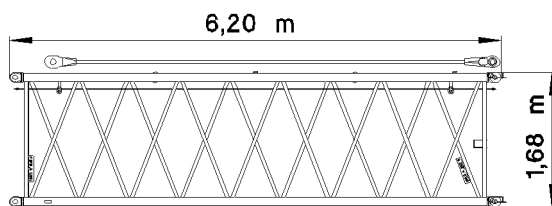

Fig.120056: F-intermediate section 6 m , 1916.06

Component	Weight	Width
F-intermediate section 6 m , 1916.06	1.0 t	2.0 m

1.28 F-intermediate section 12 m , 1916.06

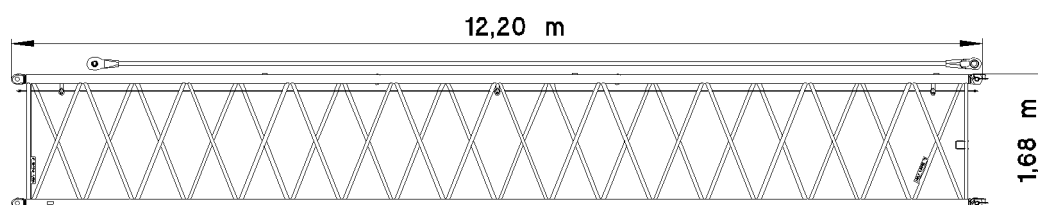

Fig.120057: F-intermediate section 12 m , 1916.06

Component	Weight	Width
F-intermediate section 12 m , 1916.06	1.7 t	2.0 m

1.29 F-end section

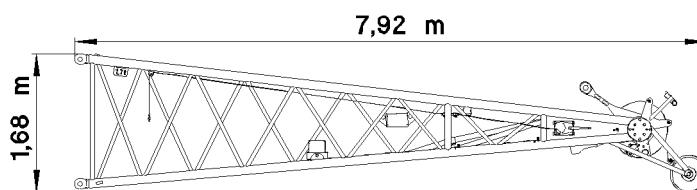

Fig.120058: F-end section

Component	Weight	Width
F-end section	1.7 t	2.0 m

1.30 D-pivot section 9.5 m

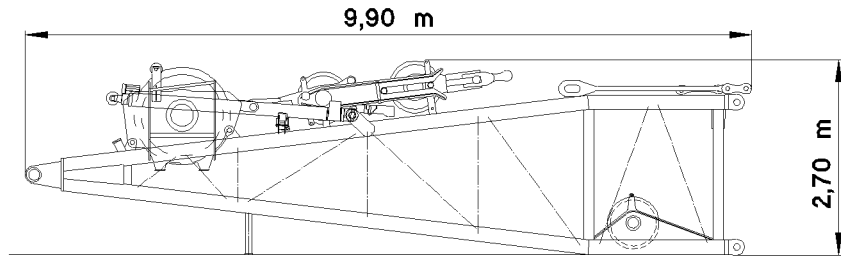

Fig.120059: D-pivot section 9.5 m

Component	Weight	Width
D-pivot section 9.5 m	22.8 t	3.0 m

1.31 D-end section 8.5 m

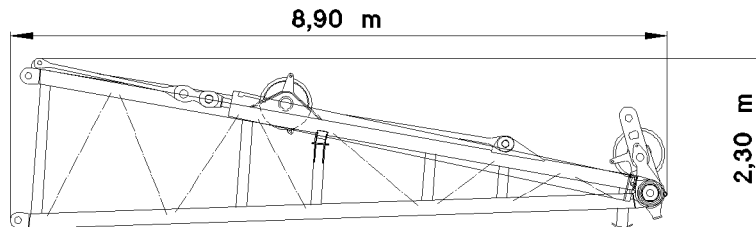

Fig.120060: D-end section 8.5 m

Component	Weight	Width
D-end section 8.5 m	13.3 t	2.7 m

1.32 D-intermediate section 6 m , 2420.16

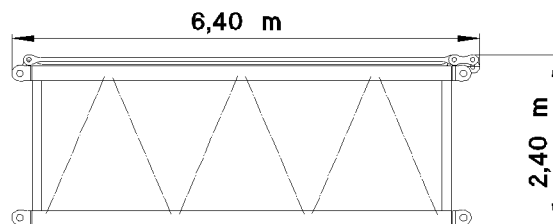

Fig.120071: D-intermediate section 6 m , 2420.16

Component	Weight	Width
D-intermediate section 6 m , 2420.16	4.4 t	2.6 m

LWE/LR 1600-2-008/18109-09-02/en

1.33 D-intermediate section 12 m , 2420.20

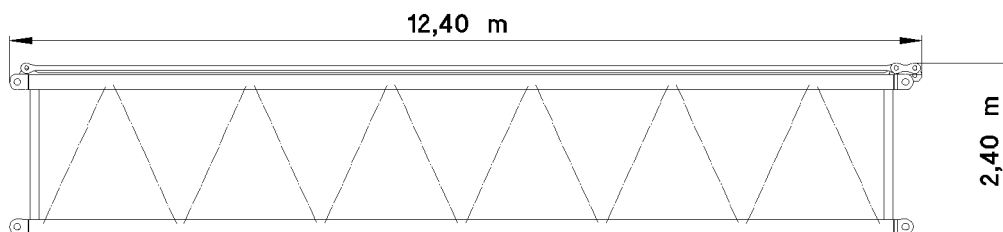

Fig.120072: D-intermediate section 12 m , 2420.20

Component	Weight	Width
D-intermediate section 12 m , 2420.20	8.1 t	2.6 m

1.34 W-pivot section 10.75 m with pivot section WA-frame 1 (transport unit 1)

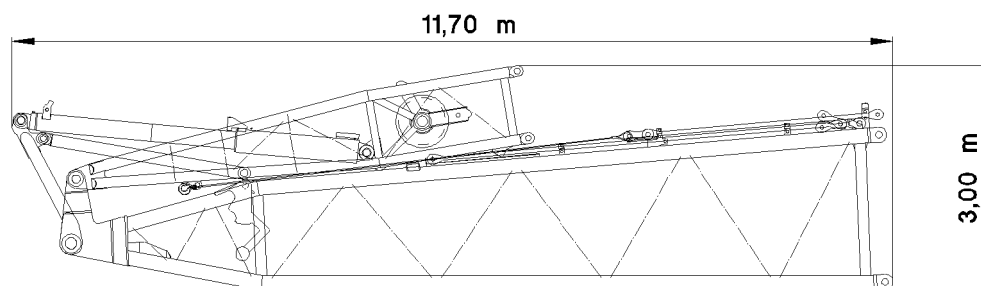

Fig.120073: W-pivot section 10.75 m with pivot section WA-frame 1 (transport unit 1)

Component	Weight	Width
W-pivot section with pivot section WA-frame 1	12.0 t	2.8 m

1.35 WA-frame 1 and WA-frame 2, end sections (transport unit 2)

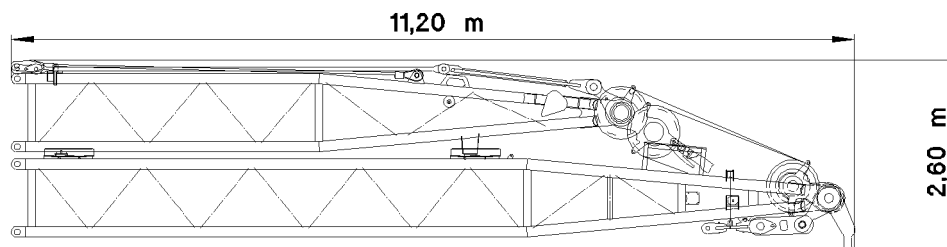

Fig.120074: WA-frame 1 and WA-frame 2, end sections (transport unit 2)

Component	Weight	Width
WA-frame 1 and WA-frame 2 end sections	8.7 t	2.7 m

1.36 WA-frame 2, pivot section (transport unit 3)

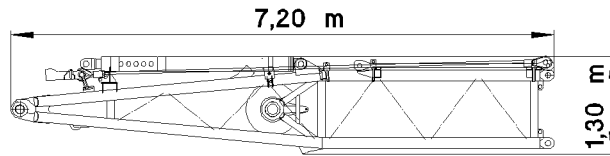

Fig.120075: WA-frame 2, pivot section (transport unit 3)

Component	Weight	Width
WA-frame 2, pivot section	3.6 t	2.7 m

1.37 W-connector head

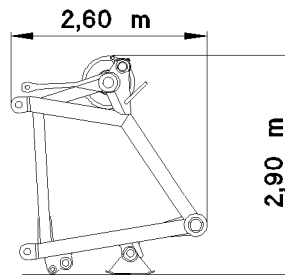

Fig.120076: W-connector head

Component	Weight	Width
W-connector head	5.0 t	2.7 m

1.38 Ballast trailer

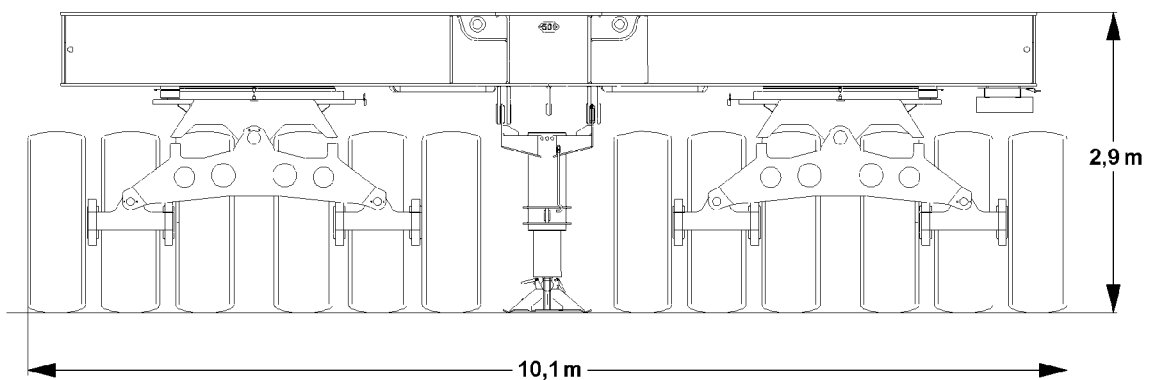

Fig.120077: Ballast trailer

Component	Weight	Width
Ballast trailer	47.2 t	2.9 m

LWE/LR 1600-2-008/18109-09-02/en

1.39 Guide complete for ballast trailer

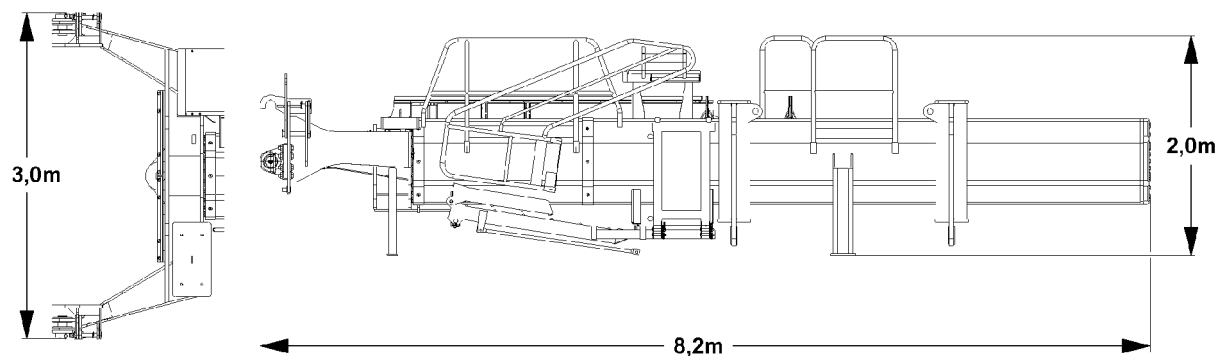

Fig.120078: Guide complete for ballast trailer

Component	Weight	Width
Guide complete for ballast trailer	15.9 t	3.0 m

1.40 Ballast trailer with wheel drive

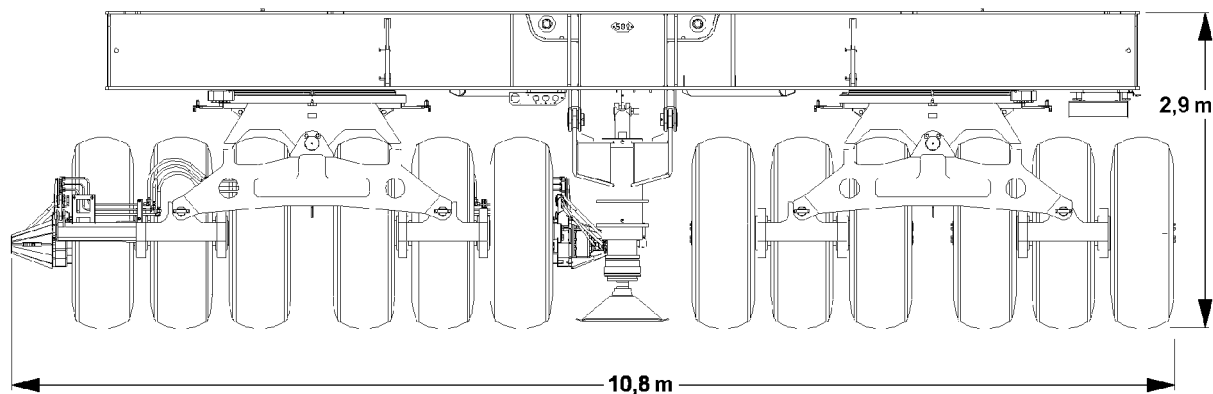

Fig.120079: Ballast trailer with wheel drive

Component	Weight	Width
Ballast trailer with wheel drive	50.0 t	2.9 m

1.41 Guide with adapter complete, for ballast trailer

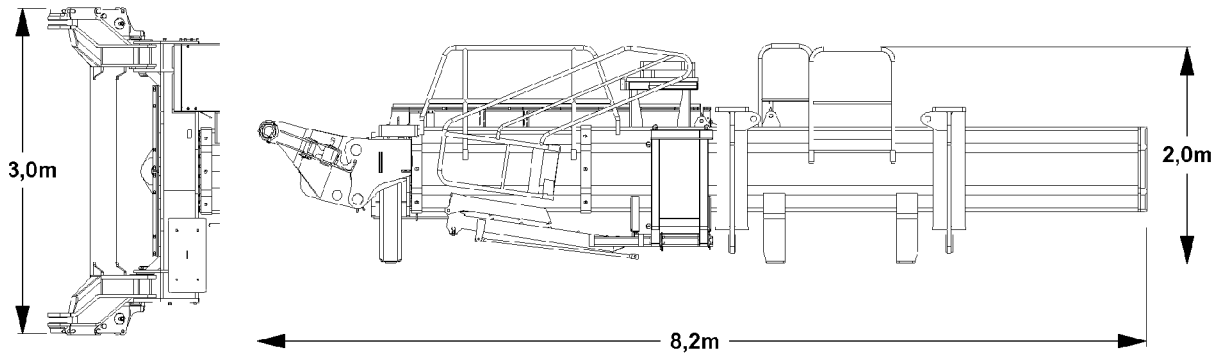

Fig.120080: Guide with adapter complete, for ballast trailer

Component	Weight	Width
Guide with adapter complete, for ballast trailer	15.9 t	3.0 m

1.42 Ballast pallet suspended ballast

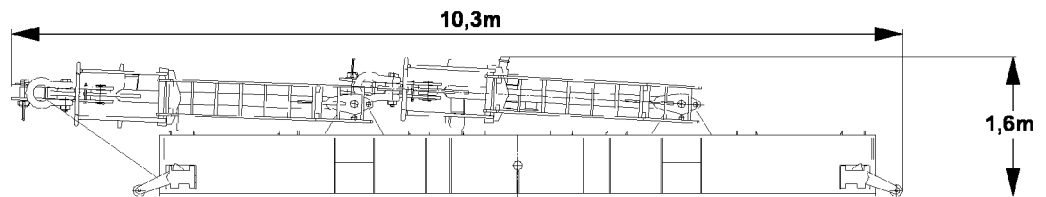

Fig.120081: Ballast pallet suspended ballast

Component	Weight	Width
Ballast pallet suspended ballast	11.0 t	2.4 m

1.43 Suspended ballast guide B2, pivot section

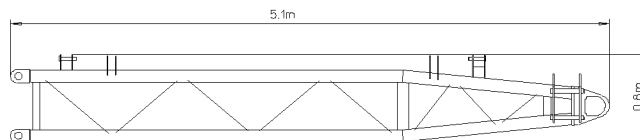

Fig.120082: Suspended ballast guide B2, pivot section

Component	Weight	Width
Suspended ballast guide B2, pivot section	1.2 t	3.1 m

LWE/LR 1600-2-008/18109-09-02/en

1.44 Suspended ballast guide B2, intermediate section

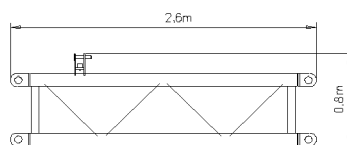

Fig.120083: Suspended ballast guide B2, intermediate section

Component	Weight	Width
Suspended ballast guide B2, intermediate section	0.6 t	2.9 m

1.45 Suspended ballast guide B2, end section

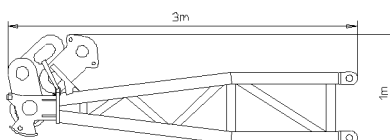

Fig.120084: Suspended ballast guide B2, end section

Component	Weight	Width
Suspended ballast guide B2, end section	1.4 t	4.3 m

2 Load handling equipment



Note

► For load handling equipment, see load chart manual.

3 Ground pressure



Note

► Determination of ground pressures of crane, see Operating instructions LICCON job planner.

4 Noise emission

Control platform Crane cab	
Sound pressure level [L_{pA}], according to EN13000	73 db(A)

5 Vibrations

Vibrations transferred to the operator	Value
Total vibration value to which the upper body limbs are exposed	not more than 2.5 m/s ²
Effective value of weighted acceleration to which the entire body is exposed to	not more than 0.5 m/s ²

6 Crane speeds



Note

► The crane speeds refer to an engine rpm of 1900 min⁻¹ !

Drives	Speed
Winch 1	0 m/min to 132 m/min for single strand
Winch 2	0 m/min to 132 m/min for single strand
Winch 3	0 m/min to 130 m/min for single strand
Winch 5	0 m/min to 132 m/min for single strand
Winch 6	0 m/min to 94 m/min for single strand
Winch 4	2 × 78 m/min for single strand

Drives	RPM
Slewing gear	0 rpm to 0.95 rpm

7 Ropes

7.1 Hoist ropes

	Rope diameter	Rope category number RCN
Winch 1	28 mm	See Rope certificate
Winch 2	28 mm	See Rope certificate
Winch 6 (Type 1)	28 mm	See Rope certificate
Winch 6 (Type 2)	25 mm	See Rope certificate

7.2 Control ropes

	Rope diameter	Rope category number RCN
Winch 3	28 mm	See Rope certificate
Winch 4	28 mm	See Rope certificate
Winch 5	28 mm	See Rope certificate

7.3 Guy ropes

	Rope diameter	Rope category number RCN
Auxiliary guying	34 mm	See Rope certificate

7.4 Assembly rope

	Rope diameter	Rope category number RCN
Assembly winch	8 mm	See Rope certificate

2 Safety

LWE/LR 1600-2-008/18109-09-02/en

LWE/LR 1600-2-008/18109-09-02/en

2.03 Job planning

1 Planning Crane operation

3

LWE/LR 1600-2-008/18109-09-02/en

Fig.195219

LWE/LR 1600-2-008/18109-09-02/en

1 Planning Crane operation

In addition to a perfectly working crane and a well-trained crew, the **planning for crane operation** is an important principle for safe crane operation.



WARNING

Missing information!

Death, severe bodily injuries, property damage.

► Obtain the required information and adhere to it.

Obtain the following information before crane operation and adhere to it:

- Type of crane operation
- National laws and regulations
- Height and width clearance measurements
- When mobile crane: Job site, distance and travel route
- Space prerequisites at the job site
- Electrical transmission lines with voltage data
- Movement restrictions caused by buildings
- Weight and dimensions of the load(s) to be lifted
- Geometric form and air resistance coefficient of the load(s) to be lifted
- Required lifting height and boom projection
- Ground bearing capacity at the job site
- Required space for the assembly and disassembly of the crane
- Weather data and weather forecasts

Assemble the equipment for crane operation:

- Hook block / load hook
- Auxiliary boom
- Fastening equipment
- Counterweight
- Base materials for support plates

Empty page!

LWE/LR 1600-2-008/18109-09-02/en

2.04 General safety technical guidelines

1	Dangers on the crane	3
2	Danger zone of crane	4
3	Traffic endangerment and environmental damage	5
4	Endangering air traffic	5
5	Movement on the crane	6
6	Emergency exit	6
7	Personal protective equipment	8
8	Securing persons to prevent them from falling	14
9	Rescuing the assembly personnel	16
10	Crane cab	17
11	Transport	21
12	Fastening	22
13	Heated crane components	22
14	Crane operator responsibilities	22
15	Selecting the location	24
16	Slopes and excavations	28
17	Loads on the ground due to crane operation	31
18	Support	35
19	Aligning the crane	37
20	Checking the safety measures	38
21	Safety guidelines in case of external power supply	39
22	Grounding	39
23	Working in the vicinity of transmitters	41
24	Crane operation in case of thunderstorms	42
25	Wind influences	43
26	Lifting a load with two cranes	49
27	Working ranges of several cranes overlap	51
28	Hand signals for guidance	52
29	Travel operation	60
30	Crane operation	62
31	Lifting of personnel	68
32	Securing personnel on shut off crane	70
33	Welding work on the load	72

Fig.195219

LWE/LR 1600-2-008/18109-09-02/en

**Note**

- ▶ The illustrations in this chapter are only examples. The illustrations may differ depending on the crane model.

1 Dangers on the crane

1.1 California Proposition 65

Proposition 65 of the US State of California warns against chemicals that are known to cause cancer, birth defects and other reproductive harm.

For additional information, see the website: www.P65Warnings.ca.gov.

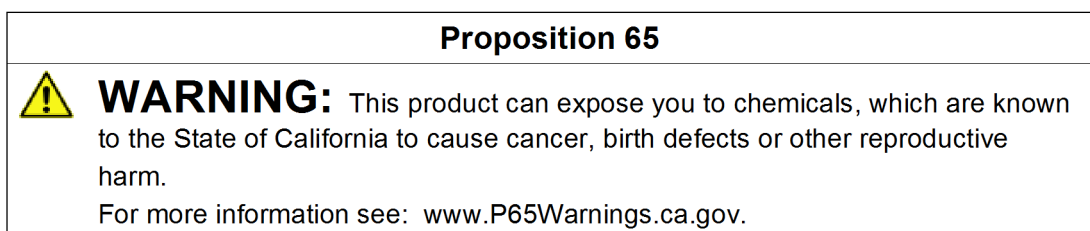

Fig.147844: Example of a Proposition 65 sign for USA: Chemicals

Proposition 65 WARNING: This product can release chemicals that have been classified by the state of California to cause cancer, birth defects and other reproductive harm.

1.2 Exhaust emissions

Proposition 65 of the US State of California warns against chemicals that are known to cause cancer, birth defects and other reproductive harm.

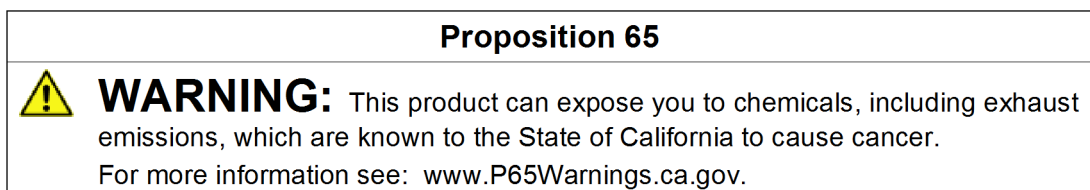

Fig.147842: Example of a Proposition 65 sign for USA: Exhaust emissions

**WARNING**

Exhaust emissions!

Damage to health such as cancer.

- ▶ Avoid exposure to exhaust emissions.
- ▶ Avoid breathing in exhaust emissions.
- ▶ **Always** work in properly ventilated spaces.
- ▶ Use personal protective equipment, such as dust masks with micro-particle filters.

1.3 Lead and lead compounds

Proposition 65 of the US State of California warns against chemicals that are known to cause cancer, birth defects and other reproductive harm.

Proposition 65	
	<p>WARNING: This product can expose you to chemicals, including lead and lead compounds, which are known to the State of California to cause birth defects or other reproductive harm.</p> <p>For more information see: www.P65Warnings.ca.gov.</p>

Fig.147843: Example of a Proposition 65 sign for USA: Lead and lead compounds



WARNING

Batteries, battery poles, battery terminals and other battery components contain lead and lead compounds!

Damage to health such as birth defects and other reproductive harm.

- ▶ Avoid direct contact with batteries and their components.
- ▶ Do not touch them with bare hands.
- ▶ Use personal protective equipment: **Always** wear protective gloves.
- ▶ After handling: Wash hands thoroughly.
- ▶ Dispose of disused batteries in an environmentally acceptable manner according to local regulations.

1.4 Hydraulic oil, diesel fuel, operating fluids



WARNING

Due to technical defects or open tank covers, hydraulic oil, diesel fuel or service fluids spill out!
Dirt from the road and ground.

Traffic endangerment: Danger of skidding, death, severe bodily injuries.

Environmental pollution: Death, severe damage to health.

- ▶ Remedy the technical defect immediately.
- ▶ Securely close the tank cover after refuelling.
- ▶ Immediately and thoroughly remove traces of hydraulic oil, diesel fuel, operating fluids.
- ▶ Avoid skin contact with hydraulic oil, diesel fuel and operating fluids.
- ▶ Use personal protective equipment, such as protective gloves.

1.5 Heated crane components



WARNING

Heated crane components! Hot surfaces!
Severe burns.

This applies in particular to exhaust systems, engines and transmissions.

- ▶ Let the components cool down before touching them.
- ▶ Proceed with special caution near heated crane components.
- ▶ Avoid skin contact with hot surfaces.
- ▶ Use personal protective equipment, such as protective gloves.

2 Danger zone of crane

2.1 Crane in operation

The danger zone of the crane is made up of the areas which are accessed during crane operation by the load or by movements of the crane or the crane components.

**WARNING**

Do not stay in danger zone!

Personnel within the danger zone can be hit by falling loads or components.

Personnel in the danger zone can be caught by moving crane components or loads.

Fatal or severe injuries can be the result.

- ▶ Warn any personnel within the danger zone with the warning device of the crane.
- ▶ After the warning is issued, wait and ensure that no personnel remains within the danger zone.
- ▶ If required, block off the danger zone with a safety distance.

2.2 Crane out of service

Place the crane out of service, failure to comply with the regulations represents considerable danger for the entire area around the crane.

**WARNING**

Actual wind speed higher than the wind speed permitted for the crane set up configuration!

Personnel within the danger zone can be hit by a toppling crane or crane components.

- ▶ Make sure that the condition of the crane complies with the regulations and the wind speed charts.
- ▶ If required, block off the danger zone with a safety distance.

**WARNING**

Icing on the boom!

Personnel within the danger zone can be hit by a falling ice.

- ▶ Make sure that there are no persons within the danger zone.
- ▶ If required, block off the danger zone with a safety distance.

3 Traffic endangerment and environmental damage

**WARNING**

Danger of slipping and skidding!

If the road becomes contaminated due to technical defects, open tank covers or leaking hydraulic oil, then this would pose a severe traffic endangerment.

Fatal accidents can result.

- ▶ Remove oil immediately and thoroughly.

4 Endangering air traffic

When working with crane, heights are reached which could endanger air traffic. This applies especially to areas near airports.

**WARNING**

Endangering air traffic!

If no protective measures are taken, this can result in endangerment to air traffic.

- ▶ Get the approval from agency responsible for air traffic.
- ▶ Install the airplane warning light on the boom head and turn it on.
- ▶ If the airplane warning lights is operated for a longer period of time, with the engine turned off, then the battery can be discharged and as the result the airplane warning light turns off. To prevent the battery from discharging, an external electrical power supply must be established.

5 Movement on the crane



WARNING

Danger of slipping and falling!

The traction of steps, walkways and hand rails changes due to effects of the weather, such as wetness, ice, snow, frost and dirt.

Personnel can be severely injured or killed.

The crane can be damaged.

- ▶ Step on the walkways and steps only by taking the present conditions into account, such as icing in winter or dirt.
- ▶ Step or place a load only on the approved walkways and steps.
- ▶ Observe the signage.
- ▶ Replace damaged safety signs (warning signs) immediately.

6 Emergency exit

6.1 Emergency exit - driver's cab

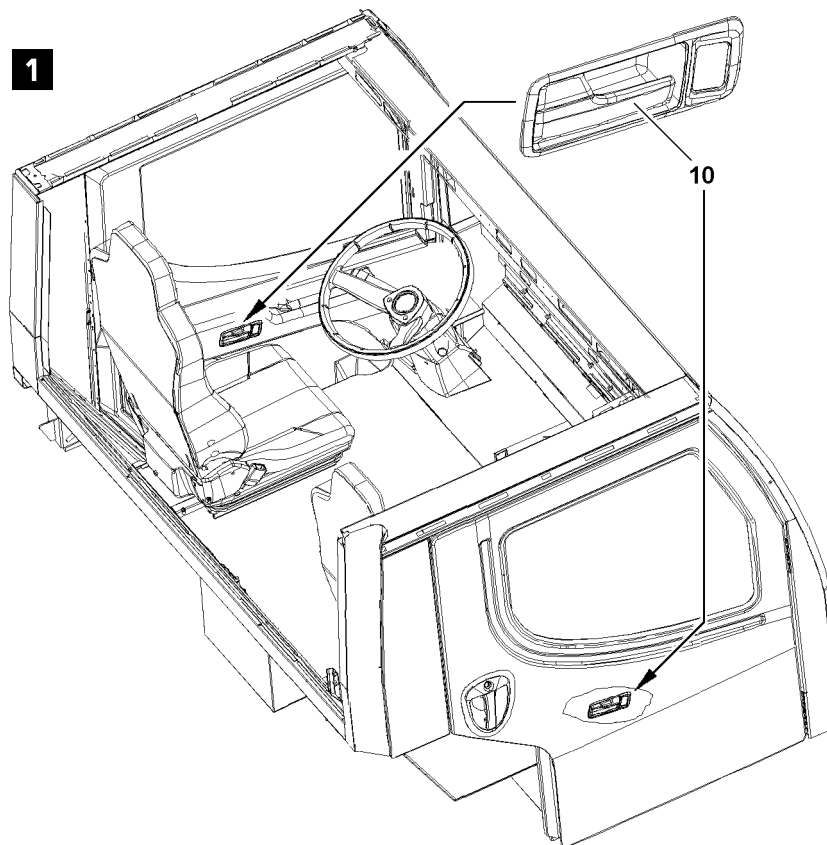

Fig.120932: Example for emergency exit - driver's cab

The driver's cab can be exited through the „left driver's door“ or the „right passenger door“, see illustration 1.



Note

- ▶ Exit the driver's cab through the „left driver's door“ or the „right passenger door“, see illustration 1: Pull and open the door handle **10** on the „left driver's door“ or the „right passenger door“.

6.2 Emergency crane cab exit



WARNING

Danger of falling!

If the crane driver cannot leave the crane cab through the door or if the crane cab is tilted, then there is a danger of falling during the emergency exit.

Death or severe injuries.

► Exit carefully in an emergency.

During the emergency exit there is an increase danger of accidents:

► Accept help from others.

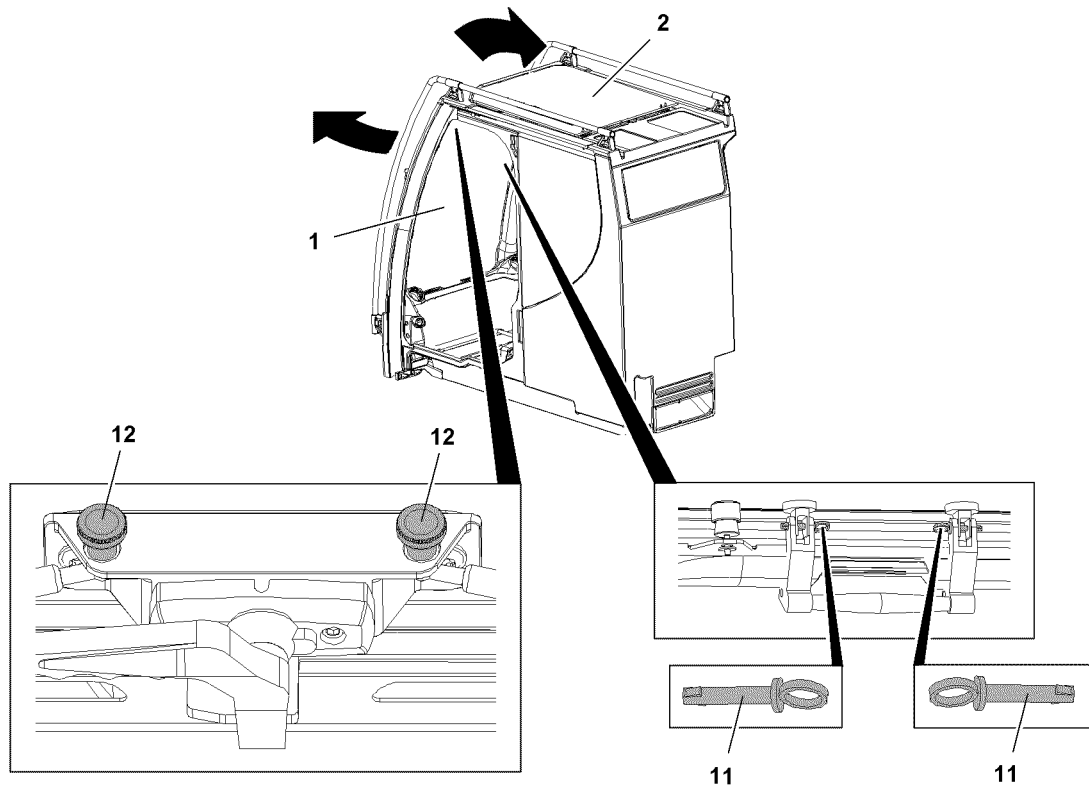

Fig.121111: Examples for emergency exit from the crane cab

If the emergency exit through the door is not possible, then the crane cab can be exited through additional openings.

The following openings are possible:

- 1 Front window
- 2 Roof window

6.2.1 Emergency exit through front window

- Unlock all turn handles.
- Open the front window 1.
- Leave the crane cab through the front window 1.

6.2.2 Emergency exit through the roof window

There are two ways to unlock the roof window 2 for the emergency exit:

- Unpin both pins 11.
- Release both thumbscrews 12.
- Unlock all turn handles.

- Unlock the roof window **2** for the emergency exit.
- Open the roof window **2**.
- Leave the crane cab through the roof window **2**.

6.2.3 Emergency exit with EMERGENCY hammer*

Certain crane types carry an EMERGENCY hammer* in the crane cab.

- Knock the front window out with the EMERGENCY hammer* or a suitable object.
- Leave the crane cab.

7 Personal protective equipment

When working on the crane, the required personal protective equipment according to national regulations and accident prevention regulations must be provided and used.

Personal protective equipment includes the following:

- Supplied fall arrest system (safety harness and height safety equipment)
- Supplied height rescue system
- Head protection with chin strap
- Safety shoes
- Protective gloves
- Safety goggles
- Warning apparel
- Hearing protection
- Respiratory protection



WARNING

Personal protective equipment when working on the crane not used!
Death, severe bodily injuries.

The crane operator must ensure the following:

- ▶ The personal protective equipment is made available.
- ▶ The provided personal protective equipment is taken along and used.
- ▶ The operating instructions and maintenance instructions of the manufacturer for the personal protective equipment are observed and complied with.
- ▶ The product identifications are regularly checked for damage.
- ▶ Personal protective equipment with damaged product identification is replaced immediately.
- ▶ Damaged fall arrest systems with height rescue systems will be replaced immediately and handed over to an authorized inspector.
- ▶ Personal protective equipment is checked for damage and completeness before use.
- ▶ Defective or damaged personal protective equipment is replaced immediately with functioning protective equipment.

7.1 Supplied fall arrest system

When no other safety measures are possible for working in the presence of a fall hazard, the supplied fall arrest system must be used.

A fall with a fall arrest system cannot exclude an injury. The fall arrest system reduces however the severity of the injuries.



WARNING

Persons not secured!
People can fall down. Death, severe bodily injuries.

- ▶ Use the supplied fall arrest system.

**WARNING**

Fall arrest system damaged!

People can fall down. Death, severe bodily injuries.

- ▶ Do **not** use a damaged fall arrest system.
- ▶ Replace a damaged fall arrest system immediately with a new fall arrest system.
- ▶ Do **not** use the fall arrest system as fastening equipment for loads.
- ▶ Protect the fall arrest system from external influences.

The fall arrest system must be protected against the following external influences:

- Extreme temperatures
- Guiding the connecting devices over or around sharp edges
- Chemical influences
- Electrical influences
- Cuts, wear
- Climatic effects

**Note**

If the fall arrest system (safety harness and height safety equipment) is not available or is damaged:

- ▶ Order is from Liebherr-Werk Eching GmbH.

Identification and operating instructions

- The supplied fall arrest system must be clearly and permanently identified.
- If the identification is no longer legible, then the supplied fall arrest system must be immediately replaced and handed over to an authorized inspector.
- The operating instructions must be available in the language of the user country.
- If the crane and the relative personal protective equipment is sold to another country, then the purchaser must make sure that the complete documentation, such as the operating instructions, the manufacturer's operating instructions, inspection log and maintenance documents, are available in the language of the user country.

7.1.1 Safety harness with height safety equipment

The fall arrest system consists of the following components:

- Safety harness **1** approved according to **EN 361**
- Single strand height safety equipment **2** approved according to **EN 360** (for horizontal use and sharp edges)
- or two strand height safety equipment **3** approved according to **EN 360** (for horizontal use and sharp edges)

Fall arrest systems that are not obtained from Liebherr-Werk Eching GmbH are **not** designed for the crane structure.

**WARNING**

Impermissible fall arrest system!

People can fall down. Death, severe bodily injuries.

- ▶ Utilize exclusively a fall arrest system from Liebherr-Werk Eching GmbH.

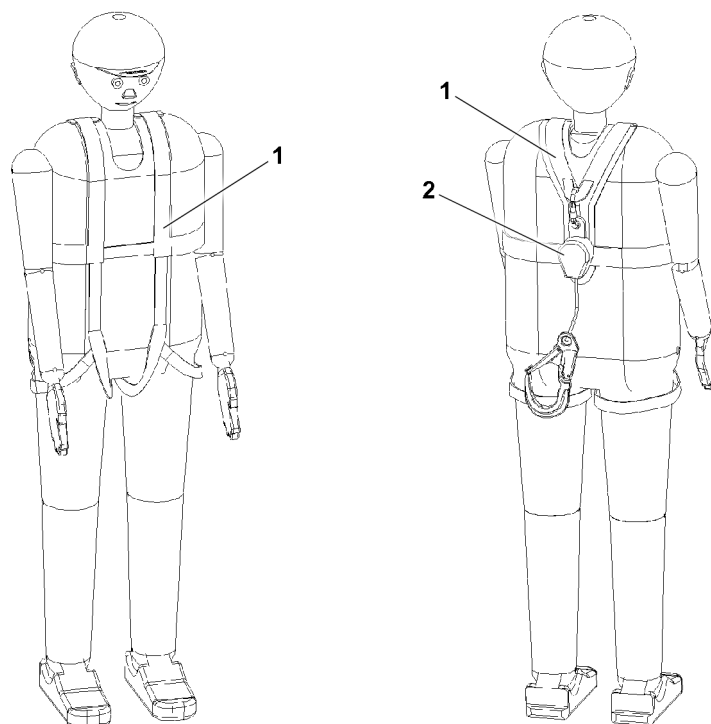

Fig.146453: Example of a safety harness 1 with a single strand height safety equipment 2

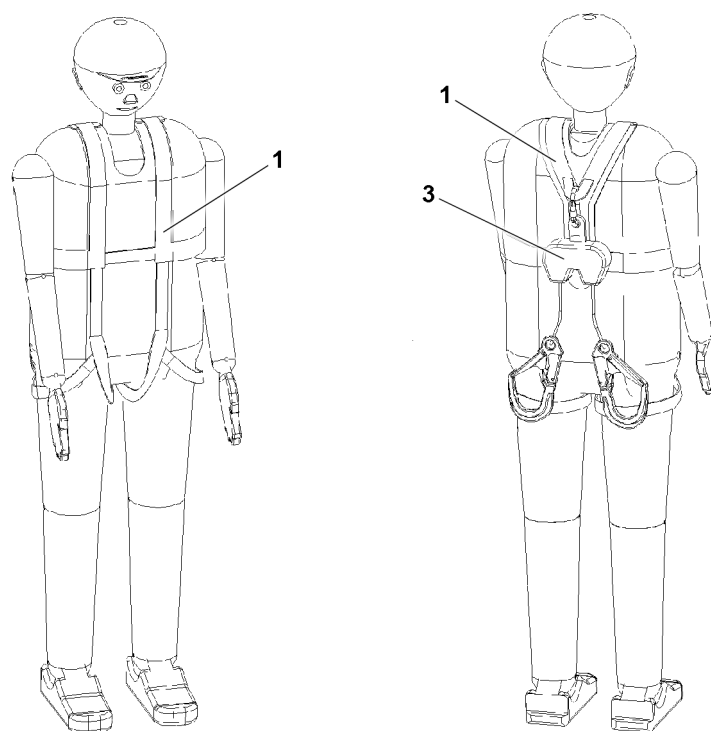

Fig.146454: Example of a safety harness 1 with a two strand height safety equipment 3

Prior to crane operation:

- Make sure that the fall arrest system is completely available and functional.
- Check the fall arrest system before use for visible defects. In the case of visible defects: Replace the fall arrest system immediately.

Handling the supplied fall arrest system:

- Observe and comply with the operating instructions of the fall arrest system.
- Check the fall arrest system before use for visible defects.

- The fall arrest system must be work where no other fall protection equipment, such as railings, can be installed for technical reasons.
- The fall arrest system is effective from a height of 2.5 m. The fall space must be free of obstacles.
- Do **not** change the configuration of the fall arrest system.
- Do **not** lengthen or shorten the fall arrest rope.
- A fall absorber is integrated in the height safety equipment. Do **not** use an additional fall absorber.
- Fasten the fall arrest system only to the hook points, safety ropes and fastening points designed for this purpose. See chapter 2.06.

Behavior in the case of a fall, damage or impairment of the functionality:

- In the case of damage or impairment of the functionality: Replace the fall arrest systems immediately and hand then over to an authorized inspector.
- After every fall: Take down the fall arrest system immediately and hand it over to an authorized inspector. The results must be documented in the fall arrest system inspection log book.
- Only after a written approval may the fall arrest system be reused. The approval must be provided in writing and documented.
- Fall arrest systems that are no longer approved must **not** be used. Unapproved fall arrest systems must be disposed of and replaced with new fall arrest systems.

Storage of the fall arrest system:

- Store the fall arrest system dry and without the effect of UV radiation in the corresponding transport bag.

The operator must ensure the following:

- Personnel must be instructed at least once a year on how to use the supplied fall arrest system (safety harness and height safety equipment) with practical exercises. Performance of the instruction and exercises must be documented.
- The safety harness and height safety equipment must be checked at least once a year by an authorized inspector. The results must be documented in the fall arrest system inspection log book.

Single strand height safety equipment

The single strand height safety equipment is equipped with a belt strap. Single strand height safety equipment is provided for all cranes that do not have walking surfaces with safety ropes.

Use the supplied height safety equipment with extendable belt strap and snap hook with swivel according to **EN 362 Class A**.

Two strand height safety equipment

The two strand height safety equipment is equipped with two belt straps. Height safety equipment with two belt straps are provided for cranes with walking surfaces and two ropes as fastening device on the left and right hand side of the walking surface, for example lattice sections, lattice booms, possibly telescopic booms or assembly units.

Use the supplied height safety equipment with two extendable belt straps and snap hooks with swivel according to **EN 362 Class A**.



WARNING

Height safety equipment incorrectly used!
People can fall down. Death, severe bodily injuries.

When two safety ropes are present on the booms, lattice sections or other components:

- ▶ Only use the height safety equipment with two belt straps.
- ▶ Hook one belt strap with snap hook for the fall arrest system per safety rope.
- ▶ When transferring to new safety equipment, a snap hook for the fall arrest system must **always** be hooked.

7.2 Height rescue system

The height rescue system is only supplied on certain crane types.

The height rescue system is an evacuation and rescue device. It is used to lift the fallen person to be able to unhook him from the height safety equipment and to lower him by rope.

The height rescue system consists of the following components:

- Rappelling rescue device
- Telescopic rod for hooking the snap hook on the safety harness



WARNING

Height rescue system not present!

Fallen person cannot be saved. Suspension trauma, death, severe bodily injuries.

- ▶ Always have the height rescue system ready.



WARNING

Height rescue system damaged!

Personnel cannot be saved.

- ▶ Do **not** use a damaged height rescue system.
- ▶ Replace a damaged height rescue system immediately with a new height rescue system.
- ▶ Protect the height rescue system from external influences.

The height rescue system must be protected against the following external influences:

- Extreme temperatures
- Chemical influences
- Electrical influences
- Cuts, wear
- Climatic effects

Prior to crane operation:

- Make sure that the height rescue system is completely available and functional.
- Check the height rescue system before use for visible defects. In the case of visible defects: Replace the height rescue system immediately.

Handling the height rescue system:

- Observe and comply with the operating instructions of the height rescue system.
- Do **not** change the configuration of the height rescue system.

Behavior in the case of a fall, damage or impairment of the functionality:

- In the case of damage or impairment of the functionality: Replace the height rescue system immediately and hand it over to an authorized inspector.
- After every use: Hand the height rescue system over to authorized inspector. The results must be documented in the height rescue system inspection log book.
- Only after a written approval may the height rescue system be reused. The approval must be provided in writing and documented.
- Height rescue systems that are no longer approved must **not** be used. Unapproved height rescue systems must be disposed of and replaced with new height rescue systems.

Storage of the height rescue system:

- Store the height rescue system dry and without the effect of UV radiation in the corresponding transport bag.

The operator must ensure the following:

- Personnel must be instructed at least once a year on how to use the height rescue system with practical exercises. Performance of the instruction and exercises must be documented.
- The height rescue system must be checked at least once a year by an authorized inspector. The results must be documented in the height rescue system inspection log book.

7.3 Hard hat

Wear a hard hat with a chin strap, if head injuries are possible. For example, due to:

- Striking
- Falling, tipping or flying objects
- Oscillating objects

Replace the hard hat immediately if:

- If is struck with force
- It has visible defects
- When reaching the maximum service life specified by the manufacturer

An industrial hard hat can protect against striking fixed objects and falling or oscillating objects, but **not** against falling loads.



WARNING

Suspended and falling loads!

Death, severe bodily injuries.

- ▶ Do **not** remain under suspended loads.

7.4 Protective gloves

Wear protective gloves, if hand injuries are possible. For example, due to:

- Pointy or sharp objects
- Hot surfaces

When working with ropes: Protective gloves must be puncture proof.

7.5 Safety shoes

Wear safety shoes, if foot injuries are possible. For example, due to:

- Oscillating or falling parts
- Pointy or sharp objects
- Impact or trapping
- Slipping on slippery ground or surfaces

7.6 Warning apparel

Avoid accidents: Wear reflecting, signal color warning clothing, when personnel must be visible and recognizable.

The „warning clothing“ category includes, for example:

- Safety vest
- Safety jacket
- Safety pants

7.7 Safety goggles

Wear safety goggles when eye injuries are possible. For example, due to:

- Corrosive fluids
- Pressurized fluids
- Flying parts

7.8 Hearing protection

Wear hearing protection when there is danger of hearing damage due to noise.

7.9 Respiratory protection

Wear respiratory protection when there is danger of damage due to polluted air.

7.10 Aids for work at a height

All work at a height, when there is a danger of falling, must be carried out with suitable aids.

Part of the category „Aids for working at a height“ are, for example:

- Work platforms

- Scaffolding
- Assembly platform
- Catwalks
- Ladders

When working at a height, working on a work platform, scaffolding, assembly platform, catwalk or similar is preferential to working on a ladder.



WARNING

Persons not secured when working at a height!
People can fall down. Death, severe bodily injuries.

When work platforms, scaffolding, catwalks or similar are not available and the work cannot be carried out from the ground:

- ▶ Secure personnel with the supplied fall arrest system to prevent falling.

When fall protection equipment such as hook points, safety ropes and fastening points are available on the crane:

- ▶ Secure personnel with the fall arrest system to the fall protection equipment. See chapter 2.06.

When stepping on a ladder:

- ▶ Do not hold any objects in your hands.
- ▶ Adhere to the 3-point support. See chapter 2.04.10.

Rules when using the aids:

- Step on the ladder only with clean shoes.
- Keep it free from heavy dirt deposits.
- Keep it free of snow and ice.

8 Securing persons to prevent them from falling



WARNING

Danger of falling!

- ▶ Wear the supplied fall arrest systems (safety harnesses and height safety equipment) correctly.
- ▶ When accessing a ladder, do not hold any objects in your hands.
- ▶ When accessing a ladder, adhere to the 3-point support. See the Crane operating instructions, chapter 2.04.10.

8.1 Working on the telescopic boom head and / or auxiliary boom

Reeve the hoist rope in or out on the pulley head:

- For ladder work, use the supplied ladder. For fastening and hook points, see Crane operating instructions, chapter 2.06.
- For cranes, which carry a ladder along **with** hook device:
Use the hook device to secure the ladder.
- For cranes, which carry a ladder along **without** hook device:
Use the rigging belt to secure the ladder.
- When ascending, the assembly personnel must ensure a 3-point support.
- If there is a danger of falling, the assembly personnel must hook themselves with the snap hooks of the fall arrest system on the fastening points and secure themselves against falling.

8.2 Walking on the telescopic boom



WARNING

Danger of falling!

The assembly personnel can fall down by slipping on the telescopic boom and be killed or severely injured!

- ▶ The telescopic boom may only be accessed if assembly personnel is protected with suitable safety measures to prevent them from falling.
- ▶ If safety ropes are present on the telescopic boom, then the assembly personnel must hook themselves with the supplied fall arrest system on the safety ropes of the telescopic boom on the left and right with both snap hooks and secure themselves against falling.
- ▶ Without safety measures, it is **strictly** prohibited to step on the telescopic boom.

Assembly of the hoist rope or the TY-guying:

- During assembly, the assembly personnel must hook themselves on the fastening devices on the left and right with both snap hooks of the fall arrest system and secure themselves against falling.

8.3 Access to lattice sections or booms

Climbing the ladder:

- When ascending, the assembly personnel must ensure a 3-point support.

Changing from ladder to catwalk **without** transition aid:

- From a transition height above 1.8 m: **Before** transitioning, the assembly personnel must hook at least one snap hook of the fall arrest system on a safety rope and secure themselves against falling.

Changing from ladder to catwalk **with** transition aid:

- **After** transitioning, the assembly personnel must hook at least one snap hook of the fall arrest system on a safety rope and secure themselves against falling.

8.4 Walking on lattice sections or booms

Walking on catwalks:

- When walking on catwalks, the assembly personnel must hook themselves on the safety ropes on the left and right with both snap hooks of the fall arrest system and secure themselves against falling.
- When changing the fall arrest system over to a new lattice section, the assembly personnel must be hooked with at least one snap hook of the fall arrest system one safety device.

8.5 Working on lattice sections or booms

Pinning, unpinning the lattice sections of pull rods:

- During pinning, unpinning of lattice sections or pull rods, the assembly personnel must hook themselves on the safety ropes on the left and right with both snap hooks of the fall arrest system and secure themselves against falling.

Fastening the lattice sections:

- When fastening the lattice sections, the assembly personnel must hook themselves on the safety ropes on the left and right with both snap hooks of the fall arrest system and secure themselves against falling.

8.6 Descending from lattice sections or booms

Accessing the ladder **without** transition aid:

- From a transition height above 1.8 m: **Before** stepping on the ladder, the assembly personnel must hook at least one snap hook of the fall arrest system on a safety rope and secure themselves against falling.
- When stepping on the ladder, the assembly personnel must ensure a 3-point support.

- The snap hook of the fall arrest system may only be unhooked after standing safely on the ladder (3-point support).

Accessing the ladder **with** transition aid:

- When stepping on the ladder, the assembly personnel must ensure a 3-point support.

Climbing down the ladder:

- When descending, the assembly personnel must ensure a 3-point support.

9 Rescuing the assembly personnel

The height rescue system is only supplied on certain crane types.

The height rescue system, consisting of the rappelling rescue device, is an evacuation and rescue device. It is used to lift the fallen person to be able to unhook him from the height safety equipment and to lower him by rope.



WARNING

Danger of falling!

- ▶ The assembly personnel must be instructed and trained properly in the correct handling of the height rescue system. Annual practice instructions and drills must be carried out.
- ▶ The supplied height rescue system must be kept available.
- ▶ The operating instructions of the manufacturer for the height rescue system must be observed and adhered to.
- ▶ The height rescue system must be inspected annually by authorized and trained expert personnel and documented in the inspection log book.

9.1 First aid measures after rescue



WARNING

Danger of fatal injury!

- ▶ After the rescue, the patient must be positioned with the upper body raised (in seated or squatting position).
- ▶ Immediate flat position or even shock position can be fatal.

10 Crane cab

10.1 Entering and exiting with a retractable / extendable step

10.1.1 Crane superstructure in the 0° position or 180° position

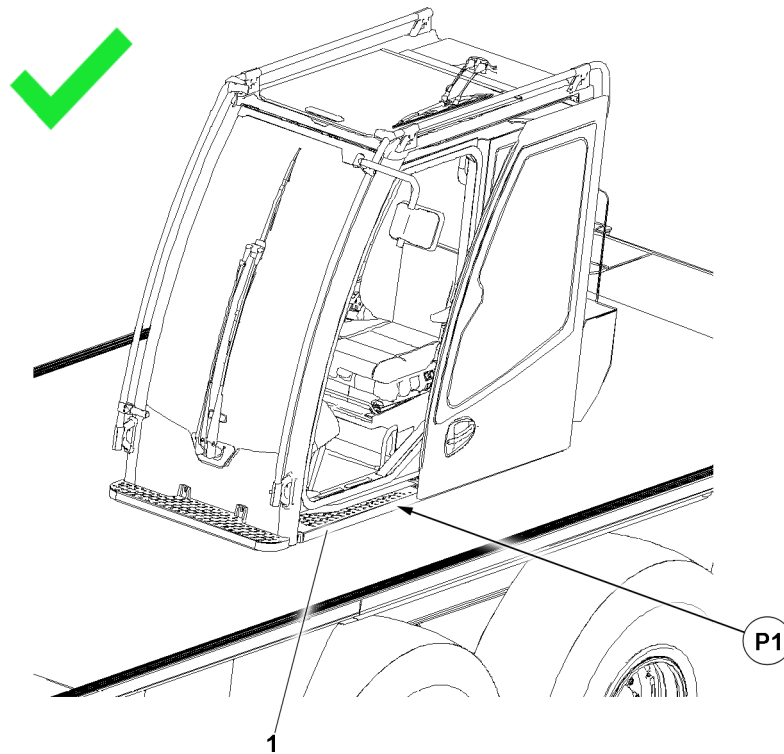

Fig.147868: Entering / exiting with the crane superstructure in the 0° position or 180° position Step retracted

Before entering or exiting the crane cab, the following prerequisites must be met:

- The crane superstructure is in the 0° position or 180° position.
- The step **1** under the crane cab is retracted in position **P1**.
- The crane cab with incline adjustment is in 0° position.
- Folding ladders are folded into the ascent and descent position.



Note

- ▶ When all folding ladders are folded into the ascent and descent position, then a safe descent is possible from every position. See also chapter 2.07.

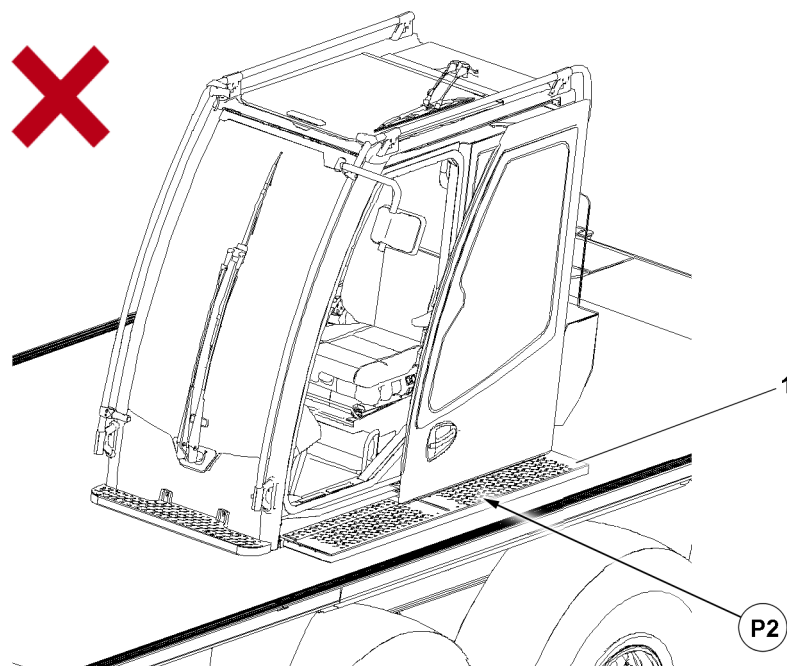

Fig.147869: Entering / exiting with the crane superstructure in the 0° position or 180° position Step **not** retracted



WARNING

The crane superstructure is in 0°-position or in 180°-position and the step **1** is **not** retracted!
Personnel can fall when entering / exiting.
Death, severe bodily injuries.

- ▶ Before entering or exiting: Retract the step **1** completely.

If the step **1** **cannot** be retracted:

- ▶ Guarantee safe entry / exit: Set up suitable climbing aids, such as a ladder or a platform.

10.1.2 Crane superstructure turned

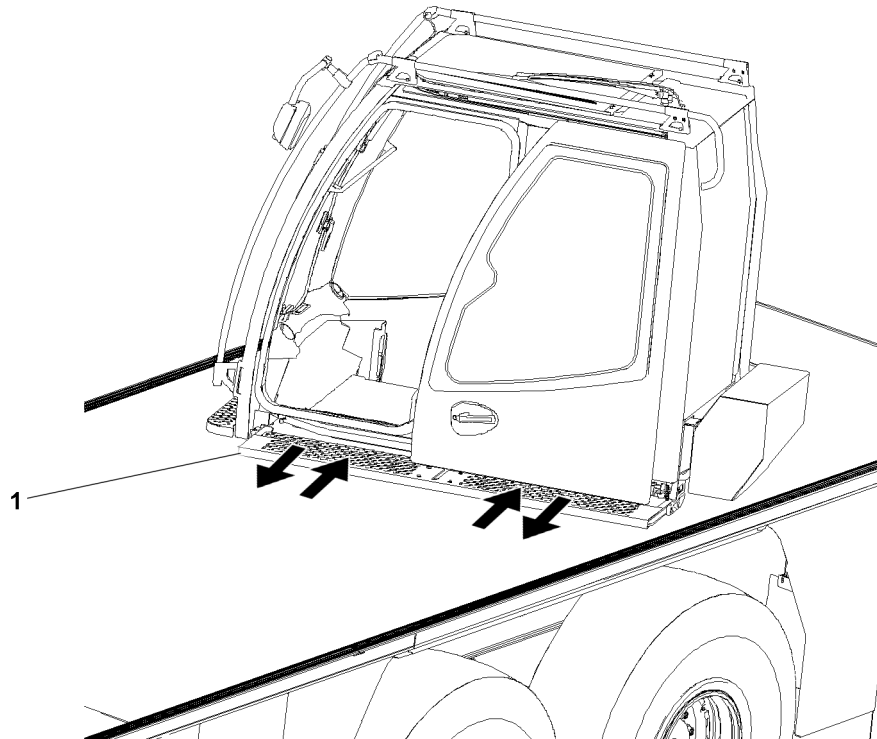

Fig.147870: Entering / exiting with a turned crane superstructure Step extended

Before entering or exiting the crane cab, the following prerequisites must be met:

- The crane superstructure is swung to the point where a safe access to walkable surfaces of the crane chassis is ensured.
- For a crane cab with incline adjustment, the crane cab is in the 0° position.
- All folding ladders are folded into the ascent and descent position.

When all folding ladders are folded into the ascent and descent position, then a safe descent is possible from every position. See also chapter 2.07.



Note

The extendable 1 step allows comfortable entry into the crane cab as well as safe exit from the crane to the crane chassis.

- ▶ Use the extendable step 1.

10.2 Crane cab with incline adjustment



WARNING

Danger of falling!

If the crane cab cannot be swung from an inclined position (for example 20° position) to the 0° position, for example due to a problem, then utmost caution must be used when entering / exiting the crane cab.

There is a danger of falling. Personnel can be severely injured or killed.

- ▶ For safety reasons, we recommend to take advantage of outside help.
- ▶ If necessary, have platforms or other suitable entry aids set up to ensure safe exit from the crane cab.

**WARNING**

Danger of accident!

If the door of the crane cab is opened in inclined position, then the door can move back suddenly. Hands can be crushed or injured.

- ▶ When the crane cab is in inclined position, open the door carefully.

10.3 Securing bracket

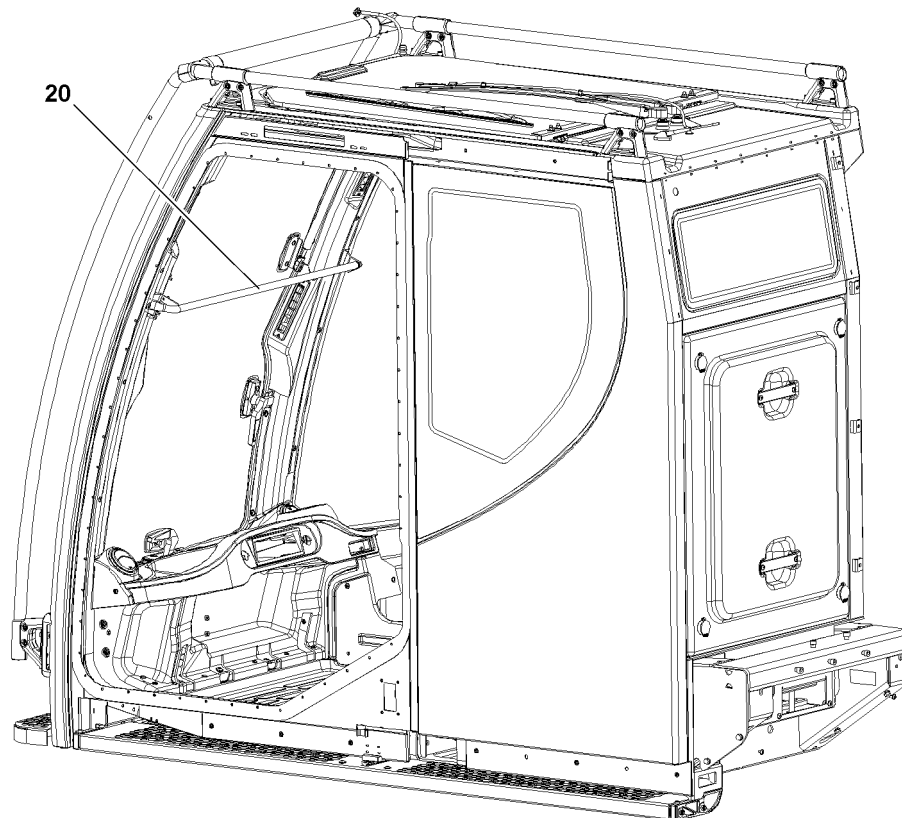

Fig.121158: Example for crane cab with securing bracket

**Note**

- ▶ The securing bracket **20** is installed to protect the crane operator from a danger of falling when the front window is open.
- ▶ Do not use the securing bracket **20** as a handle.

10.4 Closing the side window pane

**WARNING**

Danger of crushing!

Never close the side window pane carelessly or uncontrolled. Significant crushing injuries can occur.

- ▶ During closing, watch the side window pane as it moves up.
- ▶ Make sure that no personnel or objects are crushed.

11 Transport



WARNING

Error during transport!

Death, severe bodily injuries, property damage.

► To avoid accidents, observe and follow the notes provided in the following sections.

11.1 Crane and crane components

Follow the notes provided below to safely transport the crane and crane components:

- Close the crane cab and all cover doors.
- Use suitable transport vehicles.
- Use rigging devices with sufficient load capacity.
- Regularly inspect the rigging and fastening points. See the Crane operating instructions, chapter 8.01.
- Properly support and secure the components on the transport vehicle.
- Use special transport devices. See the Crane operating instructions, chapter 3.80.

11.2 Lattice sections

Follow the notes provided below to safely transport the telescoped lattice sections:

- Securely rig the lattice sections on the transport vehicle and secure them together in at least two independent points.

11.3 Mobile cranes

Follow the notes provided below for the safe transport of mobile cranes.

- To ensure the largest possible frictional coefficient to the transport surface, clean the wheels before transport.
- When driving on the transport vehicle, check the easy movement of the vehicle with the aid of a guide to avoid hitting too hard.
- Apply the parking brake. See the Crane operating instructions, chapter 3.04.
- Lower the crane with the level control to obtain a center of gravity as low as possible. Level control, see Crane operating instructions, chapter 3.03.
- Stopping the mobile crane: Place wedges under the wheels. See the Crane operating instructions, chapter 2.04.
- Close the driver's cab.

11.4 Accelerating, changing the load

NOTICE

Permissible acceleration exceeded!

Damage to crane.

- Observe the maximum permissible longitudinal acceleration of 1.0 g.
- Observe the maximum permissible lateral acceleration of 0.8 g.
- Offloading and running is prohibited during rail transport.

If higher accelerations are expected (rail transport, maneuvering operation):

- Carry out the special measures to secure the crane and crane components.

NOTICE

Frequent dynamic load change!

Premature fatigue of load bearing crane components.

- Demount and properly secure components with large masses.

Components with large masses are, for example:

- Folding jibs

- Counterweights

12 Fastening



WARNING

Defective fastening equipment or fastening points!
The load can fall down.

- ▶ Make sure that the fastening points and fastening equipment are in a perfect condition.
- ▶ Regularly inspect the rigging and fastening points. See the Crane operating instructions, chapter 8.01.
- ▶ Check the fastening equipment regularly. See the Crane operating instructions, chapter 8.01.



WARNING

Load bearing capacity of the fastening equipment is **not** sufficient!
The load can fall down.

- ▶ Determine the weight of the crane component to be fastened.
- ▶ Fasten the components solely with approved and sufficiently load bearing fastening equipment.



WARNING

Component incorrectly fastened!
The load can fall down.

- ▶ Attach the components only on the intended fastening points.

13 Heated crane components



WARNING

Danger of burns!

You can get severely burnt on the surfaces of hot components.

This applies especially to exhaust systems, the engines and the respective gears in the crane chassis and in the crane superstructure.

- ▶ Let the components cool down before touching them.
- ▶ Proceed with special caution near heated crane components.

14 Crane operator responsibilities

14.1 General

The crane operator's primary responsibility is to use and operate the crane in a manner that is safe for both himself and others.

The following important safety guidelines will help you achieve this.

Many crane accidents are caused by crane control errors.



WARNING

Danger due to operating error!

- ▶ In your interest and in the interest of others, make sure that you know your crane. Also learn to recognize all dangers connected with the work to be carried out.

Operating errors, which are made again and again while operating or driving a crane are especially careless while working, in particular:

- Slewing too quickly
- Stopping the load too quickly
- Pulling the load at an angle
- Allowing slack rope formation
- Overloading the crane
- Driving too fast with a load and / or equipment on an uneven road
- Error when fastening the load
- Unsuitable operation; especially angular pulling, breaking away stuck loads
- Wind action on suspended loads
- Errors during on-road driving, for example:
 - Overspeeding the engine when driving downhill
 - Driving with turned on differential lock
- Crashing into bridges, roofs or high voltage wires due to insufficient headroom
- Inadequate support; support base, substructure under the support plates
- Errors during assembly or removal of booms
- Incorrect positioning of the crane when it is taken out of service
- Exceeding the permissible wind speeds in operation and when out of service

In many cases, crane damage is caused by improper maintenance:

- Insufficient oil, grease or antifreeze
- Contamination
- Broken cable wires, defective tires, worn components
- Emergency limit switch or load torque limiter (LMB) not operating properly
- Brake and clutch failure
- Hydraulic defects; for example cracked hoses
- Loose bolts

14.2 Working on the crane superstructure or boom



WARNING

Danger of falling!

When working on the crane superstructure or boom, personnel must be secured with appropriate safety measures to prevent them from falling. If this is not observed, working personnel can fall and be killed or severely injured.

- ▶ For all work on the crane where there is a danger of falling, suitable safety measures must be taken.
- ▶ The crane superstructure or the boom may not be accessed without suitable aids.
- ▶ Suitable aids are, for example: Lifting platforms, scaffoldings, ladders, assembly platforms, auxiliary crane.
- ▶ If railings are present on the crane superstructure, then they must be swung into operating position and secured for all work, see Crane operating instructions, chapter 2.06.
- ▶ Step on aids and stepping surfaces on the crane only with clean shoes.
- ▶ Keep aids and stepping surfaces on the crane clean and free from snow and ice.
- ▶ If the work cannot be carried out with such aids nor from the ground, then the assembly personnel must secure themselves with supplied fall arrest systems to avoid falling, see section „Personal protective equipment“.
- ▶ It is prohibited to step on the driver's cab or crane cab roof and specially marked surfaces, see Crane operating instructions, chapter 2.05.

14.3 Obligations of the crane operator

1. Before starting to work, the crane operator must check the brake function and the emergency shut off devices. He must monitor the condition of the crane for obvious defects. On wireless controlled cranes, he must check the assignment of control unit and crane.
2. The crane operator must cease crane operation in case of problems endangering the safety.

3. The crane operator must report all defects on the crane to the appropriate supervisor, also to his replacement in case of crane change.
4. The crane operator must make sure that:
 - All control systems are set to neutral or idle position before release of the energy supply to the drive components.
 - The control systems are set to neutral or idle position and the energy supply is shut off before leaving the control platform.
 - When taking down the control unit for wireless control, the control unit is secured to prevent unauthorized operation.
5. The crane operator must ensure that cranes subjected to wind are not operated past the limits which were set by the crane manufacturer, and that the boom is taken down at least when the critical wind speeds for the crane are reached and at the end of the work.
6. The crane operator must monitor the load during all crane movements or the load handling equipment when moving the crane without a load, if they could cause a dangerous situation. If observation is not possible, then the crane operator may move the crane only with the aid of a guide.
7. The crane operator must give warning signs when necessary.
8. The crane operator may not move loads over personnel.
9. Any loads attached by hand may only be moved by the crane operator after he received a clear sign from the person who attached the load, the guide or any other responsible party which was assigned to that task by the contractor. If signals must be used to communicate with the crane operator, then these signals must be agreed upon before use between the responsible party and the crane operator. If the crane operator determines that the loads are not properly attached, then he may not move these loads.
10. As long as a load is suspended on the crane, the crane operator must keep the control systems within reach. This does not apply for towing of vehicles with towing cranes.
11. The crane operator may not run up to end positions operationally, if they are limited by the emergency limit switches.
12. After a load torque limiter was triggered, the crane operator may not pick up an overload by pulling in / raising the boom.
13. The crane operator may **not** bypass the overload protection to increase the hoisting power of the crane.

15 Selecting the location

In the following illustrations 1 to 3 the possible situations are shown as an example.

It is very important to choose an appropriate placement location in order to minimize safety risks.

It must always be possible to take down the crane in order to take down the crane in a timely manner in the case of unexpected weather conditions.

It must always be possible to position the crane in a safe out of service position.

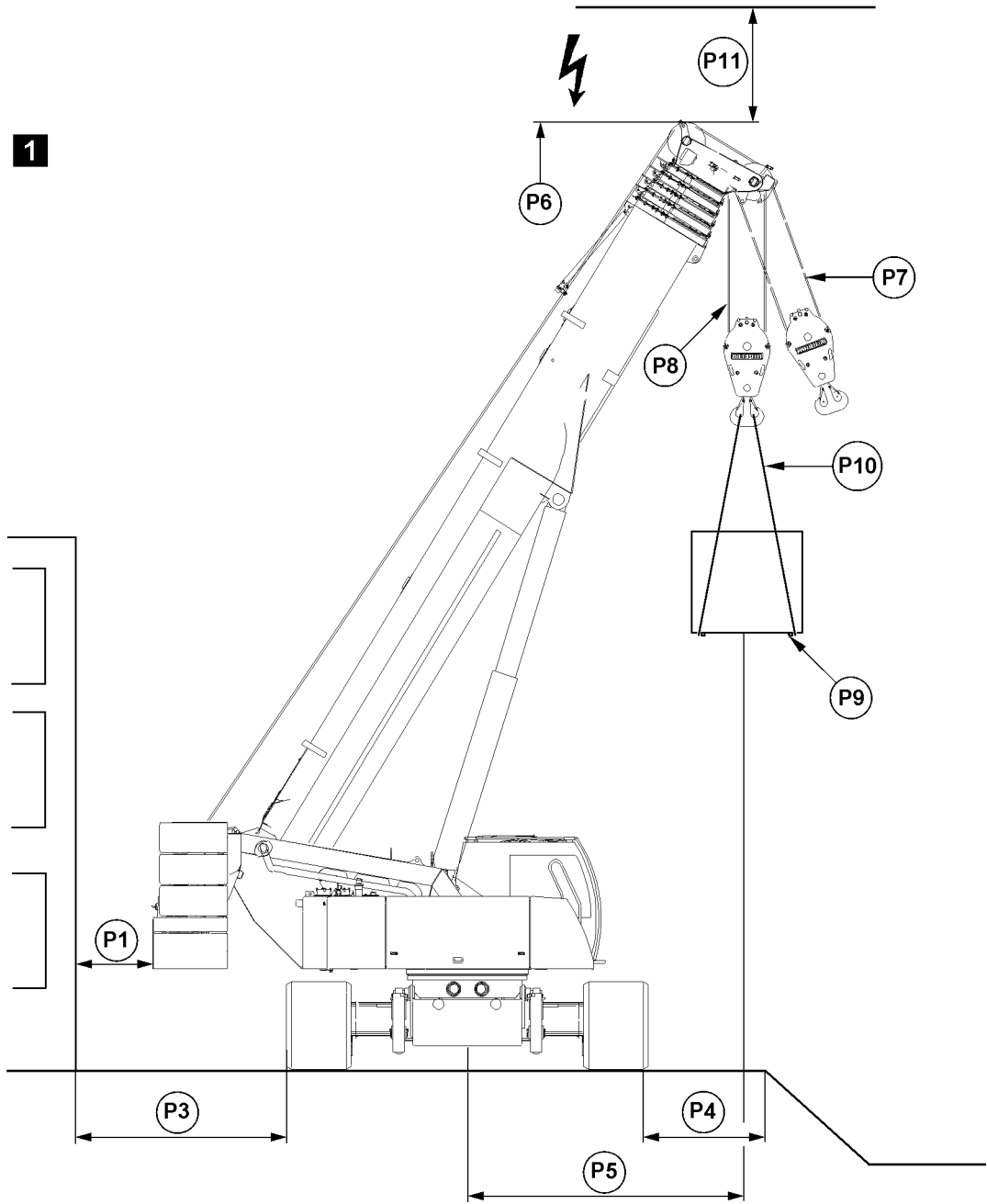

Fig.121166: Example for crawler crane with telescopic boom

LWE/LR 1600-2-008/18109-09-02/en

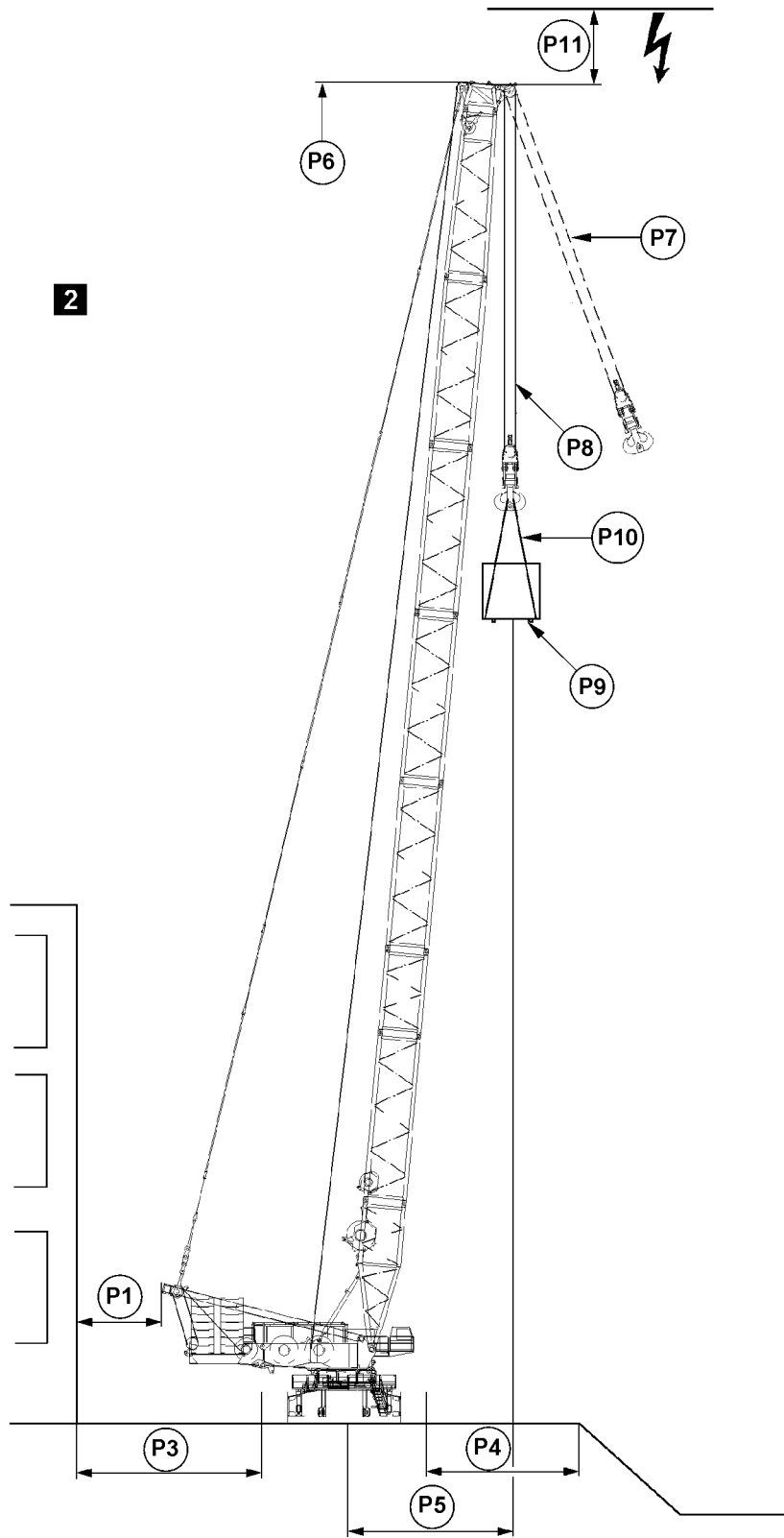

Fig.121167: Example for crawler crane with lattice mast boom

LWE/LR 1600-2-008/18109-09-02/en

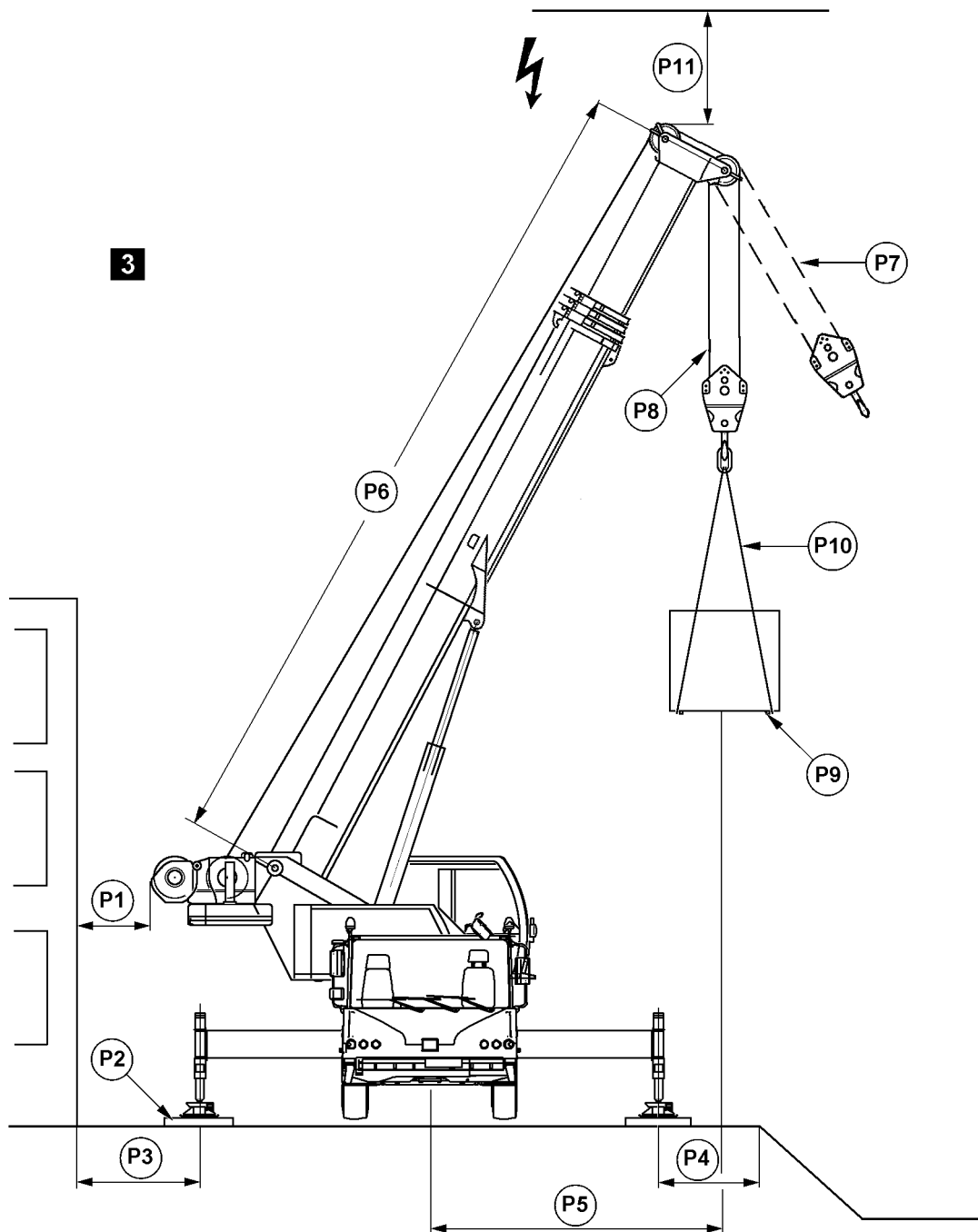

Fig.121168: Example for mobile cranes



DANGER

Danger of accidents due to ground with **insufficient** load bearing capacity!

If the crane is supported or driven on ground with **insufficient** load bearing capacity, then the crane can topple over and kill personnel.

- ▶ Only support or drive the crane on ground with sufficient load bearing capacity.
- ▶ Act responsibly when planning and selecting the crane location and route.
- ▶ Observe the following points.

Sign	When selecting the placement location for the crane, observe and adhere to the following:
P1	Select the placement location in such a way that crane movements can be carried out without collision and that the supports can be extended to the support base specified in the load charts. Make sure that no personnel is injured or killed. Always keep a safety distance of 0.5 m. If this is not possible, block the danger zone off.
P2	When crane support is required: Support the crane correctly and support the support plates large enough according to the load bearing capacity of the ground and the placement location.
P3	Maintain a safe distance from basements or similar.
P4	Maintain a safe distance from slopes or similar.
P5	Keep the boom radius as small as possible.
P6	Select the correct boom length for the load case.
P7	Angular pull is prohibited.
P8	Select the correct reeving of the hoist rope for the load case.
P9	Keep in mind the weight and the wind exposure surface of the load.
P10	Select fastening equipment according to the weight of the load, the type of attachment and the incline angle.
P11	Maintain a sufficient distance from electrical overhead wiring.

16 Slopes and excavations

In the following illustrations 4 and 5 the possible situations are shown as an example.

The crane may not be set up too close to slopes or excavations. Maintain adequate safety distance **A** and safety distance **B** in accordance with the type of soil.

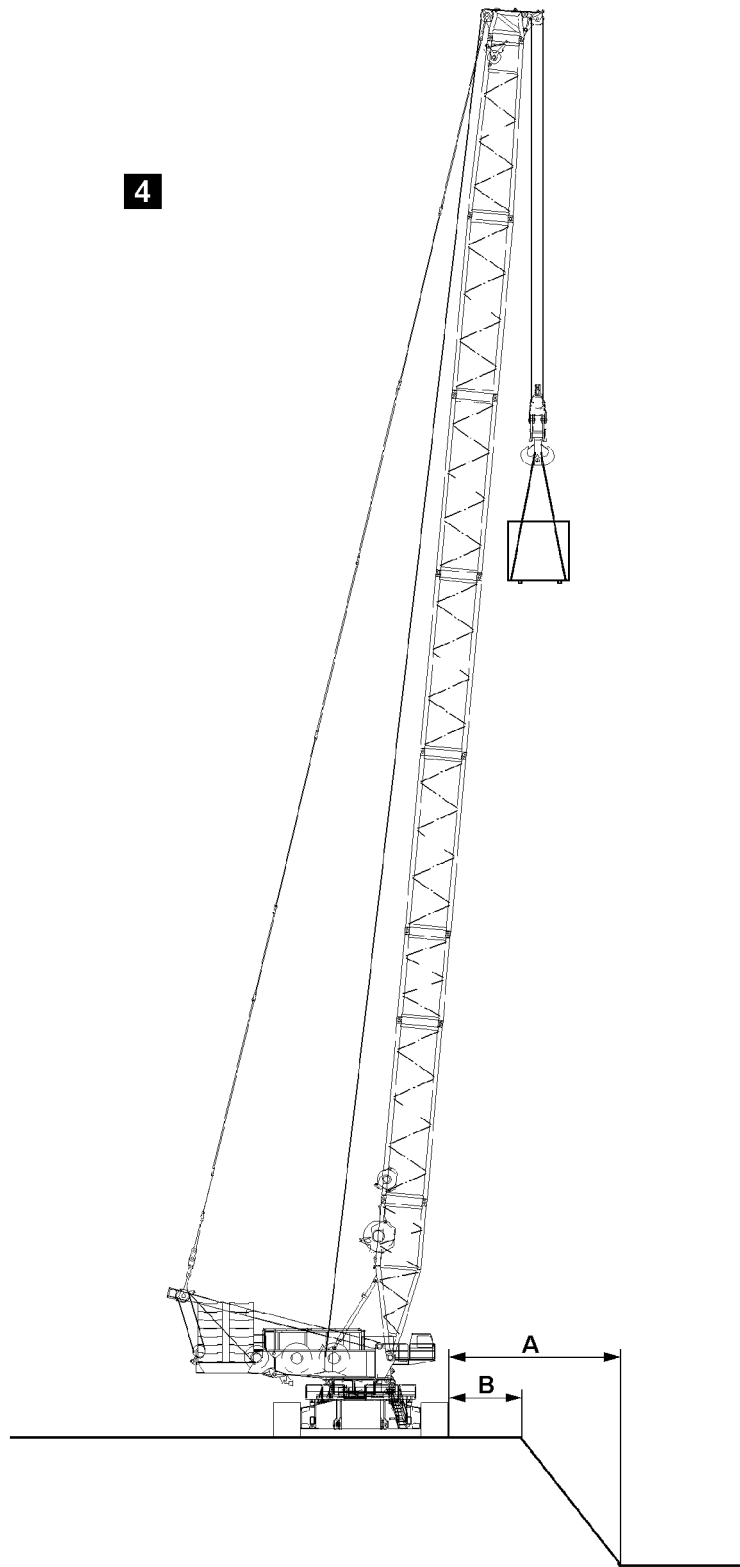

Fig.121162: Example for crawler cranes

- A** Distance to bottom of excavation
- B** Distance to excavation

LWE/LR 1600-2-008/18109-09-02/en

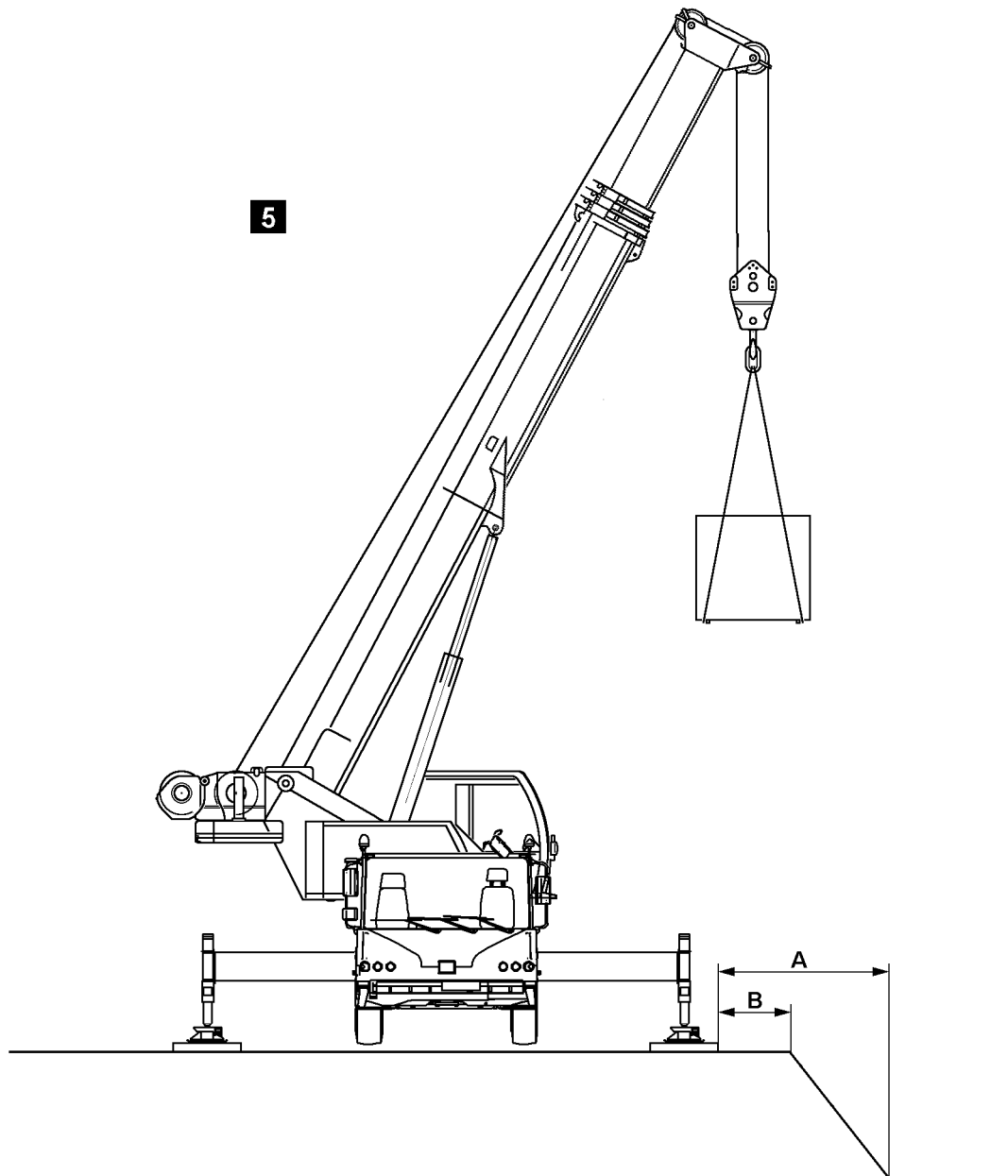

Fig.121163: Example for mobile cranes

- A** Distance to bottom of excavation **B** Distance to excavation



WARNING

Safety distance **A** or safety distance **B** are too small!
 The edge or the slope or the edge of the excavation can cave in.
 The crane can topple over. Death, severe bodily injuries, property damage.
 ► Maintain the safety distance **A** and safety distance **B**.

Have the safety distance **A** and safety distance **B** calculated by an authorized inspector.

17 Loads on the ground due to crane operation



Note

- ▶ Take into account that on a crane with high counterweight the crawler pressures or support forces at low load can be higher than at high load.

17.1 Load burdens on the ground on cranes on crawlers

For cranes on crawlers significant forces are transferred via the track pads of the crawlers into the ground (crawler pressures).

- The ground must be able to safely withstand the resulting pressure.
- If the area of the track pads is inadequate, then the crawlers must be supported from below according to the load bearing capacity of the ground.
- The required substructure can be calculated from the load bearing capacity of the ground and the crawler pressures of the crane.



WARNING

Load bearing capacity of the ground insufficient!
The ground can give, the crane can topple over.
Death or severe bodily injuries.

- ▶ Support large enough, according to the load bearing capacity of the ground with suitable materials, such as wooden beams or steel plates.

To obtain an even pressure distribution over the substructure surface:

- ▶ Set the crawlers centered on the substructure.



Note

- ▶ The respective ideal crawler pressure can be determined with the job planner program.

17.2 Load burdens on the ground on cranes on supports

When the crane is supported, significant forces (support forces) are transferred by the support cylinders via the support plates into the ground.

The ground must be able to safely withstand the resulting pressure.

If the support plate surface area is inadequate, then the support plates must be supported from below according to the load bearing capacity of the ground.

The required support surface areas can be calculated from the load bearing capacity of the ground and the support forces of the crane.



WARNING

Load bearing capacity of the ground insufficient!
The ground can give, the crane can topple over.
Death or severe bodily injuries.

- ▶ Support large enough, according to the load bearing capacity of the ground with suitable materials, such as wooden beams or steel plates.

To obtain an even pressure distribution over the substructure surface:

- ▶ Set the support plates centered on the substructure.

17.3 Examples for the load bearing capacity of the ground

Soil type		Permissible ground pressure [kN/m ²]
1.	Organic ground: Peat, sludge, muck	0
2.	Uncompacted fill: Construction debris	0 to 100
3.	Non-cohesive ground: Sand, gravel, rocks and mix	200
4.	Cohesive soil:	
	a) Clayed silt, mixed with topsoil	120
	b) Silt, consisting of poor clay and coarse clay	130
	c) Plastic clay, consisting of potter's clay and fill	
	Stiff	90
	Semi-solid	140
	Solid	200
	d) Mixed granular ground, clay to sand, gravel and rocky areas	
	Stiff	150
	Semi-solid	220
	Solid	330
5.	Rock in evenly solid condition:	
	a) Brittle, with traces of decomposition	1500
	b) Not brittle	4000

Examples: Permissible ground pressure of the ground

If there is any doubt about the load bearing capacity of the ground at the placement location, soil tests must be carried out by an authorized inspector, for example with a ram penetrometer.

17.4 Calculation examples

The following are general calculation examples. The values are used only to explain the calculation steps. The crane specific values are in chapter 1.03 of the crane operating instructions.

Example: Calculation of ground pressure of support plates for cranes on supports		□
Support force according to Crane operating instructions, chapter 1.03 for example: 720 kN	720 kN	
Surface of square support plate with 550 mm side length according to chapter 1.03, for example: 0.55 m x 0.55 m = 0.3 m ²	0.3 m ²	
80 % as carrying surface of support plate: 0.3 m ² x 0.8 = 0.24 m ²	0.24 m ²	
Ground pressure = Support force / load bearing surface support plate	720 kN / 0.24 m ² = 3000 kN/m ²	
Ground pressure per support:	3000 kN/m²	

Example: Calculation of ground pressure

- The value of the ground pressure is far higher than the permissible ground pressure for all types of granular soil.
- If this crane is utilized on bedrock, gravel type of ground, permissible ground pressure 200 kN/m², then the support surface must be increased.

Example: Calculation of required support surface for cranes on supports		□
Support force according to Crane operating instructions, chapter 1.03 for example: 720 kN	720 kN	
Ground pressure from chart <i>Permissible ground pressures</i> for example: 200 kN/m ²	200 kN/m ²	
Required support surface = Support force / permissible ground pressure	720 kN / 200 kN/m ² = 3.6 m ²	
Required support surface per support:	3.6 m²	

Example: Calculation of support surface

- The surface of the substructure for each support plate must be at least **3.6 m²**.
- The height of the substructure must be selected depending on the load distribution angle.



Note

- ▶ The corresponding ideal support forces can be determined with the Job planner.

17.5 LICCON job planner

The calculation of support forces and crawler pressures with the LICCON job planner are based on idealized assumptions: level and homogenous ground, rigid crane structure, no consideration in regard to wind.

Side deformations of the boom system due to wind, incline position and elastic compliance of the steel structure can lead to increase of support forces or to increase of crawler pressures.

The determination of the values, taking wind load on the crane and the load into account, as well as the elastic deformation of the crane can only be carried out by the crane manufacturer or a qualified authorized inspector.

17.5.1 Example for crane on crawler with derrick boom, suspended ballast and short (main) boom system

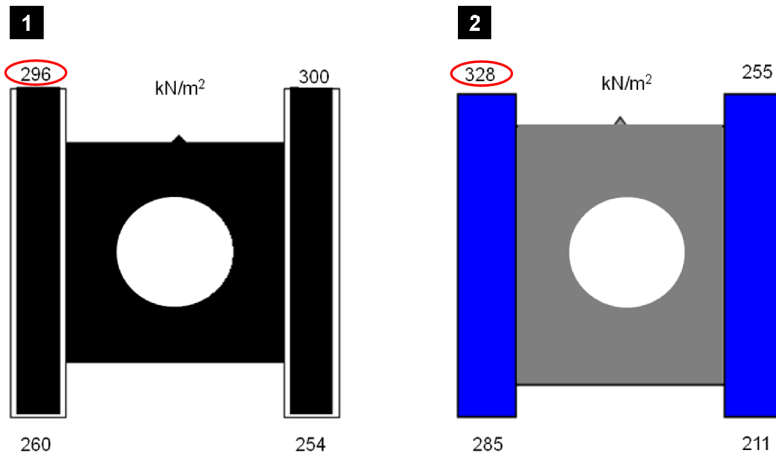

Fig.125052: Example for crane on crawler with derrick boom, suspended ballast and short (main) boom system

Illustration 1: Idealized crawler pressures from Job planner calculated with the aid of a rigid body system and no consideration regarding wind

Illustration 2: Idealized crawler pressures with consideration of elastic deformation and wind on crane and load

17.5.2 Example for crane on crawler with derrick boom, suspended ballast and long (main) boom system

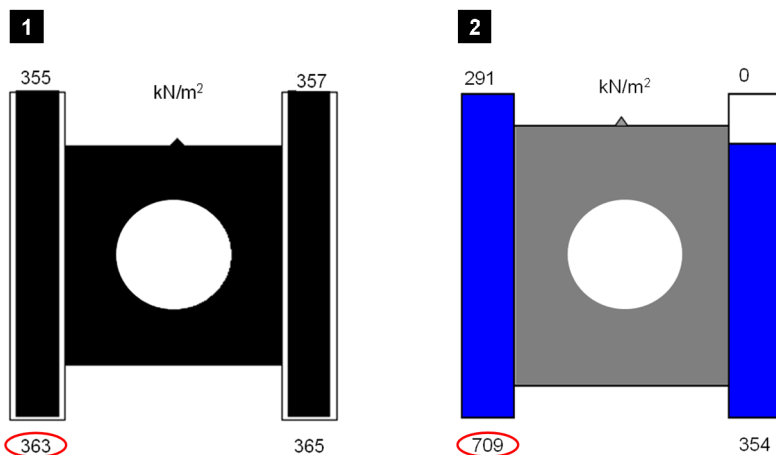

Fig.125053: Example for crane on crawler with derrick boom, suspended ballast and long (main) boom system

Illustration 1: Idealized crawler pressures from Job planner calculated with the aid of a rigid body system and no consideration regarding wind

Illustration 2: Idealized crawler pressures with consideration of elastic deformation and wind on crane and load

17.5.3 Example for crane on supports

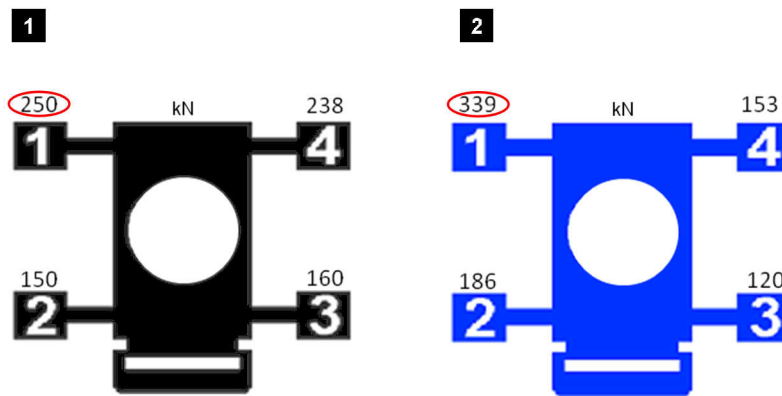

Fig.125054: Example for crane on supports

Illustration 1: Support forces from Job planner calculated with the aid of a rigid body system and no consideration regarding wind

Illustration 2: Support forces with consideration of elastic deformation and wind on crane and load

18 Support

18.1 Support plates

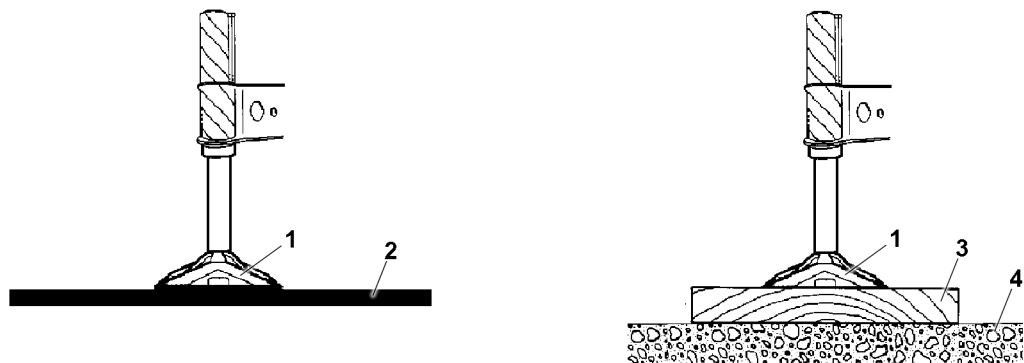

Fig.144244: Support plates

- | | | | |
|---|------------------------------------|---|---------------------------------|
| 1 | Support plate | 3 | Substructure |
| 2 | Ground (no substructure necessary) | 4 | Ground (substructure necessary) |

When supporting the crane, the support plates must lay horizontally on the ground or on the substructure.



WARNING

The support plate are **not** laying horizontally!
The crane can topple over, death, property damage.

- ▶ Before supporting the crane, align the support plates horizontally.

18.2 Supporting the crane



WARNING

The crane is **not** horizontally aligned!
The crane can topple over, death, property damage.
▶ Align the crane horizontally to 0.0° during the support procedure.



DANGER

The crane can topple over!
When actuating the supports with attached load and / or at loaded derrick ballast guying, the incline and the force conditions of the entire boom system change.
There is **no** shut-off by the LICCON overload protection.
The crane can topple over.
Personnel can be severely injured or killed.
▶ When a load is suspended it is prohibited to actuate the support.
▶ When the derrick ballast guying is loaded it is prohibited to actuate the support.

It is absolutely essential that the crane be supported with the support base exactly in accordance with the load chart to ensure safe crane operation.

The match of the sliding beams placement surfaces must be observed to ensure proper force transfer between the sliding beams.

The crane may only be supported in these extension conditions.



WARNING

The crane can topple over!
If only the sliding beams on the load side are extended, then the crane can topple over and kill personnel.
▶ Move all 4 sliding beams and support cylinders out according to the data in the load chart and pin.
▶ In intermediate positions between the support bases, do **not** support.
▶ Pin the sliding beams to support base according to the load chart.
▶ Fully insert and secure the pins.



WARNING

Risk of toppling the crane due to incorrect extension of the sliding beams!
The load suspended on the hook causes tension and deformation of the hoist rope and telescopic boom. The same applies for operation with lattice jib and guy ropes. If the load is dropped from the fastening ropes or if the fastening or hoist rope breaks in this situation, a sudden relief occurs. The boom snaps back quickly. This can cause the crane to topple over.
Despite previous assumption, it might become necessary to swing the load to the opposite side. This can cause the crane to topple over.
The boom and / or counterweight momentum may cause the crane to topple when turning from the longitudinal vehicle direction.
▶ Extend all 4 sliding beams and support cylinders according to the data in the load chart.

18.3 Supporting the crane with *variable support*

When supporting the crane with *variable support* special measures are required. These measures are described in detail in the Crane operating instructions, chapter 6.26.

19 Aligning the crane

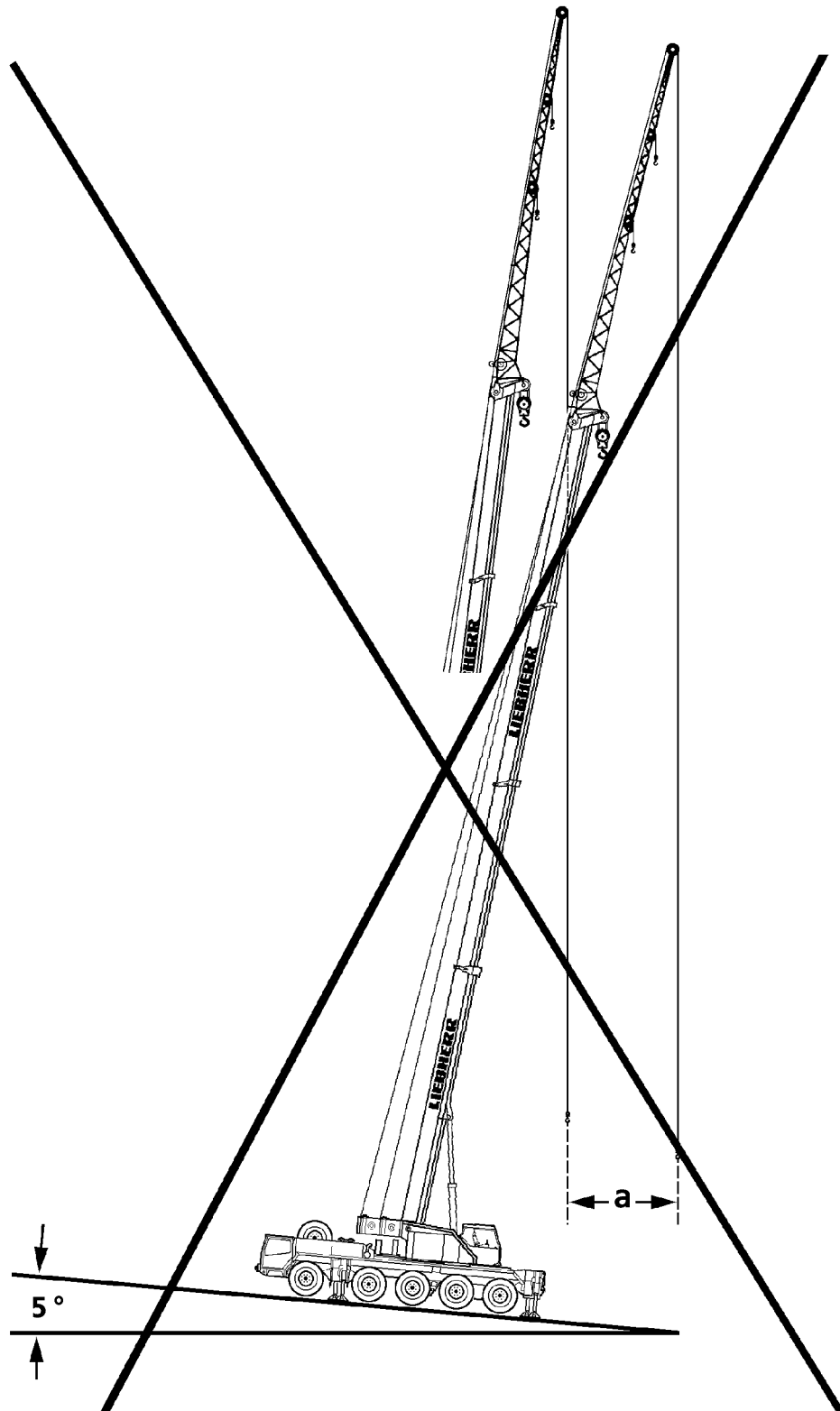

Fig. 121164: Example for **non-permissible** incline position

In addition to the proper substructure for the supports, the horizontal alignment of the crane is of utmost importance for safe crane operation.

**DANGER**

The crane can topple over due to the incline position!

If the crane is positioned at an incline, and if the boom is turned towards the slope, then the boom radius is increased as a result.

It is possible that the slewing gear can no longer hold the crane superstructure and, in extreme cases, the crane can topple over.

Personnel can be severely injured or killed.

▶ Align the crane horizontally before starting crane operation.

If the horizontal alignment of the crane has to be readjusted:

▶ Set the load down on the ground before readjusting the crane.

For cranes on crawlers, readjustment is **not** possible:

▶ If possible, use load charts for limited terrain incline.

Example: At a boom length of 50 m, an incline position of the crane by only 5° at a boom radius of 10 m causes an increase of the radius of $a = 4$ m.

20 Checking the safety measures

- The placement location has been selected so that all planned lifts included in the load chart for the erected set up configuration can be lifted.
- The load bearing capacity of the ground is adequate.
- There is safe clearance to excavations and slopes.
- There are no live transmission wires within the working range of the crane.
- There are no obstacles that will hinder required crane movements.
- The crane is horizontally aligned.
- When crane support is required:
 - All four sliding beams and support cylinders have been extended according to the support base given in the load chart.
 - The sliding beams have been secured with pins to prevent them from moving.
 - The support plates are pinned and secured in the operating position.
- On mobile cranes:
 - The axle suspension is blocked.
 - The axles are relieved, which means the tires do not touch the ground.

21 Safety guidelines in case of external power supply



Fig.197720

A potential danger exists when supplying a crane with an external power supply from a low voltage distribution system (100 V AC to 400 V AC).

A special electrical hazard is present when a protective conductor is interrupted (caused by the mechanical stress on flexible supply lines or the service connection), loose terminal connections, high wire or contact resistance, mixed up conductors, defective or missing protective equipment (FI / fault interrupters) in combination with a body contact on the crane.



WARNING

Danger of fatal injury if the body conducts current!

Water and / or defective devices can cause hazardous stray voltages when touched. The person touching the crane is subject to lethal currents.

- ▶ The external supply cable must be in good working order.

Make sure that the external flexible supply cable is in good working order.

Where applicable, we recommend the use of a power isolating transformer.

22 Grounding

22.1 Grounding the crane



WARNING

Danger of fatal injury due to electric shock!

There is a danger of electrical shock, if the crane is not properly grounded.

- ▶ Properly ground the crane.
- ▶ Make sure that there is a potential equalization between the crane and the ground.

The crane must be grounded before start up:

- Near transmitters (radio and TV transmitters, radio stations, etc.)

- Near high frequency switching stations
- In case of severe possibility of thunderstorms or potential thunderstorms

The crane can become electrostatically charged, especially if the crane is equipped with synthetic support mats or if the support mats are placed on insulating materials (such as wooden planks).

22.2 Grounding the load



WARNING

Danger of fatal injury due to electric shock!

There is a danger of electrical shock, if the load is not properly grounded.

- ▶ Properly ground the load.
 - ▶ Make sure that there is a potential equalization between the load and the ground.
-

The load must be grounded before start up:

- Near transmitters (radio and TV transmitters, radio stations, etc.)
- Near high frequency switching stations
- In case of severe possibility of thunderstorms or potential thunderstorms

The load can become electrostatically charged, even if the crane is grounded. This applies in particular if a hook block with pulleys made of synthetic material and non-conductive fastening equipment (for example plastic or manila ropes) are used.

23 Working in the vicinity of transmitters

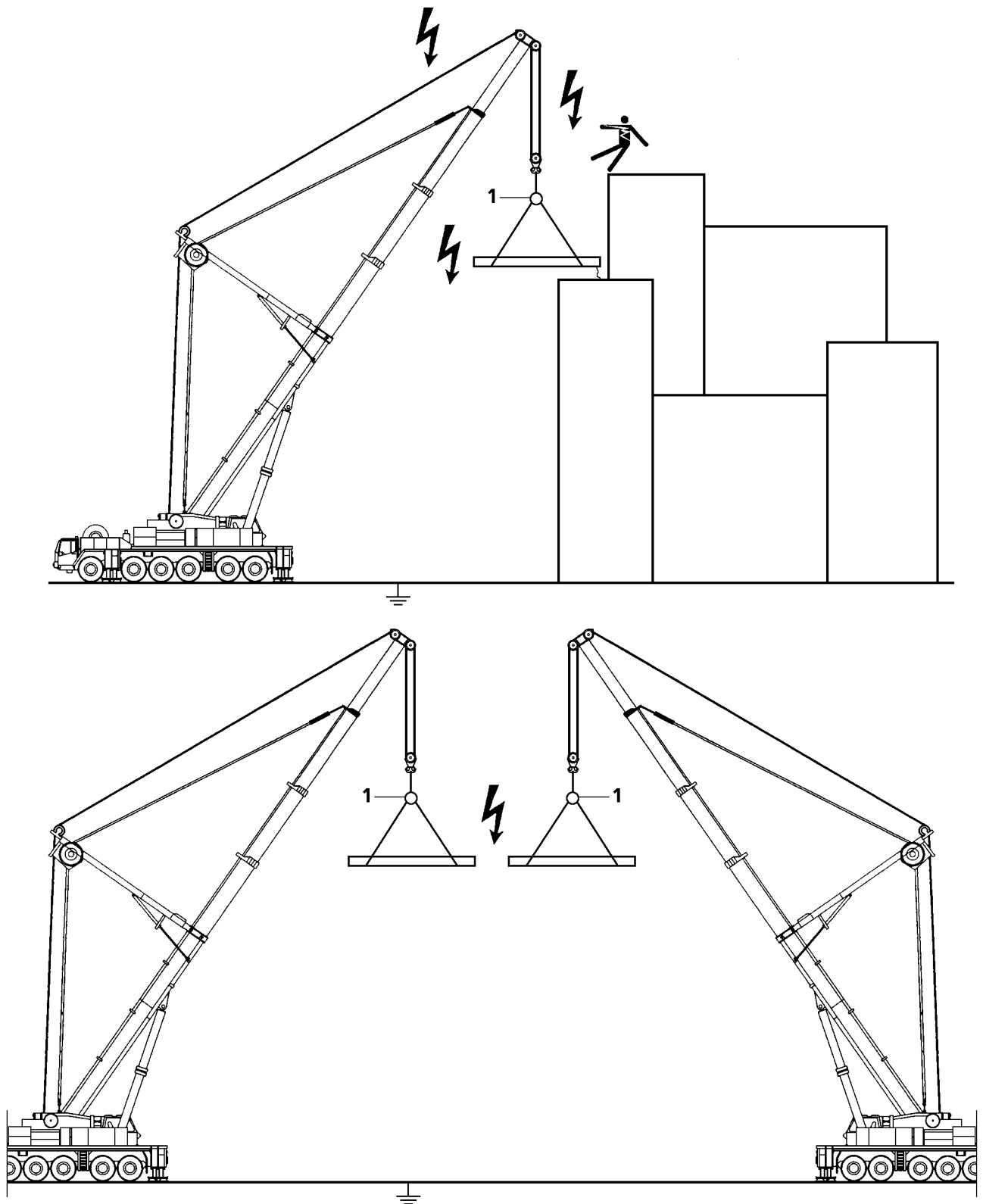

Fig.121165: Example for electrostatic charge

Strong electromagnetic fields are likely to be present if the construction site is close to a transmitter.

These electromagnetic fields can pose direct or indirect danger to persons or objects, for example:

- Effect on human organs due to temperature increase.

- Danger of burns or inflammation due to temperature increase.
- Spark or electric arc formation.



DANGER

Danger due to electromagnetic fields!

- ▶ Before operating a crane in the vicinity of transmitters, be sure to consult with Liebherr-Werk Ehingen GmbH.
- ▶ Also consult a high frequency specialist.

High frequency (HF) radiation from a transmitter requires supplementary work safety protection and special environmental specifications for crane operators and personnel:

1. Each crane must be „fully“ grounded. Check visually or with a simple continuity tester to ensure that ladder, crane cab and rope pulleys are grounded.
2. All personnel working on the crane or with large metal objects must protect themselves from burns by wearing non-conductive synthetic gloves and suitable clothing while working.
3. There is no need to panic if you feel your hand warm up. Always work under the assumption that the respective workpiece, structural steel member or support is „hot“.
4. The temperature of objects affected by high frequency radiation depends on their „size“. Cranes, carriers and coverings, for example, are „hotter“.
5. Contact with other crane loads is not permitted when operating the crane (arcing). Since defects caused by burns considerably reduce rope's load bearing capacity, any such occurrences must be reported immediately to the customer service of Liebherr-Werk Ehingen GmbH so that the ropes can be inspected.
6. An insulator **1** is required at all times between the crane load hook and fastening equipment. It is strictly prohibited to remove this insulator **1**.
7. Do not touch the ropes above the insulator **1**.
8. Loads that are attached to the crane may not be touched by any unprotected parts of the body after the load has been lifted or set down.
9. Do not work with a bare upper torso or in short pants, this is prohibited.
10. To minimize absorption of high-frequency radiation, larger loads should be transported horizontally if possible.
11. Loads must be grounded, or additional insulation used (rubber material between the object and gloves) when manual work is required.
12. Use a suitable measuring instrument to check the „temperature“ of the workpiece.
For example, if 500 V can be measured on a workpiece at a distance of 1 cm to 2 cm, then the workpiece may not be touched with bare hands.
The greater the distance, the higher is the voltage on the object:
At 10 cm distance, approx. 600 V are present, at 30 cm distance approx. 2000 V are present.
13. When refueling the crane, it must be ensured that no sparks are created within a radius of 6 m, neither by handling larger metallic parts nor by other work.
14. To avoid secondary accidents, use personal protective equipment when working on components that are high off the ground.
15. Any accidents and unexpected events must immediately be reported to the local construction supervisor and the safety engineer.

24 Crane operation in case of thunderstorms

In weather conditions, which can include lightning:

- Stop work on the crane.
- If possible, take the load down.
- If possible, telescope the boom in and / or take it down in the boom receptacle and bring it into a safe condition.

If this is not possible, the crane cab must remain occupied by the crane operator to keep the crane and the load always under control.

**WARNING**

Danger of accidents due to lightning strikes!

- ▶ Make sure that there are no persons near the immediate area of the crane.

25 Wind influences

**Note**

- ▶ The wind speeds are valid for a 360° wind direction for a 3-second wind gust at the highest point of the crane.

**WARNING**

Disregard of permissible wind speeds!

If the permissible wind speeds are disregarded, the crane can topple over. Personnel can be severely injured or killed.

- ▶ It is prohibited to erect the crane to measure the wind speed.
- ▶ Observe the permissible wind speeds depending on the assembly / crane conditions and act accordingly, see following chart.

Assembly / crane conditions	Reference for permissible wind speed
Erection and take-down of various boom configurations	Wind speed charts and / or erection and take-down charts.
Crane operation	Load chart manual
When the permissible wind speed according to the load charts is exceeded in crane operation, then crane operation is prohibited .	Wind speed charts
Interruption of crane operation when crane remains equipped	Wind speed charts
Crane out of operation, when crane remains equipped	Wind speed charts

**Note**

No wind speed charts available!

For a set up configuration for which no wind speed charts are available:

- ▶ Observe and adhere the maximum wind speeds of the load charts.

The wind load on the crane boom has **not** been taken into account for the planning of crane operation with the LICCON job planner.

- As a result, the actual values of the support force and / or the crawler pressure can be significantly higher than the values determined with the LICCON Job planner.
- The wind affecting the crane and the load, the elastic distortion of the crane structure, incline position as well as wind exposure surface (A_w) per ton of hoist load larger than 1.2 m²/t can significantly increase the support force and / or the crawler pressure.

**WARNING**

Increase of support force and / or the crawler pressure!

The resulting pressure on the ground becomes larger.

The permissible ground pressure can be exceeded.

- ▶ Do not exceed the permissible ground pressure.

**Note**

- ▶ The determining factor for all crane work in the actual wind speed at the job site of the crane.
- ▶ The current wind speed can be checked at the nearest weather bureau.
- ▶ Be aware that the wind speed on the boom jib is higher than near the ground.
- ▶ Always observe the national valid regulations.

25.1 Wind speed charts for *variable support*

For *variable support*: Observe and adhere to the wind speed charts according to the support base for the smallest extension length of the sliding beams.

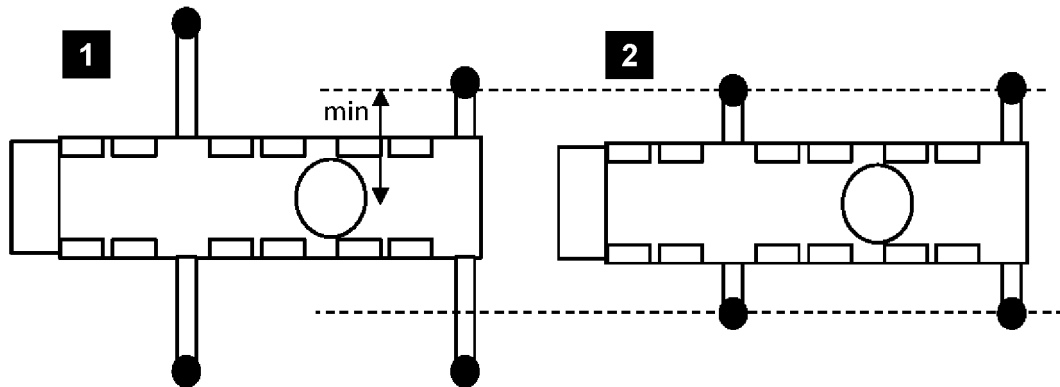

Fig.121577: Example for the selection of wind speed charts for *variable support*

Example for the selection of wind speed charts for *variable support*:

- The crane is supported with *variable support* according to illustration 1.
- Select wind speed charts according to the support base in illustration 2.

**Note**

No wind speed charts available!

If the smallest extension length of a sliding beam is less than those of the wind speed charts on hand:

- ▶ Observe and adhere the maximum wind speeds of the load charts.

25.2 Wind speed, wind gust speed and wind direction

The depiction of the wind is made by statement of wind speed (wind force), wind gust speed and wind direction.

High above the ground, the wind is less influenced by the surface condition of the ground. In the lower layers of the atmosphere, the wind speed is reduced by the ground friction. One differentiates between roughness of terrain, influence of obstacles and influence of terrain contours. Vegetation, buildings etc have great influence on the wind speed, wind gust speed and wind direction.

The site selection is thus especially important for wind measurement.

The wind speed, wind gust speed and wind direction are subject to significant time and local fluctuations. For that reason it is important to have reliable information regarding the expected wind speed, wind gust speed and wind direction during a load lift and to carry out exact wind measurements.

For mobile cranes, always assume a wind load of 360°. The determining factor is the „3 second gust speed“ on the highest point of the boom.

25.3 Measurement of wind speed

The anemometer installed on the crane boom measures the wind speed on the tip of the boom and shows the current wind speed in the crane cab.

The function of the anemometer must be checked every time before erection of the boom by manually actuating the shell start for easy movement and proper function.

Before lifting a load, especially with large wind exposure surface, the wind speed and the wind direction expected during the lift must be known. Information can be obtained for example at the local weather bureau. The determining factor is the „3 second gust speed“ on the highest point of the boom.



WARNING

Overload of crane!

The acoustic wind warning is only issued if the standard wind exposure surface in the load chart is exceeded (wind surface per ton load: 1 m², drag coefficient: 1.2) given wind speed.

If the permissible wind speed must be reduced for loads due to large wind exposure surfaces, no acoustic wind warning is issued.

There is no shut-off of crane movement.

- ▶ The wind exposure surface and the wind resistance coefficient for the load to be lifted must be known.
- ▶ The maximum permissible wind speed specified in the load chart must be reduced for large wind exposure surfaces as described in the load chart manual chapter "Wind influences during crane operation".

For safe determination of wind speed, the crane must be turned before application by 360°. The highest measured value while doing so must be compared with the „maximum permissible wind speed“ for the load according to the load chart. Thus the possibility that the result of the measurement is distorted due to nearby buildings, cranes or components is eliminated.

In gusty wind conditions, the probability of sudden high wind speed increases. In gusty wind conditions no large surface loads may be lifted.



Note

- ▶ If in doubt and in case of questions for further information and / or training in the area of „Wind influences in crane operation“ contact the Customer Service at Liebherr-Werk Ebingen GmbH.

25.4 Conversion chart for wind force



Note

- ▶ The influence of the wind on the surrounding is described clearly in the Beaufort scale to provide an orientation for the crane driver.
- ▶ The wind force of the Beaufort scale refers to the wind speed determined over 10 minutes at a height of 10 m.

Beaufort number	Wind force Designation	Wind speed		Effect of the wind Inland
		[m/s]	[km/h]	
0	Calm	0 to 0.2	1	Calm, smoke rises vertically
1	Slight air movement (draft)	0.3 to 1.5	1 to 5	Wind direction is shown only by observing the trail of smoke, not by the wind sock
2	Light breeze	1.6 to 3.3	6 to 11	Wind can be felt on the face, the leaves rustle, wind sock moves slightly
3	Gentle breeze	3.4 to 5.4	12 to 19	Leaves and small twigs in constant motion Wind extends a flag
4	Moderate breeze	5.5 to 7.9	20 to 28	Swirls up dust and loose paper, moves twigs and thin branches

Wind force		Wind speed		Effect of the wind Inland
Beaufort number	Designation	[m/s]	[km/h]	
5	Fresh breeze	8.0 to 10.7	29 to 38	Small deciduous trees begin to sway, whitecaps form at sea
6	Strong breeze	10.8 to 13.8	39 to 49	Thicker branches move; telephone lines begin to whistle, umbrellas are difficult to use
7	Near gale	13.9 to 17.1	50 to 61	Entire trees swaying; difficult to walk into wind
8	Gale force wind	17.2 to 20.7	62 to 74	Breaks branches off trees, impedes walking in open areas considerably
9	Gale	20.8 to 24.4	75 to 88	Minor damage to property (chimney caps and roofing tile are blown off)
10	Severe storm	24.5 to 28.4	89 to 102	Trees are uprooted, significant damage to property
11	Violent storm	28.5 to 32.6	103 to 117	Extensive, widespread storm damage
12	Hurricane	32.7 and more	118 and more	Major destruction

Beaufort scale

25.5 Height dependant wind speed



Note

- ▶ The maximum permissible wind speed (v_{max}) and the maximum permissible wind speed according to the load chart (v_{max_TAB}) always refer to the 3 second wind gust speed, which is present at the maximum height of the crane.
- ▶ Instead of the 3 second wind gust speed, weather information services often report a wind speed (v_m), which is averaged within a time period of 10 minutes (so-called 10 minute average). It refers to the wind force on the Beaufort scale, normally to the medium value of the wind speed, which is determined within a time from of 10 minutes at a height of 10 m above ground or above sea level.
- ▶ The determining factor for the calculation of the 3 second wind gust speed in maximum height of the crane is significantly higher than the medium value of the wind speed, which is determined over a time of 10 minutes at a height of 10 m above ground.



Note

- ▶ The following chart shows the 3-second wind gust speed depending on the height and the Beaufort number and / or the wind speed determined over a time of 10 minutes at a height of 10 m.
- ▶ With the aid of this chart the 3-second wind gust speed for a certain height can be determined.

Beaufort number	3	4	5 ^a	5	6	7 ^a	7	8	9	10
v_m [m/s ^b]	5.4	7.9	10.1	10.7	13.8	14.3	17.1	20.7	24.4	28.4
z [m]	$v(z)$ [m/s]									
10	7.6	11.1	14.1	15.0	19.3	20.0	23.9	29.0	34.2	39.8
20	8.1	11.9	15.2	16.1	20.7	21.5	25.7	31.1	36.6	42.7
30	8.5	12.4	15.8	16.8	21.6	22.4	26.8	32.4	38.2	44.5
40	8.7	12.8	16.3	17.3	22.3	23.1	27.6	33.4	39.4	45.8
50	8.9	13.1	16.7	17.7	22.8	23.6	28.3	34.2	40.3	46.9

Beaufort number	3	4	5 ^a	5	6	7 ^a	7	8	9	10
60	9.1	13.3	17.0	18.0	23.3	24.1	28.8	34.9	41.1	47.9
70	9.3	13.5	17.3	18.3	23.6	24.5	29.3	35.5	41.8	48.7
80	9.4	13.7	17.6	18.6	24.0	24.8	29.7	36.0	42.4	49.4
90	9.5	13.9	17.8	18.8	24.3	25.1	30.1	36.4	42.9	50.0
100	9.6	14.1	18.0	19.1	24.6	25.4	30.4	36.9	43.4	50.6
110	9.7	14.2	18.2	19.2	24.8	25.7	30.8	37.2	43.9	51.1
120	9.8	14.3	18.3	19.4	25.1	25.9	31.1	37.6	44.3	51.6
130	9.9	14.5	18.5	19.6	25.3	26.2	31.3	37.9	44.7	52.0
140	10.0	14.6	18.7	19.8	25.5	26.4	31.6	38.2	45.1	52.5
150	10.0	14.7	18.8	19.9	25.7	26.6	31.8	38.5	45.4	52.9
160	10.1	14.8	18.9	20.1	25.9	26.8	32.1	38.8	45.7	53.2
170	10.2	14.9	19.1	20.2	26.0	27.0	32.3	39.1	46.0	53.6
180	10.3	15.0	19.2	20.3	26.2	27.1	32.5	39.3	46.3	53.9
190	10.3	15.1	19.3	20.4	26.4	27.3	32.7	39.5	46.6	54.2
200	10.4	15.2	19.4	20.6	26.5	27.4	32.8	39.8	46.9	54.6
^a Wind stages for the crane in operation: 1 light $v_m = 10.1$ m/s at $z = 10$ m $v(z) = 14.1$ m/s $q(z) = 125$ N/m ² 2 normal $v_m = 14.3$ m/s at $z = 10$ m $v(z) = 20.0$ m/s $q(z) = 250$ N/m ²										
^b Upper limit of Beaufort scale										

3-second wind gust speed depending on the height and the Beaufort number and / or the wind speed determined over a time of 10 minutes at a height of 10 m

Sign	Unit	Definition
v_m	[m/s]	Wind speed determined over a time of 10 minutes at a height of 10 m
z	[m]	Height above level ground
$v(z)$	[m/s]	Speed effective at height z , decisive for the calculation of a 3 second gust
$q(z)$	[N/m ²]	At a height z effective quasi-static back pressure, determined from $v(z)$

Symbol

25.6 Wind influences during erection and take-down



WARNING

The crane can topple over!

If a boom or a boom system is erected or taken down and the expected wind speeds are larger than the maximum permissible wind speeds according to the wind speed chart, then the crane can topple over and fatally injure personnel.

- ▶ If wind speeds are expected which are larger than the maximum permissible wind speeds for erection, then erection of the boom or erection of the boom system is prohibited.
- ▶ If wind speeds are expected, which are larger than the maximum permissible wind speeds for take-down, then the boom or the boom system must be taken down immediately.

**WARNING**

Wind speed higher than permissible!

When the permissible wind speed for „Crane out of operation“ is higher than the permissible wind speed for take-down: Take-down of the boom is not permissible in case of unexpected increase of wind speed.

The crane can topple over! Death, severe injury, property damage.

- ▶ If wind speeds are expected that are higher than the maximum permissible wind speeds for "Crane out of operation", then take the equipment and the boom down.
- ▶ Always take the boom down for safety reasons if weather conditions are unclear, see the Erection and take-down charts.
- ▶ Observe the permissible wind speeds for take-down.

25.7 Wind influences during crane operation

**WARNING**

The crane can topple over!

Unforeseeable factors, such as sudden wind gusts on the crane and the load cannot be exactly predicted in advance.

- ▶ The size and shape of the load has a significant influence on the permissible wind speed during crane operation.
- ▶ Carry out a professional job planning with authorized and trained expert personnel. All environmental conditions, such as weather forecast and wind speeds must be taken into account.
- ▶ The authorized and trained expert personnel must have sufficient knowledge in the area of „Wind influences in crane operation“.

**Note**

- ▶ Calculation examples are included in the load charts. If you need further information, contact Liebherr-Werk Ehingen GmbH.

Depending on crane application, for example:

1. Lifting of large surfaced loads.
2. Working with long boom combinations.
3. Erection and take-down of boom combinations.

The crane operator must check with appropriate information sources about the expected wind speeds, at:

1. The start of crane operation.
2. Interruption of crane operation.
3. Resumption of crane operation

**WARNING**

The crane can topple over!

If the crane is operated at wind speeds which are larger than the maximum permissible wind speeds according to the load chart, then the crane can topple over and kill personnel.

- ▶ If wind speeds are expected that are larger than the maximum permissible wind speeds for the equipped crane, then the equipment and the boom must be taken down.
- ▶ If wind speeds are expected that are larger than the maximum permissible winds speeds for crane operation, then it is prohibited to lift a load.

25.8 Wind influences for „Crane out of operation“



WARNING

The crane can topple over! Death, severe injury, property damage!

If the crane is taken out of operation in set up condition and the expected wind speeds are higher than the maximum permissible wind speeds according to the wind chart, then the crane can topple over and fatally injure personnel.

- ▶ If wind speeds are expected that are higher than the maximum permissible wind speeds for „Crane out of operation“, then take the equipment and the boom down.
- ▶ Always take the boom down for safety reasons if weather conditions are unclear, see the Erection and take-down charts.
- ▶ Observe the permissible wind speeds for take-down.

26 Lifting a load with two cranes

Before lifting a load with two cranes, the crane operator or a representative of the operator must determine the work sequence and assign a responsible supervisory person for the operation. The responsible supervisor must monitor the operation and remain in constant contact with the crane operators.



WARNING

Overload and toppling of the cranes!

If the load is not lifted or lowered exactly evenly by both cranes, then the center of gravity changes. The cranes can be overloaded and topple over.

Personnel can be killed or seriously injured.

- ▶ Make sure that the cranes are horizontally aligned.
- ▶ Observe the national valid standards, regulations and accident prevention guidelines.
- ▶ Determine the utilization degree of the cranes in operation, depending on the complexity of the load lift.
- ▶ Plan for sufficient safety reserves.
- ▶ Avoid side load on the boom.
- ▶ Carry out crane movements synchronously and slowly.



Note

- ▶ The total weight and the center of gravity of the load must be known exactly.
- ▶ Carry out the job planning in detail and with care.
- ▶ Avoid fastening points below the center of gravity of the load.

When the operational conditions or the work to be carried out require:

- ▶ Set up an assembly plan and operating instructions for the operation.

In the drawing is shown how the center of gravity for the load changes if the load is lifted or lowered unevenly. Already a slight incline of the load can cause the crane to be overloaded.

If the load on crane 2 (F_2) is lowered, the load on crane 1 (F_1) increases. Crane 1 can thereby be overloaded.

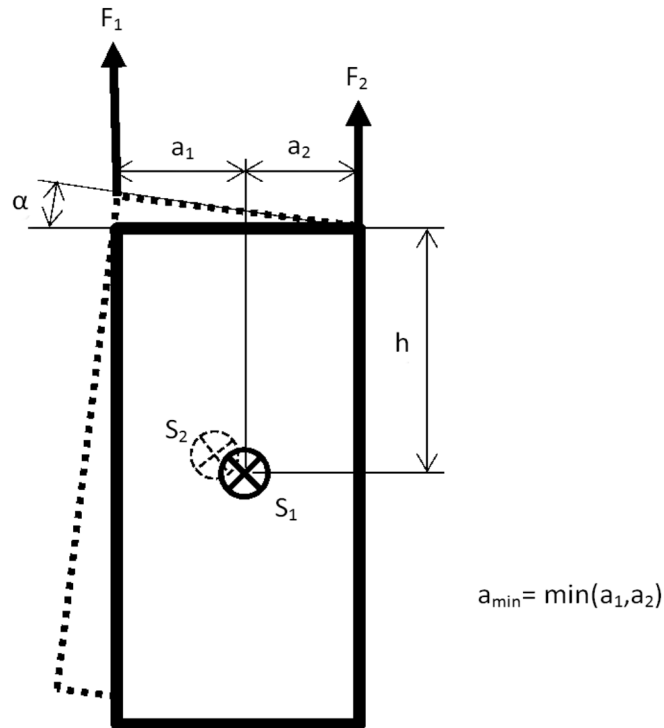

Fig.124126: Geometric conditions

F_1	Load on crane 1	F_2	Load on crane 2
S_1	Center of gravity of load	S_2	Center of gravity of load at incline position
h	Vertical distance between center of gravity of load and fastening points	α	Angle of load at incline position
a_1	Horizontal distance between center of gravity of load and fastening point crane 1	a_2	Horizontal distance between center of gravity of load and fastening point crane 2
a_{\min}	Smallest horizontal distance between center of gravity of load and fastening point (minimum from a_1 and a_2)		

The following diagram shows the dependence of the ratio of h/a_{\min} at a maximum permissible incline position of the load of 3° in reference to the permissible load utilization of cranes in percentages.

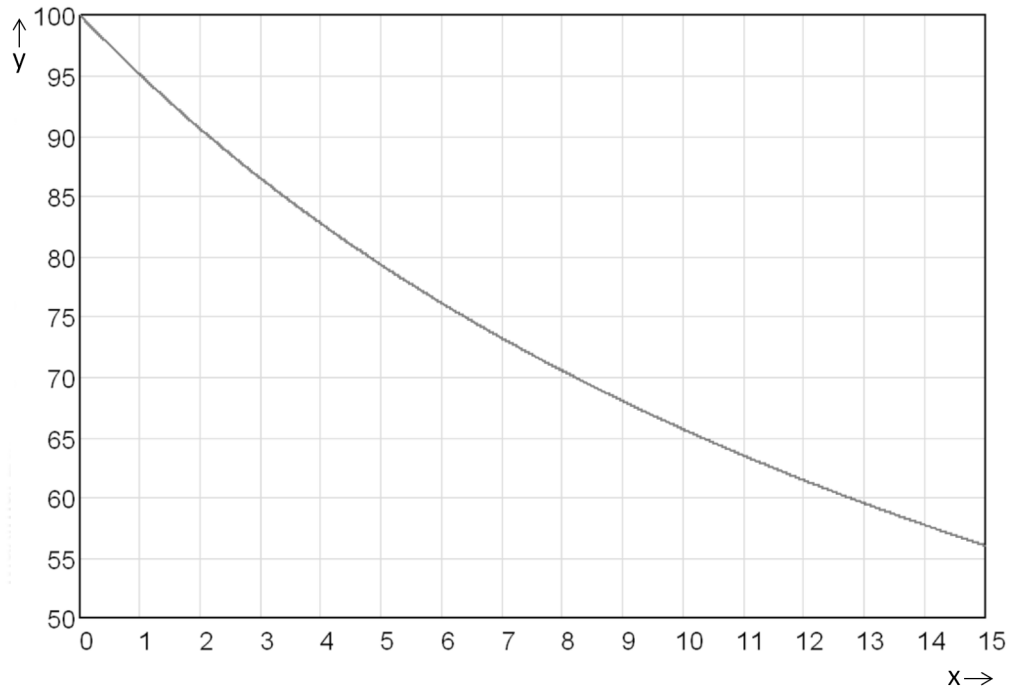

Fig.124127: Maximum permissible load utilization

- | | | | |
|----------|-------------------------|----------|--|
| x | Ratio of h to a_{min} | y | Maximum permissible load utilization in percentages, if α is smaller or equal to 3° |
|----------|-------------------------|----------|--|

Example: A ratio h to a_{min} of 6, when retaining the incline position of the load of maximum 3° results in a maximum permissible load utilization of both cranes of approx. 76 % each.

27 Working ranges of several cranes overlap



WARNING

Danger of collision!

If the working ranges of several cranes overlap, there is a danger of collision.

Personnel can be injured or killed.

Significant property damage can result.

- ▶ The contractor or his representative must determine the work sequence in detail in advance.
- ▶ The contractor or his representative must ensure flawless communication between crane operators.
- ▶ The crane operators must ensure through calm operating mode, that no collisions occur due to uncontrolled movements. The crane operators must have been trained and instructed accordingly.

If the communication between the crane operators is not ensured by sound or visual connection, then suitable measures must be taken, such as using radio communication, guides or similar. When using derrick booms or TY-guying, it is necessary to proceed with extreme caution as these components protrude far past the rear turning radius of the turntable.



Note

- ▶ If guides are used, then the signals must be agreed upon between them and the crane operators, see section „Hand signals for guidance“.

28 Hand signals for guidance

For all crane movements, the crane operator must always keep the load as well as the crane hook or load handling equipment when the crane is not loaded, in his field of vision.



WARNING

Danger of accident if standing under suspended loads!

- ▶ Always keep loads in sight.
- ▶ Standing under suspended loads is prohibited.

If this is not possible, the crane operator may only operate the crane if he is signed by an assigned guide.

The operator may be guided by hand signals or a two-way radio. It must be ensured that there are no misunderstandings.



WARNING

Danger of accident caused by misunderstood hand signals!

- ▶ Hand signals must be mutually agreed upon and clearly executed.
- ▶ In any case, **national regulations** must be observed.

28.1 Hand signals

28.1.1 Start operation, follow my instructions

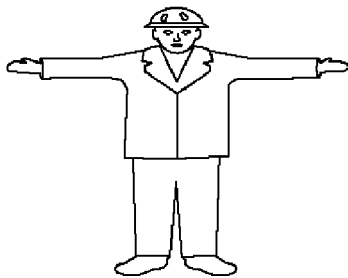

Fig.111700: Start operation, follow my instructions

Both arms stretched out horizontally with hands open and palms directed to the front.

28.1.2 Stop (normal stop)



Fig.144245: Stop (normal stop)

Arm stretched out, palm of hand facing down, move the arm horizontally backward and forward.

28.1.3 Emergency stop (quick stop)

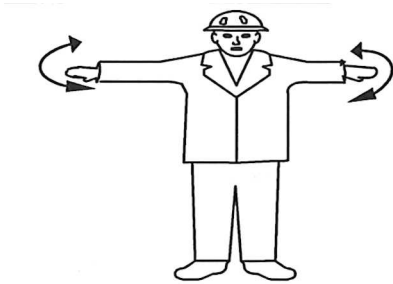

Fig.144246: Emergency stop (quick stop)

Both arms stretched out, both hand palms facing down, move arms horizontally backward and forward.

28.1.4 End operation, no longer follow my instructions

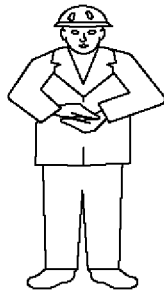

Fig.111703: End operation, no longer follow my instructions

Fold hands together at chest height in front of body.

28.1.5 Creeper gear or very slow movement

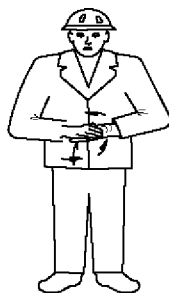

Fig.111704: Creeper gear or very slow movement

Rub palms together in circular motion. After this sign, all other applicable hand signals apply.

28.2 Vertical movements

28.2.1 Showing the vertical distance

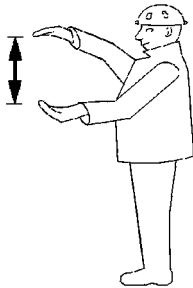

Fig.121364: Showing the vertical distance

Both arms stretched out in front of the body one on top of the other, with opposing palms.

28.2.2 Lifting / lowering a load with even speed



Fig.111706: Lifting / lowering a load with even speed

Lift one arm overhead with closed hand and index finger pointing upward, with small horizontal circular movements with forearm.

28.2.3 Lifting slowly



Fig.121365: Lifting slowly

Give lift signal with one hand, the other palm is not moving and positioned over the hand, which gives the signal.

28.2.4 Lowering the load while stationary

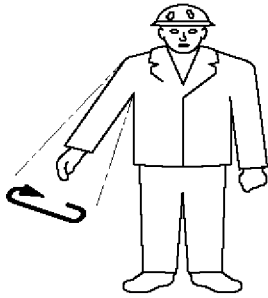

Fig.111708: Lowering the load while stationary

Point one arm away from the body, downward, with hand closed and index finger pointing down. Make small circular movements with forearm.

28.2.5 Lowering slowly



Fig.121366: Lowering slowly

Give lowering signal with one hand, do not move the other palm and hold it under the hand, pointing to the hand which gives the signal.

28.3 Horizontal movements

28.3.1 Driving / swinging in specified direction

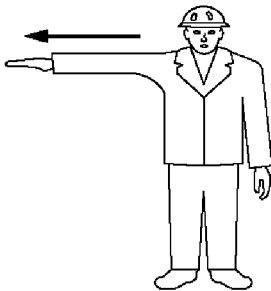

Fig.111710: Driving / swinging in specified direction

Hold stretched out arm horizontally into the desired direction, with the hand open and the palm pointing down.

28.3.2 Moving away from me

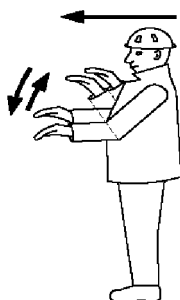

Fig.111711: Moving away from me

Stretch out both arms simultaneously with forearms in front, with both hands open and the palms pointing down. Move the forearms repeatedly between the horizontal and vertical position up and down.

28.3.3 Moving toward me

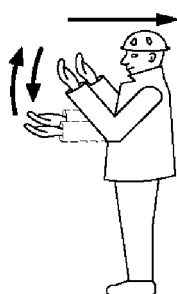

Fig.111712: Moving toward me

Stretch out both arms simultaneously with forearms vertically, with both hands open and the palms pointing to the rear. Move the forearms repeatedly up and down.

28.3.4 Moving both track chains

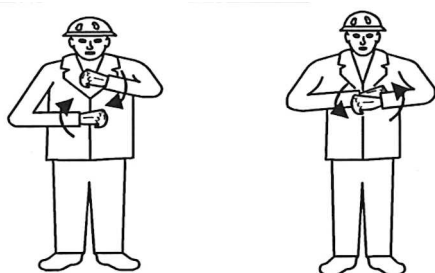

Fig.144247: Moving both track chains

Turn both fists around each other in front of the body in direction of the movement (forward or reverse).

28.3.5 Moving one track chain



Fig.144248: Moving one track chain

Lift one fist to show blockage of chain on one side. Turn the other fist vertically in front of the body to signal movement of the opposite chain.

28.3.6 Showing the horizontal distance

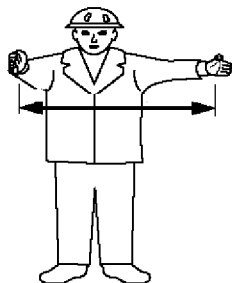

Fig.121380: Showing the horizontal distance

Keep both arms stretched out horizontally in front of the body with the palms opposite each other.

28.3.7 Transfer (between two cranes or two hooks)

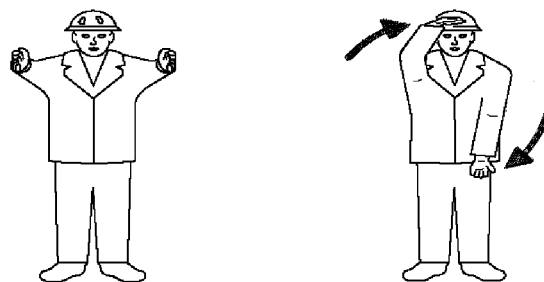

Fig.121368: Transfer (between two cranes or two hooks)

Hold both arms stretched out to the front, parallel and horizontally and turn by 90° in direction of the transfer.



WARNING

Load bearing capacity is **not** sufficient!

The crane can topple over, death, property damage.

- ▶ Make sure that the load bearing capacity of the individual crane and hook is sufficient even if the transfer of the load is suddenly asymmetric.

28.4 Machine related movements

28.4.1 Lifting with main winch

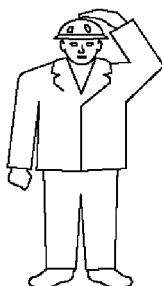

Fig.111719: Lifting with main winch

Place one hand on your head and hold the other arm on the side of the body.

After this signal all other hand signals apply only for the main winch.



Note

- ▶ If two or more main winches are present, then the signaller can show the number of the crane by pointing to it or signal with one finger.

28.4.2 Lifting with auxiliary winch



Fig.111720: Lifting with auxiliary winch

Hold one forearm vertically with closed hand and touch the elbow of this arm with the other hand.

After this signal all other hand signals apply only for the auxiliary winch.

28.4.3 Lifting the boom

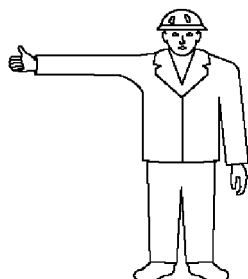

Fig.111721: Lifting the boom

Hold one arm horizontally with thumb directed upward.

28.4.4 Lowering the boom

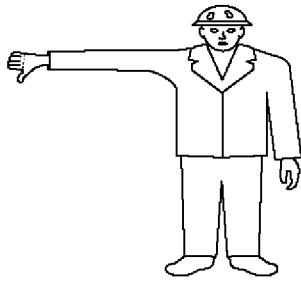

Fig.111722: Lowering the boom

Hold one arm horizontally with thumb directed downward.

28.4.5 Extending the boom



Fig.144249: Extending the boom

Hold both hands (with closed fists) stretched out to the front, with both thumbs directed away from each other.

28.4.6 Retracting the boom



Fig.144250: Retracting the boom

Hold both hands (with closed fists) stretched out to the front, with both thumbs directed toward each other.

28.4.7 Lifting the boom and lower the load at the same time

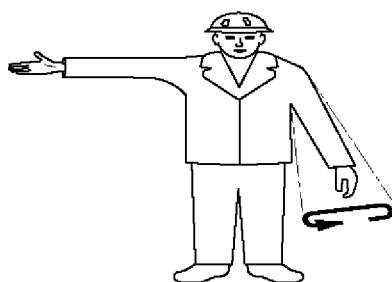

Fig.111725: Lifting the boom and lower the load at the same time

Hold one arm stretched out horizontally with thumb directed upward and stretch the other arm downward and away from the body, make small flat circles with the forearm.

28.4.8 Lowering the boom and lift the load at the same time

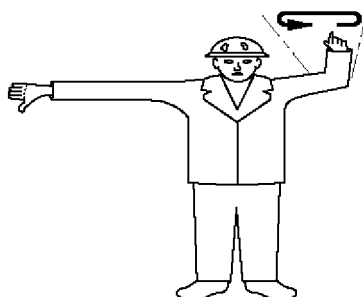

Fig.111726: Lowering the boom and lift the load at the same time

Hold one arm stretched out with thumb pointing down, stretch the other forearm upward and make small flat circles.

29 Travel operation

29.1 Starting to drive

Before starting to drive the crane

- Close all doors.
- Keep the doors closed during the travel operation.

29.2 Turning / driving in reverse



WARNING

Danger of accidents when turning or driving in reverse!

When turning or driving in reverse, personnel can be overlooked and killed.

Objects can be severely damaged.

- ▶ When turning or driving in reverse, the driver must act in such a way that he does not endanger other traffic participants.
- ▶ The driver may only drive in reverse or reset when persons or devices are **not** endangered. If this can **not** be ensured, then he must use a guide.
- ▶ An acoustical back up warning device will never replace the guide.
- ▶ Make sure that there are no persons or objects behind the vehicle when driving in reverse.
- ▶ Make sure that no personnel is injured or killed.
- ▶ Make sure that no objects are damaged.
- ▶ Driving in reverse is only permissible at slow driving speed (maneuvering speed).
- ▶ Adhere to the national regulations.

29.3 Driving with a trailer

Driving with a trailer depends on the weight of the mobile crane. The minimum weight of the mobile crane in trailer mode is 70 percent of the permissible total weight.

Number of axles	Permissible total weight of the mobile crane	Minimum weight of the mobile crane in trailer mode
4	48000 kg	approx. 33000 kg
5	60000 kg	approx. 42000 kg
6	72000 kg	approx. 50000 kg

29.3.1 Driving with a reduced load

The load of the vehicle crane has been reduced to a range between the permissible total weight and the minimum weight for trailer mode. The load of the vehicle crane can be reduced by disassembling equipment.

The vehicle crane has a different, strong braking behavior. The vehicle crane can reeve out.

29.3.2 Driving with an extremely reduced load

The load of the vehicle crane has been reduced to the minimum weight for trailer mode or less. The load of the vehicle crane can be reduced extremely for example by disassembling the telescopic boom and by disassembling other equipment.



WARNING

Driving with a trailer with an extremely reduced load!

The mobile crane has a different, strong braking behavior. The mobile crane can reeve out.

Danger of accident, death, property damage.

- ▶ In the case of an extremely reduced load, do **not** drive the crane vehicle with a trailer.

29.4 Stopping the mobile crane

Make sure that the following prerequisites are met:

- The mobile crane is standing on load bearing, level and tractive ground.
- The parking brake is applied.

**WARNING**

Parking brake is **not** applied!

The mobile crane can roll off, death, property damage.

▶ Park the mobile crane exclusively with applied parking brake.

– Turn off the ignition and pull out the ignition key.

When a battery master switch is present:

– Turn off the battery master switch and remove the switch cams.

**WARNING**

Downhill or uphill slope is too large!

The mobile crane can roll off, death, property damage.

▶ Park the mobile crane at an downhill or uphill slope of no more than maximum 18 %.

Under the following conditions the mobile crane must be additionally secured with wheel chocks to prevent it from rolling off:

– The mobile crane is parked on a slope or an incline.

– The mobile crane is defective, particularly when the brake system is defective.

**WARNING**

Wedges incorrectly placed!

The mobile crane can roll off, death, property damage.

▶ So that the wedges have an immediate braking action and hold the mobile crane in park position:

Place all wedges tightly directly under the wheel.

▶ Place all specified wedges.

▶ All wedges must counteract the downhill slope force.

If necessary:

– Place the wedges.

30 Crane operation

30.1 Before starting to work

Before starting to work with the crane:

– Close all doors.

– Keep the doors closed during crane operation.

30.2 While working with the crane

**WARNING**

Defective crane!

Death, severe bodily injuries, property damage.

If an erroneous function of a crane movement is recognized during crane operation:

▶ Telescope the boom in completely and place it down, find the source of the problem and remedy it.

30.3 Crane operation with a load



WARNING

The crane can topple over!

If the crane is in condition which is **not** operationally safe, the crane can topple over or crane components can fall down.

Personnel can be severely injured or killed.

- ▶ Before starting to work, the crane operator must ensure that the crane is in operationally safe condition.
- ▶ If safe crane operation cannot be ensured by the crane operator, then crane operation is prohibited until an operationally safe condition for the crane is established.
- ▶ Safety equipment, for example: Load torque limiter, hoist limit switch, brakes must be fully functioning, otherwise crane operation is prohibited.

Make sure that the following prerequisites are met:

- The load torque limiter must be adjusted according to the current set up configuration of the crane.
- The loads given in the load chart may not be exceeded.
- The crane may never be subjected to a load that exceeds what is specified in the load charts.
- The weight, center of gravity and dimensions of the load to be lifted must be known.
- Load carriers, load handling and fastening equipment must be in accordance with specified requirements.



Note

- ▶ Make sure that the weight of the hook block and the weight of the fastening equipment is subtracted from the load given in the load chart, see the following chart.

Example:		
Maximum permissible load according to chart		30.000 t
Weight of the hook block	350 kg	- 0.350 t
Weight of the fastening rope	50 kg	- 0.050 t
Actual load capacity of the crane		= 29.600 t

The weight of the load to be lifted, in this example, may not exceed **29.6 t**.



DANGER

There is a high danger of accidents should the following points not be observed!

- ▶ Observe the following points.

Great danger of accidents exists if:

- The load torque limiter is not set in accordance with the current crane set up configuration and is therefore not able to provide proper protection.
- The load torque limiter is defective or taken out of operation.
- The hoist limit switches are defective or not functioning.
- For crawler cranes and mobile cranes with luffing lattice jib:
The angle sensor and the force test brackets are not functioning.
- For mobile cranes and crawler cranes with support:
The sliding beams of the hydraulic supports are not extended to the dimensions specified in the load chart.
- On crawler cranes:
The crawlers are not supported with stable base material sufficiently large for the ground conditions.
- For mobile cranes and crawler cranes with support:
The support plates are not supported with stable materials large enough for the ground conditions.
- Angular pulling is performed.

Angular pulling to the side is particularly dangerous, because the boom has only minimal lateral resistance momentum.

Angular pull is prohibited.

- Load attached during disassembly is too heavy and is freely suspended on the crane after release.
- The load hook is used to break away stuck loads.
Even if the weight of a stuck load does not exceed the permissible load capacity, the crane can topple over backwards if the load is suddenly released due to the tension of the boom, which can cause it to tip backwards.
- Working when the wind is excessively strong.
Comply with the load chart specifications.
- The crane is not levelled and the load is slewed in the direction of the slope.
- If improper control of crane movements cause the suspended load to swing like a pendulum.
- The loads and boom radii specified in the load charts are exceeded.
- When working in the vicinity of electricity transmission lines:
 - The electricity transmission lines were not turned off by expert electricians.
 - The danger zone was not covered or blocked off.



WARNING

Danger of current transfer!

If electricity transmission lines are not shut off nor covered nor blocked off, then there is an increased danger of accident due to current transfer.

- ▶ Adhere to the safety distance according to the following chart.

If the crane becomes electrified despite having taken all necessary precautions, proceed as follows:

- ▶ Remain calm!
- ▶ Do not leave the crane cab.
- ▶ Warn people outside: Stay in place and do not touch the crane.
- ▶ Move the crane away from the danger zone.

Nominal voltage	Safety clearance	
Up to 50 kV	4 m	10 ft
More than 50 kV to 200 kV	5 m	15 ft
More than 200 kV to 350 kV	7 m	20 ft
More than 350 kV to 500 kV	8 m	25 ft
More than 500 kV to 750 kV	11 m	35 ft
More than 750 kV to 1000 kV	14 m	45 ft
More than 1000 kV	Determination by power supplier or authorized electrician	Determination by power supplier or authorized electrician

Safety distance to electrical power lines depending on the nominal voltage

30.3.1 Counterweight and / or ballast

The type of counterweight and / or ballast required depends on the weight of the load to be lifted and the boom radius required for crane operation. The deciding factor for the selection of the counterweight and / or ballast is the data in the corresponding load chart.



WARNING

The crane can topple over!

If the counterweight and / or ballast is not installed according to the load chart, then the crane can topple over and fatally injure personnel.

- ▶ Install the counterweight and / or ballast according to the load chart.

30.3.2 Hoist gear, hoist rope

The lifting capability of the crane depends on the pull force of the hoist gear and the number of possible hoist rope reevings. When using a single strand, the crane can only lift a load that is pulled by the hoist gear.

If the load to be lifted is heavier than the pull force of the hoist gear, then the hoist rope must be reeved as needed according to the principle of a pulley between the pulley head on the boom and the hook block.

When reeving, carefully observe the load chart specifications and the operating instructions.



WARNING

Hoist rope failure!

If the maximum pull force of the hoist gear is exceeded, the hoist rope can break or the hoist gear can be damaged.

The load can fall and kill personnel.

- ▶ Observe the maximum tensile force of the hoist gear.

30.3.3 Hydraulically adjustable auxiliary boom



WARNING

Impermissible luffing of the auxiliary boom!

Damage to the auxiliary boom due to collision with the ground or other objects. Component failure. Death, severe bodily injuries, property damage.

- ▶ Do **not** luff the auxiliary boom down onto the ground or other objects by means of hydraulic adjustment.
- ▶ Do **not** luff the auxiliary boom down onto the ground or other objects by means of luffing down the main boom.

30.4 Interrupting crane operation



WARNING

Impermissible weather conditions!

If the crane is exposed to impermissible weather conditions during interruption of crane operation, situations can occur which could bring the crane into an unsafe condition.

Toppling crane, death, severe bodily injuries, property damage.

- ▶ Get the weather forecast for the entire period during which the crane is set up.

If the predicted wind speeds are above the permissible values according to the load chart and / or the wind speed chart:

- ▶ Take the boom and equipment down in time before impermissible wind speeds occur. See Crane operating instructions, wind speed charts and Erection and take down charts.

When wind conditions are present, which are above the permissible values of the wind speed chart and the boom can no longer be taken down:

- ▶ Make sure that there is no danger for persons, crane and surrounding area. Secure the crane and surrounding area of the crane far enough against access. Warn persons in the surrounding area and bring them in safety.

A weather forecast includes information about:

- Changing weather conditions
- Wind
- Ice
- Precipitation
- Flooding
- Lightning

**WARNING**

Defective crane!
Death, severe bodily injuries, property damage.

If a crane movement occurs during the interruption of crane operation:

- ▶ Make sure, when an unintentional crane movement occurs, for example as a result of leak, no danger for persons, crane and surrounding is created.

Leaks can occur all on pressurized hydraulic cylinders, for example on the following cylinders:

- Support cylinder
- Luffing cylinder
- Telescoping cylinder
- Control cylinder

**Note**

- ▶ Movements can occur on hydraulic cylinders also as a result of changing oil temperature.

**WARNING**

Set up crane is not supervised!

Situations during interruption of crane operation may occur which could cause the crane to become unsafe if left unsupervised.

Toppling crane, death, severe bodily injuries, property damage.

- ▶ Always watch the crane and keep it under control.

If the crane is in set up condition:

- ▶ Do **not** leave the crane.

If the crane can **not** be constantly kept under control:

- ▶ Take the equipment down and telescope the boom in and place it down.
- ▶ The boom on the crane may only be placed down if the predicted wind speeds according to the wind speed charts are less than the maximum permissible wind speeds during assembly and disassembly.
- ▶ Before the crane is unsupervised: Establish an emergency plan.
- ▶ Carry out the measures listed below.

**Note**

- ▶ An emergency plan includes information how the crane is brought into a safe condition if an unforeseen event occurs.

If possible:

- Take down and secure the equipment, see the erection and take-down charts.
- Telescope the boom in and secure it. The crane boom may only be telescoped when the prevalent wind speed is lower than the wind speed indicated in the load chart for the boom.
- Take the boom down and secure it. The crane boom may only be placed down if the wind speeds are lower than the maximum permitted wind speeds according to the wind speed charts or does not exceed them according to the assembly / disassembly instructions.

On mobile cranes:

- Lift the axles to the maximum position and block the hydraulic suspension.

On lattice mast cranes:

- Set the Derrick ballast, if present, down on the ground.
- Place the load completely on the ground and unhook it from the crane hook.
- Remove the fastening ropes from the hook.
- Place the load completely on the ground and unhook it from the crane hook.
- Remove the fastening ropes from the hook.

When the hook block remains installed:

- Lift the hook block into the highest position.
- Make sure that the hook block does not touch other crane parts or obstacles.

- Make sure that all measures were taken to keep the crane in a safe condition if something happens.
- If possible, turn the engines off.
- Set all control levers into neutral position or into a locked position.
- Turn all secondary systems off, except systems, which are required for restart.
- Establish the energy supply and functionality of safety equipment.
- Close off all control devices, which are not in use.
- Disconnect all control devices, which are connected with cables, if possible, and secure them to prevent unauthorized use.
- Secure control devices without cables to prevent unauthorized use.
- Make sure that the batteries in control devices without cables are charged.
- Make sure that access to the crane and operation for unauthorized personnel is excluded: Lock the driver's cab and the crane cab.
- Secure all keys to prevent unauthorized access.

If the construction site has limited space:

- The decision not to take the boom down while the crane is unsupervised can only be made by an authorized and qualified crane operator, who is familiar with the construction site.
- Make sure that no danger can occur for persons, crane and its surroundings should something unforeseen happen.
- Make sure for the duration of the interruption of crane operation, that the predicted wind speeds do not exceed the permissible values for the respective set up configuration, see wind speed chart.
- If the wind speed charts do not provide values for the set up condition, the permissible wind speed in the load chart shall be observed.

If crane operation with a set up crane is interrupted:

- Make sure measures are initiated in time by trained, qualified personnel to bring the crane into a safe condition if anything happens.
- Make sure that no danger can occur for persons, crane and its surroundings should something unforeseen happen.

If the predicted wind speeds are above the permissible values:

- Bring the boom and equipment in time into a permissible condition before impermissible wind speeds occur, depending on the predicted wind speed, or take it down completely on the ground. See Crane operating instructions, wind speed charts and Erection and take down charts.
- Telescope the telescopic boom in and luff down to 0°. Position the boom and auxiliary boom, see the Crane operating instructions, wind speed charts and erection and take-down charts.

Incidents are for example:

- Vandalism
- The ground giving way due to severe rain
- Melting ice under the supports
- Storm and thunderstorm
- Storm and wind
- Lightning
- Flooding
- Landslides
- Washouts
- For mobile cranes and crawler cranes with support:
Slippage of support cylinders (leak, temperature changes)
- For cranes with a telescopic boom:
Slippage of luffing cylinders (leak, temperature changes)

30.5 Resuming crane operation

Before resuming crane operation, the crane operator is obligated, among others, but not exclusively, to inspect the crane condition, the safety equipment, as well as the environmental conditions.

**WARNING**

Danger of accident!

When the crane operator leaves the crane cab:

- ▶ Before resuming work, check the operating mode setting and reset, if necessary.

30.6 Ending crane operation

Before the crane operator may leave the crane, the following prerequisites must be met:

- Place the load fully on the ground and unhook from the crane hook.
- On crane with telescopic boom: Telescope the telescopic boom all the way in and take down the boom in the boom receptacle.
- On crane with lattice mast boom: Take the lattice mast boom down and disassemble if necessary.
- Bring the control lever (master switch) to 0-position.
- Apply the parking brake on the crane chassis.
- Turn the engine off and pull out the ignition key.
- When a battery master switch is present: Turn off the battery master switch and remove the switch cams.
- Lock the crane cab.
- Secure the crane to prevent unauthorized use.
- For mobile crane: Make sure that the driver's cab is **not** occupied. Lock the driver's cab. Secure the crane to prevent it from rolling off unintentionally, see section „Parking the vehicle“.
- Make sure that no danger can occur for persons, crane and its surroundings should something unforeseen happen.

31 Lifting of personnel

31.1 Destined use

- The destined use of the crane is **lifting of loads**.
- **Lifting of personnel** is **not** considered to be destined use of the crane.

**Note**

- ▶ These instructions do **not** apply for work platforms, which are attached on the crane boom and are used to lift personnel. This subject is governed by international standards for mobile aerial work platforms.

**WARNING**

Non-designated use of the crane!

Personnel can be severely injured or killed.

- ▶ The crane is **not** intended to lift personnel.
- ▶ Lifting persons on the variable support is prohibited.
- ▶ The crane may **not** be used for recreational purposes and exhibitions, such as lifting personnel for shows, bungee jumping or Dinner in the sky.
- ▶ The crane may **not** be used for lifting of devices with personnel on them or under the device, such as lifting of tents.
- ▶ Exception: If lifting of personnel for special work situations is the least dangerous possibility to carry out the work, then personnel may be lifted or brought into a suspended position when using lifting cages (cherry pickers).

31.2 Prerequisites for lifting of personnel

Make sure that the following prerequisites are met:

- Lifting personnel with cranes is permissible by national and local laws in the country where this crane application is carried out.

**DANGER****Lifting of personnel!**

Accidents which occur when lifting personnel often result in severe injuries or even death.

- ▶ This exceptional application is within the scope of responsibility of the user and is only permitted if the requirements and instructions in the next sections are observed and adhered to.
- ▶ The company, the supervisor, the crane operator and auxiliary personnel must proceed especially carefully and safety conscious.
- ▶ Before the lifting procedure, a meeting must be held with all associated personnel.
- ▶ The following warning notes and safety regulations must be strictly observed.

31.2.1 Legal prerequisites

Make sure that the following prerequisites are met:

- Special arrangements were made for the use of the lifting cage (cherry picker) according to the requirements of national laws.
- If required by national laws: The use of the crane to lift personnel was reported to the state agency for occupational health and safety. The lifting procedure may possibly require a special permit.
- Before the implementation of the lifting procedure with the aid of a work-specific risk analysis for the possibility of rescuing personnel in emergencies was defined.
- To rescue personnel in emergencies, precautionary measures must be present on the crane, if they are required by national laws.
- The measures for safe operation near power lines, depending on the conditions on the job site and the national laws / national regulations were observed and adhered to.

31.2.2 Prerequisites for crane equipment and accessories

Make sure that the following prerequisites are met:

- The hoist gear to lift personnel must also be able to be moved in emergency operation.
- Before lifting personnel, the crane was inspected. No damage was found.
- The lifting cage (cherry picker) is utilized according to national laws and / or standards and according to intended purpose.
- Before lifting personnel, the lifting cage (cherry picker) was carefully inspected. No damage was found.
- Every emergency rescue device was inspected and its operational readiness was determined, if required by national laws.
- Any hooks in use must be equipped with a latch, which prevents the hook mouth to open. According to national laws, the latch must be manually closable or lockable or must automatically close via a spring.

31.2.3 Inspection before start up

Make sure that the following inspections are made before starting up the lifting cage (cherry picker):

- On every new construction site and after every modification or repair: To ensure the operating safety of the lifting cage (cherry picker) and the lifting equipment, a test with 125 % of the nominal load carrying capacity of the lifting cage (cherry picker) without personnel must be carried out. During the test, the lifting cage (cherry picker) may only be lifted just above the ground.
- A test lift with loaded lifting cage (cherry picker) without personnel must be carried out. The weight in the lifting cage (cherry picker) for the test lift must be at least as large as the weight of the personnel and the weight with the work equipment carried along. For this test lift, the course of all planned movements of the lifting procedure must be simulated.
- This test lift must be carried out for every location on a construction site, where personnel must be carried.

31.2.4 Prerequisites for operation with lifting cage (cherry picker)

Make sure that the following prerequisites are met for operation with lifting cage (cherry picker):

- The personnel and technical prerequisites for safe use and operation of the emergency control of the crane are present.
- The emergency control for emergency rescue of the person in the lifting cage is functioning.

- The rope pull is limited to 50 % of the maximum rope pull.
- The crane is utilized only to 50 % of its maximum load bearing capacity of the valid load chart.

32 Securing personnel on shut off crane

32.1 Terms and abbreviations

- PSAgA: Personal protective equipment to prevent falling
- HSG: Height safety device

32.2 Destined use

Cranes are **not** designed to protect personnel against falling.

When the following prerequisites are met, the personnel protection may be permissible:

- A justified individual case is present.
- A project-specific written risk assessment and work procedure for the precise case by the employer is on hand.
- The specific safety measures are strictly adhered to.
- The crane is intended by the manufacturer for personnel protection.

Limitations for movement and operation:

- Moving the secured person on the crane **from** job site and **to** job site is impermissible.
- Moving the secured person on the crane **from** job site and **to** job site is permissible only in case of a rescue operation.
- Operation of the crane by the secured person is impermissible.

32.3 Prerequisites



WARNING

Prerequisites for personnel protection are **not** met!
Danger of accident. Death, severe bodily injuries.

- ▶ Carry out the personnel protection on the shut off crane only when **all** prerequisites in this section have been met.

Make sure that the following prerequisites are met:

- The country-specific, legal regulations are being observed.
- The written risk assessment shows:
 - Technical protective measures with at least the same protective effect are **not** available.
 - The normal fastening devices can **not** be used.
 - Personnel protection on the shut off crane is the safest and most useful method to carry out this work.
- Last transport and personnel protection occur independent of each other:
 - Do **not** carry out personnel protection at the same time as load transport. Simultaneous personnel movement is impermissible.
 - Riding along on the load is impermissible.
- Determination of fastening points and rescue plan for the precise case is on hand from the employer.

32.3.1 Personnel and qualification

Make sure that the following prerequisites for personnel and qualification are met:

- The crane operator is suited and competent to operate the crane.
- Person, which is secured, must be trained in handling the PSAgA.
- The following persons are present on the job site and separately instructed:
 - A supervisor

- The crane operator
- The required number of rescue staff according to the rescue plan
- Access protection, fall protection on the shut off crane is made in accordance with the project-specific risk assessment on hand and the measures to be taken.
- The supervisor monitors the safe execution of work. He may **not** take part in the work.
- An effective communication must be ensured between crane operator and the secured person.

32.3.2 PSAG, rescue equipment and tools

Make sure that the following prerequisites and measures are met:

- Use only HSG (height safety device) according to EN 360 in connection with a safety harness according to EN 361 to secure the person.
- Connecting device is suited for the occurring stress on the edges, see Manufacturer's documentation or device identification.
- Recurring inspections have been made. There are **no** visible defects present.
- At least 1 m connecting device of the maximum possible extension length of the HSG (height safety device) must remain in the housing.
- Fasten the HSG (height safety device) with two separate connecting devices (for example Securing on crane hook and on crane pulley block).
- Position the crane in such a way that the HSG (height safety device) is at least 5 m and plumb **over** the person, which is being secured.
- Do **not** exceed the maximum permissible deflection of the HSG (height safety device)
- Keep the required space **underneath** the person, which is being secured.
- All required objects (tools, building material) for the work are secured to prevent them from falling.

32.3.3 Crane

Make sure that the following prerequisites are met:

- The maintenance intervals and periodic crane inspections have been adhered to. There are **no** visible defects present.
- The load on the crane hook in any possible position is at least 600 kg , see Load chart (take the crane pulley block into account).
- Ensure sufficient load bearing capacity: For the load cases catching, pendular fall and possible angular pull adhere to the manufacturer's instructions.
- The crane is secured against movements and inadvertent movement (remote control is deactivated, crane control is activated).
- Only for aligning loads in the end position: Carry out a minimum of crane movements with the least possible speed.
- The overload protection is active.
- Auxiliary booms are **not** used.

32.4 Fastening device

Make sure that the following prerequisites are met:

- The crane hook is equipped with the hook safety.
- On the carrying device two connecting devices separated from each other can be fastened.
- HSG (height safety device) is redundantly fastened.
- Suitable fastening devices according to EN 795 Type B are on hand:
 - Round sling or fastening rope with steel core
 - Belt loop
- Textile components must be protected against greases, oils and other aggressive substances.
- Use only steel carabiners according to EN 362 with Tri-Lock function.

32.5 Rescue

A person in an accident must be lifted or lowered with the aid of the crane.

Carry out the following measures to ensure a safe rescue operation:

- Determine the rescue plan and rescue chain at the preparation of the mission.

- Ensure the rescue of a person involved in an accident immediately with locally available means and trained personnel.
- Have the rescue mission coordinated by another person, with visual and voice contact to the crane operator, ground personnel as well as to the person, which is rescued.

32.6 Additional risks

Make sure that the following risks are taken into account:

- Wind effect and environmental influences.
- Crushing and shearing points.
- Endangerment by additional cranes, for example material transport.

33 Welding work on the load



Note

- ▶ The load must also be grounded.
-

In case of welding work on the load, the screw clamp of the welding unit must be attached on the work piece to avoid current flow via hoist rope, crane superstructure or crane chassis.

2.04.10 Ladders

1	Safety guidelines	3
2	Safety signs	3
3	Ladder inspection	8
4	User guidelines	8
5	Ladder access	9

Fig.195219

LWE/LR 1600-2-008/18109-09-02/en

1 Safety guidelines

The ladders have been built according to the present level of technology and recognized safety technical regulations. Despite that, during their use dangers to life and physical condition of the user and / or third parties can occur.

The ladders may exclusively be used in a flawless technical condition and according to their missions as well as with constant awareness of safety and dangers.

Changes on the structure may exclusively be made with written approval of the manufacturer.

The ladders are exclusively designated for the ascent and descent of personnel.

Any other use is not as intended and therefore prohibited.

The manufacturer is **not** liable for damages, which are caused by unintended use or improper usage.



WARNING

Danger of falling!

If the following safety guidelines are not observed, personnel can fall down and be killed or severely injured.

- ▶ Observe and adhere to the assembly and safety guidelines for ladders.
- ▶ Observe and adhere to the safety signs on the ladders.
- ▶ Install and secure the ladders properly.
- ▶ Use ladders exclusively if you are healthy enough to do this.
- ▶ Climb up / down the ladder with the 3-point support.
- ▶ Use the rungs as handles.
- ▶ Step into the rungs deep enough.
- ▶ Never bring the ladder to a new position during use.
- ▶ Do not use damaged ladders and replace them immediately.
- ▶ Repair the ladder exclusively through authorized service facilities.





2 Safety signs





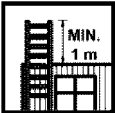

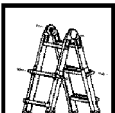
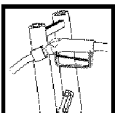
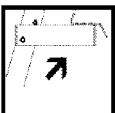
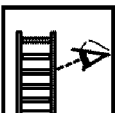







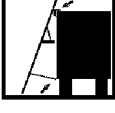

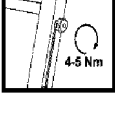





Note

- ▶ All safety signs on the ladders must be complete and always legible.
- ▶ Observe and adhere to the manufacturer's operating instructions.



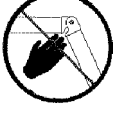

Sign	Explanation
	Read the operating instructions.
	Maximum number of users on one ladder.
	Correct set up angle 65° to 75°.

Sign	Explanation
	Before use: Engage the lift out safety.
	Ladder overhang above the exit level.
	Secure the upper / lower end of the ladder.
	Before use: Tension the safety struts on stepladders.
	Before use: Engage the locking pin joints and pull pin locks.
	To open / close the tank cover and to ascent / descent: Insert the fuel nozzle into the retainer.
	Fold the platform out before setting up the ladder.
	Before use: Check the ladder for damage.
	Check the legs of the ladder.
	Maximum load.

Sign	Explanation
	Do not use the three uppermost rungs of an extension ladders as rungs to stand on.
	Do not use the four uppermost rungs / steps of a stepladder without a platform to stand on.
	Do not use the two uppermost rungs of a stepladder with integrated extension ladder as rungs to stand on.
	If hinged ladders are used as stepladders: Spread the ladder legs to the stop.
	Place the upper placement angle flat. Hold the belt on tension.
	Hook the hook on the platform of the refueling ladder on the vehicle.
	Tighten the star knob on the beam extension tightly.
	Do not use a damaged ladder.
	Preclude any contaminants on the ground.
	Make sure the upper end of the ladder is placed correctly. Place the ladder only on safe surfaces.

Sign	Explanation
	Only one person may climb up / down on any accessible leg of the ladder.
	Avoid leaning out to the side. The body's center of gravity should be between the ladder beams.
	Face the ladder when climbing up / down the ladder.
	Use the ladder only with suitable shoes.
	Do not use a stepladder as a leaning (extension) ladder.
	Do not use the inner section of multi-part hinged ladders without outer sections as a stepladder.
	Crushing danger.
	Set the ladder up on horizontal and solid ground.
	Set the ladder up on solid ground.
	Use the ladder in the correct set up direction.

Sign	Explanation
	Do not carry along bulky objects or objects over 10 kg on the ladder.
	It is not permitted to step off the ladder to the side.
	During transport, pay attention to danger due to power lines.
	Do not use the ladder as a walkway.
	Do not transport snow and ice shovels over the ladder. Use hooks!
	Danger due to shearing point.
	Do not use a ladder to climb up to another lever.
	Make sure that both ladder sections are opened completely and secured. Avoid an incorrect ladder position.
	Only use the platform ladder with a locked spreader lock.
	Only permissible ladder rungs / platforms may be used as standing and stepping surfaces. Other surfaces such as placement surfaces for cable clips or attachment hooks may not be used as standing and stepping surfaces.

Sign	Explanation
	If a crossbar is part of the scope of delivery of the mobile platform ladder: Only use the platform ladder with the crossbar assembled.
	If auxiliary weights are part of the scope of delivery of the mobile platform ladder: Only use the platform ladder with the auxiliary weights assembled.
	If a foot brake is installed on the mobile platform ladder: Use the foot brake.
	Make sure that the joint is locked.
	In unfavorable weather conditions, do not use the ladder in the open.

3 Ladder inspection

Make sure that the following conditions are met:

- All ladders are inspected at least every 12 months. See chapter 8.17.
- The inspection may be made exclusively by authorized and trained expert personnel.

4 User guidelines

Make sure that the following prerequisites are met before using the ladder:

- A risk evaluation had been made.
 - The national legal regulations have been taken into account.
- Use are able to use a ladder as far as your health is concerned.
- The ladder is suited for the respective application.
- The ladder is complete and not damaged (visual inspection).
- The ladder is free of contaminants, such as:
 - Ice
 - Snow
 - Frost
 - Wet paint
 - Lubricants
- The legs of the ladders are not worn.
- Screws and connections have been checked for tight seating.
- The base is:
 - Level
 - Horizontal
 - Slip-resistant

- Unmoveable

Before setting the ladder up:

- Secure the locking devices of the ladder.
- Tension the spreaders of the stepladder.
- Do **not** set up the ladder from above.
- Do **not** set the ladder on braces or steps.

When using the ladder:

- Make sure that no children are playing on the ladders.
- Set the ladder up in the correct set up angle.
- Subject the ladder with no more than maximum 150 kg.
- Use the ladder exclusively as described in section „Ladder access“.
- Do **not** use the ladder outside in strong wind.
- Do **not** subject the ladder excessively to loads in side assembly work.
- Face the ladder when climbing up or down the ladder.
- Step on the ladder with suitable shoes.
- Do not use the ladder as a walkway.
- Secure the ladder to prevent it from being knocked over inadvertently.
- For leaning ladders, do not step on the uppermost three steps / rungs, in reference to the ladder placement point.
- For stepladders, do not step on the uppermost two steps / rungs.
- When working on a ladder, hold on tightly with one hand.
If this is not possible: Take additional safety measures, such as: Use the WORK POSITIONING SYSTEM (WPS).

For repair, maintenance and storage of a ladder:

- Have repairs and maintenance made by expert personnel according to the manufacturer's instructions.
- Store the ladders according to the manufacturer's instructions.

Before transporting the ladders:

- Lock and secure the ladders in their provided transport retainers.

5 Ladder access

Wearing the personal protection equipment to prevent falling and the ladder safeguard depend on the type of work, among others.

5.1 Ladder safeguards

The ladder can be secured to prevent it from sliding away to the side by:

- Restraint device, for example: Tether or side stops on component
- Friction lock, for example: Rubber caps or plastic caps on the end of the ladder beam at direct placement on a surface

The ladder can be secured to prevent it from tipping to the rear by:

- the correct placement angle

5.2 3-point support

A 3-point support is ensured when:

- Two hands have a safe hold and one leg is standing safely.
- Two legs are standing safely and one hand has a safe hold.
- Two legs are standing safely in straddle position on a stepladder which can be accessed from both sides, on the third respective rungs / steps from the top. The user locks the ladder with the knees.
- Two legs are standing safely and at the same time, the body is leaned on higher rungs / steps of the leaning (extension) ladder. The center of gravity of the body must always be between the two ladder beams.

- A WORK POSITIONING SYSTEM (WPS) is used.

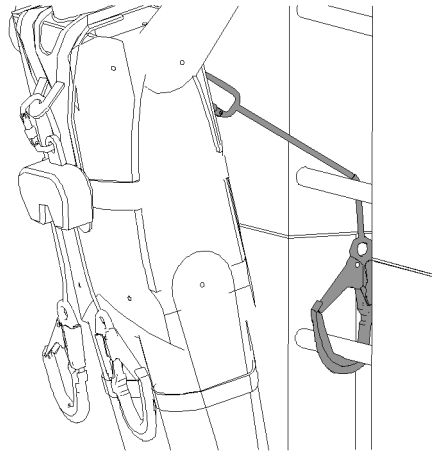

Fig.126746: Example of how to use the WPS

5.3 Light and / or heavy work

The following lists various light and heavy work

Examples for light work:

- Installing / removing retaining pins or spring retainers
- Fastening components, disengaging fastening equipment
- Pushing the transition aid out / in
- Establishing / disconnecting electrical or hydraulic connection between components
- Actuating the hand pump for the folding jib
- Reeving the auxiliary winch in / out
- Setting up / taking down foldable railings
- Carrying out maintenance and inspection work
- Refueling the crane chassis and / or crane superstructure

Examples for heavy work:

- Knocking the connector pins in / out
- Installing / removing the wind warning
- Reeving the hoist rope in / out
- Installing / removing the connector pin with assembly aid (hydraulic cylinder or mechanical assembly tool)
- Installing / removing the rope lock

5.4 Remove the end section on the leaning ladder

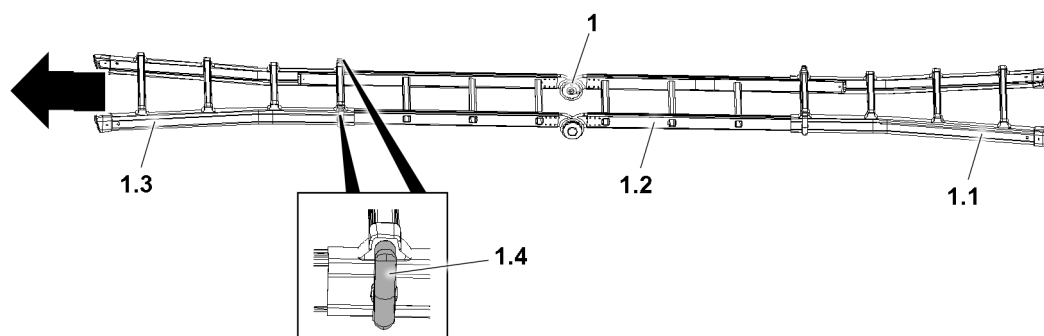

Fig.126873: Leaning (extension) ladder 1

The leaning ladder **1** consists of the following components:

- **1.1** Base
- **1.2** Center section
- **1.3** End section
- **1.4** Locks

When the end section **1.3** is wider than the leaning tube **2** or the intended placement surface, the leaning ladder **1** cannot be placed fully expanded. In order to position the leaning ladder **1** fully expanded, the end section **1.3** must be disassembled and removed.



CAUTION

Fingers in the spring range of the lock **1.4**!

Finger crushing when locking and unlocking.

▶ Grip the lock **1.4** outside of the spring range.

▶ Release the locks **1.4** on the left and right.

▶ Slide the end section **1.3** out of the center section **1.2** and remove it.

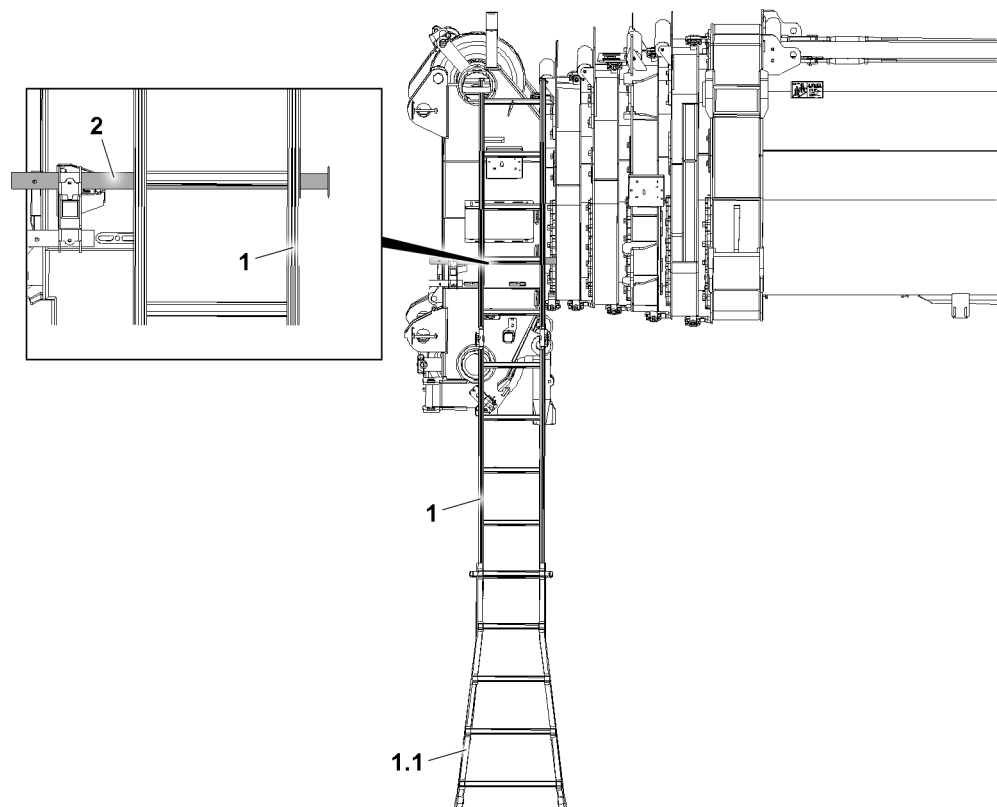

Fig.126874: Leaning ladder **1** placed on the leaning tube **2**

When placing the leaning ladder **1**, the base **1.1** must be placed on the ground.

▶ Place the leaning ladder **1** on the leaning tube **2** or the intended placement surface.



WARNING

The leaning ladder **1** is wider than the leaning tube **2** or the intended placement surface!

Assembly personnel can fall when stepping on the leaning ladder **1** and be severely injured.

▶ When stepping on the leaning ladder **1** make sure that the leaning ladder **1** **is not** wider than the leaning tube **2** or the intended placement surface.

▶ Climb on the leaning ladder **1**. Carry out the assembly work.

Before leaving the jobsite, the end section **1.3** must be reinstalled.

▶ Before leaving the jobsite: Install the end section **1.3**.

- ▶ Secure the leaning ladder **1** in transport position.

5.5 Types of ladders

5.5.1 Stepladder

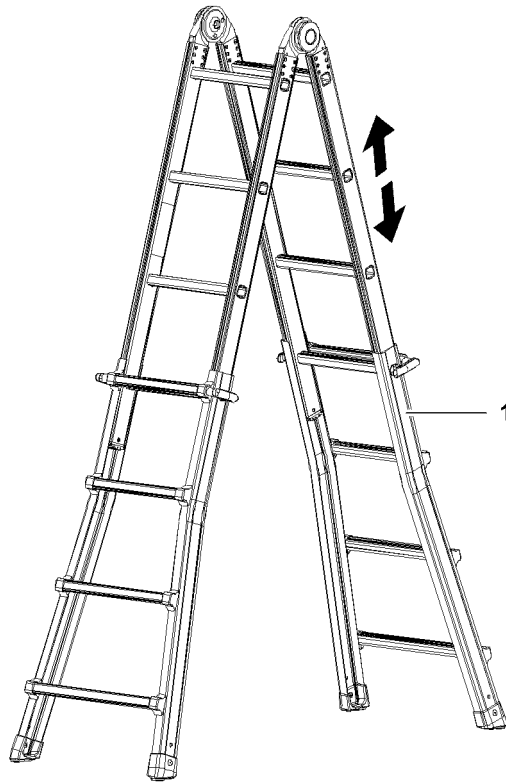

Fig.121175: Examples for stepladders



WARNING

Danger of falling when transitioning from a stepladder **1** to other components!
Personnel can fall down and be killed or severely injured.

- ▶ Do **not** transition from a stepladder **1** to other components.



WARNING

Danger of falling!
Personnel can fall down and be killed or severely injured.

- ▶ When using stepladders **1**, adhere to the 3-point support.
- ▶ Adhere to the prerequisites and conditions for the use of stepladders **1**.

Prerequisites for the use of stepladders **1**:

- Make sure that the weight of the tool carried along is not more than 10 kg.

Access	Work
Maximum rise to the third rung / step from the top	Maximum rise to the third rung / step from the top
3-point support required	3-point support required
	Rise to 1 m: Personal protective equipment to prevent falling not required

Access	Work
	Rise above 1 m to 7 m Light work: Personal protective equipment to prevent falling not required
	Rise above 1 m to 7 m Heavy work: Personal protective equipment to prevent falling required

Conditions for access and work on stepladders 1

5.5.2 Leaning (extension) ladder

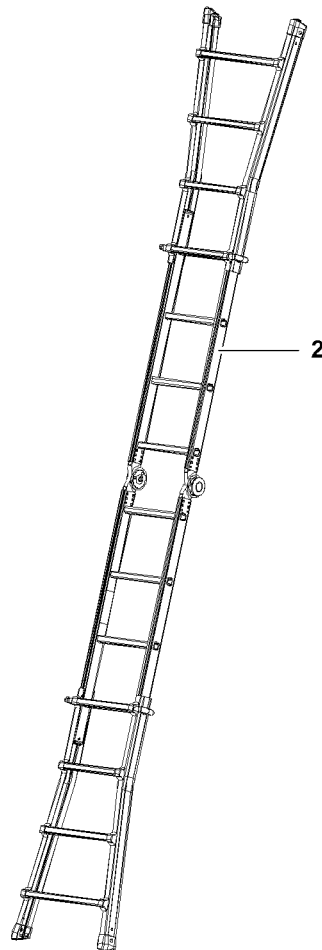

Fig.121176: Example for leaning (extension) ladders



WARNING

Danger of falling!

Personnel can fall down and be killed or severely injured.

- ▶ When using leaning (extension) ladders **2**, adhere to the 3-point support.
- ▶ Adhere to the prerequisites and conditions for the use of leaning (extension) ladders **2**.

Prerequisites for the use of leaning (extension) ladders **2**:

- Make sure that the leaning (extension) ladder **2** is positioned onto a level placement surface.

- Make sure that the leaning ladder **2** is placed in an incline angle of 65° to 75° (approx. 1:4) to the horizontal.
- Make sure that the ladder overhang when leaning it on components is selected in such a way that the leaning (extension) ladder **2** is safely placed when subjected to a load / flex due to ascending persons.
- Make sure that the weight of the tool carried along is not more than 10 kg.

Access	Work
Maximum rise to the fourth rung / step from the top, in reference to the placement point	Maximum rise to the fourth rung / step from the top, in reference to the placement point
3-point support required	3-point support required
	Rise to 1 m: Ladder safeguard not required Personal protective equipment to prevent falling not required
	Rise above 1 m to 7 m Light work: Ladder safeguard required Personal protective equipment to prevent falling not required
	Rise above 1 m to 7 m Heavy work: Ladder safeguard and protection to prevent it from tipping to the rear required Personal protective equipment to prevent falling required

Conditions for access and work on leaning (extension) ladders 2

5.5.3 Leaning (extension) ladder with transition

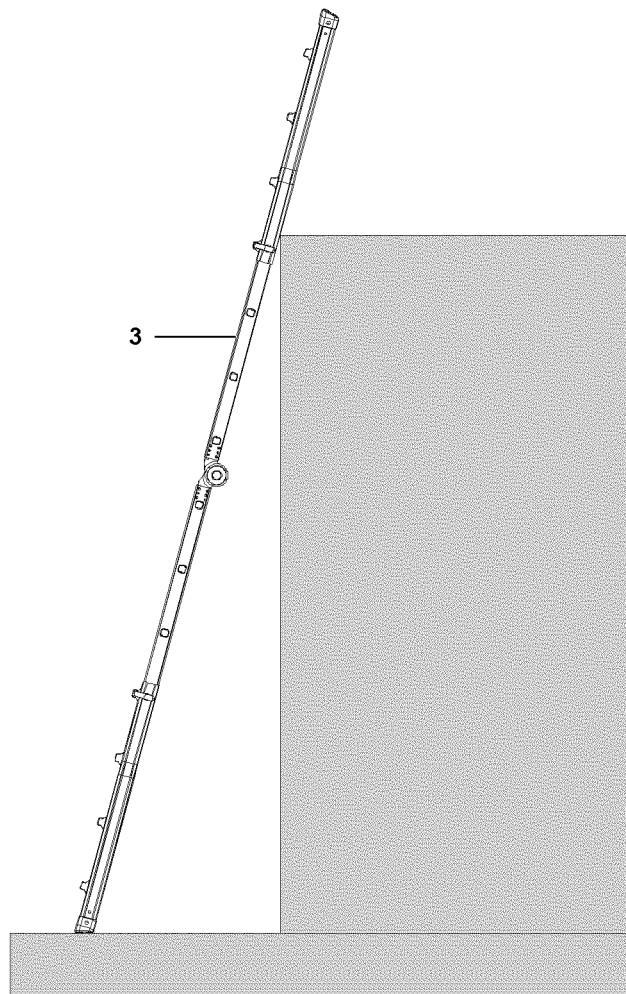

Fig.121177: Examples for leaning (extension) ladders with transition



WARNING

Danger of falling!

Personnel can fall down and be killed or severely injured.

- ▶ When transitioning, adhere to the 3-point support.
- ▶ Adhere to the prerequisites and conditions for the use of leaning (extension) ladders with transition **3**.

Prerequisites for the use of leaning (extension) ladders with transition **3**:

- Make sure that the leaning (extension) ladder with transition **3** is positioned onto a level placement surface.
- Make sure that the leaning ladder with transition **3** is placed in an incline angle of 65° to 75° (approx. 1:4) to the horizontal.
- Make sure, for transitioning to higher work locations, when no other safehold possibilities are available, that the ladders beams of the leaning (extension) ladder go past the placement location by at least 1 m.
- Make sure that the transition area is slip-resistant.
- Make sure that the ladder position can be recognized from above.
- Make sure that the ladder overhang when leaning it on components is selected in such a way that the leaning (extension) ladder is safely placed when subjected to a load / flex due to ascending persons.
- Make sure that the weight of the tool carried along is not more than 10 kg.

Access	Transition
Maximum rise to a rung / step below the placement edge	Maximum rise to a rung / step below the placement edge
3-point support required	3-point support required
Personal protective equipment to prevent falling not required	Personal protective equipment to prevent falling not required
	Rise to 1 m: Ladder safeguard not required
	Rise above 1 m to 7 m: Ladder safeguard required

Conditions for access and transition to leaning (extension) ladders with transition 3

5.5.4 Vertical ladder with transition aid

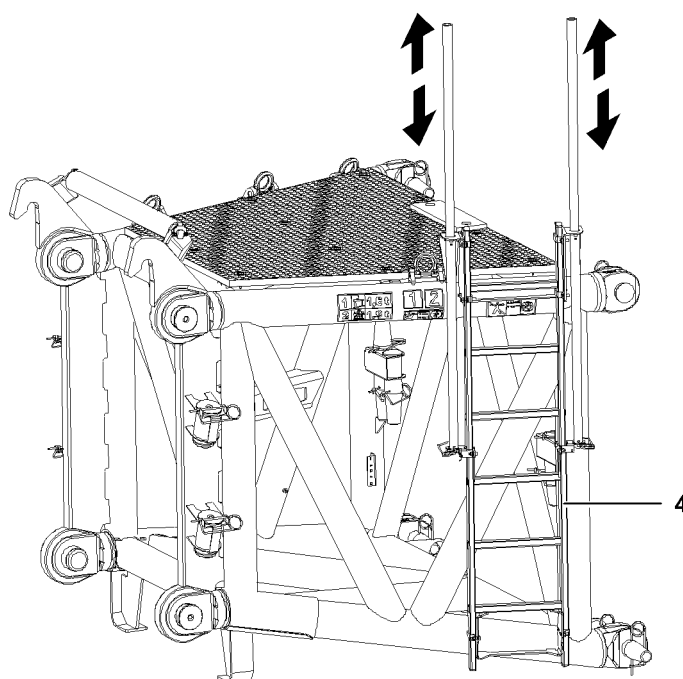

Fig.121178: Example for vertical ladder with transition aid



WARNING

Danger of falling!
Personnel can fall down and be killed or severely injured.

When using vertical ladders with transition aid 4:

- ▶ Adhere to the 3-point support.

Before transitioning:

- ▶ Hook the personal protective equipment to prevent falling on a suitable location (for example: uppermost rung, safety rope or separate hook point).
- ▶ Adhere to the prerequisites and conditions for the use of vertical ladders with transition aid 4.

Prerequisites for the use of vertical ladders with transition aid 4:

- Make sure, a centered grip reachable from the transition edge and a possibility to support oneself with the second hand is present for transitioning.
- Make sure that the transition area is slip-resistant.
- Make sure that the ladder position can be recognized from above.
- Make sure that the weight of the tool carried along is not more than 10 kg.

Access	Work
3-point support required	3-point support required
If necessary: use a WORK POSITIONING SYSTEM (WPS) at a suitable hook point.	If necessary: use a WORK POSITIONING SYSTEM (WPS) at a suitable hook point.

Conditions for access and work on vertical ladders with transition aid 4

Ascent	Transition
3-point support required	3-point support required
Rise to 5 m: Personal protective equipment to prevent falling not required	Rise to 1.8 m: Without transition aid: Personal protective equipment to prevent falling not required
Rise above 5 m: Fall arrest system with moving along fall arrest device or back protection required	Rise above 1.8 m: Without transition aid: Personal protective equipment to prevent falling required

Conditions for ascent and transition to vertical ladders with / without transition aid 4

5.5.5 Platform ladder

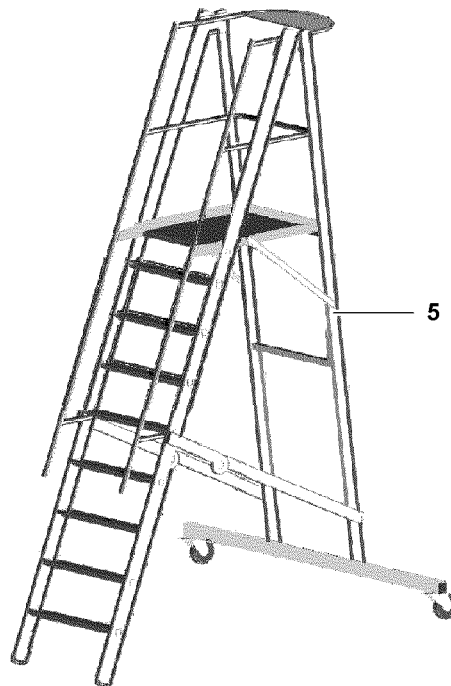

Fig.121179: Example for platform ladder

**WARNING**

Danger of falling when transitioning from a platform ladder **5** to other components!

Personnel can fall down and be killed or severely injured.

- ▶ Do **not** transition from a platform ladder **5** to other components.

**WARNING**

Danger of falling!

Personnel can fall down and be killed or severely injured.

For use of platform ladders **5**:

- ▶ Adhere to the 3-point support.
- ▶ Adhere to the prerequisite and conditions for the use of platform ladders **5**.

Prerequisite for the use of platform ladders **5**:

- Make sure that the weight of the tool carried along is not more than 10 kg.

Access	Working on the ladder	Working on the platform
Maximum rise to platform height	Maximum rise to platform height	Maximum height: Platform height
3-point support required	3-point support required	3-point support required
	Rise to 1 m: Personal protective equipment to prevent falling not required	
	Rise above 1 m to 7 m Light work: Personal protective equipment to prevent falling not required	Platform height Light work: Personal protective equipment to prevent falling not required
	Rise above 1 m to 7 m Heavy work: Personal protective equipment to prevent falling required	Platform height Heavy work: Personal protective equipment to prevent falling required

Conditions for access and work on platform ladders 5

2.05 Signs on the crane

1 Signs

3

Fig.195219

LWE/LR 1600-2-008/18109-09-02/en

1 Signs

1.1 7725039 – Warning of high voltage



Fig.116269: Warning of high voltage



Note

► Only for certain countries.

1.2 772564008 – Slewing range



Fig.116270: Slewing range



Note

► Only for certain countries.

1.3 772580408 – Limitation of maximum travel speed



Fig.106035: Limitation of maximum travel speed

1.4 Vehicle height

	Vehicle height
970610408	
970629508	
970596108	
970608708	
979459108	

Vehicle height



Note

► Vehicle height x.x m (x.x ft)

1.5 Note for assembly aid

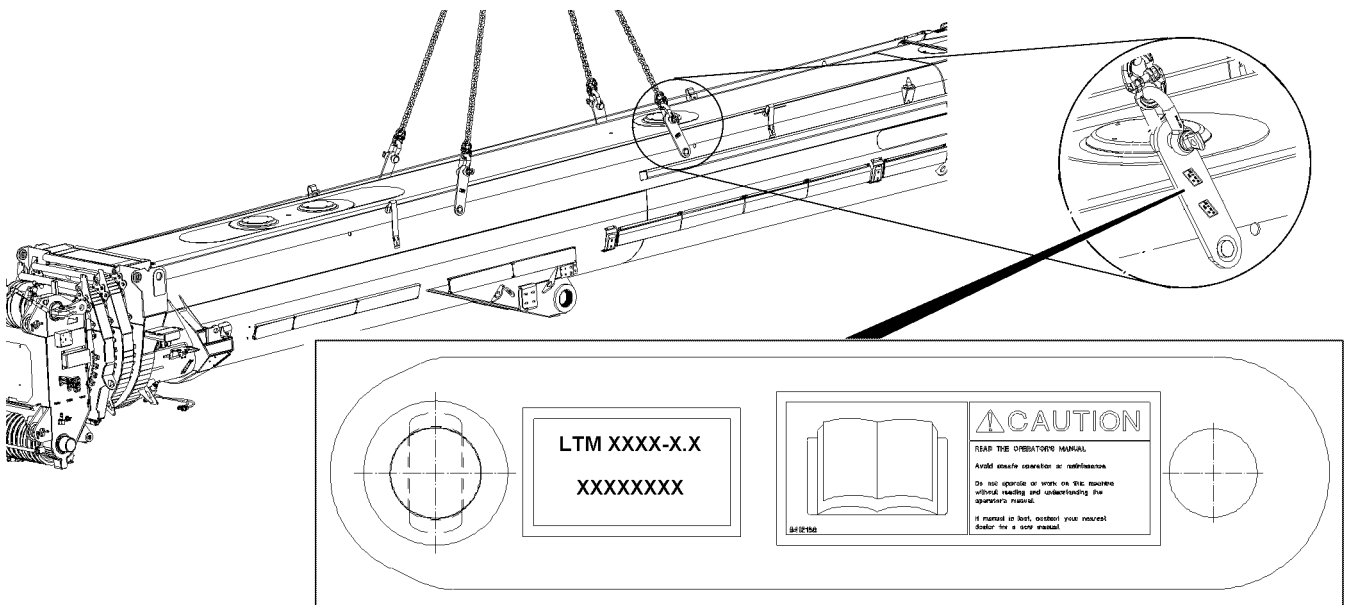

Fig.122741

Id. No.	Mobile crane
966713608	LTM 1750–9.1 LTM 1450-8.1
968483508	LTM 1500-8.1
962961708	LTM 11200-9.1, LTM 1400-7.1, LTM 1350-6.1, LTM 1300-6.2,
	LTM 1250-6.1, LTM 1250-5.1, LTM 1220-5.2, LTM 1200-5.1,
	LTM 1160-5.2, LTM 1160-5.1, LTM 1130-5.1, LTM 1100-4.2,
	LTM 1095-5.1, LTM 1090-4.1,
	LTR 11200, LTR 1220, LTR 1100

Note for assembly aid



WARNING

Incorrect assembly aids!
Falling telescopic boom, death, property damage.

To assemble and disassemble the telescopic boom:
▶ Use solely the assembly aids that belong to the crane.

1.6 9412158 – Reading the operating instructions

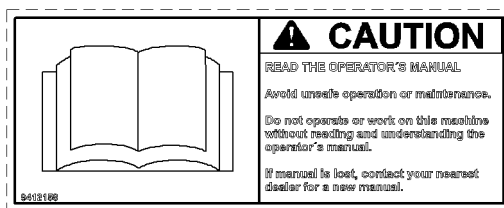

Fig.106048: Reading the operating instructions

LWE/LR 1600-2-008/18109-09-02/en

**WARNING**

Danger of accident due to non-observance of operating instructions!

If the operating instructions are not read or understood, then this can lead to unsafe operation and improper maintenance.

Accidents with bodily injuries and property damage can result.

- ▶ The crane may only be operated if the contents of the operating instructions have been read and understood.
- ▶ Replace lost or incomplete operating instructions immediately.

1.7 97004046 – Safety harness, maximum two persons



Fig.115119: Safety harness, maximum two persons

**DANGER**

Danger of accidents due to overloaded safety ropes!

If safety ropes are used by more than two persons, then the safety ropes can be overloaded and fail in case of an accident.

Personnel can be severely injured or killed.

- ▶ Safety ropes are designed to secure a maximum of two persons against falling, one on the right and one on the left.

1.8 97017585 – Falling telescopic boom during disassembly / assembly

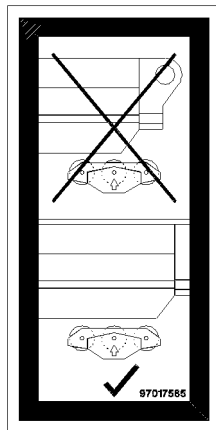

Fig.118467: Falling telescopic boom during disassembly / assembly

**WARNING**

Fatal accidents due to falling telescopic boom!

- ▶ Make sure that all pulleys are touching and carrying during the assembly and disassembly of the telescopic boom.

1.9 97018351 – Falling telescopic boom during transport!

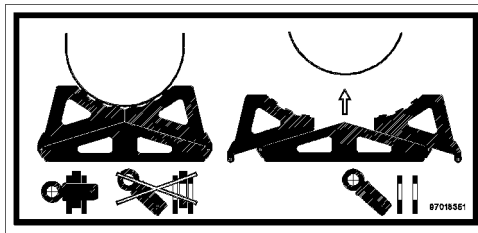

Fig.118466: Falling telescopic boom during transport



WARNING

Fatal accidents due to falling telescopic boom during transport!

- ▶ Pin and secure the transport bracket on the left and right.

1.10 97018564 – Falling telescopic boom during transport!

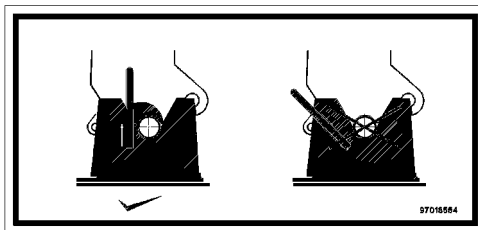

Fig.118533: Falling telescopic boom during transport



WARNING

Fatal accidents due to falling telescopic boom during transport!

- ▶ Lock the telescopic boom in the head receptacle.

1.11 97027147 – Overloading of the combi box is prohibited

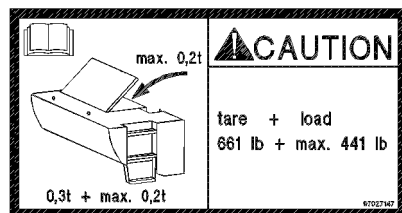

Fig.113829: Overloading of the combi box is prohibited



WARNING

Danger of overload!

If the combi box is subjected to a load of more than 0.2 t, the combi box can be damaged!

- ▶ The own weight of the combi box is 0.3 t and may be loaded with a maximum payload of 0.2 t.
- ▶ Do not subject the combi box to a weight of more than 0.2 t.

1.12 97036733 – Fastening point

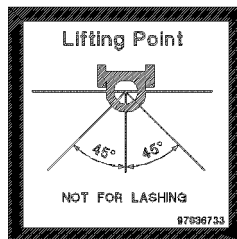

Fig.121184: Fastening point



WARNING

Damage to the fastening points!

- ▶ Use the fastening point solely to lift the load.
- ▶ Observe the maximum permissible fastening angle.



Note

- ▶ Fastening points and fastening angle.

1.13 Suspended load fastening point

	Suspended load fastening point
97038434	<p style="text-align: center;"><i>Fastening point</i></p>
97037482	
97039068	



WARNING

Mortal danger if the load falls down!

If the maximum suspended load or the maximum fastening angle is exceeded, the load can fall down and kill personnel.

- ▶ Observe the maximum permissible suspended load and fastening angle.

1.14 Suspended load fastening point

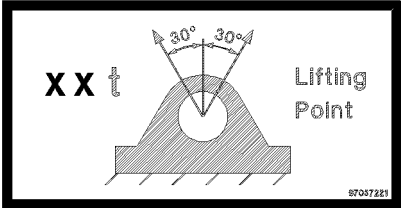
Suspended load fastening point	
97037221	
97037223	



WARNING

Mortal danger if the load falls down!

If the maximum suspended load or the maximum fastening angle is exceeded, the load can fall down and kill personnel.

- ▶ Observe the maximum permissible suspended load and fastening angle.

1.15 Suspended load fastening point

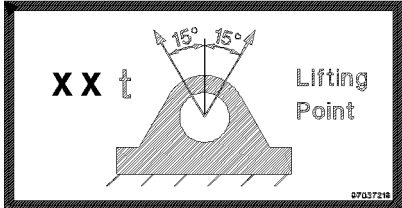
Suspended load fastening point	
97037219	



WARNING

Mortal danger if the load falls down!

If the maximum suspended load or the maximum fastening angle is exceeded, the load can fall down and kill personnel.

- ▶ Observe the maximum permissible suspended load and fastening angle.

LWE/LR 1600-2-008/18109-09-02/en

1.16 97037625 – Suspended load Fastening points / rigging points

LIFTING AND LASHING			
Type [t]	Lashing Capacity		
	LC-N [daN]	LC-Q [daN]	
4	4 000	2 000	
6,7	6 700	4 690	
10	10 000	7 000	
16	16 000	11 200	
31,5	31 500	22 050	

Fig.119988: Fastening points / rigging points



Note

- Fastening points and rigging points.

1.17 9402377 – Fastening point / lifting point

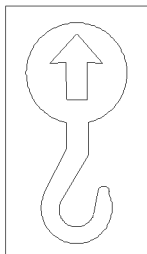

Fig.127586: Fastening point / lifting point



Note

- Fastening point / lifting point.

1.18 97106824 – Installing the N-assembly unit

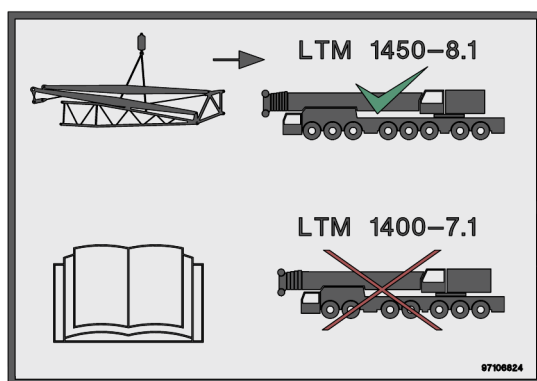

Fig.147594: Installing the N-assembly unit



WARNING

N-assembly unit installed on an impermissible crane type!
Death, severe bodily injuries, property damage.

- Use N-assembly units marked with this sign only for crane type LTM 1450-8.1.
- Observe and adhere to the operating instructions.

1.19 97096132 – Fastening points for N-assembly unit

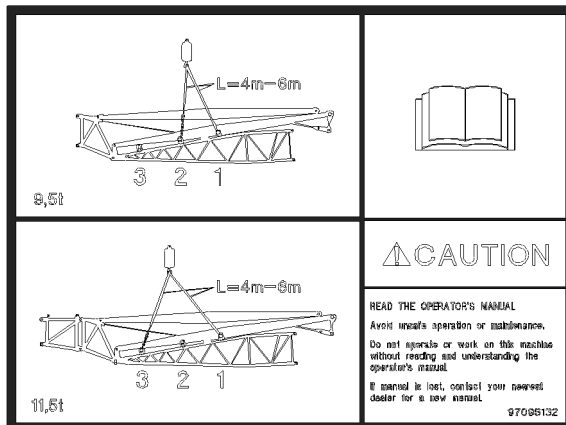

Fig.144774: Fastening points for N-assembly unit



WARNING

Incorrectly selected fastening points!

The N-assembly unit can tip over and kill personnel.

- ▶ Fasten the N-assembly unit only on the intended fastening points.
- ▶ Use fastening equipment with the correct strand length.
- ▶ Observe and adhere to the operating instructions.
- ▶ Replace lost or incomplete operating instructions immediately.

1.20 97036735 – Fastening point for lattice section

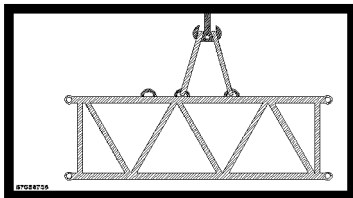

Fig.116266: Fastening point for lattice section



Note

- ▶ Fastening points for lattice section.

1.21 97036736 – Fastening point for lattice sections

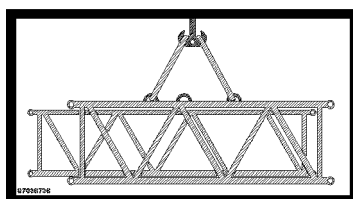

Fig.116267: Fastening point for lattice sections

**Note**

► Fastening points for lattice sections.

1.22 97038442 – Fastening point for lattice section

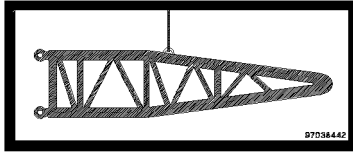

Fig.116288: Fastening point for lattice sections

**Note**

► Fastening point for lattice section.

1.23 97038452 – Fastening point for lattice sections

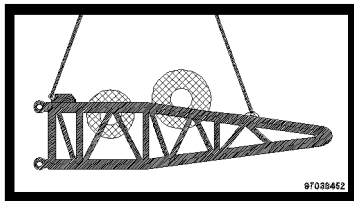

Fig.116289: Fastening point for lattice sections

**Note**

► Fastening points for lattice sections.

1.24 97038454 – Fastening point for lattice sections

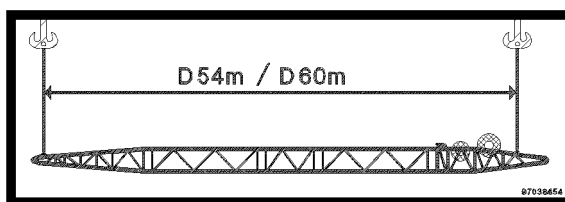

Fig.116290: Fastening point for lattice sections

**Note**

► Fastening points for lattice sections.

1.25 97037871 – Fastening points for lattice sections

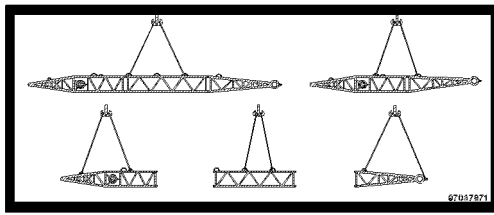

Fig.116292: Fastening points for lattice sections



Note

► Fastening points for lattice sections.

1.26 97057767 – Fastening points for lattice sections

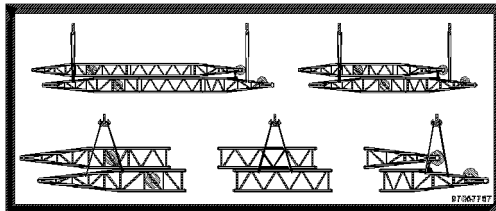

Fig.121181: Fastening points for lattice sections



Note

► Fastening points for lattice sections.

1.27 97057524 – Fastening point for assembly of lattice sections

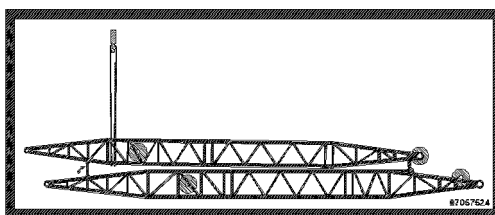

Fig.121182: Fastening point for assembly of lattice sections



Note

► Fastening point for assembly of lattice sections.

1.28 97057097 – Fastening point to turn the component

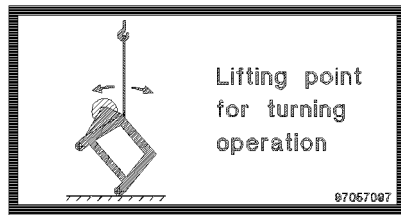

Fig.119987: Fastening point to turn the component



Note

- Fastening point to turn the component.

1.29 97039035 – Suspended load Assembly unit

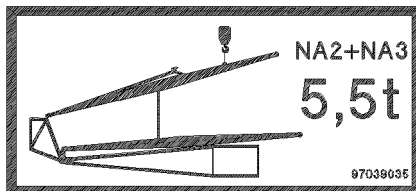

Fig.117348: Suspended load Assembly unit



Note

- Notice the suspended load.

1.30 97059339 – Suspended load Derrick pivot section

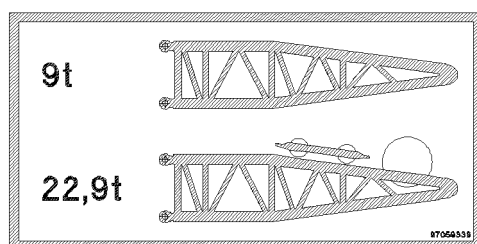

Fig.127469: Suspended load Derrick pivot section



Note

- Suspended load Derrick pivot section.
- Suspended load Derrick pivot section with rope winch and luffing pulley block.

1.31 Fastening point for end section

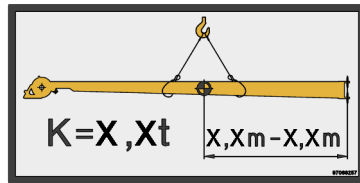

Fig.147595: Fastening point for end section

K = Weight in tons (t)

X.X to X.X = Distance of center of gravity in meters (m)



WARNING

End section improperly fastened!

The end section can tip over and fall down.

Death, severe bodily injuries, property damage.

► Fasten the end section only with two hooks.

► Select the fastening point such that the center of gravity is located within the fastening points.

1.32 97095312 – Suspended load and fastening points for counterweight frame

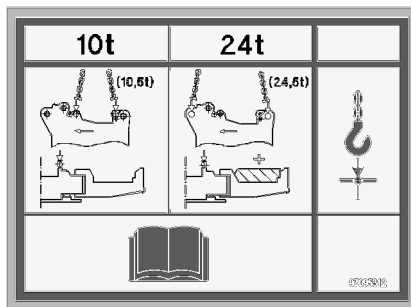

Fig.148126: Suspended load and fastening points for counterweight frame



Note

- Observe the suspended load and fastening points for counterweight frame.
- Observe and adhere to the operating instructions.

1.33 97003109 – Accessing the step ladder



Fig.109032: Accessing the step ladder

**WARNING**

Danger of falling!

If the step ladder is accessed before it is completely folded out, the assembly personnel can fall and be fatally injured.

- ▶ Before accessing the step ladder, fold the lowest step out.

1.34 97003110 – Folding the step ladder in and out

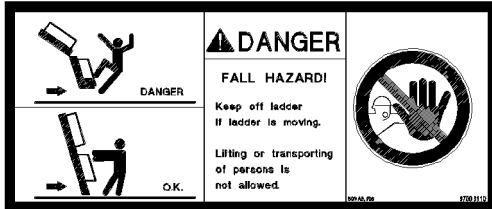

Fig.109033: Folding the step ladder in and out

**WARNING**

Danger of falling!

When folding the step ladder in or out or when driving the crane, no persons may remain on the step ladder or within the entire danger zone! Persons can fall from the step ladder or be killed as the step ladder folds in or out.

- ▶ Fold the step ladder in and out only if there are no persons within the danger zone.

1.35 97006167 – Identifying the support base

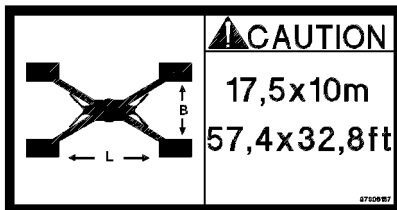

Fig.116285: Identifying the support base

**Note**

- ▶ The support beams are swung out / extended to a support base of 17.50 m x 10.0 m ; (57.4 ft x 32.8 ft).

1.36 97006167 – Identifying the support base

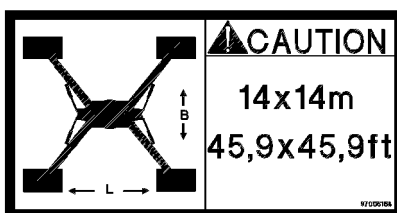

Fig.116286: Identifying the support base

**Note**

- ▶ The support beams are swung out / extended to a support base of 14.0 m x 14.0 m ; (45.9 ft x 45.9 ft).

1.37 97008514 – Warning of head injuries



Fig.110550: Warning of head injuries

**WARNING**

Head injuries!

Due to falling parts, personnel can be killed or severely injured.
Hitting the head can cause injuries.

- ▶ Protect your head with a hard hat.
- ▶ Proceed in an aware and safe manner.

1.38 97009799 – Data logger

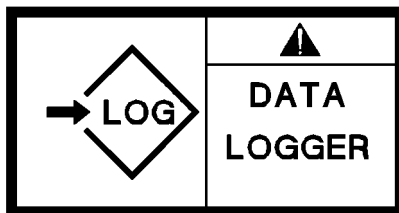

Fig.116261: Data logger

**Note**

- ▶ Data logger.

1.39 97012949 – Maximum load

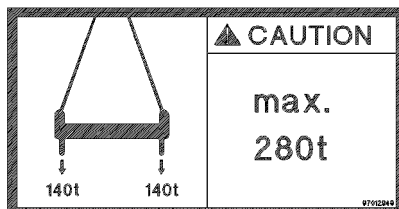

Fig.116263: Maximum load

**CAUTION**

Property damage due to overload!
If the cross beam is subjected to a higher load than permissible, damage can occur.
▶ Do not overload the cross beam.

1.40 97012095 – Maximum load

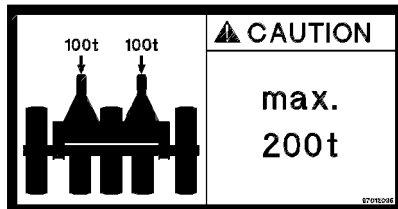

Fig.116265: Maximum load

**CAUTION**

Property damage due to overload!
If the roller cart is subjected to a higher load than permissible, damage can occur.
▶ Do not overload the roller cart.

1.41 97069053 – Storage boxes open

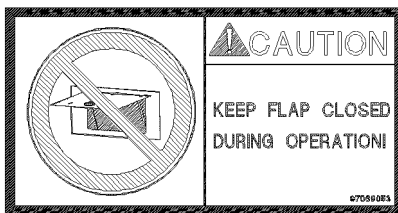

Fig.144736: Storage boxes open

NOTICE

Storage boxes open!
Damage of storage boxes.
▶ Before crane operation and before driving the crane, close the storage boxes.

1.42 97068370 – Closing the cab door

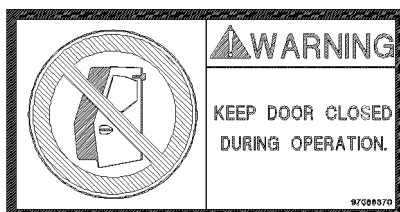

Fig.144737: Closing the cab door

**WARNING**

Cab door during crane operation **not** closed!
 The crane operator can fall down.
 Death, severe bodily injuries.
 ► Close the cab door during crane operation.

1.43 97053409 – Entanglement hazard during winch operation



Fig.144738: Entanglement hazard during winch operation

**DANGER**

Entanglement hazard during winch operation!
 Body parts can be caught and entangled.
 Death, severe bodily injuries, property damage.
 ► Do **not** stand in the hazard area of the winch.

1.44 97011689 – Danger of crushing

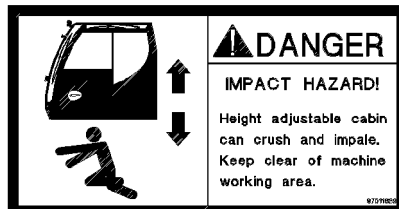

Fig.111047: Danger of crushing

**DANGER**

Danger of fatal injury!
 ► It is prohibited to remain within the danger zone of the cab.
 ► Stay away from the movement range of the cab.

1.45 97011690 – Overload of cab is prohibited

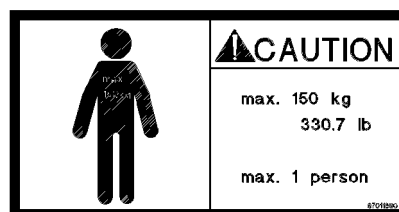

Fig.111048: Overload of cab is prohibited

**WARNING**

Danger of overload!

If the cab is subjected to a load of more than 150 kg then the cab or the telescoping arm can be damaged!

- ▶ Only one person at a time may remain in the cab!
- ▶ Do not subject the cab to a weight of more than 150 kg.

1.46 97016304 – Refueling

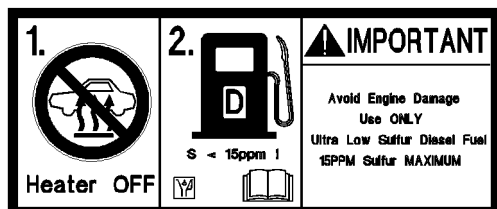

Fig.113766: Refueling

**WARNING**

Danger of fire and explosion!

- ▶ Turn the auxiliary heater* off approx. 3 min before refueling the fuel tank.
- ▶ Before refueling the fuel tank, turn the engine off.

NOTICE

Property damage to the engine!

If incorrect fuel is added, the engine can be severely damaged.

- ▶ Refuel with fuel according to the Engine manufacturer's operating instructions.

1.47 97046488 – Corrosion inhibitor - antifreeze fluids

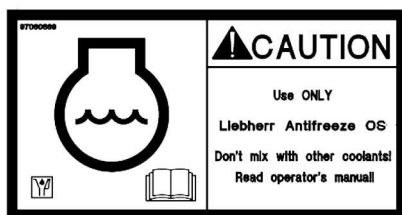

Fig.127585: Corrosion inhibitor - antifreeze fluids

NOTICE

Mixing of different corrosion inhibitor-antifreeze agents!

Damage to the cooling system!

- ▶ Fill the cooling system with corrosion inhibitor-antifreeze, see Service fill list.

1.48 97016392 – Crushing danger for feet



Fig.112474: Crushing danger for feet



WARNING

Crushing danger for feet!
Feet can be trapped or crushed.

- ▶ Keep feet away from the crushing area.

1.49 97012737 – Danger of accident



Fig.111748: Danger of accident



WARNING

Danger of accident!

- ▶ Close the windshield when driving.

1.50 97023034 – Disassembling

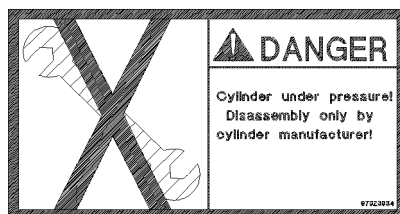

Fig.116264: Disassembling



DANGER

Danger of fatal injury due to repair!

Cylinder is pressurized.

Disassembly of the cylinder can result in death or serious injuries.

- ▶ The cylinder may only be removed by the manufacturer.

1.51 97036732 – Access via 3-point support

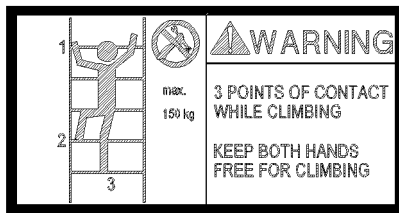

Fig.115172: Access via 3-point support



DANGER

Access via 3-point support!

While climbing up and down via a ladder, the assembly personnel can fall down and be injured severely.

- ▶ When climbing up and down, a 3-point support must be ensured.
- ▶ Use ladders only up to a weight of 150 kg.
- ▶ When climbing up and down, hands must be free.

A 3-point support is ensured when:

- two legs are standing safely and one hand has a safe hold.
- two hands have a safe hold and one leg is standing safely.

1.52 97003112 – Maximum suspended load

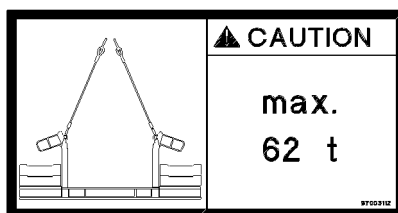

Fig.116282: Maximum suspended load



WARNING

Maximum suspended load!

If the maximum suspended load of 62 t is exceeded, the load can fall down and kill personnel.

- ▶ Observe the maximum permissible suspended load.

1.53 97036917 – Maximum suspended load

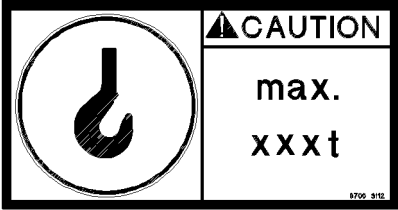
	Suspended load fastening point
97047630	
97036917	
97047630	



WARNING

Mortal danger if the load falls down!

If the maximum suspended load is exceeded, the load can fall down and kill personnel.

- ▶ Observe the maximum permissible suspended load.

1.54 97037383 – Urea

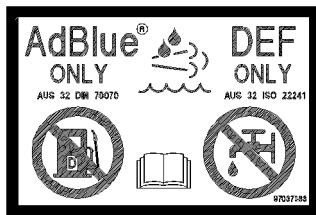

Fig.115173: Urea



CAUTION

Property damage due to incorrect operating fluids!

When refilling urea and the urea which is specified by the engine manufacturer is not used, then damage can occur.

- ▶ Refill **exclusively** urea.
- ▶ See engine manufacturer's operating instructions.

1.55 97037952 – Warning of fatal electric shock

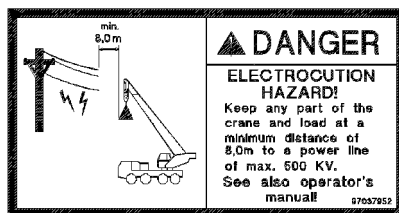

Fig.116280: Warning of fatal electric shock

LWE/LR 1600-2-008/18109-09-02/en

**DANGER**

Danger of fatal injury due to electric shock!

If the boom or the hoist rope is under electric voltage, then death or severe injuries can occur if anyone touches the crane, the vehicle or the load.

- ▶ Keep a minimum distance of 8.0 m from current carrying parts.

1.56 97042730 – Falling luffing cylinder

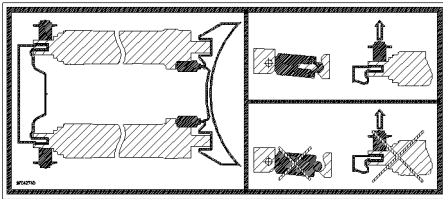

Fig.118465: Falling luffing cylinder

**WARNING**

Mortal danger if the luffing cylinders fall down!

- ▶ Make sure, before unpinning the luffing cylinder, that the erection cylinders are placed on both luffing cylinders.

1.57 97047810 – Pinning brackets

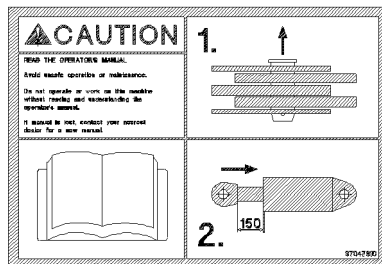

Fig.121709: Pinning brackets

NOTICE

Damage of brackets due to collision!

- ▶ Make sure, before pinning and unpinning, that the hydraulic cylinder is set to a distance of 150 mm.

1.58 97042797 – Overload of components

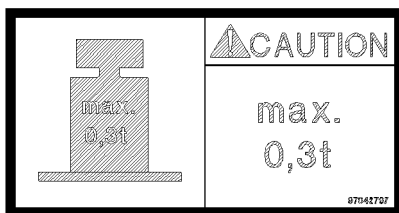

Fig.117347: Overload of components

**DANGER**

Danger of falling due to overload!

If a component, such as a sliding beam platform, is subjected to a weight of more than 0.3 t , then the sliding beam platform can break.

Personnel can fall down and be severely injured or killed.

- ▶ Subject the component (sliding beam platform) to no more than maximum 0.3 t.

1.59 97041305 – Overload of components

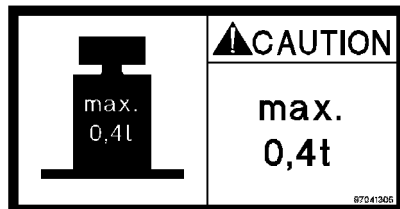

Fig.116792: Warning of overload of components

**DANGER**

Danger of falling due to overload!

If a component, such as a sliding beam platform, is subjected to a weight of more than 0.4 t , then the sliding beam platform can break.

Personnel can fall down and be severely injured or killed.

- ▶ Subject the component (sliding beam platform) to no more than maximum 0.4 t.

1.60 97070905 – Removing the auxiliary jib (boom nose)

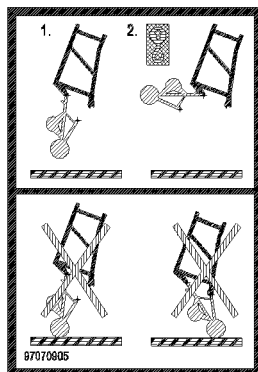

Fig.122645: Removing the auxiliary jib (boom nose)

NOTICE

Property damage

Before taking the N-head down:

- ▶ Remove the auxiliary jib (boom nose).

1.61 97033982 – Assembling / disassembling the Derrick pivot section

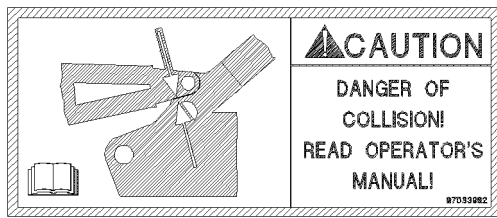

Fig.127470: Assembling / disassembling the Derrick pivot section

NOTICE

Derrick pivot section assembly procedure carried out incorrectly!

Damage to the Derrick pivot section receptacle.

- ▶ Perform the assembly procedure according to the operating instructions.

1.62 Maximum sound power level

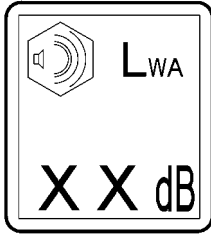
	Maximum sound power level
975809508	 <p>Maximum sound power level</p>
971693308	
971693408	
971693508	
971693608	



Note

- ▶ The maximum sound power level can be read on the outside of the crane operator's cab or in the CE declaration of conformity.

1.63 97097951 – Counterweight

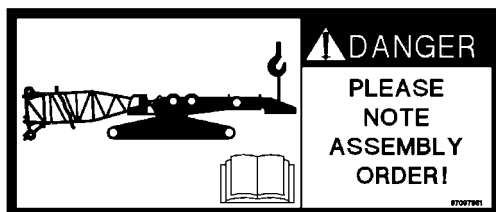

Fig.146805: Counterweight

**DANGER**

Counterweight not secured!
Falling counterweight death, property damage.

- ▶ Observe and adhere to the operating instructions.
- ▶ Do not remove the auxiliary crane until the counterweight is pinned and secured on both sides with the turntable.

1.64 97107101 – Unlocking the telescopic boom locking pin

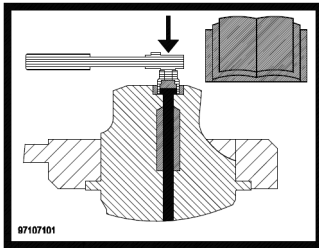

Fig.148421: Unlocking the telescopic boom locking pin

**Note**

- ▶ The locking pin may be unlocked according to the operating instructions.
- ▶ Observe and adhere to the operating instructions.

1.65 97107199 – Do not unlock the telescopic boom locking pin

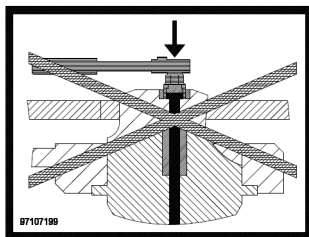

Fig.148422: Do not unlock the telescopic boom locking pin

**WARNING**

Impermissible telescopic boom locking pin unlocked!
The telescopic boom can retract in an uncontrolled manner.
Death, severe bodily injuries, property damage.

If a locking pin is marked with this sign:

- ▶ **Never** unlock the locking pin.

1.66 977055908 – Fastening point for swingable sliding beam

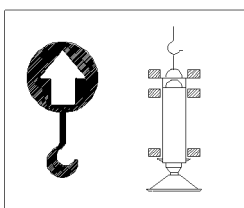

Fig.106894: Fastening point for swingable sliding beam

1.67 971494208 – Limitation of maximum travel speed

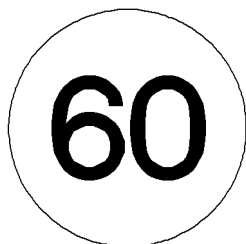

Fig.106034: Limitation of maximum travel speed

1.68 971539808 – Warning notice for unpinning the auxiliary boom on the pulley head

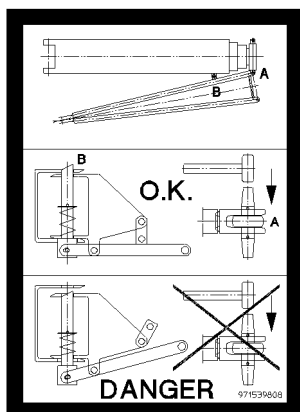

Fig.106040: Warning notice for unpinning the auxiliary boom on the pulley head



DANGER

Danger of fatal injury!

If the auxiliary boom is not locked correctly to the pivot section, it can fall down. Personnel can be severely injured or killed.

- ▶ Unpinning the auxiliary boom on the pulley head is prohibited.

1.69 971539908 – Warning notice for unlocking the auxiliary boom

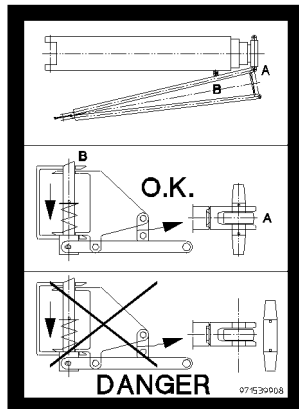

Fig.106041: Warning notice for unlocking the auxiliary boom



DANGER

Danger of fatal injury!

If the auxiliary boom is not locked correctly to the pulley head, it can fall down. Personnel can be severely injured or killed.

- ▶ Unpinning the auxiliary boom on the pivot section is prohibited.

1.70 978673908 – Warning of suspended load

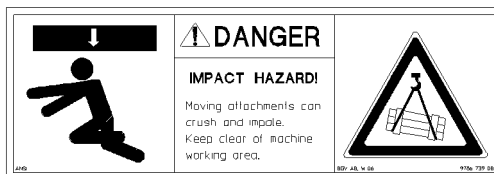

Fig.106026: Warning of suspended load



DANGER

Danger of fatal injury under suspended load!

- ▶ Standing under a suspended load is prohibited.
- ▶ Stay away from the working range of the machine.

1.71 978674008 – Access for unauthorized personnel prohibited



Fig.106037: Access for unauthorized personnel prohibited

**DANGER**

Danger of fatal injury!

If the crane or the working area is accessed by unauthorized personnel, life threatening injuries can occur as a result.

- ▶ It is prohibited for unauthorized personnel to enter the crane or the working area.

1.72 97039753 – Danger of stumbling

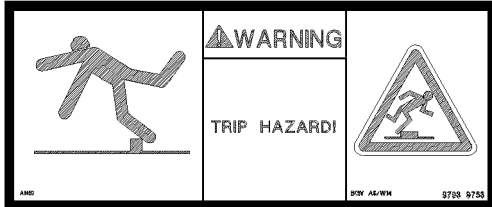

Fig.117346: Danger of stumbling

**WARNING**

Danger of stumbling!

- ▶ Move with caution.

1.73 978674108 – Warning of crushing danger

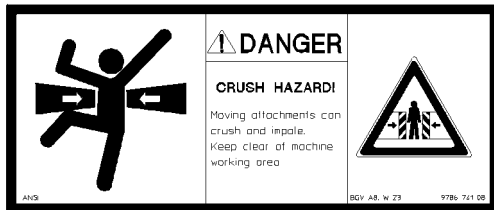

Fig.106027: Danger of crushing

**DANGER**

Danger of fatal injury when remaining in areas with crushing danger!

- ▶ It is prohibited for anyone to remain in areas where there is a crushing danger.
- ▶ Stay away from the working range of the machine.

1.74 97016911 – Danger of collision

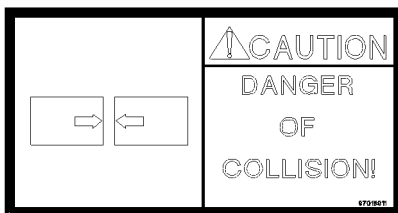

Fig.117344: Danger of collision

NOTICE

Danger of collision!
 ► Avoid a collision.

1.75 978674308 – Radio remote control

Fig.106047: Radio remote control

**WARNING**

Danger of injury due to crane operation with radio remote control!

- The crane can be operated with radio remote control!
- During crane operation, it is prohibited for anyone to remain in the danger zone!

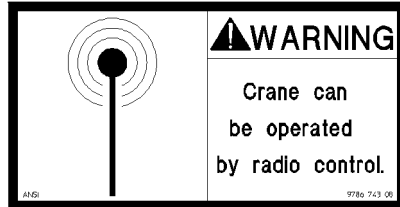
1.76 978674408 – Danger of burns to hands

Fig.106028: Danger of burns to hands

**WARNING**

Danger of burns when touching hot surfaces!

- Do not touch hot surfaces.

1.77 978674508 – Warning of rotating parts

Fig.106029: Warning of rotating parts

**WARNING**

Rotating parts!

The rotating fan blade can cause finger and hand injuries.

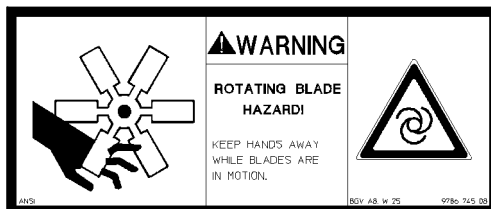
- Keep your hands away from the rotating fan blade.

1.78 978674608 - Crushing danger for hands



Fig.106030: Crushing danger for hands



WARNING

Danger of injuries for hands!

Hands can be caught, trapped or crushed within the danger zone.

► Keep hands away from the danger zone!

1.79 978674808 – Personal protective equipment



Fig.123900: Personal protective equipment



DANGER

Danger of falling!

► Use personal protective equipment.

1.80 978674908 – Accessing the area is prohibited



Fig.106038: Accessing the area is prohibited



WARNING

Danger of accident!

If the prohibited area is accessed, accidents can occur.

Personnel can be severely injured or killed.

► Do not access the prohibited area.

1.81 978675008 – Access prohibited



Fig.106039: Access prohibited



WARNING

Danger of falling!

If the crane is accessed by unauthorized personnel, life threatening injuries can occur.

- ▶ Do not get on the crane.

1.82 978687408 – Rigging point



Fig.112475: Rigging point



WARNING

Rigging point!

- ▶ Use the rigging point **solely** for rigging.
- ▶ Lifting on the rigging point is prohibited.

1.83 97036734 – Rigging point

NOT FOR LIFTING!			
Type (t)	Lashing Capacity		
	LC-N (daN)	LC-Q (daN)	
4	4 000	2 800	
9,7	8 700	4 800	
10	10 000	7 000	
16	16 000	11 200	
31,5	31 500	22 050	

Diagram on the left shows a rigging point with angles of 45° and 60° and a vertical line 'N'. Small text at the bottom left reads '97036734'.

Fig.116287: Rigging point



WARNING

Rigging point!

- ▶ Use the rigging point **solely** for rigging.
- ▶ Lifting on the rigging point is **prohibited**.

LWE/LR 1600-2-008/18109-09-02/en

1.84 978867108 – Warning of fatal electric shock

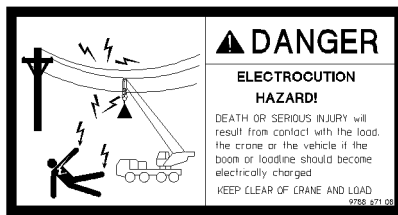

Fig.106814: Warning of fatal electric shock



DANGER

Danger of fatal injury due to electric shock!

If the boom or the hoist rope is under electric voltage, then death or severe injuries can occur if anyone touches the crane, the vehicle or the load.

► Stay away from the crane and load.

1.85 97094940 – Spark catcher

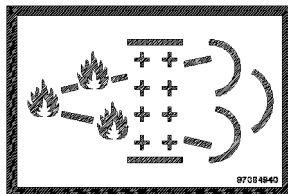

Fig.144735: Spark catcher



Note

► The exhaust system is equipped with an integrated spark catcher.

1.86 979383308 – Oil change

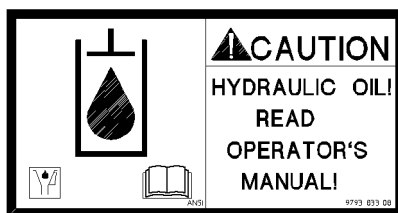

Fig.113827: Oil change



CAUTION

Property damage due to oil change!

If the oil specified in the operating instructions is not used during the oil change, it can lead to damage.

► See the Crane operating instructions, chapter 7.07.

1.87 979561108 – Counterweight

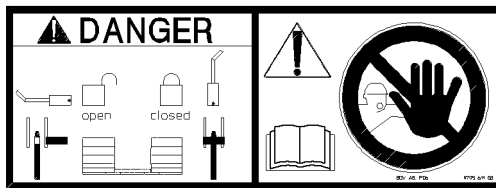

Fig.109026: Counterweight



WARNING

The counterweight can fall down!

If the auxiliary crane is removed on the counterweight before the counterweight is locked on both sides with the turntable, then the counterweight will fall down and can fatally injure assembly personnel.

- ▶ Do not remove the auxiliary crane until the counterweight is locked and secured on both sides with the turntable. See the Crane operating instructions, chapter 4.07.

1.88 97001802 – Falling platform

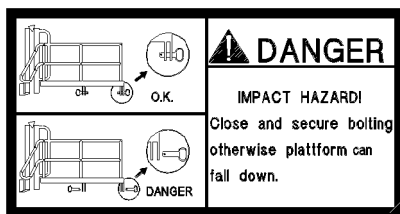

Fig.117345: Falling platform



WARNING

Falling platform!

- ▶ Pin and secure the platform in assembly / disassembly position.

1.89 973974408 - Transport weights of the components

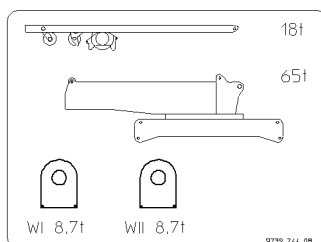

Fig.112440: Transport weights of the components

1.90 973974608 - Transport weights of the components

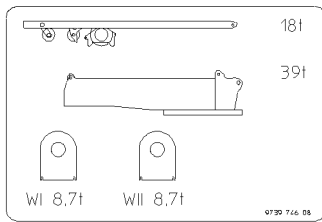

Fig.112441: Transport weights of the components

1.91 97011336 - Transport weights of the components

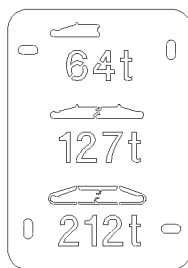

Fig.116271: Transport weights of the components

1.92 97068839 - Transport weights of the components / fastening length of the fastening equipment

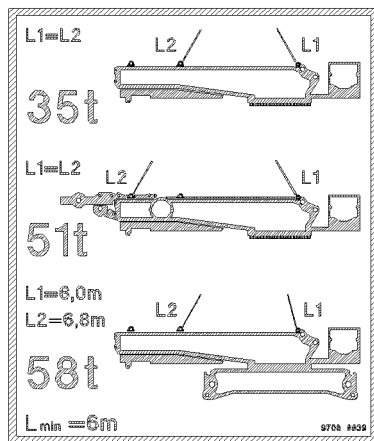
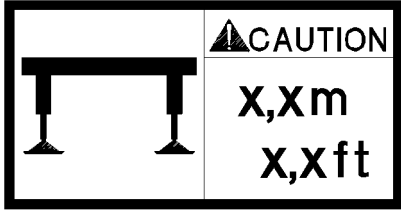

Fig.127587: Transport weights of the components / fastening length of the fastening equipment

LWE/LR 1600-2-008/18109-09-02/en

1.93 Identification of sliding beam

	Identification of sliding beam
978675108	 <p style="text-align: center;"><i>Identification of sliding beam</i></p>
978675208	
978772808	
978772908	
978809308	
978809408	
978809508	
978818408	
978818508	
978875908	
978902608	
978903108	
97029203	
978903208	
979126008	
979126108	
979210508	
979210608	
979210608	
979210708	
979309108	
979309208	
97019140	
97003224	
979410808	

Identification of sliding beam



Note

▶ Extend the sliding beams to a support width of X.X m (X.X ft).

LWE/LR 1600-2-008/18109-09-02/en

1.94 Identification Track width retracted

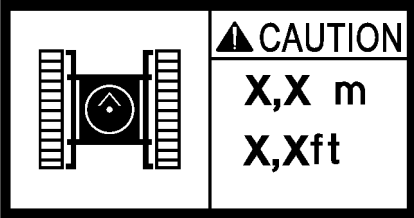
Identification Track width retracted	
97009840	 <p style="text-align: center;"><i>Identification of track width</i></p>
97009841	
97017044	
97017045	
97017046	

Identification of track width



Note

► Track width retracted to x.xx m (x.x ft)

1.95 976624808 – Fastening the load

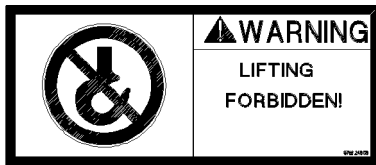

Fig.116283: Fastening the load



WARNING

Fastening the load is prohibited!

If the load is lifted on this point, the load can fall down and kill personnel.

► Lifting the load on unmarked locations is prohibited.

1.96 Note Weight sliding beams

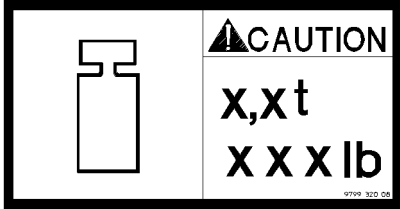
Weight of sliding beams	
979932008	 <p style="text-align: center;"><i>Weight of sliding beams</i></p>
979932108	
979932708	
979932808	



Note

► Pay attention to the weight of the sliding beams.

1.97 97047566 – Center of gravity of the counterweight

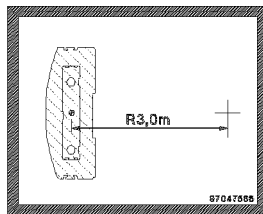

Fig.118491: Notice sign: Distance between center of gravity of counterweight and center of rotation



Note

► This notice sign indicates the distance between the center of rotation and the center of gravity of the counterweight.

1.98 97047566 – Center of gravity of the counterweight

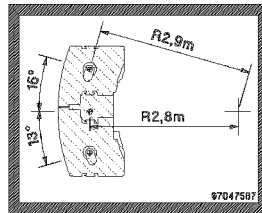

Fig.118492: Notice sign: Distance between center of gravity of counterweight and center of rotation



Note

- This notice sign indicates the distance between the center of rotation and the center of gravity of the counterweight.

1.99 97047566 – Center of gravity of the counterweight

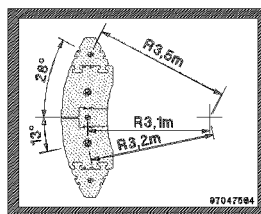

Fig.118493: Notice sign: Distance between center of gravity of counterweight and center of rotation



Note

- This notice sign indicates the distance between the center of rotation and the center of gravity of the counterweight.

1.100 97047566 – Center of gravity of the counterweight

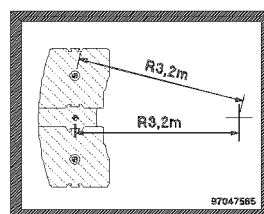

Fig.118494: Notice sign: Distance between center of gravity of counterweight and center of rotation

**Note**

- ▶ This notice sign indicates the distance between the center of rotation and the center of gravity of the counterweight.

1.101 97047566 – Center of gravity of the counterweight

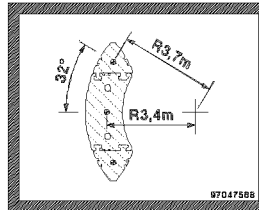

Fig.118495: Notice sign: Distance between center of gravity of counterweight and center of rotation

**Note**

- ▶ This notice sign indicates the distance between the center of rotation and the center of gravity of the counterweight.

1.102 97047566 – Center of gravity of the counterweight

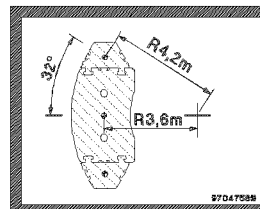

Fig.118496: Notice sign: Distance between center of gravity of counterweight and center of rotation

**Note**

- ▶ This notice sign indicates the distance between the center of rotation and the center of gravity of the counterweight.

1.103 Minimum rope reeving / minimum hook block weight





⚠ CAUTION					
LTM 1400-7.1			LTM 1450-8.1		
	 WT _{min} =?	 n _{min} =?		 WT _{min} =?	 n _{min} =?
TN			TN		
N-14,0m	3,1 t	n = 5	N-14,0m	3,1 t	n = 5
N-21,0m	2,6 t	n = 4	N-17,5m	2,6 t	n = 5
N-28,0m	1,4 t	n = 2	N-21,0m	2,6 t	n = 4
TN + 			N-24,5m	2,6 t	n = 4
N-14,0m	2,3 t	n = 3	N-28,0m	1,4 t	n = 2
N-21,0m	2,3 t	n = 2	TNH		
			N-14,0m	2,3 t	n = 3
			N-17,5m	1,8 t	n = 3
			N-21,0m	2,3 t	n = 2
			N-24,5m	1,8 t	n = 2

Fig.127972: Minimum rope reeving / minimum hook block weight with luffing lattice jib / boom nose

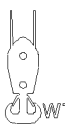

WARNING

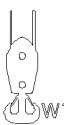
Minimum rope reeving / minimum hook block weight not adhered to!

Too low hook block weight leads to the formation of slack rope.

Rope reeving too low, hoist rope is overloaded.

► Adhere to the hook block weight and hoist rope reeving.

Example: LTM 1400-7.1

With a luffing lattice jib -TN **N-21 m** a hook block with a weight of **2.6 t** **must** be installed and minimum rope reeving of **4** must be used.

With a luffing lattice jib **N-21 m** and boom nose a hook block with a weight of **2.3 t** **must** be installed and minimum rope reeving of **2** must be used.

2.05.10 Labeling of load lifting equipment

1	Identifications on the hook block or load hook	3
2	Identifications on single hook or double hook	4
3	Identifications on auxiliary weights	5

Fig.195219

LWE/LR 1600-2-008/18109-09-02/en

1 Identifications on the hook block or load hook

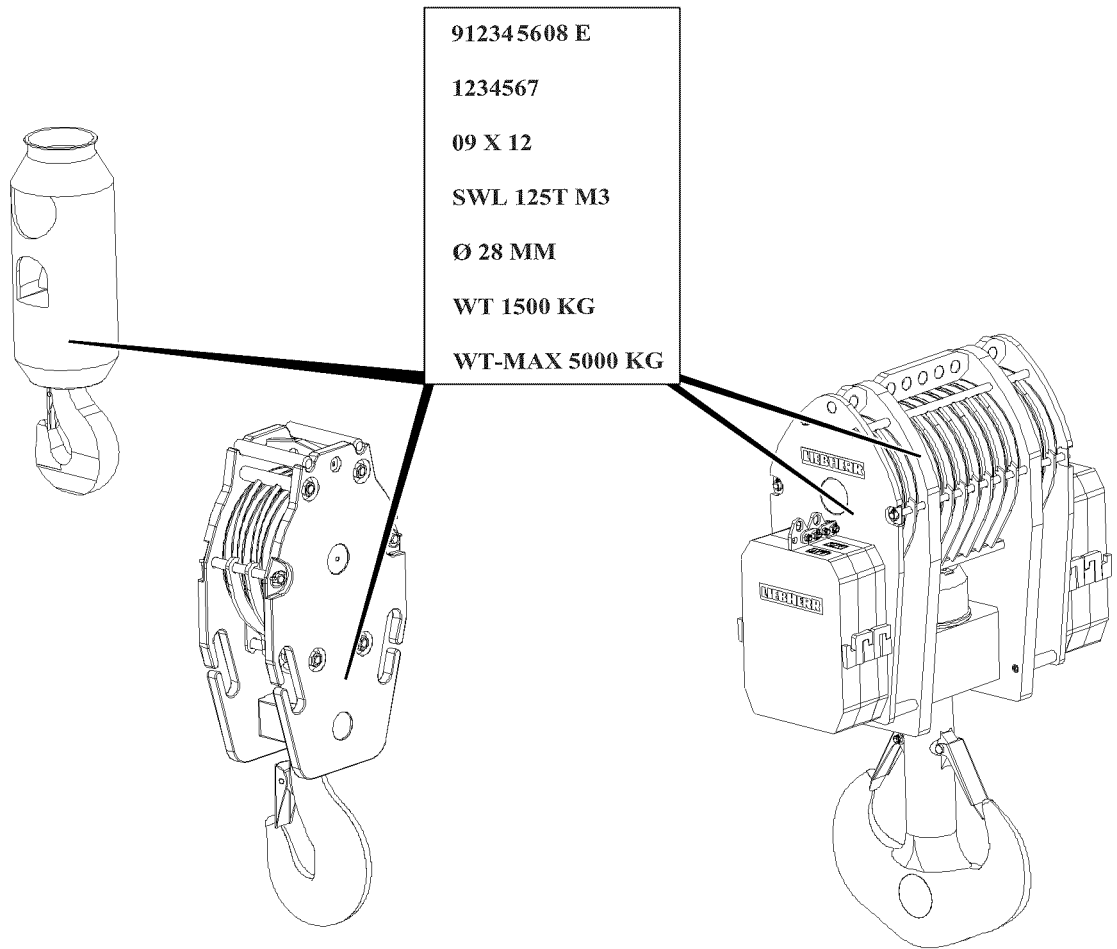

Fig.118509: Identifications on the hook block or load hook



Note

- ▶ The load hooks and hook blocks approved for this crane type can be found in the load chart.
- ▶ The hook blocks shown are examples only and can deviate from the existing hook block.

Punch mark area	Explanation
912345608 E	Liebherr ID no., „E = entschärft (deburred)“
123456	Series or factory test number
09 X 12	Month of construction / supplier marks / year of construction
SWL 125T M3	SWL (Safe Working Load) = Load carrying capacity for power train group M3
Ø 28 mm	Hoist rope diameter
WT 1500 Kg	WT (Weight Tare) = Own weight (without auxiliary weights)

LWE/LR 1600-2-008/18109-09-02/en

Punch mark area	Explanation
WT-MAX 5000 Kg	WT-Max = Maximum permissible own weight of lower pulley block and total number of progressively installed auxiliary weights
	Limits the number of installed auxiliary weights
	Determination via addition of assembled own weights (number of auxiliary weights + hook block)

Identifications on the hook block or load hook

2 Identifications on single hook or double hook

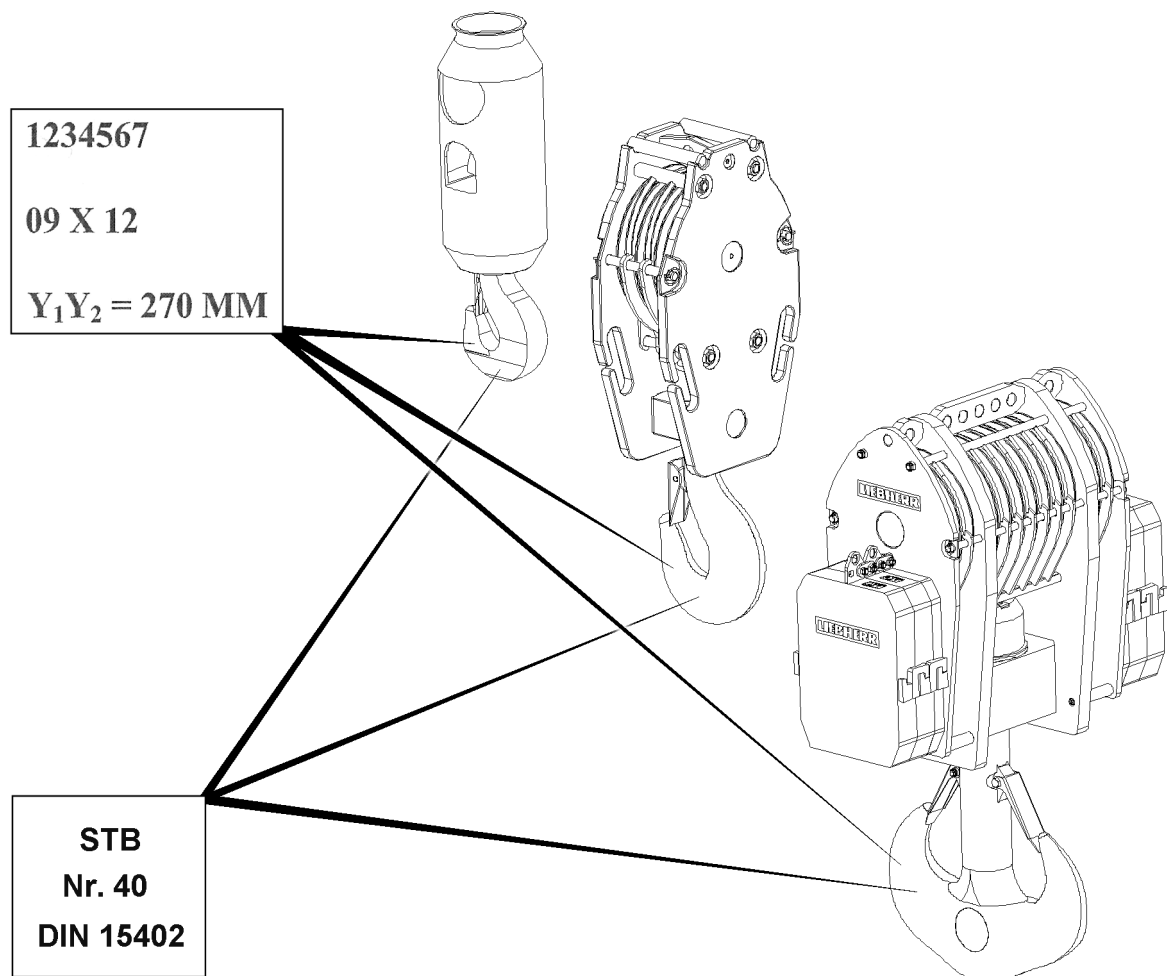

Fig.149061: Identifications on single hook or double hook

Punch mark area	Explanation
STB	Hook manufacturer
40-T	Hook number + strength class according to DIN 15 400
DIN	Hook shape according to DIN 15 401 /DIN 15 402
123456	Series or factory test number

Punch mark area	Explanation
09 X 12	Month of construction / supplier marks / year of construction
Y1Y2 = 270 mm	Dimension Y or dimension Y1 and dimension Y2 according to DIN (= Test dimensions for recurrent tests)

Identifications on single hook or double hook

3 Identifications on auxiliary weights

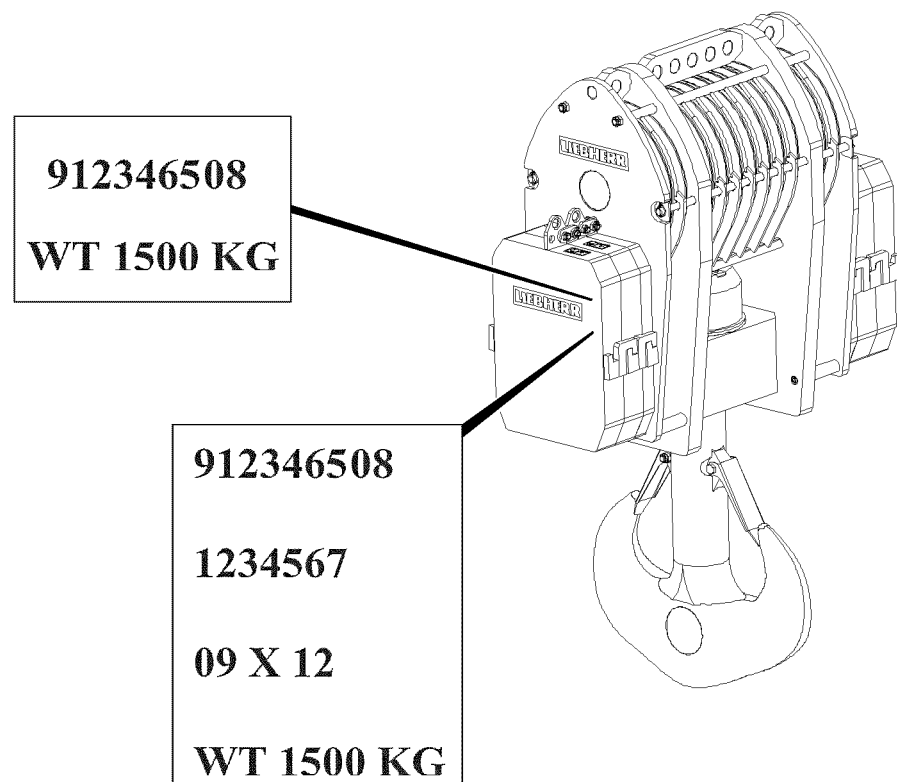

Fig.118511: Identifications on auxiliary weights



Note

- The own weight of the individual auxiliary weight is noted on the side on the respective auxiliary weight.

3.1 Identifications on auxiliary weights at delivery

Punch mark area	Explanation
912346508	Liebherr ID no.
WT 1500 Kg	WT (Weight Tare) = Own weight of individual auxiliary weight

Identifications of auxiliary weights at delivery

3.2 Identifications on auxiliary weights for reorder

Punch mark area	Explanation
912346508	Liebherr ID no.
123456	Series or factory test number
09 X 12	Month of construction / supplier marks / year of construction
WT 1500 Kg	WT (Weight Tare) = Own weight of individual auxiliary weight

Identifications of auxiliary weights at reorder

2.06 Antifall guards on the crane

1	Personal protective equipment	3
2	Fall protection equipment on the crane chassis	5
3	Fall protection equipment on the crane operator's cab	9
4	Fall protection equipment on the crane superstructure	11
5	Fall protection equipment on the counterweight brackets	13
6	Fall protection equipment on the turntable extension	15
7	Fall protection equipment on the pivot sections and lattice mast boom	19

Fig.195219

LWE/LR 1600-2-008/18109-09-02/en

1 Personal protective equipment



Fig.124519



WARNING

Danger of falling!

During assembly / disassembly, inspection and maintenance work, assembly personnel must be secured with appropriate aids to prevent them from falling.

Assembly personnel can fall down.

Death, severe bodily injuries.

- ▶ The assembly personnel must always move carefully and anticipatory on the crane, the crane components or lattice sections.
- ▶ All work at a height, when there is a danger of falling, must be carried out with suitable aids.
- ▶ If fall protection equipment is available, then it must be used.
- ▶ If aids are not available and work cannot be carried out from the ground, then the assembly personnel must secure themselves with the permissible fall arrest system to prevent falling, see Crane operating instructions, chapter 2.04.
- ▶ The fall arrest system must be attached to the fastening and hook points as well as to the safety ropes.
- ▶ Only step on the aids, ladders and catwalks with clean shoes.
- ▶ Keep aids, ladders and catwalks free of heavy dirt, snow, frost and ice.



WARNING

Danger of accident due to fall arrest system exposed to a fall!

If a fall arrest system is not replaced after a fall, then the fall arrest system can fail in case of a new fall.

Death, severe bodily injuries.

- ▶ After every fall, the fall arrest system must be removed and inspected by authorized and trained experts.
- ▶ The results must be documented in the inspection log book.
- ▶ Only after written release by expert personnel may the fall arrest system be reused.



Note

- ▶ The sign 3 marks the fastening points, where assembly personnel must hook themselves in the fall arrest system to protect against falling.

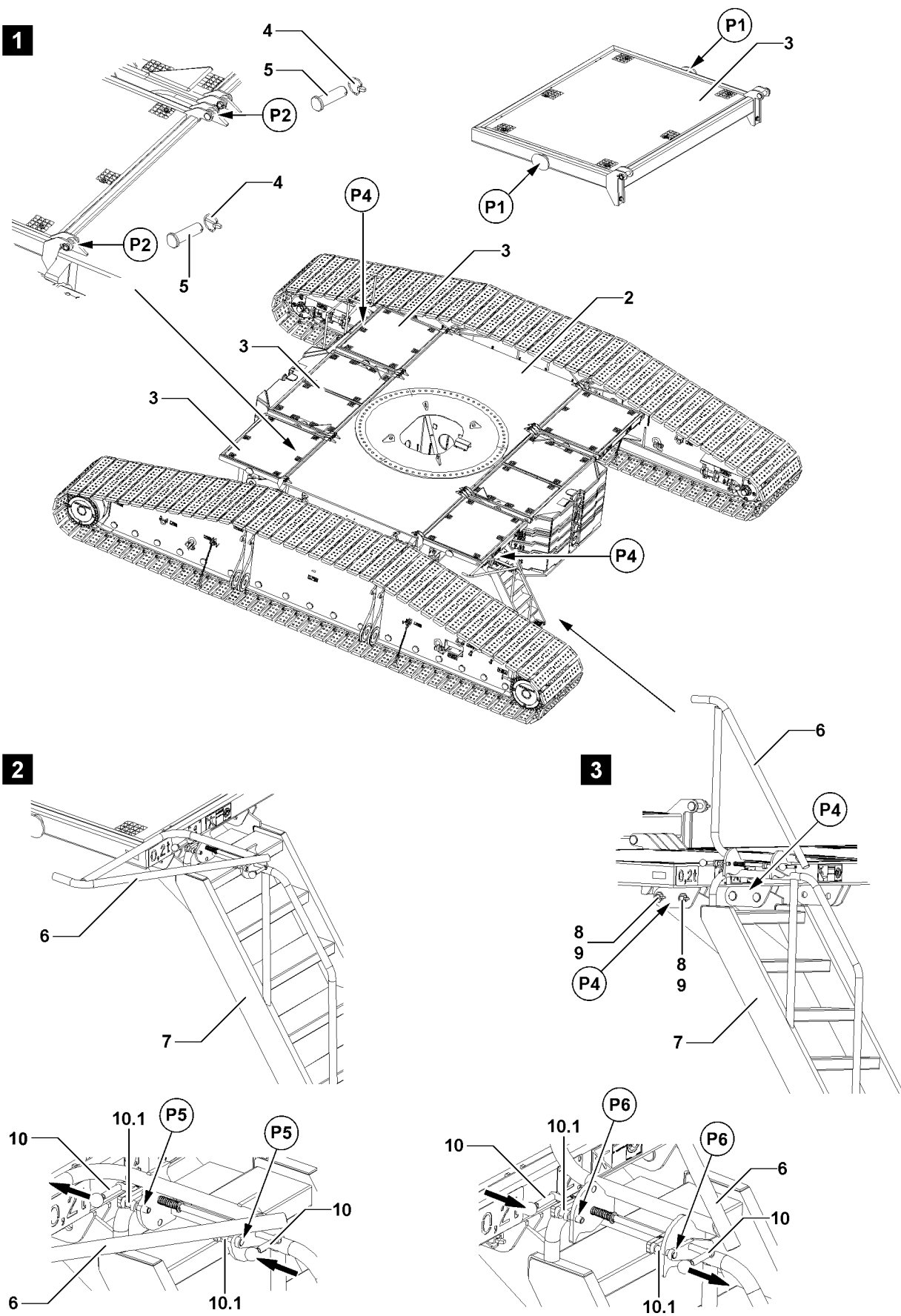

Fig.110962

LWE/LR 1600-2-008/18109-09-02/en

2 Fall protection equipment on the crane chassis



WARNING

Working at a height!

When working at a height, there is a danger of falling.

Death, severe bodily injuries.

- ▶ Properly assemble and secure all fall protection equipment, such as platforms, catwalks, ladders and railings on the crane chassis.



WARNING

Incorrect handling of the fastening equipment!

If fastening equipment cannot be attached correctly and if it is not secured sufficiently to prevent it from loosening up, loads can fall down.

Death, severe bodily injuries, property damage.

- ▶ Make sure that the fastening equipment is correctly attached on the fastening points and that it is secured sufficiently to prevent it from loosening up.

2.1 Platforms on the crane chassis

2.1.1 Installing the front and rear platforms



WARNING

Falling platform!

Death, severe bodily injuries, property damage.

- ▶ Do not remove the auxiliary crane until the platform **3** is pinned on both sides on points **P2** and until it is secured with the locking pins **4** on both sides.
- ▶ Fasten the platform **3** in points **P1** to the auxiliary crane and lift.
- ▶ Push the platform **3** in on both sides on the brackets in points **P2** on the crawler center section **2**.
- ▶ Pin the platform **3** on the crawler center section **2**: Insert the pins **5** on points **P2** from the inside to the outside and secure with locking pins **4**.
- ▶ Install three platforms respectively on the front and on the rear on the crawler center section **2**.
- ▶ Unhook the auxiliary crane from the platform **3**.

2.1.2 Removing the front and rear platforms

- ▶ Fasten the platform **3** in points **P1** to the auxiliary crane.
- ▶ Tension the fastening equipment.
- ▶ Unpin the platform **3** on the crawler center section **2**: Remove the locking pins **4** on both sides and unpin the pins **5** in points **P6**.
- ▶ Lift the platform **3** with the auxiliary crane and remove it.
- ▶ Take the platform **3** down.
- ▶ Disassemble all platforms.

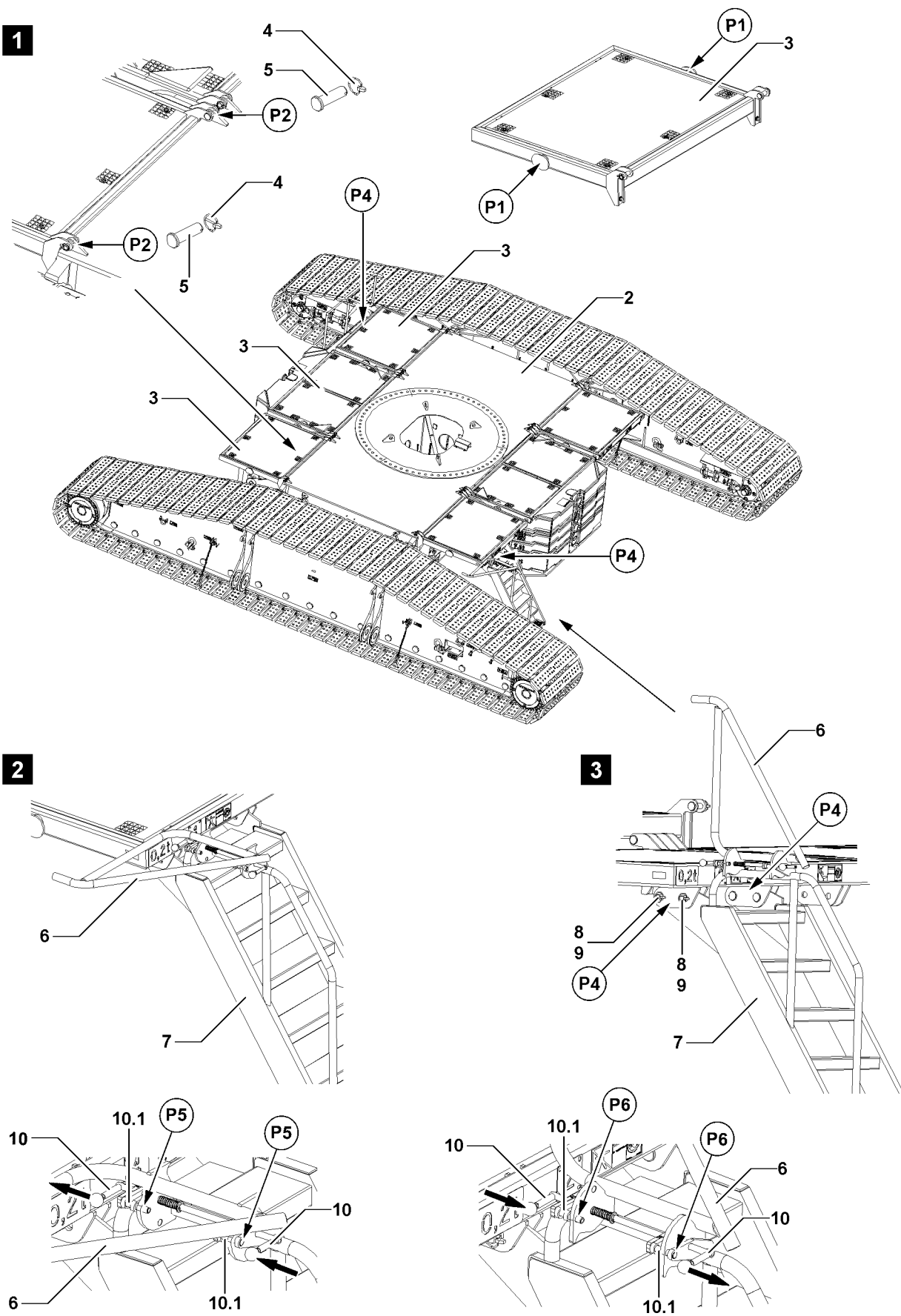

Fig.110962

LWE/LR 1600-2-008/18109-09-02/en

2.2 Steps on the crane chassis

2.2.1 Installing the steps

- ▶ Fasten the step 7 to the auxiliary crane and position it under the platforms 3 in points P4.
- ▶ Pin the step 7 on the platform 3: Insert the pins 8 in the points from the inside to the outside and secure with locking pins 9.
- ▶ Install the second step.

2.2.2 Steps during crane operation

NOTICE

Damage to the steps!

If the hand rails 6 are not folded to the side before crane operation or before driving the crane, then the hand rails 6 can be damaged during crane operation.

- ▶ Before crane operation, fold the hand rails 6 to the side.
-

Make sure that the following prerequisite is met:

- The hand rails 6 are folded upward.

Fold the hand rails to the side

- ▶ Pull the lever 10 on both sides to the rear until the pins 10.1 are unpinned on the points P5.

When the pins 10.1 are unpinned in the points P5:

- ▶ Hold the lever 10 pulled to the rear and fold the hand rail 6 to the side.
- ▶ Slowly release the lever 10 until the pins 10.1 are pinned in the points P6.

2.2.3 Steps while the crane is at a standstill



WARNING

When working at a height, there is a danger of falling!

If the hand rails 6 are not folded up and secured before stepping on the steps 7, personnel can fall down.

Death, severe bodily injuries, property damage.

- ▶ Before stepping on the ladders, fold the hand rails 6 up and secure them.
-

NOTICE

Damage to the steps!

If the hand rails 6 are not folded to the side before crane operation or before driving the crane, then the hand rails 6 can be damaged during crane operation.

- ▶ Before crane operation, fold the hand rails 6 to the side.
-

Make sure that the following prerequisite is met:

- The hand rails 6 are folded to the side.

Fold the hand rails up

The lever 10 is actuated simultaneously from top and bottom.

- ▶ Pull the lever 10 on both sides to the rear until the pins 10.1 are unpinned on the points P6.

When the pins 10.1 are unpinned in the points P6:

- ▶ Hold the lever 10 pulled to the rear and fold the hand rail 6 up.
- ▶ Slowly release the lever 10 until the pins 10.1 are pinned in the points P5.

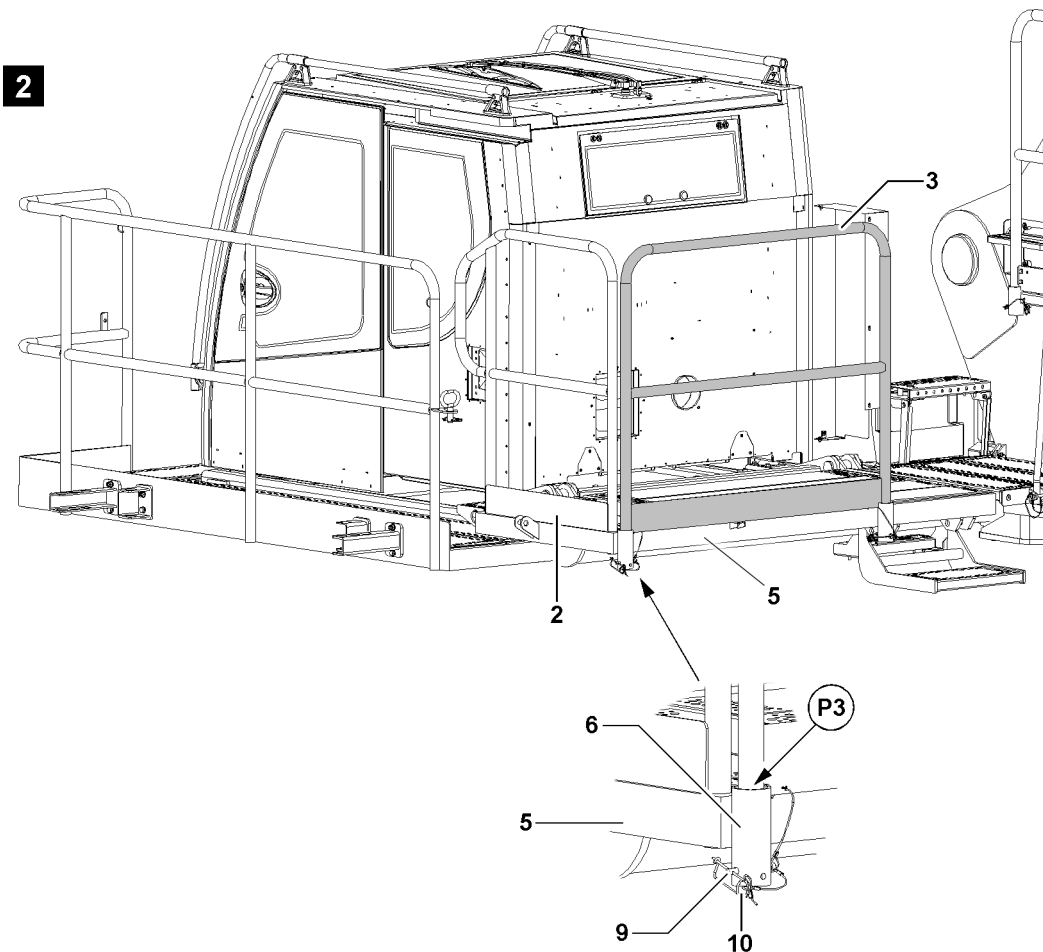
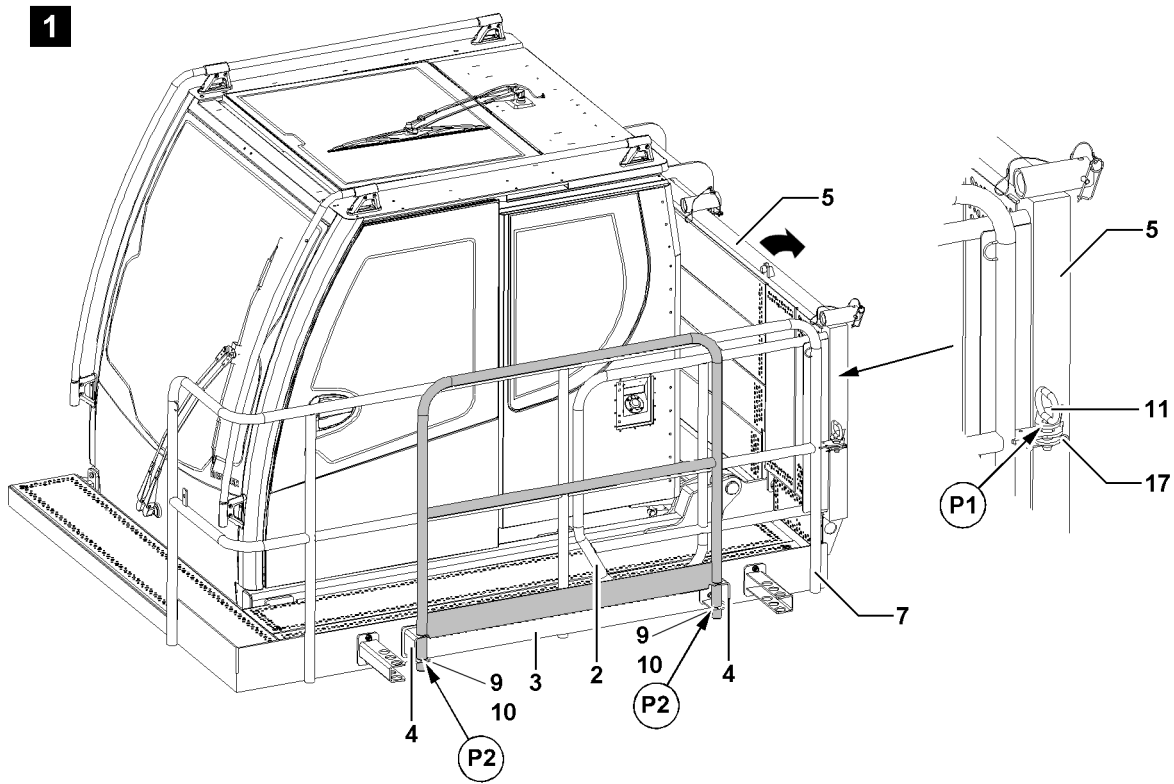

Fig.124520

LWE/LR 1600-2-008/18109-09-02/en

3 Fall protection equipment on the crane operator's cab

3.1 Installing the platform



WARNING

Folding down of the platform!
Death, severe bodily injuries, property damage.

- ▶ Fold the platform **5** carefully by hand.
- ▶ Make sure that there is no one under the platform **5** during the folding procedure.

At assembly, the platform **5** is folded down with the installed railing **2**, see illustration **1**.

- ▶ Unpin the platform **5** on the railing **7**: Remove the locking pin **17** in point **P1** and unpin the connector **11**.
- ▶ Fold the platform **5** into the horizontal position.
- ▶ Insert the connector **11** in point **P1** and secure with the locking pin **17**.

3.2 Assembling the railings

- ▶ In points **P2** remove the spring retainers **10** and unpin the pins **9**.
- ▶ Remove the railing **3** from the retainers **4** in points **P2**.
- ▶ Insert the railing **3** in the points **P3** in the receptacles **6**, see illustration **2**.
- ▶ Pin the railing **3** to the platform **5**: Insert the pins **9** and secure with the spring retainers **10**.

3.3 Removing the platform



WARNING

Folding down of the platform!
Death, severe bodily injuries, property damage.

- ▶ Fold the platform **5** carefully by hand.
- ▶ Make sure that there is no one under the platform **5** during the folding procedure.

- ▶ Unpin the railing **3** on the platform **5**: Remove the spring retainers **10** and unpin the pin **9**, see illustration **2**.
- ▶ Insert the railing **3** in the points **P2** in the receptacles **4** and secure with the pins **9** and spring retainer **10**.
- ▶ Remove the locking pin **17** and unpin the connector **11**.
- ▶ Fold the platform **5** into the vertical position.
- ▶ Pin the platform **5** to the railing **7**: Insert the connector **11** in point **P1** and secure with the locking pin **17**.

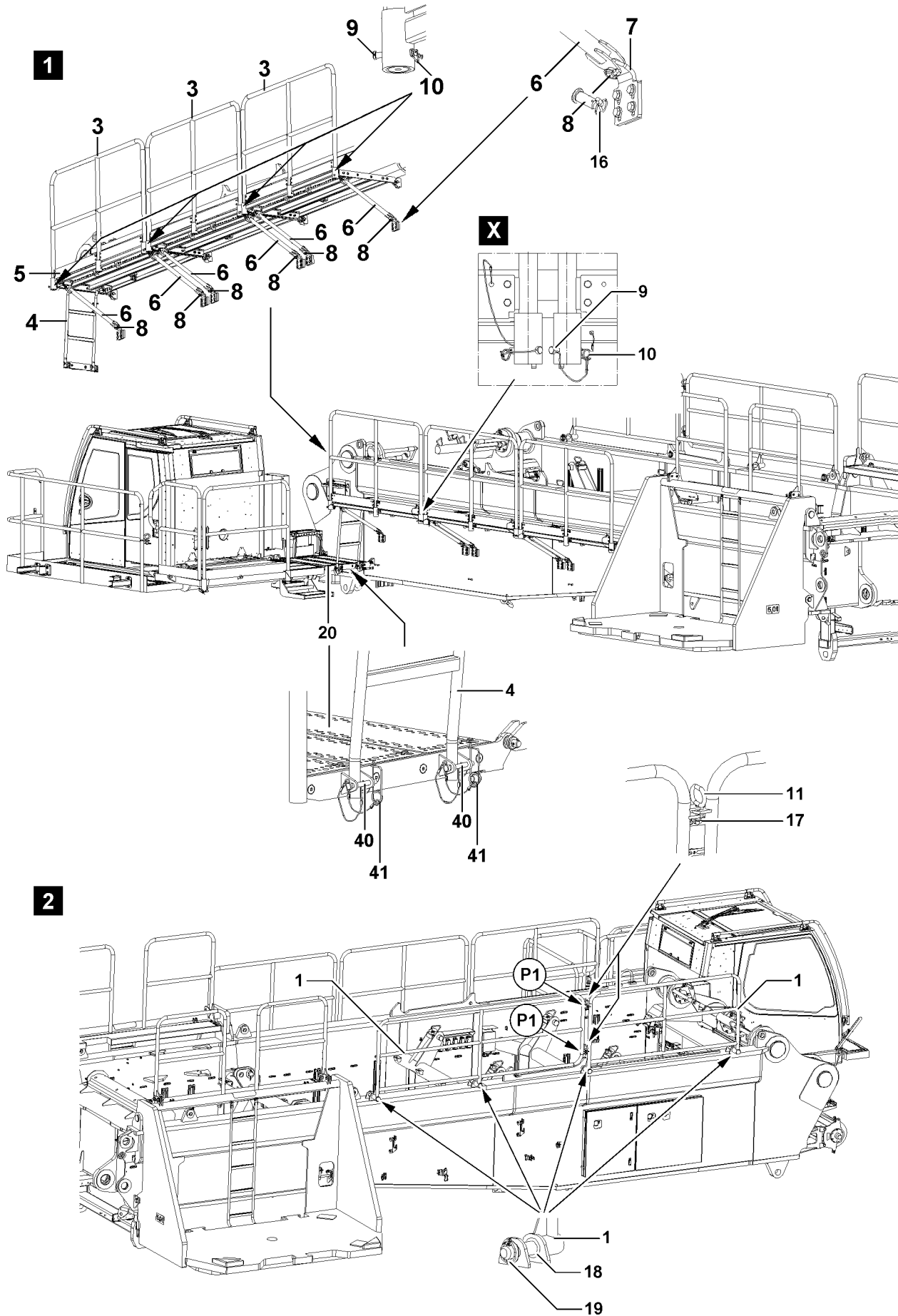

Fig.110374

LWE/LR 1600-2-008/18109-09-02/en

4 Fall protection equipment on the crane superstructure



WARNING

When working at a height, there is a danger of falling!

If fall protection equipment (railing) is intended for winches, for example, or assembly units, then it must be properly assembled and secured.

- ▶ Properly assemble and secure all fall protection equipment, such as catwalks, platforms, ladders and railings on the crane superstructure.

Retaining elements for a railing **3**, see detail **X**:

- A pin **9** and a spring retainer **10** are fastened with a rope on the railing **3**.
- A pin **9** and a spring retainer **10** are installed with a rope on the platform **5**.

4.1 Assembling platforms and ladder



WARNING

Danger of falling!

Before any assembly / disassembly work, maintenance and inspections, assembly personnel must wear approved fall arrest systems.

During assembly and disassembly, assembly personnel must be secured with appropriate aids to prevent them from falling.

If this is not observed, assembly personnel can fall down.

Death, severe bodily injuries, property damage.

- ▶ Make sure for all assembly / disassembly work, maintenance and inspection work, that the platforms **5**, railings **3**, the platform **20** and the ladder **4** are in the operating position and that they are properly installed and secured.
 - ▶ Step on all ladders and steps only with „clean shoes“.
 - ▶ Keep the ladder clean, free of snow, frost and ice.
 - ▶ Replace damaged ladders immediately.
 - ▶ Set up all ladders stable and safe to access.
-
- ▶ Fold all platforms **5** horizontally and position the supports **6** on the retainers **7**, see illustration **1**.
 - ▶ Pin all supports **6** on the retainer **7**: Insert the pin **8** and secure with the locking pin **16**.
 - ▶ Unpin the platform **20** and fold it into the horizontal position.
 - ▶ Pin the ladder **4** on the platform **20**: Insert the pins **40** and secure with the spring retainers **41**.

4.2 Assembling the railings

- ▶ Insert the railing **3** in the platforms **5**, see illustration **1**.
- ▶ Pin the railings **3** with pins **9** on the platforms **5** and secure with spring retainers **10**.
- ▶ Insert both railings **1** on top on the turntable into the bores **18** and secure with locking pins **19**, illustration **2**.
- ▶ Pin both railings **1** in points **P1** with connectors **11** and secure with locking pins **17**.

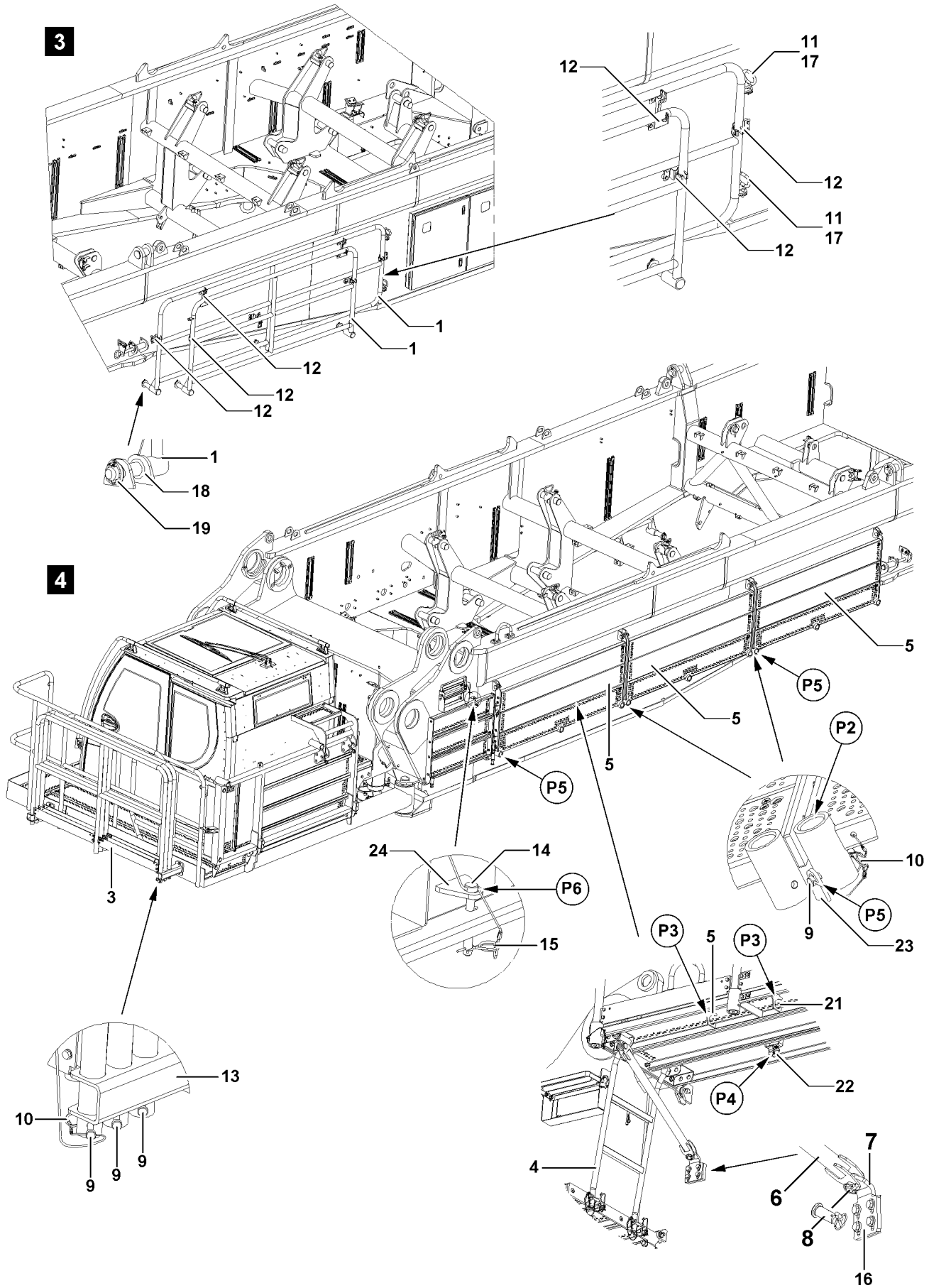

Fig.110375

LWE/LR 1600-2-008/18109-09-02/en

4.3 Removing the catwalks for transport

- ▶ Separate both railings **1** from each other: Remove the locking pin **17** and unpin the connector **11** see illustration **3**.
- ▶ Unpin the railing **1** on the turntable: Remove the locking pin **19** and pull the railing **1** from the bores **18**.

The wide railing is attached on the inside, the short railing on the outside.

- ▶ Attach the railings **1** on the retainers **12** on the turntable.
- ▶ Unpin the railings **3** on the platforms **5**: Remove the spring retainers **10** and unpin the pin **9**, see illustration **4**.
- ▶ Pull the railings **3** from the platforms **5** and insert them into the retainers **13**.
- ▶ Insert the railings **3** into the retainers **13** and secure with pins **9** and with spring retainers **10** on one side.
- ▶ Unpin the ladder **4** on the platform **20**: Remove the spring retainers **41** and unpin the pins **40**.



WARNING

Folding down of the platform!

Death, severe bodily injuries, property damage.

- ▶ Make sure that the platform **5** is secured in the horizontal position when folding the supports **6** in.

- ▶ Unpin the support **6** in the retainer **7**: Remove the locking pin **16** and unpin the pin **8**.
- ▶ Fold the supports **6** in and place them in the retainers **21** in points **P3**.
- ▶ Fold the ladder **4** in and attach it in the retainer **22** in point **P4**.
- ▶ Fold the platforms **5** down.
- ▶ Pin the platform **5** on the brackets **23**: Insert the pins **9** in the points **P5** and secure with locking pins **10**.
- ▶ Fold the platform **20** up and pin in the bracket **24**: Insert the pin **14** in point **P6** and secure with the locking pin **15**.

5 Fall protection equipment on the counterweight brackets



WARNING

When working at a height, there is a danger of falling!

If fall protection equipment (railing) is intended for winches, for example, or assembly units, then it must be properly assembled and secured.

- ▶ Properly assemble and secure all fall protection equipment, such as catwalks, platforms, ladders and railings on the crane superstructure.

5.1 Bringing the railings on the counterweight brackets into the operating position

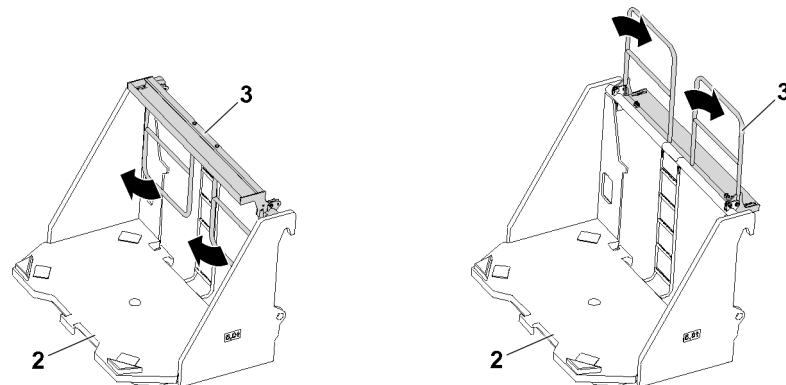

Fig.144819: Bringing the railings on the counterweight brackets into the operating position

Make sure that the following prerequisite is met:

- The counterweight bracket are located on the ground or on a load bearing substructure.



WARNING

Railing swinging down!

Death, severe bodily injuries, property damage.

- ▶ Make sure that the railings are safely held and brought to the operating position in a controlled manner.
- ▶ Swing the railing 3 „upward“ into the operating position.

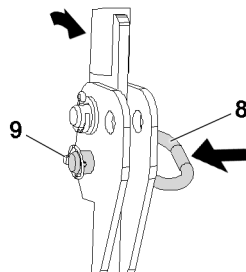

Fig.144850: Pin location

When the railing 3 is in the operating position:

- ▶ Pin the railing in the operating position with the pin 8 and secure with the retaining element 9.

5.2 Bringing the railings on the counterweight brackets into the transport position

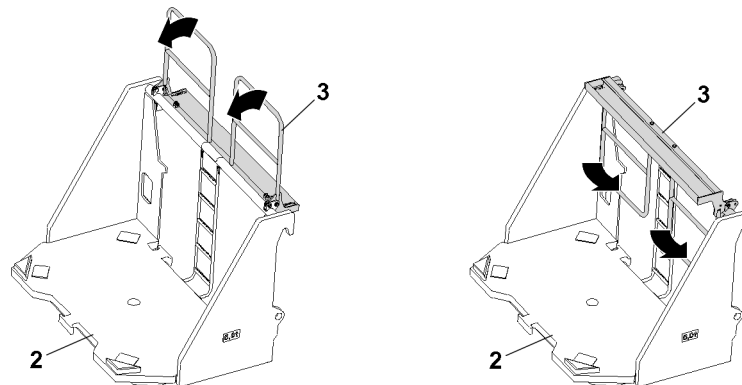

Fig.144820: Bringing the railings on the counterweight brackets into the transport position

Make sure that the following prerequisite is met:

- The counterweight bracket are located on the ground or on a load bearing substructure.
- There are no counterweight plates on the counterweight brackets.



WARNING

Railing swinging down!

Death, severe bodily injuries, property damage.

- ▶ Make sure that the railings are safely held and lowered to the transport position in a controlled manner.
- ▶ Swing the railing 3 „downward“ into the transport position.

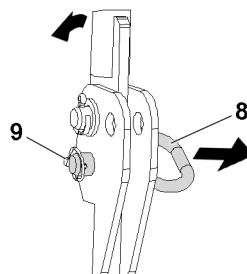

Fig.144851: Pin location

When the railing 3 is in the transport position:

- ▶ Pin the railing correctly in the transport position with the pin 8 and secure with the retaining element 9.

6 Fall protection equipment on the turntable extension



WARNING

When working at a height, there is a danger of falling!

If fall protection equipment (railing) is intended for winches, for example, or assembly units, then it must be properly assembled and secured.

- ▶ Properly assemble and secure all fall protection equipment, such as catwalks, platforms, ladders and railings on the crane superstructure.

6.1 Bringing the railing on the turntable extension into the operating position

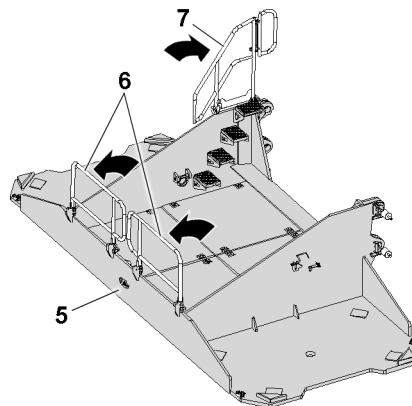

Fig.144875: Bringing the railing on the turntable extension into the operating position

Make sure that the following prerequisite is met:

- The turntable extension is located on the ground or on a substructure with load bearing capacity.



WARNING

Railing swinging down!
Death, severe bodily injuries, property damage.

- ▶ Make sure that the railings are safely held and brought to the operating position in a controlled manner.
- ▶ Swing the railing 6 and railing 7 „up“ into the operating position.

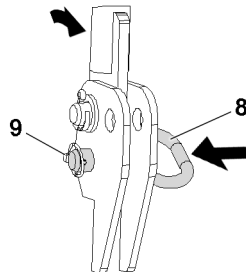

Fig.144850: Pin location

When the railing 6 is in the operating position:

- ▶ Pin the railing in the operating position with the pin 8 and secure with the retaining element 9.

When the railing 7 is in the operating position:

- ▶ Pin the railing in the operating position with the pin 8 and secure with the retaining element 9.

6.2 Bringing the railing on the turntable extension into the transport position

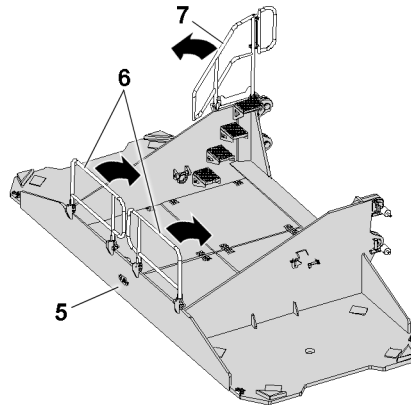

Fig.144874: Bringing the railing on the turntable extension into the transport position

Make sure that the following prerequisites are met:

- The turntable extension **5** is located on the ground or on a substructure with load bearing capacity.
- There are no counterweight plates on the turntable extension **5**.



WARNING

Railing swinging down!

Death, severe bodily injuries, property damage.

- ▶ Make sure that the railings are safely held and lowered to the transport position in a controlled manner.
- ▶ Swing the railing **6** and railing **7** „down“ into the transport position.

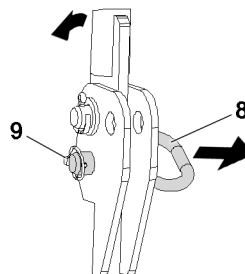

Fig.144851: Pin location

When the railing **6** is in the transport position:

- ▶ Pin the railing correctly in the transport position with the pin **8** and secure with the retaining element **9**.

When the railing **7** is in the transport position:

- ▶ Pin the railing correctly in the transport position with the pin **8** and secure with the retaining element **9**.

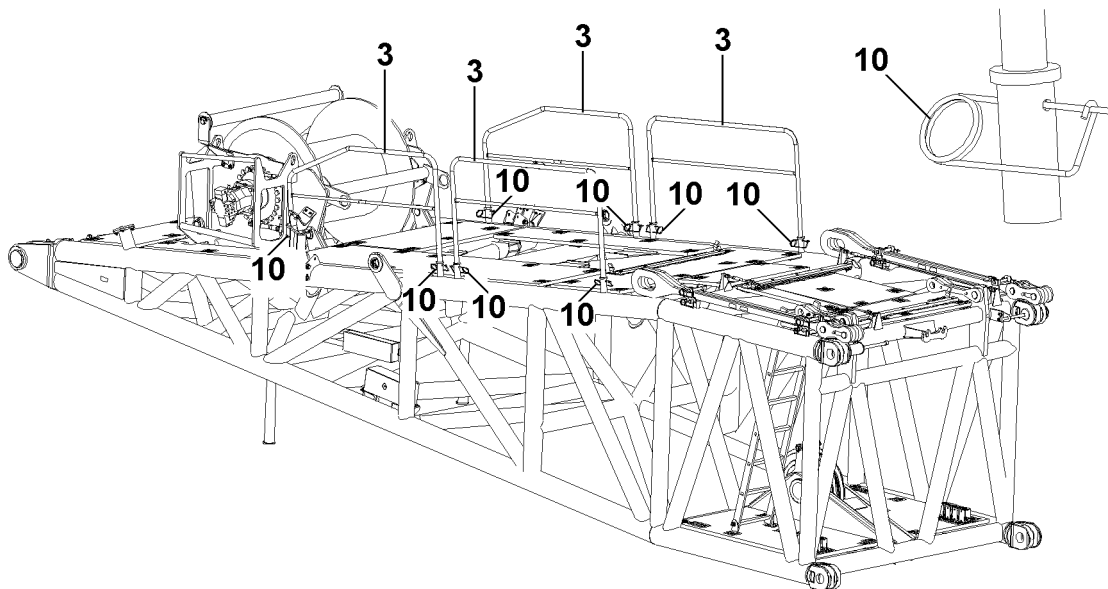
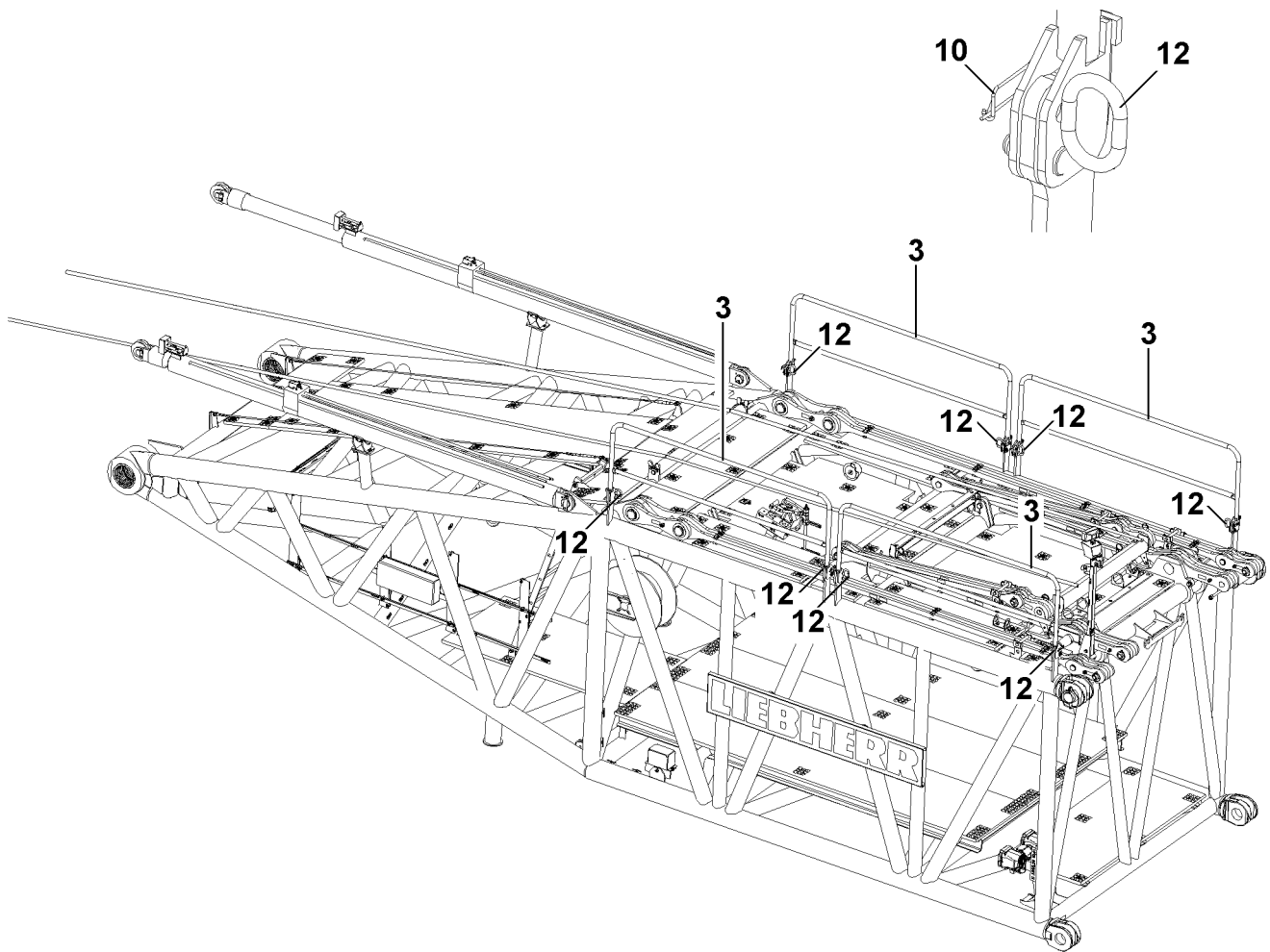

Fig.105374

7 Fall protection equipment on the pivot sections and lattice mast boom



WARNING

When working at a height, there is a danger of falling!

If fall protection equipment (railing) is intended for winches, for example, or assembly units, then it must be properly assembled and secured.

- ▶ Properly assemble and secure all fall protection equipment, such as catwalks, platforms, ladders and railings on the crane superstructure.



WARNING

Danger of falling!

Before any assembly / disassembly work, maintenance and inspections, assembly personnel must wear approved fall arrest systems.

During assembly and disassembly, assembly personnel must be secured with appropriate aids to prevent them from falling.

If this is not observed, assembly personnel can fall down.

Death, severe bodily injuries, property damage.

- ▶ For assembly / disassembly work, maintenance work and inspections on the pivot sections and the lattice mast boom, install all railings and secure.
- ▶ Only step on pivot sections and the lattice mast boom with „clean shoes“.

7.1 Assembling the railing on the S-pivot section and the derrick pivot section

- ▶ Swing the railing **3** on the S-pivot section into position, pin with pins **12** and secure with the spring retainers **10**.
- ▶ Push the railings **3** on the derrick pivot section into position and secure with the spring retainers **10**.

7.2 Assembling the railing on the SL-reducer

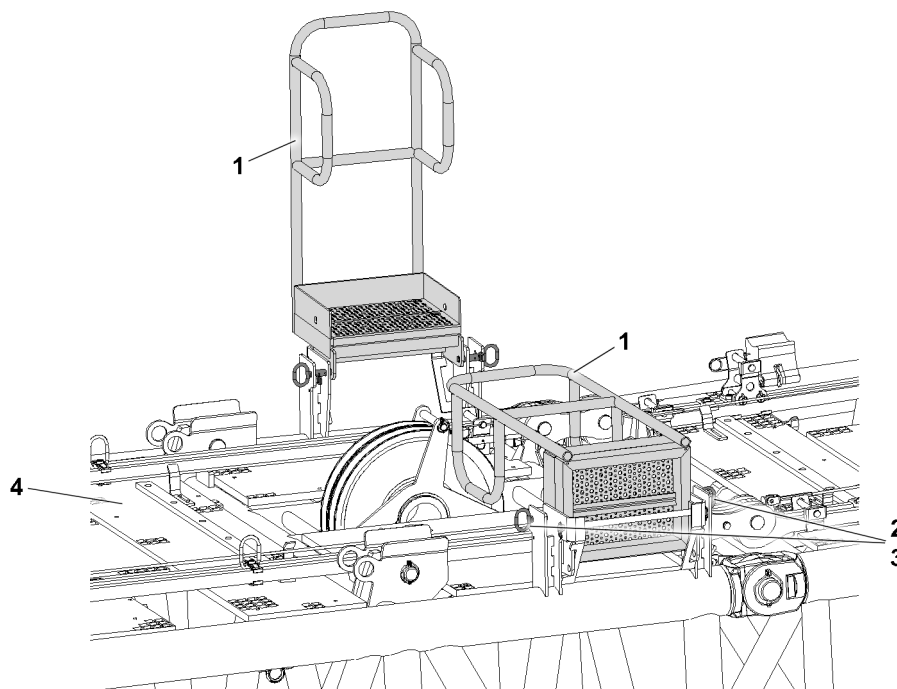

Fig.147776: Folding platforms on the SL-reducer



Note

- ▶ To retain the system dimensions for on road travel the folding platforms on the SL-reducer must be folded in into the transport position and pinned.



WARNING

Folding platform swinging down!

The folding platform can swing down uncontrolled due to its own weight when it is unpinned or pinned. Death, severe bodily injuries, property damage.

Fingers and hands can be crushed.

- ▶ For safety reasons, **two** persons must always be used to unpin or pin.
- ▶ When unpinning or pinning the pin connection, hold the folding platform.
- ▶ Do not reach with your hands into the danger zone.

7.2.1 Folding platform operating position

Release the folding platform 1 on the SL-reducer 4 from the transport position:

- ▶ Remove the retaining element 3 and unpin the socket pin 2.
- ▶ Swing the folding platform 1 upward.

Pin and secure folding platform 1 into the operating position:

- ▶ Insert the socket pin 2 again and secure with the retaining element 3.

7.2.2 Folding platform transport position

Release the folding platform 1 on the SL-reducer 4 from the operating position:

- ▶ Remove the retaining element 3 and unpin the socket pin 2.
- ▶ Swing the folding platform 1 downward.

Pin and secure the folding platform **1** in the transport position:

- ▶ Insert the socket pin **2** again and secure with the retaining element **3**.

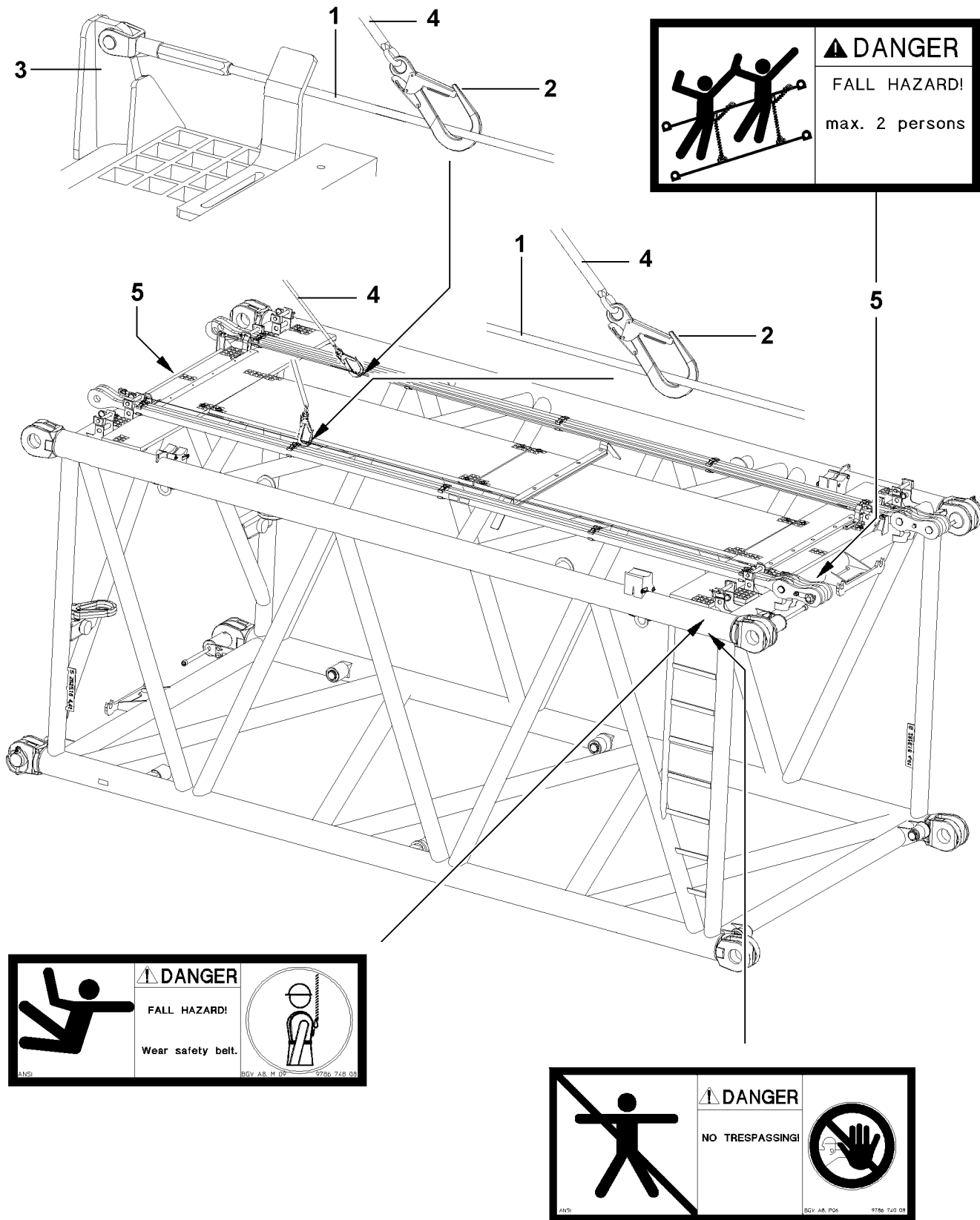

Fig.107341

7.3 Safety ropes on the lattice sections

On the lattice sections, on the upper left and right hand side, safety ropes **1** are installed as fall protection equipment.

NOTICE

Danger of damage!

- ▶ Never hang loads or objects on the safety ropes **1**.
-



WARNING

Danger of falling!

During assembly and disassembly, assembly personnel must be secured with appropriate aids to prevent them from falling. If this is not observed, assembly personnel can fall down.

Death, severe bodily injuries, property damage.

- ▶ Any work, where there is a danger of falling, must be carried out with suitable aids (for example: lifting platforms, scaffoldings, ladders, auxiliary crane).
 - ▶ If the work cannot be carried out with such aids nor from the ground, then the assembly personnel must secure themselves with approved fall arrest systems **4** to avoid falling, see Crane operating instructions, chapter 2.04.
 - ▶ Assembly personnel must hook themselves for all installation / removal work, maintenance and inspection work on the lattice mast boom with approved fall arrest systems **4** on the safety ropes **1** on the left and right hand side with both snap hooks **2** and secure themselves to prevent them from falling. (For example: Safety harness with self-actuating blocking function and an automatic tension and pull in device for the connectors)
 - ▶ The connector must be set to a length as short as possible so that it is impossible to hit the ground in case of a fall.
 - ▶ Fall absorbers may not be used, because they stretch too much in case of a fall.
 - ▶ On the safety ropes **1** on the left and right hand side, no more than **maximum two persons** may hook themselves with the snap hooks **2** and secure themselves to prevent falls, see sign **5**.
 - ▶ Changing the snap hooks **2** over is only permissible on the connecting points from lattice section to lattice section.
 - ▶ When changing the snap hook **2** from lattice section to lattice section, one snap hook **2** must always be hooked on one safety rope **1**.
 - ▶ Never release both snap hooks **2** simultaneously from the safety ropes **1**.
 - ▶ Before any assembly / disassembly work, maintenance and inspection work it must be ensured that all obstacles below have been removed from the work place and that there is sufficient clearance in case of a fall.
 - ▶ During all assembly / disassembly work, maintenance work and inspections, travel or crane operation is prohibited.
-

7.4 Replacing safety ropes subjected to a fall



WARNING

Danger of accident due to fall subjected safety ropes!

If fall subjected safety ropes **1** are not replaced after a fall, then the safety ropes can fail in case of another fall.

Death, severe bodily injuries, property damage.

- ▶ **Expert personnel** must immediately replace any safety ropes **1** which were subjected in a fall and inspect the respective anchor points **3** for damage.
 - ▶ If the anchor points **3** are damaged, then they must be replaced immediately by **expert personnel**.
-

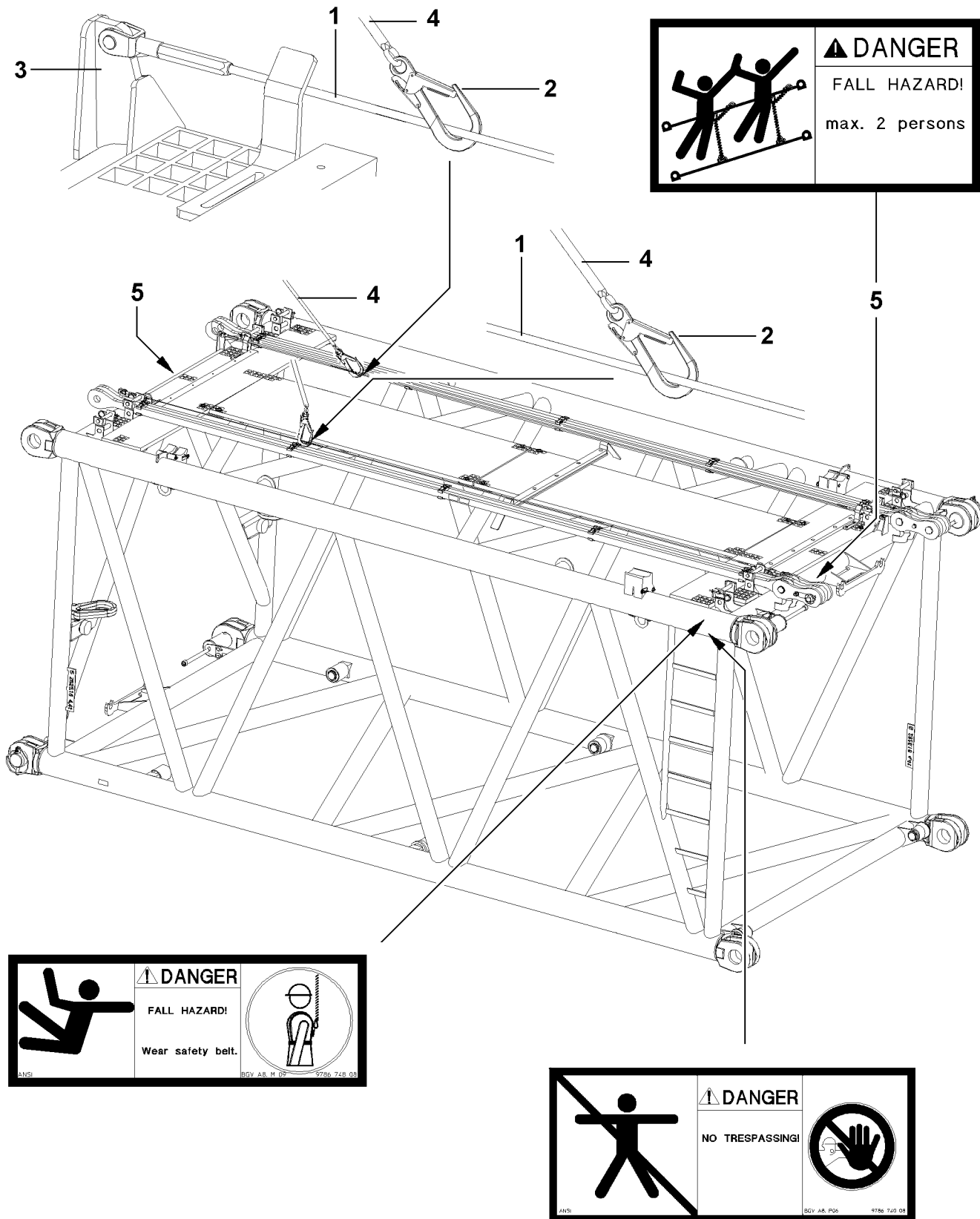

Fig.107341

7.5 Inspecting safety ropes and anchor points



WARNING

Danger of falls due to damaged safety ropes or anchor points!

The safety ropes **1** and anchor points **3** must be inspected **at least once a year** by **expert personnel** for safety and damage.

If any defects are found on the safety ropes **1** or anchor points **3** during the inspections, then the safety ropes **1** or anchor points **3** must be replaced immediately by **expert personnel**. If this is not observed, assembly personnel can fall down.

Death, severe bodily injuries, property damage.

▶ Have damaged safety ropes **1** or anchor points **3** replaced immediately by **expert personnel**.

7.6 Documenting the inspections in writing



Note

▶ The scope and results of tests should be documented to permit reproducibility. This documentation forms part of the crane records and should be safely stored during the entire service life of the crane.

Empty page!

LWE/LR 1600-2-008/18109-09-02/en

2.08 Working in low temperatures

1	Auxiliary equipment	3
2	Ambient temperatures below -20 °C	3
3	Maintenance	7

Fig.195219

LWE/LR 1600-2-008/18109-09-02/en

1 Auxiliary equipment

Without „auxiliary equipment for working at low temperatures“, the crane can be operated and stored at ambient temperatures between -20 °C and +50 °C.

At ambient temperatures below -20 °C , the crane must be modified with „auxiliary equipment for working at low temperatures“.



WARNING

Working at low temperatures without the corresponding auxiliary equipment!
The crane components can be damaged and fail. The load can rip off.
Death or severe bodily injuries.

If the crane is operated at an ambient temperature lower than -20 °C:

- ▶ Make sure that the crane is equipped with the corresponding „auxiliary equipment for working at low temperatures“.
- ▶ Match the operating fluids in time to the ambient temperature.

2 Ambient temperatures below -20 °C

2.1 Winter operation

Low temperatures, such as snow, frost and ice can impair crane operation and cause problems on the crane. Freezing takes place often at low temperatures.



WARNING

Snow and ice on the crane components!
The crane components can be damaged and fail.
Personnel can fall from the accesses!

- ▶ Remove the snow and ice from all accesses, steps and catwalks.
- ▶ Remove the snow and ice from all rope pulleys and winches.
- ▶ Remove the snow and ice from the hose drum and limit switch.
- ▶ Remove the snow and ice from the crane.



WARNING

Snow and ice below the support plates or the crawler carriers!
The crane can slip and fatally injure personnel.

- ▶ Remove the snow and ice on top and below the support plates.
- ▶ Remove the snow and ice on top and below the crawler carrier.
- ▶ Remove the snow and ice from the travel gear.

Prerequisites for start up with the ambient temperature below -20 °C

- The hose drum and cable are easily movable.
- All rope pulleys are easily movable.
- The view from the crane cab is free. The mirrors are free of snow and ice.
- Fastening equipment is approved for the ambient temperatures present.
- The load fastening points are approved for the ambient temperatures present.

2.2 Preheating time

Crane components	Preheating time
Engine preheating up to start at -40 °C ambient temperature	45 minutes
Preheat the hydraulic system in the crane superstructure and the crane chassis	30 minutes
Preheat the crane cab / driver's cab for start up at the same time up to 5 °C	10 minutes
Total preheating time	75 minutes

2.3 Engine preheating

If the ambient temperature is lower than -20 °C the chassis engine and / or superstructure engine must be preheated before starting.

Depending on the crane type, a chassis engine and / or a superstructure engine is installed.

The preheating of the chassis engine is described in the Crane operating instructions, chapter 6.01.

The preheating of the superstructure engine is described in the Crane operating instructions, chapter 6.02.

- ▶ Preheat the chassis engine and / or the superstructure engine.
- ▶ Start the chassis engine and / or the superstructure engine.

When the chassis engine and / or the superstructure engine has reached its operating temperature:

- ▶ Turn off engine preheating.

2.4 Preheating the hydraulic oil

If the ambient temperature is lower than -20 °C the hydraulic oil must be preheated prior to crane operation.

NOTICE

Hydraulic oil **not** preheated!

The hydraulic system can be damaged during crane operation.

- ▶ Preheat the hydraulic oil to at least 20 °C before crane operation.
- ▶ Retract and extend all the hydraulic cylinders in an unloaded state over the entire stroke multiple times.



WARNING

Persons in the area of the hoist movement!

Personnel can be injured.

- ▶ Observe the area of the hoist movement.
- ▶ Make sure that there are **no** persons in the area of the hoist movement.

2.4.1 Turning the hydraulic oil preheating on

Make sure that the following prerequisites are met:

- The engine is running.
- Hydraulic oil preheating is available.

The hydraulic oil preheating is described in the Crane operating instructions, chapter 4.03.

- ▶ Turn the hydraulic oil preheating on.

When the hydraulic oil is preheated:

- ▶ Turn the hydraulic oil preheating off.

2.4.2 Supporting the crane

The supporting of the mobile crane is described in the Crane operating instructions, chapter 3.05.

All support plates must be supported with suitable and stable materials.

If moveable support plates are not available, the support plates must be supported **on one side of the crane** with greased polyamide plates.



WARNING

No movable support plates or crane **not** supported with greased polyamide plates! The sliding beams can bend. The support plates can suddenly move to the side. The load can swing and fatally injure personnel.

► Use moveable support plates.

If there are no movable support plates available:

► Support the support plates **on one side of the crane** with greased polyamide plates.

When supporting the crane, extend the support cylinder a maximum of 50 %.

The wheels must not come in to contact with the ground after the crane is supported.

- Support the support plates when necessary.
- Support the crane.

2.4.3 Cranes with lattice mast boom

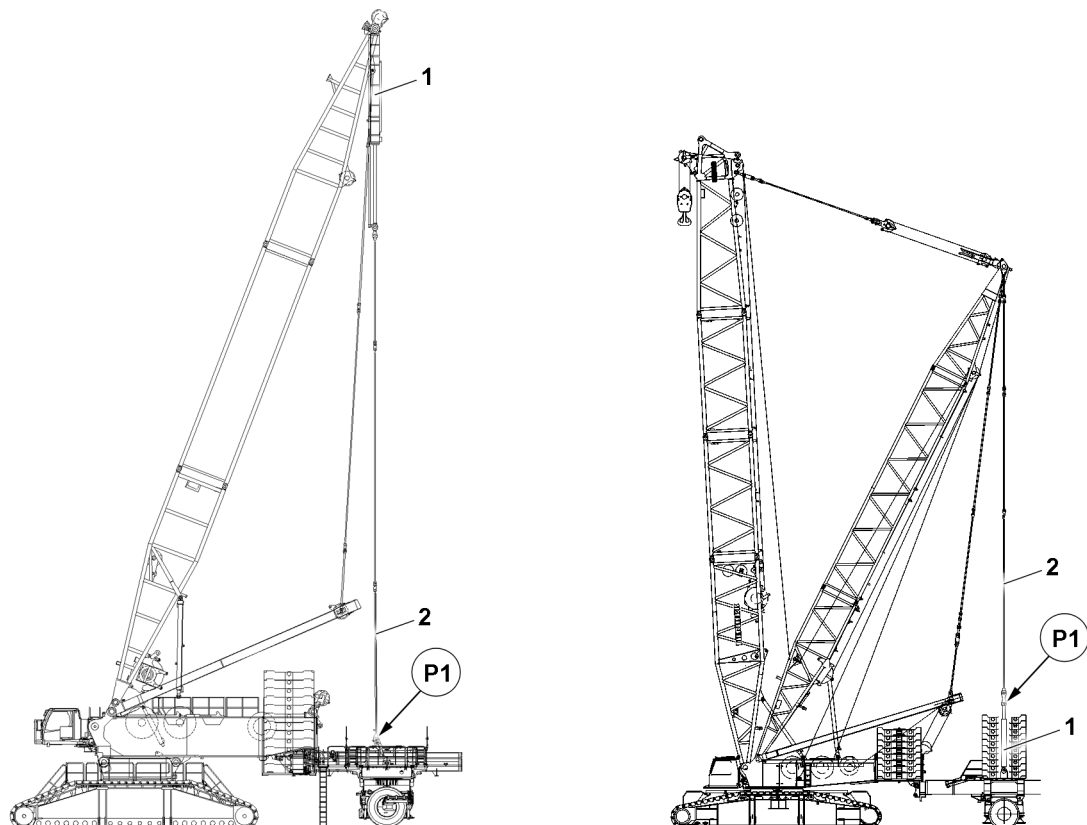

Fig.126875: Removing the guy rods on the derrick ballast

At ambient temperatures of less than $-20\text{ }^{\circ}\text{C}$, the pull cylinders must be preheated by means of retraction and extension. Before the pull cylinders can be preheated, the guy rods **2** must be removed at position **P1** on the derrick ballast.

Disassembly and assembly of the guy rods **2** on the derrick ballast is described in the Crane operating instructions, chapter 5.35 and chapter 5.36.

- ▶ Remove the guy rods **2** at position **P1** on the derrick ballast.

NOTICE

Danger of collision!

Damage of the guy rods, derrick ballast or other components.

- ▶ When retracting and extending the guy rods, avoid contact with other components.

- ▶ Retract and extend the pull cylinders **1** in an unloaded state over the entire stroke multiple times.

When additional hydraulic cylinders are installed on the crane with lattice mast:

- ▶ Retract and extend the hydraulic cylinders in an unloaded state over the entire stroke multiple times.

2.4.4 Cranes with telescopic boom

Make sure that the following prerequisites are met:

- The crane is supported and horizontally aligned.
- No load is hanging on the hook
- ▶ Retract and extend the luffing cylinder in an unloaded state over the entire stroke multiple times.
- ▶ Retract and extend the telescoping cylinder in an unloaded state over the entire stroke multiple times.

2.5 Assembling / disassembling the crane component

Below an ambient temperature of -20 °C the danger of damage is greater if the crane component is struck during assembly or disassembly. Especially the counterweight is subject to greater danger of damage if struck.

NOTICE

Striking of the crane component during assembly or disassembly!

Crane components can be damaged.

- ▶ Do **not** strike the crane component during assembly and disassembly
 - ▶ Carry out all work slowly and with utmost caution.
-

2.6 Reduce rope pull

When working at an ambient temperature below -20 °C Liebherr-Werk Ehingen recommends reducing the rope pull.

The rope pull on the hoist rope can be reduced by increasing the rope reeving.



Note

Increase of rope reeving!

Due to the increased rope reeving, the hoist rope length may not be sufficient for lowering the hook block to the ground.

- ▶ Pay attention to rope length.
-

NOTICE

Rope reeving higher than specified in the load chart!

Danger of slack rope formation due to a too low hook block weight. Damage of hoist rope.

- ▶ Increase the hook block weight accordingly.
 - ▶ Increase the rope reeving specified in the load chart.
-

2.7 Increase the hook block weight

The calculation of the minimum required hook block weight is described in the load chart.

Ambient temperature	Increase the hook block weight
-21 °C to -30 °C	Increase the minimum required hook block weight by 10 %.
-31 °C to -40 °C	Increase the minimum required hook block weight by 15 %.

- ▶ Increase the minimum required hook block weight depending on the ambient temperature. Observe and adhere to the „hook block weight“ charts.

**Note**

- ▶ Observe and comply with the permissible hook block weights for erection and take down of the boom systems in the erection and take down charts.

2.8 Crane operation

In case of an ambient temperature below -20 °C , crane operation requires an anticipatory working procedure adapted to the weather conditions.

**WARNING**

Sudden acceleration and deceleration of crane movements!

Crane components can break.

Death or severe bodily injuries.

- ▶ Accelerate and decelerate crane movements sensitively and with utmost caution.

2.8.1 Decrease crane utilization

Cranes with lattice mast boom

In the case of cranes with pull cylinders in the derrick ballast guying, if the ambient temperature is between -30 °C and -40 °C the maximum derrick ballast must be reduced. The maximum load is also reduced due to the reduction of the maximum derrick ballast.

**Note**

- ▶ Take load reduction into account during job planning.
- ▶ Reduce the maximum derrick ballast between an ambient temperature of -30 °C and -40 °C by 15 %.

Cranes with telescopic boom

In the case of cranes with a telescopic boom, if the ambient temperature is between -30 °C and -40 °C crane utilization must be reduced.

- ▶ Reduce the crane utilization at an ambient temperature between -30 °C and -40 °C by 15 %.

3 Maintenance

3.1 Load bearing crane structures

Checking the load bearing crane structure is described in the Crane operating instructions, chapter 8.01.

- ▶ The load bearing crane structure must be subjected more frequently to a visual inspection.

3.2 Rope pulleys and hydraulic cylinders

Checking the rope pulleys and the hydraulic cylinders is described in the Crane operating instructions, chapter 8.01.

- ▶ The rope pulleys and hydraulic cylinders must be subjected more frequently to a visual inspection.

2.15 General safety technical notes for operation with ballast trailer

1	Safety guidelines	3
2	Inspecting tires and disk wheels	4

Fig.195219

LWE/LR 1600-2-008/18109-09-02/en

1 Safety guidelines



WARNING

Danger of falling!

- ▶ During assembly or disassembly work on the ballast trailer, assembly personnel must be secured with appropriate aids! If this is not observed, assembly personnel can fall and suffer life-threatening or fatal injuries!

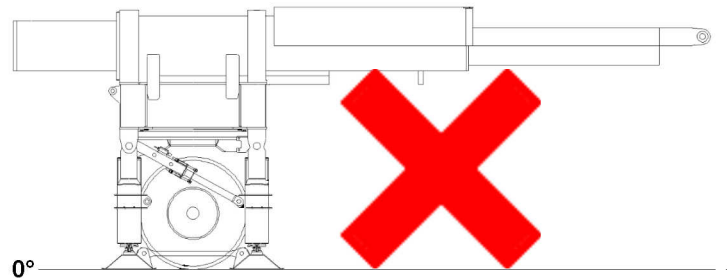
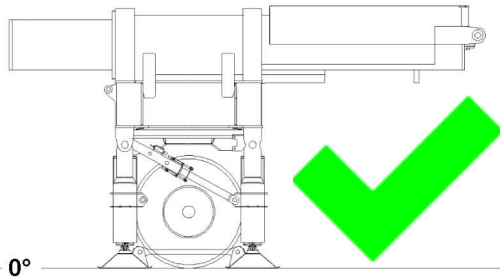

Fig.144267: Ballast trailer correctly parked // ballast trailer incorrectly parked



WARNING

Ballast trailer tipping danger!

If the following notes are not observed, the freestanding ballast trailer or the ballast trailer which needs to be disassembled can tip over.

Death, severe bodily injuries, property damage.

- ▶ The ballast trailer may only be parked on level ground with a sufficient load bearing capacity.
- ▶ The ballast trailer may only be unpinned from the crane and parked if the ballast trailer guide is fully retracted.
- ▶ The ballast trailer may only be unpinned from the crane and parked if there is sufficient ballast on the ballast trailer to ensure the stability of the ballast trailer.
- ▶ To unpin and disassemble the ballast trailer from the crane, it may be necessary for the ballast trailer guides to not be fully retracted. This is only permissible when in chapter 5.35 the procedure for this is fully described and specifically permitted. The specifications and prerequisites in chapter 5.35 must be observed and adhered to.
- ▶ The ballast trailer may only be unpinned from the crane and parked if the support cylinders are extended and the tires are relieved.
- ▶ The ballast trailer may only be unpinned from the crane and parked if the brace on the support cylinders is pinned and secured.



WARNING

Danger of fatal injury if the permissible travel speed is exceeded!

If the permissible travel speed is exceeded, the tires can be damaged.

Death, severe bodily injuries, property damage.

As a result, significant property damage can occur on the crane and on the ballast trailer.

- ▶ The travel speed of the ballast trailer when turning or driving with maximum ballast on the tires may be not more than maximum 1 km/h (0.28 m/s).

**WARNING**

The crane can topple over if the level of the roadway differs!

Due to impermissible level differences between the ballast trailer roadway and the crane placement level, the entire crane system can be pulled back suddenly.

The relapse cylinders can run out to the block position. The relapse cylinders and the boom system can be damaged.

Death, severe bodily injuries, property damage.

- ▶ Do not exceed or fall below the permissible level difference between the ballast trailer roadway and the crane placement level.
- ▶ The travel path of the crane or the circular path of the ballast trailer must be level and of sufficient load bearing capacity.
- ▶ The permissible level difference of the ballast trailer travel path and crane travel path for „towing“ and „parallel driving“ may be no more than maximum 250 mm.
- ▶ The permissible level difference of the ballast trailer path and the crane travel path in relation to the crane travel path for circular driving may be no more than maximum 250 mm - based on a constant uphill incline or constant downhill incline on a 90° turning range.

**WARNING**

The crane can topple over!

If the following notes are not observed, the crane can topple over.

Death, severe bodily injuries, property damage.

- ▶ When lifting or lowering the ballast trailer, pay attention to the horizontal alignment of the ballast trailer.
- ▶ The assembly or disassembly work must be carried out according to chapter 5.35 or chapter 5.11.

NOTICE

Danger of damage to the crane and the ballast trailer!

Due to steering movements on the crawler tracks while driving parallel, the crane and the ballast trailer can be significantly damaged.

- ▶ For parallel travel, steering the crawler track is prohibited.
- ▶ For parallel travel, the side tire distortion on the wheel sets must be observed by an instructed person over the entire travel route of the crane. If the tires distort by more than 100 mm, then the position of the wheel sets must be corrected.

**Note**

General technical safety instructions!

- ▶ The ballast trailer guy rods must be assembled and secured according to the rod plan. The numbering on the rod plan must be identical to the numbering on the guy rods.

2 Inspecting tires and disk wheels

**Note**

- ▶ See chapter 8.01.

**WARNING**

Danger of fatal injury when using non-approved tires!

Due to the use of tires that are not explicitly approved by **LIEBHERR-Werk Ehingen GmbH**, uncontrollable operation conditions on the ballast trailer can occur due to the heavy load.

The tires can be destroyed and the ballast trailer as well as the crane can be significantly damaged.

Death, severe bodily injuries, property damage.

- ▶ Use only spare tires that have been approved in writing by **LIEBHERR-Werk Ehingen GmbH**.
- ▶ Using spare tires that have been not explicitly approved in writing by **LIEBHERR-Werk Ehingen GmbH** is prohibited.

NOTICE

Damage to tires!

Due to external environmental influences (for example: rain, wind, snow, rime, frost, sun exposure) and the great weight load on the tires by the ballast trailer, the tires can become porous and the body can lose its original strength.

- ▶ The tires must be replaced according to the data of the tire manufacturer at least after 5 years, or if an expert representative of the tire manufacturer states in writing, after extensive inspection of the tires, that the tires can be utilized for an additional operation period stated by the expert representative.

**Note**

Tightening torque of ballast trailer tires!

- ▶ The tightening torque for the wheel lugs is 600 Nm.
- ▶ Check the wheel lugs according to the specified maintenance intervals for tight seating, see chapter 7.02.

2.1 Tires with air inflation

It is imperative to comply with the following instructions:

- After extended downtime, the inflation pressure must be checked before using the ballast trailer.
- The tires must be protected against UV rays during extended downtimes with tarps or wooden boards.

**Note**

Inflation pressure of ballast trailer tires!

- ▶ The inflation pressure in all tires that were approved in writing by **LIEBHERR-Werk Ehingen GmbH** is **10 bar**.
- ▶ Check the inflation pressure according to the specified maintenance intervals for tight seating, see chapter 7.02.

**WARNING**

Danger of accident due to damaged ballast trailer tires!

Due to extended downtime of the crane, when the ballast trailer tires are not relieved with supports, the tires can become irregular.

As a result, the tires can be destroyed and the ballast trailer as well as the crane can be significantly damaged.

Death, severe bodily injuries, property damage.

- ▶ During extended downtimes, the ballast trailer tires must always be relieved by the supports.

**WARNING**

Danger of accident due to damaged ballast trailer tires!

When driving the crane on insufficiently prepared ground, the tires can become damaged or punctured by large rocks or other foreign matter.

As a result, the ballast trailer as well as the crane can be significantly damaged.

Death, severe bodily injuries, property damage.

- ▶ The travel route of the crane or the ballast trailer must be level, of sufficient load bearing capacity and free of rocks or other foreign matter.
- ▶ The travel route of the crane must be walked off personally in advance by the crane operator.
- ▶ Rocks and other foreign matter on the travel route must be removed before starting to travel.
- ▶ If the crane operator cannot ensure that the ballast trailer tires may not be damaged when driving the crane, then the ballast trailer tires must be foamed with a special foam approved by **LIEBHERR-Werk Ehingen GmbH**. Contact **LIEBHERR-Werk Ehingen GmbH** in this regard.
- ▶ If you decide to foam the ballast trailer tires, then ballast trailer operation is only permissible if all tires of the ballast trailer have been foamed according to the specifications of **LIEBHERR-Werk Ehingen GmbH**.

2.2 Tires foamed with special foam

The tires of the ballast trailer are foamed with a special, high quality foam.

Due to extended downtime of the crane, when the ballast trailer tires are not relieved with supports, the tires can become irregular.

It is imperative to comply with the following instructions:

- Relieve the tires on the ballast trailer if it is at a standstill for more than 2 h via the support cylinders.
- The tires must be protected against UV rays during extended downtimes with tarps or wooden boards.



WARNING

Danger of fatal injury when using non-approved tire foams!

Due to the use of tire foams that are not explicitly approved by **LIEBHERR-Werk Ehingen GmbH**, uncontrollable operation conditions on the ballast trailer can occur due to the heavy load.

The tires can be destroyed and the ballast trailer as well as the crane can be significantly damaged. Death, severe bodily injuries, property damage.

- ▶ Use of spare tires filled with water, air or special foam of lower quality is prohibited.
- ▶ Using spare tires that have been not explicitly approved in writing by **LIEBHERR-Werk Ehingen GmbH** is prohibited.



WARNING

Danger of accident due to retreaded tires!

If tires foamed with the special foam are retreaded, the usage properties can be significantly changed in a negative manner.

The tires can be destroyed and the ballast trailer as well as the crane can be significantly damaged. Death, severe bodily injuries, property damage.

- ▶ Tires which are filled with special foam may not be retreaded, unless written approval has been provided by the tire manufacturer.

2.25 Crane on floating device

1	Non-destined use	3
2	Destined use	3
3	Floating device	3
4	Operating conditions	3
5	Crane transport on floating devices	4
6	Increased corrosion	5

Fig.195219

LWE/LR 1600-2-008/18109-09-02/en

1 Non-destined use



WARNING

Non-destined use!

The boom can break off. The crane can topple over.
Death, severe injuries, property damage.

- ▶ Only use the crane as designated.
- ▶ Comply with the operating conditions and notes provided in this chapter.

Liebherr mobile cranes and crawler cranes are **not** designed for special requirements according to „EN 13852-2, Cranes - Offshore Cranes“ or other offshore specifications and regulations.

For a precise definition of **non**-destined use, see the preface to the crane operating instructions.

2 Destined use

Liebherr mobile cranes and crawler cranes are solely designed for assembly work and erection work and can only withstand a limited number of load cycles.

Liebherr mobile cranes and crawler cranes are designed for special characteristics and movements: evenly distributed drive forces, only occasional operation and load conditions according to „EN 13000, Cranes - Mobile Cranes“ and comparable international standards.

For a precise definition of destined use, see the preface to the crane operating instructions.

3 Floating device

The term floating device includes all floating devices such as barges, ships and freight barges.

The floating device must fulfil the requirements for crane operation.

4 Operating conditions

Observe the areas of responsibility:

- The crane contractor and crane operator are responsible for ensuring that the conditions for crane operation at the job site are fulfilled. Consultation of a naval engineer is strongly recommended.
- The correct functional, technical and static interaction between the crane and the floating device is the sole responsibility of the crane contractor and the crane operator. This must be clarified and checked before operating the crane on a floating device.

Observe the following to ensure the safe operation of the crane on floating devices:

- Comply with all country-specific, legal regulations and conditions.
- Perform a risk assessment to ensure safe working conditions.
- Outtrigger forces or crawler pressures resulting from crane operation must be safely supported by the steel structure of the floating device.
- Assemble and operate the crane according to manufacturer specifications.
- Comply with the maximum permissible lateral deflection angle between the hoist rope and the rope pulley. The deflection angle consists of the lateral elastic deformation of the boom system, the inclination of the crane supporting surface and a possible diagonal pull on the hoist rope.

Maximum permissible deflection angle:

- 2.5° with a hoist rope diameter of less than 23 mm
- 5° with a hoist rope diameter of 23 mm or more
- The conditions when working on a floating device must correspond with the conditions on land.

- Lifting and lowering loads in very calm waters and on very calmly moving floating devices corresponds to lifting and lowering loads on land.

4.1 Floating device, supported/jacked up

Observe the following to ensure the safe operation of the crane on supported/jacked up floating devices:

- For crawler cranes, observe the maximum permissible ground inclination of $\pm 0.3^\circ$ for the crane, see the load charts.
- Supported/jacked up cranes must be horizontally levelled (0°).

4.2 Floating device, non-supported/non-jacked up

Observe the following to ensure the safe operation of the crane on **non-supported/non-jacked up** floating devices:

- Crane operation on a floating device is only permissible in very calm waters.
- Crane operation on a floating device is only permissible with a main boom (no derrick operation, no operation with a luffing jib permitted).
- Before the crane is operated on the floating device: The inclination of the floating device in the lateral and longitudinal direction must be calculated in advance. This inclination results from the interaction of the crane with the floating device.
- The inclination of the floating device shall **not** exceed the maximum permissible ground inclination of the crane according to the load chart.
- Comply with the maximum permissible ground inclination according to the load charts:
 - $\pm 0.3^\circ$ for cranes operating on crawler.
 - 0° for cranes operating on outriggers.
- Load values must be reduced when the above defined inclination values are exceeded.
- Load charts for higher permissible ground inclinations (for example 1° , 2°) can be provided upon request of LWE customers solely for operation with a „main boom“ and with a „main boom + auxiliary jib“.
- LTR 1060, LTR 1100 and LTR 1220 are programmed with load charts that permit operation up to a maximum ground inclination of 4° . The crane's respective maximum permissible ground inclination depends on the crane's operating mode.

5 Crane transport on floating devices

Observe the areas of responsibility:

- The crane contractor is solely responsible for transporting the crane on a floating device.
- The crane contractor and crane operator are responsible for the assembly and disassembly of the crane on the floating device.

Observe the following to ensure the safe transport of the crane on floating devices:

- When being „transported on a floating device“, the crane must be secured to prevent the following:
 - Damage to and loosening of crane components
 - Slipping of the crane
 - Inadvertent turning of the superstructure
 - Capsizing of the floating device
- Transport at sea can have a negative impact on the structural strength/stability and the fatigue strength of the crane.

Ensure that before „transport on a floating device“ the following measures are carried out:

- Lower the boom and support it by adequate means.
- For telescopic cranes: disassemble counterweight plates and secure them on the floating device.
- For crawler cranes: support slewing platform and counterweight with adequate means and secure to prevent slipping.
- Observe the instructions for transporting the crane and crane components, see chapter 3.80 of the crane operating instructions.

6 Increased corrosion

Extremely salty air in a maritime environment can cause increased corrosion to the crane.

Increased corrosion can cause premature damage of components (for example the hydraulic cylinder, wire ropes, electrical and electronic components, driver's cab).

Submerging the hook block in water causes damage to the hook block and the rope.

Crane contractor and crane operator are solely responsible for avoiding increased corrosion.

Measures to avoid corrosion:

- Avoid direct contact of the crane and its components with salt water.
- Do **not** submerge the hook block in water.

Measures to recognize premature damage:

- Have the crane checked regularly and extensively by a qualified person.

Empty page!

LWE/LR 1600-2-008/18109-09-02/en

3 Crane assembly

LWE/LR 1600-2-008/18109-09-02/en

LWE/LR 1600-2-008/18109-09-02/en

3.01 Crawler carrier assembly

1	Component overview crawler travel gear	3
2	Dimensions and weights	3
3	Installing the assembly supports	5
4	Assembly / disassembly of the crawler carriers with the auxiliary crane	11
5	Assembly / disassembly of the crawler carriers with SA-frame	27
6	Disassembling the assembly support	49

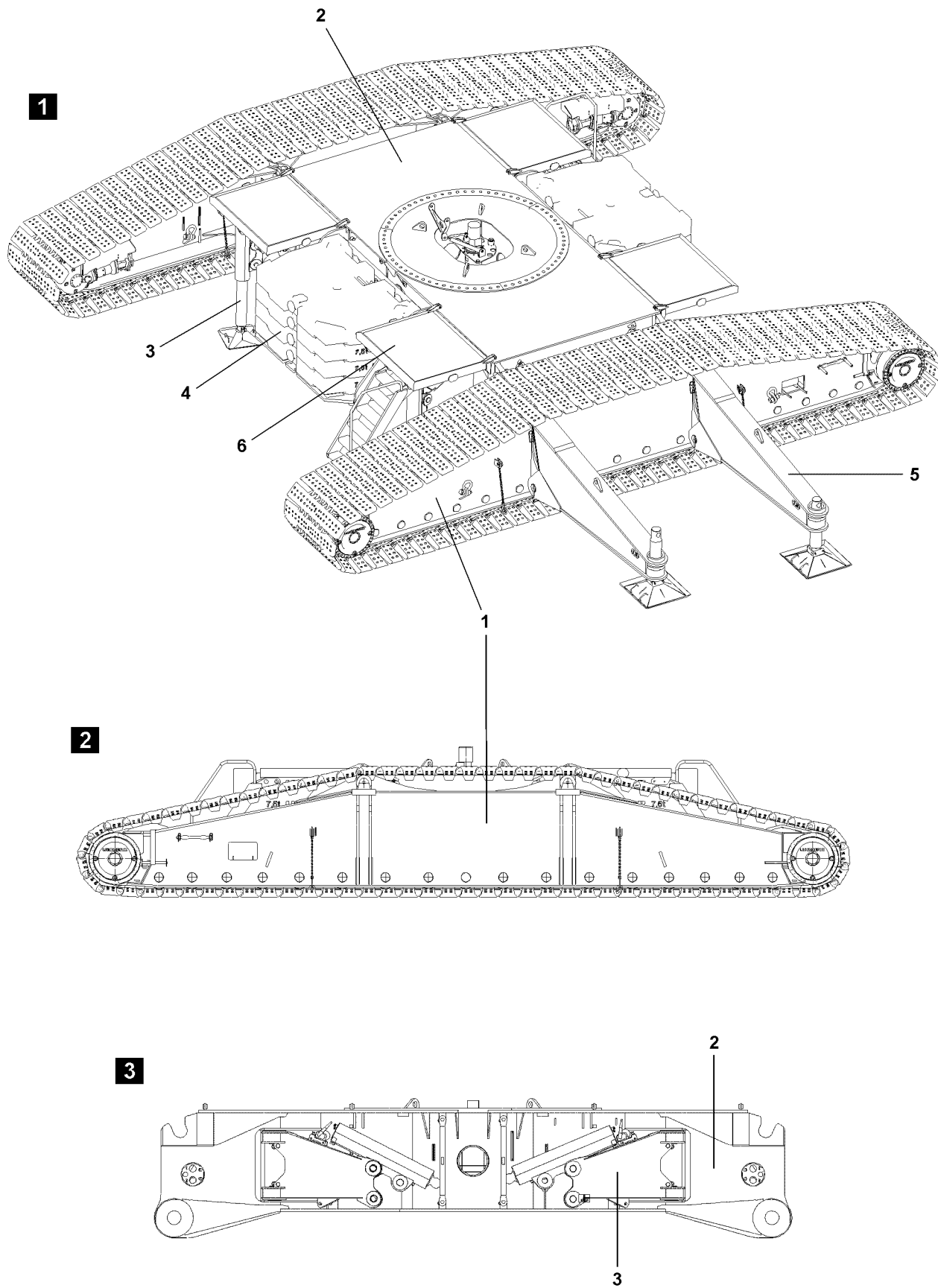

Fig.108929

1 Component overview crawler travel gear

- 1 Crawler carrier with track pads
- 2 Crawler center section with rotary connection
- 3 Hydraulic assembly supports
- 4 Central ballast
- 5 Mechanical auxiliary support
- 6 Catwalks

2 Dimensions and weights



Note

- ▶ See Crane operating instructions, chapter 1.03.
-

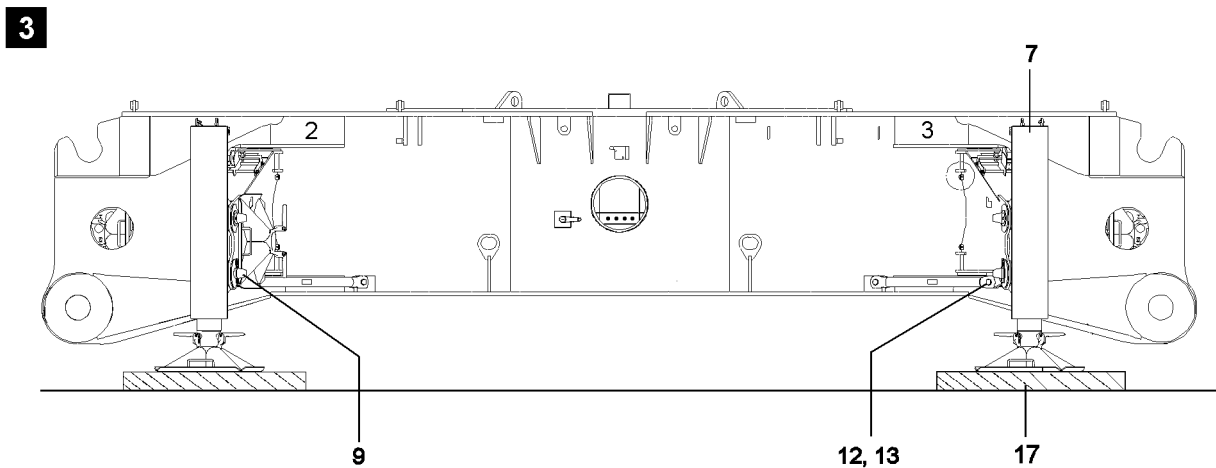
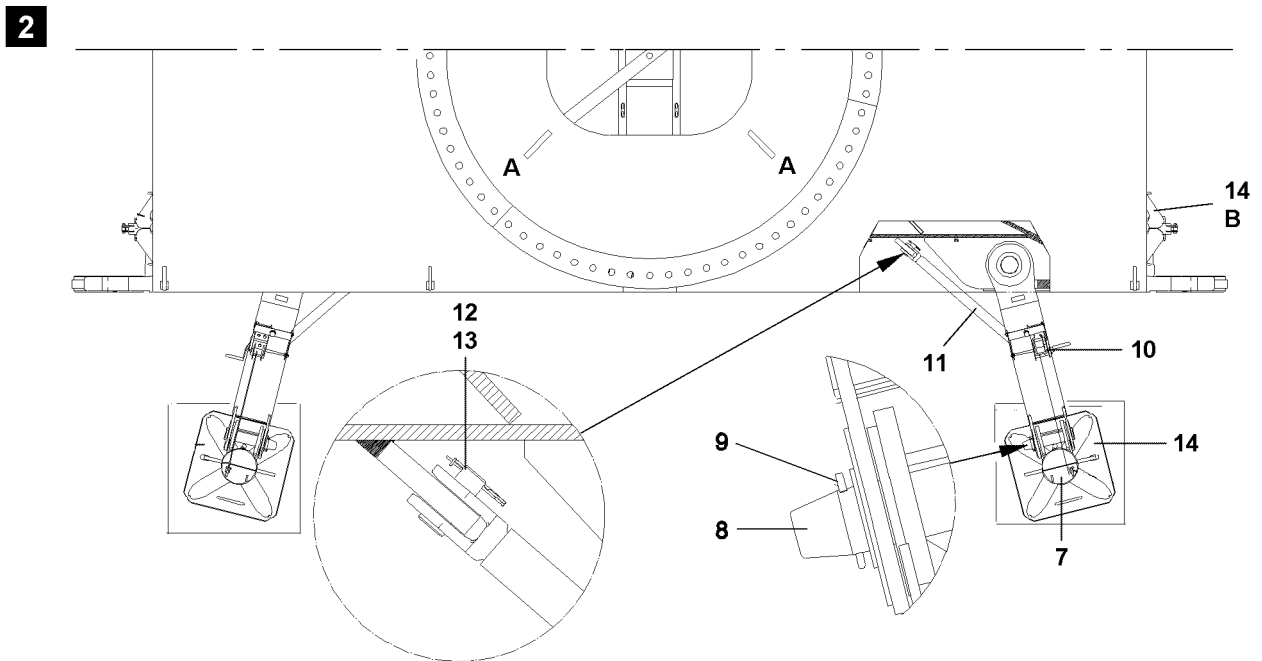
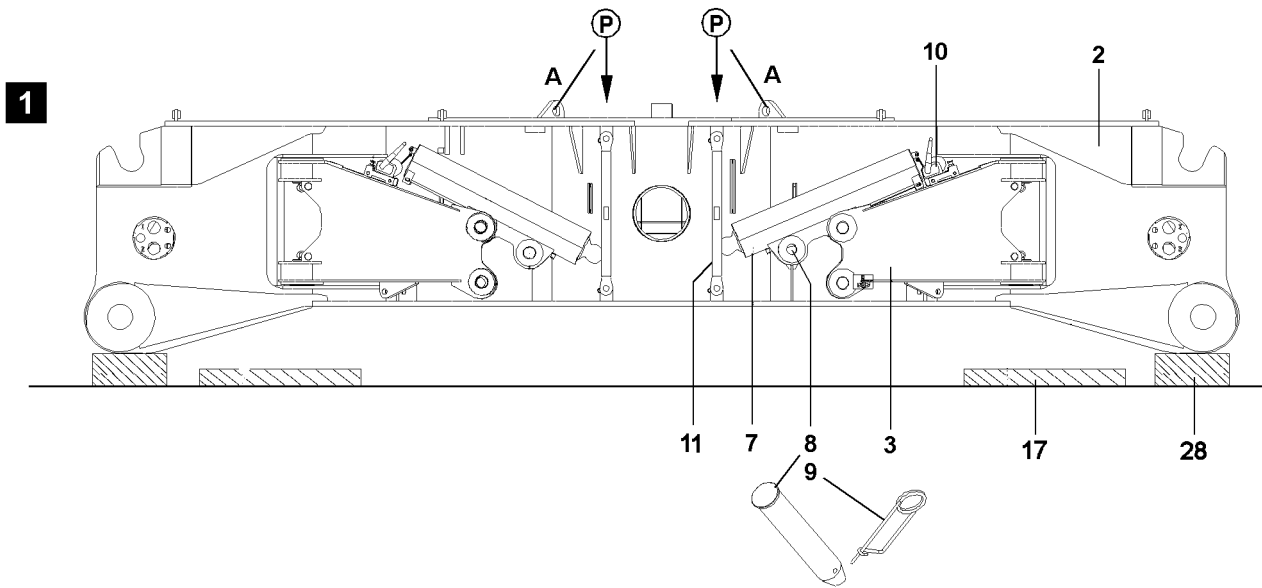

Fig.107164

LWE/LR 1600-2-008/18109-09-02/en

3 Installing the assembly supports

Make sure that the following prerequisites are met:

- An auxiliary crane with sufficient load carrying capacity is available.
- The placement location must be level and have adequate load-bearing capacity.

3.1 Supporting the crawler center section



WARNING

Danger of accidents due to improper support!

If the crawler center section is not properly supported, then it can sink into the ground.

Death, severe bodily injuries, property damage.

- ▶ The support must be able to safely take on the weight of the crawler center section, the turntable and the crawler carrier.
- ▶ The support must be made large enough for the ground conditions, with solid materials, such as wood, steel or concrete slabs, see Crane operating instructions, chapter 2.04.

Make sure that the following prerequisite is met:

- Suitable material must be available for the support of the crawler center section.



Note

- ▶ The support **28** must be high enough so that the support plates **14** with support **17** fit under the vertically positioned hydraulic cylinders **7**.
- ▶ Support the crawler center section **2** with hardwood timbers or other suitable materials from below.
- ▶ Attach the fastening equipment on the four fastening brackets **A**.
- ▶ Lift the crawler center section **2** with the auxiliary crane and set it onto the support **28**.

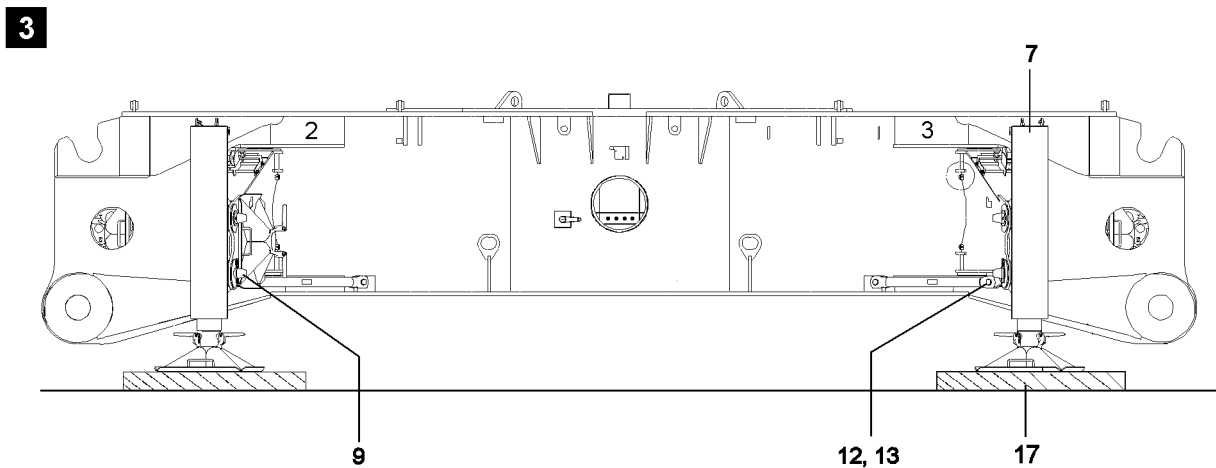
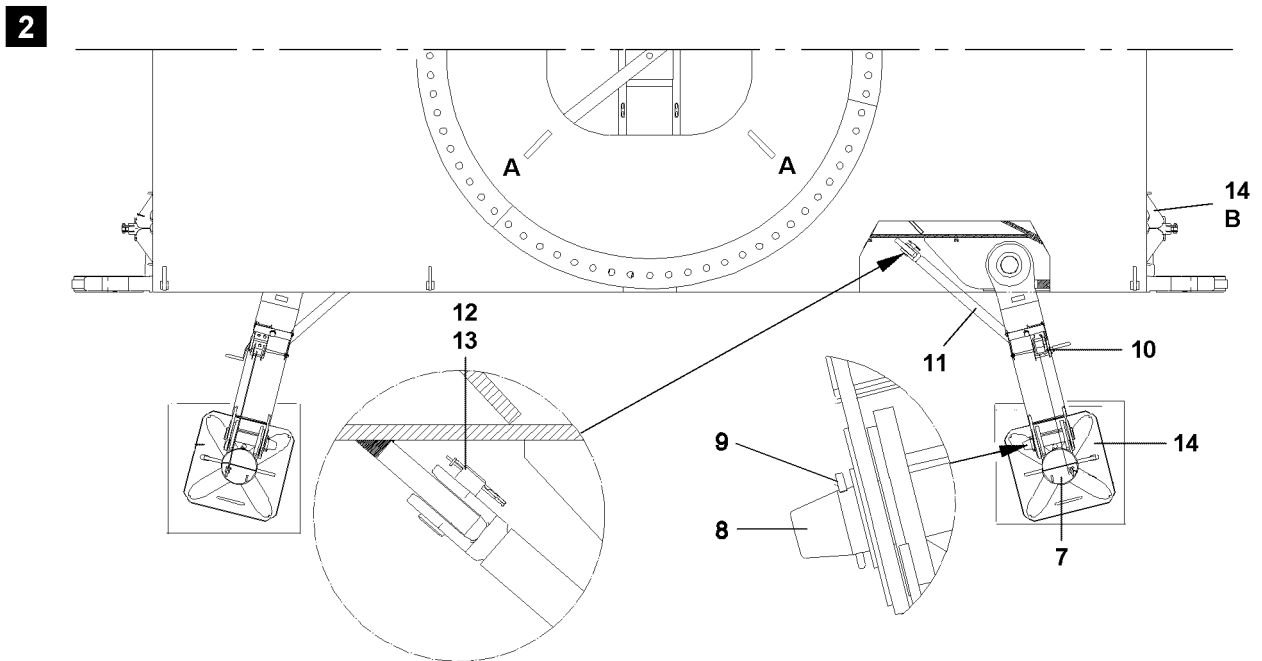
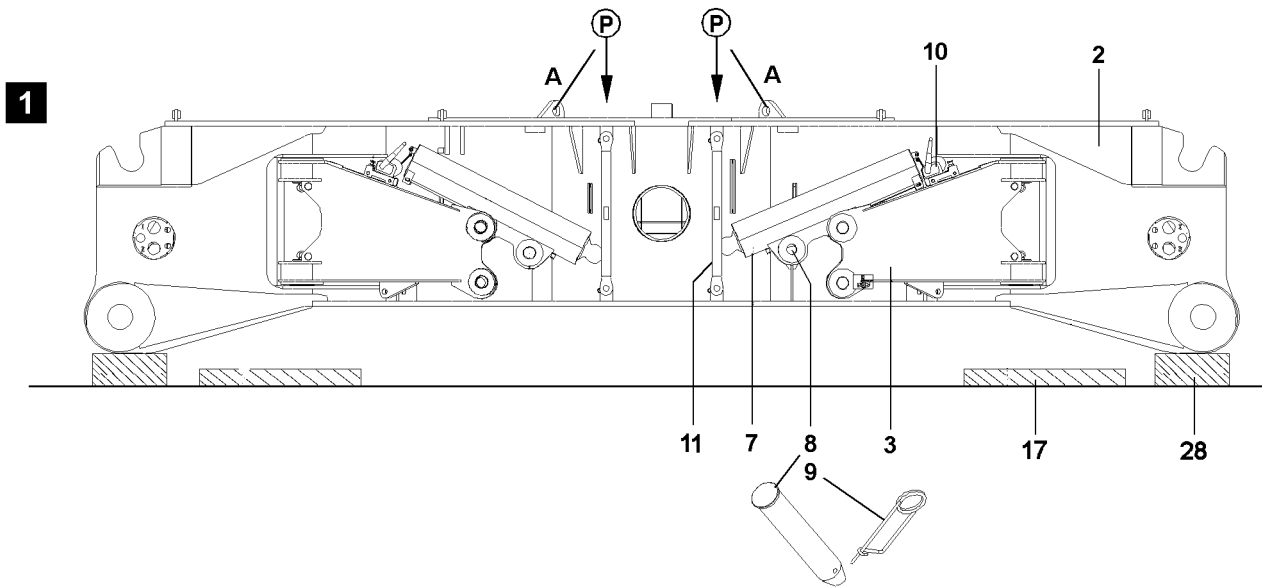

Fig.107164

LWE/LR 1600-2-008/18109-09-02/en

3.2 Installing the assembly supports



Note

- ▶ For the assembly of the crawler carriers with the SA-frame, the turntable must be assembled, see crane operating instructions chapter 3.02.

The swinging out and locking procedure of the assembly support is the same for all four assembly supports and is therefore described only once.

Make sure that the following prerequisite is met:

- The rope for the rope winch **10** is secured on the eyehook on the hydraulic cylinder **7**.

- ▶ Unpin the pin **8**: Remove the spring retainer **9** and unpin the pin **8**.

Before the rope winch **10** can be put into operation, the spring latch must be pulled and the rope winch **10** must be pushed to the side until the crank can be rotated freely and the spring latch engages again by itself.

- ▶ Pull the spring latch up and hold.
- ▶ Push the rope winch **10** in direction of the crank to the outside until the spring latch engages again by itself.

Result:

- The rope winch is locked in operating position.
- ▶ Lift the hydraulic cylinder **7** from the transport retainer by spooling up the rope winch **10**.
- ▶ Swing the assembly support **3** out.
- ▶ Remove the brace **11** from the transport position **P**: Remove the spring retainer **13** and unpin the pin **12**.
- ▶ Pin the brace **11** on the crawler center section and on the assembly support: Pin in the pin **12** and secure with spring retainer **13**, see illustration **2** and illustration **3**.
- ▶ Spool out the rope winch **10** and lower the hydraulic cylinder **7**.
- ▶ Pin the hydraulic cylinder **7** on the assembly support **3** on the bottom: Insert the pin **8** and secure with spring retainer **9**.



WARNING

Danger of accidents due to improper support!

If the crawler center section is not properly supported, then it can sink into the ground.

Death, severe bodily injuries, property damage.

- ▶ The support must be able to safely take on the weight of the crawler center section, the turntable and the crawler carrier.
- ▶ The support must be made large enough for the ground conditions, with solid materials, such as wood, steel or concrete slabs, see Crane operating instructions, chapter 2.04.

- ▶ Take the support plates **14** from the transport retainer **B** and place them on the supporting bases **17**.
- ▶ Align the support plates **14** to the hydraulic cylinders **7**.
- ▶ Establish the hydraulic connections from the hydraulic aggregate of the pin pulling device to the hydraulic cylinders **7**, see Crane operating instructions, chapter 5.30.

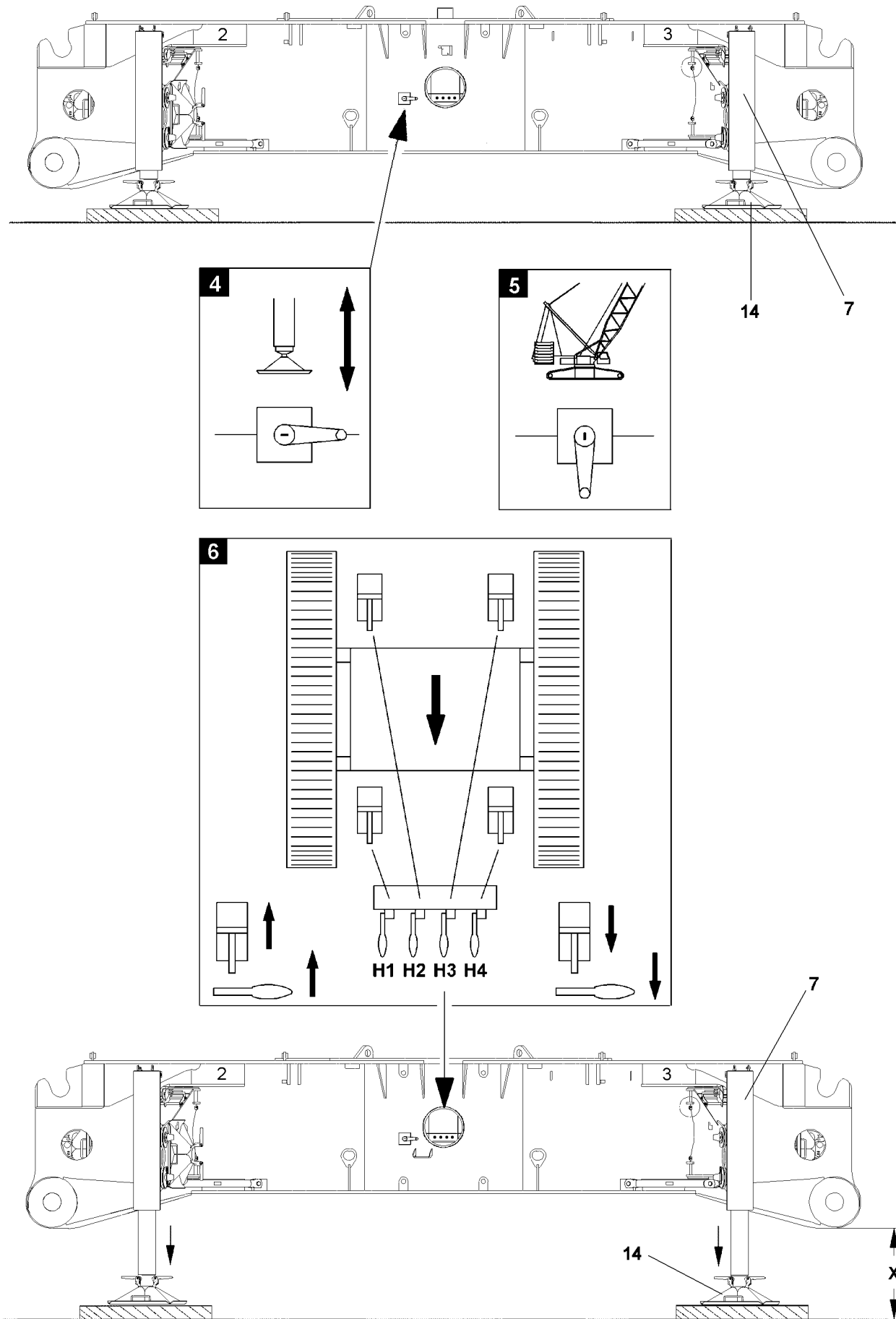

Fig.108933

LWE/LR 1600-2-008/18109-09-02/en

3.3 Lifting the crawler center section

Make sure that the following prerequisites are met:

- The assembly supports are locked with braces.
- The hydraulic cylinders pinned and secured.
- The support plates are properly supported.
- The ball valve is set to „Assembly support“, see illustration 4.

Ball valve positions	
Illustration 4	Assembly support
Illustration 5	Crane operation / crawler carrier installation with SA-frame

Function assignment of manual levers for the support cylinders	
H1	Manual lever for the hydraulic cylinder, right front
H2	Manual lever for the hydraulic cylinder, right rear
H3	Manual lever for the hydraulic cylinder, left rear
H4	Manual lever for the hydraulic cylinder, left front

- ▶ Turning the hydraulic aggregate on with the pin pulling device.
- ▶ Actuate the manual lever and enter the hydraulic cylinder **7** into the receptacle of the support plates **14**.
- ▶ Close the receptacle.



Note

- ▶ Lift the crawler center section so that the crawler carriers can be installed without restriction.
- ▶ Move the hydraulic cylinders out evenly.

- ▶ Actuate the hand lever **H1**, hand lever **H2**, hand lever **H3** and hand lever **H4**.

Result:

- The four hydraulic cylinders **7** move out.



WARNING

Danger of tipping the crawler center section!

If the hydraulic cylinders **7** are moved out unevenly, the crawler center section can tip over. Death, severe bodily injuries, property damage.

- ▶ When lifting the crawler center section, pay attention to the horizontal alignment, check visually.
- ▶ After supporting and aligning the crawler center section, set the ball valve to „Crane operation / crawler carrier installation“, see illustration 5.
- ▶ Turning the hydraulic aggregate off with the pin pulling device.

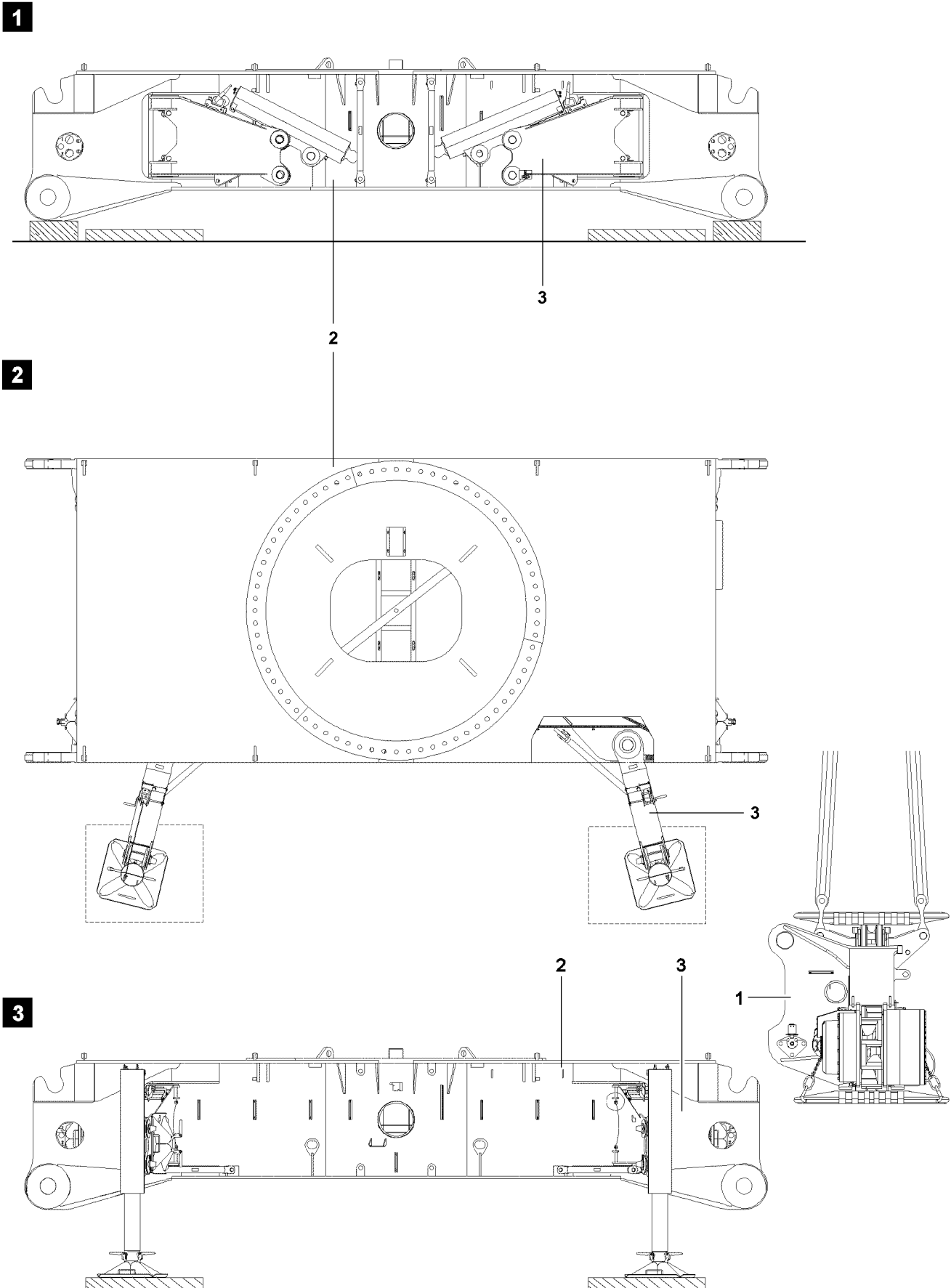

Fig.106601

LWE/LR 1600-2-008/18109-09-02/en

4 Assembly / disassembly of the crawler carriers with the auxiliary crane

4.1 Assembly of crawler carriers with the auxiliary crane



WARNING

Danger of falling!

During assembly / disassembly, inspection and maintenance work, assembly personnel must be secured with appropriate aids to prevent them from falling.

Death, severe bodily injuries, property damage.

- ▶ All work aloft, where there is a danger of falling must be carried out with suitable aids.
- ▶ If aids are not available and work cannot be carried out from the ground, then the assembly personnel must secure themselves with the supplied fall arrest system to prevent falling, see Crane operating instructions, chapter 2.04.
- ▶ If fall protection equipment is available, then it must be used, see Crane operating instructions, chapter 2.06.
- ▶ When lifting, lowering, swinging crane parts in and out, no persons may remain in the danger zone.
- ▶ When closing or opening boom systems during boom assembly or boom disassembly, no persons may remain on the boom system or in the danger zone.
- ▶ If railings are present for the crane, then they must be brought into the corresponding position and secured for assembly / disassembly work.
- ▶ Only step on the aids, ladders and catwalks with clean shoes.
- ▶ Keep aids, ladders and catwalks free of heavy dirt, snow and ice.
- ▶ During all assembly and disassembly work, maintenance work and inspections, travel or crane operation is prohibited.
- ▶ Remaining on a suspended load is prohibited.
- ▶ Stepping or walking on crane components and lattice sections, which have an incline of more than 20° is prohibited.
- ▶ For all assembly work, the crane driver of the main crane must be in voice contact with the crane driver / crane drivers of the auxiliary crane / auxiliary cranes.
- ▶ For assembly tasks, the crane driver may only initiate crane movements when the responsible guide has explicitly released the movement.



WARNING

Danger of impact / crushing!

When installing / removing crane components with the auxiliary crane, crane components can start to swing back and forth.

When lifting / lowering and positioning crane components, there is an increased danger of impacts / crushing.

Death, severe bodily injuries, property damage.

- ▶ Make sure that personnel cannot be caught by components.
- ▶ Make sure that the crane is horizontally aligned.
- ▶ When working in danger zones: Use aids to protect limbs.
- ▶ Guide components with suitable aids to minimize oscillation.

Make sure that the following prerequisites are met:

- An auxiliary crane with sufficient load carrying capacity is available.
- The assembly supports are installed.
- The crawler center section is raised: The support cylinders are moved out.

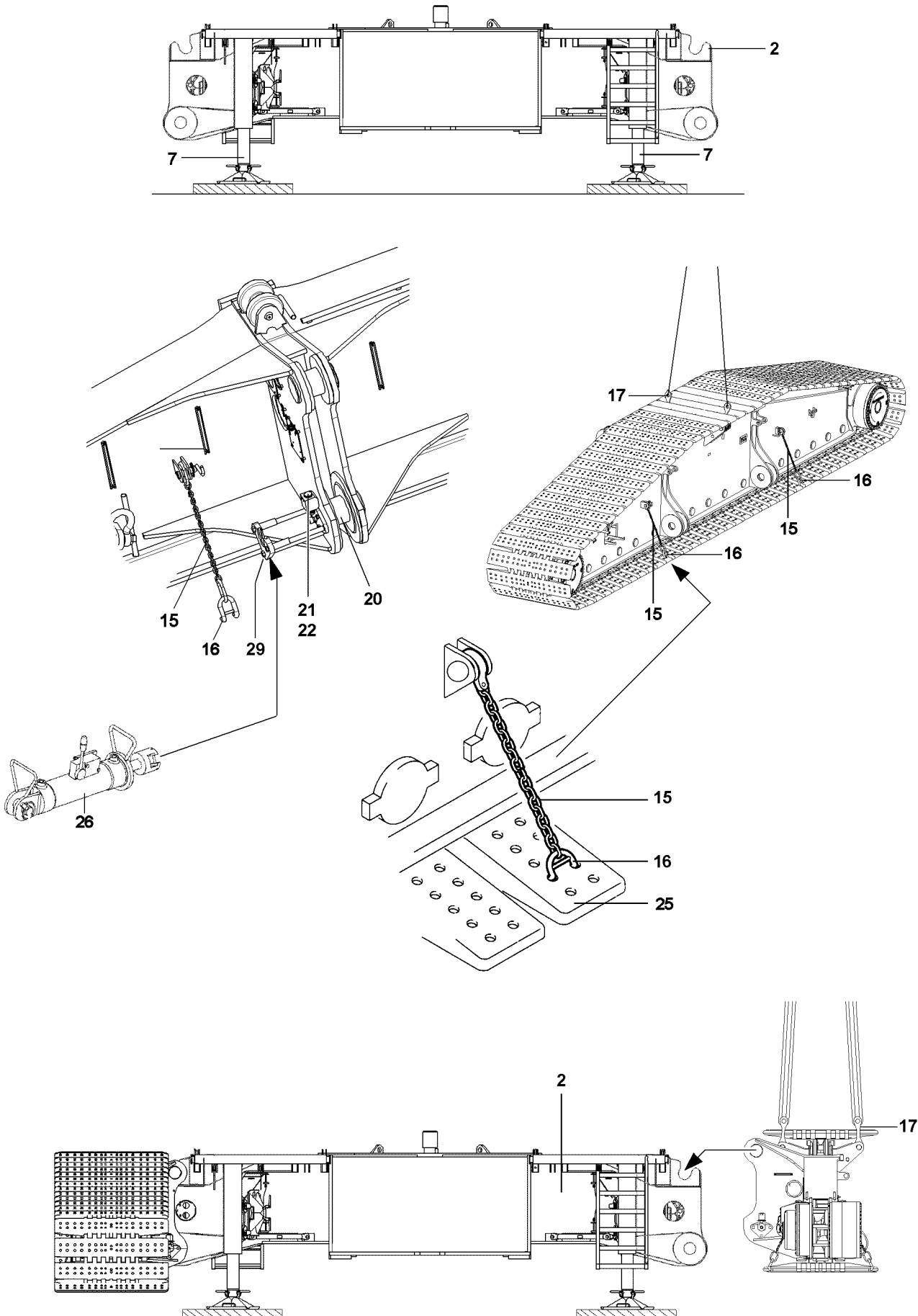

Fig.107372

LWE/LR 1600-2-008/18109-09-02/en

4.1.1 Preparing the crawler carrier for assembly



Note

- ▶ Hang in **two** chains **15** per crawler carrier side.

The track pads **25** must be secured before assembly of the crawler carriers with the chains **15** to prevent sag.

- ▶ Hang in the chains **15** with the bars **16** on the track pads.



Note

- ▶ The brackets **27** must be swung between the track pads **25**, „upward“.

- ▶ Swing the brackets **27** upward.

4.1.2 Assembling the crawler carrier



Note

- ▶ For assembly of the crawler carriers with the auxiliary crane the turntable is installed.
- ▶ Note the identification on the crawler carrier and the crawler center section.
- ▶ The crawler carrier and the crawler center section are marked with numbers.



WARNING

Danger of accidents due to improper support!

If the crawler center section is not properly supported, then it can sink into the ground.

Death, severe bodily injuries, property damage.

- ▶ The support must be able to safely take on the weight of the crawler center section, the turntable and the crawler carrier.
- ▶ The support must be made large enough for the ground conditions, with solid materials, such as wood, steel or concrete slabs, see Crane operating instructions, chapter 2.04.

Make sure that the following prerequisites are met:

- The track pads are secured with chains **15** to prevent them from hanging down.
- The pin pulling cylinder **26** is connected on the hydraulic aggregate.

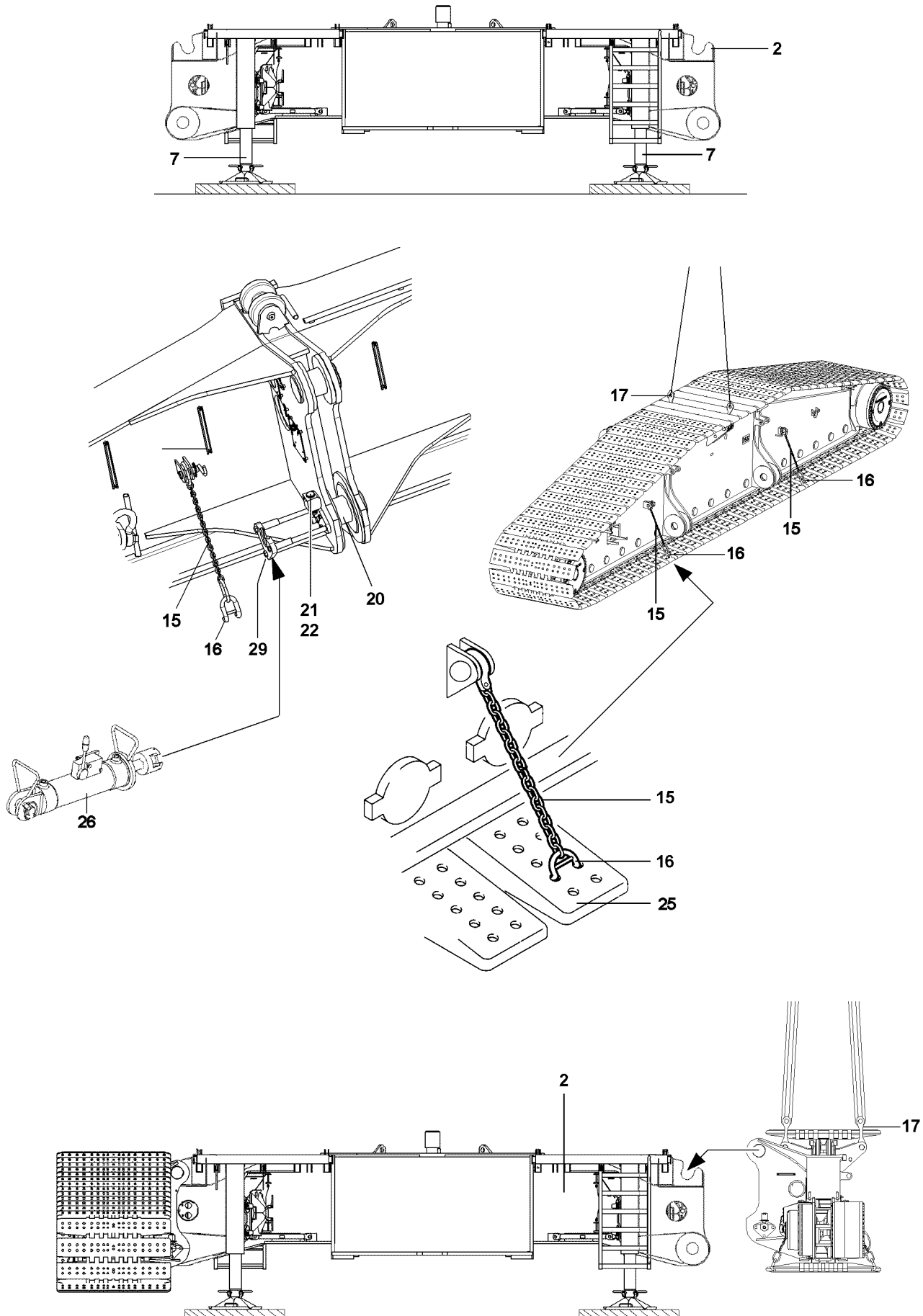

Fig.107372

LWE/LR 1600-2-008/18109-09-02/en

**Note**

- ▶ For assembly of the crawler carriers on the crawler center section, the assembly procedure and the process are identical for both crawler carrier sides.
- ▶ For that reason, the assembly of the crawler carrier is only described for one side as an example.

- ▶ Attach the fastening equipment on the brackets **27** of the crawler carrier.
- ▶ Swing in the crawler carrier with the auxiliary crane carefully to the pin points on the crawler center section **2**.
- ▶ Hang the crawler carrier on the crawler center section **2** on top.
- ▶ Insert the pin pulling cylinder **26** into the pin pulling device.

NOTICE

Danger of property damage!

If the following notes are not observed, the pin pulling device can be damaged.

- ▶ The retaining pin **21** must be secured in the upper position with the spring retainer **22**.

- ▶ Pin in the pin **20** with the pin pulling cylinder **26** and secure with retaining pin **21**.
- ▶ Secure the retaining pin **21** with spring retainer **22**.
- ▶ Remove the fastening equipment.

NOTICE

Damage to the brackets **17**!

- ▶ After removing the fastening equipment, the brackets **17** must be swung down.

- ▶ Swing the brackets **17** down.

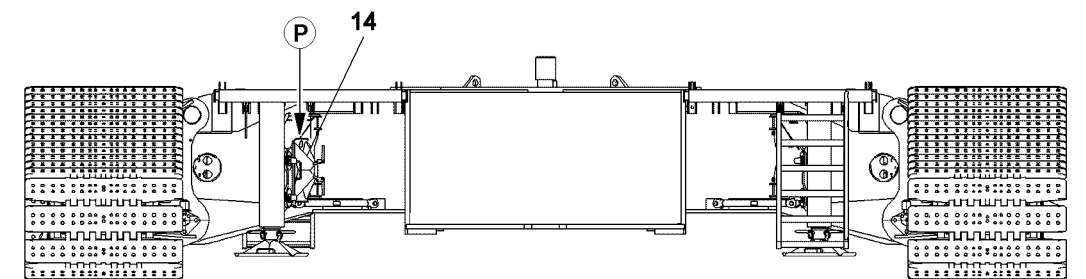
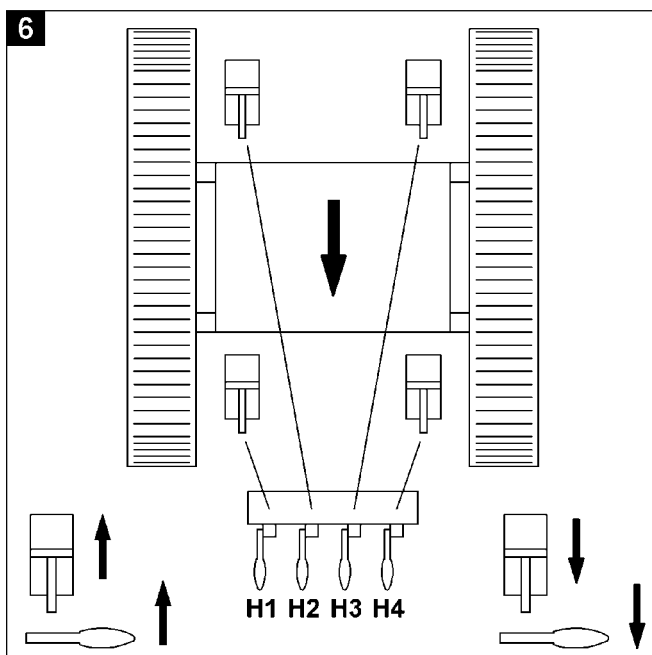
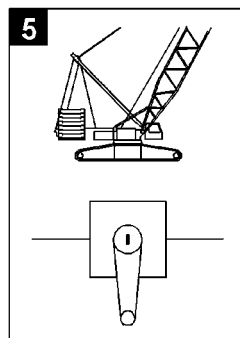
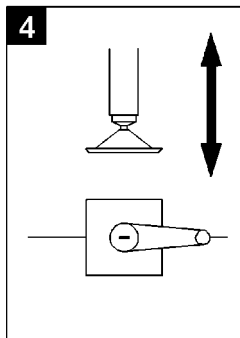
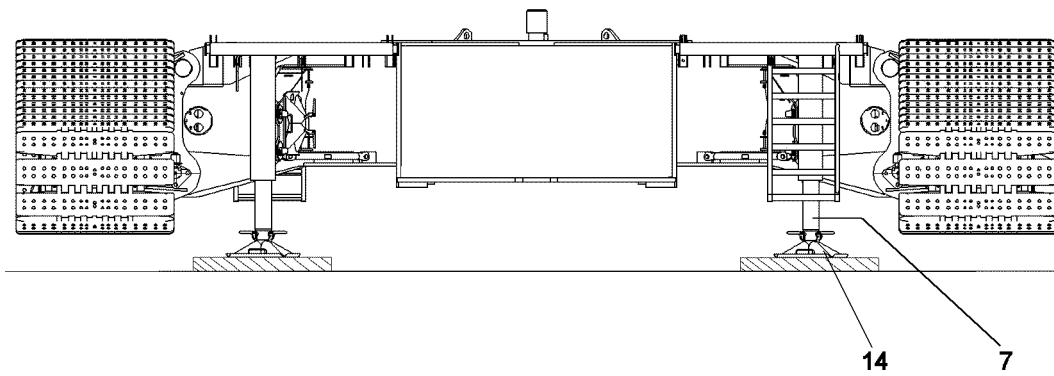

Fig.108930

LWE/LR 1600-2-008/18109-09-02/en

4.1.3 Lowering the crawler track



WARNING

Danger of tipping the crawler travel gear over!

If the hydraulic cylinder 7 are move in unevenly, the crawler travel gear can tip over.

Death, severe bodily injuries, property damage.

▶ When lowering the crawler travel gear, pay attention to the horizontal alignment, check visually.

▶ Actuate the hand lever **H1**, hand lever **H2**, hand lever **H3** and hand lever **H4**.

Result:

– The hydraulic cylinders 7 move in.

▶ Move the hydraulic cylinders 7 in until both crawler carriers on the ground and the support plates 14 are relieved.

▶ Open the receptacle on the support plates 14.

▶ Move the hydraulic cylinders 7 completely in.

▶ Secure the support plates 14 in parking position **P**.

▶ Disengage the chains 15 on the track pads.

4.1.4 Establishing the hydraulic and electrical connections to the crawler travel gear

Make sure that the following prerequisite is met:

– Both crawler carriers are properly installed, pinned and secured.

Hydraulic connections

When connecting and releasing hydraulic lines with quick couplings, make sure that the coupling procedure is carried out correctly.



DANGER

Danger of accident due to loss of pressure or leakage!

Incorrectly coupled or self-loosening quick couplings (particularly return lines) can result in serious accidents due to component failure.

▶ Check that the quick couplings have been properly connected before using the crane.

▶ Release the pressure in the hydraulic system before connecting or disconnecting. Turn the engine off and wait for short time.

▶ Connect the coupling components (sleeve and connector) and screw together with the hand-tightened nut.

▶ Tighten the hydraulic coupling by hand. Rotate the hand-tightened nut until it reaches a tangible, fixed stop position.

▶ Establish the hydraulic connections.

Electrical connections

▶ Establish the electrical connections, see separate electrical wiring diagram.

4.1.5 Assembling / disassembling the turntable



Note

▶ For assembly / disassembly of the turntable, see Crane operating instructions, chapter 3.02.

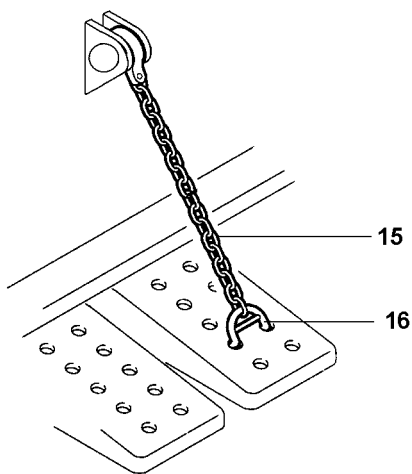
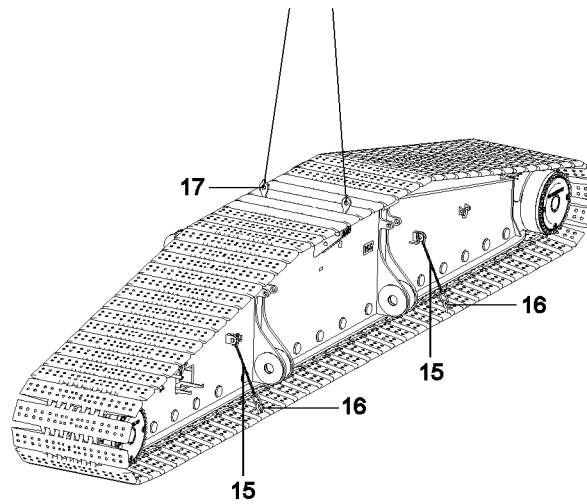
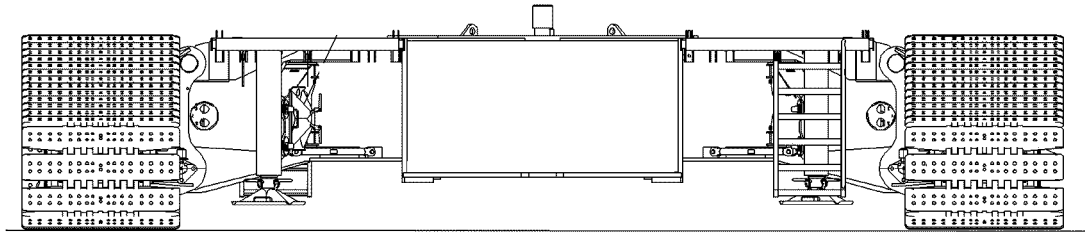

Fig.106602

4.2 Disassembly of crawler carrier with the auxiliary crane



WARNING

Danger of falling!

During assembly / disassembly, inspection and maintenance work, assembly personnel must be secured with appropriate aids to prevent them from falling.

Death, severe bodily injuries, property damage.

- ▶ All work aloft, where there is a danger of falling must be carried out with suitable aids.
- ▶ If aids are not available and work cannot be carried out from the ground, then the assembly personnel must secure themselves with the supplied fall arrest system to prevent falling, see Crane operating instructions, chapter 2.04.
- ▶ If fall protection equipment is available, then it must be used, see Crane operating instructions, chapter 2.06.
- ▶ When lifting, lowering, swinging crane parts in and out, no persons may remain in the danger zone.
- ▶ When closing or opening boom systems during boom assembly or boom disassembly, no persons may remain on the boom system or in the danger zone.
- ▶ If railings are present for the crane, then they must be brought into the corresponding position and secured for assembly / disassembly work.
- ▶ Only step on the aids, ladders and catwalks with clean shoes.
- ▶ Keep aids, ladders and catwalks free of heavy dirt, snow and ice.
- ▶ During all assembly and disassembly work, maintenance work and inspections, travel or crane operation is prohibited.
- ▶ Remaining on a suspended load is prohibited.
- ▶ Stepping or walking on crane components and lattice sections, which have an incline of more than 20° is prohibited.
- ▶ For all assembly work, the crane driver of the main crane must be in voice contact with the crane driver / crane drivers of the auxiliary crane / auxiliary cranes.
- ▶ For assembly tasks, the crane driver may only initiate crane movements when the responsible guide has explicitly released the movement.



WARNING

Danger of impact / crushing!

When installing / removing crane components with the auxiliary crane, crane components can start to swing back and forth.

When lifting / lowering and positioning crane components, there is an increased danger of impacts / crushing.

Death, severe bodily injuries, property damage.

- ▶ Make sure that personnel cannot be caught by components.
- ▶ Make sure that the crane is horizontally aligned.
- ▶ When working in danger zones: Use aids to protect limbs.
- ▶ Guide components with suitable aids to minimize oscillation.

Make sure that the following prerequisites are met:

- The turntable is removed.
- An auxiliary crane is available.
- The disassembly location must be level and have adequate load-bearing capacity.
- Suitable material must be available for the support of the assembly supports.
- The support plates are installed.

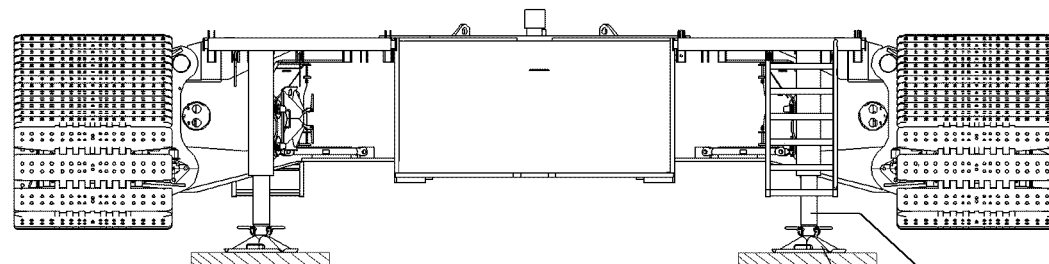
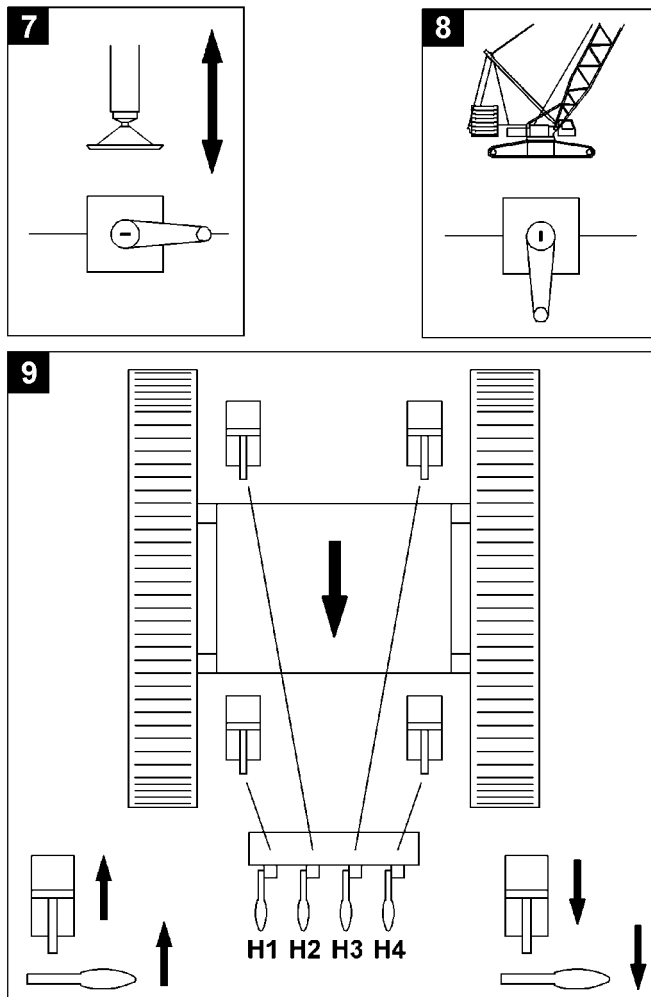
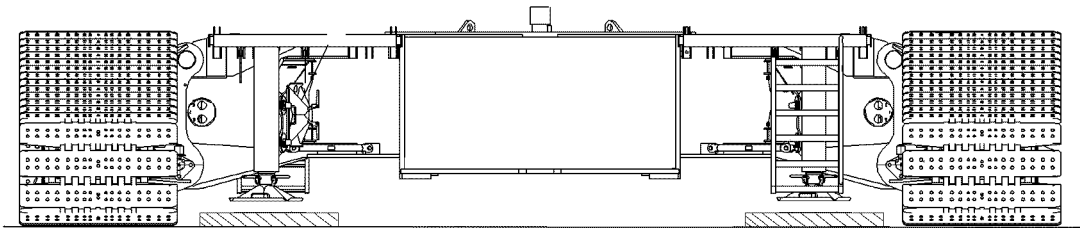

Fig.107374

4.2.1 Disconnecting the hydraulic and electrical connections to the crawler travel gear

Hydraulic connections

When connecting and releasing hydraulic lines with quick couplings, make sure that the coupling procedure is carried out correctly.



DANGER

Danger of accident due to loss of pressure or leakage!

Incorrectly coupled or self-loosening quick couplings (particularly return lines) can result in serious accidents due to component failure.

▶ Check that the quick couplings have been properly connected before using the crane.

- ▶ Release the pressure in the hydraulic system before connecting or disconnecting. Turn the engine off and wait for short time.
- ▶ Install the coupling components (sleeve and plug) with the hand-tightened nut.
- ▶ Disconnect the coupling sections.
- ▶ Properly store the hydraulic hoses on the crawler carrier.
- ▶ Protect the coupling sections with caps to prevent contamination and damage.
- ▶ Disconnect the hydraulic connections.

Electrical connections

- ▶ Unplug the electrical connections, see separate electrical wiring diagram.

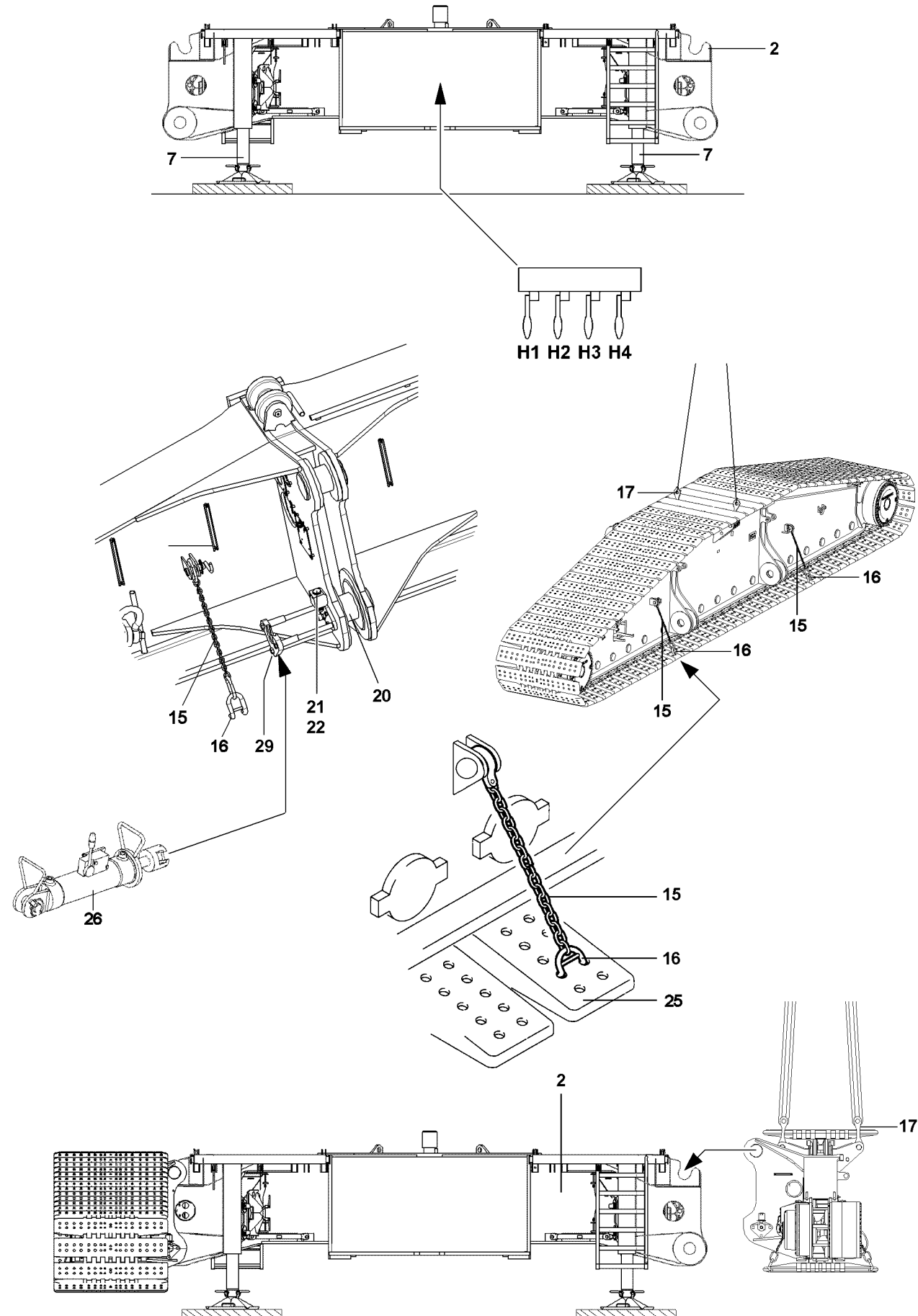

Fig.107122

LWE/LR 1600-2-008/18109-09-02/en

4.2.2 Preparing the crawler carrier for disassembly



Note

- ▶ Hang in **two** chains **15** per crawler carrier side.

The track pads **25** must be secured before removal of the crawler carriers with the chains **15** to prevent sag.

- ▶ Hang in the chains **15** with the bars **16** on the track pads.



Note

- ▶ The brackets **17** must be swung between the track pads **25**, „upward“.

- ▶ Swing the brackets **17** upward.

4.2.3 Lift the crawler track



WARNING

Danger of accidents due to improper support!

If the assembly support is not properly supported, then it can sink into the ground.

Death, severe bodily injuries, property damage.

- ▶ The supporting base must take on the weight of the crawler travel gear safely.
- ▶ The support must be made large enough for the ground conditions, with solid materials, such as wood, steel or concrete slabs, see Crane operating instructions, chapter 2.04.

Make sure that the following prerequisites are met:

- The ball valve is set to „assembly support“.
- The hydraulic aggregate of the pin pulling device is turned on.
- ▶ Establish the hydraulic connections from the hydraulic aggregate of the pin pulling device to the hydraulic cylinders **7**.



Note

- ▶ Lift the crawler travel gear so that the crawler carriers can be removed without restriction.
- ▶ Move the hydraulic cylinders out evenly.

- ▶ Actuate the hand lever **H1**, hand lever **H2**, hand lever **H3** and hand lever **H4**.

Result:

- The four hydraulic cylinders **7** move out.

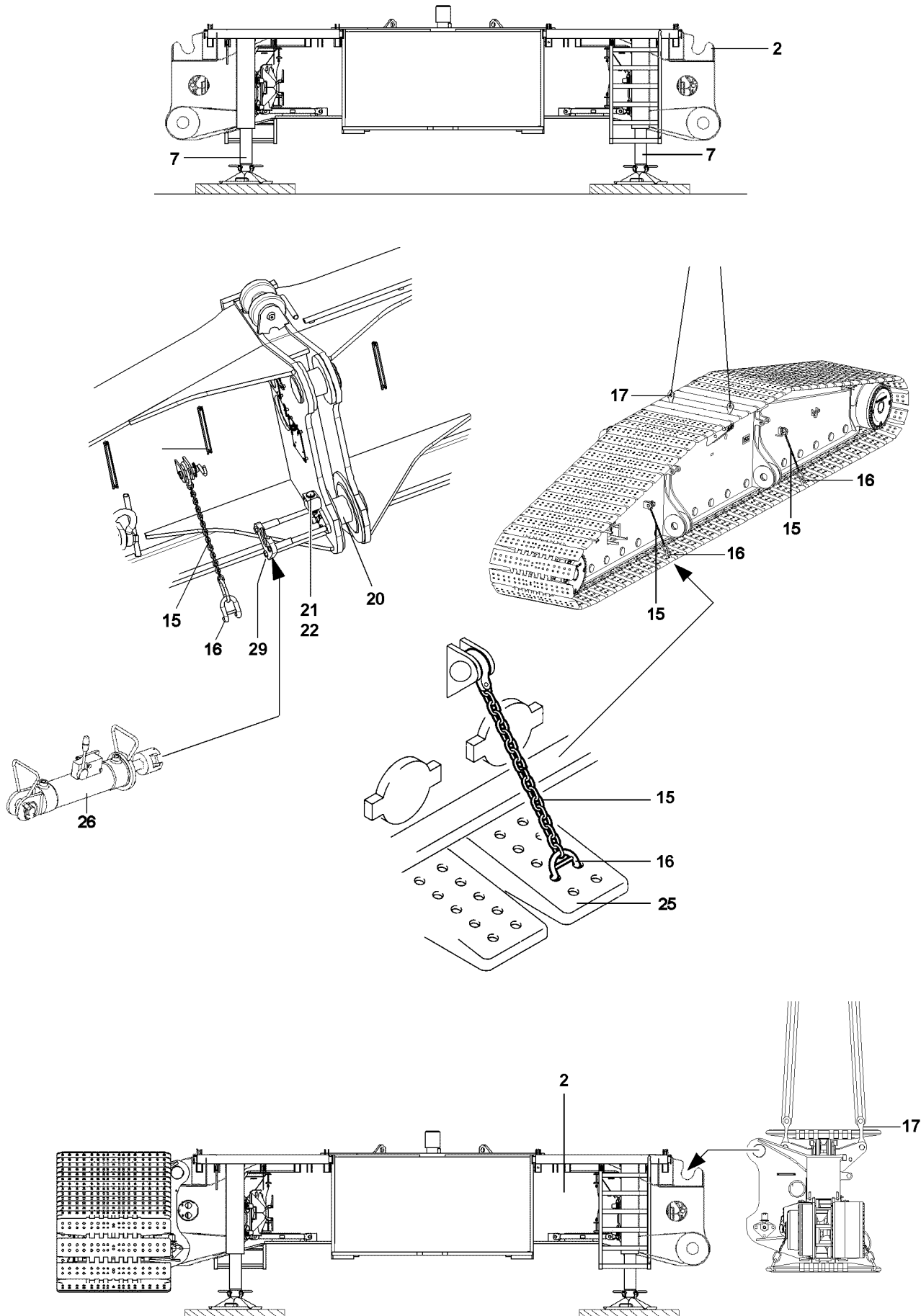

Fig.107372

LWE/LR 1600-2-008/18109-09-02/en

4.2.4 Disassembling the crawler carriers

Make sure that the following prerequisites are met:

- The turntable is removed.
- The crawler travel gear is raised.



Note

- ▶ For disassembly of the crawler carriers, the disassembly process and the process for both crawler carrier sides is identical.
- ▶ For that reason, the disassembly of the crawler carriers is only described for one side as an example.

- ▶ Attach the fastening equipment on the brackets **17** of the crawler carrier.

Unpin and release the crawler carrier **1** on the crawler center section **2** on the bottom.

- ▶ Remove the spring retainer **22** and unpin the retaining pin **21**.

NOTICE

Danger of property damage!

If the following notes are not observed, the pin pulling device can be damaged.

- ▶ The retaining pin **21** must be secured in the upper position with the spring retainer **22**.

- ▶ Secure the retaining pin **21** in the „up“ position with spring retainer **22**.
- ▶ Unpin the pin **20** with the hydraulic pin pulling device.
- ▶ Lift the crawler carrier **1** with the auxiliary crane.

When the crawler carrier is raised above the fastening points:

- ▶ Swing the crawler carrier **1** out.
- ▶ Set the crawler carrier **1** down on the ground.
- ▶ Remove the fastening equipment.

4.2.5 Disassembling the assembly support



Note

- ▶ See section „Disassembling the assembly support“.

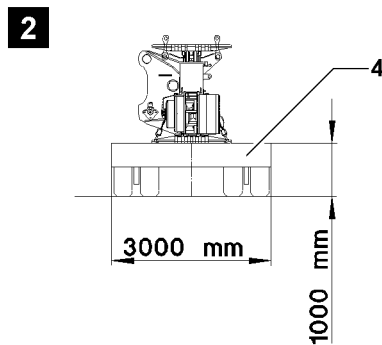
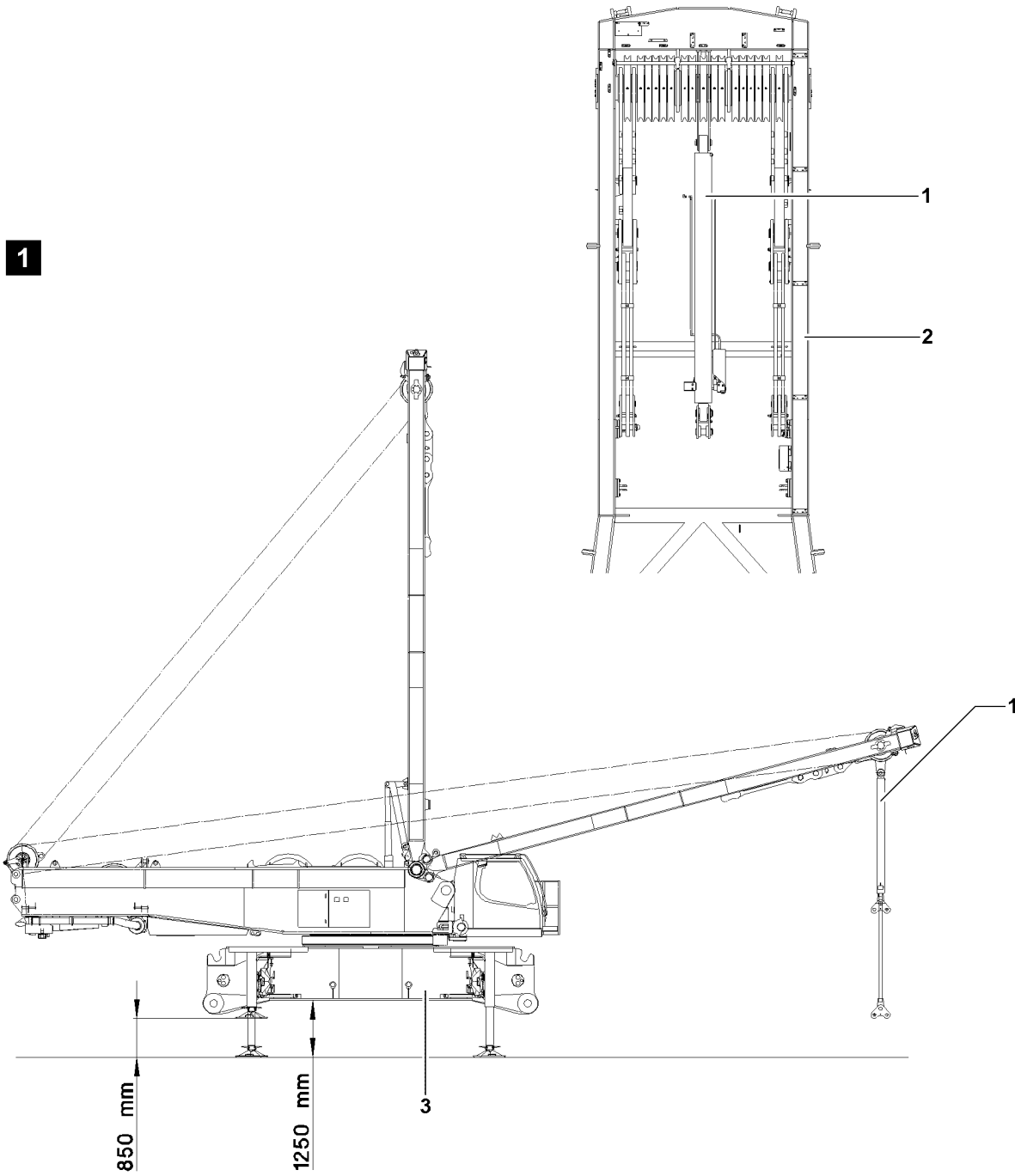

Fig.107286

LWE/LR 1600-2-008/18109-09-02/en

5 Assembly / disassembly of the crawler carriers with SA-frame



WARNING

The crane can topple over!

If the SA-frame is not in „vertical“ position before supporting the crane, the crane can topple over. Death, severe bodily injuries, property damage.

- ▶ Make sure that the ground has sufficient load bearing capacity to take on the weight of the crane safely.
- ▶ Make sure that the SA-frame is erected vertically before the assembly support is moved out and the crane is supported.

Make sure that the following prerequisite is met:

- The SA-frame is erected to 90° (vertical position), see Crane operating instructions, chapter 5.02.

5.1 Assembly of the crawler carrier with SA-frame



WARNING

Danger of falling!

During assembly / disassembly, inspection and maintenance work, assembly personnel must be secured with appropriate aids to prevent them from falling.

Death, severe bodily injuries, property damage.

- ▶ All work aloft, where there is a danger of falling must be carried out with suitable aids.
- ▶ If aids are not available and work cannot be carried out from the ground, then the assembly personnel must secure themselves with the supplied fall arrest system to prevent falling, see Crane operating instructions, chapter 2.04.
- ▶ If fall protection equipment is available, then it must be used, see Crane operating instructions, chapter 2.06.
- ▶ When lifting, lowering, swinging crane parts in and out, no persons may remain in the danger zone.
- ▶ When closing or opening boom systems during boom assembly or boom disassembly, no persons may remain on the boom system or in the danger zone.
- ▶ If railings are present for the crane, then they must be brought into the corresponding position and secured for assembly / disassembly work.
- ▶ Only step on the aids, ladders and catwalks with clean shoes.
- ▶ Keep aids, ladders and catwalks free of heavy dirt, snow and ice.
- ▶ During all assembly and disassembly work, maintenance work and inspections, travel or crane operation is prohibited.
- ▶ Remaining on a suspended load is prohibited.
- ▶ Stepping or walking on crane components and lattice sections, which have an incline of more than 20° is prohibited.
- ▶ For all assembly work, the crane driver of the main crane must be in voice contact with the crane driver / crane drivers of the auxiliary crane / auxiliary cranes.
- ▶ For assembly tasks, the crane driver may only initiate crane movements when the responsible guide has explicitly released the movement.



WARNING

Danger of impact / crushing!

When installing / removing crane components with the auxiliary crane, crane components can start to swing back and forth.

When lifting / lowering and positioning crane components, there is an increased danger of impacts / crushing.

Death, severe bodily injuries, property damage.

- ▶ Make sure that personnel cannot be caught by components.
- ▶ Make sure that the crane is horizontally aligned.
- ▶ When working in danger zones: Use aids to protect limbs.
- ▶ Guide components with suitable aids to minimize oscillation.

**Note**

- ▶ The weight of the crawler carrier, depending on the equipment configuration, is a maximum of 38 t , see Crane operating instructions, chapter 3.01.
- ▶ The assembly support on the crawler central section is connected to the turntable hydraulics.

Empty page!

LWE/LR 1600-2-008/18109-09-02/en

1

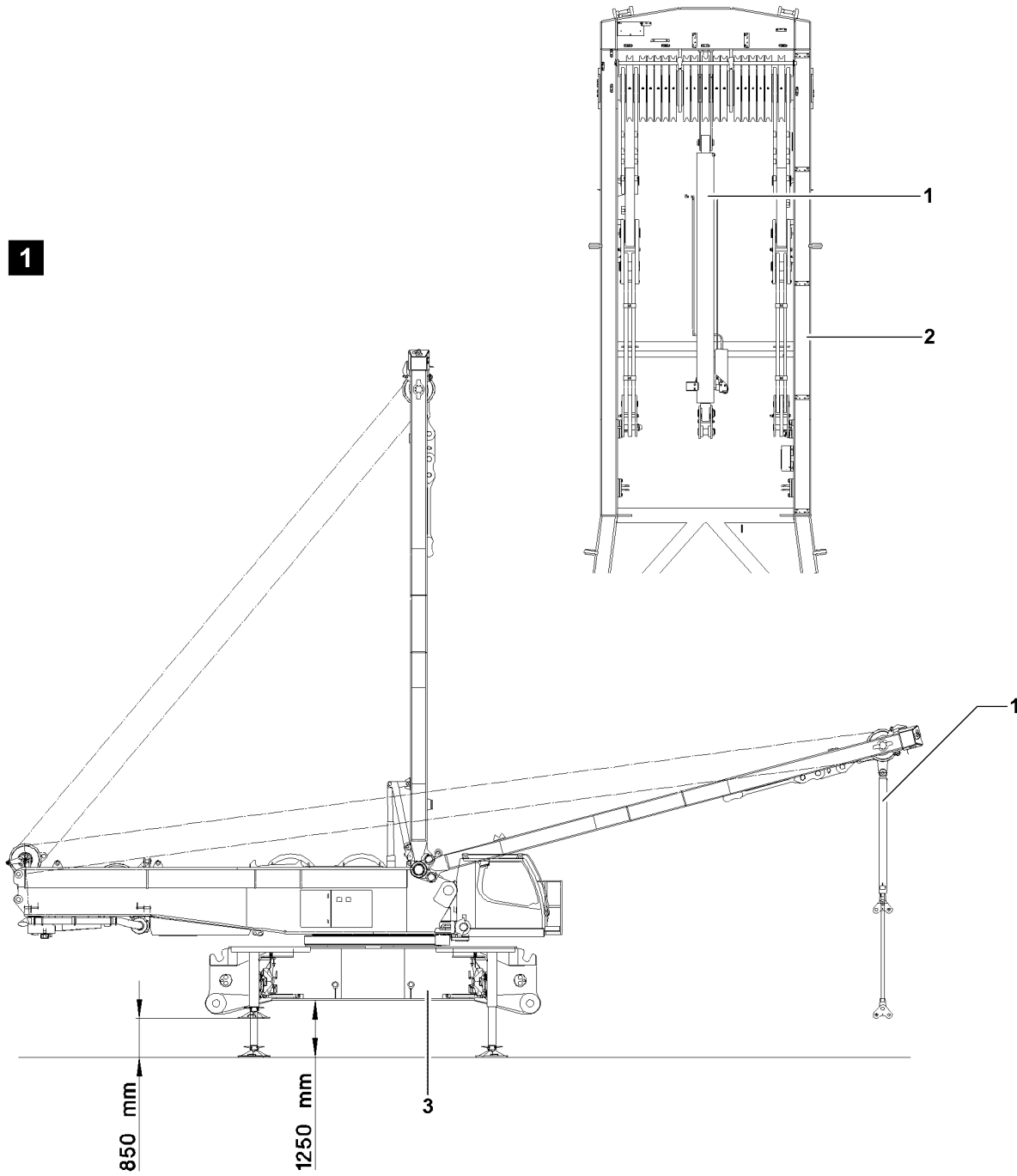

2

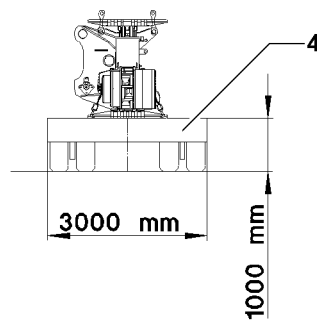

Fig.107286

LWE/LR 1600-2-008/18109-09-02/en

**Note**

- ▶ The assembly cylinder **1** lies unsecured on the SA-frame **2**.
- ▶ The assembly cylinder **1** has a stroke of 2300 mm.
- ▶ The load can be measured with the assembly cylinder **1**.

**Note**

- ▶ Function assignment for the manual lever for retracting / extending the support cylinder, see section „Lifting the crawler center section“.

**Note**

- ▶ For assembly on supports, the SA-frame must stand vertically.

Make sure that the following prerequisites are met:

- The crane must be aligned horizontally.
- The placement location must be level and have adequate load-bearing capacity.
- The operating mode „SA-frame“ has been set and confirmed on the LICCON computer system.
- The maximum height of the transport vehicle **4** may not exceed 1000 mm , see illustration **2**.
- The hydraulic support cylinders are moved out to 850 mm , see illustration **1**.

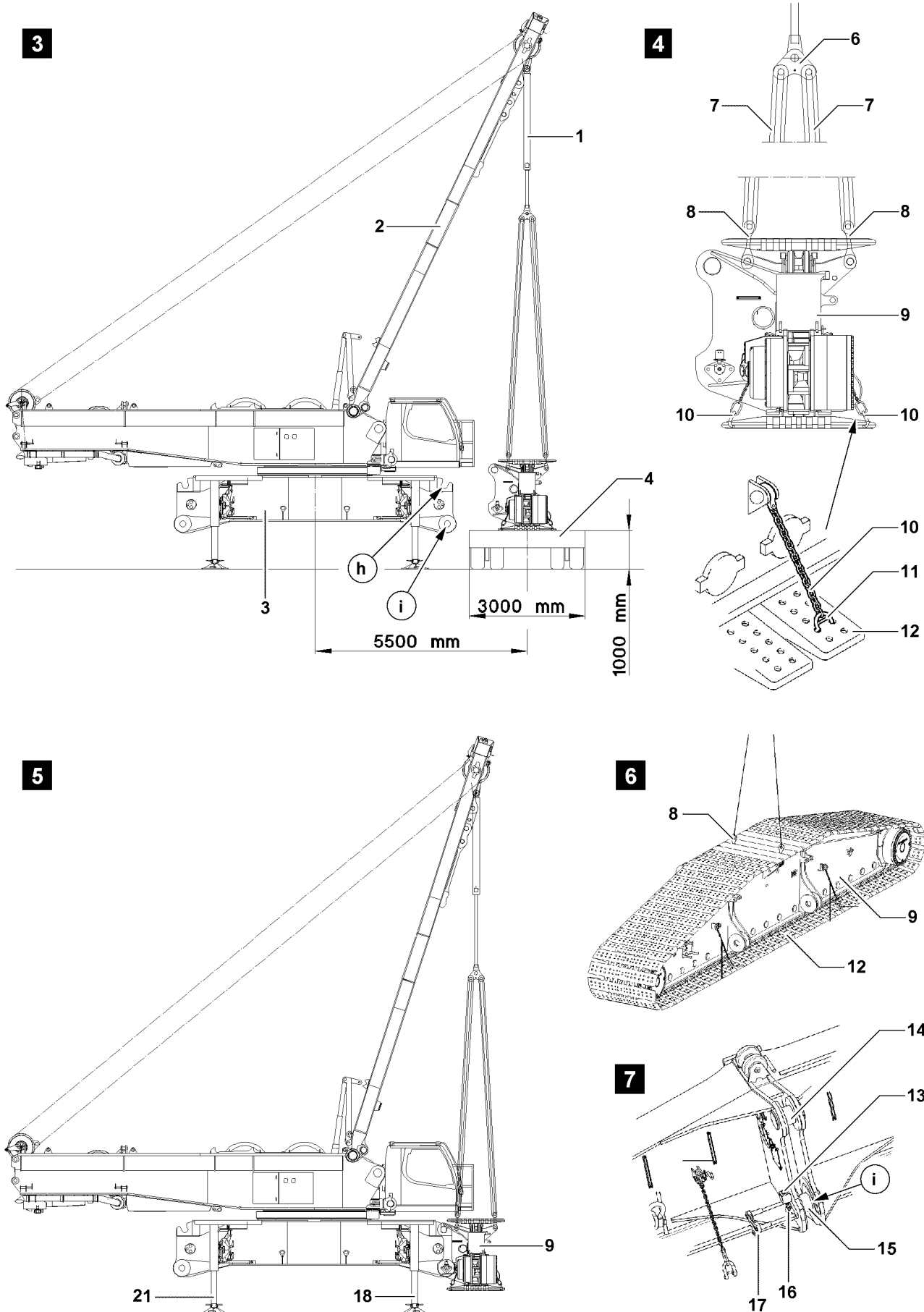

Fig.107285

LWE/LR 1600-2-008/18109-09-02/en

5.1.1 Assembling the first crawler carrier

NOTICE

Damage to crane!

If the following instructions are not observed, the crane can topple over or be severely damaged when unloading the crawler carrier.

- ▶ Make sure that the crane is horizontally aligned.
 - ▶ The maximum permissible distance of 5500 mm between the crawler carrier and the center of the turntable may not be exceeded, see illustration 3.
 - ▶ The specifications in the load charts SA-operation must be adhered to.
-

Preparing the crawler carrier for assembly

NOTICE

Damage to the crawler carrier!

If the track pads are not secured with transport retainers against sagging, the crawler carrier can be severely damaged.

- ▶ Secure the track pads **12** before assembly of the crawler carrier **9** with the chains **10** against sagging.
 - ▶ Hang the chains **10** with the bars **11** on the track pads **12**, see illustration 4.
-

**Note**

- ▶ The brackets **8** must be swung through between the track pads **12**, „upward“.
 - ▶ Swing the brackets **8** „upward“.
-

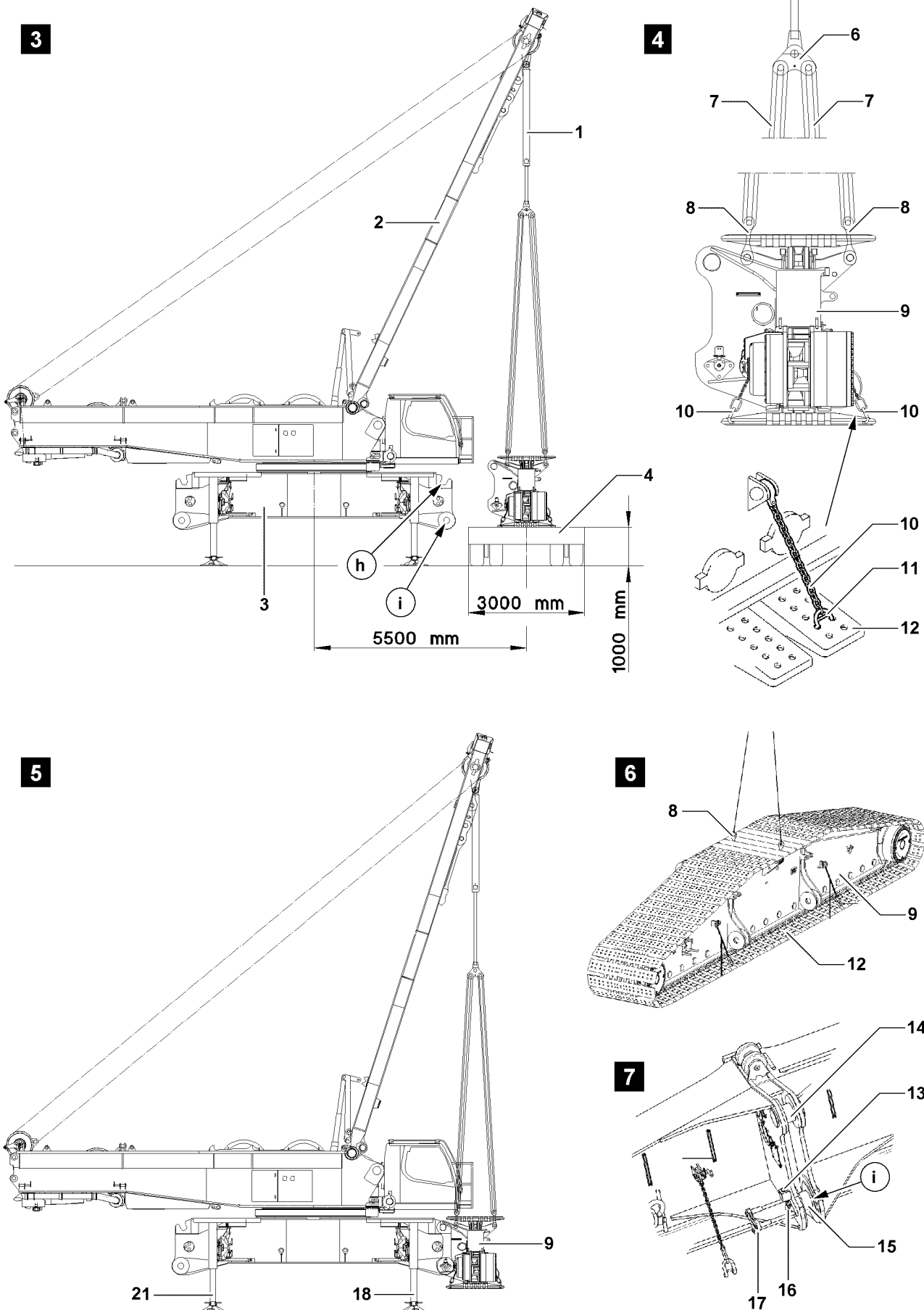

Fig.107285

LWE/LR 1600-2-008/18109-09-02/en

Assembling the crawler carrier



Note

- ▶ Note the identification on the crawler carrier and the crawler center section.
 - ▶ The crawler carrier and the crawler center section are marked with numbers.
-
- ▶ Luff the SA-frame **2** down until the assembly cylinder **1** is centered above the crawler carrier **9**.



Note

- ▶ The assembly cylinder **1** may not be moved out all the way.
 - ▶ If the assembly cylinder **1** is completely moved out and the limit switch position is reached, an error display occurs on the LICCON monitor and the LMB-Stop.
-
- ▶ Move the assembly cylinder **1** out: Actuate master switch **2**.
 - ▶ Pin the fastening ropes **7** on the assembly device **6** and secure with locking pins.
 - ▶ Move the assembly cylinder **1** in until the fastening ropes **7** are tensioned: Actuate master switch **2**.
 - ▶ Lift the crawler carrier **9** with the assembly cylinder **1** from the transport vehicle **4**: Slowly move the assembly cylinder **1** in with master switch **2**.
 - ▶ Carefully luff the SA-frame **2** up.
 - ▶ Swing the crawler carrier **9** with the SA-frame **2** to the receptacle on the crawler center section **3**.
 - ▶ Bring the crawler carrier **9** carefully into the crawler center section **3**.
 - ▶ Lower the crawler carrier **9** onto the crawler center section **3**: Hang the pins **14** on points **h**.

NOTICE

Pin is not released!

If the pin **15** is secured upon pinning through the retaining pin, the pin pulling device can be damaged.

- ▶ Secure retaining pin **13** before pinning in position above with spring retainer.
-
- ▶ Hang the pin pulling cylinder on the screw **16** and retainer **17**, see illustration **7**.
 - ▶ Pin in the pins **15** with the pin pulling cylinder on the pin points **i** and secure with retaining pins.
 - ▶ Secure the retaining pins **13** with spring retainer.
 - ▶ Release the fastening ropes **7** from the brackets **8** on the crawler carrier **9**.



WARNING

The crane can tip over!

If the support cylinders are moved out / in unevenly, the crane can tip over.

Death, severe bodily injuries, property damage.

- ▶ When moving the support cylinders in / out, pay attention to the horizontal alignment, check visually.

- ▶ Move the support cylinder in evenly until the first crawler carrier **9** is standing on the ground.

When the first crawler carrier **9** is standing on the ground:

- ▶ Move the support cylinders **18** in all the way.
- ▶ Move the support cylinder **21** out until the angle between the ground and the crawler center section is approx. 1.4°.



WARNING

Danger of tipping over!

Before turning the turntable, if the first assembled crawler carrier is not positioned on the ground, there is a danger of tipping over.

Death, severe bodily injuries, property damage.

- ▶ Before turning the turntable: Set the first installed crawler carrier on the ground.
- ▶ Hydraulic support cylinder **18** must be retracted completely on the crawler side.

- ▶ Turn the turntable by 180°.

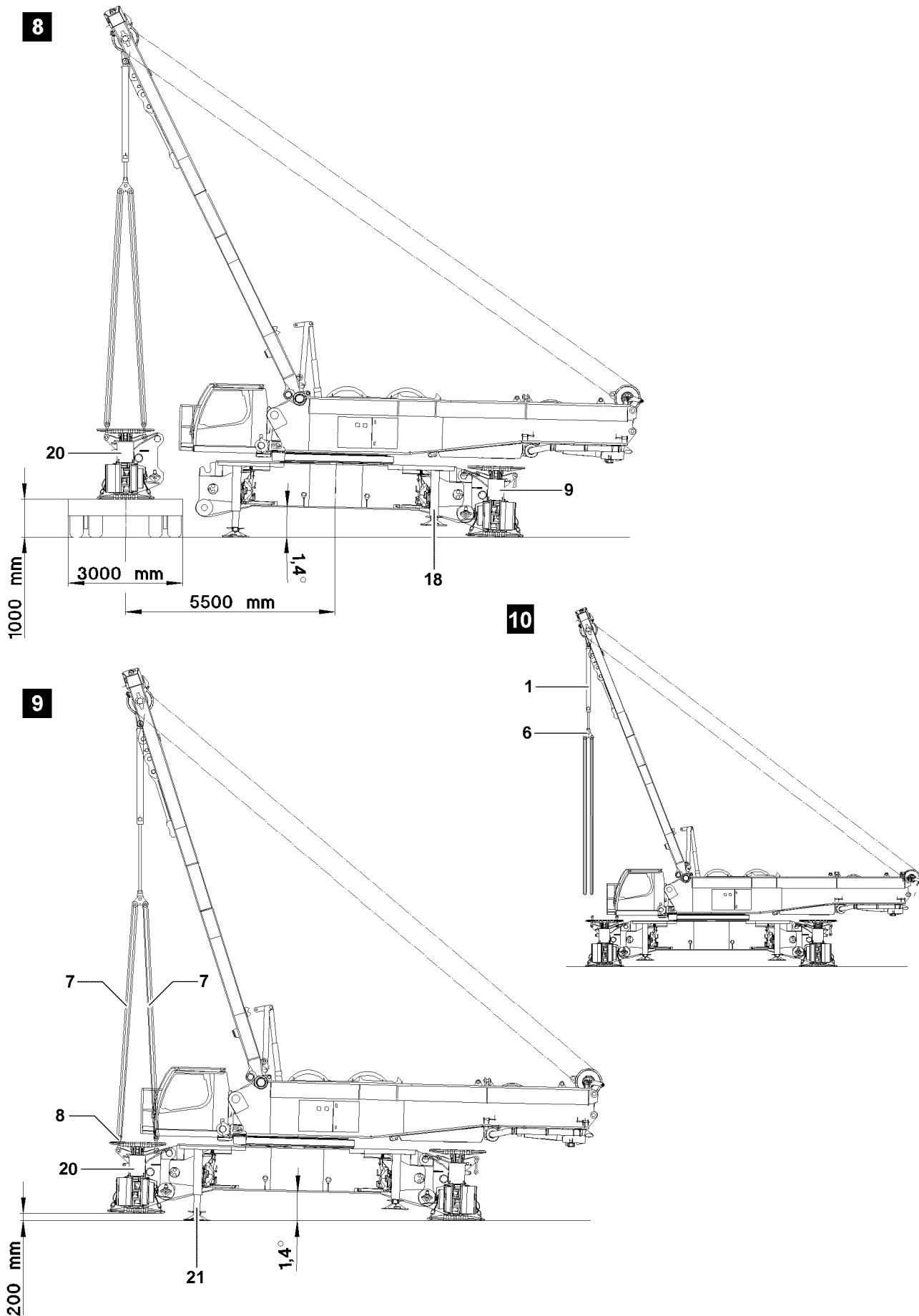

Fig.107367

LWE/LR 1600-2-008/18109-09-02/en

5.1.2 Assembly of the second crawler carrier

Make sure that the following prerequisites are met:

- The first installed crawler carrier **9** is standing on the ground.
- The second crawler carrier **20** is prepared for assembly.
- The hydraulic support cylinders **18** on the crawler side are fully moved in.
- The crane is inclined in direction of the assembled crawler carrier by approx. 1.4°, see illustration **8**.
- The turntable is turned by 180°.



Note

- ▶ Procedure for assembly of the second crawler carrier **20**, see section „Assembling first crawler carrier“.

When the second crawler carrier **20** is installed:

- ▶ Set the second crawler carrier on the ground: Move the support cylinder **21** in evenly.
- ▶ Remove the chains **10** on the track pads **12** and secure on the crawler carriers, see illustration **10**.
- ▶ Move the support cylinders **21** in all the way.



Note

- ▶ The hydraulic support must remain fully swung out.
- ▶ Unpin the fastening ropes **7** on the brackets **8** and on the assembly device **6**.

NOTICE

Damage to the brackets **8**!

- ▶ After removing the fastening equipment, the brackets **8** must be swung down.
- ▶ Swing the brackets **8** down.
- ▶ Move the assembly cylinder **1** in completely.

5.1.3 Establishing the hydraulic connection to the crawler travel gears

Make sure that the following prerequisite is met:

- Both crawler carriers are properly installed, pinned and secured.

When connecting and releasing hydraulic lines with quick couplings, make sure that the coupling procedure is carried out correctly.



DANGER

Loss of pressure or leakage!

Incorrectly coupled or self-loosening quick couplings (particularly return lines) can result in serious accidents due to component failure.

- ▶ Check that the quick couplings have been properly connected before using the crane.
- ▶ Release the pressure in the hydraulic system before connecting or disconnecting. Turn the engine off and wait for short time.
- ▶ Connect the coupling components (sleeve and connector) and screw together with the hand-tightened nut.
- ▶ Tighten the hydraulic coupling by hand. Rotate the hand-tightened nut until it reaches a tangible, fixed stop position.
- ▶ Establish the hydraulic connections.

5.1.4 Establishing the electrical connection to the crawler travel gears

- ▶ Establish the electrical connections, see separate electrical wiring diagram.

11

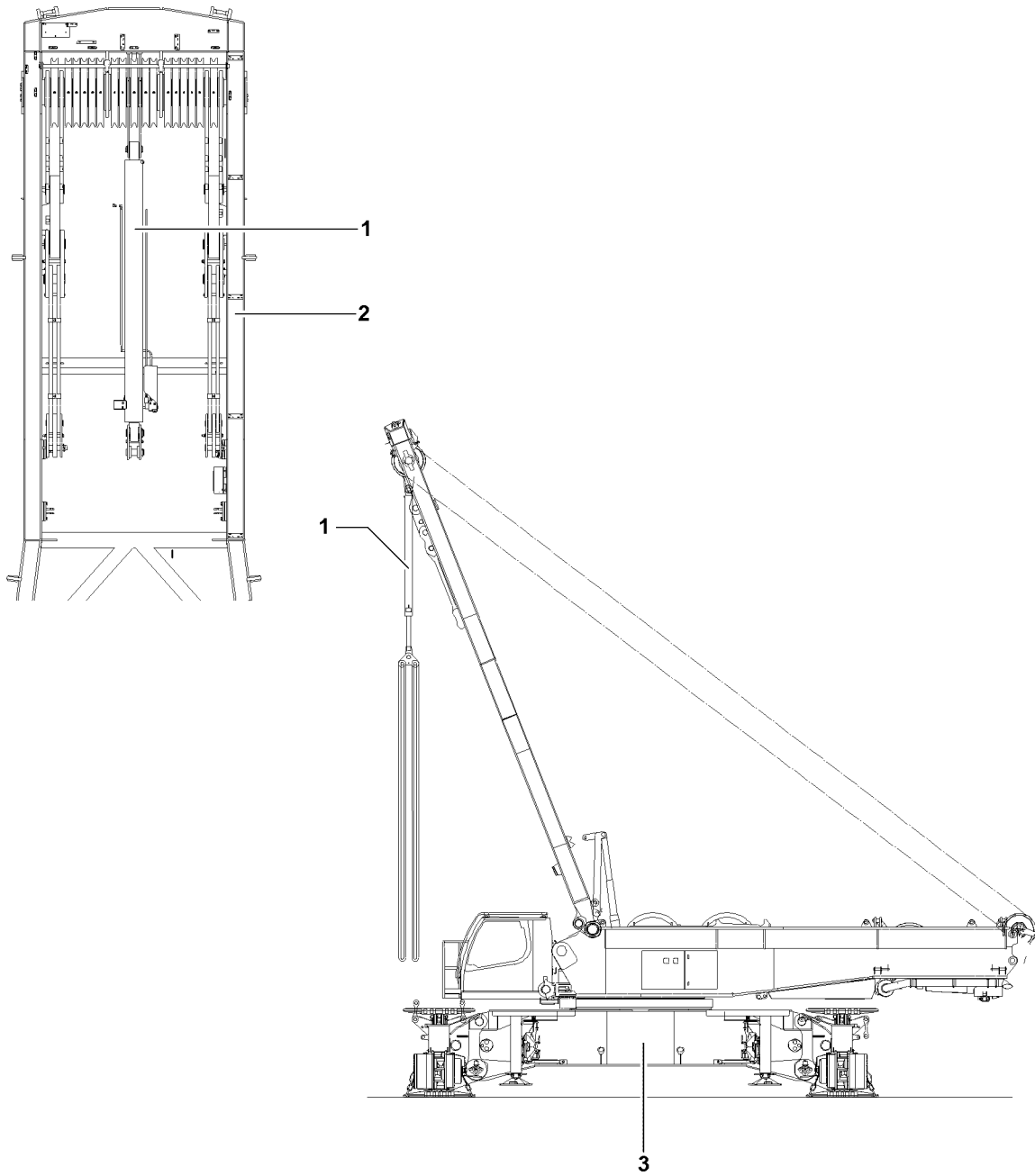

12

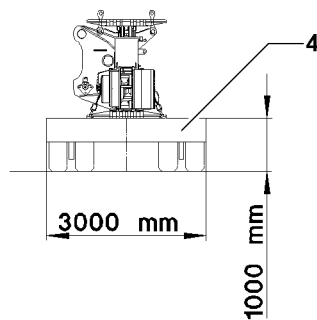

Fig.107457

LWE/LR 1600-2-008/18109-09-02/en

5.2 Disassembly of the crawler carrier with SA-frame



WARNING

Danger of falling!

During assembly / disassembly, inspection and maintenance work, assembly personnel must be secured with appropriate aids to prevent them from falling.

Death, severe bodily injuries, property damage.

- ▶ All work aloft, where there is a danger of falling must be carried out with suitable aids.
- ▶ If aids are not available and work cannot be carried out from the ground, then the assembly personnel must secure themselves with the supplied fall arrest system to prevent falling, see Crane operating instructions, chapter 2.04.
- ▶ If fall protection equipment is available, then it must be used, see Crane operating instructions, chapter 2.06.
- ▶ When lifting, lowering, swinging crane parts in and out, no persons may remain in the danger zone.
- ▶ When closing or opening boom systems during boom assembly or boom disassembly, no persons may remain on the boom system or in the danger zone.
- ▶ If railings are present for the crane, then they must be brought into the corresponding position and secured for assembly / disassembly work.
- ▶ Only step on the aids, ladders and catwalks with clean shoes.
- ▶ Keep aids, ladders and catwalks free of heavy dirt, snow and ice.
- ▶ During all assembly and disassembly work, maintenance work and inspections, travel or crane operation is prohibited.
- ▶ Remaining on a suspended load is prohibited.
- ▶ Stepping or walking on crane components and lattice sections, which have an incline of more than 20° is prohibited.
- ▶ For all assembly work, the crane driver of the main crane must be in voice contact with the crane driver / crane drivers of the auxiliary crane / auxiliary cranes.
- ▶ For assembly tasks, the crane driver may only initiate crane movements when the responsible guide has explicitly released the movement.



WARNING

Danger of impact / crushing!

When installing / removing crane components with the auxiliary crane, crane components can start to swing back and forth.

When lifting / lowering and positioning crane components, there is an increased danger of impacts / crushing.

Death, severe bodily injuries, property damage.

- ▶ Make sure that personnel cannot be caught by components.
- ▶ Make sure that the crane is horizontally aligned.
- ▶ When working in danger zones: Use aids to protect limbs.
- ▶ Guide components with suitable aids to minimize oscillation.



Note

- ▶ The weight of the crawler carrier, depending on the equipment configuration, is a maximum of 38 t, see Crane operating instructions, chapter 3.01.
- ▶ The assembly support on the crawler central section is connected to the turntable hydraulics.



Note

- ▶ The assembly cylinder 1 lies unsecured on the SA-frame 2.
- ▶ The assembly cylinder 1 has a stroke of 2300 mm.
- ▶ The load can be measured with the assembly cylinder 1.



Note

- ▶ Function assignment for the manual lever for retracting / extending the support cylinder, see section „Assemble assembly supports“.

Make sure that the following prerequisites are met:

- The crane must be aligned horizontally.
- The placement location must be level and have adequate load-bearing capacity.
- The operating mode „SA-frame“ has been set and confirmed on the LICCON computer system.
- The maximum height of the transport vehicle **4** may not exceed 1000 mm , see illustration **12**.
- Suitable material must be available for the support of the assembly supports.
- The support plates are installed.

Empty page!

LWE/LR 1600-2-008/18109-09-02/en

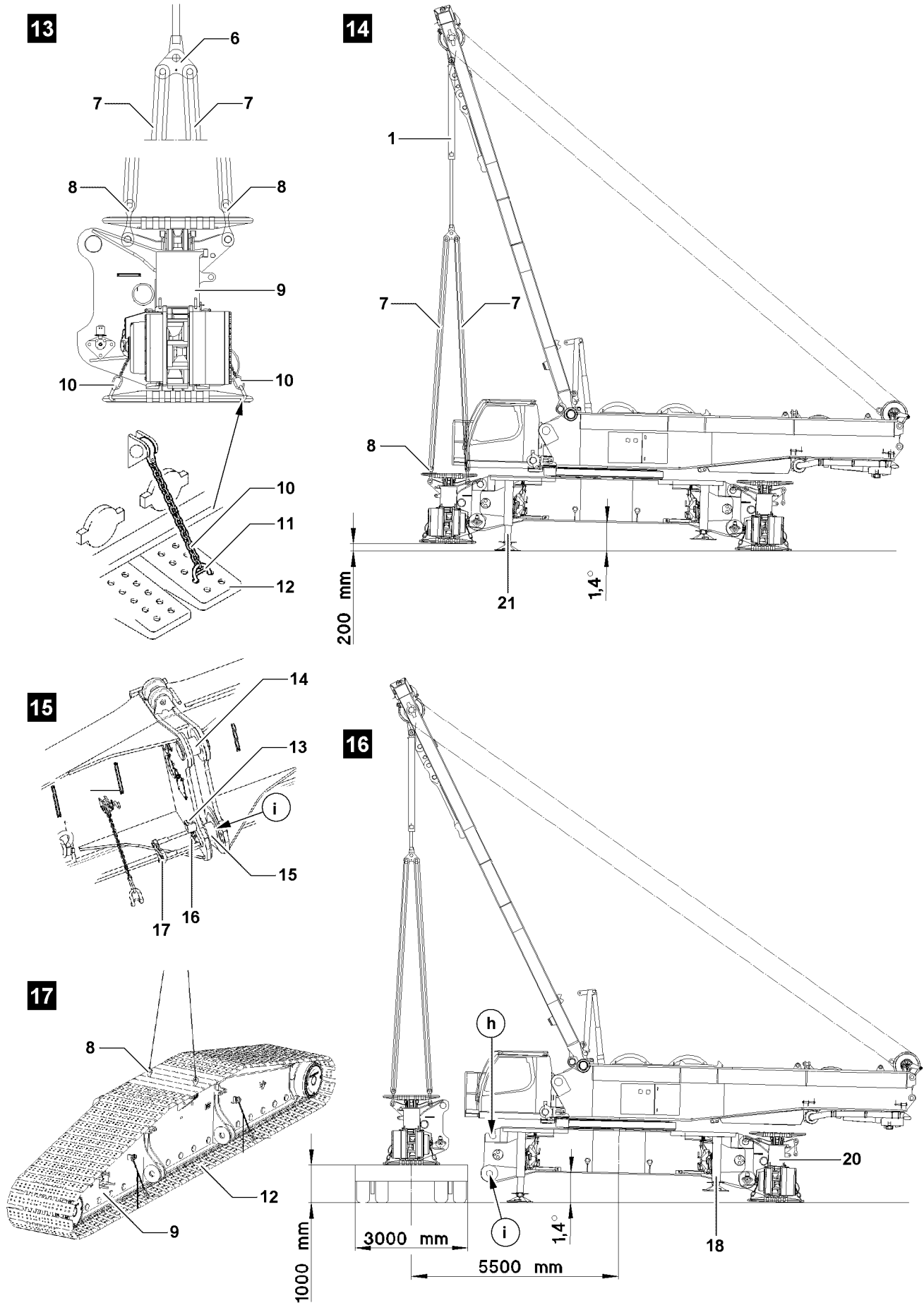

Fig.107368

LWE/LR 1600-2-008/18109-09-02/en

5.2.1 Disconnecting the hydraulic connection to the crawler travel gears

Make sure that the following prerequisite is met:

- Both crawler carriers are properly installed, pinned and secured.

When connecting and releasing hydraulic lines with quick couplings, make sure that the coupling procedure is carried out correctly.



DANGER

Loss of pressure or leakage!

Incorrectly coupled or self-loosening quick couplings (particularly return lines) can result in serious accidents due to component failure.

- ▶ Check that the quick couplings have been properly connected before using the crane.
- ▶ Release the pressure in the hydraulic system before connecting or disconnecting. Turn the engine off and wait for short time.
- ▶ Connect the coupling components (sleeve and connector) and screw together with the hand-tightened nut.
- ▶ Tighten the hydraulic coupling by hand. Rotate the hand-tightened nut until it reaches a tangible, fixed stop position.
- ▶ Establish the hydraulic connections.

5.2.2 Disconnecting the electric connection to the crawler travel gears

- ▶ Disconnect the electrical connections, see separate electrical wiring diagram.

5.2.3 Disassembling the first crawler carrier

Preparing the crawler carrier for disassembly



Note

- ▶ The track pads **12** of both crawler carriers must stand in such a way that the brackets **8** can be swung through between the track pads **12** „upward“, see illustration **13**.

NOTICE

Damage to the crawler carrier!

If the track pads are not secured with transport retainers against sagging, the crawler carrier can be severely damaged.

- ▶ Secure the track pads **12** before assembly of the crawler carrier **9** with the chains **10** against sagging.
- ▶ Hang the chains **10** with the bars **11** on the track pads **12**, see illustration **13**.



Note

- ▶ The brackets **8** must be swung through between the track pads **12**, „upward“.
- ▶ Swing the brackets **8** „upward“.

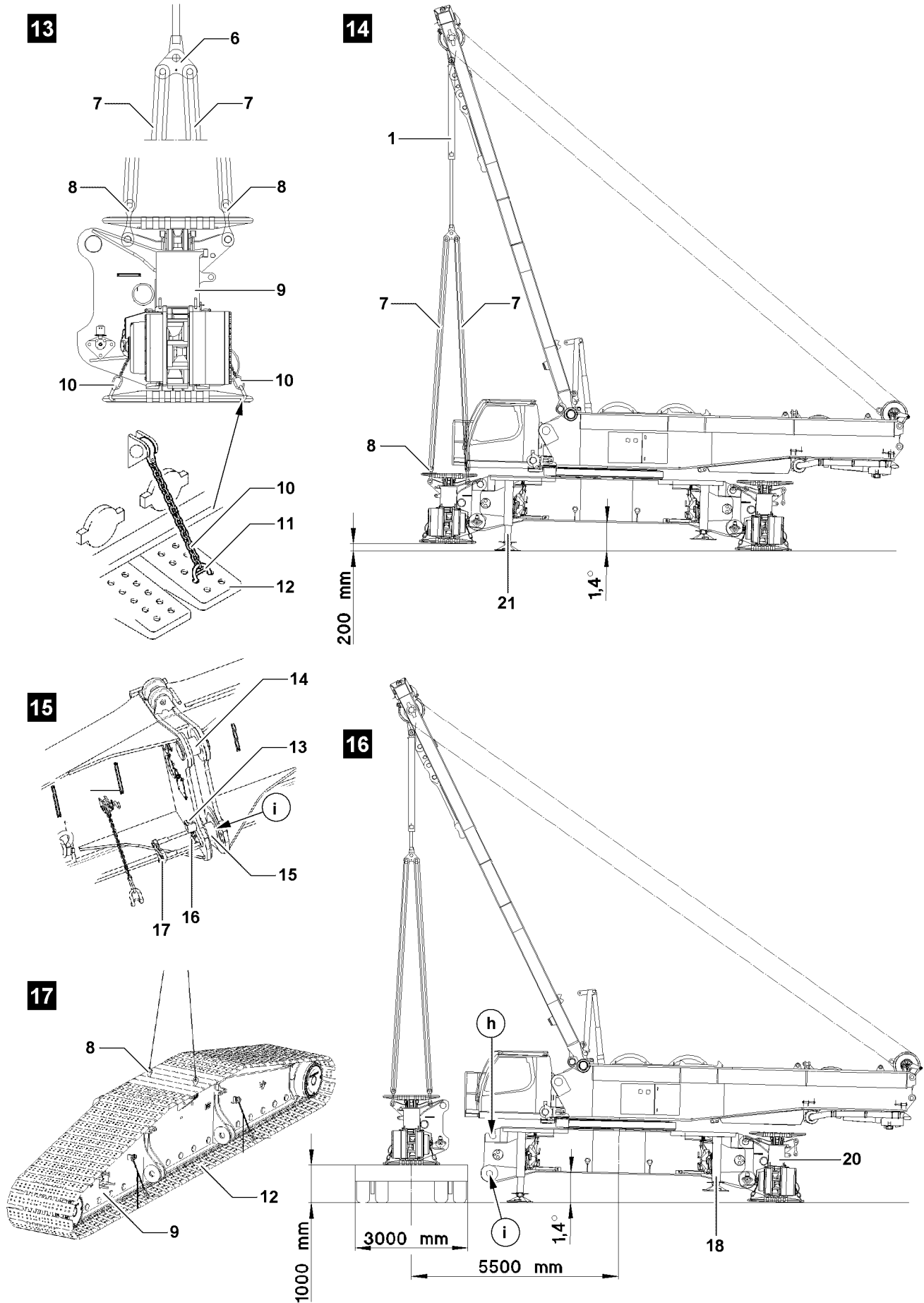

Fig.107368

LWE/LR 1600-2-008/18109-09-02/en

Disassembling the first crawler carrier



WARNING

Danger of accidents due to improper support!

If the assembly support is not properly supported, then it can sink into the ground.

Death, severe bodily injuries, property damage.

- ▶ The supporting base must take on the weight of the crawler travel gear safely.
 - ▶ The support must be made large enough for the ground conditions, with solid materials, such as wood, steel or concrete slabs, see Crane operating instructions, chapter 2.04.
-
- ▶ Lift the first crawler carrier off the ground: Move the support cylinder **21** in until the angle between ground and crawler center section is approx. 1.4° , see illustration **14**.
 - ▶ Luff the SA-frame **2** down until the assembly cylinder **1** is centered above the crawler carrier **9**.



Note

- ▶ The assembly cylinder **1** may not be moved out all the way.
 - ▶ If the assembly cylinder **1** is completely moved out and the limit switch position is reached, an error display occurs on the LICCON monitor and the LMB-Stop.
-
- ▶ Move the assembly cylinder **1** out: Actuate master switch **2**.
 - ▶ Pin the fastening ropes **7** on the assembly device **6** and secure with locking pins, see illustration **13**.

NOTICE

Pin is not released!

If the pin **15** is secured upon unpinning through the retaining pin, the pin pulling device can be damaged.

- ▶ Secure securing pins **13** before unpinning in position „above“ with spring retainer, see illustration **15**.
-
- ▶ Hang the pin pulling cylinder on the screw **16** and retainer **17**.
 - ▶ Unpin the pin **15** with the pin pulling cylinder.
 - ▶ Hang the pin pulling cylinder on the screw **16** and retainer **17**.
 - ▶ Unpin the pins **15** with the pin pulling cylinder on the pin points **i**.
 - ▶ Remove the pin pulling cylinder.
 - ▶ Move the assembly cylinder **1** in until the fastening ropes **7** are tensioned: Actuate master switch **2**.
 - ▶ Lift the crawler carrier **9** with the assembly cylinder **1** and unhook on point **h**: Slowly move the assembly cylinder **1** in with master switch **2**.
 - ▶ Luff the SA-frame **2** carefully up and place the crawler carrier **9** on the transport device.
 - ▶ Release the fastening ropes **7** from the brackets **8** on the crawler carrier **9**.

NOTICE

Damage to the brackets **8**!

- ▶ After removing the fastening equipment, the brackets **8** must be swung down.
-
- ▶ Swing the brackets **8** down.

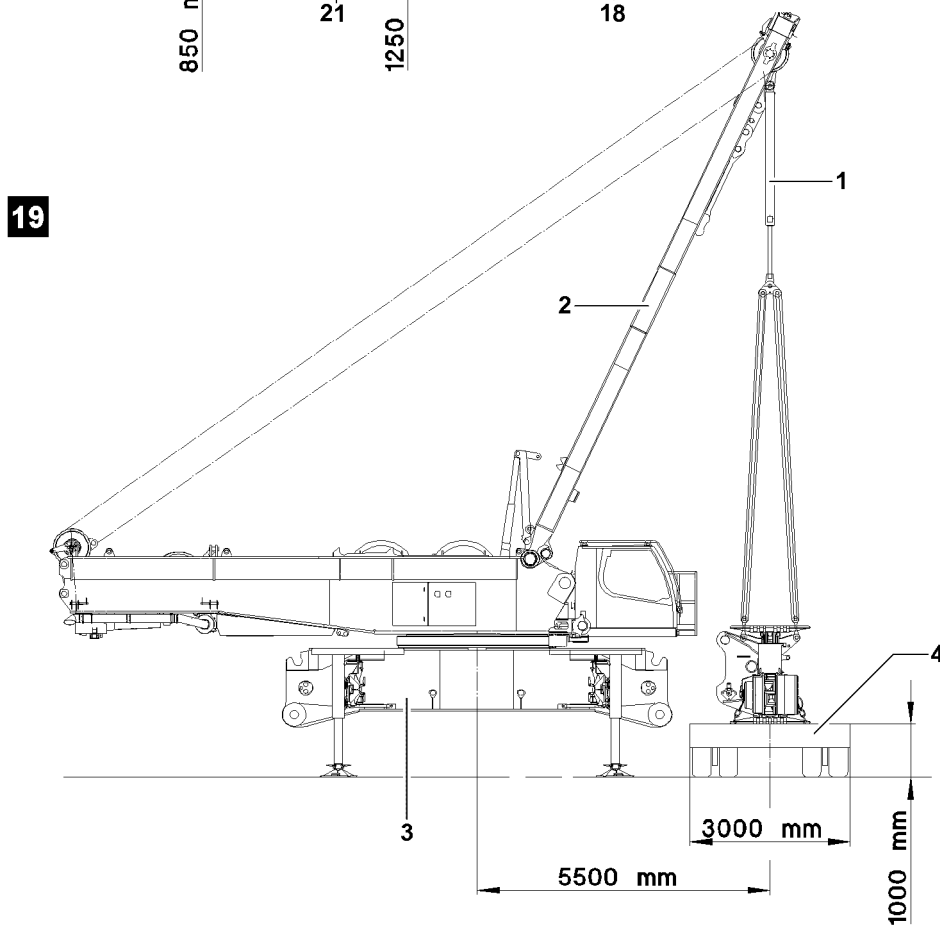
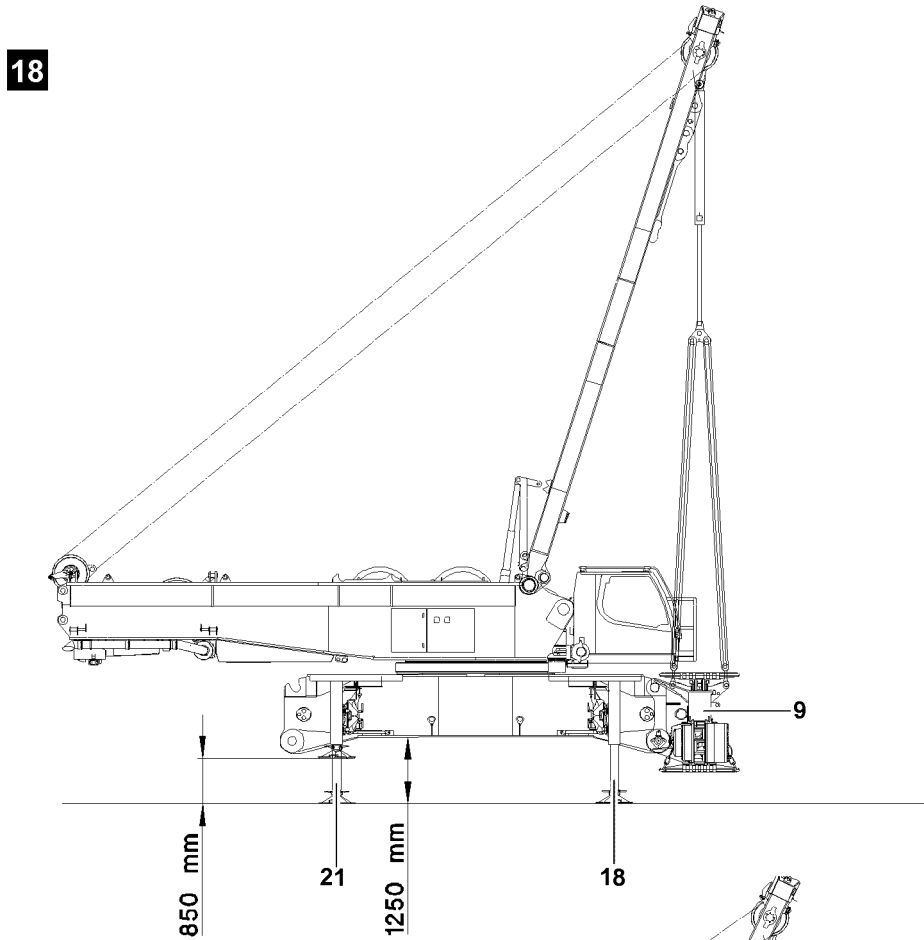

Fig.107456

LWE/LR 1600-2-008/18109-09-02/en

Moving the assembly support out



WARNING

The crane can tip over!

If the support cylinders are moved out / in unevenly, the crane can tip over.
Death, severe bodily injuries, property damage.

- ▶ When moving the support cylinders in / out, pay attention to the horizontal alignment, check visually.
-
- ▶ Move the support cylinder **18** out until the crane is in horizontal position.
 - ▶ Move all support cylinders out evenly to at least 850 mm.
 - ▶ Turn the turntable by 180°.

Disassembling the second crawler carrier

Make sure that the following prerequisites are met:

- The first crawler carrier is assembled.
- The second crawler carrier is prepared for assembly.
- The hydraulic support cylinders are moved out to at least 850 mm.
- The turntable is turned by 180°.



Note

- ▶ Procedure for disassembly of the second crawler carrier, see section „Disassemble first crawler carrier“.
-

When the second crawler carrier is disassembled:

- ▶ Disassemble assembly supports, see section „Disassembling the assembly supports“.

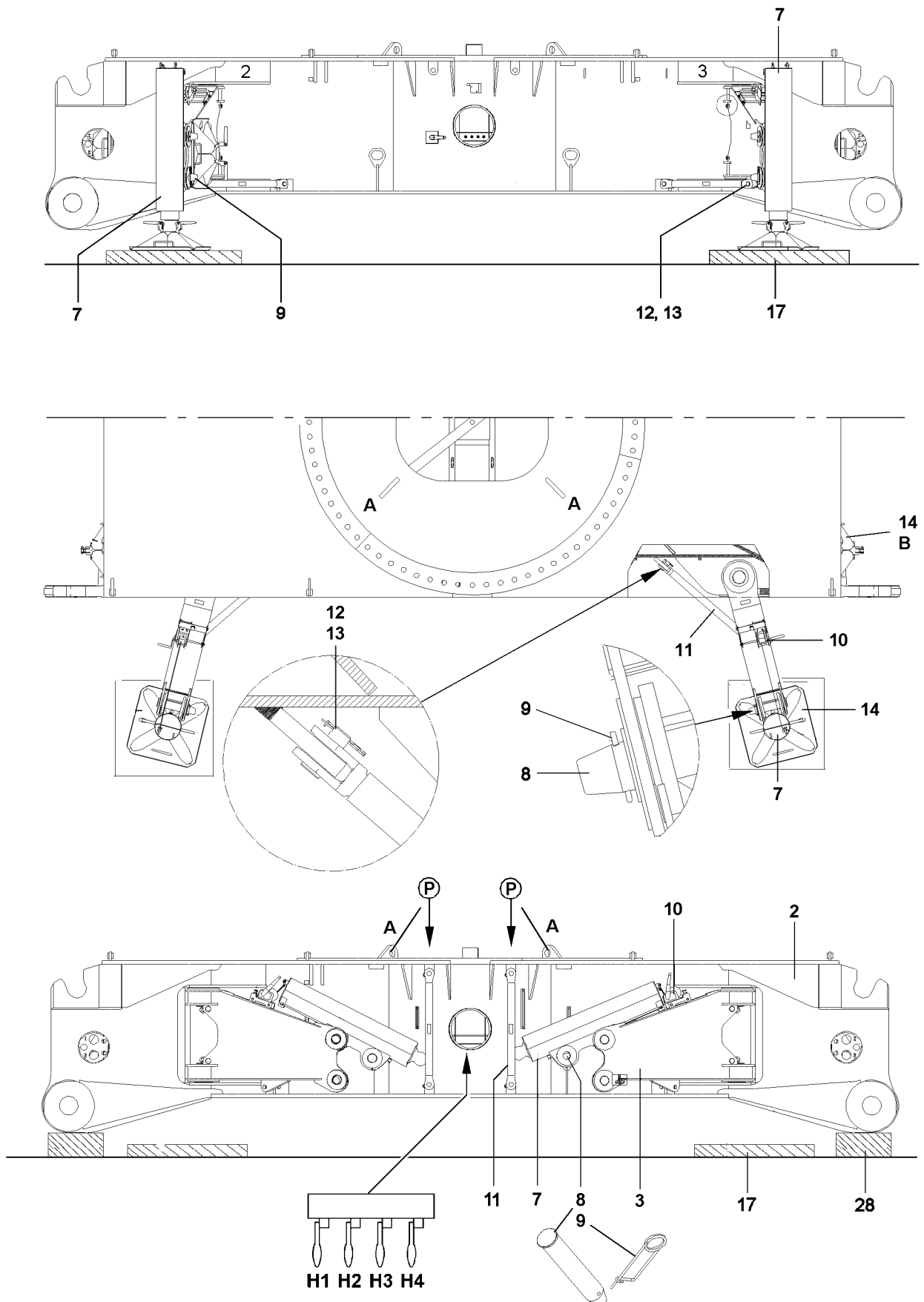

Fig.107166

LWE/LR 1600-2-008/18109-09-02/en

6 Disassembling the assembly support



Note

- ▶ For the disassembly of the assembly supports, the turntable must be disassembled, see Crane operating instructions, chapter 3.02.

6.1 Supporting the crawler center section

Make sure that the following prerequisites are met:

- The crawler carriers **1** are completely disassembled.
- The disassembly location is level and sufficiently load bearing.



Note

- ▶ The support **28** must be high enough so that the hydraulic cylinders **7** can be completely moved in and folded down in transport position.
- ▶ The support **28** must take on the weight of the crawler center section **2** safely.
- ▶ Support the crawler center section **2** with hardwood timbers or other suitable materials from below.

6.2 Lowering the crawler center section to the support

Make sure that the following prerequisite is met:

- The crawler center section is supported properly with materials of sufficient load-bearing capacity.



WARNING

Danger of tipping the crawler center section!

If the hydraulic cylinders **7** are moved in unevenly, the crawler center section can tip over. Death, severe bodily injuries, property damage.

- ▶ When lowering the crawler center section, pay attention to the horizontal alignment, check visually.
- ▶ Actuate the hand lever **H1**, hand lever **H2**, hand lever **H3** and hand lever **H4**.

Result:

- The hydraulic cylinders **7** move in.
- ▶ Move the hydraulic cylinders **7** in and set the crawler center section **2** on the supporting base **28**.

When the crawler center section has been placed on the supporting base:

- ▶ Open the receptacle on the support plates **14**.
- ▶ Move the hydraulic cylinders **7** completely in.
- ▶ Fasten the support plates **14** in transport position **B**.

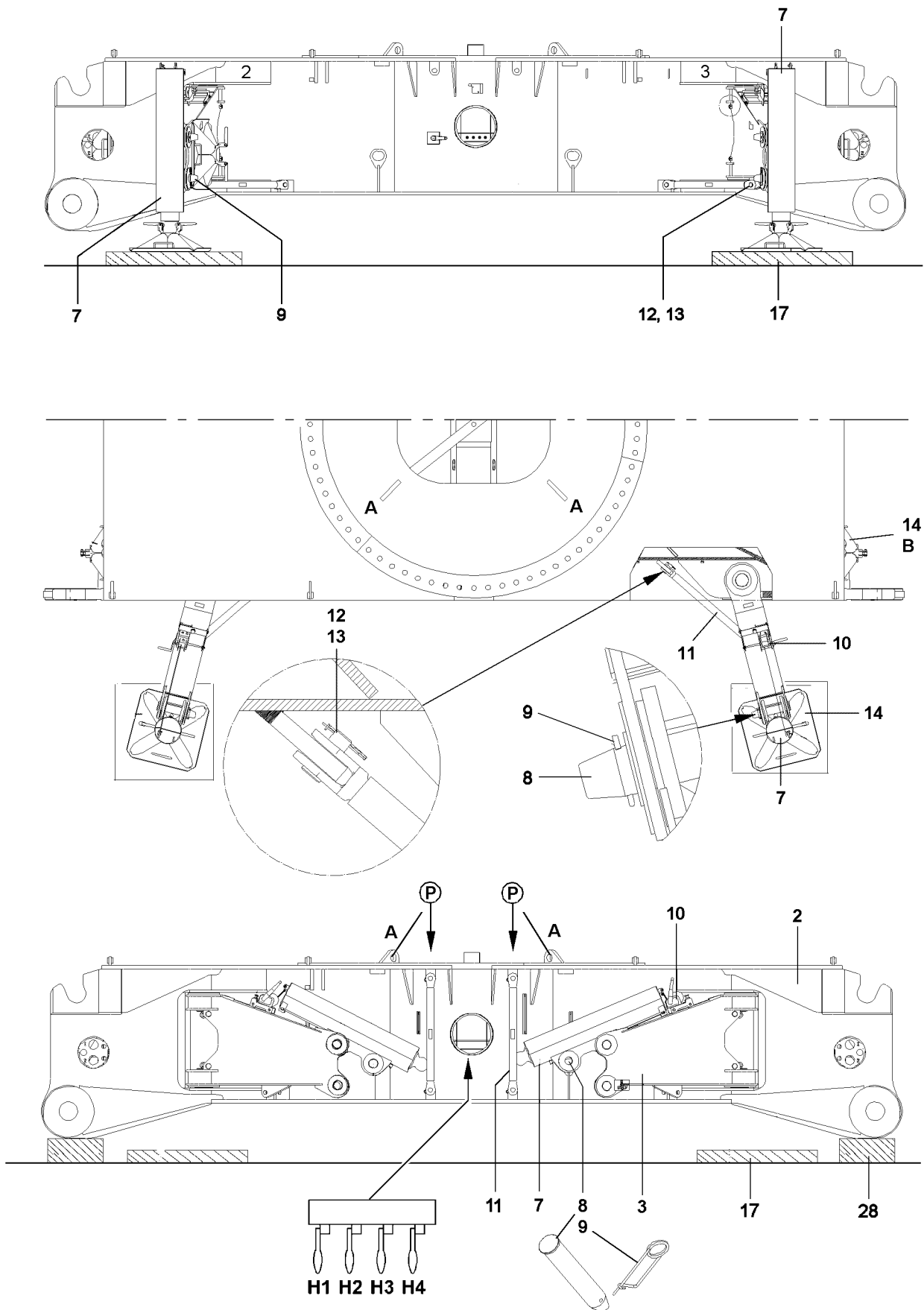

LWE/LR 1600-2-008/18109-09-02/en

Fig.107166

6.3 Disassembling the assembly supports

The swinging in and locking procedure of the assembly support is the same for all four assembly supports and is therefore described only once.

- ▶ Unpin the pin **8**: Remove the spring retainer **9** and unpin the pin **8**.
- ▶ Pull the hydraulic cylinder **7** in transport position - „to the rear“ by spooling the rope winch **10** up.
- ▶ Unpin the brace **11** on the crawler center section and on the assembly support: Remove the spring retainer **13** and unpin the pin **12**.
- ▶ Install the brace **11** in transport position **P** on the crawler center section: Use pin **12** and spring retainer **13**.
- ▶ Swing the assembly support **3** in until it locks on the crawler center section.

When the assembly support **3** is locked on the crawler center section:

- ▶ Secure the assembly support **3** with pin **8** spring retainer **9**.
- ▶ Bring the rope winch **10** into transport position: Pull the spring latch up and hold.
- ▶ Push the rope winch **10** in direction of crawler center section until the spring latch engages again by itself.

Result:

- The rope winch **10** is locked in operating position.

Empty page!

LWE/LR 1600-2-008/18109-09-02/en

3.02 Turntable assembly

1	Turntable with Quick Connection*	3
2	Installing the turntable	7
3	Removing the turntable	11

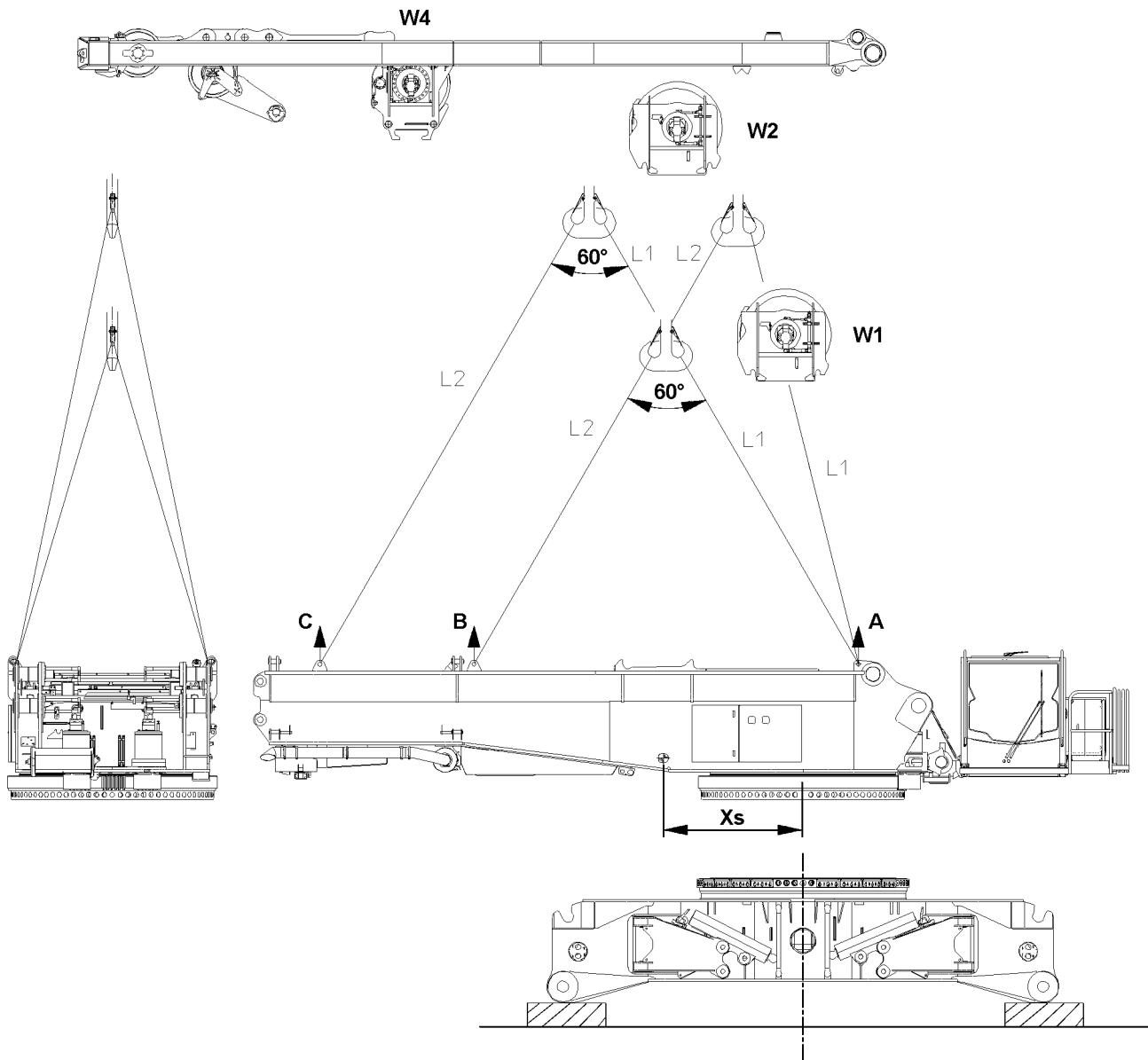

Fig.105486

1 Turntable with Quick Connection*

For transport, the turntable can be separated from the crawler center section by the Quick Connection* device. In that case, the turntable as well as the crawler center section are each transported on a separate transport vehicle.

1.1 Load take-up with an auxiliary crane

	Weight	Load			Center of gravity	Length of tackle	
		A	B	C	Xs	L1	L2
Turntable with 2 slewing gears	33.90 t	18.59 t	15.31 t	–	-1.69 m	L1 = L2	
+ SA-Bracket with winch 4 and rope	51.40 t	24.44 t	–	26.96 t	-3.24 m	L1 = L2	
+ Winch 1 with 1050 m rope	58.90 t	30.94 t	–	27.96 t	-2.86 m	L1 = L2	
+ Winch 2 with 1050 m rope	66.40 t	35.93 t	–	30.47 t	-2.74 m	L1 = L2	
Turntable + center section + 2 slewing gears	61.30 t	42.05 t	19.25 t	–	-0.94 m	6.3 m	7.1 m
+ SA-Bracket with winch 4 and rope	78.80 t	37.10 t	41.70 t	–	-2.12 m	L1 = L2	
+ Winch 1 with 1050 m rope	86.30 t	43.20 t	43.10 t	–	-1.95 m	L1 = L2	
+ Winch 2 with 1050 m rope	93.80 t	47.16 t	46.64 t	–	-1.94 m	L1 = L2	

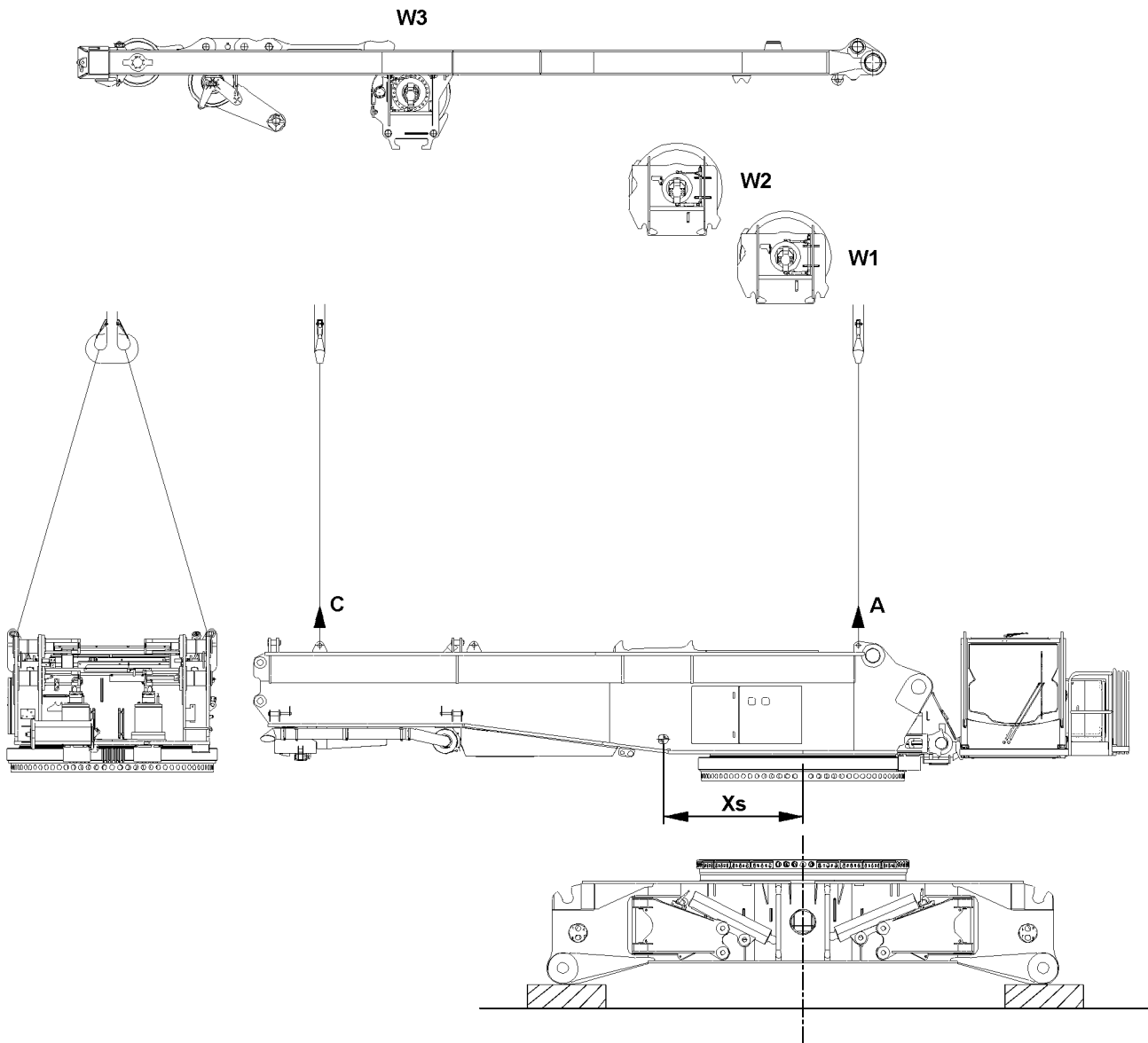

Fig.105487

1.2 Load take-on with two auxiliary cranes

	Weight	Load		Center of gravity
		A	C	Xs
Turntable with 2 slewing gears	33.90 t	22.97 t	10.93 t	-1.69 m
+ 1 slewing gear	0.55 t	+0.60 t	-0.05 t	
+ Winch 1 with 1050 m rope	7.50 t	+6.49 t	+1.01 t	
+ Winch 2 with 1050 m rope	7.50 t	+4.97 t	+2.53 t	
+ SA-Bracket with winch 4 and rope	17.50 t	+1.46 t	+16.04 t	
Turntable, complete	66.40 t	35.93 t	30.47 t	-2.74 m
Turntable + center section with 2 slewing gears	61.30 t	47.56 t	13.74 t	-0.94 m
+ 1 slewing gear	0.55 t	+0.60 t	-0.05 t	
+ Winch 1 with 1050 m rope	7.50 t	+6.49 t	+1.01 t	
+ Winch 2 with 1050 m rope	7.50 t	+4.97 t	2.53 t	
+ SA-Bracket with winch 4 and rope	17.50 t	+1.46 t	+16.04 t	
Turntable, cpl. + center section	93.80 t	60.50 t	33.30 t	-1.94 m

1.3 Lift the turntable from transport vehicle

Make sure that the following prerequisites are met:

- One or two auxiliary cranes are available.
- The corresponding tackle is available, see charts.
- The tackle is pinned on the turntable, according to the data in the charts.



DANGER

Incorrect tackle points!

If the tackle is attached on the turntable on the incorrect tackle points, the tackle can be overloaded or the turntable can tip over. Personnel can be severely injured or killed!

- ▶ Attach the tackle only in the tackle points A, B or C, see charts.
- ▶ Tension the tackle.
- ▶ Lift the turntable.

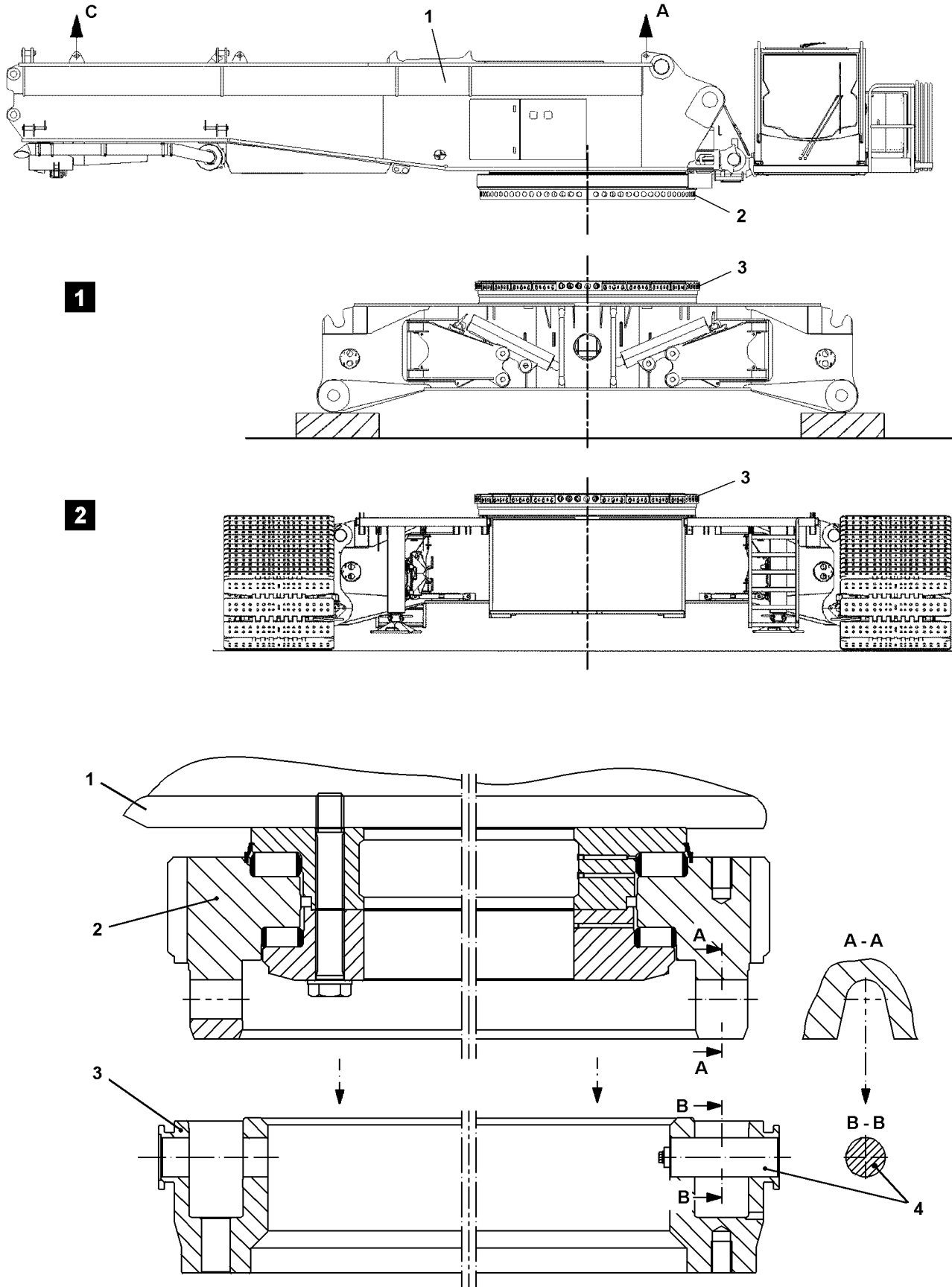

Fig.105488

2 Installing the turntable

The turntable **1** can be installed on:

- **Fig. 1**, center section installed underneath.
- **Fig. 2**, center section with installed crawler carrier.

NOTICE

Property damage!

If the rotary connection is dirty, severe damage can occur, even requiring replacement!

- ▶ Clean the upper section, the lower section as well as the pins properly.
-

Before setting the turntable onto the crawler center section, the placement surfaces or the contact surfaces as well as the pin bores on the upper section **2** and the lower section **3** on the rotary connection must be cleaned.

Make sure that the following prerequisites are met:

- The crawler or the center section is horizontally aligned.

2.1 Placing the turntable on the crawler center section

Make sure that the following prerequisites are met:

- The two centering pins **4** are installed and secured on the lower section **3** of the rotary connection.
 - The centering pins **4** are greased with water repellent grease.
-



DANGER

Risk of accident!

It is prohibited for anyone to remain within the slewing range of the auxiliary crane and under the turntable when swinging the turntable in and lowering it.

- ▶ Swing the turntable **1** with the auxiliary crane slowly over the horizontally aligned crawler center section.
-



Note

- ▶ Pay attention to the alignment of the turntable or the receptacles **A-A** to the centering pins **4**.
 - ▶ Before lowering it, bring the turntable into position in such a way that the receptacles **A-A** are positioned over the centering pins **4** on the lower section **3**.
 - ▶ Lower the turntable **1** slowly.
-



DANGER

Risk of crushed limbs!

During the installation of the upper and lower section of the rotary connection, fingers and hands can be crushed and limbs can be severed.

- ▶ Do not reach with your hands into the danger zone.
 - ▶ Lower the turntable **1** into the lower section to the point where the upper section is not yet touching but the tackle are still under „tension“.
 - ▶ Carefully place the turntable **1** on the crawler center section.
-

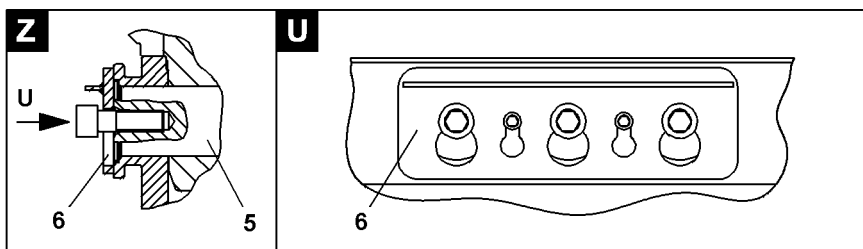
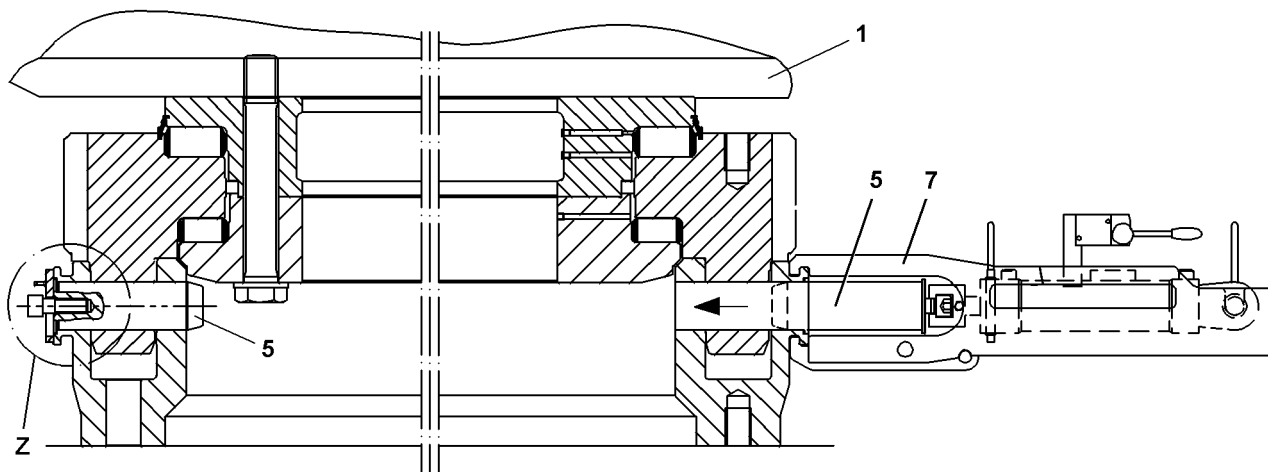
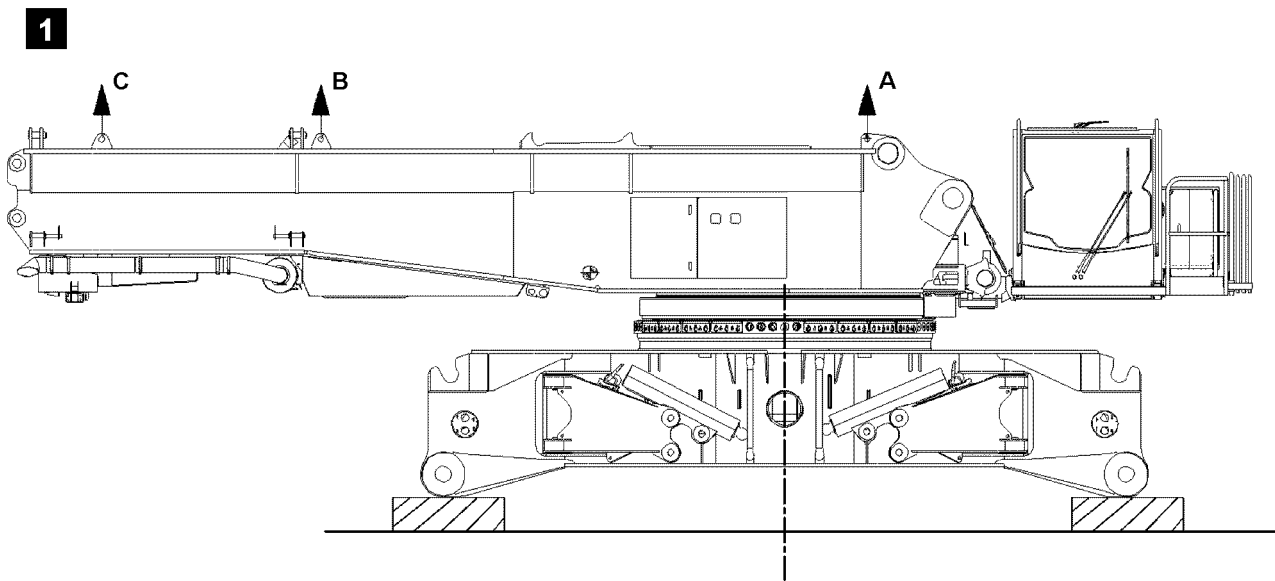

Fig.105489

2.2 Pinning the Quick Connection

Make sure that the following prerequisites are met:

- The turntable **1** is seated in lengthwise direction on the supported center section.
- The pin holes are open on the circumference of the roller slewing ring.
- The tackle is still under „tension“.
- The connector pins **5** are greased with water repellent grease.

2.2.1 Pinning

- ▶ Insert all connector pins **5** around the circumference of the roller slewing ring by hand.



Note

- ▶ Align all pin holes by lifting or lowering the turntable.
 - ▶ Use a hydraulic pin pulling device **7** to pin hard to insert pins.
-



DANGER

Danger of accidents if connector pins loosen up by themselves!
Tipping of turntable.

- ▶ After pinning, secure the connector pins **5** immediately.
 - ▶ Secure the connector pins **5** with retaining bars **6**.
-
- ▶ Attach the retaining bars **6** and secure all connector pins **5** around the circumference of the roller slewing ring, see fig. **U,Z**.
-

2.2.2 Establishing the hydraulic connection to the turntable

Ensure that the following preconditions are met:

- The turntable is pinned and secured on the rotary connection.

The hydraulic connection from the rotary connection in the crawler center section to the turntable is established with quick couplers.



Note

- ▶ The matching quick couplings are marked.
 - ▶ To connect or release the hydraulic lines with quick couplers, see chapter 5.01.
-
- ▶ Establish the hydraulic connections.

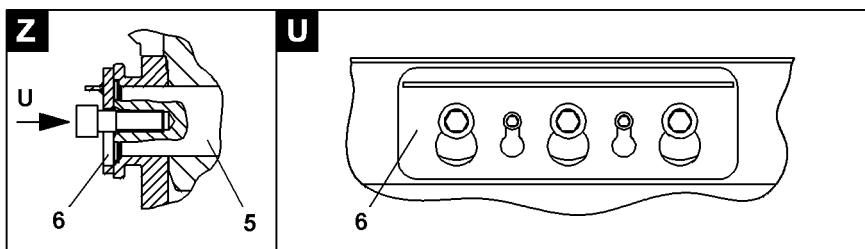
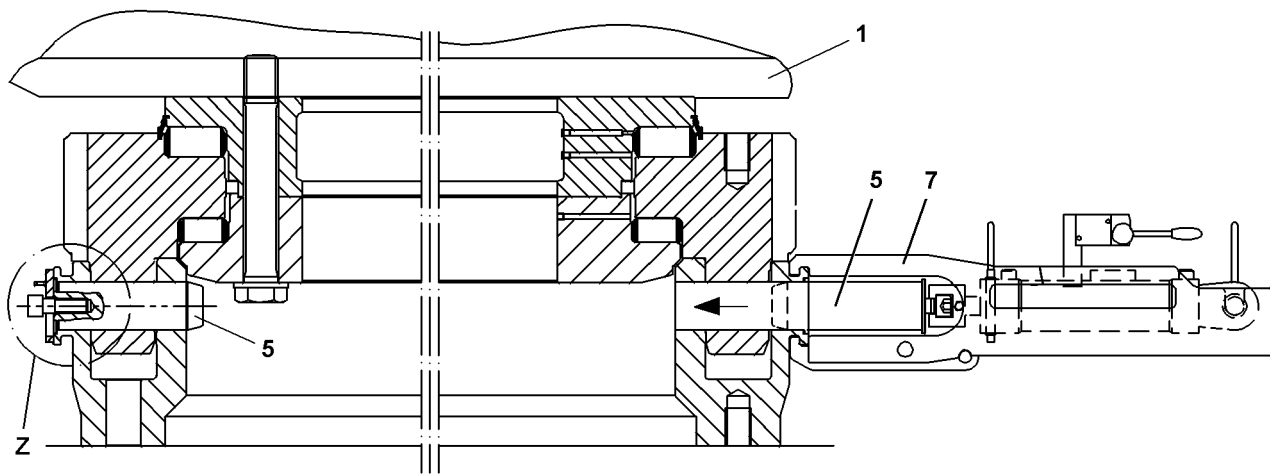
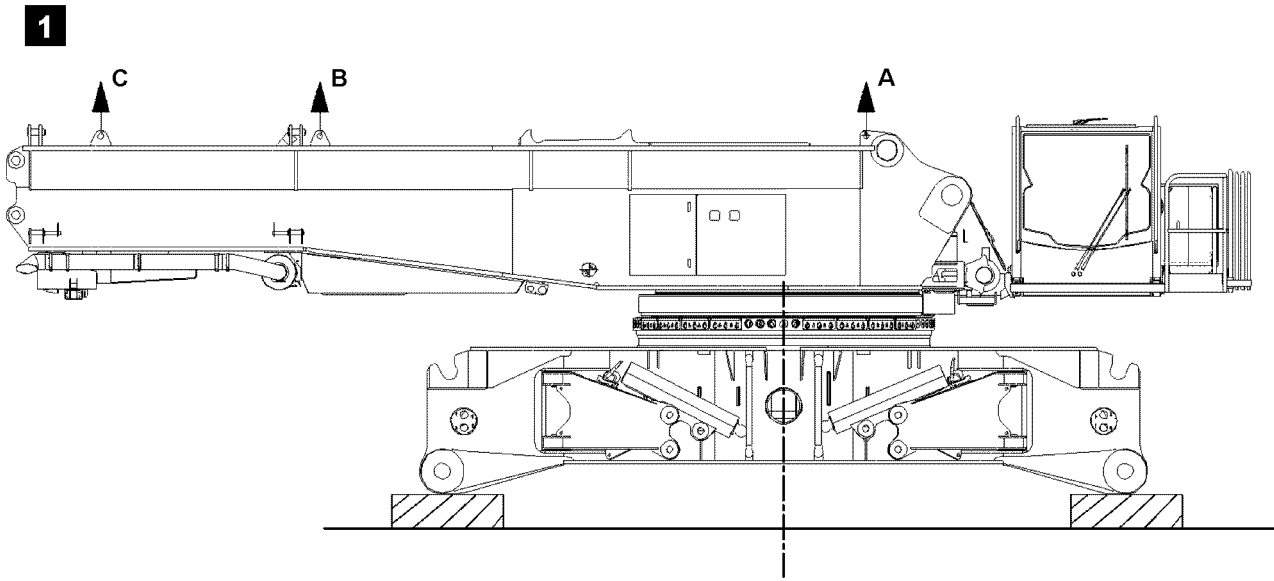

Fig.105489

3 Removing the turntable

Make sure that the following prerequisites are met:

- One or two auxiliary cranes are available.
- The turntable ballast and the boom system are removed.
- The crawler carriers are removed.
- The crawler center section is supported from below and horizontally aligned.
- The hydraulic connections on the rotary connection are separated.
- The corresponding tackle is available, see charts.
- The tackle is pinned on the turntable, according to the data in the charts.

NOTICE

Disconnect the hydraulic connection!

Connections become damaged!

- ▶ Make sure that all hydraulic connections between the rotary connection and the turntable are separated.
-

3.1 Disassembly

- ▶ Tighten the tackle with the auxiliary crane.
 - ▶ Release and remove the retaining bars **6**, see fig. **U,Z**.
 - ▶ Unpin all connector pins **5** around the circumference of the roller slewing ring with the pin pulling device.
-

NOTICE

Remove connector pins.

The roller slewing ring becomes damaged!

- ▶ Before lifting the turntable with the auxiliary crane, make sure that all connector pins on the Quick Connection are fully unpinned.
-
- ▶ Carefully lift the turntable from the crawler center section.
-



DANGER

Risk of accident!

Danger of fatal injury if anyone remains within the swing range of the auxiliary crane and under the turntable!

- ▶ It is prohibited for anyone to remain within the swing range of the auxiliary crane and under the turntable!
-
- ▶ Slowly swing the turntable **1** with the auxiliary crane away from the crawler center section.
-

Empty page!

LWE/LR 1600-2-008/18109-09-02/en

3.03 Central ballast

1	Components	3
2	Central ballast combinations	5
3	Permissible central ballast assemblies	5
4	Installing the central ballast	7
5	Removing the central ballast	19

1

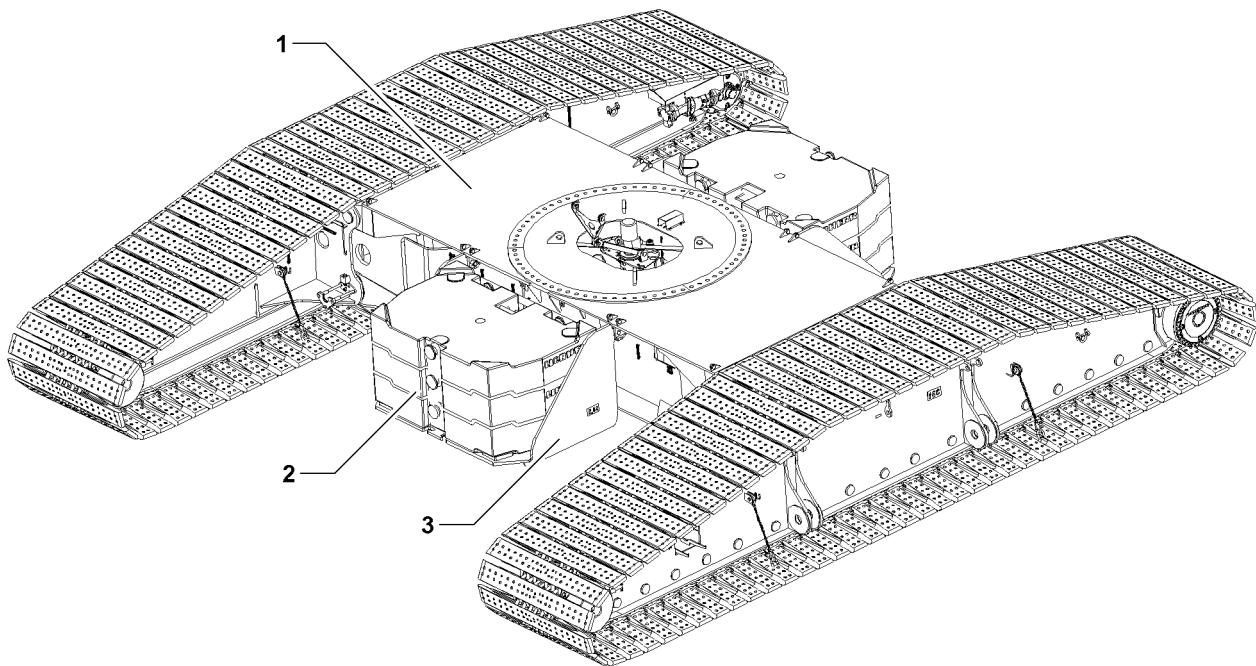

Fig.109235

LWE/LR 1600-2-008/18109-09-02/en

1 Components

For the central ballast on the crawler center section **1**, the following components are required:

- 2 Central ballast plates
- 3 Consoles central ballast

1.1 Central ballast plates



Note

► The central ballast plates **2** and the consoles **3** are marked with their own weight.

Component	Weight
Central ballast plate 2	7.5 t
	10.0 t

1.2 Consoles central ballast

Component	Weight
Console central ballast 3	2.5 t

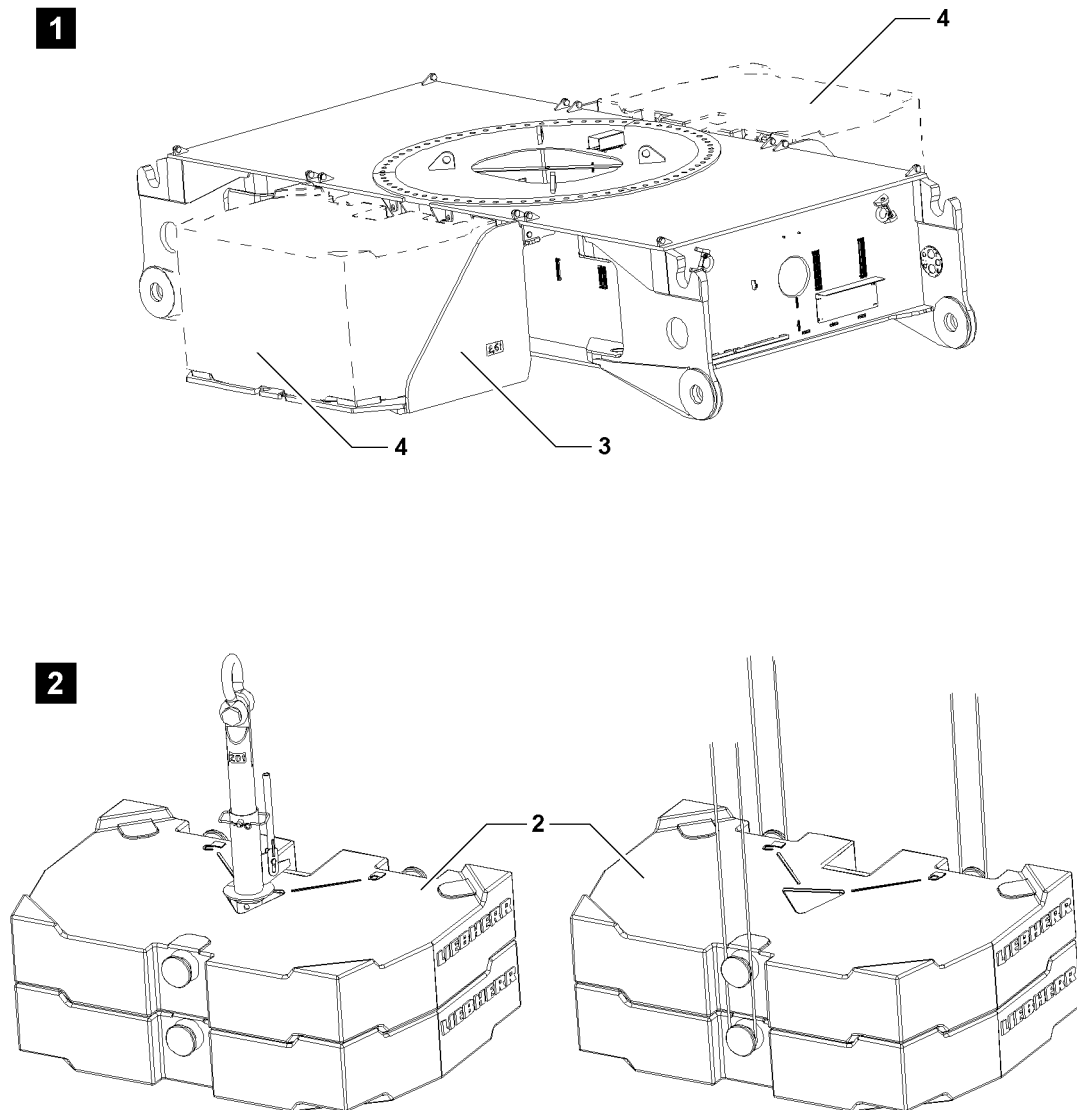

Fig.109241

2 Central ballast combinations

Various central ballast combinations can be placed in the central ballast assemblies **4**:

Central ballast	Combination	Individual weight
5 t	2 x console	2.5 t

Central ballast	Combination	Individual weight
25 t	2 x console	2.5 t
	2 x central ballast plate	10 t

Central ballast	Combination	Individual weight
65 t	2 x console	2.5 t
	8 x central ballast plate	7.5 t

Central ballast	Combination	Individual weight
65 t	2 x console	2.5 t
	6 x central ballast plate	10 t

3 Permissible central ballast assemblies



WARNING

Overload attachment points central ballast plates!

If more than the permissible number of central ballast plates **2** are lifted together, then the attachment points can be overloaded!

The central ballast plates **2** and components can fall down!

Personnel can be severely injured or killed!

► Attach only the maximum permissible number of central ballast plates **2** per lift!

Individual weight Central ballast plate	Maximum number of same central ballast plates per lift over	
	Twist lock	Bitt
7.5 t	2	2
10.0 t	2	2

1

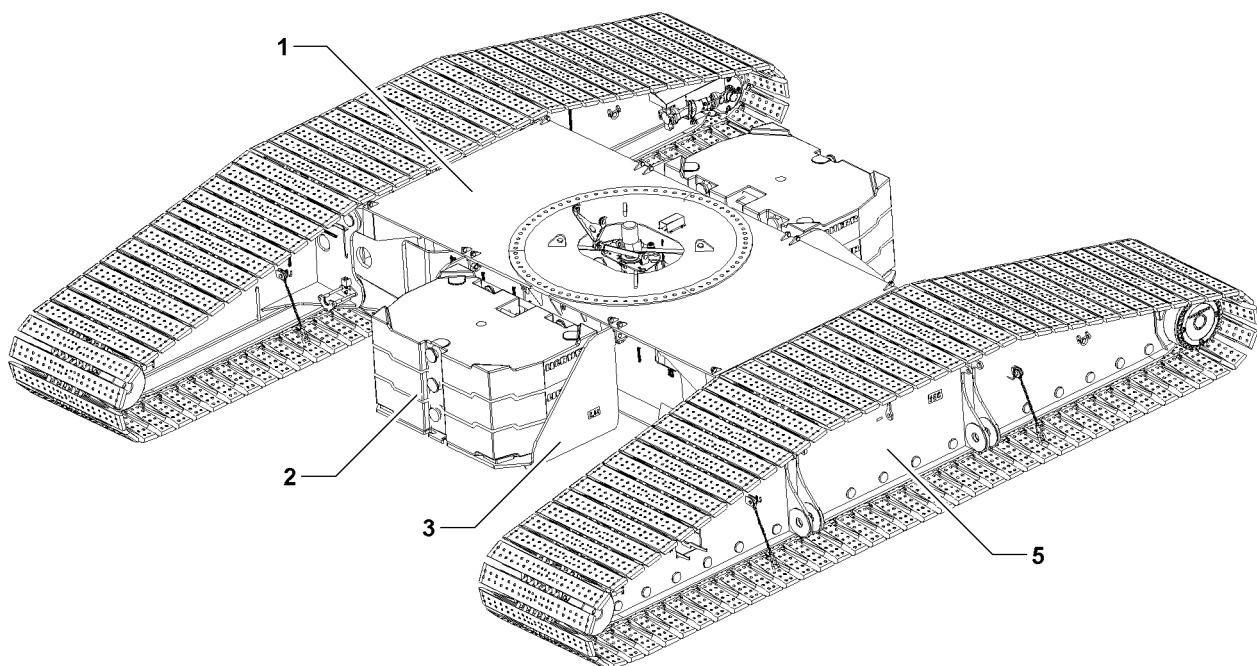

Fig.109260

LWE/LR 1600-2-008/18109-09-02/en

4 Installing the central ballast



WARNING

Danger of slipping / falling during assembly / disassembly work!

During assembly and disassembly work, personnel must be secured with appropriate antifall guards to prevent them from falling!

Weather influences, such as wetness, wind, snow, frost increase the slipping / falling danger!

Personnel can be severely injured or killed!

- ▶ All assembly / disassembly work must be carried out using suitable aids (lifting platforms, scaffolding, ladders, auxiliary crane, etc.)!
- ▶ If work cannot be carried out on the ground or using such aids, then assembly personnel must be secured with the personal fall arrest system (see Crane operating instructions, chapter 2.04) to protect against falling!
- ▶ Hang in the personal antifall system in the corresponding attachment points on the crane (see Crane operating instructions, chapter 2.06)!
- ▶ If railings are present on the components, then they must be brought into the corresponding position and secured for assembly / disassembly work!
- ▶ Step on aids and fall arresters only with clean shoes!
- ▶ Keep aids and fall arresters clean and free from snow and ice!



WARNING

Falling components and central ballast plates!

At assembly / disassembly, the components and central ballast plates **2** can fall down!

Personnel can be severely injured or killed!

- ▶ Make sure that no persons or objects are within the danger zone!



WARNING

Incorrect handling of the attachment equipment!

If attachment equipment cannot be attached correctly and if it is not secured sufficiently to prevent it from loosening up, loads can fall down. Personnel can be severely injured or killed!

- ▶ Make sure that the attachment equipment is correctly attached on the attachment points and that it is secured sufficiently to prevent it from loosening up!



WARNING

Danger of impact / crushing!

If anyone remains within the assembly / disassembly area of the ballast, they would be exposed to a danger of impact / crushing!

Personnel can be severely injured or killed!

- ▶ Make sure that there are no persons between the components which are to be assembled / disassembled on the components and the crawler travel gear!

Make sure that the following prerequisites are met:

- the installation of the crawler carrier **5** is completed
- both crawler carriers **5** are standing on the ground
- the crane is aligned in horizontal direction

2

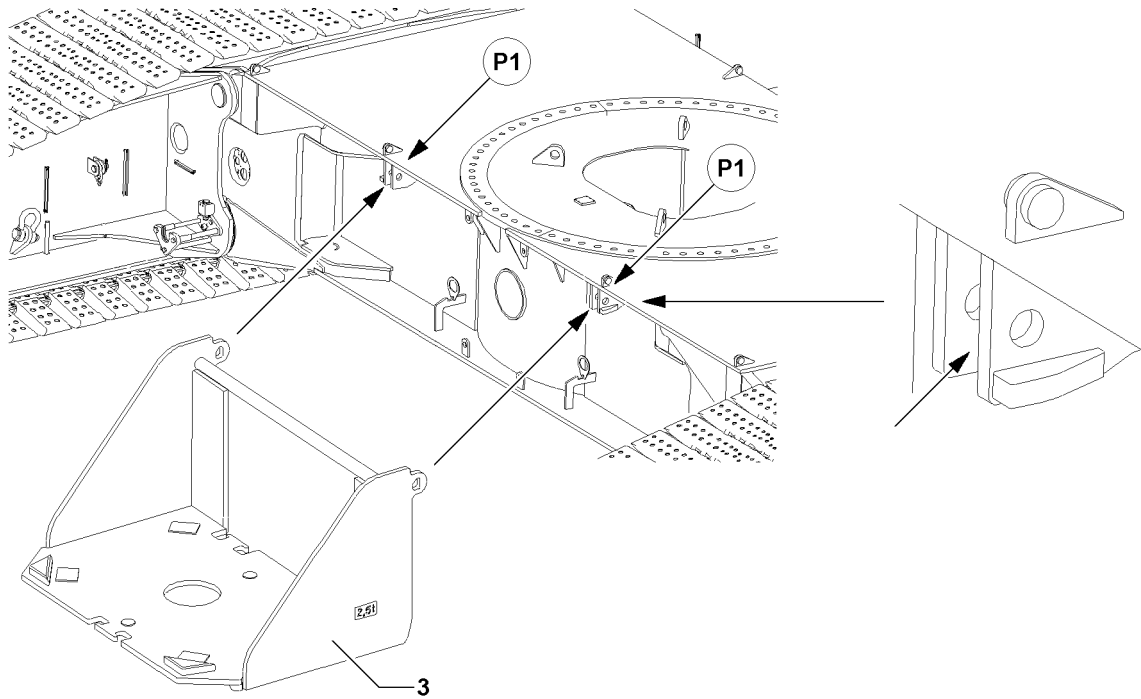

3

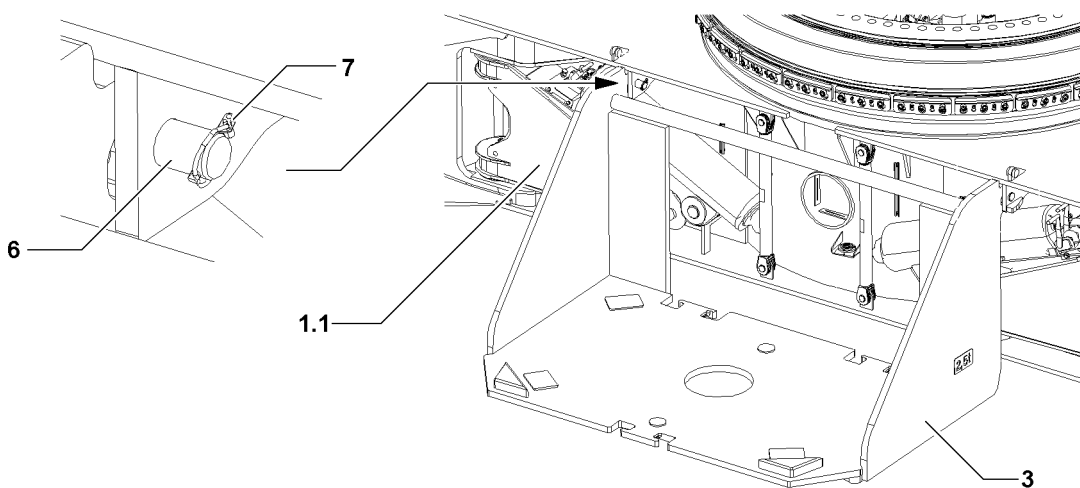

4

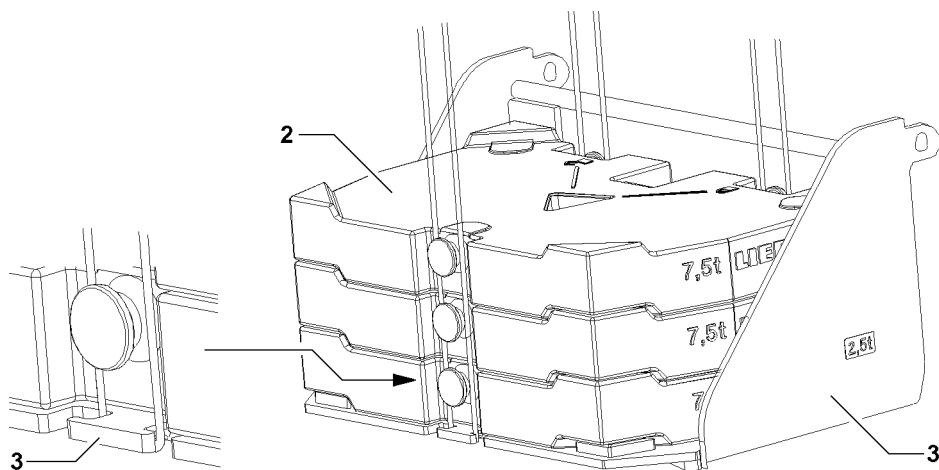

Fig.109242

LWE/LR 1600-2-008/18109-09-02/en

4.1 Installing the console

Ensure that the following prerequisite is met:

- The pin **6** is unpinned on point **P1**



Note

- ▶ It is permissible to install the consoles **3** under certain prerequisites with placed central ballast plates **2**, see illustration **4**!
- ▶ Observe section „Installing the consoles with placed central ballast plates“ in this chapter!



Note

- ▶ The consoles can be installed either with folded in or folded out assembly support **1.1**!
- ▶ Attach the console **3** onto the auxiliary crane.
- ▶ Guide the console **3** with the auxiliary crane to the brackets on point **P1** and position in the perforation.
- ▶ Insert the pins **6** and secure with linch pins **7**, see illustration **3**.

4.2 Installing the consoles with placed central ballast plates



WARNING

Overload of attachment points console!

If the console **3** is lifted with more than 22.5 t of placed central ballast plates **2**, the attachment points will be overloaded!

The console **3** and central ballast plates **2** can fall down!

Personnel can be severely injured or killed!

- ▶ Make sure that no more than maximum 22.5 t of central ballast plates **2** are placed on the console **3** to be lifted, see illustration **4**!



Note

- ▶ When placing the central ballast plates **2** on the console **3** observe section „Placing the central ballast plates“ in this chapter!

Ensure that the following prerequisite is met:

- The pin **6** is unpinned on point **P1**

- ▶ Attach the console **3** with the placed central ballast plates **2** on the auxiliary crane, see illustration **4**.
- ▶ Guide the console **3** with the auxiliary crane to the brackets on point **P1** and position in the perforation.
- ▶ Insert the pins **6** and secure with linch pins **7**, see illustration **3**.

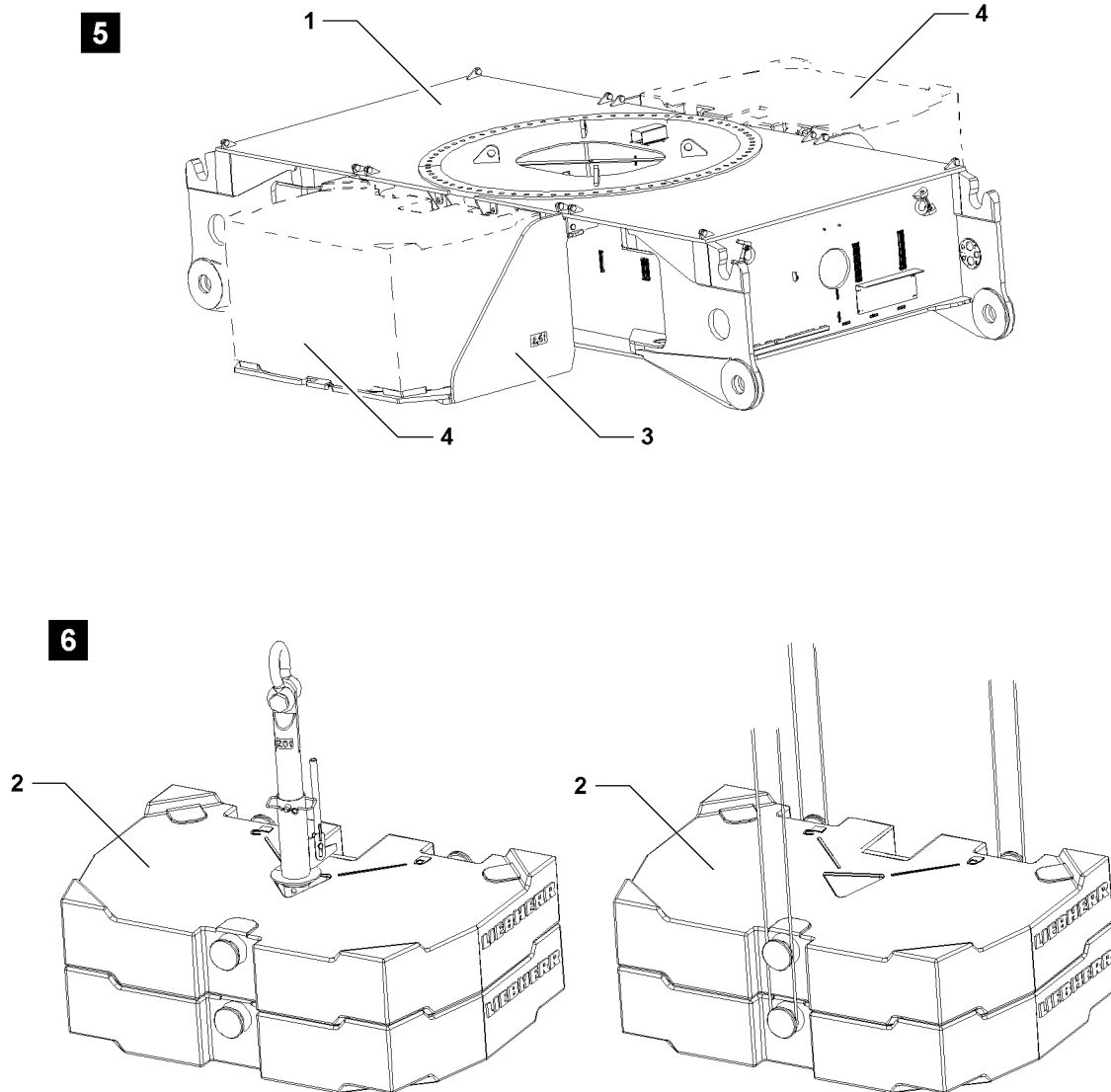

Fig.109243

4.3 Placing the central ballast plates



WARNING

Central ballast too low / too high!

If the placed central ballast deviates from the specified data in the load charts or the assembly conditions, then the crane can be damaged or topple over!

Personnel can be severely injured or killed!

► Make sure that the central ballast is placed according to the load chart!



WARNING

Damaged central ballast plates!

Damage on the central ballast plates **2** can cause the tackle to release!

The central ballast plates **2** and components can fall down!

Personnel can be severely injured or killed!

► Do not use damaged central ballast plates **2** and replace them immediately!



WARNING

Asymmetric central ballast distribution!

If the central ballast is not distributed evenly on both consoles **3**, then this can lead to overload!

The crane can be damaged and components can fall down!

Personnel can be severely injured or killed!

► Make sure that the central ballast is distributed evenly on the consoles **3**!



WARNING

Toppling central ballast assembly!

Lopsided stacked central ballast plates **2** create instability in the central ballast assembly **4**!

The central ballast plates **2** can tip from the consoles **3** and cause the crane to topple over!

Personnel can be severely injured or killed!

► Make sure that the central ballast plates **2** are placed correctly on the centerings!

Ensure that the following prerequisite is met:

- the consoles **3** are pinned and secured on the crawler center section **1**.

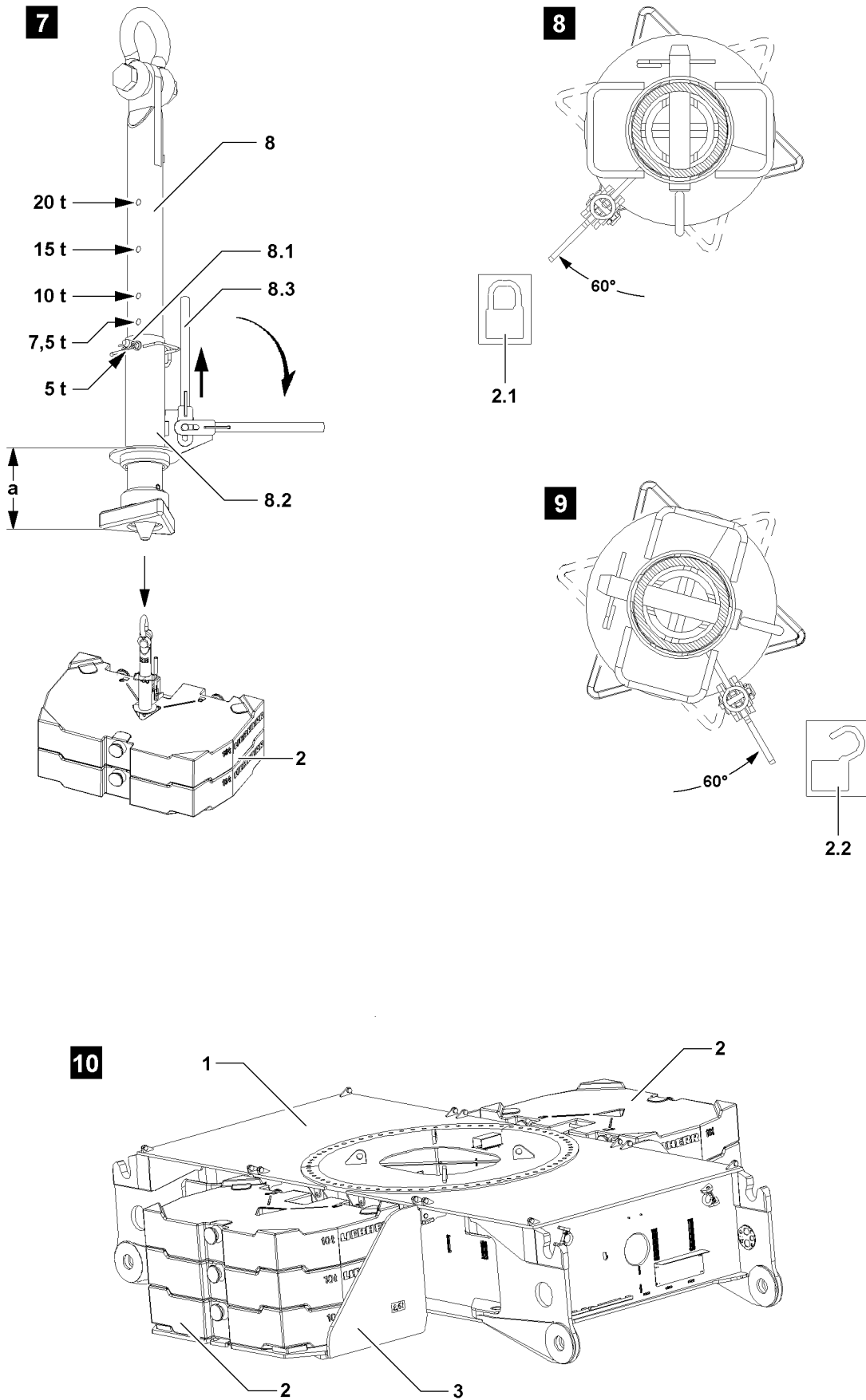

Fig.109244

LWE/LR 1600-2-008/18109-09-02/en

4.3.1 Placing the central ballast plates, attachment system: „Twist lock“



WARNING

Overload of receptacle stud and central ballast plates!

If more than the permissible number of central ballast plates **2** are lifted with the receptacle stud **8**, the receptacle stud **8** and the central ballast plates **2** can be overloaded and damaged!

Central ballast plates **2** can fall down!

Personnel can be severely injured or killed!

► Observe the chart „Permissible central ballast assemblies“ in this chapter!



WARNING

Damage of receptacle stud and central ballast plates!

If two central ballast plates **2** are lifted which do not lay correctly in their centerings, the receptacle stud **8** and the central ballast plates **2** can be damaged!

Damage can cause the central ballast plates **2** to fall down!

Personnel can be severely injured or killed!

► Make sure that the central ballast plates **2** to be lifted are placed correctly in the centerings!



WARNING

Twist lock system opens by itself!

If the receptacle stud **8** is not correctly locked, the Twist lock system can open by itself!

Central ballast plates **2** can fall down!

Personnel can be severely injured or killed!

► Make sure, when initiating a lift, that the lever **8.3** points directly on the symbol „Locked“ **2.1** of the central ballast plates **2**!



Note

- During a lift, the locked Twist lock system cannot release by itself due to its gravitational retention!
- During a lift, the locked Twist lock system cannot be released by hand due to its gravitational retention!

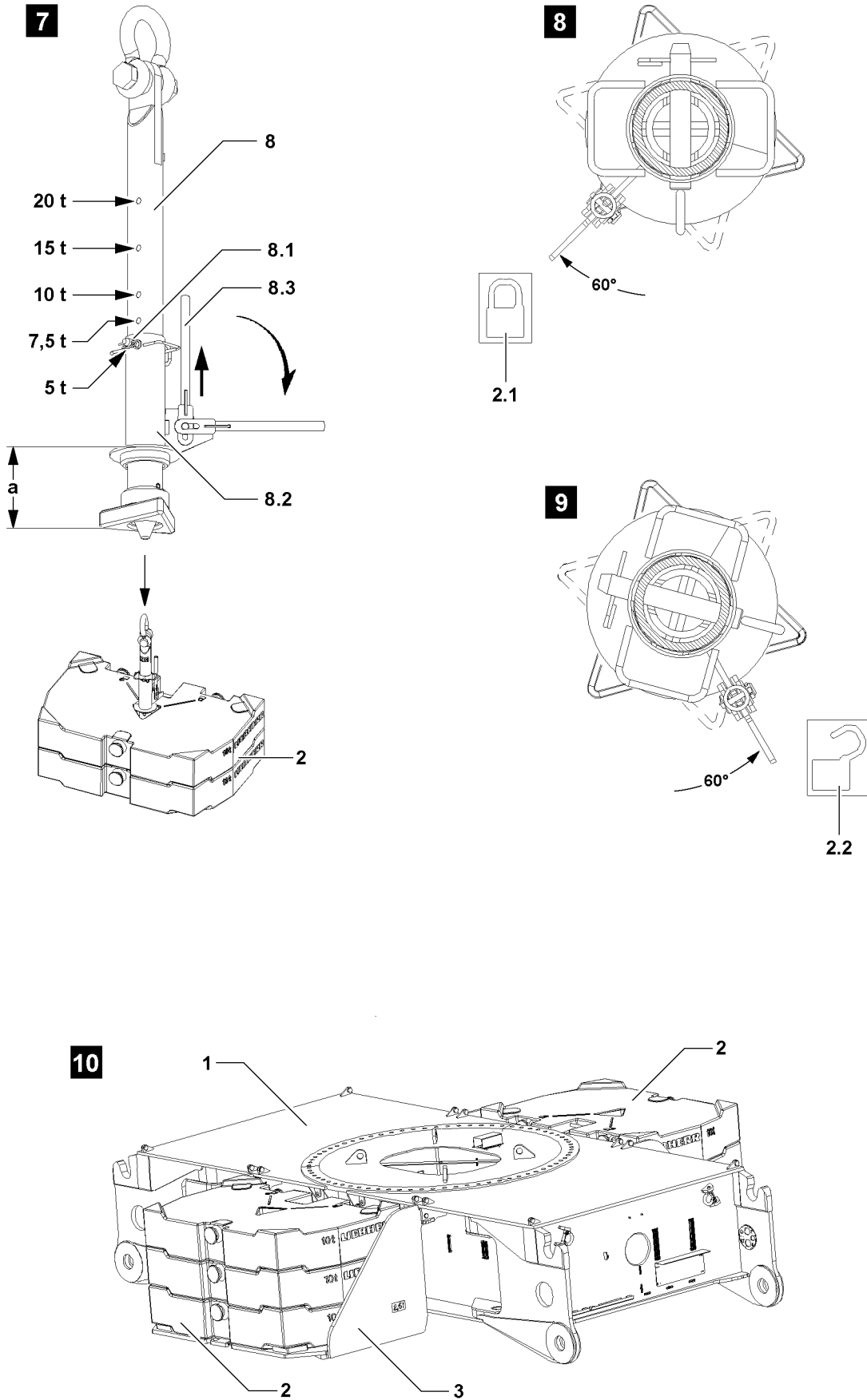

Fig.109244

LWE/LR 1600-2-008/18109-09-02/en

Before the receptacle stud **8** is guided in the central ballast plates **2**, make sure that the insertion length **a** of the receptacle stud **8** is set correctly.

The insertion length **a** of the receptacle stud **8** for central ballast plates **2** can be adjusted by hand.

If the insertion length **a** of the receptacle stud **8** is to be adjusted:

- ▶ Release and unpin the pins **8.1**.
- ▶ Adjust the insertion length **a** by moving the guide sleeve **8.2** to the desired value, observe the stages in illustration **7**.
- ▶ Insert and secure the pin **8.1**.

Result:

- The receptacle stud **8** is adjusted.



Note

- ▶ The receptacle stud **8** in illustration **7** is set to 5 t !

-
- ▶ Attach the receptacle stud **8** on the auxiliary crane and guide it into the central ballast plate(s) **2**.
 - ▶ Pull up the lever **8.3** and fold it down.
 - ▶ Turn the receptacle stud **8** with the lever **8.3** by 60° until it points to the symbol „Locked“ **2.1** of the central ballast plate **2**, see illustration **8**.



Note

- ▶ The receptacle stud **8** is locked by lifting the central ballast plate(s) **2**!

-
- ▶ Lift the central ballast plate(s) **2** or the central ballast assembly with the receptacle stud **8** and place it carefully on the centerings on the console **3** or on another central ballast plate **2**, see illustration **10**.

When the central ballast plate(s) **2** are placed down:

- ▶ Turn the receptacle stud **8** with the lever **8.3** by 60° to the stop in direction of the symbol „unlocked“ **2.2** of the central ballast plate **2**, see illustration **9**.

Result:

- The receptacle stud **8** is unlocked.
- ▶ Carefully pull out the receptacle stud **8**.
- ▶ Place the central ballast plates **2** according to the load chart.

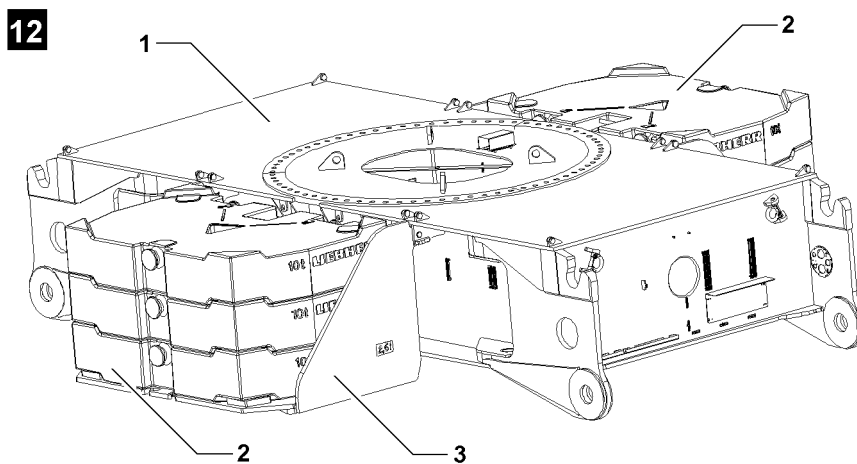
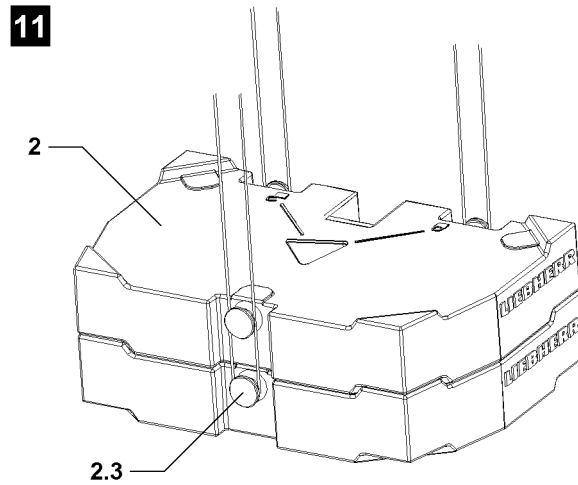

Fig.109255

LWE/LR 1600-2-008/18109-09-02/en

4.3.2 Placing the central ballast plates, attachment points: Bitt

**WARNING**

Overloaded central ballast plates!

If more than the permissible loads are lifted, the bits **2.3** are overloaded!

The central ballast plates **2** can be damaged and fall down!

Personnel can be severely injured or killed!

► Observe the chart „Permissible central ballast assemblies“ in this chapter!

**WARNING**

Incorrect handling of the attachment equipment!

If tackle cannot be attached correctly and if it is not secured sufficiently to prevent it from loosening up, the central ballast plates **2** can fall down!

Personnel can be severely injured or killed!

► Make sure that the tackle is correctly attached on the bits **2.3** and that it is secured sufficiently to prevent it from loosening up!

► Attach the central ballast plates **2** or the central ballast assembly, see illustration **11** on the auxiliary crane.

► Place the central ballast plates **2** or the central ballast assembly on the centerings of the console **3** or on another central ballast plate **2**.

1

Fig.109260

5 Removing the central ballast

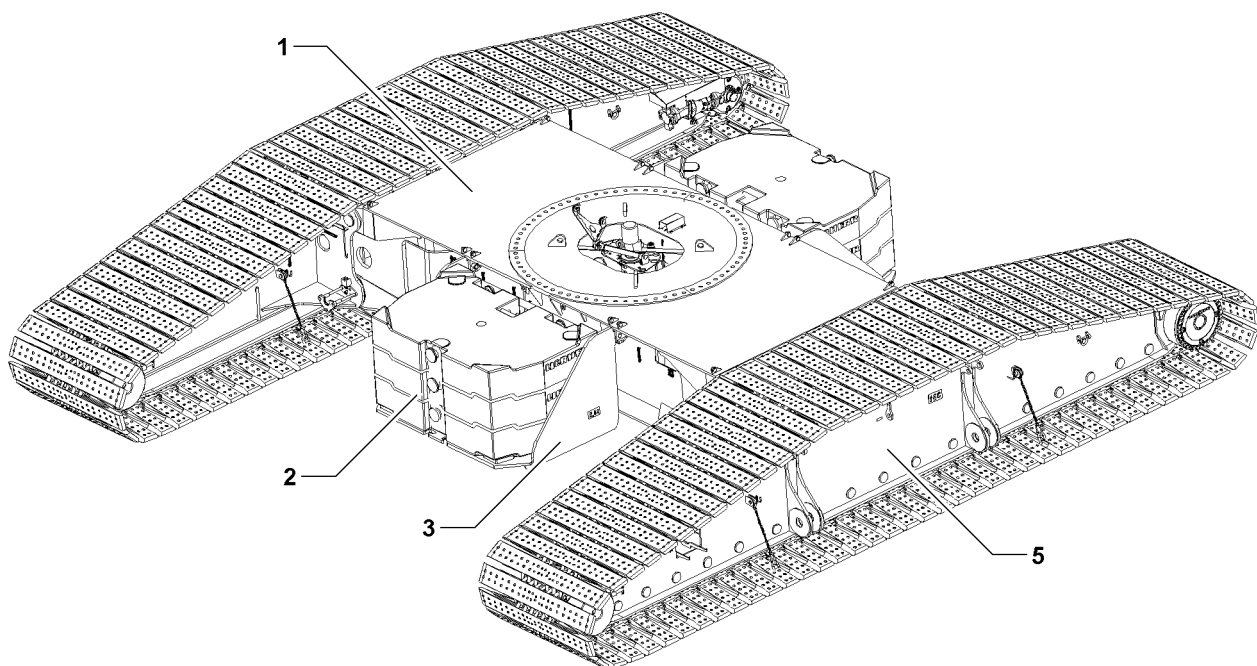

WARNING

Danger of slipping / falling during assembly / disassembly work!

During assembly and disassembly work, personnel must be secured with appropriate antifall guards to prevent them from falling!

Weather influences, such as wetness, wind, snow, frost increase the slipping / falling danger!

Personnel can be severely injured or killed!

- ▶ All assembly / disassembly work must be carried out using suitable aids (lifting platforms, scaffolding, ladders, auxiliary crane, etc.)!
- ▶ If work cannot be carried out on the ground or using such aids, then assembly personnel must be secured with the personal fall arrest system (see Crane operating instructions, chapter 2.04) to protect against falling!
- ▶ Hang in the personal antifall system in the corresponding attachment points on the crane (see Crane operating instructions, chapter 2.06)!
- ▶ If railings are present on the components, then they must be brought into the corresponding position and secured for assembly / disassembly work!
- ▶ Step on aids and fall arresters only with clean shoes!
- ▶ Keep aids and fall arresters clean and free from snow and ice!



WARNING

Falling components and central ballast plates!

At assembly / disassembly, the components and central ballast plates **2** can fall down!

Personnel can be severely injured or killed!

- ▶ Make sure that no persons or objects are within the danger zone!



WARNING

Incorrect handling of the attachment equipment!

If tackle cannot be attached correctly and if it is not secured sufficiently to prevent it from loosening up, loads can fall down!

Personnel can be severely injured or killed!

- ▶ Make sure that the attachment equipment is correctly attached on the attachment points and that it is secured sufficiently to prevent it from loosening up!



WARNING

Danger of impact and crushing!

If anyone remains within the assembly / disassembly area of the ballast, they would be exposed to a danger of impact and crushing!

Personnel can be severely injured or killed!

- ▶ Make sure that there are no persons between the components which are to be assembled / disassembled on the components and the crawler travel gear!

Make sure that the following prerequisites are met:

- both crawler carriers **5** are standing on the ground
- the crane is aligned in horizontal direction

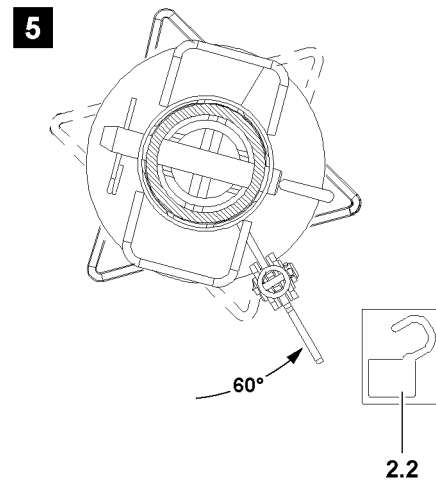
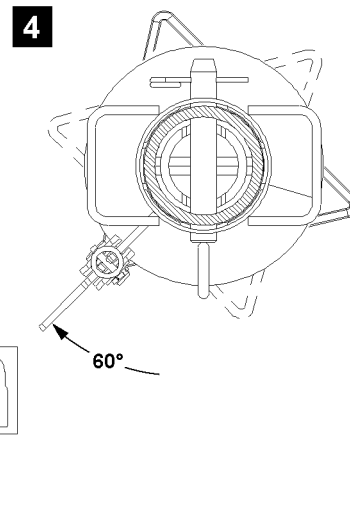
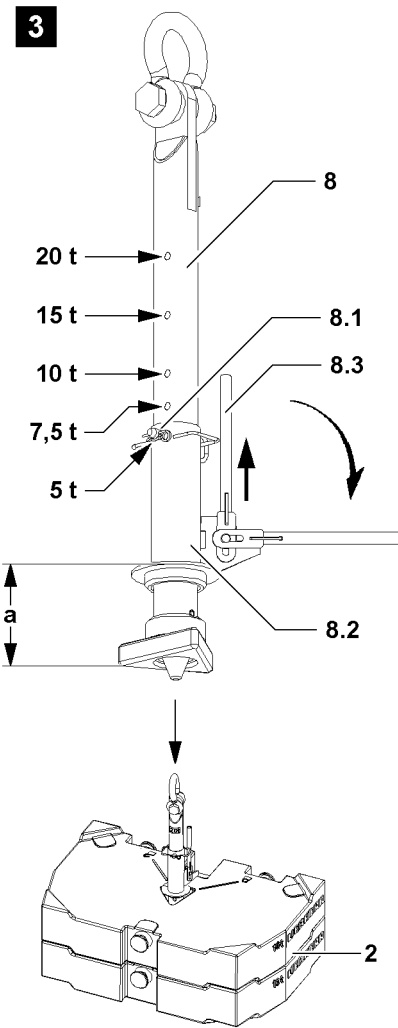
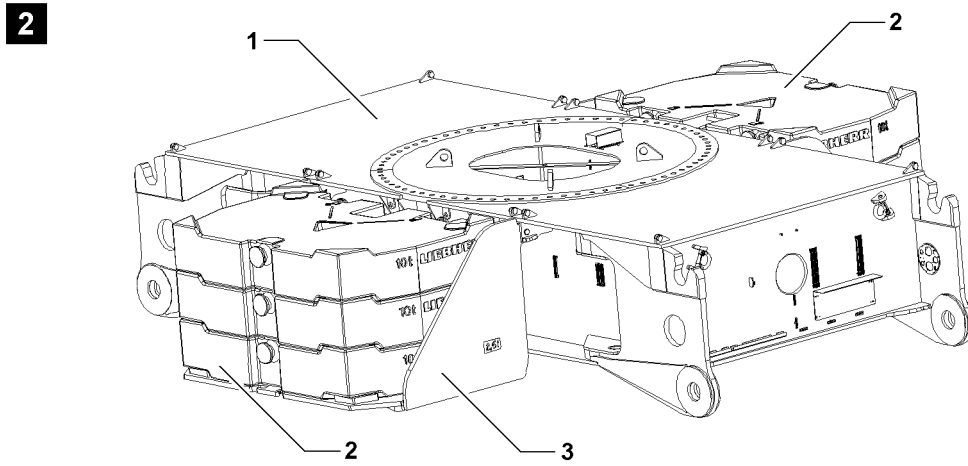

Fig.109257

LWE/LR 1600-2-008/18109-09-02/en

5.1 Removing the central ballast plates



Note

- ▶ It is permissible to remove the consoles **3** under certain prerequisites with placed central ballast plates **2**!
- ▶ Observe section „Removing the consoles with placed central ballast plates“ in this chapter!

5.1.1 Removing the central ballast plates, attachment system: „Twist lock“



WARNING

Overload of receptacle stud and central ballast plates!

If more than the permissible number of central ballast plates **2** are lifted with the receptacle stud **8**, the receptacle stud **8** and the central ballast plates **2** can be overloaded and damaged!

Central ballast plates **2** can fall down!

Personnel can be severely injured or killed!

- ▶ Observe the chart „Permissible central ballast assemblies“ in this chapter!



WARNING

Damage of receptacle stud and central ballast plates!

If two central ballast plates **2** are lifted which do not lay correctly in their centerings, the receptacle stud **8** and the central ballast plates **2** can be damaged!

Damage can cause the central ballast plates **2** to fall down!

Personnel can be severely injured or killed!

- ▶ Make sure that the central ballast plates **2** to be lifted are placed correctly in the centerings!



WARNING

Twist lock system opens by itself!

If the receptacle stud **8** is not correctly locked, the Twist lock system can open by itself!

Central ballast plates **2** can fall down!

Personnel can be severely injured or killed!

- ▶ Make sure, when initiating a lift, that the lever **8.3** points directly on the symbol „Locked“ **2.1** of the central ballast plates **2**!



Note

- ▶ During a lift, the locked Twist lock system cannot release by itself due to its gravitational retention!
- ▶ During a lift, the locked Twist lock system cannot be released by hand due to its gravitational retention!

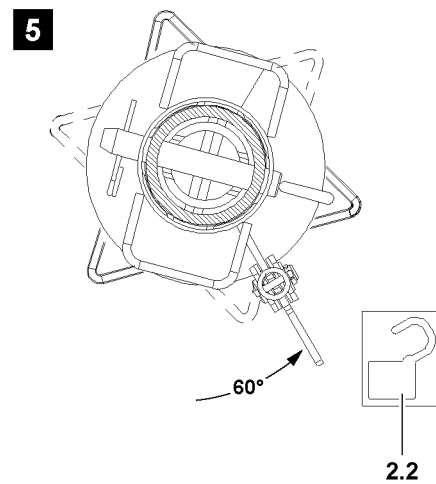
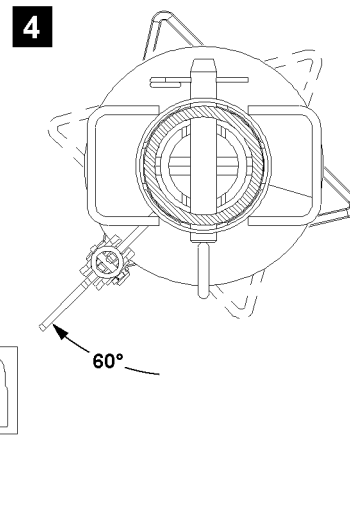
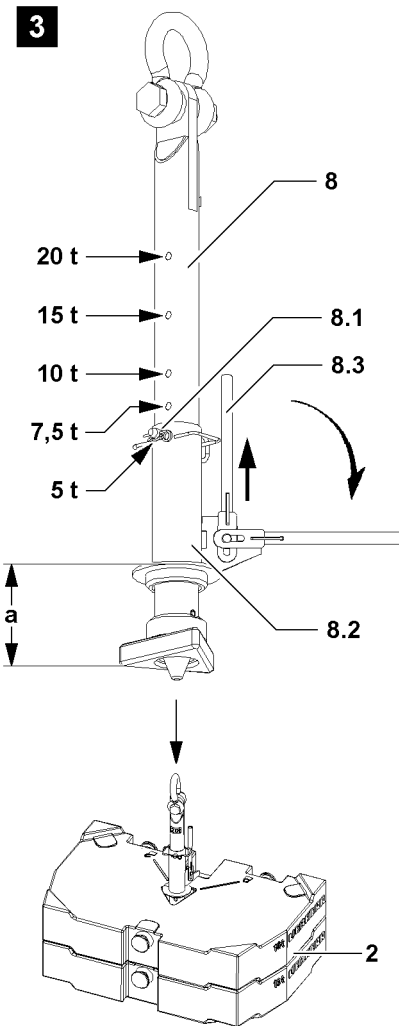
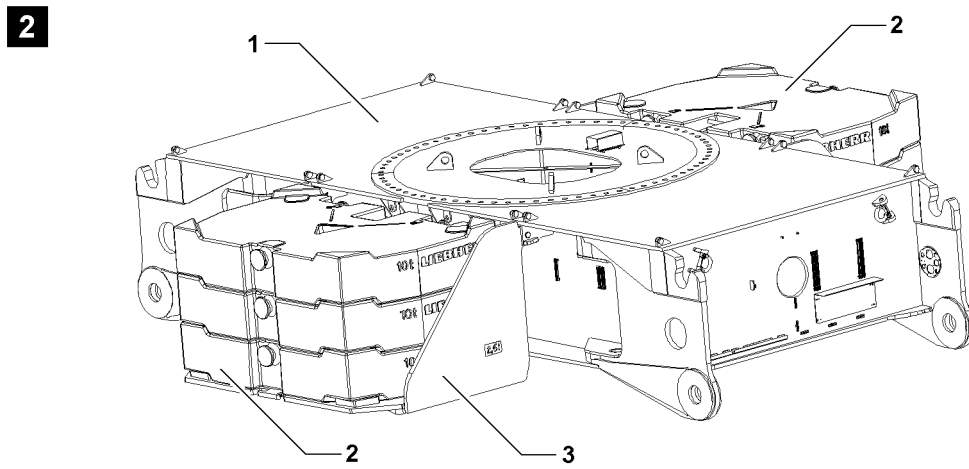

Fig.109257

LWE/LR 1600-2-008/18109-09-02/en

Before the receptacle stud **8** is guided in the central ballast plates **2**, make sure that the insertion length **a** of the receptacle stud **8** is set correctly.

The insertion length **a** of the receptacle stud **8** for central ballast plates **2** can be adjusted by hand.

If the insertion length **a** of the receptacle stud **8** is to be adjusted:

- ▶ Release and unpin the pins **8.1**.
- ▶ Adjust the insertion length **a** by moving the guide sleeve **8.2** to the desired value, observe the stages in illustration **3**.
- ▶ Insert and secure the pin **8.1**.

Result:

- The receptacle stud **8** is adjusted.



Note

- ▶ The receptacle stud **8** in illustration **3** is set to 5 t !

-
- ▶ Attach the receptacle stud **8** on the auxiliary crane and guide it into the central ballast plate(s) **2**.
 - ▶ Pull up the lever **8.3** and fold it down.
 - ▶ Turn the receptacle stud **8** with the lever **8.3** by 60° until it points to the symbol „Locked“ **2.1** of the central ballast plate **2**, see illustration **4**.



Note

- ▶ The receptacle stud **8** is locked by lifting the central ballast plate(s) **2**!

-
- ▶ Lift the central ballast plate(s) **2** or the central ballast assembly with the receptacle stud **8** and place them carefully on a suitable storage location.

When the central ballast plate(s) **2** are placed down:

- ▶ Turn the receptacle stud **8** with the lever **8.3** by 60° to the stop in direction of the symbol „unlocked“ **2.2** of the central ballast plate **2**, see illustration **5**.

Result:

- The receptacle stud **8** is unlocked.
- ▶ Carefully pull out the receptacle stud **8**.

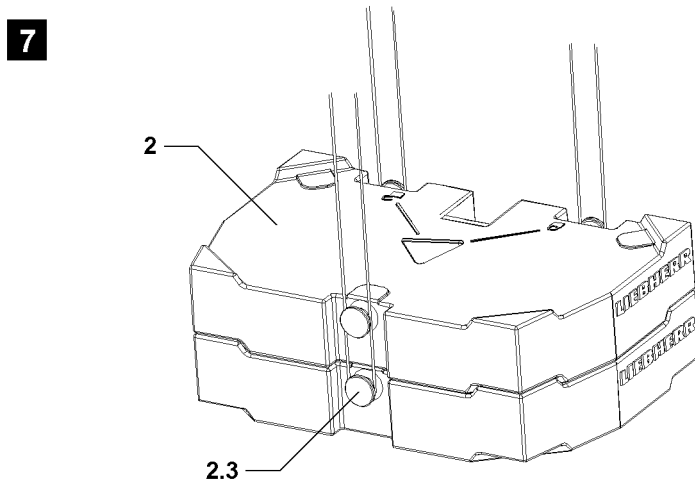
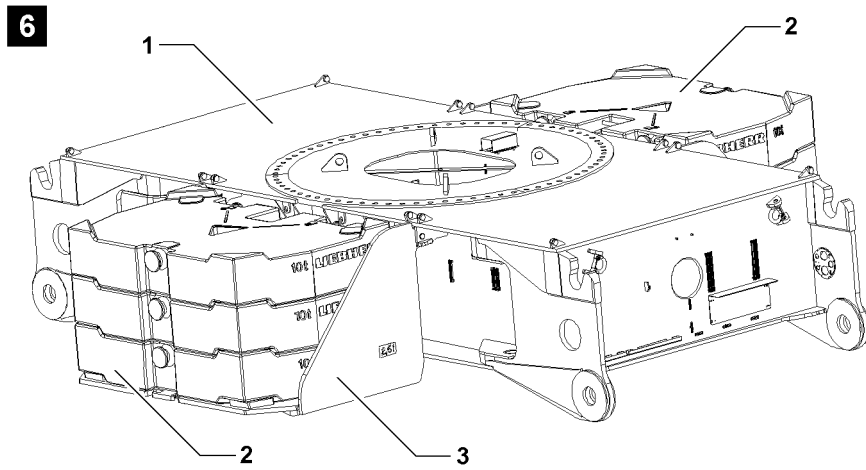

Fig.109258

LWE/LR 1600-2-008/18109-09-02/en

5.1.2 Removing the central ballast plates, attachment points: Bitt

**WARNING**

Overloaded central ballast plates!

If more than the permissible loads are lifted, the bits **2.3** are overloaded!

The central ballast plates **2** can be damaged and fall down!

Personnel can be severely injured or killed!

► Observe the chart „Permissible central ballast assemblies“ in this chapter!

**WARNING**

Incorrect handling of the attachment equipment!

If tackle cannot be attached correctly and if it is not secured sufficiently to prevent it from loosening up, the central ballast plates **2** can fall down!

Personnel can be severely injured or killed!

► Make sure that the tackle is correctly attached on the bits **2.3** and that it is secured sufficiently to prevent it from loosening up!

► Attach the central ballast plates **2** or the central ballast assembly, see illustration **7** on the auxiliary crane.

► Remove the central ballast plates **2** or the central ballast assembly from the console **3** and place it on a suitable storage location.

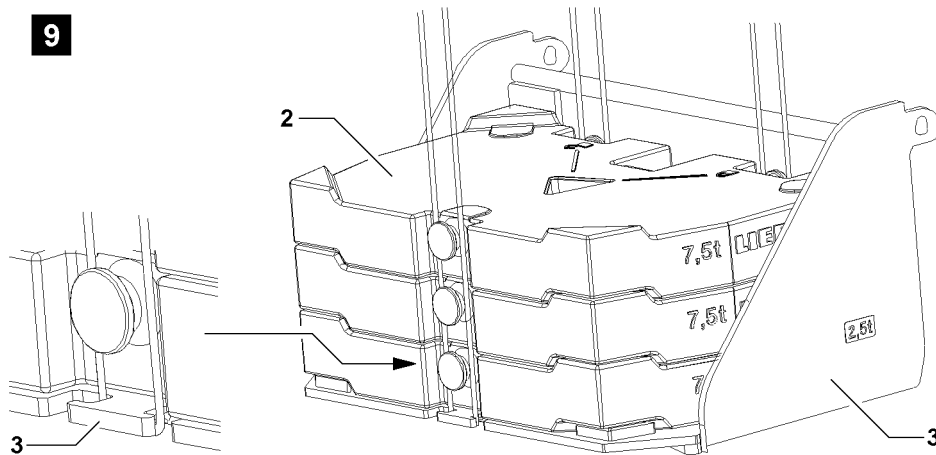
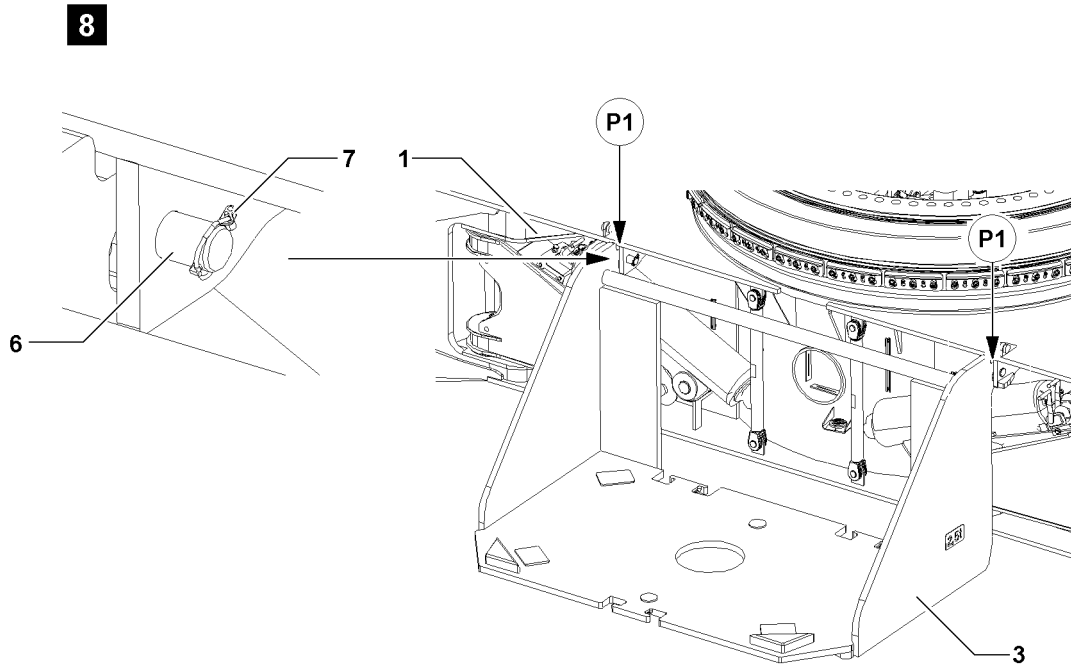

Fig.109259

LWE/LR 1600-2-008/18109-09-02/en

5.2 Removing the consoles



WARNING

Danger of accidents due to diagonal pull!

If pulled diagonally, a suspended console **3** can start to swing back and forth after releasing it from the crawler center section **1**!

Personnel can be severely injured or killed!

- ▶ Always position the tackle in the center above the attachment points!
- ▶ Take special caution when unpinning the consoles **3**!

- ▶ Position the tackle with the auxiliary crane in the center above attachment points.
- ▶ Attach the console **3** onto the auxiliary crane.
- ▶ Tighten the tackle with the auxiliary crane.
- ▶ Remove the linch pin **7** and unpin the pin **6**.
- ▶ Pull the console **3** with the auxiliary crane from the brackets on points **P1**.

5.3 Removing the consoles with placed central ballast plates



WARNING

Danger of accidents due to diagonal pull!

If pulled diagonally, a suspended console **3** can start to swing back and forth after releasing it from the crawler center section **1**!

Personnel can be severely injured or killed!

- ▶ Always position the tackle in the center above the attachment points!
- ▶ Take special caution when unpinning the consoles **3**!



WARNING

Overload of attachment points console!

If the console **3** is lifted with more than 22.5 t of placed central ballast plates **2**, the attachment points will be overloaded!

The console **3** and central ballast plates **2** can fall down!

Personnel can be severely injured or killed!

- ▶ Make sure that no more than maximum 22.5 t of central ballast plates **2** are placed on the console **3** to be lifted, see illustration **9**!



Note

- ▶ When removing the central ballast plates **2** from the console **3** observe section „Removing the central ballast plates“ in this chapter!

- ▶ Position the tackle with the auxiliary crane in the center above attachment points of the console **3**.
- ▶ Attach the console **3** with the placed central ballast plates **2** on the auxiliary crane.
- ▶ Tighten the tackle with the auxiliary crane.
- ▶ Remove the linch pin **7** and unpin the pin **6**.
- ▶ Pull the console **3** with the auxiliary crane from the brackets on points **P1**.

Empty page!

LWE/LR 1600-2-008/18109-09-02/en

3.04 Mechanical auxiliary support

1 Installing the mechanical auxiliary support

3

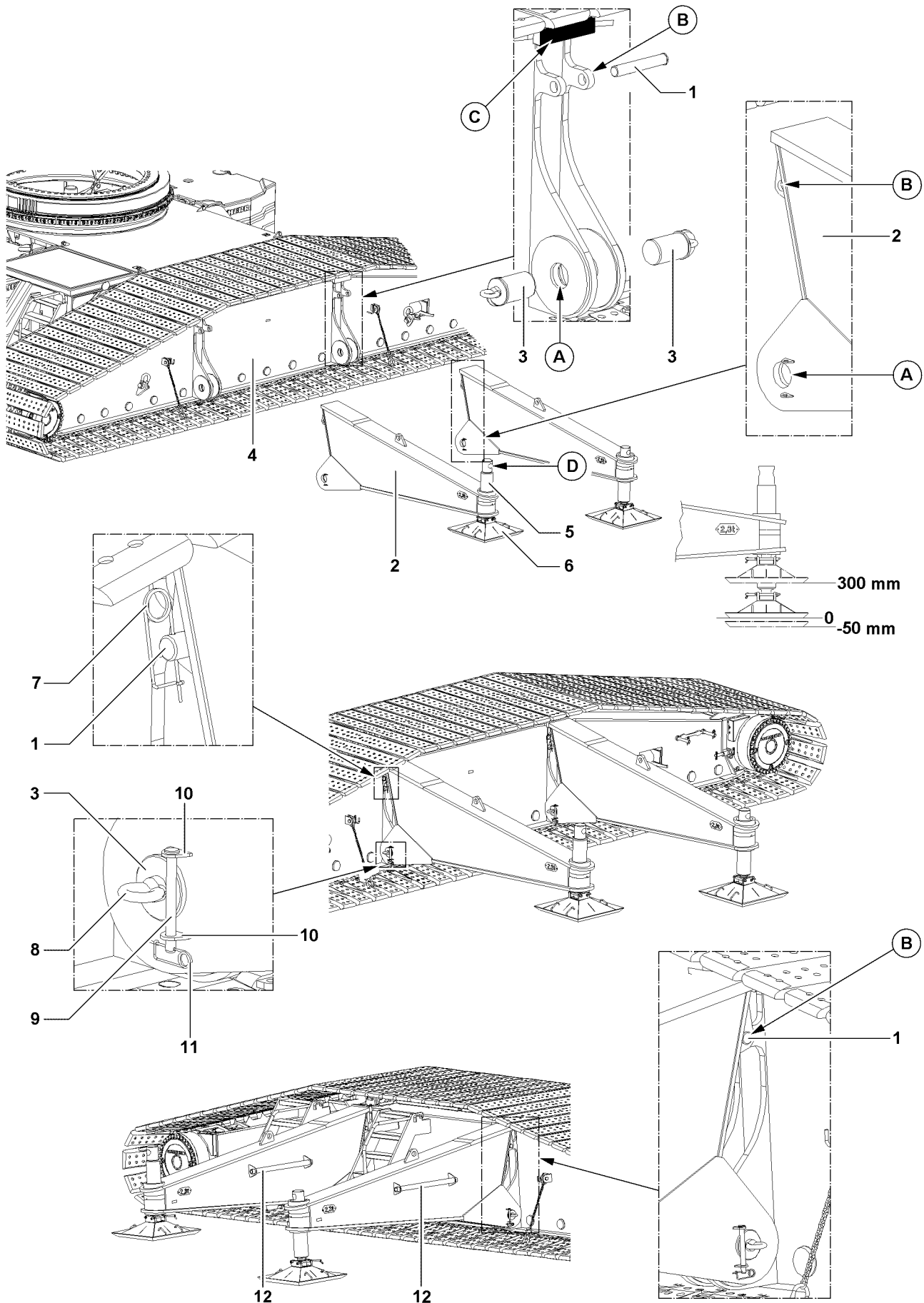

Fig.105233

LWE/LR 1600-2-008/18109-09-02/en

1 Installing the mechanical auxiliary support

Make sure that the following prerequisites are met:

- The crawler carriers are installed.
- The crane is aligned in horizontal direction.
- The ground has sufficient load bearing capacity in the area of the support pads.
- An auxiliary crane is available.



Note

- ▶ The mechanical auxiliary support is required to erect or take down long boom combinations and can be installed on the left or right crawler carrier.



WARNING

The crane can topple over!

If long boom combinations are erected or taken down without mechanical auxiliary support **2**, then the crane can topple over. Personnel can be severely injured or killed!

- ▶ Observe and adhere to the data in the erection and take down charts!
- ▶ Pin the mechanical auxiliary support **2** on the crawler carrier **4** and turn the spindle to lay the support pads on the ground.

1.1 Attaching the mechanical auxiliary support



Note

- ▶ The installation of the mechanical auxiliary support **2** is the same for both support beams on the left and right hand side!

- ▶ Hang the mechanical auxiliary support **2** on the auxiliary crane and swing into pin position.
- ▶ Align the mechanical auxiliary support **2**: Make sure that the pin bores of the auxiliary support and the crawler carrier align in points **A** and in points **B**.
- ▶ Insert the pins **3** each from the left and right on point **A**.
- ▶ Secure the pins **3** from the left and right: Insert the pins **9** into brackets **10** and secure with spring retainer **11**.
- ▶ Insert the pin **1** on point **B** and secure with spring retainer **7**.
- ▶ Remove the mechanical auxiliary support from the auxiliary crane.

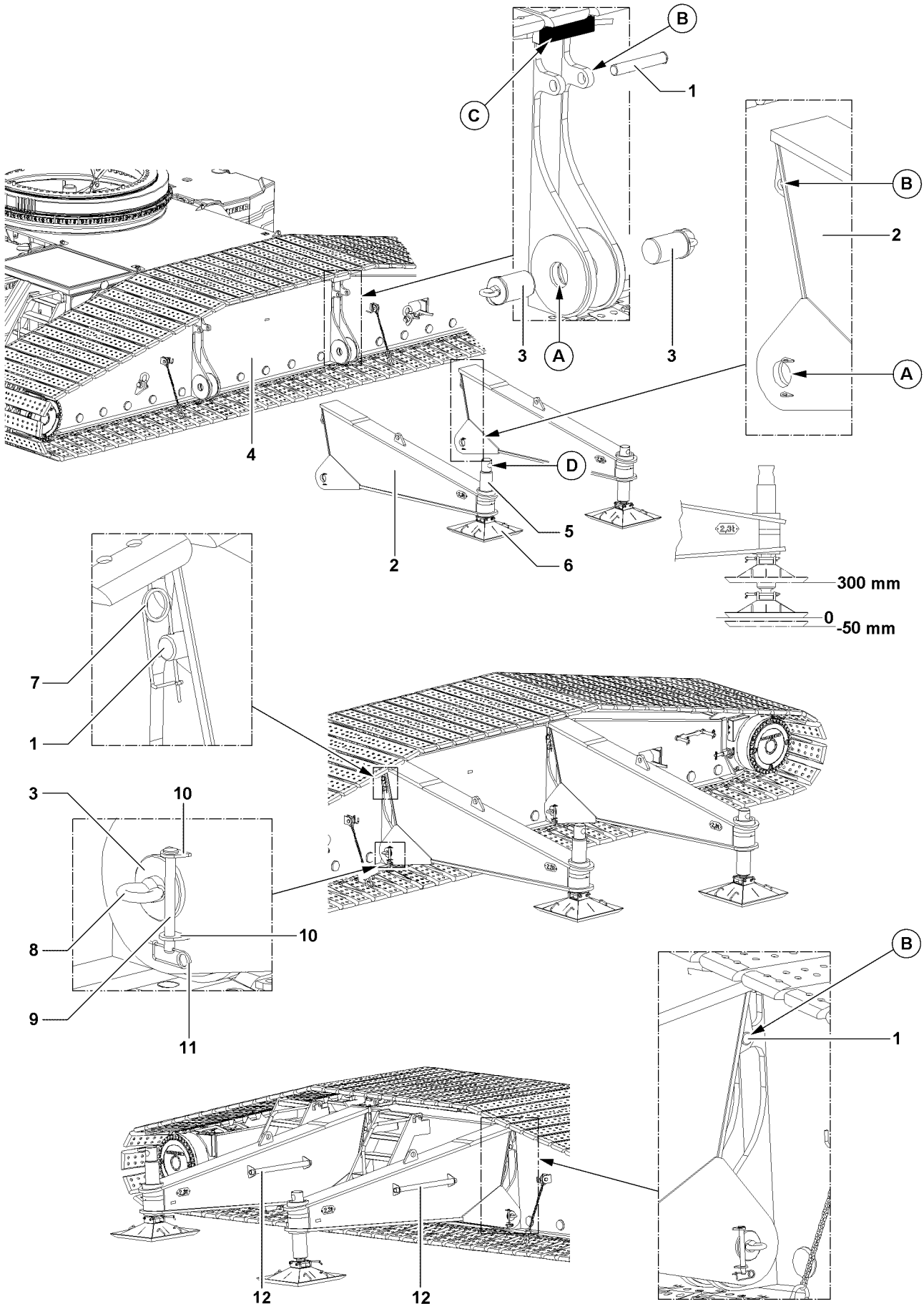

Fig.105233

LWE/LR 1600-2-008/18109-09-02/en

1.2 Adjusting the mechanical auxiliary support



Note

- ▶ The mechanical auxiliary support is only an erection and take down aid device.
- ▶ Due to the mechanical auxiliary support, the stability momentum of the crane increases toward the side, on which the auxiliary support is installed.



DANGER

The crane can topple over!

If the load moments are increased due to the use of the mechanical auxiliary support, the crane can topple over and severely or fatally injure personnel.

- ▶ The support pads must be made large enough for the ground conditions, use solid materials, such as wood, steel or concrete slabs, see chapter 2.04.



WARNING

Jerky movements of the boom system!

If the mechanical auxiliary support **2** is not placed on the crawler carrier **4** at point **C**, then the boom system can move jerkily during erection and take down.

Personnel can be severely injured or killed! The crane can be damaged.

- ▶ Turn the support pad **6** with the spindle **5** until the mechanical auxiliary support **2** touches at point **C**.



Note

- ▶ Adjustment range of support pad: - 50 mm to + 300 mm.

- ▶ Remove the pipe **12** from the transport retainer on the mechanical auxiliary support.
- ▶ Insert the pipe **12** at point **D** into the bore on the spindle **5**.
- ▶ Extend the support pad **6** by turning the spindle **5** with the pipe **12** downward until it is „tensioned“ and placed horizontally on the base support and has contact to the placement surface **C** on the crawler carrier.

Empty page!

LWE/LR 1600-2-008/18109-09-02/en

3.05 Assembly of SA bracket

1	Component overview SA-frame	3
2	Attachment points SA-frame	3
3	Assemble SA-frame	5
4	Disassemble SA-frame	13

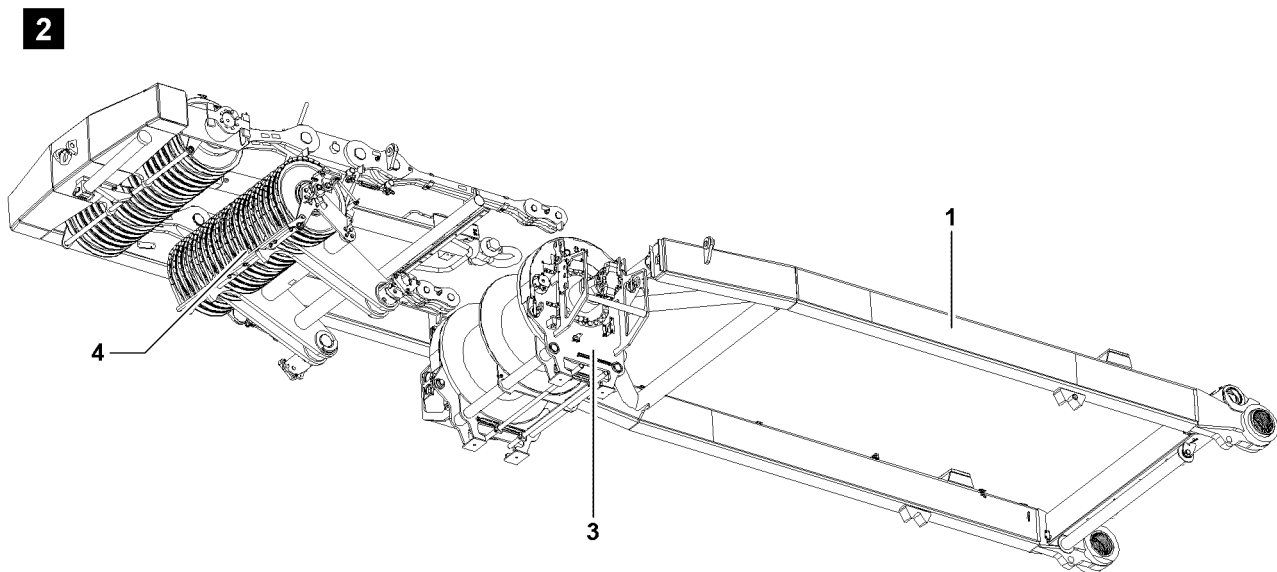
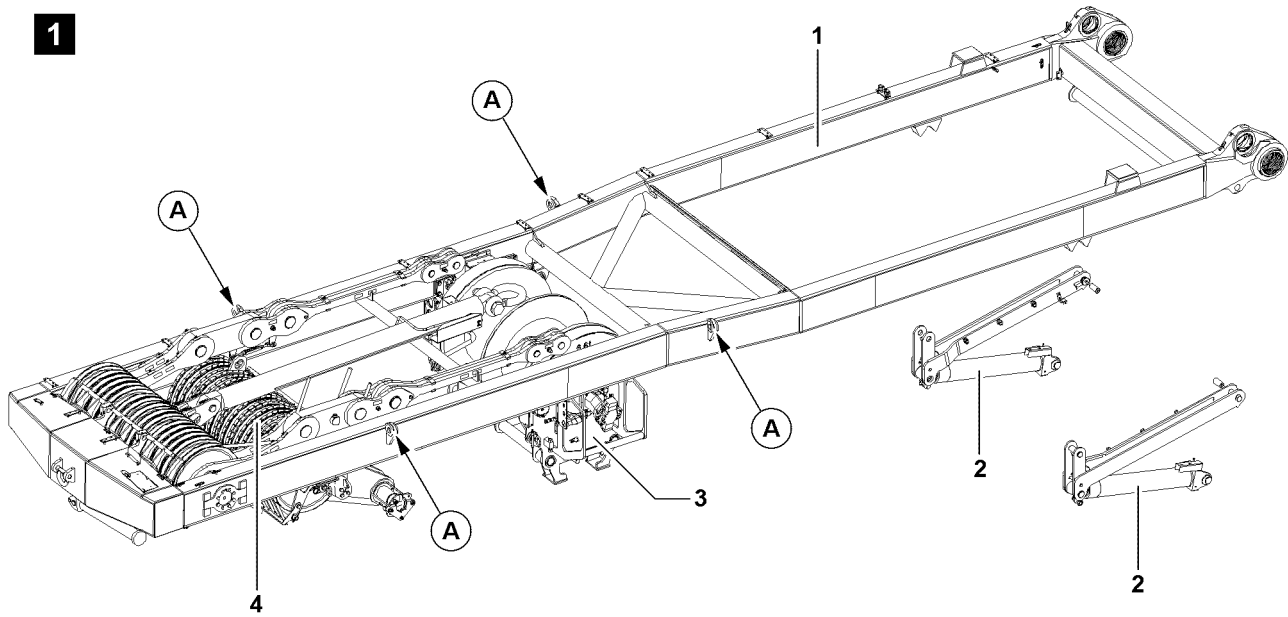

Fig.107281

1 Component overview SA-frame

Position	Component	Weight
1	SA-frame	
3	Intake gear winch 4	
4	Roller bearings	
	SA-frame complete	17.5 t
2	Erection cylinder	

2 Attachment points SA-frame



WARNING

Danger of accident due to incorrect attachment!

Life-threatening situations can arise due to improper or incorrect attachment of the corresponding components!

► The corresponding components must be attached on the intended points **A!**

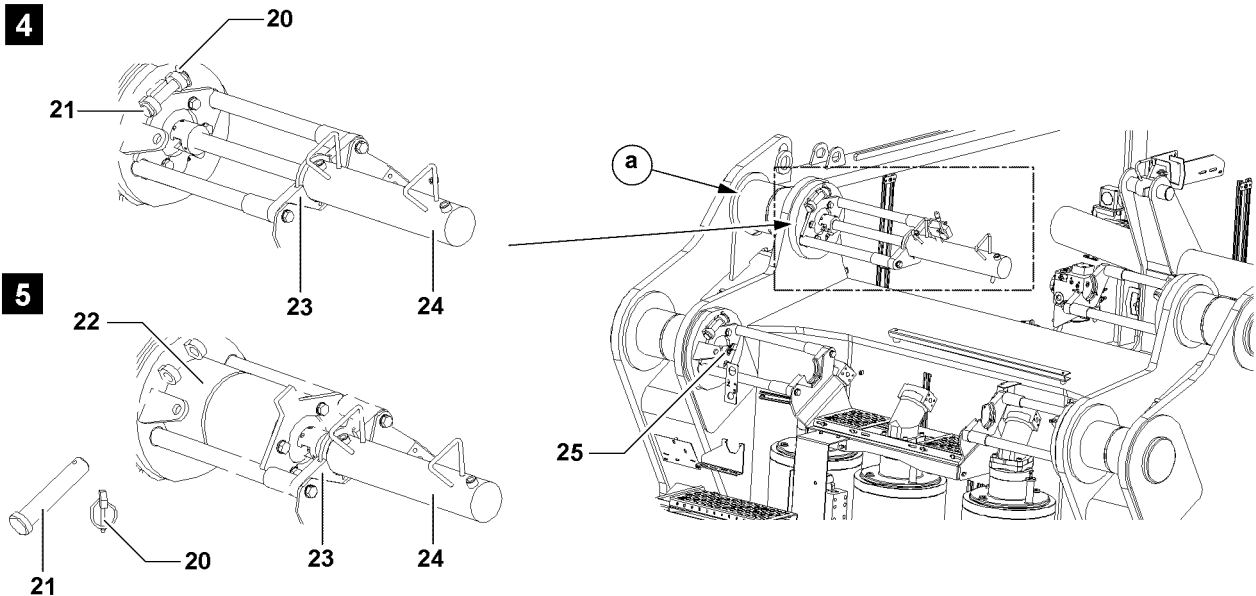
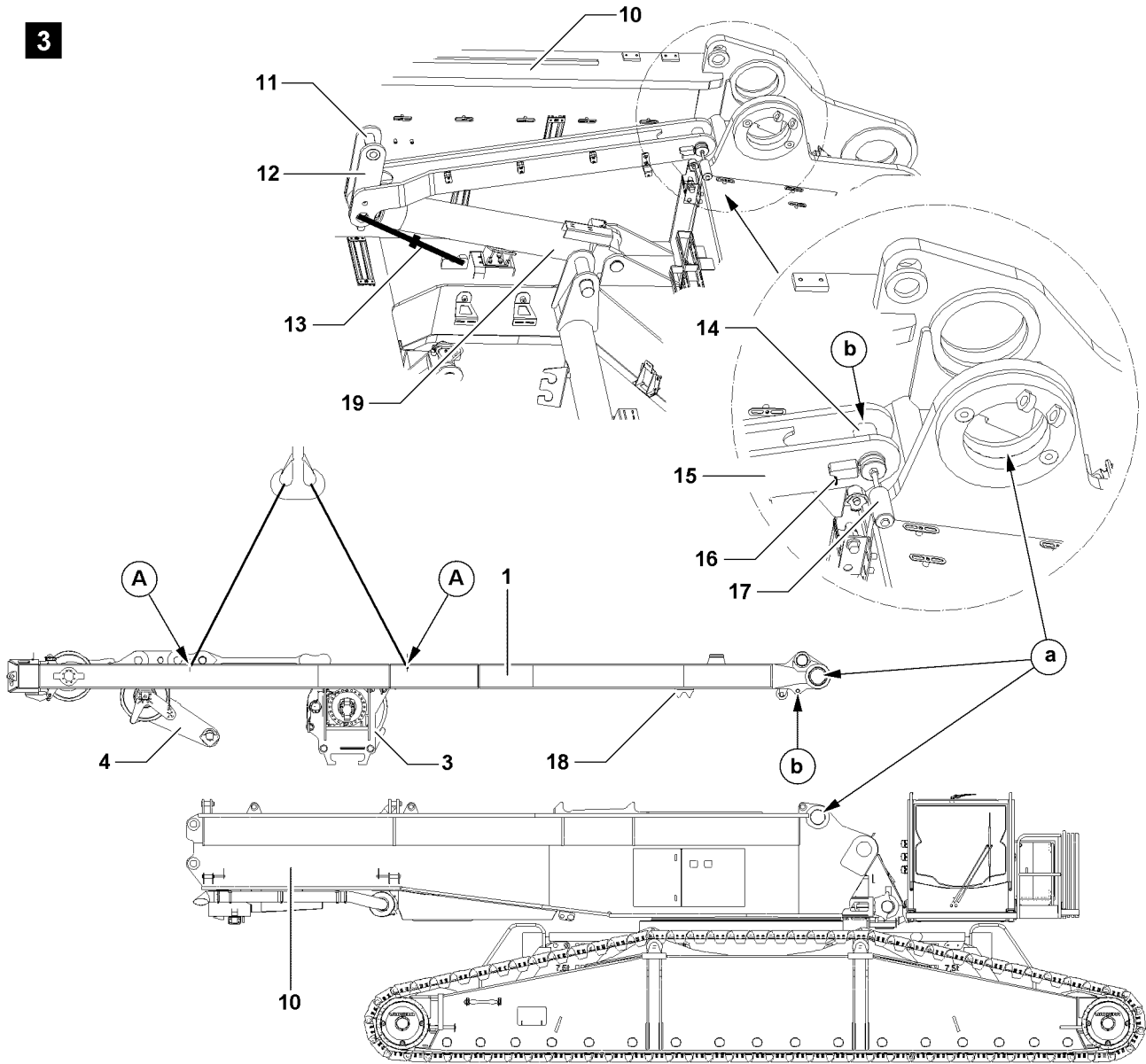

Fig.107282

LWE/LR 1600-2-008/18109-09-02/en

3 Assemble SA-frame

3.1 Pin the SA-frame on the turntable



Note

- ▶ Guarantee equally long tackle such that the SA-frame can be horizontally positioned over the turntable.

NOTICE

Collision of components!

If the SA-frame is positioned with the auxiliary crane on the turntable, roller bearings and hoist gear can collide with the turntable. Components can be damaged.

- ▶ Make sure that the roller bearing **4** does not collide with the turntable **10**.
- ▶ Make sure that the intake gear winch **4 3** does not collide with the turntable **10**.

Ensure that the following prerequisite is met:

- unpin the pins **22** on both sides,
- unpin the pins **14** on both sides.
- ▶ Remove the linch pin **20** and unpin pins **21** see illustration **5**.

Result:

- The pin **22** cannot be pinned.
- ▶ Attach the pin pulling cylinder **24** between the retainer **23** and the pull screw **25**.
- ▶ Attach SA-frame **1** with auxiliary crane on the attachment points.
- ▶ Position SA-frame **1** with auxiliary auxiliary crane on the turntable **10** so that pinning points **a** and pinning points **b** align.
- ▶ Insert the pins **22** on both sides.
- ▶ Remove the pin pulling device **24**.
- ▶ Secure the pin **22**: Insert the pin **21** and secure with linch pin **20**.
- ▶ Pull, turn and latch spring pin **16** on both sides.
- ▶ Pin pins **14** with pin device **17**.
- ▶ Pins **16** should be pinned on both sides and secured with spring retainers **14**.

NOTICE

SA frame damage!

If the turnbuckle is not unpinned before the operation, the SA-frame is damaged.

- ▶ Unpin turnbuckle **13** before operation.
- ▶ Lay down SA-frame **1** completely: Make sure that the pins **11** lie on both sides of the plate **18**.

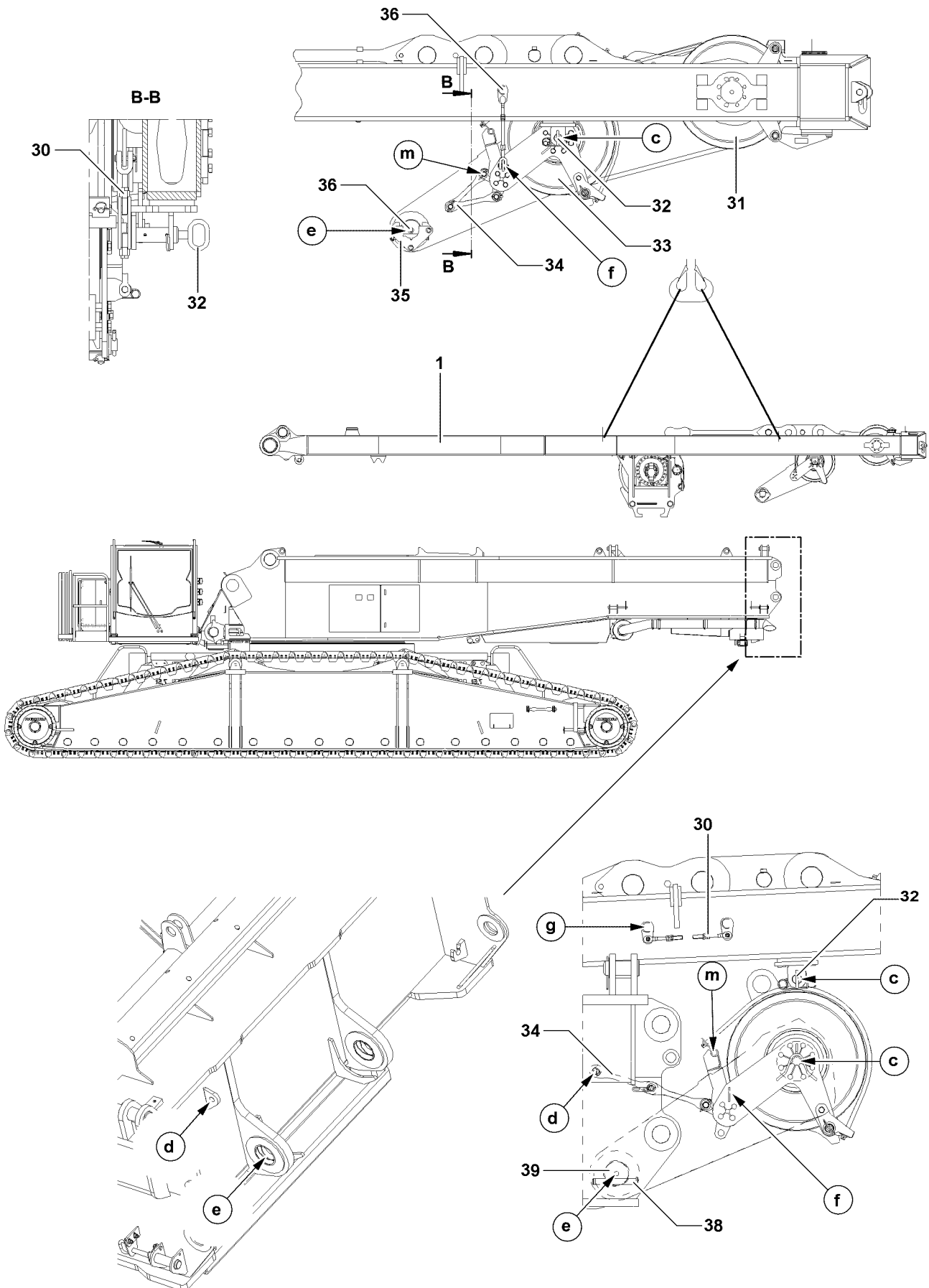

Fig.107283

LWE/LR 1600-2-008/18109-09-02/en

3.2 Pin roller bearings.

Ensure that the following prerequisite is met:

- align pinning points **e**.
- ▶ Hang the pin pulling cylinder on the retainer **35** and on the screw **36**.
- ▶ Insert the pin **39** and secure with pins **38**.
- ▶ Remove the pin pulling device.
- ▶ Hang pulley set **33** onto the auxiliary crane and and lightly lift until the retaining pin **32** may be unpinned.
- ▶ Unpin retaining pins **32**.
- ▶ Unpin turnbuckle **30** on the point **f** and pin and secure in park position **g**.
- ▶ Unpin and release the scissor clamping device **34** on the pinning point **m**.
- ▶ Lower pulley set **33** until scissor clamping device **34** may be pinned on pinning point **d**.
- ▶ Pin with scissor clamping device **34** on pinning point **d** and secure with cotter pin.
- ▶ Lower pulley set **33** with auxiliary crane, until pulley set **33** hangs completely in the rope reeving.
- ▶ Remove the auxiliary crane.

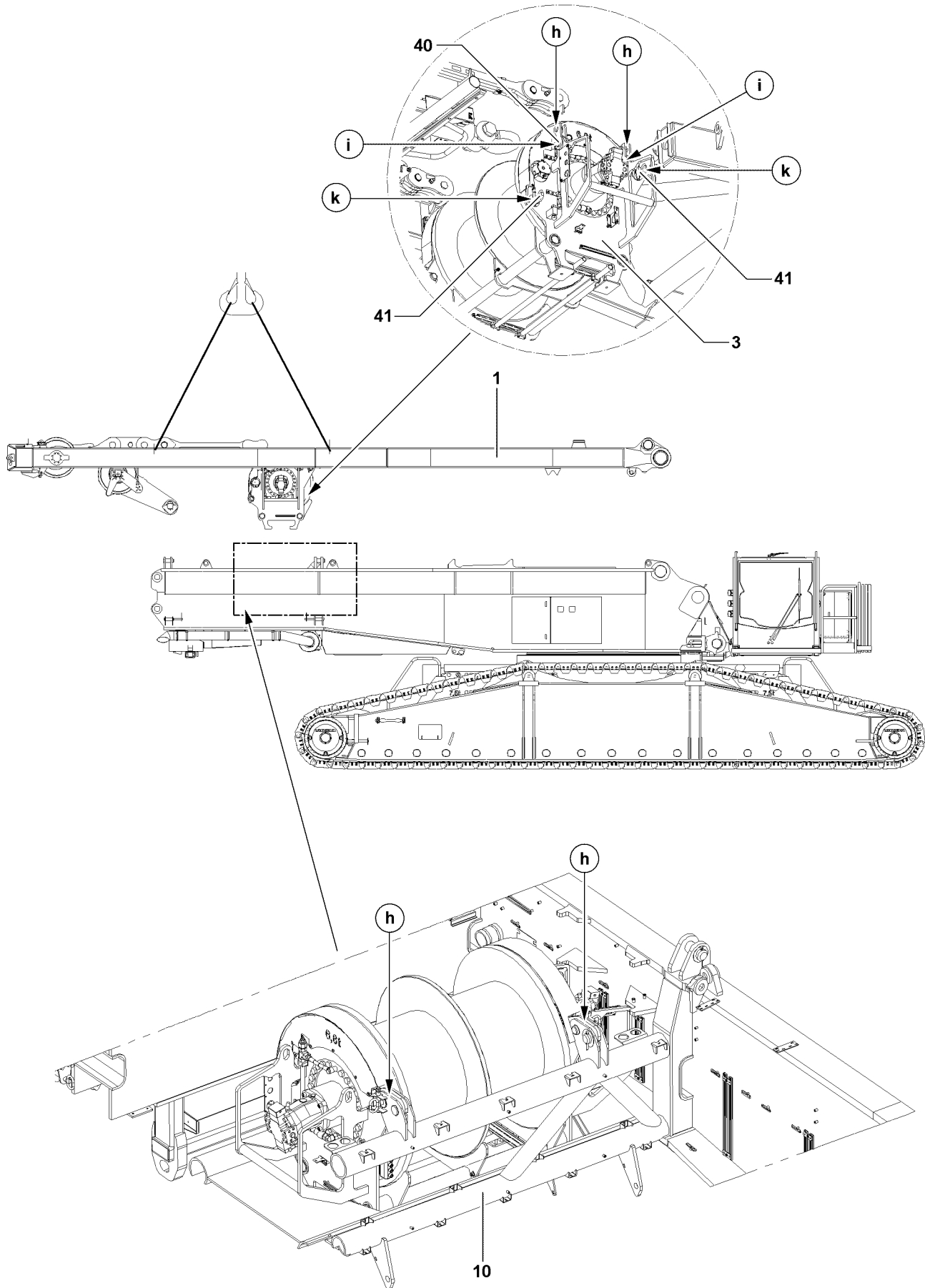

Fig.107284

LWE/LR 1600-2-008/18109-09-02/en

3.3 Pin intake gear winch 4 on turntable

- ▶ Connect intake gear winch 4 **3** with turntable **10**: Pin locking pin **41** on the pinning points **k** and secure with spring retainers.
- ▶ Separate intake gear winch 4 **3** from SA-frame **1**: Remove spring retainers on the pinning points **i** and unpin locking pins **40**.
- ▶ Secure the locking pins **40** on both sides with spring retainers in the parking positions **h**.

Fig.195219

LWE/LR 1600-2-008/18109-09-02/en

3.4 Establishing the electrical connections

**Note**

► For production of the electrical connections on the SA-boom, the separate electrical diagram is to be employed.

- Establish electric connections between turntable and SA-frame.
- Establish electric connections between turntable and intake gear winch 4.

3.5 Establish the hydraulic connections.

When hydraulic lines are connected and disconnected with quick-release couplings, make sure that the coupling procedure is being performed correctly.

**DANGER**

Risk of accident due to loss of pressure or leakage!

Incorrectly coupled or self-loosening quick-release couplings (particularly return lines) can result in serious injury due to component failure!

- Check that the quick-release couplings have been properly connected before using the crane.

**Note**

► To connect or release the hydraulic lines with quick couplers, see chapter 5.01.

- Release the pressure in the hydraulic system before connecting and disconnecting. Turn the engine off and wait for short time.
- Assembling coupling components (sleeve and connector) by using hand-tightened nut.
- Combine coupling components.

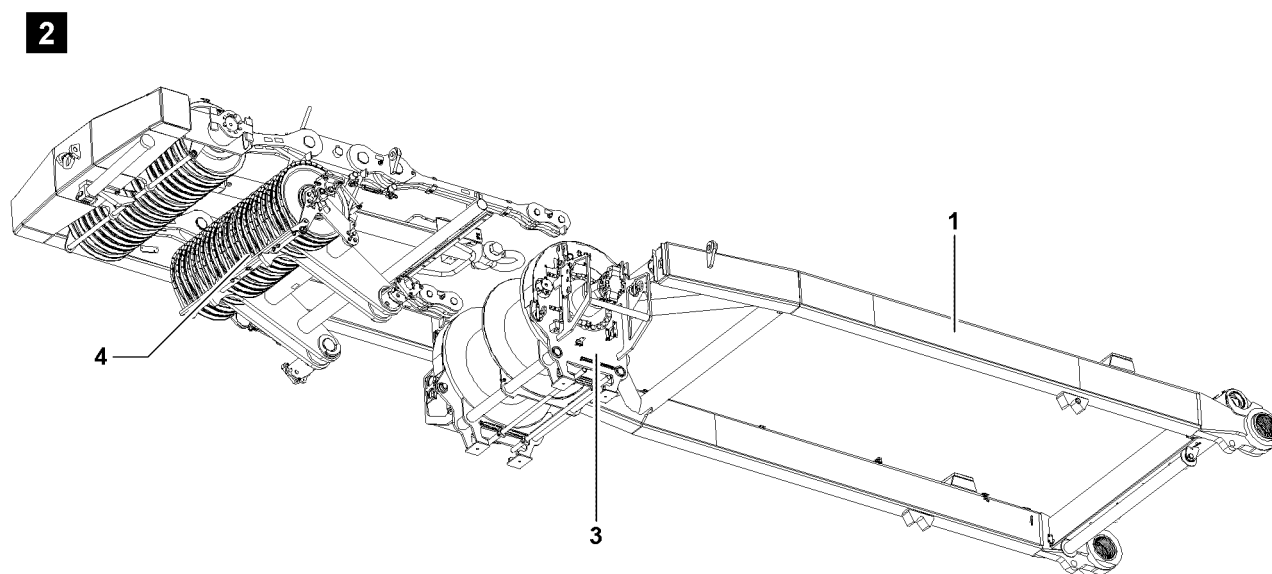
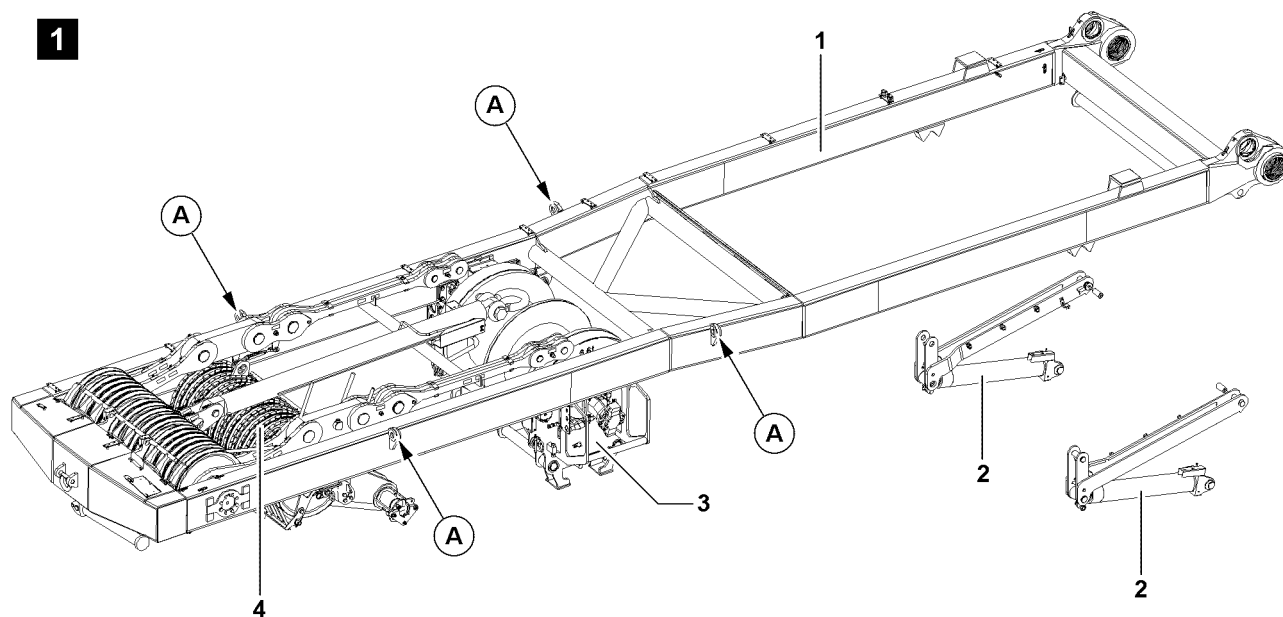

Fig.107281

4 Disassemble SA-frame

Ensure that the following prerequisite is met:

- roller bearings are found in transport position: SA-frame is found in the 0° position.

4.1 Disconnect the electrical connections

- ▶ Separate and properly store electrical connections between turntable and SA-frame.
- ▶ Separate and properly store electrical connections between turntable and winch 4.

4.2 Disconnect the hydraulic connections.

When hydraulic lines are connected and disconnected with quick-release couplings, make sure that the coupling procedure is being performed correctly.



Note

- ▶ To connect or release the hydraulic lines with quick couplers, see chapter 5.01.
-
- ▶ Release the pressure in the hydraulic system before connecting and disconnecting. Turn the engine off and wait for short time.
 - ▶ Loosen coupling components (sleeve and connector) by using hand-tightened nut.
 - ▶ Separate coupling components.
 - ▶ Properly store hydraulic hoses on the the SA-frame on the turntable.
 - ▶ Fitting the coupling components with protective caps against contamination and damage.

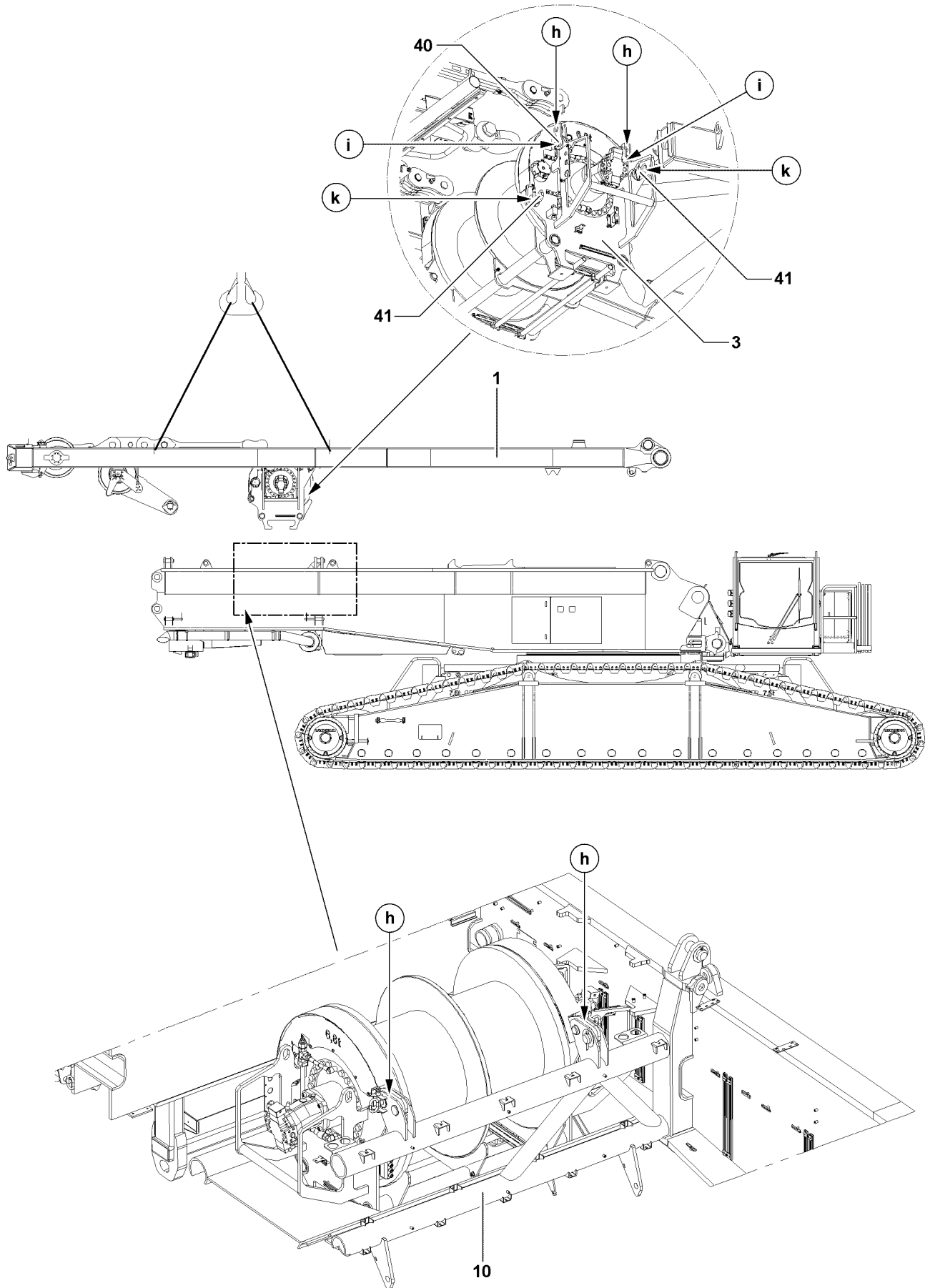

Fig.107284

LWE/LR 1600-2-008/18109-09-02/en

4.3 Prepare intake gear winch 4 for transport

- ▶ Separate intake gear winch 4 **3** from turntable **10**: Remove spring retainers on the pinning points **k** on both sides and unpin locking pins **41**.
- ▶ Connect intake gear winch 4 **3** with SA-frame **1**: Release and unpin the socket pin **40** from the park positions **h**.
- ▶ Pin locking pin **40** on the pinning points **i** and secure with spring retainers.

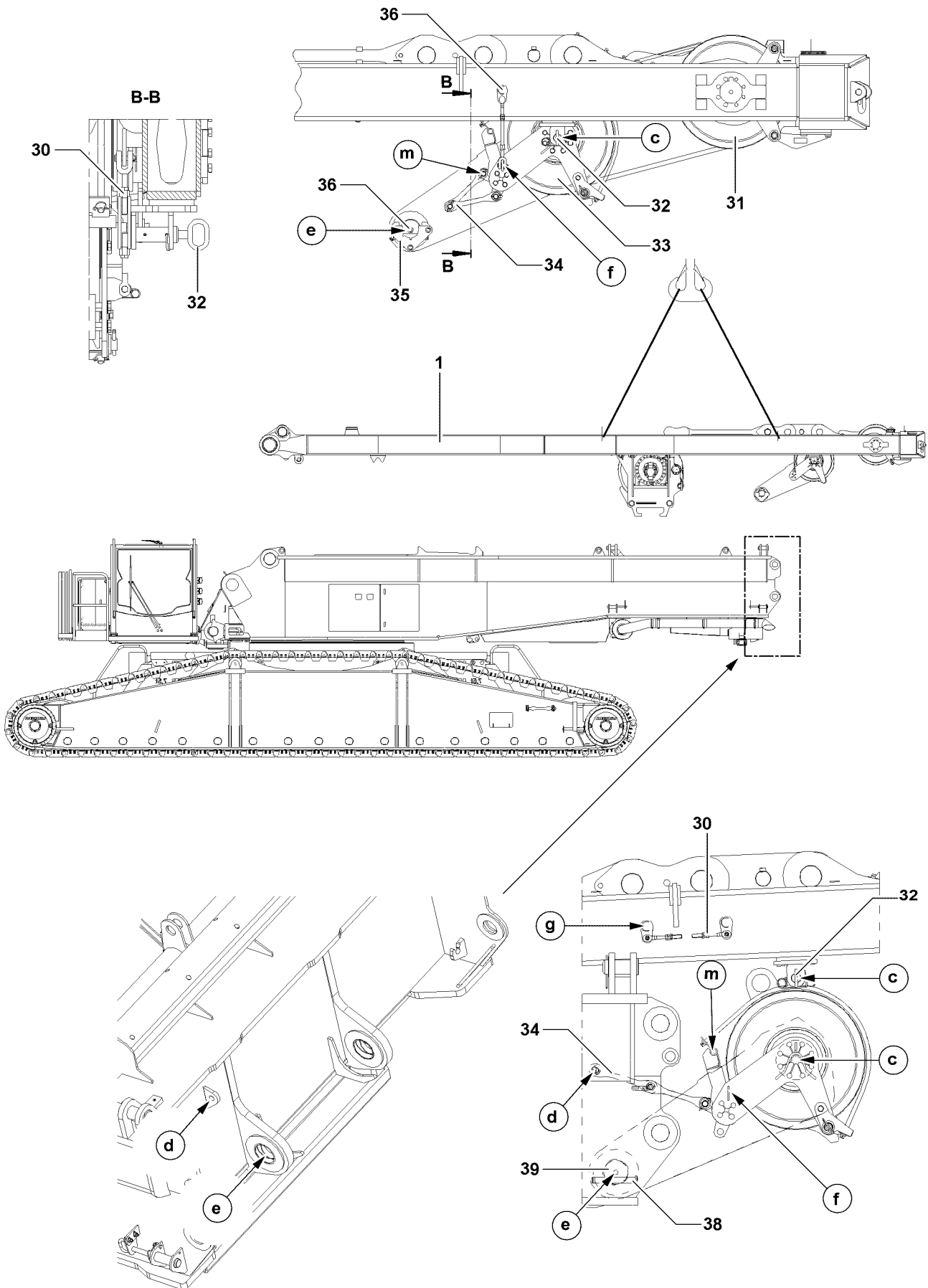

Fig.107283

LWE/LR 1600-2-008/18109-09-02/en

4.4 Preparing the roller bearings for transport

- ▶ Attach and lift pulley set **33** on auxiliary crane until scissor clamping device **34** may be pinned on pinning point **d**.
- ▶ Unpin and release the scissor clamping device **34** on the pinning point **d**.
- ▶ Pin with scissor clamping device **34** on pinning point **m** and secure with cotter pin.
- ▶ Lift pulley set **33** until pinning points **c** align.
- ▶ Pin locking pin **32** in the pinning point **c** on both sides.
- ▶ Unpin turnbuckle **30** on the park position **g** and pin and secure on position **f**.
- ▶ Remove the auxiliary crane.
- ▶ Hang the pin pulling cylinder on the retainer **35** and on the screw **36**.
- ▶ Release pin **39**: Unpin the pin **38**.
- ▶ Unpin the pin **39**.
- ▶ Remove the pin pulling device.

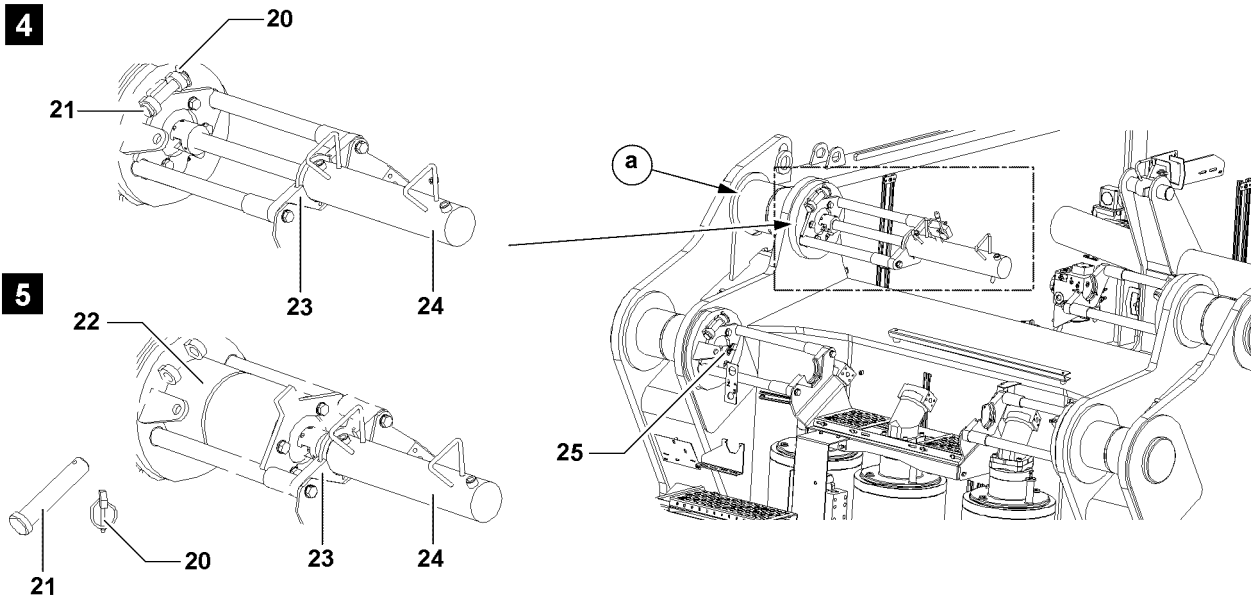
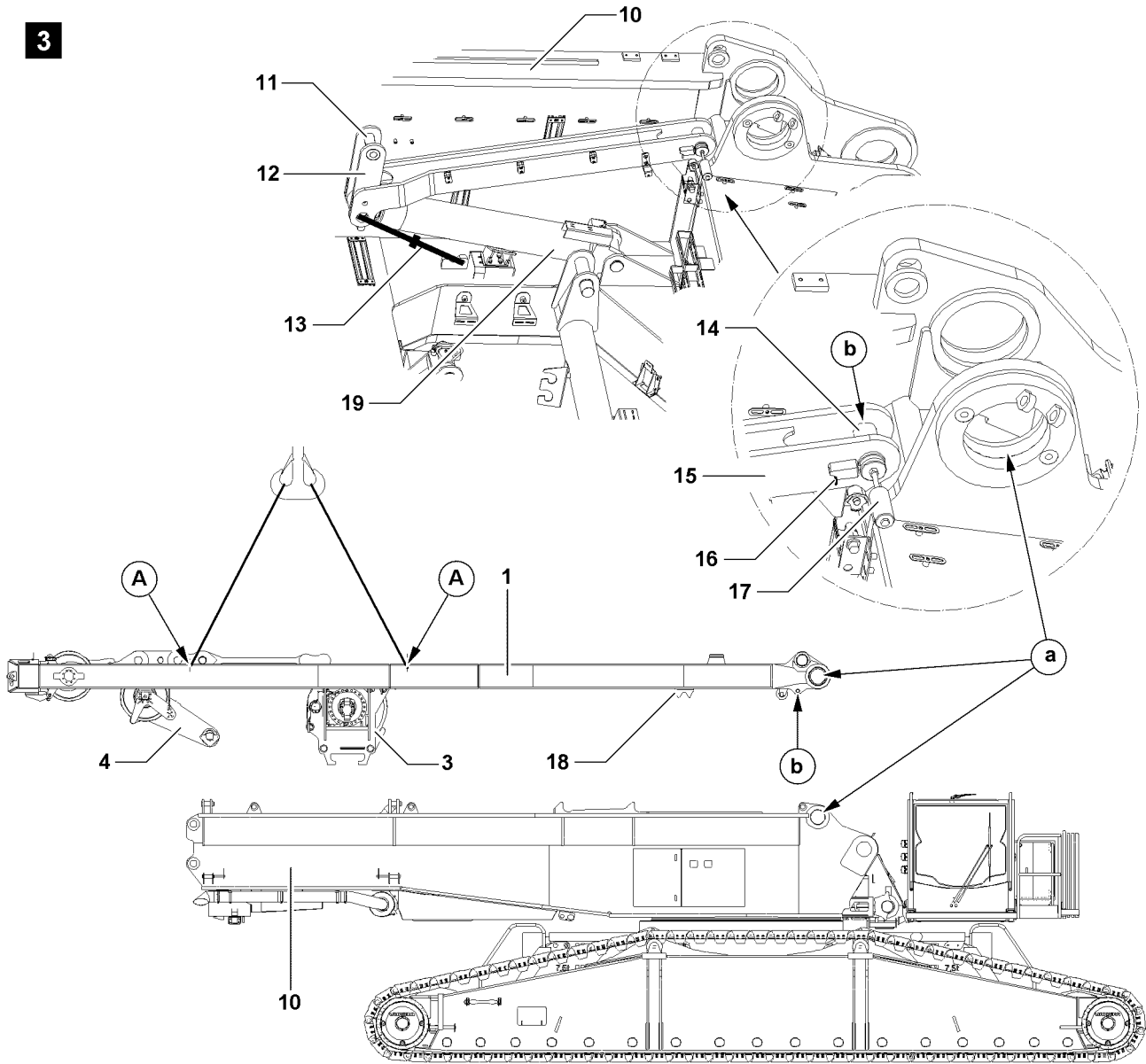

Fig.107282

LWE/LR 1600-2-008/18109-09-02/en

4.5 Unpin the SA-frame on the turntable

Ensure that the following prerequisites are met:

- intake gear winch 4 is in transport position,
 - roller bearings are in transport position.
- ▶ Secure support cylinder **19**: Assembling the turnbuckle **13**.
 - ▶ Pull, turn and latch spring pin **16** on both sides.
 - ▶ Unpin pins **14** with pin device **17**.
 - ▶ Pins **16** should be pinned on both sides and secured with spring retainers **14**.
 - ▶ Attach the pin pulling cylinder **24** between the retainer **23** and the pull screw **25**.
 - ▶ Release pin **22**: Remove the linchpin **20** and unpin the pin **21**.
 - ▶ Unpin the pin **22** on both sides.
 - ▶ Remove the pin pulling device **24**.

Result:

- SA-frame **1** is disassembled and can be lifted with the auxiliary crane.

4.6 Remove the SA-frame from the turntable



Note

- ▶ Guarantee equally long tackle such that the SA-frame can be horizontally lifted from the turntable.

NOTICE

Collision of components!

If the SA-frame is lifted with the auxiliary crane on the turntable, roller bearings and hoist gear can collide with the turntable. Components can be damaged.

- ▶ Make sure that the roller bearing **4** does not collide with the turntable **10**.
 - ▶ Make sure that the intake gear winch 4 **3** does not collide with the turntable **10**.
-
- ▶ Attach SA-frame **1** with auxiliary crane on the attachment points.
 - ▶ Carefully lift and remove SA-frame **1**.

Empty page!

LWE/LR 1600-2-008/18109-09-02/en

3.06 Assembly conditions

1 Assembly conditions for operation on crawlers

3

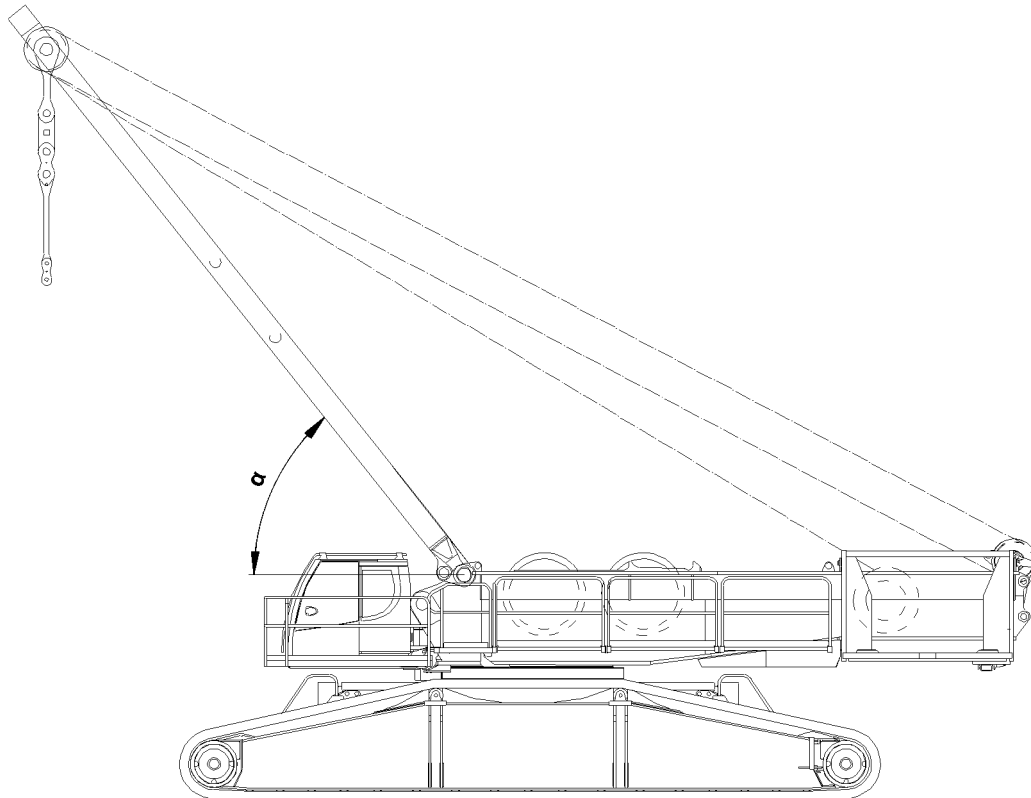

Fig.104917

1 Assembly conditions for operation on crawlers

1.1 Definition of assembly conditions

The assembly conditions take the following components into account:

- 1 SA-bracket
- 2 Winch I
- 3 Winch II
- 4 Winch IV

Assembly condition	SA-bracket, angle α	Winch I	Winch II	Winch IV	S-articulated piece
1	placed down	–	–	with rope	–
2	90°	–	–	with rope	–
3	90°	without rope	–	with rope	–
4	90°	with rope	–	with rope	–
5	90°	with rope	with rope	with rope	–
6	smaller than 60°	with rope	with rope	with rope	installed (laying on the ground)

1.2 Permissible turntable ballast - ballast combinations



Note

► Definition of assembly conditions, see chart section „Definition of assembly conditions“.

Assembly condition	360° on crawlers 8.7 m x 8.4 m Central ballast			
	65 t	25 t	5 t	0 t
	1	130 t	90 t	70 t
2	150 t	130 t	90 t	90 t
3	150 t	130 t	110 t / 115 t	90 t
4	170 t	130 t	110 t / 115 t	90 t
5	170 t	130 t	110 t / 115 t	110 t / 115 t
6	190 t	150 t	130 t	110 t / 115 t

Maximum permissible turntable ballast depending on assembly condition and central ballast

Empty page!

LWE/LR 1600-2-008/18109-09-02/en

3.07 Assembly hoist winches

1	Component overview	3
2	Dimensions and weights	3
3	Assembling winch 1	5
4	Removing winch 1	13
5	Assembly and disassembly of winch 1	17

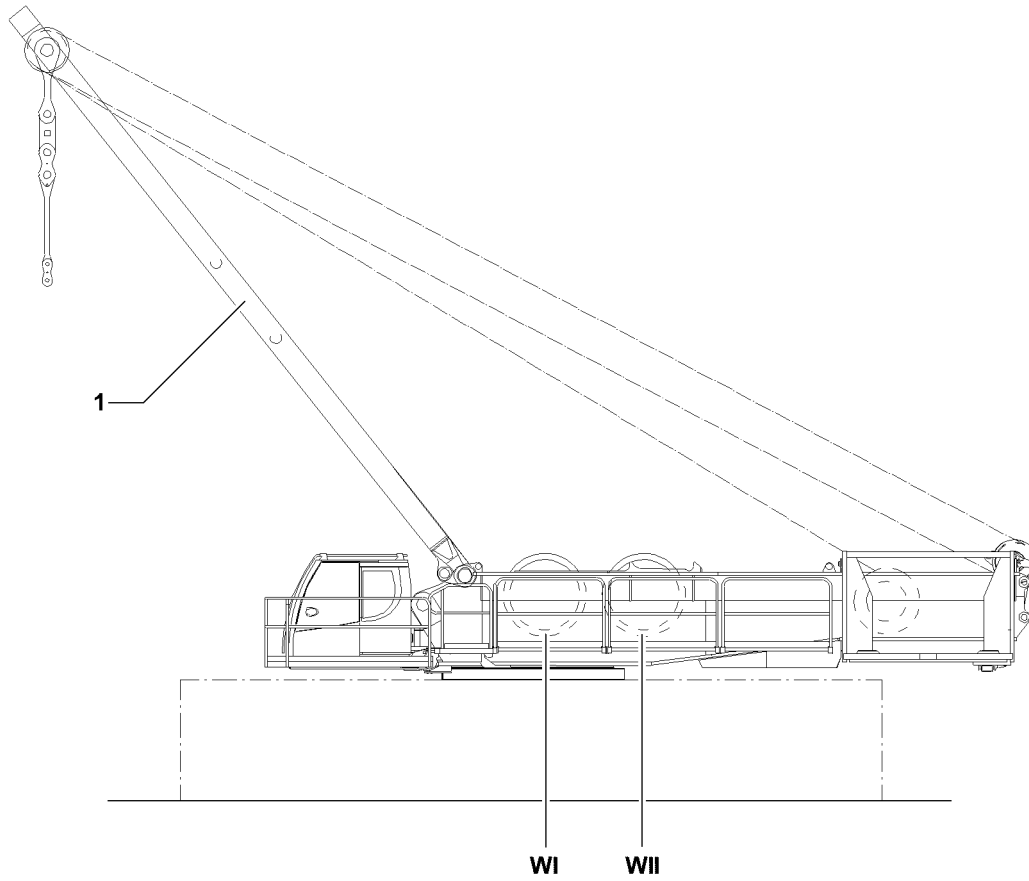

Fig.111744

1 Component overview

- 1 SA-frame
- WI** Winch 1
- WII** Winch 2

2 Dimensions and weights



Note

▶ See Crane operating instructions, chapter 1.03!

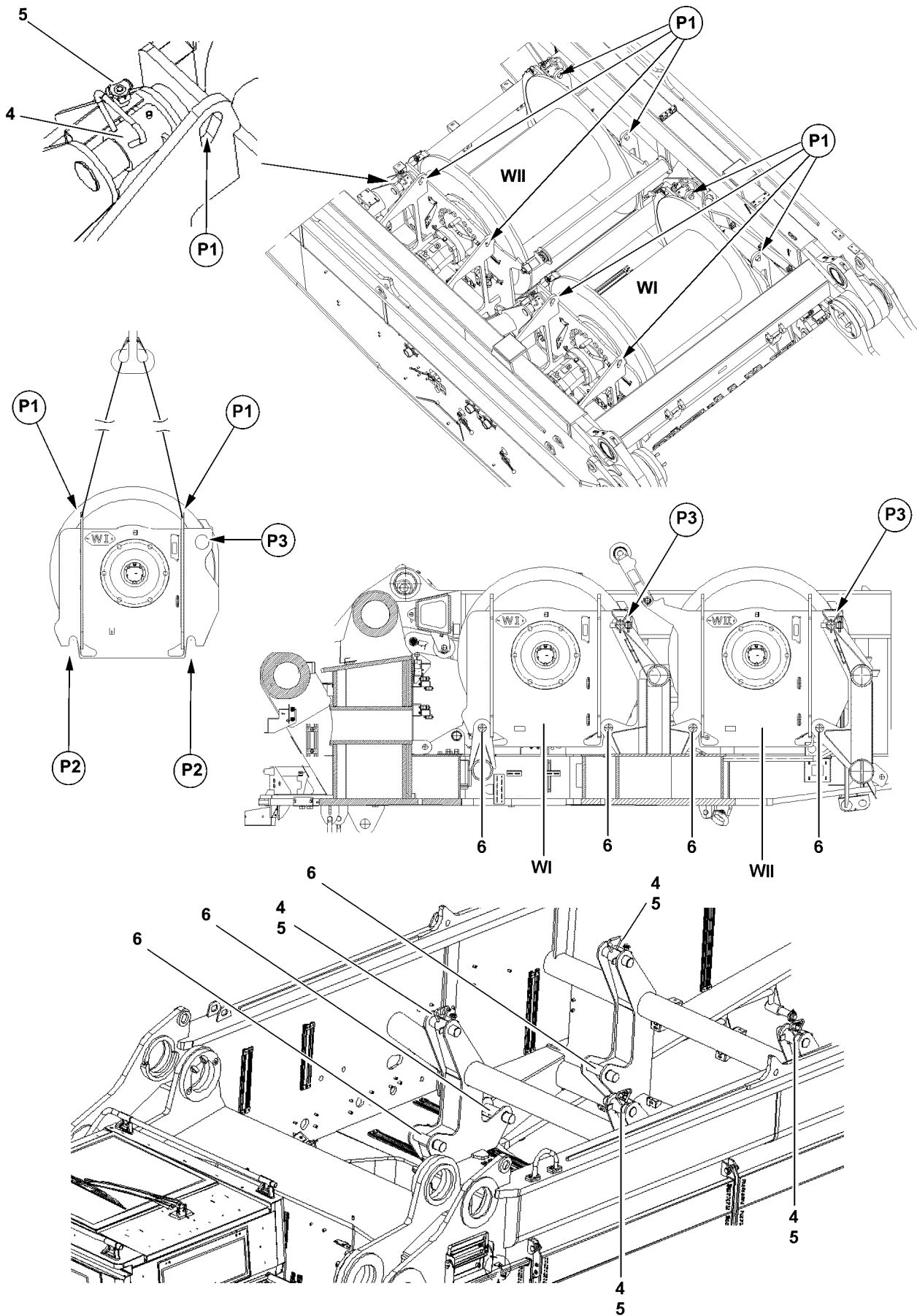

Fig.110972

LWE/LR 1600-2-008/18109-09-02/en

3 Assembling winch 1



WARNING

Risk of falling!

During assembly / disassembly work, personnel must be secured with appropriate aids to prevent them from falling. If this is not observed, assembly personnel can fall and suffer life-threatening or fatal injuries!

- ▶ Any assembly work, where there is a danger of falling must be carried out with suitable aids (for example lifting platform, scaffolding, ladder, auxiliary crane)!
- ▶ If the work cannot be carried out with such aids nor from the ground, then the assembly personnel must secure themselves with approved fall arrest systems to avoid falling, see Crane operating instructions, Chapter 2.04!
- ▶ Approved fall arrest systems must be hung into the respective fastening points on the crane, see Crane operating instructions, chapter 2.06!
- ▶ If railings are present on the components, then they must be brought into the corresponding position and secured for assembly / disassembly work!
- ▶ Step on aids and fall protection equipment only with clean shoes!
- ▶ Keep aids and fall protection equipment clean and free from snow and ice!
- ▶ During all assembly and disassembly work, maintenance work and inspections, travel and crane operation is prohibited!



WARNING

Components not pinned and secured!

If a component is released from the auxiliary crane before having been pinned and secured, the component will fall down! Personnel can be severely injured or killed!

- ▶ Do not disengage the auxiliary crane until the corresponding component is pinned and secured!



WARNING

Danger of impact / crushing!

When installing / removing counterweight components with the auxiliary crane, crane components can start to swing back and forth!

When lifting / lowering and positioning crane components, there is an increased danger of impacts / crushing!

Personnel can be caught and severely injured or killed!

- ▶ Make sure that personnel cannot be caught by components!
- ▶ When working in danger zones: Use aids to protect limbs!
- ▶ Guide components with suitable aids to minimize oscillation!

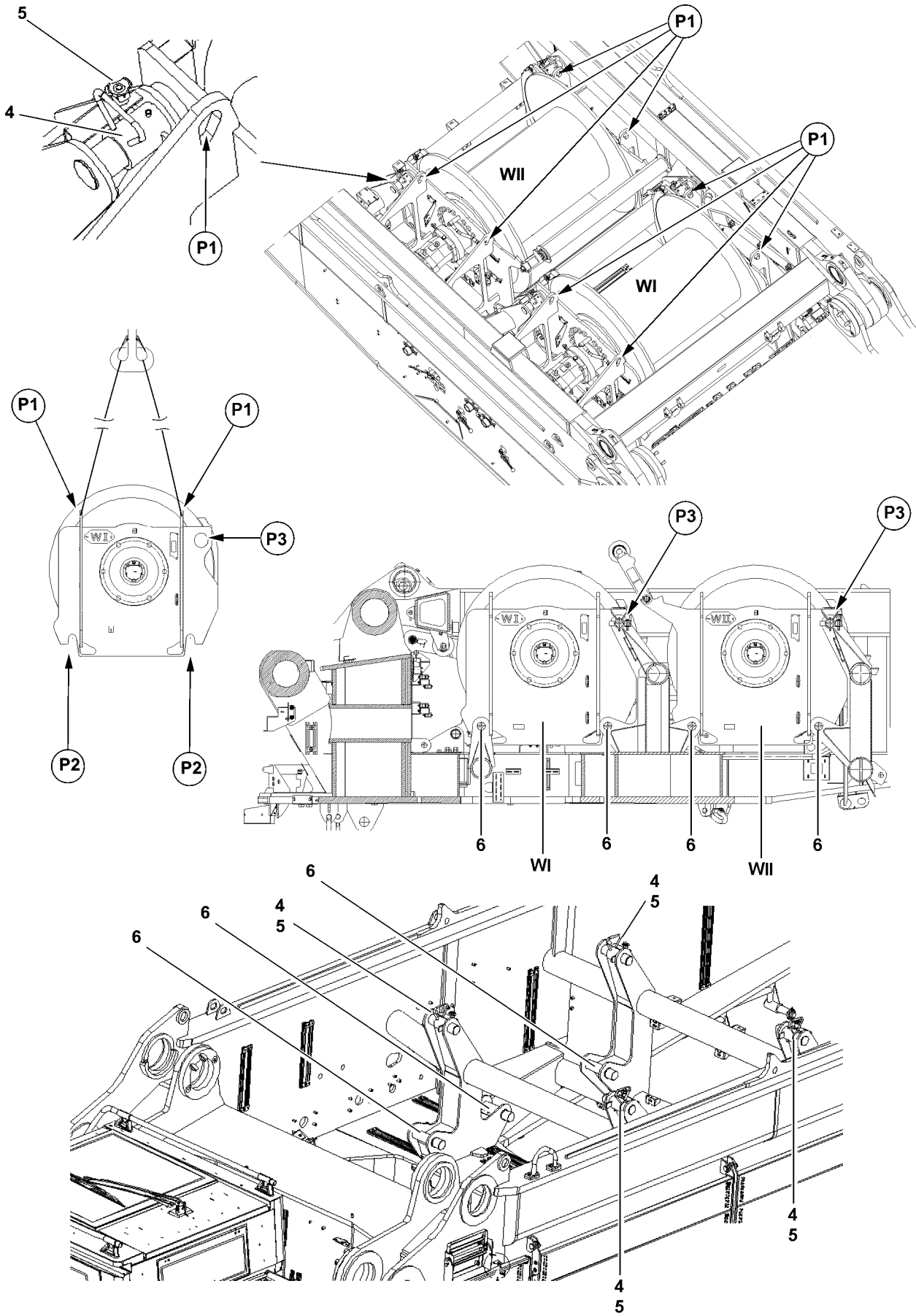

Fig.110972

LWE/LR 1600-2-008/18109-09-02/en

3.1 Lifting winch 1 from the flatbed trailer

Make sure that the following prerequisites are met:

- The installation of the turntable is completed.
- The crane is aligned in horizontal direction.
- An auxiliary crane with sufficient load carrying capacity is available.



WARNING

Danger of accident due to incorrect attachment!

Life-threatening situations can arise if the winch 1 is incorrectly or improperly attached!

Personnel can be severely injured or killed!

- ▶ Winch 1 must be attached on the intended receptacle point, point **P1**!
- ▶ Make sure that the tackle is correctly attached on winch 1 and that it is secured sufficiently to prevent it from loosening up!

-
- ▶ Attach the tackle on the receptacle points, point **P1**.
 - ▶ Bring the tackle to „tension“.
 - ▶ Release and remove the transport retainers on the flatbed trailer.



WARNING

Falling components!

When lifting winch 1 from the flatbed trailer, components or winch 1 can fall down!

Personnel can be severely injured or killed!

- ▶ Make sure that there are no persons within the danger zone!
-
- ▶ Lift winch 1 with the auxiliary crane from the flatbed trailer.

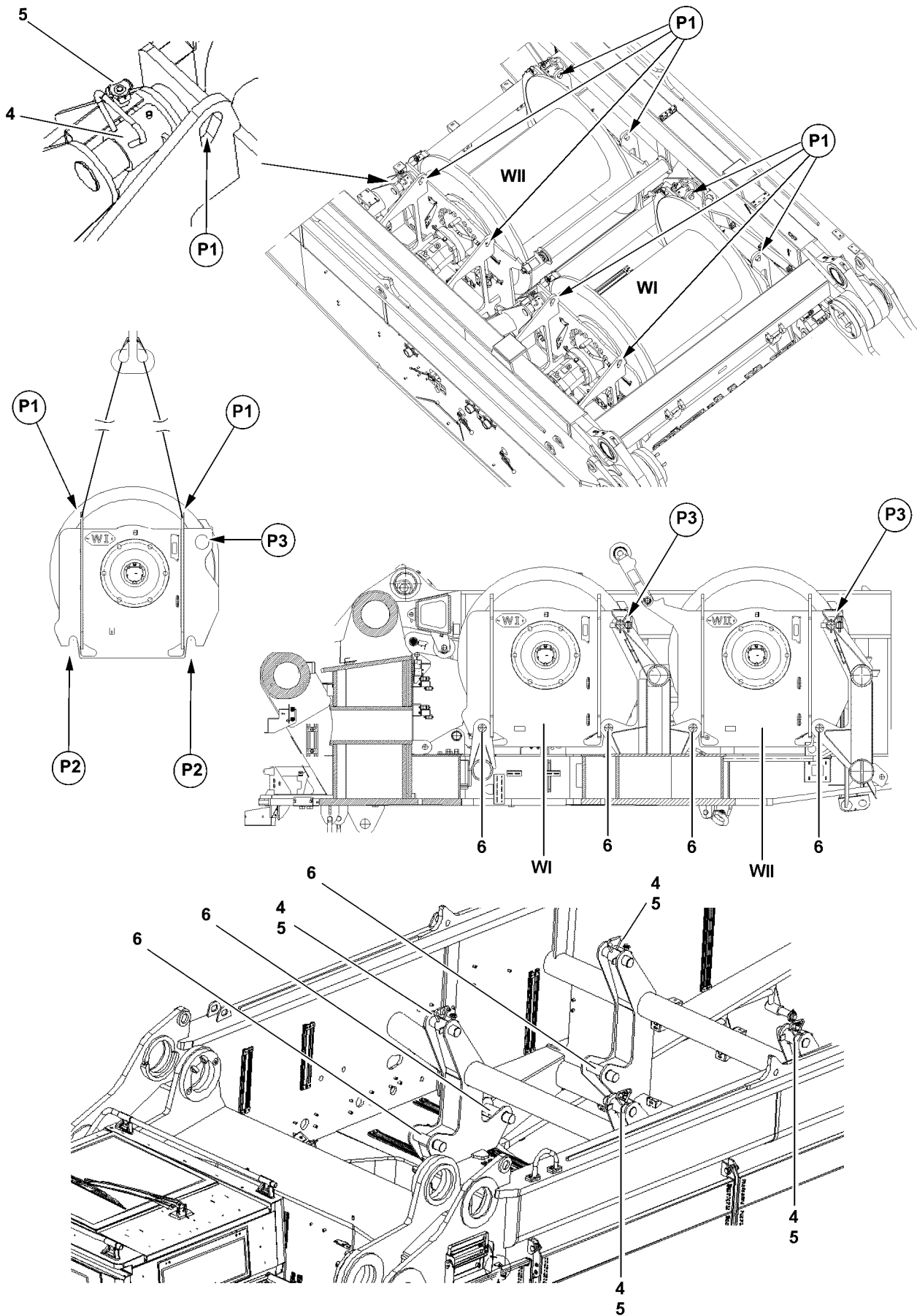

Fig.110972

LWE/LR 1600-2-008/18109-09-02/en

3.2 Setting winch 1 into the turntable

Make sure that the following prerequisites are met:

- The SA-frame is aligned / placed down to the point where the assembly area of winch 1 is easily accessible.
- The pin bores are clear.



WARNING

Danger of accident when swinging in and lowering winch 1!

When swinging in and lowering winch 1 on the turntable, limbs can be crushed or even severed!

Personnel can be severely injured or killed!

- ▶ Make sure that there are no persons within the danger zone!
- ▶ Do not reach with your hands into the danger zone!

NOTICE

Property damage!

If the following note is not observed, damage can result to the crane or winch 1!

- ▶ When moving winch 1 in with the SA-frame, it must be ensured that winch 1 does not hit against the SA-frame!



Note

- ▶ Check to ensure that the alignment of winch 1 or the receptacles, point **P2** to the pins **6** on the turntable is exact!
- ▶ Before lowering, bring winch 1 into position that the receptacles, point **P2** are above the pins **6** on the turntable!

- ▶ Move winch 1 in with the auxiliary crane between the SA-frame.
- ▶ Lower winch 1 slowly.

When winch 1 is aligned:

- ▶ Set winch 1 carefully on the pins **6** on the turntable.

3.3 Pinning winch 1 with the turntable

Make sure that the following prerequisites are met:

- Winch 1 is seated on the pins **6**.
- The tackle between winch 1 and the auxiliary crane is „tensioned“.
- ▶ Insert the pins **4**, point **P3**.



WARNING

The pins can loosen up by themselves!

- ▶ Secure pins **4** immediately after pinning with ball locking pins **5**!

When all pins **4** are completely pinned:

- ▶ Secure the pins **4** with ball locking pins **5**.
- ▶ Remove the tackle on winch 1.

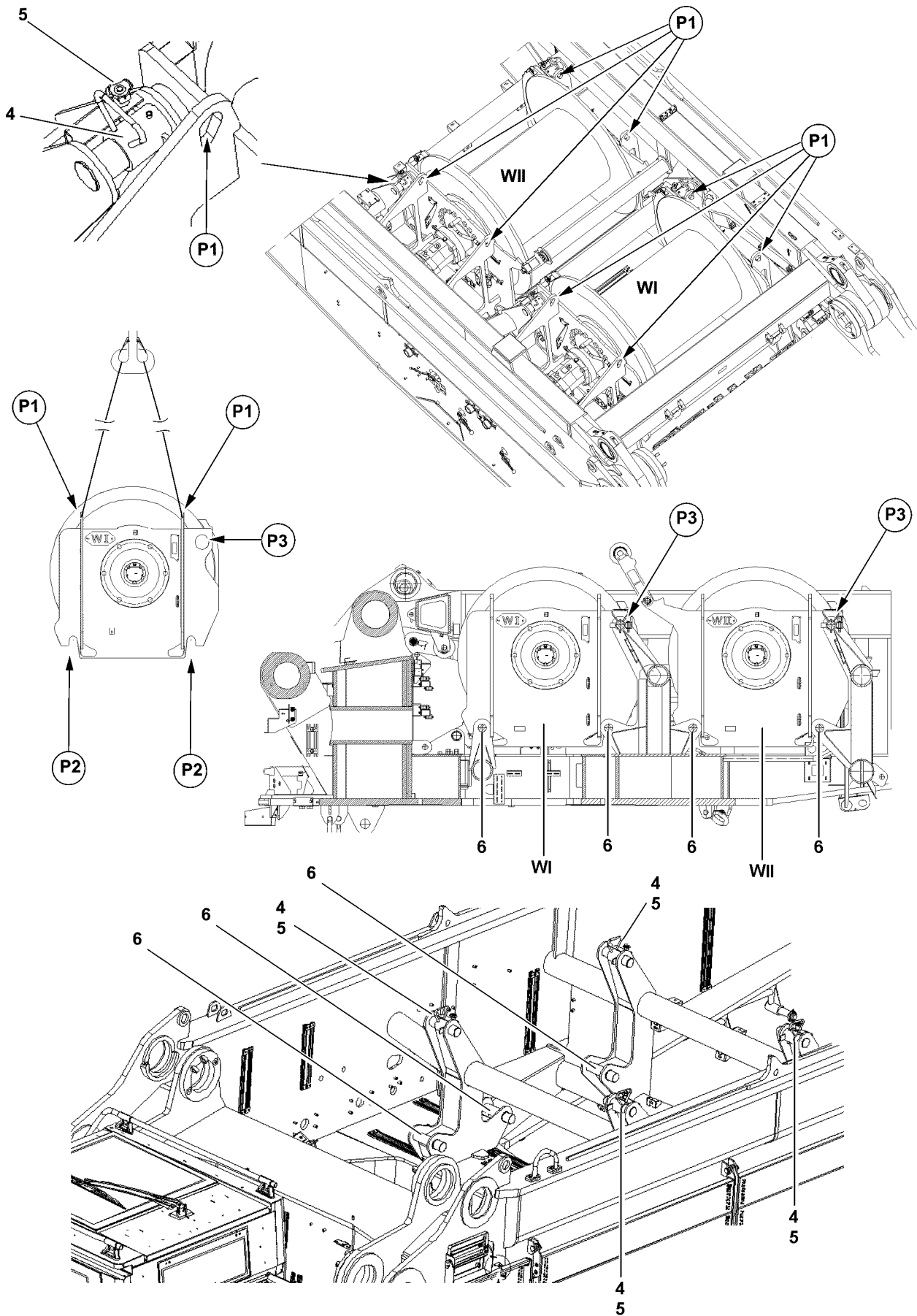

Fig.110972

LWE/LR 1600-2-008/18109-09-02/en

3.4 Establishing the connection to the turntable

Make sure that the following prerequisite is met:

- The winch is properly installed, pinned and secured.

3.4.1 Establishing the hydraulic connections to winch 1

The hydraulic connections of winch 1 are made with quick couplings.

When connecting hydraulic lines with quick couplings, make sure that the coupling procedure is carried out correctly.



WARNING

Pressure in the hydraulic lines!

If the pressure supply is not interrupted before connecting / releasing the hydraulic lines, the hydraulic oil can escape with high pressure!

Personnel can be severely injured or killed!

- ▶ Release the pressure in the hydraulic system before connecting / disconnecting: Interrupt the pressure supply and wait for a short time!



WARNING

Loss of pressure or leakage!

Incorrectly coupled or self-loosening quick-release couplings (particularly return lines) can result in serious accidents due to component failure!

- ▶ Check that the quick-release couplings have been properly connected before using the crane!

- ▶ Assemble coupling components (sleeve and connector) and screw together using hand-tightened nut.

- ▶ Tighten hydraulic coupling by hand. Rotate hand-tightened nut until it reaches a tangible, fixed stop position.

- ▶ Establish the hydraulic connection to winch 1.

3.4.2 Establishing the electrical connections to winch 1.

- ▶ Establish the electrical connections to winch 1, see electric wiring diagram.

3.4.3 Establishing the connections of the central lubrication system to winch 1

- ▶ Establish the connections of the central lubrication system to winch 1.

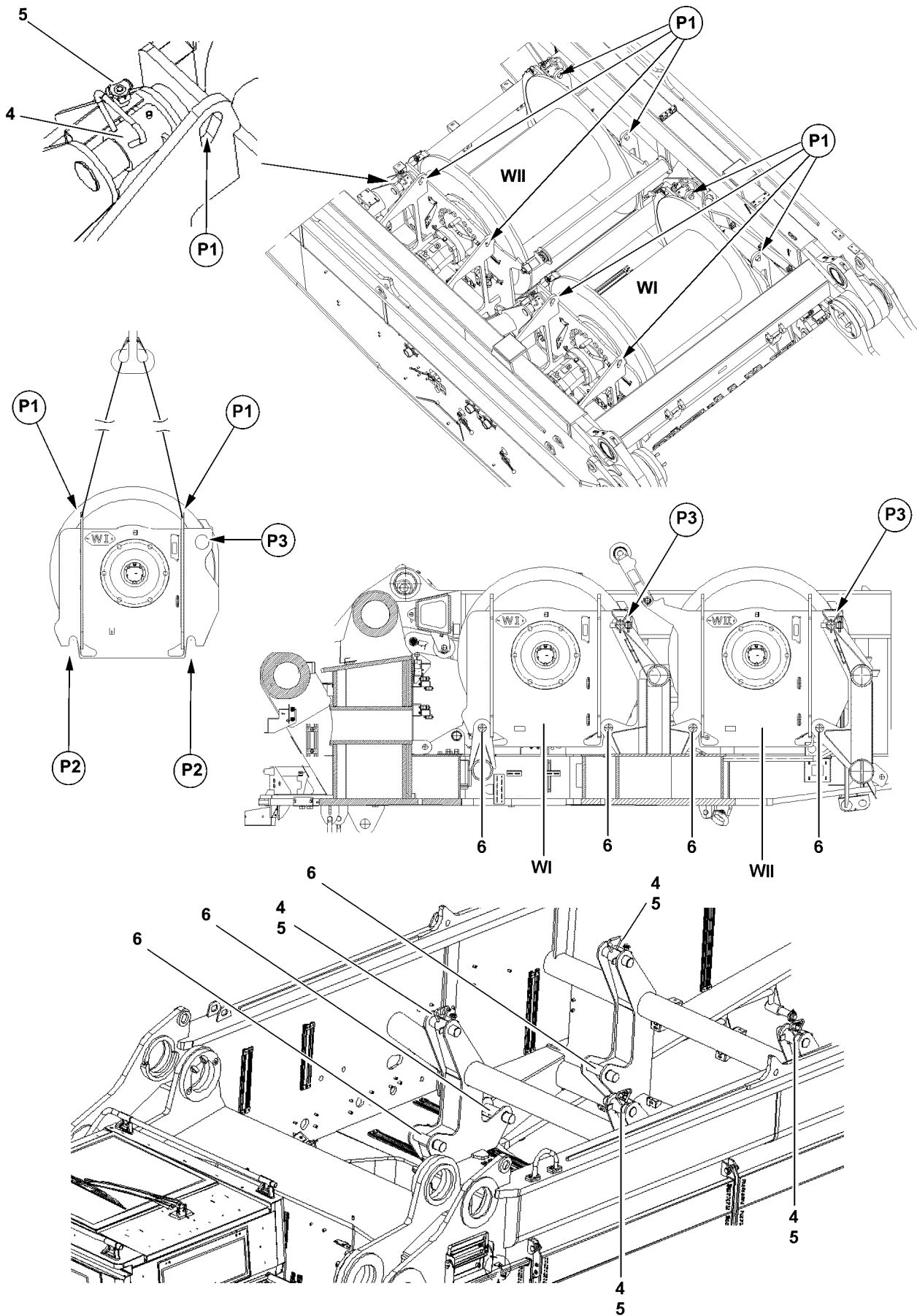

LWE/LR 1600-2-008/18109-09-02/en

Fig.110972

4 Removing winch 1



WARNING

Risk of falling!

During assembly / disassembly work, personnel must be secured with appropriate aids to prevent them from falling. If this is not observed, assembly personnel can fall and suffer life-threatening or fatal injuries!

- ▶ Any assembly work, where there is a danger of falling must be carried out with suitable aids (for example lifting platform, scaffolding, ladder, auxiliary crane)!
- ▶ If the work cannot be carried out with such aids nor from the ground, then the assembly personnel must secure themselves with approved fall arrest systems to avoid falling, see Crane operating instructions, Chapter 2.04!
- ▶ Approved fall arrest systems must be hung into the respective fastening points on the crane, see Crane operating instructions, chapter 2.06!
- ▶ If railings are present on the components, then they must be brought into the corresponding position and secured for assembly / disassembly work!
- ▶ Step on aids and fall protection equipment only with clean shoes!
- ▶ Keep aids and fall protection equipment clean and free from snow and ice!
- ▶ During all assembly and disassembly work, maintenance work and inspections, travel and crane operation is prohibited!



WARNING

Components not pinned and secured!

If a component is released from the auxiliary crane before having been pinned and secured, the component will fall down! Personnel can be severely injured or killed!

- ▶ Do not disengage the auxiliary crane until the corresponding component is pinned and secured!



WARNING

Danger of impact / crushing!

When installing / removing counterweight components with the auxiliary crane, crane components can start to swing back and forth!

When lifting / lowering and positioning crane components, there is an increased danger of impacts / crushing!

Personnel can be caught and severely injured or killed!

- ▶ Make sure that personnel cannot be caught by components!
- ▶ When working in danger zones: Use aids to protect limbs!
- ▶ Guide components with suitable aids to minimize oscillation!

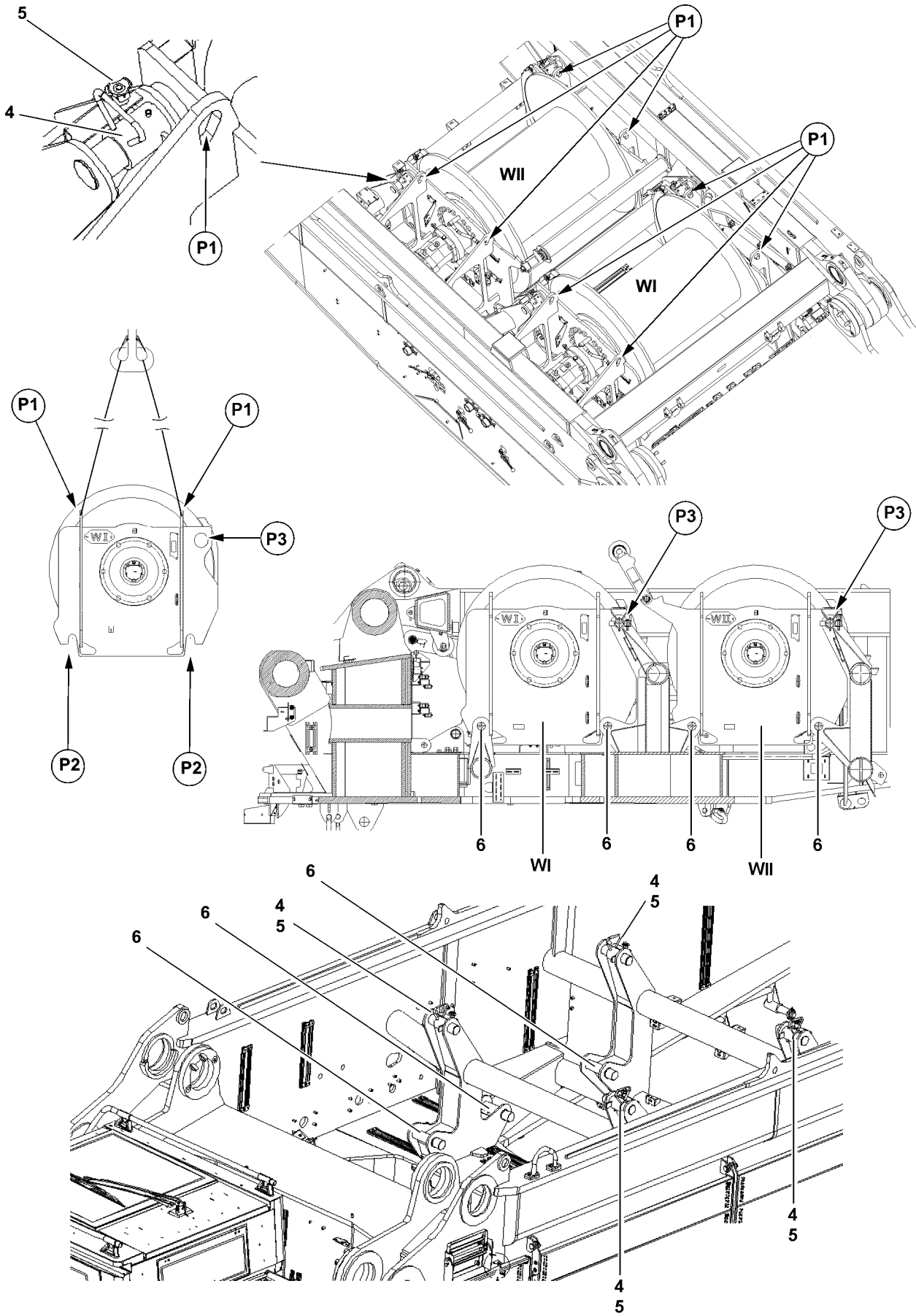

Fig.110972

LWE/LR 1600-2-008/18109-09-02/en

4.1 Disconnecting the connections to winch 1

Make sure that the following prerequisite is met:

- The hoist rope is completely spooled up.

4.1.1 Disconnecting the hydraulic connections to winch 1

When releasing hydraulic lines with quick-release couplings, make sure that the uncoupling procedure is carried out correctly.



WARNING

Pressure in the hydraulic lines!

If the pressure supply is not interrupted before connecting / releasing the hydraulic lines, the hydraulic oil can escape with high pressure!

Personnel can be severely injured or killed!

- ▶ Release the pressure in the hydraulic system before connecting / disconnecting: Interrupt the pressure supply and wait for a short time!

-
- ▶ Release the hydraulic coupling by hand.
 - ▶ Disconnect the hydraulic connection to winch 1.

4.1.2 Disconnecting the electrical connections to winch 1

- ▶ Disconnect the electrical connections to winch 1.

4.1.3 Disconnecting the connections of the central lubrication system to winch 1

- ▶ Disconnect the connections to winch 1.

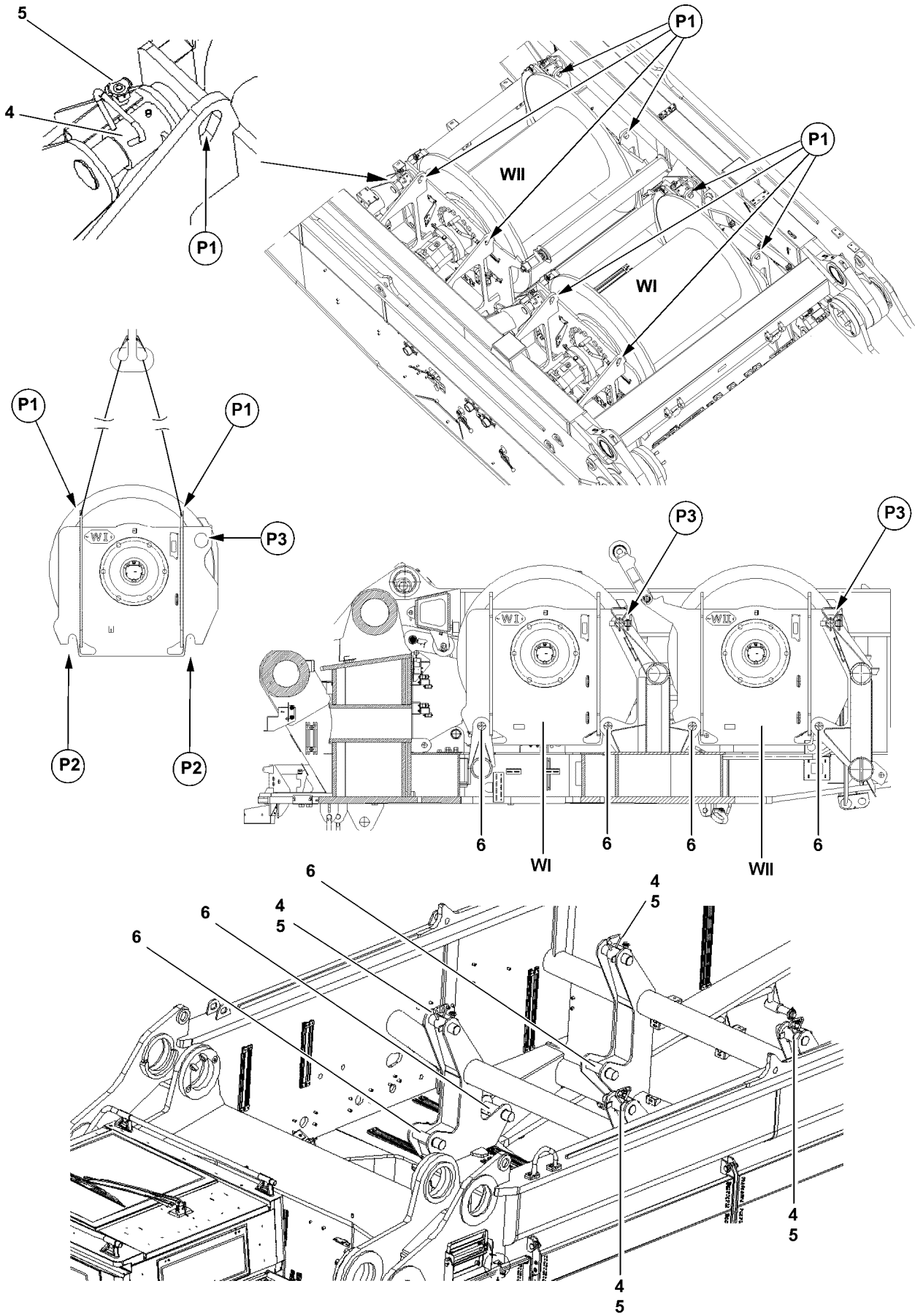

Fig.110972

LWE/LR 1600-2-008/18109-09-02/en

4.2 Unpinning winch 1 on the turntable

Make sure that the following prerequisites are met:

- The hydraulic connections are disconnected.
 - The electrical connections are disconnected.
 - The connections of the central lubrication system are disconnected.
 - The SA-frame is aligned / placed down to the point where the assembly area of winch 1 is easily accessible.
 - An auxiliary crane with sufficient load carrying capacity is available.
 - The tackle is attached on the receptacle points, point **P1** of winch 1.
- ▶ Bring the tackle to „tension“.
 - ▶ Release the ball locking pins **5**.
 - ▶ Unpin the pin **4**.

NOTICE

Damage to the connector parts!

By lifting winch 1, the connector lines can be damaged!

- ▶ Make sure that all hydraulic and electrical connections are disconnected!
 - ▶ Make sure that the connections to the central lubrication system are disconnected!
 - ▶ Make sure that all pins are removed!
-

NOTICE

Property damage!

If the following note is not observed, damage can result to the crane or winch 1!

- ▶ When moving winch 1 out with the SA-frame, it must be ensured that winch 1 does not hit against the SA-frame!
-

When the pins **4** are unpinned:

- ▶ Lift winch 1 carefully with the auxiliary crane.
-



WARNING

Falling components!

When lifting winch 1 from the turntable, components or winch 1 can fall down!

Personnel can be severely injured or killed!

- ▶ Make sure that there are no persons within the danger zone!
-

- ▶ Move winch 1 out.

When winch 1 is moved out:

- ▶ Set winch 1 on the flatbed trailer.
- ▶ Remove the auxiliary crane.

5 Assembly and disassembly of winch 1

The assembly or disassembly of winch 1 is to be carried out according to the assembly or disassembly of winch 1.

Empty page!

LWE/LR 1600-2-008/18109-09-02/en

4 Operation of crane superstructure

LWE/LR 1600-2-008/18109-09-02/en

LWE/LR 1600-2-008/18109-09-02/en

4.01 Operating and control instruments on the crane superstructure

1	Operating and monitoring instruments	3
2	Equipment in the cab	3
3	Operating units in the cab	7
4	Control units crane chassis	31

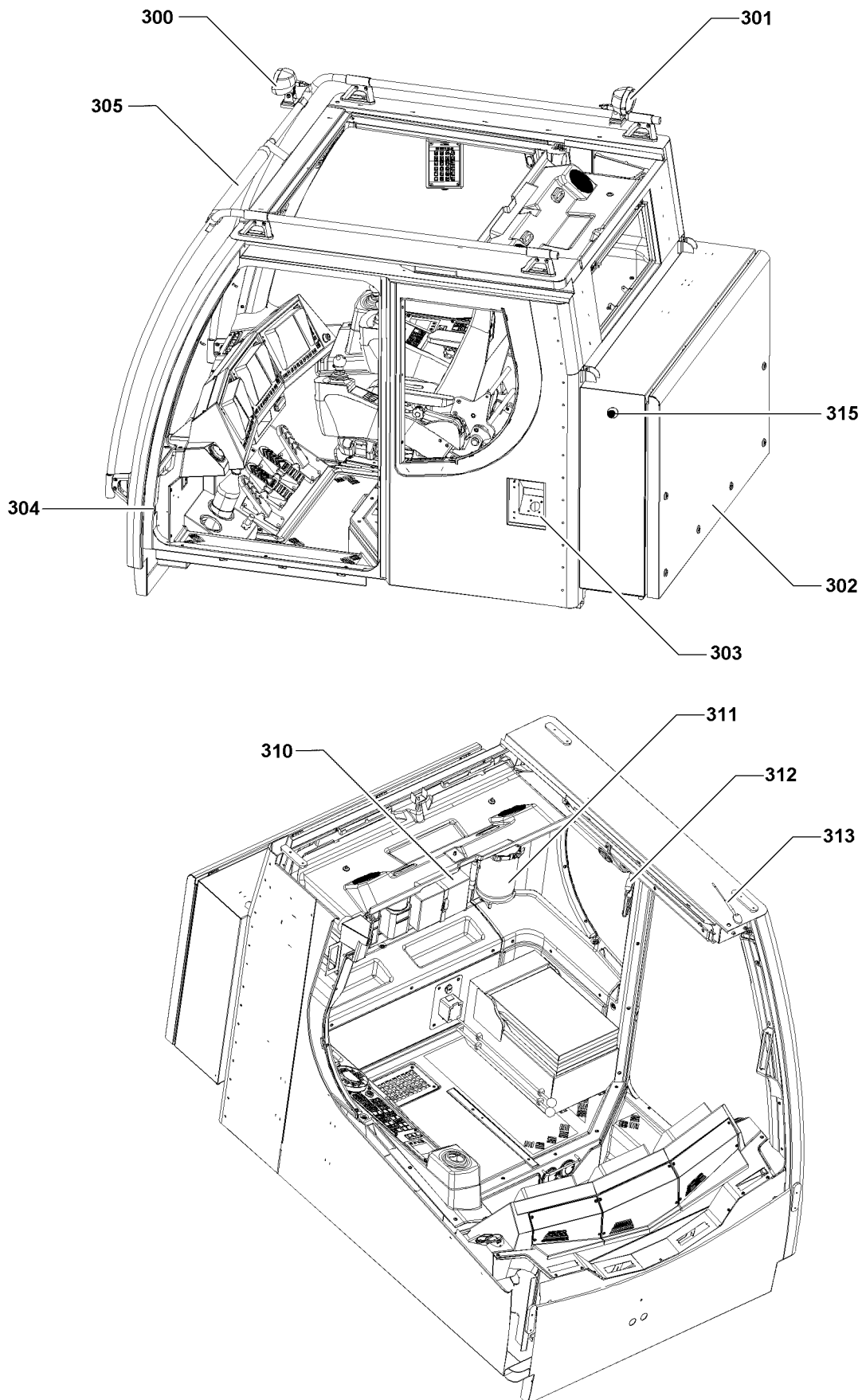

Fig.104888

LWE/LR 1600-2-008/18109-09-02/en

1 Operating and monitoring instruments

This chapter describes the elements in the cab and is divided into:

- General equipment in the cab
- Operating units in the cab

2 Equipment in the cab

2.1 Installations in the cab

- 300** Working floodlight, front
- 301** Working floodlight, rear
- 302** Control cabinet
- 303** Reservoir for window cleaning fluid
- 304** Door contact switch
- 305** Three color light
 - LMB-warnings are optically shown
- 313** Antenna

2.2 Emergency equipment

- 310** First aid kit
- 311** Fire extinguisher
- 312** Emergency hammer
- 315** EMERGENCY OFF switch

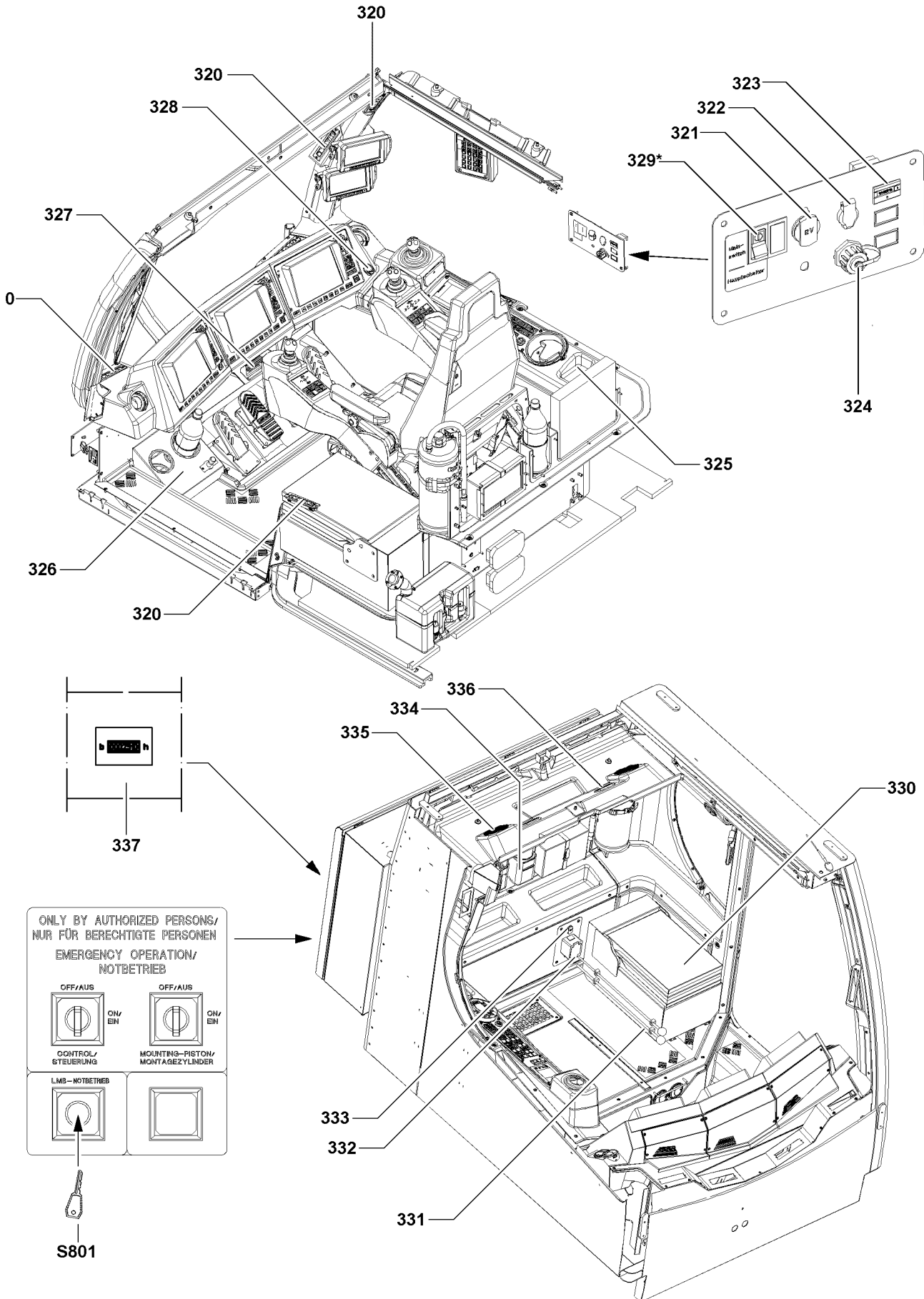

Fig.113577

LWE/LR 1600-2-008/18109-09-02/en

2.3 Interfaces

- 321 12 V socket
- 322 24 V socket
- 324 LAN socket
- 332 230 V socket*
- 333 12 V socket

2.4 Interior equipment

- 320 Outlet nozzles
- 323 Operating hour meter
 - Recording of crane operating hours
- 325 Compartment
- 326 Drink holder
- 327 Radio
- 328 Cigarette lighter
- 329 Toggle switch*
 - Shut off / turn on main current circuit
- 330 Emergency seat
- 331 Manual control lever
- 334 Drink holder
- 335 Speaker
- 336 Interior lights

2.5 Control cabinet

- 337 Operating hour meter
 - Recording of crawler operating hours
 - **Note:**
For the narrow track version of the crane, the operating hour meter for the crawler operating hours can be located in the cabinet on the crane chassis.
- S801 Key switch
 - LMB emergency operation

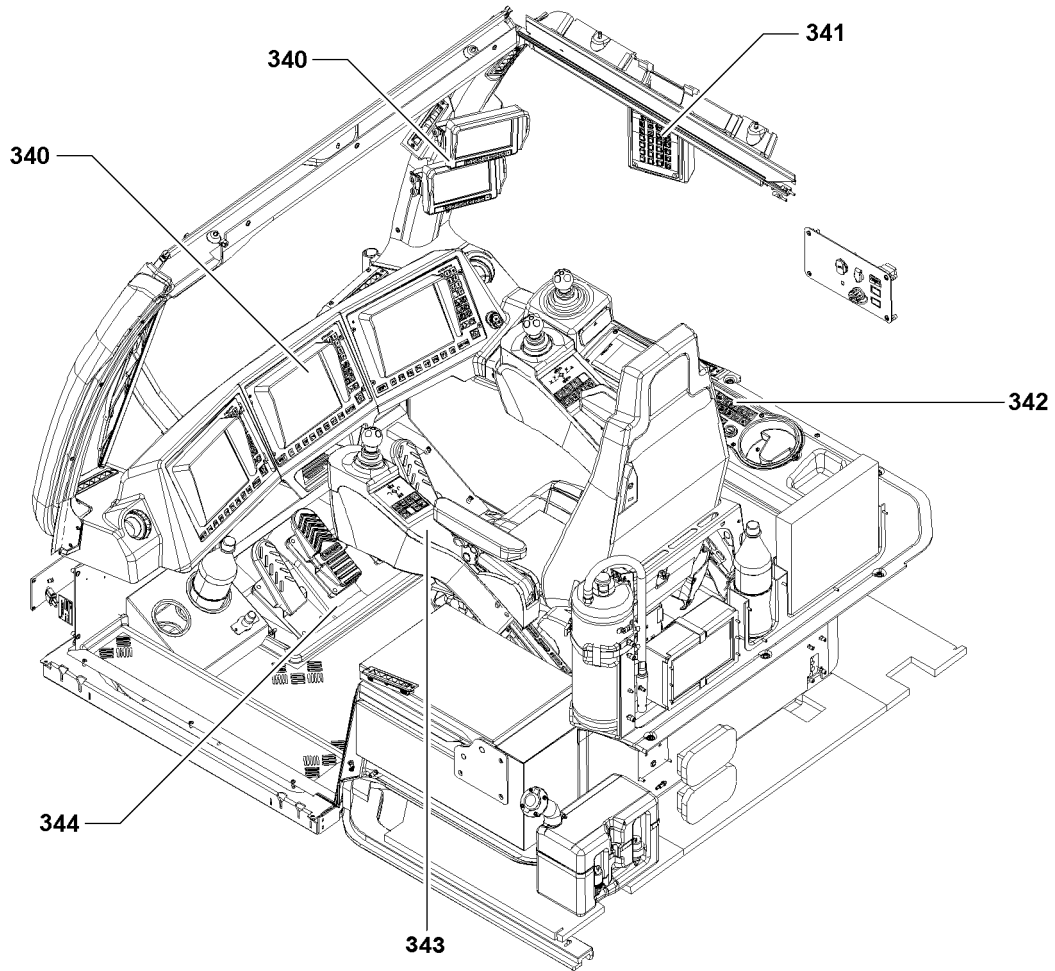

Fig.104890

LWE/LR 1600-2-008/18109-09-02/en

3 Operating units in the cab

The following operating units are in the cab:

- 340** Monitors and displays
- 341** Operating and control unit - BKE
- 342** Instrument panel
- 343** Control platform
- 344** Pedal carrier

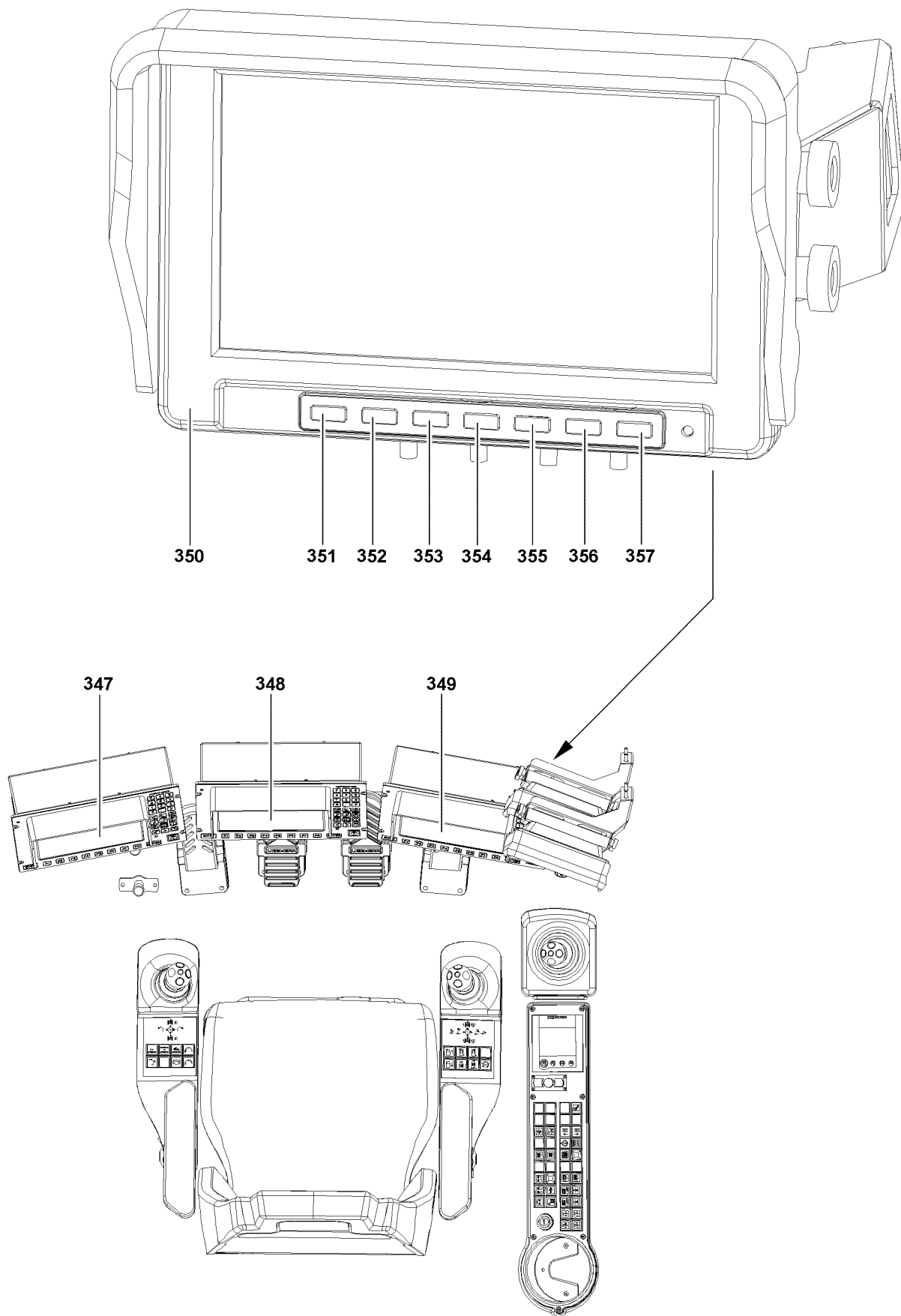

Fig.110863

3.1 Monitors and displays

3.1.1 LICCON computer system

- 347** LICCON monitor 2
 - User interface for „LICCON job planner“
- 348** LICCON monitor 1
 - User interface for operation with „derrick“ boom
- 349** LICCON monitor 0
 - User interface for entry of equipment configurations and for crane operation

3.1.2 Camera monitoring

- 350** TFT monitor
- 357** Button
 - Monitor on / off
- 351** Button „MODE“
 - By pressing the button „MODE“ the system changes between the individual display modes:
 - Single display mode
 - Split display mode
 - Tripled or quadrupled display mode
- 352** „Camera selection“ key
 - By pressing the button „Camera selection“ the system changes between the cameras:
 - Single display mode: Change between camera 1 and camera 2.
 - Split display mode: Change between cameras 1/2, cameras 2/3, cameras 3/4 and camera 4/1
 - Tripled or quadrupled display mode: Button has no function.
- 353** Menu button
 - By pressing the „Menu“ button, menus for various adjustments are called up and changed over, in the following order:
 - Color: Adjustment of color saturation
 - Brightness: Brightness adjustment
 - Contrast: Contrast adjustment
 - Standard: Reset to default settings
 - Volume: Volume adjustment
 - Language: Language adjustment (English, French, German, Spanish, Italian, Portuguese, Polish)
 - Reflection: Reflection of camera view Return to the main menu with „Enter“. End menu with „End“.
- 354** „Minus“ key
 - By pressing the „Minus“ key, the value of a setting is reduced.
- 355** „Plus“ key
 - By pressing the „Plus“ key, the value of a setting is increased.
- 356** „Change between day / night“ key
 - Press the „Change between day / night“ button to match the brightness of the display to the time of day.

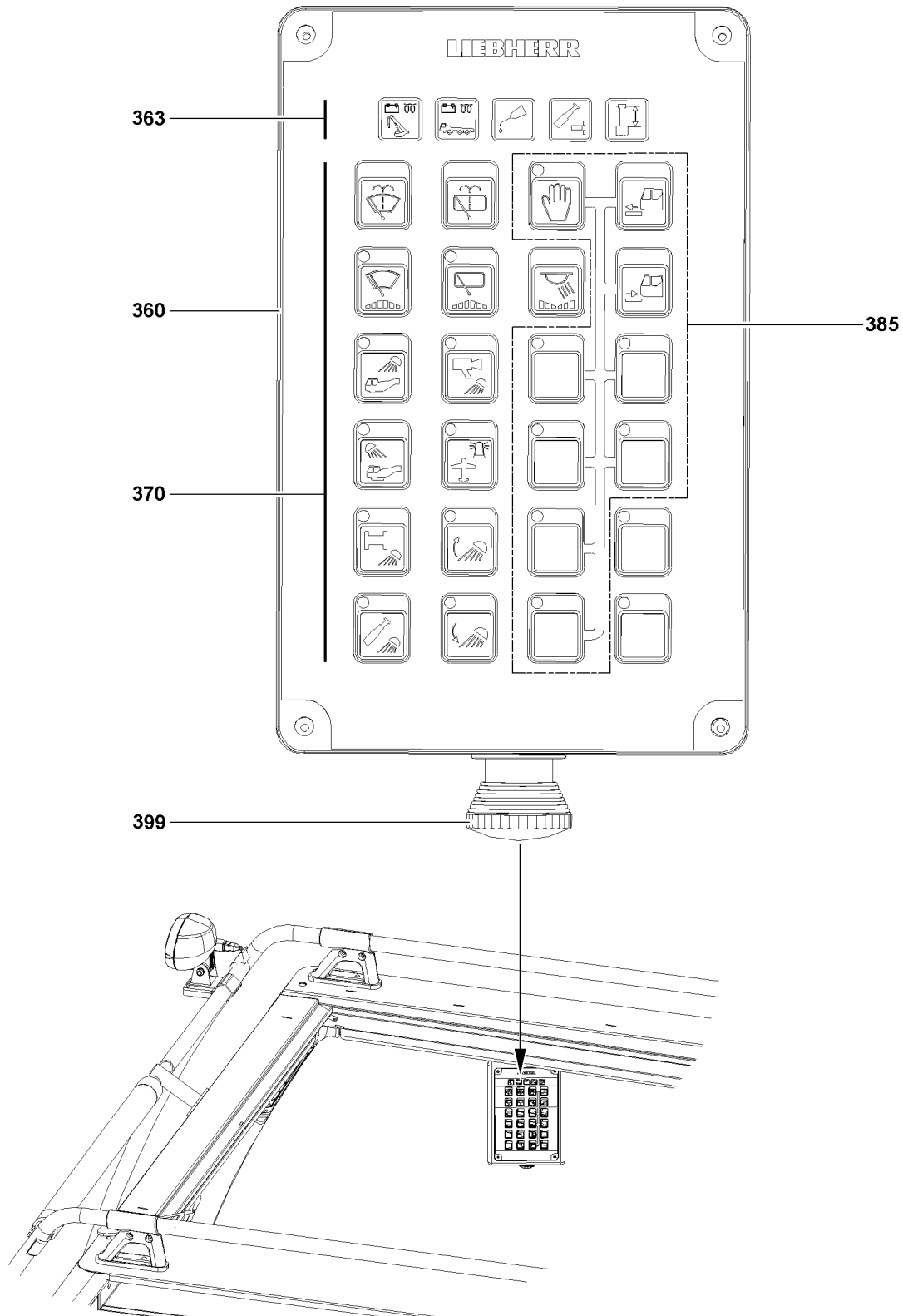

Fig.104892

LWE/LR 1600-2-008/18109-09-02/en

3.2 Operating elements on the operating and control unit (BKE)

3.2.1 Operating console







Note

► The indicator lights as well as the operating keys are described in detail in the following sections!

- 360** Operating console
 - Housing with indicator lights and buttons
- 399** EMERGENCY OFF switch
 - Impact switch
- 363** Indicator lights on the BKE
- 370** Operating buttons on the BKE
 - Standard assignment
- 385** Operating buttons on the BKE
 - Standard assignment for release controls

3.2.2 Indicator lights on the BKE „363“

Position	Button	LED condition	Description
364	 Engine monitoring superstructure	Yellow	Engine preheating active
		Yellow / red blinking	Engine ready to start
		Yellow blinking	Engine preheating Error / problem
		Off	Engine is running (after engine has been started)
		Red	The engine is running, the alternator does not charge
		Red blinking	Engine is running in emergency operation
365		Note: Indicator light not assigned!	
366	 Central lubrication	Yellow + red (orange)	Functional readiness (is shown after engine start for 1.5 s)
		Yellow	Lubrication active
		Red	Error / problem
		Off	Central lubrication not active
367		Note: Indicator light not assigned!	
368		Note: Indicator light not assigned!	





LWELR 1600-2-008/18109-09-02/en





3.2.3 Operating buttons on the BKE „370“





Note

- With the LEDs in the operating buttons, the operating conditions and problems can be recognized quickly and reliably by the crane driver!

Position	Button	Function	LED	Description
371	 Window washer system „front“	„On“	–	Clean the window: By pressing and holding the button „Front“ or „Roof“
				Note: After releasing the button „Front“ or „Roof“, three additional wipe movements are carried out before the wiper blades return to their original position.
372	 Window washer system „Roof“	„Off“	–	By releasing the button „Front“ or „Roof“
373	 Window wiper „Front“			Note: There are three different wipe stages: <ol style="list-style-type: none"> 1. Wiper „On“: Continuous operation 2. Intermittent 1: Wipe with long pauses 3. Intermittent 2: Wipe with short pauses 4. Wiper „Off“ Every time the button „Front“ or „Roof“ is pressed, the wipe stages change incrementally
374	 Window wiper, „roof“	„On“	Lights up	
		„Off“	Off	By pressing the button „Front“ or „Roof“ longer than one second until a „beep“ sounds or By pressing the button „Front“ or „Roof“ until the LED is off or Ignition „Off“
375	 Interior light cab	„On“ (100 %)	–	By opening the door or By pressing the button
		Dim	–	There are three different dimmer stages: <ol style="list-style-type: none"> 1. 75 %

Position	Button	Function	LED	Description
				2. 50 % 3. 25 % 4. Interior light „Off“ When the interior light is turned on: Each time the button is pressed, the brightness is reduced incrementally.
		„Off“	–	By pressing the button for longer than one second or By pressing the button until the lighting turns „Off“ or If the following conditions are present simultaneously for longer than 30 s: – Driver's seat not occupied – Door closed – Engine „Off“
376	 Floodlight on rear of turntable	„Off“	Off	By pressing the button
		„On“	Lights up	By pressing the button
		„On“	Blinks	Error / problem
377	 Floodlight on front of turntable	„Off“	Lights up	By pressing the button
		„On“	Lights up	By pressing the button
		„On“	Blinks	Error / problem
378	 Floodlight, winch	„Off“	Off	By pressing the button
		„On“	Lights up	By pressing the button
		„On“	Blinks	Error / problem
379	 Floodlight pivot section	„Off“	Off	By pressing the button
		„On“	Lights up	By pressing the button
		„On“	Blinks	Error / problem
380	 Camera illumination	„Off“	Off	By pressing the button
		„On“	Lights up	By pressing the button

LWE/LR 1600-2-008/18109-09-02/en

Position	Button	Function	LED	Description
		„On“	Blinks	Error / problem
381	 Airplane warning light		Note:	There are two different lighting types for the airplane warning light: Continuous light and flashing light
				<ol style="list-style-type: none"> 1. Airplane warning light continuous light on (LED turns on) 2. Airplane warning light flashing light on (LED flashes) 3. Airplane warning light off (LED off) Pressing the „airplane warning light“ button < 0.5 s , changes the light status: OFF ⇒ continuous light ⇒ flashing light ⇒ OFF
		„Off“	Off	Pressing the „airplane warning light“ button ≥ 1 s with continuous light Continuous light ⇒ OFF
382	 Floodlight swing „boom“ up	„Off“	Off	By pressing the button
		„On“	Lights up	By pressing the button
		„On“	Blinks	Error / problem
383	 Floodlight swing „boom“ down	„Off“	Off	By pressing the button
		„On“	Lights up	By pressing the button
		„On“	Blinks	Error / problem

3.2.4 Operating buttons on the BKE „385“





Note

- ▶ For this crane, there are no functions which require a release!

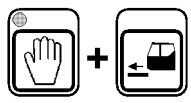

Note

- ▶ The „release button“ is active for 30 s. If an operating button is pressed during this time, the release time is reset to 30 s. The release stops after 30 s!
- ▶ A function is triggered by activation of the „release button“ and then pressing the corresponding operating button!
- ▶ For the listed button combinations, hold the corresponding operating button until the desired end position is reached!

Position	Button	Function	LED	Description
385	 Release button			<p>Note: For this crane, there are no functions which require a release.</p> <p>After actuating the „release button“, the functions, which require a release can be activated.</p>
		„On“	Lights up	By pressing the button
		„Off“	Off	By pressing the button or as long as no button is pressed, which requires a release: Automatically after 30 s
385+386				Note: Key combination not assigned!
385+387				Note: Key combination not assigned!

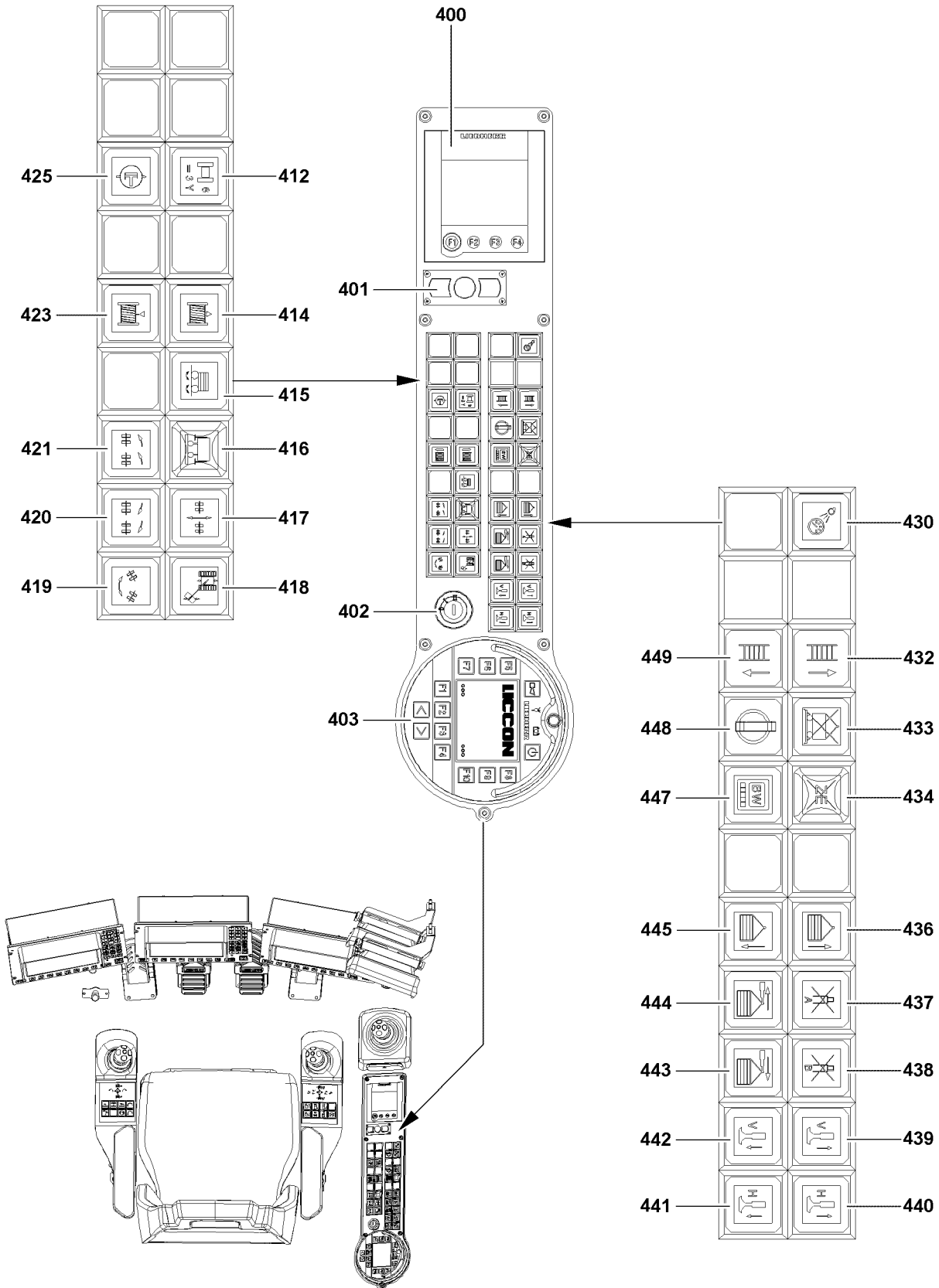

Fig.113687

LWE/LR 1600-2-008/18109-09-02/en

3.3 Instrument panel

- 400** Touch display
- Heater and air conditioning system



Note

- Refer to the Crane operating instructions, chapter 6.01 for a detailed description of the heater / air conditioning and ventilation settings!
-

- 401** Micro module (Mouse)
- Operation LICCON job planner
- 402** Ignition switch
- Engine
- 403** Charging cradle
- **Note:**
Only available in connection with cranes with narrow tracks!
 - **Note:**
The rechargeable battery of the BTT is being recharged as soon as the Bluetooth™ Terminal (BTT) is plugged into the charging cradle **403!**
For a detailed description of the „BTT“ refer to the Crane operating instructions, chapter 5.31 (the chapter is only available in connection with cranes with narrow tracks)!
- 412** Switch
- Assignment of winch 6 on master switch MS3y
- 414** Button
- Spooling the assembly winch up
- 415** Switch with indicator light*
- Ballast trailer drive
- 416** Warning light
- Ballast trailer support retracted
- 417** Button with indicator light
- Turn ballast trailer wheels into travel position (towing)
- 418** Button with indicator light
- Turn ballast trailer wheels into parallel driving position
- 419** Button with indicator light
- Turn ballast trailer wheels into turning position (circular travel)
- 420** Button with indicator light
- Steering, turn ballast trailer wheels to the right
- 421** Button with indicator light
- Steering, turn ballast trailer wheels to the left
- 423** Button
- Spool the assembly winch out
- 425** Switch with indicator light
- Pressure supply for auxiliary users

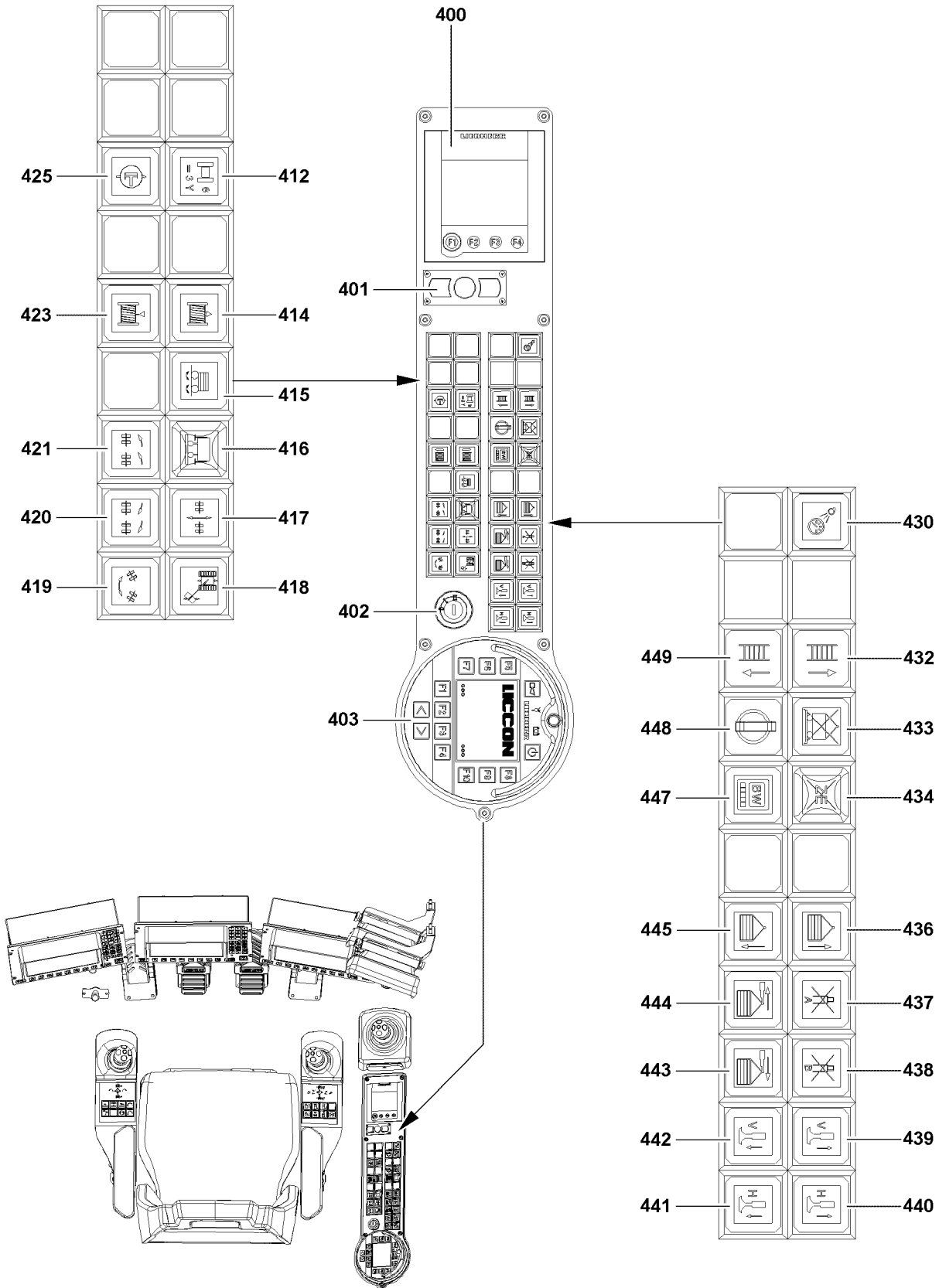

Fig.113687

LWE/LR 1600-2-008/18109-09-02/en

- 430** Switch with indicator light
- Instrument panel illumination, reading light
- 432** Button
- Ladder cab up
- Note:**
Only available in connection with cranes with narrow tracks!
- Note:**
As long as the button is pressed, the ladder moves out / in until the end position is reached!
- 433** Button with warning light
- Ballast trailer not lifted off.
 - Press the button **433** to turn off "Ballast trailer lifted off". The warning light in the button turns off.
- 434** Warning light
- Control ballast trailer is not running or one of the turn sensors or length sensors is defective or missing.
- 436** Button
- Pull derrick ballast up
- 437** Button
- Stop cylinder (A) on the derrick ballast
- 438** Button
- Stop cylinder (B) on the derrick ballast
- 439** Button
- Support cylinder ballast trailer front up
- 440** Button
- Support cylinder ballast trailer rear up
- 441** Button
- Support cylinder ballast trailer rear down
- 442** Button
- Support cylinder ballast trailer front down
- 443** Button
- Telescope ballast trailer out
- 444** Button
- Telescope ballast trailer in
- 445** Button
- Lowering the derrick ballast
- 447** Switch with indicator light
- Switch monitor 1 to test system ballast trailer
- Note:**
Can only be switched over when the engine is off.
- 448** Key button
- Ballast trailer lifted off, see Crane operating instructions, chapter 5.35.
 - Press momentarily to turn on "Ballast trailer lifted off", self retention. The warning light in the button **433** blinks.
- 449** Button
- Ladder cab down
- Note:**
Only available in connection with cranes with narrow tracks!
- Note:**
As long as the button is pressed, the ladder moves out / in until the end position is reached!

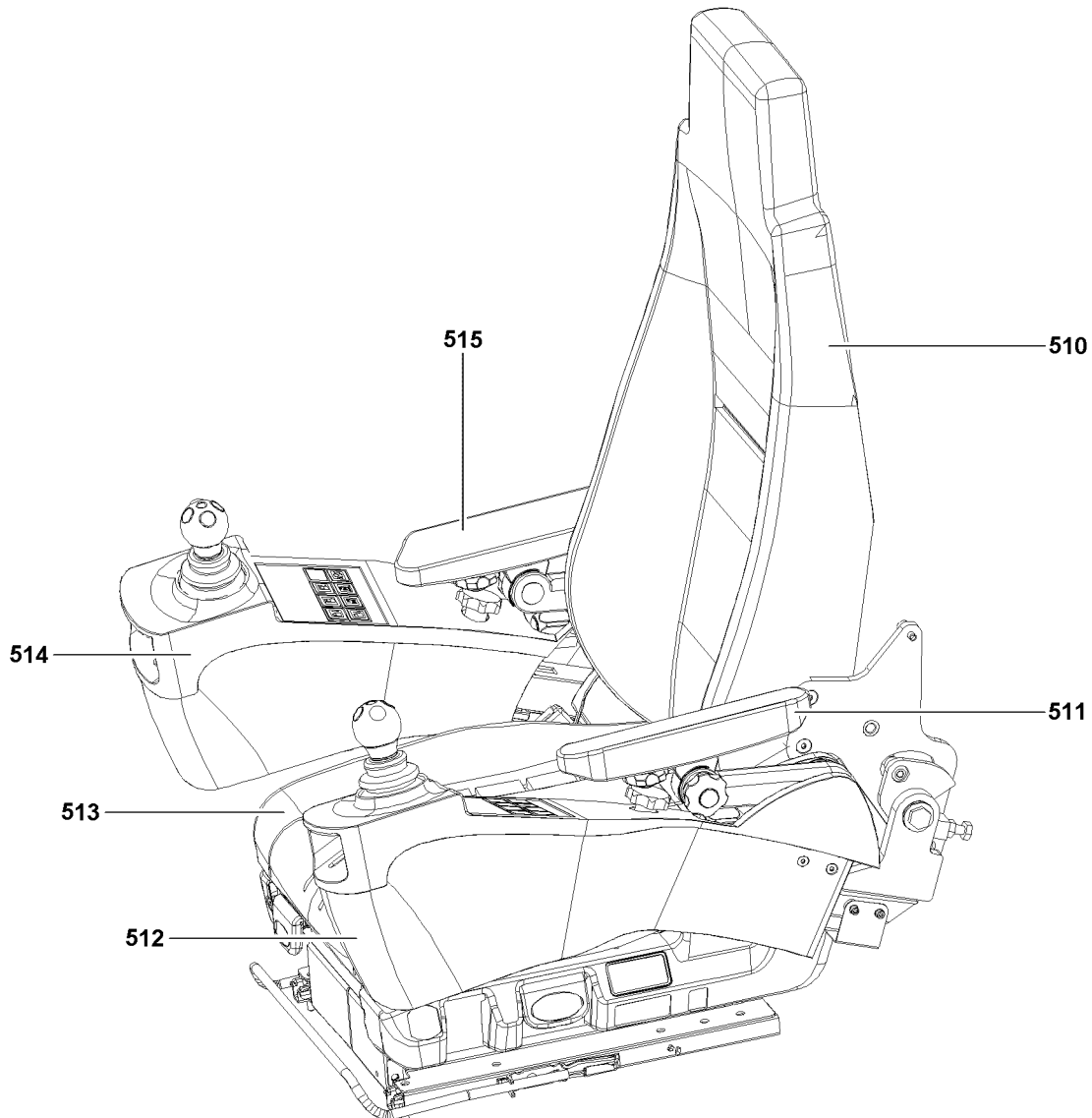

Fig.104895

3.4 Operating elements on control platform

The control platform consists of the following elements:

- 510** Crane operator's seat
- 511** Left armrest
- 512** Control panel, left
- 513** Seat contact switch
- 514** Control panel, right
- 515** Right armrest

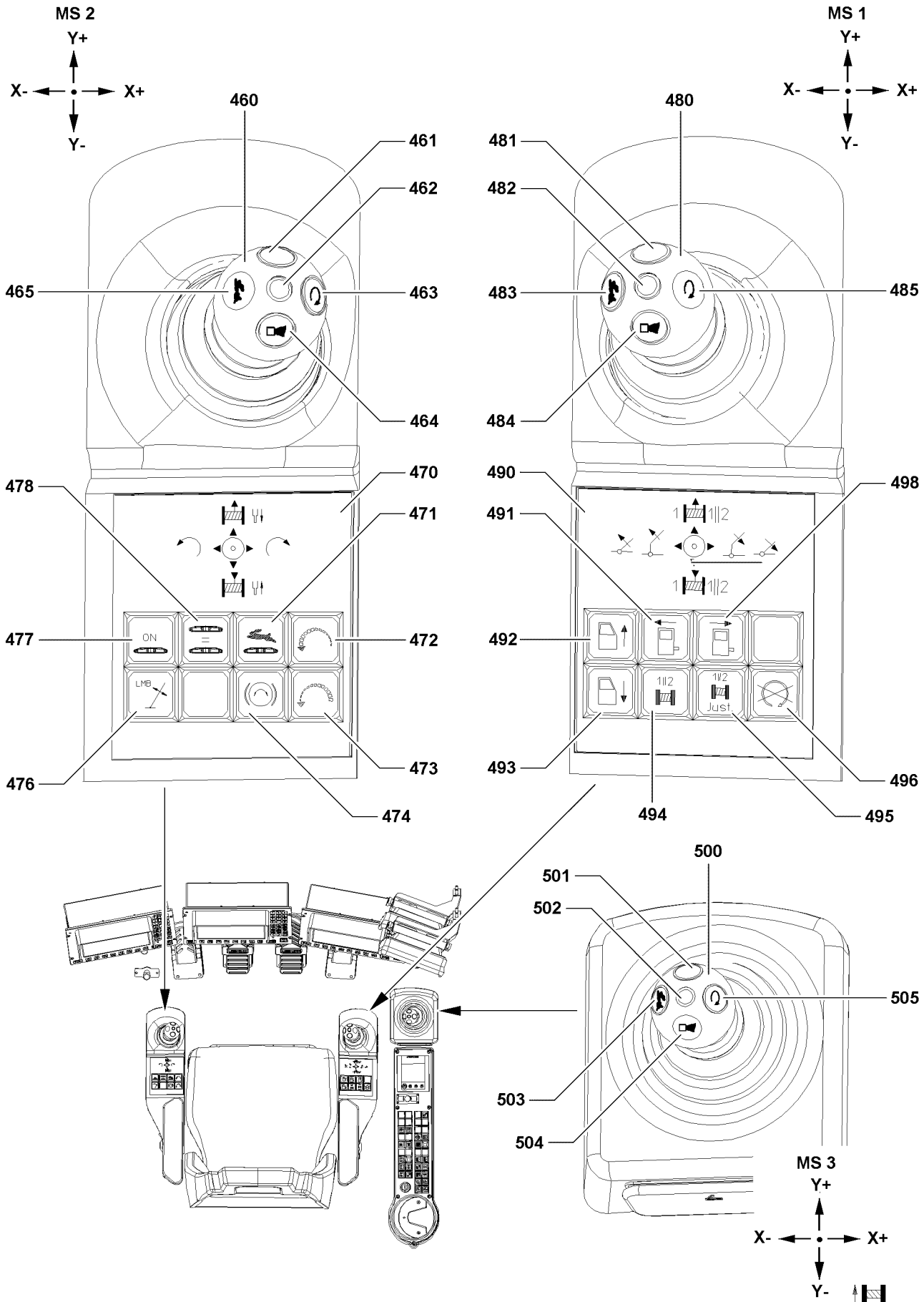

Fig.110699

LWE/LR 1600-2-008/18109-09-02/en

3.4.1 Operating elements on the control panels

Control panel, left

Master switch assignment MS 2:

460 Master switch - left (MS 2)

- **Note:**

For assignment of master switch to operating modes, see Crane operating instructions, chapter 4.05!

461 Button

- Bypass of the seat contact switch **or** if the seat contact switch is actuated: Addition of the vibration sensor **462**.

462 Vibration sensor

- Turn sensor and winches

463 Button

- Engine rpm lock

- **Note:**

By pressing the button **463** the engine rpm is locked in the current state.

464 Button

- Horn

465 Button

- Power Plus addition, crane operation

Instruments Control panel:

470 Instruments Control panel

471 Switch with indicator light

- Crawler rapid gear On / Off

472 Button

- Increase engine rpm

473 Button

- Decrease engine rpm

474 Switch with indicator light

- Turn slewing gear brake slewing gear off / on

- **Note:**

Indicator light lights up when the slewing gear brake is „on“.

476 Button

- Exceeding the overload protection, used to luff in with suspended load.

- **DANGER**

The exceedance may only be carried out if the overload was caused by luffing down at freely suspended load and the crane operator is absolutely certain that luffing up the load will take it out of the overload range.

477 Switch with indicator light

- Crawler operation On / Off

478 Switch with indicator light

- Crawler parallel driving On / Off

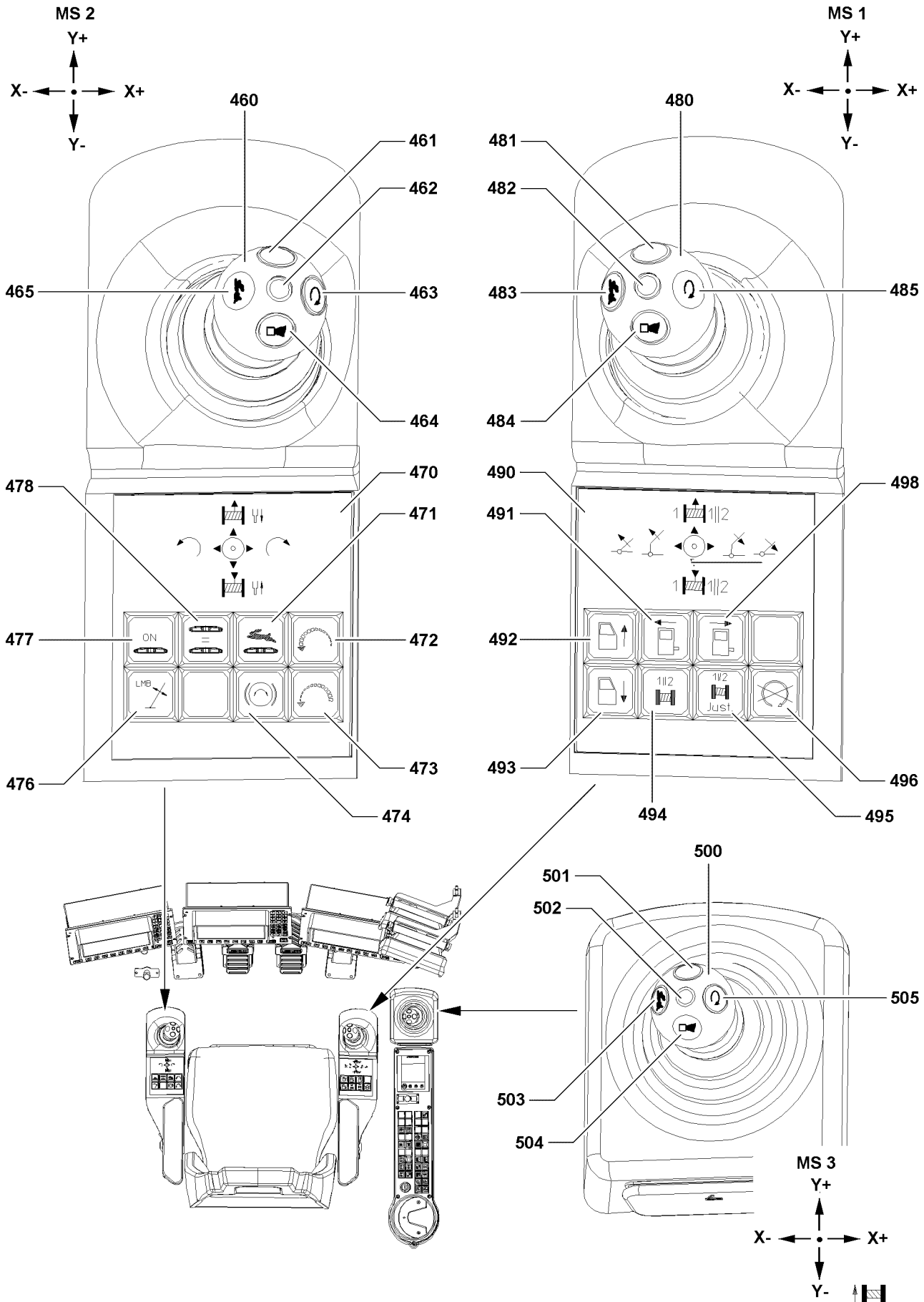

Fig.110699

LWE/LR 1600-2-008/18109-09-02/en

Control panel, right

Master switch assignment MS 1:

- 480** Master switch - right (MS 1)
- 481** Button
 - Bypass of the seat contact switch **or** if the seat contact switch is actuated: Addition of the vibration sensor **482**.
- 482** Vibration sensor
 - Turn sensor and winches
- 483** Button
 - Power Plus addition, crane operation
- 484** Button
 - Horn
- 485** Button
 - Engine rpm lock

Note:
By pressing the button **485** the engine rpm is locked in the current state.

Instruments Control panel

- 490** Instruments Control panel
- 491** Button
 - Swing the cab into working position
- 492** Button
 - Tilt the cab upward
- 493** Button
 - Tilt the cab downward
- 494** Switch with indicator light
 - Parallel operation Winch 1II2
- 495** Button
 - Adjust parallel control winch 1II2

Note:
Adjust only with parallel hook blocks, parallel control Winch 1II2.
- 496** Button
 - Engine stop
- 498** Button
 - Swing the cab into transport position

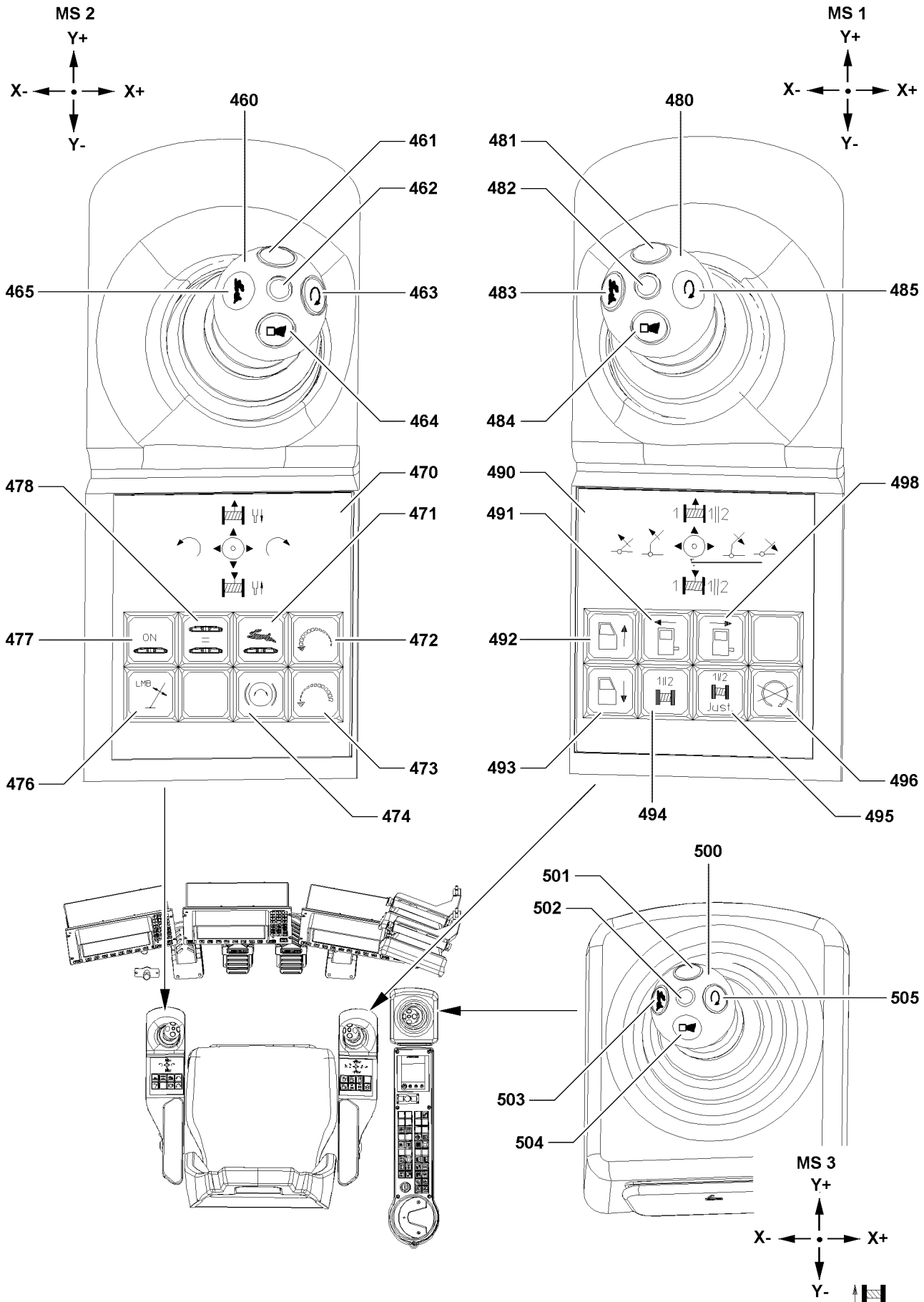

Fig.110699

LWE/LR 1600-2-008/18109-09-02/en

3.4.2 Operating elements Master switch (MS) 3

500 Master switch (MS 3)

501 Button

- Bypass of the seat contact switch **or** if the seat contact switch is actuated: Addition of the vibration sensor **502**.

502 Vibration sensor

- Turn sensor and winches

503 Button

- Power Plus addition, crane operation

504 Button

- Horn

505 Button

- Engine rpm lock

Note:

By pressing the button **505** the engine rpm is locked in the current state.

3.4.3 Operating elements crane operator's seat



Note

- For detailed description of operating elements to adjust the crane operator's seat, see Crane operating instructions, chapter 4.03!
-

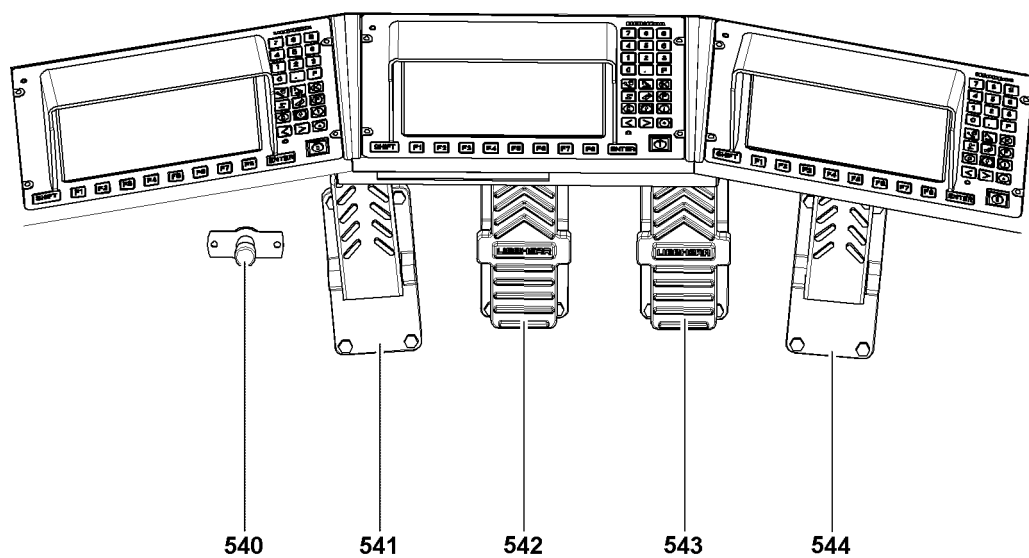

Fig.104896

3.5 Pedal carrier

- 540** Foot button
 - Freewheeling slewing gear
- 541** Pedal
 - Slewing gear brake
- 542** Foot rocker (MS4)
 - Drive the crawler forward or backward on the left hand side
- 543** Foot rocker (MS5)
 - Drive the crawler forward or backward on the right hand side
- 544** Pedal
 - Engine regulation

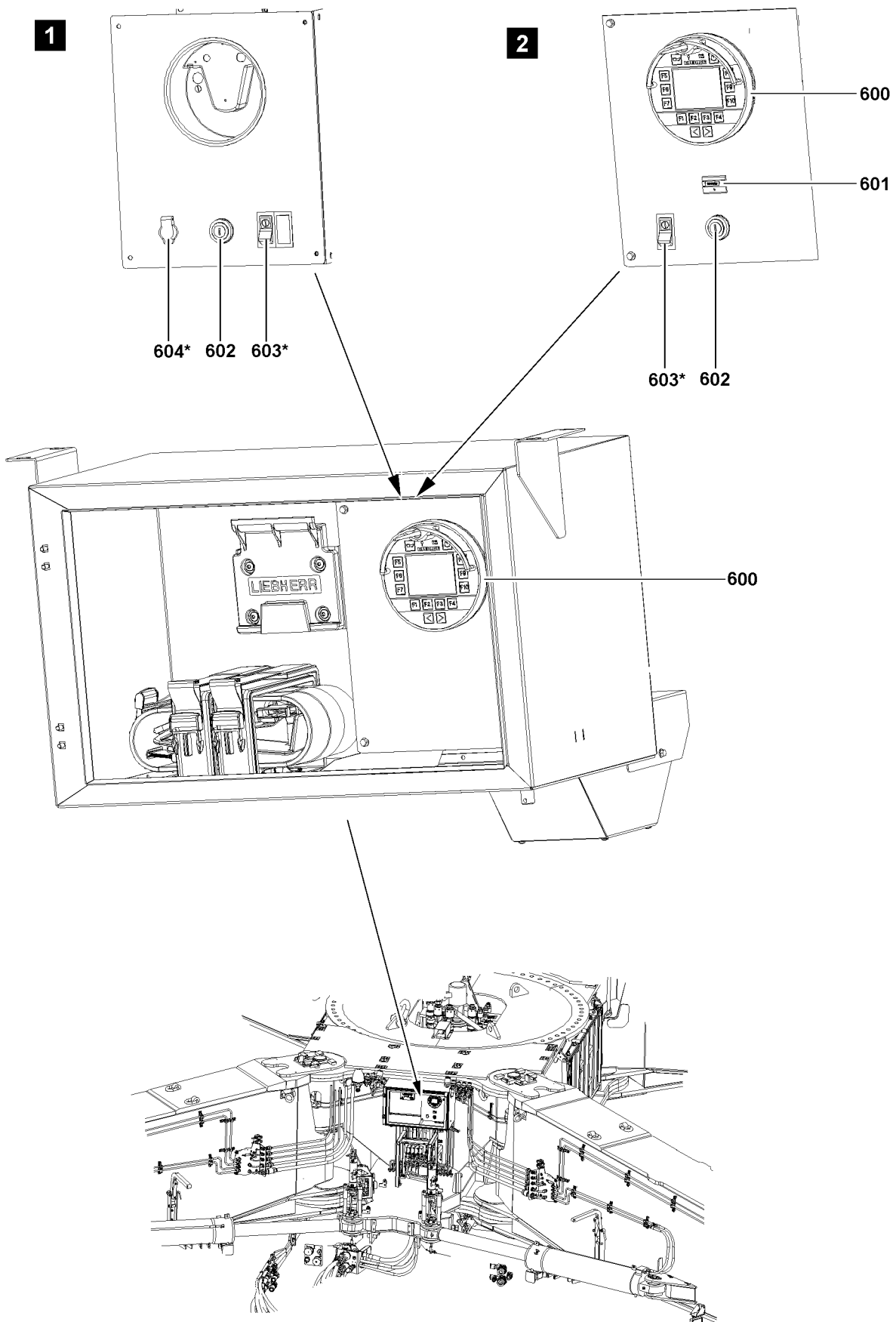

Fig.113579

LWE/LR 1600-2-008/18109-09-02/en

4 Control units crane chassis

4.1 Fixtures in cabinet

**Note**

- ▶ Only available in connection with cranes with narrow tracks!
- ▶ Depending on the equipment of the crane, the number and the version of the control elements can differ, see illustration 1 and illustration 2.

600 Charging cradle**Note:**

The rechargeable battery of the BTT is being recharged as soon as the Bluetooth™ Terminal (BTT) is plugged into the charging cradle **600!**

For a detailed description of the „BTT“, refer to Crane operating instructions, chapter 5.31!

601 Operating hour meter*

- Recording of crawler operating hours

Note:

Depending on the version of the crane, the operating hour meter for the crawler operating hours can be in the control cabinet or in the crane operator's cab.

602 Ignition switch

- Starting the engine

603 Rocker switch*

- Shut off / turn on main current circuit

604 24V socket*

Empty page!

LWE/LR 1600-2-008/18109-09-02/en

4.02 LICCON computer system

1	General	3
2	LICCON computer system boot up	7
3	Operating mode preselection on the LICCON computer system	7
4	Operating elements of the LICCON computer system on monitor 0	11
5	The set up program	15
6	The winch - pulley head assignment screen	39
7	The Crane operation program on monitor 0	59
8	Operating elements of the LICCON computer system on monitor 1	135
9	The Crane operation program on monitor 1	137
10	The Control parameter program	181
11	The Support program	189
12	The Working range limitation program*	205
13	The Engine monitoring program	209
14	LICCON computer system in stand-by mode	217

Fig. 199898

1 General



Note

- ▶ The monitor illustrations in this chapter are only examples!
- ▶ The numerical values in the individual icons and charts do not have to necessarily match the crane exactly!
- ▶ Numbers and letters can be replaced by place holders!
- ▶ In addition, many of the illustrations show the maximum configuration of the LICCON monitor with icons!
- ▶ In normal crane operation, an identical display will **not** appear on the LICCON monitor!

The LICCON computer system is a computer system for controlling and monitoring mobile and crawler cranes. In addition to the overload protection (Load moment limitation = **LMB**) there are a number of application programs that can be used for controlling and monitoring the crane movements.

Currently the LICCON computer system includes the following application programs:

- Set up program
- Crane operation program
 - Crane operation program on monitor 0
 - Crane operation program on monitor 1
- Control parameter program
- Support program (only narrow track crawler track)
- Working range limitation program*
- Engine monitoring program
- LICCON computer system in stand-by mode

The electrical and electronic components are linked via data bus transmission technology (Liebherr System Bus = LSB).

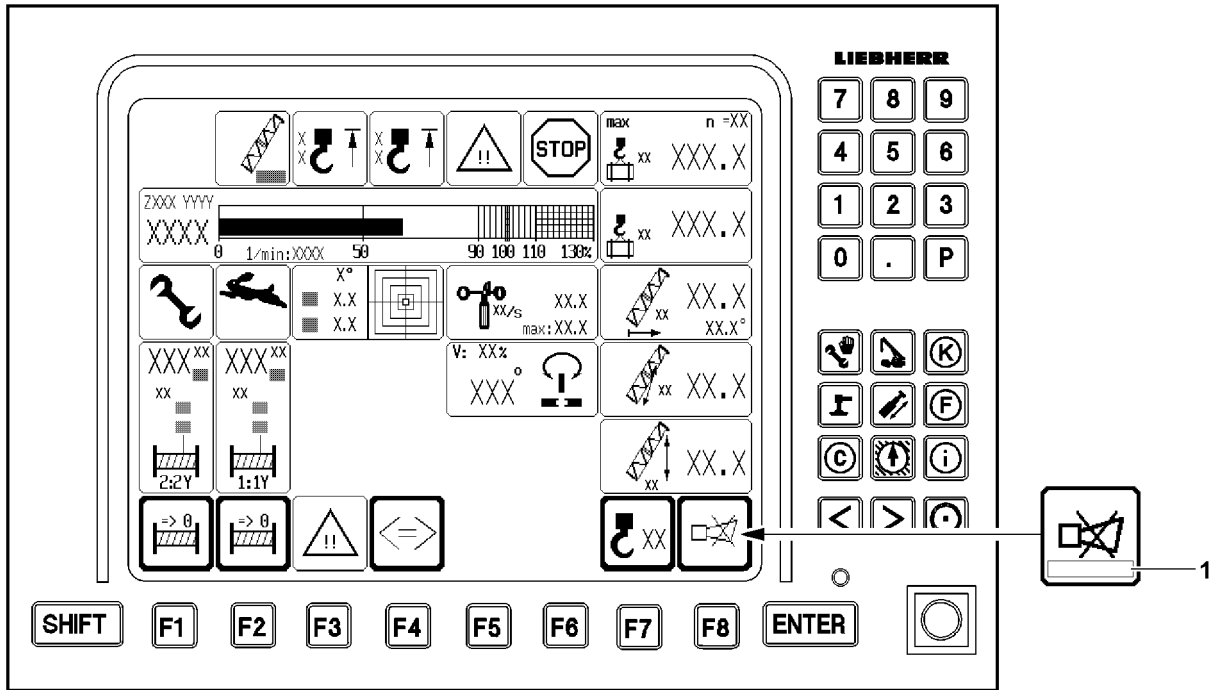

Fig.112991

1.1 Overload protection (LMB)

The overload protection is implemented in microprocessor CPU 0 of base assembly 0. The LICCON computer system works on the principle of comparing the current / actual load with the „maximum permissible load according to the load chart and reeving“.

1.1.1 Actual load

The current load is determined by recording variable values.

The **load on the crane** results from the load momentum and the boom momentum together. It exerts a force in the boom guying, which is measured by force test sensors.

The **boom momentum** is calculated from angle sensor information (boom angle) and the crane data (boom weights) for the set operating mode.

The **radius** is calculated with data from the angle sensors (boom angle) and the geometric data for the set operating mode. This also takes into account the boom flexation due to its own weight and the weight of the load.

The actual load is calculated from the total load, the boom momentum and the boom radius.

1.1.2 Maximum load according to load chart and reeving

Crane data such as load charts, boom weights and geometry data are stored in the central data memory of the LICCON computer system.

The „maximum load according to the load chart and reeving“ is constantly determined for the set crane configuration, for the set reeving and for the calculated radius, based on the load charts.

1.1.3 Comparison

The actual load and the „maximum load according to the loading chart and reeving“ are compared. When they approach the specified limit, an advance warning is issued. If the specified limit is exceeded, a LMB STOP is triggered due to overload. When a LMB STOP is triggered, load moment increasing crane movements are shut off.

1.2 Error messages

The LICCON computer system monitors the crane permanently for operating / system errors.

If errors occur, error messages **1** are issued. Error messages appear in the horn icon of LICCON monitor 0.



Note

- ▶ Always pay attention to error messages **1**!
- ▶ For procedure in case of error messages, see Diagnostics manual and the respective chapter in the Crane operating instructions!

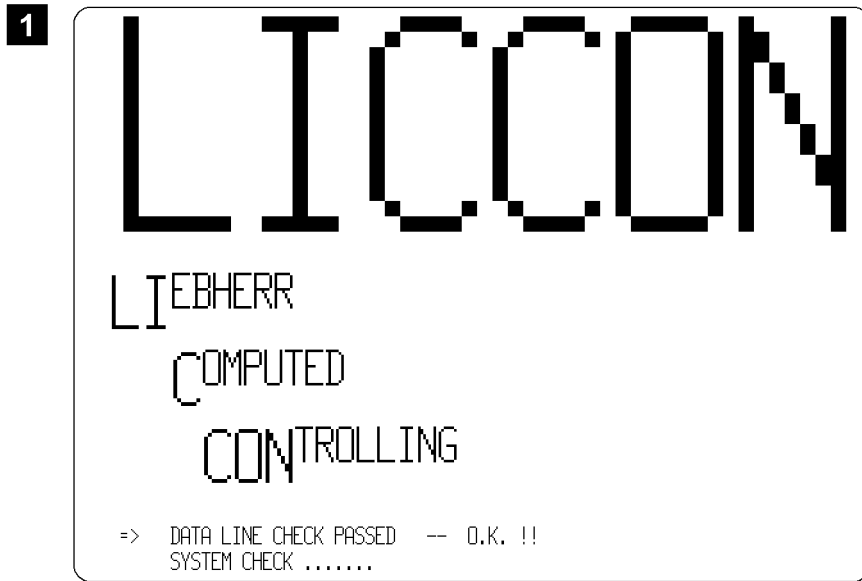

Fig.199899

LWE/LR 1600-2-008/18109-09-02/en

2 LICCON computer system boot up

There are two operating modes for the LICCON computer system:

- LICCON computer system in normal mode (crane engine turned on).
- LICCON computer system in stand-by mode (crane engine turned off).

Starting in normal mode:

- Boot up of LICCON computer system in connection with a started crane engine.

Starting in stand-by mode:

- See Section „LICCON computer system in stand-by mode“.

After it is turned on, the LICCON computer system performs a self test.

First the connections from the microprocessor CPU (ZE 0) to the monitor are checked. If no error was found during the test, then the monitor shows the message „O.K. !!“, see illustration 1.

If the test finds no connection problems, there is a system test of all the microprocessor CPUs (CPU). The incremental sequence of the self test can be monitored on the 7 segment displays of the CPUs. If no error was found during the system test, then the monitor shows the message „O.K. !!“, see illustration 2.

Shortly after that, this general initialisation screen appears on the monitor, see illustration 3.



Note

Errors during LICCON computer system boot up!

If an error is found while the LICCON computer system boots up, then the boot up procedure is interrupted!

- ▶ For procedure if an error occurs while the LICCON computer system boots up, see Diagnostics manual!

3 Operating mode preselection on the LICCON computer system



WARNING

Danger of accident due to deviating set up configuration!

If the equipment set up configuration and the operating mode of the crane set on the LICCON computer system **does not** match, then the crane can be overloaded unnoticed and topple over!

Personnel can be severely injured or killed!

- ▶ In the operating mode preselection, only the operating mode may be selected which actually corresponds to the equipment set up configuration of the crane!

When the starting procedure is completed successfully after a successful self test of the LICCON computer system, the following appears on:

- **LICCON Monitor 0** for approx. 3 seconds the operating mode preselection screen.
- **LICCON Monitor 1** the title screen with the words: „**LIEBHERR-WERK EHINGEN**“

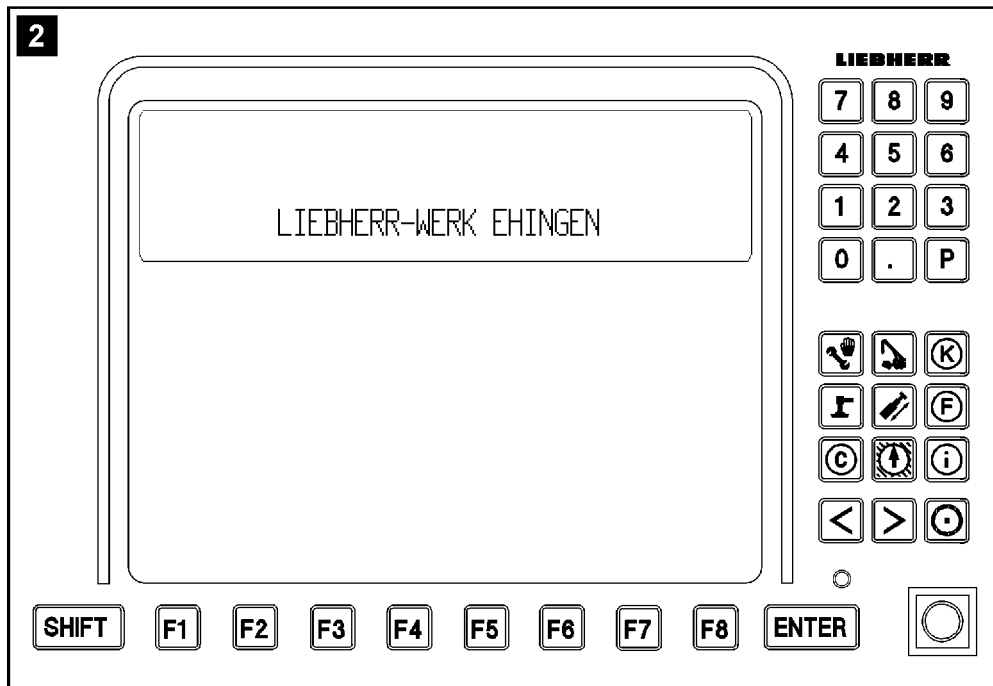
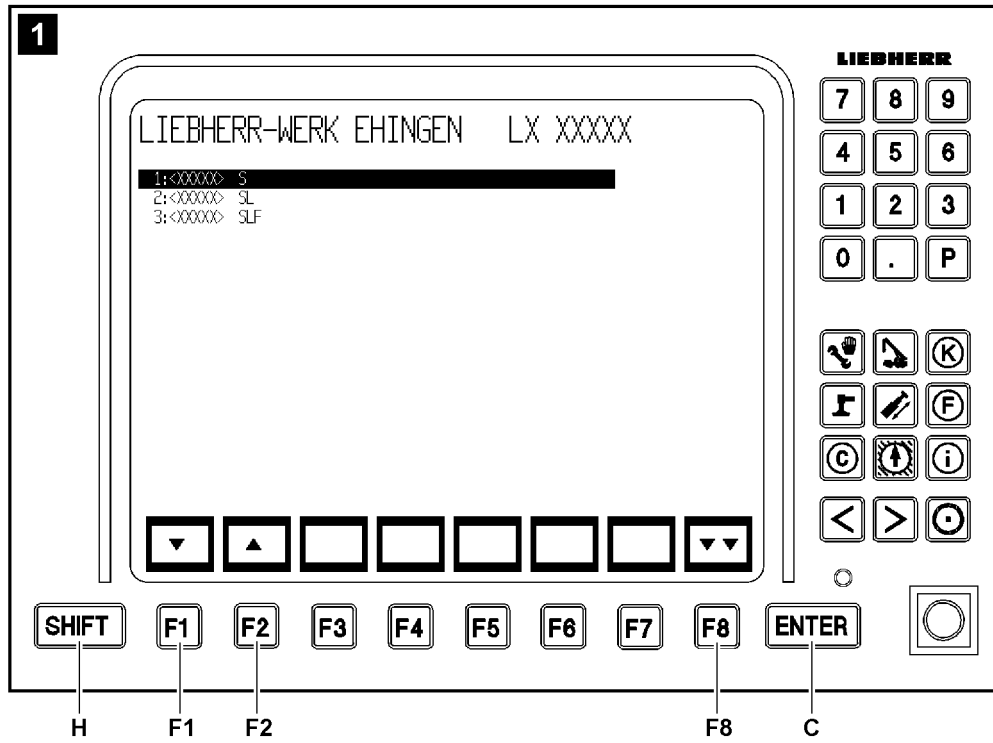

Fig.112992

LWE/LR 1600-2-008/18109-09-02/en

3.1 LICCON Monitor 0

After successful starting procedure, the operating mode preselection screen appears on the **LICCON monitor 0** for approximately three seconds, see illustration 1.



Note

- ▶ The operating mode preselection screen is skipped if the crane only has one level! For example: The crane has only one S-boom (only S-operation possible)! In this case, the system changes directly into the set up screen for the only possible level!
- ▶ If the memory loses its data (for example as a result of a cold start) the previous operating mode is „rejected“ and the first operating mode in the operating mode selection menu is activated! In this case, the corresponding set up screen appears!

The function key **F1** or the function key **F2** is pressed within three seconds when the operating mode preselection screen appears.

Result:

- The operating mode preselection screen is retained until the settings are confirmed by pressing the function key **F8** or the ENTER key **C**.



Note

- ▶ If neither the function key **F1** nor the function key **F2** are pressed within three seconds, then the last active operating mode remains set. The corresponding set up screen appears automatically!

To select the required operating mode group for crane operation, press the function key **F1** (cursor down) or function key **F2** (cursor up).



Note

- ▶ The selected operating mode group is highlighted in black in the operating mode preselection screen on the monitor!

Press the function key **F8** or the ENTER key **C**.

Result:

- The set operating mode group is taken over into the LICCON computer system and the set up program appears with the corresponding set up screen.

3.2 LICCON Monitor 1

After successful starting procedure, the title screen with the words appears on the **LICCON monitor 1**: „**LIEBHERR-WERK EHINGEN**“, see illustration 2.



Note

- ▶ Depending on the set up configuration of the crane, it is possible that a note for an operating mode appears!

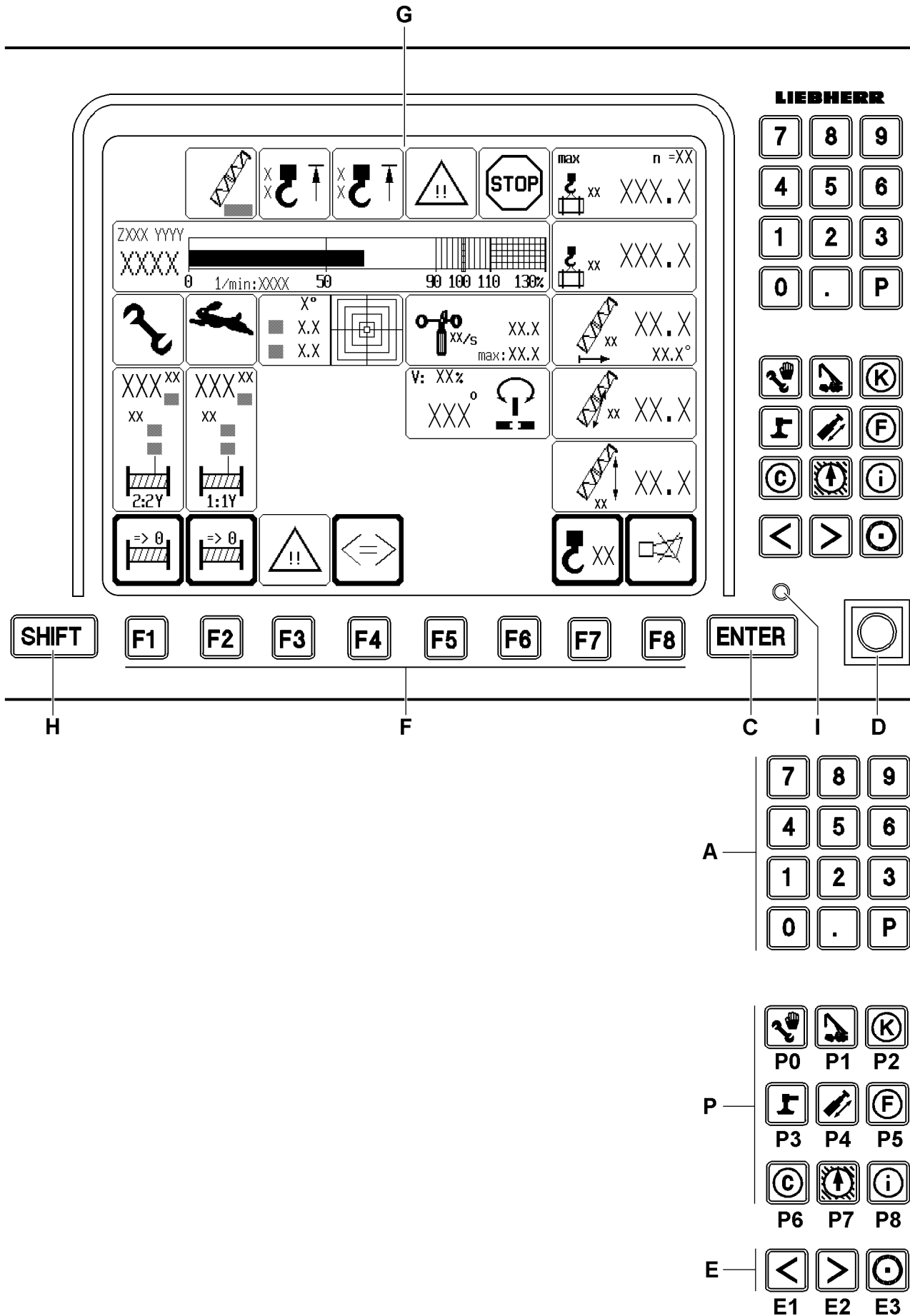

Fig.112357

4 Operating elements of the LICCON computer system on monitor 0

The functions of the individual monitor operating elements are program-dependent and can differ, depending on the LICCON program which is currently running. This will be described in more detail in the description of the individual LICCON programs.

- A** Keypad
- P** Program keys
 - Selection of the individual LICCON programs
- P0** Set up
 - SHIFT **H** and program key **P0**: Engine monitoring
- P1** Crane operation
- P2** Crane acceptance
 - Correction coefficients (program blocked - for LIEBHERR service personnel only)
- P3** Crane support
 - Only narrow track crawler track!
- P4** —
 - Program key not assigned!
- P5** Winch - pulley head assignment screen
 - Selecting a pulley head and assigning it to winches
 - Enter the hook block weight
- P6** Control parameter
- P7** Working range limitation*
- P8** Test system
 - **Note:**
Description Test system, see Diagnostics manual!
- C** Input key ENTER
 - Confirmation of changes
- D** Set up key
 - Zero position (not actuated):
Normal operation
 - Touching:
Function „Exceedance of shut off limits of LICCON overload protection“ is released and / or the hoist limit switch is bypassed



Note

Double function set up key!

If the crane has **no** CE-mark, when actuating the set up key **D**, the release for the „Emergency operation LICCON overload protection“ is automatically engaged!

- ▶ Take into account, when actuating the set up key **D**, that the „Emergency operation LICCON overload protection“ is automatically released!



Note

- ▶ By actuating the set up key **D**, all erection / take down procedures can be carried out within the erection / take down charts, for which no load charts are available!

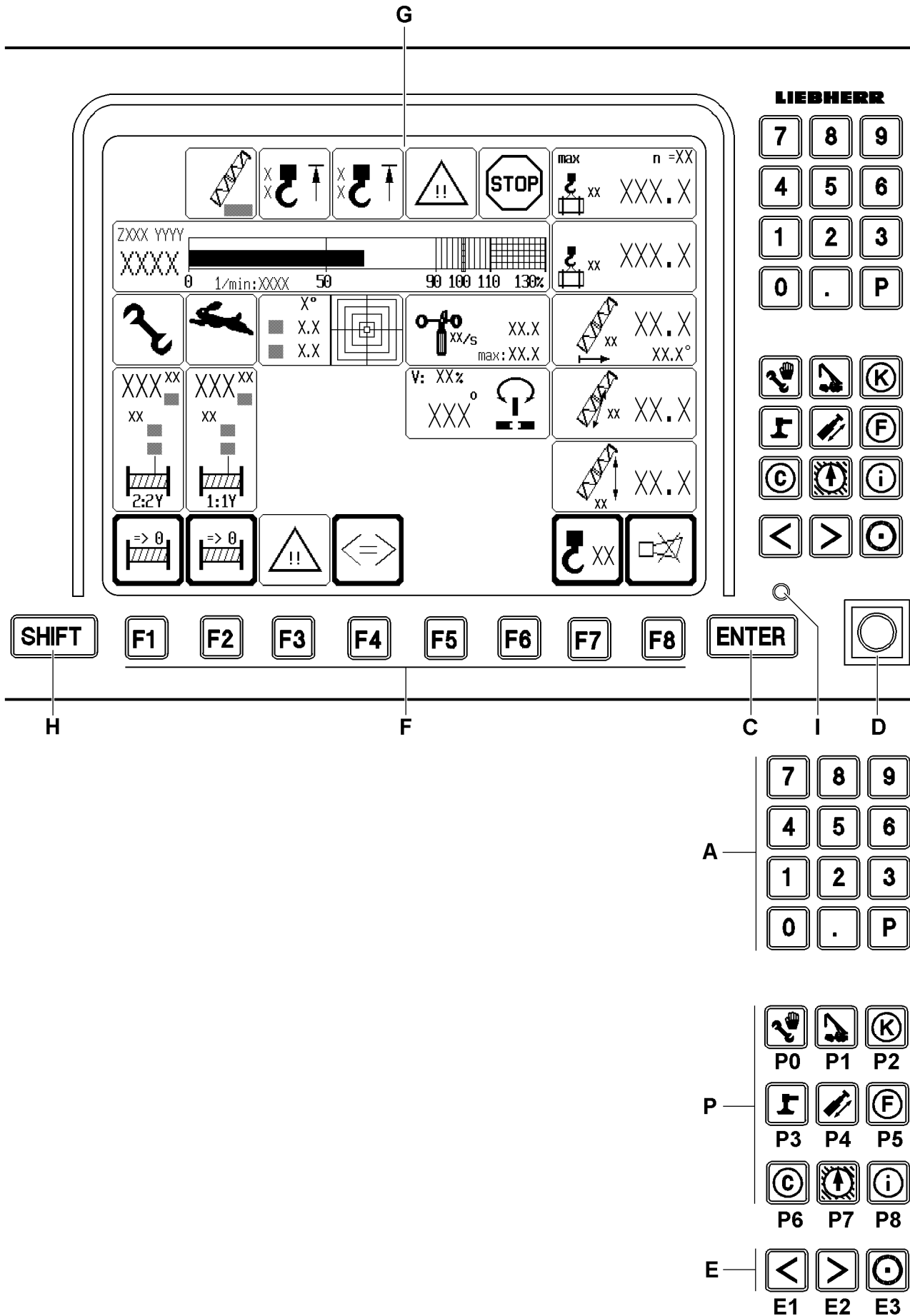

Fig.112357

E Special function keys

- Monitor brightness adjustment
- Key combination **E3** and **E1**: Turn background illumination on / off
- Key combination **E3** and **E2**: Brightness adjustment in three stages

- **Note:**

Additional functions of the special function keys are program-dependent and are further explained in the description of the individual LICCON programs!

F Function keys

- The function keys should always be viewed in conjunction with the function key icon line displayed on the monitor

G Display

- Display of the individual programs (example: Crane operation program)

H SHIFT key

- Change over key
- Second-level key assignments, for example „Supervisory function“

I LED display

- Monitor supply voltage present

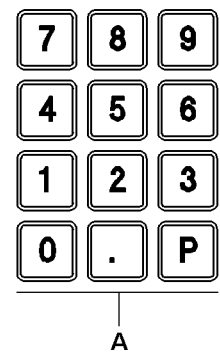
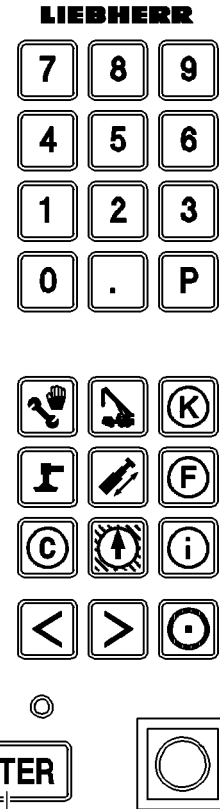
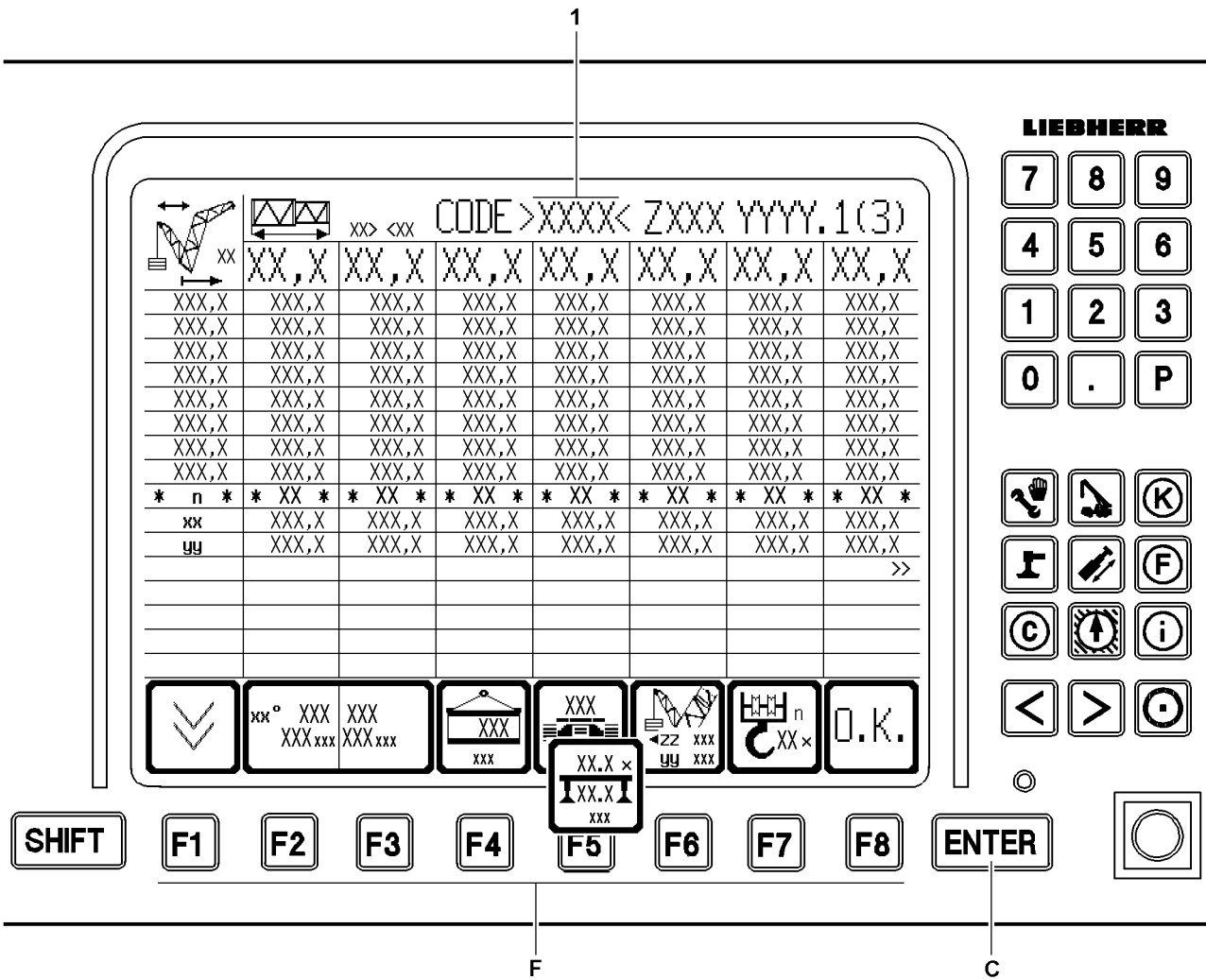

Fig.112996

LWE/LR 1600-2-008/18109-09-02/en

5 The set up program

After the LICCON computer system boots up correctly, it changes automatically into the set up program.



Note

- ▶ All entries and settings, which are to be made by the crane operator in the set up program can only be carried out on **LICCON monitor 0!**



Note

Adjustment and display of set up configuration and reeving!

- ▶ Normally, the most recently run set up configuration and the reeving used at that time will be automatically set and displayed!
- ▶ After a restart of the computer system due to a component change or updates the first valid set up configuration (first valid operating mode and reeving number „0“) can appear in the set up screen!

In the Set up program, the crane operator can set the current operating mode, the current set up configuration of the crane and the reeving number of the hoist rope.

In addition, in the set up program he can also see all the load charts programmed into the LICCON computer system.

5.1 Setting the operating mode and set up configuration

The crane operator can select the operating mode and the set up configuration with the function keys **F** or by entering a 4-digit short code **1**.

5.1.1 Setting the operating mode and set up configuration via the function keys

The function keys **F** are explained in the section „Function key line“ in this chapter.

- ▶ Select the respective function keys **F**.
- ▶ Press the ENTER key **C** to confirm and accept the settings.

Result:

- The data of the selected load chart can be viewed.

5.1.2 Setting the operating mode and set up configuration via the 4-digit short code

- ▶ Enter a 4-digit short code **1** with the keypad **A** on the **LICCON monitor 0**.
- ▶ Press the ENTER key **C** to confirm and accept the settings.

Result:

- The data of the selected load chart can be viewed.

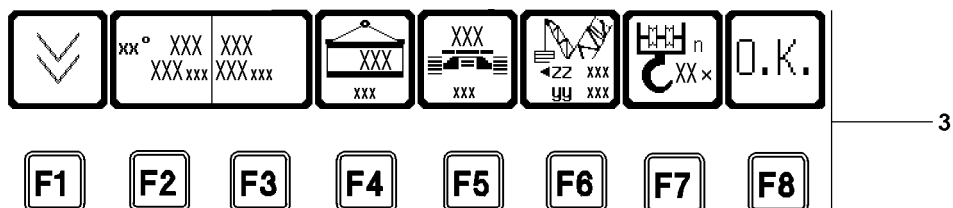
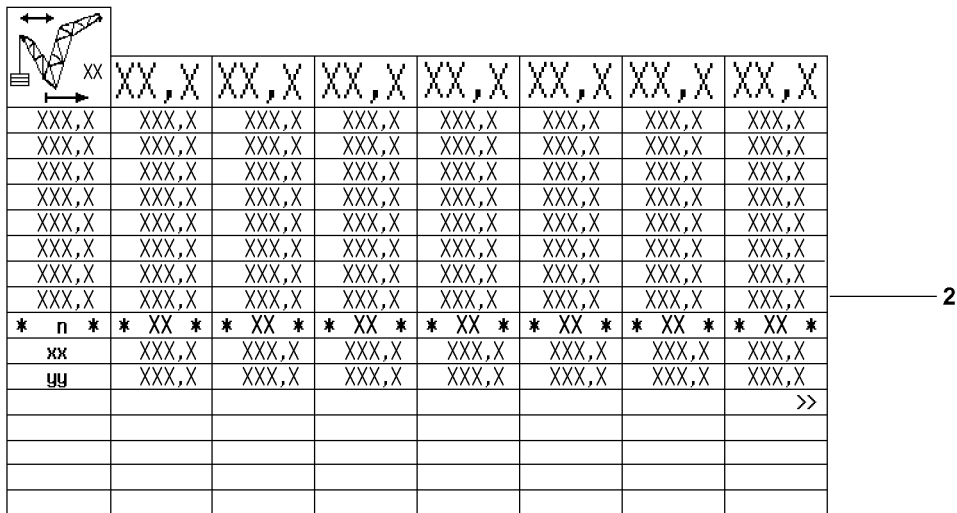
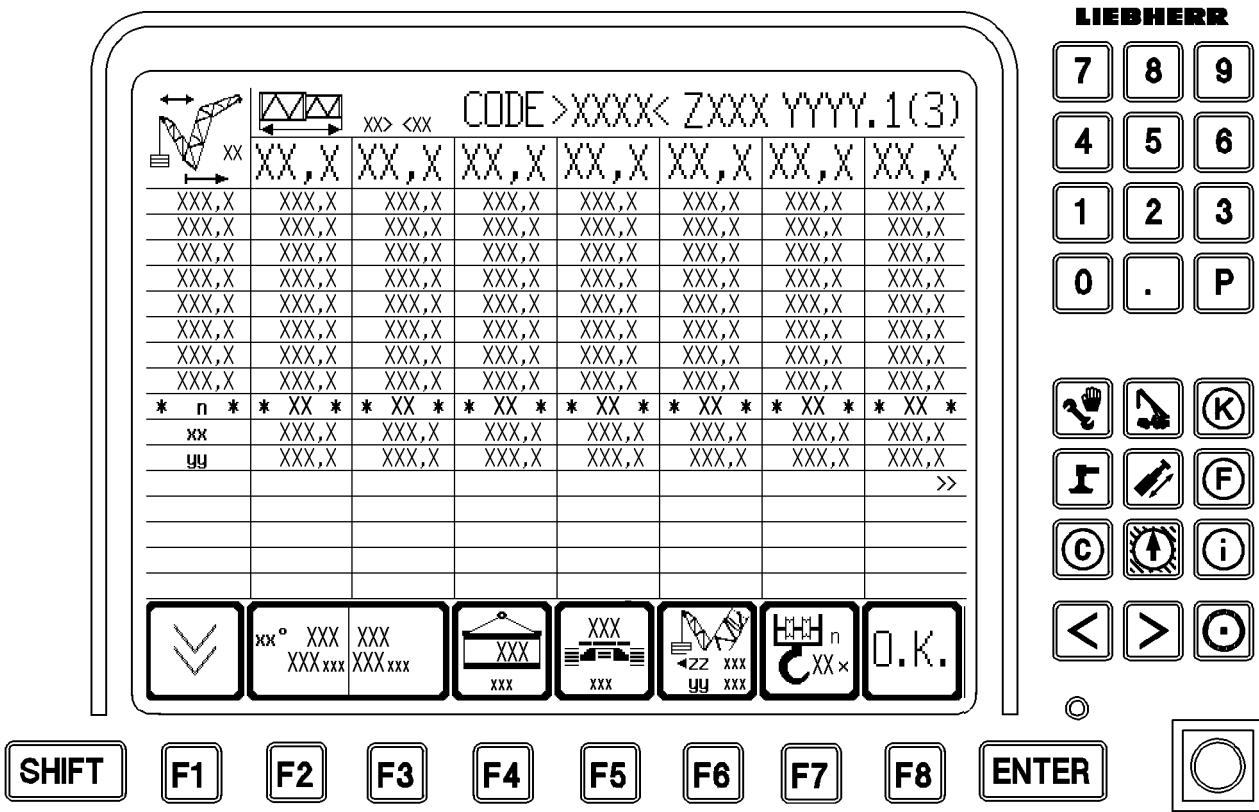

Fig.113279

LWE/LR 1600-2-008/18109-09-02/en

5.2 Set up program areas



Note

- ▶ The monitor illustrations in this chapter are only examples!
- ▶ The numerical values in the individual icons and charts do not have to necessarily match the crane exactly!
- ▶ Numbers and letters can be replaced by place holders!
- ▶ The programmed load charts for the crane are binding!

The monitor is divided into three areas in the Set up program:

- 1 General information line
- 2 Display area of load chart values
- 3 Function key line with assigned icons

5.2.1 General information line

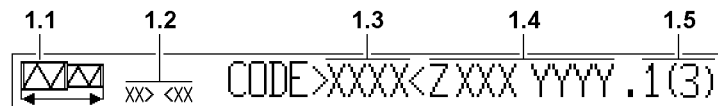

Fig.111920

- 1.1 Main boom length icon
 - The icon is identical for all operating modes.
- 1.2 Measuring unit
 - For the programmed length units (LE) and weight units (GE)
- 1.3 4-digit short code
 - It is located next to the text „CODE“ inside angled brackets
 - Each short code uniquely identifies a crane configuration. The valid set up configuration and their associated short code numbers for the crane can be found in the load chart manual of the crane.
- 1.4 Organization number
 - For internal Liebherr load chart administration
- 1.5 Page number
 - Relates to the currently displayed part of the load chart
 - Separated from the organization number with „.“
 - The total number of pages in this load chart is in parentheses

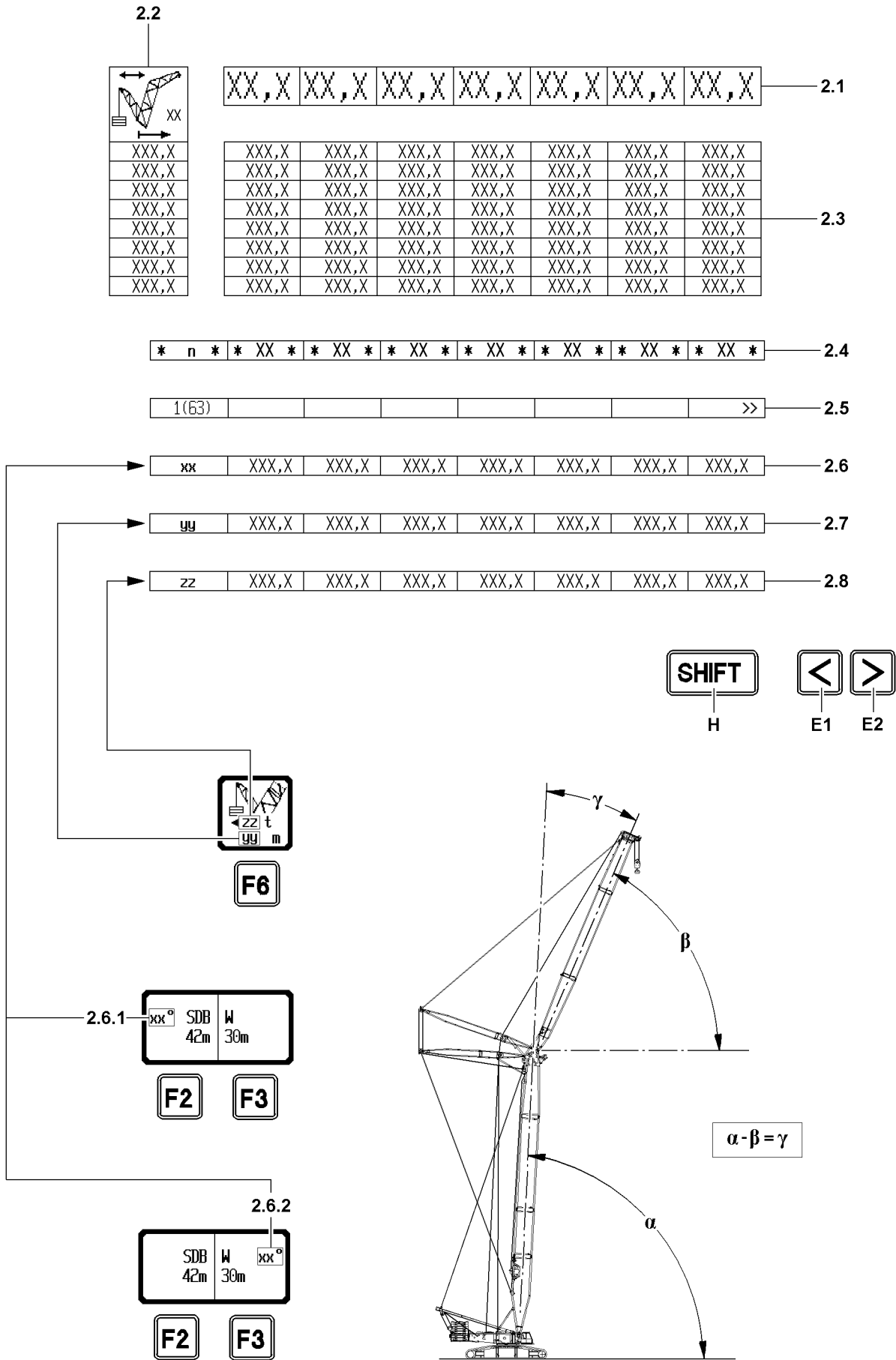

Fig.113278

LWE/LR 1600-2-008/18109-09-02/en

5.2.2 Display area of load chart values

2.1 Main boom lengths

- In [m] or [ft]
- Maximum of 7 columns per display page



Note

View „Boom radius“ icon **2.2!**

- ▶ Depending on the operating mode of the crane, the view changes from the „Boom radius“ icon **2.2!**
- ▶ In the illustration, the „Boom radius“ icon **2.2** shows an operating mode with (luffing) auxiliary boom / accessory, derrick boom and derrick ballast!

2.2 „Boom radius“ icon

- In [m] or [ft]
- Maximum 10 lines of radius values
- Vertical axis of load value field

2.3 Load value field

- Columns under the main boom lengths and in the lines to the right of radius values
- Load values depending on boom length and radius

2.4 Reeving number of hoist rope

- * n *

n = Reeving number of the hoist rope between the boom head and hook block, in order to be able to lift the maximum load in the corresponding load chart column in single winch operation

- Enter and confirm the reeving on the LICCON monitor 0, according to the reeving on the boom head

NOTICE

Special equipment necessary!

- ▶ If a load value in the column exceeds that of a load that can be lifted with the maximum possible reeving, then there is an exclamation mark beside the reeving number („!“). This exclamation mark indicates that special equipment is needed to lift this load!



Note

Parallel operation of hoist winches!

- ▶ For parallel operation of hoist winches (1||2), when reeving in the hoist rope, enter the total reeving of winch 1 and winch 2 on the LICCON computer system!
- ▶ **Example:** Winch 1 and winch 2 are each reeved 7ways, the total reeving is therefore n=14!
- ▶ The total reeving **must** always show an even number value in parallel operation!

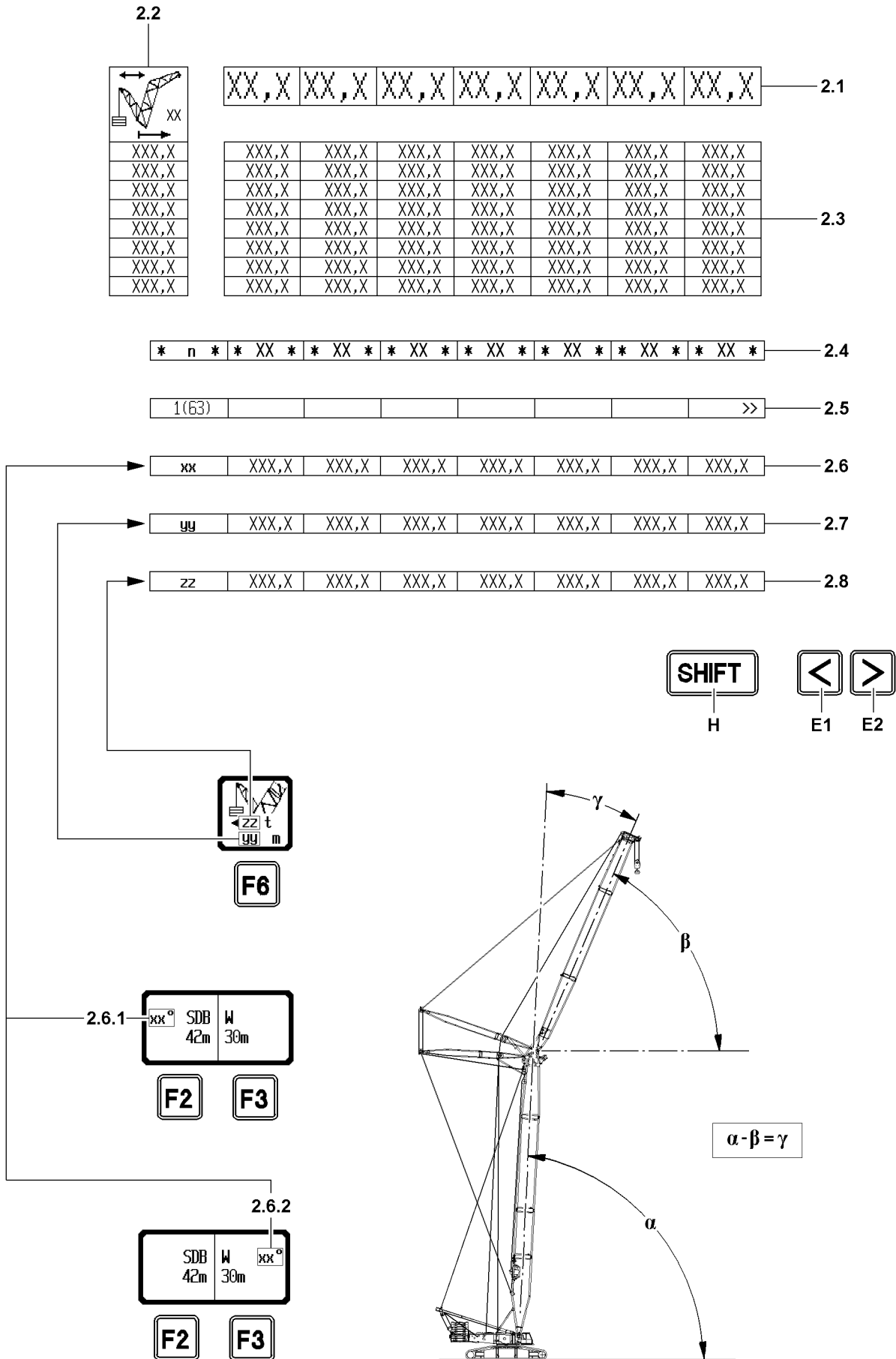

Fig.113278

LWE/LR 1600-2-008/18109-09-02/en

2.5 Line for special displays

- If a load chart consists of more than seven columns, it cannot be fully displayed because of the size of the monitor. In that case, marking arrows in the first or the seventh field in this line indicate that there are additional chart columns to the left or right of the displayed chart. They can be shown by pressing the key **E1** or the key **E2**.

- **Note:**

Using the key combination **SHIFT** and key **E1** or **SHIFT H** and key **E2**, you can, where possible, scroll left or right by 7 load chart columns (corresponds to 1 page)!

2.6 Boom angle

- Line **xx**
- In [°]
- **Note:**

Appears **only** in operating modes with luffing auxiliary boom / accessory!

2.6.1 Boom angle main geometry

- Appears „**xx**°“ in main geometry status icon (for example: „**xx**° **SDB**“) means „**xx**°“ = main boom angle α in [°].
- In the line **xx** the main boom angles are listed, which must be set in order to be able to lift the load values in the corresponding load chart column.

2.6.2 Boom angle auxiliary geometry

- Appears „**xx**°“ in auxiliary geometry icon (for example: „**W**“ „**xx**°“) then means „**xx**°“ = relative angle auxiliary boom / accessory γ in [°].
- In the load chart columns, the relative angles auxiliary boom / accessory, which must be set to be able to lift the load values in the corresponding load chart column are listed next to each other.

**Note**

- ▶ Main boom angle α : The angle of the main boom to the placement surface of the crane!
- ▶ Angle auxiliary boom / accessory β : The angle of the auxiliary boom / accessory to the placement surface of the crane!
- ▶ Relative angle auxiliary boom / accessory γ : The angle of the auxiliary boom / accessory is determined relative to the main boom!

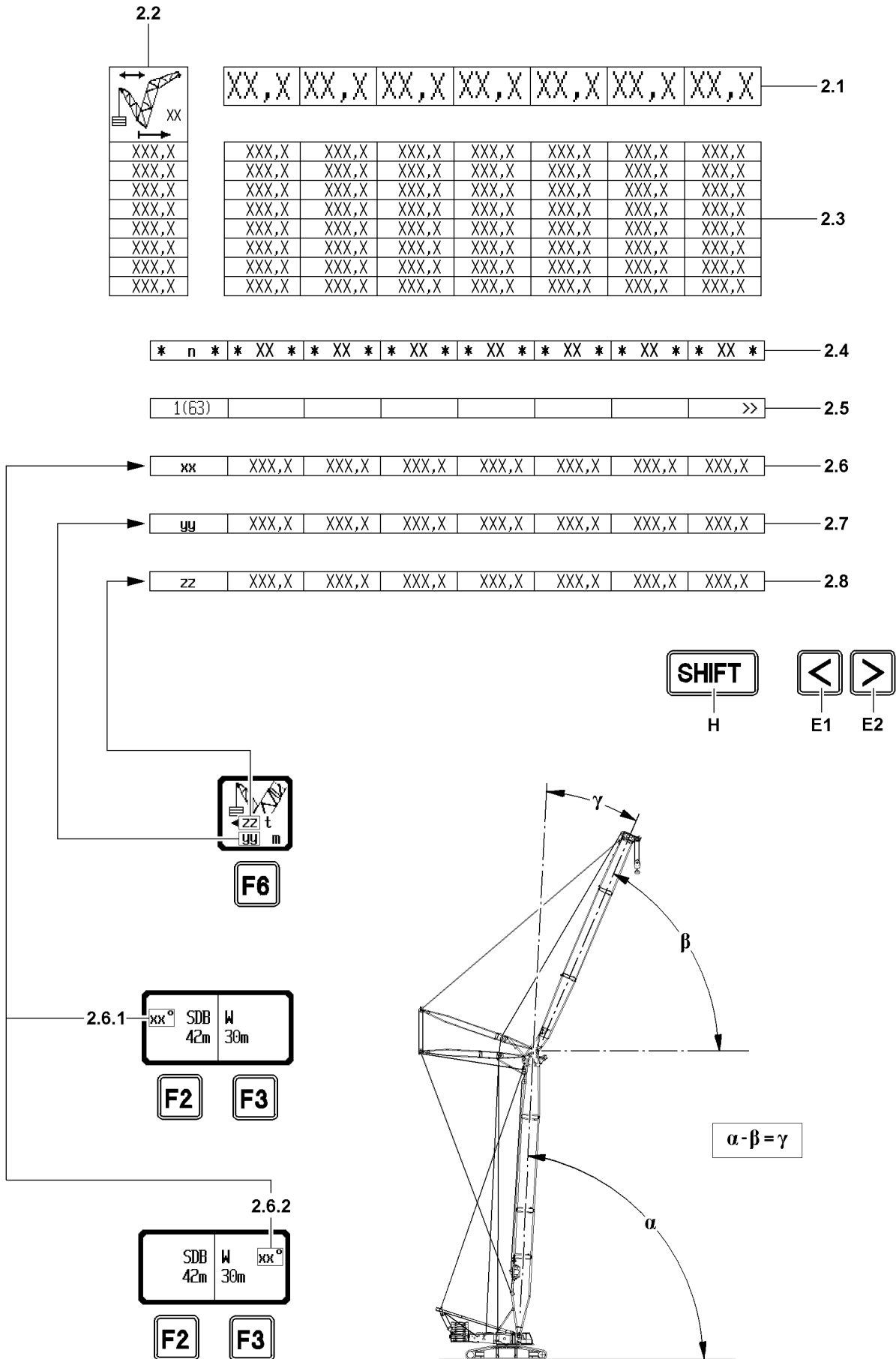

Fig.113278

LWE/LR 1600-2-008/18109-09-02/en

2.7 Derrick ballast radius

- Line **yy**
- In [m] or [ft]
- **Note:**
Appears **only** in operating modes with derrick ballast!
- In the line **yy** the derrick ballast radii are listed, which must be set in order to be able to lift the load values in the corresponding load chart column.

2.8 Derrick ballast weight

- Line **zz**
- In [t] or [lbs]
- **Note:**
Appears **only** in operating modes with derrick ballast!
- In the line **zz** the derrick ballast weights are listed, which must be attached in order to be able to lift the load values in the corresponding load chart column.

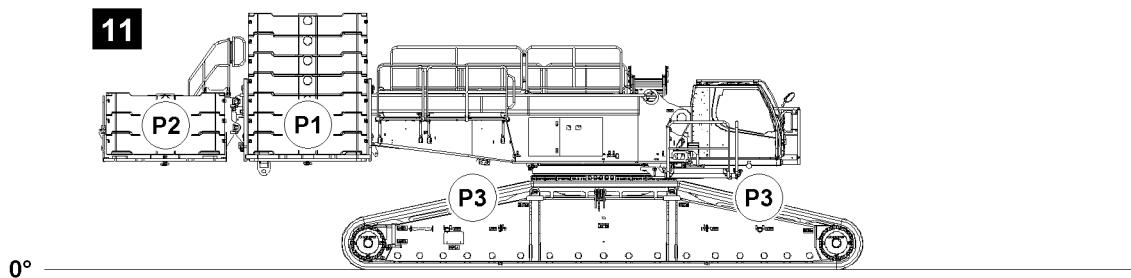
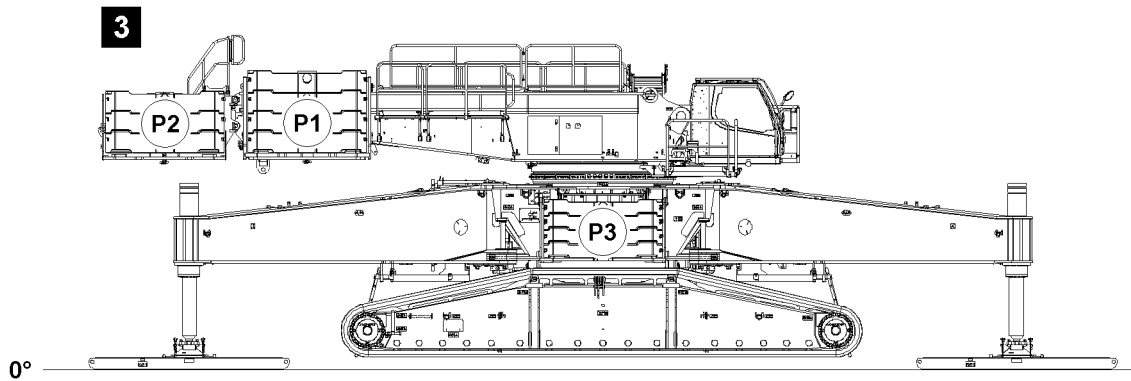
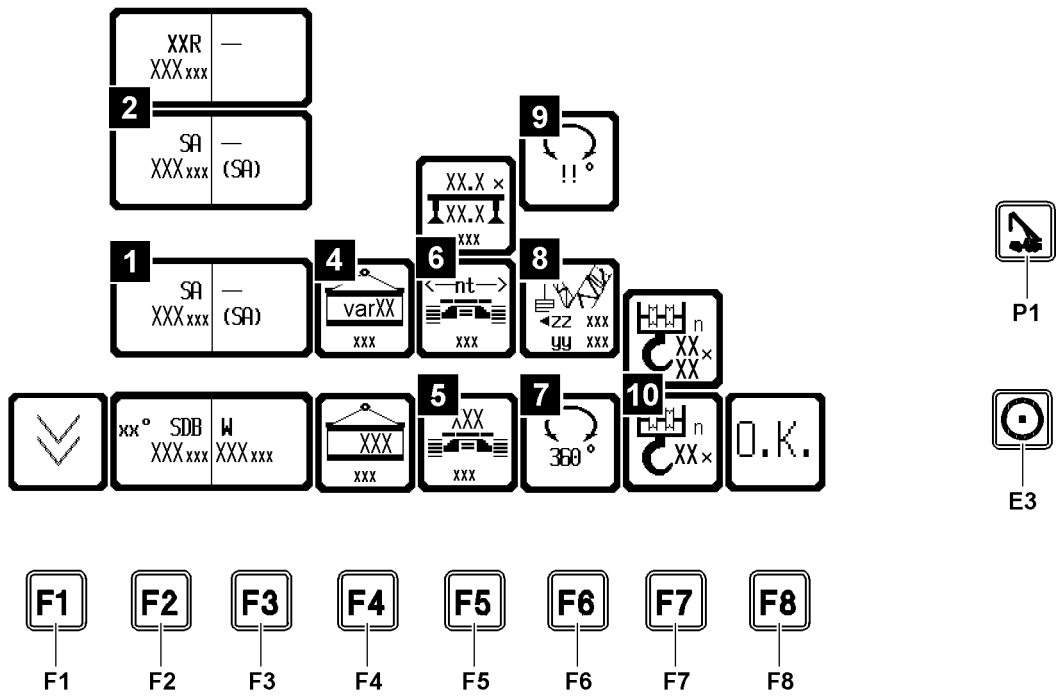

Fig.147113

LWE/LR 1600-2-008/18109-09-02/en

5.2.3 Function key line in the set up program

The function key line consists of function keys **F1** to **F8** and the function key icon bar above it. The function keys correspond to the various function key icons above them.

Various functions are indicated by the function key icons, or they may refer to changes of:

- Operating mode and
- set up configuration.

Not all function keys have to be assigned icons on the LICCON monitor. This depends on the program selection.

Pressing a function key changes the appearance of the icon above, its meaning, or its textual content.

F1 Vertical paging

- Depending on the size of the monitor, up to 10 load chart lines can be displayed at once. If a chart consists of more than 10 lines, then the display is spread over several pages. When pressing a key, the next page of the load chart will be displayed, and the number of the current page in the „general information line“ will be counted up by 1. When the last page is reached, page 1 will appear again after pressing the function key **F1**.

F2 Main boom geometry

- Adjustment possibility of different main boom operating modes and main boom lengths of the crane (if available). The types are described by abbreviations (for example: **SDB** = heavy main boom, derrick boom and suspended ballast) and length data in the icon.
- **Note (only standard crawler track):**
In addition to the main boom operating modes, the assembly operating mode SA can be set via the function key **F2**, see illustration 1.
- **Note (only narrow track crawler track):**
In addition to the main boom operating modes, the assembly operating mode SA as well as the operating mode XXR (back equipped, no crane operation - only for driving the crane) can be set via the function key **F2**, see illustration 2.

SHIFT and **F2**

- Press the key combination **SHIFT H** and program key **F2**:
Previous main boom geometry (if available).

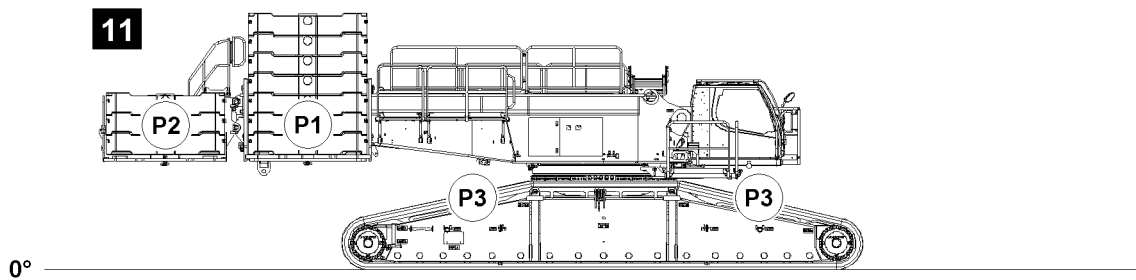
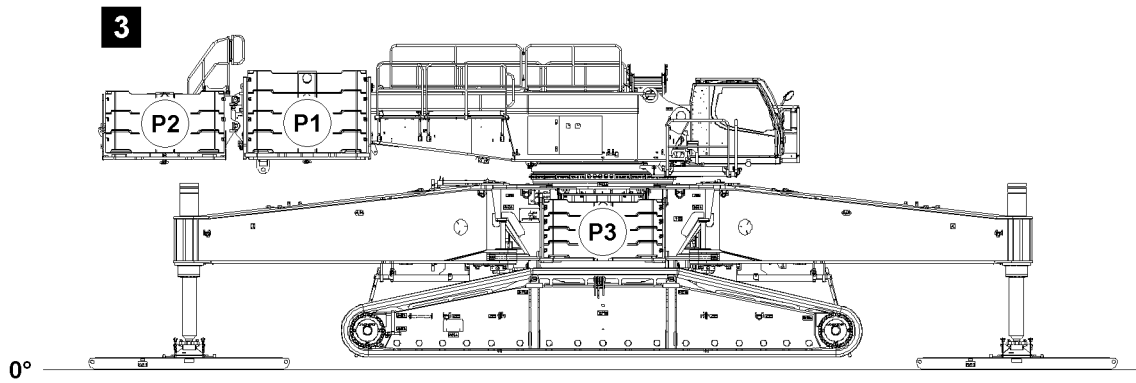
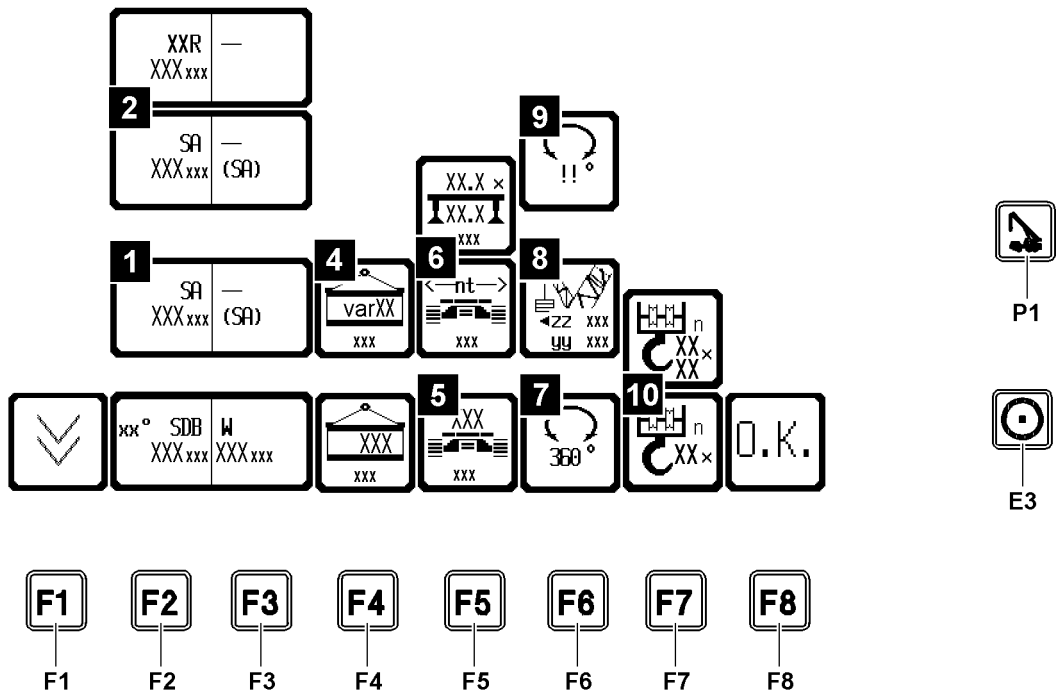

Fig.147113

LWE/LR 1600-2-008/18109-09-02/en

F3 Boom geometry auxiliary boom / accessory

- Adjustment possibility of different auxiliary boom operating modes and auxiliary boom lengths of the crane (if available). The types are described by abbreviations (for example: **W** = luffing lattice jib) and length data in the icon. Possibly additional angle data is noted in the icon.
- **Note:**
Pressing the function key **F2** and / or the function key **F3** removes all data (operating mode, set up configuration) from the monitor and sets the short code in the general information line to „CODE >????“!
- **Operating mode data:**
 - Boom length icon in the general information line
 - Length units and weight units
 - Load chart organization number
 - Boom radius icon
 - Boom length data
- **Set up dependent data:**
 - Numbering of current page number and total number of pages in load chart
 - Radius values in length units
 - Load values in weight units

**Note**

Pressing the function key **F2** and / or the function key **F3** removes all data (operating mode, set up configuration) from the monitor and sets the short code in the general information line to „CODE >????“!

- ▶ Confirm the new set up configuration, see description function key **F8**.

SHIFT and F3

- Press the key combination **SHIFT H** and program key **F3**:
Previous auxiliary boom geometry (if available).

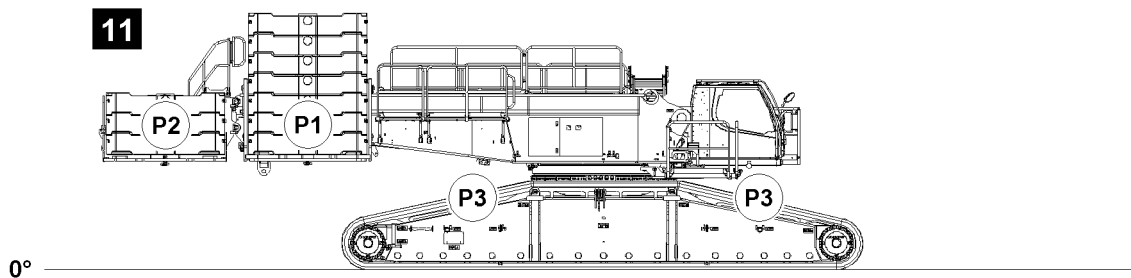
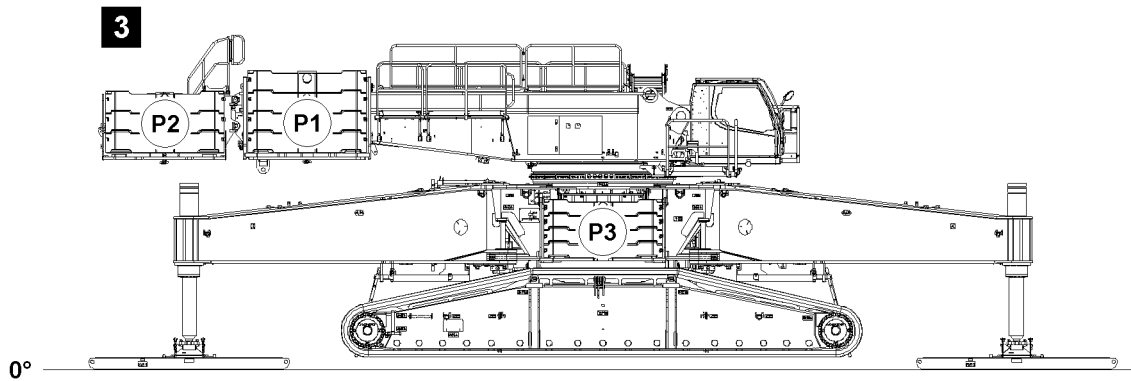
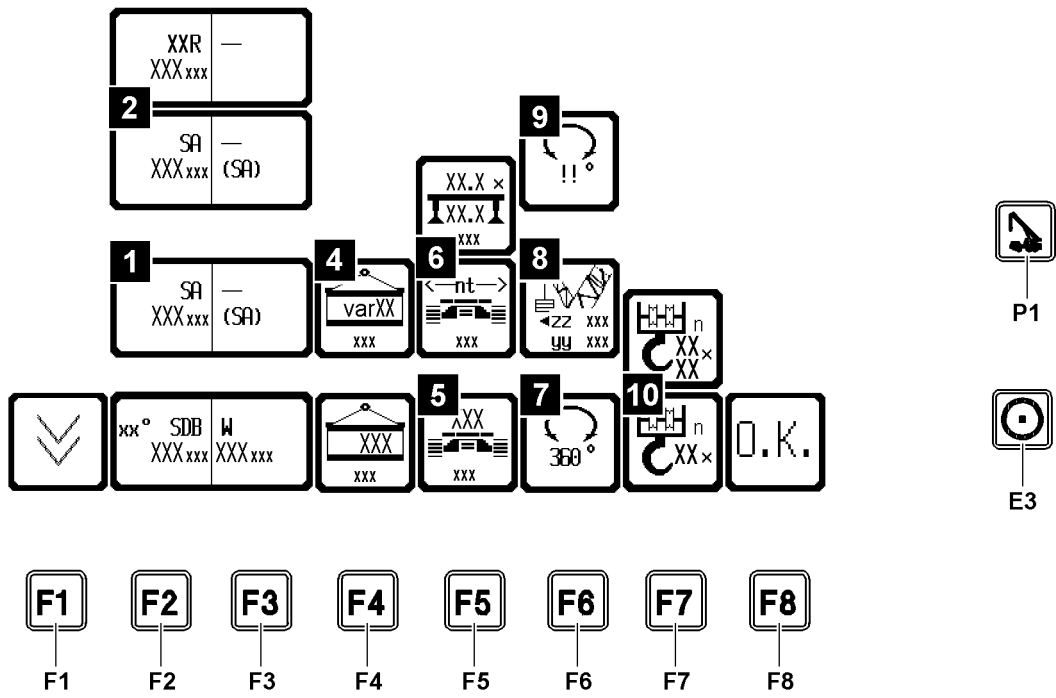

Fig.147113

LWE/LR 1600-2-008/18109-09-02/en

F4 Counterweight

- Adjustment possibility for current counterweight, which must be on the turntable in order to obtain the values in the current chart. When pressing a key, the following icon appears with additional text in the counterweight icon.
- Example:
„ 110 t “ = total counterweight of 110 t
- **Note (only narrow track crawler track, illustration 3):**
The counterweight can be shown on certain variations by a coding (illustration 4), see chart.

Coding (illustration 4)	Turntable (P1)	Turntable extension (P2)	Central ballast (P3)	Overall
var1	90 t	67.5 t	65 t	90 t / 67.5 t / 65 t
var2	90 t	67.5 t	45 t	90 t / 67.5 t / 45 t
var3	90 t	47.5 t	45 t	90 t / 47.5 t / 45 t
var4	90 t	27.5 t	45 t	90 t / 27.5 t / 45 t

- **Note (only standard crawler track, illustration 11):**
The counterweight can be shown on certain variations by a coding (illustration 4), see chart.

Coding (illustration 4)	Turntable (P1)	Turntable extension (P2)	Central ballast (P3)	Overall
var5	150 t	67.5 t	65 t	150 t / 67.5 t / 65 t

F5 Crane chassis

- Adjustment possibility „Set up configuration chassis“ (for example: crawler, support, central ballast variation).
- **Note (only standard crawler track, illustration 5):**
For operating modes where there are various central ballast variations, this can be set with function key **F5**.
- **Note (only narrow track crawler track, illustration 6):**
For operating modes where there are various crane chassis variations, this can be set with function key **F5**.

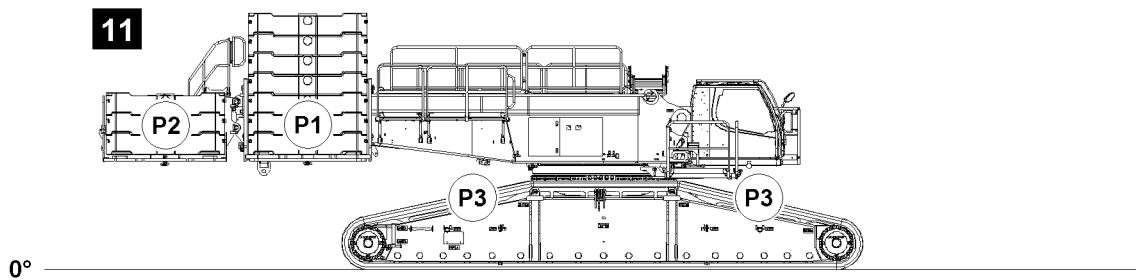
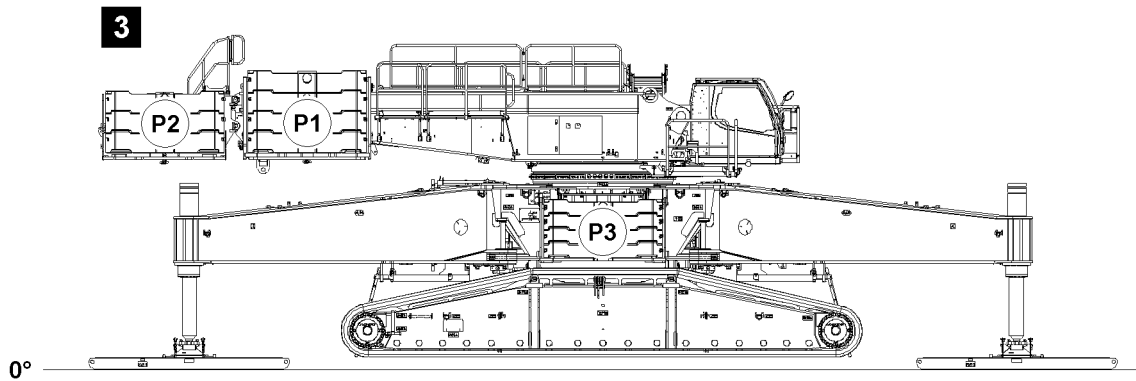
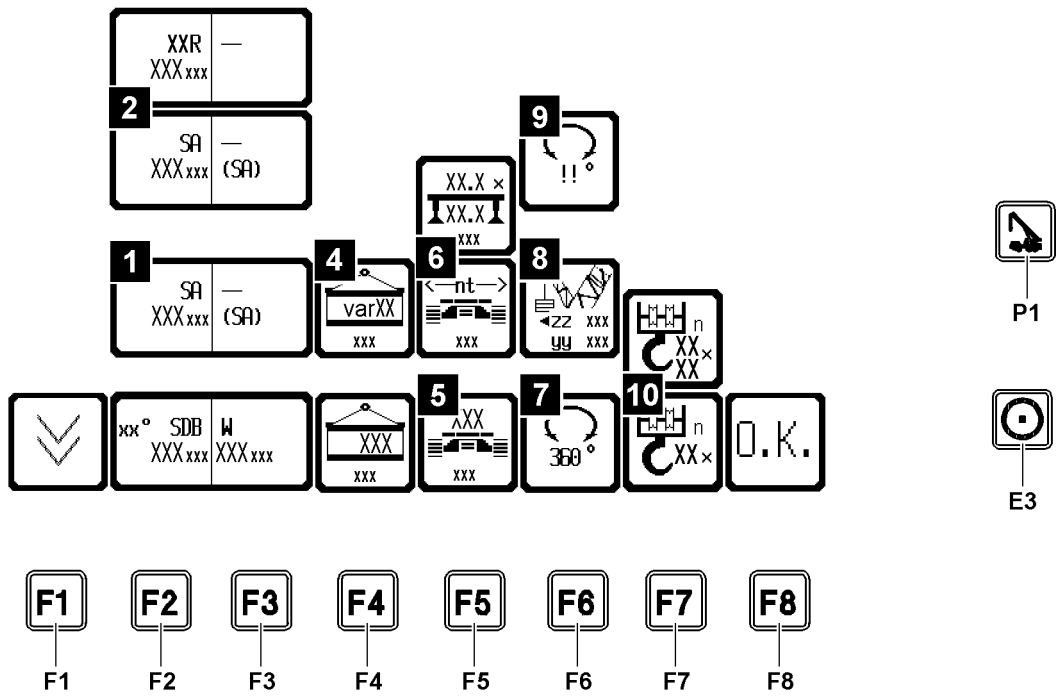

Fig.147113

LWE/LR 1600-2-008/18109-09-02/en

**Note**

- ▶ For crane operating modes without derrick ballast, the slewing range icon crane superstructure appears at **F6!**
- ▶ For crane operating modes with derrick ballast, the derrick ballast radius icon appears at **F6!**

F6 Slewing range crane superstructure

- Slewing range icon 360° - Slewing range crane superstructure not restricted, illustration 7

or

F6 Derrick ballast radius

- See illustration 8
- Set the set up configuration derrick ballast radius **yy** in [m] or [ft]
- Set the set up status derrick ballast weight **zz** in [t] or [lbs]

or

F6 Slewing range crane superstructure

- **Note (only narrow track crawler track, illustration 9):**
- The crane superstructure may not be turned (operating mode dependent)

F7 Hoist rope reeving

- Depending on the installed accessories, one or two values can be set, see illustration 10.
- Adjustment possibility for the **number of hoist rope strands on the boom and accessories** to obtain a certain load carrying capacity.
- Press the key: Reeving number is increased by 1.
- If no hook block is reeved on the boom, for example during the boom assembly, then set the value to 0, if possible.

Note: The reeving 0 is not possible for all operating modes.**SHIFT** and **F7**

- Press the key combination **SHIFT H** and program key **F7**:
Reeving number on boom is reduced by 1.

**Note**

- ▶ The displayed number of hoist rope strands (reeving) in the icon will be increased with every keystroke by one counter, up to a fixed maximum value (depending on operating mode)! If the maximum value is exceeded, the counter starts again at the minimum value!
- ▶ If the set value is still within the minimum and maximum values when switching to another operating mode, it remains valid! Otherwise it will be set to the minimum value for the new operating mode!

**Note**

Parallel operation of hoist winches!

- ▶ For parallel operation of hoist winches (1II2), when reeving in the hoist rope, enter the total reeving of winch 1 and winch 2 on the LICCON computer system!
- ▶ **Example:** Winch 1 and winch 2 are each reeved 7ways, the total reeving is therefore n=14!
- ▶ The total reeving **must** always show an even number value in parallel operation!

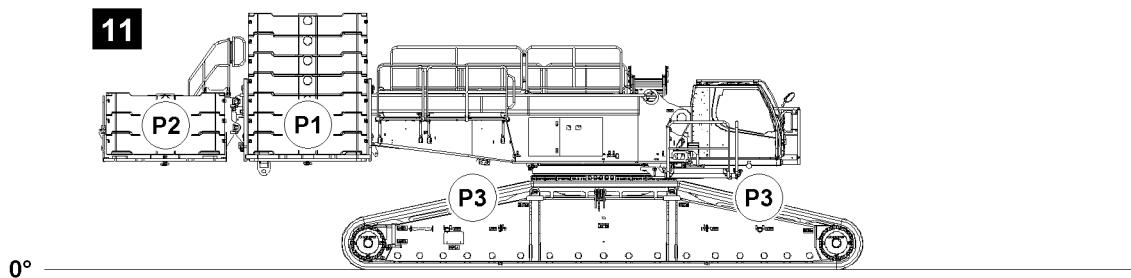
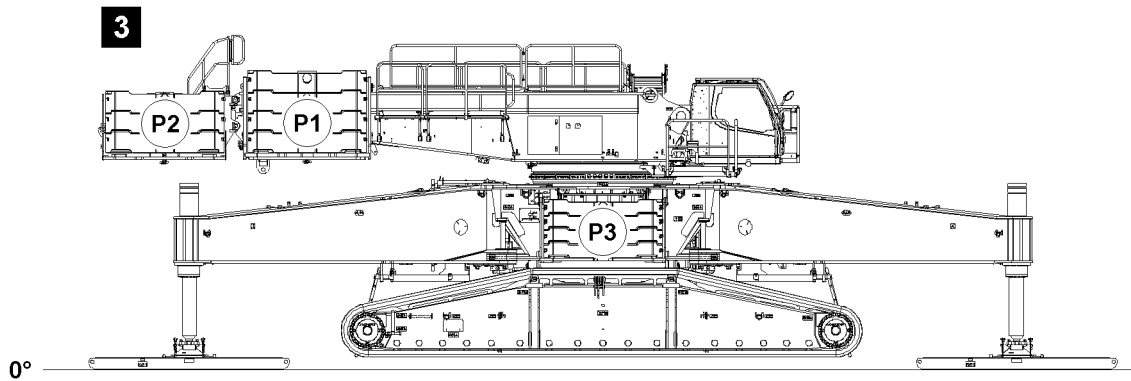
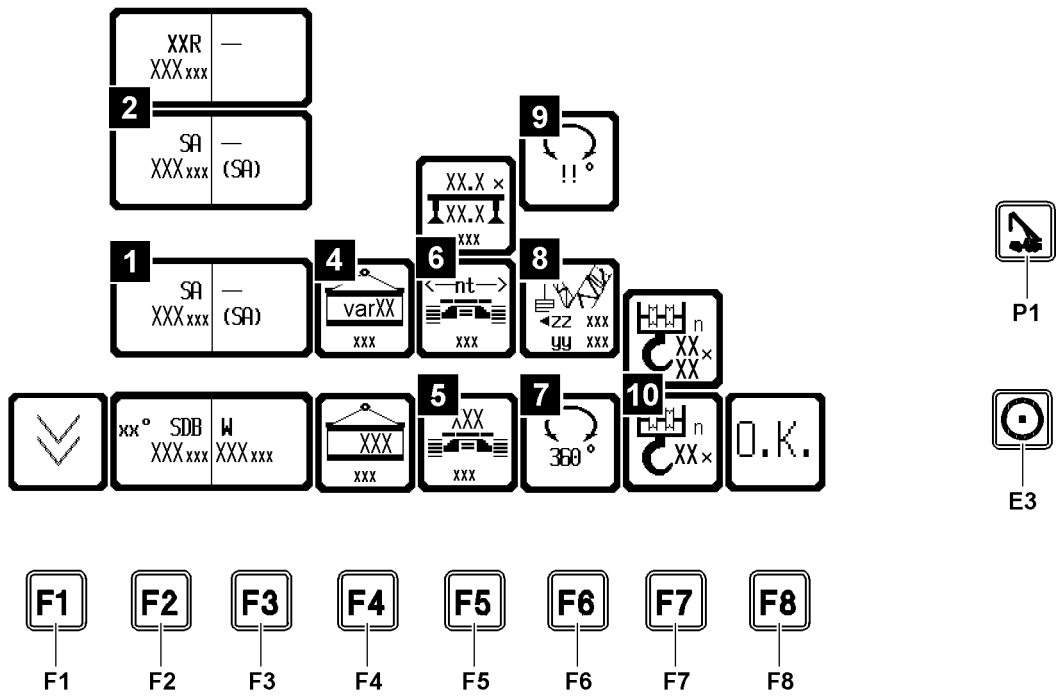

Fig.147113

LWE/LR 1600-2-008/18109-09-02/en

E3 and F7

- Adjustment possibility for the **number of hoist rope strands on the accessory (for example boom nose)** to obtain a certain load carrying capacity.
- Press the button: Reeving number on accessory (upper number in „Hoist rope reeving“ icon) is increased by 1.

SHIFT and E3 and F7

- Press the key combination **SHIFT H** and special function key **E3** and function key **F7**: Reeving number on accessory (upper number in „Reeving“ icon) is decreased by 1.

**Note**

Display reeving accessory!

- ▶ The reeving for the accessory (for example boom nose*) is only shown (illustration 10), when the accessory is installed and recognized by the crane control!
- ▶ If the accessory is installed during operation, then the reeving must be correctly entered for it in the set up program!

F8 Confirmation key

- For confirmation of selected set up configuration
- **Prerequisites:**
 - The entry of the set up configuration must be completed all the way. A valid short code is shown and in the chart field are load values.
 - The external conditions for this set up configuration, if stipulated, must be met.
 - The crane may not be utilized by more than 20 % in the previous set up configuration (applies only if the load suspended on the hook is heavier than 0.5 t). Switching to the crane operation program can otherwise only be done with the program key **P1**. In that case, the newly entered set up configuration is not accepted.

**Note**

- ▶ Make sure that the selected set up configuration (short code) and the hoist rope reevings are taken over after switching into the operating screen!

**Note**

Display of operating errors from the set up program!

- ▶ Operating errors created in the set up program are displayed in the icon above the function key **F8** and are saved in the error stack for about 5 seconds!
- ▶ If the function key **F8** is pressed within 5 seconds, the program will switch automatically to the error determination screen in the test system and the error will be displayed documentarily!
- ▶ The operating error will not be saved!
- ▶ Operating errors are always placed on top in the error stack, see Diagnostics manual!

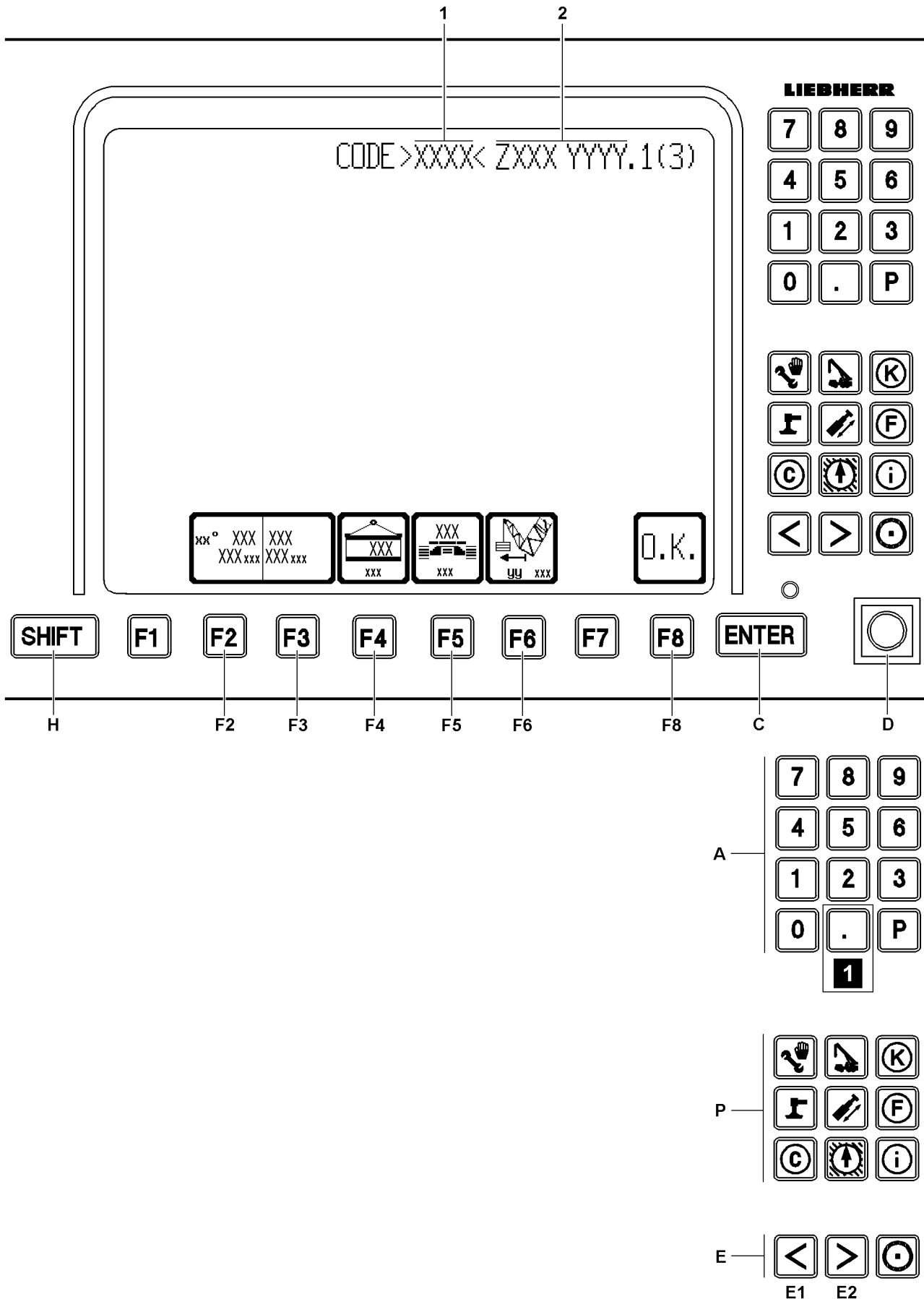

Fig.112308

LWE/LR 1600-2-008/18109-09-02/en

5.2.4 Operating errors in the set up program

A Keypad

- Pressing the keypad deletes all operating mode and set up configuration dependent data from the monitor
- The keys **0** to **9** on the keypad can be used to enter the short code directly into the LICCON monitor
- The key **P** and the key „**“** (illustration 1) have no function in the set up program

P Program keys

- Selection of individual programs. The settings in the set up program are discarded and the set up configuration and reeving, which were last confirmed with the function key **F8** (OK) are continued to be used.
A program currently running **cannot** be called again using its program key.

C Input key ENTER

- Confirmation of input both for short codes **1** as well as for any change in the set up configuration via the function keys
- **ENTER** after entering the short code, the short code **1** is searched for in all stored load charts. If the matching load chart has been programmed, it will be displayed in full. Otherwise there is an error message in the form of „????“ in the second part of the organization number **2** and the acoustic signal „Horn“ sounds.
- **ENTER** after a changing the operating mode using the function key **F2** and the function key **F3** searches for this operating mode. If successful, sets its first set up configuration and displays the load chart and its short code **1**. In the event of an error, the short code **1** remains on „CODE ?????“, the organization number **2** is displayed as „ZXXX????“ and the acoustic signal „Horn“ sounds.
- **ENTER** after a change in the set up configuration with the function keys **F4** and **F5** as well as the function key **F6** this load chart (if the chart exists) displays with short code **1** on the monitor. In the event of error, the short code **1** remains on „CODE ?????“ and the acoustic signal „Horn“ sounds.



Note

Use of place holders

- ▶ The Short code **1** and the Organization number **2** are shown in this chapter with place holders (for example XXXX or ZXXX) instead of real numbers and letters!

D Set up key

- Has no function in the Set up program

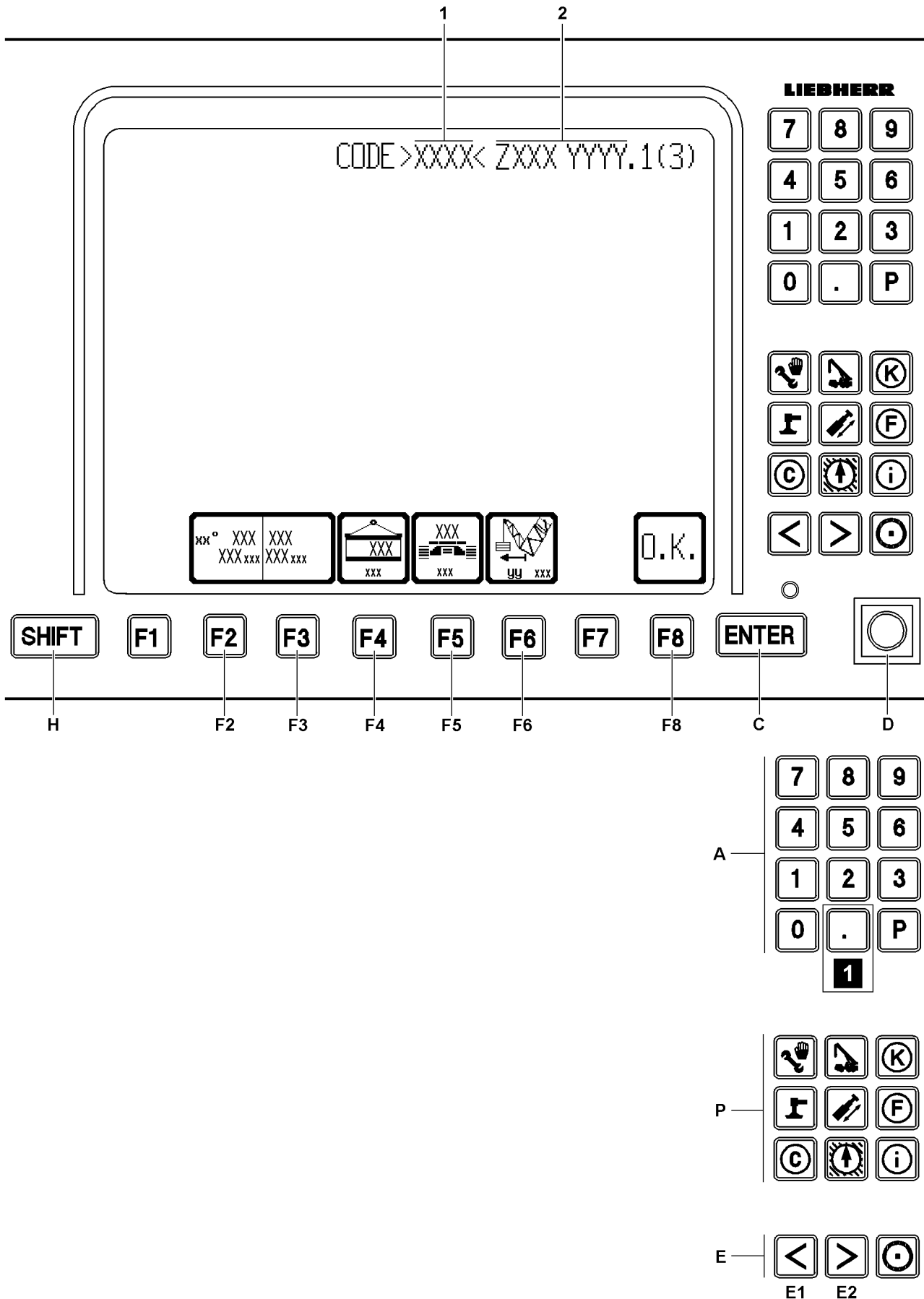

Fig.112308

LWE/LR 1600-2-008/18109-09-02/en

E Horizontal paging• **Note:**

The key **E1** and key **E2** only have a function if this is indicated in the „Line for special displays“!

- If a load chart consists of more than 7 columns, the first display of the set up configuration only shows columns 1 to 7
- Pay attention to the double arrow on the right (>>) and / or on the left (<<) edge of the line of the load chart! It points to additional columns in the respective direction!
- Press the key **E1** to display the next left chart column
- Press the key **E2** to display the next right chart column

• **Note:**

Using the key combination SHIFT **H** and key **E1** or SHIFT **H** and key **E2**, you can, where possible, scroll left or right by 7 load chart columns (corresponds to 1 page)!

H SHIFT key

- For example Supervisory function
- By pressing and holding down the SHIFT **H** key and then pressing one of the function keys, which must correspond to the corresponding function, the previous main boom geometry, the auxiliary boom geometry and the previous reeving are reset
- **Note:**
See section „The function key line“ in the set up program!

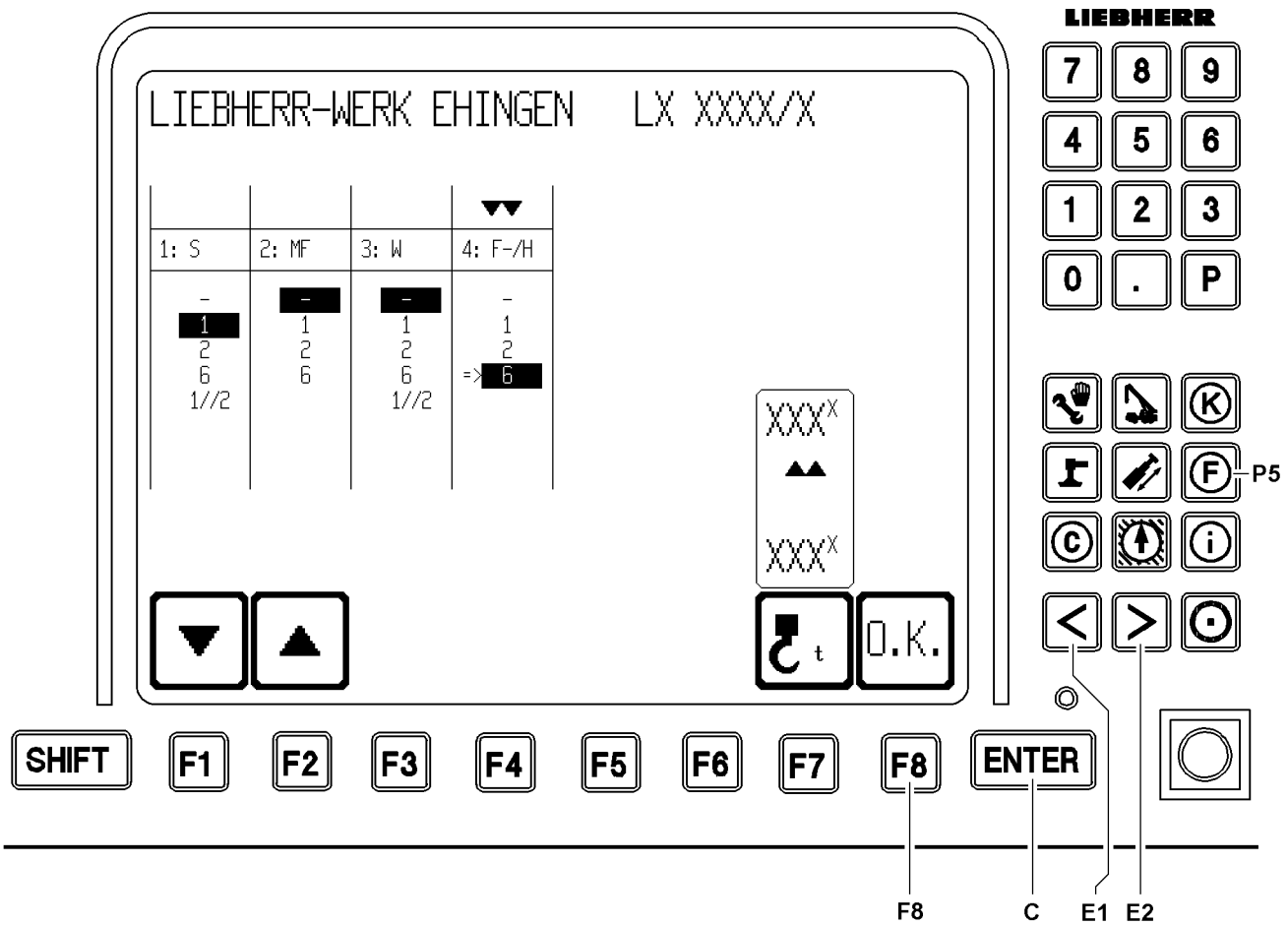

LIEBHERR-WERK EHINGEN LX XXXX/X—1

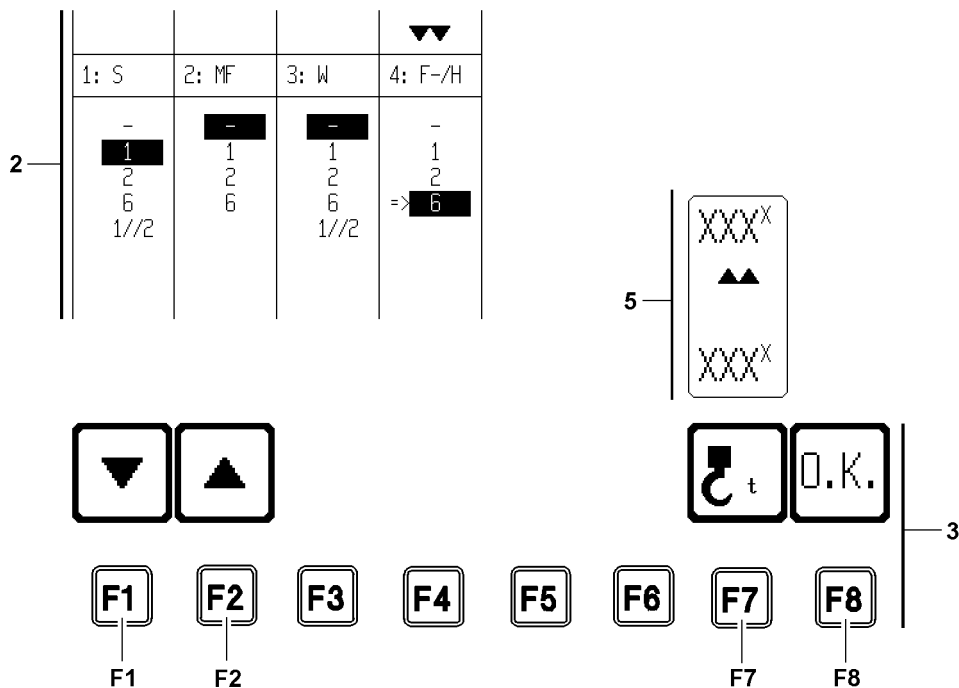

Fig.113268

LWE/LR 1600-2-008/18109-09-02/en

6 The winch - pulley head assignment screen

After the set equipment set up has been confirmed in the „Set up“ program with the function key **F8** (OK), the set up parameters are taken over by the LICCON computer system and the „winch - pulley head assignment screen“ appears automatically.

6.1 Starting the winch - pulley head assignment screen

In the „winch - pulley head assignment screen“ the crane operator must assign the required winch(es) for crane operation to the respective pulley heads (S, MF, W, F-/H) and additionally determine the appropriate hook block weight for the operating mode for erection and take down of the boom or the boom system according to the erection and take down charts.

By pressing the function key **F8** (OK) in the „Set up“ program, the LICCON computer system changes automatically into the „winch - pulley head assignment screen“.

Starting the „winch - pulley head assignment screen“:

- ▶ Press the function key **F8** (OK) in the set up screen.
- or
- Press the program key **P5**.

6.2 Areas in the winch - pulley head assignment screen

The LICCON monitor is divided into three areas in the „winch - pulley head assignment“:

- 1 Crane type identification
- 2 Assignment overview
 - For the „winch - pulley head assignment“
- 3 Function key line
- 5 Hook block weight icon

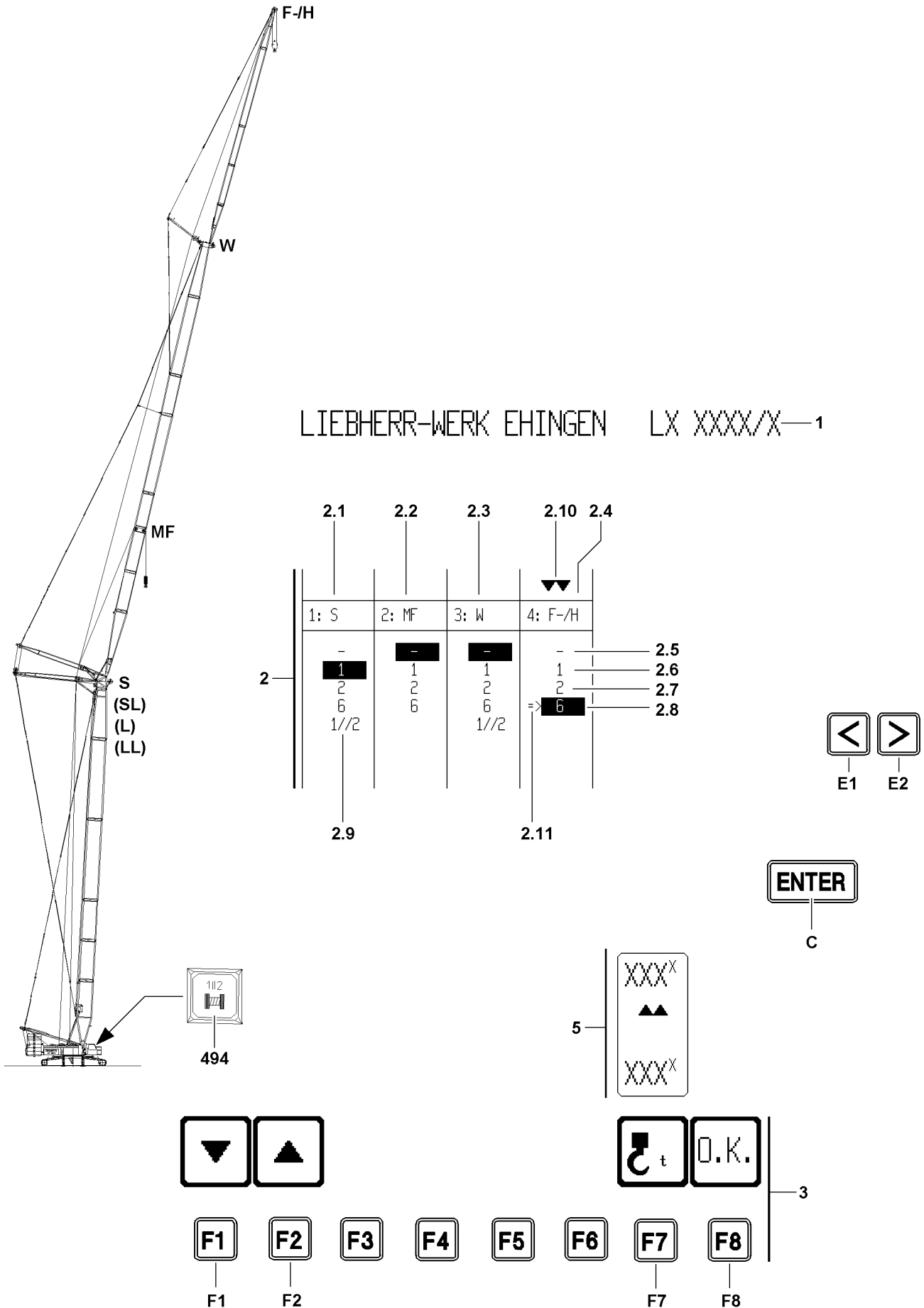

Fig.113266

LWE/LR 1600-2-008/18109-09-02/en

6.3 User interface

- 1 Crane type identification
- 2 Assignment overview
 - **Note:**
The winches are assigned to the pulley heads within the assignment overview.
- 2.1 „Pulley head 1“
 - Pulley head on main boom
 - Valid for main boom operating modes (L, LL, SL, S, if present)
- 2.2 „Pulley head 2**“
 - „Midfall“ (MF)
 - Pulley head on the center pulley of the luffing jib
- 2.3 „Pulley head 3“
 - Pulley head on the „luffing jib**“
- 2.4 „Pulley head 4“
 - Pulley head on the „fixed jib**“ or on the „boom nose**“
- 2.5 No winch assigned
- 2.6 Winch 1
 - Not selected
- 2.7 Winch 2
 - Not selected
- 2.8 Winch 6*
 - Selected (background is black)
- 2.9 Winch 1 and winch 2 in parallel operation
 - Not selected
- 2.10 Selector arrow
 - Double arrow pointing down
 - Select pulley head
- 2.11 Winch selector
 - Arrow to the right
 - Select winch, which is to be assigned to the pulley head
- 3 Function key line
- 5 Hook block weight icon

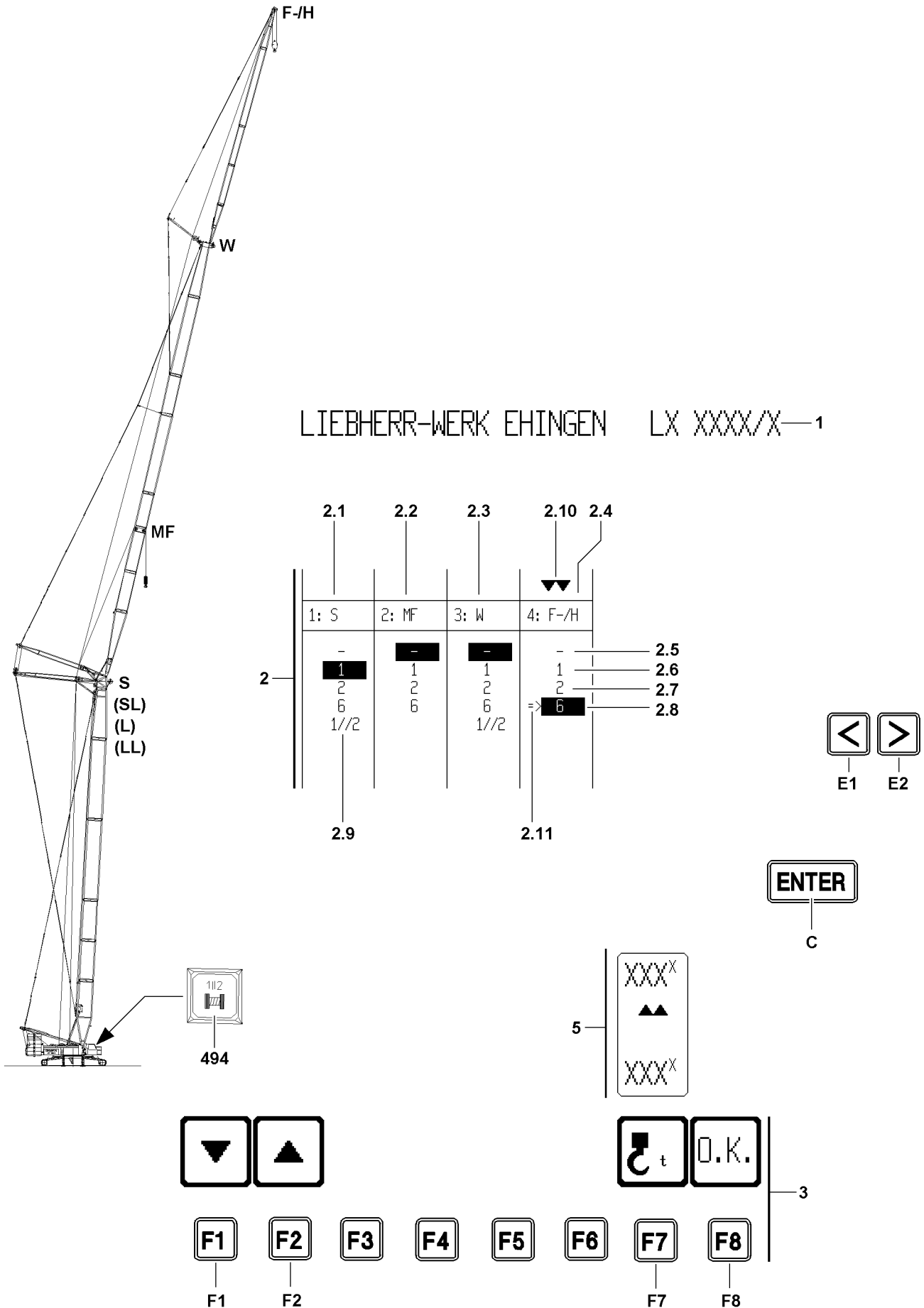

Fig.113266

LWE/LR 1600-2-008/18109-09-02/en

- F1** Function key
 - Move winch selector **2.11** „down“
- F2** Function key
 - Move winch selector **2.11** „up“
- F8** Function key „OK“
 - Confirmation of settings in the „winch - pulley head assignment screen“ and take over of settings into the „crane operation“ program
- C** ENTER
 - According to winch selection:
 - The winch selected with the winch selector **2.11**, after pressing the ENTER **C** key, is highlighted in black and is therefore preselected.
 - According to entry of a hook block weight:
 - The entered hook block weight is accepted after pressing the ENTER **C** key from the input field into the current input value.
- E1** Special function key
 - Move the selector arrow **2.10** to the left to select the pulley head
 - Note:**
The winch selector **2.11** is taken over into the corresponding column at the same time with the selector arrow **2.10!**
- E2** Special function key
 - Move the selector arrow **2.10** to the right to select a pulley head
 - Note:**
The winch selector **2.11** is taken over into the corresponding column at the same time with the selector arrow **2.10!**

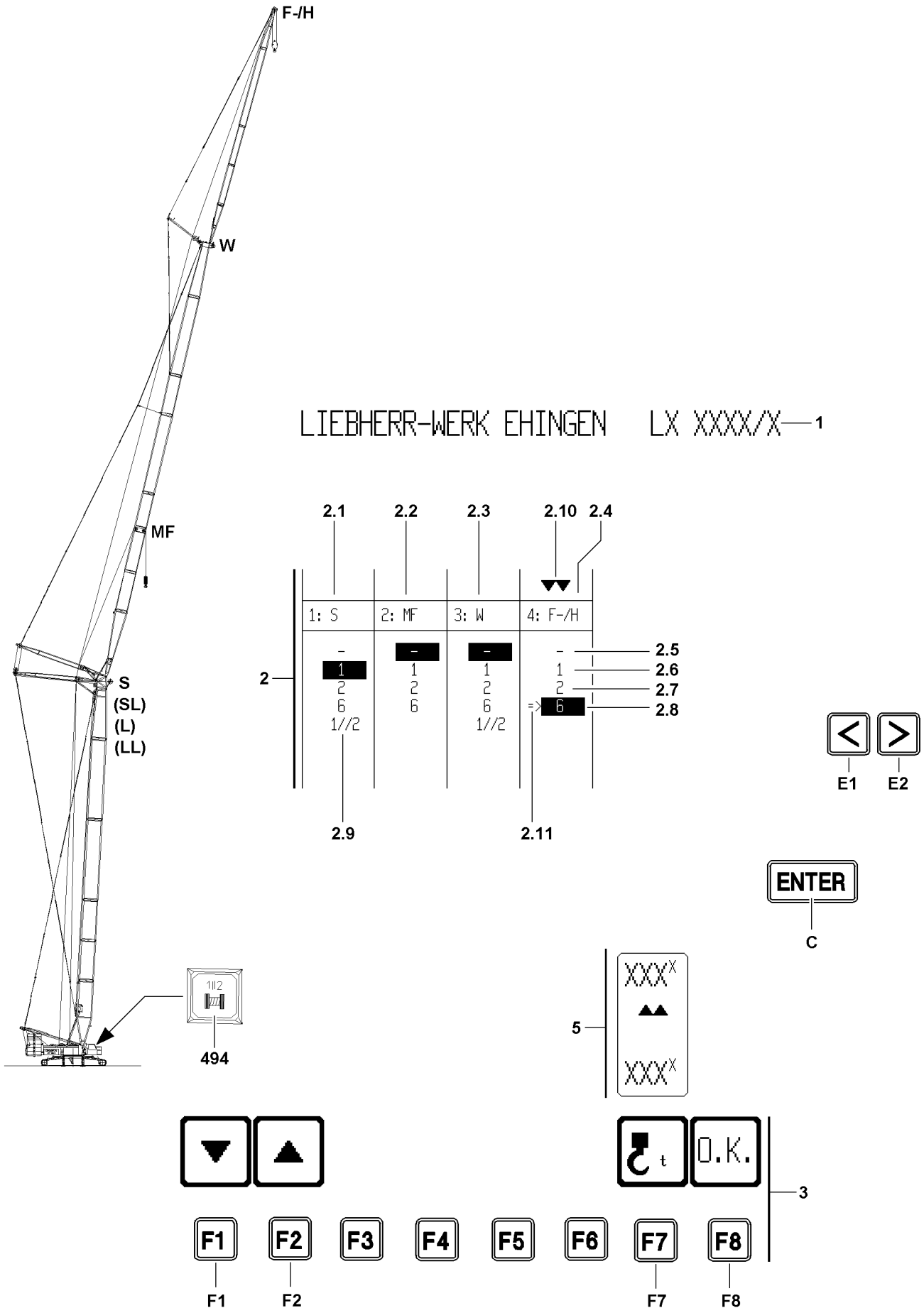

Fig.113266

LWE/LR 1600-2-008/18109-09-02/en

6.4 Selecting a pulley head and assigning it to winches

Make sure that the following prerequisites are met:

- The set up parameters from the set up screen have been confirmed by pressing the function key **F8** „OK“.
- The „winch - pulley head assignment screen“ is shown on the LICCON monitor.



DANGER

The crane can topple over!

If an incorrect winch is assigned to a pulley head, then there is the possibility that the LMB does not recognize an overload condition or recognizes it too late, since a thick hoist rope is assumed for the calculation of the „load capacity“, even though actually a thin hoist rope has been placed (the „load capacity“ might be calculated too large in such a case)!

If an incorrect winch is assigned to a pulley head, then there is the possibility that the LMB does not recognize an overload condition or recognizes it too late, since a hoist rope lever arm, which is too small, is assumed for the calculation of the „actual load“ and as a result, the „actual load“ will be calculated too small!

The crane can be overloaded unnoticed and topple over!

Personnel can be severely injured or killed!

- ▶ The crane operator must ensure that the „winch - pulley head assignment“ matches the installed boom system and the set operating mode!



WARNING

Impermissible „winch - pulley head assignment“!

If a „winch - pulley head assignment“ is recognized by the LICCON computer system as impermissible, then the following display appears - after take over of the settings with the function key **F8** (OK) – on the winch icons of the crane operating screen (for winch 1, winch 2 and winch 6): „ ??“

▶ **Crane operation with impermissible settings is prohibited!**

- ▶ The crane operator must carefully check the settings in the „set up“ program and in the „winch - pulley head assignment“ and correct them, if necessary!
- ▶ The crane operator must ensure that the „winch - pulley head assignment“ matches the installed boom system and the set operating mode!
- ▶ The crane operator must ensure that the „winch - pulley head assignment“ has been taken over by the control correctly after confirmation of the settings with the function key **F8** (OK)! The correct boom identifications must appear in the winch icons in the crane operating screen! If necessary, recheck the settings!
- ▶ If there is any doubt, contact the Service Dept. at Liebherr-Werk Ehingen GmbH!

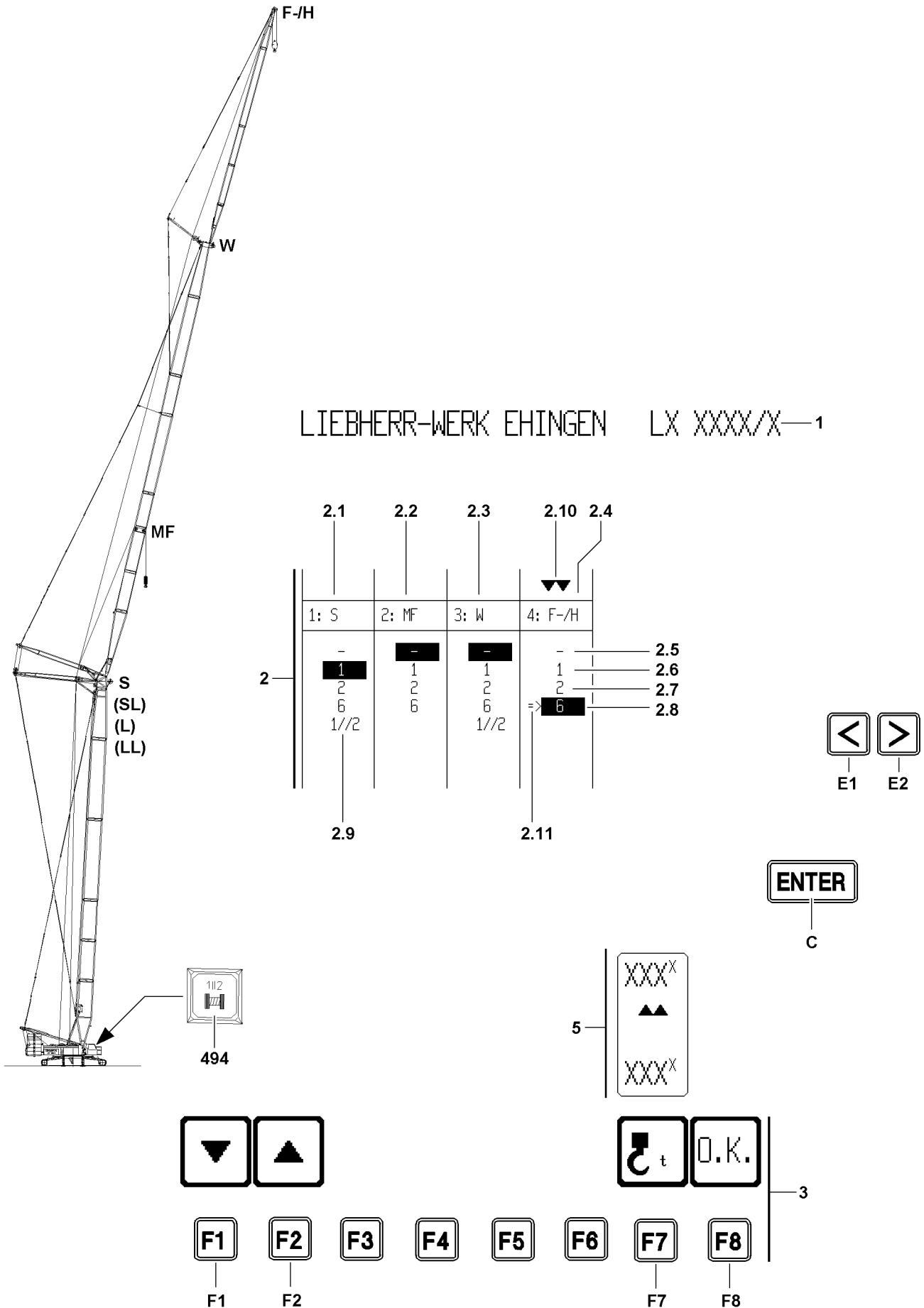

Fig.113266

LWE/LR 1600-2-008/18109-09-02/en

6.4.1 Selecting a pulley head



Note

- ▶ The pulley heads are located in such a way that the radius increases from pulley head 1 to pulley head 4!
 - ▶ A crane equipment consists of maximum four pulley heads!
 - ▶ The selection of the desired pulley head by the selector arrow **2.10** is made by pressing the special function key **E1** or the special function key **E2**!
-

Move the selector arrow **2.10** into the desired column.

Move the selector arrow to the left

- ▶ Press the special function key **E1**.

Result:

- The selector arrow **2.10** and the winch selector **2.11** move by one column to the „left“.
- The winch selector **2.11** jumps automatically to the selected winch (black background).

Move the selector arrow to the right

- ▶ Press the special function key **E2**.

Result:

- The selector arrow **2.10** and the winch selector **2.11** move by one column to the „right“.
- The winch selector **2.11** jumps automatically to the selected winch (black background).

When the required pulley head is selected:

- ▶ Select the winch(es) as outlined in section „Assigning winch(es)“!

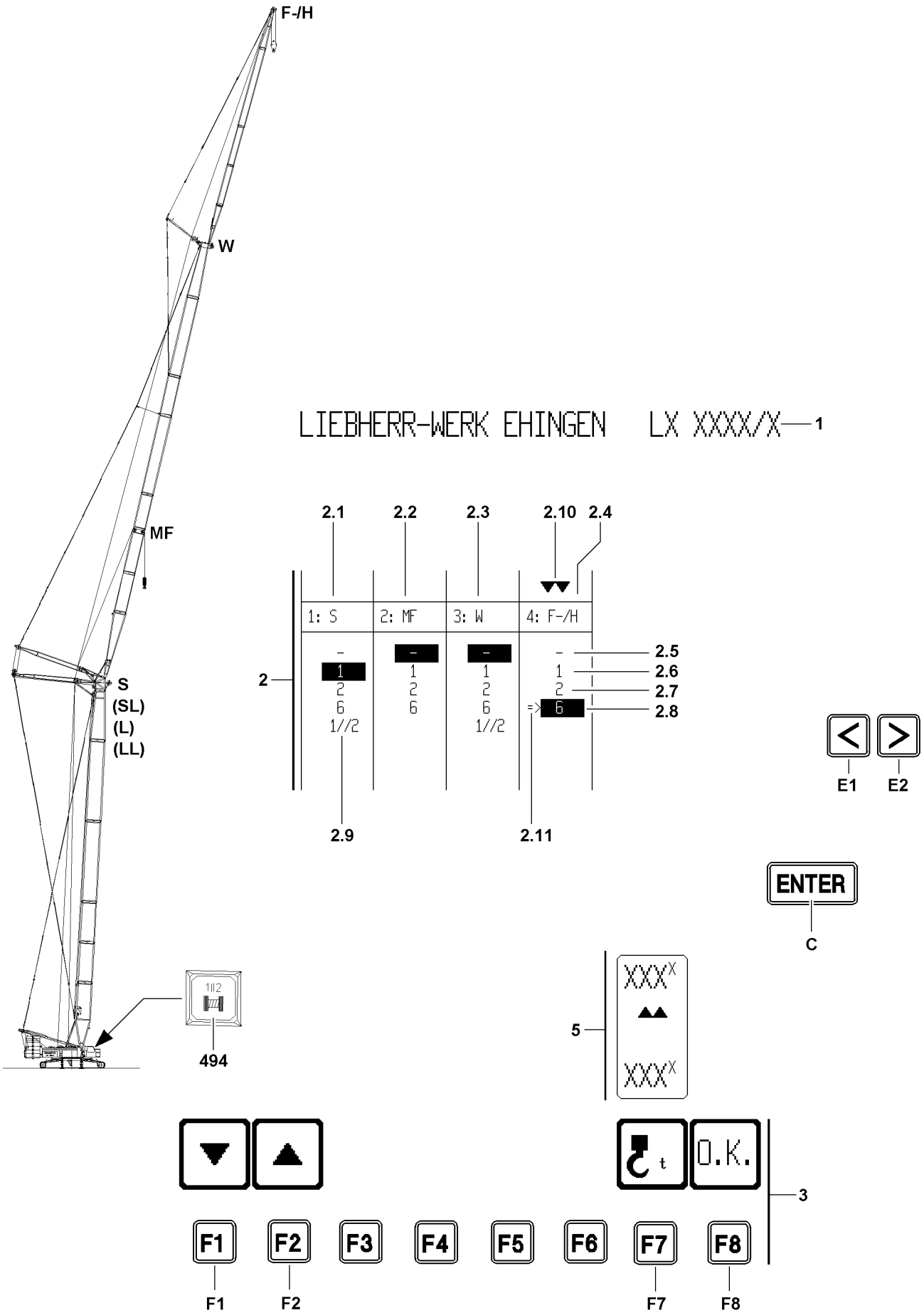

Fig.113266

LWE/LR 1600-2-008/18109-09-02/en

6.4.2 Assigning winch(es)



WARNING

The crane can topple over!

Due to incorrect settings during the winch assignment, dangerous operating situations can occur, up to toppling the crane!

Personnel can be severely injured or killed!

- ▶ At winch assignment of winch 1 and winch 2 in parallel operation (11I2), turn the switch **494** (parallel operation) in the control console on the right on!
- ▶ At winch assignment of winch 1 and winch 2 in single operation, turn the switch **494** in the control console on the right **off**!



Note

- ▶ The winch selector **2.11** is coupled to the selector arrow **2.10** and moves automatically into the same column as the selector arrow **2.10**. The winch selector **2.11** „jumps“ automatically to the selected winch (black background)!
- ▶ The winch required for crane operation is selected by pressing the function key **F1** and the function key **F2**. This selection is confirmed by pressing the ENTER **C** key!
- ▶ A winch which is already assigned to another pulley head is ignored and passed over when the function key is pressed. The winch selector **2.11** jumps automatically to the next „free“ winch!
- ▶ One winch can only be assigned to one pulley head!



Note

- ▶ For pulley heads, which are not assembled, **or** which are assembled but no winch is to be assigned to them, instead of a winch, the sign „no winch selected“ **2.5** must be assigned!

Make sure that the following prerequisite is met:

- The desired pulley head is selected.

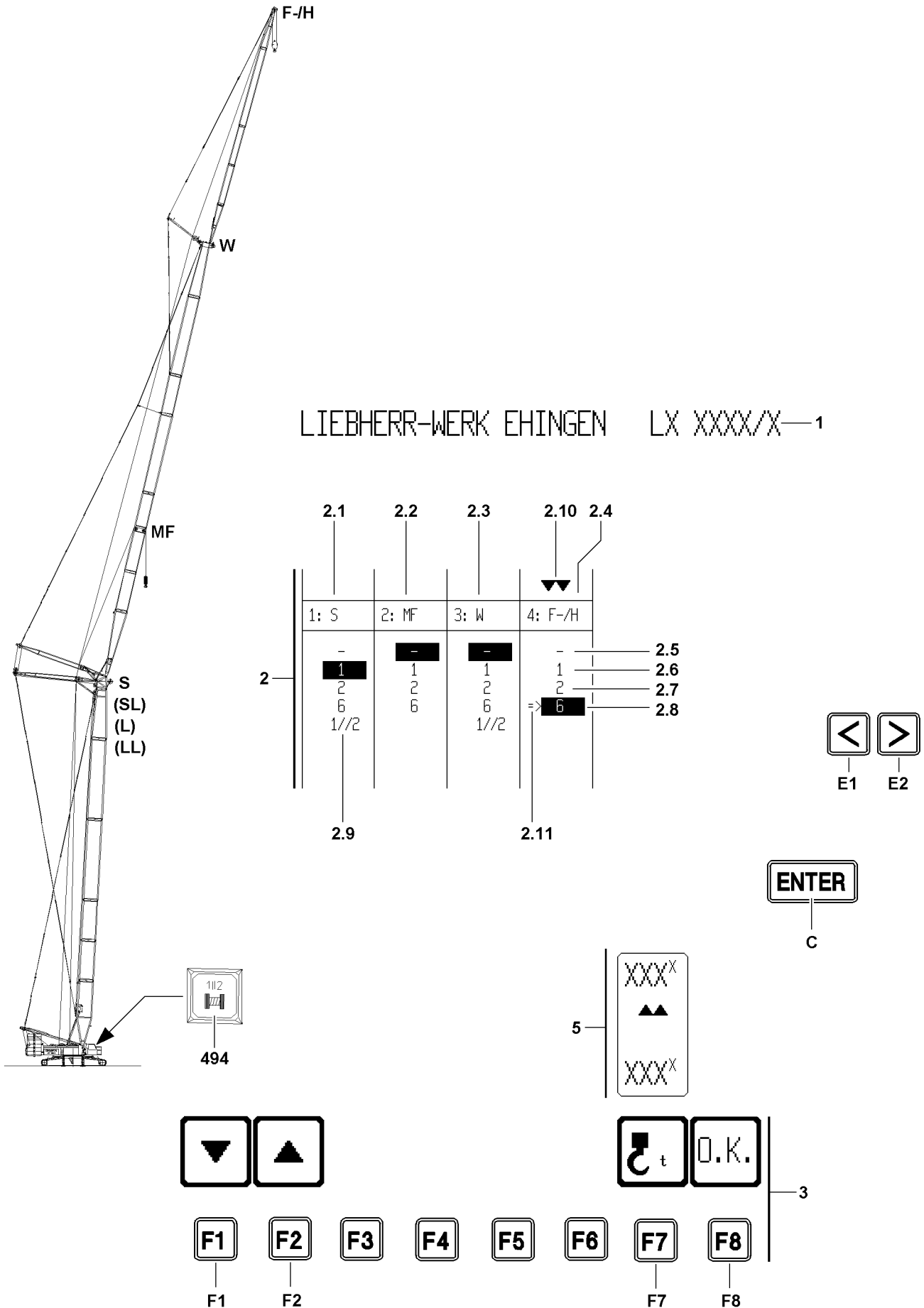

Fig.113266

LWE/LR 1600-2-008/18109-09-02/en

Move the winch selector „down“

- ▶ Press the function key **F1**.

Result:

- The winch selector **2.11** moves „down“.

Move the winch selector „up“

- ▶ Press the function key **F2**.

Result:

- The winch selector **2.11** moves „up“.

Confirm the selection

If the desired winch is assigned to a pulley head, the crane operator must confirm the setting for this pulley head with **ENTER C**.

- ▶ Every assignment of a winch to a pulley head must be confirmed separately with the **ENTER C** key!

Result:

- The selected winch is highlighted in black.

6.4.3 Taking over the settings into the crane operating screen

If the „winch - pulley head assignment“ is completed for all required pulley heads, the data is taken over into the crane operating view and the control by pressing the function key **F8 „OK“**.

- ▶ Press the function key **F8 „OK“**.

Result:

- The settings are completely taken over into the control.
- The crane operating screen appears on the LICCON monitor.

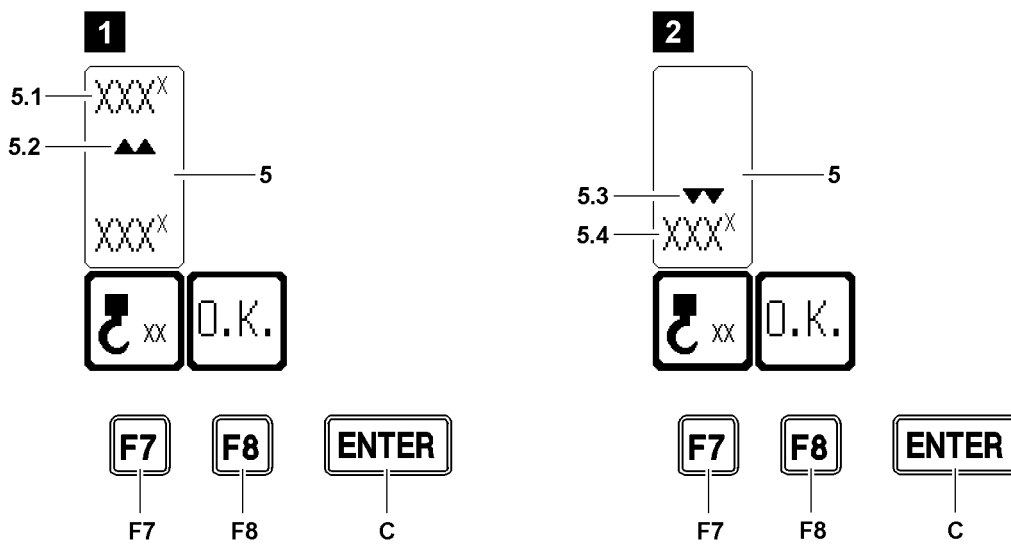
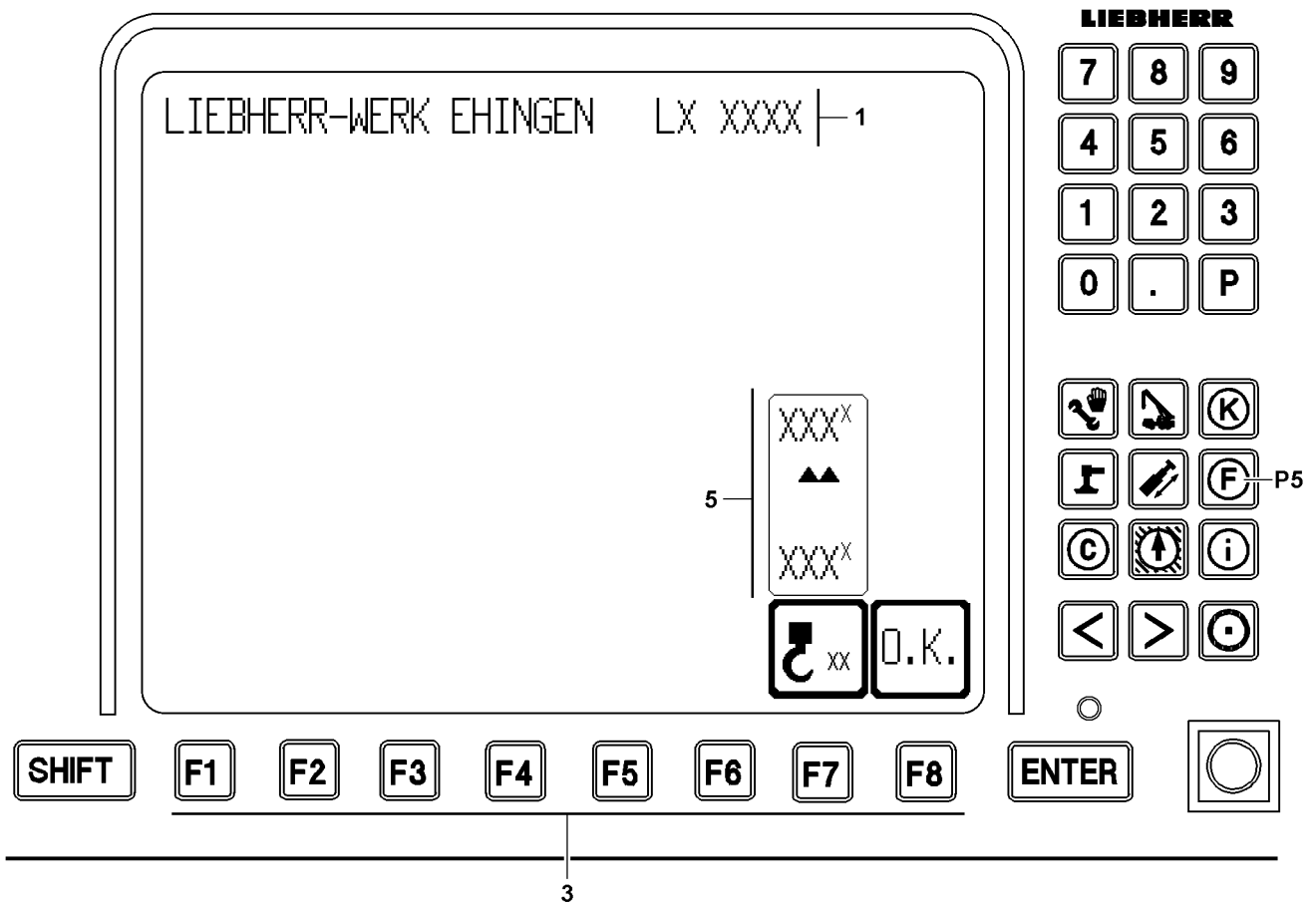

Fig.113267

6.5 Input window hook block weight

After the selected set up configuration was confirmed in the set up program with the function key **F8**, the set up parameters are taken over by the LICCON computer system. Then the input window hook block weight appears automatically.



WARNING

Deviation from specifications of erection and take down charts!

In case of a deviation from the specifications of the erection and take down charts, the crane can be overloaded and topple over!

Personnel can be severely injured or killed!

- ▶ The entered value must be taken from the erection and take down charts, depending on the selected set up configuration!
- ▶ If the actual weight of the hook block exceeds the permissible hook block weight, then the hook block must be carried along for erection / take down of the boom!
- ▶ The entered hook block weight is recorded with the data logger!

6.5.1 Starting the input window hook block weight

In the input window hook block weight, the crane operator must determine a hook block weight corresponding on the operating mode for erection / take down of the boom systems according to the erection / take down charts.

- ▶ Press the function key **F8** in the set up configuration screen.
or
Press the program key **P5**.

Result:

- The input window hook block weight appears.

6.6 User interface

- 1 Crane type identification
- 3 Function key line
- 5 Hook block weight icon
- 5.1 Input field for the hook block weight
- 5.2 Double arrow pointing up
 - Input field is active, illustration 1
- 5.3 Double arrow pointing down
 - Current input value is active, illustration 2
- 5.4 Current input value of hook block weight

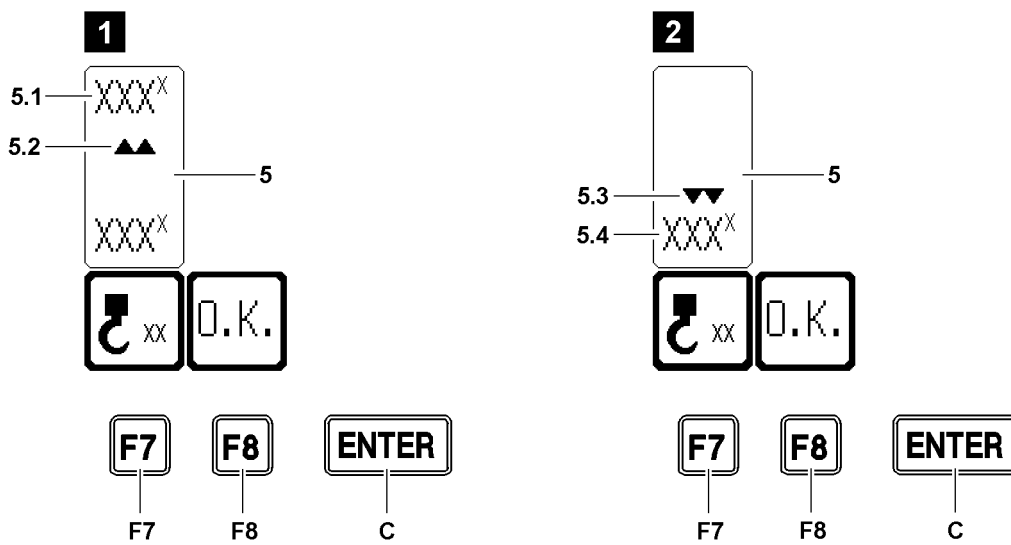
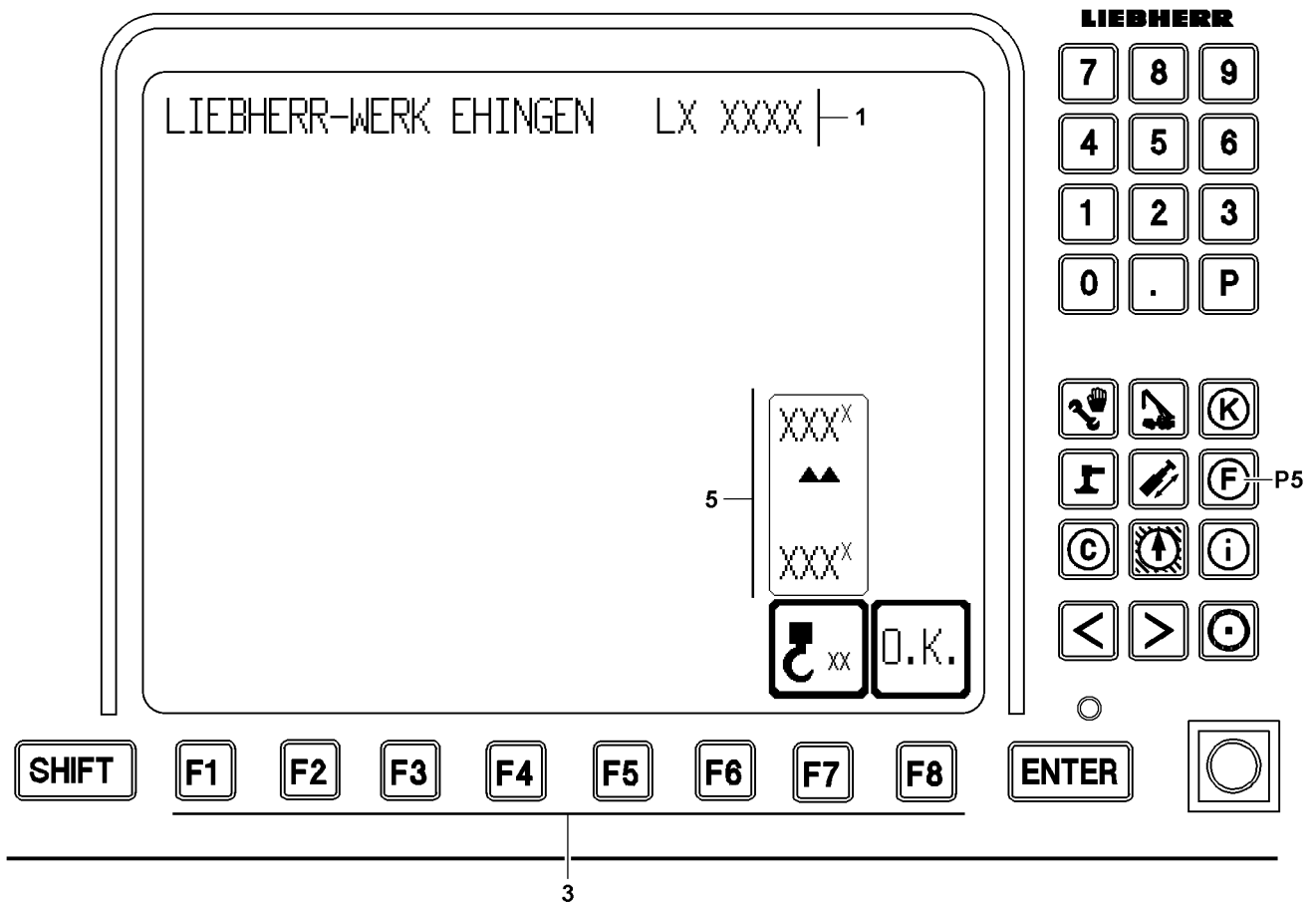

Fig.113267

LWE/LR 1600-2-008/18109-09-02/en

6.7 Enter the hook block weight

To be able to erect / take down a boom system, a valid hook block weight must first be entered in the input window hook block weight on the LICCON computer system and confirmed.

Take permissible weight of the hook block must be taken according to the selected set up configuration from the erection and take down charts.

Make sure that the following prerequisite is met:

- A valid set up configuration is entered and confirmed.

▶ Press the function key **F7**.

Double arrow up **5.2** is shown, input field hook block weight **5.1** is active.

▶ Enter the hook block weight via the keypad.

When the entered hook block weight is shown in the input field hook block weight **5.1**:

▶ Press the ENTER **C** key.

Result:

- The hook block weight is taken over as current input value hook block weight **5.4**, illustration 2.
- The input field hook block weight **5.1** is faded out.
- Double arrow down **5.3** is shown.



Note

▶ By pressing the function key **F7** again, the entered hook block weight can be changed!

When the entered hook block weight has been accepted:

▶ Press the function key **F8(OK)**.

Result:

- The entered hook block weight is accepted into the LICCON computer system.
- The crane operating screen appears.

Problem remedy

When luffing the boom up / down **with the hook block**, the maximum load according to the load chart and reeving is exceeded and a LMB stop is triggered?

▶ Place the hook block down and carry it along.

Problem remedy

When erecting / taking down the boom **with the hook block**, a higher value than the actual weight on the hook block is shown in the „Current load“ icon (crane operating screen)?

▶ For further procedure, see section „Adapt the input value hook block weight“.

Problem remedy

When erecting / taking down the boom **without the hook block** (load weighting), a value of more than 0 t is shown in the „Current load“ icon (crane operating screen)?

▶ For further procedure, see section „Adapt the input value hook block weight“.

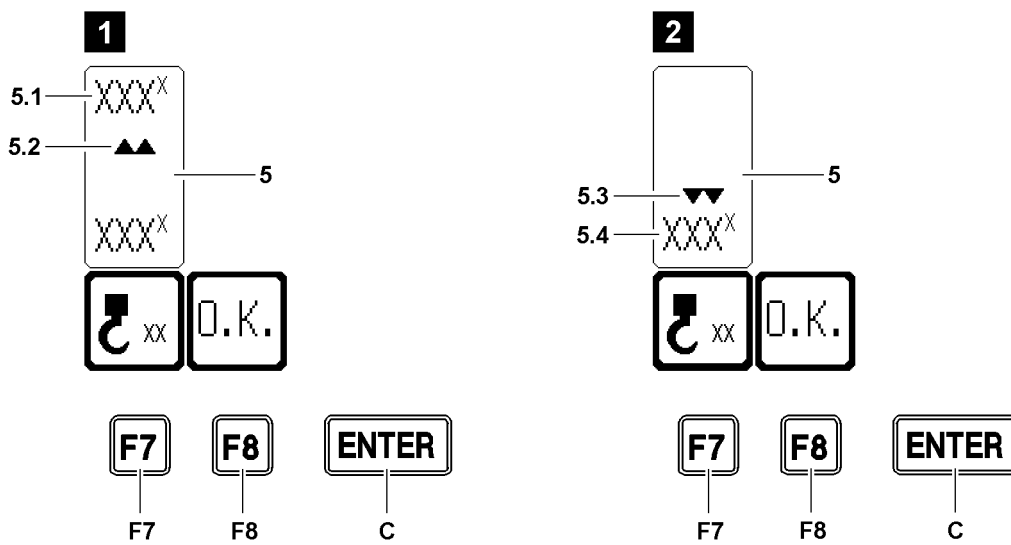
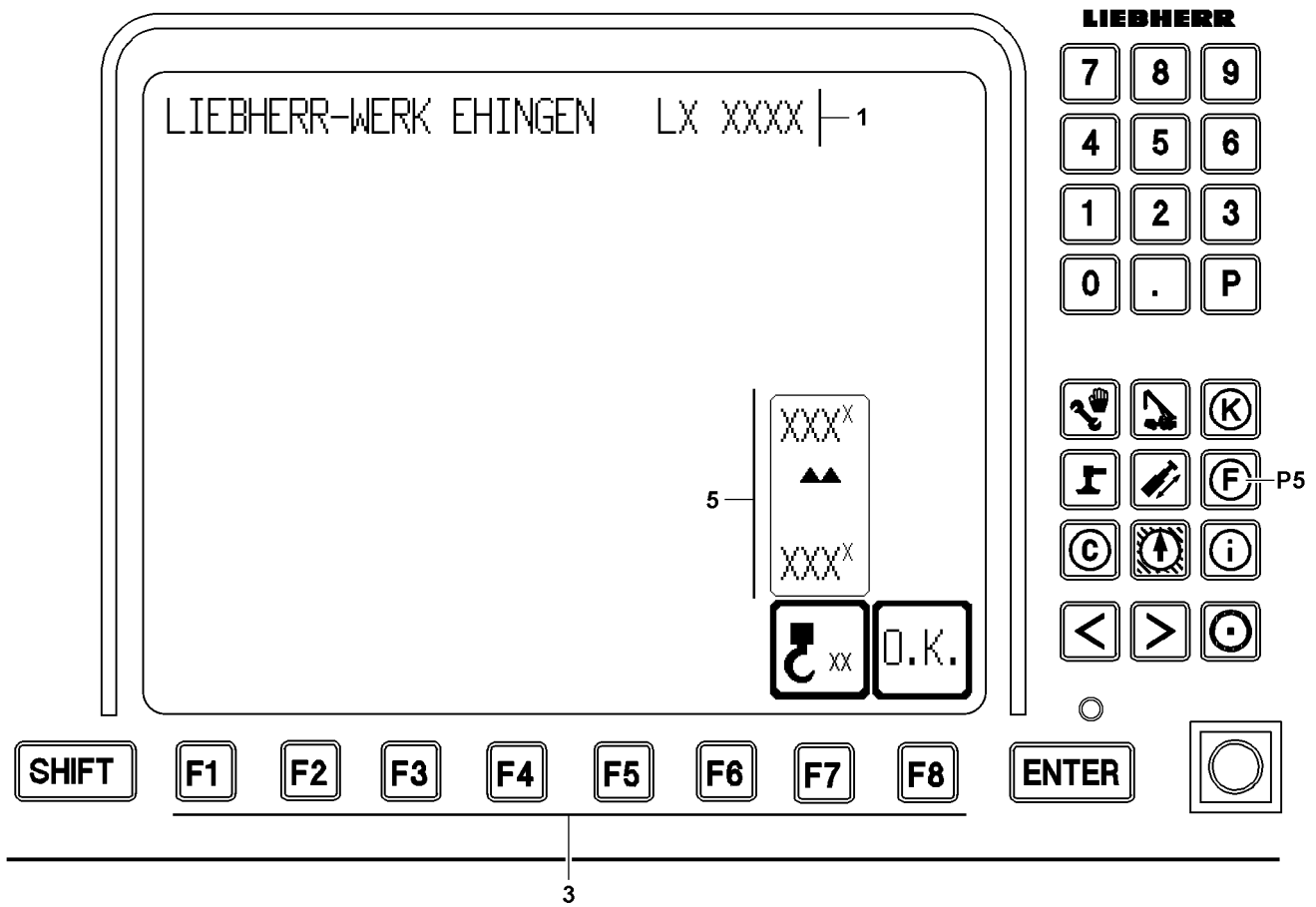

Fig.113267

LWE/LR 1600-2-008/18109-09-02/en

6.8 Adapting the input value hook block weight

It may be possible that the crane movement is shut off due to overload when trying to erect / take down the boom.

The reason for the shut off may be a weighing error.



Note

Weighing error!

- ▶ A weighing error is a combination of environmental influences, manufacturing and sensor tolerances!
- ▶ This combination can cause an increased display value in the „Current load“ icon (crane operating screen)!

A weighing error can be compensated for by adapting the input value hook block weight.



WARNING

All-inclusive adaptation of the hook block weight!

If the input value hook block weight is adapted and no weighing error was determined, then the crane can be overloaded and topple over!

Personnel can be severely injured or killed!

- ▶ Before adapting the input value hook block weight, an existing weighing error must have been found!
- ▶ Only the determined weighing error may be added to the permissible hook block weight!

If a weighing error is suspected, then the crane operator must ensure, before carrying out additional steps, that:

- A valid set up configuration has been entered on the LICCON computer system!
- The assembled boom system matches the entered set up configuration of the crane!
- The boom system is assembled according to the rod plans!
- All attachment parts on the boom have been removed!
- No guy rods are on the boom!
- The boom is free of snow and ice!
- The wind influence onto the boom is not too great!
- The weighing error is plausible and comprehensible!

If it is ensured that the above listed prerequisites are adhered to, then the determined weighing error may be added to the permissible hook block weight and entered in the hook block weight icon.

- ▶ Enter the adapted hook block weight, see section „Entering the hook block weight“.

Problem remedy

The adapted value of the hook block weight is **not** taken over into the LICCON computer system, even though the weighing error is plausible and comprehensible?

- ▶ For erection of the boom system, carry the hook block along.

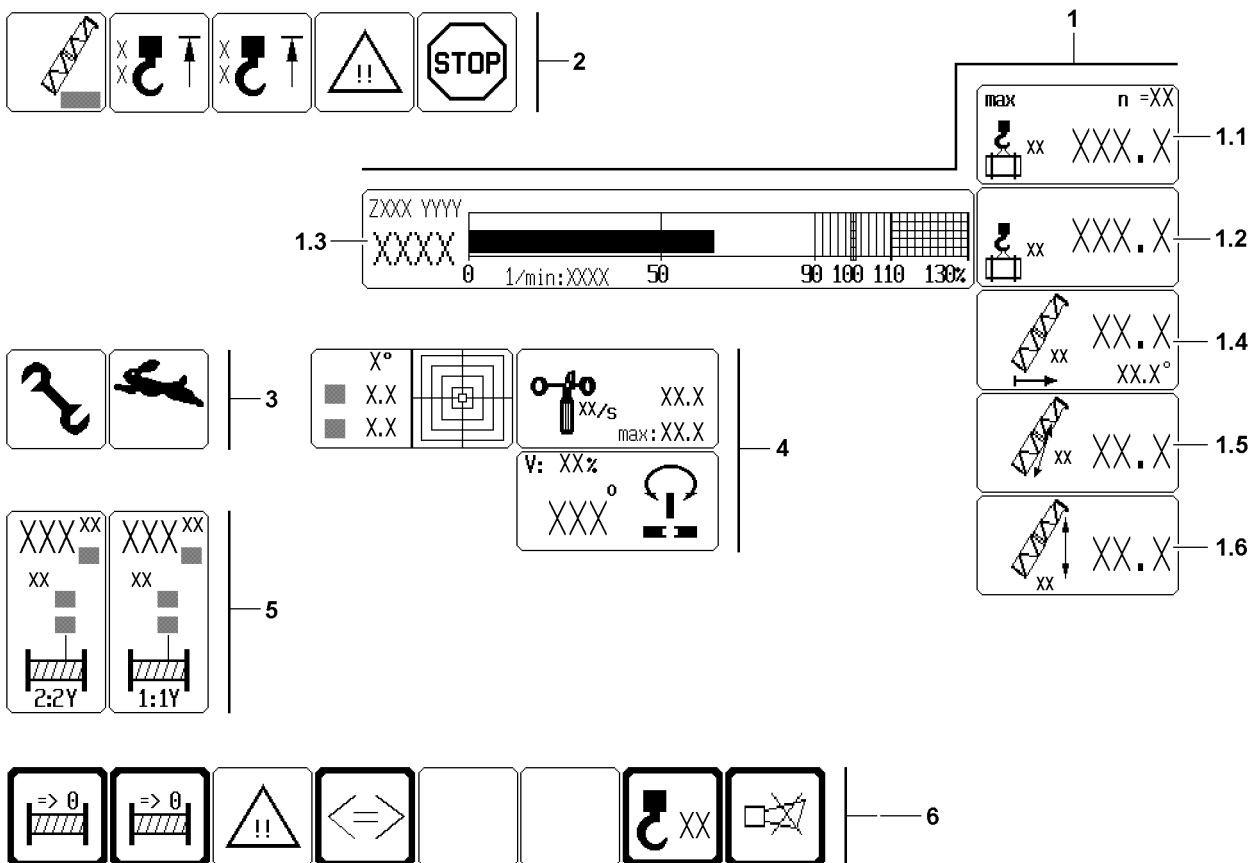
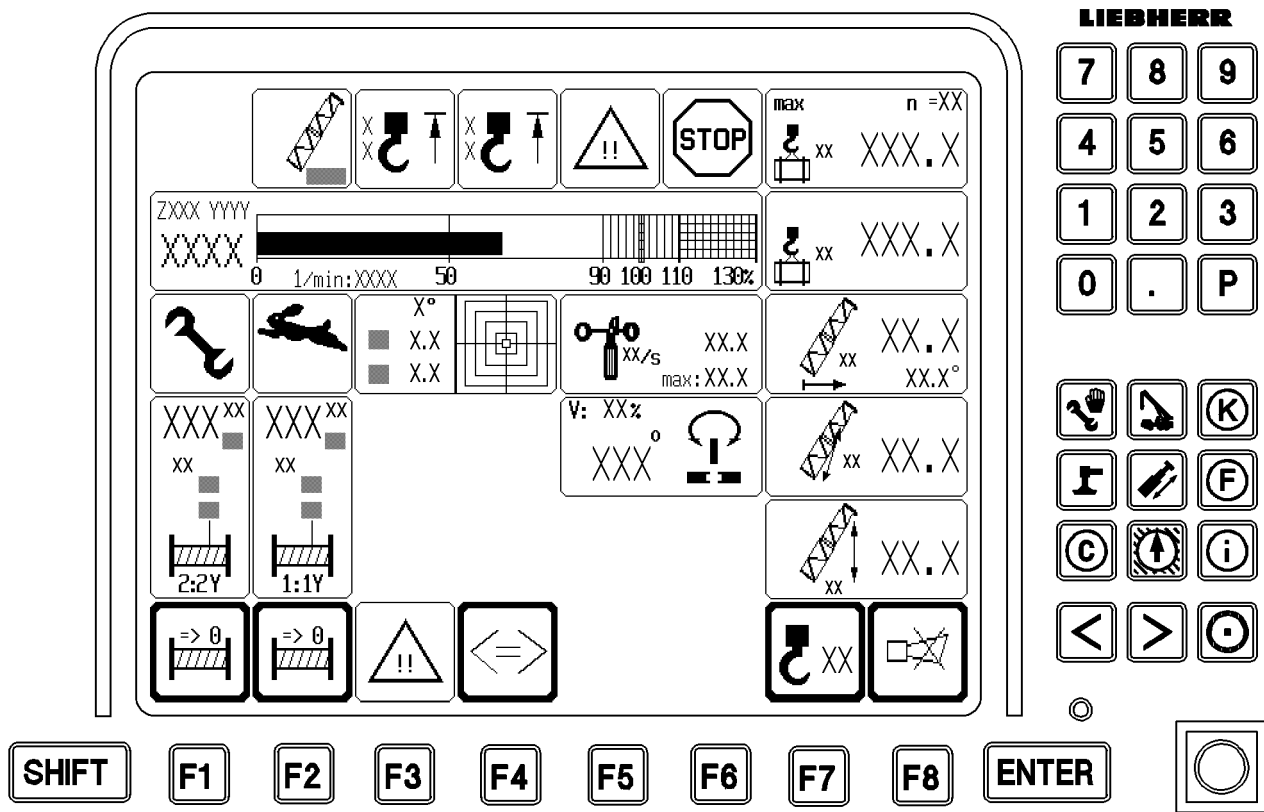

Fig.113450

LWE/LR 1600-2-008/18109-09-02/en

7 The Crane operation program on monitor 0

The LICCON program Crane operation assists the crane operator by displaying the data needed for operating the crane clearly on **monitor 0**. An acoustic signal accompanies all critical displays. Depending on the equipment, a range of other icons may also be turned on as additional displays, either as required by the crane operator, or automatically in the event of a problem.

It also alerts the crane operator to imminent overload conditions. In the event of overload and many error conditions, which could be hazardous during crane operation, the system shuts off.

The LICCON monitor is divided into six areas in the Crane operation program:

- 1 Crane geometry and load information
- 2 Alarm functions
- 3 Special functions
- 4 Monitored auxiliary functions
- 5 Winch display
 - Winch 1 and winch 2
- 6 Function key line



Note

- ▶ The monitor illustrations in this chapter are only examples!
- ▶ The numerical values in the individual icons and charts do not have to necessarily match the crane exactly!
- ▶ The configuration of the LICCON monitor with icons is only descriptive!
- ▶ An identical icon display will **not** appear during crane operation!

7.1 Crane geometry and load information



Note

- ▶ The crane illustrations in this section are only examples and are generalized!
- ▶ They may differ from the crane type and equipment!

The information regarding crane geometry and load is shown in six icons:

- 1.1 „Maximum load“ icon
- 1.2 „Current load“ icon
- 1.3 „Dynamic utilization bar“ icon
- 1.4 „Boom radius“ icon
- 1.5 „Boom length“ icon
- 1.6 „Pulley head height“ icon

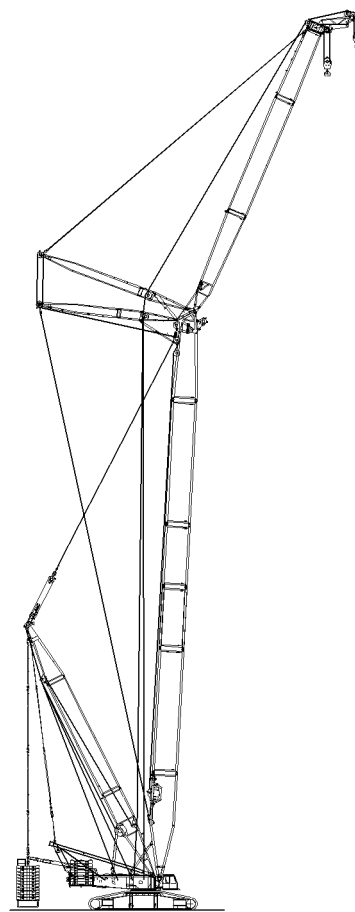
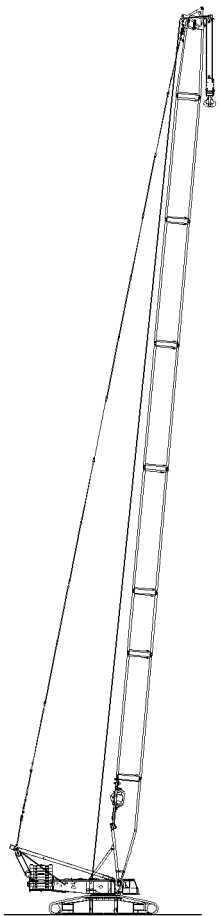
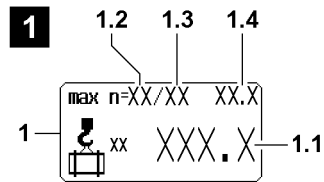
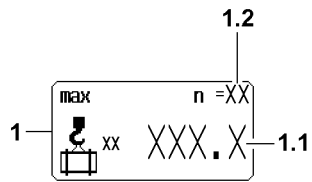

Fig.111931

LWE/LR 1600-2-008/18109-09-02/en

7.1.1 Maximum load

According to the set up configuration, the following changes:

- The illustration of the icon.
- The position of values in the icon, see sample illustration 1!

1 „Maximum load“ icon

- In [t] or [lbs]

1.1 Maximum load on the boom

- In [t] or [lbs]
- The load capacity depends on:
 - The selected operating mode
 - The selected set up configuration (load chart)
 - The boom radius
 - The various boom angles
 - The derrick ballast radius*
 - The currently pulled derrick ballast*
 - The reeving of the hoist rope on the boom

• Note:

The maximum load on the boom (also: Maximum load according to the load chart and the reeving on the boom) is the load, which the crane can lift in its current operating condition with the maximum utilized ballast / counterweight!

• Note:

„? ? ? . ?“ is shown when no load chart value can be accessed!

An error message is issued, see Diagnostics manual!

- Example:

The crane is not in the range of the load chart!

or

The value cannot be calculated / determined!

• Note:

In assembly operating mode SA, the maximum load capacity is shown in [t] or [lbs], according to the corresponding load chart.

1.2 Reeving number hoist rope on boom

- n = reeving number of hoist rope on the pulley head selected via the load chart. The reeving number has been set first in the set up program.

• Note:

- In the assembly operating mode SA, the reeving number is always 0.

1.3 Reeving number hoist rope on accessory* 1.3, for example boom nose*

- n = Reeving number of hoist rope on installed accessory. The reeving number has been set first in the set up program.

1.4 Maximum load on accessory* 1.4, for example boom nose*

- In [t] or [lbs]

• Note:

The „Maximum load carrying capacity“ of the accessory depends on the set reeving!

• Note:

The maximum load carrying capacities on the boom (1.1) and on the accessory* (1.4) are monitored simultaneously!

If the load on one position is exceeded, then an LMB stop is issued!

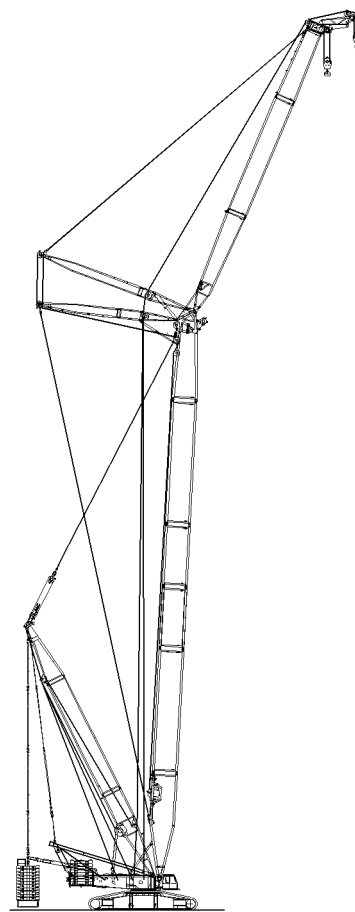
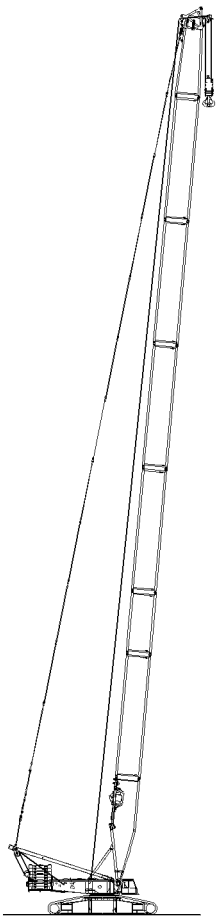
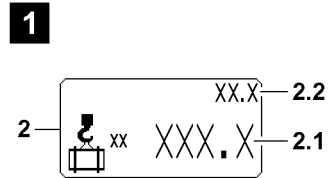
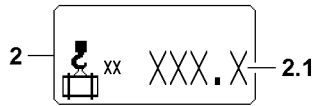

Fig.111932

LWE/LR 1600-2-008/18109-09-02/en

7.1.2 Current load

According to the set up configuration, the following changes:

- The illustration of the icon.
- The position of values in the icon, see sample illustration 1!

2 „Current load“ icon

- In [t] or [lbs]

2.1 Current load on the boom

- Actual load display = current load (in [t] or [lbs]) on the selected boom
- Display of the calculated total load including the weights of the carrying equipment, the lifting equipment (hook block) and / or the fastening equipment, but **without** the nominal weight of the hoist rope.

- **Note:**

„? ? ? . ?“ is shown if the value cannot be calculated / determined!

An error message is issued, see Diagnostics manual!



Note

Assembly operating mode SA

- ▶ In assembly operating mode SA, the SA-frame is treated as the boom!
- ▶ The current load on the SA-frame is determined via pressure sensors on the assembly cylinder and shown in the „Current load“ icon 2.

2.2 Current load on accessory*

- Actual load display = current load in [t] or [lbs] on the accessory*, for example the boom nose*.
- Display of the calculated total load on the accessory*, including the weights of the carrying equipment, the load handling equipment (hook block) and / or the fastening equipment, **including** the hoist rope.

- **Note:**

„? ? ? . ?“ is shown if the value cannot be calculated / determined!

An error message is issued, see Diagnostics manual!



WARNING

Tolerances at actual load display!

Due to tolerances, there may be a deviation in the actual load display in the „Current load“ icon 2!

The current load display in the „Current load“ icon 2 is no calibrated weighing device!

- ▶ Always observe the actual weight of the load in connection with the load charts and the set up configuration!



Note

Net load display in the „Current load“ icon 2!

- ▶ By using the function „Tare“ (see description of function key **F7** in section „Function key icon line“) the display can be changed over to display the net load! In the icon appears additionally the word „Net“!

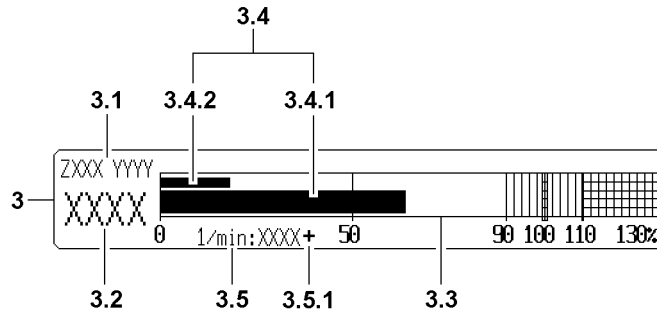

Fig.111933

7.1.3 Dynamic utilization bar

- 3 „Dynamic utilization bar“ icon
 - In percent [%]
- 3.1 Organization number
 - For internal Liebherr load chart administration
- 3.2 Short code
 - Identifies the selected set up configuration
- 3.3 Utilization scale
 - Marking from a utilization of 90 %: **Advance warning**
 - Marking at a utilization of 100 %: **STOP shut off**
- 3.4 Utilization bar
 - 3.4.1 Utilization bar of crane
 - According to load chart and reeving
 - **Note:**
The utilization bar is the measurement for the current utilization of the crane!

Utilization of crane according to load chart and reeving	=	$\frac{\text{Current load on the boom head}}{\text{Maximum load according to load chart and reeving}}$
--	---	--

- 3.4.2 Utilization bar Accessory
 - **Note:**
Maximum load on accessory*, for example boom nose*: Load which can be lifted by the accessory alone!
Prerequisite: Sufficiently high load capacity on the boom head!

Utilization of accessory*	=	$\frac{\text{Current load carrying capacity of the accessory*}}{\text{Maximum load carrying capacity of the accessory*}}$
---------------------------	---	---

- 3.5 Engine speed
 - In [rpm] or [n/min]
 - **Note:**
„????“ is displayed in case of an error in rpm value for approximately 5 seconds!
Then the nominal rpm for the diesel engine is set for the output regulation of the drives!
The set nominal rpm is shown blinking!
An error message is issued!
 - 3.5.1 Engine rpm lock
 - The engine rpm can be locked on the master switch. If the engine rpm has been locked, the icon „+“ appears behind the rpm display.

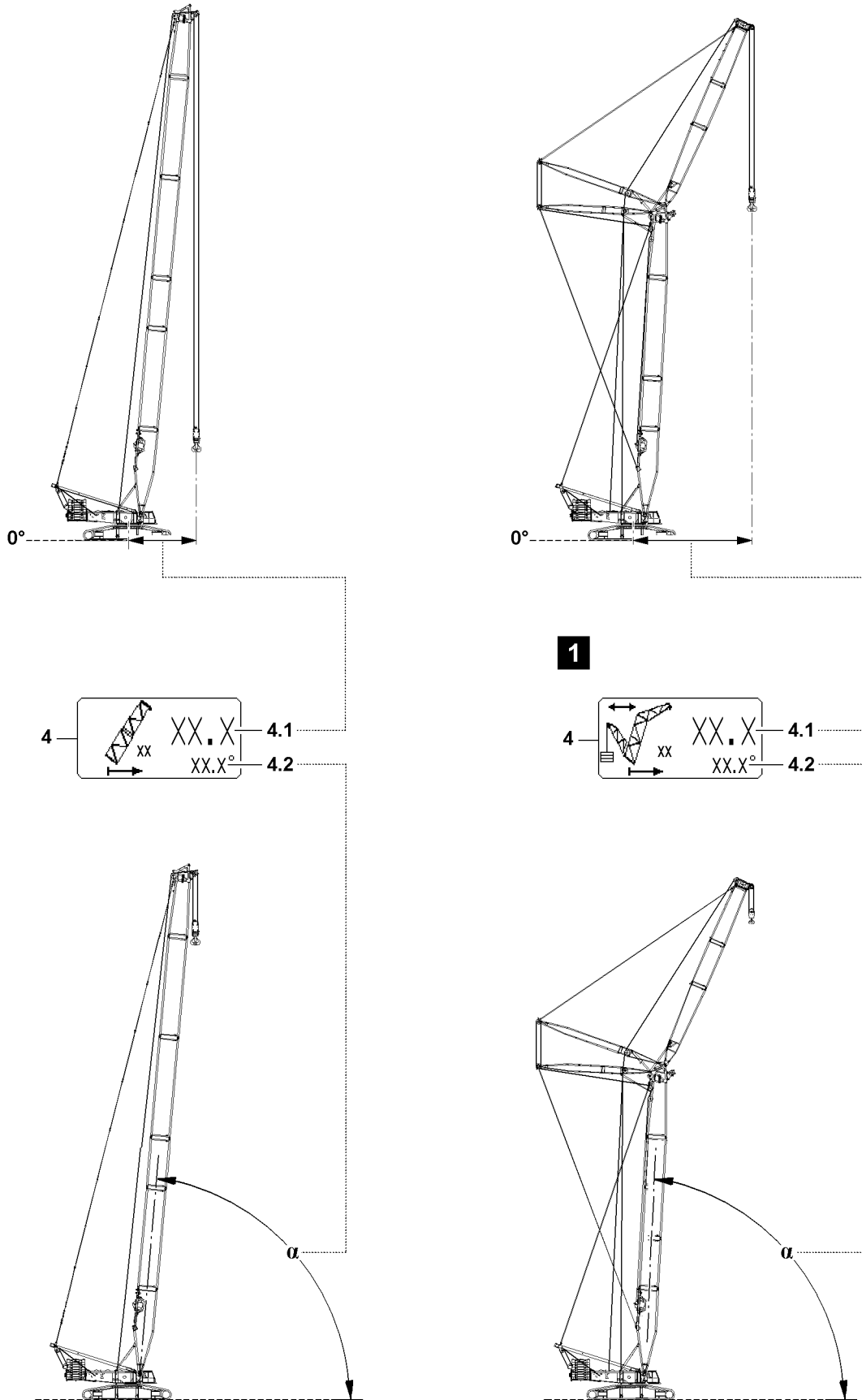

Fig.112633

LWE/LR 1600-2-008/18109-09-02/en

7.1.4 Radius

According to the set up configuration, the following changes:

- The illustration of the icon.
- The position of values in the icon, see sample illustration 1!

4 „Boom radius“ icon

4.1 Radius

- In [m] or [ft]

Denotes the horizontal distance of the load hook from the center of rotation of the crane superstructure, measured on the ground! This also takes into account the boom flexation due to its own weight and the suspended weight of the load!

- **Note:**

„? ? ? . ?“ is shown if the value cannot be calculated / determined!

An error message is issued, see Diagnostics manual!

4.2 Main boom angle

- In [°]

Displayed is the medium value of the angle sensor in the main boom pivot section and the angle sensor in the main boom pulley head.

- **Note:**

„? ? ? . ?“ is shown if the value cannot be calculated / determined!

An error message is issued, see Diagnostics manual!



Note

► Main boom angle 4.2 (angle α): The angle of the main boom to the placement surface of the crane!

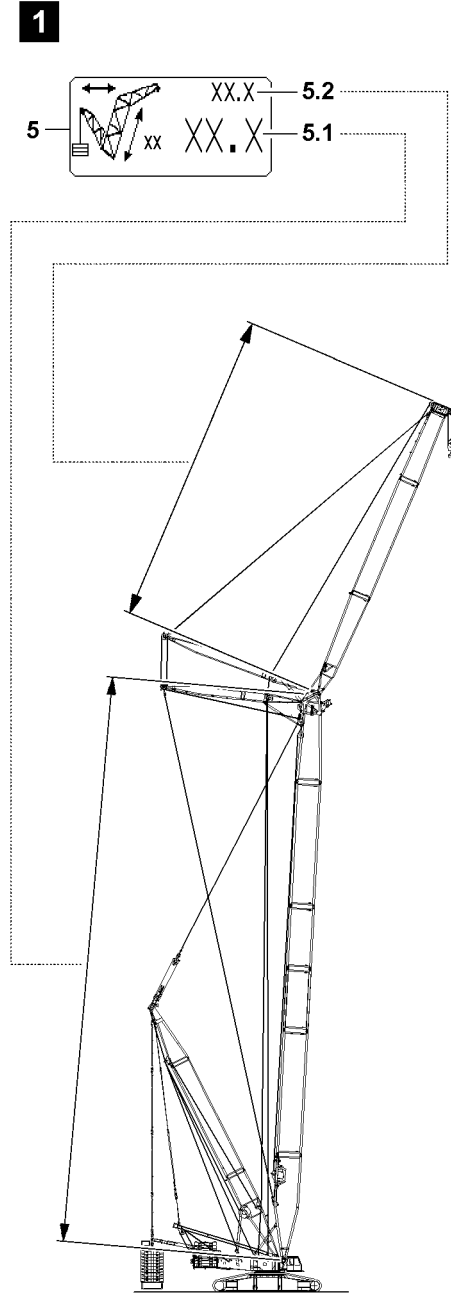
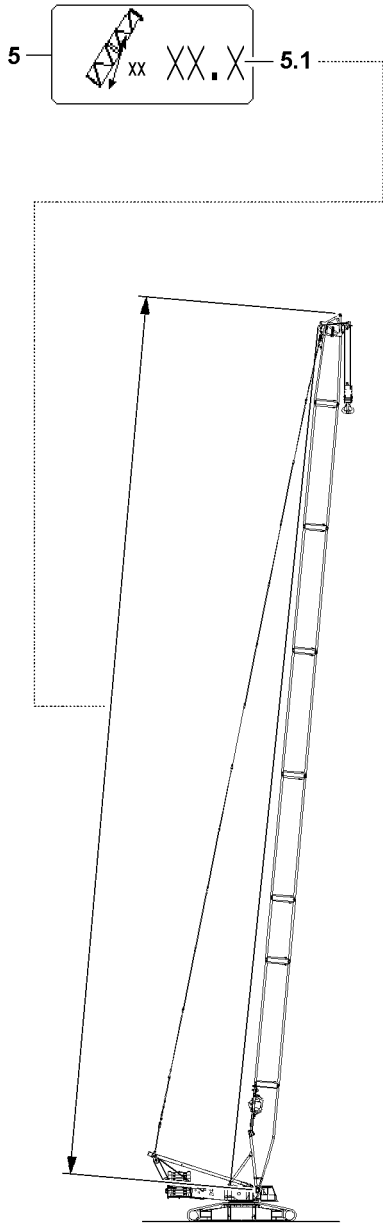

Fig.112638

LWE/LR 1600-2-008/18109-09-02/en

7.1.5 Boom length

According to the set up configuration, the following changes:

- The illustration of the icon.
- The position of values in the icon, see sample illustration 1!

5 „Boom length“ icon

5.1 Length of main boom

- In [m] or [ft]

5.2 Length of auxiliary boom / accessory

- In [m] or [ft]

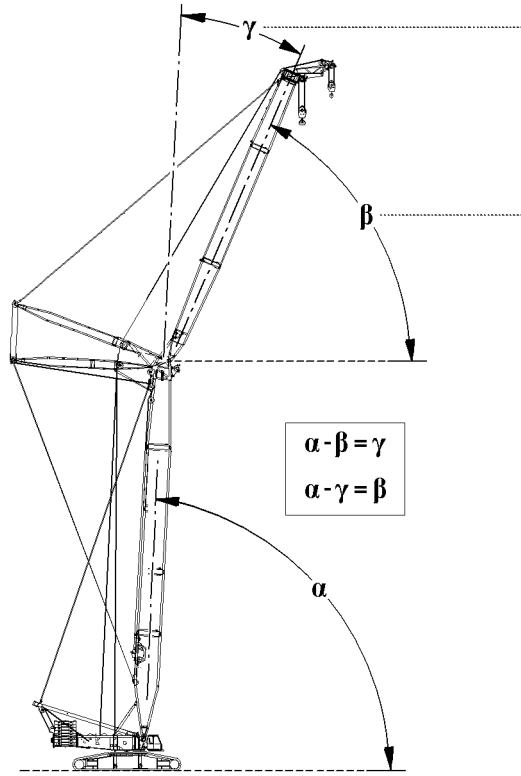

1

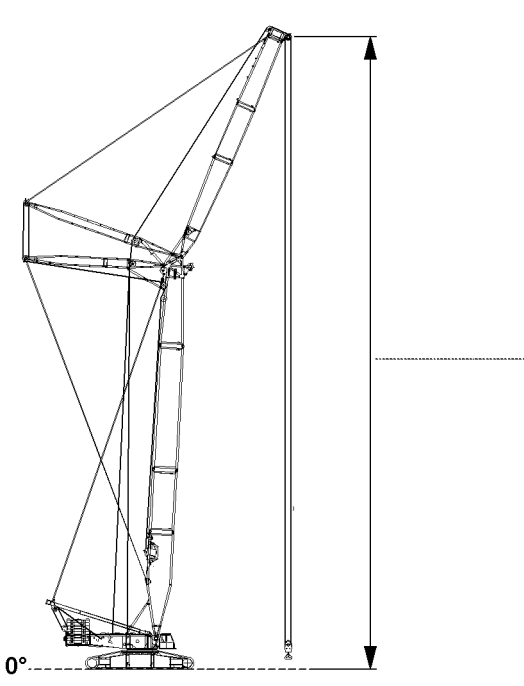
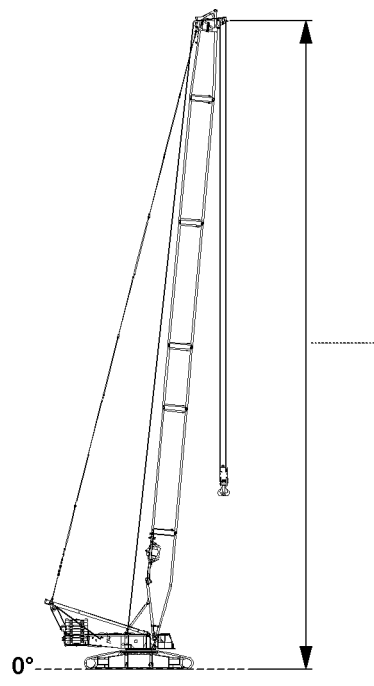
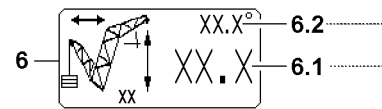
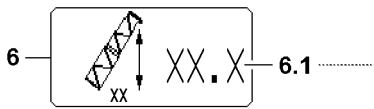

Fig.112639

LWE/LR 1600-2-008/18109-09-02/en

7.1.6 Pulley head height



Note

- ▶ Main boom angle α : The angle of the main boom to the placement surface of the crane!
- ▶ Angle auxiliary boom / accessory β : The angle of the auxiliary boom / accessory to the placement surface of the crane!
- ▶ Relative angle auxiliary boom / accessory γ : The angle of the auxiliary boom / accessory is determined relative to the main boom!

According to the set up configuration, the following changes:

- The illustration of the icon.
- The position of values in the icon, see sample illustration 1!

6 „Pulley head height“ icon

6.1 Pulley head height

- In [m] or [ft]
- Marks the vertical distance from the placement surface of the crane to the selected pulley head axle.
The displayed maximum load is valid for the selected pulley head axle.

• Note:

„? ? ? . ?“ is shown if the value cannot be calculated / determined!
An error message is issued, see Diagnostics manual!

6.2 Angle auxiliary boom / accessory

- In [°]

• Note:

„? ? ? . ?“ is shown if the value cannot be calculated / determined!
An error message is issued, see Diagnostics manual!



Note

- ▶ Depending on the set up configuration and the load chart, a differentiation is made between an absolute angle display or a relative angle display!

β Absolute angle auxiliary boom / accessory

- The angle of the auxiliary boom / accessory to the horizontal (placement surface of the crane) in [°]
- Display absolute angle: For operating modes with load chart for a fixed defined main boom angle!

or

γ Relative angle auxiliary boom / accessory

- Angle between the main boom and the auxiliary boom / accessory in [°]
- Display relative angle: For operating modes with load chart for a fixed defined angle auxiliary boom / accessory!

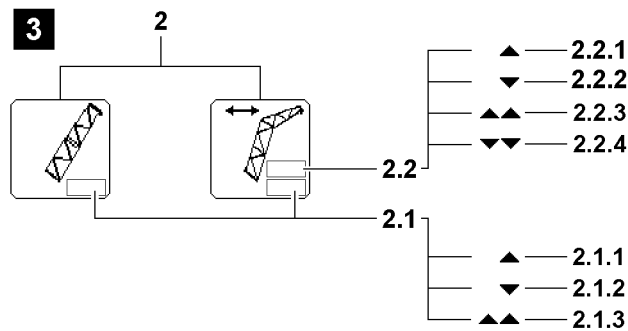
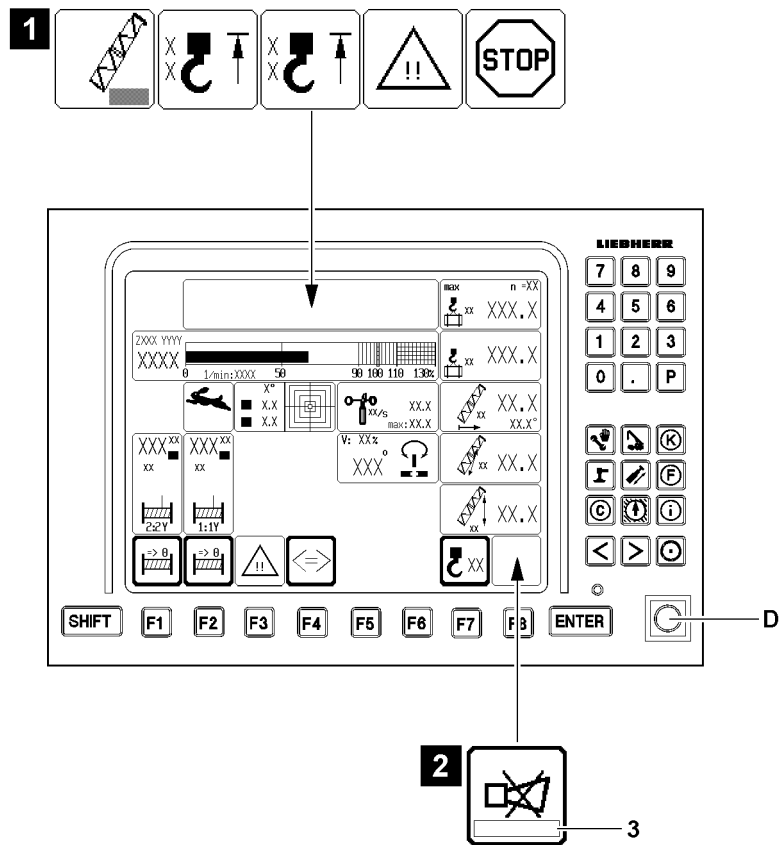

Fig.111930

7.2 Alarm functions

NOTICE

Triggered alarm function!

If an alarm function is triggered (for example a advance warning occurrence or LMB Stop), the cause must be determined!

- ▶ Always pay attention to triggered alarm functions!
- ▶ Alarm functions can flash over the monitor!

The limit ranges of the crane movements are monitored. When the limit ranges are reached, the crane operator is warned by the alarm functions.

The alarm functions are shown by the LICCON monitor:

- Optically with icons, see illustration 1.
- Acoustically by a warning sound „Horn“, see illustration 2.

In case of a failure of the relevant sensors / limit switches, special error messages **3** are added.

7.2.1 Boom limitation

See illustration 3

Limit signs main boom



Note

- ▶ The icon „Boom limitation“ **2** can change in different operating modes, but it is shown always at the same position in the LICCON monitor!
- ▶ The field **2.1** „on the bottom“ refers to the main boom!
- ▶ The field **2.2** „on the top“ refers to the auxiliary boom / accessory!

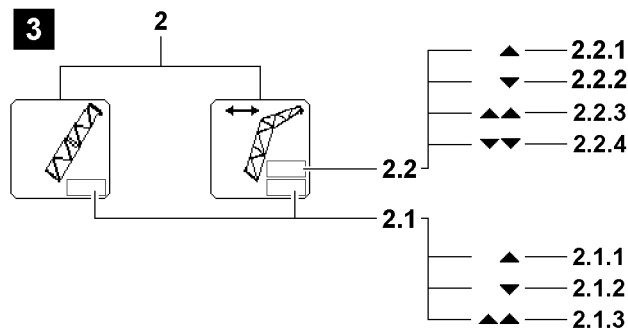
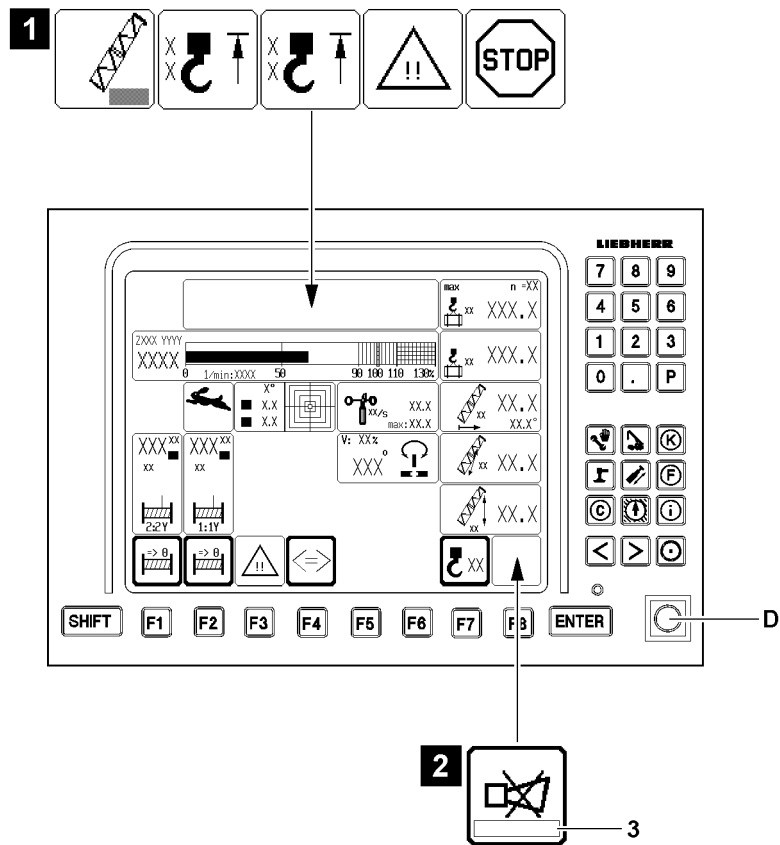



Fig.111930

2.1 „Boom limitation Main boom“ icon

- The luffing range of the main boom is limited both upwards and downwards
- This icon appears if an end position determined by the load chart is reached when luffing the boom or when luffing the boom is disabled by a proximity switch
- Exclamation marks show when an associated sensor is defective

Position	Icon	Description
2.1.1		The shut off „Luffing up the main boom“ is made by running against the upper load chart limit or Utilization larger than 95 % and falling load carrying capacity when luffing up the main boom. Note: Luffing down the main boom is still possible!
2.1.2		The shut off „Luffing down the main boom“ is made by running against the lower load chart limit. Note: Luffing up the main boom is still possible!



WARNING

Alarm function deactivated!

When the set up key **D** is actuated, there is no shut off of crane movement via position **2.1.1** and position **2.1.2!**

► Observe the Crane operating instructions, chapter 4.20!

Position	Icon	Description
2.1.3		The shut off „Luffing up the main boom“ is triggered by running against the block limit switch of the main boom relapse cylinders on the left / right (boom steep) or due to an error in one block limit switch of the main boom relapse cylinders. Note: Luffing down the main boom is still possible!

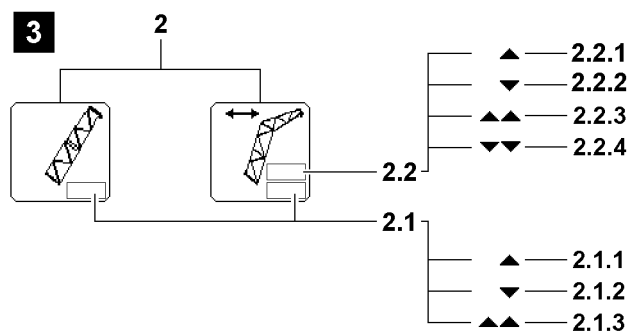
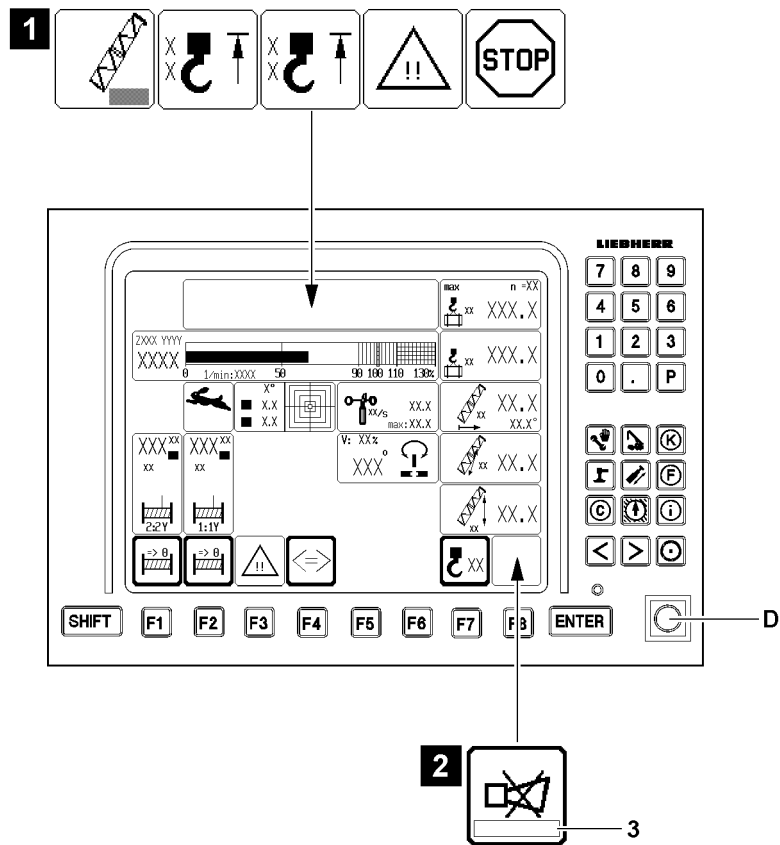

Fig.111930

Limit sign auxiliary boom / accessory



Note

- ▶ The icon „Boom limitation“ 2 can change in different operating modes, but it is shown always at the same position in the LICCON monitor!
- ▶ The field 2.1 „on the bottom“ refers to the limit sign main boom!
- ▶ The field 2.2 „on the top“ refers to the limit sign auxiliary boom / accessory!

2.2 „Boom limitation auxiliary boom / accessory“ icon

- The luffing range of the auxiliary boom / accessory is limited both upwards and downwards.
- This icon appears if an end position determined by the load chart is reached when luffing the auxiliary boom / accessory or when luffing is disabled by a limit switch.
- Exclamation marks show when an associated sensor is defective.

Position	Icon	Description
2.2.1	▲	The shut off „Luffing up the auxiliary boom / accessory“ is triggered by running against the upper load chart limit. Note: Luffing the auxiliary boom / accessory down remains possible!
2.2.2	▼	The shut off „Luffing down the auxiliary boom / accessory“ is triggered by running against the lower load chart limit. Note: Luffing the auxiliary boom / accessory up remains possible!



WARNING

Alarm function deactivated!

When the set up key **D** is actuated, there is no shut off of crane movement via position **2.2.1** and position **2.2.2**!

- ▶ Observe the Crane operating instructions, chapter 4.20!

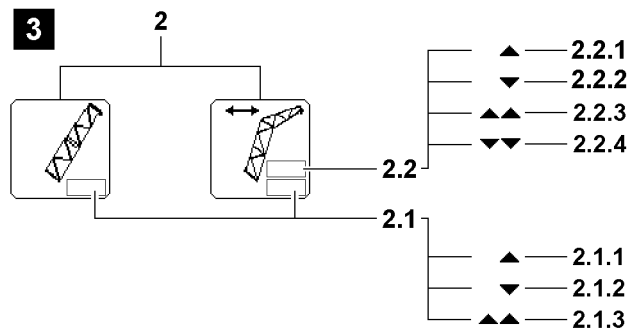
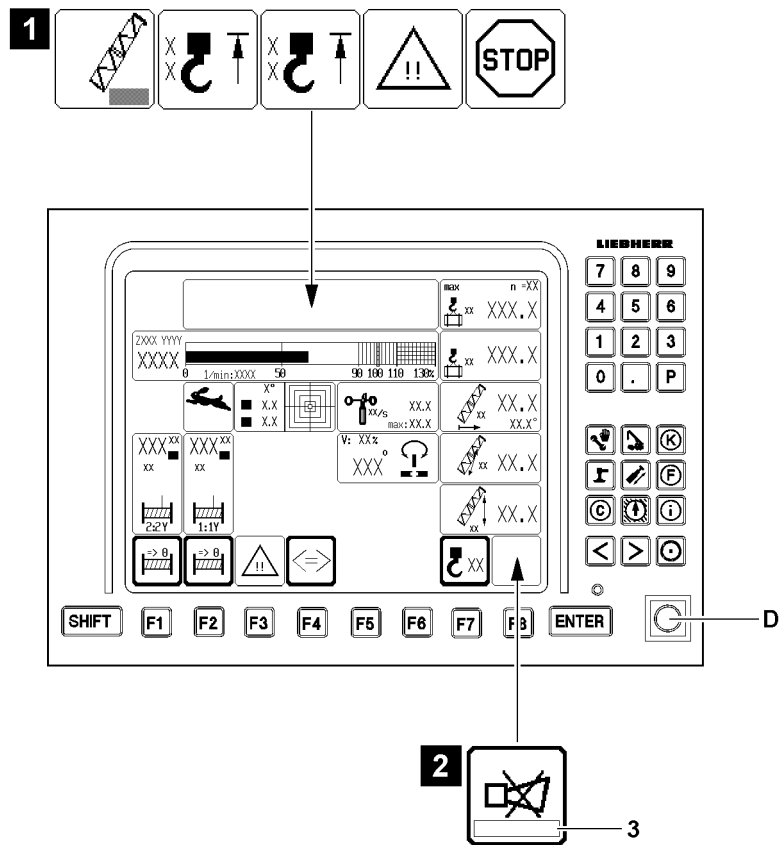



Fig.111930

Position	Icon	Description
2.2.3		<p>The shut off „Luffing up the auxiliary boom / accessory“ is triggered by running against a block limit switch of the relapse cylinders auxiliary boom / accessory</p> <p>or</p> <p>the relapse flap</p> <p>or</p> <p>an error on one limit switch occurs.</p> <p>Note: Luffing the auxiliary boom / accessory down remains possible!</p>
2.2.4		<p>The shut off „Luffing down the auxiliary boom / accessory“ is triggered by running against a block limit switch („Auxiliary boom / accessory lower left / right“)</p> <p>or</p> <p>an error on one of these limit switches occurs.</p> <p>Note: Luffing the auxiliary boom / accessory up remains possible!</p>

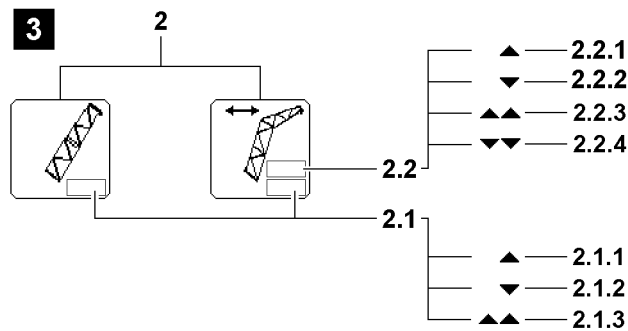
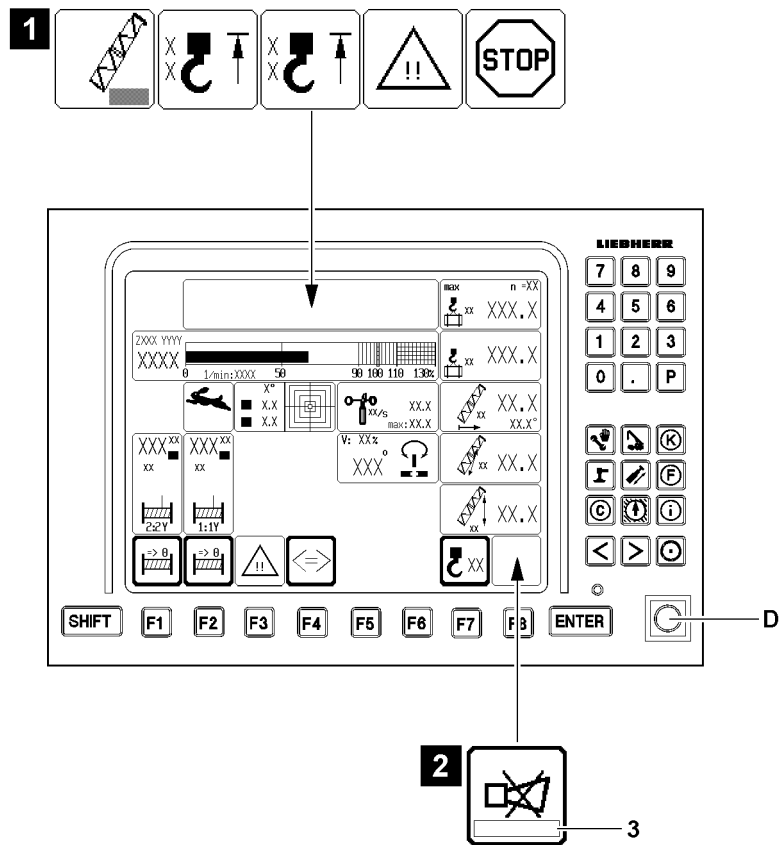

Fig.111930

7.2.2 Failure of sensor / limit switch

NOTICE

Failure of sensor / limit switch!

Depending on the classification of the sensor / limit switch, the crane can continue to be operated with limitation or is shut off by the control!

If an error message is issued in the horn icon **3**, see illustration **2**!

The error message shows defective sensors / limit switches, see Diagnostics manual!

- ▶ The error must be remedied immediately!
- ▶ Crane movements after a failure of a sensor / limit switch must be carried out anticipatorily and with extreme caution!

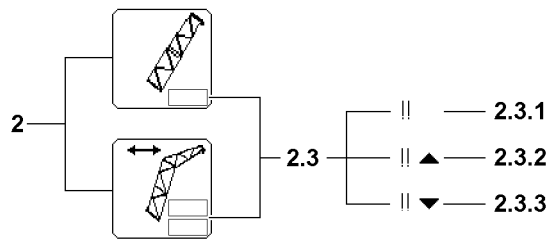

Fig.111928

Position	Icon	Description
2.3.1	!!	On the auxiliary boom / accessory, at least one associated sensor / limit switch is defective / missing. If an alarm function occurs at the same time, then the icon can be shown differently, see position 2.3.1, position 2.3.2 or position 2.3.3.
2.3.2	!!▲	
2.3.3	!!▼	Note: Not every failure of a sensor / limit switch on the boom is shown in the „Boom limitation“ icon 2. Observe the error message in Horn 3 icon!



Note

- ▶ Depending on the classification of the sensor / limit switch, the respective crane movement is shut off in case of a failure **unbypassably**!
- ▶ When deflecting the master switch, an error message is issued in the horn icon **3**! The error message shows defective sensors / limit switches!
- ▶ If the error cannot be remedied by yourself, contact Liebherr Service!

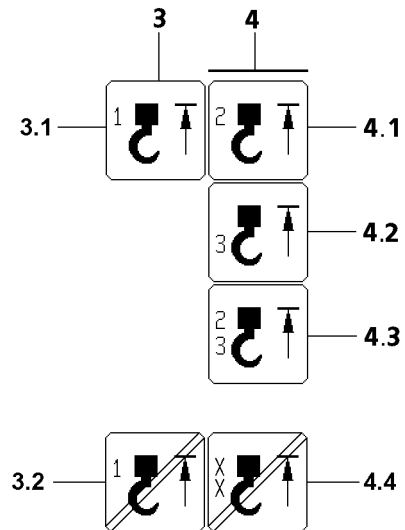

Fig.112365

7.2.3 Hoist top limit switch HES1

3 „Hoist top on HES1“ icon

- In order to prevent the crane from being operated without hoist limit switches (HES), the minimum hoist limit switch configuration is continuously monitored. If a hoist limit switch required for a particular operating mode is not plugged in, therefore not active on the LSB bus system, a LMB STOP is triggered and an error message is also issued.
- **Note:**
HES1 (HES1A + HES1B) must be present for all operating modes with main boom!
HES1 (HES1A + HES1B) turn the same functions off as the remaining hoist limit switches!

3.1 HES1

- Installation location HES1A:
Main boom end section: left, bus address: 27
- Installation location HES1B:
Main boom end section: right, bus address: 28
- The „**HES1**“ icon appears if:
 - The hook block runs against the HES1A.
 - HES1A is not active, although it must be present on the bus.
 - HES1A has an internal error.
 - The hook block runs against the HES1B.
 - HES1B is not active, although it must be present on the bus.
 - HES1B has an internal error.
- **Note:**
The crane movements spool the hoist winches up, luff the boom down as well as luff the derrick boom down are turned off!

3.2 „Hoist top on boom bypassed“ icon

- The icon appears when the „Hoist top shut off“ is bypassed.

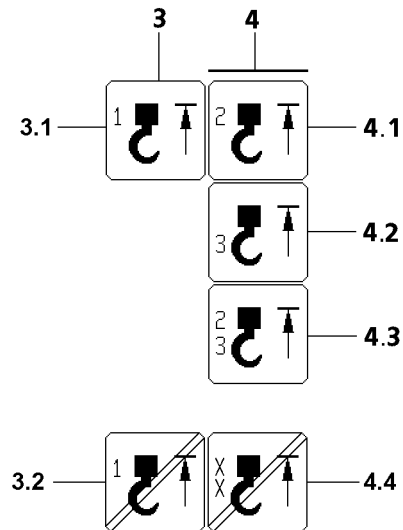

Fig.112365

7.2.4 Hoist top limit switch HES2 and HES3

4 „Hoist top on HES2 / HES3“ icon

- In order to prevent the crane from being operated without hoist limit switches (HES), the minimum hoist limit switch configuration is continuously monitored. If a hoist limit switch required for a particular operating mode is not plugged in, therefore not active on the LSB bus system, a LMB STOP is triggered and an error message is also issued.
- **Note:**
HES2 (HES2A + HES2B) must be present for all operating modes with auxiliary boom / accessory!
HES1 (HES2A + HES2B) turn the same functions off as the remaining hoist limit switches!
- **Note:**
HES3 must be present for all operating modes with accessory*!
HES3 turn the same functions off as the remaining hoist limit switches!

4.1 HES2

- Installation location HES2A: Auxiliary boom / accessory*
Bus address: 27
- Installation location HES2B: Auxiliary boom / accessory*
Bus address: 28
- The „**HES2**“ icon appears if:
 - The hook block moves against the HES2A on the auxiliary boom / accessory.
 - HES2A is not active, although it must be present on the bus.
 - HES2A has an internal error.
 - The hook block moves against the HES2B on the auxiliary boom / accessory.
 - HES2B is not active, although it must be present on the bus.
 - HES2B has an internal error.
- **Note:**
The crane movements spool the hoist winches up, luff the boom down as well as luff the derrick boom down are turned off!

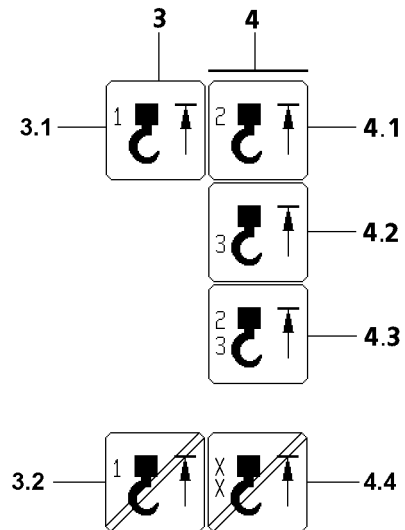

Fig.112365

4.2 „Hoist top on HES3“ icon

Installation location(s):

- Main boom accessory 1, bus address: 24*
- Main boom accessory 2, bus address: 25*
- Main boom accessory 3, bus address: 26*
- Auxiliary boom / accessory accessory 1, bus address: 24*
- Auxiliary boom / accessory accessory 2, bus address: 25*
- Auxiliary boom / accessory accessory 3, bus address: 26*
- The „**HES3**“ icon appears if:
 - The hook block runs against the HES3.
 - HES3 is not active, although it must be present on the bus.
 - HES3 has an internal error.

Note:

The crane movements spool the hoist winches up, luff the boom down as well as luff the derrick boom down are turned off!

4.3 HES2 and HES3

- The icon appears when icon HES2 and HES3 appear simultaneously

4.4 „Hoist top on boom bypassed“ icon

- The icon appears when the „Hoist top shut off“ is bypassed.

Note:

Only the icons for active and bypassed hoist limit switches appear!

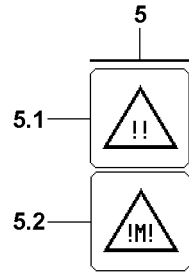

Fig.112366

LWE/LR 1600-2-008/18109-09-02/en

7.2.5 Advance warning LMB / advance warning engine monitoring

5 „Advance warning“ icon

5.1 Advance warning LMB

- The current load chart utilization is calculated from the „current load“ and the „maximum load according to the load chart and the reeving“.
- The „Advance warning“ icon appears if:
 - The current load chart utilization of the crane, according to the „Load chart and reeving“ exceeds the programmed limit (**90 percent**) for the advance warning.
 - or**
 - The current utilization of the accessory* exceeds the programmed limit (**90 %**) for the advance warning.

5.2 Advance warning engine monitoring

- If a warning event occurs in the engine monitoring system, the „Engine monitoring advance warning“ icon is displayed on the LICCON monitor.

NOTICE

Shut off engine monitoring!

Outside of the crane operation program, the engine monitoring is turned off!

When the engine monitoring is turned off, problems and warning occurrences are not recognized!

This could result in crane failure!

- ▶ If work is not carried out in the crane operation program, then turn the crane engine off and operate the LICCON computer system in stand-by mode, see section „LICCON computer system in stand-by mode“!
 - ▶ If work has to be carried out for a longer period outside of the crane operation program, with the engine running, then switch regularly into the engine monitoring screen!
-

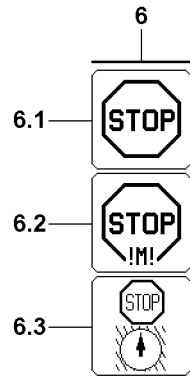

Fig.113264

7.2.6 LMB STOP / Engine monitoring STOP

6 „STOP“ icon

6.1 LMB STOP

- The „STOP“ icon appears when the load chart utilization exceeds the **100 % mark** (LMB STOP).

- **Note:**

All crane movements that increase the load momentum are shut off!

or

6.1 Sensor error

- The „STOP“ icon appears when a sensor which is required to monitor the load chart has an error (LMB STOP is actuated).

- **Note:**

All crane movements that increase the load momentum are shut off!

or

6.1 No load chart

- The „STOP“ icon appears if no load chart is available (LMB STOP is actuated).

- **Note:**

All crane movements that increase the load momentum are shut off!

6.2 Engine monitoring STOP

- If a STOP event occurs in the engine monitoring system, the system automatically switches over (from the Crane operation program) to the Engine monitoring program.

NOTICE

Shut off engine monitoring!

Outside of the crane operation program, the engine monitoring is turned off!

When the engine monitoring is turned off, problems and warning occurrences are not recognized!

This could result in crane failure!

- ▶ If work is not carried out in the crane operation program, then turn the crane engine off and operate the LICCON computer system in stand-by mode, see section „LICCON computer system in stand-by mode“!
- ▶ If work has to be carried out for a longer period outside of the crane operation program, with the engine running, then switch regularly into the engine monitoring screen!

6.3 Working range limitation*

- If a programmed working range limit* is reached, then this condition is indicated by the STOP icon working range limitation* **6.3** instead of the standard „STOP“ icon **6**.



Note

- ▶ If an LMB STOP occurs simultaneously, the STOP working range limitation* **6.3** icon continues to be displayed!
 - ▶ The LMB STOP is identifiable if the utilization bar exceeds 100 % or if a maximum load carrying capacity of 0 t is permitted!
-

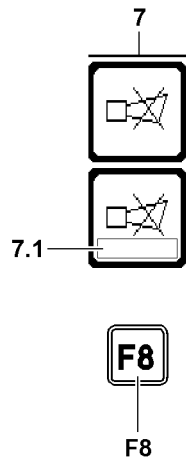

Fig.111270

7.2.7 Acoustic warning on monitor 0

Acoustic warnings on monitor 0 are indicated by the warning sound „Horn“.

The warning sound „Horn“ is divided into two categories:

- „Horn“ is a beeping sound of a duration of approximately 0.5 seconds, which is repeated in a second cycle.
- „Short horn“ is a beeping sound of a duration of approximately 0.1 seconds, which is repeated in a second cycle.

7 Horn icon

- When the horn icon is shown in the LICCON monitor, any acoustic signals which will occur can be shut off by the LICCON monitor **0** by pressing the function key **F8**.
- If an error message is shown in the horn icon **7** in field **7.1**, then the present error can be determined through it in the diagnostics manual. Pressing the function key **F8** twice, automatically changes to the error determination screen of the test system. The error is displayed there in documentary form.

Acoustic signal „Horn“

1. Sounds in addition to the visual display of an error message in field **7.1** in case of operational errors are found, which lead to a shut off of a crane movement.

Operational errors are:

- Overload
- Boom outside of the angle / radius range of the load chart

2. In case of application errors with error number (LICCON Error Code LEC). For example sensor errors, which occur due to insufficient sensor signals or a defective sensor.

The following sensors are monitored:

- Length sensors
- Angle sensors
- Pressure sensors
- Pull test brackets (force test boxes)
- Inductive sensors
- Hoist limit switch
- Wind sensor
- Battery voltage

Acoustic signal „Short horn“

Sounds in addition to the visual display of error messages without an error number and which do not lead directly to crane movement shut off by the LICCON overload protection.

Monitored error messages are:

- Maximum permissible wind speed exceeded (only for activated wind sensor*).
- Maximum or minimum support force exceeded (only with active support force monitoring*).
- Crane utilization value for „Advance warning“ (90 %) reached.

Priority acoustic signal

- The „Horn“ alarm has higher priority than the „Short horn“ alarm, i.e. „Horn“ takes preference over „Short horn“.
- The „Horn“, as well as the „Short horn“ immediately become active again if an error recurs!

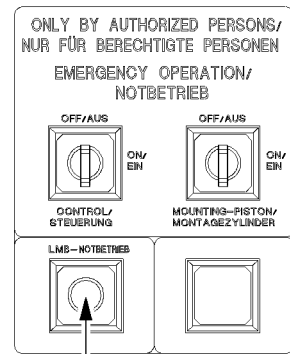
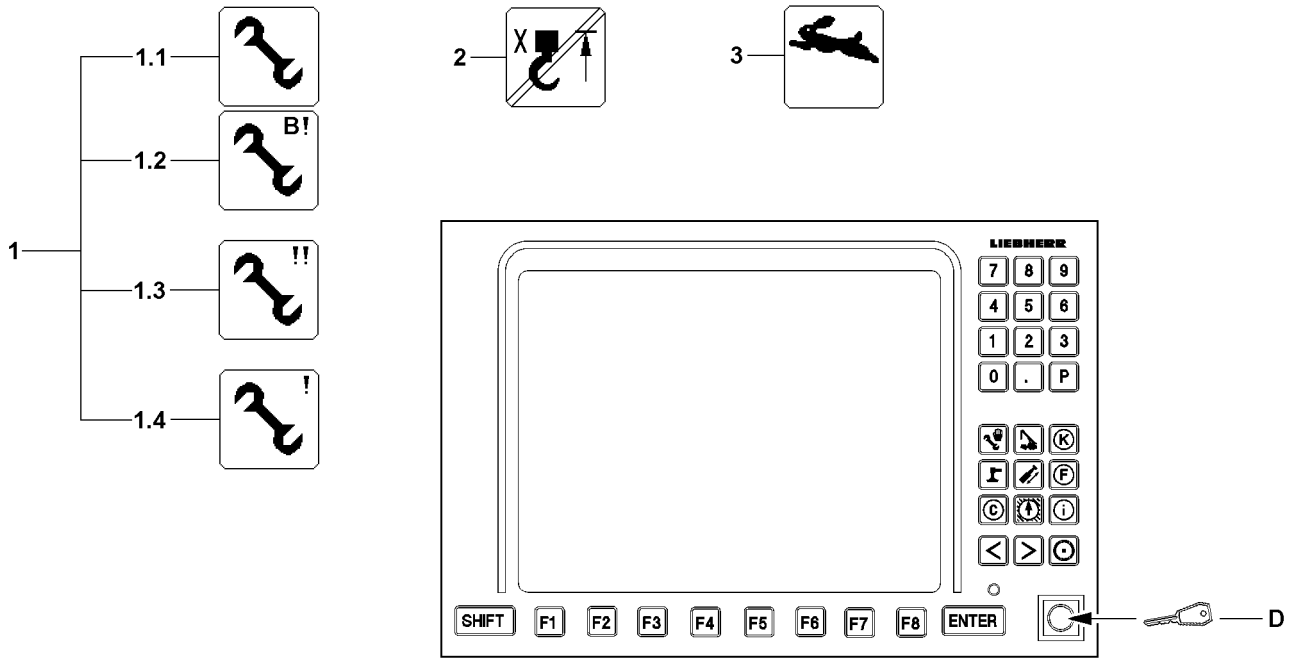

S801

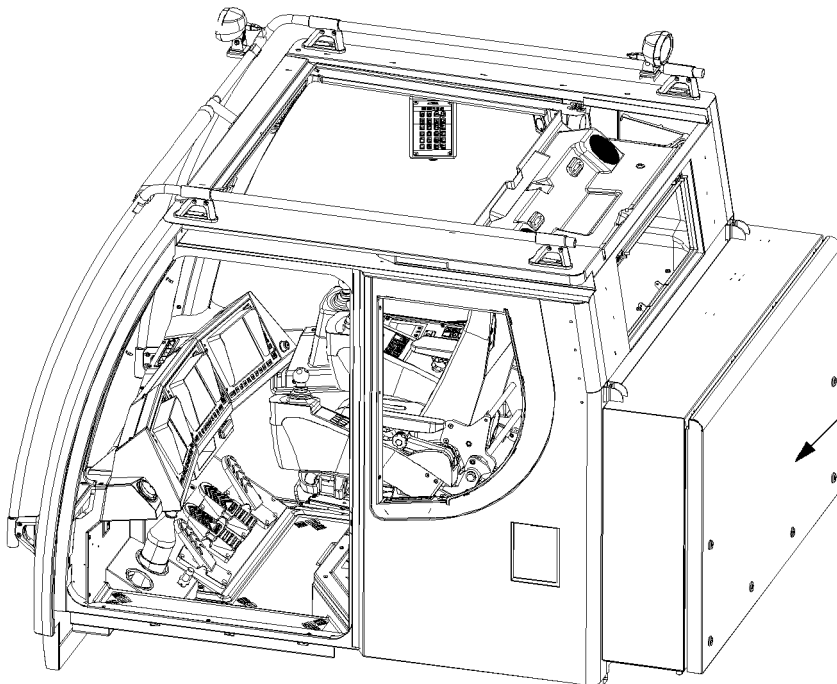

Fig.112993

LWE/LR 1600-2-008/18109-09-02/en

7.3 Special functions



WARNING

Danger of accident due to function „Exceedance of shut off limits of the LICCON overload protection“! If the shut off limits of the LICCON overload protection are exceeded, there is no additional protection against crane overload!

Due to erroneous operation or deliberate misuse, the crane can collapse, the boom can break off or the crane can topple over!

Personnel can be severely injured or killed!

- ▶ The function „Exceedance of shut off limits of the LICCON overload protection“ is only permissible in emergencies and for assembly purposes!
- ▶ The set up key **D** may only be actuated by persons who are aware of the effects of their acts regarding the function „Exceedance of shut off limits of the LICCON overload protection“!
- ▶ The function „Exceedance of shut off limits of the LICCON overload protection“ requires the presence of an authorized person and must be performed with utmost caution!
- ▶ Crane operation with activated function „Exceedance of shut off limits of the LICCON overload protection“ is prohibited!



Note

Double function set up key!

If the crane control „EN13000:2010 not active“ is programmed, then, when actuating the set up key **D**, the release for the „Emergency operation LICCON overload protection“ is automatically engaged!

- ▶ Take into account, when actuating the set up key **D**, that the „Emergency operation LICCON overload protection“ is automatically released!

Before pressing the set up key **D** make sure that:

- Conditions and specifications for using the set up key **D** are known
- Conditions and specifications for using the set up key **D** were understood and adhered to



Note

- ▶ The various icons **1** are shown on the same position in the LICCON monitor, depending on the situation. Only one icon **1** can be shown at a time.
- ▶ For operation and specifications for using the set up key **D**, see Crane operating instructions, chapter 4.02, chapter 4.20 and chapter 7.15.

7.3.1 Exceeding the shut off limits of the LICCON overload protection

1.1 Assembly

- The icon appears:
 - when a special case for operation of the LICCON overload protection was activated, for example the shut off limits of the LICCON overload protection were bypassed by the set up key **D**.
 - **Note:**
The „Crane operation“ program is locked, meaning, no other program can be turned on via the program keys.

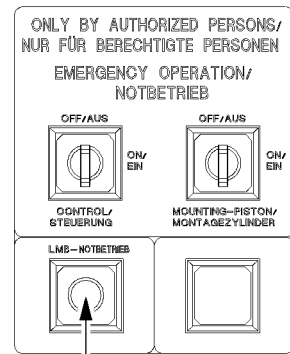
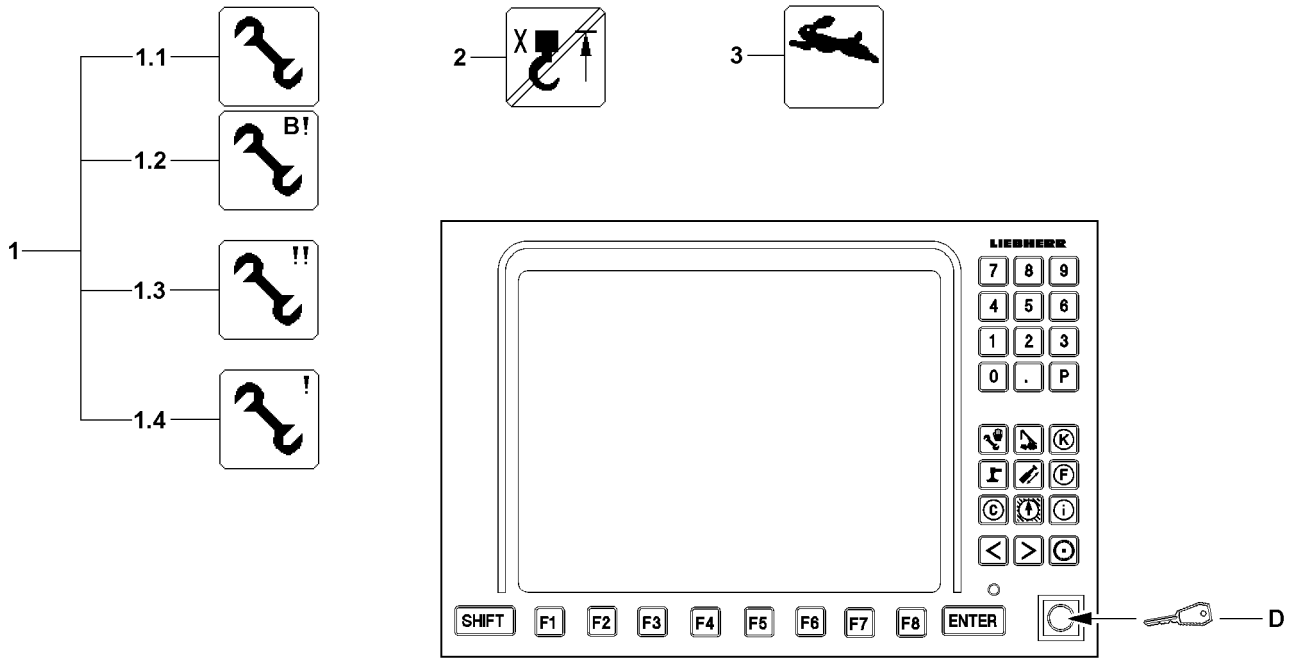

S801

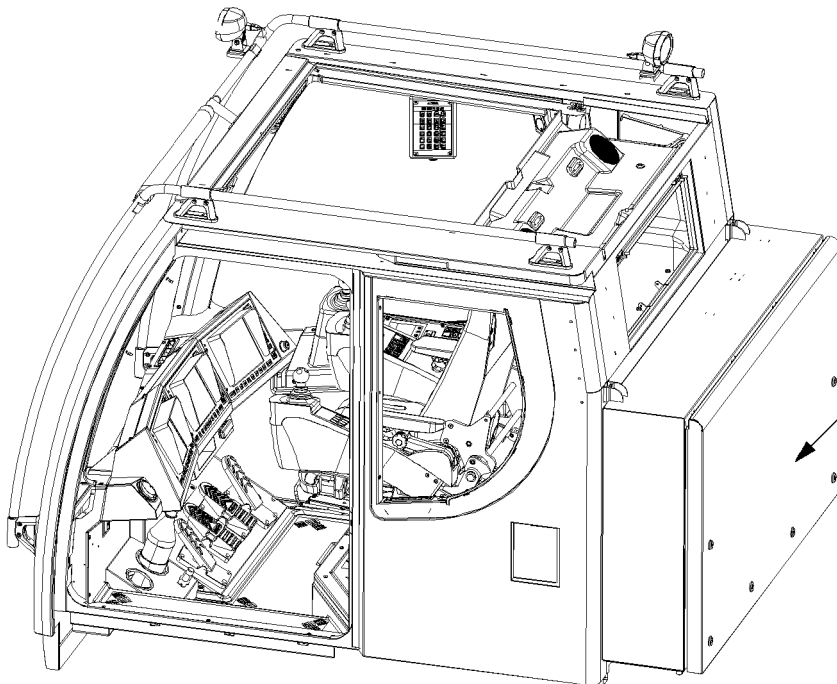

Fig.112993

LWE/LR 1600-2-008/18109-09-02/en

7.3.2 No load chart is available

1.2 Assembly - no load chart

- The icon appears:
 - When the shut off limits of the LICCON overload protection are bypassed via the set up key **D** and no load chart is available.
 - The crane may only be operated according to the specifications of the load charts and / or the erection / take down charts.
- **Note:**
By actuating the set up key **D**, all erection / take down procedures can be carried out within the erection / take down charts, for which no load charts are available!

7.3.3 Emergency operation LICCON overload protection (EN 13000:2010 active)



WARNING

Increased danger of accident during emergency operation of the LICCON overload protection! In emergency operation, the crane movements are no longer monitored by the LICCON overload protection!

- ▶ The emergency operation may only be activated by persons who are aware of the consequences of their actions!
- ▶ A shut off by the LICCON overload protection may not be circumvented by the emergency operation!
- ▶ If normal „crane operation“ is possible, then the emergency operation may not be activated!
- ▶ All crane movements must be carried out with extreme caution and anticipatorily!

1.3 Emergency operation activated

- The icon appears:
 - when the emergency operation LICCON overload protection (LMB emergency operation) is activated via the keyed button **S801**.
- **Note:**
The Crane operation program is locked, meaning, no other program can be turned on via the program keys.

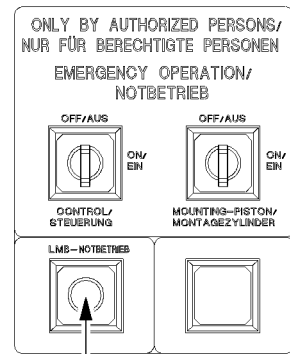
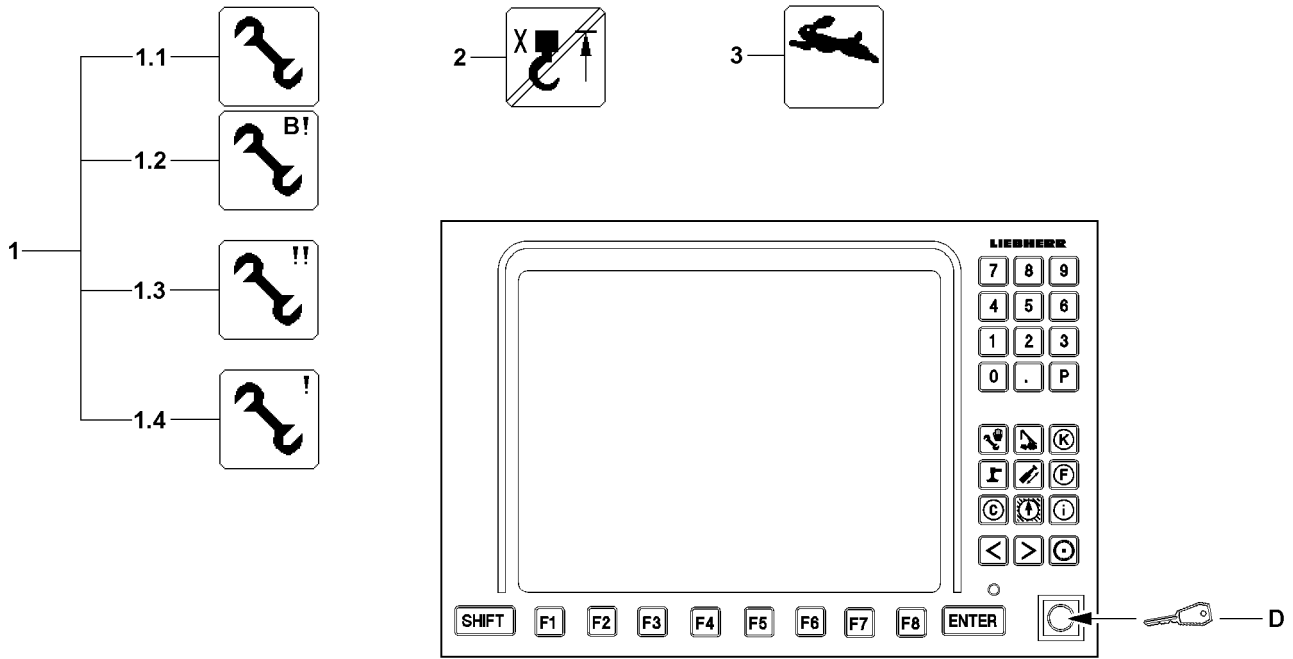

S801

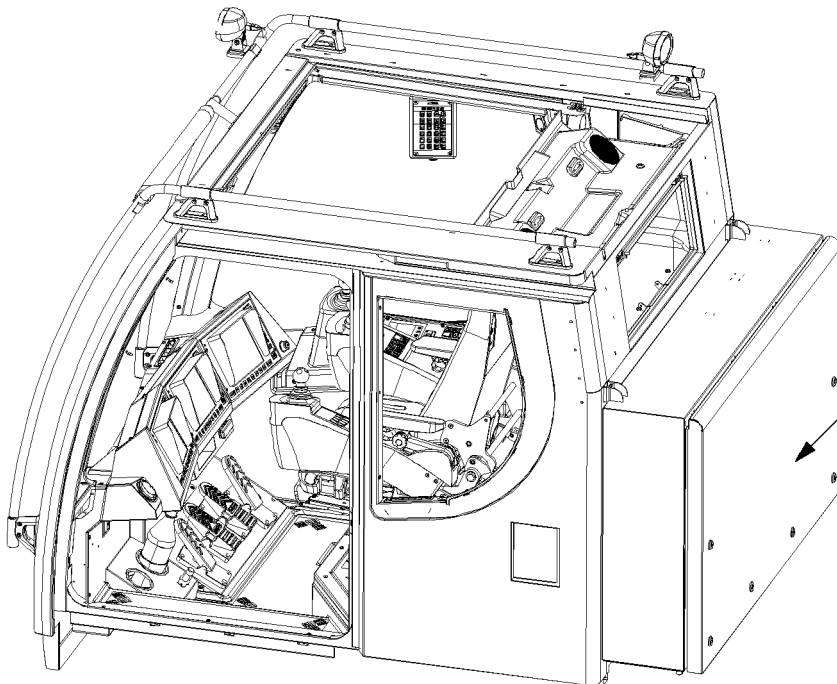

Fig.112993

LWE/LR 1600-2-008/18109-09-02/en

7.3.4 Emergency operation LICCON overload protection (crane without CE mark)



Note

If the crane control „EN 13000:2010 not active“ is programmed, then the functions of the „Emergency operation of the LICCON overload protection“ are engaged by the set up key **D**!

- ▶ If the emergency operation LICCON overload protection is needed, press the keyed button **S801** or the set up key **D**!

1.3 Emergency operation activated

- Icon appears:
 - when the emergency operation is activated by the keyed button **S801** or the set up key **D**.
- **Note:**

Depending on the reason for the emergency operation, the icon for no load chart available **1.2** can also appear.
- **Note:**

The Crane operation program is locked, meaning, no other program can be turned on via the program keys.

7.3.5 Additional emergency operating modes



WARNING

Erroneous operation of the crane!

If one of the icons for additional emergency operating modes **1.4** appears, then there is a risk of accidents due to erroneous operation of the crane!

Personnel can be killed or injured!

This could result in property damage!

- ▶ Deactivate additional operating modes **1.4** again or contact Liebherr Service and coordinate further procedure.

1.4 Additional emergency operating modes

- Icon **1.4** appears if additional emergency operating modes were activated.

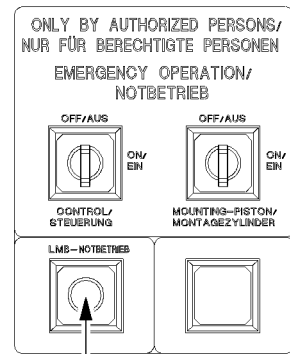
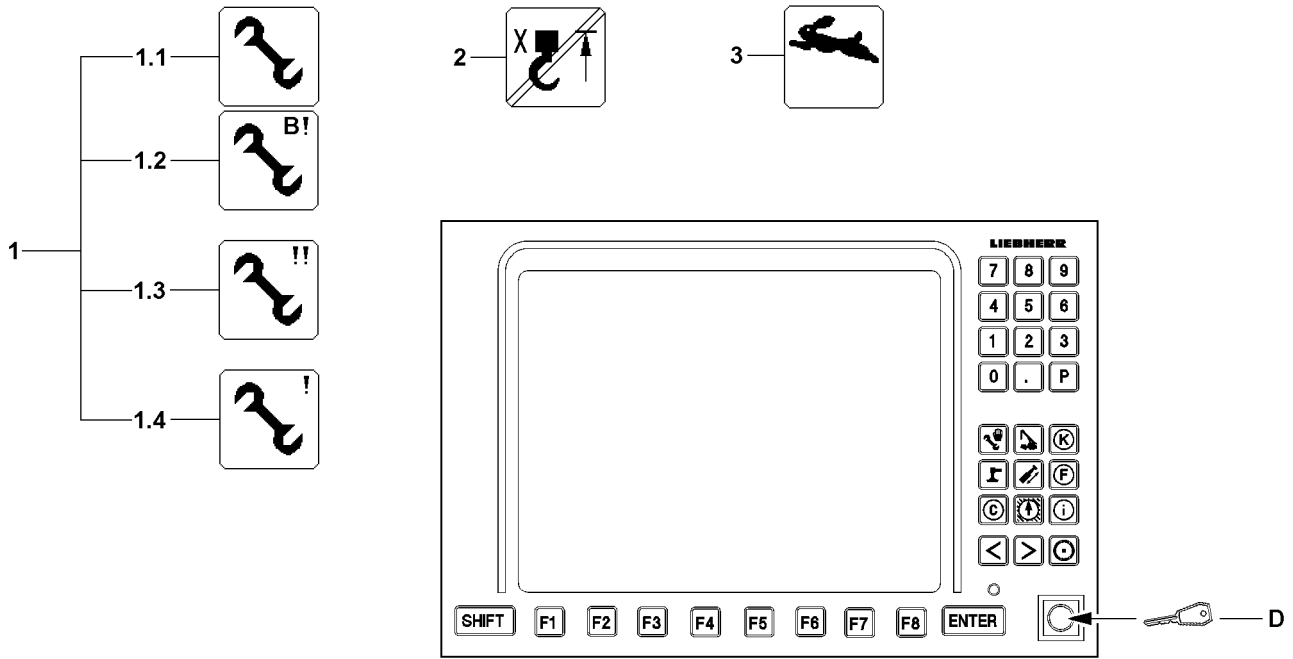

S801

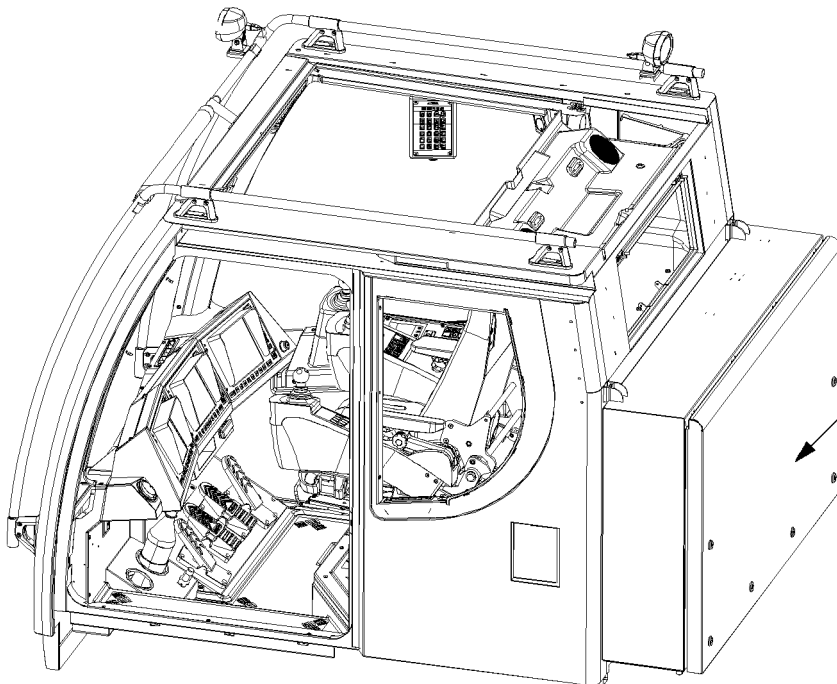

Fig.112993

LWE/LR 1600-2-008/18109-09-02/en

7.3.6 Bypass „Hoist top“

2 Bypass „Hoist top“

- The icon appears:
 - When the shut off „hoist top“ is bypassed via the set up key **D**
 - **Note:**
The Crane operation program is locked, meaning, no other program can be turned on via the program keys.

7.3.7 Fast mode (Rapid gear)

3 „Rapid gear“ icon

- The icon appears if the rapid gear is enabled during a crane movement.
- This is possible for the following crane movements:
 - Lift / lower hoist gears
 - Luff the boom up / down

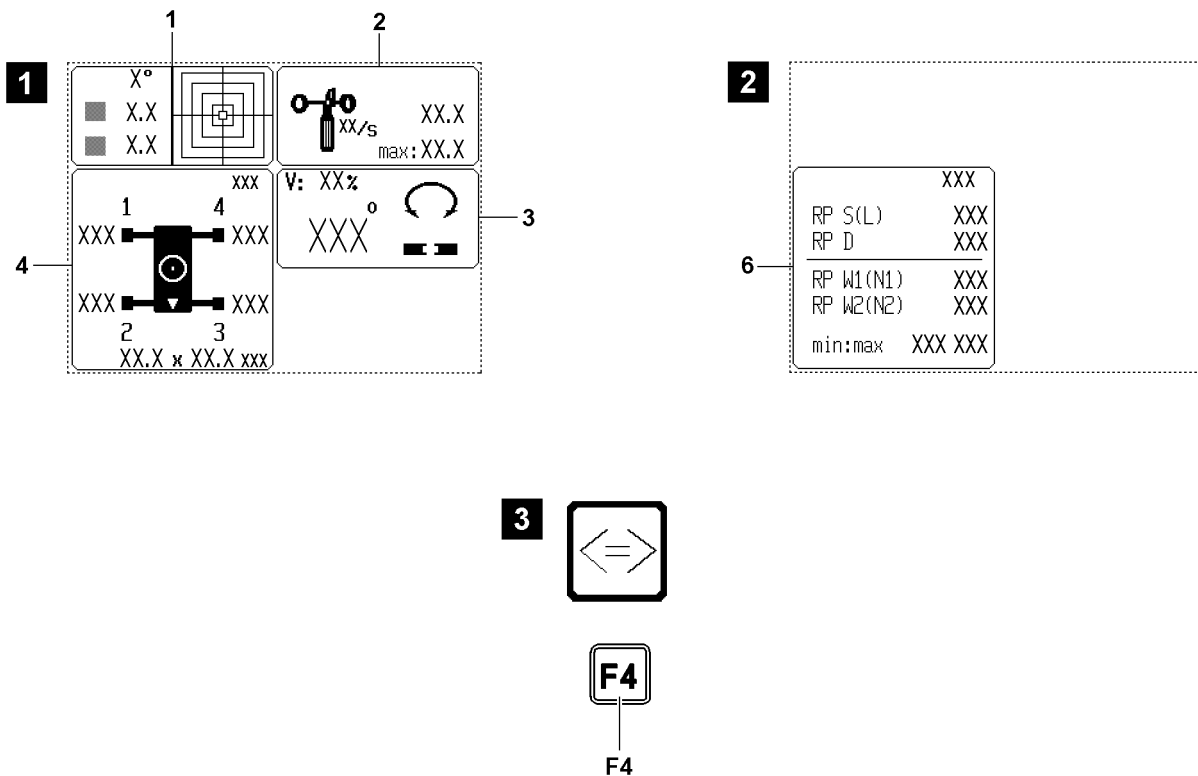
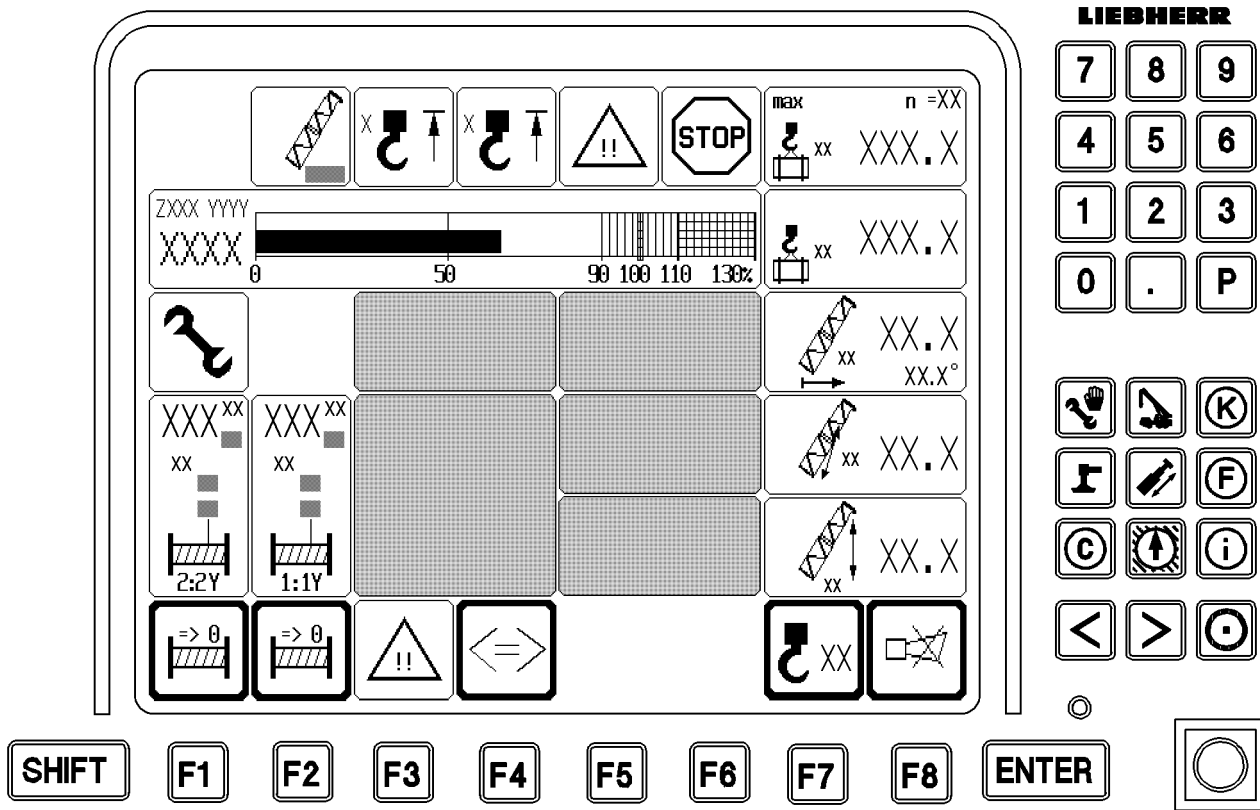

Fig.112998

7.4 Monitored auxiliary functions for crane operation

There are several monitored auxiliary functions, which can be displayed when needed or automatically.

The monitoring of all auxiliary functions is always active, only the icons can be faded out. The icons of the monitored auxiliary functions have their fixed place on the LICCON monitor.



Note

- ▶ Using the function key **F3**, you can show the icons for the monitored auxiliary functions. Since not all icons of the auxiliary functions fit on one page (at maximum assignment), they are split over two pages. The icons on page 2 (if available) can be shown with the function key **F4**!

Page 1 (illustration 1):

- 1 Crane incline
- 2 Wind speed
- 3 Slewing range
- 4 Support force display

- **Note:**
only for narrow track crawler track.

Page 2 (illustration 2):

- 6 Monitoring of relapse cylinders



Note

- ▶ Depending if the monitored auxiliary functions are turned off or on, the illustration of the monitored auxiliary functions differs!
- ▶ The „Change page“ icon can be actuated if it appears / blinks via the function key **F4**, see illustration 3!

Monitored auxiliary functions turned off:

- No error:
Icons are not shown.
- Only error in one function on page 1:
Icon is displayed on page 1.
- Only error in one function on page 2:
Icon is displayed on page 2.
- Error in one function on page 1 and 2:
Icon is displayed on page 1 and icon for „Change page“ via function key **F4** blinks (= indicates an error in a function on page 2).

Monitored auxiliary functions turned on:

- No error:
Optional icons (customer request) are displayed.
If there are optional icons on page 2, the icon „Change page“ via the function key **F4** is activated (= indication for change option).
- Error in one function on page 2:
Icon „Change page“ blinks (= indication regarding an error of a function on the other page).
- Error in one function on page 1 and 2:
Icon is displayed on page 1.
Icon „Change page“ blinks (= indication regarding an error of a function on the other page).

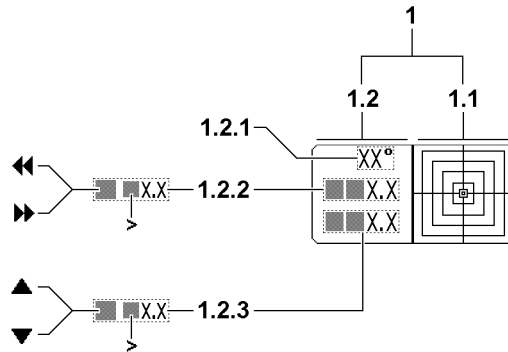

Fig.113445

7.4.1 General



Note

„?“ instead of display value!

- ▶ The value cannot be determined due to an error!
- ▶ If an error occurs and an error message is issued, see Diagnostics manual!
- ▶ Always pay attention to error messages!
- ▶ Remedy the error always as quick as possible!

7.4.2 Crane incline



WARNING

The crane can topple over!

The „larger than symbol“ shows that the crane is inclined further than can be shown!

The exact incline can then not be read!

- ▶ Do not exceed the permissible incline of the crane!

1 „Incline“ icon

- Display of the incline of the crane to the horizontal in longitudinal and lateral direction. The display is graphic as well as numeric.
- The directional data refers to the direction of the crane superstructure (view from the cab).

1.1 Graphic part

- The graphic display is in the form of a spirit level, with a moving dot representing the air bubble. The center of the dot shows the precise incline value.

1.2 Numeric part

1.2.1 Incline range

- This value describes the resolution of the graphic view. The resolution is matched automatically to the incline.

1.2.2 Lateral direction

- Incline of crane in lateral direction in [°]
- The double arrow shows the direction of the incline
- If the „larger than symbol“ appears, then the crane is inclined further than can be shown!

1.2.3 Longitudinal direction

- Incline of crane in longitudinal direction in [°]
- The arrow shows the direction of the incline
- If the „larger than symbol“ appears, then the crane is inclined further than can be shown!

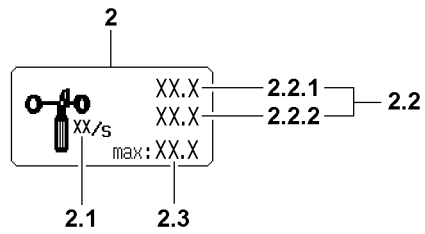

Fig.111265

7.4.3 Wind speed

- 2 „Wind speed“ icon
 - The wind speeds are displayed in [m/sec.] or [ft/sec.] depending on the units of measurement shown in the load chart
- 2.1 „Wind speed“ unit
 - [m/s] or [ft/s]
- 2.2 Current wind speed



Note

- ▶ Depending on the set up configuration of the crane, a certain number of wind sensors must be present on the LSB bus!
- ▶ If no value can be determined for a wind sensor which must be present, then current wind speed **2.2** „???“ appears in the display!
- ▶ If a wind sensor does not have to be present and is not plugged in, then there is no display in the „Wind speed“ icon **2**!

2.2.1 Current wind speed

- Wind sensor 2
- Wind sensor 3
- **Note:**

The priority of wind sensor 2 is larger than that of wind sensor 3, this means: If both wind sensors are present, then the value of wind sensor 2 is shown!

2.2.2 Current wind speed

- Wind sensor 1
- **Note:**

If several wind sensors are attached on the LSB bus, then the location of the wind sensor determines the corresponding display in the „Wind speed“ icon! The priority depends on the installation location of the wind sensor, from „outside“ (for example luffing jib) to „inside“ (for example boom head). The wind speed of the „exterior“ wind sensor is displayed in **2.2.1** and the wind speed of the „interior“ wind sensor is displayed in **2.2.2**.



WARNING

Crane operation without display value of wind speed!

If the current wind speed **2.2** „???“ appears in the display, then a wind sensor which must be present is missing or there is an error in the wind sensor!

- ▶ Remedy the error immediately!
- ▶ If an error cannot be remedied, then it must be ensured that the wind speed is monitored otherwise!

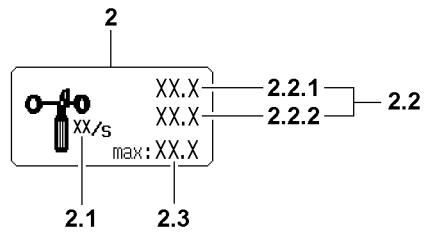

Fig.111265

2.3 Maximum permissible wind speed

- The value depends on the operating mode and the set up configuration

- **Note:**

If access to a load chart is not possible, then the maximum value starts to blink and the acoustic alarm „Short horn“ sounds!

If the current wind speed value exceeds the displayed maximum value, the maximum value starts to blink and the acoustic alarm „Short horn“ sounds!



WARNING

Wind speed too high!

If the maximum permissible wind speed is exceeded with erected boom system, there is a danger of accidents!

Dangerous situations can arise, such as oscillating load or shaking crane!

The crane can topple over, personnel can be severely injured or killed!

▶ **The crane movements will not be shut off!**

▶ The danger notes, see Crane operating instructions, chapter 2.04 must be strictly observed and adhered to!

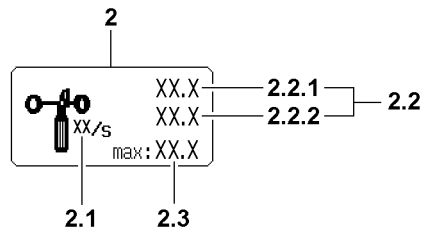

Fig.111265

2.3 Maximum permissible wind speed

- With icon text „max:“
- The value depends on the operating mode and the set up configuration
- **Note:**
If access to a load chart is not possible, then the maximum value starts to blink and the acoustic alarm „Short horn“ sounds!
If the current wind speed value exceeds the displayed maximum value, the maximum value starts to blink and the acoustic alarm „Short horn“ sounds!



WARNING

Wind speed too high!

If the maximum permissible wind speed is exceeded with erected boom system, there is a danger of accidents!

Dangerous situations can arise, such as oscillating load or shaking crane!

The crane can topple over, personnel can be severely injured or killed!

▶ **The crane movements will not be shut off!**

▶ The danger notes, see Crane operating instructions, chapter 2.04 must be strictly observed and adhered to!

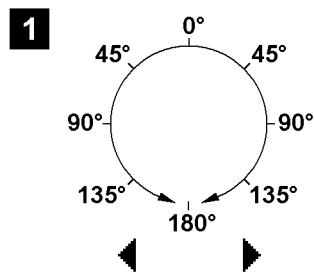
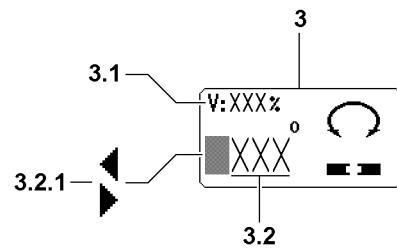

Fig.112352

7.4.4 Slewing range



DANGER

Danger of accidents in case of excessive slewing speed!

► Make the selection of the slewing speed according to the specifications in the load chart manual!

3 „Slewing range“ icon

3.1 Maximum slewing speed

- V: [%]
- Identifies the current (selected) „Maximum slewing speed“ of the slewing gear with a fully deflected master switch, relating to the maximum attainable slewing speed of the slewing gear.
This value may be selected in fixed percentage stages in the LICCON program Control parameter.

3.2 Current position of the crane superstructure

- In relation to the main working direction (0 [°]).
Increasing to the maximum value of 180°, see illustration 1.

3.2.1 Direction of deviation

- The arrow in front of the value indicates the deviation direction
 - Arrow to the right: Crane superstructure is turned to the right.
 - Arrow to the left: Crane superstructure is turned to the left.

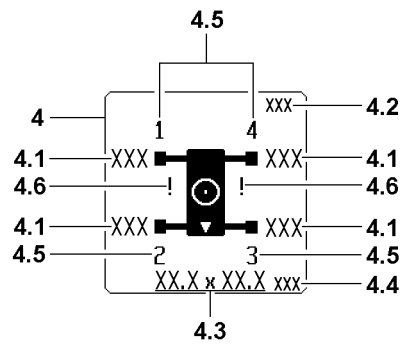

Fig.116741

7.4.5 Support force display



Note

- ▶ Only crane with narrow track crawler track.

4 „Support force display“ icon

- **Note:**

The „support force display“ icon **4** appears only when the crane is supported. For crane operation on crawlers, the „support force display“ icon **4** does not appear.

- The LICCON support force monitoring system continuously records the current hydraulic pressure present in all 4 support cylinders during crane operation using a pressure sensor, and converts this into a support force [t] value for each support.

The „Support force display“ icon* **4** can be displayed in the „Operation“ program, if required, or the icon appears automatically with the alarm signal „short horn“ when a critical situation occurs, when a support has reached or exceeded the maximum force or has reached or fallen below the minimum force. The corresponding value is shown by a blinking display.

- **Note:**

The same maximum support force and a common minimum support force is programmed for each support at the factory. These 5 values may be changed in the „Support“ program, depending on the situation. (refer to section „Changing the minimum and maximum support force monitoring“).

Independently of the programmed minimum / maximum values, monitoring is continuous, when the total of the two lowest support forces is less than 15 % of the total support forces. If this limit is fallen below, the two supports with the lowest forces are shown.



WARNING

The crane can topple over!

When reaching the programmed minimum / maximum support forces, **no** automatic shut off of the crane movements occurs!

When the two supports with the lowest forces are in boom direction, then certain crane movements are turned off, pay attention to error message!

- ▶ Be especially careful!

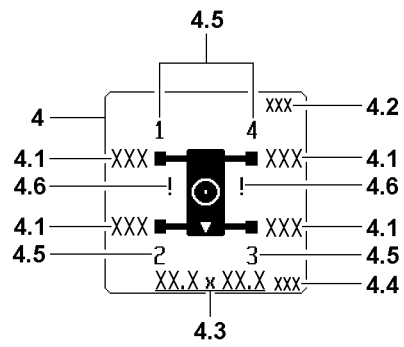

Fig.116741

- 4.1 Display of current support force
- Display of support force for each support



WARNING

Danger due to erroneous support force display!

The support force display may in some circumstances be defective or inaccurate!

- ▶ Be especially careful!
 - ▶ Also refer to hazard warnings in section „Support / Comments“!
-

- 4.2 Weight unit of support force
- In [t] or [lbs]
- 4.3 Display of support base
- 4.4 Measuring unit support base
- 4.5 Numbering support beam
- 4.6 Exclamation mark „!“
- Monitoring of the support beams is bypassed.

Note:

The exclamation mark „!“ 4.6 appears when the monitoring of the support beams is bypassed.

The monitoring of the support beams can only be bypassed in the Support program, see section „The support program“.

**WARNING**

The crane can topple over!

If the support is not correct, the crane can topple over and cause fatal injuries!

- ▶ Crane operation with incorrect support is prohibited!
 - ▶ Support the crane correctly!
-

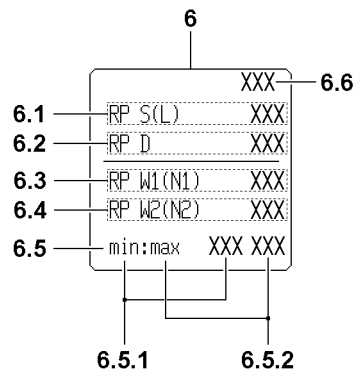

Fig.111897

7.4.6 Monitoring of relapse cylinders



Note

Display values pressure display!

- ▶ Pressure display = „0“, if these relapse cylinders are not present for the set operating mode!
- ▶ Pressure display = „??“, if the pressure sensor signal is erroneous! There is an error display with error number!

6 „Monitoring relapse cylinder“ icon

6.1 Pressure display RP S(L)

- Relapse cylinder S-, SL- or L-boom

6.2 Pressure display RP D

- Relapse cylinder Derrick boom

6.3 Pressure display RP W1(N1)

- Pressure W1-relapse cylinder (=RP W1) at W-operation
- or**
- Pressure N1-relapse cylinder (=RP N1) at N-operation

6.4 Pressure display RP W2(N2)

- Pressure W2-relapse cylinder (=RP W2) at W-operation
- or**
- Pressure N2-relapse cylinder (=RP N2) at N-operation

6.5 Pressure limits

- Monitored pressure limits of relapse cylinders (W/N)
Minimum / maximum pressure for RP W1(N1) and RP W2(N2)

6.5.1 Minimum pressure (W/N)

- If a pressure limit value is being exceeded, then this is shown by a blinking pressure actual value and an additional error message.
- This monitored minimum pressure is calculated from the angle of the main boom and the auxiliary boom / accessory. If one of the angles is invalid and is shown in the display with „??“, then no monitoring of the minimum pressure can occur.

6.5.2 Maximum pressure (W/N)

- If a pressure limit value is being exceeded, then this is shown by a blinking pressure actual value and an additional error message.

6.6 „Monitoring relapse cylinder“ measuring unit

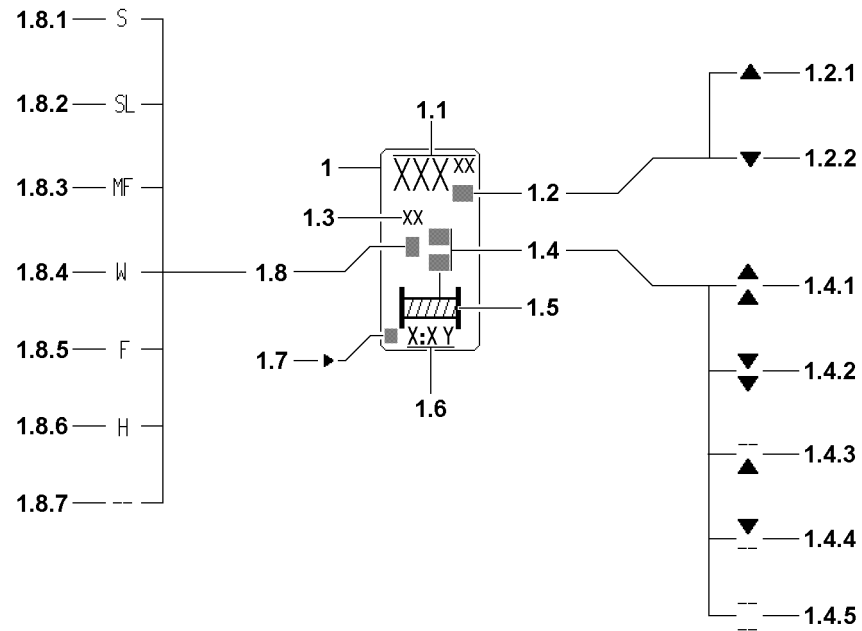

Fig.112994

LWE/LR 1600-2-008/18109-09-02/en

7.5 Winch display

1 Winch icon

- The winch 1 and winch 2 icons have the same meaning and are explained on one icon.
- The icon for winch 1 or winch 2 is shown only on monitor 0, when the crane is equipped with the respective winch.

1.1 Completed path

- In [m] or [ft]
From a zero point to be determined
- For single operation with the reeving setting made in the Set up program: Completed hook path
- For parallel operation with the set total reeving made in the set up program: Distance completed by hook block.
- The positions before the decimal point are displayed with a maximum of three large digits. The digits after the decimal point are displayed with small digits. (Setting to zero point, see section „The function key line“).
- A prerequisite for a correct display is that the reeving value entered equals the actual number of rope strands between the boom head and the hook block



Note

Display area winch displays!

- ▶ The „Completed path“ display **1.1** has only three positions before the decimal point, any positions before that are cut off! The crane operator must evaluate for himself if, for example 200 m rope are spooled up on a winch or 1200 m. **The display in both cases would be identical with 200 m !**
- ▶ The hook path calculation only works accurately if the load is suspended freely and is not luffed during the lifting procedure! Not taken into account are flexation and rope expansion!
- ▶ The length display (hook path display) is only accurate and the layer jump is only taken into account correctly if the winch has been calibrated and no interruptions of the CPU power supply have occurred (cold start)!

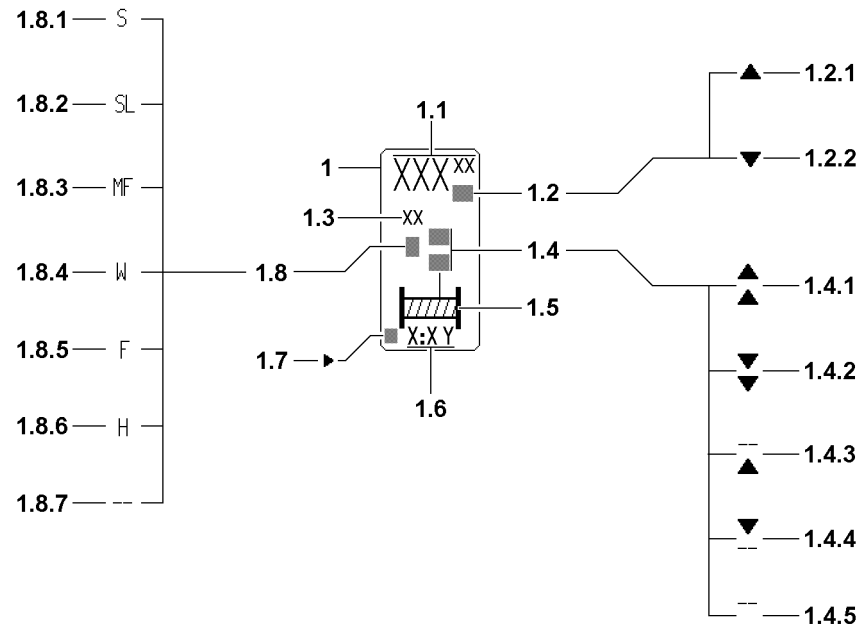

Fig.112994

LWE/LR 1600-2-008/18109-09-02/en

1.2 Direction of hook movement

The arrows on the length value show the direction of the hook movement in relation to the zero point:

- Arrow up **1.2.1**: Hook moves upward from the zero point.
- Arrow down **1.2.2**: Hook moves downward from the zero point.

1.3 Measuring unit hook path display

1.4 Winch status display

- There are five winch status icons (all blinking):

1.4.1 Spool out

1.4.2 Spool up

1.4.3 Spooled out

- Spooling out is blocked

1.4.4 Spooled up

- Spooling up is blocked

1.4.5 Winch is deactivated or unplugged

- Spooling up and spooling out are blocked (via Control parameter program).

- **Note:**

If no winch status icon appears, the activated winch is inactive and is neither spooled up nor out!

1.5 Winch icon

- (with rope end for winch status icon)

1.6 Winch number with master switch number and master switch operating direction

- Example: 1 : 1 Y
First digit: Winch number
Second digit: Master switch number
Letter: Master switch operating direction

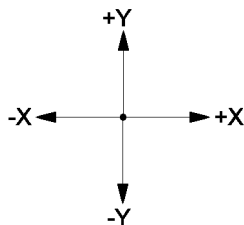

Fig.195422

1.7 Vibration sensor

- If the vibration sensor for a winch is added on the master switch, then an arrow appears in this winch icon for the added vibration sensor.

- **Note:**

The vibration sensor is added for the first actuated crane function!

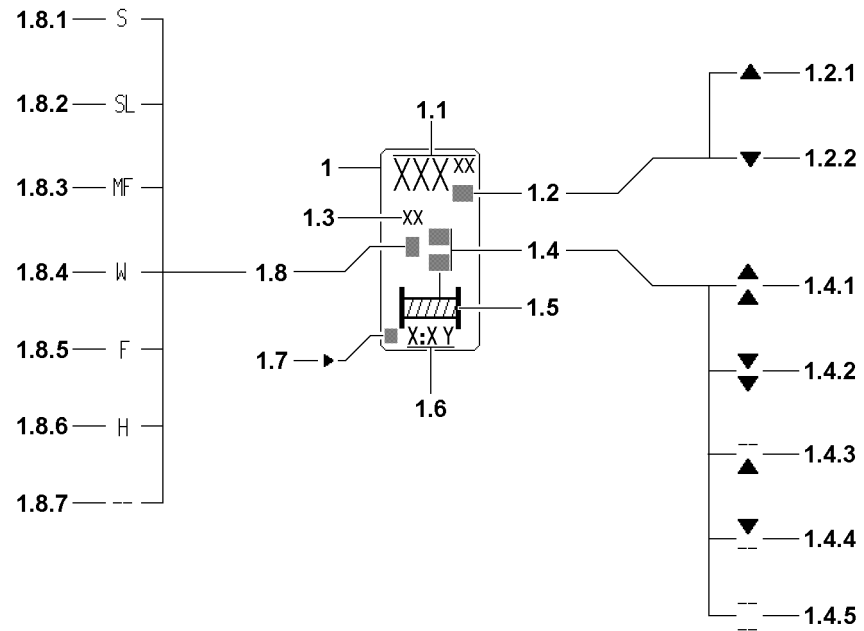

Fig.112994

1.8 Reeved in boom

- To check the settings for „winch pulley head assignment“ of various hoist winches, the respective boom symbol, on which the winch must be reeved according to the winch pulley head assignment is shown in the symbol element „winch display“

Note:

The reeved boom **1.8** icon is shown in the winch icon of winch 1, winch 2 and winch 6.

1.8.1 S

- Winch is reeved on the pulley head of the S-main boom

1.8.2 SL

- Winch is reeved on the pulley head of the SL-main boom

1.8.3 MF

- Winch is reeved on the pulley head of the center pulley of the luffing jib

1.8.4 W

- Winch is reeved on the pulley head of the luffing jib

1.8.5 F

- Winch is reeved on the pulley head of the F-lattice jib

1.8.6 H

- Winch is reeved on the pulley head of the boom nose

1.8.7 – –

- Winch is not reeved on **any** pulley head

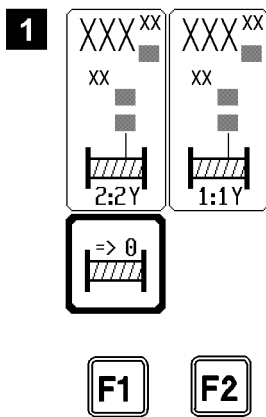
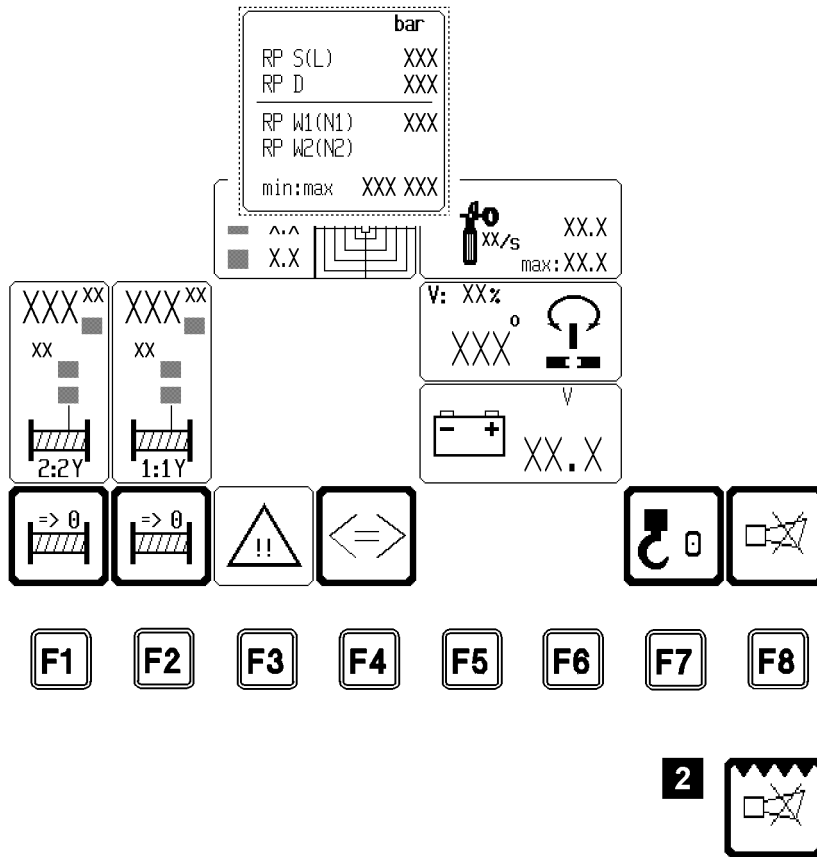

Fig.112364

7.6 The function key line in the Crane operation program

The function key line consists of function keys **F1** to **F8** and the function key icon bar above it. The function keys correspond to the various function key icons above them.

The function key icons may trigger a function or they change their appearance upon the push of a key (function keys) and thereby their definition.

Not all function keys have icons assigned to them. This depends on the „active“ program selection.

Pressing a function key changes the appearance of the icon above, its meaning, or its textual content.

F1 Function key

- Zero point for hook path display, winch 2
- Pressing the function key **F1** causes the „Set winch display to zero“ icon to appear, i.e. the winch 2 hook path display in the winch icon above is set to „000.00“ when the key is pressed. The path measurement begins here.

F2 Function key

- Zero point for hook path display, winch 1
- Pressing the function key **F2** causes the „Set winch display to zero“ icon to appear, i.e. the winch 1 hook path display in the winch icon above is set to „000.00“ when the key is pressed. The path measurement begins here.
- **Note:**
When winch 1 and winch 2 work in parallel operation, then the lengths displays of winch 1 and winch 2 can only be set together with the function key **F1** to „000.00“! Then the function key **F2** has no function, see illustration 1!

F3 Function key

- Turn monitoring icons on / off
- The function key **F3** can be used to turn all the monitored auxiliary functions in the crane on or off.
- The appearance of the icon changes according to the status:
„Thick border“ = auxiliary function icons turned off
„Thin border“ = auxiliary function icons turned on
- **Note:**

F4 Function key

- Change monitoring page (if present)
see also section „Monitored auxiliary functions for crane operation“



Note

- ▶ The monitoring of all auxiliary functions is always active, even if the monitoring icons are hidden!
- ▶ When a monitored limit is exceeded, then an acoustic warning (horn) sounds and the respective icon is shown!

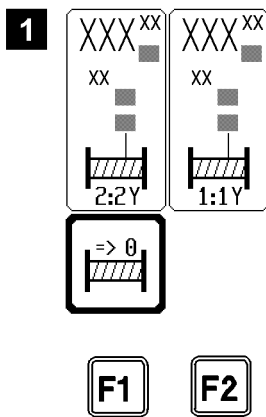
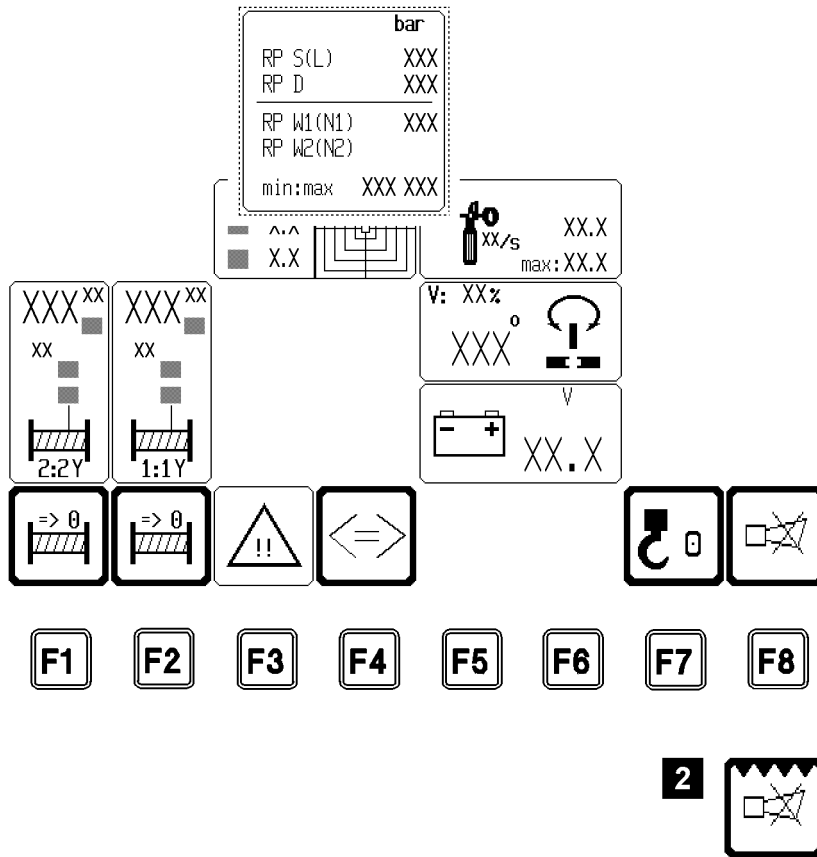

Fig.112364

- F5** Function key
- Not assigned
- F6** Function key
- Not assigned
- F7** Function key
- Taring
 - When the function key **F7** is pressed, the actual load display is set to „zero“. At the same time, the word „net“ appears in the icon of the actual load display. This function, for example, makes it possible to eliminate the weights of the hoist rope, load carriers, lifting and fastening equipment and only display the weight of the load that must be lifted (net load).
If the taring is cancelled, the word „net“ disappears from the icon „Actual load display“ and the gross load value is displayed.
 - Tare is cancelled by one of the following two actions:
 1. Pressing the function key **F7** again.
 2. By luffing by more than $\pm 4^\circ$.
 - **Note:**
The function key **F7** acts the same way to the actual load display of the accessory, if the accessory is installed!
- F8** Function key
- Turn off the acoustic warning
The „Horn“ and „Short horn“ acoustic warnings can be turned off by pressing the function key **F8**.
 - **Note:**
A new error turns the acoustic warning on again!



WARNING

Malfunctions in the crane control!

A special program is available for LIEBHERR crane acceptance in the LICCON computer system!

This program is blocked after conclusion of the crane acceptance!

If an additional marking is displayed in the „Horn“ icon (talons along the upper margin, see illustration 2), then the special program is activated!

- ▶ Contact LIEBHERR Service immediately!
 - ▶ In order to prevent error functions, access to the special program is only permitted for trained LIEBHERR personnel!
-

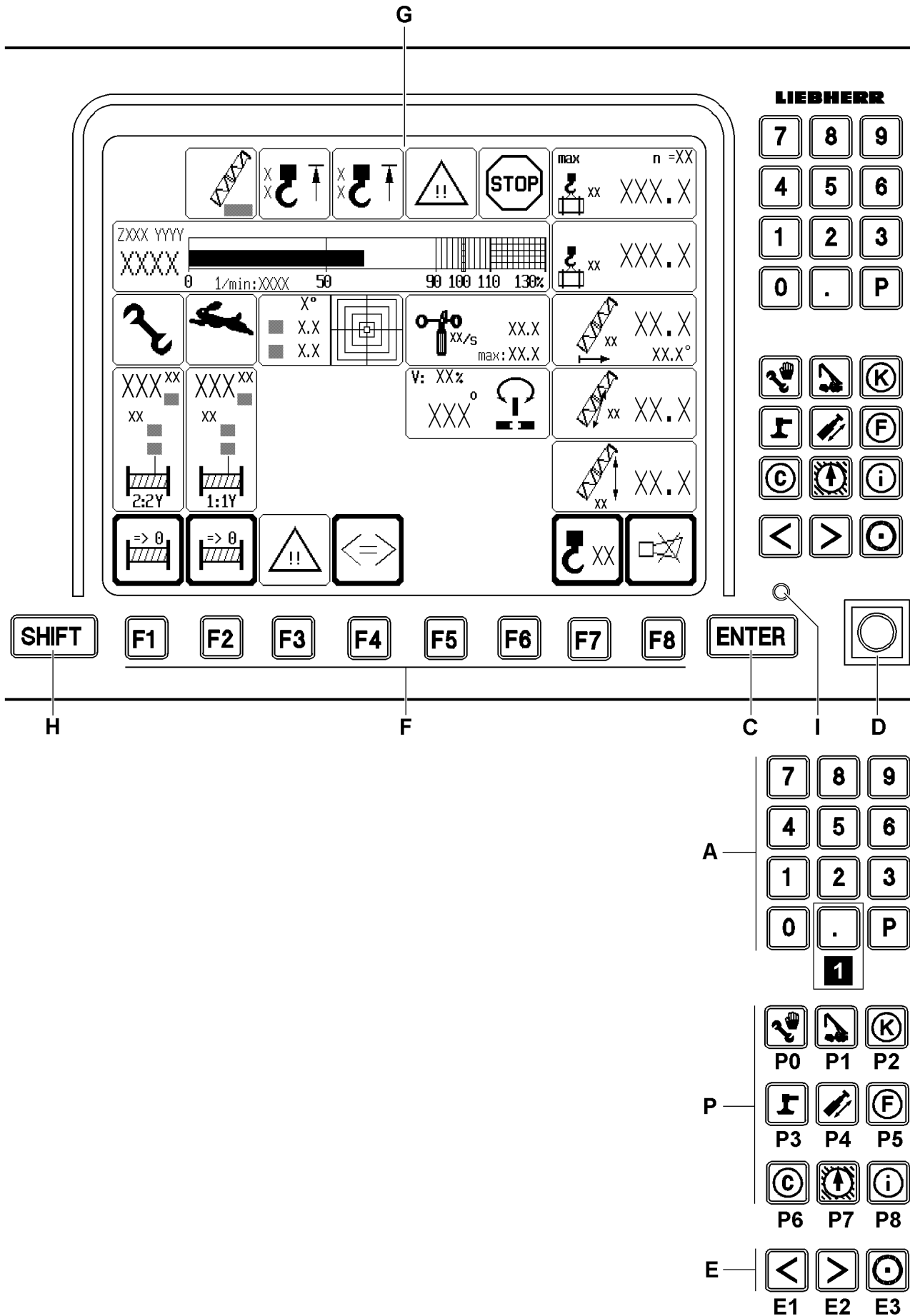

Fig.112354

7.7 Other operating elements

The following functions are assigned to the other operating elements of the display and operating unit of the LICCON computer system in the crane operation program.

A Keypad

- Keys „0“ to „9“ and „P“ have no function in the Crane operation program

- Key „.“, illustration 1

With the key „.“ the so-called test screen function is turned on and off. All existing icons appear with a test value on the LICCON monitor.

- **Note:**

The monitored auxiliary functions must be opened in the desired page to appear in the test screen!

The test screen display can be held by pressing the SHIFT key **H** and the key „.“!

By pressing the key „.“ again, the normal crane operating screen appears again!

If the test screen is not held, then the normal crane operating screen appears after 10 seconds!

P Program keys

- The program keys are used to select individual programs. However, the appropriate program-specific features (for example, switching from set up to crane operation once with „O.K.“) must be noted.

- **Note:**

A program currently running **cannot** be called again using its program key!

The programs can only be called up with their program key when the set up key was not actuated before!

C Input key ENTER

- No function in crane operation program

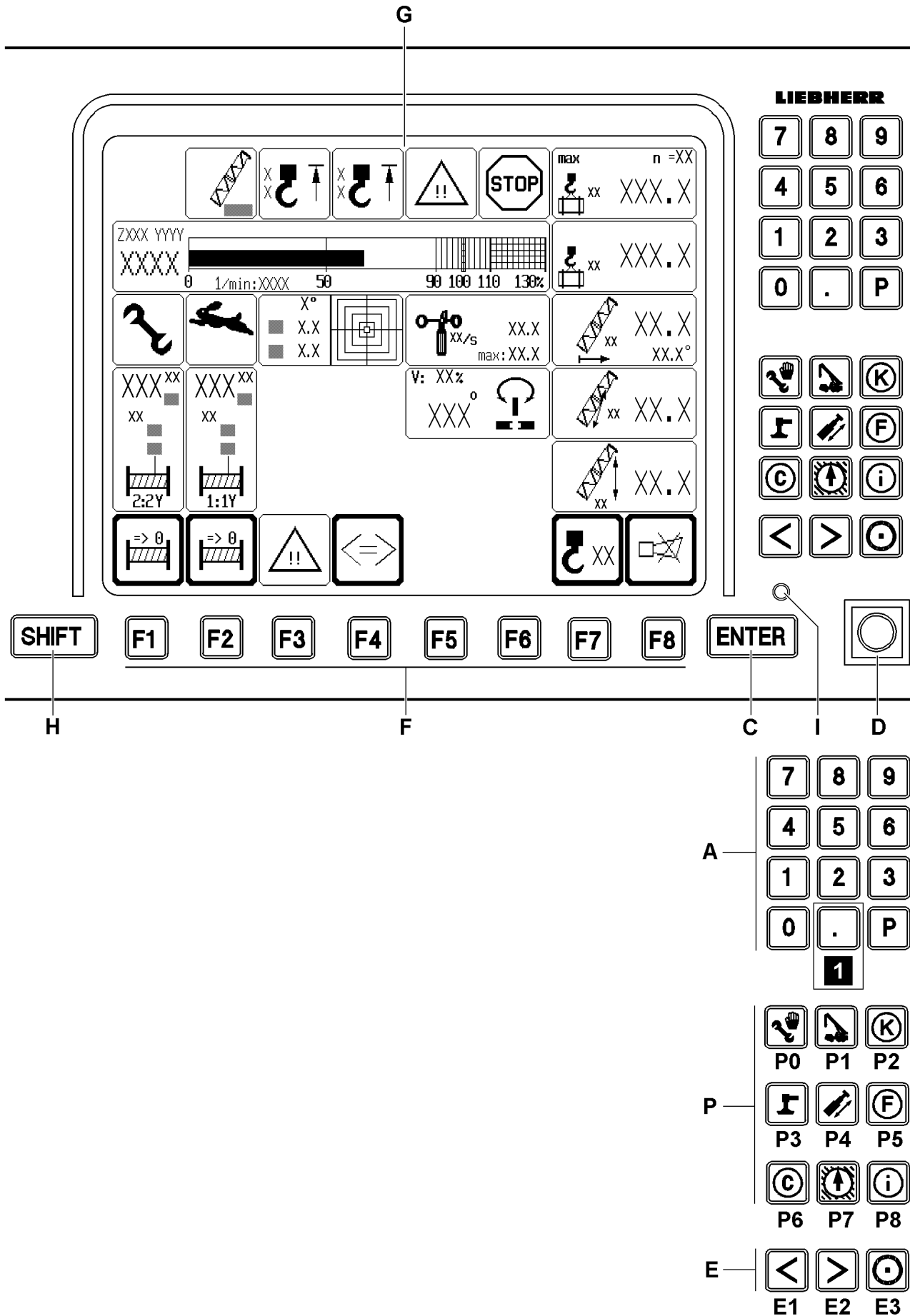

Fig.112354

LWE/LR 1600-2-008/18109-09-02/en

D Set up key

- Zero position (not actuated):
Normal operation
- Touching:
Function „Exceedance of shut off limits of the LICCON overload protection“ released.
- **Exceeding the shut off limits of the LICCON overload protection!**
If the shut off limits of the LICCON overload protection are exceeded, the LICCON overload protection shuts the crane movements off!
These shut offs can be exceeded by the set up key **D** in the „Right touching“ position!
To do so, chapter 4.20 in the Crane operating instructions must be observed!

**Note**

Double function set up key!

If the crane has **no** CE-mark, when actuating the set up key **D**, the release for the „Emergency operation LICCON overload protection“ is automatically engaged!

- ▶ Take into account, when actuating the set up key **D**, that the „Emergency operation LICCON overload protection“ is automatically released!
-

**Note**

Carry out the erection / take down procedures!

- ▶ By actuating the set up key **D**, all erection / take down procedures can be carried out within the erection / take down charts, for which no load charts are available (assembly operation)!
-

- **Bypass of the hoist top shut off**

If the hook block contacts the hoist limit switch weight during its upward movement, the hoist limit switch is triggered. The crane movement „spool up winches“ and others are turned off. This shut off can be bypassed by the set up key **D** in the „right touching“ position. To do so, chapter 4.20 in the Crane operating instructions must be observed!

E Special function keys

- Monitor brightness adjustment
 - Key combination **E3** and **E1**: Turn background illumination on / off
 - Key combination **E3** and **E2**: Brightness adjustment in three stages
-

**Note**

- ▶ Additional functions of the special function keys **E** are program-dependent and are further explained in the description of the individual LICCON programs!
-

H SHIFT key

- Second level key assignment

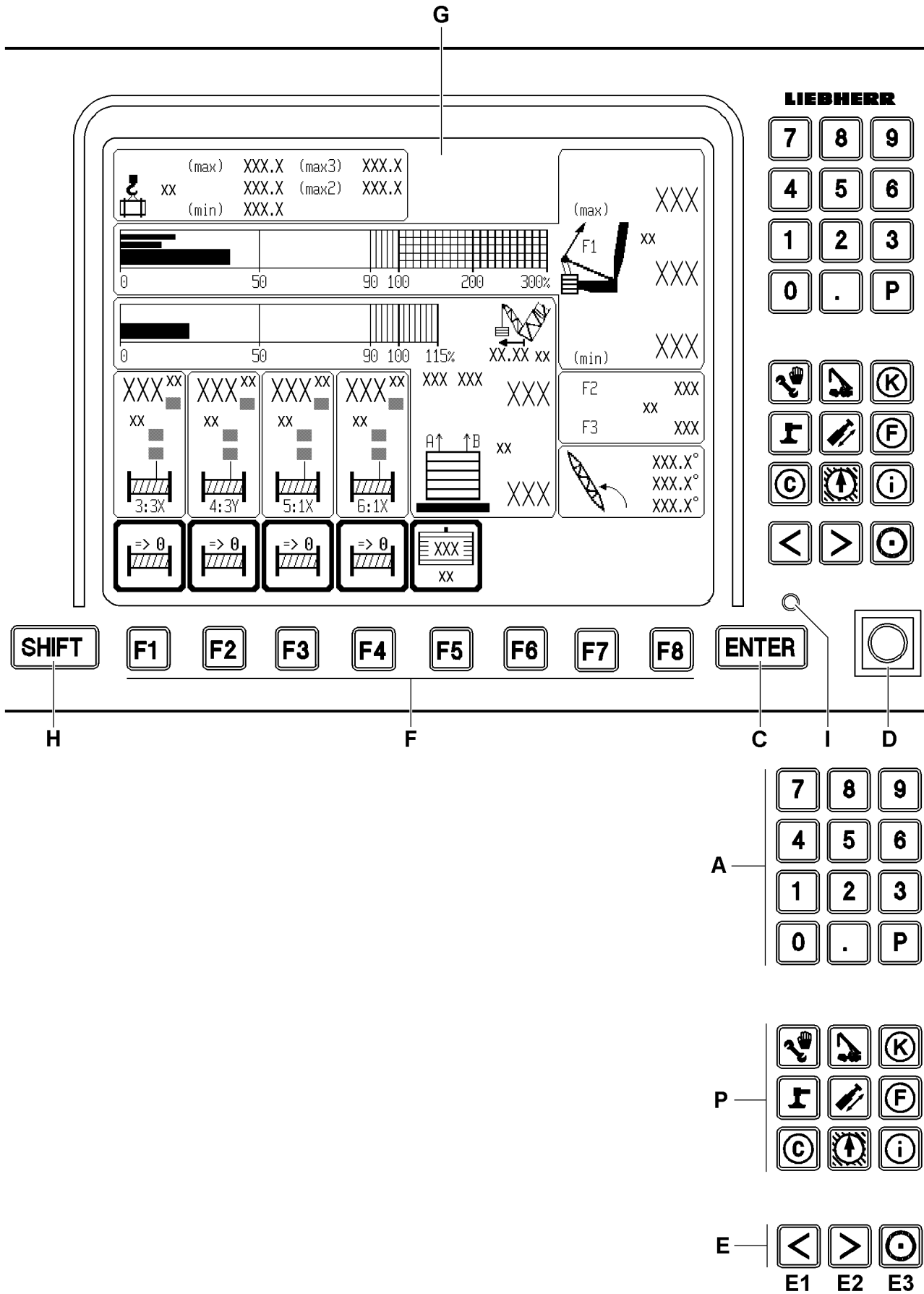

Fig.112941

8 Operating elements of the LICCON computer system on monitor 1

- A** Keypad
 - For input of derrick ballast value
- P** Program keys
 - No function
- C** Input key ENTER
 - Confirmation of changes
- D** Key button
 - Acoustic signals which can be shut off of bell / horn turntable can be shut off
- E** Special function keys
 - Monitor brightness adjustment
 - Key combination **E3** and **E1**: Turn background illumination on / off
 - Key combination **E3** and **E2**: Brightness adjustment in three stages



Note

- Additional functions of the special function keys **E** are program-dependent and are further explained in the description of the individual LICCON programs!
-

- F** Function keys
 - The function keys should always be viewed in conjunction with the function key icon line displayed on the monitor
- G** Display
 - In the display appears „normally“ the crane operation screen of monitor 1.
- H** SHIFT key
 - No function
- I** LED display
 - Monitor supply voltage present

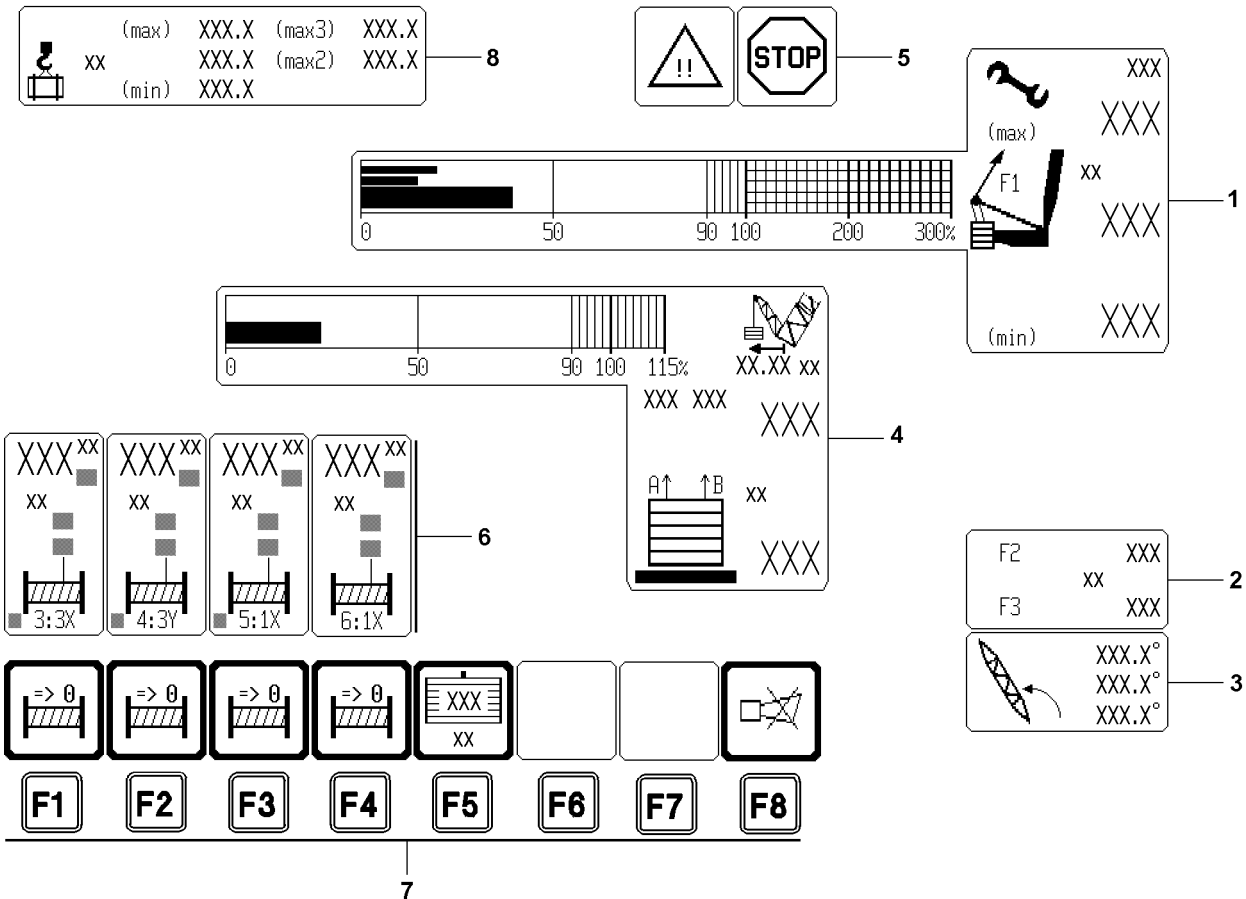
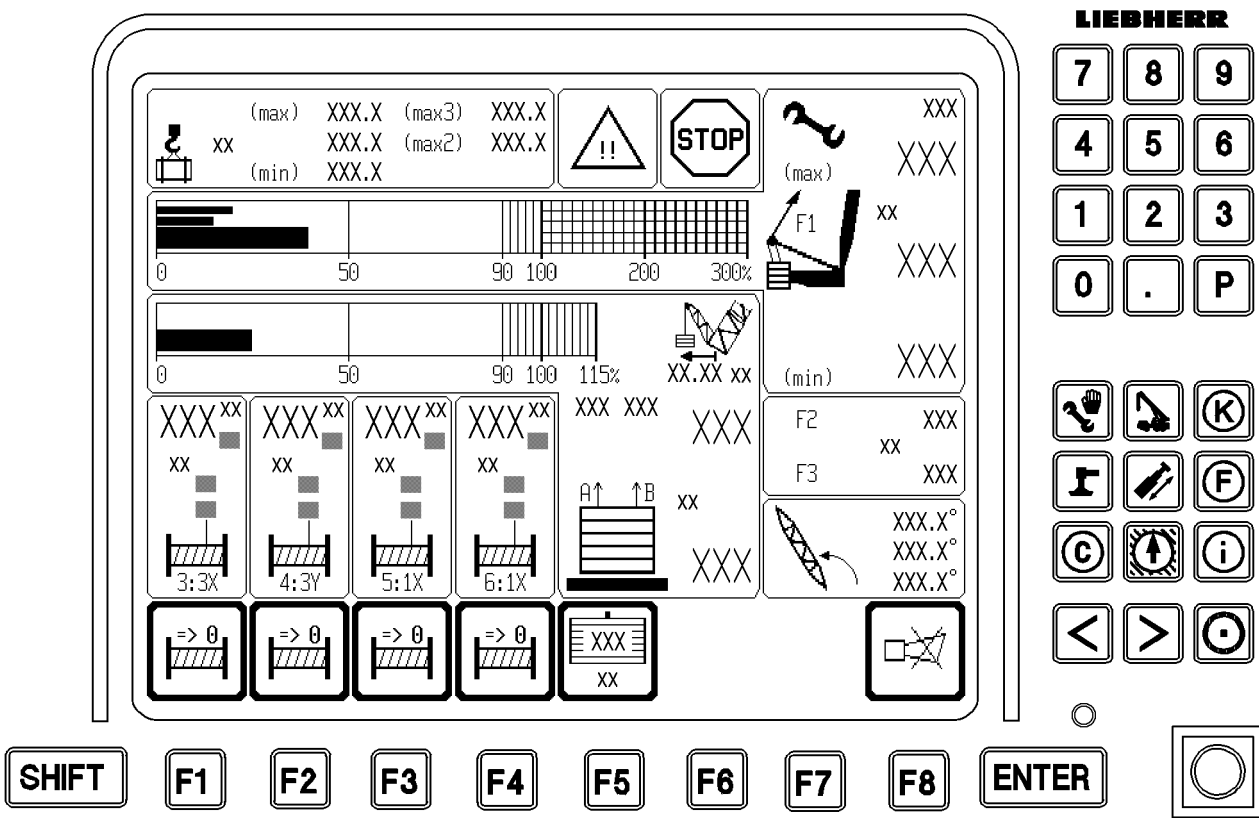

Fig.112942

LWE/LR 1600-2-008/18109-09-02/en

9 The Crane operation program on monitor 1



Note

- ▶ The suspended ballast and the ballast trailer* are generally described as **derrick ballast!**
- ▶ The fixed compensation weight which is assembled on the turntable is generally described as the **counterweight!**

In the crane operation program on monitor 1, the monitor is divided into eight areas:

- 1 Test point 1 = F1
 - F1-load display
 - Pull test brackets on test points 1A and 1B in the SA-frame guying
- 2 Test points 2/3 = F2/F3
 - Pull test brackets on test points 2A and 2B in the N/W guying
 - Pull test brackets on test points 3A and 3B in the S-guying in derrick operation
- 3 Derrick boom angle
- 4 Derrick ballast, weight and utilization
 - Derrick ballast, placed and pulled
 - Derrick ballast radius
 - Derrick ballast utilization
- 5 Alarm functions
 - „Advance warning“ and „**STOP**“ icons
- 6 Winch displays
 - Winch 3*
 - Winch 4
 - Winch 5*
 - Winch 6*
- 7 Function key line
 - Function keys always refer to the icon shown directly above
 - **Note:**
If no icon is shown in the line directly above the function key, then no function is assigned in the program to the function key!
See for example function key F6 and function key F7!
- 8 Load min / max

9.1 Test point 1 = F1



DANGER

Overload of crane in assembly operation!

If the crane is utilized in assembly operation past the assembly limit, then crane components can be overloaded!

The crane can topple over and personnel can be severely injured or killed!

- ▶ In assembly operation, the crane operator must make sure that the crane is not subjected to loads to the assembly limit!
- ▶ The crane may always only be erected / taken down **without load**, according to the data in the operating instructions and the erection and take down charts!

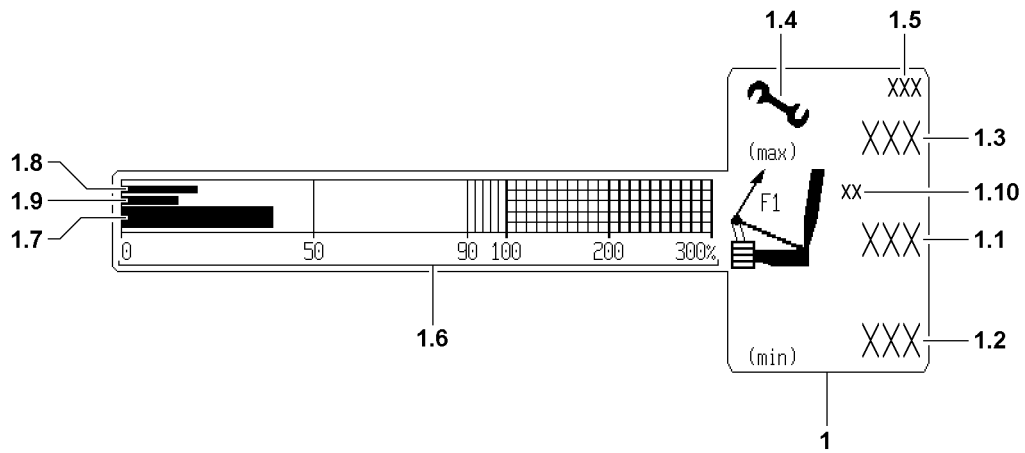

Fig.111912

9.1.1 F1-assembly maximum force

The F1-assembly-maximum force is abbreviated in the chapter as $F1_{\text{max-assembly}}$.



Note

- ▶ A load chart is available in the operating range of the crane! Outside of the operating range, no load chart is available, the specifications for assembly operation apply!
- ▶ $F1_{\text{max-assembly}} 1.5$ can be larger within the operating range for static reasons than $F1_{\text{max-assembly}} 1.5$ outside the operating range!
- ▶ When luffing out of the operating range with load chart, the value $F1_{\text{max-assembly}} 1.5$ can therefore be significantly reduced!



DANGER

Failure of angle sensor!

If angle sensor on the boom for the LMB are defective, then the LMB uses the highest permissible $F1_{\text{max-assembly}} 1.5$ as the non-bypassable maximum value!

This ensures that the boom can always be taken down, even with a defective angle sensor!

If the crane is not taken down after a failure of the angle sensors exactly according to the data in the operating instructions and the erection / take down charts, then it can be overloaded!

The crane can topple over and personnel can be severely injured or killed!

- ▶ Take the crane down if needed exactly according to the data in the operating instructions and the erection / take down charts!

Operating modes without derrick boom

For operating modes without derrick boom, there is a unbyassable $F1$ -limit value:

- $1.5 F1_{\text{max-assembly}}$
as upper limit for erection / take down of the boom
and
for crane operation with load chart

Operating modes with derrick boom

For operating modes with derrick boom there are two $F1$ -limit values

- $F1_{\text{max-assembly}} 1.5$ outside the operating range
For erection and assembly of the crane (non-bypassable)
- $1.3 F1_{\text{max-operation}}$
As upper limit for crane operation with load chart (and a few angle degrees next to it)

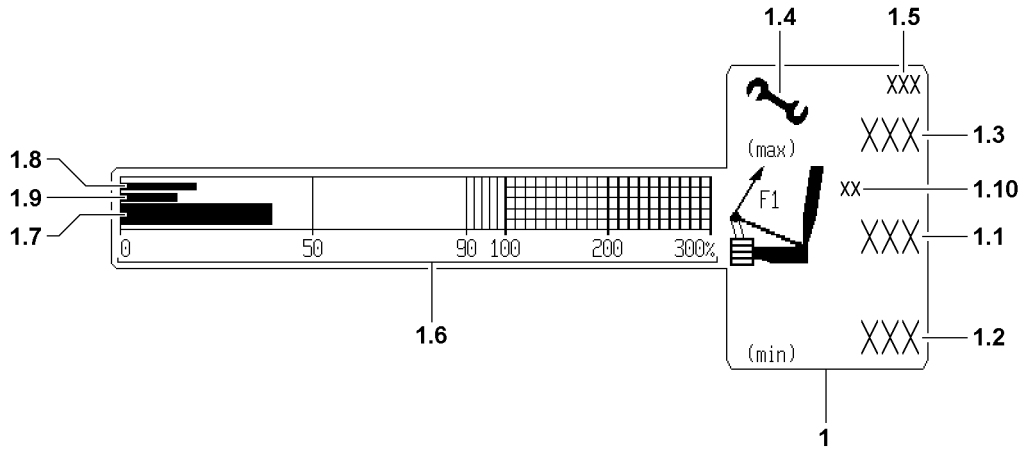

Fig.111912

9.1.2 Test point 1 = F1 / icon description

Pull test brackets Test point 1A and 1B are in the SA-frame guying

Position	Icons / display values	Type of display	Is shown
1	Icon „Test point 1“	Static	Always
1.1	F1-actual force = $F1_{actual}$ $F1_{actual} = F1A_{actual} + F1B_{actual}$ $F1A_{actual} = F1$ -actual force test point 1A (SA-frame left) $F1B_{actual} = F1$ -actual force test point 1B (SA-frame right)	Static „???“ blinking	For valid value For invalid value
1.2	F1-minimum force = $F1_{min}$	Static	Always when $F1_{min}$ is larger than 0 Note: A shut off occurs when falling below $F1_{min}$ If no value is shown $F1_{min} = 0!$
1.3	F1-operational maximum force = $F1_{max-operation}$	Static	Only in operating modes with derrick ballast (DB/DBW) Note: $F1_{max-operation}$ is the maximum value which may be reached in crane operation! In crane operation, the shut off occurs at $F1_{actual}$ larger than $F1_{max-operation} + F1_{addition}$ for shut off For cranes with maximum load carrying capacity up to 1000 t applies $F1_{addition}$ for shut off = 20 t



Note

Shut off $F1_{min}$

- ▶ If the utilization of the derrick ballast is below 50 %, then there is no immediate shut off when falling below $F1_{min}$ **1.2!**
- ▶ The acoustical and optical warnings remain unaffected by the utilization of the derrick ballast!

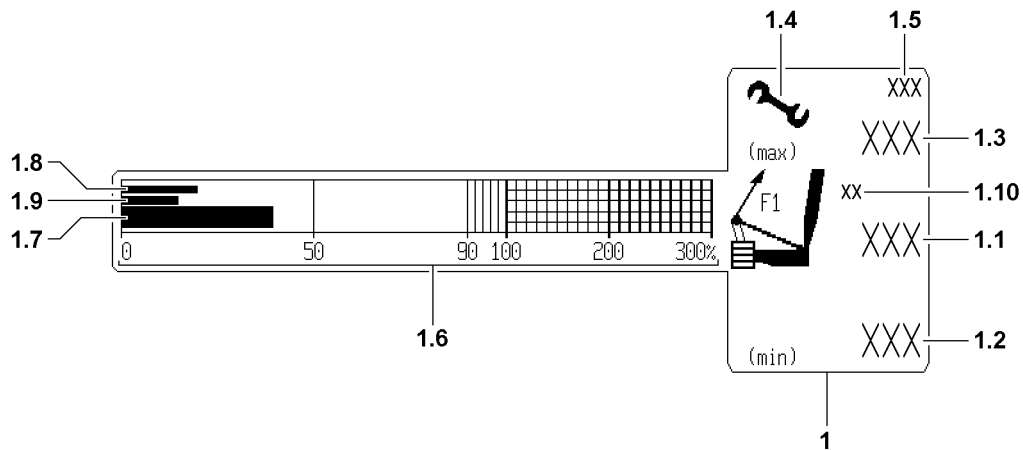

Fig.111912

Position	Icons / display values	Type of display	Is shown
1.4	Assembly icon	Static / blinking	In „Assembly operation: Boom not in operating range“ and / or Advance warning / shut off: Observe F1 limit values!
1.5	F1-assembly maximum force = $F1_{\text{max-assembly}}$	Static / blinking	In „Assembly operation: Boom not in operating range“ and / or Advance warning / shut off: Observe F1 limit values!
1.6	F1-utilization scale in percent [%]	Static	Always
1.7	F1-utilization bar = Ratio $F1_{\text{actual}}$ to $F1_{\text{max-operation}}$ No display (0 percent) at: $F1_{\text{max-operation}} = 0$ or No value or $F1_{\text{min}} = \text{invalid}$	Dynamic	In operating modes with derrick ballast (DB/DBW)

**Note**

- The F1-assembly maximum force ($F1_{\text{max-assembly}}$) appears at $F1_{\text{is}}$ larger than 90 % of $F1_{\text{max-assembly}}$

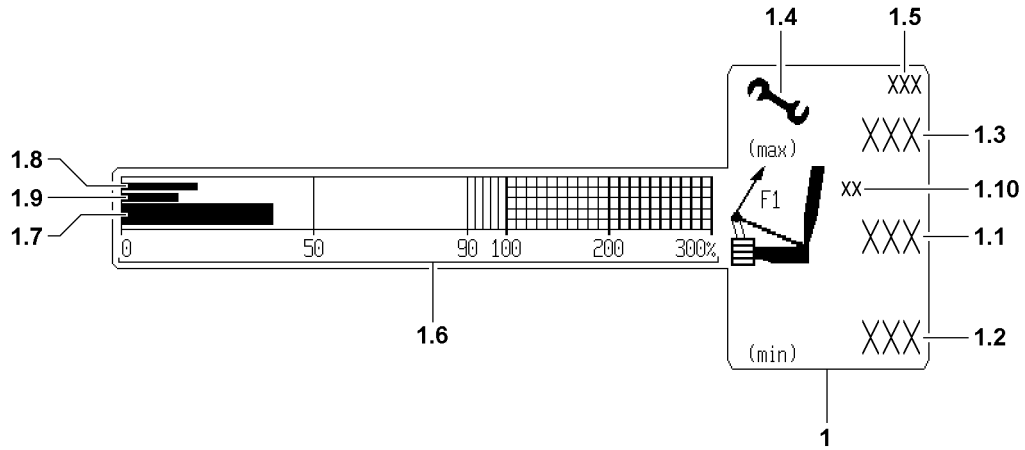

Fig.111912

Position	Icons / display values	Type of display	Is shown
1.8	<p>F1-Min-warning bar =</p> <p>Ratio $F1_{\text{min-warning value}}$ to $F1_{\text{max-operation}}$</p> <p>($F1_{\text{min-warning value}} = F1_{\text{min}} + \Delta_{F1}$)</p> <p>No display (0 percent) at:</p> <p>$F1_{\text{max-operation}} = 0$</p> <p>or</p> <p>No value</p> <p>or</p> <p>$F1_{\text{max-operation}} = \text{invalid}$</p>	Dynamic	<p>In operating modes with derrick ballast (DB/DBW)</p> <p>$\Delta_{F1} =$</p> <p>15 t for cranes with max- load smaller than 1000 t</p>
1.9	<p>F1-Min-Stop bar =</p> <p>Ratio $F1_{\text{min}}$ to $F1_{\text{max-operation}}$</p> <p>0 percent [%] for:</p> <p>$F1_{\text{max-operation}} = 0$</p> <p>or</p> <p>No value</p> <p>or</p> <p>$F1_{\text{max-operationb}} = \text{invalid}$</p>	Dynamic	In operating modes with derrick ballast (DB/DBW)
1.10	Measuring unit icon	Static	Always

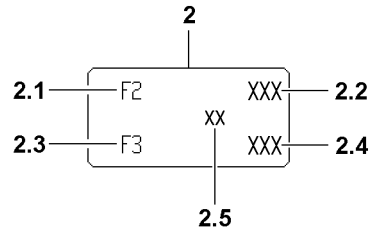

Fig.111913

9.2 Test point 2 = F2 and test point 3 = F3

Pull test brackets test point 2A and 2B are in the N/W-guying

Pull test brackets test point 3A and 3B are in the guying derrick boom / main boom on the main boom head

Position	Icons / display values	Type of display	Is shown
2	Icon for N/W-guy force and main boom guy force in derrick operation	Static	In operating modes with auxiliary boom / accessory and / or derrick boom
2.1	Icon F2 for N/W-guy force test point 2	Static	In operating modes with auxiliary boom / accessory
2.2	$F2_{\text{actual}} = F2_{\text{actual}}$	Static	In operating modes with auxiliary boom / accessory and valid F2-value
	$F2_{\text{actual}} = F2A_{\text{actual}} + F2B_{\text{actual}}$ Test point 2A = left Test point 2B = right	„???“ blinking	In operating modes with auxiliary boom / accessory and invalid F2-value
2.3	Icon F3 for main boom guy force test point 3	Static	In operating modes with derrick boom
2.4	$F3_{\text{actual}} = F3_{\text{actual}}$	Static	In operating modes with derrick boom and valid F3-value
	$F3_{\text{actual}} = F3A_{\text{actual}} + F3B_{\text{actual}}$ Test point 3A = left Test point 3B = right	„???“ blinking	In operating modes with derrick boom and invalid F3-value
2.5	Measuring unit icon	Static	Always

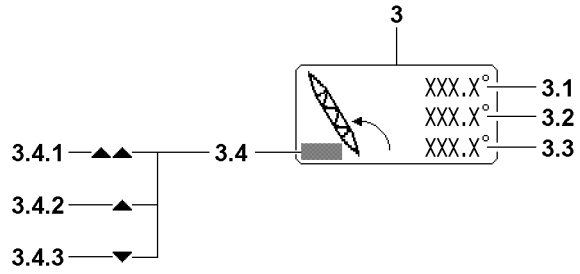

Fig.111914

LWE/LR 1600-2-008/18109-09-02/en

9.3 Derrick boom angle

Position	Icons / display values	Type of display	Is shown
3	Derrick boom angle icon	Static	In operating modes with derrick boom
3.1	Maximum derrick boom angle in crane operation = angle-D _{max} in [°]	Static	In operating modes with derrick boom and angle-D _{current} smaller or same as angle-D _{max}
		Blinking	In operating modes with derrick boom and angle-D _{current} larger than angle-D _{max}
3.2	Current derrick boom angle = angle-D _{current} in [°]	Static	In operating modes with derrick boom and valid value
		„???“ blinking	In operating modes with derrick boom and invalid value
3.3	Minimum derrick boom angle during crane operation = angle-D _{min} in [°]	Static	In operating modes with derrick boom and angle-D _{current} larger or same as angle-D _{min}
		Blinking	In operating modes with derrick boom and angle-D _{current} smaller than angle-D _{min}
3.4	Alarm functions derrick boom		Limitation / monitoring of relapse cylinders Note: As an icon appears, an error message is issued!
3.4.1	Two arrows pointing up	Static	Relapse cylinder on block (limit switch actuated) or sensor / limit switch defective
3.4.2	Arrow up	Static	In angle-D _{current} larger than angle-D _{max}
3.4.3	Arrow down	Static	In angle-D _{current} smaller than angle-D _{min}

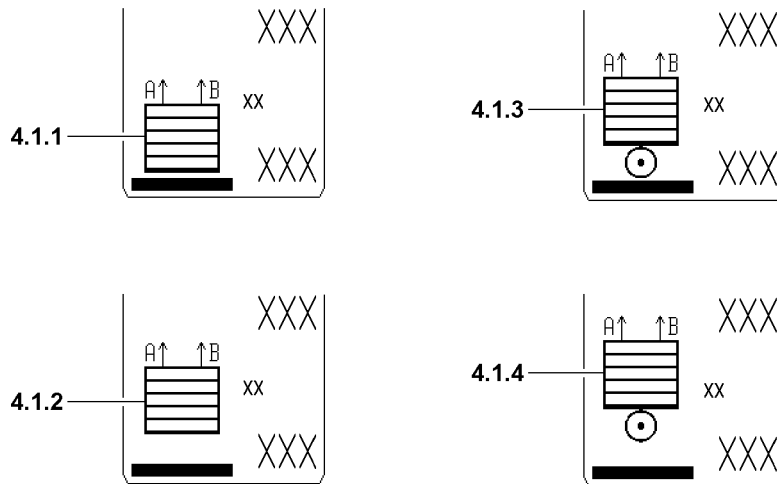
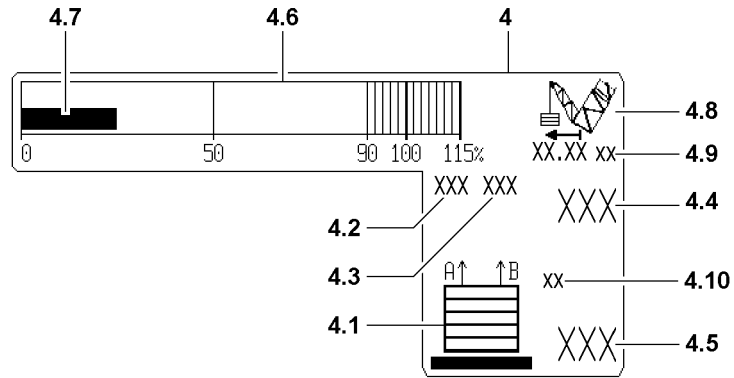

Fig.112995

9.4 Derrick ballast, weight and utilization

Test points derrick ballast guying A are:

- Test point 4A = pressure sensor ring surface left F4A
- Test point 5A = pressure sensor piston surface left F5A

Test points derrick ballast guying B are:

- Test point 4B = pressure sensor ring surface right F4B
- Test point 5B = pressure sensor piston surface right F5B

Position	Icons / display values	Type of display	Is shown
4	„Derrick ballast, weight and utilization“ icon	Static	In operating modes with derrick ballast
4.1	„Derrick ballast“ icon	Static	In operating modes with derrick ballast, depending on the type and the condition of the derrick ballast (see 4.1.1 - 4.1.4)



Note

- ▶ The view of the „derrick ballast“ 4.1 icon changes depending on if the derrick ballast is set up as a suspended ballast or as a ballast trailer!
- ▶ During crane operation observe the respective chapters for suspended ballast or ballast trailer in the Crane operating instructions!

Position	Icons / display values	Type of display	Is shown
4.1.1	„Suspended ballast on the ground“ icon	Static	Ground contact sensor reports „Suspended ballast not suspended “
4.1.2	„Suspended ballast suspended“ icon	Static	Ground contact sensor reports „Suspended ballast suspended “
4.1.3	„Ballast trailer on the ground“ icon	Static	Key button ballast trailer in position „Ballast trailer not suspended “
4.1.4	„Ballast trailer suspended“ icon	Static	Key button ballast trailer in position „Ballast trailer suspended “

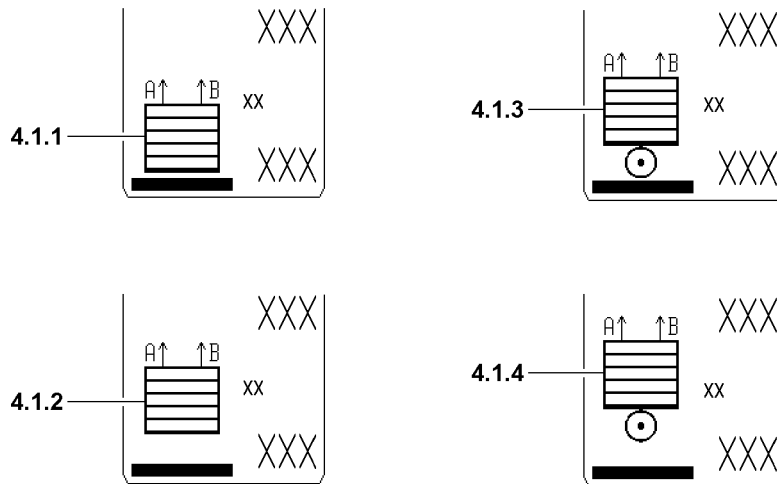
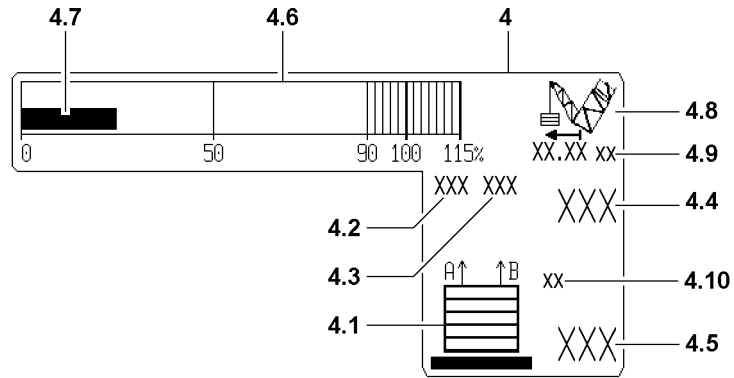

Fig.112995

Position	Icons / display values	Type of display	Is shown
4.2	Force Derrick ballast guying A (left) Test point 4A Test point 5A	Static	„Values test points“ valid
		Blinking	„Values test points“ valid and Difference between guy force A and B is larger than permissible
		„???“ Blinking	At least one „Value test point“ invalid
4.3	Force Derrick ballast guying B (left) Test point 4B Test point 5B	Static	„Values test points“ valid
		Blinking	„Values test points“ valid and Difference between guy force A and B is larger than permissible
		„???“ Blinking	At least one „Value test point“ invalid

**Note**

Failure of pressure sensor!

- ▶ If only one pressure sensor fails, for example F5A (test point 5A) invalid, then the LICCON computer system assumes F5A = F5B in the interim! An error message is issued!
- ▶ The error must be remedied immediately!

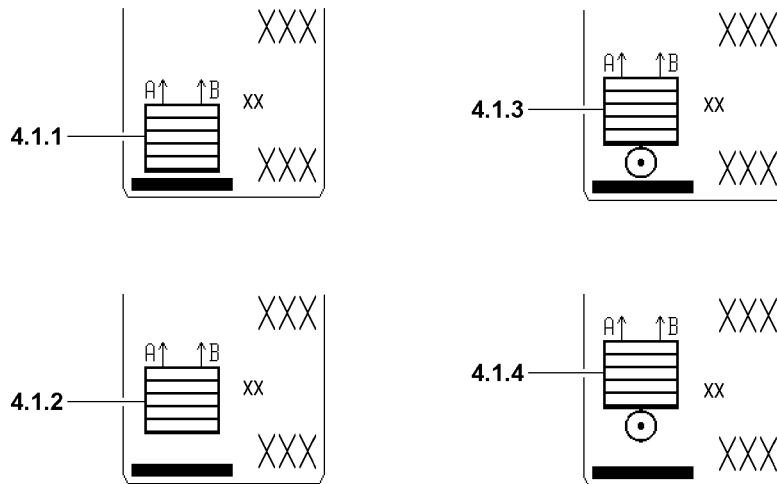
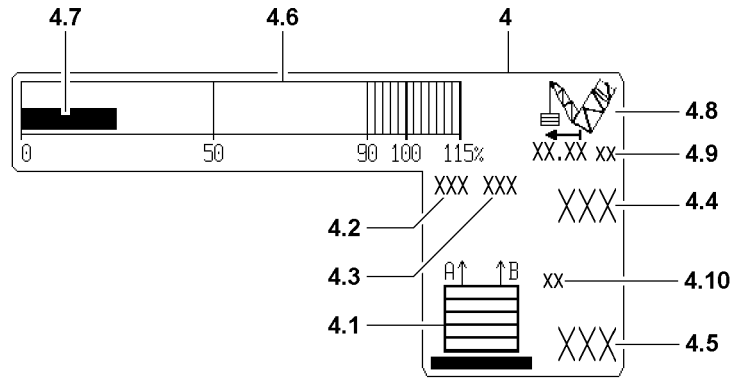

Fig.112995

Position	Icons / display values	Type of display	Is shown
4.4	Pulled derrick ballast = BA_{pulled} = vertical force components in derrick ballast guying, calculated from test points 4A, 4B, 5A and 5B Note: The sum of forces in the derrick ballast guying A and B is larger or the same as the pulled derrick ballast (BA_{pulled})!	Static	If value BA_{pulled} valid
		„???“ Blinking	If value BA_{pulled} invalid or Operating mode with BW and derrick ballast radius invalid
4.5	Placed derrick ballast = BA_{placed} Note: This value has been entered by hand and confirmed with the ENTER key! The value is saved when turning off and is valid again after turning on until it is changed with the function key „ F5 “!	Static	If value BA_{placed} permissible
		Blinking	If value BA_{placed} questionable
		„???“ blinking	If value BA_{placed} invalid

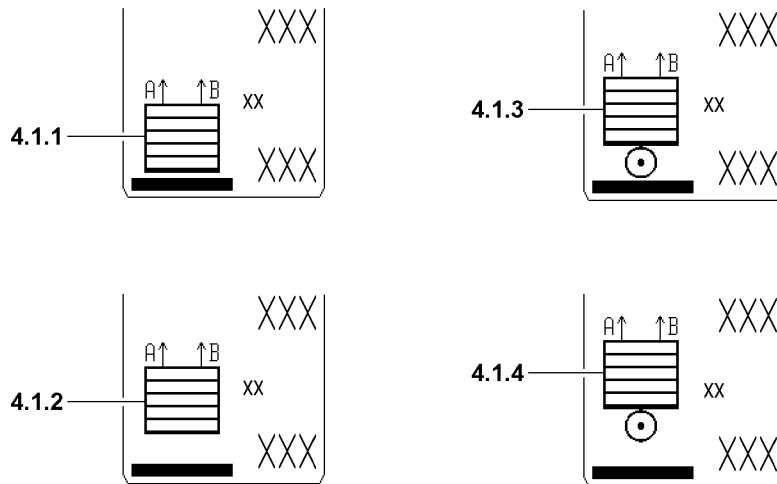
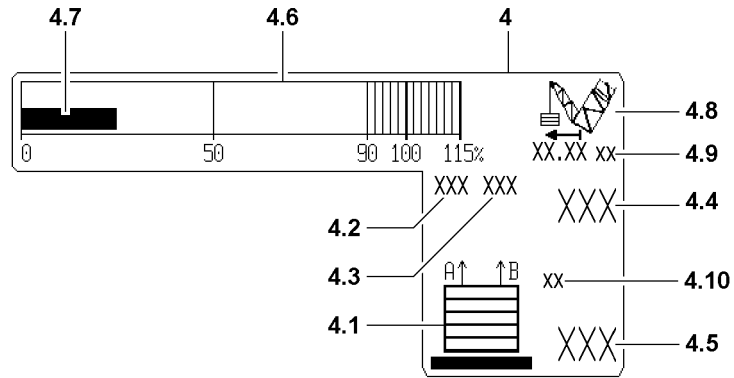

Fig.112995

Position	Icons / display values	Type of display	Is shown
4.6	Ballast utilization scale	Static	Always
4.7	Derrick ballast utilization bar = Ratio BA_{pulled} to BA_{placed} in percent Derrick ballast utilization bar is 0 at: BA_{placed} smaller than BA_{placed_min} or BA_{pulled} = invalid	Dynamic	In operating modes with derrick ballast Note: The utilization bar can show max. 115 %!
4.8	„Derrick ballast radius“ icon	Static	In operating modes with derrick ballast
4.9	Display of derrick ballast radius with measuring unit	Static	When value derrick ballast radius valid
		„???“ blinking	When value derrick ballast radius invalid
4.10	Measuring unit Derrick ballast weight	Static	Always



Fig.112317

9.5 Alarm functions

NOTICE

Triggered alarm function!

If an alarm function is triggered (for example a advance warning occurrence or LMB Stop), the cause must be determined!

- ▶ Always pay attention to triggered alarm functions!
- ▶ Alarm functions can flash over the monitor!



Note

Shut off delay LMB stop!

- ▶ A LMB stop with shut off delay remains for a certain period of time! Possible fluctuating movements of the crane can be thereby minimized!

Position	Icons / display values	Type of display	Is shown
5	„Advance warning“ icon	Blinking	If an advance warning occurs, for example: $F1_{\text{min-advance warning}}$ $F1_{\text{actual}}$ smaller than $F1_{\text{min-warning value}}$
6	„STOP“ icon	Blinking	If an LMB stop occurrence results, for example: At $F1_{\text{min-stop}}$ ($F1_{\text{is}}$ smaller than $F1_{\text{min}}$) with shut off delay 3 s or At $F1_{\text{max-operation stop}}$ ($F1$ larger or same as $F1_{\text{max-operation shut off value}}$) with shut off delay three seconds or $F1_{\text{max-assembly-stop}}$ ($F1_{\text{is}}$ larger or same as $F1_{\text{max-assembly}}$) with shut off delay three seconds Note: $F1_{\text{max-operation shut off value}} = F1_{\text{max-operation}} + F1_{\text{addition for shut off}}$

LWE/LR 1600-2-008/18109-09-02/en

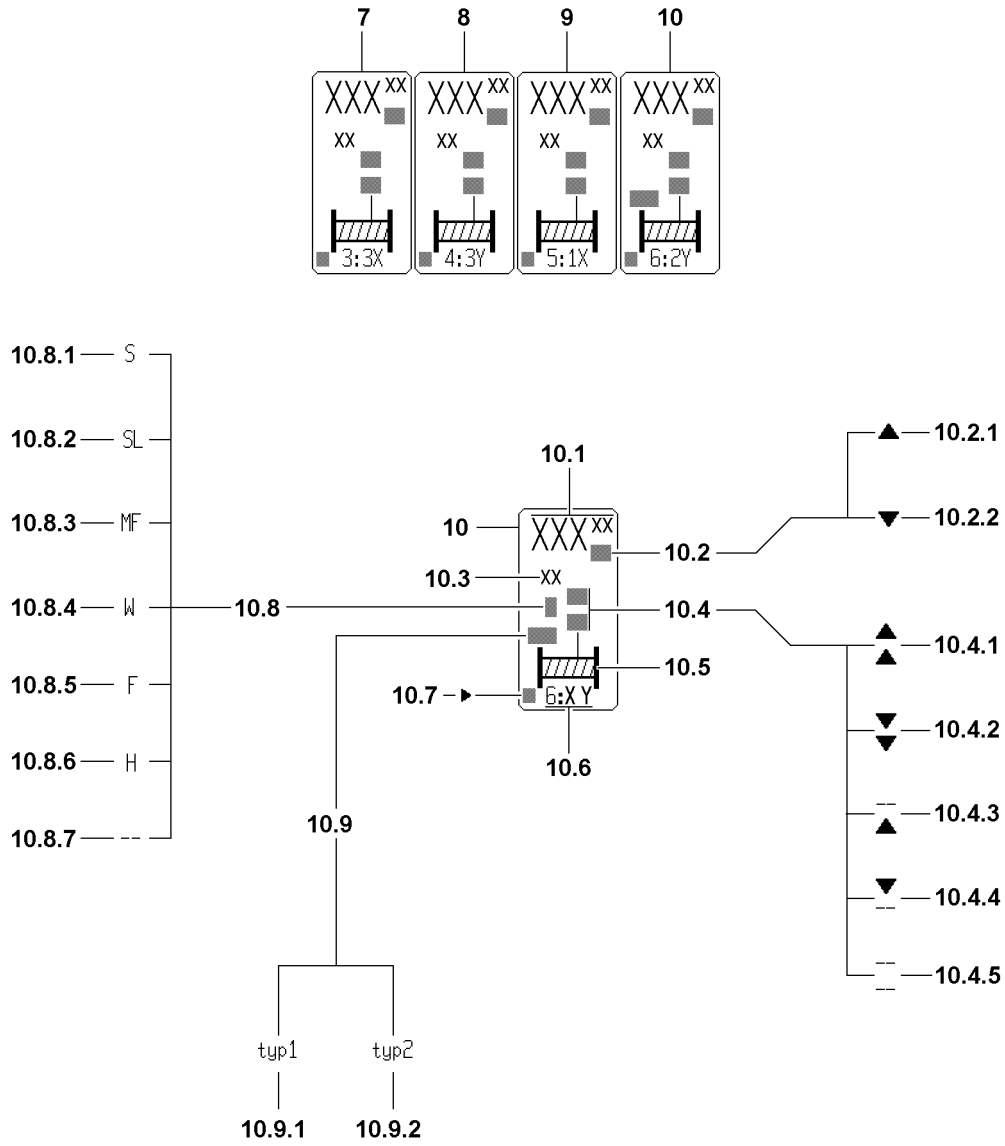

Fig.116851

9.6 Winch displays

9.6.1 Winches 3 to 6

The icons for winch 3*, winch 4, winch 5* and winch 6* are only shown on monitor 1, if the crane is equipped with these winches and the winches are activated.

The display of winches is the same as the display of winch 1 and 2 on LICCON monitor 0.



Note

- ▶ If one of the winches is used as hoist winch according to the set operating mode, then the **completed hook path** is shown in the winch icon. The value, which was tared by the corresponding function key is still shown unchanged, even after turning off and on or after an operating mode change!
- ▶ If one of the winches is used as a control winch, then the current **rope length on the winch drum** is shown, not the hook path. Then taring is possible, but after turning on and off again or after an operating mode change, the original value „Rope length on the rope drum“ is shown again!

Position	Icons / display values	Type of display	Is shown
7	Winch display winch 3*	Static	For installed and activated winch 3*
8	Winch display winch 4	Static	For installed and activated winch 4
9	Winch display winch 5*	Static	For installed and activated winch 5*
10	Winch display winch 6*	Static	For installed and activated winch 6*



Note

- ▶ „Winch 3*“, „winch 4“ and „winch 5*“ are always calculated as control winches!
- ▶ „Winch 6*“ is calculated as hoist winch, if the reeving cannot be derived from the „reeving of the boom“ and the „reeving of the boom nose“. In these cases, n = 1 is used as reeving!
- ▶ For winch 4 (intake gear), the rope length is valid equally for the left and the right half of the rope drum!

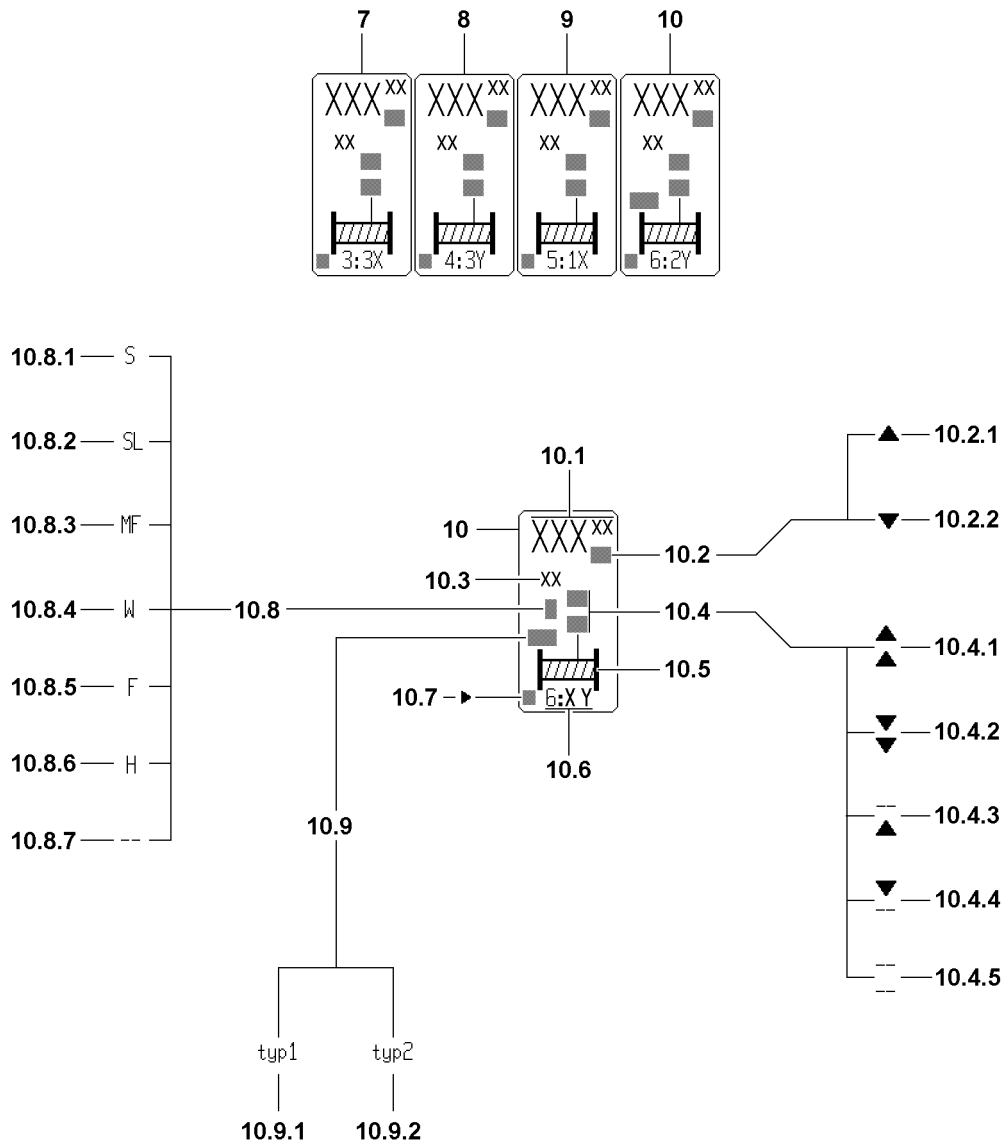

Fig.116851

9.6.2 Winch display

The winch 3 to 6 icons have the same meaning, which are explained for the „Winch 6“ **10** icon.



Note

- ▶ If one of the winches is used as hoist winch according to the set operating mode (for example „winch 3“ at derrick operation), then the **hook path** is shown in the winch icon. The value, which was tared by the corresponding function key is still shown unchanged, even after turning off and on or after an operating mode change!
- ▶ If one of the winches is used as a control winch, then **the current rope length on the winch drum** is shown, not the path of the hook block. Then taring is possible, but after turning on and off again or after an operating mode change, the original value „Rope length on the rope drum“ is shown again!



Note

Display area winch displays!

- ▶ The „Completed path“ display **1.1** has only three positions before the decimal point, any positions before that are cut off! The crane operator must evaluate for himself if, for example 200 m rope are spooled up on a winch or 1200 m. **The display in both cases would be identical with 200 m !**
- ▶ The hook path calculation only works accurately if the load is suspended freely and is not luffed during the lifting procedure! Not taken into account are flexation and rope expansion!
- ▶ The length display (hook path display) is only accurate and the layer jump is only taken into account correctly if the winch has been calibrated and no interruptions of the CPU power supply have occurred (cold start)!



Note

Error in winch path measurement!

- ▶ In case of an error in the winch path measurement, blinking „???“ appear as display value **10.1!**
- ▶ If an error occurs and an error message is issued, see Diagnostics manual!

10 „Winch 6“ icon

10.1 Completed hook path

- In [m] or [ft]
From a zero point to be determined

• **Note:**

Is statically shown when the winch is calculated as **hoist winch** and a manually entered reeving must be assigned to this winch!

or

10.1 Rope length of the winch drum

- In [m] or [ft]

• **Note:**

Is statically shown when the winch is calculated as **control winch!**

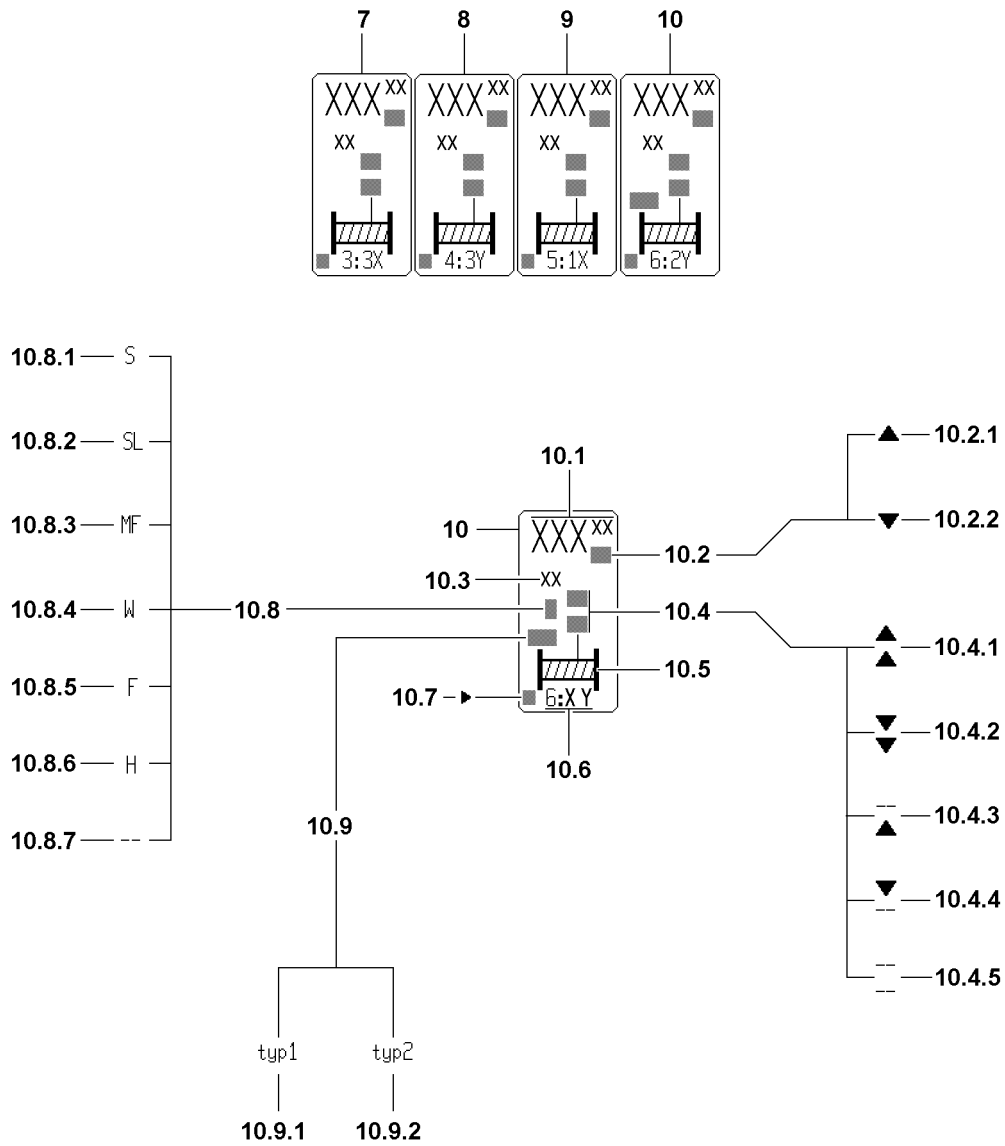

Fig.116851

10.2 Direction of hook movement

The arrows on the length value show the direction of the hook movement in relation to the zero point:

- Arrow up **10.2.1**: Hook has moved upward from the zero point.
- Arrow up **10.2.2**: Hook has moved down from the zero point.

10.3 Length unit for hook path display

- In [m] or [ft]

10.4 Winch status display

- There are five winch status icons (all blinking):

10.4.1 Spool out**10.4.2** Spool up**10.4.3** Spooled out

- Spooling out is blocked

10.4.4 Spooled up

- Spooling up is blocked

10.4.5 Winch is deactivated

- Spooling up and spooling out are blocked (via Control parameter program).

• **Note:**

If no winch status icon appears, the activated winch is inactive and is neither spooled up nor out!

10.5 Winch icon

- (with rope end for winch status icon)

10.6 Winch number with master switch number and master switch operating direction

- Example: 6:2Y

First digit: Winch number

Second digit: Master switch number

Letter: Master switch operating direction

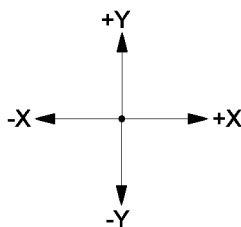

Fig.199930

10.7 Vibration sensor

- If the vibration sensor for a winch is added on the master switch, then an arrow appears in this winch icon for the added vibration sensor.

• **Note:**

The vibration sensor is added for the first actuated crane function!

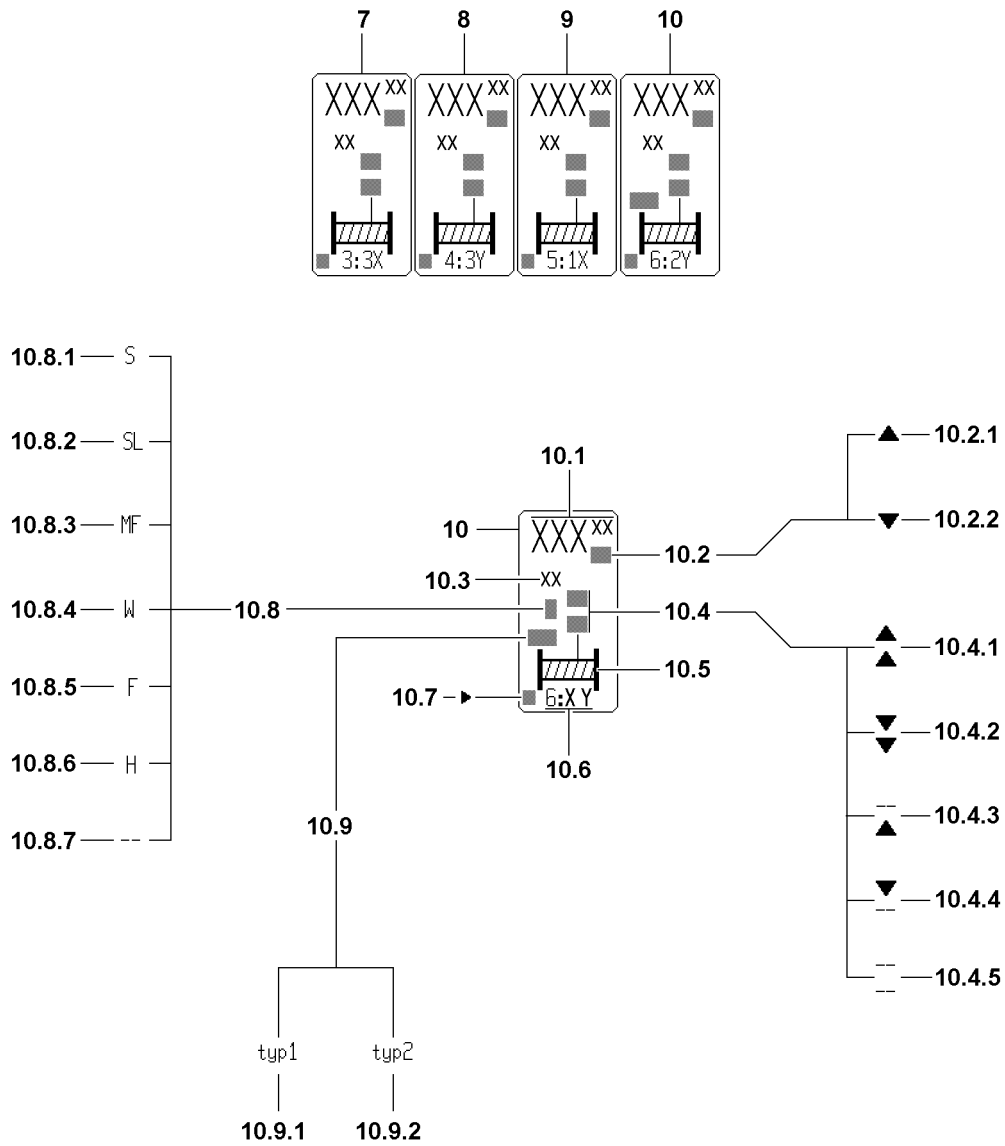

Fig.116851

10.8 Reeved in boom

- To check the settings for „winch pulley head assignment“ of various hoist winches, the respective boom symbol, on which the winch must be reeved according to the winch pulley head assignment is shown in the symbol element „winch display“

Note:

The reeved boom **10.8** icon is shown only in the winch icon of winch 1, winch 2 and winch 6.

10.8.1 S

- Winch is reeved on the pulley head of the S-main boom

10.8.2 SL

- Winch is reeved on the pulley head of the SL-main boom

10.8.3 MF

- Winch is reeved on the pulley head of the center pulley of the luffing jib

10.8.4 W

- Winch is reeved on the pulley head of the luffing jib

10.8.5 F

- Winch is reeved on the pulley head of the F-lattice jib

10.8.6 H

- Winch is reeved on the pulley head of the boom nose

10.8.7 – –

- Winch is not reeved on **any** pulley head

**Note**

- The winch type* (type1 or type2) is only shown in the winch icon of winch 6!

10.9 Winch type*

- The crane control recognizes the respective winch type when winch 6 is installed.

10.9.1 Type1

- Winch 6 with rope diameter 28 mm

10.9.2 Type2

- Winch 6 with rope diameter 25 mm

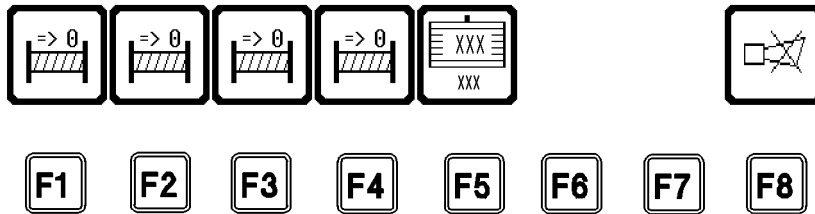

Fig.113270

9.7 Function key line

Position	Function / function key line	Type of display	Is shown
F1	Tare length display of winch 3* Note: Tare = length display is set to 0!	Static	If winch display for winch 3* is shown
F2	Tare the length display of winch 4 Note: Tare = length display is set to 0!	Static	If winch display for winch 4 is shown
F3	Tare length display of winch 5* Note: Tare = length display is set to 0!	Static	If winch display for winch 5* is shown
F4	Tare length display of winch 6* Note: Tare = length display is set to 0!	Static	If winch display for winch 6* is shown

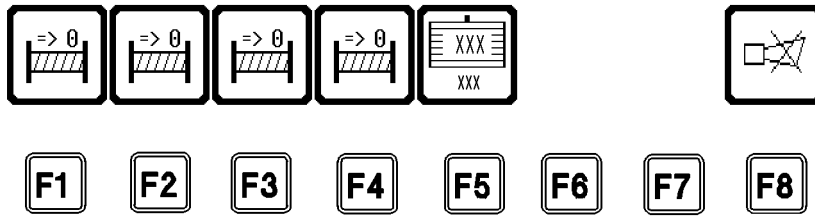

Fig.113270

Position	Function / function key line	Type of display	Is shown
F5	<p>Ballasting key*</p> <p>When pressing function key F5, the thick icon frame changes to a thin icon frame. A blinking cursor appears in the ballast input field. The value for the placed ballast can only be entered in the displayed weight unit [t] or [kips] via the keypad on monitor 1.</p> <p>The ballast input can be ended by:</p> <ul style="list-style-type: none"> - Pressing the ENTER key C <p>= Take over value The entered value appears now as value for the placed ballast (BA_{placed}) in the ballast icon</p> <p>or</p> <ul style="list-style-type: none"> - Pressing „F5“ key <p>= abort ballast input. The change is discarded. The old value of BA_{placed} remains in the ballast icon.</p>	Static	In operating modes with derrick ballast



Note

- ▶ When entering the ballast, make sure to observe the respective section regarding the derrick ballast, see Crane operating instructions, chapter 4.03!

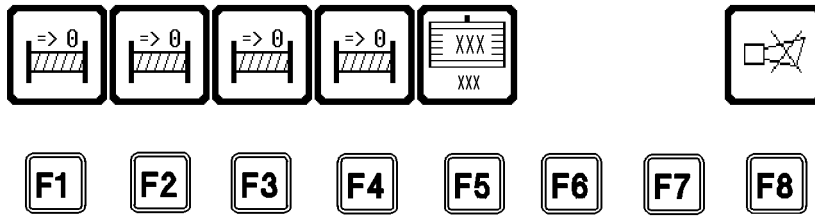

Fig.113270

Position	Function / function key line	Type of display	Is shown
F5*	Ballast input value (BA _{edit})* = entered ballast value in function key icon of „F5“	Static	For valid ballast input value
		„???“ blinking	For invalid ballast input value
F6	Not assigned		
F7	Not assigned		
F8	„Horn“ icon - Turn off the acoustic signal „Horn“ on monitor 1 by pressing the „F8“ key.	Blinking	If the acoustic signal „Horn“ sounds on monitor 1. See paragraph „Acoustic warning on monitor 1“.

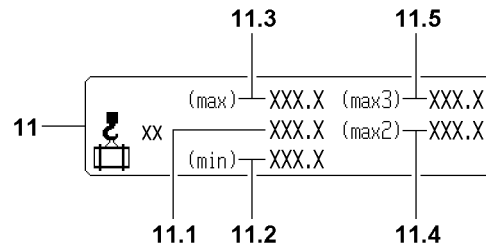

Fig.112946

9.8 Load min / max

The „load capacity min / max“ **11** icon appears on monitor 1 only if an operating mode with derrick ballast has been selected.

- 11** Load min / max
 - In [t] or [kips])

11.1 Current load on the boom

- Actual load display = **Load**, which currently hangs on the selected boom.
- Display of the calculated total load including the weights of the carrying equipment, the lifting equipment (hook block) and / or the fastening equipment, but **without** the nominal weight of the hoist rope

- **Note:**

The „current load on the boom“ **11.1 cannot** „be tared“ and set to zero on monitor 1. If the „current load on the boom“ **2.1** was not tared („zeroed out“) on monitor 0, then the following applies:

The „current load on the boom“ **11.1** of monitor 1 and the „current load on the boom“ **2.1** of monitor 0 are identical. The displayed values must match.

11.2 Min-load

- Is the minimum load which the crane must pull in the current operating condition with the currently pulled derrick ballast, so that $F1_{\text{actual}}$ is larger than $F1_{\text{min}}$ and no $F1_{\text{min}}$ -shut off occurs as a result.
If this „min-load“ is **not** reached, then the $F1_{\text{min}}$ -shut off occurs.
- The „min-load“ is an approximate calculated value, which can still change slightly when lifting / setting down the load.
- When the „min-load“ is larger then the weight of the hook and the fastening equipment, then this means that the load can only be set down if the pulled derrick ballast is also reduced. This means a suspended derrick ballast must be set down on the ground, otherwise the $F1_{\text{min}}$ -shut off occurs.

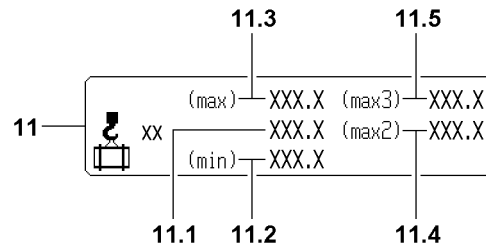

Fig.112946

11.3 Max-load

- Is the maximum load („maximum load according to load chart and reeving on the boom“ **1.1**), which the crane can lift in the current operating condition with the currently **pulled** derrick ballast.

Note:

Die „max-load“ on monitor 1 and the „Maximum load“ on monitor 0 are identical. The displayed values must always match.

11.4 Max2-load

- Is the maximum load, which the crane can lift in the current operating condition, when the **placed** derrick ballast is fully **pulled**.

11.5 Max3-load

- Is the maximum load, which the crane can lift in the current operating condition, when the **optimum** derrick ballast is placed and fully **pulled**.

Note:

The optimum derrick ballast is reached when a further increase of the derrick ballast results in **no higher maximum load**.

**Note**

The following display values of the „min / max load“ **11** icon correspond:

- ▶ The „current load on the boom“ **11.1** and the actual force „F1_{is}“ **1.1**.
- ▶ The „min-load“ **11.2** and the minimum force „F1_{min}“ **1.2**.
- ▶ The „max-load“ **11.3** and the maximum operating force „F1_{max-operation}“ **1.3**.

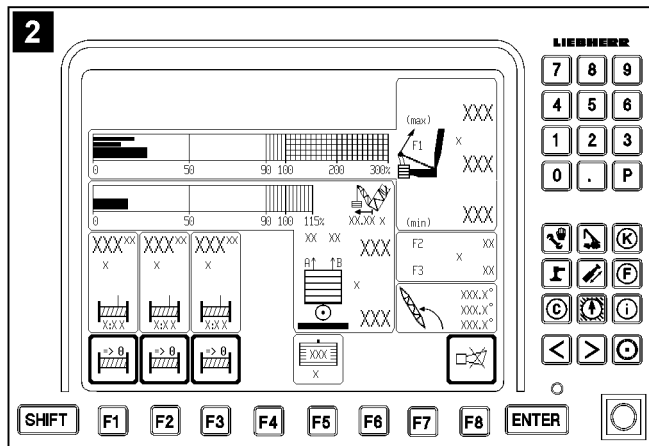
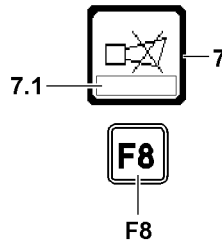
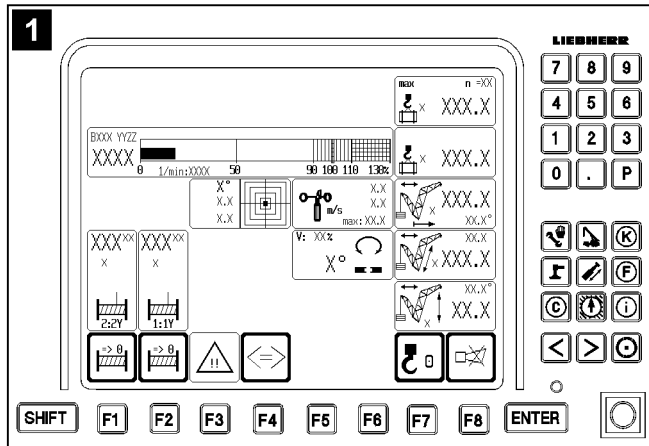

Fig.112359

9.9 Acoustic warning on monitor 1

Acoustic warnings on monitor 1 (illustration 2) are indicated by the warning sound „Horn“.

Error messages are only shown in the Horn icon 7 of LICCON monitor 0 (illustration 1).

The warning sound „Horn“ is divided into two categories:

- „Horn“ is a beeping sound of a duration of approximately 0.5 seconds, which is repeated in a second cycle.
- „Short horn“ is a beeping sound of a duration of approximately 0.1 seconds, which is repeated in a second cycle.

7 Horn icon

- When the Horn icon 7 is shown in the LICCON monitor, any acoustic signals which will occur can be shut off by the LICCON monitor 1 by pressing the function key **F8**.

9.9.1 Acoustic signal „Horn“

For some operational errors found on the CPU 1, which can lead to a shut off of a movement, it is important to check the operating screen on monitor 1 and monitor 0. These errors are reported by the acoustic signal „Horn“ on monitor 1 and additionally as visual display of the error message 7.1 on monitor 0.

Operational errors are:

- Exceeding of test point 1 - Assembly maximum threshold
- Exceeding of test point 1 - Operation -Max- shut off threshold
- Exceeding of test point 1 - Minimum threshold
- Exceeding of maximum derrick boom angle
- Falling below minimum derrick boom angle

Operational errors with error messages (LICCON-Error-Code LEC) are:

- Derrick ballast input error.
- Derrick ballast guy force: Difference between right (A) and left (B) too large.



Note

- ▶ The sensor monitored by CPU1 (pull test brackets, pressure sensors, angle sensors) are shown in case of an error by an error message on LICCON monitor 0!
- ▶ There is **no** acoustic signal „Horn“ on monitor 1!

9.9.2 Acoustic signal „Short horn“

Sounds in addition to the visual display of error messages without an error number and which do not lead directly to crane movement shut off by the LICCON overload protection.

Monitored error messages are:

- Advance warning threshold of test point 1 - minimum force has been reached.

9.9.3 Priority acoustic signal

- The „Horn“ alarm has higher priority than the „Short horn“ alarm, i.e. „Horn“ takes preference over „Short horn“.
- The „Horn“, as well as the „Short horn“ immediately become active again if an error recurs!

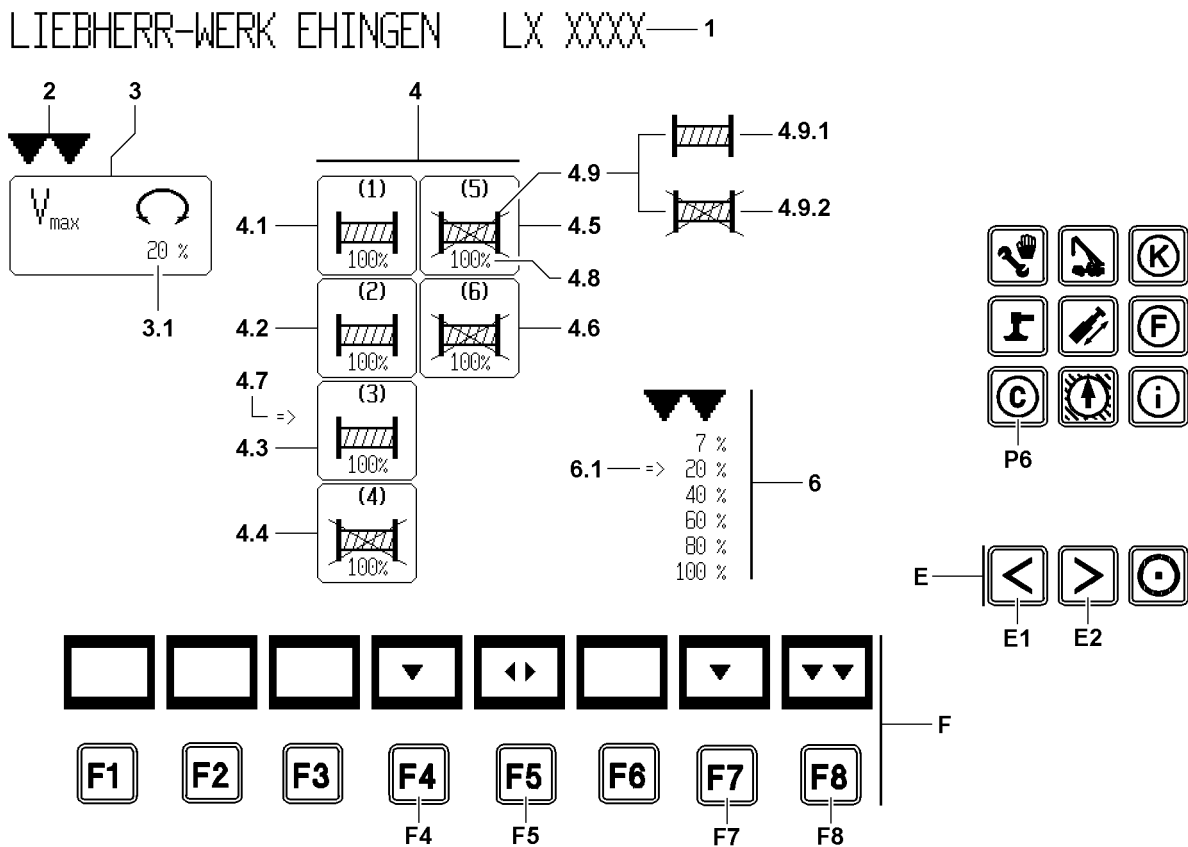
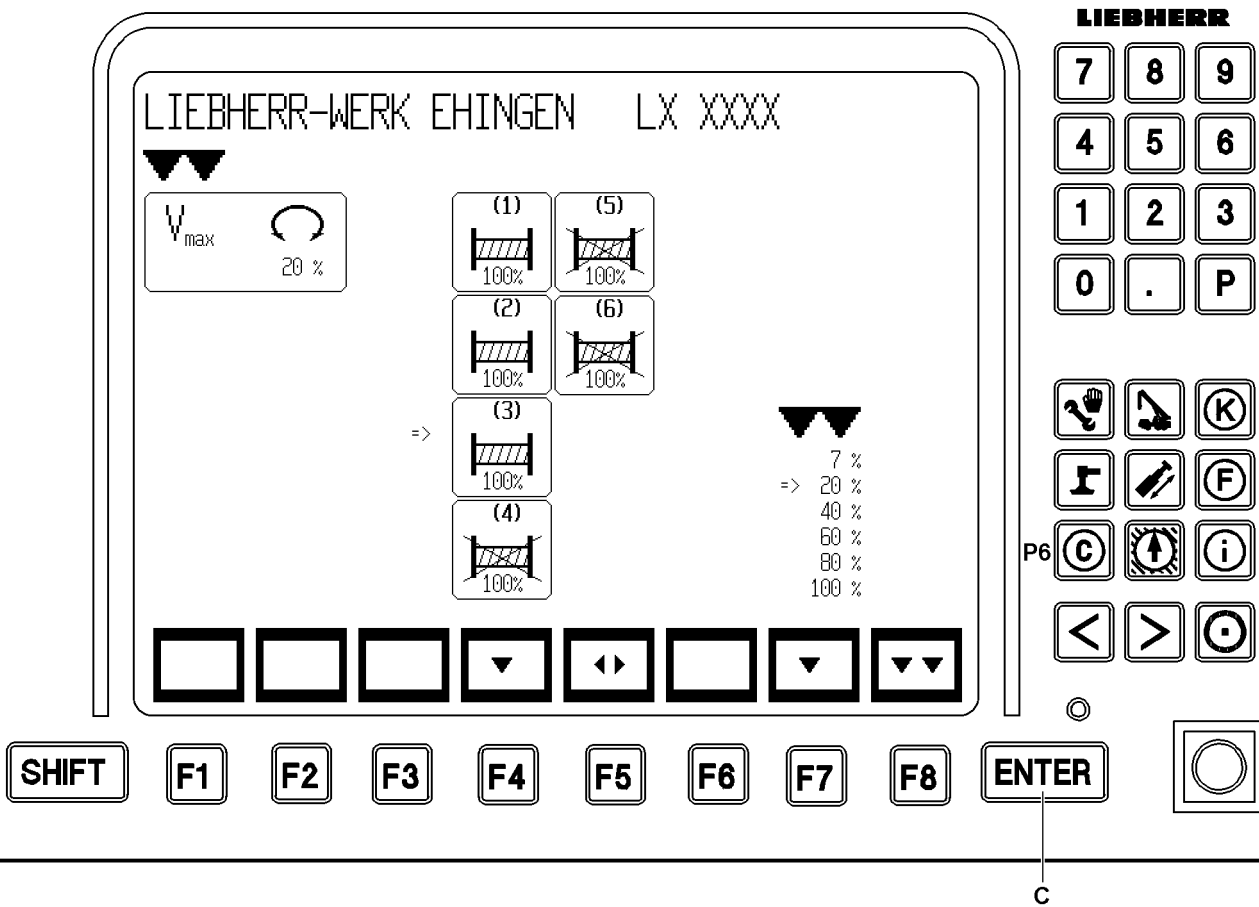

Fig.112947

LWE/LR 1600-2-008/18109-09-02/en

10 The Control parameter program

The Control parameter program offers the following possibilities:

- Preselection of maximum slewing speed of slewing gear.
- Preselection of maximum rotation speed of individual winches.
- Activation / deactivation of individual winches.

During the Control parameter program, the exceedance of shut off limits of the LICCON overload protection may not be activated. Otherwise the system switches back immediately into the Crane operation program.



DANGER

Danger of accident!

- ▶ **Never** change the speeds or the activation / deactivation of the winches while actuating a crane movement!
-

10.1 Starting the program

- ▶ Press the program key **P6**.

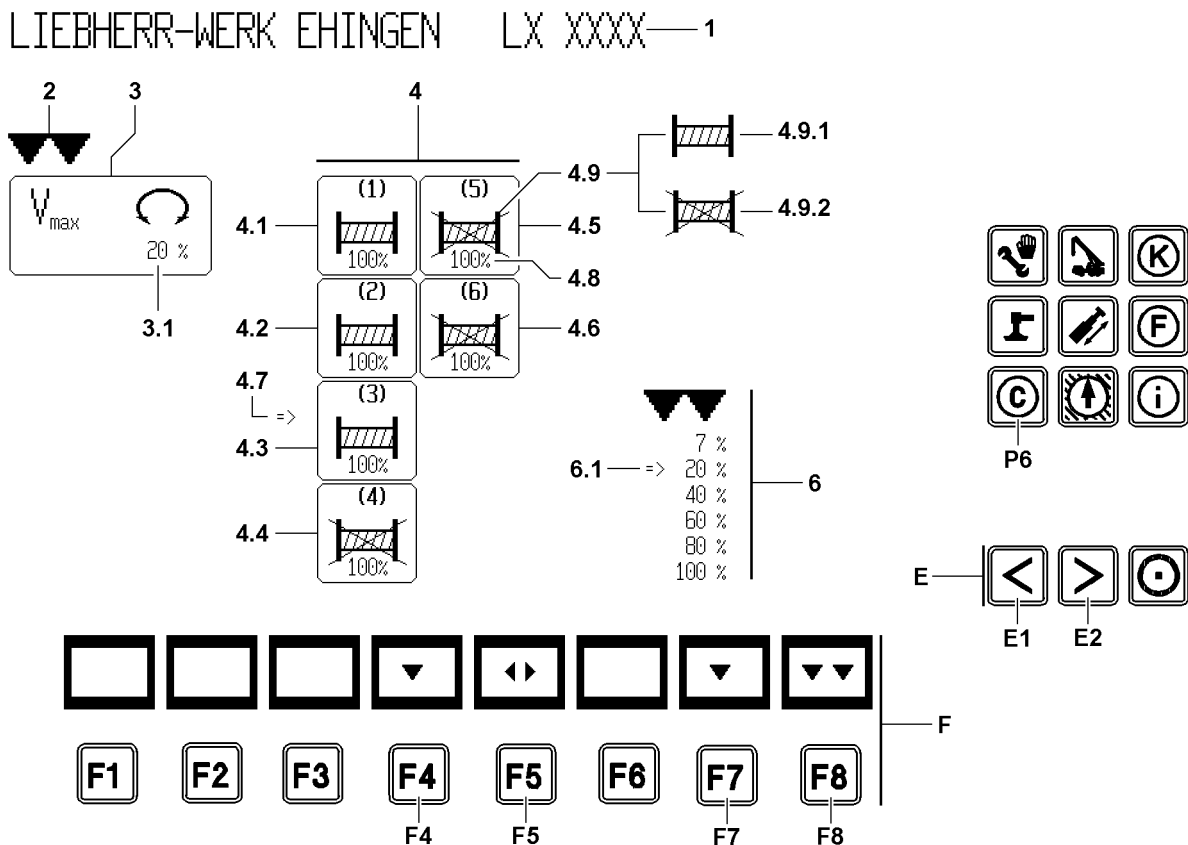
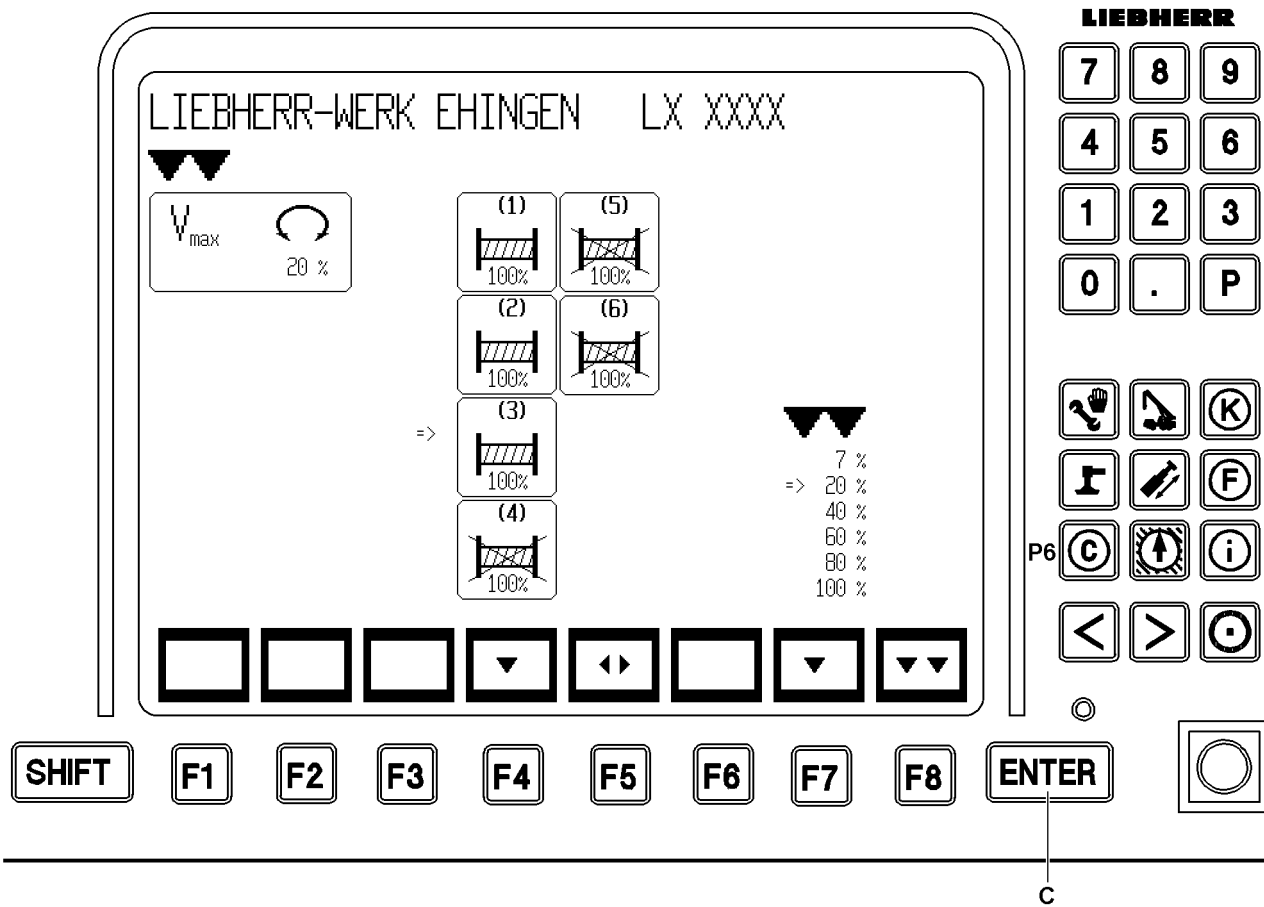

Fig.112947

LWE/LR 1600-2-008/18109-09-02/en

10.2 User interface

- 1 Crane type
- 2 Selector „Icon selection“
 - Shown via double arrow down
 - Select icon
- 3 „Slewing gear“ icon
- 3.1 „Maximum rotation speed“
 - V_{max} in percent [%]
- 4 „Winches“ icon group



Note

- The setting possibilities are the same for all winches and are explained on the Winch 5* icon **4.5!**

- 4.1 Winch 1
- 4.2 Winch 2*
- 4.3 Winch 3*
- 4.4 Winch 4
- 4.5 Winch 5*
- 4.6 Winch 6*
- 4.7 Winch selector
 - Shown via arrow to right
 - Select the winch, for which the „properties“ are to be changed
- 4.8 Winch speed
 - In percent [%]
 - Current for the selected speed for the respective winch
- 4.9 Winch icon
 - 4.9.1 Winch activated
 - 4.9.2 Winch deactivated
- 6 Value field with selector
 - The percentage values describe the speed with maximum deflection of the manual control lever, always in relation to the maximum achievable speed of the drive, with 100 % preselected speed. Six stages may be preselected.
- 6.1 Speed selector
 - Arrow to the right
 - Select percentage value(s) for speed stages
- F Function key line
 - F4 Function key
 - Select winch
 - F5 Function key
 - Activate / deactivate selected winch(es)
 - F7 Function key
 - Select percentage value of corresponding speed in value field
 - F8 Function key
 - Return to the crane operation program and take over parameter
- C Input key ENTER
 - Take over the selected speed setting for the preset functions
- E Special function keys
 - E1 Special function key
 - Move the selector **2** for selecting icons to the left
 - E2 Special function key
 - Move the selector **2** for selecting icons to the right

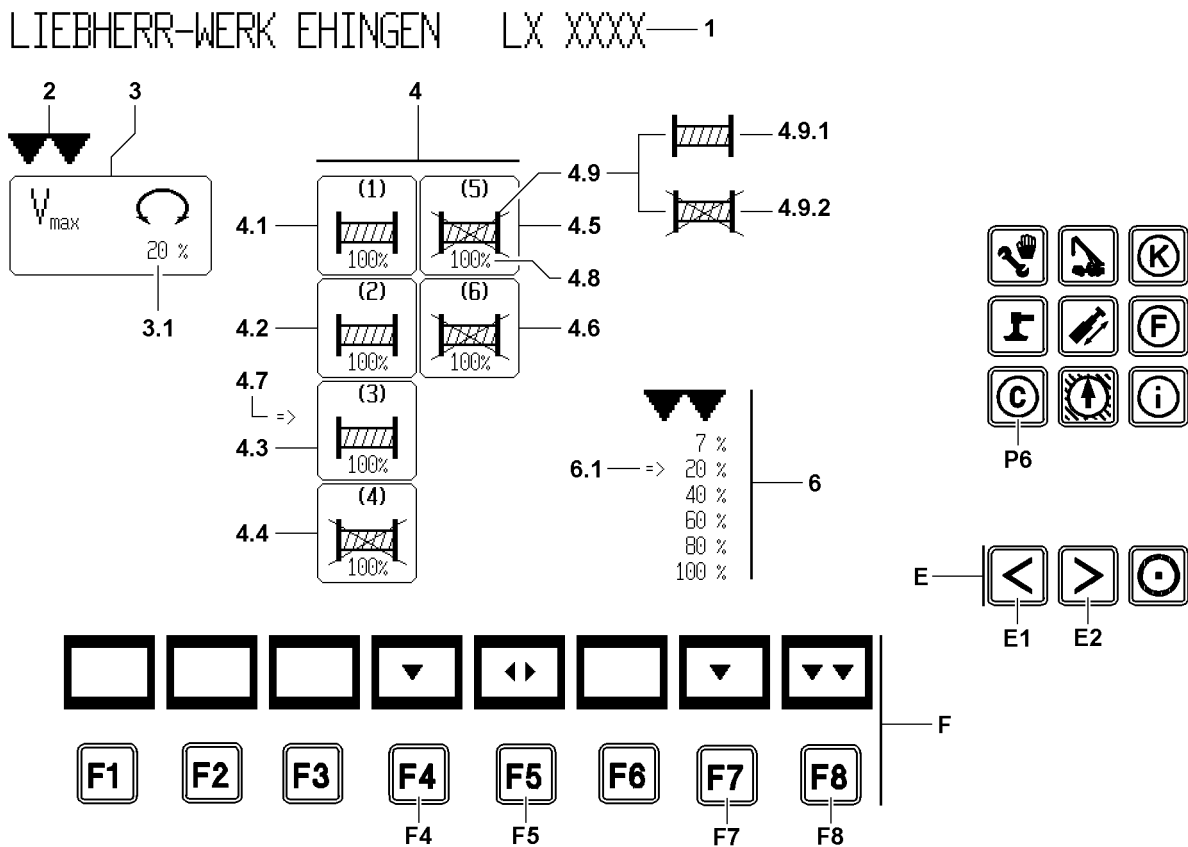
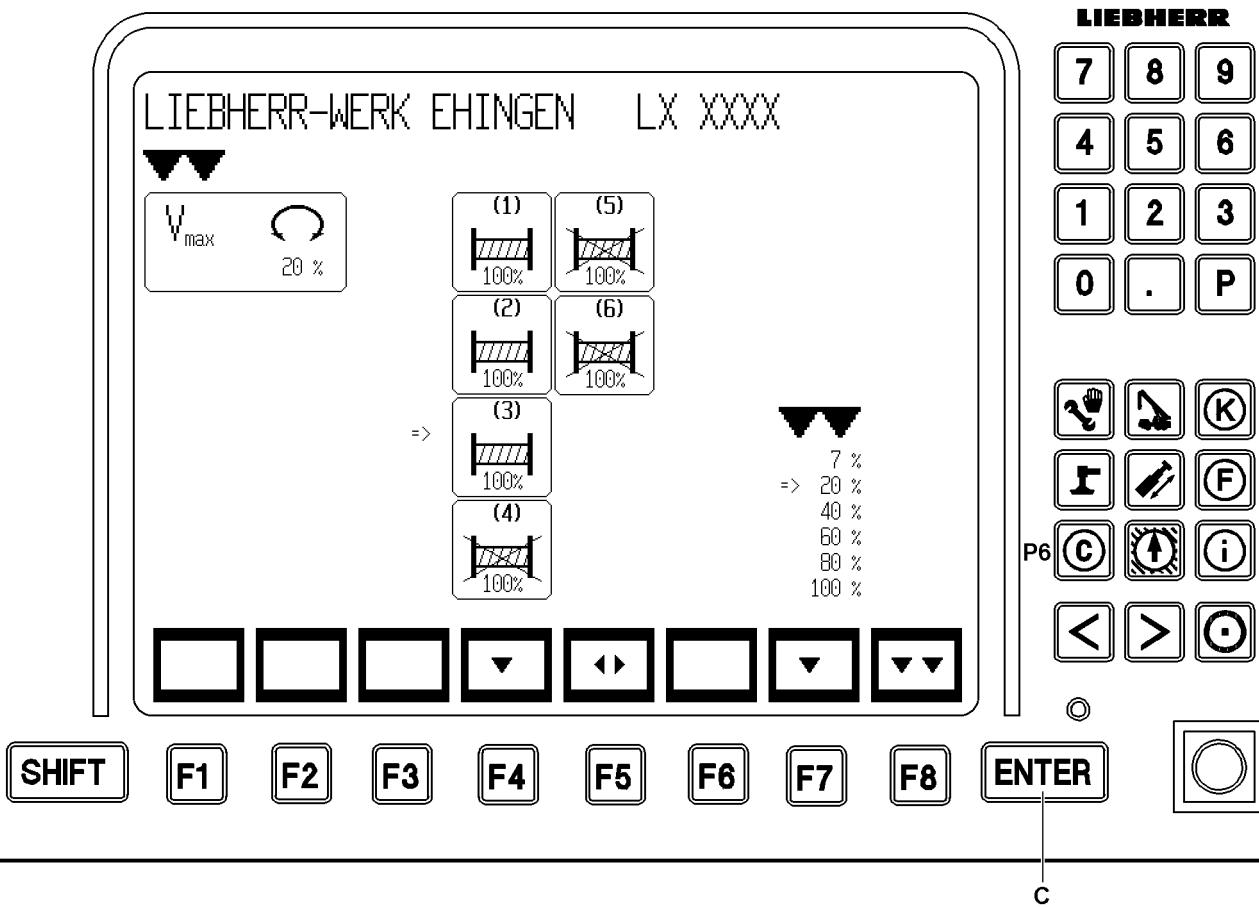

Fig.112947

LWE/LR 1600-2-008/18109-09-02/en

10.3 Changing the maximum rotation speed of slewing gear



DANGER

Danger of accident!

- ▶ During crane operation with load, always adhere to the maximum rotation speeds depending on boom length and operating modes (according to load charts)!
- ▶ The longer and heavier the boom is and the greater the load, the smaller the set „Maximum rotation speed“ must be!
- ▶ **Never** deflect the master switch for the slewing gear to the stop at maximum load!

- ▶ Use the special function key **E1** or special function key **E2** to select the „slewing gear“ icon **3**.

Result:

- Selector (double arrow down) **2** appears above the „slewing gear“ icon **3**.

- ▶ Select the maximum rotation speed in percent with function key **F7**.

Result:

- Selector (arrow to right) **6.1** shows the selected percentage value.

- ▶ Use the ENTER key **C** to confirm the selected „Maximum rotation speed“.

Result:

- The value of the „maximum rotation speed“ is shown in the icon and taken over into the control.

10.4 Winches

10.4.1 Changing maximum winch speed

- ▶ Using the special function key **E1** or special function key **E2**, select the icon group „Winches“ **4**.

Result:

- Selector (double arrow down) **2** appears above the icon group „Winches“.

- ▶ With the function key **F4**, select the icon for „winch 1“, **or** „winch 2“, **or** „winch 3“*, **or** „winch 4“, **or** „winch 5“* **or** „winch 6“*.

Result:

- Selector (arrow to right) **4.7** shows the selected winch.

- ▶ Select the „maximum winch speed“ in percent with function key **F7**.

Result:

- Selector (arrow to right) **6.1** shows the selected percentage value.

- ▶ Use the ENTER key **C** to confirm the selected „maximum winch speed“.

Result:

- The value of the „maximum winch speed“ is shown in the selected winch icon and taken over into the control.

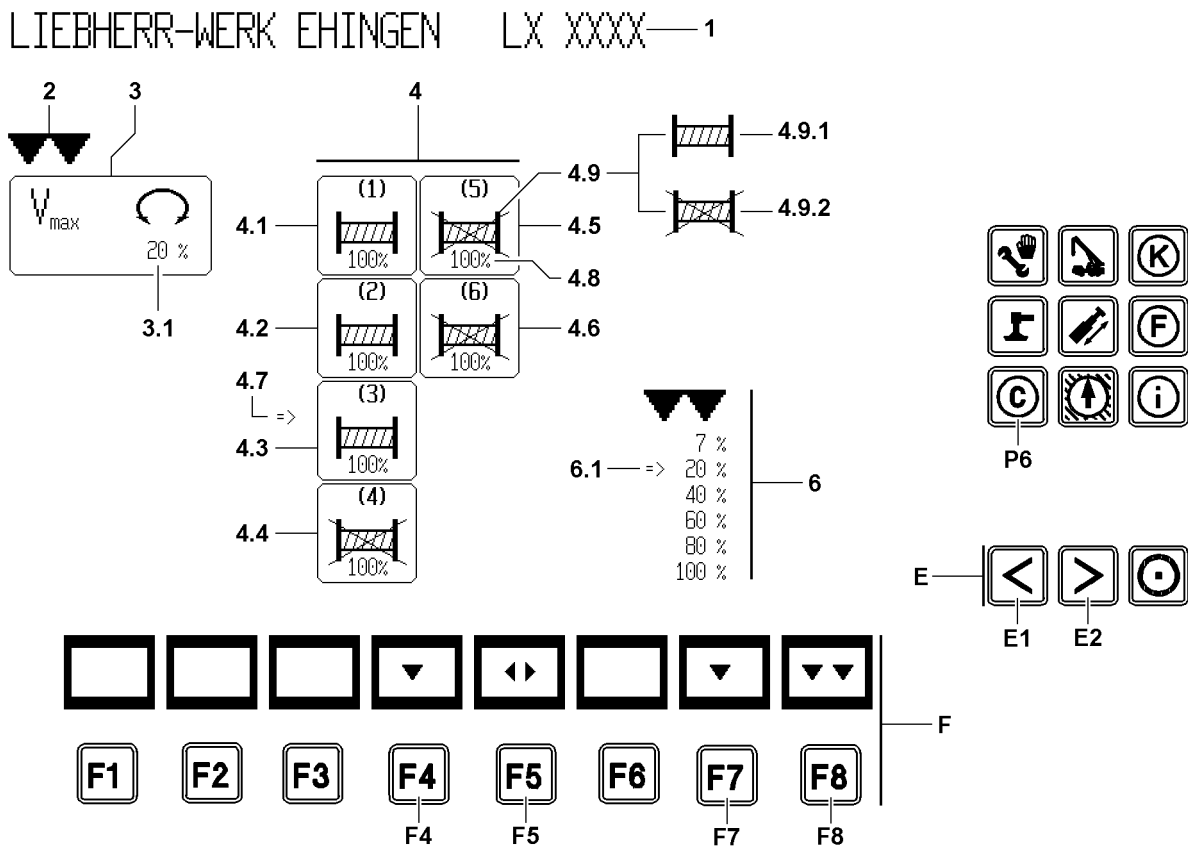
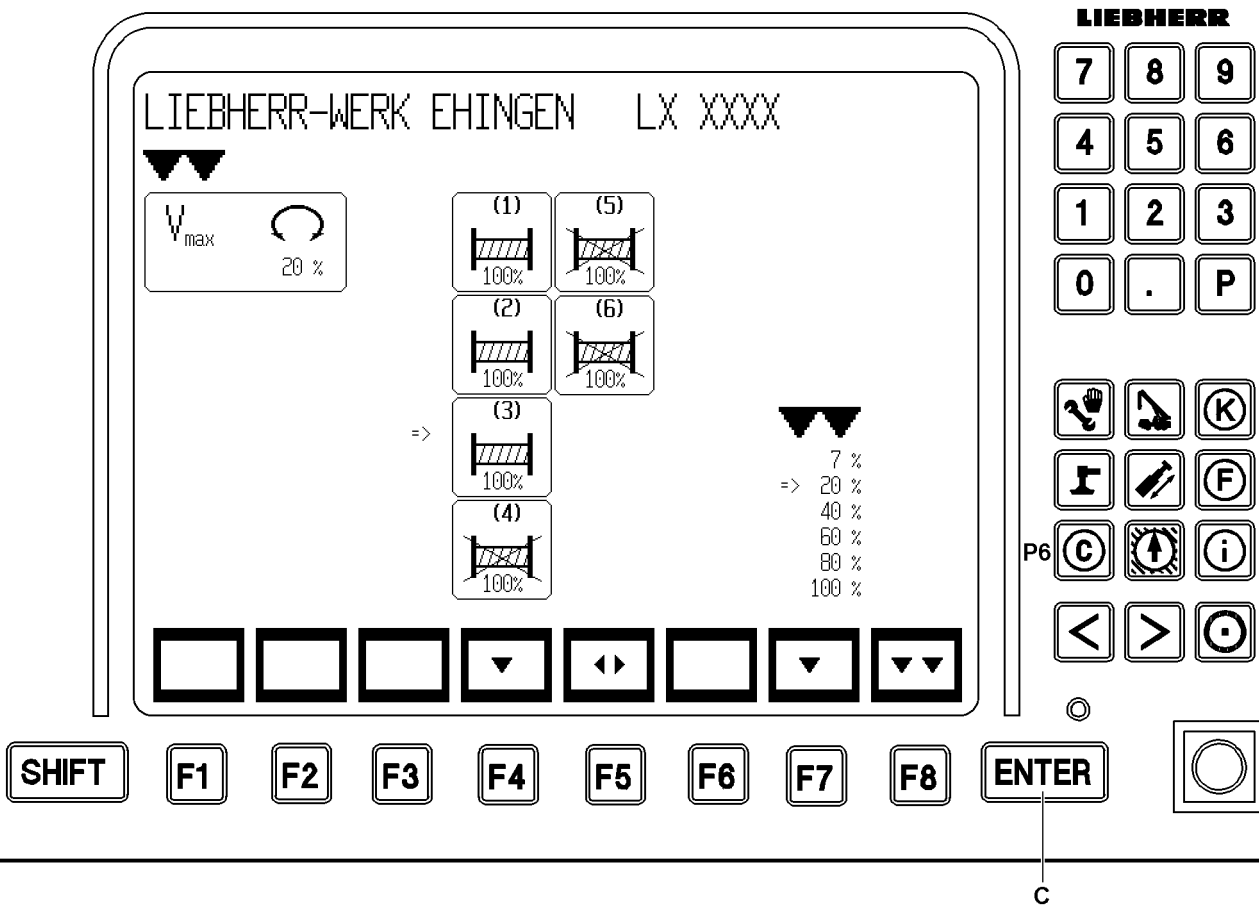

Fig.112947

LWE/LR 1600-2-008/18109-09-02/en

10.4.2 Activating / deactivating individual winches

In order to prevent unintentional activation of a winch that is currently not required, deactivate individual winches.

- ▶ Using the special function key **E1** or special function key **E2**, select the icon group „Winches“ **4**.

Result:

- Selector (double arrow down) **2** appears above the icon group „Winches“ **4**.

- ▶ With function key **F4**, select the icon for „Winch 1“ or „Winch 2“* or „Winch 3“* or „Winch 4“ or „Winch 5“* or „Winch 6“*.

Result:

- Selector (arrow to right) **4.7** shows the selected winch.

- ▶ Using the function key **F5**, activate or deactivate the selected winch.

Result:

- The winch icon in the icon changes the appearance.

Winch icon not crossed out = winch activated **4.9.1**.

Winch icon crossed out = winch deactivated **4.9.2**.

10.5 Switching back to the crane operation program

- ▶ Press the function key **F8**.

Result:

- The parameters previously confirmed with the ENTER key **C** will be taken over into the control.

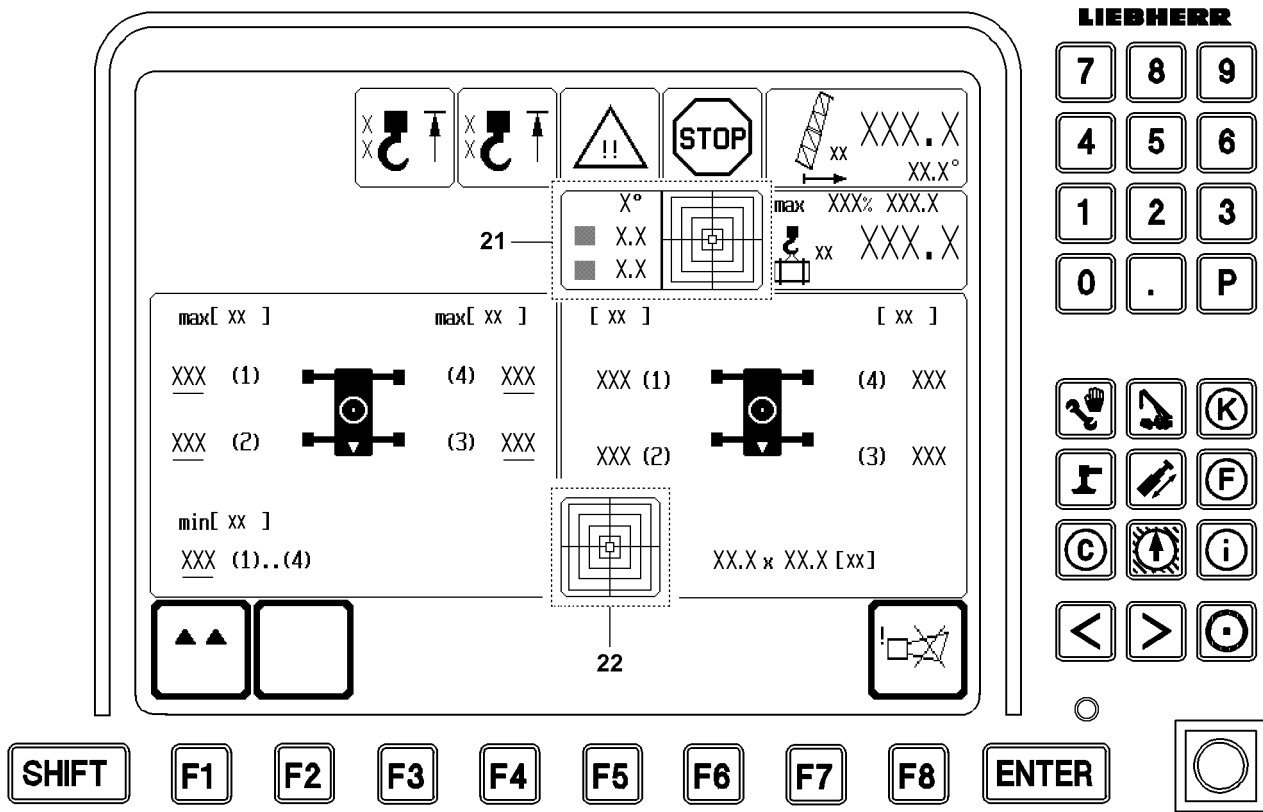

Fig.113275

11 The Support program



Note

- ▶ Only crane with narrow track crawler track!

The monitor screen shows the complete configuration of the support program. Depending on the customer request or crane type, the individual parts of the program are inactive and therefore not visible on the LICCON monitor. The numerical values in the icons are only examples and may differ from the crane.



Note

In the support program, the incline of the crane is shown in two different icons:

- ▶ Incline of the crane in relation to the alignment of the crane superstructure: „Incline crane superstructure“ icon **21**!
- ▶ Incline of the crane in relation to the alignment of the crane chassis: „Incline crane chassis“ icon **22**!
- ▶ Example: If the crane superstructure is turned by 90°, then the „Incline crane superstructure“ icon **21** adjusts to the changed position of the crane superstructure, the display in the „Incline crane chassis“ icon **22** keeps its direction!

11.1 Starting / stopping the program

11.1.1 Starting the program



Note

- ▶ For a detailed description of the crane support, see Crane operating instructions, chapter 3.10!

- ▶ Press program key **P3**.

Result:

- The support program is started.

11.1.2 Stopping the program

- ▶ Press program key **P1**.

Result:

- The Support program is terminated.
- System switches back to the crane operation program.

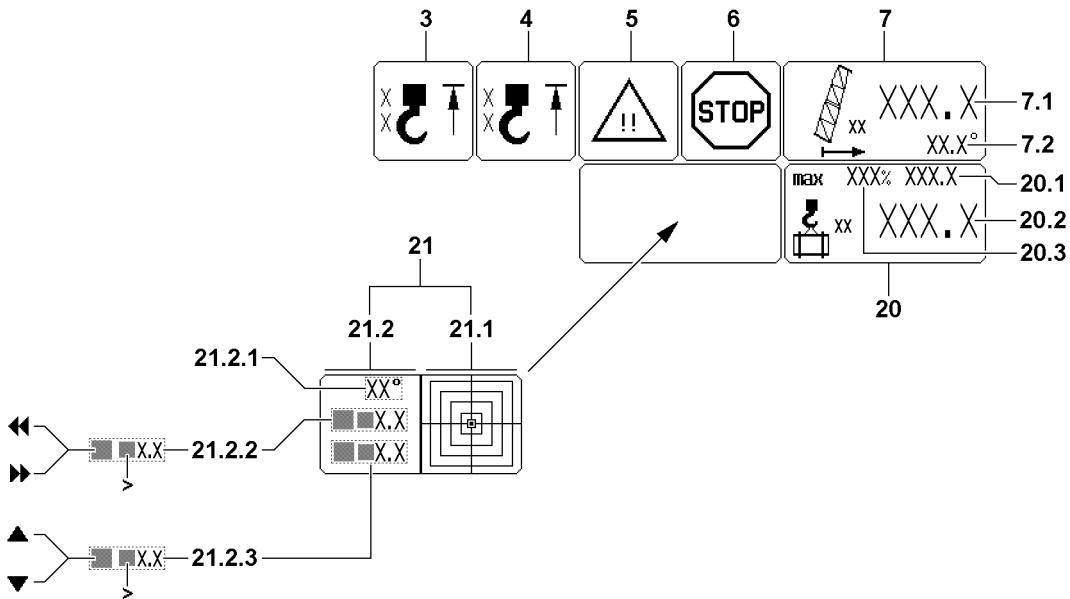
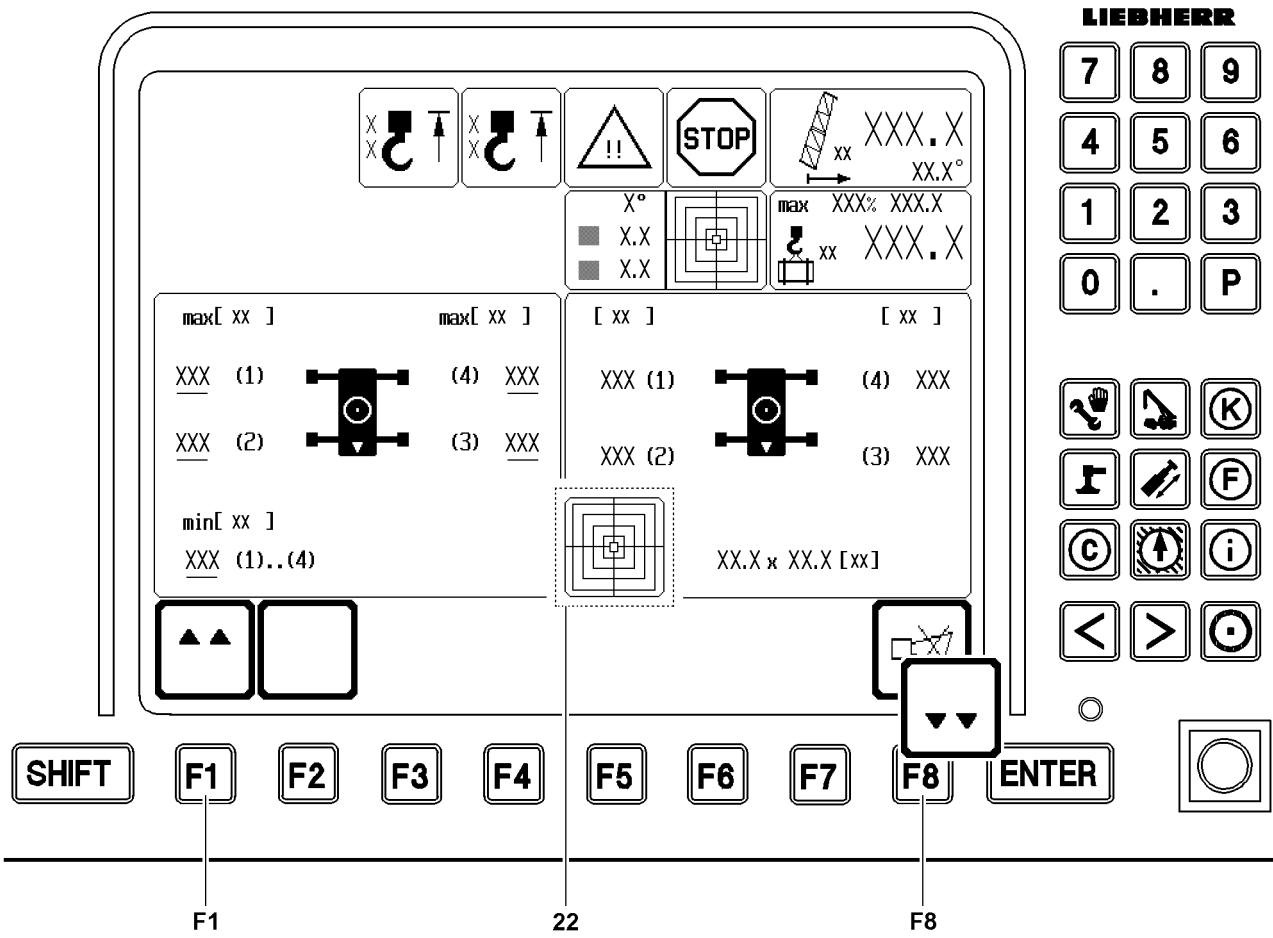

Fig.113446

LWE/LR 1600-2-008/18109-09-02/en

11.2 Crane operation in Support program



Note

- ▶ This function is only enabled for the „Support force monitoring“* option.
- ▶ For more detailed description of icons 3 to 6, see section „Alarm functions“ in the crane operation program.



WARNING

Missing display values for wind speed!

No wind speed is shown in the support program during crane operation!

- ▶ If wind conditions are unclear, crane operation in the support program is not permissible!



WARNING

Missing display values for crane operation with boom nose!

The utilization of the boom nose during crane operation in the support program is not shown!

- ▶ Crane operation with boom nose is not permissible in the support program!

- 3 „Hoist top“ icon
 - On HES1
- 4 „Hoist top“ icon
 - On HES2 and / or HES3
- 5 „Advance warning“ icon
- 6 „STOP“ icon
- 7 „Boom radius and main boom angle“ icon
 - Detailed description, see section „Crane geometry and load information“
- 7.1 Radius
- 7.2 Boom angle
- 20 „Maximum load“ icon
 - 20.1 Maximum load on the boom
 - In [t] or [lbs]
 - 20.2 Current load on the boom
 - In [t] or [lbs]
 - 20.3 Utilization of main boom
 - In percent [%]

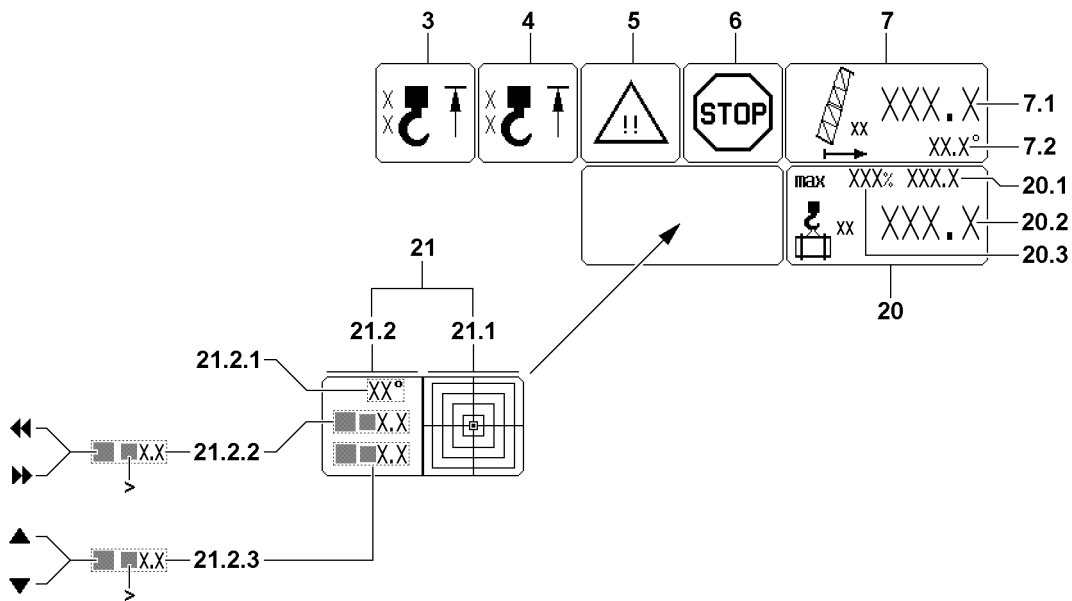
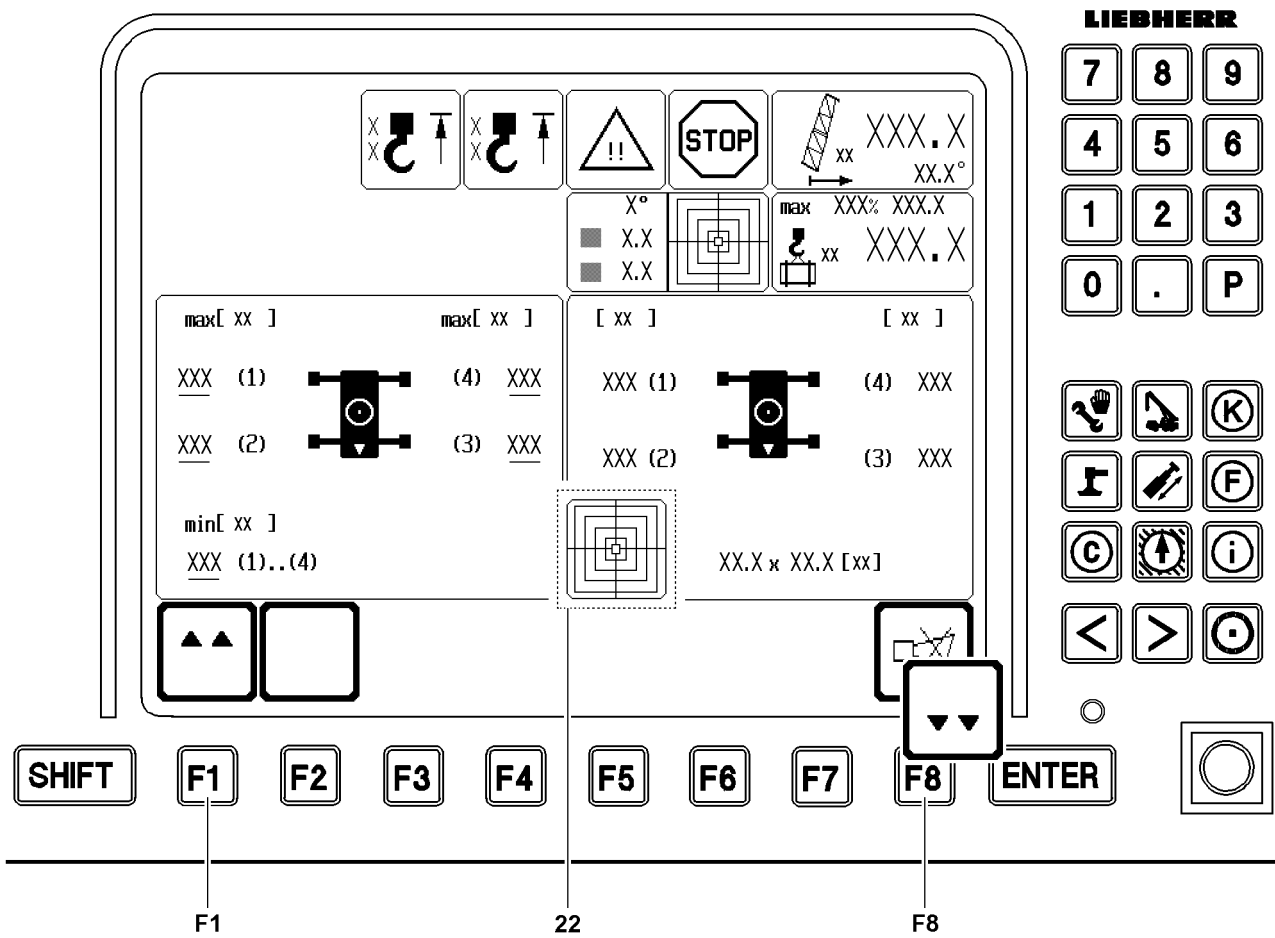

Fig.113446

LWE/LR 1600-2-008/18109-09-02/en

21 „Incline crane superstructure“ icon

- Display of the incline of the crane to the horizontal in longitudinal and lateral direction. The display is graphic as well as numeric. The directional data refers to the direction of the crane superstructure (view from the cab).

21.1 Graphic part

- The graphic display is in the form of a spirit level, with a moving dot (small square) representing the air bubble. The center of the dot shows the precise incline value.

21.2 Numeric part**21.2.1** Incline range

- This value describes the resolution of the graphic view. The resolution is matched automatically to the incline.

21.2.2 Lateral direction

- Incline of crane in lateral direction in [°]
- The double arrow shows the direction of the incline
- If the „larger than symbol“ appears, then the crane is inclined further than can be shown!

21.2.3 Longitudinal direction

- Incline of crane in longitudinal direction in [°]
- The arrow shows the direction of the incline
- If the „larger than symbol“ appears, then the crane is inclined further than can be shown!

22 „Incline crane chassis“ icon

- Display of the incline of the crane chassis to the horizontal in longitudinal and lateral direction. The display is made graphically.

F1 Function key

- Switching over into the adjustment field for support limit forces (refer to section „Support force monitoring“)
- **Note:**
At actuation, an LMB STOP is triggered! All hoist and luffing moments are stopped and the icons for crane operation disappear.

F8 Function key

- Turn off acoustical signal / error determination screen
or
- End adjustment mode

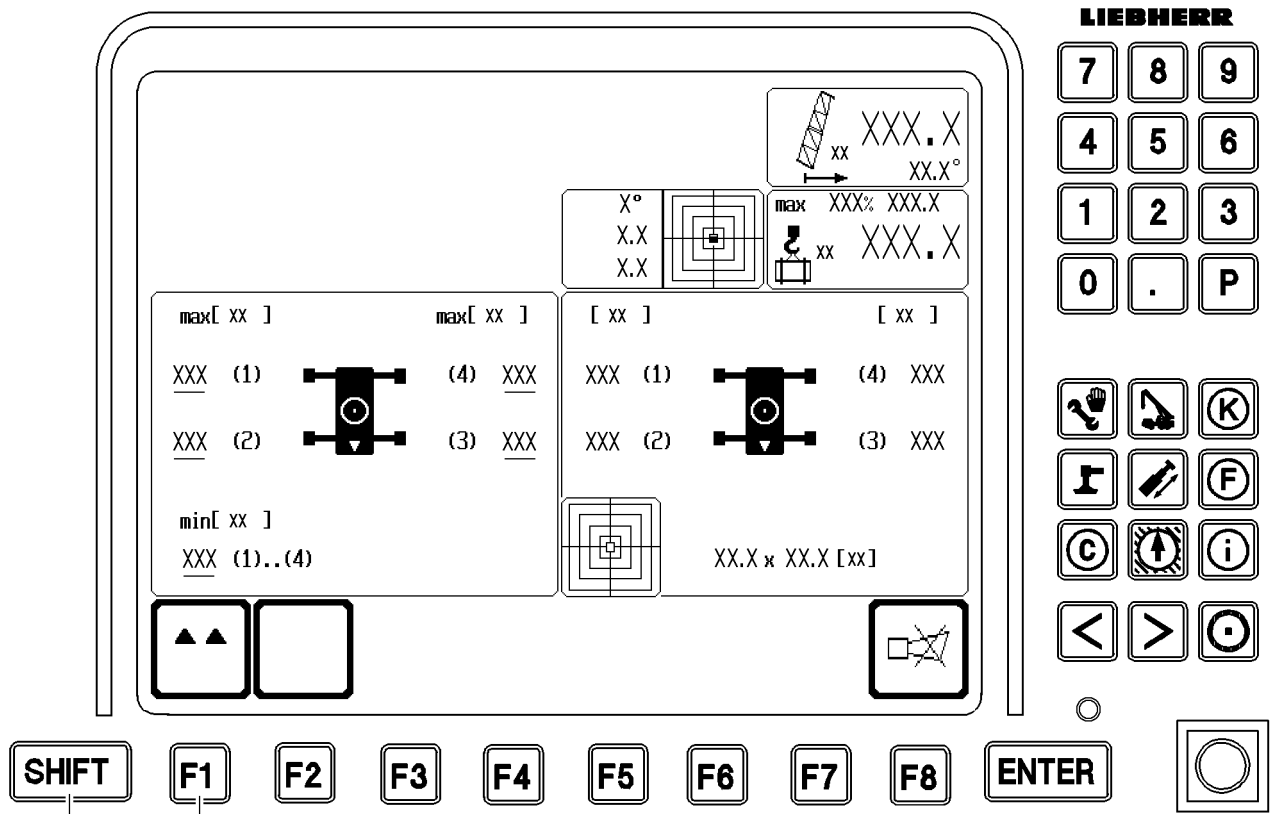

H

F1

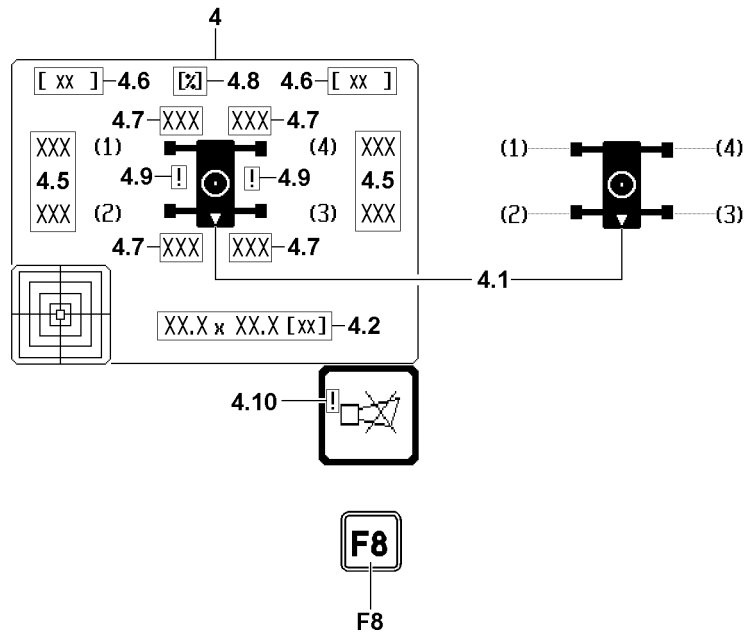

Fig.116742

11.3 Monitoring support beams*

- 4 Monitoring and control field
- 4.1 Crane icon
 - Crane icon with assigned support numbers
- 4.2 Support base
 - In [m] or [ft]
- 4.5 Support force values
 - For respective support
In [t] or [kibs]
- 4.6 Unit of displayed support forces
 - In [t] or [kibs]
- 4.7 Swing cylinder
 - Extension length of swing cylinder in percentages **4.8**
 - The values swing cylinder **4.7** blink in ranges, which are not suitable for support.
0 % – support beams folded in
56 % - reduced support base 17.5 m x 10.0 m
100 % – wide support base (14.0 m x 14.0 m)
- 4.9 Exclamation mark „!“
 - Monitoring of the support beams is bypassed.
Note: The exclamation mark „!“ **4.9** will appear in the support screen **and** in the respective icon in the Crane operation screen when the support beam monitoring is bypassed.
- 4.10 Exclamation mark „!“
 - Sliding beam length monitoring can be bypassed
Note: The exclamation mark „!“ **4.10** will only appear in the horn icon when it is possible to bypass the support beam monitoring.
- F1 Function key
 - Switch to settings field for support limit forces
- F8 Function key
 - Press once:
Turn the acoustic signal off.
 - Press twice:
In the „Horn“ icon, fields are automatically displayed on the error determination screen (see Diagnostics manual).

11.3.1 Bypass of support beam monitoring

If the exclamation mark „!“ **4.10** appears in the horn icon, then it is possible to bypass the support beam monitoring.



WARNING

Bypass of support beam monitoring!

If the support beam monitoring is bypassed, there will be no additional warning or shut off in case of a deviation from the nominal support base.

The crane can topple over and personnel can be killed or severely injured.

- ▶ The crane operator must carry out the bypass of the support beam monitoring with extreme caution and he must constantly monitor the stability of the crane himself.

Press the SHIFT key **H** and function key **F8** simultaneously: The support beam monitoring is bypassed, the exclamation marks „!“ **4.9** appear.

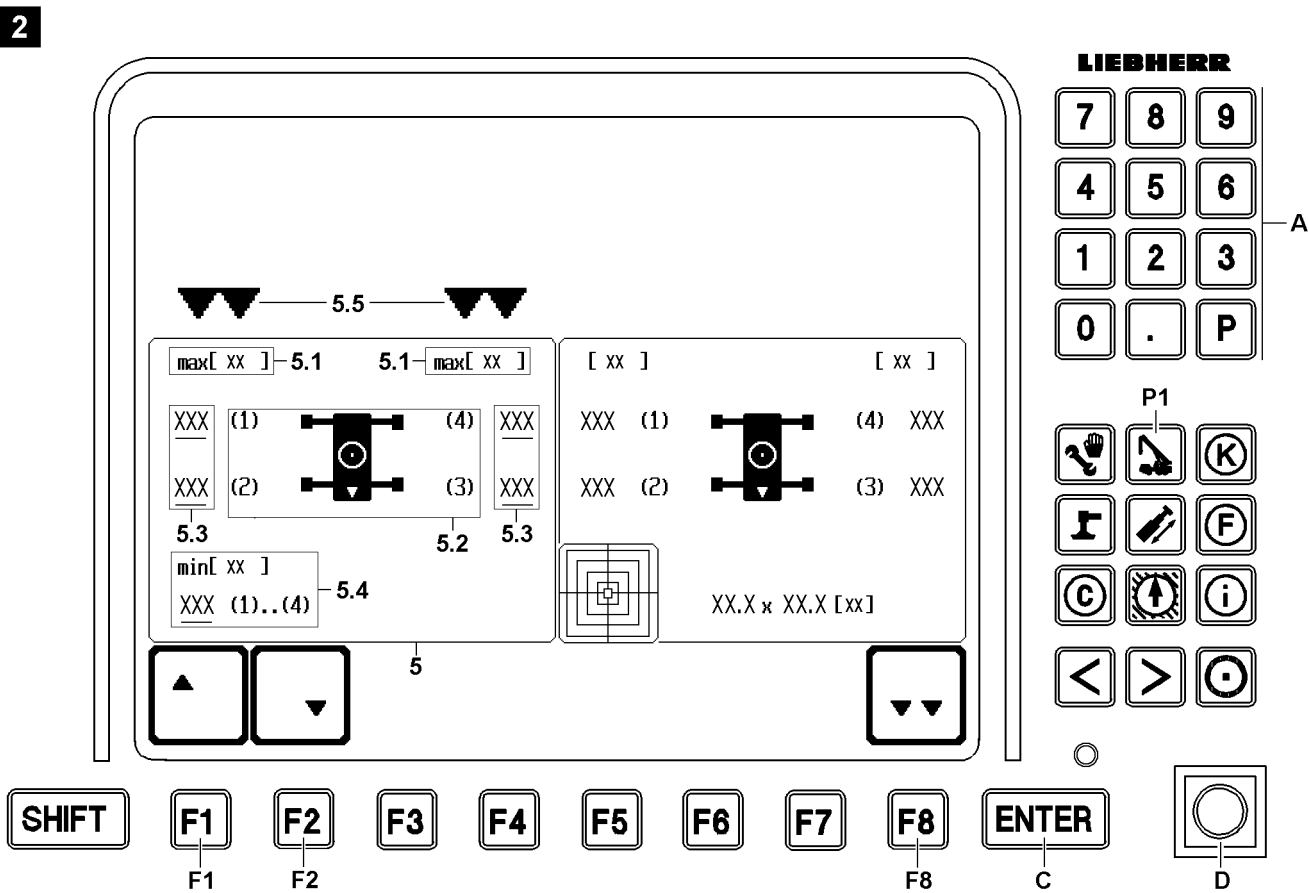
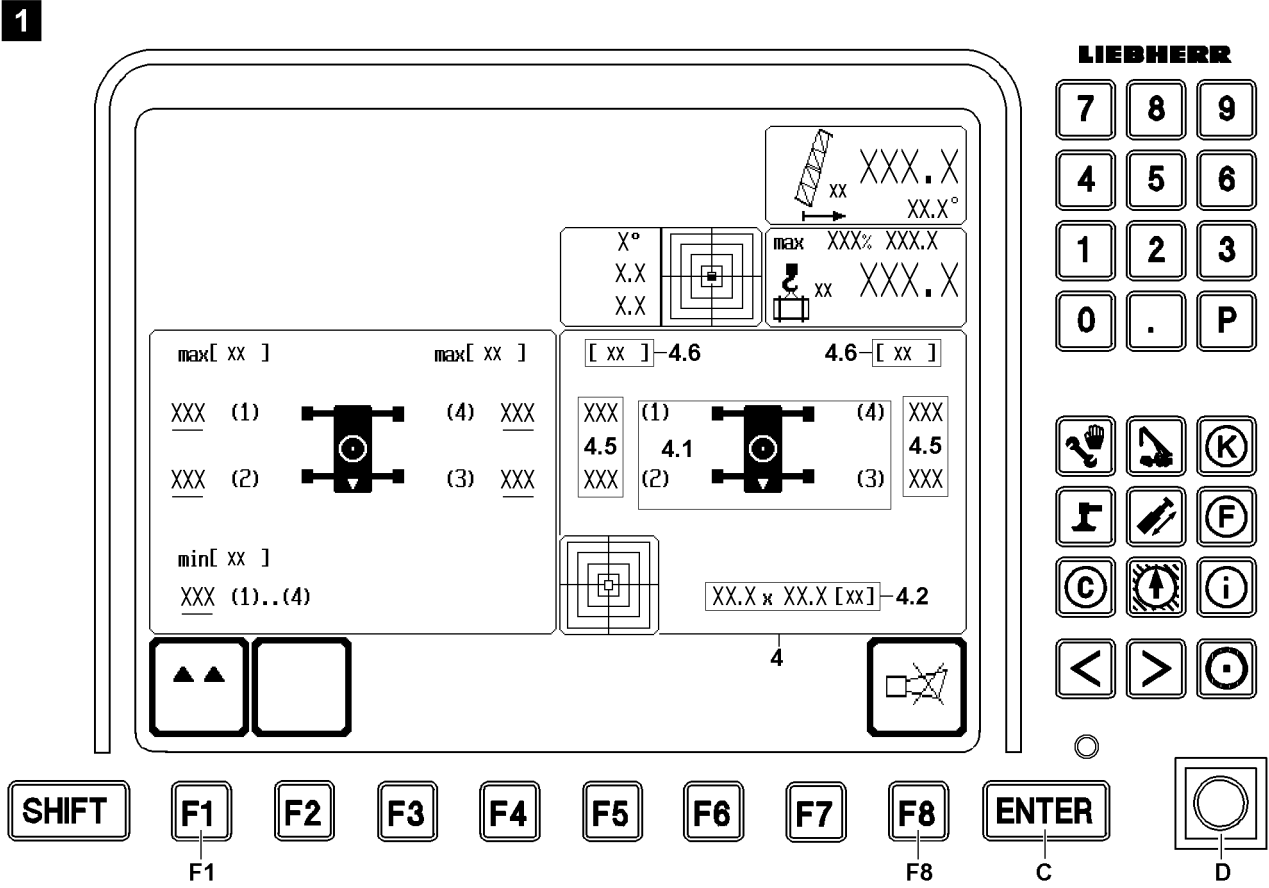

Fig.113265

LWE/LR 1600-2-008/18109-09-02/en

11.4 Support force monitoring*



DANGER

Danger of accident!

- ▶ The LICCON support force monitoring is only an aid. It does **not** prevent a possible crane overload!
- ▶ Never use the support force monitoring to utilize the crane up to its tipping limit!

The support force monitoring constantly determines the current pressure on all 4 support cylinders during operation. The support force for each support is determined from that.

Due to the possibility to specify limit values, the support force monitoring can be utilized for individual advance warning.

Example: For application under certain placement conditions, the:

- Maximum permissible support force is 100 t.
- Desired advance warning 10 % before
which results in: Maximum support limit force value to be programmed is 90 t.

11.4.1 Monitoring mode / control mode

See illustration 1

- 4 Monitoring and control field
 - 4.1 Crane icon with support numbers
 - 4.2 Support base
 - 4.5 Support force values
 - For respective support
In [t] or [kibs]
 - 4.6 Unit of displayed support forces
 - In [t] or [kibs]
 - F1 Function key
 - Switch to settings field for support limit forces
 - F8 Function key
 - Press once:
Turn the acoustic signal off.
 - Press twice:
In the „Horn“ icon, fields are automatically displayed on the error determination screen (see Diagnostics manual).

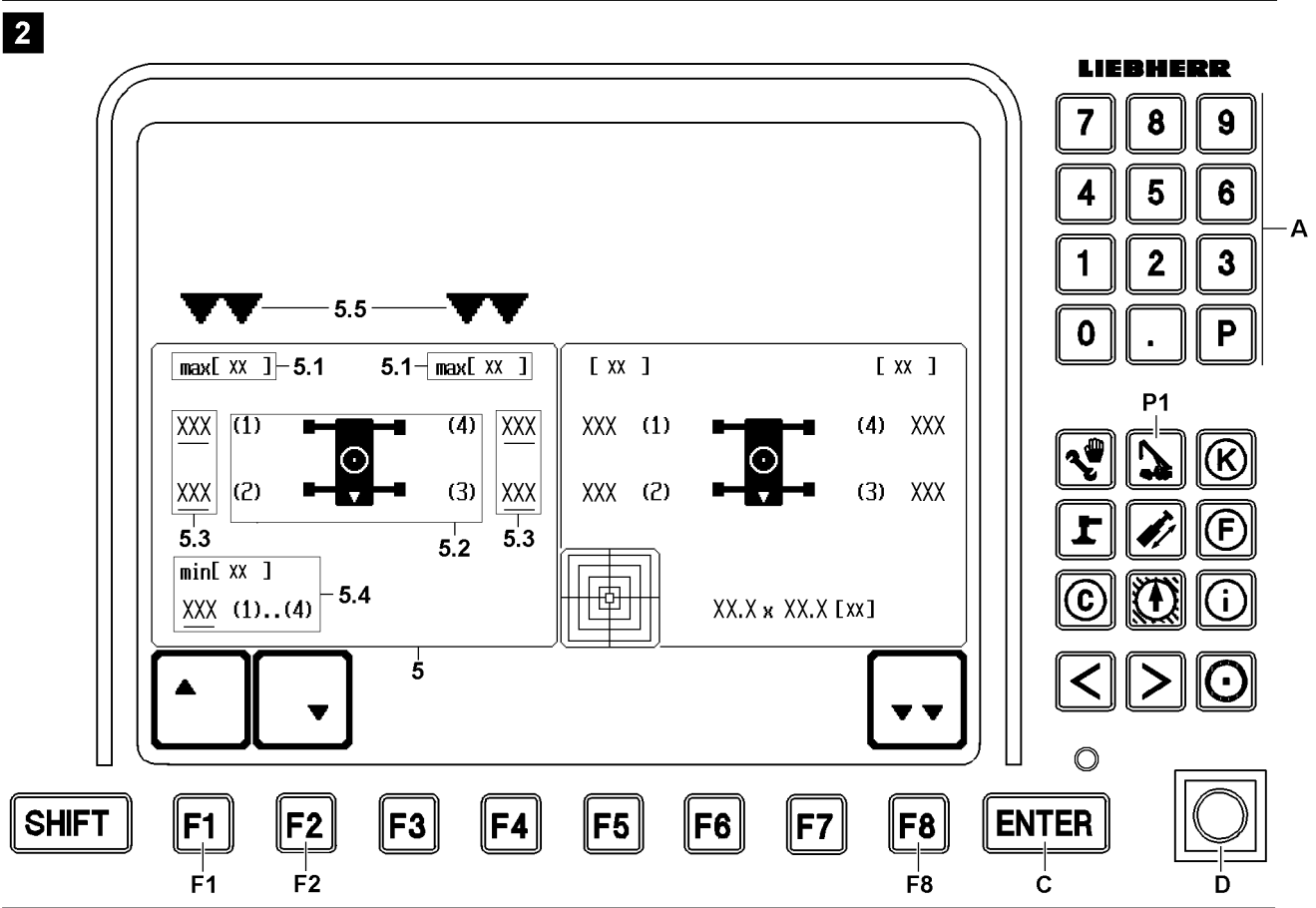
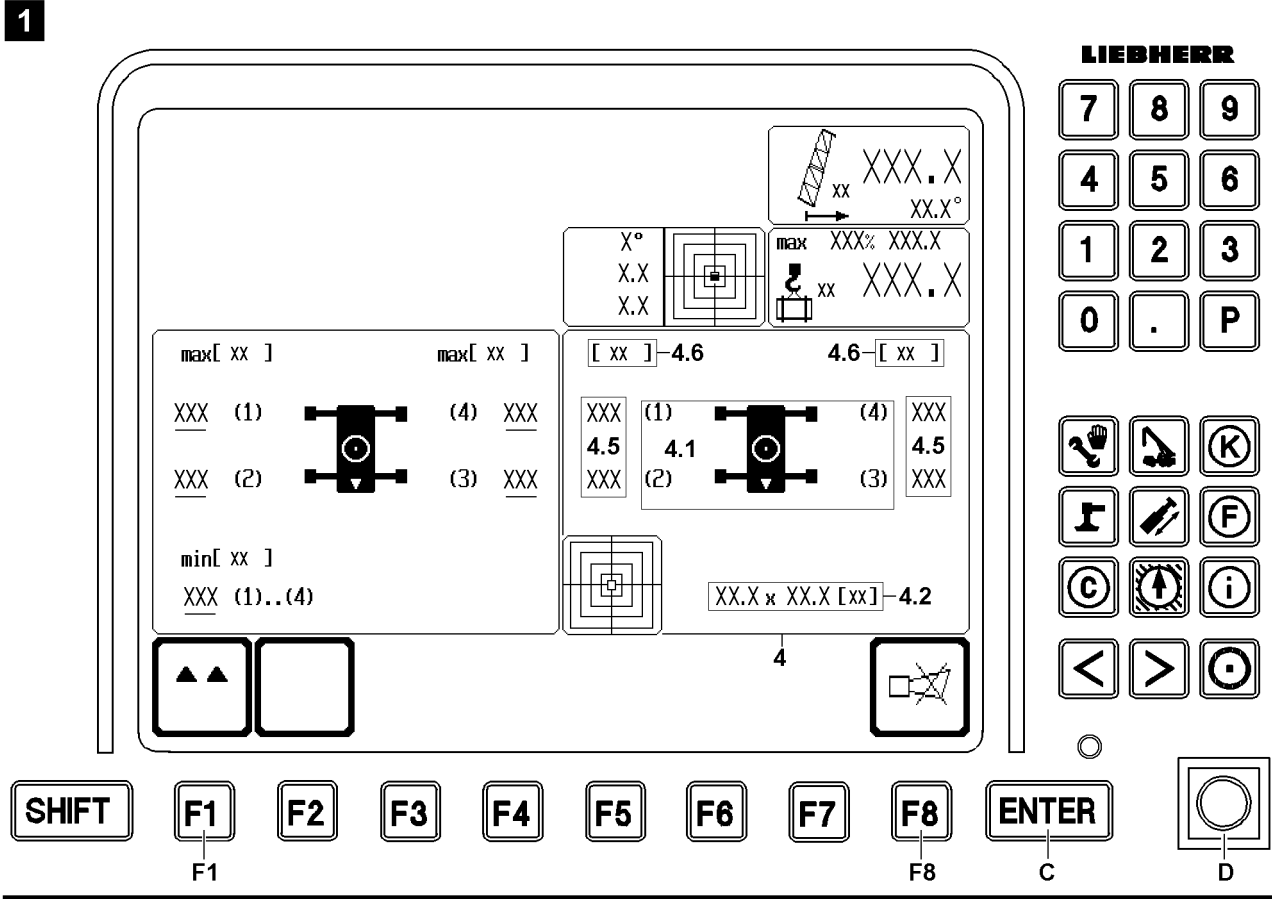

Fig.113265

LWE/LR 1600-2-008/18109-09-02/en

11.4.2 Setting mode

See illustration 2

- 5** Setting field for support force limits
 - 5.1** Unit of maximum support force limit values
 - In [t] or [kibs]
 - 5.2** Crane icon with support numbers
 - 5.3** Maximum support force limit values
 - For respective support
 - Maximum value in [t] or [kibs]
 - 5.4** Minimum support force limit value
 - Minimum value in [t] or [kibs]
 - Valid for all four supports
 - 5.5** Selector arrows
 - Point to the active settings field
- F1** Function key
 - Move cursor (input pointer) to next support force limit value
- F2** Function key
 - Move cursor (input pointer) to previous support force limit value
- F8** Function key
 - Switch back to Monitoring and control field 4

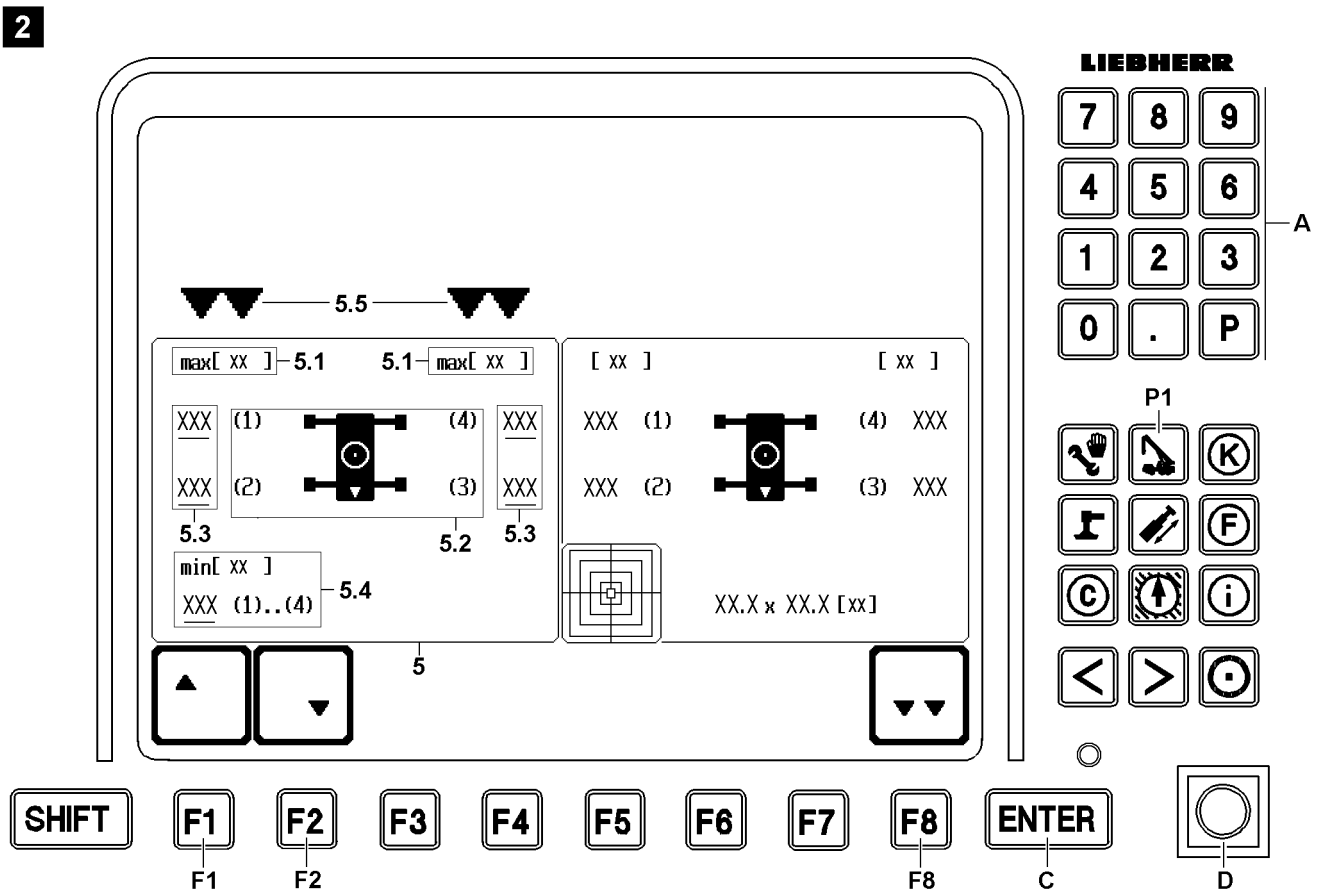
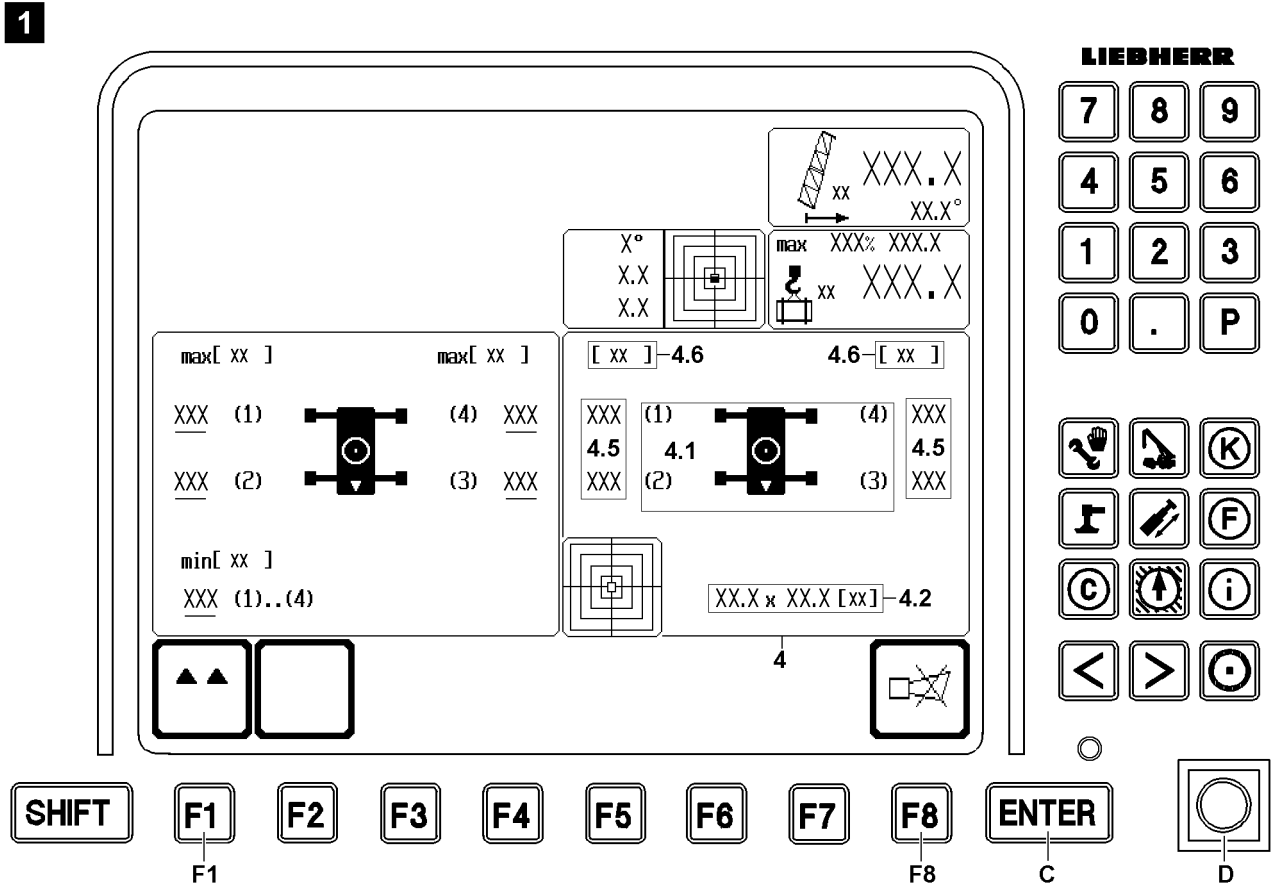

Fig.113265

LWE/LR 1600-2-008/18109-09-02/en

11.4.3 Display current support forces

**Note**

- ▶ Display current support forces in crane operating screen, see „Monitored auxiliary functions for crane operation“!

The current support force values **4.5** are shown in the monitoring and control field **4**.

11.4.4 Remarks

Because of the option to determine limit values yourself, the LICCON support force monitoring can also be used as an advance warning device:

- Any trends in changes of the support forces during crane operation can be quickly recognized.
- Advance warning limits for the support forces can be individually programmed.

**WARNING**

Tolerances and erroneous operation of the support force monitoring

For technical reasons, a test deviation of up to $\pm 2\%$ in relation to the maximum load capacity of the crane is possible!

If the support cylinders are moved on „block bottom“ or „block top“, then the display of the support forces is erroneous!

- ▶ Make sure that there is no block position on the support cylinders!
- ▶ Take the tolerances in the display value into account!
- ▶ Take additional influences onto the tolerance field into account!

The tolerance field expands:

- In case of large support forces.
- In case of far extended support cylinders.
- When extending the support cylinders and up to 15 minutes afterwards.

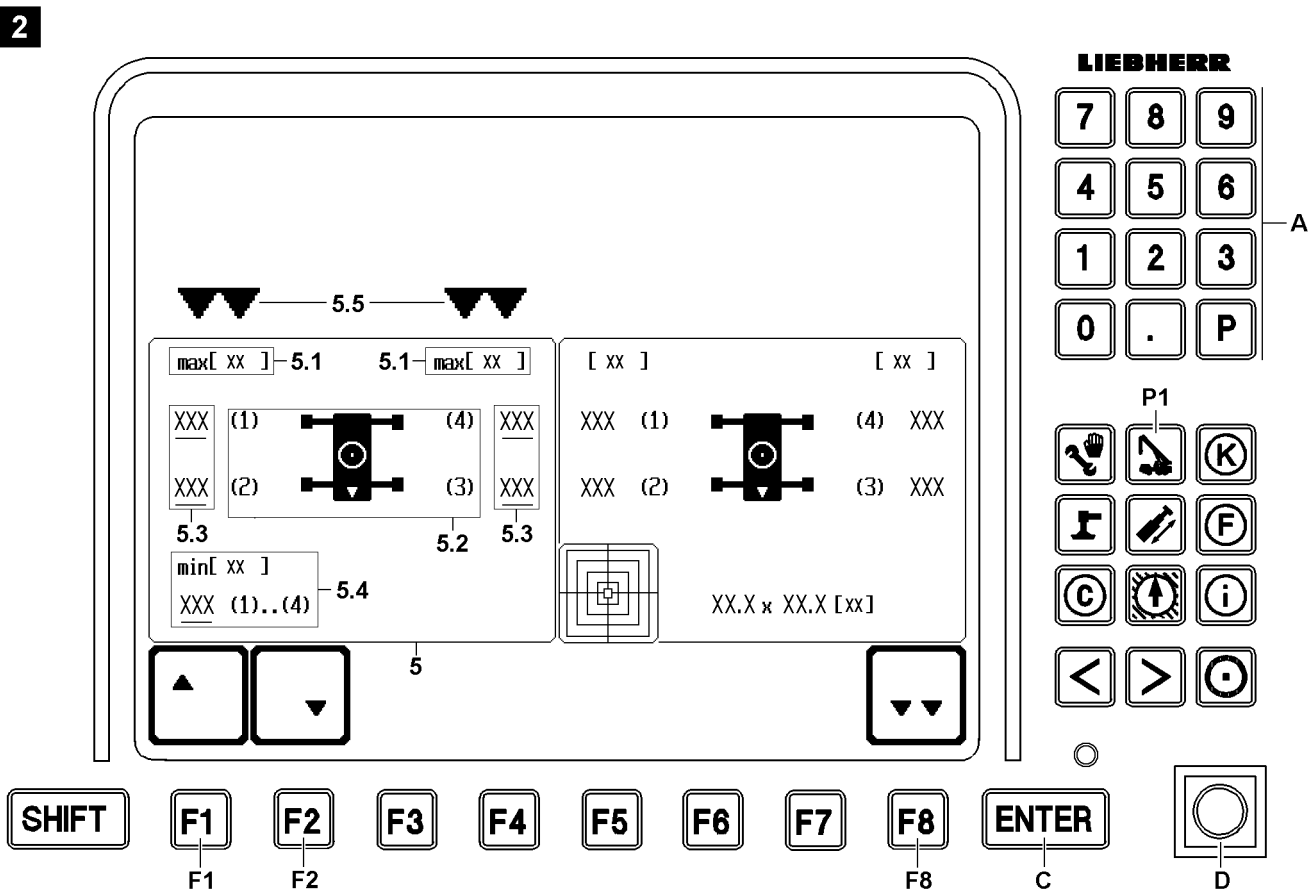
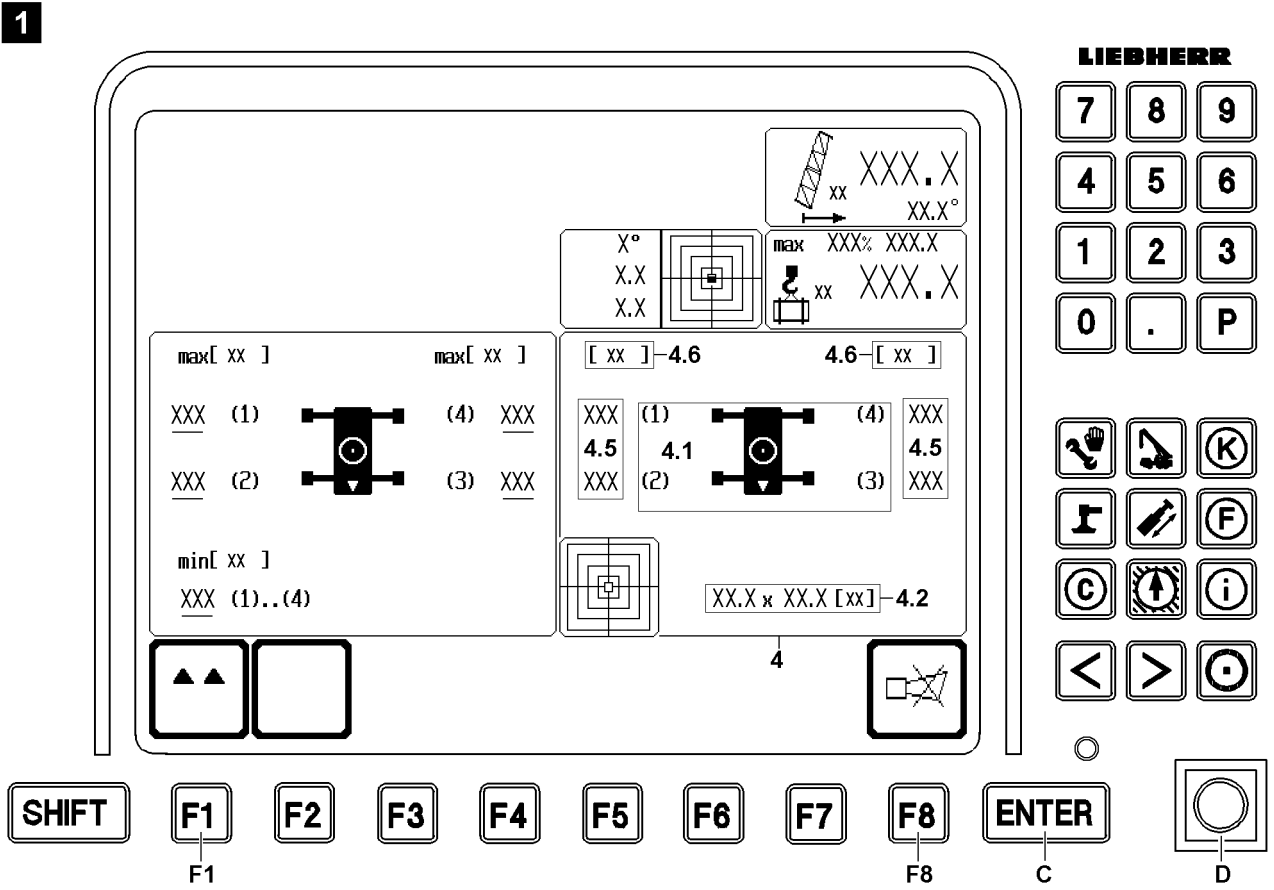

Fig.113265

LWE/LR 1600-2-008/18109-09-02/en

11.4.5 Changing minimum and maximum support force limits

As an additional safety precaution, this program monitors the set up key **D**. If the set up key **D** is actuated, the system switches back to the Crane operation program.

In the Monitoring and control field **4** the current support force values are displayed.

If one or more of the values are below or above the programmed maximum values for the support force limits, then they are displayed blinking.

The programmed maximum / minimum values for the support force limits are displayed in the Setting field **5**.

Make sure that the following prerequisites are met:

- The crane is supported and horizontally aligned.
- The set up key **D** is not pressed.

The program initially runs in monitoring mode. All icons relevant to crane operation are displayed.



Note

Switching to the adjustment field for support limit forces.

- ▶ By pressing the function key **F1**, an LMB STOP / operational error is triggered immediately. All hoist and luffing moments are stopped and the icons for crane operation disappear.

When pressing the function key **F1**, the two double arrows **5.5** point to the settings field **5** for support limit forces. The cursor appears on the maximum value of the support limit force on support 1.

By pressing the function key **F1** or function key **F2** you switch the cursor to the next or previous maximum value for the support limit force or the minimum value for the support limit force (valid for all four support cylinders).



Note

Testing the validity range for the support limit force values.

Every newly entered support limit force value will be tested for its validity range.

- ▶ If valid, the entered value will be accepted.
- ▶ If invalid, the value will be rejected as too small or too big with an error message.

With the keypad **A** you can change the support limit force values and then close the input function using the ENTER key **C**.

Use the function key **F8** to switch back to the Monitoring and control field **4**.

Use the program key **P1** to switch back to the crane operation program.

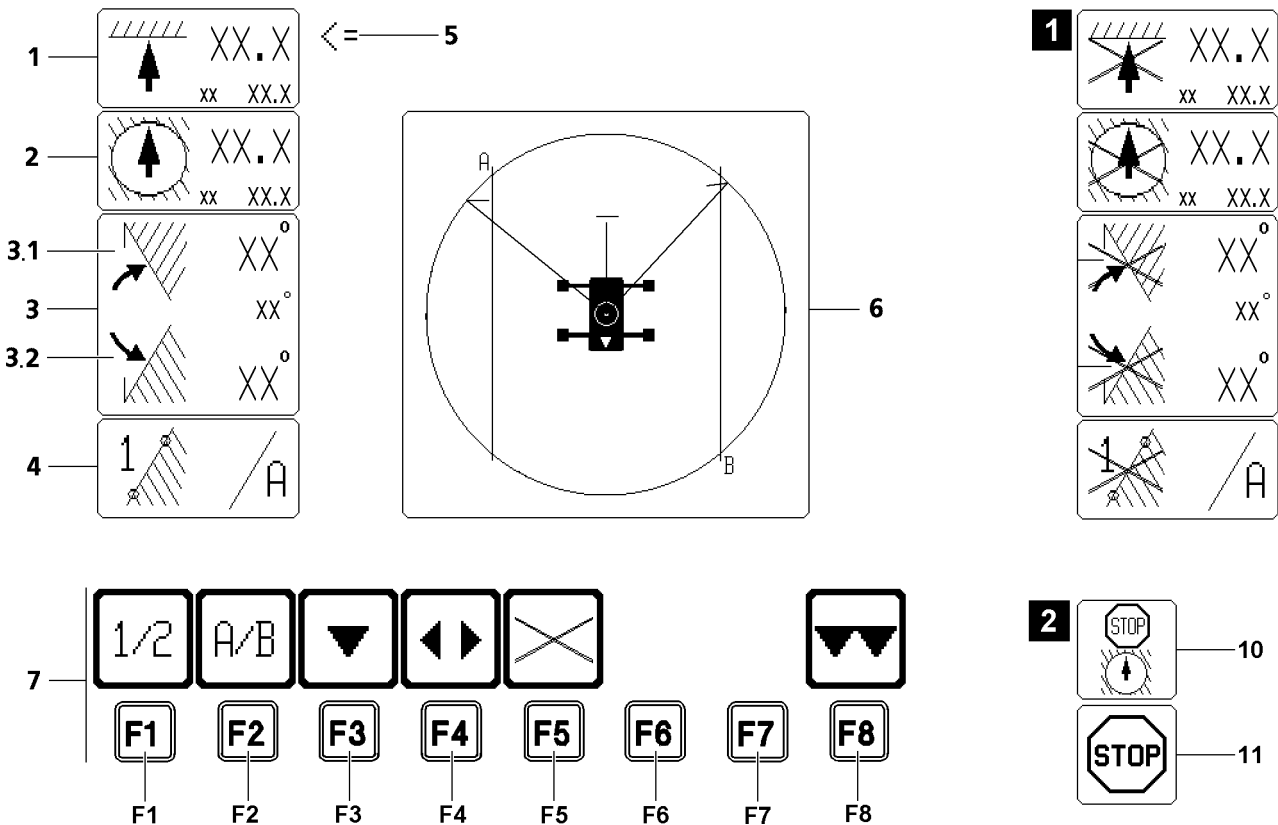
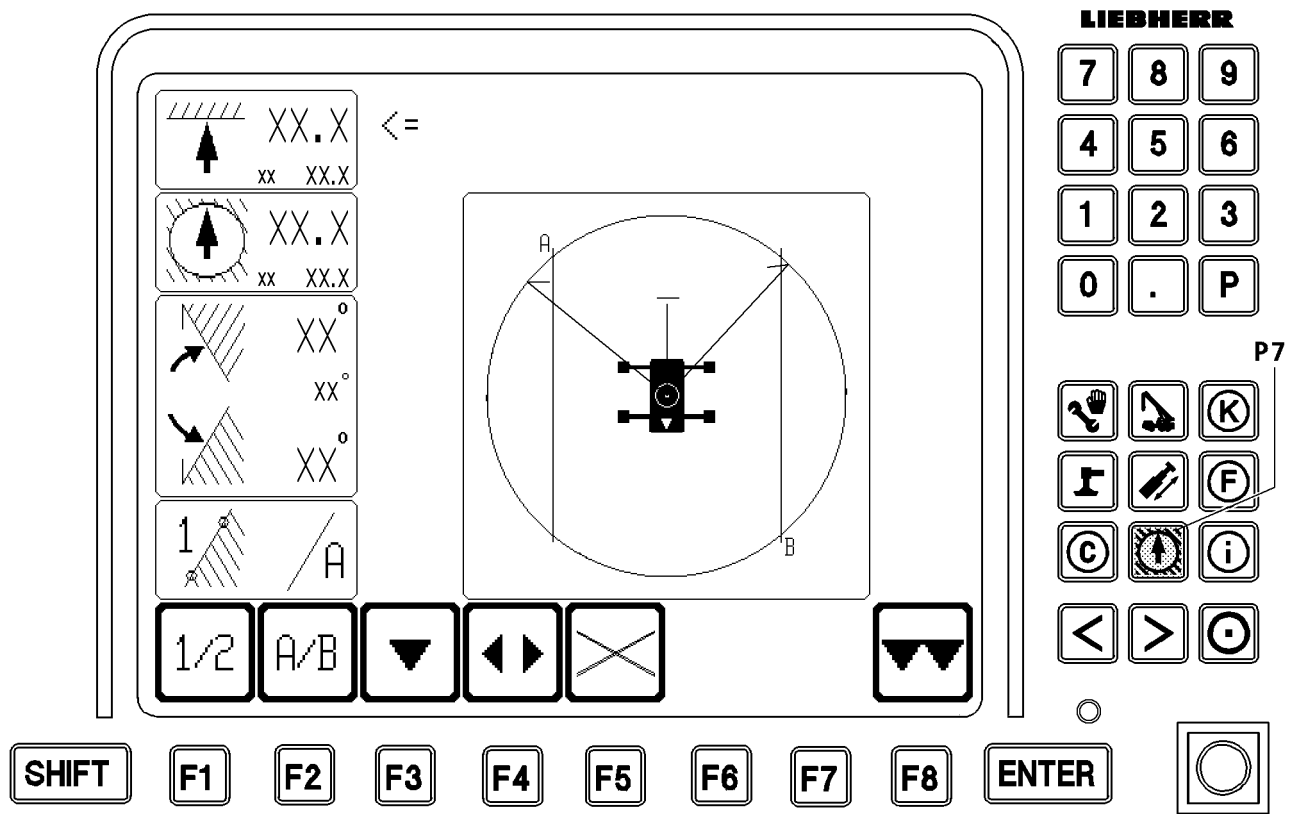

Fig.113273

LWE/LR 1600-2-008/18109-09-02/en

12 The Working range limitation program*



Note

► For detailed description of the working range limitation, see the „Working range limitation“ manual!

12.1 Starting the program

► Press program key **P7**.

12.2 User interface

- 1 „Limitation of pulley head height“ icon
- 2 „Radius limitation“ icon
- 3 „Slewing limit stop“ icon
- 3.1 Right slewing limit stop
- 3.2 Left slewing limit stop
- 4 „Edge limit with edge and point selection“ icon
- 5 Function selector
 - For selecting limit functions
- 6 „Graphic display of programmed limits“ icon
 - **Note:**
Depending on crane type, either the crane icon crane chassis or crawler travel gear are shown!

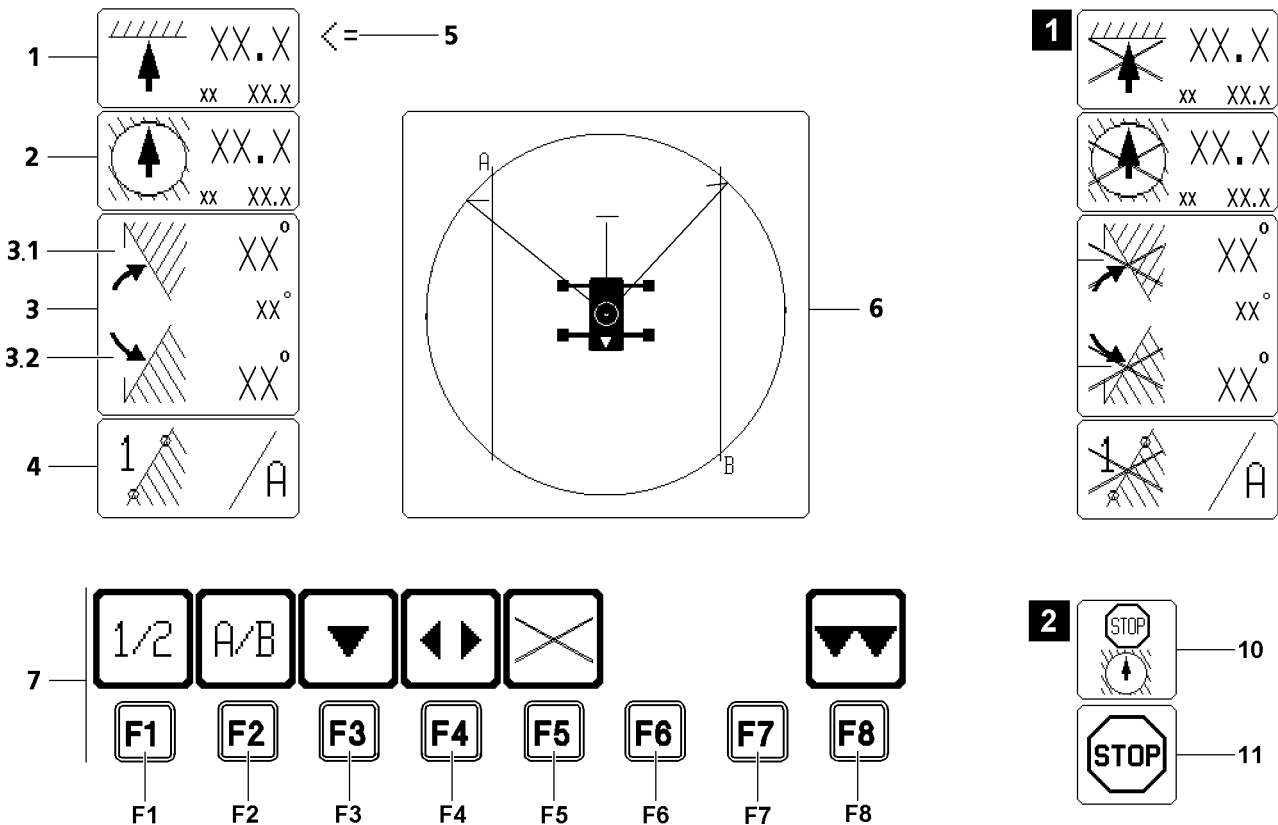
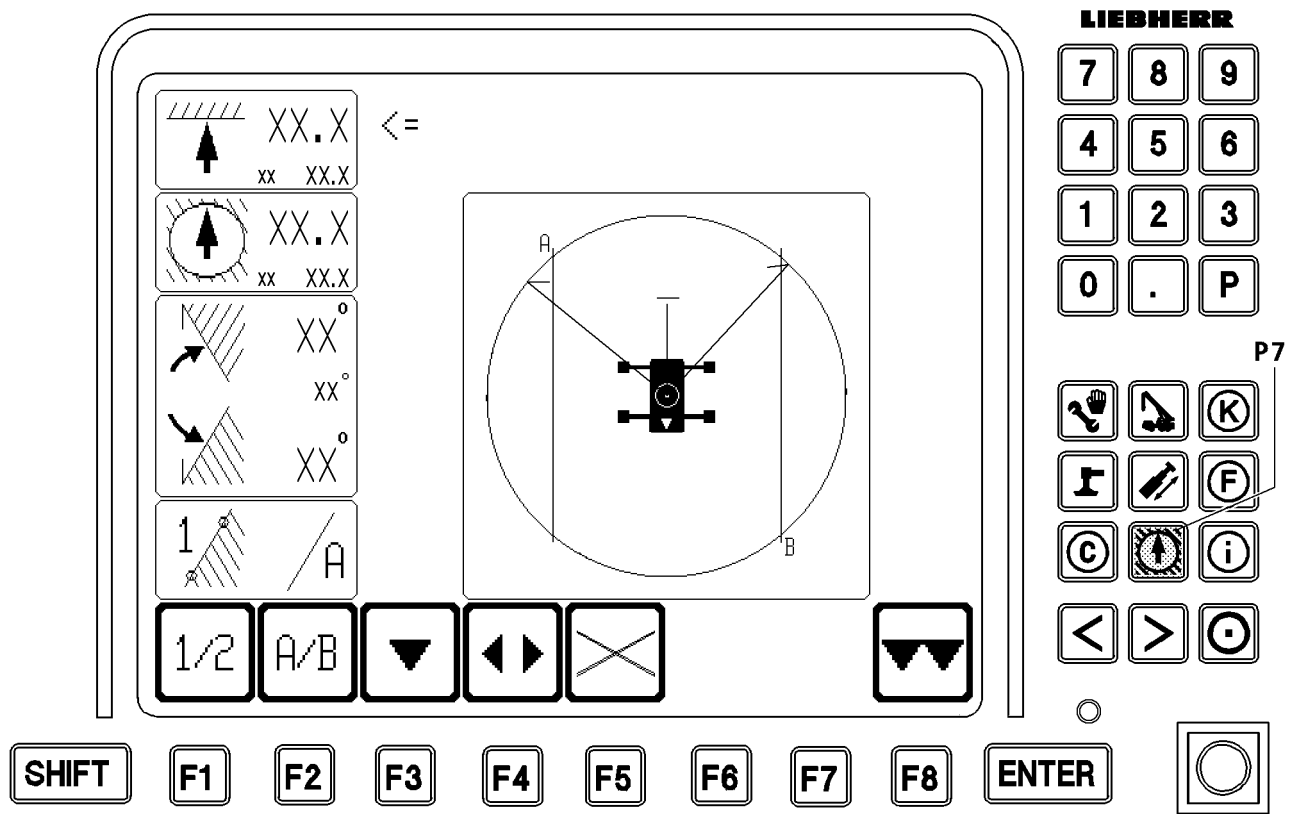

Fig.113273

LWE/LR 1600-2-008/18109-09-02/en

12.2.1 Function key line

The function key line **7** is operated via the function key located below.

- F1** Function key
 - Selection of point 1 or 2 of selected edge A or B
- F2** Function key
 - Selection of edge A or B that is being programmed
- F3** Function key
 - The function selector is moved down by one limit function
- F4** Function key
 - The limit function selected with the function selector changes its status. If previously active, it will now be inactive when the function key **F4** is pressed, and vice versa. An inactive limit function is identified by a crossed out icon. If the function selector shows a turning limit to the left or the right, then both limits will always be switched.
 - **Note:**
For the edge limit, only the preselected edge will be switched! The edge that is not displayed can be active or inactive at the same time!
- F5** Function key
 - All limit functions become inactive, icons crossed out - see illustration 1
- F6** Function key
 - Not assigned in the working range limitation program
- F7** Function key
 - Not assigned in the working range limitation program
- F8** Function key
 - Exit the program and return to the crane operation program

12.3 Displays in the crane operation program

If a programmed working range limitation is activated, then this status is indicated in the „Crane operation“ program by an alternative STOP icon **10** on the position of the normal LMB STOP icon **11**, see illustration 2.

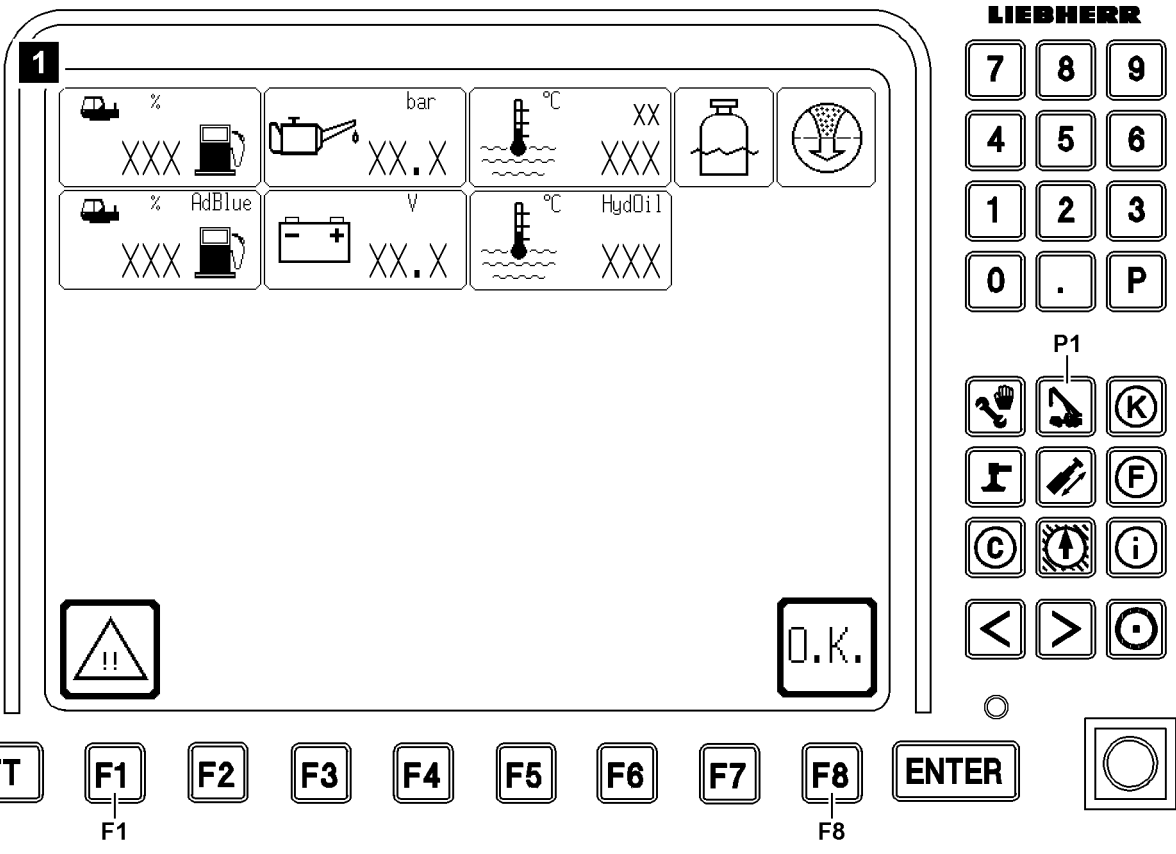
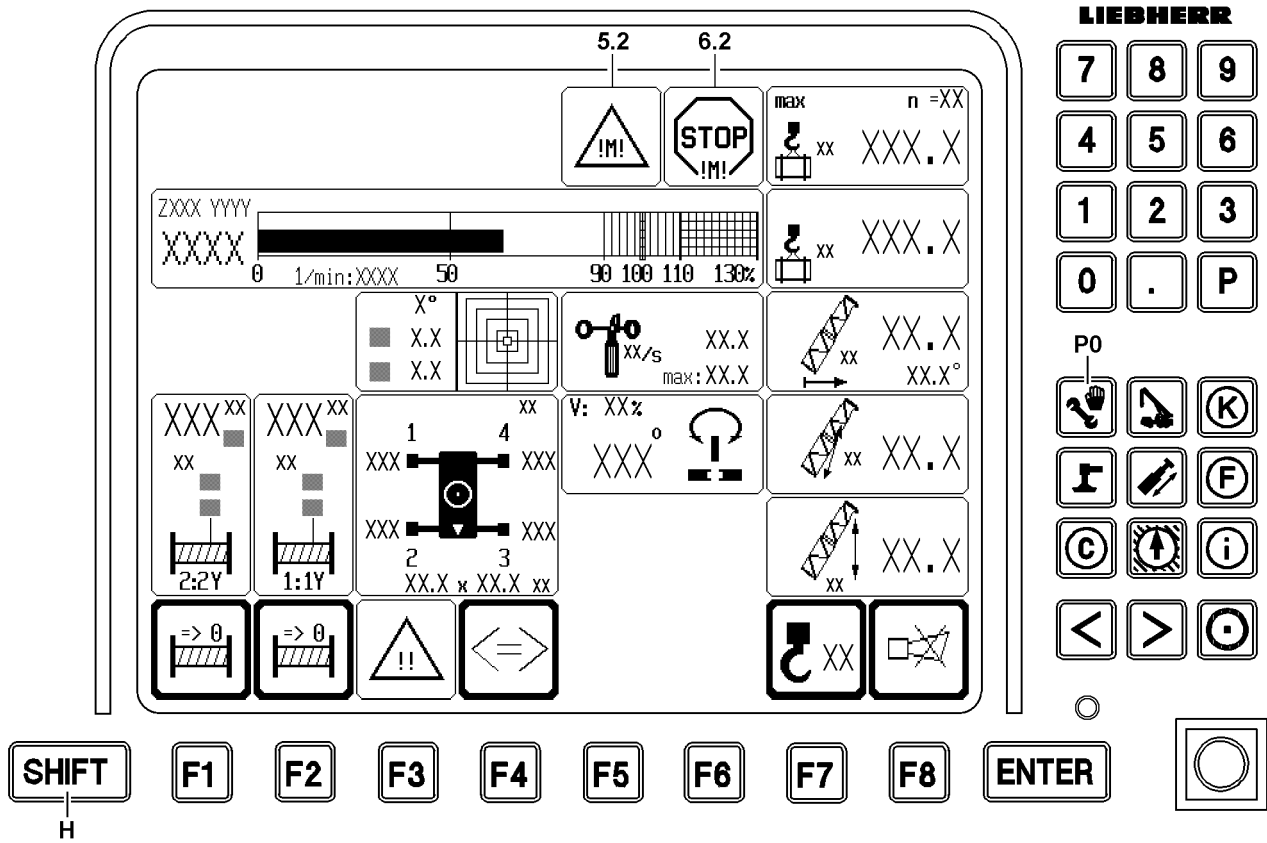

Fig.126906

LWE/LR 1600-2-008/18109-09-02/en

13 The Engine monitoring program

All engine-related data is displayed by the engine monitoring program, such as the engine oil pressure, coolant temperature etc. The change from the crane operation into the engine monitoring program is made automatically in case of a problem.

13.1 Starting the program

NOTICE

Danger of severe engine damage!

If the engine monitoring program reports a problem and / or warning occurrence, then you must react immediately and remedy the problem!

- ▶ React to problems / or warning occurrences immediately and remedy the problem!
 - ▶ If necessary, stop crane operation and turn the engine off!
-

NOTICE

Shut off engine monitoring!

Outside of the crane operation program, the engine monitoring is turned off!

When the engine monitoring is turned off, problems and warning occurrences are not recognized!

This could result in crane failure!

- ▶ If work is not carried out in the crane operation program, then turn the crane engine off and operate the LICCON computer system in stand-by mode, see section „LICCON computer system in stand-by mode“!
 - ▶ If work has to be carried out for a longer period outside of the crane operation program, with the engine running, then switch regularly into the engine monitoring screen!
-

The program starts automatically:

- ▶ Once if a STOP event of the engine monitoring takes place during **crane operation** on the crane operation program (at least one master switch is deflected or activated). The engine monitoring screen is displayed for approx. 5 seconds and then automatically reverts to the crane operating screen.

or

At an advance warning, warning or STOP event of the engine monitoring during the boot up of the LICCON computer system.

This is how you start the program at the prompt:

- ▶ Press the key combination SHIFT **H** + program key **P0**.

Result:

- The engine monitoring screen is displayed, see illustration 1.
- All **load moment increasing** crane movements are blocked or turned off.

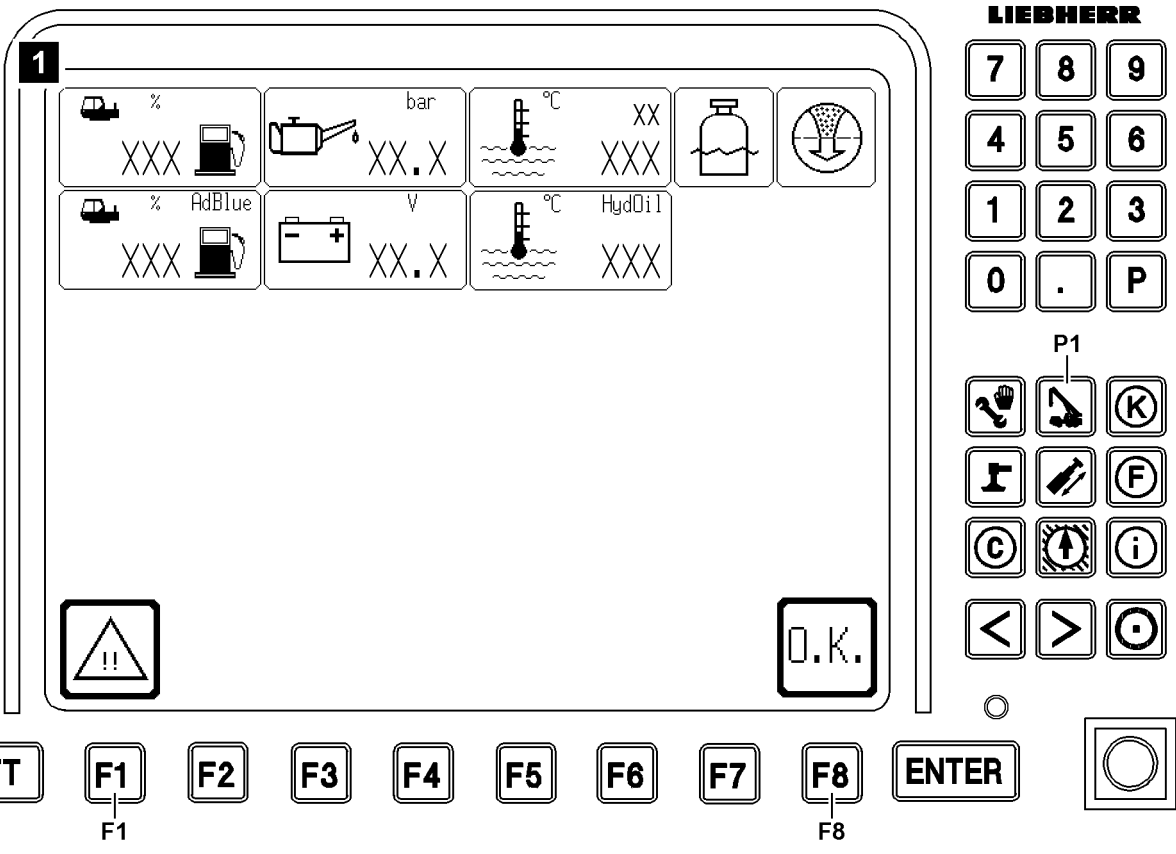
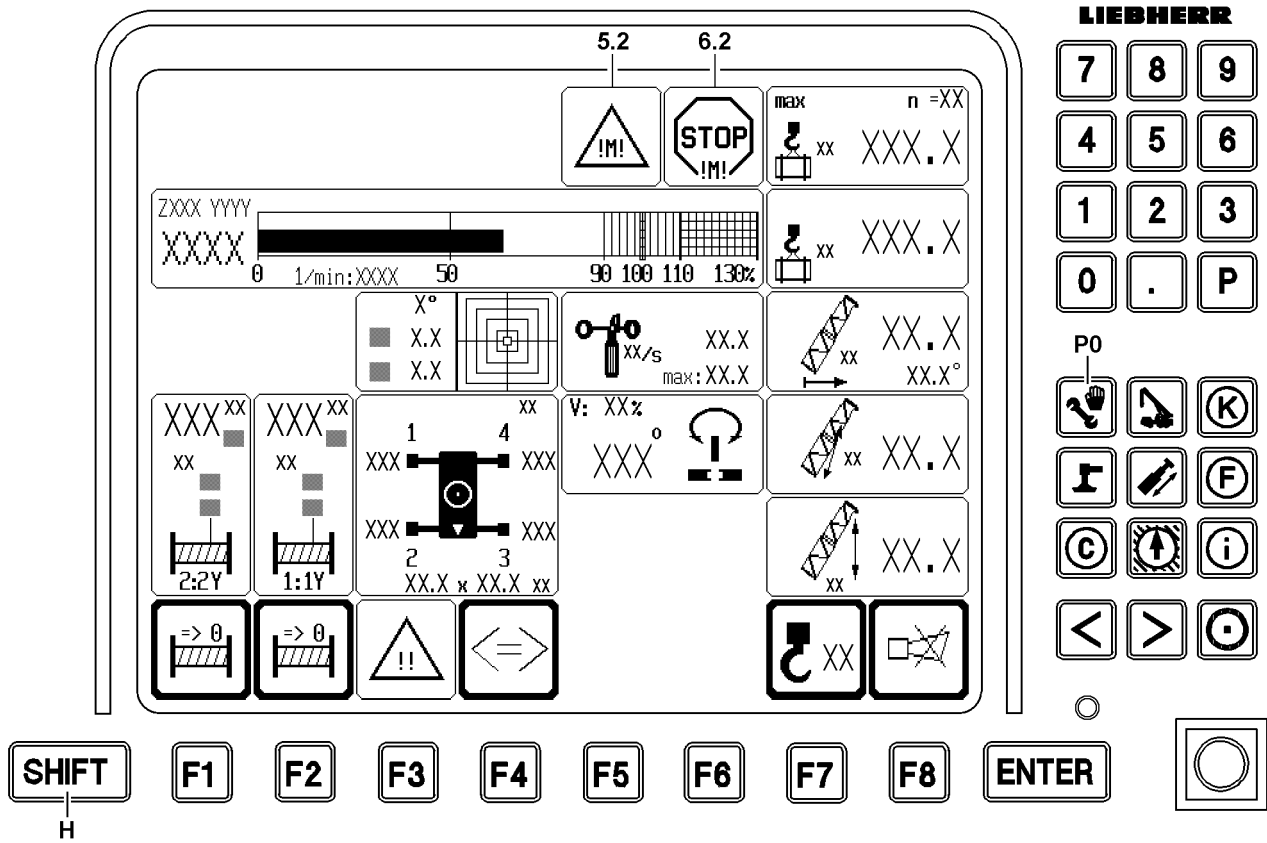

Fig.126906

LWE/LR 1600-2-008/18109-09-02/en

13.2 Possible engine monitoring advance warning, warning and STOP events

Events	Advance warning	Warning 5.2	STOP 6.2
Engine oil pressure (display value) missing		x	
Erroneous engine oil pressure (display value)		x	
Engine oil pressure warning active			x
Coolant / charge air temperature (display value) missing		x	
Erroneous coolant / charge air temperature (display value)		x	
Coolant / charge air temperature warning active			x
Coolant level warning active			x
Hydraulic oil temperature (display value) missing	x		
Erroneous hydraulic oil temperature (display value)	x		
Hydraulic oil temperature (display value) too high		x	
Air filter monitoring		x	
Battery voltage (display value) missing	x		
Erroneous battery voltage (display value)	x		
Battery voltage not between 16 V and 36 V	x		
Fuel reserve (display value) missing	x		
Erroneous fuel reserve (display value)	x		
Fuel reserve (display value) 10 % or less	x		
Fuel reserve (display value) 6 % or less		x	
Fuel reserve (display value) 1 % or less			x

If the system automatically switches to the „Engine monitoring“ program when an engine STOP event occurs, there is an option for retaining the engine monitoring screen within 5 seconds (retaining the engine monitoring screen is achieved by pressing the function key **F1**) (illustration 1). Switch back to the operating screen using the function key **F8** (OK) or the program key **P1** (crane operation). If the engine monitoring screen is **not** retained, then after 5 seconds the system switches back automatically to the „Crane operation“ program.

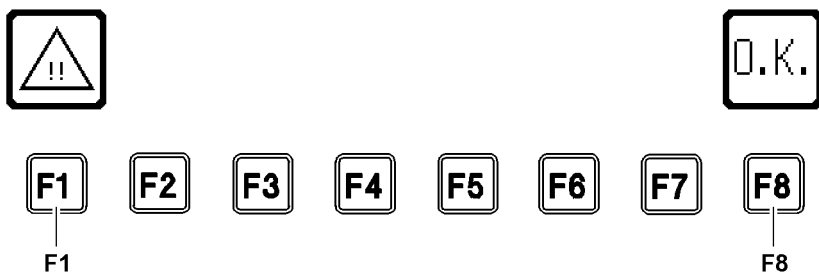
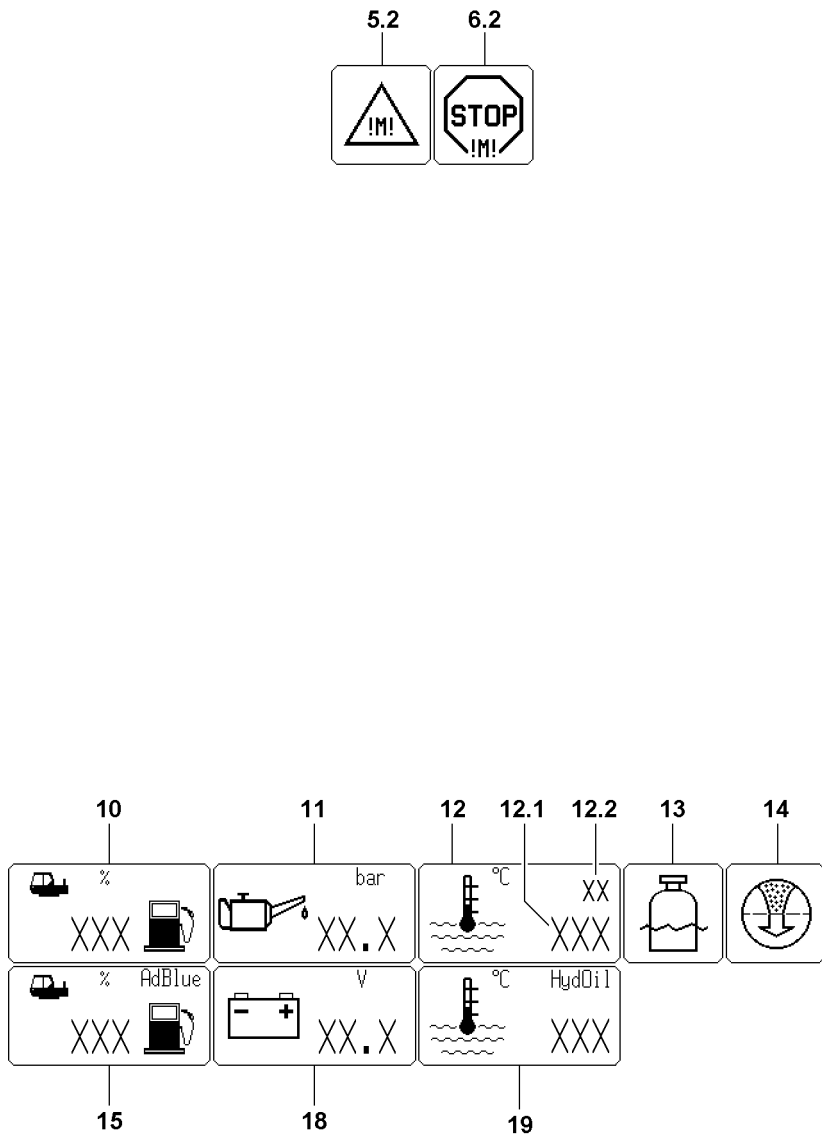

Fig.126907

13.3 Retaining the engine monitoring screen

The automatic change over into the engine monitoring screen is only made from the „Crane operation“ program.

If you confirm a monitoring event in the engine monitoring screen with the function key **F8**, then there will be **no** automatic change over to the engine monitoring screen for the same event.

On switching back to the „Crane operation“ program, the STOP icon **6.2** or the Advance warning icon **5.2** appears. The system does **not** alert again to other advance warnings in the „Crane operation“, since the advance warning already exists.



WARNING

There is a danger of severe damage to the engine if STOP events are ignored!

If other programs are used for extended periods of time, for example the „Set up“ or „Test system“, it is essential to switch occasionally to the engine monitoring screen in order to ensure that no engine monitoring events have occurred, which could lead to damage or destruction of the engine.

▶ Switch over occasionally to the engine monitoring screen!

The automatic change over in the engine monitoring screen has been made:

▶ Press the function key within 5 seconds **F1**.

Result:

- Retain the engine monitoring screen.
- Icon frames are displayed with a thin border.
- All load torque increasing crane movements will be turned off or locked.

Switch back to the „Crane operation“ program:

▶ Press function key **F8**.

Result:

- System switches back to the „Crane operation“ program.
- The block of the load moment increasing crane movements will be lifted.
- The advance warning or STOP icons are faded into the „Crane operation“ program.

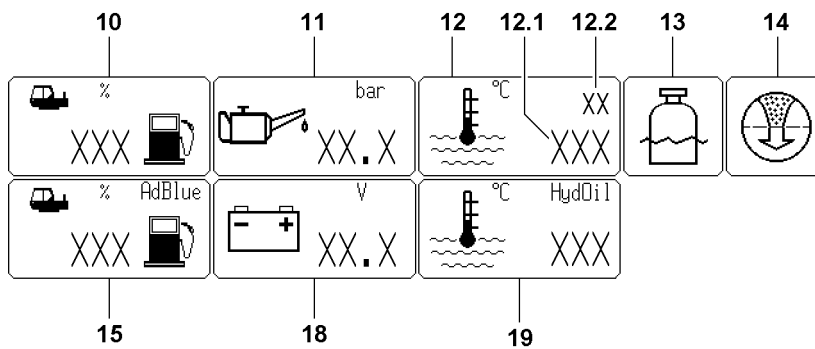
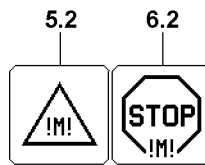

F1

F8

Fig.126907

LWE/LR 1600-2-008/18109-09-02/en

13.4 Engine monitoring icons

13.4.1 Crane engine

- 10 Tank content
 - In [%]
 - Icon blinks when the fuel reserve of the crane engine has reached insufficient fill level
- 11 Oil pressure
 - In [bar]
 - Numeric display in icon blinks if the engine oil pressure is too low.
- 12 Coolant / charge air temperature
 - In [°C]
- 12.1 Coolant temperature
 - Numeric display blinks if the coolant temperature is too high
- 12.2 Charge air temperature
 - Numeric display blinks if the charge air temperature is too high
- 13 Coolant level too low
 - Icon appears if the coolant level is too low
- 14 Air filter is dirty
 - Icon appears if the air filter is dirty
- 15 Urea reserve
 - **Note:** Only for crane types with SCR exhaust aftertreatment
 - In [%]
 - Observe the respective indicator lights in the roof console Crane operator's cab, see Crane operating instructions, chapter 4.01.
- 18 Battery voltage
 - In [V]
 - Numeric display in icon blinks if the operating voltage is less than 16 V or above 36 V
- 19 Hydraulic oil temperature
 - In [°C]
 - Numeric display blinks if the hydraulic oil temperature is too high.

13.5 Function key line

- F1 Function key
 - Retaining the engine monitoring screen
- F8 Function key
 - Switching back to the crane operation program



Note

► The function keys „F2“ to „F7“ are **not** used in the engine monitoring program!

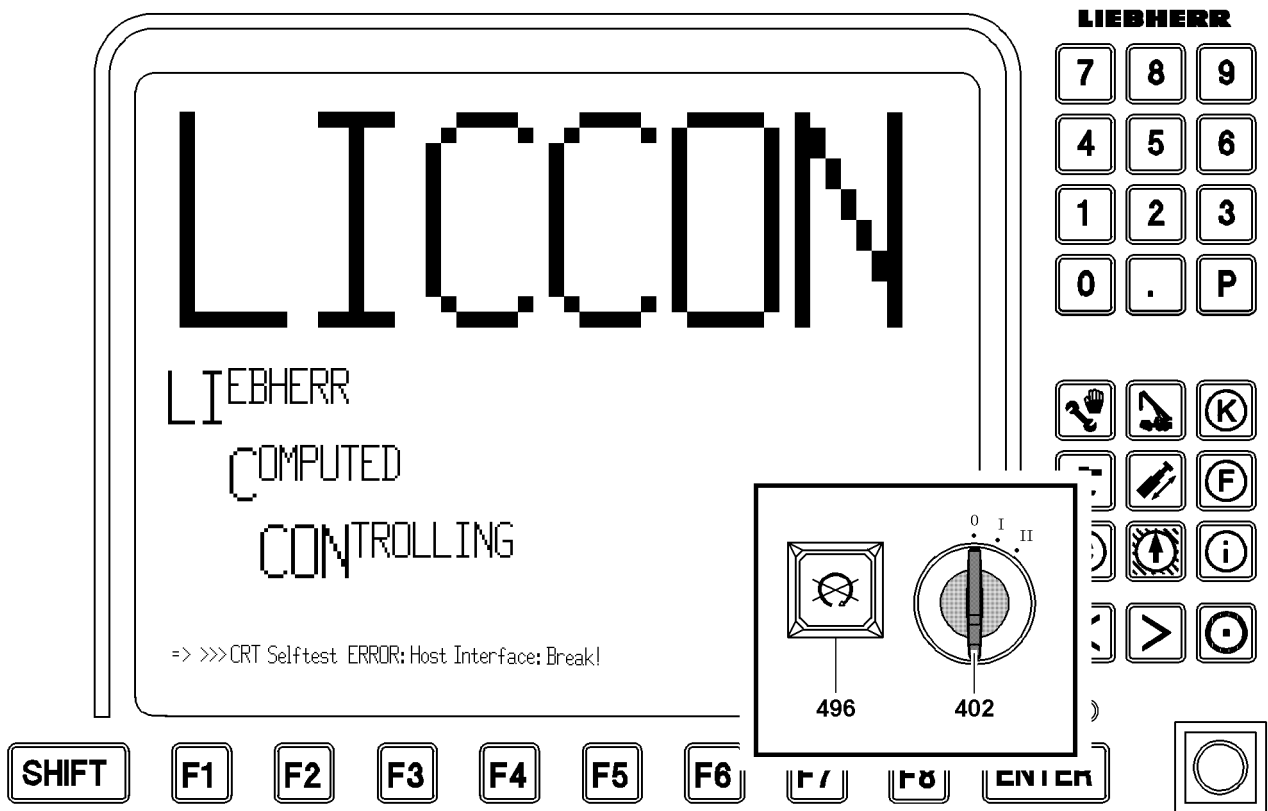
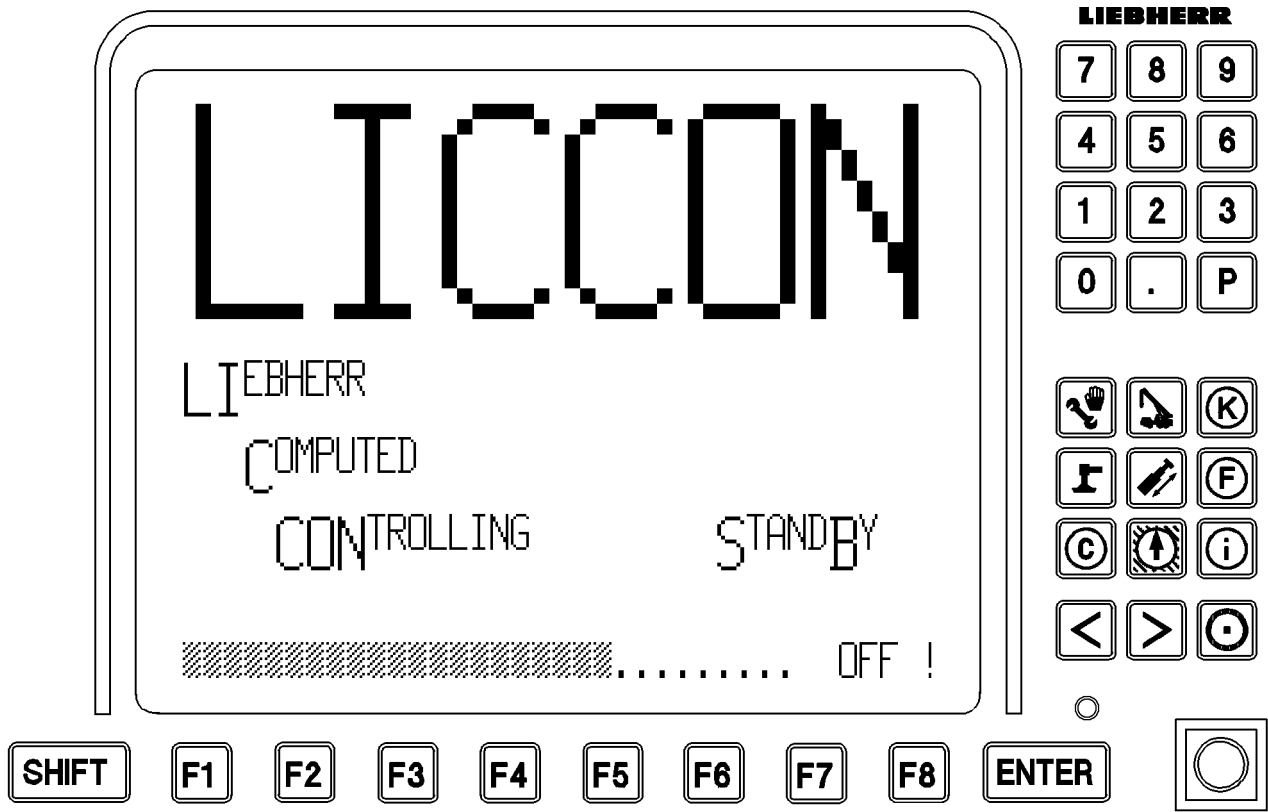

Fig.105190

LWE/LR 1600-2-008/18109-09-02/en

14 LICCON computer system in stand-by mode

14.1 Starting LICCON computer system in stand-by mode

There are two ways of achieving stand-by mode with the LICCON computer system.

Starting the LICCON computer system without the engine running:

- ▶ Turn the ignition switch **402** to position „I“ and leave it there.

Result:

- The LICCON computer system runs and the LICCON monitor shows the set up screen, or alternatively for a stop / warning / advance warning, the engine monitoring screen.

- ▶ Press function key **F8** (O.K.).

Result:

- System switches to the „Crane operation“ program.

Turning off the running engine with the engine stop button:

- ▶ Press the button **496**.
- ▶ Leave the ignition switch **402** in position „I“.

Result:

- The engine is turned off, the LICCON computer system continues to run.

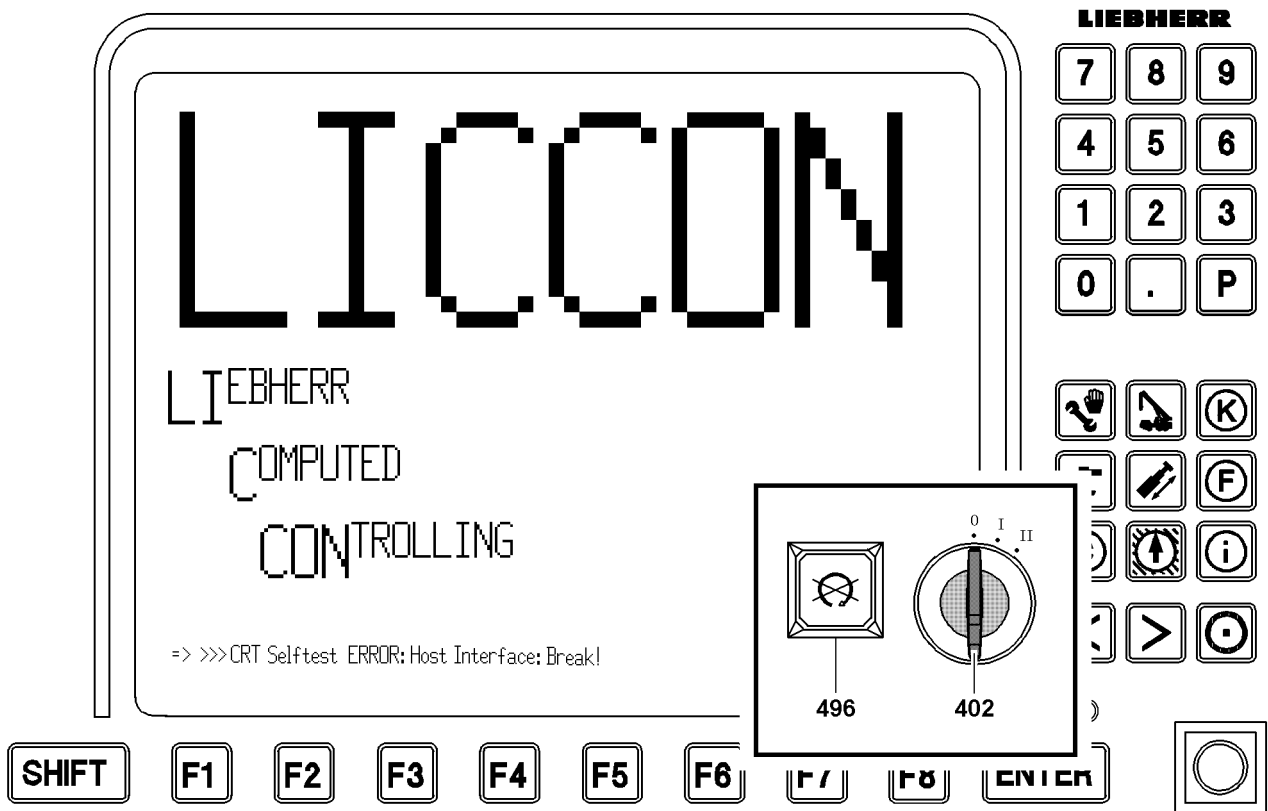

Fig.105190

LWE/LR 1600-2-008/18109-09-02/en

14.2 Active stand-by operation / alarm

The operating programs and the monitor displays function exactly the same as in the turn-on procedure for the LICCON computer system with engine start (crane operation).

No crane movements are possible. If a crane movement is selected anyway, a message appears on the LICCON monitor.

Example: **Control turning shut off, the crane engine is not running.**

The duration of the stand-by operation is 15 minutes, of which 3 minutes are the stand-by alarm. Operating the LICCON computer system during stand-by operation automatically extends the stand-by time.

► In **Stand-by operation** no keys are pressed on the monitor.

Result:

- The stand-by alarm (horn) is reached after 12 minutes.
- This screen appears on the monitor: **STANDBY** (see illustration).

► Now press any key on the LICCON monitor.

Result:

- System switches back to the interrupted program.
- The stand-by time is extended by another 15 minutes.

► During the **stand-by alarm** (Duration: 3 minutes) **no** keys on the monitor are pressed.

Result:

- The LICCON computer system shuts completely off. The shut off is announced by acoustical signals 60 seconds in advance (short horn) and 30 seconds in advance (long horn). The power supply of the LICCON computer system turns off.
- This screen appears on the LICCON monitor: **CRT Selftest ERROR: Host Interface: Break!** (see illustration). This is not an error message from the LICCON computer system, the error message appears only on the monitor because the connection between the monitor and the CPU is broken.

14.3 Start prevention

Starting the engine again after complete shut down of the LICCON computer system:

- Return the ignition switch **402** first to position „0“.
- Turn the ignition switch **402** to position „I“ (note the preheating time).
- Turn the ignition switch **402** briefly to position „II“.

Result:

- The engine starts.

Empty page!

LWE/LR 1600-2-008/18109-09-02/en

4.03 Crane start up and taking the crane out of service

1	Power supply for the crane*	3
2	Checks before start up	7
3	Work station - Crane operator's cab	15
4	Starting and stopping the engine	25
5	LICCON computer system after engine start	35
6	Load weighing and load display	41

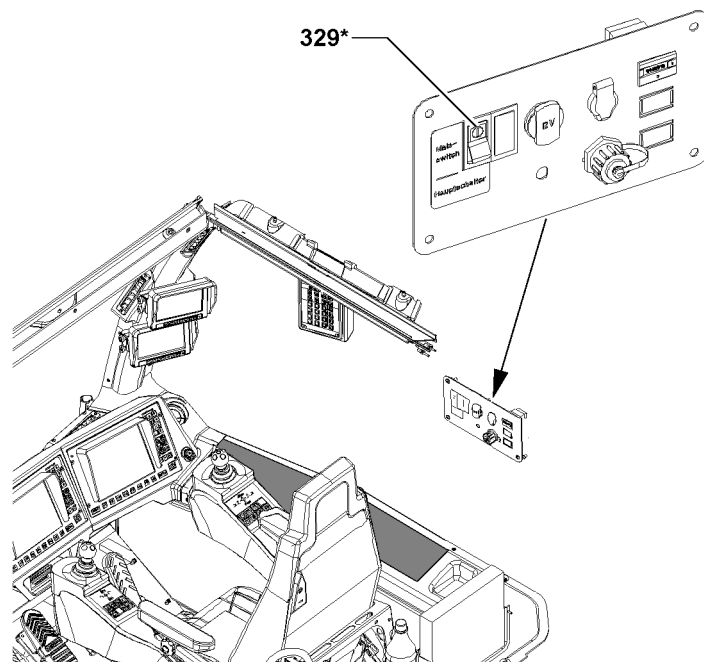

LWE/LR 1600-2-008/18109-09-02/en

Fig.113581

1 Power supply for the crane*

Before starting-up the crane, turn the power supply of the main current circuit on.

The **actuation** of the main current circuit releases the power supply for all systems relevant for crane operation.

The **shut-off** of the main current circuit disconnects all systems relevant for crane operation from the power supply of the power circuit.



Note

- ▶ Before the crane can be operated, turn the main current circuit on via the toggle switch* **329**.
- ▶ For the narrow track version of the crane, the main current circuit can be turned on via the toggle switch* **329** in the crane operator's cab or via the toggle switch* **603** in the cabinet on the crane chassis.

1.1 Airplane warning light



DANGER

Endangering air traffic!

If a proper and continuous operation of the airplane warning light(s) is not ensured through electrical external feed, then air traffic can be significantly endangered! This could result in serious accidents! Personnel can be severely injured or killed!

- ▶ After turning the main current circuit off, the airplane warning light can **no longer** be operated on the crane.
- ▶ For operation of the airplane warning light, leave the main current circuit on and ensure the electrical supply of the crane via external power supply.

The electrical supply of the airplane warning light must be ensured via external power supply:

- When turning the crane off after completion of the daily tasks.
- At downtime of the crane, which exceeds the duration of no more than one day.
- When turning the crane off in a work environment which requires the use of the airplane warning light continuously.



Note

- ▶ If the airplane warning light is operated via external power supply, then the main current circuit must be turned on!
- ▶ Actuate the main current circuit.
- ▶ Ensure the power supply of the crane via an external power supply.

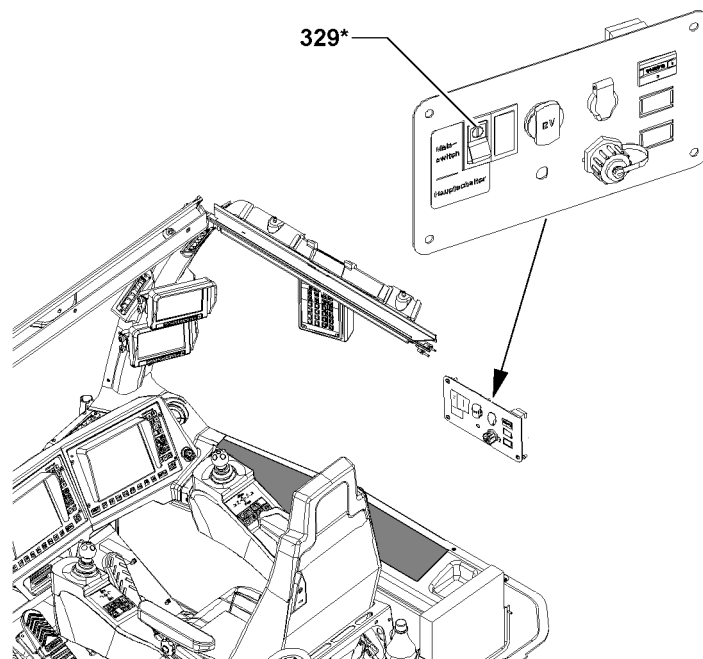

LWE/LR 1600-2-008/18109-09-02/en

Fig.113581

1.2 Turning the power supply of the main current circuit on / off

1.2.1 Actuating the main current circuit

If the main current circuit was turned off:

- ▶ Press the toggle switch* **329**.
- or
- Press the toggle switch* **603**.

Result:

- The power supply of the main current circuit is actuated.

1.2.2 Turning the main current circuit off

If the local application conditions of the crane permit, we recommend to turn the main current circuit of the crane or the crane off before leaving the jobsite every day.

Due to this measure, the fast discharge of the batteries by electrical users is prevented.



Note

- ▶ The discharge of the batteries is significantly accelerated due to the influence of cold weather conditions!

NOTICE

Total discharge of batteries!

If the main current circuit of the crane is not turned off daily when leaving the jobsite, then the batteries can be totally discharged which can destroy the batteries!

High replacement costs can result!

- ▶ Due to the local application conditions of the crane, no airplane warning light is required: Always turn the main current circuit off before leaving the jobsite / crane.

- ▶ Press the toggle switch* **329**.
- or
- Press the toggle switch* **603**.

Result:

- The main current circuit is disconnected from the power supply.

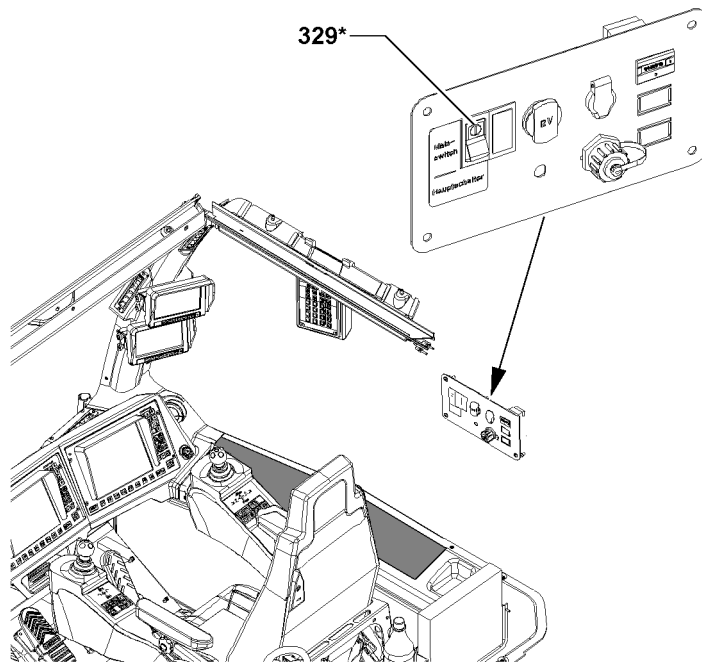

LWE/LR 1600-2-008/18109-09-02/en

Fig.113581

2 Checks before start up



WARNING

Emergency devices not operational!

If emergency devices, such as the EMERGENCY OFF switch, ladders etc. are not accessible or operational, then they cannot be used in case of an emergency!

Personnel can be injured or killed because the emergency devices are not operational!

- ▶ Check emergency devices before start up for accessibility or operational readiness!
- ▶ Open or remove anti theft devices, such as locks on the emergency devices!



Note

- ▶ For detailed description of fill quantities, service items and lubricants, see Crane operating instructions, chapter 7.06 and chapter 7.07!

Carry out various checks every time before operating the crane.

If an item is low or lacking during an inspection, then it must be refilled or brought to normal status before operating the crane.

If the inspection shows a very dirty filter, then it must be replaced before operating the crane.

2.1 Visual inspections

Make sure that the following prerequisites are met:

- The ignition switches are in position „I“.
- The engine is off.
- The engine is at ambient temperature.
- The LICCON computer system is in stand-by mode.

2.1.1 Checking the oil levels and filters

- ▶ Check the engine oil level.
- ▶ Check the oil level in the hydraulic tank.
- ▶ Check the filter on the hydraulic tank.

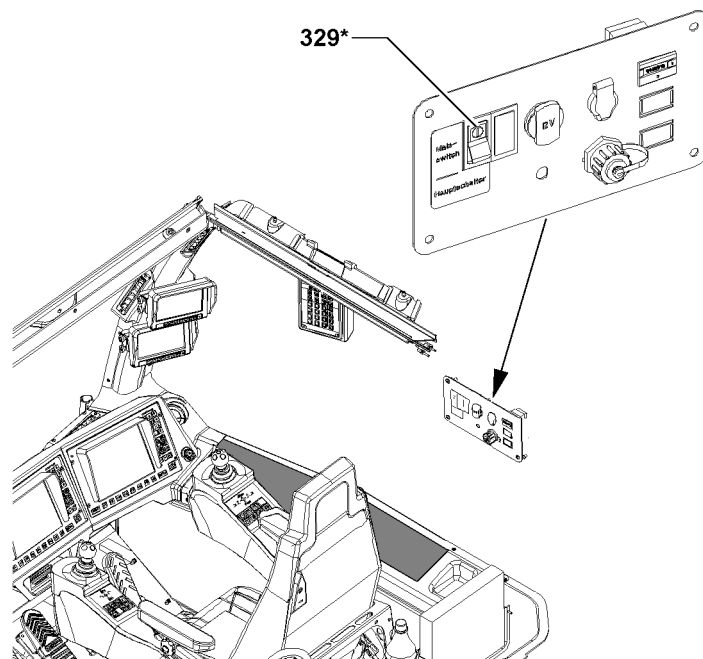

LWE/LR 1600-2-008/18109-09-02/en

Fig.113581

2.1.2 Checking the central lubrication system

For detailed description of lubricants and fill quantities, see Crane operating instructions, chapter 7.06 and chapter 7.07!

NOTICE

Property damage due to insufficient lubrication!

- ▶ Check the fill quantity of the grease containers!

If the fill quantity falls below the marked minimum amount:

- ▶ Fill the grease container with grease!
-

2.1.3 Checking the coolant level

For detailed description of lubricants and fill quantities, see Crane operating instructions, chapter 7.06 and chapter 7.07!



WARNING

Danger of burns due to hot coolant!

Coolant at operating temperature is under pressure. If the cooling system is opened, there is the danger of scalding!

- ▶ Check the coolant level only when the engine is cold!
-

NOTICE

Property damage due to insufficient cooling!

- ▶ Check the coolant level!

If the coolant level of the coolant expansion tank falls below the overflow on the filler neck:

- ▶ Add coolant!
-

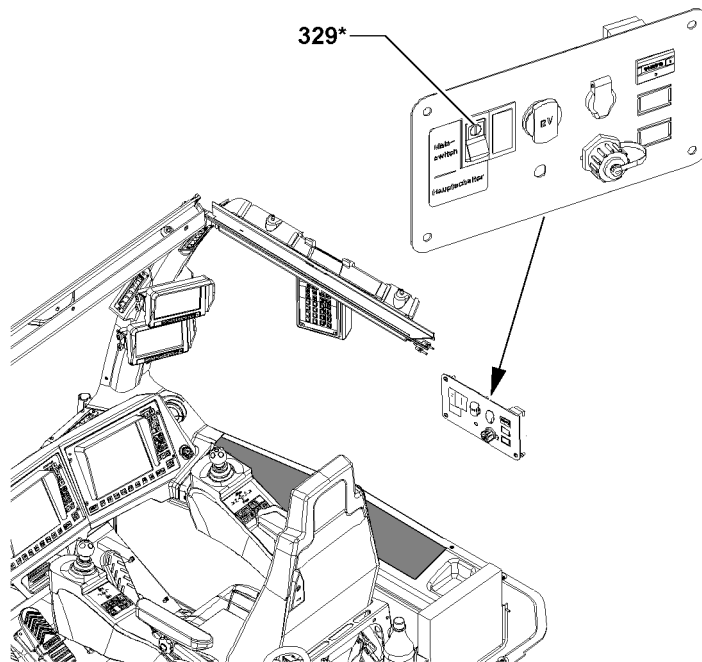

LWE/LR 1600-2-008/18109-09-02/en

Fig.113581

2.1.4 Checking the window cleaning fluid

NOTICE

Frozen window cleaning fluid!

If the window cleaning fluid is not frost resistant, then the window washer system can freeze during the cold time of the year!

Failure of the window washer system is the result!

The window washer system can be damaged!

- ▶ Change the window cleaning fluid in time to a frost resistant type!
-

Before the start of the cold season:

- ▶ Empty the container for the window cleaning fluid and refill it with a commercially available, frost resistant window cleaning fluid.

2.1.5 General checks



WARNING

Danger of fatal injury due to falling parts!

If parts fall from the main boom during erection, personnel can be severely injured or killed!

- ▶ Before erecting the boom: Make sure that there are no loose parts on the boom system, such as pins, spring retainers or ice!
 - ▶ Make sure that the cable / rope drum and the limit switches are free of snow and ice!
 - ▶ Make sure that the crane is horizontally aligned.
 - ▶ Make sure that all safety lights and working floodlights are functioning.
 - ▶ Make sure that the gear ring of the slewing ring connection is clean and greased.
 - ▶ Make sure that the air supply to the oil and water cooler is clear.
 - ▶ Make sure that side covers are closed and locked.
 - ▶ Make sure that no persons or objects are within the danger zone of the crane.
-

2

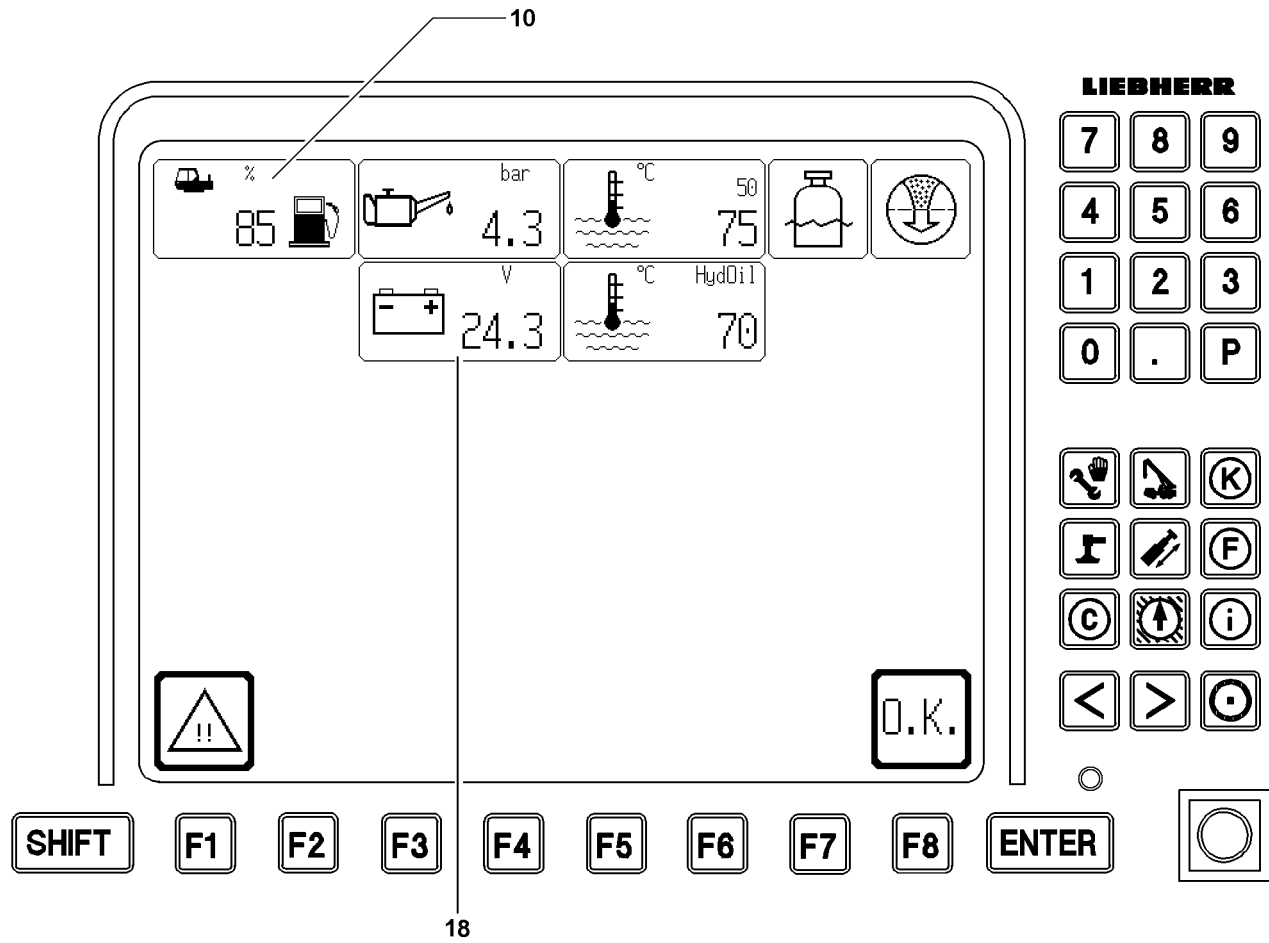

Fig.110809

2.2 Checks via the LICCON computer system

If a control value has reached the limit value, then the LICCON computer system switches momentarily into the engine monitoring program during boot up and shows the monitored values graphically, see illustration 2.



Note

- ▶ For a detailed description of the LICCON computer system, see Crane operating instructions, chapter 4.02!

2.2.1 Checking the fuel level



Note

Fuel tank empty!

If the fuel tank has run dry, then the fuel system must be bled!

- ▶ Refuel in time!



Note

- ▶ In the engine monitoring program, the fuel level in the tank **10** is shown in percentages!

- ▶ Call up the monitor display engine monitoring in the LICCON computer system and check the fuel level.

2.2.2 Checking the battery voltage



Note

The battery voltage must be checked in regular intervals, especially if the crane has been „out of service“ for a longer period of time and users, such as the airplane warning lights - are checked and the battery must be recharged if necessary!

- ▶ Recharge the battery, see Crane operating instructions, chapter 7.05!



Note

Reduced battery performance requires greater power requirements!

- ▶ Ensure that batteries are well charged, particularly during the colder months!

- ▶ Check the battery voltage, see icon **18**.

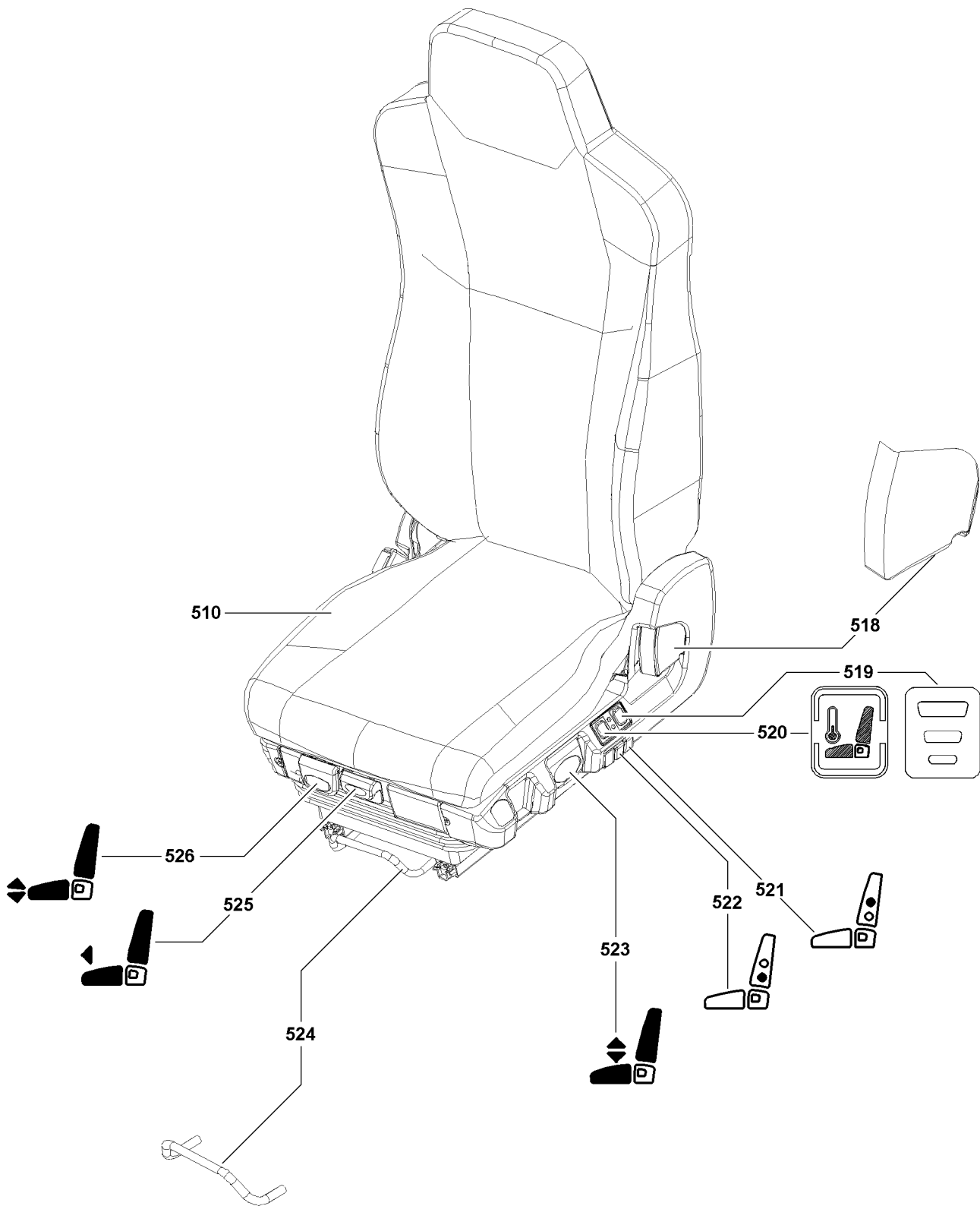

Fig.104902

LWE/LR 1600-2-008/18109-09-02/en

3 Work station - Crane operator's cab

3.1 Adjusting the crane operator's seat

The crane operator's seat can be adjusted to suit different body sizes.

Adjust the seat position

- ▶ With the lever **518** adjust the angle of the backrest.
- ▶ With the button **521** adjust the lumbar area support „on top“.
- ▶ With the button **522** adjust the lumbar area support „on the bottom“.
- ▶ With the lever **523** adjust height of seat.
- ▶ Unlock the horizontal seat adjustment with the bracket **524**.
- ▶ With the lever **525** adjust the seat cushion by moving it back or forth.
- ▶ With the lever **526** adjust the seat incline.

Turn the seat heater / climate control on

The seat heater or climate control is turned on and off with the switch **520**.

There are three switch positions:

- Center position: Heater and climate control is turned off.
 - Pushed on top: Heater turned on (red light).
 - Pushed on the bottom: Climate control turned on (blue light).
- ▶ Turn the seat heater / climate control on with switch **520**.
 - ▶ Adjust the fan stage with switch **519**.

3.2 Adjusting the consoles

The control platform, with the consoles on the left and right hand side of the crane operator's seat **510** allows the crane driver to adjust the consoles for „crane operation“ to suit his body size optimally.



Note

- ▶ The left and right consoles are individually adjustable!
-

Two different console positions are possible:

- „Crane operating position“
- „Entering / exiting“

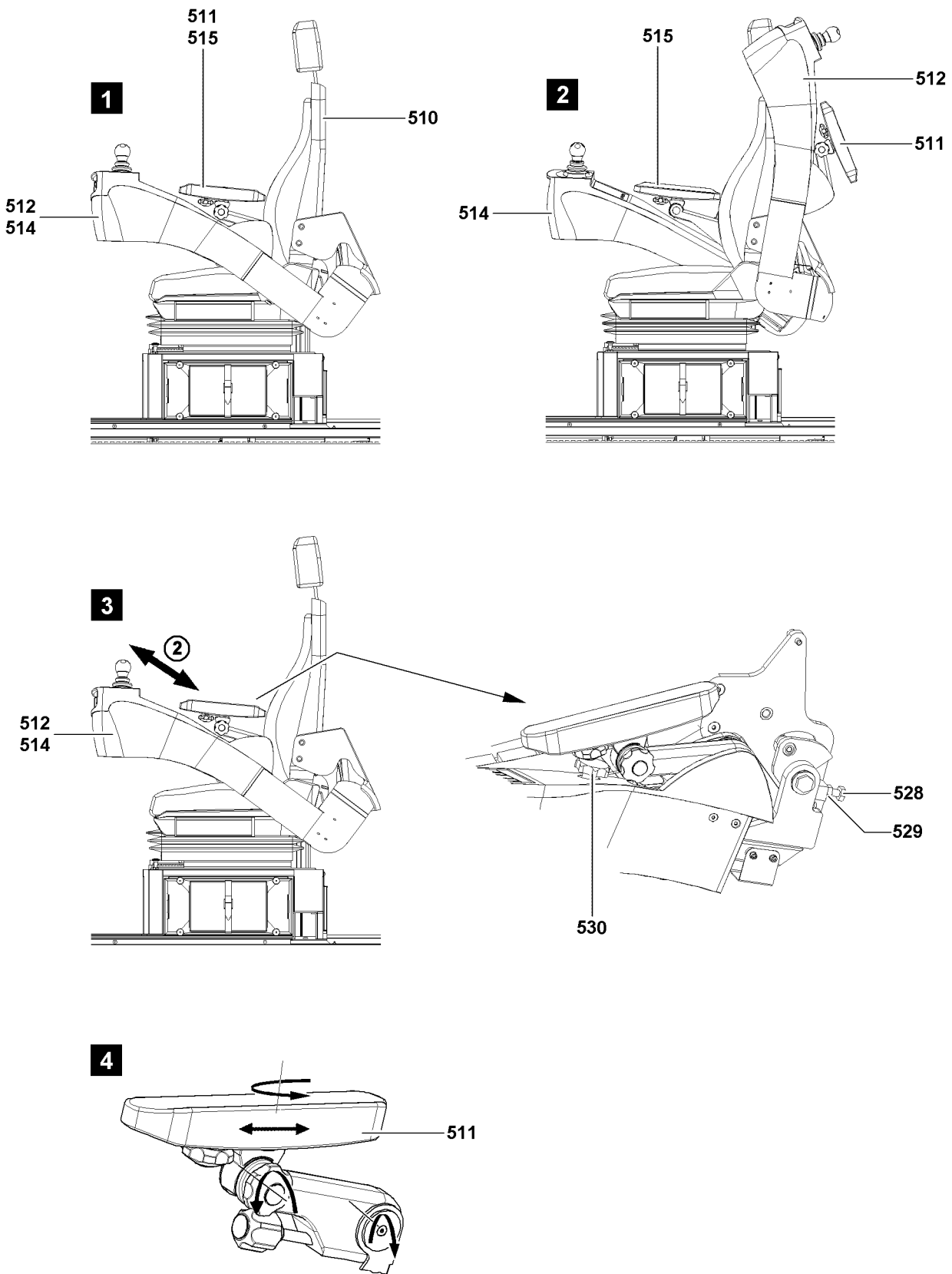

Fig.105888

LWE/LR 1600-2-008/18109-09-02/en

**WARNING**

Danger of accidents due to folded down console!

If the left console **512** is swung up (position „entering / exiting“), see illustration **2**, when operating the crane - specially during severe braking maneuvers - there is an increased risk of accidents as well as a danger of property damage due to uncontrolled „down“ or „forward“ swing of the console(s).

- ▶ Driving the crane with upward swung consoles is **prohibited!**
- ▶ Before starting to travel, always bring the consoles into „Crane operating position“!

You can move the left console from „crane operating position“ to „entering / exiting“ position by swinging it up.

**Note**

- ▶ When swinging the console upward, hold on to it until the end position „entering / exiting“ is reached!
- ▶ When the console is swung down, it returns to the previously set „Crane operating position“!

The consoles can be adjusted with **one hand**.

3.2.1 Adapting the consoles to the crane driver

**Note**

- ▶ The consoles can be adjusted to suit the crane driver as described for the left console **512!**

Adjust the incline

- ▶ Adjust the stop screw **528** until the console has reached the desired incline.
- ▶ Secure the stop screw with the nut **529**.

Move the console horizontally

- ▶ Fold the armrest up.
- ▶ Loosen the lock screw **530** until the console can be moved.
- ▶ Adjust the horizontal position of the console by moving it back or forth (point **2**).
- ▶ Tighten the lock screw **530**.
- ▶ Fold the armrest down.

Result:

- The console is adjusted.

3.2.2 Adjusting the arm rests

The left armrest **512** and the right armrest **514** offer a multitude of adjustment possibilities, see illustration **4**.

**Note**

- ▶ To ensure fatigue free and concentrated work with the crane, the armrests should be adjusted in such a way that you can comfortably reach and operate the master switches!

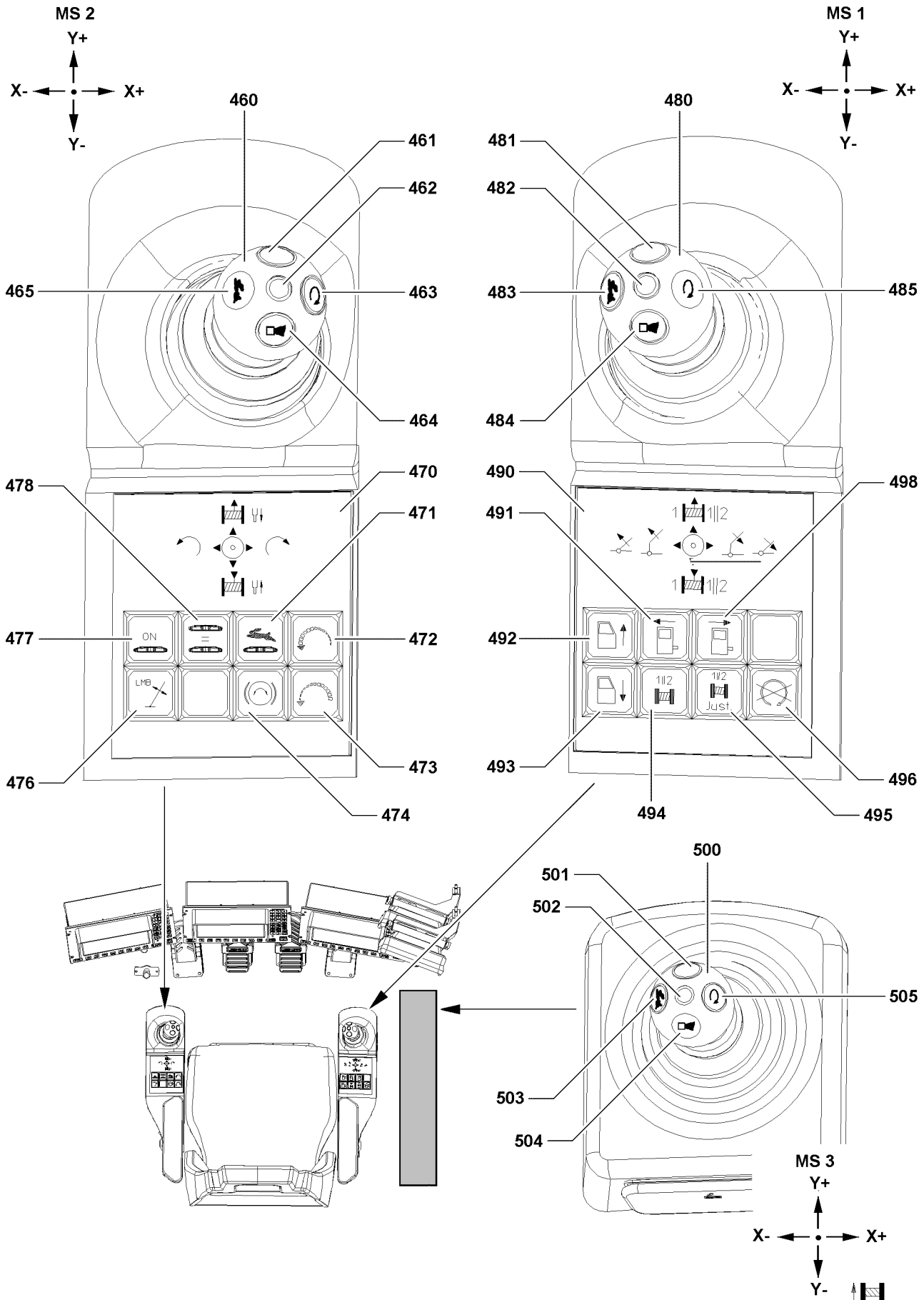

Fig.110807

LWE/LR 1600-2-008/18109-09-02/en

3.3 Turning the heater and climate control system on

The crane cab can be heated or ventilated depending on the desired temperature, see Crane operating instructions, chapter 6.01!

3.4 Tilting the crane cab

To give the crane driver a better field of view, the cab can be tilted upward.



Note

▶ After ending crane operation: Move the cab to the horizontal position!

3.4.1 Tilting the cab upward

▶ Press the button **492**.

Result:

– The cab swings upward.

3.4.2 Moving the cab to the horizontal position

▶ Press the button **493**.

Result:

– The cab swings downward.

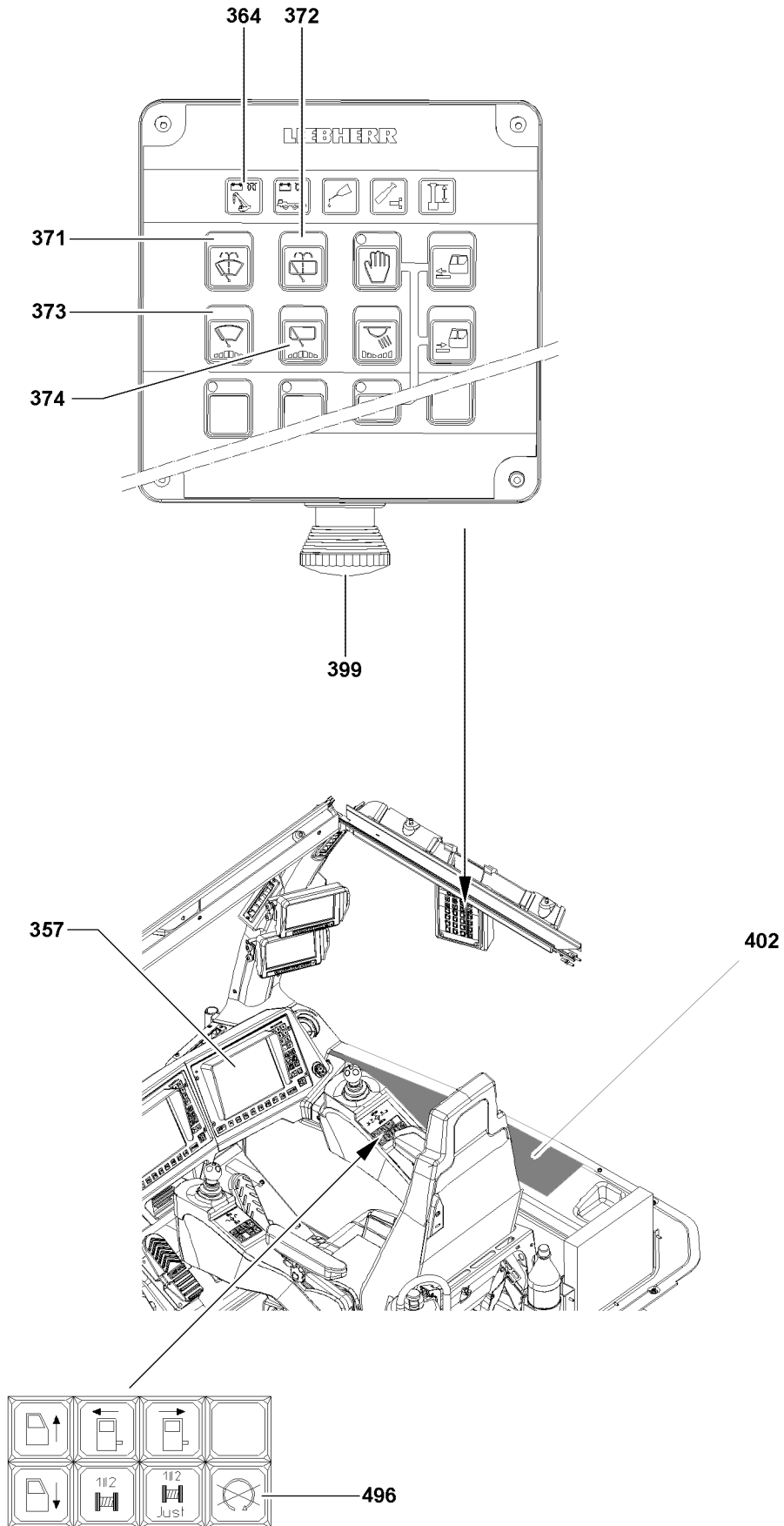

LWE/LR 1600-2-008/18109-09-02/en

Fig.110806

3.5 Operating the window wiper / window washer system

3.5.1 Operating the window wipers

The windshield wipers on the front and roof window can be operated via the function buttons on the operating and control unit. Each window has a button assigned to it.

Turning the window wiper on

There are four different wipe stages.

Pressing the button **373** or the button **374** (less than 0.5 s) reduces the wiper speed incrementally:

1. Continuous operation
2. Intermittent 2
3. Intermittent 1
4. Wiper off

A beep sounds in wipe stage „Wiper off“.

To activate the window wiper on the front window:

- ▶ Press the button **373** until the desired wipe stage is reached.
- or**

To activate the window wiper on the roof window:

Press the button **374** until the desired wipe stage is reached.

Turn the window wiper off

In continuous operation:

- ▶ Press the button **373** or the button **374** for at least one second.

or

Press the button **373** or the button **374** (less than 0.5 s) until a „beep“ sounds.

or

Turn the ignition switch **402** off.

3.5.2 Operating the window washer system

The windshield washer system on the front and roof window can be operated via the function buttons on the operating and control unit. Each window has a button assigned to it.

After releasing the button **371** or the button **372**, three additional wipe movements are carried out before the wiper blades return to their original position.

The wiper motor and the water pump run as long as the button **371** or button **372** is pressed down.

To activate the windshield washer system for the front window:

- ▶ Press the button **371**.

or

To activate the windshield washer system for the roof window:

Press the button **372**.

3.5.3 Filling the windshield washer system

For the location of the reservoir for the window cleaning fluid, see Crane operating instructions, chapter 4.01!

Before the start of the cold season:

- ▶ Fill the reservoir for the window cleaning fluid with commercially available antifreeze.

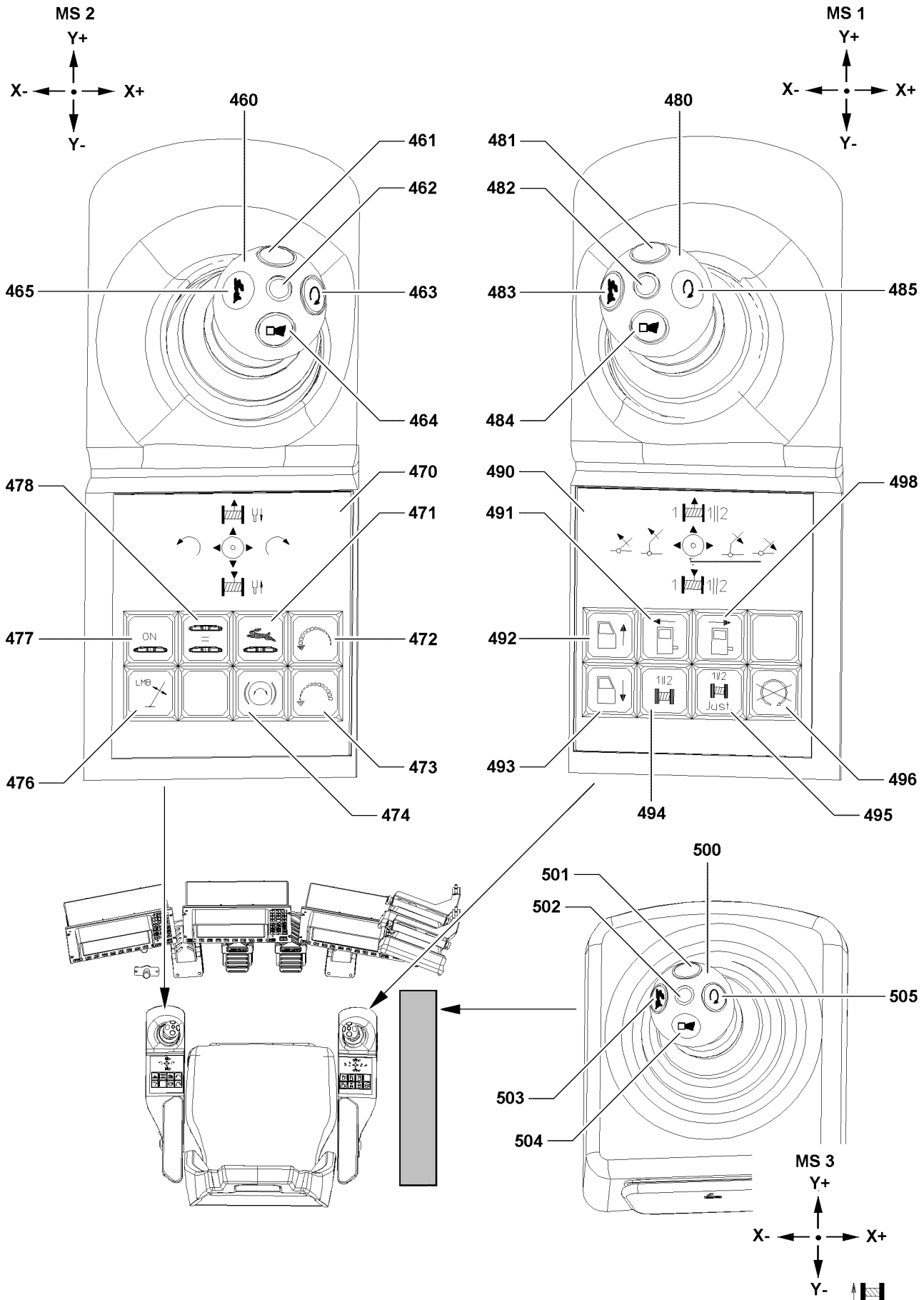

Fig.110807

LWE/LR 1600-2-008/18109-09-02/en

3.6 Opening the roof window

**CAUTION**

Danger of injury if hands get jammed!

- ▶ Watch your hands when closing the roof window!

A pair of nitrogen gas cylinders support the lifting movement of the roof window.

- ▶ To open from inside, press on the roof window.
or

If you only want to partly open the window:

Adjust the window in the desired position with the provided perforated belt.

3.7 Checking the horn

**Note**

Use of the horn!

- ▶ Use the horn only in dangerous situations to maintain its warning effect!

- ▶ Before starting to work, check that the horn is functioning: Press the button **464**.
or
Press the button **484**.
or
Press the button **504**.

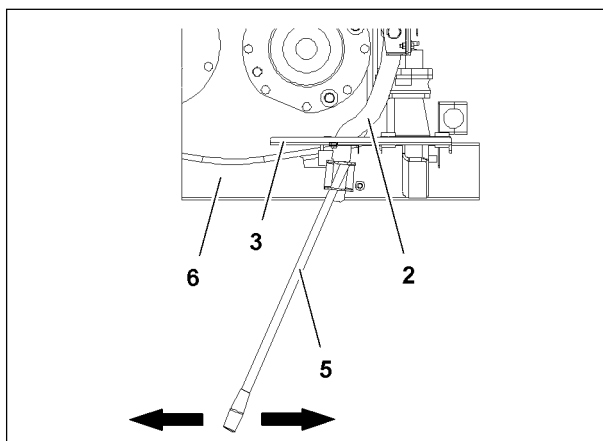
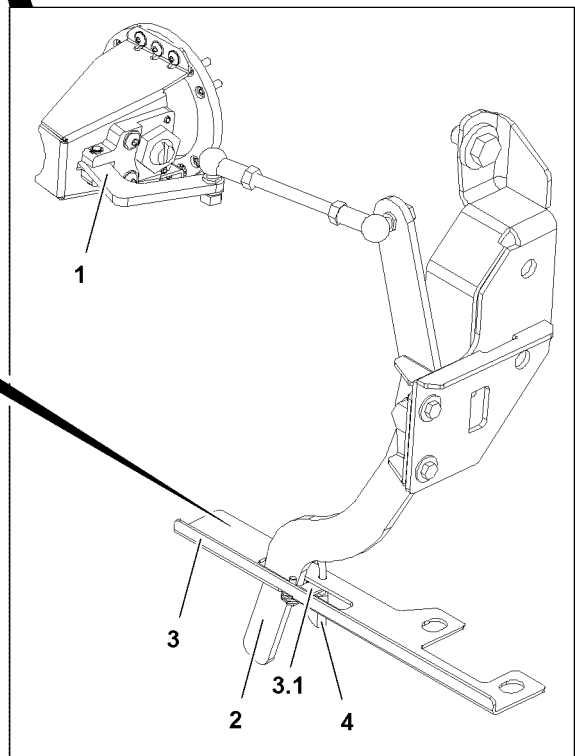
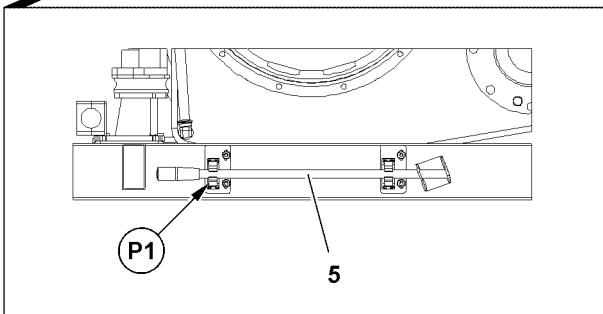
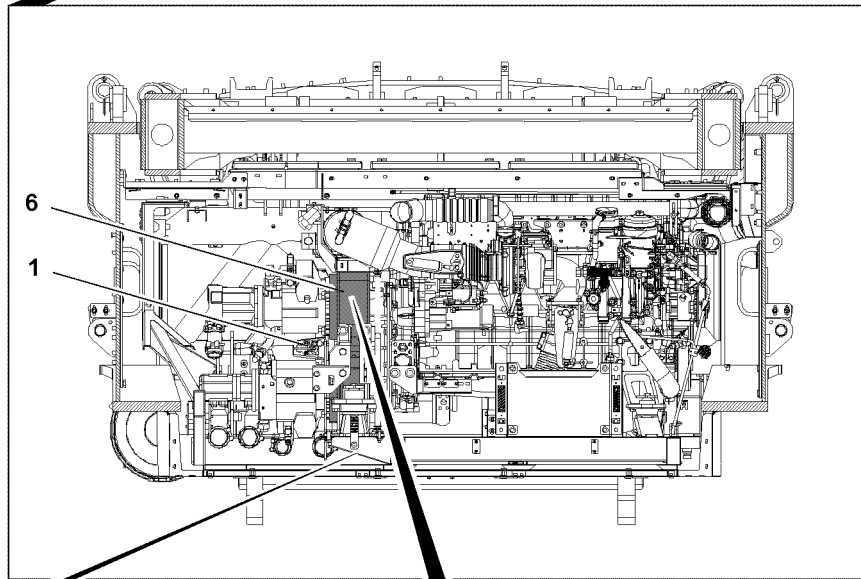
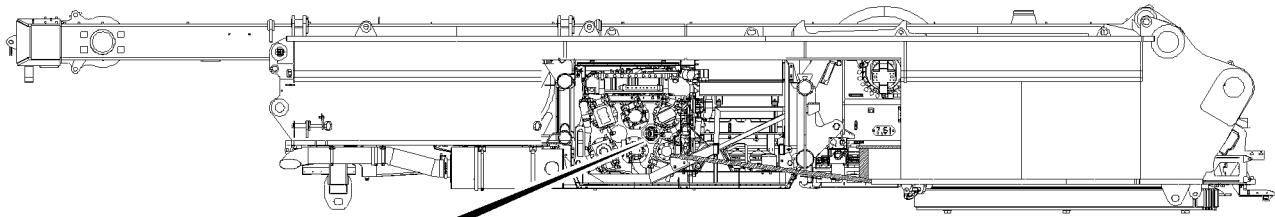

Fig.117893

LWE/LR 1600-2-008/18109-09-02/en

4 Starting and stopping the engine



Note

- ▶ The engine must be operated according to the separately supplied Engine operating instructions!

4.1 Disengage / engage the coupling control on the pump distributor gear



Note

- ▶ In high altitude application and at low ambient temperatures it may be necessary to disengage the coupling control **1** of the pump distributor gear **6** before starting the engine.
- ▶ The cold start behavior of the engine is thereby improved.

NOTICE

Danger of damaging the engine!

When the coupling control **1** is disengaged and the engine temperature is not constantly monitored, the engine can overheat.

This could result in high property damage.

- ▶ Monitor the engine temperature constantly while the engine is running.
- ▶ Make sure that the engine does not overheat.
- ▶ If there is any doubt, turn the engine off.

4.1.1 Disengage the coupling control

Make sure that the following prerequisite is met:

- The engine is turned off.
- ▶ Remove the padlock **4**.
- ▶ Remove the lever extension **5** from park position at point **P1**.
- ▶ Set the lever extension **5** on the linkage **2**.
- ▶ Actuate the linkage **2** with the lever extension **5** to the stop.

Result:

- The coupling control **1** is disengaged.
- The pumps on the pump distributor gear **6** are **not** driven at engine start.
- ▶ Remove the lever extension **5** and store it in the park position **P1**.



WARNING

Danger of accident due to rotating parts!

- ▶ Make sure that there are no persons within the danger zone of the engine.
- ▶ Start the engine, see section „Starting the engine“.
- ▶ Let the engine warm up.

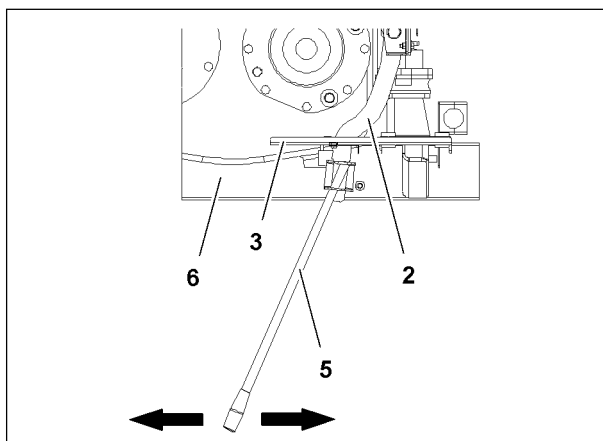
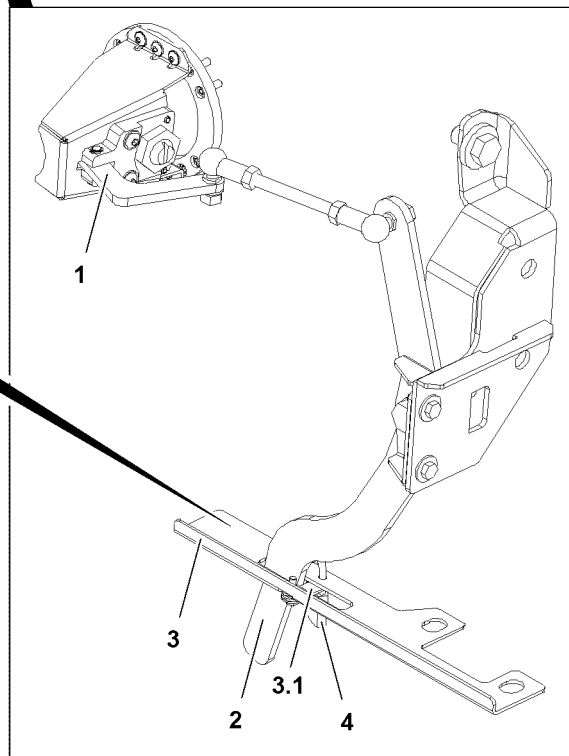
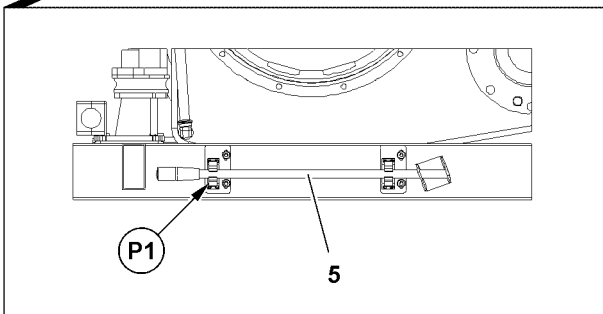
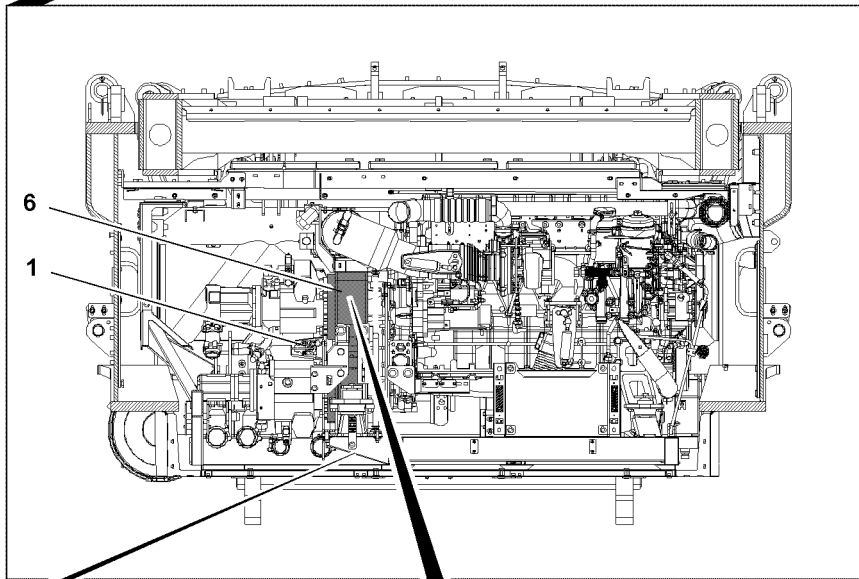
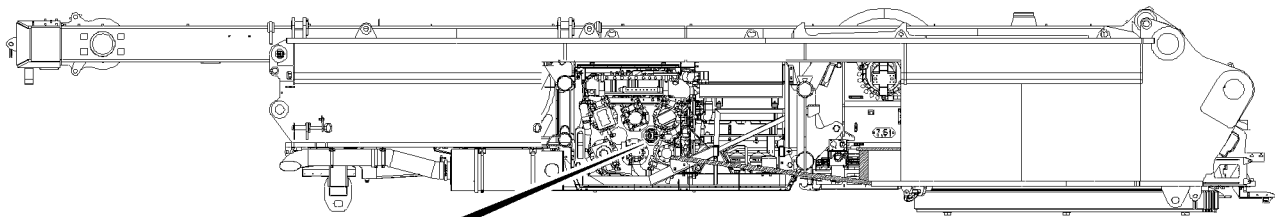

Fig.117893

LWE/LR 1600-2-008/18109-09-02/en

4.1.2 Engaging the coupling control

NOTICE

Property damage on the pump distributor gear!

- ▶ Make sure that the coupling control is engaged when the engine is at a standstill.
-

When the engine has reached operating temperature:

- ▶ Turn the engine off.

When the engine has come to a complete standstill:

- ▶ Engage the coupling control **1** with the lever extension **5**.
-

Problem remedy

The coupling control **1** cannot be engaged on the pump distributor gear **6**?

- ▶ Start the engine for a short time and turn it off again until the coupling control **1** can be engaged.
-

When the coupling control **1** is completely engaged:

- ▶ Close the safety bar **3.1** and secure the linkage with a padlock **4** to prevent unauthorized access.
- ▶ Remove the lever extension **5** and store it in the park position **P1**.

Result:

- At engine start, the hydraulic pumps on the pump distributor gear **6** are driven.

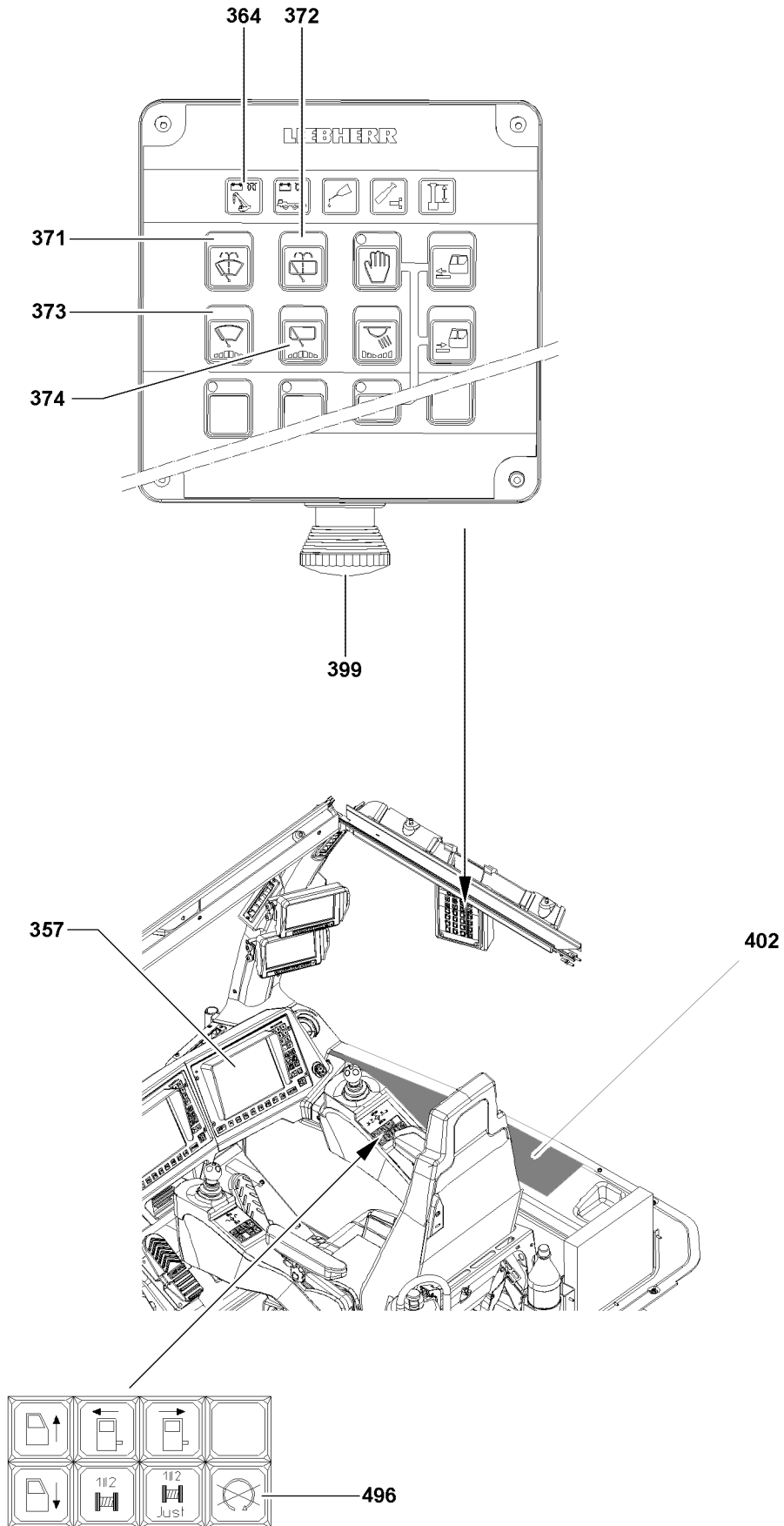

LWE/LR 1600-2-008/18109-09-02/en

Fig.110806

4.2 Starting the engine

- ▶ Turn the ignition switch **402** to position „I“.

Result:

- The indicator light **364** lights up yellow.
- The engine preheating is active.

NOTICE

Property damage due to insufficient engine preheating!

If the engine is not preheated sufficiently, the engine will not start or the engine has a false start!

- ▶ Start the engine only if the indicator light **364** blinks yellow (1 Hz)!
-



Note

Engine preheated too long!

The indicator light **364** turns off automatically after a certain time!

- ▶ Turn the ignition switch **402** to position „0“ and wait a little!
 - ▶ Start again!
-

When the indicator light **364** blinks yellow (1 Hz), the engine is ready to start:

- ▶ Turn the ignition switch **402** to position „II“.

Result:

- The engine starts.
 - The indicator light **364** turns off.
-

Problem remedy

Indicator light **364** blinks yellow (2 Hz)?

The engine is not preheated sufficiently or there is a problem in the cold start system.

- ▶ Turn the ignition switch **402** off, wait a little and retry.
 - ▶ or: Check the error message on the LICCON monitor 0 **357**. If possible, remedy the error.
 - ▶ or: Contact the next Liebherr Service location or Liebherr-Werk Ehingen.
-

Problem remedy

The indicator light **364** lights up red?

The engine is running, the alternator does not charge.

- ▶ Check the V-belt.
 - ▶ or: Check the error message on the LICCON monitor 0 **357**. If possible, remedy the error.
 - ▶ or: Contact the next Liebherr Service location or Liebherr-Werk Ehingen.
-

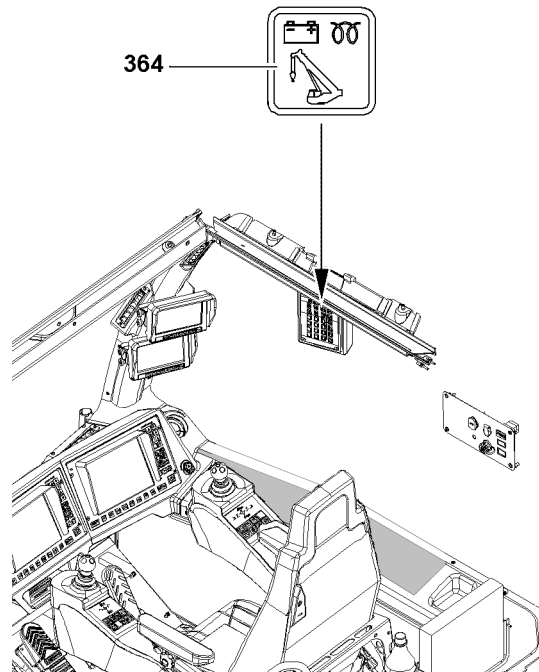
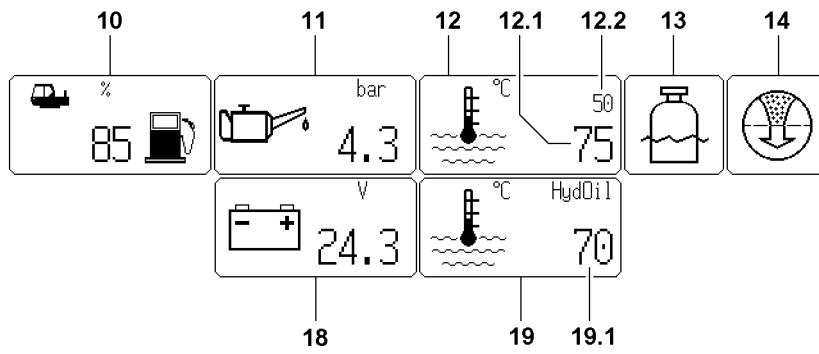

Fig.104899

LWE/LR 1600-2-008/18109-09-02/en

4.3 After engine start: Checking the instruments on the LICCON monitor

As soon as a stable voltage is present with the engine running, the electric crane control and the LICCON computer system are turned on automatically. A self-test of the microprocessor system follows and after a few seconds the set up configuration screen appears on the monitor.

The following icons must turn off when the engine is running:

- ▶ Check the indicator light **364**.
- ▶ Check the icon **11** „Engine oil pressure“ on the LICCON monitor.

Problem remedy

Does the numerical display for the engine oil pressure in the icon **11** blink after approximately 10 seconds or does it start to blink during crane operation?

The engine oil pressure is too low. The engine can be damaged as a result of insufficient oil pressure.

- ▶ Turn the engine off immediately and determine the cause.

-
- ▶ Check the numerical display for the coolant temperature in the icon **12.1**.

Problem remedy

Does the numerical display for the „coolant temperature“ in the icon **12.1** blink during operation?

The coolant temperature is too high. Excessive coolant temperature can lead to engine damage.

- ▶ Turn the engine off immediately.

-
- ▶ Check the icon **10** for „fuel content“.
 - ▶ Check the icon **19** for „hydraulic oil temperature“.
 - ▶ Check the icon **12.2** for „charge air temperature“.
 - ▶ Check the icon **13** for „coolant level“.
 - ▶ Check the icon **14** for „air filter“.
 - ▶ Check the icon **18** for „battery voltage“.

4.4 Engine monitoring

For a detailed description of engine monitoring, see Crane operating instructions, chapter 4.02.

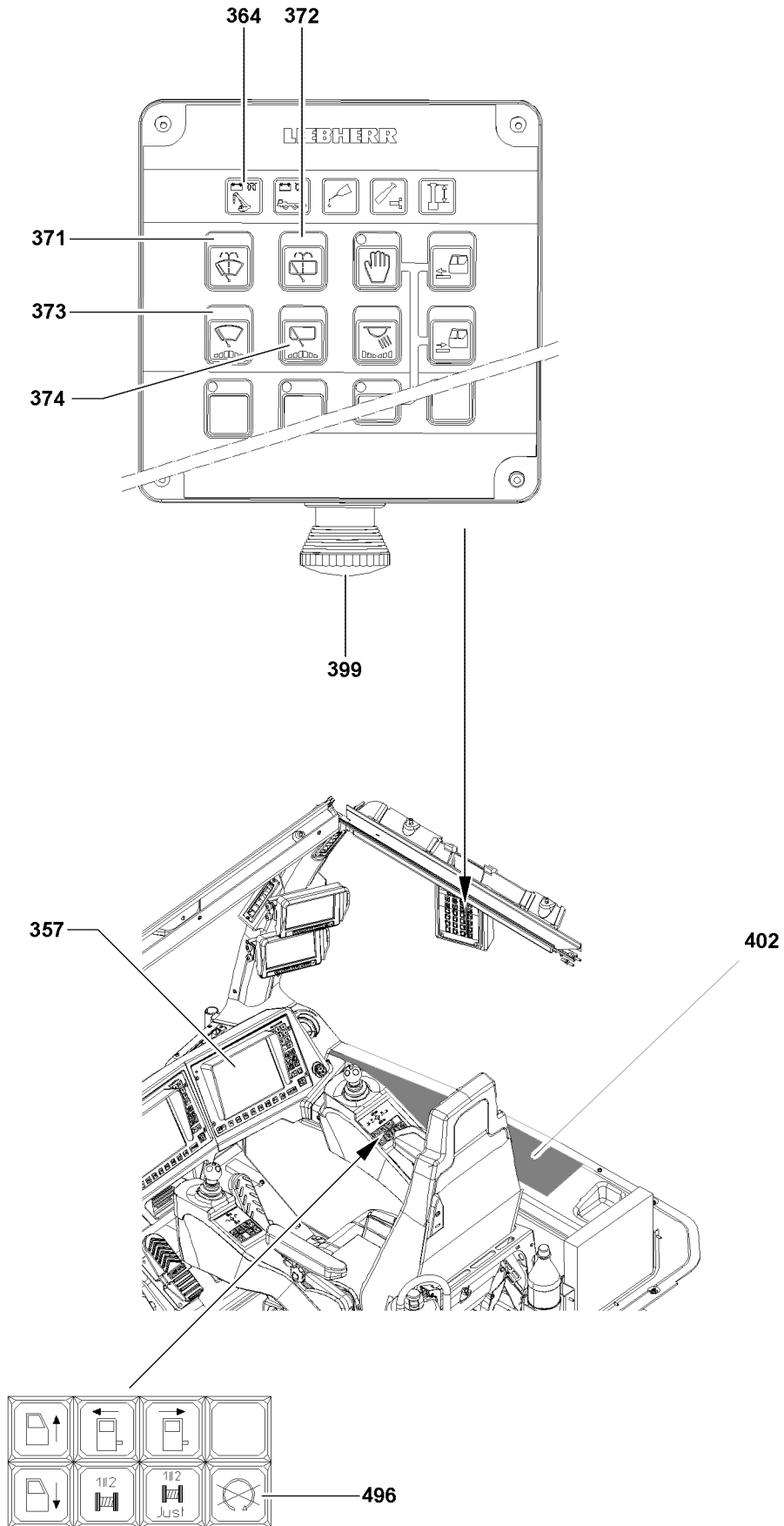

LWE/LR 1600-2-008/18109-09-02/en

Fig.110806

4.5 Turning the engine off

4.5.1 Turning the engine off in the event of danger



WARNING

Danger of accident due to falling loads!

If crane movements are stopped via EMERGENCY OFF, loads can start to swing and fall down! Personnel can be severely injured or killed!

- ▶ Operational use of the EMERGENCY OFF switch **399** is prohibited!
- ▶ Only use the EMERGENCY OFF switch **399** in clear emergency situations!

- ▶ Press the EMERGENCY OFF switch **399**.

Result:

- The engine will be turned off immediately.

4.5.2 Turning the engine off

Turning the engine off with the ignition key

After operation with full engine load, let the engine run without a load for 3-5 minutes at idling speed.

- ▶ Turn the ignition switch **402** back to the stop to zero.

Result:

- The engine is turned off.
- ▶ Pull the ignition key and store it in a safe place.

Turning the engine off with the engine stop button

If the engine is turned off with the engine stop button, the LICCON computer system switches to „Stand-by“ mode.

For detailed description of „Stand-by“ mode of the LICCON computer system, see Crane operating instructions, chapter 4.02.

- ▶ Press the button **496**.

Result:

- The engine is turned off.
- The LICCON computer system is in „Stand-by“ mode.

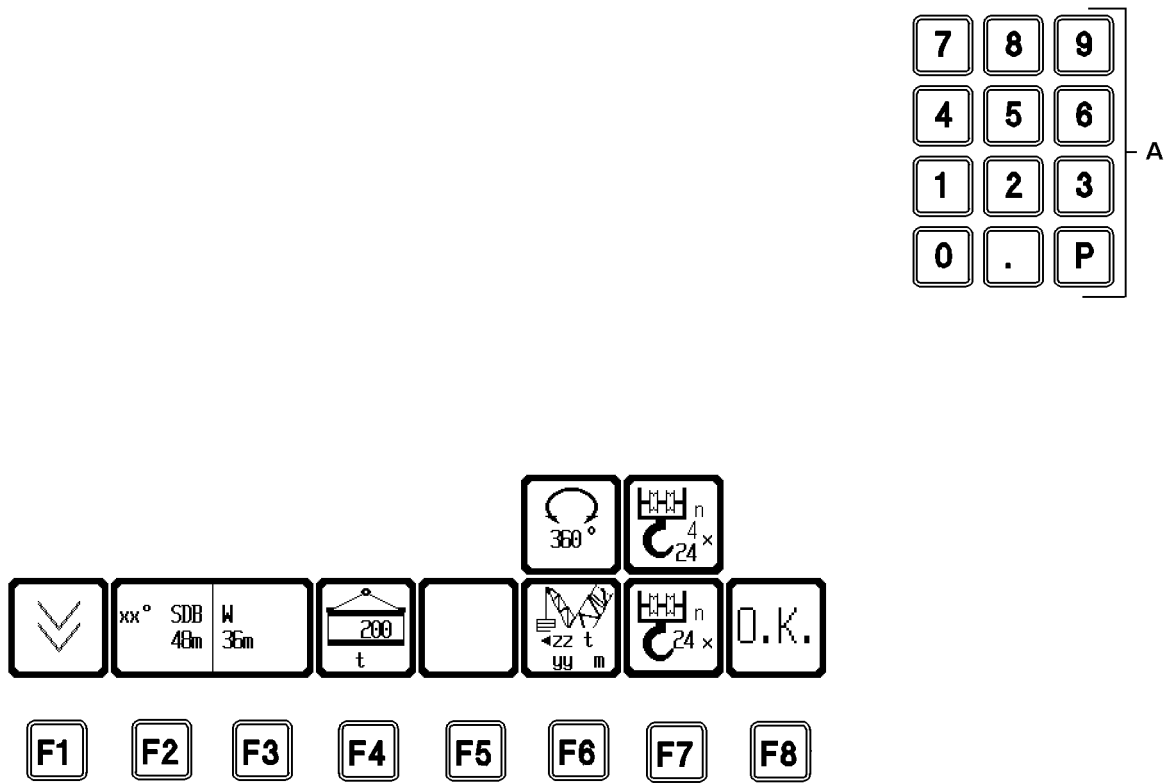

Fig.104900

5 LICCON computer system after engine start

5.1 Waiting for the boot up phase

After being turned on, the LICCON computer system boots up and carries out a self-test, see Crane operating instructions, chapter 4.02.

► Wait for the boot up phase.

Result:

- The operating mode preselection appears.
- After 3 s: The set up screen appears on the LICCON monitor.
- Normally, the most recently set equipment set up configuration and reeving number will be displayed.

If a master switch is moved away from the zero position during the boot up phase, then the function circuit of the electrical safety chain is interrupted.

In this case:

► Turn the engine and ignition off and then restart, so that the crane control can carry out a valid test of the electrical safety chain.

Problem remedy

An error message appears on the LICCON monitor?

- Turn the engine and ignition off and start again.
 - The LICCON computer system automatically displays the error determination screen.
-

Problem remedy

The LICCON monitor does **not** show the most recently set up configuration state and reeving number?

If there has been a data loss in the memory (cold start), then the first valid set up configuration appears in the set up screen. The reeving number is set to „0“.

► Set the set up configuration and reeving number again.

5.2 Taking over the previously selected set up configuration and hoist rope reeving

Check in the set up screen if the correct short code and the correct reeving number have been set, see Crane operating instructions, chapter 4.02.

If the settings on the set up screen are correct:

► Press the function key **F8**.

Result:

- The „Set up“ program is terminated and the adjusted parameters are accepted for the newly started „Operation“ program.

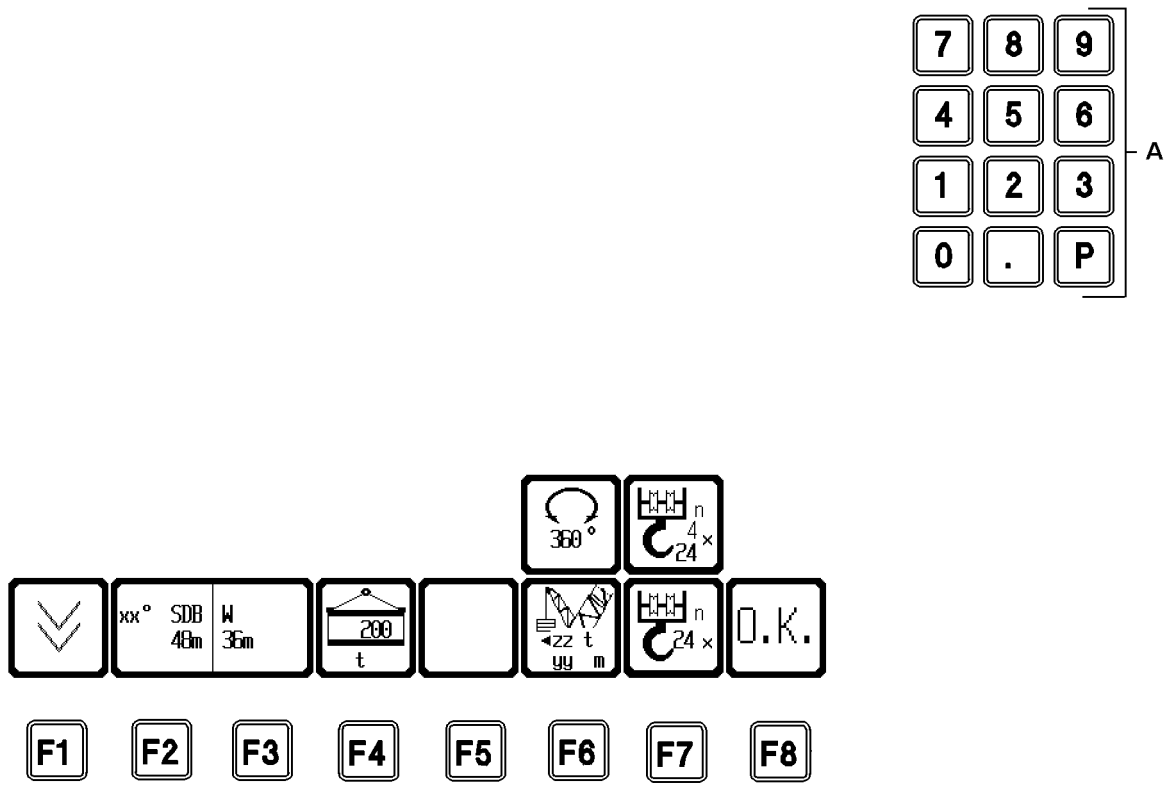

Fig.104900

5.3 Changing the set up configuration and hoist rope reeving

The selected and displayed set up configuration can be changed with the function keys or by entering the short code.

5.3.1 Setting the set up configuration with the function keys

- ▶ Press the function key **F2** until the desired main geometry status is selected.
- ▶ Press the function key **F3** until the desired accessory status is selected.
- ▶ Press the function key **F4** until the desired counterweight is selected.
- ▶ Press the function key **F5** until the desired central ballast is selected.
- ▶ For crane operation **without** derrick ballast: Press the function key **F6** until the desired turning range is selected.
- ▶ For crane operation **with** derrick ballast: Press the function key **F6** until the desired derrick ballast radius or the derrick ballast weight is selected.
- ▶ Press the **ENTER** key.
- ▶ Check the set load chart.

5.3.2 Selecting the set up configuration with short code

The short code is taken from the load chart manual or from the job planner.

- ▶ Entering the 4-digit short code with the keypad **A**.
- ▶ Confirm with the **ENTER** key.

Result:

- The data of the selected load chart can be viewed.

For a more detailed description of the „Set up“ program, see Crane operating instructions, chapter 4.02.

- ▶ Check the set load chart.

5.3.3 Setting the hoist rope reeving

- ▶ Press the function key **F7** until the desired reeving number is selected.
or
Press the function key **SHIFT** and the function key **F7** until the desired reeving numbers are selected.

5.3.4 Checking and accepting the changed set up configuration and hoist rope reeving

If the settings on the set up screen are correct:

- ▶ Press the function key **F8**.

Result:

- The „Set up“ program is terminated and the adjusted parameters are accepted for the newly started „Operation“ program.
- ▶ Check in the operating screen if the correct short code and the correct reeving number have been set, see Crane operating instructions, chapter 4.02.

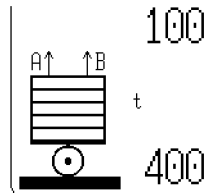
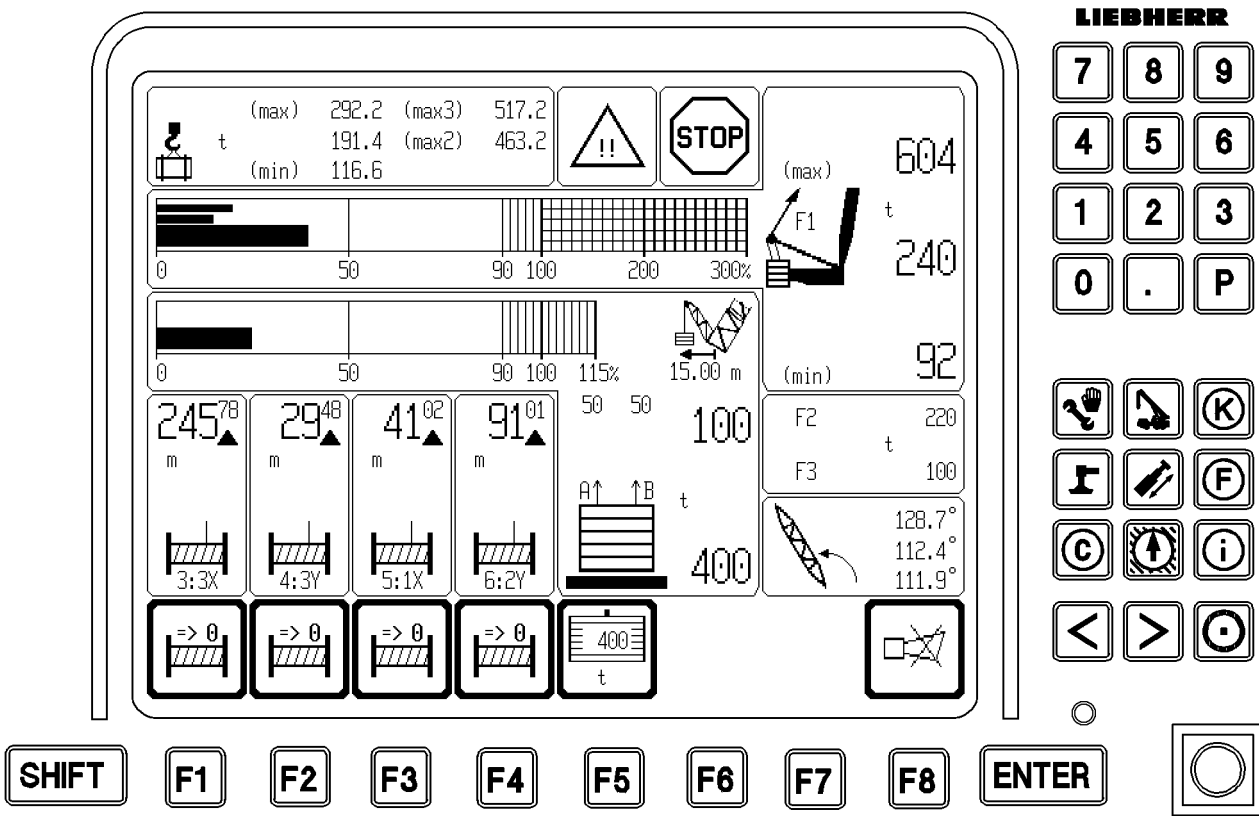

Fig.104480

5.4 Adjusting the control parameters



Note

- ▶ For detailed description to adjust the control parameters, see Crane operating instructions, chapter 4.02.

5.5 Adjusting the derrick ballast

For detailed description to adjust the derrick ballast, see Crane operating instructions, chapter 4.02.

The weight of the derrick ballast consists of:

- The weight of the empty ballast pallet or the empty ballast trailer
- The weight of the placed derrick ballast plates



WARNING

Danger of accident due to toppling crane!

If an incorrect derrick ballast value is entered, the safety shut offs from test point 1 (F1_{min}) become ineffective!

The crane can topple over and personnel can be severely injured or killed!

- ▶ If a derrick ballast value is set, which is too low, then the displayed derrick ballast utilization is too large!
- ▶ If a derrick ballast value is set, which is too large, then the displayed derrick ballast utilization is too small!
- ▶ Make sure that the set derrick ballast value matches the actually installed derrick ballast weight!



Note

During ballast editing, the remaining monitor displays cannot be updated!

The operating screen on the monitor is frozen and can even show incorrect values!

- ▶ Quickly complete the ballast setting!

If a master switch is actuated during the adjustment of the ballast, the adjustment procedure is automatically aborted. The old value of the placed ballast (BA_{placed}) remains in the ballast icon.

- ▶ LICCON monitor 1: Enter the derrick ballast with key **F5**.

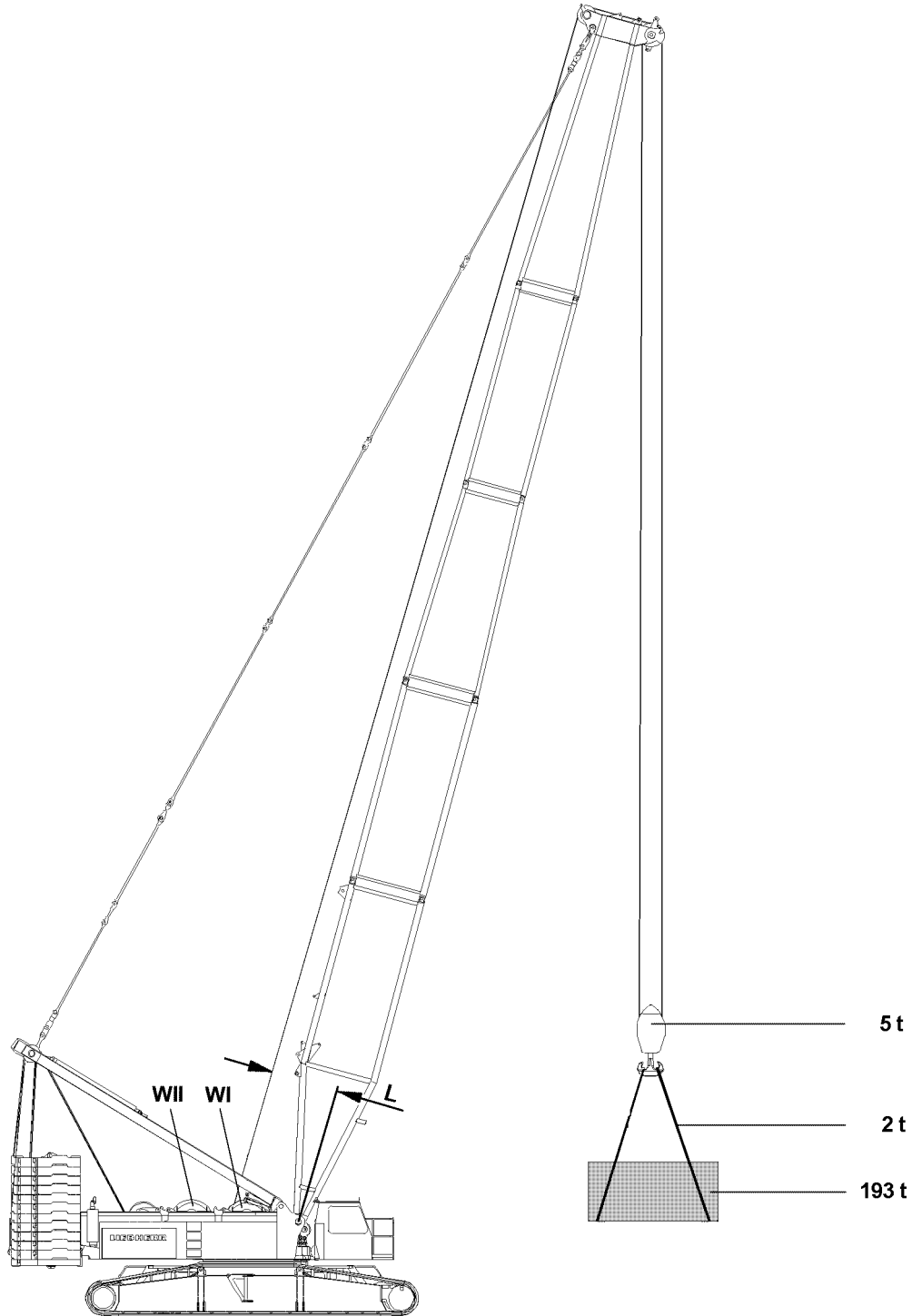

Fig.103667

LWE/LR 1600-2-008/18109-09-02/en

6 Load weighing and load display

In the loads stated in the load chart, the weight of the lifting equipment (hoist rope at nominal reeving) has been taken into account.



Note

- ▶ The weight of the hook block and the weights of the fastening equipment must be subtracted from the load given in the load chart!

Example:		
Maximum permissible load according to chart		200 t
Weight of the hook block	5t	- 5 t
Weight of the fastening rope	2t	- 2 t
Actual load capacity of the crane		= 193 t

In this case, the load to be lifted may not exceed **193 t**.



Note

- ▶ In the LMB calculation, the lever arm to winch **2** is not used, but always the lever arm **L** to winch **1**!
- ▶ For that reason, to ensure an exact load weighing to lift the load on the main boom and on the fixed accessories (for example the fixed jib), winch **1** must be used!



DANGER

Danger of accidents due to overload!

In case of inaccurate load weighing or load display, a danger exists due to unrecognized overload of the crane!

- ▶ The crane operator must know the weight, the center of gravity and the dimensions of the load to be lifted before operating the crane!
- ▶ The crane driver must check, before lifting the load, if he may even lift the load according to the data in the load chart!

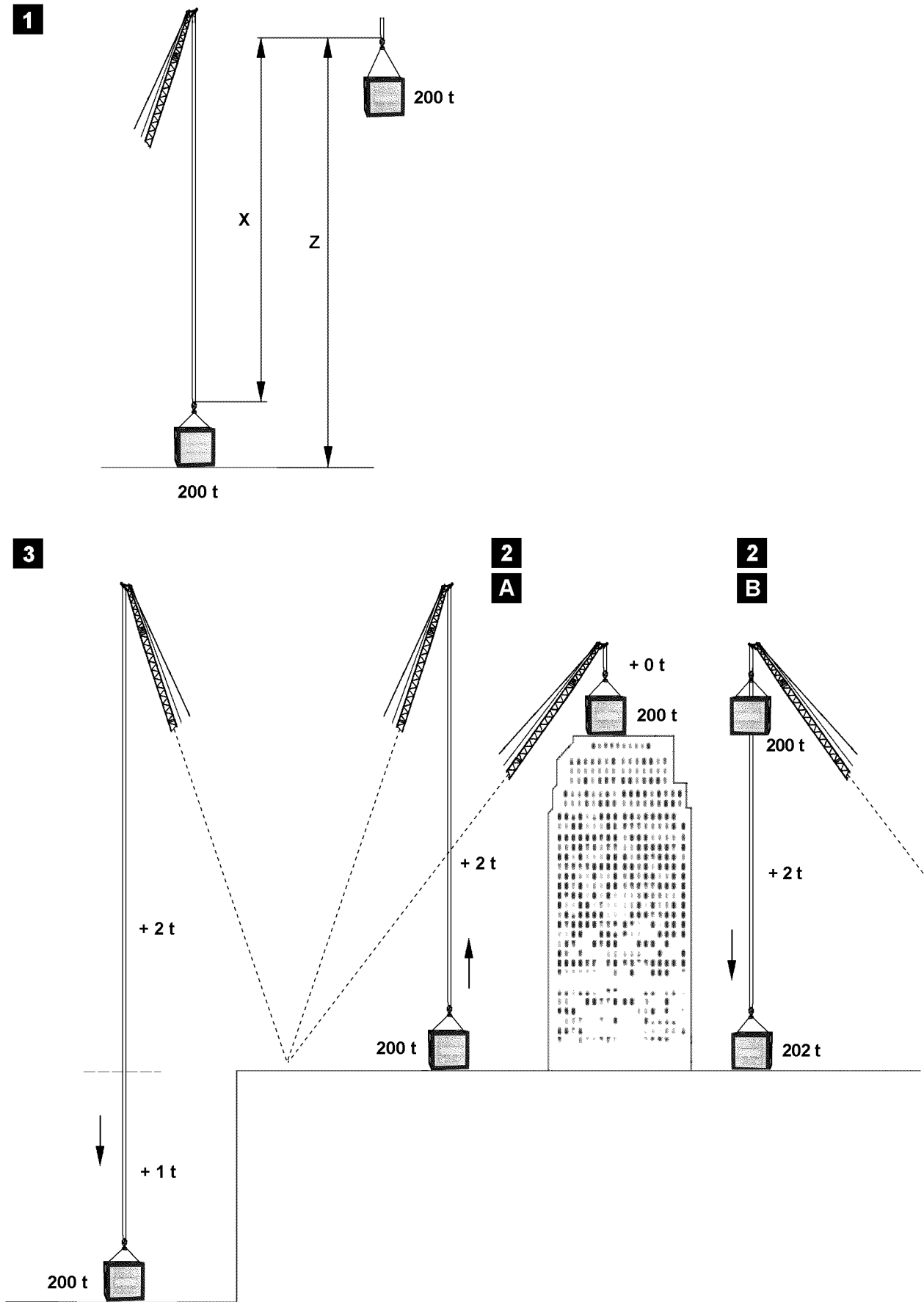

Fig.103643

LWE/LR 1600-2-008/18109-09-02/en

6.1 Load weighing

Make sure that the following prerequisites are met:

- The angle sensors are functioning.
- The incline sensors are functioning.
- The turn sensor in the turntable is functioning.
- The pressure sensors are functioning.
- The pull sensors are functioning.

The boom position where the relapse cylinders are actuated must be recognized by the LICCON precisely via the sensors, because otherwise the relapse cylinders have a strong effect on the load - weighing error.



Note

- ▶ If only one of these sensors is not functioning, a LEC error display is issued, then the load display and the load weighing are not exact!
- ▶ The calculation is made anyway, but the result is not exact!

6.1.1 Possible weighing errors

For an exact load weighing, exact signals of the pull test bracket, angle sensor, incline sensors and pressure sensors are required.

Since all sensor values are always within a certain tolerance, a weighing error can occur.

The weighing error is increasingly larger if:

- The hoist winch sits in the turntable instead of in the main boom.
- The reeving is small.
- The hoist winch sits far to the rear in the turntable.
- Several hoist winches are used (parallel operation).
- The boom, on which the load is suspended, is short.
- The boom, on which the load is suspended, is standing steeply.



DANGER

Danger of accidents due to overload!

Overload due to weighing error!

- ▶ When the prerequisites for small weighing errors are not given, special caution must be exercised!

6.1.2 Adjustment of reeving

The number of reeving must be correctly set on the LICCON. The reeving should not be higher than the nominal reeving, otherwise the hoist ropes reeved above the nominal reeving count as part of the load.



Note

- ▶ The nominal reeving determines for which maximum reeving the load chart values of a load chart are valid!
- ▶ If the crane is in a position outside of the load chart, the hoist rope is added to the load, because no nominal reeving is recognized outside the load chart!

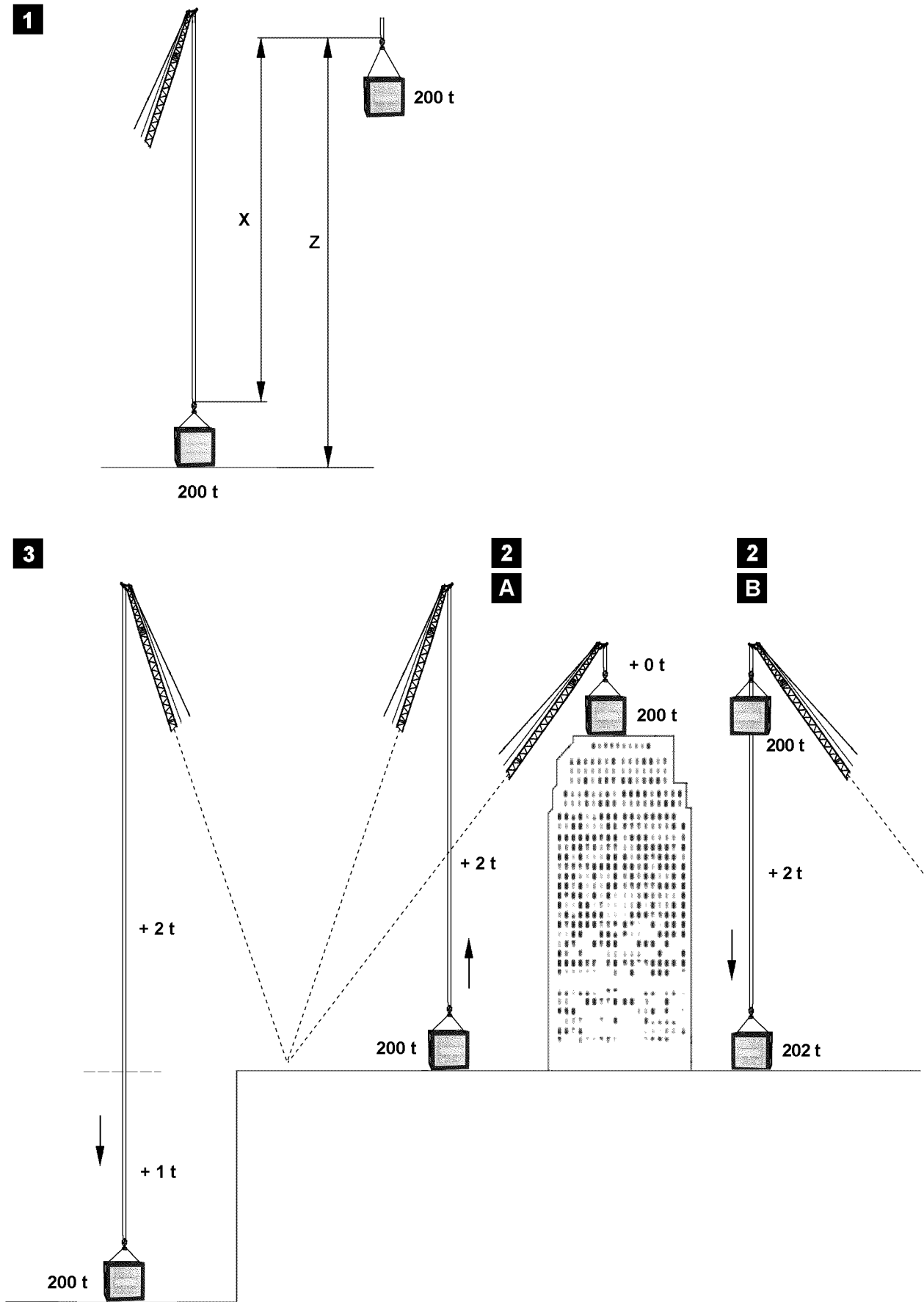

Fig.103643

LWE/LR 1600-2-008/18109-09-02/en

6.2 Load display

6.2.1 Lifting, illustration 1

For the calculation of the displayed actual load, the weight of the hoist rope to the ground is deducted from the total load **Z**, which hangs on the pulley head **X**, see illustration 1.

In that case, the number of the reevings set on the LICCON are taken into account, but no more than the nominal reeving.



Note

- ▶ If the load is raised far above the ground, see illustration 1, then the load display is too small, by the weight of the hoist rope from the load to the ground!

6.2.2 Lifting above ground level, illustration 2A

When the load is raised above the crane level (high rise), then the hoist rope to the ground is always deducted anyway for the display, therefore the load seems increasing lighter when lifting than it did on the ground.

Therefore a somewhat larger load can be lifted in large heights than on the ground, without triggering the LMB overload shut off at 100 %.

This poses no danger because the load stress for the crane is the same if, for example 200 t if load on the bottom and 2 t rope or 202 t load on top and 0 t rope hang on the pulley head.

6.2.3 Load take up on high rise, illustration 2B

When a load is taken up on the high rise on top (=100 %), for example 200 t, and then lowered to the ground, the weight of the hoist rope below the high rise level is calculated as load and displayed.

6.2.4 Lifting below ground, illustration 3

When a load is lowered below the crane level (excavation), then the hoist rope below the crane level is calculated as load and displayed.



DANGER

Danger of accidents due to overload!

It must be noted that the load display in illustration 2B and illustration 3 is correct, the overload of the crane is also shown in the utilization bar, but no shut off of the lowering movement occurs.

- ▶ At LMB overload, all crane movements are shut off, which would increase the danger of overload, however, lowering the load at 100 % -LMB shut off remains clear because one normally assumes that the overload was caused by lifting the load!
- ▶ However, the crane can also be overloaded by lowering the load, especially in case of high reevings with high hoist rope weight on the pulley head. The crane driver must know this, so that he can relieve the crane by careful lifting again in this special case, even though the lifting and not the lowering of the load is automatically shut off!

Empty page!

LWE/LR 1600-2-008/18109-09-02/en

4.04 Safety equipment

1	General	3
2	Quick test Crane geometry	3
3	Quick test Overload protection	3
4	LICCON computer system	3
5	Safety devices on the crane	9

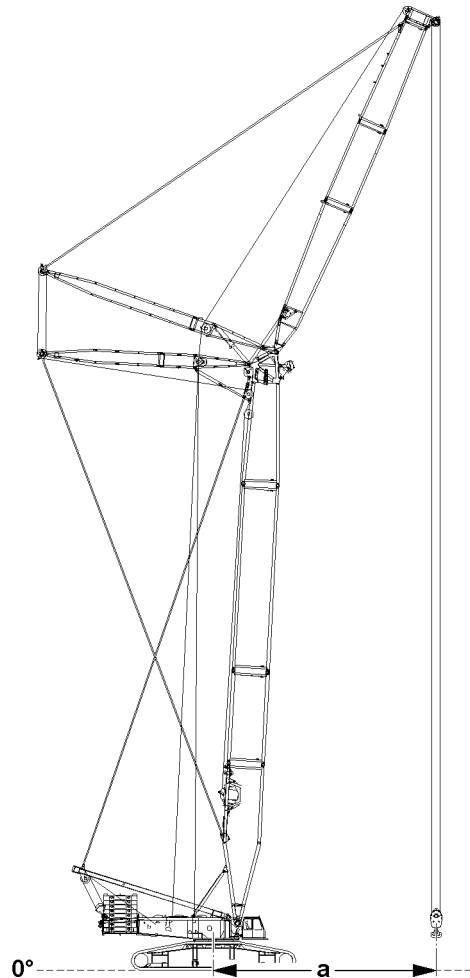
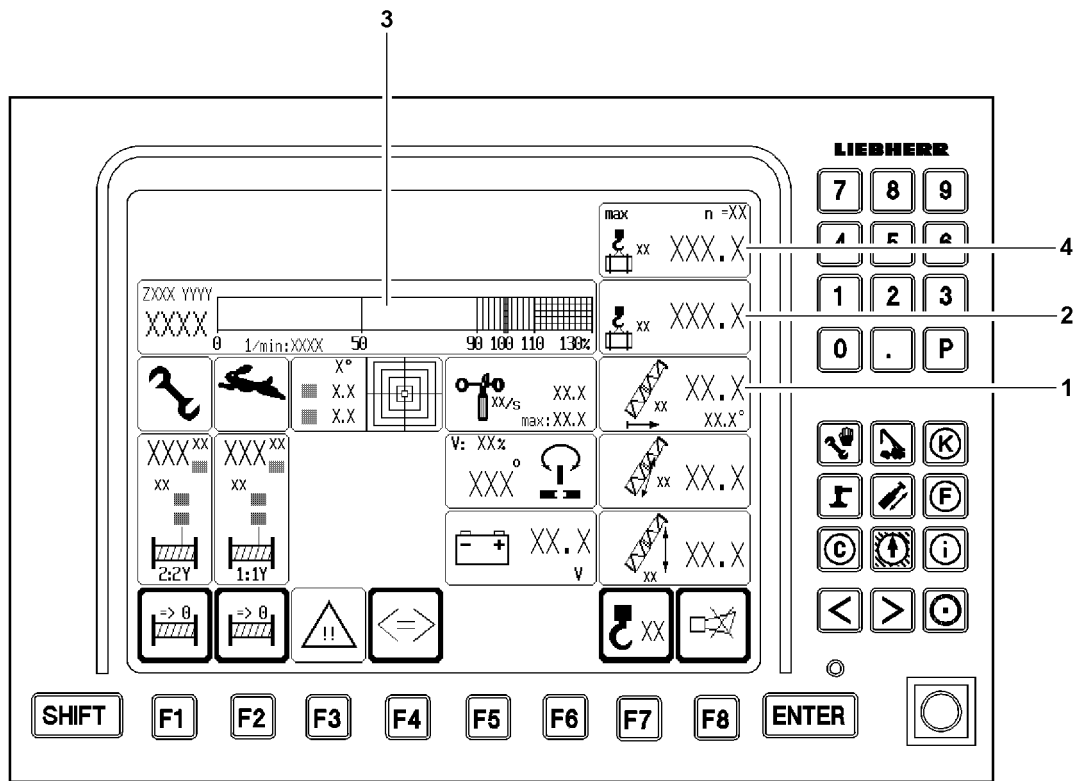

Fig.112968

LWE/LR 1600-2-008/18109-09-02/en

1 General

The crane operator is obligated before every crane operation to ensure that the warning and safety devices are functioning.



WARNING

Danger of accident due to defective warning and safety systems!

If the crane is operated with defective warning and safety devices, then there is a danger of accidents! Personnel can be killed or seriously injured!

This could result in property damage!

- ▶ Make sure that all warning and safety devices are functioning.
- ▶ Make sure that the overload protection is functioning.

2 Quick test Crane geometry

Make sure that the following prerequisites are met:

- The crane is aligned in horizontal direction.
- The set up status has been entered correctly into the LICCON computer system.
- There is no load on the hook.

Measure the horizontal distance of the load hook from the center of rotation of the crane superstructure on the ground:

- The value display radius **1** must match the measured value **a**.

3 Quick test Overload protection

Lift a known weight completely, such as the hook block or a counterweight plate and then set it down.

Make sure that the following prerequisite is met:

- The crane is aligned in horizontal direction.

The respective displayed values must be plausible:

- **2** Actual load display
- Utilization bar **3**: Ratio of value of Actual load display **2** to maximum load value **4**
- Example:
Value Actual load display **2** is 40 t.
Maximum load value **4** is 80 t.
Utilization bar **3** shows 50 %.

4 LICCON computer system

The LICCON computer system is a system for controlling and monitoring mobile cranes. In addition to the LICCON overload protection (Load torque limiter = LMB), there are a number of application programs that can be used for controlling and monitoring the crane movements. For a detailed description see Crane operating instructions, chapter 4.02 and chapter 4.20.

4.1 LICCON overload protection

The LICCON overload protection is programmed to **shut off** the crane movements if the permissible load moment is exceeded (LMB-STOP).

The LICCON overload protection may not be used as an operational shut off device for crane movements of any kind.

An overload protection cannot detect all occurring conditions by itself. Careful and diligent crane operation by the crane operator is important.

The basis for the calculation of the utilization of the crane are:

- The currently data and values recorded by the crane control.
- The set up configuration entered by the crane operator.

Direct influence has, for example:

- Failure of a test device (for example: Pull test brackets, angle sensor, pressure sensor).
- A set up configuration incorrectly entered by the crane operator.
- Environmental influences not considered (such as wind influence, ground with insufficient load bearing capability).
- Assembly and operating errors.



WARNING

Danger of accident due to assembly and operating errors!

Due to assembly and operating errors it is possible that the overload protection is not effective or shut off is delayed!

A set up configuration which deviates from the load chart cannot be detected by the overload protection!

Environmental influences which are not considered cannot be detected by the overload protection!

Dangerous situations and accidents can result!

Personnel can be killed or seriously injured!

This could result in property damage!

- ▶ Always assemble and operate the crane carefully!



WARNING

Operational utilization of the overload protection!

If the LICCON overload protection is utilized as an operational shut off device for crane movements, then there is a danger of accidents!

For example, crane movements can be shut off abruptly or uncontrolled!

The behavior of load and crane cannot be foreseen in such a case!

Personnel can be killed or seriously injured!

This could result in property damage!

- ▶ Do not use the LICCON overload protection as an operational shut off device for crane movements!



WARNING

Lifting of unknown loads!

The presence of the overload protection does not relieve the crane operator of his obligation for care and attention!

The crane may not only be operated according to the displays of the LICCON overload protection!

Lifting of loads with unknown weight and unknown properties can lead to accidents!

Personnel can be killed or seriously injured!

This could result in property damage!

- ▶ Before lifting a load, its weight and properties must be known to the crane operator!
- ▶ The crane operator must check with the load chart if the crane is able to carry out the work safely!

The LICCON computer system detects various values, which result in optical and acoustical warnings if exceeded:

Within the crane operator's cab:

- Acoustic warning „Horn / short horn“ on the LICCON monitor
- Optical warning „blinking value / display“ on the LICCON monitor

Outside the crane operator's cab:

- Acoustic warning via the horn on the slewing platform
- Optical warning via the warning light on the slewing platform

All warnings, even those which do not lead to an immediate shut off must be noted by the crane operator and personnel within the danger zone.

The overload protection can **not** detect (examples of cases):

- The hooking of the load or the load suspension equipment.
- Excessive retarding forces.
- Loads falling onto the rope.
- Angular pulling.
- Driving the crane on ground with large slope.
- Collapsing ground.

4.1.1 Failure of the overload protection



WARNING

Crane operation without overload protection!

If the LICCON overload protection is no longer functioning properly because of one or more errors, then there is a danger of accidents if crane operation is continued!

Due to operation of the crane with failed LICCON overload protection, the crane can be overloaded and collapse!

Personnel can be killed or seriously injured!

This could result in property damage!

- ▶ Crane operation without overload protection is prohibited!
- ▶ Do not take up crane operation again until the overload protection is functioning again!

A failed overload protection:

- Must be repaired before the crane can be operated again.
- May only be bypasses in emergency cases or emergency situations.

4.2 Bypass of overload protection

The overload protection can be bypassed in case of:

- Failure of the overload protection.
- In an emergency situation (according to EN 13000:2010).

4.2.1 Bypass of overload protection: Failure of the overload protection



Note

- ▶ Does **not** apply for cranes with CE-mark and configuration according to EN 13000:2010!

To bring the crane into safe condition after failure of a component required for the overload protection, it can be necessary that the overload protection has to be bypassed.



WARNING

Bypassed overload protection!

If the overload protection is bypassed, crane movements are no longer monitored!

The crane can be overloaded and collapse!

Personnel can be killed or seriously injured!

This could result in property damage!

- ▶ Only carry out crane movements within the range of the load chart as well as the erection / take down charts!



Note

- ▶ For procedure in case of problems, see Crane operating instructions, chapter 7.15.
- ▶ For procedure of shut off of crane movement, see Crane operating instructions, chapter 4.20.

4.2.2 Bypass of overload protection: Failure of overload protection (according to EN 13000:2010)



Note

- ▶ Applies **only** apply for cranes configuration according to EN 13000:2010!

To bring the crane into safe condition after failure of a component required for the overload protection, it can be necessary that the overload protection has to be bypassed.

With the specification that:

- The bypass is automatically reset at engine stop.
- The bypass is automatically reset after no later than 30 minutes.
- The bypass of the overload protection limits the working speed to no more than maximum 15%.



WARNING

Bypassed overload protection!

If the overload protection is bypassed, crane movements are no longer monitored!

The crane can be overloaded and collapse!

Personnel can be killed or seriously injured!

This could result in property damage!

- ▶ Only carry out crane movements within the range of the load chart as well as the erection / take down charts!



Note

- ▶ For procedure in case of problems, see Crane operating instructions, chapter 7.15.
- ▶ For procedure of shut off of crane movement, see Crane operating instructions, chapter 4.20.

4.2.3 Bypass of overload protection: Emergency situation (according to EN 13000:2010)

In an emergency situation, a bypass of the overload protection may become necessary.

With the specification that:

- The bypass is automatically reset at engine stop.
- The bypass is automatically reset after no later than 30 minutes.
- The bypass of the overload protection limits the working speed to no more than maximum 15%.



DANGER

Overload of crane!

After a bypass of the overload protection, the crane movements are no longer shut off in case of a danger of overload of the crane!

A bypass of the crane can result in severe damage or collapse!

Personnel can be killed or seriously injured!

This could result in property damage!

- ▶ Do not subject the crane to such a load that it collapses!
- ▶ Clear and secure the danger zone of the crane!



Note

- ▶ Location of bypass device, see Crane operating instructions, chapter 4.01 and chapter 4.02.

Empty page!

LWE/LR 1600-2-008/18109-09-02/en

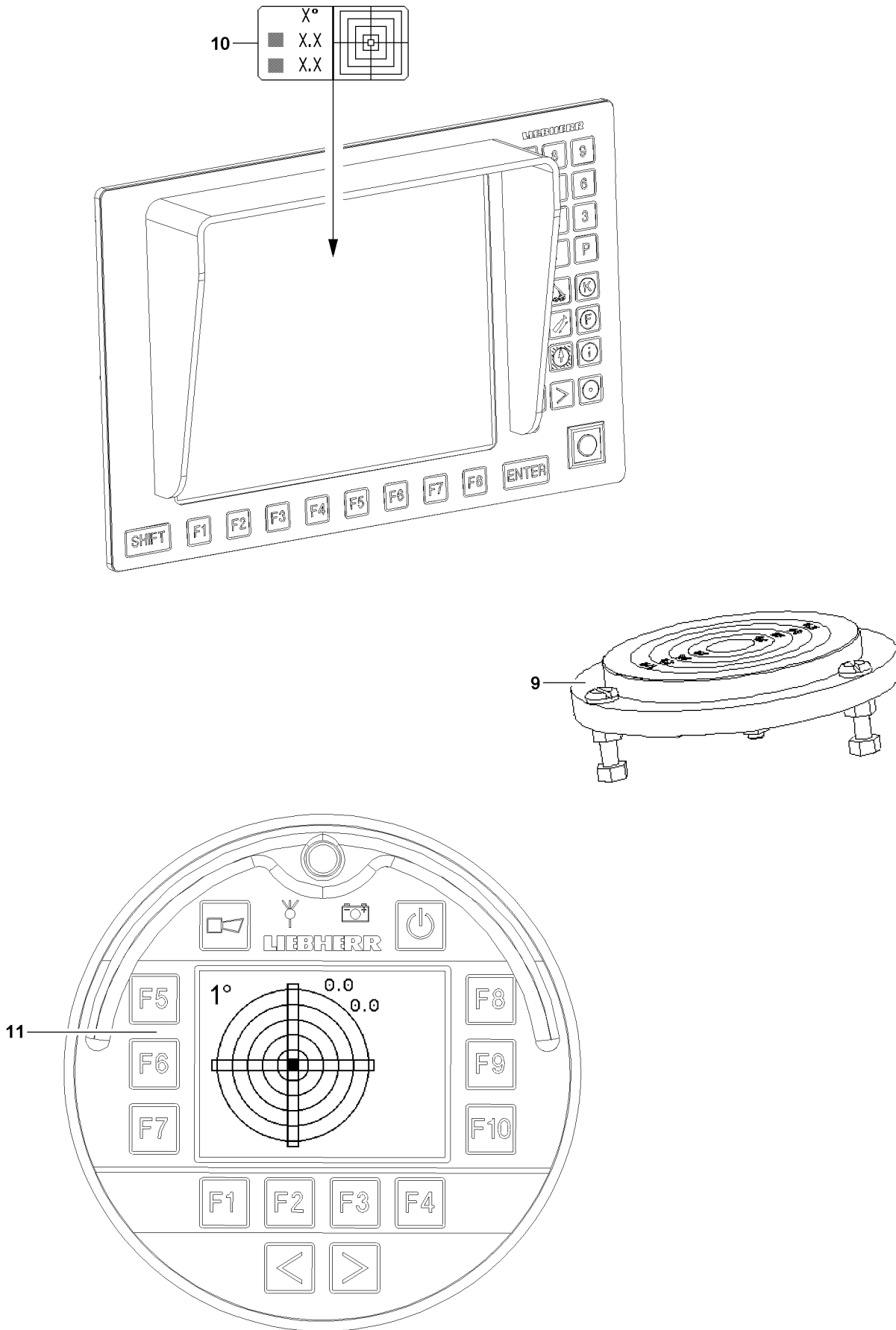

LWE/LR 1600-2-008/18109-09-02/en

Fig.112969

5 Safety devices on the crane

5.1 Leveling instruments

To ensure the working safety of the crane, the crane must be aligned on level ground with sufficient load bearing capacity according to the load chart.

The current values are continuously shown in the Incline icon **10**, see Crane operating instructions, chapter 4.02.

The incline is shown manually in the sight gauge **9** on the crawler travel gear.



WARNING

The crane can topple over!

If the leveling instruments are defective or incorrectly adjusted, there is a danger that the crane is not aligned according to the load chart!

A crane which is not aligned according to the load chart can topple over!

Personnel can be killed or seriously injured!

This could result in property damage!

► Make sure to align the crane according to the load chart!

5.1.1 Leveling instruments in the LICCON monitor

The incline of the crane is shown in the Incline icon **10** graphically as well as numerically, see Crane operating instructions, chapter 4.02.

5.1.2 Leveling instrument in the BTT

Only LR1600/2-W.

The incline of the crane is shown in the Incline display menu **11** graphically as well as numerically, see Crane operating instructions, chapter 3.10 and chapter 5.31.

5.1.3 Quick test Leveling instrument



Note

The horizontal alignment of the crane can be checked with a spirit level on the top of the slewing ring, for example.

► The alignment of the top of the slewing ring is the determining factor for the incline display.

Make sure that the following prerequisites are met:

- The crane is aligned in horizontal direction.
- There is no load on the hook.

For horizontally aligned crane:

- The sight gauge **9** on the crawler travel gear must show 0°.
- In the incline icon **10** 0° must be shown.

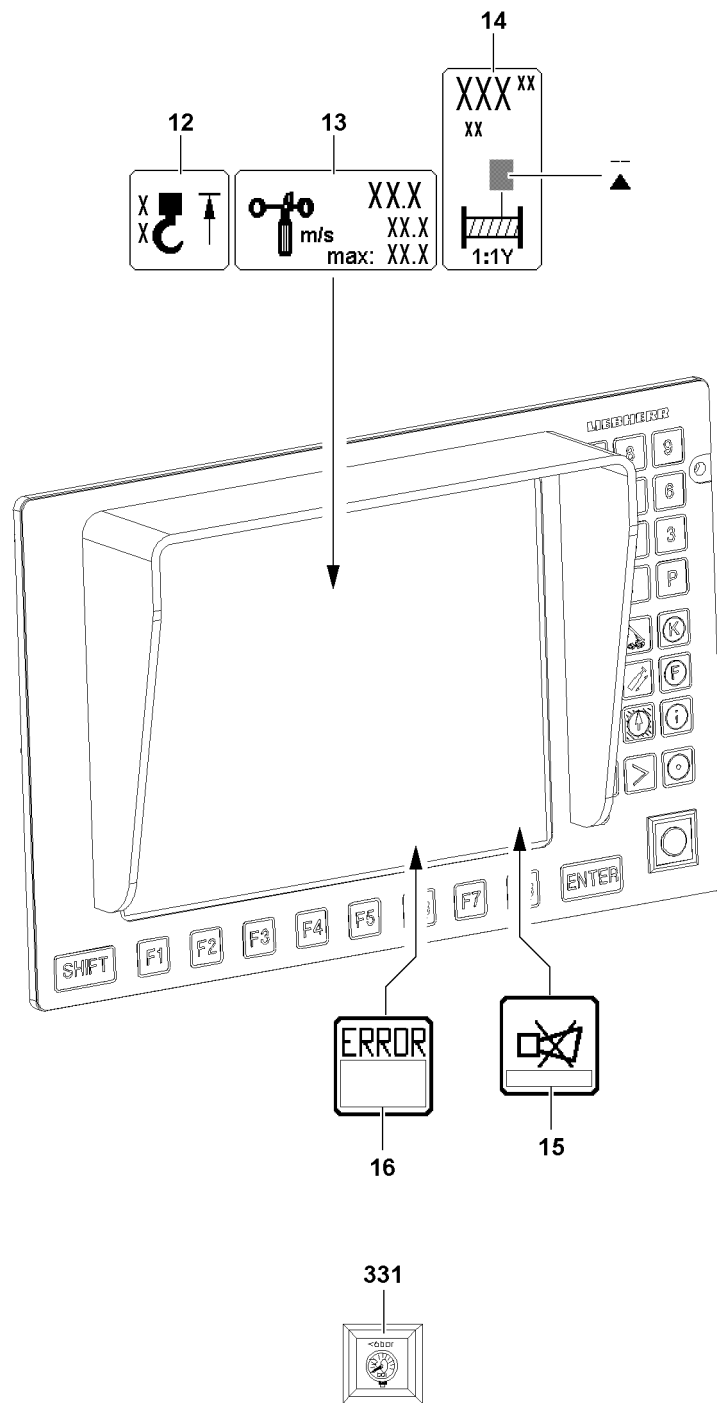

Fig.112972

5.2 Acoustic and optical warning devices



Note

► Overview of acoustic and optical warnings, see Crane operating instructions, chapter 4.20.

- The acoustic and optical warning devices must be functioning and operational.
- Take care of any possible detriments in function, such as snow on the warning lights.

5.3 Hoist limit switch „Hoist top“

The hoist limit switch is intended to prevent the hook block from running against the boom head.

Before every crane application, the function of the hoist limit switch must be checked by running against the switch weight with the hook block.

For installation purposes and in emergency cases, the hoist limit switch can be bypassed, see Crane operating instructions, chapter 4.20.



WARNING

Falling load and property damage!

If the hoist limit switch is defective, there is the danger that the hook block or the load hook is pulled against the pulley head!

Falling load and property damage can result!

Personnel can be severely injured or killed!

- Crane operation without or with defective hoist limit switch is prohibited!
- Repair or replace a defective hoist limit switch!

The hoist limit switch must actuate when the hoist limit switch weight is lifted by the load hook / hook block:

- When the hoist limit switch is actuated, the icon **12** „Hoist top“ appears in the operating screen. The crane movement „Spool winch up“ as well as other crane movements which have an influence on the hoist rope are shut off.

5.3.1 Quick test Hoist limit switch

When the hoist limit switch weight is lifted:

- The icon **12** „Hoist top“ must appear in the operating screen.
- The actuated crane movement must be shut off.

5.4 Error messages by the LICCON computer system

Two types are differentiated (all crane types except LR1400/2):

- Operating errors
 - Displayed in field **15** by error number / LEC: B.....
- System errors in LICCON computer system
 - Displayed in field **15** by error number / LEC: E.....

Only LR1400/2:

- Error messages
 - Displayed in field **16**

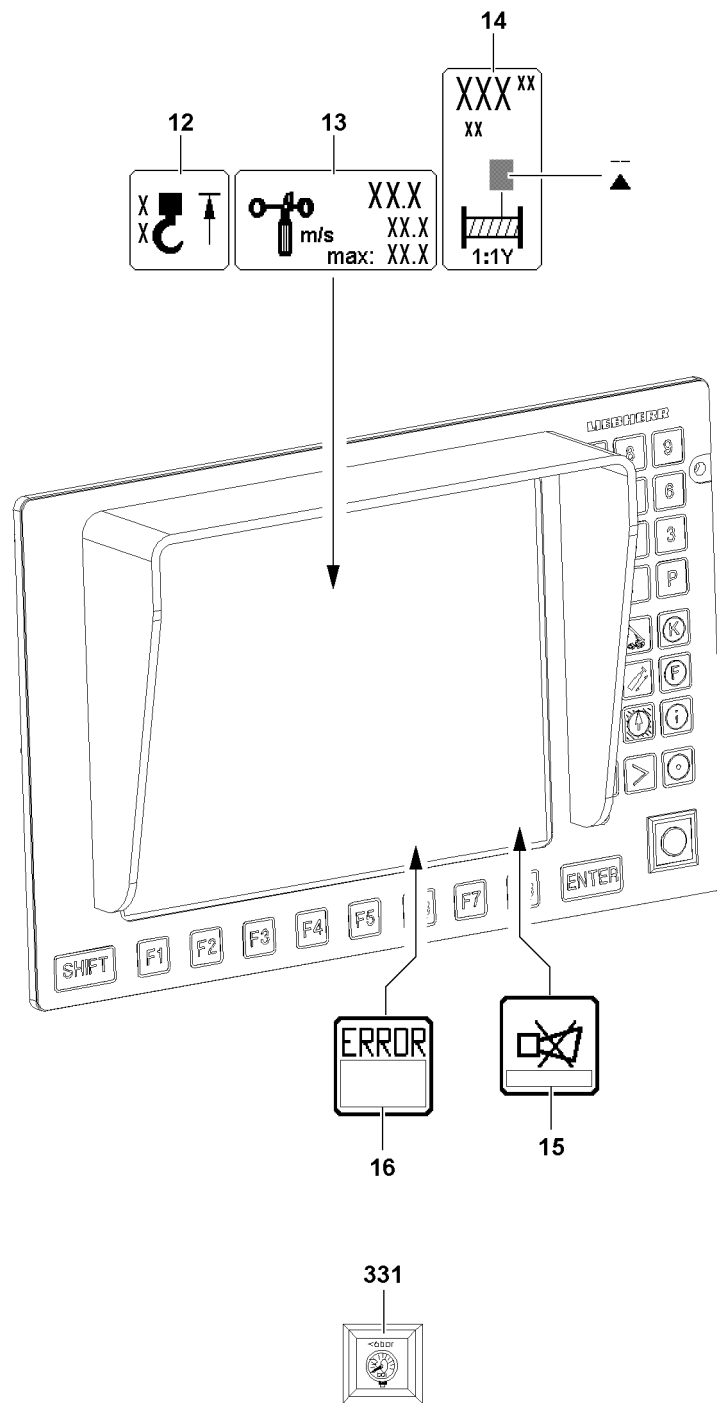

Fig.112972

5.5 Wind speed sensor

The wind warning by the warning speed sensor appears in the operating screen of the LICCON computer system.



WARNING

The crane can topple over!

If the crane is operated with a defective wind speed sensor, then there is the danger that excessively high wind speeds are not recognized!

The crane can topple over!

Personnel can be killed or seriously injured!

This could result in property damage!

- ▶ Crane operation with a defective wind speed sensor is prohibited!
- ▶ Repair / replace a defective wind speed sensor!

If wind occurs, then the wind speed sensor must report it speed:

- If the actual wind speed value exceeds the displayed maximum value, the value in the icon **13** „Wind speed“ starts to blink and the acoustic alarm „Short horn“ sounds on the LICCON monitor. But there is **no shut off** of crane movements.

5.5.1 Quick test Wind speed sensor

When blowing in the cups:

- The wind speed sensor must start to move.
- An actual value must be shown in the icon **13** „Wind speed“.

5.6 Limit switch winch spooled out

The limit switches for the winches are adjusted at the factory. If used properly, the winches will not need readjustment.



Note

Minimum rope coils on the shut off point!

For the winches, a minimum of three rope coils are set for each drum.

- ▶ The shut off must occur **before** reaching the third minimum rope coil.



WARNING

The load can fall off!

If the limit switch „Winch spooled out“ does not turn off **before** three minimum rope coils are reached, then there is the danger, when it is further spooled out, that the rope mounting locks are ripped out and the load falls down!

Falling load can cause the crane to sway and / or topple over!

Personnel can be severely injured or killed!

This could result in property damage!

- ▶ Crane operation with an incorrectly or non-adjusted winch is strictly prohibited!
- ▶ If the winch falls below the three minimum rope coils per winch, have it readjusted by **Liebherr Service!**

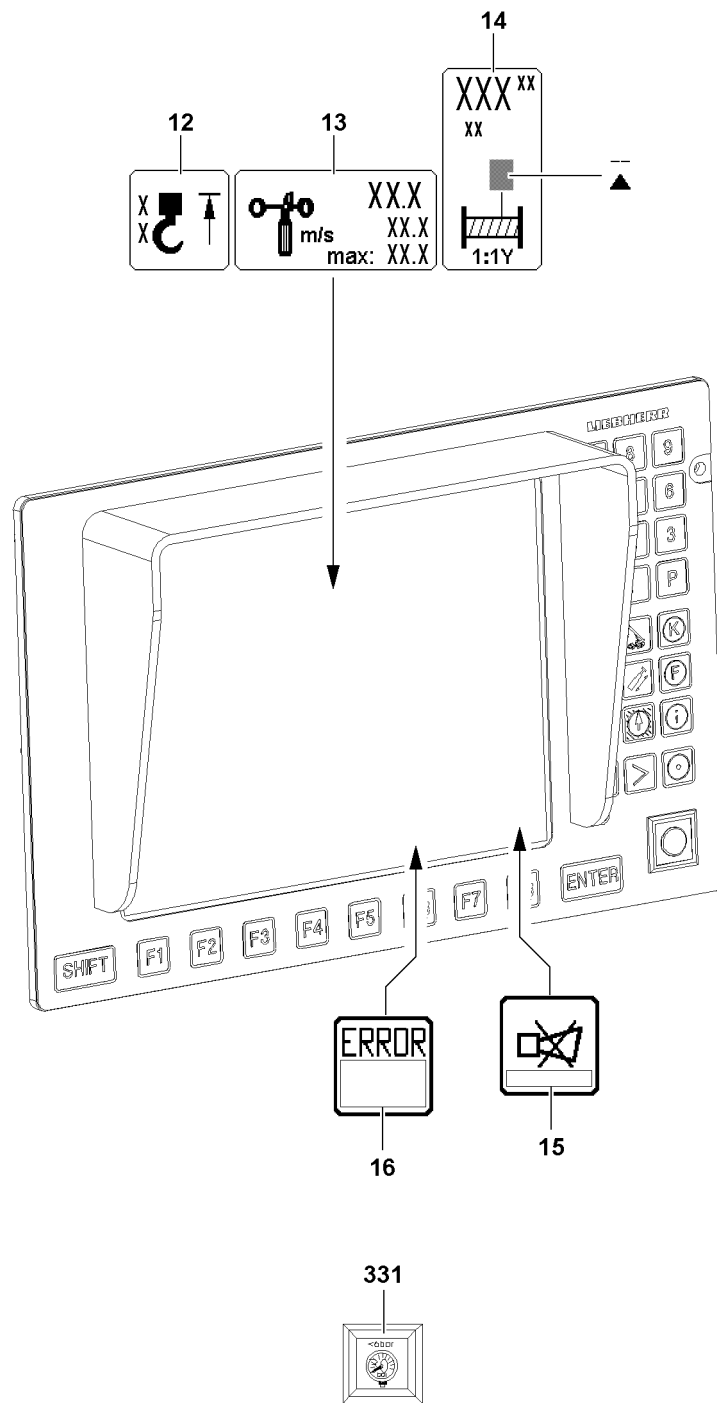

Fig.112972

**WARNING**

The load can fall off!

If the rope is not spooled up or out properly, then the adjustment of the limit switch „Winch spooled out“ is changed!

If the adjustment of the limit switch „Winch spooled out“ has changed, then the minimum rope coils are fallen below!

The load can fall down!

Falling load can cause the crane to sway and / or topple over!

Personnel can be severely injured or killed!

This could result in property damage!

- ▶ **Never** pull the end of rope underneath the winch by spooling up the rope winch!
- ▶ **Never** pull the rope from the „stationary“ winch!
- ▶ If you suspect that the limit switch „Winch spooled out“ is not adjusted correctly: Check the shut off without a load on the hook!

The limit switch „Winch spooled out“ must shut off when the minimum rope coils for the winch are reached:

- When the minimum rope coil for the winch is reached, then the display „Winch spooled out“ appears in the Winch icon **14**, see illustration. The crane movement „Spool winch out“ is shut off.

5.6.1 Quick test Limit switch winch

When the minimum rope coil is reached:

- The display „Winch spooled out“ must appear in the Winch icon **14**.
- The crane movement „Spool winch out“ must be shut off.

5.7 Servo oil pressure monitoring in the winches

All crane types except LR1400/2:

- If no servo oil pressure is present when the master switch is actuated, a corresponding error message appears in field **15**.

Only LR1400/2:

- If the servo oil pressure is too low, then the indicator light **331** in the right instrument panel appears.

5.8 Pressure monitoring in the relapse cylinders

Pressure sensors are installed in the hydraulic cylinders. The pressure measured with the pressure sensor is shown on the LICCON monitor, see Crane operating instructions, chapter 4.02.

**WARNING**

Risk of accident due to crane toppling over or destruction of the crane!

If the pressure drops, the relapse cylinder can no longer stabilize the boom!

The crane can topple over or be destroyed!

Personnel can be severely injured or killed!

- ▶ During crane operation: Constantly monitor the pressure in the relapse cylinders!

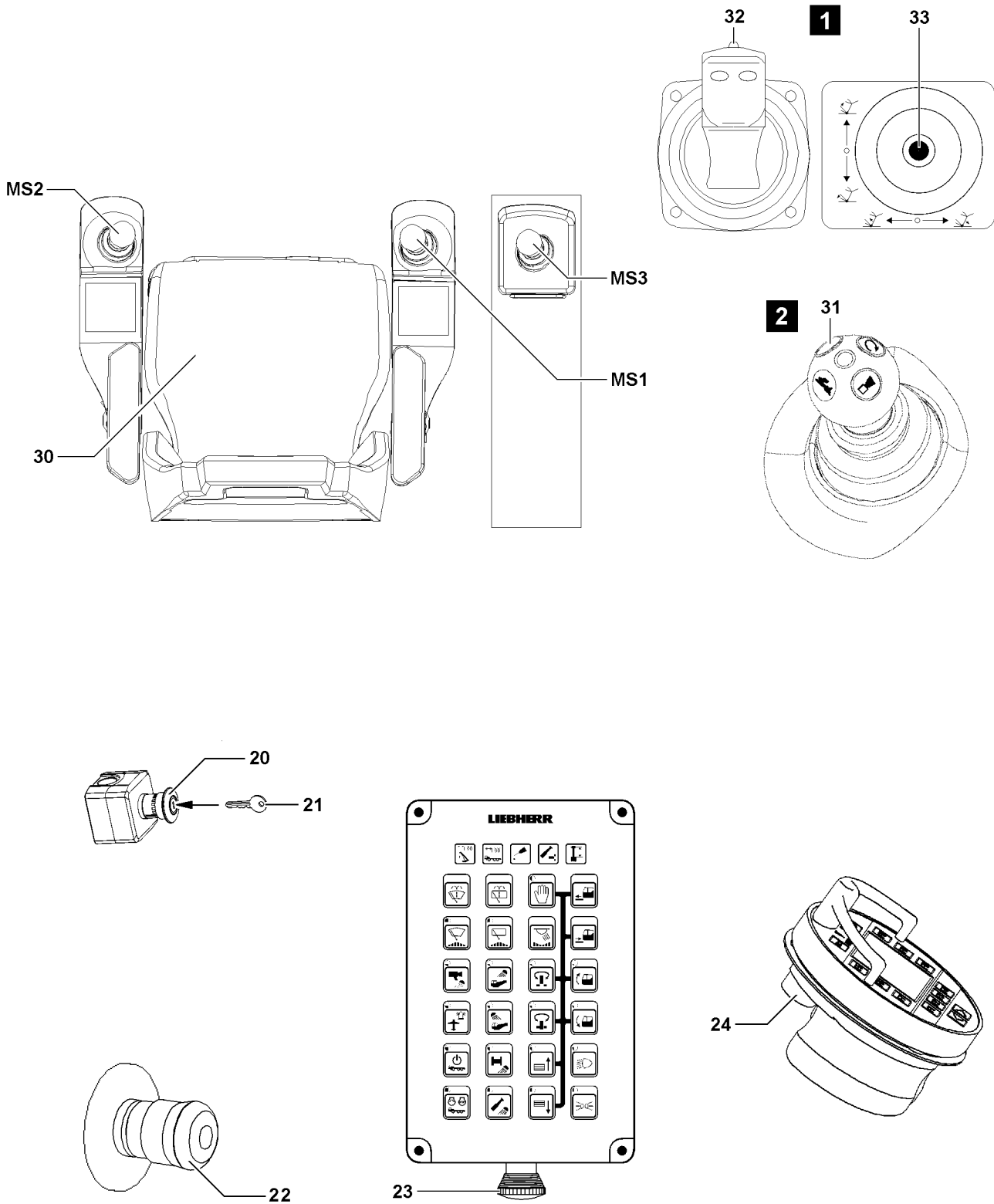

Fig.112970

LWE/LR 1600-2-008/18109-09-02/en

5.9 EMERGENCY STOP switch / EMERGENCY OFF switch

If an EMERGENCY STOP switch / EMERGENCY OFF switch is actuated, then the crane movement can be stopped with it.



WARNING

Defective EMERGENCY STOP switch / EMERGENCY OFF switch!

If the crane is operated with a defective EMERGENCY STOP switch / EMERGENCY OFF switch, then the crane movement cannot be stopped by actuating the EMERGENCY STOP switch!

This could result in accidents!

Personnel can be killed or seriously injured!

This could result in property damage!

▶ Crane operation with a defective EMERGENCY STOP switch / EMERGENCY OFF switch is prohibited!

▶ Repair or replace a defective EMERGENCY STOP switch / EMERGENCY OFF switch!

NOTICE

Operational actuation of the EMERGENCY STOP switch / EMERGENCY OFF switch

Actuation of the EMERGENCY STOP switch / EMERGENCY OFF switch causes the crane movement to stop abruptly!

Abruptly stopping the crane movement can cause the load to swing!

Swinging loads can cause accidents!

▶ Do not use the EMERGENCY STOP switch / EMERGENCY OFF switch operationally!

▶ Use the EMERGENCY STOP switch / EMERGENCY OFF switch only in emergency situations!

The EMERGENCY STOP switch / EMERGENCY OFF switch is available in various versions, depending on the crane type:

- After actuation of a switch of version* **20**, the release is only obtained by an authorized person with key **21** and by subsequently turning the ignition „Off - On“ momentarily.
- After actuation of the switch of version* **22**, the release is obtained by turning and unlocking the knob and subsequently turning the ignition „Off - On“ momentarily.
- After actuation of the switch of version* **23**, the release is obtained by turning and unlocking the knob and subsequently turning the ignition „Off - On“ momentarily.
- After actuation of the switch of version* **24**, the release is obtained by turning and unlocking the knob and subsequently turning the ignition „Off - On“ momentarily.



Note

▶ Which EMERGENCY STOP switch / EMERGENCY OFF switch is on the crane depends on the crane type.

▶ The switch **24** on the BTT is only activated when working with the BTT.

5.9.1 Quick test EMERGENCY STOP switch / EMERGENCY OFF switch

After actuation of the EMERGENCY STOP switch / EMERGENCY OFF switch:

- The crane movements must be stopped.
- No crane movements must be possible until the release was issued by turning and unlocking the knob and then turning the ignition „Off - On“ momentarily.

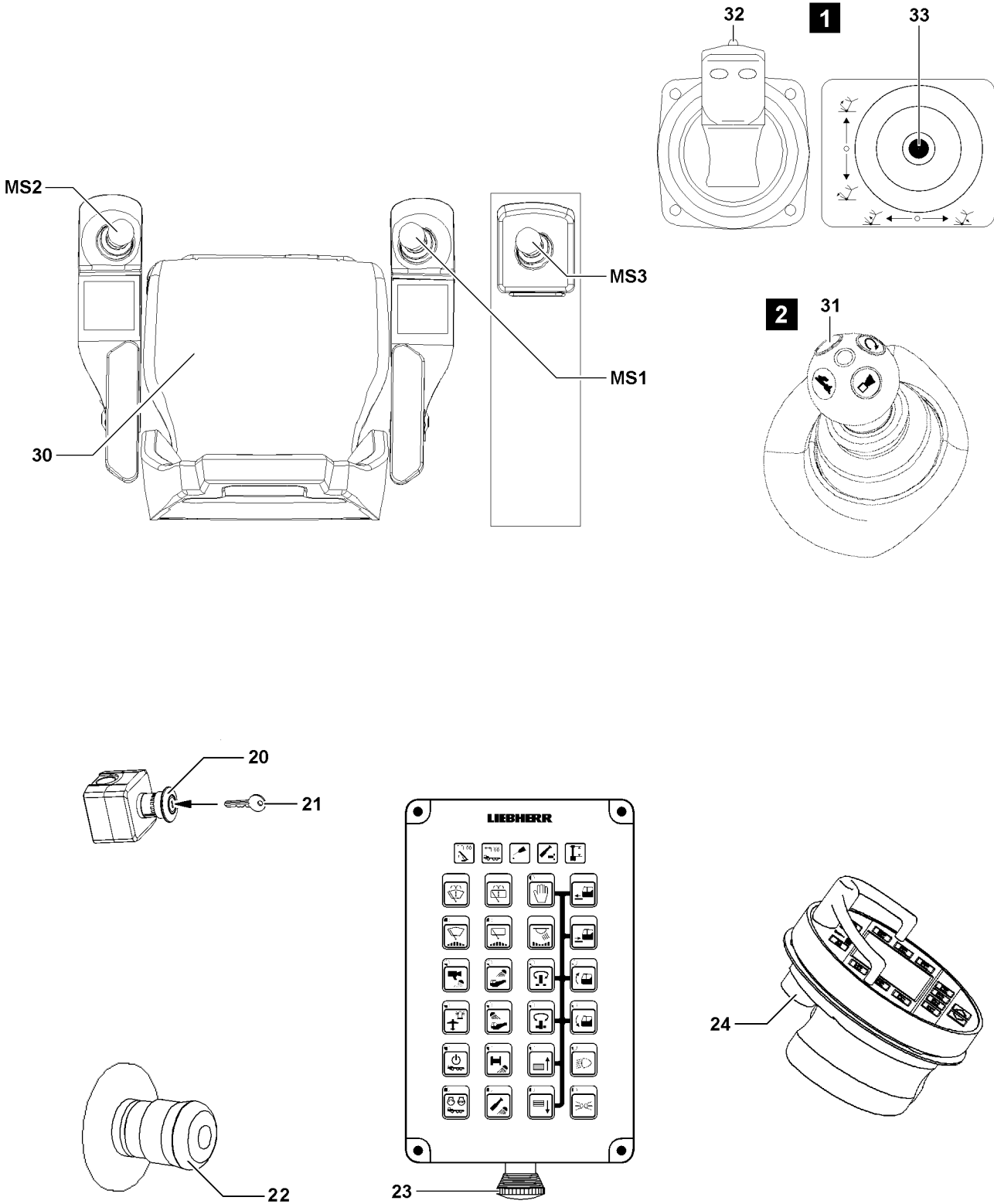

Fig.112970

5.10 Control release

The control release can be made via three switches:

- **30** Seat contact button
- Button **31** on master switch **MS1** and **MS2** and **MS3**.
- or
- Button **32** on master switch **MS1** and **MS2** (only LR1400/2)
- Button **33** on master switch **MS3** (only LR1400/2)

The seat contact button **30** shuts down the crane control as soon as the crane operator gets up from the seat.

This prevents unintended crane movements by accidentally touching the master switch, for example when getting in or out of the cab.

Button **31** or button **32** and the button **33** bypass the seat contact switch **30**, if necessary, for example, when work must be performed standing.

5.11 Hydraulic safety valves

A differentiation is made between three types:

- Pressure relief valves
 - Prevent pipe and hose bursts due to excessive pressure.
- Shut off valves
 - Control and secure the working cylinders.
- Check valves
 - Control and secure the flow direction.

5.12 Gravity actuated relapse retainer



Note

- ▶ Only for cranes with luffing accessories.

The gravity actuated relapse retainer (oscillation guard / flap / relapse support) prevent luffing accessory from tipping to the rear in „steepest position“.



WARNING

The crane can topple over!

If the gravity actuated relapse retainer (oscillation guard / flap / relapse support) is hard to move, then it will no longer function.

Shut off and limit functions can be set out of service!

The crane can be overloaded and topple over!

Personnel can be killed or seriously injured!

This could result in property damage!

- ▶ Before erecting the crane, check the relapse retainer for easy movement!
- ▶ Crane operation with hard to move relapse retainer is prohibited!

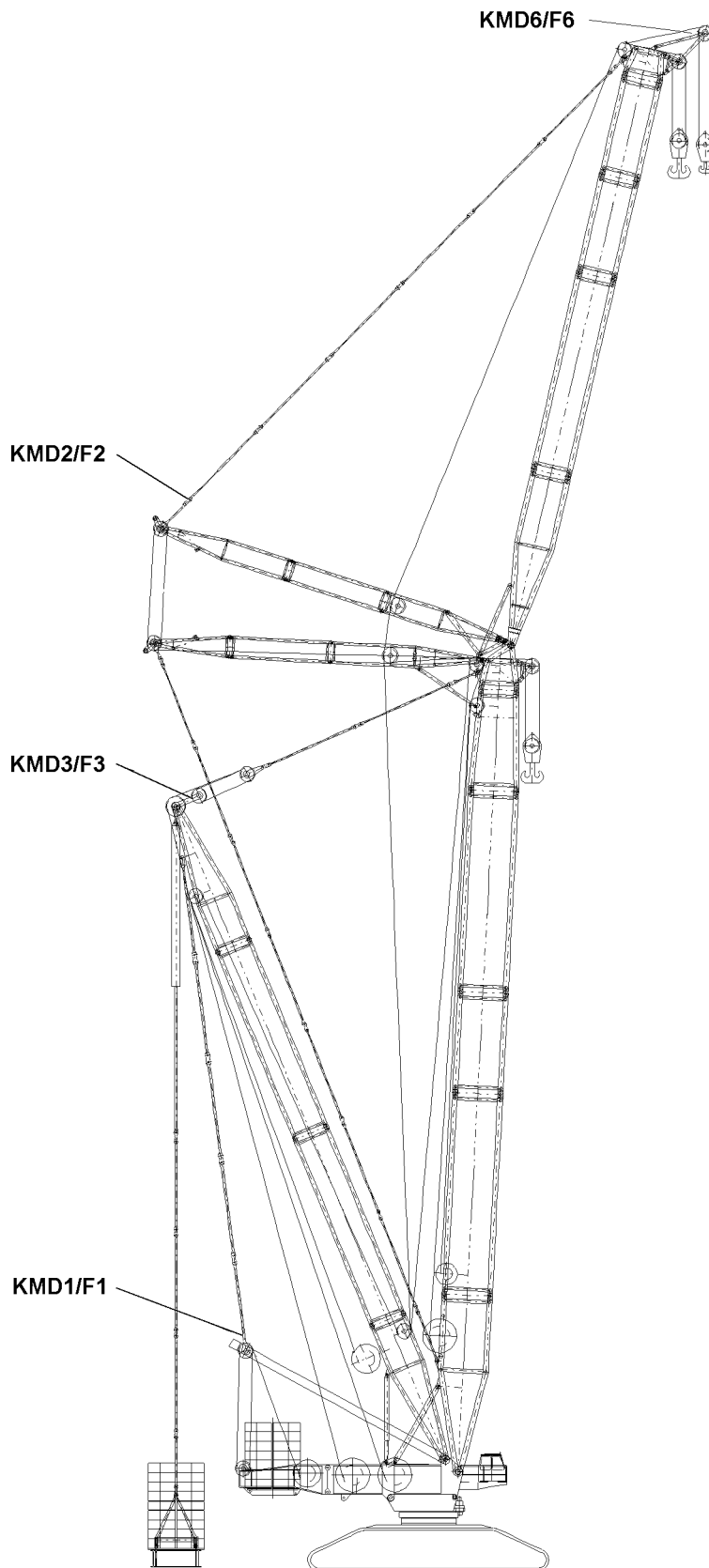

Fig.112971

5.13 Angle sensors

Component	Description - Angle sensor (WG)
S-pivot section	Main boom bottom
S/W-end section, if used on boom	Main boom top
S/W-end section, if used on luffing jib	Luffing jib up
W-pivot section	Luffing jib bottom
W-connector head	Main boom top
D-pivot section	Derrick bottom
D-end section	Derrick top
SA-frame	SA-frame

5.14 Test brackets (KMD = force test box)

The test brackets measure the force in the guying, which results from the load and the boom momentum.

The test brackets are located:

- **KMD 1**, in the boom guying, SA-frame to boom for all operating modes **without** derrick
- **KMD 1**, in the derrick guying, SA-frame to derrick for all operating modes **with** derrick
- **KMD 2**, in the lattice jib guying, WA-frame 1 to lattice jib end section
- **KMD 3**, in the boom guying, derrick to boom for all operating modes **with** derrick
- **KMD 6**, in the boom nose (not LR1400/2)

5.15 Limit switch Boom system



WARNING

Danger of toppling or destroying the crane!

If the crane movement is stopped by the block limit switches, then the load forces cannot be absorbed and calculated by the control!

The crane can be overloaded and topple over!

Personnel can be hit and killed or seriously injured!

This could result in property damage!

- ▶ Do **not** use the hoist limit switch as an operational shut off device!
- ▶ Do not actuate the block limit switches!

Empty page!

LWE/LR 1600-2-008/18109-09-02/en

4.05 Crane operation

1	LICCON computer system	3
2	Winch and master switch assignment to operating modes	3
3	Carrying out crane movements	5

Fig.195219

LWE/LR 1600-2-008/18109-09-02/en

1 LICCON computer system



WARNING

Danger of accidents due to overload!

- ▶ Constantly monitor the displays on the LICCON monitor!
- ▶ Observe changing utilization conditions and forces!



WARNING

Danger of accident!

- ▶ The crane operator must evaluate constantly if the data shown in the operating view can even be correct. He may not rely blindly on the LICCON system but must think for himself and must recognize a possible error or overload conditions!

For detailed description of the operation of the LICCON computer system, refer to Crane operating instructions, chapter 4.02!

2 Winch and master switch assignment to operating modes

The assignment of the master switches to the winches is different, according to the operating modes.



WARNING

The crane can topple over!

If the master switch assignment in the electric wiring diagram is ignored, the crane can topple over!

Personnel can be severely injured or killed!

Severe damage on the crane can result!

- ▶ The winch use is regulated in the master switch assignment in the Electric wiring diagram. The winches may only be operated according to this master switch assignment specified in the Electric wiring diagram.

Fig.195219

LWE/LR 1600-2-008/18109-09-02/en

3 Carrying out crane movements

Make sure that the following prerequisites are met:

- The crane is **supported**.
(Only available in connection with cranes with narrow tracks)
- The crane is aligned in horizontal direction.
- The counterweight is installed and secured according to the data in the load chart.
- The ground is able to carry the weight of the crane, the load and the load tackle.
- The hook block is correctly reeved as shown in reeving plan.
- The crawler operation is turned off.
- The crane engine is running.
- All safety equipment has been adjusted according to the data in the load chart.
- The winches are correctly assigned to the respective pulley heads, see Crane operating instructions, chapter 4.02.
- There are no persons or objects in the danger zone.



WARNING

Danger of accident!

- ▶ In order to protect the crane and reduce the danger of accidents, always operate the master switch slowly and sensitively!
 - ▶ Ensure that there are no obstacles in the working range of the crane and that there are no persons within the danger zone!
 - ▶ Give a warning signal before initiating a crane movement!
 - ▶ Observe the danger notes for crane operation, see Crane operating instructions, chapter 5.01!
-

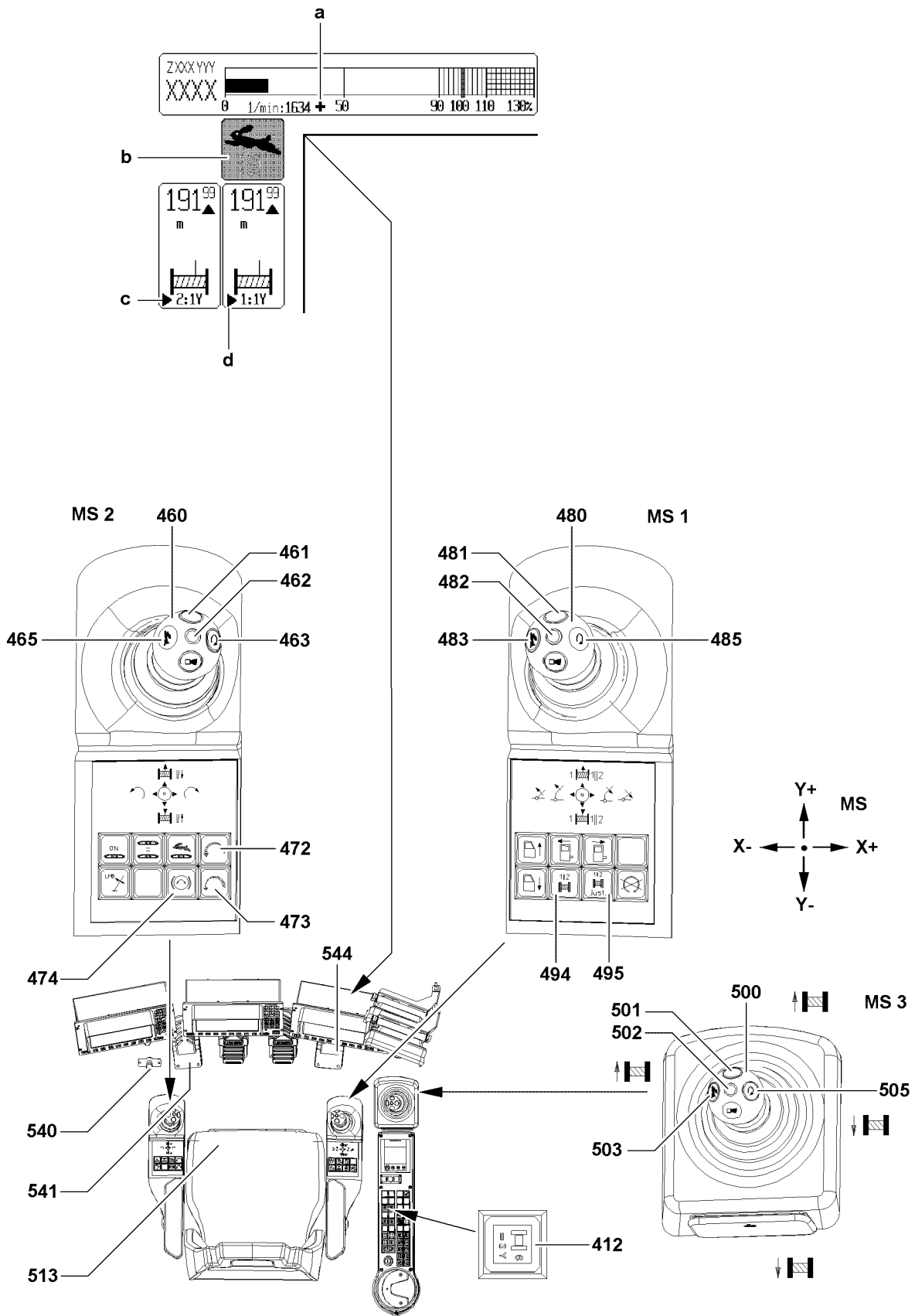

Fig.110868

LWE/LR 1600-2-008/18109-09-02/en

3.1 Regulating the engine rpm

3.1.1 Locking the engine rpm

Locking the engine rpm relieves the crane operator if he needs to work for an extended period with constant rpm. The engine rpm can be locked in any position.

- ▶ Press the pedal **544** down for the engine regulation until the desired rpm is reached.
- ▶ Press the button **463**.
 - or
 - Press button **485** or button **505**.

Result:

- The pedal **544** is locked and the engine rpm is saved.
- The icon **a** appears on the monitor.

3.1.2 Increasing the engine rpm via the pedal

Make sure that the following prerequisite is met:

- The maximum rpm has not yet been reached.

When the engine rpm is locked, the engine rpm can be increased with the pedal.

When the pedal is released, the engine rpm drops to the saved value.

- ▶ Press the pedal **544** and increase the engine rpm.

When this engine rpm is to be saved:

- ▶ Press the button **463**.
 - or
 - Press button **485** or button **505**.

3.1.3 Increasing and decreasing the engine rpm with the button

If both feet are already used for operation, for example when „driving the crawler“, the engine rpm can be changed with the button **472** or the button **473** on the control panel.

A regulation with the buttons deletes the saved engine rpms.

Increase engine rpm

- ▶ Press the button **472** and hold it until the desired engine rpm is reached.

Result:

- The engine rpm increases steplessly.
- The engine rpm increases steplessly.

Decrease engine rpm

- ▶ Press the button **473** and hold it until the desired engine rpm is reached.

Result:

- The engine rpm decreases steplessly.

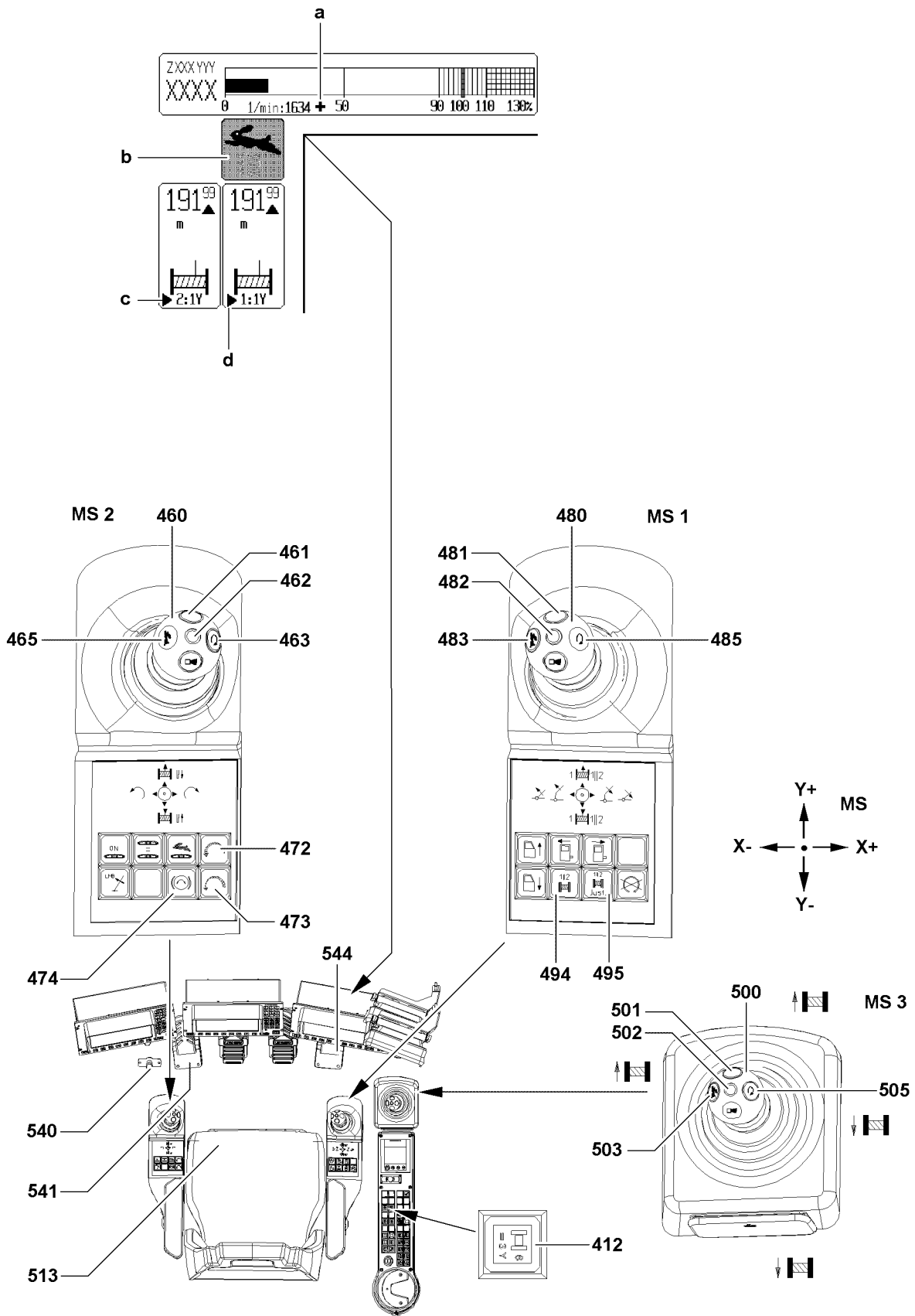

Fig.110868

LWE/LR 1600-2-008/18109-09-02/en

3.1.4 Releasing the engine rpm lock

If the engine rpm is locked:

- ▶ Press the button **463**.
- or**
- Press button **485** or button **505**.

Result:

- The lock is released.
- The icon **a** turns off on the monitor.
- The rpm reduces to low idle rpm.

3.1.5 „Power Plus“



Note

When „Power Plus“ is turned on, observe the following:

- ▶ If a crane movement has reached its maximum speed due to the current utilization, then no speed increase is possible by adding the „Power Plus“!
- ▶ If the total power requirement of all actuated crane movements is larger than the available power, then those crane movements are reduced which require the most power!
- ▶ If another crane movement is added or taken back to one or more actuated crane movements then this has an influence on the other movements. For that reason we recommend in situations in which an interference of the individual crane movements is troublesome, not to add the „Power Plus“ or to turn the „Power Plus“ off!

Adding „Power Plus“

The speed of the „lift / lower“ crane movement is increased with the button **465**, button **483** or button **503**.



WARNING

Danger of accidents in case of single to triple sheave reeving!

- ▶ Do **not** add „Power Plus“ if the crane is utilized by more than 50 % of its maximum permissible load carrying capacity for the corresponding radius!

- ▶ Press the button **465**.
- or**
- Press button **483** or button **503**.

Result:

- „Power Plus“ is added.
- The icon **b** appears on the LICCON monitor.

Turning the „Power Plus“ off

If the „Power Plus“ is added:

- ▶ Press the button **465** again.
- or**
- Press button **485** or button **503** again.

Result:

- „Power Plus“ is turned off.
- The icon **b** turns off on the LICCON monitor.

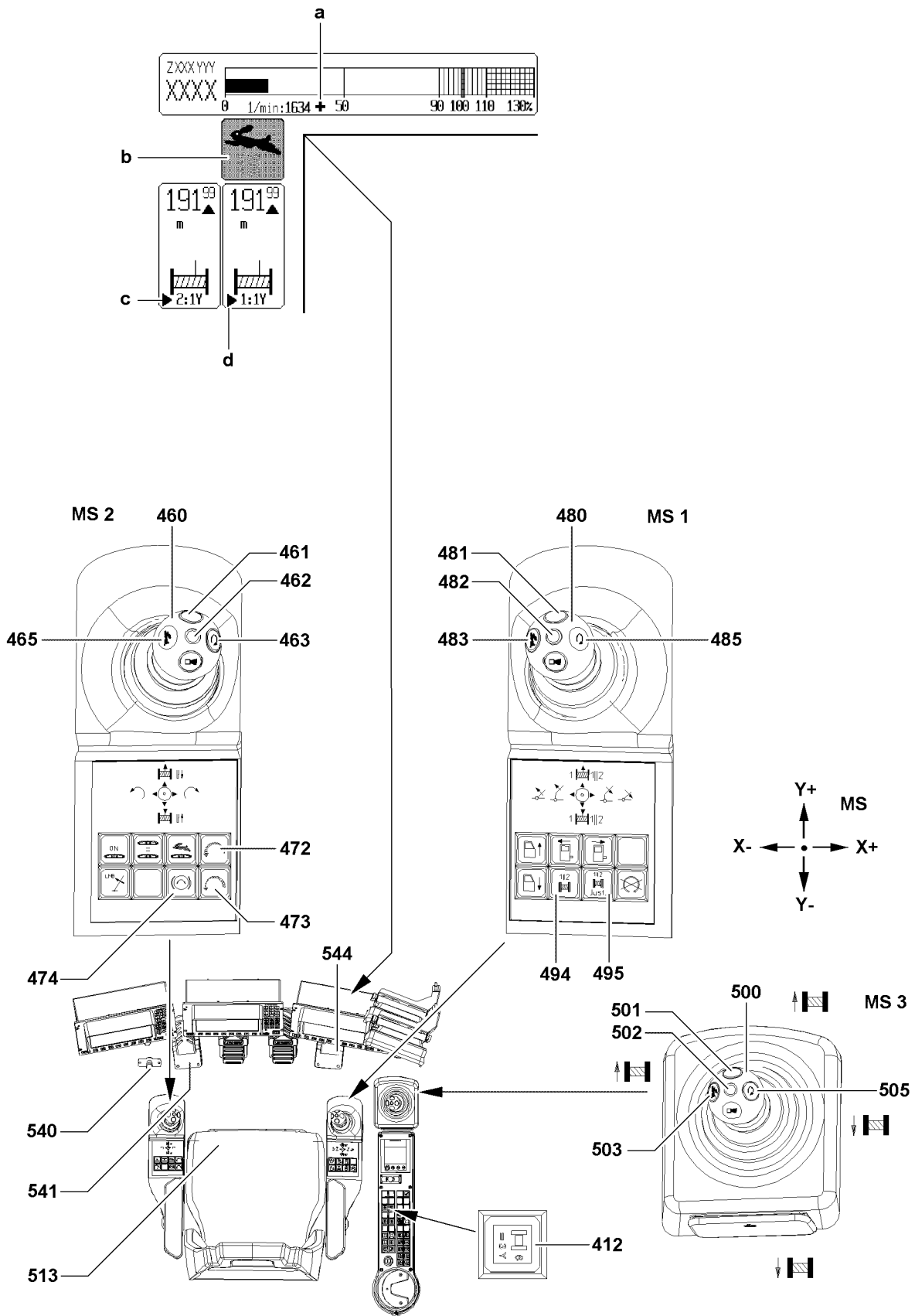

Fig.110868

LWE/LR 1600-2-008/18109-09-02/en

3.2 Vibration sensor

By adding the vibration sensor, a crane movements can be detected by vibration of the master switch.

Make sure that the following prerequisite is met:

- The seat contact switch **513** is activated.

3.2.1 Vibration sensor winch 1

Adding the vibration sensor

- ▶ Press the button **481**.

Result:

- The vibration sensor **482** is turned on.
The icon **d** is turned on.

Turning the vibration sensor off

When the vibration sensor **482** is turned on:

- ▶ Press the button **481** again.

Result:

- The vibration sensor **482** is turned off.
The icon **d** is turned off.

3.2.2 Vibration sensor winch 2 or slewing gear

If winch 2 and the slewing gear are operated, then the vibration sensor **462** will react to the first deflected movement.

Adding the vibration sensor

- ▶ Press the button **461**.

Result:

- The vibration sensor **462** is turned on.
The icon **c** is turned on.

Turning the vibration sensor off

When the vibration sensor **462** is turned on:

- ▶ Press the button **461** again.

Result:

- The vibration sensor **462** is turned off.
The icon **c** is turned off.

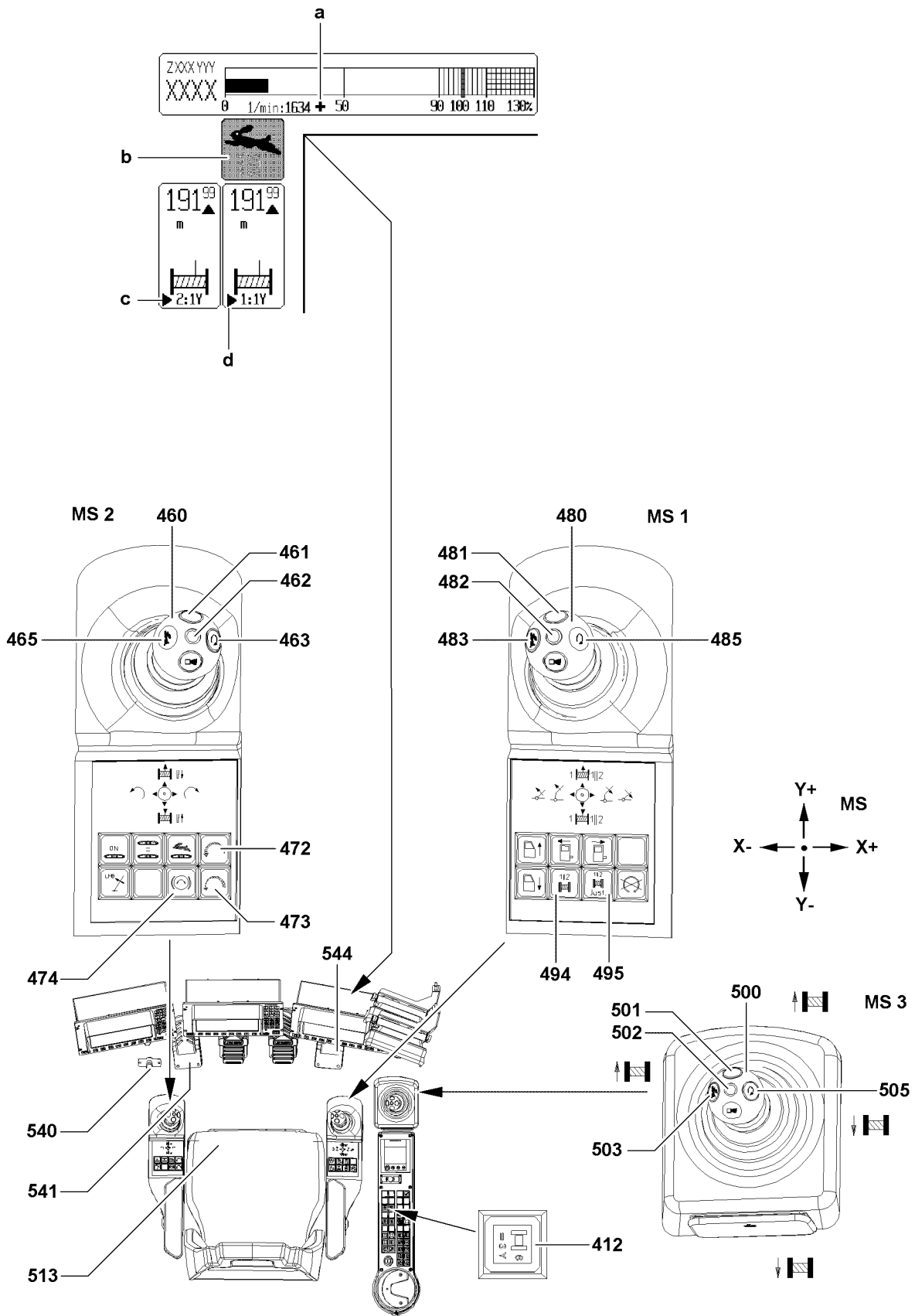

Fig.110868

LWE/LR 1600-2-008/18109-09-02/en

3.3 Lifting / lowering a load

NOTICE

Rope damage due to slack rope!

- ▶ When spooling the winches up / out, check visually to make sure that no slack rope forms!

The speed of crane movement „lifting and lowering“ is controlled via the deflection of the corresponding master switch and via the pedal **544** of the engine regulation.

In the „Control Parameter“ program, it is possible to preselect the maximum winch speed. It is also possible to deactivate or activate the individual winches.

See Crane operating instructions, chapter 4.02!

Make sure that the following prerequisite is met:

- The winches are correctly assigned to the respective pulley heads, see Crane operating instructions, chapter 4.02!

3.3.1 Operating winch 1 - hoist winch

In the winch icon is shown with the arrow icons that the winch is turning, even if no hook movement is visible due to multiple reeving and low speed.

- ▶ Deflect master switch 1 **480** in direction Y+.

Result:

- Winch 1 spools out and the load is lowered.

- ▶ Deflect master switch 1 **480** in direction Y-.

Result:

- Winch 1 spools up and the load is lifted.

3.3.2 Operating winch 2 - hoist winch

In the winch icon is shown that the winch is turning, even if no hook movement is visible due to multiple reeving and low speed.

- ▶ Deflect master switch 2 **460** in direction Y+.

Result:

- Winch 2 spools out and the load is lowered.

- ▶ Deflect master switch 2 **460** in direction Y-.

Result:

- Winch 2 spools up and the load is lifted.

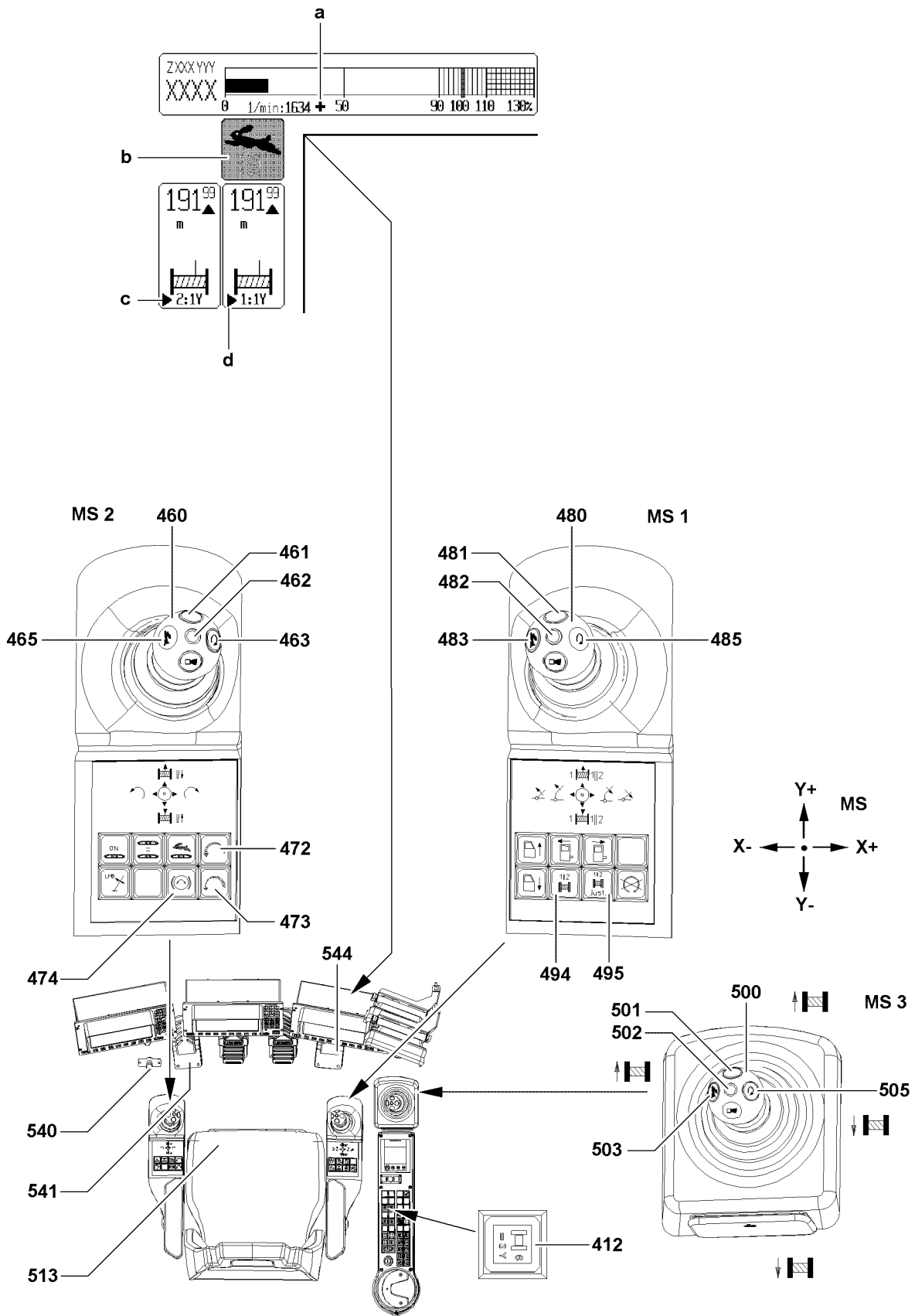

Fig.110868

LWE/LR 1600-2-008/18109-09-02/en

3.3.3 Setting up parallel operation

For parallel operation, winch 1 and winch 2 are used.

In parallel operation, actuation of winch 1 and winch 2 is made only together with master switch 1 **480**.

Make sure that the following prerequisites are met:

- The double hook blocks are installed together, see Crane operating instructions, chapter 4.06.
- The double hook blocks are reeved according to the load charts.
- The double hook blocks are properly reeved according to the reeving plan, see Crane operating instructions, chapter 4.06.
- The total reeving has been entered on the LICCON monitor.
- The reeving number on both winches 1 and 2 must be the same and even.



WARNING

Danger of accident!

- ▶ The total reeving number on winch 1 and winch 2 must be the same and even in parallel operation. If the minimum value of the reeving is uneven, then - in parallel operation - the next higher, even reeving must be selected.
- ▶ Make sure to unpin the transport pins on the hook block before horizontal alignment and before crane operation!
- ▶ Make sure that the danger zone of the hook block is free of any personnel!

Aligning the hook blocks horizontally

Make sure that the following prerequisites are met:

- Individual operation for winch 1 and winch 2 is set.
- The switch **494** is turned off: Parallel control is turned off.
- There is no load on the hook.

Check visually and align the hook blocks horizontally. To do so, spool the winches manually up or out.

- ▶ Deflect master switch 1 **480** or master switch 2 **460** in direction Y.

Result:

- Winch 1 or winch 2 spools out or up until the hook blocks are horizontally aligned.

Adjusting the parallel control of winch 1 and winch 2

Make sure that the following prerequisites are met:

- The double hook blocks are horizontally aligned, check visually.
- There is no load on the hook.

- ▶ Turn on the switch **494** for the parallel operation.
- ▶ Press the button **495**.

Result:

- The parallel control of winch 1 and winch 2 is adjusted.

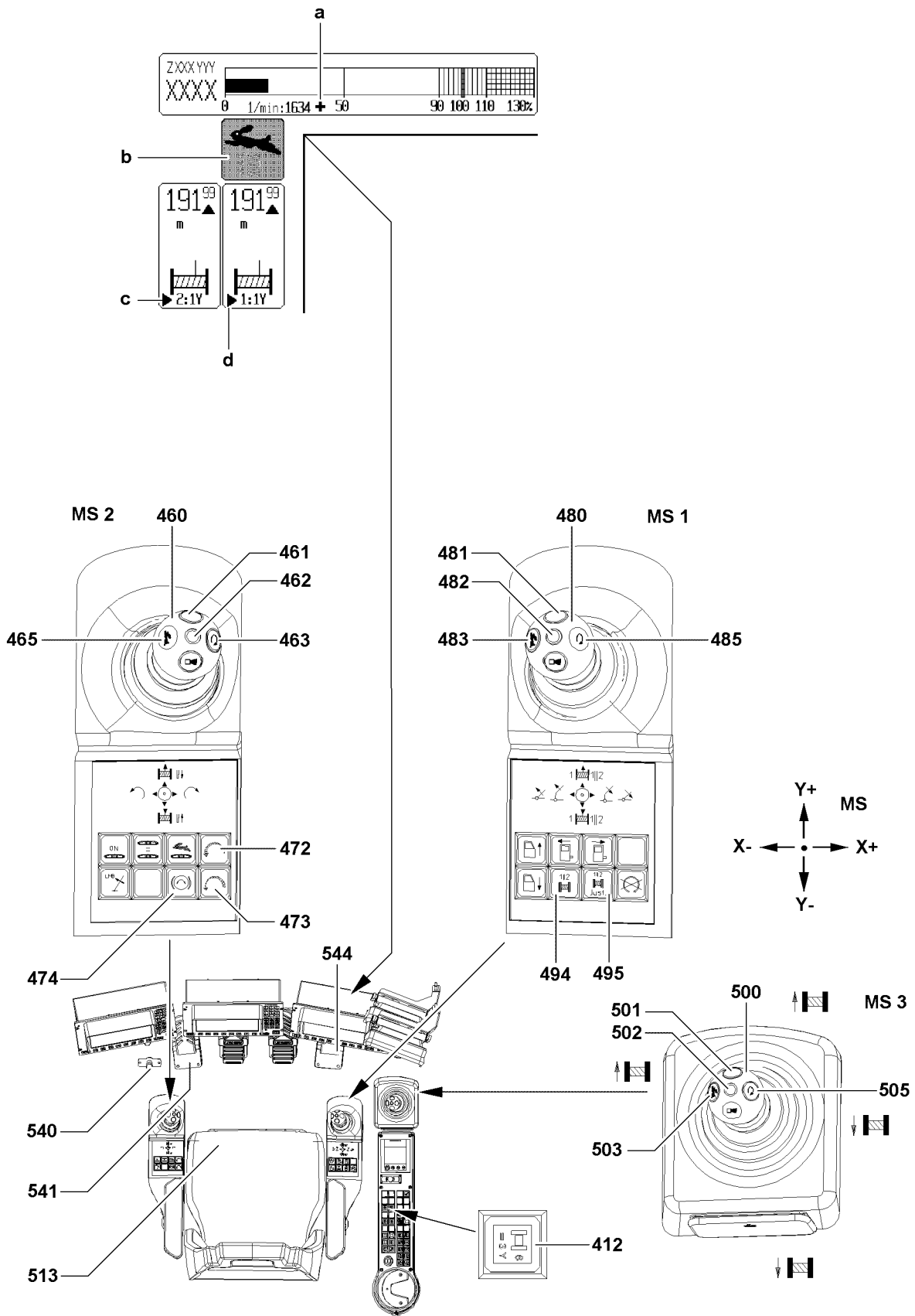

Fig.110868

LWE/LR 1600-2-008/18109-09-02/en

3.3.4 Parallel operation: Lifting / lowering a load



WARNING

Danger of accidents due to overload!

If the compensation cross bar is inclined, then significant load increases will occur on the individual hook blocks!

If this is not observed, then the hook block, boom or rope can be overloaded, resulting in property damage and personal injury!

- ▶ Make sure that the compensation cross bar is always aligned horizontally on the double hook blocks!



WARNING

Danger of accidents due to different level of hook blocks!

The electronic parallel control only monitors the same rotational speed of the two winches, however, it does **not** consider the following errors:

- Uneven rope length
- Different rope diameters
- Different winding behavior
- Uneven reeving

- ▶ The crane operator must ensure and is responsible for that the hook blocks are always on the same level, despite electronic monitoring!



Note

- ▶ The winch movement is shut off if the difference range of the parallel control is being exceeded! In that case, the winches must be again parallel adjusted!

Make sure that the following prerequisites are met:

- The double hook blocks are horizontally aligned, check visually.
- There is no load on the hook.
- Parallel control of winches is adjusted.
- The button **494** for parallel operation is turned on.

- ▶ Deflect master switch 1 **480** in direction Y+.

Result:

- Winch 1 and winch 2 spool out together: The load is lowered.

- ▶ Deflect master switch 1 **480** in direction Y-.

Result:

- Winch 1 and winch 2 spool up together: The load is lifted.

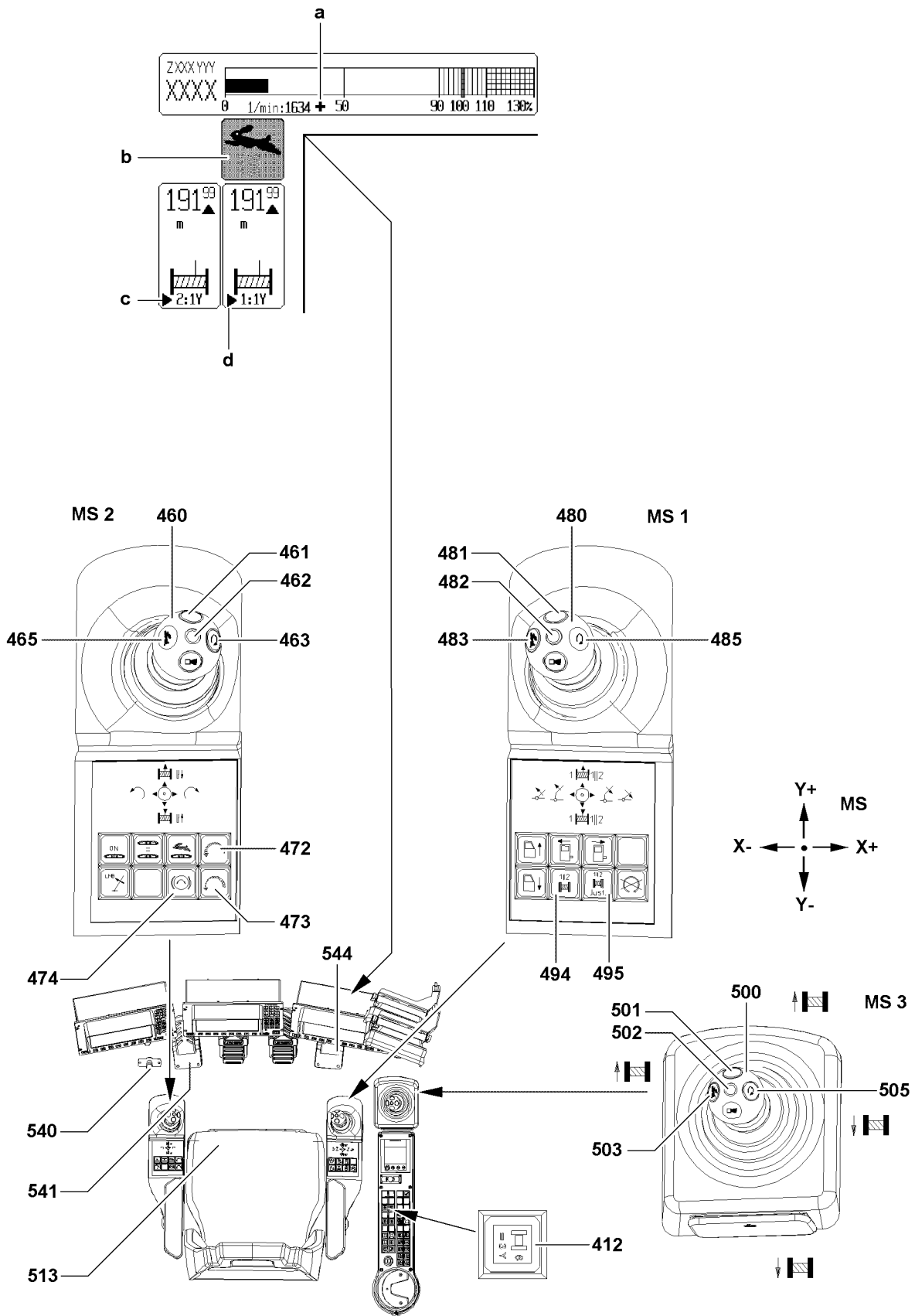

Fig.110868

LWE/LR 1600-2-008/18109-09-02/en

3.3.5 Operating winch 6 - hoist winch

In the winch icon is shown that the winch is turning, even if no hook movement is visible due to multiple reeving and low speed.



Note

- ▶ In individual operation of winch 1 and winch 2, no master switch is assigned to winch 6!
- ▶ To be able to run winch 6 in individual operation, the switch **412** must be turned on, this assigns winch 6 to the master switch **3 500**!
- ▶ In parallel operation, winch 1 and winch 2 are actuated with the master switch **1 480**! When the switch **412** is turned off, then the master switch **2 460** is assigned to winch 6!

Operating winch 6 in parallel operation of winch 1 and winch 2

Make sure that the following prerequisites are met:

- The switch **494** is turned on.
- The switch **412** is turned off.
- ▶ Deflect master switch **2 460** in direction Y+.

Result:

- Winch 6 spools out and the load is lowered.
- ▶ Deflect master switch **2 460** in direction Y-.

Result:

- Winch 6 spools up and the load is lifted.

Operating winch 6 in single operation of winch 1 and winch 2

Make sure that the following prerequisites are met:

- The switch **494** is turned off.
- The switch **412** is turned on.
- ▶ Deflect master switch **3 500** in direction Y+.

Result:

- Winch 6 spools out and the load is lowered.
- ▶ Deflect master switch **3 500** in direction Y-.

Result:

- Winch 6 spools up and the load is lifted.

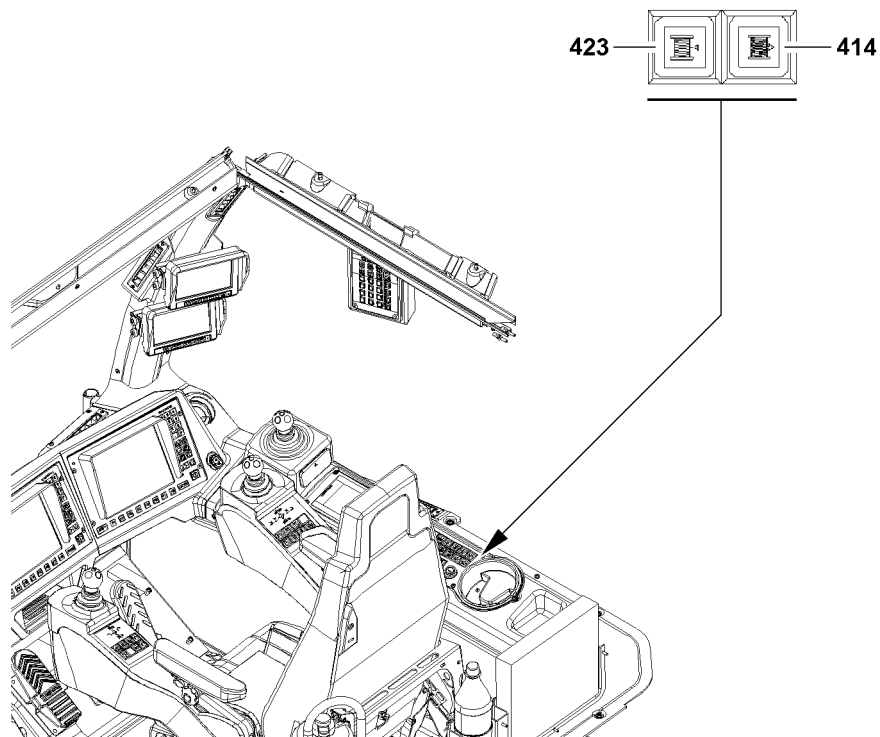

Fig.110869

LWE/LR 1600-2-008/18109-09-02/en

3.3.6 Operating the assembly winch

Spool the assembly winch out

If the assembly winch is to be stopped:

- ▶ Release the button **423**.
- ▶ Press the button **423** and hold.

Result:

- The assembly winch spools out.

Spool the assembly winch up

If the assembly winch is to be stopped:

- ▶ Release the button **414**.
- ▶ Press the button **414** and hold.

Result:

- The assembly winch spools up.

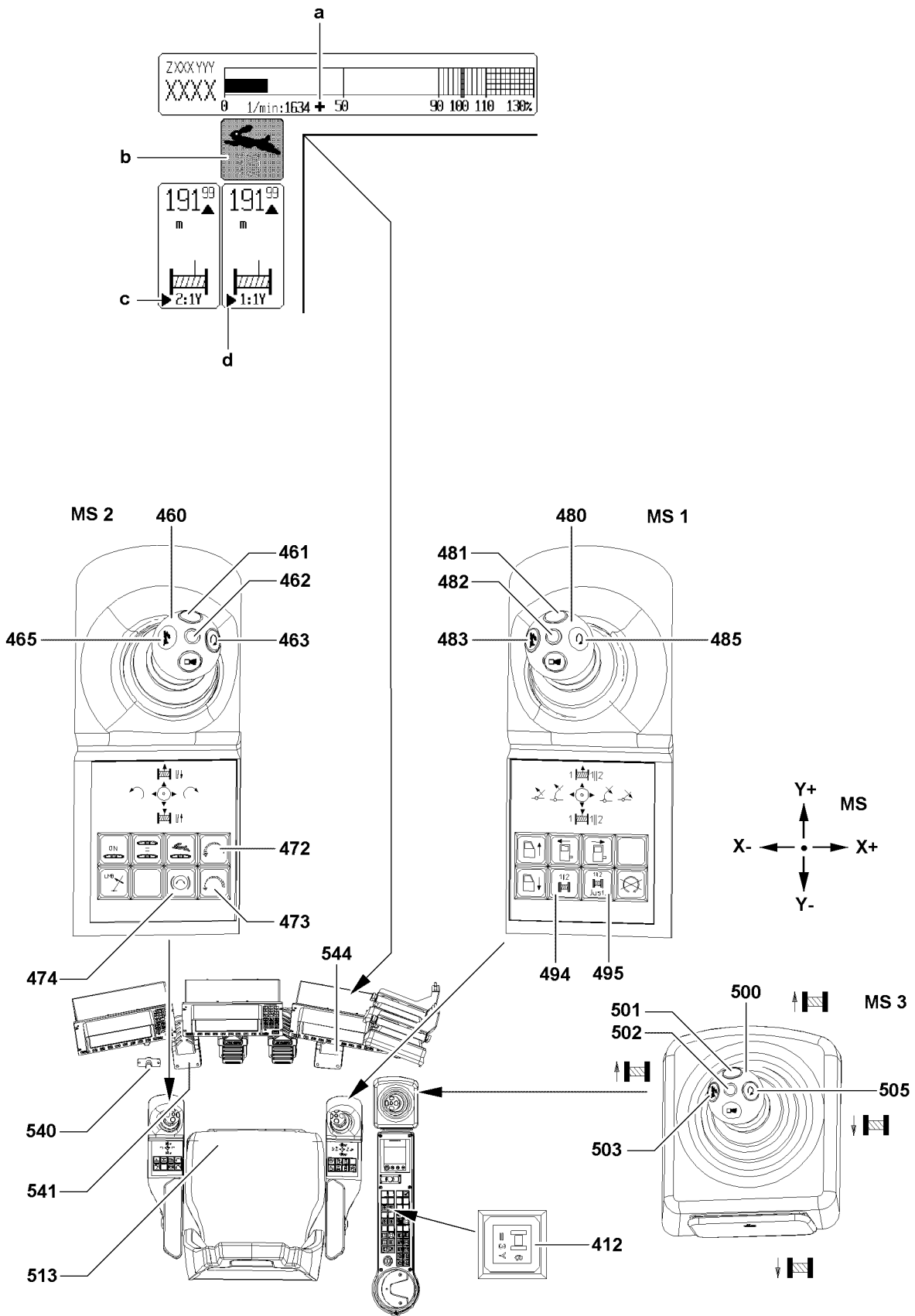

Fig.110868

LWE/LR 1600-2-008/18109-09-02/en

3.4 Luffing the boom



DANGER

Danger of accident due to toppling crane!

If the LICCON overload protection turns off while trying to lift the load with the winch, then a subsequent luffing movement can cause the crane to topple over or damage it. Personnel can be severely injured or killed!

▶ Do not lift the load by luffing up the boom, see Crane operating instructions, chapter 4.04!

The speed of crane movement „luffing“ is controlled by the deflection of the corresponding master switch and via the pedal **544** of the engine regulation.



Note

▶ The operating modes are explained in the load chart manual!

▶ Not all operating modes are available in connection with narrow track crane versions!

3.4.1 Luffing the boom in S/SL/SLF/SL2DB/SDB/SDWV(B/BW) operating modes

▶ Deflect the master switch 1 **480** in direction X-.

Result:

– The boom is luffed up.

▶ Deflect the master switch 1 **480** in direction X+.

Result:

– The boom is luffed down.

3.4.2 Luffing the main boom in operating mode SW

Make sure that the following prerequisite is met:

– The switch **412** is **not** switched to winch 6, master switch 3 **500**.

▶ Deflect master switch 3 **500** in direction Y-.

Result:

– The boom is luffed up.

▶ Deflect master switch 3 **500** in direction Y+.

Result:

– The boom is luffed down.

3.4.3 Luffing the main boom in operating mode SDW (B/BW)

▶ Deflect the master switch 3 **500** in direction X-.

Result:

– The boom is luffed up.

▶ Deflect the master switch 3 **500** in direction X+.

Result:

– The boom is luffed down.

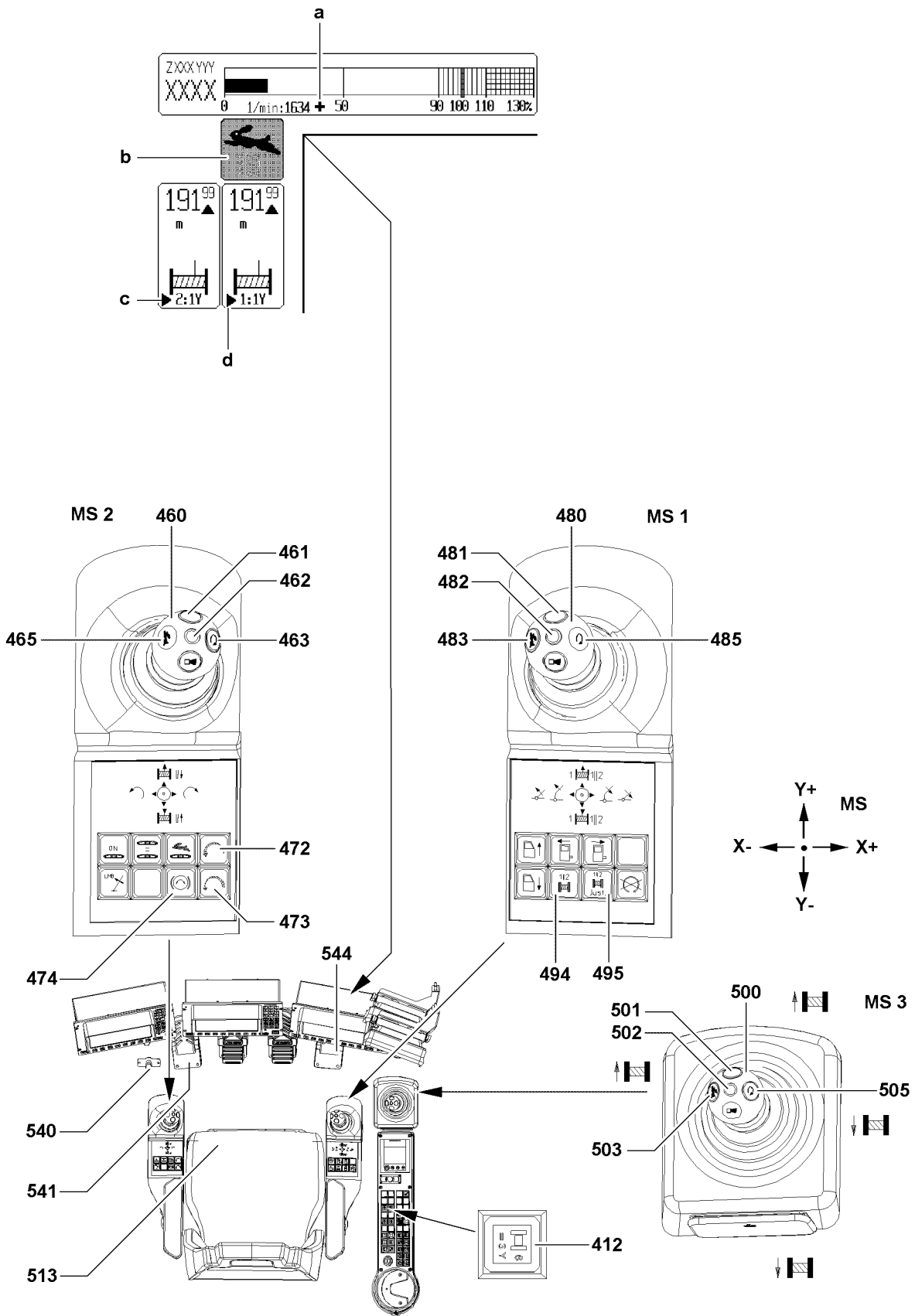

Fig.110868

LWE/LR 1600-2-008/18109-09-02/en

3.4.4 Luffing the lattice jib during SW/SDW/(B/BW) operation

- ▶ Deflect the master switch 1 **480** in direction X-.

Result:

- The lattice jib is luffed up.

- ▶ Deflect the master switch 1 **480** in direction X+.

Result:

- The lattice jib is luffed down.

3.4.5 Luffing the lattice jib during SDWV(B/BW) operation

- ▶ Deflect the master switch 3 **500** in direction X-.

Result:

- The lattice jib is luffed up.

- ▶ Deflect the master switch 3 **500** in direction X+.

Result:

- The lattice jib is luffed down.

3.4.6 Luffing the derrick, for all D-operating modes

Make sure that the following prerequisite is met:

- The switch **412** is **not** switched to winch 6, master switch 3 **500**.

- ▶ Deflect master switch 3 **500** in direction Y-.

Result:

- The derrick is luffed up.

- ▶ Deflect master switch 3 **500** in direction Y+.

Result:

- The derrick is luffed down.

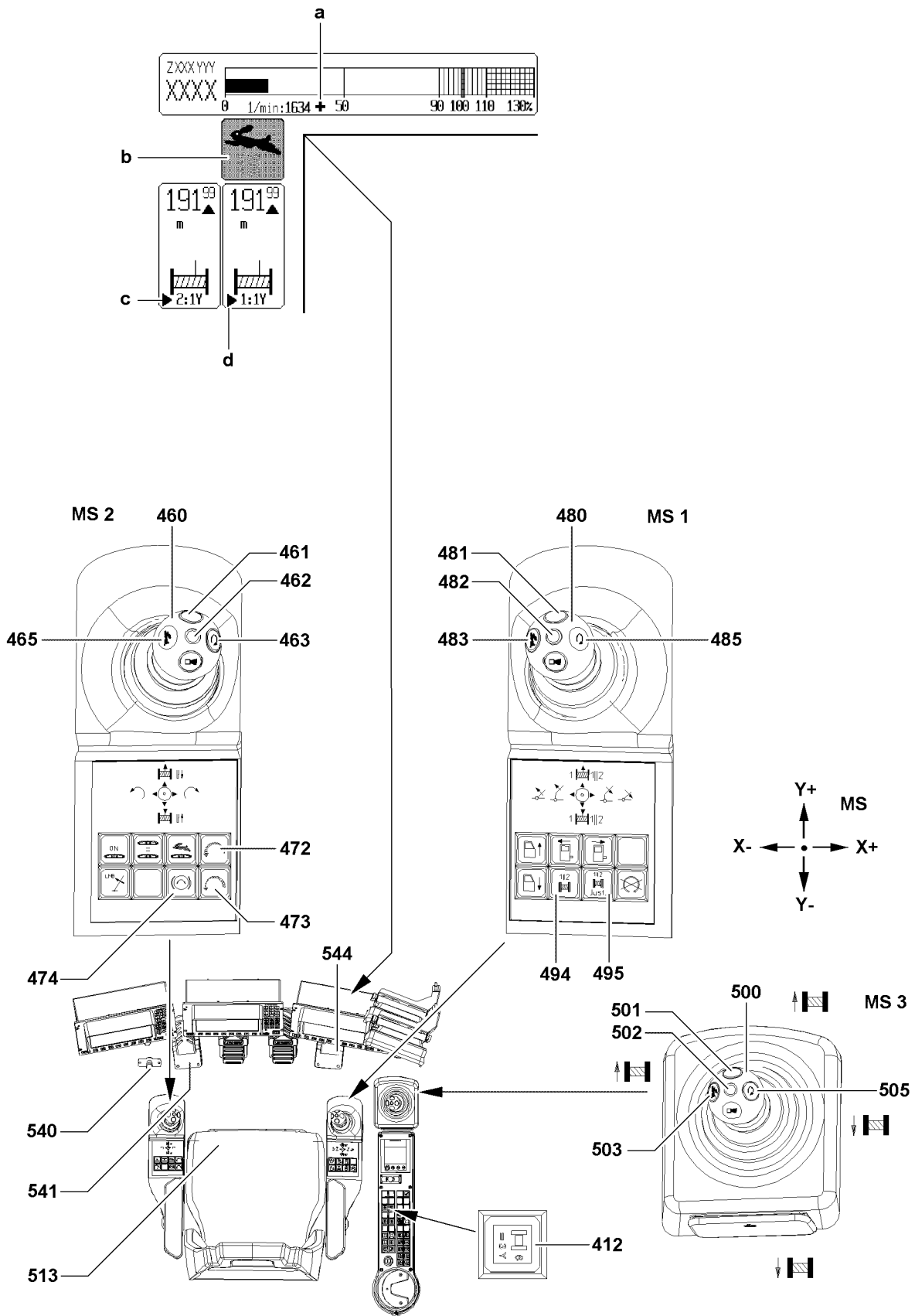

Fig.110868

LWE/LR 1600-2-008/18109-09-02/en

3.5 Slowing down a slewing movement

This crane is equipped with a slewing gear in a closed hydraulic circuit.

Various braking functions are differentiated:

1. Working with automatic slewing gear brake: The hydraulic system brakes the slewing movement, the slewing gear brake is applied after completion of the integration period.
2. Working with manually opened slewing gear brake: The slewing gear brake can be opened and closed manually.
3. Working in strong side wind with additional actuation of the slewing gear brake with the pedal.

3.5.1 Applying and releasing the slewing gear brake manually

Releasing the slewing gear brake manually



DANGER

Danger of accident due to uncontrolled turning crane!

If the slewing gear brake is released manually and the master switch 2 **460** is **not** deflected, the crane superstructure, as a result of external forces, such as wind, incline position of the crane, etc., can turn slowly due to leakage in the closed hydraulic circuit!

When the slewing gear brake is released manually and the master switch 2 **460** is **not** deflected:

- ▶ Make sure that the crane is not turning uncontrolled!



Note

- ▶ Observe the data in section „Actuating the slewing gear brake with the pedal“!

The slewing gear brake closes automatically if:

- The crane operator gets up from the crane operator's seat.
- The engine is turned off.

The slewing gear **cannot** be opened at:

- Slewing gear shut off by the LICCON overload protection.
- Activated working range limitation.

- ▶ Actuate the switch **474**.

Result:

- The slewing gear brake is released.
- The indicator light **474** lights up.

Applying the slewing gear brake manually

- ▶ Press the button **474**.

Result:

- The slewing gear brake is applied.
- The indicator light **474** turns off.

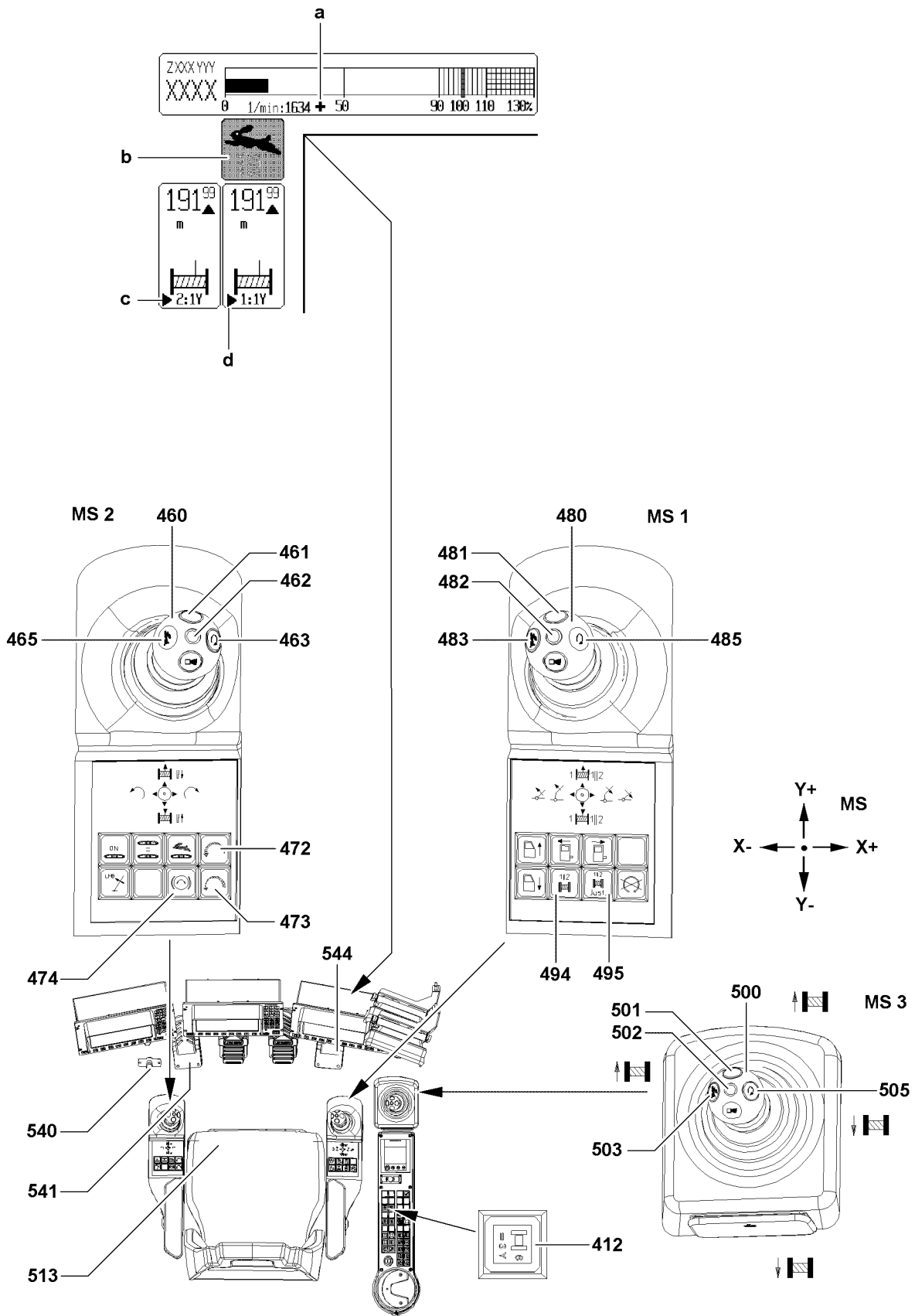

Fig.110868

LWE/LR 1600-2-008/18109-09-02/en

3.5.2 Applying the slewing gear brake with the pedal

NOTICE

Danger of property damage on the slewing ring connection!

When actuating the slewing gear brake with the pedal **541**, only part of the braking momentum of the slewing gear brake can be created!

- ▶ Use the pedal **541** to actuate the slewing gear brake only at minimum slewing speeds, which means the master switch **2 460** is almost in zero position!
 - ▶ Do not brake the turning movement of the crane by moving the master switch **2 460** back to the neutral position and/or by abruptly applying the slewing gear brake with the pedal **541**!
-

Use the pedal **541** to actuate the slewing gear brake only in the following cases:

- Starting out in strong side wind
- Stopping the slewing movement in strong side wind

Starting out in strong side wind

When turning against the wind in strong side wind and with a long boom systems, then the superstructure, due to leakage in the hydraulic motor, will turn into the opposite direction, in relation to the deflection of the master switch.

This can be avoided as follows:

- ▶ Actuate the pedal **541** and deflect the master switch **2 460** into the desired turning direction.
- ▶ Slowly release the pedal **541** until the superstructure turns in the desired turning direction.

Stopping the slewing movement in strong side wind

- ▶ Slow down the crane with master switch **2 460** to minimum slewing speed.
- ▶ Apply the pedal **541** carefully, until the crane has come to a standstill at the desired position.

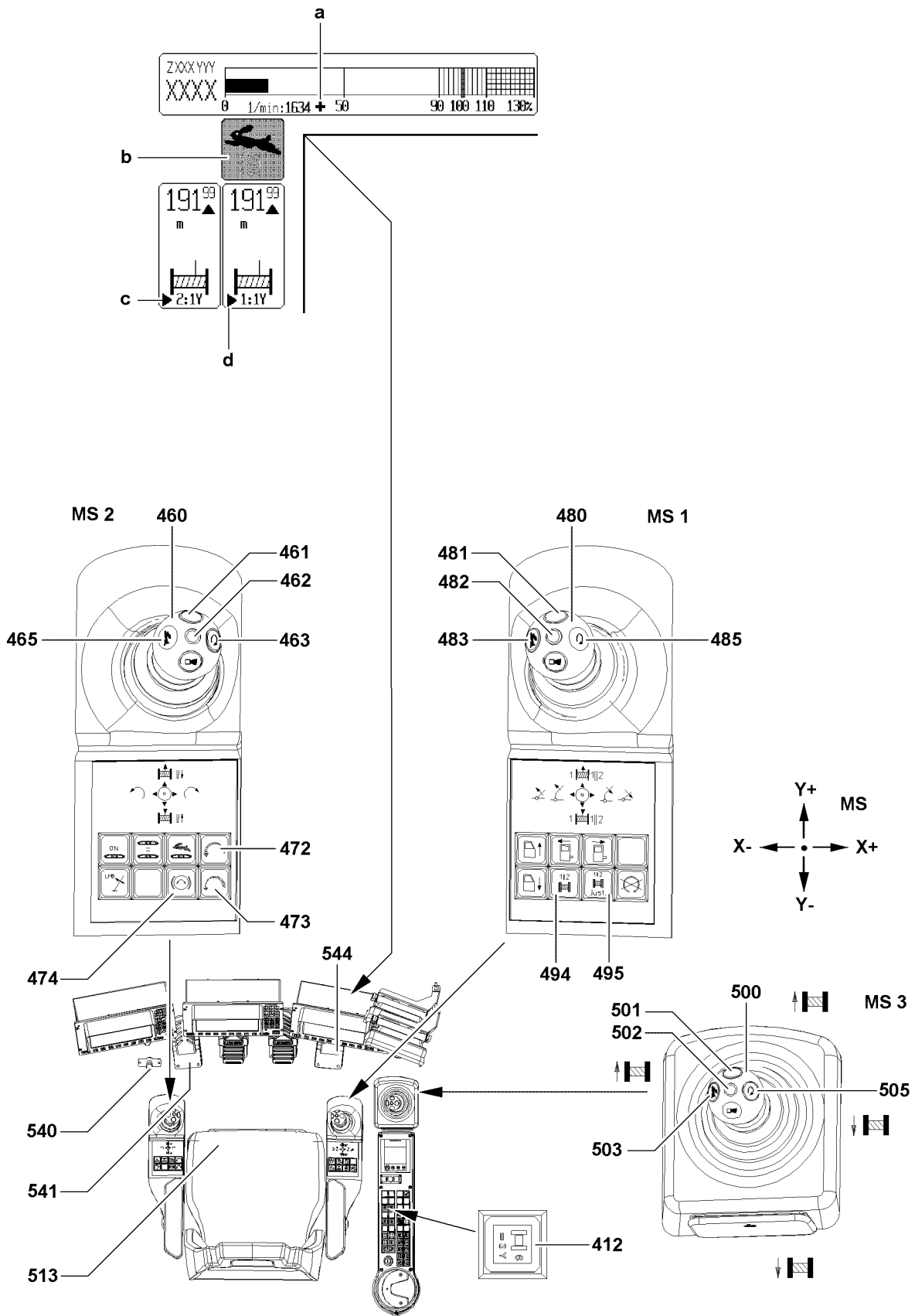

Fig.110868

LWE/LR 1600-2-008/18109-09-02/en

3.6 Switching the slewing gear to freewheeling

In order to position the boom over the load more easily, the slewing gear can be switched to freewheeling.

The master switch 2 **460** may not be deflected while doing so.

The slewing gear **cannot** be switched to coasting in these situations:

- Slewing gear shut off by the LICCON overload protection.
- Activated working range limitation.

▶ Press the foot button **540**.

Result:

- The slewing gear is switched to freewheeling / coasting.

Problem remedy

With the slewing gear released, the superstructure turns unintentionally (for example due to wind).

- ▶ Do not release the foot button **540**.
 - ▶ Deflect the master switch 2 **460** in slewing direction and then release the foot button **540**.
 - ▶ Slow down the slewing movement by slowly resetting the master switch 2 **460**.
-

3.7 Turning the crane superstructure



Note

- ▶ The crane superstructure can only be turned when the ball valve for the slewing gear brake is open (only possible in connection with narrow rack crane versions)!
-



WARNING

Danger of accident!

- ▶ Ensure that there are no obstacles in the turning range for the crane and that there are no persons within the danger zone!
 - ▶ Give a short warning signal (horn) before initiating a crane movement!
-



WARNING

Danger of accident due to toppling crane!

If the slewing speed is exceeded, there is the danger that the loads start to swing. The crane can be damaged or topple over. Personnel can be severely injured or killed!

- ▶ Turning with a load: Initiate and slow down a turning movement extremely sensitively!
 - ▶ Longer boom and larger load: Operate the crane with lower turning speed!
 - ▶ Observe and adhere to the values in the load chart manual!
-

The speed of the „turning“ crane movement is controlled via the deflection of master switch 2 **460** and via the pedal **544** of the engine regulation.

In the „Control Parameter“ program, it is possible to preselect the maximum rotational speed.

See Crane operating instructions, chapter 4.02!

- ▶ Deflect the master switch 2 **460** in direction X+.

Result:

- The crane superstructure turns to the right.

- ▶ Deflect the master switch 2 **460** in direction X-.

Result:

- The crane superstructure turns to the left.

Empty page!

LWE/LR 1600-2-008/18109-09-02/en

4.06 Rope reeving

1	Wire ropes and rope end connections	3
2	Reeving in the hoist rope	5
3	Reeving the hook block in and out	8
4	Reeving in / reeving out the hook block, L-shaped rope end connection (LR 11000 only)	11
5	Attaching and removing the load hook*	16
6	Attaching / removing the hoist limit switch weight	19
7	Assembling / disassembling the wedge lock	21
8	Rope reeving	22

Fig.195219

LWE/LR 1600-2-008/18109-09-02/en

1 Wire ropes and rope end connections

1.1 Wire ropes

Check if a **rotating resistant** or a **non-rotating** rope is required for the application. The selected type of rope then requires the corresponding rope end connections, see Crane operating instructions, chapter 8.04.



Note

- ▶ Correct choice and use of the wire rope and the rope end connections are a decisive precondition for proper and accident-free crane operation.



DANGER

Incorrect rope type!

Danger of severe injuries to personnel and property damage.

- ▶ **Never** use rotation-resistant ropes with a rotating rope end connection.
- ▶ **Never** install a twist compensator / swivel.

1.2 Rope end connections

Rope end connections are grouped into:

- Rope end connections with locking clamp or locking cast sleeve
- The L-shaped rope end connection with locking clamp or locking cast sleeve (LR 11000 only)
- Rope end connection **without** locking clamp or locking cast sleeve



Note

- ▶ The locking clamp **8** is pressed on the rope.
- ▶ The locking cast sleeve **8** is cast with the rope.

1.2.1 Rope end connections with locking clamp or locking cast sleeve

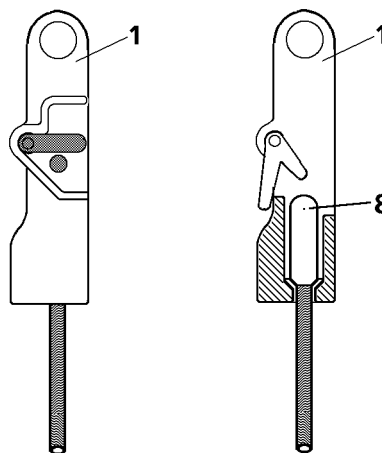

Fig.144019: Rope end connections with locking clamp **8** or locking cast sleeve **8**

- Rope end connections **with** locking clamp **8** or locking cast sleeve **8**.
A rope end connection **1** or an L-shaped rope end connection **24** should be used for this.

1.2.2 The L-shaped rope end connection with locking clamp or locking cast sleeve (LR 11000 only)



WARNING

Load can be ripped off!

Death, severe bodily injuries, property damage.

- ▶ The L-shaped rope end connection **24** is only permitted for use on LR 11000.
- ▶ It is prohibited to use the L-shaped rope end connection **24** on other crane types.
- ▶ Make sure that the L-shaped rope end connection is only used for **reeving with a even number of strands**.

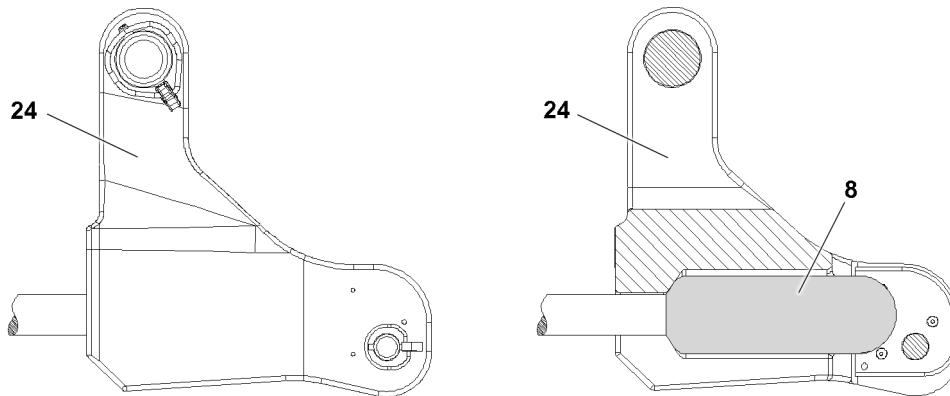

Fig.144020: L-shaped rope end connection **24** with locking clamp **8** or locking cast sleeve **8**

- Rope end connections **with** locking clamp **8** or locking cast sleeve **8**.
An L-shaped rope end connection **24** or a rope end connection **1** should be used for this.

1.2.3 Rope end connection without locking clamp or locking cast sleeve

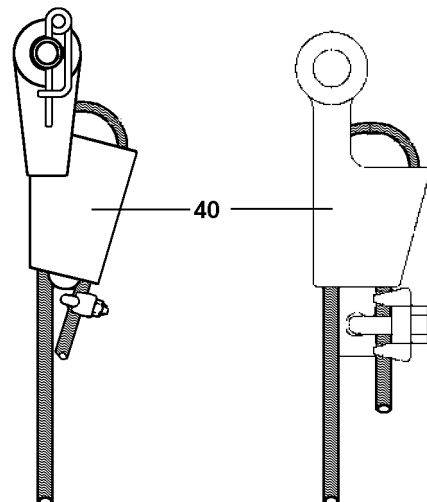

Fig.144021: Rope end connection without locking clamp or locking cast sleeve

- Rope end connections **without** locking clamp **8** or locking cast sleeve **8**.
For that, use a wedge lock **40**.

2 Reeving in the hoist rope



WARNING

Slipping at assembly work!

Danger of falling.

Death, severe injury, property damage.

- ▶ The boom system may only be accessed if the assembly personnel is protected with suitable safety measures to prevent them from falling.
- ▶ If retaining ropes are present on the boom system, then the assembly personnel must hang an approved fall arrest system to the retaining ropes of the boom system on the left and right with both snap hooks and secure themselves to prevent them from falling.
- ▶ Without appropriate safety measures it is **strictly** prohibited to step on the boom system.
- ▶ If railings are present for the crane, then they must be brought into the corresponding position and secured for assembly / disassembly.
- ▶ Carry out all assembly work from a safe location.
- ▶ Observe the assembly guidelines in the Crane operating instructions, chapter 5.01.

Make sure that the following prerequisites are met:

- The ground is level and of sufficient load carrying capacity.
- **Only for cranes with crane support:** The crane is properly supported.
- The crane is horizontally aligned.
- The crane is ballasted according to the load chart.
- The LICCON overload protection has been set according to the load chart.
- The slewing gear brake is applied.
- The boom end section is just above the ground.

2.1 Reeving in the hoist rope with the assembly winch

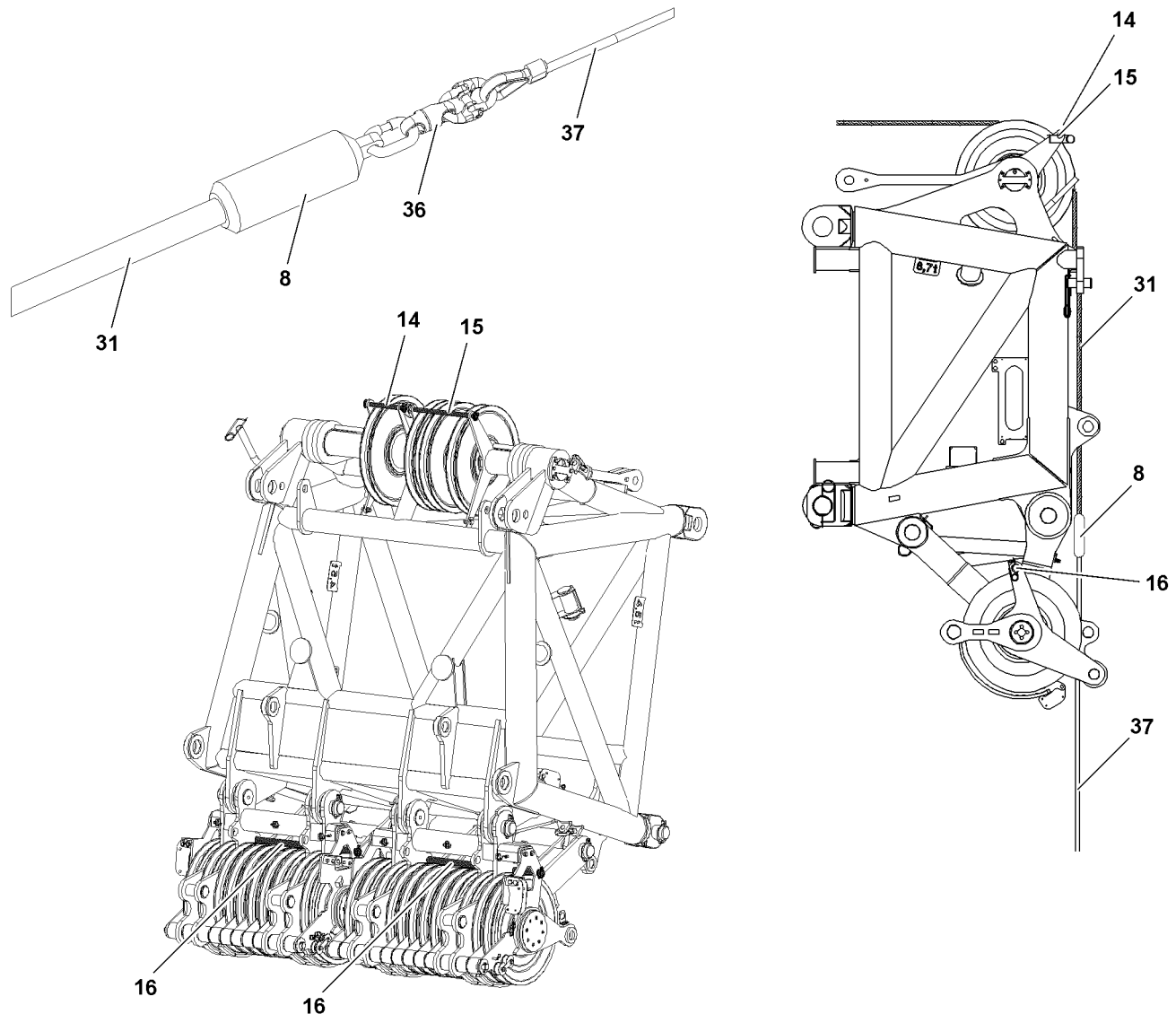

Fig.121853: Reeving in with assembly winch

- ▶ Wear approved fall arrest system and protective equipment, see Crane operating instructions, chapter 2.04.
- ▶ Bring the fall protection equipment on the crane superstructure and on the lattice boom in operating position and secure, see Crane operating instructions, chapter 2.06.
- ▶ Properly hang the fall arrest system on the intended safety ropes and / or fastening points.
- ▶ Switch the assembly winch to freewheeling.
- ▶ Remove the rope retaining pin **14**, rope retaining pin **15** and rope retaining pin **16**.
- ▶ Connect the auxiliary rope **37** with the auxiliary reeving rope (hemp rope).
- ▶ Reeve in the auxiliary rope **37** in the reverse direction between the hook block and the pulley head.
- ▶ Bring the auxiliary rope **37** with the auxiliary reeving rope (hemp rope) upward over the back pulley, which is to be reeved according to the reeving plan.
- ▶ Pull the auxiliary rope **37** to the rear to the hoist winch.
- ▶ Release the auxiliary reeving rope (hemp rope) from the auxiliary rope **37**.

When the auxiliary rope is on the hoist winch:

- ▶ Connect the auxiliary rope **37** with the hoist rope **31**: Open the connecting link **36**, connect it with the eyehook of the lock clamp **8** and close the connecting link **36**.
- ▶ Turn the freewheeling off on the assembly winch.

NOTICE

Hoist rope tension too low!

Slack rope formation.

- ▶ Permit no slack rope on the hoist winch and the assembly winch.

-
- ▶ Reeve in the hoist rope **31**: Spool the hoist rope **31** from the hoist winch and simultaneously spool up the auxiliary rope **37** on the assembly winch.

When the hoist rope **31** is reeved:

- ▶ Release the auxiliary rope **37** from the hoist rope **31**.
- ▶ Spool the auxiliary rope on the assembly winch.
- ▶ Pin and secure the rope retaining pin **14**, rope retaining pin **15** and rope retaining pin **16**.
- ▶ Hang the hoist rope properly in on the rope lock, see section „Hanging the hoist rope in on the rope lock“.

When the hoist rope is properly hung in on the rope lock:

- ▶ Attach the hoist limit switch weight, see section „Attaching the hoist limit switch weight“.

**Note**

Parallel operation of winch 1 and winch 2!

- ▶ Repeat the above described reeving procedure with the second hoist rope.
 - ▶ Observe the reeving plan.
-

3 Reeving the hook block in and out

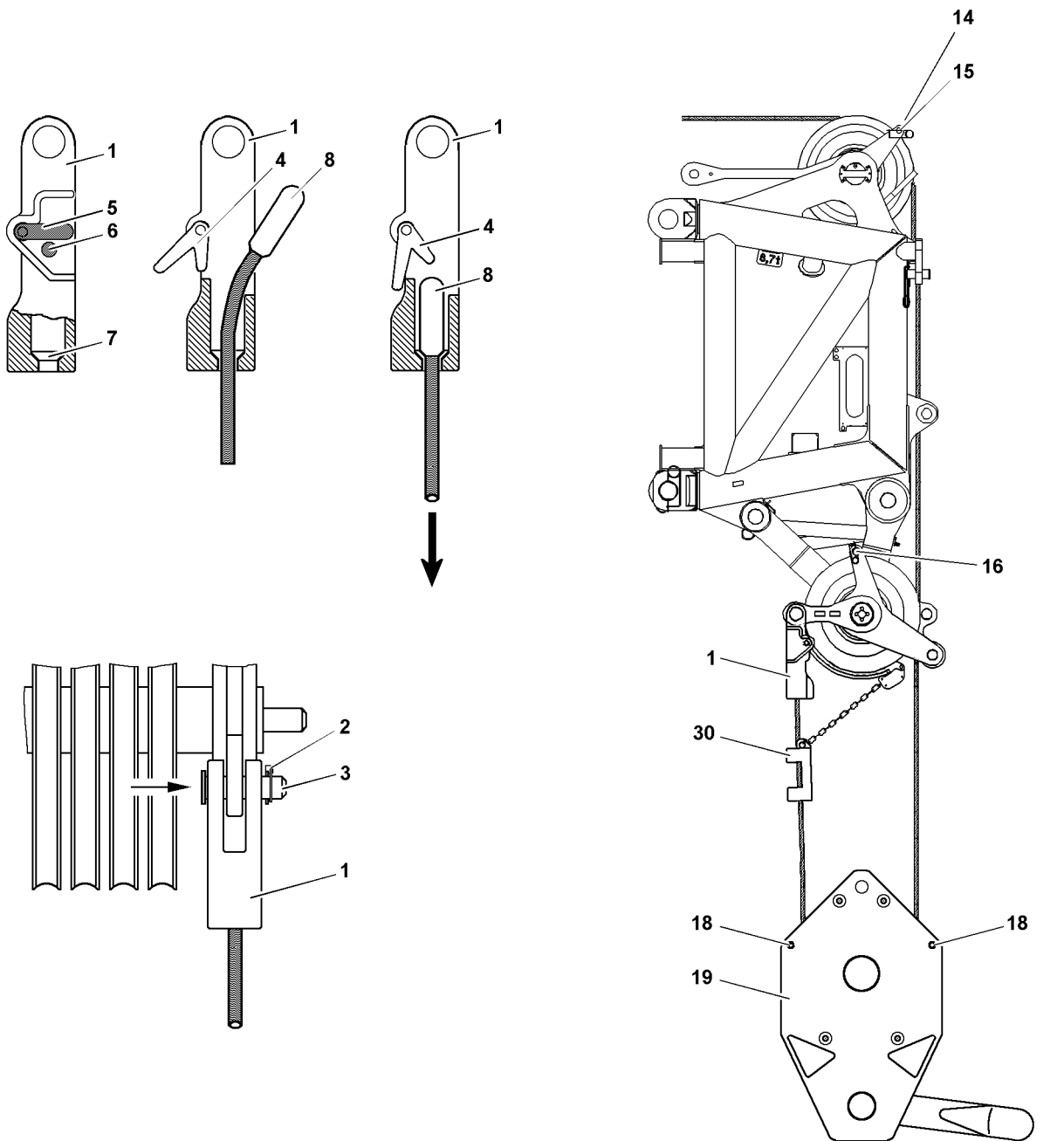

Fig.144024: Details Reeving Hook block

3.1 Reeving in the hook block



WARNING

Toppling of hook block!

If the retaining pins are **not** pinned in the roller block / the pulley blocks of the hook block before placing the hook block down, then the pulley blocks / the hook block can topple over when unreeving the hoist rope.

Death, severe injury, property damage.

- ▶ Pin the retaining pins, see Crane operating instructions, chapter 5.19 or separate operating instructions.

3.1.1 Preparing the hook block

Make sure that the following prerequisites are met:

- The crane is horizontally aligned.
- The slewing gear brake is applied.
- The hook block is set down on the ground properly.
- The boom is luffed down to the point where the pulley head is above the hook block.
- An assistant is present to guide the hoist rope.



WARNING

Danger of accident due to side wind!

If the slewing gear brake is released after reeving in / reeving out the hook block / the load hook, then the crane can turn uncontrolled in strong side wind.

Death, severe injury, property damage.

The crane can collide with close-by structures or objects.

- ▶ Make sure that the current wind speed does not exceed the values from the wind speed chart when releasing the slewing gear brake.

NOTICE

Hook block incorrectly reeved!

Damage to the hoist rope.

- ▶ Carry out the reeving of the hoist rope according to the reeving plan.
- ▶ Select the rope fixed point on the hook block is in such a way that the last strand runs parallel to the remaining rope strands, as much as possible.
- ▶ Set the required hook block under the boom head.
- ▶ At the hook block **19**, remove the spring retainers **18** for both rope retaining pins and pull them both out.



WARNING

Slipping at assembly work!

Danger of falling.

Death, severe injury, property damage.

- ▶ The boom system may only be accessed if the assembly personnel is protected with suitable safety measures to prevent them from falling.
- ▶ If retaining ropes are present on the boom system, then the assembly personnel must hang an approved fall arrest system to the retaining ropes of the boom system on the left and right with both snap hooks and secure themselves to prevent them from falling.
- ▶ Without appropriate safety measures it is **strictly** prohibited to step on the boom system.
- ▶ If railings are present for the crane, then they must be brought into the corresponding position and secured for assembly / disassembly.
- ▶ Carry out all assembly work from a safe location.
- ▶ Observe the assembly guidelines in the Crane operating instructions, chapter 5.01.

- ▶ Reeve the hook block.
- ▶ Insert the rope retaining pins again and secure with spring retainers.

3.1.2 Hooking the hoist rope on the rope lock

NOTICE

Hoist rope is incorrectly installed!
Damage to the hoist rope.

- ▶ Always insert the pins **3** from „inside to outside“ and secure from the outside.
- ▶ The rope lock **1** must be pinned in either at the pulley head or on the hook block and secured with locking pins **2**, depending on reeving.
- ▶ On the rope lock **1**, push the safety pin **6** in.
- ▶ Swing the lever **5** „down“ and hold it in this position.

Result:

- The latch **4** is swung „downward“.
- ▶ Attach the rope end with the locking clamp **8** in the rope lock **1** and pull „down“ firmly (in direction of arrow), until the locking clamp **8** is touching in the cone **7**.



WARNING

Locking clamp is incorrectly installed!
Danger of accident.
Death, severe injuries, property damage.

- ▶ The locking clamp **8** must touch on the cone **7** after hanging it into the rope lock **1** and must be secured by the latch **4**.

- ▶ Release the lever **5**.

Result:

- The lever **5** returns to the initial position and is locked by the safety pin **6**.
- ▶ Check the rope retainer. Visual check.

3.2 Unreeving the hook block



WARNING

Toppling of hook block!
If the retaining pins are **not** pinned in the roller block / the pulley blocks of the hook block before placing the hook block down, then the pulley blocks / the hook block can topple over when unreeving the hoist rope.

Death, severe injury, property damage.

- ▶ Pin the retaining pins, see Crane operating instructions, chapter 5.19 or separate operating instructions.

Make sure that the following prerequisites are met:

- The ground is level and of sufficient load carrying capacity.
- **Only for cranes with crane support:** The crane is properly supported.
- The crane is horizontally aligned.
- The crane is ballasted according to the load chart.
- The LICCON overload protection has been set according to the load chart.
- The slewing gear brake is applied.
- The boom end section is just above the ground.



WARNING

Danger of accident due to side wind!

If the slewing gear brake is released after reeving in / reeving out the hook block / the load hook, then the crane can turn uncontrolled in strong side wind.

Personnel can be severely injured or killed.

The crane can collide with close-by structures or objects.

- ▶ Make sure that the current wind speed does not exceed the values from the wind speed chart when releasing the slewing gear brake.

3.2.1 Lowering the hook block



WARNING

Crushing of hands!

When unreeving the hook block, it can topple over.

Death, severe injury, property damage.

- ▶ Use the handles in the safe area of the hook block.
- ▶ Make sure the hook block is safely positioned.

- ▶ Lower the hook block and set it on the ground.
- ▶ Remove the hoist limit switch weight.

3.2.2 Detaching the hoist rope

- ▶ On the rope lock **1**, push the safety pin **6** in.
- ▶ Swing the lever **5** „down“ and hold it in this position.

Result:

- The latch **4** is swung downward.
- The locking clamp **8** is released.
- ▶ Push the hoist rope up and detach the locking clamp **8**.
- ▶ Release and unpin the rope retaining pin on the hook block.
- ▶ Unreeve the hoist rope from the hook block and the pulley head.
- ▶ Insert the rope retaining pins again and secure with spring retainers.

4 Reeving in / reeving out the hook block, L-shaped rope end connection (LR 11000 only)



WARNING

Load can be ripped off!

Death, severe bodily injuries, property damage.

- ▶ The L-shaped rope end connection **24** is only permitted for use on LR 11000.
- ▶ It is prohibited to use the L-shaped rope end connection **24** on other crane types.
- ▶ Make sure that the L-shaped rope end connection is only used for **reeving with a even number of strands**.

Depending on the number of rope strands, with the even reeving of the hook block, the L-shaped rope end connection must be installed on one of the pin points (pin point **P1** to pin point **P4**) on the roller set / roller sets.

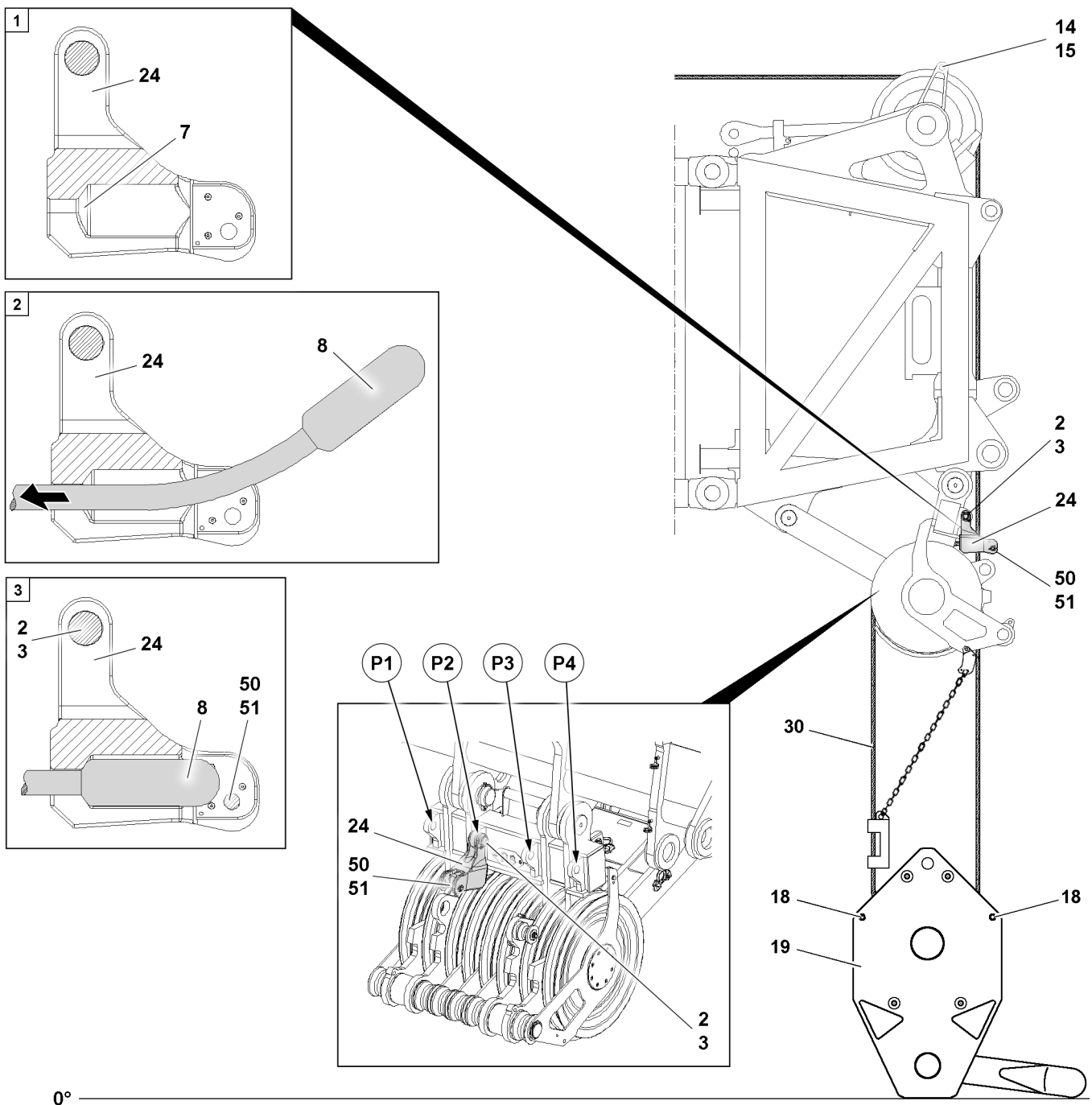

Fig.144022: Details reeving hook block, L-shaped rope end connection 24

LWE/LR 1600-2-008/18109-09-02/en

4.1 Reeving in the hook block



WARNING

Toppling of hook block!

If the retaining pins are **not** pinned in the roller block / the pulley blocks of the hook block before placing the hook block down, then the pulley blocks / the hook block can topple over when unreeving the hoist rope.

Death, severe injury, property damage.

- ▶ Pin the retaining pins, see Crane operating instructions, chapter 5.19 or separate operating instructions.

4.1.1 Preparing the hook block

Make sure that the following prerequisites are met:

- The crane is horizontally aligned.
- The slewing gear brake is applied.
- The hook block is set down on the ground properly.
- The boom is luffed down to the point where the pulley head is above the hook block.
- An assistant is present to guide the hoist rope.



WARNING

Danger of accident due to side wind!

If the slewing gear brake is released after reeving in / reeving out the hook block / the load hook, then the crane can turn uncontrolled in strong side wind.

Death, severe injury, property damage.

The crane can collide with close-by structures or objects.

- ▶ Make sure that the current wind speed does not exceed the values from the wind speed chart when releasing the slewing gear brake.

NOTICE

Hook block incorrectly reeved!

Damage to the hoist rope.

- ▶ Carry out the reeving of the hoist rope according to the reeving plan.
- ▶ Select the rope fixed point on the hook block in such a way that the last strand runs parallel to the remaining rope strands, as much as possible.
- ▶ Set the required hook block under the boom head.
- ▶ At the hook block **19**, remove the spring retainers **18** for both rope retaining pins and pull them both out.



WARNING

Slipping at assembly work!

Danger of falling.

Death, severe injury, property damage.

- ▶ The boom system may only be accessed if the assembly personnel is protected with suitable safety measures to prevent them from falling.
- ▶ If retaining ropes are present on the boom system, then the assembly personnel must hang an approved fall arrest system to the retaining ropes of the boom system on the left and right with both snap hooks and secure themselves to prevent them from falling.
- ▶ Without appropriate safety measures it is **strictly** prohibited to step on the boom system.
- ▶ If railings are present for the crane, then they must be brought into the corresponding position and secured for assembly / disassembly.
- ▶ Carry out all assembly work from a safe location.
- ▶ Observe the assembly guidelines in the Crane operating instructions, chapter 5.01.

- ▶ Reeve the hook block.
- ▶ Insert the rope retaining pins again and secure with spring retainers.

4.1.2 Fitting the hoist rope on the rope lock, L-shaped rope end connection

NOTICE

Hoist rope is incorrectly installed!
Damage to the hoist rope.

- ▶ Always insert the pins **50** from „inside to outside“ and secure from the outside.
- ▶ Only pin the rope lock **24** on the roller set / roller sets and secure with a locking pin **2**.
- ▶ On the rope lock **24**, release and unpin the retaining pin **50**.
- ▶ Fit the rope end with the locking clamp **8** in the rope lock **24** and pull the rope firmly in the direction of the arrow, until the locking clamp **8** contacts the cone **7**.



WARNING

Locking clamp is incorrectly installed!
Danger of accident.
Death, severe injuries, property damage.

- ▶ The locking clamp **8** must touch on the cone **7** after fitting it into the rope lock **24** and must be secured by the retaining pin **50**.
- ▶ Insert the retaining pin **50** and secure properly with the retaining element **51**.
- ▶ Check the rope retainer. Visual check.

4.2 Unreeving the hook block



WARNING

Toppling of hook block!

If the retaining pins are **not** pinned in the roller block / the pulley blocks of the hook block before placing the hook block down, then the pulley blocks / the hook block can topple over when unreeving the hoist rope.

Death, severe injury, property damage.

- ▶ Pin the retaining pins, see Crane operating instructions, chapter 5.19 or separate operating instructions.

Make sure that the following prerequisites are met:

- The ground is level and of sufficient load bearing capacity.
- **Only for cranes with crane support:** The crane is properly supported.
- The crane is horizontally aligned.
- The crane is ballasted according to the load chart.
- The LICCON overload protection has been set according to the load chart.
- The slewing gear brake is applied.
- The boom end section is just above the ground.



WARNING

Danger of accident due to side wind!

If the slewing gear brake is released after reeving in / reeving out the hook block / the load hook, then the crane can turn uncontrolled in strong side wind.

Personnel can be severely injured or killed.

The crane can collide with close-by structures or objects.

- ▶ Make sure that the current wind speed does not exceed the values from the wind speed chart when releasing the slewing gear brake.

4.2.1 Lowering the hook block

**WARNING**

Crushing of hands!

When unreeving the hook block, it can topple over.

Death, severe injury, property damage.

- ▶ Use the handles in the safe area of the hook block.
- ▶ Make sure the hook block is safely positioned.

- ▶ Lower the hook block and set it on the ground.
- ▶ Remove the hoist limit switch weight.

4.2.2 Detaching the hoist rope

- ▶ On the rope lock **24**, release and unpin the retaining pin **50**.

Result:

- The locking clamp **8** is released.
- ▶ Push the hoist rope forward and detach the locking clamp **8**.
- ▶ Release and unpin the rope retaining pin on the hook block.
- ▶ Unreeve the hoist rope from the hook block and the pulley head.
- ▶ Insert the rope retaining pins again and secure with spring retainers.

5 Attaching and removing the load hook*

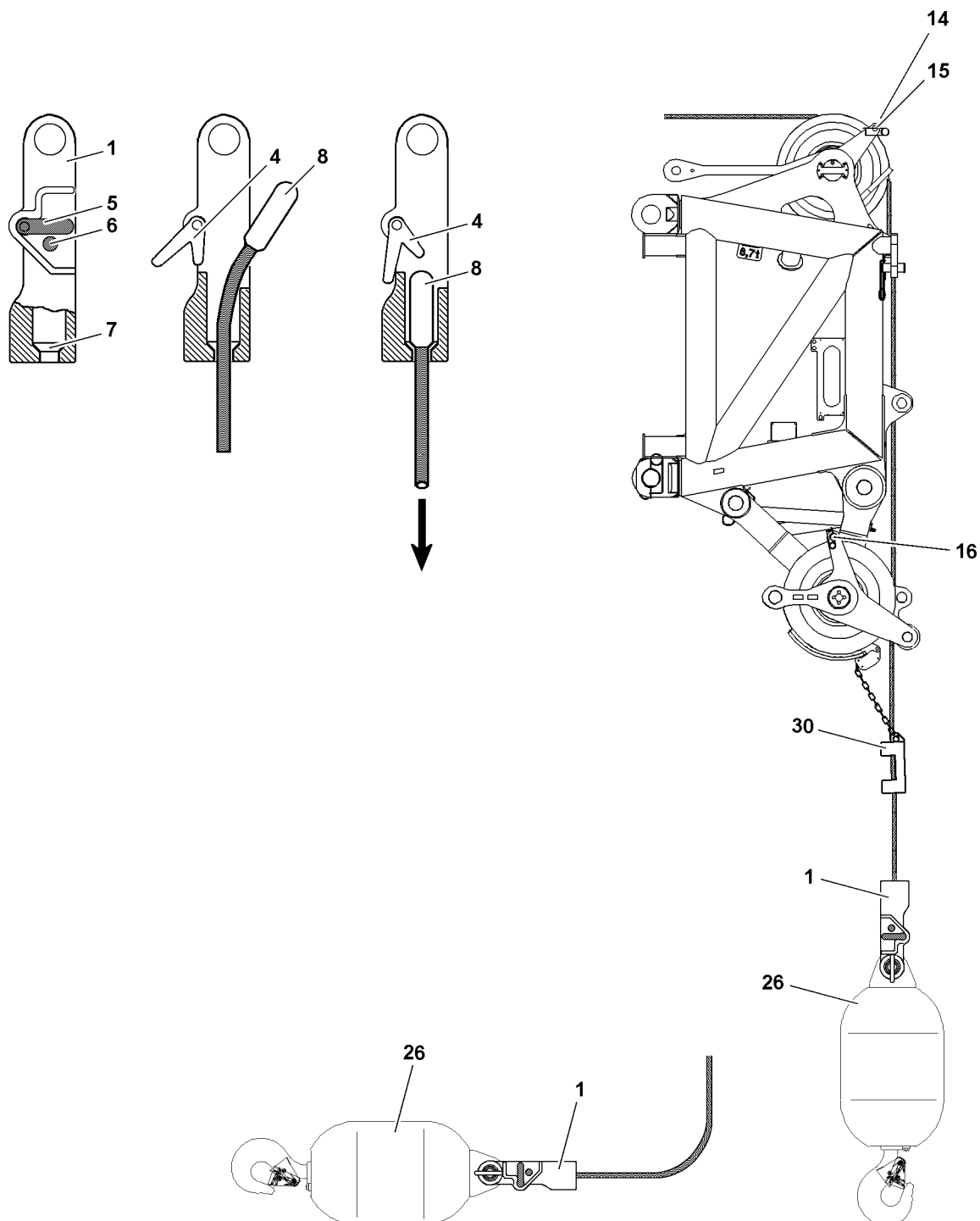

Fig.121854: Fastening load hook

5.1 Fastening the load hook*

5.1.1 Assembling the load hook*

- ▶ Place the load hook under the pulley head of the boom.
- ▶ Release and unpin the rope retaining pins on the back pulley and on the pulley head.

**WARNING**

Slipping at assembly work!

Danger of falling.

Death, severe injury, property damage.

- ▶ The boom system may only be accessed if the assembly personnel is protected with suitable safety measures to prevent them from falling.
- ▶ If retaining ropes are present on the boom system, then the assembly personnel must hang an approved fall arrest system to the retaining ropes of the boom system on the left and right with both snap hooks and secure themselves to prevent them from falling.
- ▶ Without appropriate safety measures it is **strictly** prohibited to step on the boom system.
- ▶ If railings are present for the crane, then they must be brought into the corresponding position and secured for assembly / disassembly.
- ▶ Carry out all assembly work from a safe location.
- ▶ Observe the assembly guidelines in the Crane operating instructions, chapter 5.01.

- ▶ Place the hoist rope over the back pulley on the boom head.
- ▶ Insert the rope retaining pins again and secure with spring retainers.
- ▶ Pin the rope lock **1** in the load hook **26** and secure with spring retainers.

5.1.2 Fastening the hoist rope

Make sure that the following prerequisites are met:

- The crane is horizontally aligned.
- The slewing gear brake is applied.
- The hook block is set down on the ground properly.
- The boom is luffed down to the point where the pulley head is above the hook block.
- An assistant is present to guide the hoist rope.

**WARNING**

Danger of accident due to side wind!

If the slewing gear brake is released after reeving in / reeving out the hook block / the load hook, then the crane can turn uncontrolled in strong side wind.

Personnel can be severely injured or killed.

The crane can collide with close-by structures or objects.

- ▶ Make sure that the current wind speed does not exceed the values from the wind speed chart when releasing the slewing gear brake.
- ▶ On the rope lock **1**, push the safety pin **6** in.
- ▶ Swing the lever **5** „down“ and hold it in this position.

Result:

- The latch **4** is swung „downward“.
- ▶ Attach the rope end with the locking clamp **8** in the rope lock and pull „down“ firmly (in direction of arrow), until the locking clamp **8** is touching in the cone **7**.

**WARNING**

Locking clamp is incorrectly fastened!

Damage to locking clamp.

Death, severe injuries, property damage

- ▶ The locking clamp **8** must touch on the cone **7** after hanging it into the rope lock **1** and must be secured by the latch **4**.

- ▶ Release the lever **5**.

Result:

- The lever **5** returns to the initial position and is locked by the safety pin **6**.

5.2 Removing the load hook*

Make sure that the following prerequisites are met:

- The ground is level and of sufficient load carrying capacity.
- **Only for cranes with crane support:** The crane is properly supported.
- The crane is horizontally aligned.
- The slewing gear brake is applied.
- The load hook is prepared for assembly.
- An assistant is present to guide the hoist rope.

5.2.1 Lowering the load hook



WARNING

Crushing of hands!

When unreeving the hook block, it can topple over.
Death, severe injury, property damage.

- ▶ Use the handles in the safe area of the hook block.
- ▶ Make sure the hook block is safely positioned.

- ▶ Place the load hook **26** on the ground.
- ▶ Remove the hoist limit switch weight.

5.2.2 Detaching the hoist rope



WARNING

Danger of accident due to side wind!

If the slewing gear brake is released after reeving in / reeving out the hook block / the load hook, then the crane can turn uncontrolled in strong side wind.

Death, severe injury, property damage.

The crane can collide with close-by structures or objects.

- ▶ Make sure that the current wind speed does not exceed the values from the wind speed chart when releasing the slewing gear brake.

- ▶ On the rope lock **1**, push the safety pin **6** in.
- ▶ Swing the lever **5** „down“ and hold it in this position.

Result:

- The latch **4** is swung „downward“.
- The locking clamp **8** is released.
- ▶ Push the hoist rope in the direction of the load hook and detach the locking clamp **8**.
- ▶ Remove the rope retaining pins on the pulley head and on the back pulley.
- ▶ Lift the hoist rope from the rope pulleys.
- ▶ Insert the rope retaining pins again and secure with spring retainers.

6 Attaching / removing the hoist limit switch weight

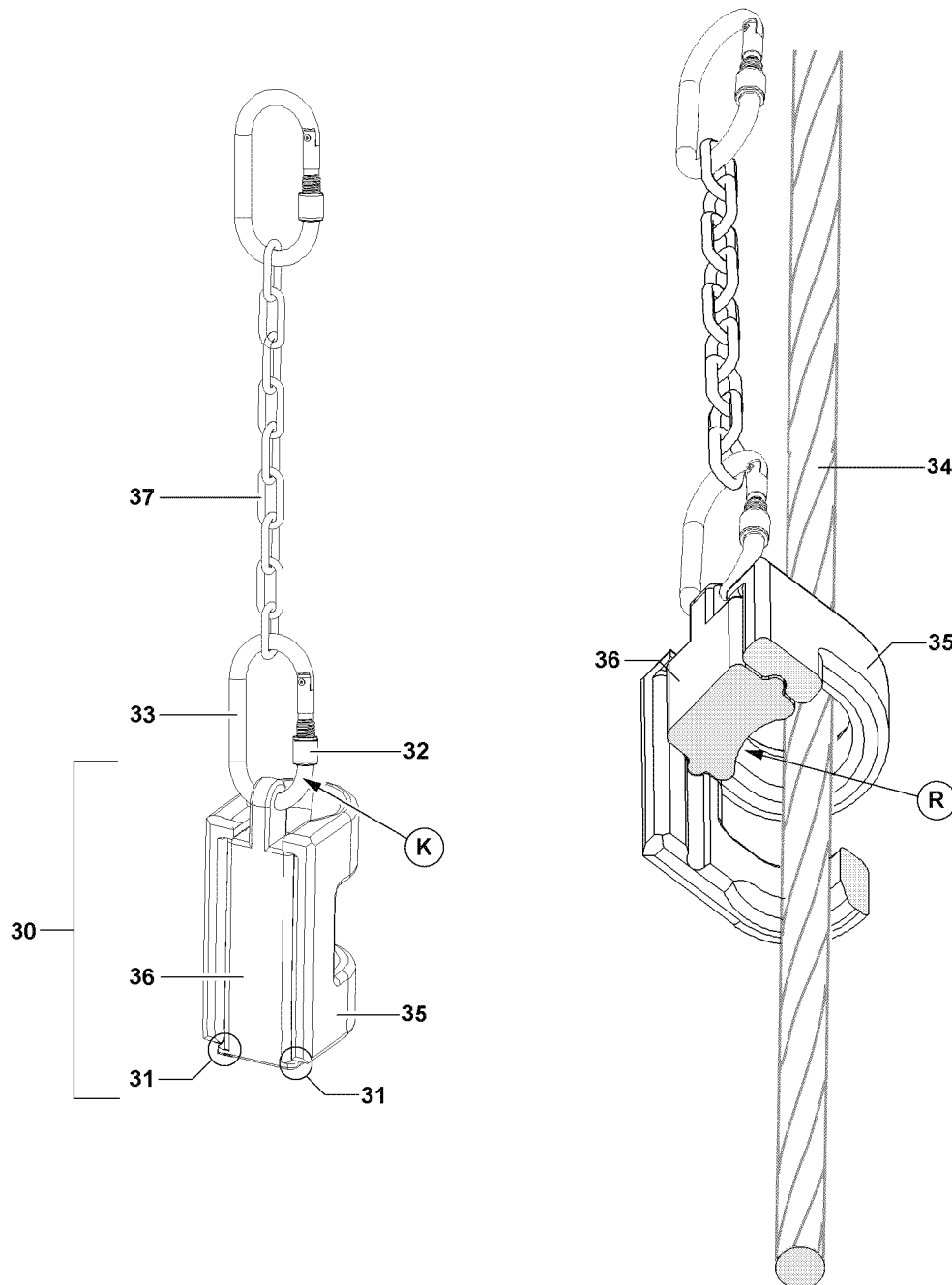

Fig.122728: Details Hoist limit switch weight

6.1 Attaching the hoist limit switch weight

The hoist limit switch weight **30** consists of two parts, which are pushed into each other:

- The weight **35**
- The carrier section **36**

► Loosen and open the screw retainer **32**.

**WARNING**

Hoist limit switch weight is incorrectly installed!

Hoist limit switch weight can fall down. Death, severe injuries.

- ▶ Do not replace the snap hook **33** with other parts, such as a shackle or similar.
- ▶ When detaching or attaching the hoist limit switch weight **30** make sure that the weight **35** and the carrier section **36** do not fall down.
- ▶ Make sure that the curvature **R** of the carrier section **36** points to the hoist rope **34**.
- ▶ Make sure that the noses **31** of the carrier section **36** is placed on the weight **35**.
- ▶ Make sure that the screw retainer **32** can be turned to be closed from top to bottom, point **K**.

The attachment of the hoist limit switch weight **30** depends on the position of the rope fixed point.

Rope fixed point on the pulley head:

- In the event of multiple hoist rope reeving, the hoist limit switch weight **30** must always be laid around the „stationary rope strand“, in other words around the rope strand that leads directly to the cable lock.

Rope fixed point on hook block:

- The hoist limit switch weight **30** is laid around the outer strand which shows the least angular pull, i.e. the one with the smallest angle between the hanging hoist limit switch weight and the hoist rope.

**Note**

- ▶ The chain **37** must be attached in full length during crane operation and may not be shortened.
- ▶ Push the weight **35** with one hand on the hoist rope **34** and hold.
- ▶ With the other hand, guide the carrier section **36** behind the hoist rope **34** and under the weight **35**. The curvature **R** of the carrier section **36** must point to the hoist rope **34**.
- ▶ Push the weight **35** on the carrier section **36**.
- ▶ Hang in the hoist limit switch weight **30** with the carrier section **36** in the snap hook **33**.

The snap hook **33** must be secured with the screw retainer **32**.

- ▶ Screw the screw retainer **32** closed on the snap hook **33**.

6.2 Removing the hoist limit switch weight

**WARNING**

Hoist limit switch weight is incorrectly installed!

Hoist limit switch weight can fall down. Death, severe injuries.

- ▶ When detaching or attaching the hoist limit switch weight **30** make sure that the weight **35** and the carrier section **36** do not fall down.
- ▶ It is prohibited to remain within the danger zone.
- ▶ Release and open the screw retainer **32** on the snap hook **33**.
- ▶ Detach the hoist limit switch weight **30** from the snap hook **33**.
- ▶ Hold the weight **35** with one hand and with the other hand, push the carrier section **36** from the weight **35**.
- ▶ Store the weight **35** and carrier section **36** safely.

7 Assembling / disassembling the wedge lock

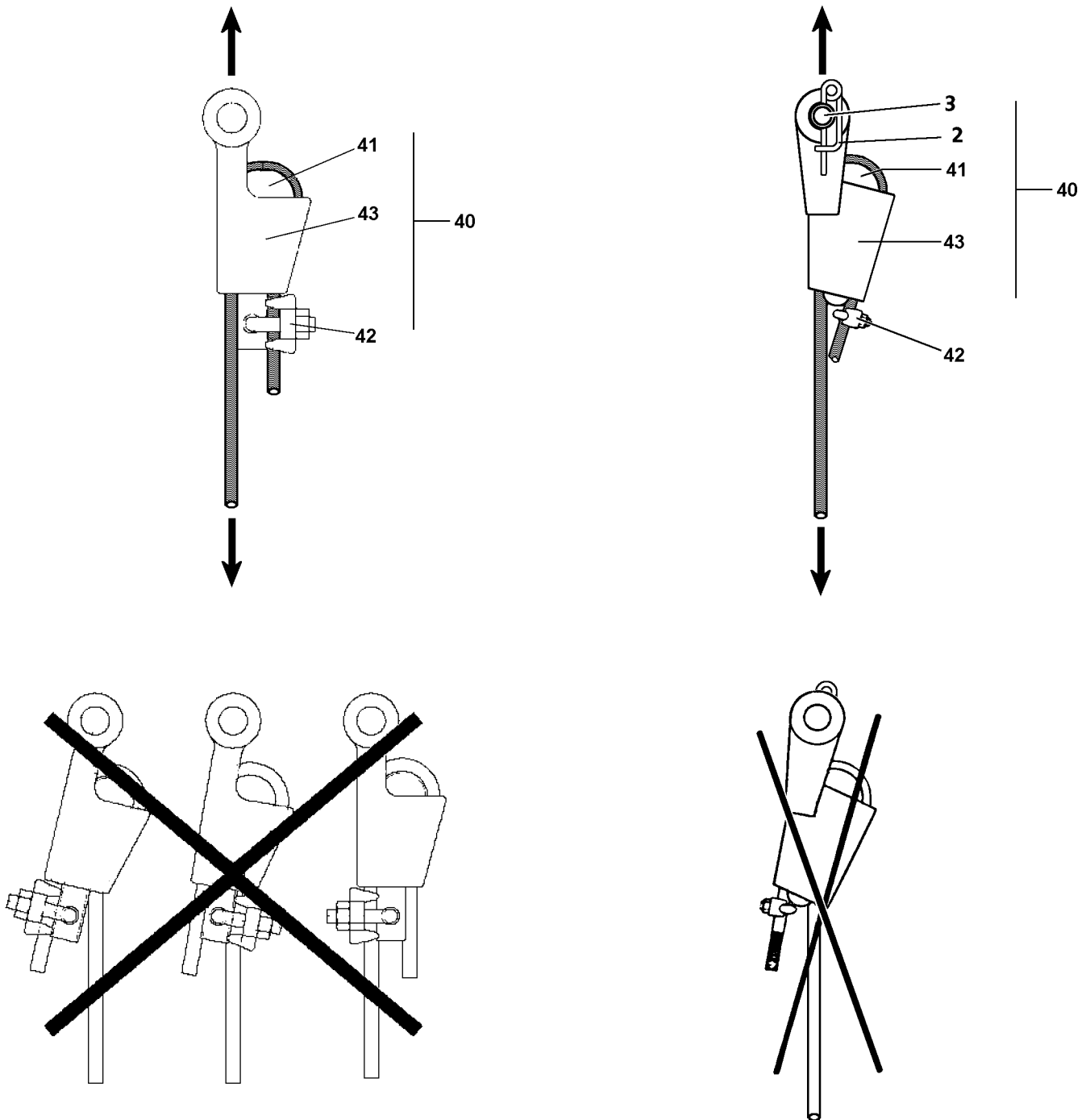

Fig.122729: Wedge lock

Make sure that the following prerequisites are met:

- The rope clamp is cut off on the hoist rope.
- The hook block or the load hook is ready for assembly.

LWE/LR 1600-2-008/18109-09-02/en

7.1 Installing the wedge lock



WARNING

Wedge lock is incorrectly installed!

Hook block or load can fall down. Death, severe injuries, property damage.

- ▶ Use only a wedge lock **40** approved by Liebherr-Werk Ehingen.
- ▶ Install the wedge lock **40** correctly.
- ▶ Place the hoist rope with the wedge **41** into the housing **43** in such a way that the rope strand runs in the pull axle of the wedge lock **40**.
- ▶ The dead end of the rope must be secured by the clamp **42** to prevent it from being pulled through.
- ▶ It is prohibited for personnel to remain in the danger zone.

- ▶ Take a matching wedge lock **40** from the tool box.
- ▶ Place the hoist rope with the wedge **41** into the housing **43**.
- ▶ If possible, assemble the clamp **42** through the wedge **41** on the dead end of the rope.

NOTICE

Damage to the hoist rope!

If the pin **3** has been assembled incorrectly, the hoist rope may rub against the pin **3** or on the lynch pin **2**.

- ▶ Always insert the pins **3** from „inside to outside“ and secure from the outside.
- ▶ Pin and secure the wedge lock **40** on the fixed point of the pulley head or on the fixed point of the hook block or on the load hook, depending on the reeving plan.

7.2 Removing the wedge lock

- ▶ Unpin the wedge lock **40** on the fixed point.
- ▶ Remove the clamp **42** and pull the hoist rope with the wedge from the housing.
- ▶ Store the wedge lock **40**.

8 Rope reeving



Note

- ▶ See separate reeving plans.

4.07 Counterweight

1	Component overview	3
2	Fastening points	4
3	Permissible counterweight assemblies	5
4	Installing the counterweight	6
5	Disassembling the counterweight	15

Fig.195219

LWE/LR 1600-2-008/18109-09-02/en

1 Component overview

The ballast installed on the turntable is generally referred to as the counterweight.

The components are marked with their own weight.

Description of the **turntable extension**, see chapter 4.07.10

Dimensions and weights, see chapter 1.03.

1.1 Counterweight

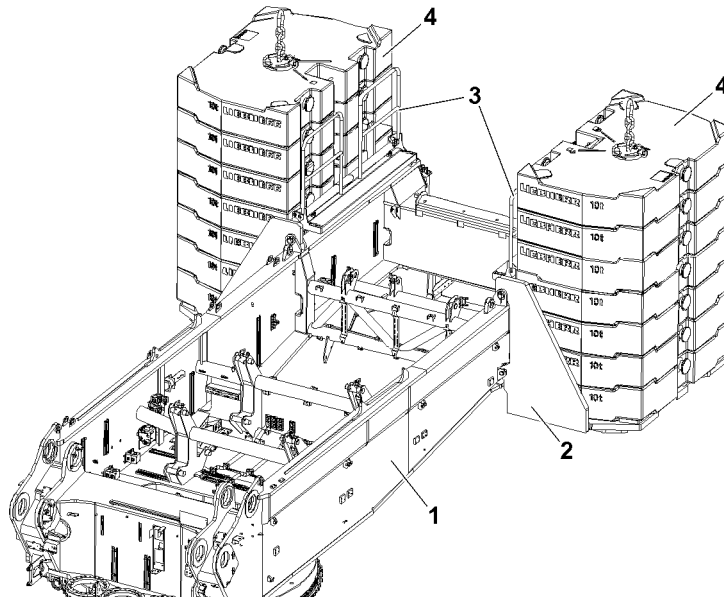

Fig.147048: Component overview counterweight

- | | | | |
|---|-----------------------|---|----------------------|
| 1 | Turntable | 3 | Railings |
| 2 | Counterweight bracket | 4 | Counterweight plates |

1.2 Counterweight plate

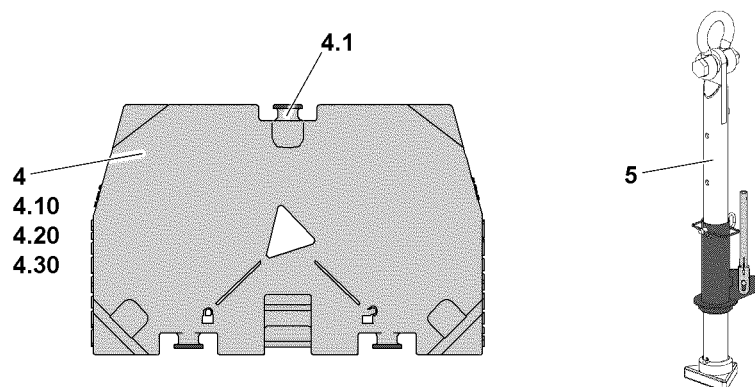

Fig.147026: Counterweight plate component overview

- | | | | |
|------|----------------------------|------|---------------------------|
| 4 | Counterweight plate | 4.20 | 7.5 t counterweight plate |
| 4.1 | Bit | 4.30 | 5.0 t counterweight plate |
| 4.10 | 10.0 t counterweight plate | 5 | Receptacle stud |

LWE/LR 1600-2-008/18109-09-02/en

2 Fastening points



WARNING

Danger of falling!

Death, severe bodily injuries, property damage.

- ▶ Make sure that the fastening equipment is properly fastened on the fastening points.
- ▶ Make sure that the fastening equipment has a sufficient length.
- ▶ Make sure that there are no persons or obstacles within the danger zone.
- ▶ Pay attention to the labels of the fastening points.

2.1 Counterweight bracket

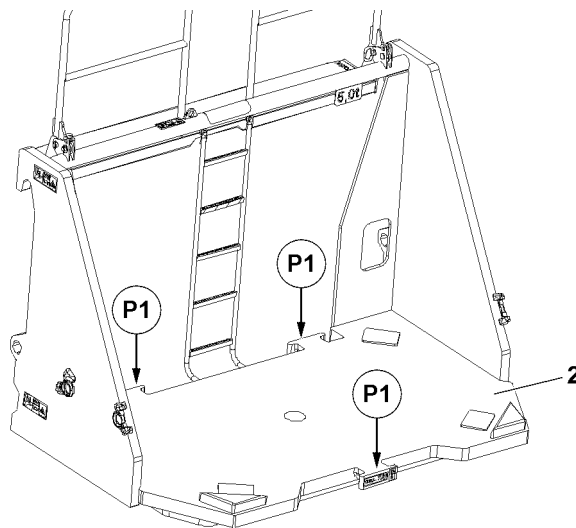

Fig.147044: Fastening points Counterweight bracket

Fastening points	
P1	Counterweight bracket

2.2 Counterweight plate

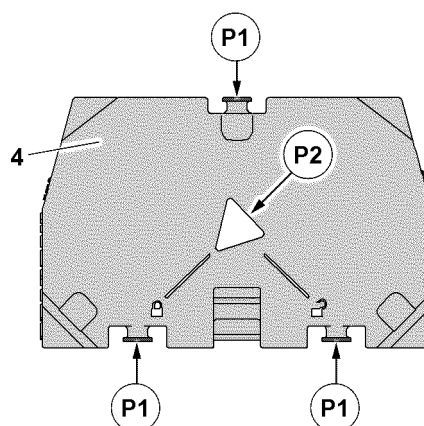

Fig.147027: Fastening points Counterweight plate

„Bitt“ fastening system	
P1	Counterweight plate

„Twistlock“ fastening system (with help of the receptacle stud)	
P2	Counterweight plate

3 Permissible counterweight assemblies

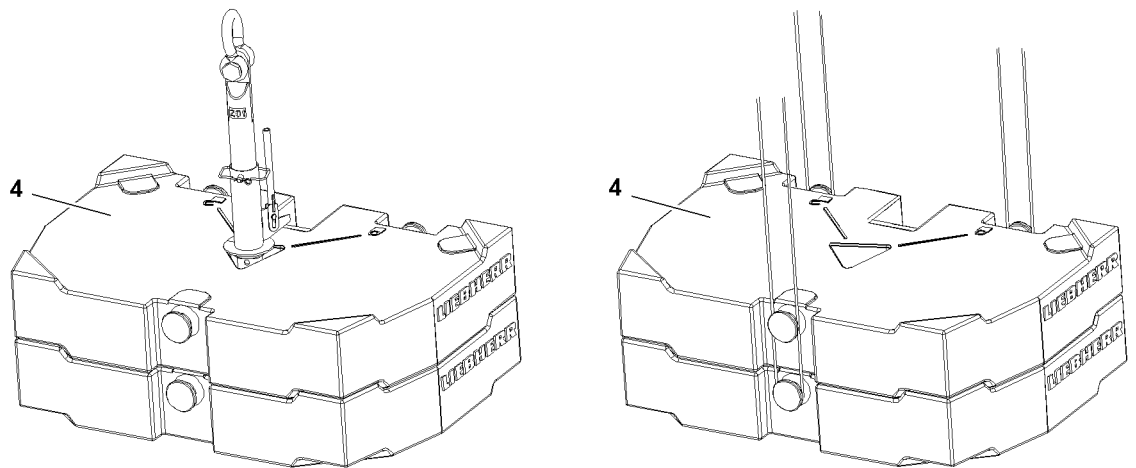

Fig.118980: Counterweight plates: fastened with Twistlock // fastened with bitts



WARNING

Overload of fastening points counterweight plates!

If more than the permissible number of counterweight plates are lifted together, then the bitt or the receptacle stud can be overloaded.

The counterweight plates and components can fall down.

Death, severe bodily injuries, property damage.

► Fasten only the maximum permissible number of counterweight plates per lift.



WARNING

Incorrect structure of counterweight assemblies!

When lifting mixed weight counterweight assemblies, and the heavier counterweight plates are placed on top, the fastening points can be overloaded.

The counterweight plates and components can fall down.

Death, severe bodily injuries, property damage.

► Always stack the heavier counterweight plate on the bottom in the counterweight assembly.

Individual weight Counterweight plate	Maximum number of same counterweight plates per lift over	
	Twistlock	Bitt
5.0 t	2	1
7.5 t	2	2
10.0 t	2	2

LWE/LR 1600-2-008/18109-09-02/en

4 Installing the counterweight



WARNING

Danger of falling!

During assembly / disassembly, inspection and maintenance work, personnel must be secured with appropriate aids to prevent them from falling.

If this is not observed, assembly personnel could fall and be killed or seriously injured.

- ▶ All work at a height, when there is a danger of falling, must be carried out with suitable aids.
- ▶ If aids are not available and work cannot be carried out from the ground, then the assembly personnel must secure themselves with the supplied fall arrest system to prevent falling, see the Crane operating instructions, chapter 2.04.
- ▶ If fall protection equipment is available, then it must be used, see the Crane operating instructions, chapter 2.06.
- ▶ When lifting, lowering, swinging crane parts in and out, no persons may remain in the danger zone.
- ▶ If railings are present on the components, then they must be brought into the corresponding position and secured for assembly / disassembly work.
- ▶ Only step on the aids, ladders and catwalks with clean shoes.
- ▶ Keep aids, ladders and catwalks free of heavy dirt, snow and ice.
- ▶ During all assembly and disassembly work, maintenance work and inspections, travel or crane operation is prohibited.
- ▶ Remaining on a suspended load is prohibited.
- ▶ Stepping or walking on crane components and lattice sections, which have an incline of more than 20° is prohibited.
- ▶ For all assembly work, the crane operator of the main crane must be in voice contact with the crane operator / crane operators of the auxiliary crane / auxiliary cranes.
- ▶ For assembly / disassembly tasks, the crane operator may only initiate crane movements when the responsible guide has explicitly released the movement.



WARNING

Danger of impact / crushing!

When installing / removing crane components with the auxiliary crane, crane components can start to swing back and forth.

When lifting / lowering and positioning crane components, there is an increased danger of impacts / crushing.

Personnel can be caught and thereby injured or killed.

- ▶ Make sure that personnel cannot be caught by components.
- ▶ When working in danger zones: Use aids to protect limbs.
- ▶ Guide components with suitable aids to minimize oscillation.



DANGER

The components can fall down!

If the corresponding components are disengaged from the auxiliary crane before the corresponding component is pinned, the corresponding component can fall down and fatally injure personnel.

- ▶ Do not disengage the auxiliary crane until the respective component is pinned and secured.



WARNING

The crane can topple over!

If the turntable with installed counterweight is turned without the boom installed, then the crane can topple over.

Death, severe bodily injuries, property damage.

- ▶ Always leave the turntable with an installed counterweight and without a boom in travel position.

Make sure that the following prerequisites for **LR 1600/2** are met:

- The crane is horizontally aligned.
- The turntable is positioned in the „travel direction“ (parallel to the crawler travel gear).
- The central ballast is properly installed.
- The SA-frame is erected to at least 90°.
- The boom is not assembled.
- An auxiliary crane is available.

Make sure that the following prerequisites for **LR 1600/2-W** are met:

- The crane is properly supported.
- The crane is horizontally aligned.
- The turntable is positioned in the „travel direction“ (parallel to the crawler travel gear).
- The central ballast is properly installed.
- The SA-frame is erected to at least 90°.
- The boom is not assembled.
- An auxiliary crane is available.

4.1 Bringing the railings on the counterweight brackets into the operating position

The counterweight brackets are located on the ground or on a substructure with load bearing capacity:

- ▶ Bring the railing into the operating position, see chapter 2.06.

4.2 Climbing up / climbing down the counterweight bracket

To pin the counterweight brackets **2** on the turntable **1**, assembly personnel must climb down from the upper belt of the turntable using the ladder **2.1** on the counterweight brackets **2**. After pinning the counterweight brackets **2**, they must climb up again using the ladder **2.1** on the upper belt of the turntable.

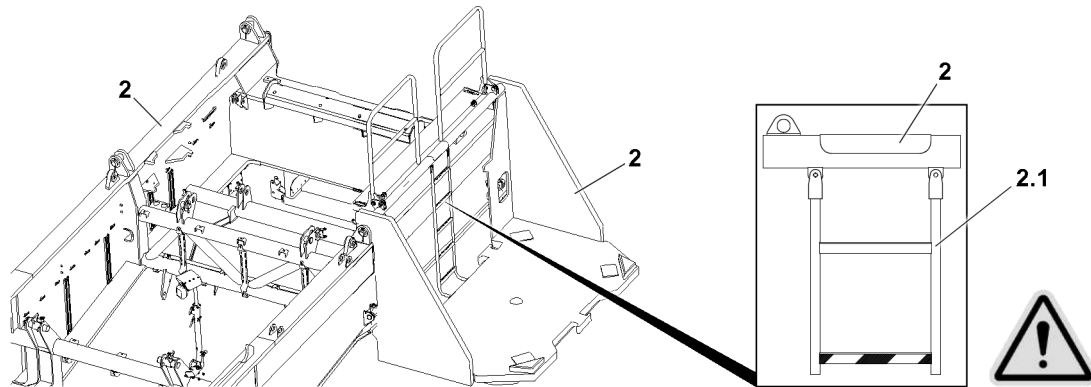

Fig.149272: Climbing up / climbing down the counterweight bracket



WARNING

Danger of slipping due to small step depth!
Death, severe bodily injuries.

- ▶ Step on the ladders always with utmost caution.
- ▶ When climbing up the ladder, always use the 3-point support, see chapter 2.04.10.
- ▶ When climbing down the ladder, always use the 3-point support, see chapter 2.04.10.



WARNING

Danger of falling!
During assembly work on the counterweight bracket, personnel can fall down.
Death, severe bodily injuries.

- ▶ Use personal protective equipment.
- ▶ Climb on the ladder **2.1** and counterweight bracket **2** with extreme caution.

4.3 Assembling the counterweight brackets on the turntable

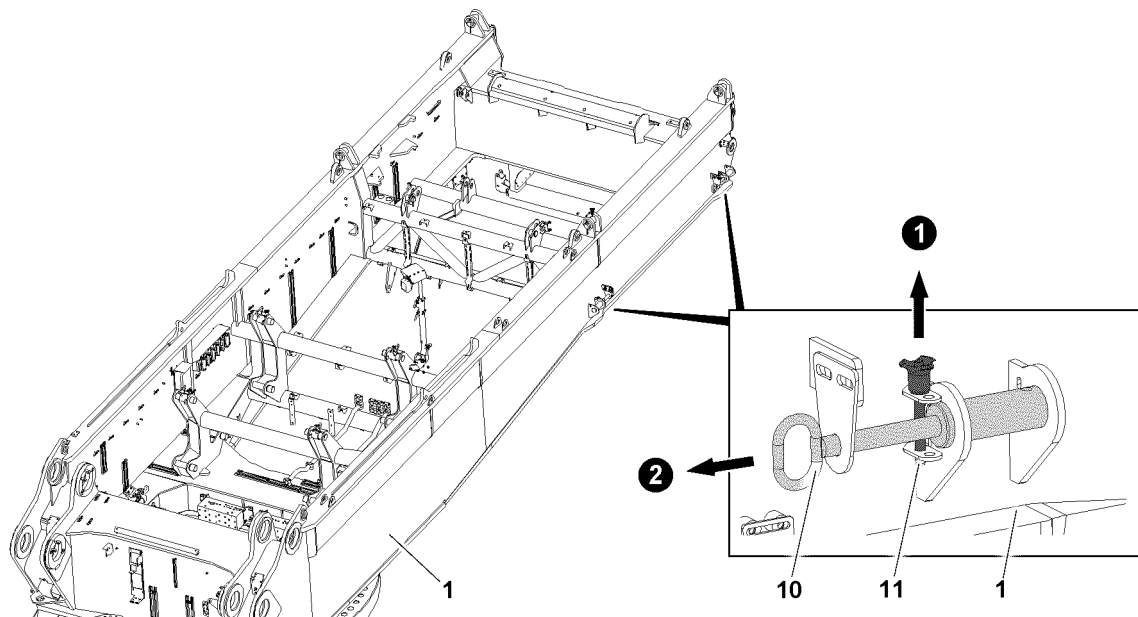

Fig.147038: Preparing the turntable for the assembly of the counterweight brackets



Note

► The assembly / disassembly of the counterweight brackets is explained on a counterweight bracket as an example.

Make sure that the following prerequisites are met:

- The retaining elements **11** are removed on all four pin points on the turntable **1**.
- The pins **10** are completely unpinned on both sides on the turntable **1**.

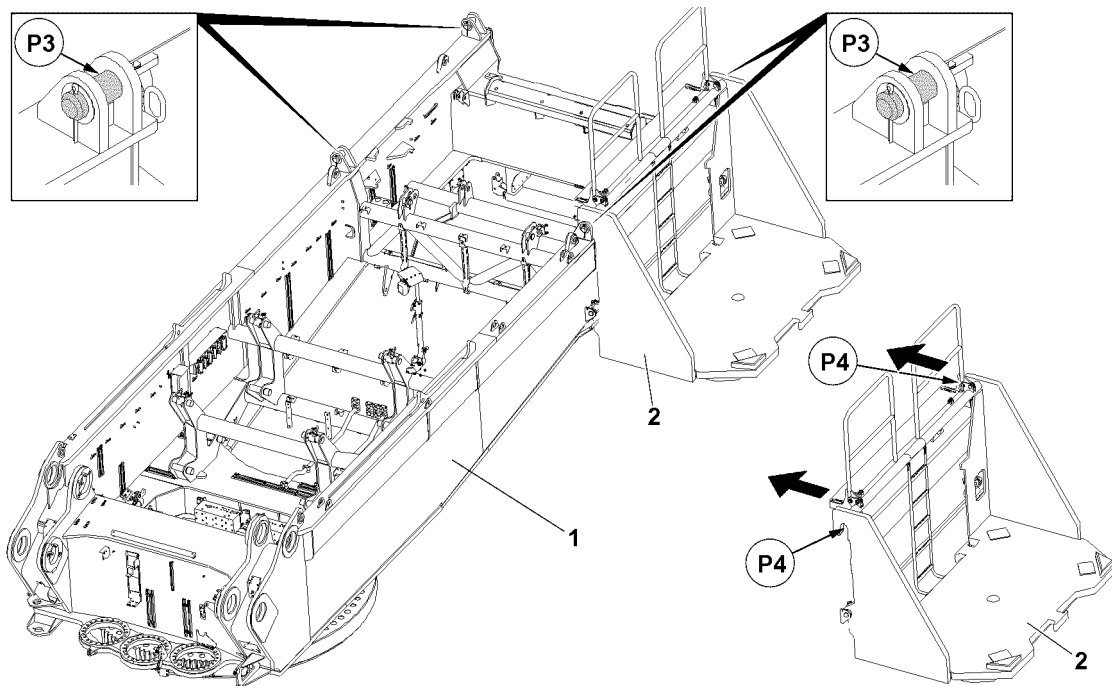

Fig.147039: Assembling the counterweight bracket

► Fasten the counterweight bracket **2** properly to the auxiliary crane, see section „Fastening points“.

- ▶ Swing the counterweight bracket **2** in with the auxiliary crane to the hook pins at the points **P3** on the turntable.
- ▶ Hang the counterweight bracket **2** with the hangers (points **P4**) on the hook pins at the points **P3** on the side on the turntable **1**.
- ▶ Lower the counterweight bracket **2** completely on the hook pins (points **P3**).

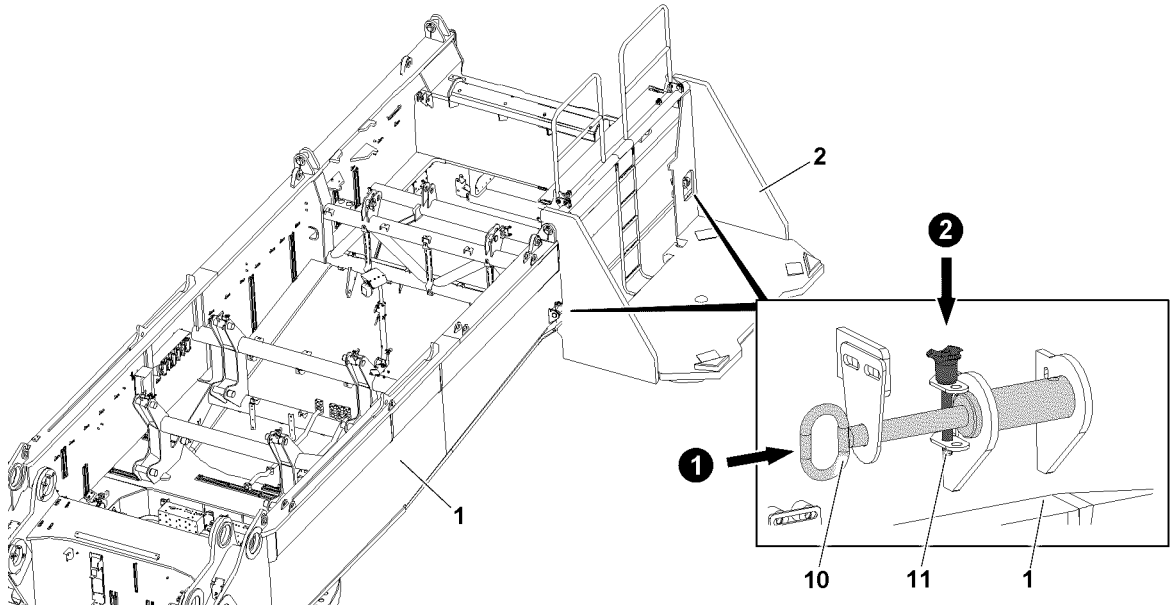

Fig.147040: Securing the counterweight bracket on the turntable

When the counterweight bracket **2** is properly hooked on the hook pins:

- ▶ Insert the pins **10** on both sides and secure with the retaining element **11**.

Result:

- The counterweight bracket **2** is pinned with the turntable **1**.
- ▶ Make sure that the pins **10** are secured with the retaining elements **11**.
- ▶ Release the fastening equipment on the counterweight bracket **2** and remove the auxiliary crane.
- ▶ Properly assemble the second counterweight bracket **2**.

4.4 Placing the counterweight plates



WARNING

Damaged counterweight plates!
Damage on the counterweight plates can cause the fastening equipment to release.
The counterweight plates and components can fall down.
Death, severe bodily injuries, property damage.

- ▶ Do not use damaged counterweight plates and replace them immediately.



WARNING

Counterweight too low / too high!
If the placed counterweight deviates from the specified data in the load charts or the assembly condition, then the crane can be damaged or topple over.
Death, severe bodily injuries, property damage.

- ▶ Place the counterweight according to the data in the load chart.
- ▶ Before placing the counterweight plates, observe the maximum permissible counterweight depending on the assembly conditions, see chapter 3.06.

**WARNING**

Asymmetrical counterweight distribution!

If more than 20 t are asymmetrically placed on / removed from the counterweight stacks, the crane can topple over.

Death, severe bodily injuries, property damage.

- ▶ A weight difference between the right and left counterweight stack of more than 20 t is prohibited.
- ▶ Place / remove the counterweight assemblies alternately symmetrically on the left and right on the counterweight stack.

**WARNING**

Toppling counterweight stack!

Lopsided stacked counterweight plates create instability in the counterweight stack.

The counterweight plates can tip from the counterweight brackets and cause the crane to topple over.

Death, severe bodily injuries, property damage.

- ▶ Make sure that the counterweight plates are placed correctly in the centerings.

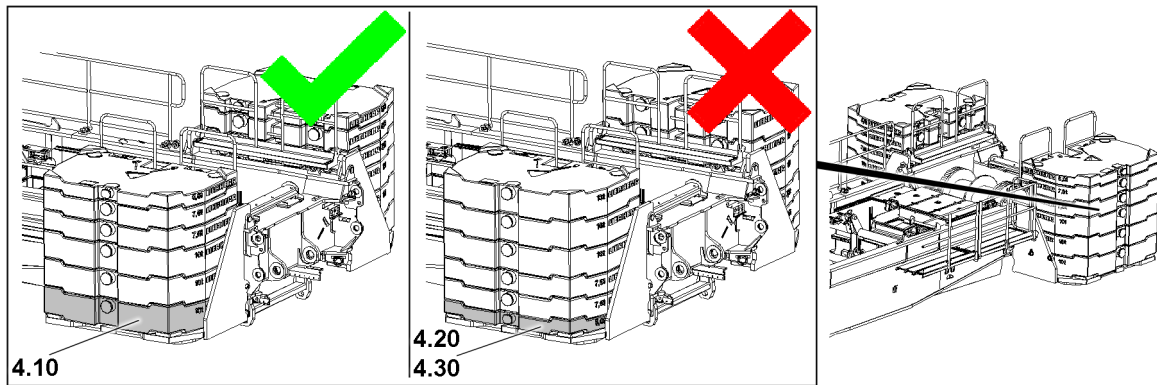

Fig.147041: Ballasting the counterweight stack

**WARNING**

Falling counterweight plates!

If the ballasting sequence is not adhered to when placing the counterweights on the counterweight brackets, the counterweight plate located at the bottom of the counterweight stack may be damaged.

The counterweight plates can fall down from the counterweight stack.

Death, severe bodily injuries, property damage.

- ▶ Make sure that the counterweight stack is only started with 10 t counterweight plates **2.10**.
- ▶ Make sure that the counterweight stack is never started with 5.0 t counterweight plates **2.20** or 7.5 t counterweight plates **2.30**.
- ▶ Further ballasting from the first 10 t counterweight plates **2.10** in the counterweight stack can be continued with 5.0 t or 7.5 t counterweight plates.

Make sure that the following prerequisite is met:

- There are no obstacles, objects or personnel in the danger zone.

4.4.1 Placing the counterweight plates, fastening system: „Twistlock“

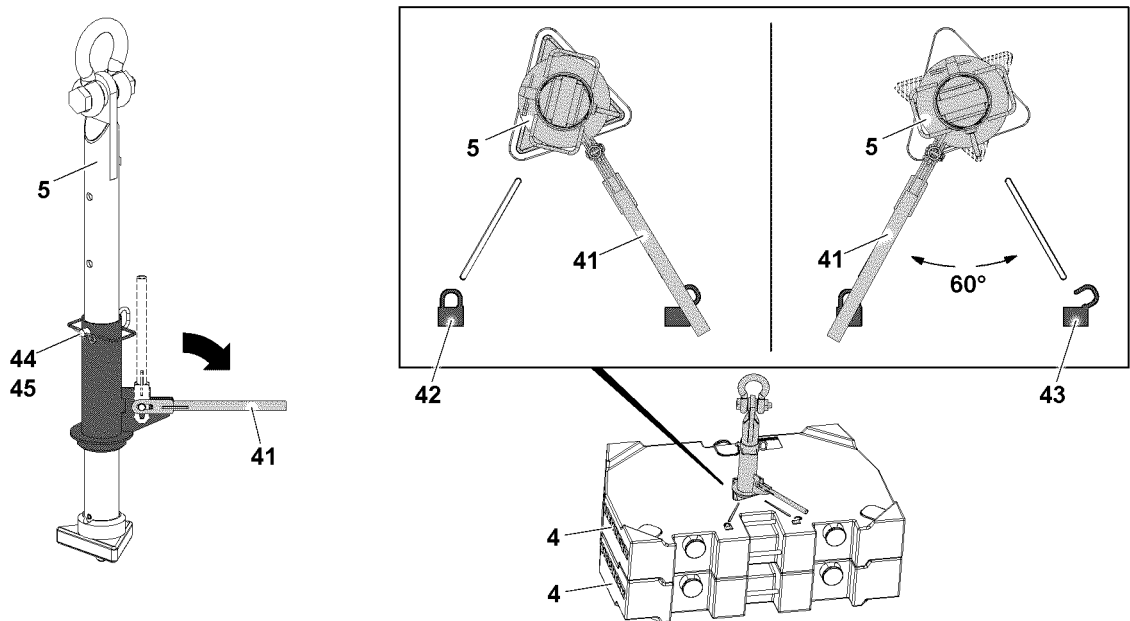

Fig.147033: Counterweight plates, fastening system: „Twistlock“



WARNING

Danger of accident!

If more than the permissible two counterweight plates are lifted with the receptacle stud, the receptacle stud will be overloaded and can be damaged.

Death, severe bodily injuries, property damage.

- ▶ Make sure that the counterweight plates are placed correctly in the centerings.
- ▶ Replace damaged counterweight plates.



WARNING

The Twistlock system opens by itself!

If the receptacle stud is not correctly locked, the Twistlock system can open by itself. Counterweight plates can fall down.

Death, severe bodily injuries, property damage.

- ▶ Make sure, when initiating a lift, that the lever points directly to the „Locked“ icon.



WARNING

Damage of receptacle stud and counterweight plates!

If two counterweight plates are lifted which do not lay correctly in their centerings, the receptacle stud and the counterweight plates can be damaged!

Damage can cause the counterweight plates to fall down.

Death, severe bodily injuries, property damage.

- ▶ Make sure that the counterweight plates to be lifted are placed correctly in the centerings.



Note

- ▶ During a lift, the locked Twistlock system cannot release by itself due to its gravitational retention.
- ▶ During a lift, the locked Twistlock system cannot be released by hand due to its gravitational retention.

To stack the counterweight plate(s), use the receptacle stud **5**.

Before the receptacle stud **5** is guided into the counterweight plates, it must be ensured that the length of the receptacle stud is set correctly. The length of the receptacle stud **5** can be adjusted with the pin **44**.

If the length of the receptacle stud **5** is to be adjusted:

- ▶ Release and unpin the pin **44**.
- ▶ Adjust the length of the receptacle stud by moving the receptacle stud **5**.
- ▶ Insert the pin **44** and secure it with the retaining element **45**.
- ▶ Fasten the receptacle stud **5** to the auxiliary crane and guide it into the counterweight plate(s) **4**.
- ▶ Pull the lever **41** up and fold it down.
- ▶ Turn the lever **41** 60° until the lever **41** points to the icon **42**.

Result:

- The receptacle stud **5** is locked with the counterweight plate(s) **4**.
- ▶ Lift the counterweight plate(s) **4** with the receptacle stud **5** and take down carefully onto the centerings on the counterweight bracket.

When the counterweight plate(s) are taken down:

- ▶ Turn the lever **41** 60° until the lever **41** points to the icon **43**.

Result:

- The receptacle stud **5** is unlocked.
- ▶ Carefully pull the receptacle stud **5** out from the counterweight plate(s) **4**.
- ▶ Stack the counterweight plate(s) **4** alternately on both sides according to the load chart, observe the danger notes.

4.4.2 Placing the counterweight plates, fastening points: Bitt

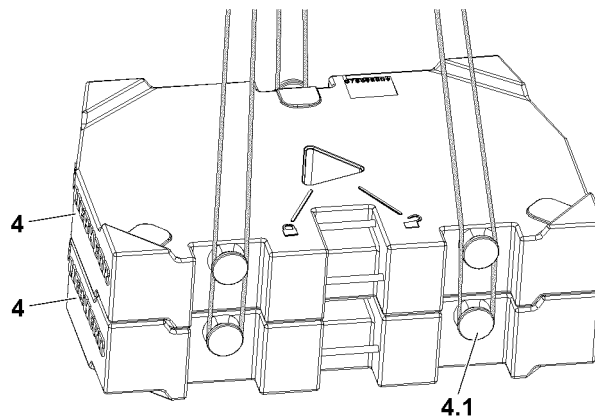

Fig.147034: Counterweight plates, fastening system: „Bitt“



WARNING

Falling counterweight plates!

If more than the permissible loads are lifted, then the bits **4.1** are overloaded and the counterweight plates can fall down.

Death, severe bodily injuries, property damage.

- ▶ Place the counterweight plates individually or as a package, maximum 20 t , 3 fastening points.
- ▶ Replace damaged counterweight plates immediately.



WARNING

Incorrect handling of the fastening equipment!

If fastening equipment cannot be attached correctly and if it is not secured sufficiently to prevent it from loosening up, loads can fall down.

Death, severe bodily injuries, property damage.

- ▶ Make sure that the fastening equipment is correctly attached on the bits **4.1** and that it is secured sufficiently to prevent it from loosening up.

- ▶ Fasten the counterweight plate(s) **4** to the auxiliary crane.
- ▶ Place the counterweight plate **4** individually or in an assembly of maximum two plates with the auxiliary crane on the centerings on the counterweight bracket.
- ▶ Stack the counterweight plate(s) **4** alternately on both sides according to the load chart, observe the danger notes.

4.5 Securing the counterweight

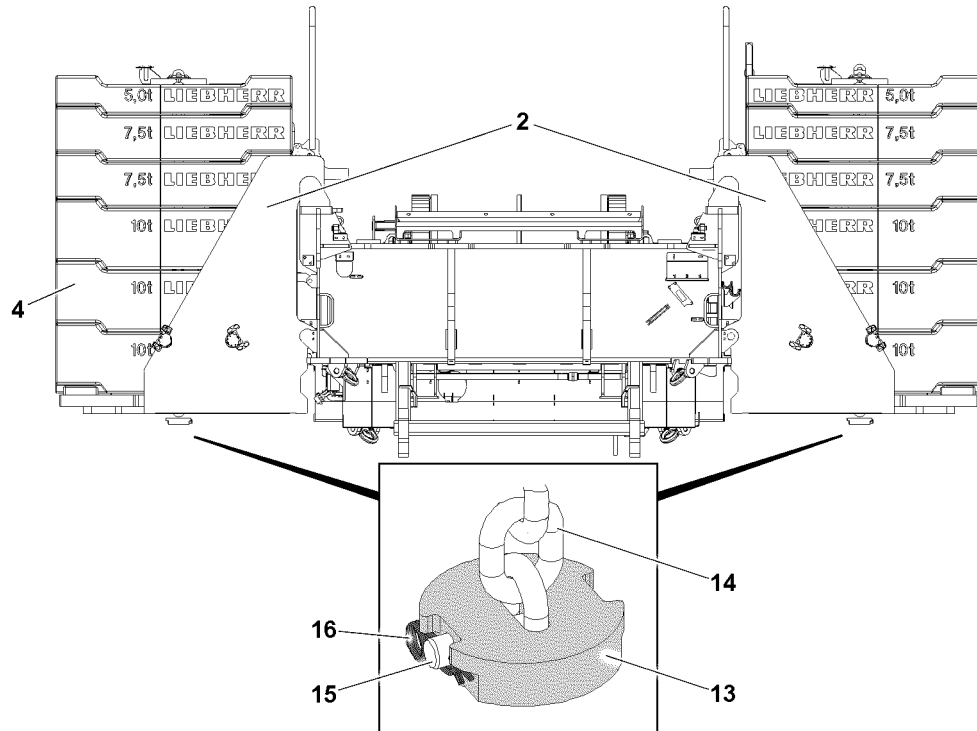

Fig.147042: Securing the counterweight stack



WARNING

Unsecured counterweight plates!

If the counterweight is not or not correctly secured, then it can fall down.

Death, severe bodily injuries, property damage.

- ▶ Before starting crane operation, the complete counterweight must be secured.

Make sure that the following prerequisite is met:

- The counterweight has been stacked according to the load chart and the operating instructions.
- ▶ Guide the retaining chain **14** carefully on the auxiliary crane from top through the counterweight stack.
- ▶ Pin the retaining chain **14** on the bottom with the retaining plate **13**: Insert the pin **15** in the lowest chain link and secure with the retaining element **16**.
- ▶ Carefully tighten the retaining chain **14** with the auxiliary crane vertically.

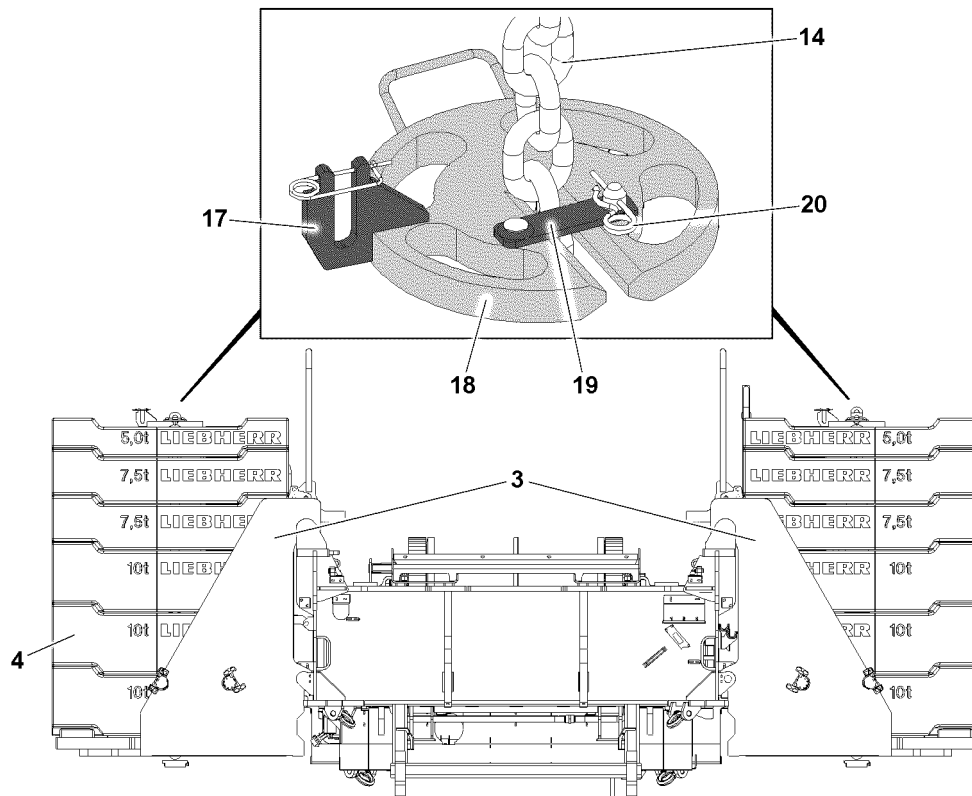

Fig.147043: Securing the counterweight stack



Note

- ▶ To optimally secure the counterweight stack, keep the retaining chain between the retaining plates as short as possible!
- ▶ Push the retaining plate **18** on top on the side over the retaining chain **14**.
- ▶ Insert the retaining plate **19** in the retaining plate **18**.
- ▶ Secure the retaining plate **19** with the retaining element **20**.

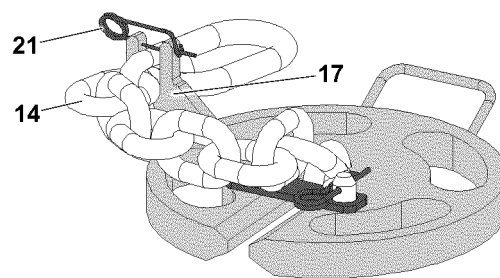

Fig.147037: Securing the chain overhang



WARNING

Danger of accident due to chain overhang!

If the stack height of the counterweight plates is not high enough, the chain overhang of the retaining chain **14** on the side on the counterweight stack can fall down.

Death, severe bodily injuries, property damage.

- ▶ Secure the chain overhang from falling down.
- ▶ Hang the chain overhang of the retaining chain **14** into the fork **17** and secure with retaining element **21** to prevent it from falling down.

5 Disassembling the counterweight



WARNING

Danger of falling!

During assembly / disassembly, inspection and maintenance work, personnel must be secured with appropriate aids to prevent them from falling.

If this is not observed, assembly personnel could fall and be killed or seriously injured.

- ▶ All work at a height, when there is a danger of falling, must be carried out with suitable aids.
- ▶ If aids are not available and work cannot be carried out from the ground, then the assembly personnel must secure themselves with the supplied fall arrest system to prevent falling, see the Crane operating instructions, chapter 2.04.
- ▶ If fall protection equipment is available, then it must be used, see the Crane operating instructions, chapter 2.06.
- ▶ When lifting, lowering, swinging crane parts in and out, no persons may remain in the danger zone.
- ▶ If railings are present on the components, then they must be brought into the corresponding position and secured for assembly / disassembly work.
- ▶ Only step on the aids, ladders and catwalks with clean shoes.
- ▶ Keep aids, ladders and catwalks free of heavy dirt, snow and ice.
- ▶ During all assembly and disassembly work, maintenance work and inspections, travel or crane operation is prohibited.
- ▶ Remaining on a suspended load is prohibited.
- ▶ Stepping or walking on crane components and lattice sections, which have an incline of more than 20° is prohibited.
- ▶ For all assembly work, the crane operator of the main crane must be in voice contact with the crane operator / crane operators of the auxiliary crane / auxiliary cranes.
- ▶ For assembly / disassembly tasks, the crane operator may only initiate crane movements when the responsible guide has explicitly released the movement.



WARNING

Danger of impact / crushing!

When installing / removing crane components with the auxiliary crane, crane components can start to swing back and forth.

When lifting / lowering and positioning crane components, there is an increased danger of impacts / crushing.

Personnel can be caught and thereby injured or killed.

- ▶ Make sure that personnel cannot be caught by components.
- ▶ When working in danger zones: Use aids to protect limbs.
- ▶ Guide components with suitable aids to minimize oscillation.



DANGER

The components can fall down!

If the corresponding components are disengaged from the auxiliary crane before the corresponding component is pinned, the corresponding component can fall down and fatally injure personnel.

- ▶ Do not disengage the auxiliary crane until the respective component is pinned and secured.



WARNING

The crane can topple over!

If the turntable with installed counterweight is turned without the boom installed, then the crane can topple over.

Death, severe bodily injuries, property damage.

- ▶ Always leave the turntable with an installed counterweight and without a boom in travel position.

Make sure that the following prerequisites for **LR 1600/2** are met:

- The crane is horizontally aligned.
- The turntable is positioned in the „travel direction“ (parallel to the crawler travel gear).
- The central ballast is properly installed.
- The SA-frame is erected to at least 90°.
- The boom is not assembled.
- An auxiliary crane is available.

Make sure that the following prerequisites for **LR 1600/2-W** are met:

- The crane is properly supported.
- The crane is horizontally aligned.
- The turntable is positioned in the „travel direction“ (parallel to the crawler travel gear).
- The central ballast is properly installed.
- The SA-frame is erected to at least 90°.
- The boom is not assembled.
- An auxiliary crane is available.

5.1 Releasing the counterweight

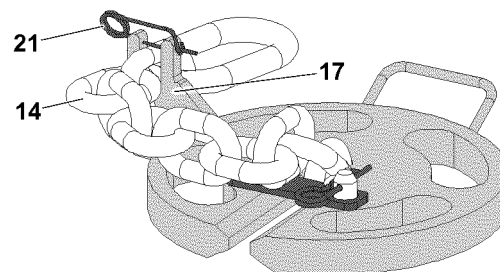

Fig.147037: Releasing the chain overhang

With a secured chain overhang:

- ▶ Remove the retaining element **21**, unhook the retaining chain **14** from the fork **17**.

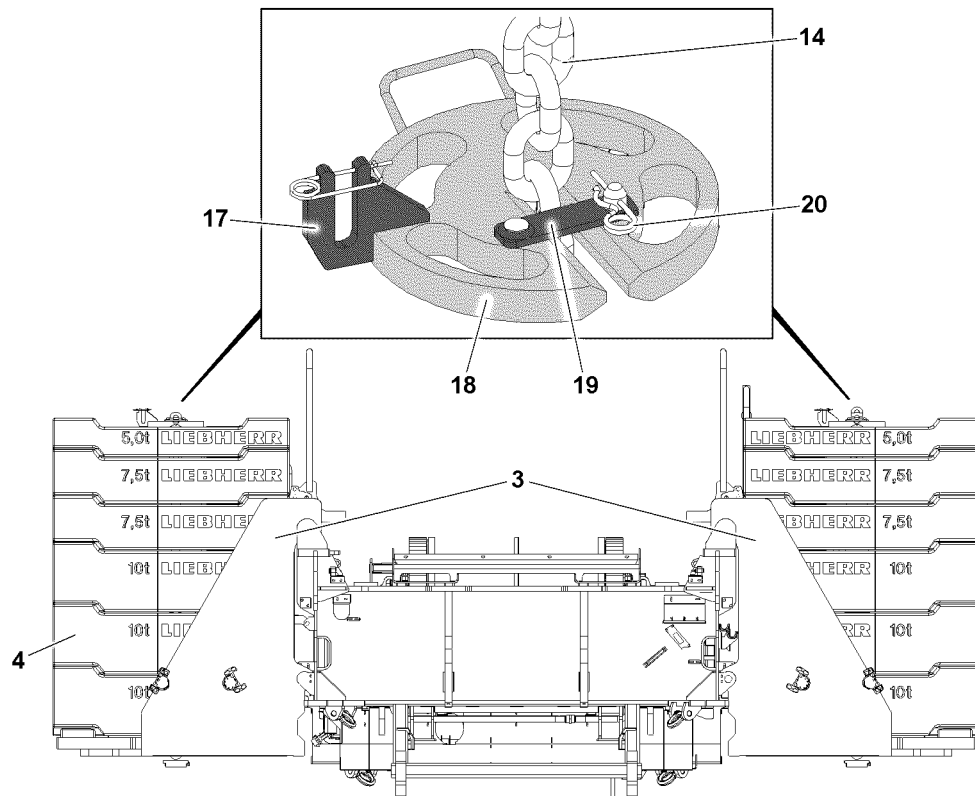

Fig.147043: Releasing the counterweight

- ▶ Fasten the retaining chain **14** to the auxiliary crane and tension it slightly.
- ▶ Release and remove the retaining plate **19**. Remove the retaining element **20**.
- ▶ Remove the retaining plate **18** on the side.

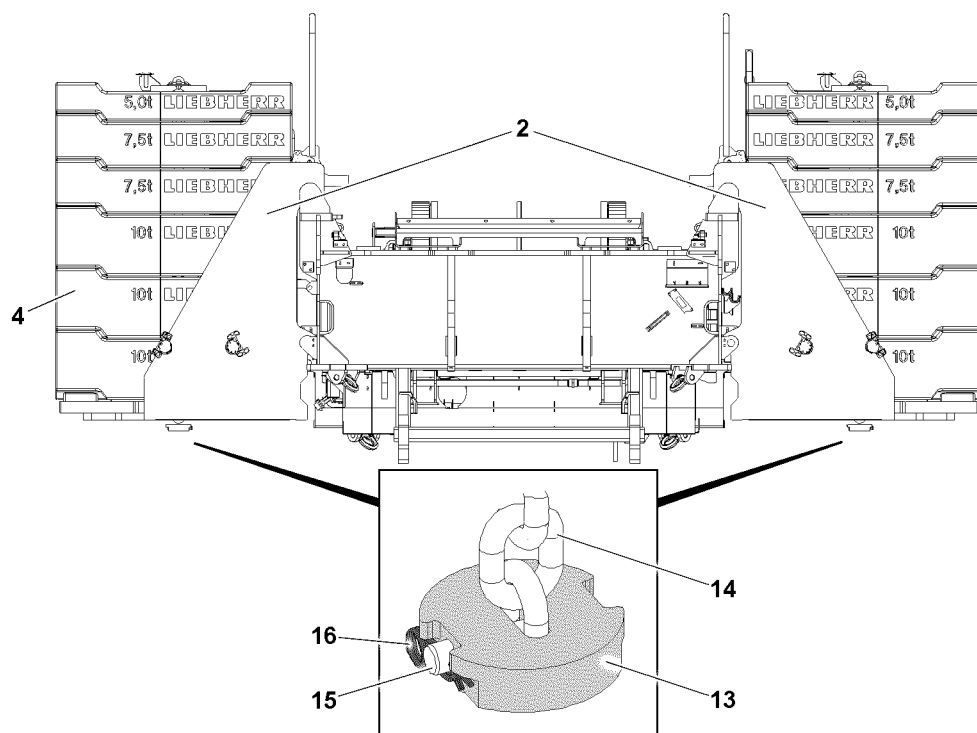

Fig.147042: Releasing the counterweight

- ▶ Lower the retaining chain **14** until the lower retaining plate **13** is freely accessible.
- ▶ Remove the retaining element **16** and unpin the pin **15**.

- ▶ Remove the retaining plate **13**.
- ▶ Carefully pull the retaining chain **14** through upward and remove it.

5.2 Removing the counterweight plates



WARNING

Damaged counterweight plates!

Damage on the counterweight plates can cause the fastening equipment to release.

The counterweight plates and components can fall down.

Death, severe bodily injuries, property damage.

- ▶ Do not use damaged counterweight plates and replace them immediately.



WARNING

Asymmetrical counterweight distribution!

If more than 20 t are asymmetrically placed on / removed from the counterweight stacks, the crane can topple over.

Death, severe bodily injuries, property damage.

- ▶ A weight difference between the right and left counterweight stack of more than 20 t is prohibited.
- ▶ Place / take-down the counterweight assemblies alternately symmetrically on the left and right on the counterweight stack.



Note

- ▶ The counterweight plates are marked with their own weights!

Make sure that the following prerequisite is met:

- The retaining chains are disassembled.

5.2.1 Removing the counterweight plates, fastening system: „Twistlock“

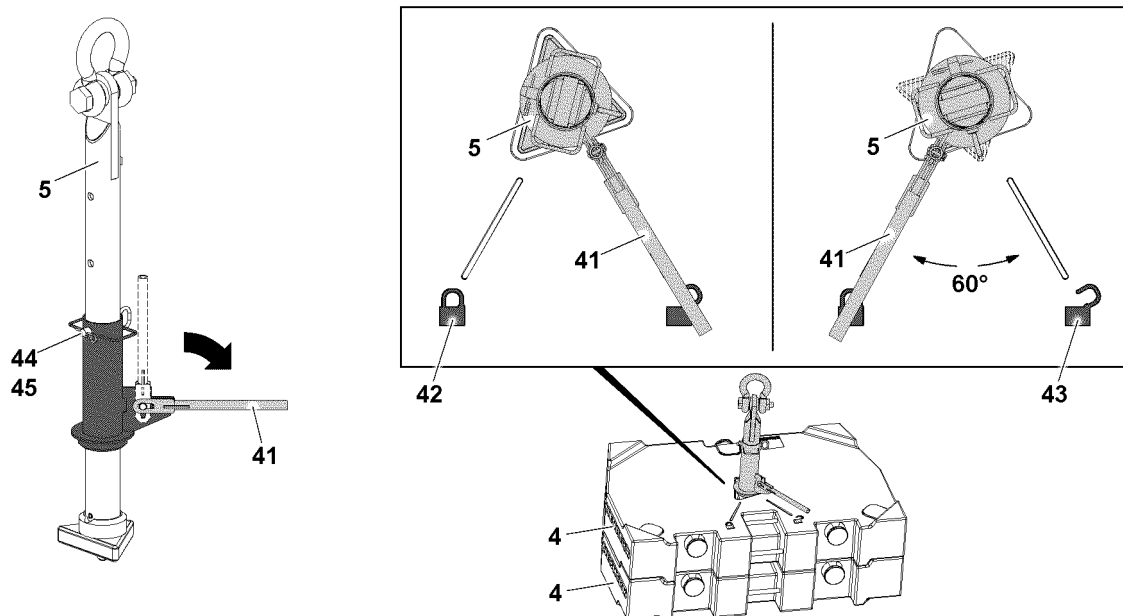

Fig.147033: Counterweight plates, fastening system: „Twistlock“

**WARNING**

Danger of accident!

If more than the permissible two counterweight plates are lifted with the receptacle stud, the receptacle stud will be overloaded and can be damaged.

Death, severe bodily injuries, property damage.

- ▶ Make sure that the counterweight plates are placed correctly in the centerings.
- ▶ Replace damaged counterweight plates.

**WARNING**

The Twistlock system opens by itself!

If the receptacle stud is not correctly locked, the Twistlock system can open by itself.

Counterweight plates can fall down.

Death, severe bodily injuries, property damage.

- ▶ Make sure, when initiating a lift, that the lever points directly to the „Locked“ icon.

**WARNING**

Damage of receptacle stud and counterweight plates!

If two counterweight plates are lifted which do not lay correctly in their centerings, the receptacle stud and the counterweight plates can be damaged!

Damage can cause the counterweight plates to fall down.

Death, severe bodily injuries, property damage.

- ▶ Make sure that the counterweight plates to be lifted are placed correctly in the centerings.

**Note**

- ▶ During a lift, the locked Twistlock system cannot release by itself due to its gravitational retention.
- ▶ During a lift, the locked Twistlock system cannot be released by hand due to its gravitational retention.

To remove the counterweight plate(s), use the receptacle stud **5**.

Before the receptacle stud **4** is guided into the counterweight plate(s) **4**, it must be ensured that the length of the receptacle stud is set correctly. The length of the receptacle stud **5** can be adjusted with the pin **44**.

If the length of the receptacle stud **5** is to be adjusted:

- ▶ Release and unpin the pin **44**.
- ▶ Adjust the length of the receptacle stud by moving the receptacle stud **5**.
- ▶ Insert the pin **44** and secure it with the retaining element **45**.
- ▶ Fasten the receptacle stud **5** to the auxiliary crane and guide it into the counterweight plate(s) **4**.
- ▶ Pull the lever **41** up and fold it down.
- ▶ Turn the lever **41** 60° until the lever **41** points to the icon **42**.

Result:

- The receptacle stud **5** is locked with the counterweight plate(s) **4**.
- ▶ Lift the counterweight plate(s) **4** with the receptacle stud **5** and remove it from the counterweight stack.

When the counterweight plate(s) **4** are taken down:

- ▶ Turn the lever **41** 60° until the lever **41** points to the icon **43**.

Result:

- The receptacle stud **5** is unlocked from the counterweight plate(s) **4**.
- ▶ Carefully pull the receptacle stud **5** out from the counterweight plate(s) **4**.
- ▶ Alternately remove the counterweight plate(s) **4** from both sides.

5.2.2 Removing the counterweight plates, fastening points: Bitt

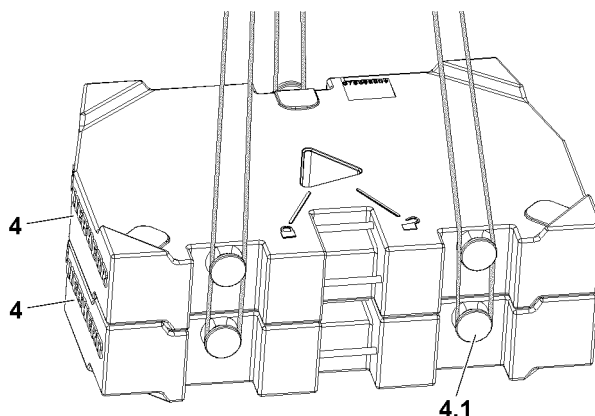

Fig.147034: Counterweight plates, fastening points: Bitt



WARNING

Falling counterweight plates!

If more than the permissible loads are lifted, then the bits **4.1** are overloaded and the counterweight plates can fall down.

Death, severe bodily injuries, property damage.

- ▶ Place the counterweight plates individually or as a package, maximum 20 t , 3 fastening points.
- ▶ Replace damaged counterweight plates immediately.



WARNING

Incorrect handling of the fastening equipment!

If fastening equipment cannot be attached correctly and if it is not secured sufficiently to prevent it from loosening up, loads can fall down.

Death, severe bodily injuries, property damage.

- ▶ Make sure that the fastening equipment is correctly attached on the bits **4.1** and that it is secured sufficiently to prevent it from loosening up.
- ▶ Lift the counterweight plate **4** or maximum two plates in an assembly and remove from the counterweight stack.
- ▶ Alternately remove the counterweight plate(s) **4** from both sides.

5.3 Removing the counterweight brackets on the turntable

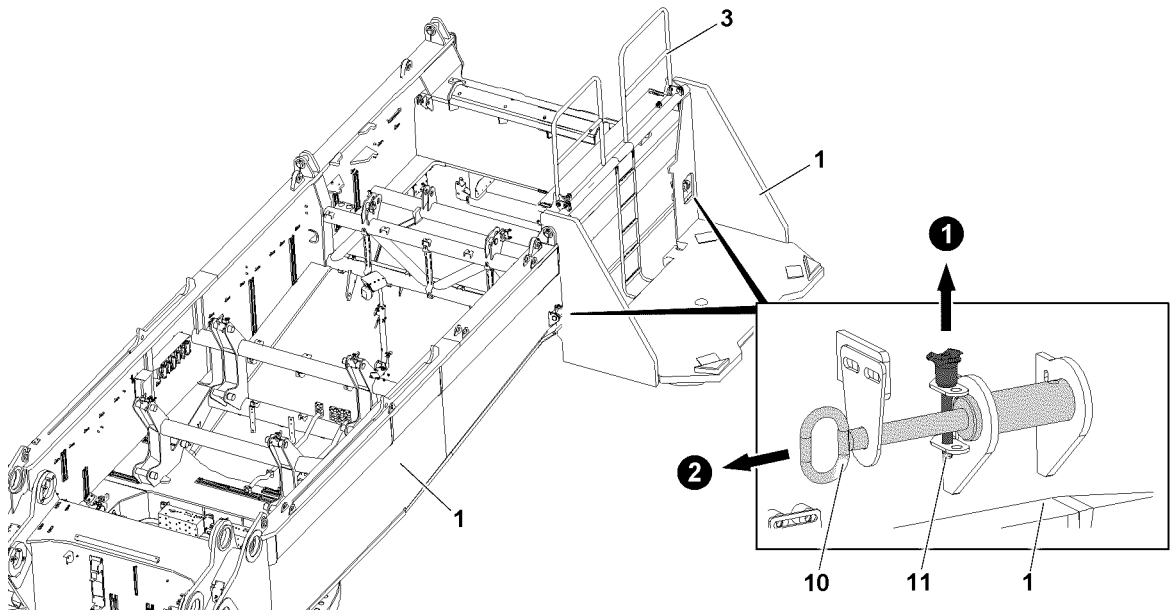

Fig.147045: Releasing the counterweight bracket on the turntable



Note

- ▶ The assembly / disassembly of the counterweight brackets is explained on a counterweight bracket as an example.

Make sure that the following prerequisites are met:

- The railings **3** on the counterweight brackets **2** are in the operating position.
- ▶ Fasten the counterweight bracket **2** to the auxiliary crane, see section „Fastening points“.



WARNING

Tipping of counterweight bracket!
Death, severe bodily injuries, property damage.

- ▶ Make sure that the fastening equipment has a sufficient length.
- ▶ Make sure that there are no persons within the danger zone when lifting the counterweight bracket **2**.

When the fastening equipment is tensioned properly on the counterweight bracket **2**:

- ▶ Release the pin **10**: Remove the retaining element **11**.
- ▶ Unpin the pins **10** on both sides.

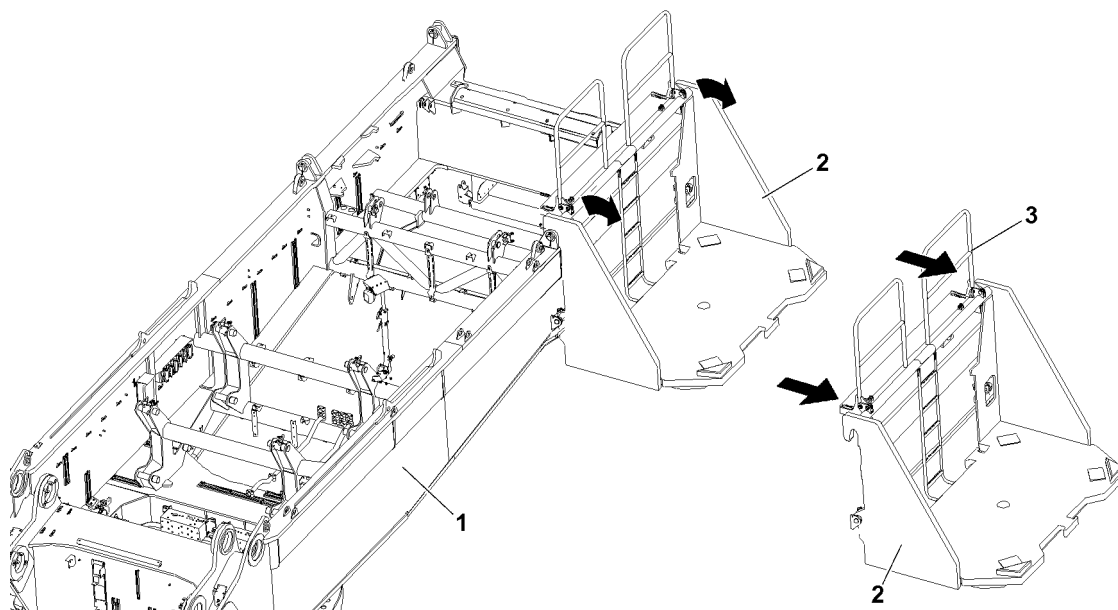

Fig.147046: Lifting the counterweight bracket and swinging it out

When the pins are fully unpinned on both sides:

- ▶ Lift the counterweight bracket **2** with the auxiliary crane and swing out.
- ▶ Set the counterweight bracket **2** on a load bearing substructure or on a flatbed trailer.

When the counterweight bracket **2** is properly set on the substructure or on the flatbed trailer:

- ▶ Remove the fastening equipment and the auxiliary crane.

When the counterweight bracket **2** is properly removed:

- ▶ Insert the pin **10** again and secure with the retaining element **11**.
- ▶ Properly disassemble the second counterweight bracket.

5.4 Bringing the railings on the counterweight brackets into the transport position



Note

The counterweight brackets are located on the ground or on a substructure with load bearing capacity:

- ▶ Bring the railing into the transport position, see chapter 2.06.

4.07.10 Turntable extension

1	Component overview	3
2	Fastening points	4
3	Permissible counterweight assemblies	5
4	Assembling the turntable extension	6
5	Disassembling the turntable extension	14

Fig.195219

LWE/LR 1600-2-008/18109-09-02/en

1 Component overview

The ballast installed on the turntable is generally referred to as the counterweight.

The components are marked with their own weight.

Description of the **counterweight**, see chapter 4.07.

Dimensions and weights, see chapter 1.03.

1.1 Counterweight

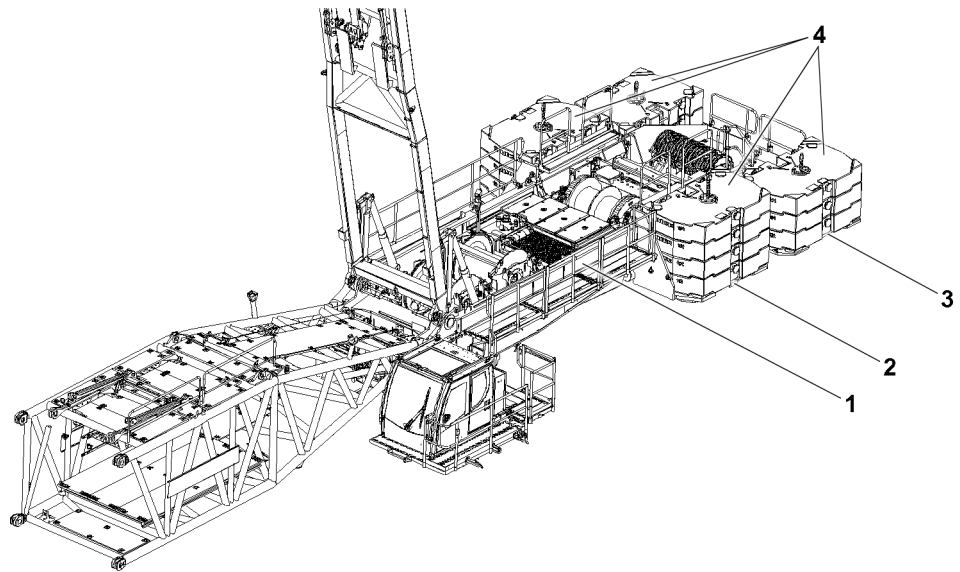

Fig.149285: Component overview counterweight

- | | | | |
|---|-----------------------|---|----------------------|
| 1 | Turntable | 3 | Turntable extension |
| 2 | Counterweight bracket | 4 | Counterweight plates |

1.2 Counterweight plate

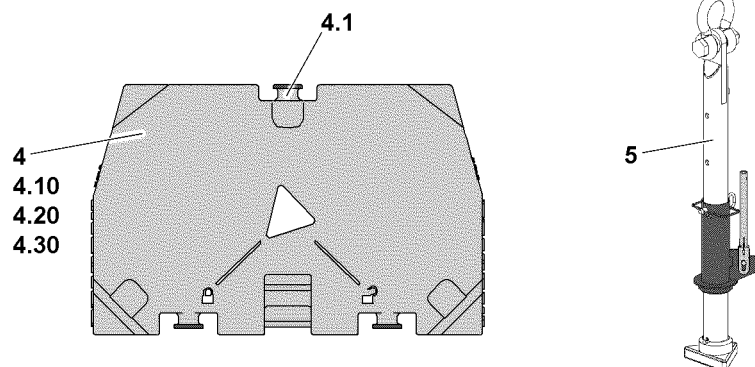

Fig.147026: Counterweight plate

- | | | | |
|------|----------------------------|------|---------------------------|
| 4 | Counterweight plate | 4.20 | 7.5 t counterweight plate |
| 4.1 | Bit | 4.30 | 5.0 t counterweight plate |
| 4.10 | 10.0 t counterweight plate | 5 | Receptacle stud |

LWE/LR 1600-2-008/18109-09-02/en

2 Fastening points



WARNING

Danger of falling!

Death, severe bodily injuries, property damage.

- ▶ Make sure that the fastening equipment is properly fastened on the fastening points.
- ▶ Make sure that the fastening equipment has a sufficient length.
- ▶ Make sure that there are no persons or obstacles within the danger zone.
- ▶ Pay attention to the labels of the fastening points.

2.1 Turntable extension

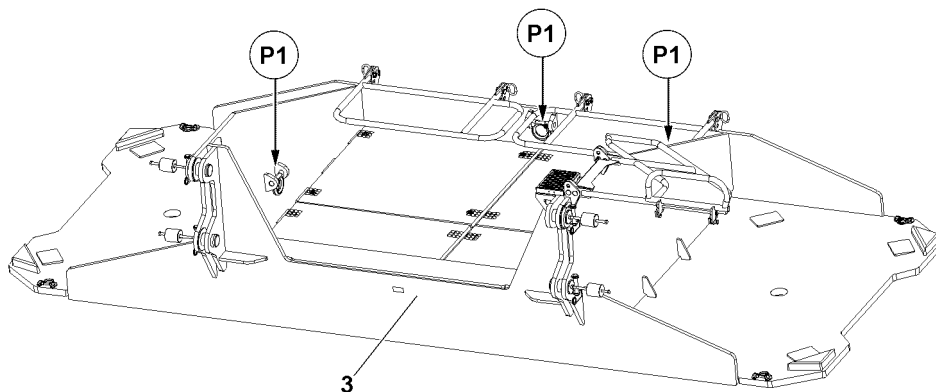

Fig.147028: Turntable extension fastening points

Fastening points	
P1	Turntable extension

2.2 Counterweight plate

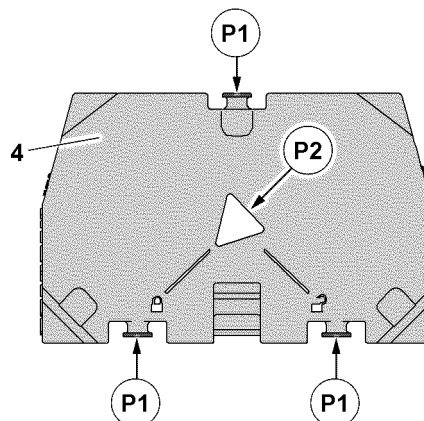

Fig.147027: Fastening points Counterweight plate

„Bitt“ fastening system	
P1	Counterweight plate

„Twistlock“ fastening system (with help of the receptacle stud)	
P2	Counterweight plate

3 Permissible counterweight assemblies

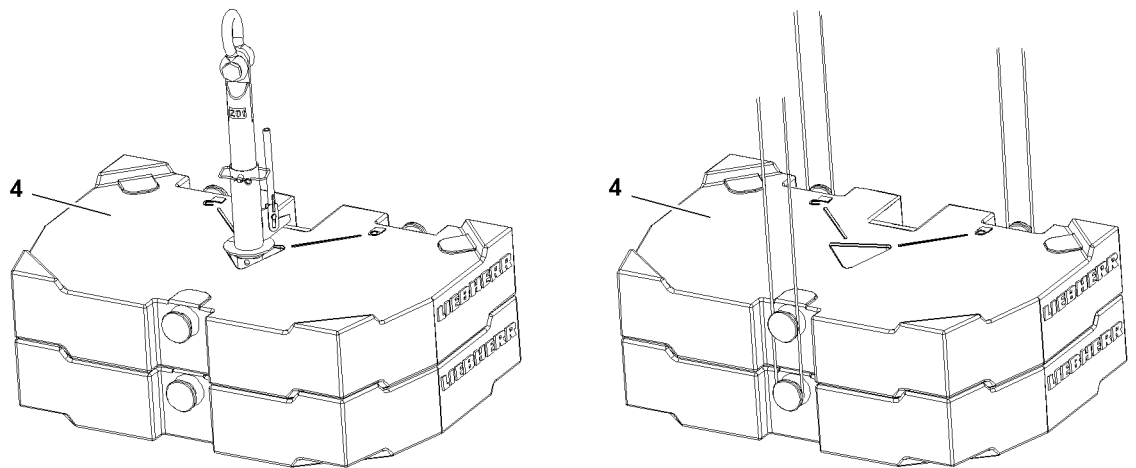

Fig.118980: Counterweight plates: fastened with Twistlock // fastened with bitts



WARNING

Overload of fastening points counterweight plates!
 If more than the permissible number of counterweight plates are lifted together, then the bitt or the receptacle stud can be overloaded.
 The counterweight plates and components can fall down.
 Death, severe bodily injuries, property damage.
 ► Fasten only the maximum permissible number of counterweight plates per lift.



WARNING

Incorrect structure of counterweight assemblies!
 When lifting mixed weight counterweight assemblies, and the heavier counterweight plates are placed on top, the fastening points can be overloaded.
 The counterweight plates and components can fall down.
 Death, severe bodily injuries, property damage.
 ► Always stack the heavier counterweight plate on the bottom in the counterweight assembly.

Individual weight Counterweight plate	Maximum number of same counterweight plates per lift over	
	„Twistlock“	„Bitt“
5.0 t	2	1
7.5 t	2	2
10.0 t	2	2

LWE/LR 1600-2-008/18109-09-02/en

4 Assembling the turntable extension



WARNING

Danger of falling!

During assembly / disassembly, inspection and maintenance work, assembly personnel must be secured with appropriate aids to prevent them from falling.

Death, severe bodily injuries, property damage.

- ▶ All work at a height, when there is a danger of falling, must be carried out with suitable aids.
- ▶ If aids are not available and work cannot be carried out from the ground, then assembly personnel must secure themselves with the supplied fall arrest system to prevent falling, see chapter 2.04.
- ▶ If fall protection equipment is available, then it must be used, see chapter 2.06.
- ▶ When lifting, lowering, swinging crane parts in and out, no persons may remain in the danger zone.
- ▶ When closing or opening boom systems during boom assembly or boom disassembly, no persons may remain on the boom system or in the danger zone.
- ▶ If railings are present on the components, then they must be brought into the corresponding position and secured for assembly / disassembly work.
- ▶ Only step on the aids, ladders and catwalks with clean shoes.
- ▶ Keep aids, ladders and catwalks free of heavy dirt, snow and ice.
- ▶ During all assembly and disassembly work, maintenance work and inspections, travel or crane operation is prohibited.
- ▶ Remaining on a suspended load is prohibited.
- ▶ Stepping or walking on crane components and lattice sections, which have an incline of more than 20° is prohibited.
- ▶ For all assembly work, the crane driver of the main crane must be in voice contact with the crane driver / crane drivers of the auxiliary crane / auxiliary cranes.
- ▶ For assembly tasks, the crane driver may only initiate crane movements when the responsible guide has explicitly released the movement.



WARNING

Danger of impact / crushing!

When installing / removing crane components with the auxiliary crane, crane components can start to swing back and forth.

When lifting / lowering and positioning crane components, there is an increased danger of impacts / crushing.

Death, severe bodily injuries, property damage.

- ▶ Make sure that personnel cannot be caught by components.
- ▶ Make sure that the crane is horizontally aligned.
- ▶ When working in danger zones: Use aids to protect limbs.
- ▶ Guide components with suitable aids to minimize oscillation.



DANGER

The components can fall down!

If the corresponding component is disengaged from the auxiliary crane before the corresponding component is pinned, then the corresponding component can fall down.

Death, severe bodily injuries, property damage.

- ▶ Do not disengage the auxiliary crane until the respective component is pinned and secured.



WARNING

The crane can topple over!

If the turntable with installed counterweight is turned without the boom installed, then the crane can topple over.

Death, severe bodily injuries, property damage.

- ▶ Always leave the turntable with an installed counterweight and without a boom in travel position.

Make sure that the following prerequisites for **LR 1600/2** are met:

- The crane is horizontally aligned.
- The turntable is positioned in the „travel direction“ (parallel to the crawler travel gear).
- The boom is installed with at least 72 m boom length.
- A weight of 65 t is installed on the central ballast.
- A counterweight of 150 t is installed on the turntable.
- The SA-frame is erected to at least 90°.
- An auxiliary crane is available.

Make sure that the following prerequisites for **LR 1600/2-W** are met:

- The crane is properly supported.
- The crane is horizontally aligned.
- The turntable is positioned in the „travel direction“ (parallel to the crawler travel gear).
- The boom is not assembled.
- The central ballast is properly installed.
- A counterweight of 90 t is installed on the turntable.
- The SA-frame is erected to at least 145°.
- An auxiliary crane is available.

4.1 Bringing the railing on the turntable extension into the operating position

The turntable extension is located on the ground or on a substructure with load bearing capacity:

- ▶ Bring the railing into the operating position, see chapter 2.06.

4.2 Assembling the turntable extension on the turntable

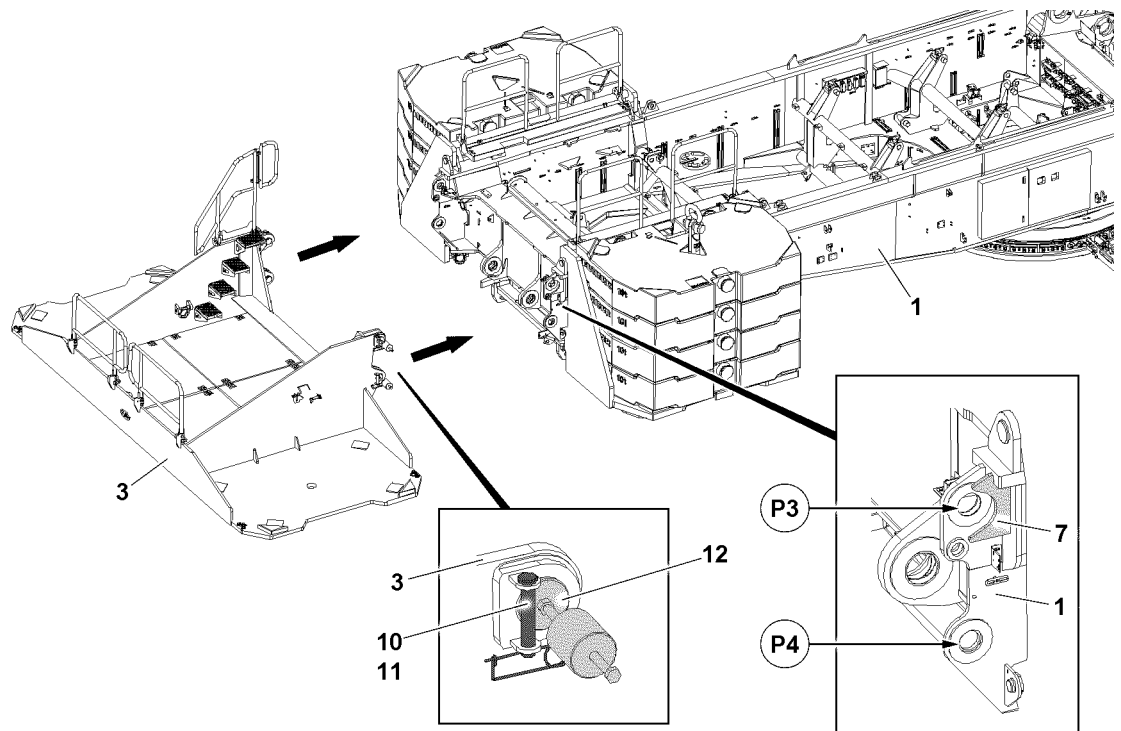

Fig.147030: Assembling the turntable extension

Make sure that the following prerequisite is met:

- The pins **12** are unpinned on both sides.
- ▶ Fasten the turntable extension **3** to the auxiliary crane.
- ▶ Lift the turntable extension **3** with the auxiliary crane and position it with the centering aid **7** in such a way that it can be pinned on points **P3**.

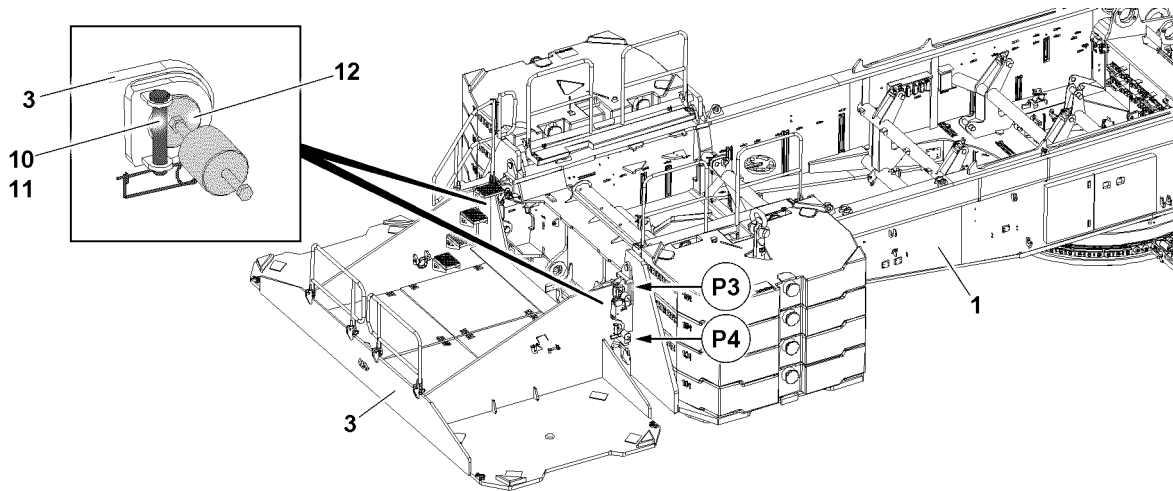

Fig.147031: Pinning the turntable extension on the turntable

- ▶ Pin the turntable extension 3 with the turntable 1: Pin the upper connector pins 12 on both sides on points P3 and secure with retaining pin 10 and retaining element 11.
- ▶ Lower the turntable extension 3 with the auxiliary crane so that it can be pinned on points P4.
- ▶ Pin the turntable extension 3 with the turntable 1: Pin the lower connector pins 12 on both sides on points P4 and secure with retaining pin 10 and retaining element 11.

Result:

- The turntable extension 3 is pinned with the turntable 1.
- ▶ Release and remove the fastening equipment.

4.3 Placing the counterweight plates



WARNING

Damaged counterweight plates!

Damage on the counterweight plates can cause the fastening equipment to release.

The counterweight plates and components can fall down.

Death, severe bodily injuries, property damage.

- ▶ Do not use damaged counterweight plates and replace them immediately.



WARNING

Counterweight too low / too high!

If the placed counterweight deviates from the specified data in the load charts or the assembly condition, then the crane can be damaged or topple over.

Death, severe bodily injuries, property damage.

- ▶ Place the counterweight according to the data in the load chart.
- ▶ Before placing the counterweight plates, observe the maximum permissible counterweight depending on the assembly conditions, see chapter 3.06.



WARNING

Asymmetrical counterweight distribution!

If more than 20 t are asymmetrically placed on / removed from the counterweight stacks, the crane can topple over.

Death, severe bodily injuries, property damage.

- ▶ A weight difference between the right and left counterweight stack of more than 20 t is prohibited.
- ▶ Place / remove the counterweight assemblies alternately symmetrically on the left and right on the counterweight stack.

**WARNING**

Toppling counterweight stack!

Lopsided stacked counterweight plates create instability in the counterweight stack.

The counterweight plates can tip from the counterweight brackets and cause the crane to topple over. Death, severe bodily injuries, property damage.

- ▶ Make sure that the counterweight plates are placed correctly in the centerings.

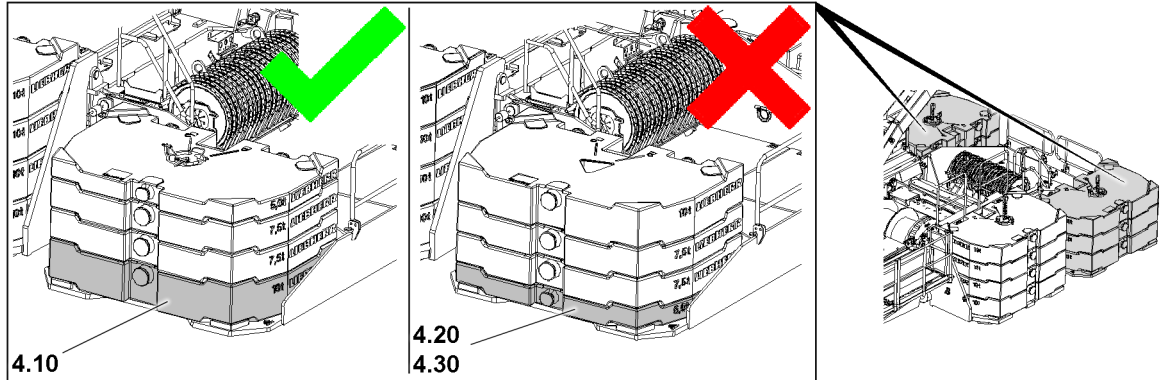

Fig.149004: Ballasting the counterweight stack

**WARNING**

Falling counterweight plates!

If the ballasting sequence is not adhered to when placing the counterweights on the counterweight brackets, the counterweight plate located at the bottom of the counterweight stack may be damaged.

The counterweight plates can fall down from the counterweight stack.

Death, severe bodily injuries, property damage.

- ▶ Make sure that the counterweight stack is only started with 10 t counterweight plates **2.10**.
- ▶ Make sure that the counterweight stack is never started with 5.0 t counterweight plates **2.20** or 7.5 t counterweight plates **2.30**.
- ▶ Further ballasting from the first 10 t counterweight plates **2.10** in the counterweight stack can be continued with 5.0 t or 7.5 t counterweight plates.

Make sure that the following prerequisite is met:

- There are no obstacles, objects or personnel in the danger zone.

4.3.1 Placing the counterweight plates, fastening system: „Twistlock“

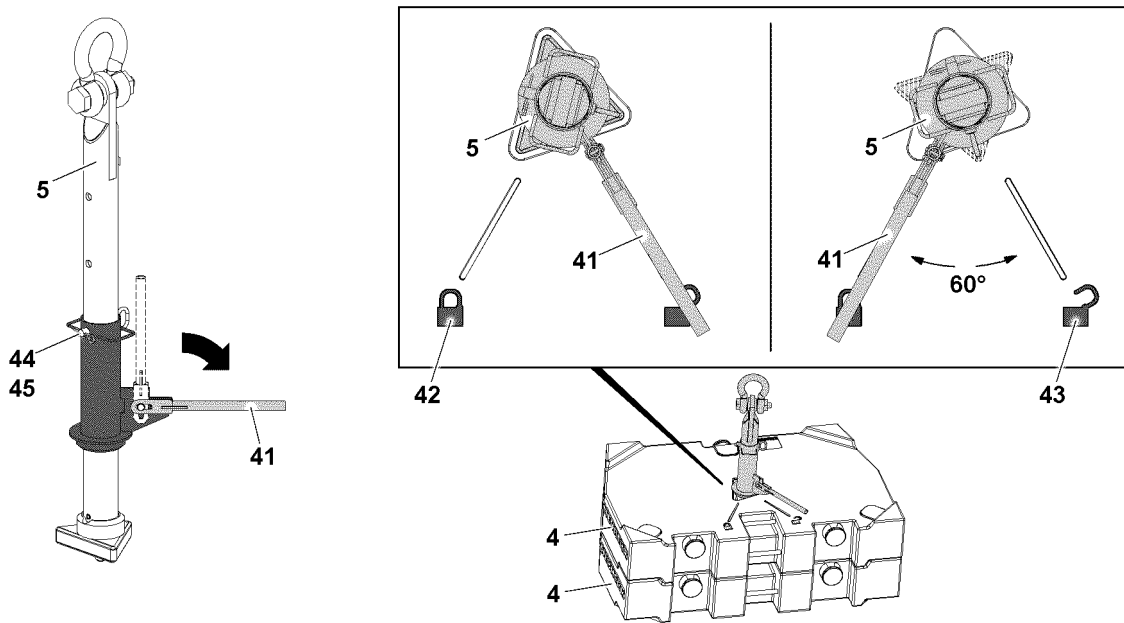

Fig.147033: Counterweight plates, fastening system: „Twistlock“



WARNING

Danger of accident!

If more than the permissible two counterweight plates are lifted with the receptacle stud, the receptacle stud will be overloaded and can be damaged.

Death, severe bodily injuries, property damage.

- ▶ Make sure that the counterweight plates are placed correctly in the centerings.
- ▶ Replace damaged counterweight plates.



WARNING

The Twistlock system opens by itself!

If the receptacle stud is not correctly locked, the Twistlock system can open by itself.

Counterweight plates can fall down.

Death, severe bodily injuries, property damage.

- ▶ Make sure, when initiating a lift, that the lever points directly to the „Locked“ icon.



WARNING

Damage of receptacle stud and counterweight plates!

If two counterweight plates are lifted which do not lay correctly in their centerings, the receptacle stud and the counterweight plates can be damaged!

Damage can cause the counterweight plates to fall down.

Death, severe bodily injuries, property damage.

- ▶ Make sure that the counterweight plates to be lifted are placed correctly in the centerings.



Note

- ▶ During a lift, the locked Twistlock system cannot release by itself due to its gravitational retention.
- ▶ During a lift, the locked Twistlock system cannot be released by hand due to its gravitational retention.

To stack the counterweight plate(s), use the receptacle stud **5**.

Before the receptacle stud **5** is guided into the counterweight plates, it must be ensured that the length of the receptacle stud is set correctly. The length of the receptacle stud **5** can be adjusted with the pin **44**.

If the length of the receptacle stud **5** is to be adjusted:

- ▶ Release and unpin the pin **44**.
- ▶ Adjust the length of the receptacle stud by moving the receptacle stud **5**.
- ▶ Insert the pin **44** and secure it with the retaining element **45**.
- ▶ Fasten the receptacle stud **5** to the auxiliary crane and guide it into the counterweight plate(s) **4**.
- ▶ Pull the lever **41** up and fold it down.
- ▶ Turn the lever **41** by 60° until the lever **41** points to the icon **42**.

Result:

- The receptacle stud **5** is locked with the counterweight plate(s) **4**.
- ▶ Lift the counterweight plate(s) **4** with the receptacle stud **5** and take down carefully onto the centerings on the counterweight bracket.

When the counterweight plate(s) are taken down:

- ▶ Turn the lever **41** by 60° until the lever **41** points to the icon **43**.

Result:

- The receptacle stud **5** is unlocked.
- ▶ Carefully pull the receptacle stud **5** out from the counterweight plate(s) **4**.
- ▶ Stack the counterweight plate(s) **4** alternately on both sides according to the load chart, observe the danger notes.

4.3.2 Placing the counterweight plates, fastening points: Bitt

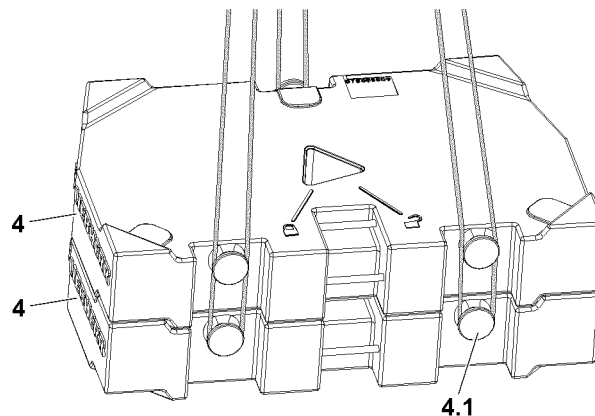

Fig.147034: Counterweight plates, fastening system: „Bitt“



WARNING

Falling counterweight plates!

If more than the permissible loads are lifted, then the bits **4.1** are overloaded and the counterweight plates can fall down.

Death, severe bodily injuries, property damage.

- ▶ Place the counterweight plates individually or as a package, maximum 20 t , 3 fastening points.
- ▶ Replace damaged counterweight plates immediately.



WARNING

Incorrect handling of the fastening equipment!

If fastening equipment cannot be attached correctly and if it is not secured sufficiently to prevent it from loosening up, loads can fall down.

Death, severe bodily injuries, property damage.

- ▶ Make sure that the fastening equipment is correctly attached on the bits **4.1** and that it is secured sufficiently to prevent it from loosening up.

- ▶ Fasten the counterweight plate(s) **4** to the auxiliary crane.
- ▶ Place the counterweight plate **4** individually or in an assembly of maximum two plates with the auxiliary crane on the centerings on the counterweight bracket.
- ▶ Stack the counterweight plate(s) **4** alternately on both sides according to the load chart, observe the danger notes.

4.4 Securing the counterweight

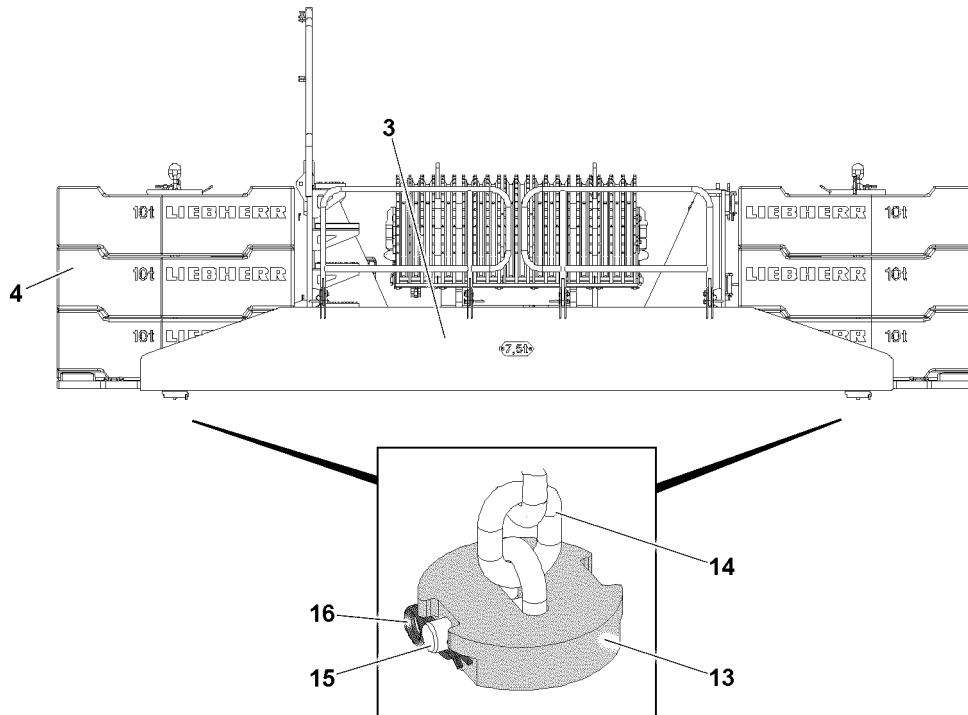

Fig.147035: Securing the counterweight stack



WARNING

Unsecured counterweight plates!

If the counterweight is not or not correctly secured, then it can fall down.

Death, severe bodily injuries, property damage.

- ▶ Before starting crane operation, the complete counterweight must be secured.

Make sure that the following prerequisite is met:

- The counterweight has been stacked according to the load chart and the operating instructions.
- ▶ Guide the retaining chain **14** carefully on the auxiliary crane from top through the counterweight stack.
- ▶ Pin the retaining chain **14** on the bottom with the retaining plate **13**: Insert the pin **15** in the lowest chain link and secure with the retaining element **16**.
- ▶ Carefully tighten the retaining chain **14** with the auxiliary crane vertically.

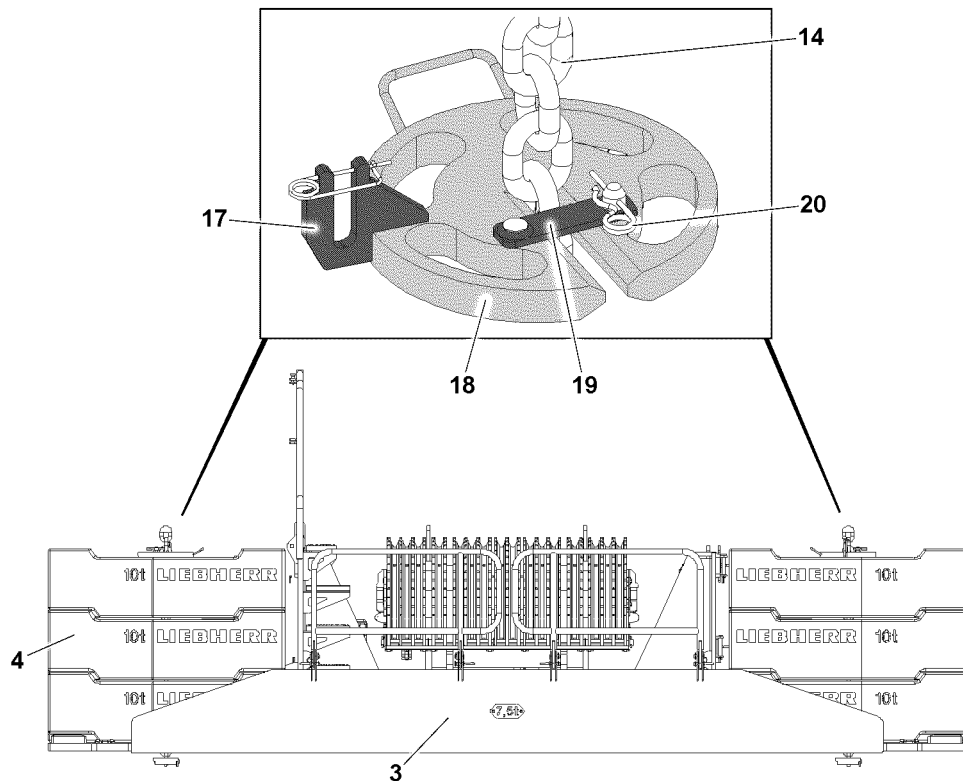

Fig.147036: Securing the counterweight stack



Note

- ▶ To optimally secure the counterweight stack, keep the retaining chain between the retaining plates as short as possible!
- ▶ Push the retaining plate **18** on top on the side over the retaining chain **14**.
- ▶ Insert the retaining plate **19** in the retaining plate **18**.
- ▶ Secure the retaining plate **19** with the retaining element **20**.

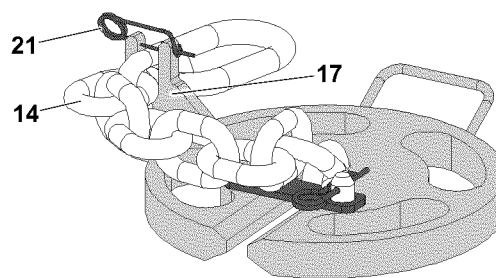

Fig.147037: Securing the chain overhang



WARNING

Danger of accidents due to chain overhang!

If the stack height of the counterweight plates is not high enough, the chain overhang of the retaining chain **14** on the side on the counterweight stack can fall down.

Death, severe bodily injuries, property damage.

- ▶ Secure the chain overhang from falling down.
- ▶ Hang the chain overhang of the retaining chain **14** into the fork **17** and secure with retaining element **21** to prevent it from falling down.

5 Disassembling the turntable extension



WARNING

Danger of falling!

During assembly / disassembly, inspection and maintenance work, assembly personnel must be secured with appropriate aids to prevent them from falling.

Death, severe bodily injuries, property damage.

- ▶ All work at a height, when there is a danger of falling, must be carried out with suitable aids.
- ▶ If aids are not available and work cannot be carried out from the ground, then assembly personnel must secure themselves with the supplied fall arrest system to prevent falling, see chapter 2.04.
- ▶ If fall protection equipment is available, then it must be used, see chapter 2.06.
- ▶ When lifting, lowering, swinging crane parts in and out, no persons may remain in the danger zone.
- ▶ When closing or opening boom systems during boom assembly or boom disassembly, no persons may remain on the boom system or in the danger zone.
- ▶ If railings are present on the components, then they must be brought into the corresponding position and secured for assembly / disassembly work.
- ▶ Only step on the aids, ladders and catwalks with clean shoes.
- ▶ Keep aids, ladders and catwalks free of heavy dirt, snow and ice.
- ▶ During all assembly and disassembly work, maintenance work and inspections, travel or crane operation is prohibited.
- ▶ Remaining on a suspended load is prohibited.
- ▶ Stepping or walking on crane components and lattice sections, which have an incline of more than 20° is prohibited.
- ▶ For all assembly work, the crane driver of the main crane must be in voice contact with the crane driver / crane drivers of the auxiliary crane / auxiliary cranes.
- ▶ For assembly tasks, the crane driver may only initiate crane movements when the responsible guide has explicitly released the movement.



WARNING

Danger of impact / crushing!

When installing / removing crane components with the auxiliary crane, crane components can start to swing back and forth.

When lifting / lowering and positioning crane components, there is an increased danger of impacts / crushing.

Death, severe bodily injuries, property damage.

- ▶ Make sure that personnel cannot be caught by components.
- ▶ Make sure that the crane is horizontally aligned.
- ▶ When working in danger zones: Use aids to protect limbs.
- ▶ Guide components with suitable aids to minimize oscillation.



DANGER

The components can fall down!

If the corresponding component is disengaged from the auxiliary crane before the corresponding component is pinned, then the corresponding component can fall down.

Death, severe bodily injuries, property damage.

- ▶ Do not disengage the auxiliary crane until the respective component is pinned and secured.



WARNING

The crane can topple over!

If the turntable with installed counterweight is turned without the boom installed, then the crane can topple over.

Death, severe bodily injuries, property damage.

- ▶ Always leave the turntable with an installed counterweight and without a boom in travel position.

Make sure that the following prerequisites for **LR 1600/2** are met:

- The crane is horizontally aligned.
- The turntable is positioned in the „travel direction“ (parallel to the crawler travel gear).
- The boom is installed with at least 72 m boom length.
- A weight of 65 t is installed on the central ballast.
- A counterweight of 150 t is installed on the turntable.
- The SA-frame is erected to at least 90°.
- An auxiliary crane is available.

Make sure that the following prerequisites for **LR 1600/2-W** are met:

- The crane is properly supported.
- The crane is horizontally aligned.
- The turntable is positioned in the „travel direction“ (parallel to the crawler travel gear).
- The boom is not assembled.
- The central ballast is properly installed.
- A counterweight of 90 t is installed on the turntable.
- The SA-frame is erected to at least 145°.
- An auxiliary crane is available.

5.1 Releasing the counterweight

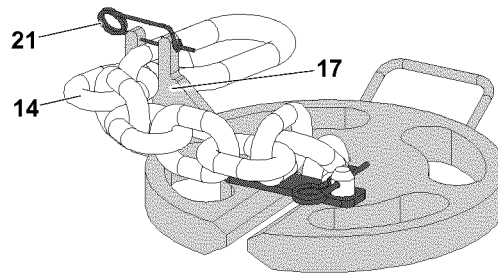

Fig.147037: Releasing the chain overhang

With a secured chain overhang:

- ▶ Remove the retaining element **21**, unhook the retaining chain **14** from the fork **17**.

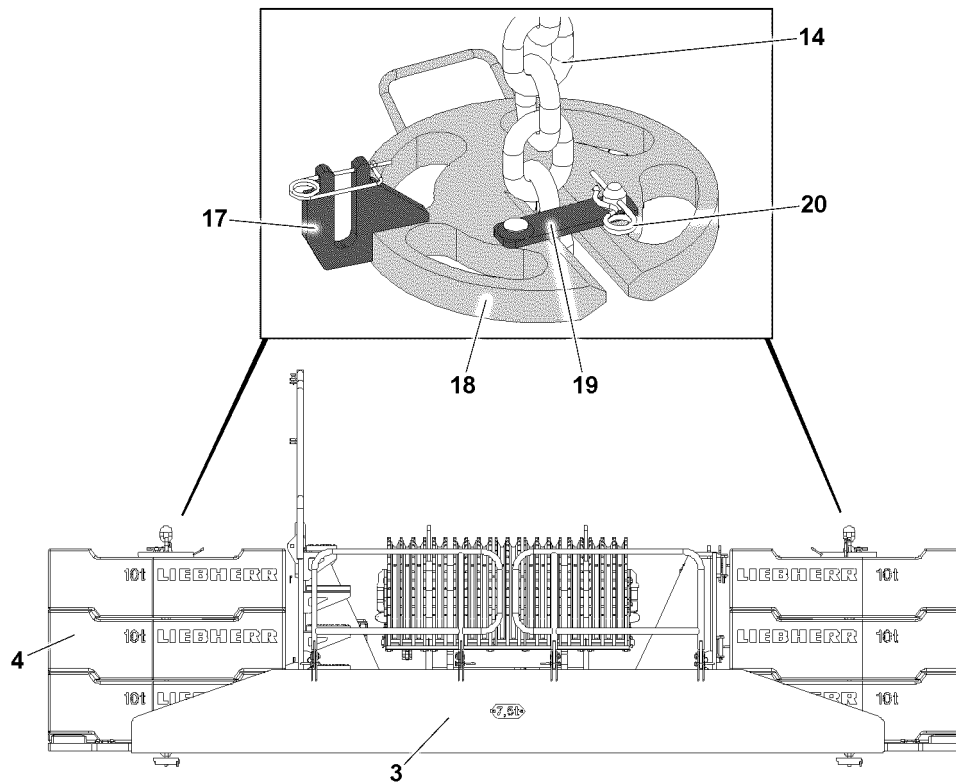

Fig.147036: Releasing the counterweight

- ▶ Fasten the retaining chain 14 to the auxiliary crane and tension it slightly.
- ▶ Release and remove the retaining plate 19. Remove the retaining element 20.
- ▶ Remove the retaining plate 18 on the side.

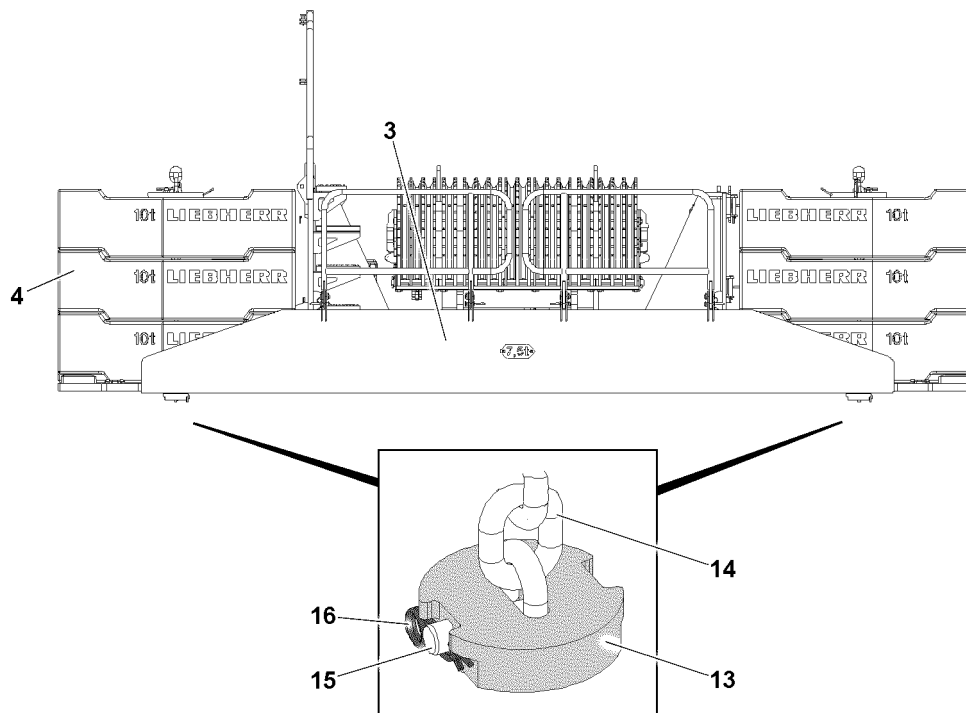

Fig.147035: Releasing the counterweight

- ▶ Lower the retaining chain 14 until the lower retaining plate 13 is freely accessible.
- ▶ Remove the retaining element 16 and unpin the pin 15.

- ▶ Remove the retaining plate **13**.
- ▶ Carefully pull the retaining chain **14** through upward and remove it.

5.2 Removing the counterweight plates



WARNING

Damaged counterweight plates!
 Damage on the counterweight plates can cause the fastening equipment to release.
 The counterweight plates and components can fall down.
 Death, severe bodily injuries, property damage.
 ▶ Do not use damaged counterweight plates and replace them immediately.



WARNING

Asymmetrical counterweight distribution!
 If more than 20 t are asymmetrically placed on / removed from the counterweight stacks, the crane can topple over.
 Death, severe bodily injuries, property damage.
 ▶ A weight difference between the right and left counterweight stack of more than 20 t is prohibited.
 ▶ Place / take-down the counterweight assemblies alternately symmetrically on the left and right on the counterweight stack.



Note

▶ The counterweight plates are marked with their own weights!

Make sure that the following prerequisite is met:

- The retaining chains are disassembled.

5.2.1 Removing the counterweight plates, fastening system: „Twistlock“

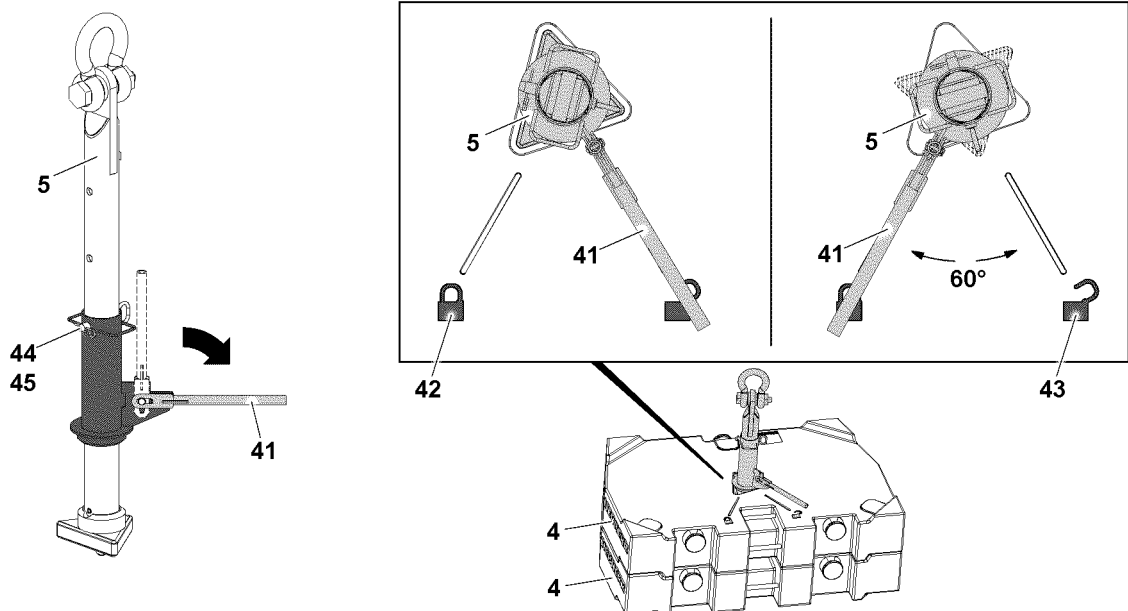

Fig.147033: Counterweight plates, fastening system: „Twistlock“

**WARNING**

Danger of accident!

If more than the permissible two counterweight plates are lifted with the receptacle stud, the receptacle stud will be overloaded and can be damaged.

Death, severe bodily injuries, property damage.

- ▶ Make sure that the counterweight plates are placed correctly in the centerings.
- ▶ Replace damaged counterweight plates.

**WARNING**

The Twistlock system opens by itself!

If the receptacle stud is not correctly locked, the Twistlock system can open by itself.

Counterweight plates can fall down.

Death, severe bodily injuries, property damage.

- ▶ Make sure, when initiating a lift, that the lever points directly to the „Locked“ icon.

**WARNING**

Damage of receptacle stud and counterweight plates!

If two counterweight plates are lifted which do not lay correctly in their centerings, the receptacle stud and the counterweight plates can be damaged!

Damage can cause the counterweight plates to fall down.

Death, severe bodily injuries, property damage.

- ▶ Make sure that the counterweight plates to be lifted are placed correctly in the centerings.

**Note**

- ▶ During a lift, the locked Twistlock system cannot release by itself due to its gravitational retention.
- ▶ During a lift, the locked Twistlock system cannot be released by hand due to its gravitational retention.

To remove the counterweight plate(s), use the receptacle stud **5**.

Before the receptacle stud **4** is guided into the counterweight plate(s) **4**, it must be ensured that the length of the receptacle stud is set correctly. The length of the receptacle stud **5** can be adjusted with the pin **44**.

If the length of the receptacle stud **5** is to be adjusted:

- ▶ Release and unpin the pin **44**.
- ▶ Adjust the length of the receptacle stud by moving the receptacle stud **5**.
- ▶ Insert the pin **44** and secure it with the retaining element **45**.
- ▶ Fasten the receptacle stud **5** to the auxiliary crane and guide it into the counterweight plate(s) **4**.
- ▶ Pull the lever **41** up and fold it down.
- ▶ Turn the lever **41** by 60° until the lever **41** points to the icon **42**.

Result:

- The receptacle stud **5** is locked with the counterweight plate(s) **4**.
- ▶ Lift the counterweight plate(s) **4** with the receptacle stud **5** and remove it from the counterweight stack.

When the counterweight plate(s) **4** are taken down:

- ▶ Turn the lever **41** by 60° until the lever **41** points to the icon **43**.

Result:

- The receptacle stud **5** is unlocked from the counterweight plate(s) **4**.
- ▶ Carefully pull the receptacle stud **5** out from the counterweight plate(s) **4**.
- ▶ Alternately remove the counterweight plate(s) **4** from both sides.

5.2 Removing the counterweight plates, fastening points: Bitt

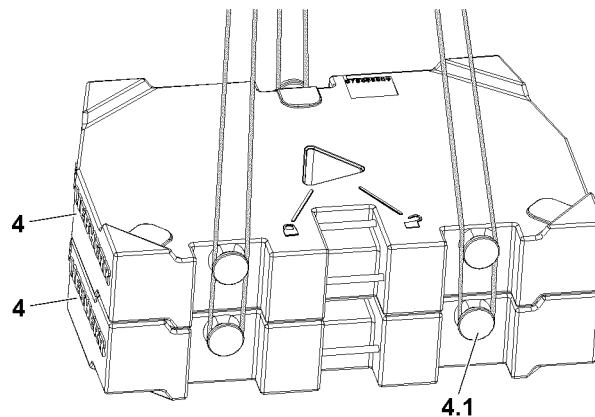

Fig.147034: Counterweight plates, fastening points: Bitt



WARNING

Falling counterweight plates!

If more than the permissible loads are lifted, then the bits **4.1** are overloaded and the counterweight plates can fall down.

Death, severe bodily injuries, property damage.

- ▶ Place the counterweight plates individually or as a package, maximum 20 t , 3 fastening points.
- ▶ Replace damaged counterweight plates immediately.



WARNING

Incorrect handling of the fastening equipment!

If fastening equipment cannot be attached correctly and if it is not secured sufficiently to prevent it from loosening up, loads can fall down.

Death, severe bodily injuries, property damage.

- ▶ Make sure that the fastening equipment is correctly attached on the bits **4.1** and that it is secured sufficiently to prevent it from loosening up.
- ▶ Lift the counterweight plate **4** or maximum two plates in an assembly and remove from the counterweight stack.
- ▶ Alternately remove the counterweight plate(s) **4** from both sides.

5.3 Disassembling the turntable extension on the turntable

Make sure that the following prerequisite is met:

- There are no counterweight plates in the turntable extension.

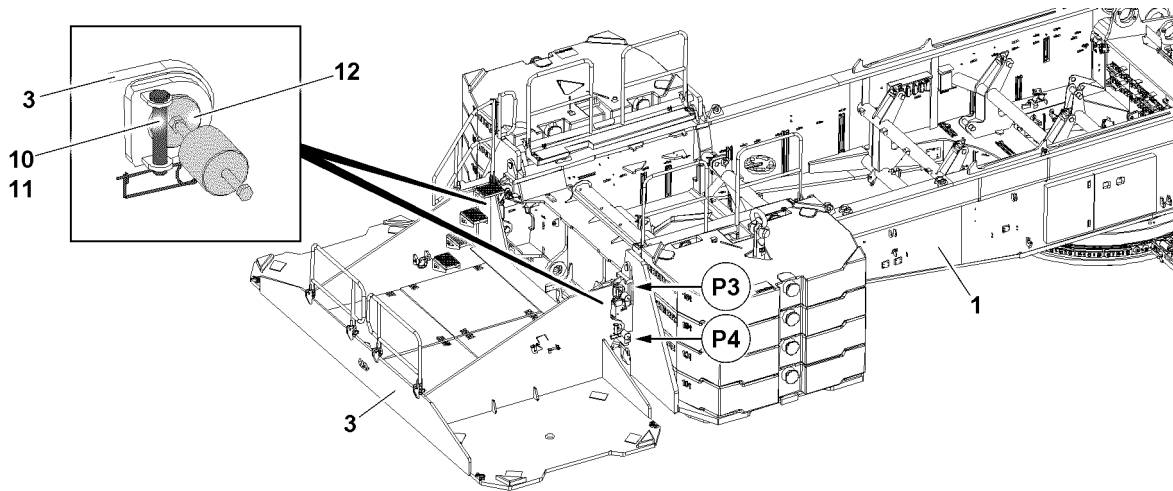

Fig.147031: Unpinning the turntable extension on the turntable

- ▶ Fasten the turntable extension **3** to the auxiliary crane, see section „Fastening points“.



WARNING

Tipping of the turntable extension!
Death, severe bodily injuries, property damage.

- ▶ Make sure that the fastening equipment has a sufficient length.
- ▶ Make sure that there are no persons within the danger zone when lifting the turntable extension.
- ▶ Make sure that the fastening equipment between the turntable extension and the auxiliary crane is tensioned before the turntable extension is unpinned on the turntable.

When the fastening equipment is tensioned properly on the turntable extension **3**:

- ▶ Remove the retaining element **11** on both sides at the pin points **P4** and unpin the retaining pins **10**.
- ▶ Unpin the lower connector pins **12** on the pin points **P4**.
- ▶ Remove the retaining element **11** on both sides at the pin points **P3** and unpin the retaining pins **10**.
- ▶ Unpin the upper connector pins **12** on the pin points **P3**.

When the pins are fully unpinned on both sides:

- ▶ Lift the turntable extension **3** with the auxiliary crane and swing out.
- ▶ Set the turntable extension **3** on a load bearing substructure or on a flatbed trailer.

When the turntable extension **3** is properly set on the substructure or on the flatbed trailer:

- ▶ Remove the fastening equipment and the auxiliary crane.
- ▶ Insert the pins **12** on the turntable extension **3** again at pin points **P3** and pin points **P4**. Secure the pins **12** with the retaining pin **10** and the retaining element **11**.

5.4 Bringing the railing on the turntable extension into the transport position



Note

- The turntable extension is located on the ground or on a substructure with load bearing capacity:
- ▶ Bring the railing into the transport position, see chapter 2.06.

4.08 Working with a load

1	Safety guidelines	3
2	Checks before starting to work with the crane	4
3	Crane movement - Telescoping	5
4	Taking on a load	7
5	Crane operation	13
6	Crane rope pretension	15

Fig.195219

LWE/LR 1600-2-008/18109-09-02/en

1 Safety guidelines

In addition, observe the general technical safety instructions in chapter 2.04.

In steep boom positions for which no loads are specified in the load charts, there is a danger of tipping to the rear to the counterweight side.

The danger of tipping to the rear exists especially in case of:

- Crane operation on tires
- Supported, with retracted sliding beams
- Reduced support base



WARNING

Crane operation in steep boom positions for which no loads are specified in the load charts!

The crane can tip to the rear and fatally injure personnel.

- ▶ Comply with the boom radius specified in the load chart.
- ▶ Crane operation outside the permissible set up configurations, boom radii and slewing ranges according to the load chart is prohibited.



WARNING

Incorrect reeving number set up!

If the reeving number on the pulley head is less than the reeving number set on the LICCON computer system, it can result in an overload of the hoist rope.

The hoist rope can rip. The load can fall down and fatally injure personnel.

- ▶ Comply with the reeving numbers specified in the load chart for maximum loads.
- ▶ Make sure that the reeving on the pulley head and the reeving set on the LICCON computer system match.

The minimum rope coils must remain on the rope winches. The number of minimum rope coils depends on if the rope winch is equipped with a cam limit switch or a winch speed sensor.



WARNING

Minimum rope coils fallen below!

The rope will be ripped out. The load falls down.

Personnel can be killed.

- ▶ Make sure that the minimum rope coils remain on the rope winch.
- ▶ Observe and comply with the number of the minimum rope coils in chapter 5.01.



WARNING

Lift the load by luffing up!

The crane can topple over and fatally injure personnel.

- ▶ Lift the load with the hoist gear.

Always comply with the maximum loads specified in the load chart.

The weight of the hook block according the load chart must be taken into account. Subtract the weight of the hook block from the load chart value. The minimum hook block weight must be determined according to the reeving number and the data in the load charts.

For the lift, use the hook block which is suited best for the existing set up configuration in connection with the load chart.

Initiate all crane movements carefully. Also slow down the crane movements carefully. That way you can avoid a swinging or pendulum motion in the suspended load.

2 Checks before starting to work with the crane

Before starting work with the crane, the crane operator must carry out a further inspection to satisfy himself about the crane's operational safety:

- Check that the crane is properly supported and level.
- Check that the set up configuration set in the control matches the actual set up configuration.
- Check that all values in the load chart that apply to the current equipment configuration have been entered and met.
- Ensure that there are no people or objects within the danger zone of the crane.



WARNING

Persons in the slewing range!
Crushing danger, death, severe bodily injuries.

- ▶ Monitor the slewing range.
- ▶ Make sure that there are **no** persons within the slewing range.
- ▶ Block off the slewing range if necessary.



WARNING

Obstacle in the slewing range!
Property damage on crane and on obstacle.

- ▶ Make sure that there are **no** obstacles within the turning range of the crane and the crane components.

2.1 Visual check for damage



WARNING

Danger of accident!

If the crane is operated despite existing defects, personnel can be severely injured or killed.

- ▶ In the event of deficiencies which threaten operational safety, stop crane operation immediately.

The following deficiencies threaten the crane's operational safety:

- Damage to load-bearing parts of the crane design, such as booms, supports etc.
- Failure of the hoist gear brake and consequent slipping of the load
- Functional failures in the crane control system
- Functional defects in the indicator and warning lights
- Damage to the hoist ropes
- Safety defects in the safety equipment
- Leaks on safety relevant components of the crane hydraulic

Inform the appropriate supervisor about the deficiencies on the crane and also inform your relief when crane operators are changed.

2.2 Telescopic boom distortion because of sunshine on one side

A temperature difference occurs between the side facing the sun and the side facing away from the sun for cranes with telescopic booms. This causes telescopic boom side distortion, which can reduce the load bearing capacity of the telescopic boom.

For example, a temperature difference between the two boom sides of 30 °C and a boom length of 60 m results in a length difference caused by the temperature difference between the two sides of the telescopic boom of approximately 22 mm. With narrow boom parts, this causes the profiles to bend sideways.

If the maximum load is being utilized when a telescopic boom extension such as a fixed lattice jib, luffing lattice jib or folding jib is being used, then it must be ensured through a visual inspection before picking up the load that the boom is not showing signs of side deformation due to one-sided sun exposure.

**WARNING**

Danger of accident due to component overload!

If the telescopic boom has become distorted because of one-sided sunlight, this can cause component overload and therefore accidents.

- ▶ Turn the crane so that both sides of the boom are heated up equally, eliminating side deformation due to temperature difference.

3 Crane movement - Telescoping

If the telescopic boom is telescoped with the jib boom or telescopic boom extension, before the telescoping procedure, ensure that:

- The crane is properly supported and horizontally aligned.
- The telescopic boom is evenly warmed up by solar radiation.
- There is no strong side wind.

**WARNING**

Damage to the telescopic boom or the hoist rope!

If these 3 factors are not adhered to, damage of the telescopic boom or the hoist rope can occur and lead to accidents.

- ▶ Support the crane properly and align it horizontally.
- ▶ Keep both sides of the boom at about the same temperature.
- ▶ Telescope only to the permissible wind speed according to the load chart.
- ▶ If the actual wind speed is higher than the permissible wind speed noted on the load chart, telescoping is prohibited.

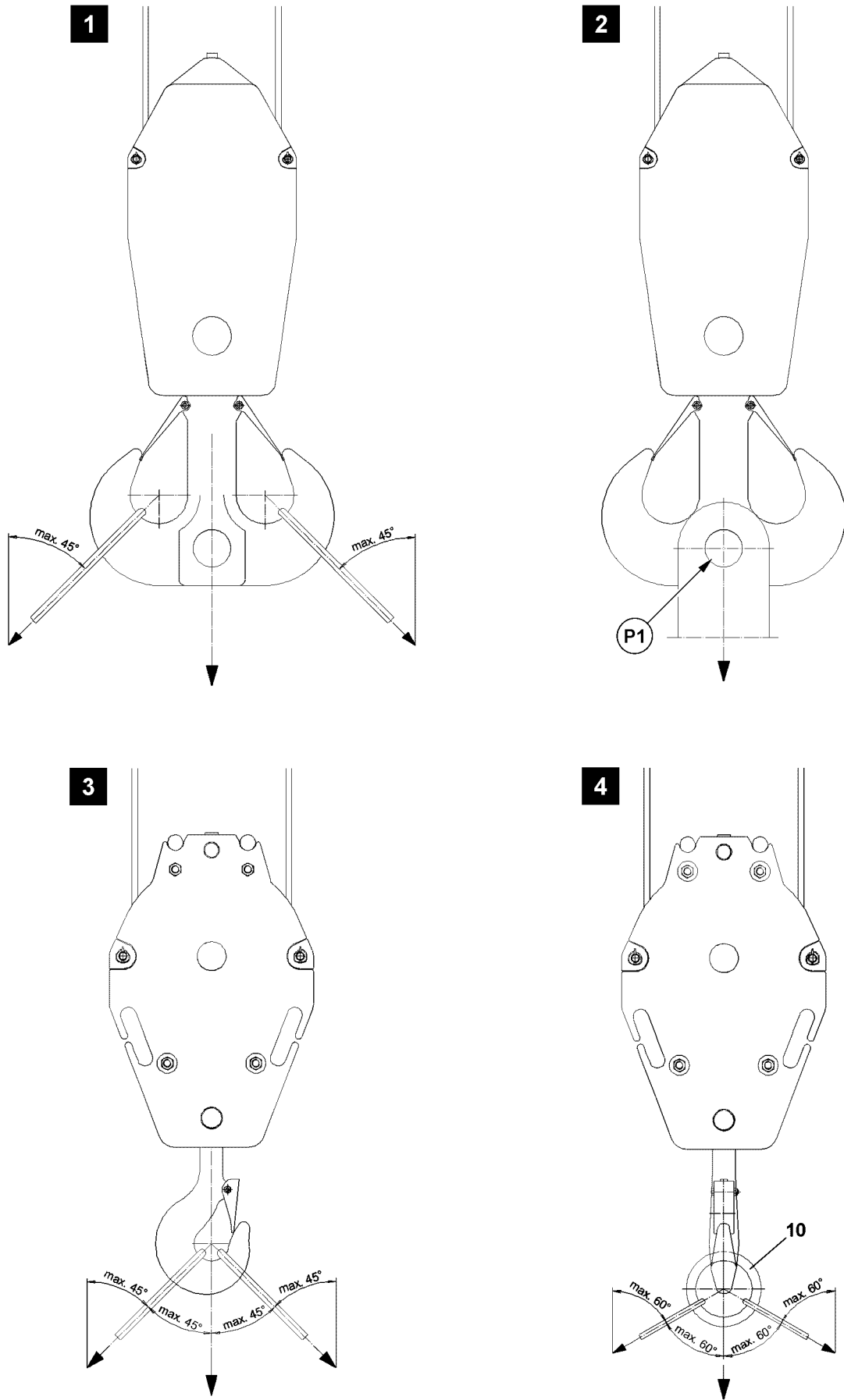

Fig.121650

LWE/LR 1600-2-008/18109-09-02/en

4 Taking on a load

The crane must always be operated in such a way that its load-bearing parts are not destroyed or damaged and its stability is ensured.

Make sure that the following prerequisites are met:

- The crane is supported and horizontally aligned.
- The LICCON overload protection has been set according to the load chart and the set up configuration.
- The LICCON overload protection is active.
- In the case of cranes with central ballast: The central ballast is installed according to the load chart.
- The counterweight is installed according to the load chart.
- In the case of cranes with derrick ballast: The derrick ballast is installed according to the load chart.
- The hook block or the load hook is correctly reeved.

4.1 Fastening the load



WARNING

Load can be ripped off!

If impermissible fastening and / or load handling equipment is used when taking on a load on the centric bore on the double hook at point **P1** (illustration 2), then the double hook as well as the hook block can be damaged.

The load can rip off and fall down.

Personnel can be severely injured or killed.

- ▶ Lift the load via the centric bore on the double hook (point **P1**): For the technical requirements and the technical design of the fastening and / or load handling equipment contact the hook block manufacturer.



WARNING

The crane can topple over!

If the following conditions are not met, the crane can topple over.

Personnel can be severely injured or killed.

This could result in high property damage.

- ▶ Pay attention to the own weight of the load handling equipment.
- ▶ Pay attention to the load bearing capacity of the load handling equipment!
- ▶ The maximum permissible incline of the strands fastened on the single or double hook in the hook jaws is 45°. See illustration 1 and illustration 3.

If necessary for the single hook:

- ▶ Use fastening equipment with a suspension link **10**. The maximum permissible incline in this case is 60°. See illustration 4.
- ▶ Load a single and double hook symmetrically. A maximum deviation of $\pm 3^\circ$ from the direction of the center of gravity is permissible.

If necessary:

- ▶ Use cross beam or two cranes for taking on the load.

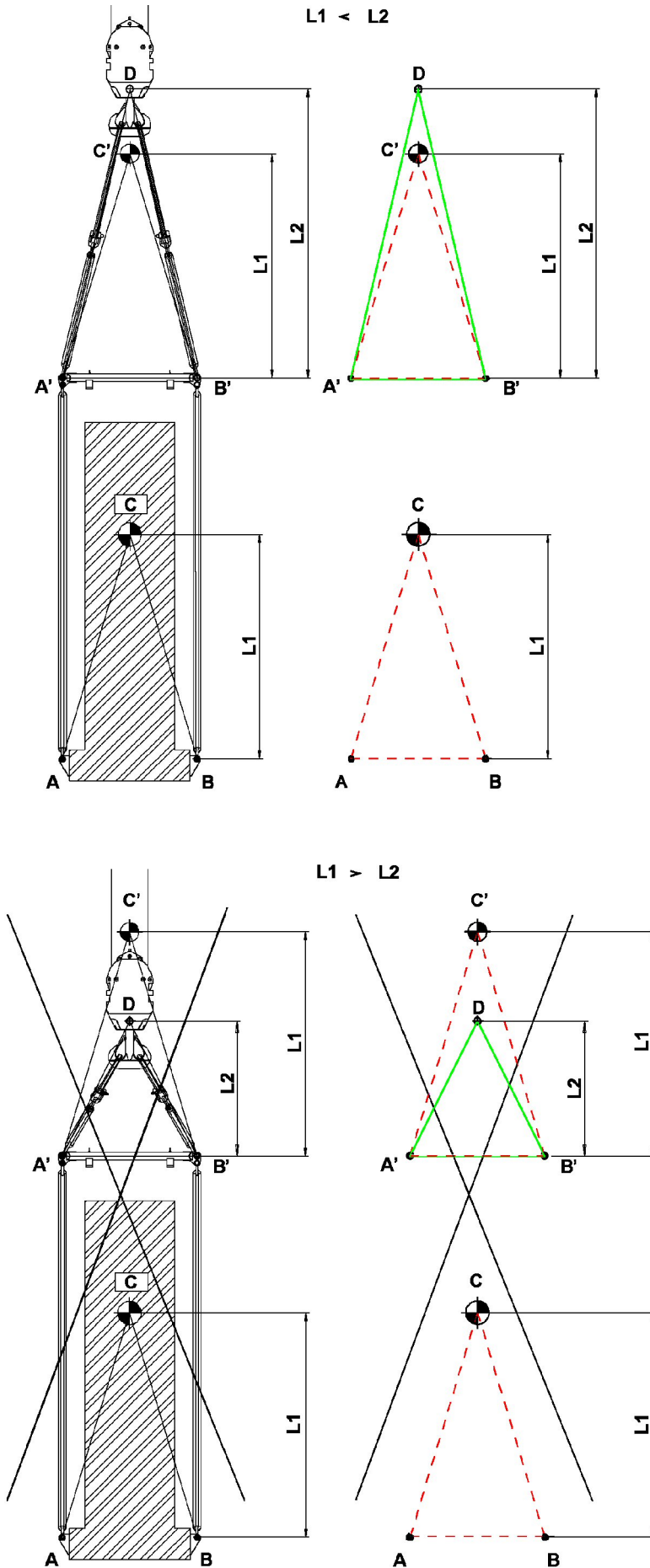

Fig.116274

LWE/LR 1600-2-008/18109-09-02/en

4.2 Taking on a load with cross beam

Cross beam are load handling equipment between crane hook and load.

The distance of the center of gravity **L1** is the vertical dimension from the fastening point of the load to the center of gravity of the load.

The cross beam height **L2** is the vertical dimension from the point of rotation of the crane hook to the next lower linkage point of the cross bar.



WARNING

Tipping of load to the side!

If fastening ropes are used which are too short, so that the load center of gravity is above the fastening point, then there is a danger of the load tipping to the side.

Personnel can be severely injured or killed.

- ▶ The load center of gravity must be below the crane hook.
- ▶ The distance of the center of gravity **L1** must be smaller than the cross beam height **L2** ($L1 < L2$).
- ▶ The triangle **A'B'C'** must be within the triangle **A'B'D**.

4.3 Transporting the hook block



WARNING

Danger of accident!

If a hook block is fastened incorrectly for transport, personnel can be injured.

- ▶ Fasten the hook block for transport on the fixed point in the center.
- ▶ Fastening the complete hook block on the auxiliary weights is prohibited.
- ▶ When setting down, secure the hook block against falling over.
- ▶ Prevent the load hook from rolling away.

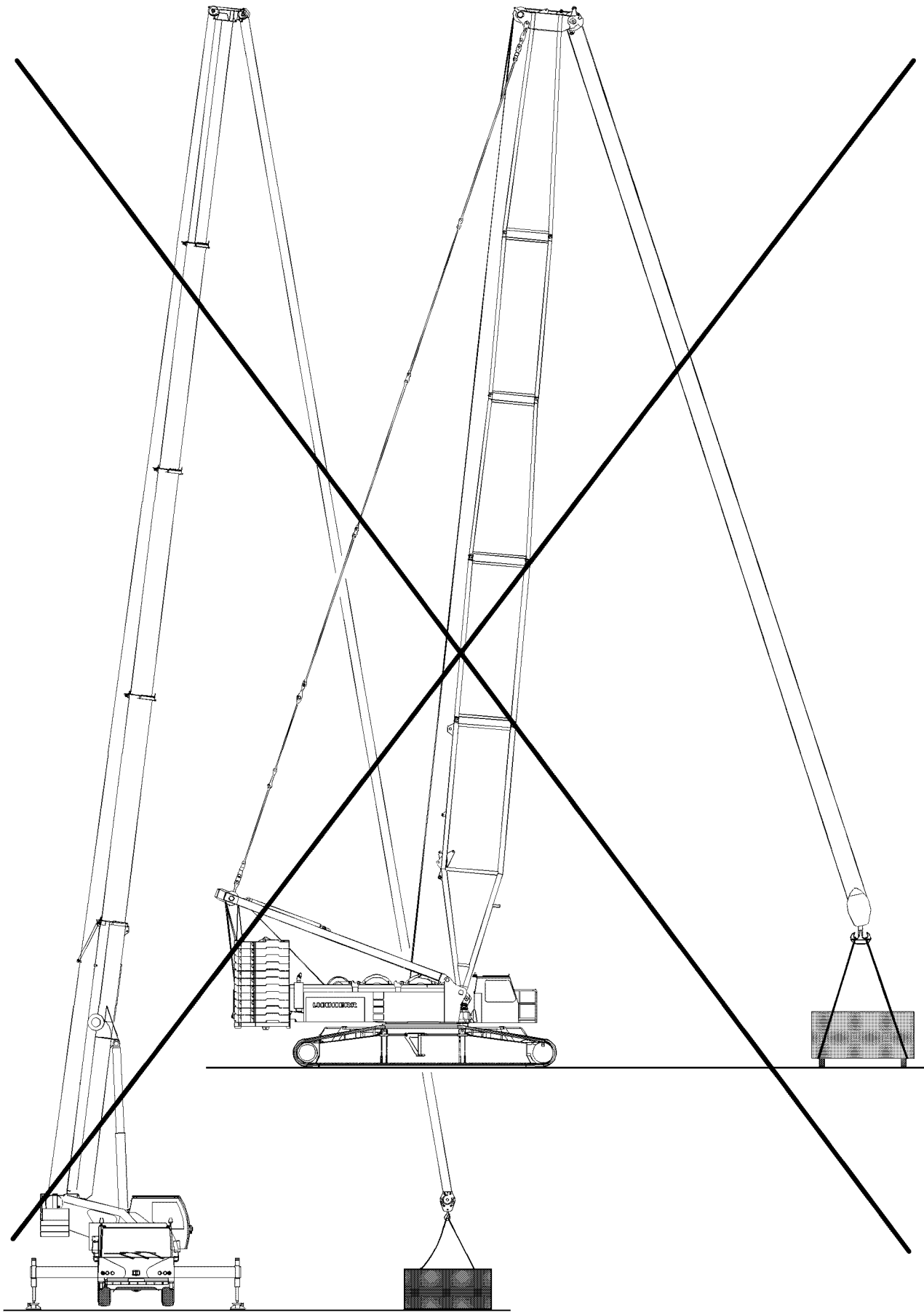

Fig.102716

LWE/LR 1600-2-008/18109-09-02/en

4.4 Lifting the load



WARNING

Danger of crushing for people in the load zone!

If personnel is located between the load to be lifted and a possible interfering edge (such as a wall of a building or similar) when the load is lifted, personnel can be severely injured or killed.

- ▶ Before lifting the load it must be ensured that there are no persons within the danger zone.
- ▶ It is prohibited to remain in the danger zone.
- ▶ It is prohibited for anyone to be under the load. Maintain a safe distance.
- ▶ Swinging the load is prohibited.
- ▶ Exercise extreme caution when lifting a load.



WARNING

The crane can topple over!

If an attempt to lift a load over the hoist gear causes the LICCON overload protection to turn off, then the load may not be lifted by luffing up the boom. This causes overload or toppling the crane. Personnel can be severely injured or killed.

- ▶ Do not lift the load by luffing up the boom off the ground.



Note

When using the assembly winch* observe the following:

- ▶ Use the assembly winch* only for assembly and not for lifting loads.
- ▶ Lifting of loads with the auxiliary winch is prohibited.

If the fastening rope is manually attached by an assistant to the load to be lifted:

- Make sure that the assistant's hands are not crushed by the tightened ropes between the load and the fastening rope.
- Make sure that the assistant's body parts (hands, legs etc.) are not crushed by a swaying movement of the load during lifting.

4.5 Angular pulling



WARNING

The crane can topple over!

Angular pulling can destroy the crane or cause it to topple over.

Personnel can be severely injured or killed.

- ▶ Fasten (hang) the hook block always vertically over the center of gravity of the load to be lifted.
- ▶ Do not use the slewing gear to pull and set up loads.
- ▶ When lifting, compensate for boom deflection.
- ▶ Angular pull is prohibited.

The crane is designed only to lift loads vertically. During angular pulling, regardless of whether this is done in the same direction as the boom or laterally, horizontal forces are generated from the load in addition to the vertical forces, for which the boom is not designed.

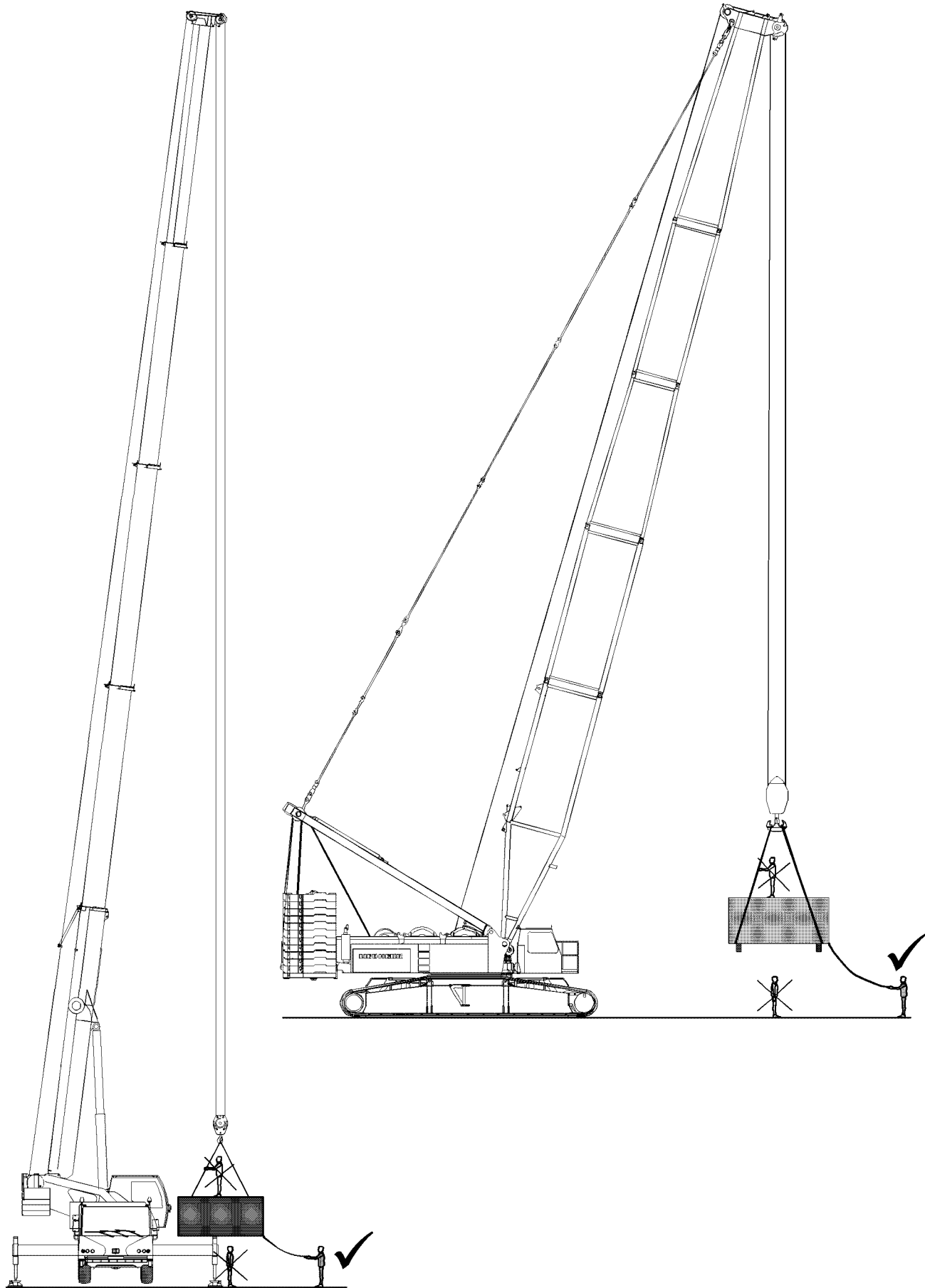

Fig.102717

LWE/LR 1600-2-008/18109-09-02/en

4.6 Breaking away fixed loads



WARNING

The crane can topple over!

Ripping stuck loads free can destroy the crane or cause it to topple over.

Personnel can be severely injured or killed.

- ▶ Ripping stuck loads free is prohibited.

5 Crane operation

The maximum load capacity of the crane is not just limited by the stability, but in many cases a load-bearing component breaks when the crane is overloaded **before** the crane topples over. Components that are susceptible to buckling such as the telescopic boom may fail suddenly **without showing signs of distortion beforehand** if the crane is overloaded.



WARNING

Danger of accidents for cranes with luffing cylinders!

When the luffing cylinder is on block position, the overload protection is not functioning.

- ▶ Crane operation at block position of luffing cylinders is prohibited.

5.1 General

A suspended load must always be kept under control. A fundamental requirement for this is the safe and delicate control of the crane's functions.



WARNING

Danger of accident due to swaying loads!

A swaying load can damage the crane and cause it to topple.

- ▶ All crane movements must be executed slowly and delicately.
- ▶ Initiate all crane movements slowly.
- ▶ Apply the brakes slowly in all crane movements.
- ▶ Crane operation with swaying load is prohibited.

NOTICE

Damage of rope pulleys!

- ▶ Place down hook blocks, booms, folding jibs, jib booms and boom noses in such a way that the rope pulleys do not lie on the ground and are damaged.

5.2 Guiding the load

The use of guide ropes is recommended to help the crane operator manage the load more precisely and to prevent the load from swaying. This will prevent undesirable movements of the load and consequent damage.

5.3 Danger of crushing



WARNING

Danger of fatal injury!

Extreme care is needed when lowering a load. Danger of fatal injury exists for personnel in the immediate area of the load being lowered.

Personnel can be severely injured or killed.

- ▶ Standing under a suspended loads is strictly prohibited.
- ▶ Observe the danger of tipping when setting down the load. For example, small support surfaces or unsuitable ground.

5.4 Danger of falling



WARNING

Danger of fatal injury!

If persons are on the suspended load, then they can fall down and be severely injured or killed.

- ▶ Remaining on a suspended load is strictly prohibited.
- ▶ Remaining on or within crane components (for example: At assembly of boom sections, lattice sections) which are moved during lifting, lowering, turning or closing procedures is strictly prohibited.

5.5 Working in the vicinity of electricity transmission lines

If there are electricity transmission lines in the immediate vicinity of the building site, then the electrical transmission lines must be turned off by qualified electricians. If this is not possible, the danger area must be covered over or cordoned off.



WARNING

Danger of current transfer!

If electricity transmission lines are not shut off nor covered nor blocked off, then there is an increased danger of accident due to current transfer.

- ▶ For rated voltages to 500 kV AC: Adhere to a safety distance of 8 m.

If the crane becomes electrified despite having taken all necessary precautions, proceed as follows:

- ▶ Remain calm!
- ▶ Do not leave the crane cab.
- ▶ Warn people outside: Stay in place and do not touch the crane.
- ▶ Move the crane away from the danger zone.

5.6 Ram work or pulling sheet piles

Vibration can be transmitted to the supporting steel structure of the crane during ram work or when pulling sheet piles with the crane. This vibration can cause premature fatigue of the material and therefore cracks in the supporting steel structure.



DANGER

Important instructions for „ram work“ or „pulling sheet piles“.

If the crane is used for ram work or pulling sheet piles, then the following instructions must be followed. Failure to follow the instructions can result in damage to the crane.

- ▶ The ramming equipment may not pass on vibrations into the boom.
- ▶ When pulling sheet piles, the maximum pull force of the crane is limited according to the load chart. Restricting the maximum pull force via the crane overload protection **only** is prohibited. The pull force must be additionally checked by measuring.

6 Crane rope pretension

Damage that can occur with multi layer spooling:

- Friction
- Broken wires and loop formation
- Flattenings, deformations

NOTICE

Crane rope pretension too low!

Loosely coiled rope layers.

Rope damage. Reduced service life of the crane rope.

Cutting of the crane rope into the lower rope layers. The load can not be lowered any further.

- ▶ To maximize the service life of the crane rope, carry out the measures in the following sections.
-



Note

- ▶ Liebherr recommends to shorten crane ropes with damage in the cross over area of the coils, in order to lengthen the service life. Shortening the crane rope, see Crane operating instructions, chapter 7.05.50.
-

6.1 Working with a high rope pull

If multiple lifts are performed with a high rope pull, loosen the lower rope layers that are rarely or never spooled out.

NOTICE

Loosely spooled out rope layers!

Rope damage.

Upper rope layers with a high rope pull deform the lower rope layers in the cross over area of the crane rope.

Spooling deformed rope sections over rope pulleys reduces the service life of the crane rope.

- ▶ Place a shorter crane rope.

When the lower rope layers are **not** used during repeat work:

- ▶ Increase the pretension of the lower rope layers: Spool out the entire rope length and then spool back up with the highest rope pull possible. See section „Increasing the hoist rope pretension“.
-

6.1.1 Placing a shorter crane rope



Note

- ▶ Liebherr recommends using the entire rope length.
-

Unused rope sections cause the loosening of the lower rope layers.

When only a part of the crane rope length is used for a longer period of time:

- ▶ Place a shorter crane rope.

6.1.2 Reducing rope unwinding

Telescopic boom

When telescoping out less, then the smallest amount of fixed coiled up crane rope is spooled out.

- ▶ Telescope out as little as possible.

Picking up the fastening equipment

If the fastening equipment with a flat boom system must be picked up, then the smallest possible amount of crane rope is spooled up loose.

- ▶ Establish a flat boom system: Telescope out or luff up the boom.
- ▶ Pick up the fastening equipment.

6.1.3 Restoring hoist rope pretension

Brief description

If a multi-pulley hook block is reeved, then the entire hoist rope length can be spooled out from the rope drum.

- ▶ Spool the hoist rope out until three safety coils.
- ▶ Create 10 % maximum strand pull: Attach the load.

While the hoist rope is spooled up:

- Hold the load just off the ground.
 - In the permissible range of the load chart of the relevant set up configuration: Increase the load radius by luffing down.
- ▶ Spool the hoist rope up.

Description using the example LR 1600-2, SL3F

This section explains the procedure with the help of the set up configuration for LR 1600-2 with boom system SL3F.

The crane-specific parameters ensure that rope is spooled out until four rope coils and as many rope coils with pretension as possible can be spooled up.

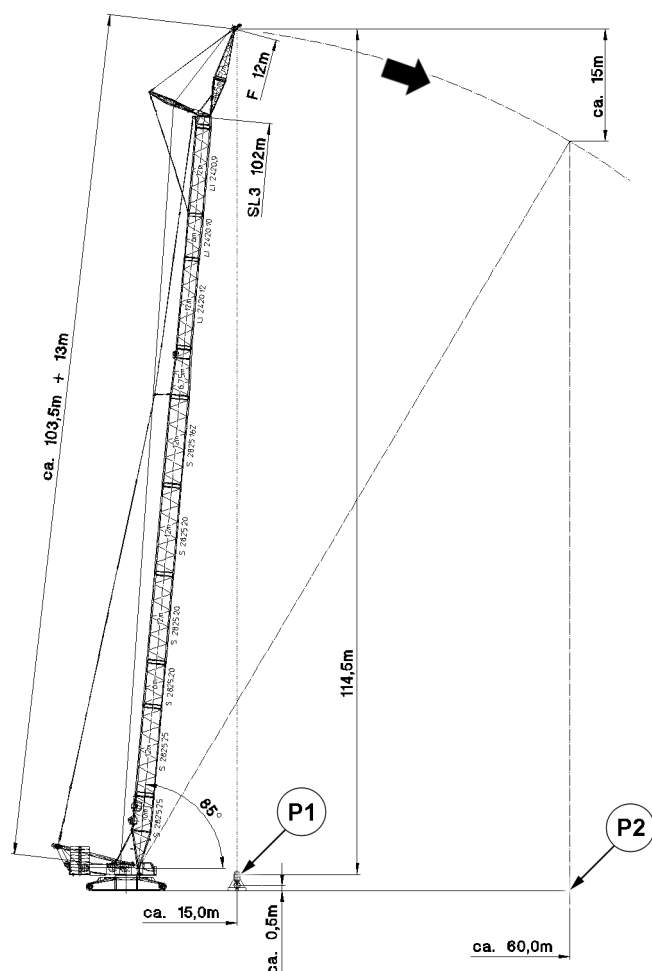

Fig.127131: LR 1600-2, SL3F: Spooling up hoist rope with pretension

Boom radius	Load	10 % of maximum strand pull
60 m	14.4 t	1.8 t

Load example: LR 1600-2, SL3 102, F12, according to the load charts

Hoist rope for this example:

- Hoist rope with a length of 1050 m

Hook block for this example:

- Hook block 200 DM, 5-pulley, reeved 8 times
- The weight of the hook block with ten auxiliary weights is 7.0 t

To reach sufficient rope pull, another load must be hung in addition to the hook block.

Make sure that the following prerequisites are met when hanging the load:

- Load is hung as short as possible.
- For a boom radius of 15.0 m, the hoist rope can be spooled out on the winch until four coils.
- The load is suspended over the ground.

- ▶ Pick up the load with 7.4 t.
- ▶ Set the boom system to boom radius 15.0 m.
- ▶ Spool the hoist rope out.

Result:

- In position **P1** there are 9 m of hoist rope (four coils) on the hoist winch:

Spoiled out rope section	Length
8-way reeving, distance of ground to the F-jib with boom radius 15 m	8 x 114,5 m = 916,0 m
Winch to FA-frame	103.5 m
F-head	13.0 m
Rope pulleys	7.5 m
Total of spoiled out hoist rope	1040.0 m

Rope lengths in position P1

While the hoist rope is spooled up:

- Hold the load just off the ground.
- In the permissible range of the load chart of the relevant set up configuration: Increase the load radius by luffing down.
- ▶ Spool up the hoist rope and luff down the boom at the same time until boom radius 60.0 m is reached.
- ▶ Set down the load.

Result:

- The pretension of the first and second position of the rope coils is restored.
- In position **P2** there are 130 m of hoist rope (23 coils) on the hoist winch:

Spoiled up rope section	Length
Four coils initial situation	9 m
8-way reeving, F-jib height difference with boom radius 60 m	8 x 15 m = 120 m
Total of spoiled up hoist rope	130 m

Rope lengths in position P2

- ▶ Make sure that the hoist rope on the winch remains pretensioned: Reeve out the hook block and reeve in with slower reeving. See Reeving plan.

6.2 Picking up and lowering overhead loads

The load is picked up overhead in the following application examples:

- Repowering wind power plants
- Disassembly of slewing tower cranes

NOTICE

Load picked up overhead with loosely coiled rope layers!

The rope pull increases when the load is picked up. The rope coils in the lower rope layers move laterally and are compressed. The hoist rope can cut into the lower rope layers.

- ▶ Spool up the hoist rope without a load only with rope pretension.
-

NOTICE

Load lowered with cut in rope layers!

The hoist rope is pulled jerkily from the lower rope layers. Vibrations are introduced into the crane system.

Cut in hoist rope clamped between the lower rope layers. The load can **not** be lowered any further.

- ▶ To prevent the cutting in of the hoist rope, carry out the measures in the following sections.
-

6.2.1 Increasing the reeving number

NOTICE

Higher reeving number than indicated on the load chart!

Slack rope formation.

The crane load drops due to additional weight from the rope strands and hook block.

If a higher reeving number is not considered in the set up configuration, the load display on the LIC-CON monitor no longer corresponds.

- ▶ Redetermine the hook block weight according to the load chart manual and adjust if necessary.
 - ▶ Check if the crane load is sufficient for higher reeving.
 - ▶ After telescoping out, check if the hook block can still reach the desired position for putting down the load.
-

A higher reeving number reduces the rope pull. A lower rope pull prevents the cutting in of the hoist rope in the lower rope layers.

- ▶ Select the highest reeving number possible for the hoist rope.

6.2.2 Increasing the hook block weight

NOTICE

Lift the hook block without a load!

The hoist rope is spooled up with a low rope pull. The rope layers are spooled up loose on the rope pulley.

- ▶ Increase the rope pull: Increase the hook block weight.
-

A higher hook block weight increases the rope pull.

- ▶ Increase the hook block weight.

If the crane load is sufficient:

- ▶ Attach an auxiliary weight between the load and hook block.

6.2.3 Pretensioning the hoist rope with pretensioning ballast with two hook operation

The pretensioning ballast is **not** included in the Liebherr scope of delivery.

NOTICE

Lift the hook block without a load!

The hoist rope is spooled up with a low rope pull. The rope layers are spooled up loose on the rope drum.

- ▶ Pretension the hoist rope with pretensioning ballast with two hook operation.
-

Make sure that the following prerequisites are met:

- The crane is equipped for two hook operation.
- The pretensioning ballast is present.

Properties of the pretensioning ballast:

- Developed by Liebherr.
- The weight is 4 t.
- Special tow coupling

- ▶ Fasten the pretensioning ballast on the main hook and on the auxiliary hook.

The pretensioning ballast is lifted with the main hook, the auxiliary hook is carried along without a load.

- ▶ Lift the pretensioning ballast.

When the main hook has reached the required height:

- ▶ Stop the main hook.

After the load is completely transferred to the auxiliary hook, the main hook fastening ropes release automatically.

- ▶ Lift the auxiliary hook until the pretensioning ballast hangs completely on the auxiliary hook.

When the main hook fastening ropes have released:

- ▶ Lower the pretensioning ballast with the auxiliary hook and place it on the ground.

Result:

- The full load is present on the main hook.

Empty page!

LWE/LR 1600-2-008/18109-09-02/en

4.10 Driving from the crane operator's cab

1	Prerequisites for driving / moving crawler cranes (crawler operation)	3
2	Driving with a load and / or Derrick ballast	8
3	Driving without a load and without derrick ballast	9
4	Driving uphill / downhill	11
5	Driving the crawler crane	21

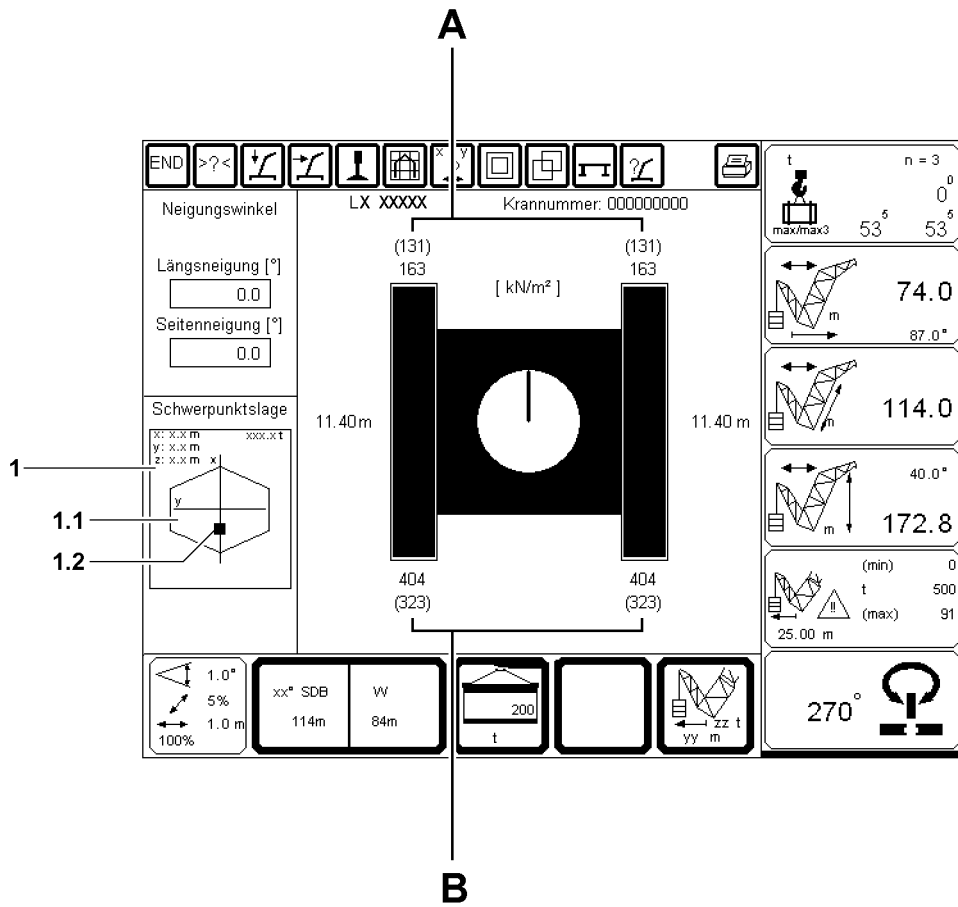

Fig.109839

LWE/LR 1600-2-008/18109-09-02/en

1 Prerequisites for driving / moving crawler cranes (crawler operation)



WARNING

The crane can topple over!

If the following instructions are not observed, the crane can topple over.

Personnel can be severely injured or killed.

- ▶ Before moving the crane with the attachment, the optimum boom position must be determined with the aid of the job planner, to obtain as even a surface pressure on the crawler track as possible.
- ▶ The maximum permissible wind speed from the load chart is not exceeded.



WARNING

Crane with narrow crawler track!

- ▶ When moving cranes with narrow crawler track (example: LR1600/2-W) and respective equipment, in addition to the „prerequisites for driving the crane“, the special travel charts and danger notes must be observed and adhered to, see „Moving the crane with equipment in place“.



WARNING

The crane can topple over!

If the turntable is not parallel to the crawler track when driving the crane, the crawler crane can topple over.

- ▶ For downhill gradients of more than 0.3° , make sure that the turntable is aligned parallel to the crawler track in 0° or 180° position before moving the crawler crane!



WARNING

The crane can topple over!

If the following specifications, instructions and prerequisites are not observed, then the crane can topple over or be overloaded.

Personnel can be severely injured or killed.

- ▶ The crane operator is responsible for adhering to all specifications, instructions and prerequisites in the crane documentation.
- ▶ The crane operator may not drive the crane if not all specifications, instructions and prerequisites in the crane documentation can be adhered to.
- ▶ The crane operator is responsible for the correct and complete data entry into the LICCON computer system and into the LICCON job planner, if applicable.
- ▶ All acceleration and delay maneuvers must be initiated with extreme caution and at the least possible speed.
- ▶ Depending on the situation, additional observers, who are acoustically or visually connected with the crane operator (for example by radio or sight), may have to support the crane operator with shared responsibility.



WARNING

Combined crane movements at crawler operation!

- ▶ In crawler operation, do not carry out any additional crane movements.
- ▶ Carry out additional crane movements while the crane is at a standstill, if possible.

Make sure that the following prerequisites are met:

- No personnel or objects are within the danger zone.
- The crane is in operational condition.
- The crane is in a set up configuration permitted for travel operation.
- Installed ballast (central ballast, counterweight and derrick ballast) is locked and secured.
- There are no loose objects on the crane.

1.1 Travel route



WARNING

The crane can topple over!

If the following specifications, instructions and prerequisites are not observed, then the crane can topple over or be overloaded.

Personnel can be severely injured or killed.

- ▶ The transfer from the horizontal into an uphill slope and from the uphill slope into the horizontal must be made evenly, i.e.: There may be no edges which can cause the crane to topple over. Any incline changes must be made continuously.
- ▶ If the travel route cannot safely take on the surface pressure, then measures must be taken to be able to safely induce the forces into the ground.
- ▶ If measures were taken to induce the forces into the ground, then they must be checked by an expert before starting to drive for proper execution and sufficient supportability.
- ▶ An insufficient ground condition can cause accidents, for example the crane can slide away to the side and as a result get into an impermissible incline position.

Make sure that the following prerequisites are met:

- Before starting to drive, the travel route was determined.
- Before starting to drive, the condition of the ground has been checked.
- The entire travel route can safely absorb the surface pressure.
- All inclines occurring on the travel route can be driven safely by the crane.
- The entire travel route is free of obstacles.
- The friction coefficient between crawler track and ground is sufficiently large to absorb the occurring drive forces or to eliminate the crane from slipping away in an incline position.
- Possible environmental influences while driving the crane (among others precipitation and wind) were taken into account for the travel route.
- The travel route was selected and prepared in such a way that the boom system can be taken down at any time.
- Select the travel route in such a way that no steering movements are required, if possible.
- With load on the hook: Setting down the load is possible at any time.
- The entire travel route is secured as a danger zone.
- The travel route has been selected in such a way that a sufficient distance to local facilities (among others power lines) can be retained.

For falling terrain gradients outside the range of a valid load chart, the following applies additionally:

- Before starting to drive, the travel route was checked in connection with the actual set up configuration of the crane on the LICCON job planner.
- Before starting to drive, the optimum positions for the boom system were determined to obtain as even a surface pressure as possible - the LICCON job planner can be used for this purpose.



Note

- ▶ For a detailed description of the LICCON job planner on the crane, see the operating instructions LICCON job planner.
- ▶ For a detailed description of the computer program LICCON job planner, see separate description.

1.1.1 Optimizing measures for travel route

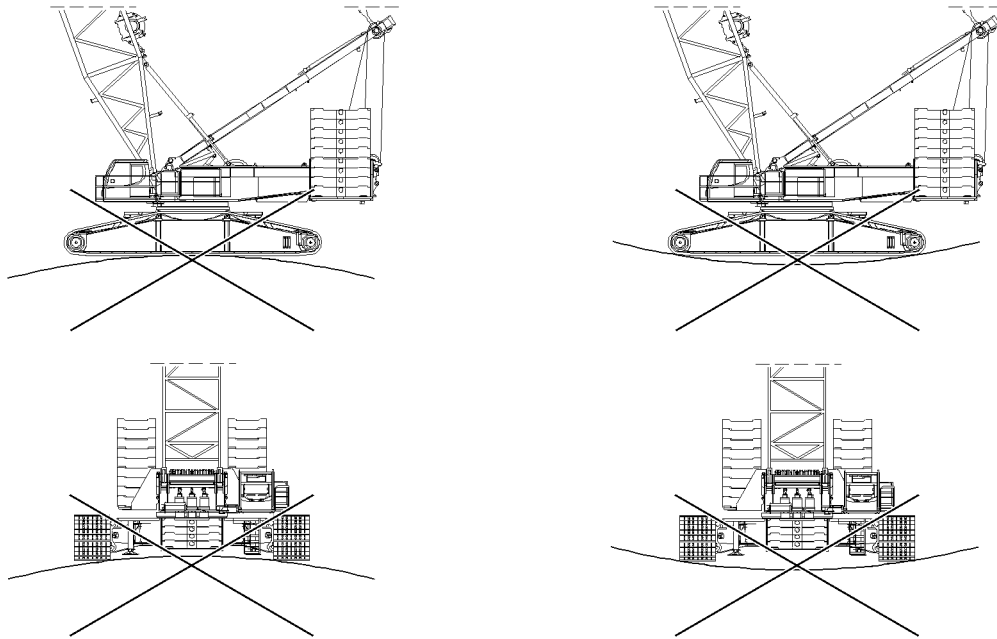

Fig.119598: Depressions, crests, track grooves and other uneven areas of the travel route cause punctiform strain to the track.

NOTICE

Damage to the track!

Continuous punctiform strain to the track causes increased wear.

Continuous increased wear can cause damage to the track.

- ▶ Set up the travel routes in such a way that the track is not subjected to continuous punctiform strain.
- ▶ For extended travel operation shorten the maintenance intervals.

Through the following configuration features of the travel route, wear on the track can be minimized:

- Shapings of the travel route (such as depressions, crests, track grooves) have been eliminated via suitable measures.
- Lay out the travel route in such a way that no steering movements are required, if possible.

1.2 Travel gears / hydraulic motors / track rollers

NOTICE

Damage to the travel gear, hydraulic motors and track rollers!

On longer travel routes and / or when driving uphill / downhill, the travel gears, hydraulic motors and / or track rollers can be overheated and damaged.

- ▶ Make sure that the travel gears - before driving the crane - are on maximum fill level.
- ▶ With suitable measuring devices make sure that the maximum permissible temperature of the travel gears, hydraulic motors and / or track rollers in travel operation over longer distances is below 90 °C. For a short time (**maximum** 10 minutes), the temperature may increase to a value between 90 °C and 100 °C.
- ▶ As soon as the maximum permissible temperature on one position is exceeded, take a break for cooling off.
- ▶ The crane operator is responsible for any damage on travel gears, hydraulic motors and / or track rollers.

When the maximum permissible temperature range on a travel gear and / or hydraulic motor is reached:

- ▶ Take a break until the temperature on travel gear(s), hydraulic motor(s) and / or track rollers had dropped considerably.

Maximum permissible temperature range on travel gear(s) / hydraulic motor(s)		
	To 90 °C	between 90 °C and 100 °C
Duration of exposure	continuous	not longer than 10 minutes

When the temperature has dropped on all travel gears / hydraulic motors under 90 °C:

- ▶ Travel operation is permissible again.

1.3 Center of gravity display



WARNING

Shifting of center of gravity!

The calculation of the values for the display of the center of gravity in the job planner are based on ideal assumptions.

- ▶ Side deformations of the boom system due to wind, inclined position and elastic resilience of the steel structure are not taken into account but they can lead to a shifting of the center of gravity.

Position	Description
1	Center of gravity display
1.1	Core surface
1.2	Center of gravity



WARNING

Center of gravity of the crane is outside the core area!

If the center of gravity **1.2** of the crane is outside the core area **1.1**, then the crane can topple over. Personnel can be severely injured or killed.

- ▶ To drive the crane, the center of gravity **1.2** must always be within the core area **1.1**.
- ▶ If the center of gravity is outside of the core area, then it is prohibited to drive the crane.



Note

- ▶ If the center of gravity **1.2** of the crane is within the core area **1.1**, then the center of gravity **1.2** is shown in green.
- ▶ If the center of gravity **1.2** of the crane is outside the core area **1.1**, then the center of gravity **1.2** is shown in red.

The following specifications and instructions must be observed:

- By luffing the boom system up and down, the position of the center of gravity **1.2** must be corrected in such a way that the overall center of gravity remains within the core area **1.1**.

1.4 Distribution of surface pressure



WARNING

Increased surface pressure!

The calculation of the values for the display of the surface pressure in the job planner are based on ideal assumptions.

- ▶ Side deformations of the boom system due to wind, inclined position and elastic resilience of the steel structure are not taken into account but they can lead to an increase of the surface pressure.

**Note**

- ▶ The boom must be luffed down before driving until the load is even distributed on the tracks.
- ▶ If the counterweight on the turntable is large, then it is required to position the boom in such a way that a suitable distribution of surface pressure for driving is obtained.

1.5 Suitable distribution of surface pressure

If the distribution of the surface pressure is even (surface pressure front and surface pressure rear approx. the same value), then steering is difficult or not possible at all.

For the suitable distribution of surface pressure, the following applies:

- A = Surface pressure on the side of the two tracks which has the lower load
- B = Surface pressure on the side of the two tracks which has the higher load
- The center of gravity must however always be within the core area **1.1**.

Distribution of surface pressure A to B			
A	/	B	=
			Should be greater than 0.3

In case of unfavorable distribution of surface pressure it is required to position the boom system in such a way that a suitable distribution of the surface pressure is reached for driving.

- ▶ The turntable should be turned while at a standstill: The boom system should be luffed in such a way that the crawlers are subjected to a load as evenly as possible.
- ▶ Driving uphill: The boom system should be luffed in such a way that the side of the crawler track which has less of a load is on the rear.
- ▶ Driving downhill: The boom system should be luffed in such a way that the side of the crawler track which has less of a load is on the front.

1.6 Steering ability

**Note**

High load on the crane!

When driving the crane, steering movements cause a high load on the crane travel gear.

- ▶ If possible, forego steering movements with load on the hook and / or derrick ballast.
- ▶ Select the travel route in such a way that no steering movements are required, if possible.
- ▶ If not otherwise possible, before initiating a steering movement, set down the load and / or derrick ballast.

The steering ability of the crane depends on the following factors:

- Friction conditions under the chains
- Evenness of the ground:
 - Steering is not possible if the crawler travel gear is only making contact with the ground at the front and rear.
- Load bearing capacity of the ground:
 - If the crawler travel gear sinks into the ground, then the steering ability is significantly restricted.
- Position of the overall center of gravity:
 - If the overall center of gravity - under consideration of the suspended load - is at the center of the crane, then steering is hard or not possible at all.

The steering ability can be improved by:

- Placing metal sheeting, sand, gravel, water underneath
- By taking the load bearing capacity of the ground and the position of the center of gravity into account: Changing the center of gravity.

2 Driving with a load and / or Derrick ballast



WARNING

The crane can topple over!

If the following prerequisites are not observed for crawler operation, the crane can topple over. Personnel can be severely injured or killed.

- ▶ Make sure that the prerequisites for crawler operation are read and have been understood - before „driving with a load and / or Derrick ballast“.

2.1 Prerequisites for driving with a load and / or derrick ballast



WARNING

The crane can topple over!

If load charts with lateral inclines of more than 0.3° are available, then the crane may be driven with a load within these load charts.

If the following points are not observed, the crane can topple over.

Personnel can be severely injured or killed.

- ▶ The following prerequisites for driving with a load must be adhered to.
- ▶ Driving the crane with lateral and longitudinal inclines of more than $\pm 0.3^\circ$ - with installed derrick ballast - is prohibited.



Note

- ▶ The permissible inclines from the load charts apply for driving with a load.
- ▶ Take the maximum permissible wind speed from the load charts.

Permissible inclines for driving with a load	
Overall incline	$\pm 0.3^\circ$

**WARNING**

The crane can topple over!

If the following conditions are not observed, the crane can topple over.

Personnel can be severely injured or killed.

- ▶ The ground must be level ($\pm 0.3^\circ$) and have adequate load bearing capacity.
- ▶ The ground must be able to safely take on the maximum occurring surface pressures.

**WARNING**

The crane can topple over!

If the crane is driven in lateral and longitudinal inclines of more than $\pm 0.3^\circ$ with a load or derrick ballast, then crane structures can fail and the crane can topple over.

Personnel can be severely injured or killed.

- ▶ Driving uphill / downhill with a load and / or derrick ballast is prohibited.

**WARNING**

The crane can topple over!

The crane can be driven with the given loads from the load charts, if the following prerequisites are met.

If the following prerequisites are not observed, the crane can topple over.

Personnel can be severely injured or killed.

- ▶ The maximum permissible travel speed of the crawler with load and / or derrick ballast may **not** exceed 0.05 m/s **or** 3 m/min **or** 0.18 km/h.
- ▶ Steering the crawler with suspended load and / or installed derrick ballast is difficult and often not possible at all. Make sure that the slewing gear free wheeling is actuated for steering.
- ▶ Avoid jerky driving movements.
- ▶ Secure the suspended load to avoid oscillation.
- ▶ Lift the suspended ballast no more than maximum 250 mm off the ground.
- ▶ Luff the main boom up or down until a medium utilization is obtained on test point 1 **MS1**.

3 Driving without a load and without derrick ballast

**WARNING**

The crane can topple over!

If the following prerequisites are not observed for crawler operation, the crane can topple over.

Personnel can be severely injured or killed.

- ▶ Make sure that the prerequisites for crawler operation are read and have been understood - before „driving without a load and without Derrick ballast“.

3.1 Prerequisites for driving without a load and without derrick ballast

Make sure that the following prerequisites are met:

- The maximum permissible oil fill quantity in the diesel motor is present.
- The oil level in the hydraulic oil tank must be lowered by extending the cylinders so that an overflow is not possible.
- The contents of the fuel tank must be reduced so that an overflow is not possible.
- The maximum permissible wind speed of 9 m/s is not being exceeded.
- the travel speed may not exceed 0.4 m/s or 24 m/min or 1.44 km/h
- The turntable is aligned parallel to the crawler track, 0° or 180° position.



WARNING

The crane can topple over!

When driving in lateral inclines, the crane can slip off or topple over.

Personnel can be severely injured or killed.

- ▶ Make sure that the overall center of gravity of the crane is in the center of rotation when driving in lateral inclines.
- ▶ The overall center of gravity for driving without a load must be constantly checked with the LICCON job planner.
- ▶ Make sure that the permissible lateral and longitudinal inclines are not exceeded.



Note

- ▶ By luffing the boom up and down, the position of the center of gravity **1.2** must be corrected in such a way that the overall center of gravity remains within the core area **1.1**.
- ▶ When driving the crane in terrain with a longitudinal and lateral incline, then the required boom position must be determined with the aid of the LICCON job planner via the position of the overall center of gravity, see section „Display of center of gravity“.



WARNING

The crane can topple over!

When driving in lateral inclines with boom lengths of more than 150 m the crane can topple over.

Personnel can be severely injured or killed.

- ▶ Driving in lateral inclines with boom lengths of more than 150 m is **exclusively** permitted after a written release is obtained from **Liebherr-Werk Ehingen GmbH**.



WARNING

Crane with narrow crawler track!

- ▶ When driving cranes with narrow tracks and corresponding equipment, the special travel charts and danger notes must be observed and adhered to.

Permissible lateral inclines for driving without a load / derrick ballast	
Overall length of boom	Maximum permissible lateral incline
Shorter / equal to 96 m	± 3°
97 m to 150 m	± 2°

Permissible longitudinal inclines for driving without a load / derrick ballast	
Overall length of boom	Maximum permissible longitudinal incline
To 150 m	± 10°

**WARNING**

The crane can topple over!

If the following conditions are not met when driving the crawler crane uphill / downhill, then the crane can topple over.

Personnel can be severely injured or killed.

- ▶ The ground must be able to take on the occurring surface pressures.
- ▶ The friction coefficient between the roadway and the ground must be large enough to take on the occurring drive forces.
- ▶ Slippery ground, especially ice, frost and snow can cause the crane to slide off sideways in longitudinal and lateral inclines and therefore cause the crane to topple over.
- ▶ The turntable must be parallel to the crawler carriers and secured to prevent it from turning.
- ▶ All acceleration and delay maneuvers must be initiated with extreme caution and at the least possible speed.
- ▶ The transfer from the horizontal into an uphill / downhill slope and from the uphill / downhill slope into the horizontal must be made evenly.
- ▶ Edges, over which the crane tilts are impermissible.
- ▶ Any incline changes must be made continuously.
- ▶ The surface pressures which will occur should be determined with the job planner before travel.
- ▶ The ground must be sufficiently load bearing and have sufficient traction to prevent the crane from slipping.
- ▶ The counterweight on the turntable must be secured with a chain, see chapter 4.07 of the Crane operating instructions.
- ▶ The center of gravity of the crane must lie within the core area **1.1** of the crane.
- ▶ The appropriate and permissible boom position for the respective equipment configuration must be determined with the job planner.

4 Driving uphill / downhill

The maximum climbing ability of the crawler crane is limited by the following criteria:

- The location of the center of gravity for the complete crawler crane
- The friction coefficient between roadway and track pads
- The transit between the horizontal and the uphill / downhill slope
- The maximum permissible longitudinal incline of $\pm 10^\circ$ up to a boom length of 150 m
- The oil level in the diesel engine
- The oil level in the travel gears

4.1 Calculation of required length of transfers in uphill / downhill slopes

The required length **L** for transfers results from the existing uphill angle α and the length of the tracks **LC**.

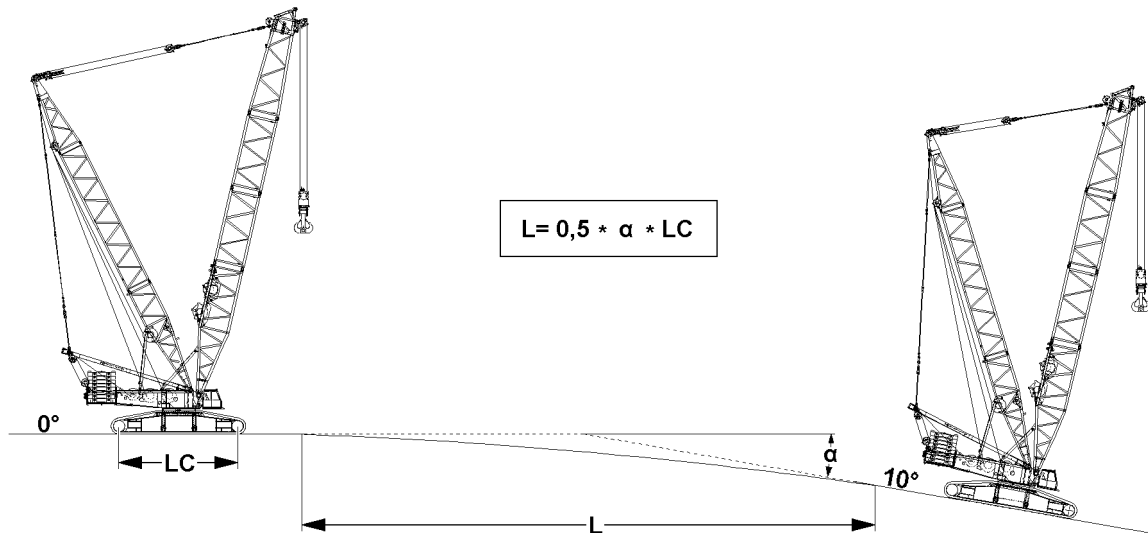

Fig.119612

Abbreviation	Description
L	Required length of transfers
α	Angle Rising / falling inclines in degrees
LC	Length of crawlers between drive wheels / steering wheels

4.1.1 Calculation example

Given:

$$\alpha = 10^\circ$$

LC = 17.3 m (use only the actual value of the crane!)

Wanted:

$$L = ?$$

Calculation formula						
L	=	0,5	*	α	*	LC
L	=	0,5	*	10	*	17.3 m
L	=	86.5				

4.2 Prerequisites for driving under observation of the boom position



Note

- ▶ The illustrations in this section are only examples and may not match to your crane.
- ▶ The determining factor for driving uphill / downhill is the exact knowledge of the existing operational conditions on the jobsite and the surface pressures, permissible boom angles and inclines as well as the overall center of gravity which were determined from them with the job planner.



WARNING

The crane can topple over!

If the following note is not observed, the crane can topple over.
Personnel can be severely injured or killed.

- ▶ Driving uphill / downhill must always be anticipatory, with utmost caution and at the slowest speed.

- There are two different possibilities to drive crawler cranes uphill / downhill:
- with boom angle adjustment
 - without boom angle adjustment

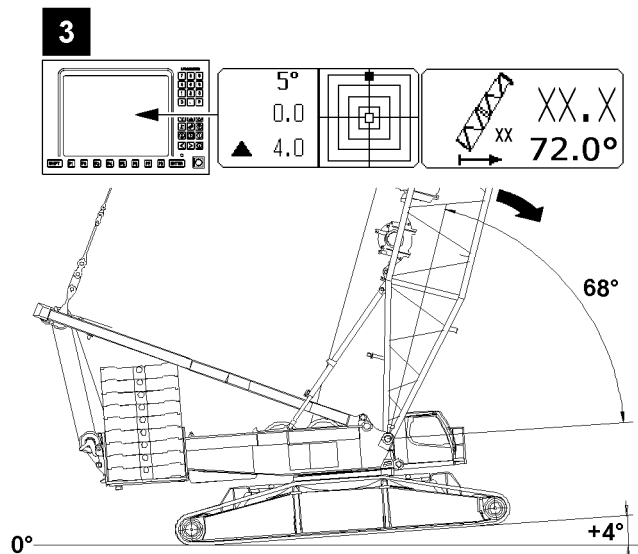
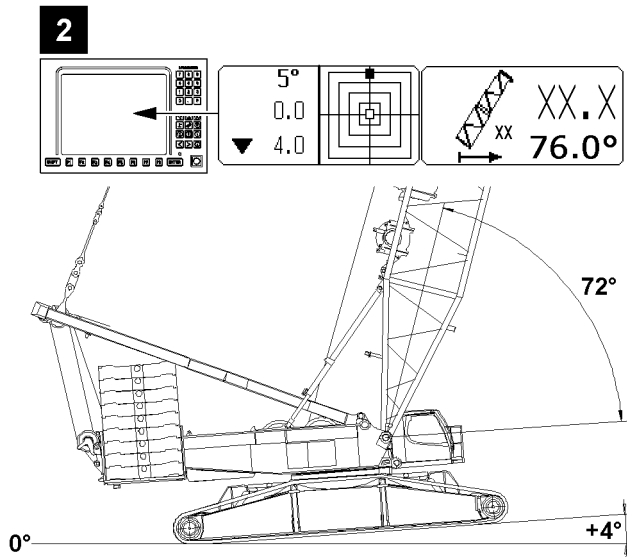
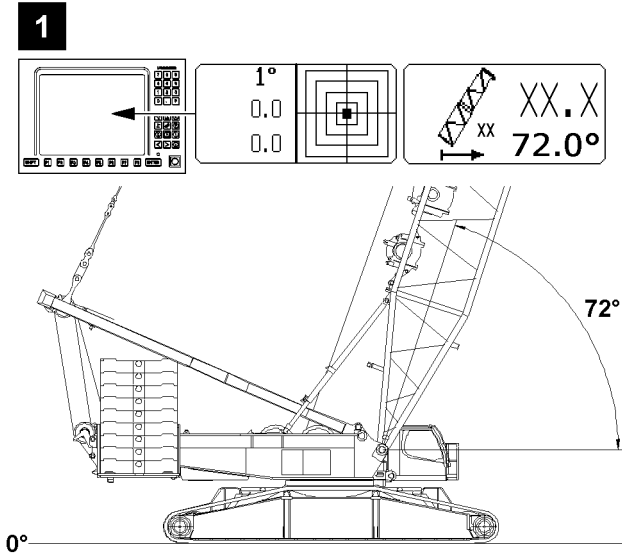

Fig.117601

LWE/LR 1600-2-008/18109-09-02/en

4.2.1 Prerequisites for driving on uphill / downhill slopes with boom angle adjustment



Note

- ▶ When driving into an uphill / downhill slope, during the transition between the horizontal into the uphill / downhill incline, the original boom angle must be changed continuously in such a way that the original boom angle always remains between the boom and the horizontal. This angle must be retained in the uphill / downhill incline.
- ▶ When driving out of an uphill / downhill slope, during the transition between the uphill / downhill incline into the horizontal, the original boom angle must be changed continuously in such a way that the original boom angle always remains between the boom and the horizontal.
- ▶ In addition, the overall center of gravity of the crane must be observed.



WARNING

The crane can topple over!

When driving in uphill / downhill inclines with a load or derrick ballast, structural parts can break, the carrying crane structures can be damaged or the crane can topple over.

If the boom angle is not matched to the uphill / downhill incline when driving the crane in uphill / downhill slopes, then the crane can topple over.

Personnel can be severely injured or killed.

- ▶ Driving uphill / downhill with a load and / or derrick ballast is prohibited.
- ▶ Match the boom angle to the uphill / downhill incline.

Positive longitudinal incline (illustration 1 to 3)



Note

- ▶ When driving in positive longitudinal inclines (uphill slopes), the boom / the luffing jib must be luffed down continuously - maximum by the **uphill incline angle α** .
- ▶ The uphill incline angle α is 4° in the displayed example, see opposite graphic.
- ▶ View of incline and boom angle (as seen from the crane operator's cab in the direction of travel).

– Illustration 1:

- Crane is horizontally aligned

– Illustration 2:

- Crane at 4° uphill incline (positive longitudinal incline), no lateral incline
- **Note:**
The boom angle is always shown to the horizontal.
Example Display boom angle = 76° ($72^\circ + 4^\circ$)
Correct the boom angle.

– Illustration 3:

- Crane at 4° uphill incline (positive longitudinal incline), no lateral incline
- **Note:**
The boom angle is always shown to the horizontal.
Luff the boom down by the uphill angle (4°) so that the display boom angle = 72° (68° plus 4°)

4

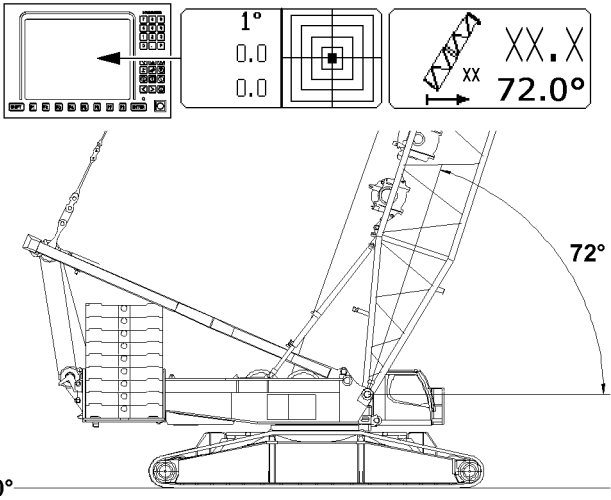

5

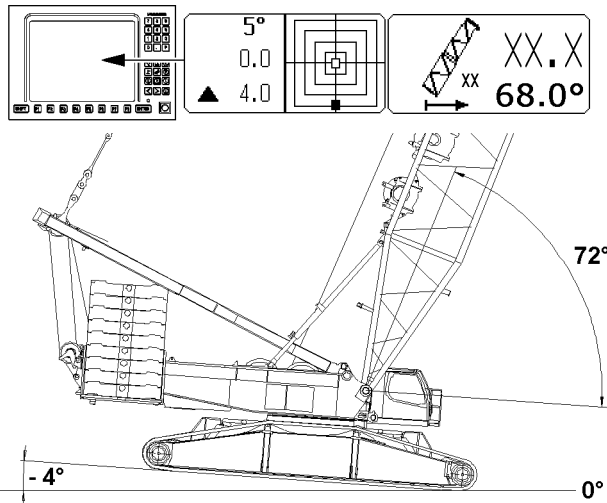

6

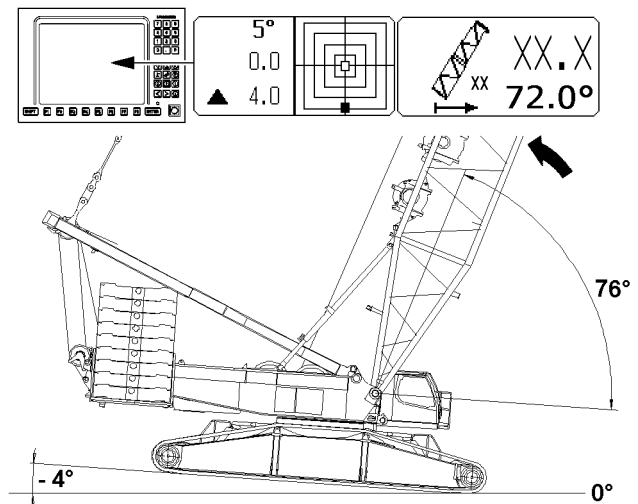

Fig.117607

LWE/LR 1600-2-008/18109-09-02/en

Negative longitudinal incline (illustration 4 to 6)



Note

- ▶ When driving in negative longitudinal inclines (downhill slopes), the boom / the luffing jib must be luffed up continuously - maximum by the **uphill incline angle α** .
- ▶ The uphill incline angle α is 4° in the displayed example, see opposite graphic.
- ▶ View of incline and boom angle (as seen from the crane operator's cab in the direction of travel).

– Illustration 1:

- Crane is horizontally aligned

– Illustration 2:

- Crane at 4° downhill slope (negative longitudinal incline), no lateral incline

- **Note:**

The boom angle is always shown to the horizontal.

Example Display boom angle = 68° (72° minus 4°)

Correct the boom angle.

– Illustration 3:

- Crane at 4° downhill slope (positive longitudinal incline), no lateral incline

- **Note:**

The boom angle is always shown to the horizontal.

Luff the boom up by the uphill angle (4°) so that the display boom angle = 72° (76° minus 4°)

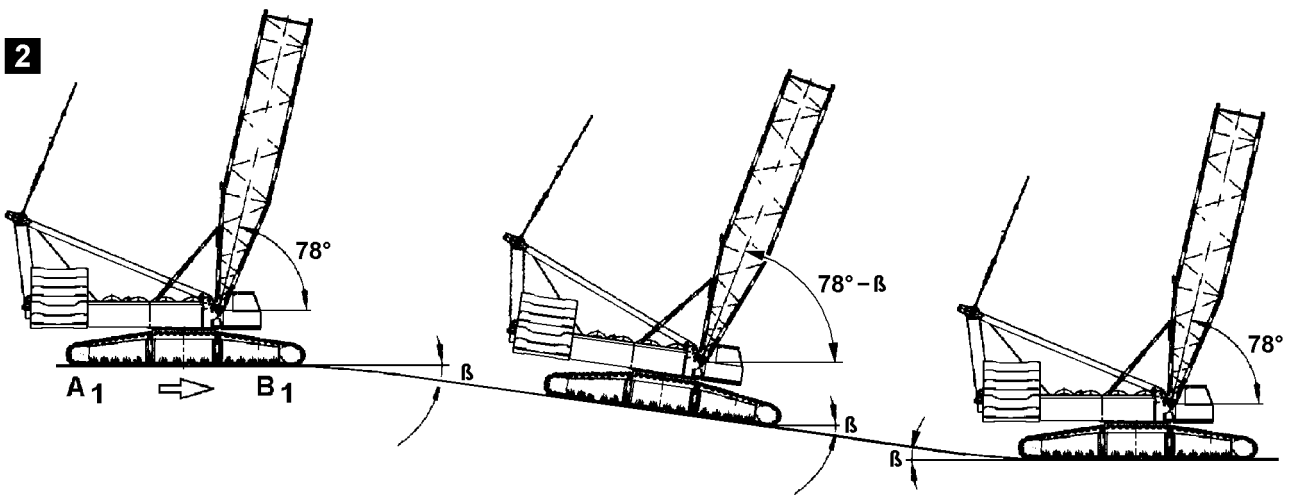
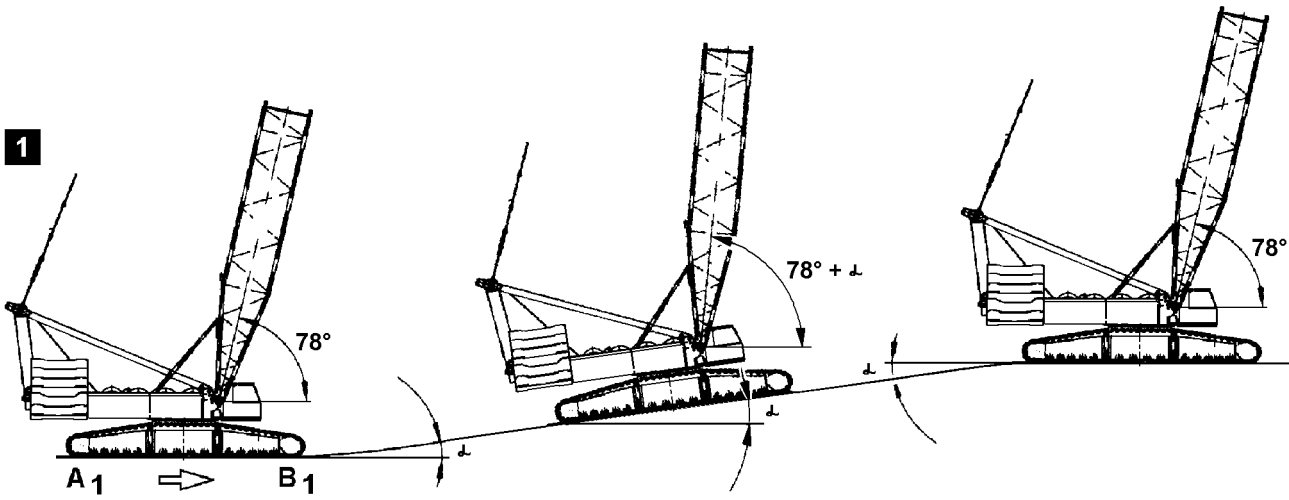

Fig.109866

LWE/LR 1600-2-008/18109-09-02/en

4.2.2 Prerequisites for driving on uphill / downhill slopes without boom angle adjustment



WARNING

The crane can topple over!

If the overall center of gravity of the crane is outside the core area when driving on uphill / downhill inclines without boom angle adjustment, then the crane can topple over.

Personnel can be severely injured or killed.

- ▶ Before driving into uphill / downhill slopes, check the change of the center of gravity with the job planner.
- ▶ To be able to approximately determine the changes of the center of gravity in uphill / downhill slopes with the job planner, the boom angle must be increased by the incline angle α when driving in uphill / downhill inclines, illustration 1.
- ▶ To be able to approximately determine the changes of the center of gravity in downhill slopes with the job planner, the boom angle must be decreased by the incline angle β when driving in downhill slopes, illustration 2.
- ▶ Before driving the crane, determine exactly with the job planner if the crane may drive on the intended route without changing the boom angle.
- ▶ If the intended uphill / downhill incline cannot be driven without changing the boom angle according to the job planner, then the boom angle must be changed to be able to drive on the uphill / downhill incline.

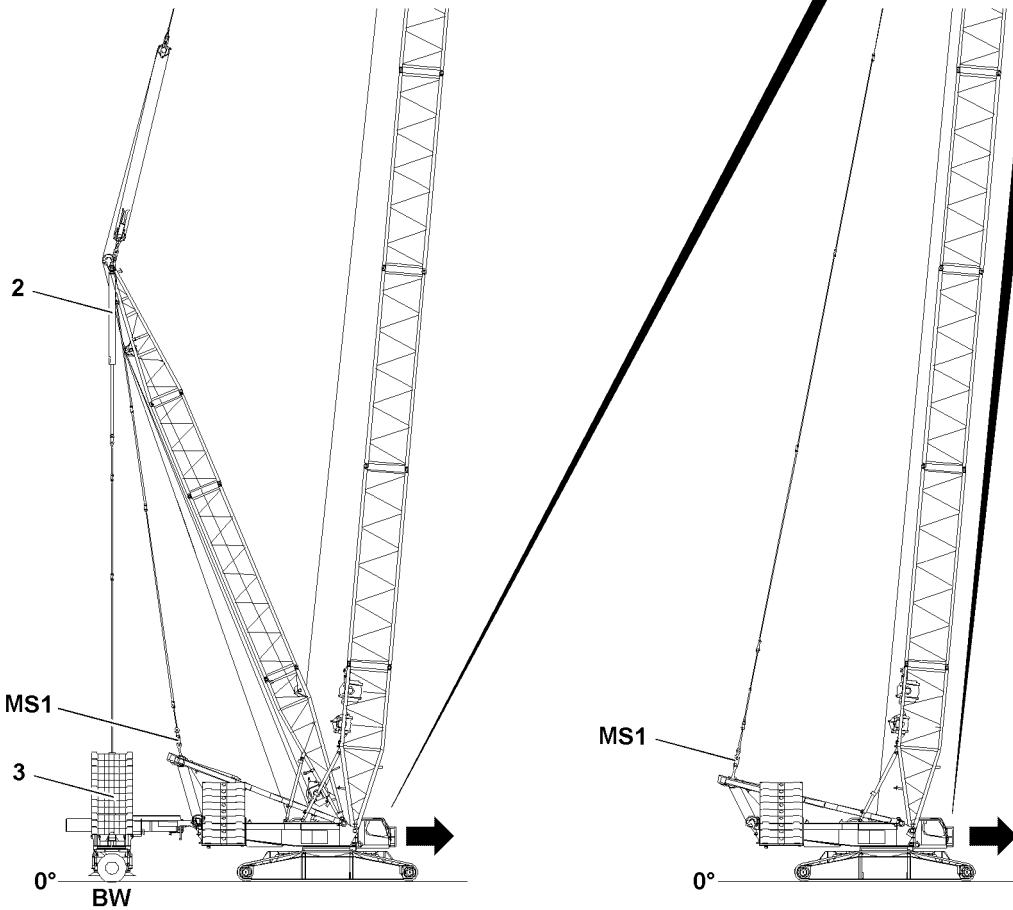
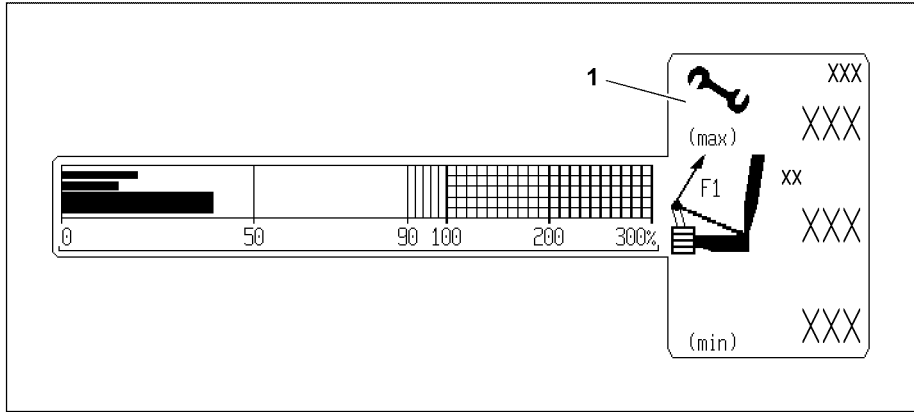

Fig.117598

LWE/LR 1600-2-008/18109-09-02/en

5 Driving the crawler crane



Note

- ▶ Test point 1 **MS1** = F1 in icon 1.
- ▶ For description of test point 1, see Crane operating instructions, chapter 4.02.



WARNING

The crane can topple over!

When driving the crane - this also applies for „circular travel“ - the ballast trailer **3** is raised due to ground unevenness, the force on test point 1 **MS1** increases very quickly and the crane will be overloaded.

If the ballast trailer **3** sinks while driving due ground unevenness, the force on test point 1 **MS1** drops and the ballast trailer **3** lifts off the ground, or the entire boom system is pulled backward.

There is no LMB shut off.

The crane can topple over and personnel can be severely injured or killed.

- ▶ The crane operator must constantly observe the displays on the LICCON monitor while driving the crawler crane.
- ▶ The crane operator must correct the force changes on test point 1 **MS1** to a permissible operating range already when an advance warning occurrence on the LICCON monitor is issued, by actuating the pull cylinder in the derrick ballast guying.



WARNING

The crane can topple over!

If the following instructions are not observed, the crane can topple over.

Personnel can be severely injured or killed.

- ▶ Before driving the crane with the attachment, the optimum boom position must be determined with the aid of the job planner, to obtain as even a surface pressure as possible.
- ▶ When driving crawler cranes, it must be ensured that the ground can take on the surface pressures safely, which have been calculated with the job planner, over the entire intended travel route. If this is not the case, appropriate measures must be taken to be able to discharge the forces into the ground.
- ▶ An additional monitor, who is connected by radio contact with the crane operator must ensure that there are no persons or obstacles within the danger zone of the crane.

Make sure that the following prerequisite is met:

- The crane engine is running.

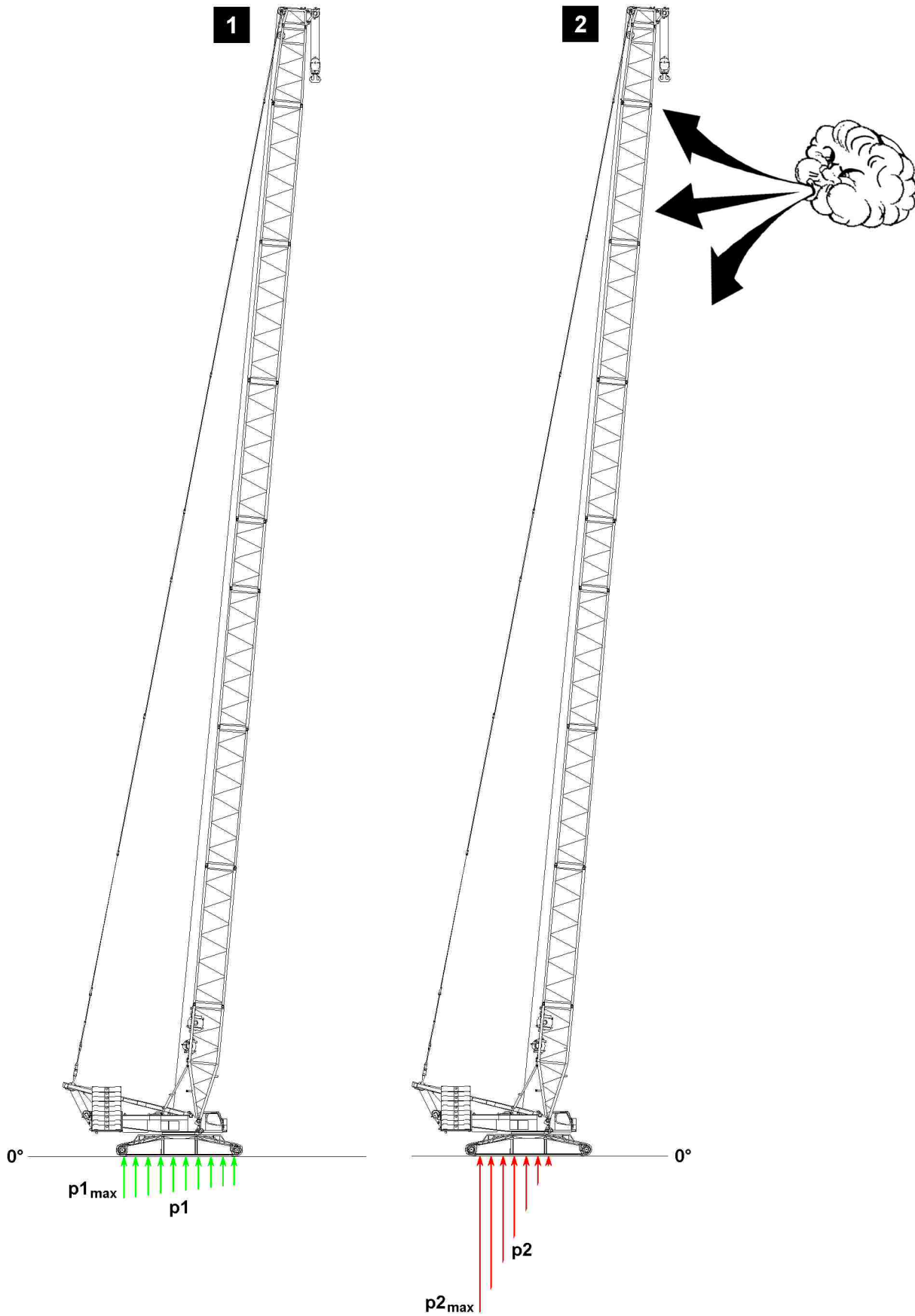

Fig.117599: $p2_{max}$ larger than $p1_{max}$

LWE/LR 1600-2-008/18109-09-02/en

5.1 Surface pressures and force distribution when driving the crane



WARNING

The crane can topple over!

When driving crawler cranes, surface pressures can significantly increase or change due to different factors.

This can cause the crane to topple over.

Personnel can be severely injured or killed.

- ▶ Make sure that the ground has sufficient load bearing capacity in the entire working range and / or over the entire travel route, to be able to safely take on even increased surfaces pressures of the crane.
- ▶ Make sure that the center of gravity is always within the core surface, see section „Prerequisites for crawler operation“ and LICCON job planner.

5.1.1 Surface pressures in case of wind load on boom



WARNING

The crane can topple over!

When driving the crane with long boom lengths and / or when driving with large sized loads and / or at high wind speeds, the surface pressures can increase significantly.

This can cause the crane to topple over.

Personnel can be severely injured or killed.

- ▶ Make sure that the entire travel route of the crane is sufficiently load bearing to be able to take on even increase surface pressures - for example if „wind is coming front the front on the boom“.
- ▶ Change of surface pressures on crawler track under wind load, see opposite graphic.

Illustration 1:

- Surface pressures **p1** on crawler track without wind load

Illustration 2:

- Surface pressures **p2** on crawler track in case of wind load from the front

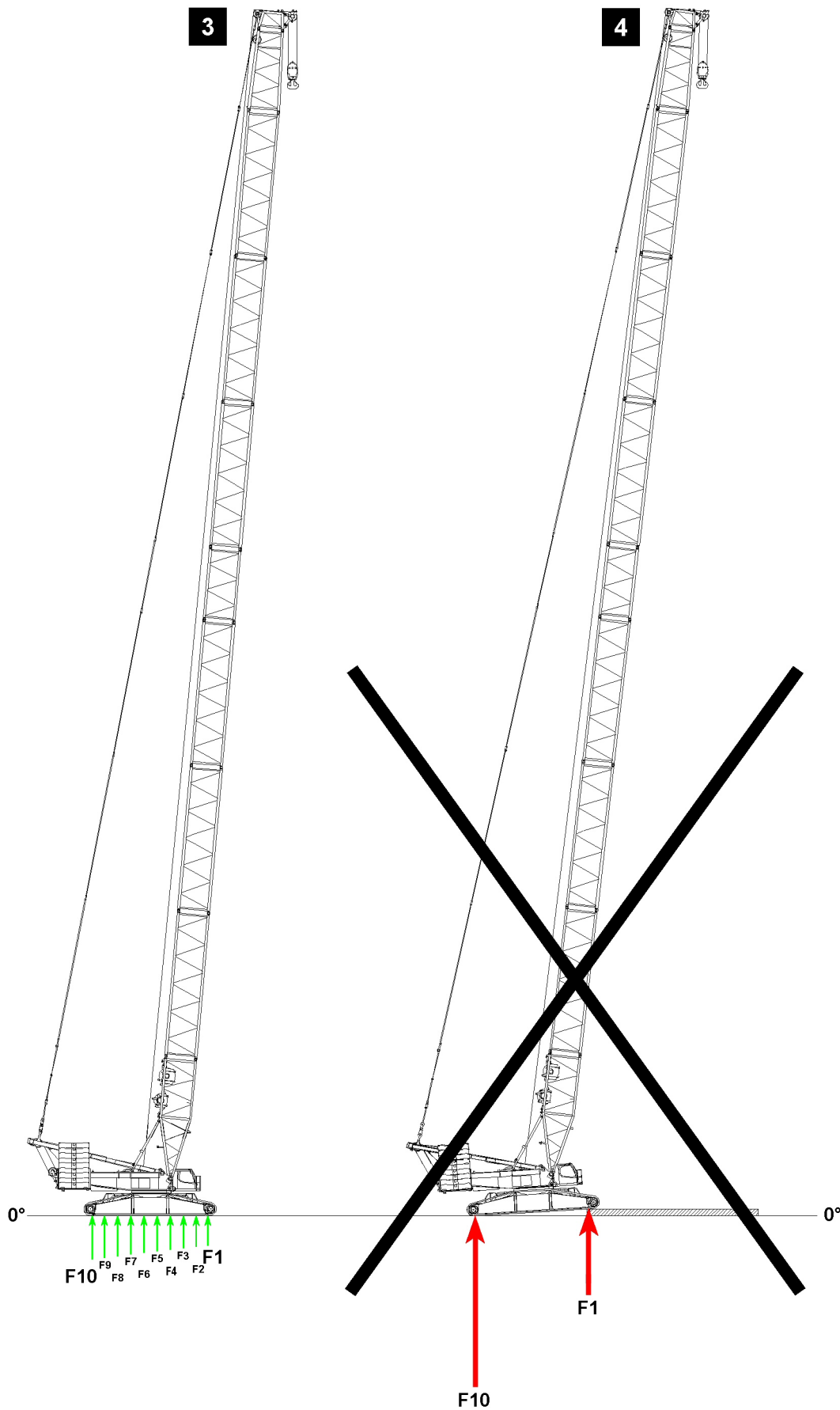

LWE/LR 1600-2-008/18109-09-02/en

Fig.117600: Force distribution in normal operation // driving on pressure distributor plates

5.1.2 Force distribution when driving on pressure distributor plates



WARNING

The crane can topple over!

When driving the crane on pressure distributor plates, a movement of forces occurs due to the reduction of the ground contact surfaces on the crawler track. The forces concentrate at force **F1** and force **F10**, see illustration 4.

This can cause the crane to topple over.

Personnel can be severely injured or killed.

- ▶ Make sure, before driving the crane on pressure distributor plates, that a load bearing transfer (height equalization) was established, see section „Calculation of required length of transfers“.
- ▶ Driving the crane on pressure distributor plates without transfer (height equalization) is prohibited.

Illustration 3:

- Force distribution on crawler track of crane (normal operation)
 - Without wind influence

Illustration 4:

- Not permissible

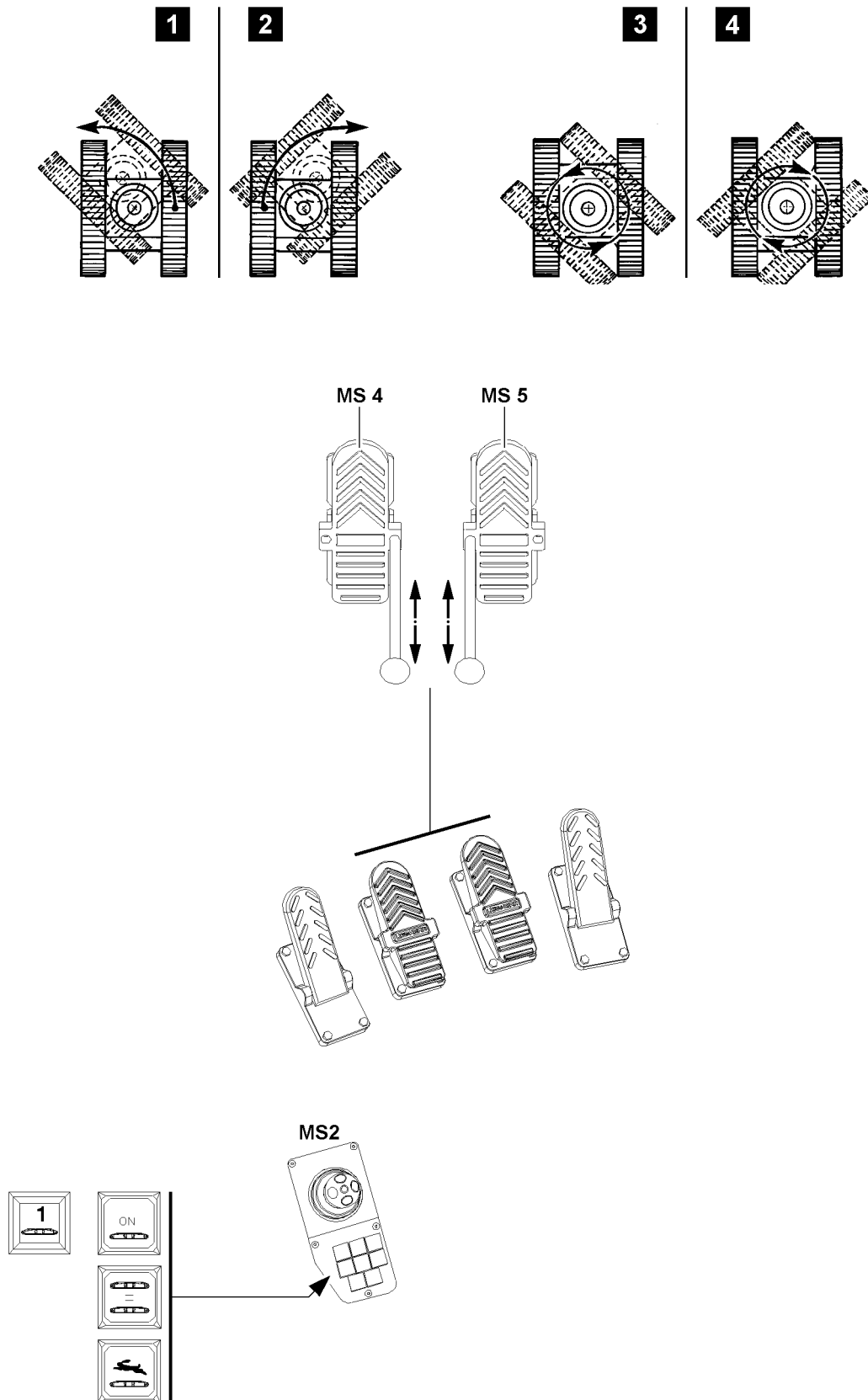





Fig.107964





LWE/LR 1600-2-008/18109-09-02/en

5.2 Operating elements for the crawler operation

5.2.1 Pedal carrier

Pedal carrier (Pedal assignment, see opposite illustration)				
				
	<i>Pedal</i>	<i>Foot rocker MS4</i>	<i>Foot rocker MS5</i>	<i>Pedal</i>
Function:	Slewing gear brake	Crawler travel „left“	Crawler travel „right“	Engine regulation:
Note: See also Crane operating instructions, chapter 4.01 and chapter 4.05				

5.2.2 Switch for crawler operation

Control panel MS2			
			
	Switch „Crawler operation“	Switch „Crawler parallel travel“	Switch „Rapid gear“
	or:		
			
	Switch „Crawler operation“		
Function:	On / Off	On / Off	On / Off
Note: See Crane operating instructions, chapter 4.01.			

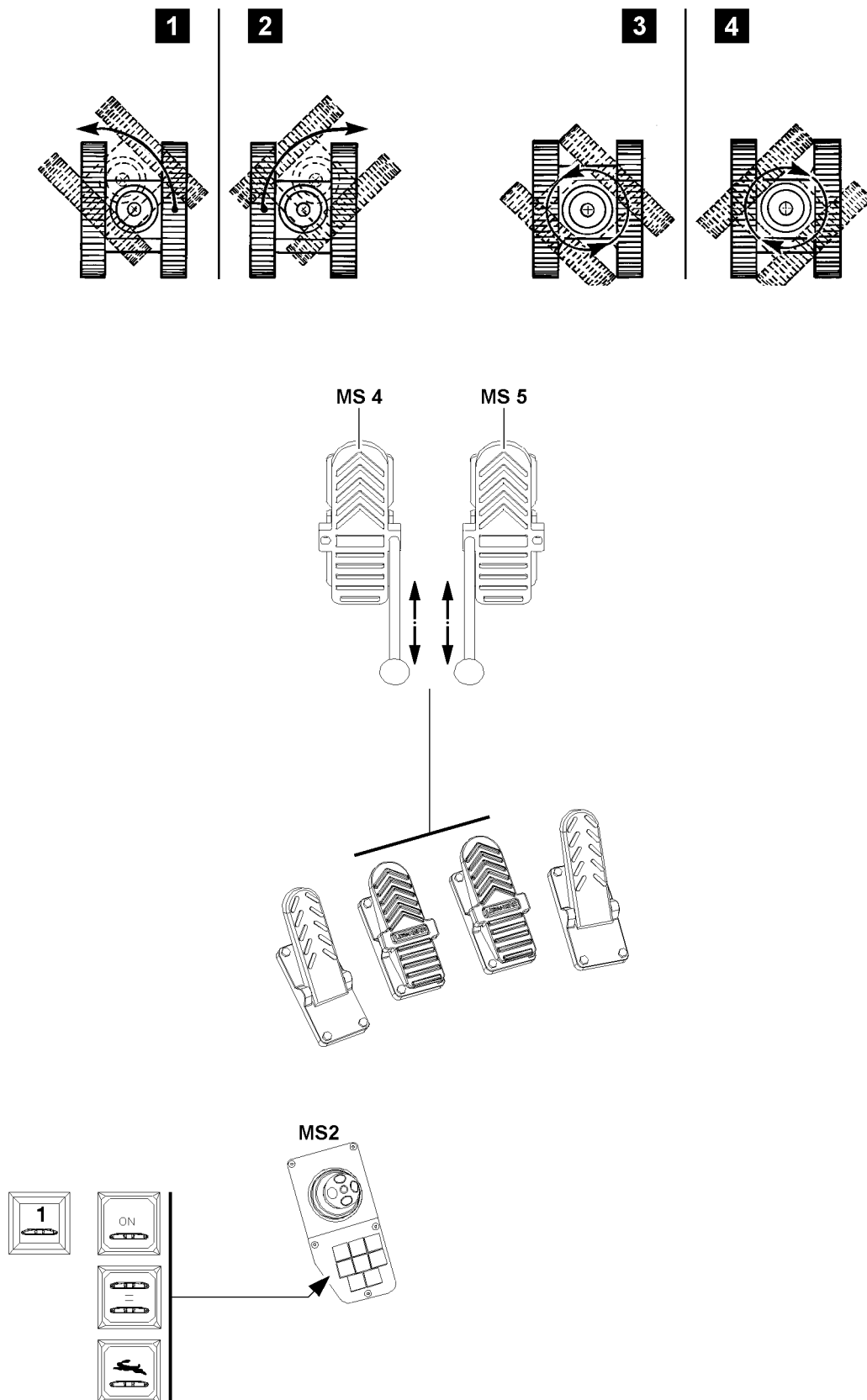

Fig.107964

LWE/LR 1600-2-008/18109-09-02/en

5.3 Activating crawler operation



Note

- ▶ The engine rpm is increased or decreased via the pedal „engine regulation“.
- ▶ The switch „crawler operation“ can differ somewhat, depending on the crane type.

- ▶ Actuate the switch „Crawler operation“.

Result:

- Crawler operation is activated.
- The indicator light in the switch „crawler operation“ lights up.

To deactivate crawler operation:

- ▶ Actuate the switch „Crawler operation“.

Result:

- Crawler operation is deactivated.
- The indicator light in the switch „crawler operation“ turns off.

5.4 Selecting the travel speed

This crawler crane has 2 possible speeds:

1. Speed stage 1:
Creeper gear
2. Speed stage 2:
Fast mode (Rapid gear)

5.4.1 Activating the creeper gear

Make sure that the following prerequisites are met:

- The switch „Rapid gear“ is not actuated.
- The indicator light in the switch „Rapid gear“ is off.

- ▶ Actuate the switch „Crawler operation“.

Result:

- The creeper gear is active.

5.4.2 Turning the rapid gear on



WARNING

The crane can topple over!

If the crane is driven in rapid gear with a load or derrick ballast, then the crane can topple over. Personnel can be severely injured or killed.

- ▶ Driving with a load or derrick ballast in rapid gear is prohibited.

Make sure that the following prerequisites are met:

- The switch „Parallel travel crawler“ is not actuated.
- The indicator light in switch „Parallel travel crawler“ is off.
- Inching gear is active

To select speed stage 2:

- ▶ Actuate the switch „Rapid gear“.

Result:

- The rapid gear is activated.
- The indicator light in the switch „Rapid gear“ lights up.

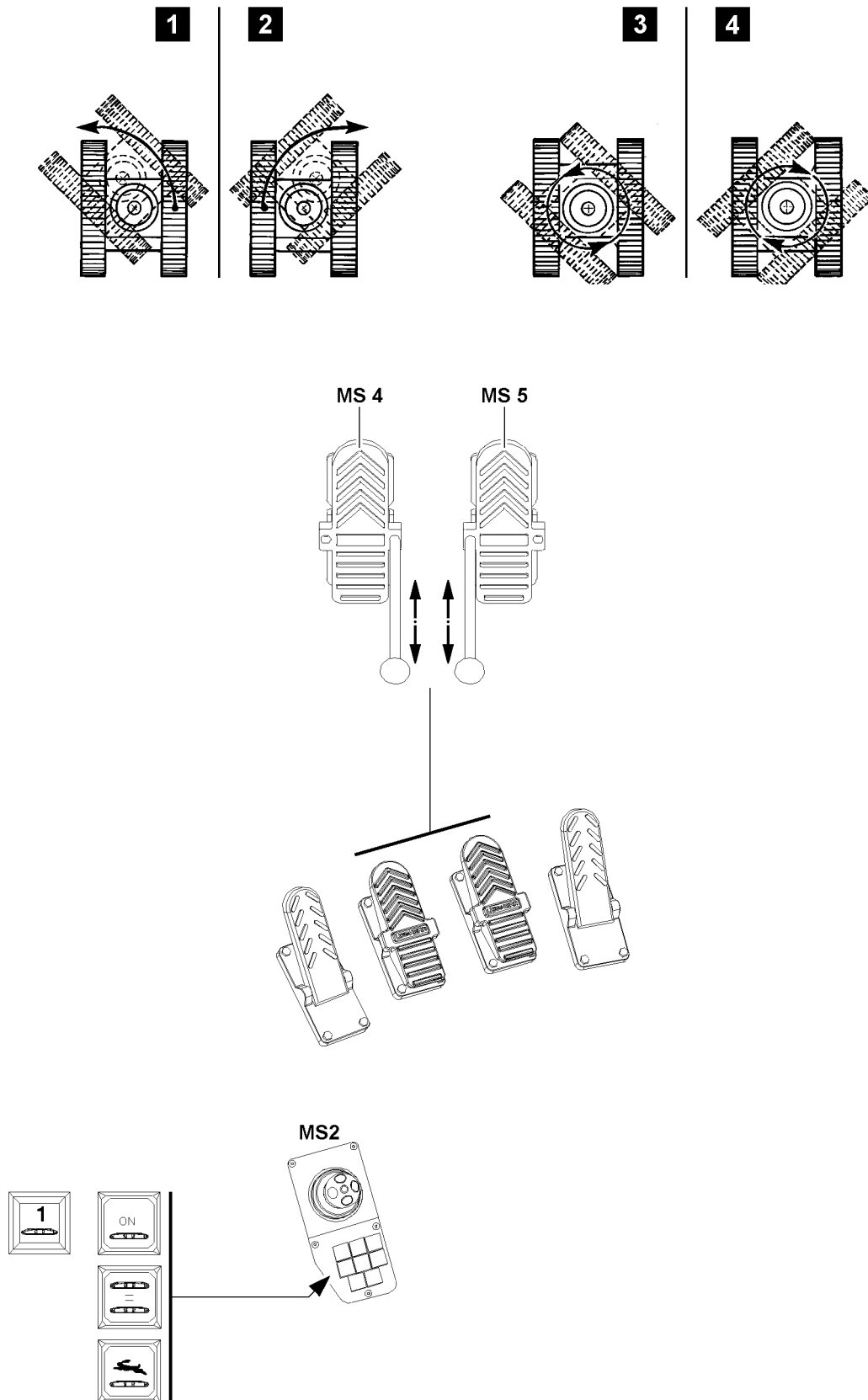

Fig.107964

LWE/LR 1600-2-008/18109-09-02/en

5.5 Driving the crawler



WARNING

The crane can topple over!

If a crane is driven with a load and / or derrick ballast in rapid gear, then the load and / or the boom can start to swing, structural components can be damaged and the crane can topple over.

Personnel can be severely injured or killed.

- ▶ Driving with a load and / or derrick ballast in rapid gear is prohibited.
- ▶ The maximum permissible travel speed of the crawler with load and / or derrick ballast may not exceed 0.05 m/s or 3 m/min or 0.18 km/h.
- ▶ Steering the crawler with suspended load and / or installed derrick ballast is prohibited.



WARNING

Personnel present in danger zone.

Personnel within the danger zone of the crane can be severely injured or killed.

- ▶ An additional monitor, who is connected by radio contact with the crane operator must ensure that there are no persons or obstacles within the danger zone of the crane.
- ▶ The observer may not remain in the danger zone of the crane.



Note

- ▶ Take the hand level from the transport retainer in the crane operator's cab.
- ▶ The technical design of the hand levers is completely identical. The differentiation of the two hand levers is only in their assignment to the corresponding foot rockers in assembled (pushed on) condition.

Make sure that the following prerequisite is met:

- The switch „crawler operation“ is actuated.

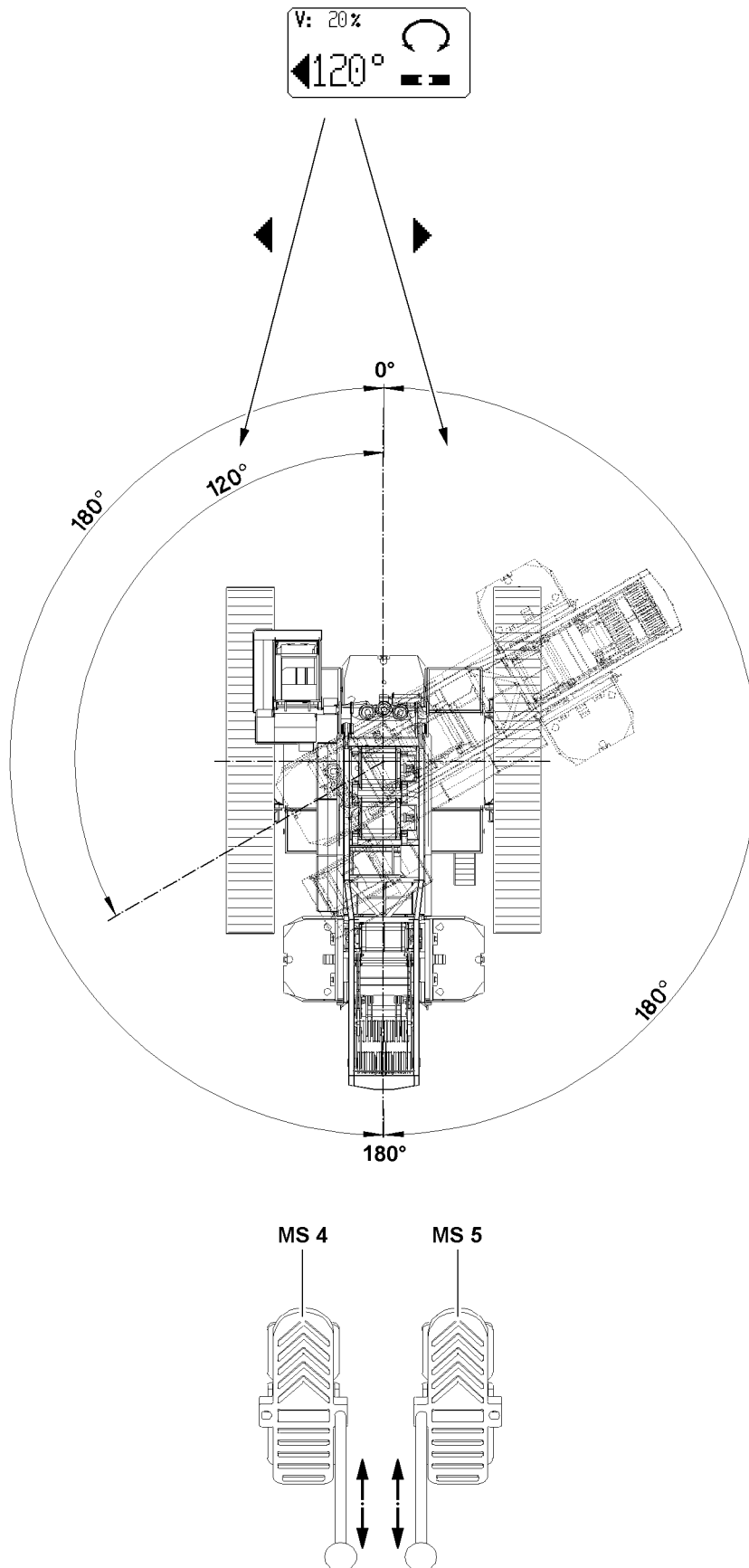

Fig.107974

LWE/LR 1600-2-008/18109-09-02/en

5.5.1 Changing the travel direction



Note

- ▶ At 0°, the crane superstructure is exactly in position „to the front“.
 - ▶ At 180°, the crane superstructure is exactly in position „to the rear“.
-

The travel direction relates to the position of the crane superstructure:

- If the crane superstructure is turned past 90°, then the „forward / reverse“ travel direction changes.
- If the crane superstructure with actuated foot rocker **MS 4** or foot rocker **MS 5** is turned past 90°, then the travel direction remains until the corresponding foot rocker / manual control lever is „returned“ to neutral position.

This means the new travel direction becomes active only if the corresponding foot rocker / manual control lever is no longer actuated.

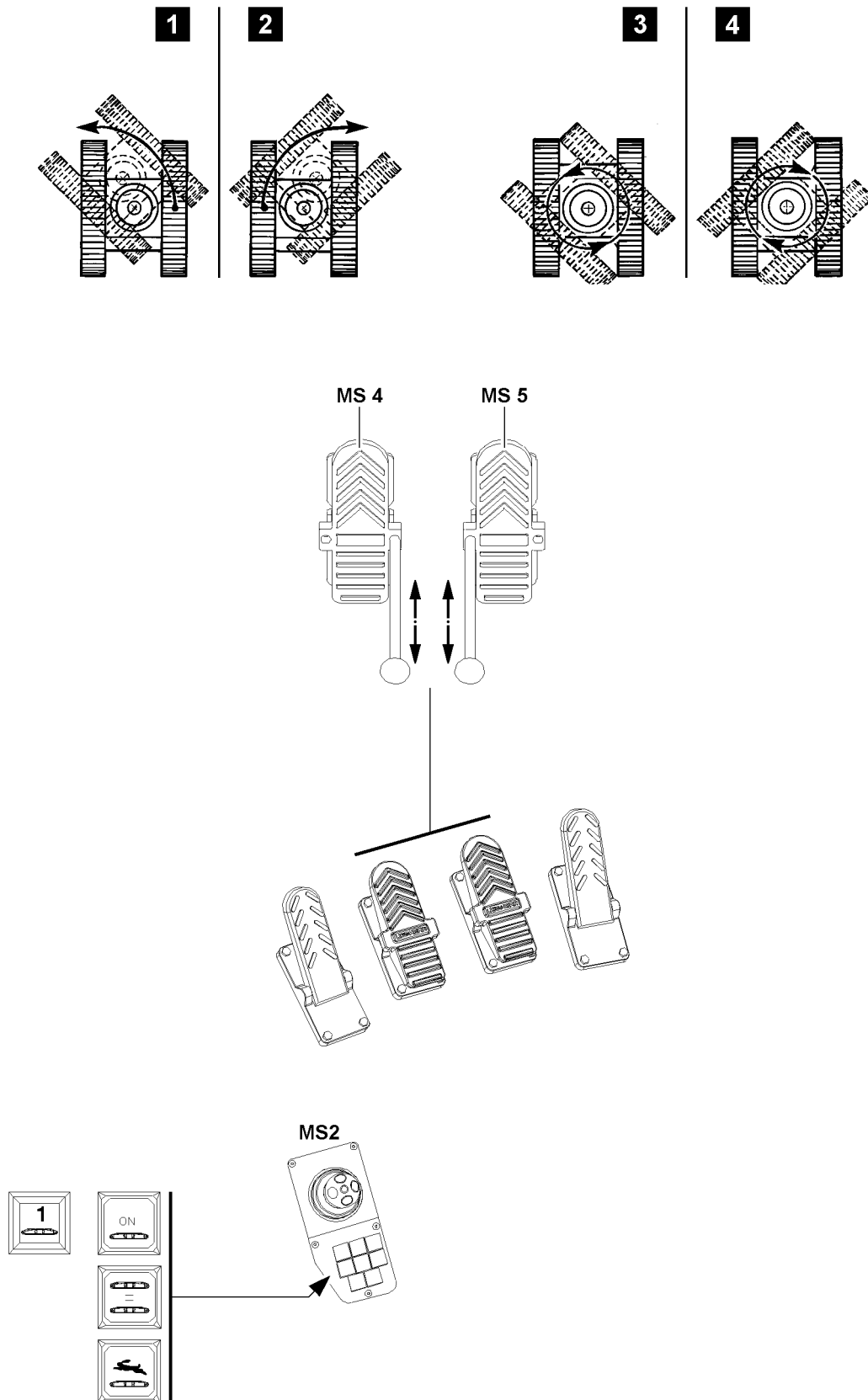

Fig.107964

LWE/LR 1600-2-008/18109-09-02/en

5.5.2 Driving the crawler forward and backward

The tracks can be operated with the foot rockers:

- Crawler track left: Foot rocker **MS4**
- Crawler track right: Foot rocker **MS5**

Alternatively, a manual lever can be installed (inserted) on the foot rocker **MS4** and the foot rocker **MS5** in order to control the travel movements of the crawler precisely.

Driving the crawler forward

- ▶ Push the right foot rocker **MS5** forward.
or
Move the manual lever on the foot rocker **MS5** forward.

Result:

- The right track moves forward.

- ▶ Push the left foot rocker **MS4** forward.
or
Move the manual lever on the foot rocker **MS4** forward.

Result:

- The left track moves forward.

Move the crawler backward.

- ▶ Push the right foot rocker **MS5** back.
or
Move the manual lever on the foot rocker **MS5** backward.

Result:

- The right track moves backward.

- ▶ Push the left foot rocker **MS4** back.
or
Move the manual lever on the foot rocker **MS4** backward.

Result:

- The left track moves backward.

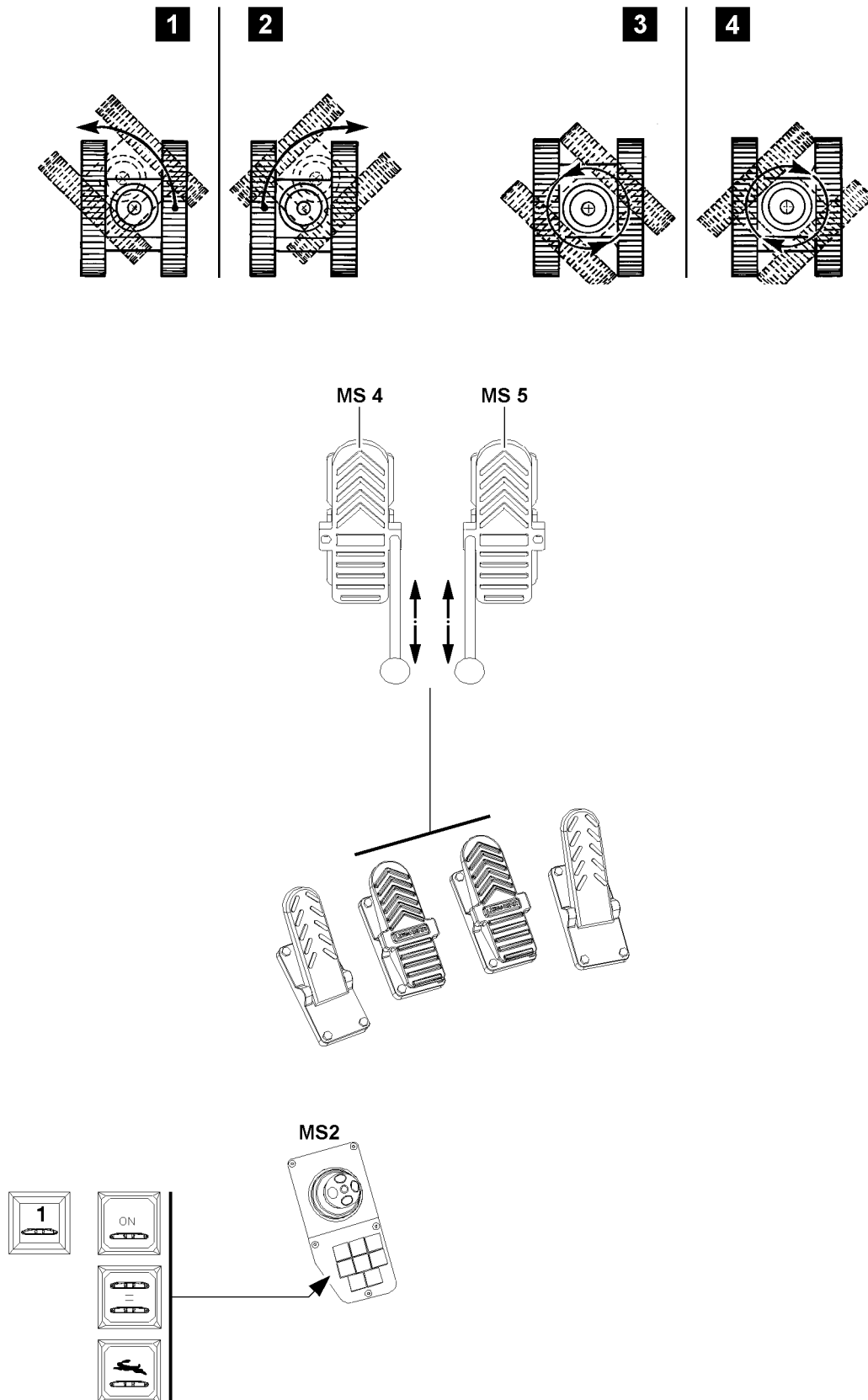

Fig.107964

LWE/LR 1600-2-008/18109-09-02/en

5.5.3 Activating „parallel travel“

If „parallel travel crawler“ is added, both tracks are simultaneously controlled by pressing down on foot rocker **MS4** or foot rocker **MS5**. The foot rocker, which is actuated first serves as the control for both crawler tracks. This makes it possible to drive the tracks exactly straight forward on suitable ground.



Note

- ▶ If, with the „rapid gear“ turned on, the function „parallel travel crawler“ is added, then the function „rapid gear“ is deactivated: The indicator light in the switch „rapid gear“ turns off. However, the switch remains actuated.
 - ▶ If the function „parallel travel crawler“ is turned off again, the rapid gear activates automatically: The indicator light in the switch „Rapid gear“ lights up.
-

Make sure that the following prerequisite is met:

- Rapid gear is deactivated: The indicator lights in switch „rapid gear“ is off.
- ▶ Actuate the switch „parallel travel crawler“.

Result:

- „Parallel travel crawler“ is activated.
- The indicator light in the switch „parallel travel crawler“ lights up.

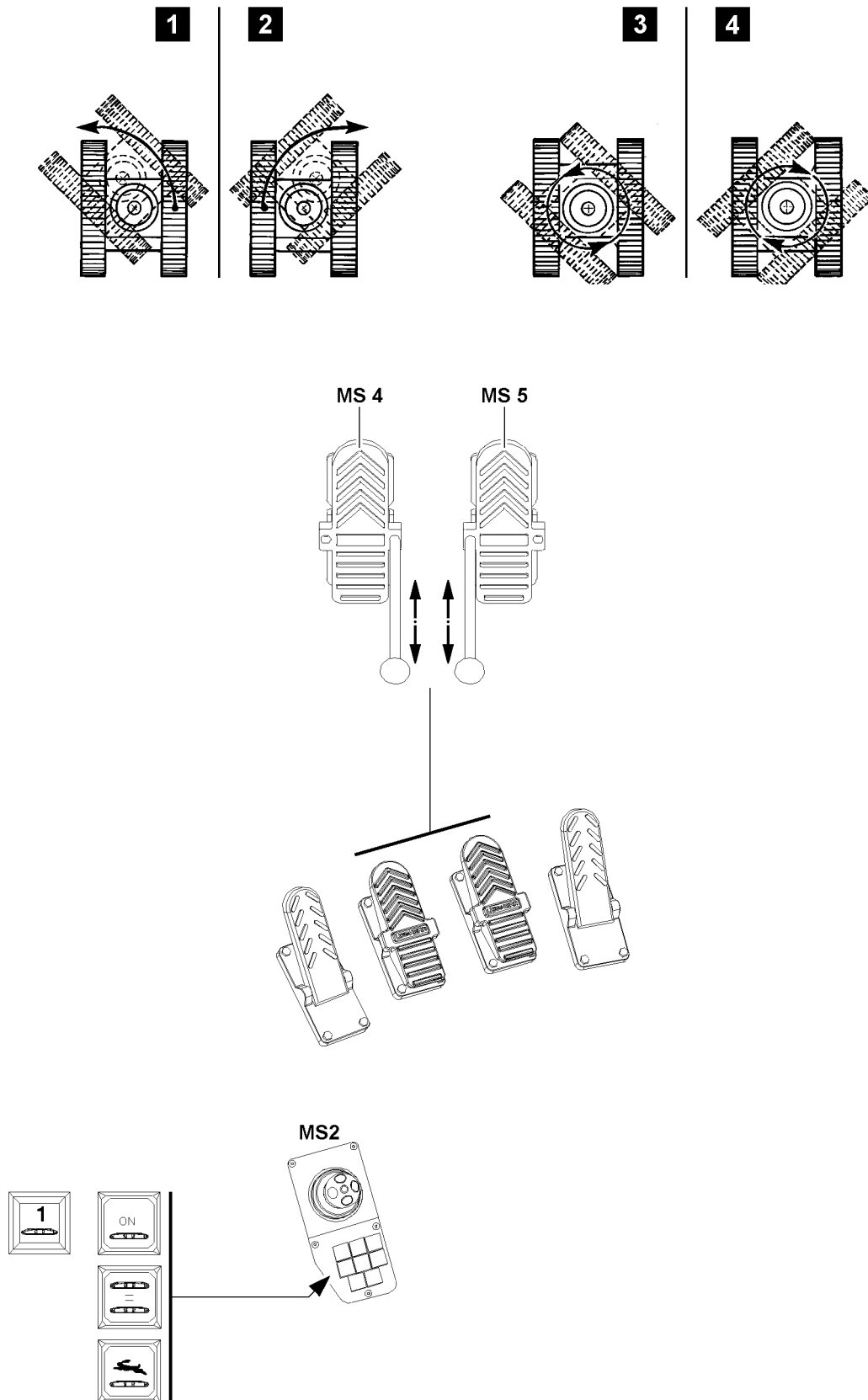

Fig.107964

LWE/LR 1600-2-008/18109-09-02/en

5.5.4 Steering the crane



WARNING

The crane can topple over!

If the crane is steered with applied slewing gear brake, then the boom system can be damaged due to high side acceleration.

Personnel can be severely injured or killed.

- ▶ When steering the crawler, always activate the slewing gear freewheeling.



WARNING

The crane can topple over!

If the crawler is steered with a sagging chain, then the centering cams of the track pads can no longer be centered and guided in the drive wheels and the track rollers.

The centering cams are damaged and / or the chain can jump from the drive wheels and damage them.

Personnel can be severely injured or killed.

- ▶ Stop steering movements immediately.
- ▶ Drive straight forward until all centering cams are centered again in the track rollers.
- ▶ If possible, retension the track chain, see Crane operating instructions, chapter 7.04.



WARNING

The crane can topple over!

When steering in small radii or when steering in counterrotation, the crawler tracks can „dig“ into the ground and cause the crane to topple over.

Personnel can be severely injured or killed.

- ▶ Steer the tracks in as large a radius as possible.
- ▶ Avoid counterrotation.

Steering the tracks to the left

See illustration 1.

- ▶ Push the right foot rocker **MS5** forward.
- or
- ▶ Move the manual lever on the foot rocker **MS5** forward.

Steering the tracks to the right

See illustration 2.

- ▶ Push the left foot rocker **MS4** forward.
- or
- ▶ Move the manual lever on the foot rocker **MS4** forward.

Counter-rotating the tracks to the left

See illustration 3.

- ▶ Push the right foot rocker **MS5** forward and the left foot rocker **MS4** backward.
- or
- ▶ Move the manual lever on the foot rocker **MS5** forward and move the foot rocker **MS4** backward.

Counter-rotating the tracks to the right

See illustration 4.

- ▶ Push the left foot rocker **MS4** forward and the right foot rocker **MS5** backward.
- or
- ▶ Move the manual lever on the foot rocker **MS4** forward and move the foot rocker **MS5** backward.

Empty page!

LWE/LR 1600-2-008/18109-09-02/en

4.20 Procedure for shut off of crane movements

1	General	3
2	Instructions for resuming crane movements for cranes with CE mark	7
3	Instructions for resuming crane movements for cranes without CE mark	55

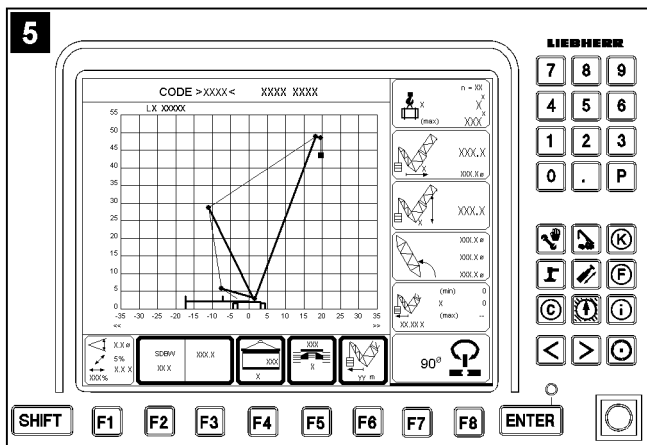
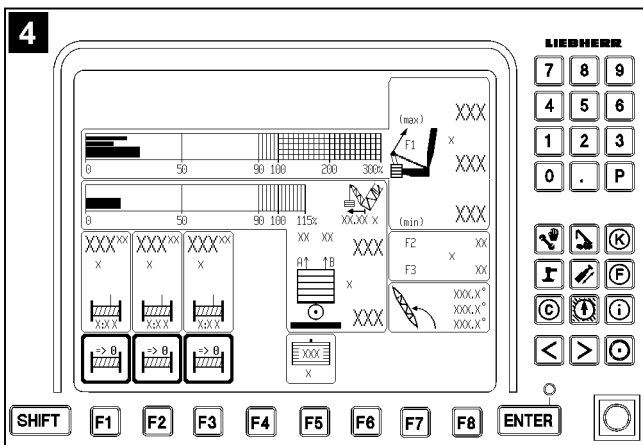
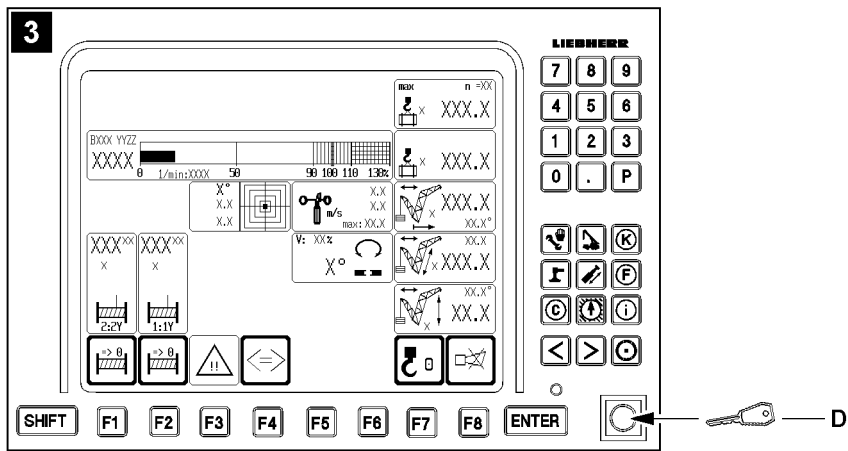
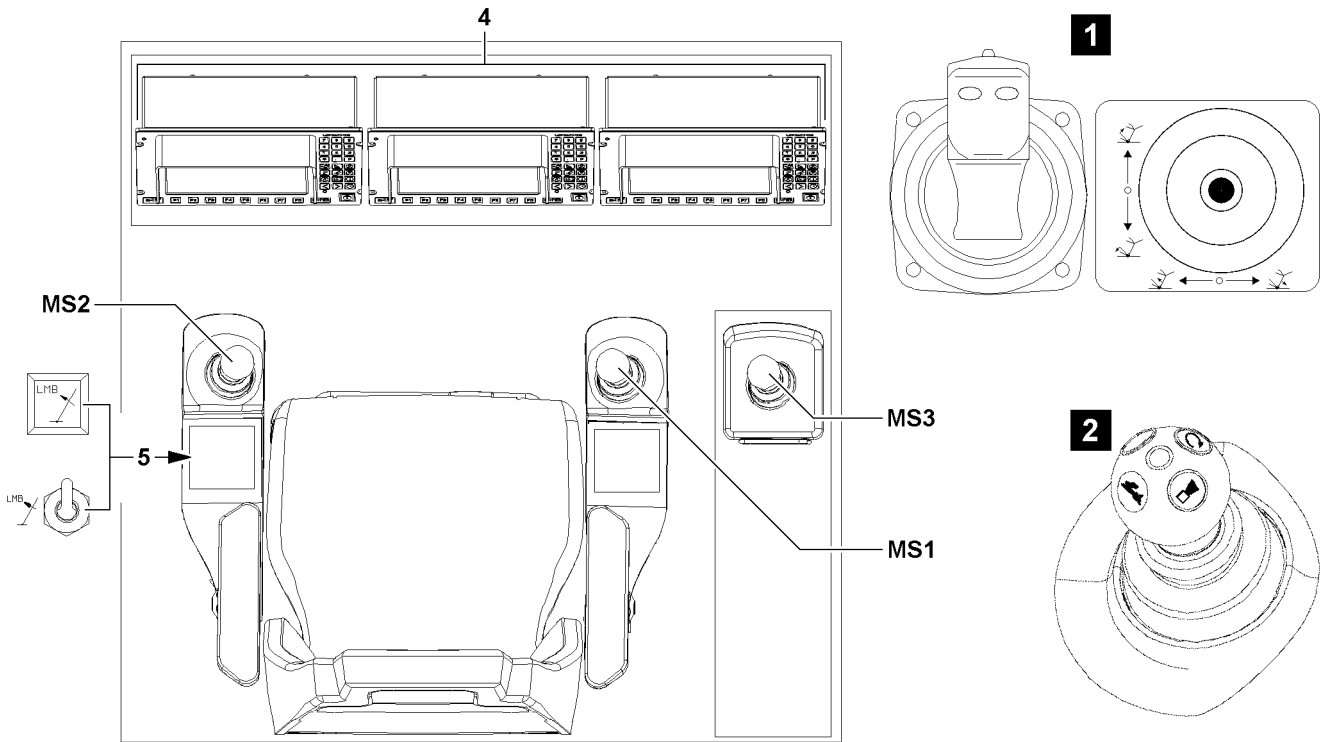

Fig.112332

LWE/LR 1600-2-008/18109-09-02/en

1 General

To operate the crane, three manually actuated master switches (MS1, MS2, MS3) are available.

- **MS1** Master switch
 - Right control console
- **MS2** Master switch
 - Left control console
- **MS3** Master switch
 - Right instrument panel

To monitor the crane, depending on the crane type, two or three LICCON monitors **4** are in the instrument panel.

- LICCON monitor, illustration **3**
 - User interface for entry of equipment configurations and for crane operation (crane operating screen), also described as LICCON monitor 0
- LICCON monitor, illustration **4**
 - User interface for operation with „Derrick“ boom, also described as LICCON monitor 1
- LICCON monitor, illustration **5**
 - User interface for „LICCON job planner“ (only for crane types with three monitors), also described as LICCON monitor 2

Equipment in the crane cab		
Crane type	Manually actuated master switches	LICCON monitors
LR 1350/1	Three (version illustration 2)	Two (three*)
LR 1400/2	Three (versions illustration 1)	Two
LR 1600/2	Three (version illustration 2)	Three
LR 1600/2–W	Three (version illustration 2)	Three
LR 1750	Three (version illustration 2)	Three
LR 1750/2	Three (version illustration 2)	Three
LG 1750	Three (version illustration 2)	Three
LR 11350	Three (version illustration 2)	Three

In the crane operator's cab, two buttons are installed to make it possible to bring the crane from an emergency situation after a shut off of the LICCON overload protection.

- Set up key **D** (Function „Exceeding the shut off limits for the LICCON overload protection“) on the LICCON monitor with crane operating screen, illustration **3**
- Button **5** „Luffing in with suspended load“ in the left control console

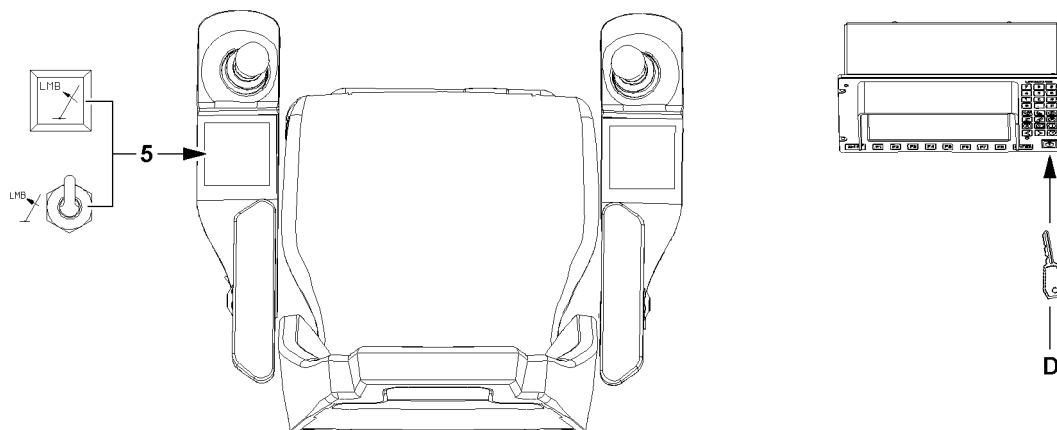

Fig. 112333

The function „Exceedance of shut off limits of the LICCON overload protection“, which is activated with the set up key **D** includes the following:

- Exceedance of the maximum permissible load moment
- Bypass of the hoist top shut off
- Exceedance of limit values from load charts
- Exceedance of maximum value test point 1 (force F1)
- Allowance of individual, limited crane movements after LMB STOP (error message)
- Completion of crane movements outside of load charts (erection / take down procedures)

NOTICE

Multi action function „Exceedance of shut off limits of the LICCON overload protection“!

If the set up key **D** is actuated, then it is possible to exceed several shut off limits of the LICCON overload protection simultaneously.

The LICCON overload protection as a whole is deactivated or limited.

There is no additional protection against crane overload.

- ▶ When the set up key **D** is actuated, it must be taken into account that the LICCON overload protection as a whole is deactivated or limited.



Note

The set up key **D** has two functions, independent of each other:

- ▶ If no crane movement can be carried out due to the shut off of crane operation by the LICCON overload protection, then by pressing the set up key **D**, a 100 % utilization can be exceeded and / or an active shut off can be bypassed. The crane can thereby be controlled again in normal operating status (utilization below 100 % and no active shut off).
- ▶ When the set up key **D** is actuated, all erection / take down procedures can be carried out within the erection / take down charts (assembly operation).

**WARNING**

Danger of accident due to function „Exceedance of shut off limits of the LICCON overload protection“! If the shut off limits of the LICCON overload protection are exceeded, there is no additional protection against crane overload.

Due to erroneous operation or deliberate misuse, the crane could collapse, the boom can break off or the crane can topple over.

Personnel can be severely injured or killed.

- ▶ The button **5** „Luffing in with suspended load“ and the set up key **D** may only be actuated when it is ensured that no normal operating condition (utilization below 100 % and no active shut off) can be reached without the function „Exceedance of shut off limits of the LICCON overload protection“!
- ▶ Actuate the set up key **D** only when no normal operating condition (utilization below 100 % and no active shut off) can be reached with the button **5** „Luffing in with suspended load“.
- ▶ The function „Exceeding the shut off limits of the LICCON overload protection“ is only permissible in emergencies and for assembly purposes.
- ▶ The set up key **D** may only be actuated by persons who are aware of the effects of their acts regarding the function „Exceeding the shut off limits of the LICCON overload protection“.
- ▶ The function „Exceeding the shut off limits of the LICCON overload protection“ requires the presence of an authorized person and must be performed with utmost caution.
- ▶ Crane operation with activated function „Exceeding the shut off limits of the LICCON overload protection“ is prohibited.

**WARNING**

Expanded working / danger zone of the crane!

Due to the function „Exceedance of shut off limits of the LICCON overload protection“ it is possible that the working / danger zone of the crane is significantly expanded.

If these circumstances are not observed, collisions and accidents can occur.

Personnel can be severely injured or killed.

- ▶ With activated function „Exceedance of shut off limits of the LICCON overload protection“ take an expanded working / danger zone of the crane into account and monitor it.

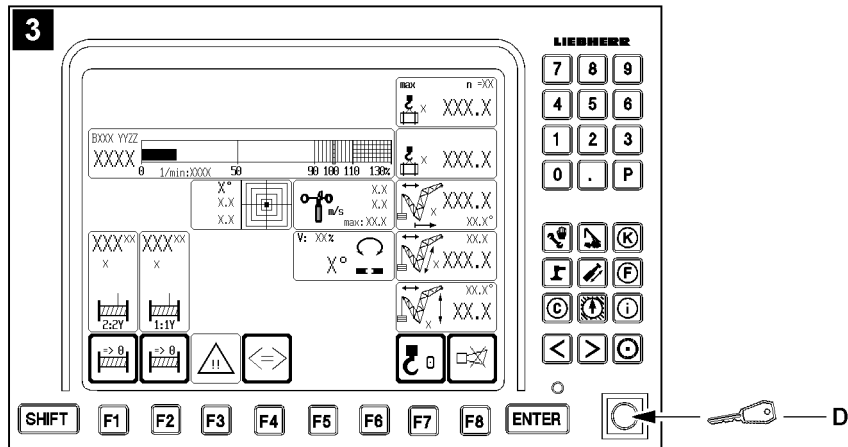
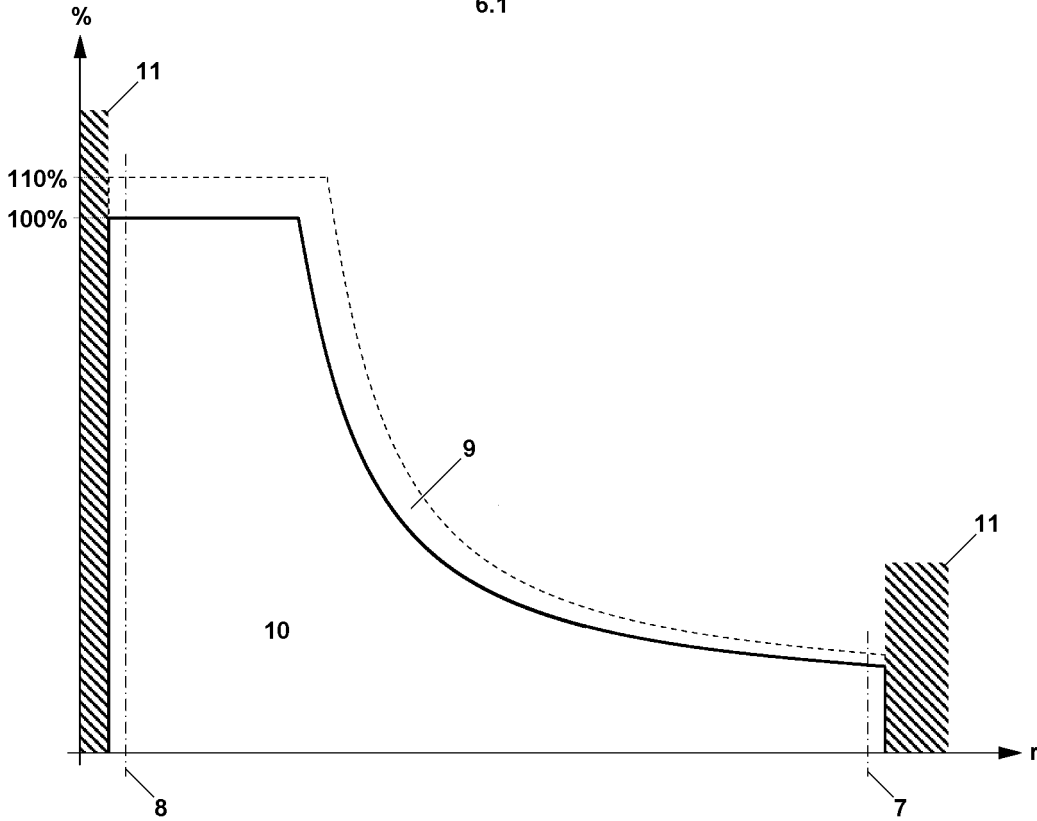
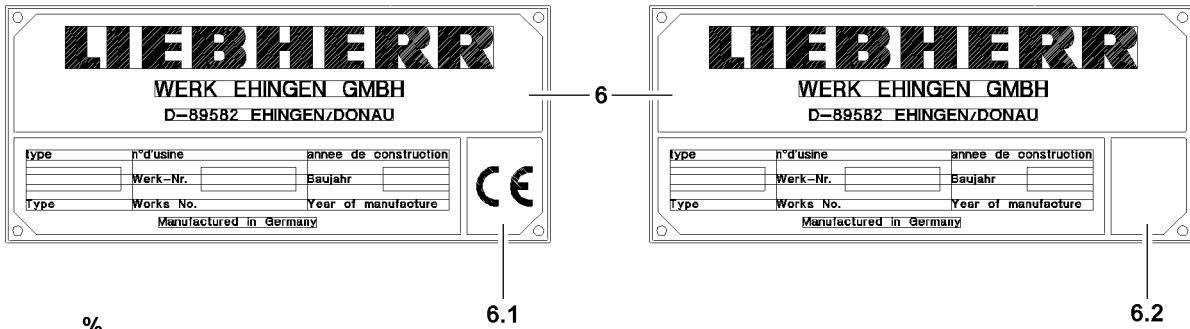

Fig.111211

LWE/LR 1600-2-008/18109-09-02/en

2 Instructions for resuming crane movements for cranes with CE mark



WARNING

Danger of accident!

If the following points are not observed, personnel can be severely injured or killed.

- ▶ The crane operator bears the sole and full responsibility for the adherence to measures to be taken in case of shut off of crane movement.
- ▶ The crane operator must make sure, before crane operation, that he is using the correct description for the current programming.



Note

- ▶ Check the data tag **6** to determine if your crane has a CE mark.
- ▶ The following section applies to a crane with CE mark, see data tag **6.1**.
- ▶ If your crane does not have a CE mark, see data tag **6.2**, then you must observe the description in section „Instructions for resuming a crane movement for cranes without CE mark“.

2.1 Overview load chart for cranes with CE mark

Axle	Description
r	Radius boom (working radius)
%	Utilization of the crane in percentages

Position	Description
7	Lower limit angle load chart
8	Upper limit angle load chart
9	Utilization up to 110 % with reduced working speed
10	Range „Load chart available“
11	Range „No load chart available“



Note

- ▶ If the set up key **D** (LICCON monitor with crane operating screen, illustration **3**) is actuated in the area „load chart available“, then the working speed is reduced and all displays of the LICCON overload protection remain functional.
- ▶ If the set up key **D** is actuated in the area „no load chart available“, then the working speed is not reduced.

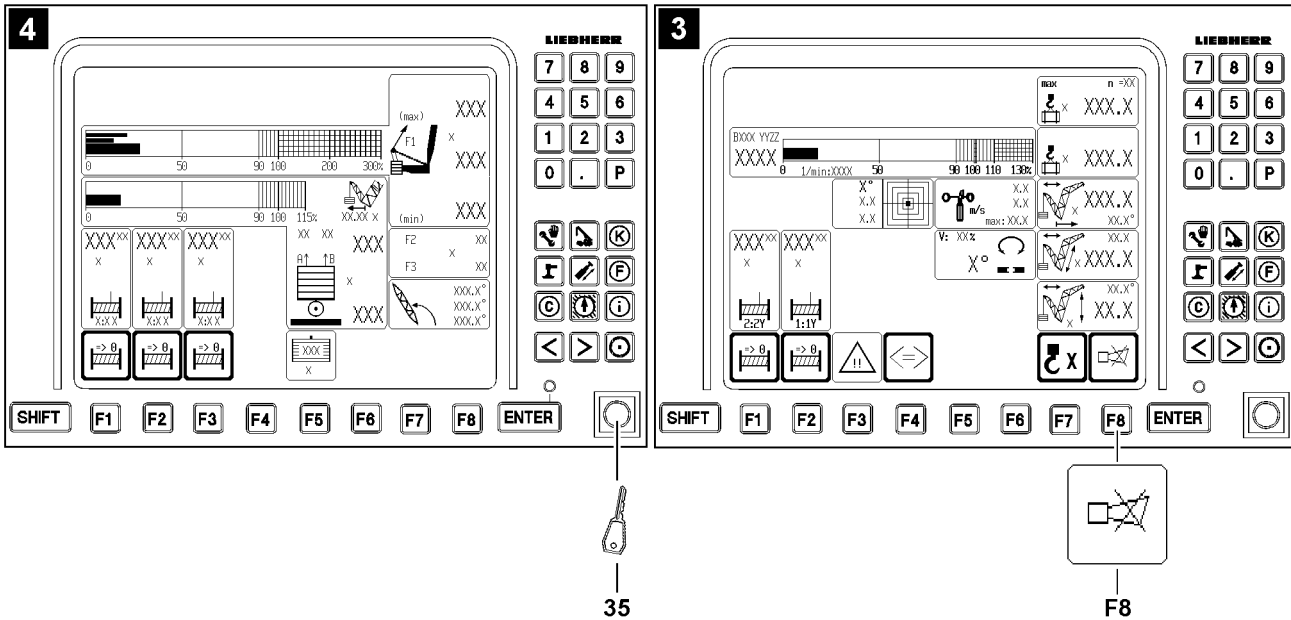
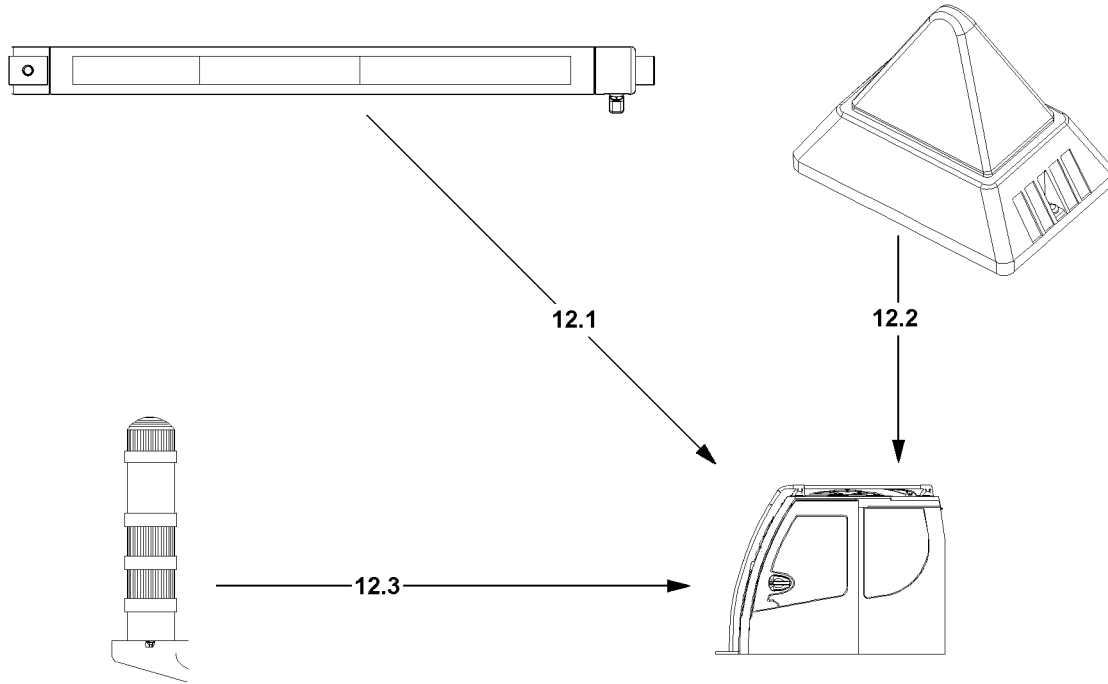

Fig.111212

LWE/LR 1600-2-008/18109-09-02/en

2.2 Overview of acoustic / visual warnings for cranes with CE mark

- Depending on the crane type, either a warning light **12.1** or a flashing beacon **12.2** or a combination of flashing beacon **12.2** and warning light* **12.3** are installed.
- The acoustic warnings within the crane operator's cab are turned off by pressing the button **F8** on the LICCON monitor with crane operating screen (illustration **3**).
- The acoustic warnings outside the crane operator's cab are turned off by actuating the key button **35** on the LICCON monitor with derrick operating screen (illustration **4**).

2.2.1 Description of acoustic / visual warnings

The case numbers from the chart „Overview of case numbers“ are valid for the following charts in this chapter:

- „Acoustic / visual warnings on the LICCON monitor“
- „Warning light 12.1“
- „Flashing beacon 12.2“
- „Warning light 12.3“

Overview of case numbers	
Case number	Description Case
Case 001	Utilization of crane from 0 % to 89 %
Case 002	Utilization of crane from 90 % to 100 %
Case 003	Utilization of crane over 100 %
Case 004	Shut off of crane movements - LMB STOP
Case 005	Luffing in with suspended load
Case 006	Participating sensor (LMB) defective
Case 010	Exceeding the shut off limits of the LICCON overload protection
Case 011	Bypass of shut off hoist top
Case 016	Bypass of shut off luffing down the boom / auxiliary boom / accessories, „Load chart available“
Case 018	Bypass of shut off luffing down the boom / auxiliary boom / accessories, „No load chart available“
Case 020	Exceeding the shut off limits of the LICCON overload protection during erection / take down procedures, „No load chart available“

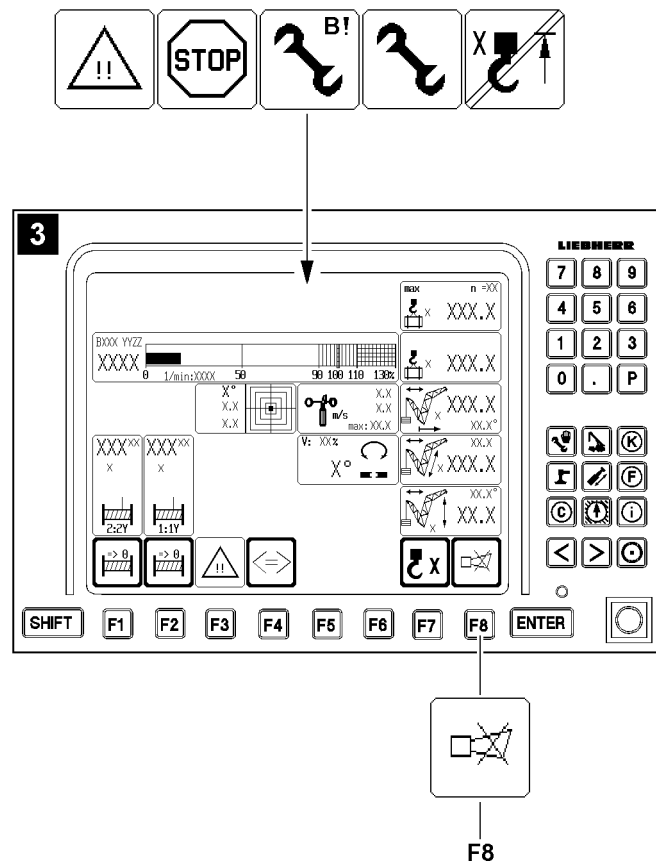

Fig.111209

2.2.2 Acoustic / visual warnings within the crane operator's cab



Note

► Description of individual case numbers, see chart „Overview of case numbers“.

Acoustic / visual warnings on the LICCON monitor									
Case number	Acoustic warning LICCON monitor at utilization of crane			Visual warning LICCON monitor					
	Short sound	Long sound	Long sound	Utilization of crane		Occurrence			
	From 90 %	Above 100 %	Always	From 90 %	Above 100 %	LMB STOP	Appears if the set up key D is actuated		
Case 001							—	—	—
Case 002	X ²			○			—	—	—
Case 003		X ²		○	○		—	—	—
Case 004			X ²		○		—	—	—
Case 005	X ²	X ²		○	○		—	—	—
Case 006			X ²			○	Cannot be bypassed ⁵		
Case 010	X ²	X ²		○	○		○		
Case 011			X ²	○	○	○	○		○
Case 016	X ²	X ²		○	○		○		
Case 018			X ²			○		○	
Case 020			X ²			○		○	

○ = cannot be turned off

X² = can be turned off immediately on the LICCON monitor key **F8**

Cannot be bypassed⁵ = contact Liebherr Service

LWE/LR 1600-2-008/18109-09-02/en

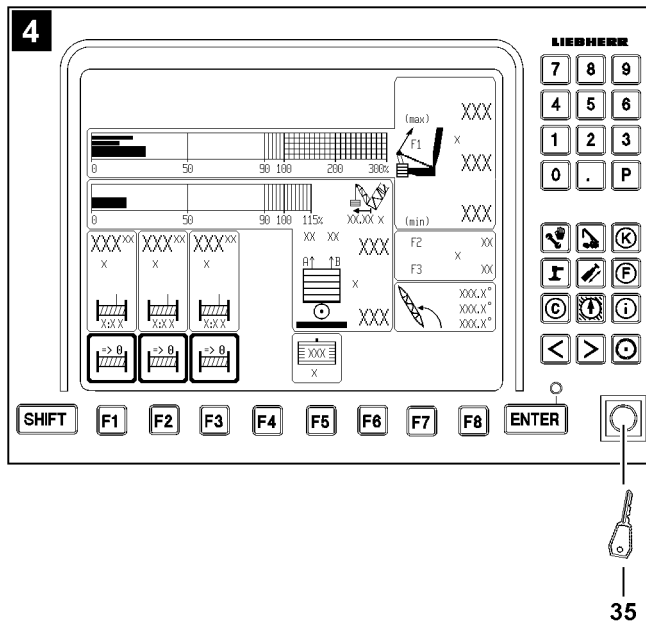
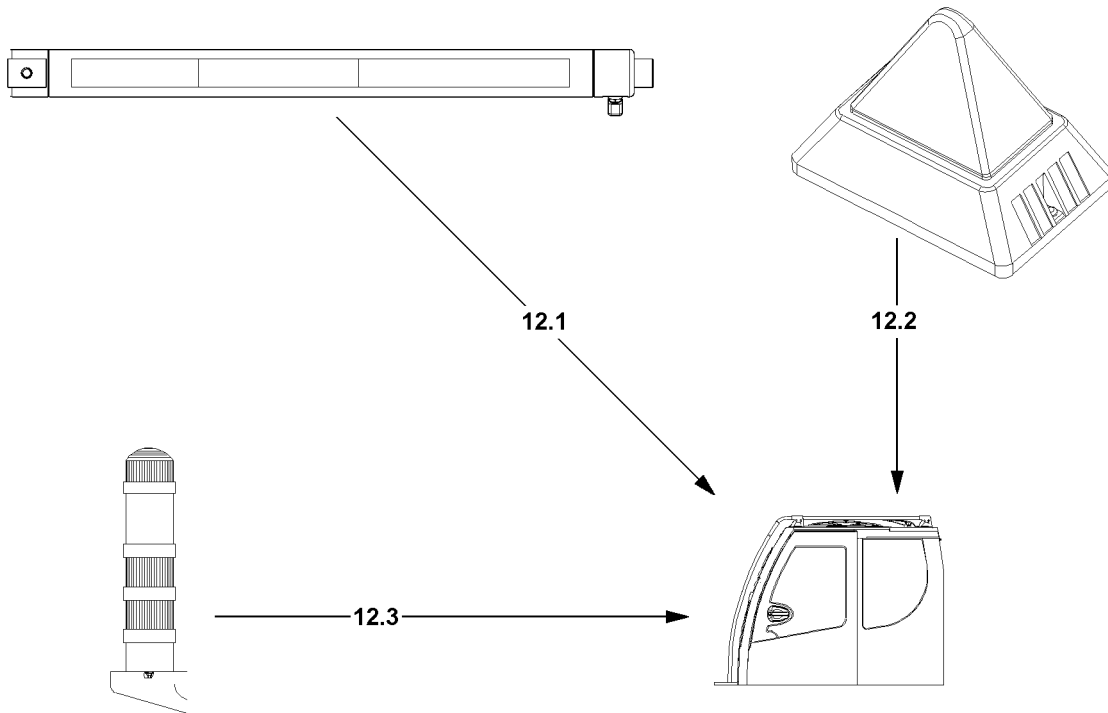

Fig.111206

2.2.3 Acoustic / visual warnings outside the crane operator's cab



Note

► Description of individual case numbers, see chart „Overview of case numbers“.

Warning light 12.1					
Case number	At utilization of crane	Acoustic warning	Visual warning		
		Signal turntable	Green	Yellow	Red
Case 001	From 0 % to 89 %		O ¹		
Case 002	From 90 % to 100 %			O ¹	
Case 003	Above 100 %	X ¹			O ¹
Case 004	-				O ¹
Case 005	From 0 % to 89 %		O ¹		
Case 005	From 90 % to 100 %			O ¹	
Case 005	Above 100 %	X ¹			O ²
Case 006	-				O ¹
Case 010	From 0 % to 89 %		O ¹		
Case 010	From 90 % to 100 %			O ¹	
Case 010	Above 100 % to 110 %			O ²	
Case 010	Above 110 %	X ¹			O ¹
Case 011	Up to 110 %			O ²	
Case 011	Above 110 %	O			O ²
Case 016	From 0 % to 89 %		O ¹		
Case 016	From 90 % to 100 %			O ¹	
Case 016	Above 100 % to 110 %			O ²	
Case 016	Above 110 %	X ¹			O ¹
Case 018	No value available			O ²	
Case 020	No value available			O ²	

O = cannot be turned off

O¹ = warning light **12.1** lights up

O² = warning light **12.1** blinks

X¹ = can be turned off by actuating (right touching) the key button **35** on the LICCON monitor with the derrick operating screen (illustration **4**), effective after at least 5 seconds

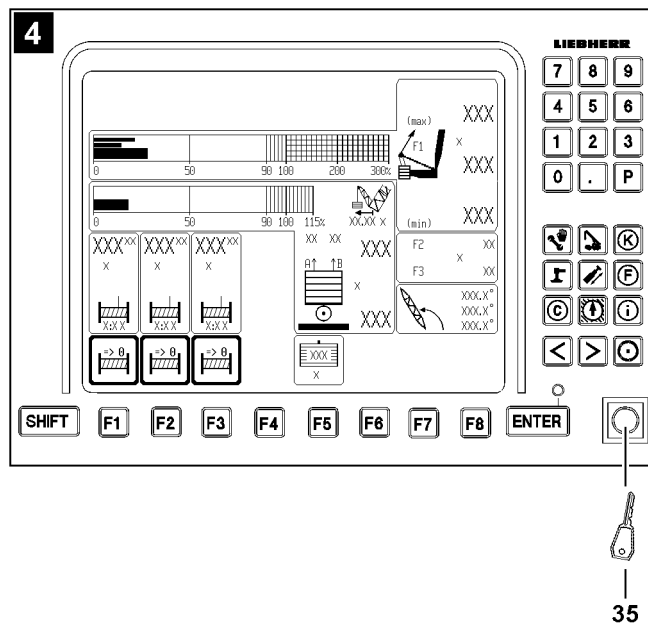
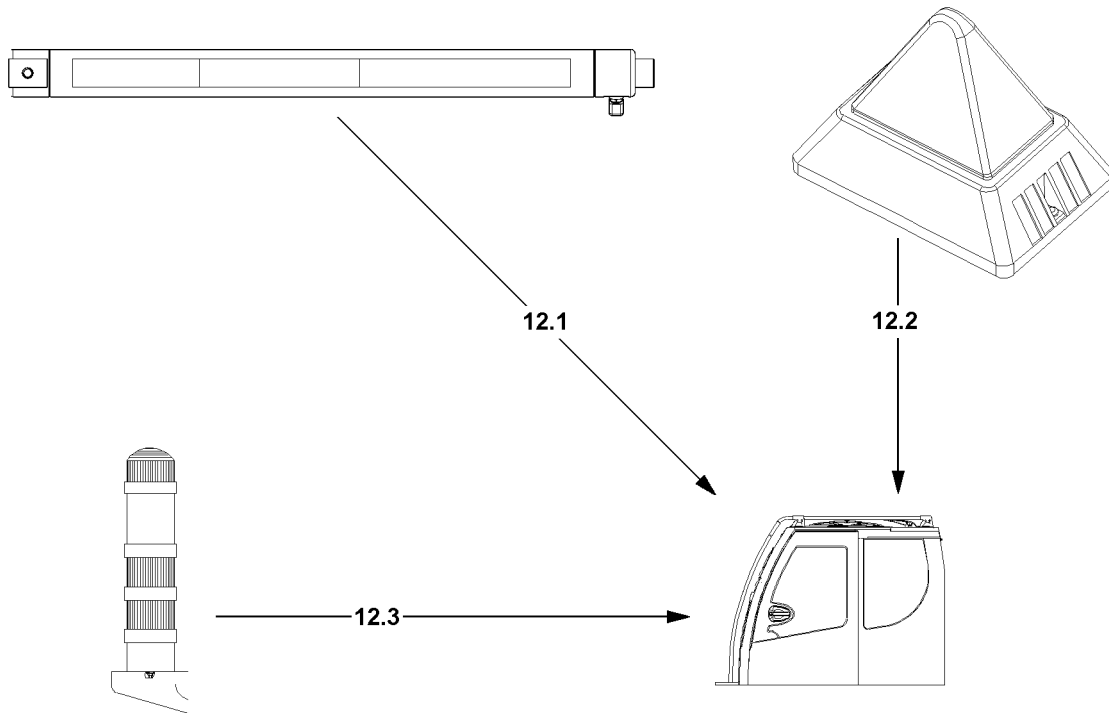

Fig.111206

**Note**

► Description of individual case numbers, see chart „Overview of case numbers“.

Flashing beacon 12.2			
Case number	At utilization of crane	Acoustic warning	Visual warning
		Signal turntable	Red
Case 001	0 % to 89 %	-	-
Case 002	90 % to 100 %	-	-
Case 003	Above 100 %	X ¹	O ²
Case 004	-		O ²
Case 005	Above 100 %	X ¹	O ²
Case 006	-		O ²
Case 010	Above 110 %	X ¹	O ²
Case 011	Above 110 %	X ¹	O ²
Case 016	Above 110 %	X ¹	O ²
Case 018	No value available		O ²
Case 020	No value available		O ²

O = cannot be turned off

O² = flashing beacon **12.2** blinks

X¹ = can be turned off by actuating (right touching) the key button **35** on the LICCON monitor with the derrick operating screen (illustration **4**), effective after at least 5 seconds

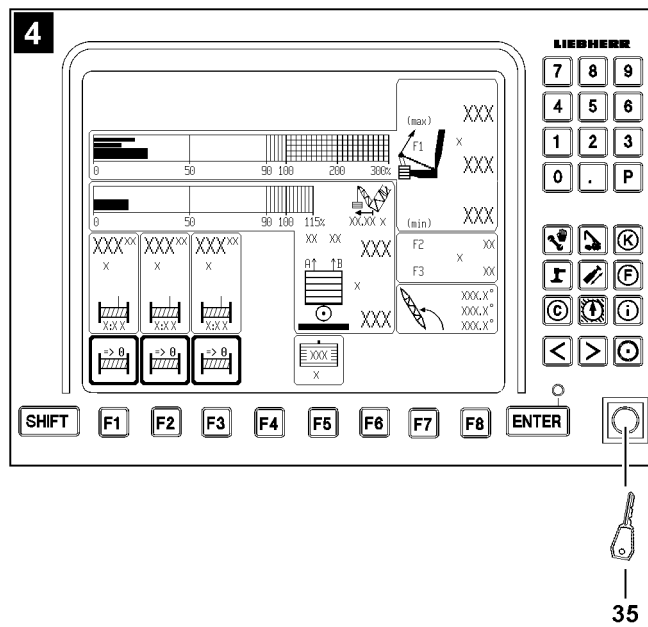
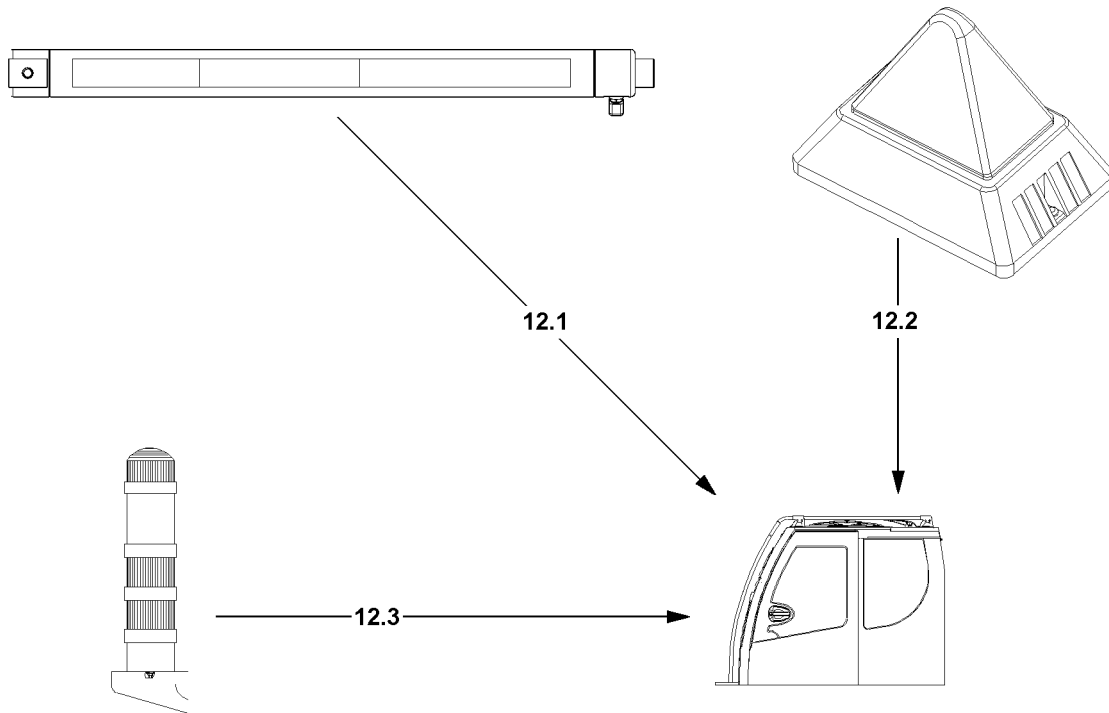

Fig.111206

**Note**

► Description of individual case numbers, see chart „Overview of case numbers“.

Warning light 12.3					
Case number	At utilization of crane	Acoustic warning	Visual warning		
		Signal turntable	Green	Yellow	Red
Case 001	From 0 % to 89 %		O ¹		
Case 002	From 90 % to 100 %			O ¹	
Case 003	Above 100 %	X ¹			O ²
Case 004	-				O ²
Case 005	From 0 % to 89 %		O ¹		
Case 005	From 90 % to 100 %			O ¹	
Case 005	Above 100 %	X ¹			O ²
Case 006	-				O ²
Case 010	From 0 % to 89 %		O ¹		
Case 010	From 90 % to 110 %			O ¹	
Case 010	Above 110 %	X ¹			O ²
Case 011	Up to 110 %			O ¹	
Case 011	Above 110 %	X ¹			O ²
Case 016	From 0 % to 89 %		O ¹		
Case 016	From 90 % to 110 %			O ¹	
Case 016	Above 110 %	X ¹			O ²
Case 018	No value available				O ²
Case 020	No value available				O ²

O = cannot be turned off

O¹ = warning light **12.3** lights up

O² = warning light **12.3** blinks

X¹ = can be turned off by actuating (right touching) the key button **35** on the LICCON monitor with the derrick operating screen (illustration **4**), effective after at least 5 seconds

2.3 Monitoring of crane movement

**Note**

- If the LICCON overload protection turns the crane movement off, then the exact cause for the shut off must be determined first.
- As a first step, try to rescind the crane movement which has caused a shut off.
- If it is not possible to rescind the affected crane movement, then the additional steps are described in the following sections of the chapter.

**Note**

- For detailed description of the individually listed symbols, see Crane operating instructions, chapter 4.02.

The LICCON overload protection carries out the following shut offs if a limit value is exceeded in crane operation:

- Shut off luffing the main boom up / down
- Shut off Upper limit shut off angle (OGAW)
- Shut off Luffing the auxiliary boom / accessory up / down
- Shut off maximum / minimum value test point 1 (force F1)
- Shut off spooling the winch up / out
- Shut off Hoist top
- Shut off due to error message

The LICCON overload protection warns if the limit values are exceeded, but does not turn off:

- Minimum / maximum support forces

2.3.1 Shut off luffing the main boom up / down

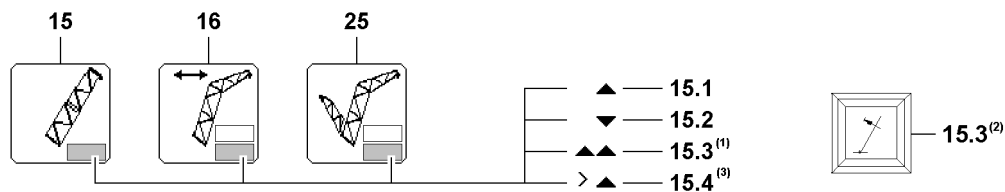

Fig.124701

⁽¹⁾not LR 1400/2

⁽²⁾only LR 1400/2

⁽³⁾Only for certain crane types

In symbol **15**, or symbol **16**, or symbol **25** appears in the lower field symbol **15.1**, or symbol **15.2** or symbol **15.4** and the LICCON overload protection has shut the crane movement off.

„Luffing the main boom up“ (symbol **15.1**) or „Luffing the main boom down“ (symbol **15.2**) or „upper limit shut off angle“ reached (symbol **15.4**), was shut off because the upper / lower limit angle of the selected load chart was exceeded / fallen below.

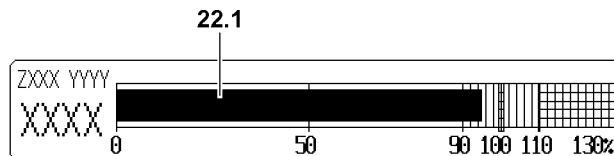

Fig.112340



Note

- ▶ If the utilization of the crane is more than 95 % (utilization bar **22.1** exceeds 95 %) and the maximum load according to the load chart (falling load capacity) drops by continuing to luff up the boom, then the symbol **15.1** also appears and the crane movement „Luffing the main boom up“ is turned off.

If the symbol / warning light **15.3** appears, then:

- **either** it was luffed up to a limit switch or the limit switch has turned off the crane movement „Luffing the main boom up“
- **or** there is an error on one of the limit switches „Main boom top“

The symbol **15.1** appears and the crane movement „Luffing the main boom up“ was turned off:

- ▶ Luff the main boom down.

Result:

- Crane operation is possible again.

The symbol **15.2** appears and the crane movement „Luffing the main boom down“ was turned off:

- ▶ Luff the main boom up.

Result:

- Crane operation is possible again.

The symbol / warning light **15.3** appears and the crane movement „Luffing the main boom up“ was turned off:

- ▶ Luff the main boom down.

Result:

- Crane operation is possible again.

Problem remedy

The symbol / warning light **15.3** appears continuously?

If a symbol / warning light **15.3** appears without having luffed the main boom up to a limit switch, then there may be an error in the limit switches „Main boom top“.

- ▶ Check if there is an error message from the LICCON computer system, see Diagnostics manual.
- ▶ If yes: Remedy the error immediately.

The symbol **15.4** appears and the crane movement „Luffing the main boom up“ (upper limit shut off angle) was turned off:

- ▶ Luff the main boom down.

Result:

- Crane operation is possible again.



WARNING

Limited warning functions!

If one of the double version limit switches is not ok and the crane is continued to be operated, then the warning functions of the LICCON overload protection are limited.

- ▶ The crane can only be operated in an emergency after failure of a double version limit switch.
- ▶ Carry out crane movements in such a way that no repeated shut off by the LICCON overload protection occurs.

2.3.2 Shut off Luffing the auxiliary boom / accessory up / down

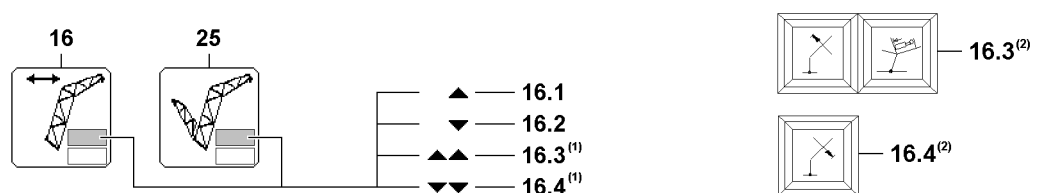

Fig.124702

⁽¹⁾not LR 1400/2

⁽²⁾only LR 1400/2

In symbol **16** or symbol **25** appear in the upper field symbol **16.1** or symbol **16.2** and the LICCON overload protection has shut off the crane movement.

„Luffing the auxiliary boom / accessory up“ (symbol **16.1**) or „Luffing the auxiliary boom / accessory down“ (symbol **16.2**) was shut off because the upper / lower limit angle of the selected load chart was exceeded / fallen below.

If the symbol / warning light **16.3** appears, then:

- **either** it was luffed up to a limit switch or the limit switch has turned off the crane movement „Luffing the auxiliary boom / accessory up“

- **or** the mechanical relapse support has turned off the crane movement „Luffing the auxiliary boom / accessory up“
- **or** there is an error on one of the limit switches „Auxiliary boom / accessory top“.

If the symbol / warning light **16.4** appears, then:

- **either** it was luffed down to a limit switch „Auxiliary boom / accessory bottom“ and the limit switch has turned off the crane movement „Luffing the auxiliary boom / accessory up“
- **or** there is an error on one of the limit switches „Auxiliary boom / accessory bottom“

The symbol **16.1** appears and the crane movement „Luffing the auxiliary boom / accessory up“ was turned off:

- ▶ Luff the auxiliary boom / accessory down.

Result:

- Crane operation is possible again.

The symbol **16.2** appears and the crane movement „Luffing the auxiliary boom / accessory down“ was turned off:

- ▶ Luff the auxiliary boom / accessory up.

Result:

- Crane operation is possible again.

The symbol / warning light **16.3** appears and the crane movement „Luffing the auxiliary boom / accessory up“ was turned off:

- ▶ Luff the auxiliary boom / accessory down.

Result:

- Crane operation is possible again.

Problem remedy

The symbol / warning light **16.3** appears continuously?

If a symbol / warning light **16.3** appears without having luffed up to a limit switch, then there may be an error in the limit switches „Auxiliary boom / accessory top“.

- ▶ Check if there is an error message from the LICCON computer system, see Diagnostics manual.
- ▶ If yes: Remedy the error immediately.

The symbol / warning light **16.4** appears and the crane movement „Luffing the auxiliary boom / accessory down“ was turned off:

- ▶ Luff the auxiliary boom / accessory up.

Result:

- Crane operation is possible again.

Problem remedy

The symbol / warning light **16.4** appears continuously?

If a symbol / warning light **16.4** appears without having luffed down to a limit switch, then there may be an error in the limit switches „Auxiliary boom / accessory bottom“.

- ▶ Check if there is an error message from the LICCON computer system, see Diagnostics manual.
- ▶ If yes: Remedy the error immediately.



WARNING

Limited warning functions!

If one of the double version limit switches is not ok and the crane is continued to be operated, then the warning functions of the LICCON overload protection are limited.

- ▶ The crane can only be operated in an emergency after failure of a double version limit switch.

- ▶ Carry out crane movements in such a way that no repeated shut off by the LICCON overload protection occurs.

2.3.3 Shut off maximum / minimum value test point 1 (force F1)



Note

- ▶ The force determined on test point 1 is generally described as $F1_{\text{actual}}$ (actual value F1).
- ▶ In the icon 17 (F1-load display), the force relationship as well as the number values are shown in number values as well as a bar display (called F1-bar display).
- ▶ The value $F1_{\text{max-operation}}$ 17.3 corresponds to 100 % in the F1-bar display.
- ▶ The F1-utilization bar 17.1 shows the relationship $F1_{\text{actual}}$ 17.2 to $F1_{\text{max-operation}}$ 17.3.
- ▶ In crane operation without derrick ballast, fewer values may be shown in the icon 17 (F1-load display).

Shut off maximum value F1 in crane operation

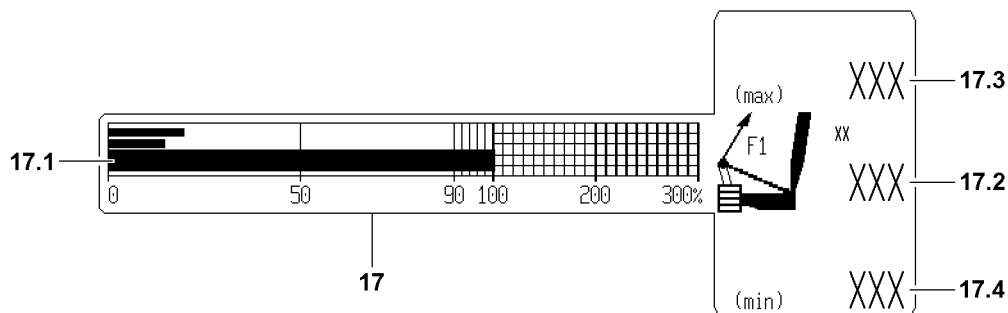

Fig.110991

In the icon 17(F1-load display) the F1-utilization bar 17.1 exceeds the 100 % mark and the LICCON overload protection has shut off the crane movement. The value $F1_{\text{actual}}$ 17.2 has exceeded the value $F1_{\text{max-operation}}$ 17.3.

All further movements, which lead to an increase of the force F1(value $F1_{\text{actual}}$) are shut off.

- ▶ Reverse any crane movement which has caused the shut off.
or
Initiate an alternative crane movement, which lowers the force F1 (value $F1_{\text{actual}}$).

Result:

- Crane operation is possible again.

Problem remedy

The crane operation is limited because the value $F1_{\text{max-operation}}$ apparently is being reached too early?

- ▶ Make sure that a valid set up status has been entered on the LICCON computer system.
- ▶ Make sure that the crane is assembled according to the assembly drawings.
- ▶ Make sure that the actual set up status and the entered set up status of the crane match.
- ▶ Make sure that all attachment parts and guy rods on the boom system, which are not needed, have been removed (weight).
- ▶ Make sure that the boom system is free of snow and ice (weight).
- ▶ Make sure that the wind influence onto the boom is not too great.

If no irregularities can be found:

- ▶ Contact Liebherr Service.

Shut off minimum value F1 in crane operation



Note

- ▶ A shut off minimum value F1 ($F1_{\text{min}}$) only occurs in operating modes with derrick ballast. The status $F1_{\text{actual}} = F1_{\text{min}}$ cannot be reached in all other operating modes.

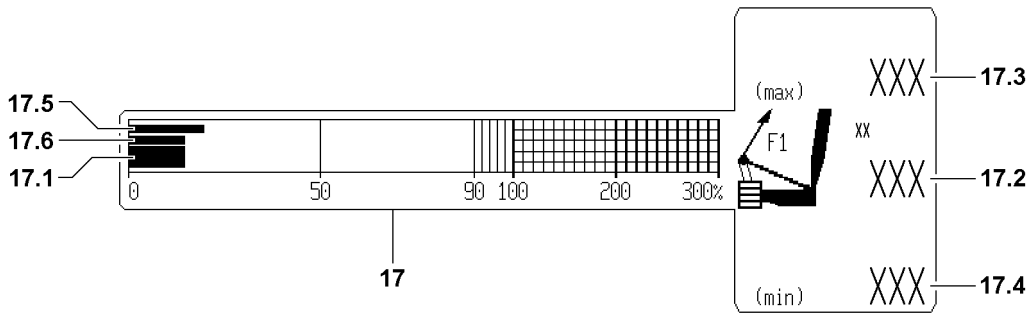

Fig.110992

In the icon **17** (F1-load display), when falling below the $F1_{min}$ advance warning bar **17.5**, a warning of the upcoming shut off is issued by the F1-utilization bar **17.1**.

If the F1-utilization bar **17.1** falls below the $F1_{min}$ -STOP bar **17.6**, then the LICCON overload protection shuts off the crane movement. The value $F1_{actual}$ **17.2** has fallen below the value $F1_{min}$ **17.4**.

**Note**

Shut off $F1_{min}$

- ▶ If the utilization of the derrick ballast is below 50 %, then there is no immediate shut off when falling below value $F1_{min}$.

All further movements, which lead to an decrease of the force $F1$ (value $F1_{actual}$) are shut off.

- ▶ Reverse any crane movement which has caused the shut off.
or
Initiate an alternative crane movement, which increases the force $F1$ (value $F1_{actual}$).

Result:

- Crane operation is possible again.

Problem remedy

The crane operation is limited because the value $F1_{min}$ apparently is being reached too early?

- ▶ Make sure that a valid set up status has been entered on the LICCON computer system.
- ▶ Make sure that the crane is assembled according to the assembly drawings.
- ▶ Make sure that the actual set up status and the entered set up status of the crane match.
- ▶ Make sure that all attachment parts and guy rods on the boom system, which are not needed, have been removed (weight).
- ▶ Make sure that the boom system is free of snow and ice (weight).
- ▶ Make sure that the wind influence onto the boom is not too great.

If no irregularities can be found:

- ▶ Contact Liebherr Service.

2.3.4 Shut off spooling the winch up / out

Fig.110878

In symbol **18** appears symbol **18.1**, symbol **18.2** or symbol **18.3** and the LICCON overload protection has shut off the crane movement.

„Spooling the winch out“ (symbol **18.1**) or „spooling the winch up“ (symbol **18.2**) was shut off because the upper / lower limit value of the rope for the selected winch was exceeded or fallen below.

If symbol **18.3** appears blinking in the symbol **18**, then the affected winch is deactivated.

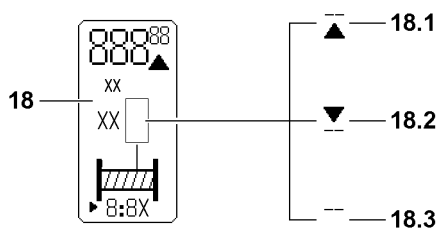
The symbol **18.1** appears and the crane movement „Spooling the winch out“ was turned off:

▶ Spool the winch up.

Result:

– Crane operation is possible again.

The symbol **18.2** appears and the crane movement „Spooling the winch up“ was turned off:

▶ Spool the winch out.

Result:

– Crane operation is possible again.

The line / line **18.3** appear and the winch is deactivated:

▶ Activate the winch, see Crane operating instructions, chapter 4.02.

Result:

– Crane operation is possible again.

2.3.5 Shut off hoist top

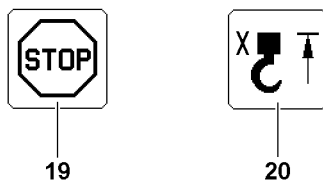

Fig.110875

The symbol **19** and hoist top icon **20** appear in the LICCON monitor and the LICCON overload protection has turned the crane movement off.

Spooling the hoist winch up was turned off because the hook block or the load hook has run against a hoist limit weight during the upward movement and the affected hoist limit switch was triggered.



WARNING

Property damage / falling load!

▶ After shut off spool hoist winch up (hoist top), for every further crane movement, the distance between the hook block / load hook and the boom head must be checked.



Note

▶ After a hoist top shut off occurred, further crane movements, which affect the length of the hoist rope are also shut off.

▶ Spool the hoist winch out.

Result:

– Crane operation is possible again.

2.3.6 Shut off due to error message

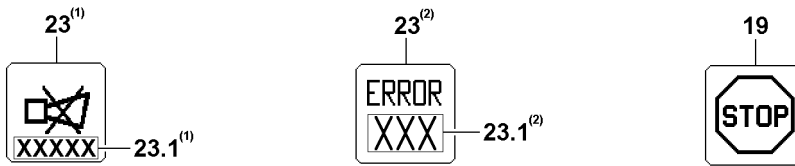

Fig.112331

⁽¹⁾not LR 1400/2

⁽²⁾only LR 1400/2

In the icon **23** appears an error message, the icon **19** appears in the LICCON monitor and the LICCON overload protection has turned off crane movement.

- ▶ Determine the existing error with the help of the error message from the error field **23.1** in icon **23**, see Diagnostics manual.
- ▶ Remedy the error.

If the error cannot be remedied:

- ▶ Contact Liebherr Service.

Problem remedy

The erection of the crane, for example after assembly on a new job site or with another equipment configuration, is not possible due to an error message?

- ▶ Evaluate the error message.
- ▶ Make sure that all electrical connections are established correctly.
- ▶ Check if all sensors or dummy plugs with integrated electric have been connected properly.



Note

- ▶ If there is a defect on a participating sensor (LMB), then the crane can no longer be operated in normal operating condition. Contact Liebherr Service and fix / replace the sensors.

2.3.7 Minimum / maximum support forces



Note

- ▶ Applies only for cranes with support force monitoring*.
- ▶ Description of support force monitoring, see Crane operating instructions, chapter 4.02.

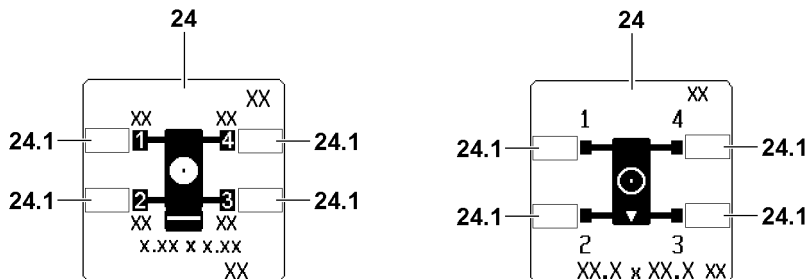

Fig.110881

**WARNING**

The crane can topple over!

When reaching the programmed minimum / maximum support forces there is no automatic shut off of crane movements.

The displayed support force values are subjected to fluctuating influences, for example crane operation, surrounding and environmental influences.

The resulting tolerance field of the determined values may not be utilized by the support force display to determine the tipping limit of the crane.

If this is disregarded, then the crane can topple over.

Personnel can be severely injured or killed.

- ▶ The displayed support force values of the support force display may not be used to utilize the crane up to the tipping limit.
- ▶ Make sure that all support force values are within the minimum / maximum support forces.

The icon **24** (depending on the crane, similar to the left or right illustration) is shown in the LICCON monitor with blinking value in one or several fields **24.1**. Blinking values in the fields **24.1** signal exceedance of the minimum / maximum support forces.

- ▶ Reverse the crane movements, which caused the support forces to be outside the minimum / maximum values.

Result:

- All values in the fields **24.1** are within the minimum / maximum support forces.
- ▶ Carry out crane movements in such a way that the support forces always remain within the minimum / maximum values.

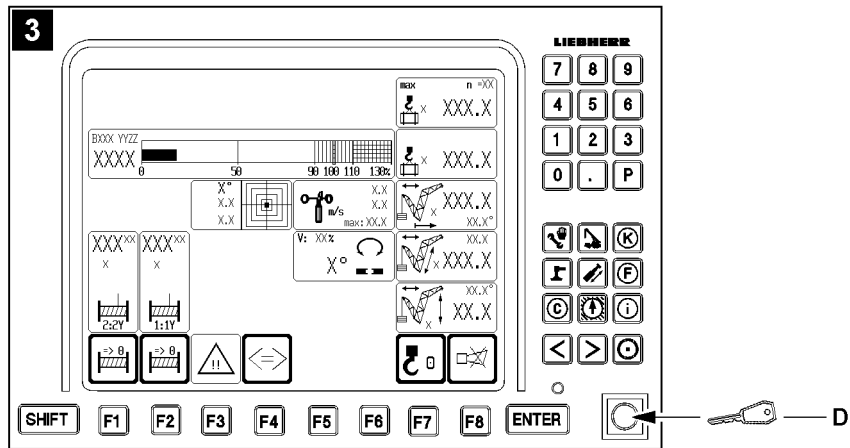
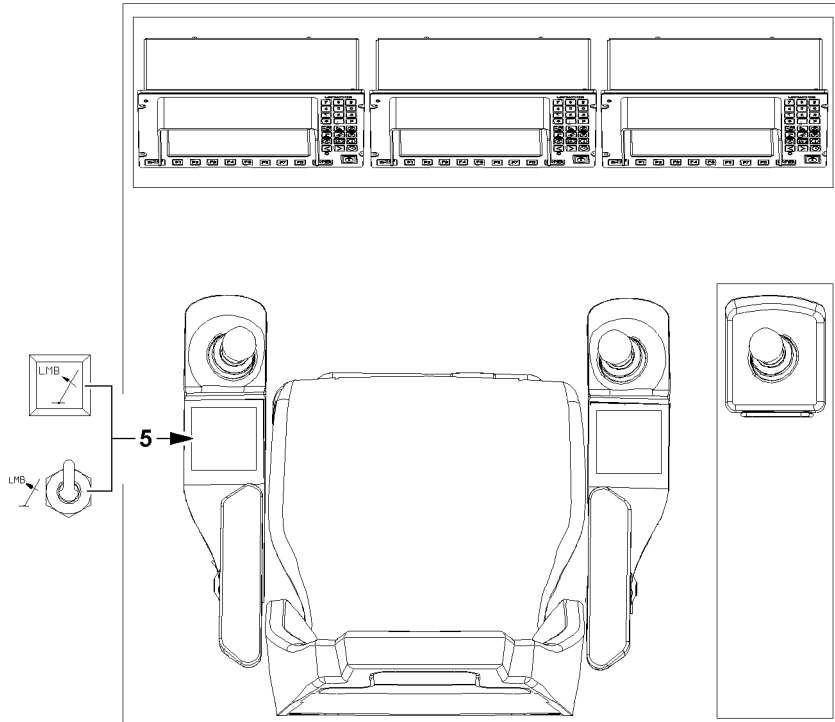

Fig.112334

LWE/LR 1600-2-008/18109-09-02/en

2.4 Shut off of crane movement: LMB STOP by LICCON overload protection



WARNING

Risk of overload and toppling the crane!

If the shut off limits of the LICCON overload protection are exceeded without knowing the exact cause for the shut off by the LICCON overload protection, then the crane can be overloaded and topple over. Personnel can be severely injured or killed.

- ▶ Before activating the function „Exceedance of shut off limits of the LICCON overload protection“ determine the exact cause for the shut off.



WARNING

Danger of accident due to function „Exceedance of shut off limits of the LICCON overload protection“! If the shut off limits of the LICCON overload protection are exceeded, there is no additional protection against crane overload.

Due to erroneous operation or deliberate misuse, the crane could collapse, the boom can break off or the crane can topple over.

Personnel can be severely injured or killed.

- ▶ The button **5** „Luffing in with suspended load“ and the set up key **D** may only be actuated when it is ensured that no normal operating condition (utilization below 100 % and no active shut off) can be reached without the function „Exceedance of shut off limits of the LICCON overload protection“!
- ▶ Actuate the set up key **D** only when no normal operating condition (utilization below 100 % and no active shut off) can be reached with the button **5** „Luffing in with suspended load“.
- ▶ The function „Exceeding the shut off limits of the LICCON overload protection“ is only permissible in emergencies and for assembly purposes.
- ▶ The set up key **D** may only be actuated by persons who are aware of the effects of their acts regarding the function „Exceeding the shut off limits of the LICCON overload protection“.
- ▶ The function „Exceeding the shut off limits of the LICCON overload protection“ requires the presence of an authorized person and must be performed with utmost caution.
- ▶ Crane operation with activated function „Exceeding the shut off limits of the LICCON overload protection“ is prohibited.



WARNING

Expanded working / danger zone of the crane!

Due to the function „Exceedance of shut off limits of the LICCON overload protection“ it is possible that the working / danger zone of the crane is significantly expanded.

If these circumstances are not observed, collisions and accidents can occur.

Personnel can be severely injured or killed.

- ▶ With activated function „Exceedance of shut off limits of the LICCON overload protection“ take an expanded working / danger zone of the crane into account and monitor it.

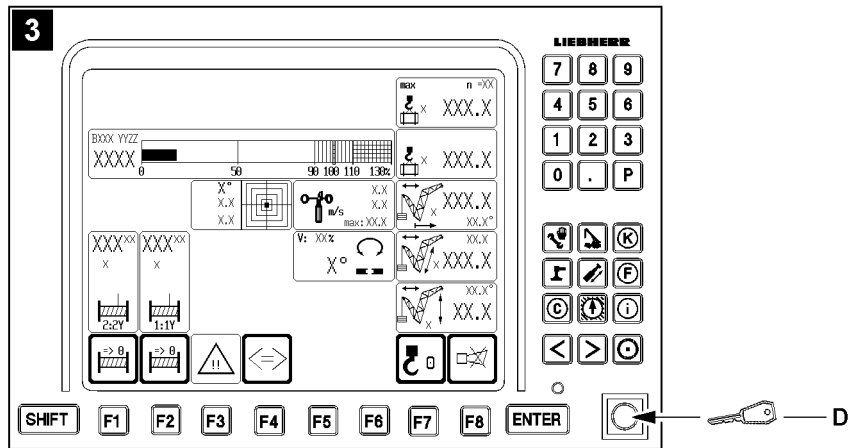
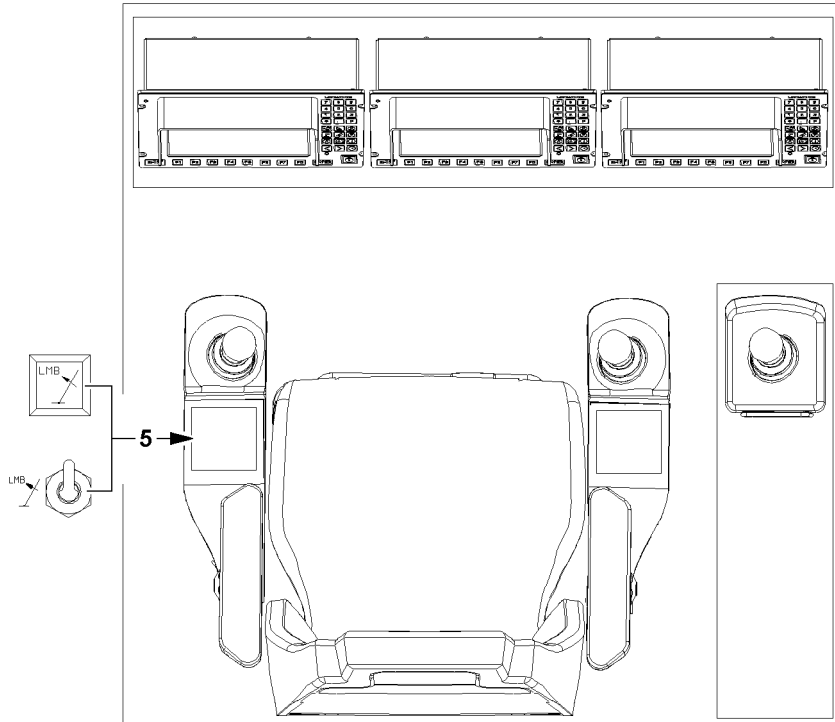

Fig.112334

LWE/LR 1600-2-008/18109-09-02/en

**WARNING**

Overload of crane!

When taking on a load by luffing the boom up, the crane can be overloaded.

This could result in serious accidents.

- ▶ Taking on load by luffing up the boom is prohibited.
- ▶ Take on a load only with the hoist gear.

**Note**

- ▶ If the set up key **D** is actuated in the area „load chart available“, then the working speed is reduced.
- ▶ If the set up key **D** is actuated in the area „no load chart available“, then the working speed is not reduced.

There are two possibilities to exceed the shut off limits of the LICCON overload protection after LMB STOP:

- With button **5** „Luffing in with suspended load“ in the left control console
- With the set up key **D** on the LICCON monitor with crane operating screen, see illustration **3**

NOTICE

Danger of mix up!

The function „Exceedance of shut off limits of LICCON overload protection“ can only be activated with the set up key **D** on the LICCON monitor with crane operating screen, see illustration **3**.

The key buttons on the other monitors are not assigned with this function.

- ▶ Do not mix up the set up key **D** with the other key buttons.
- ▶ In case of mix up: Deactivate the activated function.

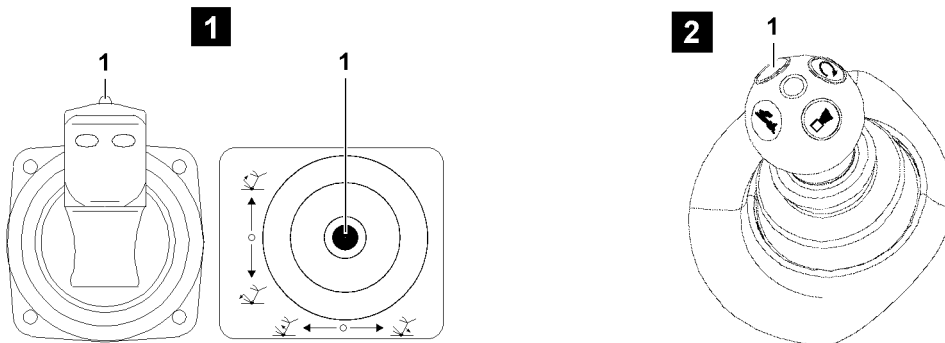
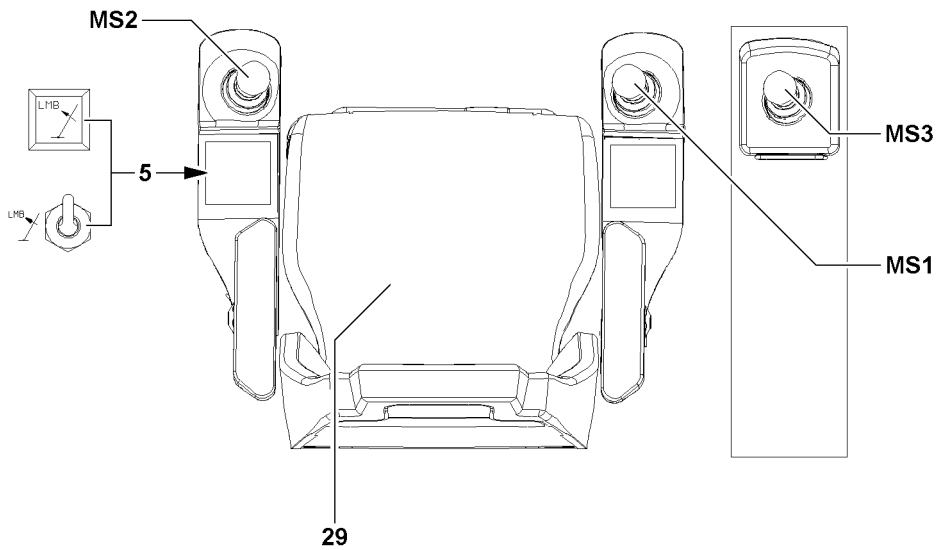
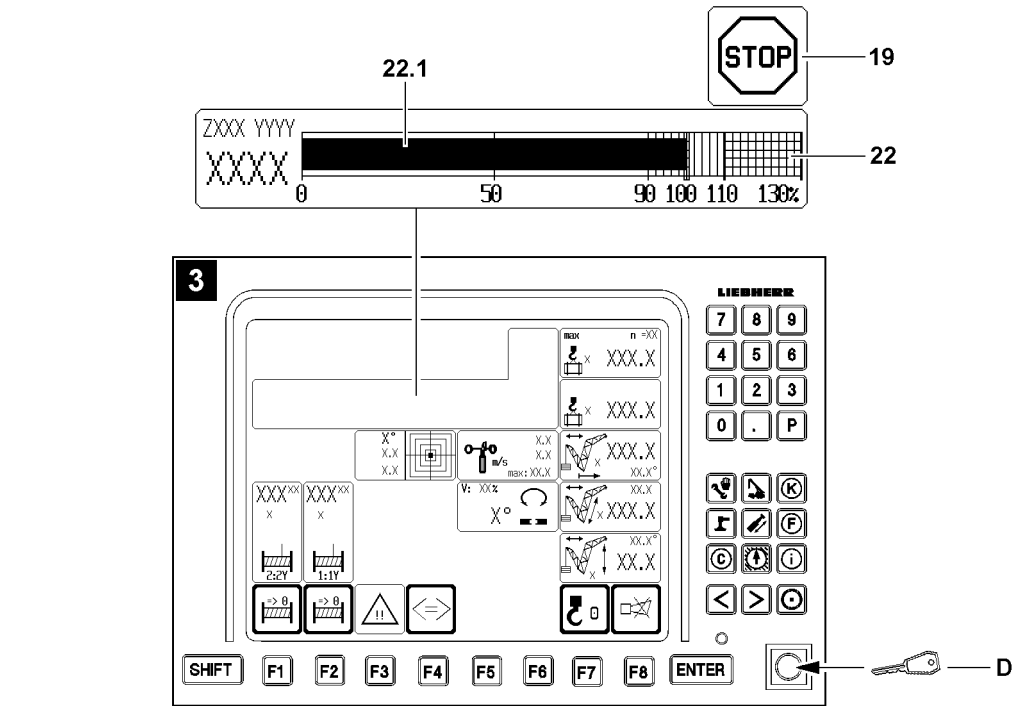

Fig.112335

LWE/LR 1600-2-008/18109-09-02/en

2.4.1 Luffing in with suspended load

If the maximum permissible load torque is exceeded, the LICCON overload protection turns off all crane movements that increase load torque.

In the icon **22** (load moment display) the utilization bar **22.1** has exceeded the 100 % mark and in the LICCON monitor appears the icon **19**.

This shut off limit can be exceeded by actuating the button **5** „Luffing in with suspended load“.

Make sure that the following prerequisite is met:

- Either the seat contact button **29** or one of the buttons **1** of the master switches (MS1, MS2, MS3) is actuated.



Note

- ▶ If the load is reduced by luffing up, then the button **5** „Luffing in with suspended load“ is possibly not functioning.
- ▶ For the procedure when the button **5** „Luffing in with suspended load“ is not functioning, see section „Exceedance of maximum permissible load moment“.

- ▶ Press the function key **5** „Luffing in with suspended load“ and hold it.

Result:

- The LICCON overload protection is inactive.

- ▶ Luff the load in.

Result:

- If the crane reaches a normal operation status (utilization below 100 % and no active shut off) then the icon **19** turns off, normal crane operation is possible again.

The function „Luffing in with suspended load“ is deactivated:

- When the function key **5** „Luffing in with suspended load“ is not longer actuated.
- When neither the seat contact button **29** nor one of the buttons **1** of the master switches (MS1, MS2, MS3) is actuated.
- In case of defect of an associated sensor (LMB).
- At engine stop.

The function „Luffing in with suspended load“ is deactivated:

- The LICCON overload protection is active.
- ▶ Carry out crane movements in such a way that no repeated shut off by the LICCON overload protection occurs.

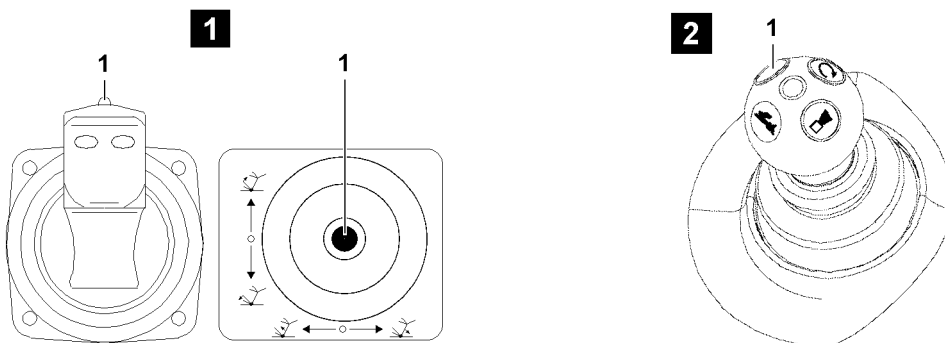
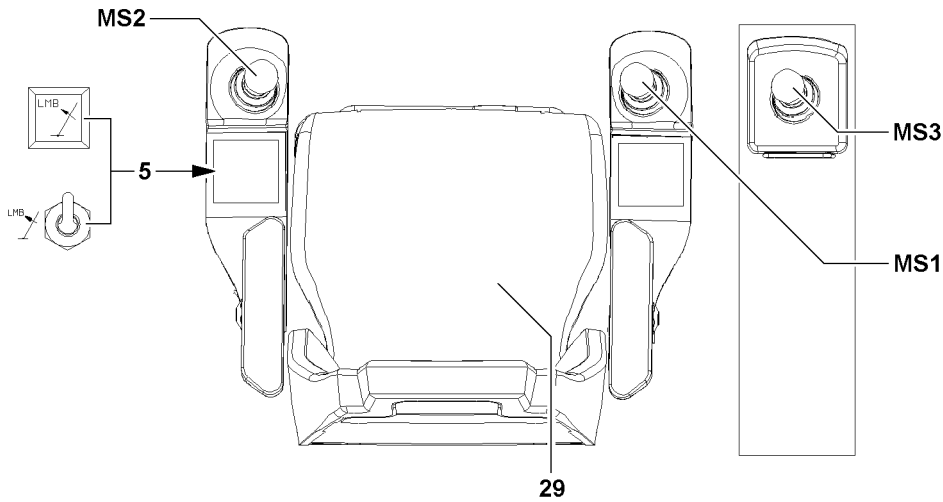
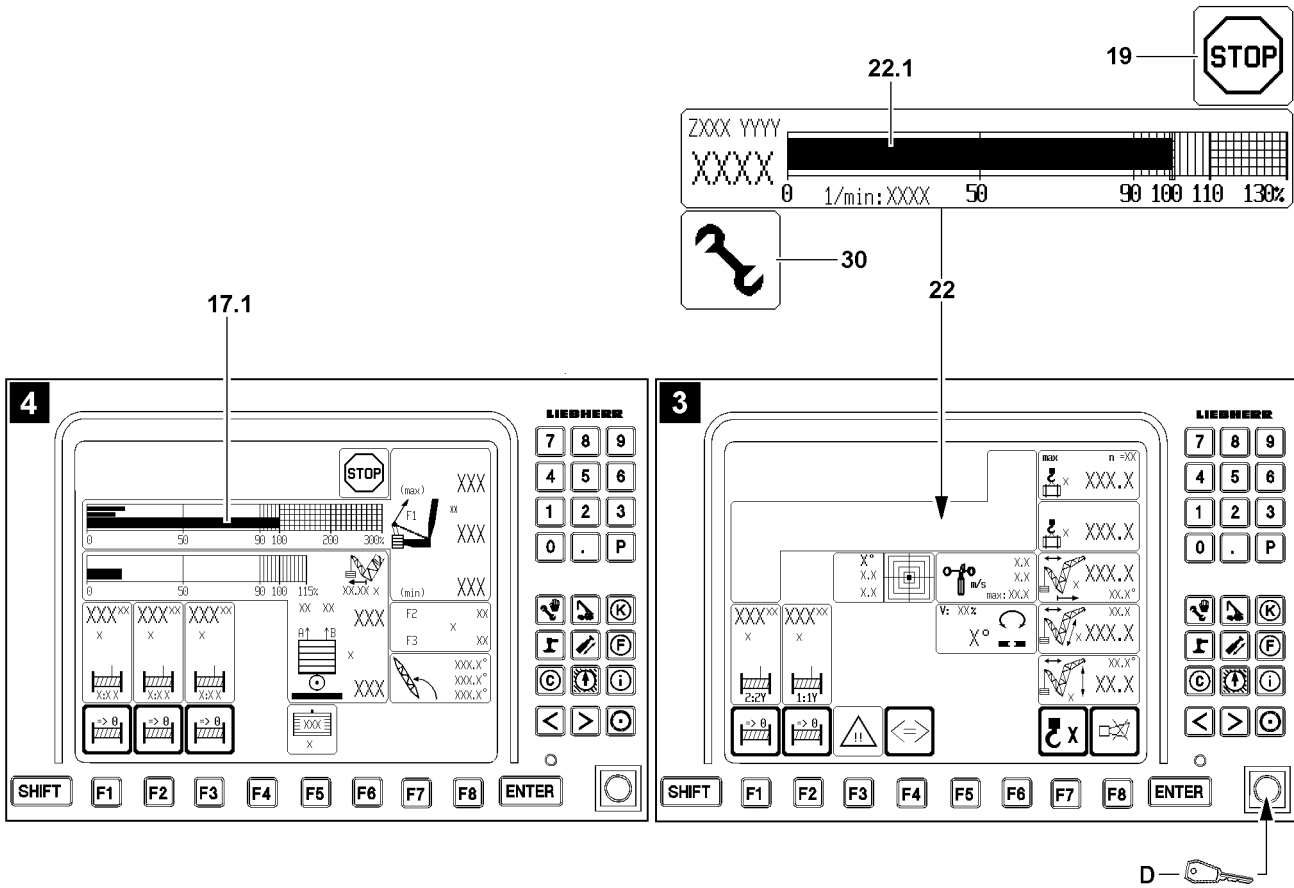

Fig.112336

LWE/LR 1600-2-008/18109-09-02/en

2.4.2 Exceedance of the maximum permissible load moment

If the maximum permissible load torque is exceeded, the LICCON overload protection turns off all crane movements that increase load torque.

In the icon **22** (load moment display) the utilization bar **22.1** has exceeded the 100 % mark and in the LICCON monitor appears the icon **19**.

This shut off can be exceeded by the set up key **D** in the „right touching“ position.



WARNING

Shut off safety device!

If the function „Exceedance of shut off limits of LICCON overload protection“ is activated by actuating the set up key **D** then it is possible to exceed the maximum permissible load moment. The function „Exceedance of maximum value test point 1“ is automatically activated too. Thus there is no shut off when exceeding the maximum value test point 1.

- ▶ All notes regarding the function „Exceedance of shut off limits of LICCON overload protection“ must be observed.
- ▶ The utilization bar $F1_{\text{actual}}$ **17.1** of the F1 load display must be observed.



Note

- ▶ In emergency situations, the function „Exceedance of shut off limits of the LICCON overload protection“ can be activated with the set up key **D** and the maximum permissible load moment can be exceeded by 10 % to maximum 110 %.

The set up key **D** on the LICCON monitor has two positions:

- Operating position (not actuated): Crane is in normal operation
- Position to right (touching): The function „Exceedance of shut off limits of the LICCON overload protection“ is activated, the assembly icon **30** appears in the LICCON monitor.

Make sure that the following prerequisites are met:

- With the button **5** „Luffing in with suspended load“ no normal operating status (utilization below 100 % and no active shut off) can be reached.
- All master switches (MS1, MS2, MS3) are in zero position (not deflected).
- Either the seat contact button **29** or one of the buttons **1** of the master switches (MS1, MS2, MS3) is actuated.
- Radio operation* is not active.
- The load moment display 110 % has not been reached and a load chart is available.
- ▶ Turn the set up key **D** to the right (touching).

Result:

- The LICCON overload protection is inactive.
- The assembly icon **30** appears in the LICCON monitor.
- The working speed in the area „Load chart available“ is reduced for all functions.

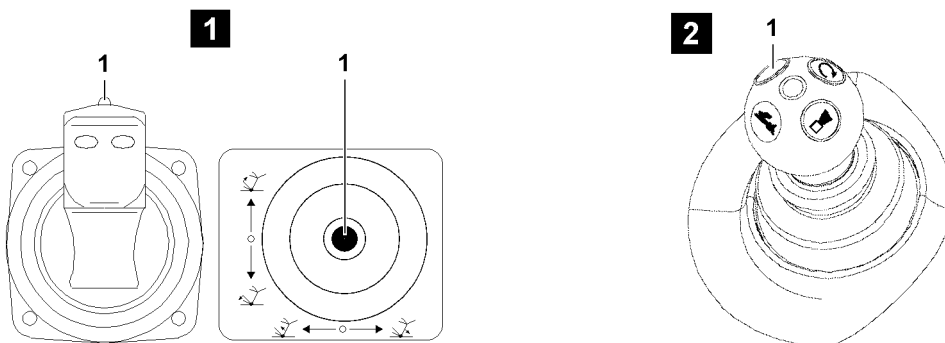
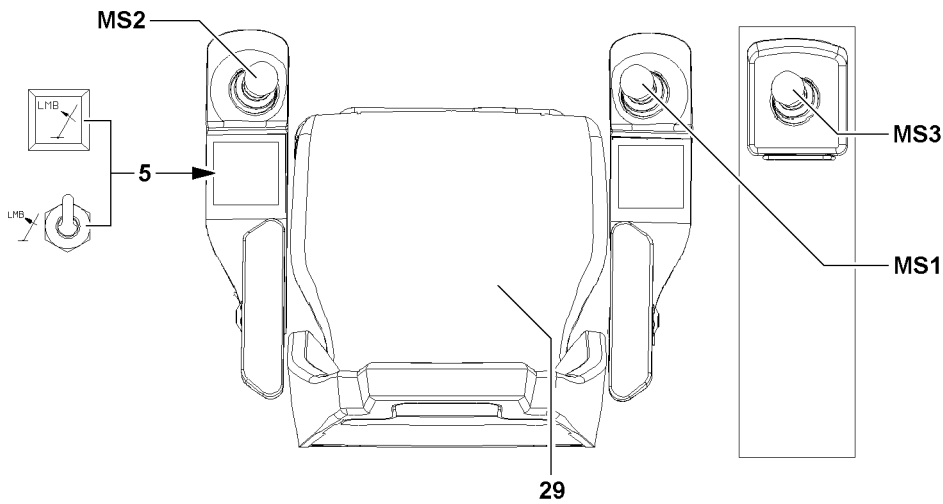
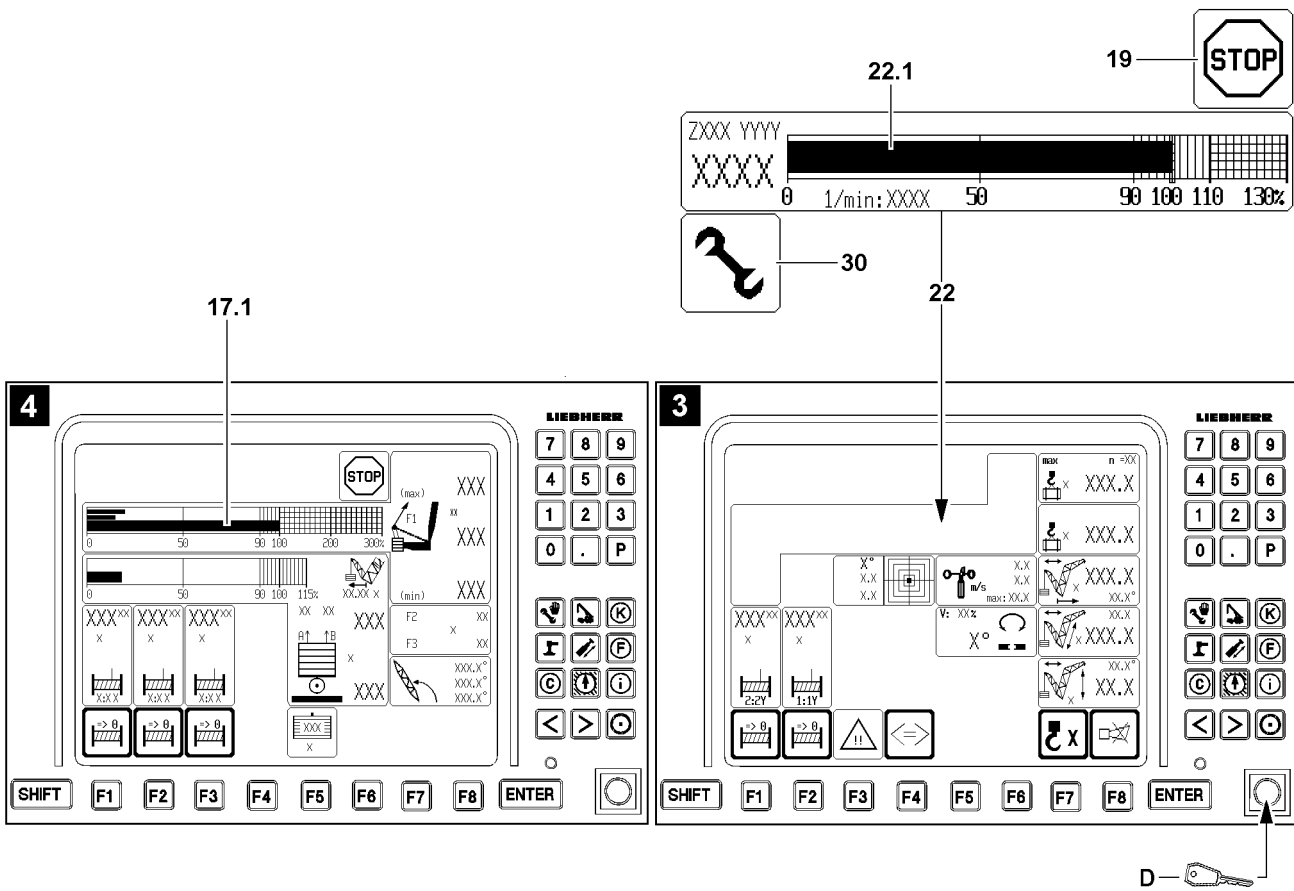

Fig.112336

LWE/LR 1600-2-008/18109-09-02/en

- ▶ Initiate crane movements which directly lead to a normal operating status (utilization below 100 % and no active shut off).

Result:

- If a crane reaches a normal operation status (utilization below 100 % and no active shut off), then the function „Exceedance of shut off limits of the LICCON overload protection“ shuts off, the assembly icon **30** and icon **19** in the LICCON monitor turn off.

In addition, the function „Exceedance of shut off limits of LICCON overload protection“ turns off immediately:

- If the set up key **D** is actuated again.
- If all master switches (MS1, MS2, MS3) are in neutral position for 10 seconds (with load chart available).
- When neither the seat contact button **29** nor one of the buttons **1** of the master switches (MS1, MS2, MS3) is actuated.
- If radio operation* is activated.
- At engine stop.
- At hoist top shut off.
- When leaving the angle range of the load chart.
- When the utilization bar **22.1** (load moment display) exceeds a utilization of 110 %.



Note

- ▶ The function „Exceedance of shut off limits of the LICCON overload protection“ is only turned off when the assembly icon **30** in the LICCON monitor turns off.
- ▶ If the function „Exceedance of shut off limits of the LICCON overload protection“ does not turn off after pressing the set up key **D** once, then press the set up key **D** again until the assembly icon **30** in the LICCON monitor turns off.

The function „Exceedance of shut off limits of the LICCON overload protection“ has / was shut off:

- The assembly icon **30** in the LICCON monitor turns off.
- The working speed is reduced until all master switches (MS1, MS2, MS3) are in zero position at the same time.
- ▶ Make sure that the assembly icon **30** does no longer appear in the LICCON monitor.
- ▶ Carry out crane movements in such a way that no repeated shut off by the LICCON overload protection occurs.

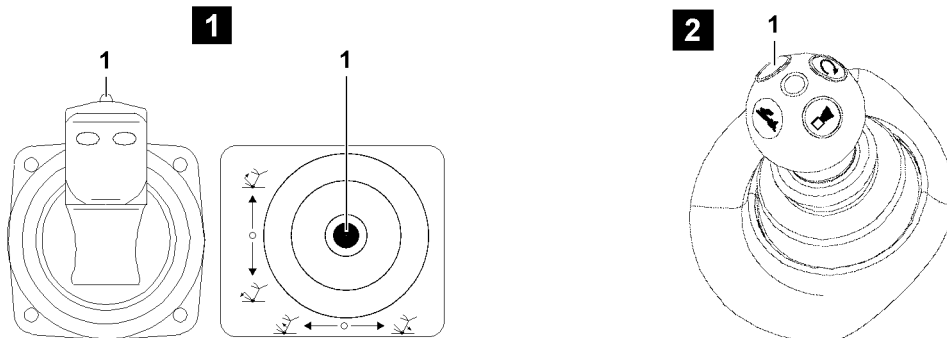
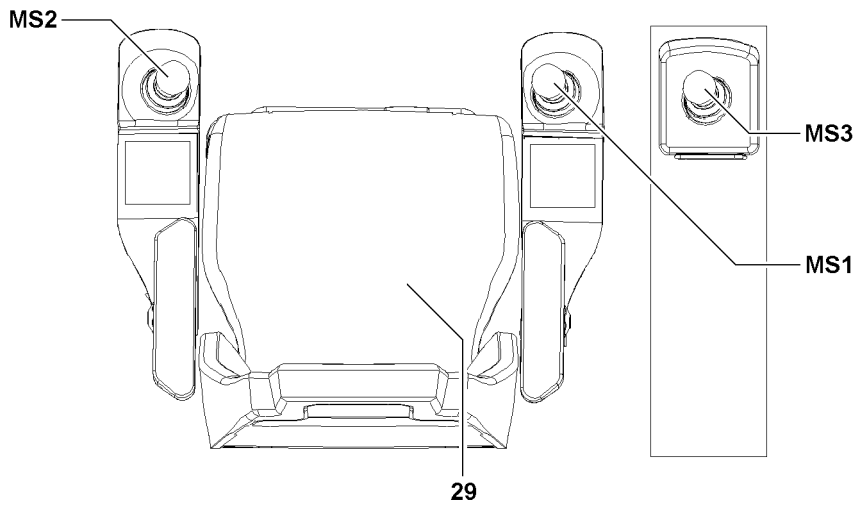
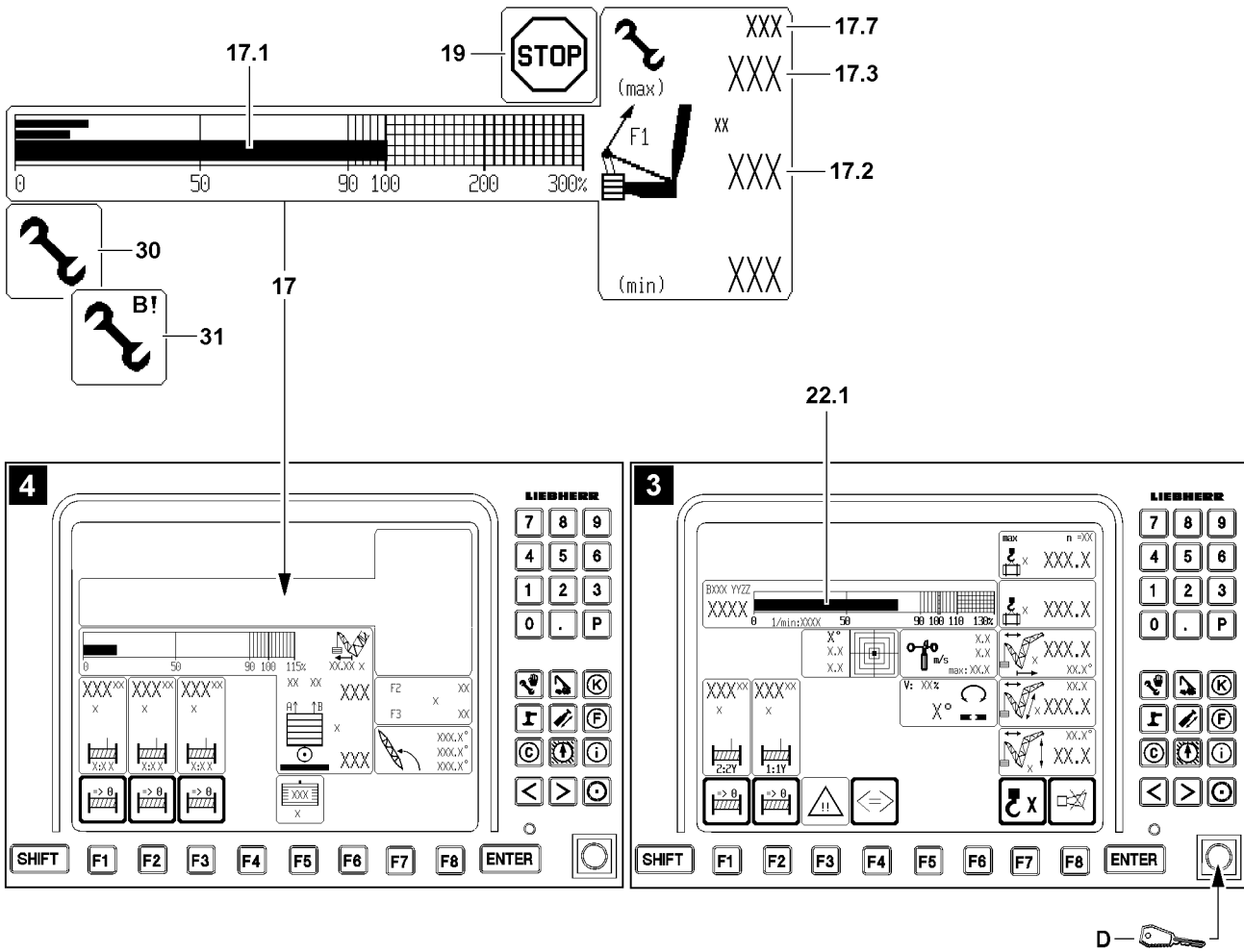

Fig.112337

LWE/LR 1600-2-008/18109-09-02/en

2.4.3 Exceedance of maximum value test point 1 (force F1) in crane operation



WARNING

Leaving the load chart with load on hook!

If, by actuating the set up key **D**, the shut off is bypassed by value $F1_{\text{max-operation}}$ **17.3** and exceeded by more than 110 %, then the crane is in assembly operation, the assembly icon **31** appears in the LICCON monitor.

There is no load chart available any longer and various display values may not be shown any longer in the crane operating screen.

The load on the hook is no longer monitored by the load chart.

Severe accidents due to crane overload can result.

Personnel can be severely injured or killed.

▶ In assembly operation, the data in the erection / take down charts is binding.



WARNING

Shut off safety device!

If, by actuating the set up key **D**, the function „Exceedance of maximum value test point 1“ is activated, then the function „Exceedance of shut off limits of LICCON overload protection“ is also activated automatically. Thus there is no shut off if the maximum permissible load moment is exceeded.

▶ All notes regarding the function „Exceedance of shut off limits of LICCON overload protection“ must be observed.

▶ The utilization bar **22.1** of the load moment display must be observed.



Note

▶ The force determined on test point 1 is generally described as $F1_{\text{actual}}$ (actual value F1).

▶ In the icon **17** (F1-load display), the force relationship as well as the number values are shown in number values as well as a bar display (called F1-bar display).

▶ The value $F1_{\text{max-operation}}$ **17.3** corresponds to 100 % in the F1-bar display.

▶ The F1-utilization bar **17.1** shows the relationship $F1_{\text{actual}}$ **17.2** to $F1_{\text{max-operation}}$ **17.3**.

▶ In crane operation without derrick ballast, fewer values may be shown in the icon **17** (F1-load display).

▶ If the actual load is **larger** than the permissible hook block weight according to the erection / take down charts, then it can be exceeded up to maximum 110 % of $F1_{\text{max-operation}}$ **17.3**.

▶ If the actual load is **smaller** than the permissible hook block weight according to the erection / take down charts, then the assembly operation becomes active above 110 % of $F1_{\text{max-operation}}$ **17.3**. In assembly operation, there is no load chart available.

▶ The value $F1_{\text{max-assembly}}$ **17.7** appears in crane operation when 90 % of its nominal value is exceeded.

In the icon **17** (F1 load display) the utilization bar $F1_{\text{actual}}$ **17.1** exceeds the 100 % mark and the LICCON overload protection has shut off the crane movement. The value $F1_{\text{actual}}$ **17.2** has exceeded the value $F1_{\text{max-operation}}$ **17.3**.

All further movements, which lead to an increase of the force (value $F1_{\text{actual}}$) are shut off.

In the LICCON monitor with the derrick operating screen (illustration **4**) appears the icon **19**.

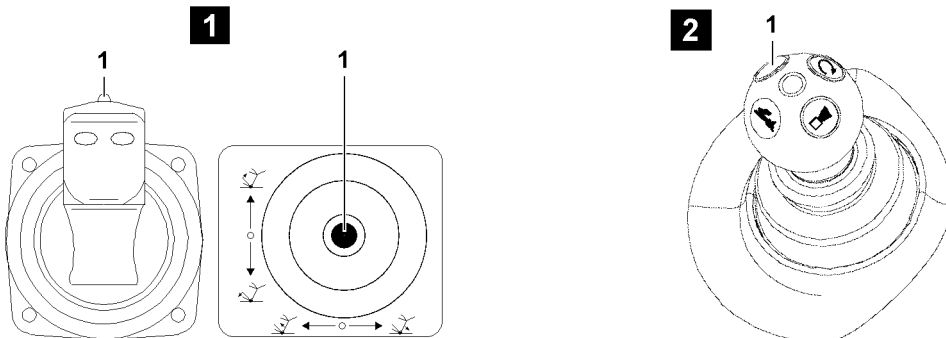
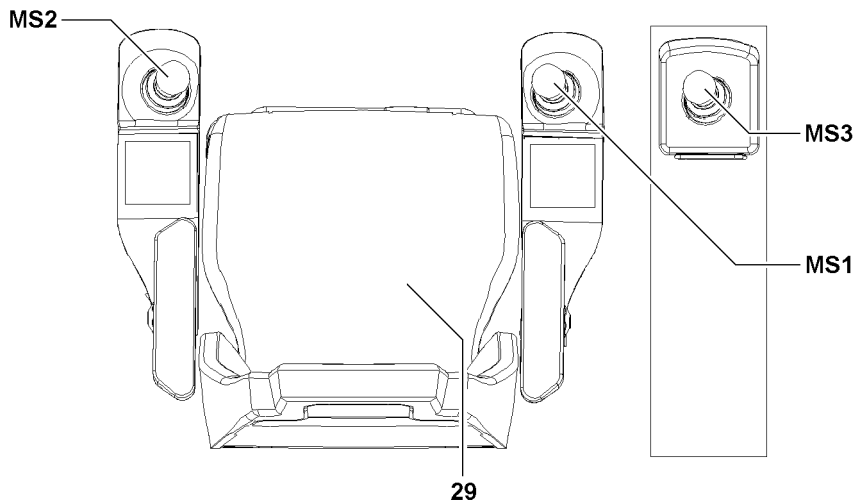
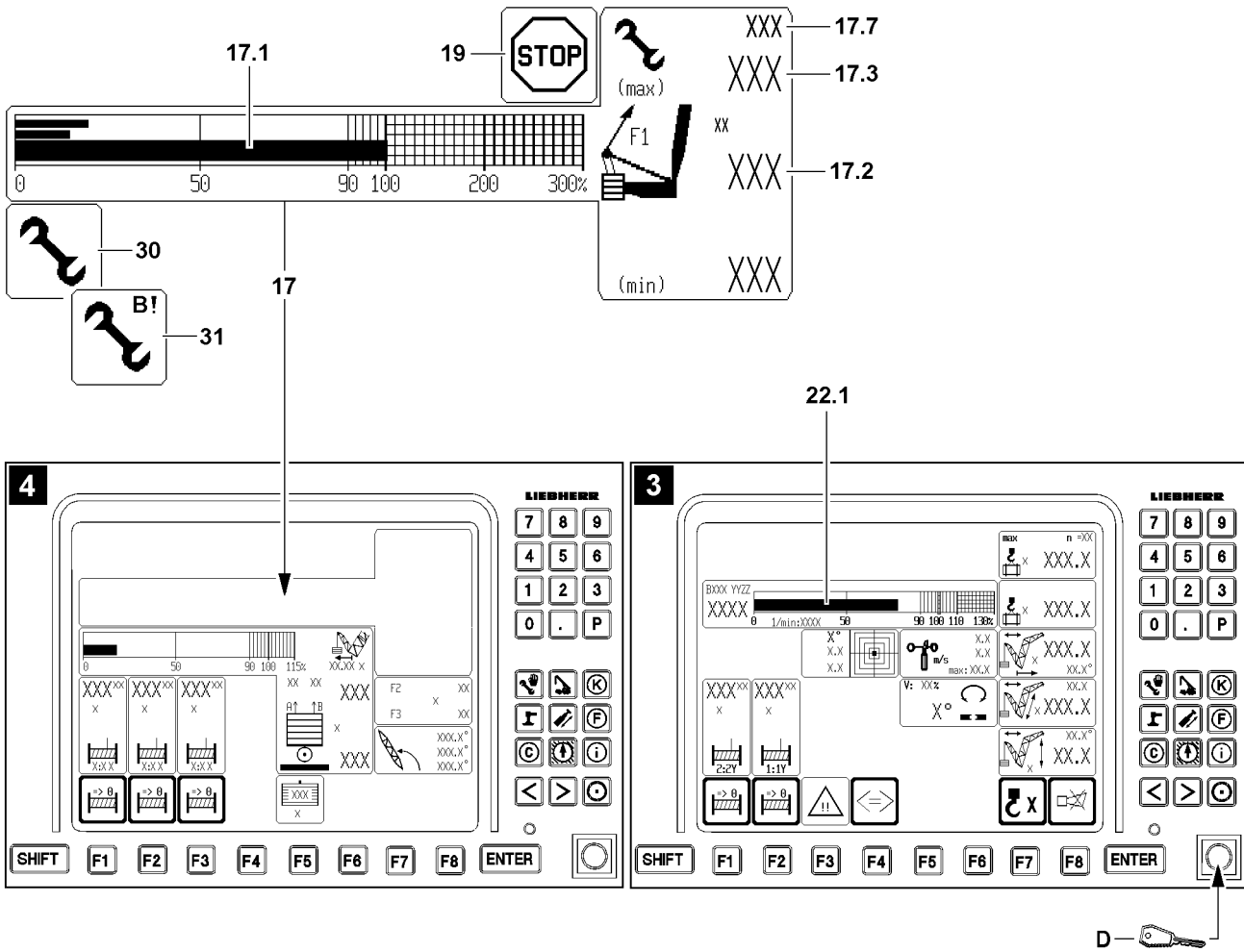

Fig.112337

LWE/LR 1600-2-008/18109-09-02/en

Make sure that the following prerequisites are met:

- All master switches (MS1, MS2, MS3) are in zero position (not deflected).
 - Either the seat contact button **29** or one of the buttons **1** of the master switches (MS1, MS2, MS3) is actuated.
 - Radio operation* is not active.
 - The F1 load display 110 % has not been reached and a load chart is available.
- ▶ Turn the set up key **D** to the right (touching).

Result:

- The function „Exceedance of maximum value test point 1“ is activated in connection with the function „Exceedance of the shut off limits of the LICCON overload protection“.
- $F1_{\text{max-operation}}$ **17.3** can be exceeded.

The function „Exceedance of shut off limits of the LICCON overload protection“ in connection with the function „Exceedance of the maximum value test point 1“ also shuts off immediately:

- If the set up key **D** is actuated again.
- If all master switches (MS1, MS2, MS3) are in neutral position for 10 seconds (with load chart available).
- When neither the seat contact button **29** nor one of the buttons **1** of the master switches (MS1, MS2, MS3) is actuated.
- If radio operation* is activated.
- At engine stop.
- At hoist top shut off.



Note

- ▶ The function „Exceedance of shut off limits of the LICCON overload protection“ is only turned off when the assembly icon **30** in the LICCON monitor turns off.
- ▶ If the function „Exceedance of shut off limits of the LICCON overload protection“ does not turn off after pressing the set up key **D** once, then press the set up key **D** again until the assembly icon **30** in the LICCON monitor turns off.

The function „Exceedance of shut off limits of the LICCON overload protection“ has / was shut off:

- The assembly icon **30** in the LICCON monitor turns off.
 - The working speed is reduced until all master switches (MS1, MS2, MS3) are in zero position at the same time.
- ▶ Make sure that the assembly icon **30** does no longer appear in the LICCON monitor.
- ▶ Carry out crane movements in such a way that no repeated shut off by the LICCON overload protection occurs.

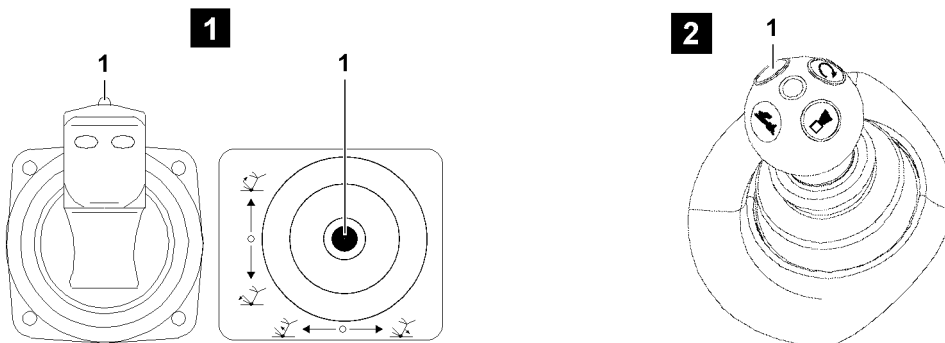
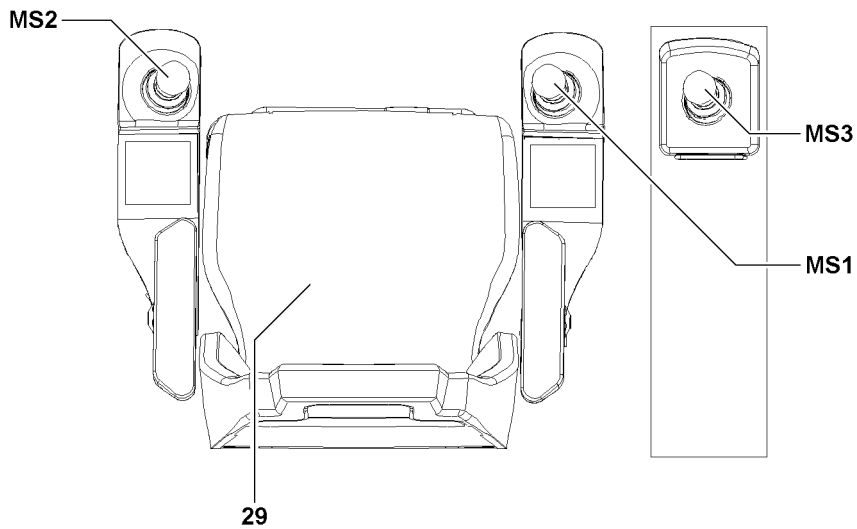
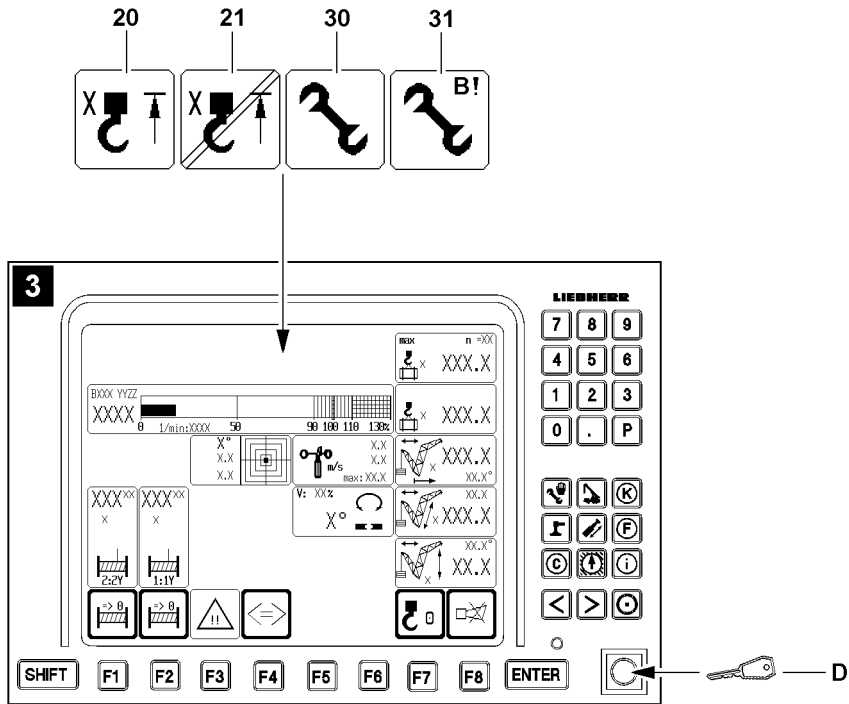

Fig.111230

LWE/LR 1600-2-008/18109-09-02/en

2.5 Bypass of the hoist top shut off



WARNING

Improper use of the function „Bypass of hoist top shut off“!

- ▶ The function „Bypass of hoist top shut off“ may never be used to increase the lifting height during crane operation.



WARNING

Property damage and falling load!

If the function „Bypass of hoist top shut off“ is activated, there is the danger that the hook block or the load hook is pulled against the pulley head.

This danger exists especially when the hoist winch is continued to be spooled up and for crane movements which have an influence on the hoist rope, for example luffing the boom, the auxiliary boom / accessory or the derrick boom.

Property damage and falling load can result.

Personnel can be severely injured or killed.

- ▶ The function „Bypass of hoist top shut off“ may only be carried out by an authorized person, along with a guide. The guide must be in direct contact with the crane operator and must continually monitor the distance between the hook block / load hook and the boom head.
- ▶ Carry out all crane movements with utmost caution.



Note

- ▶ The activation of the function „Bypass of hoist top shut off“ is only possible if the hoist limit switch was touched and the hoist top shut off has occurred.
- ▶ If the hoist limit switch is triggered when the set up key **D** is actuated (function „Exceedance of shut off limits of the LICCON overload protection“ is active, the assembly icon **30** or the assembly icon **31** appear), then a hoist top shut off occurs and the function „Exceedance of shut off limits of the LICCON overload protection“ is deactivated.
- ▶ For assembly purposes or in emergency cases, if the activation of the function „Bypass of hoist top shut off“ **and** activation of the function „Exceedance of shut off limits of the LICCON overload protection“ is necessary, then the set up key **D** must be actuated until the icon **21** and assembly icon **30** or assembly icon **31** (assembly operation) appear.

Make sure that the following prerequisites are met:

- A hoist top shut off has occurred, the hoist top icon **20** appears in the LICCON monitor.
- Either the seat contact button **29** or one of the buttons **1** of the master switches (MS1, MS2, MS3) is actuated.
- All master switches (MS1, MS2, MS3) are in zero position (not deflected).
- The radio operation* is not active.

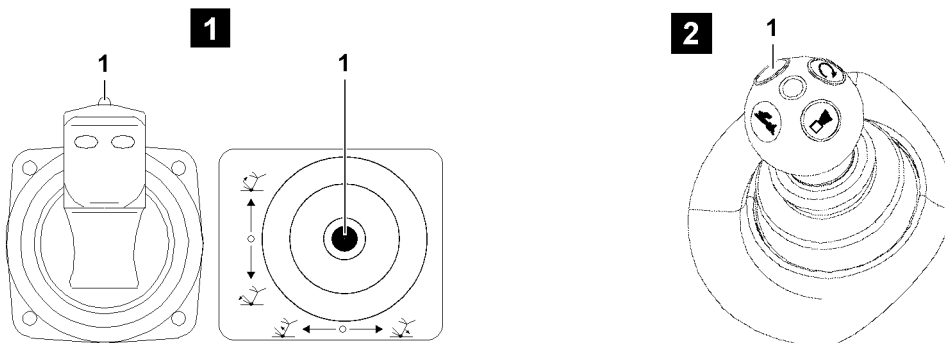
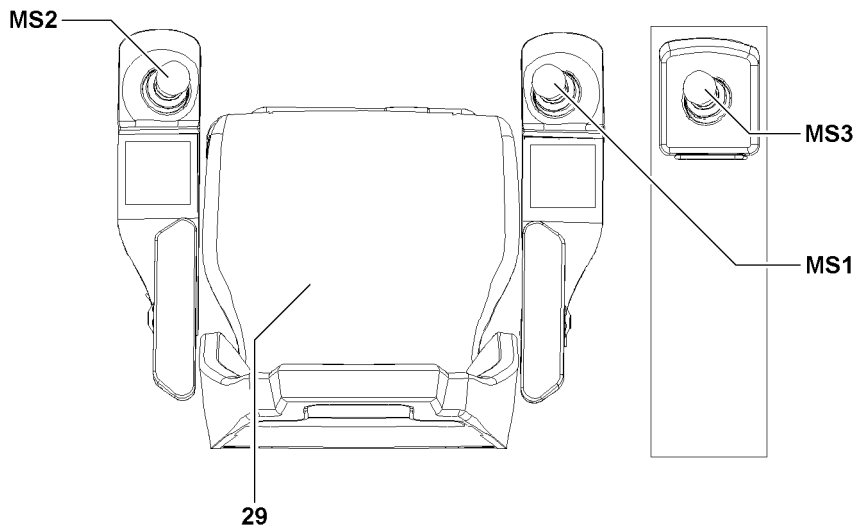
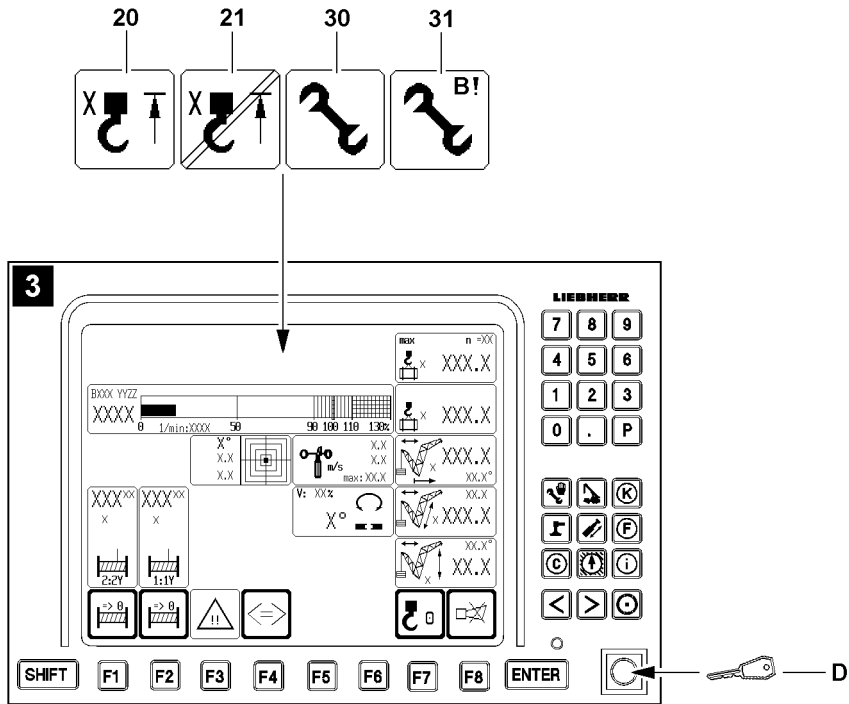

Fig.111230

LWE/LR 1600-2-008/18109-09-02/en

- ▶ Turn the set up key **D** to the right (touching).

Result:

- The assembly icon **30** or the assembly icon **31** (assembly operation) appear in the LICCON monitor.
 - The hoist top icon **20** in the LICCON monitor changes to the icon **21**.
 - The working speed is reduced for all functions (if load chart is available).
 - All hoist limit switches are bypassed.
- ▶ Carry out a crane movement with bypassed hoist limit switches with utmost caution and by taking the safety guidelines into account.

The function „Bypass of the hoist top shut off“ turns off:

- If the set up key **D** is actuated again.
- When no master switch (MS1, MS2, MS3) was deflected for 10 seconds.
- When neither the seat contact button **29** nor one of the buttons **1** of the master switches (MS1, MS2, MS3) is actuated.
- If there is no longer a shut off of a hoist limit switch.
- If the radio operation* is active.
- At engine stop.

The function „Bypass of the hoist top shut off“ has / was turned off:

- The assembly icon **30** or the assembly icon **31** (assembly operation) in the LICCON monitor turn off.
 - The icon **21** on the LICCON monitor turns off.
 - The working speed is reduced until all master switches (MS1, MS2, MS3) are in zero position at the same time.
- ▶ Make sure that the assembly icon **30** or the assembly icon **31** (assembly operation) as well as the icon **21** no longer appear in the LICCON monitor.
 - ▶ Carry out the crane movements in such a way that no repeated hoist top shut off occurs.

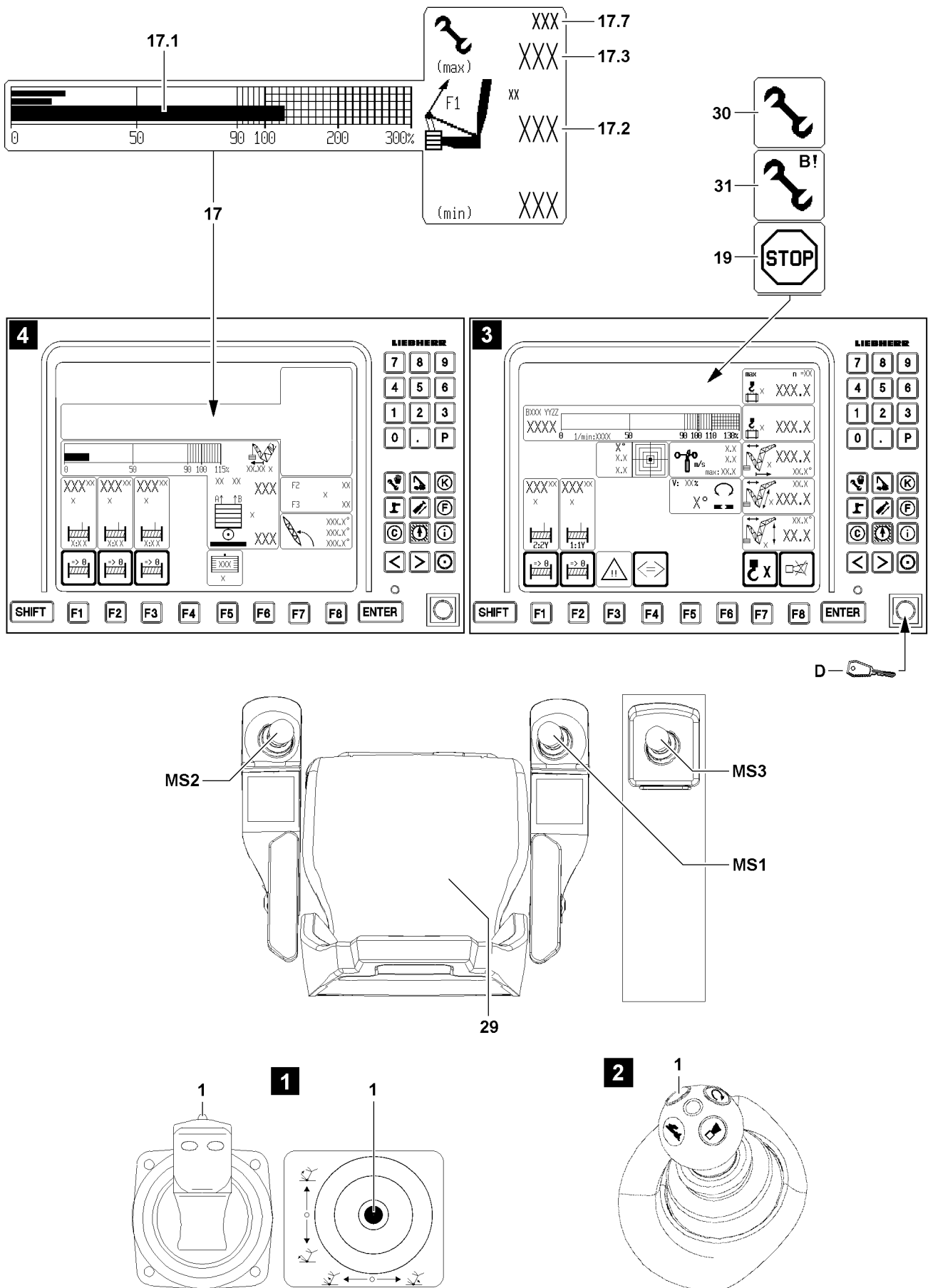

Fig.112343

LWE/LR 1600-2-008/18109-09-02/en

2.6 Exceeding the shut off limits of the LICCON overload protection during erection / take down procedures (assembly operation)



Note

- ▶ If the crane is in the range „No load chart available“ then there is a shut off of the crane control by the LICCON overload protection. The icon **19** appears in the LICCON monitor.
- ▶ By an actuated set up key **D**, the function „Exceedance of shut off limits of the LICCON overload protection“ can be activated, all erection / take down procedures can be carried out within the erection / take down charts, for which no load charts are available.



WARNING

Danger of accident during erection / take down procedures!

If the erection / take down charts are not observed, the crane could collapse, the boom can break off or the crane can topple over.

Personnel can be severely injured or killed.

- ▶ The erection / take down charts must be observed.
- ▶ Press the set up key **D** only when the configuration status has been entered correctly in the LICCON computer system and matches the actual situation.



Note

- ▶ The force determined on test point 1 is generally described as $F1_{\text{actual}}$ (actual value F1).
- ▶ In the icon **17** (F1-load display), the force relationship as well as the number values are shown in number values as well as a bar display (called F1-bar display).
- ▶ The value $F1_{\text{max-operation}}$ **17.3** corresponds to 100 % in the F1-bar display.
- ▶ The F1-utilization bar **17.1** shows the relationship $F1_{\text{actual}}$ **17.2** to $F1_{\text{max-operation}}$ **17.3**.
- ▶ In crane operation without derrick ballast, fewer values may be shown in the icon **17** (F1-load display).
- ▶ If a load chart is available, then the value $F1_{\text{max-operation}}$ **17.3** is valid as the limit value for a shut off of crane operation.
- ▶ When leaving the area „Load chart available“, the assembly icon **30** turns off and the assembly icon **31** appears.
- ▶ When leaving the area „Load chart available“ then $F1_{\text{max-assembly}}$ **17.7** is valid as the upper limit value.
- ▶ $F1_{\text{max-assembly}}$ **17.7** might only appear when 90 % of its nominal value is exceeded.

2.6.1 Carrying out erection procedures (assembly operation)

Make sure that the following prerequisites are met:

- All master switches (MS1, MS2, MS3) are in zero position (not deflected).
- Either the seat contact button **29** or one of the buttons **1** of the master switches (MS1, MS2, MS3) is actuated.
- Radio operation* is not active.
- The set up configuration corresponds to the erection / take down charts.
- The set up status has been entered correctly into the LICCON computer system.

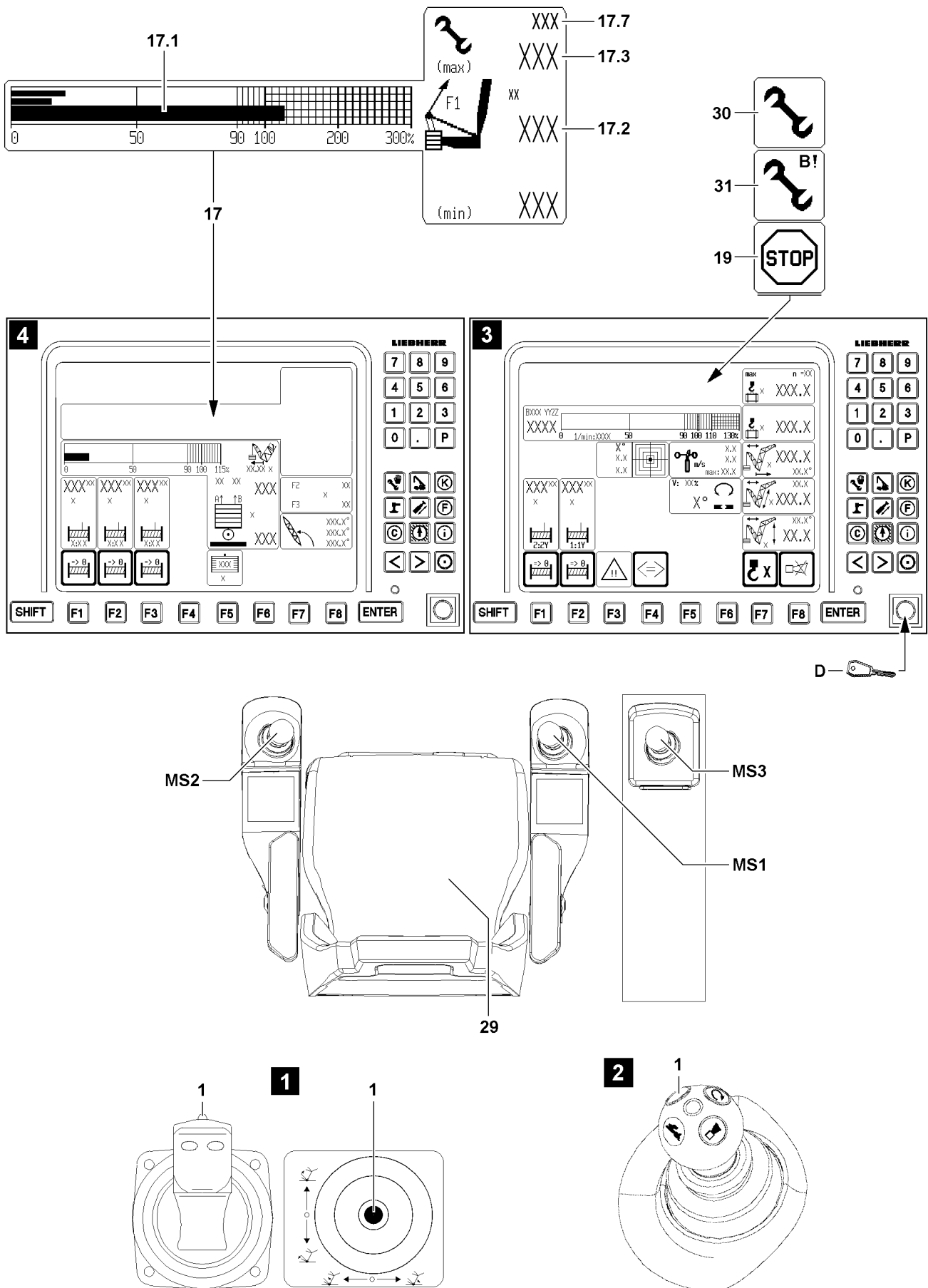

Fig.112343

LWE/LR 1600-2-008/18109-09-02/en

- ▶ Turn the set up key **D** to the right (touching).

Result:

- The assembly icon **31** appears in the area „No load chart available“.
- The erection / take down procedures can be carried out.
- ▶ Watch the icon **17** (F1-load display), the value $F1_{\text{actual}}$ **17.2** may not exceed the value $F1_{\text{max-assembly}}$ **17.7**.

Problem remedy

The erection / take down procedure cannot be carried out due to shut off „ $F1_{\text{max-assembly}}$ **17.7** exceeded“?

- ▶ See section „Danger of exceeding $F1_{\text{max-assembly}}$ “.
-

Problem remedy

The function „Exceedance of shut off limits of the LICCON overload protection“ can not be activated during erection / take down procedures?

- ▶ Check the error messages.
 - ▶ Check the electrical connections.
 - ▶ Check if all sensors or dummy plugs with integrated electric have been connected properly.
-

The function „Exceedance of shut off limits of the LICCON overload protection“ turns off:

- If the set up key **D** is actuated again.
- When an range with existing load chart is reached (erection procedure).
- If all master switches (MS1, MS2, MS3) are in neutral position for 10 seconds (with „Load chart available“).
- When neither the seat contact button **29** nor one of the buttons **1** of the master switches (MS1, MS2, MS3) is actuated.
- At engine stop.

The function „Exceedance of shut off limits of the LICCON overload protection“ has / was shut off:

- The assembly icon **30** or the assembly icon **31** in the LICCON monitor turns off.
- ▶ After completion of the erection / take down procedures, make sure that the assembly icon **30** or the assembly icon **31** no longer appear in the LICCON monitor.

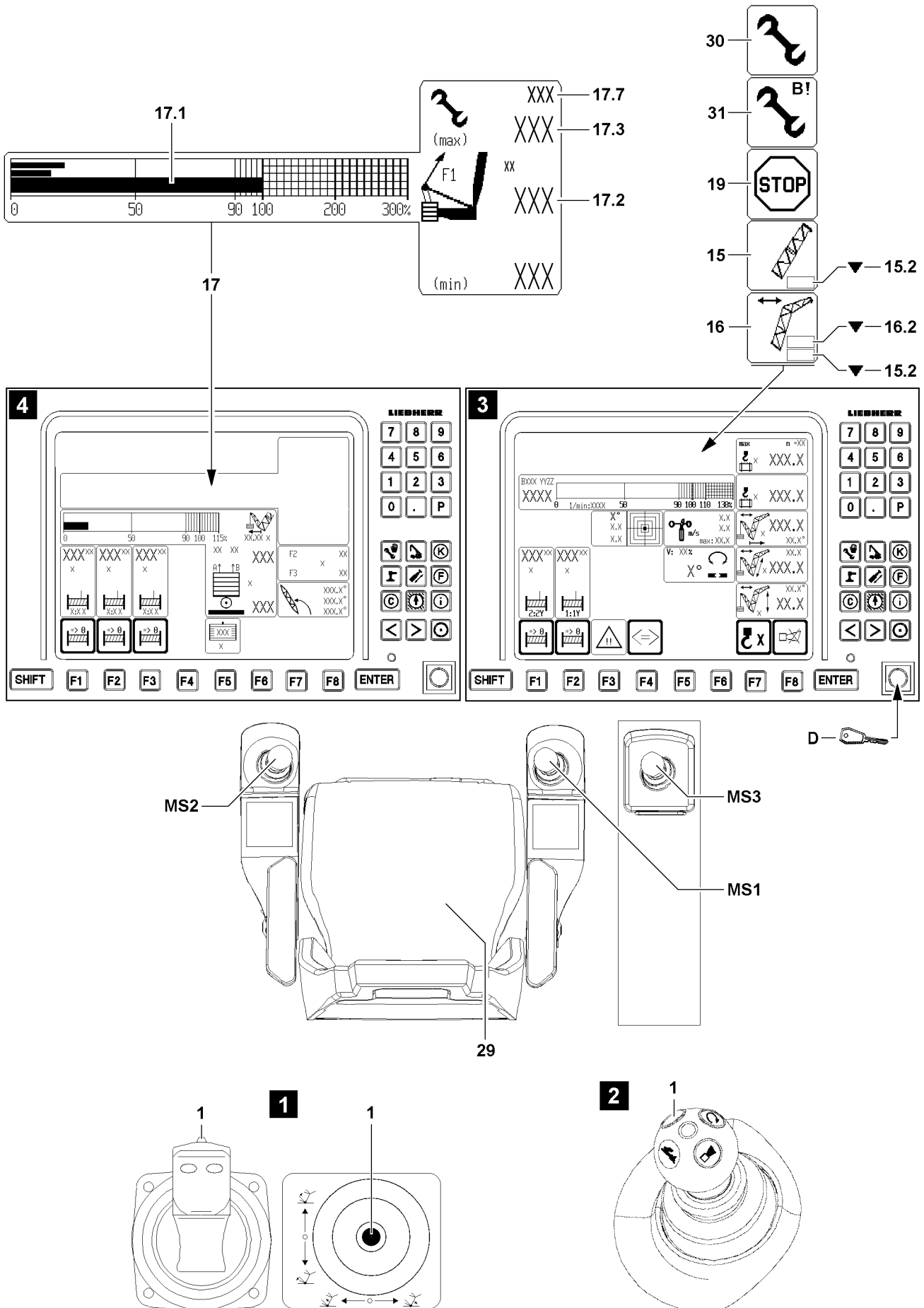

Fig.112341

2.6.2 Carrying out take down procedures (assembly operation)



WARNING

Increased danger of accidents due to bypass of shut off of luffing the main boom / auxiliary boom / accessory down!

When the shut off luffing the main boom / auxiliary boom / accessory down is bypassed, then the LICCON overload protection as a whole is deactivated or limited.

When the shut off luffing the main boom / auxiliary boom / accessory down is bypassed and the main boom and / or the auxiliary boom / accessory is further luffed down, then there is no load chart available any longer.

Crane operation with bypassed shut off luffing the main boom / auxiliary boom / accessory down is prohibited, since severe accidents can result.

Personnel can be severely injured or killed.

- ▶ Activate the bypass of the shut off luffing the main boom / auxiliary boom / accessory down only in emergency cases or for erection / take down procedures with erection / take down charts.
- ▶ Carry out all crane movements with utmost caution.

Make sure that the following prerequisites are met:

- In symbol **15** or symbol **16** appear symbol **15.2** or symbol **16.2** and the LICCON overload protection has shut off the crane movement.
- Either the seat contact button **29** or one of the buttons **1** of the master switches (MS1, MS2, MS3) is actuated.
- All master switches (MS1, MS2, MS3) are in zero position (not deflected).
- The radio operation* is not active.

- ▶ Turn the set up key **D** to the right (touching).

Result:

- The assembly icon **30** appears in the LICCON monitor.
- The function „Exceedance of shut off limits of the LICCON overload protection“ is activated and has bypassed the shut off luffing the main boom / auxiliary boom / accessory down.



Note

- ▶ If a load chart is available, then the value $F1_{\text{max operation}}$ **17.3** is valid as the limit value for a shut off of crane operation.
- ▶ When leaving the area „Load chart available“, the assembly icon **30** turns off and the assembly icon **31** appears.
- ▶ When leaving the area „Load chart available“ then $F1_{\text{max assembly}}$ **17.7** is valid as the upper limit value.
- ▶ If no derrick boom is installed, then the icon **17** only shows $F1_{\text{actual}}$ **17.1** and $F1_{\text{max-assembly}}$ **17.7**.
- ▶ $F1_{\text{max-assembly}}$ **17.7** might only appear when 90 % of its nominal value is exceeded.

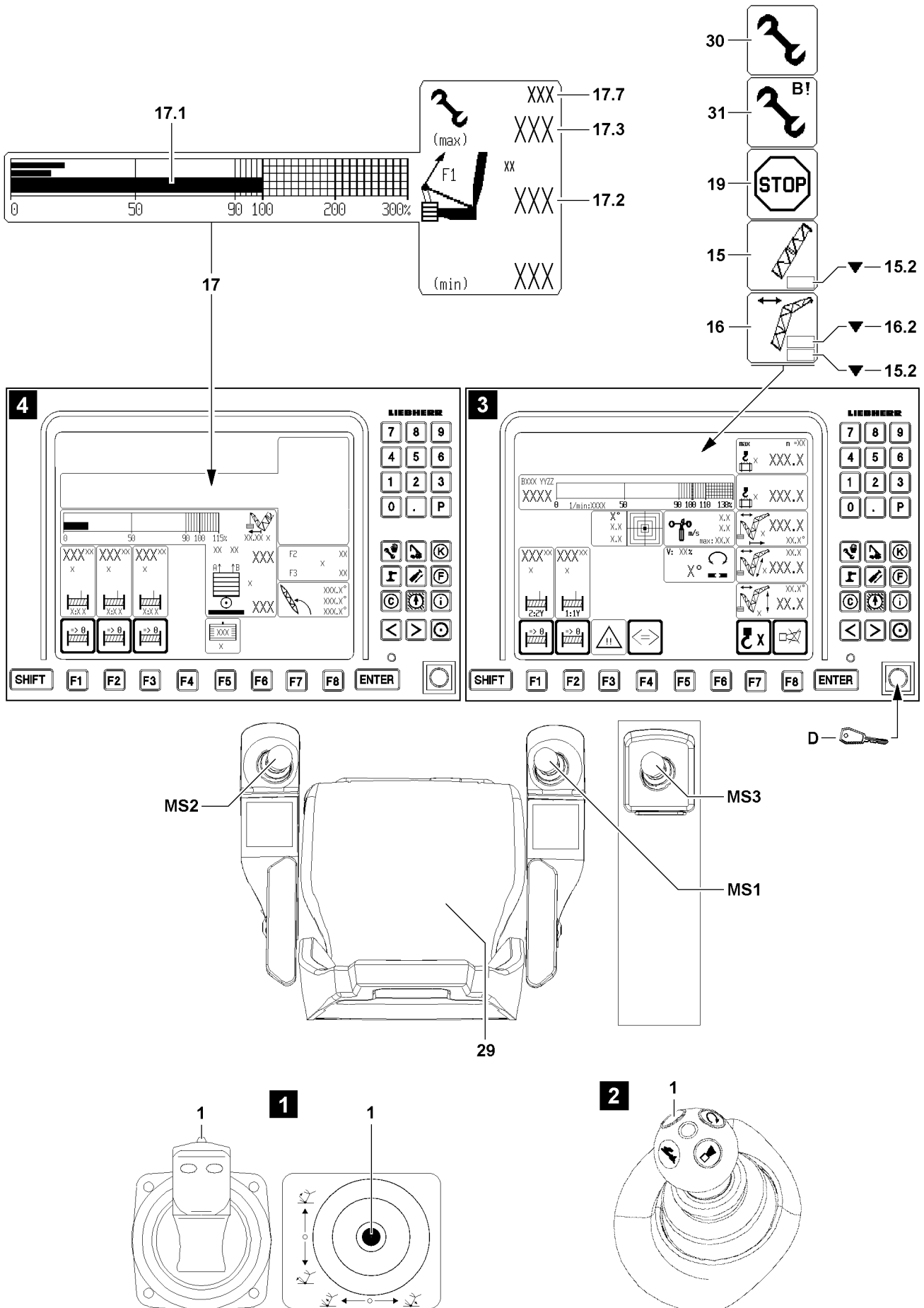

Fig.112341

LWE/LR 1600-2-008/18109-09-02/en

**DANGER**

The crane can topple over!

There is **no** shut off of the luff down movement after reaching the limit value $F1_{\text{max assembly}}$ **17.7**.

If the warnings by the LICCON overload protection are ignored, then the crane will be overloaded or topples over.

Personnel can be severely injured or killed.

- ▶ The symbol **17** (F1-load display) must be watched permanently. It must be ensured that the value $F1_{\text{actual}}$ **17.2** is smaller than the value $F1_{\text{max assembly}}$ **17.7**.
- ▶ The luff down movement must be stopped before the value $F1_{\text{actual}}$ **17.2** exceeds the limit value $F1_{\text{max assembly}}$ **17.7**.

- ▶ During the take down procedure watch the icon **17** (F1-load display).

Problem remedy

The take down procedure cannot be carried out due to danger of exceeding the $F1_{\text{max assembly}}$ **17.7**?

- ▶ See section „Danger of exceeding $F1_{\text{max assembly}}$ “.

The bypass of the shut off luffing the main boom / auxiliary boom / accessory down turns off:

- If the set up key **D** is actuated again.
- When neither the seat contact button **29** nor one of the buttons **1** of the master switches (MS1, MS2, MS3) is actuated.
- When an area with existing load chart is reached.
- If the radio operation* is active.
- At engine stop.

The bypass of the shut off luffing the main boom / auxiliary boom / accessory down has / was turned off:

- The assembly icon **31** or the assembly icon **30** in the LICCON monitor turns off.
- ▶ Make sure that the assembly icon **30** or the assembly icon **31** no longer appear in the LICCON monitor.

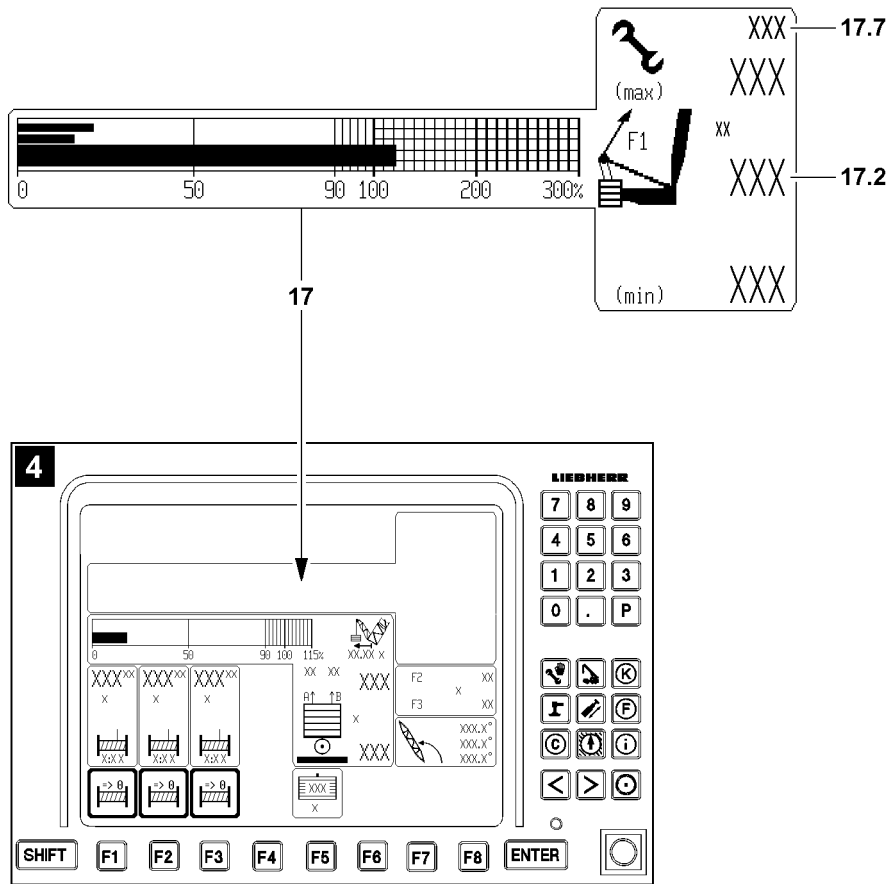

Fig.112344

2.6.3 Danger of exceeding $F1_{\text{max assembly}}$



Note

- ▶ $F1_{\text{max-assembly}}$ **17.7** might only appear when 90 % of its nominal value is exceeded.



DANGER

The crane can topple over!

There is **no** shut off of the luff down movement after reaching the limit value $F1_{\text{max assembly}}$ **17.7**.

If the warnings by the LICCON overload protection are ignored, then the crane will be overloaded or topples over.

Personnel can be severely injured or killed.

- ▶ The luff down movement must be stopped before the value $F1_{\text{actual}}$ **17.2** exceeds the limit value $F1_{\text{max assembly}}$ **17.7**.

In the icon **17** (F1-load display), the value $F1_{\text{actual}}$ **17.2** has reached the upper limit value $F1_{\text{max-as-sembly}}$ **17.7**.

- ▶ Check if a crane movement, which can lower the force $F1$ (value $F1_{\text{actual}}$ **17.2**) can be initiated, for example setting down the hook block / load hook.
- ▶ Check if the correct set up configuration has been entered on the LICCON computer system.
- ▶ Check if the actual set up configuration matches the entered set up configuration.
- ▶ Check if the correct hook block weight has been entered.
- ▶ Check if the respective hook block / load hook is installed.
- ▶ Check if all attachment parts and guy rods on the boom system, which are not needed, have been removed.
- ▶ Check if environmental influences (wind, snow or ice) on the crane are not too great.



Note

- ▶ Hook block weight entry and correction of weighing errors, see Crane operating instructions, chapter 4.02.

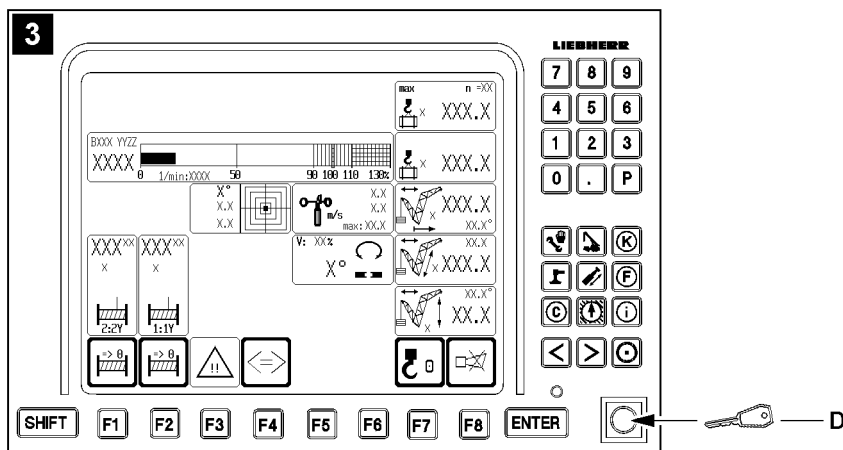
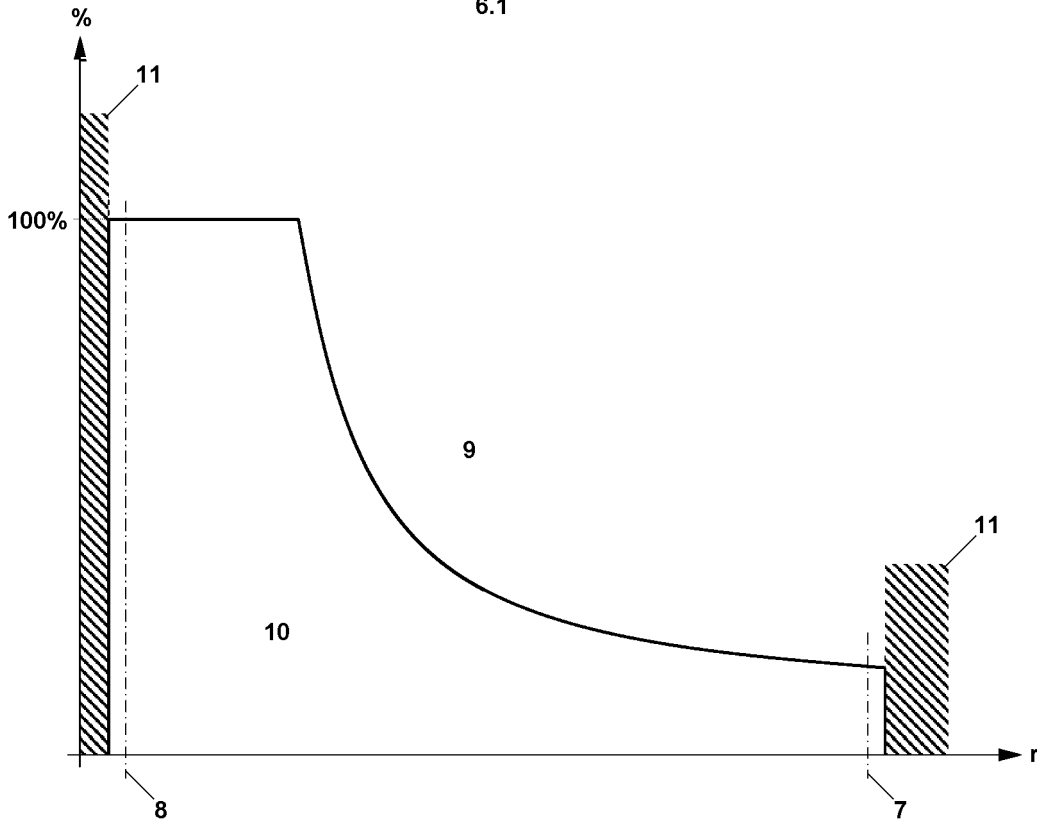
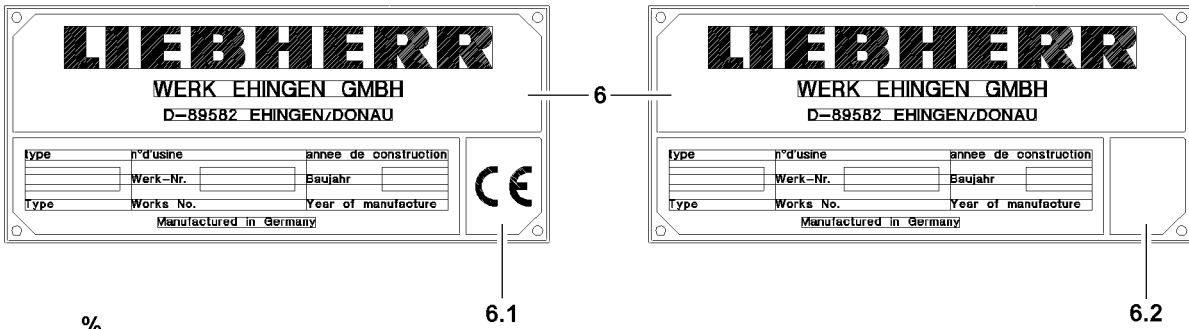

Fig.111208

LWE/LR 1600-2-008/18109-09-02/en

3 Instructions for resuming crane movements for cranes without CE mark



WARNING

Danger of accident!

If the following points are not observed, personnel can be severely injured or killed.

- ▶ The crane operator bears the sole and full responsibility for the adherence to measures to be taken in case of shut off of crane movement.
- ▶ The crane operator must make sure, before crane operation, that he is using the correct description for the current programming.



Note

- ▶ Check the data tag **6** to determine if your crane has a CE mark.
- ▶ The following section applies to a crane without CE mark, see data tag **6.2**.
- ▶ If your crane does have a CE mark, see data tag **6.1**, then you must observe the description in section „Instructions for resuming a crane movement for cranes with CE mark“.

3.1 Overview load chart for cranes without CE mark

Axle	Description
r	Radius boom (working radius)
%	Utilization of the crane in percentages

Position	Description
7	Lower limit angle load chart
8	Upper limit angle load chart
9	Area „Exceeding the overload protection“
10	Range „Load chart available“
11	Range „No load chart available“



Note

- ▶ If the set up key **D** (LICCON monitor with crane operating screen, illustration **3**) is actuated, the working speed is not reduced.

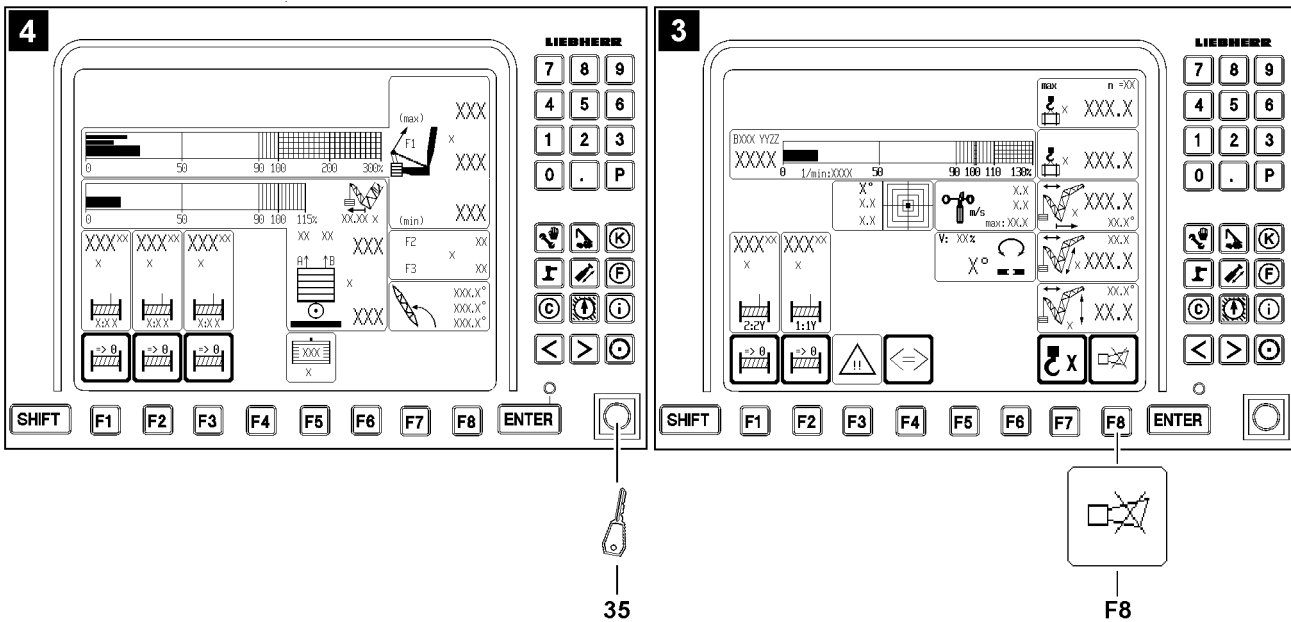
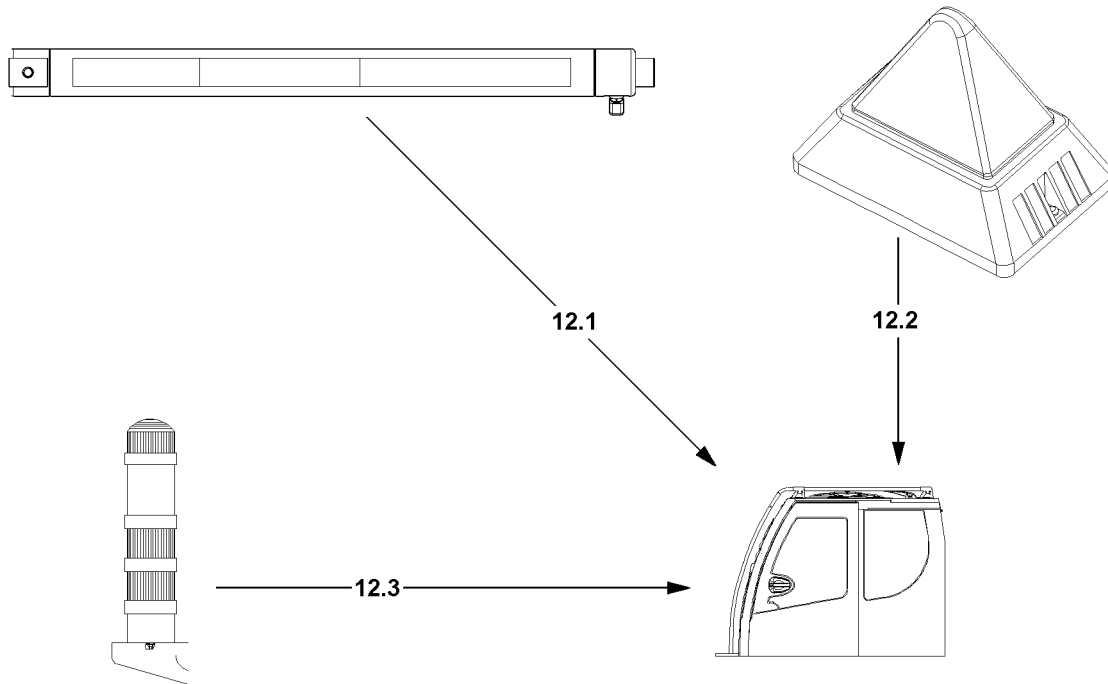

Fig.111212

LWE/LR 1600-2-008/18109-09-02/en

3.2 Overview of acoustic / visual warnings for cranes without CE mark

- Depending on the crane type, either a warning light **12.1** or a flashing beacon **12.2** or a combination of flashing beacon **12.2** and warning light* **12.3** are installed.
- The acoustic warnings within the crane operator's cab are turned off by pressing the button **F8** on the LICCON monitor with crane operating screen (illustration **3**).
- The acoustic warnings outside the crane operator's cab are turned off by actuating the key button **35** on the LICCON monitor with derrick operating screen (illustration **4**).

3.2.1 Description of acoustic / visual warnings

The case numbers from the chart „Overview of case numbers“ are valid for the following charts in this chapter:

- „Acoustic / visual warnings on the LICCON monitor“
- „Warning light 12.1“
- „Flashing beacon 12.2“
- „Warning light 12.3“

Overview of case numbers	
Case number	Description Case
Case 001	Utilization of crane from 0 % to 89 %
Case 002	Utilization of crane from 90 % to 100 %
Case 003	Utilization of crane over 100 %
Case 004	Shut off of crane movements - LMB STOP
Case 005	Luffing in with suspended load
Case 006	Participating sensor (LMB) defective
Case 010	Exceeding the shut off limits of the LICCON overload protection
Case 011	Bypass of shut off hoist top
Case 016	Bypass of shut off luffing down the boom / auxiliary boom / accessories, „Load chart available“
Case 018	Bypass of shut off luffing down the boom / auxiliary boom / accessories, „No load chart available“
Case 020	Exceeding the shut off limits of the LICCON overload protection during erection / take down procedures, „No load chart available“

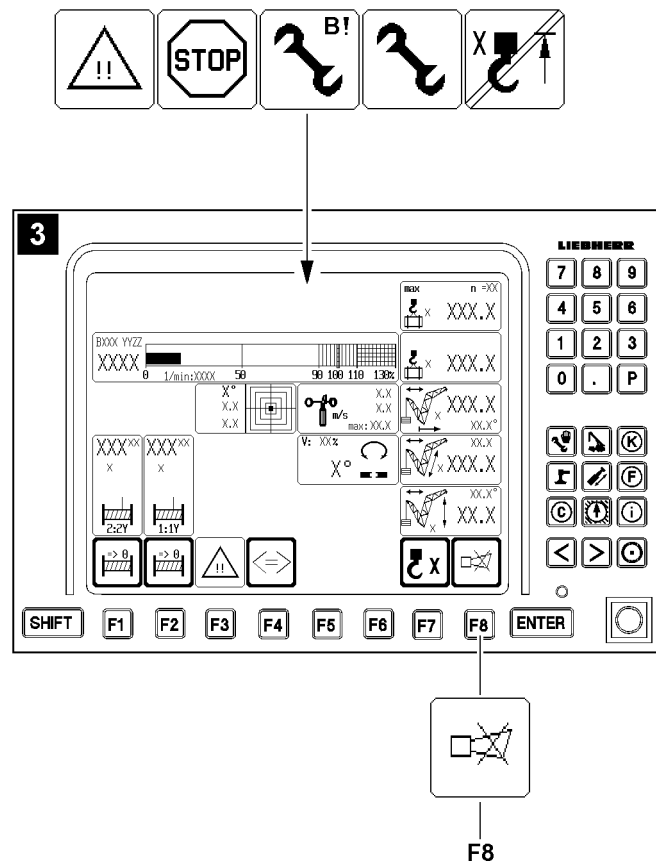

Fig.111209

3.2.2 Acoustic / visual warnings within the crane operator's cab



Note

► Description of individual case numbers, see chart „Overview of case numbers“.

Acoustic / visual warnings on the LICCON monitor									
Case number	Acoustic warning LICCON monitor at utilization of crane			Visual warning LICCON monitor					
	Short sound	Long sound	Long sound	Utilization of crane		Occurrence			
	From 90 %	Above 100 %	Always	From 90 %	Above 100 %	LMB STOP	Appears if the set up key D is actuated		
Case 001							—	—	—
Case 002	X ²			○			—	—	—
Case 003		X ²		○	○		—	—	—
Case 004			X ²		○		—	—	—
Case 005	X ²	X ²		○	○		—	—	—
Case 006			X ²			○		○	
Case 010	X ²	X ²		○	○		○		
Case 011			X ²	○	○	○	○		○
Case 016	X ²	X ²		○	○		○		
Case 018			X ²			○		○	
Case 020			X ²			○		○	

○ = cannot be turned off

X² = can be turned off immediately on the LICCON monitor key **F8**

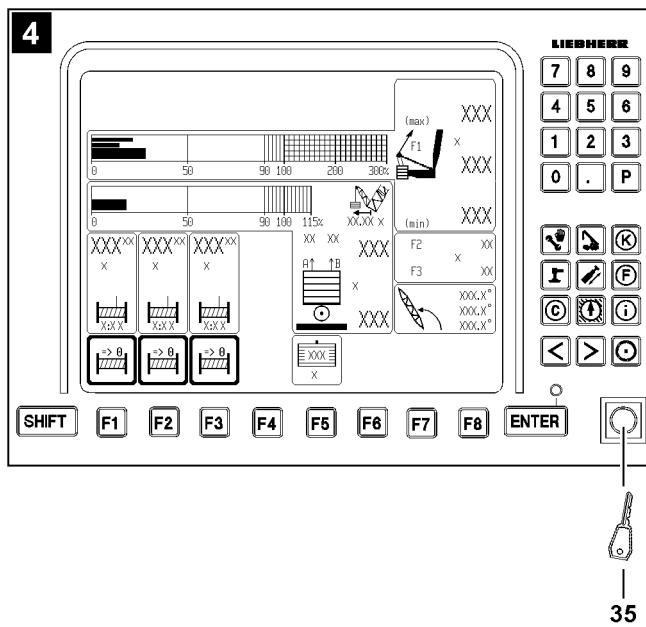
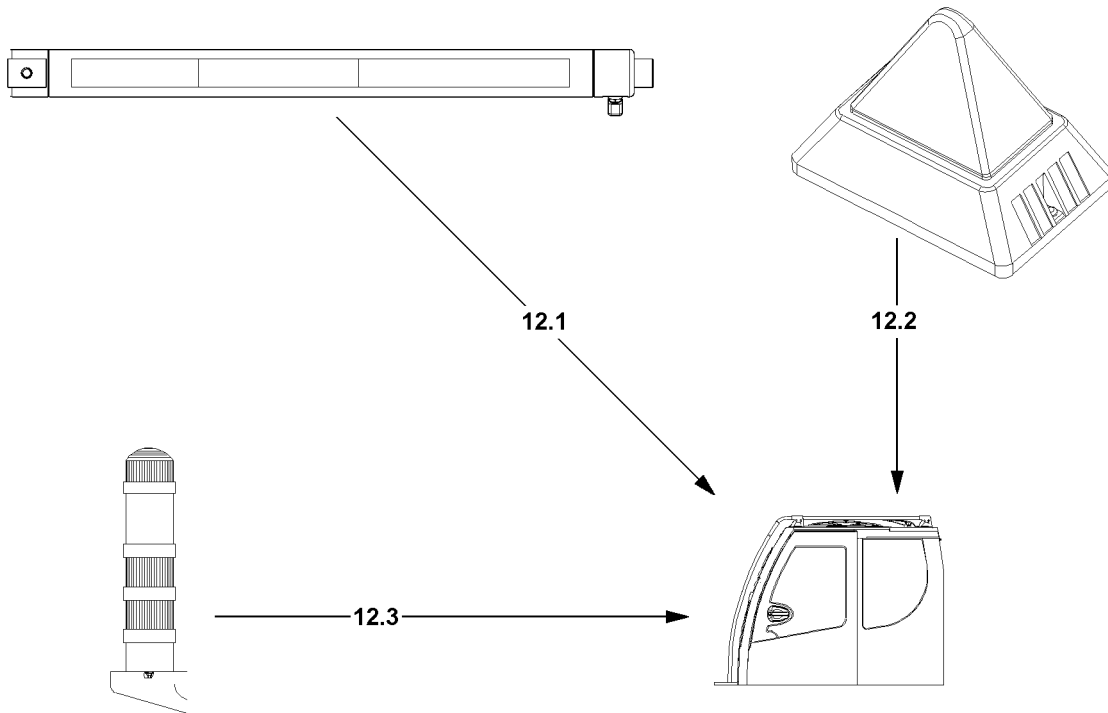

Fig.111206

LWE/LR 1600-2-008/18109-09-02/en

3.2.3 Acoustic / visual warnings outside the crane operator's cab



Note

► Description of individual case numbers, see chart „Overview of case numbers“.

Warning light 12.1					
Case number	At utilization of crane	Acoustic warning	Visual warning		
		Signal turntable	Green	Yellow	Red
Case 001	From 0 % to 89 %		O ¹		
Case 002	From 90 % to 100 %			O ¹	
Case 003	Above 100 %	X ¹			O ¹
Case 004	-				O ¹
Case 005	From 0 % to 89 %		O ¹		
Case 005	From 90 % to 100 %			O ¹	
Case 005	Above 100 %	X ¹			O ²
Case 006	-			O ²	
Case 010	From 0 % to 89 %		O ¹		
Case 010	From 90 % to 100 %			O ¹	
Case 010	Above 100 %	O			O ²
Case 011	From 0 % to 100 %			O ²	
Case 011	Above 100 %	O			O ²
Case 016	Up to 90 %		O ¹		
Case 016	Above 90 % to 100 %			O ¹	
Case 016	Above 100 %	O			O ²
Case 018	No value available			O ²	
Case 020	No value available			O ²	

O = cannot be turned off

O¹ = warning light 12.1 lights up

O² = warning light 12.1 blinks

X¹ = can be turned off by actuating (right touching) the key button 35 on the LICCON monitor with the derrick operating screen (illustration 4), effective after at least 5 seconds

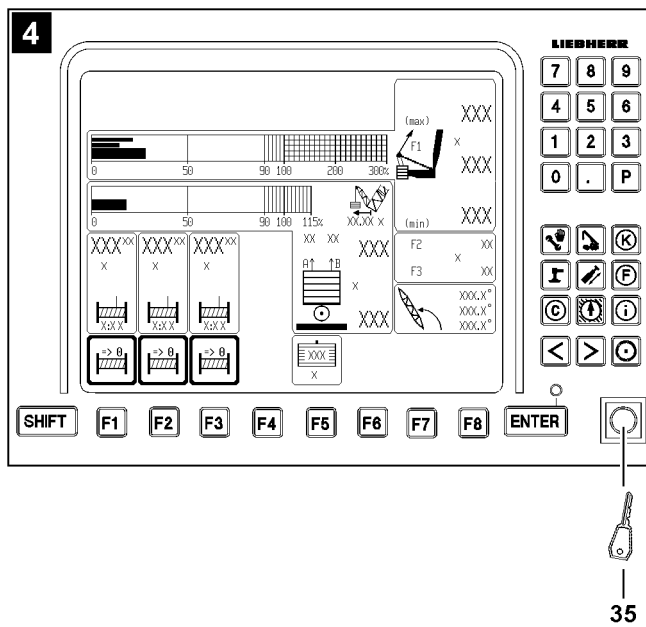
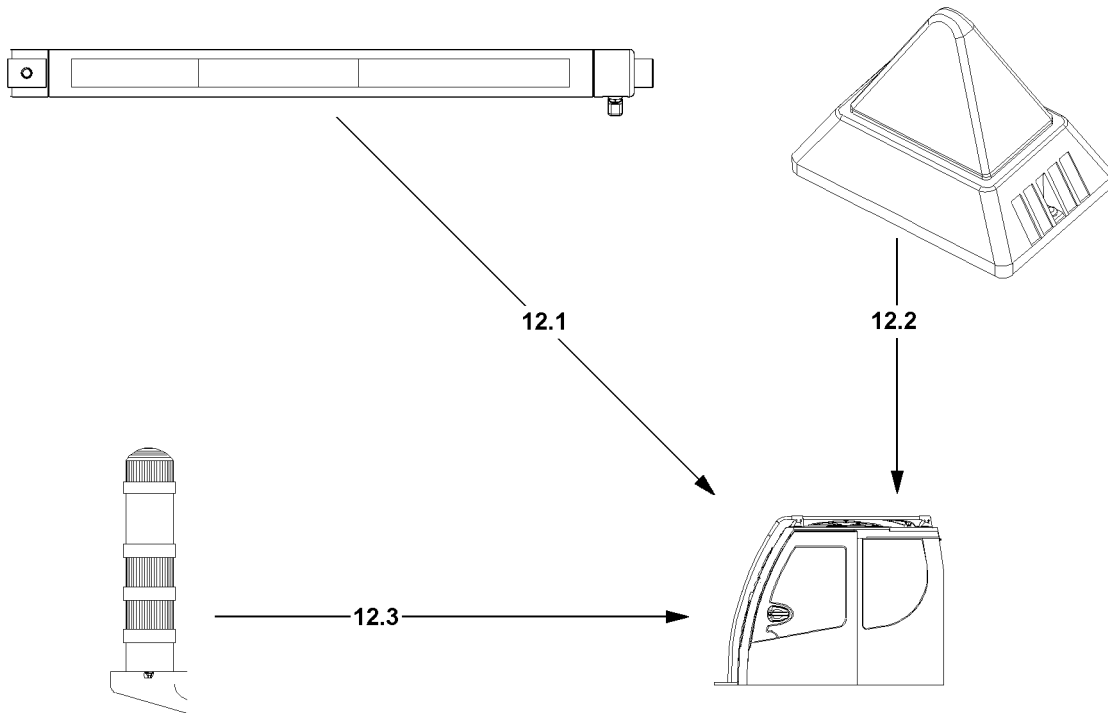

Fig.111206

LWE/LR 1600-2-008/18109-09-02/en

**Note**

► Description of individual case numbers, see chart „Overview of case numbers“.

Flashing beacon 12.2			
Case number	At utilization of crane	Acoustic warning	Visual warning
		Signal turntable	Red
Case 001	0 % to 89 %	-	-
Case 002	90 % to 100 %	-	-
Case 003	Above 100 %	X ¹	O ²
Case 004	-		O ²
Case 005	Above 100 %	X ¹	O ²
Case 006	-		O ²
Case 010	Above 100 %	O	O ²
Case 011	Above 100 %	O	O ²
Case 016	Above 100 %	O	O ²
Case 018	No value available		O ²
Case 020	No value available		O ²

O = cannot be turned off

O² = flashing beacon **12.2** blinks

X¹ = can be turned off by actuating (right touching) the key button **35** on the LICCON monitor with the derrick operating screen (illustration **4**), effective after at least 5 seconds

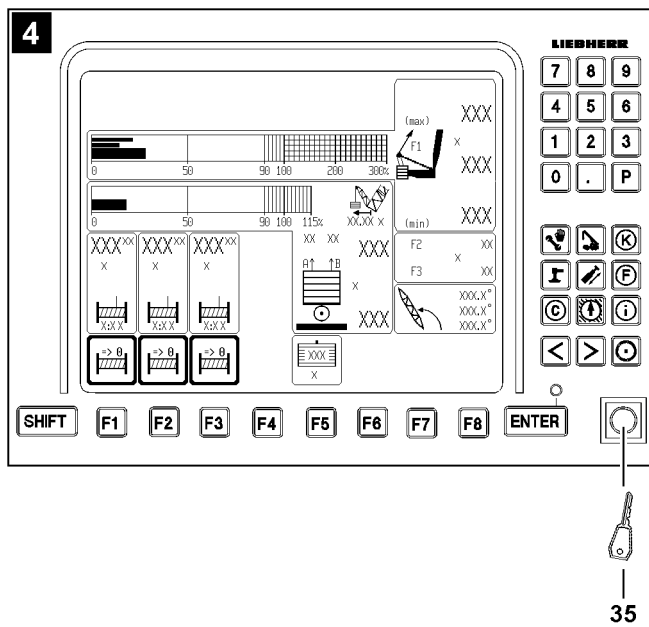
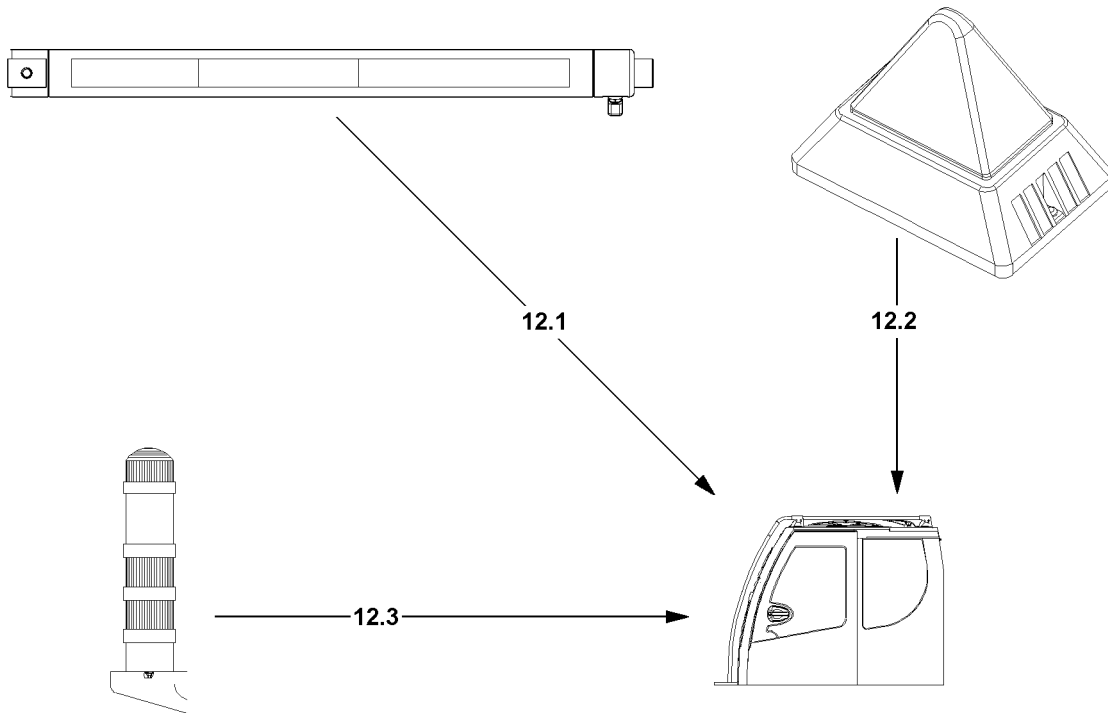

Fig.111206

**Note**

► Description of individual case numbers, see chart „Overview of case numbers“.

Warning light 12.3					
Case number	At utilization of crane	Acoustic warning	Visual warning		
		Signal turntable	Green	Yellow	Red
Case 001	From 0 % to 89 %		O ¹		
Case 002	From 90 % to 100 %			O ¹	
Case 003	Above 100 %	X ¹			O ²
Case 004	-				O ²
Case 005	From 0 % to 89 %		O ¹		
Case 005	From 90 % to 100 %			O ¹	
Case 005	Above 100 %	X ¹			O ²
Case 006	-				O ²
Case 010	From 0 % to 89 %		O ¹		
Case 010	From 90 % to 100 %			O ¹	
Case 010	Above 100 %	O			O ²
Case 011	From 0 % to 100 %			O ¹	
Case 011	Above 100 %	O			O ²
Case 016	From 0 % to 89 %		O ¹		
Case 016	From 90 % to 100 %			O ¹	
Case 016	Above 100 %	O			O ²
Case 018	No value available				O ²
Case 020	No value available				O ²

O = cannot be turned off

O¹ = warning light **12.3** lights up

O² = warning light **12.3** blinks

X¹ = can be turned off by actuating (right touching) the key button **35** on the LICCON monitor with the derrick operating screen (illustration **4**), effective after at least 5 seconds

3.3 Monitoring of crane movement

**Note**

- If the LICCON overload protection turns the crane movement off, then the exact cause for the shut off must be determined first.
- As a first step, try to rescind the crane movement which has caused a shut off.
- If it is not possible to rescind the affected crane movement, then the additional steps are described in the following sections of the chapter.

**Note**

- For detailed description of the individually listed symbols, see Crane operating instructions, chapter 4.02.

The LICCON overload protection carries out the following shut offs if a limit value is exceeded in crane operation:

- Shut off luffing the main boom up / down
- Shut off Upper limit shut off angle (OGAW)
- Shut off Luffing the auxiliary boom / accessory up / down
- Shut off maximum / minimum value test point 1 (force F1)
- Shut off spooling the winch up / out
- Shut off Hoist top
- Shut off due to error message

The LICCON overload protection warns if the limit values are exceeded, but does not turn off:

- Minimum / maximum support forces

3.3.1 Shut off luffing the main boom up / down

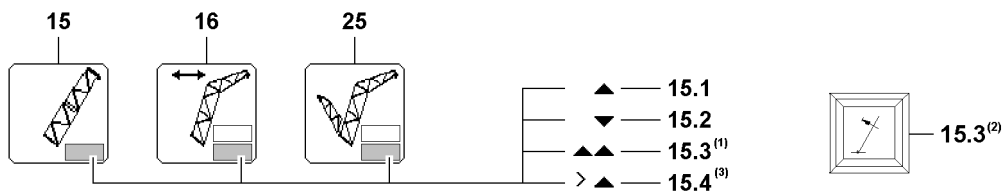

Fig. 124701

⁽¹⁾not LR 1400/2

⁽²⁾only LR 1400/2

⁽³⁾Only for certain crane types

In symbol **15**, or symbol **16**, or symbol **25** appears in the lower field symbol **15.1**, or symbol **15.2** or symbol **15.4** and the LICCON overload protection has shut the crane movement off.

„Luffing the main boom up“ (symbol **15.1**), „Luffing the main boom down“ (symbol **15.2**) or „upper limit shut off angle“ reached (symbol **15.4**), was shut off because the upper / lower limit angle of the selected load chart was exceeded / fallen below.

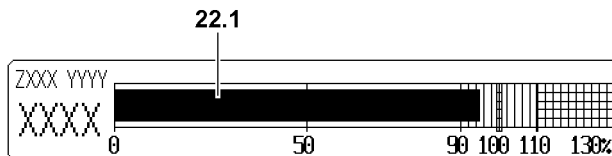

Fig. 112340



Note

- ▶ If the utilization of the crane is more than 95 % (utilization bar **22.1** exceeds 95 %) and the maximum load according to the load chart (falling load capacity) drops by continuing to luff up the boom, then the symbol **15.1** also appears and the crane movement „Luffing the main boom up“ is turned off.

If the symbol / warning light **15.3** appears, then:

- **either** it was luffed up to a limit switch or the limit switch has turned off the crane movement „Luffing the main boom up“
- **or** there is an error on one of the limit switches „Main boom top“

The symbol **15.1** appears and the crane movement „Luffing the main boom up“ was turned off:

- ▶ Luff the main boom down.

Result:

- Crane operation is possible again.

The symbol **15.2** appears and the crane movement „Luffing the main boom down“ was turned off:

- ▶ Luff the main boom up.

Result:

- Crane operation is possible again.

The symbol / warning light **15.3** appears and the crane movement „Luffing the main boom up“ was turned off:

- ▶ Luff the main boom down.

Result:

- Crane operation is possible again.

Problem remedy

The symbol / warning light **15.3** appears continuously?

If a symbol / warning light **15.3** appears without having luffed the main boom up to a limit switch, then there may be an error in the limit switches „Main boom top“.

- ▶ Check if there is an error message from the LICCON computer system, see Diagnostics manual.
- ▶ If yes: Remedy the error immediately.

The symbol **15.4** appears and the crane movement „Luffing the main boom up“ (upper limit shut off angle) was turned off:

- ▶ Luff the main boom down.

Result:

- Crane operation is possible again.



WARNING

Limited warning functions!

If one of the double version limit switches is not ok and the crane is continued to be operated, then the warning functions of the LICCON overload protection are limited.

- ▶ The crane can only be operated in an emergency after failure of a double version limit switch.
- ▶ Carry out crane movements in such a way that no repeated shut off by the LICCON overload protection occurs.

3.3.2 Shut off Luffing the auxiliary boom / accessory up / down

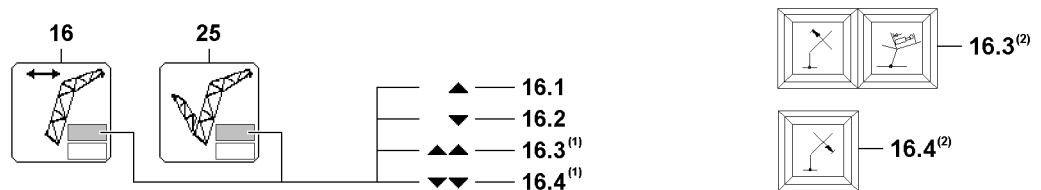

Fig.124702

⁽¹⁾not LR 1400/2

⁽²⁾only LR 1400/2

In symbol **16** or symbol **25** appear in the upper field symbol **16.1** or symbol **16.2** and the LICCON overload protection has shut off the crane movement.

„Luffing the auxiliary boom / accessory up“ (symbol **16.1**) or „Luffing the auxiliary boom / accessory down“ (symbol **16.2**) was shut off because the upper / lower limit angle of the selected load chart was exceeded / fallen below.

If the symbol / warning light **16.3** appears, then:

- **either** it was luffed up to a limit switch or the limit switch has turned off the crane movement „Luffing the auxiliary boom / accessory up“

- **or** the mechanical relapse support has turned off the crane movement „Luffing the auxiliary boom / accessory up“
- **or** there is an error on one of the limit switches „Auxiliary boom / accessory top“.

If the symbol / warning light **16.4** appears, then:

- **either** it was luffed down to a limit switch „Auxiliary boom / accessory bottom“ and the limit switch has turned off the crane movement „Luffing the auxiliary boom / accessory up“
- **or** there is an error on one of the limit switches „Auxiliary boom / accessory bottom“

The symbol **16.1** appears and the crane movement „Luffing the auxiliary boom / accessory up“ was turned off:

- ▶ Luff the auxiliary boom / accessory down.

Result:

- Crane operation is possible again.

The symbol **16.2** appears and the crane movement „Luffing the auxiliary boom / accessory down“ was turned off:

- ▶ Luff the auxiliary boom / accessory up.

Result:

- Crane operation is possible again.

The symbol / warning light **16.3** appears and the crane movement „Luffing the auxiliary boom / accessory up“ was turned off:

- ▶ Luff the auxiliary boom / accessory down.

Result:

- Crane operation is possible again.

Problem remedy

The symbol / warning light **16.3** appears continuously?

If a symbol / warning light **16.3** appears without having luffed up to a limit switch, then there may be an error in the limit switches „Auxiliary boom / accessory top“.

- ▶ Check if there is an error message from the LICCON computer system, see Diagnostics manual.
- ▶ If yes: Remedy the error immediately.

The symbol / warning light **16.4** appears and the crane movement „Luffing the auxiliary boom / accessory down“ was turned off:

- ▶ Luff the auxiliary boom / accessory up.

Result:

- Crane operation is possible again.

Problem remedy

The symbol / warning light **16.4** appears continuously?

If a symbol / warning light **16.4** appears without having luffed down to a limit switch, then there may be an error in the limit switches „Auxiliary boom / accessory bottom“.

- ▶ Check if there is an error message from the LICCON computer system, see Diagnostics manual.
- ▶ If yes: Remedy the error immediately.



WARNING

Limited warning functions!

If one of the double version limit switches is not ok and the crane is continued to be operated, then the warning functions of the LICCON overload protection are limited.

- ▶ The crane can only be operated in an emergency after failure of a double version limit switch.

- ▶ Carry out crane movements in such a way that no repeated shut off by the LICCON overload protection occurs.

3.3.3 Shut off maximum / minimum value test point 1 (force F1)



Note

- ▶ The force determined on test point 1 is generally described as $F1_{\text{actual}}$ (actual value F1).
- ▶ In the icon **17** (F1-load display), the force relationship as well as the number values are shown in number values as well as a bar display (called F1-bar display).
- ▶ The value $F1_{\text{max-operation}}$ **17.3** corresponds to 100 % in the F1-bar display.
- ▶ The F1-utilization bar **17.1** shows the relationship $F1_{\text{actual}}$ **17.2** to $F1_{\text{max-operation}}$ **17.3**.
- ▶ In crane operation without derrick ballast, fewer values may be shown in the icon **17** (F1-load display).

Shut off maximum value F1 in crane operation

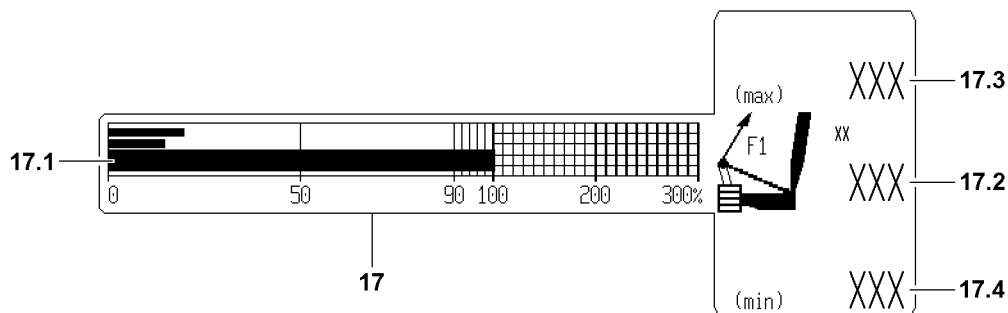

Fig. 110991

In the icon **17**(F1-load display) the F1-utilization bar **17.1** exceeds the 100 % mark and the LICCON overload protection has shut off the crane movement. The value $F1_{\text{actual}}$ **17.2** has exceeded the value $F1_{\text{max-operation}}$ **17.3**.

All further movements, which lead to an increase of the force F1 (value $F1_{\text{actual}}$) are shut off.

- ▶ Reverse any crane movement which has caused the shut off.
- or
- Initiate an alternative crane movement, which lowers the force F1 (value $F1_{\text{actual}}$).

Result:

- Crane operation is possible again.

Problem remedy

The crane operation is limited because the value $F1_{\text{max-operation}}$ apparently is being reached too early?

- ▶ Make sure that a valid set up status has been entered on the LICCON computer system.
- ▶ Make sure that the crane is assembled according to the assembly drawings.
- ▶ Make sure that the actual set up status and the entered set up status of the crane match.
- ▶ Make sure that all attachment parts and guy rods on the boom system, which are not needed, have been removed (weight).
- ▶ Make sure that the boom system is free of snow and ice (weight).
- ▶ Make sure that the wind influence onto the boom is not too great.

If no irregularities can be found:

- ▶ Contact Liebherr Service.

Shut off minimum value F1 in crane operation



Note

- ▶ A shut off minimum value F1 ($F1_{\text{min}}$) only occurs in operating modes with derrick ballast. The status $F1_{\text{actual}} = F1_{\text{min}}$ cannot be reached in all other operating modes.

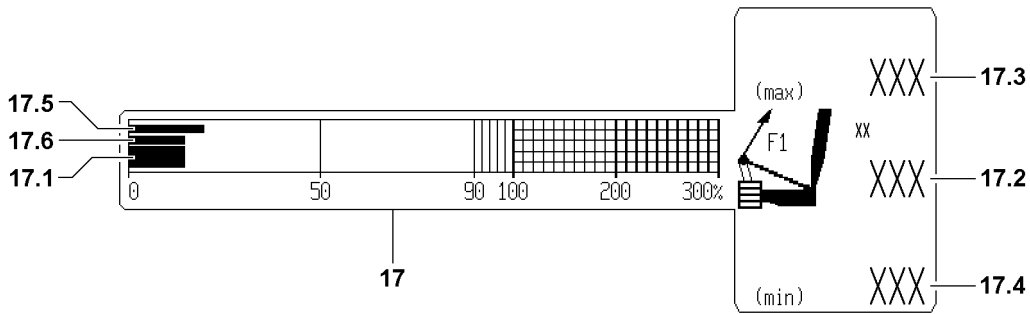

Fig.110992

In the icon **17** (F1-load display), when falling below the $F1_{min}$ advance warning bar **17.5**, a warning of the upcoming shut off is issued by the F1-utilization bar **17.1**.

If the F1-utilization bar **17.1** falls below the $F1_{min}$ -STOP bar **17.6**, then the LICCON overload protection shuts off the crane movement. The value $F1_{actual}$ **17.2** has fallen below the value $F1_{min}$ **17.4**.

**Note**

Shut off $F1_{min}$!

- ▶ If the utilization of the derrick ballast is below 50 %, then there is no immediate shut off when falling below value $F1_{min}$ **17.4**.

All further movements, which lead to an decrease of the force $F1$ (value $F1_{actual}$) are shut off.

- ▶ Reverse any crane movement which has caused the shut off.
or
Initiate an alternative crane movement, which increases the force $F1$ (value $F1_{actual}$).

Result:

- Crane operation is possible again.

Problem remedy

The crane operation is limited because the value $F1_{min}$ apparently is being reached too early?

- ▶ Make sure that a valid set up status has been entered on the LICCON computer system.
- ▶ Make sure that the crane is assembled according to the assembly drawings.
- ▶ Make sure that the actual set up status and the entered set up status of the crane match.
- ▶ Make sure that all attachment parts and guy rods on the boom system, which are not needed, have been removed (weight).
- ▶ Make sure that the boom system is free of snow and ice (weight).
- ▶ Make sure that the wind influence onto the boom is not too great.

If no irregularities can be found:

- ▶ Contact Liebherr Service.

3.3.4 Shut off spooling the winch up / out

Fig.110878

In symbol **18** appears symbol **18.1**, symbol **18.2** or symbol **18.3** and the LICCON overload protection has shut off the crane movement.

„Spooling the winch out“ (symbol **18.1**) or „spooling the winch up“ (symbol **18.2**) was shut off because the upper / lower limit value of the rope for the selected winch was exceeded or fallen below.

If symbol **18.3** appears blinking in the symbol **18**, then the affected winch is deactivated.

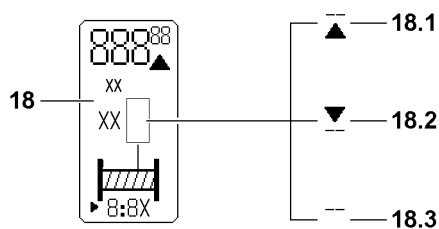
The symbol **18.1** appears and the crane movement „Spooling the winch out“ was turned off:

▶ Spool the winch up.

Result:

– Crane operation is possible again.

The symbol **18.2** appears and the crane movement „Spooling the winch up“ was turned off:

▶ Spool the winch out.

Result:

– Crane operation is possible again.

The symbol **18.3** appears and the winch is deactivated:

▶ Activate the winch, see Crane operating instructions, chapter 4.02.

Result:

– Crane operation is possible again.

3.3.5 Shut off hoist top

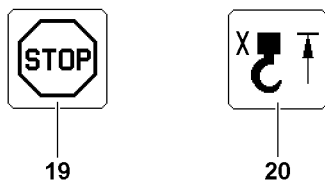

Fig.110875

The symbol **19** and hoist top icon **20** appear in the LICCON monitor and the LICCON overload protection has turned the crane movement off.

Spooling the hoist winch up was turned off because the hook block or the load hook has run against a hoist limit weight during the upward movement and the affected hoist limit switch was triggered.



WARNING

Property damage / falling load!

▶ After shut off spool hoist winch up (hoist top), for every further crane movement, the distance between the hook block / load hook and the boom head must be checked.



Note

▶ After a hoist top shut off occurred, further crane movements, which affect the length of the hoist rope are also shut off.

▶ Spool the hoist winch out.

Result:

– Crane operation is possible again.

3.3.6 Shut off due to error message

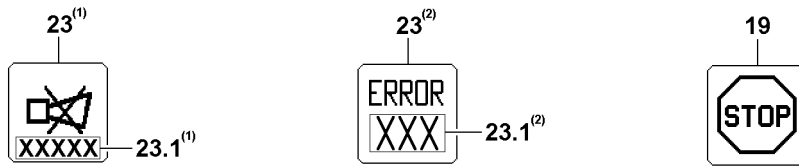

Fig.112331

⁽¹⁾not LR 1400/2

⁽²⁾only LR 1400/2

In the icon **23** appears an error message, the icon **19** appears in the LICCON monitor and the LICCON overload protection has turned off crane movement.



WARNING

Limited warning functions!

If there is a defect on a participating sensor (LML) and the crane is continued to be operated by bypassing the sensor other otherwise, then the warning functions and the shut offs of the LICCON overload protection are deactivated.

- ▶ If there is a defect on a participating sensor (LMB), then the crane may be operated further only in emergency cases.
- ▶ Fix / replace the sensor before starting crane operation again.

- ▶ Determine the existing error with the help of the error message from the error field **23.1** in icon **23**, see Diagnostics manual.
- ▶ Remedy the error.

Problem remedy

The erection of the crane, for example after assembly on a new job site or with another equipment configuration, is not possible due to an error message?

- ▶ Evaluate the error message.
- ▶ Make sure that all electrical connections are established correctly.
- ▶ Check if all sensors or dummy plugs with integrated electric have been connected properly.

If the error cannot be remedied:

- ▶ Contact Liebherr Service.

3.3.7 Minimum / maximum support forces



Note

- ▶ Applies only for cranes with support force monitoring*.
- ▶ Description of support force monitoring, see Crane operating instructions, chapter 4.02.

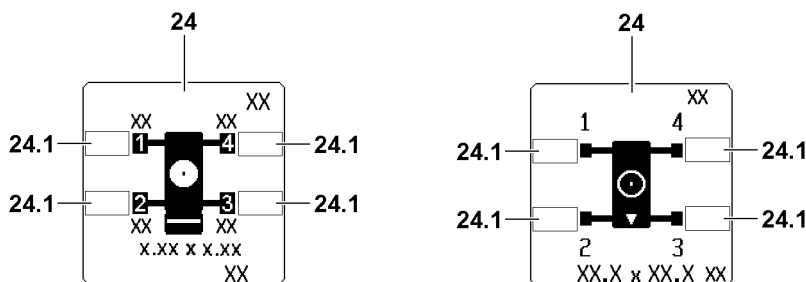

Fig.110881

LWE/LR 1600-2-008/18109-09-02/en

**WARNING**

The crane can topple over!

When reaching the programmed minimum / maximum support forces there is no automatic shut off of crane movements.

The displayed support force values are subjected to fluctuating influences, for example crane operation, surrounding and environmental influences.

The resulting tolerance field of the determined values may not be utilized by the support force display to determine the tipping limit of the crane.

If this is disregarded, then the crane can topple over.

Personnel can be severely injured or killed.

- ▶ The displayed support force values of the support force display may not be used to utilize the crane up to the tipping limit.
- ▶ Make sure that all support force values are within the minimum / maximum support forces.

The icon **24** (depending on the crane, similar to the left or right illustration) is shown in the LICCON monitor with blinking value in one or several fields **24.1**. Blinking values in the fields **24.1** signal exceedance of the minimum / maximum support forces.

- ▶ Reverse the crane movements, which caused the support forces to be outside the minimum / maximum values.

Result:

- All values in the fields **24.1** are within the minimum / maximum support forces.
- ▶ Carry out crane movements in such a way that the support forces always remain within the minimum / maximum values.

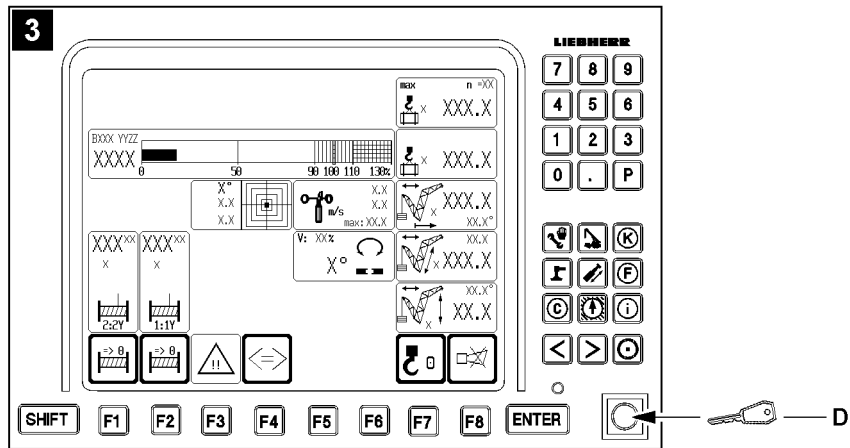
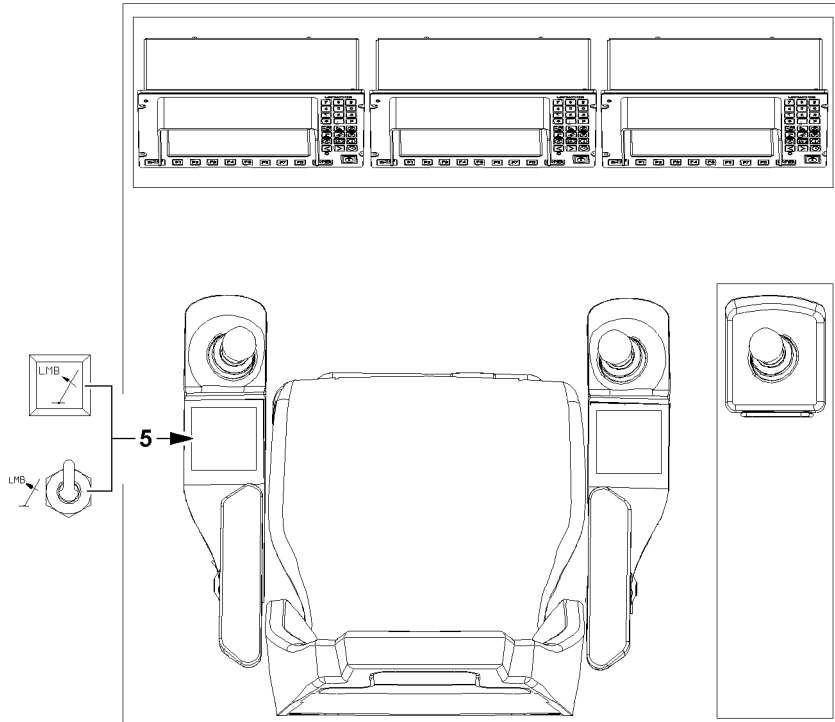

Fig.112334

LWE/LR 1600-2-008/18109-09-02/en

3.4 Shut off of crane movement: LMB STOP by LICCON overload protection



WARNING

Risk of overloading and toppling of the crane!

If the shut off limits of the LICCON overload protection are exceeded without knowing the exact cause for the shut off by the LICCON overload protection, then the crane can be overloaded and topple over. Personnel can be severely injured or killed.

- ▶ Before activating the function „Exceedance of shut off limits of the LICCON overload protection“ determine the exact cause for the shut off.



WARNING

Danger of accident due to function „Exceedance of shut off limits of the LICCON overload protection“! If the shut off limits of the LICCON overload protection are exceeded, there is no additional protection against crane overload.

Due to erroneous operation or deliberate misuse, the crane could collapse, the boom can break off or the crane can topple over.

Personnel can be severely injured or killed.

- ▶ The button **5** „Luffing in with suspended load“ and the set up key **D** may only be actuated when it is ensured that no normal operating condition (utilization below 100 % and no active shut off) can be reached without the function „Exceedance of shut off limits of the LICCON overload protection“!
- ▶ Actuate the set up key **D** only when no normal operating condition (utilization below 100 % and no active shut off) can be reached with the button **5** „Luffing in with suspended load“.
- ▶ The function „Exceeding the shut off limits of the LICCON overload protection“ is only permissible in emergencies and for assembly purposes.
- ▶ The set up key **D** may only be actuated by persons who are aware of the effects of their acts regarding the function „Exceeding the shut off limits of the LICCON overload protection“.
- ▶ The function „Exceeding the shut off limits of the LICCON overload protection“ requires the presence of an authorized person and must be performed with utmost caution.
- ▶ Crane operation with activated function „Exceeding the shut off limits of the LICCON overload protection“ is prohibited.



WARNING

Expanded working / danger zone of the crane!

Due to the function „Exceedance of shut off limits of the LICCON overload protection“ it is possible that the working / danger zone of the crane is significantly expanded.

If these circumstances are not observed, collisions and accidents can occur.

Personnel can be severely injured or killed.

- ▶ With activated function „Exceedance of shut off limits of the LICCON overload protection“ take an expanded working / danger zone of the crane into account and monitor it.

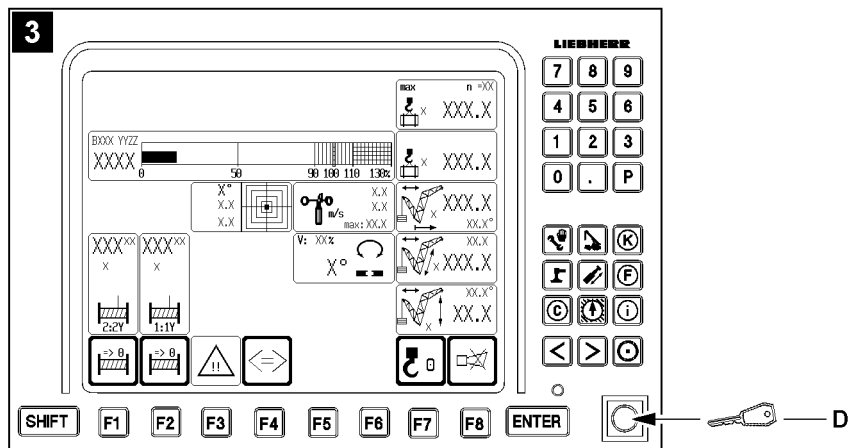
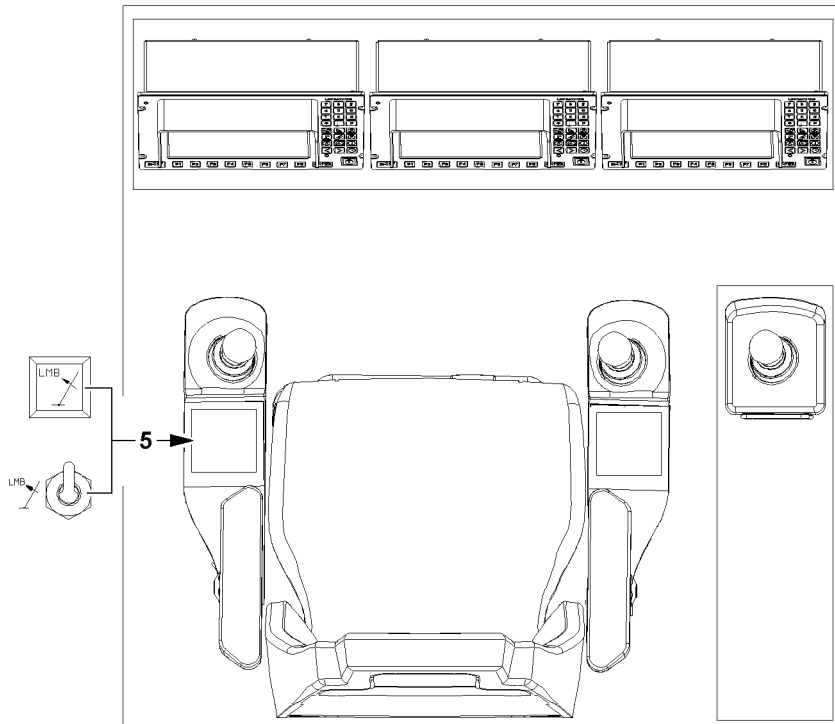

Fig.112334

LWE/LR 1600-2-008/18109-09-02/en

**WARNING**

Overload of crane!

When taking on a load by luffing the boom up, the crane can be overloaded.

This could result in serious accidents.

- ▶ Taking on load by luffing up the boom is prohibited.
- ▶ Take on a load only with the hoist gear.

There are two possibilities to exceed the shut off limits of the LICCON overload protection after LMB STOP:

- With button **5** „Luffing in with suspended load“ in the left control console
- With the set up key **D** on the LICCON monitor with crane operating screen, see illustration **3**

NOTICE

Danger of mix up!

The function „Exceedance of shut off limits of LICCON overload protection“ can only be activated with the set up key **D** on the LICCON monitor with crane operating screen, see illustration **3**.

The key buttons on the other monitors are not assigned with this function.

- ▶ Do not mix up the set up key **D** with the other key buttons.
- ▶ In case of mix up: Deactivate the activated function.

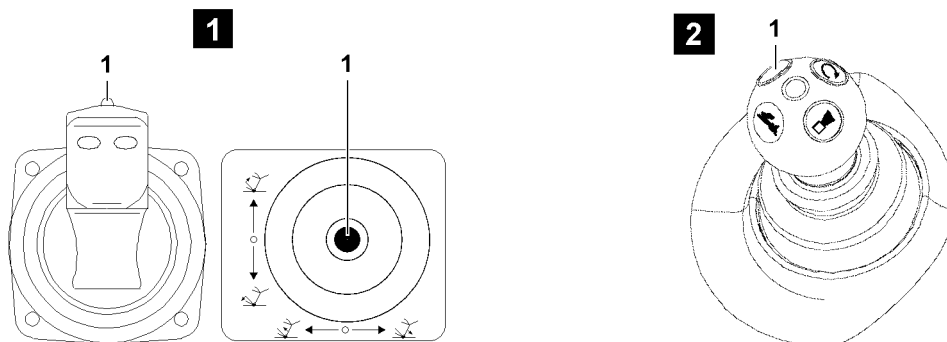
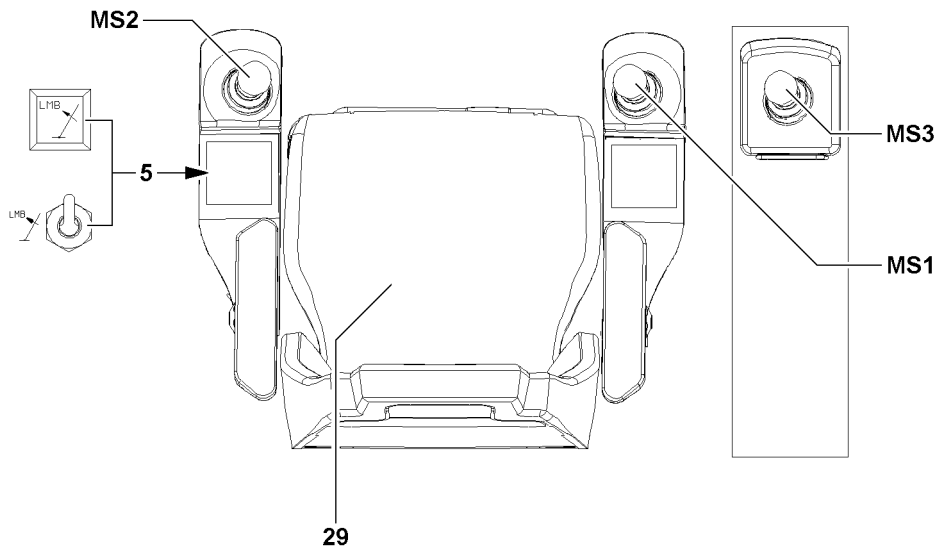
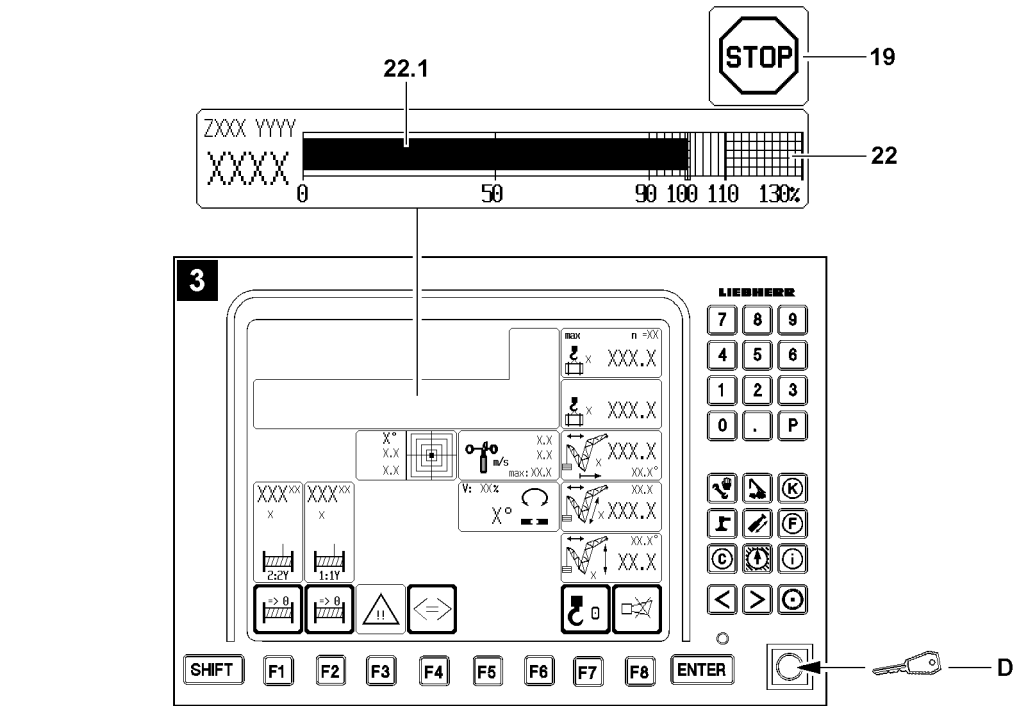

Fig.112335

LWE/LR 1600-2-008/18109-09-02/en

3.4.1 Luffing in with suspended load

If the maximum permissible load torque is exceeded, the LICCON overload protection turns off all crane movements that increase load torque.

In the icon **22** (load moment display) the utilization bar **22.1** has exceeded the 100 % mark and in the LICCON monitor appears the icon **19**.

This shut off limit can be exceeded by actuating the button **5** „Luffing in with suspended load“.

Make sure that the following prerequisite is met:

- Either the seat contact button **29** or one of the buttons **1** of the master switches (MS1, MS2, MS3) is actuated.



Note

- ▶ If the load is reduced by luffing up, then the button **5** „Luffing in with suspended load“ is possibly not functioning.
- ▶ For the procedure when the button **5** „Luffing in with suspended load“ is not functioning, see section „Exceedance of maximum permissible load moment“.

- ▶ Press the function key **5** „Luffing in with suspended load“ and hold it.

Result:

- The LICCON overload protection is inactive.

- ▶ Luff the load in.

Result:

- If the crane reaches a normal operation status (utilization below 100 % and no active shut off) then the icon **19** turns off, normal crane operation is possible again.

The function „Luffing in with suspended load“ is deactivated:

- When the function key **5** „Luffing in with suspended load“ is not longer actuated.
- When neither the seat contact button **29** nor one of the buttons **1** of the master switches (MS1, MS2, MS3) is actuated.
- At engine stop.

The function „Luffing in with suspended load“ is deactivated:

- The LICCON overload protection is active.
- ▶ Carry out crane movements in such a way that no repeated shut off by the LICCON overload protection occurs.

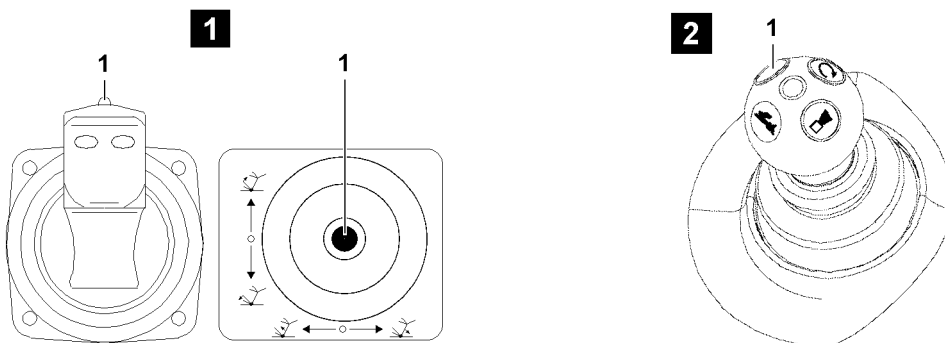
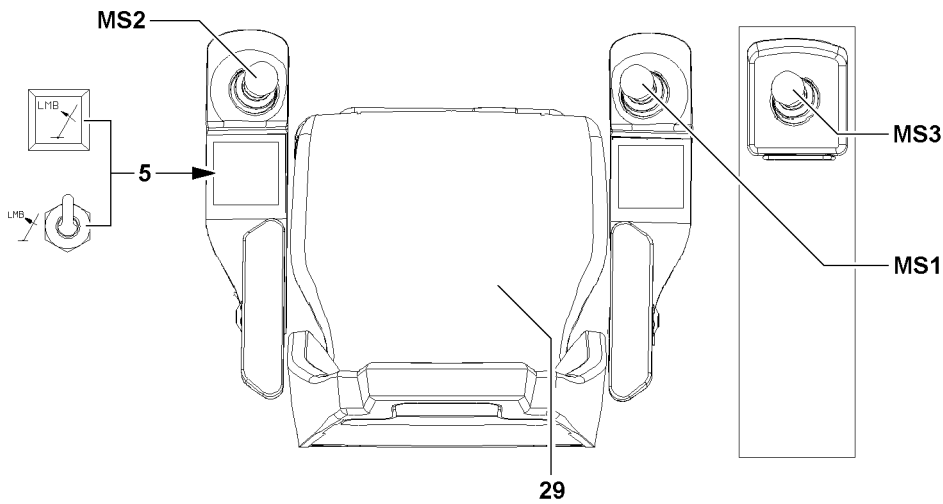
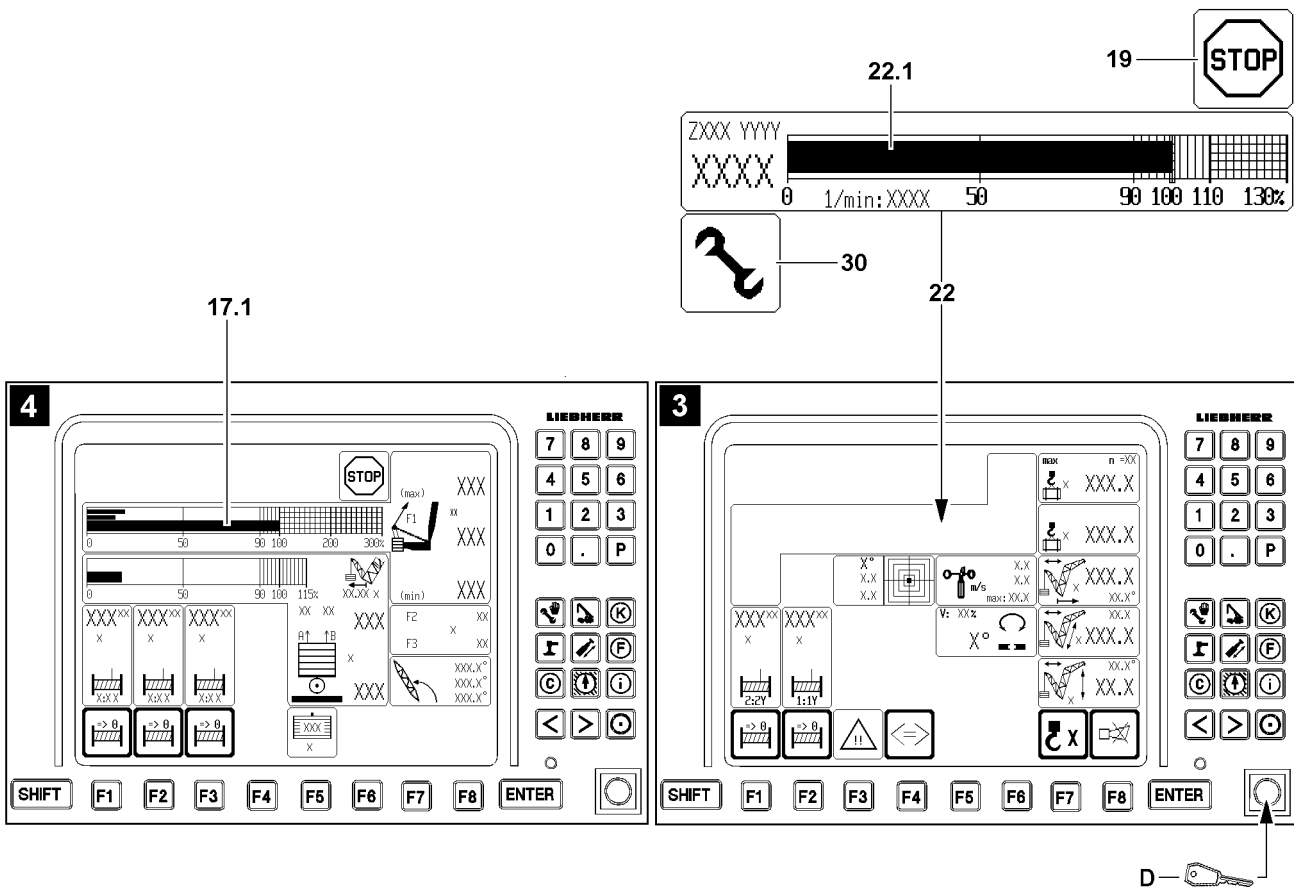

Fig.112336

LWE/LR 1600-2-008/18109-09-02/en

3.4.2 Exceedance of the maximum permissible load moment

If the maximum permissible load torque is exceeded, the LICCON overload protection turns off all crane movements that increase load torque.

In the icon **22** (load moment display) the utilization bar **22.1** has exceeded the 100 % mark and in the LICCON monitor appears the icon **19**.

This shut off can be exceeded by the set up key **D** in the „right touching“ position.



WARNING

Shut off safety device!

If the function „Exceedance of shut off limits of LICCON overload protection“ is activated by actuating the set up key **D** then it is possible to exceed the maximum permissible load moment. The function „Exceedance of maximum value test point 1“ is automatically activated too. Thus there is no shut off when exceeding the maximum value test point 1.

- ▶ All notes regarding the function „Exceedance of shut off limits of LICCON overload protection“ must be observed.
- ▶ The utilization bar $F1_{\text{actual}}$ **17.1** of the F1 load display must be observed.



Note

- ▶ In emergency situations, the function „Exceedance of shut off limits of the LICCON overload protection“ can be activated with the set up key **D** and the maximum permissible load moment of 100 % can be exceeded.

The set up key **D** on the LICCON monitor has two positions:

- Operating position (not actuated): Crane is in normal operation
- Position to right (touching): The function „Exceedance of shut off limits of the LICCON overload protection“ is activated, the assembly icon **30** appears in the LICCON monitor.

Make sure that the following prerequisites are met:

- With the button **5** „Luffing in with suspended load“ no normal operating status (utilization below 100 % and no active shut off) can be reached.
 - All master switches (MS1, MS2, MS3) are in zero position (not deflected).
 - Either the seat contact button **29** or one of the buttons **1** of the master switches (MS1, MS2, MS3) is actuated.
 - Radio operation* is not active.
- ▶ Turn the set up key **D** to the right (touching).

Result:

- The LICCON overload protection is inactive.
- The assembly icon **30** appears in the LICCON monitor.

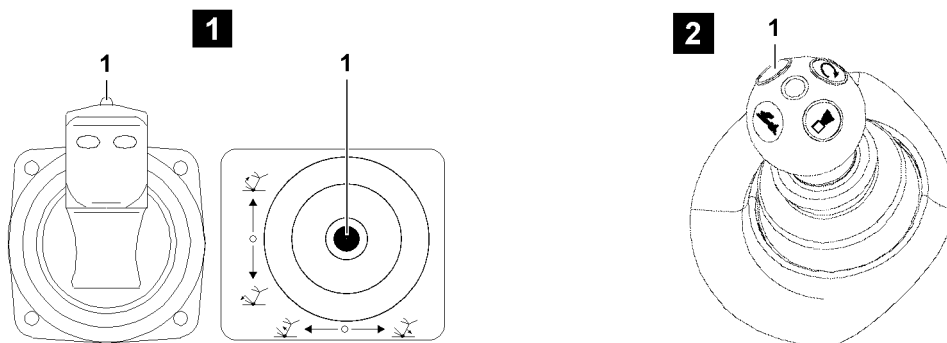
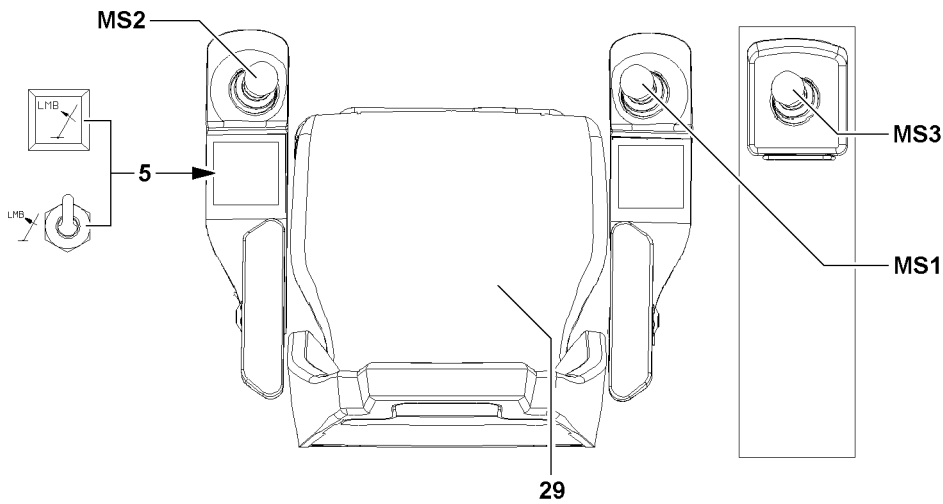
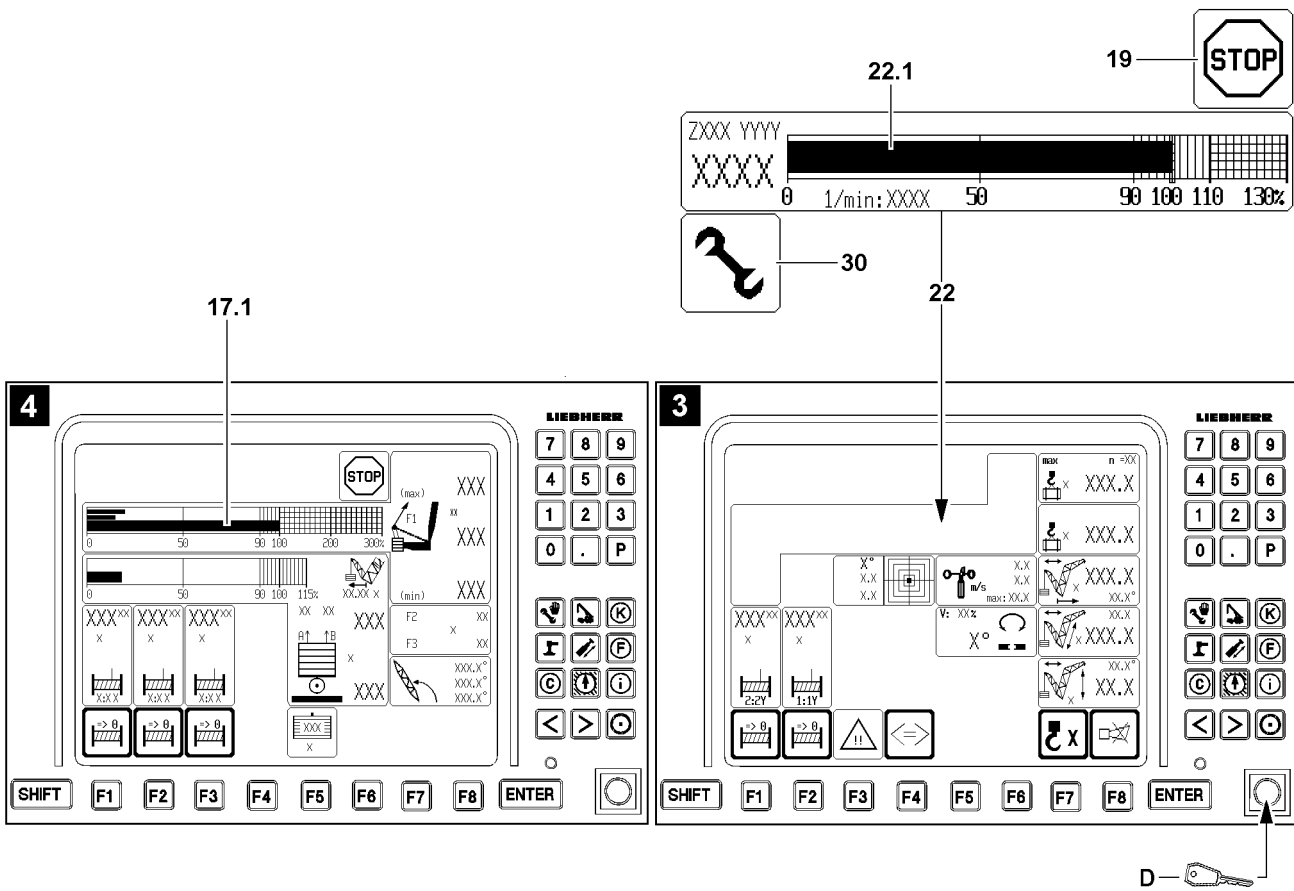

Fig.112336

LWE/LR 1600-2-008/18109-09-02/en

- ▶ Initiate crane movements which directly lead to a normal operating status (utilization below 100 % and no active shut off).

Result:

- If a crane reaches a normal operation status (utilization below 100 % and no active shut off), then the function „Exceedance of shut off limits of the LICCON overload protection“ shuts off, the assembly icon **30** and icon **19** in the LICCON monitor turn off.

In addition, the function „Exceedance of shut off limits of LICCON overload protection“ turns off immediately:

- If the set up key **D** is actuated again.
- If all master switches (MS1, MS2, MS3) are in neutral position for 10 seconds (with load chart available).
- When neither the seat contact button **29** nor one of the buttons **1** of the master switches (MS1, MS2, MS3) is actuated.
- If radio operation* is activated.
- At engine stop.
- At hoist top shut off.
- When leaving the angle range of the load chart.



Note

- ▶ The function „Exceedance of shut off limits of the LICCON overload protection“ is only turned off when the assembly icon **30** in the LICCON monitor turns off.
- ▶ If the function „Exceedance of shut off limits of the LICCON overload protection“ does not turn off after pressing the set up key **D** once, then press the set up key **D** again until the assembly icon **30** in the LICCON monitor turns off.

The function „Exceedance of shut off limits of the LICCON overload protection“ has / was shut off:

- The assembly icon **30** in the LICCON monitor turns off.
- ▶ Make sure that the assembly icon **30** does no longer appear in the LICCON monitor.
- ▶ Carry out crane movements in such a way that no repeated shut off by the LICCON overload protection occurs.

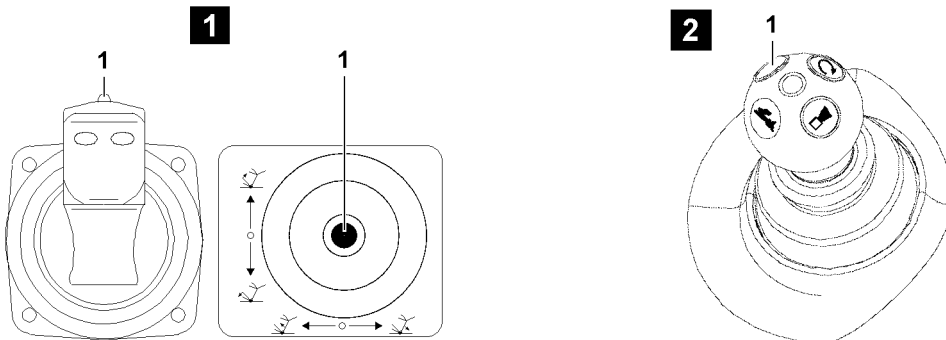
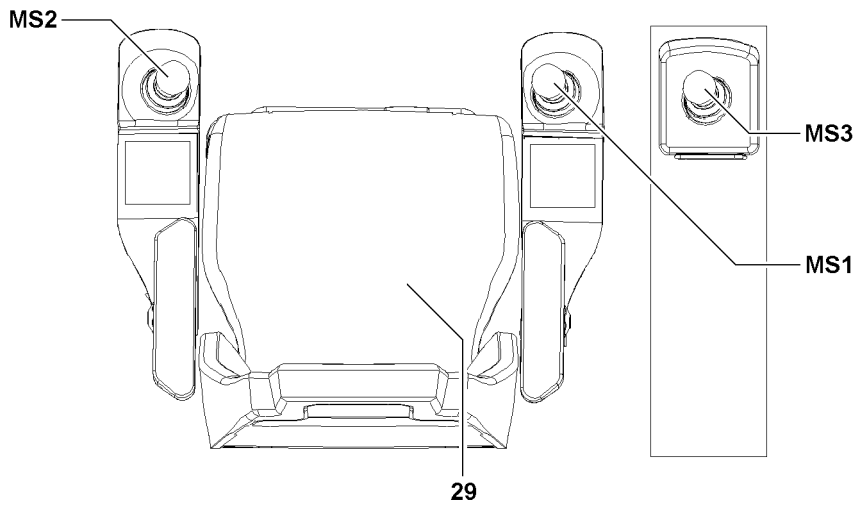
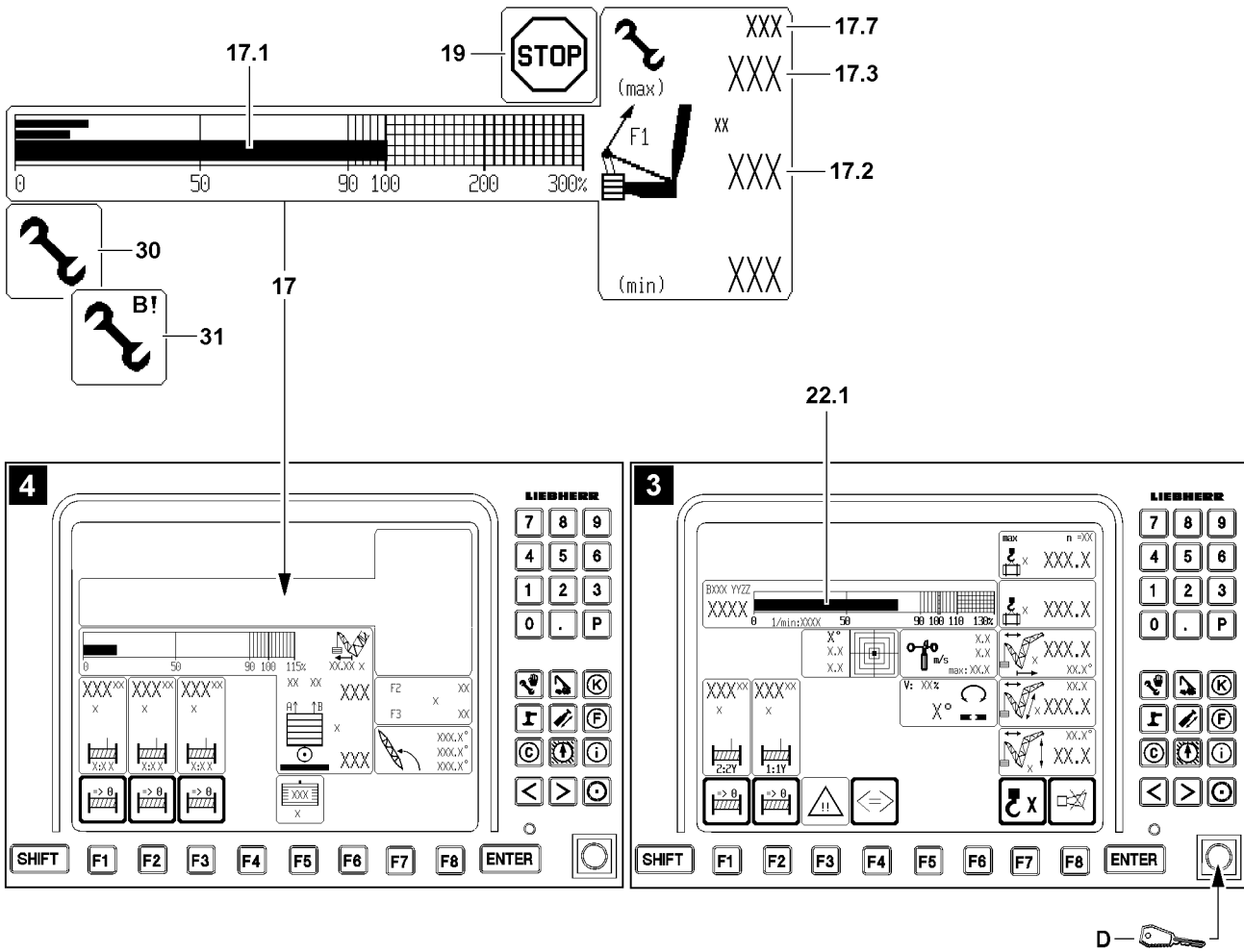

Fig.112337

LWE/LR 1600-2-008/18109-09-02/en

3.4.3 Exceedance of maximum value test point 1 (force F1) in crane operation



WARNING

Leaving the load chart with load on hook!

If, by actuating the set up key **D**, the shut off is bypassed by value $F1_{\text{max-operation}}$ **17.3** and exceeded by more than 110 %, then the crane is in assembly operation, the assembly icon **31** appears in the LICCON monitor.

There is no load chart available any longer and various display values may not be shown any longer in the crane operating screen.

The load on the hook is no longer monitored by the load chart.

Severe accidents due to crane overload can result.

Personnel can be severely injured or killed.

▶ In assembly operation, the data in the erection / take down charts is binding.



WARNING

Shut off safety device!

If, by actuating the set up key **D**, the function „Exceedance of maximum value test point 1“ is activated, then the function „Exceedance of shut off limits of LICCON overload protection“ is also activated automatically. Thus there is no shut off if the maximum permissible load moment is exceeded.

▶ All notes regarding the function „Exceedance of shut off limits of LICCON overload protection“ must be observed.

▶ The utilization bar **22.1** of the load moment display must be observed.



Note

▶ The force determined on test point 1 is generally described as $F1_{\text{actual}}$ (actual value F1).

▶ In the icon **17** (F1-load display), the force relationship as well as the number values are shown in number values as well as a bar display (called F1-bar display).

▶ The value $F1_{\text{max-operation}}$ **17.3** corresponds to 100 % in the F1-bar display.

▶ The F1-utilization bar **17.1** shows the relationship $F1_{\text{actual}}$ **17.2** to $F1_{\text{max-operation}}$ **17.3**.

▶ In crane operation without derrick ballast, fewer values may be shown in the icon **17** (F1-load display).

▶ If the actual load is **larger** than the permissible hook block weight according to the erection / take down charts, then it can be exceeded up to maximum 110 % of $F1_{\text{max-operation}}$ **17.3**.

▶ If the actual load is **smaller** than the permissible hook block weight according to the erection / take down charts, then the assembly operation becomes active above 110 % of $F1_{\text{max-operation}}$ **17.3**. In assembly operation, there is no load chart available.

▶ The value $F1_{\text{max-assembly}}$ **17.7** appears in crane operation when 90 % of its nominal value is exceeded.

In the icon **17** (F1 load display) the utilization bar $F1_{\text{actual}}$ **17.1** exceeds the 100 % mark and the LICCON overload protection has shut off the crane movement. The value $F1_{\text{actual}}$ **17.2** has exceeded the value $F1_{\text{max-operation}}$ **17.3**.

All further movements, which lead to an increase of the force (value $F1_{\text{actual}}$) are shut off.

In the LICCON monitor with the derrick operating screen (illustration **4**) appears the icon **19**.

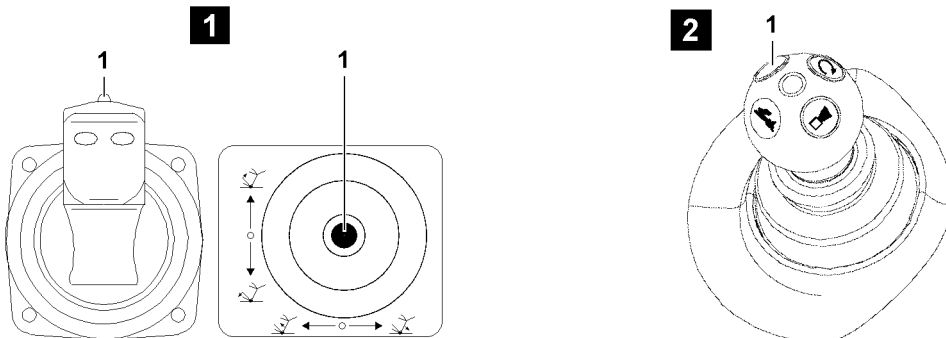
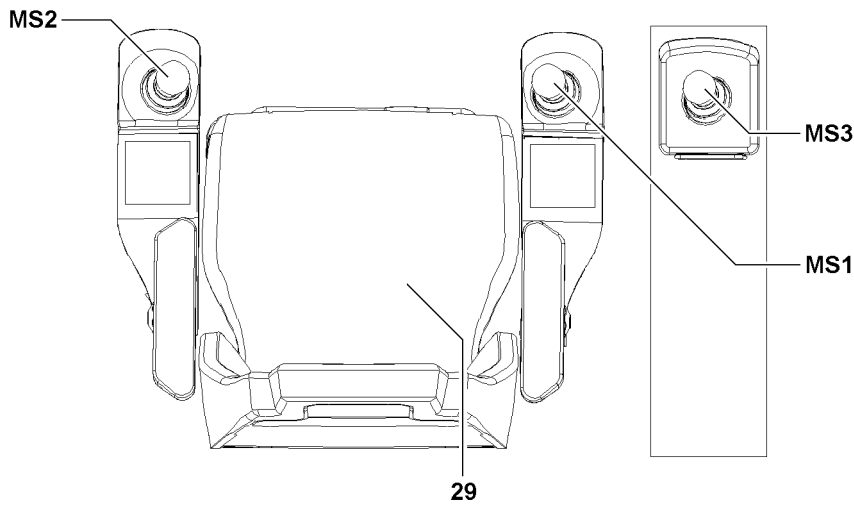
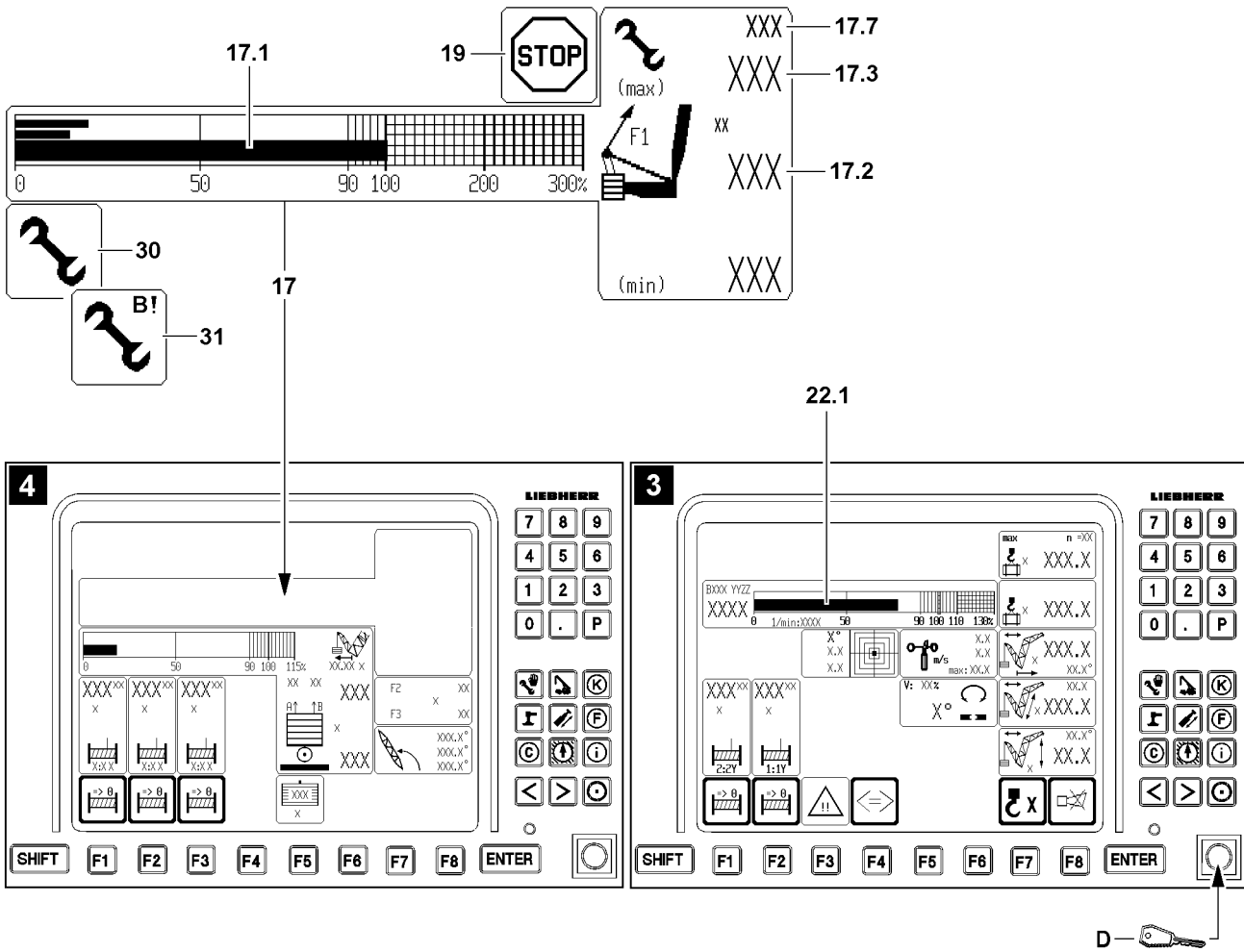

Fig.112337

LWE/LR 1600-2-008/18109-09-02/en

Make sure that the following prerequisites are met:

- All master switches (MS1, MS2, MS3) are in zero position (not deflected).
 - Either the seat contact button **29** or one of the buttons **1** of the master switches (MS1, MS2, MS3) is actuated.
 - Radio operation* is not active.
 - The F1 load display 110 % has not been reached and a load chart is available.
- ▶ Turn the set up key **D** to the right (touching).

Result:

- The function „Exceedance of maximum value test point 1“ is activated in connection with the function „Exceedance of the shut off limits of the LICCON overload protection“.
- $F1_{\text{max-operation}}$ **17.3** can be exceeded.

The function „Exceedance of shut off limits of the LICCON overload protection“ in connection with the function „Exceedance of the maximum value test point 1“ also shuts off immediately:

- If the set up key **D** is actuated again.
- If all master switches (MS1, MS2, MS3) are in neutral position for 10 seconds (with load chart available).
- When neither the seat contact button **29** nor one of the buttons **1** of the master switches (MS1, MS2, MS3) is actuated.
- If radio operation* is activated.
- At engine stop.
- At hoist top shut off.



Note

- ▶ The function „Exceedance of shut off limits of the LICCON overload protection“ is only turned off when the assembly icon **30** in the LICCON monitor turns off.
- ▶ If the function „Exceedance of shut off limits of the LICCON overload protection“ does not turn off after pressing the set up key **D** once, then press the set up key **D** again until the assembly icon **30** in the LICCON monitor turns off.

The function „Exceedance of shut off limits of the LICCON overload protection“ has / was shut off:

- The assembly icon **30** in the LICCON monitor turns off.
 - The working speed is reduced until all master switches (MS1, MS2, MS3) are in zero position at the same time.
- ▶ Make sure that the assembly icon **30** does no longer appear in the LICCON monitor.
- ▶ Carry out crane movements in such a way that no repeated shut off by the LICCON overload protection occurs.

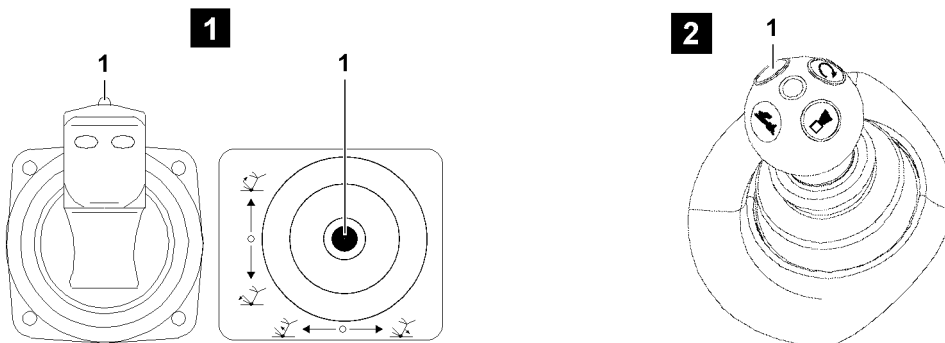
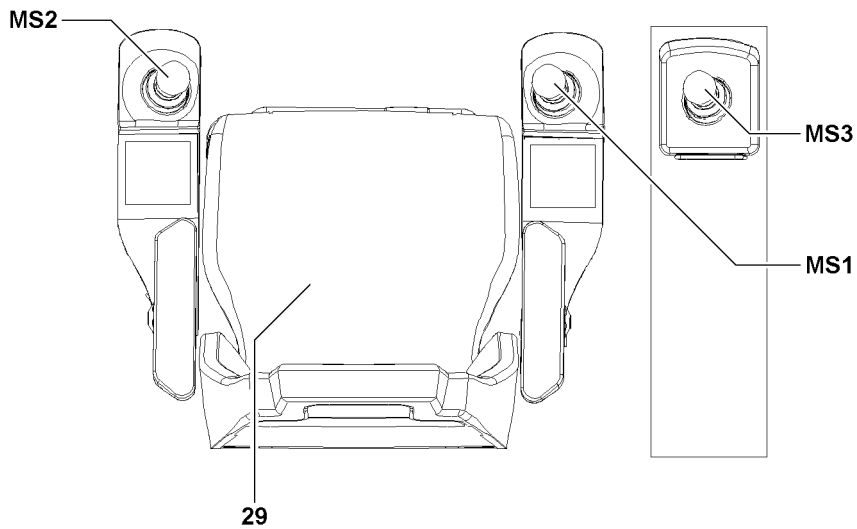
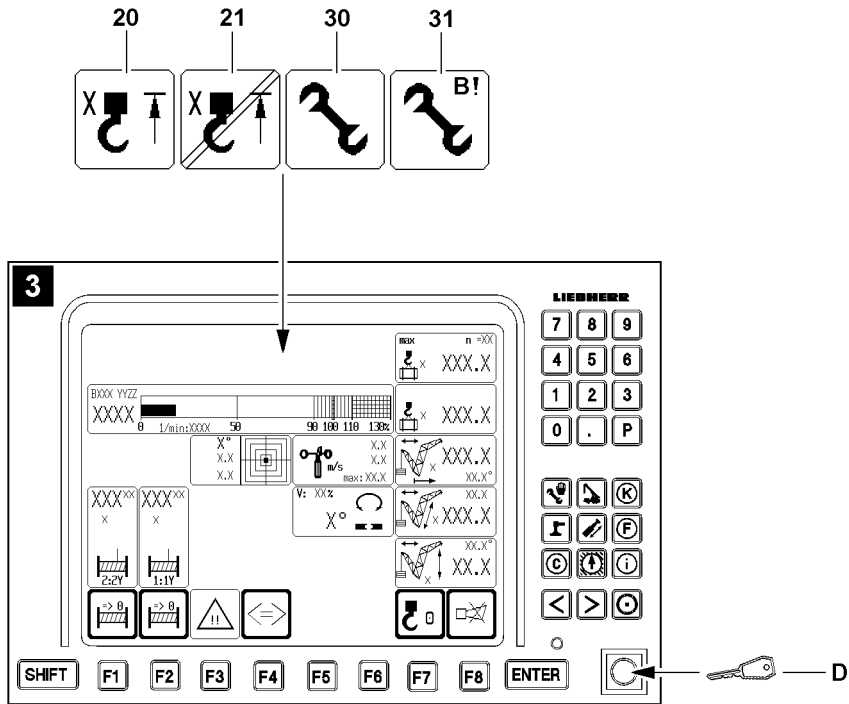

Fig.111230

LWE/LR 1600-2-008/18109-09-02/en

3.5 Bypass of the hoist top shut off



WARNING

Improper use of the function „Bypass of hoist top shut off“!

- ▶ The function „Bypass of hoist top shut off“ may never be used to increase the lifting height during crane operation.



WARNING

Property damage and falling load!

If the function „Bypass of hoist top shut off“ is activated, there is the danger that the hook block or the load hook is pulled against the pulley head.

This danger exists especially when the hoist winch is continued to be spooled up and for crane movements which have an influence on the hoist rope, for example luffing the boom, the auxiliary boom / accessory or the derrick boom.

Property damage and falling load can result.

Personnel can be severely injured or killed.

- ▶ The function „Bypass of hoist top shut off“ may only be carried out by an authorized person, along with a guide. The guide must be in direct contact with the crane operator and must continually monitor the distance between the hook block / load hook and the boom head.
- ▶ Carry out all crane movements with utmost caution.



Note

- ▶ The activation of the function „Bypass of hoist top shut off“ is only possible if the hoist limit switch was touched and the hoist top shut off has occurred.
- ▶ If the hoist limit switch is triggered when the set up key **D** is actuated (function „Exceedance of shut off limits of the LICCON overload protection“ is active, the assembly icon **30** or the assembly icon **31** appear), then a hoist top shut off occurs and the function „Exceedance of shut off limits of the LICCON overload protection“ is deactivated.
- ▶ For assembly purposes or in emergency cases, if the activation of the function „Bypass of hoist top shut off“ **and** activation of the function „Exceedance of shut off limits of the LICCON overload protection“ is necessary, then the set up key **D** must be actuated until the icon **21** and assembly icon **30** or assembly icon **31** (assembly operation) appear.

Make sure that the following prerequisites are met:

- A hoist top shut off has occurred, the hoist top icon **20** appears in the LICCON monitor.
- Either the seat contact button **29** or one of the buttons **1** of the master switches (MS1, MS2, MS3) is actuated.
- All master switches (MS1, MS2, MS3) are in zero position (not deflected).
- The radio operation* is not active.

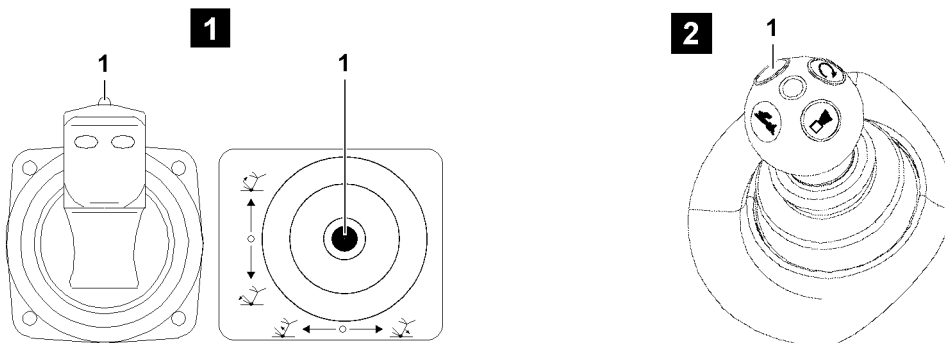
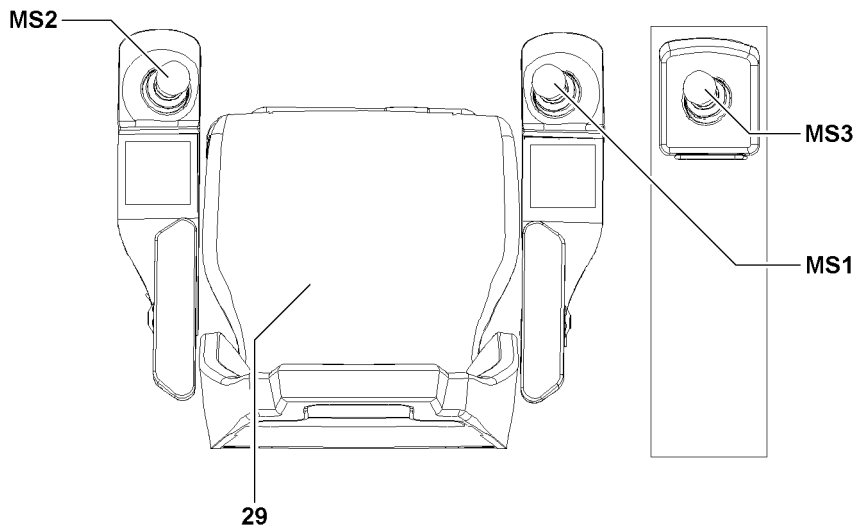
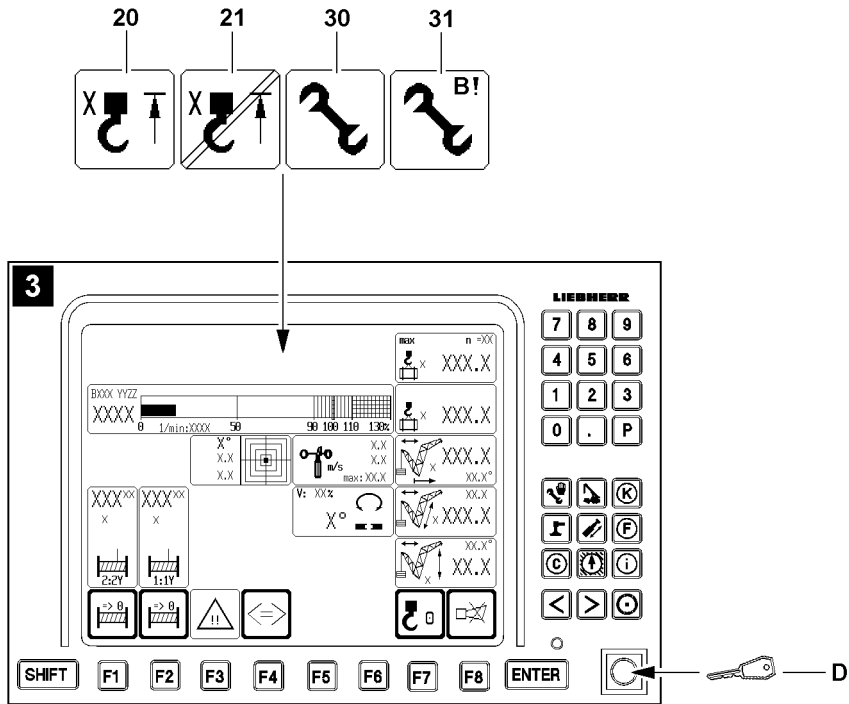

Fig.111230

LWE/LR 1600-2-008/18109-09-02/en

- ▶ Turn the set up key **D** to the right (touching).

Result:

- The assembly icon **30** or the assembly icon **31** (assembly operation) appear in the LICCON monitor.
 - The hoist top icon **20** in the LICCON monitor changes to the icon **21**.
 - All hoist limit switches are bypassed.
- ▶ Carry out a crane movement with bypassed hoist limit switches with utmost caution and by taking the safety guidelines into account.

The function „Bypass of the hoist top shut off“ turns off:

- If the set up key **D** is actuated again.
- When no master switch (MS1, MS2, MS3) was deflected for 10 seconds.
- When neither the seat contact button **29** nor one of the buttons **1** of the master switches (MS1, MS2, MS3) is actuated.
- If there is no longer a shut off of a hoist limit switch.
- If the radio operation* is active.
- At engine stop.

The function „Bypass of the hoist top shut off“ has / was turned off:

- The assembly icon **30** or the assembly icon **31** (assembly operation) in the LICCON monitor turn off.
 - The icon **21** on the LICCON monitor turns off.
- ▶ Make sure that the assembly icon **30** or the assembly icon **31** (assembly operation) as well as the icon **21** no longer appear in the LICCON monitor.
 - ▶ Carry out the crane movements in such a way that no repeated hoist top shut off occurs.

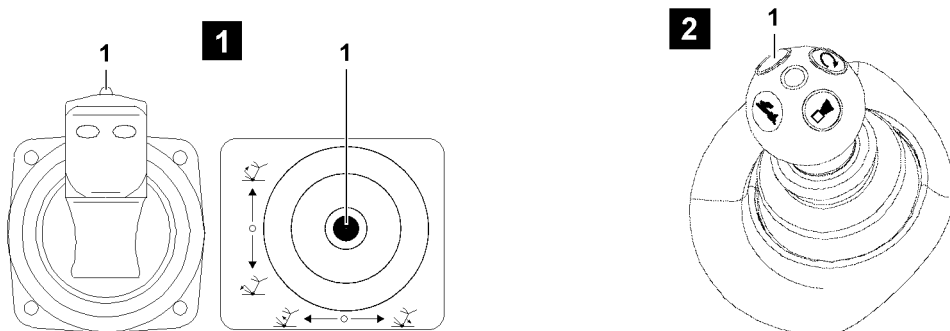
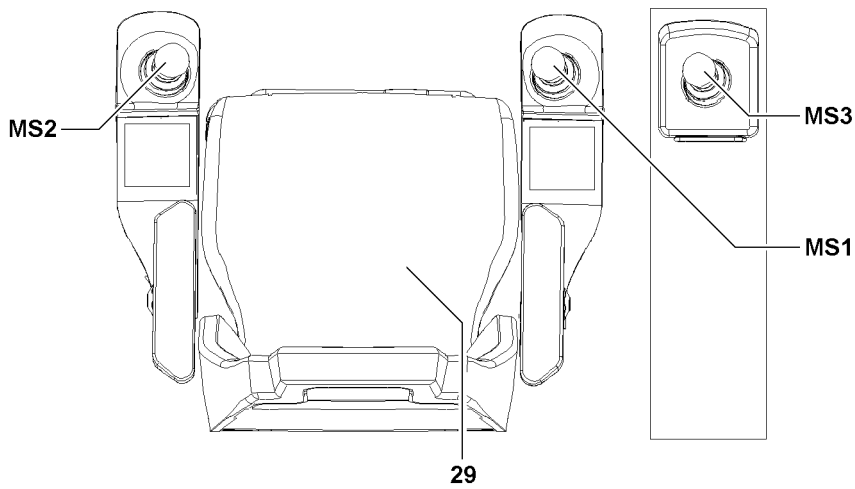
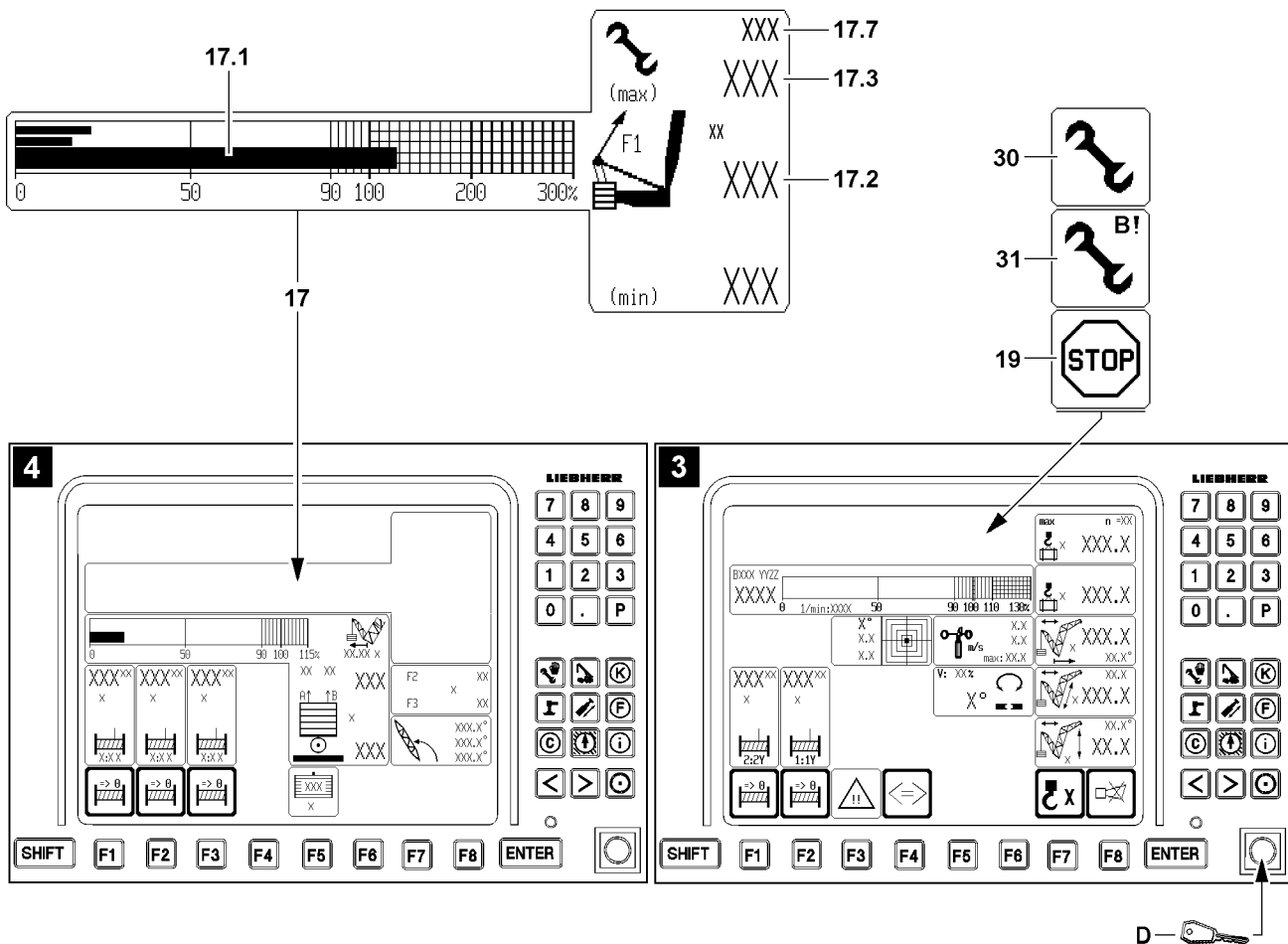

Fig.112343

LWE/LR 1600-2-008/18109-09-02/en

3.6 Exceeding the shut off limits of the LICCON overload protection during erection / take down procedures (assembly operation)



Note

- ▶ If the crane is in the range „No load chart available“ then there is a shut off of the crane control by the LICCON overload protection. The icon **19** appears in the LICCON monitor.
- ▶ By an actuated set up key **D**, the function „Exceedance of shut off limits of the LICCON overload protection“ can be activated, all erection / take down procedures can be carried out within the erection / take down charts, for which no load charts are available.



WARNING

Danger of accident during erection / take down procedures!

If the erection / take down charts are not observed, the crane could collapse, the boom can break off or the crane can topple over.

Personnel can be severely injured or killed.

- ▶ The erection / take down charts must be observed.
- ▶ Press the set up key **D** only when the configuration status has been entered correctly in the LICCON computer system and matches the actual situation.



Note

- ▶ The force determined on test point 1 is generally described as $F1_{\text{actual}}$ (actual value F1).
- ▶ In the icon **17** (F1-load display), the force relationship as well as the number values are shown in number values as well as a bar display (called F1-bar display).
- ▶ The value $F1_{\text{max-operation}}$ **17.3** corresponds to 100 % in the F1-bar display.
- ▶ The F1-utilization bar **17.1** shows the relationship $F1_{\text{actual}}$ **17.2** to $F1_{\text{max-operation}}$ **17.3**.
- ▶ In crane operation without derrick ballast, fewer values may be shown in the icon **17** (F1-load display).
- ▶ If a load chart is available, then the value $F1_{\text{max-operation}}$ **17.3** is valid as the limit value for a shut off of crane operation.
- ▶ When leaving the area „load chart available“, the assembly icon **30** turns off and the assembly icon **31** appears.
- ▶ When leaving the area „Load chart available“ then $F1_{\text{max-assembly}}$ **17.7** is valid as the upper limit value.
- ▶ $F1_{\text{max-assembly}}$ **17.7** might only appear when 90 % of its nominal value is exceeded.

3.6.1 Carrying out erection procedures (assembly operation)

Make sure that the following prerequisites are met:

- All master switches (MS1, MS2, MS3) are in zero position (not deflected).
- Either the seat contact button **29** or one of the buttons **1** of the master switches (MS1, MS2, MS3) is actuated.
- Radio operation* is not active.
- The set up configuration corresponds to the erection / take down charts.
- The set up status has been entered correctly into the LICCON computer system.

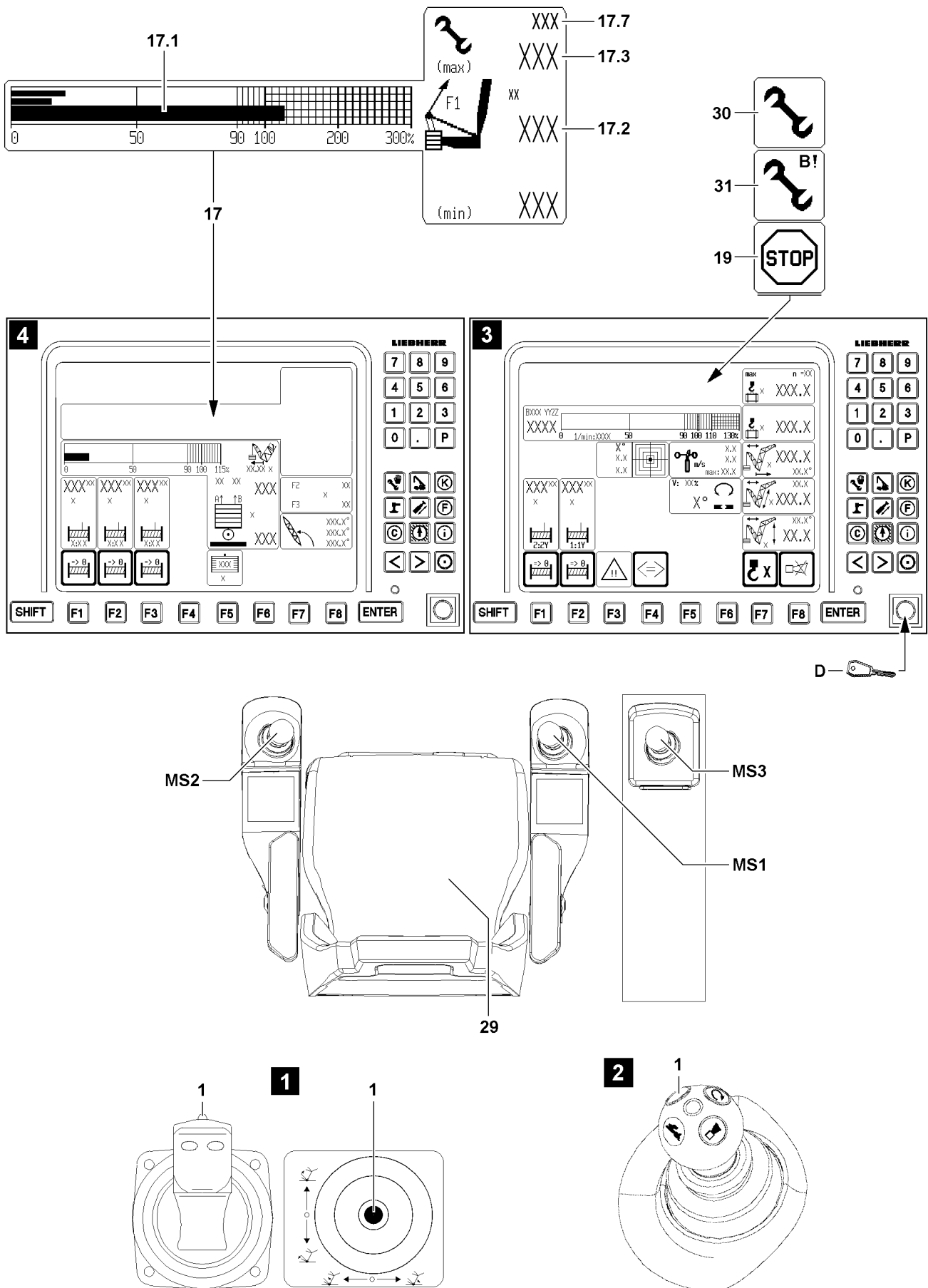

Fig.112343

LWE/LR 1600-2-008/18109-09-02/en

- ▶ Turn the set up key **D** to the right (touching).

Result:

- The assembly icon **31** appears in the area „No load chart available“.
- The erection / take down procedures can be carried out.
- ▶ Watch the icon **17** (F1-load display), the value $F1_{\text{actual}}$ **17.2** may not exceed the value $F1_{\text{max-assembly}}$ **17.7**.

Problem remedy

The erection / take down procedure cannot be carried out due to shut off „ $F1_{\text{max-assembly}}$ **17.7** exceeded“?

- ▶ See section „Danger of exceeding $F1_{\text{max-assembly}}$ “.
-

Problem remedy

The function „Exceedance of shut off limits of the LICCON overload protection“ can not be activated during erection / take down procedures?

- ▶ Check the error messages.
 - ▶ Check the electrical connections.
 - ▶ Check if all sensors or dummy plugs with integrated electric have been connected properly.
-

The function „Exceedance of shut off limits of the LICCON overload protection“ turns off:

- If the set up key **D** is actuated again.
- When an range with existing load chart is reached (erection procedure).
- If all master switches (MS1, MS2, MS3) are in neutral position for 10 seconds (with „Load chart available“).
- When neither the seat contact button **29** nor one of the buttons **1** of the master switches (MS1, MS2, MS3) is actuated.
- At engine stop.

The function „Exceedance of shut off limits of the LICCON overload protection“ has / was shut off:

- The assembly icon **30** or the assembly icon **31** in the LICCON monitor turns off.
- ▶ After completion of the erection / take down procedures, make sure that the assembly icon **30** or the assembly icon **31** no longer appear in the LICCON monitor.

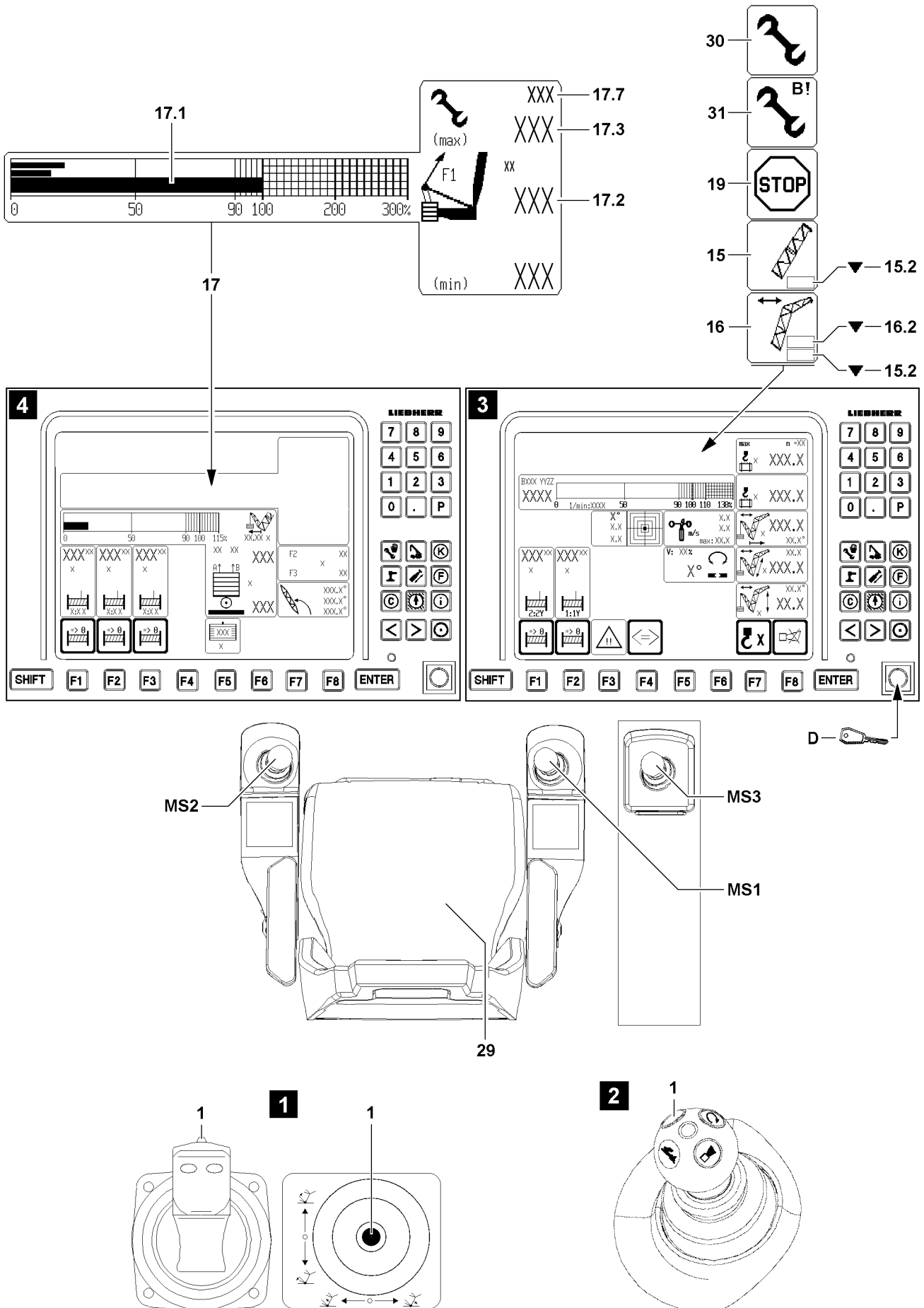

Fig.112341

LWE/LR 1600-2-008/18109-09-02/en

3.6.2 Carrying out take down procedures (assembly operation)



WARNING

Increased danger of accidents due to bypass of shut off of luffing the main boom / auxiliary boom / accessory down!

When the shut off luffing the main boom / auxiliary boom / accessory down is bypassed, then the LICCON overload protection as a whole is deactivated or limited.

When the shut off luffing the main boom / auxiliary boom / accessory down is bypassed and the main boom and / or the auxiliary boom / accessory is further luffed down, then there is no load chart available any longer.

Crane operation with bypassed shut off luffing the main boom / auxiliary boom / accessory down is prohibited, since severe accidents can result.

Personnel can be severely injured or killed.

- ▶ Activate the bypass of the shut off luffing the main boom / auxiliary boom / accessory down only in emergency cases or for erection / take down procedures with erection / take down charts.
- ▶ Carry out all crane movements with utmost caution.

Make sure that the following prerequisites are met:

- In symbol **15** or symbol **16** appear symbol **15.2** or symbol **16.2** and the LICCON overload protection has shut off the crane movement.
- Either the seat contact button **29** or one of the buttons **1** of the master switches (MS1, MS2, MS3) is actuated.
- All master switches (MS1, MS2, MS3) are in zero position (not deflected).
- The radio operation* is not active.

- ▶ Turn the set up key **D** to the right (touching).

Result:

- The assembly icon **30** appears in the LICCON monitor.
- The function „Exceedance of shut off limits of the LICCON overload protection“ is activated and has bypassed the shut off luffing the main boom / auxiliary boom / accessory down.



Note

- ▶ If a load chart is available, then the value $F1_{\text{max operation}}$ **17.3** is valid as the limit value for a shut off of crane operation.
- ▶ When leaving the area „load chart available“, the assembly icon **30** turns off and the assembly icon **31** appears.
- ▶ When leaving the area „Load chart available“ then $F1_{\text{max assembly}}$ **17.7** is valid as the upper limit value.
- ▶ If no derrick boom is installed, then the icon **17** only shows $F1_{\text{actual}}$ **17.1** and $F1_{\text{max-assembly}}$ **17.7**. $F1_{\text{max-assembly}}$ **17.7** might only appear when 90 % of its nominal value is exceeded.

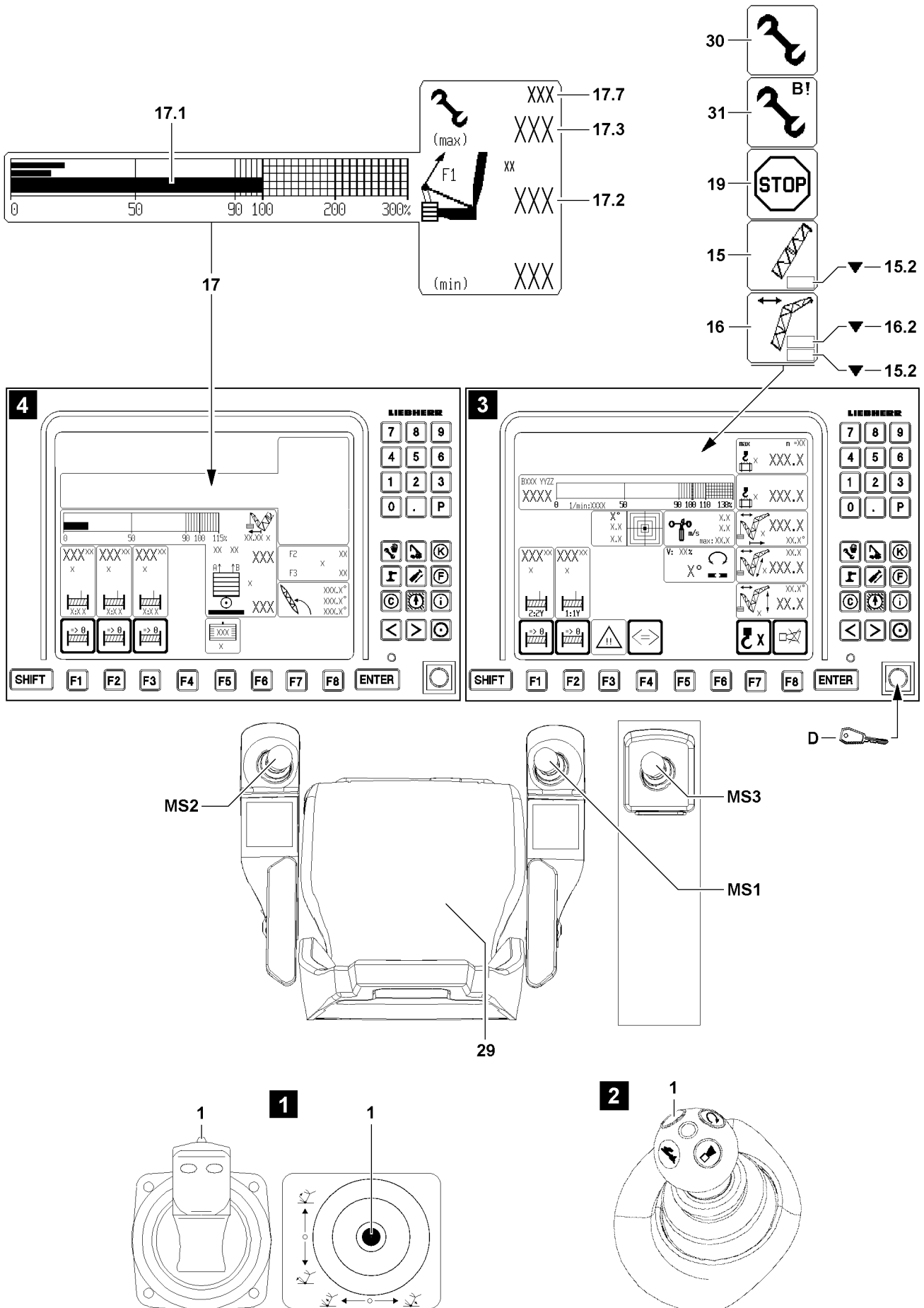

Fig.112341

LWE/LR 1600-2-008/18109-09-02/en

**DANGER**

The crane can topple over!

There is **no** shut off of the luff down movement after reaching the limit value $F1_{\text{max assembly}}$ **17.7**.

If the warnings by the LICCON overload protection are ignored, then the crane will be overloaded or topples over.

Personnel can be severely injured or killed.

- ▶ The symbol **17** (F1-load display) must be watched permanently. It must be ensured that the value $F1_{\text{actual}}$ **17.2** is smaller than the value $F1_{\text{max assembly}}$ **17.7**.
- ▶ The luff down movement must be stopped before the value $F1_{\text{actual}}$ **17.2** exceeds the limit value $F1_{\text{max assembly}}$ **17.7**.

- ▶ During the take down procedure watch the icon **17** (F1-load display).

Problem remedy

The take down procedure cannot be carried out due to danger of exceeding the $F1_{\text{max assembly}}$ **17.7**?

- ▶ See section „Danger of exceeding $F1_{\text{max assembly}}$ “.

The bypass of the shut off luffing the main boom / auxiliary boom / accessory down turns off:

- If the set up key **D** is actuated again.
- When neither the seat contact button **29** nor one of the buttons **1** of the master switches (MS1, MS2, MS3) is actuated.
- When an area with existing load chart is reached.
- If the radio operation* is active.
- At engine stop.

The bypass of the shut off luffing the main boom / auxiliary boom / accessory down has / was turned off:

- The assembly icon **31** or the assembly icon **30** in the LICCON monitor turns off.
- ▶ Make sure that the assembly icon **30** or the assembly icon **31** no longer appear in the LICCON monitor.

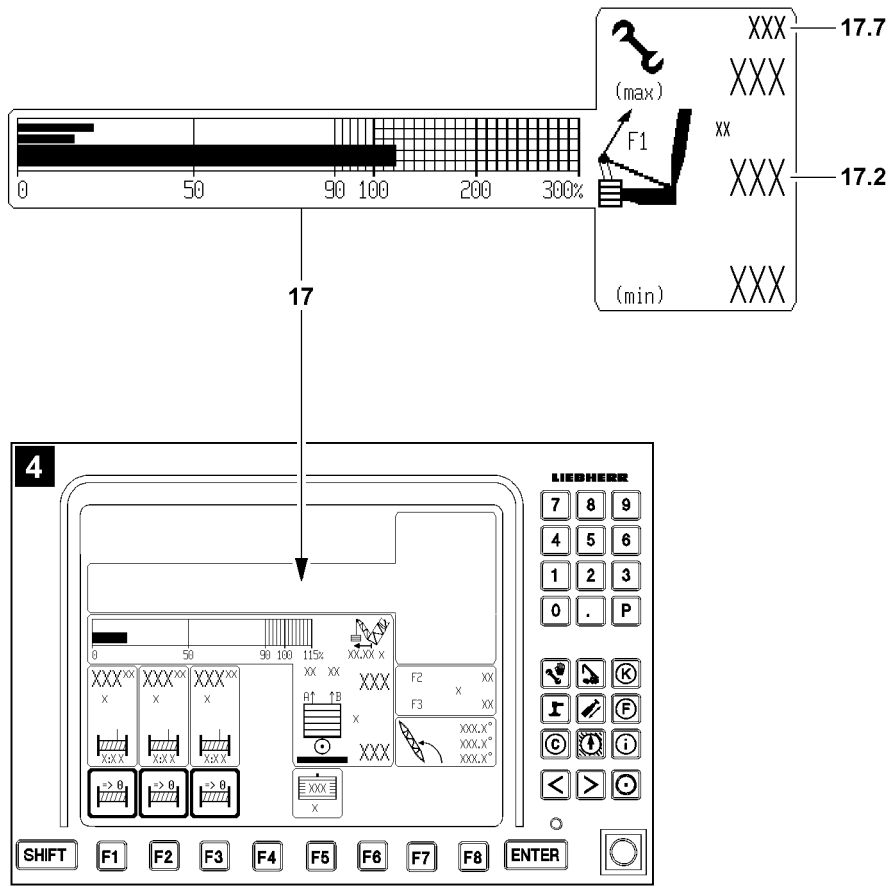

Fig.112344

3.6.3 Danger of exceeding $F1_{\text{max assembly}}$



Note

- ▶ $F1_{\text{max-assembly}}$ **17.7** might only appear when 90 % of its nominal value is exceeded.



DANGER

The crane can topple over!

There is **no** shut off of the luff down movement after reaching the limit value $F1_{\text{max assembly}}$ **17.7**.

If the warnings by the LICCON overload protection are ignored, then the crane will be overloaded or topples over.

Personnel can be severely injured or killed.

- ▶ The luff down movement must be stopped before the value $F1_{\text{actual}}$ **17.2** exceeds the limit value $F1_{\text{max assembly}}$ **17.7**.

In the icon **17** (F1-load display), the value $F1_{\text{actual}}$ **17.2** has reached the upper limit value $F1_{\text{max-assembly}}$ **17.7**.

- ▶ Check if a crane movement, which can lower the force $F1$ (value $F1_{\text{actual}}$ **17.2**) can be initiated, for example setting down the hook block / load hook.
- ▶ Check if the correct set up configuration has been entered on the LICCON computer system.
- ▶ Check if the actual set up configuration matches the entered set up configuration.
- ▶ Check if the correct hook block weight has been entered.
- ▶ Check if the respective hook block / load hook is installed.
- ▶ Check if all attachment parts and guy rods on the boom system, which are not needed, have been removed.
- ▶ Check if environmental influences (wind, snow or ice) on the crane are not too great.



Note

- ▶ Hook block weight entry and correction of weighing errors, see Crane operating instructions, chapter 4.02.

Empty page!

LWE/LR 1600-2-008/18109-09-02/en

5 Equipment

LWE/LR 1600-2-008/18109-09-02/en

LWE/LR 1600-2-008/18109-09-02/en

5.01 Safety technical notes for assembly and disassembly

1	Rope pulleys	3
2	Ropes	3
3	Control measures	4
4	Relapse cylinder	6
5	Pneumatic springs	7
6	Manual rope winches	7
7	Weights	7
8	Guy rods	8
9	Auxiliary guying	8
10	Bypassing the overload protection	9
11	Bypassing the hoist top shut-off	11
12	Pin connections	11
13	Retaining elements	14
14	Assembling / disassembling	22
15	Erecting / taking down	67

Fig.195219

LWE/LR 1600-2-008/18109-09-02/en

1 Rope pulleys



WARNING

Danger of crushing due to rotating rope pulleys!

Arms and legs can be caught and crushed or severed between the rope pulley and the rope due to rotating rope pulleys.

- ▶ It is prohibited to touch the ropes or rope pulleys during operation.
- ▶ Adhere to the safety distance to ropes and rotating rope pulleys.

2 Ropes



WARNING

Danger of accident!

- ▶ The ropes must be checked by an expert before assembly and checks must be performed at regular intervals in order to detect possible damage or wear and tear at an early stage. See Crane operating instructions, chapter 8.04.

The ropes must be removed immediately if any of the following damage is detected:

- Breakage of a strand
- Wire breaks
- Broken wire nests
- Reduction in the rope diameter by 10 % or more of the nominal size
- Rope deformations

2.1 Placing the hoist rope or the control rope

In order to guarantee safety and operating characteristics, only original Liebherr replacement parts or parts approved by Liebherr may be used.

NOTICE

Damage to the hoist rope or the control rope!

If a hoist rope or control rope is placed with worn rope pulleys, damage can occur.

- ▶ Before placing a rope, check the rope pulleys. See the Operating instructions, chapter 8.01.
- ▶ Replace worn or damaged rope pulleys.

2.2 Minimum rope coils

NOTICE

If the following notes are not observed, the cam limit switch / winch speed sensor must be readjusted!

- ▶ When the hoist rope is spooled up, the end of the hoist rope must remain in front of the winch and may not be pulled over the winch.
- ▶ Pull the hoist rope end never under the winch by spooling the winch up.
- ▶ Pull the hoist rope never off from the „stationary“ winch.
- ▶ The winch speed sensor must also be readjusted, if it is determined during operation or when changing the hoist rope that the winch does not shut off when the minimum rope coils are reached.

2.2.1 Cranes with cam limit switch

The cam limit switch is adjusted at the factory that it turns off before the minimum rope coils are reached (three hoist rope coils on the winch).

**WARNING**

Danger of accident due to falling load!

If the following instructions are not observed, the hoist rope end attachment may be torn out, causing the load to topple.

- ▶ If a new hoist rope is used, the cam limit switch must be reset.
- ▶ The cam limit switch must be adjusted so that it turns off when only 3 hoist rope coils remain on the winch.

2.2.2 Cranes with winch speed sensor

The winch speed sensor is adjusted at the factory that it turns off before the minimum rope coils are reached (four hoist rope coils on the winch). If used properly, the winch turn sensor will not need readjustment.

**WARNING**

Danger of accident due to falling load!

If the following instructions are not observed, the hoist rope end attachment may be torn out, causing the load to topple.

- ▶ If a new hoist rope is placed, the winch speed sensor must be checked.
- ▶ The winch speed sensor must be set to turn off when only 4 hoist rope coils remain on the winch.

3 Control measures

**WARNING**

The crane can topple over!

If the control measures are not carried out before crane operation, then accidents can occur. The crane can topple over, be overloaded or damaged.

Personnel can be killed or injured.

- ▶ Crane operation with safety equipment which are **not** functioning correctly is strictly prohibited.
- ▶ Start crane operation only after all safety equipment have been checked and are functioning correctly.
- ▶ Start crane operation only if the overload protection has been set according to the data in the load chart.
- ▶ Start crane operation only if the crane is properly supported and horizontally aligned.

**WARNING**

Interruption of crane operation!

If the following specifications for interruption of crane operation are not observed, accidents can occur.

- ▶ If the crane operator leaves the crane cab even if for just a short time, the crane must be secured to prevent unauthorized access.
- ▶ Before starting to work again with the crane, the crane operator is obligated to check the operating mode settings and to reset them, if necessary.



Fig.113437: Control displays

Make sure that the following prerequisites are met:

- The overload protection is not bypassed.
- No assembly operation is activated.

3.1 General controls before crane operation

- Make sure that no visible damage is present on the crane.
- Make sure that there are no loose parts on the boom, crane chassis and crane superstructure.
- Make sure that exposed rope pulleys are free of snow, frost and ice.
- Make sure that the cable / rope drums as well as the limit switches are free of snow and ice.
- Make sure that the gear ring of the slewing ring connection is clean and greased.
- Make sure that the air supply to the oil and water cooler is clear.
- Make sure that steps, ladders and platforms are in the correct position for crane operation.
- Make sure that all tool boxes, compartments, coverings, covers and cabinet doors are closed.
- Make sure that no persons or objects are within the danger zone of the crane.
- Make sure that the crane is standing on level, load bearing ground.
- Make sure that the crane is sufficiently supported depending on the load case and the ground conditions.
- Make sure that there is a sufficient safety distance to excavations and slopes.
- Make sure that no obstacles are within the working range of the crane, which obstruct the required crane movements.
- Make sure that the crane has sufficient distance to live power lines.
- Make sure that the LICCON overload protection is set according to the data in the load chart.
- Make sure that the overload protection is set according to the actual set up configuration of the crane.
- Make sure that the electrical connections, the connector plug, the pull release, the cables and the protective insulation function. Replace missing or defective parts.
- Make sure that the cable routings on the electrical connections are seated tightly. If necessary, tighten loose screw connections.
- Make sure that the existing safety equipment is functioning.
- Make sure that the overload protection is functioning.
- Make sure that the hoist limit switches are functioning.
- Make sure that the limit switch boom „steepest position“ is functioning.
- Make sure that the wind speed sensor easily moves and is functioning.

3.2 Additional controls for cranes with crane support

- Make sure that the folding / sliding beams are secured with pins to prevent them from sliding.
- Make sure that the support plates are secured in the operating position.
- Make sure that the crane is properly supported.
- Make sure that the crane is horizontally aligned.
- Make sure that the axle suspension is blocked (mobile crane).
- Make sure that the tires have no contact to the ground (mobile crane).
- Make sure that the track chains are secured to prevent them from sagging (crawler crane).

3.3 Additional controls for cranes on tires on the front and supported on the rear

- Make sure that the rear folding / sliding beams are secured with pins to prevent them from sliding.
- Make sure that the rear support plates are secured in the operating position.
- Make sure that the crane is properly supported on the rear.
- Make sure that the axle pressure compensation is correctly switched.
- Make sure that the axle suspension is blocked.
- Make sure that the tires of the rear axle group have no contact with the ground.
- Make sure that a sufficient tire pressure is present in the tires.
- Make sure that the ground for the front axle group is sufficiently level and has a sufficient load bearing capacity.

3.4 Additional controls for cranes supported on the front and on tires on the rear

- Make sure that the front folding / sliding beams are secured with pins to prevent them from sliding.

- Make sure that the front support plates are secured in the operating position.
- Make sure that the crane is properly supported on the front.
- Make sure that the axle pressure compensation is correctly switched.
- Make sure that the axle suspension is blocked.
- Make sure that the tires of the front axle group have no contact with the ground.
- Make sure that a sufficient tire pressure is present in the tires.
- Make sure that the ground for the rear axle group is sufficiently level and has a sufficient load bearing capacity.

3.5 Additional controls for freestanding crane operation (on tires)

- Make sure that all prerequisites for freestanding crane operation are met.
- Make sure that sufficient tire pressure is in all tires for crane operation on tires.
- Make sure that the ground is sufficiently level for crane operation on tires and has a sufficient load bearing capacity.

3.6 Additional controls for cranes with a derrick boom

- Make sure that the shut-off via the limit switch - derrick is functioning.
- Make sure that the entire slewing range of the suspended ballast / ballast trailer is free of personnel and obstacles.

3.7 Additional controls for cranes with luffing auxiliary boom / accessories

- Make sure that the shut-off via the limit switch luffing auxiliary boom / accessories „steepest position“ is functioning.
- Make sure that the shut-off via the limit switch luffing auxiliary boom / accessories „lowest position“ is functioning.
- Make sure that the shut-off via the limit switch flap in „steepest position“ position is functioning.
- Make sure that the pendulum of the mechanical relapse retainer moves easily over the entire slewing range and is functioning.

3.8 Additional controls for certain crawler cranes

For existing crawler assembly key button:

- Make sure that the crawler assembly key button is turned off.

4 Relapse cylinder

4.1 Block position of the relapse cylinders when setting down the load

NOTICE

Damage to the boom or the relapse cylinders!

If the block position of the relapse cylinders is triggered by the boom or the derrick with attached, freely suspended load, then there is a danger of damaging the boom or the relapse cylinders when setting the load on the ground. By setting down the load, the crane is relieved, and this movement causes the boom system to move to the rear.

There is no shut-off of the hoist gear lowering function.

- ▶ Actuate the opposite direction of movement which caused the block position and eliminate the block position.
-

5 Pneumatic springs

Pneumatic springs are installed on various crane components to simplify the assembly of these components.



WARNING

Danger of crushing!

Defective pneumatic springs no longer provide the supporting properties on the movable components. Due to falling components, personnel can be killed or severely injured.

High danger of accident.

- ▶ Always check pneumatic springs for damage before actuating the corresponding components.
- ▶ Do not use components with defective pneumatic springs. Replace defective pneumatic springs immediately.
- ▶ Make sure that no persons or objects are in the movement range of the moving components which is supported by the pneumatic spring.
- ▶ It is strictly prohibited to remain or place any objects in the movement or other danger zone of the moving crane components which are supported by the pneumatic spring.

6 Manual rope winches

Manual rope winches are installed on various components to simplify the assembly or disassembly of these components.



WARNING

Danger of crushing!

Defective manual rope winches no longer provide the supporting action on the movable components. Due to falling components, personnel can be killed or severely injured.

High danger of accident.

- ▶ Always check manual rope winches for external and functional damage before actuating the respective components.
- ▶ Check the rope of the manual rope winch for damage.
- ▶ At least two rope coils must always remain on the rope drum.
- ▶ Do not use components with defective manual rope winches. Replace defective manual rope winches.
- ▶ It is strictly prohibited for personnel or objects to remain within the movement range of the components, which are supported by the manual rope winch.
- ▶ It is prohibited for personnel or objects to remain within the danger zone of the moveable components.

7 Weights



Note

- ▶ The weight of each component is specified in the chapter 1.03 or the respective chapter in the Crane operating instructions or is stated on the tag attached to the corresponding component.
- ▶ If components are pushed into one another (for example the boom intermediate sections) or folded together (for example the folding jib), then the total weight is given by the sum of the individual components.

NOTICE

False estimation of weights

- ▶ Contact the Service department at **Liebherr-Werk Ehingen GmbH** if the weight of the respective component is not stated on the tag or in the Crane operating instructions.
- ▶ Use an auxiliary crane with sufficient load carrying capacity including judicious reserve.

8 Guy rods

**WARNING**

Boom can break off!

The arrangement of the guy rods for the boom or boom systems is stipulated in the rod plan. If the arrangement of the guy rods according to the rod plan is not observed, the crane can collapse, the boom can break off or the crane can topple over.

Personnel can be severely injured or killed.

- ▶ Always carry out the arrangement of the guy rods according to the rod plan.
- ▶ If an auxiliary guying is required for a certain boom length, then it must always be installed according to the rod plan on the position defined in the rod plan.

**WARNING**

Unutilized guy rods on boom!

If guy rods are on the lattice sections which are not used for operation, then there is a danger of accident.

Unused guy rods can loosen up and fall down.

Personnel can be severely injured or killed.

The load chart is invalid.

The load display of the LICCON computer system shows an incorrect value.

The weight of the boom is too heavy for erection.

- ▶ Disassemble and remove the guy rods that are not needed on the transport retainers before erecting the boom.

**Note**

- ▶ Inspection and maintenance of guy rods, see Crane operating instructions, chapter 8.15.
- ▶ In reference to the guy rods, observe section „Erection / take-down“.

9 Auxiliary guying

The auxiliary guying is of significant importance for safe crane operation.

The auxiliary guying is a deciding factor in relieving the boom, or the boom system during erection and take-down as well as during crane operation.

**WARNING**

The crane can topple over!

If the auxiliary guying is not installed or not installed on the position specified in the rod plan, then the crane can collapse, the boom can break off or the crane can topple over.

- ▶ If an auxiliary guying is specified in the rod plan for the required boom length, then it must be installed on the respective position.
- ▶ Make sure that the auxiliary guying is always completely installed and that all pins are properly pinned and secured.

10 Bypassing the overload protection



Fig.113438: Bypassing the overload protection

- Illustration 1: LICCON monitor (only certain crane types).
- Illustration 2: Indicator light „Assembly“ in instrument panel crane cab (only certain crane types).

The overload protection is considered bypassed for:

- all types of assembly operations.
- all types of exceeded shut off limits of the overload protection.
- all types of emergency operation.
- all types of crane operation with deactivated or defective sensors and limit switches.
- all types of deviation from specified set up configuration of the crane.



DANGER

Increased danger of accident due to bypass of the overload protection!

Proper and destined use of the crane is ensured due to the construction of the overload protection system and observance of the information in the Crane operating instructions. All **sensibly foreseeable erroneous operations** of the crane have been taken into consideration.

Impermissible crane operation with bypassed overload protection – with the aim of increasing the maximum load bearing capacity of the crane above the rated value in the load chart or of extending the designated working range of the crane – does not constitute a **reasonably foreseeable erroneous operation**, rather **deliberate improper use with high danger of accident**.

The possible risks and consequences of such improper use are detailed in the Crane operating instructions.

Such deliberate improper use can neither be prevented by means of the structural design nor by means of information in the Crane operating instructions.

- ▶ Bypass the overload protection only according to the Crane operating instructions.
- ▶ Exceed the shut off limits of the overload protection only according to the Crane operating instructions.
- ▶ Any other use of the crane with bypassed overload protection than that described in the Crane operating instructions is prohibited.

If the maximum permissible load moment is exceeded, the overload protection turns all load moment increasing crane movements off.

This shut-off can be bypassed or exceeded various ways, for example:

- exceeding the shut off limits (utilization more than 100 % or leaving the load chart).
- activating an assembly operation.
- activating an emergency operation.

The displays of the LICCON overload protection remain functioning when all associated sensors and limit switches are active and a load chart is available.

**WARNING**

Increased danger of accident due to bypass of the overload protection!

If the overload protection is bypassed, there is no longer any protection against crane overload.

In the event of improper use, the crane could collapse, the boom can break off or the crane can topple over.

Personnel can be killed.

This could result in high property damage.

- ▶ It is only permitted to bypass the overload protection for assembly or in emergencies.
- ▶ The bypass of the overload protection may only be carried out by persons who are aware of the effects of their acts.
- ▶ Bypassing the overload protection requires the presence of a person authorized by the crane operator and must be performed with utmost caution.
- ▶ It is strictly prohibited to operate the crane when the overload protection is bypassed.

10.1 Bypassing the LICCON overload protection

**Note**

- ▶ Applies only for cranes with LICCON overload protection.

Depending on the crane version, one or more operating elements are available to bypass the overload protection:

- Button in the control panel.
- Key button on the LICCON monitor.
- Key button in the instrument panel.
- Key button in the control cabinet.
- Sensor for transponder on the crane cab.

The functions of the operating elements are described in chapter 4.20.

- ▶ Actuate the respective operating element.

Result:

- The LICCON overload protection is bypassed / inactive.
- The „Assembly“ icon appears on the LICCON monitor.
- Depending on the circumstances, acoustic and / or optical warning signals (blinkers, flashing lights, bells and horns) sound.

If the LICCON overload protection is to be reactivated:

- ▶ No longer actuate the respective operating element or reset.

Result:

- The LICCON overload protection is active.
- The „Assembly“ icon no longer appears on the LICCON monitor.
- The acoustic and / or optical warning signals which were triggered by the bypass are turned off again.

10.2 Bypassing the PAT overload protection

**Note**

- ▶ Applies only for cranes with PAT overload protection.

- ▶ Actuate the bypass key button and turn the PAT overload protection off.

Result:

- The PAT overload protection is bypassed / inactive.
- ▶ Actuate the bypass key button and turn the PAT overload protection on.

Result:

- The PAT overload protection is active.

11 Bypassing the hoist top shut-off

**Note**

- ▶ Applies only for cranes with hoist limit switch.

If the hook block touches the hoist limit switch weight during the upward movement, the hoist limit switch reacts. The crane movements „Spool up winches“, „Luff boom down“ and „Telescope telescopic boom out“ are turned off. The shut-off can be bypassed.

**WARNING**

Danger of accidents due to bypass of Hoist top shut-off!

When bypassing the hoist top shut-off, there is the danger that the hook block may be pulled against the pulley head when continuing to lift or luffing down the boom. This may damage the pulleys and cause the loads to fall.

- ▶ The bypass of the hoist top shut-off in crane operation with a load may only be carried out by a person authorized by the crane operator with the aid of a „Guide“. The guide must be in direct contact with the crane operator and must continually monitor the distance between the hook block and the boom head.
- ▶ Carry out all crane movements with maximum caution and minimum speed.

12 Pin connections

**WARNING**

Pin connections **not** lubricated!

If pins or pin connections are not properly greased or lubricated before assembly, then they can corrode.

The pins can be stuck in the pin bores and be damaged.

During the unpinning procedure, the pins can suddenly release.

Death, severe bodily injuries, property damage.

- ▶ Make sure that all pins, which are not supplied with grease via the central lubrication system are sufficiently greased before assembly.
- ▶ Make sure that all lube points, which are equipped with a grease fitting, are properly greased at assembly and according to the respective interval specification.
- ▶ Never insert or unpin pins by force.

**WARNING**

Pin **not** secured to prevent it from loosening up by itself!

The pin connection could loosen up suddenly.

Death, severe bodily injuries, property damage.

- ▶ Secure all pins with retaining elements against loosening up by itself.

**WARNING**

Distorted pin!

Angular pull or excessive or low hoisting force of the auxiliary crane may result in distortion of the pins. Distorted parts can suddenly fly off when the pins are unpinned.

Death, severe bodily injuries, property damage.

- ▶ When the pins are unpinned, the lifting force of the auxiliary crane must be adapted to the weight of the components being lifted.
- ▶ Do **not** unpin difficult to remove pins by force.
- ▶ Remedy the cause of the distortion.

12.1 Pinning the collar pin

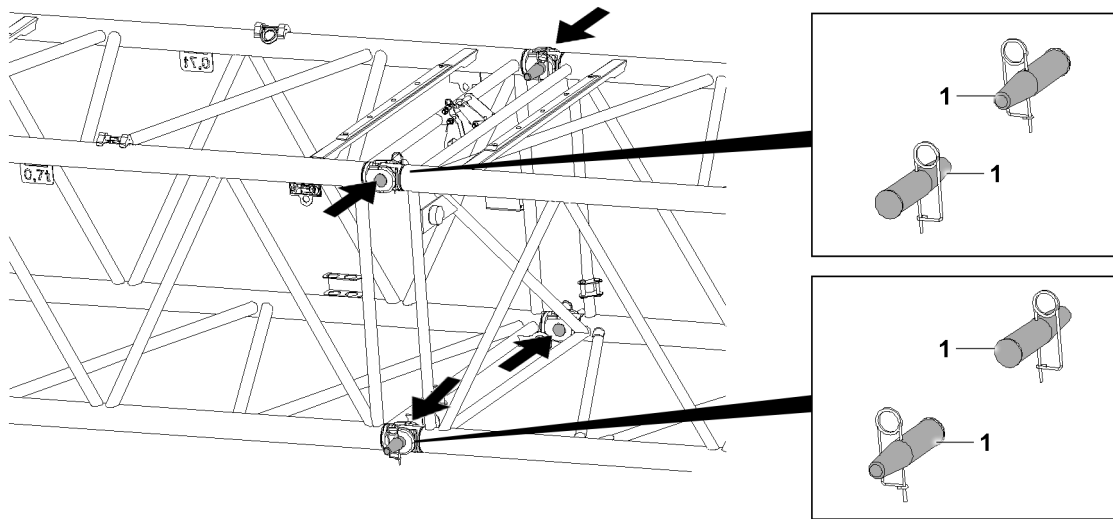

Fig.143114: Pinning the collar pin

**WARNING**

The collar pin is incorrectly pinned!

Death, severe bodily injuries, property damage.

- ▶ Insert or unpin both pins at the same horizontal level, i.e. **left and right**.
- ▶ Pin the upper collar pin **1** from the **outside to the inside** and unpin from the **inside to the outside**.
- ▶ Pin the lower collar pin **1** from the **inside to the outside** and unpin from the **outside to inside**.

12.2 Assembling the double cone pins horizontally

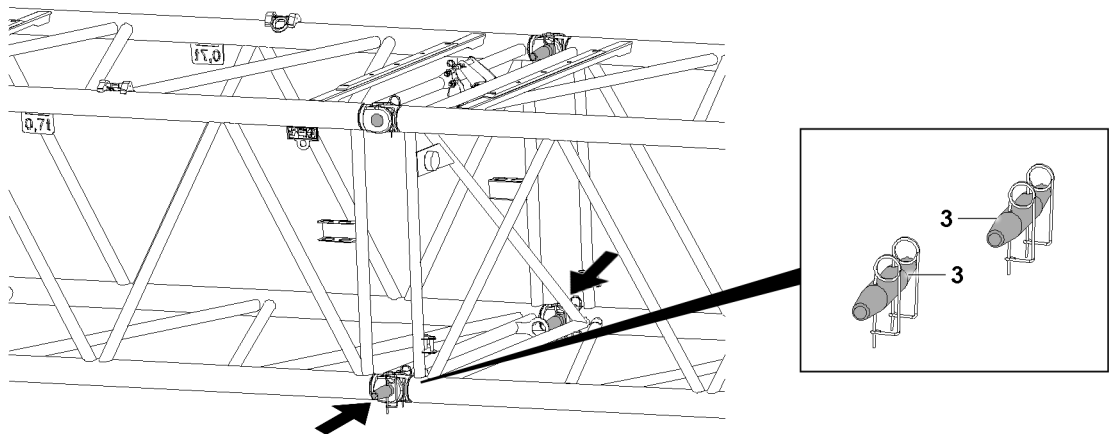

Fig.143115: Pinning the double cone pins horizontally



WARNING

Double cone pins incorrectly pinned!

Death, severe bodily injuries, property damage.

► Insert or unpin both pins at the same horizontal level, i.e. **left and right**.

► Pin and unpin horizontally installable double cone pins **3** from the **outside to the inside**.

12.3 Assembling the double cone pins vertically

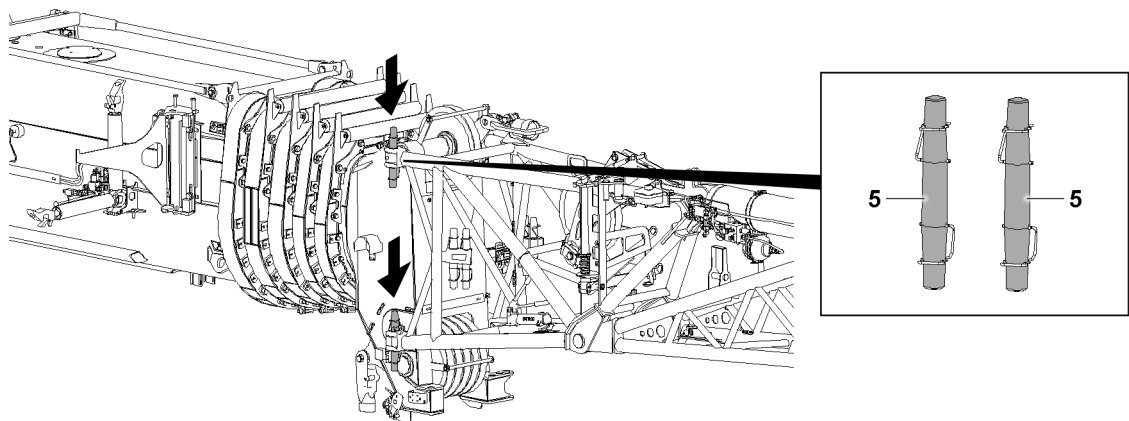

Fig.143116: Assembling the double cone pins vertically



WARNING

Double cone pins incorrectly pinned!

Death, severe bodily injuries, property damage.

► Pin and unpin vertically installable double cone pins **5** from the **top to the bottom**.

12.4 Impact protection

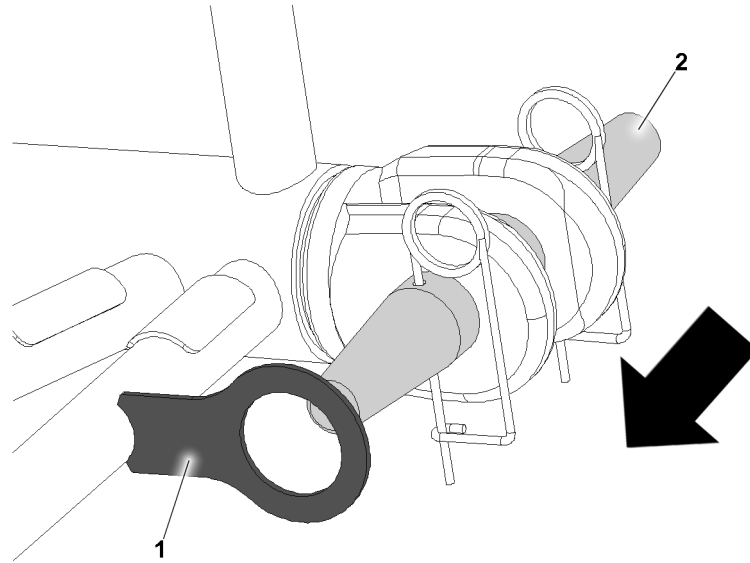

Fig.148194: Lattice section impact protection

Impact protection 1 is installed on certain lattice sections. The impact protection 1 should prevent the pins from being unpinned from the **inside to the outside**.

If impact protection 1 is installed:

- ▶ Only use double cone pins 2.
- ▶ Only pin and unpin the double cone pins 2 from the **outside to the inside**.

13 Retaining elements

13.1 Checking the retaining elements

Retaining elements are used to secure the pins. Due to mechanical damage / distortion, the function of the retaining elements can be compromised. In addition, the spring force of the retaining elements can be reduced significantly. Do **not** re-use retaining elements if there is insufficient spring force. The pin retainer must be secured with a correctly **functioning** retaining element.



WARNING

Mechanical damage or deformation of the retaining element!

The retaining elements can fail.

The pin can unpin by itself.

Death, severe bodily injury, property damage.

- ▶ Use exclusively functioning retaining elements in a proper condition.
- ▶ Replace defective retaining elements.

13.2 Overview of the retaining elements

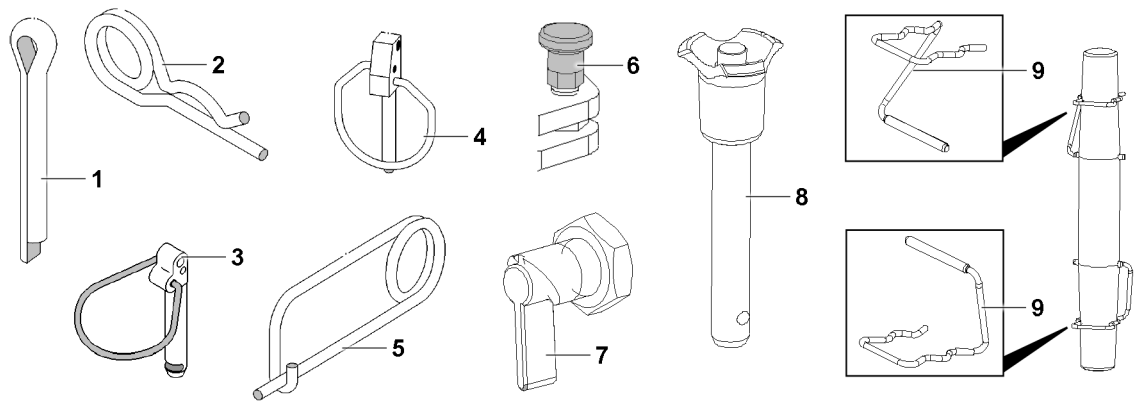

Fig.143102: Retaining elements

- | | | | |
|---|--------------------|---|------------------|
| 1 | Split pin | 6 | Detent pin |
| 2 | Cotter pin | 7 | Latch |
| 3 | Safety locking pin | 8 | Ball locking pin |
| 4 | Linch pin | 9 | Retaining clip |
| 5 | Spring retainer | | |

13.3 Split pin

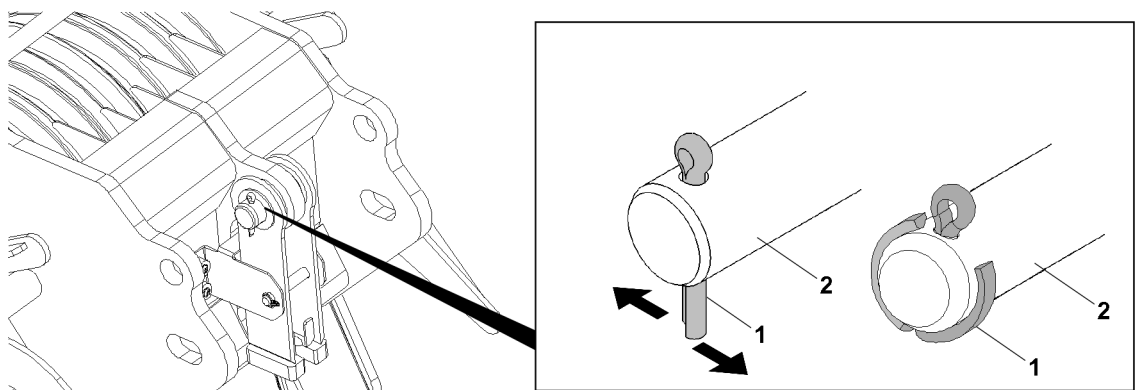

Fig.143105: Split pin

- | | | | |
|---|-----------|---|-----|
| 1 | Split pin | 2 | Pin |
|---|-----------|---|-----|



WARNING

Multiple use of a split pin 1!
The split pin 1 can break.

- ▶ Assemble the split pin 1 only once.
- ▶ Use a correctly sized split pin 1.

- ▶ Secure the pin 2: Insert the split pin 1.
- ▶ Bend the end of the split pin 1 toward the outside.

Problem remedy

Split pin 1 defective!

- ▶ Replace the split pin 1.

13.4 Cotter pin

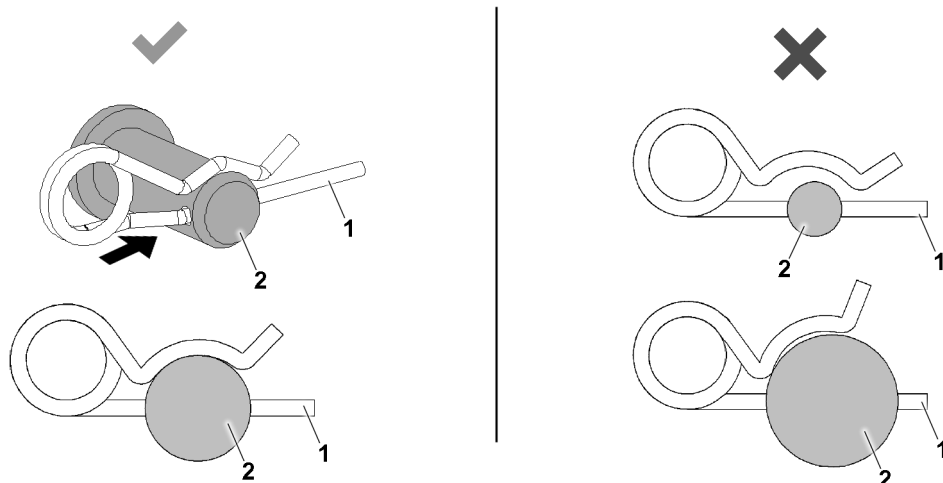

Fig.143106: Cotter pin, correct and incorrect dimensions

1 Cotter pin

2 Pin



WARNING

Improper dimensions of the cotter pin 1!
The cotter pin 1 can loosen up by itself.

- ▶ Use a correctly sized cotter pin 1.
- ▶ Secure the pin 2: Insert the cotter pin 1.

Problem remedy

Spring tension is too low?
The cotter pin 1 is defective.
▶ Replace the cotter pin 1.

13.5 Safety locking pin

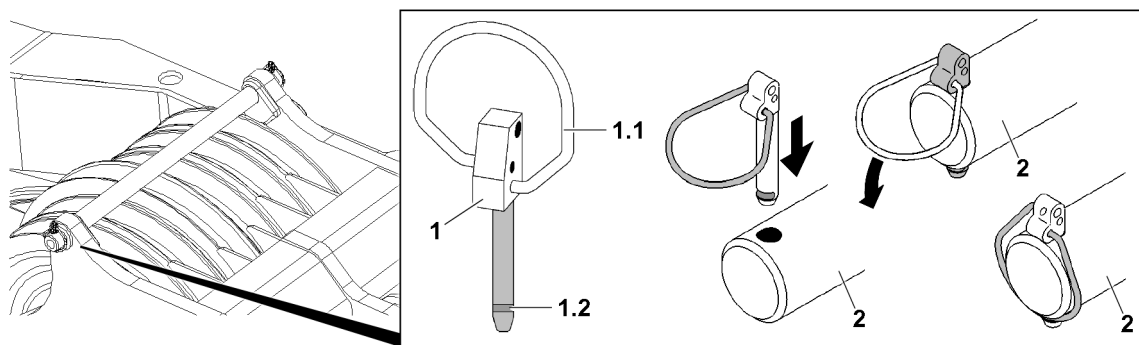

Fig.143103: Safety locking pin

1 Safety locking pin

1.2 Groove

1.1 Spring clip

2 Pin

Increased effort is necessary for opening the safety locking pin 1.



WARNING

Spring clip 1.1 not engaged!
The safety locking pin 1 can loosen up by itself.

- ▶ Engage the spring clip 1.1 completely in the groove 1.2.

- ▶ Secure the pin **2**: Insert the safety locking pin **1**.
- ▶ Close the spring clip **1.1** and engage it completely in the groove **1.2**.

Problem remedy

The spring clip **1.1** does **not** engage completely?

Tension of the spring clip **1.1** is too low.

- ▶ Replace the safety locking pin **1**.

13.6 Linch pin

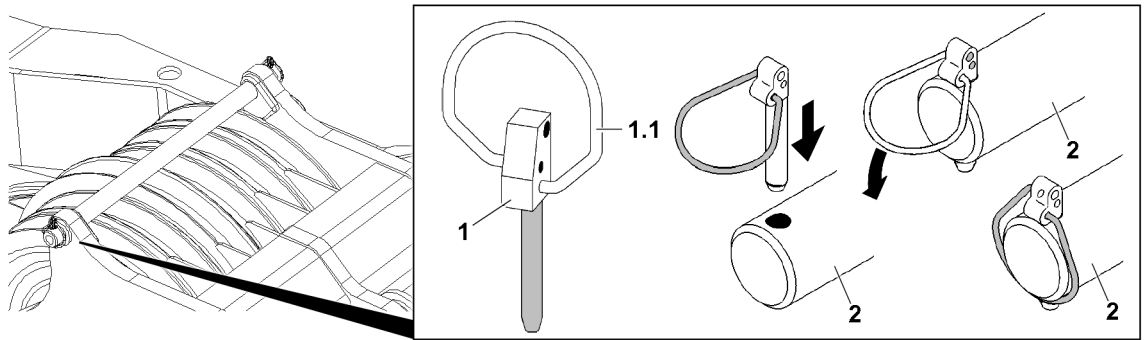

Fig.143104: Linch pin

1 Safety locking pin
1.1 Spring clip

2 Pin

**WARNING**

The locking pin **1** is **not** completely closed!

The locking pin **1** can loosen up by itself.

- ▶ Close the spring clip **1.1** completely.
- ▶ Secure the pin **2**: Insert the locking pin **1**.
- ▶ Close the spring clip **1.1** completely.

Problem remedy

The spring clip **1.1** does not close completely?

Tension of the spring clip **1.1** is too low.

- ▶ Replace the locking pin **1**.

13.7 Spring retainer

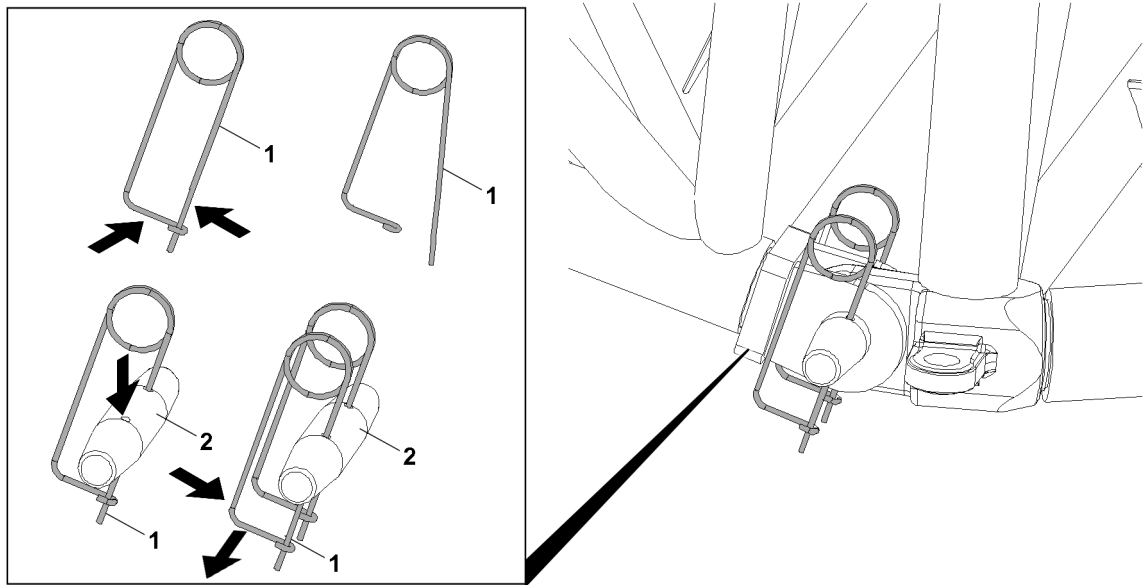

Fig.143108: Spring retainer

1 Spring retainer



WARNING

The spring retainer 1 is **not** closed!
The spring retainer 1 can loosen up by itself.

- ▶ Close the spring retainer 1.
- ▶ Secure the pin: 2 Insert the spring retainer 1.
- ▶ Close the spring retainer 1.

Problem remedy

Spring tension is too low?
The spring retainer 1 is defective.
▶ Replace the spring retainer 1.

13.8 Detent pin

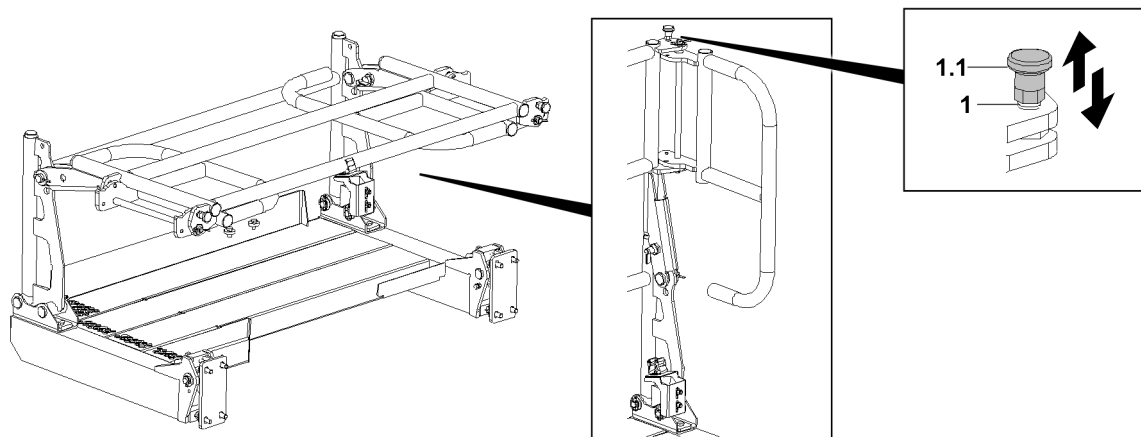

Fig.143110: Detent pin

1 Detent pin

1.1 Handle

**WARNING**

The handle **1.1** is **not** locked!
The detent pin **1** can loosen up by itself.

- ▶ Lock the detent pin **1**.

- ▶ Pull the handle **1.1**.

Result:

- The detent pin **1** is unlocked.
- ▶ Insert the detent pin **1**: Release the handle **1.1**.

Result:

- The detent pin **1** is pinned.

Problem remedy

The handle **1.1** cannot be pulled.
The detent pin **1** is defective.

- ▶ Replace the detent pin **1**.

13.9 Latch

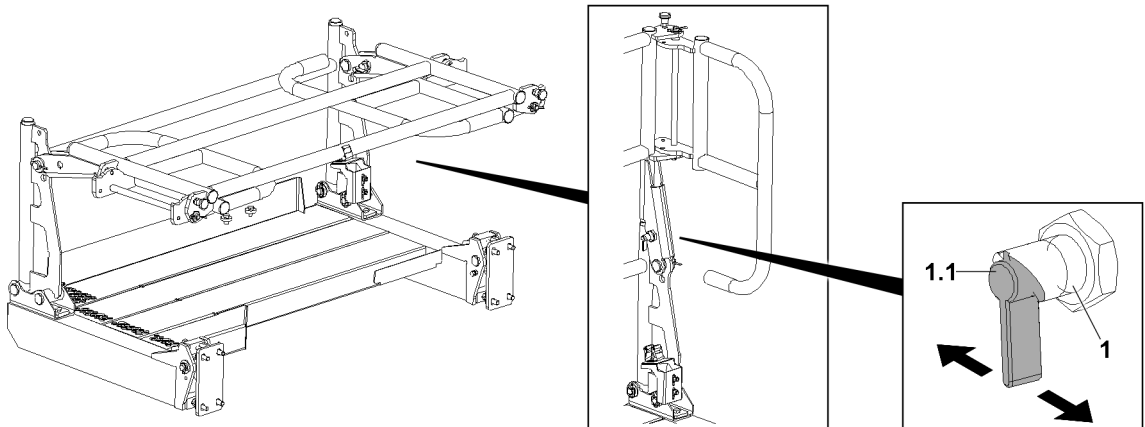

Fig.143111: Latch

1 Latch

1.1 Lever

**WARNING**

The latch **1** is **not** locked!
The latch **1** can loosen up by itself.

- ▶ Lock the latch **1**.

- ▶ Operate the lever **1.1**.

Result:

- The latch **1** is unlocked.
- ▶ Pin the latch **1**: Release the lever **1.1** and swing the railing until the latch is pinned.

Problem remedy

The lever **1.1** cannot be actuated?
The latch **1** is defective.

- ▶ Replace the latch **1**.

13.10 Ball locking pin

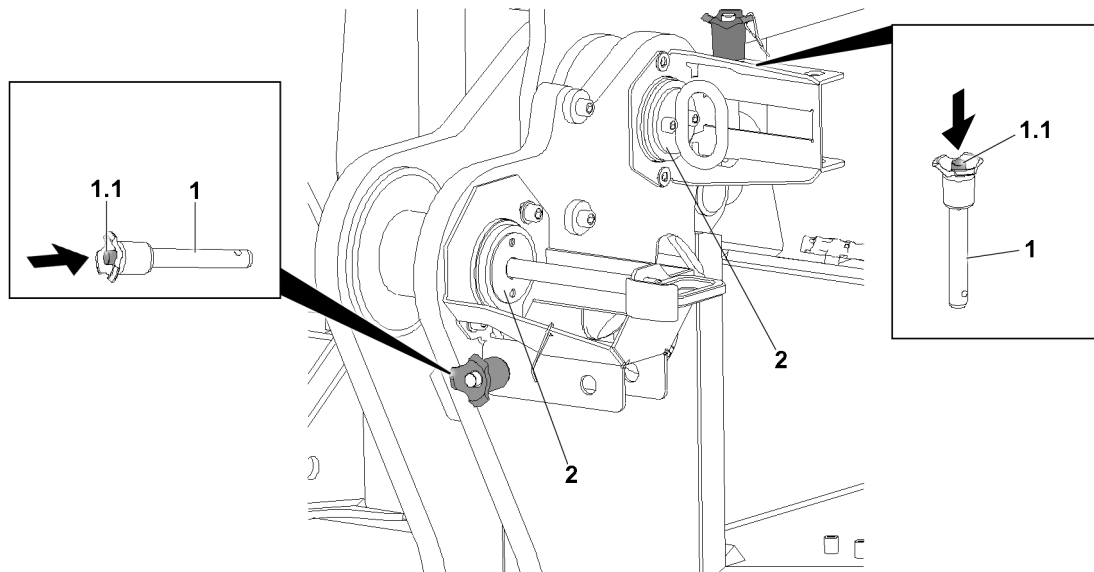

Fig.143109: Ball locking pin

- 1 Ball locking pin
 1.1 Press button
 2 Pin



WARNING

The ball locking pin **1** is **not** locked!
 The ball locking pin **1** can loosen up by itself.

- ▶ Lock the ball locking pin **1**.
- ▶ Secure the pin **2**: Actuate the press button **1.1**.

Result:

- The ball locking pin **1** is unlocked.
- ▶ Pin the ball locking pin **1** and release the press button **1.1**.

Result:

- The ball locking pin **1** is pinned and secured.

Problem remedy

The press button **1.1** cannot be actuated?

The ball locking pin **1** is defective.

- ▶ Replace the ball locking pin **1**.

13.11 Retaining clips

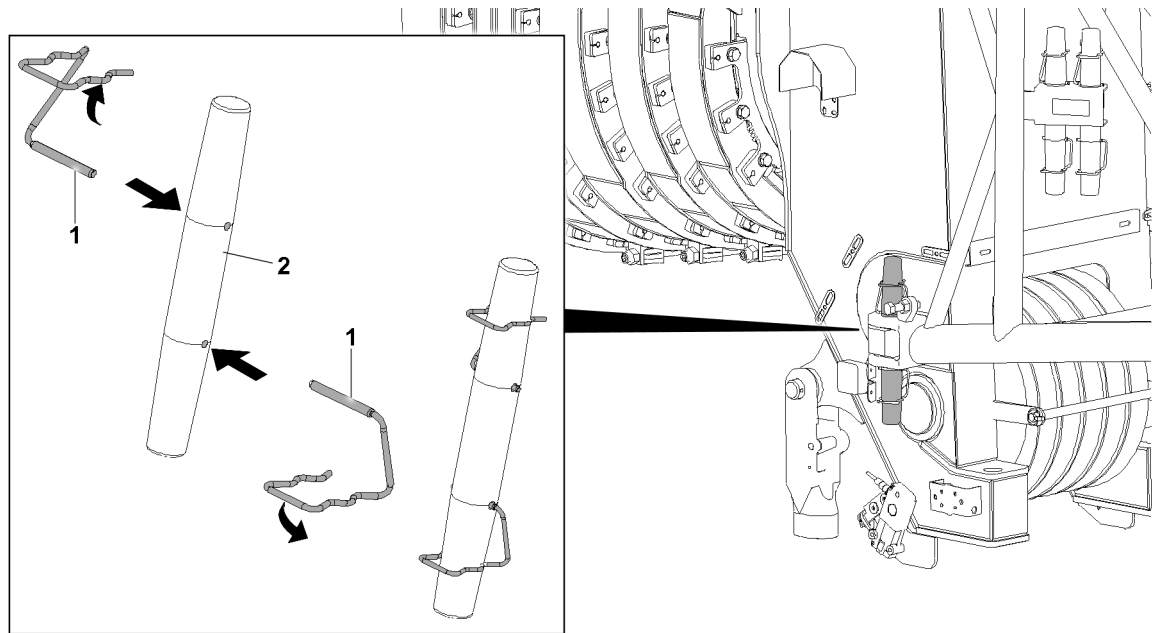

Fig.143107: Retaining clips 1

1 Retaining clip

2 Pin



WARNING

Incorrect retaining element!
Shearing off of the retaining element.

- ▶ To secure the folding jib pinning: Use retaining clips 1.
- ▶ The use of other retaining elements is **prohibited**.



WARNING

Retaining clip **not** engaged!
The retaining clip 1 can loosen up by itself.

- ▶ Engage the retaining clip 1.
- ▶ Secure the pin 2: Insert the retaining clip 1.
- ▶ Engage the retaining clip 1.

Problem remedy

Retaining clip 1 defective?
The spring force of the retaining clip 1 is too low.

- ▶ Replace the retaining clip 1.

14 Assembling / disassembling



WARNING

Danger of fatal injury due to incorrect assembly or disassembly!

The assembly / disassembly of lattice sections and / or components may never be performed by untrained personnel.

An erroneous assembly / disassembly of lattice sections and / or components can cause damage on load carrying crane structures.

Crane components can fail due to improper assembly / disassembly.

Death, severe bodily injuries, property damage.

- ▶ Make sure that the assembly / disassembly of lattice sections and / or components is carried out only by authorized and trained expert personnel.
- ▶ Make sure that the fastening equipment on lattice sections and / or components is always fastened properly.
- ▶ Make sure that lattice sections and / or components are always properly pinned and secured at assembly.
- ▶ For assembly / disassembly of individual components, also observe the chapters relating to those components.
- ▶ The boom combinations must be assembled according to the separately supplied rod plans.
- ▶ All components which must be transported separately must be transported with suitable auxiliary cranes and fastening equipment near ground level.



WARNING

Failure of auxiliary winch!

- ▶ Only use the auxiliary winch (assembly or reeving winch) for assembly and not to lift loads.
- ▶ Lifting of loads with the auxiliary winch is prohibited.



WARNING

Danger of impact / crushing!

When installing / removing crane components with the auxiliary crane, crane components can start to swing back and forth.

When lifting / lowering and positioning crane components, there is an increased danger of impacts / crushing.

Death, severe bodily injuries, property damage.

- ▶ Make sure that personnel cannot be caught by components.
- ▶ Make sure that the crane is horizontally aligned.
- ▶ When working in danger zones: Use aids to protect limbs.
- ▶ Guide components with suitable aids to minimize oscillation.
- ▶ During assembly / disassembly no one may be in the dangerous area around or underneath the suspended components before the load has been secured.

Part of the category „Aids for working at a height“ are, for example:

- Lifting platforms
- Scaffolding
- Auxiliary cranes
- Ladders

**WARNING**

Danger of falling!

During assembly / disassembly, inspection and maintenance work, assembly personnel must be secured with appropriate aids to prevent them from falling.

Death, severe bodily injuries, property damage.

- ▶ All work at a height, when there is a danger of falling, must be carried out with suitable aids.
- ▶ If aids are not available and work cannot be carried out from the ground, then assembly personnel must secure themselves with the supplied fall arrest system to prevent falling, see the Crane operating instructions, chapter 2.04.
- ▶ If fall protection equipment is available, then it must be used, see the Crane operating instructions, chapter 2.06.
- ▶ When lifting, lowering, swinging crane parts in and out, no persons may remain in the danger zone.
- ▶ When closing or opening boom systems during boom assembly or boom disassembly, no persons may remain on the boom system or in the danger zone.
- ▶ If railings are present on the components, then they must be brought into the corresponding position and secured for assembly / disassembly work.
- ▶ Only step on the aids, ladders and catwalks with clean shoes.
- ▶ Keep aids, ladders and catwalks free of heavy dirt, snow, frost and ice.
- ▶ During all assembly and disassembly work, maintenance work and inspections, travel or crane operation is prohibited.
- ▶ Remaining on a suspended load is prohibited.
- ▶ Stepping and walking on crane components and lattice sections, which have an incline of more than 20° is prohibited.
- ▶ For all assembly work, the crane driver of the main crane must be in voice contact with the crane driver / crane drivers of the auxiliary crane / auxiliary cranes.
- ▶ For all assembly work, the crane driver of the main crane must be in voice contact with the assembly personnel.
- ▶ For assembly tasks, the crane driver may only initiate crane movements when the responsible guide has explicitly released the movement.

**DANGER**

The components can fall down!

If the corresponding component is disengaged from the auxiliary crane before the corresponding component is pinned, then the corresponding component can fall down.

Death, severe bodily injuries, property damage.

- ▶ Do not disengage the auxiliary crane and the fastening equipment until the respective component is pinned and secured.

**WARNING**

The components can fall down!

If the corresponding component is unpinned without being secured by an auxiliary crane, the corresponding component can fall down.

Death, severe bodily injuries, property damage.

- ▶ Do not unpin the components until they are secured by an auxiliary crane.

**WARNING**

Falling components and tools!

Whenever working at a height, for example on the crane or on an aerial platform, components or tools can fall down.

Death, severe bodily injuries, property damage.

- ▶ Make sure that the danger zone under the work area is blocked off and marked and that no personnel is located within it.

14.1 Assembly drawings



WARNING

Use of assembly drawings!

Due to sole use of assembly drawings, dangerous situations can arise up to toppling of the crane. Death, severe bodily injuries, property damage.

- ▶ Assembly drawings should only be considered to be **additional** and **supplementary** information.
- ▶ The respective chapters in the crane operating instructions are decisive for the assembly and disassembly of crane structures, lattice sections or crane components.
- ▶ The detailed information and danger notes in the respective chapters must be observed.

14.2 Guiding crane structures, lattice sections or crane components



WARNING

Danger due to oscillating load!

During the assembly of crane structures, lattice sections or crane components with the auxiliary crane, they can start to swing back and forth.

Death, severe bodily injuries, property damage.

- ▶ To guide and position crane structures, lattice sections or crane components always use a guide rope.
- ▶ Make sure that there are no persons or obstacles within the danger zone.
- ▶ Make sure that the guide rope is long enough.

14.3 Assembling / disassembling the electrical lines



WARNING

The crane can topple over!

If mechanical crane components, which have electrical connections are not immediately electrically connected after assembly, then the limit switches and / or electrical sensors are not functioning.

Safety relevant shut offs are not recognized by the LICCON computer system.

Any errors or safety relevant messages which might occur are not shown on the LICCON computer system.

Death, severe bodily injuries, property damage.

- ▶ Make sure that the electrical connections are made immediately after installation of the respective crane components on the crane.
- ▶ Make sure that the procedure to make the electrical connections to the boom end sections in the respective assembly and set up chapters are observed.

NOTICE

Danger of damage to the electrical connections!

If the following measures are not adhered to, the electrical connections can be damaged.

- ▶ Do not plug in the plug connection or unplug them under tension.
- ▶ Do not pinch or crush electrical connections.

When pulling the cable out:

- ▶ Hold the plug and not the cable. Do not pull on the cable to release the plug connection.
- ▶ Relieve the electrical connections in operating condition.
- ▶ In case of defective or faulty electrical lines, contact Customer Service at Liebherr-Werk Ehingen GmbH.

**WARNING**

Malfunction if dummy plugs are not installed!

If the dummy plugs on the non-required electrical connections are not installed, then malfunctions or functional limitations can occur on the crane.

- ▶ Make sure that all non-required electrical connections, which have a dummy plug, are closed off with dummy plugs.
- ▶ Pay attention to the Electrical wiring diagram.

NOTICE

Property damage due to dirt and / or corrosion!

The plug connections are only protected when plugged in. If the plug connections are not plugged in, then the contact surfaces can corrode.

This could result in malfunctions.

- ▶ Always plug or screw the plug connections together properly.
- ▶ Keep plug connections clean and dry. Clean contact surfaces provide the best signal transfer.
- ▶ Close off the plug connections that are not used with dust caps.

- ▶ Establish the electrical connections to the installed crane components properly.

- ▶ As a rule, close off on-required electrical connections (for example for accessories which are not installed) with the respective dummy plugs.
- ▶ Properly close off electrical connections, which have no dummy plugs, with the corresponding protective dust or cover caps.

If a pull release for the cable drum is present:

- ▶ Hang the pull release in on the fixed point and relieve the plug connections from the pull strain.

After installing the plug connections:

- ▶ Check all plug connections for proper connection.

If a plug connection is not properly connected:

- ▶ Plug or screw the plug connection together properly.

After removing the plug connections:

- ▶ Protect the electrical connections with protective dust or cover caps or place them in intended storage retainers.
- ▶ After unplugging the electrical plug connections, install the dummy plugs, see Electrical wiring diagram.

If locking brackets are present:

- ▶ Close the locking bracket.

14.4 Assembling / disassembling the hydraulic lines

When connecting and releasing hydraulic lines with quick couplings, make sure that the coupling procedure is carried out correctly.

**WARNING**

Danger of accident due to loss of pressure or leakage!

Incorrectly coupled or self-loosening quick couplings (particularly return lines) can result in serious accidents due to component failure.

Death, severe bodily injuries, property damage.

- ▶ Check the quick couplings after assembly for correct connection.
- ▶ Make sure that the sleeve and plug after fastened after assembly with the knurled nut.

**WARNING**

Pressure in the hydraulic lines!

If the pressure supply is not interrupted before releasing the hydraulic lines, the hydraulic oil can escape with high pressure.

Death, severe bodily injuries, property damage.

- ▶ Release the pressure in the hydraulic system before releasing. Interrupt the pressure supply and wait for a short time.
-
- ▶ Release the pressure in the hydraulic system before connecting or disconnecting: Turn the engine off and wait for short time.
 - ▶ Connect the coupling components (sleeve and connector) and screw together with the knurled nut.
 - ▶ Tighten the hydraulic coupling by hand. Turn the knurled nut until it reaches a tangible, fixed stop position.

14.5 Bypass when assembling / disassembling the crawler

**Note**

- ▶ Applies only for cranes with crawler assembly key button.

**WARNING**

High danger of accident in case of actuated crawler assembly key button!

If the crawler assembly key button is actuated, the overload protection is bypassed. No shut-off at overload will occur in assembly operation nor in crane operation.

In the event of misuse, the crane can topple over.

Death, severe bodily injuries, property damage.

- ▶ The crawler assembly key button may only be actuated for assembly tasks.
- ▶ All other usage of the crawler assembly key button other than as described in the operating instructions is prohibited.
- ▶ Operating the crane with the crawler assembly key button enabled is strictly prohibited.

14.5.1 Activating the bypass at crawler assembly and crawler disassembly

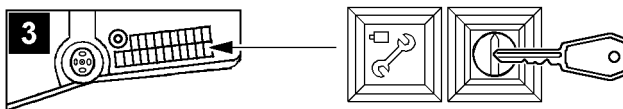

Fig.113441: Activating the bypass

- Illustration 3: Crawler assembly key button and indicator light *Crawler assembly* with touch function *Crawler assembly off*

- ▶ Actuate the crawler assembly key button.

Result:

- The LICCON overload protection is inactive.
- The indicator light *Crawler assembly* lights up.

14.5.2 Deactivating the bypass at crawler assembly and crawler disassembly

Make sure that the following prerequisites are met:

- The LICCON overload protection is bypassed / inactive and the „Bypass at assembly and disassembly“ is activated.
- The indicator light *Crawler assembly* lights up.

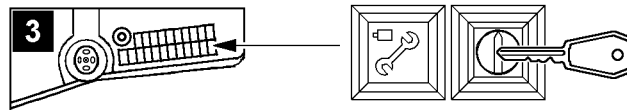

Fig. 113441: Deactivating the bypass

If the bypass at crawler assembly is to be turned off:

- ▶ Turn the crawler assembly off by pressing the off button *Crawler assembly off*.

Result:

- The indicator light in the button *Crawler assembly* turns off.

14.6 Bypass when assembling / disassembling

Depending on the crane version, the „Bypass at assembly and disassembly“ is activated by:

- The set up button (key button) on the LICCON monitor.
- The assembly key button in the instrument panel.



Note

- ▶ Applies only for cranes with LICCON overload protection.
- ▶ Indicator light *Assembly* is only present in the instrument panel for certain crane types.



WARNING

High danger of accident at crane operation with activated „Bypass at assembly and disassembly“! At activated „Bypass at assembly and disassembly“ the overload protection and possibly bypassed hoist limit switches.

In the event of improper use, the crane could collapse, the boom can break off or the crane can topple over.

Personnel can be killed.

This could result in high property damage.

- ▶ The activation of the „Bypass at assembly and disassembly“ is only permissible for assembly and disassembly purposes.
- ▶ All other usage of the „Bypass at assembly and disassembly“ other than as described in the operating instructions is prohibited.
- ▶ The „Bypass at assembly and disassembly“ may only be activated by persons who are aware of the consequences of a bypass.
- ▶ Crane operation with activated „Bypass at assembly and disassembly“ is strictly prohibited.
- ▶ The „Bypass at assembly and disassembly“ must be deactivated immediately after assembly and disassembly work.
- ▶ The crane operator or a person authorized by him must make sure that no misuse of the bypass device is possible (remove the key and store it safely, if necessary).

14.6.1 Activating the bypass at assembly and disassembly



Fig. 113438: Activating the bypass at assembly and disassembly

- Illustration 1: LICCON monitor (only certain crane types).
- Illustration 2: Indicator light „Assembly“ in instrument panel crane cab (only certain crane types).
- ▶ Actuate the respective operating element.

Result:

- The LICCON overload protection is bypassed / inactive and the „Bypass at assembly and disassembly“ is activated.
- The „Assembly“ icon appears in the LICCON monitor and / or the indicator light „Assembly“ in the instrument panel lights up.
- Depending on the circumstances, acoustic and / or optical warning signals (blinkers, flashing lights, bells and horns) sound.

14.6.2 Bypass at assembly and disassembly

Fig.113437: Bypass at assembly and disassembly

- ▶ No longer actuate the respective operating element or reset.

Result:

- The LICCON overload protection is active and the „Bypass at assembly and disassembly“ is deactivated.
- The „Assembly“ icon turns off in the LICCON monitor and / or the indicator light „Assembly“ in the instrument panel no longer lights up.
- The acoustic and / or optical warning signals which were triggered by the bypass are turned off again.

14.7 Actuating of winch and / or crane movements during assembly / disassembly**Note**

- ▶ The winches and / or crane movements can be controlled from the crane cab or, depending on the crane set up configuration, with the Bluetooth™ Terminal (BTT) or the radio remote control*.
- ▶ Observe the Crane operating instructions, chapter 4.05, chapter 5.31 and chapter 6.08.

**WARNING**

Uncoordinated procedure for assembly tasks!
Death, severe bodily injuries, property damage.

- ▶ Before starting the assembly tasks, define the course of action and agree on all steps with all involved personnel.
- ▶ Monitor all steps and continuously check the course of action.
- ▶ In the case of unforeseen events, stop the course of action and agree on the new situation with all involved personnel.
- ▶ Make sure that winches and / or crane movements are only controlled by people who are aware of the effects on the crane and / or boom system as well as the connected dangers.
- ▶ Make sure that no persons, objects or obstacles are within the danger zone of the crane.
- ▶ Prewarn persons within the surrounding area of the crane, for example via a horn signal.
- ▶ Perform all winch and / or crane movements anticipatorily and at a low speed.

14.8 Assembling / disassembling of booms



WARNING

The crane can topple over!

Angular pull can overload the crane.

Overload can cause destruction of the crane or cause it to topple over.

Death, severe bodily injuries, property damage.

- ▶ The hook block must always be attached (hooked) vertically over the center of gravity of the load to be lifted.
- ▶ Angular pull is prohibited.

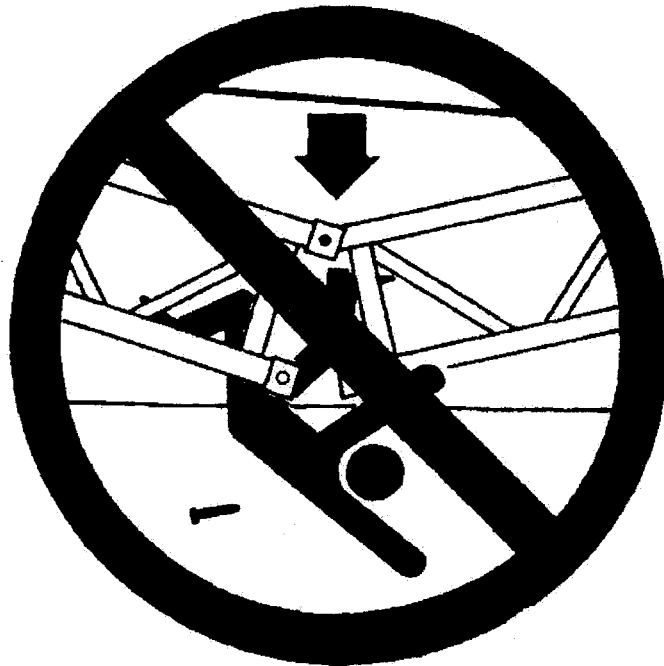

Fig.113444: Danger of accident during assembling / disassembling



WARNING

Danger of accident at assembly / disassembly of booms!

When you disassemble unsecured or unsupported booms, they can fall down.

Death, severe bodily injuries, property damage.

- ▶ Never unpin the pins under unsecured or unsupported booms.
- ▶ Never unpin the connecting pins on unsecured or unsupported booms.
- ▶ Do not stand under the booms or within the complete danger zone during the pinning and unpinning procedure of the booms.
- ▶ Secure the pins in the storage locations and in the receptacles.
- ▶ The railing at assembly and disassembly of booms must be horizontal.
- ▶ Do not lean the ladder against the component being disassembled.

Make sure that the following prerequisites are met for the closing assembly:

- If parts of the equipment (for example lattice sections) are not in contact with the ground during assembly / disassembly, then they must be supported with suitable, stable materials.
- Take down the parts of the equipment with rope pulleys in such a way that the rope pulleys are not damaged.
- During disassembly make sure that the auxiliary crane can lift the load vertically.
- Have an auxiliary crane with sufficient load carrying capacity available to be able to hold the load at a respective radius.

14.9 Fastening positions for assembling / disassembling of the lattice jib



WARNING

Danger of fatal accidents due falling components!

The maximum permissible tensile load on the fastening eye is engraved on the fastening eye.

The maximum permissible fastening load of the respective components can differ to the maximum permissible tensile load of the fastening eye.

Components can be damaged at overload and fall down during lifting.

- ▶ Observe the maximum permissible fastening load according to the operating instructions and the tags on the components.
- ▶ Fasten the lattice jib only according to the following descriptions.
- ▶ Do not overload the components.

14.9.1 Closing the end section

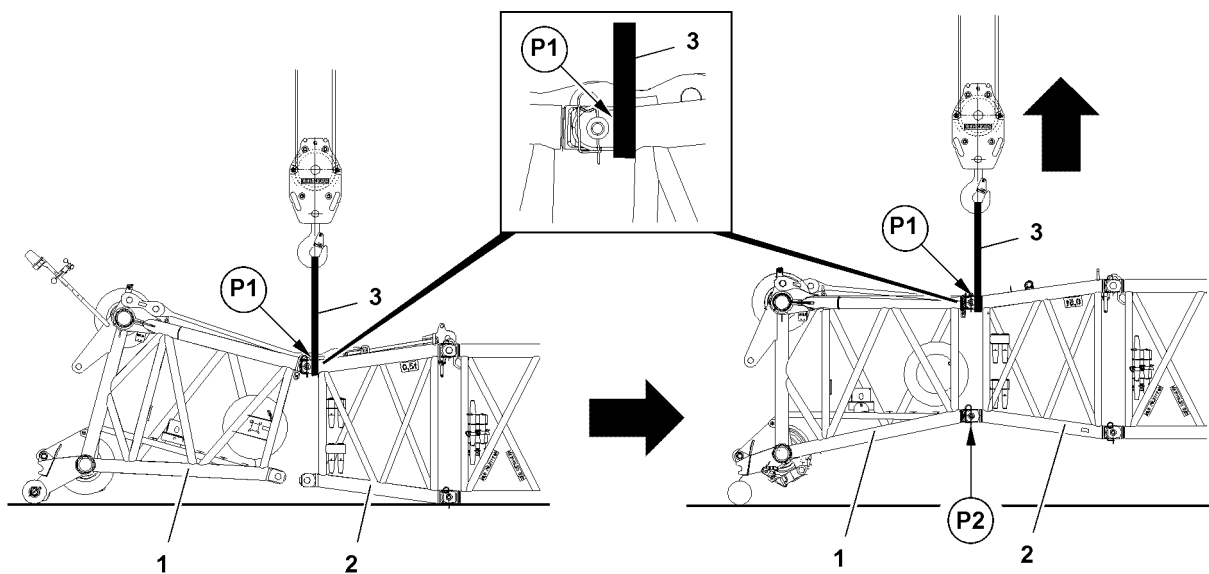

Fig.117840: Closing the end section

For closing the end section, observe the following:

- Use textile type fastening equipment **3**.
- Loop the textile type fastening equipment **3** on the left and right around on the pin points.

Before fastening:

- ▶ Check the position of the spring retainers and correct, if necessary.
- ▶ Fasten the textile type fastening equipment **3** on the upper pin points **P1** between the end section **1** and the pinned components **2**.
- ▶ Lift the lattice jib until the lower pin points **P2** align between the end section **1** and components **2**.
- ▶ Pin the end section **1** and components **2** on the lower pin points **P2** on the left and right.

After pinning:

- ▶ Remove the textile type fastening equipment **3**.

14.9.2 Taking the lattice jib down into the roller cart



Note

- ▶ The following illustrations are examples and may not match your crane exactly.

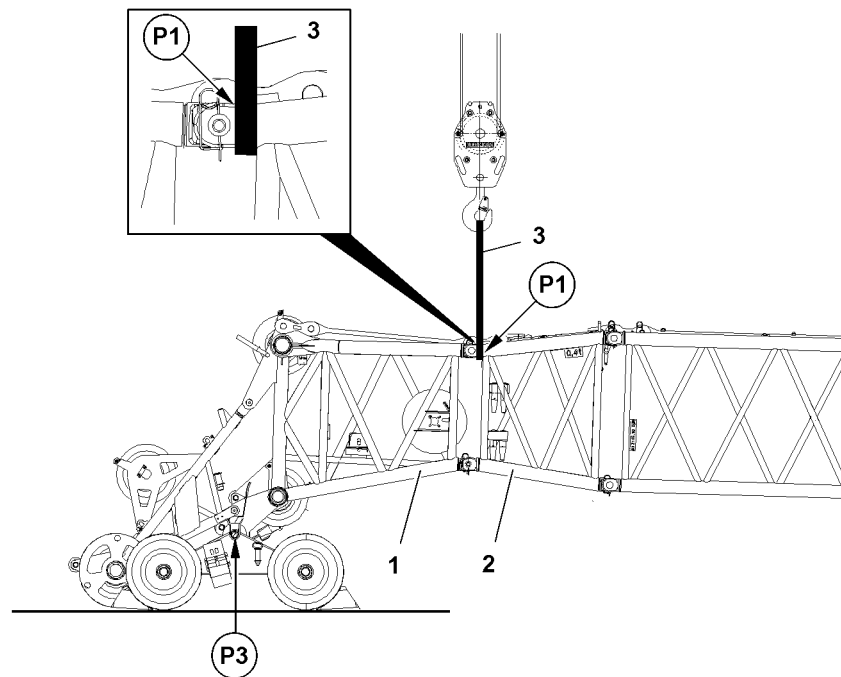

Fig.117842: Taking the lattice jib down into the roller cart (telescopic crane with lattice jib)

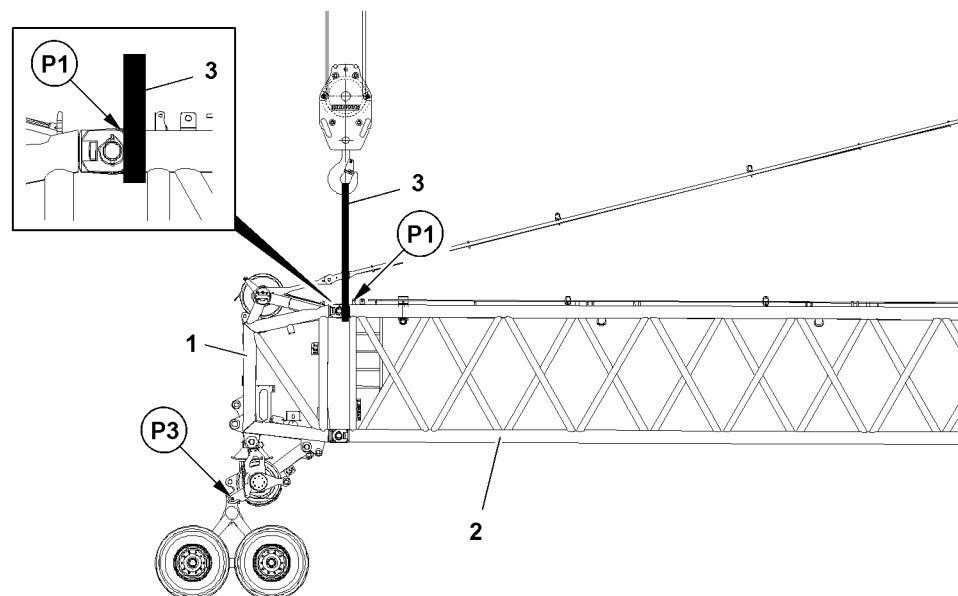

Fig.121550: Taking the lattice jib down into the roller cart (crane with lattice mast)

When taking it down into the roller cart, observe the following:

- The end section 1 is completely installed.
- Use textile type fastening equipment 3.
- Loop the textile type fastening equipment 3 on the left and right around on the pin points.

Before fastening:

- ▶ Check the position of the spring retainers and correct, if necessary.
- ▶ Fasten the textile type fastening equipment 3 on the upper pin points P1 between the end section 1 and the pinned components 2.
- ▶ Lift the lattice jib and take it down in the roller cart 4.
- ▶ Pin the end section 1 with the roller cart 4 on the pin points P3 on the left and right.
- ▶ Remove the textile type fastening equipment 3.

**Note**

- ▶ The disassembly and removal of the pulley cart **4** is handled accordingly.

14.9.3 Opening the end section

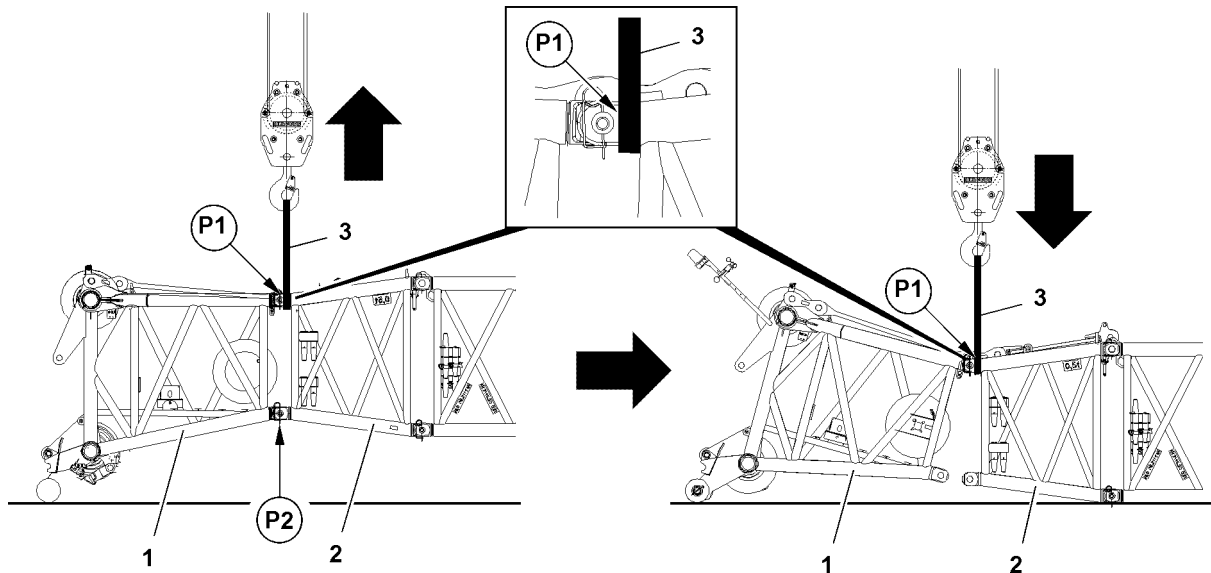

Fig.117841: Opening the end section

For opening the end section, observe the following:

- The roller cart is disassembled and removed.
- Use textile type fastening equipment **3**.
- Loop the textile type fastening equipment **3** on the left and right around on the pin points.

Before fastening:

- ▶ Check the position of the spring retainers and correct, if necessary.
- ▶ Fasten the textile type fastening equipment **3** on the upper pin points **P1** between the end section **1** and the pinned components **2**.
- ▶ Lift the lattice jib and relieve the pins on the lower pin points **P2**.
- ▶ Unpin the end section **1** and components **2** on the lower pin points **P2** on the left and right.
- ▶ Take the lattice jib down on the ground.
- ▶ Remove the textile type fastening equipment **3**.

14.9.4 Holding the luffing lattice jib

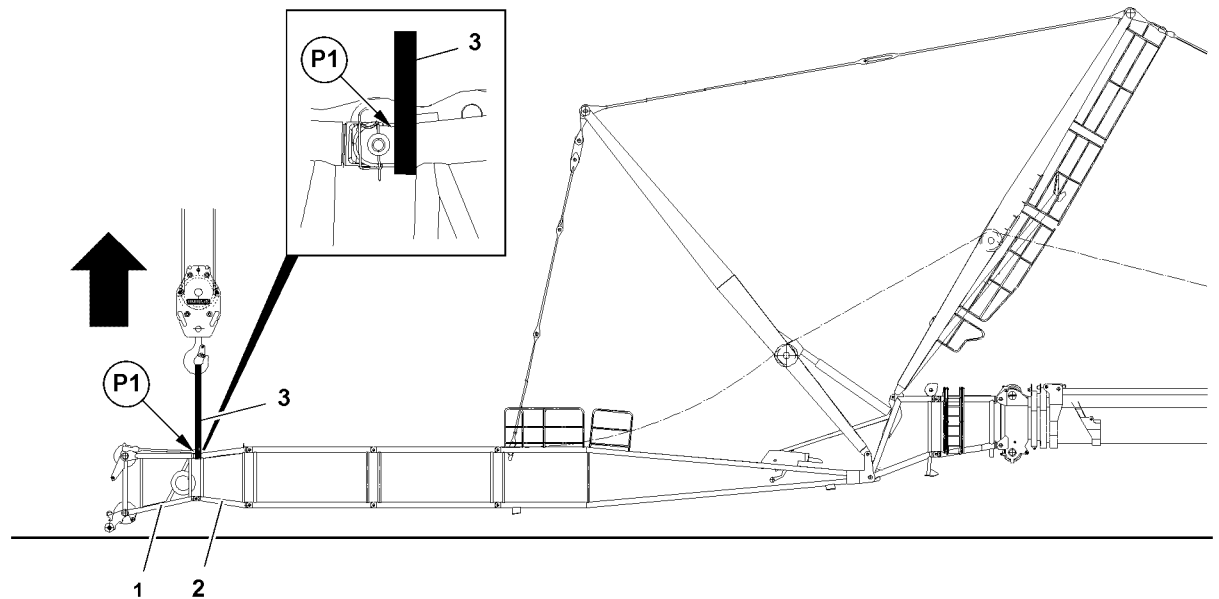

Fig.117843: Holding the luffing lattice jib

To be able to install or remove the guy rods and "flying assembly", the luffing lattice jib must be held on the upper pin points **P1**.

When holding the luffing lattice jib, observe the following:

- The lattice jib has been completely assembled.
- Use textile type fastening equipment **3**.
- Loop the textile type fastening equipment **3** on the left and right around on the pin points.

Before fastening:

- ▶ Check the position of the spring retainers and correct, if necessary.
- ▶ Fasten the textile type fastening equipment **3** on the upper pin points **P1** between the end section **1** and the pinned components **2**.
- ▶ Lift the lattice jib and install the guy rods.

When the guy rods are installed:

- ▶ Remove the textile type fastening equipment **3**.



Note

- ▶ The removal of the guy rods is handled accordingly.

14.9.5 Assembling the fixed lattice jib on the TF-adapter



WARNING

Mortal danger if the lattice jib tilts over!

Due to unfavorable center of gravity, only certain lattice jib lengths can be installed / removed as an assembled lattice jib.

If a lattice jib length cannot be installed / removed as an assembled lattice jib, then they must be installed / removed individually in flying mode.

- ▶ Check if the respective lattice jib length can be installed / removed as an assembled lattice jib. See charts in the Crane operating instructions, chapter 5.01.10.

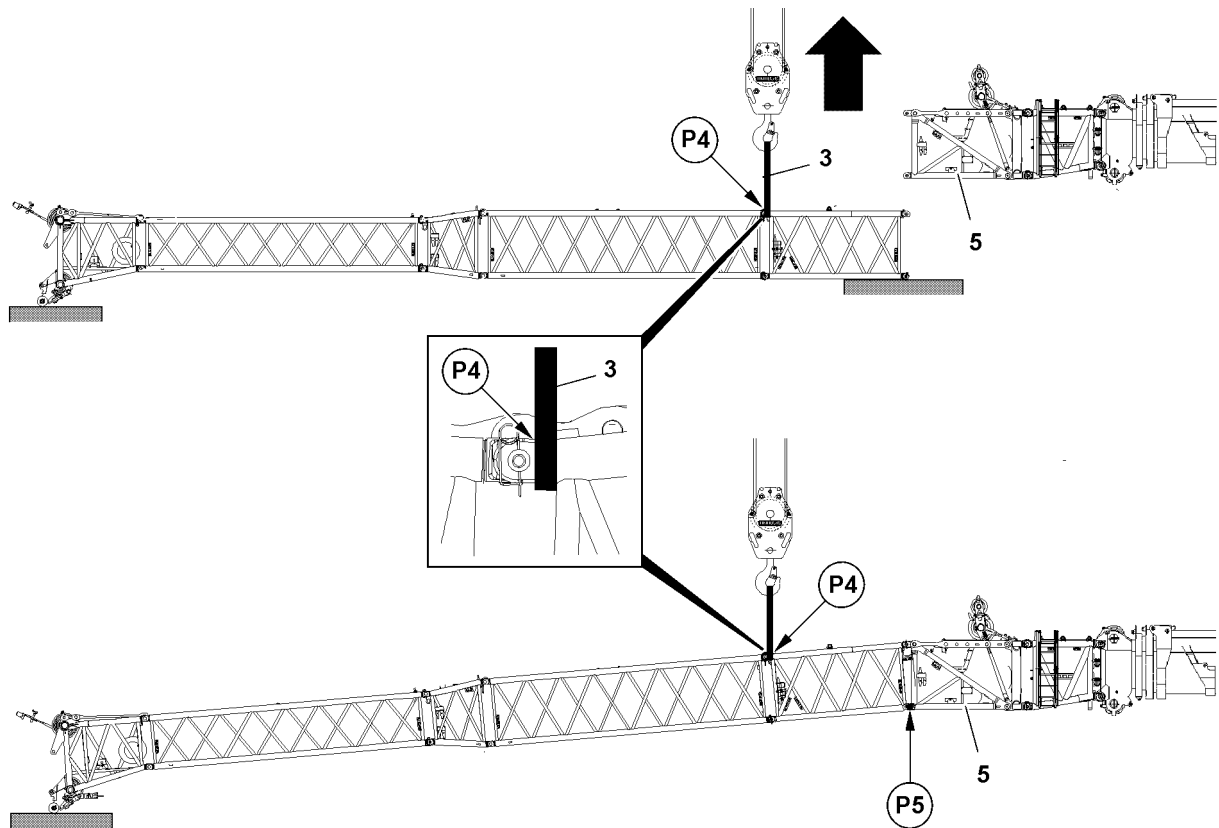

Fig.117844: Assembling the lattice jib on the TF-adapter

For installation on the TF-adapter, observe the following:

- The lattice jib has been assembled.
- The TF-adapter **5** is installed.
- Use textile type fastening equipment **3**.
- Loop the textile type fastening equipment **3** on the left and right around on the pin points.

Before fastening:

- ▶ Check the position of the spring retainers and correct, if necessary.

Fasten between the lattice sections, which are installed directly on the TF-adapter.

- ▶ Fasten the textile type fastening equipment **3** on the upper pin points **P4**.
- ▶ Lift the lattice jib and affix on the lower pin point **P5** on the TF-adapter **5**.
- ▶ Pin the lattice jib on the lower pin point **P5** with the TF-adapter **5**.

After pinning:

- ▶ Remove the textile type fastening equipment **3**.



WARNING

Mortal danger if the lattice jib tilts over!

- ▶ Make sure to always observe the permissible lattice jib length at disassembly.
- ▶ Disassemble accordingly.

14.9.6 Closing the fixed lattice jib

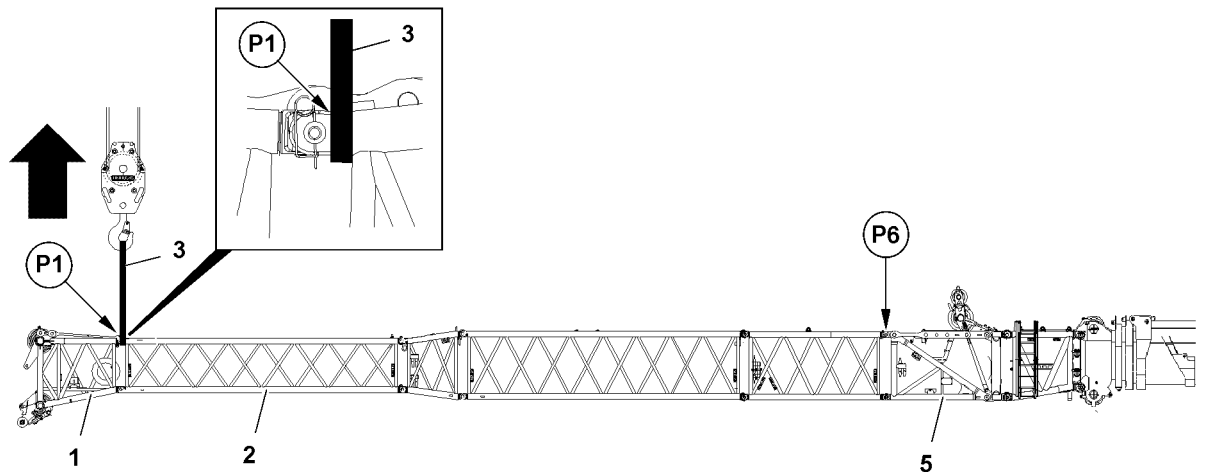

Fig.117850: Closing the lattice jib

For installation on the TF-adapter, observe the following:

- The lattice jib is pinned on the lower pin points of the TF-adapter **5**.
- Use textile type fastening equipment **3**.
- Loop the textile type fastening equipment **3** on the left and right around on the pin points.

Before fastening:

- ▶ Check the position of the spring retainers and correct, if necessary.
- ▶ Fasten the textile type fastening equipment **3** on the upper pin points **P1** between the end section **1** and the pinned components **2**.
- ▶ Lift the lattice jib and affix on the upper pin point **P6** on the TF-adapter **5**.
- ▶ Pin the lattice jib on the upper pin point **P6** with the TF-adapter **5**.

After pinning:

- ▶ Remove the textile type fastening equipment **3**.



Note

- ▶ Disassemble accordingly.

14.9.7 Angle adjustment on the fixed lattice jib with mechanical adjustment

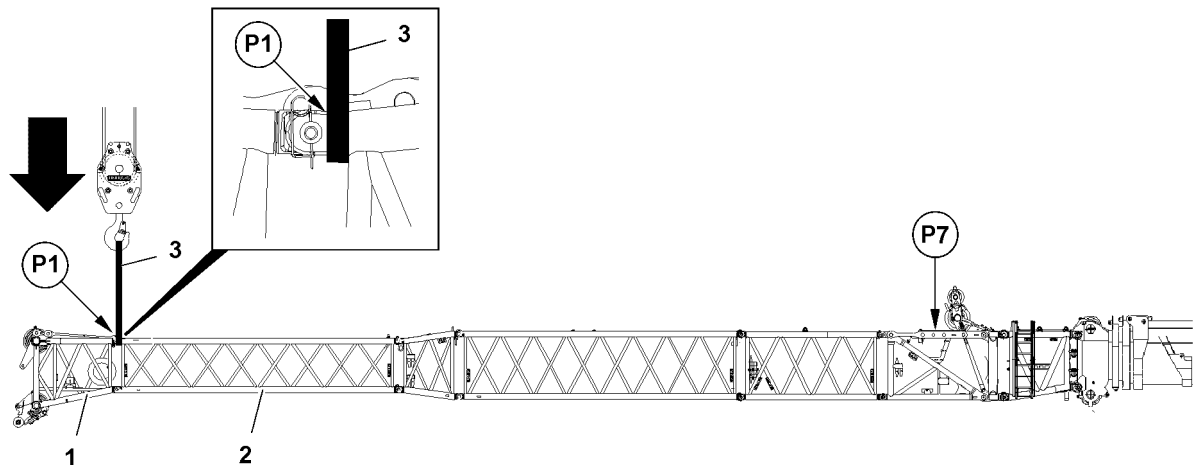

Fig.117851: Angle adjustment on the fixed lattice jib

For the angle adjustment on the fixed lattice jib, observe the following:

- The lattice jib has been completely assembled.
- Use textile type fastening equipment 3.
- Loop the textile type fastening equipment 3 on the left and right around on the pin points.

Before fastening:

- ▶ Check the position of the spring retainers and correct, if necessary.
- ▶ Fasten the textile type fastening equipment 3 on the upper pin points P1 between the end section 1 and the pinned components 2.
- ▶ Lift the lattice jib and relieve the pins on the angle adjustment P7.
- ▶ Unpin the angle adjustment P7, see Crane operating instructions, chapter 5.03.
- ▶ Set and pin a New angle on the angle adjustment P7, see Crane operating instructions, chapter 5.03.
- ▶ Lower the lattice jib.

After lowering:

- ▶ Remove the textile type fastening equipment 3.

14.9.8 Loading the preassembled lattice jib

For loading the lattice jib, observe the following:

- The lattice jib has been preassembled.
- Use textile type fastening equipment.
- Loop the textile type fastening equipment on the left and right around on the pin points.

Before fastening:

- ▶ Check the position of the spring retainers and correct, if necessary.
- ▶ Fasten the preassembled lattice jib according to the fastening points in the Crane operating instructions, chapter 5.03.

Empty page!

LWE/LR 1600-2-008/18109-09-02/en

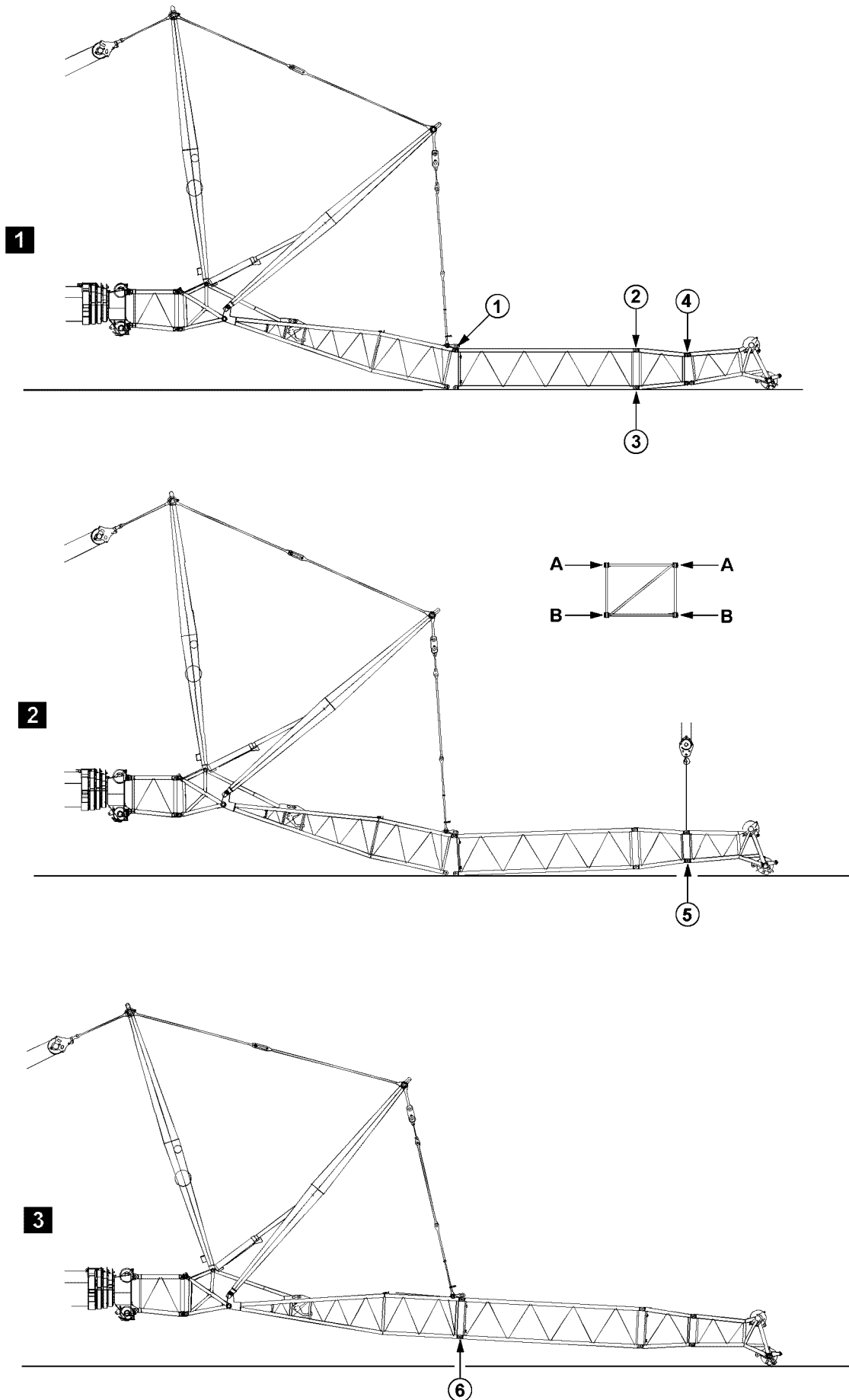

Fig.197718: Example for cranes with telescopic boom

LWE/LR 1600-2-008/18109-09-02/en

14.10 Assembling / disassembling the lattice sections on telescopic cranes with a luffing lattice jib

14.10.1 Assembling the lattice sections on a luffing lattice jib

The illustrations serve as examples. The illustrations may differ depending on the crane.



WARNING

Danger of fatal injury when assembling auxiliary booms!

If the pins are not pinned in the given sequence, then lattice sections may suddenly fold down or fall down.

Death, severe bodily injuries, property damage.

▶ Pins must be pinned in the order specified.

- ▶ Pin and secure pins at both sides (level **A**) at point **1**, illustration 1.
- ▶ Pin and secure pins at both sides (level **A**) at point **2**, illustration 1.
- ▶ Pin and secure pins at both sides (level **B**) at point **3**, illustration 1.
- ▶ Pin and secure pins at both sides (level **A**) at point **4**, illustration 1.
- ▶ Close the end section with the auxiliary crane, illustration 2.
- ▶ Pin and secure pins at both sides (level **B**) at point **5**, illustration 2.
- ▶ Lift the lattice sections, illustration 3.
- ▶ Pin and secure pins at both sides (level **B**) at point **6**, illustration 3.

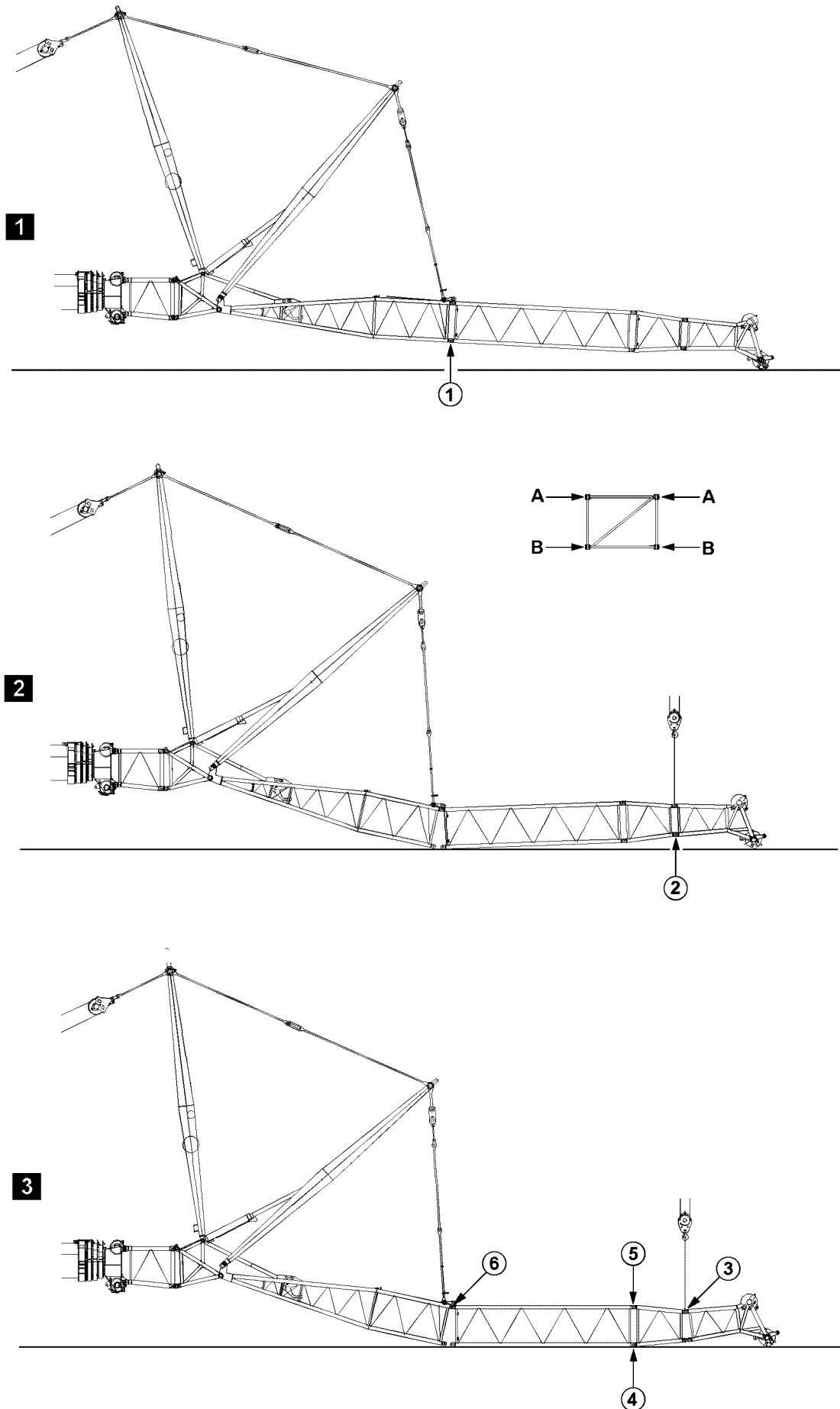

Fig.197719: Example for cranes with telescopic boom

LWE/LR 1600-2-008/18109-09-02/en

14.10.2 Disassembling the lattice sections on a luffing lattice jib

The illustrations serve as examples. The illustrations may differ depending on the crane.



WARNING

Danger of fatal injury when disassembling auxiliary booms!

If the pins are not unpinned in the given sequence, then lattice sections may suddenly fold down or fall down.

Death, severe bodily injuries, property damage.

▶ Pins must be unpinned in the order specified.

- ▶ Luff the boom down until the end section touches the ground slightly, illustration 1.
- ▶ Guy the boom with NA-frame I, illustration 1.
- ▶ Release and unpin the pins on both sides (level **B**) at point 1, illustration 1.
- ▶ Open the boom with the NA-frame I and completely take down the boom, illustration 2.
- ▶ Lift the end section with the auxiliary crane, illustration 2.
- ▶ Release and unpin the pins on both sides (level **B**) at point 2, illustration 2.
- ▶ Release and unpin the pins on both sides (level **A**) at point 3, illustration 3.
- ▶ Release and unpin the pins on both sides (level **B**) at point 4, illustration 3.
- ▶ Release and unpin the pins on both sides (level **A**) at point 5, illustration 3.
- ▶ Release and unpin the pins on both sides (level **A**) at point 6, illustration 3.

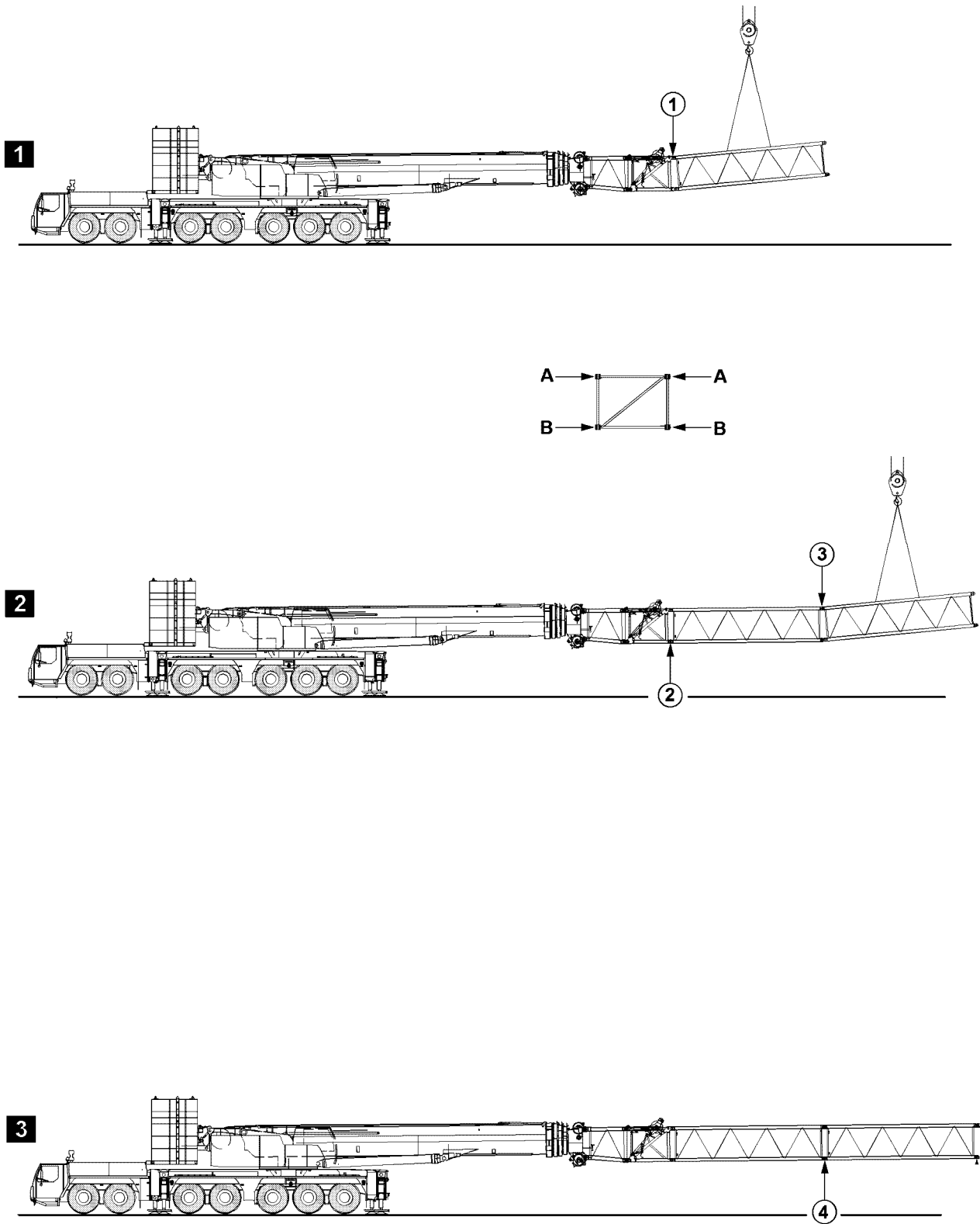

Fig.197705: Example for cranes with telescopic boom

14.11 Assembling / disassembling the lattice sections on telescopic cranes with an auxiliary boom, with an auxiliary crane

14.11.1 Assembling the lattice sections on an auxiliary boom with an auxiliary crane

The illustrations serve as examples. The illustrations may differ depending on the crane.



WARNING

Danger of fatal injury when assembling auxiliary booms!

If the pins are not pinned in the given sequence, then lattice sections may suddenly fold down or fall down.

Death, severe bodily injuries, property damage.

▶ Pins must be pinned in the order specified.

- ▶ Pin and secure pins at both sides (level **A**) at point **1**, illustration 1.
- ▶ Pin and secure pins at both sides (level **B**) at point **2**, illustration 2.
- ▶ Pin and secure pins at both sides (level **A**) at point **3**, illustration 2.
- ▶ Pin and secure pins at both sides (level **B**) at point **4**, illustration 3.

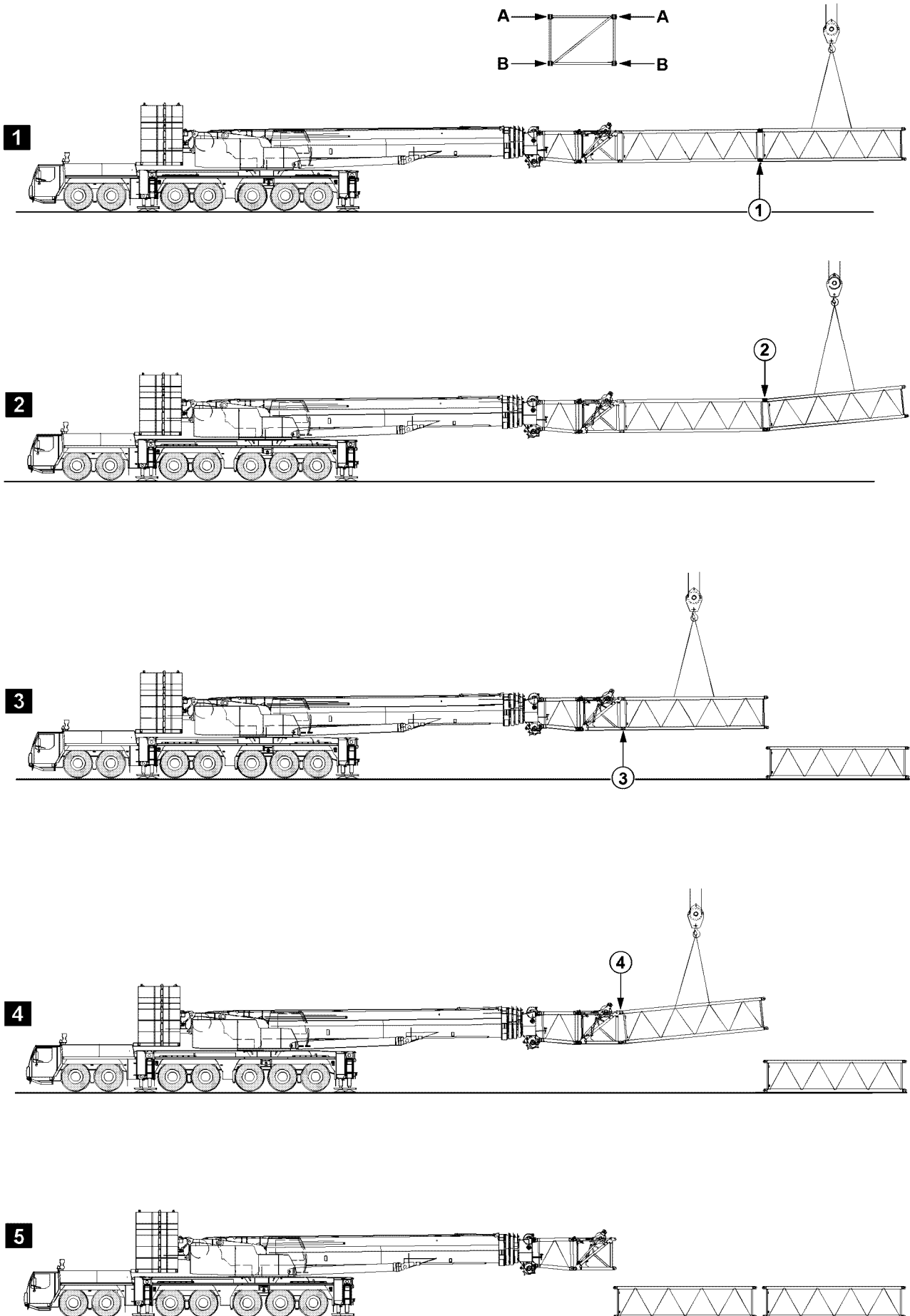

Fig.105510: Example for cranes with telescopic boom

LWE/LR 1600-2-008/18109-09-02/en

14.11.2 Disassembling the lattice sections on an auxiliary boom with an auxiliary crane

The illustrations serve as examples. The illustrations may differ depending on the crane.



WARNING

Danger of fatal injury when disassembling auxiliary booms!

If the pins are not unpinned in the given sequence, then lattice sections may suddenly fold down or fall down.

Death, severe bodily injuries, property damage.

▶ Pins must be unpinned in the order specified.

- ▶ Release and unpin the pins on both sides (level **B**) at point **1**, illustration **1**.
- ▶ Release and unpin the pins on both sides (level **A**) at point **2**, illustration **2**.
- ▶ Release and unpin the pins on both sides (level **B**) at point **3**, illustration **3**.
- ▶ Release and unpin the pins on both sides (level **A**) at point **4**, illustration **4**.

1**2****3**

Fig.197712: Example for cranes with telescopic boom

14.12 Assembling / disassembling the lattice sections on telescopic cranes with an auxiliary boom, without an auxiliary crane

14.12.1 Assembling the lattice sections on an auxiliary boom without an auxiliary crane

The illustrations serve as examples. The illustrations may differ depending on the crane.

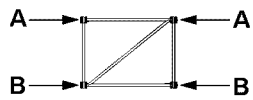
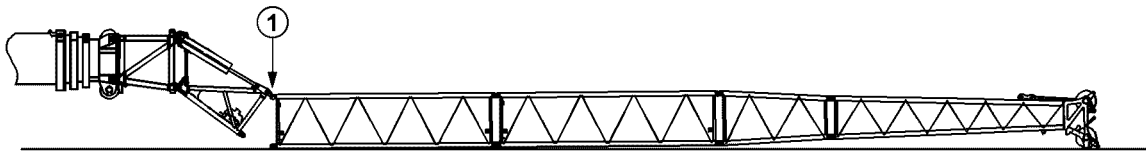
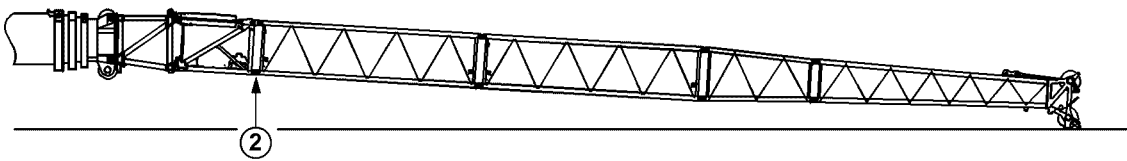
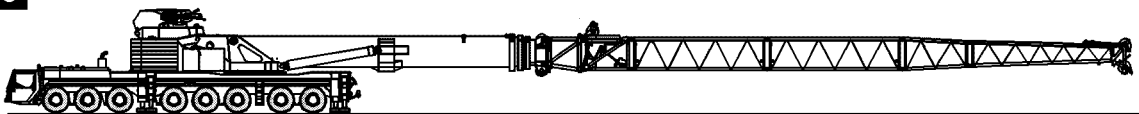

WARNING

Danger of fatal injury when assembling auxiliary booms!

If the pins are not pinned in the given sequence, then lattice sections may suddenly fold down or fall down.

Death, severe bodily injuries, property damage.

▶ Pins must be pinned in the order specified.

For cranes with hydraulic angle adjustment and self-supporting auxiliary boom, the assembly / disassembly of additional lattice sections may be performed using the crane itself.

In order to do so, proceed as follows.

- ▶ Assemble the lattice sections to the required length.
- ▶ Pin and secure pins at both sides (level **A**) at point **1**, illustration 1.
- ▶ Close the auxiliary boom until the pins can be pinned at point **2**, illustration 2.
- ▶ Pin and secure pins at both sides (level **B**) at point **2**, illustration 2.

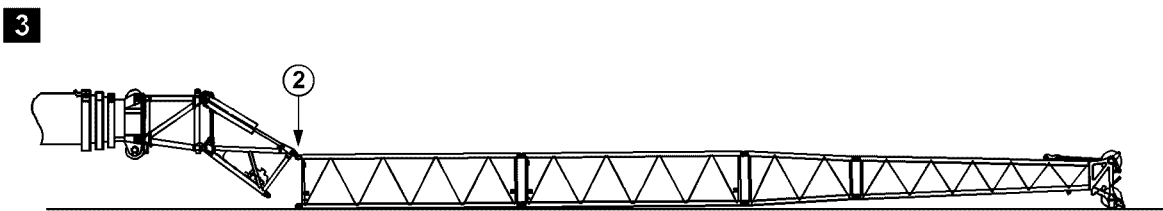
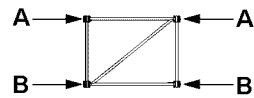
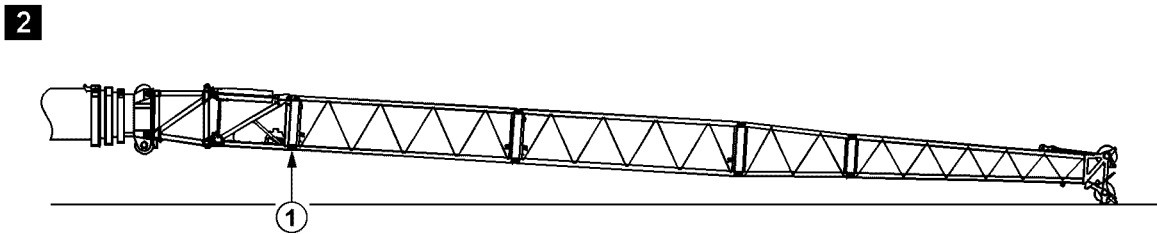
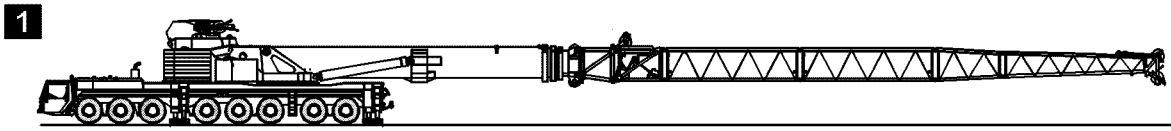

Fig.197713: Example for cranes with telescopic boom

14.12.2 Disassembling the lattice sections on an auxiliary boom without an auxiliary crane

The illustrations serve as examples. The illustrations may differ depending on the crane.



WARNING

Danger of fatal injury when disassembling auxiliary booms!

If the pins are not unpinned in the given sequence, then lattice sections may suddenly fold down or fall down.

Death, severe bodily injuries, property damage.

- ▶ Pins must be unpinned in the order specified.

For cranes with hydraulic angle adjustment and self-supporting auxiliary boom, the assembly / disassembly of additional lattice sections may be performed using the crane itself.

In order to do so, proceed as follows.

NOTICE

Damage of hydraulic cylinders on the TF-adapter!

- ▶ As soon as the lattice jib is placed, stop the luff down movement.
- ▶ It is prohibited to set down the fixed lattice jib „hard“.

- ▶ Luff the main boom down until the end section touches the ground slightly, illustration 2.

If it is not possible to luff down that far:

- ▶ Adjust the TF-adapter until the end section touches the ground slightly, illustration 2.
- ▶ Release and unpin the pins on both sides (level **B**) at point 1, illustration 2.

NOTICE

Damage of hydraulic cylinders on the TF-adapter.

- ▶ As soon as the lattice jib is placed, stop the opening movement.

- ▶ Open the auxiliary boom until the lattice sections to be removed are laying completely on the ground, illustration 3.
- ▶ Release and unpin the pins on both sides (level **A**) at point 2, illustration 3.
- ▶ Completely remove the auxiliary boom.

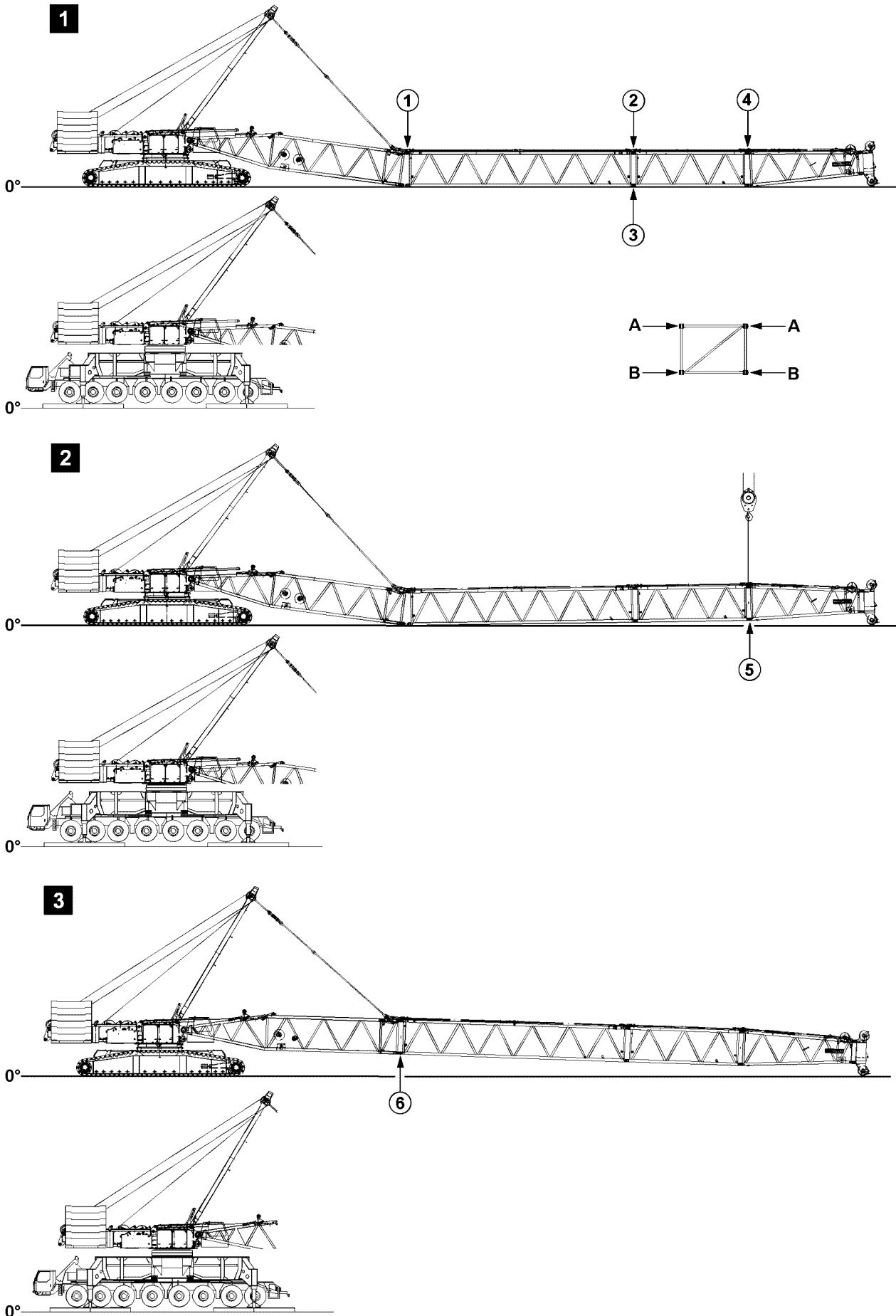

Fig.121633: Example for cranes with lattice mast booms

LWE/LR 1600-2-008/18109-09-02/en

14.13 Assembling / disassembling of lattice sections for lattice mast cranes

14.13.1 Assembling of lattice sections

The illustrations serve as examples. The illustrations may differ depending on the crane.



WARNING

Danger of fatal injury when assembling booms!

If the pins are not pinned in the given sequence, then lattice sections may suddenly fold down or fall down.

Personnel can be killed or seriously injured.

▶ Pins must be pinned in the order specified.

- ▶ Pin and secure pins at both sides (level **A**) at point **1**, illustration **1**.
- ▶ Pin and secure pins at both sides (level **A**) at point **2**, illustration **1**.
- ▶ Pin and secure pins at both sides (level **B**) at point **3**, illustration **1**.
- ▶ Pin and secure pins at both sides (level **A**) at point **4**, illustration **1**.
- ▶ Lift the end section with the auxiliary crane, illustration **2**.
- ▶ Pin and secure pins at both sides (level **B**) at point **5**, illustration **2**.
- ▶ Close the boom system with the SA-frame, illustration **3**.
- ▶ Pin and secure pins at both sides (level **B**) at point **6**, illustration **3**.

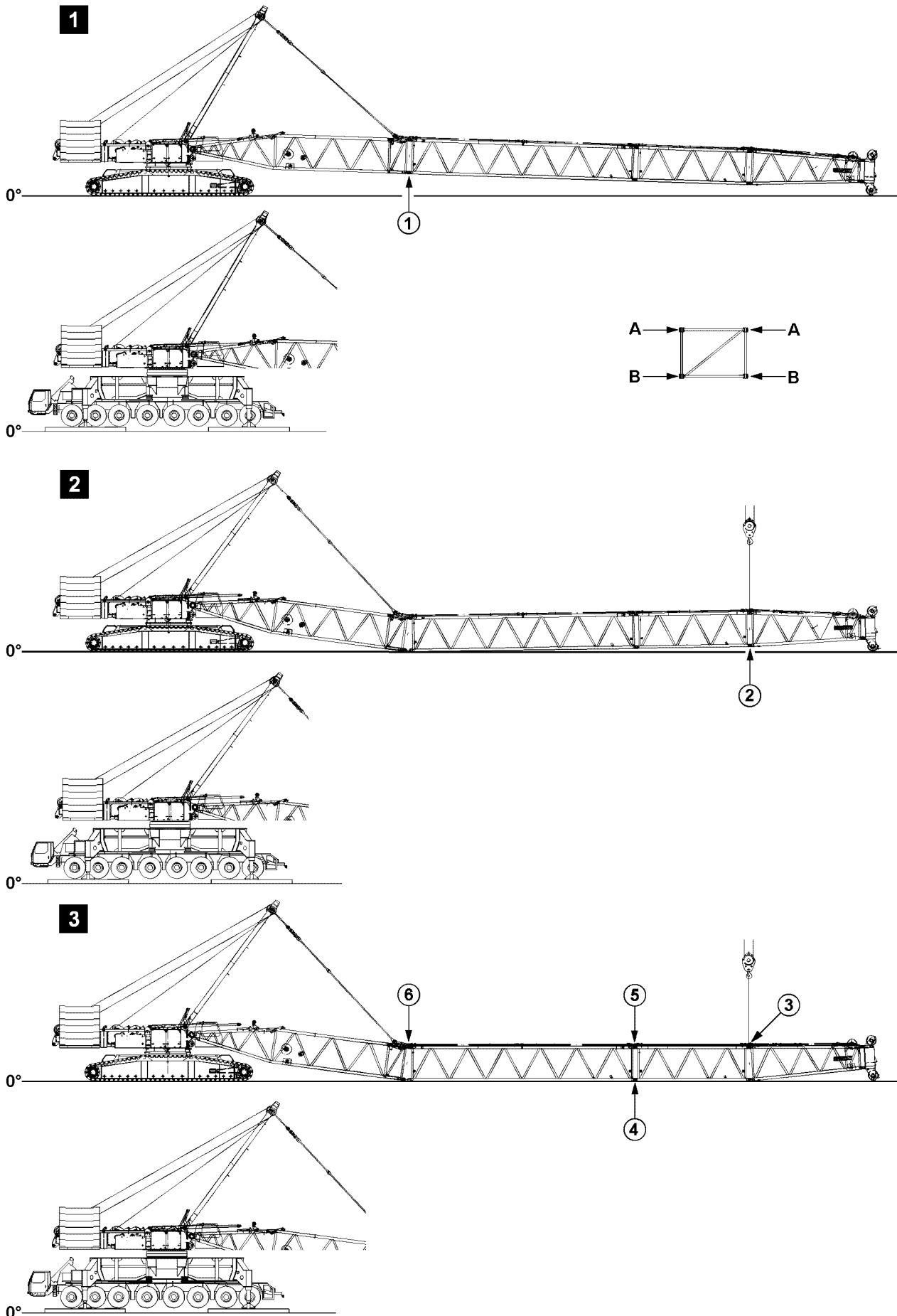

Fig.121634: Example for cranes with lattice mast booms

LWE/LR 1600-2-008/18109-09-02/en

14.13.2 Disassembling of lattice sections

The illustrations serve as examples. The illustrations may differ depending on the crane.



WARNING

Danger of fatal injury when disassembling booms!

If the pins are not unpinned in the given sequence, then lattice sections may suddenly fold down or fall down.

Personnel can be killed or seriously injured.

- ▶ Make sure that the SA-frame guying is tensioned before the pins are unpinned at point **1**, see illustration **1**.
 - ▶ Pins must be unpinned in the order specified.
-
- ▶ Luff the boom down until the end section touches the ground slightly, illustration **1**.
 - ▶ Guy the boom with SA-frame, illustration **1**.
 - ▶ Release and unpin the pins on both sides (level **B**) at point **1**, illustration **1**.
 - ▶ Open the boom system with the SA-frame, illustration **2**.
 - ▶ Take the lattice sections down completely, illustration **2**.
 - ▶ Lift the end section with the auxiliary crane, illustration **2**.
 - ▶ Release and unpin the pins on both sides (level **B**) at point **2**, illustration **2**.
 - ▶ Release and unpin the pins on both sides (level **A**) at point **3**, illustration **3**.
 - ▶ Release and unpin the pins on both sides (level **B**) at point **4**, illustration **3**.
 - ▶ Release and unpin the pins on both sides (level **A**) at point **5**, illustration **3**.
 - ▶ Release and unpin the pins on both sides (level **A**) at point **6**, illustration **3**.

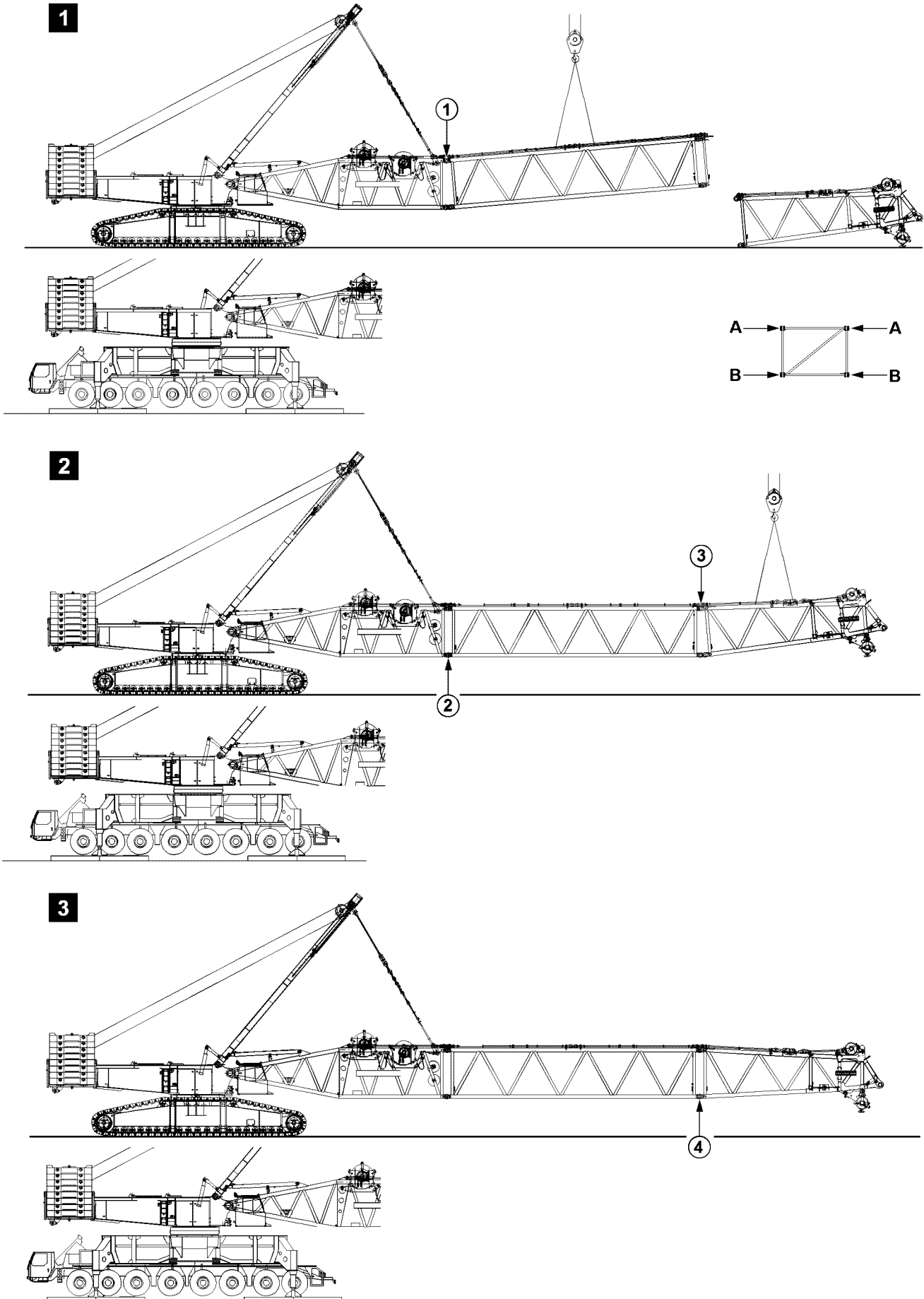

Fig.198182: Example for cranes with lattice mast booms

LWE/LR 1600-2-008/18109-09-02/en

14.14 Flying assembly / disassembly of lattice sections

14.14.1 Flying assembly of lattice sections

The illustrations serve as examples. The illustrations may differ depending on the crane.



WARNING

Danger of fatal injury when assembling booms!

If the pins are not pinned in the given sequence, then lattice sections may suddenly fold down or fall down.

Personnel can be killed or seriously injured.

▶ Pins must be pinned in the order specified.

- ▶ Pin and secure pins at both sides (level **A**) at point **1**, illustration **1**.
- ▶ Pin and secure pins at both sides (level **B**) at point **2**, illustration **2**.
- ▶ Pin and secure pins at both sides (level **A**) at point **3**, illustration **2**.
- ▶ Pin and secure pins at both sides (level **B**) at point **4**, illustration **3**.

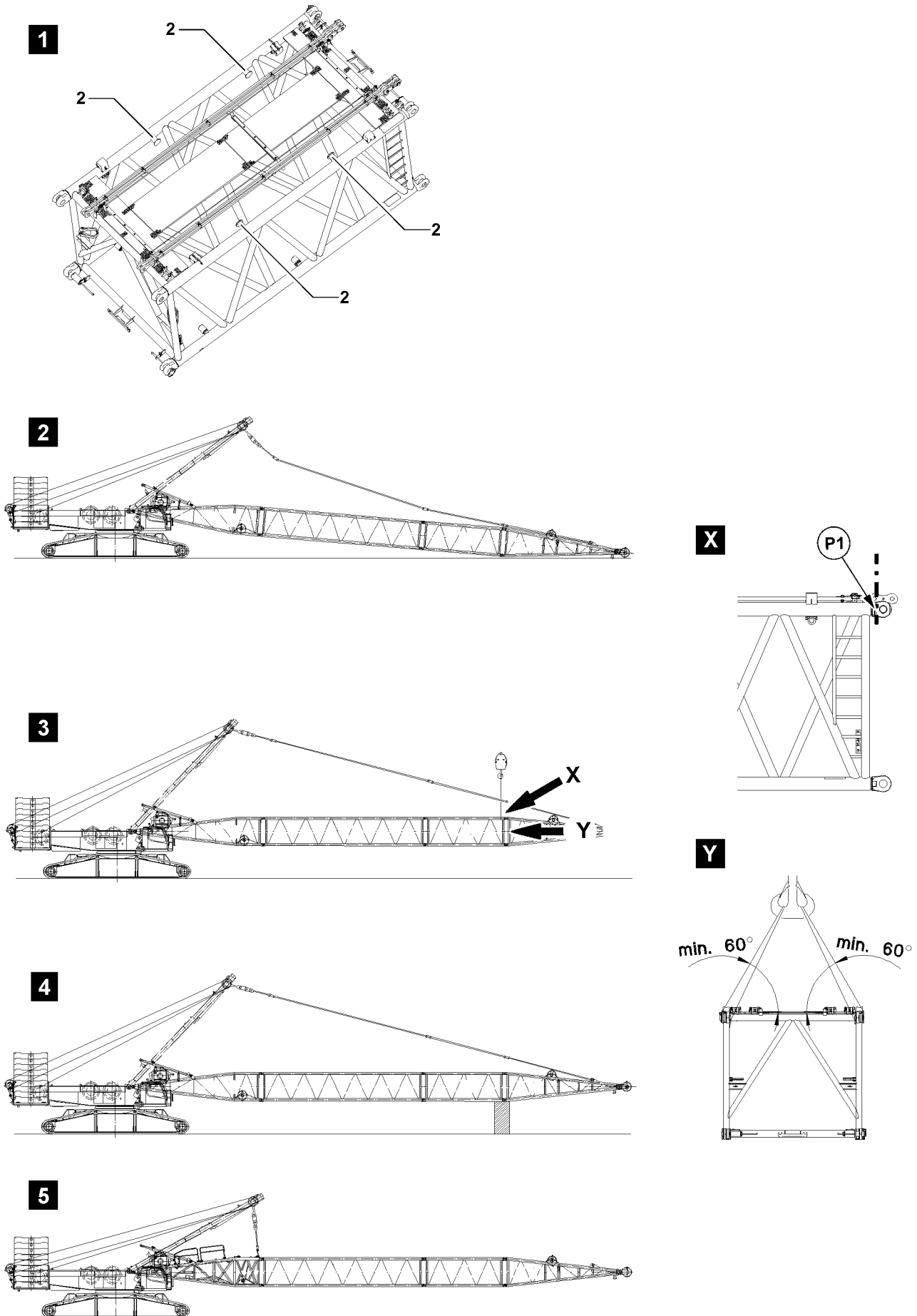

Fig.111448: Guying the pivot section with the SA-frame

LWE/LR 1600-2-008/18109-09-02/en

14.14.2 Flying disassembly of lattice sections

The illustrations serve as examples. The illustrations may differ depending on the crane.

The flying disassembly of lattice sections can be used on:

- Derrick boom
- Main boom

Make sure that the following prerequisite is met:

- Before guying the pivot section, secure the boom properly to prevent it from falling down!

Guying the pivot section in flying mode with the SA-frame

There are three ways to change the guying point for flying disassembly:

- Take down the boom on the ground.
 - Secure the boom with the auxiliary crane.
 - Support the boom.
- ▶ Take down the boom on the ground, see illustration 2.
or



WARNING

Lattice section incorrectly attached!

If the fastening equipment is attached on the bits **2** when securing the boom, then the bits will be overloaded. The lattice section will be damaged.

The boom can fall down.

Personnel can be severely injured or killed.

If an auxiliary crane is used to secure the boom for flying disassembly:

- ▶ Do **not** fasten the lattice section on the bits **2**, see illustration 1.
- ▶ Attach the fastening equipment in the area of point **P1** on both sides on the lattice section, see detail **X**.
- ▶ Make sure that the long fastening equipment is used, so that the angle between the cross section of the lattice section and guyed fastening equipment is at least 60°, see detail **Y**.

Secure the boom with the auxiliary crane, see illustration 3.

or



WARNING

Falling boom!

If the boom is not properly and securely supported from below, then the boom can fall down.

- ▶ Support the boom properly and safely with suitable material.

Support the boom, see illustration 4.

Result:

- The guy rods can be disassembled.
- ▶ Take down, secure and disassemble the guy rods.
- ▶ Pin and secure the guy rods SA-frame on the pivot section.
- ▶ Tighten the guy rods SA-frame until the boom is in horizontal position.

Result:

- Pivot section is guyed in flying mode with the SA-frame, see illustration 5.
- The lattice sections can be disassembled in flying mode.

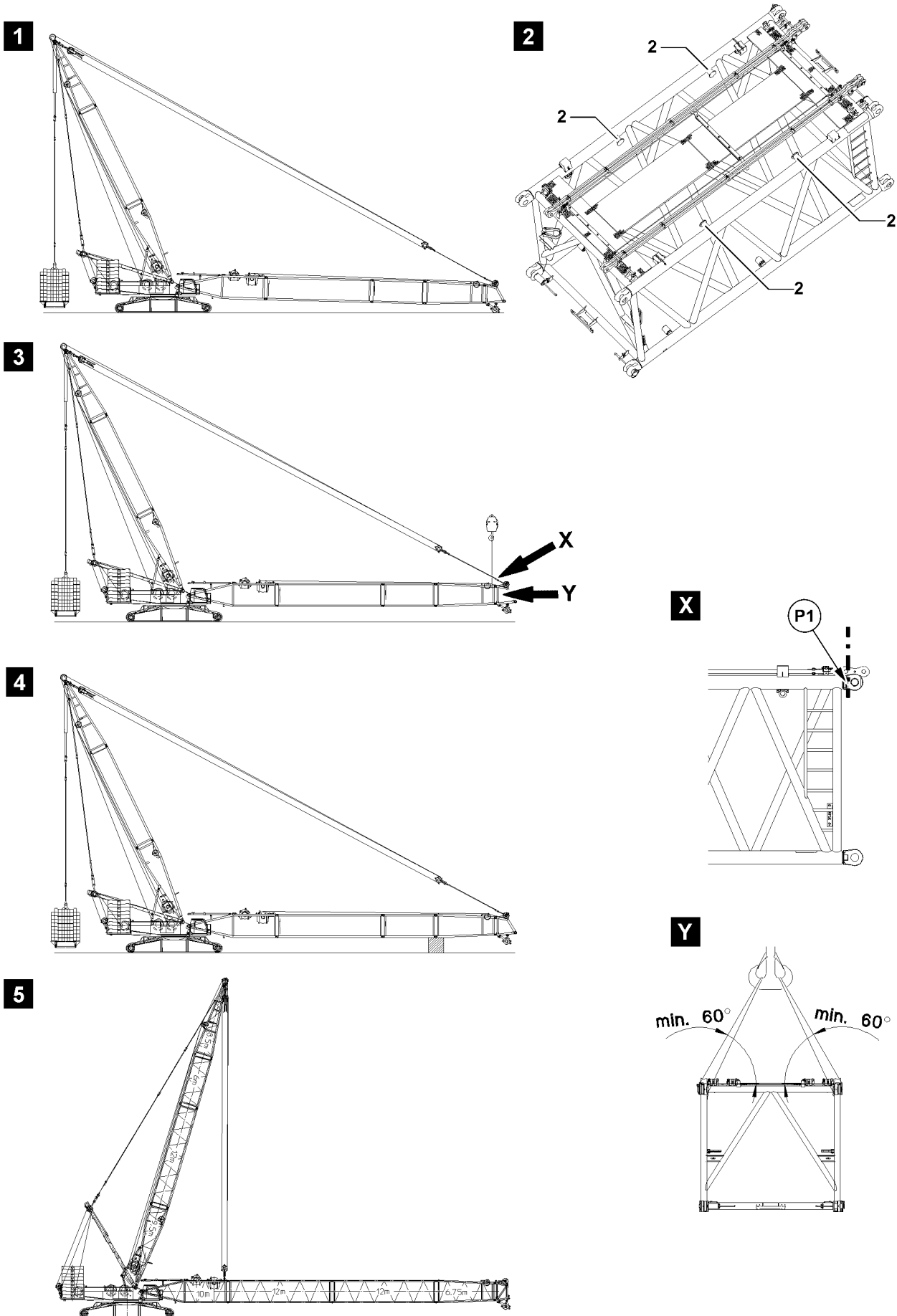

Fig.111449: Guying the pivot section with the derrick boom

LWE/LR 1600-2-008/18109-09-02/en

Guying the pivot section in flying mode with the derrick boom

There are three ways to change the guying point for flying disassembly:

- Take down the boom on the ground.
 - Secure the boom with the auxiliary crane.
 - Support the boom.
- ▶ Take down the boom on the ground, see illustration 1.
or



WARNING

Lattice section incorrectly attached!

If the fastening equipment is attached on the bitts 2 when securing the boom, then the bitts will be overloaded. The lattice section will be damaged.

The boom can fall down.

Personnel can be severely injured or killed.

If the auxiliary crane is used to secure the boom for flying disassembly:

- ▶ Do **not** fasten the lattice section on the bitts 2, see illustration 2.
- ▶ Attach the fastening equipment in the area of point P1 on both sides on the lattice section, see detail X.
- ▶ Make sure that the long fastening equipment is used, so that the angle between the cross section of the lattice section and guyed fastening equipment is at least 60°, see detail Y.

Secure the boom with the auxiliary crane, see illustration 3.

or



WARNING

Falling boom!

If the boom is not properly supported from below, then the boom can fall down.

- ▶ Support the boom properly and safely with suitable material.

Support the boom, see illustration 4.

Result:

- The guy rods can be disassembled.
- ▶ Take down, secure and disassemble the guy rods.
- ▶ Pin and secure the luffing pulley block on the pivot section.
- ▶ Tighten the control rope until the boom is in horizontal position.

Result:

- Pivot section is guyed in flying mode with the derrick boom, see illustration 5.
- The lattice sections can be disassembled in flying mode.

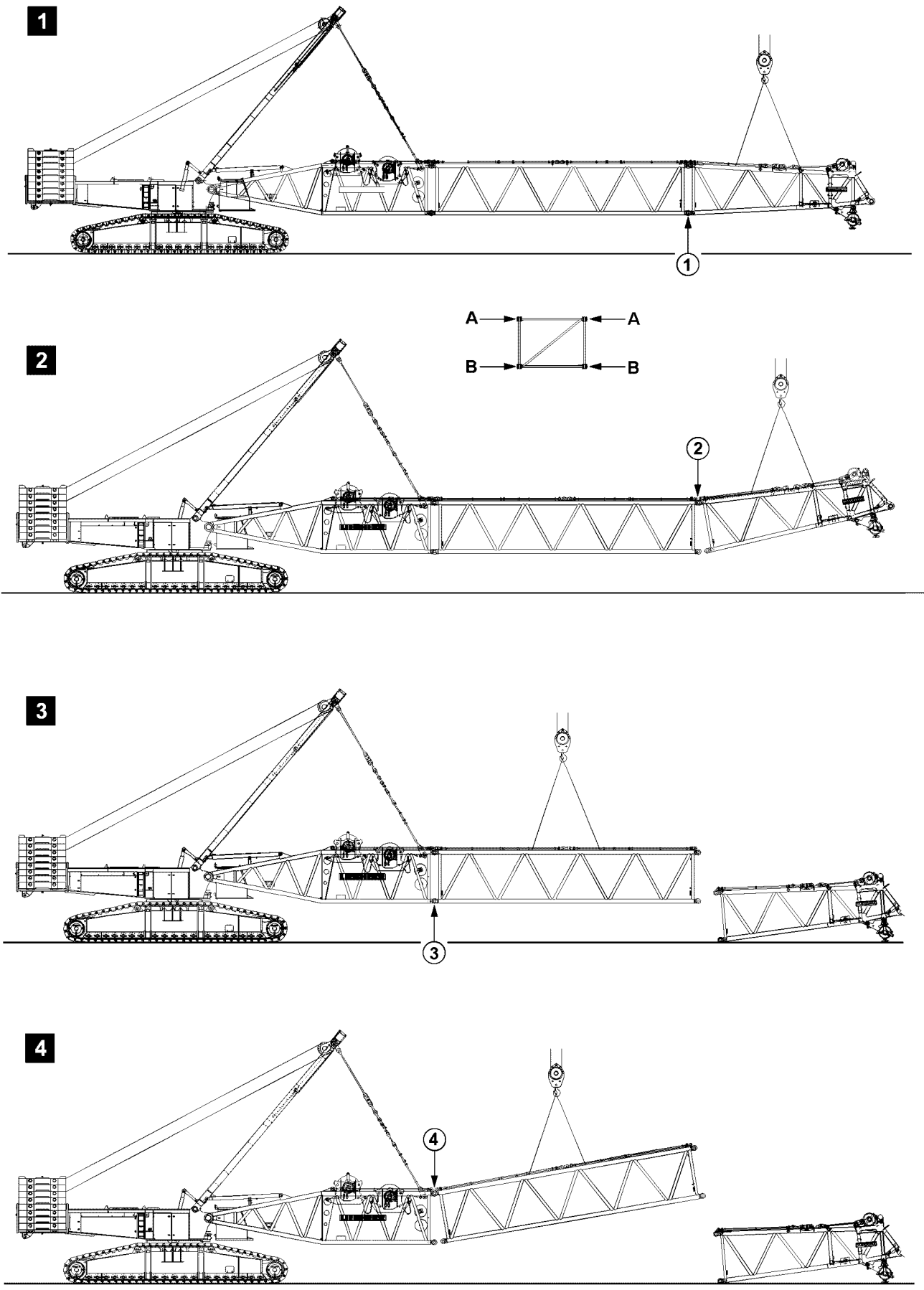

Fig.105511: Example for cranes with lattice mast booms

LWE/LR 1600-2-008/18109-09-02/en

Unpinning the lattice components



WARNING

Danger of fatal injury when disassembling booms!

If the pins are not unpinned in the given sequence, then lattice sections may suddenly fold down or fall down.

Personnel can be killed or seriously injured.

▶ Pins must be unpinned in the order specified.

- ▶ Release and unpin the pins on both sides (level **B**) at point **1**, illustration 1.
- ▶ Release and unpin the pins on both sides (level **A**) at point **2**, illustration 2.
- ▶ Release and unpin the pins on both sides (level **B**) at point **3**, illustration 3.
- ▶ Release and unpin the pins on both sides (level **A**) at point **4**, illustration 4.

14.15 Assembling / disassembling of boom systems for supporting on ascending terrain (assembly / disassembly schematic)



Note

- ▶ The following assembly steps are simplified and are examples and may not match your crane exactly.



WARNING

Danger of fatal injury when assembling / disassembling booms!

If the pins are not pinned / unpinned in the specified sequence, then lattice sections may suddenly fold down or fall down.

Personnel can be killed or seriously injured.

- ▶ Pin / unpin pins in the specified sequence, see section „Assembly of lattice sections“.
- ▶ Observe all safety technical notes in section „Assembly / disassembly“.
- ▶ Make sure that there are no persons within the danger zone.



WARNING

Horizontal movement of the boom!

- ▶ Make sure that there are no persons within the danger zone.

14.15.1 Assembling of boom systems on ascending terrain

Make sure that the following prerequisites are met:

- An auxiliary crane with sufficient load bearing capacity is available.

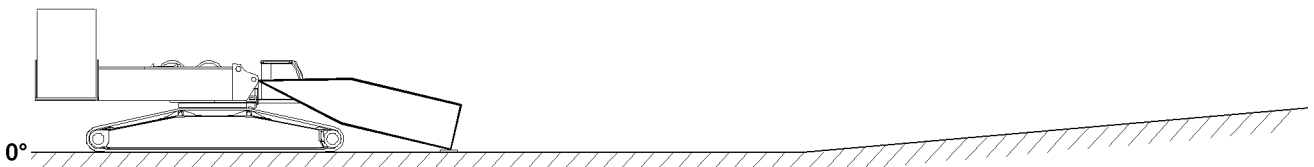

Fig. 121635: Boom - pivot section installed on turntable and placed on the ground

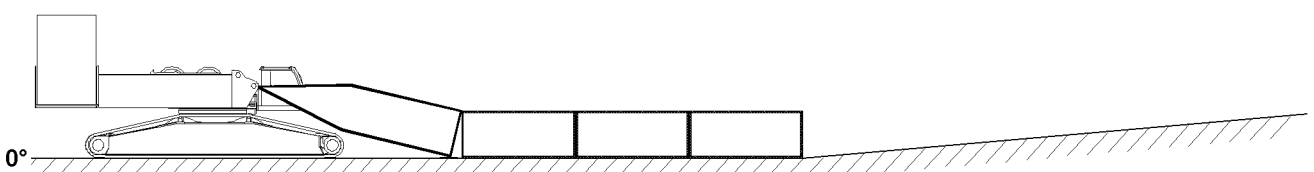

Fig. 121636: Boom - intermediate sections installed on boom - pivot section and placed on the ground

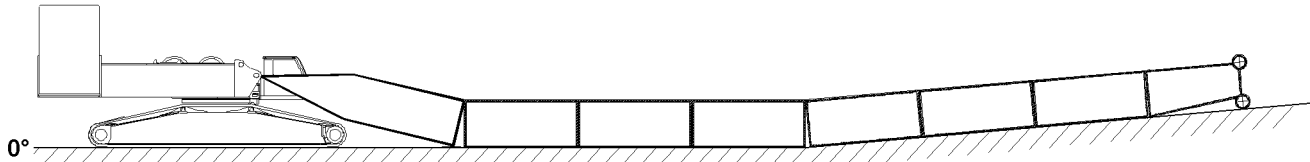

Fig.121637: Boom - intermediate sections installed and placed in ascending terrain

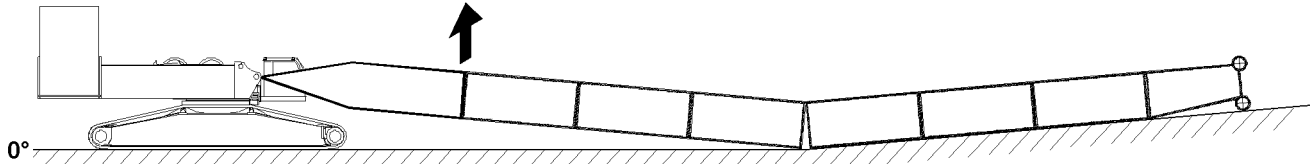

Fig.121638: Lifting and close the boom system in the area of the boom - pivot section

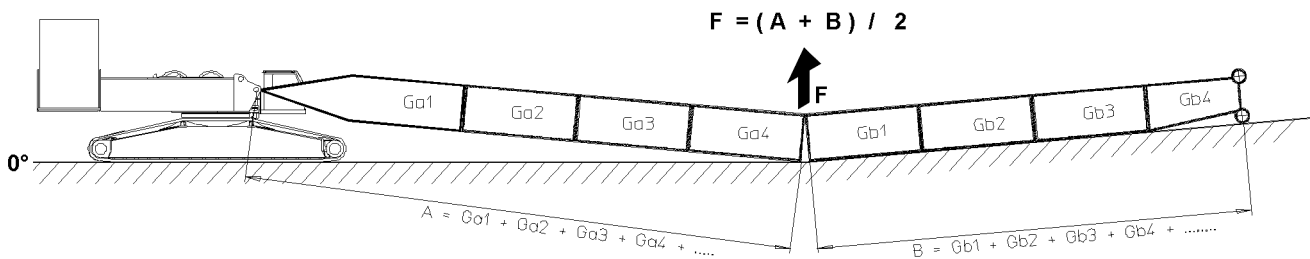

Fig.145512: Calculation of force for the closing procedure of the boom system



Note

- ▶ The abbreviations Ga1, Ga2, ... and Gb1, Gb2, ... are for the weights of the individual lattice sections.
- ▶ The weights of the lattice sections are noted on the welded on weight tags on the lattice sections.

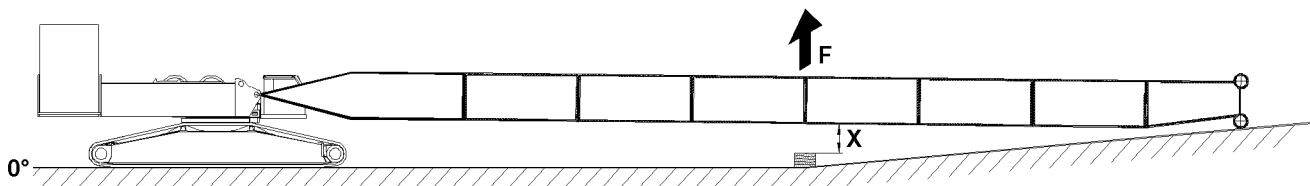

Fig.121639: Lifting and close the boom system // Support the boom system



Note

- ▶ The height of the substructure or dimension X is noted on the respective boom assembly chapter, see Crane operating instructions, chapter 5.38 or chapter 5.39.
- ▶ Support the boom system properly after the closing procedure.

14.15.2 Disassembly of boom systems on ascending terrain

Make sure that the following prerequisites are met:

- An auxiliary crane with sufficient load bearing capacity if available.

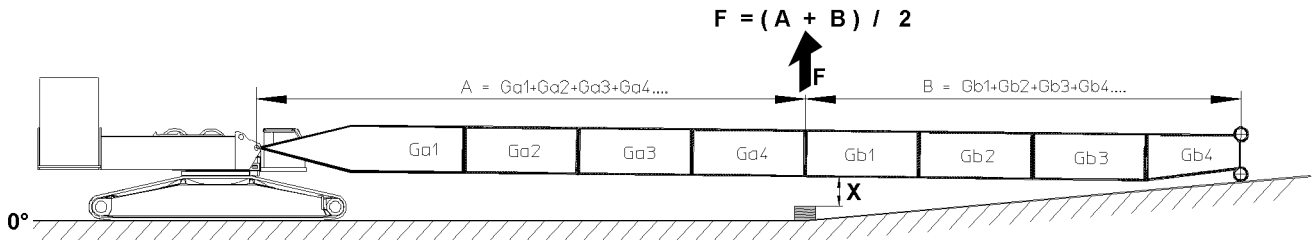

Fig. 145513: Calculation of force for opening the boom system // Lift the boom system // Remove the substructure // Open the boom system



Note

- ▶ The abbreviations Ga1, Ga2, ... and Gb1, Gb2, ... are for the weights of the individual lattice sections.
- ▶ The weights of the lattice sections are noted on the welded on weight tags on the lattice sections.

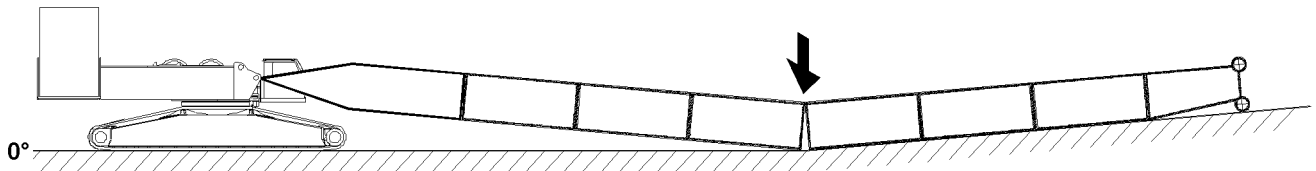

Fig. 121657: Taking the boom system down

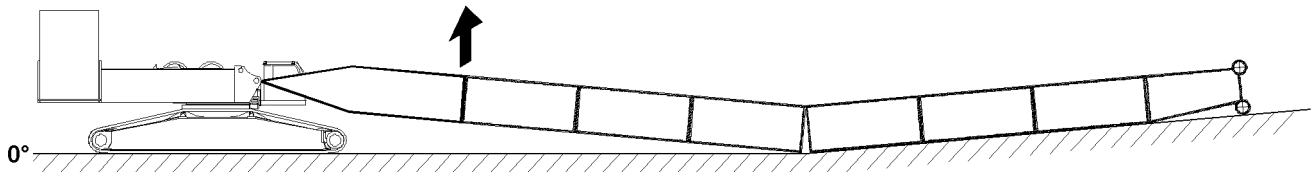

Fig. 121652: Lifting and opening the boom system

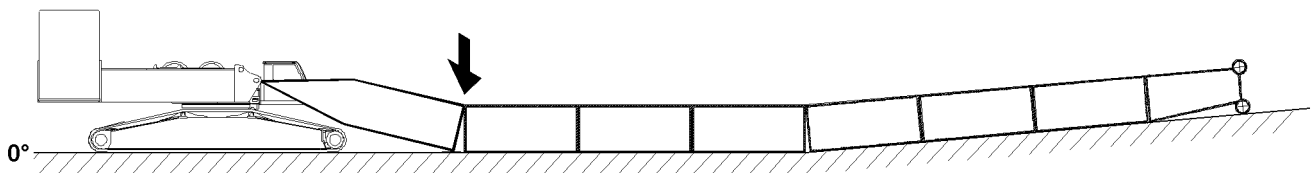

Fig. 121653: Taking the boom system down

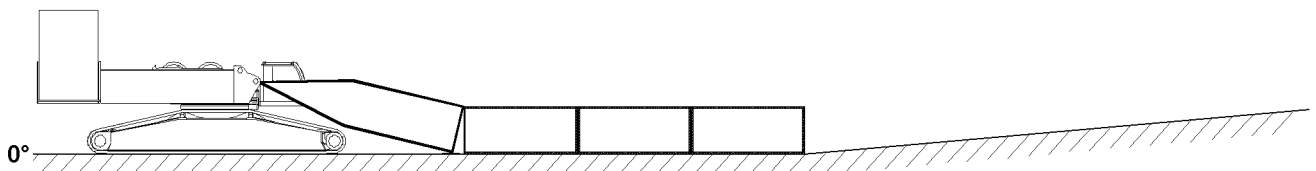

Fig. 121636: Disassembling and removing the boom - intermediate sections with the end section

LWE/LR 1600-2-008/18109-09-02/en

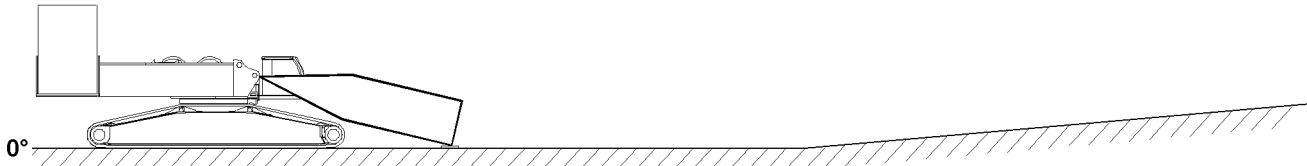

Fig.121635: Disassembling and removing the boom - intermediate sections to the boom - pivot section

- ▶ Disassemble and remove the boom - pivot section.

14.16 Assembling / disassembling of boom systems for supporting on descending terrain (assembly / disassembly schematic)



Note

- ▶ The following assembly steps are simplified and are examples and may not match your crane exactly.



WARNING

Danger of fatal injury when assembling / disassembling booms!

If the pins are not pinned / unpinned in the specified sequence, then lattice sections may suddenly fold down or fall down.

Personnel can be killed or seriously injured.

- ▶ Pin / unpin pins in the specified sequence, see section „Assembly of lattice sections“.
- ▶ Observe all safety technical notes in section „Assembly / disassembly“.
- ▶ Make sure that there are no persons within the danger zone.

14.16.1 Assembling of boom systems on descending terrain

Make sure that the following prerequisites are met:

- The lattice sections are properly assembled.
- An auxiliary crane with sufficient load bearing capacity if available.

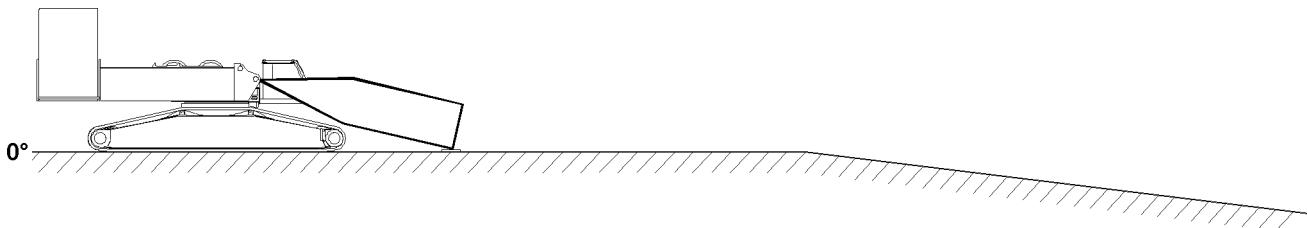

Fig.121640: Boom - pivot section installed on turntable and placed on the ground

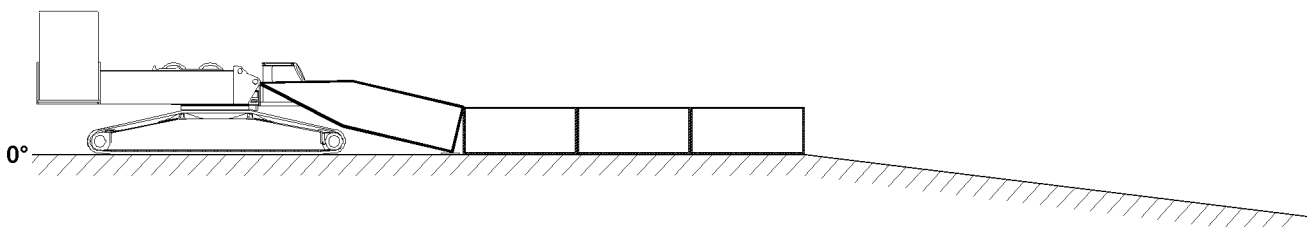

Fig.121641: Boom - intermediate sections installed on boom - pivot section and placed on the ground

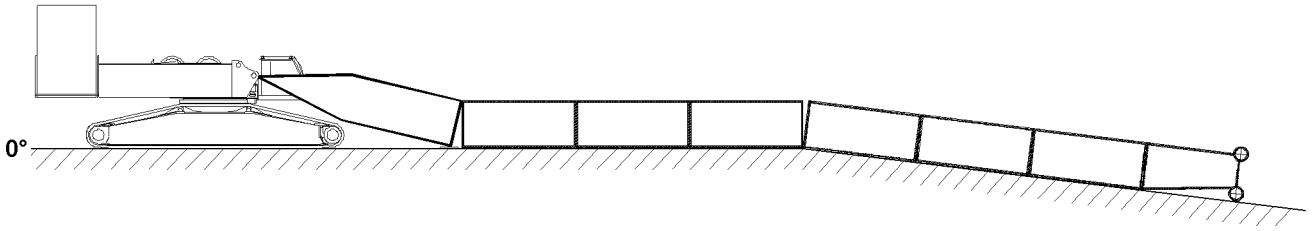

Fig.121642: Boom - intermediate sections installed and placed in descending terrain

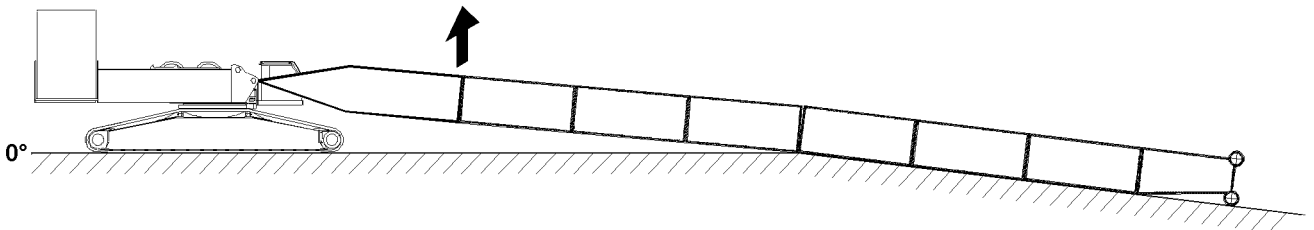
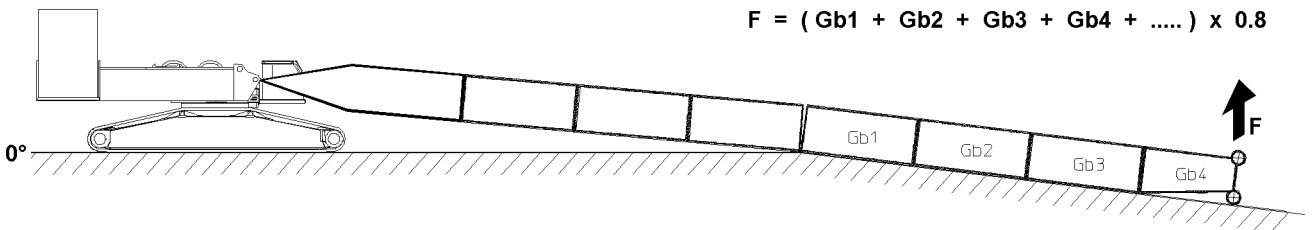

Fig.121643: Lifting and close the boom system in the area of the boom - pivot section



$$F = (Gb1 + Gb2 + Gb3 + Gb4 + \dots) \times 0.8$$

Fig.145514: Calculation of force for the closing procedure of the boom system



Note

- ▶ The abbreviations Gb1, Gb2, ... are for the weights of the individual lattice sections.
- ▶ The weights of the lattice sections are noted on the welded on weight tags on the lattice sections.

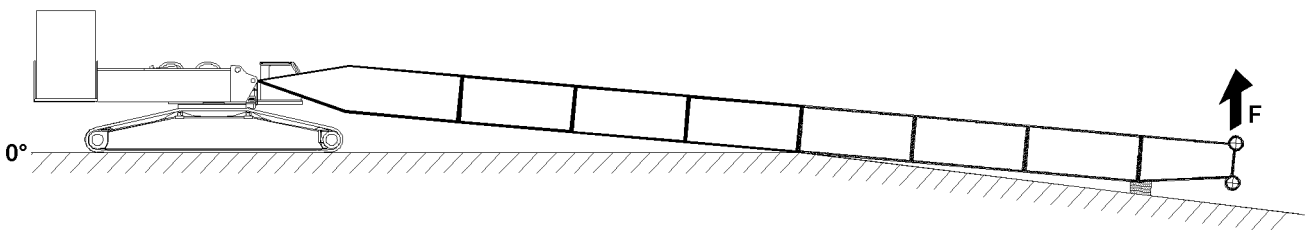

Fig.121644: Lifting and close the boom system // Support the boom system



Note

- ▶ The height of the substructure depends on the lay of the terrain and the resulting incline of the boom system.
- ▶ Support the boom system properly after the closing procedure.

14.16.2 Disassembly of boom systems on descending terrain

Make sure that the following prerequisite is met:

- An auxiliary crane with sufficient load bearing capacity if available.

LWE/LR 1600-2-008/18109-09-02/en

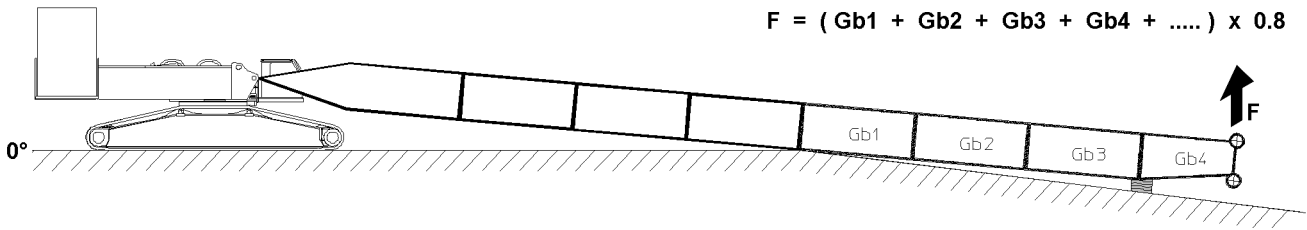

Fig.145515: Calculation of force for opening the boom system // Lift the boom system // Remove the substructure // Open the boom system



Note

- ▶ The abbreviations Gb1, Gb2, ... are for the weights of the individual lattice sections.
- ▶ The weights of the lattice sections are noted on the welded on weight tags on the lattice sections.

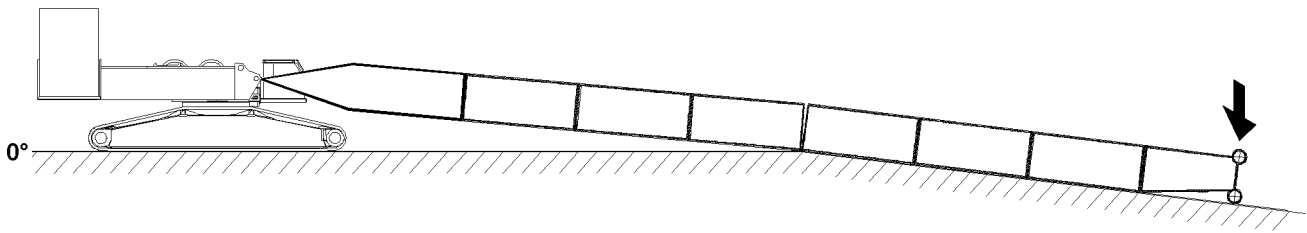

Fig.121658: Taking the boom system down

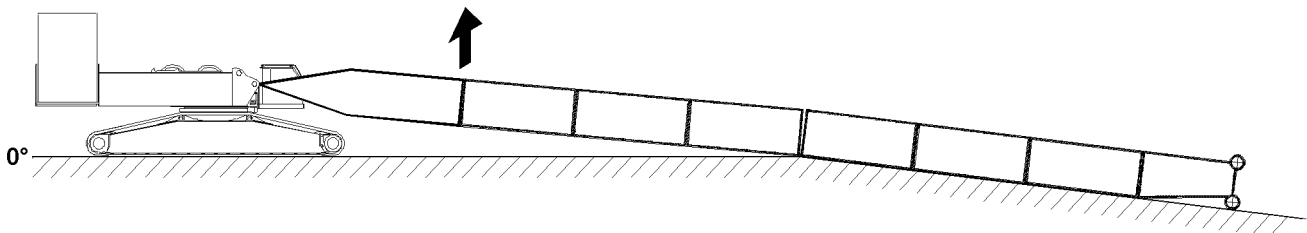

Fig.121655: Lifting and opening the boom system

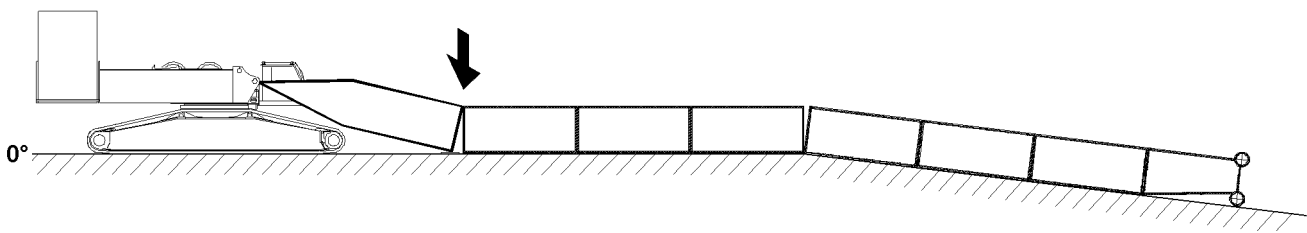

Fig.121656: Taking the boom system down

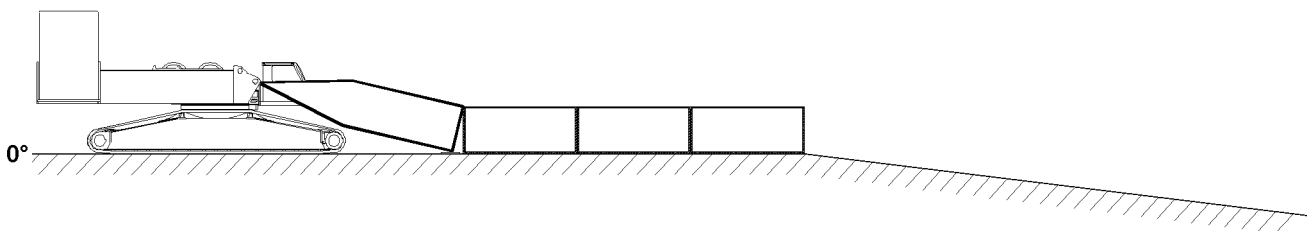

Fig.121641: Disassembling and removing the boom - intermediate sections with the end section

LWE/LR 1600-2-008/18109-09-02/en

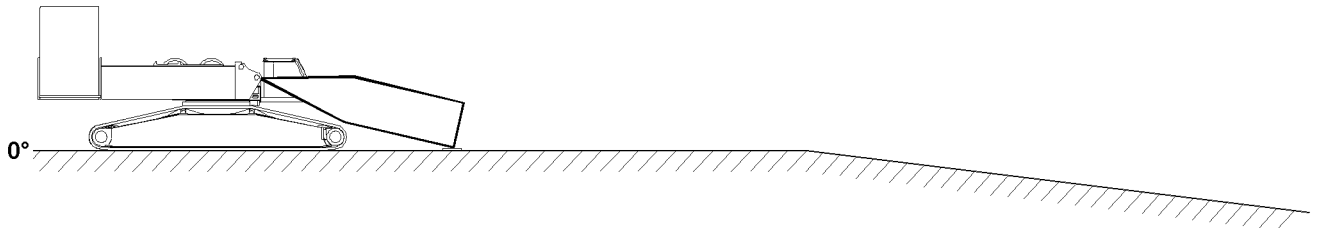

Fig.121640: Disassembling and removing the boom - intermediate sections to the boom - pivot section

- ▶ Disassemble and remove the boom - pivot section.

15 Erecting / taking down



WARNING

The crane can topple over!

Due to an unforeseen occurrence, for example: Sudden strong wind or storm can lead to dangerous operating situations, up to toppling the crane.

Personnel can be severely injured or killed.

- ▶ The boom must be able to be placed down at any time with its current equipment, observe the erection and take down charts. Observe the job planner.
- ▶ The counterweights and / or ballasts required for this must always be in direct vicinity of the crane.
- ▶ The crane operator must ensure that the required counterweight and / or the required ballast is carried along when driving the crane with the equipment in place and that the boom can be placed down at any time.



WARNING

Danger of fatal injury!

- ▶ Incorrectly installed or non-functioning limit switches as well as falling parts (pins, cotter pins, ice etc.) can cause accidents.

15.1 Erecting / taking down for mobile cranes

Make sure that the following prerequisites are met:

- The crane is properly supported.
 - The crane is horizontally aligned.
 - The counterweight has been installed on the turntable according to the load chart or the erection / take down charts.
 - In the case of cranes with derrick ballast: The derrick ballast (suspended ballast or ballast trailer ballast) is installed according to the load chart or the erection / take down charts.
 - For cranes with a telescopic boom: The telescopic boom is telescoped in all the way.
 - The boom has been installed according to the load chart and the Crane operating instructions.
 - The hoist rope has been correctly placed in the rope pulleys and prevented from jumping out with the rope retaining pins.
 - All limit switches have been correctly assembled and are fully operational.
 - All pin connections are secured.
 - No persons in the danger zone.
 - No loose parts on the boom or the auxiliary boom.
 - The exposed rope pulleys are free of snow and ice.
 - The boom and its components (limit switches, cable drums, airplane warning light, wind speed sensor etc.) must be kept free of ice and snow.
- ▶ Check if all prerequisites have been met.

15.2 Erecting / taking down for crawler cranes

Make sure that the following prerequisites are met:

- Comply with the maximum permissible incline of the crane specified in the load chart manual.
 - For cranes with a support: The crane is properly supported.
 - For cranes with a support: The crane is horizontally aligned.
 - The counterweight has been installed on the turntable according to the load chart.
 - The central ballast is installed according to the load chart.
 - The counterweight is installed according to the load chart or the erection / take down charts.
 - In the case of cranes with derrick ballast: The derrick ballast (suspended ballast or ballast trailer ballast) is installed according to the load chart or the erection / take down charts.
 - For cranes with a telescopic boom: The telescopic boom is telescoped in all the way.
 - The boom has been installed according to the load chart and the Crane operating instructions.
 - The hoist rope has been correctly placed in the rope pulleys and prevented from jumping out with the rope retaining pins.
 - All limit switches have been correctly assembled and are fully operational.
 - All pin connections are secured.
 - No persons in the danger zone.
 - No loose parts on the boom or the auxiliary boom.
 - The exposed rope pulleys are free of snow and ice.
 - The boom and its components (limit switches, cable drums, airplane warning light, wind speed sensor etc.) must be kept free of ice and snow.
- ▶ Check if all prerequisites have been met.

15.3 Rigging the guy rods on lattice booms on placed down boom system



WARNING

Danger of fatal injury due to damaged guy rods!

If the boom system is placed on the ground or a load bearing substructure in strong wind or longer downtime, the guy rods can be damaged due to wind influence on the boom guying. This wind influenced oscillations can lead to fatigue on the guy rods.

As a result, the guy rods could break or rip off under load - for example when erecting the boom system or in crane operation. The boom system can therefore fall uncontrolled forward onto the ground. Personnel can be severely injured or killed.

- ▶ Make sure that the guy rods are placed completely on the lattice sections and relieved when the boom systems are placed on the ground.
- ▶ Make sure that freely suspended guy rods are rigged on the lattice boom.
- ▶ Make sure that the upper pulley block is rigged on the lattice boom in Derrick operating modes.
- ▶ Make sure, that the guying on the luffing lattice jib is removed on lattice mast cranes.
- ▶ Make sure that the guy rods are inspected before resuming crane operation and that no damage or cracks are present.
- ▶ Make sure that the maintenance intervals of the guy rods are adhered to.



Note

- ▶ In case of strong wind or longer downtimes of the crane, the boom system must be placed on the ground or on a load bearing substructure.
- ▶ The guying must be relieved and the guy rods must be placed on the transport receptacles.
- ▶ The following illustrations are examples and may not match your crane exactly.

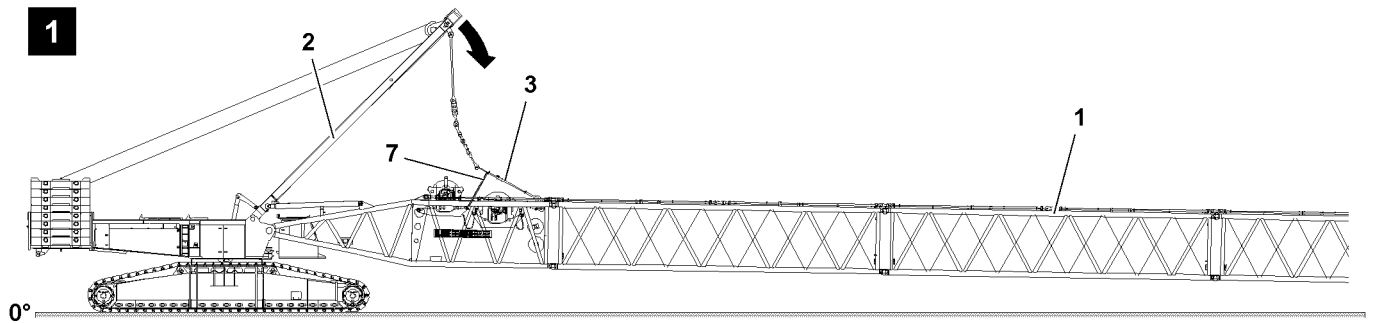

Fig.120722: Guying placed in transport receptacle and SA-frame guying relieved

- ▶ Take the guy rods down on the lattice sections 1: Luff the SA-frame 2 to the front until the guying is placed completely in the transport receptacles on the lattice sections and the SA-frame guying 3 is relieved, see illustration 1.
- ▶ To minimize side oscillation of the SA-frame guying 3 due to wind influence: Rig the SA-frame guying 3 with suitable rigging straps / ropes 7 against the boom, see illustration 1.

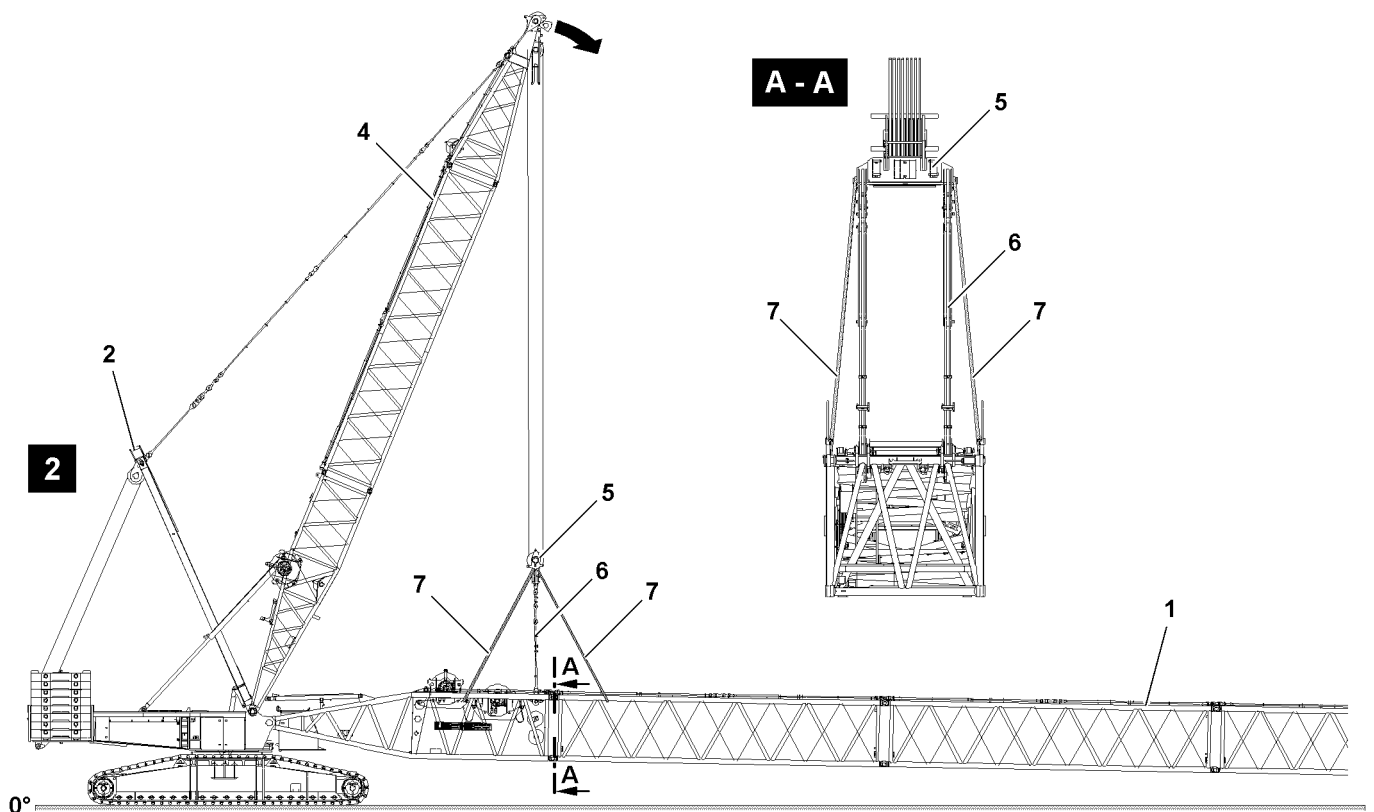

Fig.120771: Guying placed in transport receptacle and upper pulley block rigged against the boom

- ▶ Take the boom system down and - if present - release the derrick guying to the derrick ballast.
- ▶ Take the guy rods down on the lattice sections 1: Luff the D-boom 4 down to the front until the main boom guying is placed completely in the transport receptacles on the lattice sections and the upper pulley block 5 is positioned over the S-pivot section, see illustration 2.
- ▶ To minimize side oscillation of the upper pulley block 5 due to wind influence: Rig the upper pulley block 5 with suitable rigging straps / ropes 7 against the boom, see illustration 2.

For lattice mast cranes with luffing lattice jib the following applies:

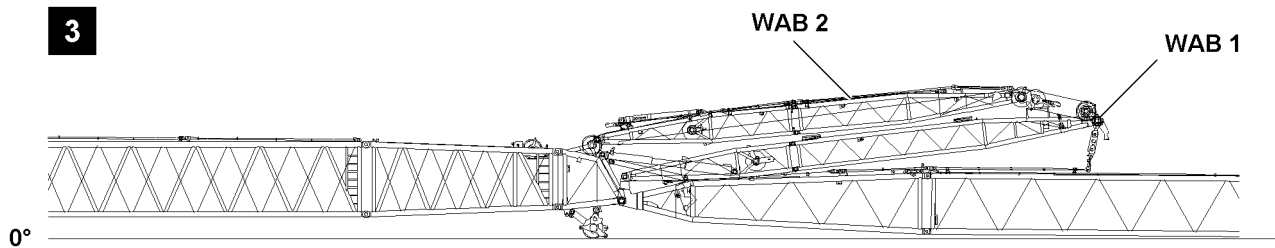

Fig.120821: Guying in transport receptacle(s) and WA-frames placed down to the front (example crane with lattice mast)



WARNING

Danger of accident when removing the W-guying!

When taking down and removing the guying dangerous situations can arise.

- ▶ Make sure that the danger notes in the respective chapter of the Crane operating instructions are observed.

- ▶ Remove the guy rods on the luffing lattice jib and take them down into the transport receptacles.
- ▶ Take the WA-frames (WA-frame 1 **WAB 1** and WA-frame 2 **WAB 2**) down to the front.

For telescopic cranes with luffing lattice jib the following applies:

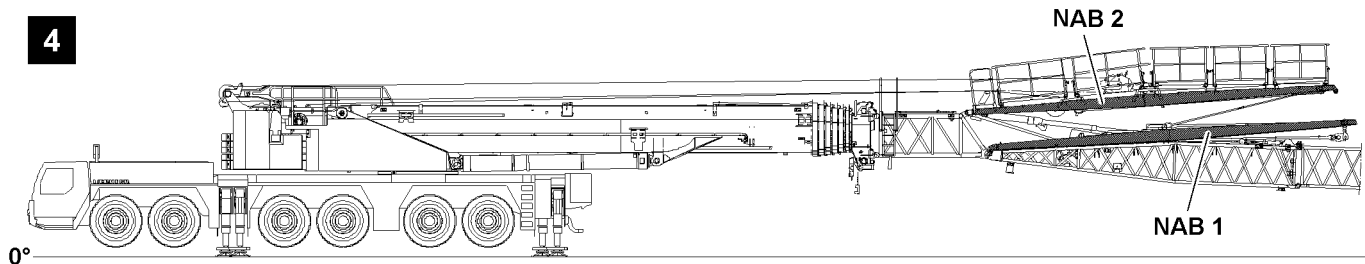

Fig.121261: Guying in transport receptacle(s) and NA-frames placed down to the front (example telescopic crane)



WARNING

Danger of accident when taking the NA-frames down!

When taking the guy rods as well as the NA-frames down dangerous situations can arise.

- ▶ Make sure that the danger notes in the respective chapter of the Crane operating instructions are observed.

- ▶ Spool the jib control winch out and take the NA-frames down to the front so that the guy rods are relieved.

5.02 SA-frame

1 SA-frame

3

LWE/LR 1600-2-008/18109-09-02/en

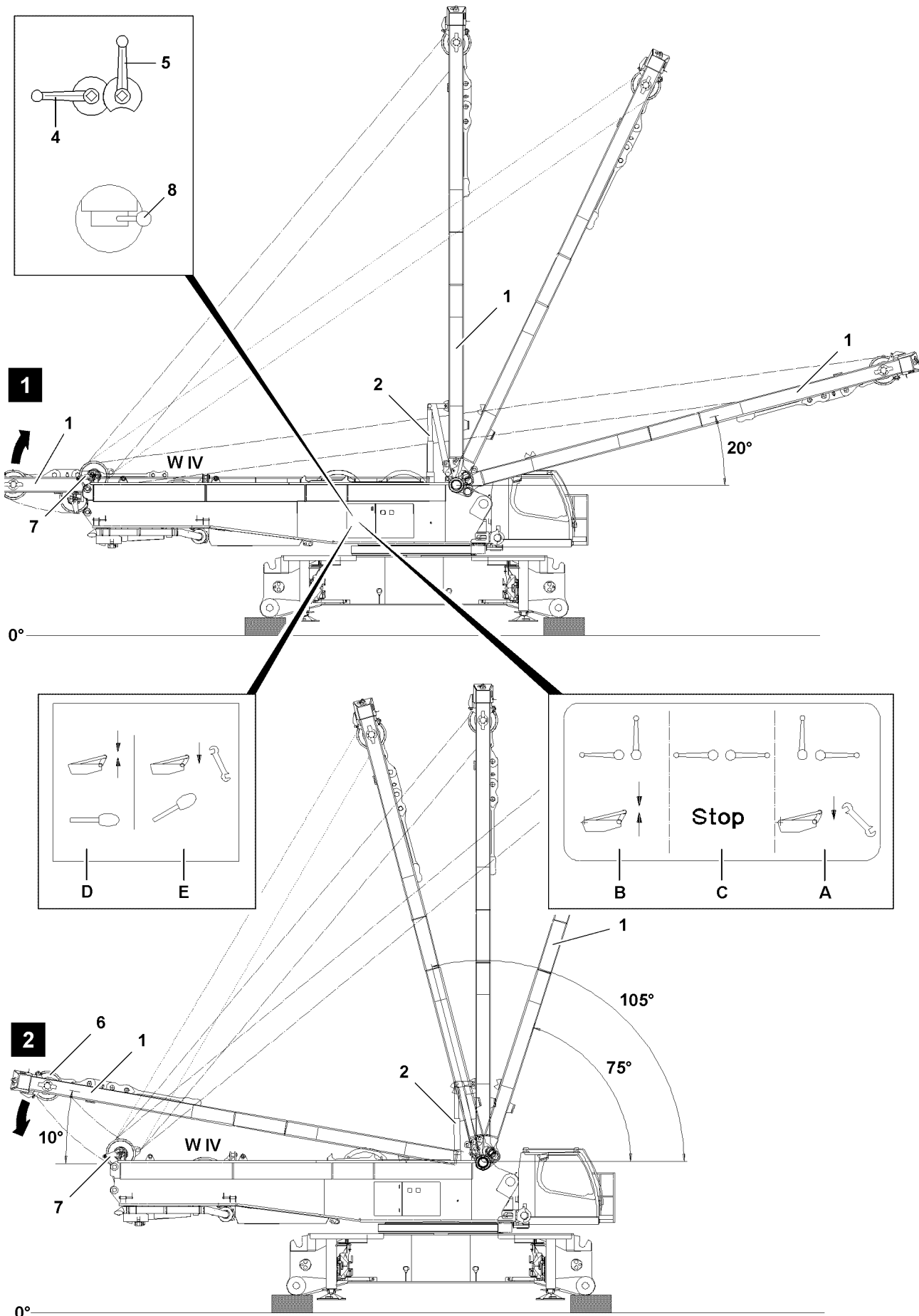

Fig.120171

LWE/LR 1600-2-008/18109-09-02/en

1 SA-frame



Note

- ▶ The SA-frame is used in assembly operation to install the crawler travel gear, see Crane operating instructions, chapter 3.01!
- ▶ In addition, the SA-frame is used in assembly operation for closing boom systems and for guying the boom in flying assembly of lattice sections, see Crane operating instructions, chapter 5.38.

Switch positions of ball valves (ball valve 4 / ball valve 5)		
Switch position	Function	Use
A	Lower the SA-frame	Lower the SA-frame into transport position
C	SA-frame stop, cylinder stop	Block erection cylinder
B	Erect the SA-frame	Assembly and crane operation

Switch position Hand lever 8		
Switch position	Function	Use
D ¹⁾	Erect the SA-frame	Assembly, crane operation
E ²⁾	Lower the SA-frame	Lower the SA-frame into transport position

1) = Hand lever 8 is in zero / basic position (not actuated)

2) = Ball valves 4 and 5 are in switch position A

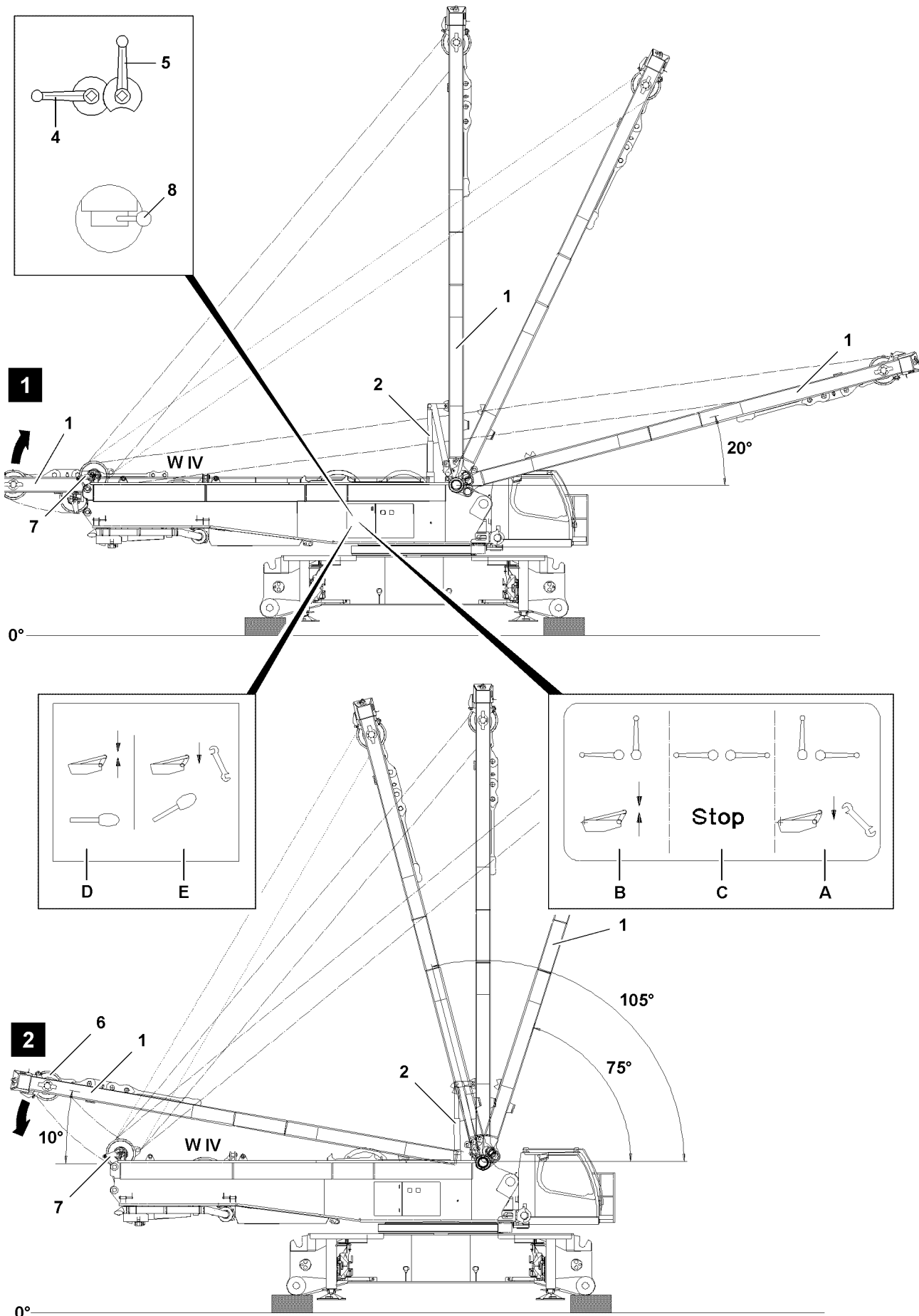

Fig.120171

LWE/LR 1600-2-008/18109-09-02/en

1.1 Erecting the SA-frame

1.1.1 Erection procedure



WARNING

The crane can topple over!

If the crawler center section is supported via the assembly support, then the crane can topple over when erecting the SA-frame.

- ▶ Make sure that the ground has sufficient load bearing capacity and that the support is sufficiently sized.
- ▶ Make sure that the crawler center section is safely laying on the support when erecting the SA-frame.
- ▶ Do not erect the SA-frame when the crawler center section is supported via the assembly support.

Make sure that the following prerequisites are met:

- The crawler center section is properly supported.
- The turntable is installed on the supported crawler center section.
- The SA-frame is in transport position.
- Winch 1 and winch 2 are installed in the turntable.
- There is no counterweight on the turntable.
- Winch 4 **W IV** is reeved on the pulley set **6** of the SA-frame **1**.
- The engine is running.
- The shut off limits of the LICCON overload protection are bypassed / exceeded, see Crane operating instructions, chapter 4.02.
- The SA-operating mode has been set and confirmed on the LICCON computer system.



WARNING

Danger of accident when bypassing / exceeding the LICCON overload protection!

If the shut off limits of the LICCON overload protection are bypassed / exceeded, there is no additional protection against overload.

Due to erroneous operation or deliberate misuse, the crane could collapse, the boom can break off or the crane can topple over.

Personnel can be severely injured or killed.

This could result in high property damage.

- ▶ The function „Exceedance of shut off limits of the LICCON overload protection“ may only be activated or used in emergencies and for assembly purposes.
- ▶ The function „Exceedance of shut off limits of the LICCON overload protection“ may only be activated or used by an authorized person who knows the effects of the bypass exactly.
- ▶ The „Exceedance of the shut off limits of the LICCON overload protection“ may only be carried out „anticipatorily“ and with utmost caution!
- ▶ The „Exceedance of shut off limits of the LICCON overload protection“ is only permissible if the set up configuration of the crane has been entered correctly into the LICCON computer system and has been confirmed.

NOTICE

Danger of slack rope formation!

If winch 4 **W IV** is spooled out too quickly during the erection procedure of the SA-frame, slack rope can form.

- ▶ The intake rope of winch 4 must be tensioned during the entire erection procedure.
- ▶ The spool out speed of winch 4 must be matched to the erection speed of the erection cylinders / the SA-frame.

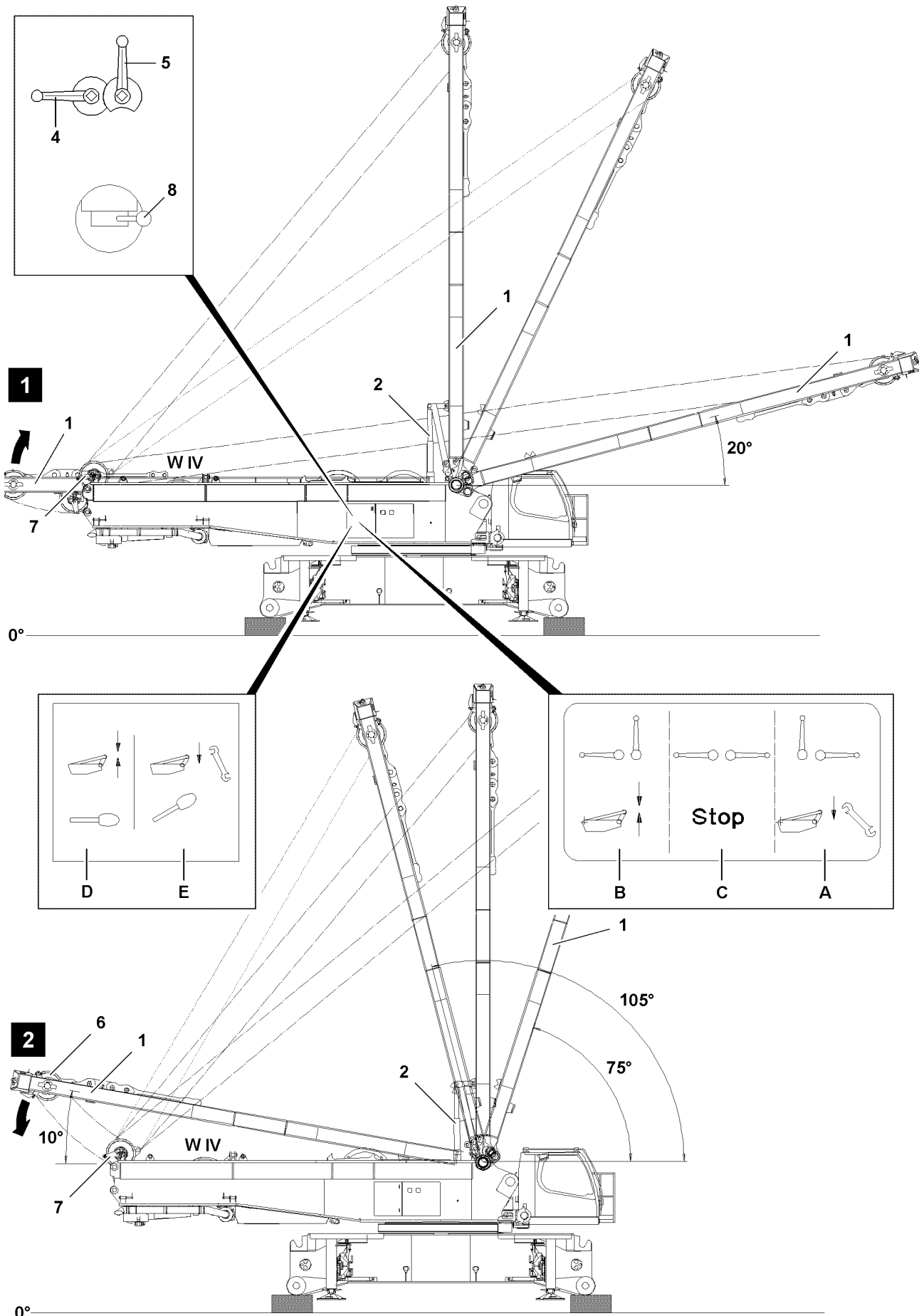

Fig.120171

LWE/LR 1600-2-008/18109-09-02/en

**WARNING**

Independent lowering of the SA-frame!

Due to incorrect ball valve positions during the erection procedure, the SA-frame can lower backward by itself.

Personnel can be severely injured or killed.

It can result in slack rope formation.

- ▶ The ball valves - ball valve **4** and ball valve **5** must be in position **B** during assembly and crane operation.
- ▶ Ball valve position **A** „lower“ and ball valve position **C** „stop“ are only permissible when lowering the SA-frame onto the turntable (transport position).

- ▶ Set the ball valve **4** and ball valve **5** in position **B**.

Result:

- The SA-frame is pushed upward by the erection cylinders **2** until the ropes are tensioned between the rope pulleys **6** and the rope pulleys **7**.

NOTICE

Damage to ropes!

- ▶ Inspect the rope pulleys visually.
- ▶ The ropes must be laying correctly in the corresponding rope pulleys.

- ▶ Deflect the master switch MS1 in direction X.

Result:

- Winch 4 **W IV** spools out and the SA-frame **1** is erected forward through the erection cylinders **2**, see illustration 1.
- The „???“ turn off and the SA-operating mode is shown.

- ▶ Deflect the master switch MS1 in direction X.

Result:

- The SA-frame is lowered to the front and is now in the operating range of operating mode-SA (20° to 105°).

**WARNING**

The crane can topple over!

If the shut off limits of the LICCON overload protection are bypassed / exceeded, there is no additional protection against overload.

Due to erroneous operation or deliberate misuse, the crane could collapse, the boom can break off or the crane can topple over.

Personnel can be severely injured or killed.

This could result in high property damage.

- ▶ When the operating range-SA is reached, turn off / deactivate the function „Exceedance of shut off limits of the LICCON overload protection“ immediately.

- ▶ Turn off / deactivate the function „Exceedance of shut off limits of the LICCON overload protection“ immediately.

Result:

- The LICCON overload protection is active.

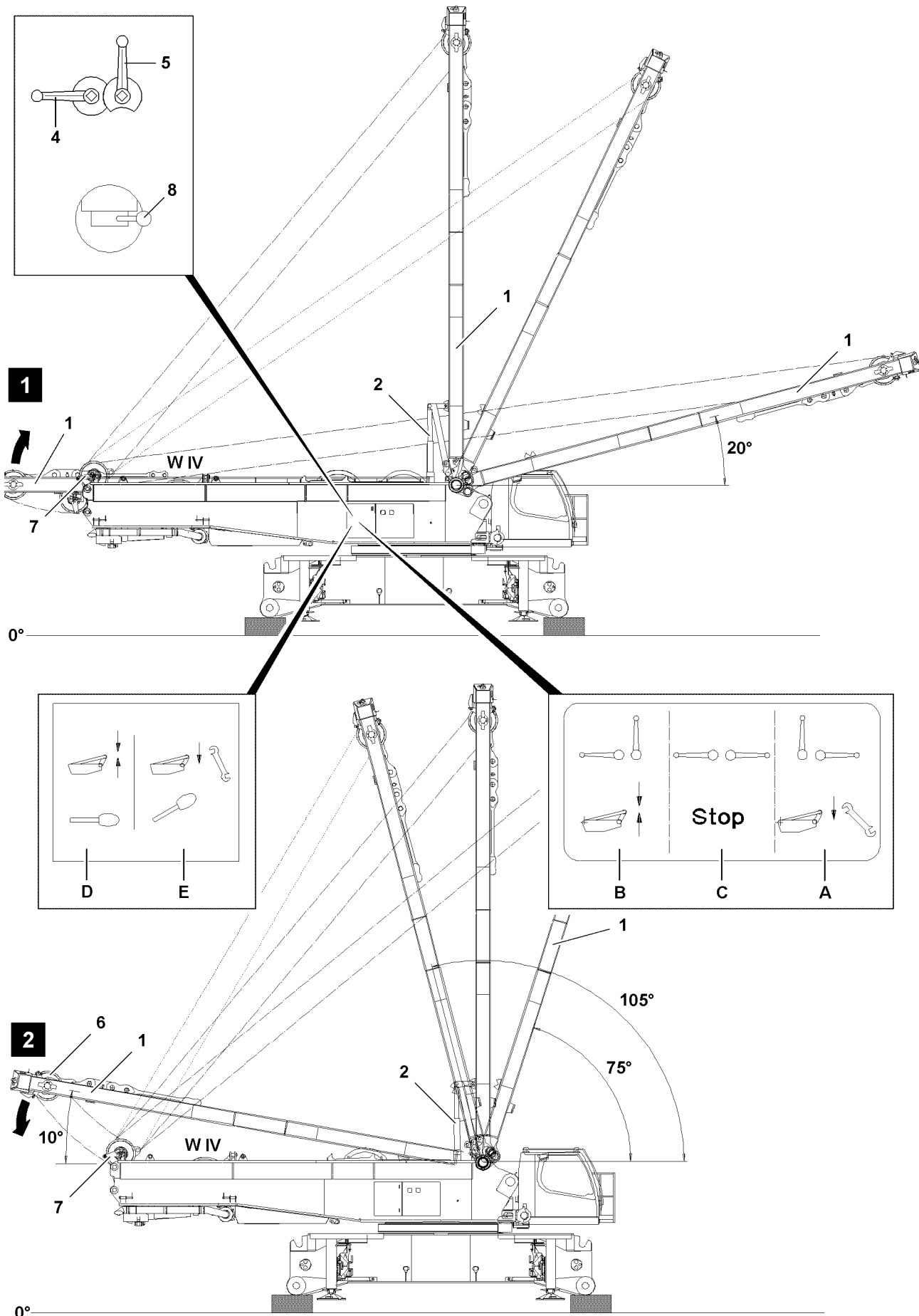

Fig.120171

LWE/LR 1600-2-008/18109-09-02/en

**Note**

- ▶ Due to the own weight of the SA-frame and by spooling out winch 4 simultaneously, the SA-frame is lowered to the front.
- ▶ After reaching the SA-frame position 20°, an error message appears on the LICCON monitor and LMB - Stop is initiated.
- ▶ Spooling out winch 4 is turned off.
- ▶ Luffing down the SA-frame is blocked.
- ▶ Luffing up the SA-frame is only possible when the shut off limits of the LICCON overload protection are bypassed / exceeded.
- ▶ If the minimum or maximum pressure is reached in the erection cylinders, winch 4 **W IV** turns off. An error is shown.

**WARNING**

Danger of accident!

Ball valve **4** and ball valve **5** must be in position **B** during assembly and crane operation.

Ball valve position **A** and ball valve position **C** are only permissible when lowering the SA-frame onto the turntable (transport position).

- ▶ Secure the ball valves immediately after assembly with a lock to prevent unauthorized access.
- ▶ Secure the ball valves.

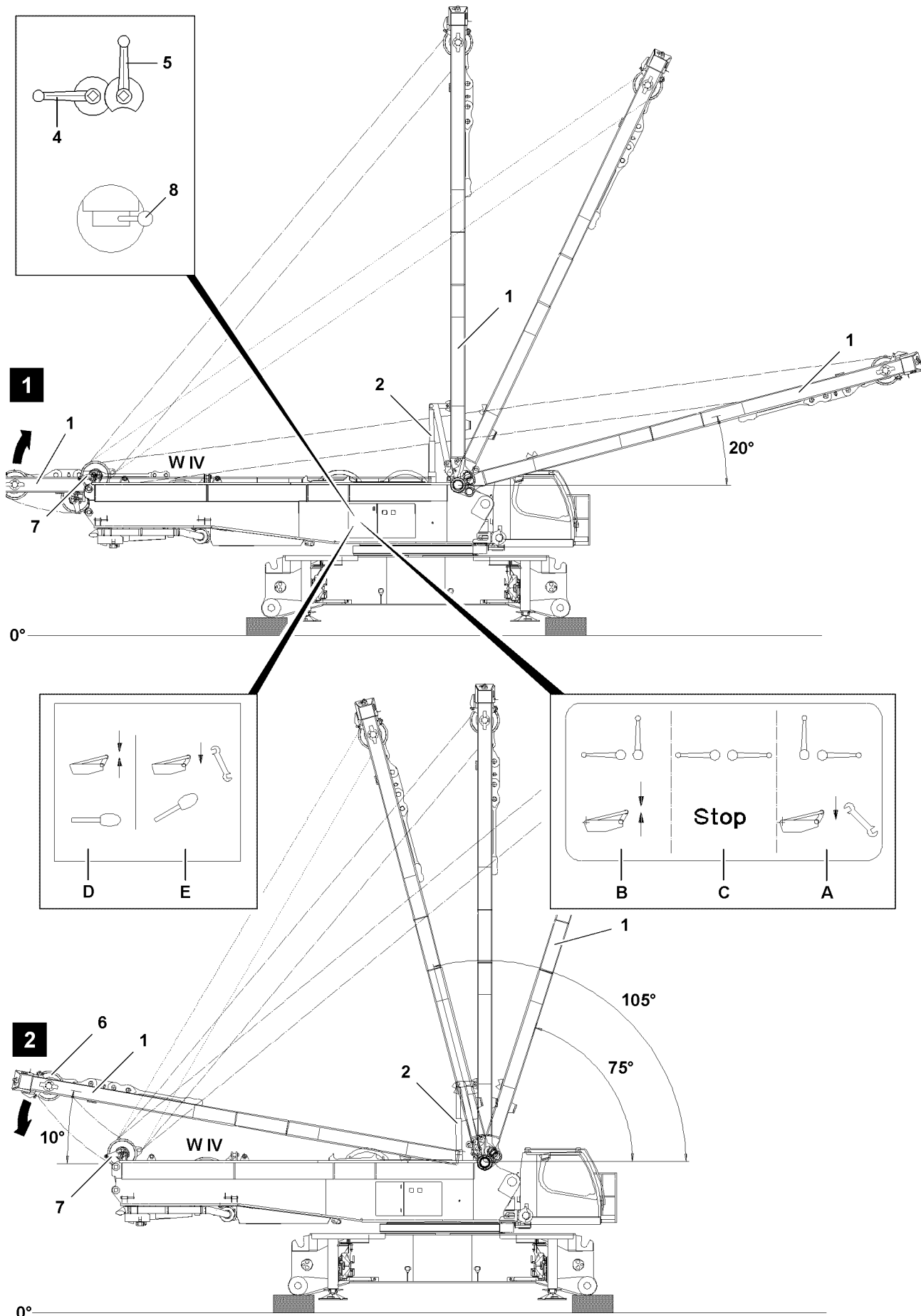

Fig.120171

LWE/LR 1600-2-008/18109-09-02/en

1.2 Placing the SA-frame onto the turntable

1.2.1 Take down procedure



WARNING

The crane can topple over!

If the crawler center section is supported via the assembly support, then the crane can topple over when taking down the SA-frame.

- ▶ Make sure that the ground has sufficient load bearing capacity and that the support is sufficiently sized.
- ▶ Make sure that the crawler center section is safely laying on the support when taking down the SA-frame.
- ▶ Do not take the SA-frame down when the crawler center section is supported via the assembly support.

Make sure that the following prerequisites are met:

- The crawler center section is properly supported.
 - The SA-operating mode has been set and confirmed on the LICCON computer system.
 - Ball valve **4** and ball valve **5** are in position **B**.
 - The SA-frame is in operating range between 20° and 105°.
- ▶ Deflect the master switch MS1 in direction X.

Result:

- Winch 4 spools up.
- The SA-frame is pulled back against the pressure in the erection cylinders.



Note

- ▶ When the SA-frame reaches the position 105° during luffing up, an **error message** and **LMB-STOP** is shown on the LICCON monitor.
- ▶ Spooling up of winch 4 is turned off.



WARNING

Danger of accident when bypassing / exceeding the LICCON overload protection!

If the shut off limits of the LICCON overload protection are bypassed / exceeded, there is no additional protection against overload.

Due to erroneous operation or deliberate misuse, the crane could collapse, the boom can break off or the crane can topple over.

Personnel can be severely injured or killed.

This could result in high property damage.

- ▶ The function „Exceedance of shut off limits of the LICCON overload protection“ may only be activated or used in emergencies and for assembly purposes.
- ▶ The function „Exceedance of shut off limits of the LICCON overload protection“ may only be activated or used by an authorized person who knows the effects of the bypass exactly.
- ▶ The „Exceedance of the shut off limits of the LICCON overload protection“ may only be carried out „anticipatorily“ and with utmost caution!
- ▶ The „Exceedance of shut off limits of the LICCON overload protection“ is only permissible if the set up configuration of the crane has been entered correctly into the LICCON computer system and has been confirmed.

- ▶ Bypassing / exceeding the LICCON overload protection, see Crane operating instructions, chapter 4.02.

Result:

- No further protection against overload of the crane is present.
- The assembly icon appears on the LICCON monitor, see Crane operating instructions, chapter 4.02.

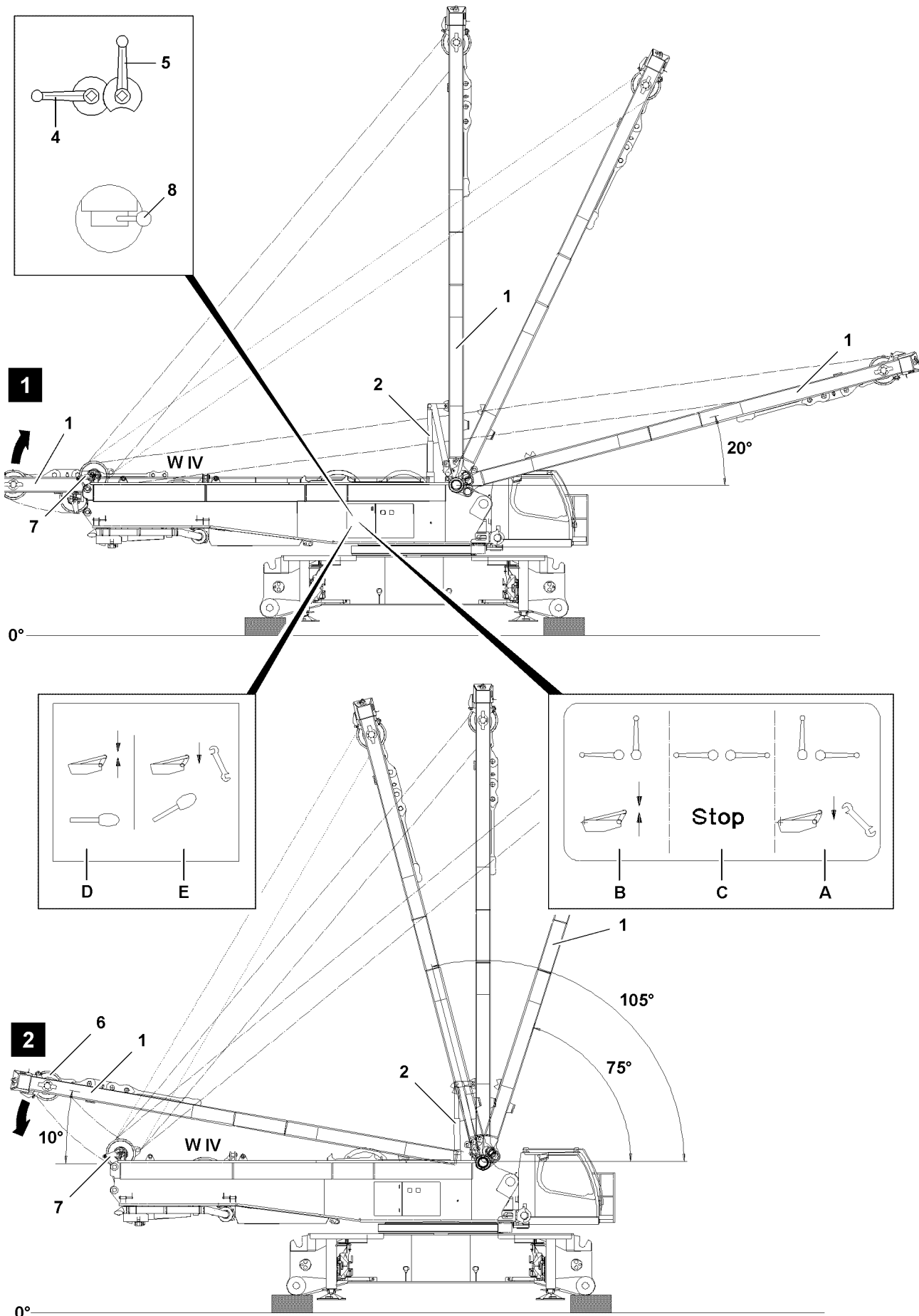

Fig.120171

LWE/LR 1600-2-008/18109-09-02/en

**WARNING**

Danger of fatal injury from SA-frame!

During the take down of the SA-frame, personnel can be severely injured or killed.

- ▶ Make sure that no persons or objects are within the danger zone.

**WARNING**

Independent lowering of the SA-frame!

Due to an incorrect ball valve position, the SA-frame can lower backward by itself.

Personnel can be severely injured or killed.

It can result in slack rope formation and to destruction of crane components.

- ▶ Ball valve **4** and ball valve **5** must be in position **B** during assembly and crane operation.
- ▶ The ball valve position **A** and ball valve position **C** are only permissible when lowering the SA-frame onto the turntable (transport position).

When the LICCON overload protection is exceeded:

- ▶ Deflect the master switch MS1 in X-direction, see Crane operating instructions, chapter 4.02.

Result:

- Due to the own weight of the SA-frame **1** and by spooling up winch **4 W IV** simultaneously, the SA-frame is lowered to the rear against the pressure in the erection cylinders **2**.

NOTICE

Damage to crane!

The ball valve position **C** and the ball valve position **A** are only permissible when lowering the SA-frame from 10° onto the turntable (transport position).

- ▶ If this is not observed, parts of the crane will be destroyed.

If the SA-frame is on approx. 10°:

- ▶ Do not actuate winch **4** any longer.
- ▶ Turn off / deactivate the function „Exceedance of shut off limits of the LICCON overload protection“.

Result:

- The LICCON overload protection is active.
- ▶ Lower the SA-frame **1** onto the turntable: Move the hand lever **8** to position **E**.

Result:

- The erection cylinders move in.
- The SA-frame **1** lowers.

When the SA-frame **1** is lowered completely on the turntable:

- ▶ Return the hand lever **8** to zero position **D** and set the ball valves, ball valve **4** and ball valve **5** to position **C** and secure.

Empty page!

LWE/LR 1600-2-008/18109-09-02/en

5.03 Boom systems

1	Boom components	3
2	Arrangement of intermediate sections on the boom	3
3	Auxiliary guying	7

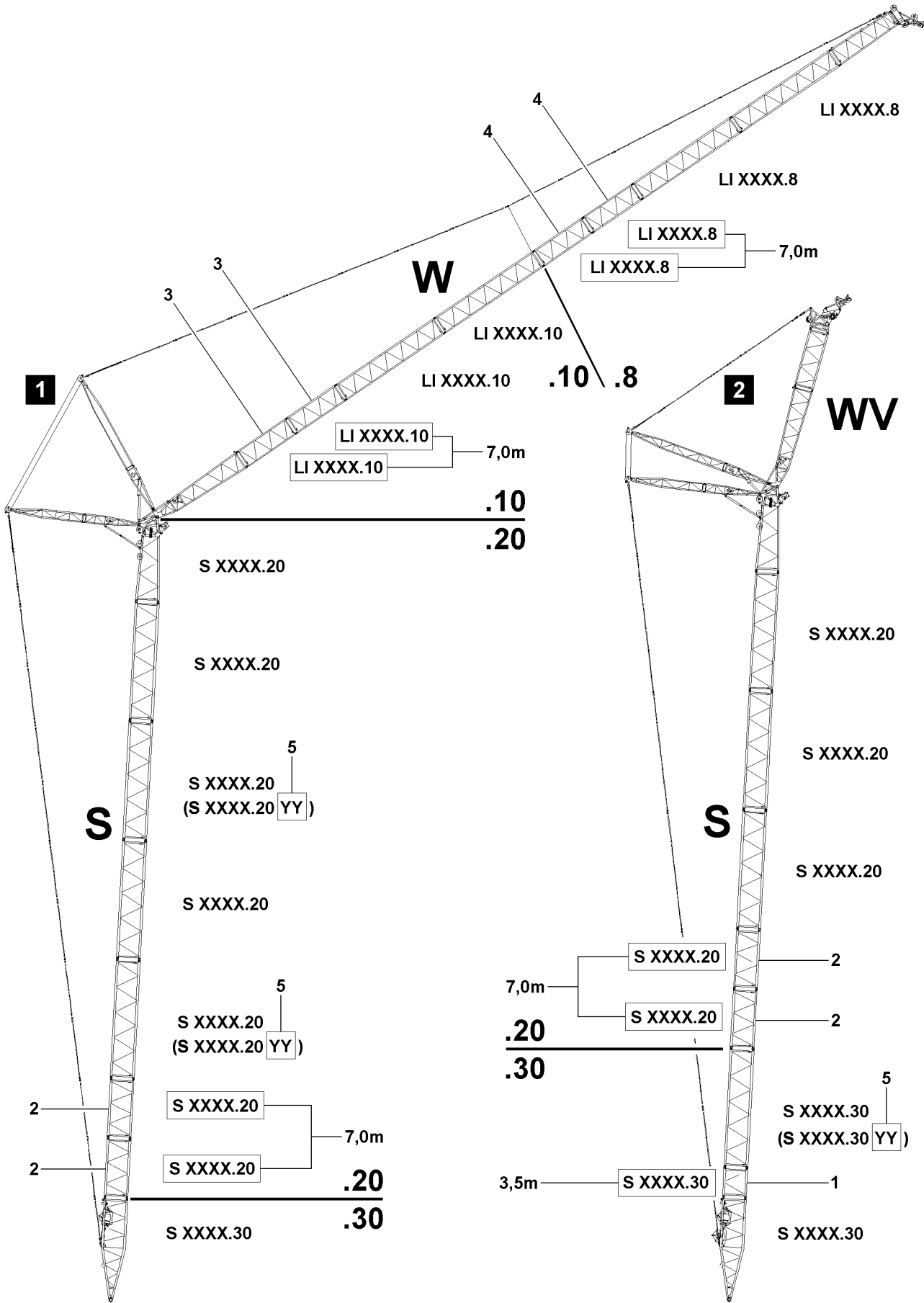

Fig.116151

LWE/LR 1600-2-008/18109-09-02/en

1 Boom components



Note

- ▶ For boom components including associated system dimensions, lengths and component weights refer to the Crane operating instructions, chapter 1.03.

2 Arrangement of intermediate sections on the boom



Note

- ▶ The following description is an example and may not exactly match to your crane.
- ▶ Lengths, weights and system dimensions of the intermediate sections are examples and may differ from the data on your crane.
- ▶ For exact crane data refer to the respective rod plan.
- ▶ For dimensions and weights of crane components, see Crane operating instructions, chapter 1.03.



WARNING

Boom can break off!

The arrangement of the intermediate sections on booms or boom systems are based on extensive static calculations. If the arrangement of the intermediate sections according to the rod plan is not observed, the crane can collapse, the boom can break off or the crane can topple over.

Death, severe bodily injuries, property damage.

- ▶ Always carry out the arrangement of the intermediate sections according to the rod plan.
- ▶ If an auxiliary guying is required for a certain boom length, then it must always be installed according to the rod plan on the position defined in the rod plan.

General specifications for the configuration of booms or boom systems:

- With the same system dimension, two short intermediate sections with a length of 3.5 m are heavier than one single intermediate section with a length of 7.0 m.
- With the same system dimension, two short intermediate sections with a length of 7.0 m are heavier than one single intermediate section with a length of 14.0 m.
- With the same system dimension, two short intermediate sections with a length of 3.5 m can be replaced by one single intermediate section with a length of 7.0 m.
- With the same system dimension, two short intermediate sections with a length of 7.0 m can be replaced by one single intermediate section with a length of 14.0 m.
- For intermediate sections with the same system dimension but different lengths, always install the short intermediate sections on the bottom in the boom, due to their weight, in direction of the slewing ring, see also illustration 1 and illustration 2.
- The heavier one intermediate section is, the higher is the value of the last two digits on the system dimension plate.
- Pay attention to the last two letters following the letter combinations (YY) 5 on the last two letters on the system dimension plate and observe them.

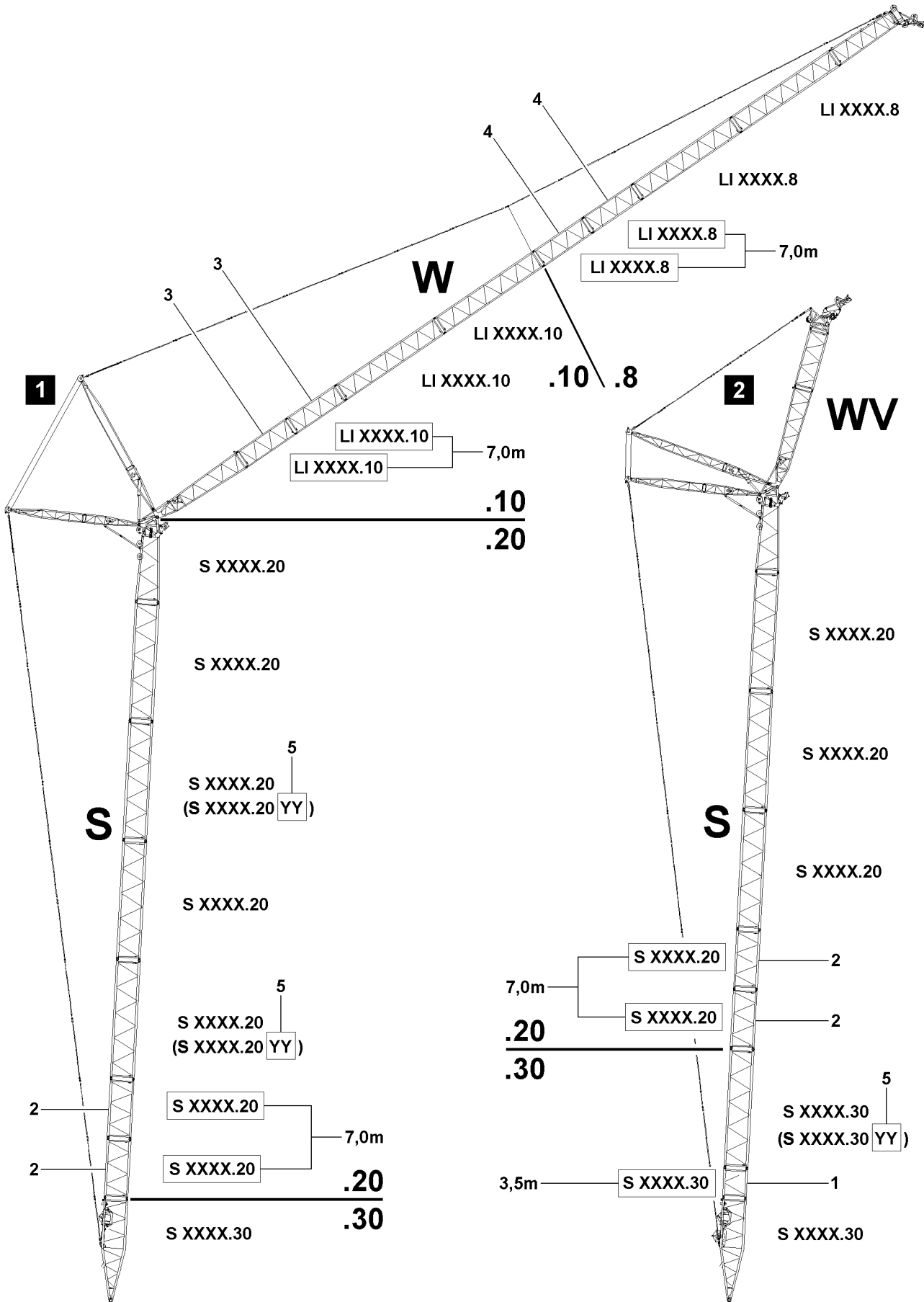

Fig.116151

LWE/LR 1600-2-008/18109-09-02/en

System dimensions and assignment				
Position	System		Heavy	Light
1	S XXXX	.30	X	
2	S XXXX	.20		X
3	LI XXXX	.10	X	
4	LI XXXX	.8		X
5	S XXXX	.40 YY	X	

2.1 Arrangement of intermediate sections



WARNING

Danger of accidents due to incorrectly assembled intermediate sections!

- ▶ Any other arrangement of the intermediate sections and guy rods than specified in the operating instructions or the rod plans is prohibited.
- ▶ There is the danger that intermediate sections are mixed up, they are differently sized and do not differ externally.
- ▶ The intermediate sections differ externally only by the welded on plates (.8, .10, .12, .16, .20, .25, .30, .40 YY).
- ▶ When assembling the boom, it must be ensured that the intermediate sections are arranged and installed according to their description as stated on the rod plan.
- ▶ Observe and adhere to the additional letter combinations (YY) **5** on the system dimension plate of the intermediate sections at assembly of the intermediate sections.



WARNING

Arrangement of intermediate sections!

If the arrangement of the intermediate sections is not carried out according to the rod plan, then the boom can be overloaded, bend down and break off.

Death, severe bodily injuries, property damage.

This could result in high property damage.

- ▶ For intermediate sections with the same system dimension but different length the shorter intermediate sections must always be installed on the bottom in the boom, in direction of the rotary connection, except if another installation position is specified in the rod plan.
- ▶ The specifications in the rod plan must be adhered to in any case.

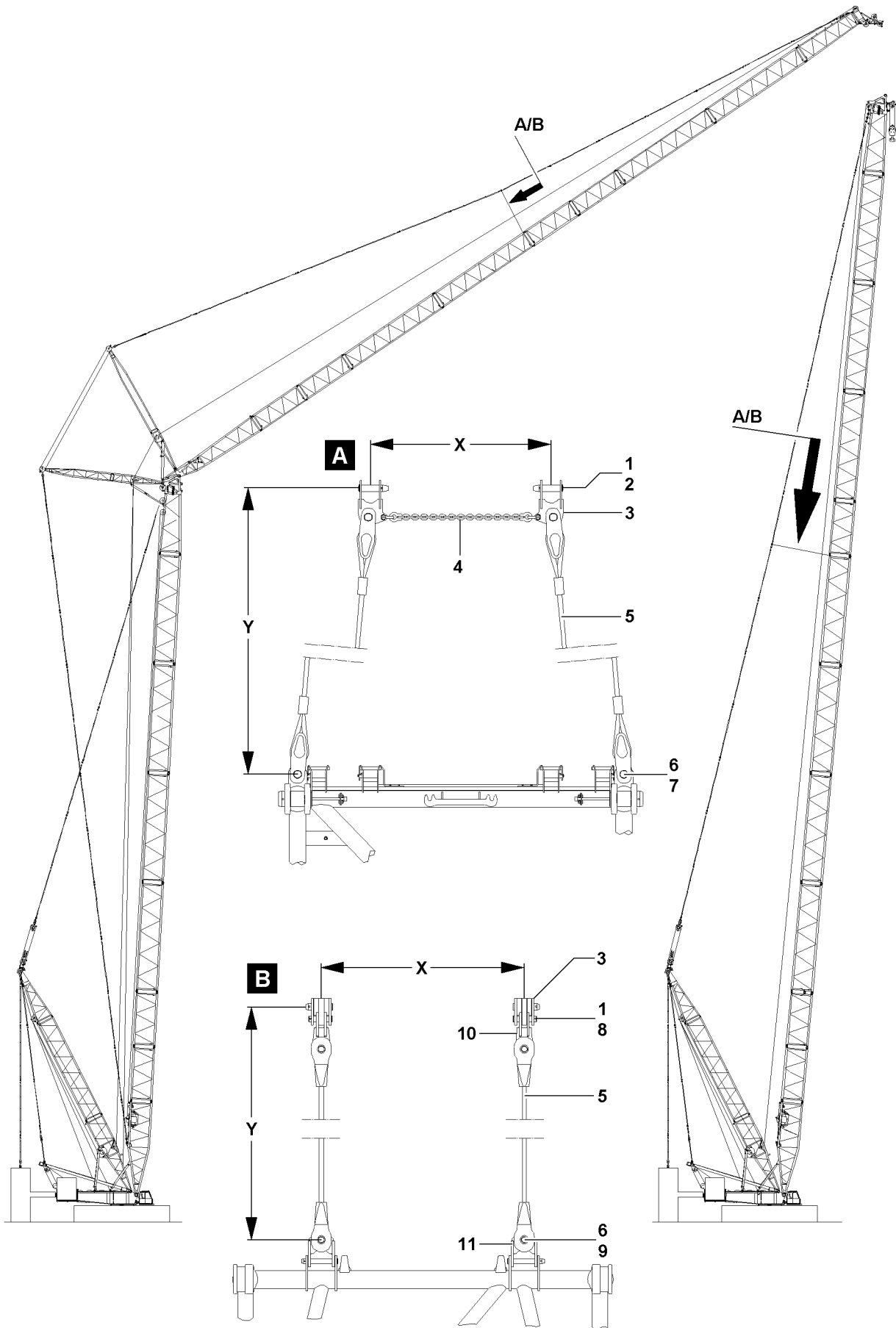

Fig.112270

LWE/LR 1600-2-008/18109-09-02/en

3 Auxiliary guying



Note

- ▶ The following description is an example and may not exactly match to your crane.
- ▶ For exact crane data refer to the respective rod plan.

3.1 Installing the auxiliary guying

The auxiliary guying, in regards to safe crane operation - especially for long boom systems - is of vital importance.

The auxiliary guying is a deciding factor in relieving the boom, or the boom system during erection and take down as well as during crane operation.



WARNING

The crane can topple over!

If the auxiliary guying is not installed or not installed on the position specified in the rod plan, then the crane can collapse, the boom can break off or the crane can topple over.

- ▶ If an auxiliary guying is specified in the rod plan for the required boom length, then it must be installed on the respective position.
- ▶ Make sure that the auxiliary guying is always completely installed and that all pins are properly pinned and secured.



Note

- ▶ The boom lengths, for which an auxiliary guying is required, can be seen in the rod plan.
- ▶ Depending on the crane type: To install the auxiliary guying, remove the standard lugs and install the „Lugs for the auxiliary guying“.

Components of auxiliary guying, illustration A	
Position	Description
1	Pin
2	Spring retainer
3	Bracket
4	Chain
5	Rope
6	Pin
7	Spring retainer

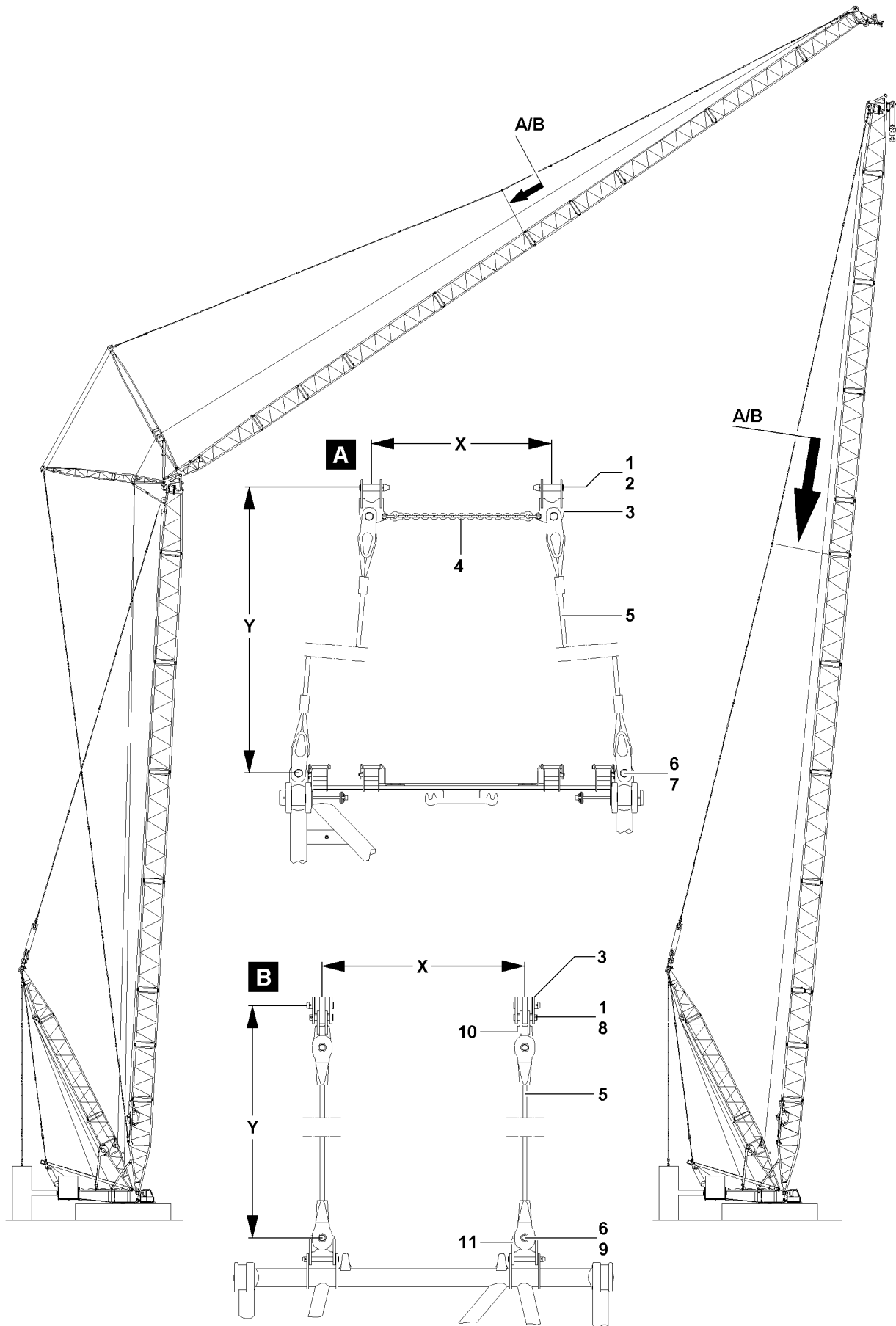

Fig.112270

LWE/LR 1600-2-008/18109-09-02/en

Components of auxiliary guying, illustration B	
Position	Description
1	Pin
3	Bracket
5	Rope
6	Pin
8	Locking pin
9	Locking pin
10	Cross-shaped lug
11	Cross-shaped lug

The lugs **3** must be installed in the guying instead of the standard lugs. The auxiliary guying is installed on the lugs **3**.

The guy ropes **5** are pinned on top on the lugs **3** of the guying or on the cross-shaped lugs **10**. The guy ropes **5** are pinned on the bottom on the lugs / connector points on the boom, see illustration **A** or on the cross-shaped lugs **11**, see illustration **B**.

- ▶ Install the guy ropes: Pin the guy ropes on top on the guying with pin **1** and secure with spring retainer **2**, see illustration **A**.

or

- Install the guy ropes: Pin the guy ropes on top on the guying with pin **1** and secure with locking pin **8**, see illustration **B**.

When the guy ropes **5** are pinned and secured on the lugs **3** of the guying or on the cross-shaped lugs **10**:

- ▶ Pin the guy ropes **5** on the lugs / connection points on the boom, see illustration **A** with pin **6** and secure with locking spring **7**.

or

- Pin the guy ropes **5** on the cross-shaped lugs **11** on the boom, see illustration **B** with pin **6** and secure with locking pin **9**.



WARNING

The crane can topple over!

If the chain **4** is not installed in connection with the auxiliary guying, then the guying can be damaged, the boom can break off and the crane can topple over.

Personnel can be severely injured or killed.

- ▶ The auxiliary guying must be installed according to the rod plans.
- ▶ If a chain **4** is specified in the rod plan, then it must always be installed in connection with the auxiliary guying, otherwise the guy rods will be pulled apart.

- ▶ Recheck the proper and complete assembly of the auxiliary guying before erecting the boom / boom system.

Empty page!

LWE/LR 1600-2-008/18109-09-02/en

5.05 D-boom

1	Components overview	3
2	Fastening points	3
3	Assembly D-boom	5
4	Disassembly D-boom	33

Fig.195219

LWE/LR 1600-2-008/18109-09-02/en

1 Components overview



Note

- ▶ The boom components as well as the dimensions and weights are described in the Crane operating instructions, chapter 1.03.
- ▶ For the combination of the various boom systems, refer to the Rod plan and the Crane operating instructions, chapter 5.03.

2 Fastening points



WARNING

Falling lattice sections!

Death, severe bodily injuries, property damage.

- ▶ Make sure that the lattice sections are properly fastened on the respective fastening points.
- ▶ Make sure that the fastening equipment has the appropriate length and a sufficient load carrying capacity.
- ▶ Pay attention and adhere to the labels on the fastening points on the lattice sections and crane components.

2.1 Fastening points D-pivot section

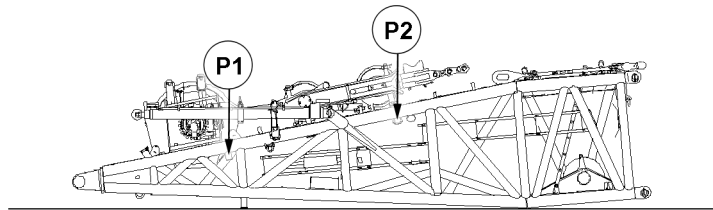

Fig.125163: Fastening points D-pivot section

Fastening points	
P1 + P2	D-pivot section with installed winch 3

2.2 Fastening points D-intermediate section 2420.20 12 m

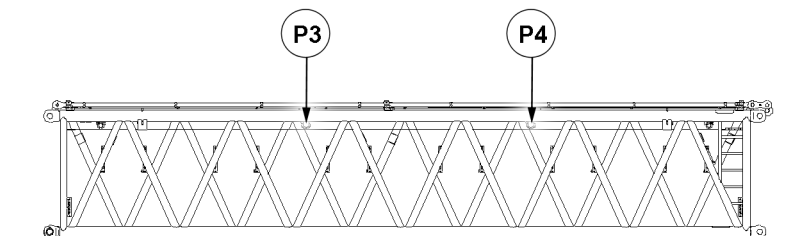

Fig.125164: Fastening points D-intermediate section 2420.20 12 m



Note

- ▶ The D-intermediate sections are available in various system dimensions.
- ▶ The lattice section must be fastened on both sides on the fastening points.

LWE/LR 1600-2-008/18109-09-02/en

Fastening points	
P3 + P4	D-intermediate section 2420.20, 12 m

2.3 Fastening points D-intermediate section 2420.16 6 m

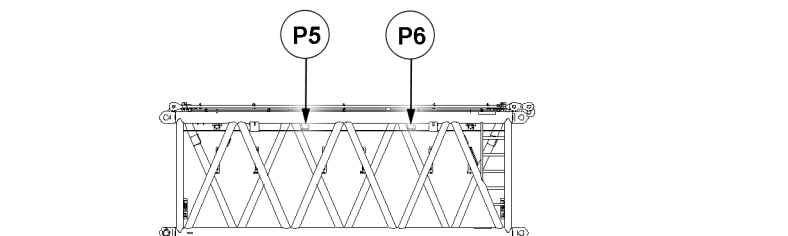

Fig.125165: Fastening points D-intermediate section 2420.16 6 m



Note

- ▶ The D-intermediate sections are available in various system dimensions.
- ▶ The lattice section must be fastened on both sides on the fastening points.

Fastening points	
P5 + P6	D-intermediate section 2420.16, 6 m

2.4 Fastening points D-end section

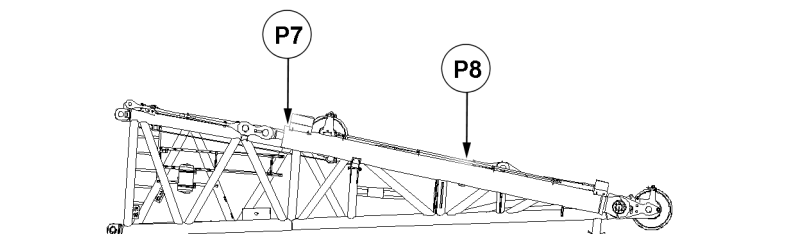

Fig.125166: Fastening points D-end section

Fastening points	
P7 + P8	D-end section

3 Assembly D-boom



WARNING

Danger of falling!

During assembly / disassembly, inspection and maintenance work, assembly personnel must be secured with appropriate aids to prevent them from falling.

Death, severe bodily injuries, property damage.

- ▶ All work aloft, where there is a danger of falling must be carried out with suitable aids.
- ▶ If aids are not available and work cannot be carried out from the ground, then the assembly personnel must secure themselves with the supplied fall arrest system to prevent falling, see Crane operating instructions, chapter 2.04.
- ▶ If fall protection equipment is available, then it must be used, see Crane operating instructions, chapter 2.06.
- ▶ When lifting, lowering, swinging crane parts in and out, no persons may remain in the danger zone.
- ▶ When closing or opening boom systems during boom assembly or boom disassembly, no persons may remain on the boom system or in the danger zone.
- ▶ If railings are present for the crane, then they must be brought into the corresponding position and secured for assembly / disassembly work.
- ▶ Only step on the aids, ladders and catwalks with clean shoes.
- ▶ Keep aids, ladders and catwalks free of heavy dirt, snow and ice.
- ▶ During all assembly and disassembly work, maintenance work and inspections, travel or crane operation is prohibited.
- ▶ Remaining on a suspended load is prohibited.
- ▶ Stepping or walking on crane components and lattice sections, which have an incline of more than 20° is prohibited.
- ▶ For all assembly work, the crane driver of the main crane must be in voice contact with the crane driver / crane drivers of the auxiliary crane / auxiliary cranes.
- ▶ For assembly tasks, the crane driver may only initiate crane movements when the responsible guide has explicitly released the movement.



WARNING

The lattice sections can fall down!

If the lattice sections are not pinned and secured correctly, then they can fall down.

Death, severe bodily injuries, property damage.

- ▶ Pin or unpin both pins at the same horizontal level, i.e. **left and right**.
- ▶ Do not stand under the lattice sections or within the entire danger zone during the pinning and unpinning procedure of the boom.
- ▶ Safely secure the pins in the storage locations as well as in the receptacles.
- ▶ It is prohibited to lean the ladder against the component being disassembled.



WARNING

Danger of impact / crushing!

When installing / removing crane components with the auxiliary crane, crane components can start to swing back and forth.

When lifting / lowering and positioning crane components, there is an increased danger of impacts / crushing.

Death, severe bodily injuries, property damage.

- ▶ Make sure that personnel cannot be caught by components.
- ▶ Make sure that the crane is horizontally aligned.
- ▶ When working in danger zones: Use aids to protect limbs.
- ▶ Guide components with suitable aids to minimize oscillation.

**DANGER**

The components can fall down!

If the corresponding component is disengaged from the auxiliary crane before the corresponding component is pinned, then the corresponding component can fall down.

Death, severe bodily injuries, property damage.

- ▶ Do not disengage the auxiliary crane until the corresponding component is pinned and secured.

**WARNING**

The crane can topple over!

- ▶ The turntable may not be turned during the assembly of the boom.

- ▶ Observe the assembly conditions, see Crane operating instructions, chapter 3.06.

**WARNING**

Danger of accident!

Death, severe bodily injuries, property damage.

- ▶ For assembly of the boom combinations, the rod plan must be observed and adhered to.

- ▶ Depending on the condition of the ground, the boom and the lattice sections must be supported from below for the assembly of the boom.

- ▶ Observe the technical safety notes, see Crane operating instructions, chapter 5.01.

Make sure that the following prerequisites are met:

- The crane is aligned in horizontal direction.
- An auxiliary crane is available.
- An assembly scaffolding / work platform is available.
- The central ballast has been attached according to the load chart.
- The counterweight has been installed on the turntable according to the load chart.
- The LICCON overload protection has been set according to the data in the load chart.
- The LICCON overload protection settings have been compared with the actual set up configuration.
- No main boom is assembled on the turntable.

3.1 Assembling the D-boom

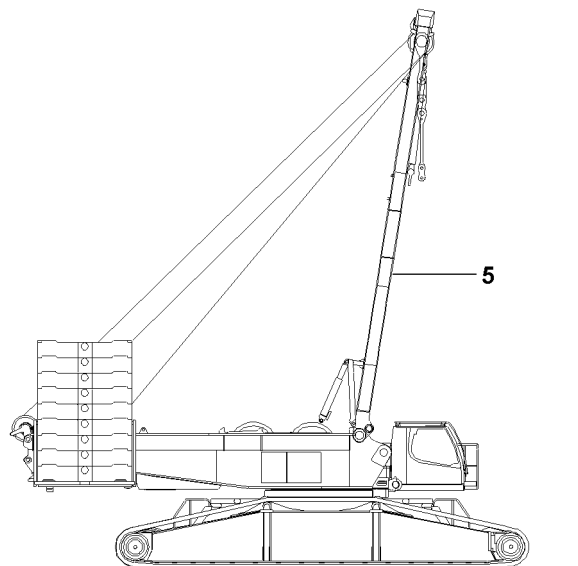

Fig.125167: Assembling the D-boom

3.1.1 Turning the turntable into assembly position



DANGER

The crane can topple over!

If the following conditions are not met before turning the turntable - **without** installed D-boom, the crane can topple over.

Death, severe bodily injuries, property damage.

- ▶ Observe the specifications in the erection and take down charts.
- ▶ For D-boom assembly, a central ballast of 65 t (including the consoles) is required.
- ▶ If no D-boom is assembled on the turntable, no more than max. 150 t counterweight may be installed on the turntable.

- ▶ Turn the turntable in longitudinal direction of the crawler travel gear or to the side.

3.1.2 Exceeding the LICCON overload protection for assembly



WARNING

Danger of accident due to function „Exceedance of shut off limits of the LICCON overload protection“! If the shut off limits of the LICCON overload protection are exceeded, there is no additional protection against crane overload.

Due to erroneous operation or deliberate misuse, the crane could collapse, the boom can break off or the crane can topple over.

Death, severe bodily injuries, property damage.

- ▶ The function „Exceeding the shut off limits of the LICCON overload protection“ is only permissible in emergencies and for assembly purposes.
- ▶ The function „Exceeding the shut off limits of the LICCON overload protection“ may only be actuated by persons who know the effects of their actions regarding the function „Exceeding the shut off limits of the LICCON overload protection“.
- ▶ The function „Exceeding the shut off limits of the LICCON overload protection“ requires the presence of an authorized person and must be performed with utmost caution.
- ▶ Crane operation with activated function „Exceeding the shut off limits of the LICCON overload protection“ is prohibited.

- ▶ Exceeding the shut off limits of the LICCON overload protection: Engage assembly operation.

Result:

- The shut off limits of the LICCON overload protection are exceeded.
- The assembly icon appears on the LICCON monitor.



Note

- ▶ See Crane operating instructions, chapter 4.02.

3.1.3 Assembling the railing on the D-pivot section

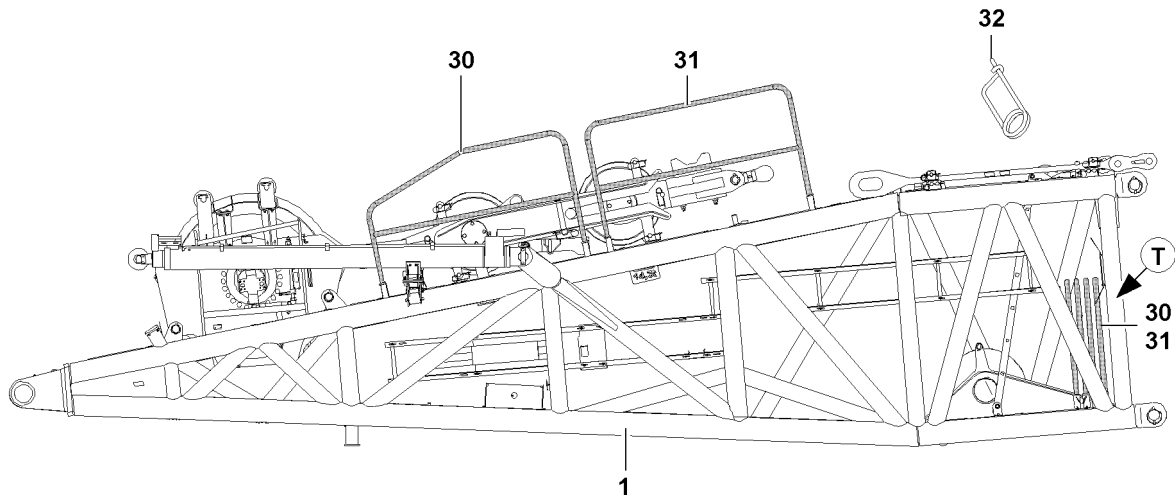

Fig.125168: Assembling the railing on the D-pivot section



WARNING

Danger of falling!

During assembly and disassembly, assembly personnel must be secured with appropriate aids to prevent them from falling.

Even for assembly of protective devices there is a danger of falling.

Death, severe bodily injuries, property damage.

- ▶ During assembly and disassembly, maintenance and testing work on the D-pivot section, all guard rails must be installed and secured.
 - ▶ Step on D-pivot section 1 only with „clean shoes“.
-
- ▶ Release the railing in the transport retainer (point T) on the D-pivot section 1: Remove the spring retainers 32.
 - ▶ Remove the railing from the transport retainer (point T) and insert into the intended fastening points on the D-pivot section 1.
 - ▶ Secure the railing 30 in the fastening points with spring retainers 32.
 - ▶ Secure the railing 31 in the fastening points with spring retainers 32.

Empty page!

LWE/LR 1600-2-008/18109-09-02/en

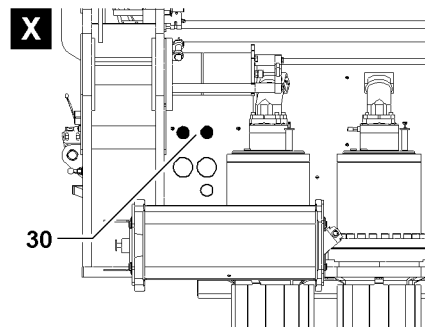
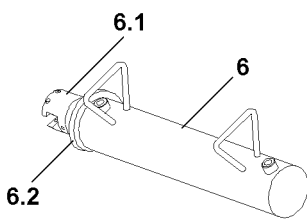
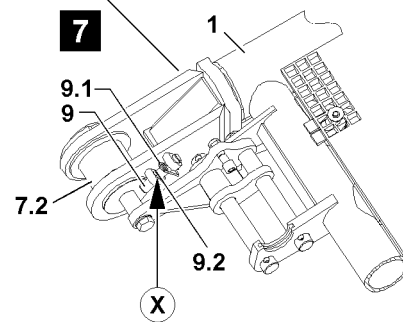
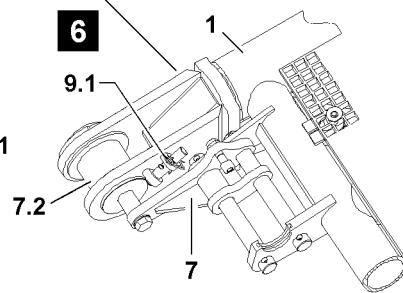
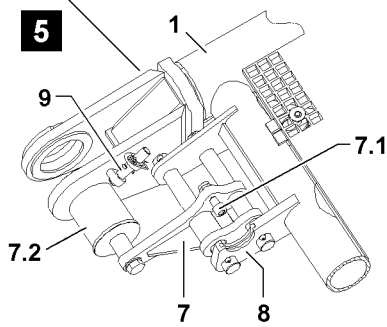
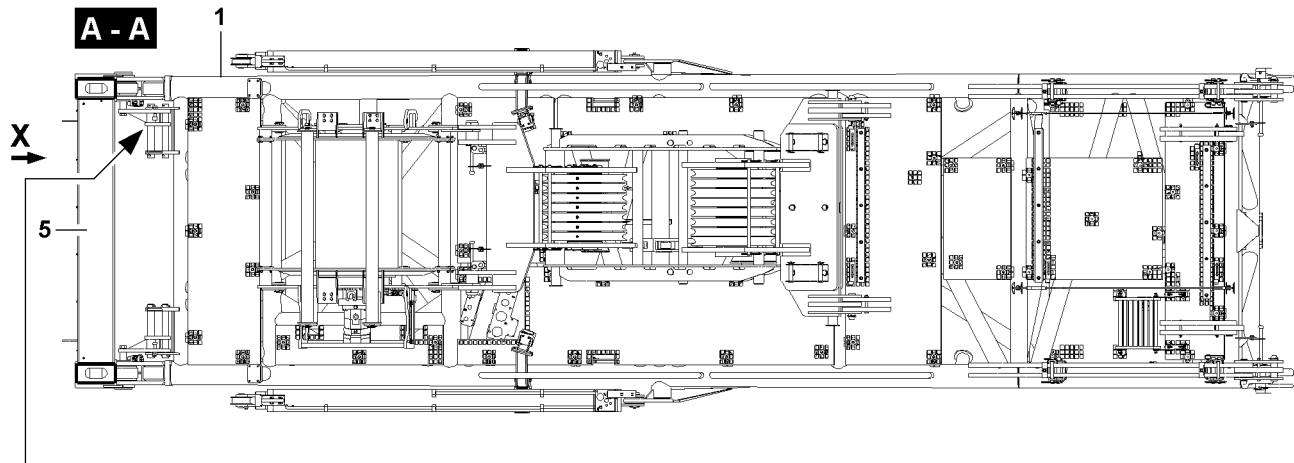
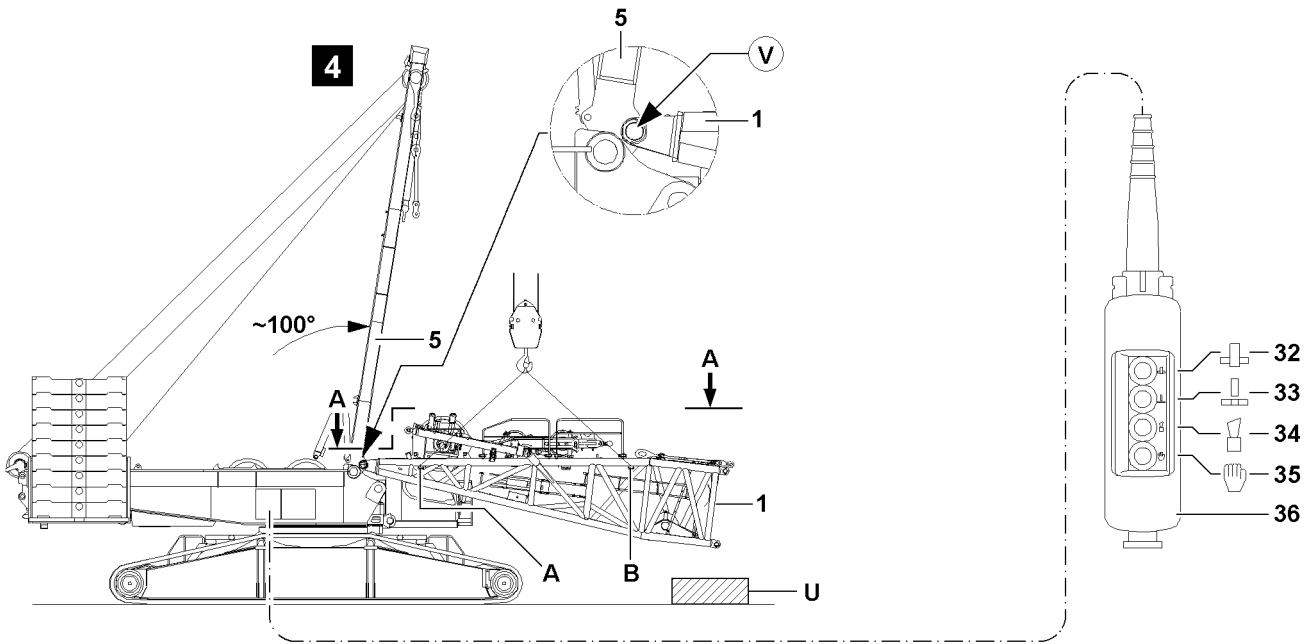

Fig.125169

LWE/LR 1600-2-008/18109-09-02/en

3.1.4 Pinning the D-pivot section on the SA-frame



DANGER

Danger of fatal accidents due falling components!

If the pin connections are not visually inspected, the pins can loosen up by themselves and cause components to fall down.

Death, severe bodily injuries, property damage.

- ▶ All pins must be secured after assembly with the intended safety elements. Check visually.
- ▶ The guy rods must be inspected regularly, see Crane operating instructions, chapter 8.15.

Make sure that the following prerequisites are met:

- The SA-frame is erected to approx. 100°.
- The connector pins 7.2 on the D-pivot section 1 are unpinned, see illustration 5.
- ▶ Attach the D-pivot section 1 on the attachment points **A** and the attachment points **B** on the auxiliary crane and swing in to the pin points **V** on the SA-frame, see illustration 4.

Establish the hydraulic connection to the pin pulling device via two quick couplers 30.



Note

- ▶ When hooking the pin pulling cylinder 6, make sure that the collar 6.2 on the cylinder mount 8 and the catch 6.1 on the screw 7.1 are properly hooked.
- ▶ Hook the pin pulling cylinders 6.
- ▶ Connect the pin pulling cylinder 6 on quick couplers 30, hydraulic turntable.



WARNING

Falling D-pivot section!

Due to non-secured or insufficiently secured connector pins, the D-pivot section can fall down.

Death, severe bodily injuries, property damage.

- ▶ The connector pins 7.2 must be secured after the pinning procedure on the SA-frame 5 with the retaining pins 9.
- ▶ Insert the connector pins 7.2 on both sides with the hydraulic pin pulling cylinder 6: Press the button 35 on the control panel 36 and „hold it down“, then press the button 32 until the connector pin 7.2 is fully pinned.

When the connector pins 7.2 are completely pinned on both sides:

- ▶ Secure the connector pins 7.2 with retaining pins 9.
- ▶ Remove the spring retainer 9.1, see illustration 6.
- ▶ Push the retaining pin 9 down until the cotter pin 9.2 is seated on the lower pin guide (point **X**), see illustration 7.
- ▶ Secure the retaining pin 9 with spring retainers 9.1, see illustration 7.

NOTICE

Damage to the D-pivot section!

When the installed D-pivot section is placed on the ground, the S-pivot section will be damaged.

- ▶ Before placing the D-pivot section on the ground, support the area with a sufficiently load-bearing and large enough supporting base.
- ▶ Make sure that the height of the supporting base on the D-pivot section does not fall below the specified minimum dimension.
- ▶ Carefully place the D-pivot section with the auxiliary crane and at low speed on the supporting base.

	Cranes without Quick-Connection (QC)	Cranes with Quick-Connection (QC)
Height of the supporting base U (minimum dimension)	200 mm	550 mm

- ▶ Carefully place the D-pivot section on the supporting base.
- ▶ Remove the auxiliary crane.

3.1.5 Establishing the electric and hydraulic connections on the D-pivot section

Establishing the electrical connections

NOTICE

Danger of damage of electrical connections!

If the electrical connection between the terminal box and the D-pivot section and the cable drum in the D-pivot section is established before the boom end section is installed and electrically connected, then the electric connection can be damaged.

- ▶ Make sure that the electric connection between the terminal box in the D-pivot section and the cable drum in the D-pivot section is only established **after** assembly and the connection of the electric wiring for the boom end section.



Note

- ▶ To establish the electrical connections on the D-pivot section: Use the Electric wiring diagram.

Make sure that the following prerequisite is met:

- The D-pivot section is completely assembled and placed on the supporting base.

- ▶ Establish the electrical connections.
- ▶ Make sure that all electrical connections to the D-pivot section have been established.



WARNING

Faulty function if dummy plugs are not installed!

If the dummy plugs on the non-required electrical connections are not installed, then faulty functions or functional limitations can occur on the crane.

- ▶ Make sure that all non-required electrical connections, which have a dummy plug are closed off with dummy plugs.
- ▶ Pay attention to the Electrical wiring diagram.
- ▶ As a rule, close off on-required electrical connections (for example for accessories which cannot be installed) with the respective dummy plugs.

NOTICE

Property damage due to dirt and / or corrosion!

If non-required electrical connections are not closed off with the respective protective caps, then dirt and / or corrosion can damage the electrical connections.

This could result in faulty functions.

- ▶ Make sure that all non-required electrical connections are always closed off properly.
- ▶ Pay attention to the Electrical wiring diagram.
- ▶ Close electrical connections, which have no dummy plugs, properly off with the corresponding protective caps.

Establishing the hydraulic connections

When connecting and releasing hydraulic lines with quick couplings, make sure that the coupling procedure is carried out correctly.



Note

- ▶ To connect or release the hydraulic lines with quick couplings, see Crane operating instructions, chapter 5.01.

**WARNING**

Pressure in the hydraulic lines!

If the pressure supply is not interrupted before connecting / releasing the hydraulic lines, the hydraulic oil can escape with high pressure.

Death, severe bodily injuries, property damage.

- ▶ Release the pressure in the hydraulic system before connecting / disconnecting: Interrupt the pressure supply and wait for a short time.

**WARNING**

Loss of pressure or leakage!

Incorrectly coupled or self-loosening quick couplings (particularly return lines) can result in serious accidents due to component failure.

- ▶ Check that the quick couplings have been properly connected before using the crane.
- ▶ Connect the coupling components (sleeve and connector) and screw together with the hand-tightened nut.
- ▶ Tighten the hydraulic coupling by hand. Rotate the hand-tightened nut until it reaches a tangible, fixed stop position.
- ▶ Establish the hydraulic connections, see Hydraulic diagram.

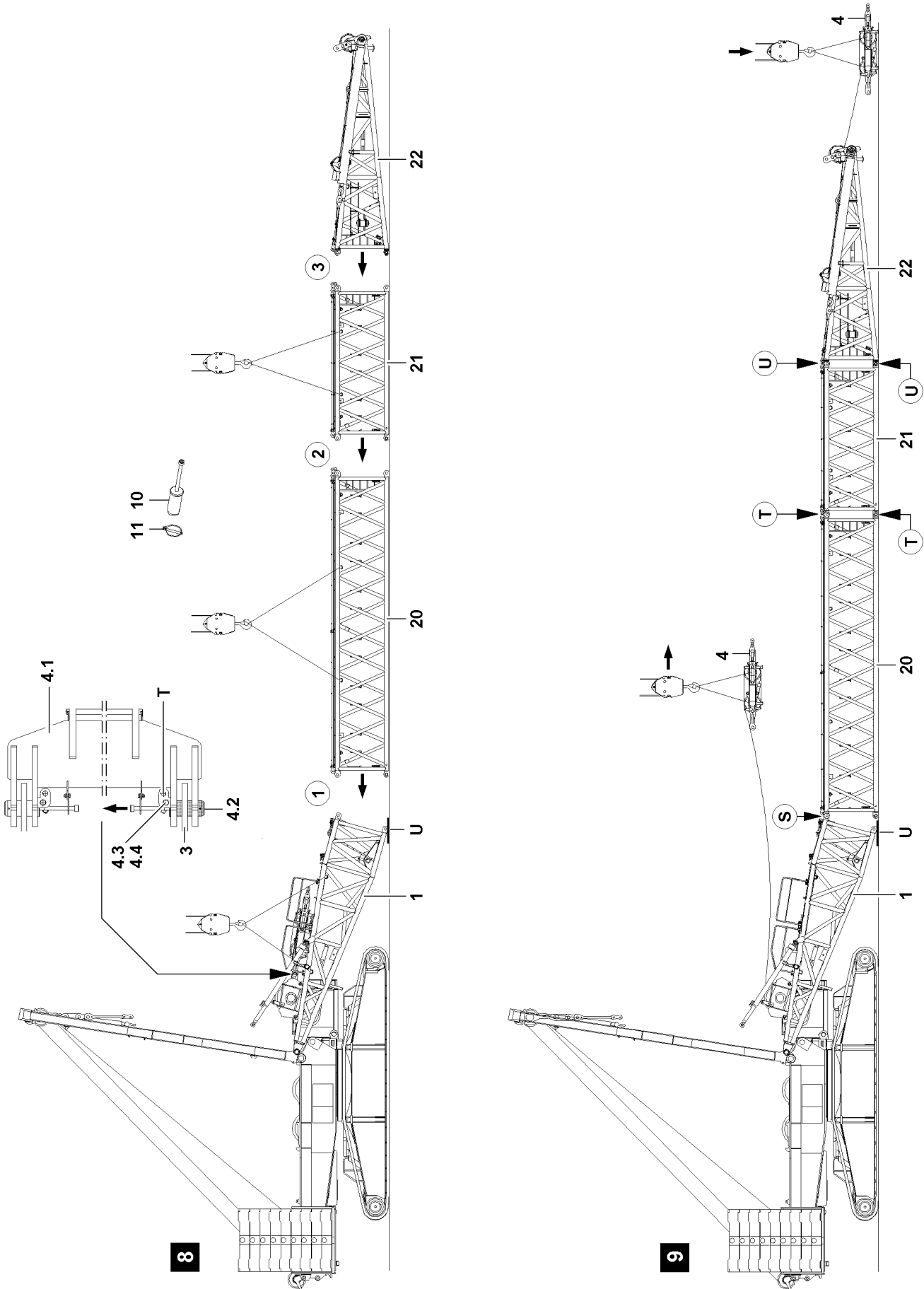

Fig.106555

LWE/LR 1600-2-008/18109-09-02/en

3.1.6 Installing the D-lattice sections on the D-pivot section

NOTICE

Damage to the D-pivot section!

When the D-pivot section is placed on the ground, the D-pivot section will be damaged.

- ▶ Before placing the D-pivot section on the ground, support the area with a sufficiently load-bearing and large enough supporting base.
- ▶ Make sure that the height of the supporting base on the D-pivot section does not fall below the specified minimum dimension.
- ▶ Carefully place the D-pivot section with the auxiliary crane and at low speed on the supporting base **U**.

Make sure that the following prerequisites are met:

- The D-pivot section is pinned and secured on the SA-frame.
- The D-pivot section is placed on the support **U** (approx. 200 cm high).
- **For cranes with Quick-Connection (QC) the following applies:** The D-pivot section is placed on the supporting base **U** (approx. 550 mm high).



Note

- ▶ Always support the D-lattice sections sufficiently for easier assembly.
- ▶ Pin and unpin the D-lattice sections with the pin pulling device, see Crane operating instructions, chapter 5.30.

Pin the D-intermediate section **20** on the D-pivot section **1** on top, (point **S**).

- ▶ Hang the D-intermediate section **20** on the auxiliary crane and align on the D-pivot section **1**.

When the pin bores on the D-pivot section **1** and on the D-intermediate section **20** (point **S**) align:

- ▶ Insert the pin **10** and secure with locking pin **11**.
- ▶ Hang the D-intermediate section **21** on the auxiliary crane and align on the D-intermediate section **20**.

When the pin bores on the D-intermediate section **21** and on the D-intermediate section **20** (point **T**) align:

- ▶ Pin and secure pins **10** on top and bottom with locking pins **11**.
- ▶ Attach the D-end section **22** on the auxiliary crane and align on the D-intermediate section **21**.

When the pin bores on the D-intermediate section **21** and on the D-end section **22** (point **U**) align:

- ▶ Pin and secure pins **10** on top and bottom with locking pins **11**.

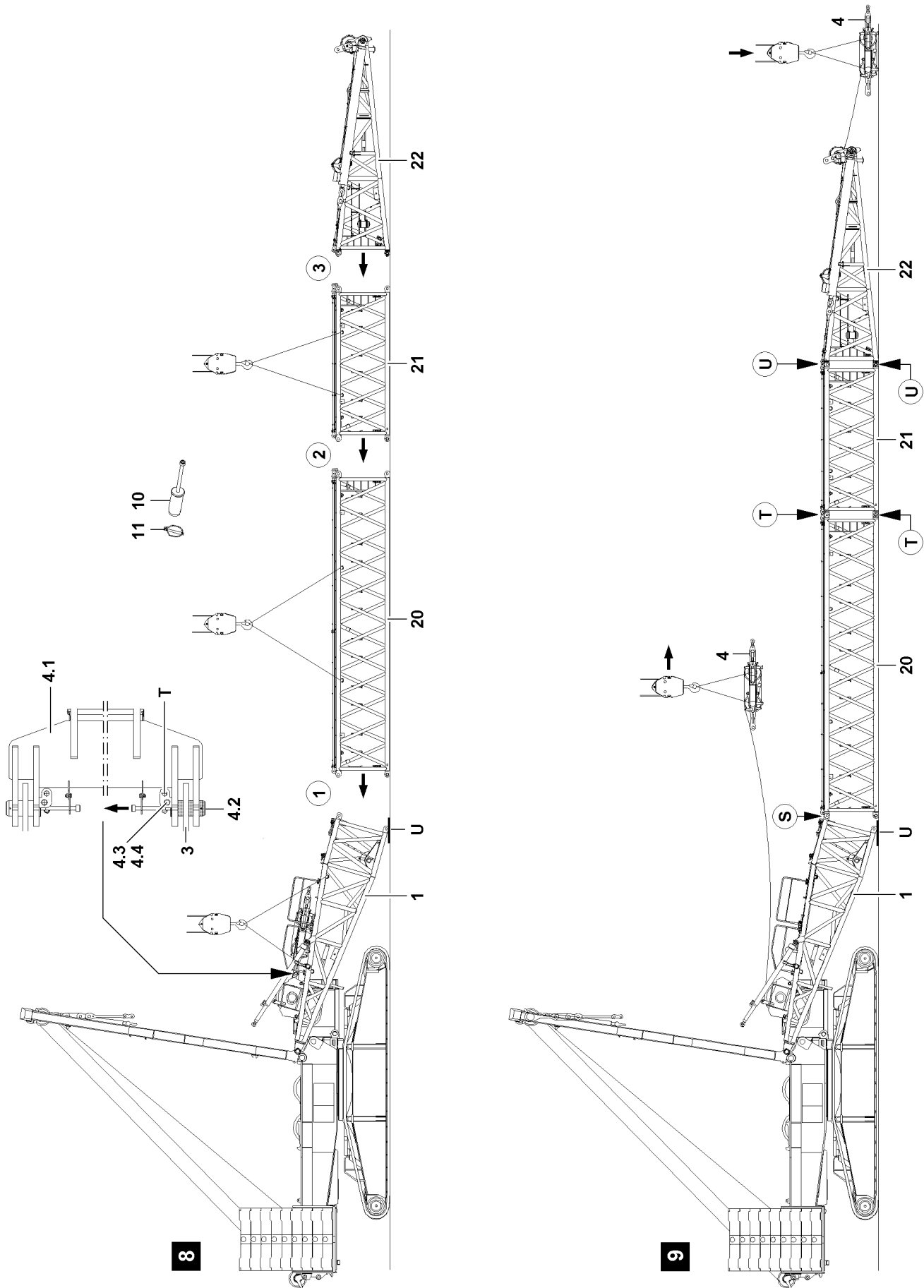

Fig.106555

LWE/LR 1600-2-008/18109-09-02/en

3.1.7 Pulling the pulley block to the D-end section and placing it down



WARNING

Slipping pulley block!

By unpinning the pulley block on winch 3, the pulley block can start to slip and severely injure personnel.

▶ The pulley block must be secured by an auxiliary crane before unpinning it on winch 3.

▶ Fasten the pulley block on the auxiliary crane.

Before assembly of the pulley block on the D-end section, the pulley block must be unpinned on the D-pivot section.

▶ Unpin the pulley block **4** on winch 3: Release the retaining pin **4.3** and unpin from the pin bore.

▶ Pin in the retaining pin **4.3** in the transport retainer **T** and secure with spring retainer **4.4**, see illustration **8**.

▶ Unpin the pin **4.2** on both sides, see illustration **8**.

NOTICE

Rope damage!

▶ When spooling winch 3 out, make sure that no slack rope forms.

▶ While spooling out winch 3, pull the pulley block **4** with the auxiliary crane to the D-end section **22** and place it on the ground on a support in sufficient distance to the D-end section, see illustration **9**.

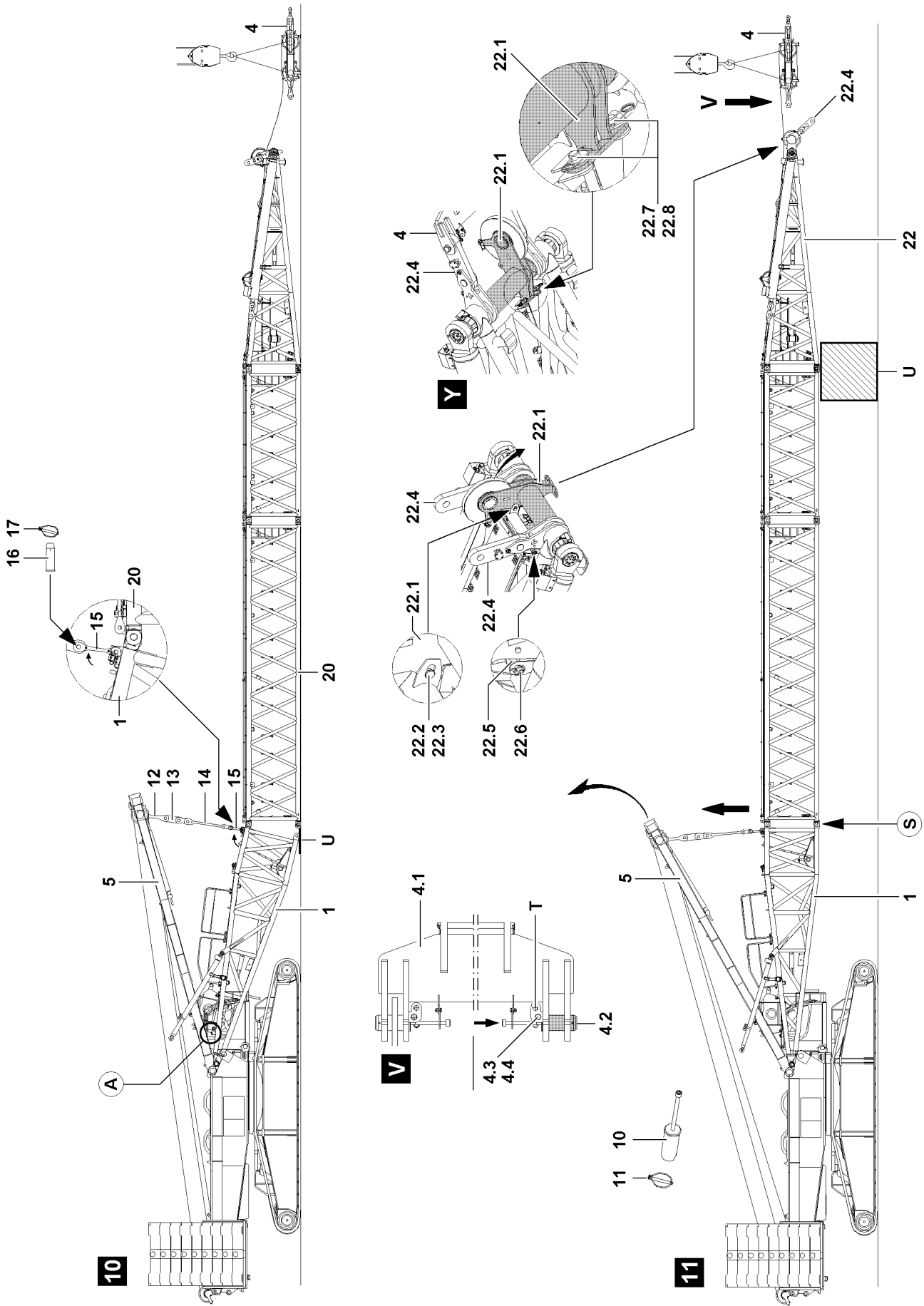

Fig.106556

LWE/LR 1600-2-008/18109-09-02/en

3.1.8 „Closing“ the D-boom

Make sure that the following prerequisites are met:

- The transport retainers for the guy rods on the SA-frame are released.
- The D-lattice sections are pinned and secured.
- The pulley block has been placed on the ground in sufficient distance to the D-end section.

▶ Lower the SA-frame to the front, see Crane operating instructions, chapter 5.02.

Lower the SA-frame carefully to the placement **A** on the D-pivot section until the guy rods **14** can be pinned with the brackets **15** of the D-pivot section **1**.

▶ Pin the guy rods **14** with the lugs **15**: Insert the pin **16** and secure with locking pin **17**.

Erect the SA-frame **5** until the pin bores on the D-pivot section **1** and on the D-intermediate section **21** „on the bottom“ (point **S**):

▶ Insert the pins **10** on both sides at point **S** and secure with locking pin **11**, illustration **11**.

NOTICE

Damage of control rope and the pulley block!

When lifting the D-boom, the control rope or the pulley block can be damaged.

- ▶ When lifting the D-boom, carefully spool out the winch 3 so that the pulley block remains on the ground.
- ▶ Check the rope run on the D-end section, carry out a visual inspection.

When the pins are properly pinned and secured on all D-lattice sections:

- ▶ Luff up the SA-frame until the D-end section lifts off the ground.
- ▶ Support the D-boom from below.
- ▶ Lower the D-boom on the support **U**.

3.1.9 Bringing the pull test brackets into operating position



WARNING

The pull test brackets can pose a mortal danger!

If the pull test brackets are not secure with an auxiliary crane during the swing procedure, they can swing forward with a large momentum due to their weight.

Death, severe bodily injuries, property damage.

- ▶ Swing the pull test brackets into operating position only with the aid of an auxiliary crane.
- ▶ Swinging the pull test bracket without an auxiliary crane is **prohibited**.

▶ Attach the pull test brackets onto the auxiliary crane.

When the pull test brackets **22.4** are secured with the auxiliary crane:

- ▶ Tension the fastening equipment carefully.
- ▶ Remove the locking pin **22.6** on the transport retainer and unpin the retaining pin **22.5**.
- ▶ Swing the pull test bracket **22.4** forward with the auxiliary crane.

When the pull test brackets **22.4** are swung forward completely:

- ▶ Remove the auxiliary crane.
- ▶ Pin in the pin **22.5** in transport position and secure with locking pin **22.6**.

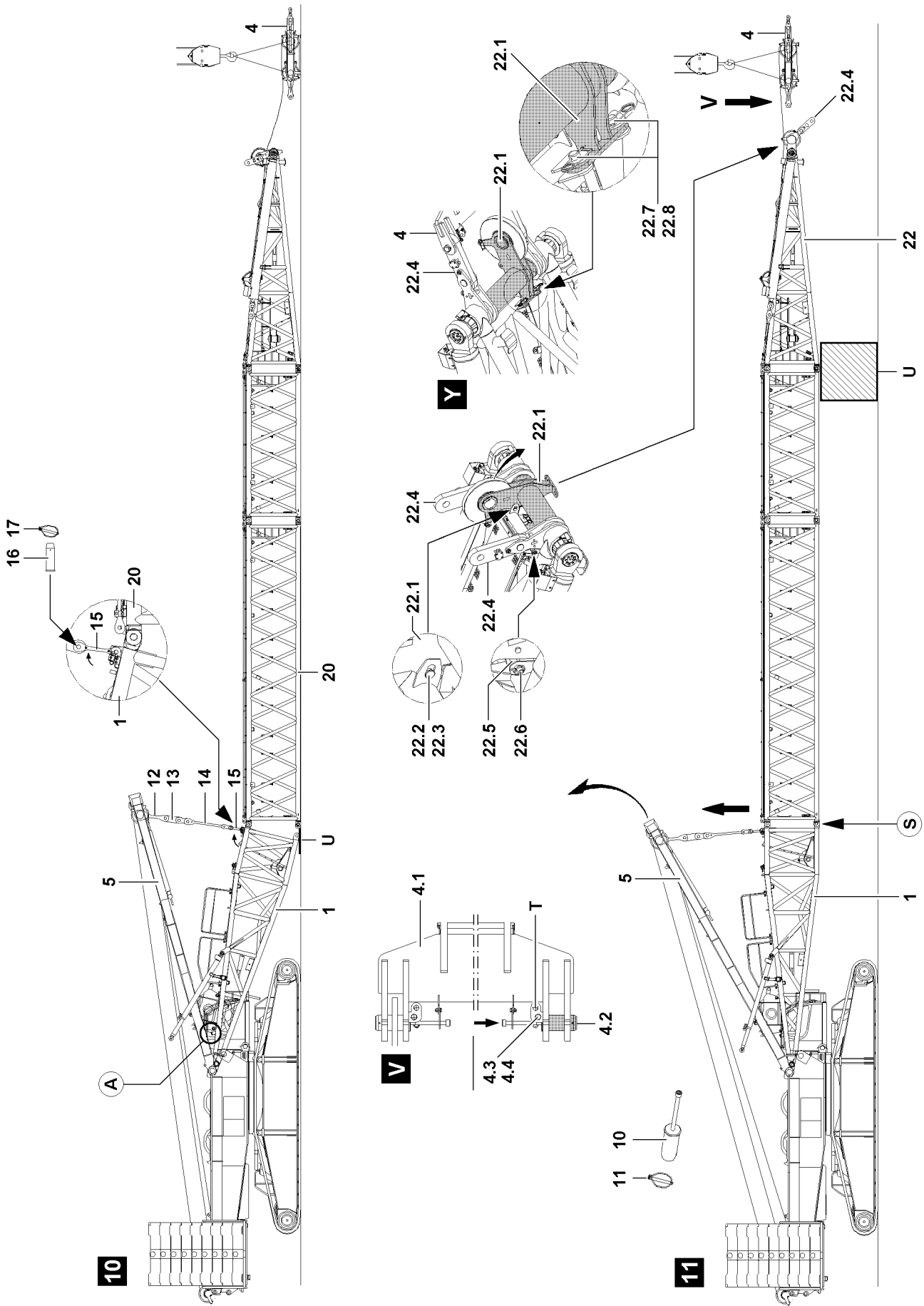

Fig.106556

LWE/LR 1600-2-008/18109-09-02/en

3.1.10 Bringing the pulley retainers into operating position



WARNING

Mortal danger due to pulley retainer!

If the pulley retainer is not secured with an auxiliary crane during the swing procedure, it can swing forward with a large momentum due to its weight.

Death, severe bodily injuries, property damage.

- ▶ Swing the pulley retainer into operating position only with the aid of an auxiliary crane.
- ▶ Swinging the pulley retainer without an auxiliary crane is **prohibited**.

- ▶ Fasten the pulley retainer on the auxiliary crane.

When the pulley retainer **22.1** is secured with the auxiliary crane:

- ▶ Tension the fastening equipment carefully.
- ▶ Remove the spring retainer **22.3** on the transport retainer and unpin the retaining pin **22.2**.
- ▶ Remove the spring retainer **22.8** and unpin the pin **22.7**, see illustration Y.
- ▶ Swing the pulley retainer **22.1** forward with the auxiliary crane.

When the pulley retainer **22.1** is in operating position:

- ▶ Remove the auxiliary crane.
- ▶ Pin in the pins **22.7** in operating position of the pulley retainer **22.1** and secure with spring retainer **22.8**.
- ▶ Pin in the retaining pin **22.2** in transport position and secure with spring retainer **22.3**.

3.1.11 Pinning the pulley block on the pull test brackets

Pin the pulley block **4** on the D-end section **22** with the pull test brackets **22.4**.

- ▶ Attach the pulley block **4** on the auxiliary crane and lift it off the ground.

Pin the pulley block **4** on the pull test brackets on the D-end section.

NOTICE

Danger of slack rope formation!

When swinging the pulley block on the D-end section in, slack rope can form on winch 3.

- ▶ When swinging the pulley block in to the D-end section, slowly and carefully spool up winch 3.

When the pulley block **4** is on the D-end section **22** positioned and aligned on the pull test brackets **22.4**:

- ▶ Pin in the pin **4.2** on both sides, see illustration **11** and illustration **V**.
- ▶ Secure the pins **4.2**: Insert the retaining pin **4.3** and secure with spring retainer **4.4**.
- ▶ Carefully lower the pulley block **4** with the auxiliary crane.

When the pulley block is laying on the ground or on the support:

- ▶ Remove the auxiliary crane.

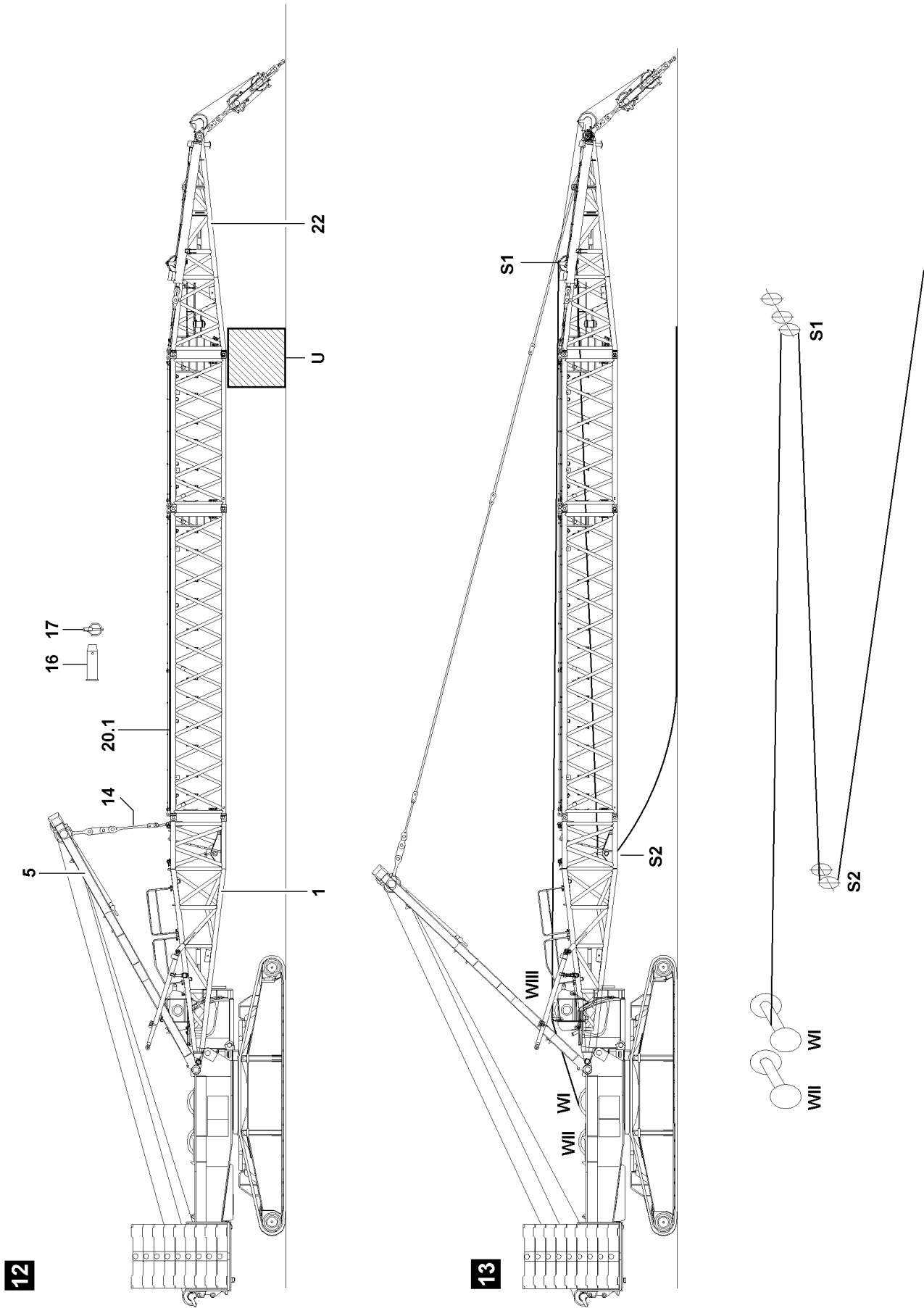

Fig.106557

3.1.12 Assembling the D-guy rods



WARNING

Neglected inspection and maintenance on guy rods.

If the regular inspection and maintenance of the guy rods is not carried out or only in irregular intervals, then severe accidents can occur due to existing and unrecognized damage on the guy rods. Death, severe bodily injuries, property damage.

- ▶ The guy rods must be checked before every assembly, see Crane operating instructions, chapter 8.15.



Note

- ▶ The D-guy rods must be assembled and secured according to the separately supplied assembly drawings. The numbering on the assembly drawings must be identical to the numbering on the guy rods.

The D-guy rods are placed and secured for transport on the D-lattice sections. Before assembly, the transport retainers must be released.

- ▶ Release the transport retainers on the guy rods.
- ▶ Lower the SA-frame to the front.



DANGER

Danger of accident.

- ▶ The pins **16** of the Derrick guy rods may only be pinned from the „inside“ to the „outside“.

Pin the guy rods **14** of the SA-frame with the guy rods **20.1** on the D-pivot section.

- ▶ Insert the pin **16** and secure with spring retainer **17**.

Pin the guy rods of the D-intermediate sections with each other.

- ▶ Insert the pin **16** and secure with spring retainer **17**.

Pin the guy rods of the D-intermediate sections with the guy rods on the D-end section.

- ▶ Insert the pin **16** and secure with spring retainer **17**.

When the guy rods are pinned and secured to each other:

- ▶ Actuate winch 4 until the guy rods are tensioned between the SA-bracket and the D-end section.



DANGER

General danger note.

If the following conditions are not met before erecting the D-boom, the hoist rope can fall down due to its own weight.

Death, severe bodily injuries, property damage.

- ▶ Enough hoist rope must be guided over the rope pulleys so that the hoist rope is **not** pulled back and falls down when erecting the D-boom.



Note

- ▶ The hoist rope reevings are shown in the Crane operating instructions, chapter 4.06.

- ▶ Pull the hoist rope over the rope pulley **S1** in the D-end section and over the rope pulley **S2** in the D-pivot section, see illustration **13**.
- ▶ Luff the D-boom up until the D-boom hangs horizontally above the ground.
- ▶ Remove the support **U**.

3.2 Establishing the electric and hydraulic connections on the D-end section

3.2.1 Establishing the electrical connections

NOTICE

Danger of damage of electrical connections!

If the electrical connection between the terminal box and the D-pivot section and the cable drum in the D-pivot section is established before the boom end section is installed and electrically connected, then the electric connection can be damaged.

- ▶ Make sure that the electric connection between the terminal box in the D-pivot section and the cable drum in the D-pivot section is only established **after** assembly and the connection of the electric wiring for the boom end section.
-



Note

- ▶ To establish the electrical connections on the D-end section: Use the Electric wiring diagram.
-

Make sure that the following prerequisite is met:

- The D-end section is completely assembled and placed on the supporting base.
 - ▶ Establish the electrical connections.
 - ▶ Make sure that all electrical connections to the D-end section have been established.
-



WARNING

Faulty function if dummy plugs are not installed!

If the dummy plugs on the non-required electrical connections are not installed, then faulty functions or functional limitations can occur on the crane.

- ▶ Make sure that all non-required electrical connections, which have a dummy plug are closed off with dummy plugs.
 - ▶ Pay attention to the Electrical wiring diagram.
 - ▶ As a rule, close off on-required electrical connections (for example for accessories which cannot be installed) with the respective dummy plugs.
-

NOTICE

Property damage due to dirt and / or corrosion!

If non-required electrical connections are not closed off with the respective protective caps, then dirt and / or corrosion can damage the electrical connections.

This could result in faulty functions.

- ▶ Make sure that all non-required electrical connections are always closed off properly.
 - ▶ Pay attention to the Electrical wiring diagram.
 - ▶ Close electrical connections, which have no dummy plugs, properly off with the corresponding protective caps.
-

3.2.2 Establishing the hydraulic connections

When connecting and releasing hydraulic lines with quick couplings, make sure that the coupling procedure is carried out correctly.



Note

- ▶ To connect or release the hydraulic lines with quick couplings, see Crane operating instructions, chapter 5.01.
-

**WARNING**

Pressure in the hydraulic lines!

If the pressure supply is not interrupted before connecting / releasing the hydraulic lines, the hydraulic oil can escape with high pressure.

Death, severe bodily injuries, property damage.

- ▶ Release the pressure in the hydraulic system before connecting / disconnecting: Interrupt the pressure supply and wait for a short time.

**WARNING**

Loss of pressure or leakage!

Incorrectly coupled or self-loosening quick couplings (particularly return lines) can result in serious accidents due to component failure.

- ▶ Check that the quick couplings have been properly connected before using the crane.
- ▶ Connect the coupling components (sleeve and connector) and screw together with the hand-tightened nut.
- ▶ Tighten the hydraulic coupling by hand. Rotate the hand-tightened nut until it reaches a tangible, fixed stop position.
- ▶ Establish the hydraulic connections, see Hydraulic diagram.

3.3 Checking the function of the safety equipment

**WARNING**

Non-functioning safety equipment!

Death, severe bodily injuries, property damage.

- ▶ Crane operation with non-functioning safety equipment is **prohibited**.

**Note**

- ▶ The function of the individual limit switches must be checked before erection.
- ▶ The function of the limit switch initiators must be checked in the test system, see Diagnostics manual.

**Note**

- ▶ If a function check on the limit switches or on the safety equipment does not lead to the desired shut offs, then the plug connections on the connector boxes or the components itself must be checked.
- ▶ If no visible connection errors or component defects can be found, contact **LIEBHERR** Service.

Make sure that the following prerequisites are met:

- All electrical connections have been made.
- The crane engine is running.
- The corresponding operating mode is set on the LICCON monitor.

3.3.1 Limit switch D-boom, relapse cylinder

**Note**

- ▶ The limit switch functions have to be checked individually before erection.
- ▶ Cover the limit switch actuators individually with a metal plate, see Crane operating instructions, chapter 8.12.

Result:

- The spool up function of winch IV (control winch) turns off in upward movement.
- The icon „derrick boom angle“ appears on LICCON monitor 1, see Crane operating instructions, chapter 4.02!

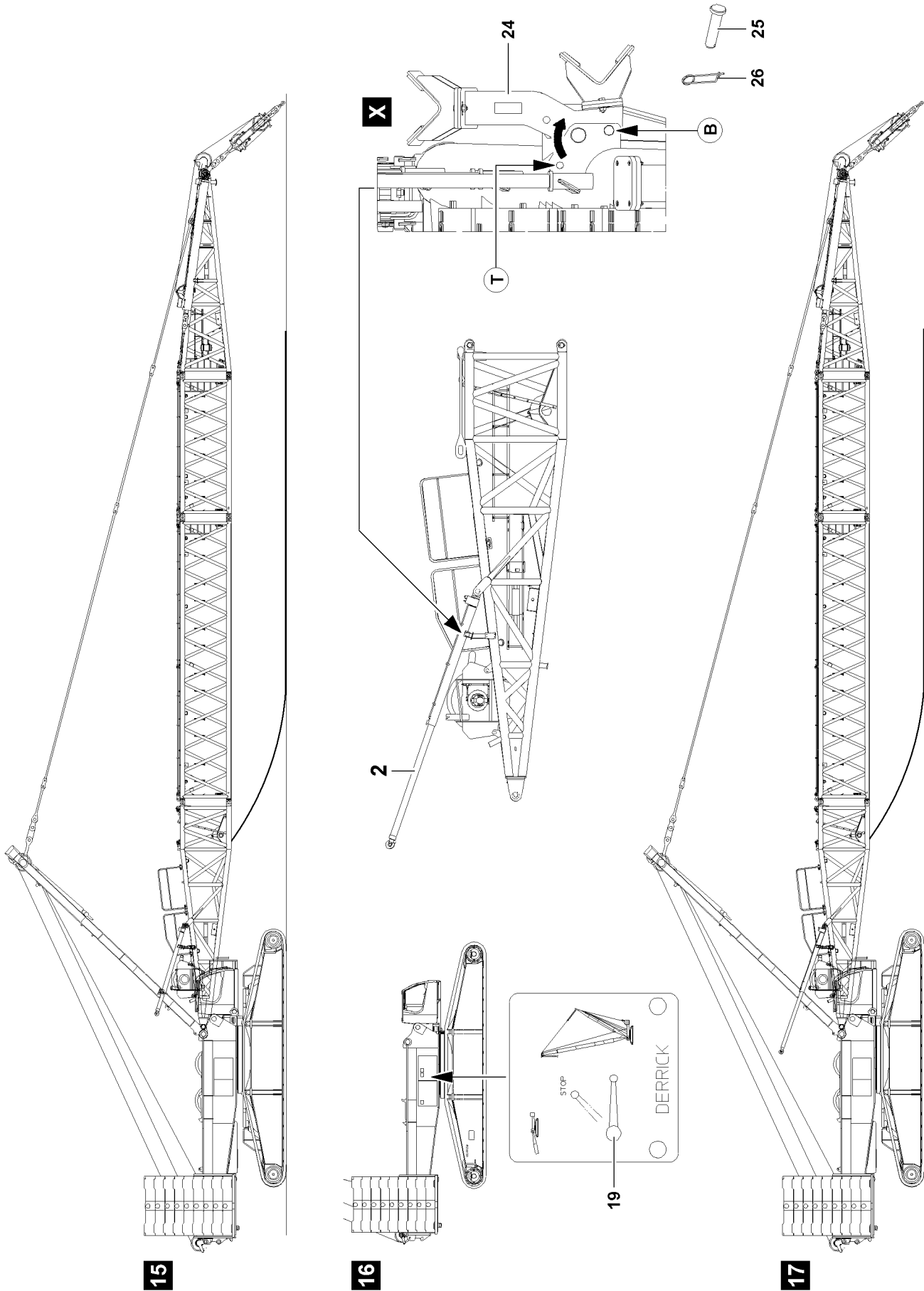

Fig.125170

LWE/LR 1600-2-008/18109-09-02/en

3.4 Swinging the folding consoles into operating position

Before extending the D-relapse cylinder **2**, bring the folding consoles **24** into operating position.

- ▶ Remove the spring retainer **26** and unpin the pin **25** from the transport position **T**, see illustration **X**.
- ▶ Attach the auxiliary crane first to the D-relapse cylinder **2**.
- ▶ Lift the D-relapse cylinder **2** with the auxiliary crane from the folding console **24**.
- ▶ Swing the folding consoles **24** into operating position, see illustration **X**.
- ▶ Insert the pins **25** in operating position **B** and secure with spring retainer **26**.

3.5 Installing the adapter for the ballast trailer on the turntable

If the ballast trailer is required for the intended crane application, then the adapter for the ballast trailer must be assembled on the turntable **before the D-boom is erected**. Otherwise access to the turntable is significantly limited by the SA-frame.



Note

- ▶ Install the adapter on the turntable before erecting the D-boom, see Crane operating instructions, chapter 5.35!

When the adapter is pinned on the turntable and secured:

- ▶ Erect the D-boom.

3.6 Erecting the D-boom



DANGER

Toppling crane.

- ▶ It is not permitted to turn the crane during the erection procedure.
- ▶ Observe the specifications in the erection and take down charts.



WARNING

Toppling crane.

If the following conditions are not met before erecting the D-boom, the crane can topple over. Death, severe bodily injuries, property damage.

- ▶ Observe the technical safety notes, see Crane operating instructions, chapter 5.01.
- ▶ Extend the D-relapse cylinder **2** before erection.
- ▶ Do not allow slack rope to build up on the control winch (winch 3)!
- ▶ The ball valve cabinet must be locked. Always pull the key and hand it to an authorized person.



WARNING

Falling hoist rope!

If the hoist rope before the erection procedure is not properly secured onto the corresponding length on the D-boom, it can fall down backward on the basis of its own weight.

Death, severe bodily injuries, property damage.

- ▶ Reeve the hoist rope before the erection procedure with sufficient length on the D-boom.
- ▶ The hoist rope must be constantly monitored during erection.
- ▶ Do not step into the danger zone.

Make sure that the following prerequisites are met:

- The crane is aligned in horizontal direction.
- All electrical connections have been made.
- All limit switches are functioning.
- The counterweight has been installed on the turntable according to the load chart.
- All pin connections have been secured.
- The folding brackets of the D-relapse cylinders are in operating position, see illustration 17.
- The D-relapse cylinders on the D-pivot section are extended.
- The hoist rope has been correctly placed in the rope pulleys and is prevented from jumping out with the rope retaining pins.
- The LICCON overload protection has been adjusted according to the data in the load chart.
- The LICCON overload protection settings have been compared with the actual set up configuration.
- The LICCON overload protection is exceeded.
- The assembly icon 11 is visible on the LICCON monitor.
- No personnel is within the danger zone.

3.6.1 Extending the D-relapse cylinder



WARNING

Mortal danger due to the D-boom!

If the D-relapse cylinders are not extended before erecting the D-boom, then the D-boom can fall backward.

Death, severe bodily injuries, property damage.

- ▶ The D-relapse cylinders must be extended before erection of the D-boom.
- ▶ The ball valve must be secured during crane operation to prevent unintended actuation.

The piston rod on the D-relapse cylinder must be extended by actuating the ball valve 19.

Ball valve positions	
Horizontal	Crane operation, extend the piston rod
Vertical	Assembly, retract the piston rod
45°	STOP (The piston rod cannot be moved in / moved out)

Make sure that the following prerequisite is met:

- All hydraulic connections have been made.
- ▶ Move the ball valve 19 into horizontal position.

Result:

- The piston rods of the D-relapse cylinders 2 extend.



Note

- ▶ The ball valve is secured by closing the cabinet door and removing the key.
- ▶ Close the cabinet door and pull the key.
- ▶ Hand the key to an authorized person.

Empty page!

LWE/LR 1600-2-008/18109-09-02/en

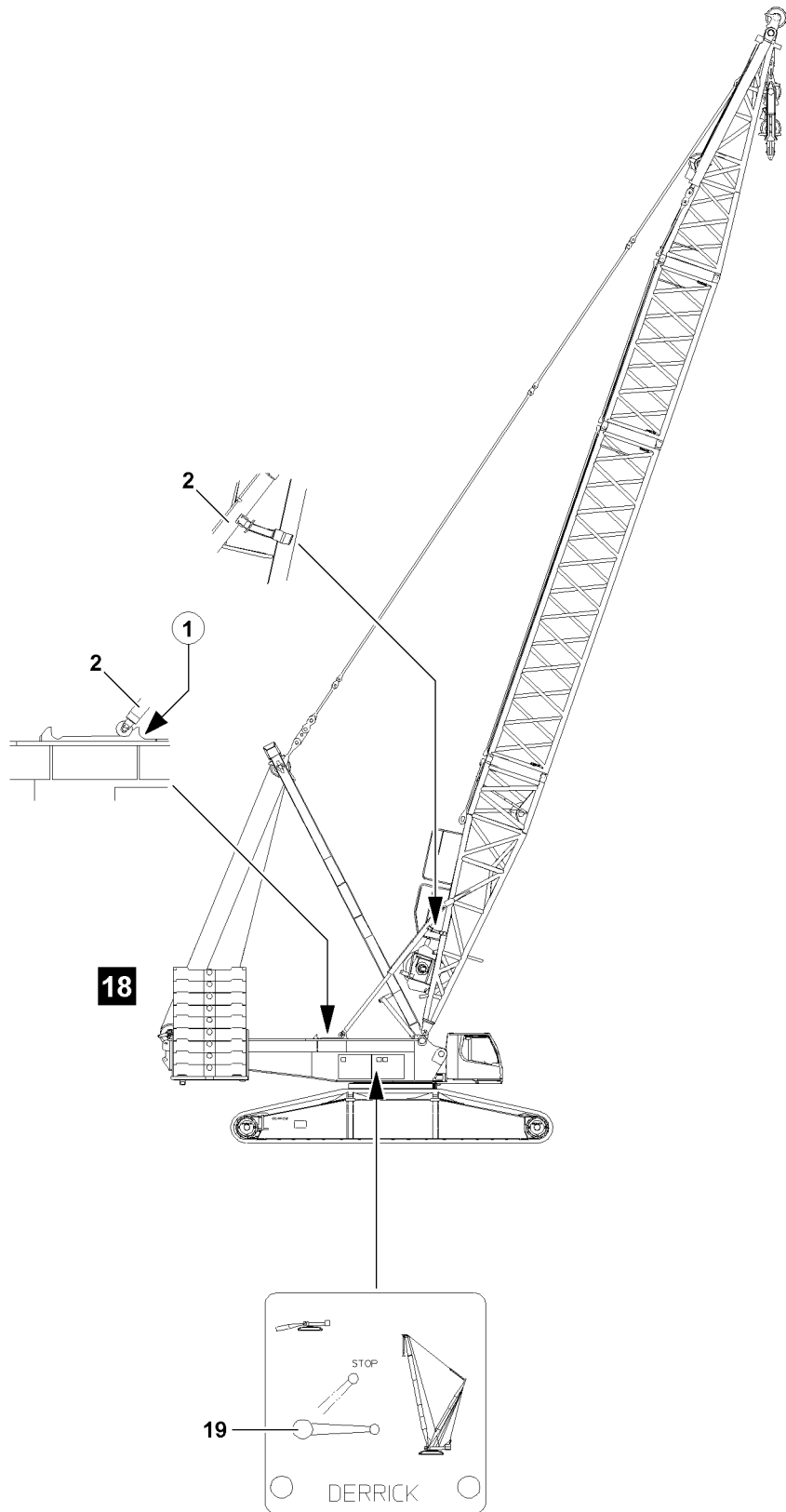

Fig.106735

LWE/LR 1600-2-008/18109-09-02/en

3.6.2 Erection procedure

Make sure that the following prerequisites are met:

- The D-relapse cylinders **2** are fully extended before erection.
- The control rope of winch 3 is properly reeved on the pulley block and properly secured on the rope fixed point.
- The connector pins between the upper pulley block and the lower pulley block are unpinned.



Note

- ▶ During the erection procedure it must be ensured that the D-relapse cylinders **2** engage past the first stop point **1** into the second stop rail on the D-relapse retainer.
-



DANGER

Toppling crane.

- ▶ It is prohibited to turn the crane superstructure during the erection procedure.
 - ▶ Do not allow slack rope to build up on the control winch (winch 3)!
 - ▶ Do not erect the D-boom further than maximum 80° to the horizontal.
-
- ▶ Actuate winch 4 and erect the D-boom to an angle range of 75° to 80°.

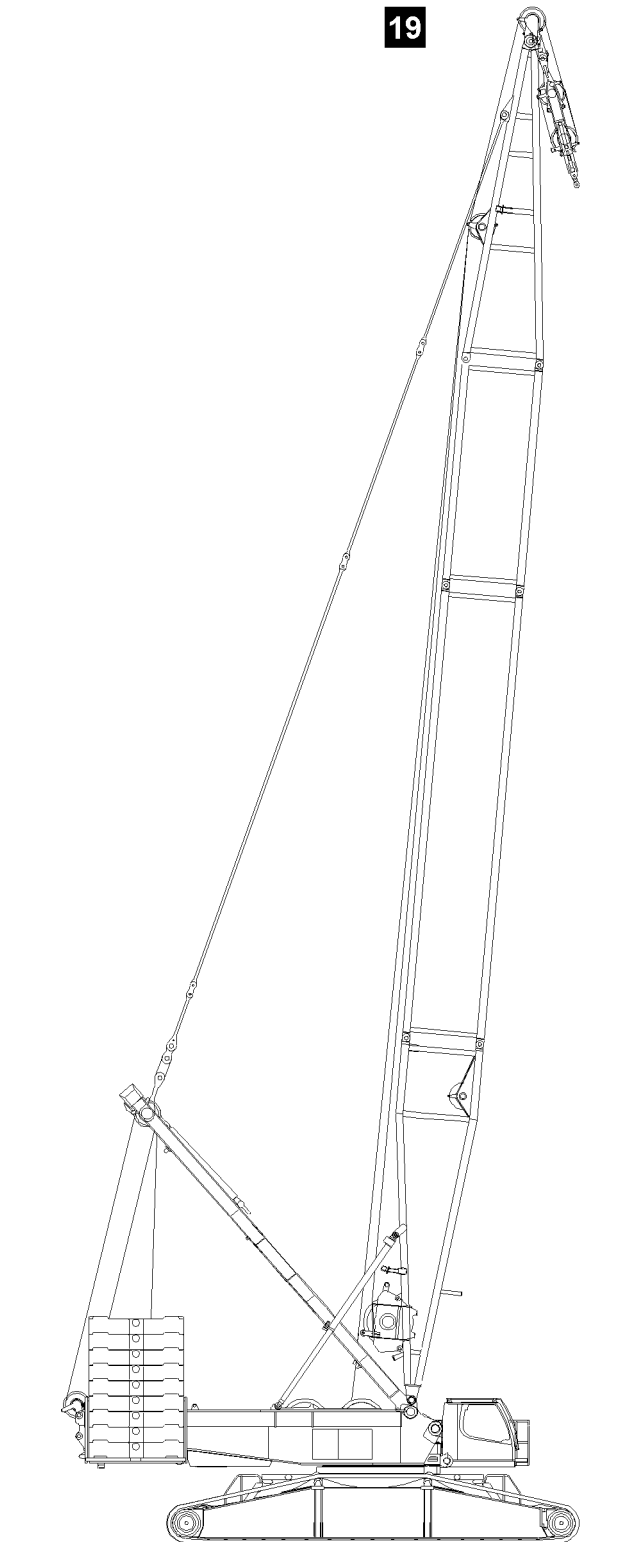

Fig.106739

LWE/LR 1600-2-008/18109-09-02/en

4 Disassembly D-boom



WARNING

Danger of falling.

During assembly / disassembly, inspection and maintenance work, assembly personnel must be secured with appropriate aids to prevent them from falling.

Death, severe bodily injuries, property damage.

- ▶ All work aloft, where there is a danger of falling must be carried out with suitable aids.
- ▶ If aids are not available and work cannot be carried out from the ground, then the assembly personnel must secure themselves with the supplied fall arrest system to prevent falling, see Crane operating instructions, chapter 2.04.
- ▶ If fall protection equipment is available, then it must be used, see Crane operating instructions, chapter 2.06.
- ▶ When lifting, lowering, swinging crane parts in and out, no persons may remain in the danger zone.
- ▶ When closing or opening boom systems during boom assembly or boom disassembly, no persons may remain on the boom system or in the danger zone.
- ▶ If railings are present for the crane, then they must be brought into the corresponding position and secured for assembly / disassembly work.
- ▶ Only step on the aids, ladders and catwalks with clean shoes.
- ▶ Keep aids, ladders and catwalks free of heavy dirt, snow and ice.
- ▶ During all assembly and disassembly work, maintenance work and inspections, travel or crane operation is prohibited.
- ▶ Remaining on a suspended load is prohibited.
- ▶ Stepping or walking on crane components and lattice sections, which have an incline of more than 20° is prohibited.
- ▶ For all assembly work, the crane driver of the main crane must be in voice contact with the crane driver / crane drivers of the auxiliary crane / auxiliary cranes.
- ▶ For assembly tasks, the crane driver may only initiate crane movements when the responsible guide has explicitly released the movement.



WARNING

The lattice sections can fall down!

If the lattice sections are not pinned and secured correctly, then they can fall down.

Death, severe bodily injuries, property damage.

- ▶ Pin or unpin both pins at the same horizontal level, i.e. **left and right**.
- ▶ Do not stand under the lattice sections or within the entire danger zone during the pinning and unpinning procedure of the boom.
- ▶ Safely secure the pins in the storage locations as well as in the receptacles.
- ▶ It is prohibited to lean the ladder against the component being disassembled.



WARNING

Danger of impact / crushing!

When installing / removing crane components with the auxiliary crane, crane components can start to swing back and forth.

When lifting / lowering and positioning crane components, there is an increased danger of impacts / crushing.

Death, severe bodily injuries, property damage.

- ▶ Make sure that personnel cannot be caught by components.
- ▶ Make sure that the crane is horizontally aligned.
- ▶ When working in danger zones: Use aids to protect limbs.
- ▶ Guide components with suitable aids to minimize oscillation.

**DANGER**

The components can fall down!

If the corresponding component is disengaged from the auxiliary crane before the corresponding component is pinned, then the corresponding component can fall down.

Death, severe bodily injuries, property damage.

- ▶ Do not disengage the auxiliary crane until the corresponding component is pinned and secured.

**WARNING**

Toppling crane.

- ▶ The turntable may not be turned during the assembly of the boom.

- ▶ Observe the assembly conditions, see Crane operating instructions, chapter 3.06.

**WARNING**

Danger of accident.

Death, severe bodily injuries, property damage.

- ▶ For assembly of the boom combinations, the rod plan must be observed and adhered to.

- ▶ Depending on the condition of the ground, the boom and the lattice sections must be supported from below for the assembly of the boom.

- ▶ Observe the technical safety notes, see Crane operating instructions, chapter 5.01.

Empty page!

LWE/LR 1600-2-008/18109-09-02/en

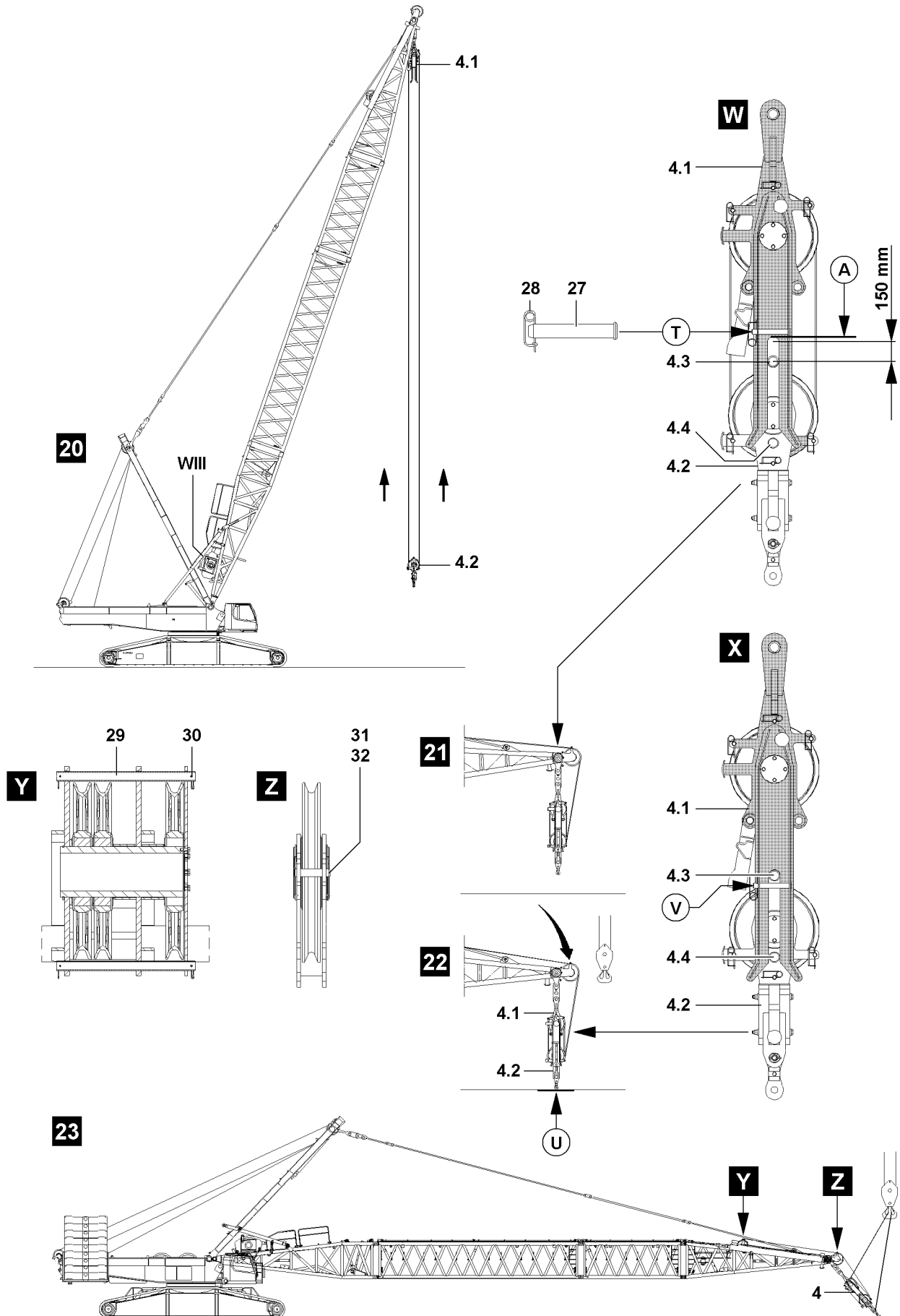

Fig.106736

LWE/LR 1600-2-008/18109-09-02/en

4.1 Disassembling the D-boom



WARNING

Falling boom!

If the D-boom is not properly supported before disassembly or held with an auxiliary crane, then the D-boom can fall down when it is unpinned.

Death, severe bodily injuries, property damage.

- ▶ Before supporting the D-boom, the ground condition must be checked regarding load bearing capability and level.

If the ground condition is not classified as sufficient:

- ▶ Support the D-boom properly and safely with suitable material.

4.1.1 Luffing the D-boom down

NOTICE

Damage to the pulley block!

If the derrick boom is lowered too quickly „forward“, significant damage can occur on the pulley block and on the D-end section.

- ▶ Lower the D-boom carefully forward.
- ▶ Lower the D-boom to the front until the pulley block is just above the ground.

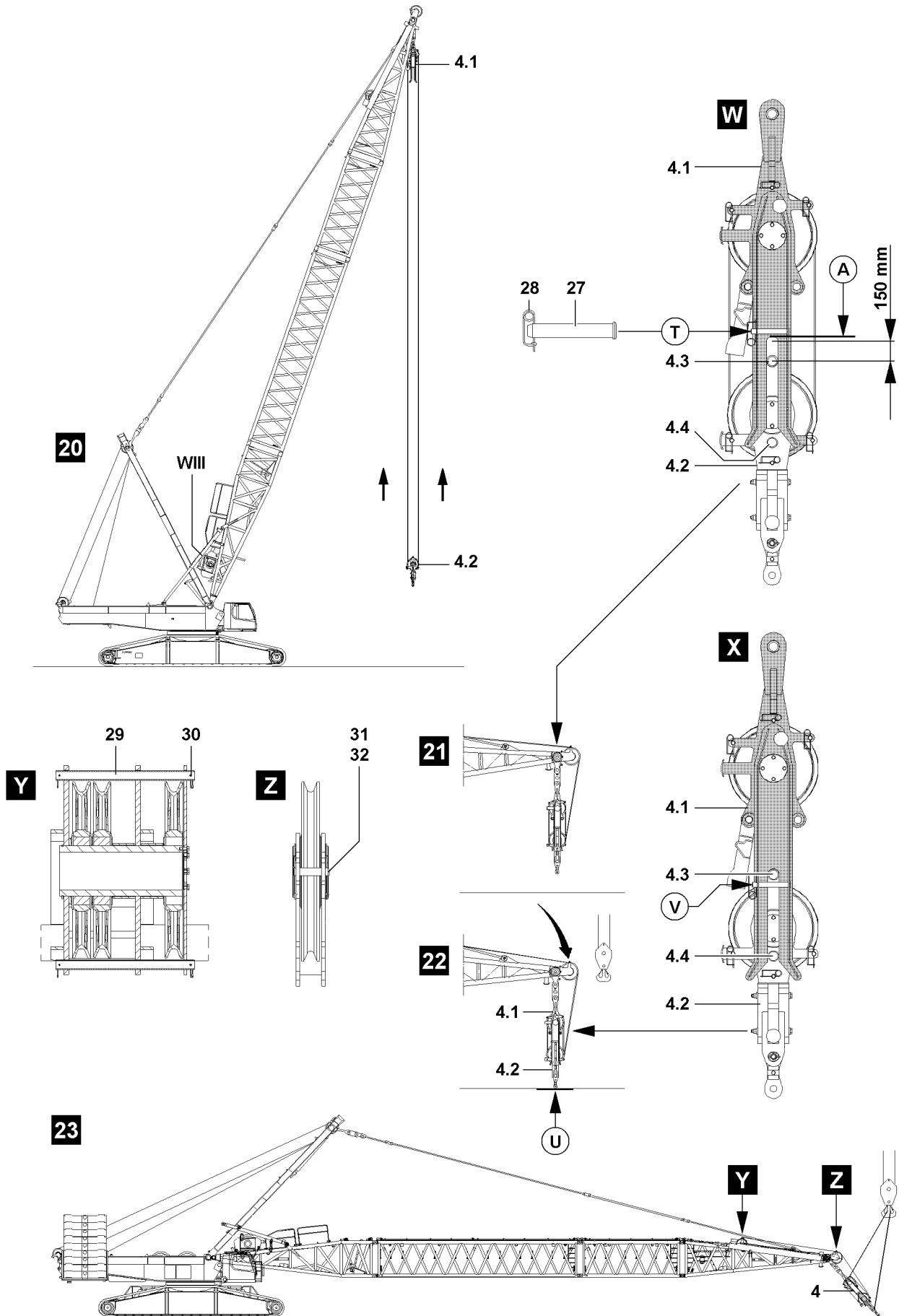

Fig.106736

LWE/LR 1600-2-008/18109-09-02/en

4.1.2 Pinning the upper pulley block with the lower pulley block

Make sure that the following prerequisites are met:

- The main boom is completely disassembled.
- The upper pulley block **4.2** hangs in reeved condition above the ground level, see illustration **20**.
- The retaining pin **27** on the bracket of the lower pulley block **4.1** is unpinned on point **V**, see illustration **W**.

The upper pulley block **4.2** must be pinned with the lower pulley block **4.1** before the complete pulley block **4** can be placed in the transport receptacle on the D-pivot section.

- ▶ Slowly luff the D-boom down and spool up winch 3 at the same time until the upper pulley block **4.2** is connected with the guide pin **4.3** in the bracket to approx. 150 mm on the stop, point **A** of the lower pulley block **4.1**, see illustration **21** and illustration **W**.

When the upper pulley block is approx. 150 mm before the stop of the lower pulley block **4.1**, point **A**:

- ▶ Slowly and carefully luff the D-boom down until the upper pulley block **4.2** is in contact with the ground (point **U**), see illustration **22**.

NOTICE

Danger of property damage on the pulley block!

If the D-boom is luffed down too quickly, then significant property damage can occur on the upper as well as the lower pulley block.

- ▶ Always use a guide when connecting the upper and lower pulley block.
 - ▶ Carry out all crane movements slowly and with utmost caution.
 - ▶ When the guide pin **4.3** reaches the stop at point **A**, stop the luff down movement of the D-boom immediately.
-

When the upper pulley block **4.2** is in contact with the ground at point **U**, illustration **22**:

- ▶ Luff the D-boom down slowly and carefully until the guide pin **4.3** is entered to the stop at point **A**.

When the guide pin **4.3** touches on stop point **A** of the lower pulley block **4.1**, illustration **X**:

- ▶ Stop the luff down movement immediately.
- ▶ Insert the retaining pins **27** on both sides on the bracket of the lower pulley block **4.1** at point **V** and secure with spring retainer **28**.

Result:

- The upper pulley block **4.2** is connected with the lower pulley block **4.1** and now forms the „transport unit“ pulley block **4**, illustration **23**.

Before the pulley block **4** can be placed in the transport receptacle on the D-pivot section, the rope retaining pin **29**, see illustration **Y** and the rope retaining pin **31**, see illustration **Z** must be removed, illustration **23**.

- ▶ Remove the spring retainer **30** on the rope retaining pin **29**.
- ▶ Unpin the rope retaining pin **29**, illustration **Y**.
- ▶ Remove the spring retainer **32** on the rope retaining pin **31**.
- ▶ Unpin the rope retaining pin **31**, illustration **Z**.

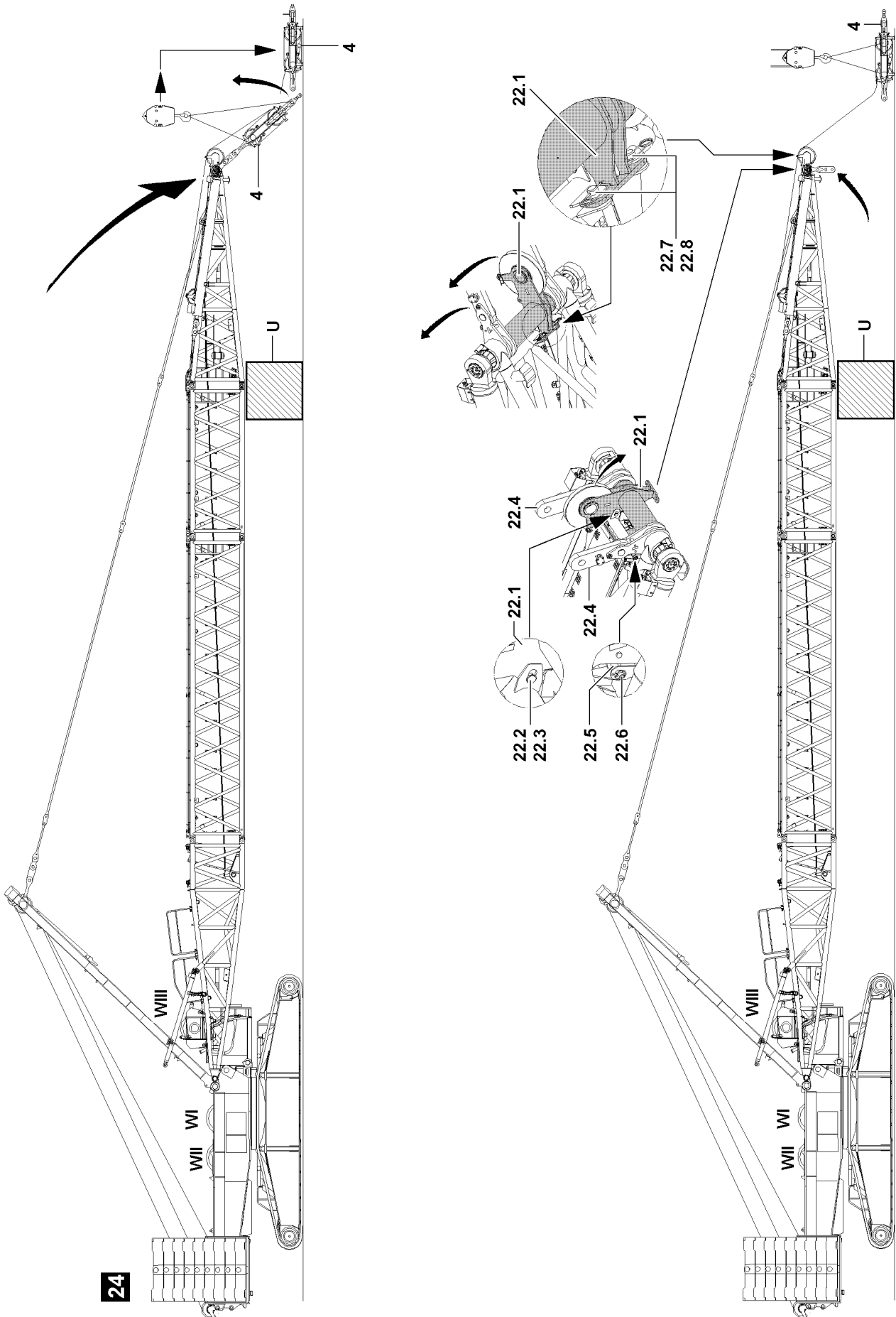

24

Fig.106753

LWE/LR 1600-2-008/18109-09-02/en

4.1.3 Placing the pulley block on the ground

NOTICE

Damage to the pulley block!

If the D-boom is placed on the supporting base **U**, the pulley block can be damaged!

- ▶ Before placing the D-boom on the supporting base **U**, lift the pulley block with the auxiliary crane off the ground!

- ▶ Fasten the pulley block **4** on the auxiliary crane and lift it off the ground, see illustration **24**.
- ▶ Luff the D-boom down carefully to the support **U**.

Disassemble the pulley block on the pull test brackets and place it on the ground in sufficient distance.

- ▶ Unpin the pulley block **4** on the pull test brackets **22.4**.
- ▶ Swing the pulley block **4** out with the auxiliary crane and spool winch 3 out at the same time.
- ▶ Place the pulley block **4** on the ground with the auxiliary crane.
- ▶ Remove the auxiliary crane.

4.1.4 Bringing the pulley retainer into transport position

Make sure that the following prerequisite is met:

- The pulley block is disassembled on the D-end section and placed on the ground.



WARNING

Mortal danger due to pulley retainer!

If the pulley retainer is not secured with an auxiliary crane during the swing procedure, it can swing forward with a large momentum due to its weight.

Death, severe bodily injuries, property damage.

- ▶ Swing the pulley retainer into transport position only with the aid of an auxiliary crane!
- ▶ Swinging the pulley retainer without an auxiliary crane is **prohibited**.

- ▶ Unpin the pulley retainer **22.1** in operating position: Remove the spring retainer **22.8** and unpin the pin **22.7**, see illustration **Y**.
- ▶ Unpin the retaining pin **22.2** in transport position of the pulley retainer: Remove the spring retainer **22.3** and unpin the retaining pin **22.2**, see illustration **28**.
- ▶ Fasten the pulley retainer **22.1** on the auxiliary crane.
- ▶ Swing the pulley retainer **22.1** upward with the auxiliary crane into transport position.

When the pulley retainer **22.1** is in transport position:

- ▶ Pin in the retaining pin **22.2** and secure with spring retainer **22.3**, see illustration **28**.

When the pulley retainer **22.1** is pinned and secured in transport position:

- ▶ Remove the auxiliary crane.

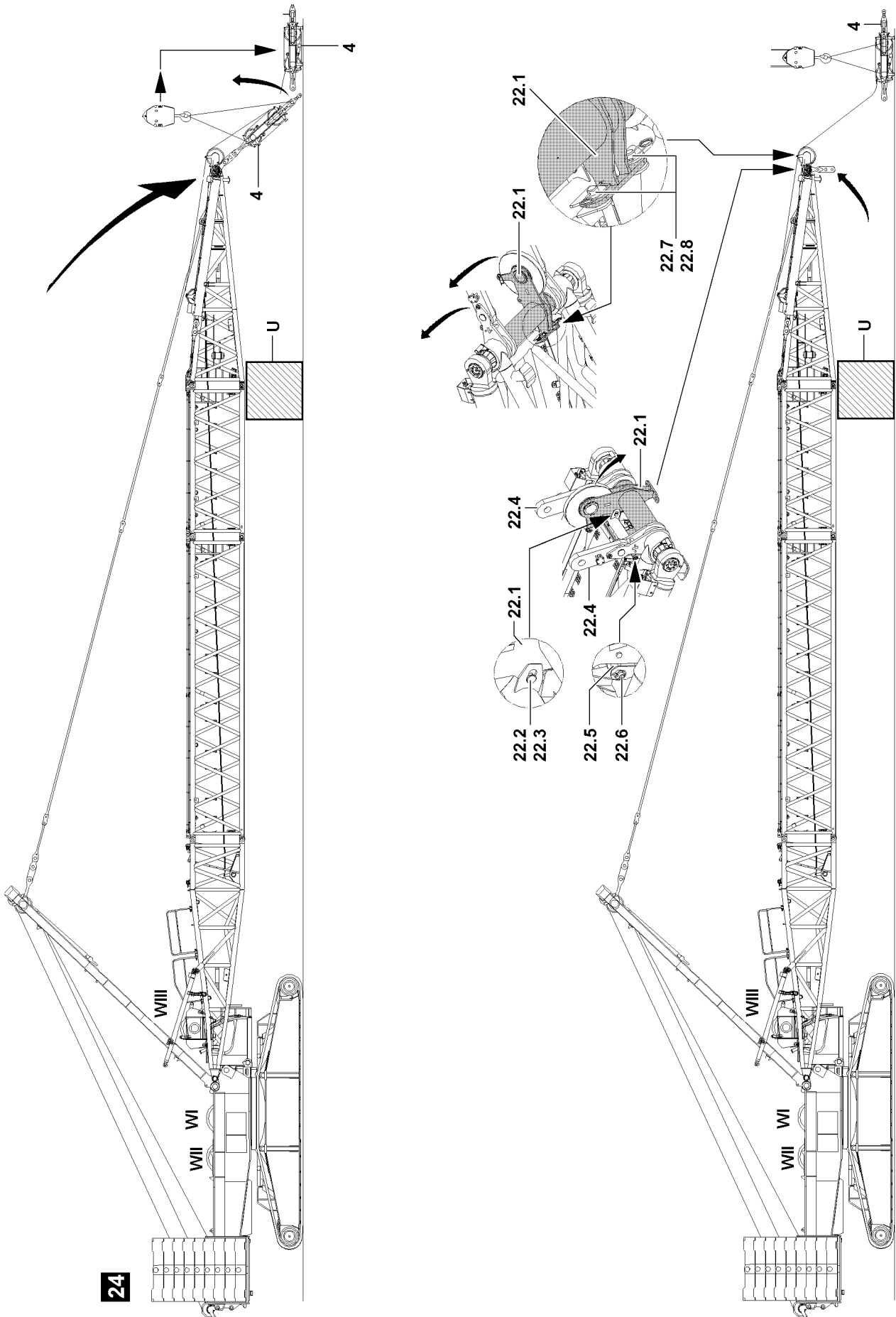

24

Fig.106753

LWE/LR 1600-2-008/18109-09-02/en

4.1.5 Bringing the pull test brackets into transport position



WARNING

Danger of crushing.

If the pull test brackets are not secured with an auxiliary crane during the swing procedure, they can swing forward with a large momentum due to their weight and severely injure personnel!

Serious crushing injuries may be the result!

- ▶ Swing the pull test brackets into operating position only with the aid of an auxiliary crane.
- ▶ Swinging the pull test brackets without an auxiliary crane is prohibited!
- ▶ Bring the pull test brackets individually into transport position!

-
- ▶ Attach the pull test bracket onto the auxiliary crane.

When the pull test bracket **22.4** is attached on the auxiliary crane:

- ▶ Tension the fastening equipment carefully.
- ▶ Remove the locking pin **22.6** on the transport retainer and unpin the retaining pin **22.5**, see illustration **28**.
- ▶ Swing the pull test bracket **22.4** upward with the auxiliary crane into transport position.

When the pull test bracket **22.4** is in transport position:

- ▶ Pin in the pin **22.5** in transport position and secure with locking pin **22.6**.

When the pull test bracket **22.4** is pinned and secured in transport position:

- ▶ Remove the auxiliary crane.

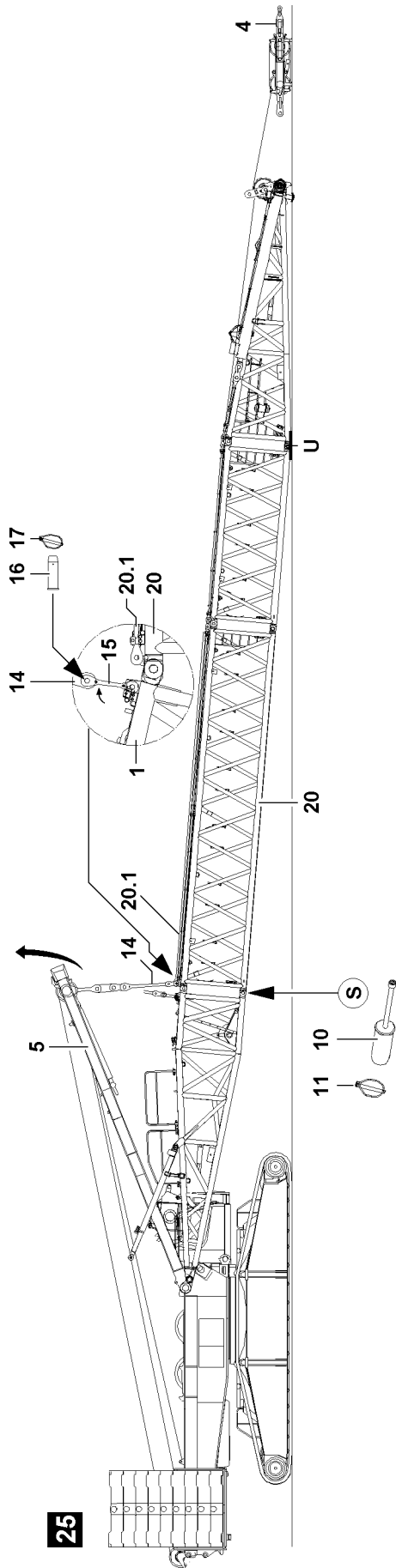
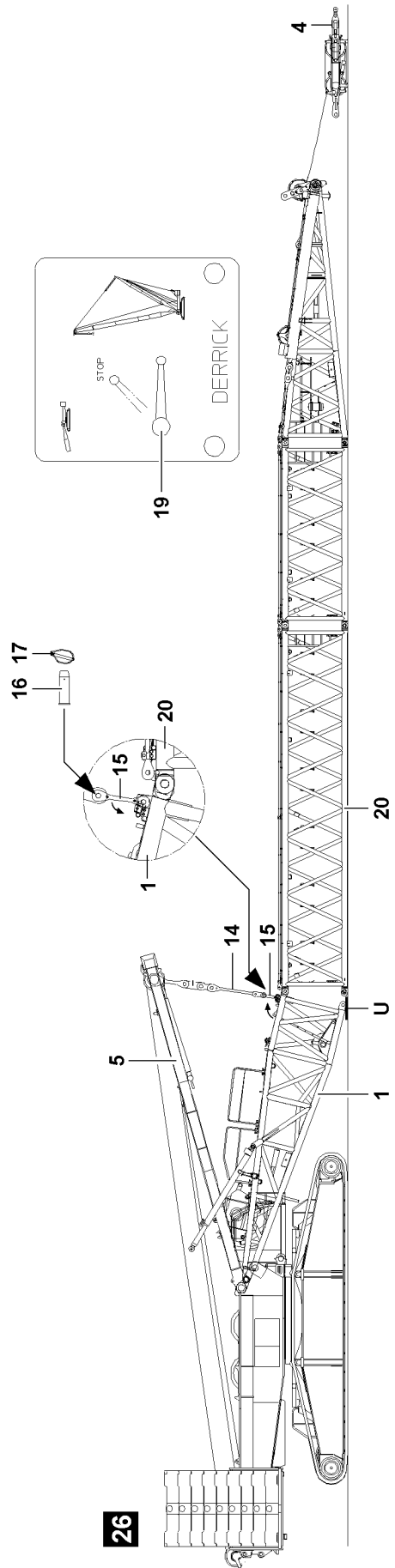

Fig.106740



26

LWE/LR 1600-2-008/18109-09-02/en

4.1.6 Disassembling the D-guy rods

- ▶ Place the guy rods into the transport retainers of the D-intermediate sections: Lower the SA-frame to the front.
- ▶ Pin and secure the guy rods in the transport retainers.
- ▶ Unpin the guy rods **14** of the SA-frame and the guy rods **20.1** of the D-intermediate section: Remove the locking pin **17** and unpin the pin **16**.

4.1.7 Disconnecting the electrical and hydraulic connections between the D-end section and the D-pivot section

- ▶ Disconnect the electrical connections on the D-boom and store properly.
- ▶ Close the electrical connections off properly with dummy plugs, protective caps or caps.
- ▶ Disconnect the hydraulic connections on the D-boom and store properly.
- ▶ Close the hydraulic connections off properly with protective caps or caps.

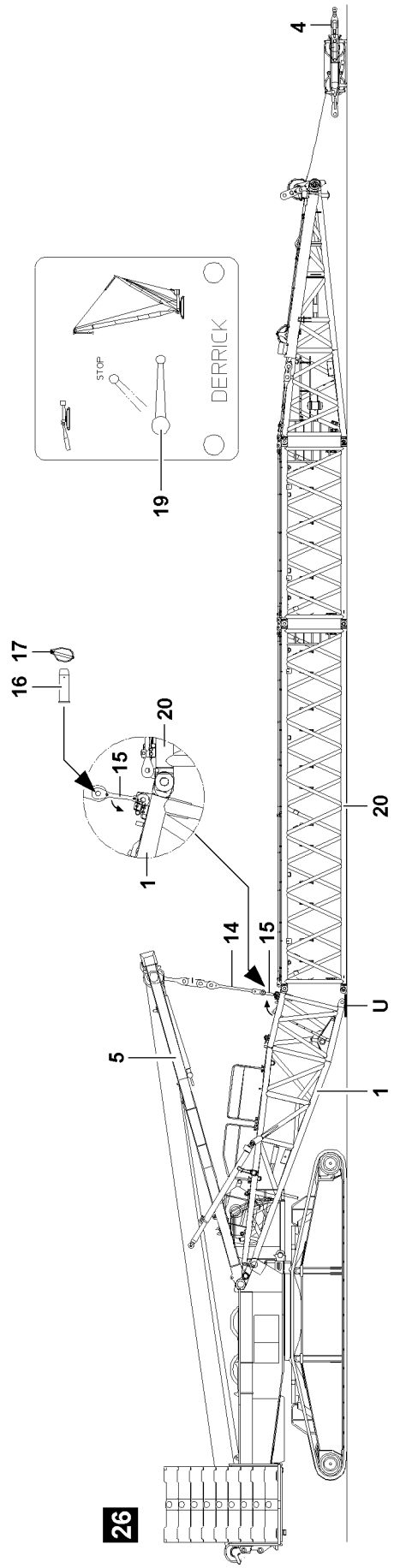
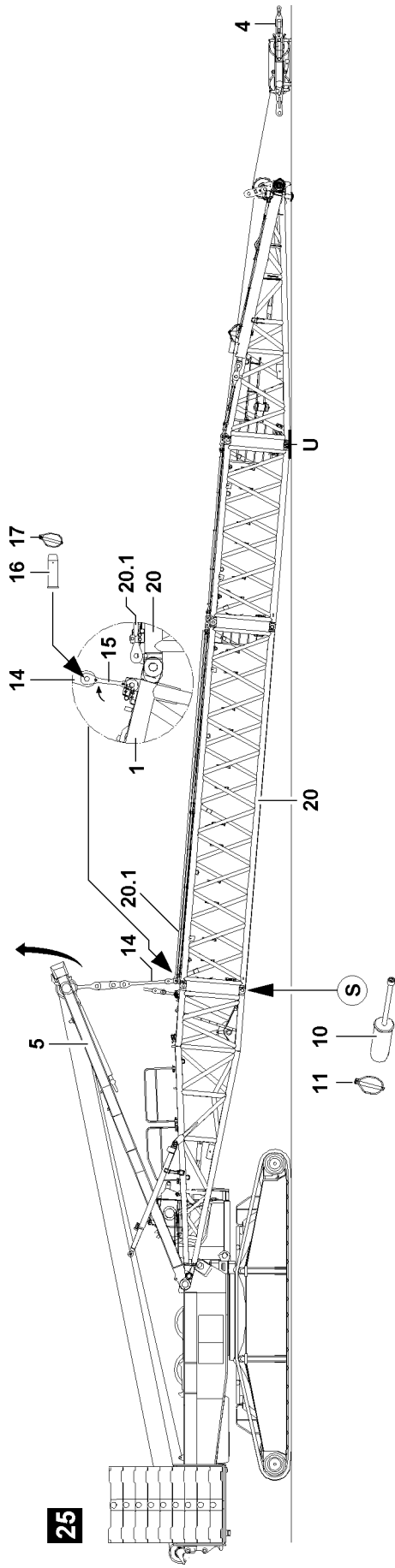

Fig.106740

LWE/LR 1600-2-008/18109-09-02/en

4.1.8 „Opening“ the D-boom and place it down



Note

- ▶ For disassembly of the D-boom, the guying of the SA-frame **5** must be pinned with the lug **15** on the D-pivot section so that the D-boom can be lowered over the SA-frame on the support **U** and removed!

When the boom guying between the guy rods **14** of the SA-frame and the guy rods **20.1** of the D-intermediate section **20** is unpinned:

- ▶ Pin the guy rods **14** of the SA-frame **5** and guy rods **15** of the D-pivot section **1**, pin in the pin **16** and secure with locking pin **17**, see illustration **25**.
- ▶ Luff the SA-frame **5** up until the guying between the SA-frame and the D-pivot section **20** is tensioned.



WARNING

Falling D-boom!

When unpinning the D-boom on the D-pivot section, the D-boom can fall down.

Death, severe bodily injuries, property damage.

- ▶ It is prohibited for anyone to remain under the D-boom during the unpinning procedure.
- ▶ Make sure that the D-boom is safely held by the guying.

- ▶ Unpin the D-pivot section **1** on the D-intermediate section **20**: Release pins **10** on both sides at point **S** and unpin.

NOTICE

Damage to the D-pivot section!

When the D-pivot section is placed on the ground, the D-pivot section will be damaged.

- ▶ Before placing the D-pivot section on the ground, support the area with a sufficiently load-bearing and large enough supporting base.
- ▶ Make sure that the height of the supporting base on the D-pivot section does not fall below the specified minimum dimension.
- ▶ Carefully place the D-pivot section with the auxiliary crane and at low speed on the supporting base **U**.

	Cranes without Quick-Connection (QC)	Cranes with Quick-Connection (QC)
Height of the supporting base U (minimum dimension)	200 mm	550 mm

When the pins **10** are unpinned on both sides at point **S**:

- ▶ Luff the SA-frame down and place the D-pivot section carefully on the support **U**, see illustration **26**.
- ▶ Luff the SA-frame down until the guying is relieved.
- ▶ Unpin the guying: Release and unpin the pin **16**.
- ▶ Luff the SA-frame up to approx. 75° to 80°.

4.1.9 Retracting the D-relapse cylinder

The piston rod on the D-relapse cylinder must be retracted by actuating the ball valve **19**.

- ▶ Move the ball valve **19** into vertical position.

Result:

- The piston rod of the D-relapse cylinder retracts.

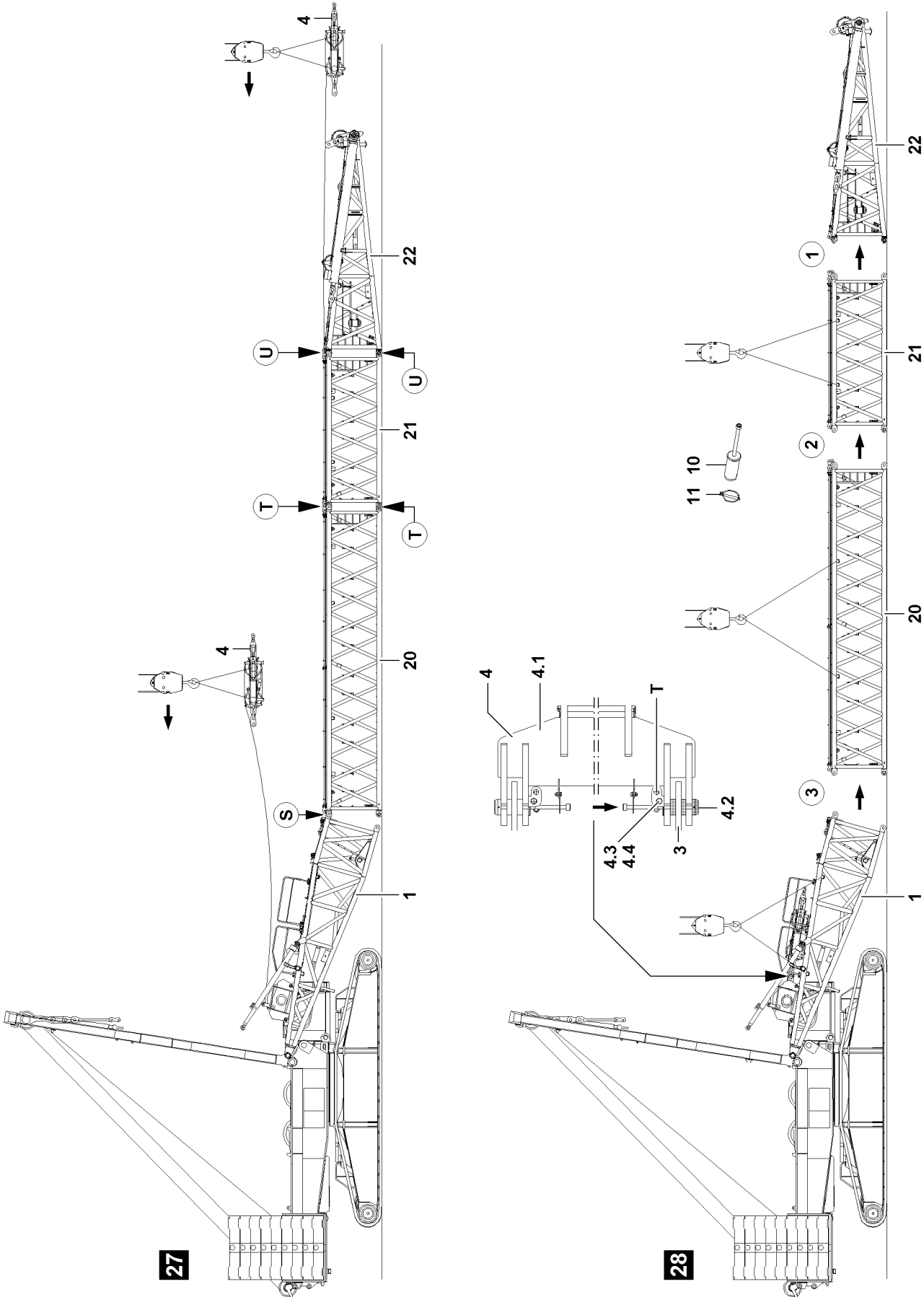

Fig.106744

LWE/LR 1600-2-008/18109-09-02/en

4.1.10 Place the pulley block into the transport receptacle on the D-pivot section

Make sure that the following prerequisites are met:

- The lower and the upper pulley block are pinned together as a „transport unit“ pulley block **4**.
- The rope retaining pins on the D-end section are released and unpinned.
- The guy rods are placed in the transport retainers and secured.
- The SA-frame is luffed up to approx. 75° to 80°.
- The D-boom is lying fully on the ground (on the support).

- ▶ Fasten the pulley block **4** on the auxiliary crane.
- ▶ Tension the fastening equipment between the pulley block and the hook block of the auxiliary crane.

NOTICE

Slack rope formation.

- ▶ Hold the control rope of winch 3 always slightly tensioned!

-
- ▶ Pull the pulley block **4** with the auxiliary crane to the D-pivot section while spooling out winch 3 at the same time.
 - ▶ Place the pulley block **4** into the transport retainer on the D-pivot section.
 - ▶ Pin and secure the pulley block **4** in the transport retainer on the D-pivot section with winch **3**: Pin in the pin **4.2** and secure with retaining pin **4.3** and spring retainer **4.4**.

4.1.11 Disassembling the D-lattice sections



WARNING

Tipping lattice sections!

When the lattice sections are unpinned, they can tip over, depending on the ground or the support. Death, severe bodily injuries, property damage.

- ▶ The lattice sections must be safely held by the auxiliary crane before unpinning them.
- ▶ The fastening equipment must be tensioned before unpinning.

Release and unpin the pin **11** „at the bottom“ at point **U**.

- ▶ Remove the locking pin **11** „on the bottom“ at point **U** on pin **10**.
- ▶ Unpin the pin **10** „at the bottom“ at point **U**.
- ▶ Hang the D-end section on the auxiliary crane.

When the D-end section is being held by the auxiliary crane:

- ▶ Release and unpin the pin **10** „on top“ at point **U**.
- ▶ Remove the D-end section with the auxiliary crane.
- ▶ Fasten the D-intermediate section **21** on the auxiliary crane.
- ▶ Release and unpin the D-intermediate section **21** on the „bottom“ at point **T**.
- ▶ Release and unpin the D-intermediate section **21** on the „top“ at point **T**.
- ▶ Remove the D-intermediate section **21** with the auxiliary crane.
- ▶ Fasten the D-intermediate section **20** on the auxiliary crane.
- ▶ Release and unpin the D-intermediate section **20** on the „top“ at point **S**.
- ▶ Remove the D-intermediate section **20** with the auxiliary crane.

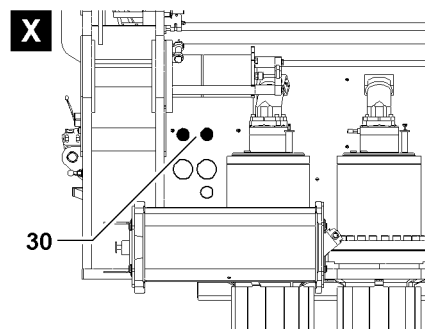
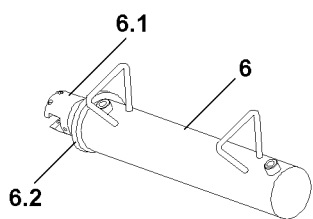
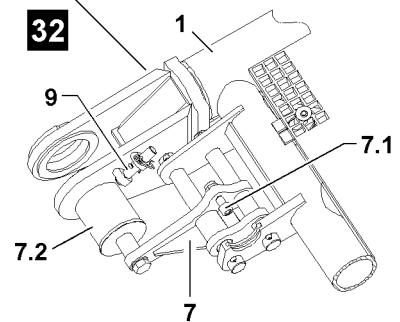
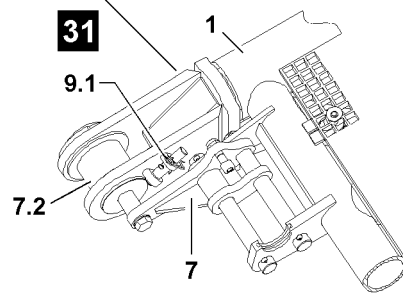
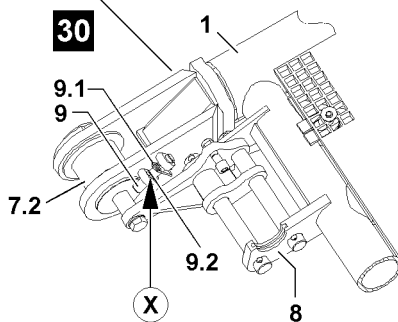
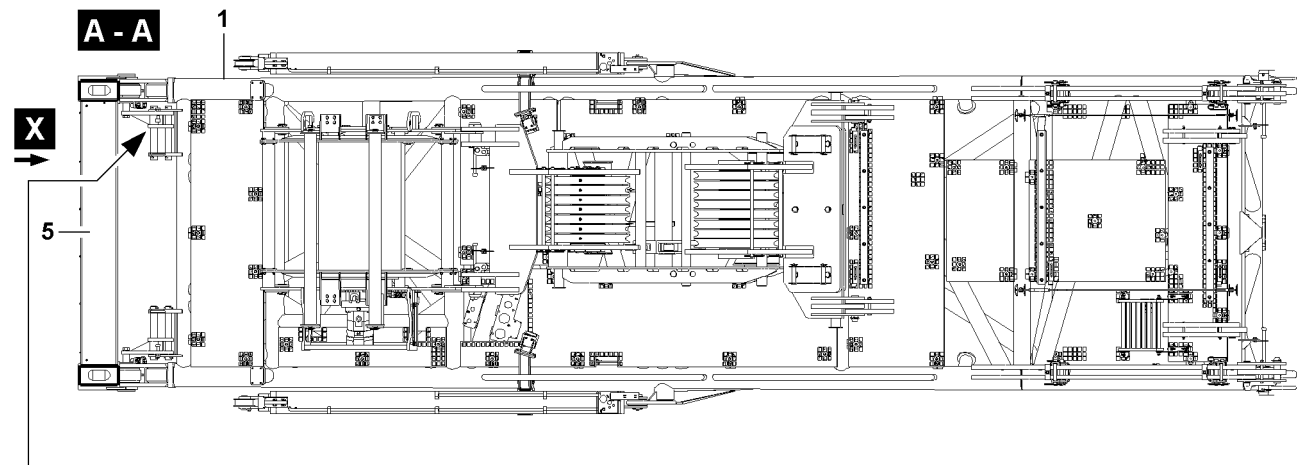
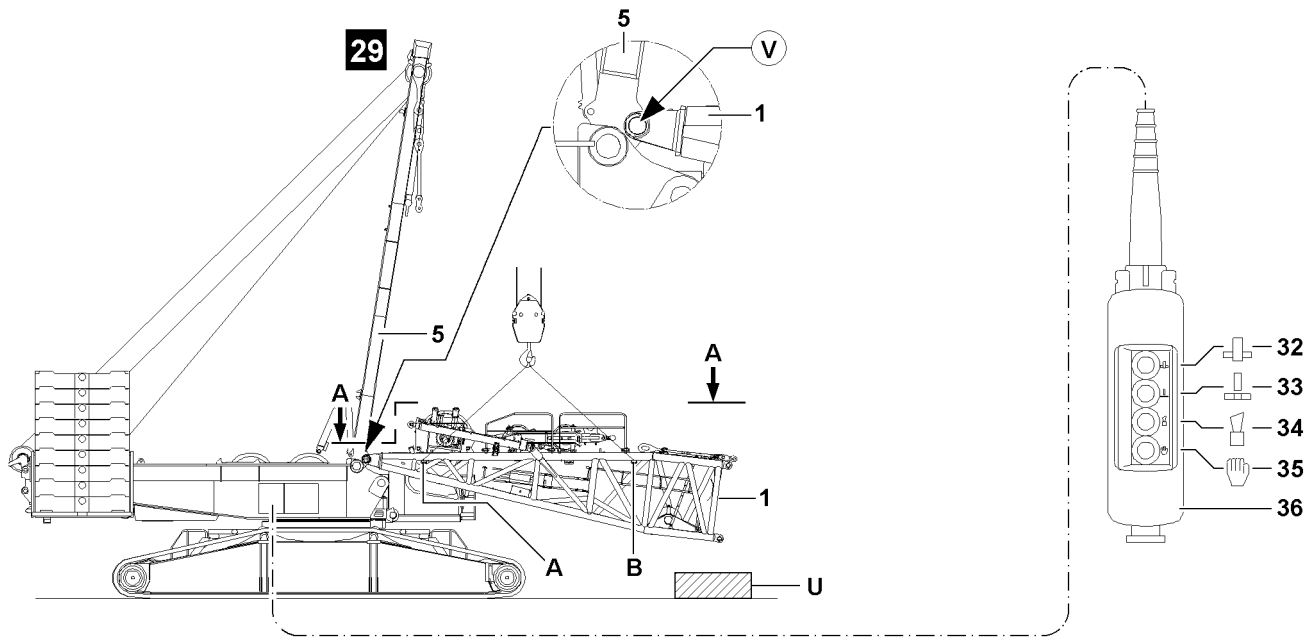

Fig.125171

LWE/LR 1600-2-008/18109-09-02/en

- ▶ Attach the D-pivot section **1** on the attachment points **A** and attachment points **B** on the auxiliary crane.
- ▶ Lift the D-pivot section **1** with the auxiliary crane off the ground.
- ▶ Hang the pin pulling cylinder **6** in the cylinder mount **8**, see illustration **30**.
- ▶ Release the connector pin **7.2**: Remove the spring retainer **9.1** and push retaining pin **9** „up“.
- ▶ Secure the retaining pin **9** in the „up“ position: Use the spring retainer **9.1**, see illustration **31**.

Establish the hydraulic connection to the pin pulling device via two quick couplers **30**, see illustration **X**.

Unpin the D-pivot section on the turntable.

- ▶ Unpin the connector pins **7.2** with the hydraulic pin pulling device.
- ▶ Unpin the connector pins **7.2** on both sides with the hydraulic pin pulling cylinder **6**: Press the button **35** on the control panel **36** and „hold it down“, then press the button **33** until the connector pin **7.2** is fully unpinned.

When the connector pins **7.2** are fully unpinned on both sides:

- ▶ Release the electrical and hydraulic connections from the turntable to the D-pivot section.
- ▶ Remove the pin pulling cylinder **6** on the D-pivot section **1**.
- ▶ Remove the D-pivot section with the auxiliary crane.

4.1.12 Disassembling the railing on the D-pivot section



Note

- ▶ To retain the transport dimensions on the D-pivot section, remove the railings!

The railings must be removed after disassembly of the D-pivot section and stored in the transport retainer.

- ▶ Insert the railings in the intended transport retainers on the D-pivot section and secure with spring retainers.

Empty page!

LWE/LR 1600-2-008/18109-09-02/en

5.07 SW/SDW boom combination

1	Component overview W-boom system	3
2	Fastening points W-transport units	3
3	Assembling the W-boom system	5
4	Operating the crane	35
5	Disassembling the W-boom system	37

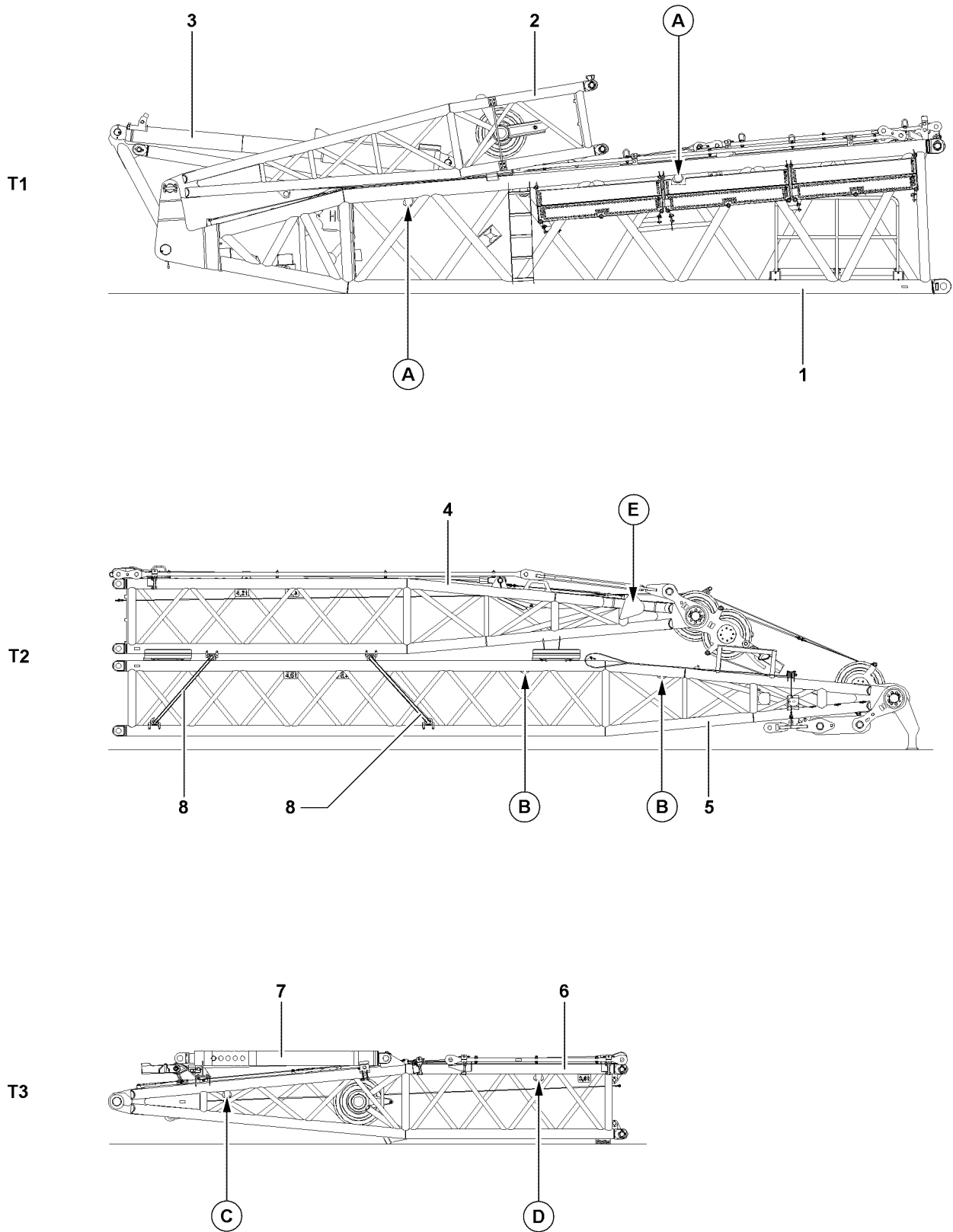

Fig.107230

LWE/LR 1600-2-008/18109-09-02/en

1 Component overview W-boom system

The transport unit **T1** consists of:

- 1 W-pivot section
- 2 WA-frame 1, pivot section
- 3 W-relapse retainer

The transport unit **T2** consists of:

- 4 WA-frame 2, end section
- 5 WA-frame 1, end section
- 8 Lashing belts

The transport unit **T3** consists of:

- 6 WA-frame 2, pivot section
- 7 Relapse support

Position	Component	Weight
T1	Transport unit 1	12 t
T2	Transport unit 2	8.7 t
T3	Transport unit 3	3.6 t

2 Fastening points W-transport units

Fastening points	
A	For transport unit 1
B	For transport unit 2
C / D	For transport unit 3
E	For WA-frame 2

Fig.195219

LWE/LR 1600-2-008/18109-09-02/en

3 Assembling the W-boom system



WARNING

Danger of falling!

During assembly / disassembly work, personnel must be secured with appropriate aids to prevent them from falling. If this is not observed, assembly personnel can fall and suffer life-threatening or fatal injuries!

- ▶ All assembly work must be carried out using suitable aids (ladders, lifting platforms, scaffolding, auxiliary crane, etc.)!
- ▶ If work cannot be carried out on the ground or using such aids, then assembly personnel must be secured with the personal fall arrest system (see Crane operating instructions, chapter 2.04) to protect against falling! The personal fall arrest system must be attached in the corresponding fastening points on the crane (see Crane operating instructions, chapter 2.06).
- ▶ If railings are present on the components, then they must be brought into the corresponding position and secured for assembly / disassembly work!
- ▶ Step on aids and fall protection equipment only with clean shoes!
- ▶ Keep aids and fall protection equipment clean and free from snow and ice!



WARNING

Falling components!

If unsecured or non-supported components are assembled or disassembled, they can fall down. Personnel can be killed or seriously injured!

- ▶ During pinning and unpinning of the lattice sections, it is prohibited for anyone to remain **under** or **on** the components as well as within the entire danger zone!
- ▶ Support the boom and components before pinning / unpinning!
- ▶ Pin or unpin both pins laying in a horizontal, i.e. **left** and **right**!
- ▶ Secure the pins in the bearing points and in the receptacles!
- ▶ Do not disengage the auxiliary crane until each component is pinned on and secured!
- ▶ It is prohibited to lean a ladder against the component being disassembled!



WARNING

Danger of crushing!

Components can swing during assembling. Hands can be crushed or severed!

- ▶ Make sure that the components do not swing back and forth during assembly!



WARNING

Neglected inspection and maintenance on guy rods!

If the regular inspection and maintenance of the guy rods is not carried out or is carried out only in irregular intervals, then severe accidents can occur due to existing and unrecognized damage to the guy rods!

Personnel can be severely injured or killed!

- ▶ Check the guy rods before every assembly, see Crane operating instructions, chapter 8.15!

1

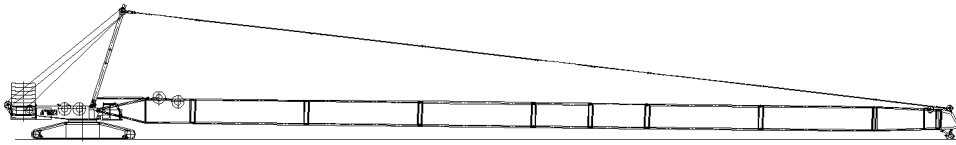

2

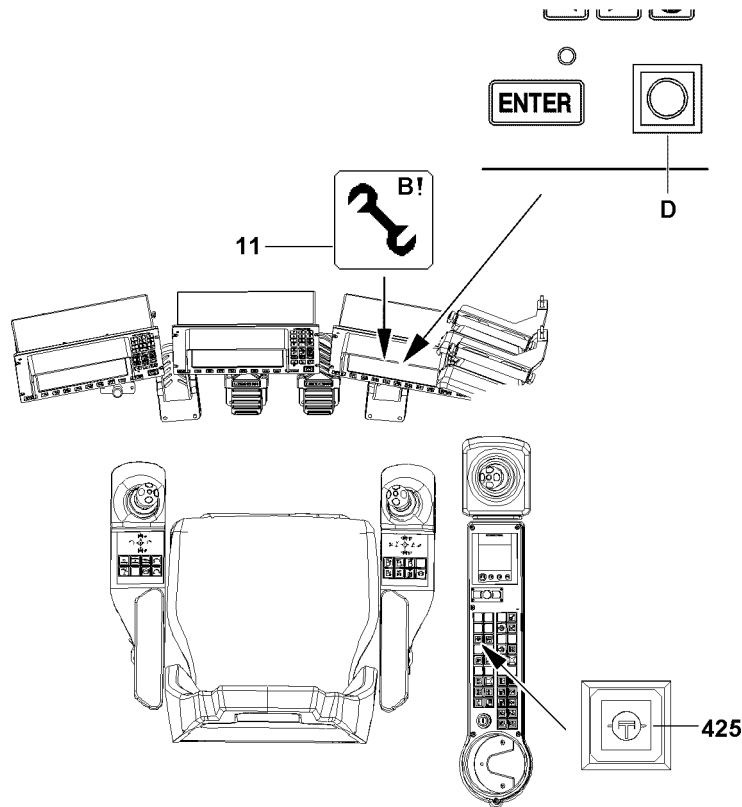
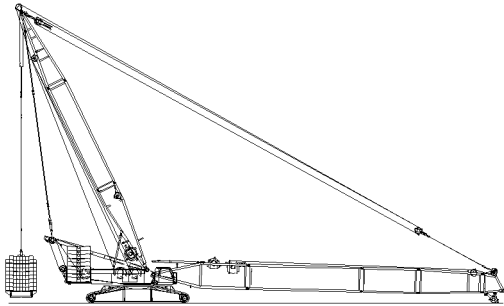

Fig.110707

**Note**

- ▶ By supporting the components during assembly / disassembly, ground unevenness is compensated for and the material is protected.

**Note**

- ▶ The W-intermediate sections are pinned and unpinned with the aid of the pin pulling device, see Crane operating instructions, chapter 5.30!

NOTICE

Property damage!

- ▶ Always insert the pins of the guy rods from the „inside“ to the „outside“!

**Note**

- ▶ The S-guy rods must be assembled and secured according to the separately supplied assembly drawings. The numbering on the assembly drawings must be identical to the numbering on the guy rods.

**Note**

- ▶ The boom combinations must be assembled according to the separately supplied rod and assembly plans!

The W-boom system can be assembled on the following basic configurations:

- S-operation, see illustration 1.
- SDB-operation, see illustration 2.

**WARNING**

Assembly with turned on set up key!

When the set up key is engaged, the LICCON overload protection is exceeded!

In the event of deliberate improper use, the crane could collapse, the boom can break off or the crane can topple over!

Personnel can be killed!

This could result in high property damage!

- ▶ The set up key **D** may only be actuated by persons who know the effects of a bypass!
- ▶ Press the set up key **D** only when the set up status was correctly entered into the LICCON computer system!
- ▶ Observe the erection / take down charts!
- ▶ Crane operation with the set up key **D** turned on is strictly prohibited!

Make sure that the following prerequisites are met:

- The crane is aligned in horizontal direction.
- The S-boom is assembled.
- In SDWB operation: The derrick boom and derrick ballast are assembled.
- The W-connector head is assembled on the S-boom.
- The counterweight is installed on the turntable and placed on the derrick ballast according to the load chart.
- The LICCON overload protection has been set according to the data in the load chart.
- The LICCON overload protection settings have been compared with the actual set up configuration.
- The LICCON overload protection is exceeded.
- The assembly icon **11** is visible on the LICCON monitor.
- An auxiliary crane is available.

3

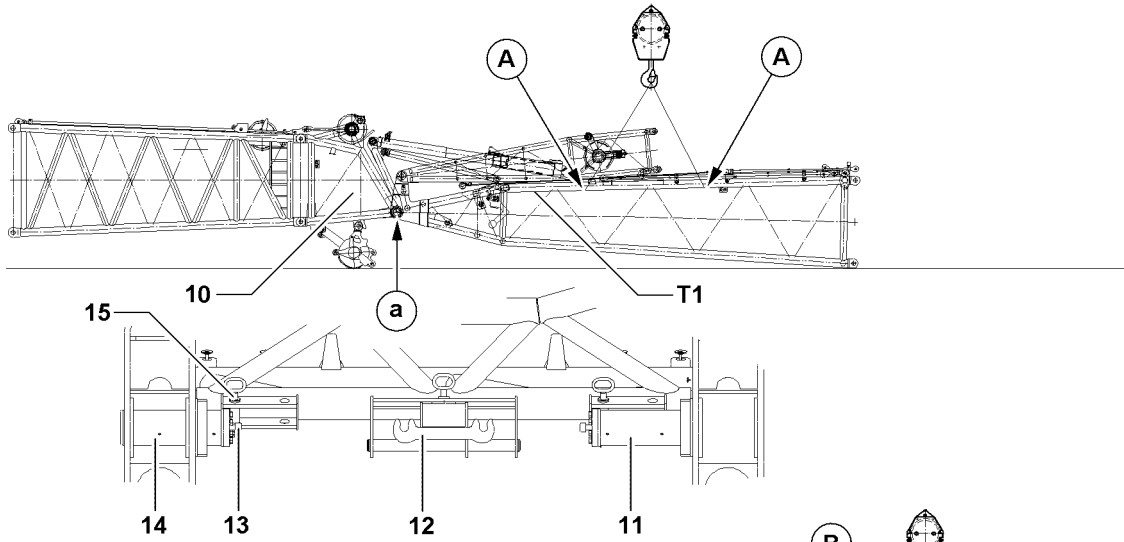

4

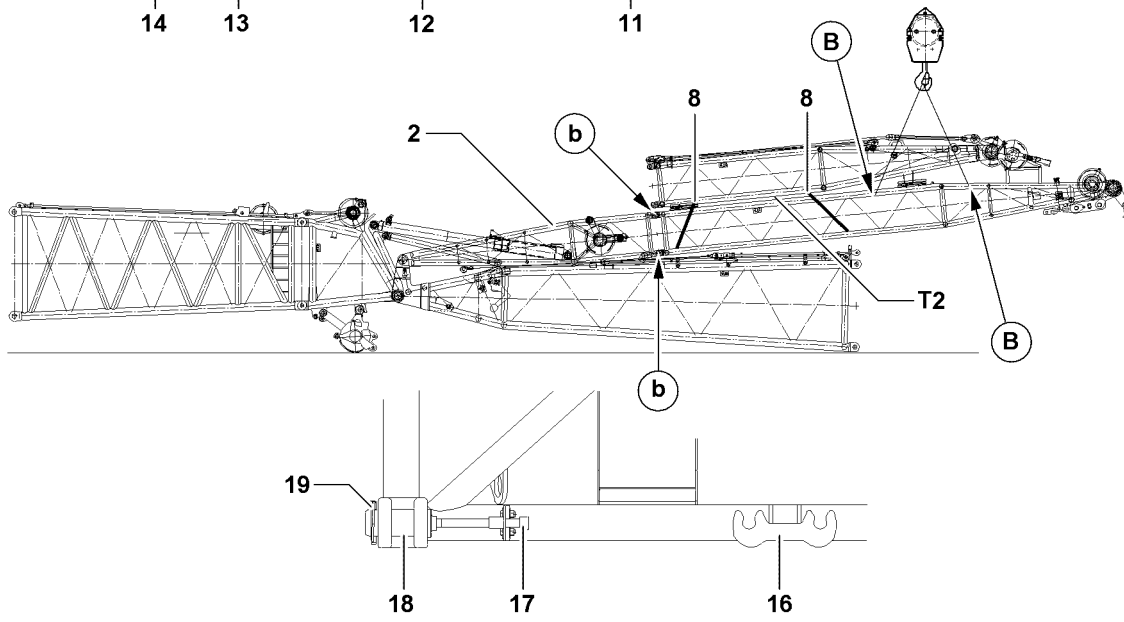

5

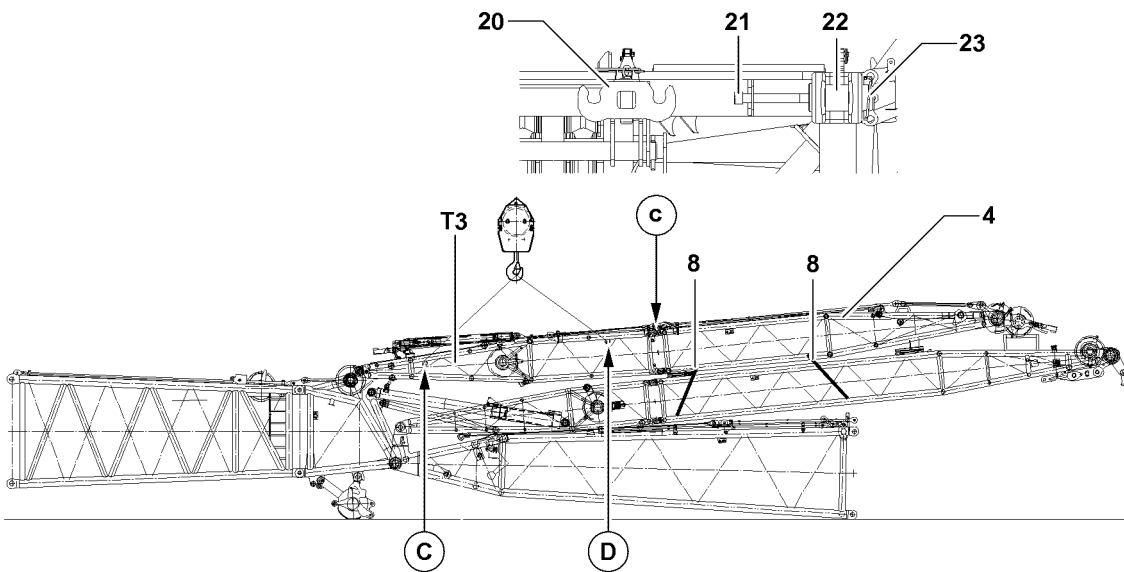

Fig.107237

LWE/LR 1600-2-008/18109-09-02/en

3.1 Assembling the W-transport units

3.1.1 Assembling the W-transport unit 1

See illustration 3

- ▶ Attach the auxiliary crane on the fastening points **A** on the transport unit **T1**.
- ▶ Hang the pin pulling cylinder on the retainer **12** and on the screw **13**.
- ▶ Make sure that the connecting pin **15** is removed.

Result:

- Pin **14** is released and can be pinned in.
- ▶ Pin transport unit **T1** on the point **a** both sides on the W-connector head **10** with pin **14** and secure with connecting pin **15**.

3.1.2 Assembling the W-transport unit 2

See illustration 4

Make sure that the following prerequisite is met:

- The lashing belts are tightly rigged on transport unit 2.



WARNING

Slipping component!

If the lashing belts are not present or insufficiently secured while raising the transport unit 2, the end section of the WA-frame 2 can slide down. Personnel can be severely injured or killed!

- ▶ Make sure that the lashing belts **8** on the transport unit **T2** are tightly secured!
- ▶ Attach the auxiliary crane on the fastening points **B** on the transport unit **T2**.
- ▶ Hang the pin pulling cylinder on the retainer **16** and on the screw **17**.
- ▶ Pin the transport unit **T2** on the WA-frame 1 pivot section **2** on both sides at the points **b** with pins **18** and secure with linchpins **19**.

3.1.3 Assembling the W-transport unit 3

See illustration 5

- ▶ Attach the auxiliary crane on the fastening points **C** on the transport unit **T3**.
- ▶ Hang the pin pulling cylinder on the retainer **20** and on the screw **21**.
- ▶ Pin the transport unit **T3** on the WA-frame 2 end section **4** on both sides on point **c** with pins **22** and secure with linchpins **23**.
- ▶ Remove lashing belts **8** on the transport unit **T2**.

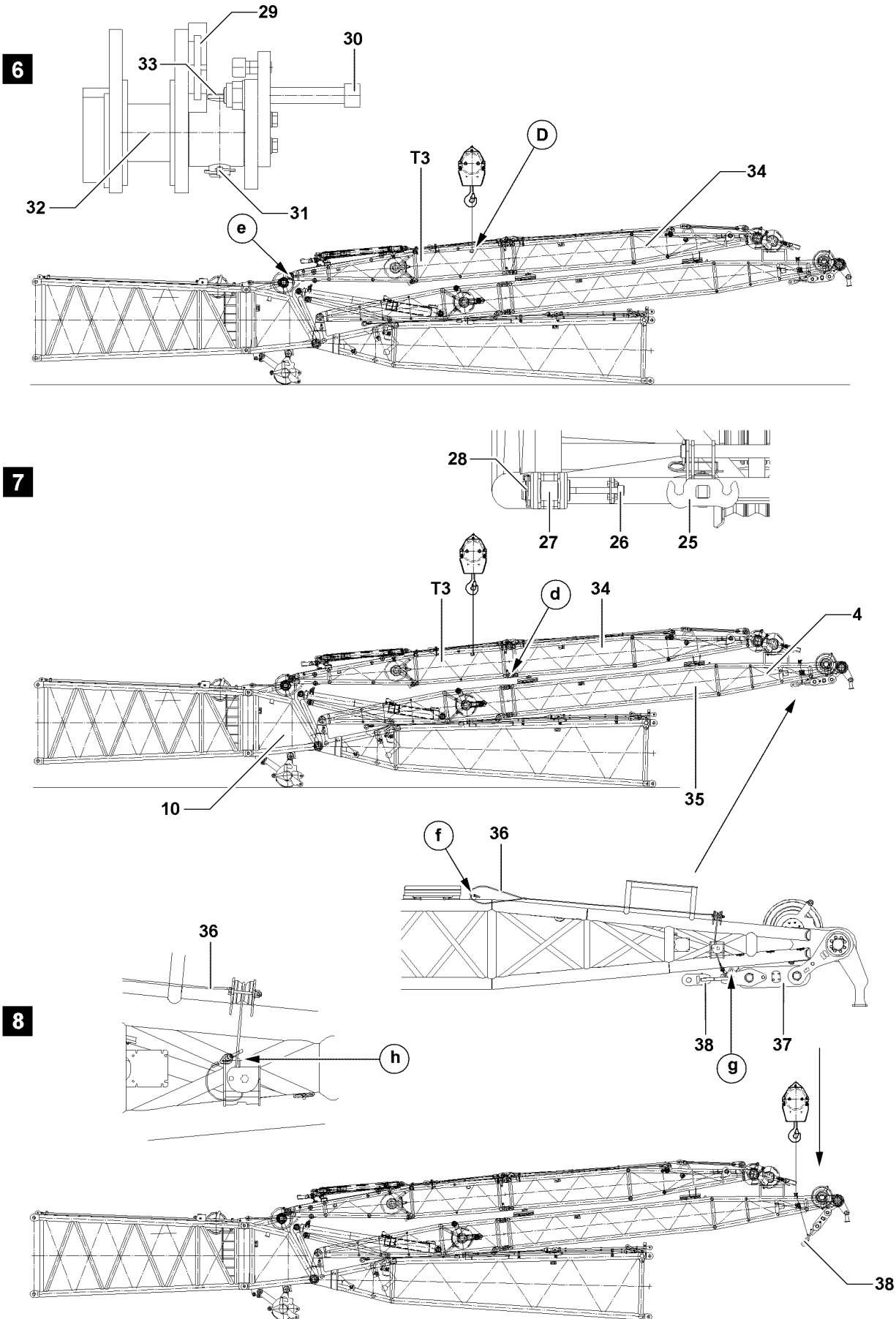

Fig.107238

LWE/LR 1600-2-008/18109-09-02/en

3.1.4 Pinning the W-transport units together

See illustration 6

- ▶ Attach the auxiliary crane on the fastening point **D** on the transport unit **T3**.

The pinning position between the transport unit and the W-connector head is established through:

- Luffing the S-boom up or down.
- Positioning of the WA-frame 2 **15** with the auxiliary crane.
- ▶ Position the WA-Bock 2 **34** until the pin points **e** align.
- ▶ Make sure that the pin **33** is removed.
- ▶ Hang the pin pulling cylinder on the retainer **29** and on the screw **30**.
- ▶ Pin the transport unit **T3** and the W-connector head **10** on both sides on point **e** with pins **32** and secure pins **33** and linchpins **31**.

See illustration 7.

- ▶ Lift the transport unit **T3** with auxiliary crane until the pin points **d** align.
- ▶ Hang the pin pulling cylinder on the retainer **25** and on the screw **26**.
- ▶ Pin the transport unit **T3** on the WA-frame 2 end section **5** on both sides on point **d** with pins **27** and secure with linchpins **28**.
- ▶ Release both sides of the ropes **36** on point **f** and hang onto the auxiliary crane.



WARNING

Components folding downward!

If the unsecured cross brace is unpinned, it will fold down. Personnel can be severely injured or killed!

- ▶ Secure the cross brace **38** with the auxiliary crane!



Note

- ▶ The cross brace **38** can be unpinned easier if it is raised with the auxiliary crane!

- ▶ Unpin the cross brace **38** on point **g**.

See illustration 8.

- ▶ Release the cross brace **38** and lower it with auxiliary crane.
- ▶ Release the ropes **36** on the cross brace **38**.
- ▶ Secure the ropes **36** on both sides in park position on point **f** and secure on point **h**.

9

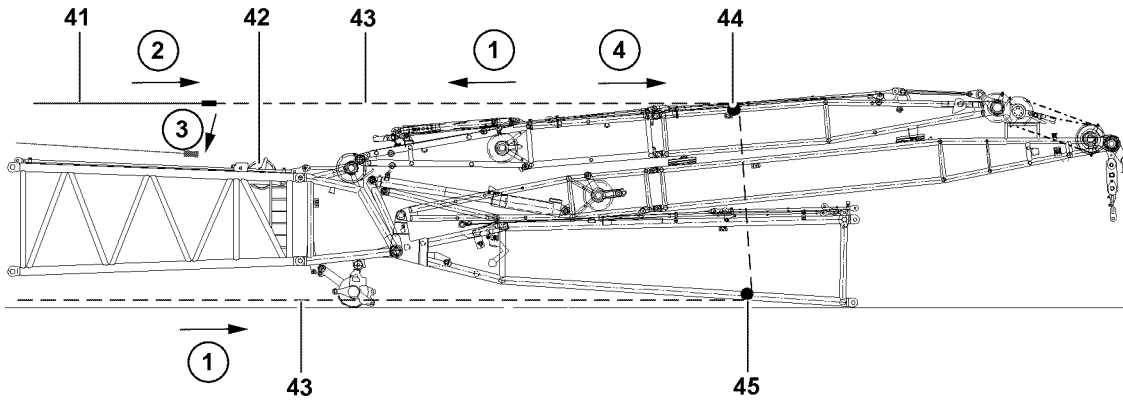

10

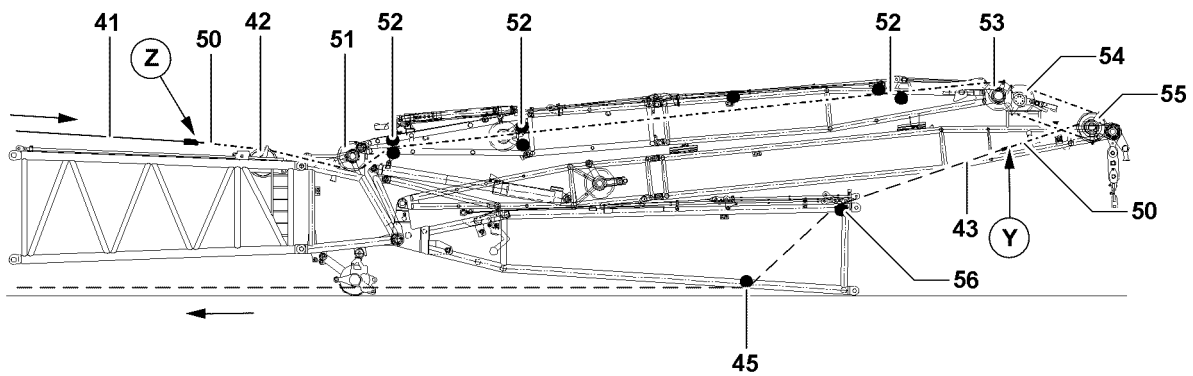

11

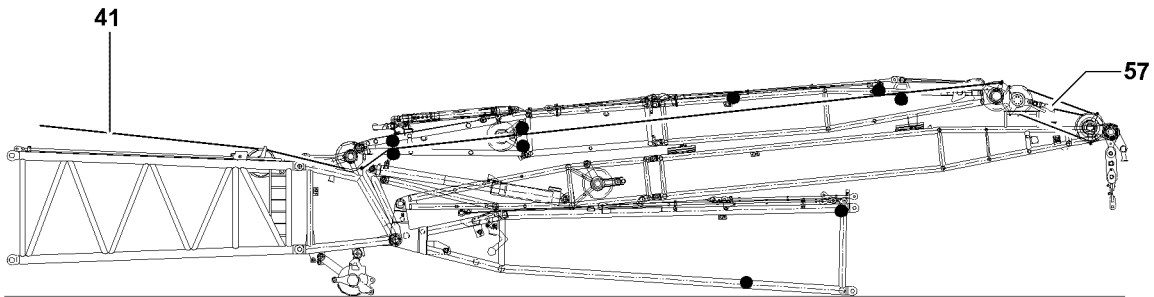

Fig.106729

LWE/LR 1600-2-008/18109-09-02/en

3.2 Reeving the W-control rope in

NOTICE

Slack rope formation!

The control rope can become damaged due to slack rope formation.

- ▶ Do not allow slack rope formation when spooling the W-control rope out!
- ▶ Keep the W-control rope tight when spooling out!



Note

- ▶ Take the reeving plan from the separately supplied drawings!

Make sure that the following prerequisite is met:

- The rope pulley **42** is pinned and secured in operating position.

3.2.1 Getting the control rope with assembly rope

Rope run for the assembly rope **43**, see illustration **9**.

- ▶ Pull the assembly rope **43** for the assembly winch over the roller **45** and the roller **44** up to winch 5, action step **1**.
- ▶ Connect the assembly rope **43** with the W-control rope **41** from winch 5.
- ▶ Pull the W-control rope **41** up to the rope pulley **42** on the S-boom: Spool the assembly winch up and simultaneously spool winch 5 out, action step **2**.
- ▶ Separate the W-control rope **41** from the assembly rope **43** and lay it down in front of the rope pulley **42**, action step **3**.
- ▶ Pull the assembly rope **43** back up to the roller **45** and lay on the ground, action step **4**.

3.2.2 Reeving the W-control rope in

Make sure that the following prerequisites are met:

- The intake ropes are interconnected on the WA-frame **2**.
- The intake role is reeved in on the W-roller sets.



Note

- ▶ Before reeving in the W-control rope, the rope retaining pins of rope pulley **42**, rope pulley **51**, rope pulley **53**, pulley set **54** and pulley set **55** must be released and unpinned!



Note

- ▶ For simplify the reeving, the W-pulley sets are raised with an auxiliary crane!

Rope run for the intake rope **50** and the assembly rope **43**, see illustration **10**.

- ▶ Connect the W-control rope **41** and the intake rope **50** on point **Z**.
- ▶ Ensure that the intake rope **50** runs between the rollers **52**.
- ▶ Lay the intake rope **50** on the rope pulley **42** and the rope pulley **51**.
- ▶ Pull the assembly rope **43** over the roller **56** to the point **Y**.
- ▶ Connect the assembly rope **43** and the intake rope **50** on point **Y**.

See illustration **11**.

- ▶ Pull the W-control rope **41** in and hook it on the rope fixed point **57**.
- ▶ Spool the assembly rope **43** on the assembly winch.

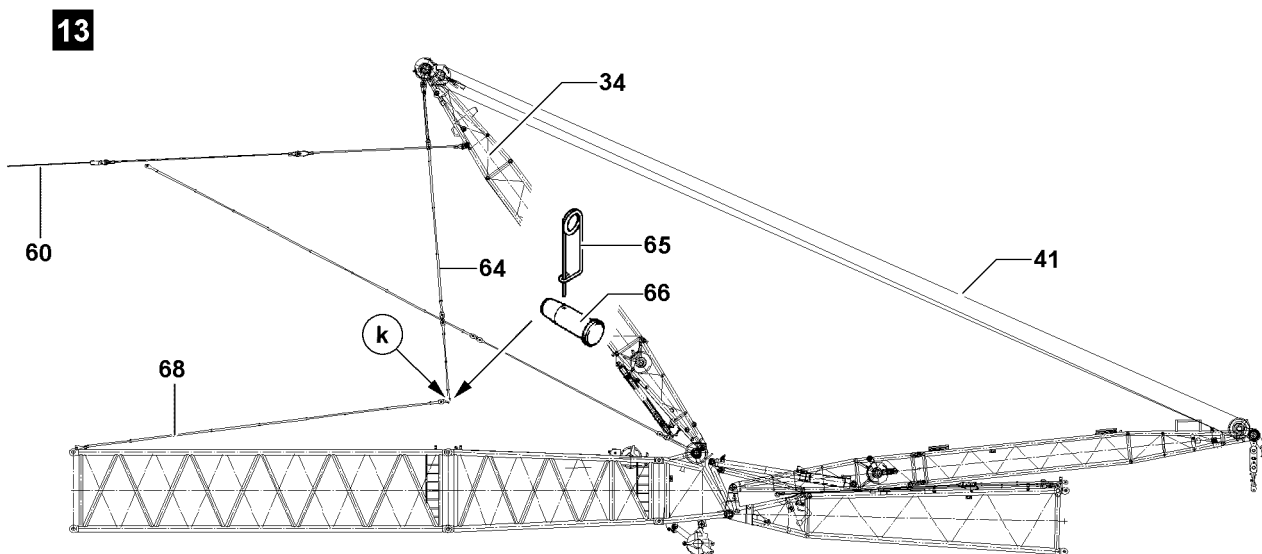
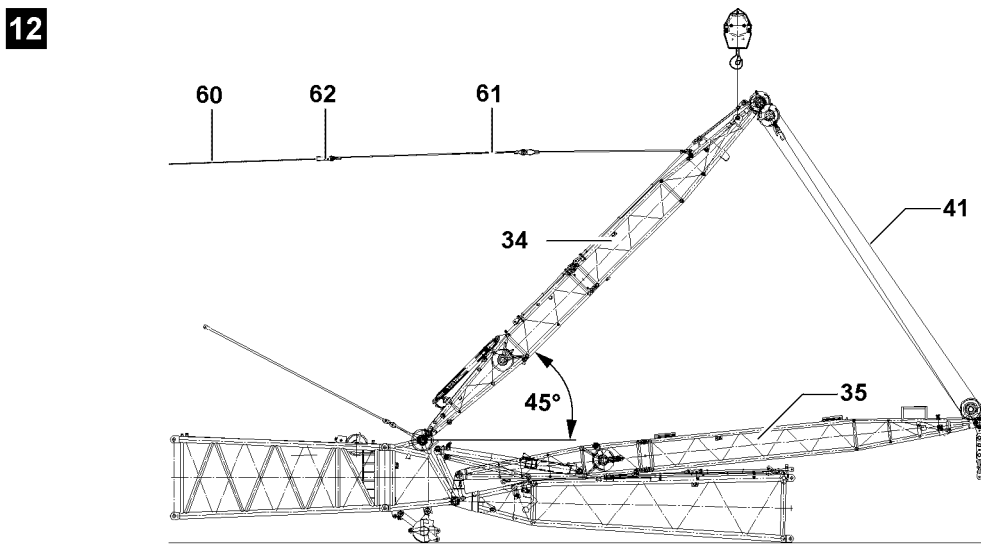
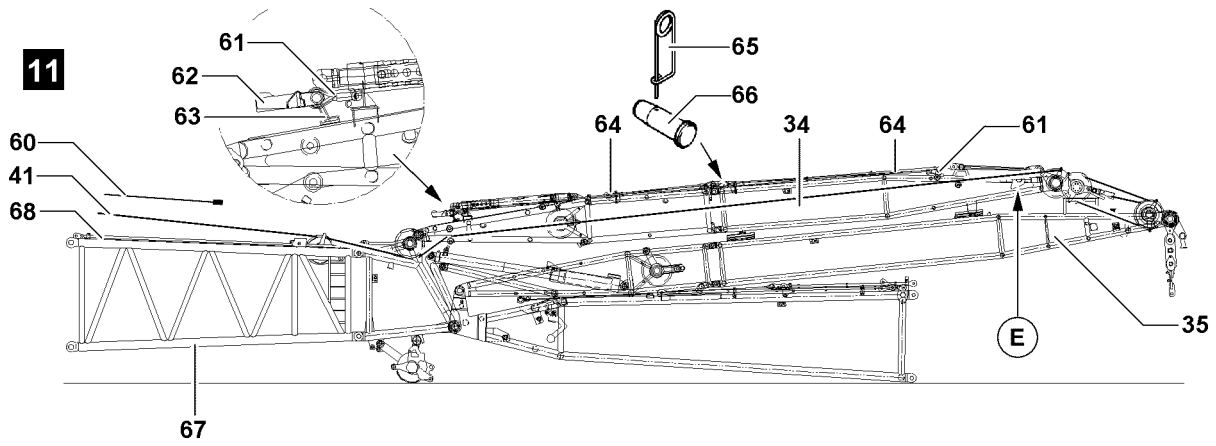

Fig.107264

LWE/LR 1600-2-008/18109-09-02/en

3.3 Assembling the guy rods WA-frame 2

NOTICE

Property damage!

- ▶ Always insert the pins of the guy rods from the „inside“ to the „outside“!

Make sure that the following prerequisite is met:

- The WA-frame 2 **34** is laying on the WA-frame 1 **35**.

See illustration **11**.

- ▶ Release and unpin transport restraints of the W-guy rods **68** on the S-lattice sections **67**.
- ▶ Release and unpin the transport retainers for the W-guy rods **64** on the WA-frame 2 **34** on both sides.
- ▶ Pin W-guy rods **64** on the WA-frame 2 **34** on both sides from the „inside“ to the „outside“ with pins **66** and secure with spring retainers **65**.
- ▶ Release the mounting **63** for the assembly rope **61** on WA-frame 2 **34**.
- ▶ Hang hoist rope **60** in the hook block **62** on the assembly rope **61**.
- ▶ Attach auxiliary crane to fastening points **E**.

See illustration **12**.



Note

- ▶ While spooling out the W-control rope, lift the WA-frame 1 **35** up slightly in order to prevent slack rope formation!
- ▶ Spool the W-control rope **41** out and simultaneously lift the WA-frame 2 **34** with an auxiliary crane by approximately 45 °.
- ▶ Tension the hoist rope **60** until the WA-frame 2 **34** is held by the hoist rope.
- ▶ Remove the auxiliary crane.

See illustration **13**.

- ▶ Spool the W-control rope **41** out and simultaneously pull the WA-frame 2 **34** backward with the hoist rope **60**.
- ▶ Pin the W-guy rods **64** on both sides in point **k** from the „inside“ to the „outside“ with pins **66** and secure with spring retainers **65**.

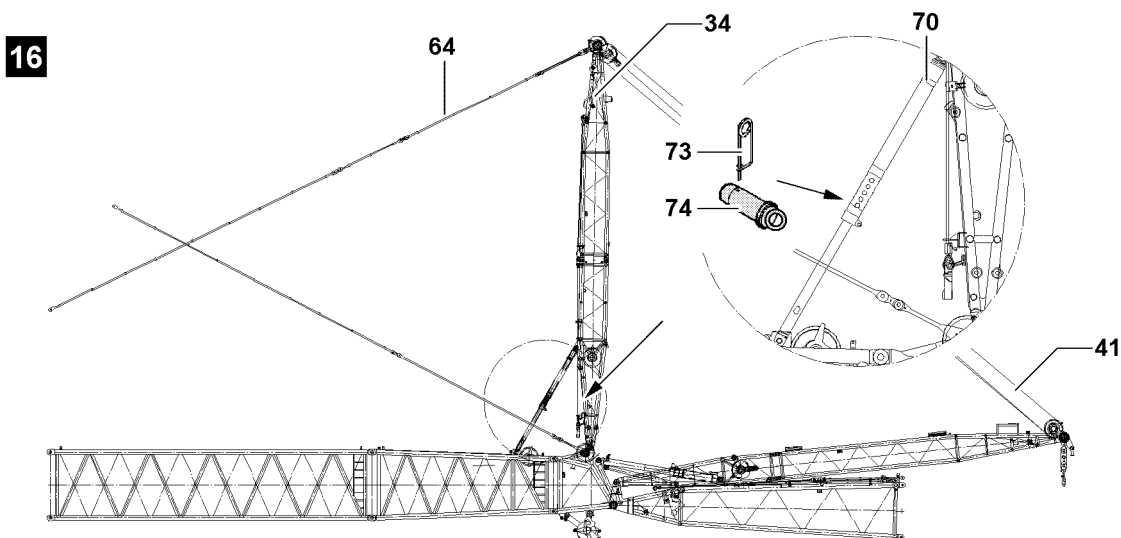
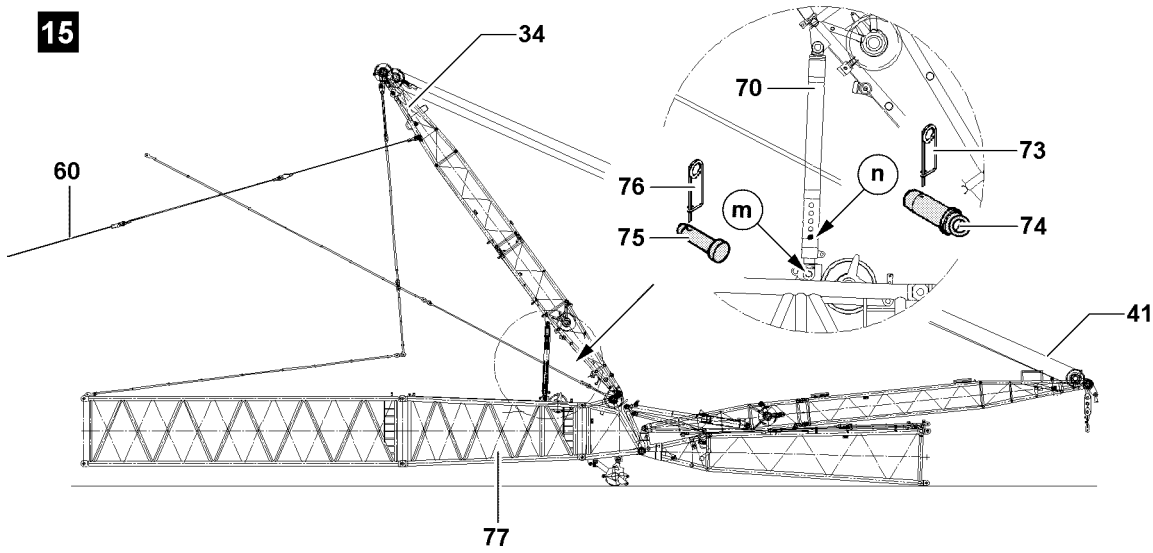
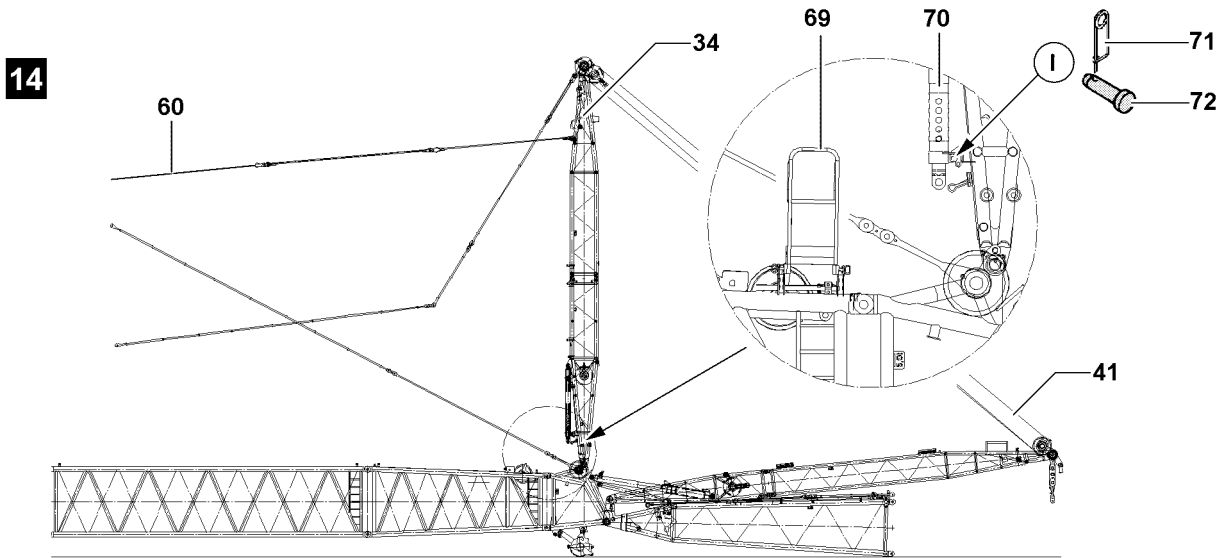

Fig.106730

LWE/LR 1600-2-008/18109-09-02/en

3.4 Pinning the relapse supports

See illustration 14.

- ▶ Erect the WA-frame 2 **34** vertically: Spool the W-control rope **41** up and simultaneously spool out the hoist rope **60**.



WARNING

Danger of falling!

If the folding brackets **69** on the SL-reducer section are not used, personnel can fall down and be severely injured or killed!

- ▶ Carry out the pinning of the relapse supports of the folding brackets on the SL-reducer section!



WARNING

Uncontrolled swinging of the relapse supports!

If the relapse supports are unpinned without the WA-frame 2 standing vertically, the relapse supports can swing without control. Personnel can be severely injured or killed!

- ▶ Unpin the relapse supports **70** after the WA-frame 2 **34** is erected vertically!
- ▶ Unpin the relapse supports **70** on point I: Remove the spring retainer **71** and unpin the connecting pins **72**.

See illustration 15.

- ▶ Spool the W-control rope **41** out and simultaneously pull back the WA-frame 2 **34** with the hoist rope **60** until the relapse supports **70** on point **m** on the SL-reducer section **77** can be pinned.
- ▶ Unpin the relapse supports **70** on point **m**: Insert the pins **75** on both sides and secure with spring retainers **76**.

NOTICE

Damage of WA-frame 2!

If the connecting pin is not unpinned before erection of WA-frame 2, the WA-frame 2 can be damaged!

- ▶ Unpin the connecting pin **74** before erection of the WA-frame 2 **34**!
- ▶ Remove the spring retainer **73** and unpin the connector pins **74** on the point **n**.

See illustration 16.

- ▶ Erect the WA-frame 2 **34** until the guy rods **64** tension: Spool the W-control rope **41** up.
- ▶ Luff up WA-frame 1 **35** until the limit switch switches off the movement.

Result:

- Relapse supports are completely tensioned.
- ▶ Insert relapse supports **70** in maximum possible length with connecting pins **74** and secure with spring retainers **73**.

17

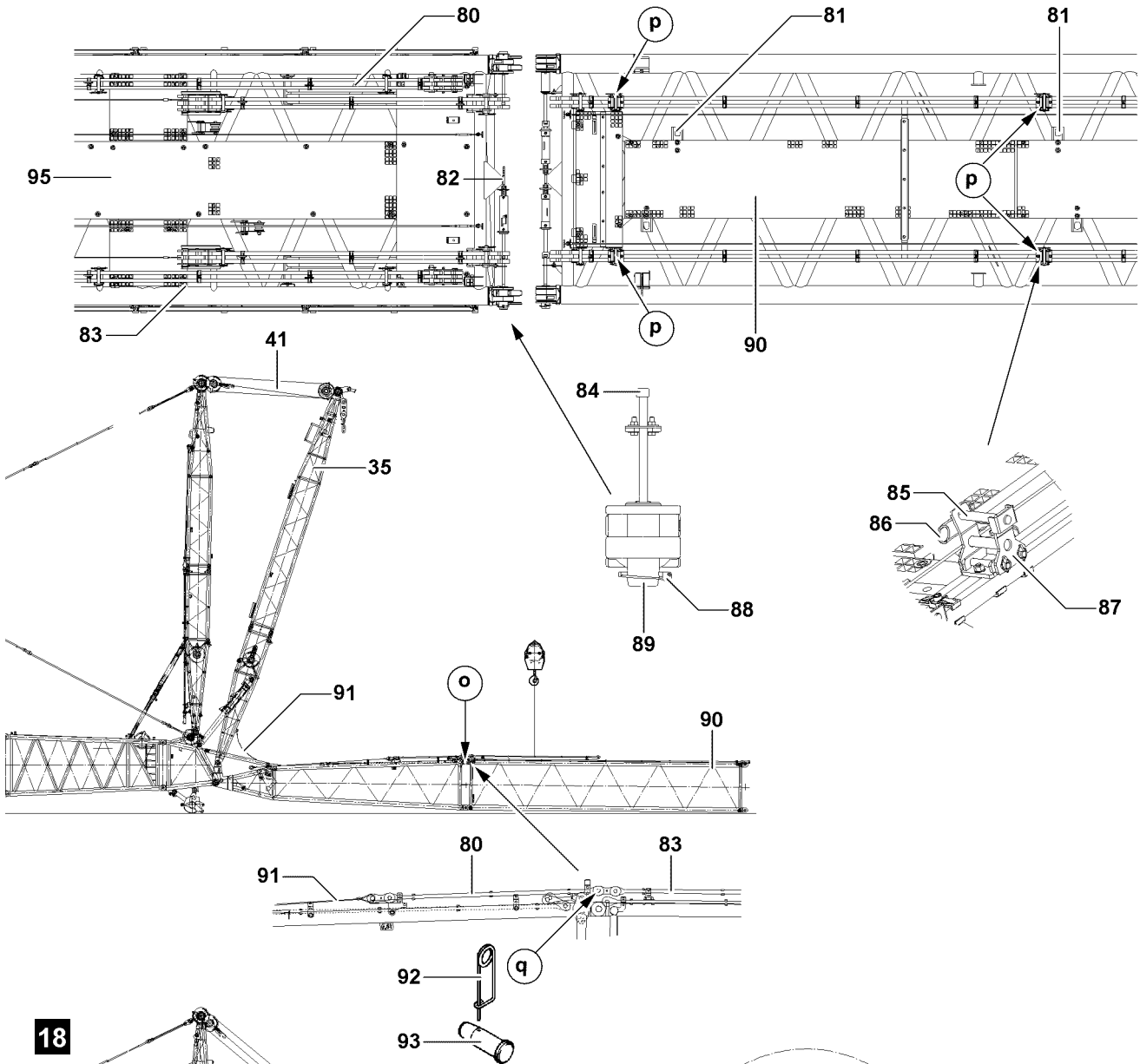

18

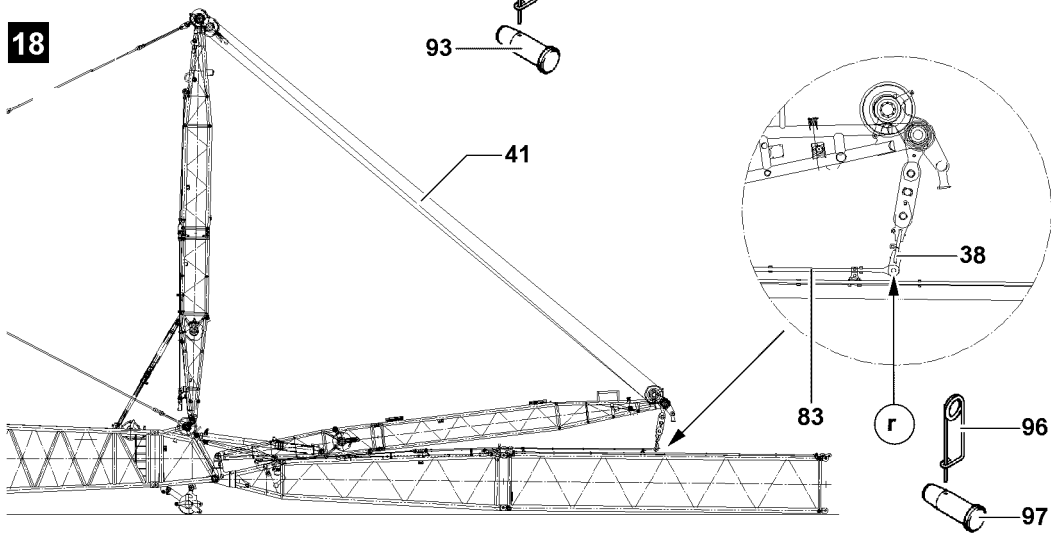

Fig.107239

3.5 Assembling the W-lattice jib



Note

- ▶ During assembly of the W-lattice jib, adhere to the pin sequence, see Crane operating instructions, chapter 5.01!

3.5.1 Assembling the W-lattice section

See illustration 17.

- ▶ Erect the WA-frame 1 **35**: Spool the W-control rope **41** up.
- ▶ Hang the pin pulling cylinder on the retainer **82** and on the screw **84**.
- ▶ Pin LI-intermediate section **90** both sides on the point **o** with pins **89** and secure with linchpins **88**.
- ▶ Remove transport retainers from guy rods **80** and guy rods **83**.
- ▶ Remove receptacle **87** from the parking position **81** and assemble points **p**.
- ▶ Remove spring retainer **86** and pins **85**.

Result:

- Guy rods **83** can be placed on the LI-intermediate section **90**.
- ▶ Lay guy rods **83** both sides with the auxiliary crane receptacle **87** on the LI-intermediate section **90**.
- ▶ Pin guy rods **80** and guy rods **83** both sides on the point **q** from „the inside“ to the „outside“ with pins **93** and secure spring retainers **92**.
- ▶ Ensure that WA-frame 1 **35** and the guy rods **80** are bound with the assembly ropes **91**.

See illustration 18.

- ▶ Put down WA-frame 1 **35** until cross brace **38** can be pinned with guy rods: Spool the W-control rope **41** out.
- ▶ Pin the cross brace **38** and the guy rods **83** both sides on point **r** from the „inside“ to the „outside“ with pins **97** and secure spring retainers **96**.

19

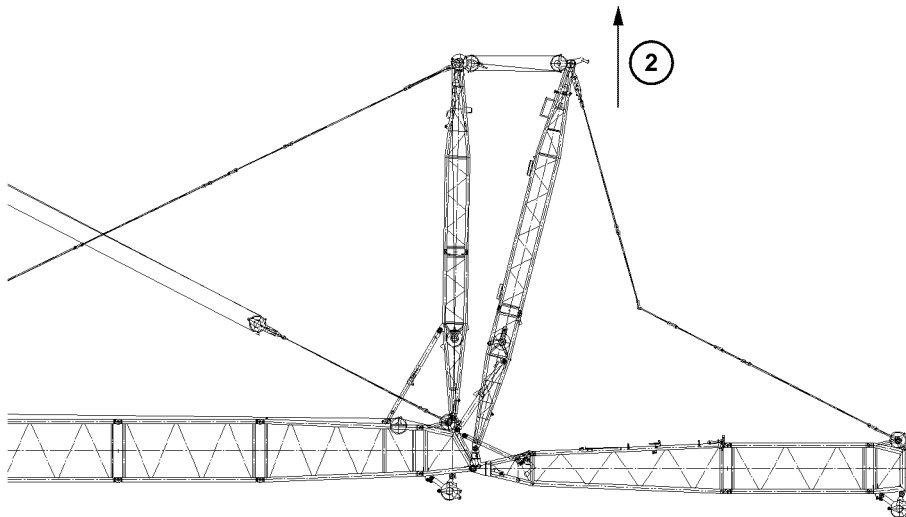
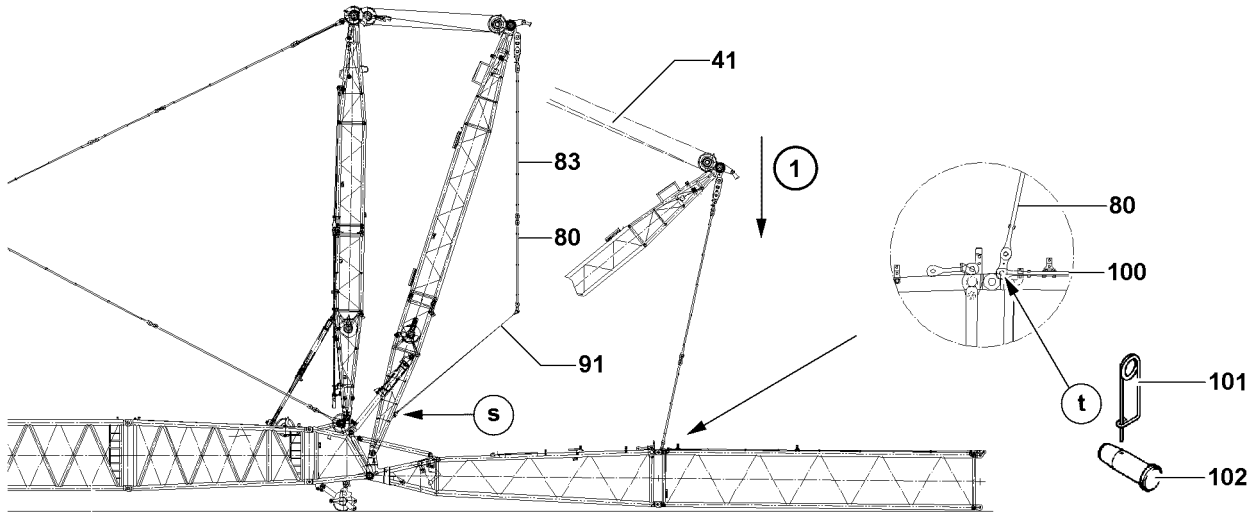

Fig.106840

LWE/LR 1600-2-008/18109-09-02/en

See illustration **19**.

- ▶ Erect the WA-frame 1 **35** until the assembly rope **91** on the point **s** can be unhooked: Spool the W-control rope **41** up.
- ▶ Unhook the assembly rope **91** on point **s**.
- ▶ Lower the WA-frame 1 **35** and unhook the assembly rope **91** on point **t**.

Make sure that the following prerequisite is met:

- The SW-end section has been placed in the pulley cart at assembly of the W-lattice jib, see Crane operating instructions, chapter 5.15.



Note

- ▶ The air pressure in the tires of the pulley cart must be 9 bar !



WARNING

Falling components!

If the intermediate sections are incompletely pinned, then components can fall down. Personnel can be severely injured or killed.

- ▶ Make sure that all components of the boom are completely pinned and secured.

- ▶ Assemble the W-lattice jib to the required length.
- ▶ Spool the hoist rope out and pull to the W-end section.

3.5.2 Assembling the W-guy rods

The W-guy rods are placed and secured for transport on the W-lattice sections. Before assembly of the W-guy rods, the transport retainers must be released.

See illustration **19**.

- ▶ Release and unpin the transport retainers of the W-guy rods.



Note

- ▶ The guy rods for the LI-intermediate sections are pinned to each other starting from the fixed point on the end section of the boom.

NOTICE

Property damage!

- ▶ Always insert the pins of the guy rods from the „inside“ to the „outside“!

- ▶ Pin and secure the guy rods for all LI-intermediate sections.

When all boom system guy rods are pinned with one another:

- ▶ Put down WA-frame 1 **35** until the guy rods can be pinned **80** with the guy rods **100** in the point **t**: Spool the W-control rope **41** out.
- ▶ Pin the guy rods **80** and the guy rods **100** on both sides on the point **t** with pins **102** and secure with spring retainers **107**.
- ▶ Tension the W-guy rods: Spool the W-control rope **41** up.

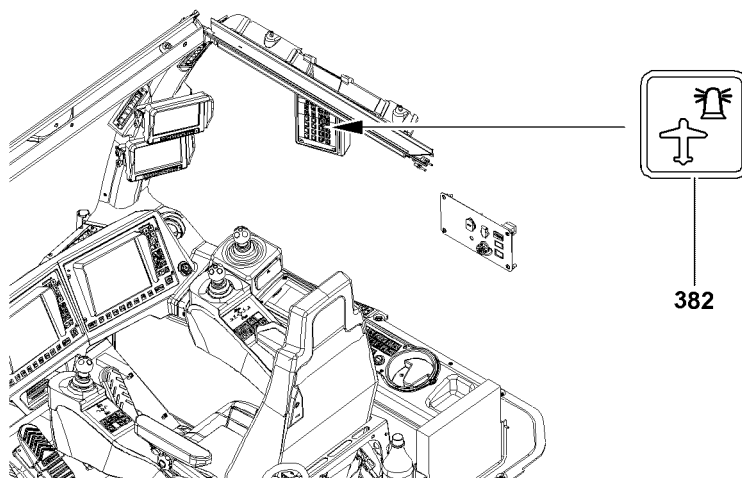
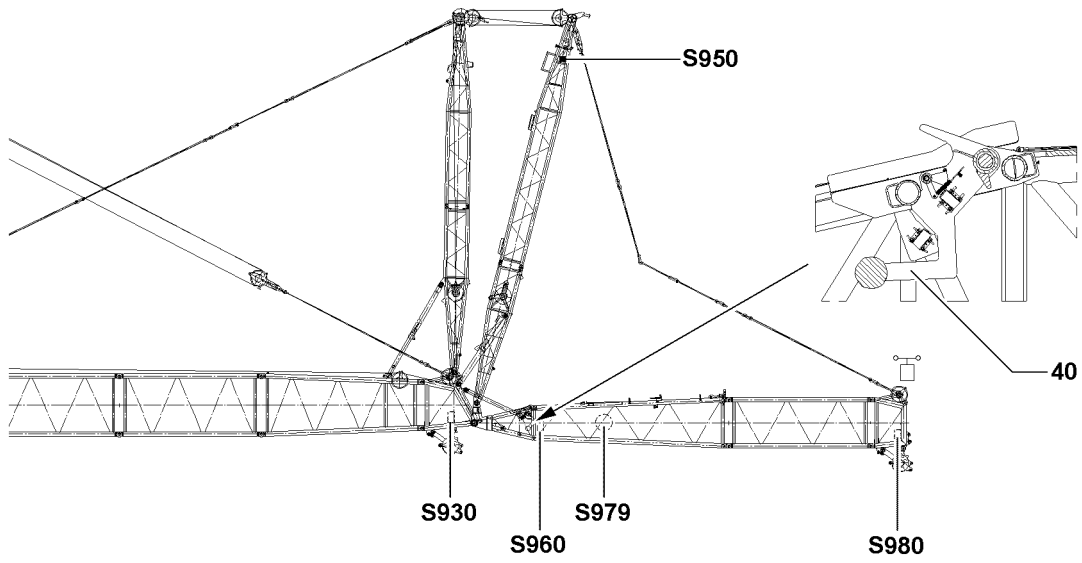

Fig.106733

3.6 Establishing the electrical connections

Make sure that the following prerequisite is met:

- The W-boom is completely assembled.
- The airplane warning light and the wind speed sensor are installed.



CAUTION

Damage to the electrical connection on the cable drum!

If the electrical connection from the cable drum to the terminal box on the W-pivot section is established first before the connection to the terminal box on the SW-end section, the electrical connection is damaged when spooling out the cable drum!

- ▶ Make the electrical connection from the cable drum in the W-pivot section to the terminal box on the SW-end section and then effect the electrical connection from the terminal box in the W-connector head to the cable drum!



Note

- ▶ To establish the electrical connections on the W-boom, the separate Electric wiring diagram must be used!

-
- ▶ Establish the electrical connections.
 - ▶ Make sure that all electrical connections on the boom are established.

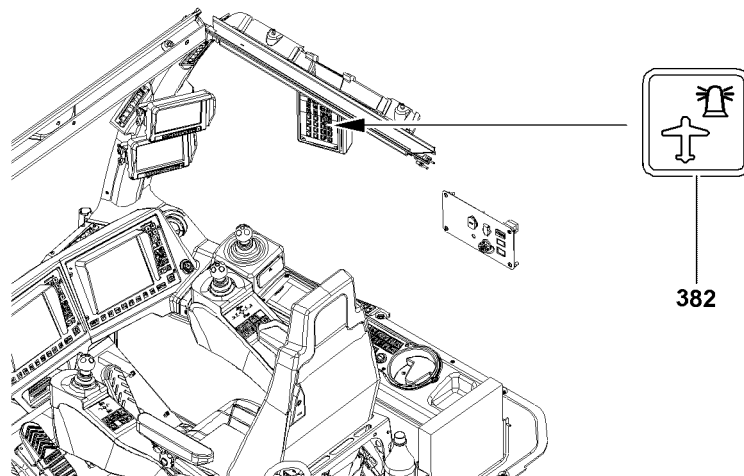
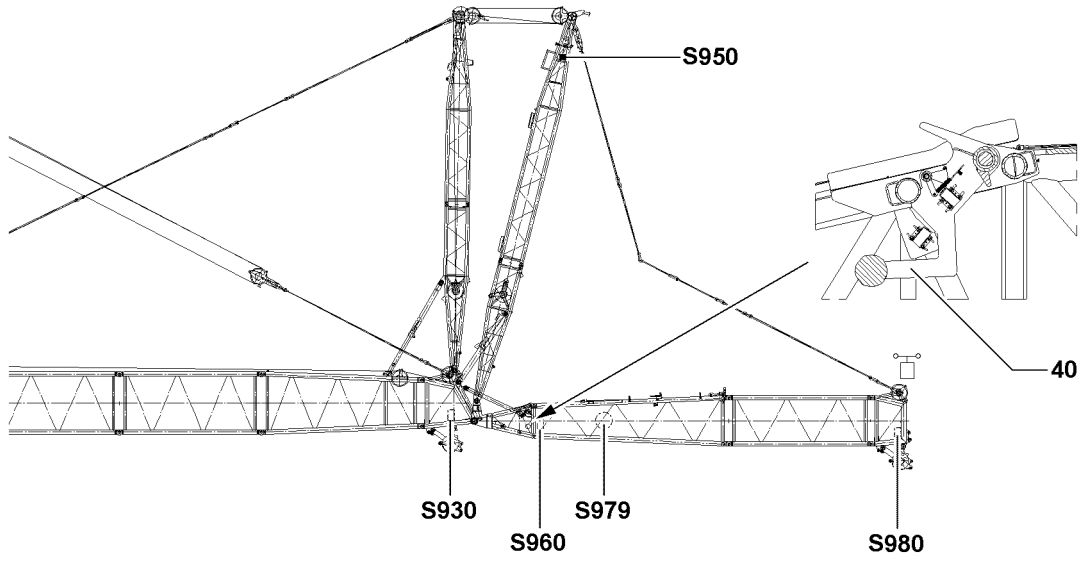

Fig.106733

3.7 Checking the function of the safety devices



WARNING

Non-functioning safety devices!

If the function of the safety devices is defective, personnel can be severely injured or killed!

- ▶ Crane operation with non-functioning safety devices is **prohibited!**



Note

- ▶ The function of the individual limit switches must be checked before erection!
- ▶ The function of the limit switch initiators must be checked in the test system, see separate „Diagnostics“ manual!



Note

- ▶ If a function check on the limit switches or on the safety devices does not lead to the desired shut offs, then the plug connections on the connector boxes or the components itself must be checked.
- ▶ If no visible connection errors or component defects can be found, contact **LIEBHERR** service!

Make sure that the following prerequisites are met:

- All electrical connections have been made.
- The crane engine is running.
- The corresponding operating mode is set on the LICCON monitor.

3.7.1 Checking the wind speed sensor

- ▶ Test the movement and the function of the wind speed sensor.

3.7.2 Checking the airplane warning light

- ▶ Turn on the airplane warning light on with the button **382**.
- ▶ Check the function visually.

3.7.3 Checking the oscillation guard



DANGER

Danger of tipping over if the oscillation guard is hard to move!

If the oscillation guard is hard to move, the mechanical relapse retainer will no longer function. The W-lattice jib can tip backwards uncontrolled and cause the crane to topple over!

- ▶ Crane operation with hard to move oscillation guard is prohibited!
- ▶ Check the oscillation guard **40** for easy movement.

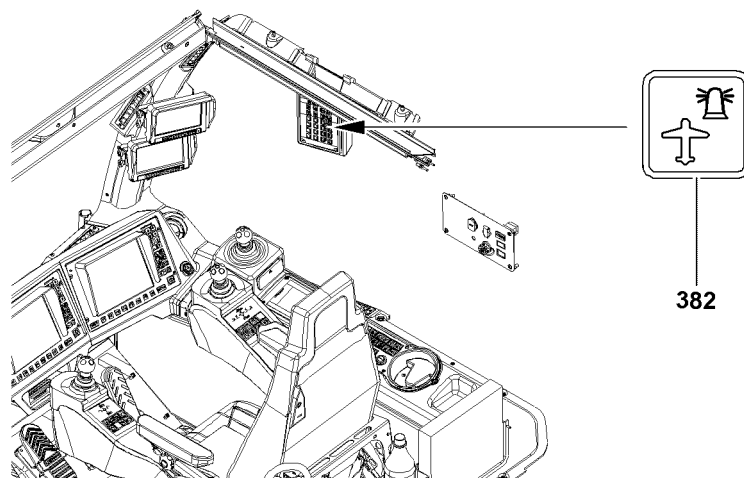
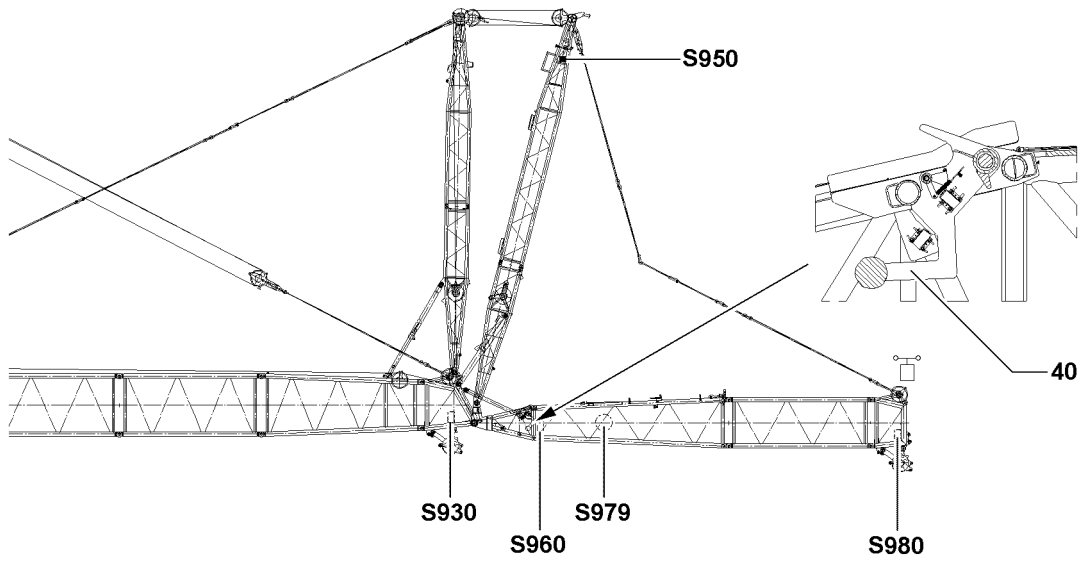

Fig.106733

3.7.4 Checking the hoist limit switch on the pulley head



Note

- ▶ When replacing or changing a hoist limit switch (HES), the corresponding hoist limit switch must have the correct bus address and the correct software version in order to be detected again by the bus system (LSB)!

- ▶ Actuate the hoist limit switch manually on the pulley head.

Result:

- The spool up function of the hoist winch turns off.
- The icon „Hoist top“ appears on the LICCON monitor 0.
- The limit switch is functioning.

3.7.5 Checking the limit switches



Note

- ▶ The limit switch functions have to be checked individually before erection!

Testing the limit switch W-lattice jib „Steepest position“, relapse cylinder

- ▶ Cover the limit switch initiators individually with a metal plate, see Crane operating instructions, chapter 8.12!

Result:

- The icon „Boom limitation“ appears on the LICCON monitor 0.
- The spool up function of winch 5 turns off.

Testing the limit switch W-lattice jib „Steepest position“, relapse cylinder

- ▶ Cover the limit switch initiators individually with a metal plate, see Crane operating instructions, chapter 8.12!

Result:

- The icon „Boom limitation“ appears on the LICCON monitor 0.
- The spool up function of winch 5 turns off.

Testing the limit switch flap W-lattice jib „Steepest position“, relapse cylinder

- ▶ Cover the limit switch initiators individually with a metal plate, see Crane operating instructions, chapter 8.12!

Result:

- The icon „Boom limitation“ appears on the LICCON monitor 0.
- The spool up function of winch 5 turns off.

3.7.6 Checking the limit switch S-boom „steepest position“

- ▶ Cover the limit switch initiators on the S-relapse cylinder individually with a metal plate.

Result:

- The limit switch is actuated manually.
- The spool up function of winch 4 (control winch) turns off.
- The icon „Boom limitation“ appears on the LICCON monitor 0.
- The limit switch is functioning.

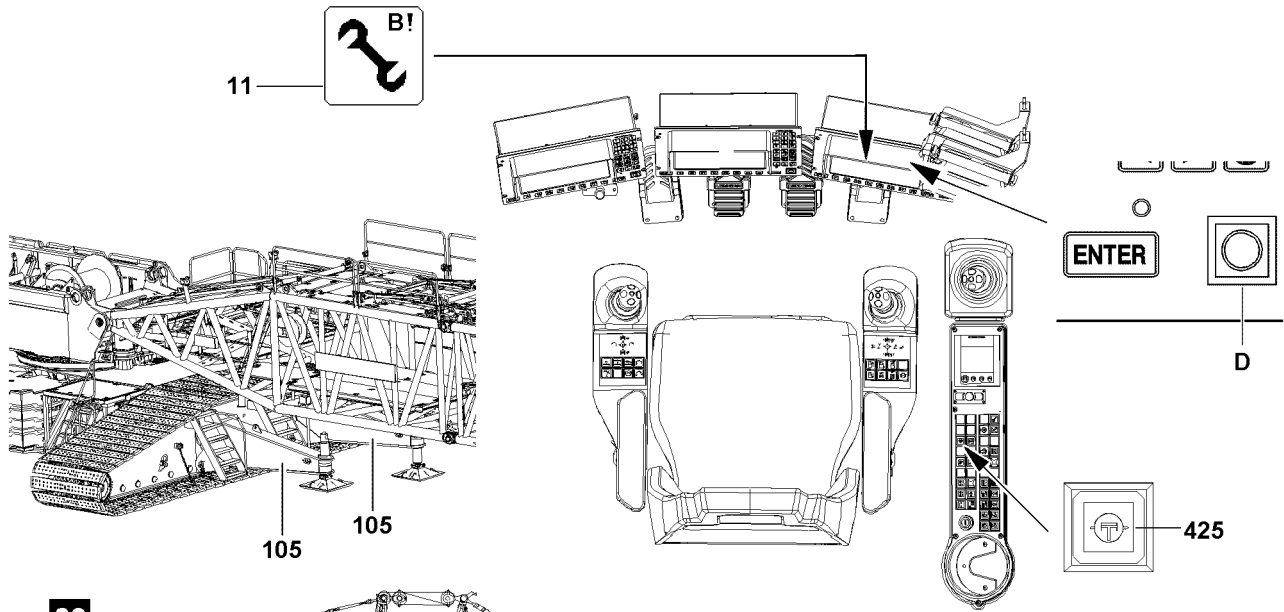

20

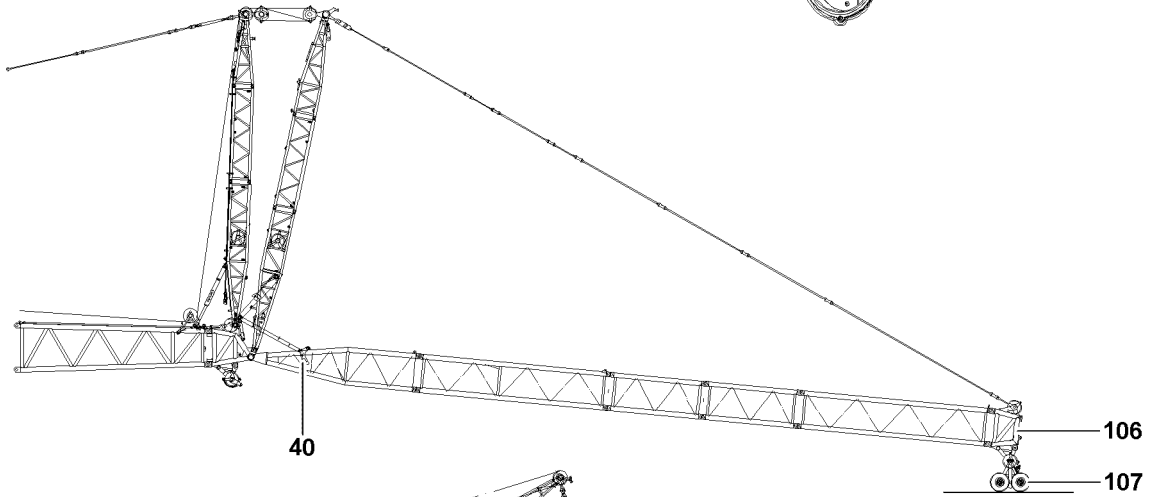

21

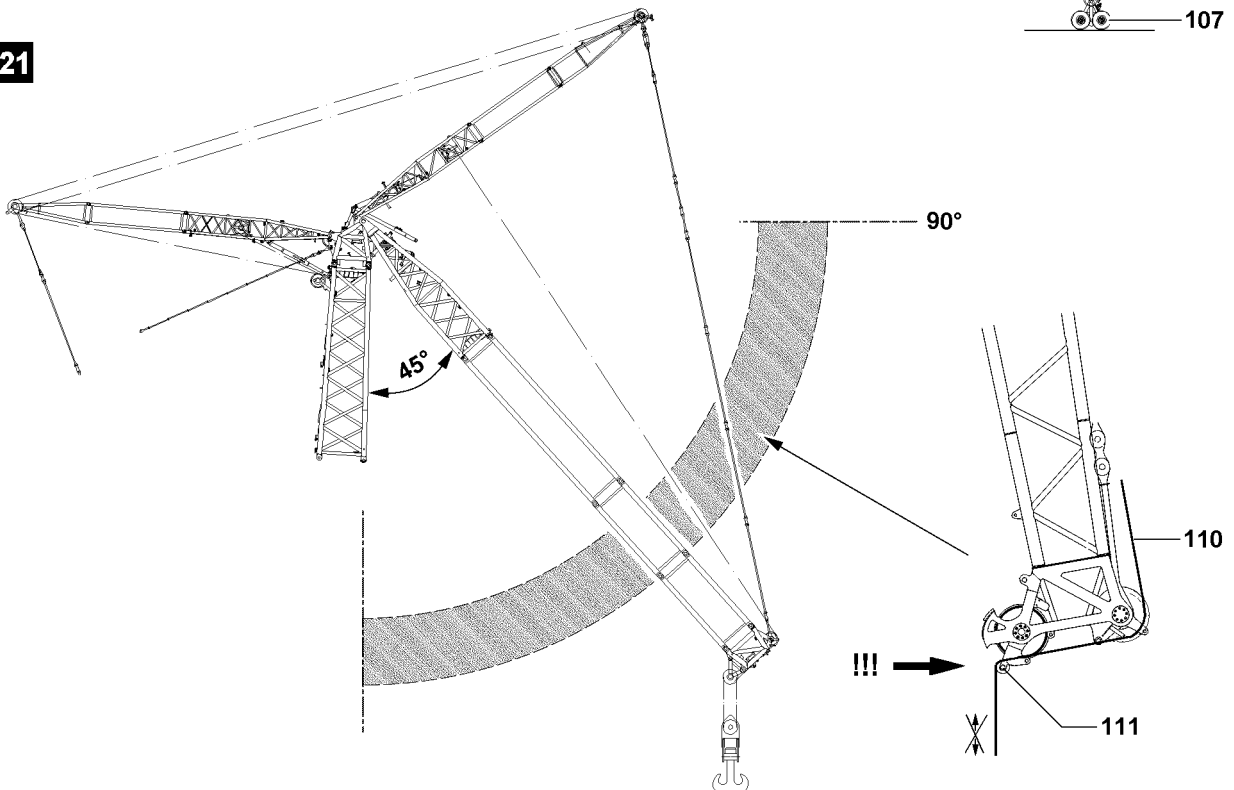

Fig.110710

LWE/LR 1600-2-008/18109-09-02/en

3.8 Erecting the boom



DANGER

The crane can topple over!

- ▶ It is not permitted to turn the crane during erection!
- ▶ Observe the data in the erection and take down charts!
- ▶ Observe the technical safety notes, see Crane operating instructions, chapter 5.01!



DANGER

The crane can topple over!

For certain boom lengths, the mechanical auxiliary supports must be assembled, see Erection and take down charts!

- ▶ The boom must be erected or taken down „to the side“ „in direction“ of the mechanical auxiliary supports **105!**
- ▶ Always erect or take down according to the data in the **Erection and take down charts!**



DANGER

Tipping lattice jib!

If the easy movement on the pendulum of the mechanical relapse support is not checked before erection or not reestablished, if necessary, then the mechanical relapse support will not engage in steep lattice jib position. As a result, the lattice jib can tip to the rear!

Personnel can be severely injured or killed!

- ▶ Check the easy movement on the pendulum **40** of the mechanical relapse support before erection!
- ▶ If the pendulum does not move easily: Make the pendulum **40** easy to move!



WARNING

The crane can topple over!

If the following conditions are not met before erecting the boom, the crane can topple over. Personnel can be severely injured or killed!

- ▶ The lattice jib must roll on the ground with its entire weight!
- ▶ Spool the lattice jib control out so that the guy rods sag slightly!
- ▶ Do not allow slack cable to build up on the control winch!
- ▶ Move the relapse cylinder out before erection!

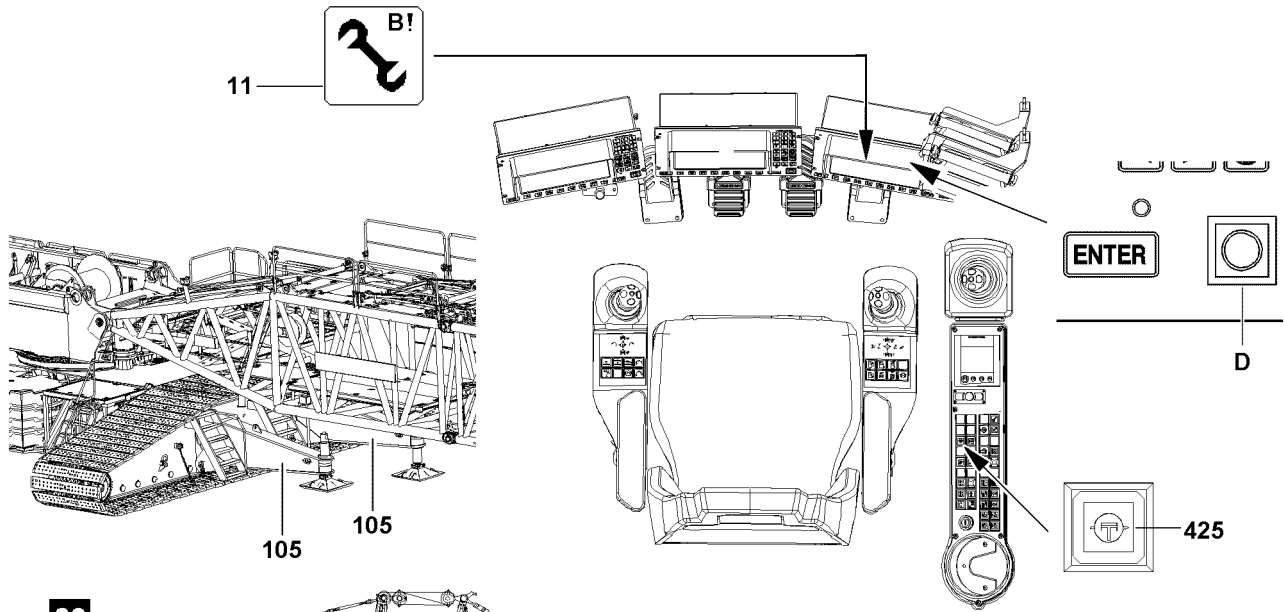

20

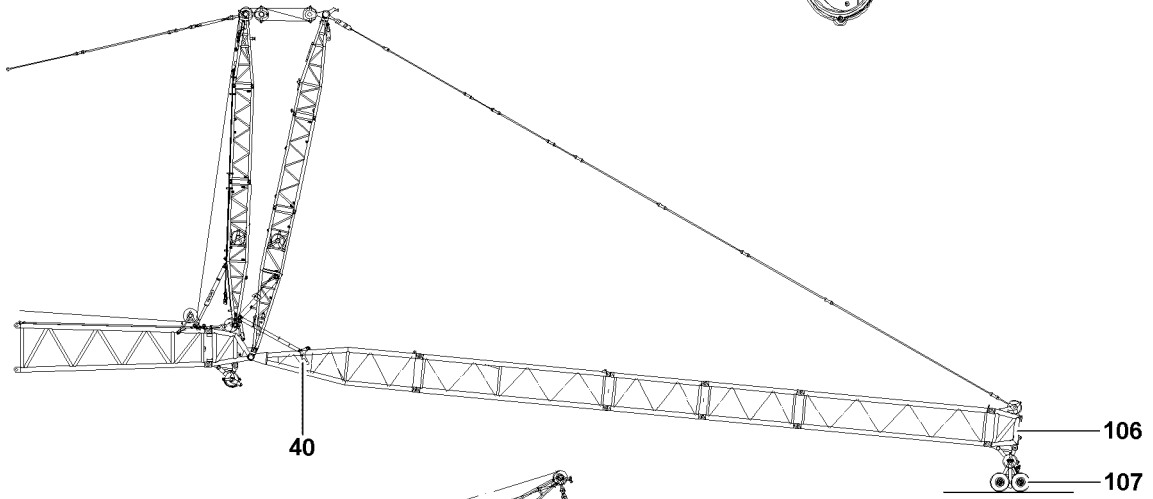

21

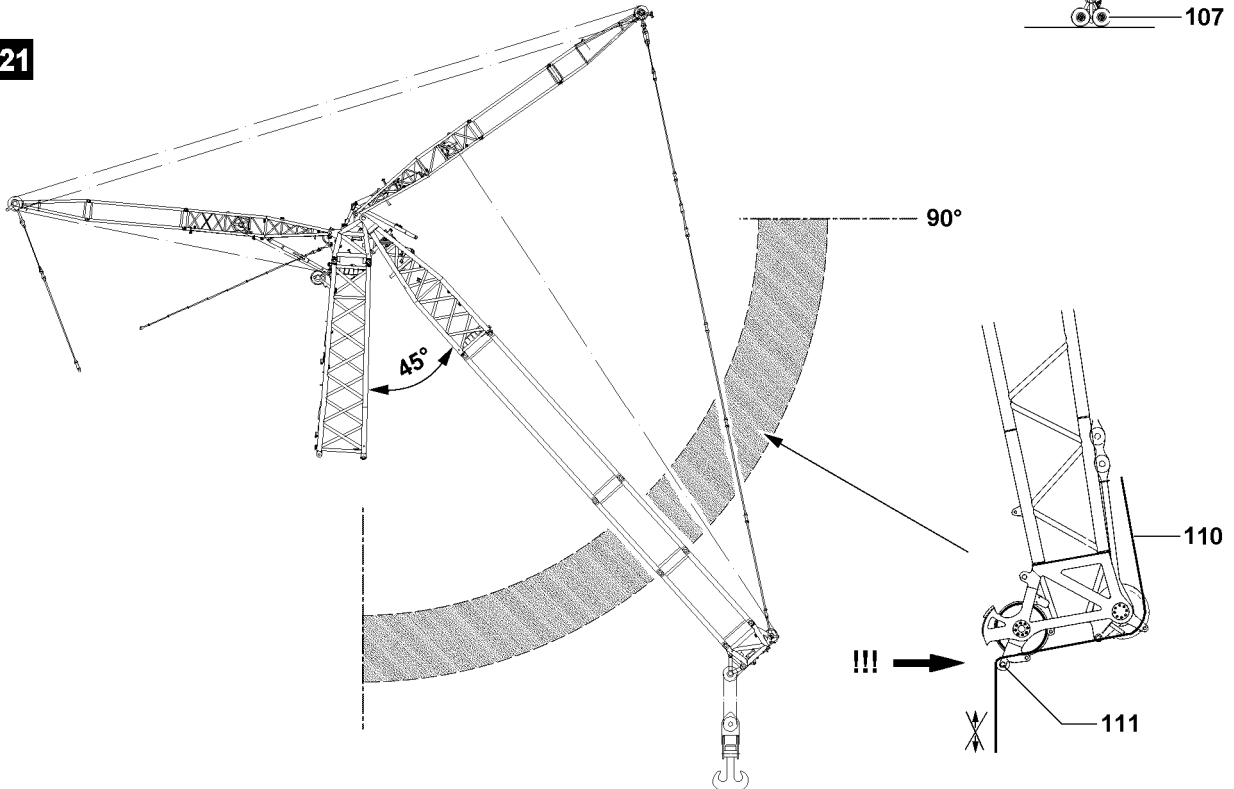

Fig.110710

LWE/LR 1600-2-008/18109-09-02/en

Make sure that the following prerequisites are met:

- The W-lattice jib is fully assembled.
- The pulley cart **107** is assembled on the SW-end section **106**, illustration **20**.
- No personnel is within the danger zone.
- The crane is aligned in horizontal direction.
- All electrical connections have been established.
- All limit switches are functioning.
- The counterweight has been installed on the turntable and on the derrick, according to the load chart.
- All pin connections have been secured.
- The hoist rope has been correctly placed in the rope pulleys and is prevented from jumping out with the rope retaining pins.
- There are no loose parts on the boom or the lattice jib.
- The boom, lattice jib and safety devices are free from snow and ice.
- The LICCON overload protection has been set according to the data in the load chart.
- The LICCON overload protection settings have been compared with the actual set up configuration.
- The LICCON overload protection is exceeded.
- The assembly icon **11** is visible on the LICCON monitor.



WARNING

Falling hoist rope!

If the hoist rope before the erection procedure is not properly secured onto the corresponding length on the W-lattice jib, it can fall down backward on the basis of its own weight. Personnel can be severely injured or killed!

- ▶ Reeve in the hoist rope with sufficient length on the W-lattice jib before the erection process!
- ▶ The hoist rope must be constantly monitored during erection!
- ▶ Do not step into the danger zone!

NOTICE

Damage to the hoist rope!

If the hoist rope **110** are reeved on the hook block and redirected over the small guard rollers **111**, the hoist gear may no longer be driven. During spooling up or spooling out, the hoist rope can become damaged!

- ▶ Do not spool the hoist rope **110** up or out, if the angle between S-boom and W-lattice jib is less than 90° , see illustration **21**.

The erection process is carried out until:

- The S-boom and the W-lattice jib form an angle of approximately 45° (switch position „W-lattice jib bottom“), see illustration **21**
- or the W-end section lifts off from the ground.
- ▶ Luff the S-boom up and simultaneously spool the W-control rope out so that the SW-end section remains on the ground with the pulley cart.
- ▶ Release the pulley cart from the SW-end section: Remove the pulley cart, see Crane operating instructions, chapter 5.15!
- ▶ Luff the S-boom up until the SW-end section lifts off the roller cart.
- ▶ Reeve in the hook block properly and secure the hoist rope on the rope fixed point, for reeving, see separate reeving plans.
- ▶ Attach the hoist limit switch weight.

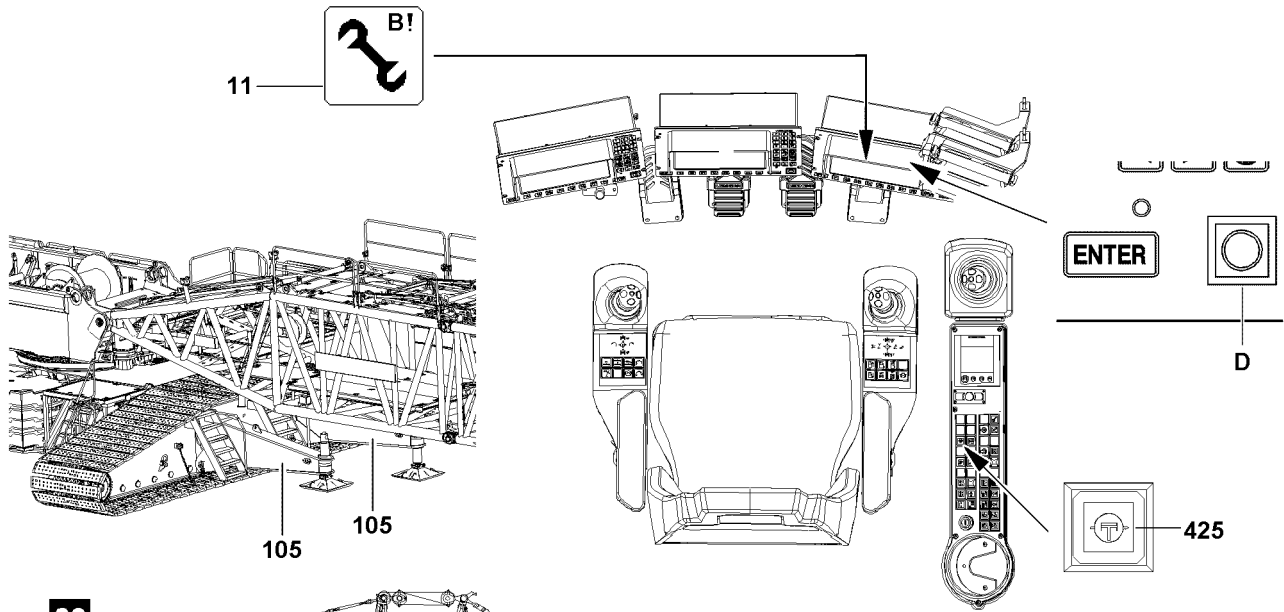

20

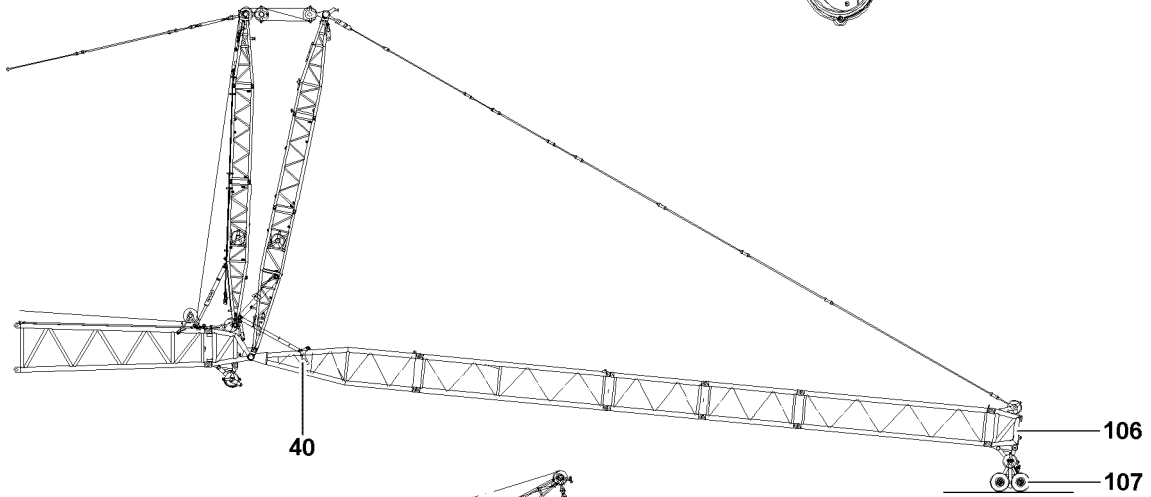

21

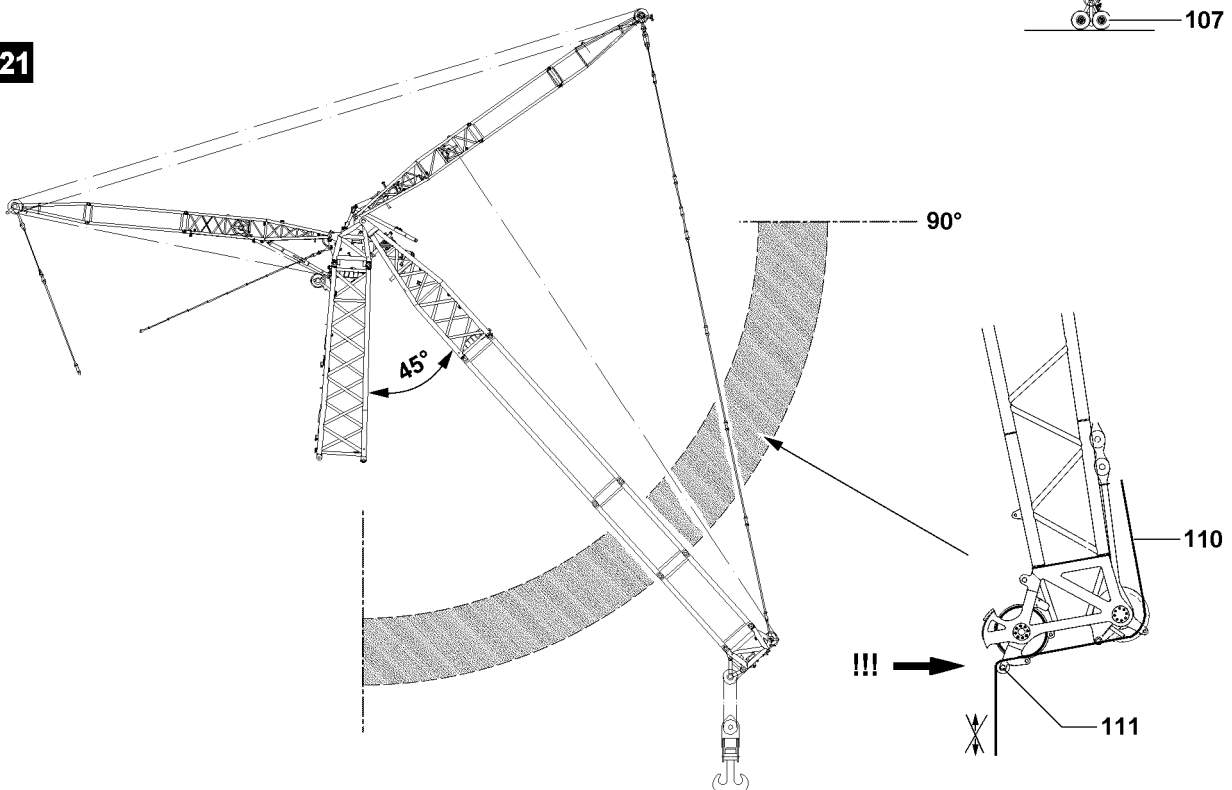

Fig.110710

LWE/LR 1600-2-008/18109-09-02/en

**DANGER**

The crane can topple over!

In crane operation with exceeded LICCON overload protection, the crane can topple over.

- ▶ Personnel can be severely injured or killed!
- ▶ The radii listed in the load chart may not be exceeded or fallen below, even if there is no load on the hook!

**Note**

- ▶ When the lowest operating position of the W-lattice jib is reached, the LICCON overload protection is activated!
- ▶ In the maximum load icon appears a load number in „t“ instead of the display „???“!

- ▶ Luff the S-boom up to the lowest operating position.
- ▶ Luff the W-lattice jib up to the lowest operating position.

When the W-lattice jib has reached the lowest operating position:

- ▶ Make sure that the assembly icon **11** on the LICCON monitor turns off.

Result:

- The LICCON overload protection is active.

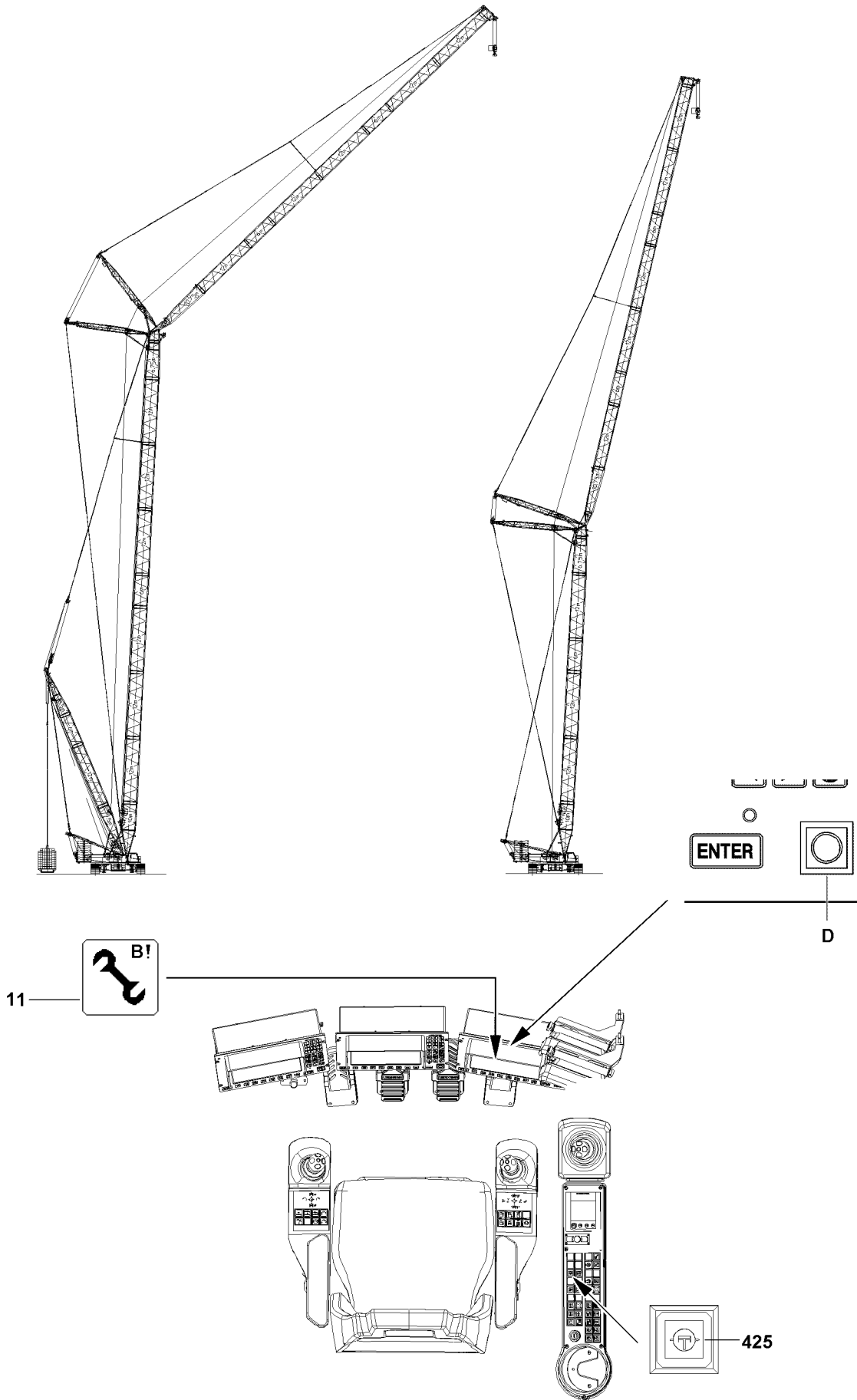

Fig.110708

LWE/LR 1600-2-008/18109-09-02/en

4 Operating the crane

4.1 Preparing for crane operation

**Note**

- ▶ Observe the notes, see Crane operating instructions, chapter 4.05, chapter 4.08 and chapter 5.01!

Make sure that the following prerequisites are met:

- The LICCON overload protection is active.
- The LICCON overload protection has been set according to the data in the load chart.

**WARNING**

The crane can topple over!

- ▶ Check the horizontal position of the crane before and during operation!
- ▶ If the crane operator leaves the cab, even for a short time, the operating mode setting must be checked and reset if necessary before resuming crane operation!

4.2 Checking the settings

- ▶ Check the function of the overload protection by running against the operating positions „on top“ and „bottom“.
- ▶ Check the hoist limit switch by running against the hoist limit switch weight.
- ▶ Check the function of the limit switches on the jib stop cylinders.

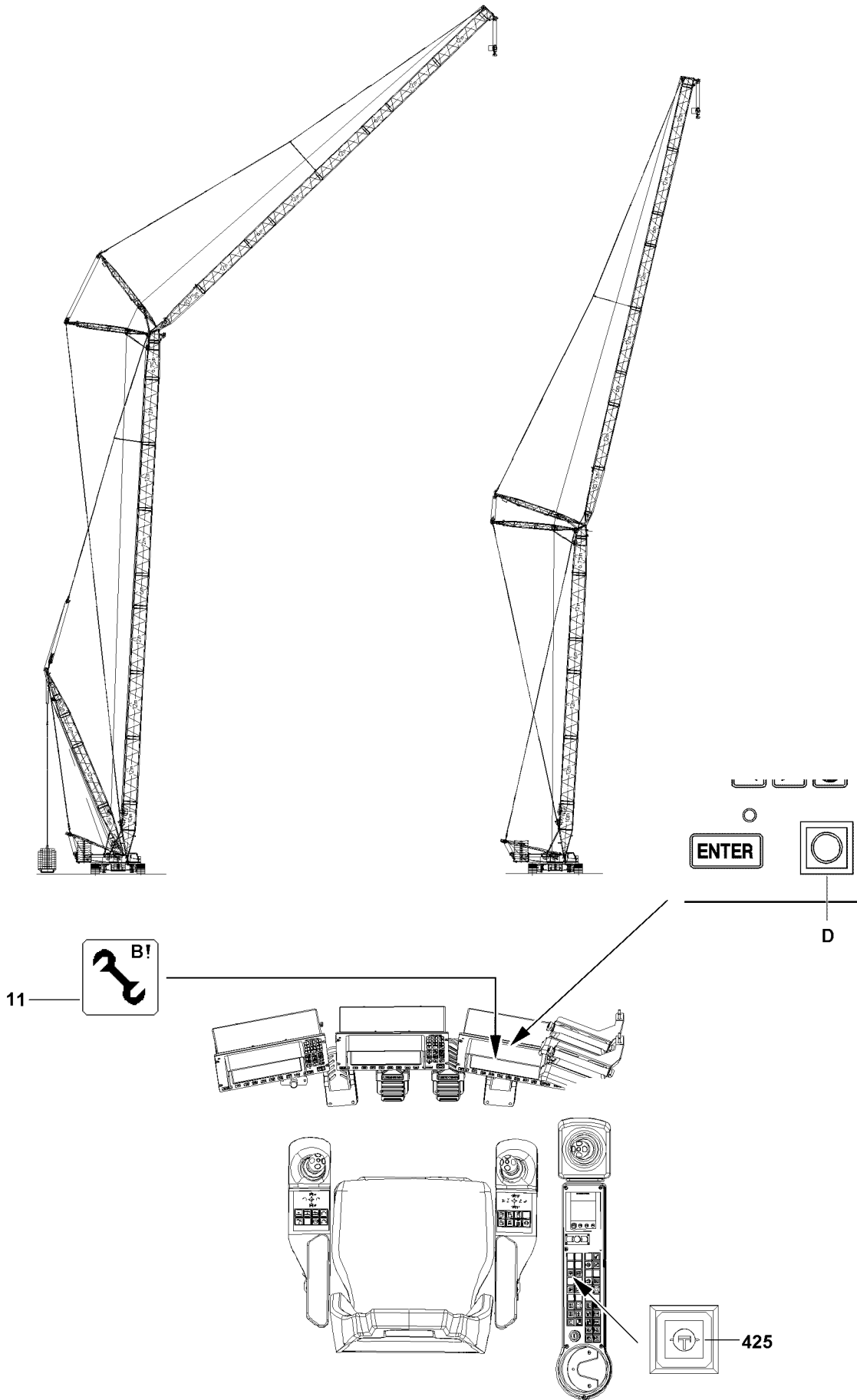

Fig.110708

LWE/LR 1600-2-008/18109-09-02/en

5 Disassembling the W-boom system



WARNING

Danger of falling!

During assembly / disassembly work, personnel must be secured with appropriate aids to prevent them from falling. If this is not observed, assembly personnel can fall and suffer life-threatening or fatal injuries!

- ▶ All assembly work must be carried out using suitable aids (ladders, lifting platforms, scaffolding, auxiliary crane, etc.)!
- ▶ If work cannot be carried out on the ground or using such aids, then assembly personnel must be secured with the personal fall arrest system (see Crane operating instructions, chapter 2.04) to protect against falling! The personal fall arrest system must be attached in the corresponding fastening points on the crane (see Crane operating instructions, chapter 2.06)!
- ▶ If railings are present on the components, then they must be brought into the corresponding position and secured for assembly / disassembly work!
- ▶ Step on aids and fall protection equipment only with clean shoes!
- ▶ Keep aids and fall protection equipment clean and free from snow and ice!



WARNING

Falling components!

If unsecured or non-supported components are assembled or disassembled, they can fall down. Personnel can be killed or seriously injured!

- ▶ During pinning and unpinning of the lattice sections, it is prohibited for anyone to remain **under** or **on** the components as well as within the entire danger zone!
- ▶ Support the boom and components before pinning / unpinning!
- ▶ Pin or unpin both pins laying in a horizontal, i.e. **left** and **right**!
- ▶ Secure the pins in the bearing points and in the receptacles!
- ▶ Do not disengage the auxiliary crane until each component is pinned on and secured!
- ▶ It is prohibited to lean a ladder against the component being disassembled!



WARNING

Danger of crushing!

Components can swing during assembling. Hands can be crushed or severed.

- ▶ Make sure that the components do not swing back and forth during assembly!

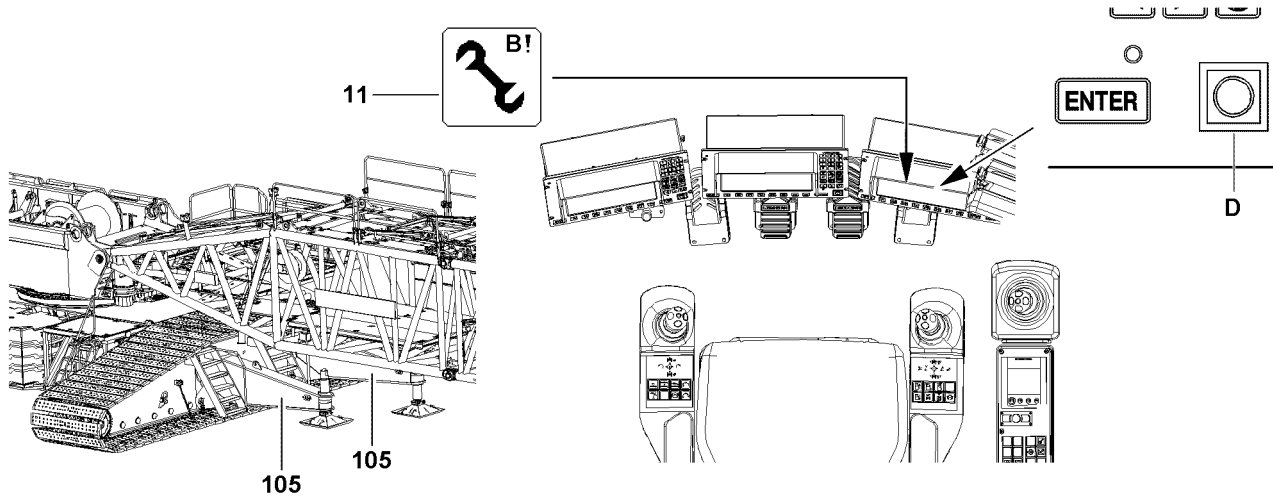
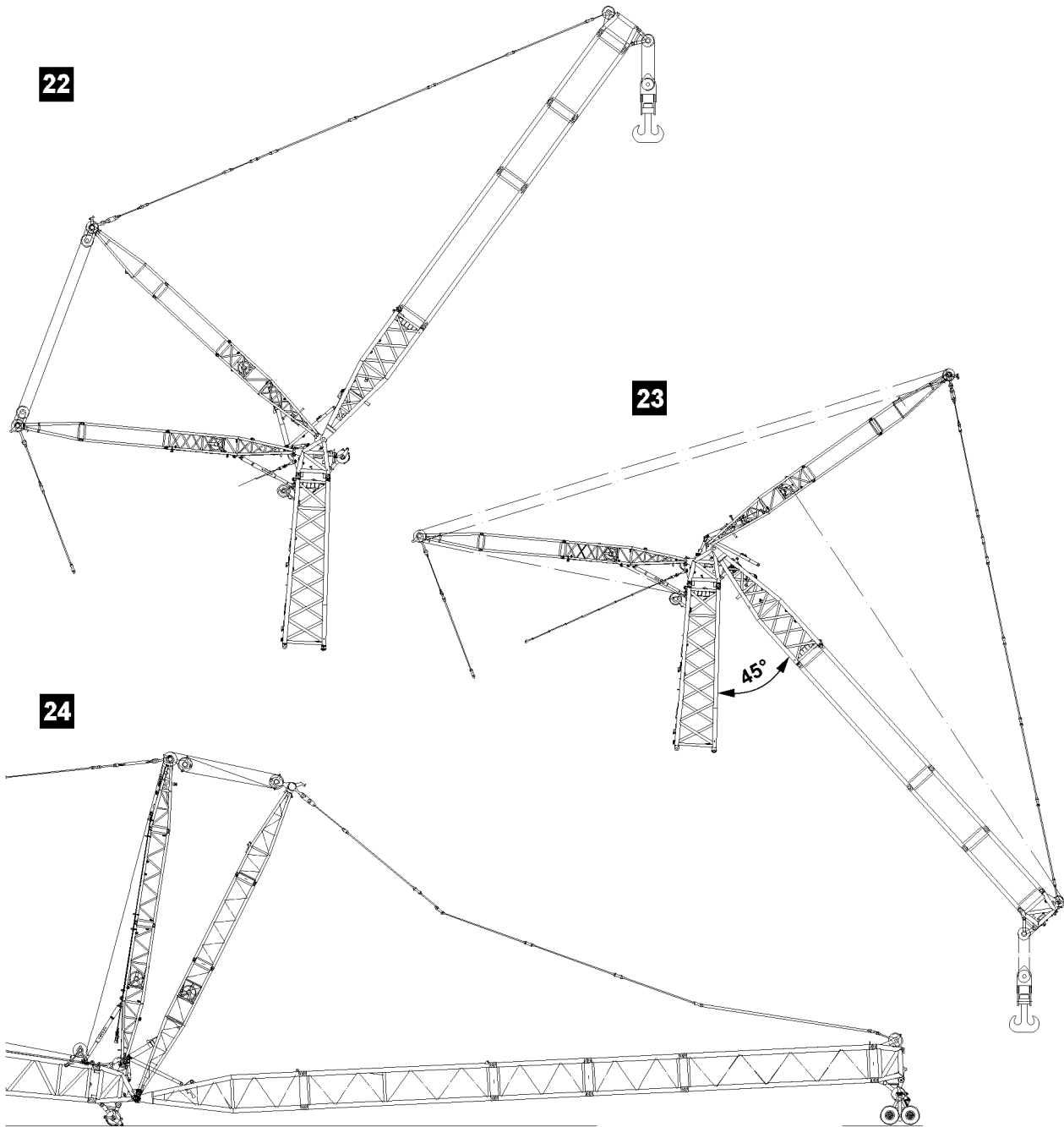

Fig.110709

LWE/LR 1600-2-008/18109-09-02/en

**Note**

- ▶ By supporting the components during assembly / disassembly, ground unevenness is compensated for and the material is protected!

**Note**

- ▶ The W-intermediate sections are pinned and unpinned with the aid of the pin pulling device, see Crane operating instructions, chapter 5.30!

**WARNING**

Danger of accident!

Personnel can be severely injured or killed.

- ▶ For pinning and unpinning with the pin pulling device, observe and follow the warning guidelines, see Crane operating instructions, chapter 5.30!

Make sure that the following prerequisites are met:

- The LICCON overload protection has been set according to the data in the load chart.
- The LICCON overload protection is exceeded.
- The assembly icon **11** is visible on the LICCON monitor.
- An auxiliary crane is available.

5.1 Placing the W-lattice jib down

**DANGER**

The crane can topple over!

For certain boom lengths, the mechanical auxiliary supports must be assembled, see Erection and take down charts!

- ▶ The boom must be erected or taken down „to the side“ „in direction“ of the mechanical auxiliary supports **105**!
- ▶ Always erect or take down according to the data in the **Erection and take down charts**!

**WARNING**

The crane can topple over!

If the following conditions are not met before taking down the boom, the crane can topple over and fatally injure personnel!

- ▶ Observe the technical safety notes, see Crane operating instructions, chapter 5.01!
- ▶ Observe the data in the erection and take down charts!

NOTICE

Damage of boom components!

Taking down the boom system can lead to a collision between the hook block and the pulley head!

The boom components can be severely damaged!

- ▶ Luff the boom system down at the same time and spool the hoist winch out!

Make sure that the following prerequisite is met:

- The S-boom is in operating position, see illustration **22**.
- The hook block is approx. 5 m below the pulley head of the lattice jib.
- The pulley cart is available.

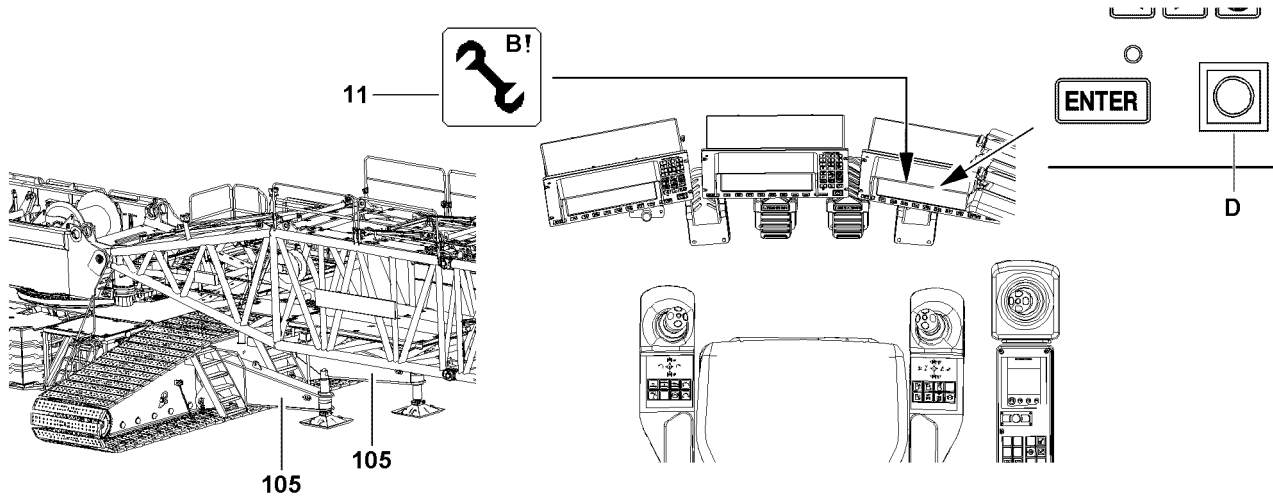
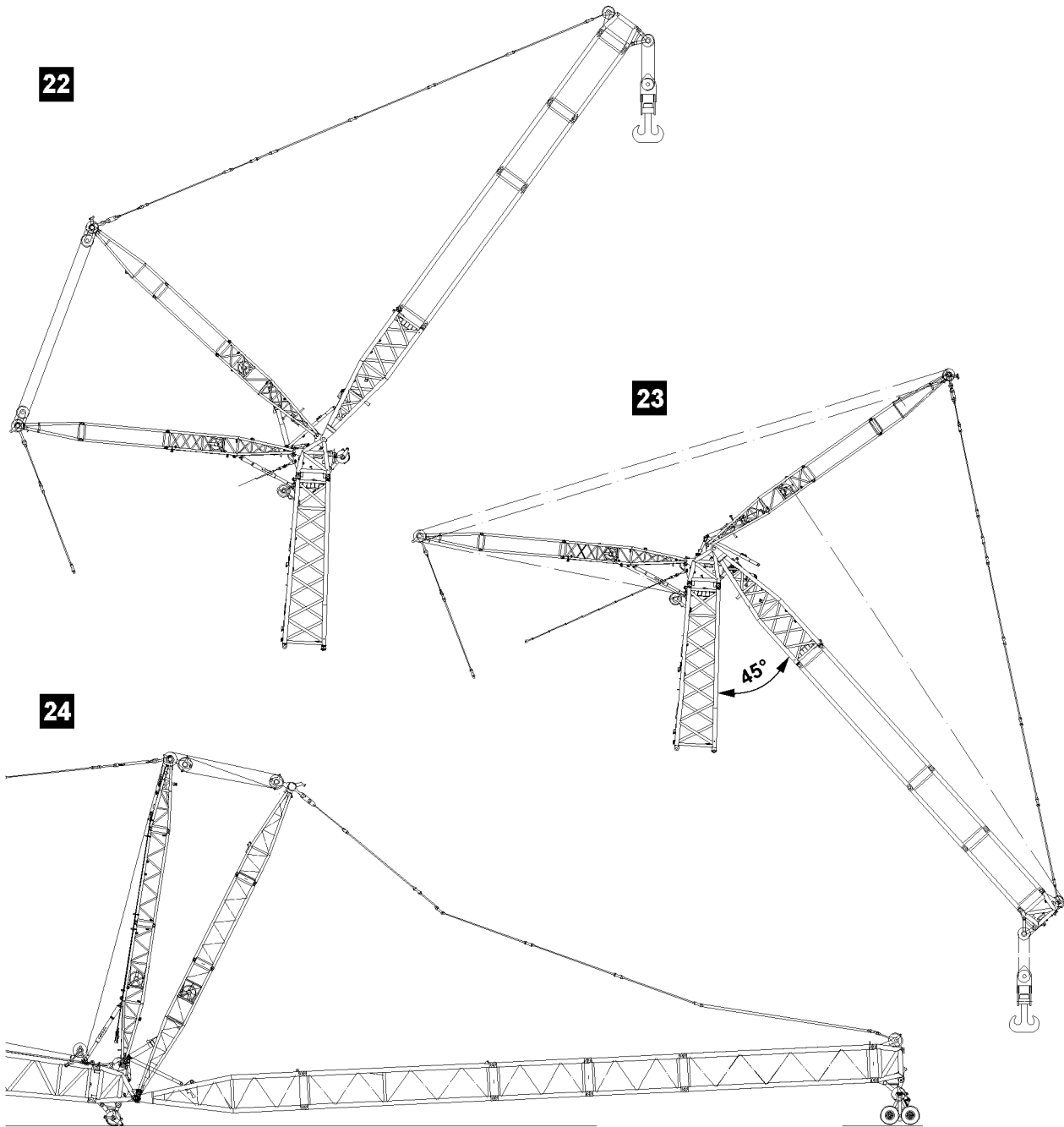

Fig.110709

LWE/LR 1600-2-008/18109-09-02/en

5.1.1 Luffing the W-lattice jib down



Note

- ▶ The luff down movement is turned off as soon as the lowest operating position is reached!
- ▶ When the lowest operating position of the W-lattice jib is reached, the load display in the maximum load icon turns off and instead of the load display appears the display „???“!
- ▶ In the crane operating screen appear alarm functions!

-
- ▶ Luff the W-lattice jib down to the „lowest“ operating position.

Result:

- The luff down movement is turned off.
- The „STOP“ icon appears on the LICCON monitor.
- The horn icon appears on the LICCON monitor.



WARNING

Assembly with turned on set up key!

When the set up key is engaged, the LICCON overload protection is exceeded!

In the event of deliberate improper use, the crane could collapse, the boom can break off or the crane can topple over!

Personnel can be killed!

This could result in high property damage!

- ▶ The set up key **D** may only be actuated by persons who know the effects of a bypass!
- ▶ Press the set up key **D** only when the set up status was correctly entered into the LICCON computer system!
- ▶ Observe the erection / take down charts!
- ▶ Crane operation with the set up key **D** turned on is strictly prohibited!

When the W-lattice jib has reached the „lowest“ operating position:

- ▶ Turn the set up key **D** to the right.

Result:

- The LICCON overload protection is deactivated.
- The assembly icon **11** appears on the LICCON monitor.

See illustration **23**.

The luff down procedure is carried out until:

- The S-boom und the W-lattice jib form an angle of approximately 45 ° (switch position „W-lattice jib bottom“)
- **or** the hook block can be reeved out.
- ▶ Luff the W-lattice jib down as specified.

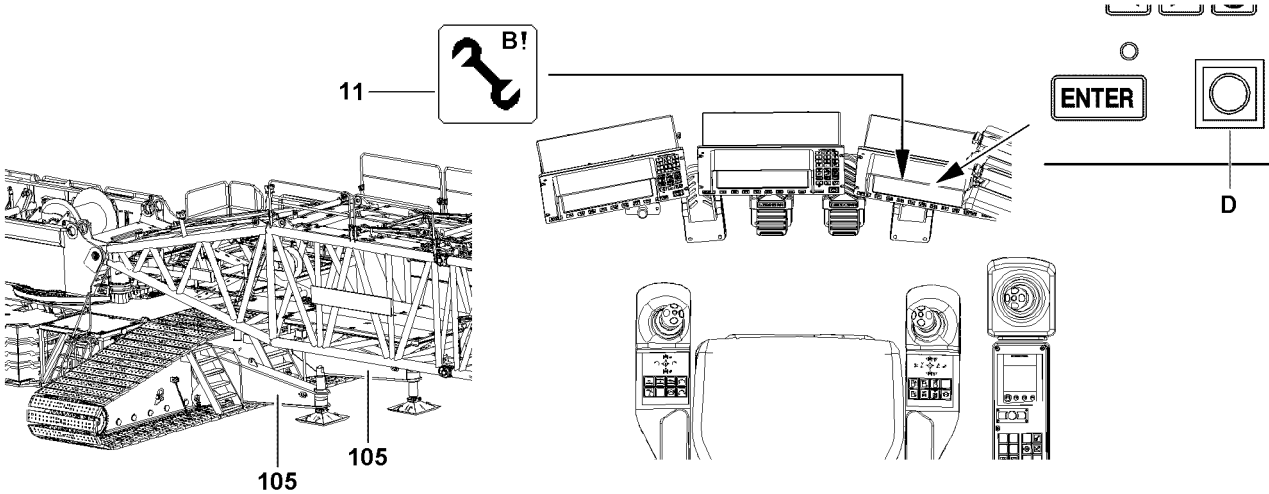
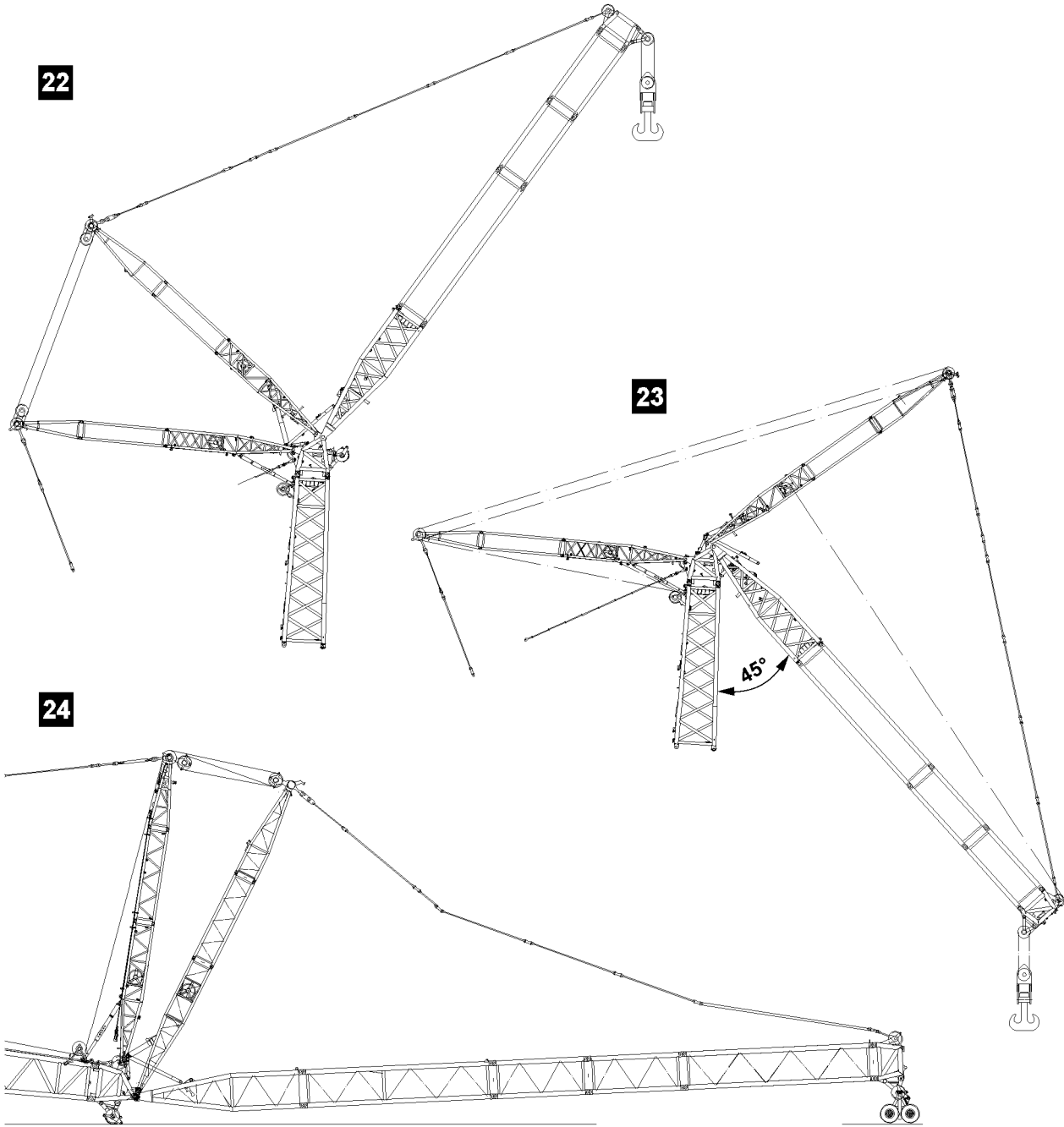

Fig.110709

LWE/LR 1600-2-008/18109-09-02/en

5.1.2 Placing the W-lattice jib down

If the hook block has not yet touched the ground:

- ▶ At the same time, spool the hoist winch out and luff the S-boom down until the hook block touches the ground.
- ▶ Remove the hoist limit switch weight.
- ▶ Unreeve the hook block.
- ▶ Luff the S-boom down until the SW-end section lies on the roller cart.
- ▶ Assemble the SW-end section on roller cart, see Crane operating instructions, chapter 5.15!



WARNING

The crane can topple over!

If the following conditions are not met before taking down the boom, the crane can topple over. Personnel can be severely injured or killed!

- ▶ Spool the lattice jib control out so that the guy rods sag slightly!
 - ▶ The lattice jib must roll on the ground with its entire weight!
 - ▶ Do not allow slack cable to build up on the control winch!
 - ▶ Do not pull the hook block along on the ground!
-
- ▶ Continue to luff down the S-boom and simultaneously spool the W-lattice jib control out so that the guy rods sag slightly.
- See illustration 24.
- ▶ Luff the S-boom down until the S-boom head is laying on the support on the ground.



WARNING

Danger of accident!

- ▶ No one may be present in the danger zone.
 - ▶ Secure the hoist rope with the assembly rope and pull it back slowly over the rope pulleys in the WA-frames and lower it toward the W-connector head.
-
- ▶ Place the hoist rope down.

5.2 Disconnecting the electrical connections

Make sure that the following prerequisite is met:

- The S-boom has been placed down.

NOTICE

Damage to cable drum or cable!

If the electrical connection between the W-end section and W-pivot section is not separated before spooling up the cable drum, the electrical connection is damaged!

If the cable drum cable is not properly spooled up on the cable drum after disconnection on the SW-end section, the cable drum or the cable can be significantly damaged!

- ▶ Make the electrical connection from the cable drum in the W-pivot section to the terminal box on the W-connector head and then separate the electrical connection from the terminal box on the SW-end section to the cable drum!
 - ▶ After unplugging, spool the cable onto the cable drum.
-
- ▶ Disconnect the electrical connections.
 - ▶ After unplugging, spool the cable onto the cable drum and secure it to prevent it from spooling out inadvertently.
 - ▶ Secure the cable: Reestablish the electrical connection between the W-connector head and the cable drum.

25

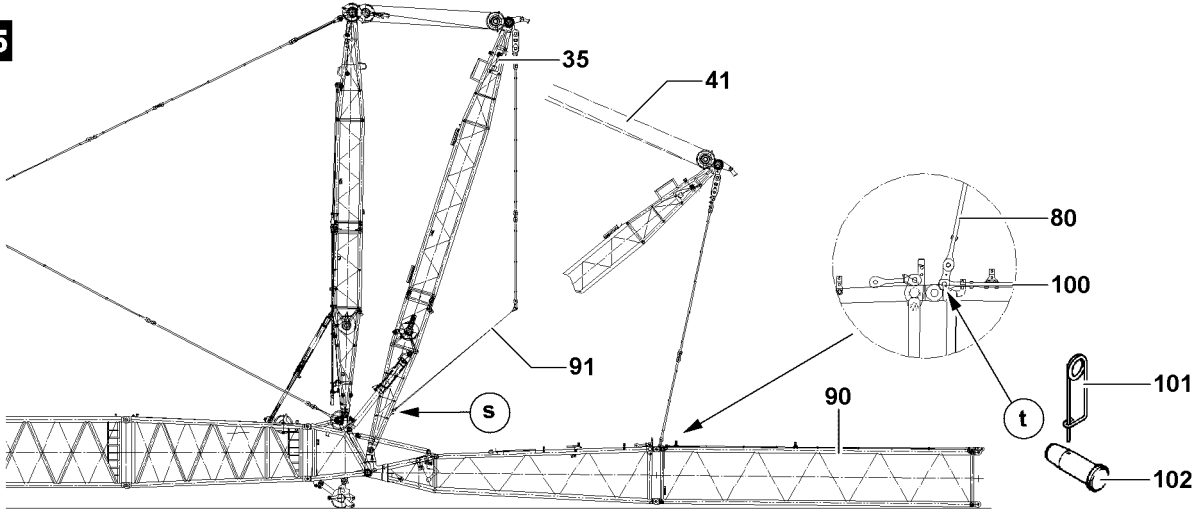

26

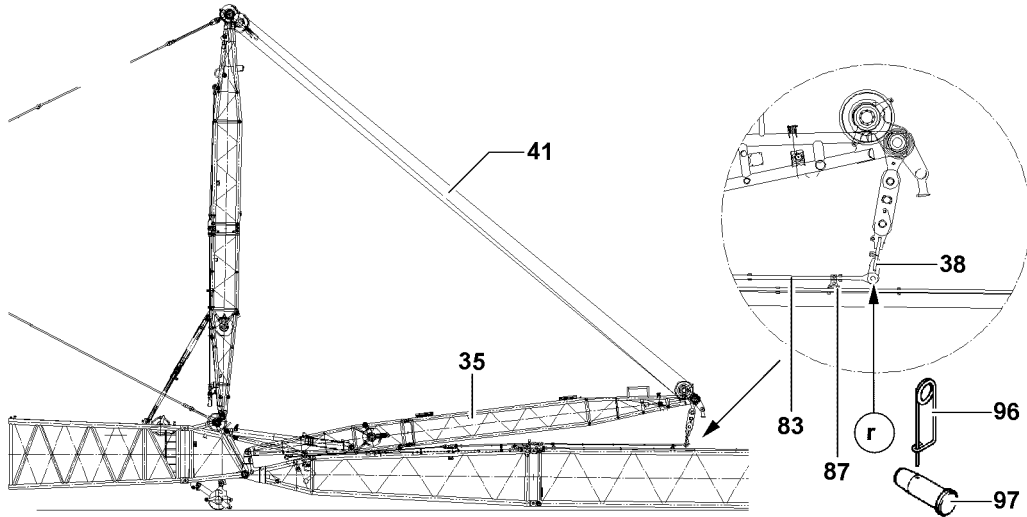

27

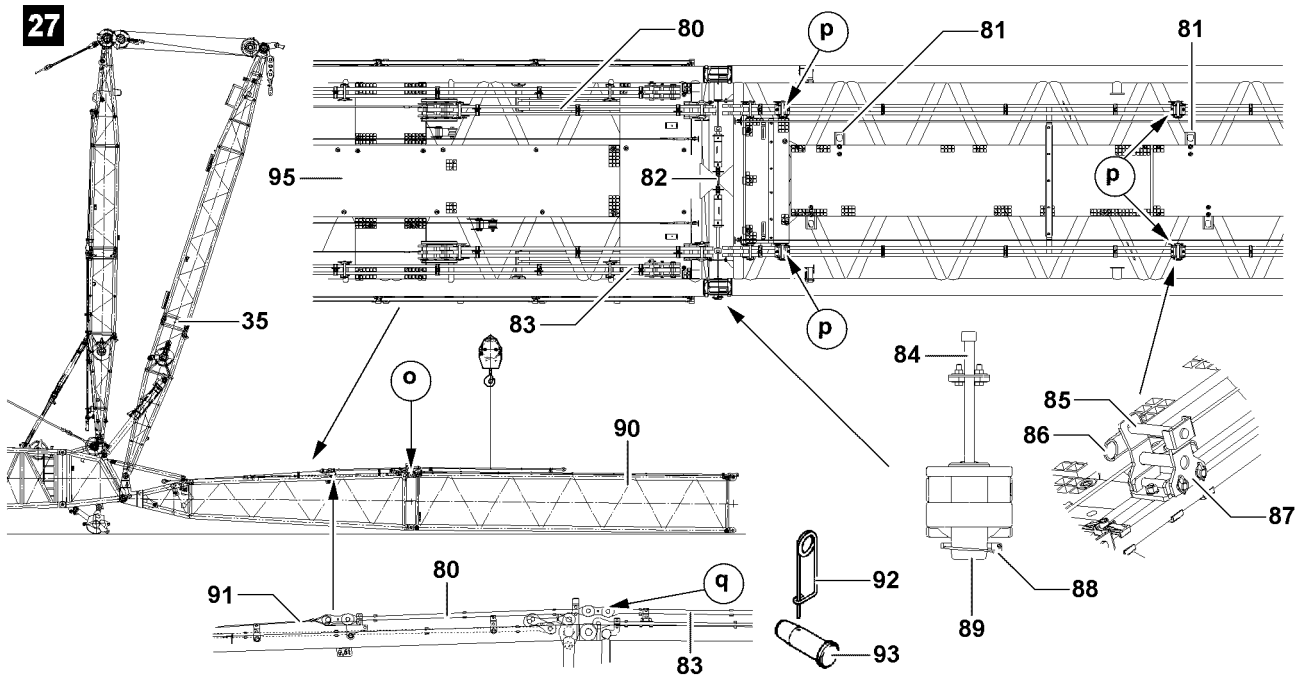

Fig.106824

LWE/LR 1600-2-008/18109-09-02/en

5.3 Disassembling the W-lattice jib



WARNING

Falling components!

If unsecured or non-supported components are assembled or disassembled, they can fall down. Personnel can be killed or seriously injured!

- ▶ During pinning and unpinning of the lattice sections, it is prohibited for anyone to remain **under** or **on** the components as well as within the entire danger zone!
- ▶ Pin or unpin both pins laying in a horizontal, i.e. **left** and **right**!
- ▶ Secure the pins in the bearing points and in the receptacles!
- ▶ Do not disengage the auxiliary crane until each component is pinned on and secured!
- ▶ It is prohibited to lean a ladder against the component being disassembled!



Note

- ▶ During disassembly of the W-lattice jib, adhere to the unpinning sequence, see Crane operating instructions, chapter 5.01!

5.3.1 Disassembling the W-guy rods

The W-guy rods are placed and secured for transport on the LI-lattice sections. Before disassembly of the W-guy rods, the transport retainers must be assembled.

See illustration **25**.

- ▶ Put down WA-frame 1 **35** until the guy rods **80** and guy rods **100** in the point **t** can be unpinned: Spool the W-control rope **41** out.
- ▶ Separate the guy rods **80** and the guy rods **100** on both sides on point **t**: Remove the spring retainer **101** and unpin the pin **102**.
- ▶ Hook the assembly rope **91** on point **t**.
- ▶ Erect the WA-frame 1 **35** until the assembly rope **91** can be hooked on point **s**: Spool the W-control rope **41** up.
- ▶ Hook the assembly rope **91** on point **s**.
- ▶ Release and unpin guy rods of all LI intermediate sections.
- ▶ Secure the W-guy rods with the transport retainers.

5.3.2 Disassembling the W-lattice section

See illustration **26**.

- ▶ Put down WA-frame 1 **35** until guy rods **80** on the W-pivot section **95** and guy rods **83** lie in the receptacles **87**: Spool the W-control rope **41** out.
- ▶ Separate guy rods **38** and guy rods **83** both sides on the point **r**: Remove the spring retainer **96** and unpin the pin **97**.
- ▶ Erect the WA-frame 1 **35**: Spool the W-control rope **41** up.

See illustration **27**.

- ▶ Separate the guy rods **80** and the guy rods **83** on both sides on point **q**: Remove the spring retainer **92** and unpin the pin **93**.
- ▶ Place the guy rods **83** with the auxiliary crane on the W-pivot section **95** and secure with transport retainers.
- ▶ Secure guy rods **83** with transport retainers.
- ▶ Hang the pin pulling cylinder on the retainer **82** and on the screw **84**.
- ▶ Disassemble SW-end section and LI-intermediate section: Remove the linchpins **88** and unpin the pins **89** with pin-pulling cylinder.
- ▶ Disassemble receptacles **87** on the points **p** and secure in the parking position **81**.

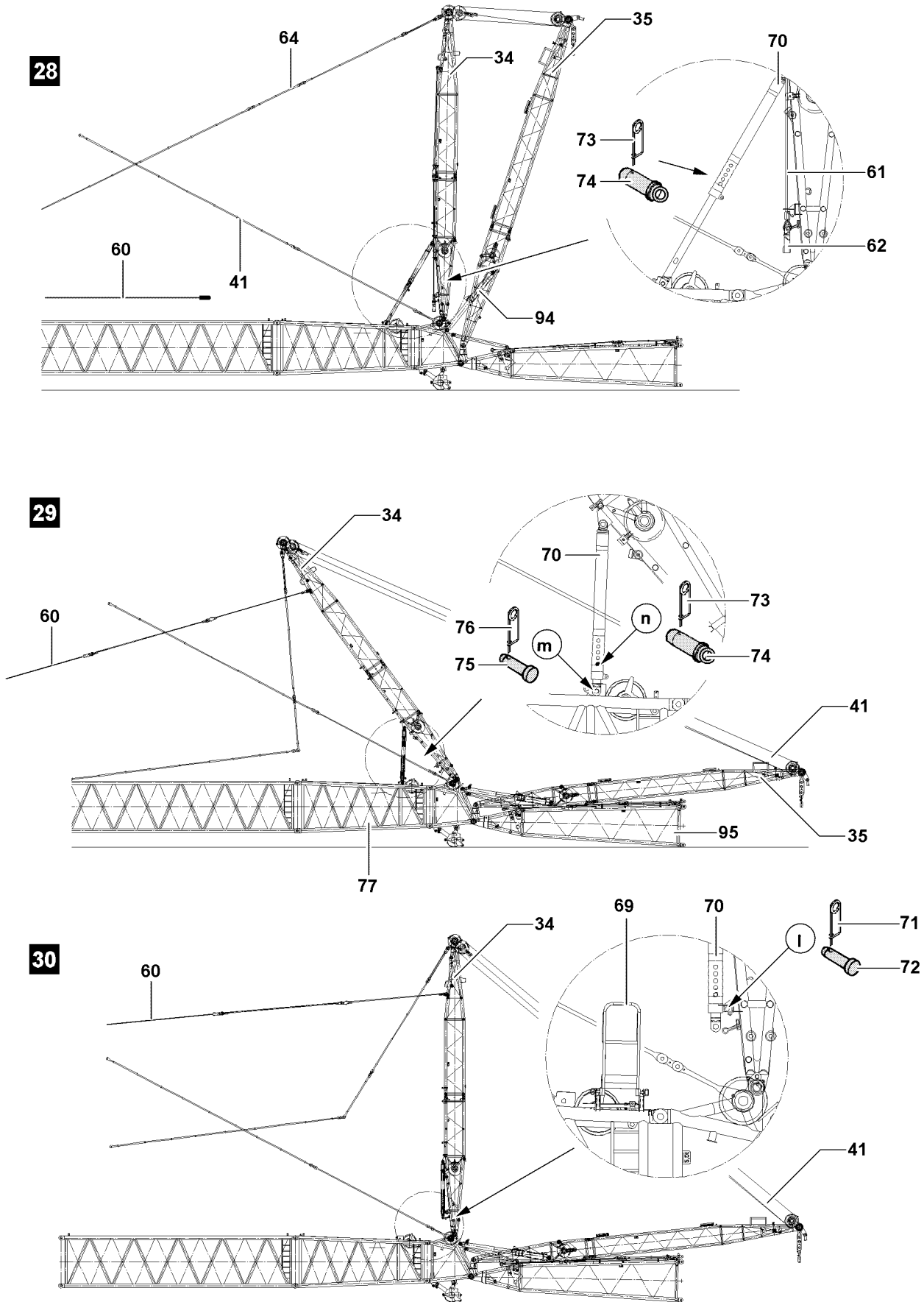

Fig.106823

LWE/LR 1600-2-008/18109-09-02/en

5.4 Unpinning the relapse supports

See illustration 28.

- ▶ Erect the WA-frame 1 **35** until the relapse cylinder **94** is completely retracted.

Result:

- The relapse supports **70** are relieved: Connecting pin **74** can be unpinned.



WARNING

Danger of falling!

If the folding brackets **69** on the SL-reducer section are not used, personnel can fall down and be severely injured or killed!

- ▶ Carry out the pinning of the relapse supports of the folding brackets on the SL-reducer section!

NOTICE

Damage of WA-frame 2!

If the connection pin on the relapse supports is pinned when the WA-frame 2 is not drawn backward, WA-frame 2 can be damaged!

- ▶ Unpin the connecting pins **74** on both sides before the WA-frame 2 **34** is pulled back!

- ▶ Remove the spring retainer **73** on both sides and unpin the connecting pins **74**.
- ▶ Release the assembly rope **61** on the WA-frame 2 **34**.
- ▶ Hang hoist rope **60** in the hook block **62** on the assembly rope **61**.

See illustration 29.



Note

- ▶ When the W-control rope is spooled out, the WA-frame 1 **35** may not be lifted!

- ▶ Place the WA-frame 1 **35** onto the W-pivot section **95**: Spool the W-control rope **41** out.
- ▶ Pull the WA-frame 2 **34** backward: Spool the W-control rope **41** out and spool the hoist rope **60** up until the relapse supports **70** are pushed in.
- ▶ Pin the connector pin **74** on point **n** and secure with spring retainer **73**.
- ▶ Unpin the relapse supports **70** on both sides on the point **m**: Remove the spring retainer **76** and unpin the pin **75**.

See illustration 30.

- ▶ Erect the WA-frame 2 **34** vertically: Spool the W-control rope **41** up and simultaneously spool out the hoist rope **60**.
- ▶ Pin the relapse supports **70** on both sides on the point **I**: Insert the pin **72** and secure with spring retainer **71**.

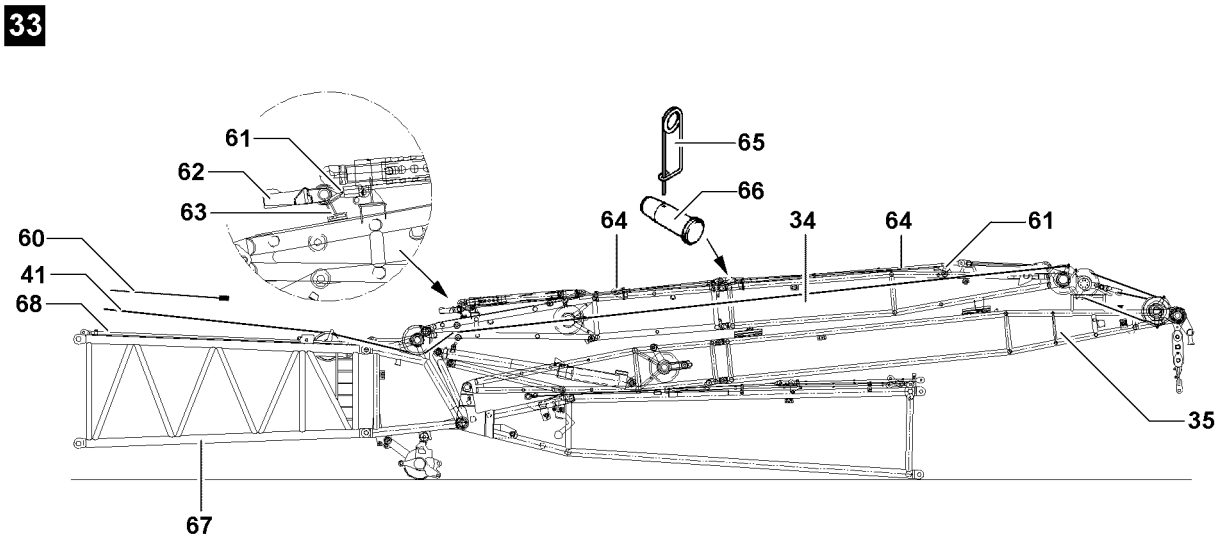
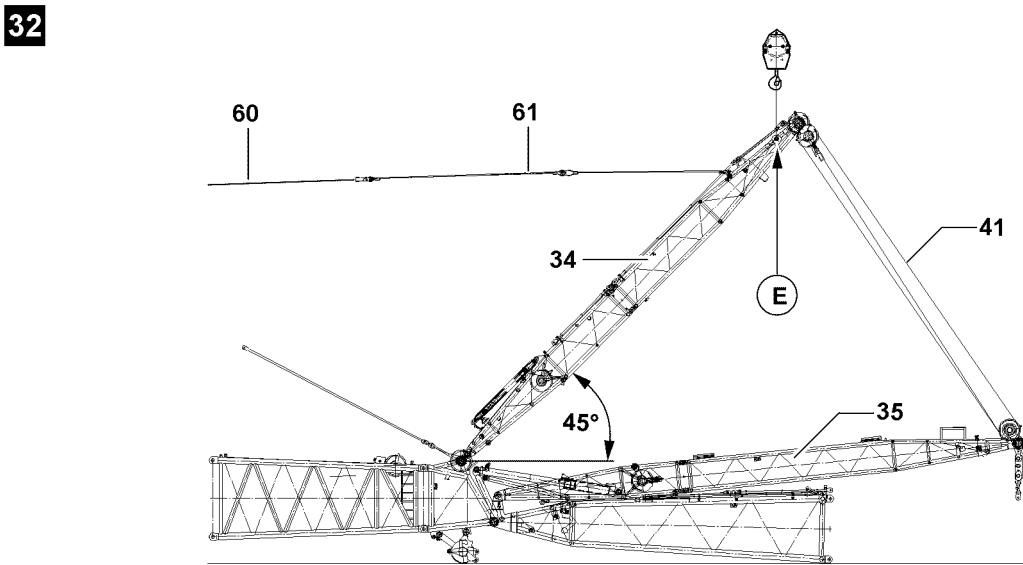
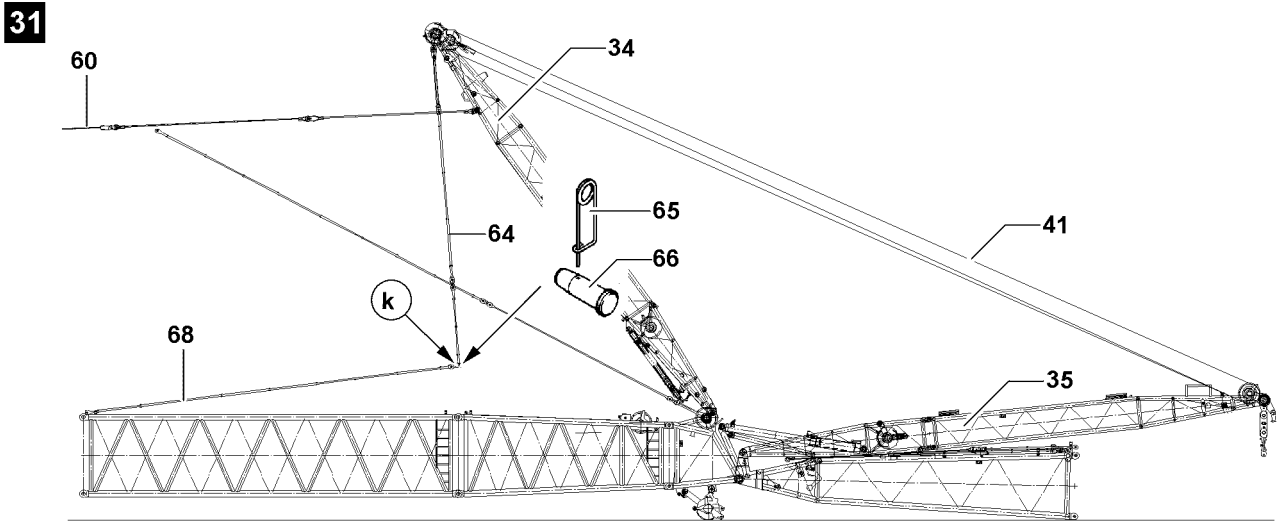

Fig.107266

LWE/LR 1600-2-008/18109-09-02/en

5.5 Disassembling the WA-frame 2 guy rods



Note

- ▶ While spooling out the W-control rope, lift the WA-frame 1 **35** slightly to prevent slack rope formation.

See illustration **31**.

- ▶ Pull the WA-frame 2 **34** back until the W-guy rods **64** hang down vertically: Spool the W-control rope **41** out and simultaneously spool the hoist rope **60** up.
- ▶ Place the W-guy rods **68** on the S / SL-boom.
- ▶ Separate the W-guy rods **64** both sides on the point **k** from the W-guy rods **68**: Remove the spring retainer **65** and unpin the pin **66**.
- ▶ Secure the W-guy rods **68** with the transport retainers.

See illustration **32**.



WARNING

WA-frame 2 folding downward!

If WA-frame 2 is not held with the auxiliary crane at 45 ° while placing it down, then it can fold down. Personnel can be severely injured or killed!

- ▶ Attach the WA-frame 2 **34** to the auxiliary crane and lower it slowly!

- ▶ Erect the WA-frame 2 **34** and tilt it forward by 45 °: Spool the W-control rope **41** up and simultaneously spool out the hoist rope **60**.
- ▶ Secure the WA-frame 2 **34**: Hang it on the fastening point **E** on the auxiliary crane.
- ▶ Spool the hoist rope **60** out until the assembly rope **61** is released.

See illustration **33**.

- ▶ Place the WA-frame 2 **34** down with the auxiliary crane on the WA-frame 1 **35**, spool the W-control rope **41** up and simultaneously spool the hoist rope **60** out.
- ▶ Secure the assembly rope **61** on the WA-frame 2 **34** and separate the hoist rope **60**.
- ▶ Spool the hoist rope **60** up.
- ▶ Separate the W-guy rods **64** on the WA-frame 2 **34**: Remove the spring retainer **65** and unpin the pin **66**.
- ▶ Secure the W-guy rods **64** with the transport retainers.

34

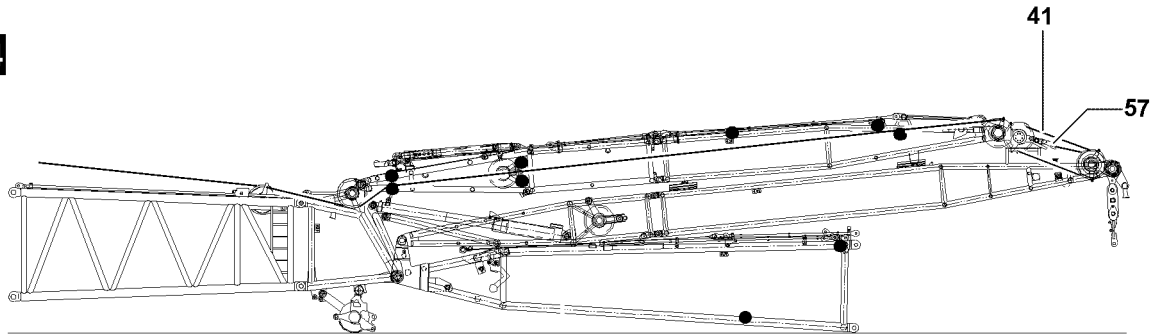

35

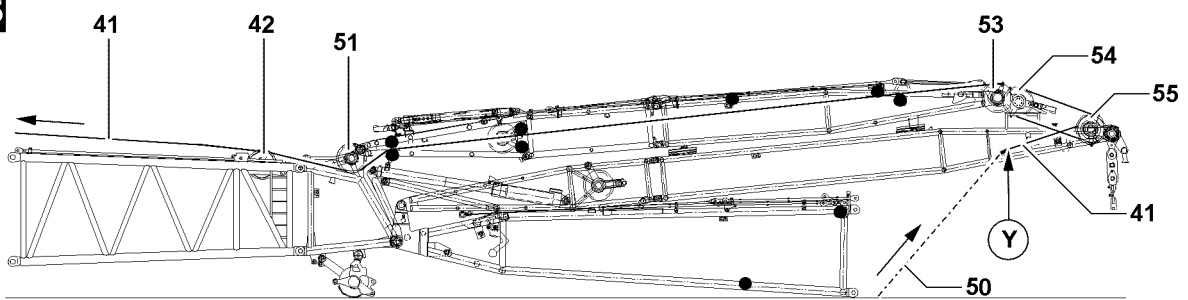

36

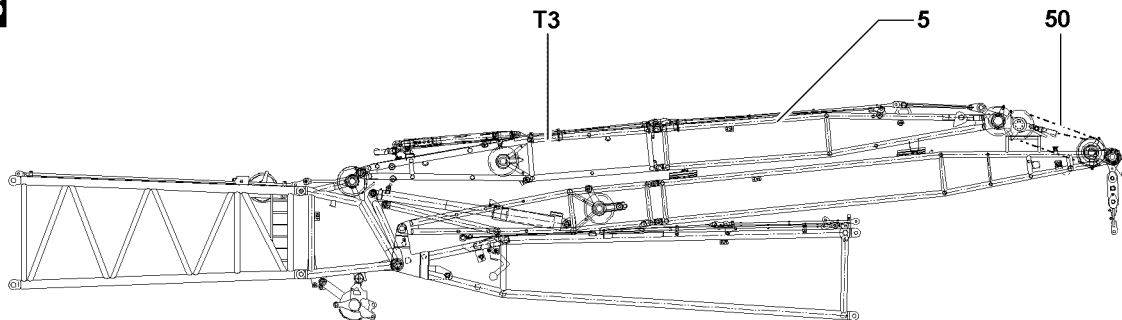

Fig.106826

LWE/LR 1600-2-008/18109-09-02/en

5.6 Unreeving the W-control rope

NOTICE

Slack rope formation!

The control rope could be damaged if any of the ropes are slack!

- ▶ Do not allow slack rope formation while spooling the W-control rope up!
- ▶ When spooling the W-control rope up, keep the rope tight!



Note

- ▶ Before unreeving the W-control rope, the rope retaining pins of the rope pulley **42**, the rope pulley **51**, the rope pulley **53** and the pulley set **54** and the pulley set **55** must be released and unpinned, see illustration **35**.

5.6.1 Unreeving the W-control rope on the pulley sets

Make sure that the following prerequisite is met:

- The intake rope for the pulley sets is available.

See illustration **34**.

- ▶ Unhook the W-control rope **41** on the rope lock **57**.

See illustration **35**.

- ▶ Pull the intake rope **50** to point **Y**.
- ▶ Connect the intake rope **50** and the W-control rope **41** on point **Y**.
- ▶ Spool the W-control rope **41** out and pull the intake rope in on the pulley set **54** and on the pulley set **55** and hook on the rope lock **57**.
- ▶ Separate the W-control rope **41** on the rope pulley **53** from the intake rope **50**.
- ▶ Install the rope retaining pins on the pulley sets and the rope pulleys.

5.6.2 Unreeving the W-control rope on the WA-frame 2

Make sure that the following prerequisite is met:

- The intake ropes for the WA-frame 2 are available.

See illustration **35**.

- ▶ Pull the W-control rope **41** from the WA-frame 2 **34** and spool onto winch 5.

See illustration **36**.

- ▶ Secure the intake rope **53** on the transport unit **T3** and on the end section WA-frame 2 **5**.
- ▶ Install the rope retaining pins on the rope pulleys.

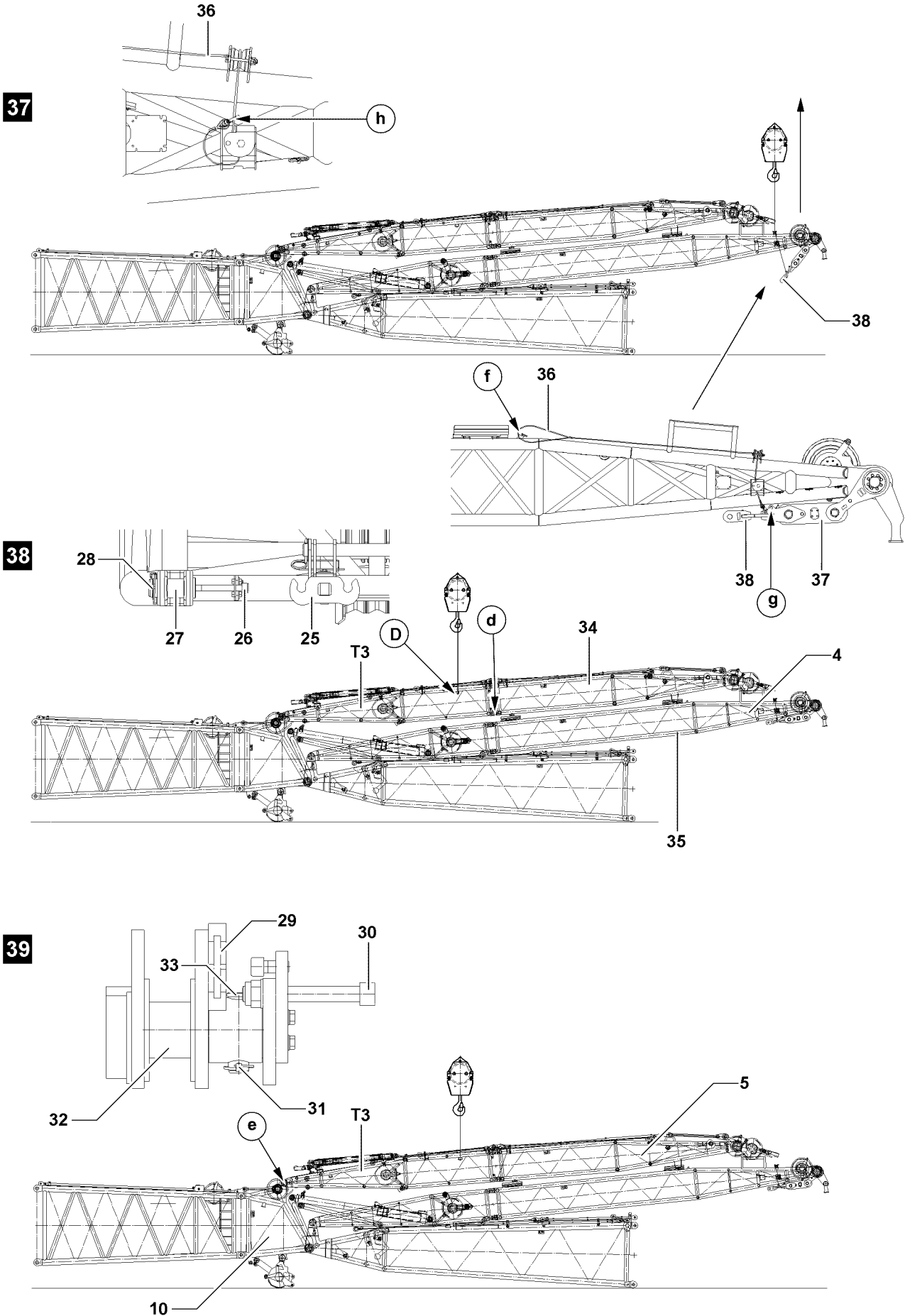

Fig.107267

LWE/LR 1600-2-008/18109-09-02/en

5.7 Disassembling the W-transport units

5.7.1 Separating the WA-frame 2

See illustration 37.

- ▶ Release the ropes **36** on both sides in park position on point **f** and secure point **h**.
- ▶ Attach the cross brace **38** with ropes **36** on the auxiliary crane.
- ▶ Raise the cross brace **38** with the auxiliary crane and pin and secure on point **g**.
- ▶ Separate the ropes **36** from the auxiliary crane and secure on point **f**.

See illustration 38.

- ▶ Secure and slightly lift the WA-frame 2 **34** with the auxiliary crane on the fastening point **D** until it can be unpinned on point **d**.
- ▶ Hang the pin pulling cylinder on the retainer **25** and on the screw **26**.
- ▶ Separate the transport unit **T3** and the WA-frame 2 end section **5** both sides on point **d**: Remove the linchpins **28** and unpin the pins **27**.

See illustration 39.

- ▶ Hang the pin pulling cylinder on the retainer **29** and on the screw **30**.
- ▶ Separate the transport unit **T3** and the W-connector head **10** on both sides on point **e**: Remove the linchpins **31** and unpin the pins **33**.
- ▶ Hang the pin pulling cylinder on the retainer **29** and on the screw **30**.
- ▶ Unpin the pin **32** with pin pulling cylinder.
- ▶ Lower the transport unit **T3** and remove the auxiliary crane.

40

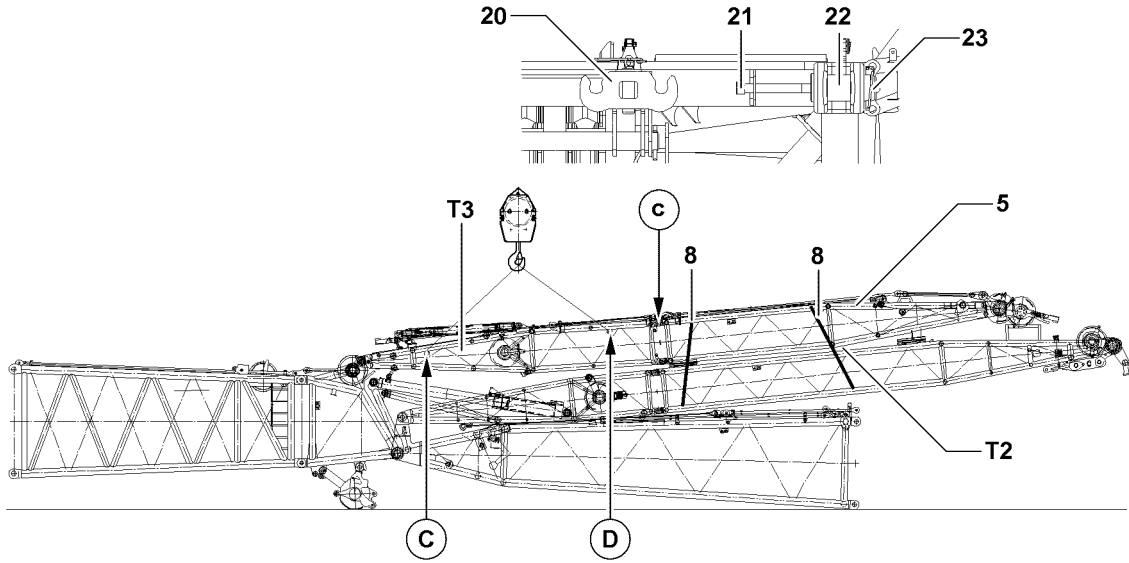

41

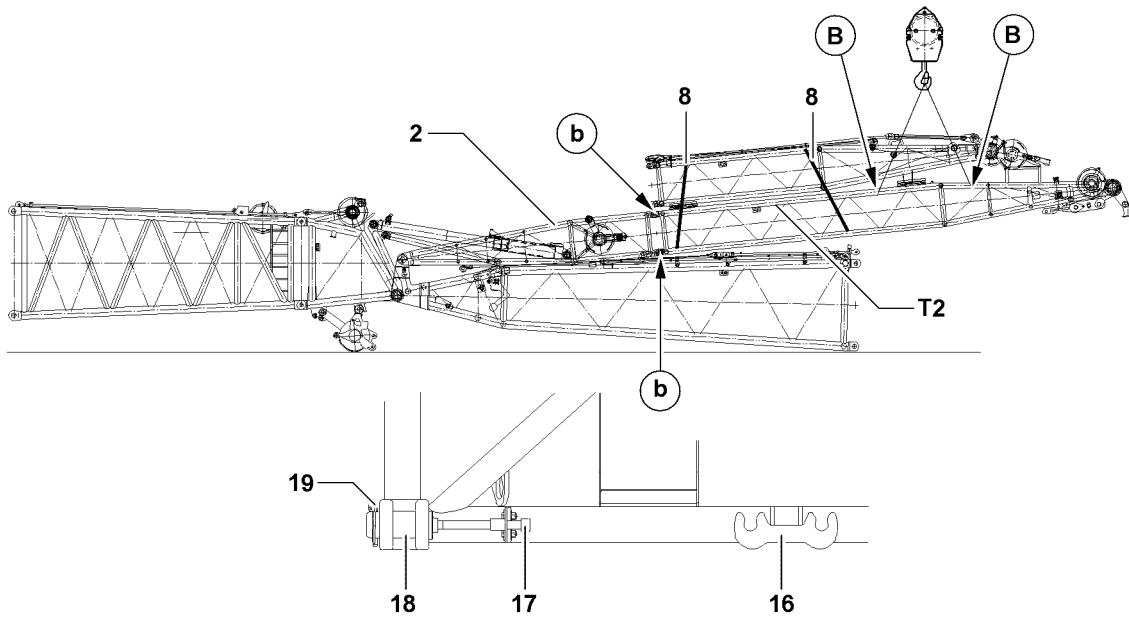

42

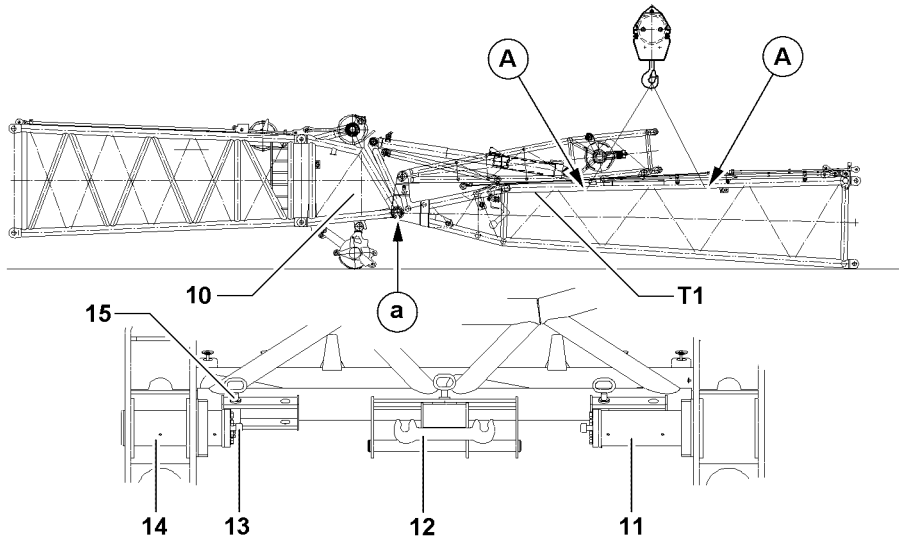

Fig.106838

LWE/LR 1600-2-008/18109-09-02/en

5.7.2 Disassembling the W-transport unit 3

See illustration 40.

- ▶ Secure the transport unit **T2** with the lashing belts **8**.
- ▶ Attach and secure the auxiliary crane on fastening point **C** and fastening point **D** on the transport unit **T3**.
- ▶ Hang the pin pulling cylinder on the retainer **20** and on the screw **21**.
- ▶ Separate the transport unit **T3** and the WA-frame 2 end section **5** both sides on point **c**: Remove linchpins **23** and pin the pins **22**.
- ▶ Remove the transport unit **T3** with the auxiliary crane.

5.7.3 Disassembling the W-transport unit 2

See illustration 41.

Make sure that the following prerequisite is met:

- The lashing belts are tightly rigged on transport unit 2.



WARNING

Slipping component!

If the lashing belts are not present or insufficiently secured while raising the transport unit 2, the end section of the WA-frame 2 can slide down.

Personnel can be severely injured or killed!

- ▶ Make sure that the lashing belts **8** are tightly rigged on transport unit 2!

- ▶ Disconnect the electrical connection for the pull test bracket between the transport unit **T2** and the transport unit **T1**.
- ▶ Attach and secure the auxiliary crane on the fastening points **B** on the transport unit **T2**.
- ▶ Hang the pin pulling cylinder on the retainer **16** and on the screw **17**.
- ▶ Separate the transport unit **T2** and the WA-frame 1 pivot section **2** both sides on the points **b**: Remove the linchpins **19** and unpin the pins **18**.
- ▶ Remove the transport unit **T2** with the auxiliary crane.

5.7.4 Disassembling the W-transport unit 1

See illustration 42.

- ▶ Attach and secure the auxiliary crane on the fastening points **A** on the transport unit **T1**.
- ▶ Hang the pin pulling cylinder on the retainer **12** and on the screw **13**.
- ▶ Separate the transport unit **T1** and the W-connector head **10** on both sides on point **a**: Remove the connector pins **15** and unpin the pins **14**.
- ▶ Remove the transport unit **T1** with the auxiliary crane.

Empty page!

LWE/LR 1600-2-008/18109-09-02/en

5.08 WV-lattice jib

1	Overview WV-lattice jib	3
2	Assembling the WV-boom system	5
3	Operating the crane	17
4	Disassembling the WV-boom system	19

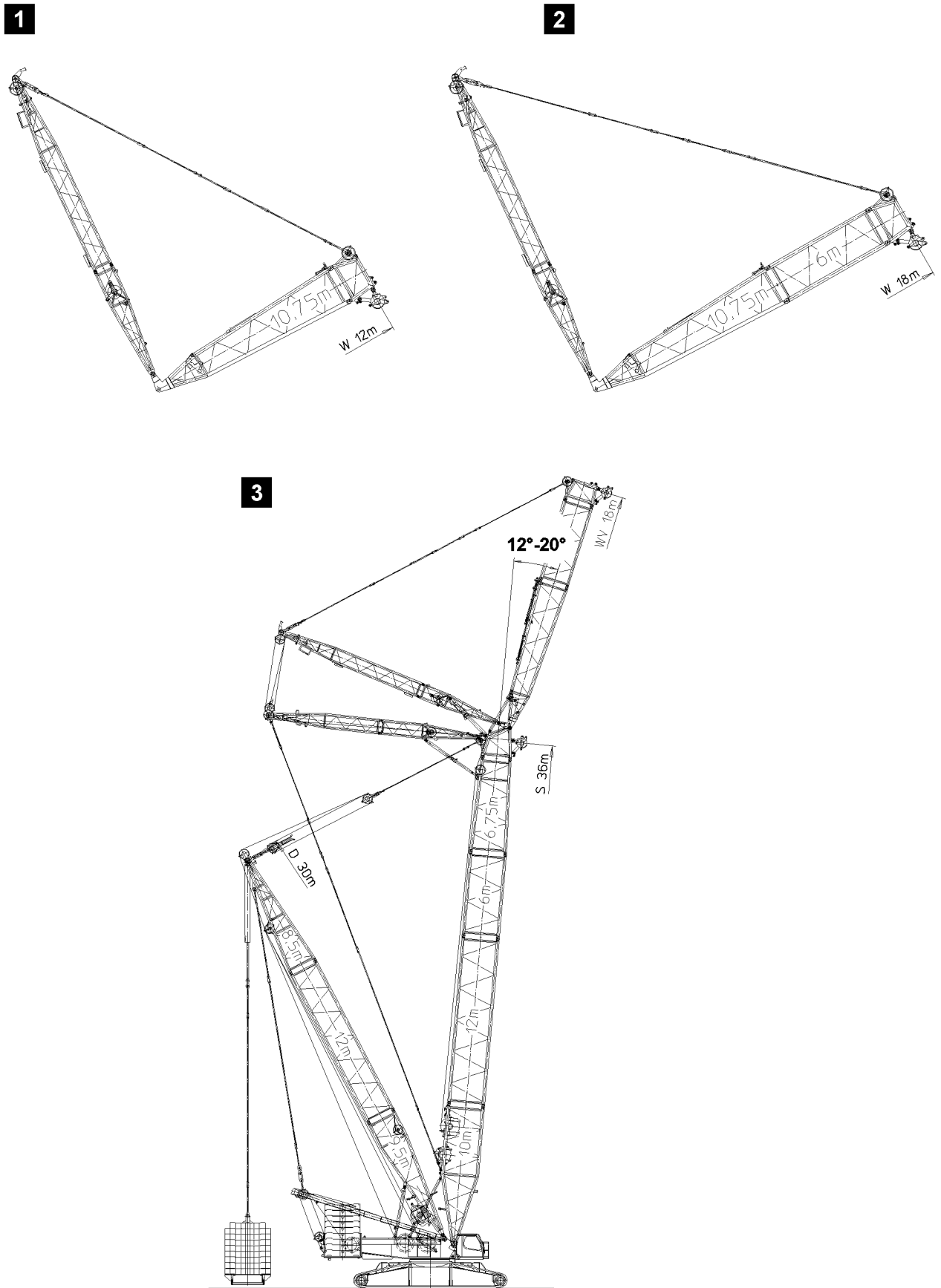

Fig.113571

LWE/LR 1600-2-008/18109-09-02/en

1 Overview WV-lattice jib

This chapter refers to the SDW-boom systems with the following WV-lattice jib lengths:

- 12 m , see illustration 1.
- 18 m , with LI-intermediate section LI 2621.10, see illustration 2.

The operating range of the WV-lattice sections to the S-boom includes an angle range between 12° and 20°.

The adjustment of the WV-lattice jib is made by winch 5.

The adjustment of the S-boom, together with the WV-lattice jib is made by winch 3.



Note

- ▶ The WV-lattice jib on this crane type is expandable up to a length of maximum 96 m.
 - ▶ The WV-lattice jib is structurally the same as the W-lattice jib.
 - ▶ The difference between the SDW-boom configuration and the SDWV-configuration is that the change of radius in the SDW-operating mode is made via the luffing jib and in the SDWV-operating mode via the main boom.
 - ▶ Since the maximum load capacities for these two operating mode differ due to static factors in various load ranges, it must first be checked with the Job planner which of the two operating modes - with a precise upcoming load case - offers the better load capacity values.
-

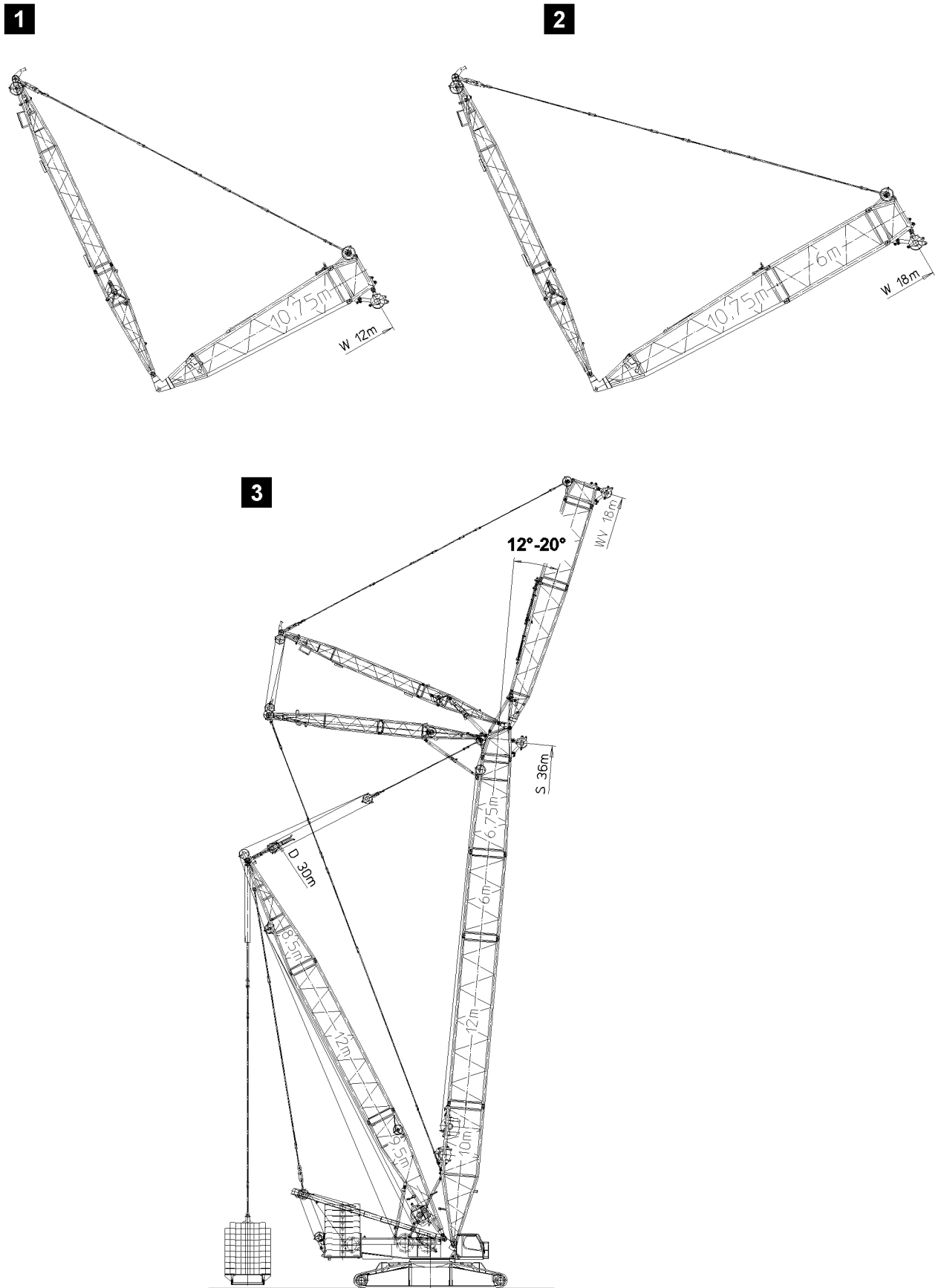

Fig.113571

2 Assembling the WV-boom system



WARNING

Risk of falling!

During assembly / disassembly work, personnel must be secured with appropriate aids to prevent them from falling. If this is not observed, assembly personnel could fall and suffer life-threatening or fatal injuries.

- ▶ All assembly work must be carried out using suitable aids (lifting platforms, scaffolding, ladder, auxiliary crane, etc.)!
- ▶ If work cannot be carried out on the ground or using such aids, then assembly personnel must be secured with the personal fall arrest system (see Crane operating instructions, chapter 2.04) to protect against falling! The personal fall arrest system must be attached in the corresponding fastening points on the crane (see Crane operating instructions, chapter 2.06)!
- ▶ If railings are present on the components, then they must be brought into the corresponding position and secured for assembly / disassembly work!
- ▶ Step on aids and fall protection equipment only with clean shoes!
- ▶ Keep aids and fall protection equipment clean and free from snow and ice!



WARNING

Falling components!

If unsecured or non-supported components are assembled or disassembled, they can fall down. Personnel can be severely injured or killed!

- ▶ During pinning and unpinning of the lattice sections, it is prohibited for anyone to remain **under** or **on** the components as well as within the entire danger zone!
- ▶ Support the boom and components before pinning / unpinning!
- ▶ Pin or unpin both pins laying in a horizontal, i.e. **left** and **right**!
- ▶ Secure the pins in the bearing points and in the receptacles!
- ▶ Do not disengage the auxiliary crane until each component is pinned and secured!
- ▶ It is prohibited to lean a ladder against the component being disassembled!



WARNING

Danger of crushing!

Components can swing during assembling. Hands can be crushed or severed!

- ▶ Make sure that the components do not swing back and forth during assembly!



WARNING

Neglected inspection and maintenance on guy rods!

If the regular inspection and maintenance of the guy rods is not carried out or is carried out only in irregular intervals, then severe accidents can occur due to existing and unrecognized damage to the guy rods!

Personnel can be severely injured or killed!

- ▶ Check the guy rods before every assembly, see Crane operating instructions, chapter 8.15!

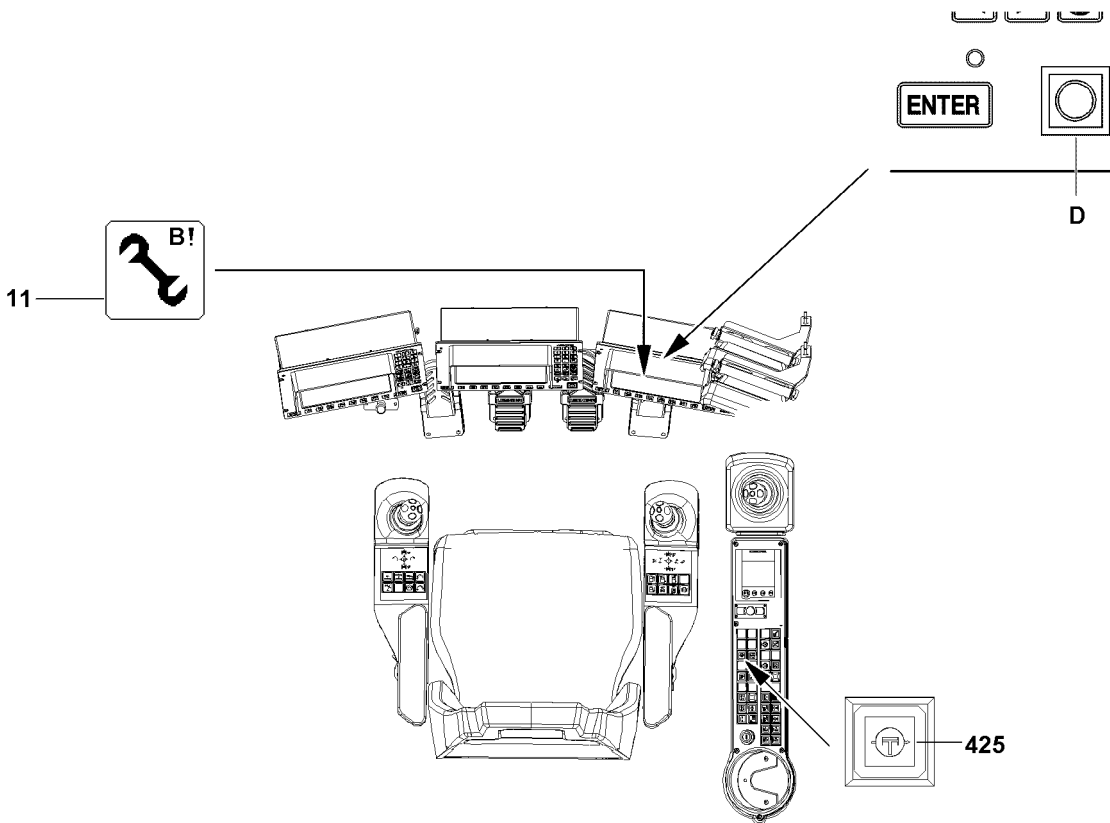
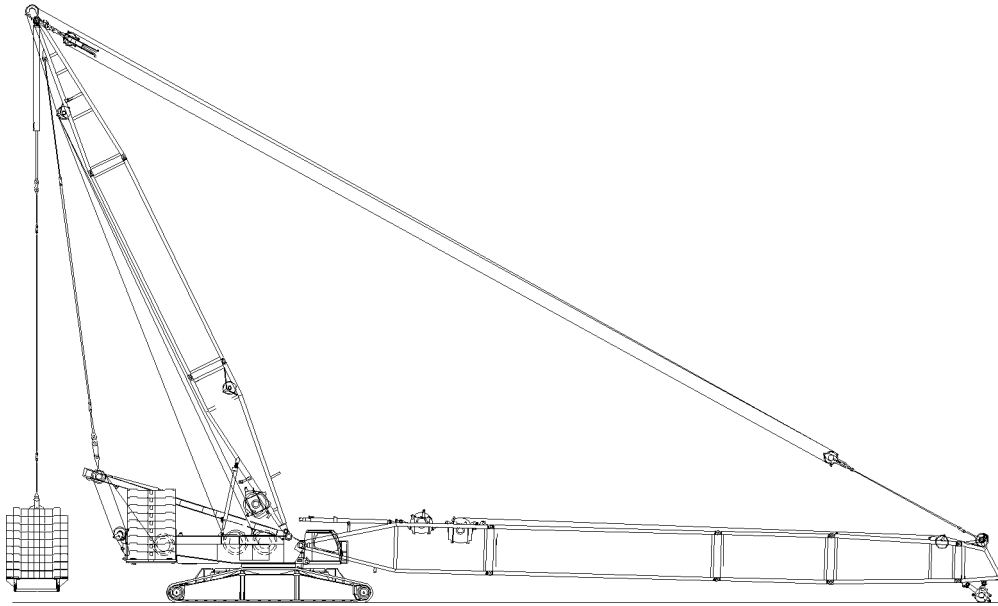

Fig.110711

LWE/LR 1600-2-008/18109-09-02/en

**Note**

- ▶ By supporting the components during assembly / disassembly, ground unevenness is compensated for and the material is protected!

**Note**

- ▶ The intermediate sections are pinned and unpinned with the aid of the pin pulling device, see Crane operating instructions, chapter 5.30!

NOTICE

Property damage!

- ▶ Always insert the pins of the guy rods from the „inside“ to the „outside“!

**Note**

- ▶ The S-guy rods must be assembled and secured according to the separately supplied assembly drawings! The numbering on the assembly drawings must be identical to the numbering on the guy rods!

**Note**

- ▶ The boom combinations must be assembled according to the separately supplied rod and assembly plans!

**WARNING**

Assembly with turned on set up key!

When the set up key is engaged, the LICCON overload protection is exceeded!

In the event of deliberate improper use, the crane could collapse, the boom can break off or the crane can topple over!

Personnel can be killed!

This could result in high property damage!

- ▶ The set up key **D** may only be actuated by persons who know the effects of a bypass!
- ▶ Press the set up key **D** only when the set up status was correctly entered into the LICCON computer system!
- ▶ Observe the erection / take down charts!
- ▶ Crane operation with the set up key **D** turned on is strictly prohibited!

Make sure that the following prerequisites are met:

- The crane is aligned in horizontal direction.
- The SD-boom combination is assembled, see Crane operating instructions, chapter 5.38 and chapter 5.05.
- The counterweight has been installed on the turntable according to the load chart.
- The derrick ballast is placed on the suspended ballast or the ballast trailer according to the load chart.
- The LICCON overload protection has been set according to the data in the load chart.
- The LICCON overload protection settings have been compared with the actual crane configuration.
- The LICCON overload protection is exceeded.
- The assembly icon **11** is visible on the LICCON monitor.
- An auxiliary crane is available.

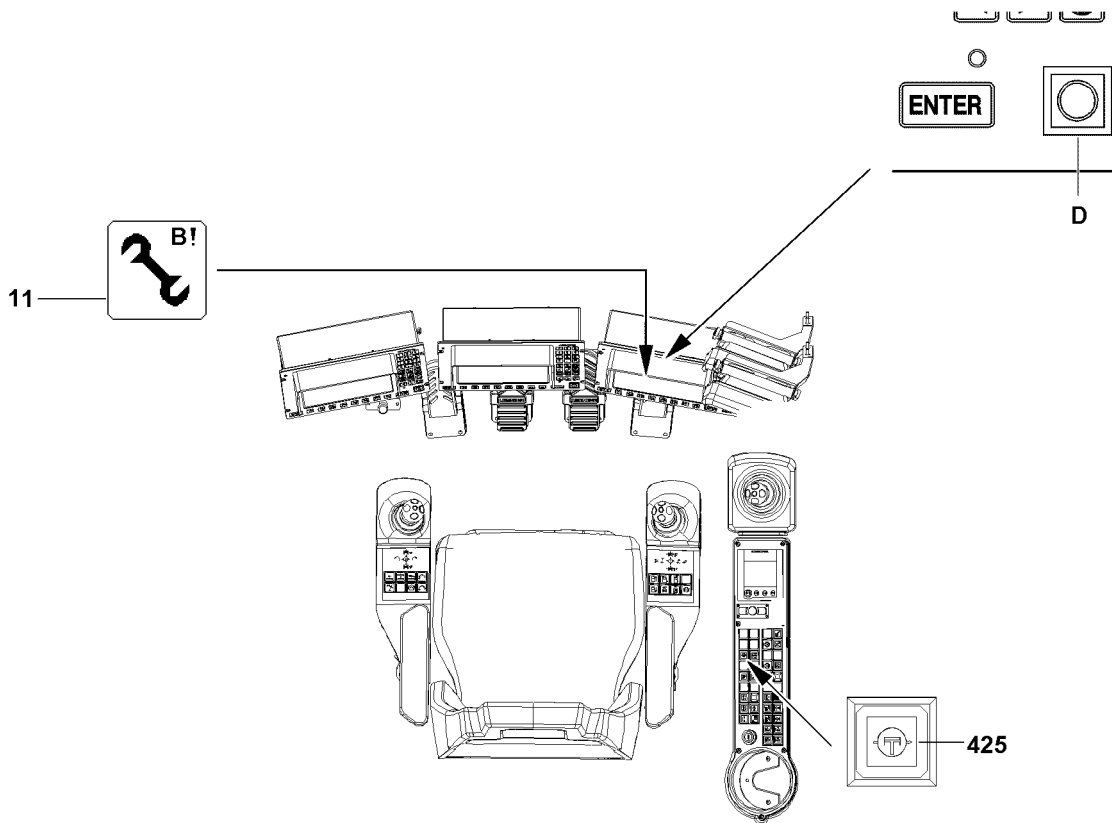
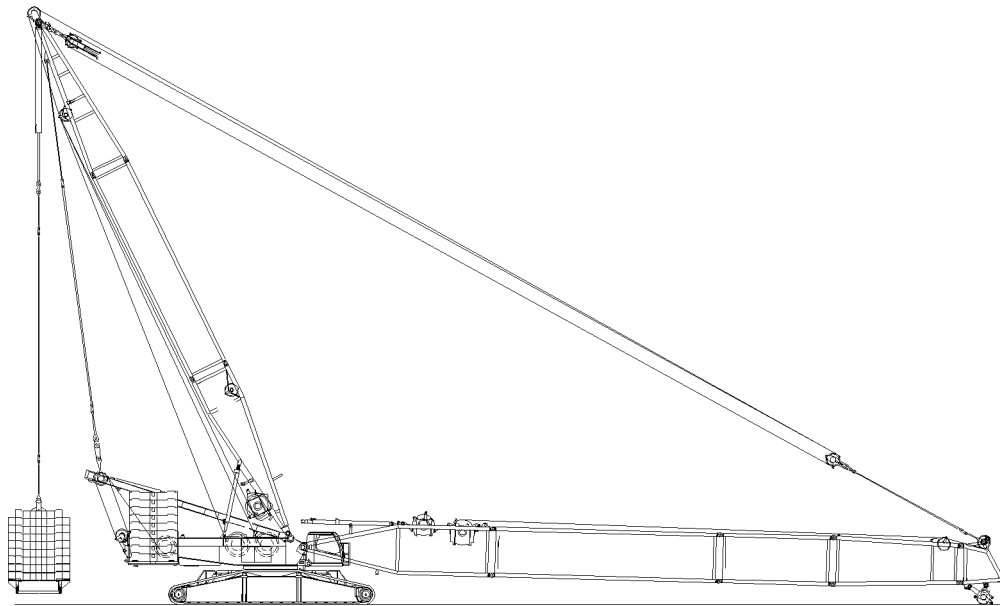

Fig.110711

LWE/LR 1600-2-008/18109-09-02/en

2.1 Assembling the W-transport units

**Note**

► Observe the instructions, see Crane operating instructions, chapter 5.07!

2.2 Reeving the W-control rope in

**Note**

► Observe the instructions, see Crane operating instructions, chapter 5.07!

2.3 Assembling the guy rods WA-frame 2

**Note**

► Observe the instructions, see Crane operating instructions, chapter 5.07!

2.4 Pinning the relapse supports

**Note**

► Observe the instructions, see Crane operating instructions, chapter 5.07!

2.5 Assembling the WV-lattice jib

**Note**

► Observe the instructions, see Crane operating instructions, chapter 5.07!

2.6 Establishing the electrical connections

**Note**

► Observe the instructions, see Crane operating instructions, chapter 5.07!

2.7 Checking the function of the safety devices

**Note**

► Observe the instructions, see Crane operating instructions, chapter 5.07!

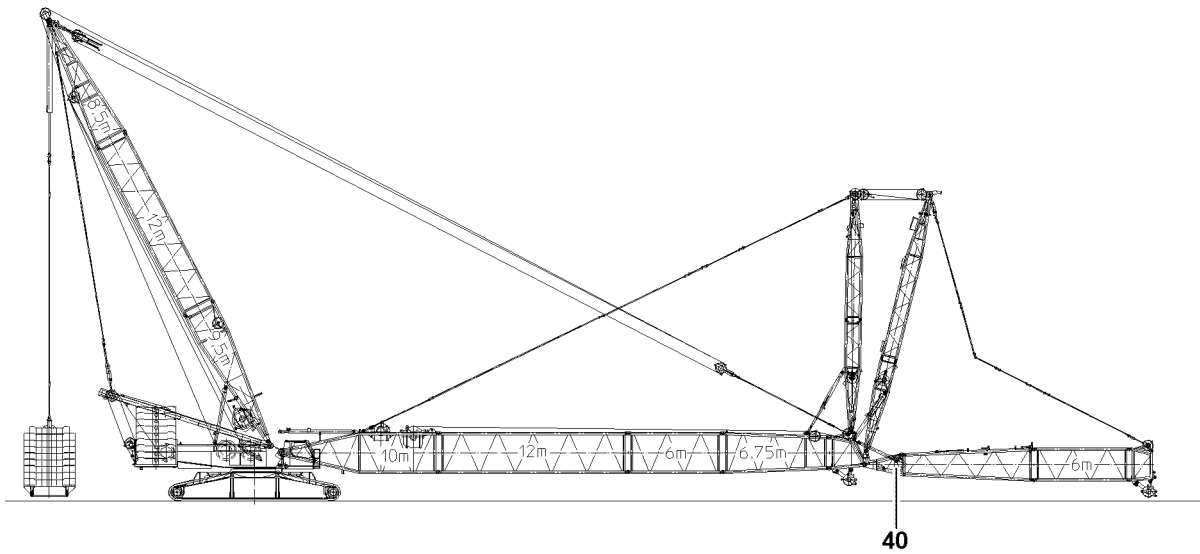
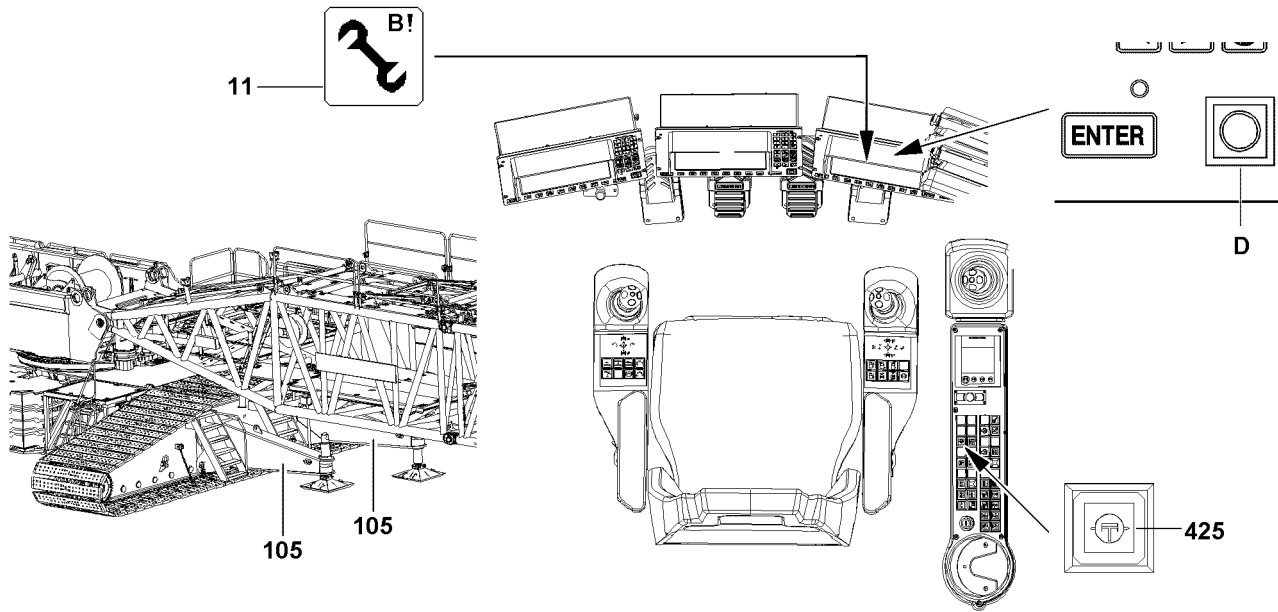

Fig.110712

LWE/LR 1600-2-008/18109-09-02/en

2.8 Erecting the boom



Note

- ▶ The erection procedure in this chapter regards the WV-lattice jibs W12 and W18. Erection procedure for longer lattice jibs, see Crane operating instructions, chapter 5.07!



DANGER

The crane can topple over!

- ▶ It is not permitted to turn the crane during erection!
- ▶ Observe the data in the erection and take down charts!
- ▶ Observe the Safety technical notes, see Crane operating instructions, chapter 5.01!



DANGER

The crane can topple over!

For certain boom lengths, the mechanical auxiliary supports must be assembled, see Erection and take down charts!

- ▶ The boom must be erected or taken down „to the side“ „in direction“ of the mechanical auxiliary supports **105**!
- ▶ Always erect or take down according to the data in the **Erection and take down charts**!



DANGER

Tipping lattice jib!

If the easy movement on the pendulum of the mechanical relapse support is not checked before erection or not reestablished, if necessary, then the mechanical relapse support will not engage in steep lattice jib position. As a result, the lattice jib can tip to the rear!

Personnel can be severely injured or killed!

- ▶ Check the easy movement on the pendulum **40** of the mechanical relapse support before erection!
- ▶ If the pendulum does not move easily: Make the pendulum **40** easy to move!



WARNING

The crane can topple over!

If the following conditions are not met before erecting the boom, the crane can topple over!

Personnel can be severely injured or killed!

- ▶ Spool the lattice jib control out so that the guy rods sag slightly!
- ▶ Do not allow slack rope to form on the control winch!
- ▶ Move the relapse cylinder out before erection!

Make sure that the following prerequisites are met:

- The WV-lattice jib is fully assembled.
- No personnel is within the danger zone.
- The crane is aligned in horizontal direction.
- All electrical connections have been established.
- All limit switches are functioning.
- The counterweight has been installed on the turntable and on the derrick, according to the load chart.
- All pin connections have been secured.
- The hoist rope has been correctly placed in the rope pulleys and is prevented from jumping out with the rope retaining pins.
- There are no loose parts on the boom or the lattice jib.
- The boom, lattice jib and safety devices are free from snow and ice.
- The LICCON overload protection has been set according to the data in the load chart.
- The LICCON overload protection settings have been compared with the actual crane configuration.
- The LICCON overload protection is exceeded.
- The assembly icon **11** is visible on the LICCON monitor.



WARNING

Falling hoist rope!

If the hoist rope is not properly secured with a corresponding length on the WV-lattice jib before the erection procedure, then it can fall backward due to its own weight!

Personnel can be severely injured or killed!

- ▶ Reeve in the hoist rope with sufficient length on the WV-lattice jib before the erection procedure!
- ▶ The hoist rope must be constantly monitored during erection!
- ▶ Do not step into the danger zone!

- ▶ Luff the S-boom down until the hook block can be reeved.
- ▶ Reeve in the hook block properly and secure the hoist rope on the rope fixed point, for reeving, see separate reeving plans.
- ▶ Attach the hoist limit switch weight.

See illustration 4

- ▶ Luff the S-boom up to 15°.



WARNING

The crane can topple over!

If the angle between the boom and the lattice jib is smaller than or equal to 30°, the mechanical re-lapse support will collide with the flap on the oscillating guard. The crane can topple over!

Personnel can be severely injured or killed!

- ▶ Make sure that the angle between the S-boom and the WV-lattice jib is more than 30° during the erection procedure!
- ▶ Make sure that the angle between the S-boom and the WV-lattice jib does not fall below 30° during the erection procedure!
- ▶ Perform a visual inspection during erection!
- ▶ Lower the WV-boom to -15° (angle between the S-boom and the WV-lattice jib is 30°).

4

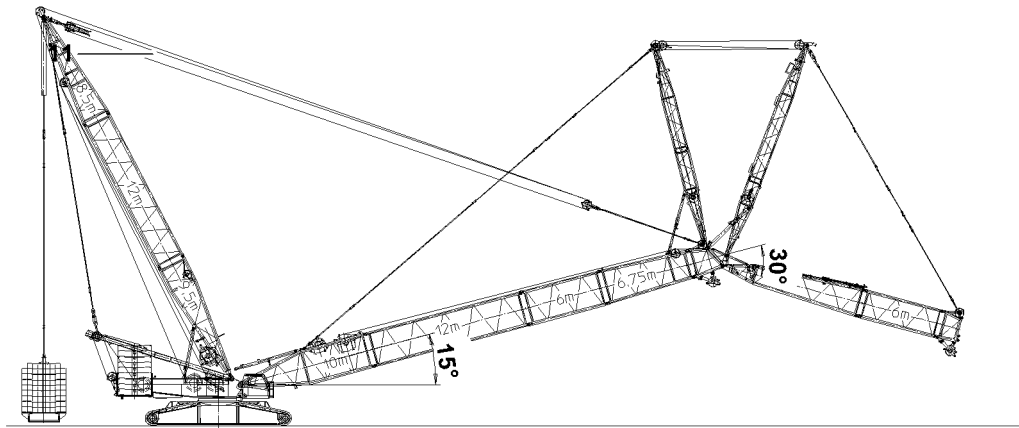

5

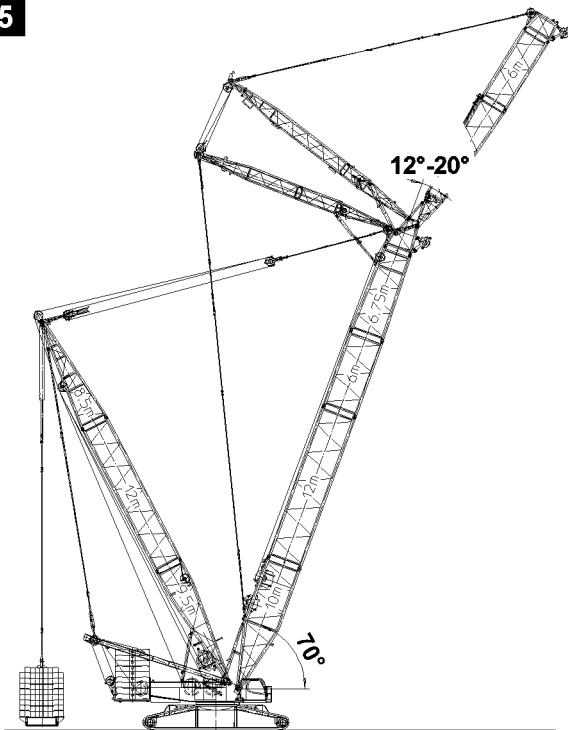

6

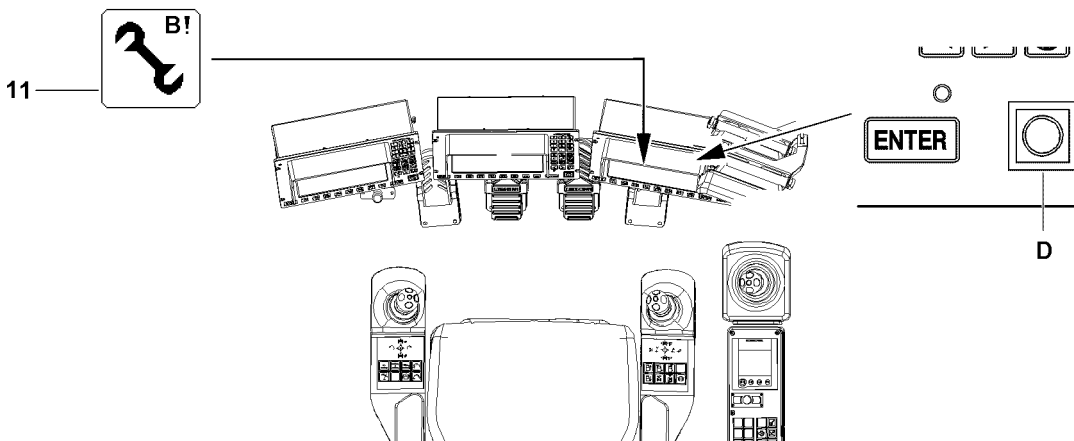
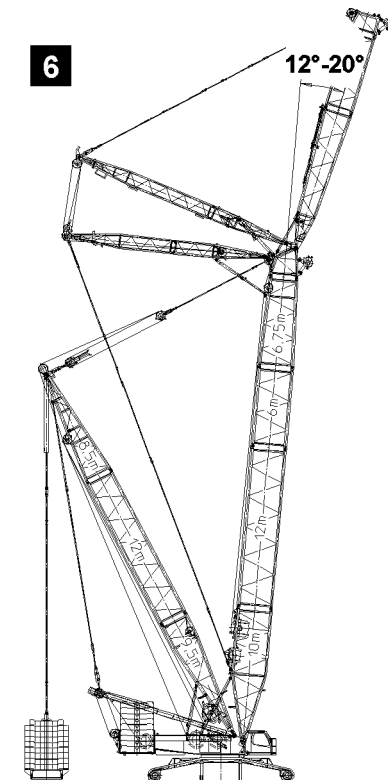

Fig.113574

LWE/LR 1600-2-008/18109-09-02/en

See illustration 5



DANGER

The crane can topple over!

In crane operation with exceeded LICCON overload protection, the crane can topple over.

- ▶ Personnel can be severely injured or killed!
- ▶ The radii listed in the load chart may not be exceeded or fallen below, even if there is no load on the hook!



Note

- ▶ When the lowest operating position of the WV-lattice jib is reached, the LICCON overload protection is activated!
- ▶ In the maximum load icon appears a load number in „t“ instead of the display „???“!

- ▶ Luff the S-boom up to the lowest operating position.

When the S-boom has reached the lowest operating position:

- ▶ Make sure that the assembly icon 11 on the LICCON monitor turns off.

Result:

- The LICCON overload protection is active.
- ▶ Luff the S-boom up to 70°.
- ▶ Luff the WV-lattice jib in operating position. The angle range to do so is between 12° and 20°.

See illustration 6

- ▶ Luff the S-boom up into operating position.

3 Operating the crane

3.1 Preparing for crane operation

**Note**

- ▶ Observe the notes, see Crane operating instructions, chapter 4.05, chapter 4.08 and chapter 5.01!

Make sure that the following prerequisites are met:

- The LICCON overload protection is active.
- The LICCON overload protection has been set according to the data in the load chart.

**WARNING**

The crane can topple over!

- ▶ Check the horizontal position of the crane before and during operation!
- ▶ If the crane operator leaves the cab, even for a short time, the operating mode setting must be checked and reset if necessary before resuming crane operation!

3.2 Checking the settings

- ▶ Check the function of the overload protection by running against the operating positions „on top“ and „bottom“.
- ▶ Check the hoist limit switch by running against the hoist limit switch weight.
- ▶ Check the function of the limit switches on the relapse cylinders.

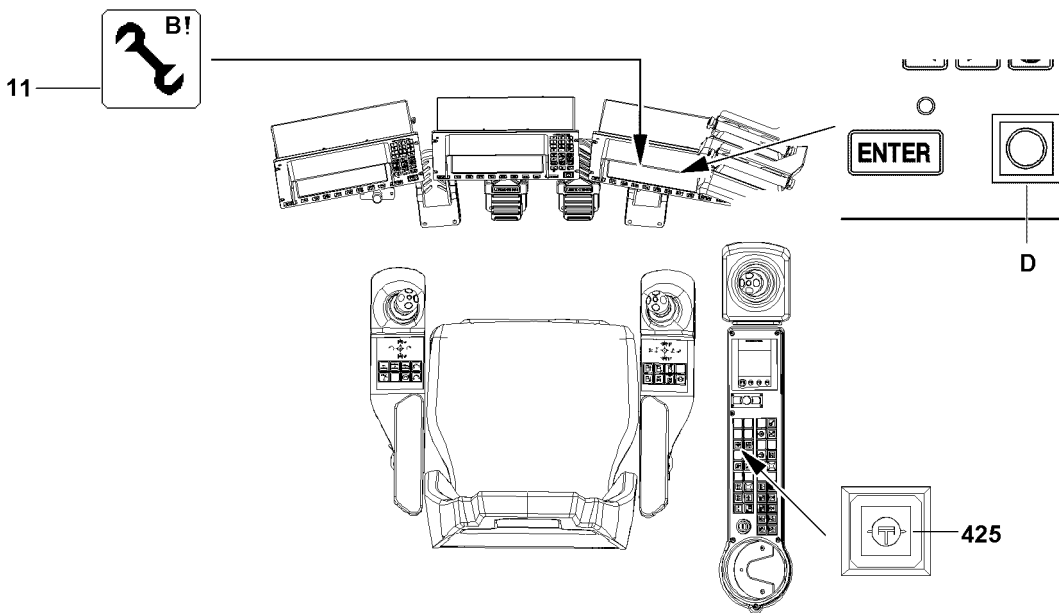
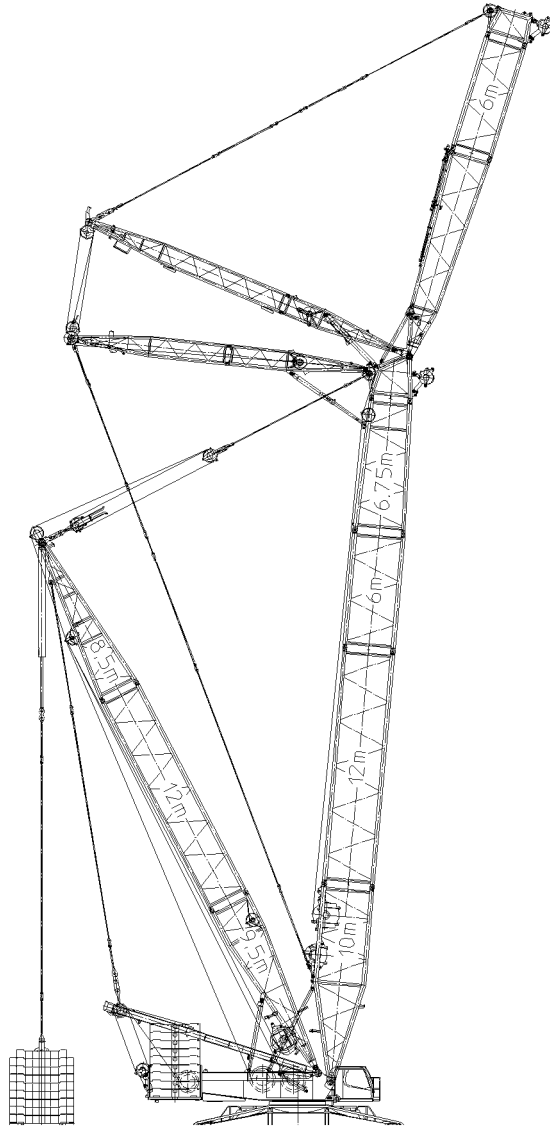

Fig.110714

LWE/LR 1600-2-008/18109-09-02/en

4 Disassembling the WV-boom system



WARNING

Risk of falling!

During assembly / disassembly work, personnel must be secured with appropriate aids to prevent them from falling. If this is not observed, assembly personnel could fall and suffer severe or fatal injuries!

- ▶ All assembly work must be carried out using suitable aids (lifting platforms, scaffolding, ladder, auxiliary crane, etc.)!
- ▶ If work cannot be carried out on the ground or using such aids, then assembly personnel must be secured with the personal fall arrest system (see Crane operating instructions, chapter 2.04) to protect against falling! The personal fall arrest system must be attached in the corresponding fastening points on the crane (see Crane operating instructions, chapter 2.06)!
- ▶ If railings are present on the components, then they must be brought into the corresponding position and secured for assembly / disassembly work!
- ▶ Step on aids and fall protection equipment only with clean shoes!
- ▶ Keep aids and fall protection equipment clean and free from snow and ice!



WARNING

Falling components!

If unsecured or non-supported components are assembled or disassembled, they can fall down. Personnel can be killed or seriously injured!

- ▶ During pinning and unpinning of the lattice sections, it is prohibited for anyone to remain **under** or **on** the components as well as within the entire danger zone!
- ▶ Support the boom and components before pinning / unpinning!
- ▶ Pin or unpin both pins laying in a horizontal, i.e. **left** and **right**!
- ▶ Secure the pins in the bearing points and in the receptacles!
- ▶ Do not disengage the auxiliary crane until each component is pinned and secured!
- ▶ It is prohibited to lean a ladder against the component being disassembled!



WARNING

Danger of crushing!

Components can swing during assembling. Hands can be crushed or severed.

- ▶ Make sure that the components do not swing back and forth during assembly!

7

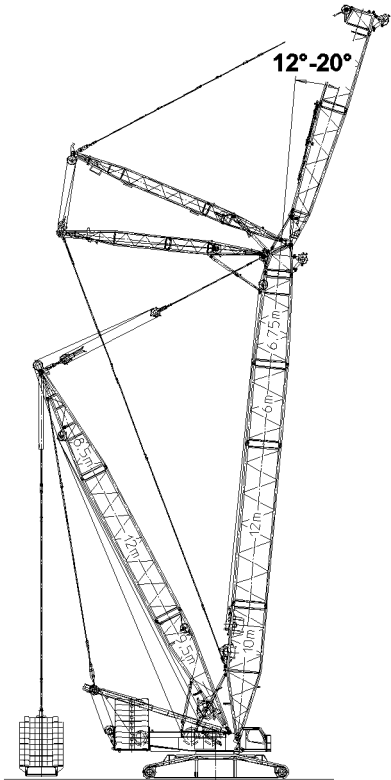

8

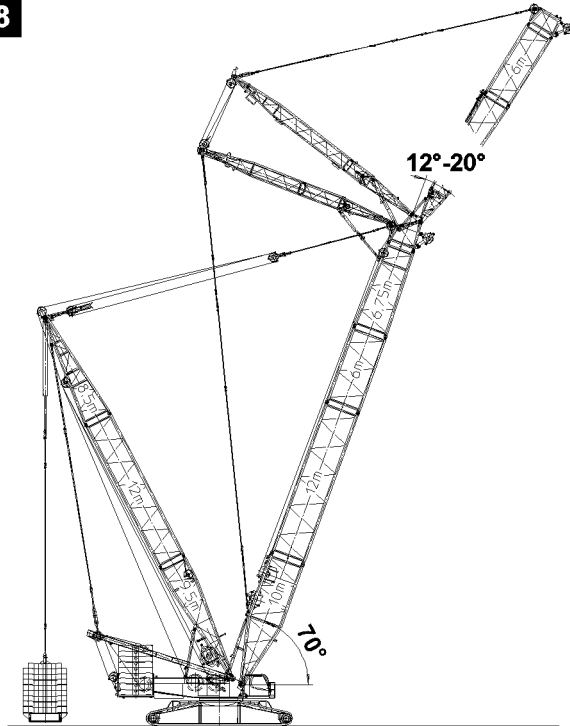

9

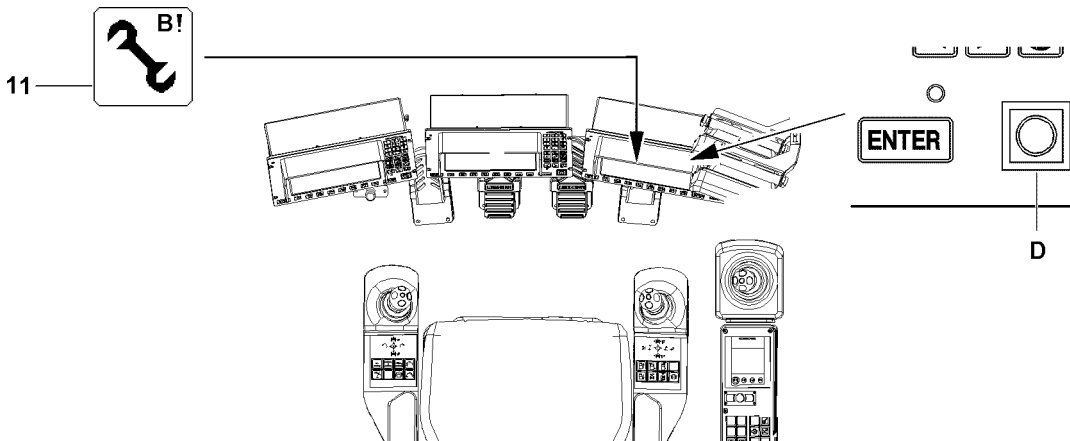
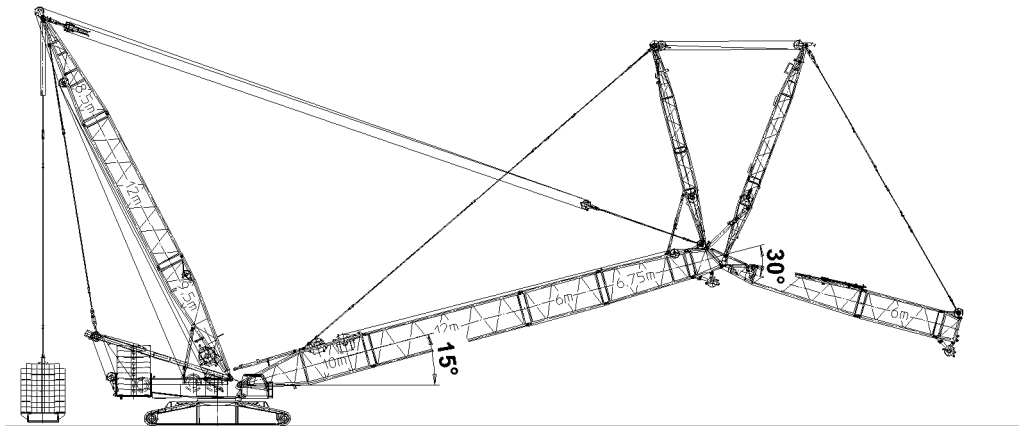

Fig.113575

LWE/LR 1600-2-008/18109-09-02/en

**Note**

- ▶ By supporting the components during assembly / disassembly, ground unevenness is compensated for and the material is protected!

**Note**

- ▶ The intermediate sections are pinned and unpinned with the aid of the pin pulling device, see Crane operating instructions, chapter 5.30!

**WARNING**

Risk of accident!

Personnel can be severely injured or killed!

- ▶ For pinning and unpinning with the pin pulling device, observe and follow the warning guidelines, see Crane operating instructions, chapter 5.30!

Make sure that the following prerequisites are met:

- The LICCON overload protection is exceeded.
- The LICCON overload protection has been set according to the data in the load chart.
- The assembly icon **11** is visible on the LICCON monitor.
- An auxiliary crane is available.

4.1 Placing the WV-lattice jib down

**DANGER**

The crane can topple over!

For certain boom lengths, the mechanical auxiliary supports must be assembled, see Erection and take down charts!

- ▶ The boom must be erected or taken down „to the side“ „in direction“ of the mechanical auxiliary supports **105**.
- ▶ Always erect or take down according to the data in the **Erection and take down charts!**

**WARNING**

The crane can topple over!

If the following conditions are not met before taking down the boom, the crane can topple over and fatally injure personnel!

- ▶ Observe the Safety technical notes, see Crane operating instructions, chapter 5.01!
- ▶ Observe the data in the erection and take down charts!

NOTICE

Damage of boom components!

Taking down the boom system can lead to a collision between the hook block and the pulley head. The boom components can be severely damaged!

- ▶ Luff the boom system down at the same time and spool the hoist winch out!

Make sure that the following prerequisites are met:

- The S-boom is in operating position, see illustration **7**.
- The hook block is approx. 5 m below the pulley head of the lattice jib.

7

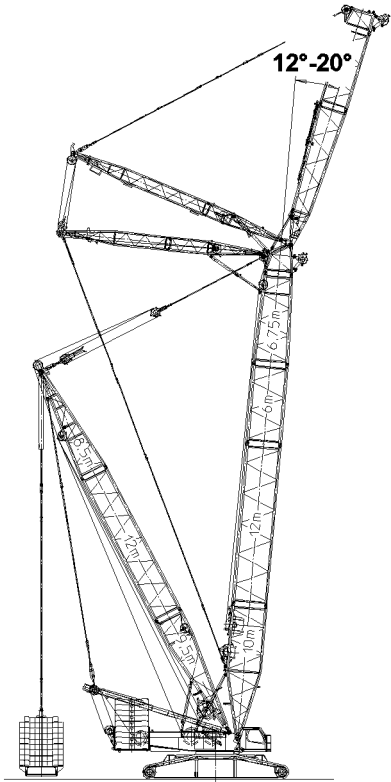

8

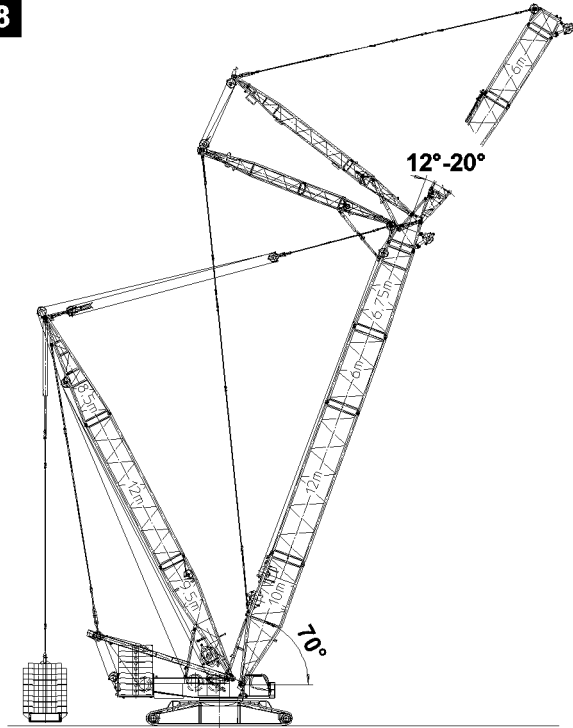

9

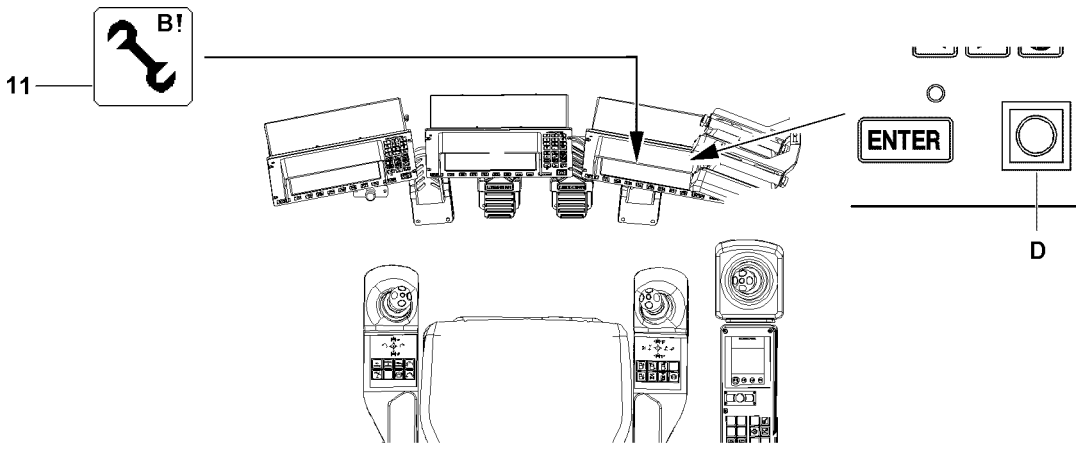
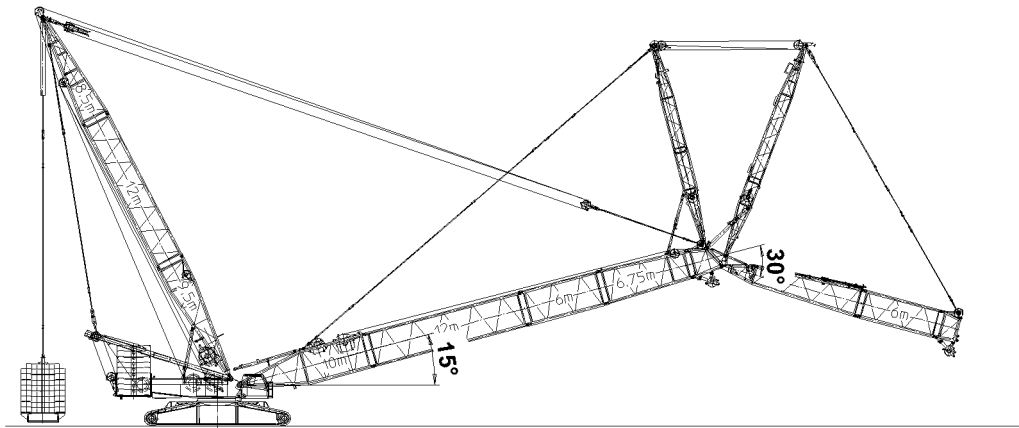

Fig.113575

LWE/LR 1600-2-008/18109-09-02/en

4.1.1 Luffing the WV-lattice jib down

- ▶ Luff the S-boom down to 70°, see illustration 8.



WARNING

The crane can topple over!

If the angle between the boom and the lattice jib is smaller than or equal to 30°, the mechanical re-lapse support will collide with the flap on the oscillating guard. The crane can topple over! Personnel can be severely injured or killed!

- ▶ Make sure that the angle between the S-boom and the WV-lattice jib is more than 30° during the complete erection procedure.
- ▶ The angle between the S-boom and the WV-lattice jib may not exceed 30° during the complete take-down procedure!
- ▶ Perform a visual inspection during erection.

- ▶ Luff the WV-lattice jib down to approx. 30° to the S-boom, see illustration 9.



Note

- ▶ The luff down movement is turned off as soon as the lowest operating position is reached!
- ▶ When the lowest operating position of the WV-lattice jib is reached, the load display in the maximum load icon turns off and instead of the load display appears the display „???“!
- ▶ In the crane operating screen appear alarm functions!

- ▶ Luff the WV-lattice jib down to the „lowest“ operating position.

Result:

- The luff down movement is turned off.
- The „STOP“ icon appears on the LICCON monitor.
- The horn icon appears on the LICCON monitor.



WARNING

Assembly with turned on set up key!

When the set up key is engaged, the LICCON overload protection is exceeded!

In the event of deliberate improper use, the crane could collapse, the boom can break off or the crane can topple over!

Personnel can be killed!

This could result in high property damage!

- ▶ The set up key **D** may only be actuated by persons who know the effects of a bypass!
- ▶ Press the set up key **D** only when the set up status was correctly entered into the LICCON computer system!
- ▶ Observe the erection / take down charts!
- ▶ Crane operation with the set up key **D** turned on is strictly prohibited!

When the WV-lattice jib has reached the „lowest“ operating position:

- ▶ Turn the set up key **D** to the right.

Result:

- The LICCON overload protection is deactivated.
- The assembly icon **11** appears on the LICCON monitor.

7

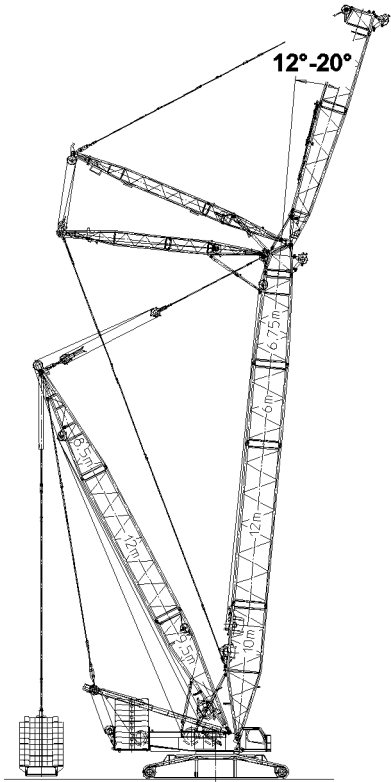

8

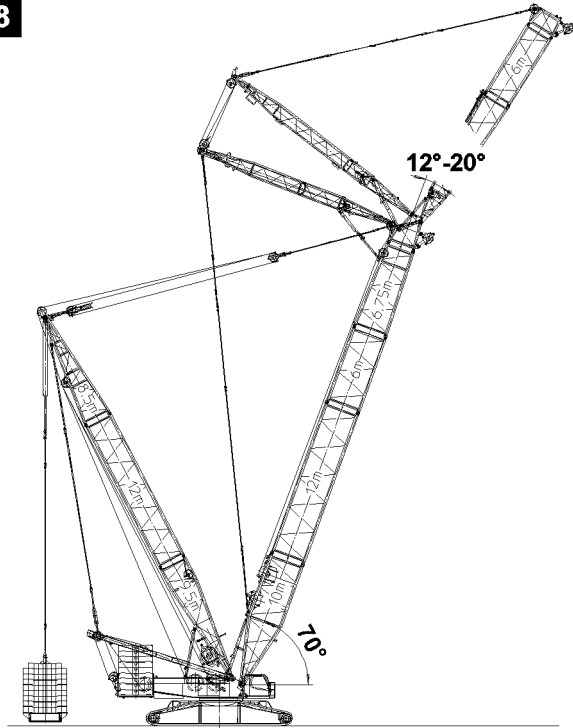

9

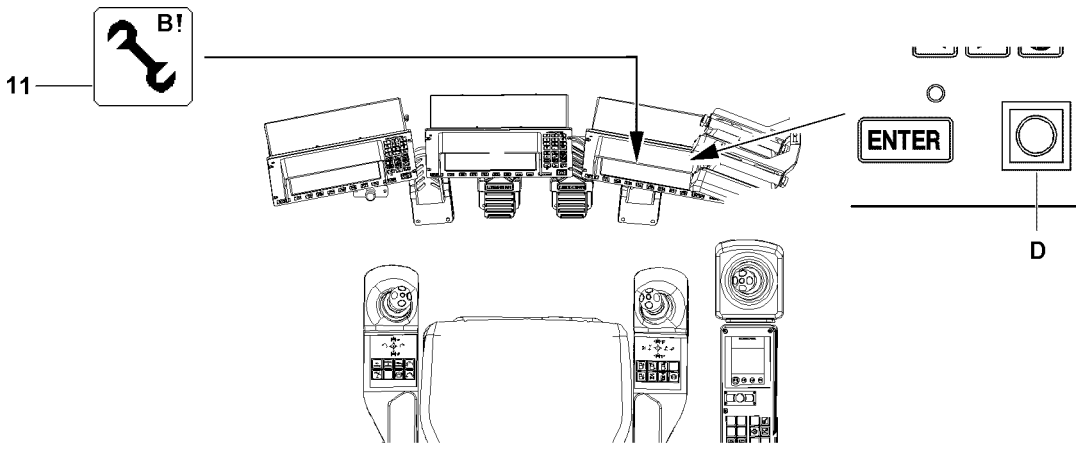
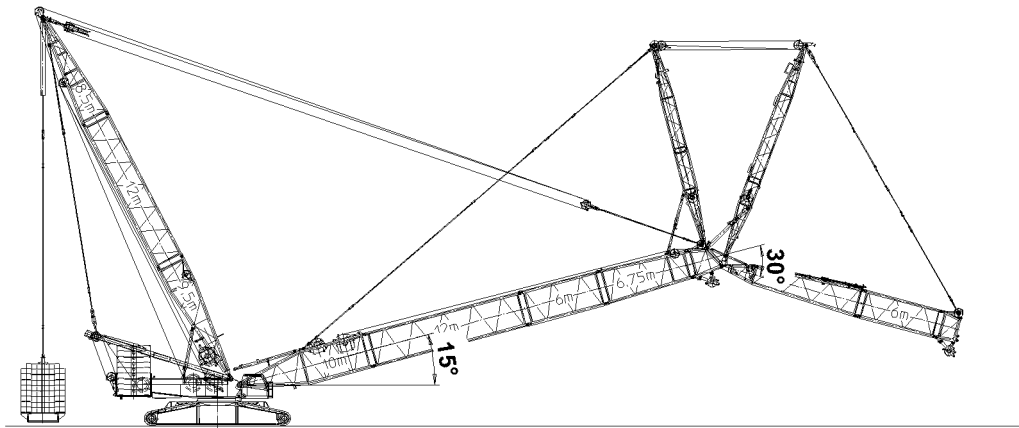

Fig.113575

LWE/LR 1600-2-008/18109-09-02/en

4.1.2 Placing the WV-lattice jib down

If the hook block has not yet touched the ground:

- ▶ At the same time, spool the hoist winch out and luff the S-boom down until the hook block touches the ground.
- ▶ Remove the hoist limit switch weight.
- ▶ Unreeve the hook block.
- ▶ Luff down S-boom until SW-end section lies on the floor.



WARNING

The crane can topple over!

If the following conditions are not met before taking down the boom, the crane can topple over!

Personnel can be severely injured or killed!

- ▶ Spool the lattice jib control out so that the guy rods sag slightly!
- ▶ Do not allow slack rope to form on the control winch!
- ▶ Do not pull the hook block along on the ground!

- ▶ Continue to luff down the S-boom and simultaneously spool the WV-lattice jib control out so that the guy rods sag slightly.
- ▶ Luff the S-boom down until the S-boom head is laying on the support on the ground.



WARNING

Risk of accident!

- ▶ Make sure that no personnel is within the danger zone!
- ▶ Secure the hoist rope with the assembly rope and pull it back slowly over the rope pulleys in the WA-frames and lower it toward the W-connector head!

- ▶ Lay the hoist rope down.

7

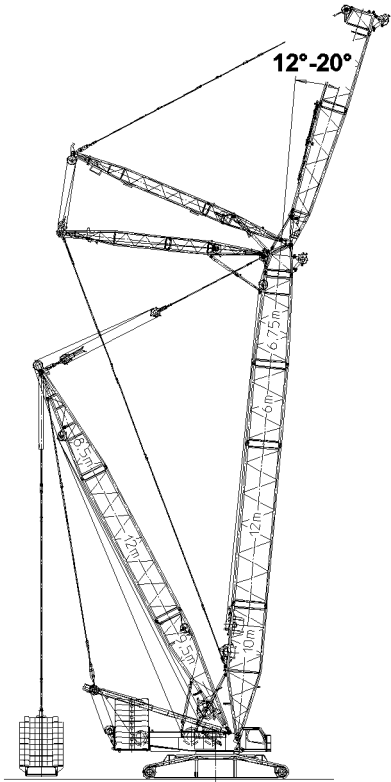

8

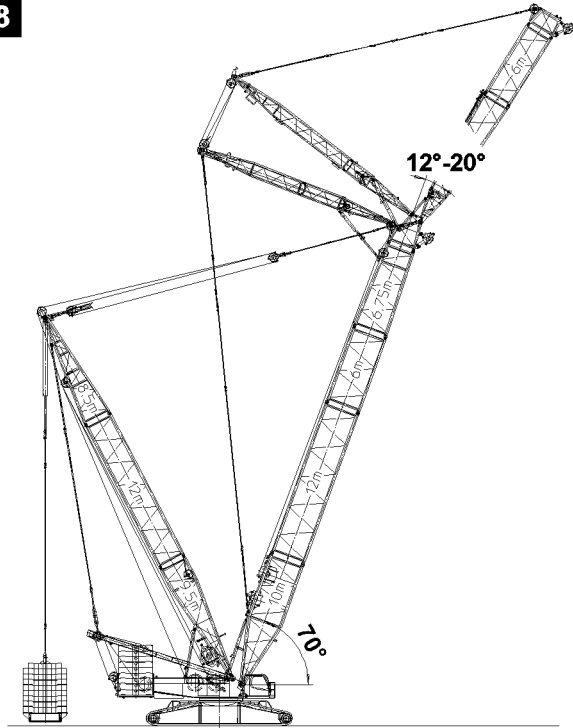

9

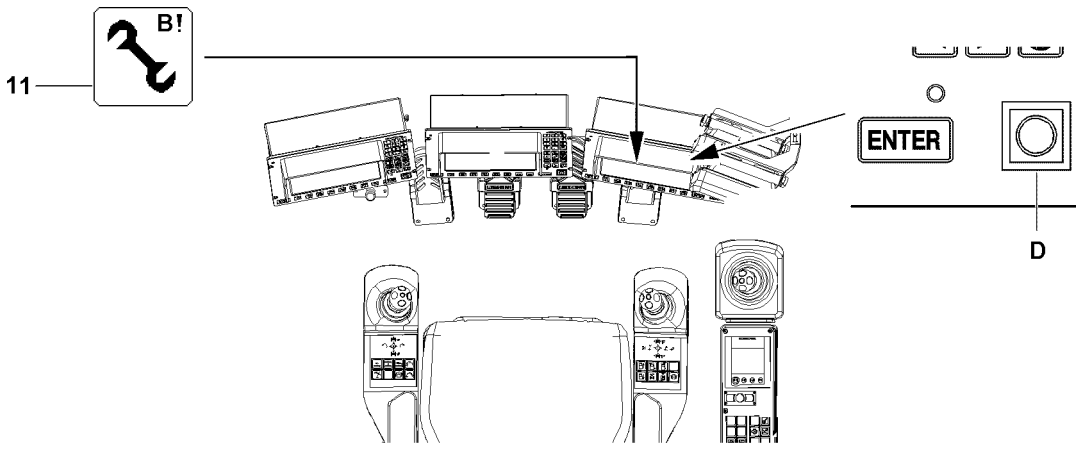
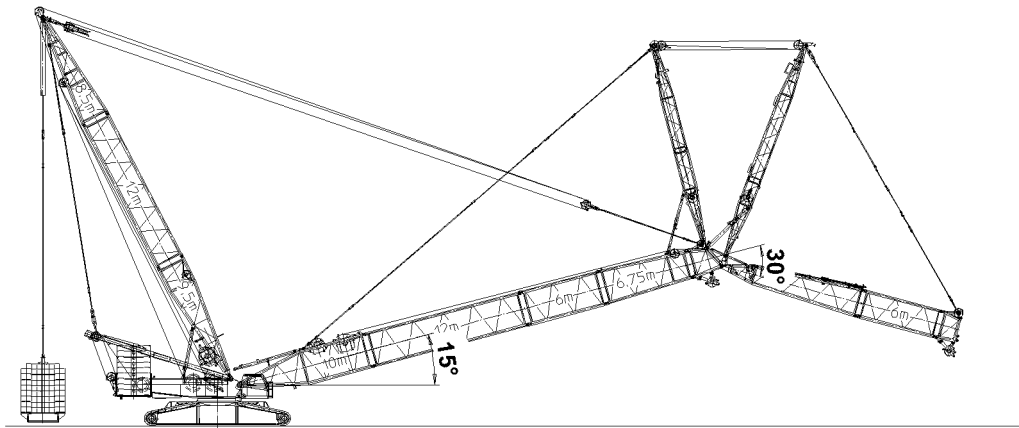

Fig.113575

LWE/LR 1600-2-008/18109-09-02/en

4.2 Disconnecting the electrical connections

**Note**

► Observe the instructions, see Crane operating instructions, chapter 5.07!

4.3 Disassembling the WV-lattice jib

**Note**

► Observe the instructions, see Crane operating instructions, chapter 5.07!

4.4 Unpinning the relapse supports

**Note**

► Observe the instructions, see Crane operating instructions, chapter 5.07!

4.5 Disassembling the WA-frame 2 guy rods

**Note**

► Observe the instructions, see Crane operating instructions, chapter 5.07!

4.6 Unreeving the W-control ropes

**Note**

► Observe the instructions, see Crane operating instructions, chapter 5.07!

4.7 Disassembling the W-transport units

**Note**

► Observe the instructions, see Crane operating instructions, chapter 5.07!

Empty page!

LWE/LR 1600-2-008/18109-09-02/en

5.10 Boom nose

1	Overview of boom nose components	3
2	Assembling the 36 t boom nose on the SW-end section	5
3	Erecting / taking down the boom	11
4	Crane operation	13
5	Disassembling the 36 t boom nose	15

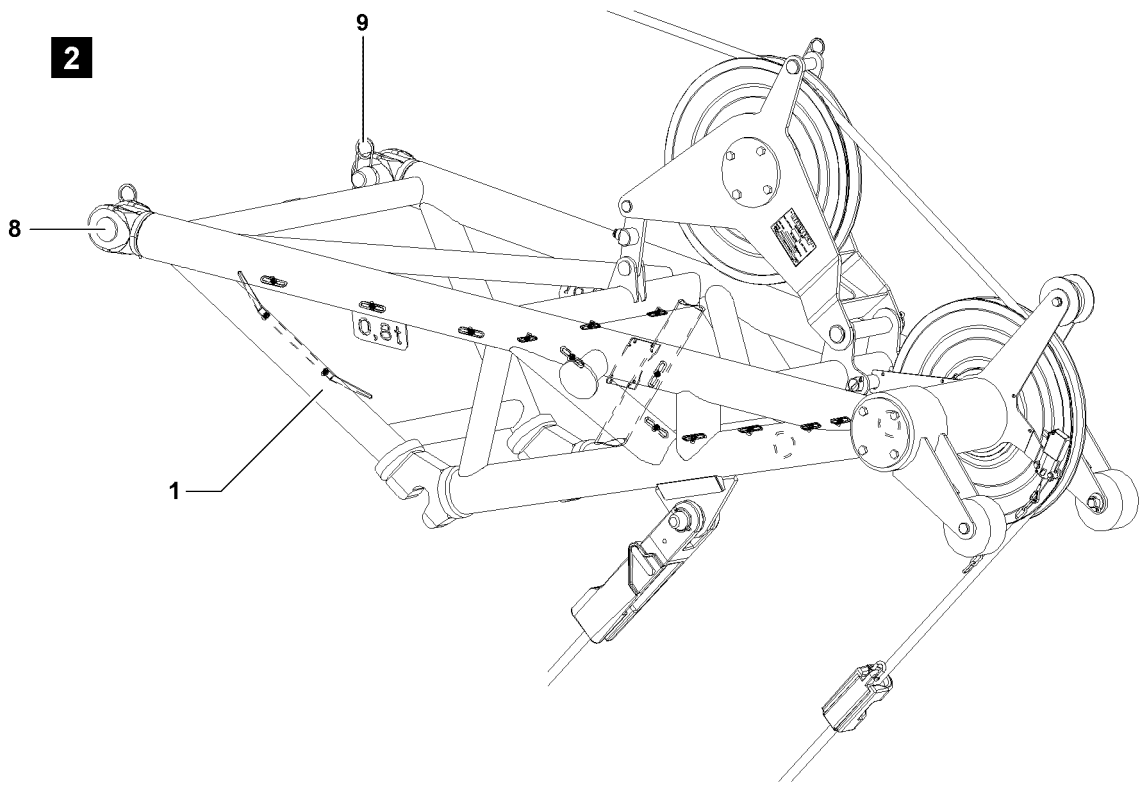
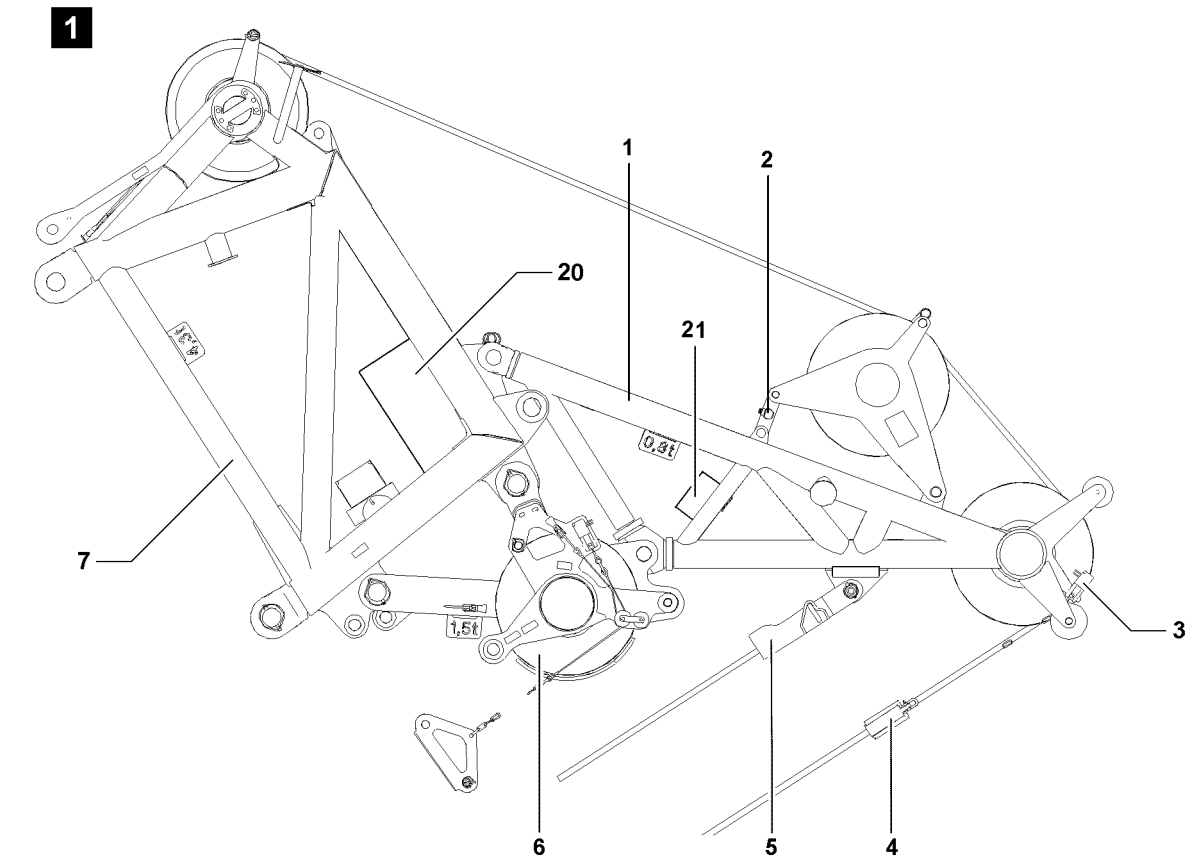

Fig.105237

LWE/LR 1600-2-008/18109-09-02/en

1 Overview of boom nose components

The 36 t boom nose **1** is assembled on the SW-end section **7** and placed on the pulley set arrangement **6**, see illustration **1**.

Position	Description
1	Boom nose, 36 t
2	Pressure test bracket
3	Hoist limit switch
4	Hoist limit switch weight
5	Rope fixed point (rope lock)
6	Roller set
7	SW-end section
8	Pin
9	Spring retainer
20	Terminal box SW-end section +S930
21	Terminal box boom nose +S1030

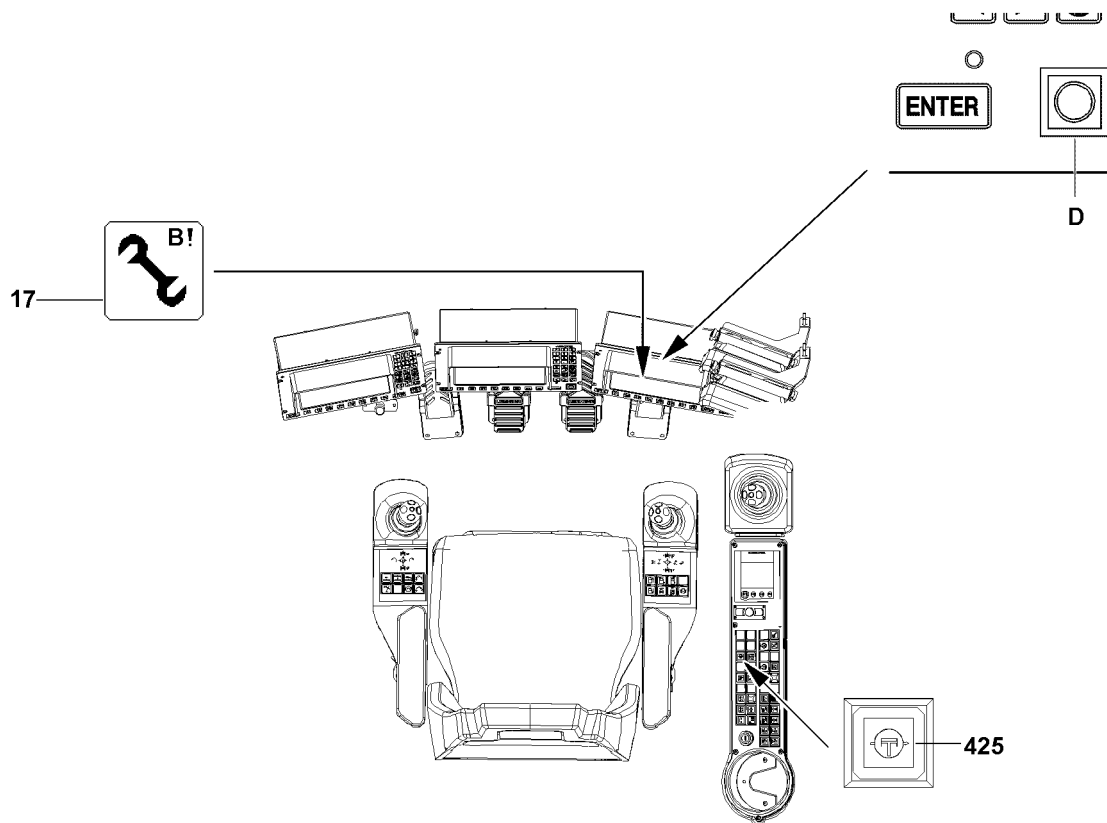

Fig.110716

2 Assembling the 36 t boom nose on the SW-end section



WARNING

Assembly with turned on set up key!

When the set up key is engaged, the LICCON overload protection is exceeded!

In the event of deliberate improper use, the crane could collapse, the boom can break off or the crane can topple over!

Personnel can be killed!

This could result in high property damage!

- ▶ The set up key **D** may only be actuated by persons who know the effects of a bypass!
- ▶ Press the set up key **D** only when the set up status was correctly entered into the LICCON computer system!
- ▶ Observe the erection / take down charts!
- ▶ Crane operation with the set up key **D** turned on is strictly prohibited!



WARNING

Falling booms at assembly / disassembly!

If unsecured or non-supported booms are removed, the booms can fall!

Personnel can be severely injured or killed!

- ▶ Never unpin the pins under unsecured or unsupported booms!
- ▶ Never unpin the connecting pins under unsecured or unsupported booms!
- ▶ Do not stand under the booms or within the complete danger zone during the pinning and unpinning procedure of the booms!
- ▶ Safely secure the pins in the bearing points as well as receptacles!
- ▶ Do not lean the ladder against the component being disassembled!



WARNING

Incorrect or missing fall guard!

Using inappropriate aids to secure the assembly personnel at assembly can result in a fall!

Personnel can be severely injured or killed!

- ▶ Secure yourself and others during all assembly work with suitable aids (lifting platforms, scaffolding, ladders, auxiliary crane etc.), basically from a height of 2 m on.
- ▶ Observe national regulations: the height from which aids must be used can differ from country to country!

When work with aids cannot be carried out from the ground:

- ▶ Secure yourself and others during all assembly work with personal protective equipment (for example safety belts) to prevent a fall!

Observe the safety guidelines for the assembly, see Crane operating instructions, chapter 5.01!

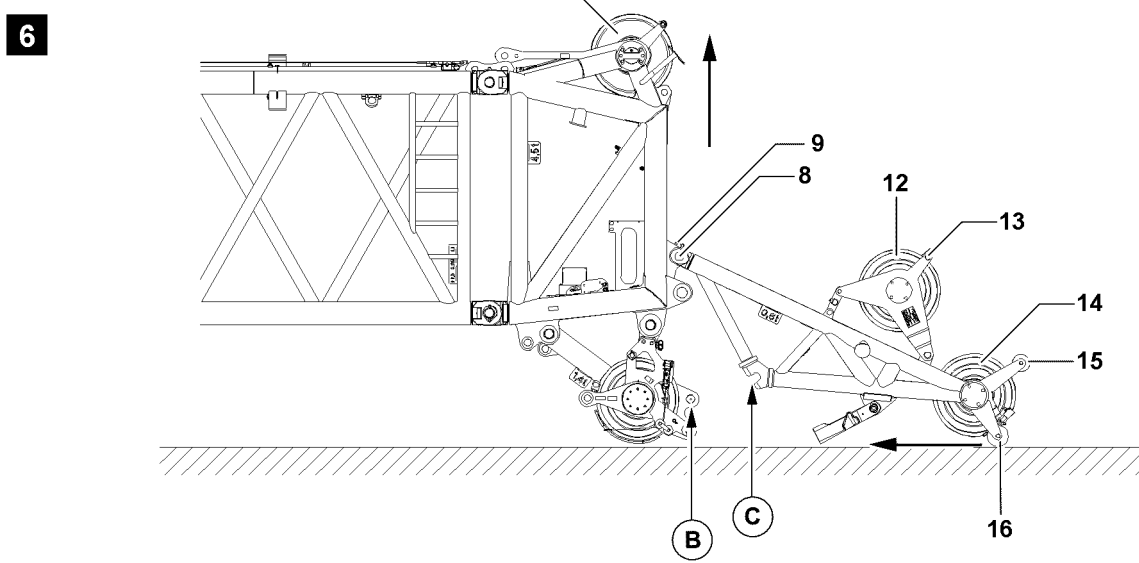
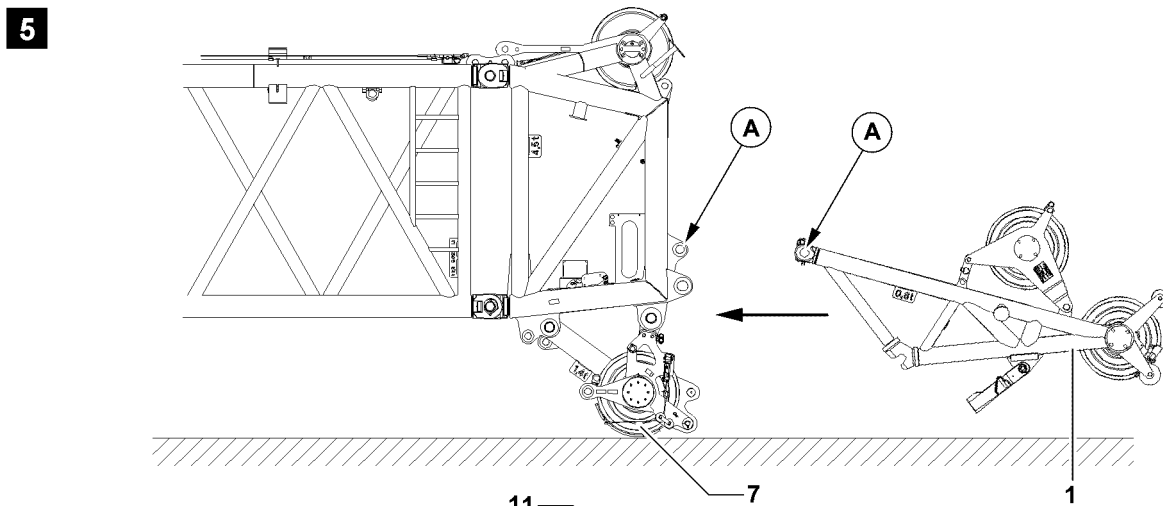
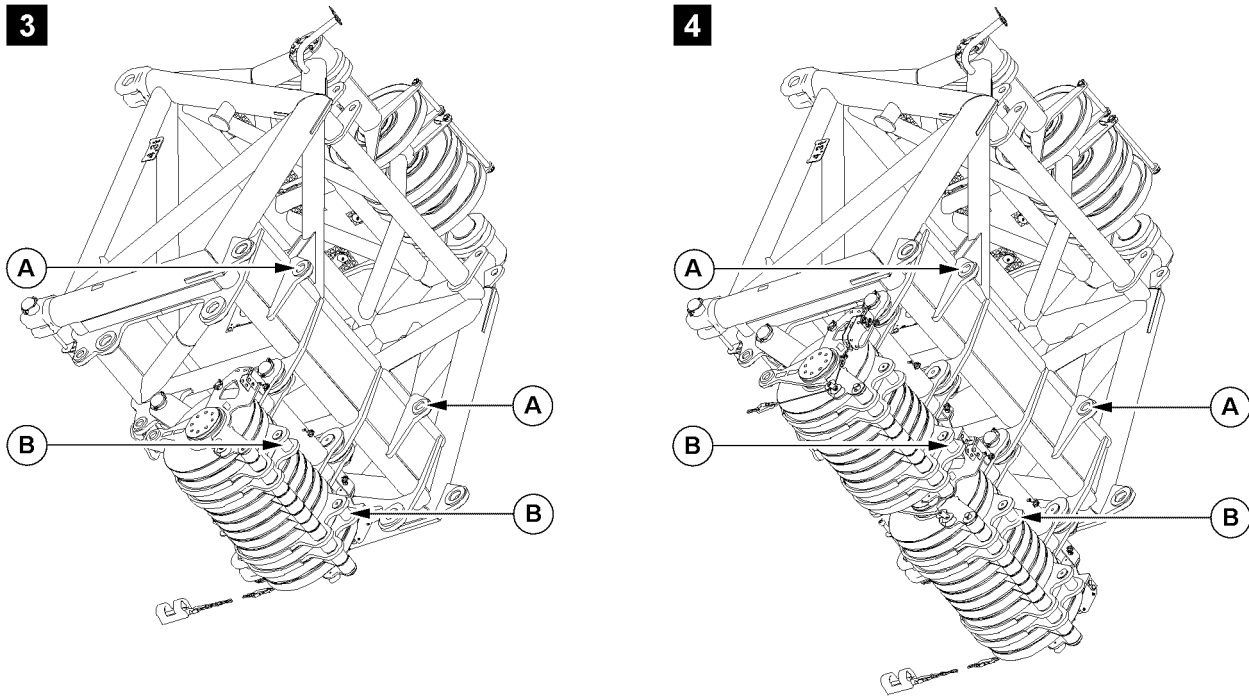

Fig.105238

LWE/LR 1600-2-008/18109-09-02/en

2.1 Assembling the boom nose

Make sure that the following prerequisites are met:

- The crane is aligned in horizontal direction.
- The counterweight has been installed to the turntable according to the load chart.
- The derrick ballast is placed on the suspended ballast or the ballast trailer according to the load chart.
- The LICCON overload protection has been set according to the data in the load chart.
- The LICCON overload protection settings have been compared with the actual crane configuration.
- The mechanical auxiliary support is installed on the crane.
- An auxiliary crane is available.
- The boom is lying with the pulley set on the ground, see illustration 5.



Note

- ▶ The weight of the 36 t boom nose is 0.45 t.

The SW-end section can be equipped with one or with two pulley sets:

- The pin points **A** and the attachment pins **B** for the assembly of the boom nose are shown in illustration 3 and illustration 4.
- ▶ Hang the boom nose 1 onto the auxiliary crane.
- ▶ Position the boom nose 1 with the auxiliary crane on the SW-end section in such a way that the pin bores align in point **A**, see illustration 5.

When the pin bores align:

- ▶ Pin in the pin 8 on the end section in point **A** and secure with spring retainer 9.
- ▶ Lower the boom nose 1 to the ground with the auxiliary crane.
- ▶ Remove the auxiliary crane.
- ▶ Release and unpin the rope retaining pin 13.
- ▶ Pull the hoist rope over the rope pulley 11 on the end section and the rope pulley 12 on the boom nose.
- ▶ Insert and secure the rope retaining pin 13.
- ▶ Guide the hoist rope between the rope pulley 14 and the rope retaining pulley 15.

NOTICE

Automatic fold out of fork connection at luff down or place down!

If the boom is luffed down or placed down at excessive speed, the boom nose can be damaged!

- ▶ Luff the boom down or place it down very carefully!

- ▶ Luff the boom up slowly.

Result:

- The boom nose moves on the pulleys 16 in direction of the boom head, see illustration 6.
- ▶ Luff the boom up until the boom nose lies on the pulley set.
- ▶ Make sure that the fork head **C** of the boom nose lies on the stop pin **B** of the pulley set.

7

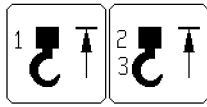

8

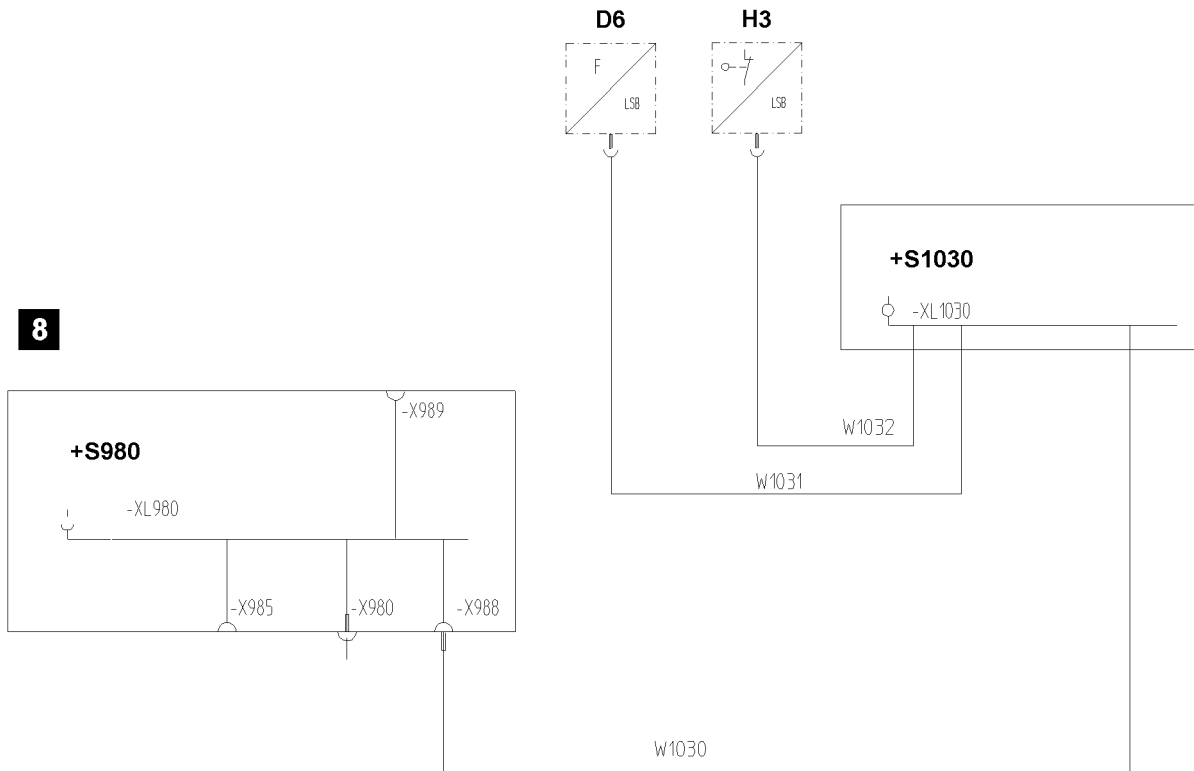

9

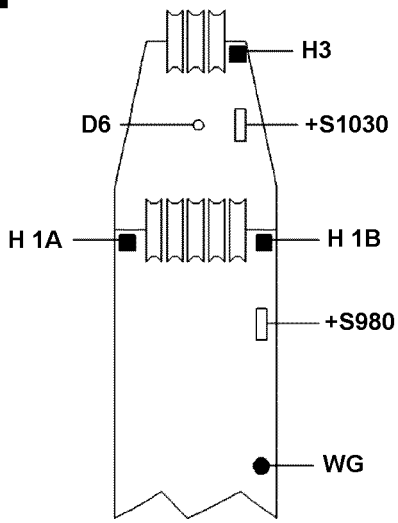

10

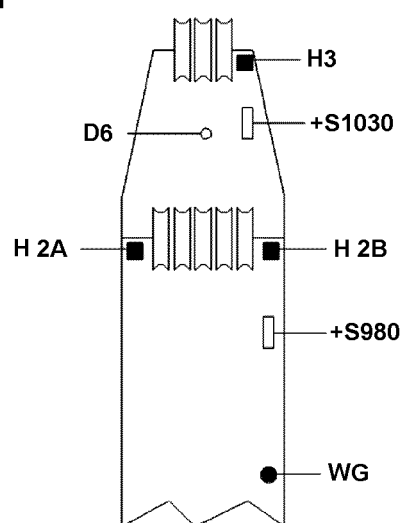

Fig.105239

LWE/LR 1600-2-008/18109-09-02/en

2.2 Establishing the electrical connections

Make sure that the following prerequisite is met:

- The boom nose is completely assembled.

For wiring diagram „Operation with boom nose“, see illustration 8.

2.2.1 Establishing the electrical connection to the hoist limit switch

- ▶ Plug the cable **W1032** from the terminal box **+S1030** into the hoist limit switch **H3**.

2.2.2 Establishing the electrical connection to the pressure test bracket

- ▶ Plug the cable **W1031** from the terminal box **+S1030** into the pressure test bracket **D6**.

2.2.3 Establishing the electrical connection between the boom nose and the SW-end section

- ▶ Plug the cable **W1030** from the terminal box **+S1030** into the terminal box **+S980**.

7

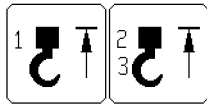

8

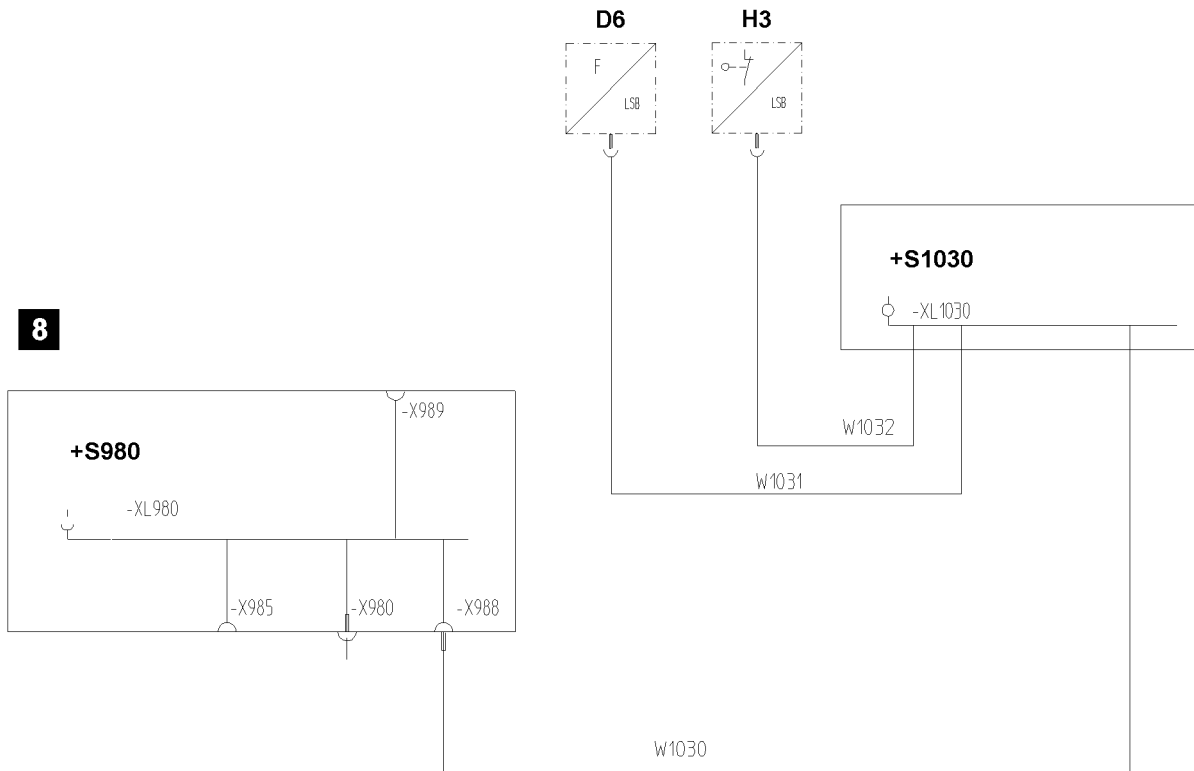

9

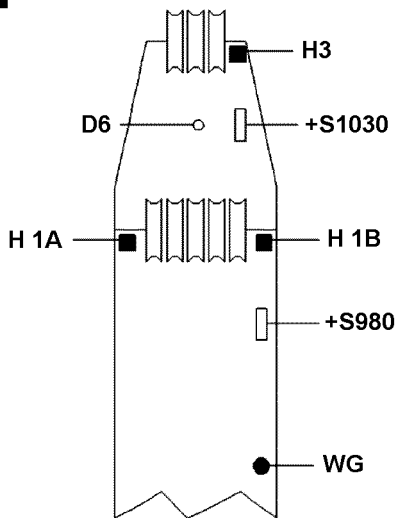

10

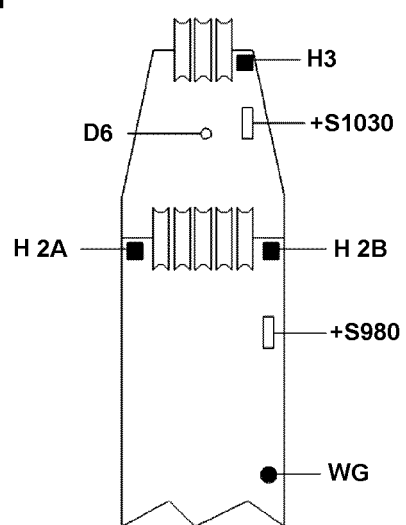

Fig.105239

LWE/LR 1600-2-008/18109-09-02/en

2.3 Checking the function of the hoist limit switch



Note

- ▶ The function of the individual limit switches must be checked before erection!
- ▶ The function of the limit switch initiators must be checked in the test system, see „Diagnostics manual“!

Make sure that the following prerequisites are met:

- All electrical connections have been established.
- The crane engine is running.
- The corresponding operating mode is set on the LICCON monitor.

Assignment of limit switches to operating modes:

- S-operation, see illustration 9.
- W-operation, see illustration 10.
- ▶ Cover the hoist limit switch initiators individually with a metal plate.

Result:

- The hoist limit switch is actuated manually.
- The corresponding symbol element „Hoist top“ appears on the LICCON monitor.
- The hoist winch turns spool up off.
- Hoist limit switch is functioning.



Note

- ▶ When replacing or changing the hoist limit switch (HES), the corresponding hoist limit switch must have the correct bus address and the correct software version in order to be detected again by the bus system (LSB)!

3 Erecting / taking down the boom



WARNING

The crane can topple over!

- ▶ Erect or take down the boom according to the data in the **Erection and take down charts!**
- ▶ Observe the Crane operating instructions, chapter 5.4!

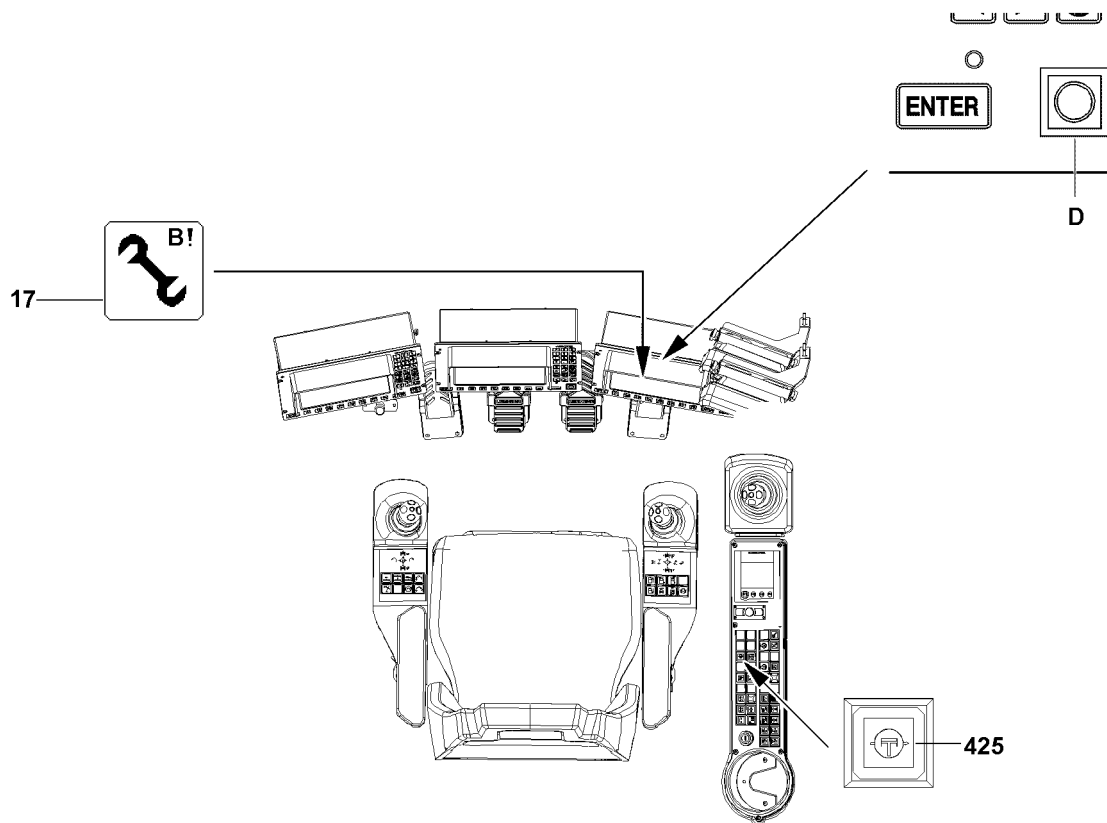

Fig.110716

4 Crane operation

The operation with boom nose is designed for quick lifts:

- with winch 2 or winch 6
- in operating modes S, SL and W

The hook block can remain reeved on the boom head.



Note

- ▶ Observe the notes, see Crane operating instructions, chapter 4.05, chapter 4.08 and chapter 5.01.
-

Make sure that the following prerequisites are met:

- The LICCON overload protection is active.
 - The LICCON overload protection has been set according to the data in the load chart.
-

**WARNING**

The crane can topple over!

- ▶ Check the horizontal position of the crane before and during operation!
 - ▶ If the crane operator leaves the cab, even for a short time, then he is obligated to check the operating mode setting before resuming crane operation and reset it, if necessary!
-

4.1 Checking the settings

- ▶ Check the function of the LICCON overload protection by running against the operating positions on top and bottom.
- ▶ Check the hoist limit switch by running against the hoist limit switch weight.
- ▶ Check the function of the limit switches on the relapse cylinders.

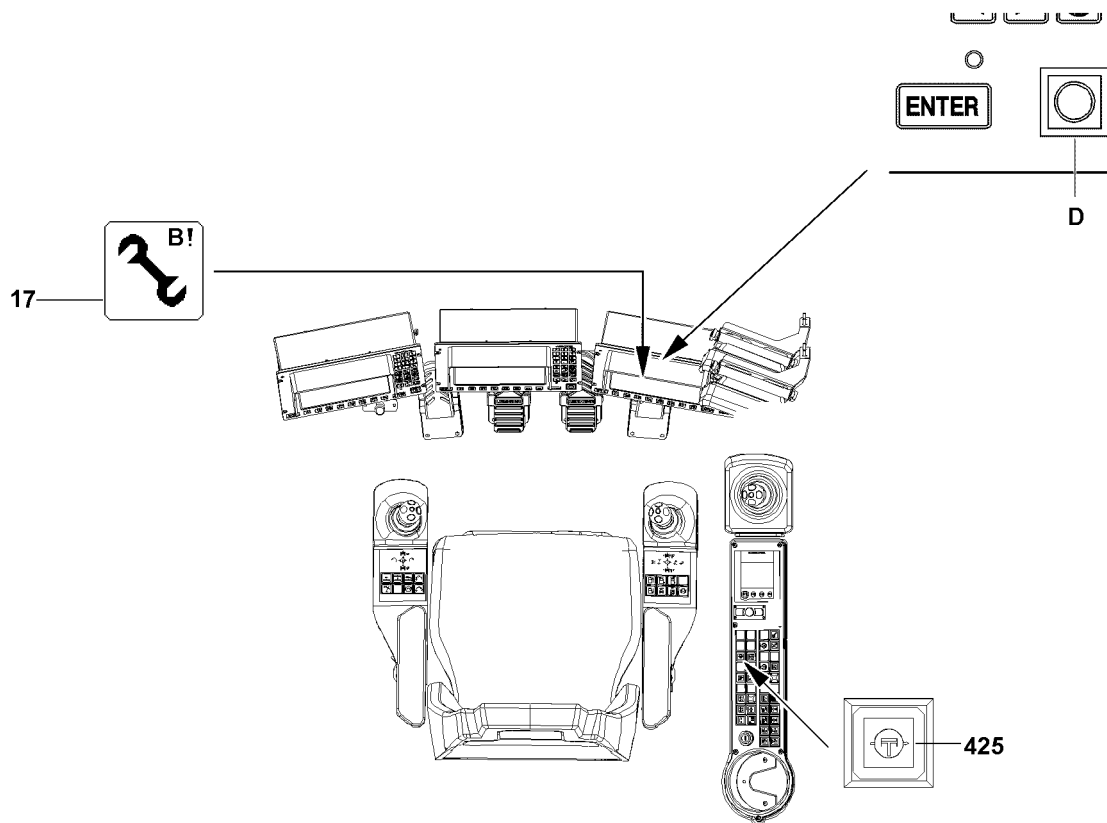

Fig.110716

5 Disassembling the 36 t boom nose



WARNING

Risk of falling!

During assembly / disassembly work, personnel must be secured with appropriate aids to prevent them from falling. If this is not observed, assembly personnel can fall and suffer life-threatening or fatal injuries!

- ▶ All assembly work must be carried out using suitable aids (lifting platforms, scaffolding, ladder, auxiliary crane, etc.)!
- ▶ If work cannot be carried out on the ground or using such aids, then assembly personnel must be secured with the personal fall arrest system (see Crane operating instructions, chapter 2.04) to protect against falling! The personal fall arrest system must be attached in the corresponding fastening points on the crane (see Crane operating instructions, chapter 2.06)!
- ▶ If railings are present on the components, then they must be brought into the corresponding position and secured for assembly / disassembly work!
- ▶ Step on aids and fall arresters only with clean shoes!
- ▶ Keep aids and fall arresters clean and free from snow and ice!



WARNING

Falling components!

If unsecured or non-supported components are assembled or disassembled, they can fall down. Personnel can be killed or seriously injured!

- ▶ During pinning and unpinning of the lattice sections, it is prohibited for anyone to remain **under** or **on** the components as well as within the entire danger zone!
- ▶ Support the boom and components before pinning / unpinning!
- ▶ Pin or unpin both pins lying in a horizontal, i.e. **left** and **right**!
- ▶ Secure the pins in the bearing points and in the receptacles!
- ▶ Do not disengage the auxiliary crane until each component is pinned on and secured!
- ▶ It is prohibited to lean a ladder against the component being disassembled!



WARNING

Danger of crushing!

Components can swing during assembling. Hands can be crushed or severed.

- ▶ Make sure that the components do not swing back and forth during assembly!



Note

- ▶ Observe the safety guidelines for the disassembly, see Crane operating instructions, chapter 5.01!

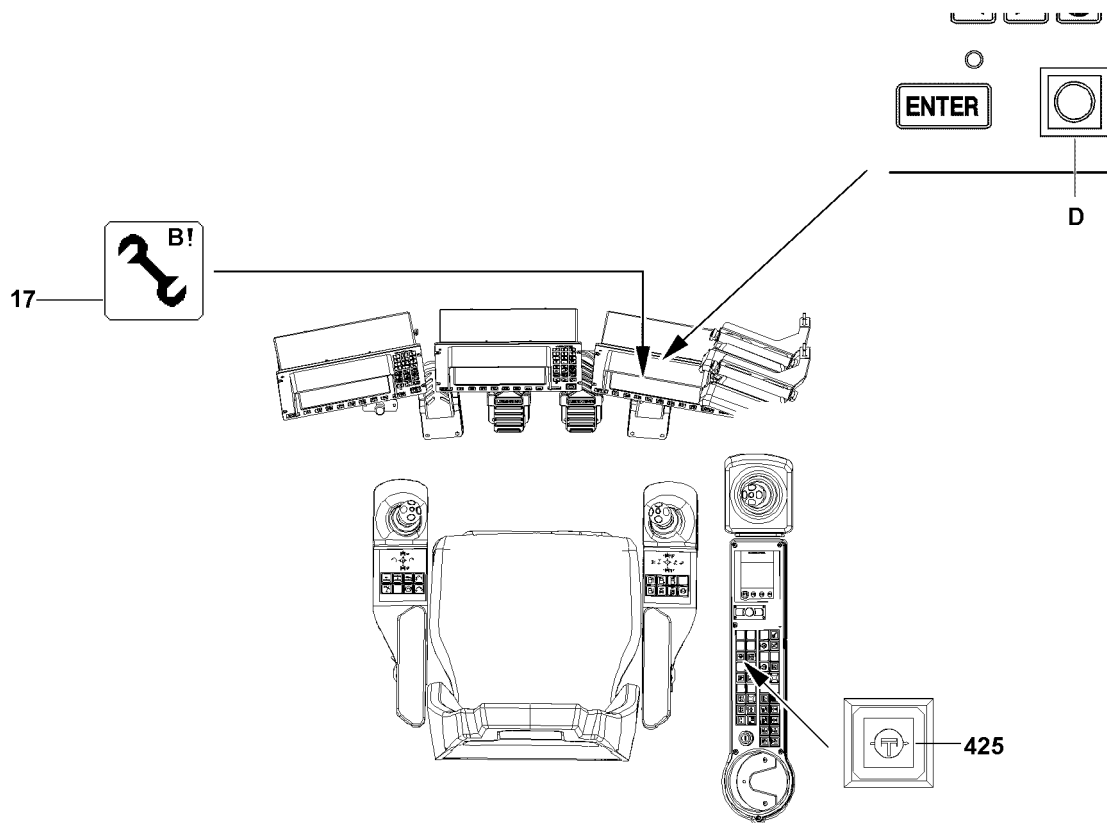

Fig.110716

5.1 Luffing the boom down

NOTICE

Hoist winch not spooled out!

If the hoist winch is not spooled out sufficiently when the boom is luffed down, then the hook block will collide with the boom nose!

When the boom is luffed down:

- ▶ Spool the hoist winch out simultaneously!



Note

- ▶ The luff down movement is turned off as soon as the lowest operating position is reached!
- ▶ When the lowest operating position of the boom is reached, the load display in the maximum load icon turns off and instead of the load display appears the display „???“!
- ▶ In the crane operating screen appear alarm functions!

- ▶ Luff the boom down to the „lowest“ operating position.

Result:

- The luffing movement is turned off.
- The „STOP“ icon appears on the LICCON monitor.
- The horn icon appears on the LICCON monitor.



WARNING

Assembly with turned on set up key!

When the set up key is engaged, the LICCON overload protection is exceeded!

In the event of deliberate improper use, the crane could collapse, the boom can break off or the crane can topple over!

Personnel can be killed!

This could result in high property damage!

- ▶ The set up key **D** may only be actuated by persons who know the effects of a bypass!
- ▶ Press the set up key **D** only when the set up status was correctly entered into the LICCON computer system!
- ▶ Observe the erection / take down charts!
- ▶ Crane operation with the set up key **D** turned on is strictly prohibited!

When the boom has reached the „lowest“ operating position:

- ▶ Turn the set up key **D** to the right.

Result:

- The LICCON overload protection is deactivated.
- The assembly icon **17** appears on the LICCON monitor.

11

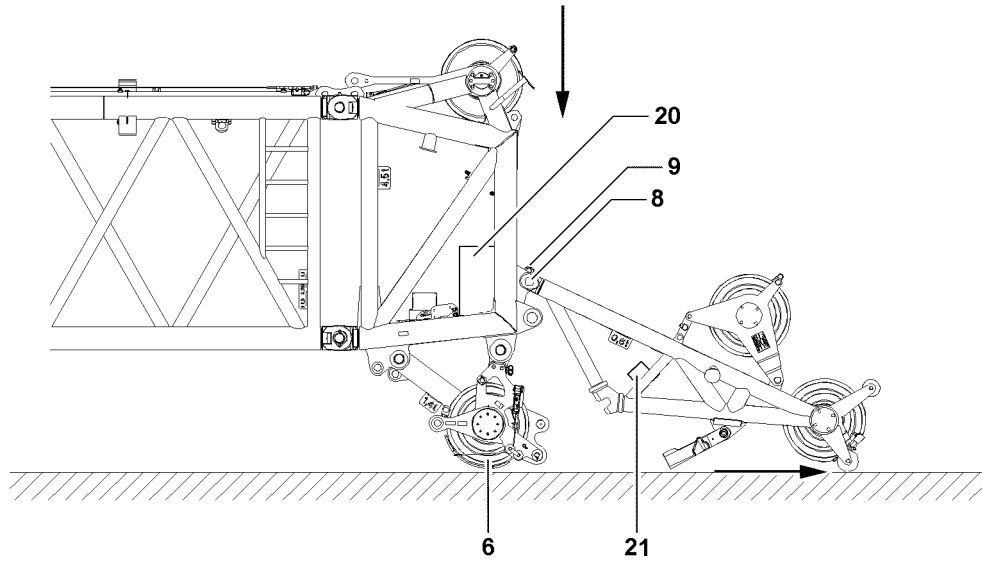

12

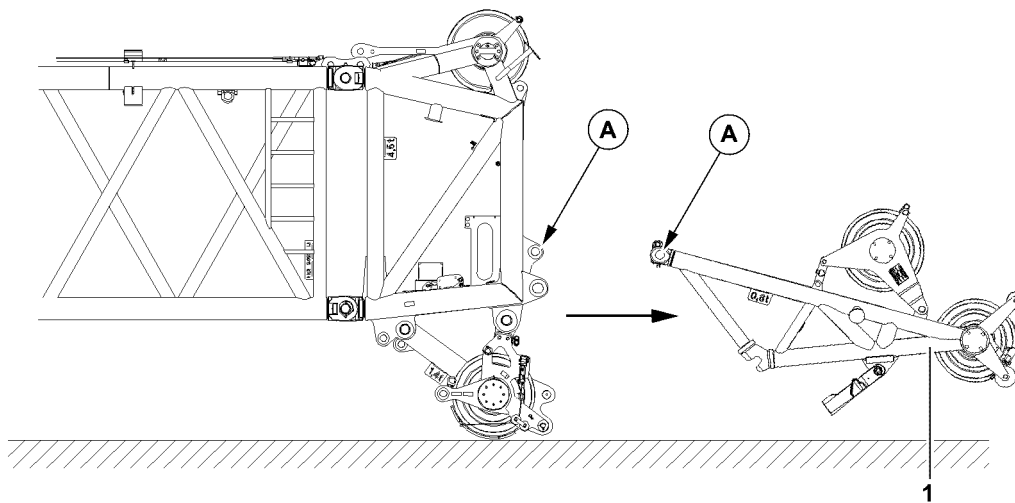

Fig.105344

- ▶ Luff the boom down until hook block touches the ground.

**Note**

- ▶ Observe the description for disassembly of the hoist limit switch weight and the hook block, see Crane operating instructions, chapter 4.06!
- ▶ Remove the hoist limit switch weight and unreeve the hook block.

NOTICE

Automatic fold out of fork connection at luff down or place down!

If the boom is luffed down or placed down at excessive speed, the boom nose can be damaged!

- ▶ Luff the boom down or place it down very carefully!
- ▶ Luff the boom down until the pulley set **6** touches the ground, see illustration **11**.
- ▶ Remove the hoist rope.

5.2 Disassembling the 36 t boom nose on the SW-end section

Make sure that the following prerequisite is met:

- The boom is lying with the pulley set **6** on the ground, see illustration **11**.
- ▶ Hang the boom nose **1** onto the auxiliary crane.
- ▶ Unplug the cable **W1030** on the terminal box +980 **20**.
- ▶ Release the pin **8** on the end section in point **A** and unpin.
- ▶ Lift the boom nose **1** with the auxiliary crane.
- ▶ Remove the boom nose with the auxiliary crane and place it down outside the working range.
- ▶ Remove the auxiliary crane from the boom nose.

Empty page!

LWE/LR 1600-2-008/18109-09-02/en

5.13 SLF-boom combination

1	Component overview	3
2	Fastening points	3
3	Assembling the auxiliary jib	4
4	Operating the crane	31
5	Disassembling the auxiliary jib	33

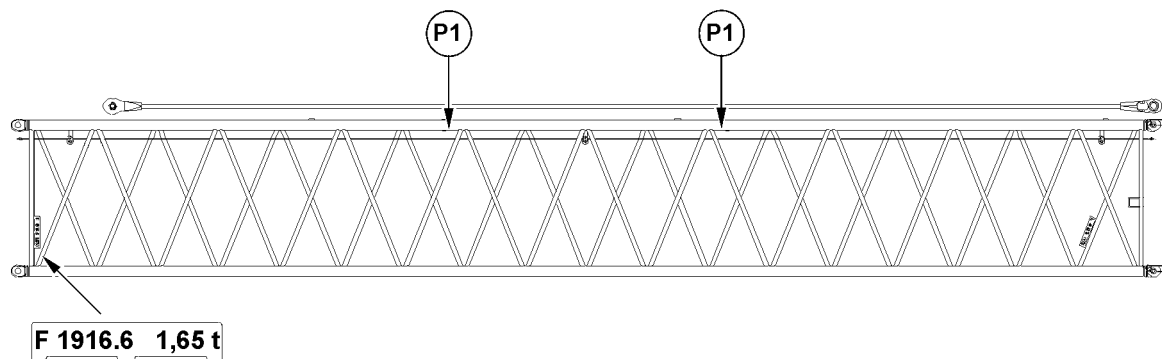
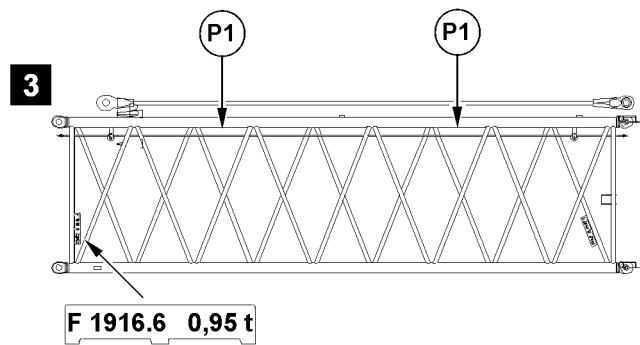
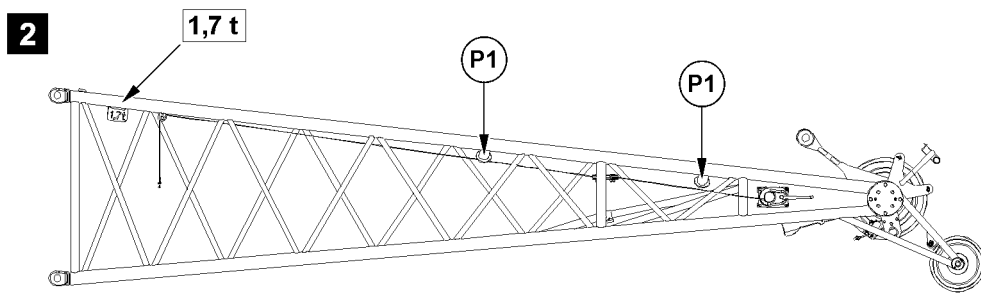
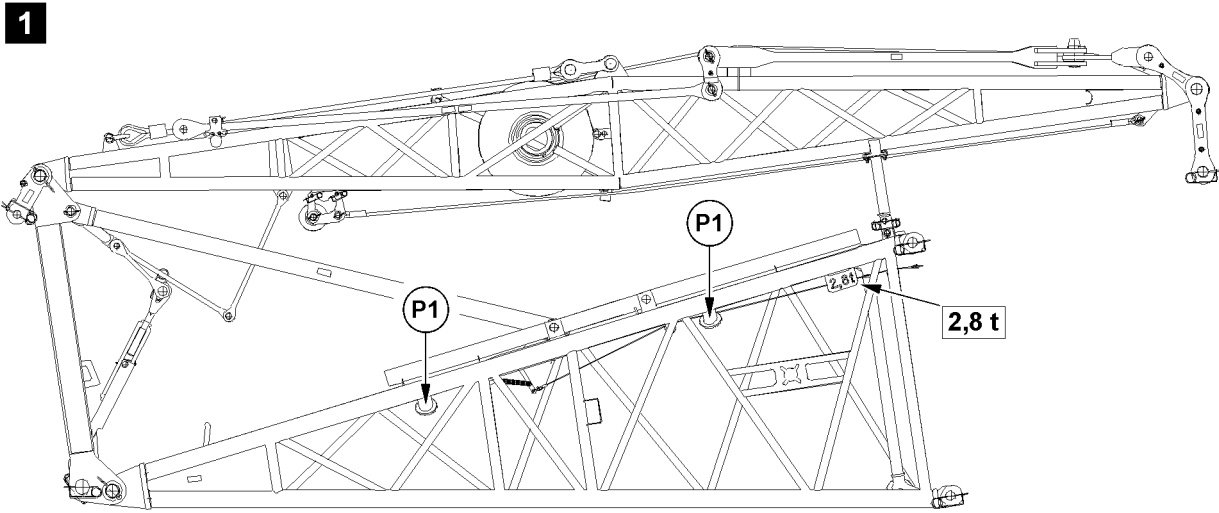

Fig.119835

LWE/LR 1600-2-008/18109-09-02/en

1 Component overview



Note

- ▶ The F-jib can be equipped optionally with a test device*.
- ▶ If your crane is equipped with a test device* for the fixed jib, then the respective rod plan must be observed at assembly.



Note

- ▶ For dimensions and weights of the components see Crane operating instructions, chapter 1.03.

2 Fastening points



WARNING

Danger of accident due to incorrect attachment!

Life-threatening situations can arise due to improper or incorrect attachment of the corresponding components.

- ▶ The corresponding components must be attached on the intended points **P1**.



Note

- ▶ For assembly or disassembly, load handling equipment with a strand length of at least **4 m** must be used.

2.1 F-assembly unit, see illustration 1

Description	Abbreviation	Weight
F-assembly unit	—	2.8 t

2.2 F-end section, see illustration 2

Description	Abbreviation	Weight
F-end section	—	1.7 t

2.3 F-intermediate sections 6 m and 12 m , see illustration 3

Description	Abbreviation	Weight
F-intermediate section (6 m) with guy ropes	F 1916.6	0.95 t

Description	Abbreviation	Weight
F-intermediate section (12 m) with guy ropes	F 1916.6	1.65 t

3 Assembling the auxiliary jib



DANGER

The crane can topple over!

If the lattice sections are not installed according to the Rod plan, then the boom system can be overloaded.

The crane can topple over.

Personnel can be severely injured or killed.

- ▶ Observe the Rod plan and the Crane operating instructions, chapter 5.03.



WARNING

Danger of falling!

During assembly / disassembly, inspection and maintenance work, assembly personnel must be secured with appropriate aids to prevent them from falling. If this is not observed, assembly personnel could fall and suffer life-threatening or fatal injuries.

- ▶ All work aloft, where there is a danger of falling must be carried out with suitable aids.
- ▶ If fall arrest equipment is available, then it must be used, see Crane operating instructions, chapter 2.06.
- ▶ If aids are not available and work cannot be carried out from the ground, then the assembly personnel must secure themselves with the specified fall arrest system to prevent falling, see Crane operating instructions, chapter 2.04.
- ▶ The fall arrest system must be fastened on the fastening and hook points as well as on the safety ropes. For safety points, see Crane operating instructions, chapter 2.06.
- ▶ Only step on the aids, ladders and catwalks with clean shoes.
- ▶ Keep aids, ladders and catwalks free of heavy dirt, snow and ice.
- ▶ Remaining on as well as under a suspended load is prohibited.
- ▶ Remaining on or within crane components (for example: At assembly of boom sections, lattice sections) which are moved during lifting, lowering, turning or closing procedures is strictly prohibited.
- ▶ During all assembly and disassembly work, maintenance work and inspections, travel or crane operation is prohibited.
- ▶ It is prohibited to step on the boom system or an auxiliary boom without suitable protective devices.
- ▶ Stepping and walking on crane components and lattice sections, which have an incline of more than 20° is prohibited.



DANGER

Danger of accident at assembly / disassembly of booms!

When you disassemble unsecured or unsupported booms, then the booms can fall down and kill or severely injure personnel.

- ▶ Never unpin the pins under unsecured or unsupported booms.
- ▶ Never unpin the connecting pins on unsecured or unsupported booms.
- ▶ Do not stand under the booms or within the complete danger zone during the pinning and unpinning procedure of the booms.
- ▶ Secure the pins in the bearing points as well as in the receptacles.
- ▶ Do not lean the ladder against the component being disassembled.



WARNING

Danger of impact and crushing!

There is a risk of impact and crushing when standing in the vicinity of suspended loads moving sideways.

- ▶ During assembly / disassembly no one may be in the dangerous area around or underneath the suspended load before the load has been secured.

**WARNING**

Components not pinned and secured!

If a component is released from the auxiliary crane before having been pinned and secured, the component will fall down. Personnel can be severely injured or killed.

- ▶ Do not disengage the auxiliary crane until the respective component is pinned and secured.

**WARNING**

The components can fall down!

If the respective component is unpinned without being secured by an auxiliary crane, the respective component can fall down and fatally injure personnel.

- ▶ Do not unpin the components until they are secured by an auxiliary crane.

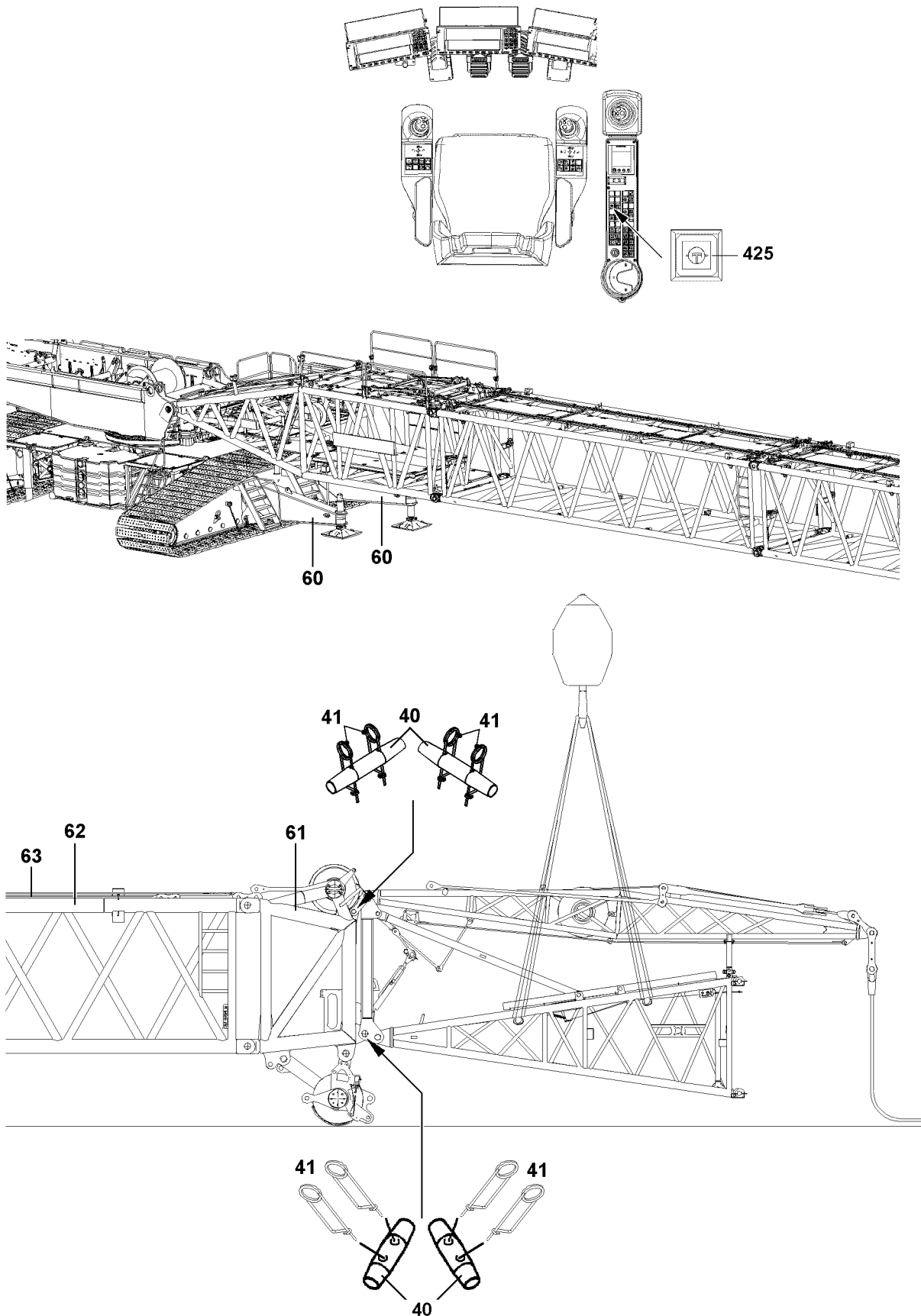

Fig.119958

LWE/LR 1600-2-008/18109-09-02/en

This crane can be equipped with an auxiliary jib. The auxiliary jib can be assembled at an angle of 10 ° , 15 ° or 30 ° to the SL-boom. Lengths of 12 m to 36 m are possible.

**Note**

► The auxiliary jib is **not** adjustable in crane operation.

Make sure that the following prerequisites are met:

- The „mechanical auxiliary supports 60“ are properly assembled on the crane, see also **Erection and take down charts**.
- The SL-boom is assembled and luffed down „to the side“ over the „mechanical auxiliary supports 60“.
- The LI-intermediate section 62 is pinned and secured on the SL-boom with the „guy brackets for the F-guying“.
- The guy rods 63 are placed on the LI-intermediate section 62 and are pinned and secured with the guy brackets.
- The corresponding SW-end section 61 is pinned and secured on the LI-intermediate section 62.
- The F-assembly unit is properly hung and secured on the auxiliary crane.
- The F-assembly unit is pinned on the SW-end section 61 with the double cone pins 40 on top and bottom and is secured with the spring retainers 41.
- The LICCON overload protection has been set according to the data in the load chart.
- The LICCON overload protection settings have been compared with the actual set up configuration.
- The LICCON overload protection is exceeded.
- The assembly icon is visible on the LICCON monitor.

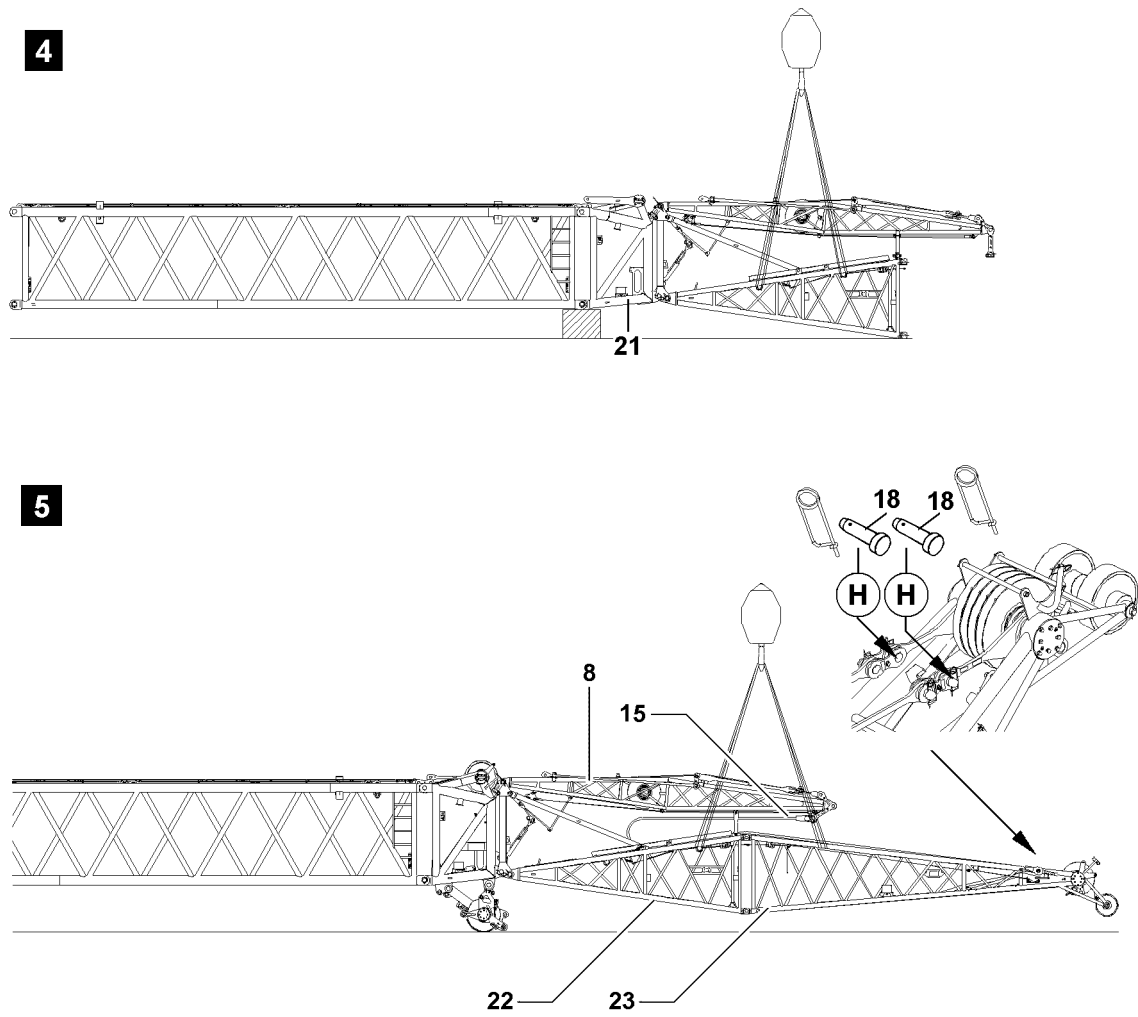

Fig.106172

3.1 SLF-assembly conditions

3.1.1 F-connector head on the boom end

The F-boom can be assembled on the following end sections:

- 55 SW-end section
- 21 F-connector head



Note

- ▶ If the F-connector head **21** is assembled on the boom end, then it must be supported for the F-assembly, see illustration **4**.

-
- ▶ Support the F-connector head for the F-assembly, see illustration **4**.

3.1.2 Special case - F-end section is pinned with F-pivot section (12 m F-jib)



Note

- ▶ If the F-end section **23** is already pinned with the F-pivot section **22**, then - before lifting the FA-frame **8** - the pins **18** between the F-guy ropes **15** and brackets on the F-end section **23** must be released on the points **H**, see illustration **5**.

-
- ▶ Carry out the remainder of the assembly as described in section „Assembling the F-assembly unit“.

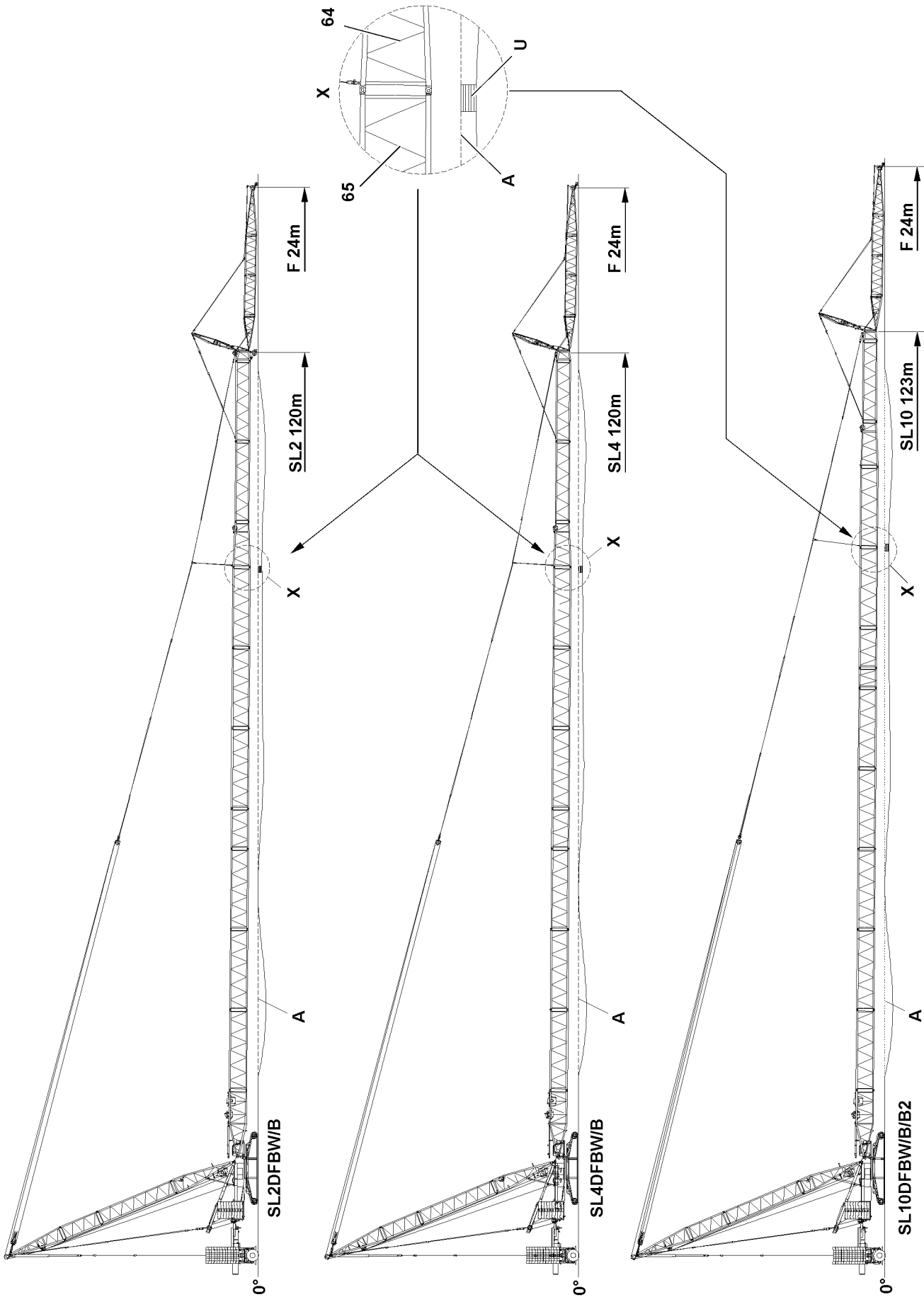

Fig.119957

LWE/LR 1600-2-008/18109-09-02/en

3.1.3 Assembling the SL2DF/SL4DF-/SL10DF-boom combination with supporting base

NOTICE

Overload of boom!

If the respective boom system is not supported before the erection procedure, then the boom will be overloaded.

The crane will be damaged.

- ▶ For boom lengths SL2DF/SL4DF from 120 m , a supporting base must be used.
- ▶ For boom lengths SL10DF, from 123 m on, a supporting base must be used.
- ▶ Support the boom with suitable material of sufficient load bearing capacity.



Note

- ▶ The supporting base is independent of the length of the F-auxiliary jib.
- ▶ The alignment level **A** is the placement level of the crane.

The required boom combination - consisting of a S-pivot section and the SL-intermediate sections - must be preassembled at a suitable location. The pre-assembled SL-boom combination must be swung in to the turntable with an auxiliary crane and pinned and secured in position at that location.

- ▶ Preassemble the SL-boom combination.
- ▶ Swing the preassembled SL-boom combination with the auxiliary crane in to the turntable.
- ▶ Pin and secure the SL-boom combination to the S-pivot section on the turntable.



Note

- ▶ The boom combination must be supported from below on the last intermediate section **65** before the reducer section **64** to the height of the alignment level **A**, see illustration.
- ▶ Make sure that the upper edge of the base support **U** is at the height of the alignment level **A**.
- ▶ Place the SL-boom combination on the supporting base.
- ▶ The electrical connections to the F-connector head or to the SW-end section have been properly established.
- ▶ Erect the SL-boom combination to the horizontal.
- ▶ Assemble the F-auxiliary jib, see section „Assembling the F-auxiliary jib“.

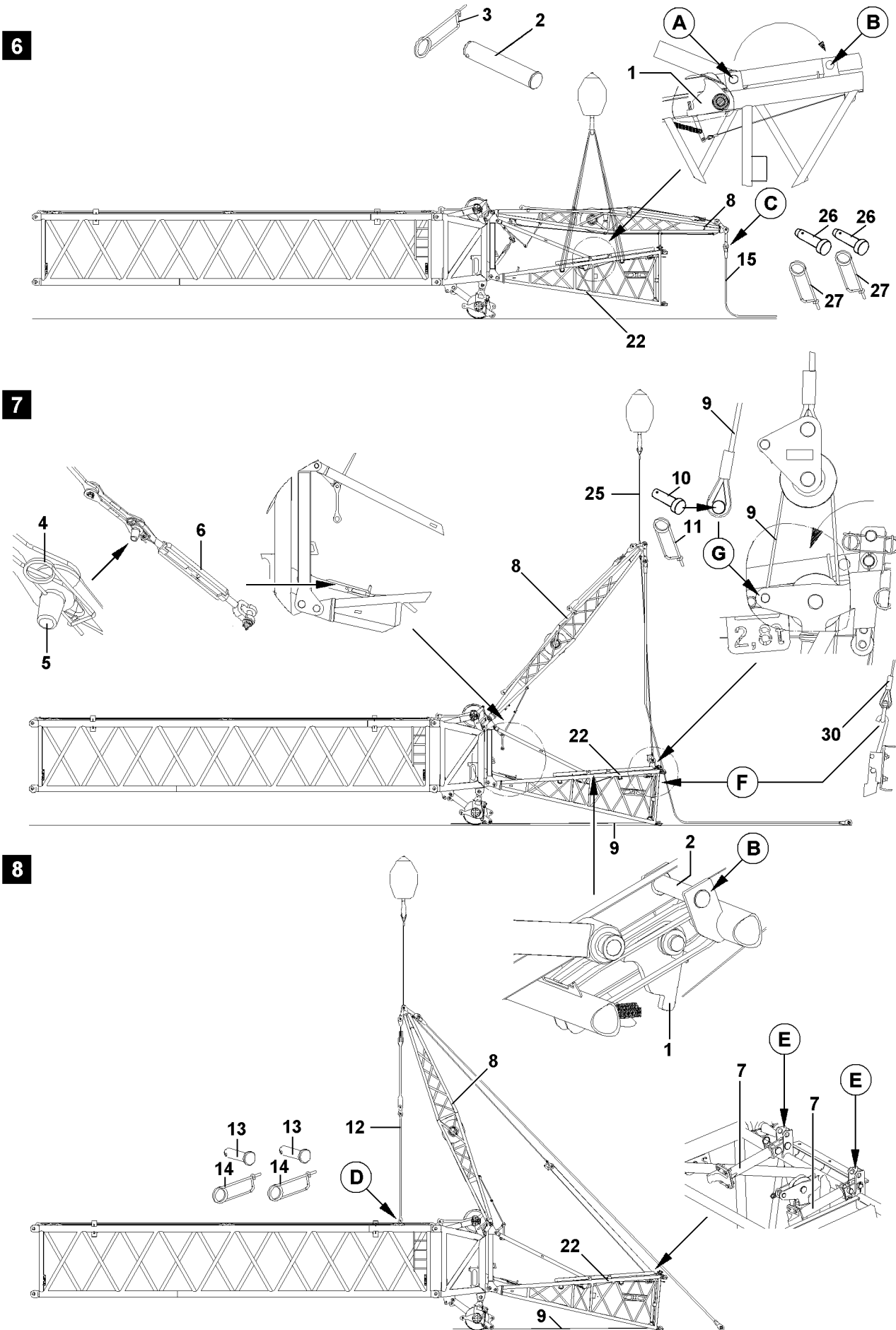

Fig.106173

3.2 Assembling the F-auxiliary jib

- ▶ Release and unpin the pin **2** from the F-pivot section and the F-relapse retainer on point **A** „Transport position“, see illustration **6**.
- ▶ Pin in the pin **2** in „stop position“ at point **B** and secure with spring retainer **3**, see illustration **6**.
- ▶ Slowly lower the F-pivot section **22** with the auxiliary crane.
- ▶ Secure the F-guy ropes **15** with the brackets of the FA-frame **8** on point **C** with pins **26** and secure with spring retainers **27**, see illustration **6**.
- ▶ Release and unpin the pin **5** on the FA-frame relapse retainer, place the turnbuckle **6** on the F-pivot section **22**, see illustration **7**.
- ▶ Pull the flap **1** on the F-pivot section **22** down and affix the rope **30** on the hook lock at point **F**, see illustration **7**.
- ▶ Hang in the FA-frame **8** with the attachment rope **25** on the auxiliary crane and lift, see illustration **7**.
- ▶ Reeve in the assembly winch rope **9** from the turntable into the rope pulleys on the F-pivot section **22** and pin on point **G** with pin **10** and secure with spring retainer **11**, see illustration **7**.

NOTICE

Danger of damage!

Before crane operation or before erecting or taking down the boom, both support frames **7** must be folded down.

- ▶ Unpin the support frames **7** on points **E** and fold them down, see illustration **8**.
-
- ▶ Carefully fold the FA-frame **8** with the auxiliary crane „in direction of the main boom“ and „spool the assembly winch rope **9** out at the same time“ until it can be pinned on point **D**, see illustration **8**.
 - ▶ Pin the F-guy rods **12** on point **D** with pins **13** and secure with spring retainers **14**, see illustration **8**.

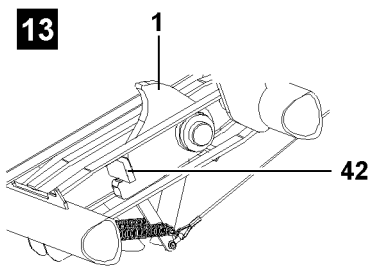
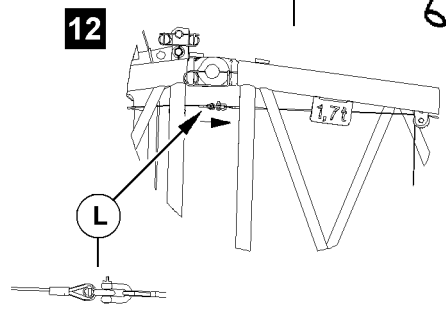
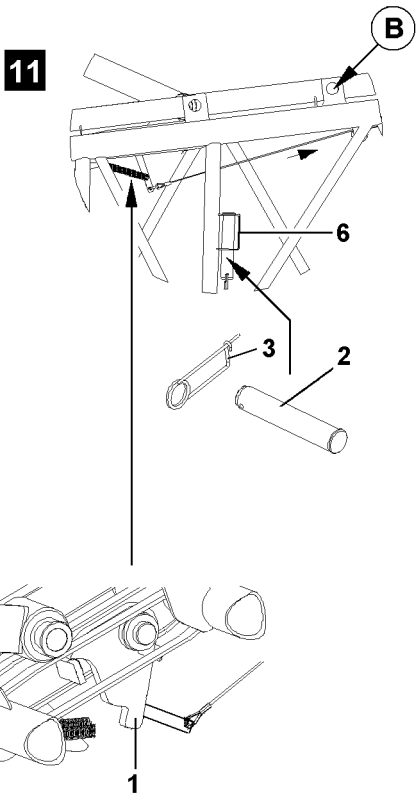
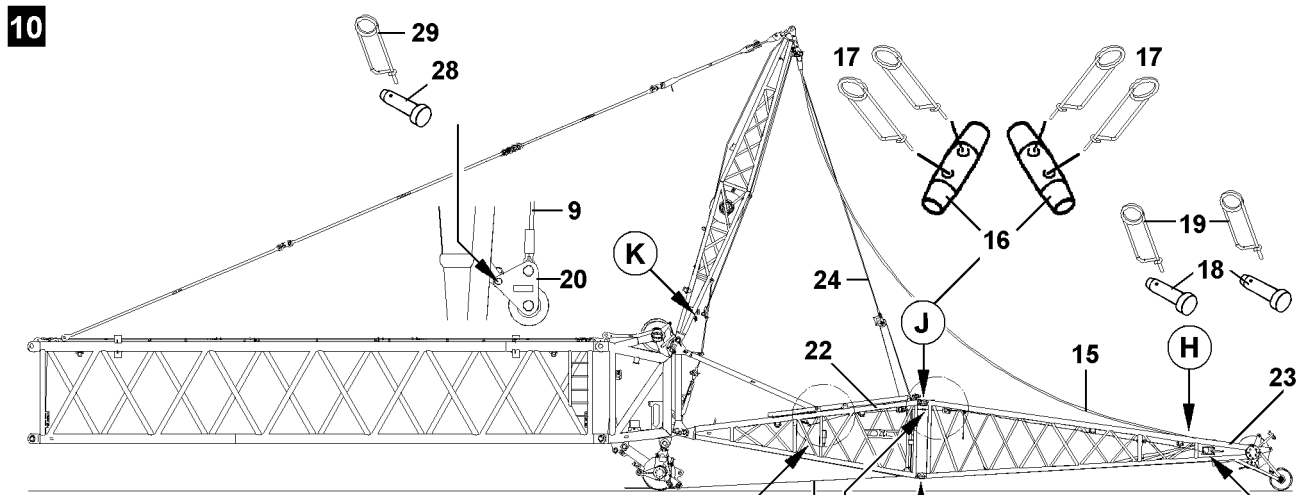
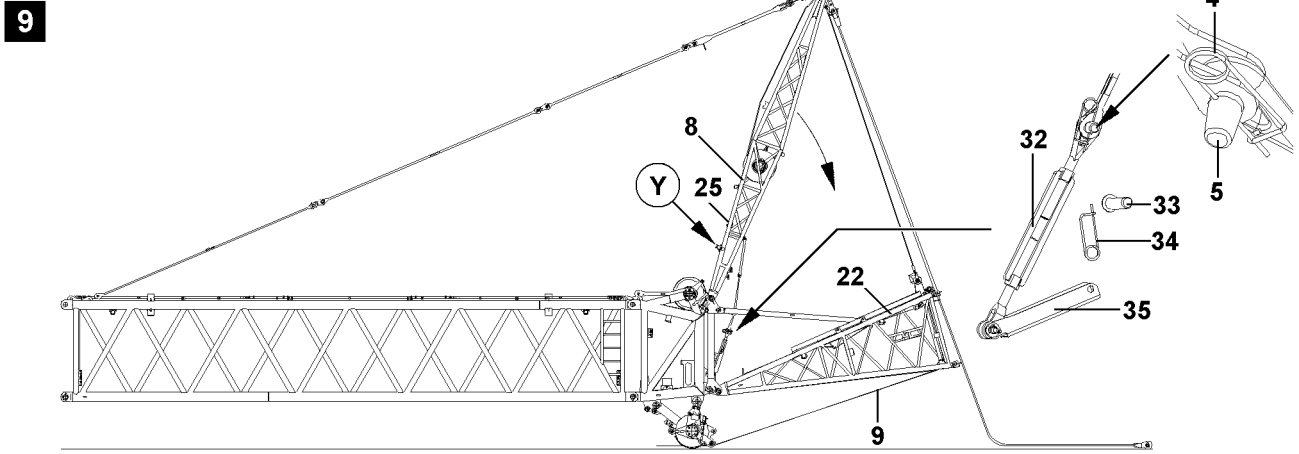

Fig.106174

LWE/LR 1600-2-008/18109-09-02/en

- ▶ Pull the FA-frame **8** with the assembly winch rope **9** in direction of the F-pivot section **22**, see illustration **9**.

**Note**

- ▶ Extend the turnbuckle **32**, if necessary so that the pin **5** can be pinned, see illustration **9**.
- ▶ Then tighten the turnbuckle **32** and close the retaining plate **35**.
- ▶ Secure the retaining plate **35** with pin **33** and spring retainer **34**.

- ▶ Connect the FA-frame relapse retainer again by pinning the pin **5** and securing it with the spring retainer **4**, see illustration **9**.

**Note**

- ▶ Pin and secure the attachment rope **25** for the auxiliary crane on the FA-frame **8** at point **Y** with a shackle, see illustration **9**.

- ▶ Lower the F-pivot section **22**, see illustration **10**.
- ▶ Properly install the F-end section **23** and the F-intermediate sections (if applicable) on the auxiliary crane and on the F-pivot section **22** and pin.
- ▶ Insert the double cone pins **16** on points **J** from the „outside to the inside“ and secure with spring retainers **17**, see illustration **10**.
- ▶ Pin the F-guy ropes **15** on the F-end section on point **H** with pins **18** and secure with spring retainers **19**, see illustration **10**.

**Note**

- ▶ If the F-intermediate sections are installed, then the additional guy ropes for the F-intermediate sections must be assembled, pinned and secured.

- ▶ Unreeve the assembly winch rope **9** after the F-jib is completely assembled.
- ▶ Pin the attachment rope **24** with the pulley block **20** on the FA-frame **8** at point **K** with pin **28** and secure with spring retainer **29**, see illustration **10**.

**Note**

- ▶ Unpin the pin **2** before erecting the boom on point **B** and insert it into the retainer **6** „park position“, see illustration **11**.

- ▶ Insert the pin **2** into the retainer **6** „park position“ and secure with spring retainer **3**, see illustration **11**.
- ▶ Connect the rope strand from flap **1** to manual rope winch **31** on the F-end section **23** at point **L**, see illustration **12**.

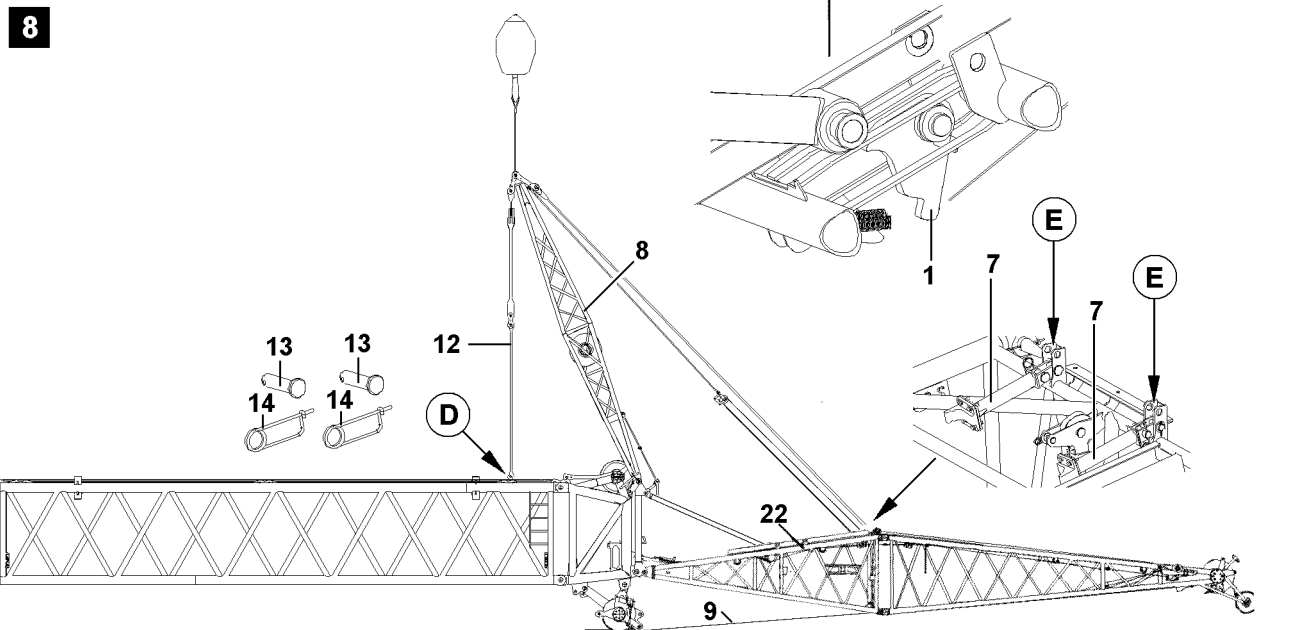
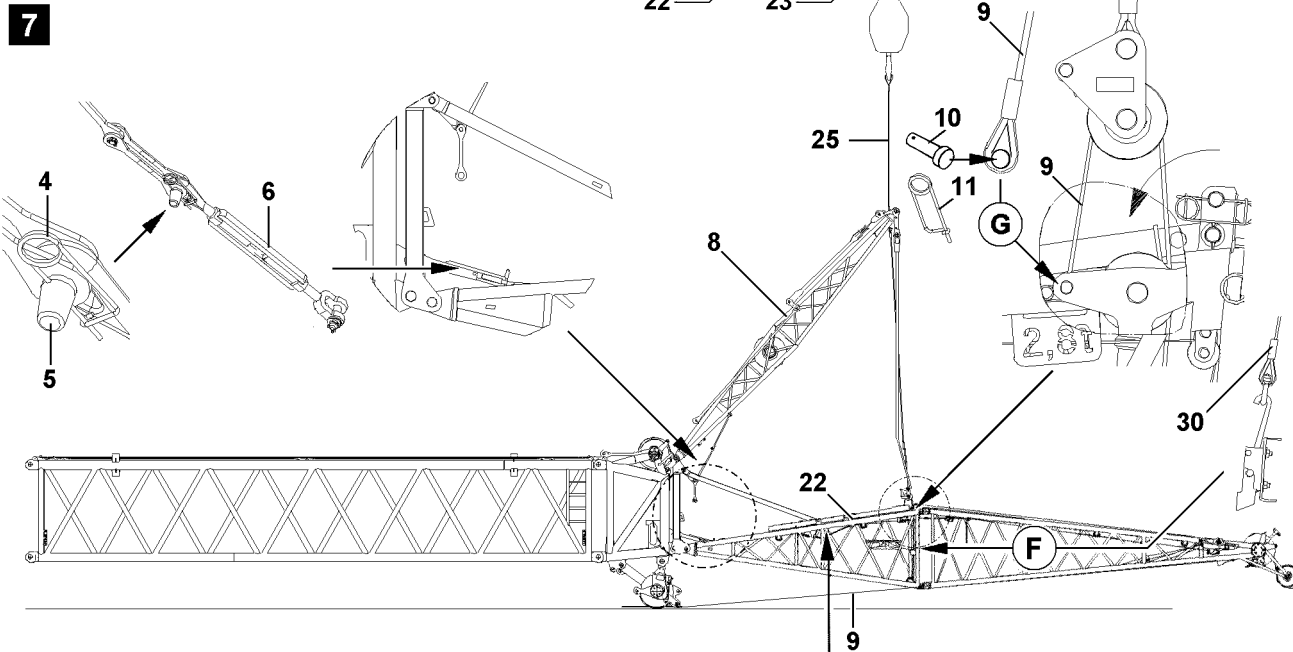
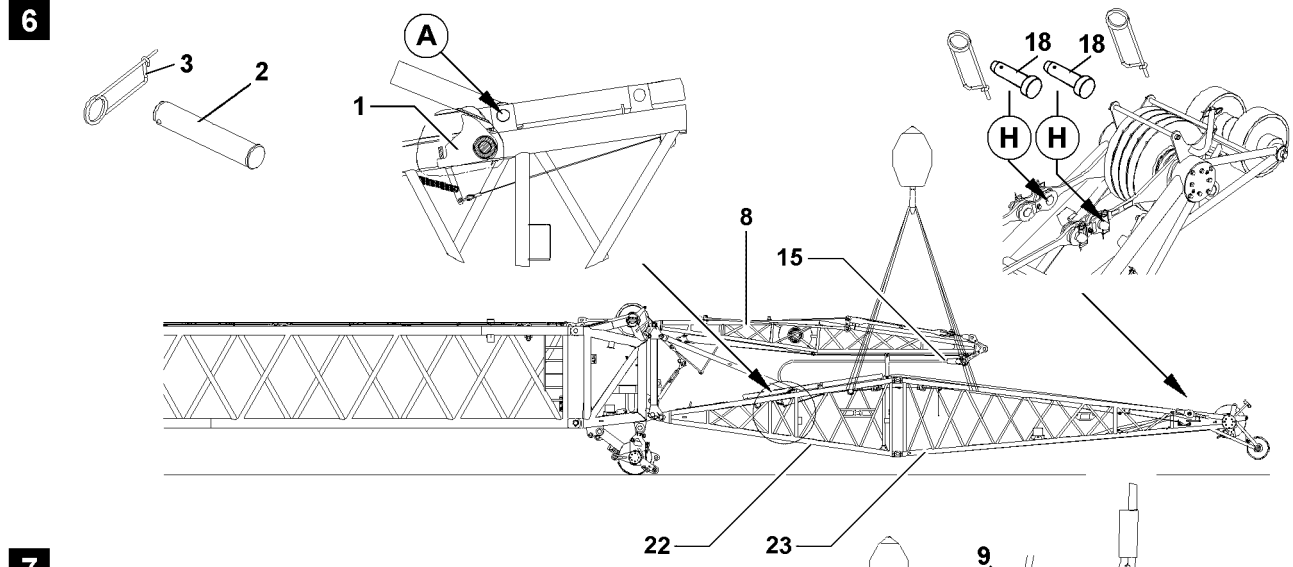

Fig.106639

LWE/LR 1600-2-008/18109-09-02/en

3.3 Flying assembly of F-auxiliary jib (12 m)

Make sure that the following prerequisite is met:

- The pin **2** of the F-pivot section and the F-relapse retainer is on point **A** „transport position“.



WARNING

Folding down of F-lattice jib!

If the pin **2** is unpinned during assembly, then the F-lattice jib folds down. Personnel can be severely injured or killed.

- ▶ The pin **2** of the F-pivot section and the F-relapse retainer must remain pinned during assembly on point **A** „Transport position“.

NOTICE

Damage of F-auxiliary jib!

- ▶ F-jibs, which are longer than 12 m may not be assembled in flying mode.

- ▶ Release and unpin the pin **5** on the FA-frame relapse retainer, place the turnbuckle **6** on the F-pivot section **22**, see illustration **7**.
- ▶ Pull the flap **1** on the F-pivot section **22** down and affix the rope **30** on the hook lock at point **F**, see illustration **7**.



Note

- ▶ Before lifting the FA-frame **8**, the pins **18** between the F-guy ropes **15** and the brackets on the F-end section **23** must be released on points **H**, see illustration **6**.

- ▶ Hang in the FA-frame **8** with the attachment rope **25** on the auxiliary crane and lift, see illustration **7**.
- ▶ Reeve in the assembly winch rope **9** from the turntable into the rope pulleys on the F-pivot section **22** and pin on point **G** with pin **10** and secure with spring retainer **11**, see illustration **7**.

NOTICE

Danger of property damage!

Before crane operation or before erecting or taking down the boom, both support frames **7** must be folded down.

- ▶ Unpin the support frames **7** on points **E** and fold them down, see illustration **8**.
- ▶ Carefully fold the FA-frame **8** with the auxiliary crane „in direction of the main boom“ and „spool the assembly winch rope **9** out at the same time“ until it can be pinned on point **D**, see illustration **8**.
- ▶ Pin the F-guy rods **12** on point **D** with pins **13** and secure with spring retainers **14**, see illustration **8**.

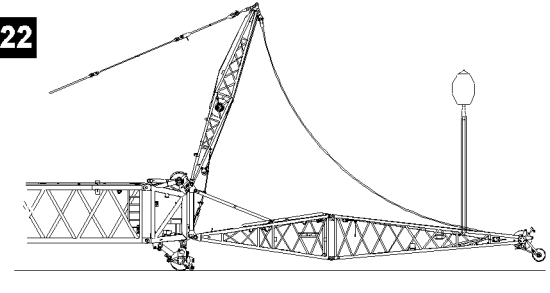
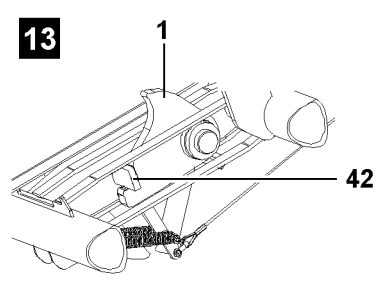
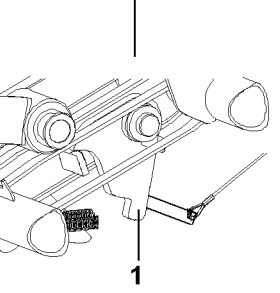
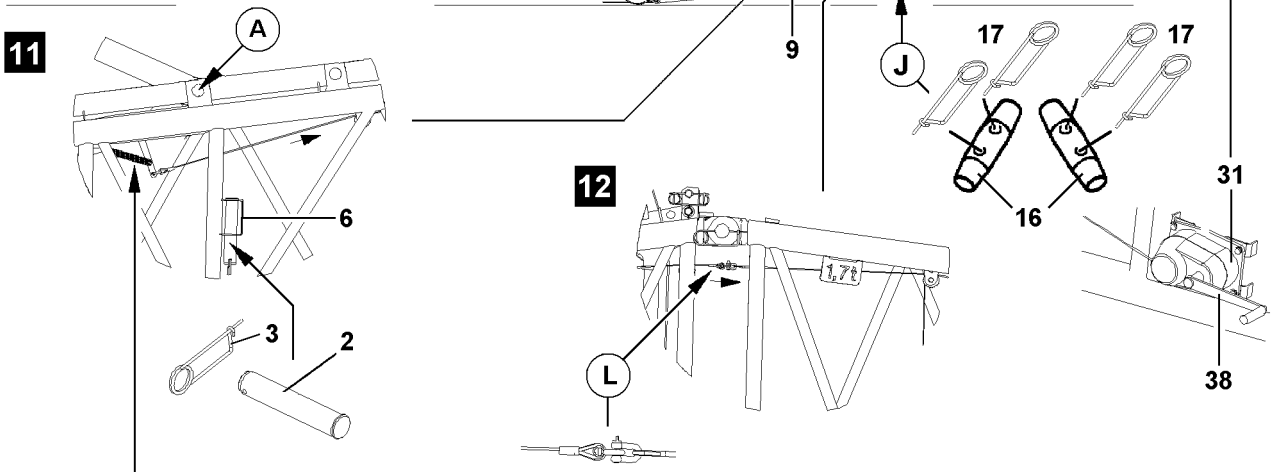
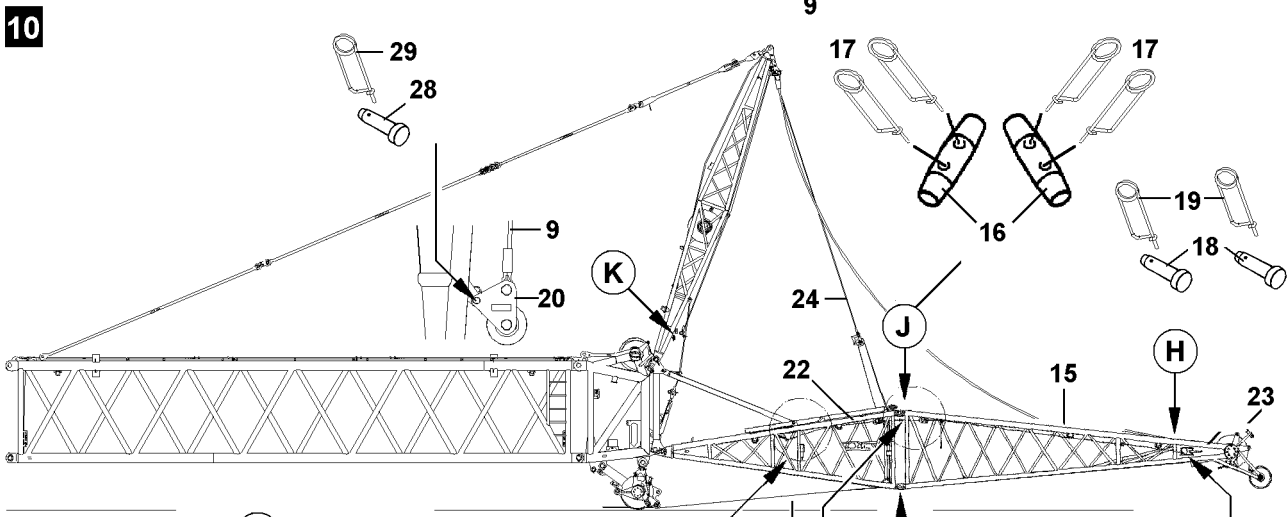
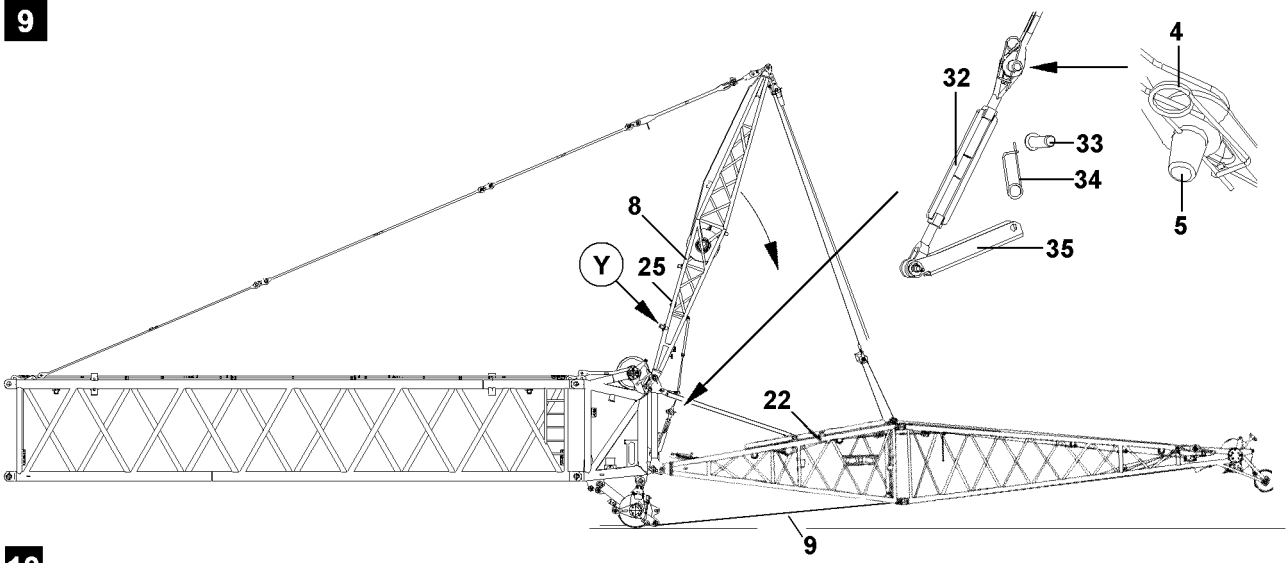

Fig.106640

LWE/LR 1600-2-008/18109-09-02/en

- ▶ Pull the FA-frame **8** with the assembly winch rope **9** in direction of the F-pivot section **22**, see illustration **9**.

**Note**

- ▶ Extend the turnbuckle **32**, if necessary so that the pin **5** can be pinned, see illustration **9**.
- ▶ Then tighten the turnbuckle **32** and close the retaining plate **35**.
- ▶ Secure the retaining plate **35** with pin **33** and spring retainer **34**.

- ▶ Connect the FA-frame relapse retainer again by pinning the pin **5** and securing it with the spring retainer **4**, see illustration **9**.

**Note**

- ▶ Pin and secure the attachment rope **25** for the auxiliary crane on the FA-frame **8** at point **Y** with a shackle, see illustration **9**.

- ▶ Lower the F-pivot section **22**, see illustration **10**.
- ▶ Pin the F-guy ropes **15** on the F-end section on point **H** with pins **18** and secure with spring retainers **19**, see illustration **10**.
- ▶ Unreeve the assembly winch rope **9** after the guy ropes are completely assembled.
- ▶ Pin the attachment rope **24** with the pulley block **20** on the FA-frame **8** at point **K** with pin **28** and secure with spring retainer **29**, see illustration **10**.

**Note**

- ▶ Lift the F-jib with the auxiliary crane until the pin **2** can be pulled on point **A**, see illustration **22**.
- ▶ Unpin the pin **2** before erecting the boom on point **A** and insert it into the retainer **6** „park position“ and secure with spring retainer **3**, see illustration **11**.
- ▶ Connect the rope strand from flap **1** to manual rope winch **31** on the F-end section **23** at point **L**, see illustration **12**.

NOTICE

Danger of property damage on the relapse support!

When taking the boom down, the flap **1** must be set in „down“ position as soon as the F-end section **23** touches the ground or as soon as the manual rope winch **31** can be reached.

If this is not observed, components on the F-assembly unit can be damaged.

- ▶ Set the flap **1** with the manual rope winch **31** in „down“ position so that the plunger **50** can „slide“ in the guide over the flap **1**, see illustration **11**.
- ▶ Set the flap **1** on the F-pivot section **22** with the manual rope winch **31** into „down“ position, see illustration **11**.

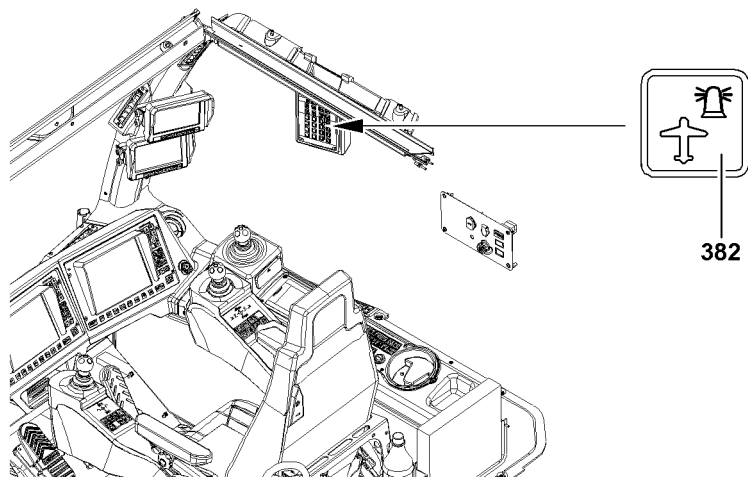
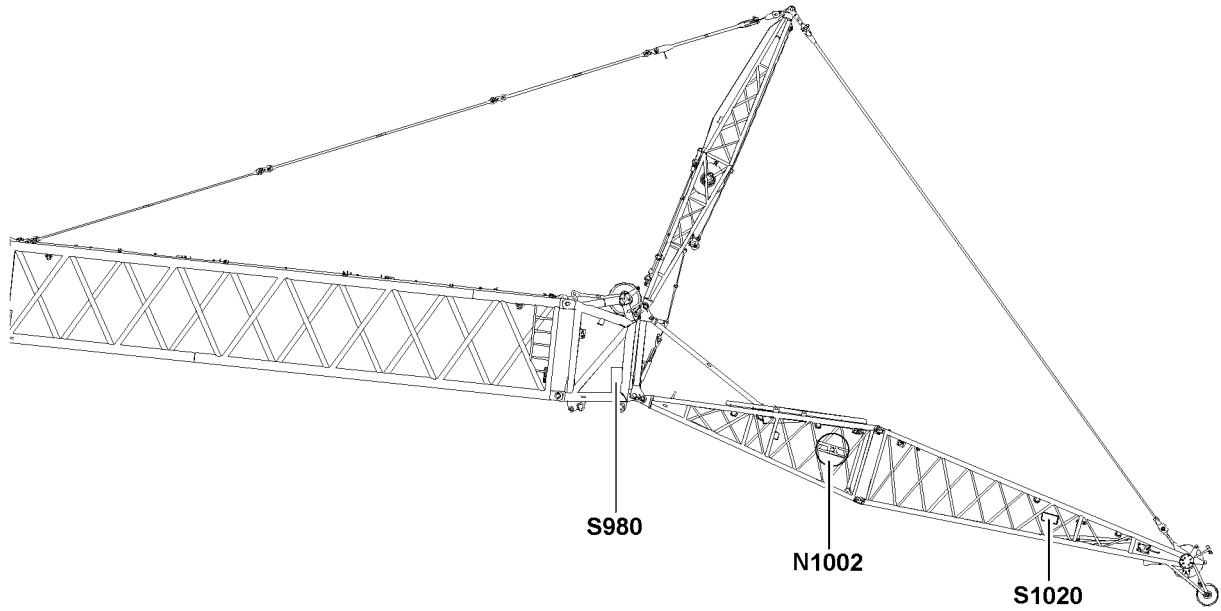

Fig.108792

3.4 Establishing the electrical connections

Make sure that the following prerequisites are met:

- The boom system is completely assembled.
- The airplane warning light and the wind speed sensor are installed.

NOTICE

Damage to the electrical connection on the cable drum!

If the electrical connection from the cable drum on the F-pivot section to the terminal box on the F-connector head or to the SW-end section is established first before the connection to the terminal box on the F-end section, then the electrical connection can be damaged when spooling out the cable drum.

- ▶ Establish the electrical connection from the cable drum on the F-pivot section to the terminal box on the F-end section first and then the electrical connection from the terminal box on the F-connector head or the SW-end section to the cable drum.
-



Note

- ▶ To establish the electrical connections on the F-auxiliary jib, use the separate electrical wiring diagram.
-

- ▶ Establish the electrical connections.
 - ▶ Make sure that all electrical connections on the boom are established.
-

3.5 Checking the function of the safety equipment



WARNING

Non-functioning safety equipment!

If the function of the safety equipment is defective, personnel can be severely injured or killed.

- ▶ Crane operation with non-functioning safety equipment is **prohibited**.
-



Note

- ▶ The function of the individual limit switches must be checked before erection.
 - ▶ The function of the limit switch initiators must be checked in the test system, see „Diagnostics manual“.
-



Note

- ▶ If a function check on the limit switches or on the safety devices does not lead to the desired shut offs, then the plug connections on the connector boxes or the components itself must be checked. If no visible connection errors or component defects can be found, contact **Liebherr** Service.
-

15

	5.9
	m/s 3.5
	max: 12.3

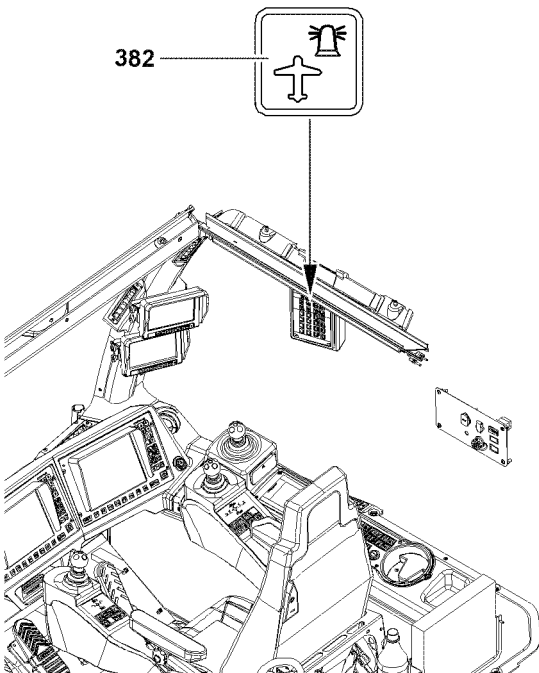
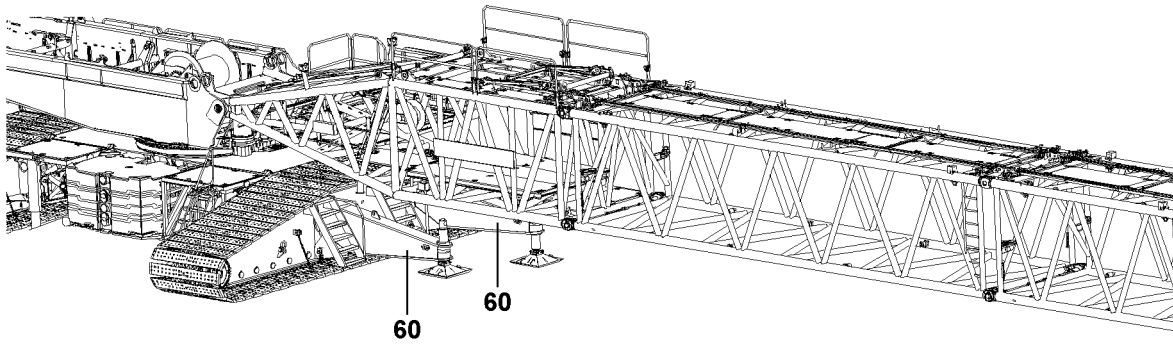

Fig.119959

LWE/LR 1600-2-008/18109-09-02/en

Make sure that the following prerequisites are met:

- All electrical connections have been made.
- The crane engine is running.
- The corresponding operating mode is set on the LICCON monitor.

3.5.1 Checking the wind speed sensor

- ▶ Check the movement and the function of the wind speed sensor.

Result:

- The icon „Wind speed“, see illustration 15, appears on the LICCON monitor.

3.5.2 Checking the airplane warning light

- ▶ Turn on the airplane warning light on with the button 382.
- ▶ Check the function visually.

3.5.3 Checking the hoist limit switch on the pulley head



Note

- ▶ When replacing or changing a hoist limit switch (HES), the corresponding hoist limit switch must have the correct bus address and the correct software version in order to be detected again by the bus system (LSB).

- ▶ Actuate the hoist limit switch manually on the pulley head.

Result:

- The spool up function of the hoist winch turns off.
- The icon „Hoist top“ appears on the LICCON monitor 0, see illustration 14.
- The limit switch is functioning.

3.5.4 Checking the limit switch S-boom „steepest position“



Note

- ▶ The limit switch functions have to be checked individually before erection.

- ▶ Cover the limit switch initiators on the S-relapse cylinders individually with a metal plate.

Result:

- The limit switch is actuated manually.
- The spool up function of winch 4 (control winch) turns off.
- The icon „Boom limitation“ appears on the LICCON monitor 0.
- The limit switch is functioning.

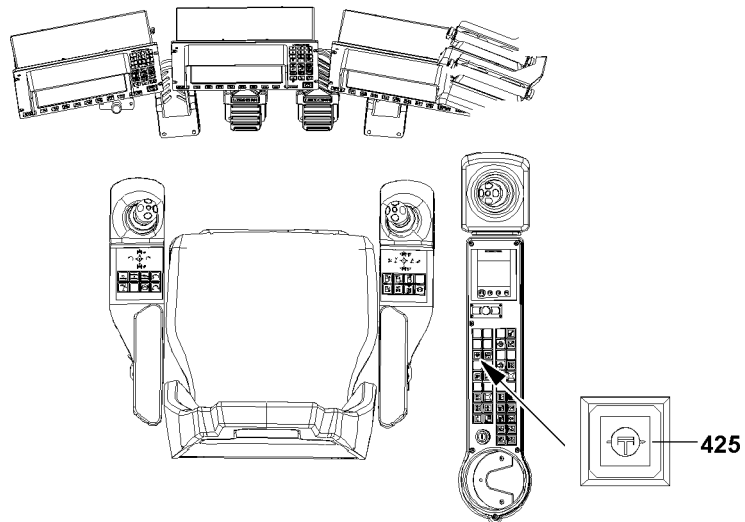
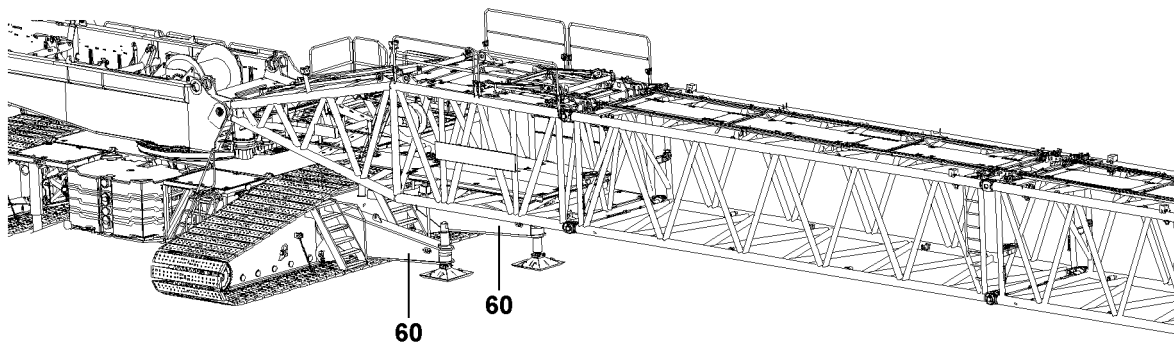

Fig.119960

3.6 Erecting the SLF-boom



DANGER

The crane can topple over!

- ▶ It is not permitted to turn the crane during the erection procedure.
- ▶ Observe the specifications in the erection and take down charts.



DANGER

The crane can topple over!

For certain boom lengths, the mechanical auxiliary supports must be assembled, see Erection and take down charts.

- ▶ The boom must be erected or taken down „to the side“ „in direction“ of the mechanical auxiliary supports **60**.
- ▶ Always erect or take down according to the data in the **Erection and take down charts**.



WARNING

The crane can topple over!

If the following conditions are not met before erecting the boom, the crane can topple over. Personnel can be severely injured or killed.

- ▶ Observe the technical safety notes, see Crane operating instructions, chapter 5.01.
- ▶ Extend the relapse cylinder before erection.
- ▶ Do not allow slack rope formation on the control winch.



WARNING

Falling hoist rope!

If the hoist rope before the erection procedure is not properly secured onto the end section, it can fall down backward on the basis of its own weight.

Personnel can be severely injured or killed.

- ▶ Secure the hoist rope properly on the head piece before the erection procedure.

Make sure that the following prerequisites are met:

- The crane is aligned in horizontal direction.
- All electrical connections have been established.
- All limit switches are functioning.
- The counterweight has been installed to the turntable according to the load chart.
- All pin connections have been secured.
- The hoist rope has been correctly placed in the rope pulleys and is prevented from jumping out with the rope retaining pins.
- There are no loose parts on the boom.
- The LICCON overload protection has been set according to the data in the load chart.
- The LICCON overload protection settings have been compared with the actual set up configuration.
- The LICCON overload protection is exceeded.
- The assembly icon is visible on the LICCON monitor.

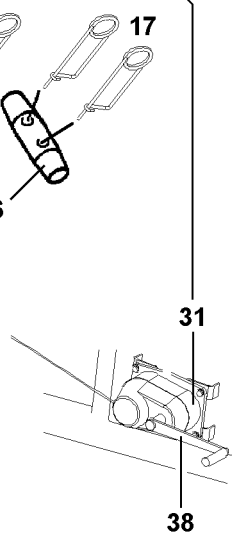
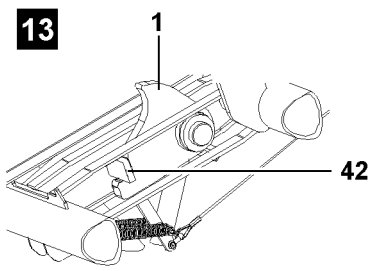
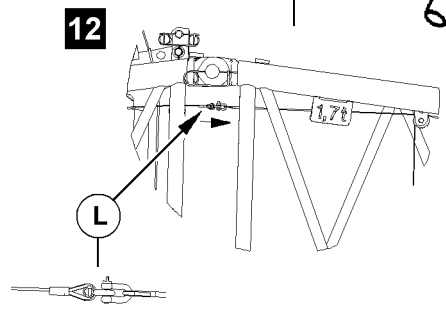
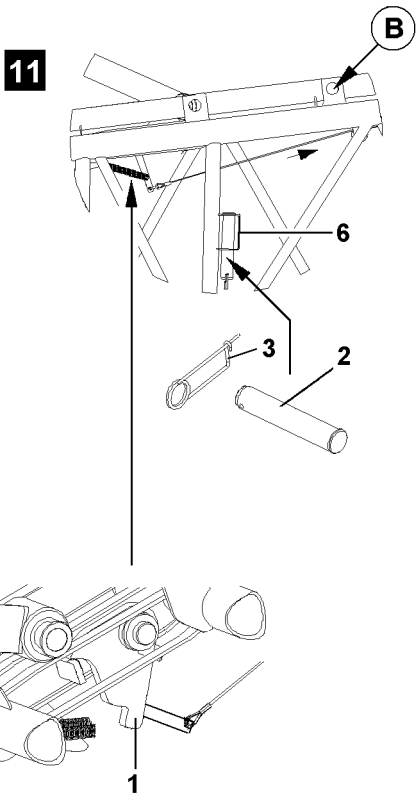
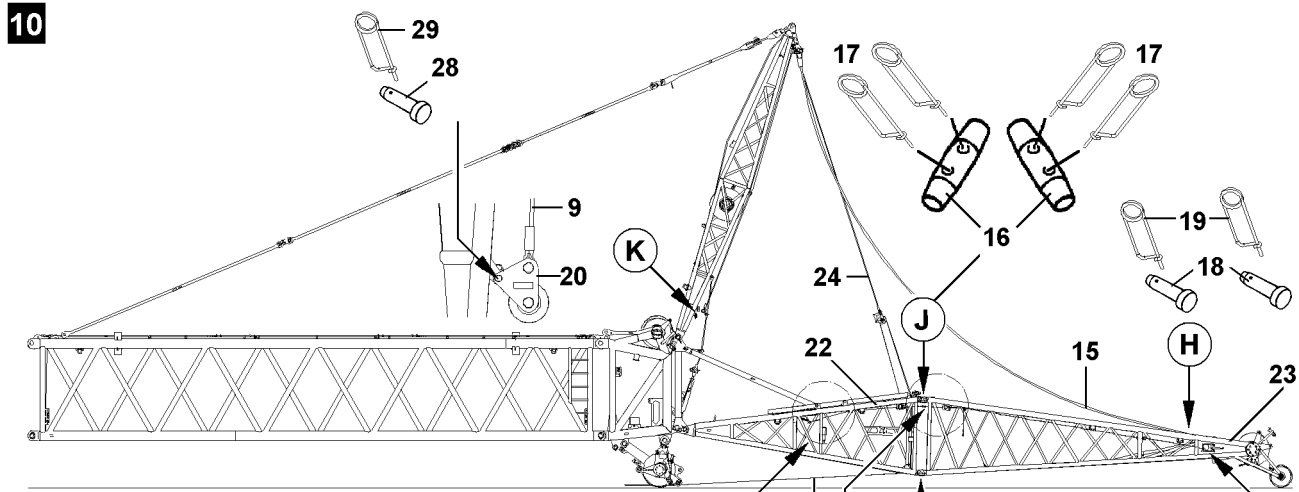
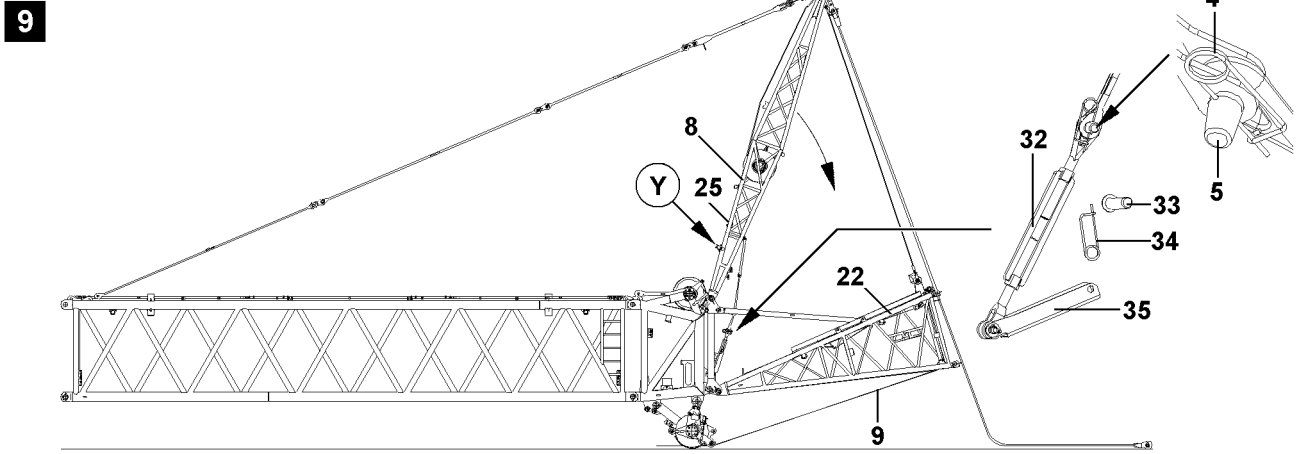

Fig.106174

LWE/LR 1600-2-008/18109-09-02/en

3.6.1 Setting the relapse retainer



WARNING

Danger of accident!

During crane operation, the flap **1** must be in „up“ position, see illustration **13**.

- ▶ Set the flap **1** **immediately before lift off** of the F-end section **23** or when erecting the boom into the relapse retainer position in the „up“ position.
 - ▶ Then remove the manual lever **38** from the manual rope winch **31** and store it in the tool box.
-
- ▶ Set the flap **1** with the manual rope winch **31** in relapse retainer position („up“ position), until the flap **1** touches on the stop **42**, see illustration **13**.
 - ▶ Remove the manual lever **38** from the manual rope winch **31**.

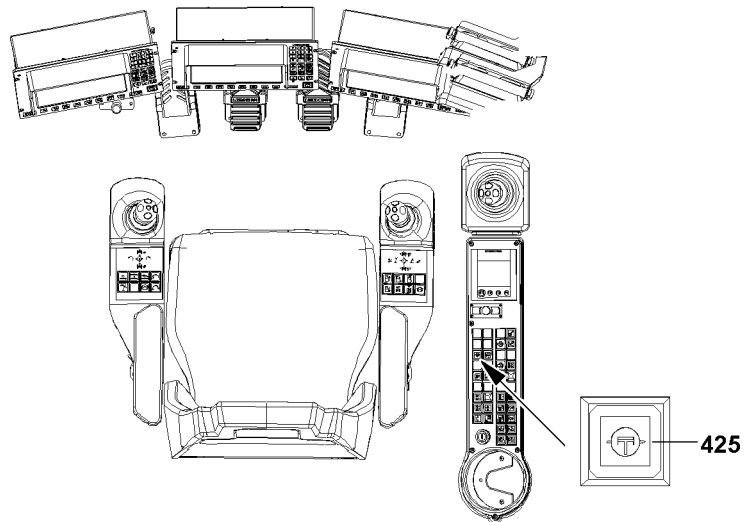
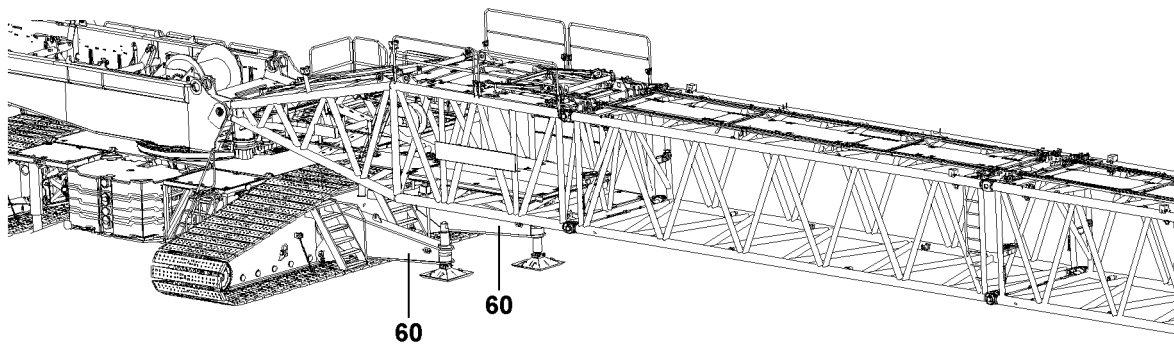

Fig.119960

3.6.2 Erection procedure



DANGER

The crane can topple over!

- ▶ It is prohibited to turn the crane superstructure while erecting the boom.
- ▶ Observe the data in the Erection and take down charts.

Reeving in the hook block

- ▶ Luff up the boom until the auxiliary jib lifts off the ground.
- ▶ Reeve in the hook block properly and secure the hoist rope on the rope fixed point, for reeving, see separate reeving plans.
- ▶ Attach the hoist limit switch weight.

Erecting the boom



DANGER

The crane can topple over!

In crane operation with exceeded LICCON overload protection, the crane can topple over.

- ▶ Personnel can be severely injured or killed.
- ▶ The radii listed in the load chart may not be exceeded or fallen below, even if there is no load on the hook.



Note

- ▶ When the lowest operating position of the boom is reached, the LICCON overload protection is activated.
- ▶ In the maximum load icon appears a load number in „t“ instead of the display „???“.
- ▶ Luff the boom up to the lowest operating position.

When the boom has reached the lowest operating position:

- ▶ Make sure that the assembly icon **3** on the LICCON monitor turns off.

Result:

- The LICCON overload protection is active.

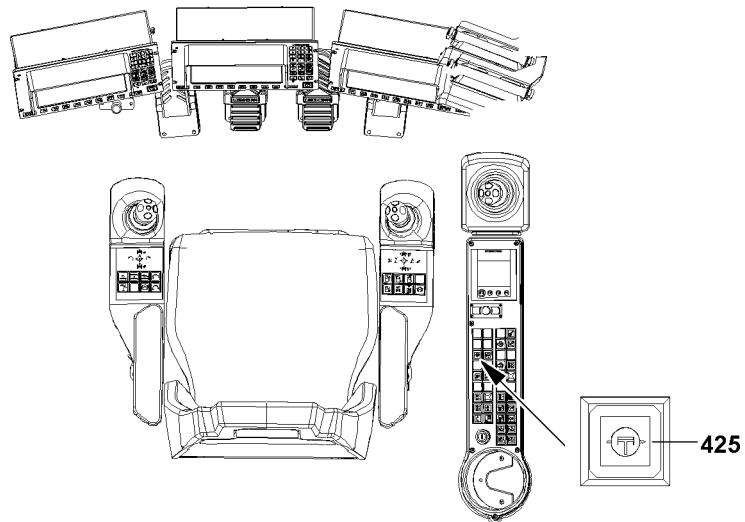
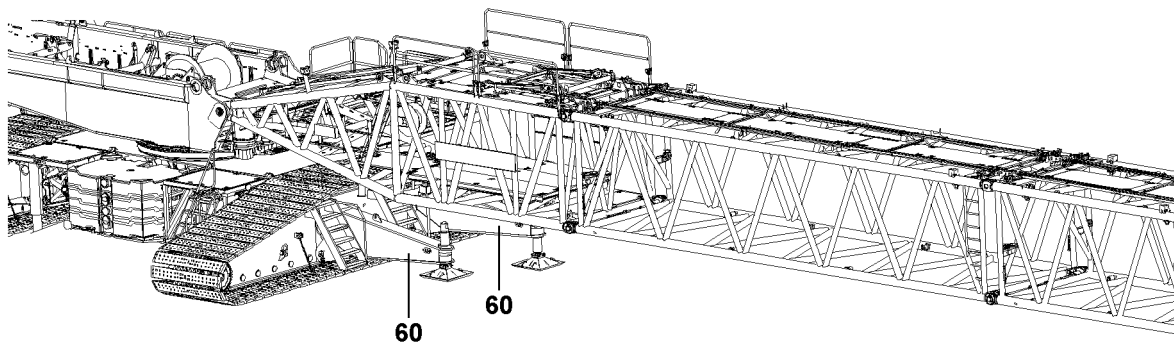

Fig.119960

4 Operating the crane

4.1 Preparing for crane operation

**Note**

- ▶ Observe the notes, see Crane operating instructions, chapter 4.05, chapter 4.08 and chapter 5.01.

Make sure that the following prerequisites are met:

- The LICCON overload protection is active.
- The LICCON overload protection has been set according to the data in the load chart.

**WARNING**

The crane can topple over!

- ▶ Check the horizontal position of the crane before and during operation.
- ▶ If the crane operator leaves the cab, even for a short time, he is obligated to check the operating mode setting and reset them if necessary before resuming crane operation.

4.2 Checking the settings

- ▶ Check the function of the overload protection by running against the operating positions „on top“ and „bottom“.
- ▶ Check the hoist limit switch by running against the hoist limit switch weight.
- ▶ Check the function of the limit switches on the relapse cylinders.

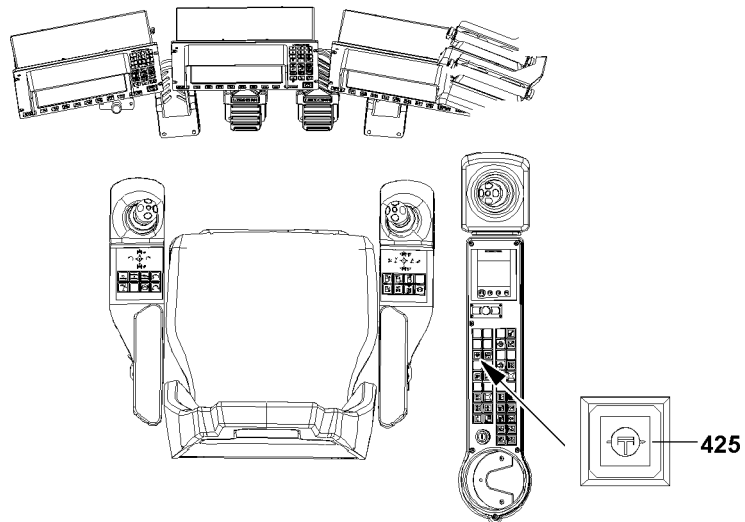
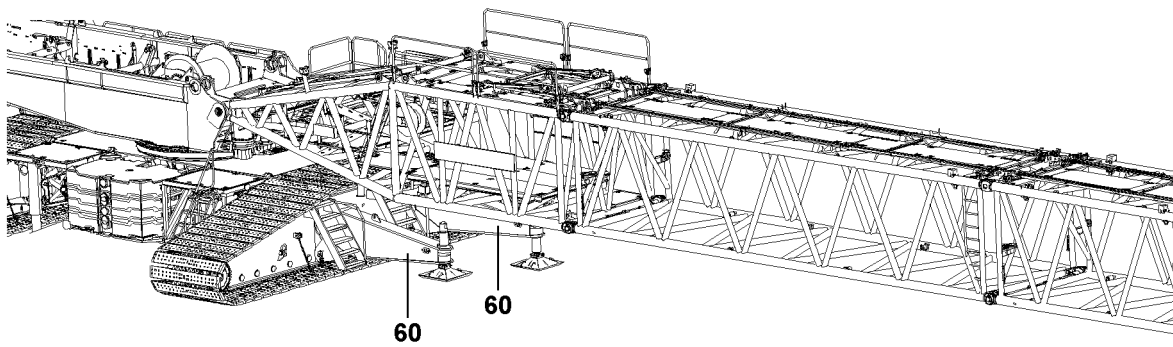

Fig.119960

5 Disassembling the auxiliary jib



WARNING

Danger of falling!

During assembly / disassembly, inspection and maintenance work, assembly personnel must be secured with appropriate aids to prevent them from falling. If this is not observed, assembly personnel could fall and suffer life-threatening or fatal injuries.

- ▶ All work aloft, where there is a danger of falling must be carried out with suitable aids.
- ▶ If fall arrest equipment is available, then it must be used, see Crane operating instructions, chapter 2.06.
- ▶ If aids are not available and work cannot be carried out from the ground, then the assembly personnel must secure themselves with the specified fall arrest system to prevent falling, see Crane operating instructions, chapter 2.04.
- ▶ The fall arrest system must be fastened on the fastening and hook points as well as on the safety ropes. For safety points, see Crane operating instructions, chapter 2.06.
- ▶ Only step on the aids, ladders and catwalks with clean shoes.
- ▶ Keep aids, ladders and catwalks free of heavy dirt, snow and ice.
- ▶ Remaining on as well as under a suspended load is prohibited.
- ▶ Remaining on or within crane components (for example: At assembly of boom sections, lattice sections) which are moved during lifting, lowering, turning or closing procedures is strictly prohibited.
- ▶ During all assembly and disassembly work, maintenance work and inspections, travel or crane operation is prohibited.
- ▶ It is prohibited to step on the boom system or an auxiliary boom without suitable protective devices.
- ▶ Stepping and walking on crane components and lattice sections, which have an incline of more than 20° is prohibited.



DANGER

Danger of accident at assembly / disassembly of booms!

When you disassemble unsecured or unsupported booms, then the booms can fall down and kill or severely injure personnel.

- ▶ Never unpin the pins under unsecured or unsupported booms.
- ▶ Never unpin the connecting pins on unsecured or unsupported booms.
- ▶ Do not stand under the booms or within the complete danger zone during the pinning and unpinning procedure of the booms.
- ▶ Secure the pins in the bearing points as well as in the receptacles.
- ▶ Do not lean the ladder against the component being disassembled.



WARNING

Danger of impact and crushing!

There is a risk of impact and crushing when standing in the vicinity of suspended loads moving sideways.

- ▶ During assembly / disassembly no one may be in the dangerous area around or underneath the suspended load before the load has been secured.



WARNING

Components not pinned and secured!

If a component is released from the auxiliary crane before having been pinned and secured, the component will fall down. Personnel can be severely injured or killed.

- ▶ Do not disengage the auxiliary crane until the respective component is pinned and secured.



WARNING

The components can fall down!

If the respective component is unpinned without being secured by an auxiliary crane, the respective component can fall down and fatally injure personnel.

- ▶ Do not unpin the components until they are secured by an auxiliary crane.

Make sure that the following prerequisites are met:

- The „mechanical auxiliary supports **60**“ are properly assembled on the crane, see also **Erection and take down charts**.
- The SL-boom is luffed down „to the side“ over the „mechanical auxiliary supports **60**“ and is luffed down to the „lowest“ operating position.
- The LICCON overload protection has been set according to the data in the load chart.
- The LICCON overload protection is exceeded.
- The assembly icon is visible on the LICCON monitor.
- The auxiliary crane is available.

Empty page!

LWE/LR 1600-2-008/18109-09-02/en

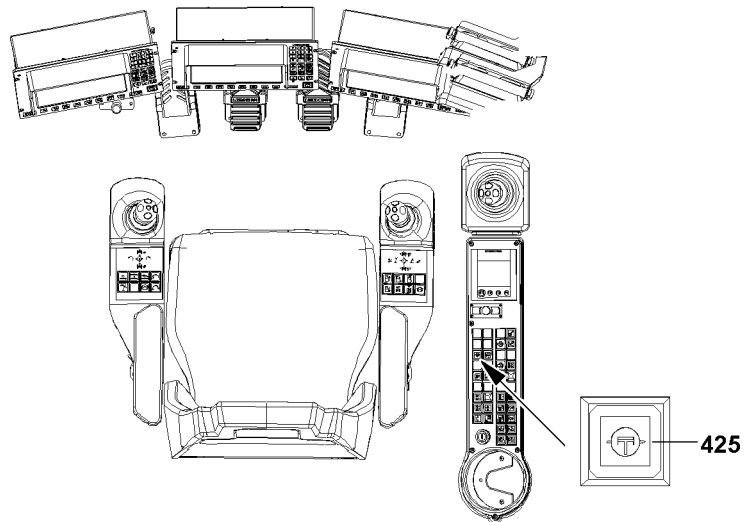
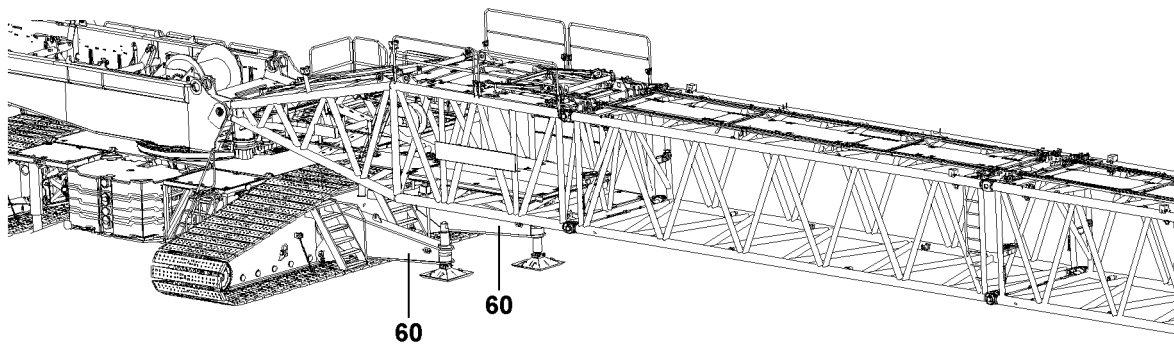

Fig.119960

5.1 Taking the SLF-boom down



WARNING

The crane can topple over!

If the following conditions are not met before taking down the boom, the crane can topple over and fatally injure personnel.

- ▶ Observe the technical safety notes, see Crane operating instructions, chapter 5.01.
- ▶ Observe the specifications in the erection and take down charts.

NOTICE

Damage of boom components!

Taking down the boom system can lead to a collision between the hook block and the pulley head. Boom components can be severely damaged.

- ▶ Luff the boom system down at the same time and spool the hoist winch out.

5.1.1 Luffing the SLF-boom down



Note

- ▶ The luff down movement is turned off as soon as the lowest operating position is reached.
- ▶ When the lowest operating position of the S-boom is reached, the load display in the maximum load icon turns off and instead of the load display appears the display „???“.
- ▶ In the crane operating screen appear alarm functions.

- ▶ Luff the S-boom down to the „lowest“ operating position.

Result:

- The luff down movement is turned off.
- The „STOP“ icon appears on the LICCON monitor.
- The horn icon appears on the LICCON monitor.



WARNING

Danger of accident due to function „Exceedance of shut off limits of the LICCON overload protection“! If the shut off limits of the LICCON overload protection are exceeded, there is no additional protection against crane overload.

Due to erroneous operation or deliberate misuse, the crane could collapse, the boom can break off or the crane can topple over.

Personnel can be severely injured or killed.

- ▶ The function „Exceeding the shut off limits of the LICCON overload protection“ is only permissible in emergencies and for assembly purposes.
- ▶ The function „Exceeding the shut off limits of the LICCON overload protection“ may only be actuated by persons who know the effects of their actions regarding the function „Exceeding the shut off limits of the LICCON overload protection“.
- ▶ The function „Exceeding the shut off limits of the LICCON overload protection“ requires the presence of an authorized person and must be performed with utmost caution.
- ▶ Crane operation with activated function „Exceeding the shut off limits of the LICCON overload protection“ is prohibited.

When the boom has reached the „lowest“ operating position:

- ▶ Exceeding the shut off limits of the LICCON overload protection: Engage assembly operation.

Result:

- The shut off limits of the LICCON overload protection are exceeded.
- The assembly icon appears on the LICCON monitor.



Note

- ▶ See Crane operating instructions, chapter 4.02.

- ▶ At the same time, spool the hoist winch out and luff the S-boom down until the hook block touches the ground.

Empty page!

LWE/LR 1600-2-008/18109-09-02/en

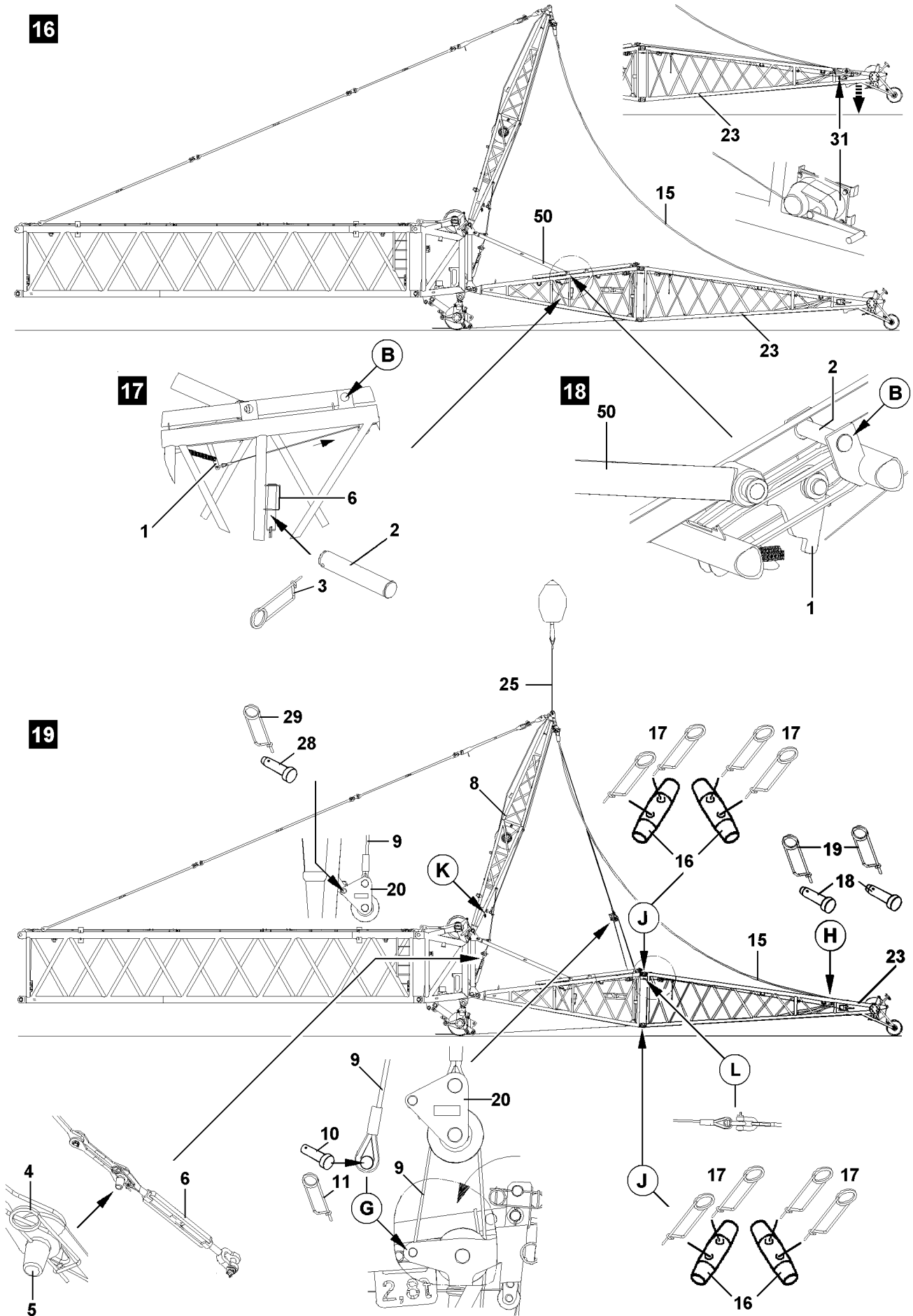

Fig.106176

5.1.2 Taking the SLF-boom down

- ▶ Actuate the master switch and luff the S-boom down until the hook block touches the ground.
- ▶ Remove the hoist limit switch weight.
- ▶ Unreeve the hook block.
- ▶ Spool up the hoist rope to the winch.
- ▶ Luff down the boom until the pulley head from the F-end section is just above the ground, see illustration **16**.
- ▶ Remove the pin **2** from the retainer **6** (park position) and insert at point **B** (attachment position) and secure with spring retainer **3**, see illustration **17**.

NOTICE

Danger of damage on the relapse support!

When taking the boom down, the flap **1** must be set in „down“ position as soon as the F-end section **23** touches the ground or as soon as the manual rope winch **31** can be reached.

If this is not observed, components on the F-assembly unit can be damaged.

- ▶ Set the flap **1** with the manual rope winch **31** in „down“ position so that the plunger **50** can „slide“ in the guide over the flap **1**, see illustration **16**.
-
- ▶ Set the flap **1** on the F-pivot section **22** with the manual rope winch **31** into „down“ position, see illustration **16**.
 - ▶ Place the boom all the way on the ground.

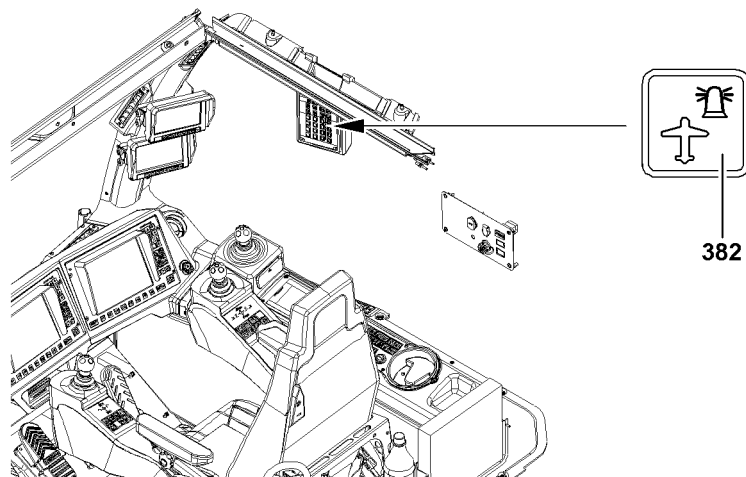
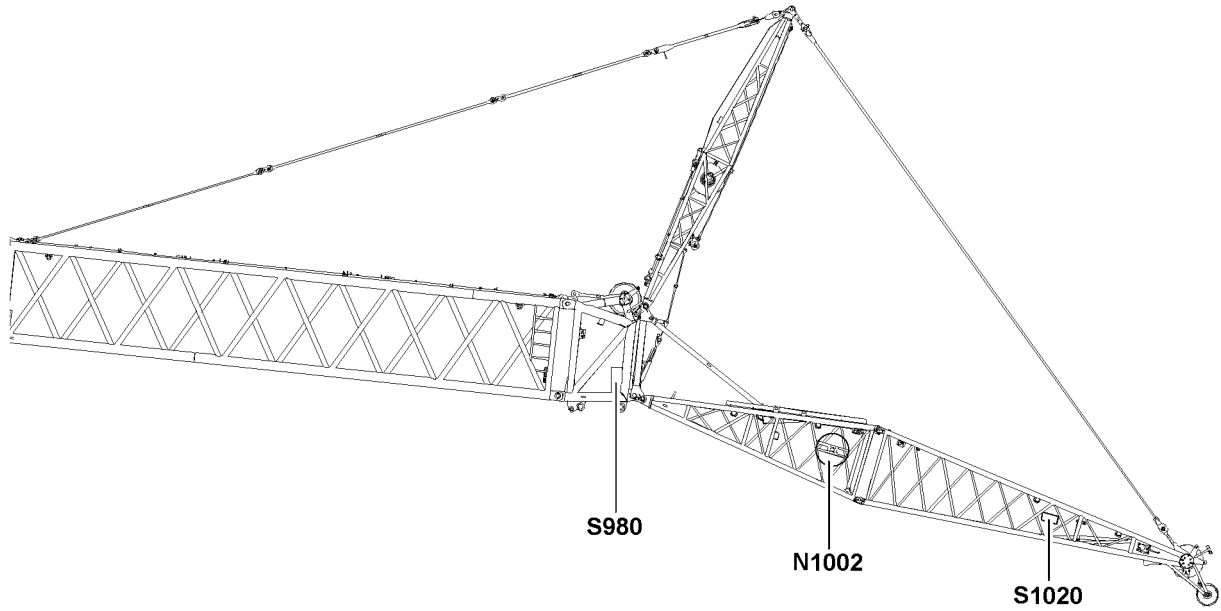

Fig.108792

5.2 Disconnecting the electrical connections

Make sure that the following prerequisite is met:

- The boom system is placed down.

NOTICE

Damage to the electrical connection on the cable drum!

If the electrical connection between the SW-end section and the F-pivot section is not separated before spooling up the cable drum, the electrical connection will be damaged.

If the cable of the cable drum is not properly spooled up on the cable drum after unplugging the F-end section, then the cable drum or the cable can be significantly damaged.

- ▶ Disconnect the electrical connection from the cable drum on the F-pivot section to the terminal box on the SW-end section first and then the electrical connection from the terminal box on the F-end section to the cable drum.
 - ▶ After unplugging, spool the cable onto the cable drum.
-
- ▶ Disconnect the electrical connections.
 - ▶ After unplugging, spool the cable onto the cable drum and secure it to prevent it from spooling out inadvertently.
 - ▶ Secure the cable: Reestablish the electrical connection between the W-connector head and the cable drum.

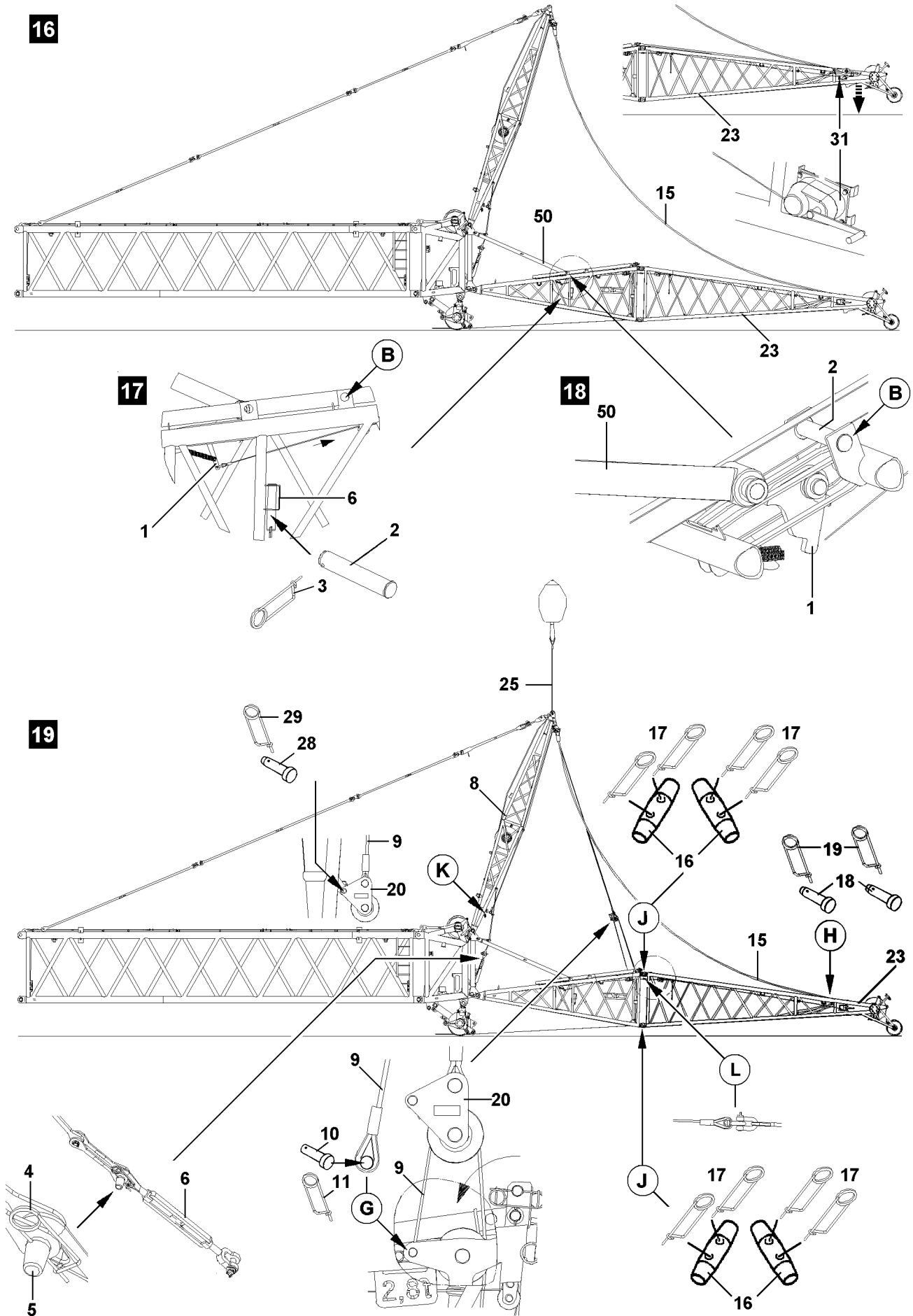

Fig.106176

LWE/LR 1600-2-008/18109-09-02/en

5.3 Disassembling the F-assembly unit

- ▶ Remove the F-guy ropes **15** on the F-end section, see illustration **19**.
- ▶ Release the pins **18** on point **H** and unpin, see illustration **19**.
- ▶ Hang in the F-end section or the F-intermediate sections properly on the auxiliary crane.
- ▶ Release the rope strand to the manual rope winch **31** on the F-end section **23** at point **L**, see illustration **19**.
- ▶ Unpin the double cone pins **16** on the points **J** from the „outside to the inside“ and remove the F-end section or the F-intermediate sections.



WARNING

The FA-frame **8** can fold back uncontrolled!

Before the FA-frame relapse retainer is released, the FA-frame **8** must be secured to prevent it from folding back uncontrolled.

- ▶ Properly hang the FA-frame **8** with the attachment rope **25** on the auxiliary crane, see illustration **19**.
 - ▶ Reeve in the assembly winch rope **9** into the rope pulley block **20** and pin, see illustration **19**.
-
- ▶ Release and unpin the rope pulley **20** on the FA-frame **8** at point **K** and unpin, see illustration **19**.
 - ▶ Reeve in the assembly winch rope **9** from the turntable into the rope pulleys and pin on point **G** with pin **10** and secure with spring retainer **11**, see illustration **17**.
 - ▶ Release the FA-frame relapse retainer by releasing the spring retainer **4** and unpinning the pin **5**, see illustration **19**.
 - ▶ Place the turnbuckle **6** on the F-pivot section **22** and secure.

20

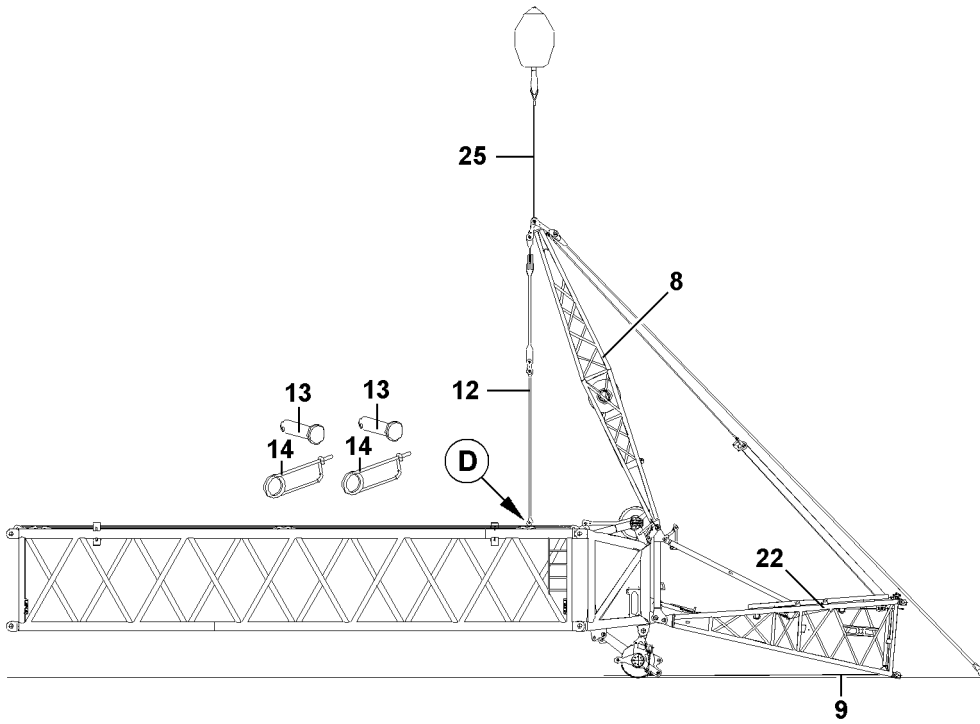

21

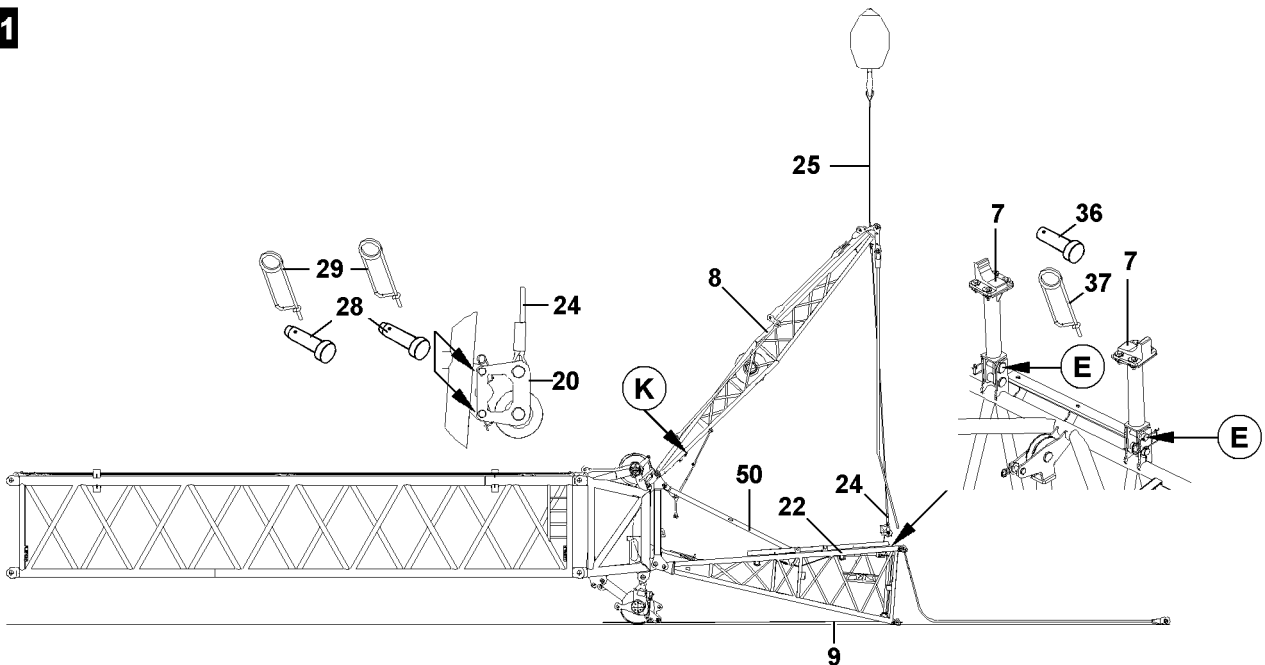

Fig.106177

- ▶ Swing the FA-frame **8** with the auxiliary crane „carefully to the rear in direction of the main boom“ and „at the same time, spool out the assembly winch rope **9**“, see illustration **20**.
- ▶ Unpin the F-guy rods **12** on point **D**, see illustration **20**.
- ▶ Release and unpin the pins **13**, see illustration **20**.
- ▶ Swing the FA-frame **8** with the auxiliary crane forward, see illustration **21**.
- ▶ Pin the attachment rope **24** with the pulley block **20** on the FA-frame **8** at point **K** with pin **28** and secure with spring retainer **29**, see illustration **21**.
- ▶ Fold the support brackets **7** up and pin on points **E** with pins **36** and secure with spring retainers **37**, see illustration **21**.

22

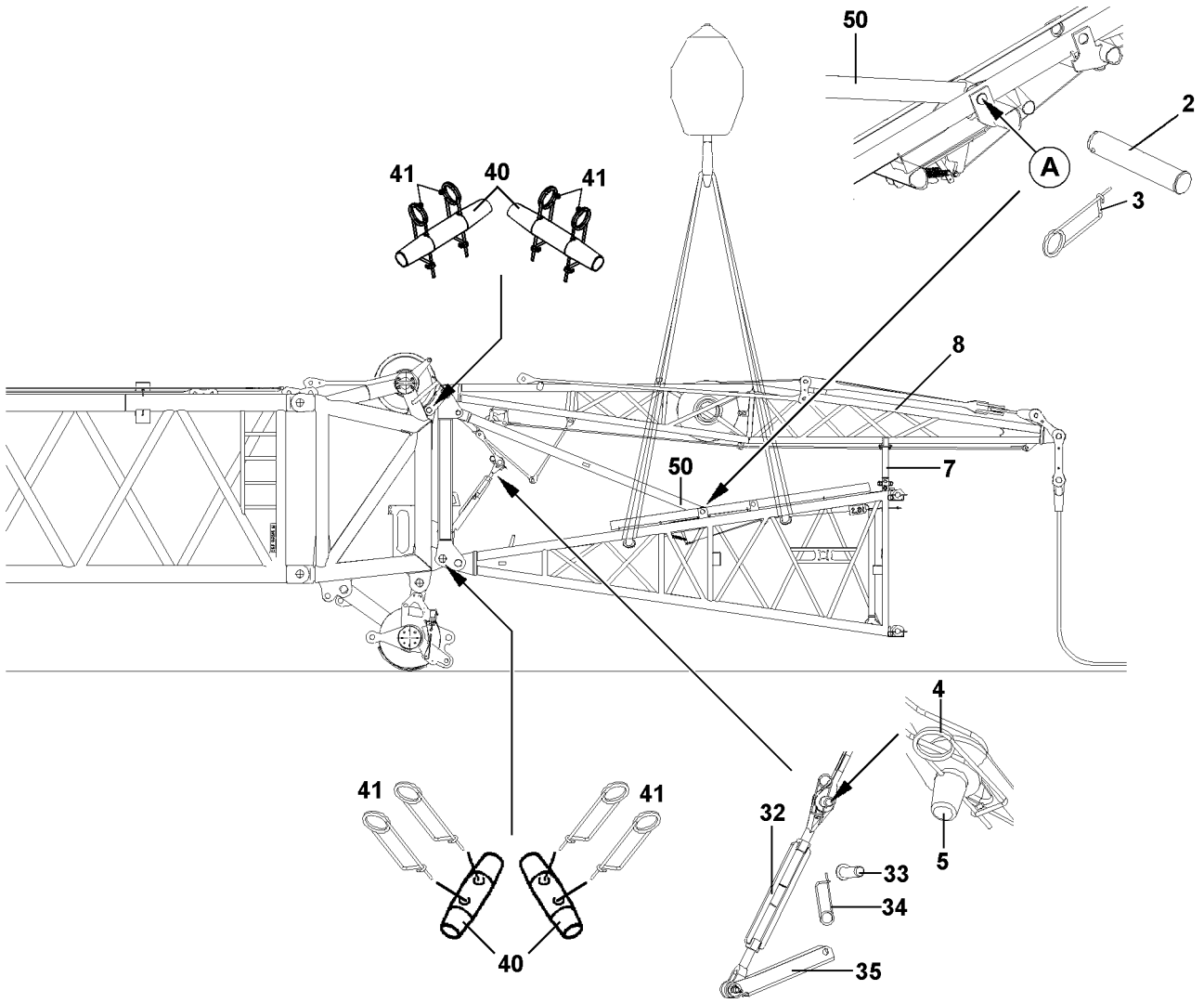

Fig.106179

- ▶ Place the FA-frame **8** with the auxiliary crane onto the support frames **7**.
- ▶ Connect the FA-frame relapse retainer by pinning the pin **5** and securing it with the spring retainer **4**, see illustration **22**.
- ▶ Tighten the turnbuckle **32** and close the retaining plate **35**, see illustration **22**.
- ▶ Secure the retaining plate **35** with pin **33** and spring retainer **34**, see illustration **22**.
- ▶ Properly hang the F-assembly unit on the auxiliary crane, see illustration **22**.



WARNING

Danger of accident!

The plunger **50** must be pinned on point **A** in „transport position“ with pin **2**, see illustration **22**.

- ▶ Insert the pin **2** on point **A** and secure with spring retainer **3**.
-
- ▶ Unpin the double cone pins **40** on top and bottom from the „outside to the inside“ and remove the F-assembly unit.

Empty page!

LWE/LR 1600-2-008/18109-09-02/en

5.13.20 SLF boom combination- fiber guy ropes

1	Component overview	3
2	Fastening points for the F-jib	5
3	Assembling the F-jib	9
4	Establishing the electrical connections	43
5	Checking the function of the safety equipment	44
6	Erecting the boom	45
7	Operating the crane	46
8	Disassembling the F-jib	47

Fig.195219

LWE/LR 1600-2-008/18109-09-02/en

1 Component overview



Note

► The assembly sections are marked with their own weight.



Note

► Dimensions and weights, see chapter 1.03.

1.1 F-pivot section

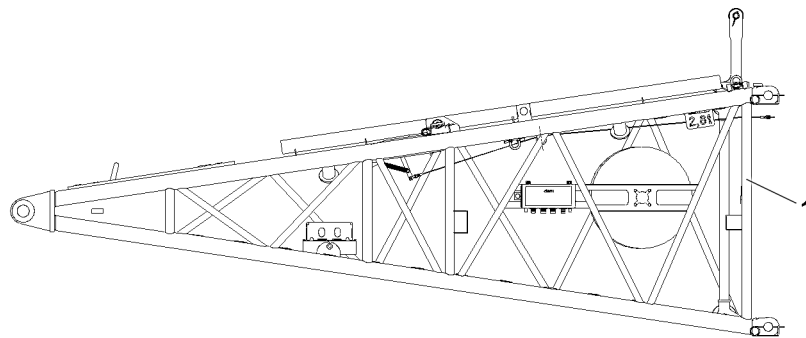

Fig.147718: F-pivot section

Position	Component
1	F-pivot section

1.2 F-intermediate section 6 m

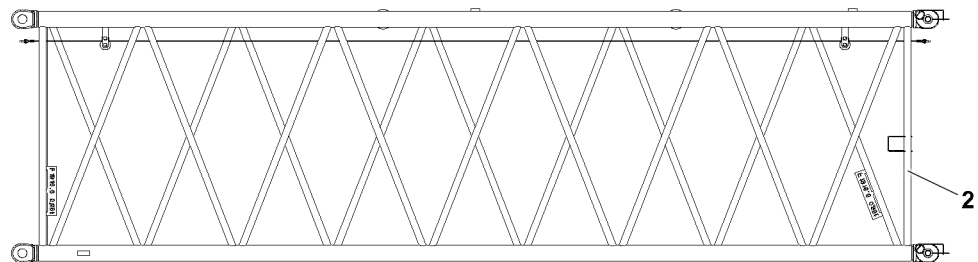

Fig.147720: F-intermediate section 6 m

Position	Component
2	F-intermediate section 6 m

LWE/LR 1600-2-008/18109-09-02/en

1.3 F-intermediate section 12 m

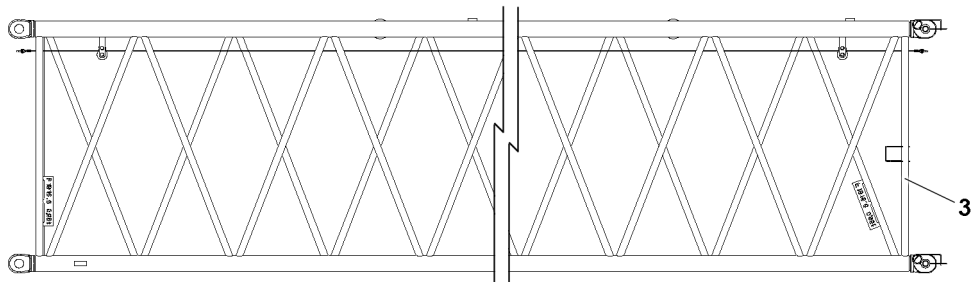

Fig.147721: F-intermediate section 12 m

Position	Component
3	F-intermediate section 12 m

1.4 F-end section

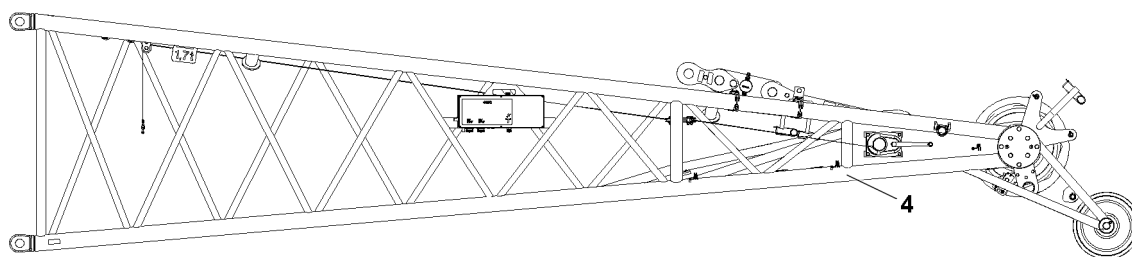

Fig.147719: F-end section

Position	Component
4	F-end section

1.5 F-assembly unit

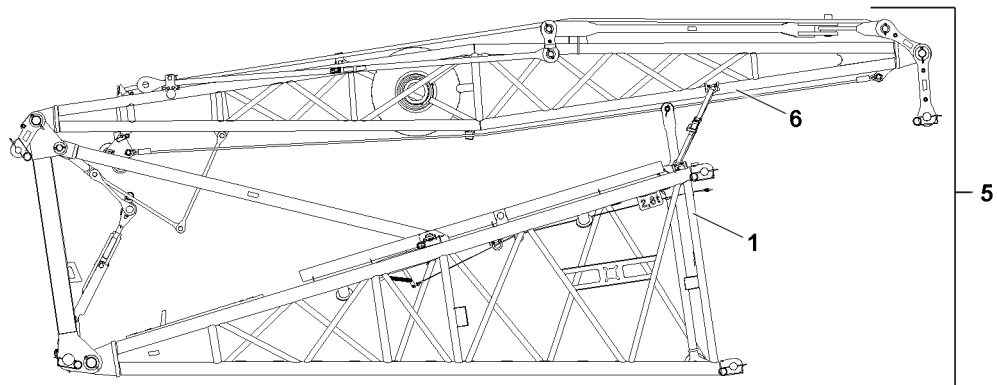

Fig.147722: F-assembly unit

Position	Component
1	F-pivot section
5	F-assembly unit
6	FA-frame (F-guying frame)

2 Fastening points for the F-jib



WARNING

Falling lattice sections!
Death, severe bodily injuries, property damage.

- ▶ Make sure that the lattice sections are properly fastened on the respective fastening points.
- ▶ Make sure that the fastening equipment has the appropriate length and a sufficient load bearing capacity.
- ▶ Pay attention and adhere to the labels on the fastening points on the lattice sections and crane components.



Note

- ▶ The recommended length for the fastening equipment is 6 m.

2.1 F-pivot section

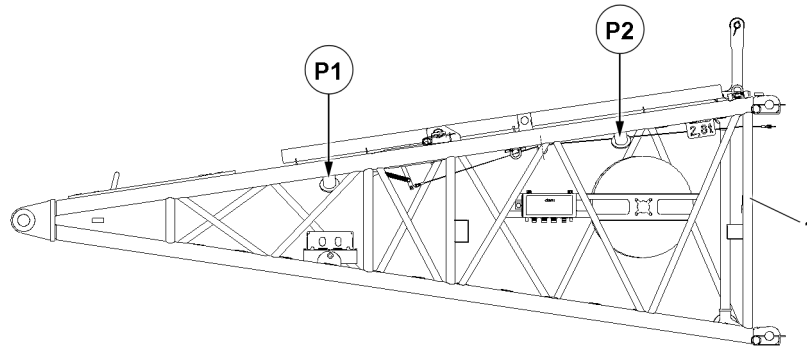

Fig.147723: F-pivot section

Fastening points	
P1 and P2	F-pivot section

2.2 F-intermediate section 6 m

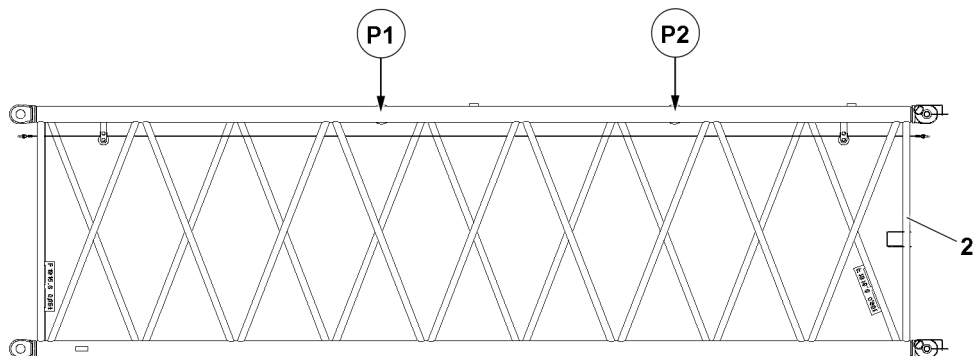

Fig.147725: F-intermediate section 6 m

Fastening points	
P1 and P2	F-intermediate section 6 m

2.3 F-intermediate section 12 m

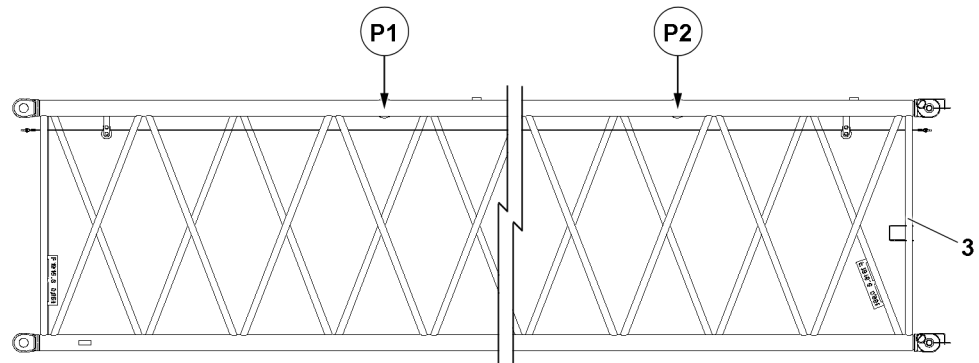

Fig.147726: F-intermediate section 12 m

Fastening points	
P1 and P2	F-intermediate section 12 m

2.4 F-end section

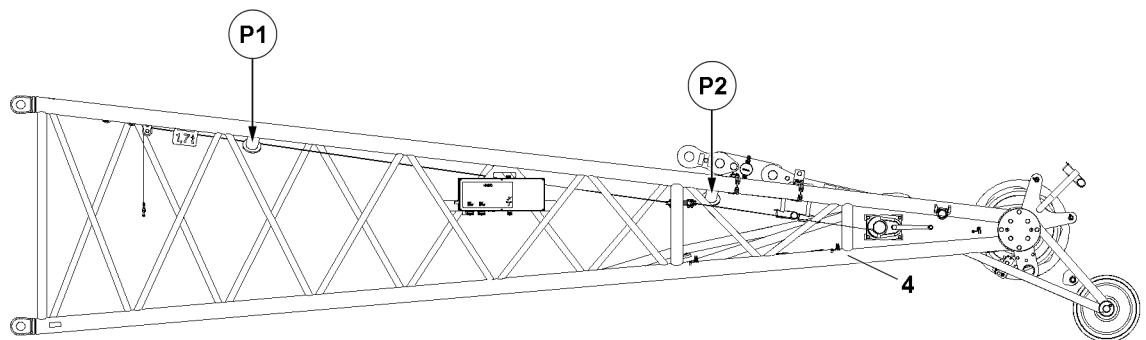

Fig.147724: F-end section

Fastening points	
P1 and P2	F-end section

LWE/LR 1600-2-008/18109-09-02/en

2.5 F-assembly unit

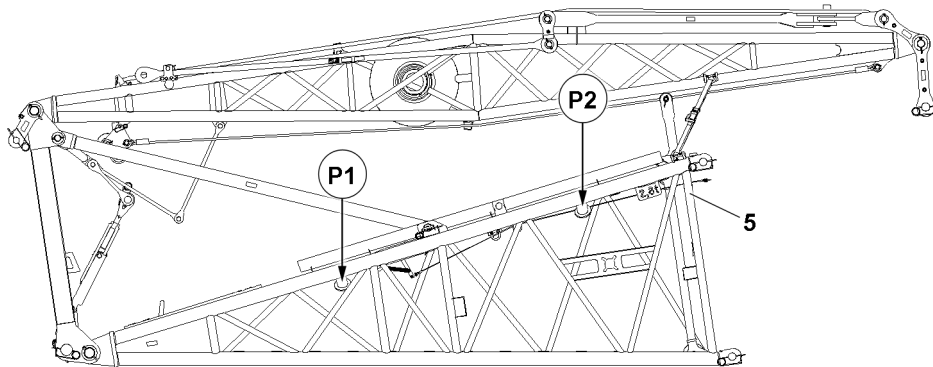

Fig.147727: F-assembly unit

Fastening points	
P1 and P2	F-assembly unit

2.6 F-jib

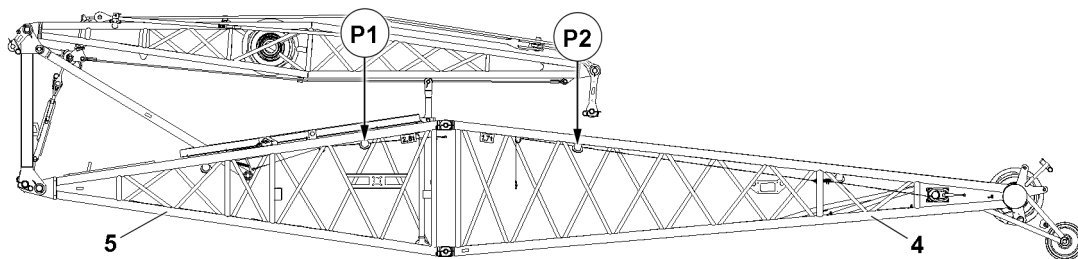

Fig.147728: F-assembly unit with F-end section

Fastening points	
P1 and P2	F-jib

LWE/LR 1600-2-008/18109-09-02/en

3 Assembling the F-jib



WARNING

Danger of falling!

During assembly / disassembly, inspection and maintenance work, personnel must be secured with appropriate aids to prevent them from falling.

Death, severe bodily injuries, property damage.

- ▶ All work at a height, when there is a danger of falling, must be carried out with suitable aids.
- ▶ If aids are not available and work cannot be carried out from the ground, then assembly personnel must secure themselves with the supplied fall arrest system to prevent falling, see chapter 2.04.
- ▶ If fall protection equipment is available, then it must be used, see chapter 2.06.
- ▶ When lifting, lowering, swinging crane parts in and out, no persons may remain in the danger zone.
- ▶ If railings are present on the components, then they must be brought into the corresponding position and secured for assembly / disassembly work.
- ▶ It is prohibited to lean the ladder against the component being disassembled.
- ▶ Only step on the aids, ladders and catwalks with clean shoes.
- ▶ Keep aids, ladders and catwalks free of heavy dirt, snow and ice.
- ▶ During all assembly and disassembly work, maintenance work and inspections, travel or crane operation is prohibited.
- ▶ Remaining on a suspended load is prohibited.
- ▶ Stepping or walking on crane components and lattice sections, which have an incline of more than 20° is prohibited.
- ▶ For all assembly work, the crane operator of the main crane must be in voice contact with the crane operator / crane operators of the auxiliary crane / auxiliary cranes.
- ▶ For assembly / disassembly tasks, the crane operator may only initiate crane movements when the responsible guide has explicitly released the movement.



WARNING

Danger of impact / crushing!

When installing / removing crane components with the auxiliary crane, crane components can start to swing back and forth.

When lifting / lowering and positioning crane components, there is an increased danger of impacts / crushing.

Death, severe bodily injuries, property damage.

- ▶ Make sure that personnel cannot be caught by components.
- ▶ When working in danger zones: Use aids to protect limbs.
- ▶ Guide components with suitable aids to minimize oscillation.
- ▶ Do not reach with your hands into the danger zone!



DANGER

The components can fall down!

If the corresponding component is disengaged from the auxiliary crane before the corresponding component is pinned, then the corresponding component can fall down.

Death, severe bodily injuries, property damage.

- ▶ Do not disengage the auxiliary crane until the respective component is pinned and secured.



WARNING

The lattice sections can fall down!

If the lattice sections are not pinned and secured correctly, then they can fall down.

Death, severe bodily injuries, property damage.

- ▶ Insert or unpin both pins at the same horizontal level, i.e. **left and right**.
- ▶ Do not stand under the lattice sections or within the entire danger zone during the pinning and unpinning procedure of the boom.
- ▶ Safely secure the pins in the storage locations as well as in the receptacles.

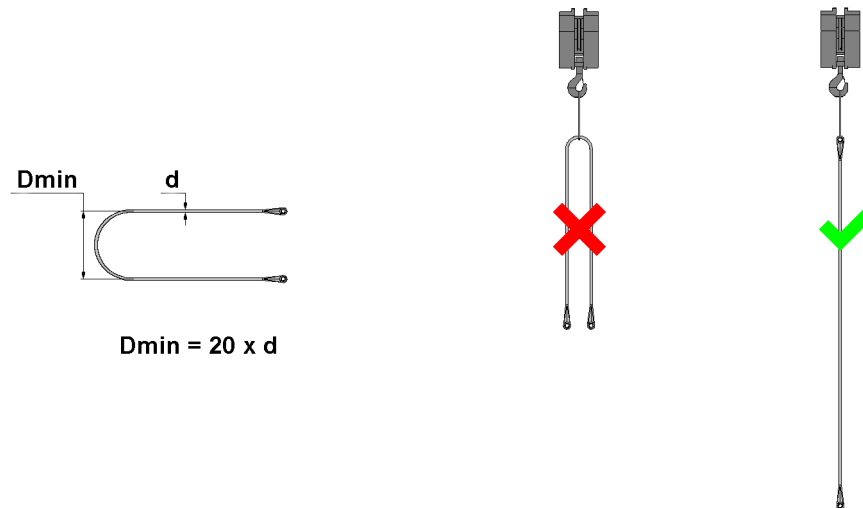

Fig.147766: Fiber guy rope / **Dmin**-minimum diameter, **d**-rope diameter



WARNING

The fiber guy ropes can rip off!

If the fiber guy ropes are installed twisted in longitudinal axis, then the load bearing capacity can be significantly reduced as a result and the fiber guy ropes can rip off.

Death, severe bodily injuries, property damage.

- ▶ Make sure that the fiber guy ropes are **never** kinked, knotted or twisted.
- ▶ Make sure the kinked, knotted or twisted fiber guy ropes are **never** installed.
- ▶ Make sure that the fiber guy ropes are never pulled over the ground or sharp edges.
- ▶ Make sure that no damaged fiber guy ropes are installed.
- ▶ Make sure that the numbering in the rod plan is identical to the numbering on the fiber guy ropes.
- ▶ Make sure that minimum bending diameter of **20** x rope diameter on the fiber guy ropes is **never** fallen below.
- ▶ Check the fiber guy ropes before every assembly.
- ▶ When using fiber guy ropes: Inspect the fiber guy ropes regularly, see chapter 8.16.
- ▶ Make sure that the fiber guy ropes are not twisted at assembly. Pay attention to the twist display - marker line along the longitudinal axis of the rope braid.



WARNING

Damage to the fiber guy ropes during storage and transport!

If the following prerequisites for storage and transport are not observed, then the load bearing capacity can be significantly reduced and the fiber guy ropes can rip off.

Death, severe bodily injuries, property damage.

- ▶ Make sure that minimum bending diameter during storage and transport of **20** x rope diameter on the fiber guy ropes is **never** fallen below.
- ▶ Make sure that the fiber guy ropes are **not** kicked or knotted during storage and transport.
- ▶ Make sure that the fiber guy ropes are **not** twisted during storage and transport. Pay attention to the twist display - marker line along the longitudinal axis of the rope braid.
- ▶ Make sure that the fiber guy ropes do **not** lie over sharp edges during storage and transport.
- ▶ Make sure that the fiber guy ropes are **not** in contact with chemicals or acids during storage and transport.
- ▶ Make sure that the fiber guy ropes are **not** stored or transported together with other components.
- ▶ Store and transport the fiber guy ropes in a closed wooden crate.

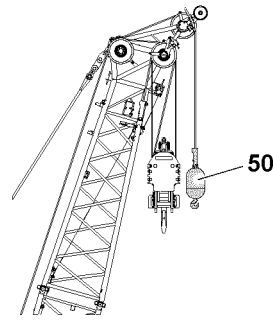

Fig.144411: Using the load hook on the boom nose

NOTICE

Danger of property damage!

If this danger note is not observed, this can lead to a danger of collision and damage to the boom nose.

- ▶ Make sure that the load hook **50** may only be attached to the integrated boom nose, see illustration.
-



WARNING

Failure to observe the danger note!

If the danger note is not observed, dangerous situations can arise. Death, severe bodily injuries, property damage.

- ▶ Make sure that during assembly, no hook block may be suspended on the F-jib.
-



Note

- ▶ The F-jib is **not** adjustable during crane operation.
 - ▶ This crane can be equipped with an F-jib. The F-jib can be assembled at an angle of 10°, 15° or 30° to the SL-boom.
 - ▶ The assembly and disassembly of the F-jibs is described using the example of only one length.
 - ▶ Observe and adhere to the Rod plan.
-

Make sure that the following prerequisites are met:

- The crane is completely supported and horizontally aligned.
- The derrick boom is installed in the required length on the crane, see chapter 5.05.
- The SL-boom combination is installed in the required length on the crane and placed on the ground or on the substructure.
- All WA-frame guy rods have been removed on the SL-boom combination.
- The suspended ballast pallet is near the crane.
- The suspended ballast pallet is aligned with the center of rotation of the crane.
- The suspended ballast is placed on the suspended ballast pallet according to the erection and take-down chart.
- The LICCON overload protection has been set according to the data in the load chart.
- The LICCON overload protection settings match the actual set up configuration of the crane.
- The LICCON overload protection is exceeded.
- The assembly icon is visible on the LICCON monitor.
- All unnecessary function keys and manual control levers are blocked on the radio remote control, see chapter 5.31 and chapter 6.08.
- An auxiliary crane is available.

3.1 Assembling the F-jib — assembly variants



WARNING

Maximum permissible assembly lengths!

If the maximum permissible assembly lengths are not complied with when assembling the F-jib, then dangerous situations can arise.

Death, severe bodily injuries, property damage.

- ▶ Make sure that the maximum permissible assembly lengths are adhered to.
-



WARNING

Non-compliance with the assembly descriptions!

Death, severe bodily injuries, property damage.

- ▶ The F-jib must always be assembled in accordance with the respective description in the respective section.
 - ▶ Make sure that the danger notes in the respective assembly description are observed.
-

3.1.1 Assembly variant V1

Assembling the F-jib in parts

- For assembly variant V1, the F-jib is assembled in individual parts.

3.1.2 Assembly variant V2

Assemble the complete F-jib (maximum length of 12 m) on the ground

- For assembly variant V2, assembly takes place using a hoist rope.

3.1.3 Assembly variant V3

Assemble the complete F-jib (maximum length of 12 m) in flying mode

- For assembly variant V3, flying assembly takes place using the assembly winch rope.

3.1.4 Assembly variant V4

Assemble the complete F-jib (maximum length of 12 m) in flying mode

- For assembly variant V4, flying assembly takes place using a hoist rope.

3.2 Pulley retainer and platforms on the SL-reducer

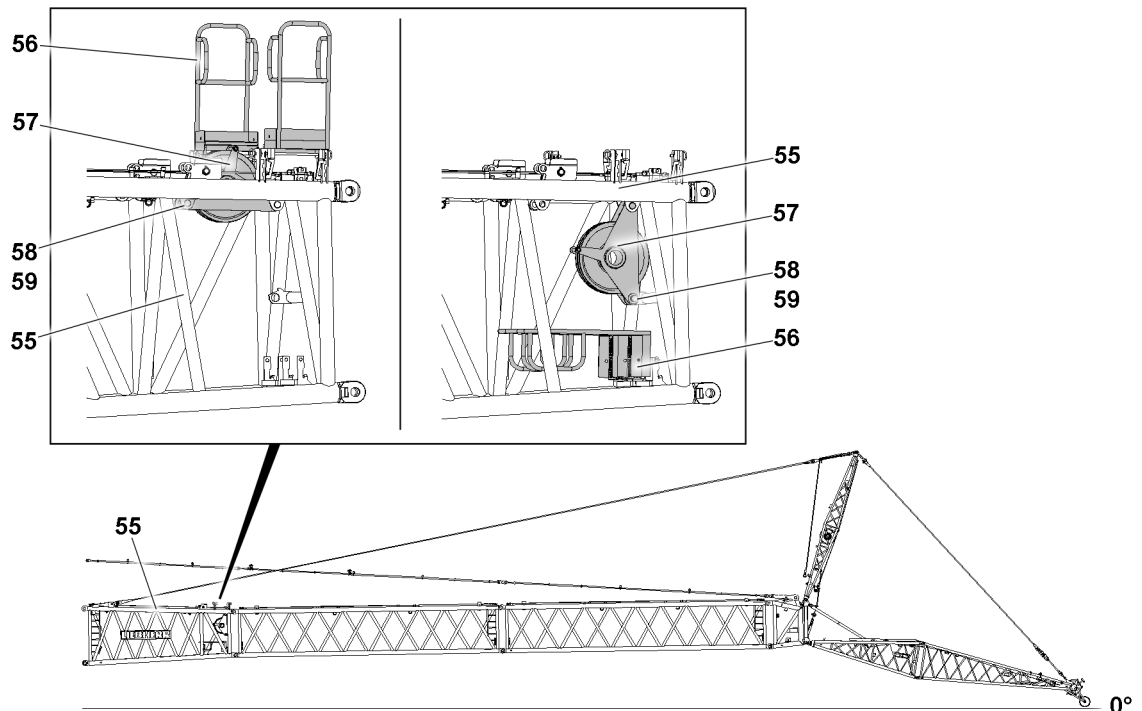

Fig.147767: Pulley retainer and platforms on the SL-reducer



Note

- ▶ Pin the platforms **56** on the SL-reducer **55** in the park position and secure, see chapter 2.06.



WARNING

Falling pulley retainer!

The pulley retainer **20** can fall down due to its own weight when unpinning it.
Death, severe bodily injuries, property damage.

- ▶ Make sure that the pulley retainer **20** is safely held when unpinning.
- ▶ Assembly personnel must be at the side of the assembly unit.

Unpin the pulley retainer **57** from the operating position:

- ▶ Remove the retaining element **59** and unpin the pin **58**.
- ▶ Swing the pulley retainer **57** downward.

Pin the pulley retainer **57** in the parking position:

- ▶ Insert the pin **58** and secure it with the retaining element **59**.

3.3 Assembly variant V1 — Assembling the F-jib in parts

3.3.1 Assembling the F-assembly unit

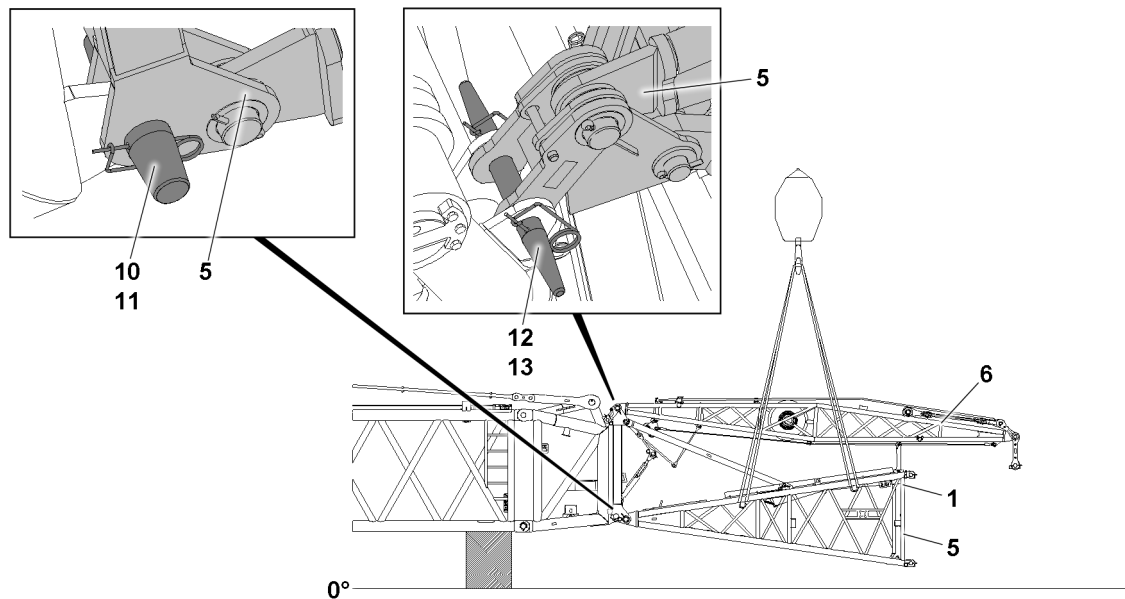

Fig.147729: Pin the F-assembly unit

- ▶ Fasten the F-assembly unit **5** to the auxiliary crane.
- ▶ Remove the rigging belts between the F-pivot section **1** and FA-frame **6**.

The F-assembly unit **5** is pinned four times on the F-connector head. Every pin point is present on both sides of the component on one level.

- ▶ Position the F-assembly unit **5** with the auxiliary crane on the F-connector head so that it can be pinned in the pin locations.
- ▶ Insert the pins **12** on both sides and secure with the retaining element **13**.



WARNING

Crushing / shearing of limbs!

While performing boom system assembly tasks, limbs can be crushed and / or sheared off. Death, severe bodily injuries, property damage.

- ▶ Make sure that no crane movements are performed while pinning in the area of the lower pin points.

- ▶ Insert the pins **10** on both sides and secure with the retaining element **11**.

3.3.2 Releasing the F-relapse support

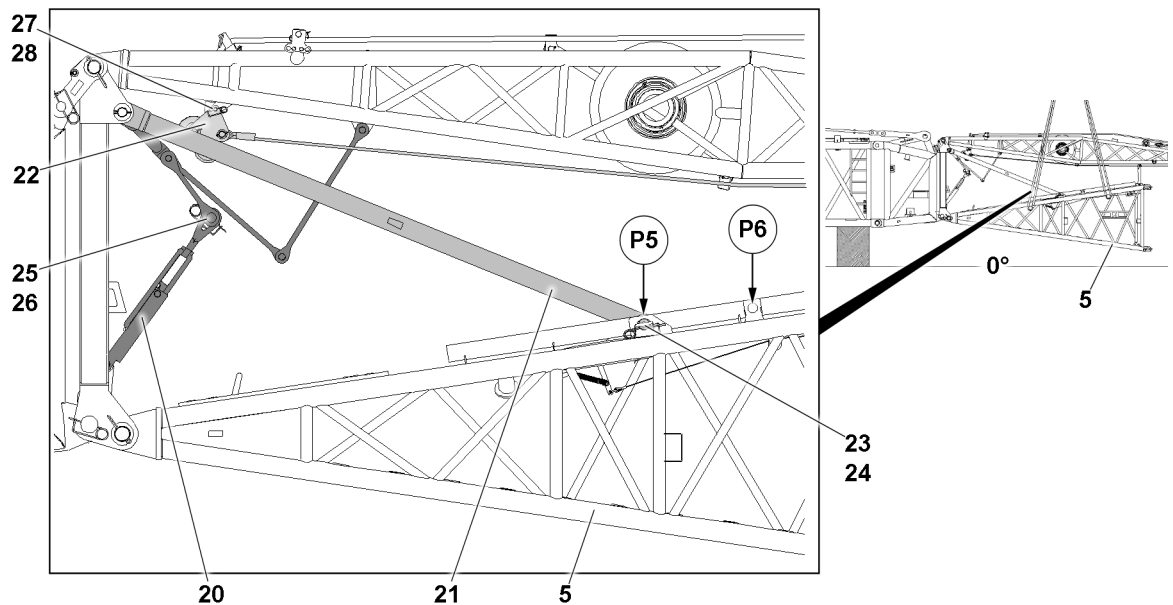

Fig.147730: F-relapse support and FA-frame relapse retainers in the transport position

Release the F-relapse support **21** from the transport position:

- ▶ Remove the retaining element **24** at point **P5** and unpin the pin **23**.
- ▶ Insert pin **23** in the stop position at point **P6** and secure with retaining element **24**.

3.3.3 Separating the FA-frame relapse retainers



WARNING

Falling and swinging FA-frame relapse retainer!

The FA-frame relapse retainer consists of tension lugs and a turnbuckle.

The turnbuckle **20** of the FA-frame relapse retainer can fall down due to its own weight during unpinning.

Death, severe bodily injuries, property damage.

- ▶ Make sure when unpinning the FA-frame relapse retainer, that the turnbuckle **20** is safely held.
- ▶ Assembly personnel must be at the side of the assembly unit.

NOTICE

Danger of property damage!

If the FA-frame relapse retainer is not separated, then it will be damaged during erection of the FA-frame.

- ▶ Make sure that the FA-frame relapse retainer is separated during the erection of the FA-frame.

Separate the FA-frame relapse retainer:

- ▶ Remove the retaining element **26** and unpin the pin **25**.
- ▶ Take the turnbuckle **20** down.
- ▶ Insert the pin **25** again and secure with the retaining element **26**.

When the FA-frame relapse retainer is separated and the F-relapse support is released:

- ▶ Slowly lower the F-assembly unit.
- ▶ Remove the auxiliary crane.

3.3.4 Preparing the rope pulley retainer for the assembly of the F-jib

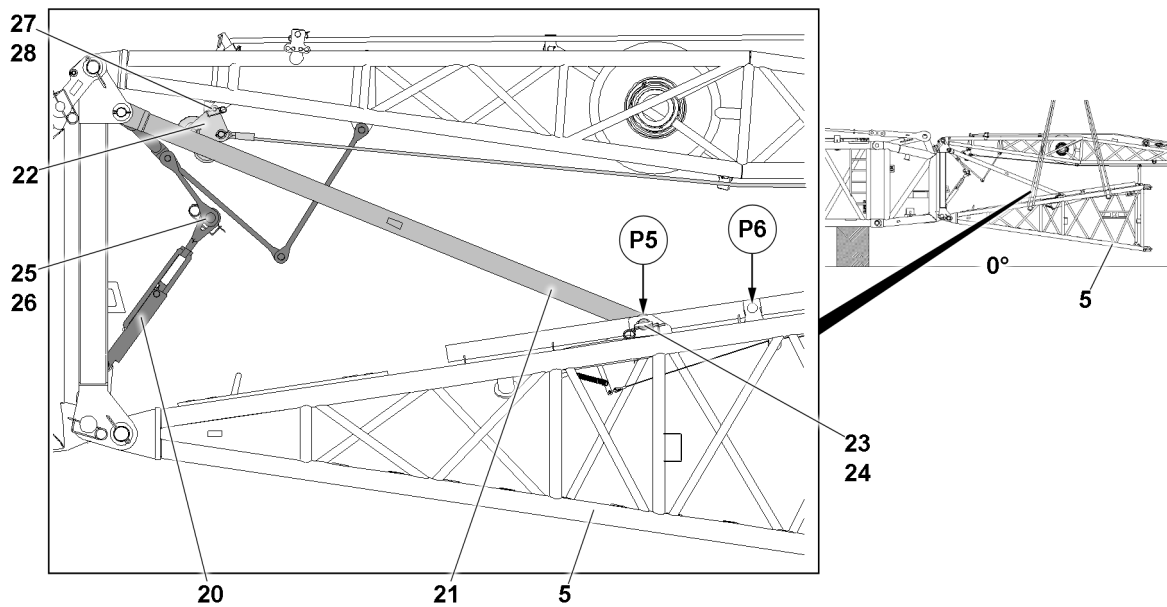

Fig.147730: Rope pulley retainer in the transport position



WARNING

Falling rope pulley retainer!

The rope pulley retainer **22** can fall down due to its own weight when unpinning it. Death, severe bodily injuries, property damage.

- ▶ Make sure that the rope pulley retainer **22** is held during unpinning.
- ▶ Assembly personnel must be at the side of the assembly unit.

Releasing the rope pulley retainer **22** from the FA-frame:

- ▶ Remove the retaining element **28** and unpin the pin **27**.
- ▶ Take the rope pulley retainer **22** down with the rope on the open end of the F-assembly unit.

3.3.5 Assembling the F-guy ropes and the FAB-guy ropes

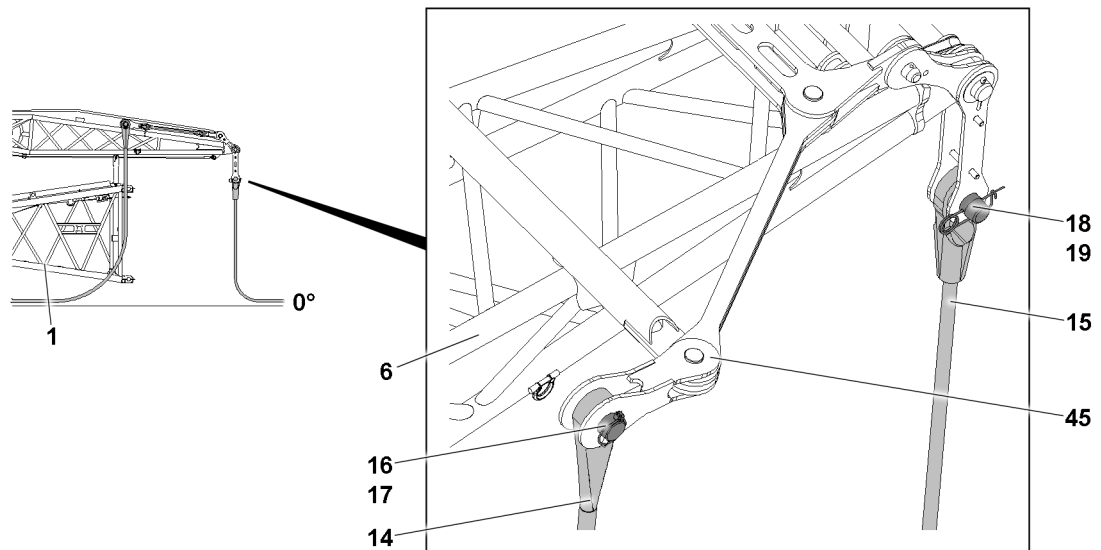

Fig.147731: F-guy ropes and FAB-guy ropes

- ▶ Swing the F-guy rope **15** in to the brackets on the FA-frame **6**.
- ▶ Pin the F-guy rope **15** on the brackets: Insert the pin **18** and secure it with the retaining element **19**.

When the first F-guy rope is properly installed and secured:

- ▶ Pin the second F-guy rope.
- ▶ Take down the free ends of the F-guy ropes to the side from the boom.
- ▶ Swing the FAB-guy rope **14** in to the swing **45** on the FA-frame **6**.
- ▶ Pin the FAB-guy rope **14** on the swing **45**: Insert the pin **16** and secure it with the retaining element **17**.

When the first FAB-guy rope is properly installed and secured:

- ▶ Pin the second FAB-guy rope.
- ▶ Take down the free ends of the FAB-guy ropes to the side from the boom.

3.3.6 Erecting the FA-frame

Make sure that the following prerequisites are met:

- The FA-frame relapse retainers are separated.
- F-relapse support is released.
- The guy ropes are installed.
- The rope pulley retainer is released from the FA-frame.

Setting the flap „downward“

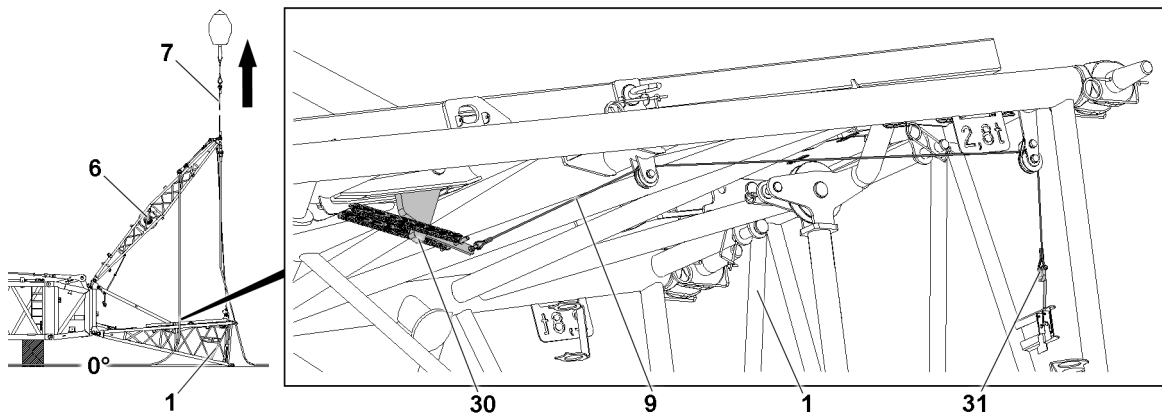

Fig.147732: Flap



WARNING

Automatic swinging of the FA-frame!

If the fastening rope 7 on the FA-frame 6 is not held under tension during assembly, the FA-frame 6 can swing suddenly to the side.

Death, severe bodily injury, property damage.

- ▶ Make sure that there are no persons within the danger zone.
 - ▶ Make sure that the fastening rope 7 never sags during assembly / disassembly operations.
-
- ▶ Release the fastening rope 7 from the transport retainer on the FA-frame 6.
 - ▶ Fasten the FA-frame 6 with the fastening rope 7 to the auxiliary crane.
 - ▶ Lift FA-frame 6 with auxiliary crane.
 - ▶ Pull the flap 30 on the F-pivot section 1 with the control rope 9 „downwards“ and fix it with the hook closure 31.

Connecting the assembly winch rope with the rope pulley retainer

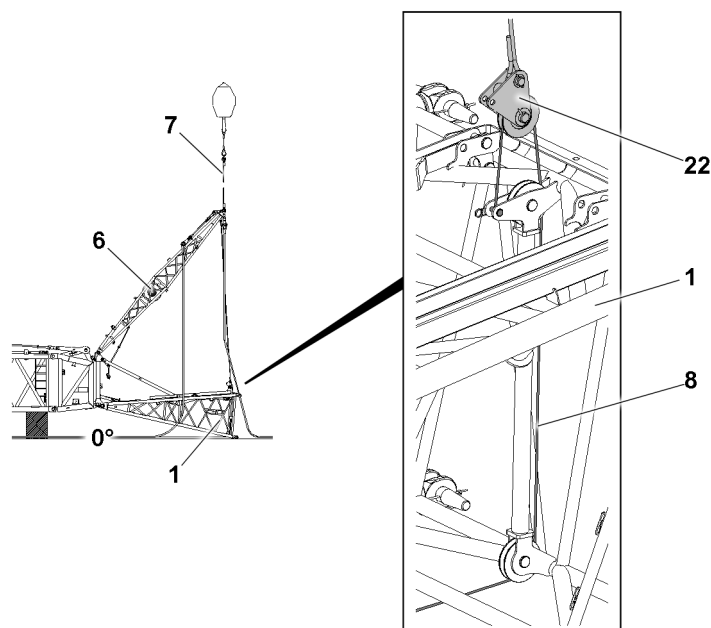

Fig.147733: Assembly winch rope with the rope pulley retainer

- ▶ Reeve in the assembly winch rope 8 on the rope pulley retainer 22 and secure on the F-pivot section 1.

Taking the support frames down

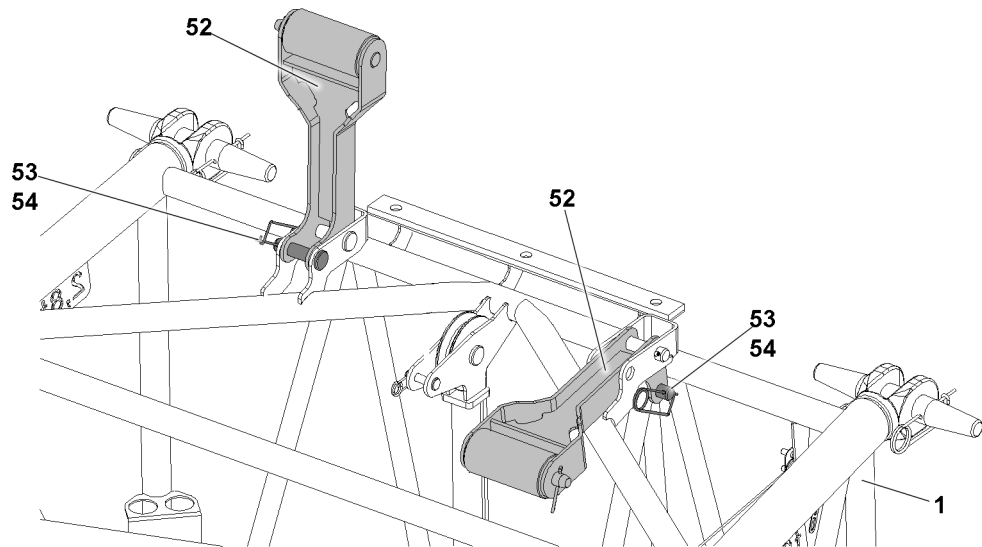

Fig.147736: Support frames



WARNING

Falling support frames!

The support frame **52** can fall down due to its own weight when unpinning it. Death, severe bodily injuries, property damage.

- ▶ Make sure that the support frame **52** is held during unpinning.
- ▶ Assembly personnel must be at the side of the assembly unit.

Swing the support frame **52** into the operating position:

- ▶ Remove the retaining element **54** and unpin the pin **53**.
- ▶ Take the support frame **52** down.
- ▶ Insert the pin **53** again and secure with the retaining element **54**.
- ▶ Take the second support frame **52** down.

Pinning the FAB-guy ropes with the lugs of the L-intermediate section

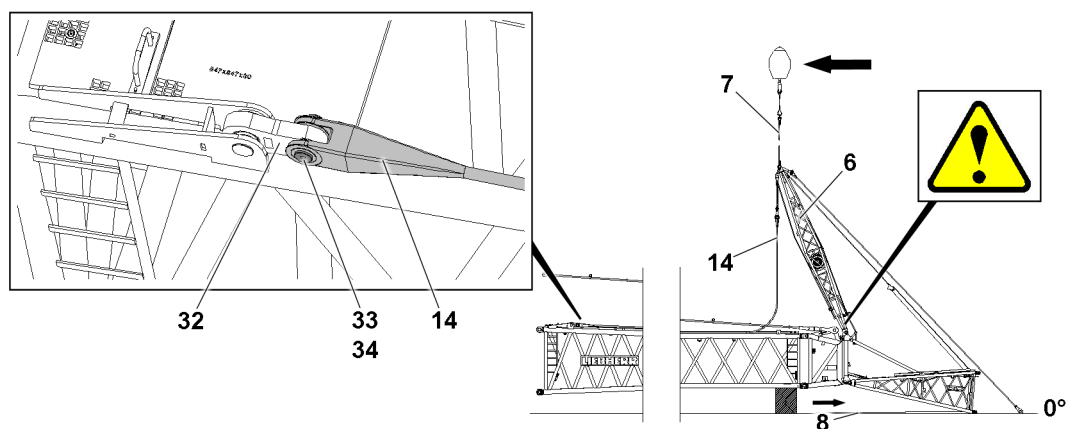

Fig.147734: FAB-guy ropes

NOTICE

Danger of property damage!

When swinging the FA-frame **6** in the direction of the main boom, damage may occur to the FA-frame **6**, the F-connector head, as well as the rope pulley retainer due to collision.

- ▶ Make sure that a guide supervises the swinging process of the FA-frame.
- ▶ Make sure that the guide is constantly in visual and acoustic contact with the crane operator.
- ▶ Make sure that the assembly winch rope **8** is spooled out during the swinging process of the FA-frame **6**.

- ▶ Carefully swing the FA-frame **6** with the auxiliary crane in direction of the main boom and spool the assembly winch rope **8** out at the same time until it can be pinned at the pin location.
- ▶ Swing the FAB-guy rope **14** in to the FAB-lugs **32** of the L-intermediate section.

Pin the FAB-guy rope **14** with the FAB-lugs **32** of the L-intermediate section:

- ▶ Insert the pin **33** and secure it with the retaining element **34**.
- ▶ Pin the second FAB-guy rope.

3.3.7 Setting the FA-frame in the operating position

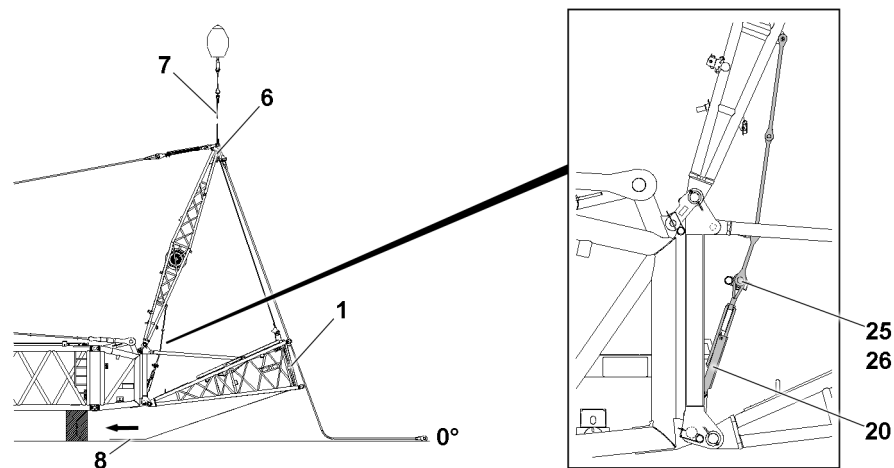

Fig.147735: Bringing the FA-frame into operating position

Make sure that the following prerequisite is met:

- The FAB-guy ropes are properly pinned and secured.
- ▶ Pull the FA-frame **6** with the assembly winch rope **8** in direction of the F-pivot section **1**.

Connect the FA-frame relapse retainer:

- ▶ Swing the turnbuckle **20** to the FA-frame relapse retainer.
- ▶ Insert the pin **25** and secure it with the retaining element **26**.

When the FA-frame relapse retainer is properly pinned and secured:

- ▶ Tighten the turnbuckle **20** and secure it to prevent twisting.

Result:

- The turnbuckle is secured to prevent it from twisting in crane operation.
- Affix the FA-frame **6** in the operating position.

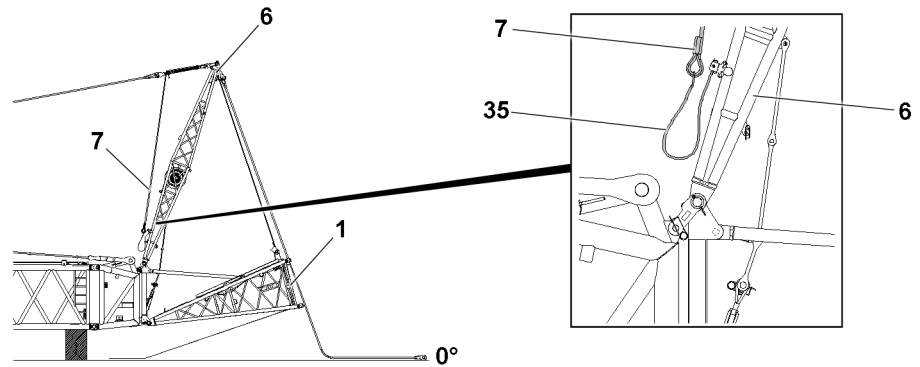

Fig.147737: Securing the fastening rope on the FA-frame for crane operation

NOTICE

Swinging fastening rope!

If the fastening rope **7** is not properly secured, then the fastening rope **7** can start to swing back and forth in crane operation and damage components.

- ▶ Make sure that the fastening rope **7** is secured on the FA-frame before starting to work with the crane.
-
- ▶ Place the fastening rope **7** over the linkage.
 - ▶ Connect the fastening rope **7** with the roundslings **35** with the shackle.
 - ▶ Fasten the roundslings **35** with the carabiner on the lug of the FA-frame **6**.

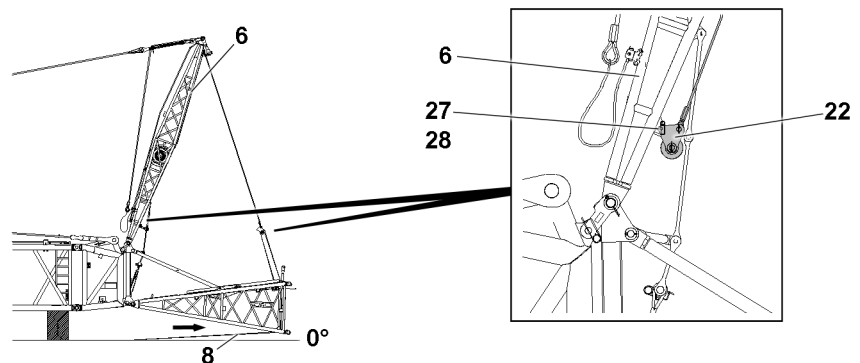

Fig.147738: Lowering the F-pivot section

Lower the F-pivot section **1**:

- ▶ Spool out the assembly winch rope **8**.
- ▶ Release and reeve out the assembly winch rope **8**.

Swing and pin the rope pulley retainer **22** on the FA-frame **6**:

- ▶ Insert the pin **27** and secure it with the retaining element **28**.

3.3.8 Assembling the lattice sections

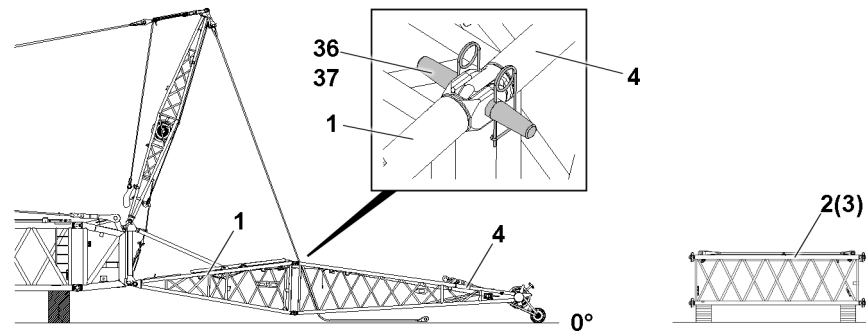

Fig.147739: Pinning the lattice sections

- ▶ Fasten the F-end section 4 and the F-intermediate sections 2 or the F-intermediate section 3 to the auxiliary crane and install and pin on the F-pivot section 1.

The F-end section 4 is pinned four times on F-pivot section 1. Every pin point is present on both sides of the component on one level.

- ▶ Insert the pin 36 at the pin points on both sides and secure with the retaining element 37.

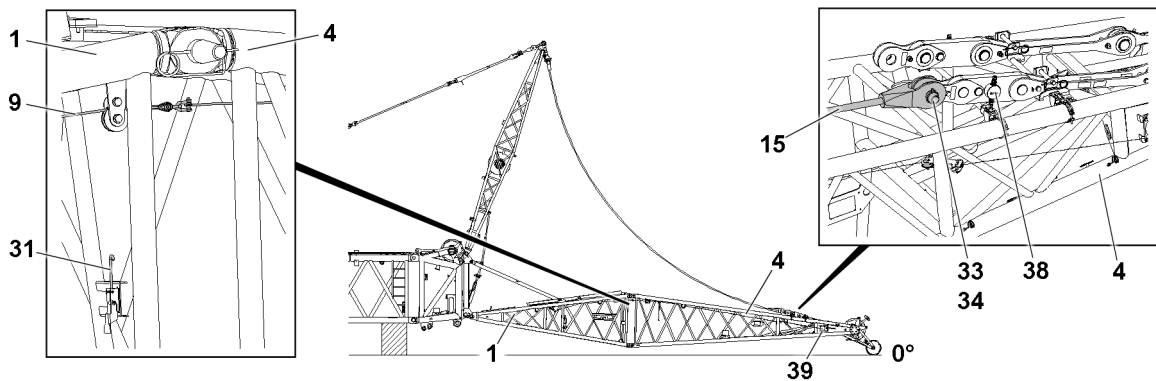

Fig.147740: Pinning the F-guy ropes



Note

- ▶ If the F-intermediate sections are installed, then the additional guy ropes for the F-intermediate sections must be assembled, pinned and secured.
- ▶ For the combination of the guy rope refer to the rod plan.

Pin the F-guy rope 15 with the lugs 38 of the F-end section 4:

- ▶ Insert the pin 33 and secure it with the retaining element 34.
- ▶ Pin the second F-guy rope.

Connect the rope strand from the flap on the F-pivot section with the manual rope winch 39 on the F-end section:

- ▶ Release the control rope 9 on the hook closure 31.
- ▶ Connect the control rope 9 between the flap and the manual rope winch 39 with the shackle.

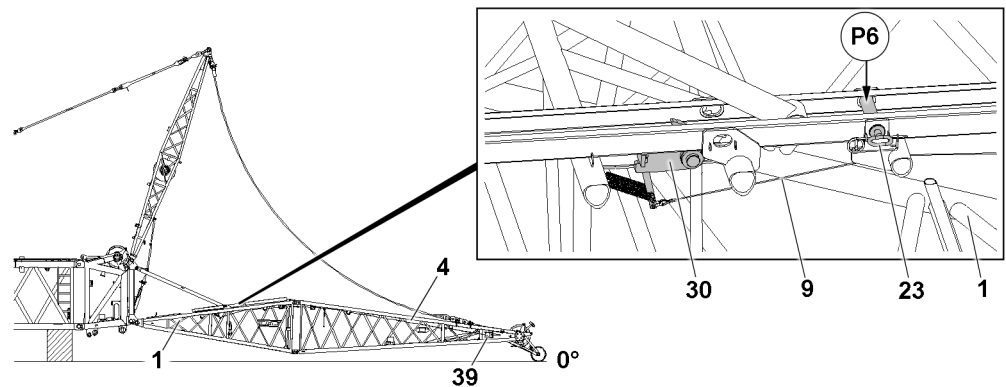

Fig.147742: Setting the flap „downward“

**Note**

- ▶ The pin **23** remains pinned in the „operating position“ during crane operation in point **P6**.
- ▶ Pull the flap **30** with the aid of the manual rope winch **39** „downwards“.

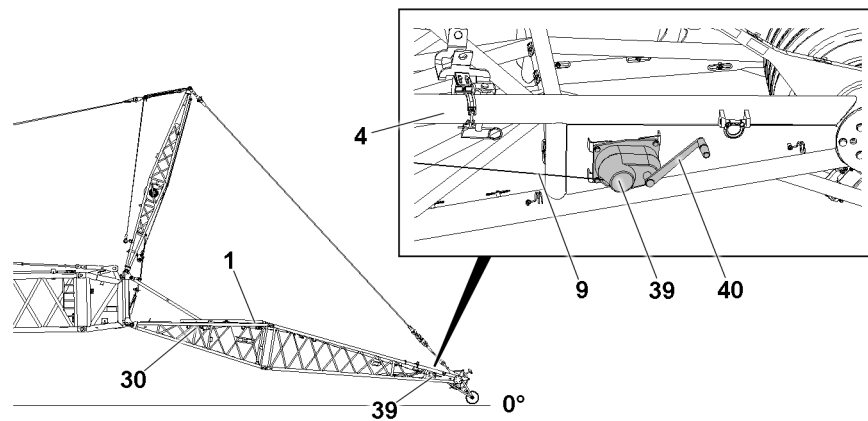

Fig.147741: Manual rope winch

**WARNING**

Danger of fatal injury due to F-auxiliary jib!

If the flap **30** is not in „up“ position, then the F-auxiliary jib can fall backward uncontrolled when erecting the boom system and in crane operation.

Death, severe bodily injuries, property damage.

- ▶ Make sure that the flap **30** is in the „up“ position immediately before lifting the F-end section or when erecting the boom.
- ▶ Make sure that the crank of the manual rope winch has been removed.
- ▶ Lift the main boom.

Immediately after the F-jib lifts off the ground, move the flap **30** „upwards“:

- ▶ Actuate the manual rope winch **39** and spool out the control rope **9**.
- ▶ Remove the crank **40** from the manual rope winch **39**.

3.4 Assembly variant V2 — Assembling the complete F-jib (maximum length of 12 m) on the ground



WARNING

Impermissible F-assembly length(s)!
Death, severe bodily injuries, property damage.

- ▶ Make sure that the assembly of the F-jib as a complete F-assembly unit with the F-end section does not exceed 12 m.
- ▶ During assembly, no hook block may be reeved on the F-jib.
- ▶ The F-jib must always be assembled in accordance with the respective description in the respective section.
- ▶ Observe and adhere to the Rod plan.

3.4.1 Assembling the F-assembly unit with F-end section

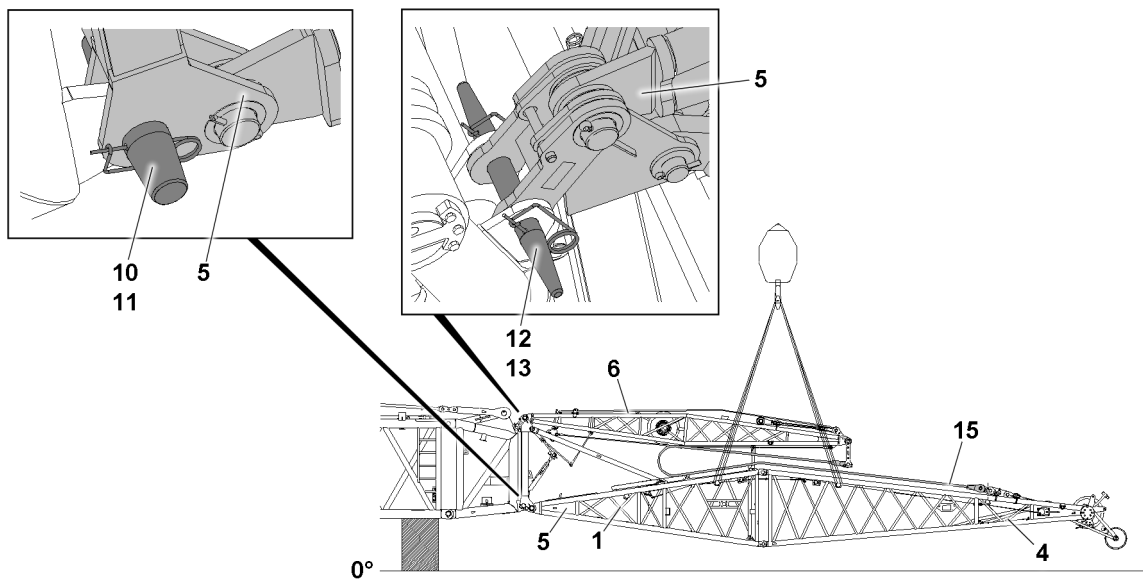

Fig.147743: Pinning the F-jib

Make sure that the following prerequisite is met:

- The F-guy ropes **15** between the F-end section **4** and the F-frame **6** are properly pinned and secured. (If necessary, release the F-guy ropes **15** from the transport retainers on the F-pivot section **1** and pin with the lugs on the F-end section **4** and with lugs on the FA-frame **6**, see section Assembly variant V1.

- ▶ Fasten the F-assembly unit **5** with the F-end section **4** to the auxiliary crane.
- ▶ Remove the rigging belts between the F-pivot section **1** and FA-frame **6**.

The F-assembly unit **5** is pinned four times on the F-connector head. Every pin point is present on both sides of the component on one level.

- ▶ Position the F-assembly unit **5** with F-end section **4** with the auxiliary crane on the F-connector head so that it can be pinned in the pin locations.
- ▶ Insert the pins **12** on both sides and secure with the retaining element **13**.



WARNING

Crushing / shearing of limbs!

While performing boom system assembly tasks, limbs can be crushed and / or sheared off.
Death, severe bodily injuries, property damage.

- ▶ Make sure that no crane movements are performed while pinning in the area of the lower pin points.

- ▶ Insert the pins **10** on both sides and secure with the retaining element **11**.

3.4.2 Releasing the F-relapse support

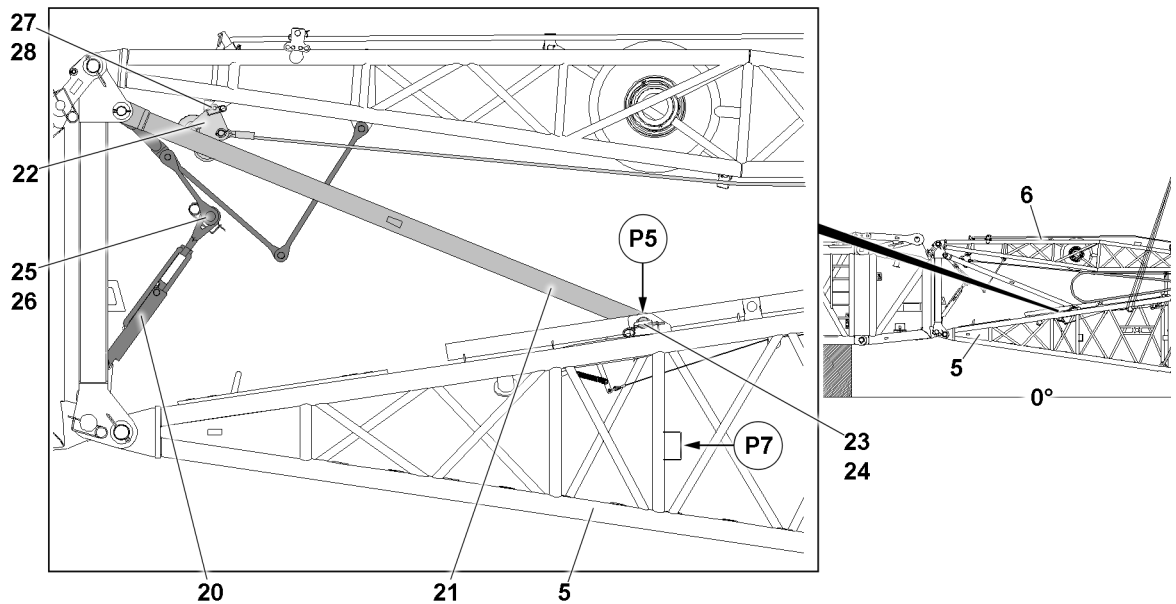

Fig.147745: F-relapse support and FA-frame relapse retainer

Release the F-relapse support **21** from the transport position:

- ▶ Remove the retaining element **24** at point **P5** and unpin the pin **23**.
- ▶ Insert pin **23** in the park position at point **P7** and secure with retaining element **24**.

3.4.3 Separating the FA-frame relapse retainers



WARNING

Falling and swinging FA-frame relapse retainer!

The FA-frame relapse retainer consists of tension lugs and a turnbuckle.

The turnbuckle **20** of the FA-frame relapse retainer can fall down due to its own weight during unpinning.

Death, severe bodily injuries, property damage.

- ▶ Make sure when unpinning the FA-frame relapse retainer, that the turnbuckle **20** is safely held.
- ▶ Assembly personnel must be at the side of the assembly unit.

NOTICE

Danger of property damage!

If the FA-frame relapse retainer is not separated, then it will be damaged when pulling up the F-jib.

- ▶ Make sure that the FA-frame relapse retainer is separated during the erection of the FA-frame.

Separate the FA-frame relapse retainer:

- ▶ Remove the retaining element **26** and unpin the pin **25**.
- ▶ Take the turnbuckle **20** down.
- ▶ Insert the pin **25** again and secure with the retaining element **26**.

When the FA-frame relapse retainer is separated:

- ▶ Lower the F-jib slowly on the ground.
- ▶ Remove the auxiliary crane.

3.4.4 Assembling the FAB-guy ropes

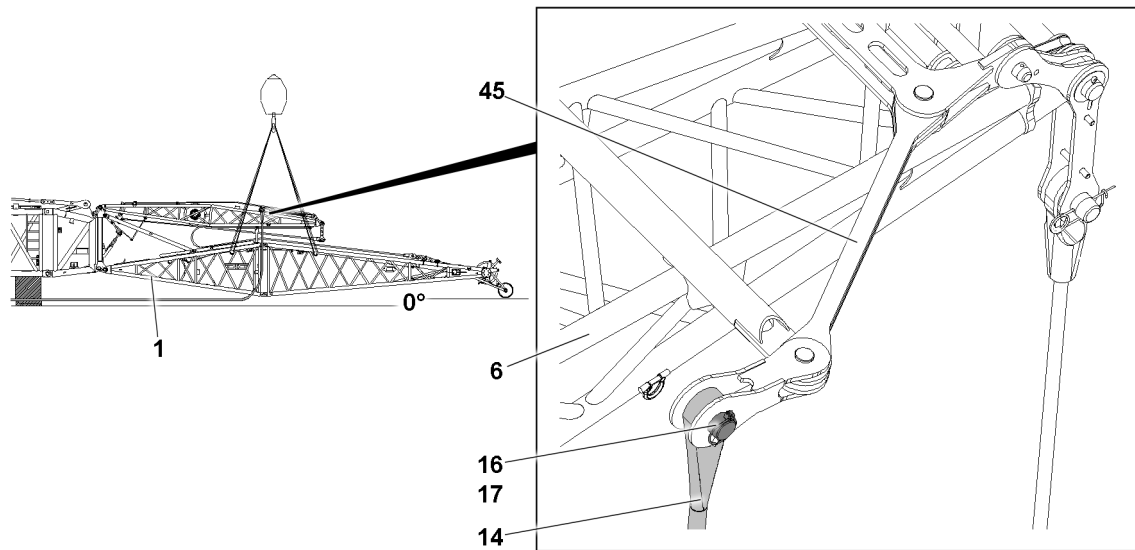

Fig.147744: FAB-guy ropes

- ▶ Swing the FAB-guy rope **14** in to the swing **45** on the FA-frame **6**.
- ▶ Pin the FAB-guy rope **14** on the swing **45**: Insert the pin **16** and secure it with the retaining element **17**.

When the first FAB-guy rope is properly installed and secured:

- ▶ Pin the second FAB-guy rope.
- ▶ Take down the free ends of the FAB-guy ropes **14** to the side from the boom.

3.4.5 Setting the flap „downward“

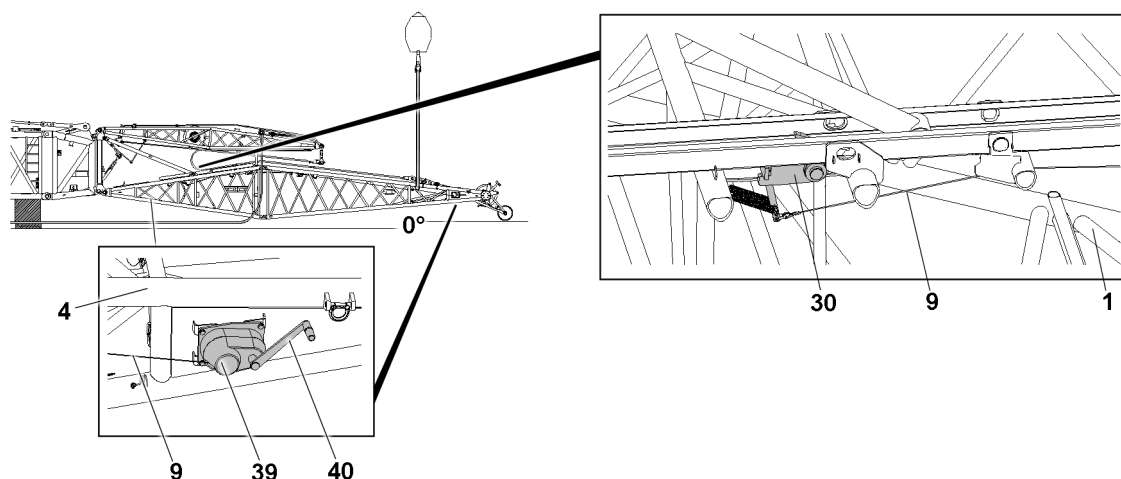

Fig.147746: Flap and manual rope winch

Make sure that the following prerequisite is met:

- The control rope **9** of the F-end section **4** and the F-pivot section **1** are connected.

- ▶ Insert the crank **40**.

Set the flap „downward“:

- ▶ Actuate the manual rope winch **39** and spool up the control rope **9**.
- ▶ Remove the crank **40** from the manual rope winch **39**.

- ▶ Fasten the auxiliary crane properly to the F-end section 4.

3.4.6 Erecting the FA-frame

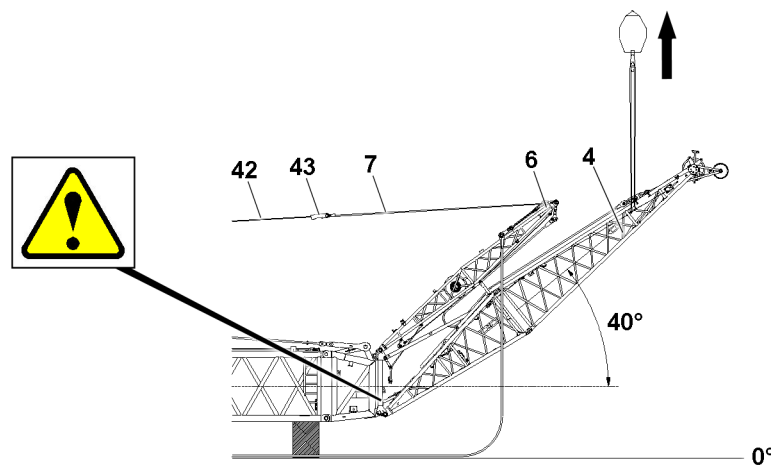

Fig.147747: Erecting the FA-frame

Make sure that the following prerequisites are met:

- The F-guy ropes are properly installed and secured between the FA-frame and the F-end section.
- The FA-frame relapse retainer is separated.
- The F-relapse support is unpinned.

NOTICE

Danger of property damage!

If the FA-frame relapse retainer is not separated, then it will be damaged during erection of the FA-frame.

- ▶ Make sure that the FA-frame relapse retainer is separated during the erection of the FA-frame.

NOTICE

Danger of collision on the F-pivot point!

When lifting the F-jib in direction of the main boom there is a danger of collision of the FA-pivot section with the attachment parts of the F-pivot point.

- ▶ When lifting the FA-jib, a guide must be used.
- ▶ The guide must be in constant visual and acoustic contact with the crane operator.
- ▶ Lift the F-jib with the auxiliary crane on the F-end section 4 until the angle between the FA-frame 6 and the main boom is at least 40°.
- ▶ Connect the fastening rope 7 of the FA-frame 6 by using the lock 43 with the hoist rope 42.
- ▶ Spool up the hoist rope 42 until the FA-frame 6 is held approx. in the 40° position by the hoist rope.

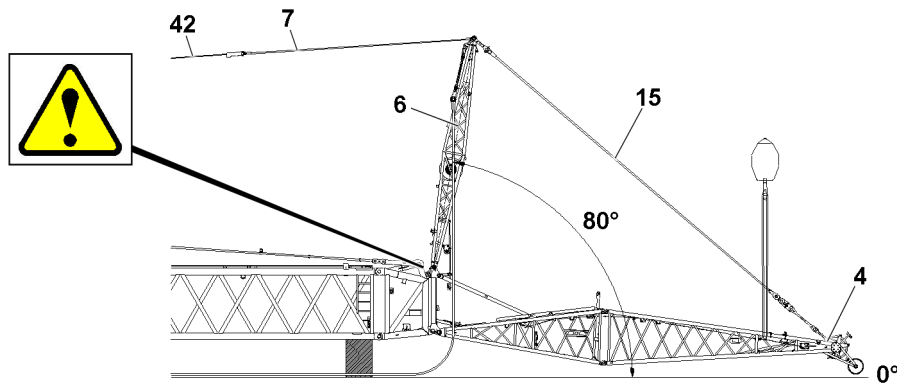

Fig.147748: Lowering the F-jib with the auxiliary crane

- ▶ Lower the F-jib with the auxiliary crane to the horizontal.

NOTICE

Danger of collision on the F-pivot point!

When swinging the FA-frame in direction of the main boom there is a danger of collision of the FA-frame with the attachment parts of the L-end section or the F-connector head.

- ▶ When swinging the FA-frame, a guide must be used.
- ▶ The guide must be in constant visual and acoustic contact with the crane operator.

NOTICE

Hoist rope contact with cross binders of the main boom auxiliary guying!

- ▶ Make sure that the hoist rope does not scrape the cross binder of the main boom auxiliary guying when erecting the FA-frame.

If the hoist rope scrapes:

- ▶ Take the main boom down on the ground or on a load bearing substructure.
 - ▶ Release the main boom guying and unhook the cross binder of the auxiliary guying.
-
- ▶ Pull the FA-frame **6** with the hoist rope **42** further in the direction of the main boom until there is a maximum 80° angle to the horizontal.
 - ▶ Lower the F-jib with the auxiliary crane until the F-guy ropes **15** are tensioned or the F-jib lies on the ground.
 - ▶ Unhook and remove the fastening equipment (fastening rope) of the auxiliary crane.

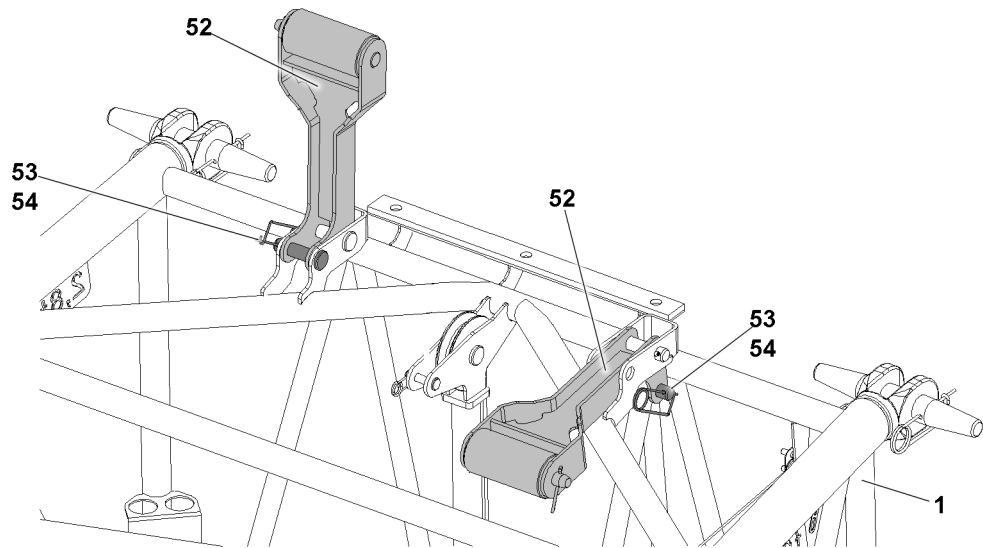

Fig.147736: Support frames

**WARNING**

Falling support frames!

The support frame **52** can fall down due to its own weight when unpinning it. Death, severe bodily injuries, property damage.

- ▶ Make sure that the support frame **52** is held during unpinning.
- ▶ Assembly personnel must be at the side of the assembly unit.

Swing the support frame **52** into the operating position:

- ▶ Remove the retaining element **54** and unpin the pin **53**.
- ▶ Take the support frame **52** down.
- ▶ Insert the pin **53** again and secure with the retaining element **54**.
- ▶ Take the second support frame **52** down.

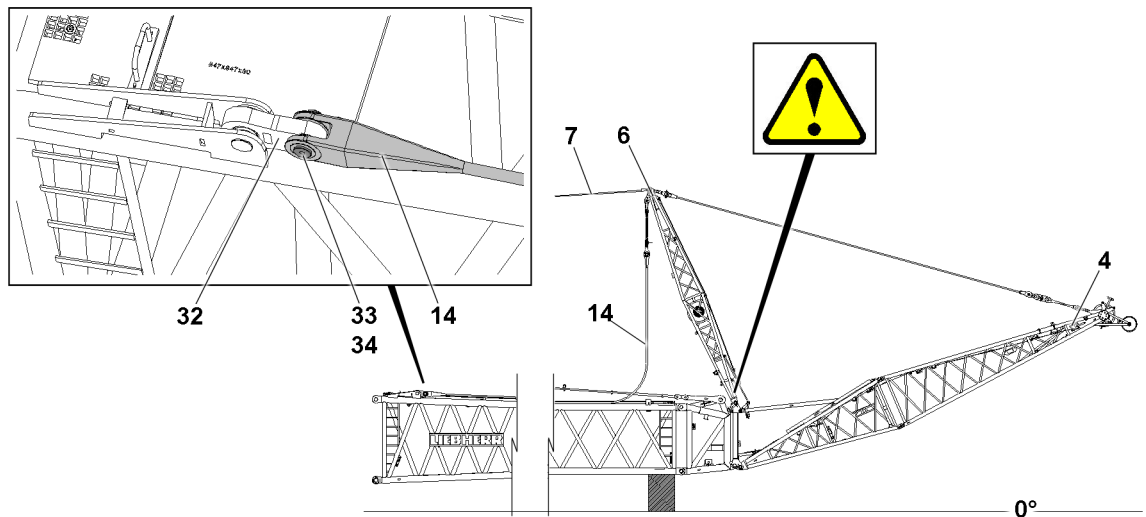

Fig.147749: Pinning the FAB-guy ropes

NOTICE

Danger of collision on the F-pivot point!

When swinging the FA-frame in direction of the main boom there is a danger of collision of the FA-pivot section with the attachment parts of the F-pivot point.

- ▶ When swinging the FA-frame, a guide must be used.
- ▶ The guide must be in constant visual and acoustic contact with the crane operator.

NOTICE

Danger of collision!

When swinging the FA-frame in direction of the main boom there is a danger of collision of the FA-frame with the attachment parts of the L-end section or the F-connector head.

- ▶ When swinging the FA-frame, a guide must be used.
- ▶ The guide must be in constant visual and acoustic contact with the crane operator.

- ▶ Continue to swing the FA-frame **6** further with the hoist rope **42** in direction of the main boom until it can be pinned at the pin location.
- ▶ Swing the FAB-guy rope **14** in to the FAB-lugs **32** of the L-intermediate section.

Pin the FAB-guy rope **14** with the FAB-lugs **32** of the L-intermediate section:

- ▶ Insert the pin **33** and secure it with the retaining element **34**.
- ▶ Pin the second FAB-guy rope.

3.4.7 Setting the FA-frame in the operating position

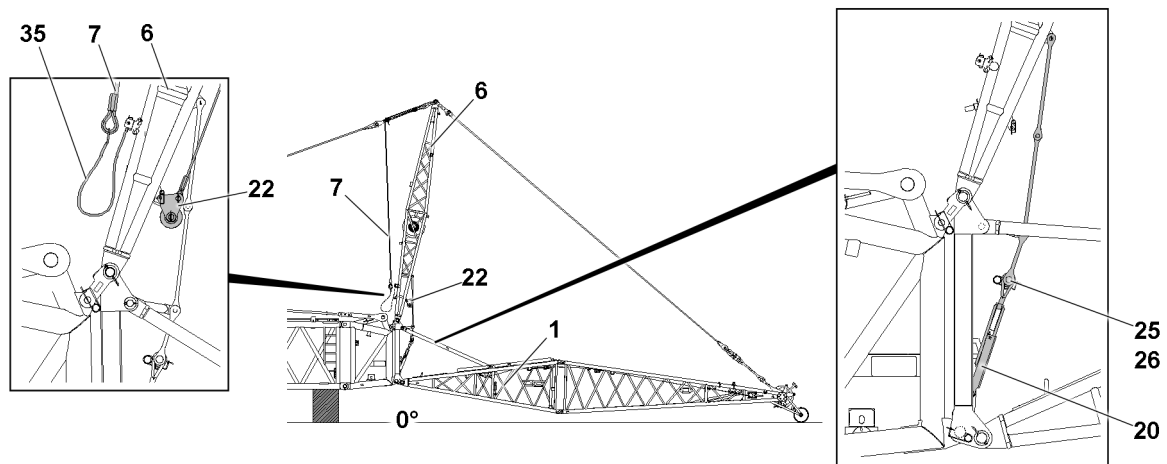

Fig.147750: Bringing the FA-frame into operating position // Assembling the FA-frame relapse retainer

Make sure that the following prerequisite is met:

- The FAB-guy ropes are properly pinned and secured.

NOTICE

Danger of slack rope formation!

- ▶ When spooling the hoist rope out, make sure that no slack rope forms.

- ▶ Lower the FA-frame **6** to the operating position (to the front): Spool out the hoist rope until the FA-frame **6** is in the operating position.

The FA-frame **6** can be pulled into the operating position as follows:

- ▶ By using the assembly winch rope over the rope pulley retainer **22**, see section „Assembly variant V1 — Assembling the F-jib in parts“.
- or
- ▶ By lifting the main boom. Use an aerial platform to tension the FA-frame relapse retainer.
- ▶ Pull the FA-frame **6** into the operating position.

Pin the FA-frame relapse retainer:

- ▶ Swing the turnbuckle **20** to the FA-frame relapse retainer.
- ▶ Insert the pin **25** and secure it with the retaining element **26**.

When the FA-frame relapse retainer is properly pinned and secured:

- ▶ Tighten the turnbuckle and secure it to prevent twisting.

Result:

- The turnbuckle is secured to prevent it from twisting in crane operation.
- Affix the FA-frame **6** in the operating position.

When the FA-frame relapse retainer is pinned and secured:

- ▶ Continue to spool out the hoist rope until the fastening rope **7** is completely relieved.
- ▶ Separate the hoist rope and the fastening rope **7**.

NOTICE

Swinging fastening rope!

If the fastening rope **7** is not properly secured, then the fastening rope can start to swing back and forth in crane operation and damage components.

- ▶ Make sure that the fastening rope **7** is properly secured on the FA-frame before starting to work with the crane.
-
- ▶ Place the fastening rope **7** over the linkage.
 - ▶ Connect the fastening rope **7** with the roundsling **35** with the shackle.
 - ▶ Fasten the roundsling **35** with the carabiner on the lug of the FA-frame **6**.

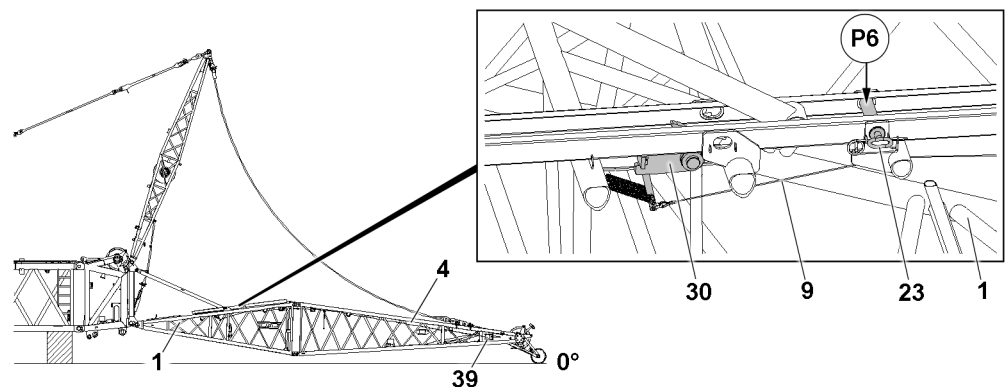

Fig.147742: Flap

- ▶ Insert the pin **23** for crane operation in the stop position at point **P6** and secure with the retaining element **24**.
- ▶ Properly hang the cross binder of the main boom auxiliary guying and secure.

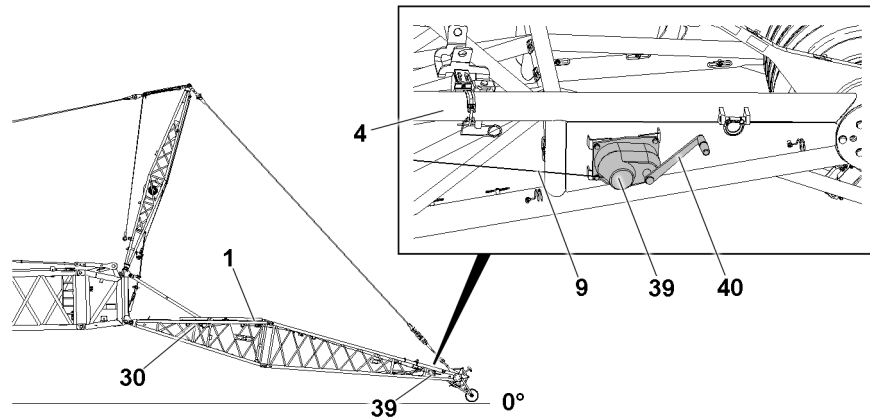

Fig.147741

**WARNING**

Danger of fatal injury due to F-auxiliary jib!

If the flap is not in „up“ position, then the F-auxiliary jib can fall backward uncontrolled when erecting the boom system and in crane operation.

Death, severe bodily injuries, property damage.

- ▶ Make sure that the flap is in the „up“ position immediately before lifting the F-end section or when erecting the boom.
- ▶ Make sure that the crank of the manual rope winch has been removed.

- ▶ Lift the main boom.

Immediately after the F-jib lifts off the ground, move the flap 30 „upwards“:

- ▶ Actuate the manual rope winch 39 and spool out the control rope 9.
- ▶ Remove the crank 40 from the manual rope winch 39.

3.5 Assembly variant V3 — Assembling the complete F-jib (maximum length of 12 m) in flying mode

**WARNING**

Impermissible F-assembly length(s)!

Death, severe bodily injuries, property damage.

- ▶ Make sure that the flying assembly length of the F-jib as a complete F-assembly unit with the F-end section does not exceed 12 m.
- ▶ During assembly, no hook block may be reeved on the F-jib.
- ▶ The F-jib must always be assembled in accordance with the respective description in the respective section.
- ▶ Observe and adhere to the Rod plan.

3.5.1 Assembling the F-assembly unit with F-end section

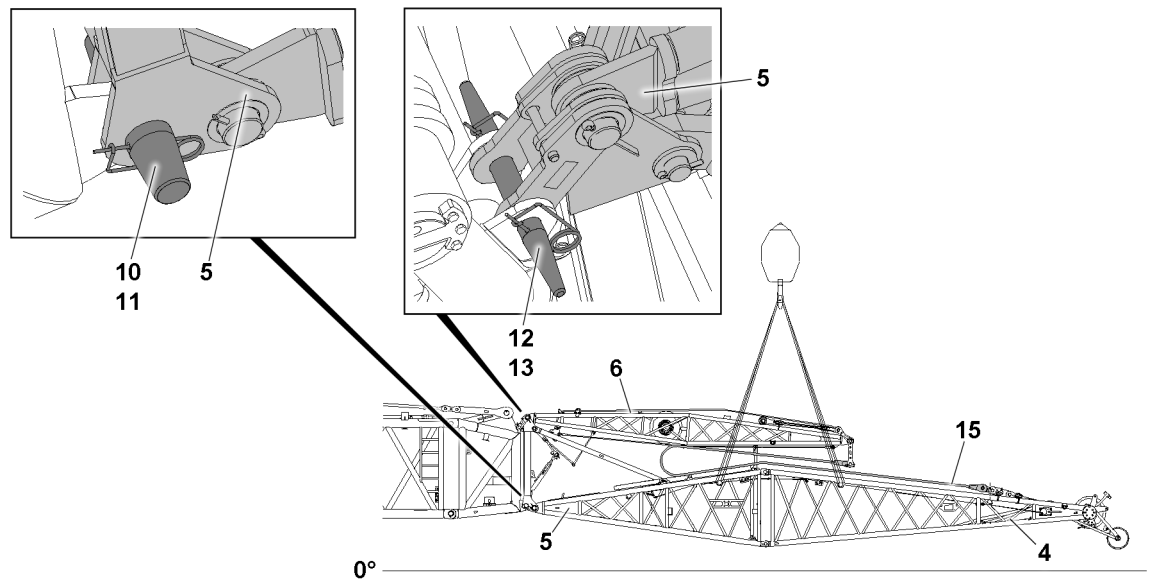

Fig.147751: Pinning the F-jib

Make sure that the following prerequisite is met:

- The F-guy ropes **15** between the F-end section **4** and the F-frame **6** are properly pinned and secured. (If necessary, release the F-guy ropes **15** from the transport retainers on the F-pivot section **1** and pin with the lugs on the F-end section **3** and with lugs on the FA-frame **6**, see section Assembly variant V1.

- ▶ Fasten the F-assembly unit **5** with the F-end section **4** to the auxiliary crane.
- ▶ Remove the rigging belts between the F-pivot section **1** and FA-frame **6**.

The F-assembly unit **5** is pinned four times on L-end section or on the F-connector head. Every pin point is present on both sides of the component on one level.

- ▶ Position the F-assembly unit **5** with F-end section **4** with the auxiliary crane on the F-connector head so that it can be pinned in the pin locations.
- ▶ Insert the pins **12** on both sides and secure with the retaining element **13**.



WARNING

Crushing / shearing of limbs!

While performing boom system assembly tasks, limbs can be crushed and / or sheared off. Death, severe bodily injuries, property damage.

- ▶ Make sure that no crane movements are performed while pinning in the area of the lower pin points.
-
- ▶ Insert the pins **10** on both sides and secure with the retaining element **11**.

3.5.2 Setting the flap „downward“

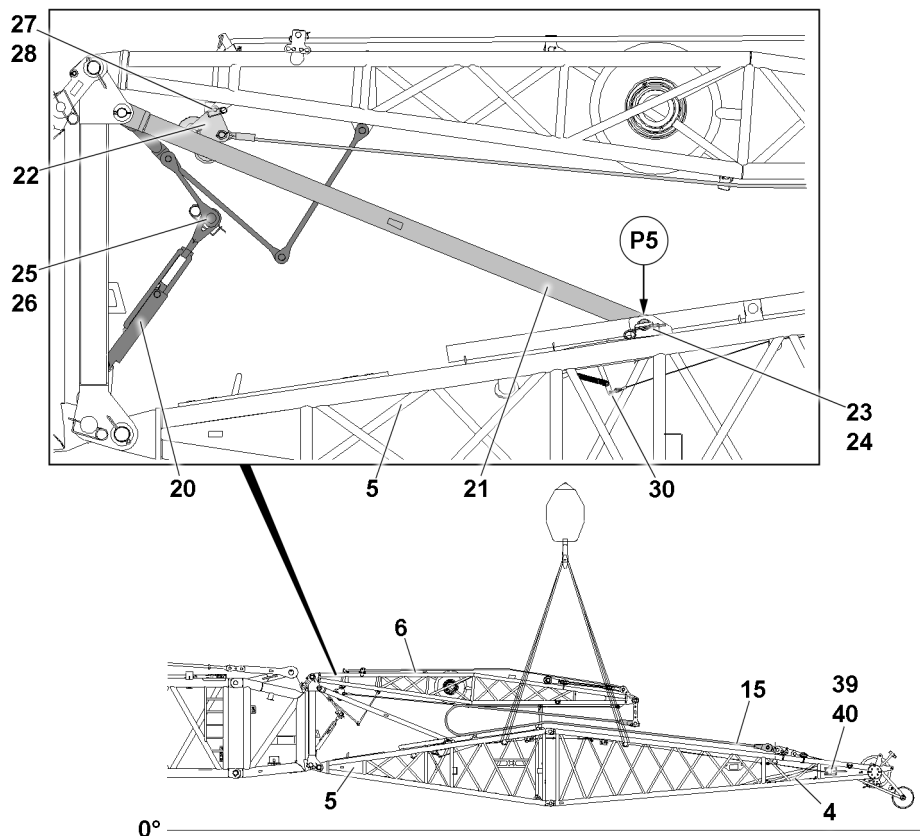

Fig.147752: F-relapse support and FA-frame relapse retainers

- ▶ Insert the crank 40.

Set the flap 30 „downward“:

- ▶ Actuate the manual rope winch 39 and spool up the control rope 9.
- ▶ Remove the crank 40 from the manual rope winch 39.

3.5.3 F-relapse support



WARNING

Automatic swinging of the F-jib!

If the pin 23 of the F-relapse support 21 is unpinning at point P5, before the F-guy rope 15 is properly assembled and secured, the F-jib could fall down by itself.

Death, severe bodily injuries, property damage.

- ▶ Make sure that the F-relapse support 21 remains pinned at point P5 until the F-guy rope 15 is properly pinned and secured on the FA-frame 6 and on the F-end section 3.
 - ▶ Do **not** unpin the F-relapse support 21 at point P5.
-
- ▶ Make sure that the F-relapse support 21 is properly pinned and secured in the transport position at point 5 with pin 23.

3.5.4 Separating the FA-frame relapse retainers



WARNING

Falling and swinging FA-frame relapse retainer!

The FA-frame relapse retainer consists of tension lugs and a turnbuckle.

The turnbuckle **20** of the FA-frame relapse retainer can fall down due to its own weight during unpinning.

Death, severe bodily injuries, property damage.

- ▶ Make sure when unpinning the FA-frame relapse retainer, that the turnbuckle **20** is safely held.
- ▶ Assembly personnel must be at the side of the assembly unit.

NOTICE

Danger of property damage!

If the FA-frame relapse retainer is not separated, then it will be damaged when pulling up the F-jib.

- ▶ Make sure that the FA-frame relapse retainer is separated during the erection of the FA-frame.

Separate the FA-frame relapse retainer:

- ▶ Remove the retaining element **26** and unpin the pin **25**.
- ▶ Take the turnbuckle **20** down.
- ▶ Insert the pin **25** again and secure with the retaining element **26**.
- ▶ Remove the auxiliary crane.

3.5.5 Preparing the rope pulley retainer for the assembly of the F-jib



WARNING

Falling rope pulley retainer!

The rope pulley retainer **22** can fall down due to its own weight when unpinning it.

Death, severe bodily injuries, property damage.

- ▶ Make sure that the assembly winch rope **22** is secured against falling down when unpinning.

Releasing the rope pulley retainer **22** from the FA-frame **6**:

- ▶ Remove the retaining element **28** and unpin the pin **27**.
- ▶ Take the rope pulley retainer **22** down with the rope on the F-assembly unit.

3.5.6 Assembling the FAB-guy ropes

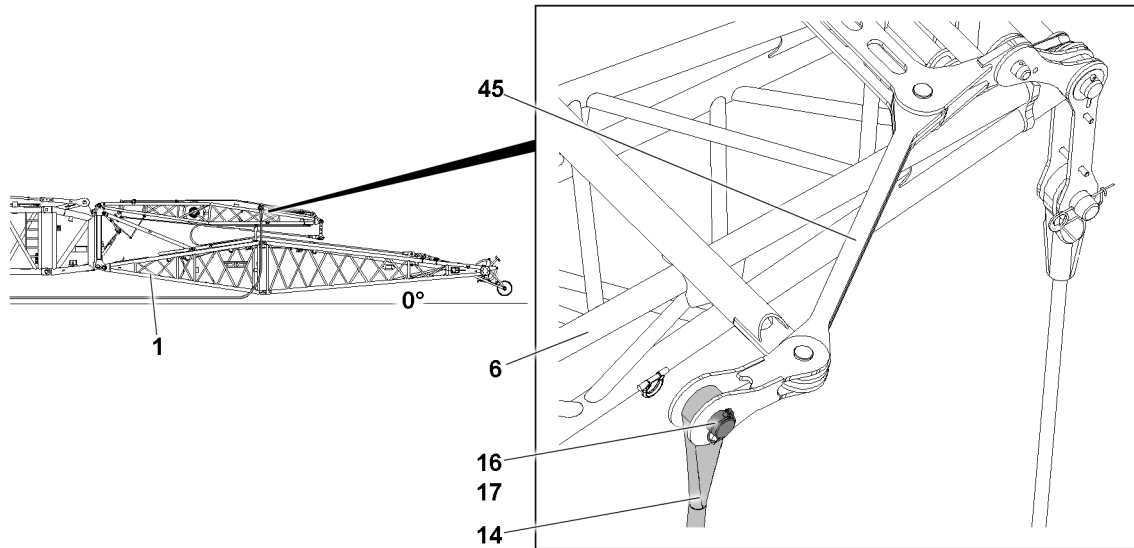

Fig.147756: FAB-guy ropes

- ▶ Swing the FAB-guy rope **14** in to the swing **45** on the FA-frame **6**.
- ▶ Pin the FAB-guy rope **14** on the swing **45**: Insert the pin **16** and secure it with the retaining element **17**.

When the first FAB-guy rope is properly installed and secured:

- ▶ Pin the second FAB-guy rope.
- ▶ Take down the free ends of the FAB-guy ropes **14** to the side from the boom.

3.5.7 Erecting the FA-frame

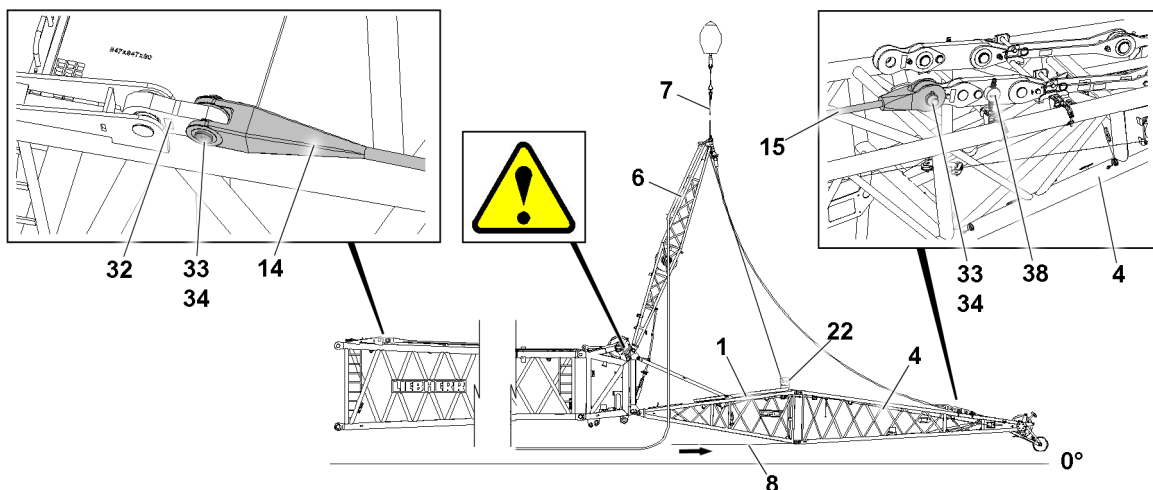

Fig.147753: Erecting the FA-frame

Make sure that the following prerequisite is met:

- The FA-frame relapse retainer is separated.

Unpin the F-guy rope **15** on the FA-end section **4**:

- ▶ Remove the retaining element **34** on both sides and unpin the pin **33** on both sides.
- ▶ Release the fastening rope **7** in the transport position on the FA-frame **6**.
- ▶ Fasten the FA-frame **6** with the fastening rope **7** to the auxiliary crane.
- ▶ Lift FA-frame **6** with auxiliary crane.

- ▶ Reeve in the assembly winch rope **8** at the rope pulley retainer **22** and secure on the F-pivot section **1**.

NOTICE

Danger of property damage!

When swinging the FA-frame **6** in the direction of the main boom, damage may occur to the FA-frame **6**, the F-connector head, as well as the rope pulley retainer.

- ▶ Make sure that a guide supervises the swinging process of the FA-frame.
 - ▶ Make sure that the guide is constantly in visual and acoustic contact with the crane operator.
 - ▶ Make sure that the assembly winch rope **8** is spooled out during the swinging process of the FA-frame **6**.
 - ▶ Make sure that the F-guy rope **15** is unpinning on the FA-end section **4**.
-
- ▶ Carefully swing the FA-frame **6** with the auxiliary crane in direction of the main boom and spool the assembly winch rope **8** out at the same time until it can be pinned at the pin location.
 - ▶ Swing the FAB-guy rope **14** in to the FAB-lugs **32** of the L-intermediate section.

Pin the FAB-guy rope **14** with the FAB-lugs **32** of the L-intermediate section:

- ▶ Insert the pin **33** and secure it with the retaining element **34**.
- ▶ Pin the second FAB-guy rope.

3.5.8 Taking the support frames down

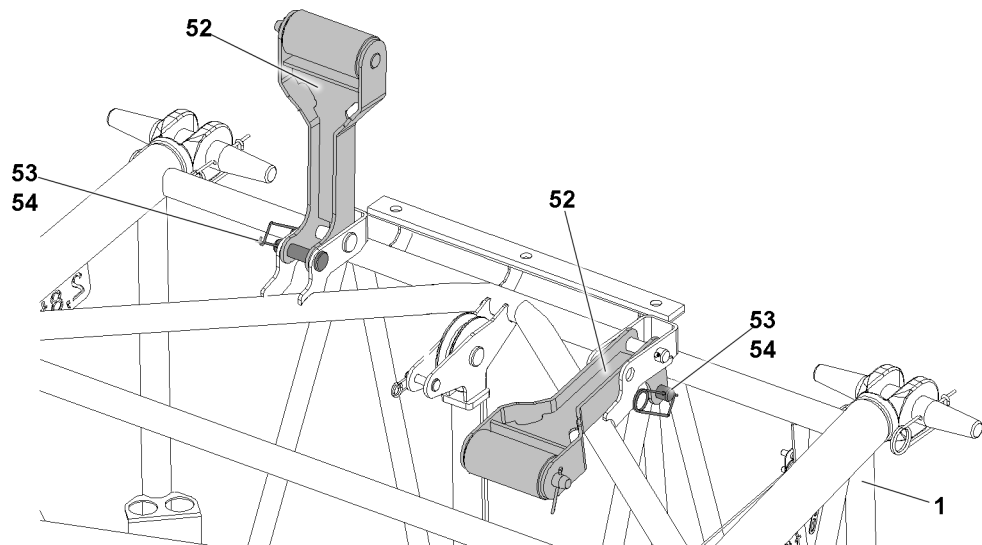

Fig.147736: Support frames



WARNING

Falling support frames!

The support frame **52** can fall down due to its own weight when unpinning it. Death, severe bodily injuries, property damage.

- ▶ Make sure that the support frame **52** is held during unpinning.
- ▶ Assembly personnel must be at the side of the assembly unit.

Swing the support frame **52** into the operating position:

- ▶ Remove the retaining element **54** and unpin the pin **53**.
- ▶ Take the support frame **52** down.
- ▶ Insert the pin **53** again and secure with the retaining element **54**.
- ▶ Take the second support frame **52** down.

3.5.9 Setting the FA-frame in the operating position

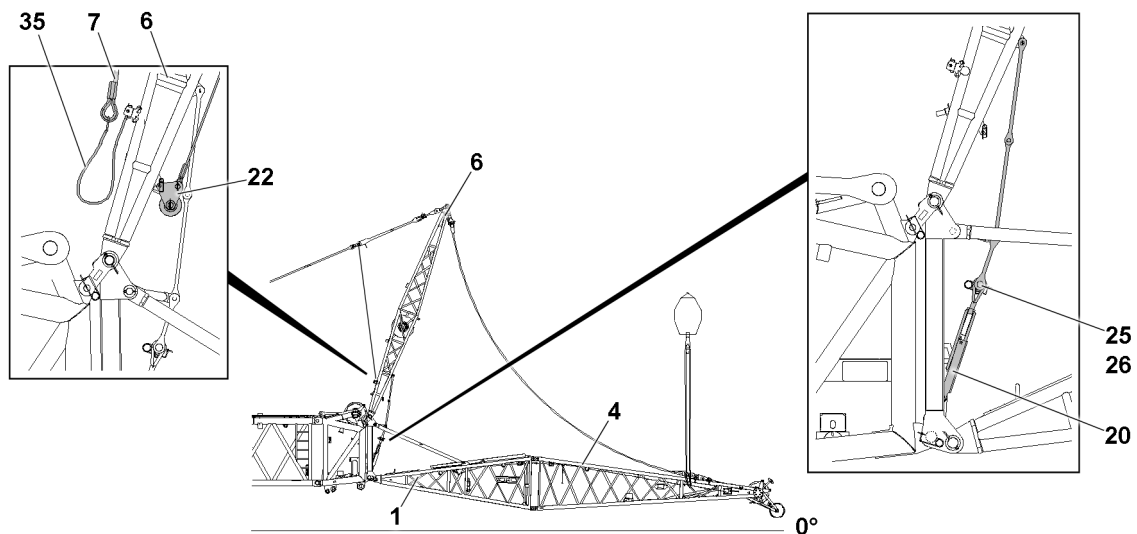

Fig.147754: Setting the FA-frame in the operating position

Make sure that the following prerequisite is met:

- The FAB-guy ropes are properly pinned and secured.

- ▶ Pull the FA-frame **6** with the assembly winch rope **8** in direction of the F-pivot section.

Connect the FA-frame relapse retainer:

- ▶ Swing the turnbuckle **20** to the FA-frame relapse retainer.
- ▶ Insert the pin **25** and secure it with the retaining element **26**.

When the FA-frame relapse retainer is properly pinned and secured:

- ▶ Tighten the turnbuckle **20** and secure it to prevent twisting.

Result:

- The turnbuckle is secured to prevent it from twisting in crane operation.
- Affix the FA-frame **6** in the operating position.

NOTICE

Swinging fastening rope!

If the fastening rope **7** is not properly secured, then the fastening rope **7** can start to swing back and forth in crane operation and damage components.

- ▶ Make sure that the fastening rope **7** is properly secured on the FA-frame before starting to work with the crane.

- ▶ Place the fastening rope **7** over the linkage.
- ▶ Remove the auxiliary crane.
- ▶ Connect the fastening rope **7** with the roundslings **35** with the shackle.
- ▶ Fasten the roundslings **35** with the carabiner on the lug of the FA-frame **6**.
- ▶ Fasten the F-jib to the auxiliary crane.
- ▶ Carefully bring the fastening equipment to tension.

When the fastening equipment is tensioned:

- ▶ Release and reeve out the assembly winch rope **8**.

Pin the rope pulley retainer **22** on the FA-frame **6**:

- ▶ Insert the pin **27** and secure it with the retaining element **28**.

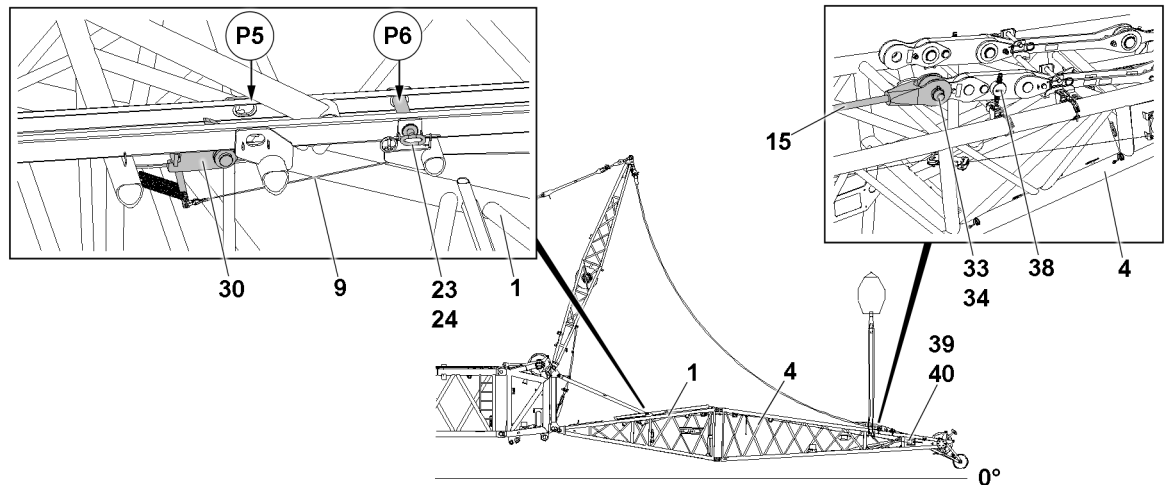

Fig.147755: Assembling the F-guy rope on the F-end section / unpinning the F-relapse support

- ▶ Pin the F-guy ropes **15** on the F-end section **4** with the lugs **38**.
- ▶ Insert the pin **33** and secure it with the retaining element **34**.

Unpin the F-relapse support **21** in the transport position in point **P5**.

When the F-jib is safely held by the auxiliary crane:

- ▶ Remove the retaining element **24** at point **P5** and unpin the pin **23**.
- ▶ Insert the pin **23** in the stop position at point **P6** and secure with retaining element **24**.
- ▶ Lower the F-jib slowly on the ground with the auxiliary crane.

When the F-jib is laying on the ground:

- ▶ Remove the auxiliary crane.



WARNING

Danger of fatal injury due to F-auxiliary jib!

If the flap is not in „up“ position, then the F-auxiliary job can fall backward uncontrolled when erecting the boom system and in crane operation.

Death, severe bodily injuries, property damage.

- ▶ Make sure that the flap is in the „up“ position immediately before lifting the F-end section or when erecting the boom.
- ▶ Make sure that the crank of the manual rope winch has been removed.

- ▶ Lift the main boom.

Immediately after the F-jib lifts off the ground, move the flap **30** „upwards“:

- ▶ Actuate the manual rope winch **39** and spool out the control rope **9**.
- ▶ Remove the crank **40** from the manual rope winch **39**.

3.6 Assembly variant V4 — Assembling the complete F-jib (maximum length of 12 m) in flying mode



WARNING

Impermissible F-assembly length(s)!

Death, severe bodily injuries, property damage.

- ▶ Make sure that the assembly of the F-jib as a complete F-assembly unit with the F-end section does not exceed 12 m.
- ▶ During assembly, no hook block may be reeved on the F-jib.
- ▶ The F-jib must always be assembled in accordance with the respective description in the respective section.
- ▶ Observe and adhere to the Rod plan.

3.6.1 Assembling the F-assembly unit with F-end section

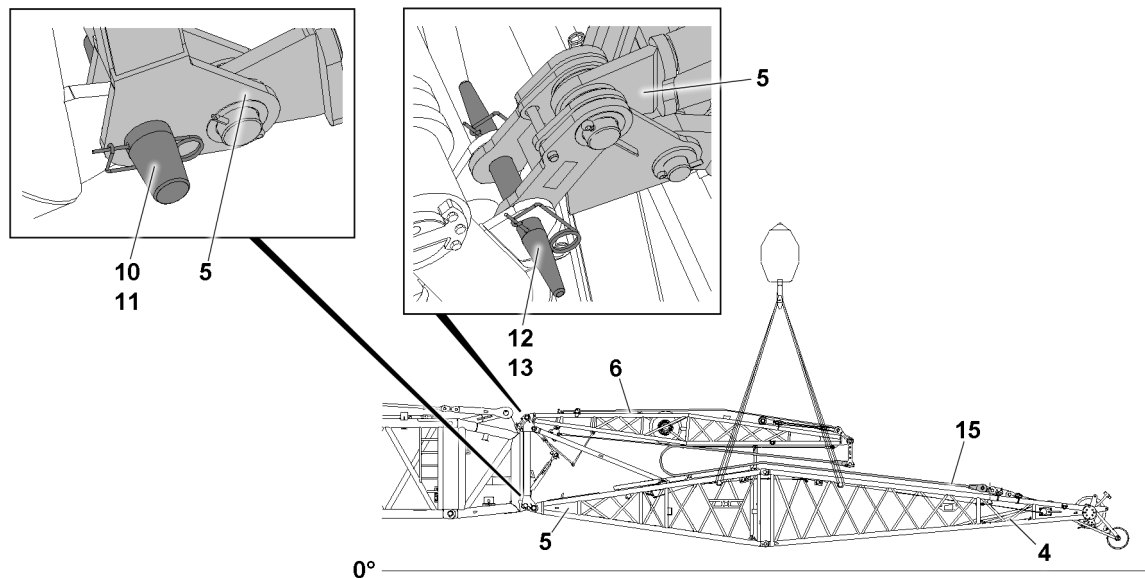

Fig.147751: Pinning the F-jib

Make sure that the following prerequisite is met:

- The F-guy ropes **15** between the F-end section **4** and the F-frame **6** are properly pinned and secured. (If necessary, release the F-guy ropes **15** from the transport retainers on the F-pivot section **1** and pin with the lugs on the F-end section **3** and with lugs on the FA-frame **6**, see section Assembly variant V1.
- ▶ Fasten the F-assembly unit **4** with the F-end section **4** to the auxiliary crane.
- ▶ Remove the rigging belts between the F-pivot section **1** and FA-frame **6**.

The F-assembly unit is pinned four times on L-end section or on the F-connector head. Every pin point is present on both sides of the component on one level.

- ▶ Position the F-assembly unit **4** with F-end section **3** with the auxiliary crane on the F-connector head so that it can be pinned in the pin locations.
- ▶ Insert the pins **12** on both sides and secure with the retaining element **13**.



WARNING

Crushing / shearing of limbs!

While performing boom system assembly tasks, limbs can be crushed and / or sheared off. Death, severe bodily injuries, property damage.

- ▶ Make sure that no crane movements are performed while pinning in the area of the lower pin points.
-
- ▶ Insert the pins **10** on both sides and secure with the retaining element **11**.
 - ▶ Remove the auxiliary crane.

3.6.2 Releasing the F-relapse support

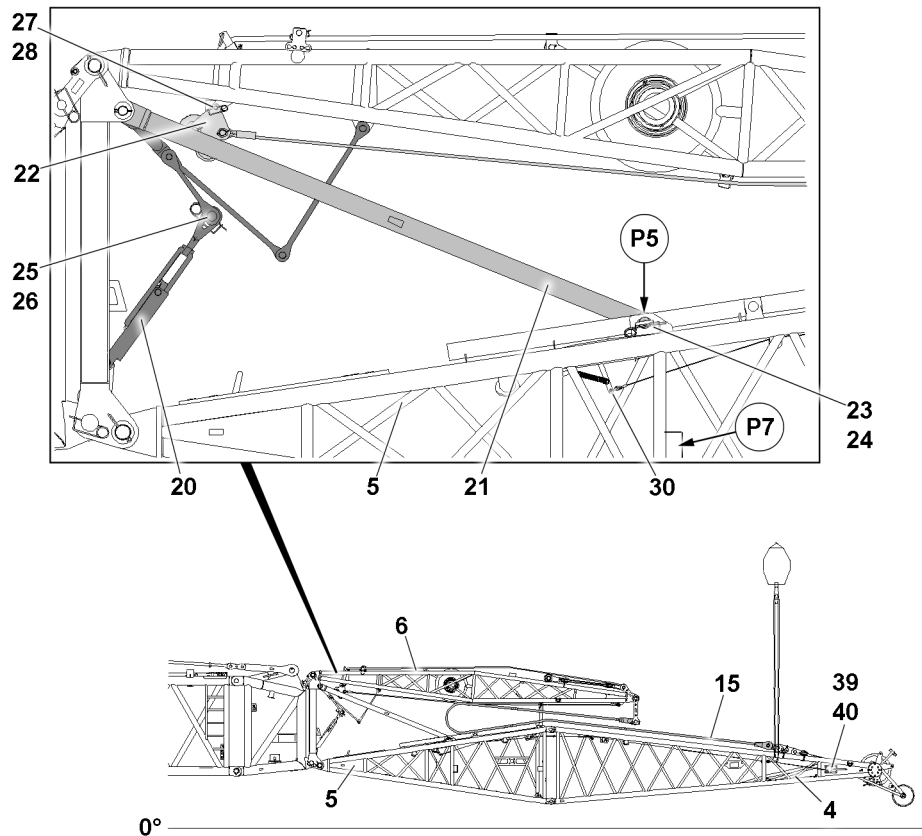

Fig.147757: F-relapse support and FA-frame relapse retainers

Make sure that the following prerequisites are met:

- The F-jib is properly pinned and secured on the F-connector head.
- The F-guy ropes **15** are properly pinned and secured between the FA-frame **6** and the F-end section **3**.
- The F-jib is properly fastened on the F-end section **4** on the auxiliary crane.

► Fasten the F-jib on the F-end section **4** to the auxiliary crane.

Release the F-relapse support **21** from the transport position:

- Remove the retaining element **24** at point **P5** and unpin the pin **23**.
- Insert pin **23** in the park position at point **P7** and secure with retaining element **24**.

3.6.3 Setting the flap „downward“

- Insert the crank **40**.

Set the flap „downward“:

- Actuate the manual rope winch **39** and spool up the control rope **9**.
- Remove the crank **40** from the manual rope winch **39**.

3.6.4 Separating the FA-frame relapse retainers



WARNING

Falling and swinging FA-frame relapse retainer!

The FA-frame relapse retainer consists of tension lugs and a turnbuckle.

The turnbuckle **20** of the FA-frame relapse retainer can fall down due to its own weight during unpinning.

Death, severe bodily injuries, property damage.

- ▶ Make sure when unpinning the FA-frame relapse retainer, that the turnbuckle **20** is safely held.
- ▶ Assembly personnel must be at the side of the assembly unit.

NOTICE

Danger of property damage!

If the FA-frame relapse retainer is not separated, then it will be damaged when pulling up the F-jib.

- ▶ Make sure that the FA-frame relapse retainer is separated during the erection of the FA-frame.

Separate the FA-frame relapse retainer:

- ▶ Remove the retaining element **26** and unpin the pin **25**.
- ▶ Take the turnbuckle **20** down.
- ▶ Insert the pin **25** again and secure with the retaining element **26**.

When the FA-frame relapse retainer is separated:

- ▶ Lower the F-jib slowly on the ground.

3.6.5 Assembling the FAB-guy ropes

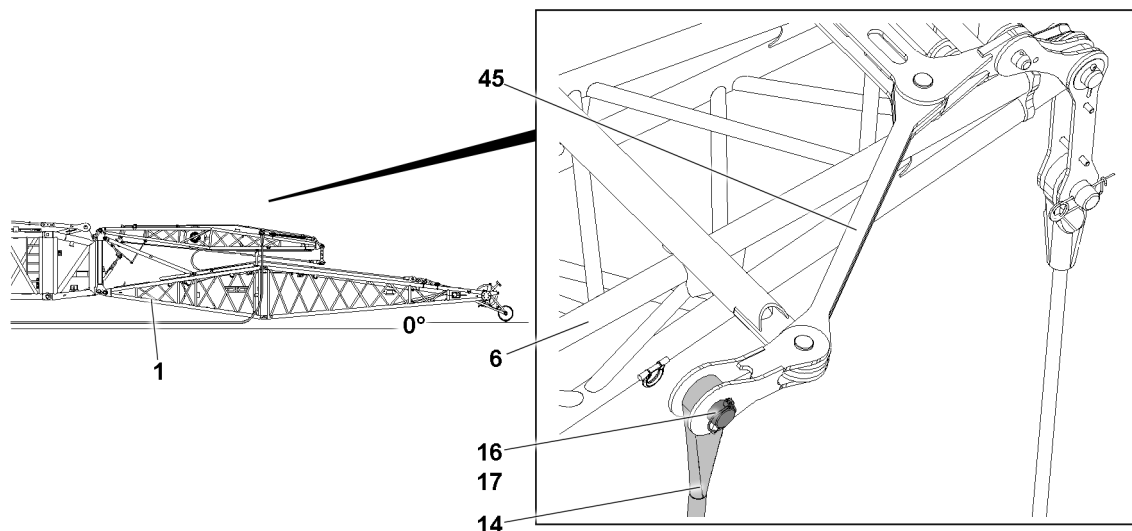

Fig.147758: FAB-guy ropes

- ▶ Swing the FAB-guy rope **14** in to the swing **45** on the FA-frame **6**.
- ▶ Pin the FAB-guy rope **14** on the swing **45**: Insert the pin **16** and secure it with the retaining element **17**.

When the first FAB-guy rope is properly installed and secured:

- ▶ Pin the second FAB-guy rope.
- ▶ Take down the free ends of the FAB-guy ropes **14** to the side from the boom.

3.6.6 Erecting the FA-frame



Note

- ▶ Erect the „FA-frame“, see description of assembly variant V2.

**WARNING**

Non-observance of safety guidelines!

If the safety guidelines are not observed, dangerous situations can arise.

Death, severe bodily injuries, property damage.

- ▶ Make sure that all danger notes in the section „Erecting the FA-frame“ are observed.

3.6.7 Taking the support frames down**Note**

- ▶ „Taking the support frames down“, see the description for assembly variant V2.

**WARNING**

Non-observance of safety guidelines!

If the safety guidelines are not observed, dangerous situations can arise.

Death, severe bodily injuries, property damage.

- ▶ Make sure that all danger notes in the section „Taking the support frames down“ are observed.

3.6.8 Setting the FA-frame in the operating position**Note**

- ▶ „Setting the FA-frame in the operating position“, see description of assembly variant V2.

**WARNING**

Non-observance of safety guidelines!

If the safety guidelines are not observed, dangerous situations can arise.

Death, severe bodily injuries, property damage.

- ▶ Make sure that all danger notes in the section „Setting the FA-frame in the operating position“ are observed.

4 Establishing the electrical connections

Make sure that the following prerequisites are met:

- The F-jib is completely assembled.
- The airplane warning light and the wind speed sensor are installed.

NOTICE

Damage to the electrical connection on the cable drum!

If the electrical connection from the cable drum on the F-pivot section to the terminal box on the L-end section or on the F-connector head is established first before the connection to the terminal box on the F-end section, the electrical connection can be damaged when spooling out the cable drum.

- ▶ Establish the electrical connection from the cable drum on the F-pivot section to the terminal box on the F-end section first and then the electrical connection from the terminal box on the F-connector head or on the L-end section to the cable drum on the F-pivot section.

**Note**

- ▶ Establish the electrical connections to the F-jib, see Electrical wiring diagram.

- ▶ Establish the electrical connections.

- ▶ Make sure that all electrical connections on the boom are established.

5 Checking the function of the safety equipment



WARNING

Non-functioning safety equipment!
Death, severe bodily injuries, property damage.

- ▶ Crane operation with non-functioning safety equipment is **prohibited**.



Note

- ▶ The function of the individual limit switches must be checked before erection of the boom system.
- ▶ The function of the limit switch initiators must be checked in the test system, see the „Diagnostics manual“.



Note

- ▶ If a function check on the limit switches or on the safety equipment does not lead to the desired shut offs, then the plug connections on the connector boxes or the components itself must be checked. If no visible connection errors or component defects can be found, contact **Liebherr Service**.

Make sure that the following prerequisites are met:

- All electrical connections have been made.
- The crane engine is running.
- The corresponding operating mode is set on the LICCON monitor.

5.1 Checking the wind speed sensor

- ▶ Check the movement and the function of the wind speed sensor.

5.2 Checking the airplane warning light

- ▶ Turn the airplane warning light on in the crane cab, see chapter 4.01.
- ▶ Check the function visually.

5.3 Checking the hoist limit switch on the pulley head



Note

- ▶ When replacing or changing a hoist limit switch (HES), the corresponding hoist limit switch must have the correct bus address and the correct software version in order to be detected again by the bus system (LSB).

- ▶ Actuate the hoist limit switch manually on the pulley head.

Result:

- The spool up function of the hoist winch turns off.
- The icon „Hoist top“ appears on the LICCON monitor 0.
- The limit switch is functioning.

5.4 Checking the limit switches in general



Note

- ▶ The limit switch functions have to be checked individually before erection.
- ▶ To check the limit switches, see corresponding chapter in the Crane operating instructions.

6 Erecting the boom



WARNING

The crane can topple over!

For certain boom lengths, the mechanical auxiliary supports must be assembled, see Erection and take down charts.

Death, severe bodily injuries, property damage.

- ▶ Observe the specifications in the erection and take-down charts.



WARNING

The crane can topple over!

If the following conditions are not met before erecting the boom, the crane can topple over.

Death, severe bodily injuries, property damage.

- ▶ Observe the technical safety instructions, see chapter 5.01.
- ▶ Extend the relapse cylinder before erection.
- ▶ Do not allow slack rope formation on the control winch.



WARNING

Falling hoist rope!

If the hoist rope before the erection procedure is not properly secured onto the end section, it can fall down backward on the basis of its own weight.

Death, severe bodily injuries, property damage.

- ▶ Secure the hoist rope properly on the end section before the erection procedure.

Make sure that the following prerequisites are met:

- The crane is horizontally aligned.
- All electrical connections have been established.
- All limit switches are functioning.
- The central ballast is placed according to the data in the erection and take-down charts.
- The counterweight has been installed to the turntable according to the data in the erection and take-down charts.
- All pin connections are secured.
- The hoist rope has been correctly placed in the rope pulleys and is prevented from jumping out with the rope retaining pins.
- There are no loose parts on the boom.
- The LICCON overload protection has been set according to the data in the load chart.
- The LICCON overload protection settings have been compared with the actual set up configuration.
- The LICCON overload protection is exceeded.
- The assembly icon is visible on the LICCON monitor.

6.1 Erection procedure



WARNING

The crane can topple over!

Death, severe bodily injuries, property damage.

- ▶ It is prohibited to turn the crane superstructure while erecting the boom.
- ▶ Observe the data in the Erection and take down charts.

6.1.1 Reeving in the hook block

Make sure that the following prerequisites are met:

- The crane is horizontally aligned.
- The slewing gear brake is applied.



WARNING

Danger of accident due to side wind!

If the slewing gear brake is released after reeving in / reeving out the hook block / load hook, then the crane can turn uncontrolled in strong side wind.

Death, severe bodily injuries, property damage.

The crane can collide with close-by structures or objects.

- ▶ Make sure that the current wind speed does not exceed the values from the wind speed chart when releasing the slewing gear brake.

- ▶ Luff up the boom until the F-jib lifts off the ground.
- ▶ Reeve in the hook block properly, see chapter 4.06 and the separate reeving plans.
- ▶ Properly secure the hoist rope on the rope fixed point, see chapter 4.06.
- ▶ Attach the hoist limit switch weight, see chapter 4.06.

6.1.2 Erecting the boom



DANGER

The crane can topple over!

Death, severe bodily injuries, property damage.

- ▶ The boom radii listed in the load chart may not be exceeded or fallen below, even if there is no load on the hook.



Note

- ▶ When the lowest operating position of the boom is reached, the set load chart of the LICCON overload protection is activated.
- ▶ In the maximum load icon, a load number appears in „t“ instead of the display „???“.
- ▶ Luff the boom up to the lowest operating position.

When the boom has reached the lowest operating position:

- ▶ Make sure that the assembly icon on the LICCON monitor turns off.

Result:

- The LICCON overload protection is active.

7 Operating the crane

7.1 Preparing for crane operation



Note

- ▶ Observe the notes, see chapter 4.05, chapter 4.08 and chapter 5.01.

Make sure that the following prerequisites are met:

- The LICCON overload protection is active.
- The LICCON overload protection has been set according to the data in the load chart.



WARNING

The crane can topple over!

Death, severe bodily injuries, property damage.

- ▶ Check the horizontal position of the crane before and during operation.
- ▶ If the crane operator leaves the crane cab, even for a short time, the operating mode setting must be checked and reset, if necessary, before resuming crane operation.

7.2 Checking the settings

- ▶ Check the function of the overload protection by running against the operating positions „on top“ and „bottom“.
- ▶ Check the hoist limit switch by running against the hoist limit switch weight.

8 Disassembling the F-jib



WARNING

Danger of falling!

During assembly / disassembly, inspection and maintenance work, personnel must be secured with appropriate aids to prevent them from falling.

Death, severe bodily injuries, property damage.

- ▶ All work at a height, when there is a danger of falling, must be carried out with suitable aids.
- ▶ If aids are not available and work cannot be carried out from the ground, then assembly personnel must secure themselves with the supplied fall arrest system to prevent falling, see chapter 2.04.
- ▶ If fall protection equipment is available, then it must be used, see chapter 2.06.
- ▶ When lifting, lowering, swinging crane parts in and out, no persons may remain in the danger zone.
- ▶ If railings are present on the components, then they must be brought into the corresponding position and secured for assembly / disassembly work.
- ▶ It is prohibited to lean the ladder against the component being disassembled.
- ▶ Only step on the aids, ladders and catwalks with clean shoes.
- ▶ Keep aids, ladders and catwalks free of heavy dirt, snow and ice.
- ▶ During all assembly and disassembly work, maintenance work and inspections, travel or crane operation is prohibited.
- ▶ Remaining on a suspended load is prohibited.
- ▶ Stepping or walking on crane components and lattice sections, which have an incline of more than 20° is prohibited.
- ▶ For all assembly work, the crane operator of the main crane must be in voice contact with the crane operator / crane operators of the auxiliary crane / auxiliary cranes.
- ▶ For assembly / disassembly tasks, the crane operator may only initiate crane movements when the responsible guide has explicitly released the movement.



WARNING

Danger of impact / crushing!

When installing / removing crane components with the auxiliary crane, crane components can start to swing back and forth.

When lifting / lowering and positioning crane components, there is an increased danger of impacts / crushing.

Death, severe bodily injuries, property damage.

- ▶ Make sure that personnel cannot be caught by components.
- ▶ When working in danger zones: Use aids to protect limbs.
- ▶ Guide components with suitable aids to minimize oscillation.

**WARNING**

The components can fall down!

If the corresponding component is disengaged from the auxiliary crane before the corresponding component is pinned, then the corresponding component can fall down.

Death, severe bodily injuries, property damage.

- ▶ Do not disengage the auxiliary crane until the respective component is pinned and secured.

**WARNING**

The lattice sections can fall down!

If the lattice sections are not pinned and secured correctly, then they can fall down.

Death, severe bodily injuries, property damage.

- ▶ Insert or unpin both pins at the same horizontal level, i.e. **left and right**.
- ▶ Do not stand under the lattice sections or within the entire danger zone during the pinning and unpinning procedure of the boom.
- ▶ Safely secure the pins in the storage locations as well as in the receptacles.
- ▶ It is prohibited to lean the ladder against the component being disassembled.

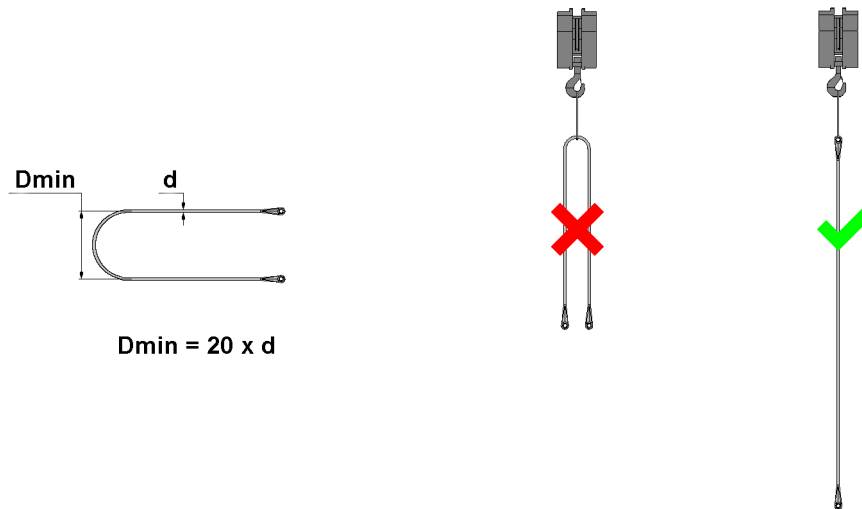

Fig.147766: Fiber guy rope / **Dmin**-minimum diameter, **d**-rope diameter

**WARNING**

The fiber guy ropes can rip off!

If the fiber guy ropes are installed twisted in longitudinal axis, then the load bearing capacity can be significantly reduced as a result and the fiber guy ropes can rip off.

Death, severe bodily injuries, property damage.

- ▶ Make sure that the fiber guy ropes are **never** kinked, knotted or twisted.
- ▶ Make sure the kinked, knotted or twisted fiber guy ropes are **never** installed.
- ▶ Make sure that the fiber guy ropes are never pulled over the ground or sharp edges.
- ▶ Make sure that no damaged fiber guy ropes are installed.
- ▶ Make sure that the numbering in the rod plan is identical to the numbering on the fiber guy ropes.
- ▶ Make sure that minimum bending diameter of **20** x rope diameter on the fiber guy ropes is **never** fallen below.
- ▶ Check the fiber guy ropes before every assembly.
- ▶ When using fiber guy ropes: Inspect the fiber guy ropes regularly, see chapter 8.16.
- ▶ Make sure that the fiber guy ropes are not twisted at assembly. Pay attention to the twist display - marker line along the longitudinal axis of the rope braid.

**WARNING**

Damage to the fiber guy ropes during storage and transport!

If the following prerequisites for storage and transport are not observed, then the load bearing capacity can be significantly reduced and the fiber guy ropes can rip off.

Death, severe bodily injuries, property damage.

- ▶ Make sure that minimum bending diameter during storage and transport of **20** x rope diameter on the fiber guy ropes is **never** fallen below.
- ▶ Make sure that the fiber guy ropes are **not** kicked or knotted during storage and transport.
- ▶ Make sure that the fiber guy ropes are **not** twisted during storage and transport. Pay attention to the twist display - marker line along the longitudinal axis of the rope braid.
- ▶ Make sure that the fiber guy ropes do **not** lie over sharp edges during storage and transport.
- ▶ Make sure that the fiber guy ropes are **not** in contact with chemicals or acids during storage and transport.
- ▶ Make sure that the fiber guy ropes are **not** stored or transported together with other components.
- ▶ Store and transport the fiber guy ropes in a closed wooden crate.

Make sure that the following prerequisites are met:

- The S-boom is luffed down to the „lowest“ operating position.
- The LICCON overload protection has been set according to the data in the load chart.
- The LICCON overload protection is exceeded.
- The assembly icon is visible on the LICCON monitor.
- All unnecessary function keys and manual control levers are blocked on the radio remote control, see chapter 5.31 and chapter 6.08.
- An auxiliary crane is on hand.

8.1 Disassembling the F-jib — disassembly variants

**WARNING**

Non-compliance with the disassembly descriptions!

Death, severe bodily injuries, property damage.

- ▶ The F-jib must always be disassembled in accordance with the respective description in the respective section.
- ▶ Make sure that the danger notes in the respective disassembly description are observed.

8.1.1 Disassembly variant V1

Disassembling the F-jib in parts

- For disassembly variant V1, the F-jib is disassembled in individual parts.

8.1.2 Disassembly variant V2

Disassemble the complete F-jib (maximum length of 12 m)

- For disassembly variant V2, disassembly takes place using a hoist rope.

8.2 Taking the S-boom down

**WARNING**

The crane can topple over!

If the following conditions are not met before taking down the boom, the crane can topple over.

Death, severe bodily injuries, property damage.

- ▶ Observe the technical safety instructions, see chapter 5.01.
- ▶ Observe the specifications in the erection and take-down charts.
- ▶ During disassembly, no hook block may be reeved on the F-jib.

NOTICE

Damage of boom components!

Taking down the boom system can lead to a collision between the hook block and the pulley head.

Boom components can be severely damaged.

- ▶ Luff the boom system down at the same time and spool the hoist winch out.

8.2.1 Luffing the S-boom down**Note**

- ▶ The luff down movement is turned off as soon as the lowest operating position is reached.
- ▶ When the lowest operating position of the S-boom is reached, the load display in the maximum load icon turns off and instead of the load display appears the display „???“.
- ▶ Alarm functions appear on the crane operation screen.

- ▶ Luff the S-boom down to the „lowest“ operating position.

Result:

- The luff down movement is turned off.
- The „STOP“ icon appears on the LICCON monitor.
- The horn icon appears on the LICCON monitor.

**WARNING**

The crane can topple over!

In assembly operation the LICCON overload protection is deactivated.

In the event of deliberate improper use, the crane could collapse, the boom can break off or the crane can topple over.

Death, severe bodily injuries, property damage.

- ▶ Activate the assembly operation only when the consequences are known.
- ▶ Enter the set up configuration correctly into the LICCON computer system.
- ▶ Observe the erection / take down charts.
- ▶ Crane operation with deactivated LICCON overload protection is prohibited.
- ▶ In assembly operation only load torque reducing crane movements may be carried out until a permissible operating and load range.
- ▶ The crane operator carries complete and sole responsibility for his actions if the LICCON overload protection is deactivated.

When the boom has reached the „lowest“ operating position:

- ▶ Activate assembly operation, see chapter 4.02.

Result:

- The LICCON overload protection is deactivated.
- The assembly icon appears on the LICCON monitor.
- ▶ At the same time, luff down the boom system and spool out the hoist winch until the hook block touches the ground.

When the hook block touches the ground:

- ▶ Properly take down / set down the hook block onto the floor or a suitable substructure.

When the hook block is properly set down:

- ▶ Disassemble the hoist limit switch weight.
- ▶ Reeve out the hook block, see chapter 4.06.
- ▶ Carefully spool the hoist rope up.
- ▶ Remove the hook block with the auxiliary crane.

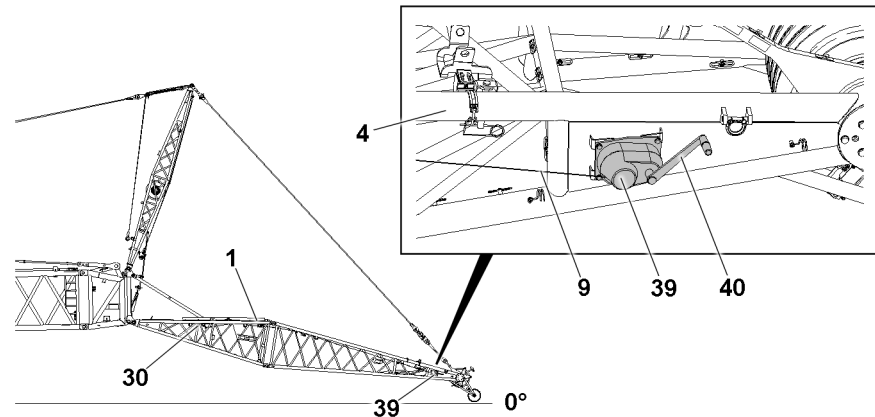

Fig.147741: Taking the boom system down

When the hook block is removed under the F-jib:

- ▶ Carefully luff the boom system down until the F-jib comes into contact with the ground.

NOTICE

Danger of property damage!

If the flap **30** is not in the „down“ position, the components will be damaged when taking down the F-jib.

- ▶ Make sure that the flap **30** is in „down“ position immediately before taking down the F-jib.

- ▶ Pull the flap **30** with the aid of the manual rope winch **39** „downwards“.
- ▶ Remove the crank **40** from the manual rope winch **39**.

NOTICE

Damage to the boom system!

- ▶ Make sure that the boom system is carefully luffed down at a slow speed.
- ▶ When the F-jib comes into contact with the ground, carefully luff the boom system down further until the main boom lies on a load bearing substructure.

- ▶ Take the boom system down on the substructure.

8.3 Disconnecting the electrical connections

Make sure that the following prerequisite is met:

- The boom system is properly taken down.

NOTICE

Damage to the electrical connection on the cable drum!

If the electrical connection between the F-connector head or the L-end section **and** the F-pivot section is not separated before spooling up the cable drum, the electrical connection will be damaged.

If the cable of the cable drum is not properly spooled up on the cable drum after unplugging the F-end section, then the cable drum or the cable can be significantly damaged.

- ▶ Disconnect the electrical connection from the cable drum on the F-pivot section to the terminal box on the L-connector head or the L-end section first **and** then the electrical connection from the terminal box on the F-end section to the cable drum.
- ▶ After unplugging, spool up the cable onto the cable drum.
- ▶ Properly disconnect the electrical connections, see the Electric wiring diagram.
- ▶ After unplugging, spool up the cable onto the cable drum and secure it to prevent it from spooling out inadvertently.
- ▶ Secure the cable: Reestablish the electrical connection between the F-connector head or the L-end section and the cable drum.
- ▶ Close the electrical connections off properly with dummy plugs or protective caps.

8.4 Disassembly variation V1 — Disassembling the F-jib in parts

8.4.1 Disassembling the lattice sections

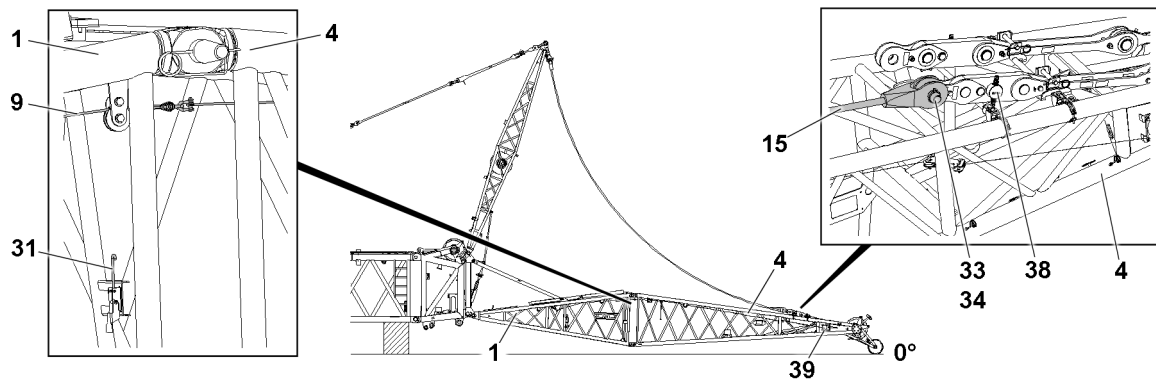

Fig.147740: Setting the flap „downward“

Unpin the F-guy rope **15** with the lugs **38** of the F-end section **4**:

- ▶ Remove the retaining element **34** and unpin the pin **33**.
- ▶ Take down the F-guy rope **15** to the side from the boom and remove the auxiliary crane.
- ▶ Unpin the second F-guy rope.

Disconnect the rope strand from the flap on the F-pivot section from the manual rope winch on the F-end section:

- ▶ Open the shackle.
- ▶ Pull the flap **30** on the F-pivot section **1** with the control rope **9** „downwards“ and fix it with the hook closure **31**.

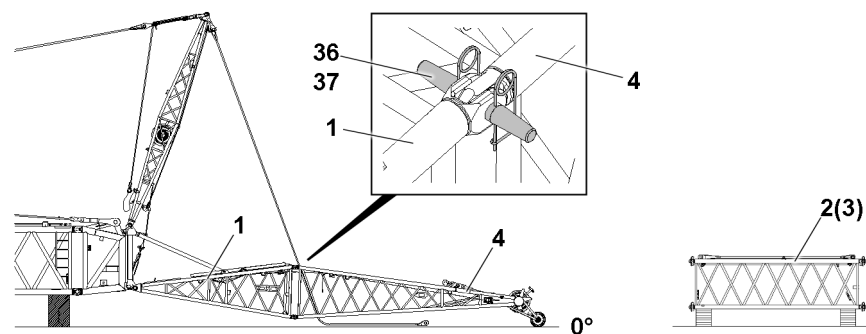

Fig.147739: Unpinning the F-end section



Note

- ▶ If F-intermediate sections are installed on the F-jib, then the additional guy ropes for the F-intermediate sections must be removed.
 - ▶ Fasten the F-end section **4** and the F-intermediate sections (if applicable) to the auxiliary crane and disassemble.
- The F-end section **4** is pinned four times on F-pivot section **1**. Every pin location is present on both sides of the component on one level.
- ▶ Fasten the auxiliary crane on the F-pivot section **1** in order to „open“ the F-jib.

**WARNING****Falling F-jib!**

When unpinning the F-jib on the F-pivot section **1**, the F-jib can fall down.
Death, severe bodily injuries, property damage.

- ▶ It is prohibited for anyone to remain under the F-jib during the unpinning procedure.
- ▶ Make sure that the F-pivot section **1** is safely held by the auxiliary crane.

- ▶ Release and unpin the F-pivot section and F-end section **4** on the „bottom“ on both sides: Remove the retaining element **37** and unpin the pin **36**.
- ▶ „Open“ the F-jib: Carefully take down the F-pivot section **1** on the substructure.
- ▶ Remove the auxiliary crane.
- ▶ Fasten the F-end section **3** to the auxiliary crane.

**WARNING****Tipping lattice sections!**

When the lattice sections are unpinned, they can tip over, depending on the ground or the substructure.

Death, severe bodily injuries, property damage.

- ▶ The lattice sections must be safely held by the auxiliary crane before unpinning them.
- ▶ The fastening equipment must be tensioned before unpinning.
- ▶ It is prohibited to remain in the danger zone.

- ▶ Release and unpin the F-pivot section **1** and F-end section **4** on the „top“ on both sides: Remove the retaining element **37** and unpin the pin **36**.

When all connector pins are unpinned:

- ▶ Swing out the F-end section **3** and the F-intermediate section (if applicable) with the auxiliary crane and take it down on a load bearing substructure.
- ▶ Remove the auxiliary crane.

8.4.2 Disassembling the FAB-guy rope

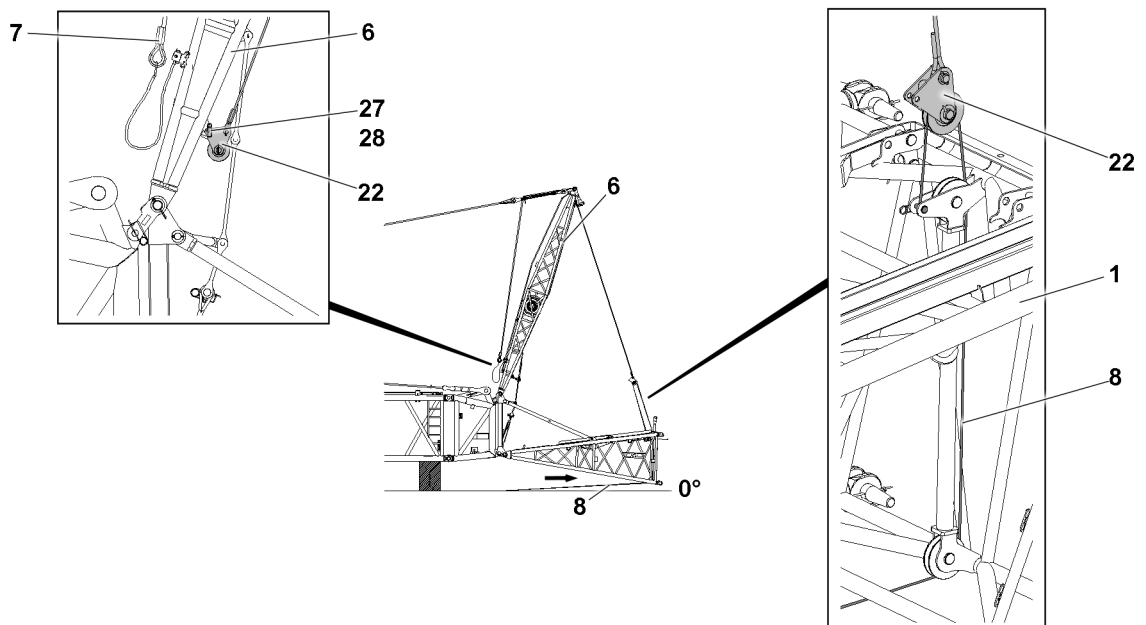

Fig.147759: Disassembling the FAB-guy rope

- ▶ Release the fastening rope **7** on the FA-frame **6**.
- ▶ Fasten the fastening rope **7** to the auxiliary crane.
- ▶ Position the auxiliary crane over the FA-frame **6** and carefully tension the fastening rope **7**.

**WARNING**

Swinging rope pulley retainer!

The rope pulley retainer **22** can swing due to its own weight when unpinning it.
Death, severe bodily injuries, property damage.

- ▶ Make sure that the rope pulley retainer **22** is held during unpinning.

Release the rope pulley retainer **22** on the FA-frame: **6**

- ▶ Remove the retaining element **28** and unpin the pin **27**.
- ▶ Reeve in the assembly winch rope **8** on the rope pulley retainer **22** and secure on the F-pivot section **1**.

NOTICE

Danger of property damage!

If the FA-frame relapse retainer is not separated, then it will be damaged during erection of the FA-frame **6**.

- ▶ Make sure that the FA-frame relapse retainer is properly separated during the erection of the FA-frame.

**WARNING**

Swinging FA-frame relapse retainer!

The FA-frame relapse retainer consists of tension lugs and a turnbuckle.

The turnbuckle **20** of the FA-frame relapse retainer can swing forward due to its own weight during unpinning.

Death, severe bodily injuries, property damage.

- ▶ Make sure when unpinning the FA-frame relapse retainer, that the turnbuckle **20** is safely held.
- ▶ Assembly personnel must be at the side of the assembly unit.

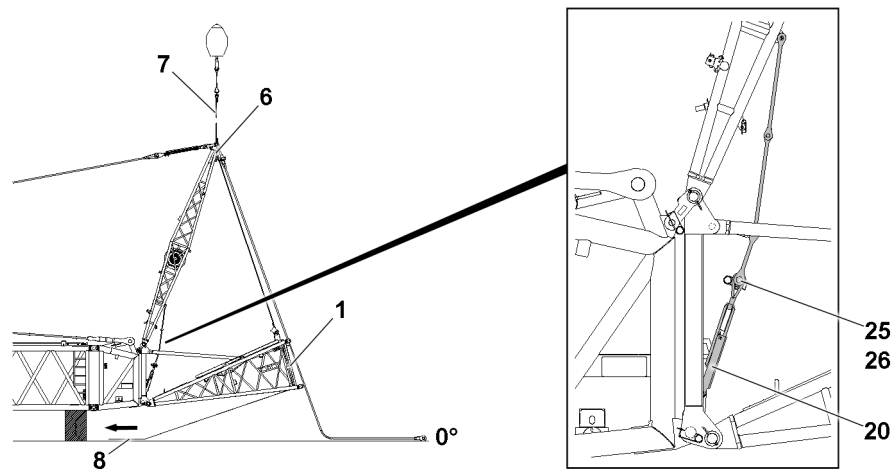

Fig.147735: Separating the FA-frame relapse retainers

Separate the FA-frame relapse retainer:

- ▶ Carefully spool up the assembly winch rope **8**.

Result:

- The F-pivot section **1** is pulled in the direction of the FA-frame **6** and lifted off the ground.
- The FA-frame relapse retainer is relieved.

When the FA-frame relapse retainer is relieved:

- ▶ Remove the retaining element **26** and unpin the pin **25**.
- ▶ Take the turnbuckle **20** down.
- ▶ Insert the pin **25** again and secure with the retaining element **26**.
- ▶ Carefully spool out the assembly winch rope **8**.

Result:

- Place the F-pivot section 1 on the ground.

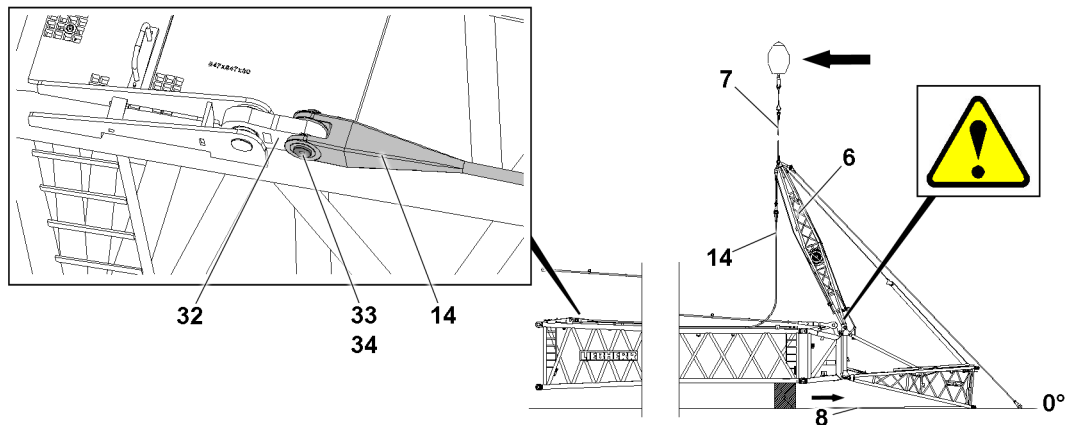

Fig.147734: Unpinning the FAB-guy rope

NOTICE

Danger of property damage!

When swinging the FA-frame 6 in the direction of the main boom, damage may occur to the FA-frame 6, the F-connector head, as well as the rope pulley retainer 22.

- ▶ Make sure that a guide supervises the swinging process of the FA-frame.
- ▶ Make sure that the guide is constantly in visual and acoustic contact with the crane operator.
- ▶ Make sure that the assembly winch rope 8 is spooled out during the swinging process of the FA-frame.

- ▶ Carefully swing the FA-frame 6 with the auxiliary crane in direction of the main boom and spool out the assembly winch rope 8 at the same time until the FAB-guy rope 14 can be unpinned.

Unpin the FAB-guy rope 14 from the FAB-lugs 32:

- ▶ Remove the retaining element 34 and unpin the pin 33.
- ▶ Take down the FAB-guy rope 14 to the side from the boom.
- ▶ Unpin the second FAB-guy rope.

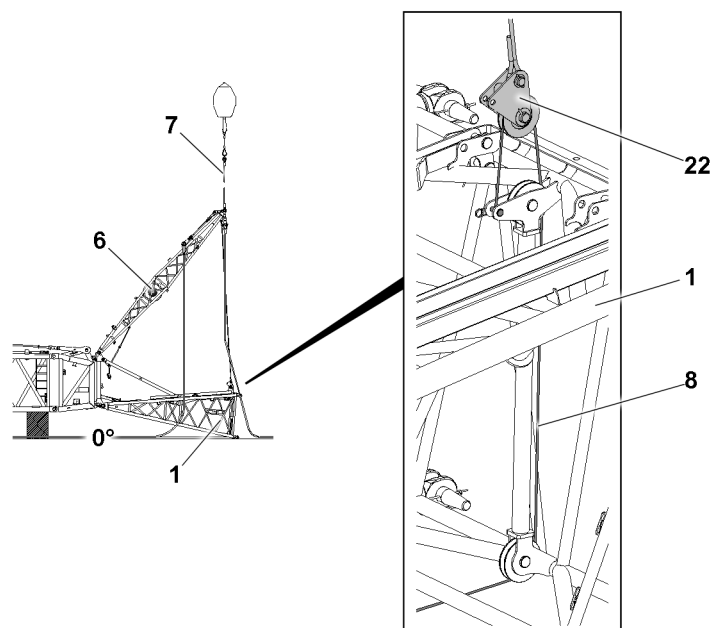

Fig.147733: Pulling the FA-frame in direction of the F-pivot section

**WARNING**

Automatic swinging of the FA-frame!

If the fastening rope **7** on the FA-frame **6** is not held under tension during assembly / disassembly operations, the FA-frame **6** can swing suddenly to the side.

Death, severe bodily injury, property damage.

- ▶ Make sure that there are no persons within the danger zone.
- ▶ Make sure that the fastening rope **7** never sags during assembly / disassembly operations.

- ▶ Pull the FA-frame **6** with the assembly winch rope **8** in direction of the F-pivot section **1**.
- ▶ Carefully spool up the assembly winch rope **8**.
- ▶ Guide the auxiliary crane.
- ▶ Lower the FA-frame **6** to approx. 40°.

8.4.3 Taking the FA-frame down

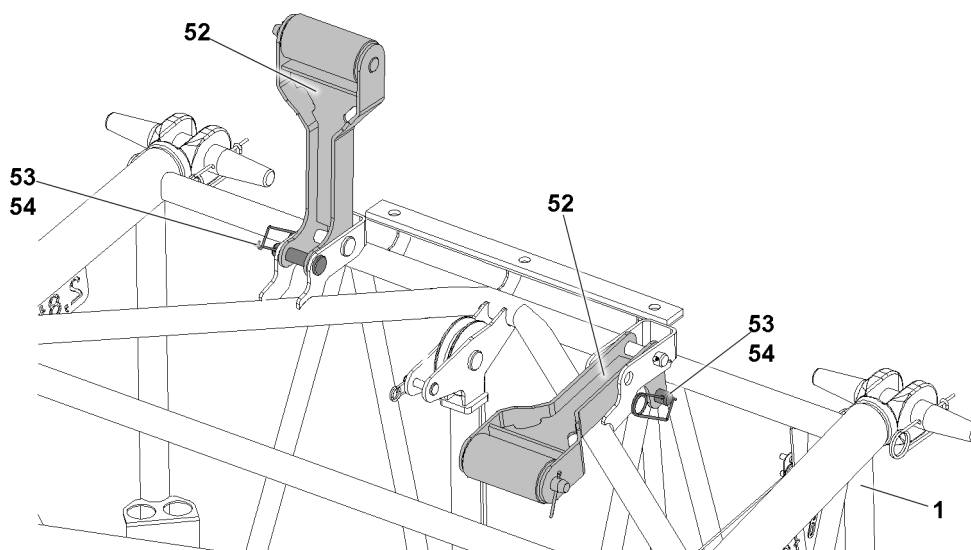

Fig.147736: Support frames

**WARNING**

Falling support frames!

The support frame **52** can fall down due to its own weight when pinning it.

Death, severe bodily injuries, property damage.

- ▶ Make sure that the support frame **52** is held during pinning.
- ▶ Assembly personnel must be at the side of the assembly unit.

Swing the support frame **52** into the transport position:

- ▶ Remove the retaining element **54** and unpin the pin **53**.
- ▶ Set up the support frame **52**.
- ▶ Insert the pin **53** again and secure with the retaining element **54**.
- ▶ Set up the second support frame **52**.

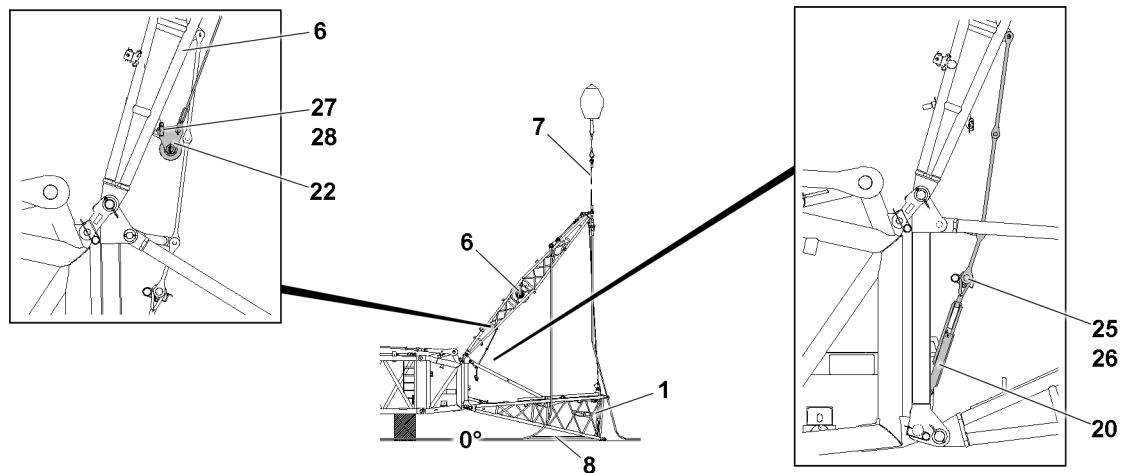

Fig.147760: Connecting the FA-frame relapse retainer

Connect the FA-frame relapse retainer:

- ▶ Swing the turnbuckle **20** to the FA-frame relapse retainer.
- ▶ Insert the pin **25** and secure it with the retaining element **26**.
- ▶ Release and reeve out the assembly winch rope **8**.

Swing and pin the rope pulley retainer **22** on the FA-frame **6**:

- ▶ Insert the pin **27** and secure it with the retaining element **28**.
- ▶ Spool the assembly winch rope **8** up.

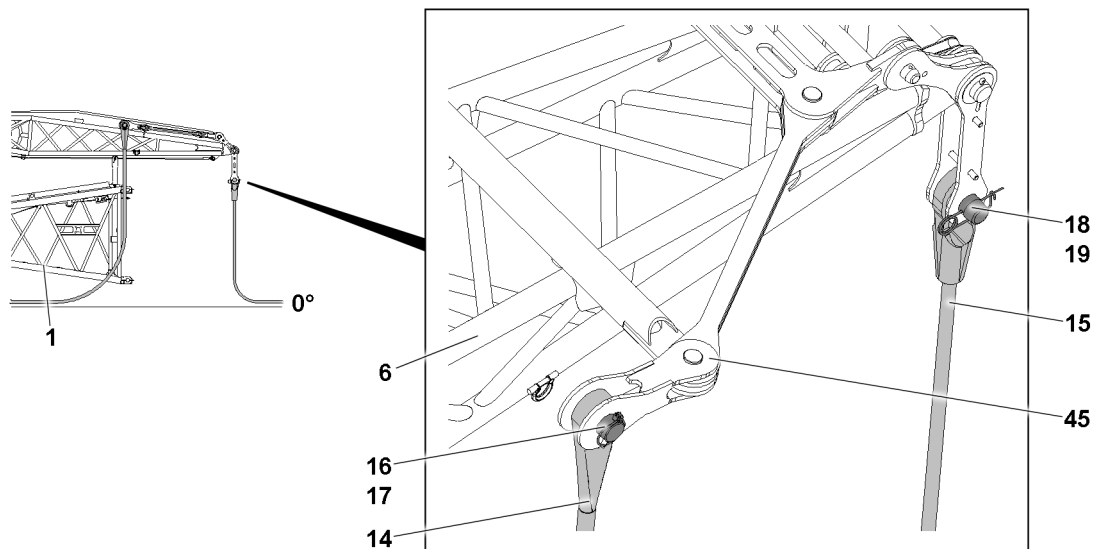

Fig.147731: Guy ropes

NOTICE

Damage to the fiber guy ropes!

Depending on the degree of severity, a damaged fiber guy rope can rip off in crane operation.

- ▶ Make sure that the fiber guy ropes are not kinked, crushed or damaged in any other way when taking down the FA-frame.
- ▶ If visible slight damage is determined on a fiber guy rope, observe chapter 8.16 and thoroughly inspect the rope.
- ▶ Make sure that a damaged fiber guy rope will only continued to be used, depending on the scope of the damage, after it has been thoroughly inspected and released by the rope manufacturer.

- ▶ Take down the FA-frame **6** with the auxiliary crane on the F-pivot section **1**.
- ▶ Remove the auxiliary crane.
- ▶ Attach the fastening rope **7** on the FA-frame **6**.

**WARNING**

Falling FAB-guy rope!

The FAB-guy rope **14** can fall down due to its own weight when pinning it.
Death, severe bodily injuries, property damage.

- ▶ Make sure that the FAB-guy rope **14** is held during pinning.
- ▶ Assembly personnel must be at the side of the assembly unit.

Unpin the FAB-guy rope **14** on the swing **45** on the FA-frame **6**:

- ▶ Remove the retaining element **17** and unpin the pin **16**.
- ▶ Take the FAB-guy rope down.
- ▶ Unpin the second FAB-guy rope.

**WARNING**

Falling FAB-guy rope!

The F-guy rope **15** can fall down due to its own weight when pinning it.
Death, severe bodily injuries, property damage.

- ▶ Make sure that the F-guy rope **15** is held during pinning.
- ▶ Assembly personnel must be at the side of the assembly unit.

Unpin the F-guy rope **15** with lugs on the FA-frame **6**:

- ▶ Remove the retaining element **19** and unpin the pin **18**.
- ▶ Take the F-guy rope down.
- ▶ Unpin the second F-guy rope.

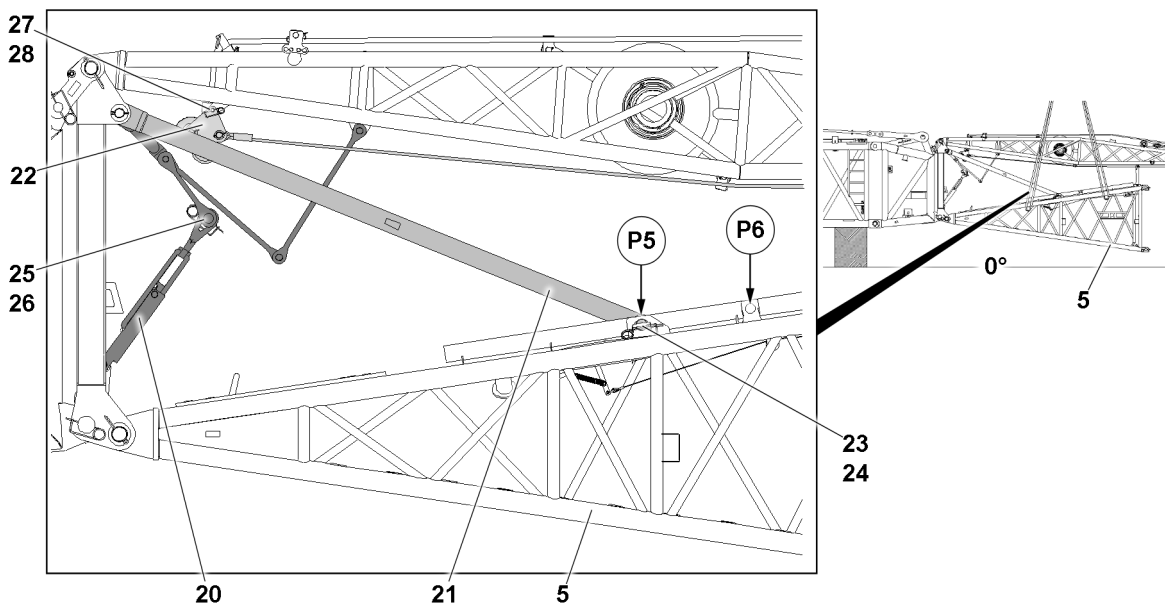

Fig.147730: Position of the F-relapse support

- ▶ Fasten the F-assembly unit **5** to the auxiliary crane.
- ▶ Lift the F-assembly unit **5** with the auxiliary crane until the F-relapse support **21** can be pinned at point **P5** in transport position.
- ▶ Remove the retaining element **24** at point **P6** and unpin the pin **23**.

Secure the F-relapse support **21** in the transport position:

- ▶ Pin the pin **23** in point **P5** and secure with the retaining element **24**.

8.4.4 Disassembling the F-assembly unit

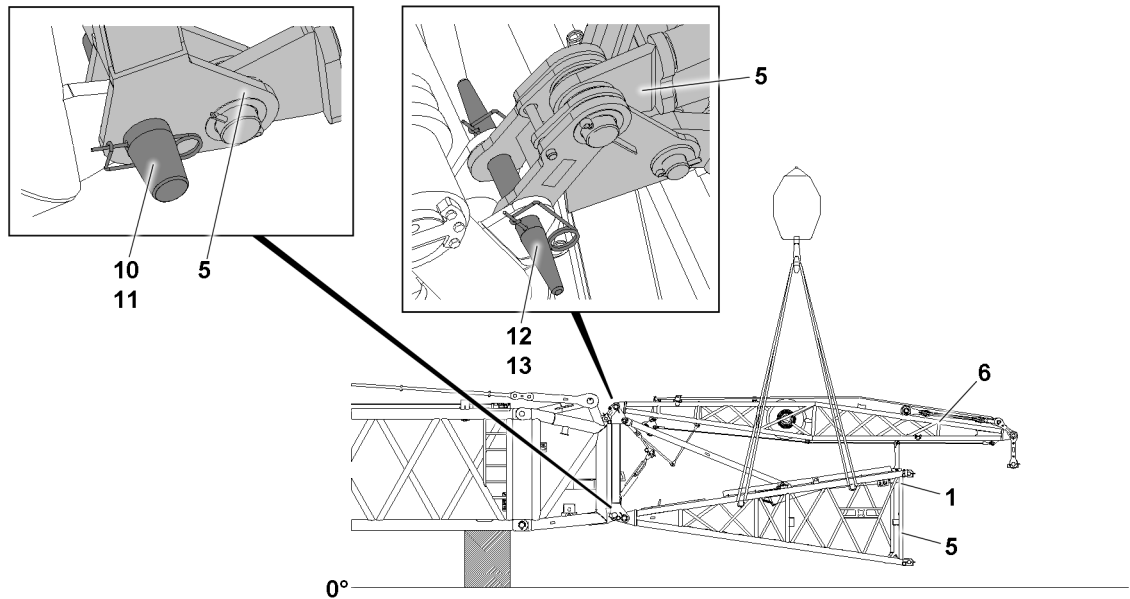

Fig.147729: Unpinning the F-assembly unit

Make sure that the following prerequisite is met:

- The F-assembly unit **5** is properly fastened on the auxiliary crane.
- The fastening equipment is tensioned.

- ▶ Remove the retaining element **11** on both sides and unpin the pin **10**.
- ▶ Remove the retaining element **13** on both sides and unpin the pin **12**.

When all pins of the are properly unpinned on both sides:

- ▶ Swing out the F-assembly unit **5** with the auxiliary crane and take it down on the ground or on a load bearing substructure.
- ▶ Attach the rigging belts between the F-pivot section **1** and FA-frame **6**.
- ▶ Insert pin **10** and pin **12** again and secure.

8.5 Disassembly variant V2 — Disassembling the F-jib completely as the F-assembly unit with the F-end section (maximum length 12 m)



WARNING

Impermissible assembly length(s)!
Death, severe bodily injuries, property damage.

- ▶ Make sure that the assembly of the F-jib as a complete F-assembly unit with the F-end section does not exceed 12 m.

8.5.1 Disassembling the FAB-guy rope

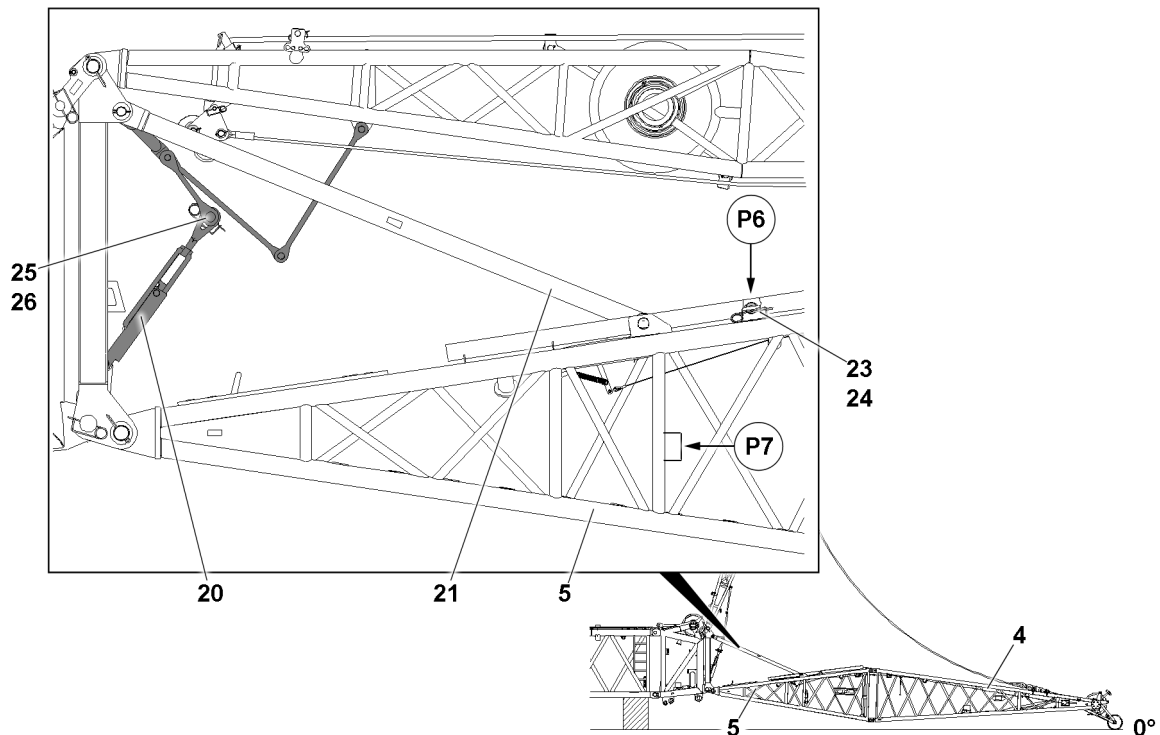

Fig.147761: F-relapse support and FA-frame relapse retainer

NOTICE

Damage of F-relapse support!

If the pin **23** is not unpinned before disassembling the FAB-guy ropes from the stop position **P6**, the F-relapse retainer can be damaged.

- ▶ Make sure that the pin **23** is unpinned before disassembling the FAB-guy ropes from the stop position **P6**.
- ▶ Unpin the pin **23** from the stop position **P6** and insert it in the park position at point **P7** and secure.

NOTICE

Danger of property damage!

If the FA-frame relapse retainer is not separated, then it will be damaged during erection of the FA-frame.

- ▶ Make sure that the FA-frame relapse retainer is separated during the erection of the FA-frame.



WARNING

Falling and swinging FA-frame relapse retainer!

The FA-frame relapse retainer consists of tension lugs and a turnbuckle.

The turnbuckle **20** of the FA-frame relapse retainer can fall down due to its own weight during unpinning.

Death, severe bodily injuries, property damage.

- ▶ Make sure when unpinning the FA-frame relapse retainer, that the turnbuckle **20** is safely held.
- ▶ Assembly personnel must be at the side of the assembly unit.

Separate the FA-frame relapse retainer:

- ▶ Remove the retaining element **26** and unpin the pin **25**.
- ▶ Take the turnbuckle **20** down.
- ▶ Insert the pin **25** again and secure with the retaining element **26**.

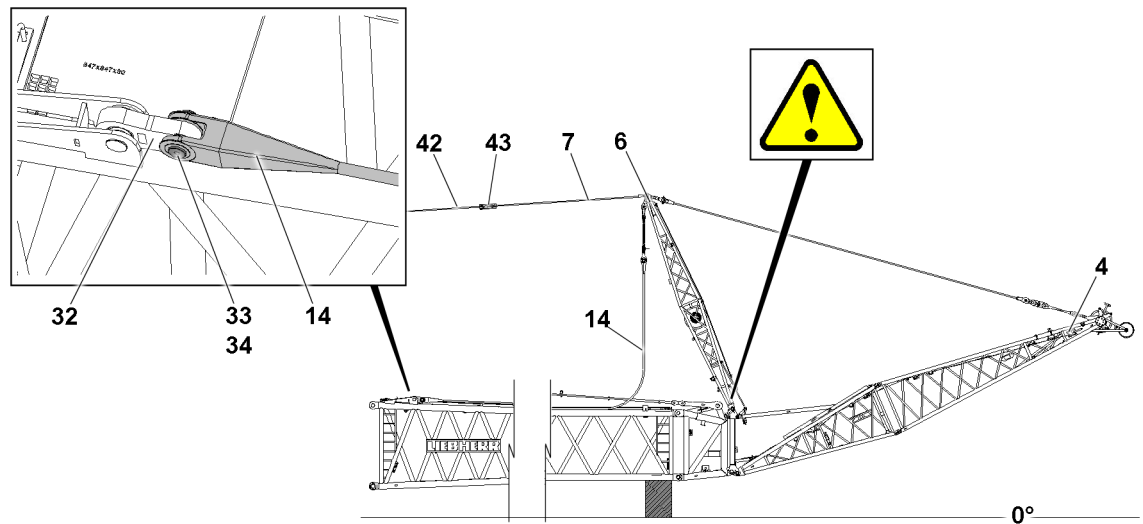

Fig.147762: FAB-guy ropes

- ▶ Release the fastening rope 7 on the FA-frame 6.
- ▶ Connect the fastening rope 7 of the FA-frame 6 using the lock 43 with the hoist rope 42.

NOTICE

Danger of property damage!

When swinging the FA-frame 6 in direction of the main boom there is a danger of collision of the FA-frame with the attachment parts of the L-end section or the F-connector head.

- ▶ When swinging the FA-frame, a guide must be used.
- ▶ The guide must be in constant visual and acoustic contact with the crane operator.

- ▶ Spool the hoist rope 42 up until the FAB-guy rope 14 can be unpinned in the pin location.

Unpin the FAB-guy rope 14 from the FAB-lugs 32 of the L-intermediate section:

- ▶ Remove the retaining element 34 and unpin the pin 33.
- ▶ Take down the FAB-guy rope 14 to the side from the boom.
- ▶ Unpin the second FAB-guy rope.

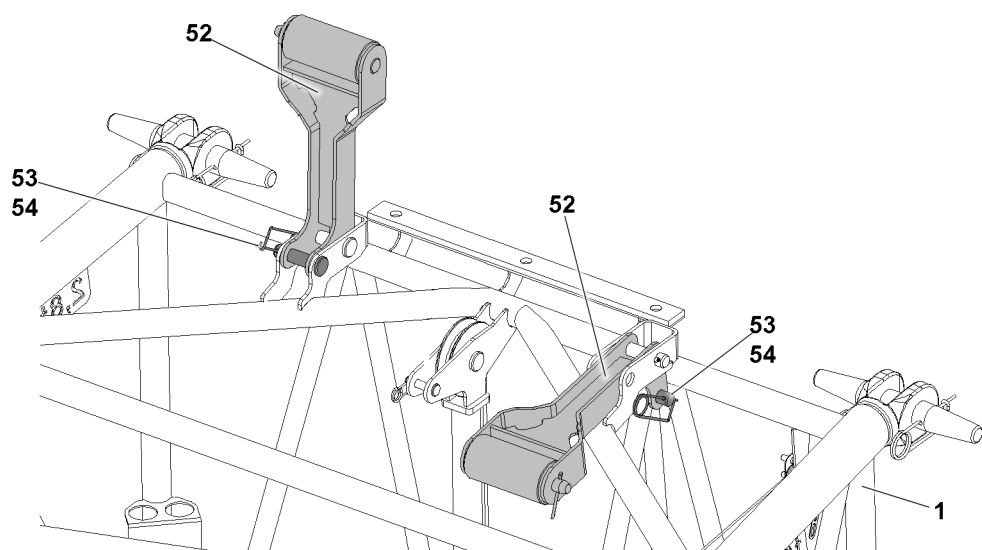

Fig.147736: Support frames

**WARNING**

Falling support frames!

The support frame **52** can fall down due to its own weight when pinning it.
Death, severe bodily injuries, property damage.

- ▶ Make sure that the support frame **52** is held during pinning.
- ▶ Assembly personnel must be at the side of the assembly unit.

Swing the support frame **52** into the transport position:

- ▶ Remove the retaining element **54** and unpin the pin **53**.
- ▶ Set up the support frame **52**.
- ▶ Insert the pin **53** again and secure with the retaining element **54**.
- ▶ Set up the second support frame **52**.

8.5.2 Taking the FA-frame down

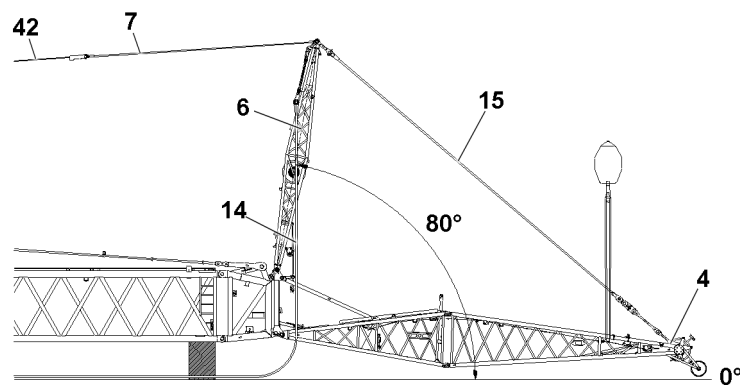

Fig.147763: Lowering the FA-frame to the front in direction of the F-pivot section

NOTICE

Damage to the fiber guy ropes!

Depending on the degree of severity, a damaged fiber guy rope can rip off in crane operation.

- ▶ Make sure that the fiber guy ropes are not kinked, crushed or damaged in any other way when taking down the FA-frame.
- ▶ If visible slight damage is determined on a fiber guy rope, observe chapter 8.16 and thoroughly inspect the rope.
- ▶ Make sure that a damaged fiber guy rope will only continued to be used, depending on the scope of the damage, after it has been thoroughly inspected and released by the rope manufacturer.

Make sure that the following prerequisite is met:

- The FAB-guy ropes are separated.
- ▶ Lower the FA-frame **6** with the hoist rope **42** in direction of the F-jib until the angle between the FA-frame and the main boom is approx. 80° and the F-jib lies on the ground.
- ▶ Fasten the F-jib to the auxiliary crane.

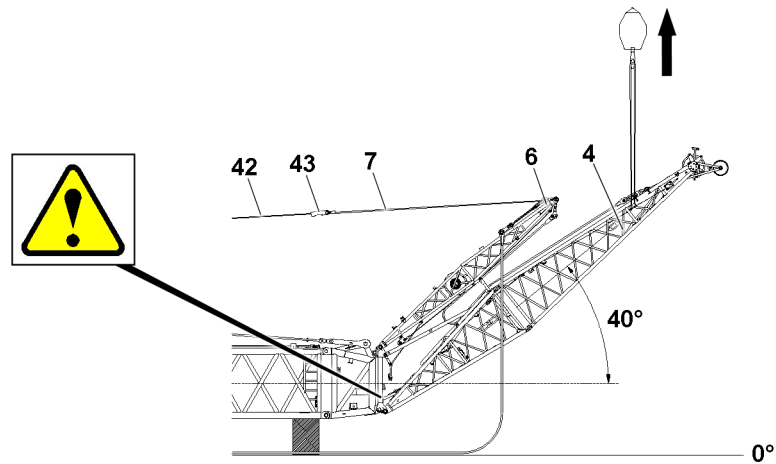

Fig.147747: Pulling up the F-assembly unit with F-end section

- ▶ Lower the FA-frame 6 with the hoist rope 42 in direction of the F-jib until the angle between the FA-frame 6 and the main boom is approx. 40°.

NOTICE

Danger of collision on the F-pivot point!

When lifting the F-assembly unit with the F-end section in direction of the main boom there is a danger of collision of the FA-pivot section with the attachment parts of the F-pivot point.

- ▶ When lifting the F-assembly unit with the F-end section, a guide must be used.
- ▶ The guide must be in constant visual and acoustic contact with the crane operator.

- ▶ Pull up the F-assembly unit with the F-end section with the auxiliary crane to the FA-frame 6.

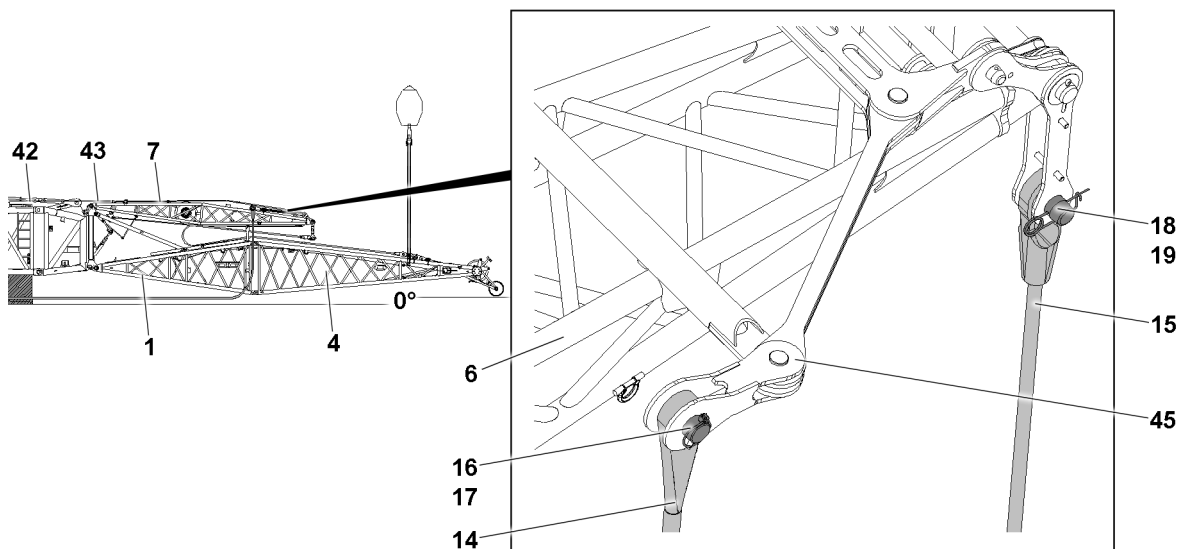

Fig.147764: Taking the F-assembly unit with F-end section down

NOTICE

Danger of slack rope formation!

When spooling the hoist rope 42 out, slack rope can form.

- ▶ When spooling out the hoist rope 42, make sure there is no slack rope.

When the F-assembly unit with the F-end section is safely held with the auxiliary crane:

- ▶ Spool the hoist rope 42 out until the hoist rope 42 is relieved.

- ▶ Take the F-assembly unit down with the F-end section on the ground with the auxiliary crane.
- ▶ Separate the hoist rope **42** and the fastening rope **7**: Open the lock **43**.
- ▶ Fasten the fastening rope **7** on the transport retainer on the FA-frame **6**.
- ▶ Remove the auxiliary crane on the F-end section **4**.



WARNING

Falling FAB-guy rope!

The FAB-guy rope **14** can fall down due to its own weight when pinning it. Death, severe bodily injuries, property damage.

- ▶ Make sure that the FAB-guy rope **14** is held during pinning.
- ▶ Assembly personnel must be at the side of the assembly unit.

Unpin the FAB-guy rope **14** on the swing **45** on the FA-frame **6**:

- ▶ Remove the retaining element **17** and unpin the pin **16**.
- ▶ Take the FAB-guy rope **14** down.
- ▶ Unpin the second FAB-guy rope.
- ▶ Fasten the F-guy rods **15** to the transport retainers on the F-pivot section. (If necessary, unpin the F-guy ropes **15** on the F-end section **4** and on the FA-frame **6** and remove, see the section Disassembly variant V1.

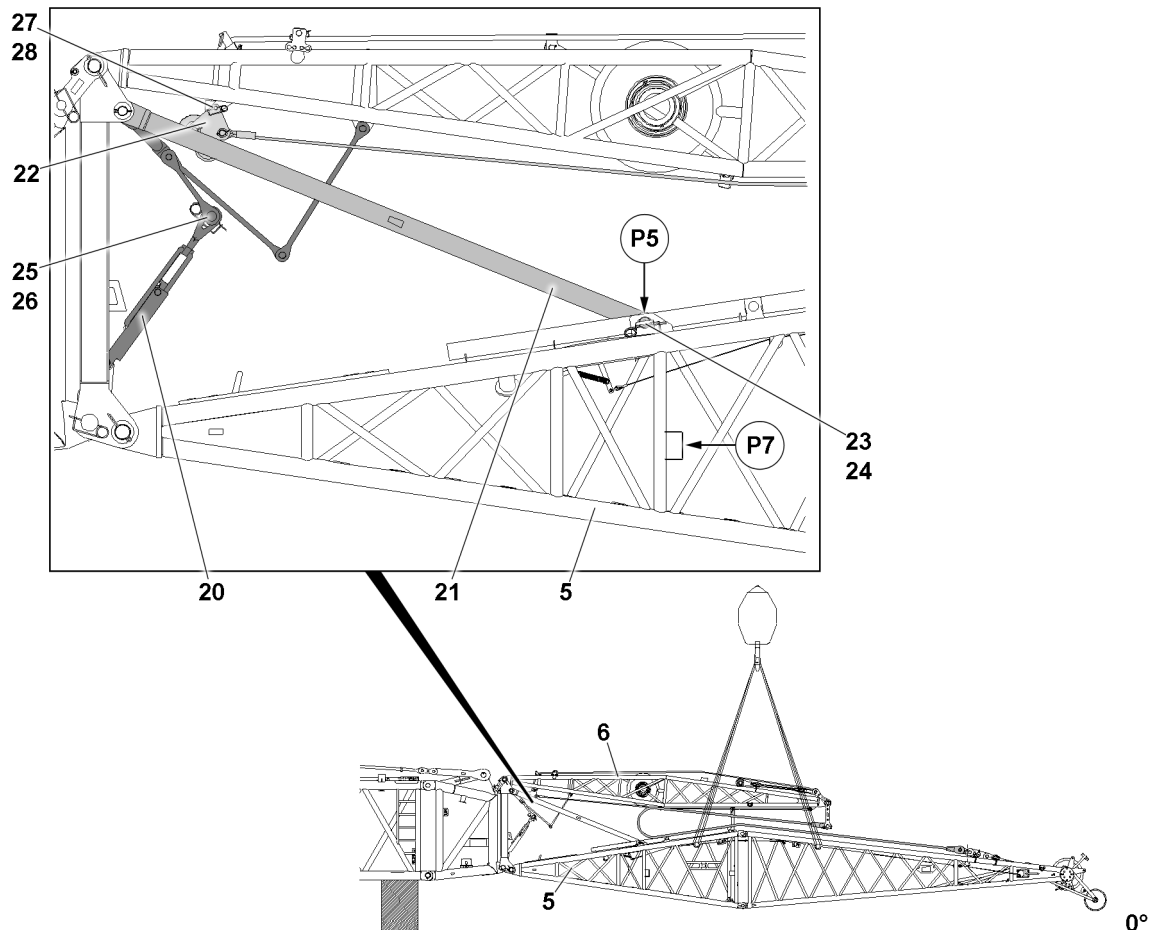

Fig.147765: FA-frame relapse retainer and F-relapse support

- ▶ Fasten the F-assembly unit with the F-end section to the auxiliary crane.

When the F-assembly unit is properly fastened with the F-end section on the fastening points to the auxiliary crane:

- ▶ Slowly and carefully lift the F-assembly unit with F-end section with the auxiliary crane until the pin bores of the F-relapse support **21** align on the pin point **P5**.

- ▶ Unpin the pin **23** from the park position at point **P7**: Remove the retaining element **24** and unpin the pin **23**.
- ▶ Insert the pin **23** at point **P5** in the transport position and secure with the retaining element **24**.
- ▶ Pin the FA-frame relapse retainer: Swing the turnbuckle **20** in, insert the pin **25** and secure with the retaining element **26**.

8.5.3 Disassembling the F-assembly unit with F-end section

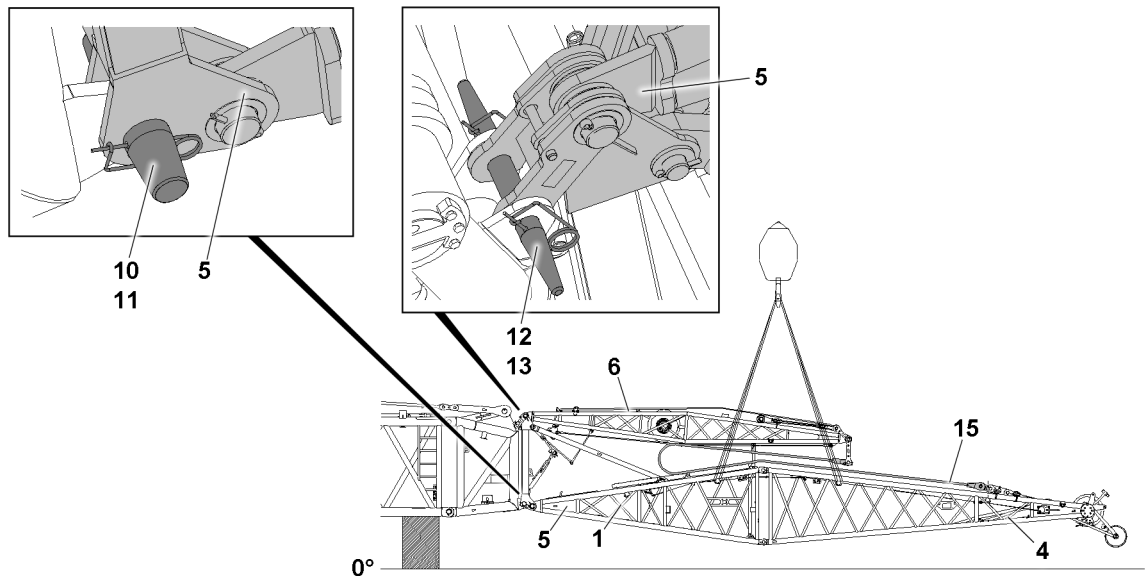

Fig.147743: Unpinning the F-assembly unit with the F-end section on the L-end section or on the F-connector head

When the F-assembly unit with the F-end section is safely held in position by the auxiliary crane:

- ▶ Remove the retaining element **11** on both sides and unpin the pin **10**.
- ▶ Remove the retaining element **13** on both sides and unpin the pin **12**.

When all four pins between the F-assembly unit with the F-end section and L-end section or F-connector head are unpinned:

- ▶ Swing out the F-assembly unit with F-end section with the auxiliary crane and take it down.
- ▶ Remove the auxiliary crane.
- ▶ Attach the rigging belts properly between the F-pivot section **1** and FA-frame **6**.
- ▶ Tighten the rigging belts.
- ▶ Insert and secure the pin **10** and pin **12** on both sides in the park position.

Empty page!

LWE/LR 1600-2-008/18109-09-02/en

5.14 Roller set

1	W-connector head components	3
2	SW-end section and roller set components	3
3	Combinations of boom heads / end sections with roller sets	4
4	Assembling / disassembling the roller set	5

Fig.195219

LWE/LR 1600-2-008/18109-09-02/en

1 W-connector head components

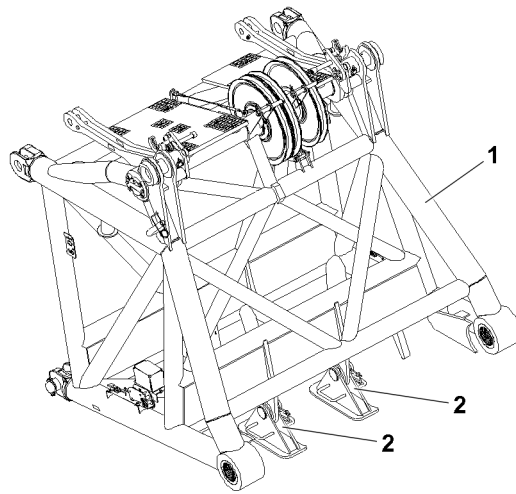

Fig.149302: W-connector head components

- 1 W-connector head
- 2 Foot

2 SW-end section and roller set components

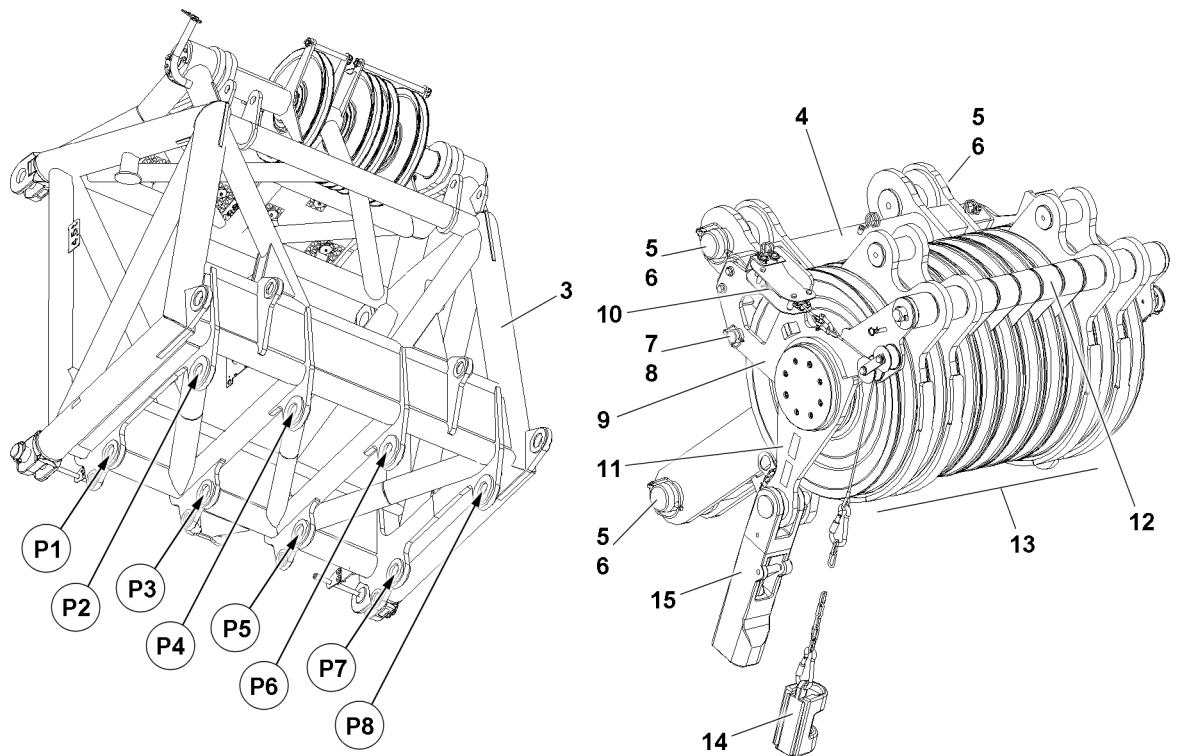

Fig.149303: SW-end section with pin points and roller set components

- 3 SW-end section
- 4 Roller set
- 5 Pin
- 6 Retaining element
- 7 Rope retaining pin
- 10 Hoist limit switch
- 11 Rope fixed point
- 12 Rope guard pulleys
- 13 Rope pulleys
- 14 Hoist limit switch weight

For continuation of legend for illustrations, see next page

LWE/LR 1600-2-008/18109-09-02/en

- 8 Retaining element
9 Retainer

15 Lock

3 Combinations of boom heads / end sections with roller sets



Note

- The use of roller sets on the corresponding boom heads / end sections is described in the load chart in section „Boom configurations for the calculation of load charts“, see the load chart manual.

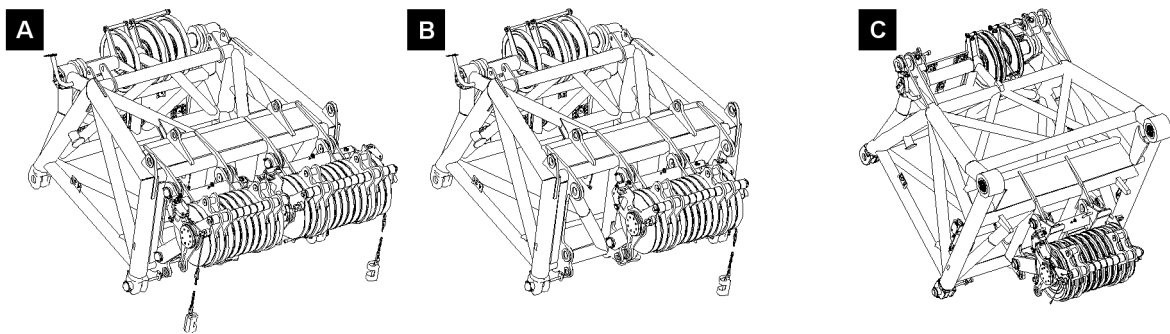

Fig.149300: Roller sets on the SW-end section and on the W-connector head

- A** SW-end section with roller sets 320 t and 300 t **C** W-connector head with roller set 300 t
B SW-end section with roller set 320 t



WARNING

The crane can topple over!

If the roller sets are improperly assembled, the crane can topple over.
Death, severe bodily injuries, property damage.

- Select roller sets according to the operating modes, as specified in the load charts.
► Observe the instructions in the erection and take-down charts.

The following applies for the SW-end section:

- The roller set 320 t can be assembled individually (illustration **B**) or in combination with the roller set 300 t (illustration **A**) on the SW-end section.



WARNING

Collision of the W-pivot section with the roller set 300 t !

When luffing down the W-lattice jib, the W-pivot section can collide with the roller set 300 t.

The W-pivot section and the roller set will be damaged.

Death, severe bodily injuries, property damage.

- The luffing down procedure must be monitored by a guide.

4 Assembling / disassembling the roller set

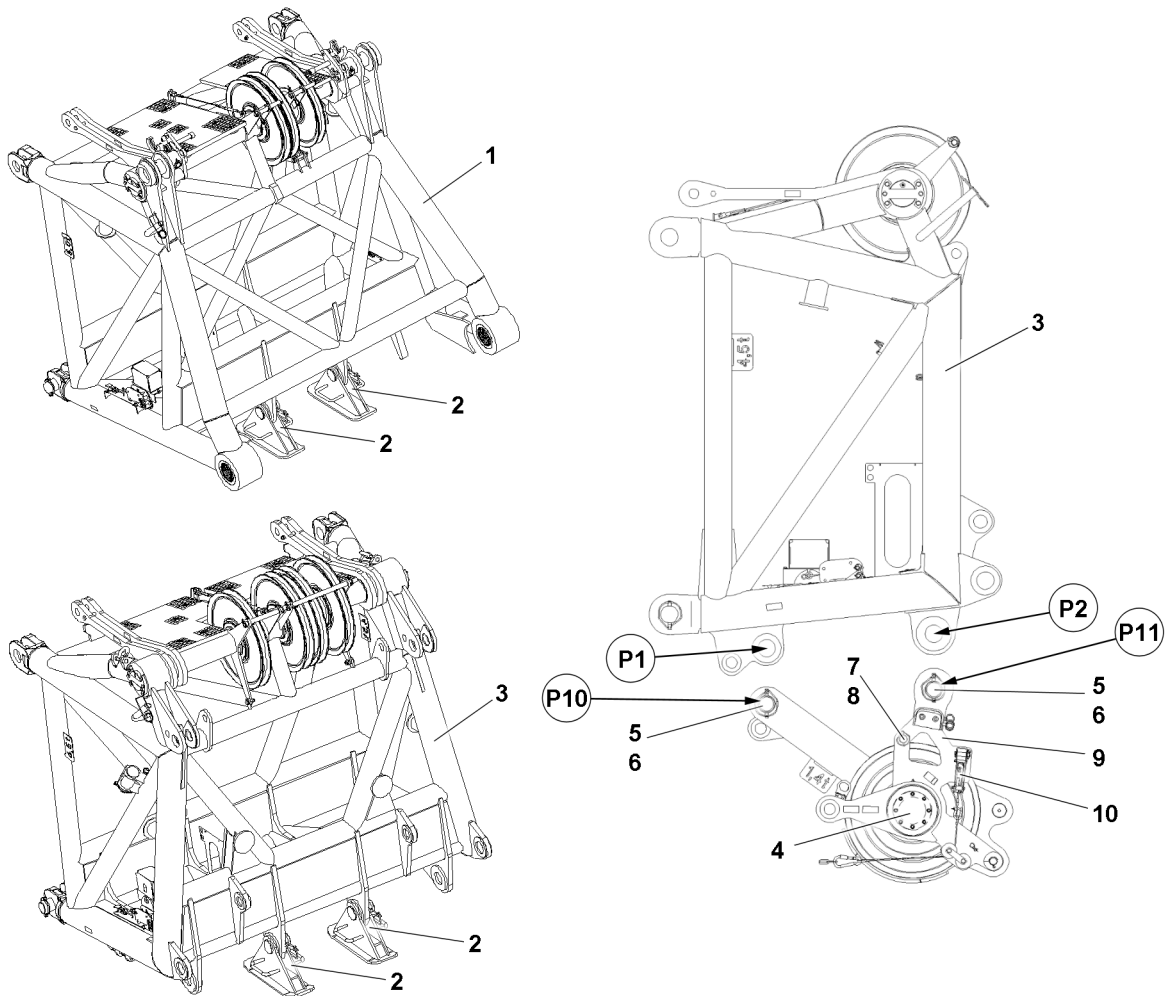

Fig.149304: Assembling the roller set on the SW-end section

1 W-connector head

3 SW-end section

Make sure that the following prerequisites are met:

- The pins **5** are released and unpinned on the roller set **4**.
- The roller sets **4** and feet **2** on the SW-end section **3** or the W-connector head **1** are disassembled.

4.1 Assembling the roller set



Note

- ▶ The weight of the roller set 320 t is 1.5 t.
- ▶ The weight of the roller set 300 t is 1.4 t.



Note

- ▶ The assembly of the roller set is described based on the sample of the SW-end section.



WARNING

The crane can topple over!

If the roller sets are improperly assembled, the crane can topple over.
Death, severe bodily injuries, property damage.

- ▶ Select the roller sets according to the operating modes, as specified in the load charts.
- ▶ Observe the instructions in the erection and take-down charts.

**WARNING**

Overload of the boom system!

If only one roller set is used and the roller set is assembled off centre of the end section, then the boom system can be overloaded.

Death, severe bodily injuries, property damage.

If only one roller set is used:

- ▶ Assemble the roller set in the center of the end section on the respective pin points (point **3**, point **4**, point **5**, point **6**).

**Note**

Assembly of two roller sets on the SW-end section!

- ▶ One roller set is assembled on the pin points (point **1**, point **2**, point **3**, point **4**).
- ▶ The other roller set is assembled on pin points (point **5**, point **6**, point **7**, point **8**).

- ▶ Position the roller set **4** on the SW-end section **3** or the W-connector head **1** in such a way that the pin bores align.

When the pin bores align:

- ▶ Insert the pins **5** in the pin points from the outside to the inside and secure with the retaining element **6**.
- ▶ Pin and secure the lock **15** on the rope fixed point **11**.

**Note**

- ▶ Reeve the hoist rope in according to the separately supplied reeving plans.

- ▶ Reeve the hoist rope in correctly.

**Note**

- ▶ Establish the electrical connections on the SW-end section and / or the W-connector head according to the electrical wiring diagram.

- ▶ Establish the electrical connections.
- ▶ Attach the hoist limit switch weight **14**.

Result:

- The roller set **4** is assembled.

4.2 Disassembling the roller set

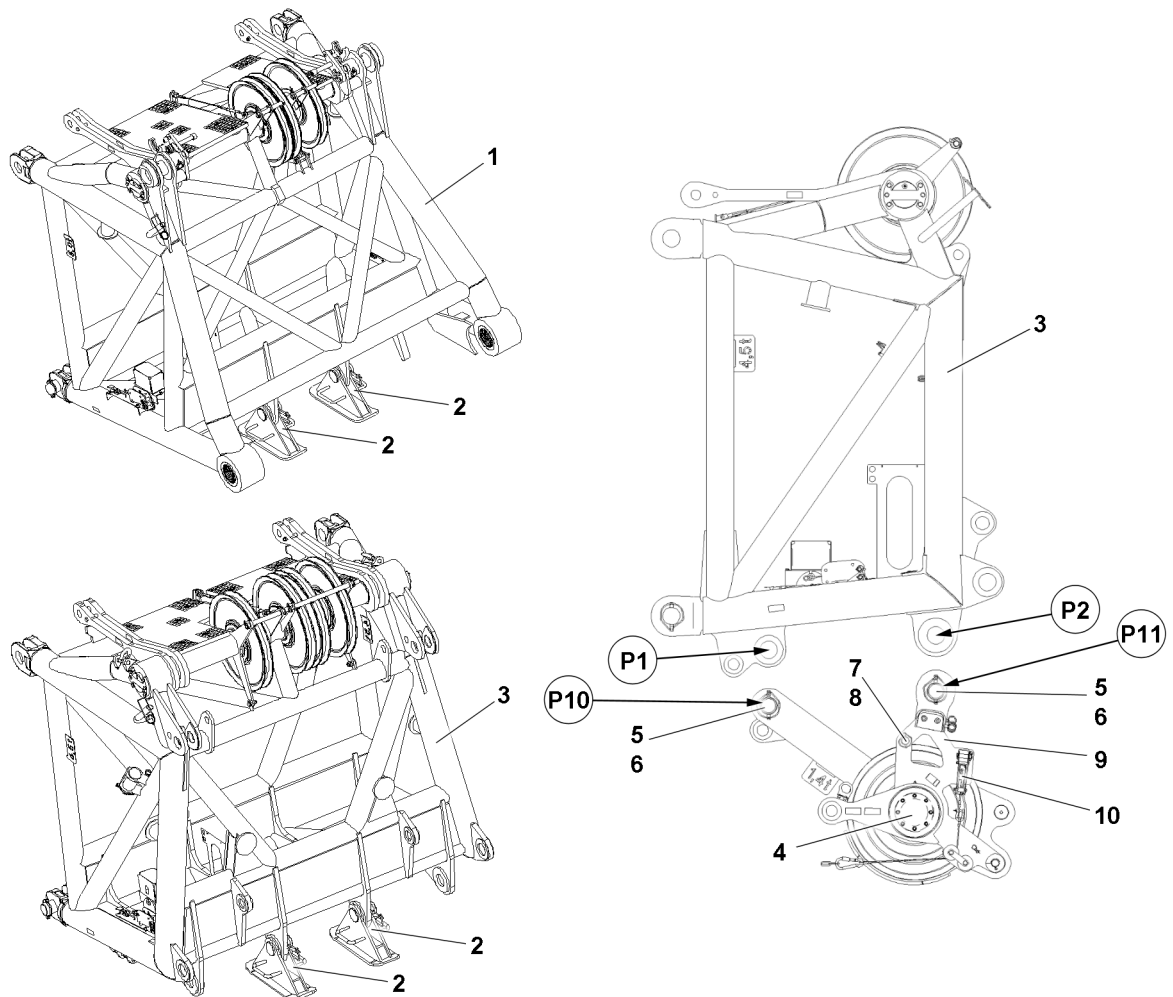

Fig.149304: Disassembling the roller set



Note

- ▶ The weight of the roller set 320 t is 1.5 t.
- ▶ The weight of the roller set 300 t is 1.4 t.



WARNING

Danger of crushing!

When luffing the boom system down, personnel can be caught and crushed.

Death, severe bodily injuries, property damage.

- ▶ Make sure that no personnel is within the danger zone when luffing the boom system down.
- ▶ Luff the boom system down with utmost caution.

When the boom head with the roller set is located just above the ground:

- ▶ Reeve the hoist rope out.

When the hoist rope is properly reeved out:

- ▶ Luff the boom down until the roller set is laying on the ground.
- ▶ Fasten the roller set to the auxiliary crane and secure it.



Note

- ▶ Disconnect the electrical connections on the SW-end section and / or the W-end section.
- ▶ Disconnect the electrical connections.

- ▶ Remove the retaining element **6** and unpin the pin **5**.
- ▶ Luff the boom up.

Result:

- The roller set **4** is removed.
- ▶ Remove the auxiliary crane.

5.17 SWF-boom combination

1	Component overview	3
2	Assembling SWF-boom	5
3	Operating the crane	21
4	Disassembling the SWF-booms	23

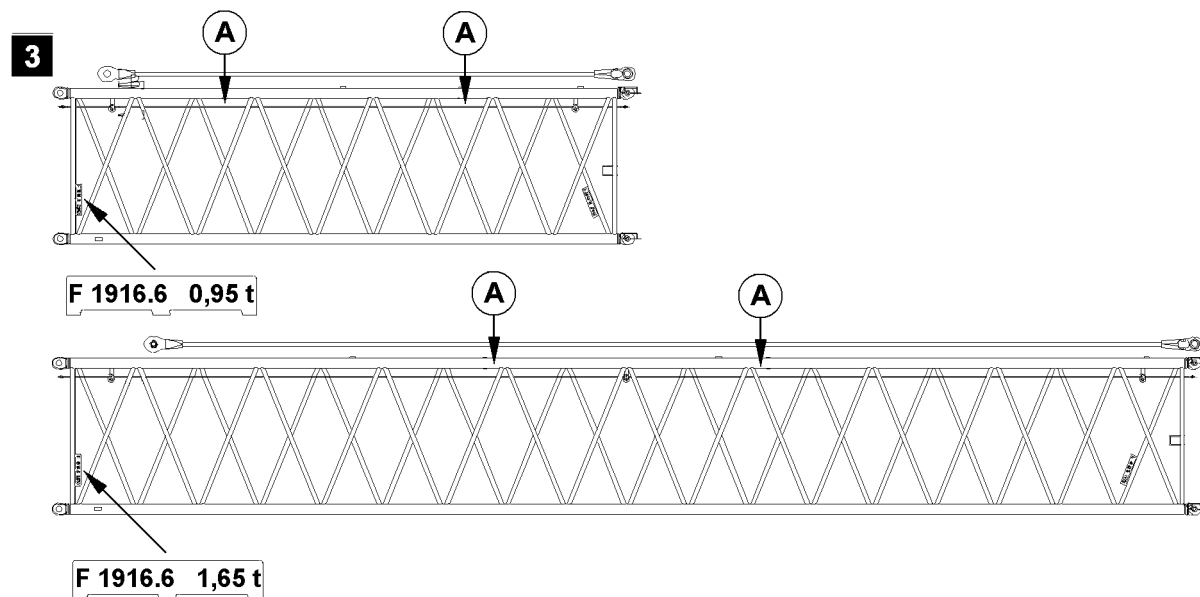
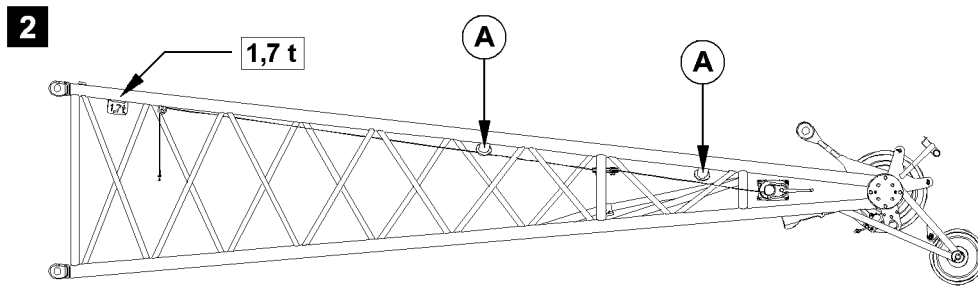
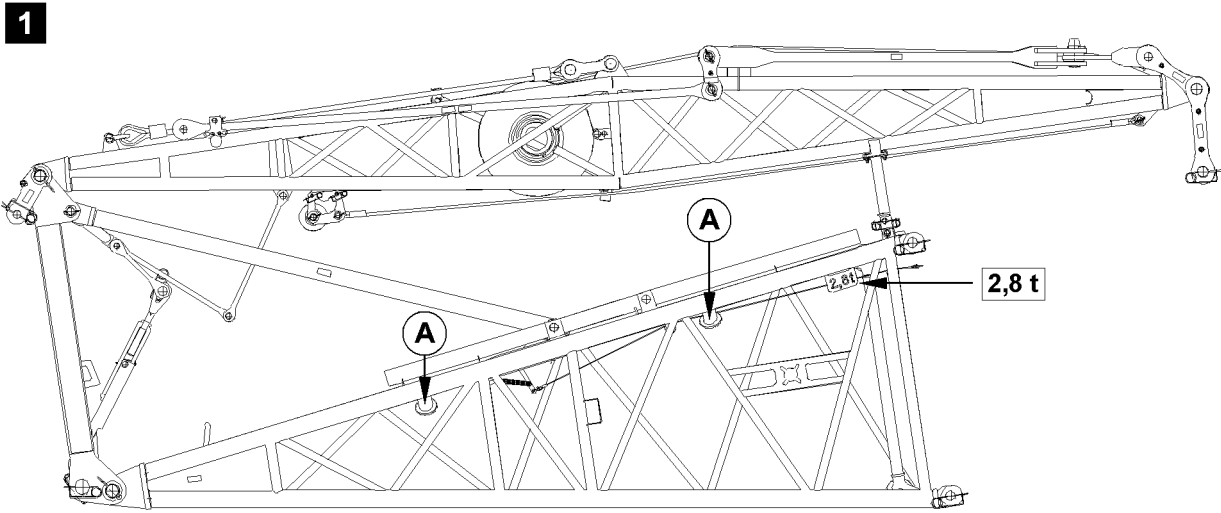

Fig.105063

1 Component overview

1.1 Fastening points



WARNING

Danger of accident due to incorrect attachment!

Life-threatening situations can arise due to improper or incorrect attachment of the corresponding components!

► The corresponding components must be attached on the intended points **A!**



Note

► For assembly or disassembly, tackle with a strand length of at least **4 m** must be used!

1.2 F-assembly unit, see illustration 1

Description	Abbreviation	Weight
F-assembly unit	—	2.8 t

1.3 F-end section, see illustration 2

Description	Abbreviation	Weight
F-end section	—	1.7 t

1.4 F-intermediate sections 6 m and 12 m , see illustration 3

Description	Abbreviation	Weight
F-intermediate section (6 m) with guy ropes	F 1916.6	0.95 t

Description	Abbreviation	Weight
F-intermediate section (12 m) with guy ropes	F 1916.6	1.66 t

Fig.195219

LWE/LR 1600-2-008/18109-09-02/en

2 Assembling SWF-boom



DANGER

The crane can topple over!

The boom combinations must be assembled according to the „separately supplied set up drawings“! Any other arrangement of the lattice sections and the guy rods than specified in the set up drawings is prohibited!

At assembly of the intermediate sections, it must be observed that they are assembled according to their identification!

- ▶ The boom combinations must be assembled according to the separately supplied rod and assembly plans!



WARNING

Risk of falling!

During assembly / disassembly work, personnel must be secured with appropriate aids to prevent them from falling. If this is not observed, assembly personnel could fall and suffer severe or fatal injuries!

- ▶ All assembly work must be carried out using suitable aids (lifting platforms, scaffolding, ladder, auxiliary crane, etc.)!
- ▶ If work cannot be carried out on the ground or using such aids, then assembly personnel must be secured with the personal fall arrest system (see Crane operating instructions, chapter 2.04) to protect against falling! The personal fall arrest system must be attached in the corresponding fastening points on the crane (see Crane operating instructions, chapter 2.06).
- ▶ If railings are present on the components, then they must be brought into the corresponding position and secured for assembly / disassembly.
- ▶ Step on aids and fall arresters only with clean shoes!
- ▶ Keep aids and fall arresters clean and free from snow and ice!



WARNING

Falling components!

If unsecured or non-supported components are assembled or disassembled, they can fall down. Personnel can be severely injured or killed!

- ▶ During pinning and unpinning of the lattice sections, it is prohibited for anyone to remain **under** or **on** the components as well as within the entire danger zone!
- ▶ Support the boom and components before pinning / unpinning!
- ▶ Pin or unpin both pins lying in a horizontal, i.e. **left** and **right**!
- ▶ Secure the pins in the bearing points and in the receptacles!
- ▶ Do not disengage the auxiliary crane until each component is pinned on and secured!
- ▶ It is prohibited to lean a ladder against the component being disassembled!



WARNING

Danger of crushing!

Components can swing during assembling. Hands can be crushed or severed.

- ▶ Make sure that the components do not swing back and forth during assembly!

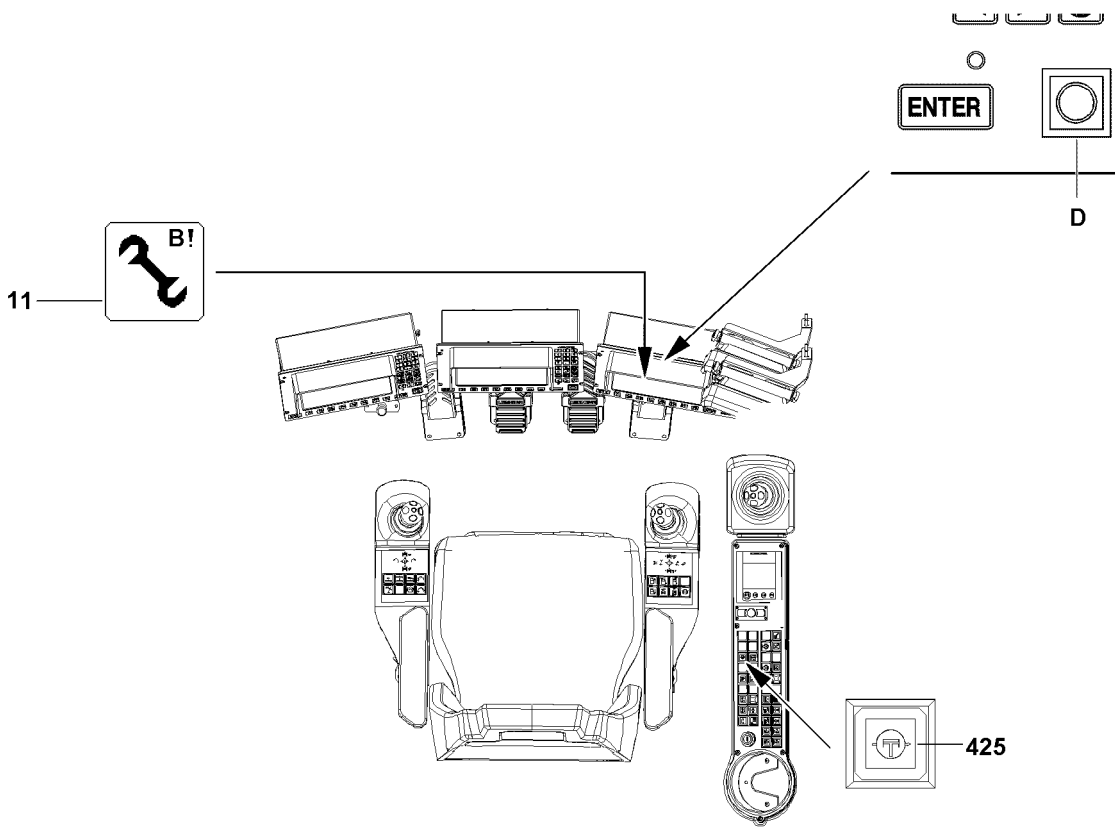
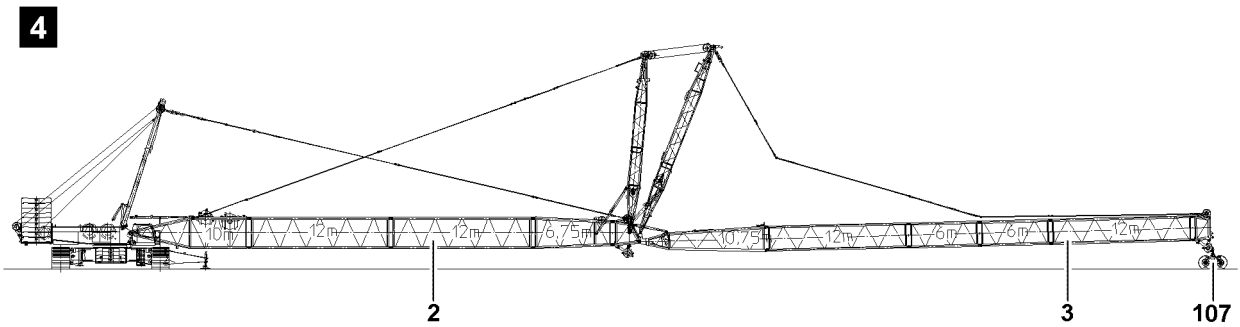

Fig.110719

LWE/LR 1600-2-008/18109-09-02/en

**WARNING**

Neglectful inspection and maintenance on guy rods!

If the regular inspection and maintenance of the guy rods is not carried out or is carried out only in irregular intervals, then severe accidents can occur due to existing and unrecognized damage to the guy rods!

Personnel can be severely injured or killed!

- ▶ Check the guy rods before every assembly, see Crane operating instructions, chapter 8.15!

**Note**

- ▶ By supporting the components during assembly / disassembly, ground unevenness is compensated for and the material is protected!

**WARNING**

Risk of accident!

Personnel can be severely injured or killed!

- ▶ For pinning and unpinning with the pin pulling device, observe and follow the warning guidelines, see Crane operating instructions, chapter 5.30!

NOTICE

Property damage!

- ▶ Always insert the pins of the guy rods from the „inside“ to the „outside“!

**Note**

- ▶ The S-guy rods must be assembled and secured according to the separately supplied assembly drawings!
- ▶ The numbering on the assembly drawings must be identical to the numbering on the guy rods!

See illustration 4.

Make sure that the following prerequisites are met:

- The crane is aligned in horizontal direction.
- The S-boom **2** is assembled.
- The W-lattice jib **3** lies assembled on the pulley cart **107** on the ground.
- The counterweight has been installed to the turntable according to the load chart.
- The LICCON overload protection has been set according to the data in the load chart.
- The LICCON overload protection settings have been compared with the actual crane configuration.
- The LICCON overload protection is exceeded.
- The assembly icon **11** is visible on the LICCON monitor.
- An auxiliary crane is available.

Fig.195219

LWE/LR 1600-2-008/18109-09-02/en

2.1 F-assembly conditions

**Note**

► Observe and adhere to the instructions, see Crane operating instructions, chapter 5.13!

2.2 Assembling the F-assembly unit

**Note**

► Observe and adhere to the instructions, see Crane operating instructions, chapter 5.13!

2.3 Flying assembly of F-auxiliary jib (12 m)

**Note**

► Observe and adhere to the instructions, see Crane operating instructions, chapter 5.13!

2.4 Establishing the electrical connections

**Note**

► Observe and adhere to the instructions, see Crane operating instructions, chapter 5.13!

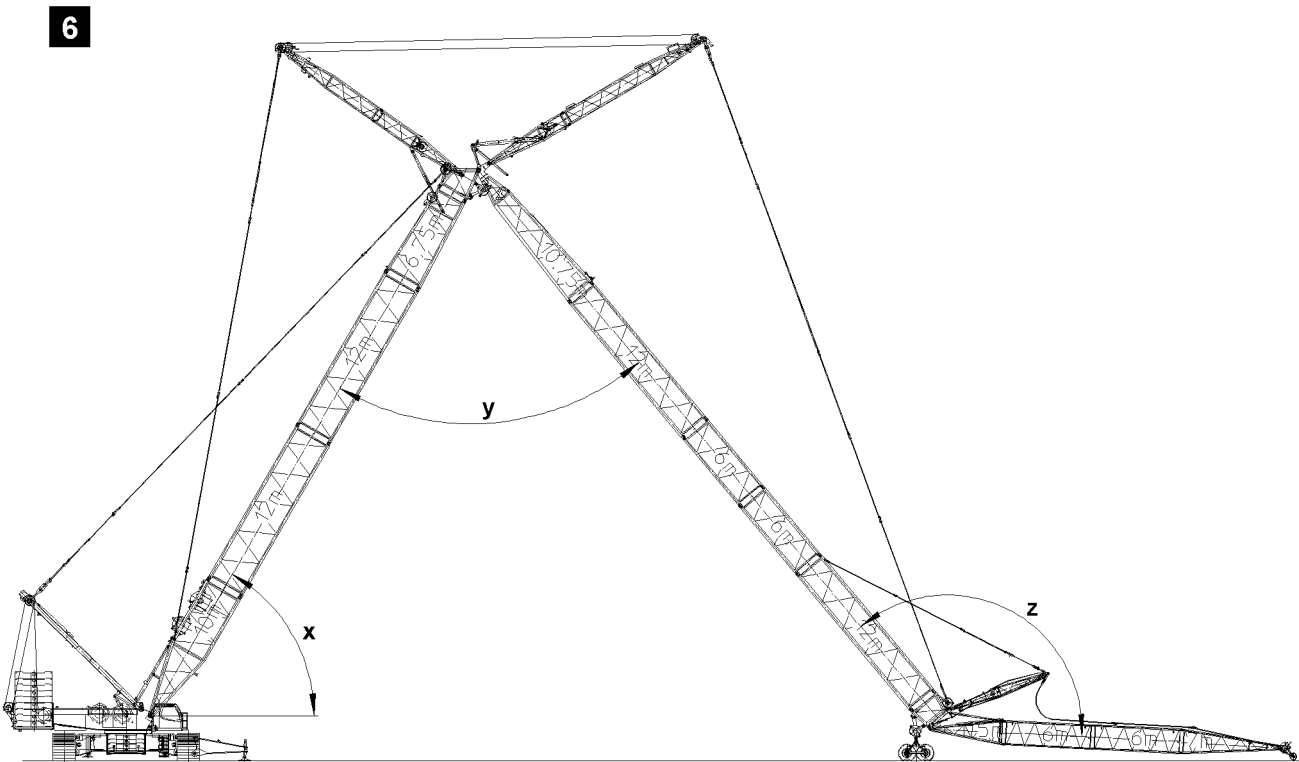
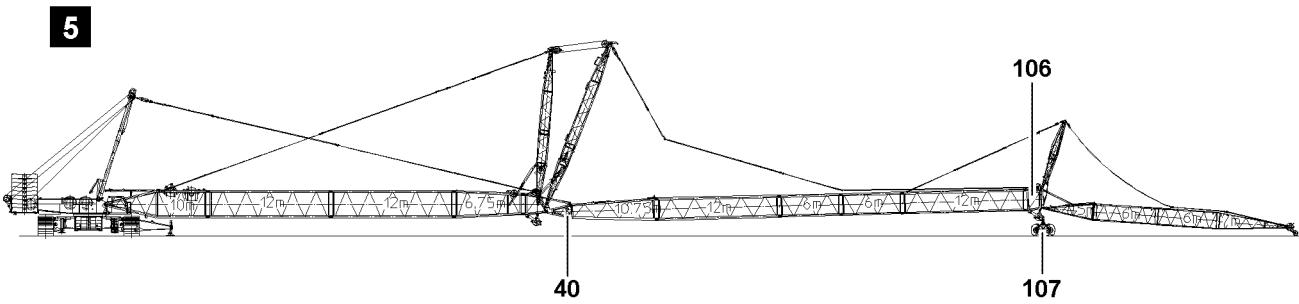
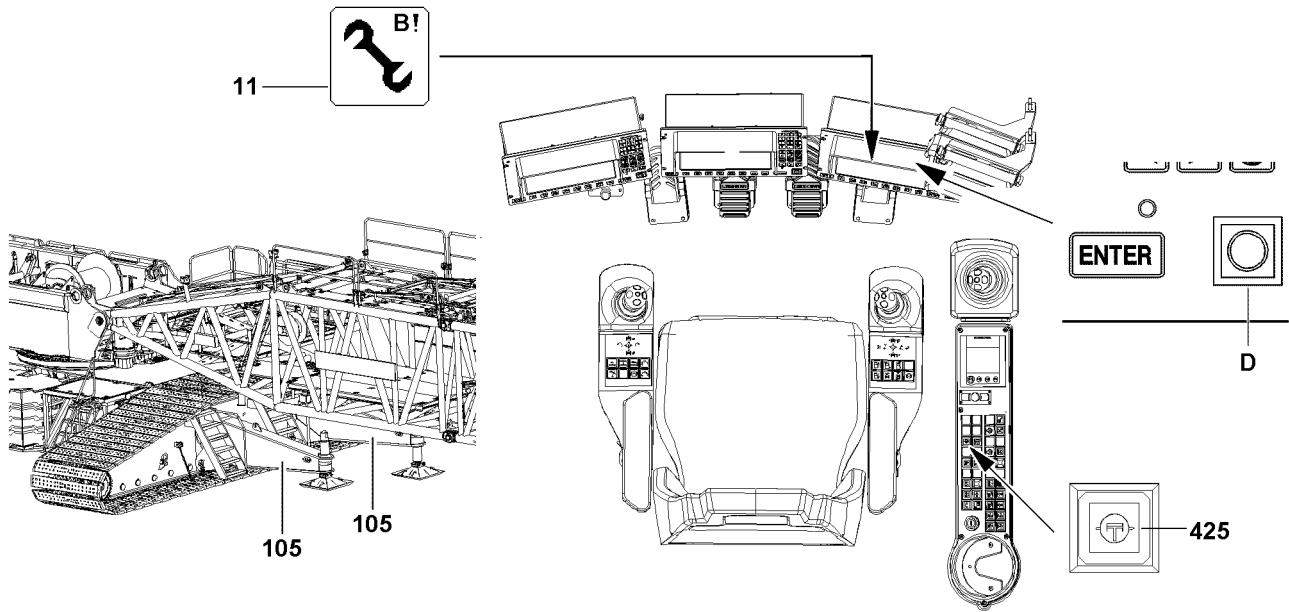

Fig.110720

LWE/LR 1600-2-008/18109-09-02/en

2.5 Erecting the SWF-booms



Note

- ▶ SWF-boom systems in stretched condition may not be completely erected!



DANGER

The crane can topple over!

- ▶ It is not permitted to turn the crane during erection!
- ▶ Observe the data in the erection and take down charts!
- ▶ Observe the Safety technical notes, see Crane operating instructions, chapter 5.01!



DANGER

The crane can topple over!

For certain boom lengths, the mechanical auxiliary supports must be assembled, see Erection and take down charts!

- ▶ The boom must be erected or taken down „to the side“ „in direction“ of the mechanical auxiliary supports **105**!
- ▶ Always erect or take down according to the data in the **Erection and take down charts**!



DANGER

Tipping lattice jib!

If the easy movement on the pendulum of the mechanical relapse support is not checked before erection or not re-established, if necessary, then the mechanical relapse support will not engage in steep lattice jib position.

As a result, the lattice jib can tip to the rear!

Personnel can be severely injured or killed!

- ▶ Check the easy movement on the pendulum **40** of the mechanical relapse support before erection.
- ▶ If the pendulum does not move easily: Make the pendulum **40** easy to move!



WARNING

The crane can topple over!

If the following conditions are not met before erecting the boom, the crane can topple over!

Personnel can be severely injured or killed!

- ▶ The lattice jib must roll on the ground with its entire weight!
- ▶ Spool the lattice jib control out so that the guy rods sag slightly!
- ▶ Do not allow slack cable to build up on the control winch!
- ▶ Extend the relapse cylinder before erection.

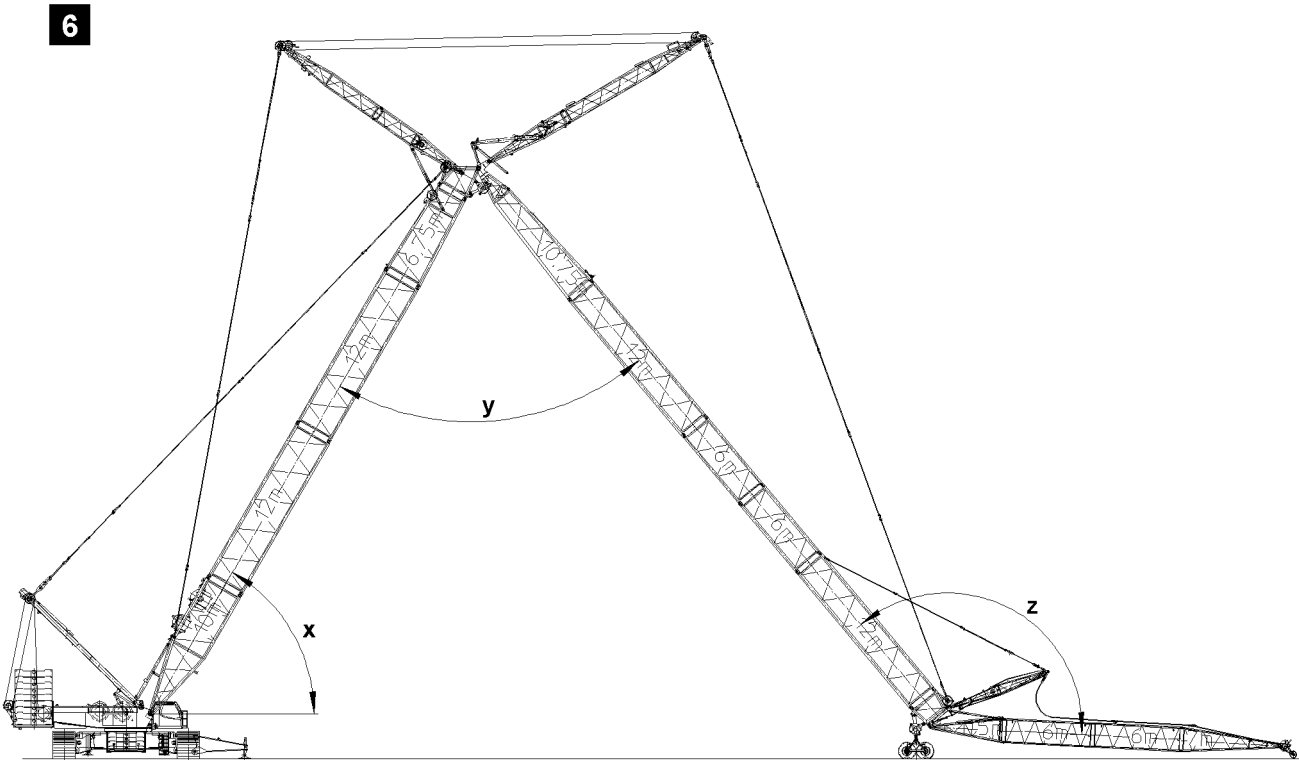
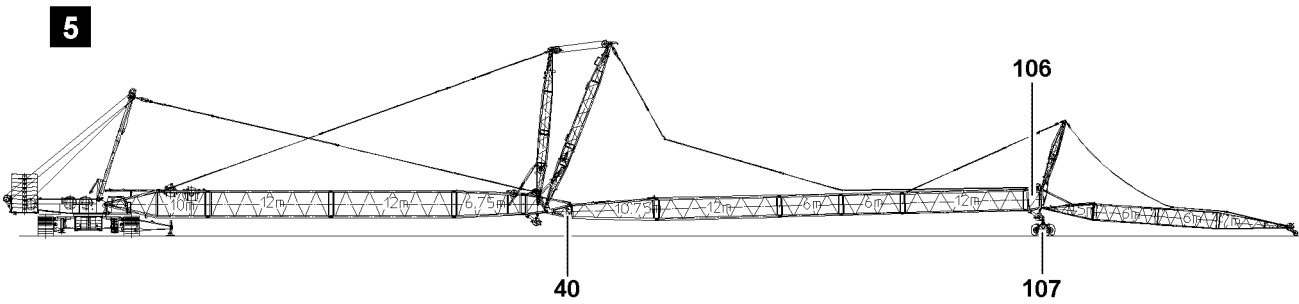
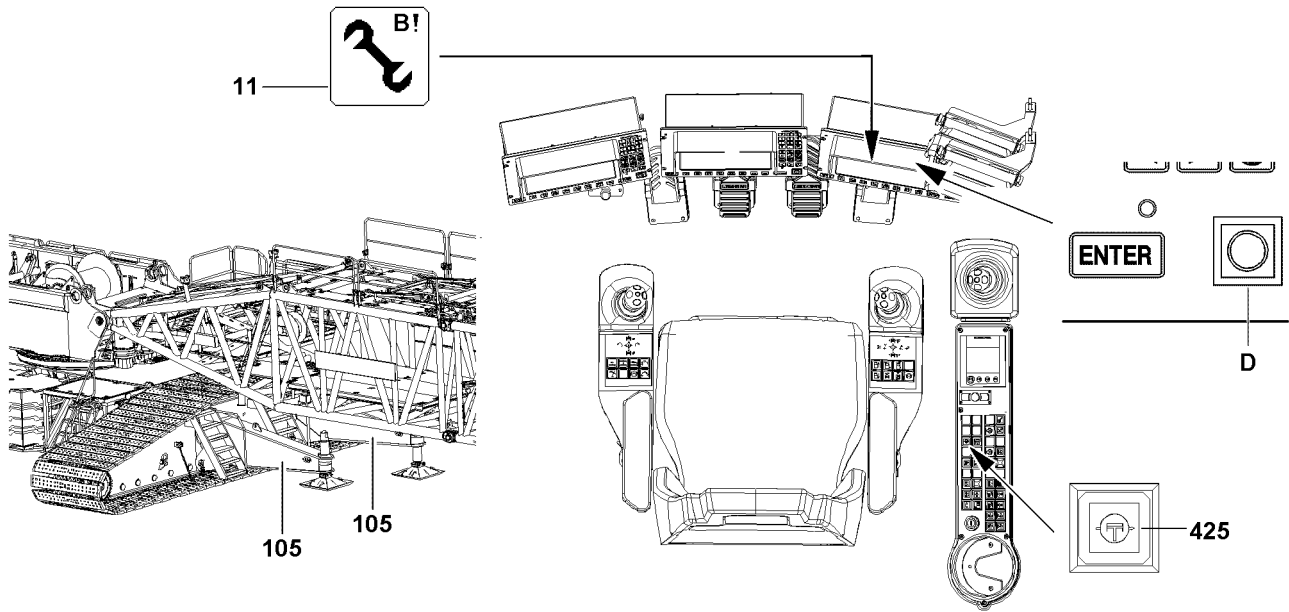

Fig.110720

LWE/LR 1600-2-008/18109-09-02/en

Make sure that the following prerequisites are met:

- The SWF-boom is fully assembled.
- The pulley cart **107** is assembled on the SW-end section **106**, illustration **5**.
- No personnel is within the danger zone.
- The crane is aligned in horizontal direction.
- All electrical connections have been established.
- All limit switches are functioning.
- The counterweight has been attached to the turntable according to the load chart.
- All pin connections have been secured.
- The hoist rope has been correctly placed in the rope pulleys and is prevented from jumping out with the rope retaining pins.
- There are no loose parts on the boom or the lattice jib.
- Boom, lattice jib and safety devices are free from snow and ice.
- The LICCON overload protection has been adjusted according to the data in the load chart.
- The LICCON overload protection settings have been compared with the actual crane configuration.
- The LICCON overload protection is exceeded.
- The assembly icon **11** is visible on the LICCON monitor.



WARNING

Falling hoist rope!

If the hoist rope is not properly secured with the corresponding length on the F-auxiliary jib before the erection procedure, then it can fall backward due to its own weight!

Personnel can be severely injured or killed!

- ▶ Reeve in the hoist rope with sufficient length on the F-auxiliary jib before the erection procedure!
- ▶ The hoist rope must be constantly monitored during erection!
- ▶ Do not step into the danger zone!



WARNING

Damage to the boom parts!

If the luffing up movement is not turned off when a warning signal sounds, then boom parts can collide!

Personnel can be severely injured or killed!

If the acoustic warning signal sounds:

- ▶ Turn the luffing up movement off.



Note

- ▶ If a warning signal sounds, an error report appears on the LICCON monitor: "Block position W/F achieved – Caution: no shut off - Danger of accident"

See illustration **6**.

The S-boom is luffed up until the warning signal sounds:

- The angle **z** between the F-auxiliary jib and W- lattice jib is 115° ,
- **or** the angle **y** between the W-lattice jib and S-boom is 45° ,
- **or** the angle **x** of the S-boom is 87° .

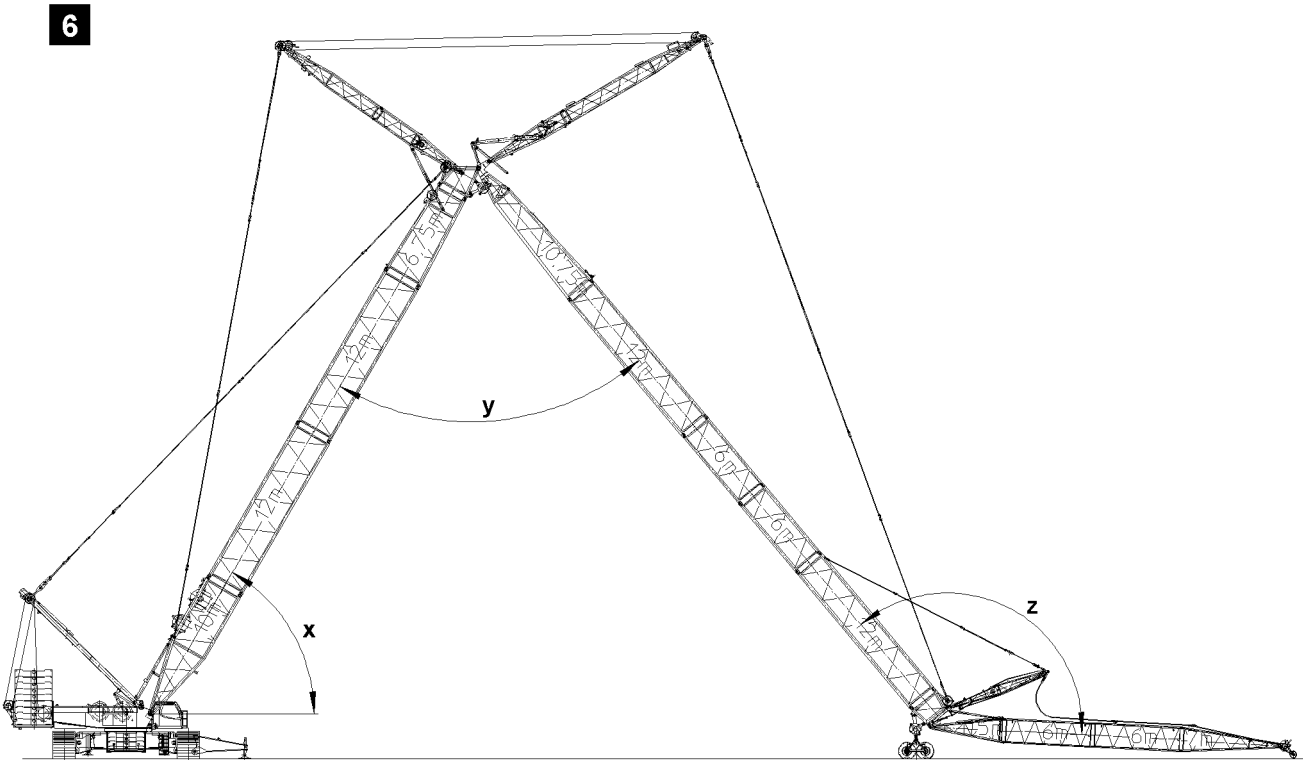
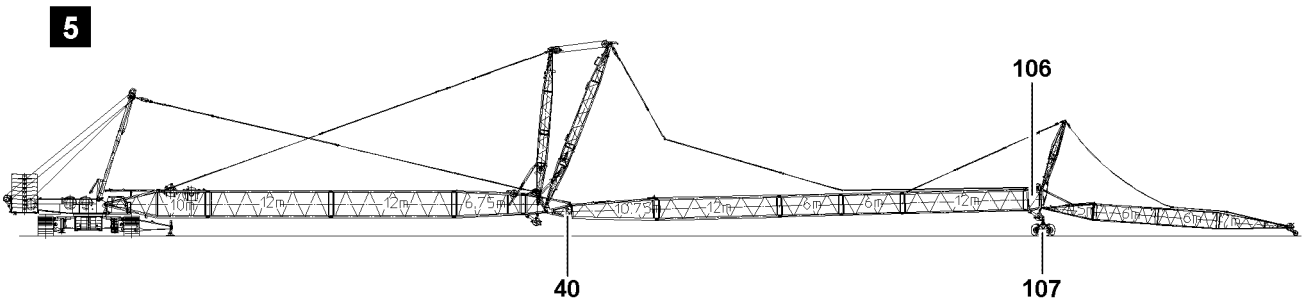
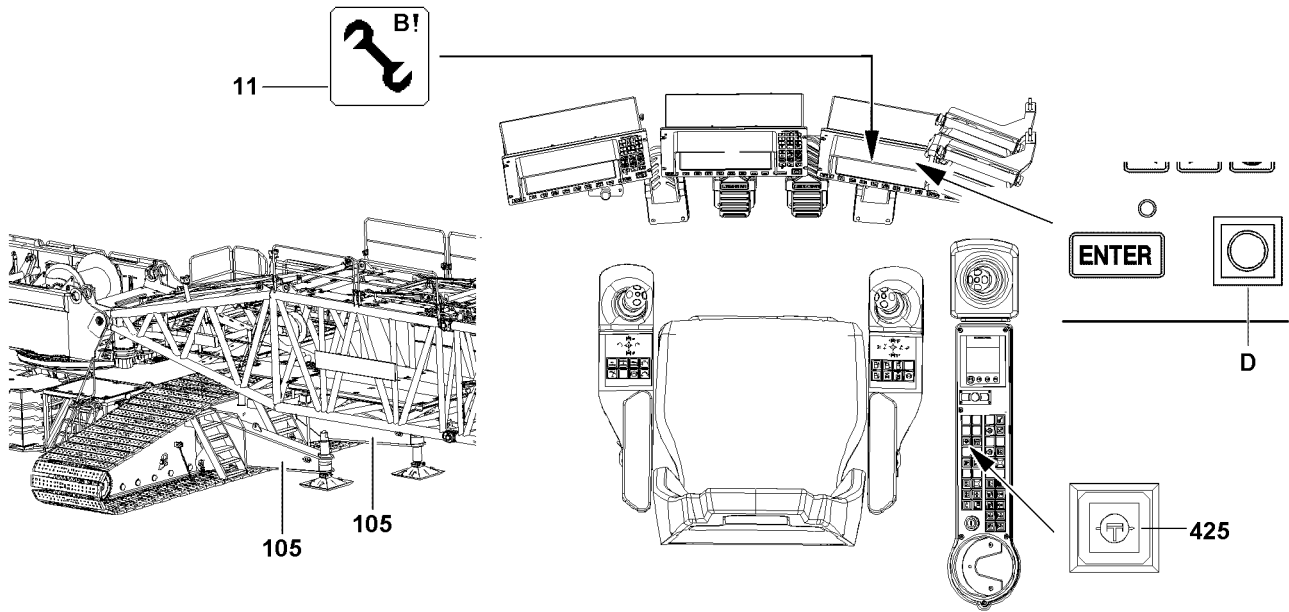

Fig.110720

LWE/LR 1600-2-008/18109-09-02/en

**Note**

- ▶ While the S-boom is luffed up, the W-guy rods must remain released so that the F-auxiliary jib remains on the ground!
- ▶ Luff the S-boom up and simultaneously spool the W-control rope out until warning signal sounds!

**WARNING**

Damage to the boom parts!

If the W-guy rods during lifting are not tensioned, the SW-end section can move in the direction of the crane. The W-connector head and the W-pivot section can collide!

Personnel can be severely injured or killed!

- ▶ Ensure that the W-guy rods are tensioned before lifting!

If acoustic warning signal sounds:

- ▶ Tension the W-guying: Spool the W-control rope up.

**WARNING**

Damage to the boom parts!

If the following conditions are not met, the boom parts can collide or be damaged!

- ▶ Make sure that the F-guy ropes do not remain hanging on the F-auxiliary jib during erection!
- ▶ Have the distances between the F-auxiliary jib and the SW-end section checked by another observer!

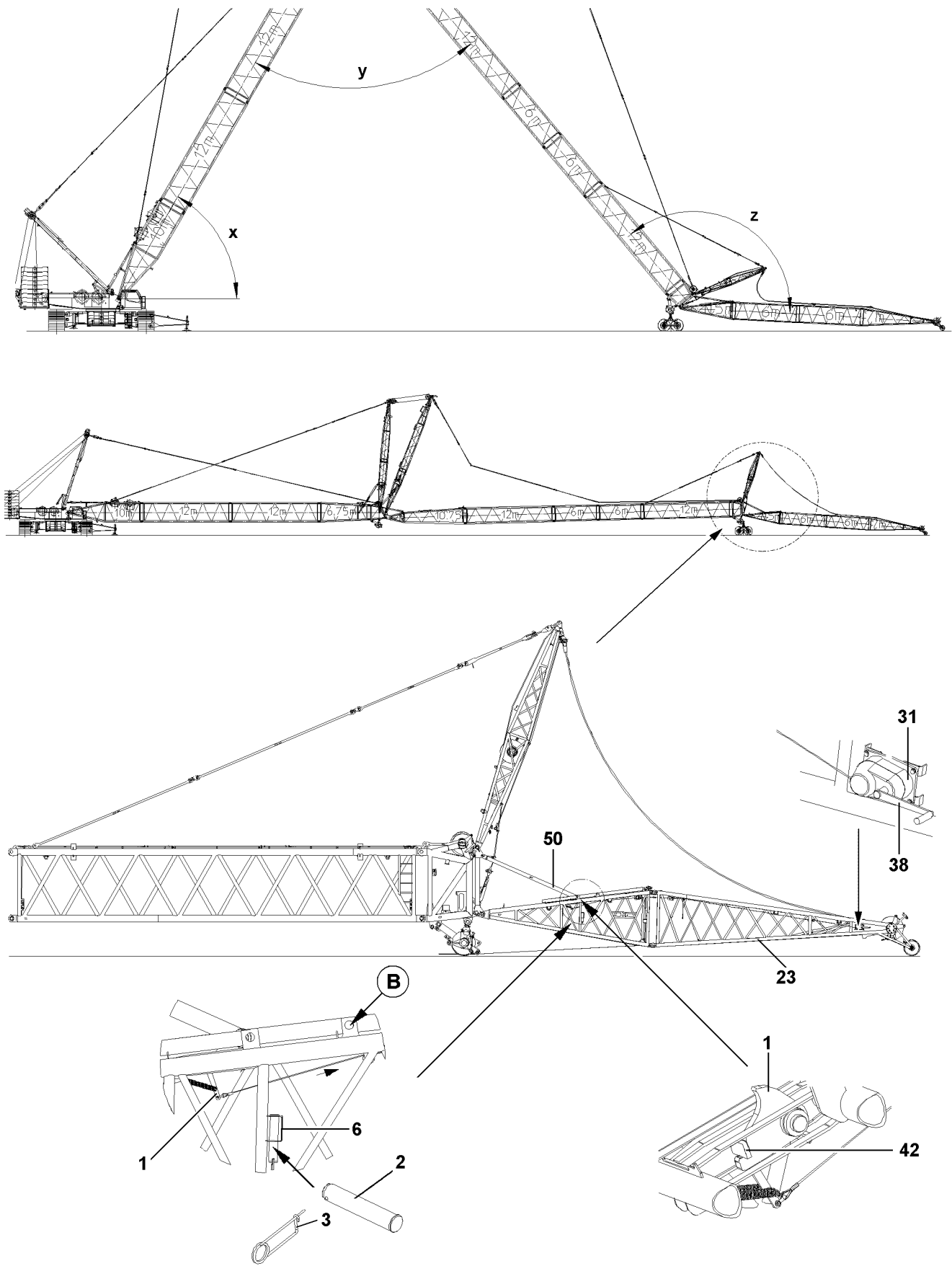

Fig.107211

LWE/LR 1600-2-008/18109-09-02/en

**WARNING**

Risk of accident!

During crane operation, the flap **1** must be in the „up“ position!

- ▶ Set the flap **1** **immediately before lift off** of the F-end section **23** or when erecting the boom into the relapse retainer position in the „up“ position!
 - ▶ Then remove the manual lever **38** from the manual rope winch **31** and store it in the tool box!
-
- ▶ Set the flap **1** with the manual rope winch **31** in relapse retainer position („up“ position), until the flap **1** touches on the stop **42**, see illustration **13**.
 - ▶ Remove the manual lever **38** from the manual rope winch **31**.

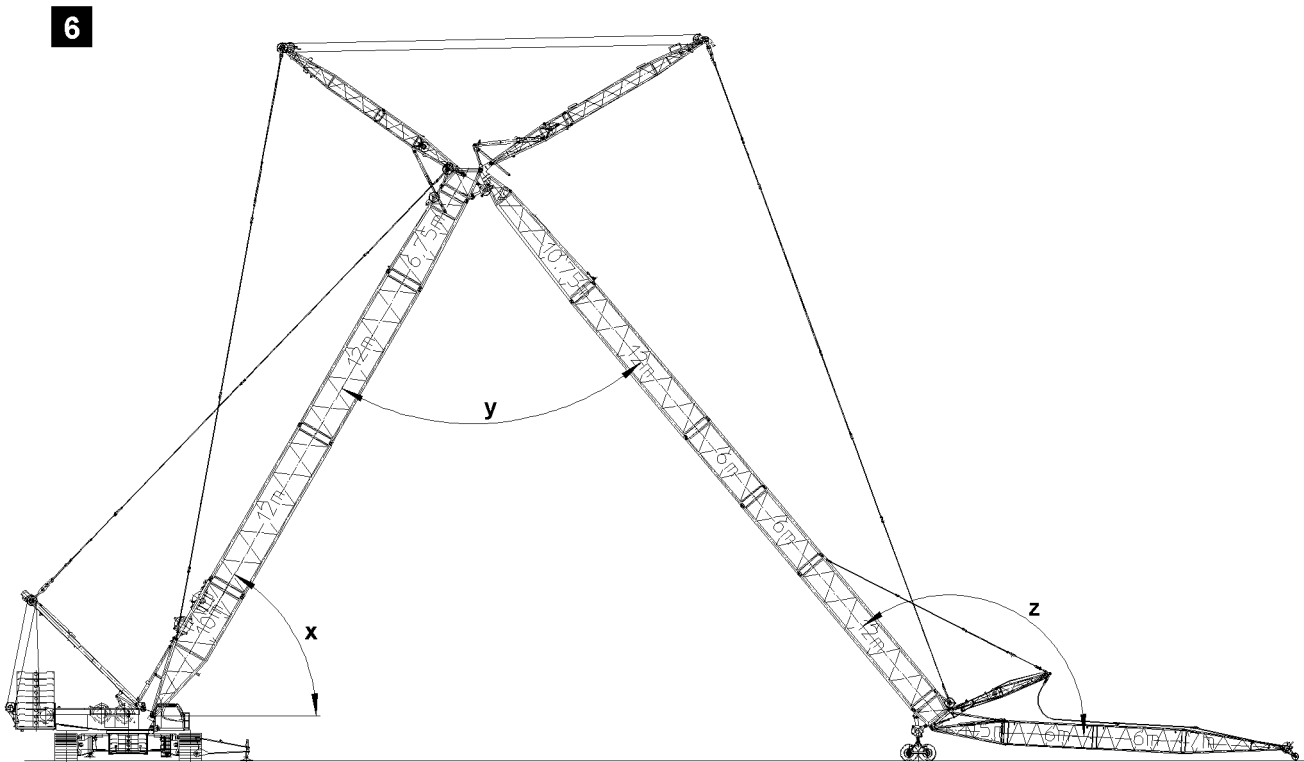
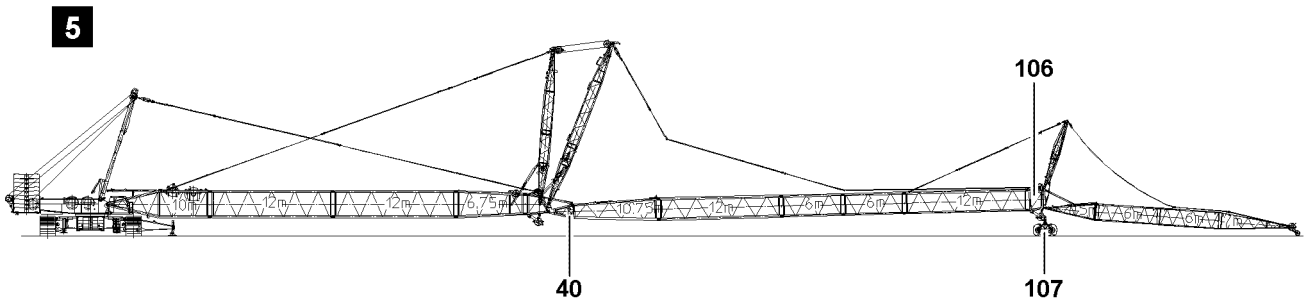
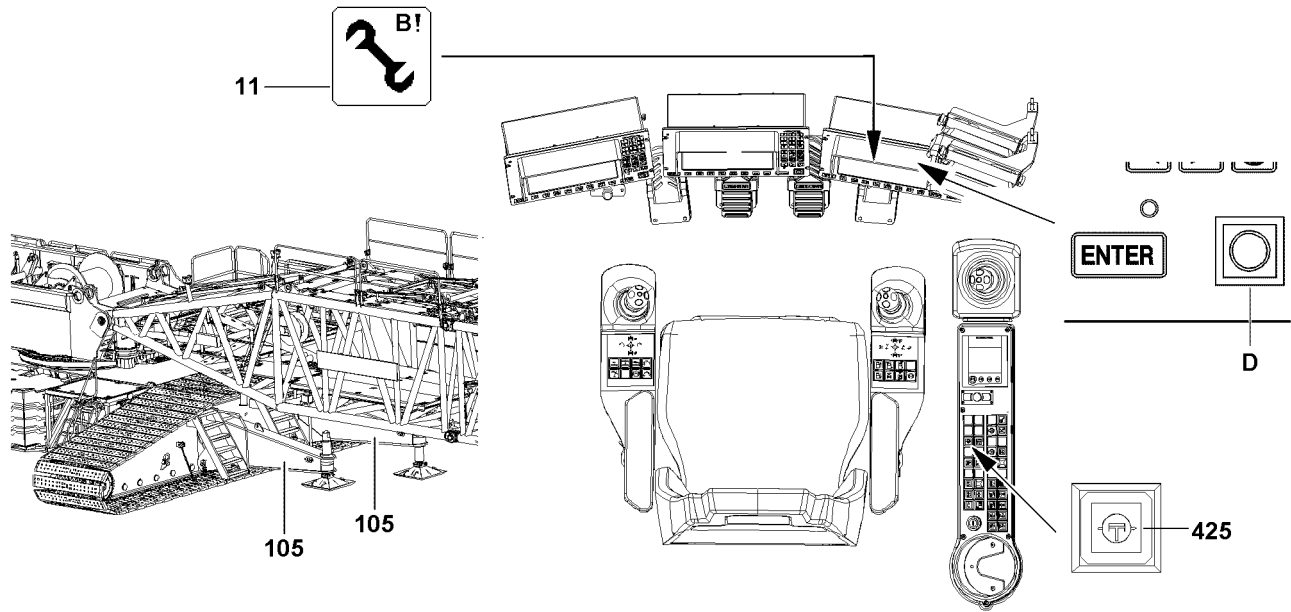

Fig.110720

LWE/LR 1600-2-008/18109-09-02/en

See illustration 5.

- ▶ Loosen pulley cart **107** from SW-end section **106**: Remove the pulley cart, see Crane operating instructions, chapter 5.15!
- ▶ Luff up boom until the hook block may reeve on the F-auxiliary jib.
- ▶ Reeve in the hook block properly and secure the hoist rope on the rope fixed point, for reeving, see separate reeving plans.
- ▶ Attach the hoist limit switch weight.

The S-boom is not yet in operating position, (the angle x is 87°):

- ▶ Luff up the S-boom to the operating position.



DANGER

The crane can topple over!

In crane operation with exceeded LICCON overload protection, the crane can topple over.

- ▶ Personnel can be severely injured or killed!
- ▶ The radii listed in the load chart may not be exceeded or fallen below, even if there is no load on the hook!



Note

- ▶ When the lowest operating position of the W-lattice jib is reached, the LICCON overload protection is activated!
- ▶ In the maximum load icon appears a load number in „t“ instead of the display „???“!

- ▶ Luff up the F-auxiliary jib to the lowest operating position.

When the W-lattice jib has reached the lowest operating position:

- ▶ Make sure that the assembly icon **11** on the LICCON monitor turns off.

Result:

- The LICCON overload protection is active.

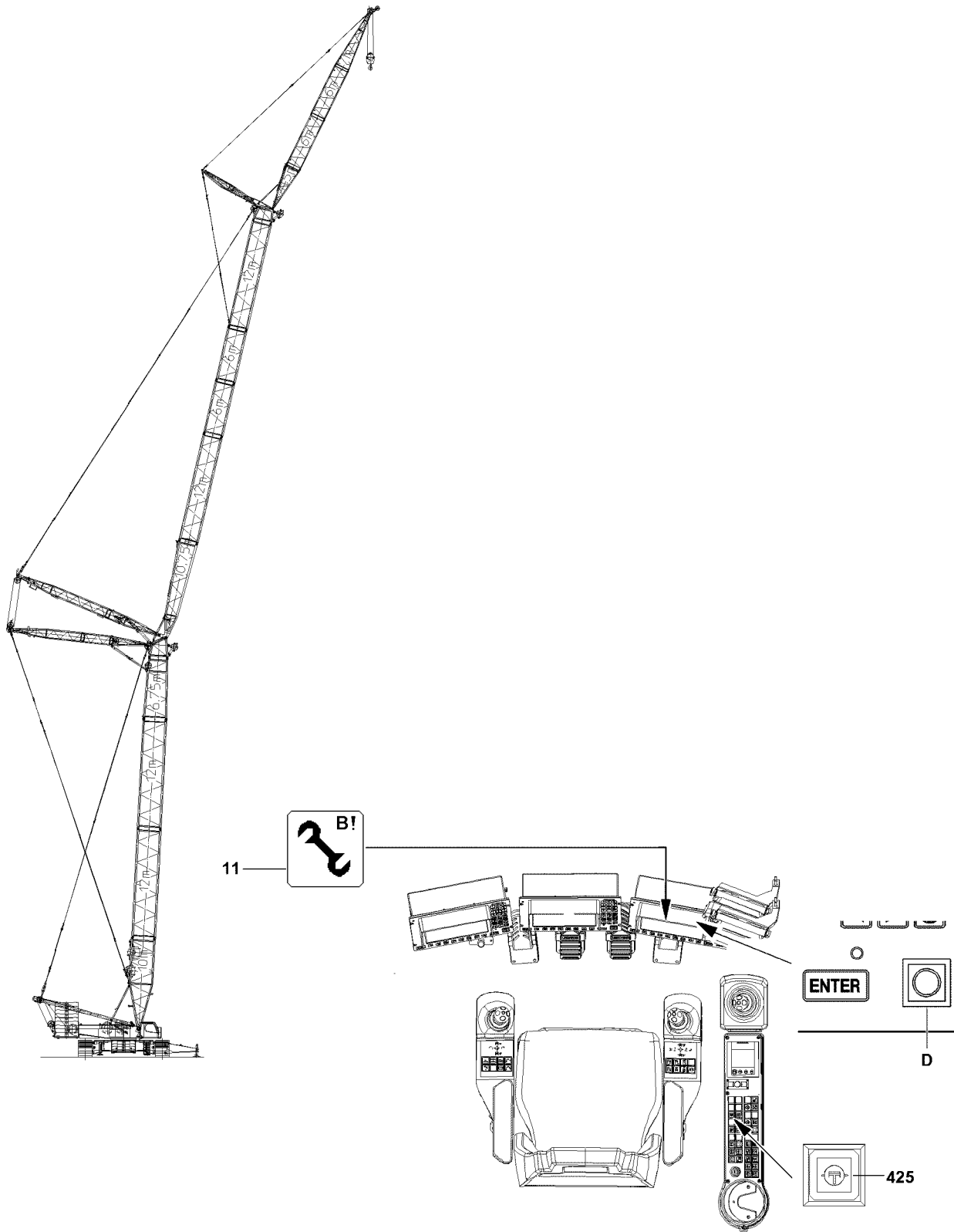

Fig.110721

LWE/LR 1600-2-008/18109-09-02/en

3 Operating the crane

3.1 Preparing for crane operation

**Note**

- ▶ Observe the notes, see Crane operating instructions, chapter 4.05, chapter 4.08 and chapter 5.01!

Make sure that the following prerequisites are met:

- The LICCON overload protection is active.
- The LICCON overload protection has been set according to the data in the load chart.

**WARNING**

The crane can topple over!

- ▶ Check the horizontal position of the crane before and during operation!
- ▶ If the crane operator leaves the cab, even for a short time, the operating mode setting must be checked and reset if necessary before resuming crane operation!

3.2 Checking the settings

- ▶ Check the function of the overload protection by running against the operating positions „on top“ and „bottom“.
- ▶ Check the hoist limit switch by running against the hoist limit switch weight.
- ▶ Check the function of the limit switches on the relapse cylinders.

Fig.195219

LWE/LR 1600-2-008/18109-09-02/en

4 Disassembling the SWF-booms



WARNING

Risk of falling!

During assembly / disassembly work, personnel must be secured with appropriate aids to prevent them from falling. If this is not observed, assembly personnel could fall and suffer life-threatening or fatal injuries.

- ▶ All assembly work must be carried out using suitable aids (lifting platforms, scaffolding, ladder, auxiliary crane, etc.)!
- ▶ If work cannot be carried out on the ground or using such aids, then assembly personnel must be secured with the personal fall arrest system (see Crane operating instructions, chapter 2.04) to protect against falling! The personal fall arrest system must be attached in the corresponding fastening points on the crane (see Crane operating instructions, chapter 2.06)!
- ▶ If railings are present on the components, then they must be brought into the corresponding position and secured for assembly / disassembly work!
- ▶ Step on aids and fall arresters only with clean shoes!
- ▶ Keep aids and fall arresters clean and free from snow and ice!



WARNING

Falling components!

If unsecured or non-supported components are installed or removed, they can fall down!

Personnel can be severely injured or killed!

- ▶ During pinning and unpinning of the lattice sections, it is prohibited for anyone to remain **under** or **on** the components as well as within the entire danger zone!
- ▶ Support the boom and components before pinning / unpinning!
- ▶ Pin or unpin both pins lying in a horizontal, i.e. **left** and **right**!
- ▶ Secure the pins in the bearing points and in the receptacles!
- ▶ Do not disengage the auxiliary crane until each component is pinned on and secured!
- ▶ It is prohibited to lean a ladder against the component being disassembled!



WARNING

Danger of crushing!

Components can swing during disassembly. Hands can be crushed or severed!

- ▶ Make sure that the components do not swing back and forth during assembly!



WARNING

Risk of accident!

Personnel can be severely injured or killed!

- ▶ For pinning and unpinning with the pin pulling device, observe and follow the warning guidelines, see Crane operating instructions, chapter 5.30!



Note

- ▶ By supporting the components during assembly / disassembly, ground unevenness is compensated for and the material is protected!



Note

- ▶ The intermediate sections of the auxiliary jib are pinned and unpinned with the aid of the pin pulling device, see Crane operating instructions, chapter 5.30!

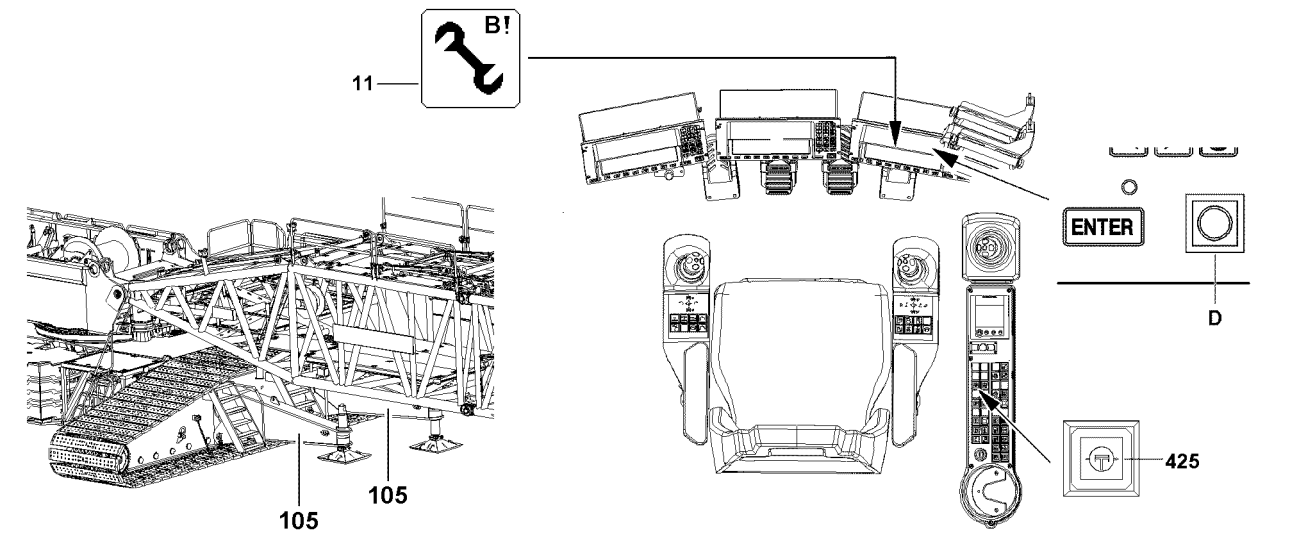
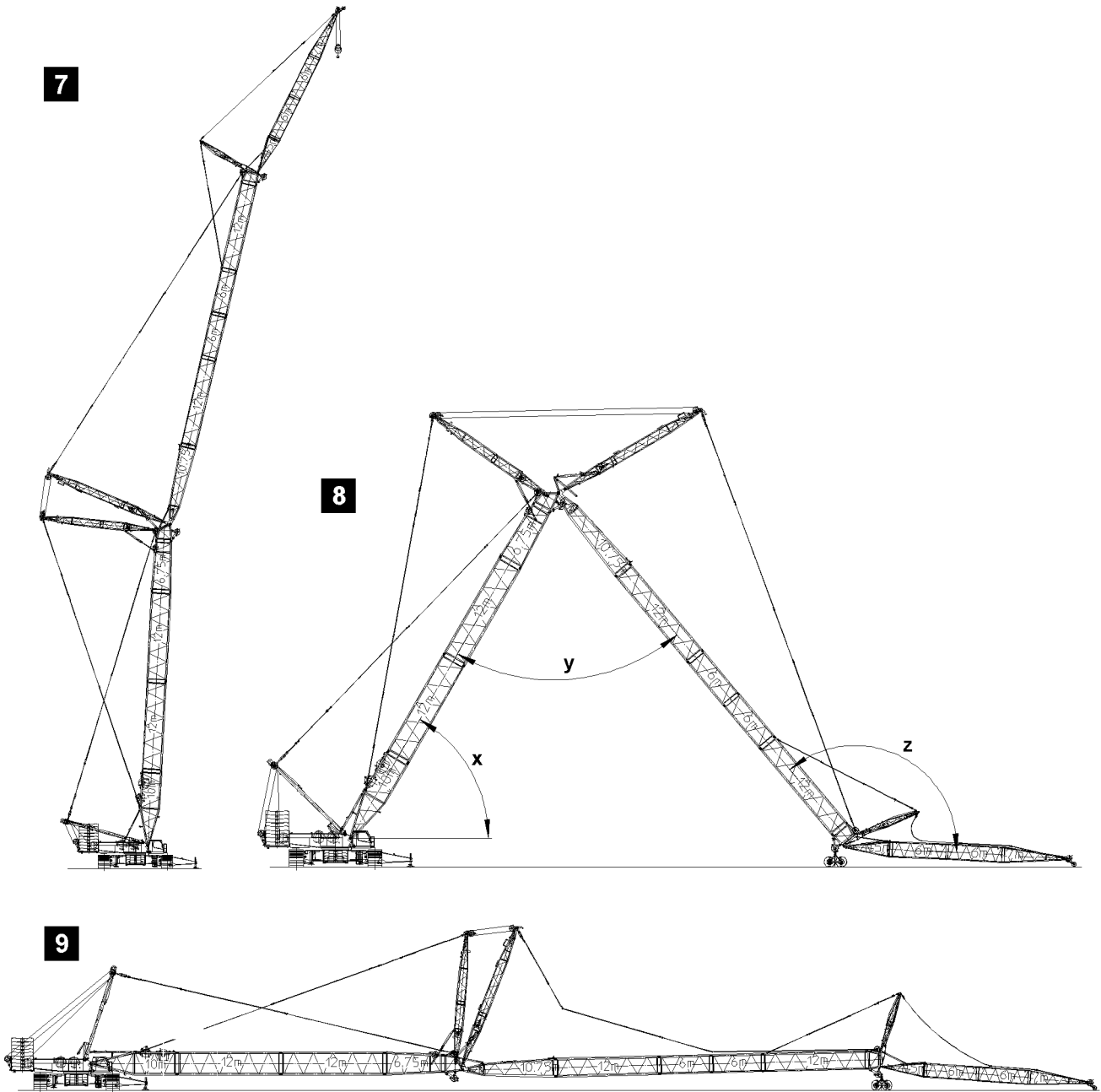

Fig.110722

LWE/LR 1600-2-008/18109-09-02/en

4.1 Taking the SWF-booms down



Note

- ▶ SWF-boom systems may not be placed in stretched condition on the ground!



DANGER

The crane can topple over!

For certain boom lengths, the mechanical auxiliary supports must be assembled, see Erection and take down charts!

- ▶ The boom must be erected or taken down „to the side“ „in direction“ of the mechanical auxiliary supports **105!**
- ▶ Always erect or take down according to the data in the **Erection and take down charts!**



WARNING

The crane can topple over!

If the following conditions are not met before taking down the boom, the crane can topple over and fatally injure personnel!

- ▶ Observe the Safety technical notes, see Crane operating instructions, chapter 5.01!
- ▶ Observe the data in the erection and take down charts!



WARNING

The crane can topple over!

If the following conditions are not met before placing the boom down, the crane can topple over! Personnel can be severely injured or killed!

- ▶ Spool the lattice jib control out so that the guy rods sag slightly!
- ▶ The lattice jib must roll on the ground with its entire weight!
- ▶ Do not allow slack cable to build up on the control winch!
- ▶ Do not pull the hook block along on the ground!



WARNING

Damage to the boom parts!

If the luffing down movement is not turned off when a warning signal sounds, then boom parts can collide!

Personnel can be severely injured or killed!

If the acoustic warning signal sounds:

- ▶ Turn the luffing down movement off!

NOTICE

Damage of boom components!

Taking down the boom system can lead to a collision between the hook block and the pulley head. The boom components can be severely damaged!

- ▶ Luff the boom system down at the same time and spool the hoist winch out.

Make sure that the following prerequisite is met:

- The S-boom is found in the steepest position, the angle x is 87° , see illustration 7.
- The hook block is approx. 5 m below the pulley head of the F-end section.
- The pulley cart is available.

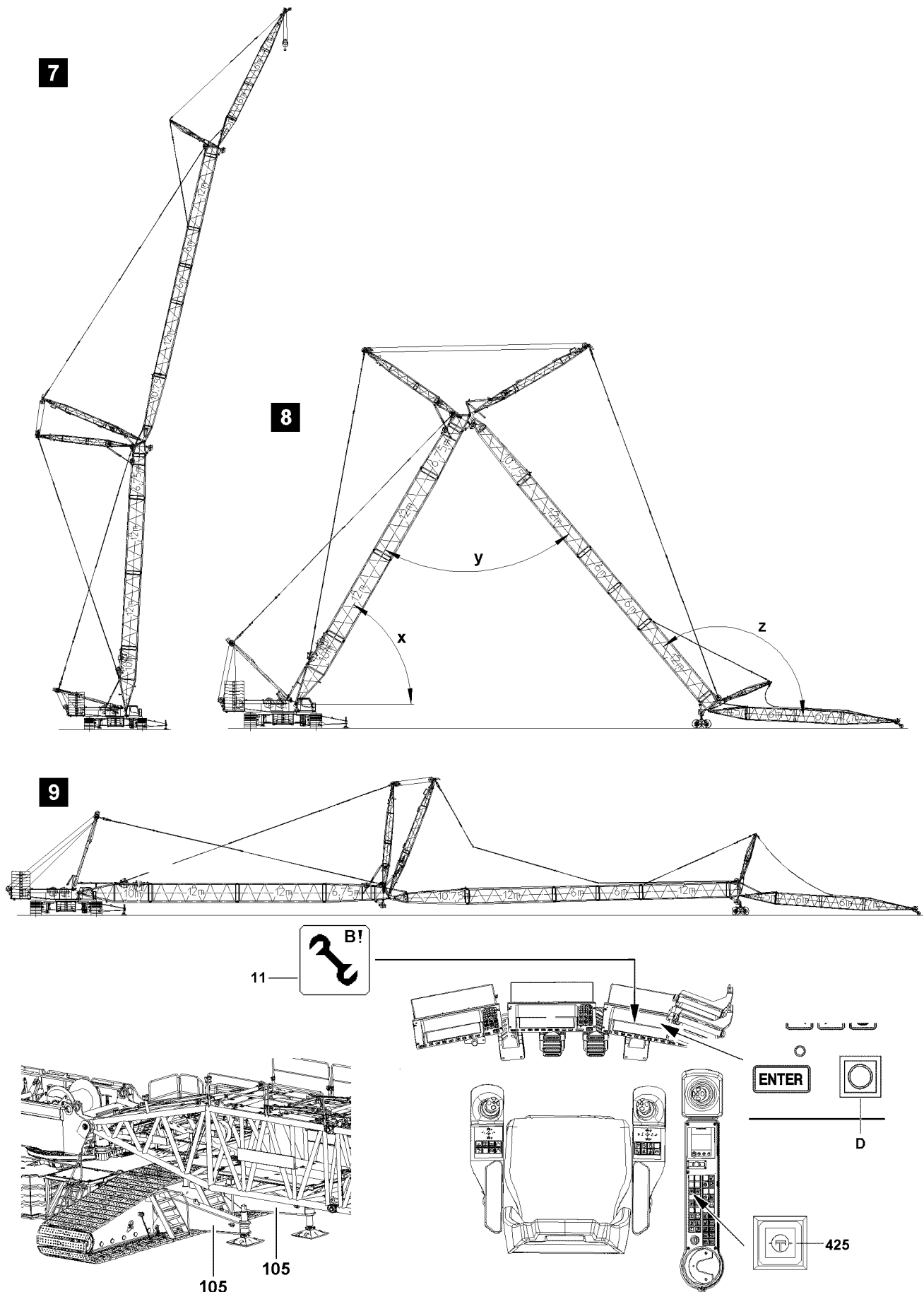

Fig.110722

LWE/LR 1600-2-008/18109-09-02/en

4.1.1 Luffing the W-lattice jib down



Note

- ▶ The luff down movement of the W-lattice jib is turned off as soon as the lowest operating position is reached!
- ▶ When the lowest operating position of the W-lattice jib is reached, the load display in the maximum load icon turns off and instead of the load display appears the display „??“!
- ▶ In the crane operating screen appear alarm functions!

- ▶ Luff the W-lattice jib down to the „lowest“ operating position.

Result:

- The luffing movement is turned off.
- The „STOP“ icon appears on the LICCON monitor.
- The horn icon appears on the LICCON monitor.



WARNING

Assembly with turned on set up key!

When the set up key is engaged, the LICCON overload protection is exceeded!

In the event of deliberate improper use, the crane could collapse, the boom can break off or the crane can topple over!

Personnel can be killed!

This could result in high property damage!

- ▶ The set up key **D** may only be actuated by persons who know the effects of a bypass!
- ▶ Press the set up key **D** only when the set up status was correctly entered into the LICCON computer system!
- ▶ Observe the erection / take down charts!
- ▶ Crane operation with the set up key **D** turned on is strictly prohibited!

When the W-lattice jib has reached the „lowest“ operating position:

- ▶ Turn the set up key **D** to the right.

Result:

- The LICCON overload protection is deactivated.
- The assembly icon **11** appears on the LICCON monitor.

The W-lattice jib is luffed down until:

- Warning signal sounds: Angle **y** between W-lattice jib and S-boom amounts to 45°,
- **or** the hook block touches the ground.
- ▶ Luff down W-lattice jib further.

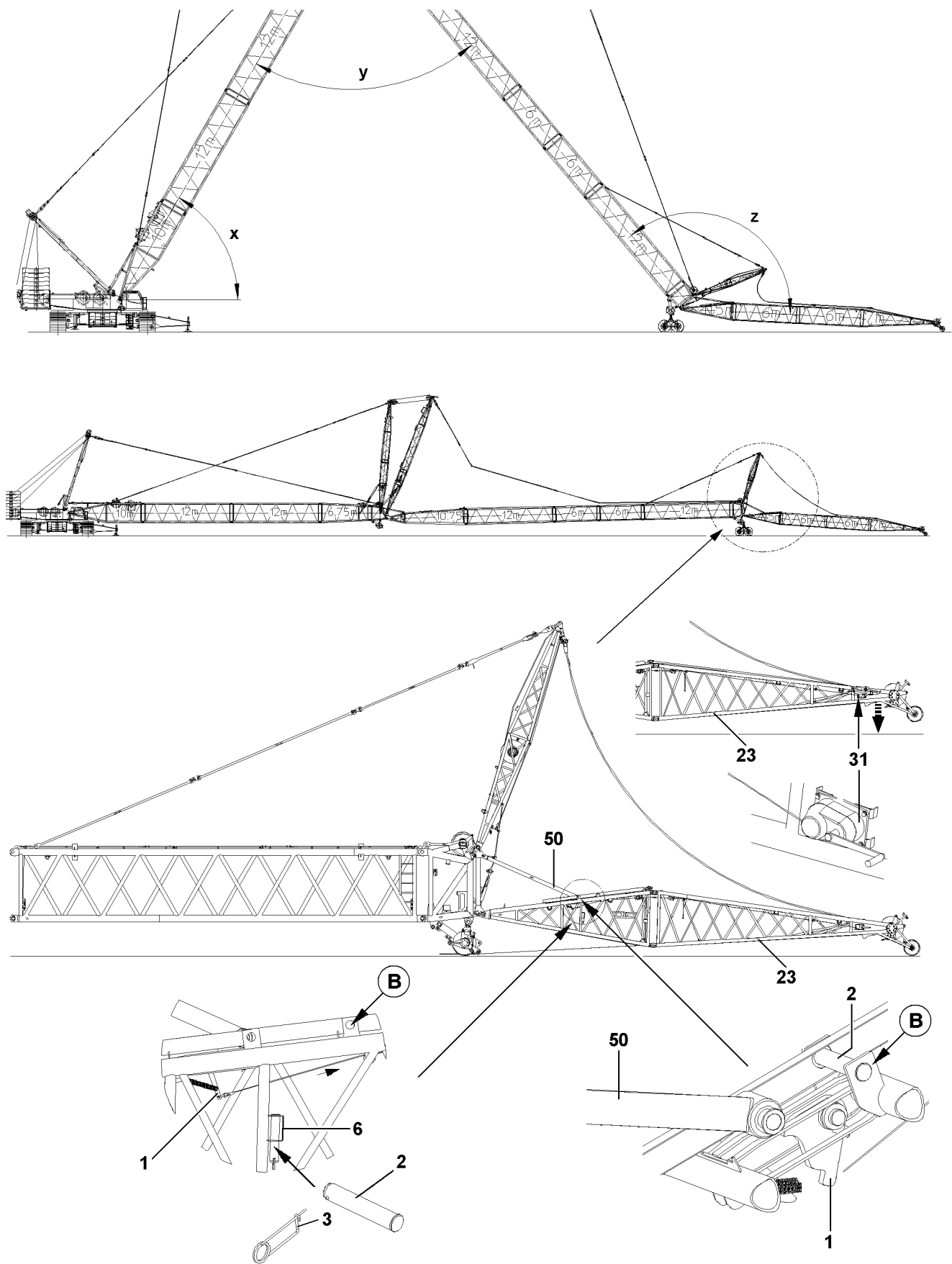

Fig.106853

LWE/LR 1600-2-008/18109-09-02/en

4.1.2 Taking the SWF-booms down

If the W-lattice jib is luffed down as far as possible with the F-auxiliary jib:

- ▶ Luff the S-boom down until the warning signal sounds.



Note

- ▶ If a warning signal sounds, an error report appears on the LICCON monitor: "Block position W/F achieved – Caution: no shut off - Danger of accident"!

If the hook block has not yet touched the ground:

- ▶ Continue to luff the S-boom down until the hook block touches the ground.
- ▶ Remove the hoist limit switch weight.
- ▶ Unreeve the hook block.
- ▶ Remove the pin **2** from the retainer **6** (park position) and insert at point **B** pin (attachment position) and secure with spring retainer **3**.



CAUTION

Danger of damage on the relapse support!

When taking the boom down, the flap **1** must be set in „down“ position as soon as the F-end section **23** touches the ground or as soon as the manual rope winch **31** can be reached!

If this is not observed, components on the F-assembly unit can be damaged!

- ▶ Set the flap **1** with the manual rope winch **31** in „down“ position so that the plunger **50** in the guide „can slide“ over the flap **1**!
- ▶ Set the flap **1** on the F-pivot section **22** with the manual rope winch **31** into „down“ position.

NOTICE

Damage to the boom parts!

If the F-auxiliary jib can not roll off forward without a problem, then the boom parts can be damaged!

- ▶ Make sure that the F-auxiliary jib can not roll off forward without a problem!



Note

- ▶ The S-boom is luffed up until the warning signal sounds: The angle α between the W-lattice jib and the F-auxiliary jib is 115° !

NOTICE

Colliding boom parts!

If the S-boom is luffed down, the F-auxiliary jib and SW-end section can collide.

- ▶ Hold the angle α continually constant: Luff the S-boom down further and simultaneously luff the W-lattice jib up!
 - ▶ Have the distances between the F-auxiliary jib and the SW-end section checked by another observer!
 - ▶ Luff the S-boom down.
- If angle between F-auxiliary jib and W- lattice jib permits:
- ▶ Set down the SW-end section in the roller cart.
 - ▶ Release W-guying.
 - ▶ Luff the S-boom down until the boom system is lying completely on the ground.

Fig.195219

LWE/LR 1600-2-008/18109-09-02/en

4.2 Disconnecting the electrical connections



Note

► Observe and adhere to the instructions, see Crane operating instructions, chapter 5.13!

Make sure that the following prerequisite is met:

- The SWF-boom has been placed down.

4.3 Disassembling the F-assembly unit



Note

► Observe and adhere to the instructions, see Crane operating instructions, chapter 5.13!

Make sure that the following prerequisite is met:

- An auxiliary crane is available.

Empty page!

LWE/LR 1600-2-008/18109-09-02/en

5.19 Hook blocks

1	Procedure in case of slack rope	3
2	Hook block overview	5
3	Installing a double hook block for single operation	7
4	Installing a double hook block for parallel operation	17
5	Single hook blocks	29

Fig.195219

LWE/LR 1600-2-008/18109-09-02/en

1 Procedure in case of slack rope

1.1 Lowering the hook block if slack rope forms

If the hook block can no longer be lowered due to slack rope formation, then the following steps must be carried out.

1.1.1 Spooling up loose hoist rope

- ▶ Spool up loose hoist rope between the boom head and the winch carefully onto the winch.



Note

- ▶ A slight rope slack must remain between the boom head and the winch!
-

1.1.2 Luffing the boom down

NOTICE

Danger of collision!

When luffing the boom down, the hoist rope length can shorten and pull the hook block against the boom head.

- ▶ Monitor the distance of the hook block to the boom head!
-

- ▶ Luff the boom down carefully.

Result:

- The hoist rope between the boom head and the winch is tensioned.

1.1.3 Lowering the hook block

- ▶ Lower the hook block carefully with the hoist gear.

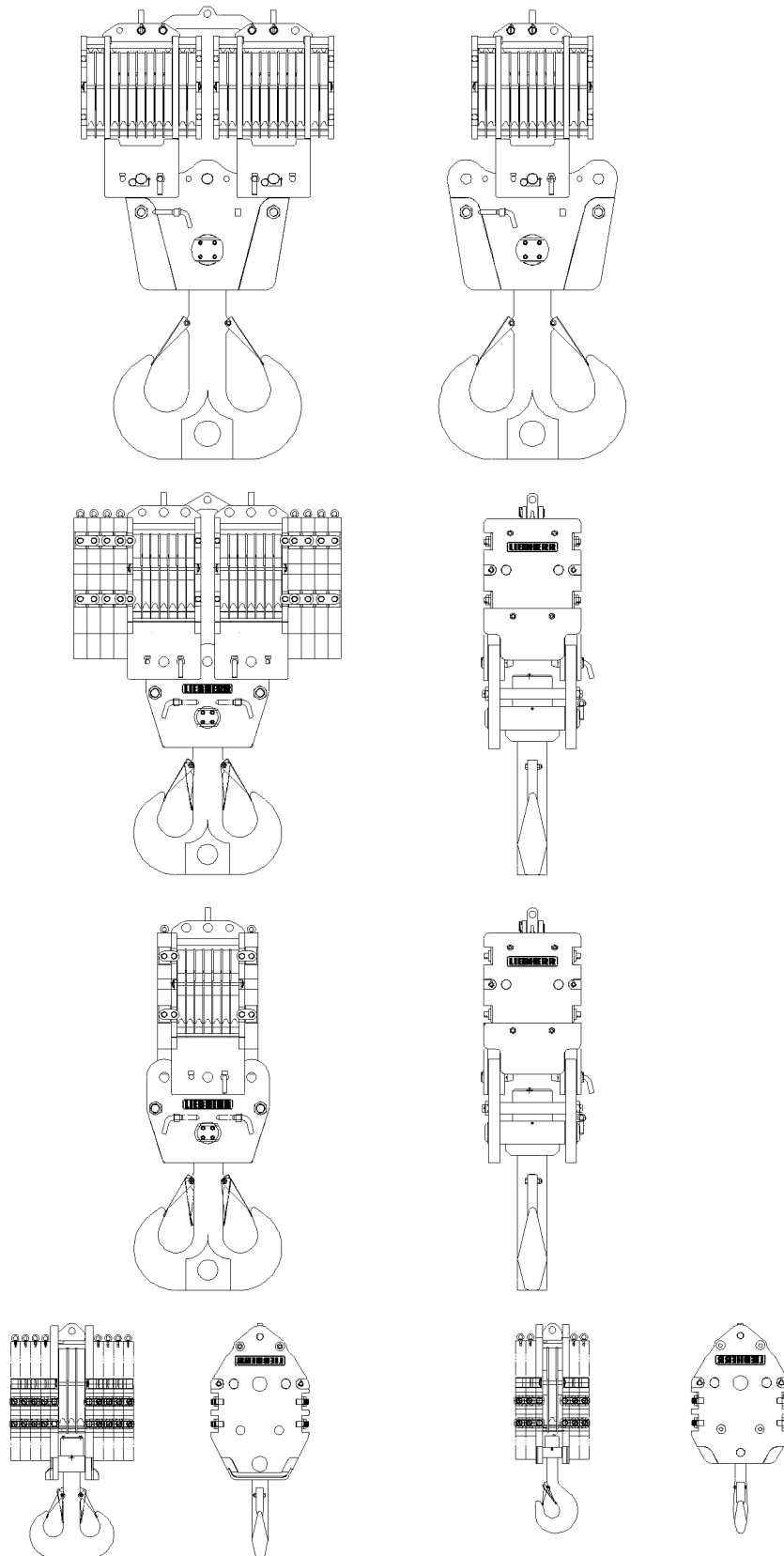

Fig.108122

2 Hook block overview

2.1 Handling of hook blocks



Note

- ▶ For the load hooks and hook blocks approved for this crane type refer to the separate load chart manual!
- ▶ The hook blocks shown in this chapter are only examples and can differ from your hook block in type and number of rope pulleys. The different assembly and disassembly procedures are therefore only an example of the description for a number of different hook blocks!



DANGER

Hook block weights!

If the data in the erection and take down charts as well as the load charts are not observed, dangerous situations up to toppling of the crane can occur!

Personnel can be severely injured or killed, in addition, high property damage can result!

- ▶ Observe the data in the erection and take down charts!
- ▶ The specifications in the load charts must be adhered to!
- ▶ The crane operator bears the sole and full responsibility for the adherence to the data in the erection and take down charts as well as the load charts!

Differently sized hook blocks can be used for various loads.

NOTICE

Rope damage due to insufficient hook block weight!

If the hook block weight is too low to tighten the hoist rope sufficiently, spooling problems may occur on the winches when lowering and lifting the hook block due to slack rope formation!

The hoist rope can be damaged!

- ▶ In order to prevent spooling problems on the winches, the hook block weight may be increased with auxiliary weights, if necessary!
- ▶ If problems develop in the assembly and set up conditions due to the weight increase of the hook block, auxiliary weights must be removed again!

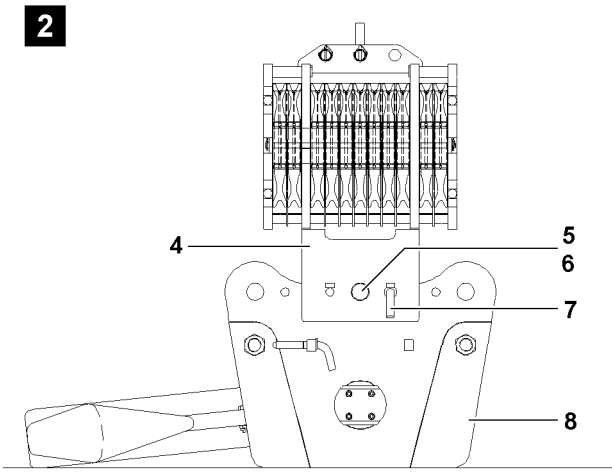
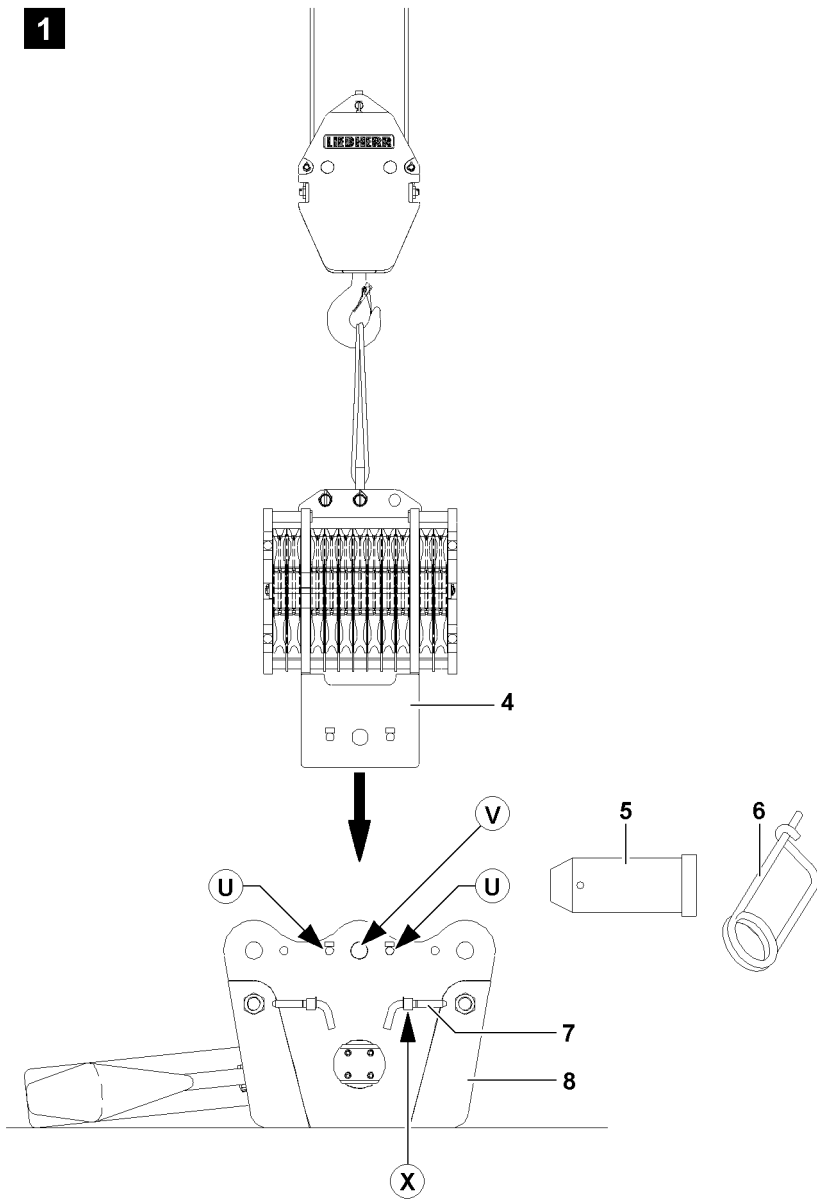

Fig.108123

LWE/LR 1600-2-008/18109-09-02/en

3 Installing a double hook block for single operation

3.1 Installing the hook block

If the hook blocks are to be used in single operation, then the pulley block **4** must be installed centered on the cross brace **8**.

3.1.1 Installing the pulley block on cross brace

Make sure that the following prerequisites are met:

- The ground is sufficiently load bearing to take on the weight of the hook block safely.
- The ground is level and horizontal.
- The cross brace **8** is placed on the ground, see illustration **1**.



DANGER

Risk of tipping the pulley block!

If the retaining pins **7**, during assembly of the pulley block **4** are not pinned on the cross brace, then the pulley block tips to the side when the auxiliary crane is removed!

Personnel remaining in the danger zone can be severely injured or killed!

- ▶ Insert the retaining pins **7** into the bores **U** on the hook block!
 - ▶ Make sure before removing the auxiliary crane that the pulley block is properly pinned and secured!
-
- ▶ Attach the pulley block **4** onto the auxiliary crane, illustration **1**.
 - ▶ Position pulley block **4** on the cross brace **8** and align the pin bore **V**.
 - ▶ Insert the pin **5** on point **V** and secure with spring retainer **6**.
 - ▶ Unpin the retaining pin **7** from the transport receptacle (point **X**).
 - ▶ Insert the retaining pins **7** into one of the bores (point **U**) on the cross brace **8**, illustration **1**.

When the pulley block **4** is secured by the retaining pins **7** at point **U**:

- ▶ Remove the auxiliary crane.

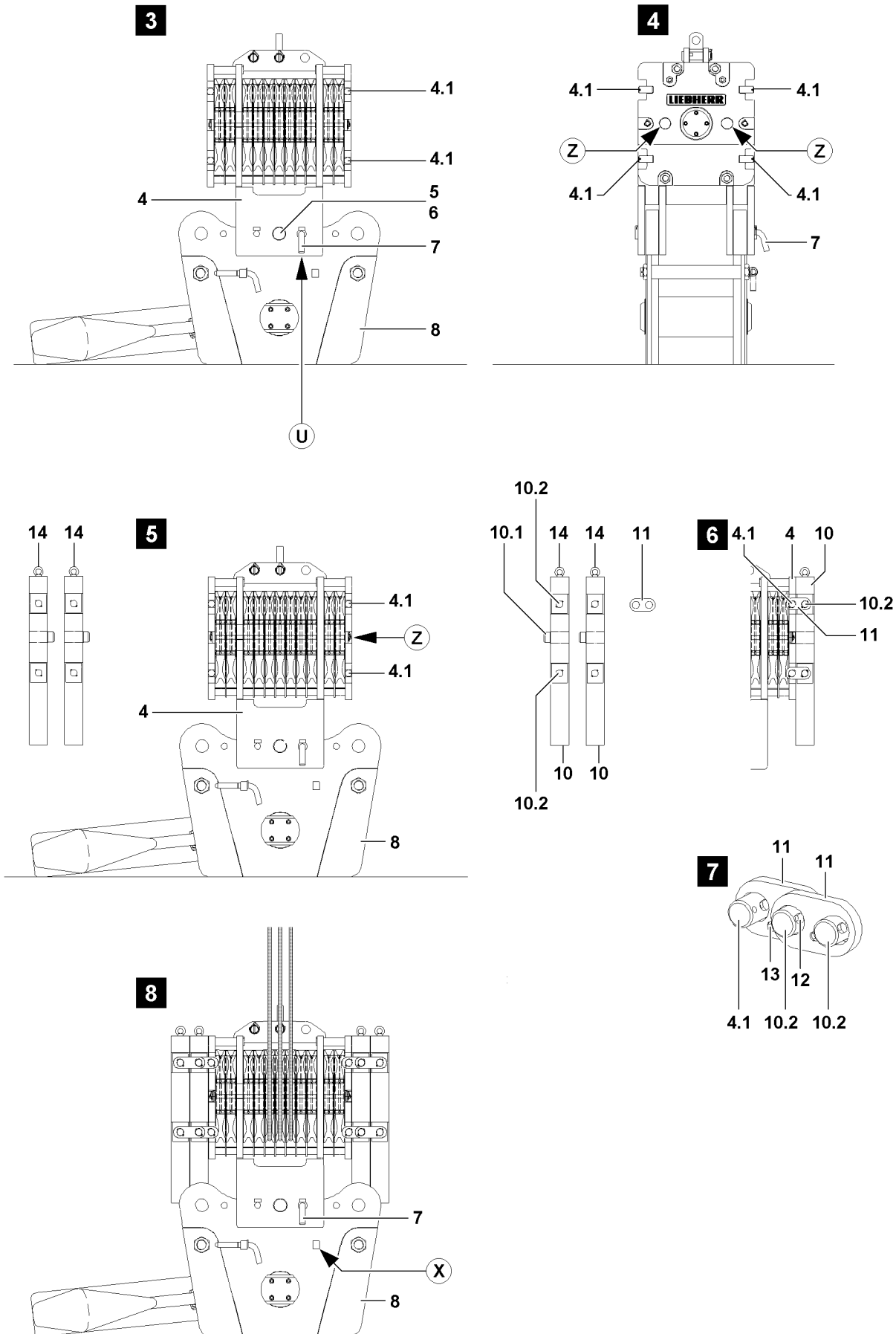

Fig.108141

3.1.2 Installing the auxiliary weights



Note

- ▶ The own weight for each auxiliary weight is marked on the auxiliary weight!



WARNING

Toppling of hook block!

If the auxiliary weights are installed one-sided, the hook block can topple over!

Personnel can be severely injured or killed!

- ▶ The auxiliary weights may only be installed **individually** and alternating left and right on the pulley block!
- ▶ When the required auxiliary weight is installed on the pulley block, the difference between the left and right side may never be more than one auxiliary weight!
- ▶ Asymmetrical installation of auxiliary weights is prohibited!
- ▶ Do not exceed the maximum permissible own weight of the hook block! The maximum permissible own weight is engraved on ballastable hook blocks. See „Engraving WT max.“.

Make sure that the following prerequisites are met:

- The hook block is placed on the ground.
- The pulley block **4** is properly installed and secured.
- The retaining pin **7** is pinned and secured at point **U**.



WARNING

Falling auxiliary weights!

If the auxiliary weights are not properly installed on the pulley block, then they can fall down during installation or in crane operation!

Personnel can be severely injured or killed!

- ▶ Standing under a suspended auxiliary weight is prohibited!
- ▶ Make sure that the auxiliary weights are properly installed and secured!
- ▶ Crane operation with insufficiently secured auxiliary weights is prohibited!

- ▶ Attach the auxiliary weight **10** on the ring screw **14** on the auxiliary crane, illustration **5**.



WARNING

Danger of crushing!

When swinging the auxiliary weights to the pulley block, personnel can be severely injured or killed!

Fingers, hands and arms can be crushed or severed!

- ▶ It is prohibited for anyone to remain between the pulley block and the auxiliary weight!
- ▶ Swing auxiliary weights in to the pulley block with utmost caution and at the least possible speed!

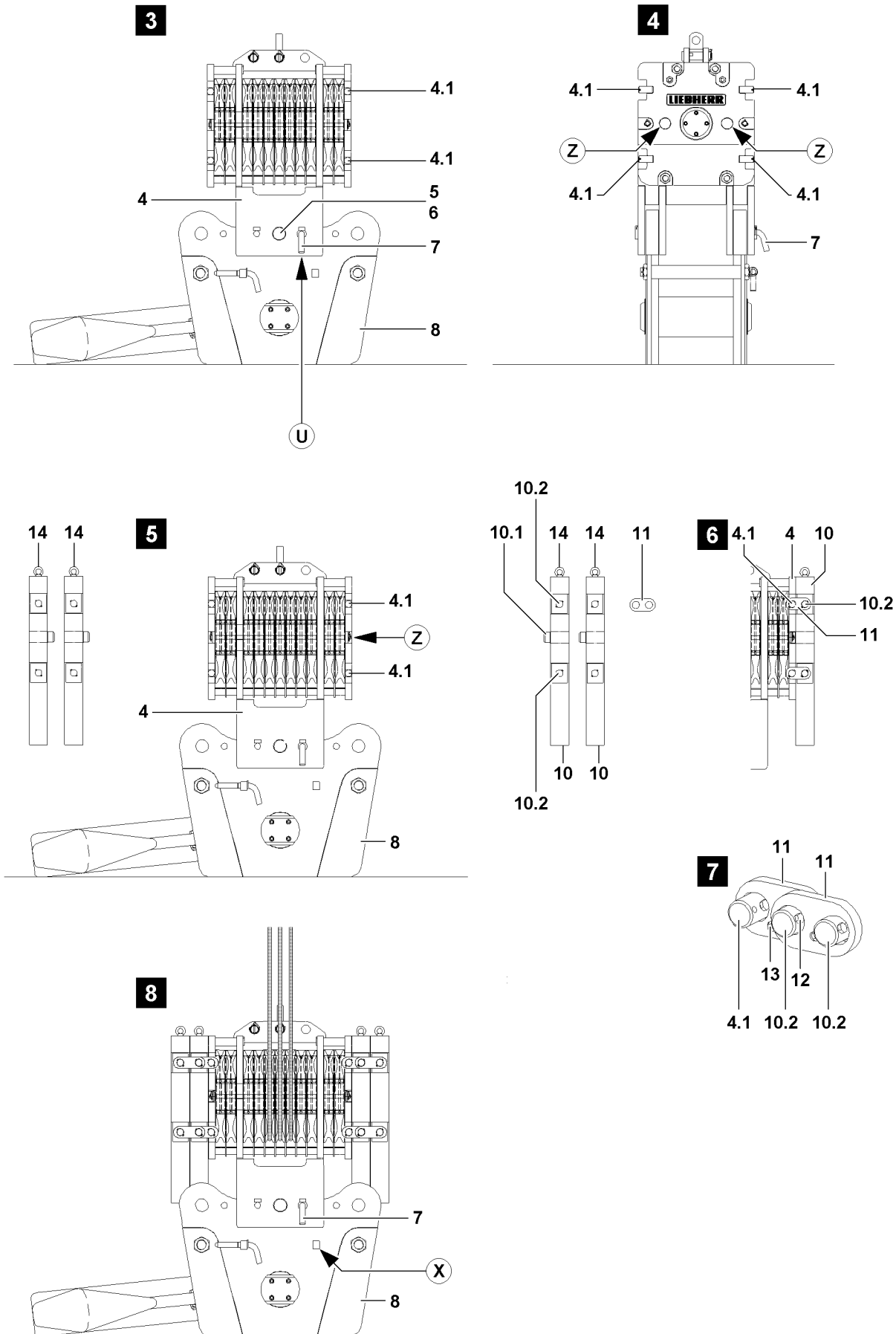

Fig.108141

LWE/LR 1600-2-008/18109-09-02/en

- ▶ Align the auxiliary weight **10** on the pulley block **4**.
- ▶ Move the centering pin **10.1** of the auxiliary weight into the centering bores **Z** on the pulley block **4**, illustration **6**.

**WARNING**

Falling auxiliary weights!

If all mounting brackets **11** are removed simultaneously on an unsecured auxiliary weight, then the auxiliary weight can fall down!

Personnel can be severely injured or killed!

- ▶ Never remove all mounting brackets **11** of an unsecured auxiliary weight at the same time!
- ▶ Always install or remove the mounting brackets **11** alternately!

▶ Install the mounting brackets **11** on the side and connect the pulley block **4** with the auxiliary weight **10**, illustration **7**.

▶ Secure the mounting brackets **11** with screws **12** and lock nuts **13**, illustration **7**.

**Note**

- ▶ Additional auxiliary weights must be connected with the mounting brackets **11**!

**WARNING**

Falling auxiliary weights!

The auxiliary weights can fall down by removing the auxiliary crane!

Personnel can be severely injured or killed!

- ▶ Remove the auxiliary crane only when it is ensured that the auxiliary weight **10** is properly secured with the mounting brackets **11**!

When the respective auxiliary weight is properly installed and secured:

- ▶ Remove the auxiliary crane.

3.1.3 Preparing the hook block for crane operation

**Note**

- ▶ The reeving of the hook blocks is described in chapter 4.06 of the Crane operating instructions!
- ▶ Observe the „permissible hook block weights“ in the erection and take down charts!

▶ Reeve the hoist rope according to the instructions in chapter 4.06 of the Crane operating instructions and the reeving plans!

NOTICE

Retaining pins **7** pinned when lifting the load!

If the retaining pin **7** is not unpinned before crane operation, then the retaining pin **7** may be shorn off when lifting the load!

- ▶ Unpin the retaining pin **7** from the hook block before crane operation!

When the hook block is properly reeved and has been lifted off the ground:

- ▶ Unpin the retaining pin **7** and pin and secure into the transport receptacle (point **X**), illustration **8**.

9

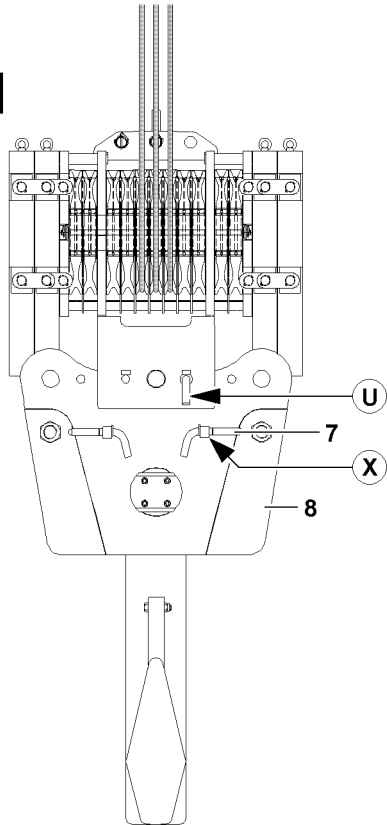

10

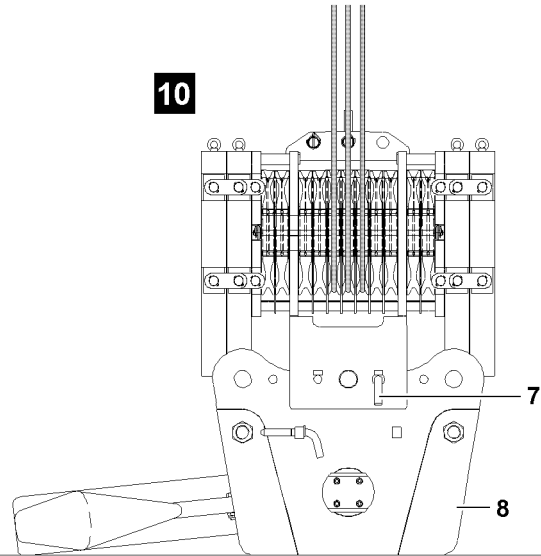

11

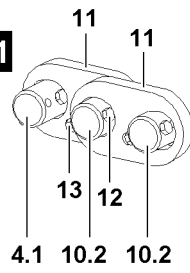

13

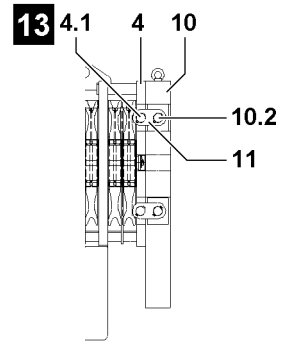

12

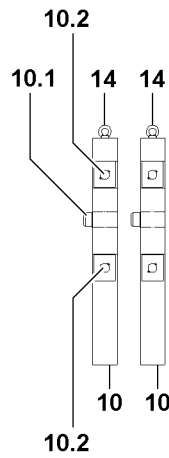
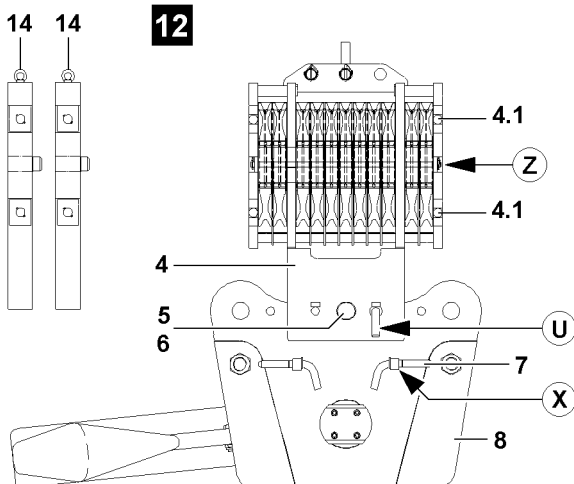

14

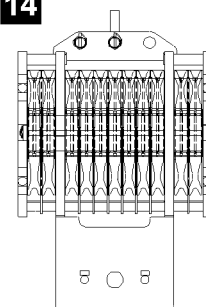

Fig.108142

LWE/LR 1600-2-008/18109-09-02/en

3.2 Removing the hook block

3.2.1 Preparing the hook block for removal



Note

- ▶ The unreeving of the hook blocks is described in chapter 4.06 of the Crane operating instructions!
- ▶ Observe the „permissible hook block weights“ in the erection and take down charts!

NOTICE

Retaining pin 7 unpinned when setting down the hook block!

If the retaining pin 7 - before setting the hook block on the ground - is not pinned, then the pulley block tips away to the side when it is set down!

Personnel can be severely injured or killed!

- ▶ Insert and secure the retaining pin 7, before setting the hook block on the ground, at point **U**!

Make sure that the following prerequisites are met:

- The ground is sufficiently load bearing to take on the weight of the hook block and the auxiliary weights safely.
- The ground is level and horizontal.

- ▶ Lower the hook block completely to the ground.

When the hook block was placed down on the ground properly:

- ▶ Unreeve the hoist rope according to chapter 4.06 of the Crane operating instructions!

3.2.2 Removing the auxiliary weights



Note

- ▶ The own weight for each auxiliary weight is marked on the auxiliary weight!



WARNING

Toppling of hook block!

If the auxiliary weights are removed one-sided, the hook block can topple over!

Personnel can be severely injured or killed!

- ▶ The auxiliary weights may only be removed **individually** and alternating left and right on the pulley block!
- ▶ The difference between the left and the right side at removal of the auxiliary weights may never be more than one auxiliary weight!
- ▶ Asymmetrical removal of auxiliary weights is prohibited!

Make sure that the following prerequisite is met:

- The retaining pin 7 is pinned and secured at point **U**.



WARNING

Falling auxiliary weights!

If the auxiliary weights on the pulley block are not properly removed, then they can fall down at removal!

Personnel can be severely injured or killed!

- ▶ Standing under a suspended auxiliary weight is prohibited!
- ▶ Attach the auxiliary weight **10** on the ring screw **14** on the auxiliary crane.
- ▶ Tension the fastening equipment carefully.

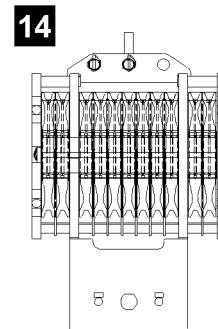
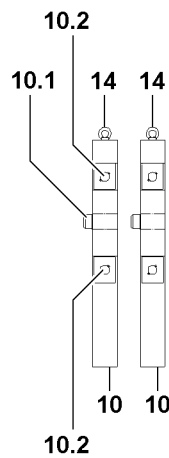
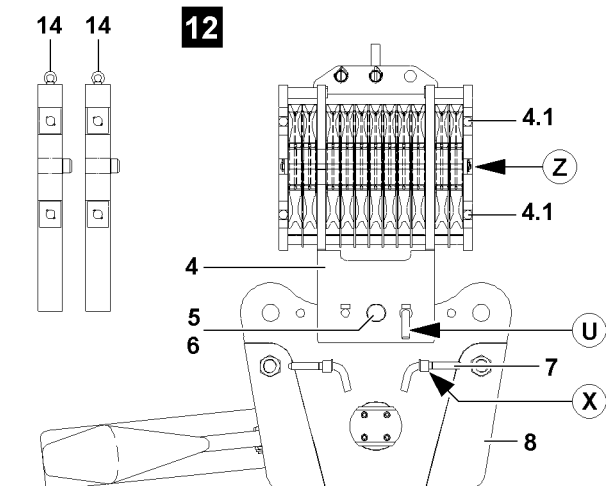
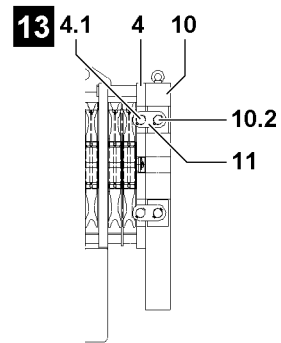
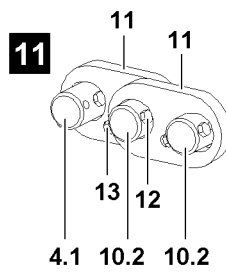
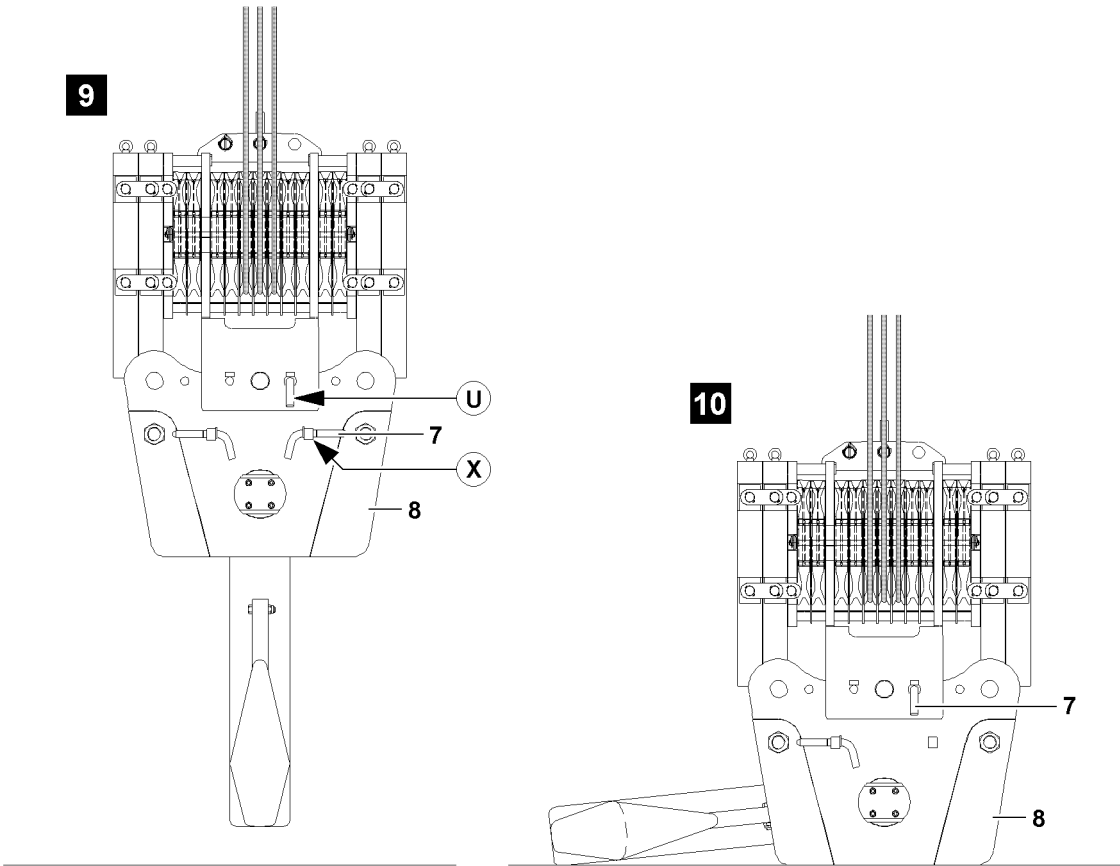

Fig.108142

LWE/LR 1600-2-008/18109-09-02/en

**WARNING**

Oscillating auxiliary weights!

During the removal of the auxiliary weights, the auxiliary weights can start to swing back and forth!
Personnel can be severely injured or killed!

- ▶ It is prohibited for anyone to remain in the danger zone!
- ▶ Make sure that the auxiliary weight which is being removed is properly attached on the auxiliary crane before releasing the mounting brackets!
- ▶ Angular pull is prohibited!

When the fastening equipment is tensioned on the auxiliary weight:

- ▶ Release the screw connection on the mounting brackets of the outermost auxiliary weight and remove the screws.

**WARNING**

Falling auxiliary weights!

If all mounting brackets **11** are removed simultaneously on an unsecured auxiliary weight, then the auxiliary weight can fall down!

Personnel can be severely injured or killed!

- ▶ Never remove all mounting brackets **11** of an unsecured auxiliary weight at the same time!
- ▶ Always install or remove the mounting brackets **11** alternately!

- ▶ Pull the mounting brackets **11** off to the side.

**WARNING**

Falling auxiliary weights!

If additional auxiliary weights which are being removed are released, then these auxiliary weights can fall down!

Personnel can be severely injured or killed!

- ▶ Make sure, before removing the outermost auxiliary weight, that the other auxiliary weights are secured with the mounting brackets!

If additional mounting brackets must be removed to release the outermost auxiliary weight:

- ▶ Reinstall the mounting brackets again immediately, so that only the auxiliary weight which is being removed is released.
- ▶ Lift the auxiliary weight with the auxiliary crane from the pulley block.
- ▶ Place the auxiliary weight onto the ground.
- ▶ Remove the auxiliary crane.
- ▶ Remove additional auxiliary weights as described above.

3.2.3 Removing the pulley block on cross brace

Make sure that the following prerequisite is met:

- The auxiliary weights have been removed.

- ▶ Attach the pulley block **4** on the auxiliary crane.
- ▶ Tension the fastening equipment carefully.
- ▶ Unpin the retaining pin **7** at point **U** and pin into the transport receptacle on the cross brace, point **X**, illustration **12**.
- ▶ Release and unpin the pin **5**.
- ▶ Swing the pulley block **4** out with auxiliary crane.
- ▶ Place the pulley block **4** on the ground, illustration **14**.
- ▶ Remove the auxiliary crane.

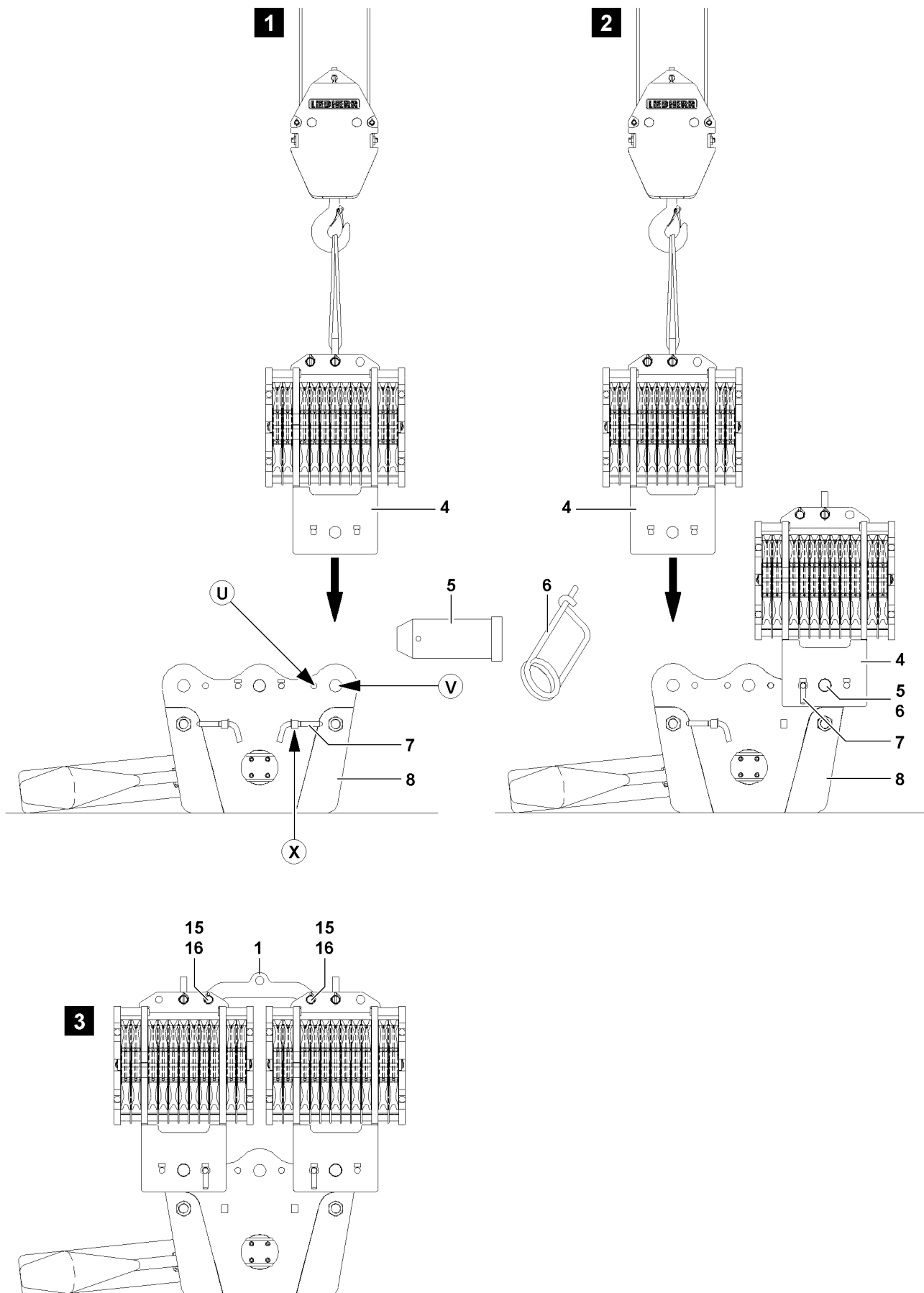

Fig.108121

LWE/LR 1600-2-008/18109-09-02/en

4 Installing a double hook block for parallel operation

4.1 Installing the hook block

If the hook blocks are to be used in parallel operation, then the pulley blocks **4** must be installed on the left and right on the cross brace **8**.

4.1.1 Installing the pulley blocks on the cross brace

Make sure that the following prerequisites are met:

- The ground is sufficiently load bearing to take on the weight of the hook block safely.
- The ground is level and horizontal.
- The cross brace **8** is placed on the ground, see illustration **1**.



DANGER

Risk of tipping the pulley blocks!

If the retaining pins **7**, during assembly of the pulley blocks **4** are not pinned on the cross brace, then the pulley blocks tip to the side when the auxiliary crane is removed!

Personnel remaining in the danger zone can be severely injured or killed!

- ▶ Insert the retaining pins **7** into the bores **U** on the hook block!
- ▶ Make sure before removing the auxiliary crane that the pulley blocks are properly pinned and secured!



Note

- ▶ The installation of two pulley blocks **4** is identical and is described on the example of one pulley block!

- ▶ Attach the pulley block **4** onto the auxiliary crane, illustration **1**.
- ▶ Position pulley block **4** on the cross brace **8** and align the pin bore **V**.
- ▶ Insert the pin **5** on point **V** and secure with spring retainer **6**.
- ▶ Unpin the retaining pin **7** from the transport receptacle (point **X**).
- ▶ Insert the retaining pins **7** into the bores (point **U**) on the cross brace **8**, illustration **1**.

When the pulley block **4** is secured by the retaining pins **7** at point **U**:

- ▶ Remove the auxiliary crane, illustration **2**.
- ▶ Install the second pulley block.

4.1.2 Installing the block connector

Make sure that the following prerequisite is met:

- The two pulley blocks **4** are installed and secured on the cross brace **8**.

Both pulley blocks **4** are pinned with the block connector **1**.

- ▶ Attach the block connector **1** on the auxiliary crane.
- ▶ Position the block connector **1** with auxiliary crane in pin position, illustration **3**.
- ▶ Insert the pins **15** on both sides on the pulley blocks **4** and secure with linch pin **16**, illustration **3**.

When the block connector **1** is pinned and secured properly:

- ▶ Remove the auxiliary crane.

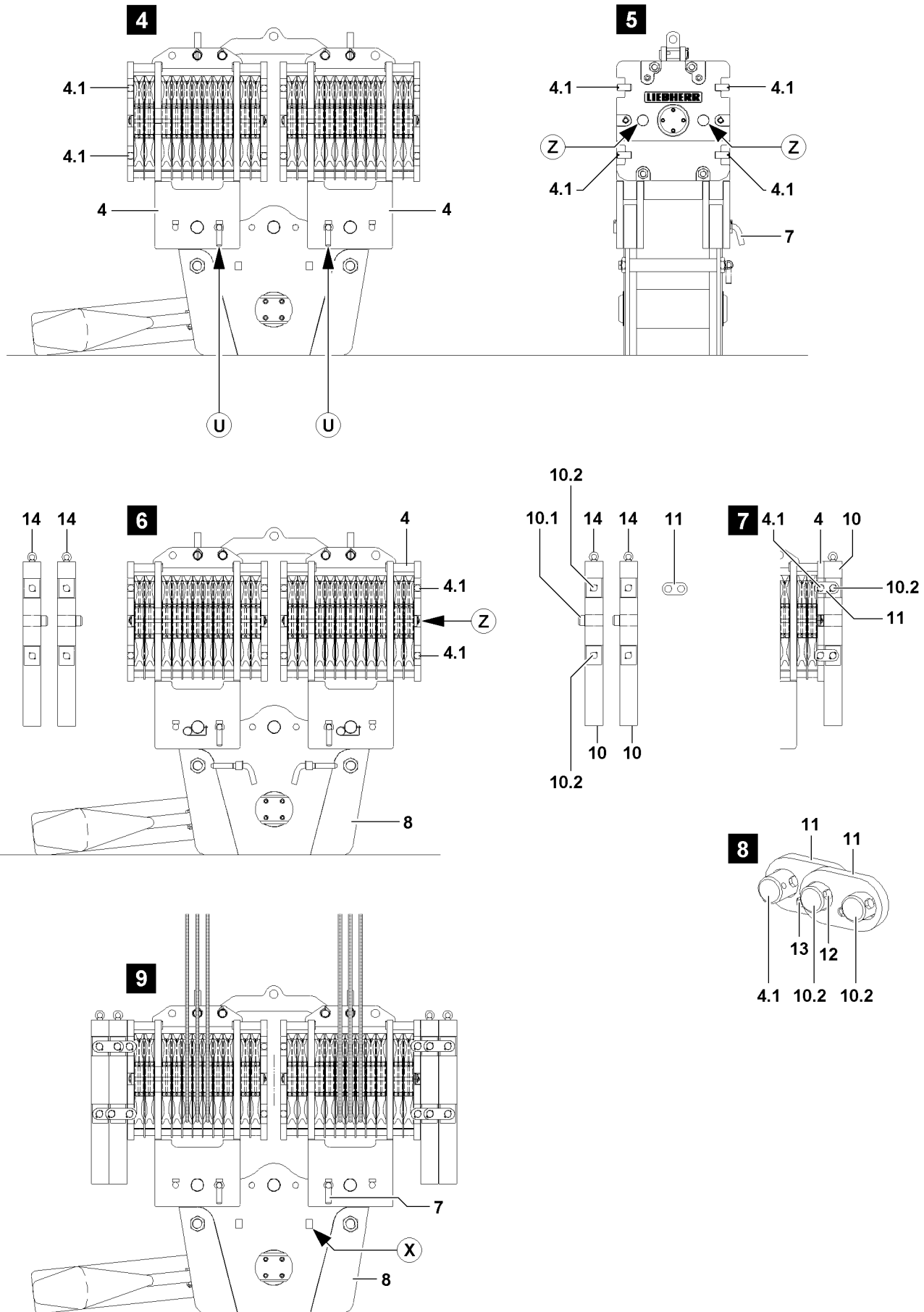

Fig.108120

LWE/LR 1600-2-008/18109-09-02/en

4.1.3 Installing the auxiliary weights



Note

- ▶ The own weight for each auxiliary weight is marked on the auxiliary weight!



WARNING

Toppling of hook block!

If the auxiliary weights are installed one-sided, the hook block can topple over!

Personnel can be severely injured or killed!

- ▶ The auxiliary weights may only be placed **individually** and alternating left and right on the pulley blocks of the hook block!
- ▶ When the required auxiliary weight is installed on the pulley blocks, the difference between the left and right side may never be more than one auxiliary weight!
- ▶ Asymmetrical installation of auxiliary weights is prohibited!
- ▶ Do not exceed the maximum permissible own weight of the hook block! The maximum permissible own weight is engraved on ballastable hook blocks. See „Engraving WT max.“.

Make sure that the following prerequisites are met:

- The hook block is placed on the ground.
- The pulley blocks **4** are properly installed and secured.
- The retaining pins **7** are pinned in and secured at point **U**.
- The block connector **1** is properly installed and secured.



WARNING

Falling auxiliary weights!

If the auxiliary weights on the pulley blocks are not properly installed, then they can fall down during installation or during crane operation!

Personnel can be severely injured or killed!

- ▶ Standing under a suspended auxiliary weight is prohibited!
 - ▶ Make sure that the auxiliary weights are properly installed and secured!
 - ▶ Crane operation with insufficiently secured auxiliary weights is prohibited!
-
- ▶ Attach the auxiliary weight **10** on the ring screw **14** on the auxiliary crane.



WARNING

Danger of crushing!

When swinging the auxiliary weights to the pulley block, personnel can be severely injured or killed!

Fingers, hands and arms can be crushed or severed!

- ▶ It is prohibited for anyone to remain between the pulley blocks and the auxiliary weight!
- ▶ Swing auxiliary weights in to the pulley block with utmost caution and at the least possible speed!

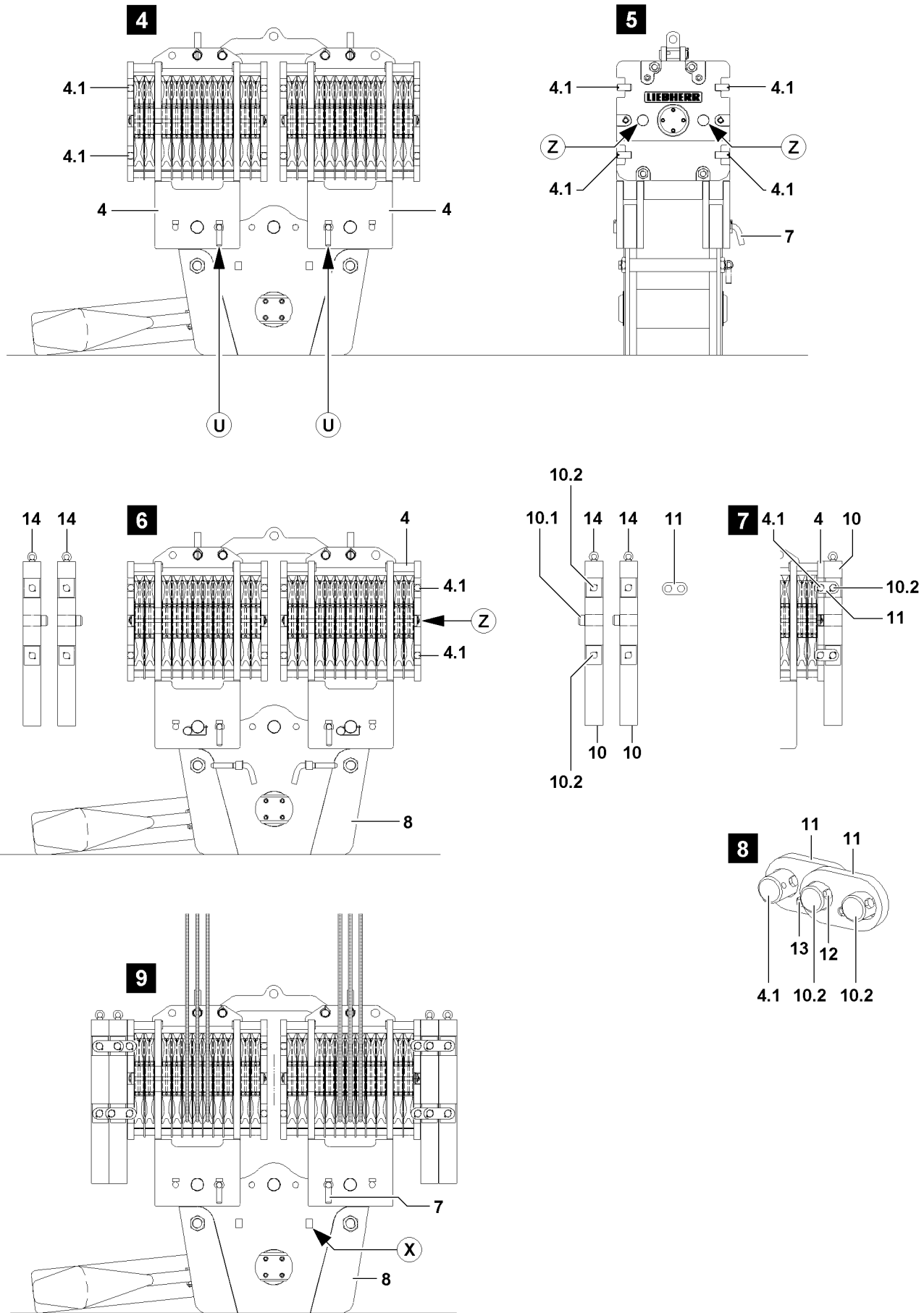

Fig.108120

- ▶ Align the auxiliary weight **10** on the pulley block **4**.
- ▶ Move the centering pin **10.1** of the auxiliary weight into the centering bores **Z** on the pulley block **4**, illustration **7**.

**WARNING**

Falling auxiliary weights!

If all mounting brackets **11** are removed simultaneously on an unsecured auxiliary weight, then the auxiliary weight can fall down!

Personnel can be severely injured or killed!

- ▶ Never remove all mounting brackets **11** of an unsecured auxiliary weight at the same time!
- ▶ Always install or remove the mounting brackets **11** alternately!

- ▶ Install the mounting brackets **11** on the side and connect the pulley block **4** with the auxiliary weight **10**, illustration **8**.

- ▶ Secure the mounting brackets **11** with screws **12** and lock nuts **13**, illustration **8**.

**Note**

- ▶ Additional auxiliary weights must be connected with the mounting brackets **11**!

**WARNING**

Falling auxiliary weights!

The auxiliary weights can fall down to the side when the auxiliary crane is removed!

Personnel can be severely injured or killed!

- ▶ Remove the auxiliary crane only when it is ensured that the auxiliary weight **10** is properly secured with the mounting brackets **11**!

When the respective auxiliary weight is properly installed and secured:

- ▶ Remove the auxiliary crane.

4.1.4 Preparing the hook block for crane operation

**Note**

- ▶ The reeving of the hook blocks is described in chapter 4.06 of the Crane operating instructions!
- ▶ Observe the „permissible hook block weights“ in the erection and take down charts!

- ▶ Reeve the hoist rope according to the instructions in chapter 4.06 of the Crane operating instructions and the reeving plans!

NOTICE

Retaining pins **7** pinned when lifting the load!

If the retaining pins **7** are not unpinned before the crane operation, then the retaining pins **7** may be shorn off when lifting the load!

- ▶ Unpin the retaining pin **7** from the hook block before crane operation!

When the hook block is properly reeved and has been lifted off the ground:

- ▶ Unpin the retaining pin **7** and pin and secure into the transport receptacle (point **X**), illustration **9**.

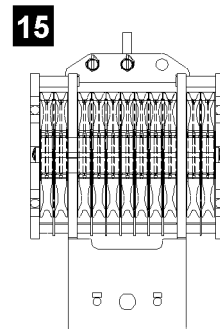
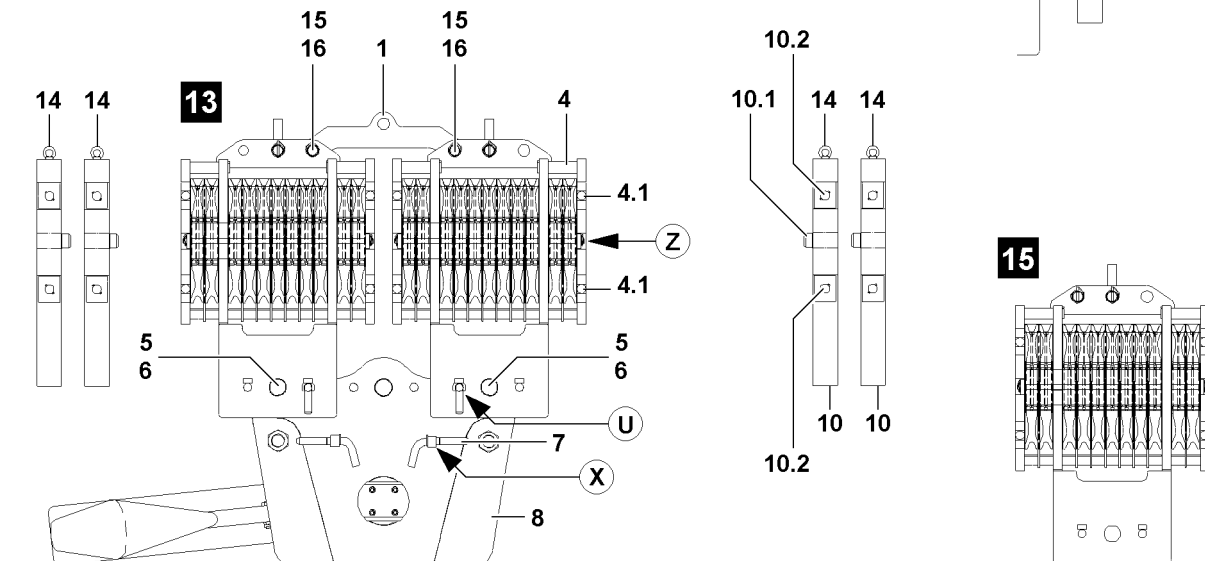
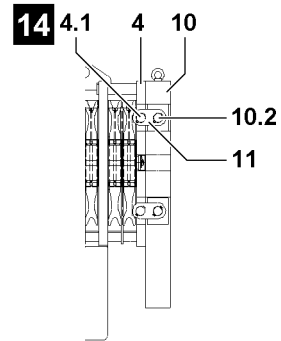
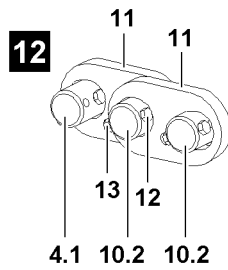
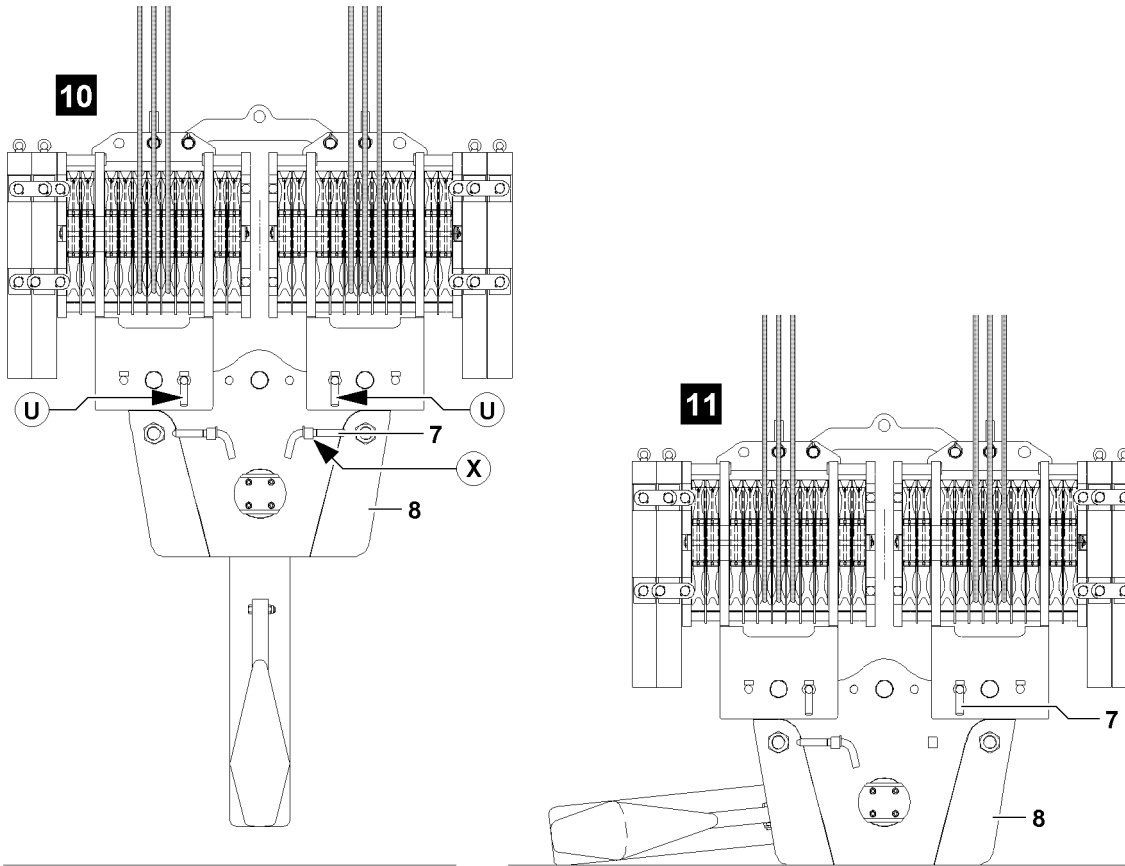

Fig.108143

LWE/LR 1600-2-008/18109-09-02/en

4.2 Removing the hook block

4.2.1 Preparing the hook block for removal



Note

- ▶ The unreeving of the hook blocks is described in chapter 4.06 of the Crane operating instructions!
- ▶ Observe the „permissible hook block weights“ in the erection and take down charts!

NOTICE

Retaining pin **7** unpinned when setting down the hook block!

If the retaining pin **7** - before setting the hook block on the ground - is not pinned, then the pulley blocks tip away to the side when the hoist rope is unreeved!

Personnel can be severely injured or killed!

- ▶ Before setting the hook block on the ground, insert and secure the retaining pins **7** on both pulley blocks at point **U**!

Make sure that the following prerequisites are met:

- The ground is sufficiently load bearing to take on the weight of the hook block and the auxiliary weights safely.
- The ground is level and horizontal.

- ▶ Lower the hook block completely to the ground.

When the hook block was placed down on the ground properly:

- ▶ Unreeve the hoist rope(s) according to chapter 4.06 of the Crane operating instructions!

4.2.2 Removing the auxiliary weights



Note

- ▶ The own weight for each auxiliary weight is marked on the auxiliary weight!



WARNING

Toppling of hook block!

If the auxiliary weights are removed one-sided, the hook block can topple over!

Personnel can be severely injured or killed!

- ▶ The auxiliary weights may only be removed **individually** and alternating left and right on the pulley blocks of the hook block!
- ▶ The difference between the left and the right side at removal of the auxiliary weights may never be more than one auxiliary weight!
- ▶ Asymmetrical removal of auxiliary weights is prohibited!

Make sure that the following prerequisites are met:

- The retaining pins **7** are pinned and secured on both sides at point **U**.
- The block connector **1** has been removed.

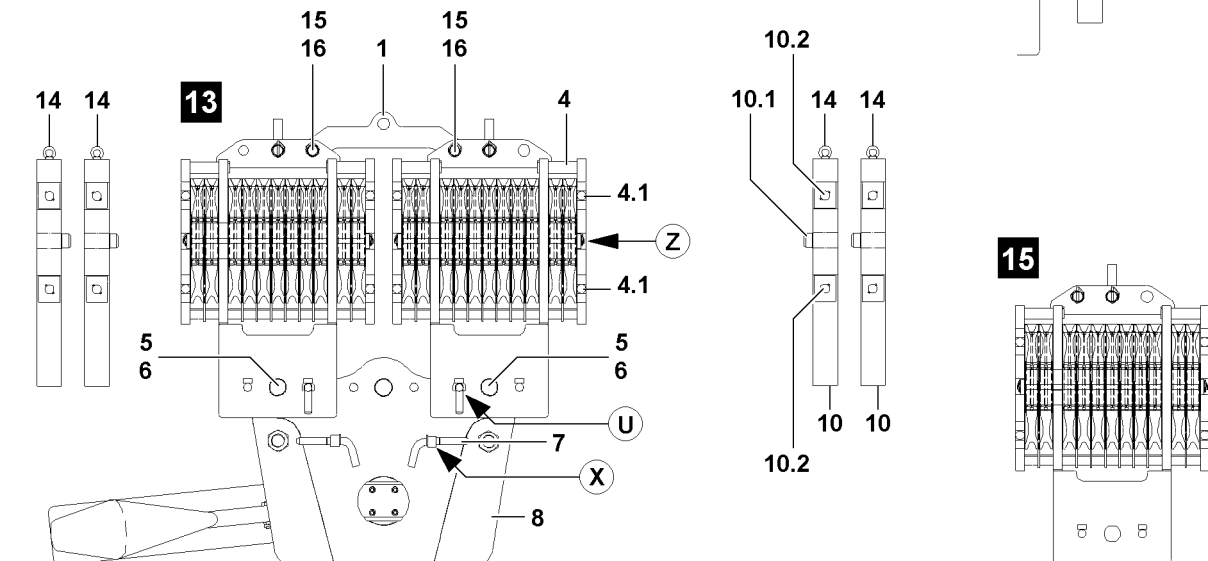
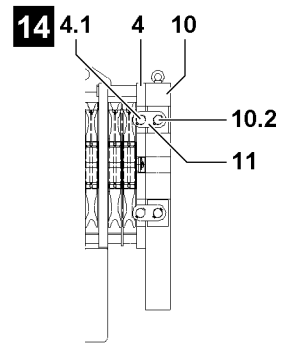
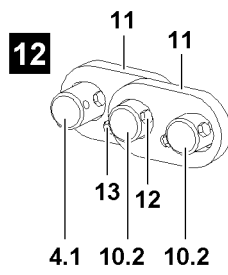
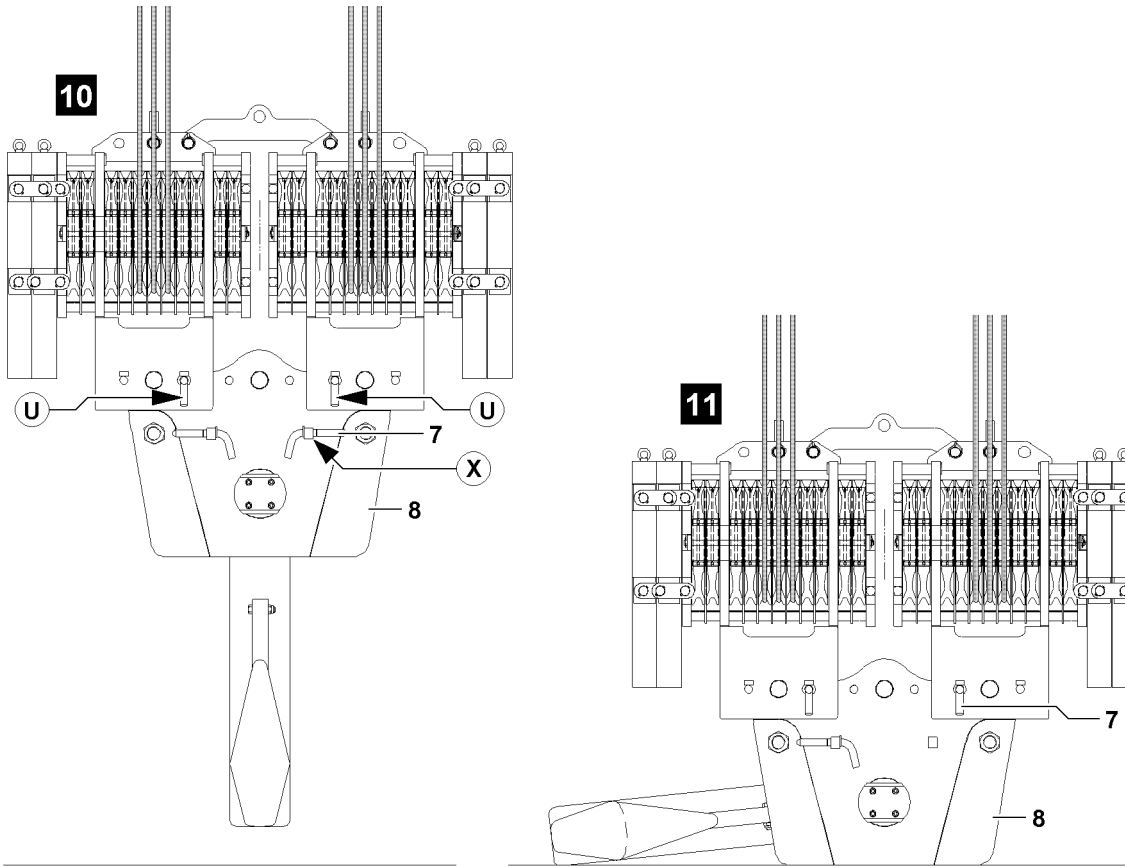

Fig.108143

LWE/LR 1600-2-008/18109-09-02/en

**WARNING**

Falling auxiliary weights!

If the auxiliary weights on the pulley blocks are not properly removed, then they can fall down at removal!

Personnel can be severely injured or killed!

▶ Standing under a suspended auxiliary weight is prohibited!

▶ Attach the auxiliary weight **10** on the ring screw **14** on the auxiliary crane.

▶ Tension the fastening equipment carefully.

**WARNING**

Oscillating auxiliary weights!

During the removal of the auxiliary weights, the auxiliary weights can start to swing back and forth!

Personnel can be severely injured or killed!

▶ It is prohibited for anyone to remain in the danger zone!

▶ Make sure that the auxiliary weight which is being removed is properly attached on the auxiliary crane before releasing the mounting brackets!

▶ Angular pull is prohibited!

When the fastening equipment is tensioned on the auxiliary weight:

▶ Release the screw connection on the mounting brackets of the outermost auxiliary weight and remove the screws.

**WARNING**

Falling auxiliary weights!

If all mounting brackets **11** are removed simultaneously on an unsecured auxiliary weight, then the auxiliary weight can fall down!

Personnel can be severely injured or killed!

▶ Never remove all mounting brackets **11** of an unsecured auxiliary weight at the same time!

▶ Always install or remove the mounting brackets **11** alternately!

▶ Pull the mounting brackets **11** off to the side.

**WARNING**

Falling auxiliary weights!

If additional auxiliary weights which are being removed are released, then these auxiliary weights can fall down!

Personnel can be severely injured or killed!

▶ Make sure, before removing the outermost auxiliary weight, that the other auxiliary weights are secured with the mounting brackets **11**!

If additional mounting brackets **11** must be removed to release the outermost auxiliary weight:

▶ Reinstall the mounting brackets again immediately, so that only the auxiliary weight which is being removed is released.

▶ Lift the auxiliary weight with the auxiliary crane from the pulley block.

▶ Place the auxiliary weight onto the ground.

▶ Remove the auxiliary crane.

▶ Remove additional auxiliary weights as described above.

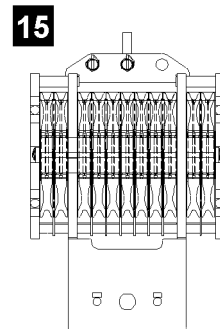
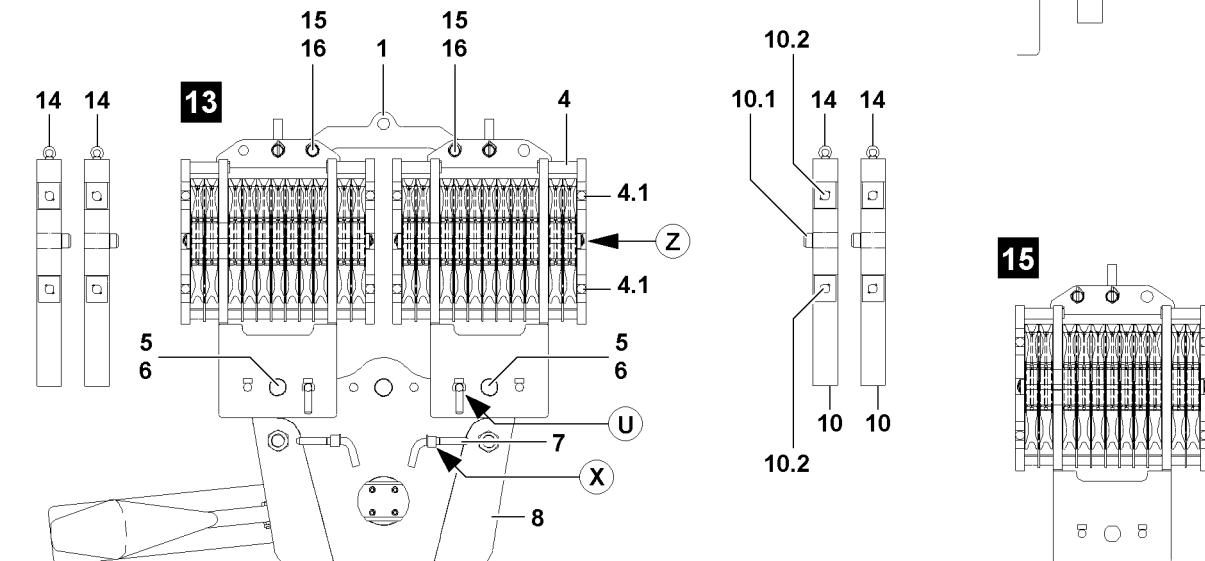
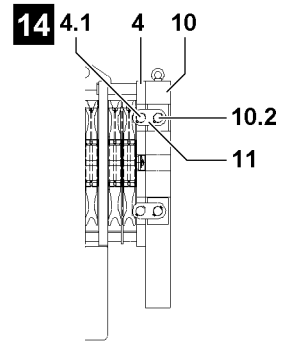
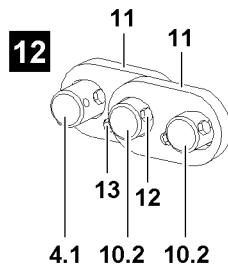
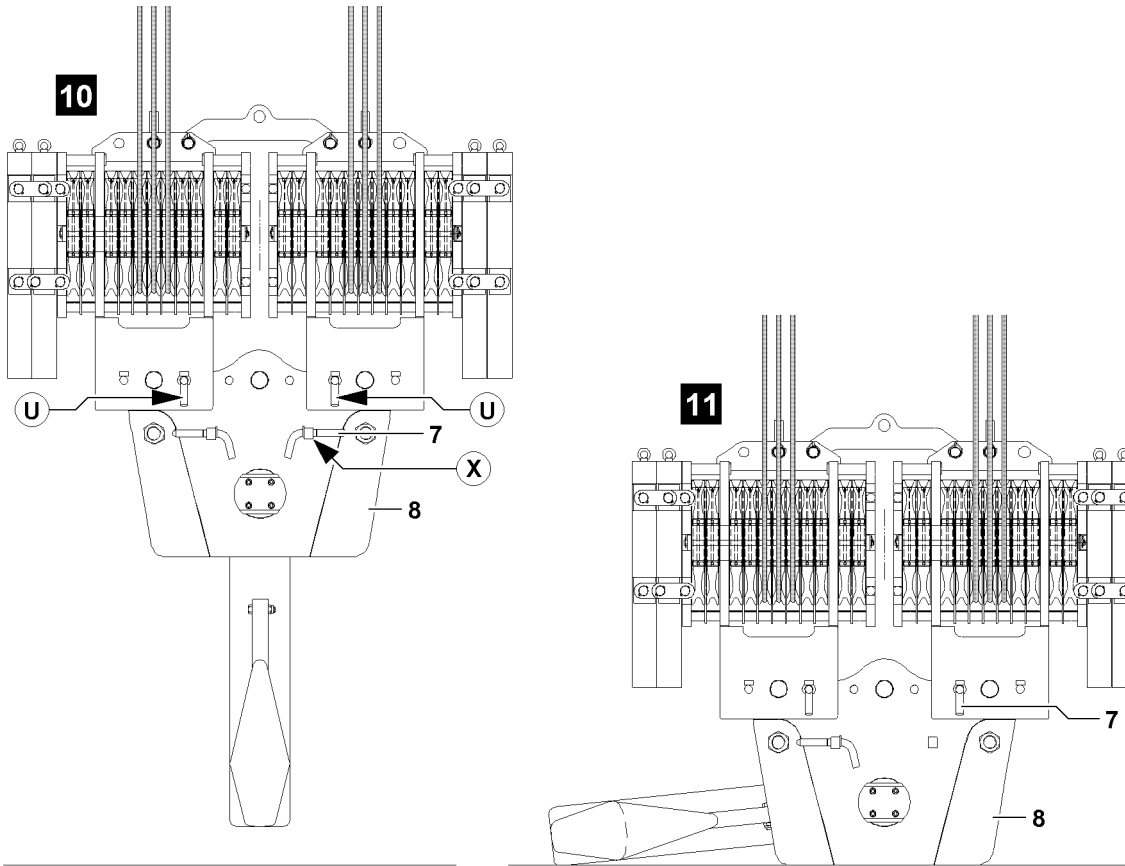

Fig.108143

LWE/LR 1600-2-008/18109-09-02/en

4.2.3 Removing the block connector

- ▶ Attach the block connector **1** on the auxiliary crane.



DANGER

Risk of tipping the pulley blocks!

If the retaining pins **7**, during removal of the block connector **1** are not pinned on the pulley blocks, then the pulley blocks tip to the side when the block connector is removed!

Personnel remaining in the danger zone can be severely injured or killed!

- ▶ Insert the retaining pins **7** into the bores **U** on the hook block!
- ▶ Make sure before removing the block connector that the pulley blocks are properly pinned and secured!

- ▶ Release and unpin the pins **15** on both sides on the pulley blocks **4**.
- ▶ Remove the block connector **1** on the auxiliary crane.
- ▶ Place the block connector **1** onto the ground.
- ▶ Remove the auxiliary crane.

4.2.4 Removing the pulley blocks on the cross brace



Note

- ▶ The removal of two pulley blocks is identical and is described on the example of one pulley block!

Make sure that the following prerequisites are met:

- The auxiliary weights have been removed.
- The block connector has been removed.

- ▶ Attach the pulley block **4** on the auxiliary crane.
- ▶ Tension the fastening equipment carefully.
- ▶ Unpin the retaining pin **7** at point **U** and pin into the transport receptacle on the cross brace, point **X**, illustration **13**.
- ▶ Release and unpin the pin **5**.
- ▶ Swing the pulley block **4** out with auxiliary crane.
- ▶ Place the pulley block **4** on the ground.
- ▶ Remove the auxiliary crane.
- ▶ Remove the second pulley block.

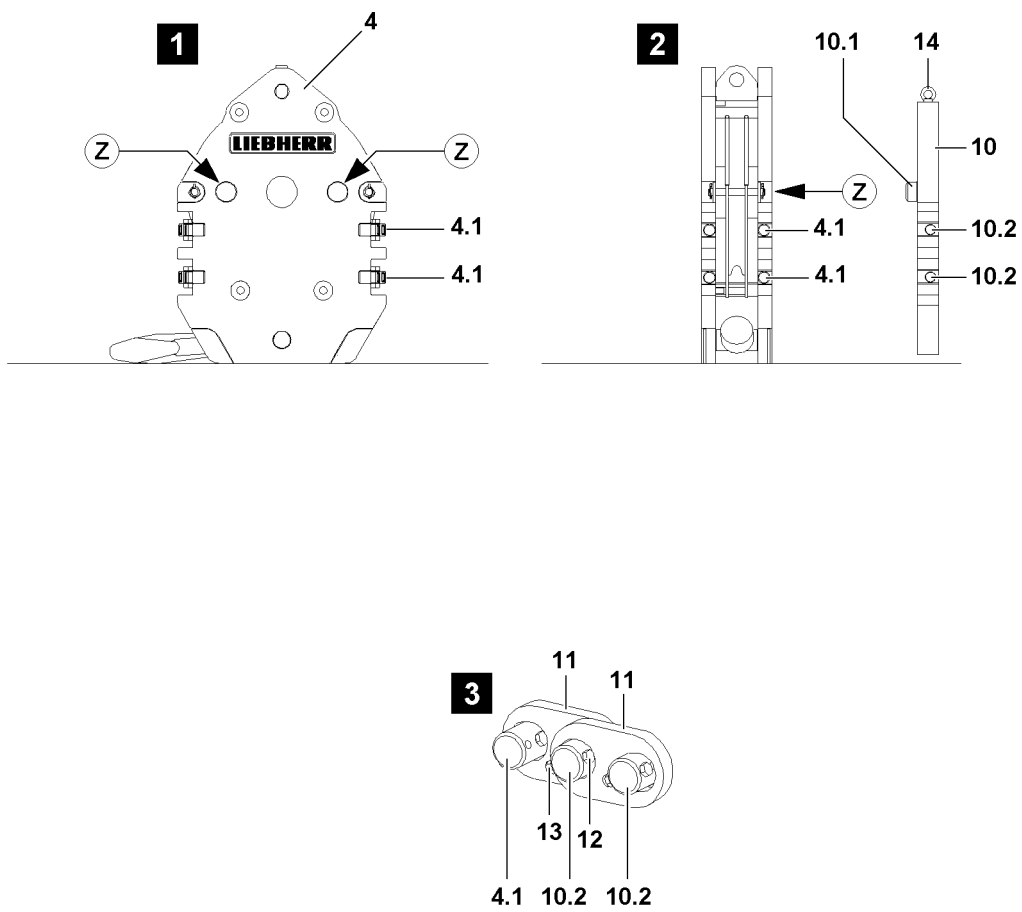

Fig.108146

5 Single hook blocks

5.1 Installing the single blocks

5.1.1 Installing the auxiliary weights



Note

- ▶ The own weight for each auxiliary weight is marked on the auxiliary weight!



WARNING

Toppling of hook block!

If the auxiliary weights are installed one-sided, the hook block can topple over!

Personnel can be severely injured or killed!

- ▶ The auxiliary weights may only be installed **individually** and alternately on the left and right on the hook block!
- ▶ When the required auxiliary weight is installed on the hook block, the difference between the left and right side may never be more than one auxiliary weight!
- ▶ Asymmetrical installation of auxiliary weights is prohibited!
- ▶ Do not exceed the maximum permissible own weight of the hook block! The maximum permissible own weight is engraved on ballastable hook blocks. See „Engraving WT max.“.

Make sure that the following prerequisite is met:

- The hook block is placed on the ground.



WARNING

Falling auxiliary weights!

If the auxiliary weights are not properly installed on the hook block, then they can fall down during installation or in crane operation!

Personnel can be severely injured or killed!

- ▶ Standing under a suspended auxiliary weight is prohibited!
- ▶ Make sure that the auxiliary weights are properly installed and secured!
- ▶ Crane operation with insufficiently secured auxiliary weights is prohibited!

- ▶ Attach the auxiliary weight **10** on the ring screw **14** on the auxiliary crane.



WARNING

Danger of crushing!

When swinging the auxiliary weights to the hook block, personnel can be severely injured or killed!

Fingers, hands and arms can be crushed or severed!

- ▶ It is prohibited for anyone to remain between the hook block and the auxiliary weight!
- ▶ Swing auxiliary weights in to the hook block with utmost caution and at the least possible speed!

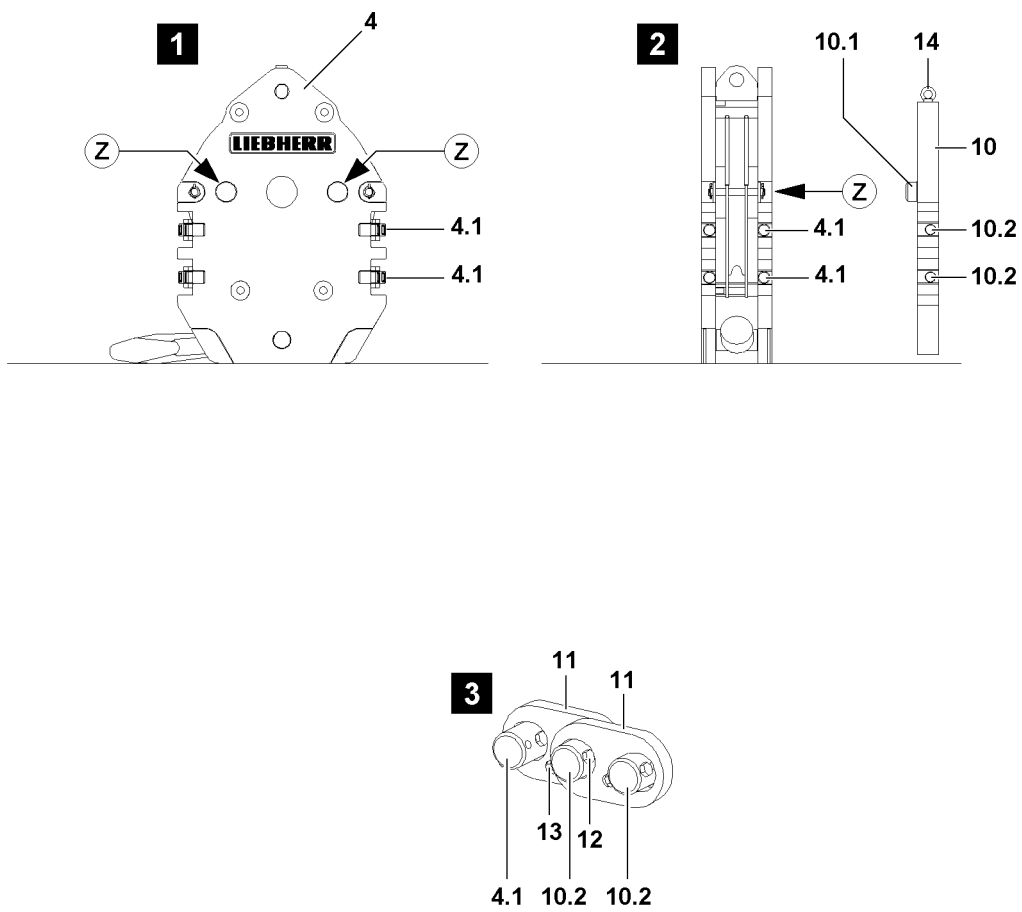

Fig.108146

LWE/LR 1600-2-008/18109-09-02/en

- ▶ Align the auxiliary weight **10** on the hook block.
- ▶ Move the centering pin **10.1** of the auxiliary weight into the centering bores **Z** on the hook block.

**WARNING**

Falling auxiliary weights!

If all mounting brackets **11** are removed simultaneously on an unsecured auxiliary weight, then the auxiliary weight can fall down!

Personnel can be severely injured or killed!

- ▶ Never remove all mounting brackets **11** of an unsecured auxiliary weight at the same time!
- ▶ Always install or remove the mounting brackets **11** alternately!

- ▶ Install the mounting brackets **11** on the side and connect the hook block with the auxiliary weight **10**, illustration **3**.
- ▶ Secure the mounting brackets **11** with screws **12** and lock nuts **13**, illustration **3**.

**Note**

- ▶ Additional auxiliary weights must be connected with the mounting brackets **11**!

**WARNING**

Falling auxiliary weights!

The auxiliary weights can fall down by removing the auxiliary crane!

Personnel can be severely injured or killed!

- ▶ Remove the auxiliary crane only when it is ensured that the auxiliary weight **10** is properly secured with the mounting brackets **11**!

When the respective auxiliary weight is properly installed and secured:

- ▶ Remove the auxiliary crane.

5.1.2 Preparing the hook block for crane operation

**Note**

- ▶ The reeving of the hook blocks is described in chapter 4.06 of the Crane operating instructions!
- ▶ Observe the „permissible hook block weights“ in the erection and take down charts!
- ▶ Reeve the hoist rope according to the instructions in chapter 4.06 of the Crane operating instructions and the reeving plans!

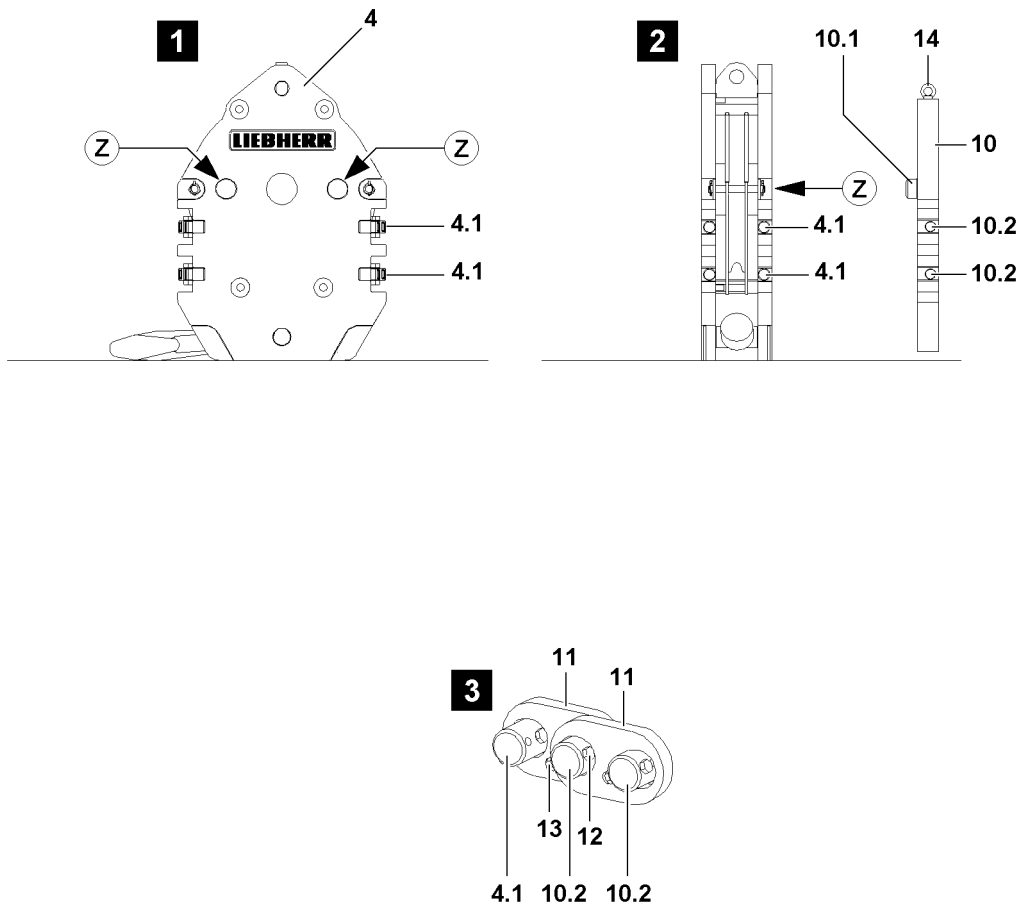

Fig.108146

LWE/LR 1600-2-008/18109-09-02/en

5.2 Removing the single blocks

5.2.1 Preparing the hook block for removal



Note

- ▶ The unreeving of the hook blocks is described in chapter 4.06 of the Crane operating instructions!
- ▶ Observe the „permissible hook block weights“ in the erection and take down charts!

Make sure that the following prerequisites are met:

- The ground is sufficiently load bearing to take on the weight of the hook block and the auxiliary weights safely.
 - The ground is level and horizontal.
- ▶ Lower the hook block completely to the ground.

When the hook block was placed down on the ground properly:

- ▶ Unreeve the hoist rope according to chapter 4.06 of the Crane operating instructions!

5.2.2 Removing the auxiliary weights



Note

- ▶ The own weight for each auxiliary weight is marked on the auxiliary weight!



WARNING

Toppling of hook block!

If the auxiliary weights are removed one-sided, the hook block can topple over!

Personnel can be severely injured or killed!

- ▶ The auxiliary weights may only be removed **individually** and alternately on the left and right on the hook block!
- ▶ The difference between the left and the right side at removal of the auxiliary weights may never be more than one auxiliary weight!
- ▶ Asymmetrical removal of auxiliary weights is prohibited!



WARNING

Falling auxiliary weights!

If the auxiliary weights on the pulley block are not properly removed, then they can fall down at removal!

Personnel can be severely injured or killed!

- ▶ Standing under a suspended auxiliary weight is prohibited!

- ▶ Attach the auxiliary weight **10** on the ring screw **14** on the auxiliary crane.
- ▶ Tension the fastening equipment carefully.

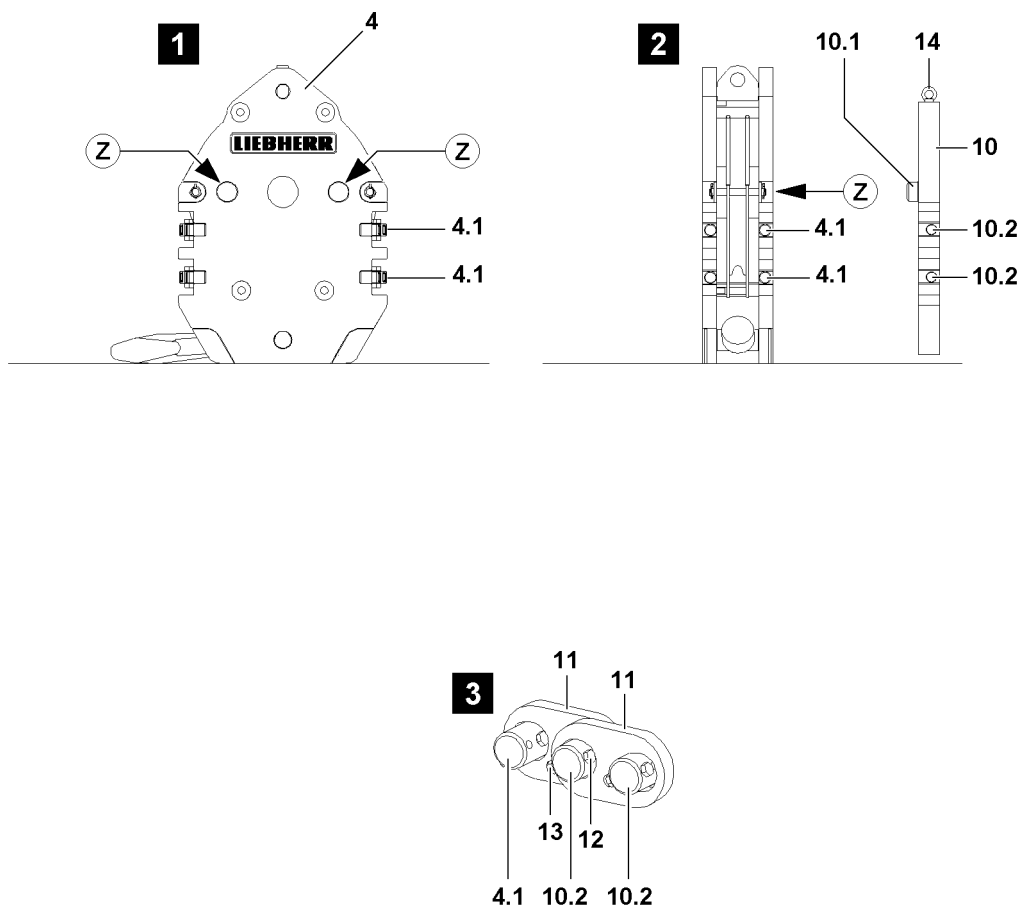

Fig.108146

**WARNING**

Oscillating auxiliary weights!

During the removal of the auxiliary weights, the auxiliary weights can start to swing back and forth!
Personnel can be severely injured or killed!

- ▶ It is prohibited for anyone to remain in the danger zone!
- ▶ Make sure that the auxiliary weight which is being removed is properly attached on the auxiliary crane before releasing the mounting brackets!
- ▶ Angular pull is prohibited!

When the fastening equipment is tensioned on the auxiliary weight:

- ▶ Release the screw connection on the mounting brackets of the outermost auxiliary weight and remove the screws.

**WARNING**

Falling auxiliary weights!

If all mounting brackets **11** are removed simultaneously on an unsecured auxiliary weight, then the auxiliary weight can fall down!

Personnel can be severely injured or killed!

- ▶ Never remove all mounting brackets **11** of an unsecured auxiliary weight at the same time!
- ▶ Always install or remove the mounting brackets **11** alternately!

- ▶ Pull the mounting brackets **11** off to the side.

**WARNING**

Falling auxiliary weights!

If additional auxiliary weights which are being removed are released, then these auxiliary weights can fall down!

Personnel can be severely injured or killed!

- ▶ Make sure, before removing the outermost auxiliary weight, that the other auxiliary weights are secured with the mounting brackets!

If additional mounting brackets must be removed to release the outermost auxiliary weight:

- ▶ Reinstall the mounting brackets **11** again immediately, so that only the auxiliary weight which is being removed is released.
- ▶ Lift the auxiliary weight with the auxiliary crane from the hook block.
- ▶ Place the auxiliary weight onto the ground.
- ▶ Remove the auxiliary crane.
- ▶ Remove additional auxiliary weights as described above.

Empty page!

LWE/LR 1600-2-008/18109-09-02/en

5.30 Pin pulling device

1	Pin pulling device	3
2	Hydraulic oil level	3
3	Pin pulling device	4
4	Pinning and unpinning the pin with pin pulling cylinder 2	6
5	Pinning and unpinning the pin with pin pulling cylinder 3	7

Fig.195219

1 Pin pulling device

The pin pulling device consists of the hydraulic aggregate and the pin pulling cylinders. The connector pins on the crawler crane and on the lattice sections are pinned and unpinned with these pin pulling cylinders.



Note

- ▶ The pin pulling cylinder **2** is used for pinning and unpinning on the chassis.



Note

- ▶ The pin pulling cylinder **3** is used for pinning and unpinning on the lattice sections.



DANGER

Danger of accident!

When you disassemble unsecured or unsupported crane parts, they can fall down.

Death, severe bodily injuries, property damage.

- ▶ Never stand **under** unsecured or unsupported crane parts and unpin the pins.
- ▶ Never unpin the connector pins on unsecured or unsupported booms.
- ▶ It is prohibited for anyone to remain under the crane components or within the complete danger zone during the pinning and unpinning procedure.
- ▶ Do not lean the ladder against the crane part being disassembled.



WARNING

Pressure in the hydraulic lines!

If the pressure supply is not interrupted before connecting / releasing the hydraulic lines, the hydraulic oil can escape with high pressure.

Death, severe bodily injuries, property damage.

- ▶ Release the pressure in the hydraulic system before connecting / disconnecting: Interrupt the pressure supply and wait for a short time.



WARNING

Loss of pressure or leakage!

Incorrectly coupled or self-loosening quick couplings (particularly return lines) can result in serious accidents due to component failure.

Death, severe bodily injuries, property damage.

- ▶ Check that the quick couplings have been properly connected before using the crane.
- ▶ Connect the coupling components (sleeve and connector) and screw together with the knurled nut.
- ▶ Tighten the hydraulic coupling by hand. Turn the knurled nut until it reaches a tangible, fixed stop position.

2 Hydraulic oil level



Note

- ▶ The hydraulic oil tank is filled when starting the hydraulic aggregate.
- ▶ Check the hydraulic oil level, see Operating and maintenance instructions for the Hydraulic aggregate.

NOTICE

Emerging hydraulic oil!

When the hydraulic aggregate is changed and / or the operational crane hydraulic is connected, then there is a danger that the hydraulic oil is supplied during the working process into the hydraulic tank circuit and thus forwarded into the hydraulic tank of the hydraulic aggregate.

The forwarded hydraulic oil quantity exceeds the tank volume of the hydraulic aggregate. Hydraulic oil runs over and contaminates the environment.

- ▶ Make sure that the hydraulic aggregate is separated from the hydraulic circuit of the crane before hydraulic components are actuated via the crane hydraulic.
- ▶ Make sure, before the hydraulic aggregate is separated from the crane, that the working process is ended with the same hydraulic aggregate.
- ▶ Make sure that the identical amount of hydraulic oil is in the hydraulic oil tank of the hydraulic aggregate after application than before.

3 Pin pulling device

Depending on the delivery condition of the crane, the crane can have the following hydraulic aggregates.

**Note**

- ▶ Operate the pin pulling device, see the Operating and maintenance instructions for the Hydraulic aggregate.

3.1 Hydraulic aggregate on wheels

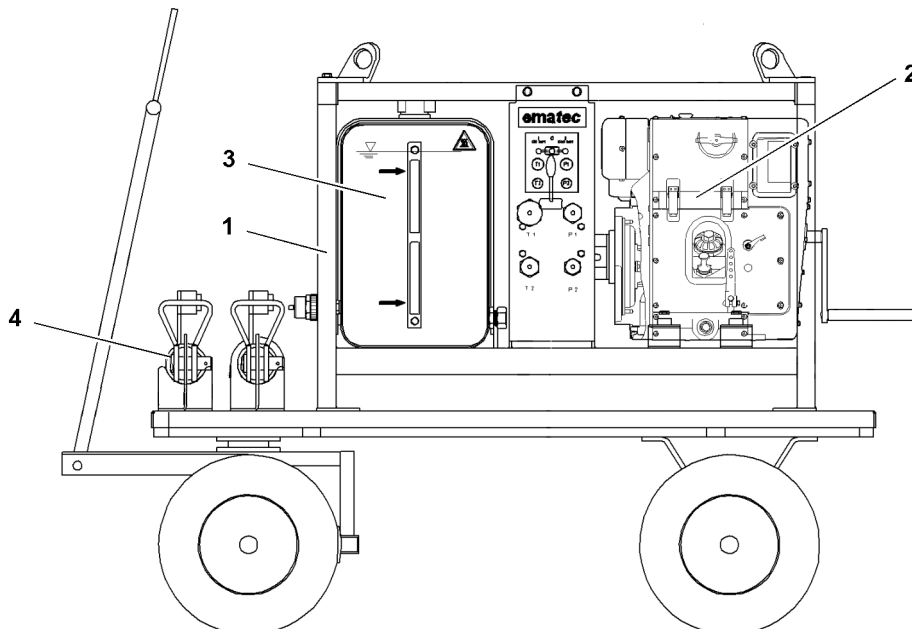

Fig.146739: Hydraulic aggregate on wheels

- | | | | |
|---|---------------------|---|----------------------|
| 1 | Pin pulling device | 3 | Hydraulic oil tank |
| 2 | Hydraulic aggregate | 4 | Pin pulling cylinder |

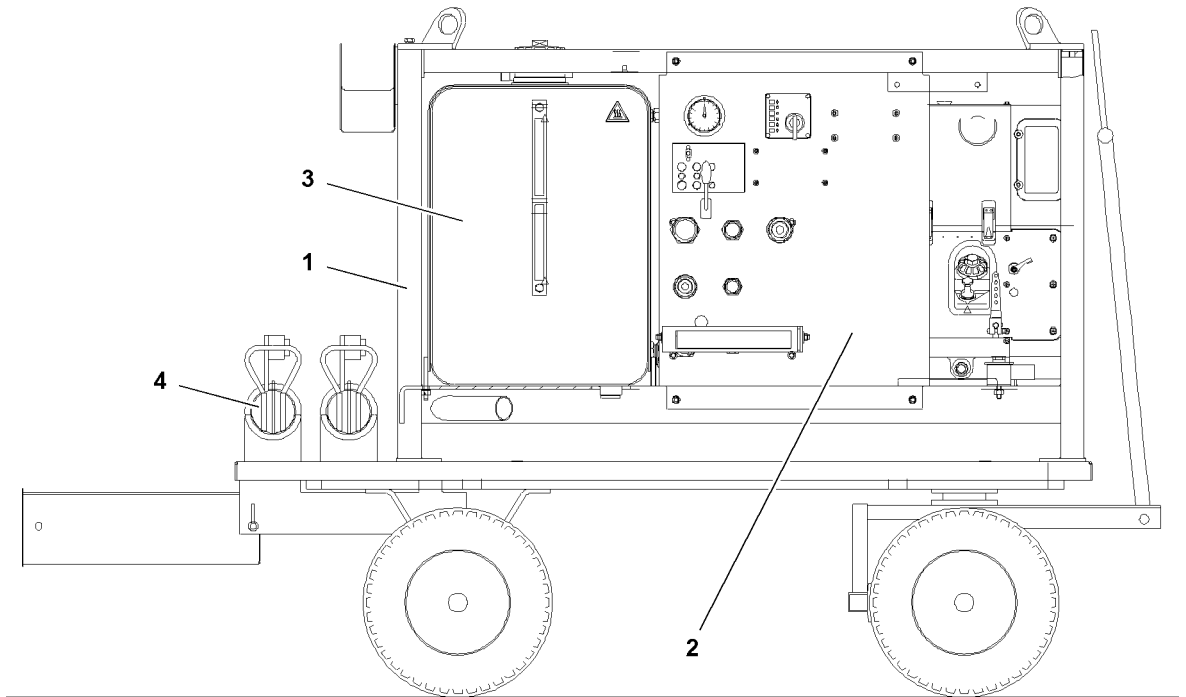

Fig.146741: Hydraulic aggregate on wheels

- | | | | |
|---|---------------------|---|----------------------|
| 1 | Pin pulling device | 3 | Hydraulic oil tank |
| 2 | Hydraulic aggregate | 4 | Pin pulling cylinder |

3.2 Hydraulic aggregate on the crawler

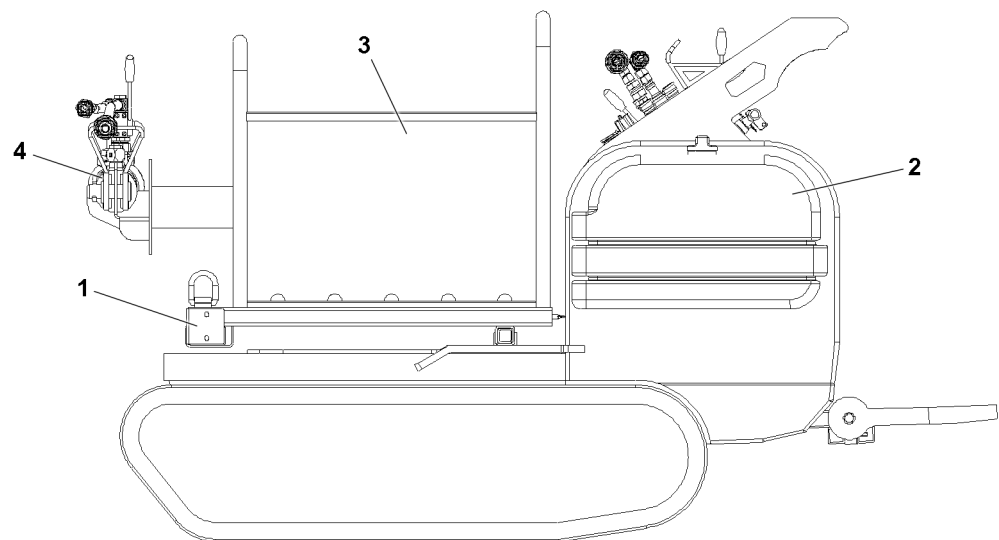

Fig.146738: Hydraulic aggregate on the crawler

- | | | | |
|---|---|---|----------------------|
| 1 | Pin pulling device on the crawler tractor | 3 | Hydraulic oil tank |
| 2 | Hydraulic aggregate | 4 | Pin pulling cylinder |

LWE/LR 1600-2-008/18109-09-02/en

4 Pinning and unpinning the pin with pin pulling cylinder 2

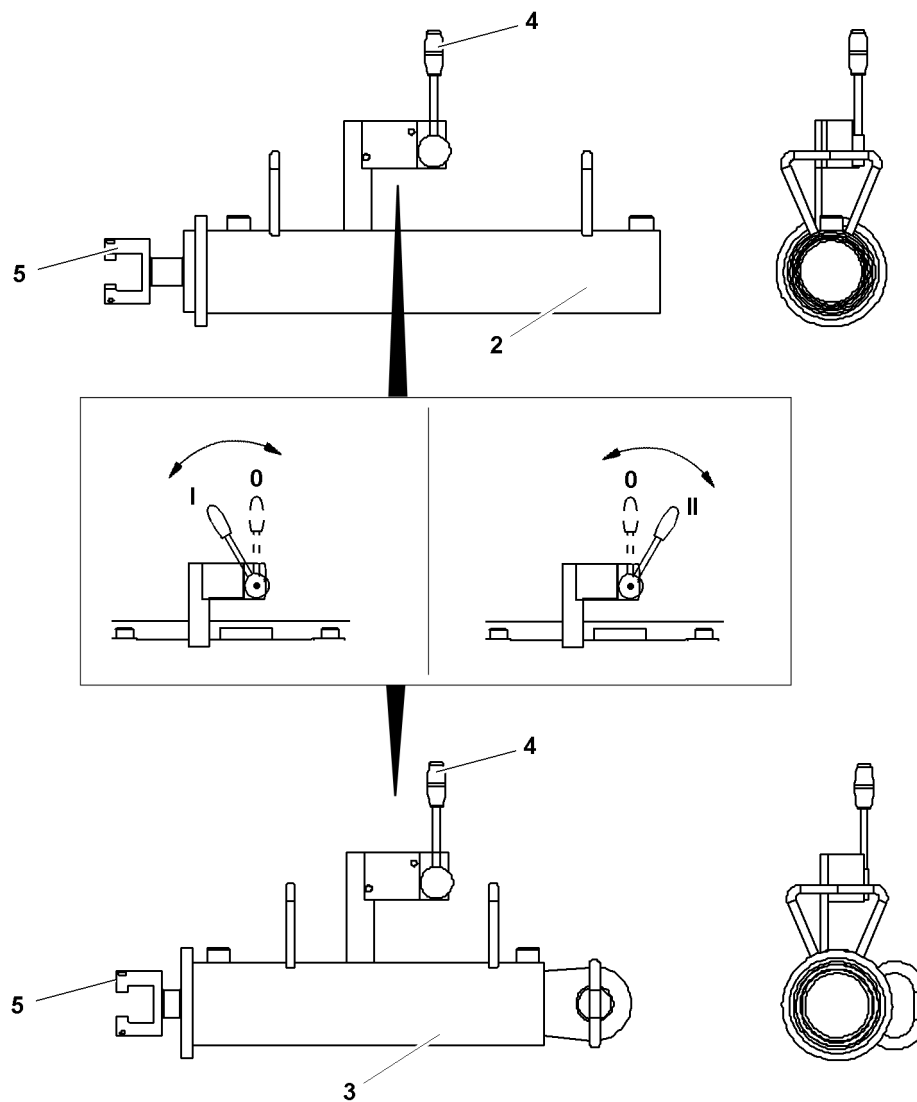

Fig.146740: Pin pulling cylinder with actuation

4.1 Preparatory work

Make sure that the following prerequisites are met:

- The hydraulic aggregate is not yet started.
- The lever **4** is in **0-position**.
- ▶ Connect the hydraulic hoses of the required pin pulling cylinder to the hydraulic aggregate.
- ▶ Hang or pin the pin pulling cylinder in the retainer on the component.
- ▶ Connect the piston rod head **5** with the screw on the pin.

4.2 Pinning or unpinning pins



Note

- ▶ Operate the hydraulic aggregate, see the Operating and maintenance instructions for the Hydraulic aggregate.
- ▶ Start the hydraulic aggregate.

- ▶ Set the engine rpm on the hydraulic aggregate.
- ▶ Operate the lever **4** on the pin pulling cylinder **2**.

**Note**

- ▶ **I-position**, insert pin.
 - ▶ **II-position**, unpin pin.
-
- ▶ Pin or unpin the pin.

5 Pinning and unpinning the pin with pin pulling cylinder 3

5.1 Preparatory work

Make sure that the following prerequisites are met:

- The hydraulic aggregate is not yet started.
 - The lever **4** is in **0-position**.
- ▶ Connect the hydraulic hoses of the required pin pulling cylinder to the hydraulic aggregate.
 - ▶ Hang or pin the pin pulling cylinder in the retainer on the component.
 - ▶ Connect the piston rod head **5** with the screw on the pin.

5.2 Pinning or unpinning pins

**Note**

- ▶ The pin pulling cylinder **3** is actuated for safety reasons on the hydraulic aggregate.
 - ▶ Before pinning and unpinning the lattice sections, engage the lever **4** in **position I** or **position II**.
-
- ▶ Engage the lever **4** on the pin pulling cylinder **3** in **position I** or **position II**.

**Note**

- ▶ **Position I**, insert the pin.
- ▶ **Position II**, unpin the pin.

**Note**

- ▶ Operate the hydraulic aggregate, see the Operating and maintenance instructions for the Hydraulic aggregate.
-
- ▶ Start the hydraulic aggregate **1**.
 - ▶ Set the engine rpm on the hydraulic aggregate **1**.
 - ▶ Operate the change over lever on the hydraulic aggregate **1**.

Result:

- The piston rod of the pin pulling cylinder **3** moves in or out.

Empty page!

LWE/LR 1600-2-008/18109-09-02/en

5.35.10 Derrick ballast - ballast trailer

1	Component description and general notes	3
2	Assembling the ballast trailer	9
3	Setting the ballast trailer radii	35
4	Steering programs	37
5	Driving with the ballast trailer	57
6	Crane operation with derrick ballast	71
7	Removing the ballast trailer	91
8	Emergency operation with a defective CPU	109
9	Maintenance intervals / maintenance instructions for the ballast trailer	117

Fig.195219

1 Component description and general notes

Ballast trailer, complete, consisting of:

- 2 axle lines with 2 each oscillating wheel sets
- 1 Ballast trailer
- 2 Ballast trailer guide
- 3 Support cylinder

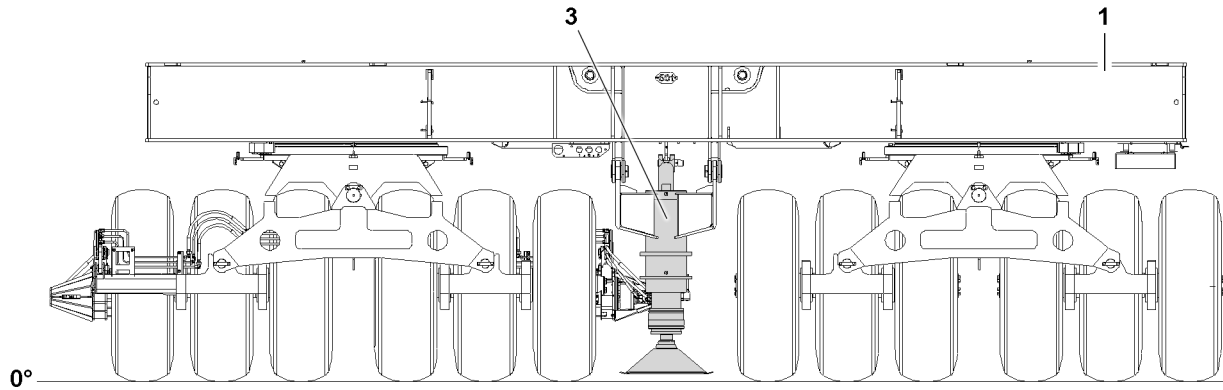

Fig.146342: Ballast trailer

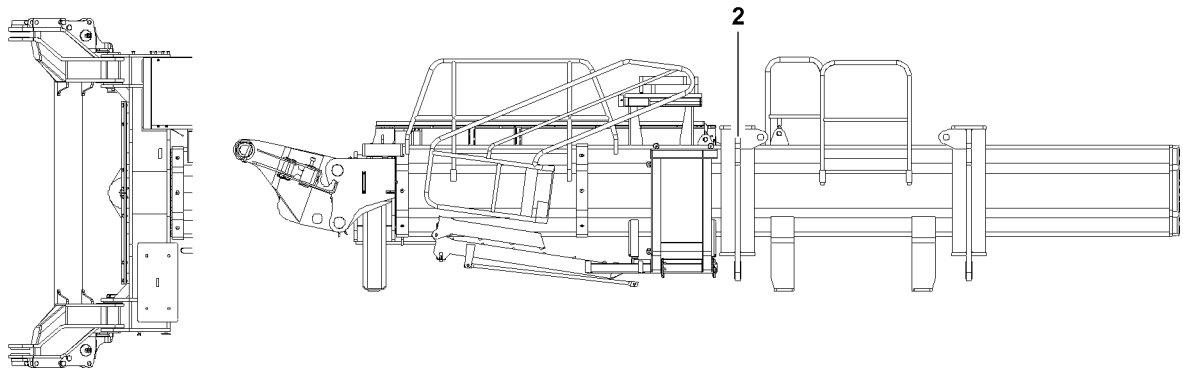

Fig.146341: Ballast trailer guide



Note

- ▶ Dimensions and weights, see chapter 1.03.

Hydraulic telescopic ballast trailer guide for ballast trailer radii of R 13 m - R 18 m.

The pull cylinders for the ballast trailer are assembled on the D-end section and can be actuated under load.

Hydraulic, mechanical steering is electronically adjustable for:

- Towing
- Circular travel
- Parallel travel
- Manual corrective steering

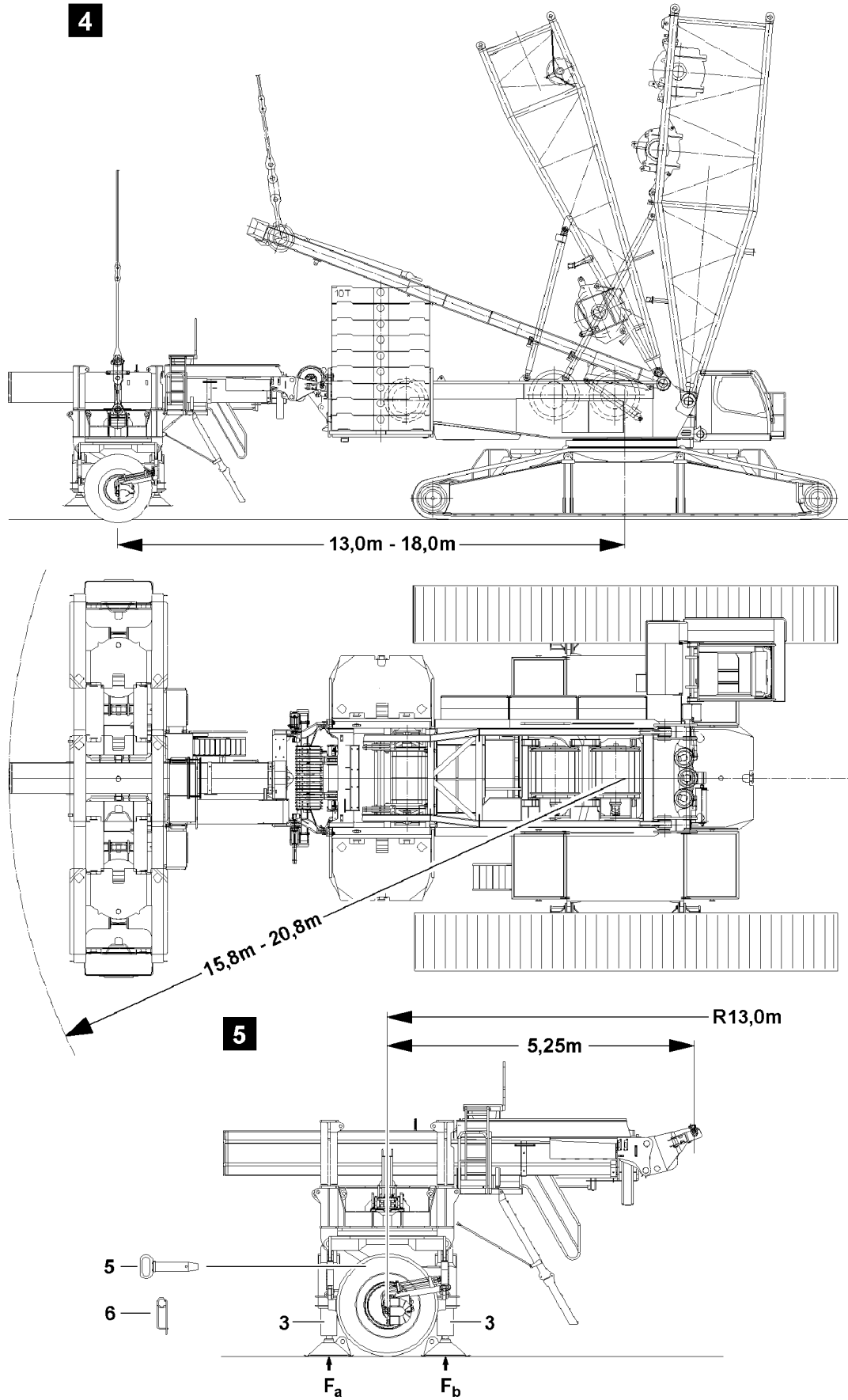

Fig.113690

1.1 Radii

Derrick boom radius	Ballast trailer radius
13.0 m	13.0 m
13.0 m	15.0 m
13.0 m	18.0 m

1.2 Stability and tipping safety for ballast trailer not assembled on the turntable

Make sure that the following prerequisites are met:

- The ballast trailer guide is hydraulically fully retracted.
- The ballast trailer is supported and horizontally aligned.



WARNING

Ballast trailer tipping danger!

If the ballast trailer is not installed on the turntable and the ballast trailer guide is not fully retracted, then the ballast trailer can tip over.

Death, severe bodily injuries, property damage.

- ▶ Before the disassembly of the ballast trailer on the turntable, the locking pin **5** must be pinned on the strut of the ballast trailer and secured with the spring retainer **6**.
- ▶ The ballast trailer guide must be fully moved in before disassembly of the ballast trailer on the turntable.
- ▶ The support cylinders **3** are extended to the point where the tires are relieved.

Illustration	Ballast trailer radius	Ballast	Maximum support pressure F_a	Maximum support pressure F_b
5	R = 13.0 m	0 t	23.6 t	39.6 t

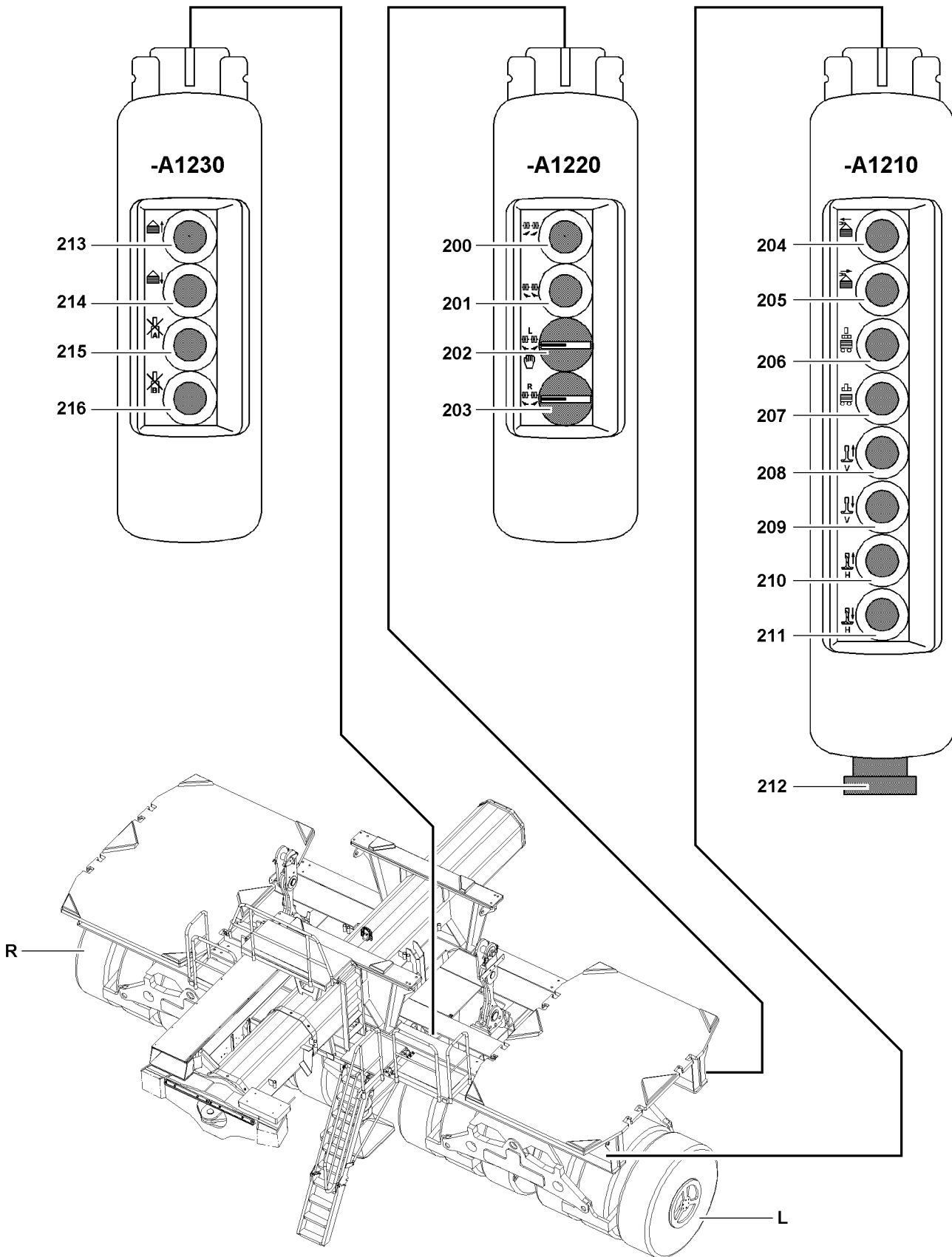

Fig.113691

LWE/LR 1600-2-008/18109-09-02/en

1.3 Operating elements on the control panels

Control panel - A1220

200	Button	• Corrective steering, turn wheel sets to left
201	Button	• Corrective steering, turn wheel sets to right
202	Rotary switch	• Turn the wheel set on the left side L to the right or left • Manual operation for assembly or emergency operation
203	Rotary switch	• Turn the wheel set on the right side R to the right or left • Manual operation for assembly or emergency operation

Control panel - A1210

204	Button	• Ballast trailer, retract the guide cylinder
205	Button	• Ballast trailer, extend the guide cylinder
206	Button	• Ballast trailer on turntable - unpin
207	Button	• Ballast trailer on turntable - pin
208	Button	• Retracting the front support cylinder
209	Button	• Extending the front support cylinder
210	Button	• Retract the rear support cylinder
211	Button	• Extend the rear support cylinder out
212	Switch	• EMERGENCY OFF

Control panel - A1230

213	Button	• Retract the pull cylinder, lift the ballast trailer
214	Button	• Extend the pull cylinder, lower the ballast trailer
215	Button	• Stop pull cylinder A
216	Button	• Stop pull cylinder B

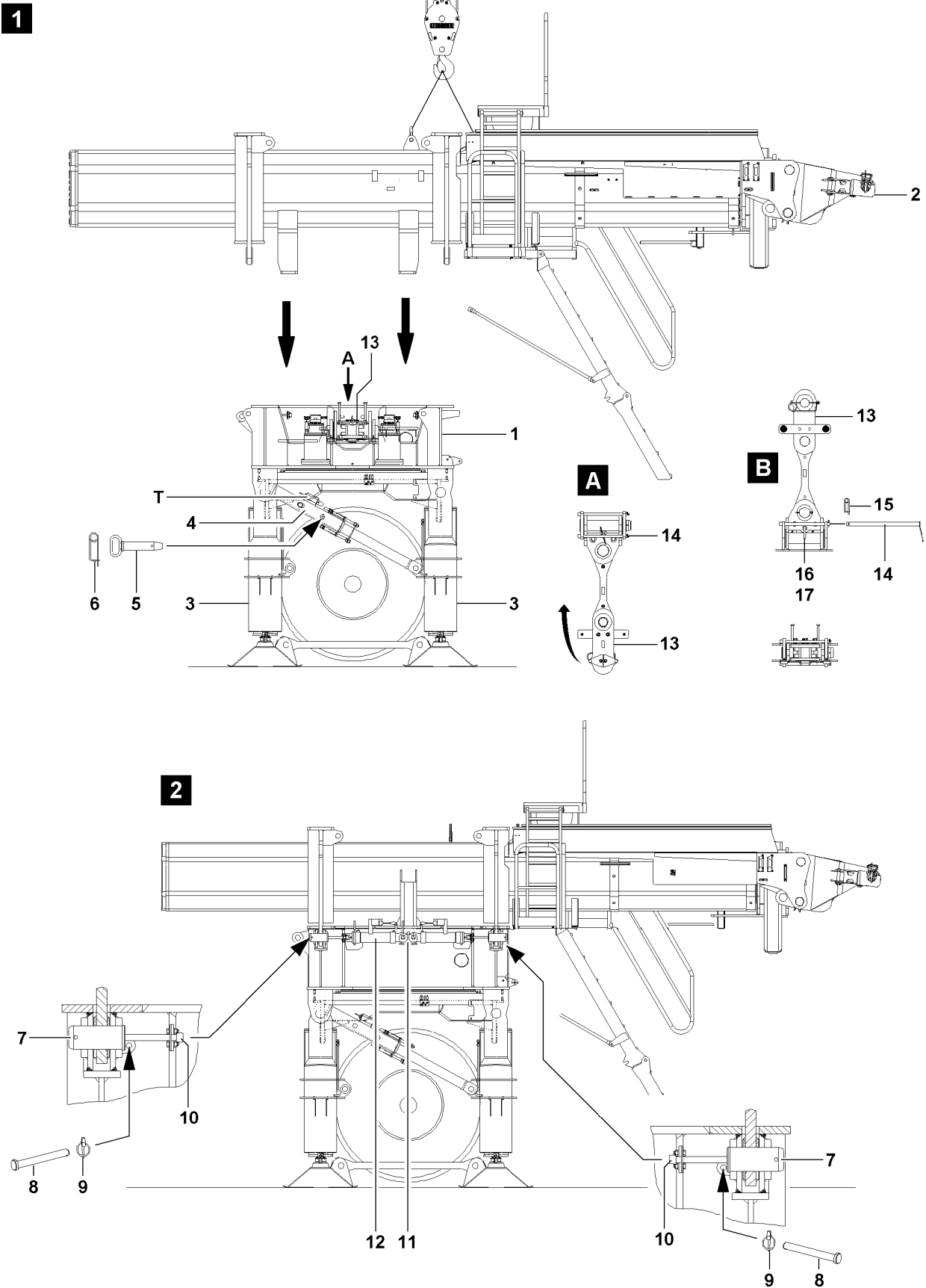

Fig.113692

LWE/LR 1600-2-008/18109-09-02/en

2 Assembling the ballast trailer



WARNING

Danger of falling!

During assembly / disassembly, inspection and maintenance work, assembly personnel must be secured with appropriate aids to prevent them from falling.

Death, severe bodily injuries, property damage.

- ▶ All work at a height, when there is a danger of falling, must be carried out with suitable aids.
- ▶ If aids are not available and work cannot be carried out from the ground, then assembly personnel must secure themselves with the supplied fall arrest system to prevent falling, see the Crane operating instructions, chapter 2.04.
- ▶ If fall protection equipment is available, then it must be used, see the Crane operating instructions, chapter 2.06.
- ▶ When lifting, lowering, swinging crane parts in and out, no persons may remain in the danger zone.
- ▶ When closing or opening boom systems during boom assembly or boom disassembly, no persons may remain on the boom system or in the danger zone.
- ▶ If railings are present on the components, then they must be brought into the corresponding position and secured for assembly / disassembly work.
- ▶ Only step on the aids, ladders and catwalks with clean shoes.
- ▶ Keep aids, ladders and catwalks free of heavy dirt, snow and ice.
- ▶ During all assembly and disassembly work, maintenance work and inspections, travel or crane operation is prohibited.
- ▶ Remaining on a suspended load is prohibited.
- ▶ Stepping or walking on crane components and lattice sections, which have an incline of more than 20° is prohibited.
- ▶ For all assembly work, the crane driver of the main crane must be in voice contact with the crane driver / crane drivers of the auxiliary crane / auxiliary cranes.
- ▶ For assembly tasks, the crane driver may only initiate crane movements when the responsible guide has explicitly released the movement.



WARNING

Danger of impact / crushing!

When installing / removing crane components with the auxiliary crane, crane components can start to swing back and forth.

When lifting / lowering and positioning crane components, there is an increased danger of impacts / crushing.

Death, severe bodily injuries, property damage.

- ▶ Make sure that personnel cannot be caught by components.
- ▶ Make sure that the crane is horizontally aligned.
- ▶ When working in danger zones: Use aids to protect limbs.
- ▶ Guide components with suitable aids to minimize oscillation.



DANGER

The components can fall down!

If the corresponding component is disengaged from the auxiliary crane before the corresponding component is pinned, then the corresponding component can fall down.

Death, severe bodily injuries, property damage.

- ▶ Do not disengage the auxiliary crane until the respective component is pinned and secured.

**WARNING**

Ballast trailer tipping danger!

Due to improperly carried out assembly or improper assembly conditions, the ballast trailer can tip over.

Death, severe bodily injuries, property damage.

- ▶ The assembly of the ballast trailer may only be carried out by authorized personnel.
- ▶ Carry out the assembly of the ballast trailer only on level ground of sufficient load bearing capacity.
- ▶ The ballast trailer has **no** brake system. The ballast trailer must be supported with the support cylinders if it is **not** pinned on the turntable.

Make sure that the following prerequisites are met:

- The ground is level and of sufficient load carrying capacity.
- An auxiliary crane is available.

2.1 Pre-assembling the ballast trailer

**Note**

- ▶ Park the ballast trailer for assembly of the ballast trailer guide on level ground with sufficient load bearing capacity in the vicinity of the crane.
- ▶ Observe the safety guidelines, see chapter 2.15.

Make sure that the following prerequisites are met:

- The locking pin **5** is pinned in and secured in the strut **4**.
- The ballast trailer is supported with the support cylinders **3** and aligned horizontally.

**DANGER**

Danger of tipping over!

If the safety guidelines for the stability and tipping safety are not observed and the strut **4** is not pinned with the locking pin **5**, there is a danger of tipping over.

- ▶ Observe the specified stability and tipping safety for ballast trailer not assembled on the turntable.
- ▶ The strut **4** must be pinned and secured with the locking pin **5**.

2.1.1 Assembling the ballast trailer guide

Make sure that the following prerequisites are met:

- The ballast trailer guide **2** is fully retracted.
- The retaining pins **8** are released and unpinned (4x), illustration 2.
- The connector pins **7** are unpinned (4x), illustration 2.

**WARNING**

Danger of fatal injury due to tipping ballast trailer!

Due to unsecured or insufficiently secured connector pins, the ballast trailer guide can loosen up from the ballast frame and the ballast trailer can tip over.

Death, severe bodily injuries, property damage.

- ▶ Make sure before starting any crane work with the ballast trailer that all **four** connector pins **7** are properly pinned and secured.

- ▶ Fasten the ballast trailer guide **2** to the auxiliary crane and swing it in and lower it to the pin points on the ballast frame **1**, see illustration 1.

- ▶ Attach the pin pulling cylinder **12** to the retainer **11** and hook into the screw head **10**.

- ▶ Establish the hydraulic connection of the pin pulling cylinder **12** to the hydraulic aggregate, see chapter 5.30.

When the ballast trailer guide **2** is lying completely on the ballast frame **1** and the pin bores align:

- ▶ Actuate the lever on the pin pulling cylinder **12** and insert the connector pin **7**.
- ▶ Secure the connector pin **7**: Insert the retaining pin **8** and secure with the linch pin **9**.

When all four connector pins **7** are inserted and secured:

- ▶ Remove the auxiliary crane.

- ▶ Fold the access to the ballast trailer down into operating position.

1

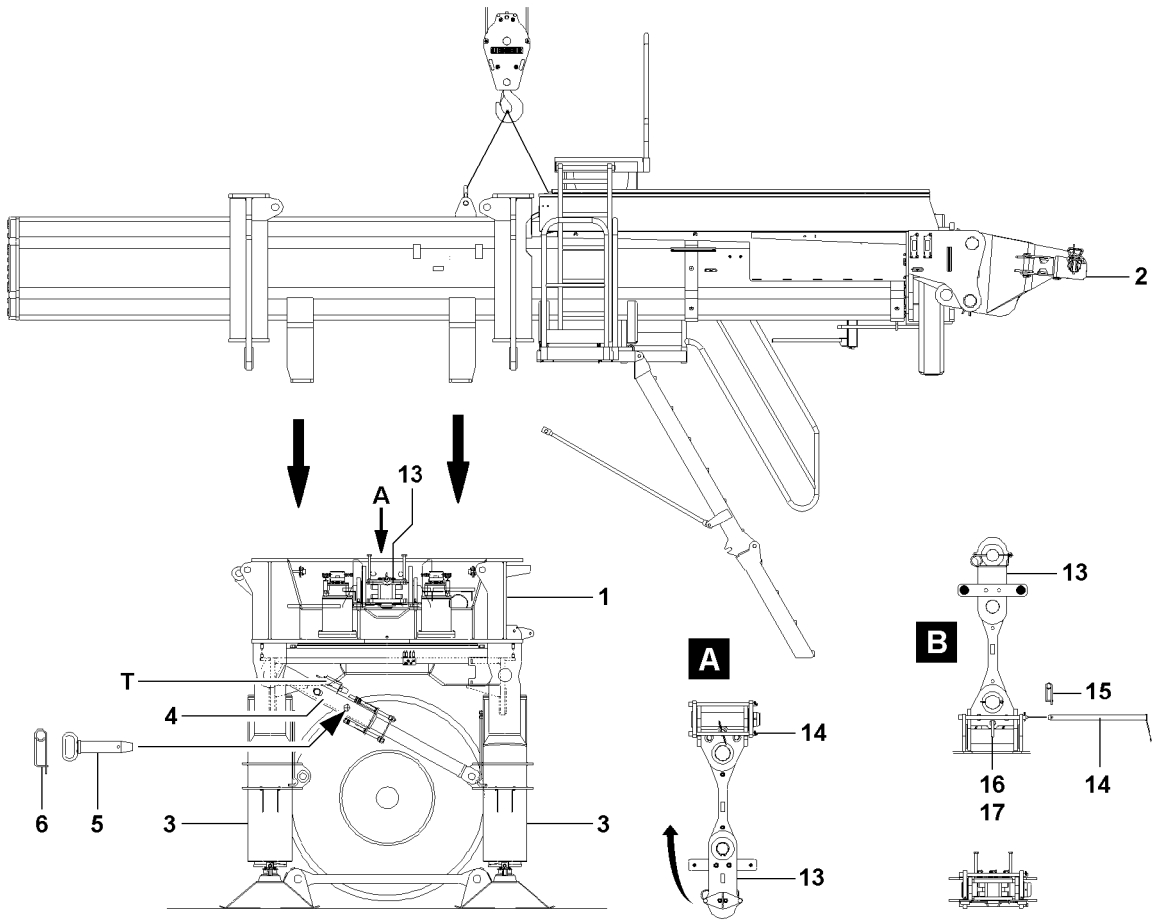

2

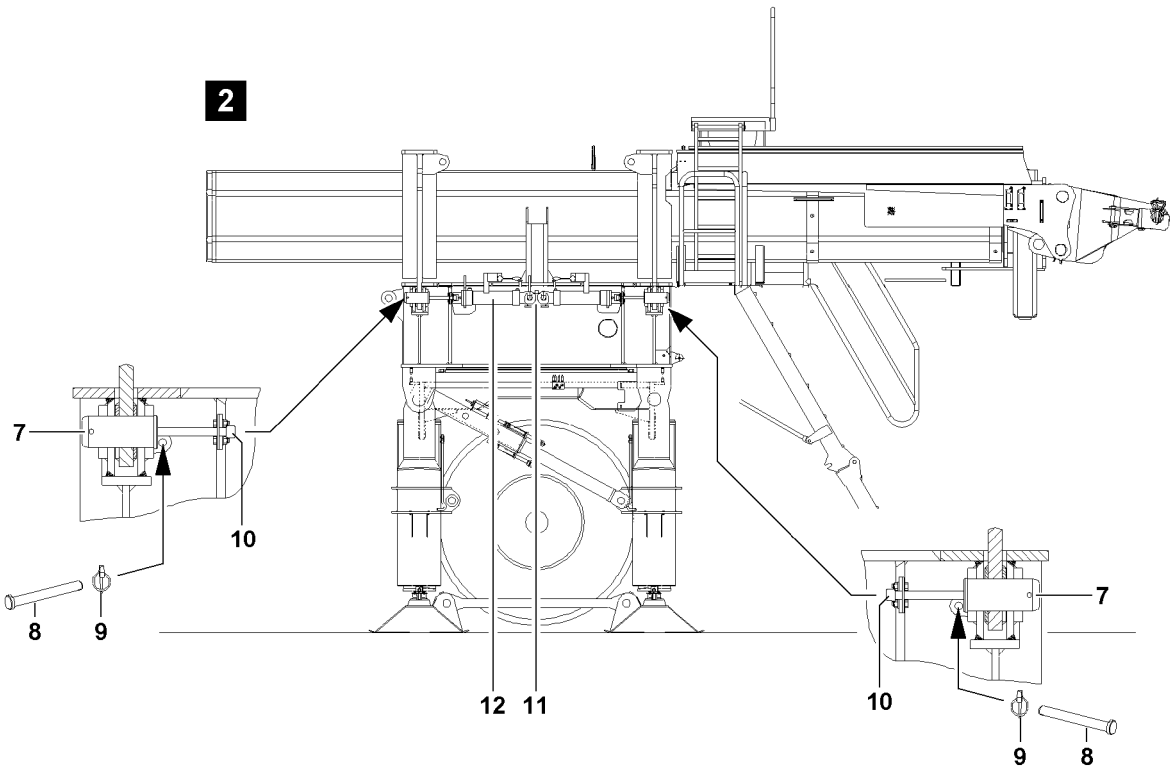

Fig.113692

LWE/LR 1600-2-008/18109-09-02/en

2.1.2 Bringing the guy rods on the ballast trailer into the operating position

The guy rods **13** are folded down and secured in transport position on the side on the ballast frame, see illustration **1** and illustration **A**.

Make sure that the following prerequisites are met:

- The ballast trailer guide **2** is assembled and secured on the ballast frame **1**.
- The access to the ballast trailer is in the operating position.
- The stability and tipping safety of the ballast trailer is ensured.

Bring one guy rod into the operating position.



WARNING

Danger of falling!

Assembly personnel can fall from the ballast trailer if the following notes are not observed. Death, severe bodily injuries, property damage.

- ▶ Use only the steps on the ballast trailer.
 - ▶ Step on the access with utmost caution.
-
- ▶ Release and unpin the retaining pins **14**, see illustration **A**.
 - ▶ Fasten the guy rod **13** to the auxiliary crane.
 - ▶ Erect the guy rod **13** with the auxiliary crane to the vertical position.



DANGER

Retaining pins **not** inserted!

When removing the auxiliary crane, the erected guy rod **13** drops sideways. Death, severe injury, property damage.

- ▶ Make sure, before removing the auxiliary crane on the guy rod **13**, that both retaining pins **14** are always pinned and secured. Perform a visual inspection.
- ▶ Make sure, before removing the auxiliary crane on the guy rod **13**, that the retaining pin **16** is pinned and secured. Perform a visual inspection.

When the guy rods is erected vertically:

- ▶ Insert both retaining pins **14** and secure with spring retainers **15**, see illustration **B**.

When both retaining pin **14** and retaining pin **16** are pinned and secured:

- ▶ Remove the auxiliary crane.
- ▶ Bring the second guy rod into operating position.

3

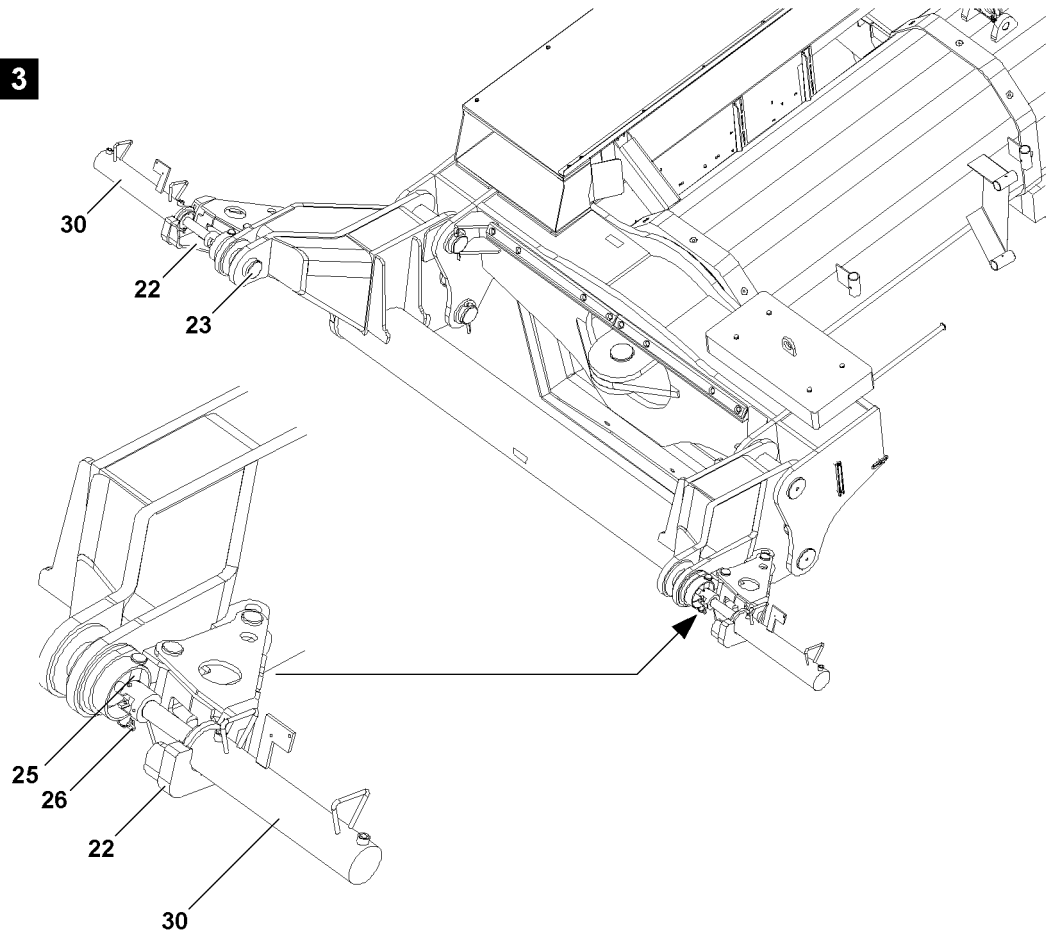

4

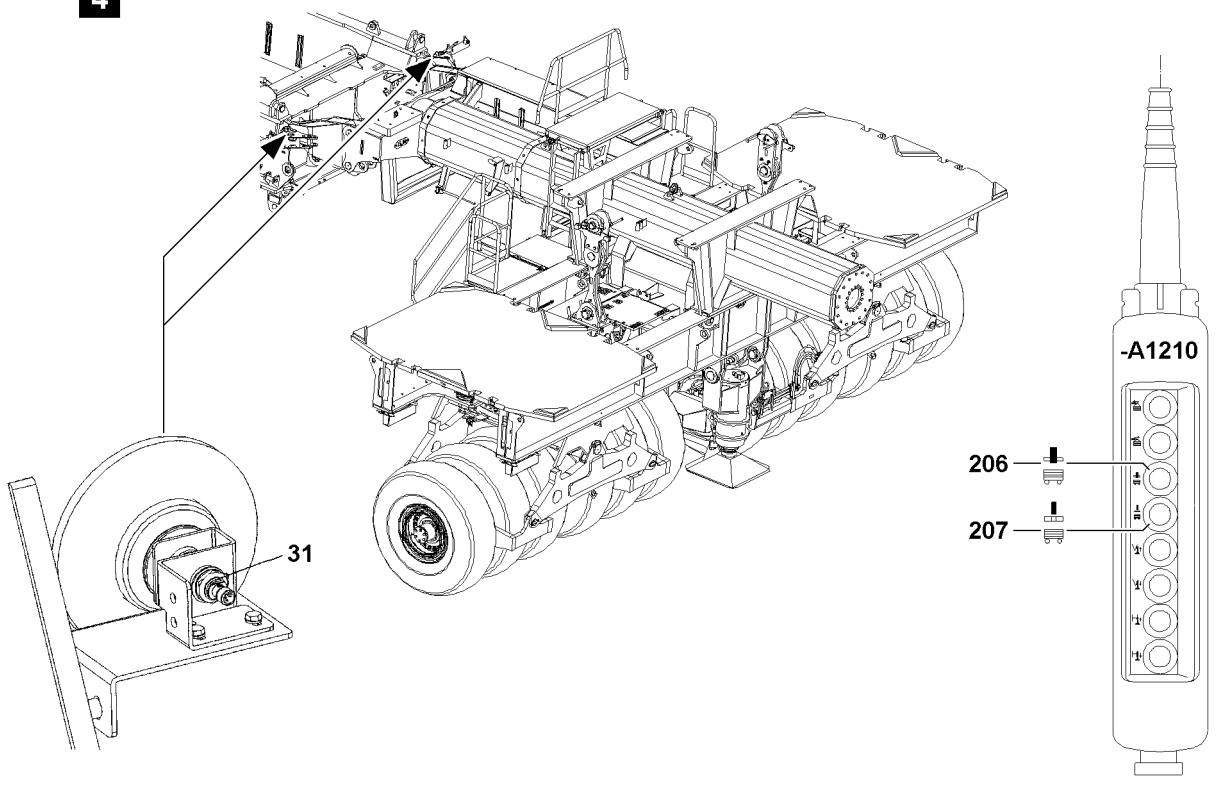

Fig.113693

LWE/LR 1600-2-008/18109-09-02/en

2.2 Pinning the ballast trailer on the turntable

Make sure that the following prerequisites are met:

- The crane is axially aligned, as close as possible to the ballast trailer guide.
- The crane engine is turned off.
- The ballast trailer is supported.

2.2.1 Establishing the electrical connection from the ballast trailer to the turntable



Note

- ▶ For assembly of the ballast trailer, the electrical connection from the ballast trailer to the turntable must be established to be able to control the support cylinders, if necessary.
- ▶ The „Ballast UP / DOWN“ release is independent of whether the ballast trailer is attached, providing the conditions in the shut off diagram are fulfilled.
- ▶ The „Ballast UP“ release allows the retraction of the pull and support cylinders.
- ▶ The „Ballast DOWN“ release allows the extension of the pull and support cylinders.
- ▶ This means that the support cylinder and the pull cylinder can be moved, even if the „Ballast trailer pinned“ signal is not yet present.



Note

- ▶ To establish the electrical connections, use the separate electrical wiring diagram.
- ▶ Establish the electrical connections.

2.2.2 Establishing the hydraulic connection from the ballast trailer to the turntable

When connecting and releasing hydraulic lines with quick couplings, make sure that the coupling procedure is carried out correctly.



DANGER

Danger of accident due to loss of pressure or leakage!

Incorrectly coupled or self-loosening quick couplings (particularly return lines) can result in serious accidents due to component failure.

- ▶ Check that the quick couplings have been properly connected before using the crane.
- ▶ Release the pressure in the hydraulic system before connecting or disconnecting: Turn the engine off and wait a short time.
- ▶ Connect the coupling components (sleeve and connector) and screw together with the knurled nut.
- ▶ Tighten the hydraulic coupling by hand: Turn the knurled nut until it reaches a tangible, fixed stop position.

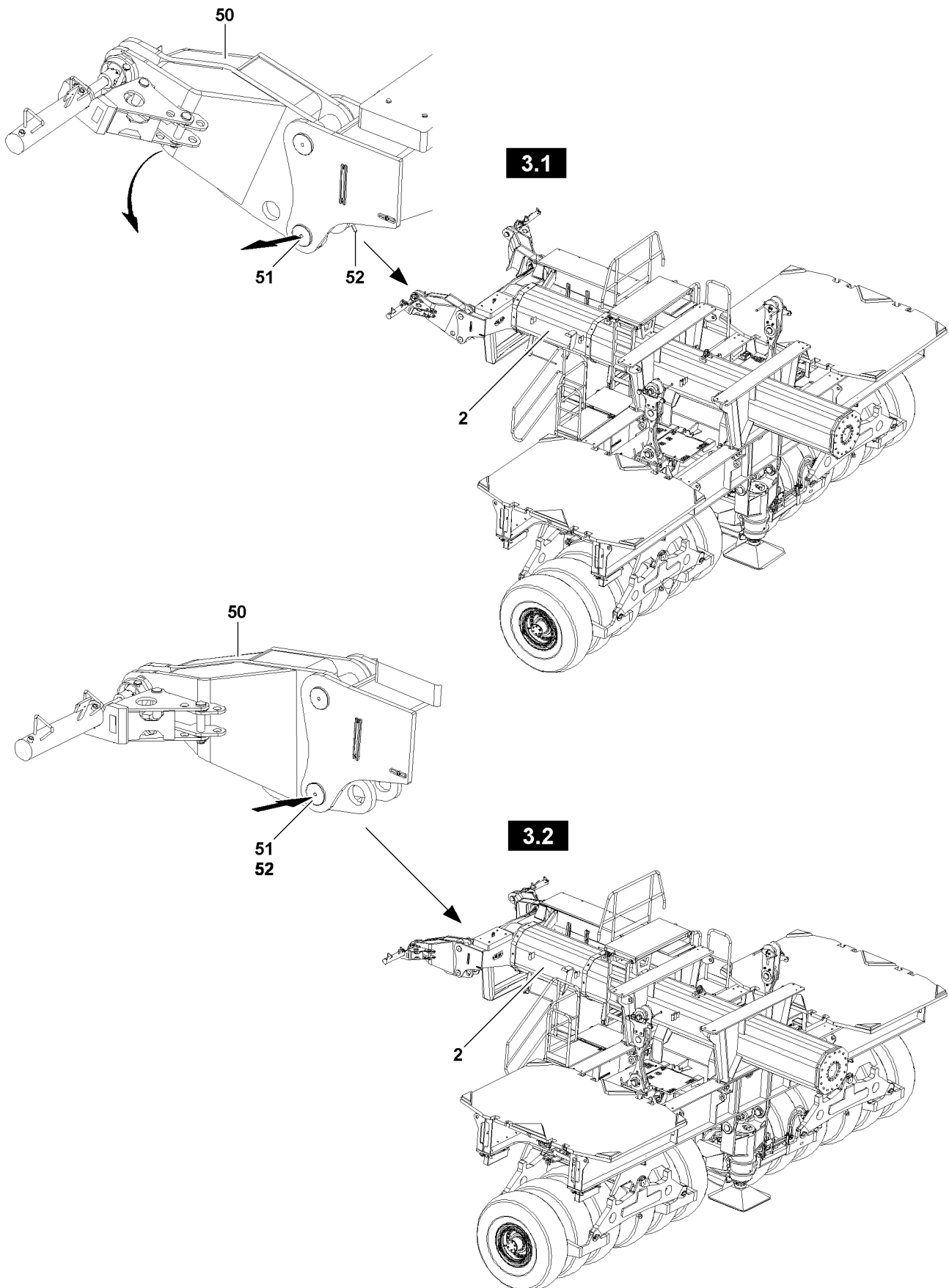

Fig.113699

2.2.3 Setting the adapter on the ballast trailer guide



Note

- ▶ If the ballast trailer is to be installed on a crane **with** QC (Quick Connection), bring the adapter to the „up“ position - illustration **3.1** - and pin.
- ▶ If the ballast trailer is to be installed on a crane **without** QC, bring the adapter to the „down“ position - illustration **3.2** - and pin.

Adapter position	Description
„Up“	For installation on cranes with QC (Quick Connection)
„Down“	For installation on cranes without QC (Quick Connection)

Set the adapter downward

- ▶ Fasten the adapter **50** to the auxiliary crane.
- ▶ Tension the fastening equipment carefully between the auxiliary crane and the adapter **50**.

When the fastening equipment is tensioned:

- ▶ Release and unpin the pins **51** on both sides.
- ▶ Lower the adapter **50** slowly with the auxiliary crane.

When the pin bores on the adapter **50** align in the down position, illustration **3.2**:

- ▶ Insert the pins **51** on both sides from the outside to the inside and secure with the split pin **52**.

Set the adapter upward

- ▶ Fasten the adapter **50** to the auxiliary crane.
- ▶ Tension the fastening equipment carefully between the auxiliary crane and the adapter **50**.

When the fastening equipment is tensioned:

- ▶ Release and unpin the pins **51** on both sides.
- ▶ Raise the adapter **50** slowly with the auxiliary crane.

When the pin bores on the adapter **50** align in the up position, illustration **3.1**:

- ▶ Insert the pins **51** on both sides from the outside to the inside and secure with the split pin **52**.

3

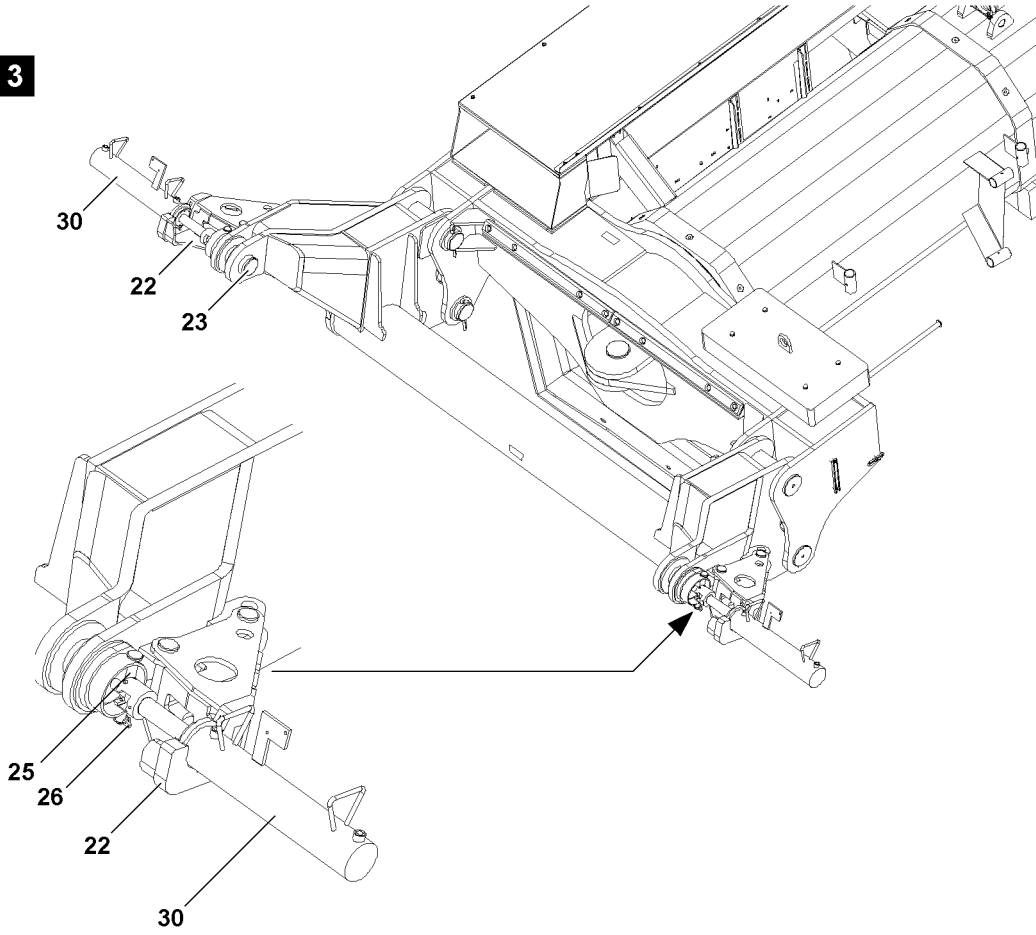

4

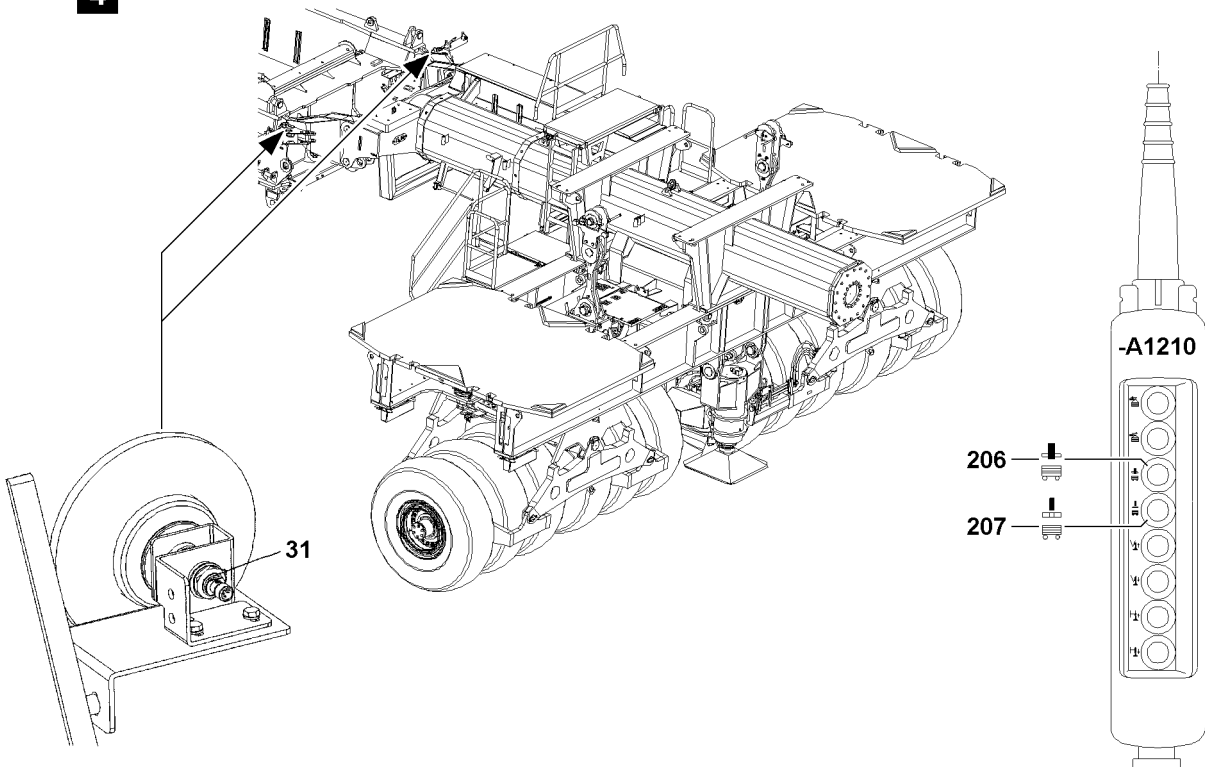

Fig.113693

LWE/LR 1600-2-008/18109-09-02/en

2.2.4 Aligning the ballast trailer

Make sure that the following prerequisites are met:

- The electrical and hydraulic connections from the turntable to the ballast trailer are established.
 - The connector pins **23** are unpinned.
 - The adapter **50** is set to the correct pin height.
 - The crane is moved to the pin points on the ballast trailer guide.
- ▶ Align the ballast trailer by lifting or lowering it in such a way that the pin bores on the turntable and the ballast trailer guide align.



Note

- ▶ To be able to align the pin bores between the turntable and the ballast trailer guide, it may be necessary to „swing“ the turntable somewhat, check visually.



DANGER

Danger due to operating error!

When „swinging“ the turntable, severe accidents can occur.

Death, severe bodily injuries, property damage.

- ▶ Initiate all movements with utmost caution and at the least possible speed.
 - ▶ It is prohibited to stand in the danger zone while „swinging“.
- ▶ Align the ballast trailer until the pin bores align.

2.2.5 Pinning procedure

Make sure that the following prerequisites are met:

- The ballast trailer is aligned with the turntable.
- The pin bores between the turntable and the ballast trailer guide align.

NOTICE

Damage to the pin pulling device!

If the retaining pins **25** are not unpinned before the pin procedure, the pin pulling device **22** can be damaged.

- ▶ The retaining pins **25** on the pin pulling device **22** must be released and unpinned before pinning the connector pins **23**.
- ▶ Release the retaining pins **25** and unpin at both sides.
- ▶ Press the button **207** on the control panel **-A1210**.

Result:

- The pin pulling cylinders **30** extend.
- The connector pins **23** extend and the ballast trailer is pinned on the turntable.

3

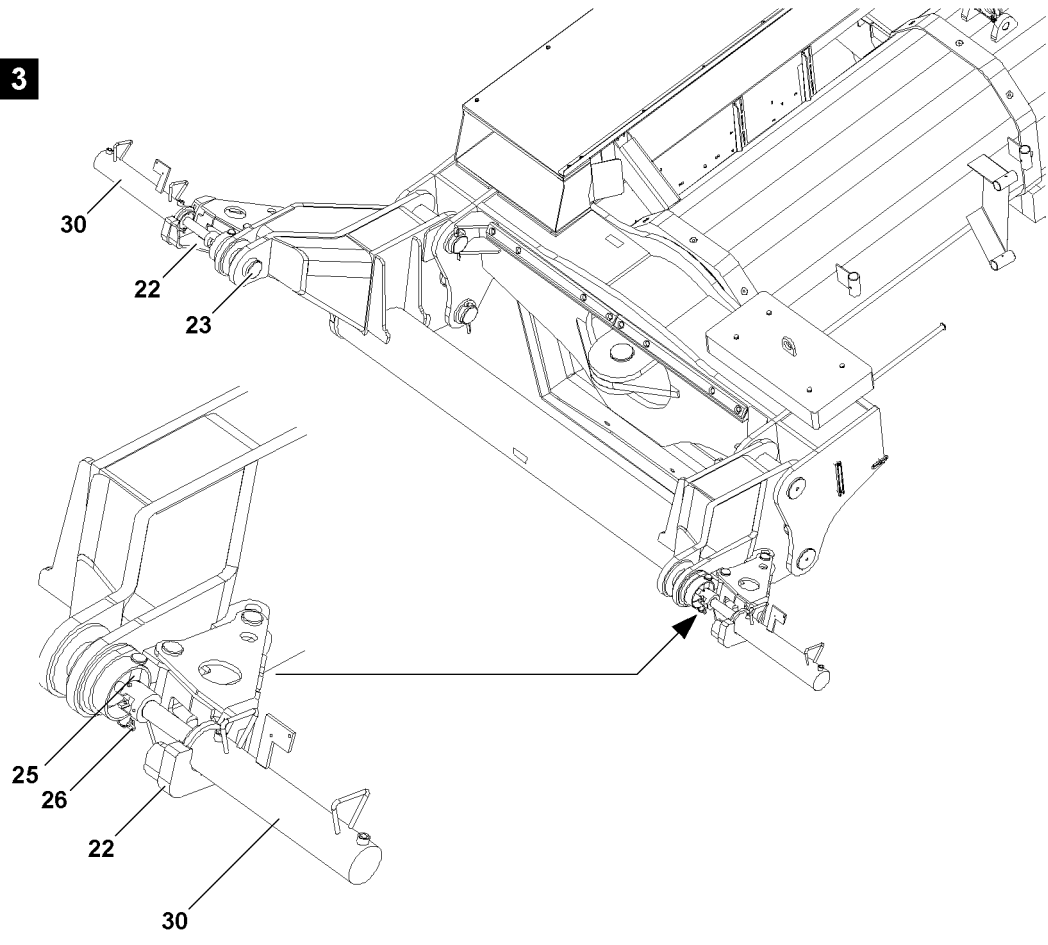

4

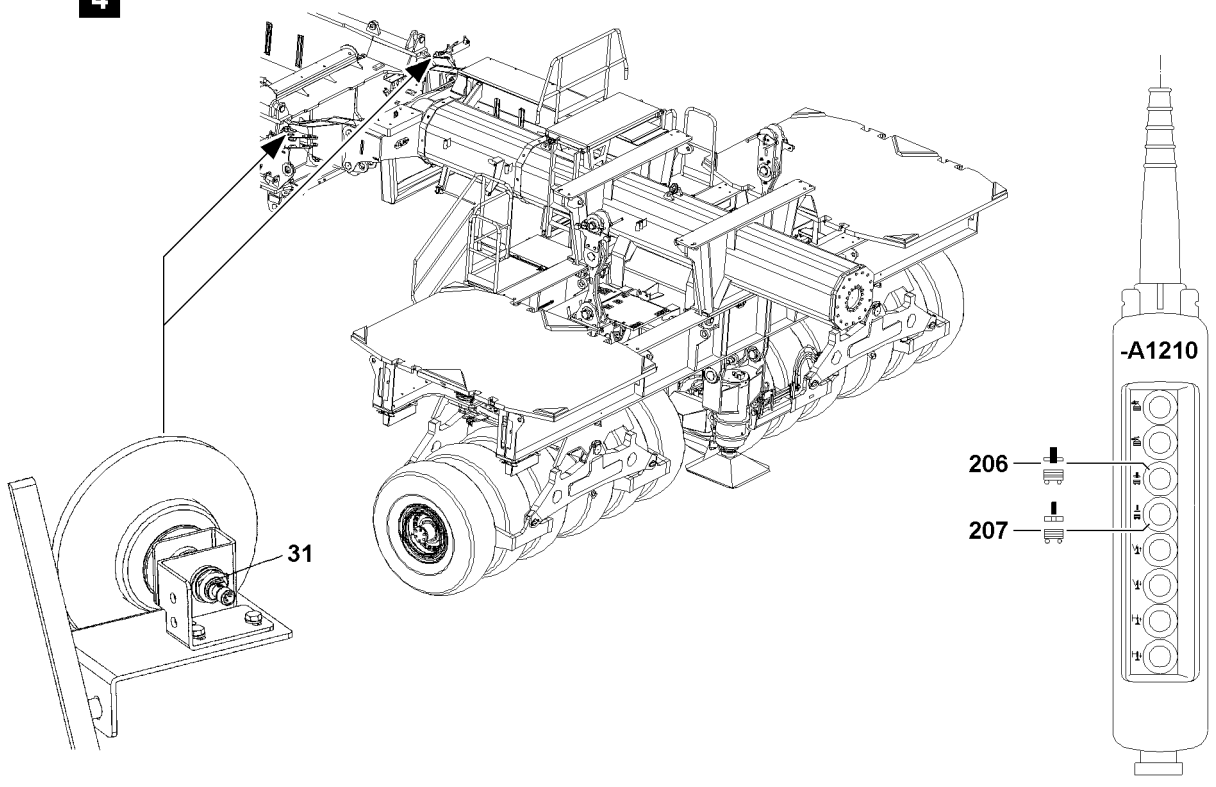

Fig.113693

LWE/LR 1600-2-008/18109-09-02/en

**Note**

- ▶ The crane control system recognized with the left and right limit switch initiators **31** of the pin points, if the connector pins **23** on the turntable are fully pinned.
- ▶ If both connector pins **23** are fully and correctly pinned, the crane control, via the limit switch initiators **31** receives the message, „Ballast trailer installed on left“ and „Ballast trailer installed on right.“ Which means: The turntable can no longer be turned and the crawler cannot be moved.
- ▶ After pinning, it must be checked again if the electrical and hydraulic connector lines are fully and correctly connected.
- ▶ The control release for the crane is only made when the wheels sets are in one of the required positions, „Circular travel“, „Towing“ or „Parallel travel“.

**DANGER**

Danger due to operating error!

If only one connector pin **23** is pinned and if the crane control therefore has only one message „Ballast trailer installed“ from a limit switch initiator, then the turntable can be turned anyway and the crane can be driven.

Death, severe bodily injuries, property damage.

- ▶ All movements are to be performed with extreme caution and at the lowest possible speed.

When the ballast trailer is pinned on the turntable on both sides:

- ▶ Secure the connector pins **23** through the retaining pins **25**, see illustration **3**.
- ▶ Insert the retaining pin **25** in the safety device.
- ▶ Secure the retaining pins **25** with the linch pins **26**.

Problem remedy

The second connector pin **23** cannot be pinned?

You did not align the ballast trailer exactly before assembly.

- ▶ Slightly lift or lower the ballast trailer via the support cylinder.
- ▶ Carefully telescope the ballast trailer guide in or out.
- ▶ Carefully swing the turntable after.

When the second pin bore aligns between the turntable and ballast trailer guide **2** align:

- ▶ Pin in the second connector pin **23** with the pin pulling device.

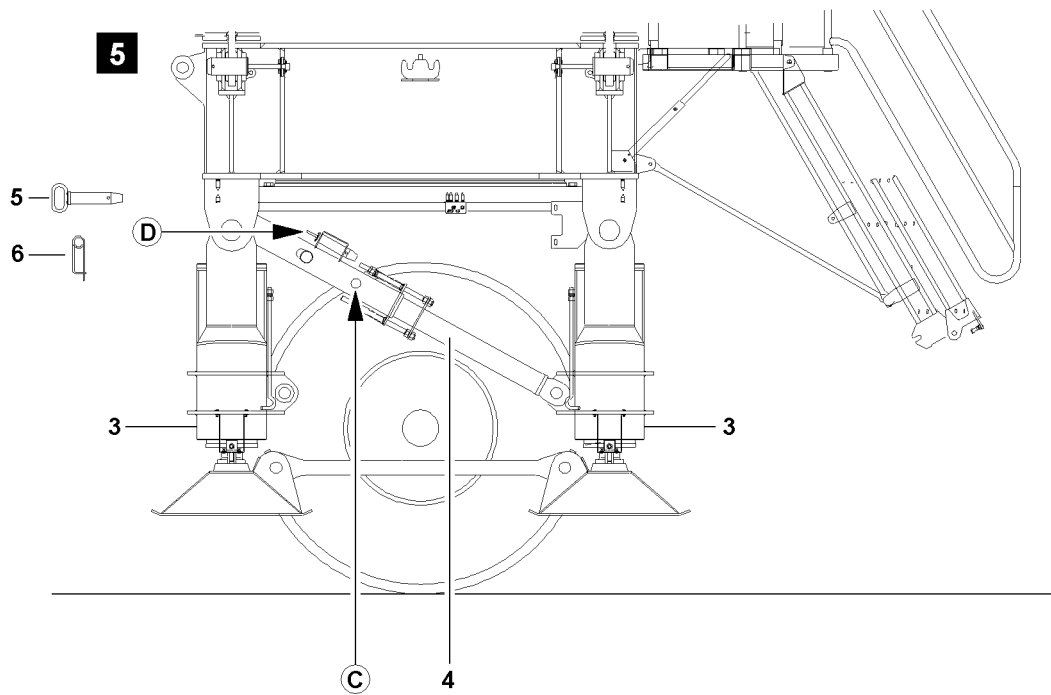
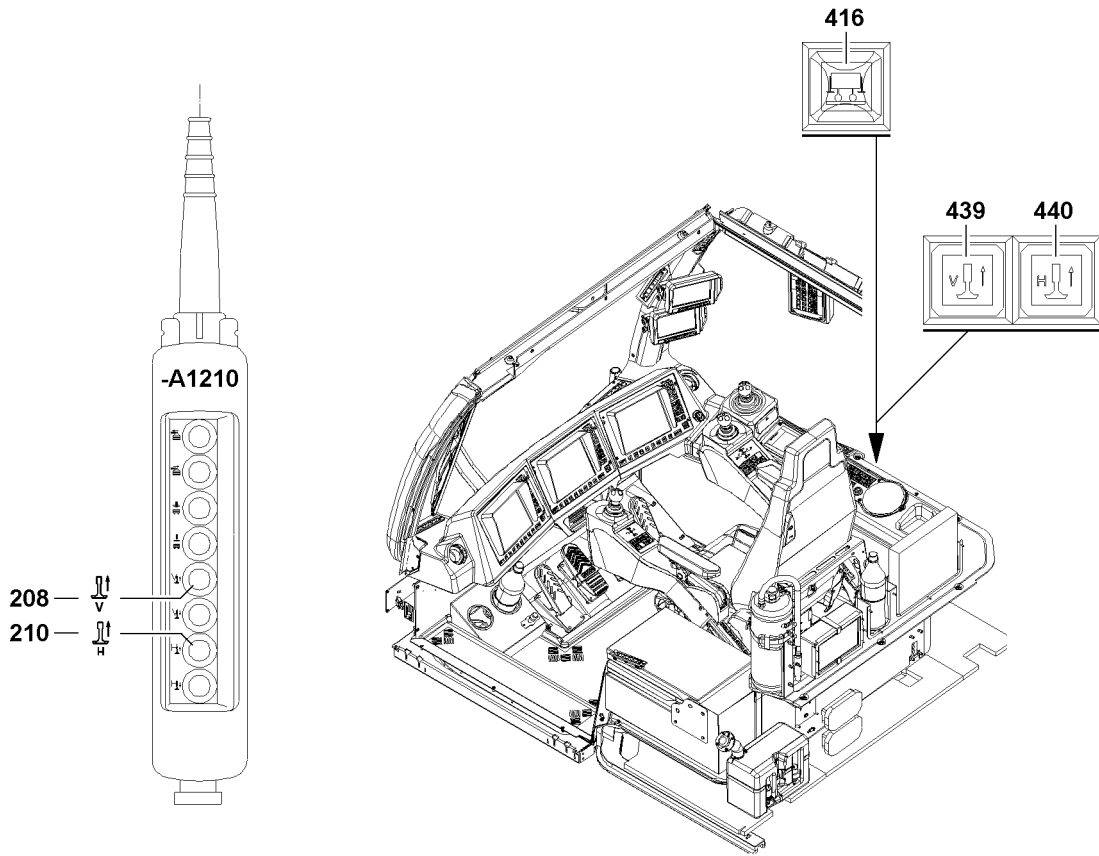

Fig.108968

LWE/LR 1600-2-008/18109-09-02/en

2.3 Retracting the support cylinders



Note

- ▶ The support cylinders **3** can be moved in via the control panel **-A1210**, or via the corresponding button on the instrument panel of the crane operator's cab.
- ▶ When the pinning procedure between the ballast trailer and the turntable is completed, move the support cylinders **3** in.

Make sure that the following prerequisites are met:

- The ballast trailer is pinned and secured on the turntable on both sides.
- The electrical and hydraulic connections are connected.

Retract the support cylinders **3** completely on the front and rear:

- ▶ Press the button **439** and button **440** in the crane operator's cab.
or
Press the button **208** and button **210** on the control panel **-A1210**.

Result:

- The support cylinders **3** retract.



Note

- ▶ The locking pin **5** can only be unpinned if the support cylinders **3** are relieved.

When the support cylinders **3** are relieved:

- ▶ Release and unpin the locking pin **5** on the strut **4** at point **C**.
- ▶ Insert the locking pin **5** into the transport retainer, point **D**, and secure with spring retainer **6**.

NOTICE

Damage to the ballast trailer!

If the following notes are not observed, the support cylinders of the ballast trailer can be significantly damaged.

- ▶ Unpin the locking pins **5** as soon as the ballast trailer is assembled on the turntable and the support is relieved.
- ▶ When the ballast trailer is assembled and ballasted on the turntable, then the locking pin **5** **must** be unpinned so that the level between the strut **4** and the support cylinders **3** can be adjusted.
- ▶ Supporting the ballasted ballast trailer with pinned strut **4** is prohibited.

- ▶ Retract the support cylinders **3** completely.

Result:

- The warning light **416** („Ballast trailer support moved in“) lights up.

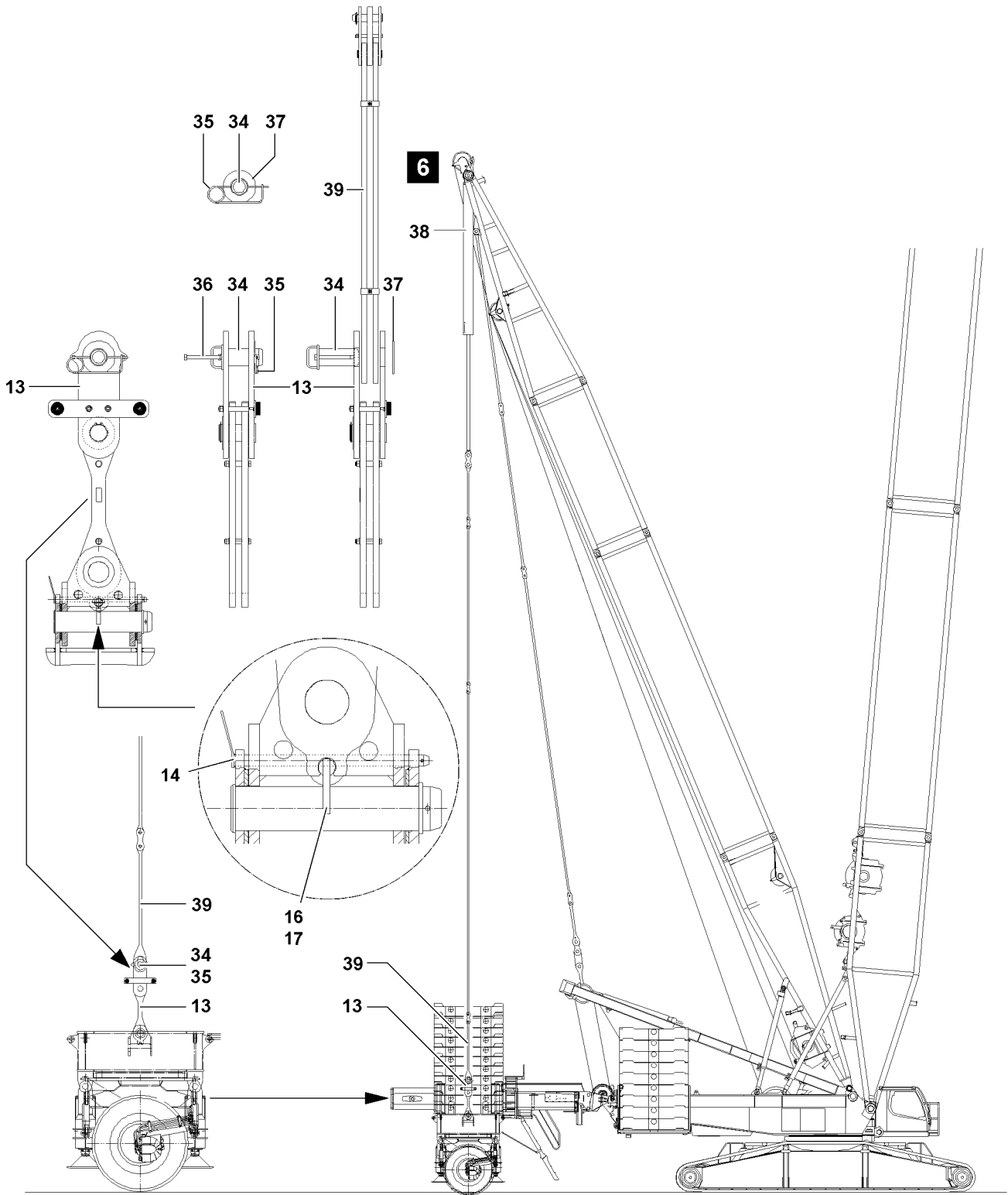

Fig.121379

LWE/LR 1600-2-008/18109-09-02/en

2.4 Assembling the ballast trailer guying

Make sure that the following prerequisites are met:

- The derrick boom radius is 13 m.
- The ballast trailer radius is 13 m.
- The guy rods **13** on the ballast trailer are in the operating position and are pinned and secured, see section „Bringing the guy rods on the ballast trailer into operating position“.
- The guy rods on the derrick boom are pinned and secured.



Note

- ▶ The ballast trailer guy rods must be assembled and secured according to the data in the Rod plan. The numbering in the rod plan must be identical to the numbering on the guy rods.



DANGER

Guy rods **not** pinned!

By removing the retaining pin **14** or the retaining pin **16** the guy rods **13** drop sideways. Death, severe injuries, property damage.

- ▶ Before unpinning the retaining pins **14**, make sure that the entire derrick guying is properly pinned and secured. Perform a visual inspection.
- ▶ Before unpinning the retaining pins **16**, make sure that the entire derrick guying is properly pinned and secured. Perform a visual inspection.

The guy rods **39** of the derrick boom are to be pinned with the guy rods **13** on the ballast trailer. The connector pins **34** are held in the „pulled“ condition by the Allen screws **36** in the pin position.

- ▶ Unpin the connector pin **34**: Remove the spring retainer **35** and unpin connector pins **34** on both sides.
- ▶ Position the guy rods **39** by extending the pull cylinder **38** out over the guy rods **13**.
- ▶ Align the guy rods **39** on the guy rods **13**.
- ▶ Pin the guy rods **39** on both sides with the guy rods **13**: Insert the connector pins **34**.
- ▶ Secure the connector pins **34** with washer **37** and spring retainer **35**.

NOTICE

Retaining pins are pinned in crane operation. Ballast trailer will be damaged.

- ▶ Make sure, that during crane operation with the ballast trailer, both retaining pin **14** and retaining pin **16** are unpinned on the cross bracket.
- ▶ When the guy rods **39** are pinned and secured with the guy rods **13** on both sides:
- ▶ Perform a visual inspection. On each cross bracket, release and unpin both retaining pin **14** and retaining pin **16**.

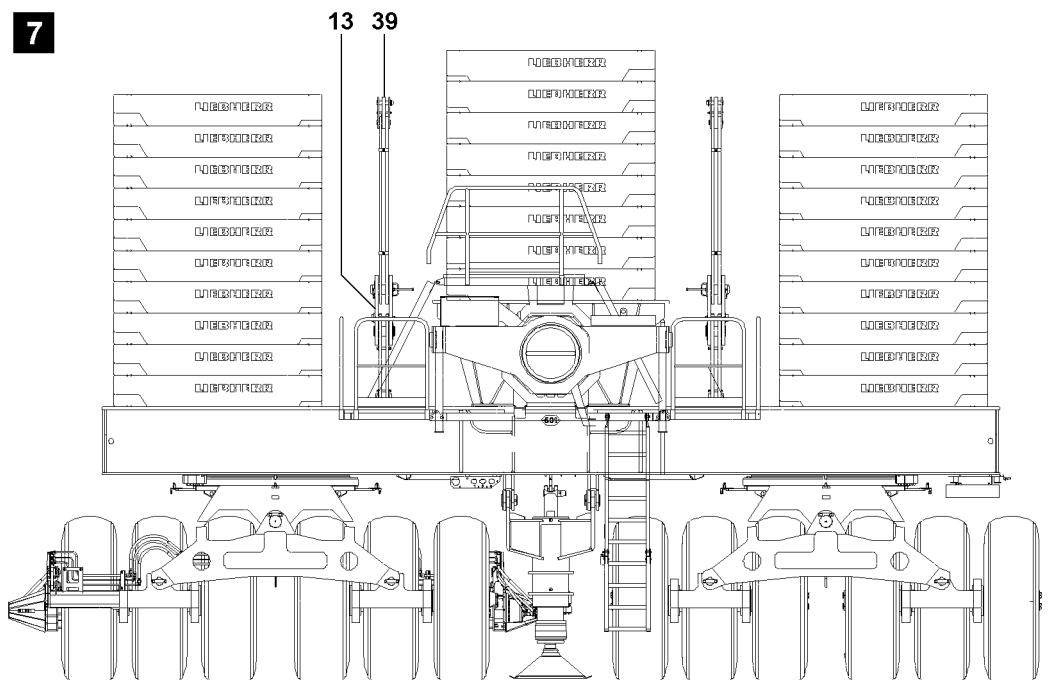

Fig.113695

2.5 Ballasting the ballast trailer



Note

- ▶ The ballast plates are marked with their own weights.



WARNING

The crane can topple over!

If the following danger notes are not observed, the ballast plates or the ballast stack can slip on the ballast trailer and fall down.

Death, severe bodily injuries, property damage.

- ▶ The ground on which the ballast trailer is ballasted must be level and have adequate load-bearing capacity.
- ▶ Always place the ballast plates symmetrically, in reference to the longitudinal axis.
- ▶ The outer ballast stacks must always weigh the same and be the same height after ballasting.
- ▶ The ballast stacks may only be stacked to three times the height of the ballast plate width.
- ▶ When adding and removing ballast in **suspended condition**, the weight difference between the left and right ballast stack may be no more than maximum 20.0 t.
- ▶ The outer ballast stacks can differ in stack height from the inner ballast stacks.
- ▶ The maximum permissible total weight of the ballast trailer may not exceed 350 t.
- ▶ Secure all ballast plates so they cannot move and fall down.
- ▶ Replace damaged ballast plates immediately with new ballast plates.

Make sure that the following prerequisites are met:

- The ballast trailer is pinned and secured on the turntable on both sides.
- The ballast trailer is properly pinned and secured to the Derrick ballast guying.
- On every cross bracket, both retaining pins **14** and the retaining pin **16** are unpinned.
- An auxiliary crane is available.

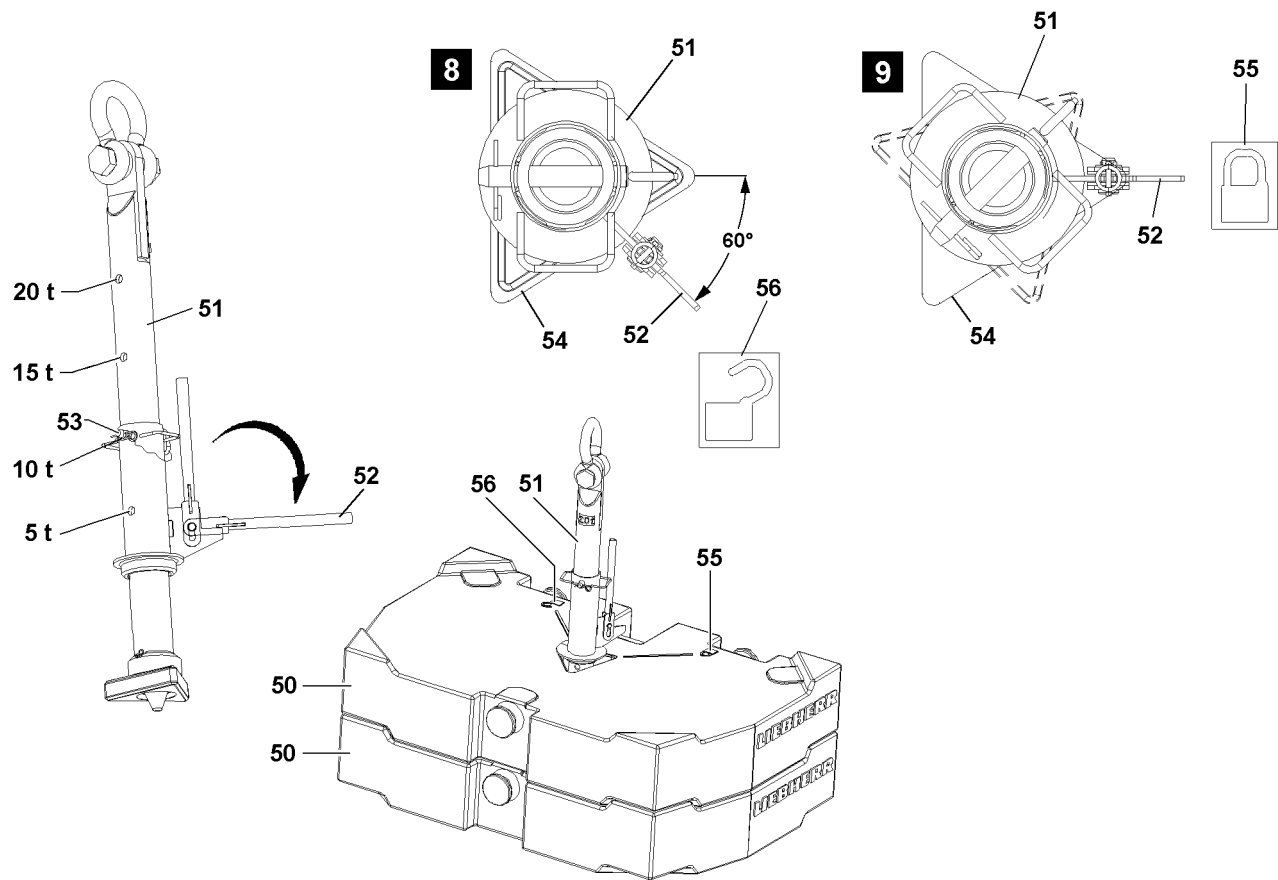
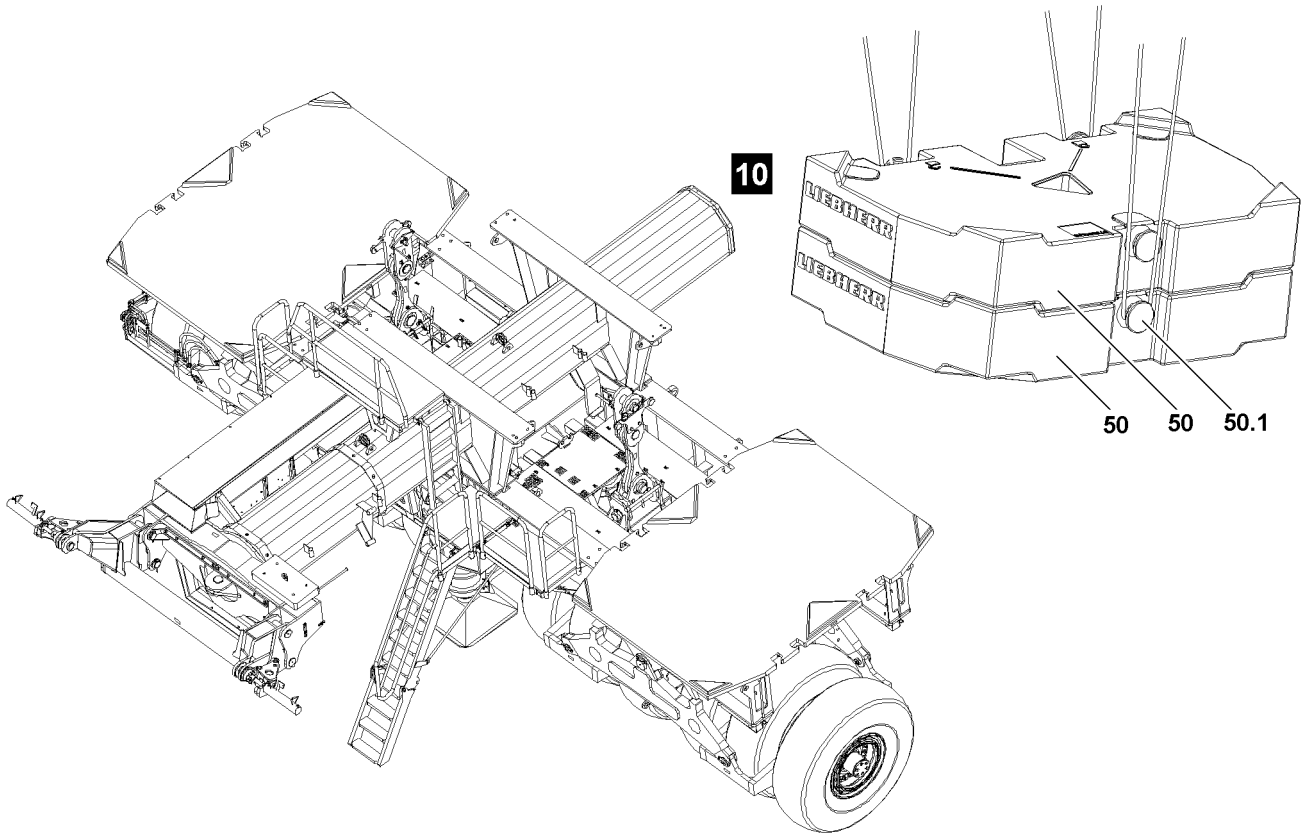

Fig.113696

LWE/LR 1600-2-008/18109-09-02/en

2.5.1 Stacking the ballast plates on the ballast trailer, fastening system „Twistlock“



WARNING

Danger of accident!

If more than the permissible two ballast plates are lifted with the receptacle stud, the receptacle stud will be overloaded and can be damaged.

Death, severe bodily injuries, property damage.

- ▶ Make sure that the ballast plates are placed correctly in the centerings.
- ▶ Replace damaged ballast plates.

To stack the ballast plate(s) **50**, use the receptacle stud **51**.

Before the receptacle stud **51** is guided into the ballast plates, it must be ensured that the length of the receptacle stud **51** is set correctly. The length of the receptacle stud **51** can be adjusted with the pin **53**.

If the length of the receptacle stud **51** is to be adjusted:

- ▶ Release and unpin the pin **53**.
- ▶ Adjust the length of the receptacle stud by moving the receptacle stud **51**.
- ▶ Insert the pin **53** and secure with the spring retainer.
- ▶ Fasten the receptacle stud **51** to the auxiliary crane and guide it into the ballast plate(s).
- ▶ Pull the lever **52** up and fold it down.
- ▶ Turn the lever **52** by 60° until the lever **52** points to the icon **55**, see illustration 9.

Result:

- The receptacle stud **51** is locked with the ballast plate.
- ▶ Lift always one ballast plate with the receptacle stud **51** and take it down carefully on the centerings on the ballast trailer or on another ballast plate **4**.
- ▶ Turn the lever **52** by 60° until the lever **52** points to the icon **56**, see illustration 8.

Result:

- The receptacle stud **51** is unlocked.
- ▶ Carefully pull the receptacle stud **51** out of the ballast plate.
- ▶ Stack the ballast plates according to the load chart, observe the danger notes.

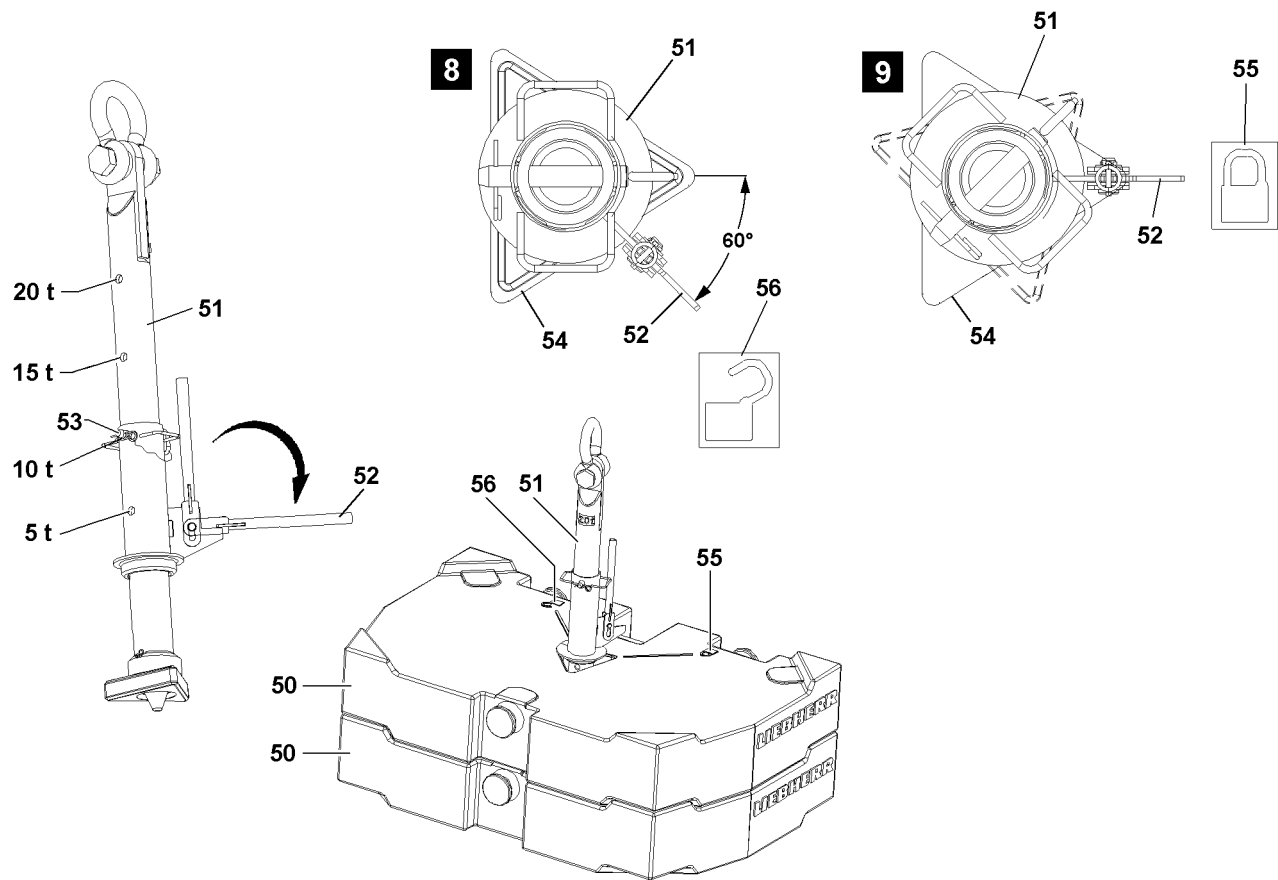
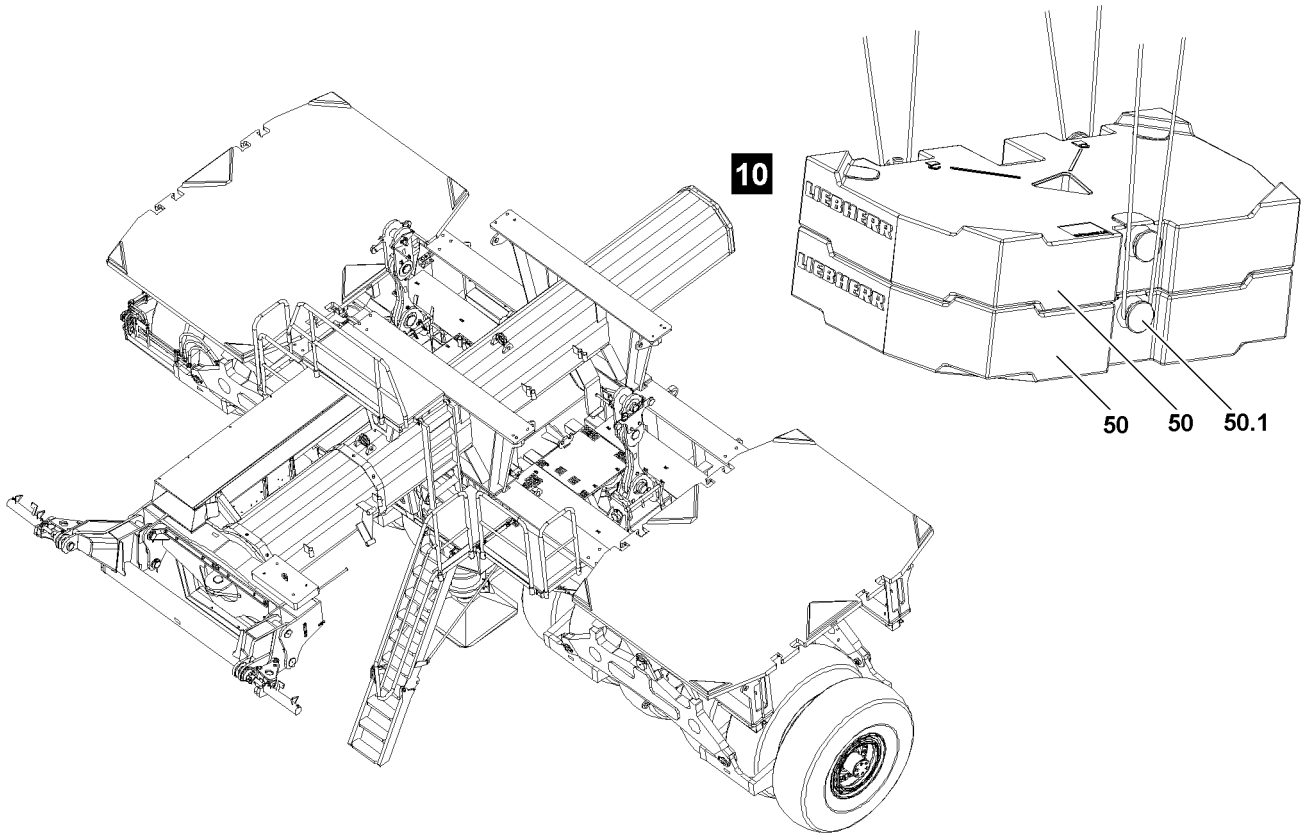

Fig.113696

LWE/LR 1600-2-008/18109-09-02/en

2.5.2 Stacking the ballast plates on the ballast trailer, fastening points: Bitt



WARNING

Falling ballast plates!

If more than the permissible loads are lifted, then the bitts **3.1** are overloaded and the ballast plates can fall down.

Death, severe bodily injuries, property damage.

- ▶ Lift no more than maximum 20 t with the ropes, 3 fastening points.
- ▶ Replace damaged ballast plates immediately.



WARNING

Incorrect handling of the fastening equipment!

If fastening equipment cannot be attached correctly and if it is not secured sufficiently to prevent it from loosening up, loads can fall down.

Death, severe bodily injuries, property damage.

- ▶ Make sure that the fastening equipment is correctly attached on the bitts **50.1** and that it is secured sufficiently to prevent it from loosening up.



Note

- ▶ Place the ballast plates individually or as a ballast assembly, maximum 20 t.
 - ▶ The weight difference between the outer ballast stacks no more than maximum 20 t.
 - ▶ 20 t ballast assembly, see illustration **10**.
-
- ▶ Use the auxiliary crane to evenly distribute the ballast plates **50** on the ballast trailer and center them on the centering points.
 - ▶ Stack the ballast plates according to the load chart.

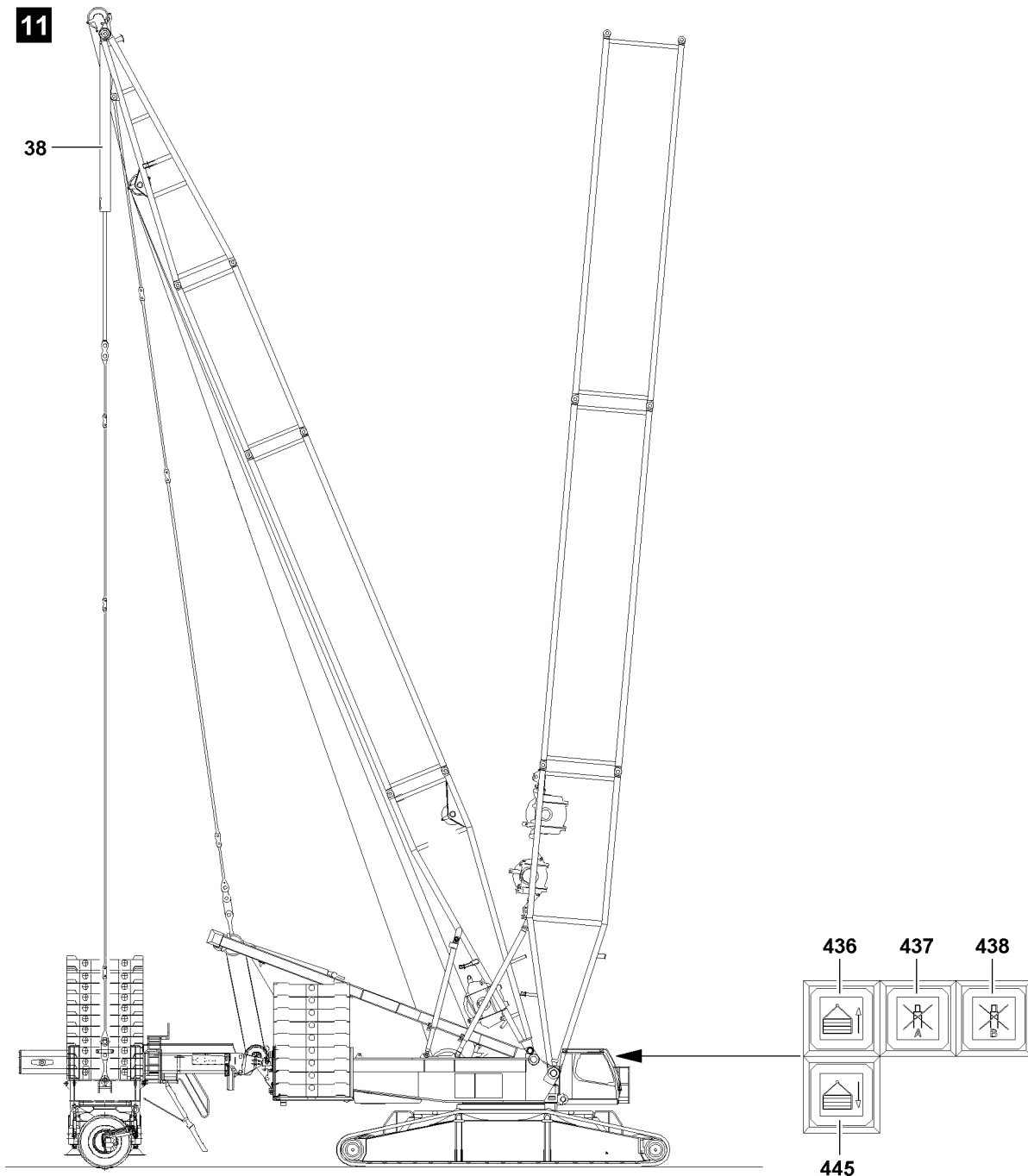

Fig.113697

LWE/LR 1600-2-008/18109-09-02/en

2.6 Lifting and lowering the ballast trailer with the pull cylinders

The pull cylinders **38** in the derrick ballast guying can only be controlled from the crane operator's cab.



Note

- ▶ If the ballast trailer is raised via the button **436** or lowered via the button **445**, then the horizontal alignment of the ballast trailer is automatically regulated by a level sensor.
- ▶ For a ballast utilization of **more than** or **equal to** 90 %, the level sensor regulates the ballast trailer level to $\pm 0.45^\circ$.
- ▶ At a ballast utilization of **less than** 90 %, the level sensor regulates the ballast trailer level to $\pm 2.5^\circ$. This makes it possible to set the ballast trailer down to a ground slope of 2.5° .



DANGER

Danger of accident!

Death, severe bodily injuries, property damage.

- ▶ When lifting or lowering the ballast trailer, pay attention to the horizontal alignment of the ballast trailer.
- ▶ When lifting or lowering the ballast trailer, the forces in the ballast guyings must be regularly checked on the LICCON monitor. If the difference of forces between „derrick ballast guying A“ and „derrick ballast guying B“ is too large, an acoustic warning sounds and the values on the LICCON monitor blink, see section „Differential force monitoring of ballast guying“.
- ▶ When pressing the button **437** („Stop cylinder A on the derrick ballast“) or the button **438** („Stop cylinder B on the derrick ballast“) then the level sensor is bypassed and the ballast trailer can be included within the limited angle range. This is only permitted when setting down the ballast trailer on uneven ground and applying utmost caution.

2.6.1 Lifting the ballast trailer

- ▶ Press the button **436**.

Result:

- The ballast trailer is raised.

2.6.2 Lowering the ballast trailer

- ▶ Press the button **445**.

Result:

- The ballast trailer is lowered.

2.6.3 Stopping the pull cylinder on the derrick ballast

- ▶ Press the button **437**.

Result:

- The pull cylinder (A) on the derrick ballast is stopped.

- ▶ Press the button **438**.

Result:

- The pull cylinder (B) on the derrick ballast is stopped.

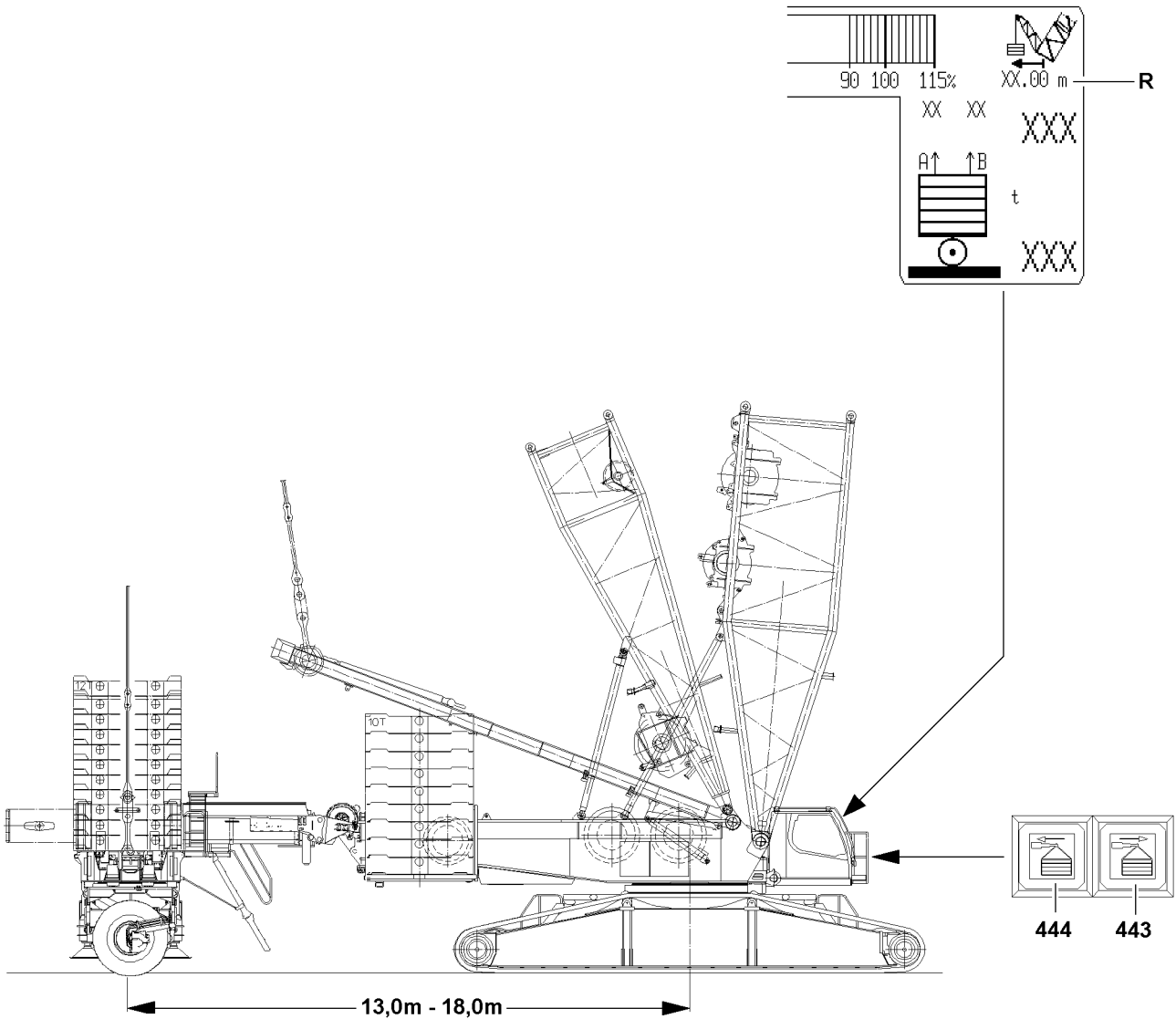

Fig.113698

3 Setting the ballast trailer radii

The ballast trailer can be telescoped steplessly hydraulically from 13 m to 18 m.

The ballast trailer is equipped with a telescopeable ballast trailer guide. This allows the derrick ballast radius to be adjusted to suit the environment or type of lifting work. The derrick ballast radius **R** is displayed on the LICCON monitor.



Note

- ▶ The release for telescoping the ballast trailer guide out and in is only given when the wheel sets are in „towing“ mode, see section „Towing“.
- ▶ If the ballast trailer is supported for assembly on the turntable, then it is possible to telescope the ballast trailer guide out and in with reduced pressure.
- ▶ When telescoping the ballast trailer guide out, monitor the derrick ballast radius **R** on the LICCON monitor constantly.
- ▶ The crane operator may not blindly rely on the derrick ballast radius measurement, he must think for himself and check if the length sensor measure functions correctly, see chapter 4.02.

3.1 Telescoping the ballast trailer guide out

Make sure that the following prerequisite is met:

- The wheel sets of the ballast trailer are in the „Towing“ position.

- ▶ Press the button **443**.

Result:

- The ballast trailer guide moves out.

- ▶ Observe the force display in the derrick guying $F_{1_{min}}-F_{1_{max}}$.

3.2 Telescoping the ballast trailer guide in

Make sure that the following prerequisite is met:

- The wheel sets of the ballast trailer are in the „Towing“ position.

- ▶ Press the button **444**.

Result:

- The ballast trailer guide moves in.

- ▶ Observe the force display in the derrick guying $F_{1_{min}}-F_{1_{max}}$.

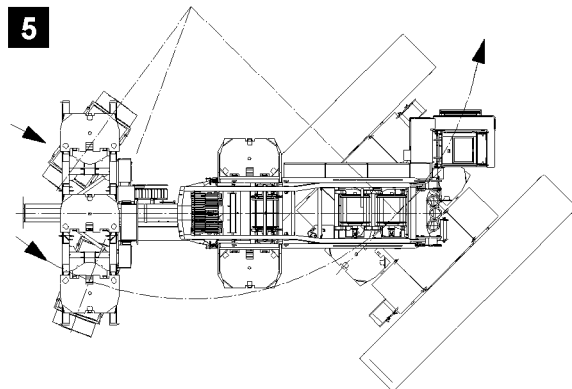
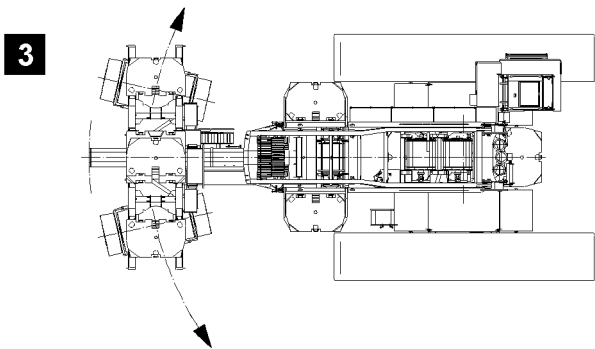
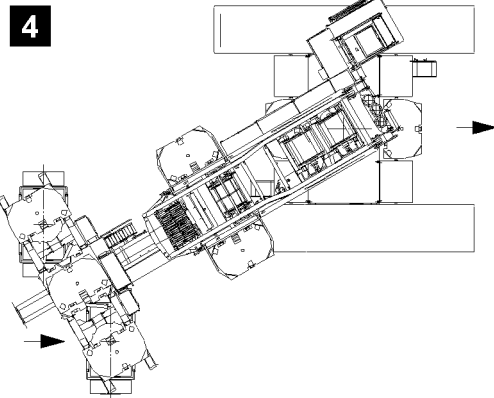
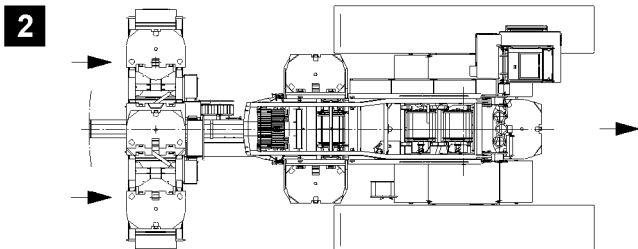
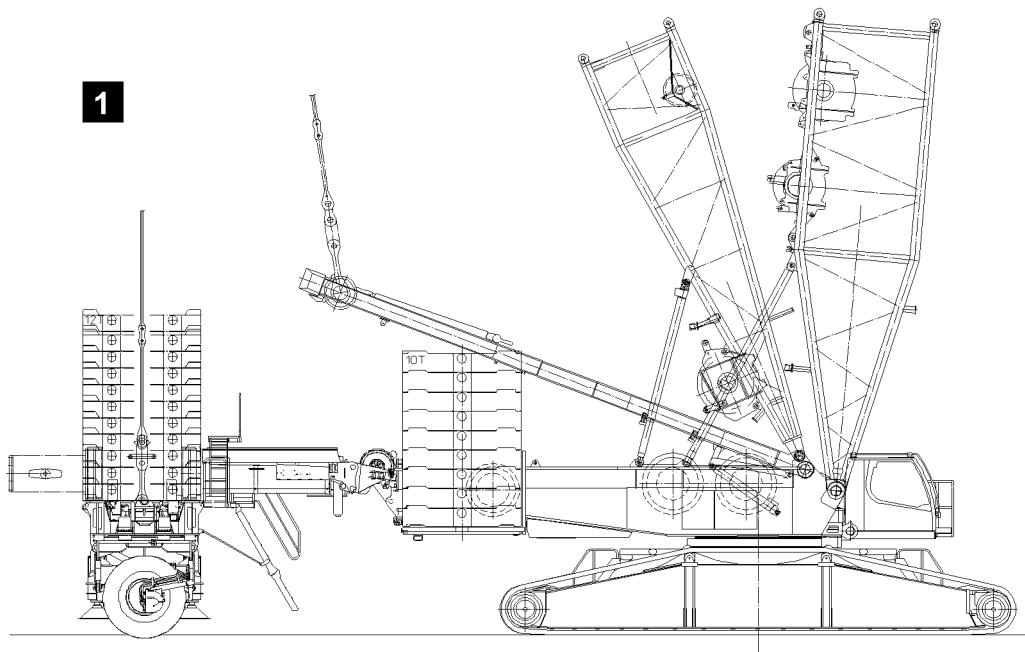

Fig.113700

LWE/LR 1600-2-008/18109-09-02/en

4 Steering programs

The ballast trailer has the following computer controlled steering programs:

- Towing, illustration 2
- Circular travel, illustration 3
- Parallel travel, illustration 4
- Corrective steering, illustration 5

The steering programs „Towing“, „Circular travel“ and „Parallel travel“ can only be actuated from the crane operator's cab.



WARNING

Danger when moving the wheel sets on the ballast trailer!
Death, severe bodily injuries, property damage.

- ▶ The crane operator as well as any operating personnel must make sure that there are no persons within the danger zone - between the wheel sets.
 - ▶ It is prohibited for anyone to remain between the wheel sets for all setting / adjustment work on the ballast trailer.
 - ▶ It is prohibited to anyone to remain between the wheel sets when selecting the various steering programs.
-

6

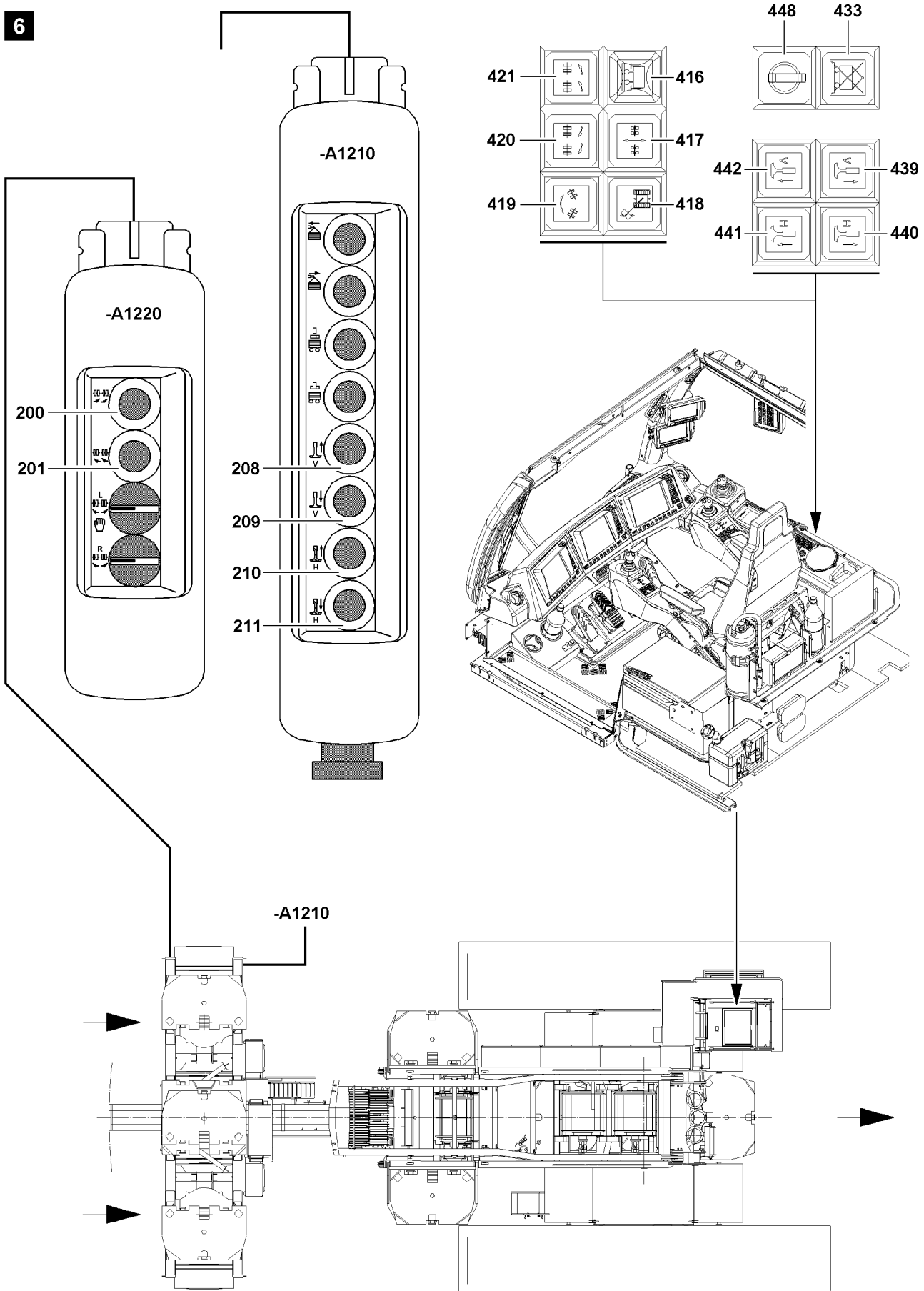

Fig.108970

LWE/LR 1600-2-008/18109-09-02/en

4.1 Notes to change the wheel sets



Note

- ▶ The buttons for the setting of the various steering programs are in the instrument panel of the crane operator's cab, see chapter 4.01.

Moving the wheel sets for „Towing“ is made with the button **417**.

Moving the wheel sets for „Circular travel“ is made with the button **419**.

Moving the wheel sets for „Parallel travel“ is made with the button **418**.

The wheel sets are steered correctively „to the right“ with the button **420** from the crane operator's cab, or with the button **201** from the control panel **-A1220** on the ballast trailer.

The wheel sets are steered correctively „to the left“ with the button **421** from the crane operator's cab, or with the button **200** from the control panel **-A1220** on the ballast trailer.

The manual change of the wheel sets for assembly purposes is only possible with the buttons on the control panel **-A1220** on the ballast trailer.



Note

- ▶ If the ballast trailer is suspended above the ground, the wheel sets can be positioned in any mode, if the key button **448** „Ballast trailer lifted off“ was turned on. Turning and driving of the crane is possible.

NOTICE

Danger of accidents when turning or driving!

If the lifted off ballast trailer scrapes on the ground - with turned on key button **448** - when turning or driving the crane, then the ballast trailer and the crane can be significantly damaged.

- ▶ If the ballast trailer has been lifted off the ground, the key button **448** „Ballast trailer lifted off“ is actuated, then it must be checked that the wheels do **not scrape on the ground**. An instructed person must check visually.
- ▶ It is prohibited to remain in the danger zone.



WARNING

The crane can topple over!

If the ballast trailer is lifted off the ground past the **maximum permissible** 250 mm , then the crane can topple over to the rear if the load rips off.

Death, severe bodily injuries, property damage.

- ▶ Do not lift the ballast trailer by more than 250 mm off the ground.

6

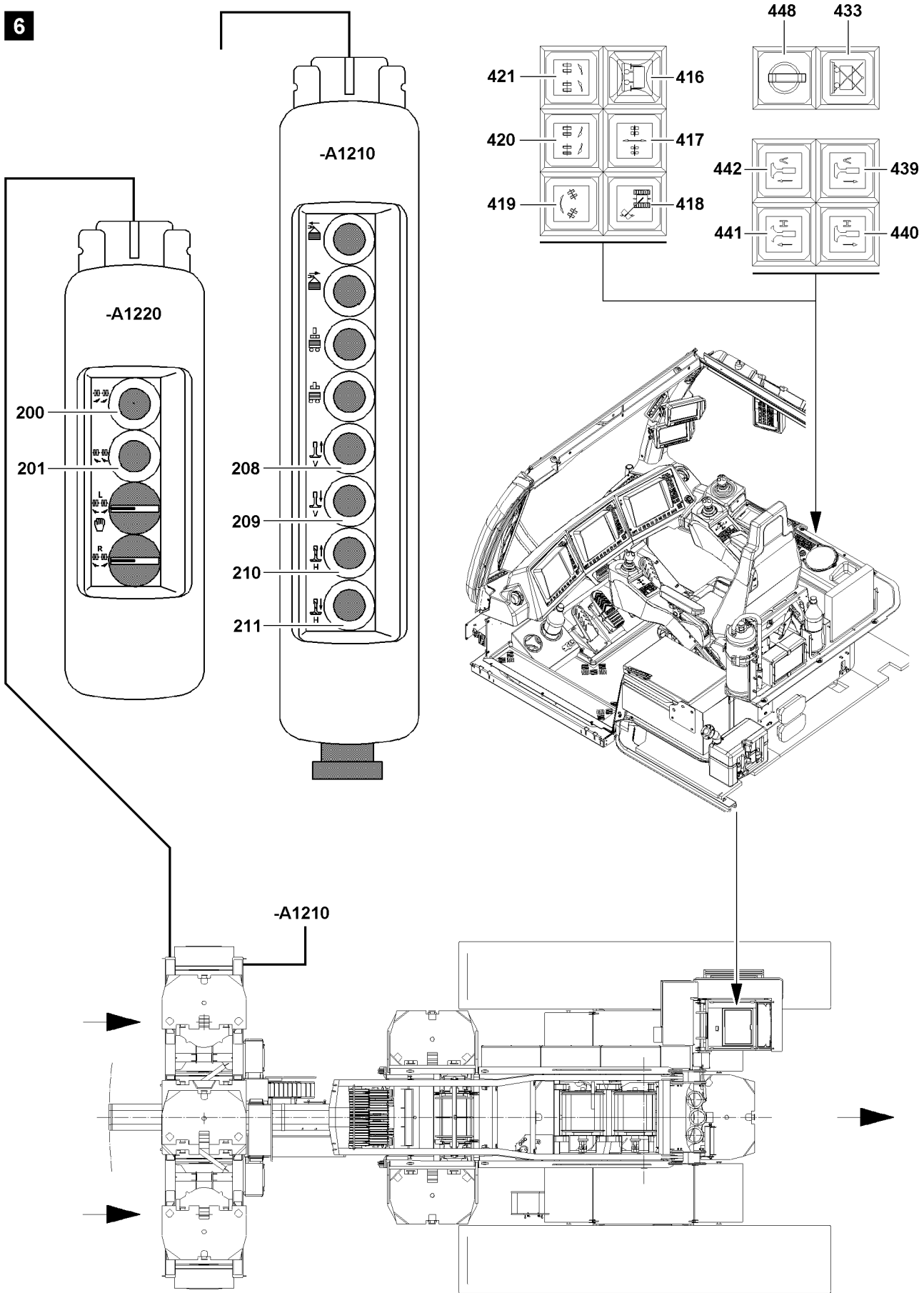

Fig.108970

LWE/LR 1600-2-008/18109-09-02/en

4.2 Adjustment procedure

The adjustment procedure for the various steering programs is identical.



Note

- ▶ If the ballast trailer is **not loaded**, the wheel sets can be changed without relieving the tires.
- ▶ If the ballast trailer is **loaded**, the ballast trailer must be raised first with the support cylinders until the tires are relieved.



DANGER

Danger of accident due to crane overload!

By raising the ballast trailer with the support cylinders, the force at test point 1 (MS1) can increase to the permissible maximum value. The extension of the support cylinders is then turned off.

- ▶ Monitor the actual force display of test point 1 (MS1) on the LICCON monitor and stop the extending of the support cylinders in time before the shut-off, see chapter 4.02.
- ▶ Actuate the support cylinders from the crane operator's cab and at the same time, monitor the „Actual force display of test point 1 (MS1)“ on the LICCON monitor.
- ▶ Before reaching the maximum operating force „F1_{max-operation}“: Stop the extension of the support cylinders.

6

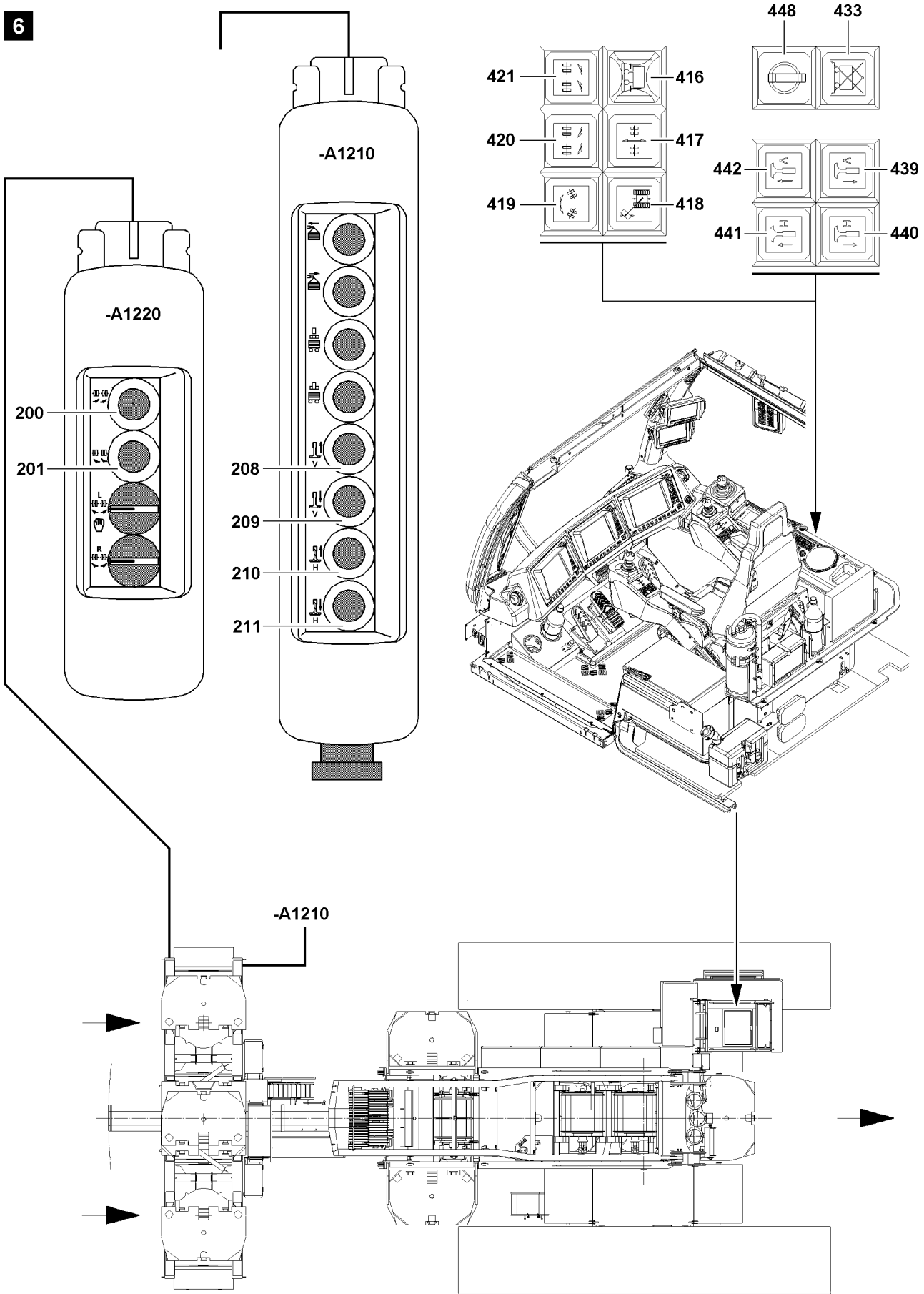

Fig.108970

LWE/LR 1600-2-008/18109-09-02/en

4.3 Towing

4.3.1 Lifting the ballast trailer with the support cylinders



Note

- ▶ The support cylinders of the ballast trailer must always be extended evenly.

Extend the front and rear support cylinders:

- ▶ Press the button **442** and button **441** in the crane operator's cab.
or
Press the button **209** and button **211** on the control panel **-A1210**.

4.3.2 Aligning the wheel sets in the towing position

Make sure that the following prerequisite is met:

- The ballast trailer is raised via the support cylinders to the point where the wheel sets are relieved.
- ▶ Press the button **417**.

Result:

- The wheel sets of the ballast trailer are aligned in towing position.
- During the turning procedure of the wheel sets, the indicator light in the button **417** **blinks**.
- When the towing position is reached, the indicator light in the button **417** **lights up**.

4.3.3 Lowering the ballast trailer with the support cylinders



Note

- ▶ The support cylinders of the ballast trailer must always be moved in evenly.

Retract the support cylinders completely on the front and rear:

- ▶ Press the button **439** and button **440** in the crane operator's cab.
or
Press the button **208** and button **210** on the control panel **-A1210**.

Result:

- The support cylinders retract.



Note

- ▶ The release to drive the crane in steering program „Towing“ is only made when both wheel sets are in travel direction (neutral position) and the support cylinders are fully moved in.
- ▶ Check the settings of the wheel sets and the support cylinders before driving the crane.
- ▶ Retract the support cylinders completely.

Result:

- The warning light **416** („Ballast trailer support moved in“) **lights up**.

6

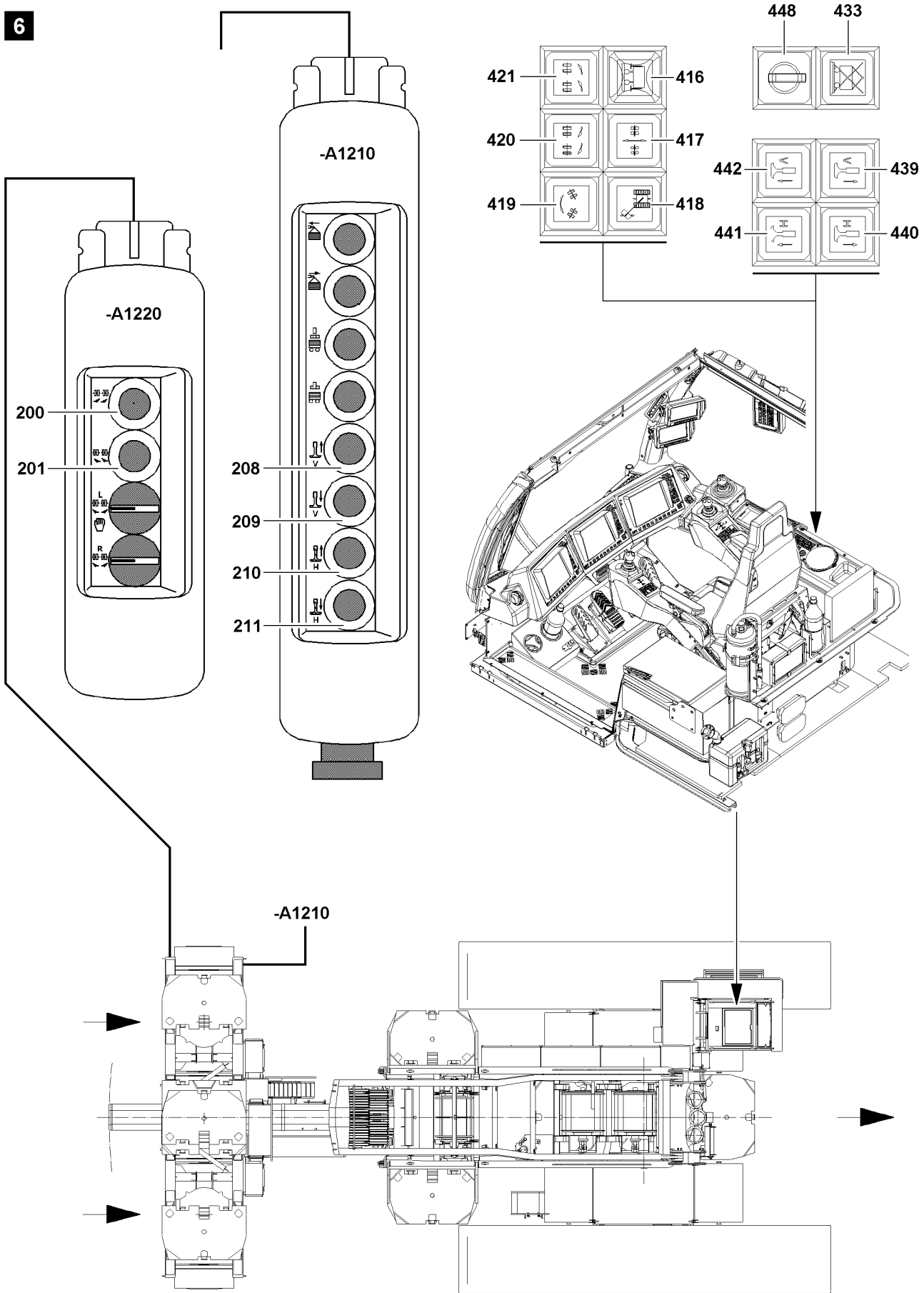

Fig.108970

LWE/LR 1600-2-008/18109-09-02/en

4.3.4 Corrective steering the wheel sets

NOTICE

Damage to the ballast trailer!

Through corrective steering of wheel sets while at a standstill, the ballast trailer can be damaged.

- ▶ If the ballast trailer is ballasted, the corrective steering of the wheel sets at a standstill is **prohibited**.
 - ▶ When the ballast trailer is ballasted, the corrective steering of the wheel sets is only permissible while driving.
 - ▶ Monitor the distortion of the tires.
-



Note

- ▶ Changing from the steering program „Towing“ into the steering program „Corrective steering“ and back is possible while driving the crawler.
 - ▶ If the steering program „Corrective steering“ is switched into the steering program „Towing operation“ then the indicator light **blinks** on the „button“ **417** until the towing operation position of the wheel sets is reached.
 - ▶ If one of the wheel sets deviates from the specified limit angle, the „indicator light in the button“ **417** blinks and the wheel sets must be reset as described above.
 - ▶ **In general, the following applies:** The wheel sets only move if either the button **420**, the button **421**, or the button **417** in the crane operator's cab, or the button **200** or the button **201** on the control panel is pressed in the respective steering program or if the crawler is driven.
-

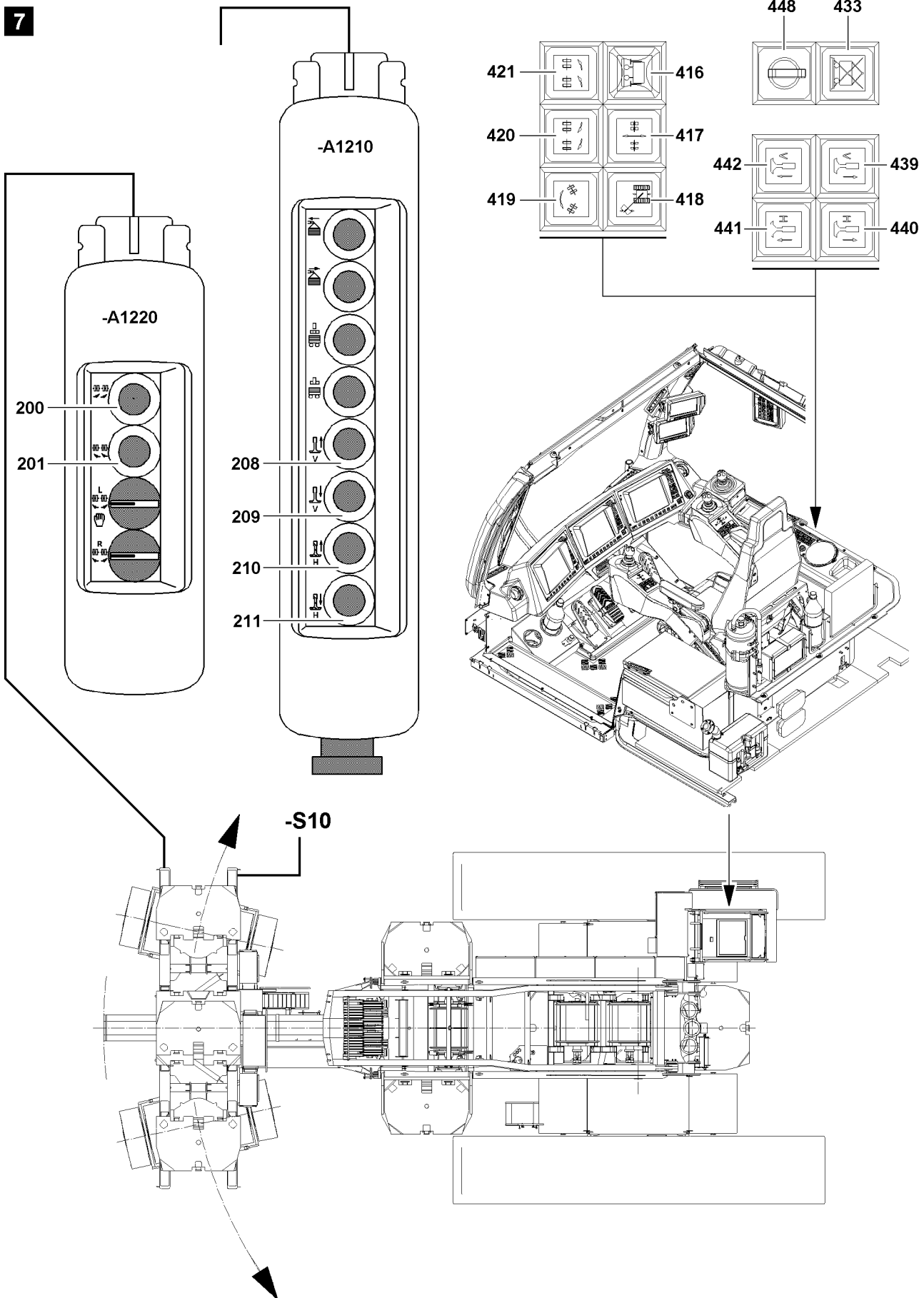

Fig.108971

LWE/LR 1600-2-008/18109-09-02/en

4.4 Circular travel

Make sure that the following prerequisite is met:

- The ballast trailer guide is telescoped out to the required derrick ballast radius.

4.4.1 Lifting the ballast trailer with the support cylinders



Note

- ▶ See section Towing operation.

4.4.2 Aligning the wheel sets in the circular travel position

Make sure that the following prerequisite is met:

- The ballast trailer is raised via the support cylinders to the point where the wheel sets are relieved.

- ▶ Press the button **419**.

Result:

- The ballast trailer wheel sets are aligned in the circular travel position.
- During the turning procedure of the wheel sets, the indicator light in the button **419 blinks**.
- When the circular travel position is reached, the indicator light in the button **419 lights up**.



Note

- ▶ If one of the wheel sets deviates from the specified angle, the indicator light in the button **419 blinks** and the wheel sets must be reset as described above.

- ▶ Press the button **419** again.

4.4.3 Lowering the ballast trailer with the support cylinders



Note

- ▶ See section Towing operation.



Note

- ▶ The release for turning the turntable in the steering program „Circular travel“ is only made when both wheel sets are in turning position (circular travel) and the support cylinders are completely moved in.
- ▶ Check the settings for the wheel sets and support cylinders before inspecting turning of the turntable.

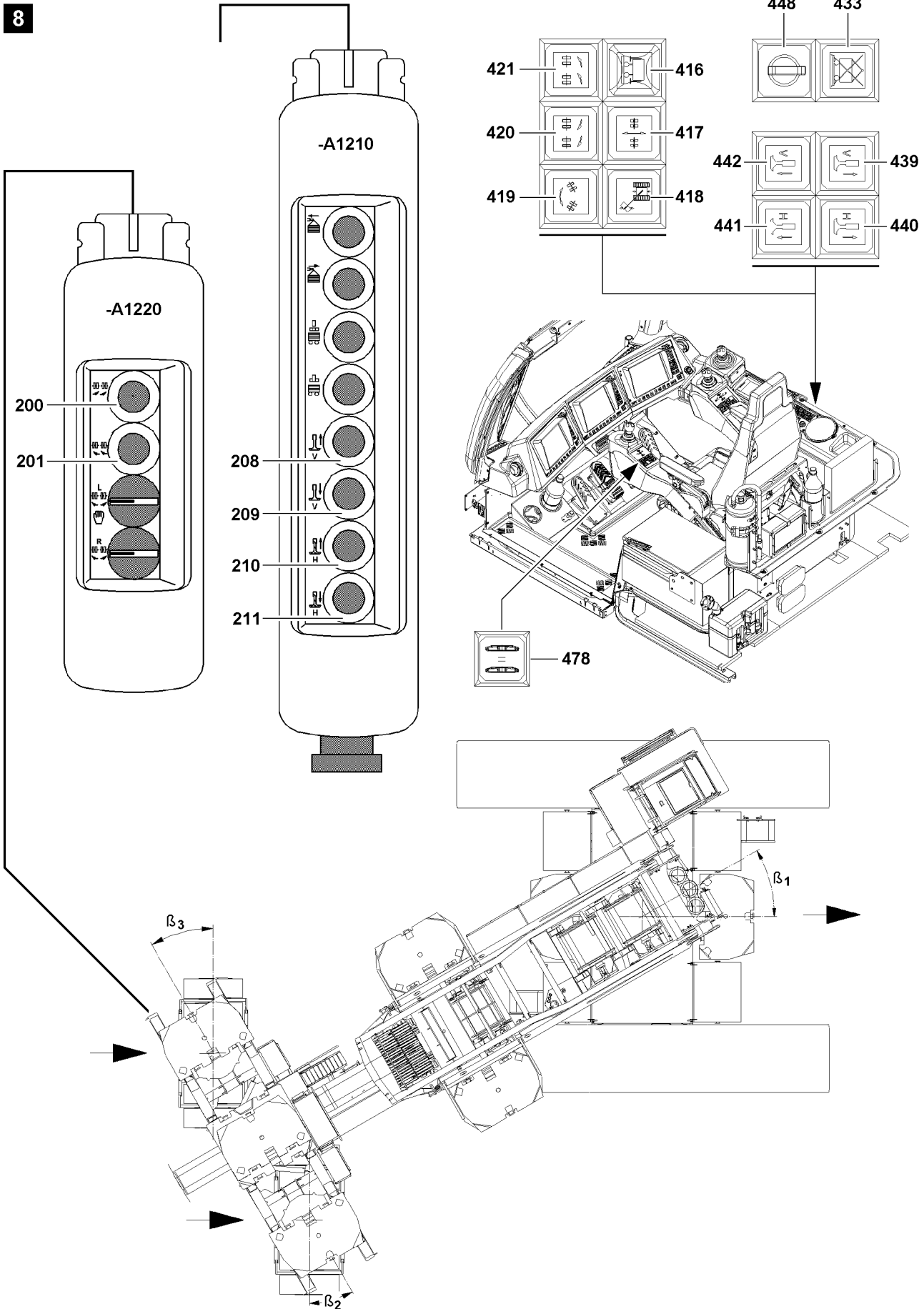

Fig.108972

LWE/LR 1600-2-008/18109-09-02/en

4.5 Parallel travel

NOTICE

Danger of damage to the crane and the ballast trailer!

Due to steering movements on the crawler track during parallel travel, the crane and the ballast trailer can be significantly damaged.

- ▶ For parallel travel, steering the crawler track is **prohibited**.
- ▶ For parallel travel, the side tire distortion on the wheel sets must be observed by an instructed person over the entire travel route of the crane. If the tires distort by more than 100 mm, then the position of the wheel sets must be corrected.



Note

- ▶ Independently of whether the ballast trailer stands on the ground or is lifted off the ground, the wheel sets must always stand in a „Parallel travel“ position.
- ▶ In deviating position for the wheel sets, the control turns itself off.
- ▶ To drive the crane in „Parallel travel“, the switch **478** on the left control panel is to be actuated.



Note

- ▶ The travel drive of the crawler is locked until the wheel sets are in parallel travel position.
- ▶ When driving the crawler, the slewing gear brake of the crane remains applied and the hydraulic coasting is opened.
- ▶ If the angles β_2 and β_3 deviate in relation to β_1 by more than the permissible limit angle, the crawler track is stopped, the indicator light in the button **418** blinks.
- ▶ Only through renewed alignment of the wheel sets to the required specified angle can the crawler track be driven again.
- ▶ If the „Crawler parallel travel“ switch **478** is turned on, the crawler moves straight forward on appropriate terrain. This simplifies driving the crane with the ballast trailer in steering program „Parallel travel“.

4.5.1 Lifting the ballast trailer with the support cylinders



Note

- ▶ See section „Towing operation“.

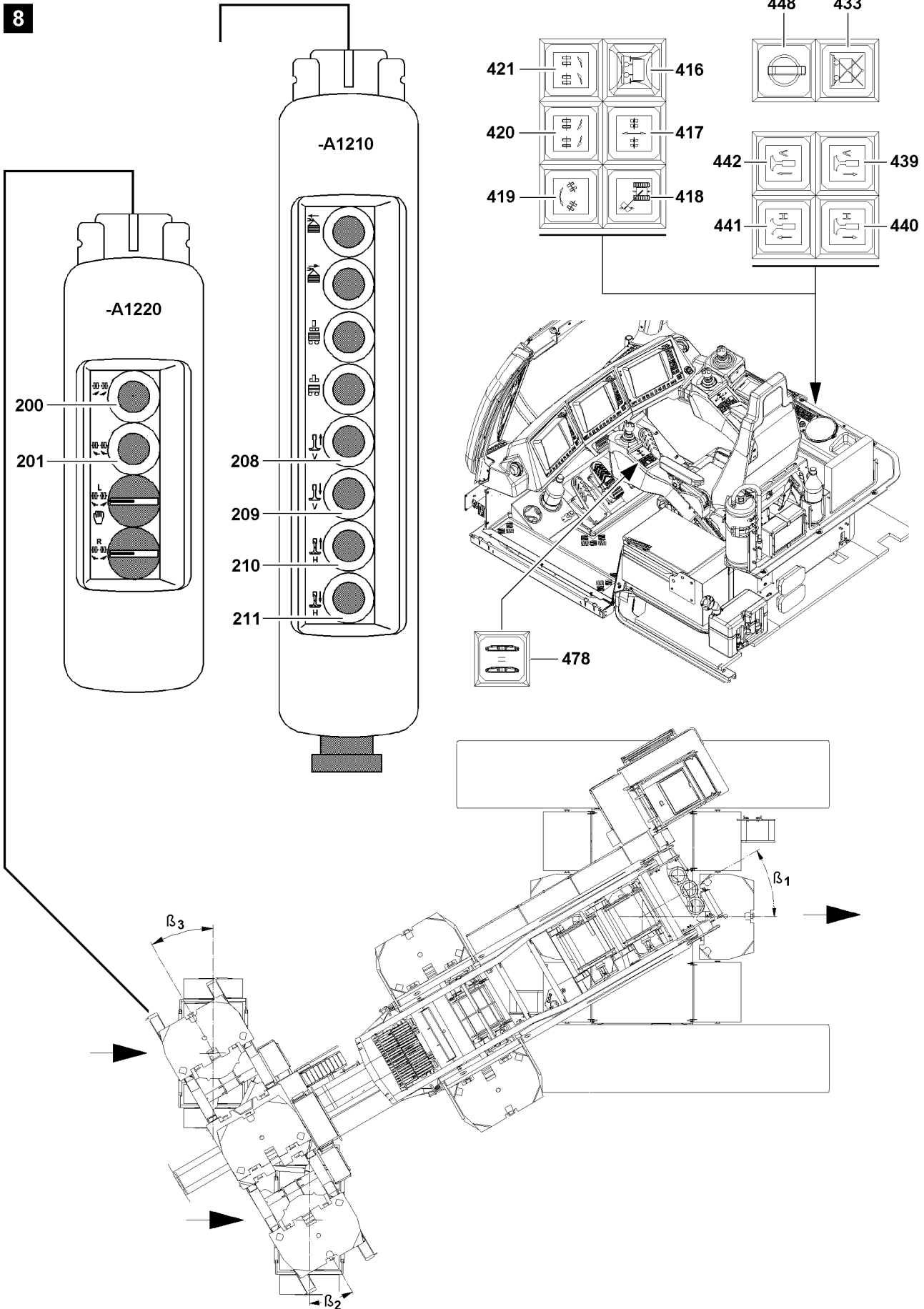

Fig.108972

LWE/LR 1600-2-008/18109-09-02/en

4.5.2 Aligning the wheel sets into parallel travel position

Make sure that the following prerequisite is met:

- The ballast trailer is raised via the support cylinders to the point where the wheel sets are relieved.

▶ Press the button **418**.

Result:

- The ballast trailer wheel sets are aligned in the parallel travel position.
- During the turning procedure of the wheel sets, the indicator light in the button **418 blinks**.
- When the parallel travel position is reached, the indicator light in the button **418 lights up**.



Note

- ▶ If one of the wheel sets deviates from the specified angle, the indicator light in the button **418** blinks and the wheel sets must be reset as described above.

▶ Check the parallel position of the wheel sets.

4.5.3 Lowering the ballast trailer with the support cylinders



Note

- ▶ See section Towing operation.
-

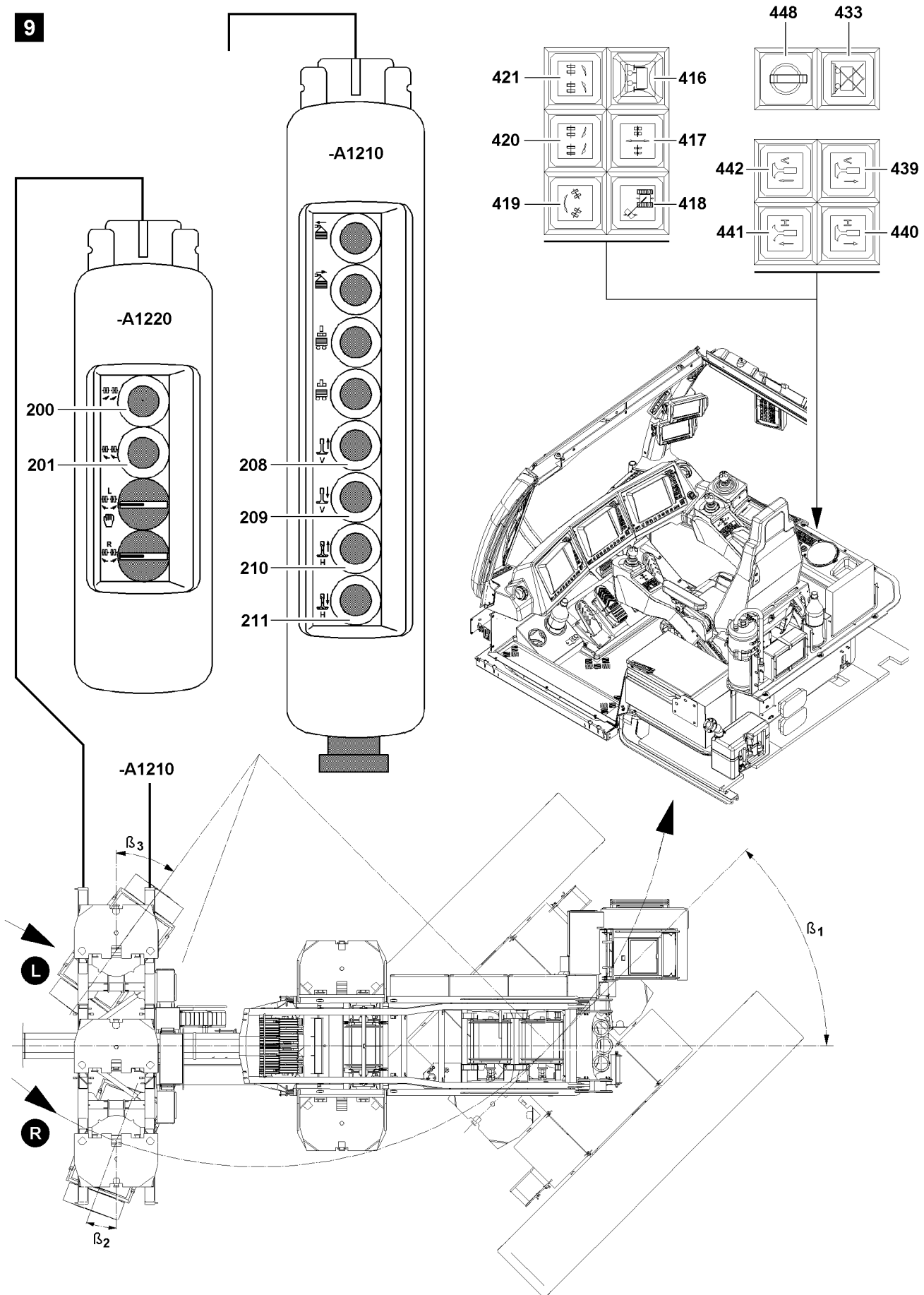

Fig.108973

LWE/LR 1600-2-008/18109-09-02/en

4.6 Corrective steering

Make sure that the following prerequisite is met:

- Crawler operation is turned on.

4.6.1 Steering and corrective steering of the wheel sets

Make sure that the following prerequisites are met:

- The steering program „Towing“ is selected **and** the wheel sets are in the towing position.
- Control light in button **417** illuminates.

Turn wheel sets to the right:

- ▶ Press the button **420** in the crane operator's cab.
or
Press the button **200** on the control panel **-A1220**.

Turn wheel sets to the left:

- ▶ Press the button **421** in the crane operator's cab.
or
Press the button **201** on the control panel **-A1220**.

The right wheel set is regulated by the computer-controlled steering program so that there is always a center steering position. The angle β_1 is determined by the driving of the crawler and the angle β_3 is determined by the steering of the operator, whereby the angle β_2 is continually corrected. Switching from the steering program „Corrective steering“ into the steering program „Towing“ and back, after achieving the towing position, is possible while driving the crawler. If the steering program „Corrective steering“ is selected from the steering program „Towing“ the indicator light in the button **420** and the indicator light in the button **421** lights up.



Note

- ▶ The left wheel set can be steered to the specified limit angle β_3 . It is not possible to steer beyond this limit angle.
 - ▶ The right wheel set is corrected to follow the center steering position. If the right correctively steered wheel set cannot follow the left wheel set, then the left wheel set is stopped until the right correctively steered wheel set has caught up.
 - ▶ If the right wheel set still deviates from the specified limit angle, the indicator light in the button **420** and the indicator light in the button **421** blinks and you must begin again with „Towing“.
 - ▶ If the crawler is driven and exceeds the angle β_1 , the turntable automatically switches the specified value into the steering program „Towing“. The indicator light in the button **420**, the indicator light in the button **421** and the indicator light in the button **417** blink.
 - ▶ When the towing position is reached, manual corrective steering can continue. The indicator light in the button **417** lights up.
 - ▶ **In general, the following applies:** The wheel sets only move during corrective steering if either the button **420** or the button **421** from the crane operator's cab, **or** the button **200** or the button **201** on the control panel is pressed in the respective steering program or if the crawler is driven.
-
- ▶ Check the settings.

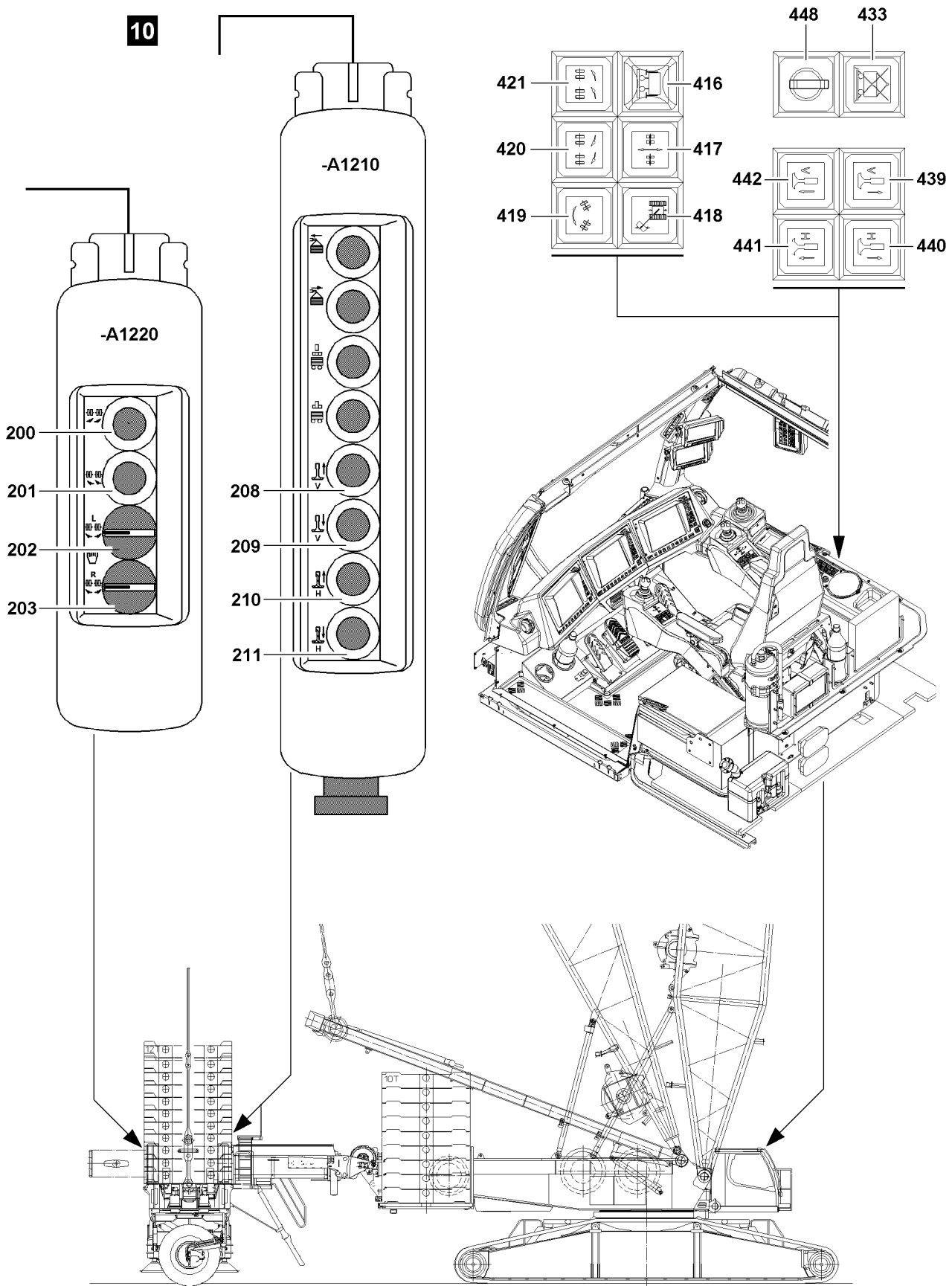

Fig.113701

LWE/LR 1600-2-008/18109-09-02/en

4.7 Manual operation for assembly

The ballast trailer is equipped with a program which allows for each wheel set to be turned individually at assembly.

4.7.1 Lifting the ballast trailer with the support cylinders

**Note**

▶ See section Towing operation.

4.7.2 Setting the wheel sets

To set the wheel sets, the rotary switches on the control panel **-A1220** are to be activated.

▶ Turn rotary switch **202** to the right.

Result:

– Turn left wheel set to right.

▶ Turn rotary switch **202** to the left.

Result:

– Turn left wheel set to the left.

▶ Turn rotary switch **203** to the right.

Result:

– Turn right wheel set to right.

▶ Turn rotary switch **203** to the left.

Result:

– Turn right wheel set to the left.

4.7.3 Lowering the ballast trailer with the support cylinders

**Note**

▶ See section Towing operation.

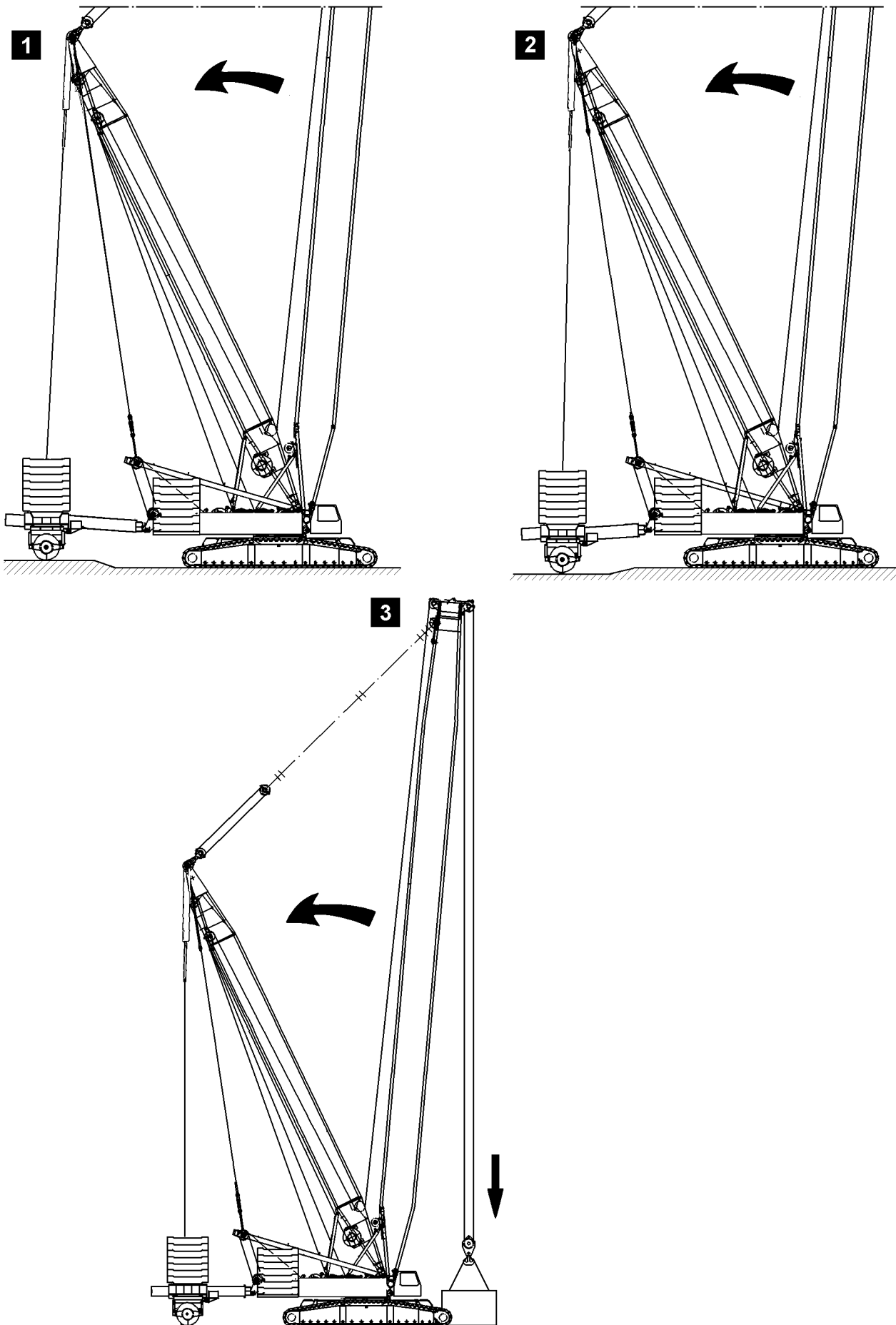

Fig.108976

LWE/LR 1600-2-008/18109-09-02/en

5 Driving with the ballast trailer

5.1 Procedure



Note

- ▶ It is only permitted to drive the ballast trailer on level ground capable of supporting the load.
- ▶ Driving over obstacles is not permitted.



DANGER

The crane can topple over!

In case of non-permissible level difference between the ballast trailer travel route and the crane position level, the entire crane system can be pulled back suddenly.

The relapse cylinders can thereby run into the mechanical block position and be significantly damaged.

Death, severe bodily injuries, property damage.

- ▶ Do not exceed or fall below the permissible level difference between the ballast trailer roadway and the crane placement level.

5.1.1 Pressure monitoring in extension cylinder

Through propelling force of the crawler track upon forward and backward travel, the extension cylinder can be overloaded in the pull and push direction if the ballast trailer travels over ground unevenness or slopes.



Note

- ▶ If the maximum permissible pressure in the extension cylinder is exceeded, an acoustic signal will sound and an error message appears.
- ▶ There is **no** shut-off.

NOTICE

Piston rod on block!

If the piston rod of the extension cylinder is already on block through telescoping out or in of the ballast trailer guide, no pressure monitoring occurs.

The extension cylinder can be significantly damaged.

- ▶ It is prohibited to move the piston rod in or out up to the block position.

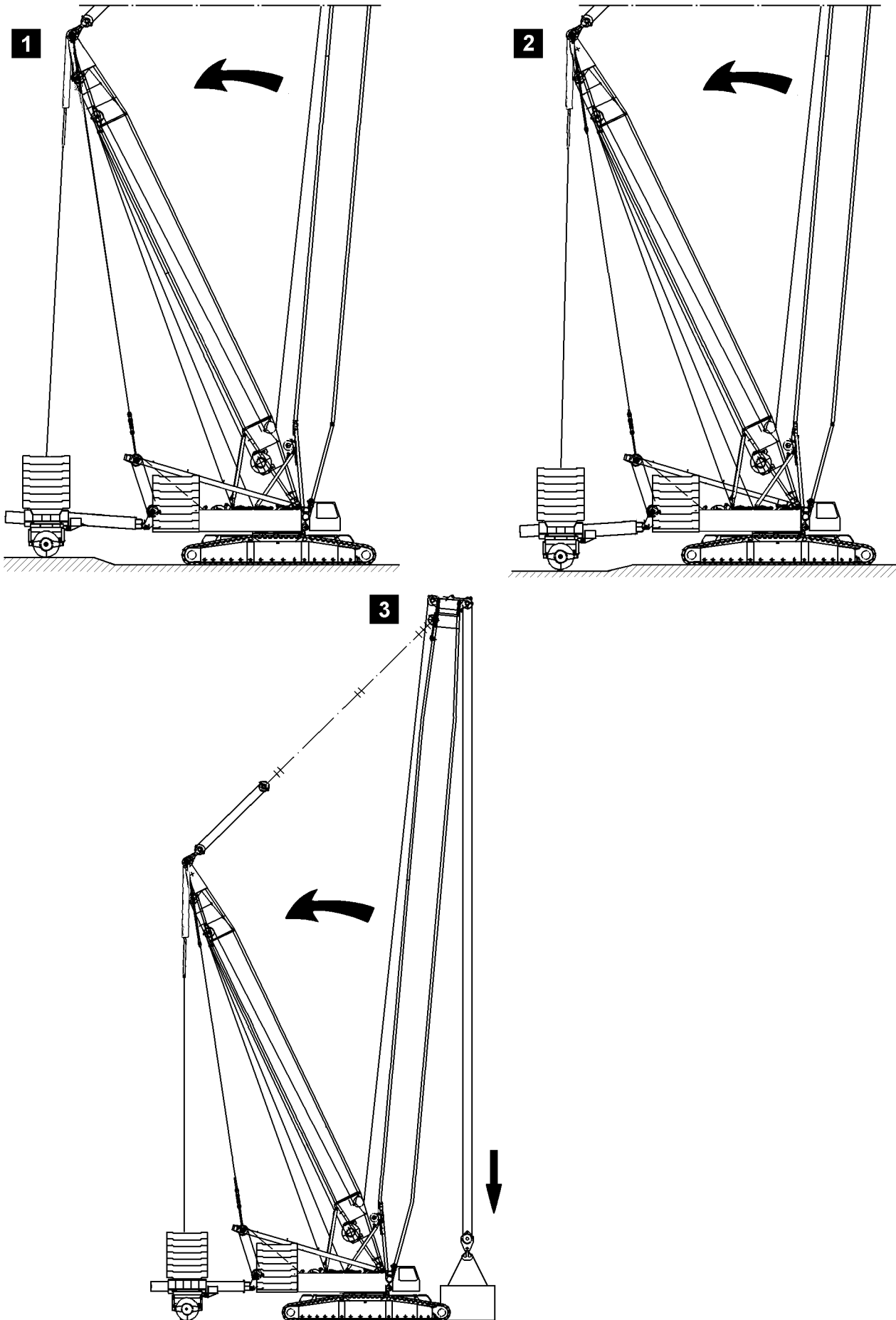

Fig.108976

LWE/LR 1600-2-008/18109-09-02/en

5.2 Safety guidelines for travel operation

5.2.1 Relapse cylinder

When the steepest operating position of the main boom is reached, luffing up is turned off by the LICCON overload protection in all operating modes.



Note

- ▶ However, in certain cases the movement of the entire crane system to the rear can cause the relapse cylinders to mechanically latch in the block position.

5.2.2 Block position relapse cylinders

NOTICE

Damage to the relapse cylinder and the boom!

Through level difference between the ballast trailer and crane route, the boom can suddenly be pulled backward and the relapse cylinder can go into the block position.

The relapse cylinder or the boom can be damaged.

- ▶ Make sure before taking up the driving mode, or before turning the crane superstructure, that the crane driving track or the ballast trailer circular path is even and capable of supporting the load.

In normal crane operation without bypass of the LICCON overload protection, a block position is not possible. Should a block position still occur, the movement is shut off and the boom limitation icon shown on the operating screen indicates which block position has been started up.

With this boom limitation icon it is to be determined which limit switch on which relapse cylinder has been actuated. Reverse the last movement which was carried out until the corresponding limit switch is released again.

5.2.3 Case 1



Note

- ▶ Refer to illustration 1.

When driving or turning the crane with steeply positioned boom, the ballast trailer can be lowered, due to the level differences. This causes the whole boom system to be pulled backward and there is a danger of reaching the block position in the relapse cylinders. The same danger applies when turning if the ballast trailer sinks due to level differences.



Note

- ▶ Due to the signals „Main boom relapse cylinder on block“ or „Derrick relapse cylinder on block“ in operation with ballast trailer, the movements „Crawler driving“ and „Turning“ are automatically turned off.

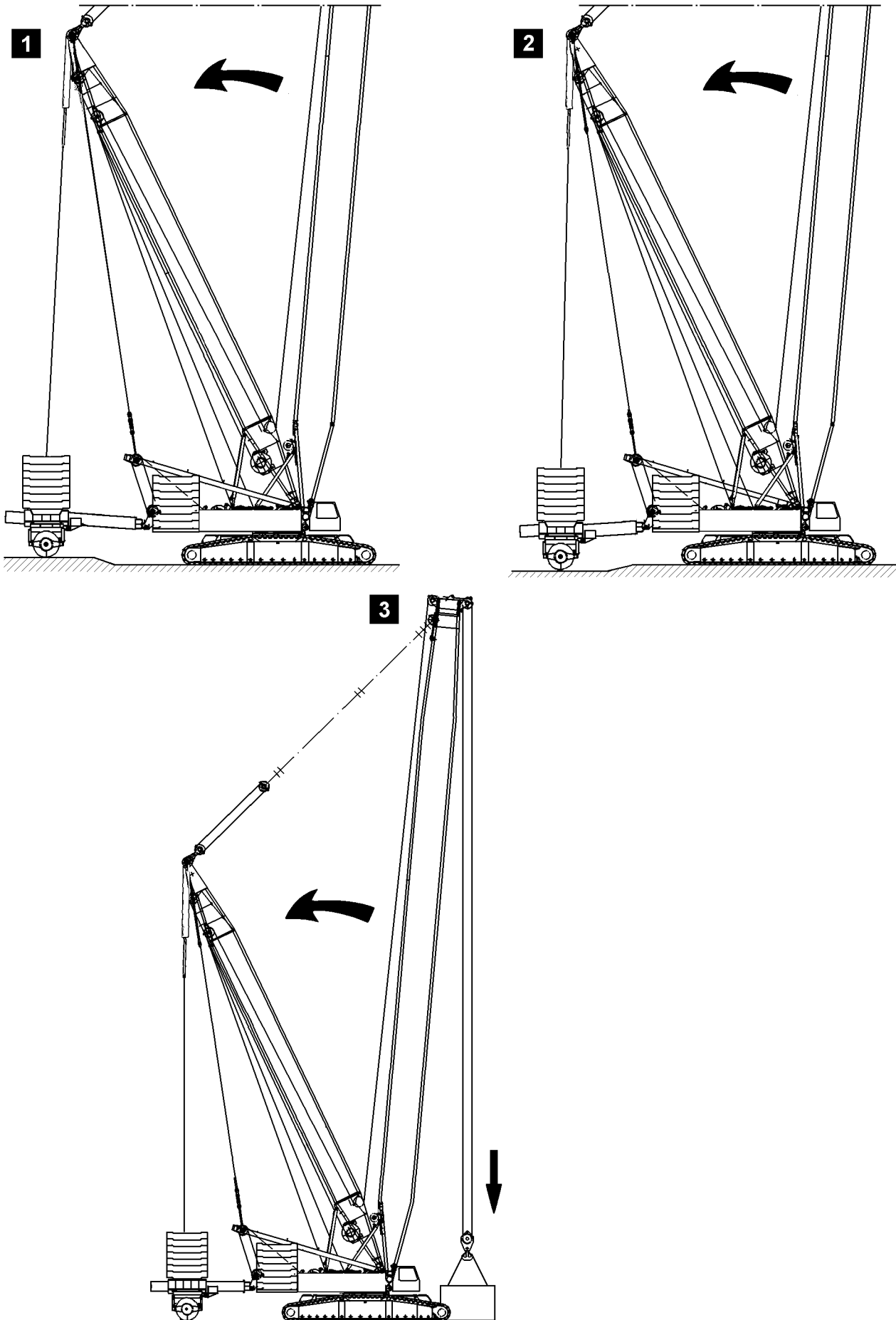

Fig.108976

LWE/LR 1600-2-008/18109-09-02/en

5.2.4 Case 2



Note

- ▶ Refer to illustration 2.

If the level under the crane increases, the boom system is also pulled back. There is a danger that the relapse cylinders reach the block position.



Note

- ▶ Due to the signals „Main boom relapse cylinder on block“ or „Derrick relapse cylinder on block“ in operation with ballast trailer, the movements Crawler driving and Turning are automatically turned off.

5.2.5 Case 3



Note

- ▶ Refer to illustration 3.

When the load is set down with the hoist gear, the crane is relieved. This causes the booms to move backward, refer to section „Monitoring the minimum force F1“.

5.3 Maximum permissible ground unevenness



WARNING

The crane can topple over!

By exceeding the maximum permissible value for ground unevenness while driving the crane, the crane can topple over.

Death, severe bodily injuries, property damage.

- ▶ The permissible ground unevenness may not be exceeded.

Level change between placement surface of the crane and the ballast trailer during towing, parallel and circular travel may not exceed a maximum permissible value.



Note

- ▶ The level difference of the ballast trailer route in relation to the crane route during **towing** and **parallel travel** may be no more than ± 250 mm.
- ▶ The level difference of the ballast trailer route in relation to the crane route during **circular travel** may be no more than ± 250 mm - with a constant uphill or downhill slope over a 90° slewing range.

5.3.1 Compensating for ground unevenness

The maximum permissible ground unevenness can be compensated by means of pull cylinders by lifting or lowering the ballast trailer.



Note

- ▶ The pull cylinders are operated from the crane operator's cab.

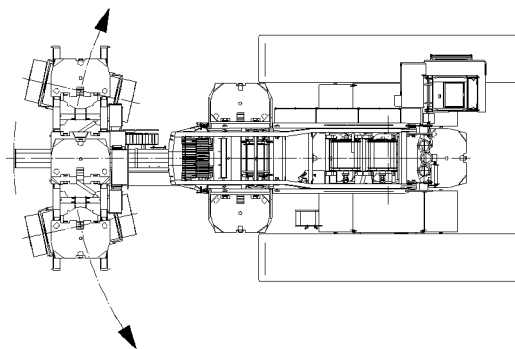
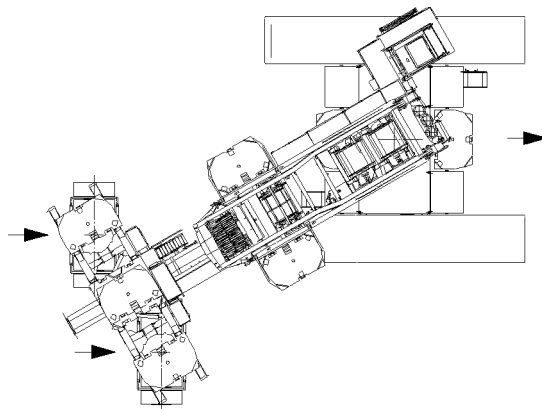
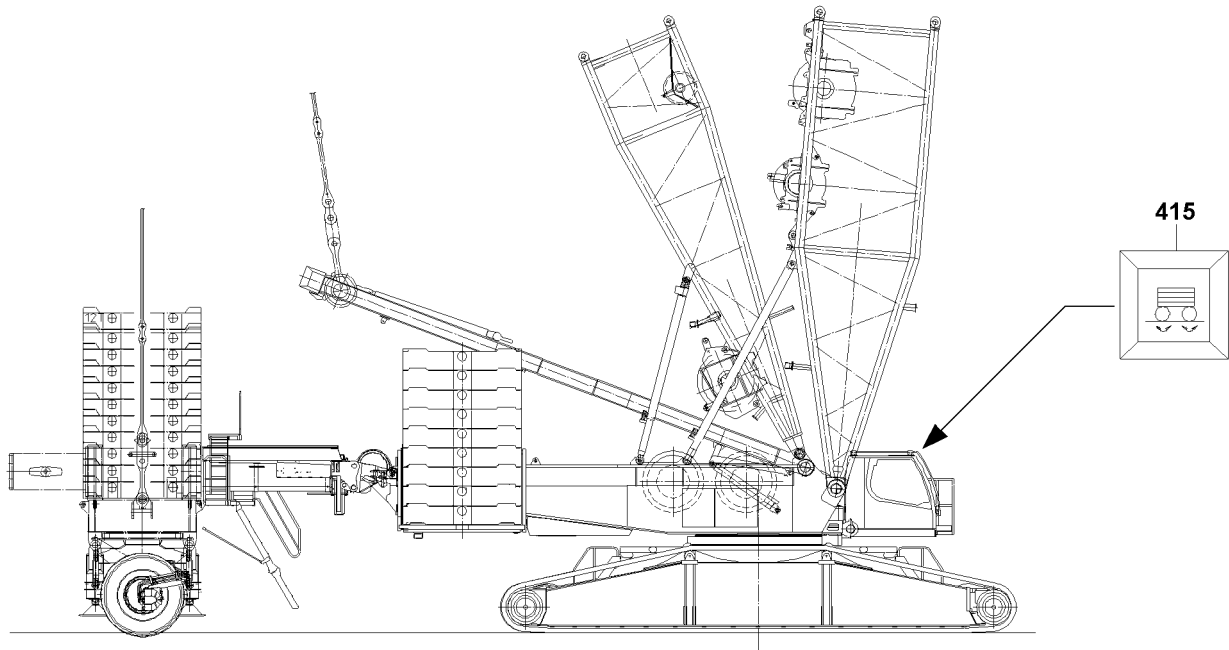

Fig.113680

LWE/LR 1600-2-008/18109-09-02/en

5.3.2 Ballast trailer drive*

A ballast trailer is equipped with a wheel set with its own drive. The drive is added in the crane operator's cab.



Note

- ▶ The addition of the drive is only possible in circular and parallel travel.
 - ▶ The additional drive may be required when driving over uneven ground.
-

If the road surface is level, no additional drive is required.

Add the drive only when no turning / travel movement occurs when the control lever is deflected.

Turn the drive on with switch **415** in the crane operator's cab.



Note

- ▶ Turn the drive off as soon as the unlevel ground has been passed.
 - ▶ Turn the drive off with the switch **415** in the crane operator's cab.
-

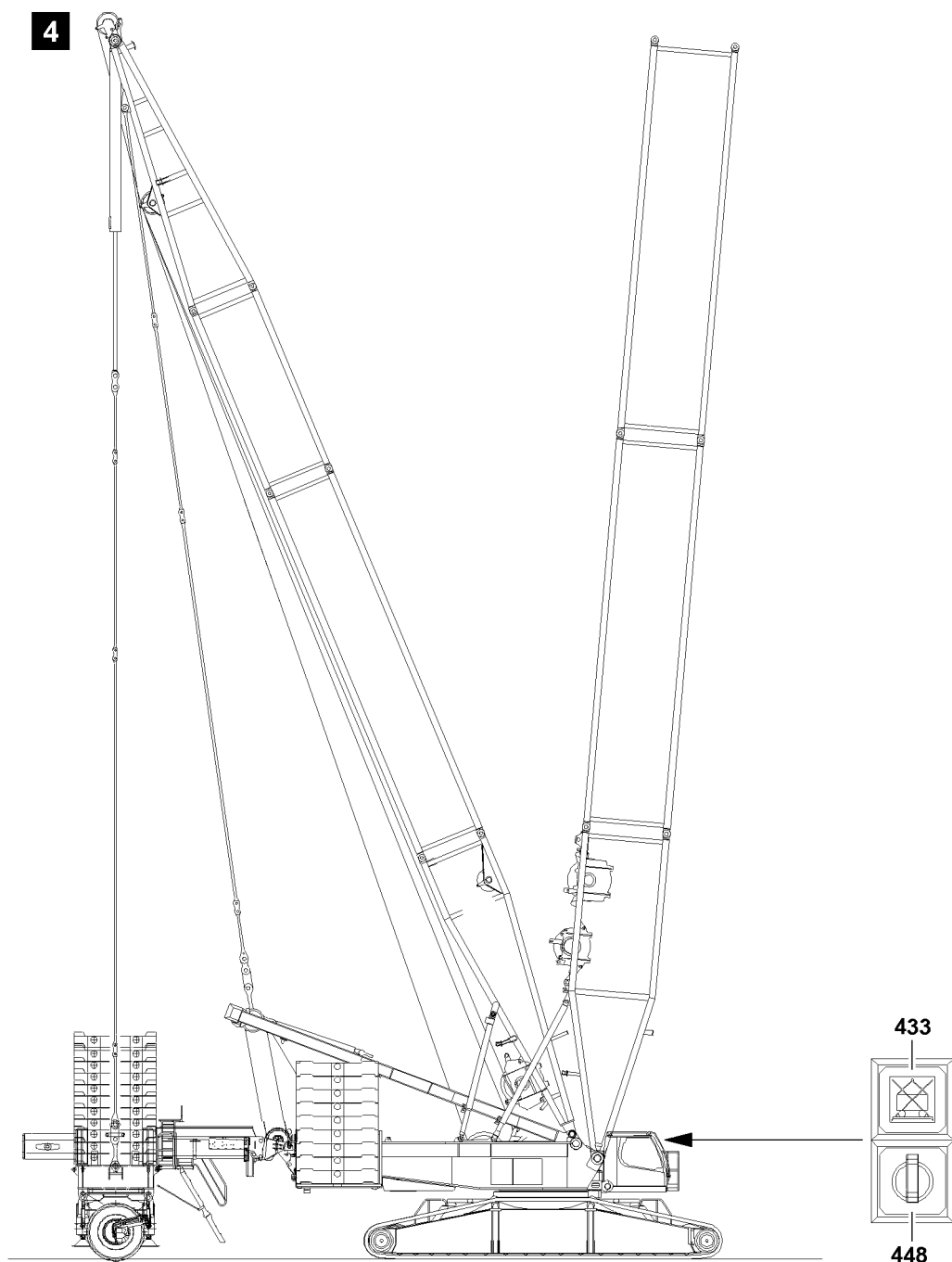

Fig.113736

LWE/LR 1600-2-008/18109-09-02/en

5.4 Key button „Ballast trailer lifted off“

When „Crawler driving“ and key button **448** is not operated, i.e. „Ballast trailer not lifted off“, the slewing gear brake and hydraulic slewing gear coasting are opened. For „crawler driving“ if driving with **ballast trailer lifted off** (constant visual check), the key button **448** „Ballast trailer lifted off“ must be turned on.



DANGER

Danger of accident!

If the ballast trailer is lifted from the ground during crawler driving in the steering program „Towing“, there is a danger that the wind turns the turntable to the side during „Crawler driving“.

- ▶ After lifting the ballast trailer, the key button **448** „Ballast trailer lifted off“ must be turned on immediately, so that the slewing gear brake remains closed for „Crawler driving“, however the hydraulic coasting remains open.
- ▶ If, when „Driving the crawler“, the ballast trailer scrapes on the ground or gets stuck on the ground, so that the turntable twists with the ballast trailer against the crawler track, the slewing gear brake can slip. The slewing gear will not be damaged.
- ▶ However, if the wheel sets of the ballast trailer are not aligned in „Towing position“, the ballast trailer or the crane will be damaged.



Note

- ▶ When the function „Ballast trailer lifted off“ is turned on, the warning light in the button **433** blinks, it is possible to turn the turntable or to drive the crane even though the wheel sets of the ballast trailer are not set on „Circular travel“, „Towing“ or „Parallel travel“.

Add „Ballast trailer lifted off“:

- ▶ Press key button **448** „Ballast trailer lifted off“.

Result:

- The warning light in the button **433** blinks.
- The ballast trailer icon on LICCON monitor 1 is represented „suspended“.

Turn „Ballast trailer lifted off“ off:

- ▶ Press the button **433**.

Result:

- The warning light in the button **433** turns off.
- The ballast trailer icon on LICCON monitor 1 is represented „on the ground“ (placed down).

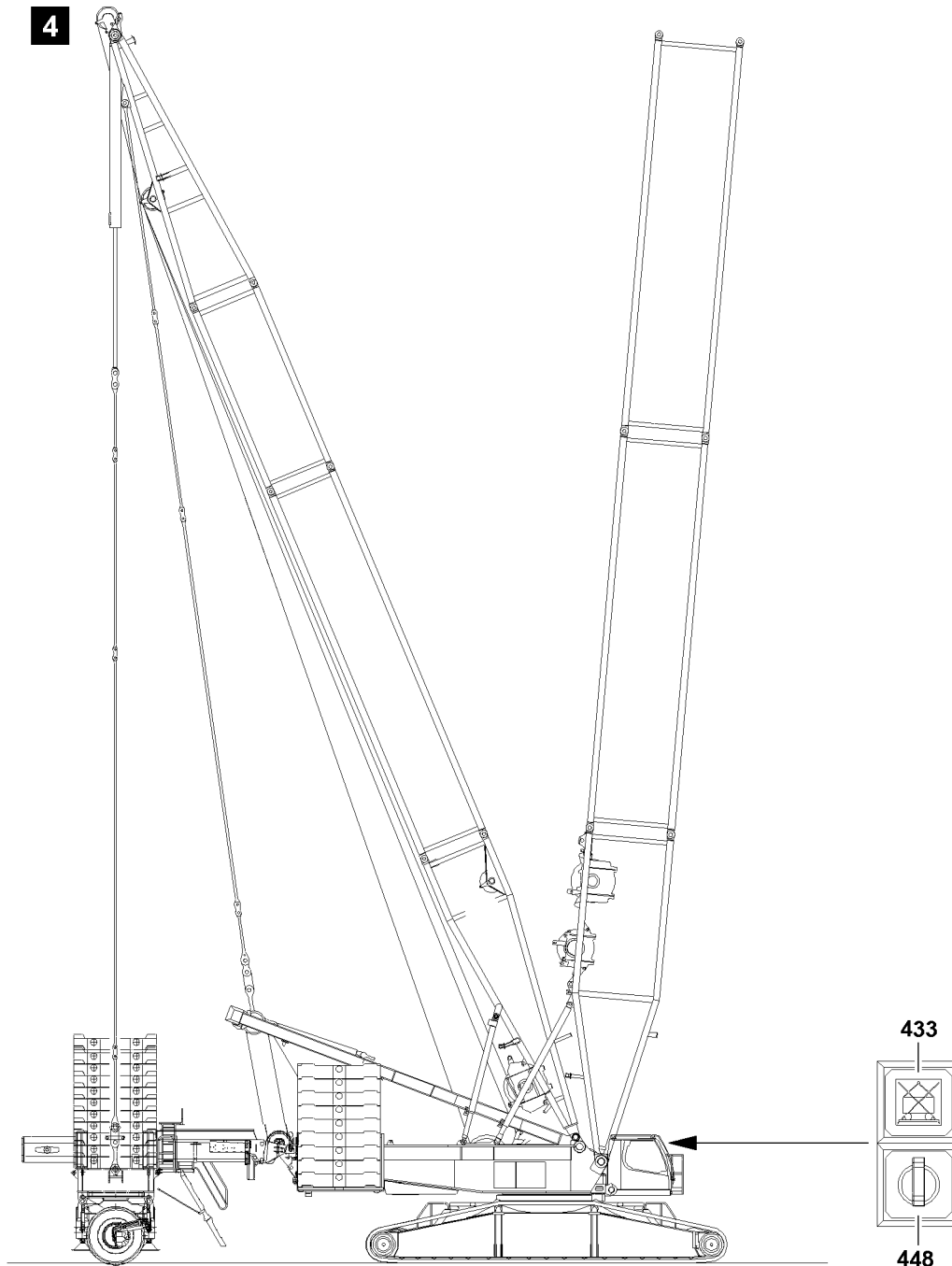

Fig.113736

LWE/LR 1600-2-008/18109-09-02/en

5.5 Defined ballast trailer operation



DANGER

Danger of accident!

If the ballast trailer is operated in an undefined condition, it can result in severe accidents up to toppling of the crane.

Death, severe bodily injuries, property damage.

- ▶ The ballast trailer must always be in a defined condition.
- ▶ Operation of the ballast trailer in an undefined state is prohibited.

The ballast trailer may not be lifted or set down when driving, rather this must be done **before** starting to travel.

5.5.1 Ballast trailer lifted

„Ballast trailer defined lifted from the ground“ means:

The ballast trailer is lifted from the ground and the „**Ballast trailer lifted off**“ key button **448** is pressed. As a result, the slewing gear brake does **not** open during „Crawler driving“ and the wind cannot turn the turntable during „Crawler driving“.

Make sure that the following prerequisites are met:

- The ballast trailer has been completely lifted off the ground.
- The key button **448** is actuated.
- The warning light in the button **433** blinks.

5.5.2 Ballast trailer on the ground

„Ballast trailer defined on the ground“ means:

That the ballast trailer and its residual load are resting on the ballast trailer tires and the key button **448** is **not** pressed. This residual load is large enough to prevent the wind from turning the turntable, if the slewing gear brake is opened when actuating „Crawler driving“.

Make sure that the following prerequisites are met:

- The ballast trailer is positioned with a residual load on the ground.
- The key button **448** is **not** pressed.
- The warning light in the button **433** does **not** blink.

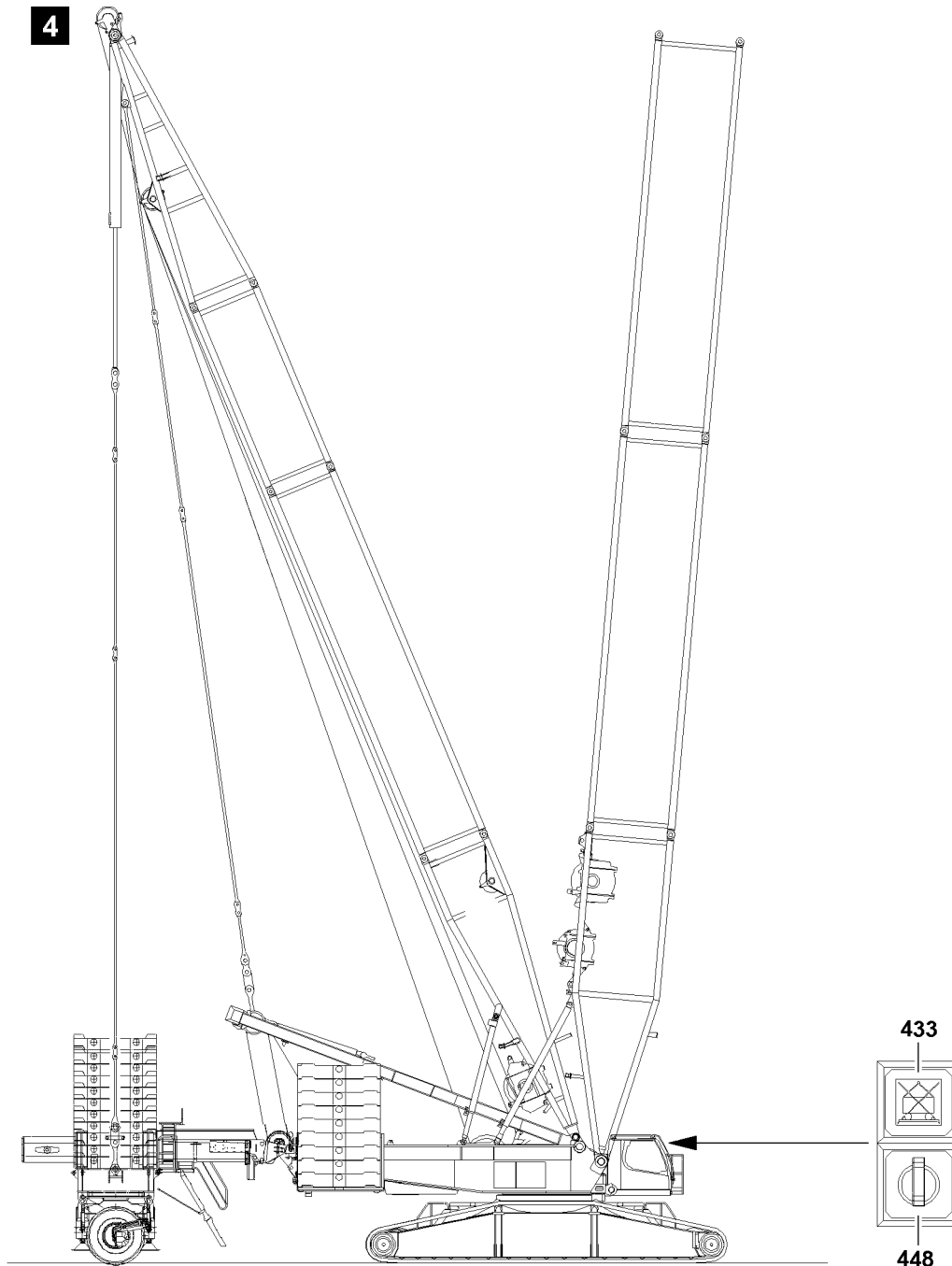

Fig.113736

LWE/LR 1600-2-008/18109-09-02/en

5.6 Undefined ballast trailer operation



DANGER

Danger of accident!

If the ballast trailer is operated in an undefined condition, it can result in severe accidents up to toppling of the crane.

Death, severe bodily injuries, property damage.

- ▶ The ballast trailer must always be in a defined condition.
- ▶ Operation of the ballast trailer in an undefined state is prohibited.

5.6.1 Ballast trailer lifted



Note

- ▶ Only operate the ballast trailer in a defined condition.

„Ballast trailer undefined lifted off the ground“ means:

That the ballast trailer with a residual load of approx 1 t is placed on the ballast trailer tires and the key button **448** is pressed. As a result, the slewing gear brake does **not** open when cornering the „crawler“ and the ballast trailer tires or the slewing gear brake slip.

5.6.2 Ballast trailer on the ground



Note

- ▶ Only operate the ballast trailer in a defined condition.



DANGER

Swinging load!

Death, severe bodily injuries, property damage.

- ▶ Operation of the ballast trailer in an undefined state is prohibited.

„Ballast trailer undefined on the ground“ means: That the ballast trailer with a residual load of approx. 1 t is placed on the ballast trailer tires and the key button **448** is **not** pressed. This residual load is so small that the wind can turn the turntable, if the slewing gear brake opens when actuating „Crawler driving“.

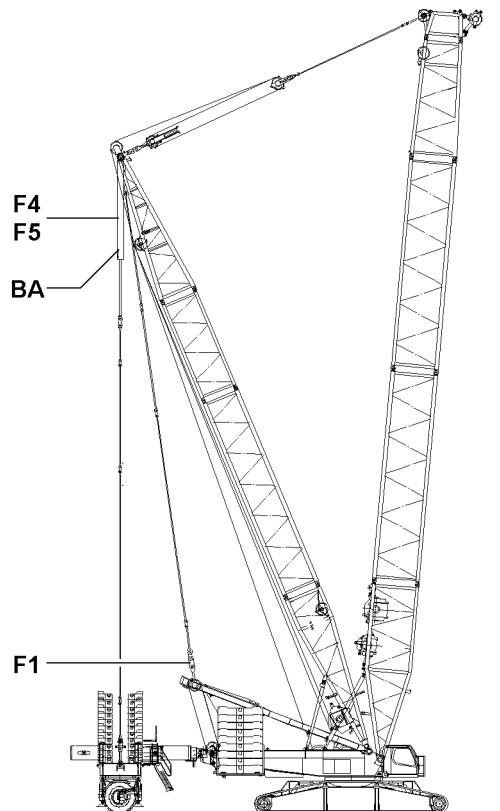
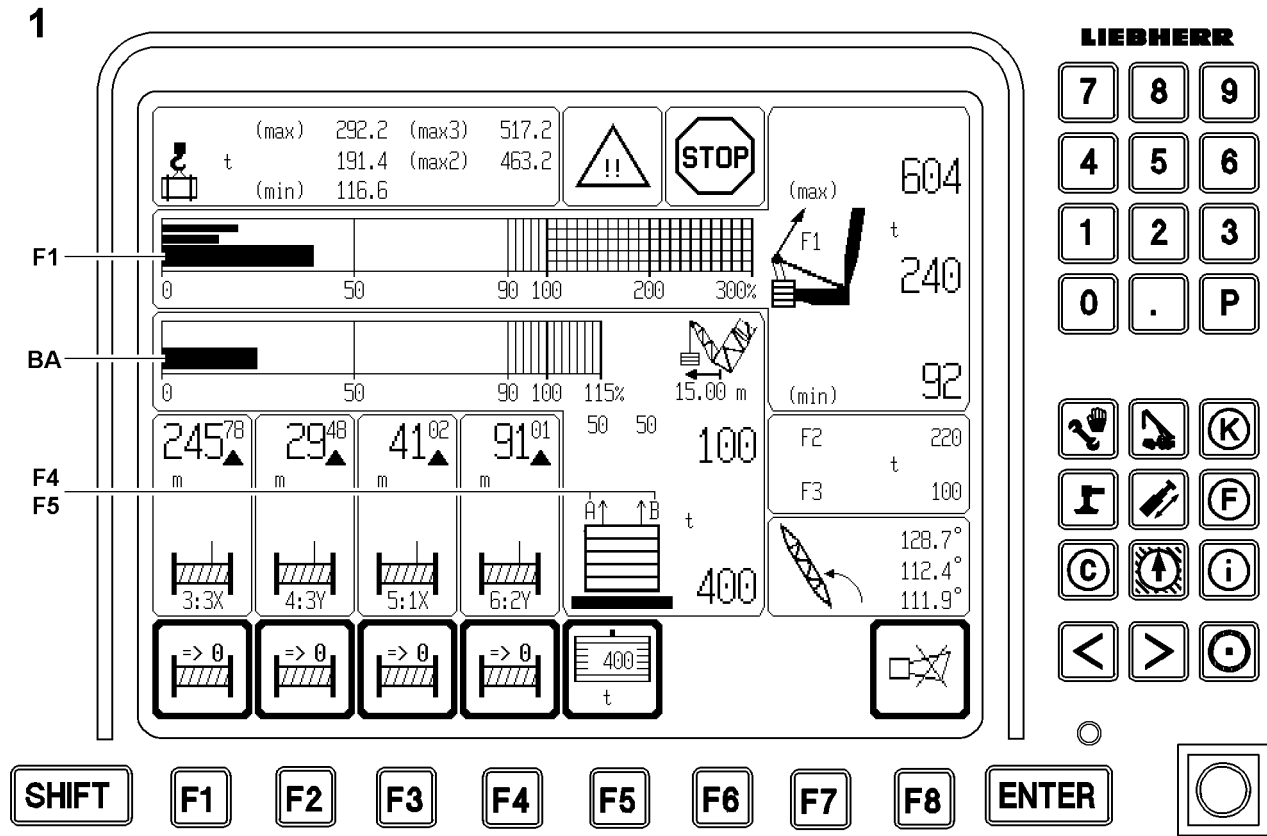

Fig.113742

LWE/LR 1600-2-008/18109-09-02/en

6 Crane operation with derrick ballast

6.1 Safety guidelines



Note

- ▶ The test points must be checked for function before taking on crane operation.
- ▶ The weight of the load to be lifted must be known.
- ▶ The placement level of the ballast trailer may be no more than maximum 250 mm above or 250 mm below the placement level of the crane.
- ▶ There may be no obstacles within the slewing range of the crane, the suspended derrick ballast and the load.
- ▶ The lift off of the derrick ballast must be monitored by the crane operator or a guide.
- ▶ Before setting down the load and the suspended derrick ballast, the crane operator must make sure that a safe placement is ensured.
- ▶ The placement level of the ballast trailer, at the end of the load lift, must be level, horizontal and have sufficient load bearing capacity to safely take on the weight of the ballast trailer.



DANGER

Danger of accidents due to angular pull!

The crane can topple over by angular pulling of the load.

Death, severe bodily injuries, property damage.

- ▶ Angular pull is prohibited.
- ▶ When picking up the load, it must be ensured that the derrick ballast, the center of rotation of the turntable and the load are in one line.

When picking up the load, the guying between the derrick ballast and derrick end section must be relieved to the point where the actual force F_1 ($F_{1_{actual}}$) is larger than the F_1 minimum force ($F_{1_{min}}$).



DANGER

Danger of accident!

If the guying between the SA-frame and the derrick end section is without force ($F_{1_{min}}$ is fallen below), then this can lead to uncontrolled movements of the boom system and cause the crane to topple over.

- ▶ The guying between the SA-frame and the derrick end section, test point 1 **F1**, may never be without power.
- ▶ The F_1 -minimum force ($F_{1_{min}}$) may not be fallen below.

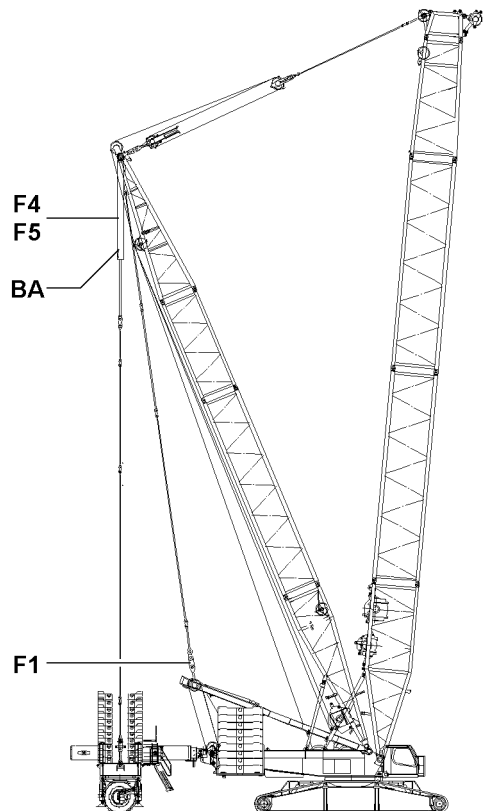
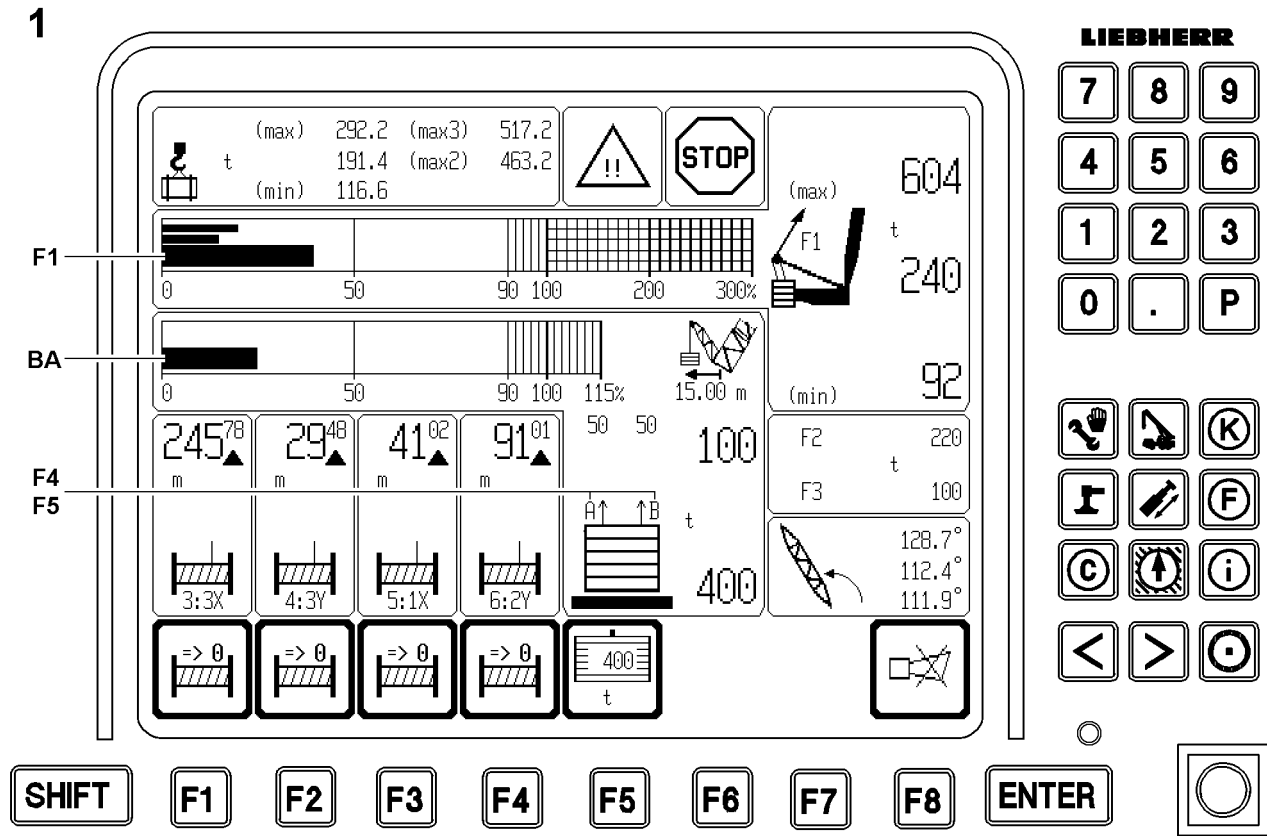

Fig.113742

LWE/LR 1600-2-008/18109-09-02/en

6.2 LICCON overload protection

On cranes with derrick ballast, during operation also under load, by increasing or reducing the derrick ballast, the maximum load or the minimum load required for the balance of the crane, can be increased or decreased.



Note

- ▶ The suspended ballast and the ballast trailer are generally referred to as the **derrick ballast**.
- ▶ The fixed compensation weight that is installed on the turntable is generally referred to as the **counterweight**.

Make sure that the following prerequisites are met:

- The derrick ballast is applied according to the load chart. and exactly entered and confirmed in the LICCON overload protection.
- The D-boom is in the crane operating position.

6.2.1 Presettings

- ▶ Set the LICCON overload protection according to the data in the load chart and confirm.



Note

- ▶ Enter the actually present derrick ballast weight in the LICCON overload protection.
- ▶ Enter the actually present reeving in the LICCON overload protection.
- ▶ Enter the derrick ballast weight and derrick ballast radius into the LICCON overload protection, see chapter 4.02 and chapter 4.03.



DANGER

Danger of accident due to set-up parameters!

Dangerous operational situations can occur due to an incorrect ballast entry.

Death, severe bodily injuries, property damage.

- ▶ The set derrick ballast must match the actually placed derrick ballast weight.
- ▶ All settings carried out in the „Set up“ program must agree with the actual settings on the crane.
- ▶ Check the settings.

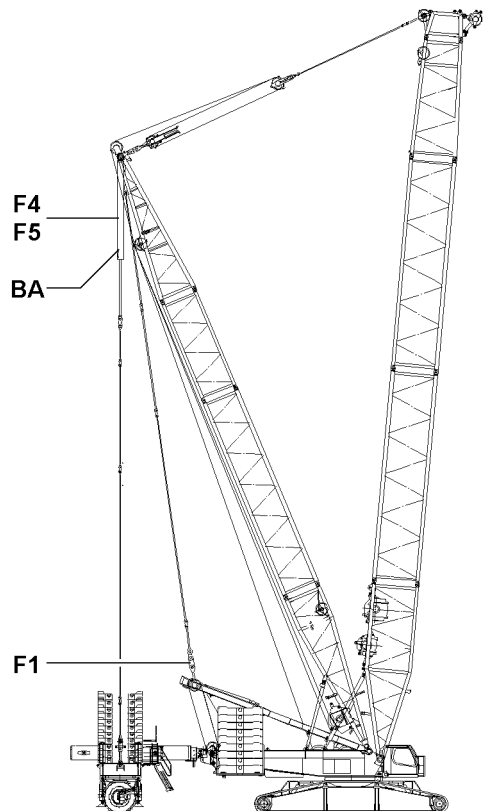
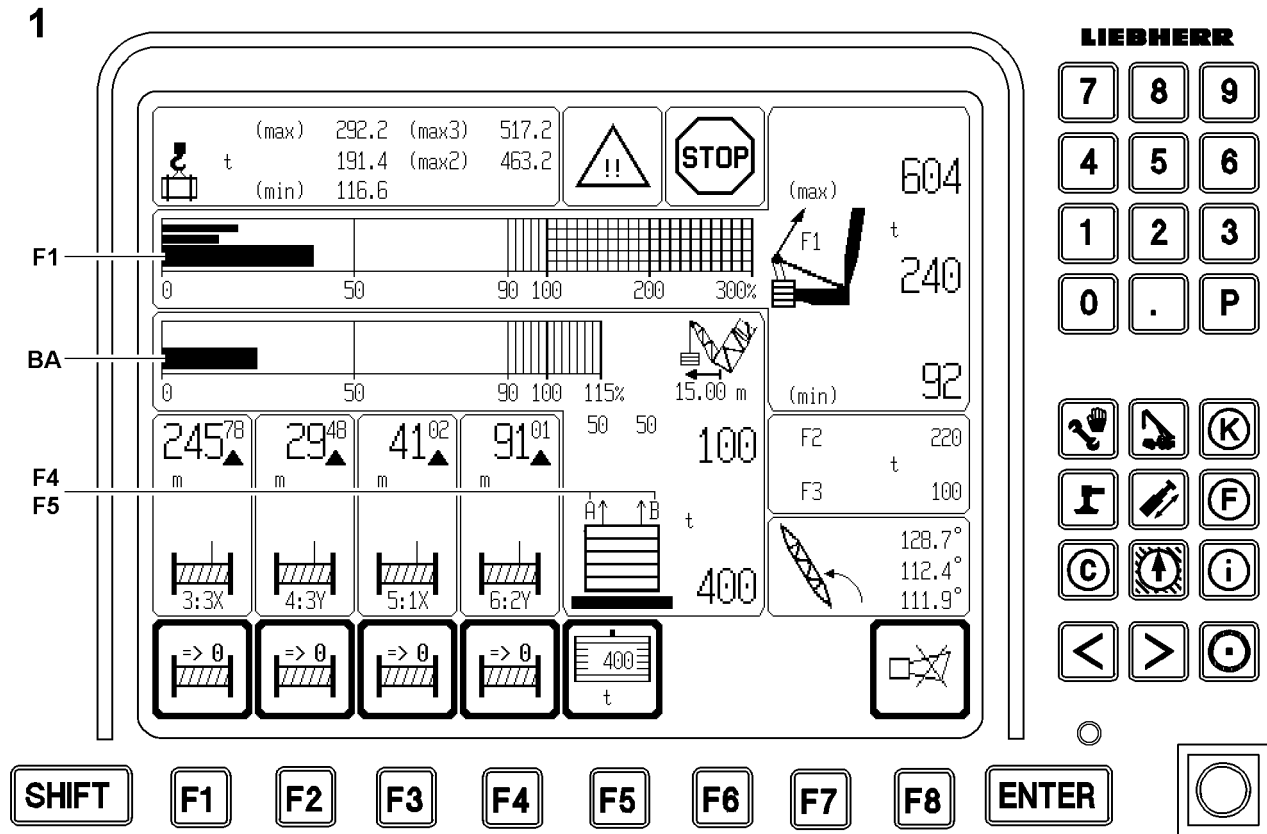

Fig.113742

LWE/LR 1600-2-008/18109-09-02/en

6.2.2 Crane operation



Note

- ▶ For crane operation with derrick ballast, the data must be observed and adhered to, see chapter 4.02.
-



WARNING

Danger of toppling the crane!

The jerky execution / braking of turning maneuvers can cause the load or suspended derrick ballast to swing.

This can cause the boom to break or the crane to topple over.

Death, severe bodily injuries, property damage.

- ▶ There may be no persons or obstacles within the slewing range of the crane and the ballast trailer.
 - ▶ While turning, a guide must watch the main boom, D-boom and derrick ballast for a danger of collision.
 - ▶ The turning movement or braking must be initiated extremely carefully when turning with a load and suspended derrick ballast.
-



Note

- ▶ For crane operation, observe the section „lifting and lowering the ballast trailer with pull cylinders“ and „ballasting guying differential force monitoring“.
-

- ▶ Observe the extension condition of the pull cylinder and the inclination of the ballast trailer.

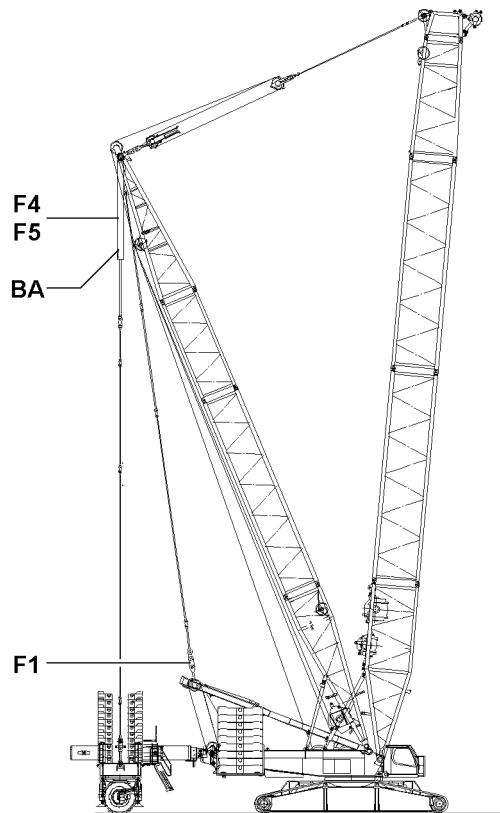
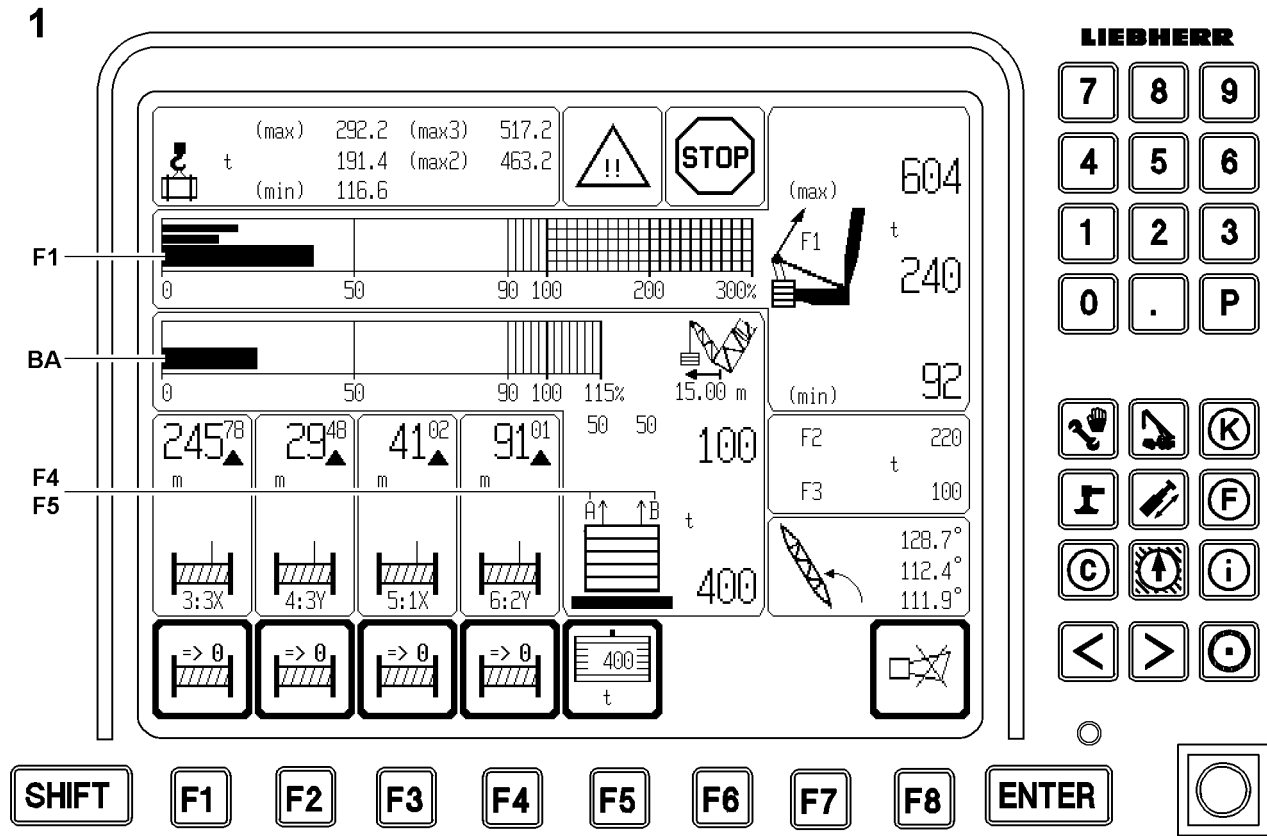

Fig.113742

LWE/LR 1600-2-008/18109-09-02/en

6.3 Determination of forces in operating mode with derrick ballast

In all operating modes with derrick ballast, the load is divided between the guy rods from the derrick head to the SA-frame (F1) and the derrick ballast (F4/5).



Note

► See chapter 4.02.

6.3.1 Force F1 (test point 1) between guying SA-frame and the derrick end section

The force F1 (test point 1) is determined in the guy rods from the SA-frame to the derrick head by 2 force test boxes and is shown on the LICCON monitor as total force of the guying.

The F1-utilization results from the „Operating force“ (F1) and the „Maximum operating force“ (F1_{max-operation}). This is shown on the LICCON monitor on the utilization bar in percent.

6.3.2 Force F4/F5 (test point 4/5) in the guying derrick ballast - derrick end section

The forces F4/F5 (test point 4/5) are effective in the guy rods from the derrick ballast to the derrick end section.

The existing forces in the guy rods (A = left and B = right) are calculated from the four pressure sensors, which are attached to the pull cylinders and shown on the LICCON monitor as individual forces.

The pulled ballast is calculated from the forces of the individual guying, which means the part of the ballast pulled up by the guying. The remaining part is laying on the ground. The ballast utilization results from the pulled ballast and the placed ballast. This is shown on the LICCON monitor with a utilization bar (BA in %).

Pull cylinder on block



DANGER

The crane can topple over!

By completely retracting one or both pull cylinders (block position moved in), the pressure increases strongly on the ring surface of the pull cylinder and the weighing of the currently pulled derrick ballast is incorrectly calculated and displayed.

The LICCON overload protection therefore assumes that a larger derrick ballast is pulled than is actually the case, and calculates too large a load capacity as a result.

An overload of the crane is recognized too late by the LICCON overload protection and the crane can topple.

Death, severe bodily injuries, property damage.

- If the pull cylinders are „retracted“ in the block position, **crane operation is explicitly prohibited**.
- The forces in the derrick ballast guying A and B must be carefully monitored on the LICCON monitor.
- Any error messages that are displayed must be observed.



WARNING

The LICCON overload protection shuts off too early!

By extending one or two pull cylinder completely out (block position moved out), the LICCON overload protection calculates a load which is too low.

Possible shut-off by the LICCON overload protection takes place too early.

- If the pull cylinders are in block position „moved out“, crane operation on the basis of reduced load is not meaningful.

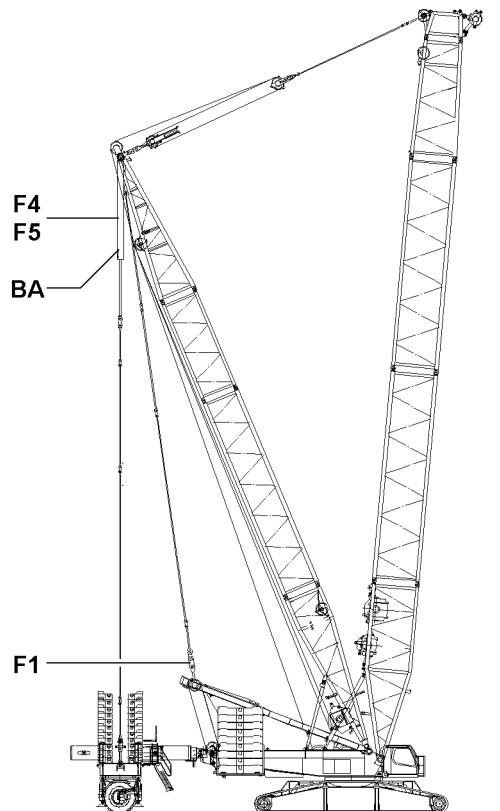
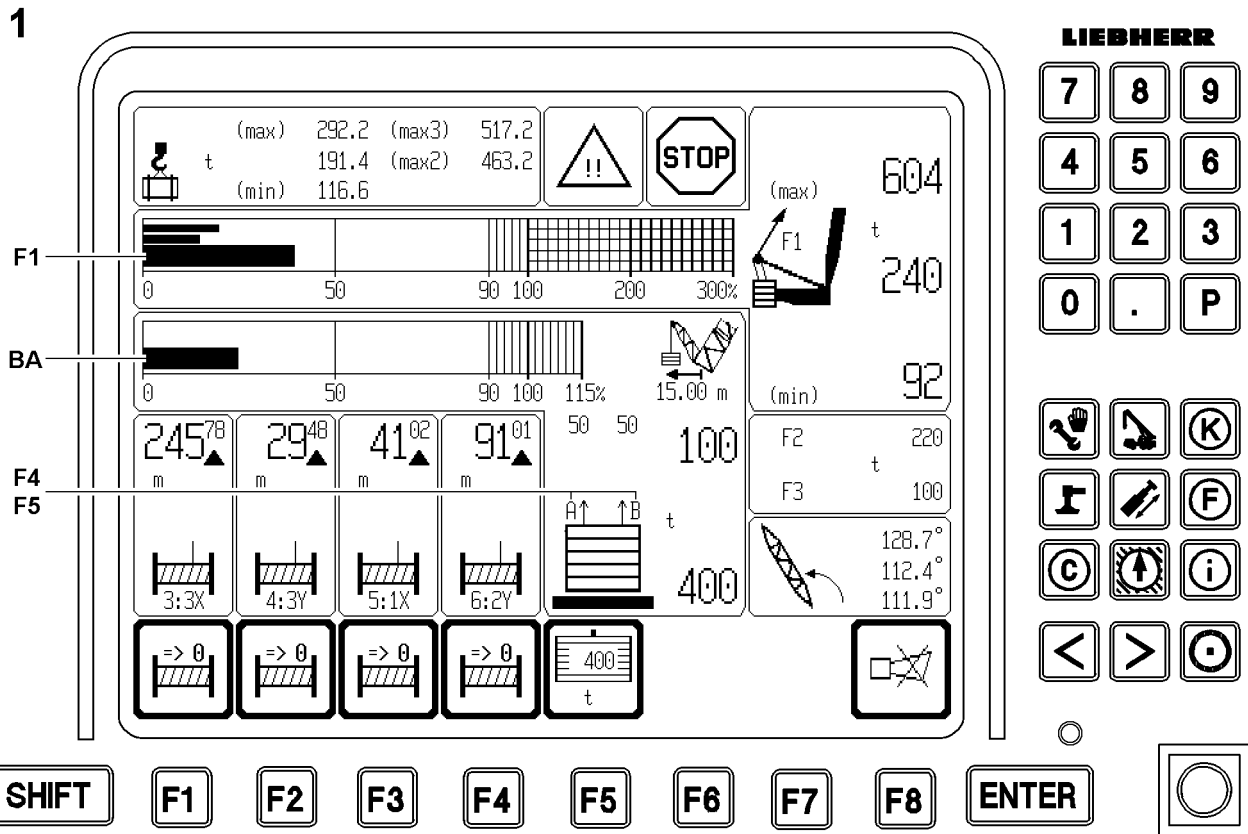

Fig.113742

LWE/LR 1600-2-008/18109-09-02/en

6.3.3 Monitoring of minimum force F1

If more than 50 percent of the set derrick ballast is being pulled (ballast utilization bar > 50 percent) and the minimum force $F1_{\min}$ (test point 1) is fallen below, all crane movements that **increase load torque** are turned off.



DANGER

Danger of accident!

It is prohibited to fall below the minimum force $F1_{\min}$ (test point 1) if more than 50 % of the derrick ballast is pulled. If this is not observed, in case of loose guying from test point 1 (F1) and **derrick ballast on the ground**, the derrick ballast can suddenly lift off the ground due to the increased load moment and the boom system can suddenly move forward. This causes the load to swing back and forth too much, which could damage the boom and the crane.

- ▶ Do not fall below the minimum force - $F1_{\min}$.

If more than 90 % of the set derrick ballast is being pulled (ballast utilization bar greater than 90 %) and the force drops below the minimum value $F1_{\min}$ (test point 1) fall below, all crane **movements that increase the load moment** and all **crane movements that decrease the load moment** are turned off. This also turns off the „spooling out“ movement of the winch.



DANGER

Danger of accident!

It is prohibited to fall below the minimum force $F1_{\min}$ (test point 1) if more than 90 % of the derrick ballast is pulled. If this is not observed and the load torque is decreased when the guying is slack at test point 1 (F1) and the derrick ballast is suspended, the derrick ballast can suddenly drop to the ground, causing the boom system to suddenly move backwards. As a result, the relapse cylinders can be pressed on the block and be overloaded. There is the danger that the relapse cylinders on the boom and D-boom will be damaged. This causes the load to swing back and forth too much, which could damage the boom and the crane.

- ▶ Do not fall below the minimum force - $F1_{\min}$.



Note

- ▶ By bypassing / exceeding the LICCON overload protection, the test point 1 - minimum force ($F1_{\min}$) is reduced by a few tons, this makes it possible to reverse the movement and retreat from the situation in which the $F1_{\min}$ shut-off occurred.
- ▶ This is the only exception on the crane, where, after a shut-off, by bypassing / exceeding the LICCON overload protection, a load moment increasing movement may be continued.



DANGER

Danger of accident!

If the LICCON overload protection is bypassed / exceeded, there is no further protection against crane overload.

There is an increased danger of accident.

Death, severe bodily injuries, property damage.

- ▶ The crane operator alone is responsible completely for his actions during bypass / exceedance of the LICCON overload protection.

After a shut-off via $F1_{\min}$, the force F1 on test point 1 must be increased by a movement. If the derrick ballast is suspended, this can be achieved by setting down the ballast.

If the assembly operation is already activated and the F1-force continues to drop below the minimum force $F1_{\min}$, then the $F1_{\min}$ shut-off can no longer be bypassed.

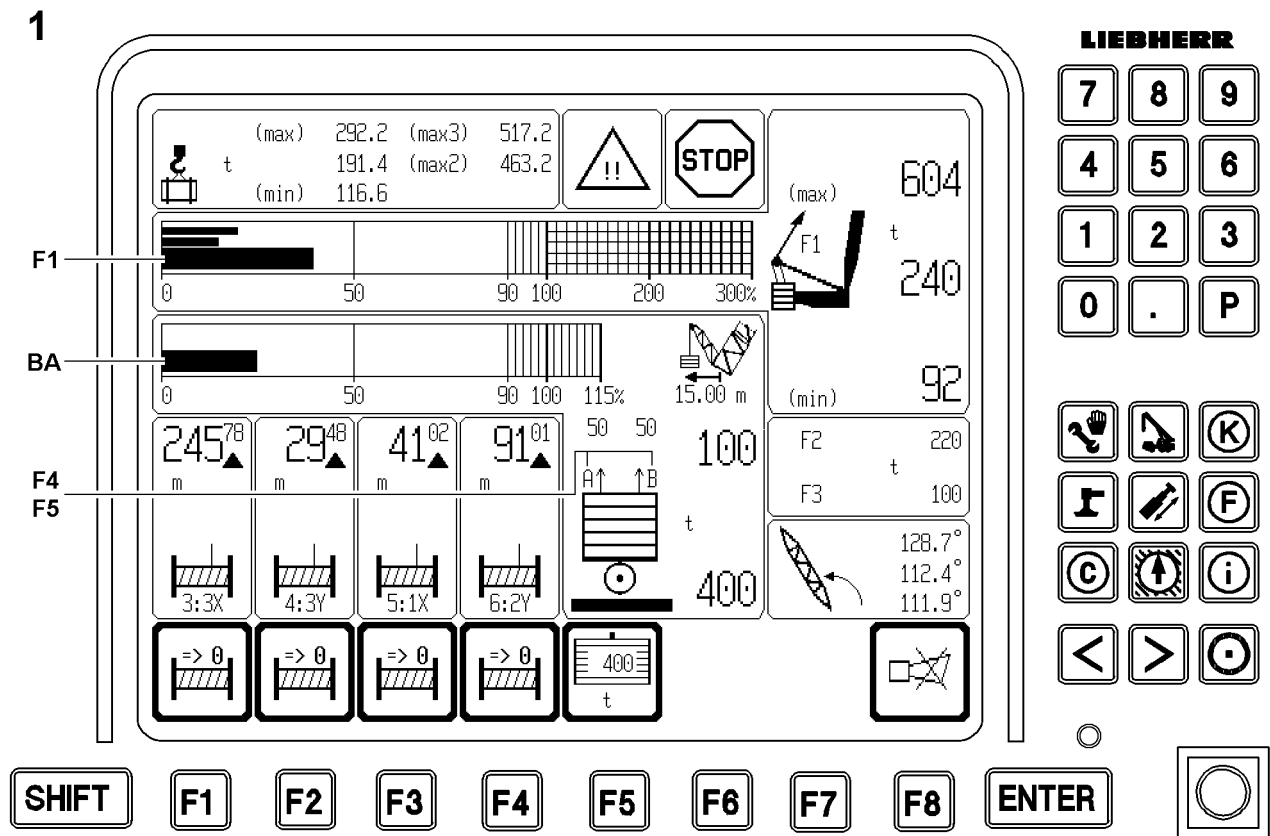
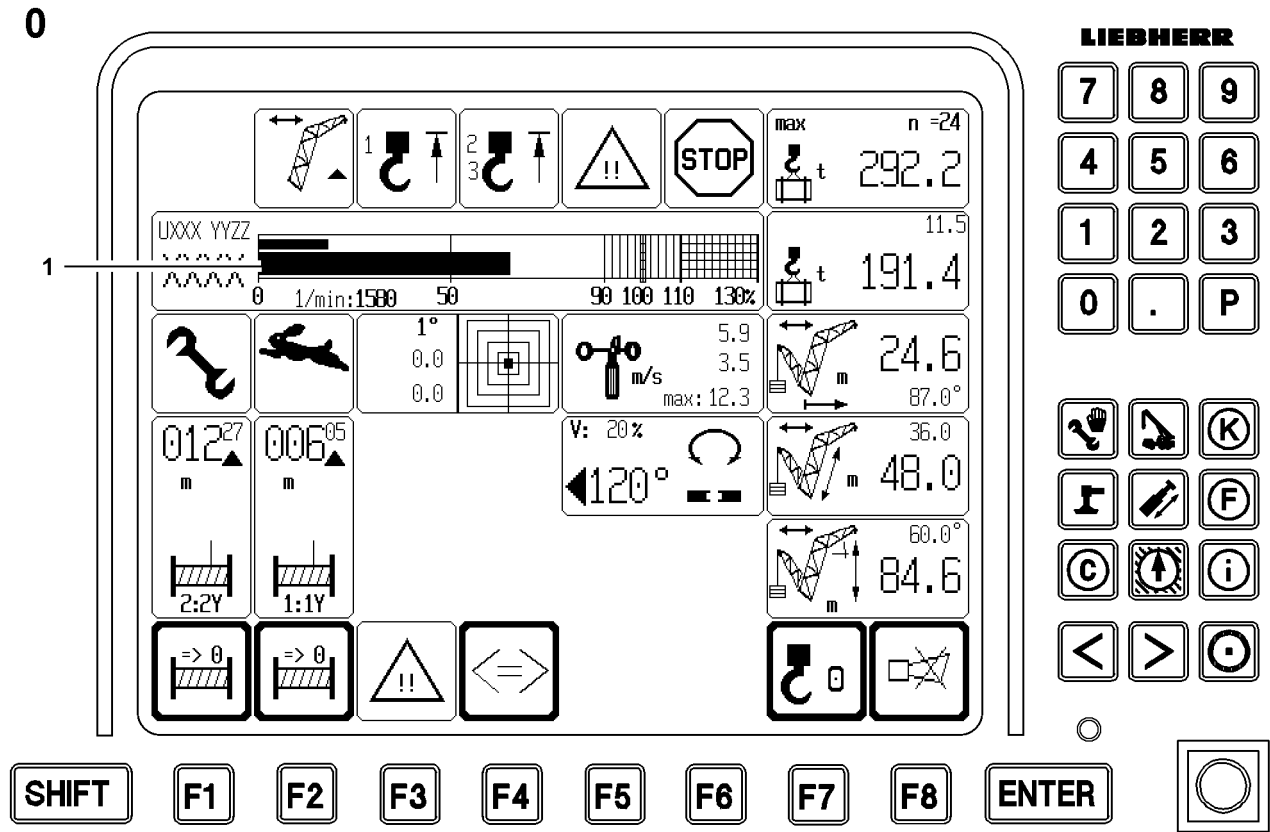

Fig.113743

LWE/LR 1600-2-008/18109-09-02/en

6.4 Overload monitoring in operating mode with derrick ballast

In operating modes with derrick ballast, the „maximum load for the current crane condition“ is monitored two ways:

1. Monitoring of maximum load on the LICCON monitor 0
2. Monitoring of test point 1-operational maximum force LICCON monitor 1.

6.4.1 Monitoring of maximum load on the LICCON monitor 0

It monitors the „maximum load according to load chart and reeving“.

In operating modes with derrick ballast, this is the maximum load of the current crane condition. It is shown on LICCON monitor 0. The current utilization of the crane results from the utilization bar (1) on LICCON monitor 0.

If the load utilization bar reaches 90 %, an advance warning is given in the form of a „notice icon“ and a „SHORT HORN“ on LICCON monitor 0.

At 100 % on the load utilization bar, the shut-off of all load moment increasing movements with the „stop icon“ and the acoustical warning „HORN“ occurs on LICCON monitor 0.



Note

- ▶ The „maximum load of the current crane condition“ can possibly be increased further, refer to section „utilization conditions“.

6.4.2 Monitoring of test point 1-operational maximum force (= $F1_{max}$ operation)

It is shown on LICCON monitor 1. When $F1$ is greater than $F1_{max-shut-off\ value}$, a shut off of all movements which could increase load torque occurs with the stop icon and the acoustic warning „HORN“ by LICCON monitor 1.



Note

- ▶ The maximum load can be safely monitored by the „LICCON overload protection“ itself.
- ▶ The „ $F1_{max}$ -monitoring“ is an additional monitoring function which shows the overload parallel to the „LICCON overload protection“.
- ▶ In all cases where the maximum load according to the load chart „max-load“ is less than the maximum load of the current set up configuration with optimal derrick ballast „max3-load“, which means „max-load“ is less than „max3-load“, when lifting the maximum load, the monitor display looks as if the „utilization bar of the crane“ is at 100 percent and the „ $F1$ utilization bar“ is approximately at 100 percent.
- ▶ At the just completed LMB-Stop („current load“ / „max-load“ greater than 100 percent) $F1_{actual}$ can already lie just over $F1_{max}$ or just below. There is a certain tolerance due to the component weights and the wind influences. To ensure that the maximum load can always be lifted, shut-off will not occur at $F1_{actual} / F1_{max}$ greater than 100 %. Shut-off will only occur at $F1_{actual} / F1_{max\ operation\ shut\ off\ value}$. For this crane, the following applies: $F1_{max-operation\ shut-off\ value} = F1_{max-operation} + F1_{addition\ for\ shut\ off}$ (see chapter 4.02). The $F1_{addition\ for\ shut-off}$ is selected such that $F1_{max-operation\ shut-off}$ should normally never happen. This shut-off provides an additional safety, particularly in cases with „max-load“ smaller „max3-load“. For example, if the load weighing is far too low due to a sensor failure, then a load would be pulled which would be greater than the maximum permissible load without shut off of the LICCON overload protection. The crane could be overloaded. In this particular case, with the „max-load“ smaller than the „max3-load“, with $F1_{max}$ larger $F1_{max-operation\ shut-off\ value}$ the $F1_{max\ shut-off}$ triggers. In this case, the crane is already slightly overloaded, however shut-off prevents an overload in certain cases or toppling of the crane. This means that the $F1_{max-operation\ shut-off}$ can protect the crane from overload in certain cases.
- ▶ Make sure that the load weighing and the shut-off function reliably on the maximum load.

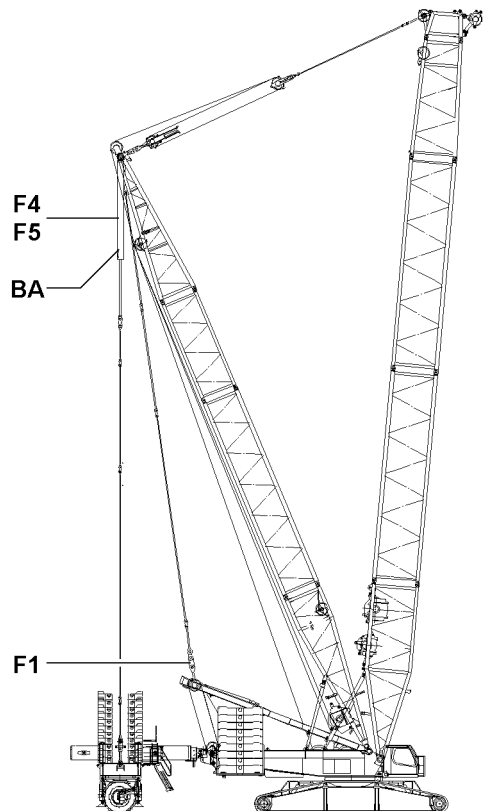
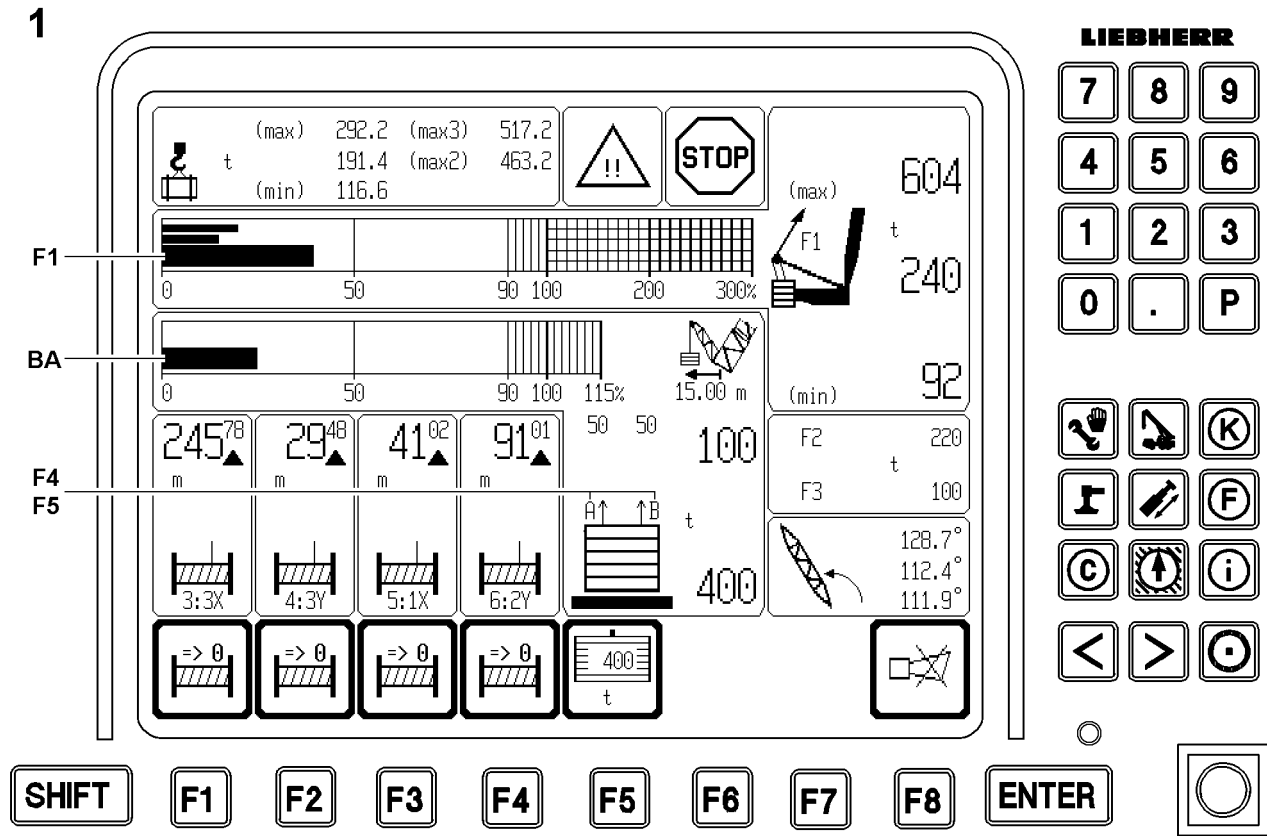

Fig.113742

LWE/LR 1600-2-008/18109-09-02/en

**DANGER**

The crane can topple over!

In cases with „max-load“ = „max3-load“, the $F_{1_{max}}$ -shut off value does not offer safety. The $F_{1_{max}}$ shut off value is so high that the crane will probably topple over or be damaged before the shut off value is reached.

- ▶ Carefully monitor the displays on the LICCON monitor.

**WARNING**

Danger of accident!

- ▶ The test point 1-Operation-Maximum force not only depends on the current set up configuration but also on the force measured with the pressure sensors in the pull cylinders.
- ▶ If the pulled derrick ballast is larger, then the maximum permissible $F_{1_{max}}$ force is generally reduced and vice versa.
- ▶ It is therefore important to carefully monitor the ballast weighing and the value for the pulled derrick ballast to ensure that this value is even plausible.

**DANGER**

The crane can topple over!

If the pulled derrick ballast value has been incorrectly determined and is too low, the calculated $F_{1_{max}}$ may be too high and the crane could be overloaded or topple over without this becoming evident.

- ▶ Carefully monitor the displays on the LICCON monitor.

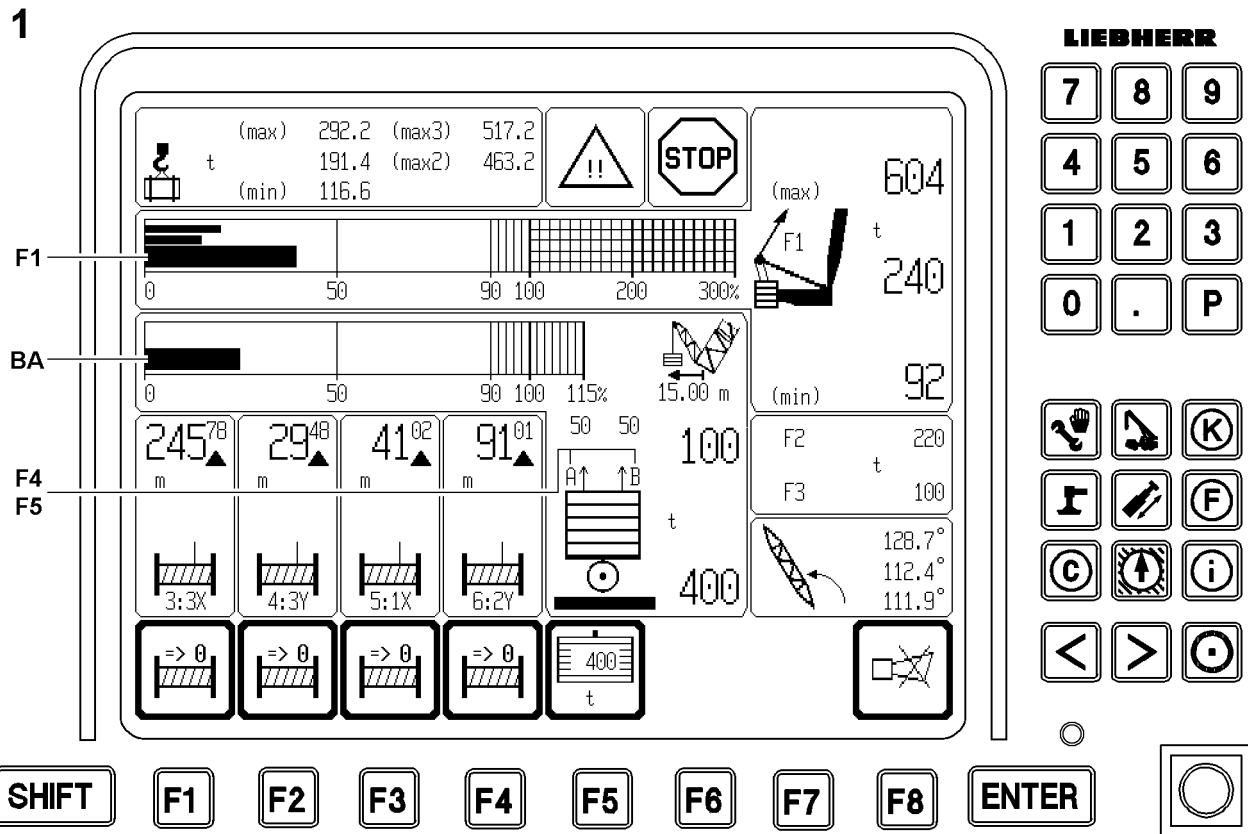
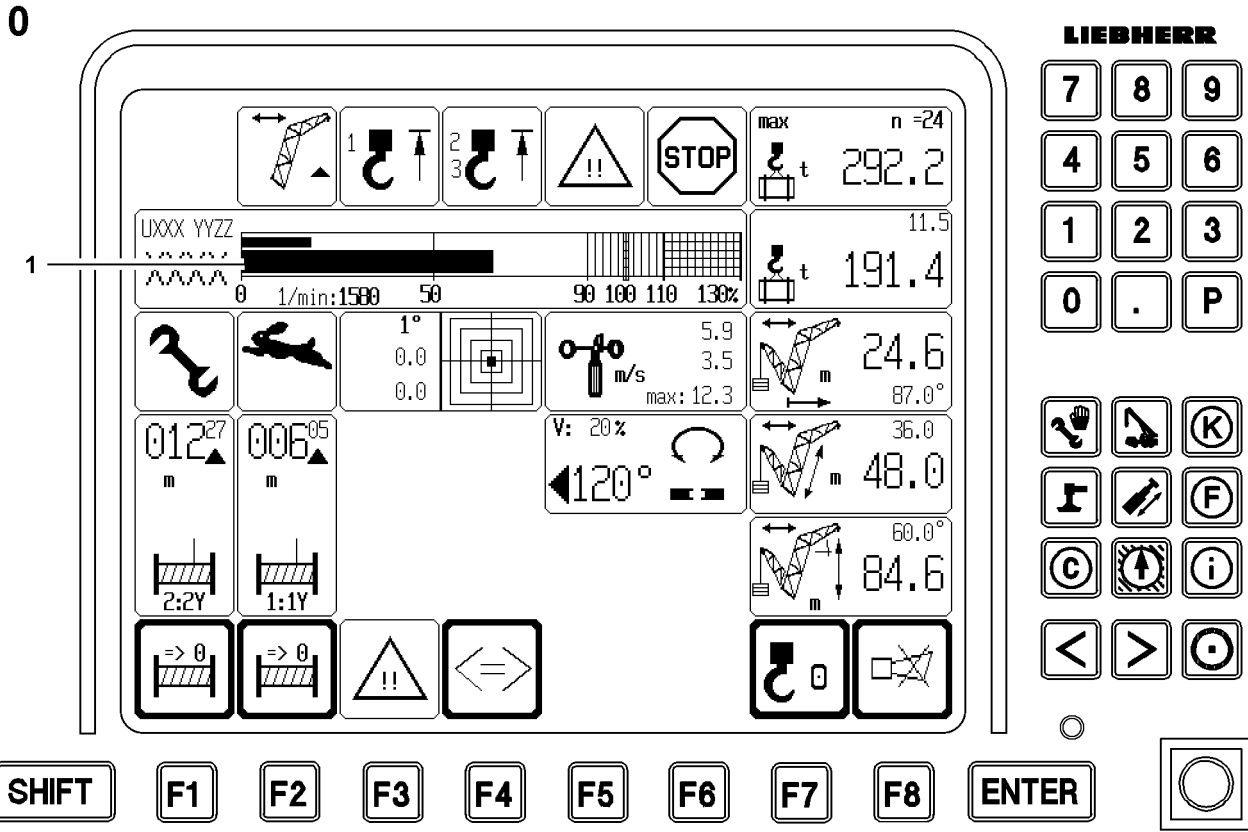

Fig.113743

LWE/LR 1600-2-008/18109-09-02/en

6.4.3 Utilization conditions

The current utilization of the crane results from the „utilization bar of the crane“ **1** on the LICCON monitor **0**.

Max. load:

- The „maximum load capacity in the current operating condition („**max-load**““ is obtained, when the „utilization bar of the crane“ **1** displays 100 percent.
This is the case when the „utilization of the crane according to the load chart and reeving“ reaches 100 % („Current load“ is equal to the „Maximum load“).
When the „max-load“ is smaller than or equal to the „max2-load“, then the „max-load“ can be increased through:
 - Pulling up the derrick ballast, if the derrick ballast is not already suspended and the currently pulled derrick ballast is still smaller than the optimum derrick ballast

Max2-load:

- The „maximum load of the current crane equipment“ („**max2-load**““ is reached when the „utilization bar of the crane“ **1** is at 100 percent **and** the „derrick ballast utilization bar display“ **BA** is greater than or equal to 100 percent (the current derrick ballast is completely lifted off the ground), and the derrick ballast input value and the ballast weighing are correct.
This is the case when the „current load“ and the „max2-load“ reach 100 percent („current load“ is equal to the „max2-load“).
When the „max2-load“ is smaller than the „max3-load“, then the „max-load“ can be increased through:
 - Increasing the derrick ballast by adding additional ballast plates if the placed derrick ballast is still smaller than the optimum derrick ballast.

Max3-load:

- The „maximum load of the current set up configuration with optimum derrick ballast“ („**max3-load**““ is obtained when the „crane utilization bar“ **1** is at 100 % **and** the „derrick ballast utilization bar display“ **BA** is at 100 % (the optimal derrick ballast is placed and completely lifted off the ground), and the derrick ballast input value and the ballast weighing are correct.
This is the case when the „current load“ and the „max3-load“ reach 100 percent („current load“ is equal to the „max3-load“).
Here, the optimum derrick ballast is already entirely pulled.
Further increasing the derrick ballast at this derrick ballast radius will not increase the load capacity further than „max3-load“.



Note

- ▶ In some cases it may be possible to increase the load, in some cases reducing the derrick ballast radius as well; refer to the load chart manual or LICCON job planner.

This also applies for:

- „Current load“ equal to „max-load“.
- „Current load“ equal to „max2-load“.

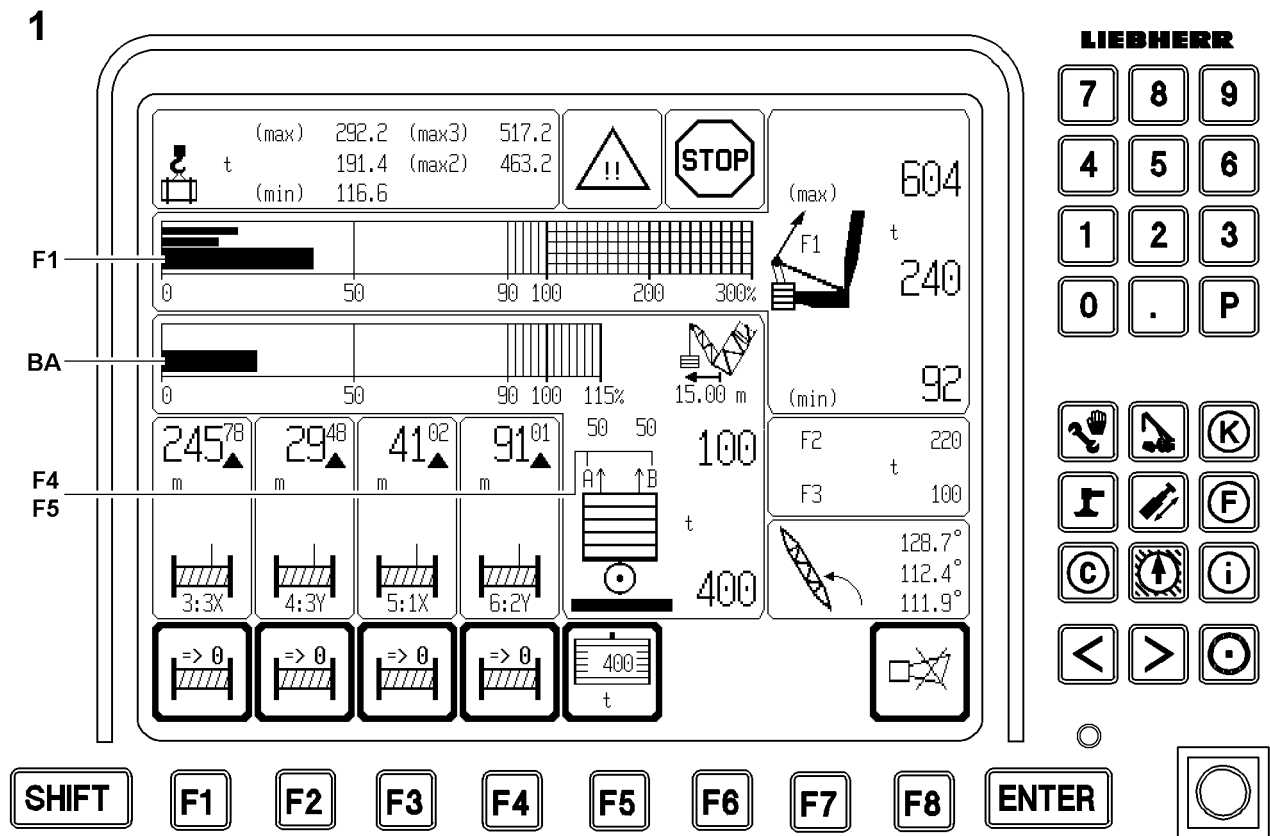
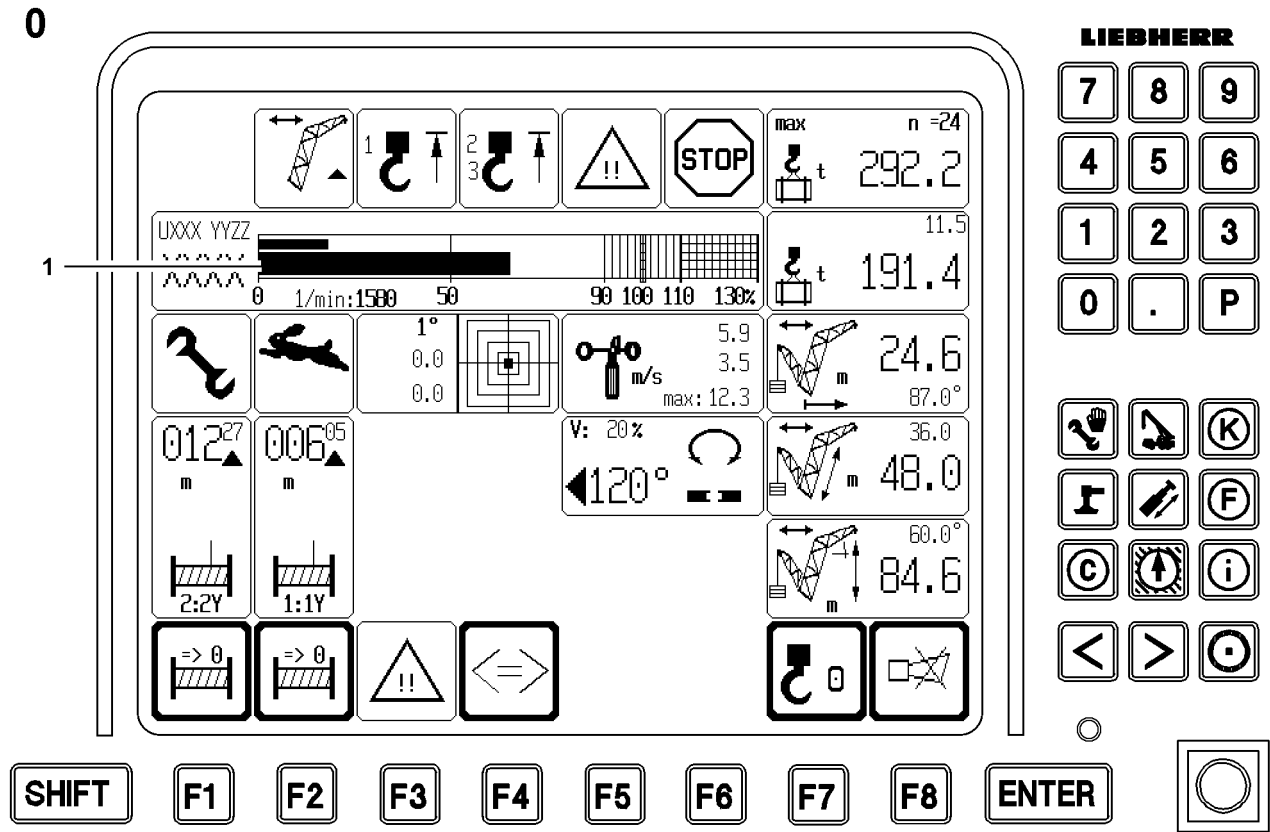

Fig.113743

LWE/LR 1600-2-008/18109-09-02/en

The LICCON overload protection can be bypassed / exceeded after a LMB-Stop - due to a load chart utilization of more than 100 % - by:

1. bypassing / exceeding the LICCON overload protection.
2. activating the assembly operation.
3. **Note:**
The test point 1-assembly - maximum force shut-off (= F1 max-assembly) cannot be bypassed.



DANGER

The crane can topple over!

If the LICCON overload protection is bypassed / exceeded, there is no further protection against crane overload.

The crane can be overloaded without being noticed and topple over.

Death, severe bodily injuries, property damage.

- ▶ When the LICCON overload protection is bypassed / exceeded, only load moment reducing crane movements may be carried out until a permissible operating and load range.
- ▶ Activate the LICCON overload protection immediately after reaching the permissible load range.
- ▶ The crane operator alone is responsible completely for his actions during bypass / exceedance of the LICCON overload protection.



Note

- ▶ The „Lift derrick ballast“ or „Lower derrick ballast“ movement requires utmost attention by the crane operator.

6.5 Checking the length sensor value on the ballast trailer



CAUTION

Danger of accident!

If the derrick ballast radius is measured incorrectly, the false radius value will result in the calculated maximum lifted load and F1-Operation-max-force being too high.

The crane will be overloaded unnoticed and can topple over.

Death, severe bodily injuries, property damage.

- ▶ The crane driver may not rely blindly on the derrick ballast radius measurement, but he must think for himself and check, if the measurement is still working correctly.
- ▶ If the derrick ballast is fully telescoped out or in, the display „Derrick ballast radius“ must show almost the end position of the radius 13 m or 18 m.



Note

- ▶ When telescoping the ballast trailer guide, the indicator must change the display „Derrick ballast radius“ on the LICCON monitor corresponding to the movement of the derrick ballast. If this is not the case, the crane operator can immediately recognize that if the length sensor rope drum jams when spooling in or out.
- ▶ When telescoping the derrick ballast in and out, the „Derrick ballast radius“ display must be observed carefully on the LICCON monitor.

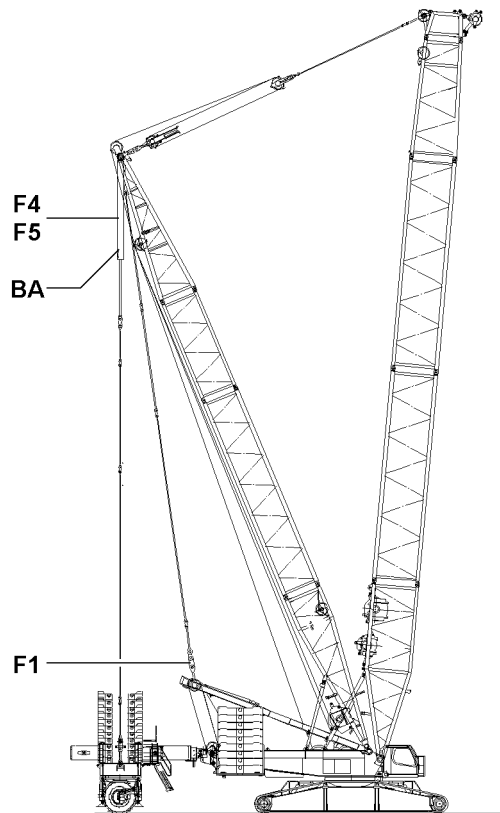
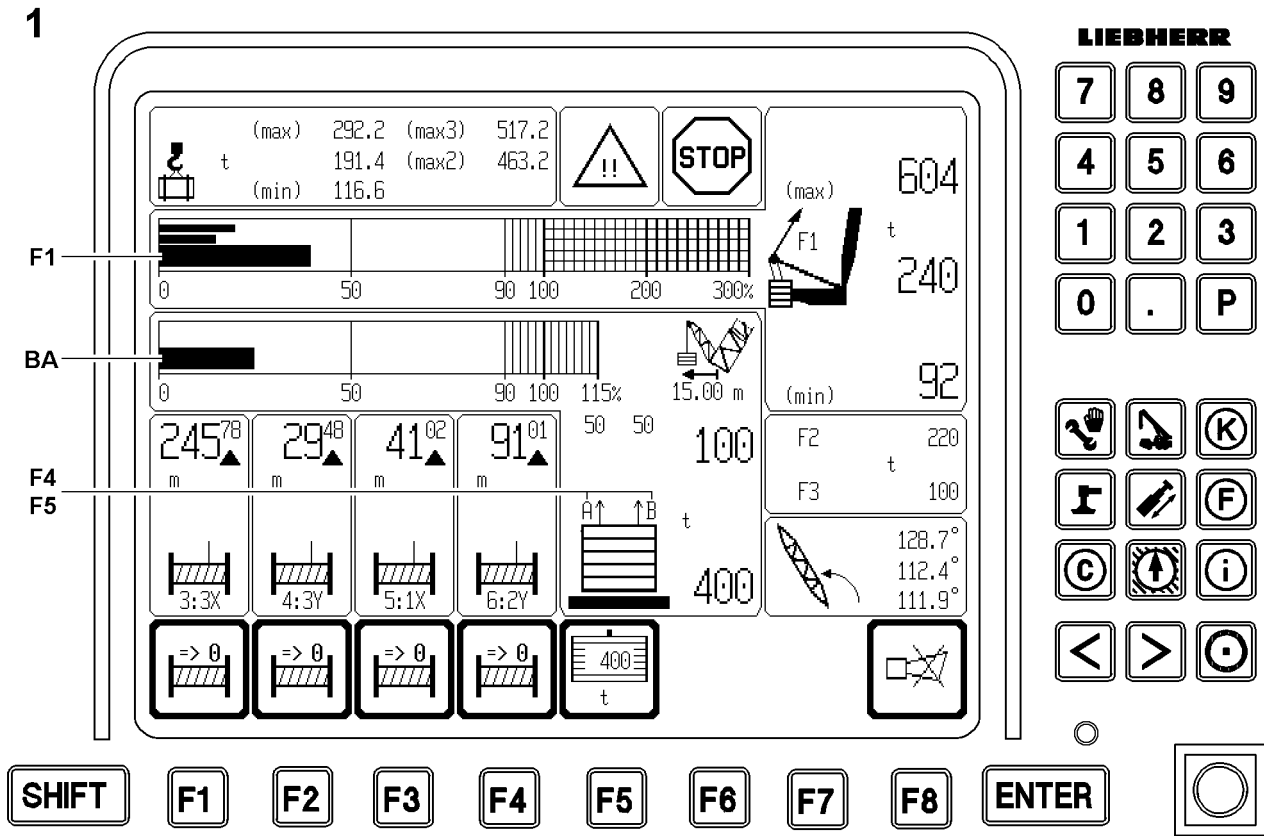

Fig.113742

LWE/LR 1600-2-008/18109-09-02/en

6.6 Difference force monitoring of ballast guying

In operating modes with derrick ballast, the difference of the forces between derrick ballast guyings A and B is monitored on LICCON monitor 1. If the difference exceeds a permissible value, an acoustic warning is issued and the two force values blink.



WARNING

Danger of accident due to damaged crane components!

Too high a difference in the derrick ballast guying A and B can have the result that the derrick ballast moves in an impermissible inclined position, and thereby the derrick end section, the ballast guide or other crane components may be damaged.

Death, severe bodily injuries, property damage.

- ▶ The forces in the derrick ballast guyings A and B must be carefully monitored on the LICCON monitor.
- ▶ If the specified limit value is exceeded, **no shut-off** of crane movement occurs.

Exceeding the limit value can have the following causes:

- Picking up the load: by relieving the tires on the ballast trailer or flexing of the turntable.
- The ground under the derrick ballast is uneven.
- The crane is leaning to one side.
- The derrick ballast is loaded one-sided.
- The force measurement in one derrick ballast guying is incorrect.

The crane driver must recognize the correct cause and take countermeasures:

- Error message appears.
- The error, which caused the one-sided force, must be remedied.
- The following measures are permitted providing the ground is only slightly uneven:
Lock one pull cylinder and with the other pull cylinder lift the derrick ballast or „Derrick ballast lower“ activate until the difference between the forces A and B is smaller.
- If the sensor values are implausible: Check whether the ballast weighing pressure sensors or inputs for the ballast weighing are faulty. If necessary, pull out the sensor or replace the CPU.

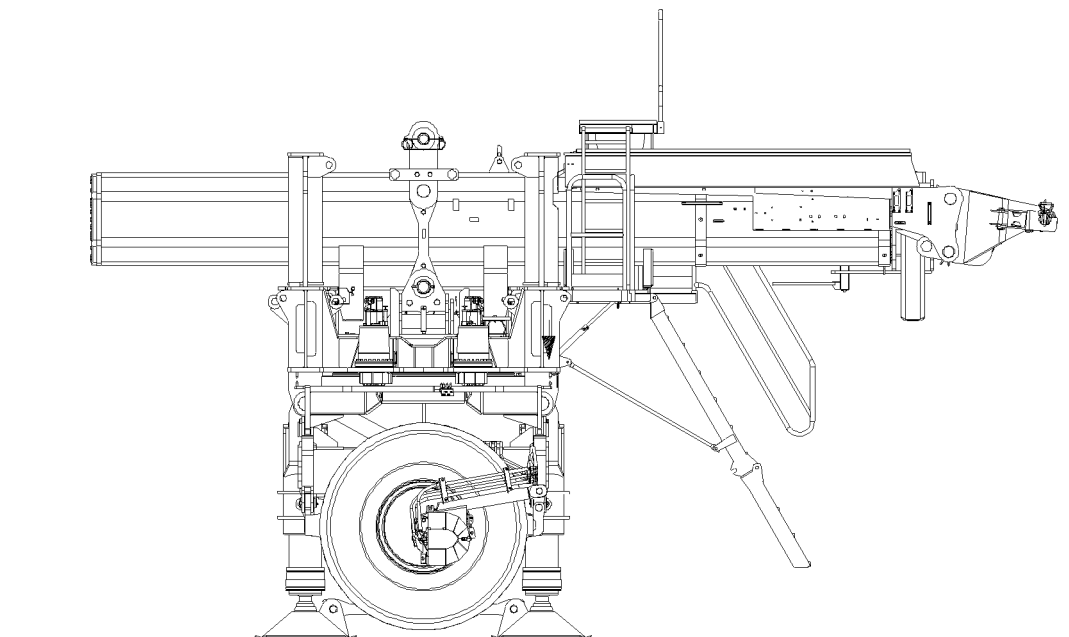

Fig.113728

7 Removing the ballast trailer



WARNING

Danger of falling!

During assembly / disassembly, inspection and maintenance work, assembly personnel must be secured with appropriate aids to prevent them from falling.

Death, severe bodily injuries, property damage.

- ▶ All work at a height, when there is a danger of falling, must be carried out with suitable aids.
- ▶ If aids are not available and work cannot be carried out from the ground, then assembly personnel must secure themselves with the supplied fall arrest system to prevent falling, see the Crane operating instructions, chapter 2.04.
- ▶ If fall protection equipment is available, then it must be used, see the Crane operating instructions, chapter 2.06.
- ▶ When lifting, lowering, swinging crane parts in and out, no persons may remain in the danger zone.
- ▶ When closing or opening boom systems during boom assembly or boom disassembly, no persons may remain on the boom system or in the danger zone.
- ▶ If railings are present on the components, then they must be brought into the corresponding position and secured for assembly / disassembly work.
- ▶ Only step on the aids, ladders and catwalks with clean shoes.
- ▶ Keep aids, ladders and catwalks free of heavy dirt, snow and ice.
- ▶ During all assembly and disassembly work, maintenance work and inspections, travel or crane operation is prohibited.
- ▶ Remaining on a suspended load is prohibited.
- ▶ Stepping or walking on crane components and lattice sections, which have an incline of more than 20° is prohibited.
- ▶ For all assembly work, the crane driver of the main crane must be in voice contact with the crane driver / crane drivers of the auxiliary crane / auxiliary cranes.
- ▶ For assembly tasks, the crane driver may only initiate crane movements when the responsible guide has explicitly released the movement.



WARNING

Danger of impact / crushing!

When installing / removing crane components with the auxiliary crane, crane components can start to swing back and forth.

When lifting / lowering and positioning crane components, there is an increased danger of impacts / crushing.

Death, severe bodily injuries, property damage.

- ▶ Make sure that personnel cannot be caught by components.
- ▶ Make sure that the crane is horizontally aligned.
- ▶ When working in danger zones: Use aids to protect limbs.
- ▶ Guide components with suitable aids to minimize oscillation.



DANGER

The components can fall down!

If the corresponding component is disengaged from the auxiliary crane before the corresponding component is pinned, then the corresponding component can fall down.

Death, severe bodily injuries, property damage.

- ▶ Do not disengage the auxiliary crane until the respective component is pinned and secured.

Make sure that the following prerequisites are met:

- The boom equipment is placed down.
- The ballast trailer guide is telescoped in all the way.
- The ballast plates on the ballast trailer are removed.
- An auxiliary crane and a lifting platform are available.



Note

- ▶ Observe the information in the erection and take-down charts when taking down the boom equipment.



WARNING

Ballast trailer tipping danger!

If the ballast trailer is unpinned on the turntable, there is a danger of tipping over.

Death, severe bodily injuries, property damage.

- ▶ The disassembly of the ballast trailer may only be carried out by authorized personnel.
- ▶ The disassembly of the ballast trailer may only be conducted on a level and load-bearing surface.
- ▶ The ballast trailer has **no** brake system. The ballast trailer must be supported with the support cylinders if it is **not** pinned on the turntable.
- ▶ Before unpinning the ballast trailer on the turntable it must be ensured that the stability and tipping safety of the ballast trailer is ensured, see section „Stability and tipping safety for ballast trailers not assembled on the turntable“.

7.1 Removing the ballast plates

Make sure that the following prerequisite is met:

- The ballast retainers are removed.



Note

- ▶ The ballast plates are marked with their own weights.



WARNING

The crane can topple over!

If more than 20 t are removed with one lift from a ballast stack or if the ballast is removed asymmetrically, then the crane can topple over.

Death, severe bodily injuries, property damage.

- ▶ A weight difference between the right and left ballast stack of more than 20 t * is prohibited.
- ▶ Alternately remove no more than maximum 20 t ballast assemblies from the ballast stack, symmetrically on the left and right.

Empty page!

LWE/LR 1600-2-008/18109-09-02/en

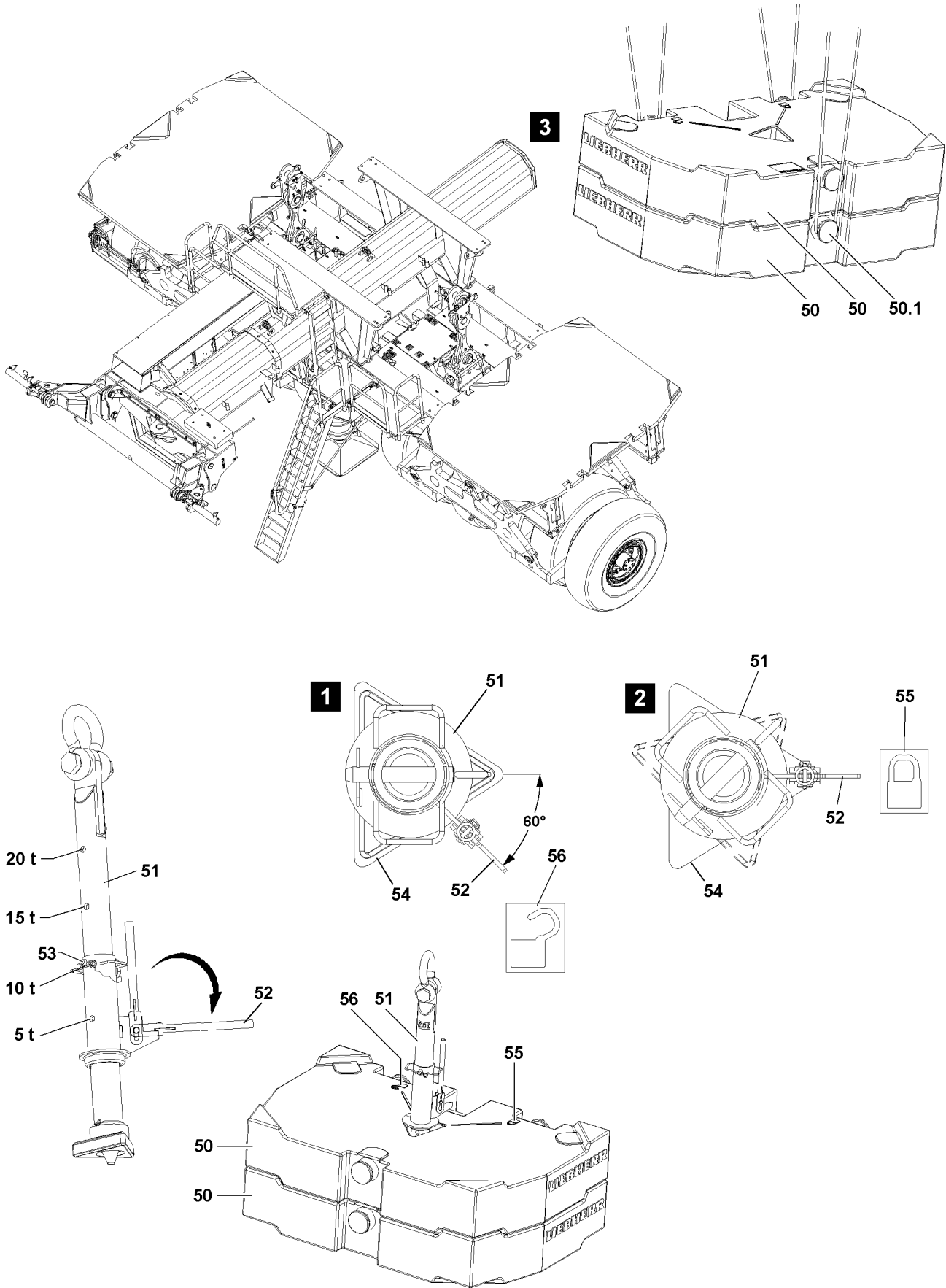

Fig.113729

7.1.1 Removing the ballast plates, fastening system: „Twistlock“



DANGER

Danger of accident!

If more than the permissible two ballast plates are lifted with the receptacle stud, the receptacle stud will be overloaded and can be damaged.

Death, severe bodily injuries, property damage.

- ▶ Make sure that the ballast plates are placed correctly in the centerings.
- ▶ Replace damaged ballast plates.

To remove the ballast plate(s) **50**, use the receptacle stud **51**.

Before the receptacle stud **51** is guided into the ballast plates, it must be ensured that the length of the receptacle stud **51** is set correctly. The length of the receptacle stud **51** can be adjusted with the pin **53**.

If the length of the receptacle stud **51** is to be adjusted:

- ▶ Release and unpin the pin **53**.
- ▶ Adjust the length of the receptacle stud by moving the receptacle stud **51**.
- ▶ Insert the pin **53** and secure with the spring retainer.
- ▶ Fasten the receptacle stud **51** to the auxiliary crane and guide it into the ballast plate(s).
- ▶ Pull the lever **52** up and fold it down.
- ▶ Turn the lever **52** 60° until the lever **52** points to the icon **55**. See illustration 2.

Result:

- The receptacle stud **51** is locked with the ballast plate.
- ▶ Lift the ballast plate with the receptacle stud **51** and remove it from the ballast stack or the ballast pallet.
- ▶ Turn the lever **52** 60° until the lever **52** points to the icon **56**. See illustration 1.

Result:

- The receptacle stud **51** is unlocked from the ballast plate.
- ▶ Carefully pull the receptacle stud **51** out of the ballast plate.
- ▶ Alternately remove the ballast plates on both sides.

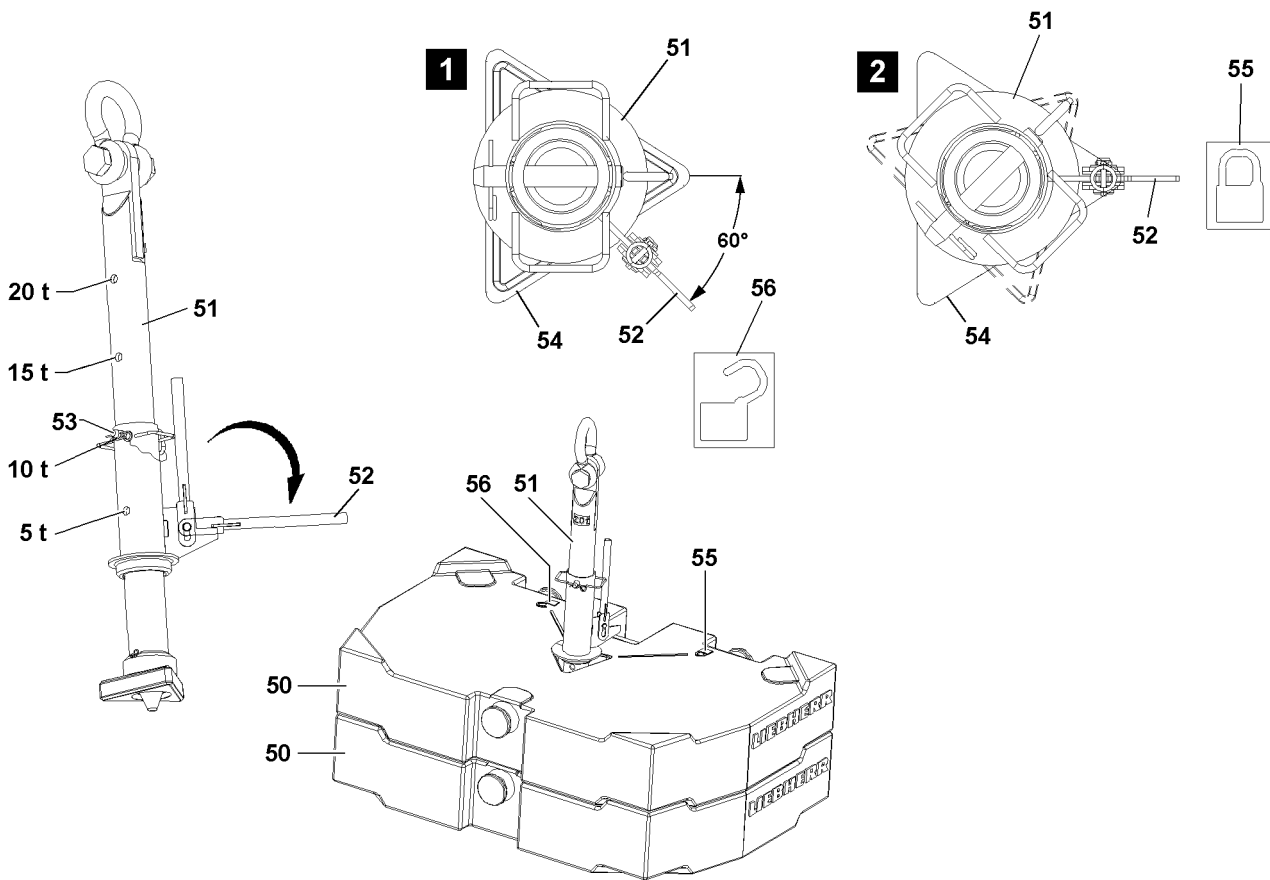
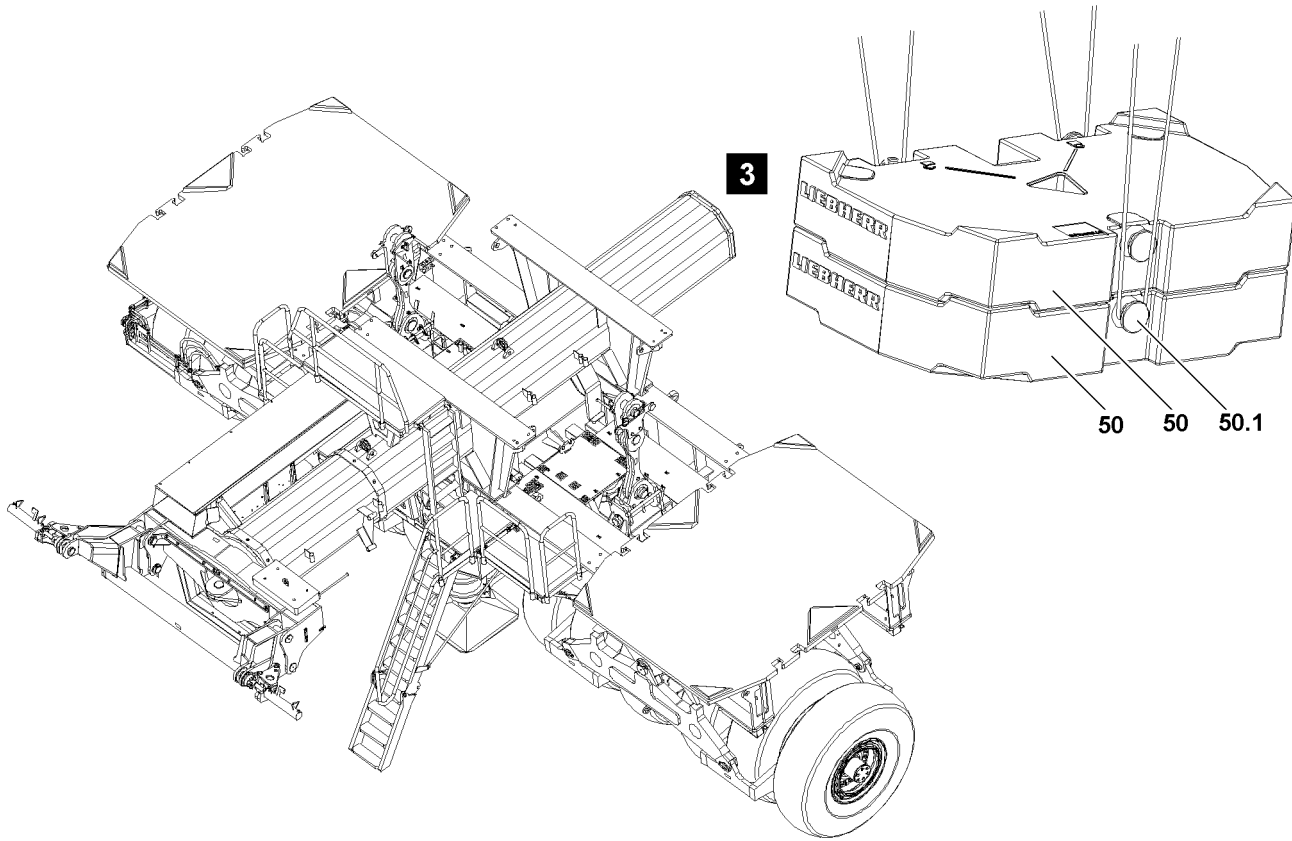

Fig.113729

LWE/LR 1600-2-008/18109-09-02/en

7.1.2 Removing the ballast plates, fastening points: Bitt



WARNING

Falling ballast plates!

If more than the permissible loads are lifted, then the bitts **50.1** are overloaded and the ballast plates can fall down.

Death, severe bodily injuries, property damage.

- ▶ Lift no more than maximum 20 t with the ropes, 3 fastening points.
- ▶ Replace damaged ballast plates immediately.



WARNING

Incorrect handling of the fastening equipment!

If fastening equipment cannot be attached correctly and if it is not secured sufficiently to prevent it from loosening up, loads can fall down.

Death, severe bodily injuries, property damage.

- ▶ Make sure that the fastening equipment is correctly attached on the bitts **50.1** and that it is secured sufficiently to prevent it from loosening up.



Note

- ▶ Remove the ballast plates individually or as a ballast assembly, maximum 20 t.
 - ▶ The weight difference between the outer ballast stacks no more than maximum 20 t.
 - ▶ 20 t ballast assembly, see illustration **3**.
-
- ▶ Lift the ballast plate **50** or ballast assembly, see illustration **3** and remove it from the ballast stack or the ballast pallet.

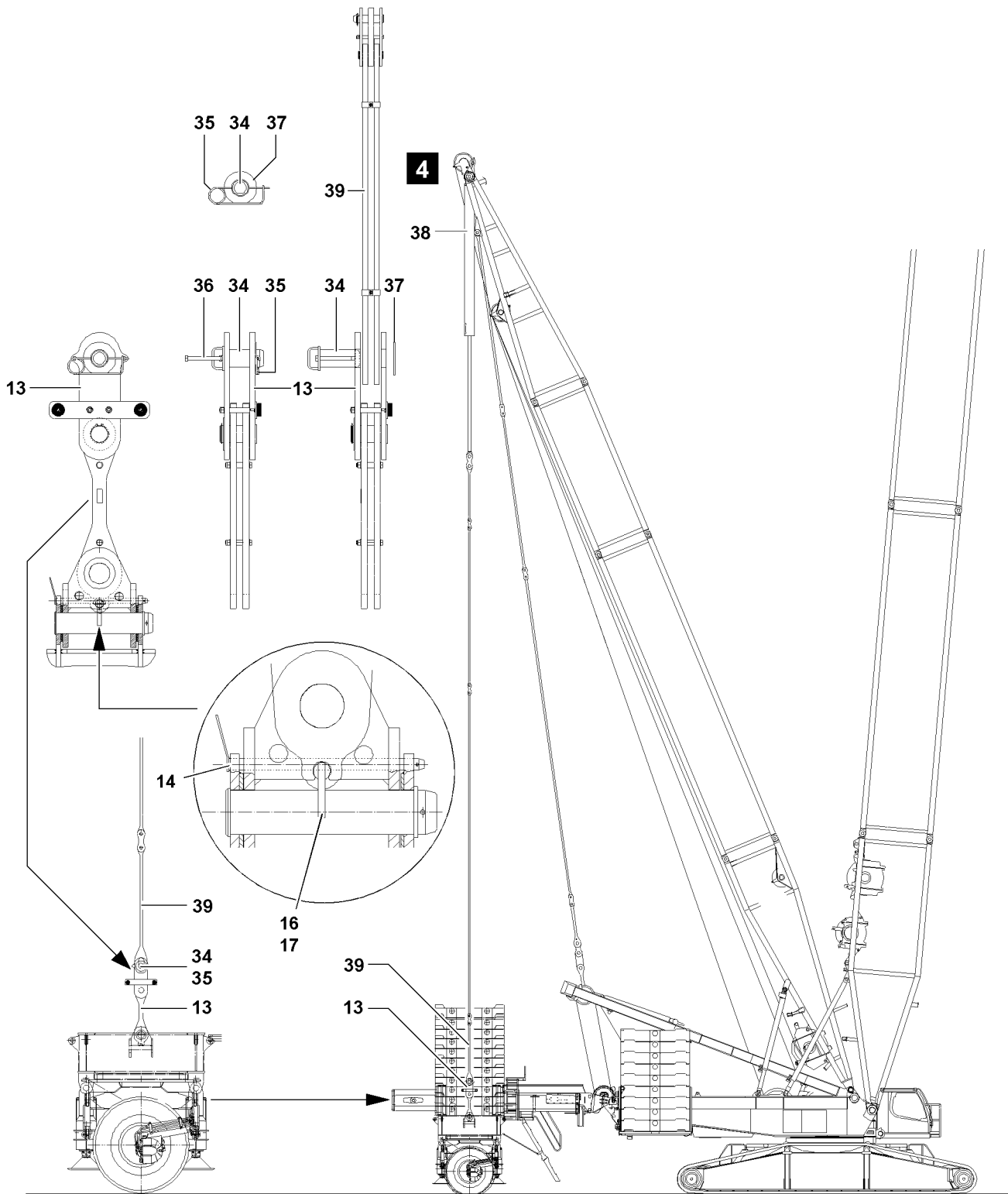

Fig.144788

LWE/LR 1600-2-008/18109-09-02/en

7.2 Disassembling the ballast trailer guying

7.2.1 Unpinning the guy rods

Make sure that the following prerequisites are met:

- The ballast trailer guide is fully retracted.
- The derrick boom radius and the ballast trailer radius are identical (13.0 m).
- The guy rods hang vertically.
- The guy rods are relieved by extending the pull cylinders.



WARNING

Danger of accident due to oscillating guy rods!

The guy rods can oscillate during the unpinning procedure.

Death, severe bodily injuries, property damage.

- ▶ Set the derrick boom and derrick ballast to the same radius before unpinning.
- ▶ If this is not possible, secure the guy rods against oscillating with the auxiliary crane.



DANGER

Retaining pins **not** inserted!

By unpinning the guy rods **39** the guy rods **13** will fall sideways.

Death, severe injury, property damage.

- ▶ Make sure, before unpinning the connector pins **34**, that both retaining pins **14** are pinned and secured on each guy rod.
- ▶ Make sure, before unpinning the connector pins **34**, that both retaining pins **16** are pinned and secured on each guy rod.

- ▶ Pin and secure the retaining pin **14**.

- ▶ Pin and secure the retaining pin **16**.

When both retaining pins **14** and the retaining pin **16** are pinned and secured on each guy rod:

- ▶ Perform a visual inspection. Unpin the guy rods **39** on the guy rods **13**: Remove the spring retainer **35** and unpin the connector pin **34**.
- ▶ Retract the pull cylinders **38** and pull the guy rods **39** up.

7.2.2 Bringing the guy rods on the ballast trailer into the transport position

Make sure that the following prerequisites are met:

- The guy rods **39** are unpinned.
- The guying is pulled over the pull cylinder **38** „upward“.

- ▶ Fasten the guy rod **13** to the auxiliary crane.

If the guy rod **13** is securely attached on the auxiliary crane:

- ▶ Release and unpin the retaining pin **14**.
- ▶ Take the guy rod **13** down with the auxiliary crane to the side.

If the guy rod **13** is laterally placed on the ballast trailer:

- ▶ Insert the retaining pin **14** and secure with the spring retainer.
- ▶ Remove the auxiliary crane.

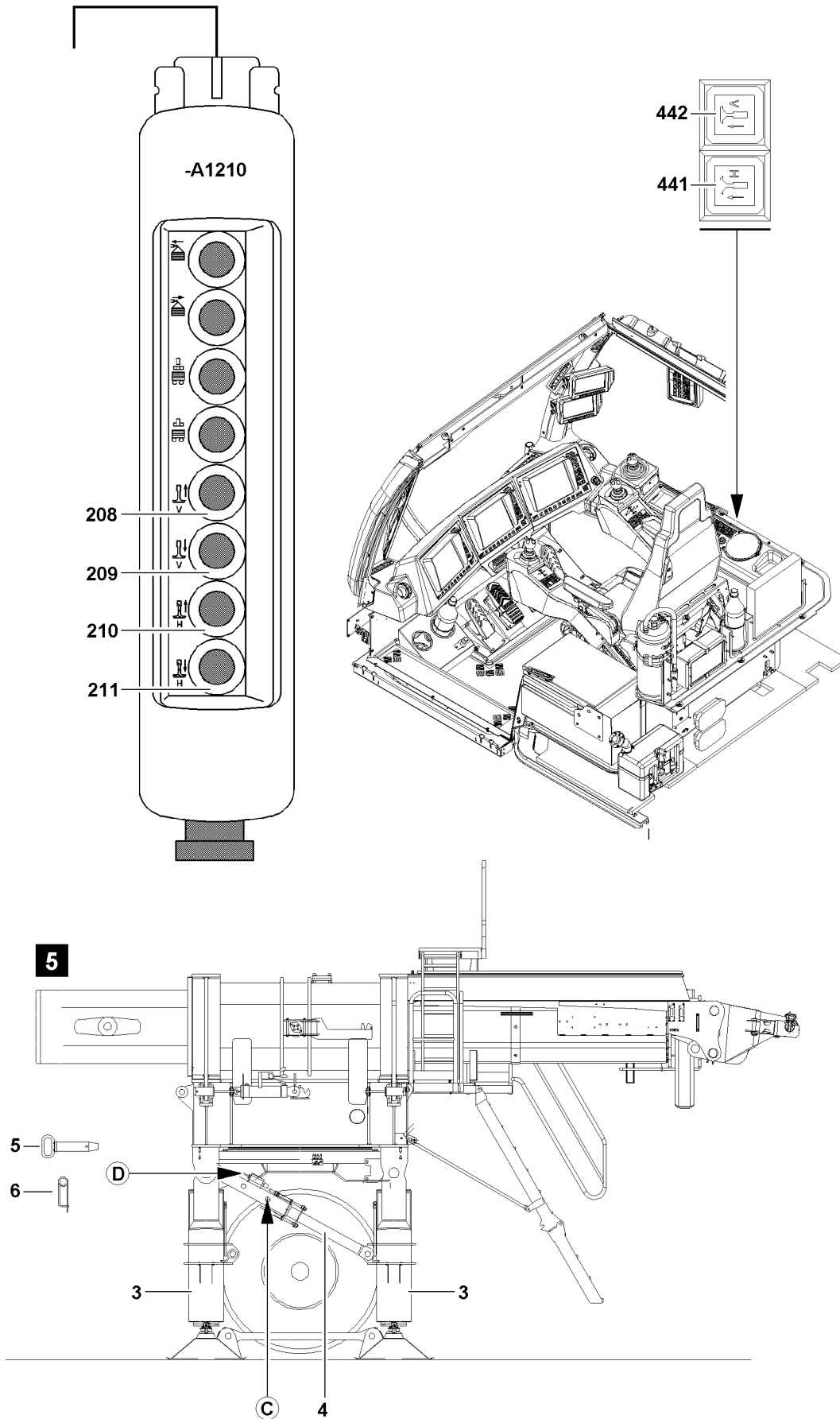

LWE/LR 1600-2-008/18109-09-02/en

Fig.113731

7.3 Supporting the ballast trailer

The ballast trailer must be supported before unpinning it from the turntable.

Before supporting the ballast trailer, the locking pin **5** must be pinned and secured on the strut **4**.

Make sure that the following prerequisites are met:

- The ballast plates and the guy rods are disassembled.
- The ballast trailer guide is fully retracted.
- The crane is horizontally aligned.

7.3.1 Pinning the strut on the ballast trailer



WARNING

Risk of tipping the ballast trailer!

If the strut **31** is not pinned before ballast trailer disassembly at point **C**, then the ballast trailer can tip over.

Death, severe bodily injuries, property damage.

▶ Always pin the strut **31** before disassembly of the ballast trailer.

▶ Release and unpin the locking pin **32** from the transport receptacle **D**.

▶ Pin locking pin **32** into operating position **C** and secure with spring retainer **33**.

7.3.2 Extending the support cylinders

Extend the front and rear support cylinders:

▶ Press the button **442** and button **441** in the crane operator's cab.

or

Press the button **209** and button **211** on the control panel **-A1210**.

▶ Check the moved out support cylinder visually.

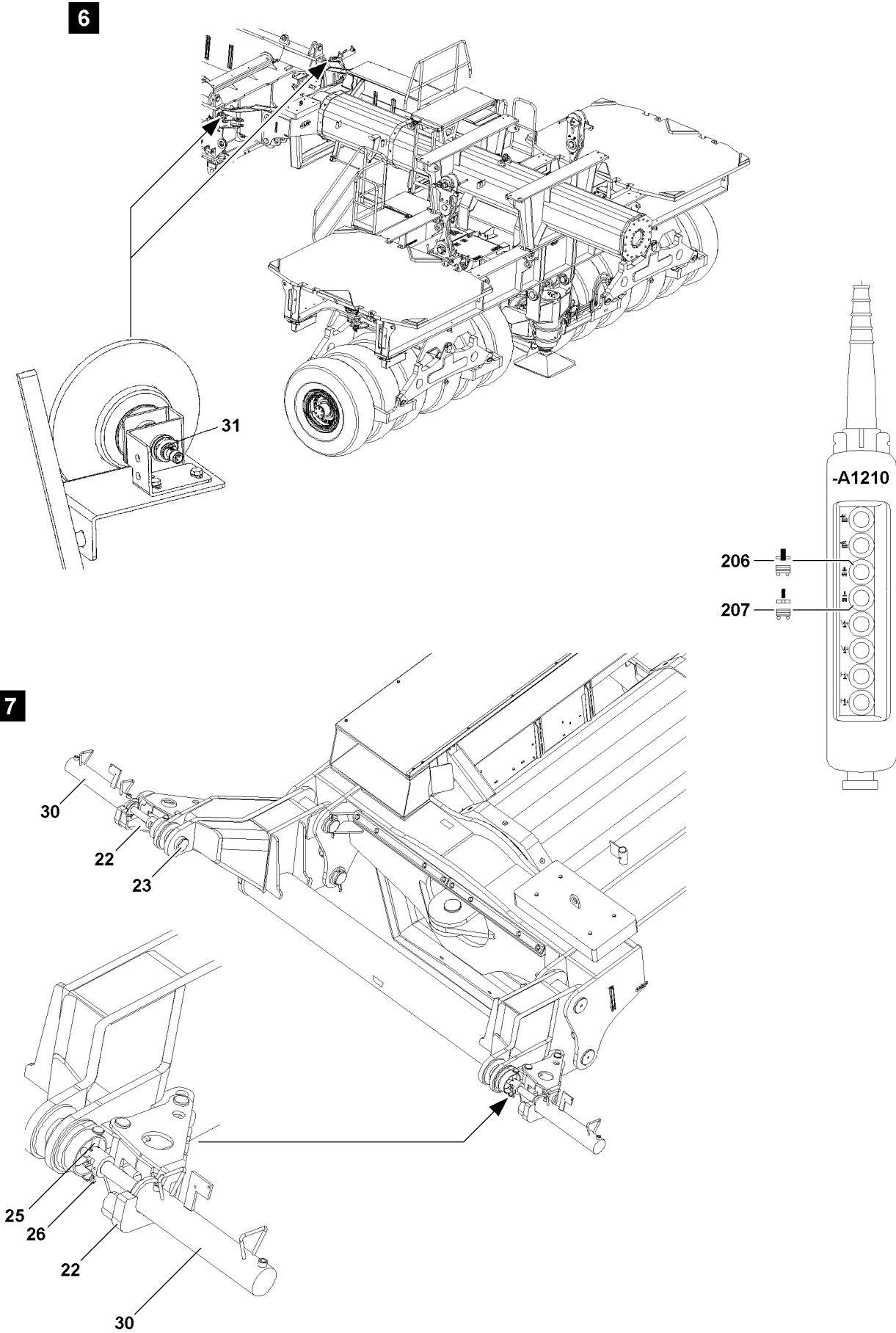

Fig.113732

LWE/LR 1600-2-008/18109-09-02/en

7.4 Unpinning the ballast trailer on the turntable

Make sure that the following prerequisites are met:

- The ballast trailer is supported.
- The hydraulic and electrical connections are available.

7.4.1 Unpinning procedure

NOTICE

Damage to the retaining pins!

If the retaining pins **25** are not unpinned before the unpinning procedure, the pin pulling device can be damaged.

- ▶ The retaining pins **25** must be released and unpinned on both sides before unpinning the connector pins **23**.

If the retaining pins **25** are completely unpinned on both sides:

- ▶ Press the button **206** on the control panel **-A1210**.

Result:

- The pin pulling cylinders retract.
- The connector pins **23** are unpinned on the turntable.

NOTICE

Damage to the ballast trailer or to the turntable!

When unpinning the ballast trailer, only one connector pin **23** can be unpinned on the turntable due to distortions, (signal „Ballast trailer installed“ is no longer present), then the crane control no longer recognizes that the ballast trailer is installed, even though the ballast trailer is still connected with the turntable via the second connector pin **23**.

Due to the missing signal, „Ballast trailer installed“, it is possible to turn the turntable, to drive the crane or to telescope the ballast trailer guide out / in.

This could significantly damage the crane or the ballast trailer.

- ▶ All crane movements are to be limited to a „minimum degree“ and must be driven with extreme caution and the least possible speed.
- ▶ After unpinning of the second connector pin **23**, it must again be checked if both connector pins are completely unpinned.

-
- ▶ Perform a visual inspection.

If the ballast trailer guide has been telescoped out during the unpinning procedure:

- ▶ Retract the ballast trailer guide all the way.

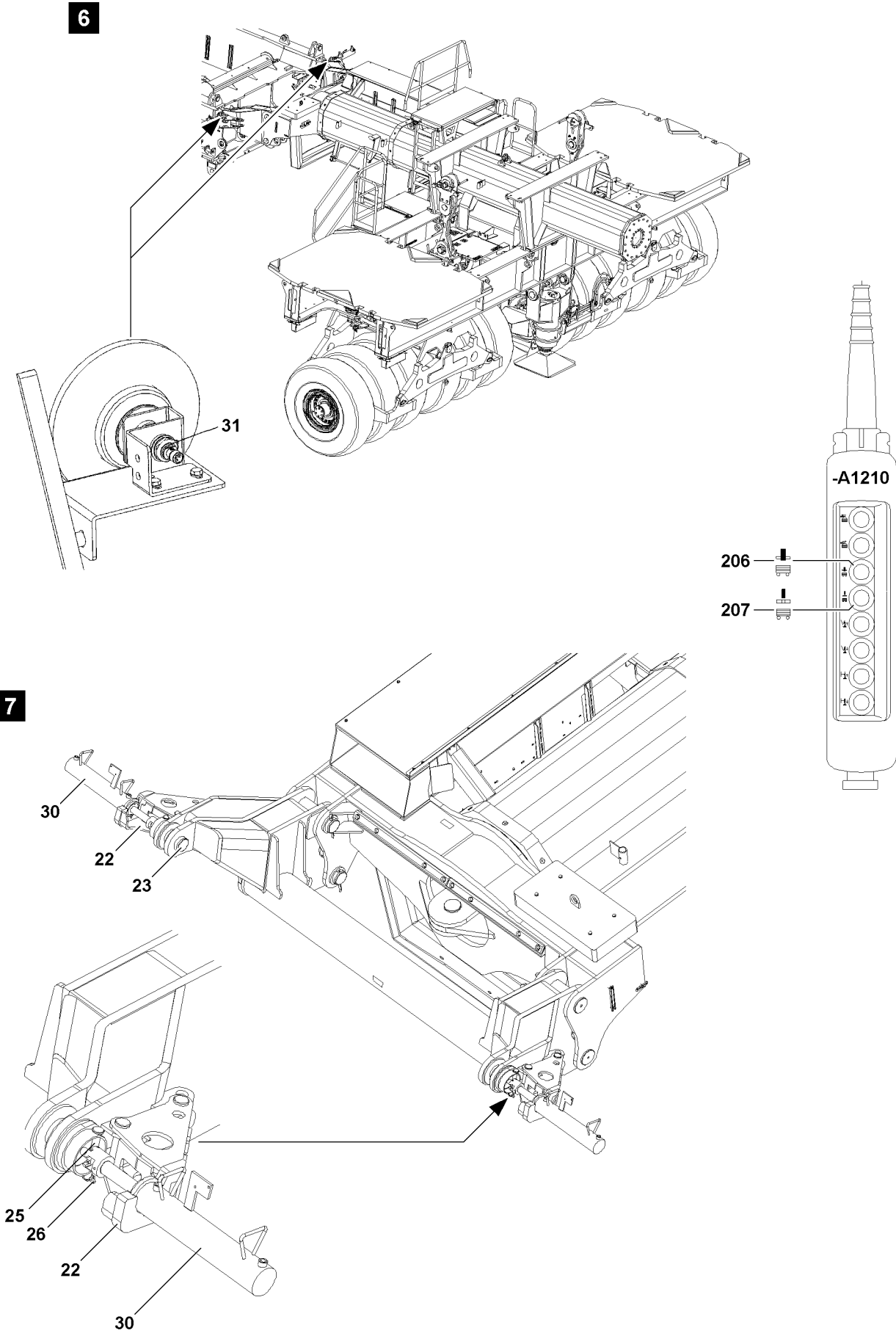

Fig.113732

LWE/LR 1600-2-008/18109-09-02/en

7.4.2 Releasing the electrical connection from the ballast trailer to the turntable



Note

- ▶ Release the electrical connections only when the ballast trailer is completely unpinned on the turntable, which means both connector pins **23** must be unpinned.

Make sure that the following prerequisite is met:

- The ballast trailer is completely unpinned on the turntable.
- ▶ Disconnect the electrical connections and store properly on the ballast trailer.

7.4.3 Releasing the hydraulic connections from the ballast trailer to the turntable

When connecting and releasing hydraulic lines with quick couplings, make sure that the coupling procedure is carried out correctly.



DANGER

Danger of accident due to loss of pressure or leakage!

Incorrectly coupled or self-loosening quick couplings (particularly return lines) can result in serious accidents due to component failure.

- ▶ Check that the quick couplings have been properly connected before using the crane.
- ▶ Release the pressure in the hydraulic system before connecting or disconnecting. Turn the engine off and wait for short time.
- ▶ Install the coupling components (sleeve and connector) with the knurled nut.
- ▶ Disconnect the coupling sections.
- ▶ Store hydraulic hoses on the ballast trailer properly.
- ▶ Protect the coupling sections with caps to prevent contamination and damage.

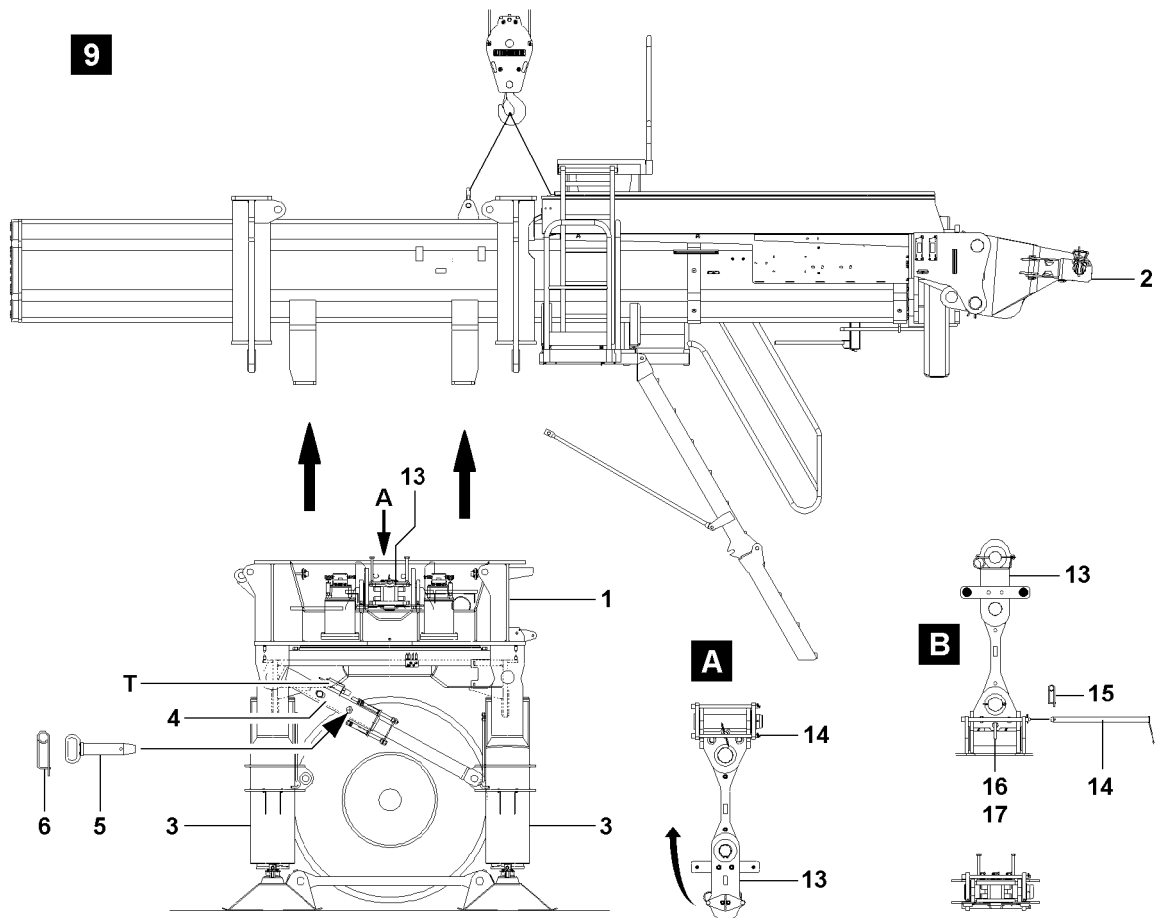
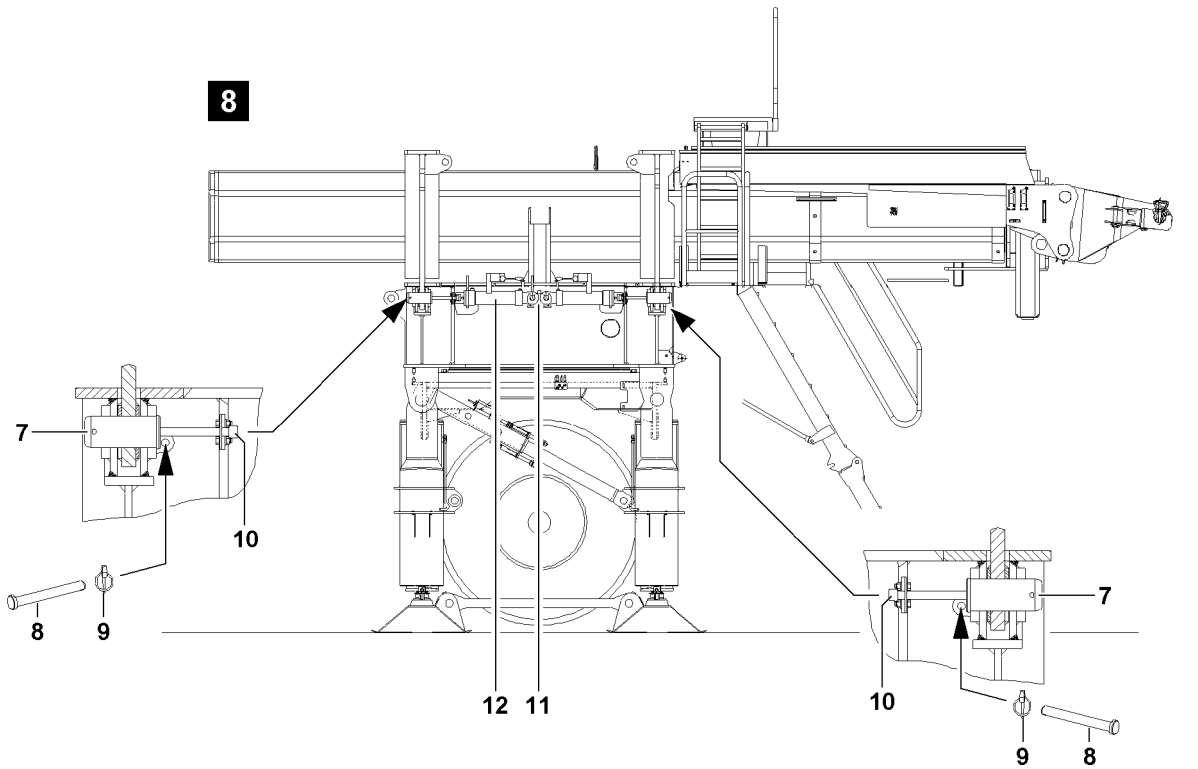

Fig.113733

LWE/LR 1600-2-008/18109-09-02/en

7.5 Disassembling the ballast trailer guide

Make sure that the following prerequisites are met:

- The locking pin **5** is pinned in and secured in the strut **4**.
- The ballast trailer is supported with the support cylinders **3** and aligned horizontally.
- The wheel sets are relieved.
- The access to the ballast trailer is in the transport position.



WARNING

Ballast trailer tipping danger!

If the stability and tipping safety guidelines for the ballast trailer are not observed, the ballast trailer can tip over.

Death, severe bodily injuries, property damage.

- ▶ Observe section „Stability and tipping safety for ballast trailer not assembled on the turntable“.

- ▶ Fasten the ballast trailer guide **2** to the auxiliary crane.
- ▶ Tension the fastening equipment with caution.
- ▶ Attach the pin pulling cylinder **12** to the retainer **11** and hook into the screw head **10**.
- ▶ Establish the hydraulic connection of the pin pulling cylinder **12** to the hydraulic aggregate, see chapter 5.30.
- ▶ Remove the locking pin **9** on the retaining pins **8**, see illustration **8**.
- ▶ Unpin the retaining pin **8**.

When the retaining pins **8** are unpinned and the fastening equipment on the ballast trailer guide **2** are tensioned:

- ▶ Actuate the lever on the pin pulling cylinder and unpin the connector pins **7**.

When all four connector pins **7** are completely unpinned:

- ▶ Lift and swing ballast trailer guide **2** with auxiliary crane from the ballast trailer, see illustration **9**.
- ▶ Disassemble ascent for the ballast trailer.
- ▶ Take ballast trailer guide **2** down on suitable and sufficiently load-bearing substructure.
- ▶ Remove the auxiliary crane.

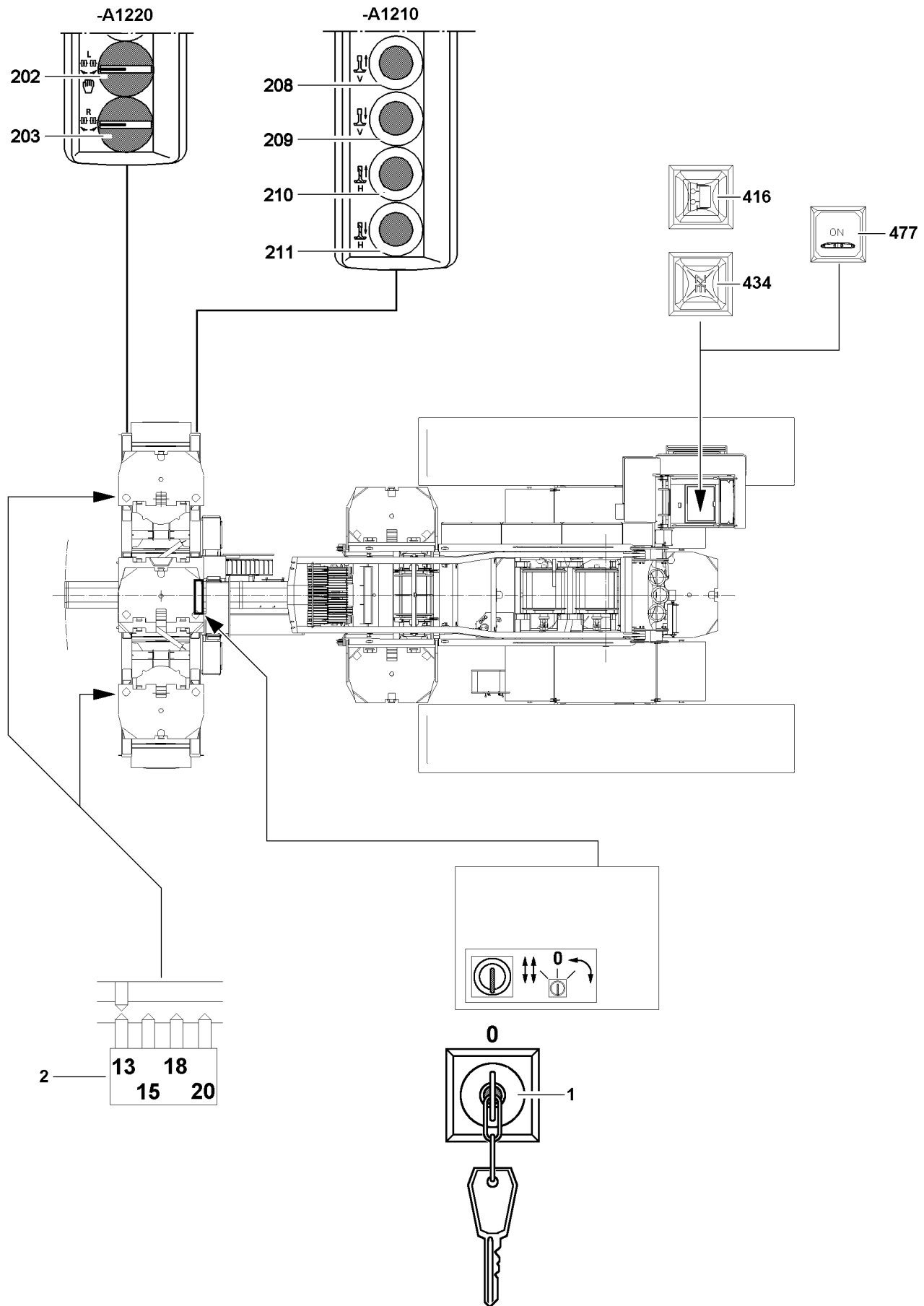

LWE/LR 1600-2-008/18109-09-02/en

Fig.107254

8 Emergency operation with a defective CPU

8.1 Emergency operation of ballast trailer

With a defect on the ballast trailer CPU, a warning light **434** is lit, the electronic steering of the ballast trailer can no longer be steered.

The signals „Towing“ and „circular travel“ are no longer transmitted by the ballast trailer control to the crane control.

However, by actuating the key switch **1** in the control cabinet on the ballast trailer, the CPU can be bypassed.

Key switch positions

- 0 (center) = no emergency operation
- I (left) = emergency operation towing
- II (right) = emergency operation circular travel

NOTICE

Damage to the ballast trailer!

By activating the key switch **1** the signal „Towing“ or „Circular travel“ is released in the crane control, even though the wheel sets could potentially be incorrectly aligned.

This can result in severe damage on the ballast trailer or on the crane.

- ▶ Operate the key switch **1** only if the electronic fails.
- ▶ Before driving the crane, check the alignment of the wheel sets.
- ▶ All travel movements may only be conducted with utmost caution, minimum acceleration and careful braking.
- ▶ If the key switch **1** is activated, then the crane operator bears the full and sole responsibility for his actions.



WARNING

Danger of accident due to faulty operation!

If the key switch **1** is activated, there is an increased danger of accidents due to the bypassed ballast trailer control.

Death, severe bodily injuries, property damage.

- ▶ It is prohibited to remain within the danger zone of the ballast trailer.
 - ▶ The alignment of wheel sets is to be monitored manually, visual inspection.
 - ▶ Observe the angle scale on the ballast trailer.
 - ▶ Emergency operation should only be carried out by authorized personnel. They must be aware of all related supervisory tasks and hazards.
 - ▶ If the key switch **1** is activated, then the crane operator bears the full and sole responsibility for his actions.
-

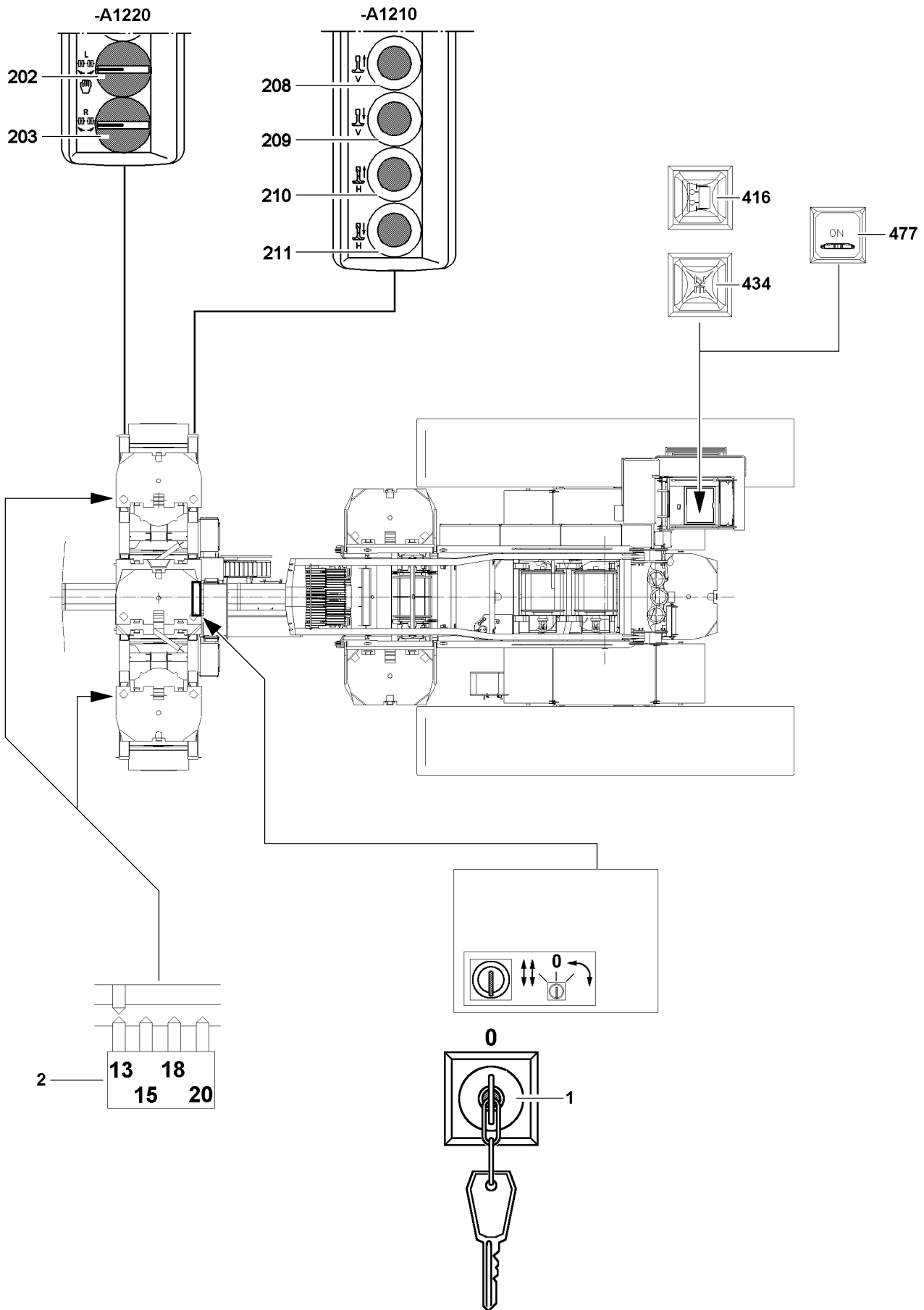

LWE/LR 1600-2-008/18109-09-02/en

Fig.107254

8.2 Emergency operation - towing

Make sure that the following prerequisites are met:

- The ballast trailer is properly assembled.
- The crawler operation is turned on (switch **477**).

8.2.1 Lifting the ballast trailer with the support cylinders



Note

- ▶ The support cylinders of the ballast trailer must always be extended evenly.

Extend the front and rear support cylinders:

- ▶ Press the button **209** and the button **211**.

8.2.2 Aligning the wheel sets in the towing position

To be able to align the wheel sets in towing position, the ballast trailer must be lifted with the support cylinders.

Make sure that the following prerequisite is met:

- The ballast trailer is raised via the support cylinders to the point where the wheel sets are relieved.
- ▶ Turn the key switch **1** on the ballast trailer to the „left“.



Note

- ▶ By activating the key switch **1** into position „left“, the order „Towing“ is passed on to the crane and emergency operation is turned on.
- ▶ During emergency operation the support can only be actuated from the control panel **-A1210** on the ballast trailer.

When the wheel sets are relieved:

- ▶ Activate the rotary switch **202** on the control panel **-A1220** and align the left wheel set into towing position.
- ▶ Activate the rotary switch **203** on the control panel **-A1220** and align the right wheel set into towing position.
- ▶ Check the settings.

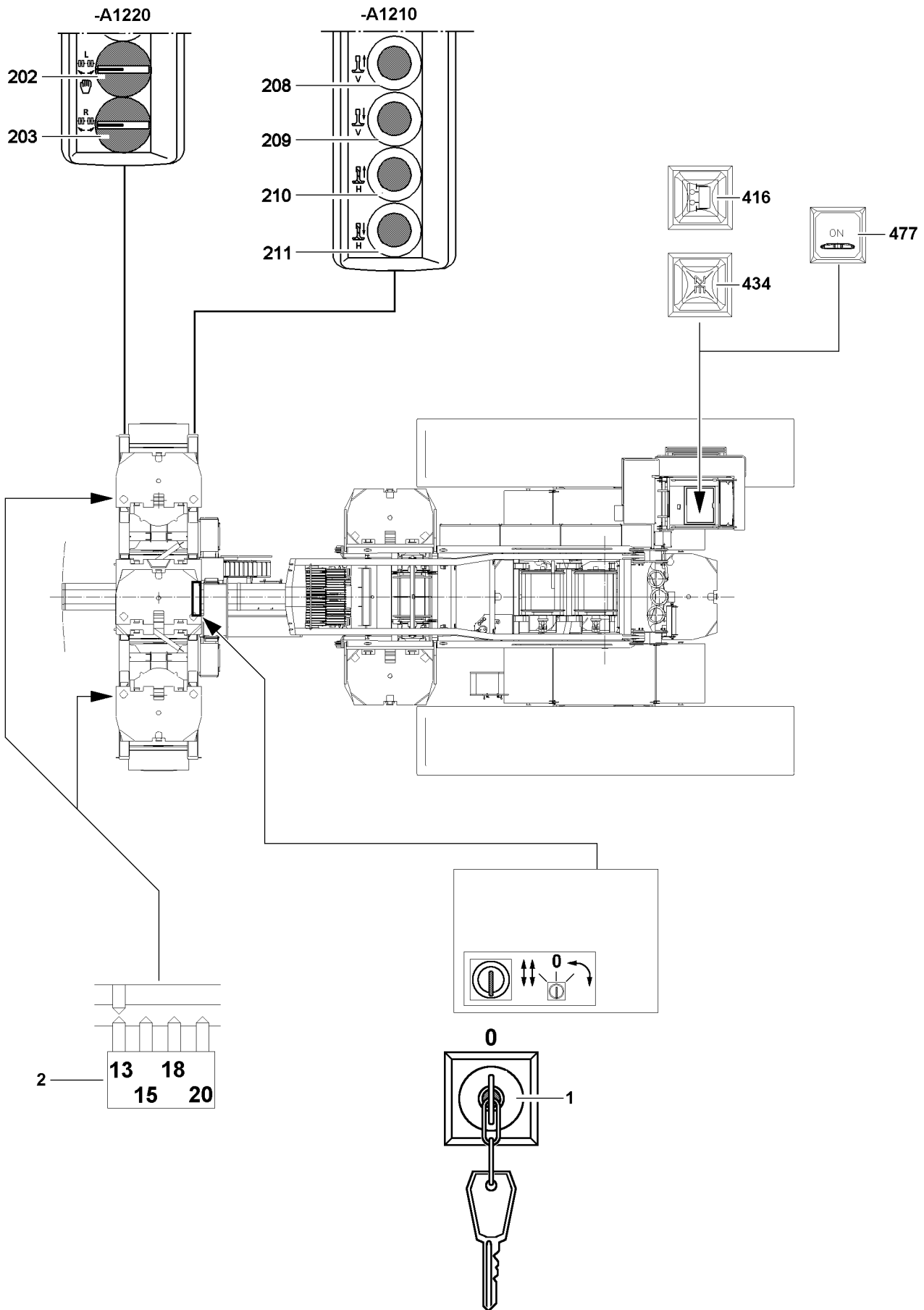

LWE/LR 1600-2-008/18109-09-02/en

Fig.107254

8.2.3 Lowering the ballast trailer with the support cylinders



Note

- ▶ The support cylinders of the ballast trailer must always be moved in evenly.
-

Retract the support cylinders completely on the front and rear:

- ▶ Press the button **208** and the button **210**.

Result:

- The support cylinders retract.
- ▶ Retract the support cylinders completely.

Result:

- The warning light **416** („Ballast trailer support moved in“) **lights up**.

8.2.4 Towing

Make sure that the following prerequisites are met:

- The wheel sets are in the towing position.

NOTICE

Damage to the ballast trailer!

If the angle settings on the wheel sets are not monitored during driving in emergency operation, it can lead to significant damage on the wheel sets.

- ▶ The angle settings **2** on the wheel sets are to be constantly checked.
 - ▶ Constantly monitor the alignment of the wheel sets while driving.
 - ▶ If the wheel sets become excessively deformed, then they must be realigned.
-

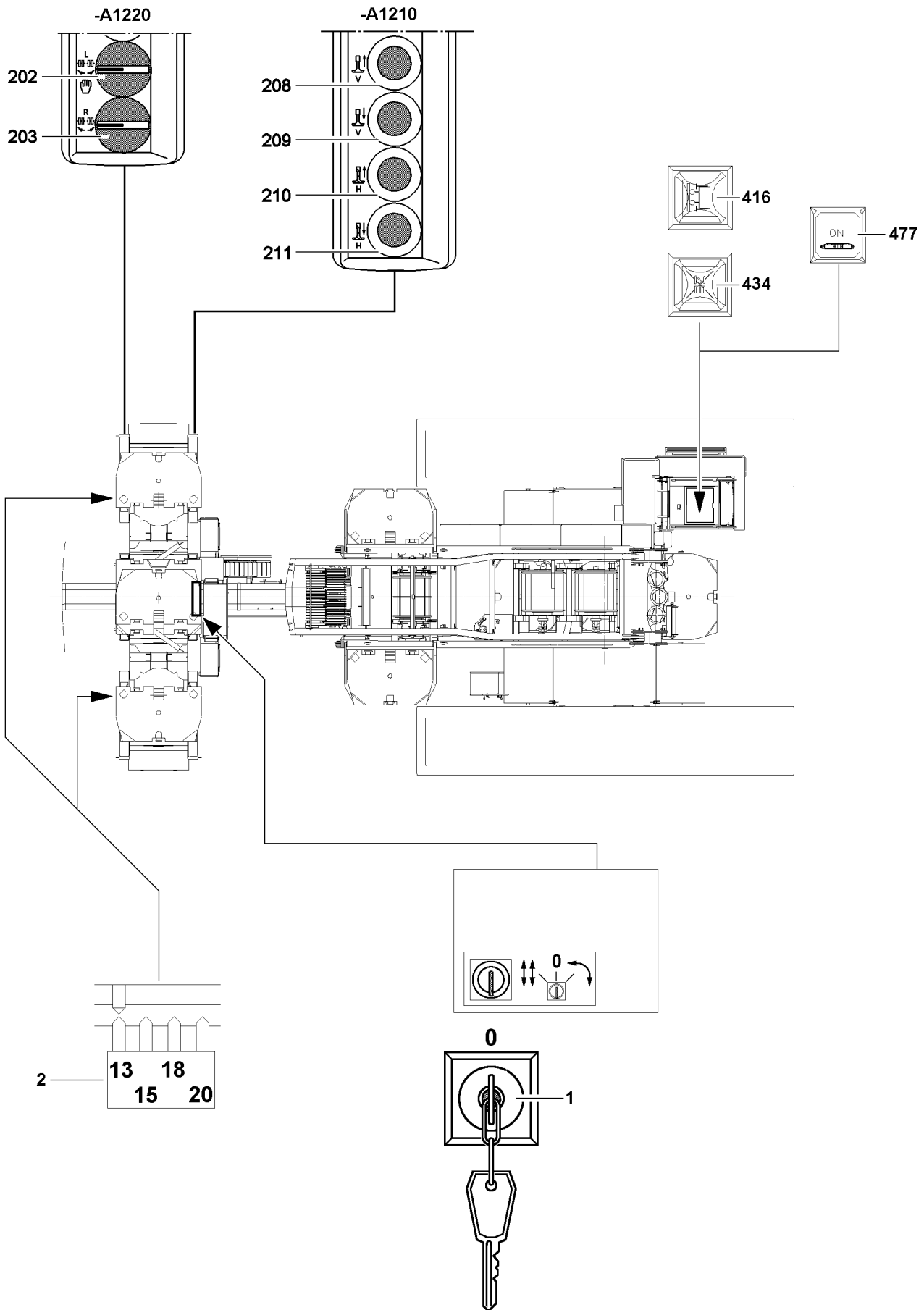

LWE/LR 1600-2-008/18109-09-02/en

Fig.107254

8.3 Emergency operation - circular travel

Make sure that the following prerequisites are met:

- The ballast trailer is properly assembled.
- The crawler operation is turned on (switch **477**).

8.3.1 Lifting the ballast trailer with the support cylinders



Note

- ▶ The support cylinders of the ballast trailer must always be extended evenly.

Extend the front and rear support cylinders:

- ▶ Press the button **209** and the button **211**.

8.3.2 Aligning the wheel sets in the circular travel position

To be able to align the wheel sets in circular travel position the ballast trailer must be lifted with the support cylinders.

Make sure that the following prerequisite is met:

- The ballast trailer is raised via the support cylinders to the point where the wheel sets are relieved.
- ▶ Turn the key switch **1** on the ballast trailer to the „right“.



Note

- ▶ By actuating the key switch **1** in position „right“, the command „Circular travel“ is transmitted to the crane and emergency operation is turned on.
- ▶ During emergency operation the support can only be actuated from the control panel **-A1210** on the ballast trailer.

When the wheel sets are relieved:

- ▶ Activate the rotary switch **202** on the control panel **-A1220** and align the left wheel set into circular travel.
- ▶ Activate the rotary switch **203** on the control panel **-A1220** and align the right wheel set into circular travel.
- ▶ Check the settings.

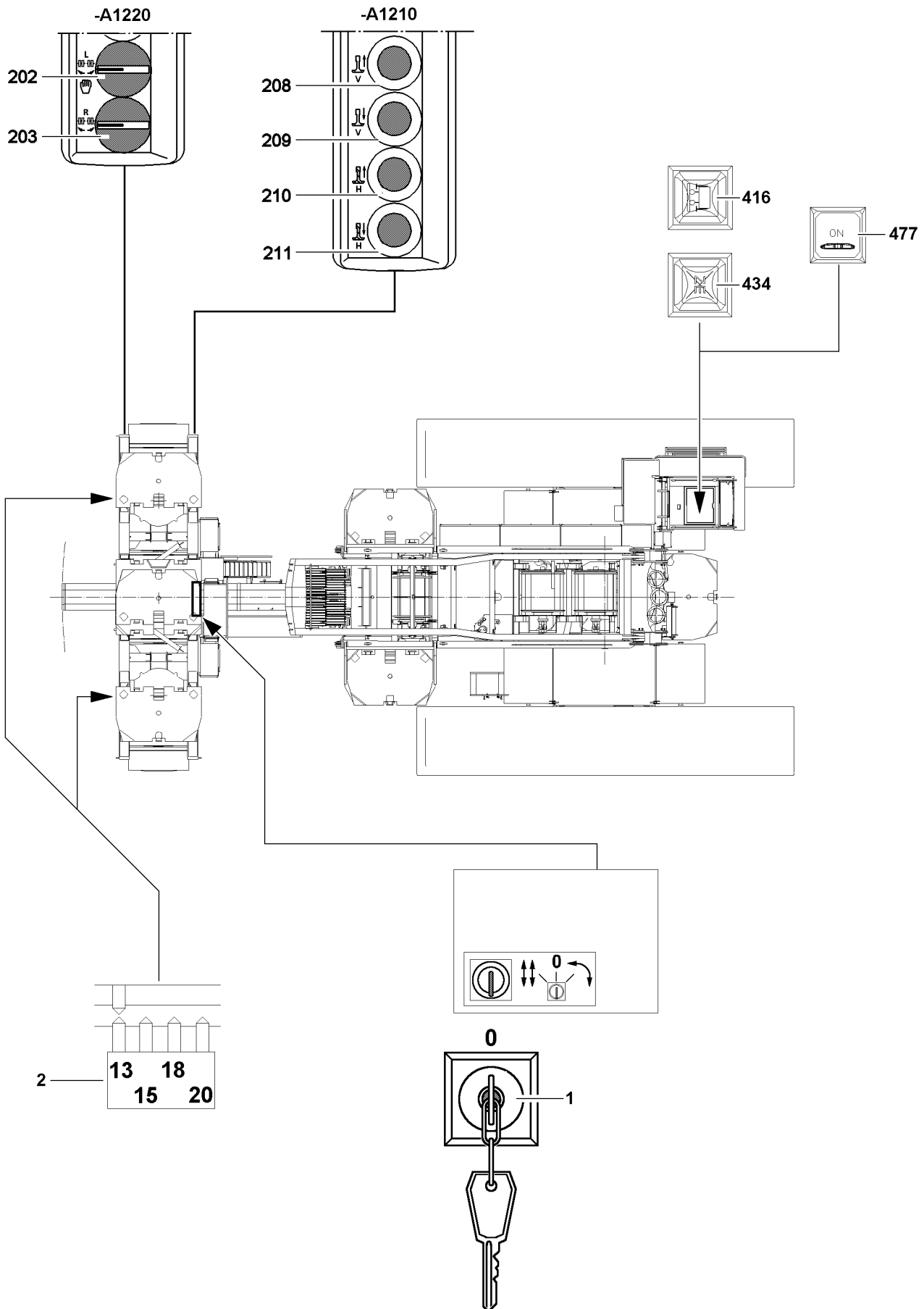

LWE/LR 1600-2-008/18109-09-02/en

Fig.107254

8.3.3 Lowering the ballast trailer with the support cylinders



Note

- ▶ The support cylinders of the ballast trailer must always be moved in evenly.
-

Retract the support cylinders completely on the front and rear:

- ▶ Press the button **208** and the button **210**.

Result:

- The support cylinders retract.
- ▶ Retract the support cylinders completely.

Result:

- The warning light **416** („Ballast trailer support moved in“) **lights up**.

8.3.4 Circular travel

Make sure that the following prerequisites are met:

- The wheel sets are in the circular travel position.

NOTICE

Damage to the ballast trailer!

If the angle settings on the wheel sets are not monitored during driving in emergency operation, it can lead to significant damage on the wheel sets.

- ▶ The angle settings **2** on the wheel sets are to be constantly checked.
 - ▶ Constantly monitor the alignment of the wheel sets while driving.
 - ▶ If the wheel sets become excessively deformed, then they must be realigned.
-

9 Maintenance intervals / maintenance instructions for the ballast trailer



Note

- ▶ See chapter 7.02.50 and chapter 7.04.50.
-

Empty page!

LWE/LR 1600-2-008/18109-09-02/en

5.36.10 Derrick ballast - suspended ballast

1	Component overview of suspended ballast	3
2	Fastening points	4
3	Derrick ballast radii and standing levels	7
4	Derrick ballast radii and standing levels - standard crane	11
5	Derrick ballast radii and standing levels - narrow track crane	14
6	Assembling	19
7	Assembling the suspended ballast guide*	20
8	Assembling the suspended ballast pallet	31
9	Ballasting the suspended ballast pallet	38
10	Function check before lifting the derrick ballast	41
11	Lifting and lowering the derrick ballast using the pull cylinders	42
12	Crane operation with derrick ballast	44
13	Crawler operation with derrick ballast	56
14	Disassembly	57
15	Setting down the suspended ballast pallet	58
16	Removing the ballast plates	59
17	Disassembling the suspended ballast pallet	61
18	Disassembling the suspended ballast guide*	67

Fig.195219

1 Component overview of suspended ballast



Note

- ▶ The crane components are marked with their own weights.
- ▶ Dimensions and weights, see chapter 1.03.

Definitions and limits:

- The suspended ballast and ballast trailer are generally referred to as the derrick ballast.
- The compensation weight which is installed on the turntable is generally referred to as the counterweight.

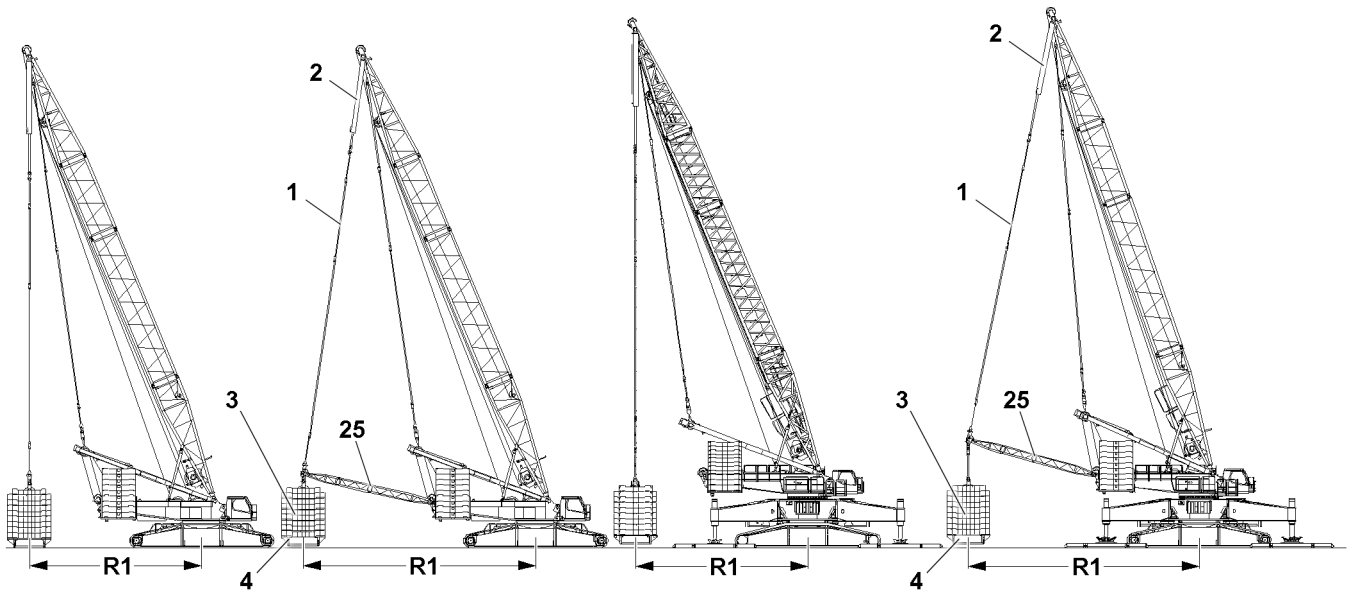

Fig.149286: Suspended ballast without / with suspended ballast guide

- | | | |
|-----------------|----------------------------|--------------------------------|
| 1 D-guying | 3 Ballast plates | 25 Suspended ballast guide B2* |
| 2 Pull cylinder | 4 Suspended ballast pallet | R1 Derrick ballast radius |

1.1 Suspended ballast guide*

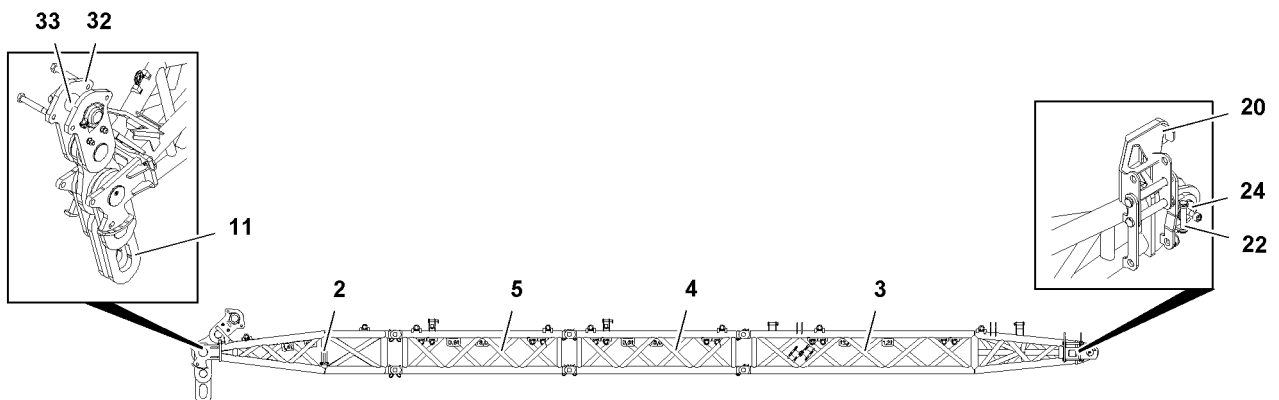

Fig.119255: Components of suspended ballast guide R1 20 m

- | | | |
|------------------------|------------------|--------|
| 2 End section | 11 Lug | 32 Lug |
| 3 Pivot section | 20 Console | 33 Pin |
| 4 Intermediate section | 22 Retaining pin | |
| 5 Intermediate section | 24 Pin | |

LWE/LR 1600-2-008/18109-09-02/en

1.2 Suspended ballast pallet

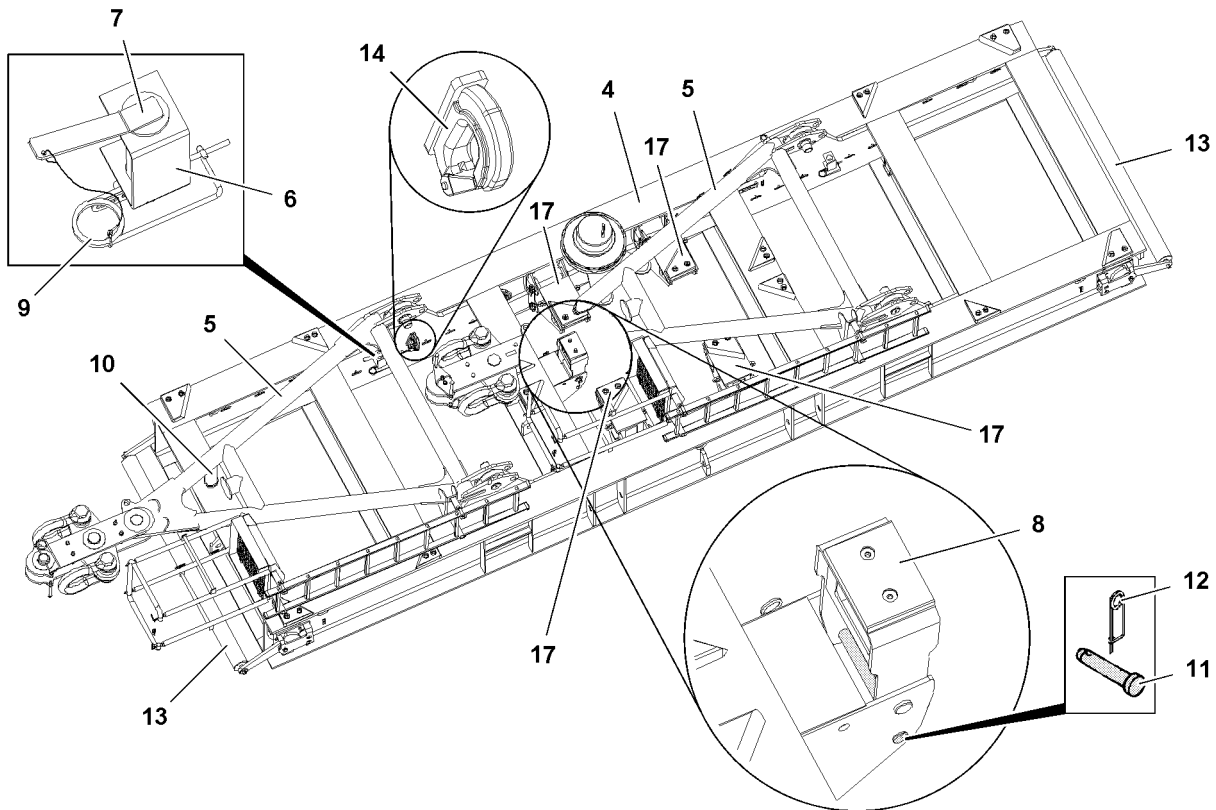

Fig.119780: Components of the suspended ballast pallet

4	Suspended ballast pallet	8	Support for erection rack	12	Spring retainer
5	Erection rack	9	Spring retainer	13	Limit switch
6	Receptacle for retaining pin 7	10	Assembly support	14	Hook (fastening point)
7	Retaining pins for erection	11	Pin	17	Consoles for ballast centering rack

2 Fastening points



WARNING

Falling crane components!

Incorrectly fastened crane components can become detached from the fastening equipment and fall down during transport and / or assembly.

Death, severe bodily injuries, property damage.

- ▶ Fasten the components on all defined fastening points.
- ▶ Make sure that the fastening equipment is properly fastened on the fastening points.

2.1 Suspended ballast guide*



Note

- ▶ The suspended ballast guide with installed components is fastened on four fastening points.

For transport the individual parts are installed as a transport unit.

Every fastening points is present on both sides of the component on a horizontal level.

2.1.1 Transport unit

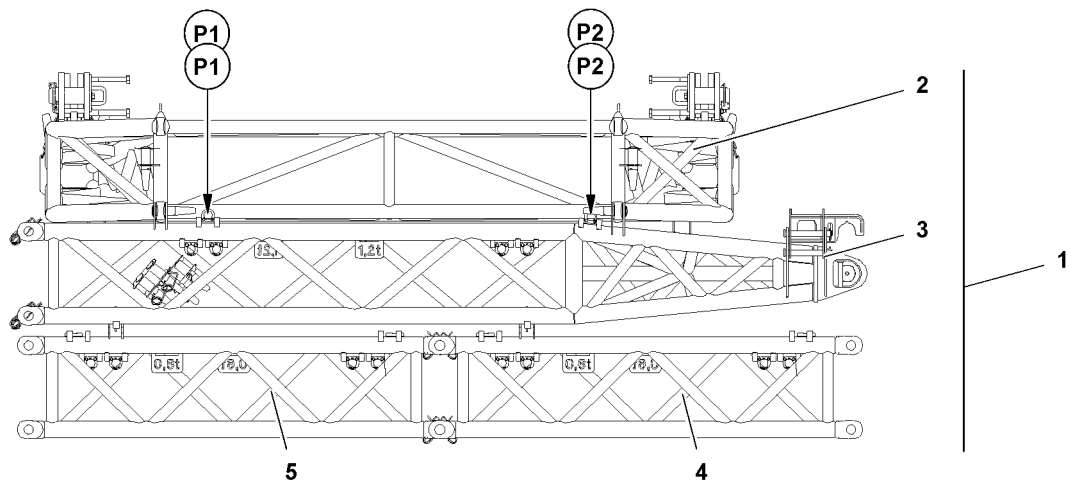

Fig.118548: Transport unit fastening points

- | | | | |
|---|----------------|---|----------------------|
| 1 | Transport unit | 4 | Intermediate section |
| 2 | End section | 5 | Intermediate section |
| 3 | Pivot section | | |

Fastening points	
P1 and P2	Transport unit 1

2.1.2 End section

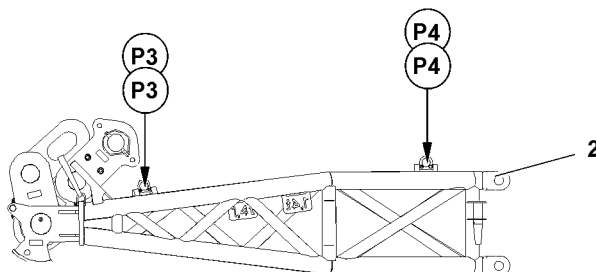

Fig.119209: End section fastening points

Fastening points	
P1 and P2	End section 2

LWE/LR 1600-2-008/18109-09-02/en

2.1.3 Pivot section

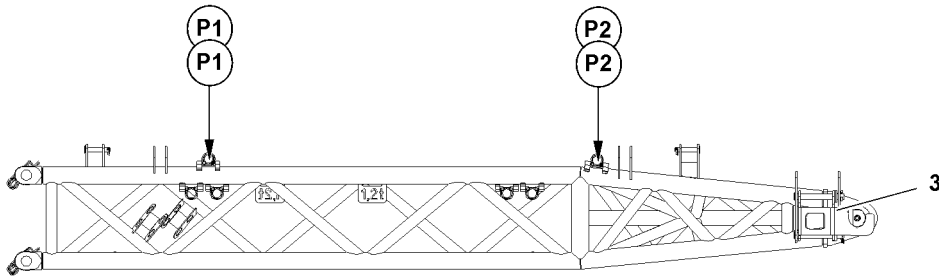

Fig.119251: Pivot section fastening points

Fastening points	
P1 and P2	Pivot section 3

2.1.4 Intermediate sections

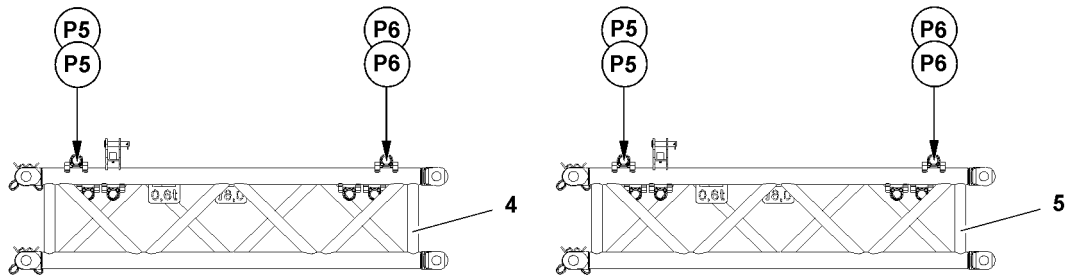

Fig.119252: Intermediate section fastening points

Fastening points	
P5 and P6	Intermediate section 4 and intermediate section 5

2.2 Suspended ballast pallet

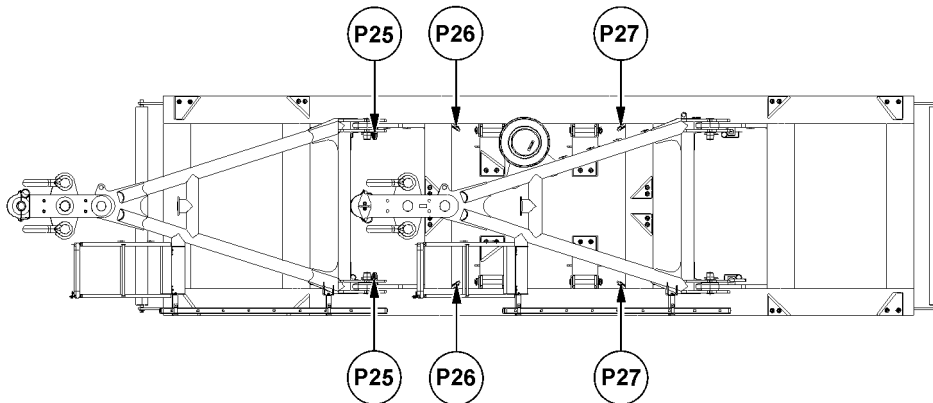

Fig.119208: Suspended ballast pallet fastening points, view from above, erection racks taken down

LWE/LR 1600-2-008/18109-09-02/en

Fastening points	
P25 and P27	Suspended ballast palette 4 , erection racks taken down
P26 and P27	Suspended ballast palette 4 , erection racks erected

3 Derrick ballast radii and standing levels



WARNING

The crane can topple over.

If the derrick ballast is lifted past the maximum permissible 250 mm from the respective standing level of the derrick ballast, then the crane can be topple over to the rear if the load rips off.

Death, severe bodily injuries, property damage.

- ▶ There may be no personnel, objects or obstacles within the entire slewing range of the crane, derrick ballast and the load.
- ▶ In crane operation, lift the derrick ballast no more than maximum 250 mm from the respective standing level of the derrick ballast.
- ▶ The position of the standing level depends on the set up configuration of the crane, see the following charts.
- ▶ The ground in the entire working area of the crane - including the derrick ballast and the load - must be even and of sufficient load bearing capacity, in order to be able to securely absorb the encountered ground pressures and weight loads.



Note

- ▶ Lifting of the derrick ballast must be observed by a guide.

P1 Derrick ballast standing level at the level of the crane standing level

P2 Derrick ballast standing level above the crane standing level (above ground level)

P3 Derrick ballast standing level below the crane standing level (below ground level)

3.1 Standing levels at D 30 m without guide

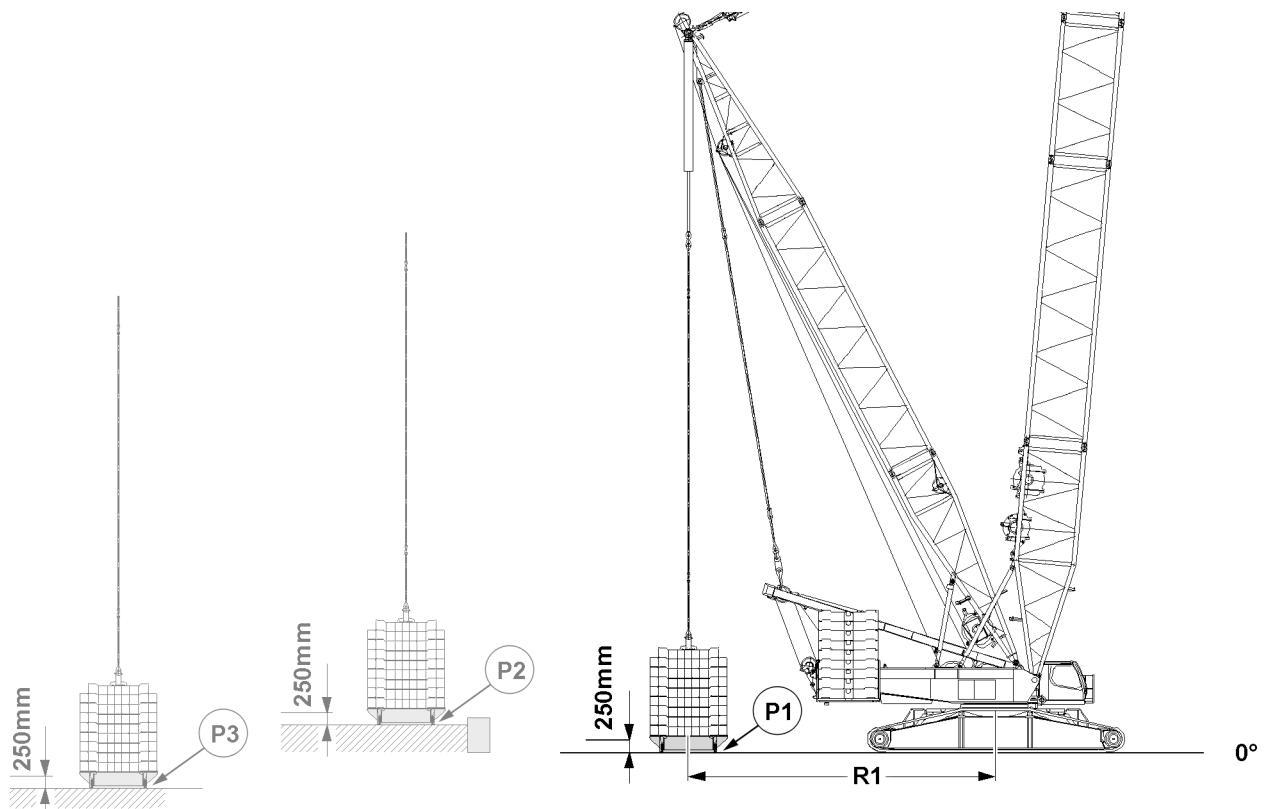

Fig.149266: Lifting the suspended ballast no more than maximum 250 mm from the standing level of the derrick ballast for crane operation

3.2 Standing levels at D 36 m with guide B2

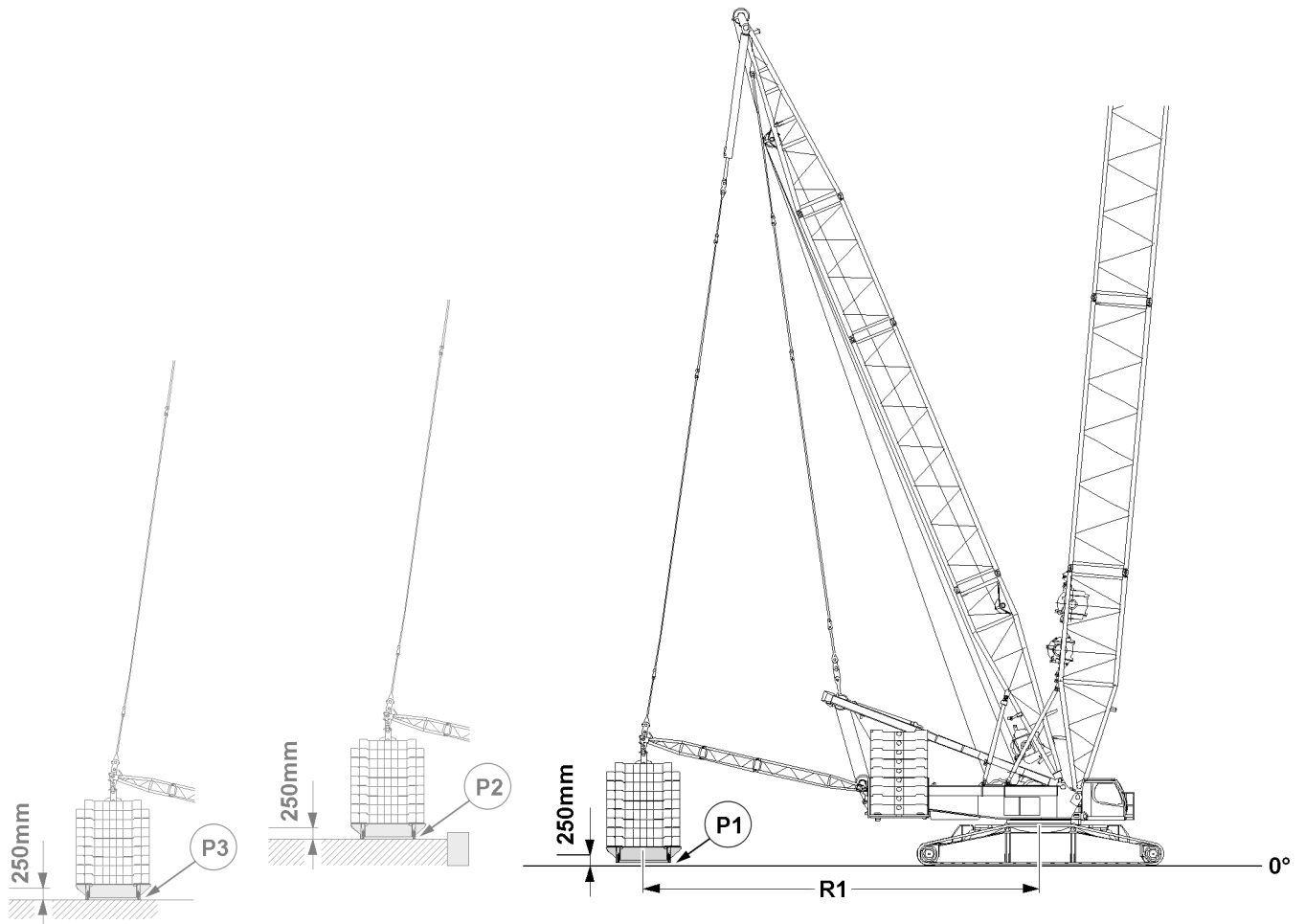

Fig.149271: Lifting the suspended ballast no more than maximum 250 mm from the standing level of the derrick ballast for crane operation

3.3 Narrow track crane: Standing levels at D 36 m without guide

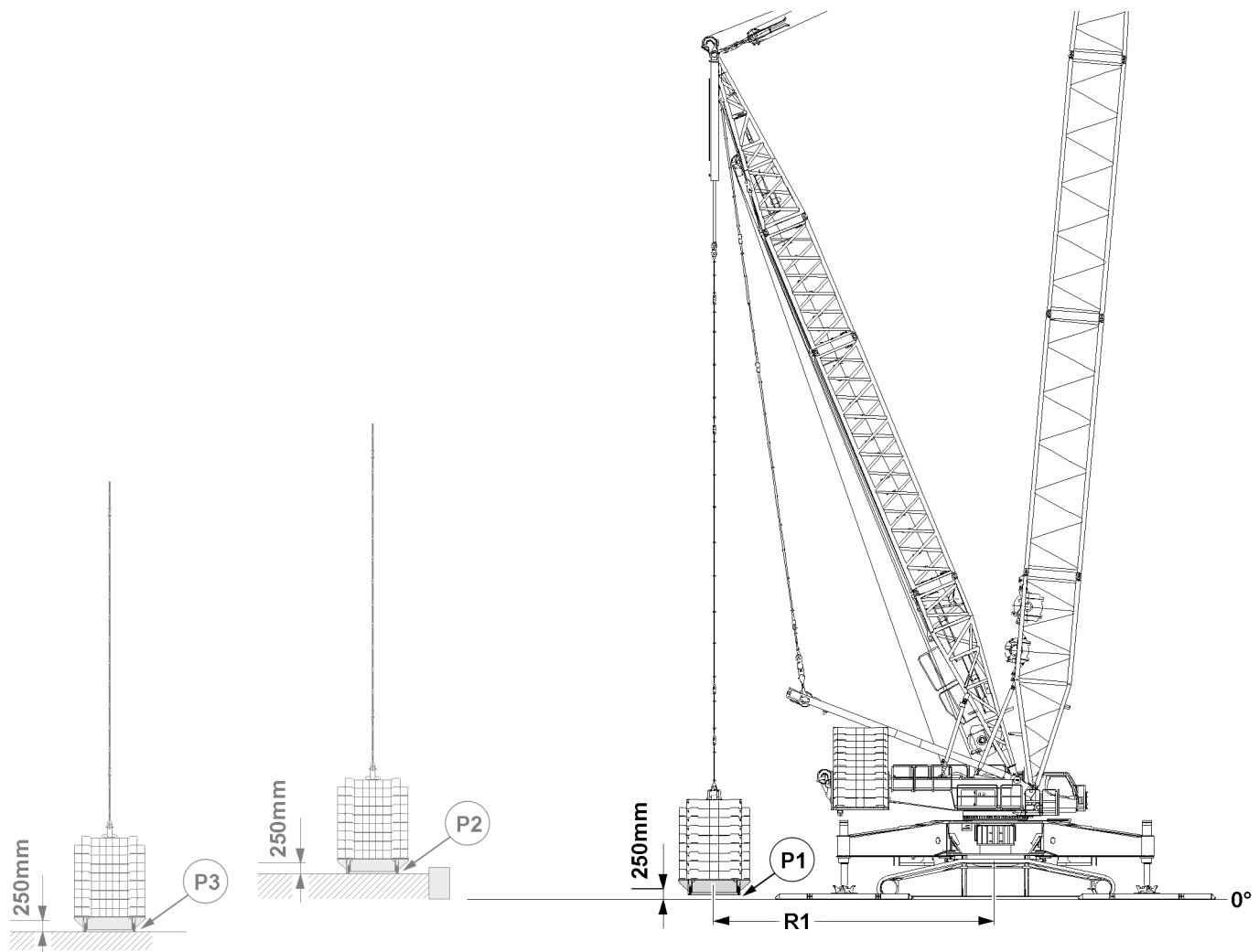

Fig. 149280: Narrow track crane: Lifting the suspended ballast no more than maximum 250 mm from the standing level of the derrick ballast for crane operation

3.4 Narrow track crane: Standing levels at D 36 m with guide B2

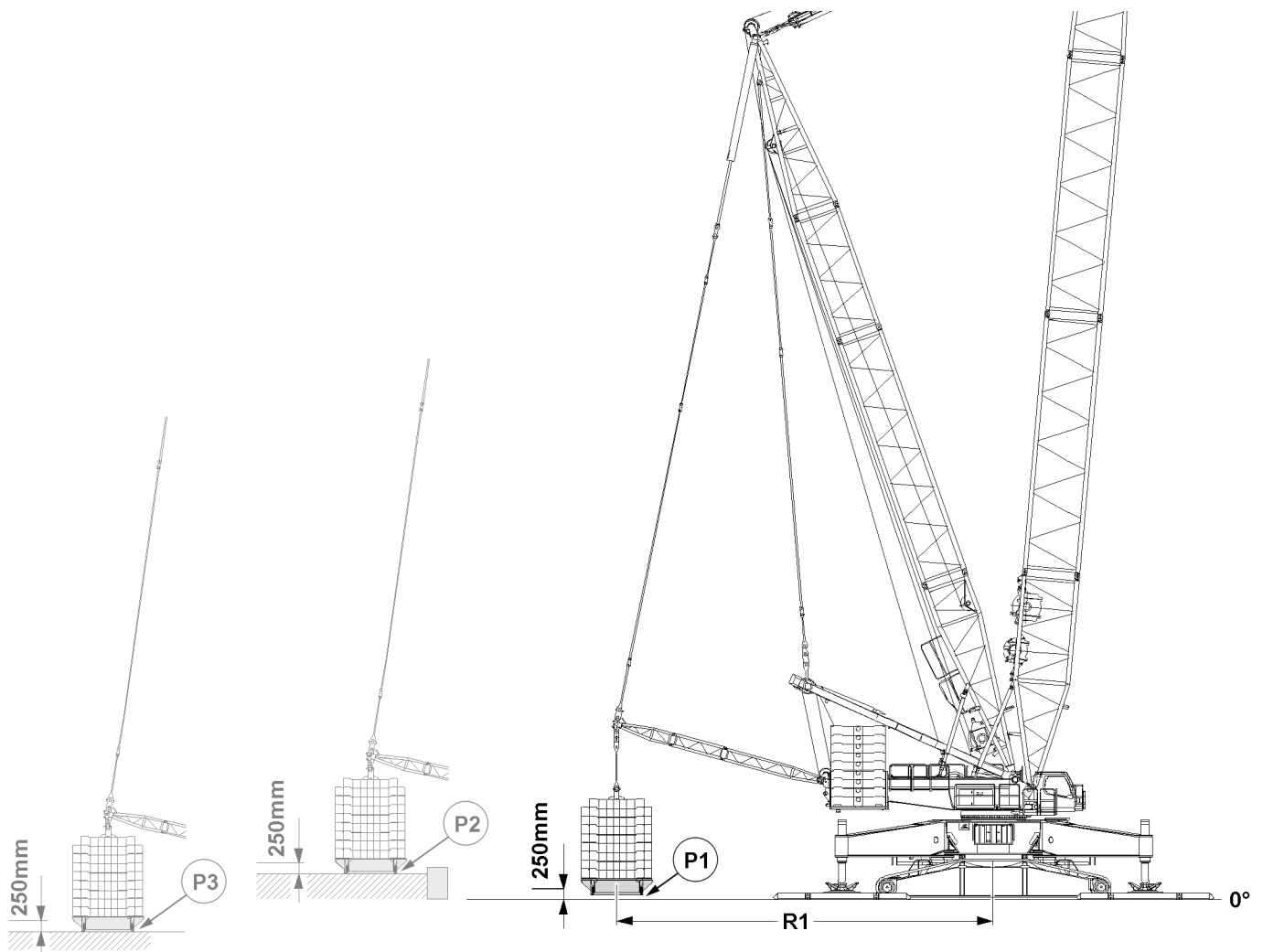

Fig.149277: Narrow track crane: Lifting the suspended ballast no more than maximum 250 mm from the standing level of the derrick ballast for crane operation

4 Derrick ballast radii and standing levels - standard crane

4.1 Derrick ballast without suspended ballast guide

The required derrick ballast radius is set by adjusting the derrick boom.

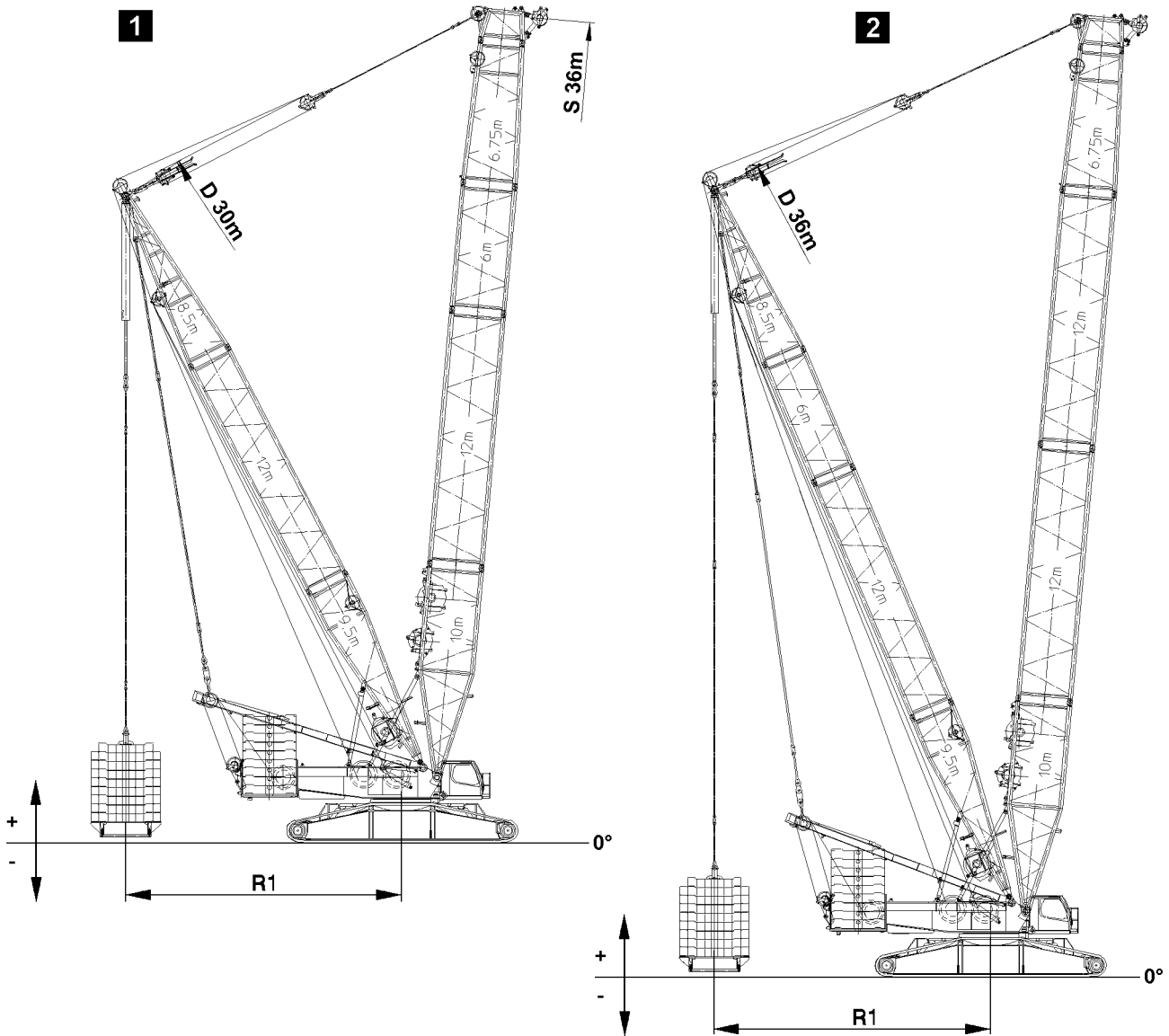

Fig.119205: Derrick ballast standing levels without suspended ballast guide

4.1.1 30 m derrick



Note

► For the 30 m derrick there is only one operating mode with S- 36 m , observe the load chart.

Derrick ballast radius R1	Derrick ballast standing level	
	Over standing level	Below standing level
10 m	+ 4050 mm	- 950 mm
15 m	+ 1550 mm	- 3450 mm

30 m derrick without suspended ballast guide: Derrick ballast radius depending on the lifting height

LWE/LR 1600-2-008/18109-09-02/en

4.1.2 36 m derrick

Derrick ballast radius R1	Derrick ballast standing level	
	Over standing level	Below standing level
10 m	+ 4410 mm	- 590 mm
18 m	+ 750 mm	- 4250 mm

36 m derrick without suspended ballast guide: Derrick ballast radius depending on the lifting height

4.2 Derrick ballast with suspended ballast guide



Note

- ▶ The **derrick ballast radius** is **not** identical to the **derrick radius**.
- ▶ One suspended ballast guide is installed between the turntable and the suspended ballast pallet.

The required derrick ballast radius is set by the length of the suspended ballast guide and by adjusting the derrick boom.

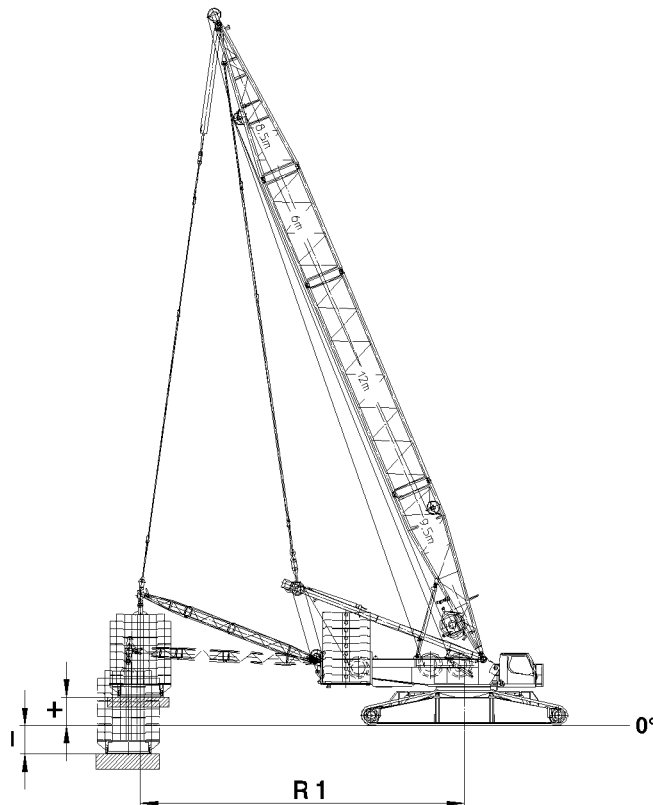

Fig.119256: Derrick ballast standing levels with suspended ballast guide

4.2.1 36 m derrick

Derrick ballast radius R1	Derrick ballast standing levels	
	Over standing level	Below standing level
15 m	+ 1500 mm	- 1500 mm
17.5 m	+ 1500 mm	- 1500 mm
20 m	+ 1500 mm	- 1500 mm

36 m derrick with suspended ballast guide: Derrick ballast radius depending on the lifting height

5 Derrick ballast radii and standing levels - narrow track crane

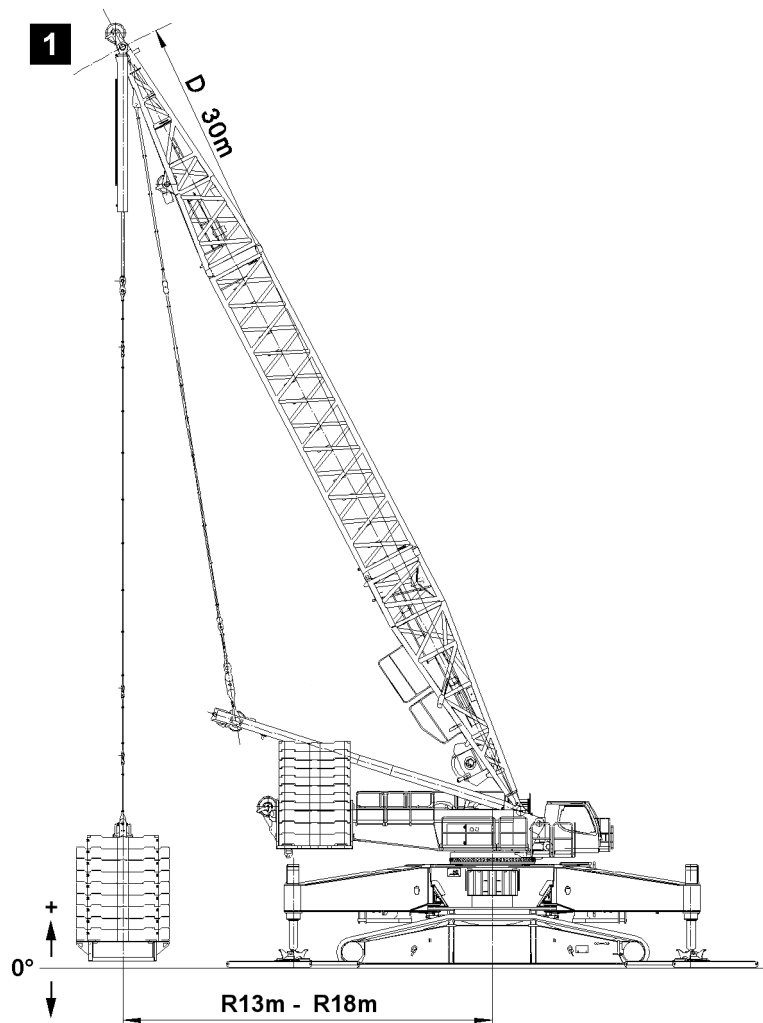

Fig.146509: Derrick ballast standing levels without suspended ballast guide



Note

- ▶ No guide is installed between the turntable and the suspended ballast pallet.
- ▶ The derrick ballast radius and the derrick boom radius are identical.
- ▶ The derrick ballast radius changes depending on the derrick boom radius.

The following derrick ballast radii can be set:

- R 13 m
- R 16 m
- R 18 m

5.1 30 m derrick

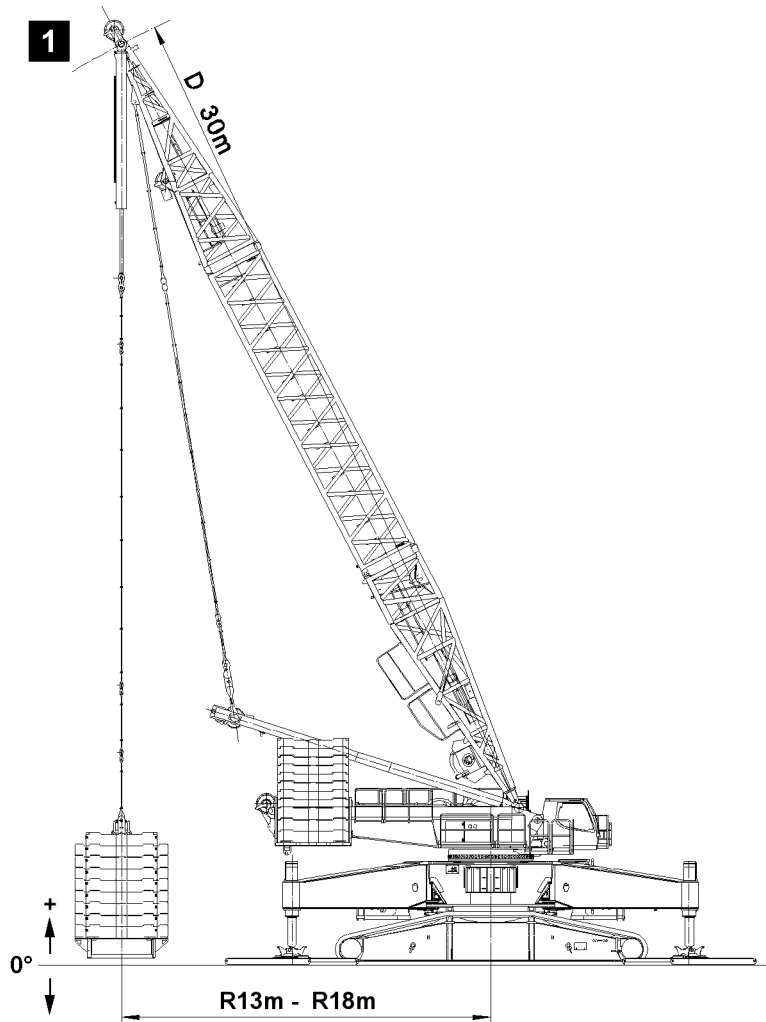

Fig.146509

With the 30 m derrick, the following radii are possible: R 13 m and R 16 m , see illustration 1.

5.1.1 Standing levels of the suspended ballast, reference placement surface of the crawler

Derrick ballast radius	Derrick ballast standing levels	
	Above standing levels	Below standing levels
R 13 m		
Crawler and support cylinder are standing on the ground	2370 mm	- 2620 mm
Support cylinder extended all the way	+ 2840 mm	- 2150 mm

LWE/LR 1600-2-008/18109-09-02/en

Derrick ballast radius R 16 m	Derrick ballast standing levels	
	Above standing levels	Below standing levels
Crawler and support cylinder are standing on the ground	+ 580 mm	- 4400 mm
Support cylinder extended all the way	+ 1050 mm	- 3930 mm

5.2 36 m derrick

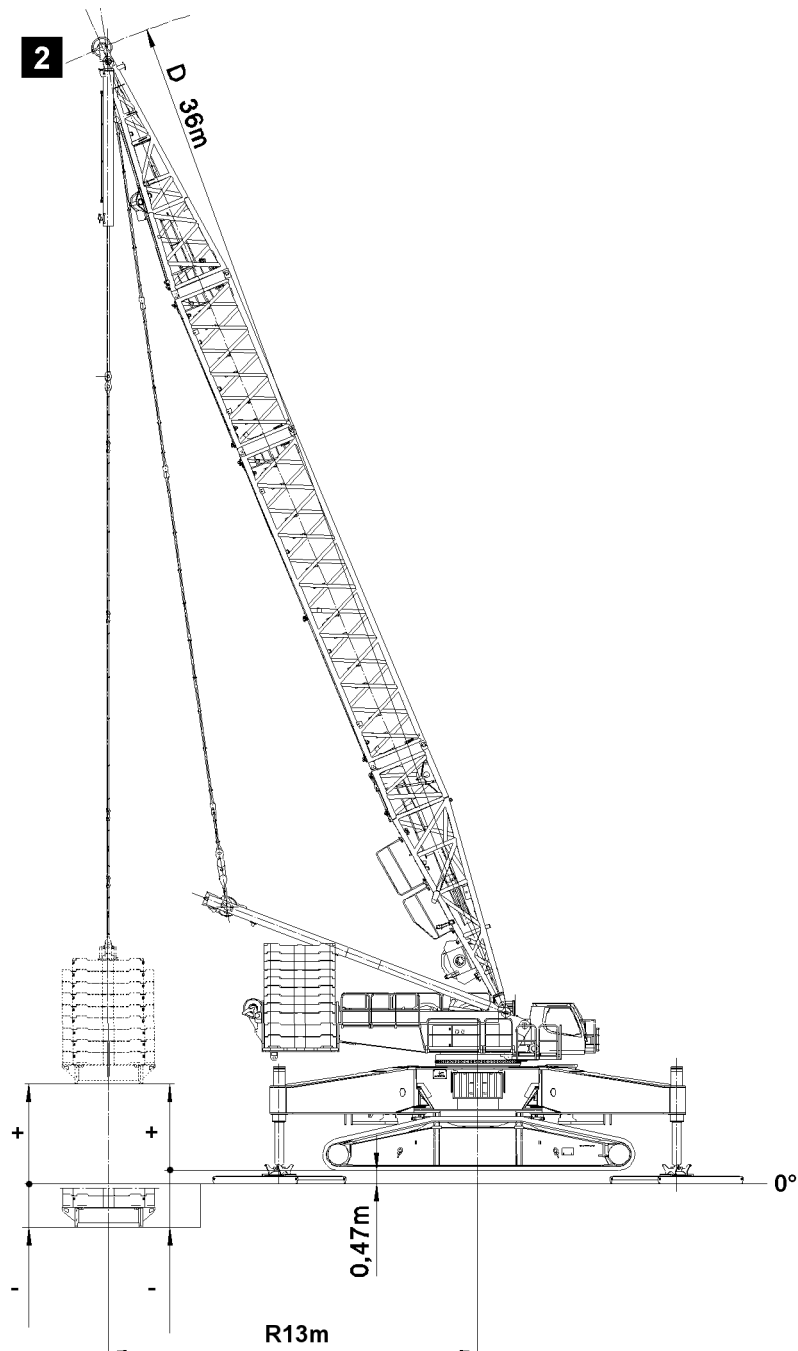

Fig. 146511

With the 36 m derrick, the following radii are possible: R 13 m and R 18 m.

Example: 36 m derrick with radius R 13 m , see illustration 2.

5.2.1 Standing levels of the suspended ballast, reference placement surface of the crawler

Example: 36 m derrick with radius R 13 m , see illustration 2.

Derrick ballast radius R 13 m	Derrick ballast standing levels	
	Over standing level	Below standing level
Crawler and support cylinder are standing on the ground	+ 3000 mm	- 2000 mm
Support cylinder extended all the way	+ 3470 mm	- 1530 mm

Derrick ballast radius R 18 m	Derrick ballast standing levels	
	Over standing level	Below standing level
Crawler and support cylinder are standing on the ground	+ 430 mm	- 4560 mm
Support cylinder extended all the way	+ 900 mm	- 4090 mm

5.3 36 m derrick with suspended ballast guide

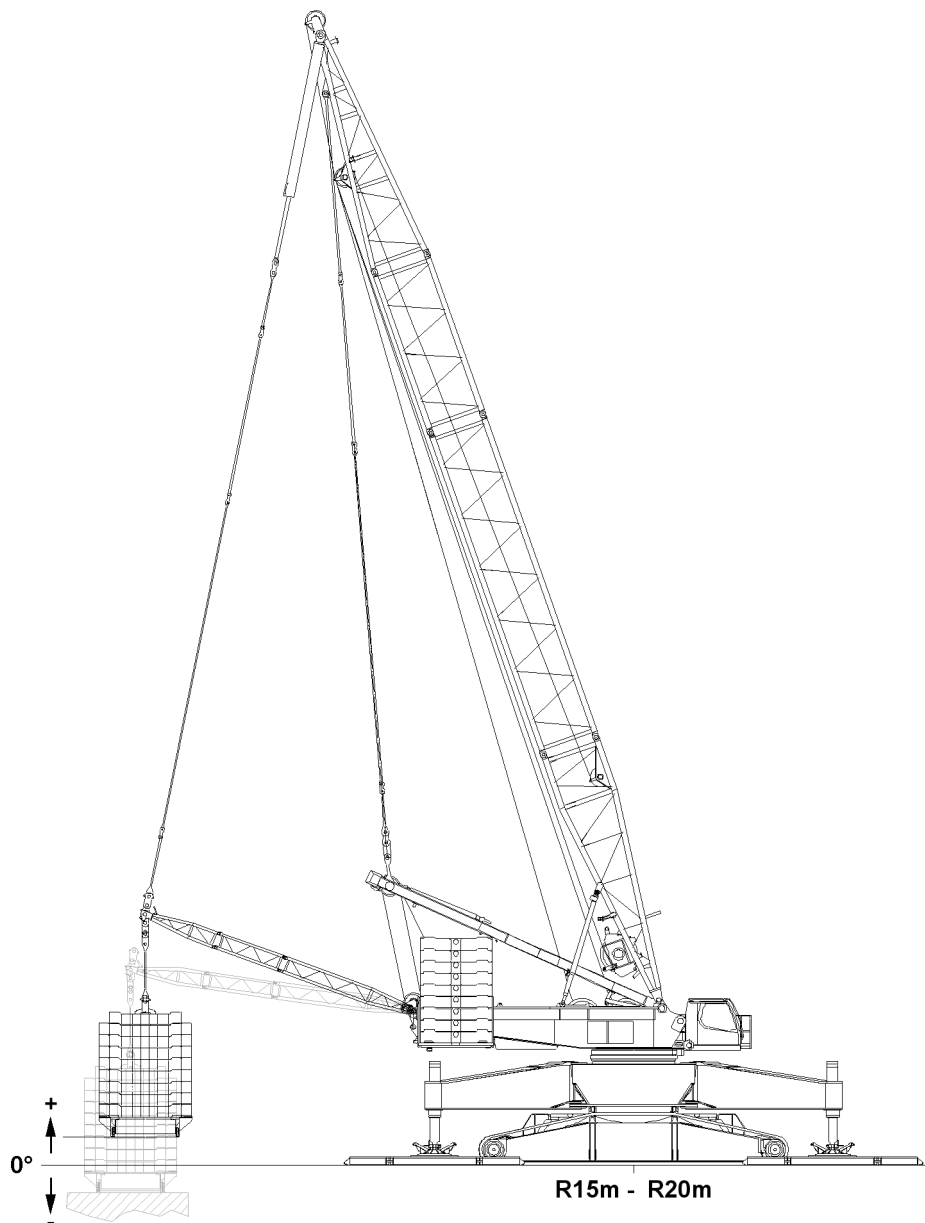

Fig.146513: Derrick ballast standing levels with suspended ballast guide

With the 36 m derrick, the following radii are possible: R 15 m to R 20 m.

5.3.1 Standing levels of the suspended ballast



Note

► Reference: Crane placement surface with crane support / narrow track and suspended ballast placement surface.

Example: 36 m derrick with derrick ballast radius R 15 m to R 20 m.

Derrick ballast radius R 15 m to R 20 m	Derrick ballast standing level	
	Over standing level	Below standing level
Crawler and support cylinder are standing on the ground	- 1000 mm	+ 1000 mm

6 Assembling



WARNING

Danger of falling!

During assembly / disassembly, inspection and maintenance work, personnel must be secured with appropriate aids to prevent them from falling.

If this is not observed, the assembly personnel can fall down.

Death, severe bodily injuries, property damage.

- ▶ All work at a height, when there is a danger of falling, must be carried out with suitable aids.
- ▶ If aids are not available and work cannot be carried out from the ground, then assembly personnel must secure themselves with the supplied fall arrest system to prevent falling, see chapter 2.04.
- ▶ If fall protection equipment is available, then it must be used, see chapter 2.06.
- ▶ When lifting, lowering, swinging crane parts in and out, no persons may remain in the danger zone.
- ▶ If railings are present on the components, then they must be brought into the corresponding position and secured for assembly / disassembly work.
- ▶ Only step on the aids, ladders and catwalks with clean shoes.
- ▶ Keep aids, ladders and catwalks free of heavy dirt, snow and ice.
- ▶ During all assembly and disassembly work, maintenance work and inspections, travel or crane operation is prohibited.
- ▶ Remaining on a suspended load is prohibited.
- ▶ Stepping or walking on crane components and lattice sections, which have an incline of more than 20° is prohibited.
- ▶ For all assembly work, the crane operator of the main crane must be in voice contact with the crane operator / crane operators of the auxiliary crane / auxiliary cranes.
- ▶ For assembly / disassembly tasks, the crane operator may only initiate crane movements when the responsible guide has explicitly released the movement.



WARNING

Danger of impact / crushing!

When installing / removing crane components with the auxiliary crane, crane components can start to swing back and forth.

When lifting / lowering and positioning crane components, there is an increased danger of impacts / crushing.

Death, severe bodily injuries, property damage.

- ▶ Make sure that personnel cannot be caught by components.
- ▶ When working in danger zones: Use aids to protect limbs.
- ▶ Guide components with suitable aids to minimize oscillation.



DANGER

The components can fall down!

If the corresponding component is disengaged from the auxiliary crane before the corresponding component is pinned, then the corresponding component can fall down.

Death, severe bodily injuries, property damage.

- ▶ Do not disengage the auxiliary crane until the respective component is pinned and secured.

Make sure that the following prerequisites are met:

- The crane is properly supported (LR1600/2-W narrow track).
- The crane is horizontally aligned.
- An auxiliary crane is available.
- The main boom and the derrick boom are installed on the turntable.
- The main boom and the derrick boom are in crane operating position.
- The counterweight has been installed on the turntable according to the load chart.
- The LICCON overload protection has been set according to the data in the load chart.
- The LICCON overload protection settings have been compared with the actual set up configuration.

7 Assembling the suspended ballast guide*

The mechanical suspended ballast guide makes different derrick ballast radii possible.

The derrick ballast radius determines the number of intermediate sections which must be installed, see chart.

Derrick ballast radius R1	Number of intermediate sections
15.0 m	0
17.5 m	1
20.0 m	2

Dependency between derrick ballast radius and number of intermediate sections

7.1 Removing the transport unit

Make sure that the following prerequisites are met:

- The transport unit is on the transport vehicle.
- An auxiliary crane is available.

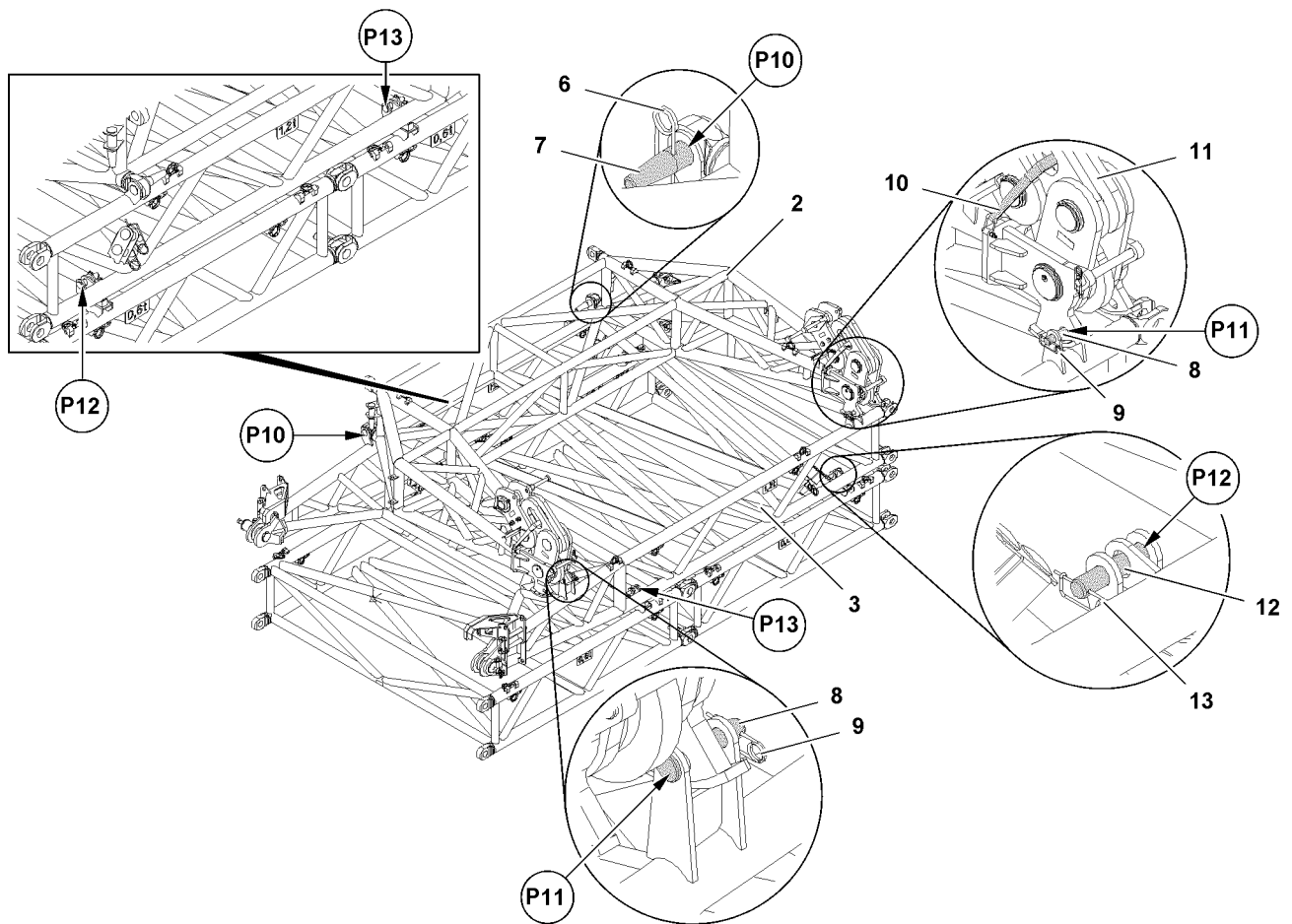

Fig.118549: Removing the suspended ballast guide transport unit



WARNING

Unsecured brackets 11!

Death, severe bodily injuries, property damage.

► Make sure that the brackets 11 on both sides are secured with transport straps 10.

- Release and remove the riggings on the transport vehicle.
- Fasten the auxiliary crane to the end section 2.
- Secure the end section 2 with an auxiliary crane to prevent it from falling.

The end section is unpinned at four points. Every point is present on both sides of the component on one level.

- Unpin the end section 2 at point P10: Remove spring retainers 6 and unpin pins 7.
- Unpin the end section 2 at point P11: Remove spring retainers 9 and unpin pins 8.
- Take the end section 2 down on the ground with the auxiliary crane.
- Fasten the auxiliary crane to the pivot section 3.
- Secure the pivot section 3 with an auxiliary crane to prevent it from falling.

The pivot section is unpinned at four points. Every point is present on both sides of the component on one level.

- Unpin the pivot section 3 on both sides at point P12: Remove spring retainers 13 and unpin pins 12.
- Unpin the pivot section 3 on both sides at point P13: Remove spring retainers 13 and unpin pins 12.
- Take the pivot section 3 down on the ground with the auxiliary crane.

7.2 Assembling the components for the suspended ballast guide



Note

- ▶ The assembly procedure is described for the 20 m derrick ballast radius.
- ▶ For the 17.5 m derrick ballast radius, an intermediate section is solely installed.
- ▶ For the 15 m derrick ballast radius, **no** intermediate section is installed.

Make sure that the following prerequisites are met:

- The transport unit is removed.
- Suitable material for support is available.

7.2.1 Assembling the pivot section

Make sure that the following prerequisite is met:

- Both intermediate sections are installed and horizontally supported.

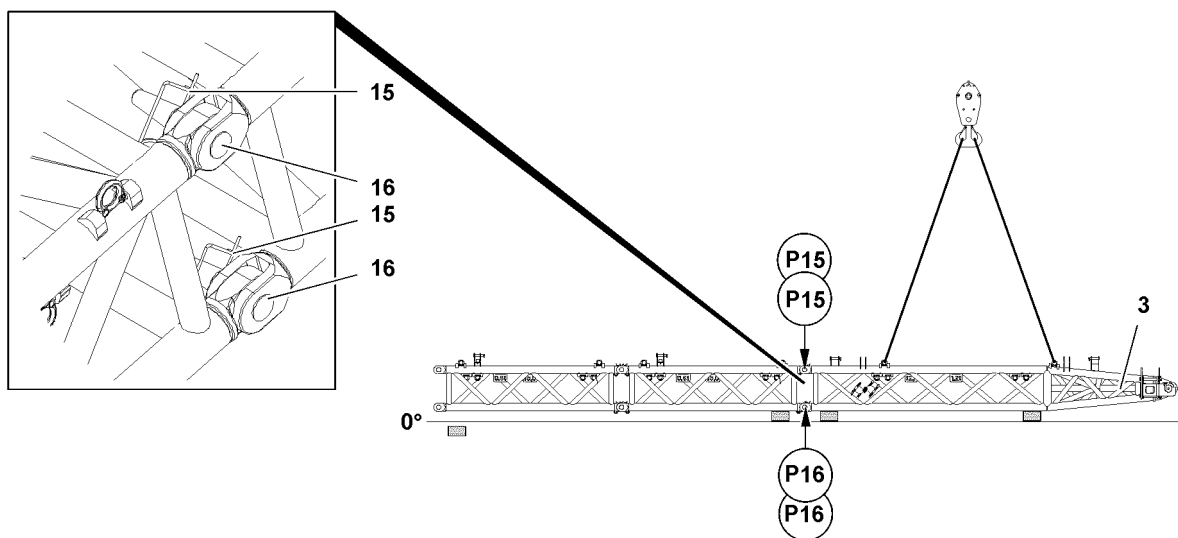

Fig.118913: Assembling the pivot section

- ▶ Make sure that the pins **16** are unpinned.
- ▶ Position the pivot section **3** on the intermediate section with the auxiliary crane until the pin points align.
- ▶ Support the pivot section **3**.

The pivot section and the intermediate section are pinned together at four points. Every point is present on both sides of the component on one level.

- ▶ Pin the pivot section **3** at point **P15** to the intermediate section: Insert the pins **16** and secure with the spring retainers **15**.
- ▶ Pin the pivot section **3** at point **P16** to the intermediate section: Insert the pins **16** and secure with the spring retainers **15**.
- ▶ Remove the fastening equipment.

7.2.2 Assembling the end section

Make sure that the following prerequisite is met:

- The assembled lattice sections are horizontally supported.

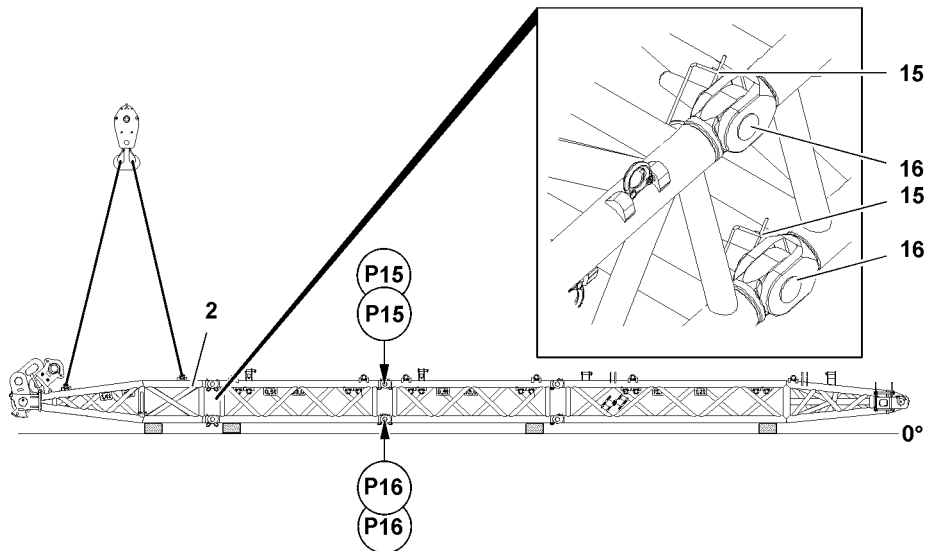

Fig.118914: Assembling the end section

- ▶ Make sure that the pins **16** are unpinned.
- ▶ Position the end section **2** on the intermediate section with the auxiliary crane until the pin points align.
- ▶ Support the end section **2**.

The end section and the intermediate section are pinned together at four points. Every point is present on both sides of the component on one level.

- ▶ Pin the end section **2** at point **P15** to the intermediate section: Insert the pins **16** and secure with the spring retainers **15**.
- ▶ Pin the end section **2** at point **P16** to the intermediate section: Insert the pins **16** and secure with the spring retainers **15**.
- ▶ Remove the fastening equipment.

Result:

- The components of the suspended ballast guide are assembled.

7.3 Assembling the suspended ballast guide on the turntable frame

Make sure that the following prerequisites are met:

- 17.5 m derrick ballast radius: Suitable material for the substructure of the end section is available.
- 20.0 m derrick ballast radius: An auxiliary crane or suitable aid is available for the substructure of the end section.

7.3.1 Folding the consoles into working position

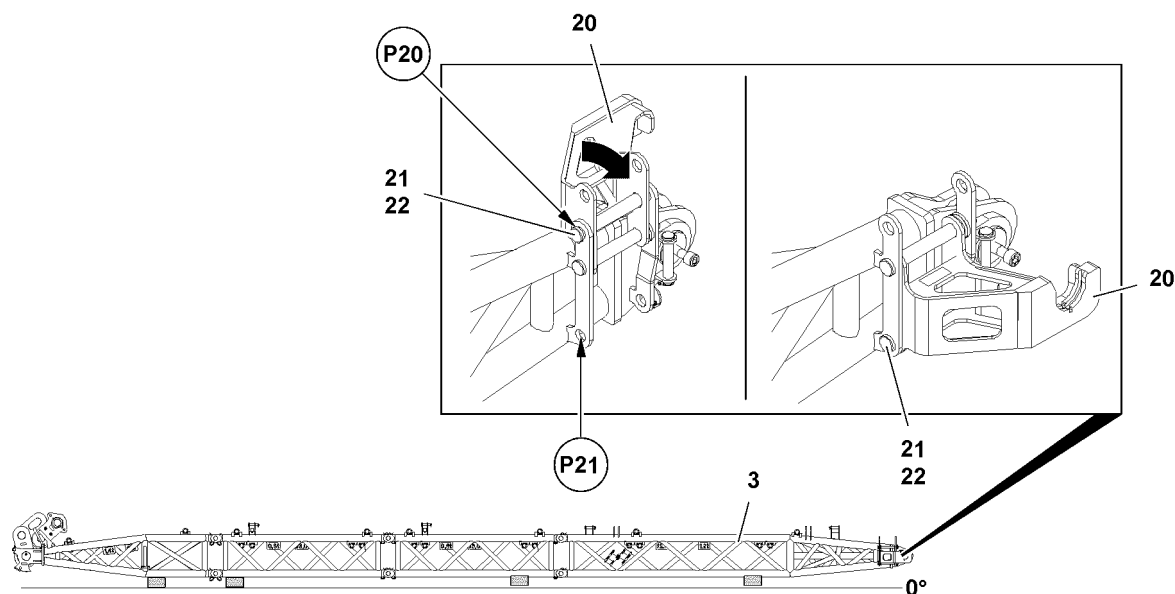

Fig.118915: Folding the consoles into working position

To be able to hang the pin pulling cylinders on the consoles, the consoles are folded on both sides on the pivot section into working position.

When the pin **21** is unpinned, then the console **20** can fold down.

- ▶ Secure the console **20** to prevent it from folding down.
- ▶ Unpin the console **20** at point **P20**: Remove the locking pin **22** and unpin the pin **21**.
- ▶ Fold the console **20** down in a controlled manner.
- ▶ Pin the console **20** at point **P21**: Insert the pin **21** and secure with the locking pin **22**.
- ▶ Fold the second console into the pin position, pin and secure.

7.3.2 Pinning the suspended ballast guide on the turntable

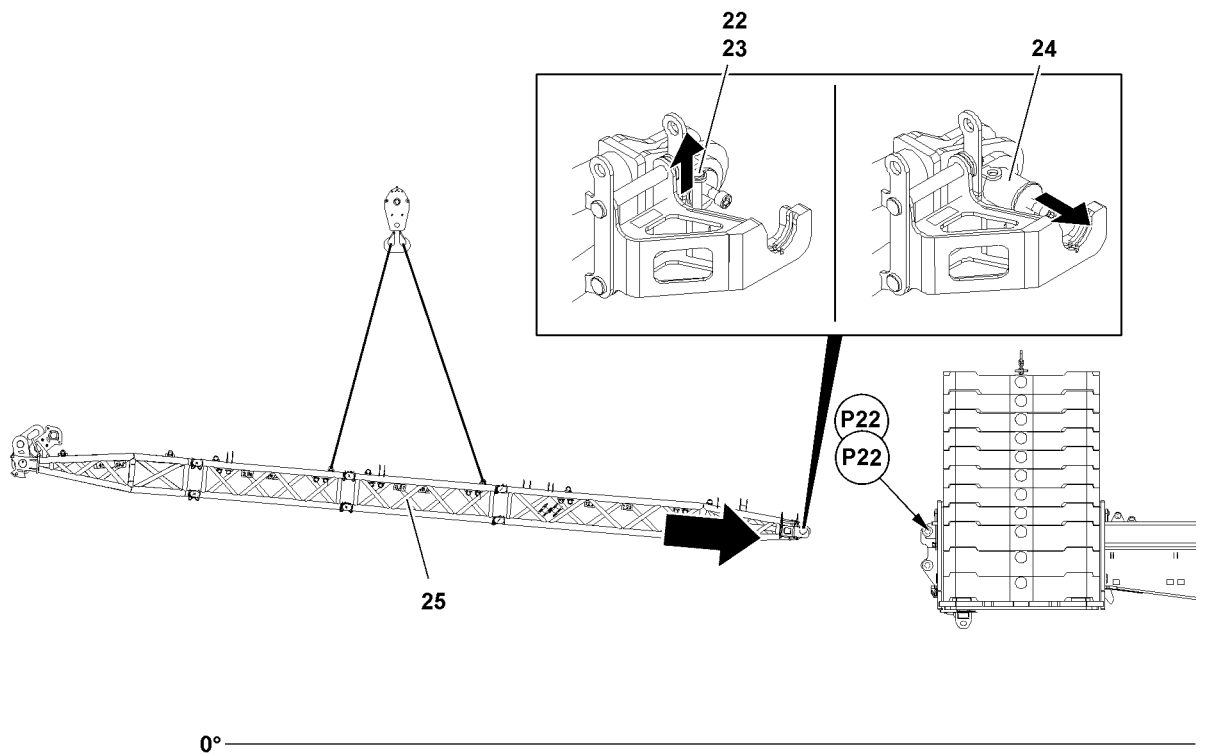

Fig.146514: Pinning the suspended ballast guide 25 on the turntable

The suspended ballast guide is fastened to the auxiliary crane in such a way that the end section is lifted slightly at an angle and the pivot section is lowered slightly at an angle.

- ▶ Fasten the suspended ballast guide 25 to the auxiliary crane.

The suspended ballast guide 25 is pinned on both sides on point P22.

- ▶ Lift the suspended ballast guide 25 to the pin points on the rear of the turntable.

The pins 24 are unpinned on both sides on the suspended ballast guide 25 so that the suspended ballast guide can be positioned on the pin points.

- ▶ Release the pin 24: Remove the spring retainer 23 and unpin the retaining pin 22.
- ▶ Unpin the second pin 24.
- ▶ Position the suspended ballast guide 25 on the rear of the turntable until the pin bores align.



Note

- ▶ Pin with the pin pulling device, see chapter 5.30.

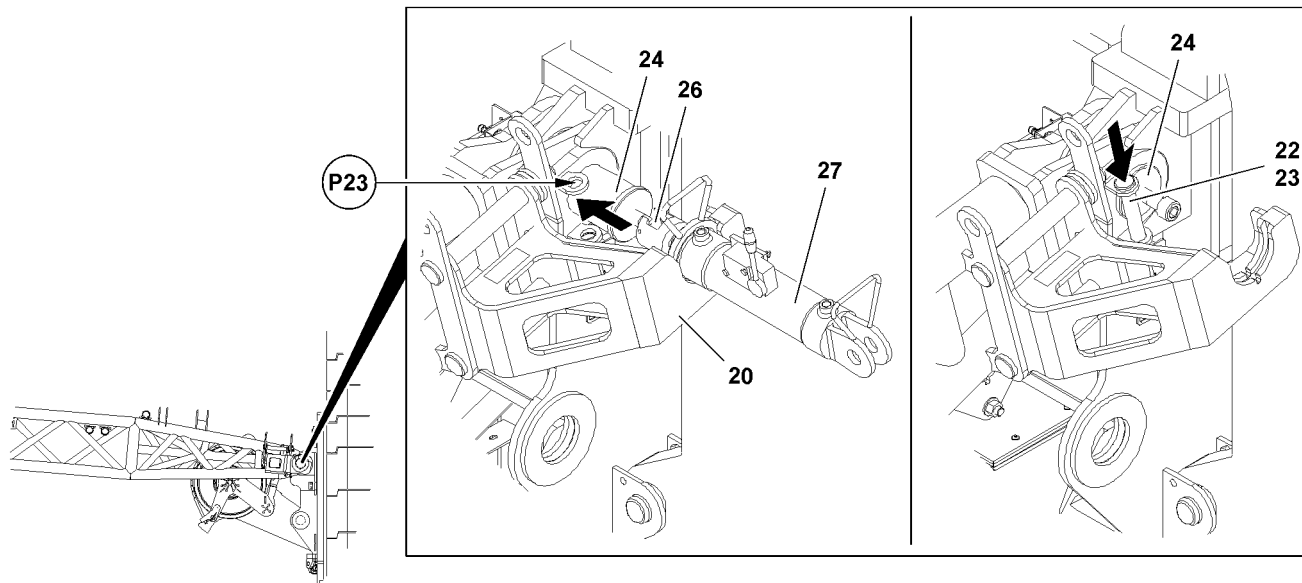

Fig.118916: Inserting the pins with the pin pulling device

The suspended ballast guide is pinned on two points. The pin procedure is described for one pin as an example.

- ▶ Insert the pin pulling cylinder **27** on the console **20** and hang on the screw **26**.
- ▶ Pin the suspended ballast guide on the turntable: Insert the pin **24** with the pin pulling cylinder **27**.
- ▶ Secure the pin **24**: Insert the retaining pin **22** at point **P23** and secure with spring retainer **23**.
- ▶ Insert the second pin **24** on the suspended ballast guide.

7.4 Assembling the guy rods on the suspended ballast guide

7.4.1 Standard crane

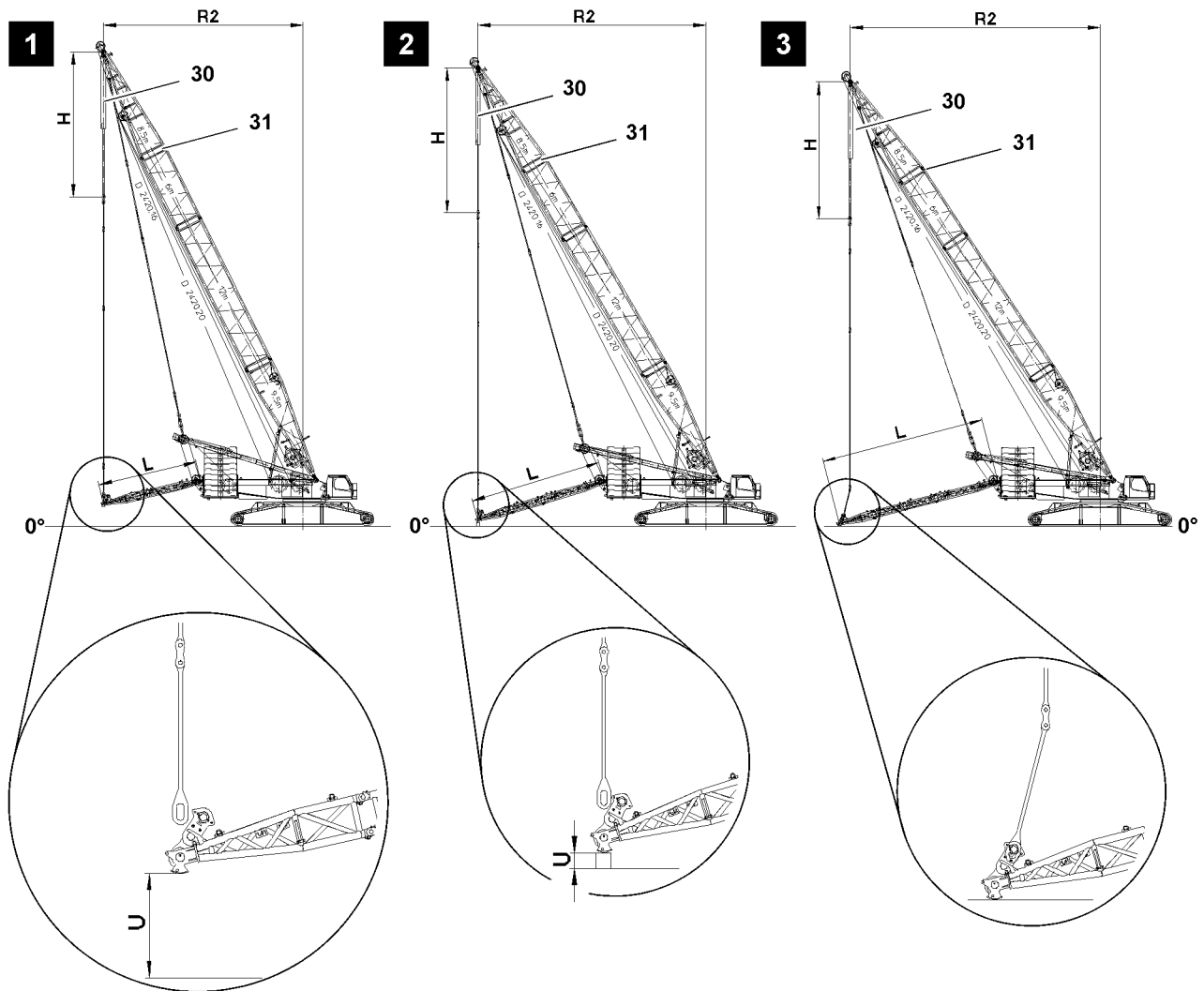

Fig.118919: Assembly positions depending on the derrick ballast radius

Make sure that the following prerequisites are met:

- The suspended ballast guide is properly pinned and secured on the rear of the turntable.
- The assembly substructure for the suspended ballast guide is properly prepared with the required height and load bearing capacity.

Depending on the derrick ballast radius, the suspended ballast guide is supported after assembly on the turntable on the end section of the suspended ballast guide. Height of the substructure **U**, see chart.

To be able to pin the end section of the suspended ballast guide on the D-guy rods, the derrick radius **R2** and the dimension **H** are set depending on the derrick ballast radius **R1** respectively with the derrick boom **31** and the hoist cylinders **30**, see chart.

Derrick ballast radius R1	Illustration	L	R2	H	U
15.0 m	1	7575 mm	15133 mm	11000 mm	1465 mm
17.5 m	2	10025 mm	17348 mm	11000 mm	250 mm
20.0 m	3	12475 mm	19000 mm	10400 mm	End section is placed on the ground

When the 15.0 m derrick ballast radius is installed:

- ▶ Lower the suspended ballast guide with the auxiliary crane to height **U** or take down the end section on a substructure, height **U**.

When the 17.5 m derrick ballast radius is installed:

- ▶ Lower the suspended ballast guide with the auxiliary crane and take down the end section on the substructure, height **U**.

When the 20.0 m derrick ballast radius is installed:

- ▶ Lower the suspended ballast guide with the auxiliary crane and take the end section down on the ground.
- ▶ Set the derrick boom **31** and the hoist cylinder **30** to the derrick radius **R2** and dimension **H**.

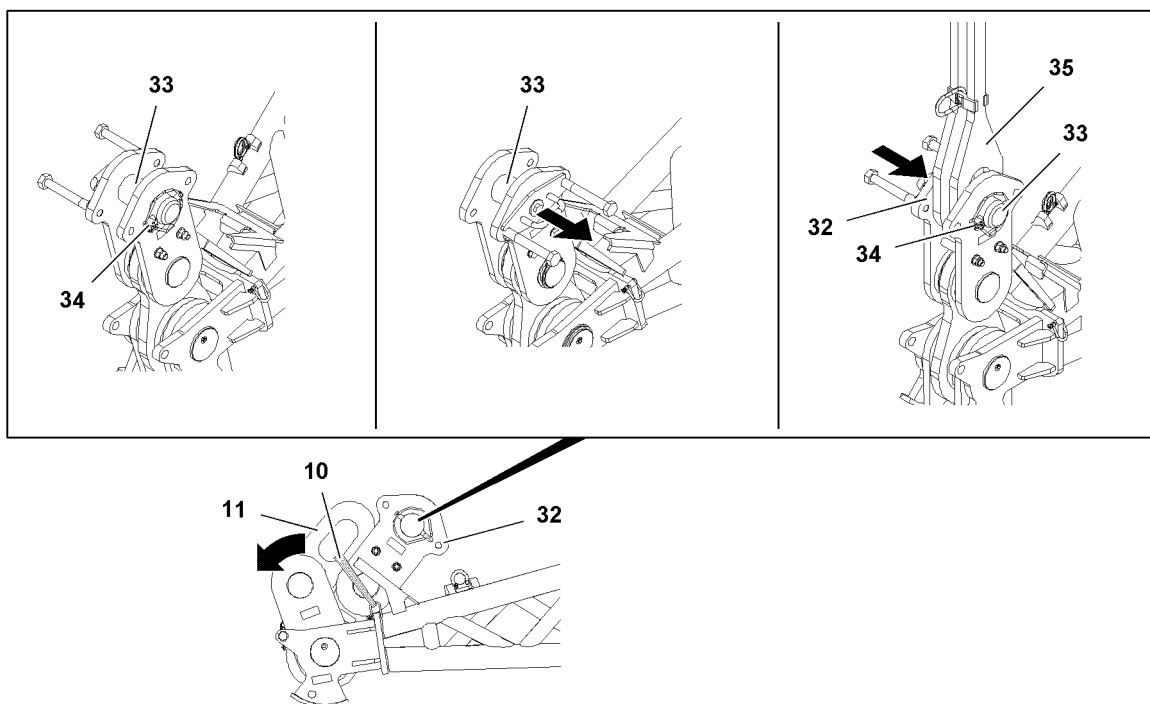

Fig.118920: Assembling the guy rods on the end section of the suspended ballast guide

- ▶ Remove the transport straps **10**.
- ▶ On both sides, take the brackets **11** down to the rear or fold them down.

The D-guy rods **35** are pinned on both sides on the end section. The pin procedure is described on the example for one D-guy rod.

- ▶ Remove the locking pin **34** and unpin the pin **33**.
- ▶ Position the brackets **32** and the D-guy rods **35** until the pin bores align.
- ▶ Pin the D-guy rods **35** on the brackets **32**: Insert the pin **33** and secure with the locking pin **34**.
- ▶ Assemble the second D-guy rod **35** on the end section of the suspended ballast guide.

Result:

- The suspended ballast guide is assembled.

7.4.2 Narrow track crane

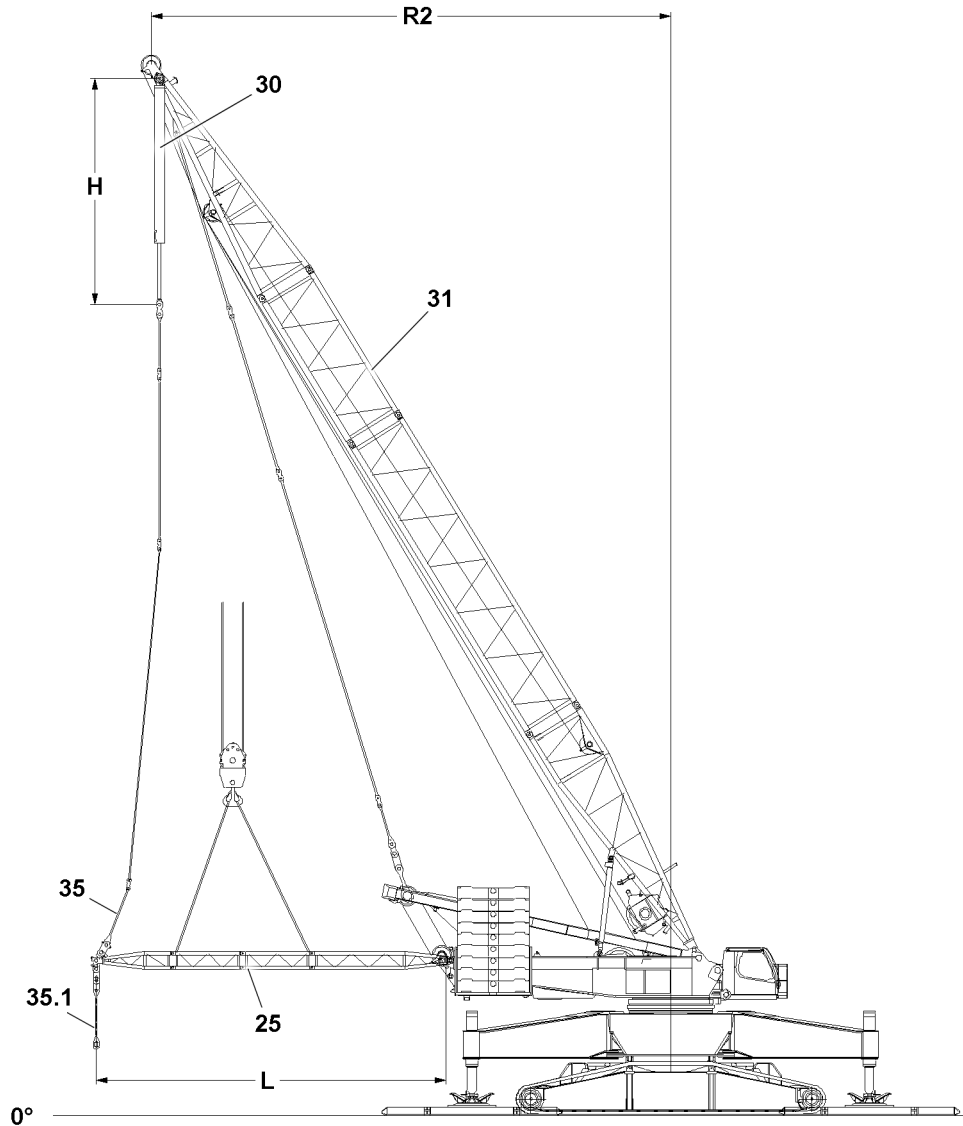

Fig.146512: Assembly positions depending on the derrick ballast radius

Make sure that the following prerequisites are met:

- The suspended ballast guide is properly pinned and secured on the rear of the turntable.
- The suspended ballast guide is safely held by the auxiliary crane.

Assembling the D-guy rods

To be able to pin the end section of the suspended ballast guide on the D-guy rods, set the derrick boom 31 to the derrick boom radius R2 and the hoist cylinder 30 to the dimension H, see chart.

Derrick ballast radius R	L	R2	H
15.0 m	7575 mm	15000 mm	—
17.5 m	10025 mm	17500 mm	—
20.0 m	12475 mm	18000 mm	7956 mm

LWE/LR 1600-2-008/18109-09-02/en

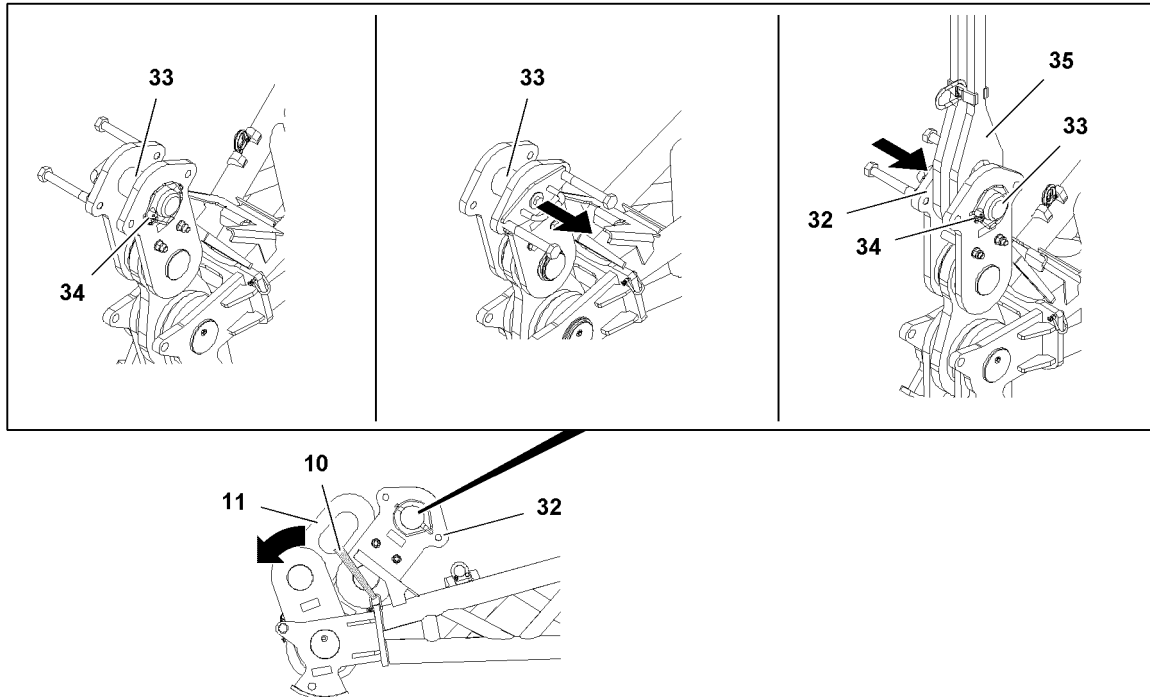

Fig.118920: Assembling the guy rods on the end section of the suspended ballast guide

- ▶ Remove the transport straps **10**.
- ▶ On both sides, take the brackets **11** down to the rear or fold them down.

The D-guy rods **35** are pinned on both sides on the end section of the suspended ballast guide. The pin procedure is described on the example for one D-guy rod.

- ▶ Remove the locking pin **34** and unpin the pin **33**.
- ▶ Position the brackets **32** and the D-guy rods **35** until the pin bores align.
- ▶ Pin the D-guy rods **35** on the brackets **32**: Insert the pin **33** and secure with the locking pin **34**.
- ▶ Assemble the second D-guy rod **35** on the end section of the suspended ballast guide.

Result:

- The suspended ballast guide is assembled.

Assembling the D-auxiliary rods for the suspended ballast



DANGER

Falling components!

If the visual inspection on the pin connections is not carried out, then the pins can release by themselves and components can fall down.

Death, severe bodily injuries, property damage.

- ▶ All pins must be secured after assembly with the intended safety elements. Check visually.
- ▶ The guy rods must be inspected regularly, see chapter 8.15.

- ▶ Fasten the D-auxiliary rods **35.1** to the auxiliary crane.
- ▶ Swing in the D-auxiliary rods **35.1** with the auxiliary crane to the suspended ballast guide.
- ▶ Position the D-auxiliary rods **2** with the auxiliary crane on the pin point of the suspended ballast guide, observe the Rod plan.
- ▶ Pin the D-auxiliary rods **35.1** on the suspended ballast guide: Insert the pin from the outside to the inside and secure properly with the retaining element.
- ▶ Assemble the second D-auxiliary rods **35.1** on the other side.

8 Assembling the suspended ballast pallet

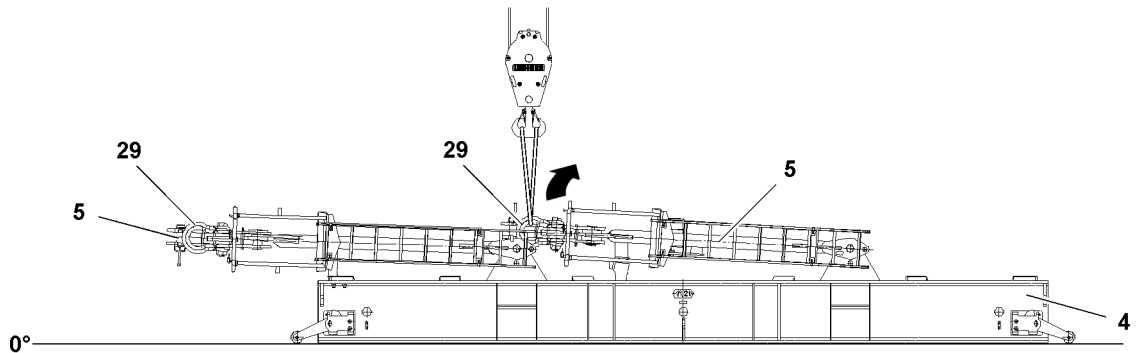

Fig.149296: Assembling the suspended ballast pallet

The pinning of the erection racks differs due to the following prerequisites:

- The suspended ballast guide* is assembled: Pin to the suspended ballast guide.
- The suspended ballast guide* is **not** assembled: Pin to the D-guy rods.

8.1 Setting the suspended ballast pallet in the assembly position

- ▶ Set the derrick boom to the required derrick boom radius.
- ▶ Hang the suspended ballast pallet **4** on the auxiliary crane and position it within the slewing range of the crane under the brackets on the suspended ballast guide*.
- or**
- ▶ Hang the suspended ballast pallet **4** on the auxiliary crane and position it within the slewing range of the crane under the D-guy rods on the derrick.



Note

- ▶ Stop the suspended ballast pallet **4** in the lengthwise direction of the turntable for easier assembly.
- ▶ Align the suspended ballast pallet **4** horizontally.

8.2 Erecting the erection racks

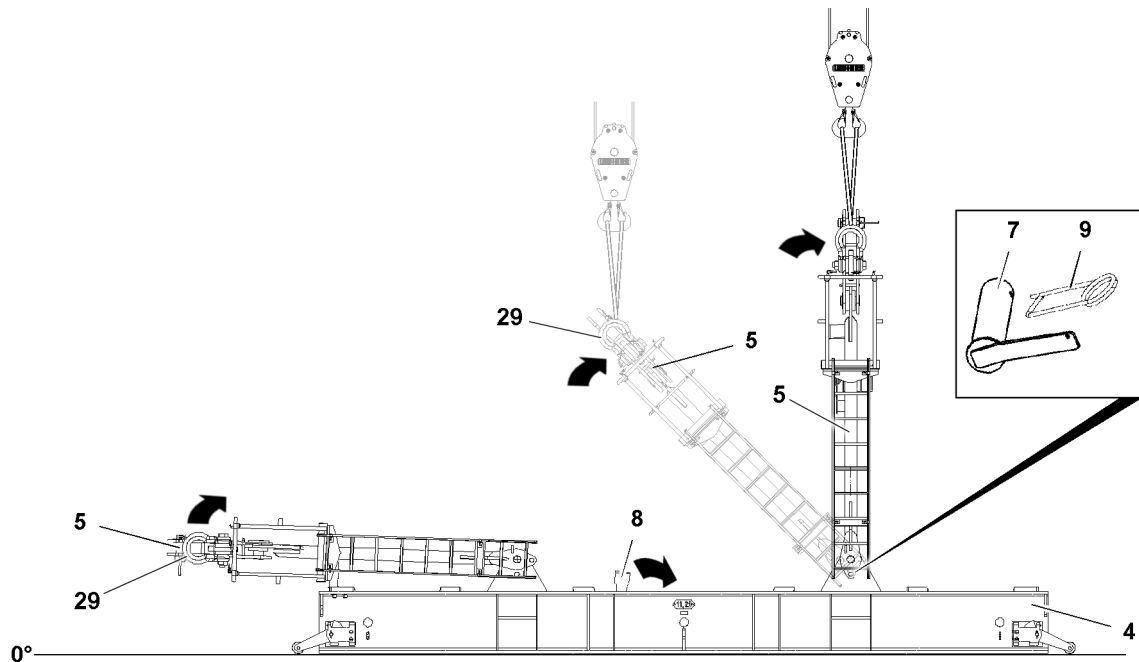

Fig.149297: Erecting the erection racks

- ▶ Assemble the shackle **29** properly on the erection racks.
- ▶ Hang the erection rack **5** on the auxiliary crane.
- ▶ Set the erection rack **5** vertically with the auxiliary crane.



DANGER

Danger of accident during assembly / disassembly of the erection racks!

The erection racks must hang securely on the auxiliary crane, otherwise the erection racks can tip over.

Death, severe bodily injuries, property damage.

- ▶ The two erection racks must be locked and secured in a vertical position with four retaining pins **7**. Only then may the auxiliary crane be removed.
- ▶ Never unpin the retaining pins of unsecured or unsupported erection racks.
- ▶ It is prohibited for anyone to remain under the erection racks or within the complete danger zone during the pinning and unpinning procedure.

- ▶ Insert the retaining pins **7** on the first erection rack **5** on both sides.
- ▶ Secure the retaining pins **7** with spring retainers **9**.
- ▶ Erect, pin and secure the second erection rack according to the assembly of the first erection rack.

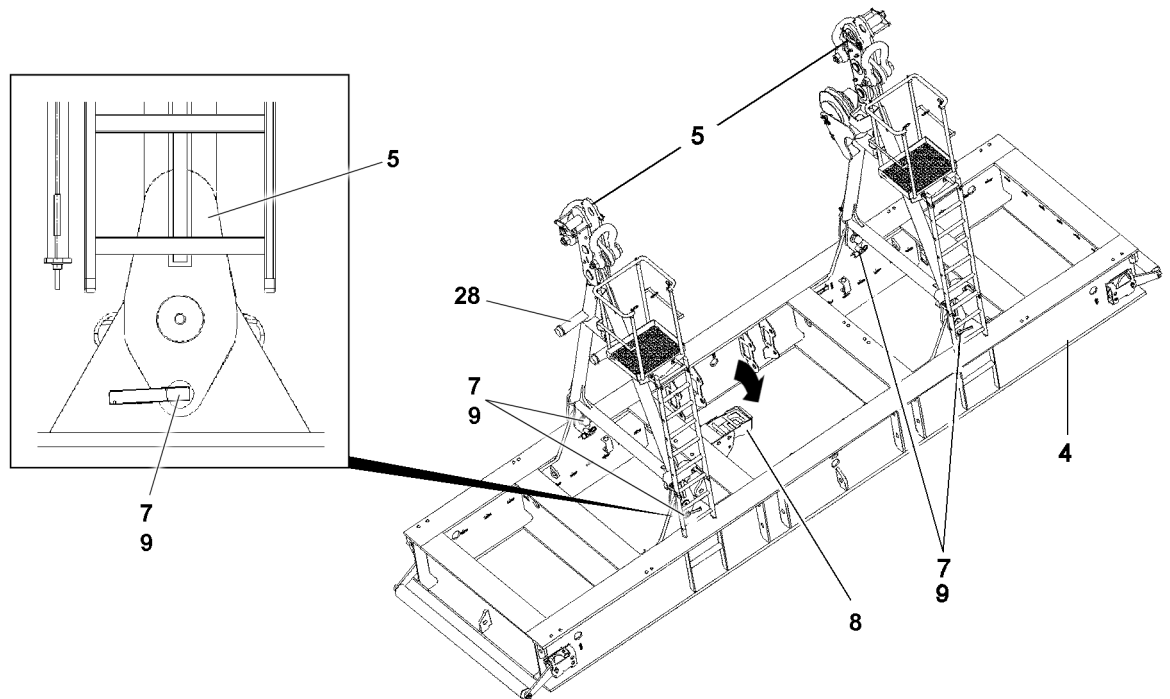

Fig. 149298

**WARNING**

Falling ballast plates!

If the support for the erection rack **8** is not brought into the park position after erecting the erection racks, then the ballast plates cannot be locked in the centerings during ballasting. The ballast plates can slip and fall from the suspended ballast pallet.

Death, severe bodily injuries, property damage.

- ▶ Make sure that the support for the erection rack **8** is folded into the park position and secured after erecting the erection racks.
- ▶ Fold the support for the erection rack **8** into the park position (arrow).
- ▶ Secure the support for the erection rack **8** in the park position with the pin and locking pin.

8.3 Assembling the consoles for ballast centering

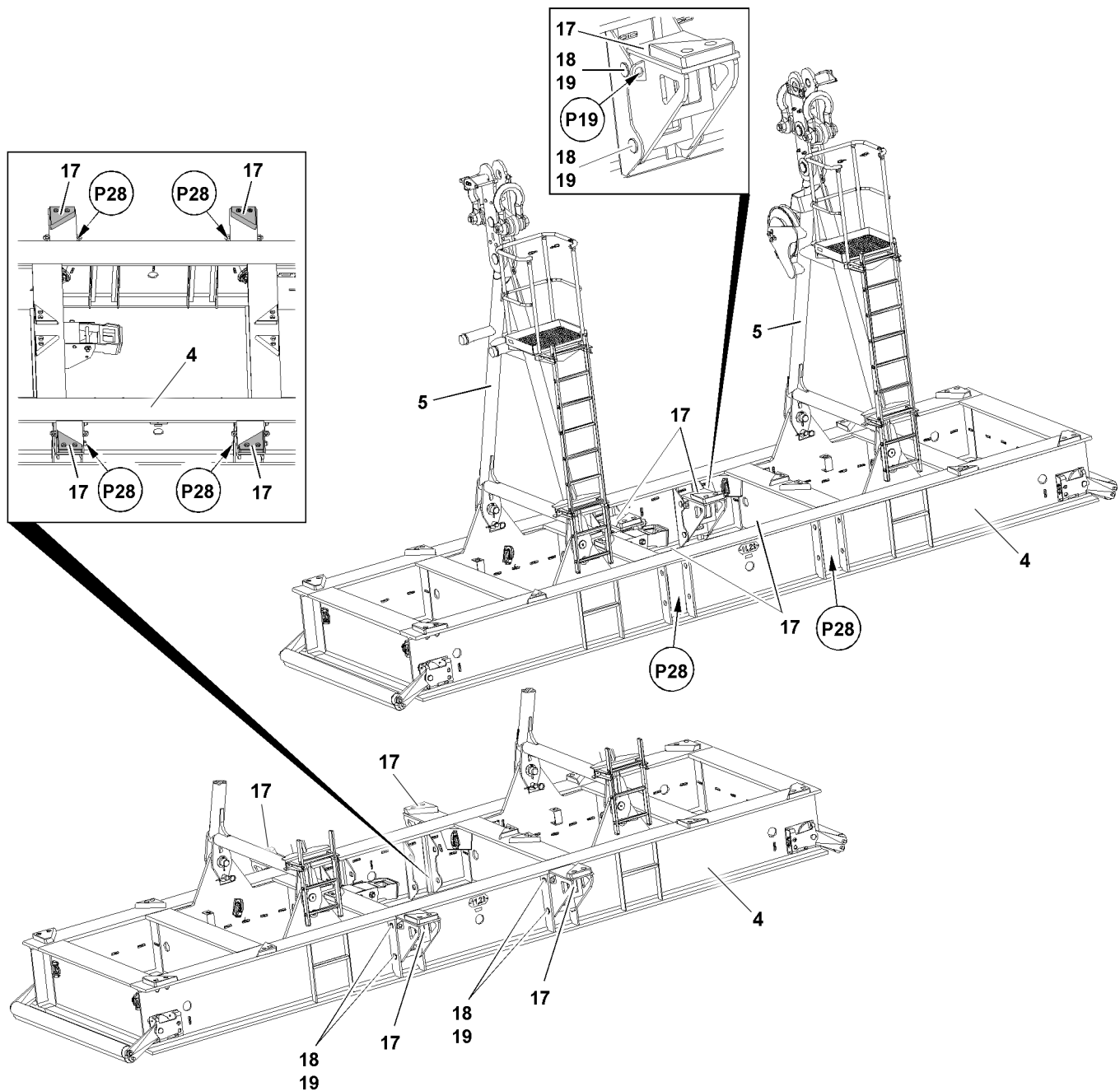

Fig.149288: Assembling the consoles for ballast centering

Make sure that the following prerequisite is met:

- The erection racks are properly pinned and secured in assembly position.



Note

- ▶ The assembly is described as an example on one console for ballast centering 17.
- ▶ The assembly of the additional consoles for ballast centering 17 is identical.

**WARNING**

Slipping ballast plates!

If the consoles for ballast centering **17** are not properly installed, then the ballast plates cannot be centered correctly.

The ballast plates can slip and fall down.

Death, severe bodily injuries, property damage.

▶ Make sure that the consoles for ballast centering **17** are properly assembled on the suspended ballast pallet. Pay attention to the alignment of the centerings.

- ▶ Fasten the console for ballast centering **17** to the auxiliary crane at points **P19**.
- ▶ Unpin the console for ballast centering **17** in the park position: Remove the spring retainer **19** and unpin the pin **18**.
- ▶ Lift the console for ballast centering **17** with the auxiliary crane from the park position **P24**.
- ▶ Swing in the console for ballast centering **17** to the operating position **P28** and pin with the pin **18** and secure with the spring retainer **19**.

When the console for ballast centering **17** is pinned and secured properly:

- ▶ Remove the auxiliary crane.
- ▶ Install additional consoles for the ballast centering **17** in operating position.

8.4 Pinning the suspended ballast pallet on the suspended ballast guide*

Make sure that the following prerequisites are met:

- The erection racks are erected and secured with four retaining pins **7**.
- Hang the brackets **11** for the suspended ballast guide over the brackets of the erection racks.
- The derrick is set to the required radius.

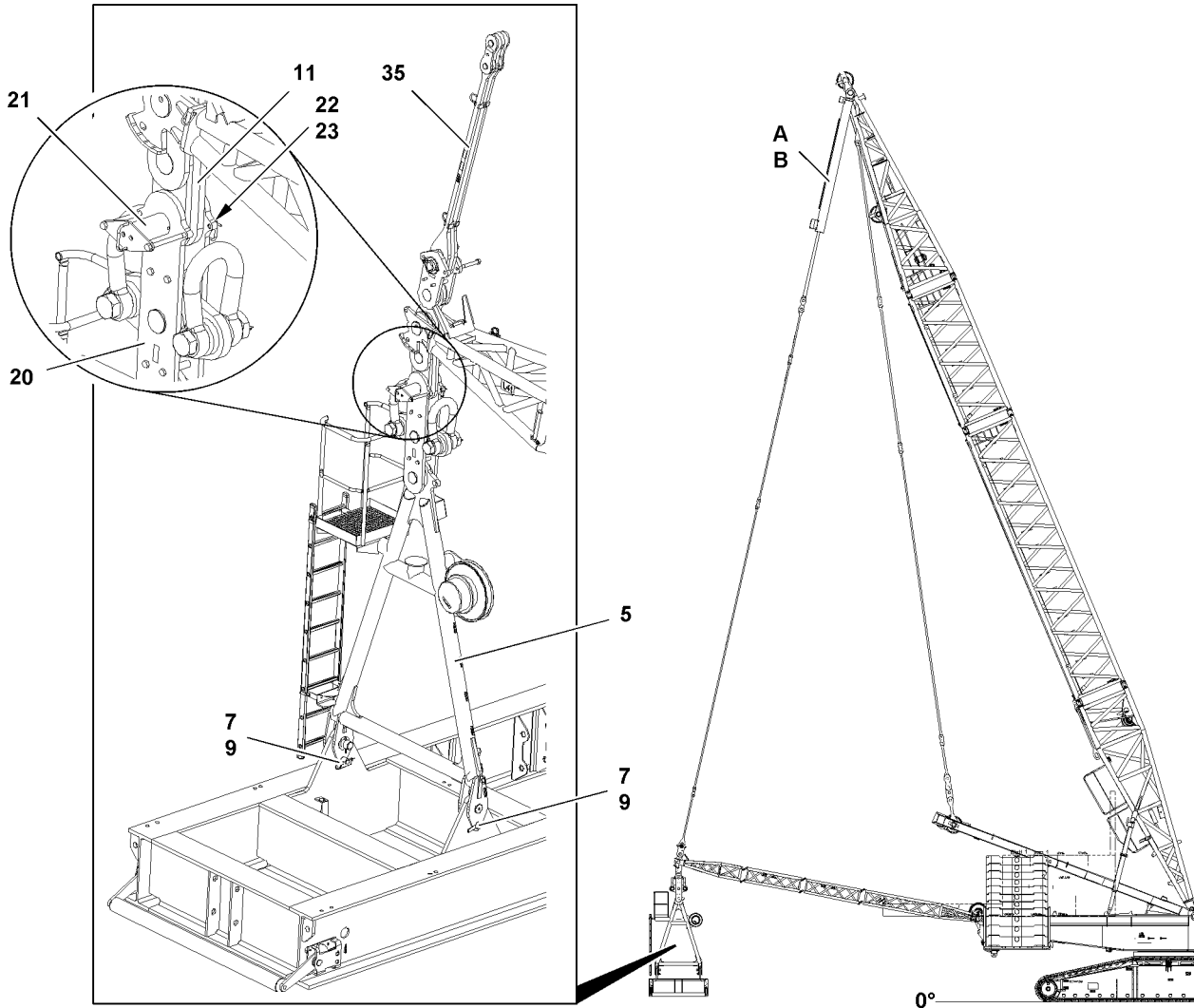

Fig.119254: Pinning the suspended ballast pallet on the suspended ballast guide

- ▶ Lower the brackets **11** by extending the piston rods on the pull cylinder **A** and on the pull cylinder **B** into the brackets **20** until the pin bores align.



WARNING

Incomplete pinning of the erection racks **5**!
Death, severe bodily injuries, property damage.

- ▶ On both erection racks: Pin the bracket **11** on the bracket **20** and secure.

The suspended ballast pallet is pinned on two points. The pin procedure is described for one pin as an example

- ▶ Pin the bracket **11** on the bracket **20**: Insert the pin **21**, insert the spacer **22** and secure with the spring retainer **23**.
- ▶ Pin the second bracket **20** to the suspended ballast guide.

8.5 Pinning the suspended ballast pallet on the D-guy rods

Make sure that the following prerequisites are met:

- The erection racks are erected and secured with four retaining pins **7**.
- The D-guy rods hang over the brackets of the erection racks.
- The derrick is set to the required radius.

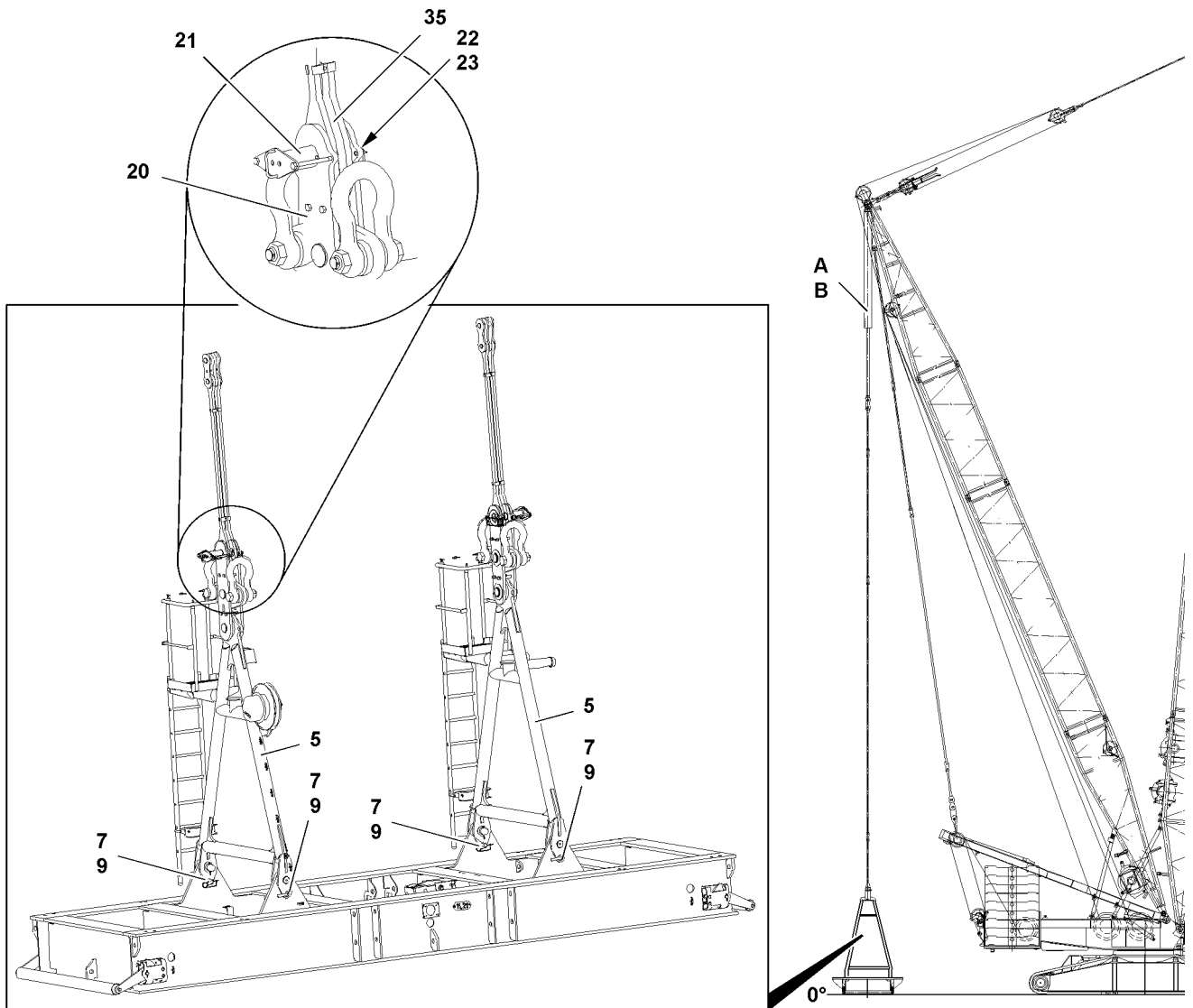

Fig.119253: Pinning the suspended ballast pallet on the D-guy rods

- ▶ Lower the D-guy rods **35** by extending the piston rods on the pull cylinder **A** and on the pull cylinder **B** into the brackets **20** until the pin bores align.



WARNING

Incomplete pinning of the erection racks **5**!
Death, severe bodily injuries, property damage.

- ▶ On both erection racks: Pin the D-guy rod **35** to the bracket **20** and secure it.

The suspended ballast pallet is pinned on two points. The pin procedure is described for one pin as an example

- ▶ Pin the D-guy rod **35** to the bracket **20**: Insert the pin **20**, insert the spacer **22** and secure with the spring retainer **23**.
- ▶ Pin the second bracket **20** to the guy rod.

8.6 Aligning the suspended ballast pallet horizontally



WARNING

Uncontrolled swinging of the suspended ballast pallet!
When the suspended ballast pallet is lifted, it can start to swing.
Death, severe bodily injuries, property damage.

- ▶ It is prohibited to remain in the danger zone.
 - ▶ Secure the suspended ballast pallet with auxiliary rope.
-
- ▶ Lift the empty suspended ballast pallet with the pull cylinder **A** and pull cylinder **B** and set it down again.

Result:

- The empty suspended ballast pallet is vertically aligned.

8.7 Unpinning the retaining pin

Make sure that the following prerequisite is met:

- The suspended ballast pallet is pinned and secured on the suspended ballast guide*.
- or:**
- The suspended ballast pallet is pinned and secured on the D-guy rods.

NOTICE

Damage to the retaining pins!

If the retaining pins **7** are not unpinned before crane operation, then they can be damaged in crane operation.

- ▶ Unpin the retaining pins **7** before starting crane operation.
-
- ▶ Release and unpin the retaining pins **7** on the erection racks on both sides.

9 Ballasting the suspended ballast pallet

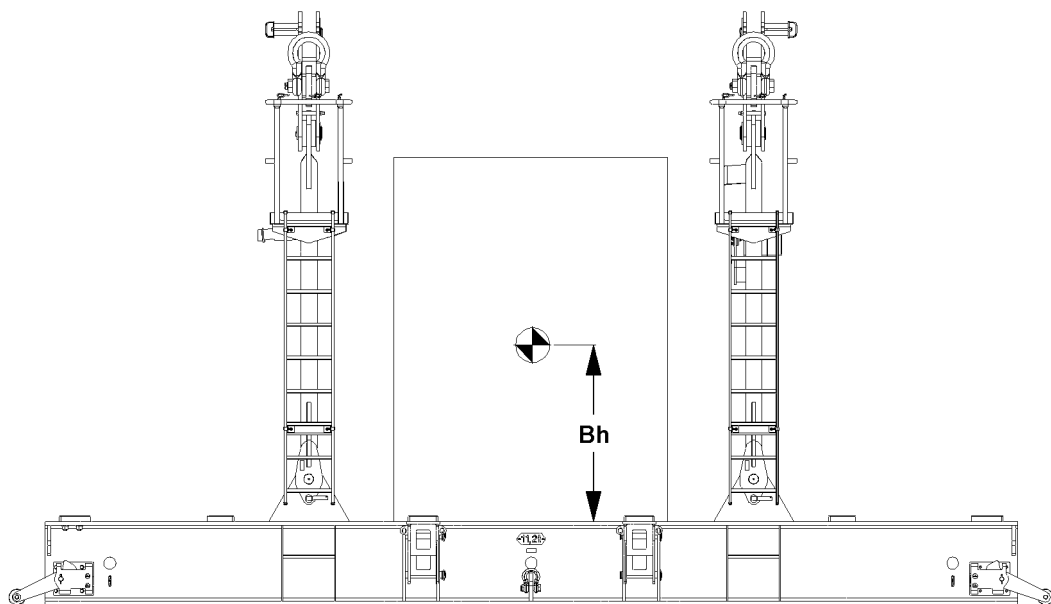

Fig.149289: Ballasting the suspended ballast pallet

**WARNING**

The crane can topple over!

If the following danger notes are not observed, the ballast plates or the ballast stack can slip on the suspended ballast pallet and fall down.

The crane can topple over.

Death, severe bodily injuries, property damage.

- ▶ The ground on which the suspended ballast pallet is ballasted must be level and have an adequate load bearing capacity.
- ▶ Always place the ballast plates symmetrically, in reference to the longitudinal axis.
- ▶ When ballasting the two outer ballast stacks, only one ballast plate may be placed at the start of every ballast stack.
- ▶ Do **not** start with the two center ballast stacks.
- ▶ The two outer ballast stacks may be ballasted with ballast assemblies of two ballast plates after the first ballast plate has been placed on each stack.
- ▶ The difference for the center ballast stack may not be more than a maximum of one ballast plate during ballasting.
- ▶ The outer ballast stacks must always weigh the same and be the same height after ballasting.
- ▶ The two center ballast stacks must always weigh the same and be the same height after ballasting.
- ▶ The outer ballast stacks can differ in stack height from the inner ballast stacks.
- ▶ The maximum permissible ballast center of gravity height **Bh** of 1750 mm may not be exceeded.
- ▶ The maximum permissible total weight of the suspended ballast may not exceed 350 t.
- ▶ Secure all ballast plates so they cannot move and fall down.
- ▶ Replace damaged ballast plates immediately with new ballast plates.

Make sure that the following prerequisites are met:

- The suspended ballast pallet is properly pinned and secured to the derrick ballast guying.
- An auxiliary crane is available.
- The support for the erection rack **8** is in the park position.
- The consoles for ballast centering **17** are properly assembled and secured in the operating position.

9.1 Placing the ballast plates, fastening system: „Twistlock“

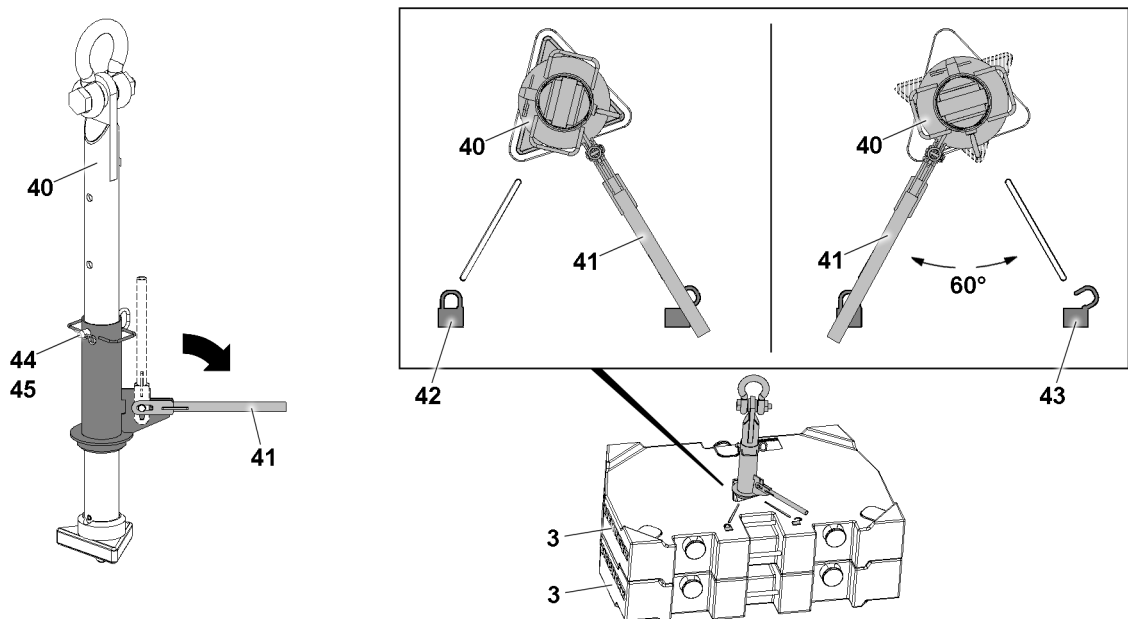

Fig.128899: Ballast plates, fastening system: „Twistlock“

**WARNING**

Danger of accident!

If more than the permissible two ballast plates are lifted with the receptacle stud, the receptacle stud will be overloaded and can be damaged.

Death, severe bodily injuries, property damage.

- ▶ Make sure that the ballast plates are placed correctly in the centerings.
- ▶ Replace damaged ballast plates.

To stack the ballast plate(s) **3**, use the receptacle stud **40**.

Before the receptacle stud **40** is guided into the ballast plates, it must be ensured that the length of the receptacle stud **40** is set correctly. The length of the receptacle stud **40** can be adjusted with the pin **44**.

If the length of the receptacle stud **40** is to be adjusted:

- ▶ Release and unpin the pin **44**.
- ▶ Adjust the length of the receptacle stud by moving the receptacle stud **40**.
- ▶ Insert the pin **44** and secure with the spring retainer.
- ▶ Fasten the receptacle stud **40** to the auxiliary crane and guide it into the ballast plate(s).
- ▶ Pull the lever **41** up and fold it down.
- ▶ Turn the lever **41** 60° until the lever **41** points to the icon **42**.

Result:

- The receptacle stud **40** is locked with the ballast plate.
- ▶ Lift one ballast plate at a time with the receptacle stud **40** and take it down carefully on the outer centerings of the suspended ballast pallet.

When the ballast plate has been taken down on the outer centerings of the suspended ballast pallet:

- ▶ Turn the lever **41** 60° until the lever **41** points to the icon **43**.

Result:

- The receptacle stud **40** is unlocked.
- ▶ Carefully pull the receptacle stud **40** out of the ballast plate.
- ▶ Stack the ballast plates according to the load chart, observe the danger notes.

9.2 Placing the ballast plates, fastening points: Bitt

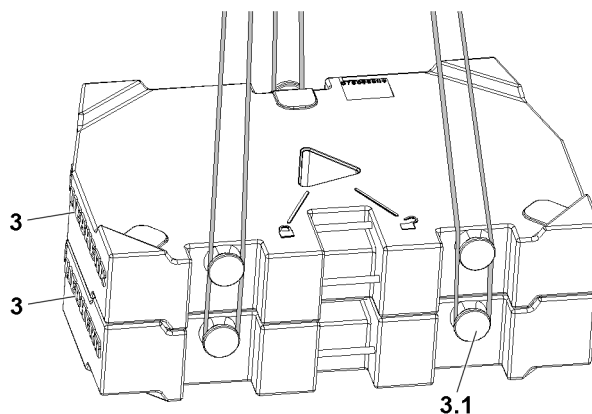

Fig.128900: Ballast plates, fastening system: „Bitt“

**WARNING**

Falling ballast plates!

If more than the permissible loads are lifted, then the bits 3.1 are overloaded and the ballast plates can fall down.

Death, severe bodily injuries, property damage.

- ▶ Lift no more than maximum 20 t with the ropes, 3 fastening points.
- ▶ Replace damaged ballast plates immediately.

**WARNING**

Incorrect handling of the fastening equipment!

If fastening equipment cannot be attached correctly and if it is not secured sufficiently to prevent it from loosening up, loads can fall down.

Death, severe bodily injuries, property damage.

- ▶ Make sure that the fastening equipment is correctly attached on the bits 3.1 and that it is secured sufficiently to prevent it from loosening up.

**Note**

- ▶ Place the ballast plates individually or as a ballast assembly, maximum 20 t.
- ▶ The weight difference between the outer ballast stacks no more than maximum 20 t.

- ▶ Place only one ballast plate at a time on the outer centerings on the suspended ballast pallet.

When a ballast plate has been placed on the outer centerings of the suspended ballast pallet:

- ▶ Place the ballast plates individually or as an assembly of a maximum of two plates alternately on the left and right with the auxiliary crane.
- ▶ Stack the ballast plates according to the load chart.

10 Function check before lifting the derrick ballast

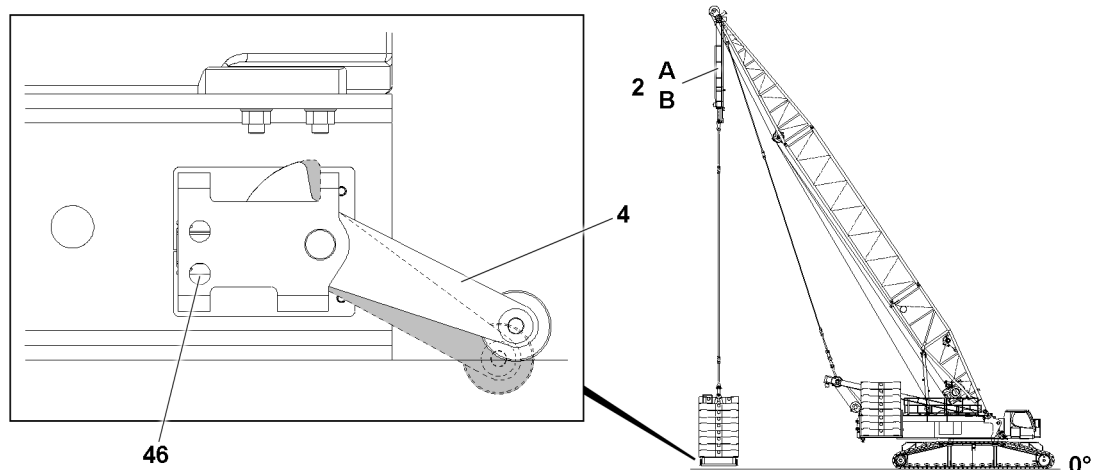

Fig.128901: Checking the function of the ground contact rollers 4 on the suspended ballast pallet

Make sure that the following prerequisites are met:

- The electrical connection from the derrick ballast to the turntable has been established.
- The cable drum cable is plugged in on the turntable.
- The ground contact rollers must move easily.



DANGER

Danger of accident if the derrick ballast touches the ground unintentionally!

If the ground is very uneven, the danger exists that the derrick ballast rests on the ground even one of the ground contact rollers **4** was not actuated.

Death, severe bodily injuries, property damage.

► If the suspended ballast pallet touches the ground, **at least one** ground contact switch **46** must be actuated via the ground contact roller **4**.

► The turning the **turntable** and **driving** the **crawler** crane movements turn off.

► Check the ease of movement of the ground contact rollers **4**.

► Manually operate the ground contact roller **4**.

Result:

- The ground contact switch **46** is actuated.
- The **turning the turntable** and **driving** the **crawler** crane movements turn off.

11 Lifting and lowering the derrick ballast using the pull cylinders

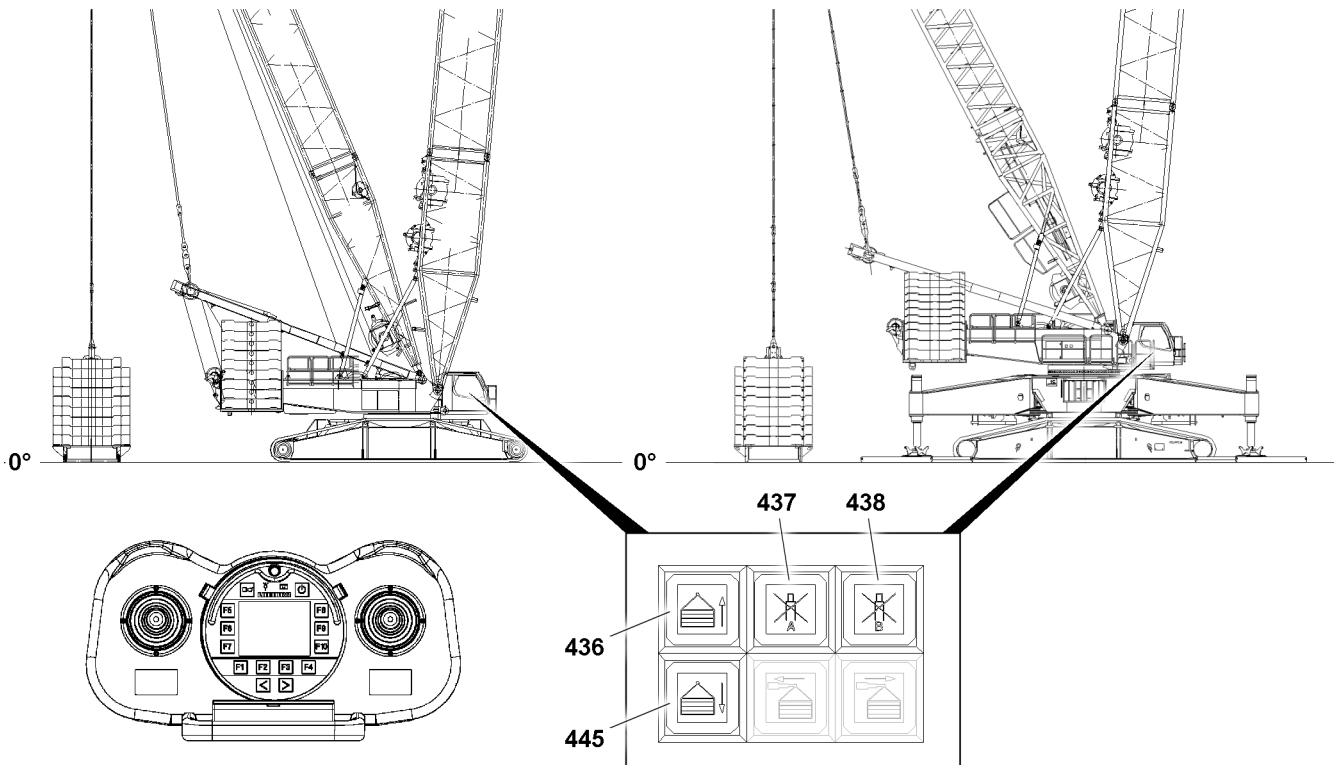

Fig.149283: Lifting and lowering the derrick ballast using the pull cylinders

**WARNING**

The crane can topple over!

If the derrick ballast is lifted up off the ground beyond the **maximum permissible** 250 mm , the crane can topple over to the rear if the load rips off.

Death, severe bodily injuries, property damage.

- ▶ Do not lift the derrick ballast more than 250 mm off the ground.
- ▶ Make sure that there are no persons within the danger zone when lifting and lowering the derrick ballast.

**Note**

- ▶ If the derrick ballast is raised or lowered using the pull cylinders, then the horizontal alignment of the derrick ballast is automatically regulated by both length sensors of the pull cylinders.
- ▶ For a ballast utilization of **more than** or **equal to** 90 percent, the level sensor regulates the pull cylinders to a difference of 1 cm.
- ▶ With a ballast utilization of **less than** 90 percent, the level sensor monitors the derrick ballast level to $\pm 2.5^\circ$. This makes it possible to set the derrick ballast down up to a ground slope of 2.5° .

**DANGER**

Danger of accident!

Death, severe bodily injuries, property damage.

- ▶ Pay attention to the horizontal alignment of the derrick ballast when lifting and lowering the derrick ballast.
- ▶ When lifting and lowering the derrick ballast, check the forces in the ballast guyings regularly on LICCON monitor 1. If the difference of forces between „derrick ballast guying **A**“ and „derrick ballast guying **B**“ is too large, an acoustic warning sounds and the values on the LICCON monitor 1 blink, see section „Differential force monitoring of ballast guying“.
- ▶ When pressing the button **437** („Stop cylinder A on the derrick ballast“) or the button **438** („Stop cylinder B on the derrick ballast“), the level sensor is bypassed and the derrick ballast can be inclined within a limited angle range. This is exclusively permitted when setting down the derrick ballast on uneven ground and only by observing utmost caution.

11.1 Lifting / lowering the derrick ballast using the instrument panel

11.1.1 Lifting the derrick ballast

- ▶ Press the button **436**.

Result:

- The derrick ballast is raised.

11.1.2 Lowering the derrick ballast

- ▶ Press the button **445**.

Result:

- The derrick ballast is lowered.

11.1.3 Stopping the pull cylinder on the derrick ballast

- ▶ Press the button **437**.

Result:

- The pull cylinder (A) on the derrick ballast is stopped.

- ▶ Press the button **438**.

Result:

- The pull cylinder (B) on the derrick ballast is stopped.

11.2 Lifting / lowering the derrick ballast using the radio remote control BTT-E



Note

- ▶ The „Lifting / lowering the derrick ballast using the radio remote control BTT-E“ assembly function is only available for cranes that are equipped with the corresponding technical prerequisites.
- ▶ Operation of the pull cylinders with the manual control levers of the radio remote control, see the radio remote control operating instructions.

12 Crane operation with derrick ballast

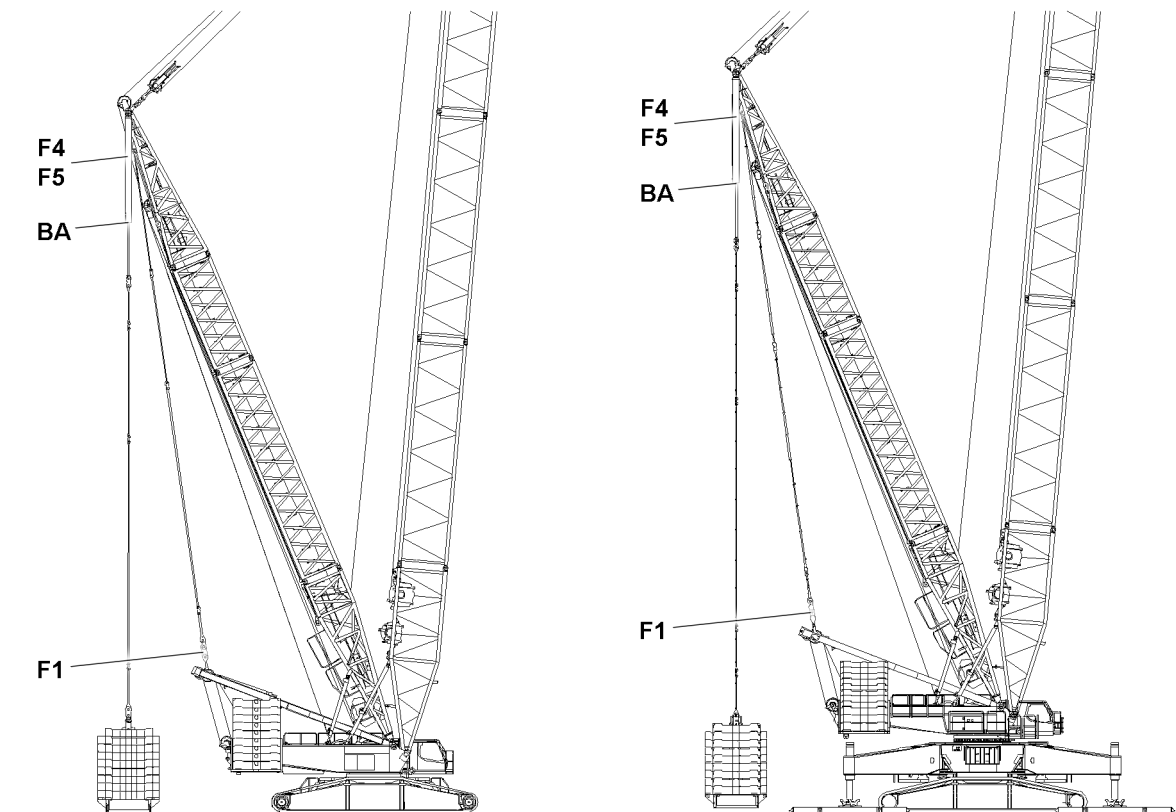
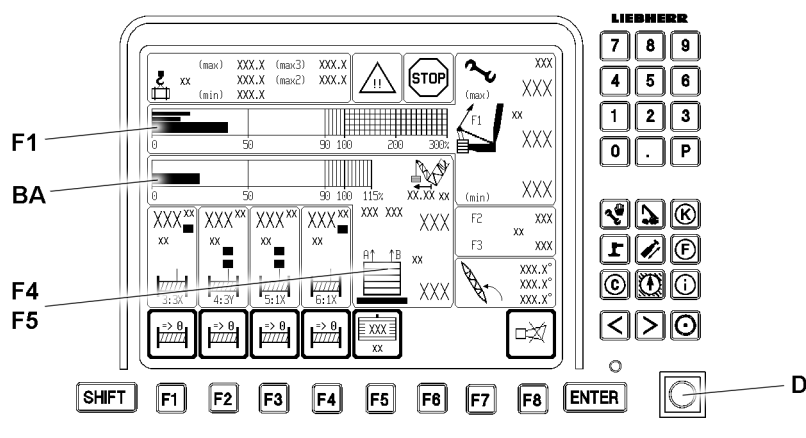

Fig.149281

LWE/LR 1600-2-008/18109-09-02/en

12.1 LICCON overload protection

The maximum or minimum load required to balance the crane can be increased or decreased on cranes with a derrick ballast operating under load by increasing or reducing the derrick ballast.



Note

- ▶ The suspended ballast and ballast trailer are generally referred to as the **derrick ballast**.
- ▶ The fixed compensation weight that is installed on the turntable is generally referred to as the **counterweight**.

Make sure that the following prerequisites are met:

- The required derrick ballast according the load chart is placed and entered and confirmed on LICCON monitor 1.
- The derrick boom is in the operating position.

12.1.1 Presettings

- ▶ Set the LICCON overload protection according to the data in the load chart and confirm.



Note

- ▶ Enter the placed derrick ballast on LICCON monitor 1.
- ▶ Enter the actual reeving on the pulley head on LICCON monitor 0.

To set the derrick ballast - see chapter 4.03.



DANGER

Danger of accident!

The set derrick ballast must match the derrick ballast weight that is actually applied.

- ▶ Incorrect entry of the ballast weight can result in dangerous operating situations.
- ▶ Check the settings.

12.2 Crane operation



WARNING

The crane can topple over!

If the derrick ballast is lifted up off the ground beyond the **maximum permissible** 250 mm , the crane can topple over to the rear if the load rips off.

Death, severe bodily injuries, property damage.

- ▶ Do not lift the derrick ballast more than 250 mm off the ground.
- ▶ Make sure that there are no persons within the danger zone when lifting and lowering the derrick ballast.

For crane operation with the derrick ballast, observe the data in the „Crane operation“ program on LICCON monitor 1, see chapter 4.02.



DANGER

Danger of accident!

There may be no persons or obstacles within the slewing range of the derrick ballast.

During the turning procedure, a guide person must closely watch the main boom, derrick and derrick ballast for any risk of collision.

The turning movement or braking must be initiated extremely carefully when turning with a load and suspended derrick ballast.

Death, severe bodily injuries, property damage.

- ▶ Jerky initiation / braking of the turning movement can cause the load or suspended derrick ballast to swing.
- ▶ This can cause the boom to break or the crane to topple over.

**Note**

- ▶ See section „Lifting and lowering with pull cylinders“ and section „Differential force monitoring for derrick ballast guying“.

Monitor the extension condition of the pull cylinders and the incline of the derrick ballast.

12.2.1 Safety guidelines

**Note**

- ▶ The test points must be checked for function before crane operation.
- ▶ The weight of the load to be lifted must be known.
- ▶ The placement surface of the derrick ballast may be no more than maximum 250 m above, or 250 m below, the placement level of the crane.
- ▶ The placement surface on which the derrick ballast is placed after the load hoist has been completed must be level, horizontal and of sufficient load bearing capacity in order to safely support the weight.

**CAUTION**

Danger of accident!

- ▶ Before setting down the load and suspended derrick ballast, the crane operator must make sure that it can be taken down safely.

**Note**

- ▶ There may not be any obstacles in the slewing range of the crane, derrick ballast and load.
- ▶ The lifting of the derrick ballast must be supervised by a guide or the crane operator.

**DANGER**

Danger of accidents due to angular pull!

- ▶ When picking up the load, angular pull must be avoided, which means the derrick ballast, the center of rotation of the turntable and the load must be on one line.
- ▶ If this is not observed, there is a danger of tipping when lifting with ballast plates and this could cause the crane to topple over.

When picking up the load, the guying from the derrick ballast to the derrick end section must be relieved to the point where the actual force at test point 1 (F_1 - actual) is higher than the minimum force- $F_{1\min}$ (test point 1).

**DANGER**

Danger of accident!

- ▶ The guying between the SA-frame and the derrick end section, test point 1, may never be without power.
- ▶ This could cause uncontrolled movements of the boom system and therefore an accident.

12.3 Determination of forces in operating mode with derrick ballast

In all operating modes with derrick ballast, the load is divided between the guy rods from the derrick head to the SA-frame (F_1) and the derrick ballast ($F_4/5$).

**Note**

- ▶ For a detailed description see Chapter 4.02.

12.3.1 Force F_1 (test point 1) guying of SA-frame - derrick end section

The force F_1 (test point 1) is determined in the guy rods from the SA-frame to the derrick end section by 2 force test boxes and is shown on the LICCON monitor 1 as total force of the guying.

The F1-utilization results from the F1 operating force and the F1-maximum operating force. This is represented on LICCON monitor 1 with the utilization bar (F1 percent).

12.3.2 Force F4/F5 (test point 4/5) in the guying derrick ballast - derrick end section

The forces F4/F5 (test point 4/5) are effective in the guy rods from the derrick ballast to the derrick head.

The existing forces in the guy rods (A = left and B = right) are calculated from the four pressure sensors, which are attached to the pull cylinders and shown on LICCON monitor 1 as individual forces.

The pulled ballast is calculated from the forces of the individual guying, which means the part of the ballast pulled up by the guying. The remaining part is laying on the ground. The ballast utilization results from the pulled ballast and the placed ballast. This is shown on LICCON monitor 1 with a utilization bar (BA in %).

Pull cylinder on block



DANGER

The crane can topple over!

By retracting one or both pull cylinders (block position moved in), the pressure increases strongly on the ring surface of the pull cylinder and the weighing of the currently pulled derrick ballast is incorrectly calculated and displayed.

The LICCON overload protection therefore assumes that a larger derrick ballast is pulled than is actually the case, and calculates too large a load capacity as a result.

An overload of the crane is recognized too late by the LICCON overload protection and the crane can topple.

Death, severe bodily injuries, property damage.

- ▶ If the pull cylinders are „retracted“ in the block position, **crane operation is explicitly prohibited**.
- ▶ The forces in the derrick ballast guying A and B must be carefully monitored on LICCON monitor 1.
- ▶ Potentially occurring error messages must be observed.



WARNING

The LICCON overload protection shuts off too early!

By extending one or two pull cylinder completely (block position moved out), the LICCON overload protection calculates a load which is too low.

Possible shut-off by the LICCON overload protection takes place too early.

- ▶ If the pull cylinders are in block position „moved out“, crane operation on the basis of reduced load is not meaningful.

12.3.3 Monitoring of minimum force F1

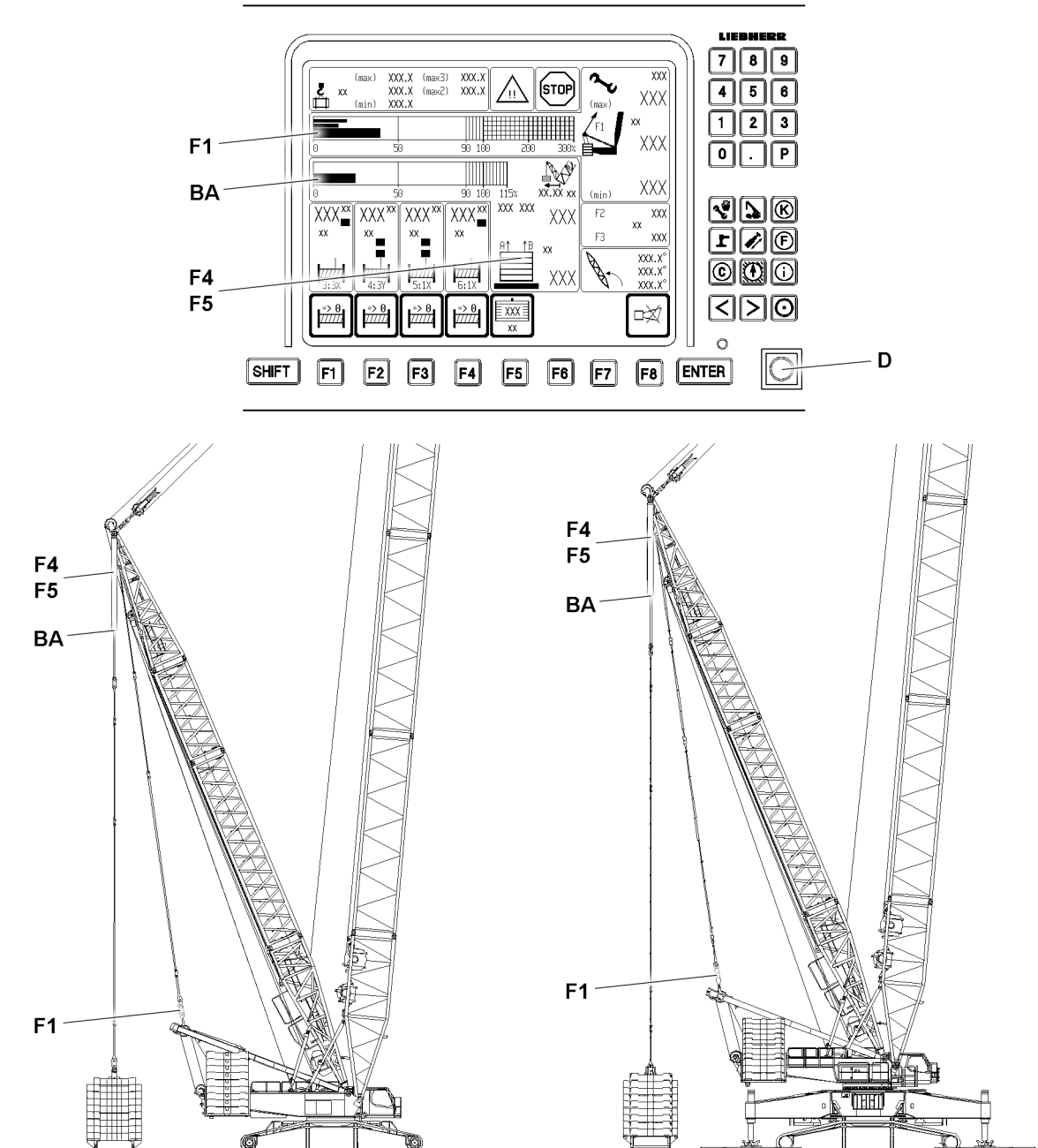

Fig.149281

If more than 50 percent of the set derrick ballast is being pulled (ballast utilization bar > 50 percent) and the minimum force $F1_{\min}$ (test point 1) is fallen below, all crane movements that **increase load torque** are turned off.



DANGER

Danger of accident!

It is prohibited to fall below the minimum force $F1_{\min}$ (test point 1) if more than 50 percent of the derrick ballast is pulled. If this is not observed, in case of slack guying from test point 1 (F1) and **derrick ballast on the ground**, the derrick ballast can suddenly lift off the ground due to the increased load torque and the boom system can suddenly move forward. This causes the load to swing back and forth too much, which could damage the main boom and the crane.

► Do not fall below the minimum force - $F1_{\min}$.

If more than 90 percent of the set derrick ballast is being pulled (ballast utilization bar greater than 90 percent) and the minimum force $F1_{min}$ (test point 1) is fallen below, all crane movements **that increase the load torque** and all crane movements **that decrease the load torque** are turned off. This also turns off the „spooling out“ movement of the winch.



DANGER

Danger of accident!

It is prohibited to fall below the minimum force $F1_{min}$ (test point 1) if more than 90 percent of the derrick ballast is pulled. If this is not observed and the load torque is decreased when the guying is slack at test point 1 ($F1$) and the derrick ballast is suspended, the derrick ballast can suddenly drop to the ground, causing the boom system to suddenly move backwards. As a result, the relapse cylinders can be pressed on the block and be overloaded. There is the danger that the relapse cylinders on the main boom and the derrick boom will be damaged. This causes the load to swing back and forth too much, which could damage the main boom and the crane.

- ▶ Do not fall below the minimum force - $F1_{min}$.



Note

- ▶ By activating the assembly operation, the test point 1 - minimum force ($F1_{min}$) is reduced by a few tons, which allows one to reverse the movement and retreat from the situation in which the $F1_{min}$ shut-off occurred.
- ▶ This is the only exception on the crane, where, after a shut-off, a load torque increasing movement may be continued in assembly operation.



DANGER

Danger of accident!

If the LICCON overload protection is bypassed, there is no further protection against crane overload. There is an increased danger of accidents.

Death, severe bodily injuries, property damage.

- ▶ The crane driver bears the complete and sole responsibility when bypassing the LICCON overload protection.

After a shut-off via $F1_{min}$, the force $F1$ on test point 1 must be increased by a movement. If the derrick ballast is suspended, this can be achieved by setting down the ballast.

If the assembly operation is already activated and the $F1$ -force continues to drop below the minimum force $F1_{min}$, which was reduced in assembly operation, then the $F1_{min}$ shut-off can no longer be bypassed.

12.4 Overload monitoring in operating mode with derrick ballast

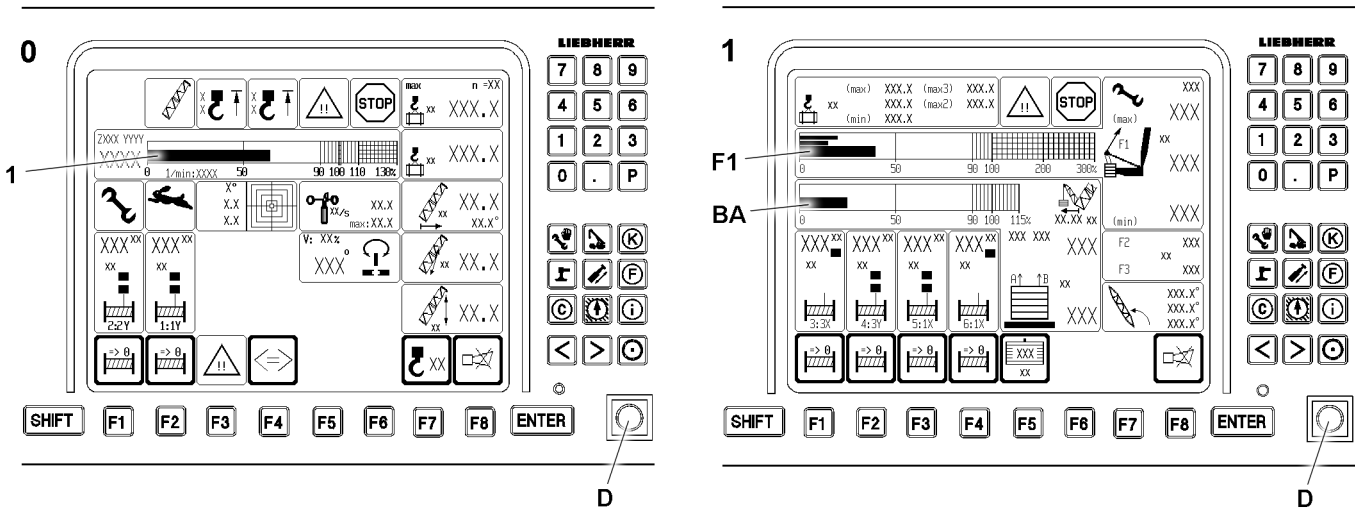

Fig. 149282

In operating modes with derrick ballast, the „maximum load for the current crane condition“ is monitored two ways:

1. Monitoring of maximum load on the LICCON monitor 0
2. Monitoring of test point 1-operational maximum force on the LICCON monitor 1

12.4.1 Monitoring of maximum load on the LICCON monitor 0

It monitors the „maximum load according to load chart and reeving“.

In operating modes with derrick ballast, this is the maximum load of the current crane condition. It is displayed on LICCON monitor 0. The current utilization of the crane results from the load utilization bar (1) on LICCON monitor 0.

If the load utilization bar reaches 90 %, an advance warning is given in the form of a „notice icon“ and a „SHORT HORN“ on LICCON monitor 0.

At 100 % on the load utilization bar, the shut-off of all load moment increasing movements occurs with the „stop icon“ and the acoustical warning „HORN“ on LICCON monitor 0.



Note

- The „maximum load of the current crane condition“ can possibly be increased further, refer to section „utilization conditions“.

12.4.2 Monitoring of test point 1-operational maximum force (= F1_{max} operation)

It is displayed on LICCON monitor 1. When F1 is greater than F1_{max-shut-off value}, a shut-off of all movements which could increase load torque occurs with the „stop icon“ and the acoustic warning „HORN“ by LICCON monitor 1.

**Note**

- ▶ The maximum load can be safely monitored by the „LICCON overload protection“ itself.
- ▶ The „F1_{max}-monitoring“ is an additional monitoring function which shows the overload parallel to the „LICCON overload protection“.
- ▶ In all cases where the maximum load according to the load chart „max-load“ is less than the maximum load of the current set up configuration with optimal derrick ballast „max3-load“, which means „max-load“ is less than „max3-load“, when lifting the maximum load, the monitor display looks as if the „utilization bar of the crane“ is at 100 percent and the „F1 utilization bar“ is approximately at 100 percent.
- ▶ At the just completed LMB-Stop („current load“ / „max-load“ greater than 100 percent) F1_{actual} can already lie just above F1_{max} or just below. There is a certain tolerance due to the component weights and the wind influences. Since the maximum load can always be raised, shut-off will not occur at F1_{actual} / F1_{max} greater than 100 %. Shut-off will only occur at F1_{actual} / F1_{max operation shut-off value}. For this crane, the following applies: F1_{max-operation shut-off value} = F1_{max-operation} + F1 addition for shut-off (see chapter 4.02). The F1_{addition for shut-off} is selected such that F1_{max-operation shut-off} should normally never happen. This shut-off provides an additional safety, particularly in cases with „max-load“ less than „max3-load“. For example, if the load weighing is far too low due to a sensor failure, then a load would be pulled which would be greater than the maximum permissible load without shut off of the LICCON overload protection. The crane could be overloaded. In this particular case, with the „max-load“ less than the „max3-load“, with F1_{max} larger F1_{max-operation shut-off value} the F1_{max shut-off} triggers. In this case, the crane is already slightly overloaded, however shut-off prevents an overload in certain cases or toppling of the crane. This means that the F1_{max-operation shut-off} can protect the crane from overload in certain cases.
- ▶ Make sure that the load weighing and the shut-off function reliably on the maximum load.

**DANGER**

The crane can topple over!

In cases with „max-load“ = „max3-load“, the F1_{max} shut-off value does not offer safety. The F1_{max} shut-off value is so high that the crane will probably topple over or be damaged before the shut-off value is reached.

- ▶ Carefully monitor the displays on LICCON monitor 1.

**WARNING**

Danger of accident!

- ▶ The test point 1-Operation-Maximum force not only depends on the current set up configuration but also on the force measured with the pressure sensors in the pull cylinders.
- ▶ If the pulled derrick ballast is larger, then the maximum permissible F1_{max} force is generally reduced and vice versa.
- ▶ It is therefore important to carefully monitor the ballast weighing and the value for the pulled derrick ballast to ensure that this value is even plausible.

**DANGER**

The crane can topple over!

If the pulled derrick ballast value has been incorrectly determined and is too low, the calculated F1_{max} may be too high and the crane could be overloaded or topple over without this becoming evident.

- ▶ Carefully monitor the displays on LICCON monitor 1.

12.4.3 Utilization conditions

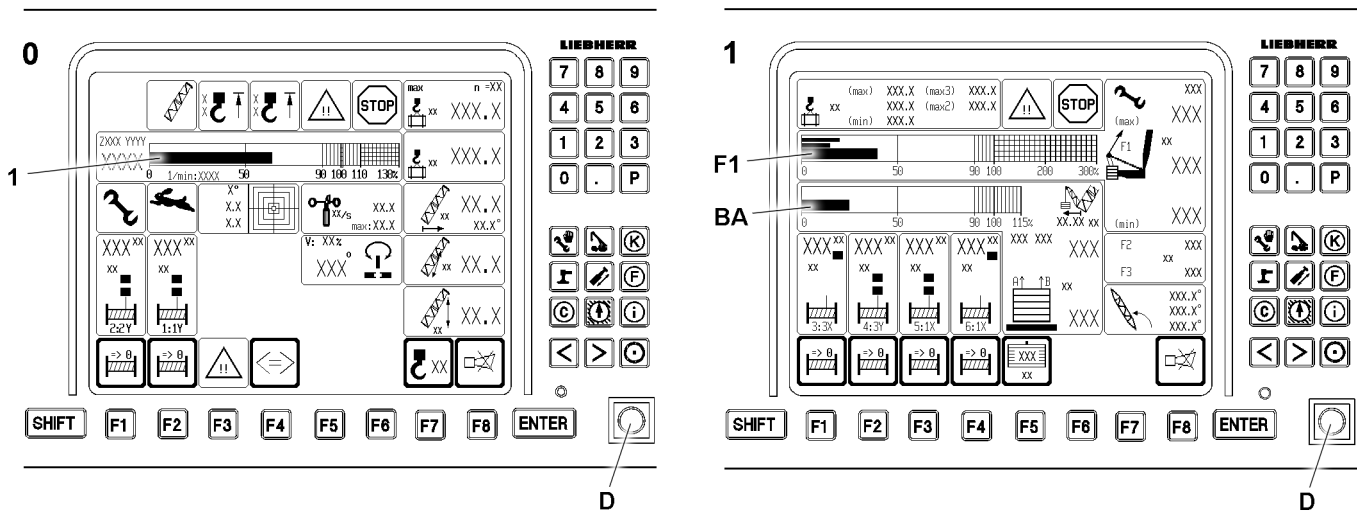

Fig. 149282

The current utilization of the crane results from the „utilization bar of the crane“ 1 on the LICCON monitor 0.

Max. load:

- The „maximum load capacity in the current operating condition („max-load““) is obtained, when the „utilization bar of the crane“ 1 displays 100 percent.
This is the case when the „utilization of the crane according to the load chart and reeving“ reaches 100 % („Current load“ is equal to the „Maximum load“).
When the „max-load“ is less than or equal to the „max2-load“, then the „max-load“ can be increased through:
 - Pulling up the derrick ballast, if the derrick ballast is not already suspended and the currently pulled derrick ballast is still smaller than the optimum derrick ballast.

Max2-load:

- The „maximum load of the current crane equipment“ („max2-load““) is reached when the „utilization bar of the crane“ 1 is at 100 percent **and** the „derrick ballast utilization bar display“ BA is greater than or equal to 100 percent (the current derrick ballast is completely lifted off the ground), and the derrick ballast input value and the ballast weighing are correct.
This is the case when the „current load“ and the „max2-load“ reach 100 percent („current load“ is equal to the „max2-load“).
When the „max2-load“ is less than the „max3-load“, then the „max-load“ can be increased through:
 - Increasing the derrick ballast by adding additional ballast plates if the placed derrick ballast is still smaller than the optimum derrick ballast.

Max3-load:

- The „maximum load of the current set up configuration with optimum derrick ballast“ („max3-load““) is obtained when the „crane utilization bar“ 1 is at 100 % **and** the „derrick ballast utilization bar display“ BA is at 100 % (the optimal derrick ballast is placed and completely lifted off the ground), and the derrick ballast input value and the ballast weighing are correct.
This is the case when the „current load“ and the „max3-load“ reach 100 percent („current load“ is equal to the „max3-load“).
Here, the optimum derrick ballast is already entirely pulled.
A further increase of the derrick ballast at this derrick ballast radius will not increase the load further than „max3-load“.



Note

- In some cases it may be possible to increase the load, in some cases reducing the derrick ballast radius as well; refer to the load chart manual or LICCON job planner.

This also applies for:

- „Current load“ equal to „max-load“.
- „Current load“ equal to „max2-load“.

Activating assembly operation / bypass of the LICCON overload protection

- Activate assembly operation, see chapter 4.02



WARNING

The crane can topple over!

When the assembly operation is activated, the LICCON overload protection is exceeded.

In the event of deliberate improper use, the crane could collapse, the main boom can break off or the crane can topple over.

Death, severe bodily injuries, property damage.

- ▶ When the assembly operation is activated, only load torque reducing crane movements may be carried out up to a permissible operating and load range.
- ▶ Make sure that the assembly operation is turned off after reaching the permissible load range.
- ▶ The crane operator alone is completely responsible for his actions during a bypass of the LICCON overload protection.



Note

- ▶ The „Lift derrick ballast“ or „Lower derrick ballast“ movement requires utmost attention by the crane operator.

12.5 Differential force monitoring for derrick ballast-guying

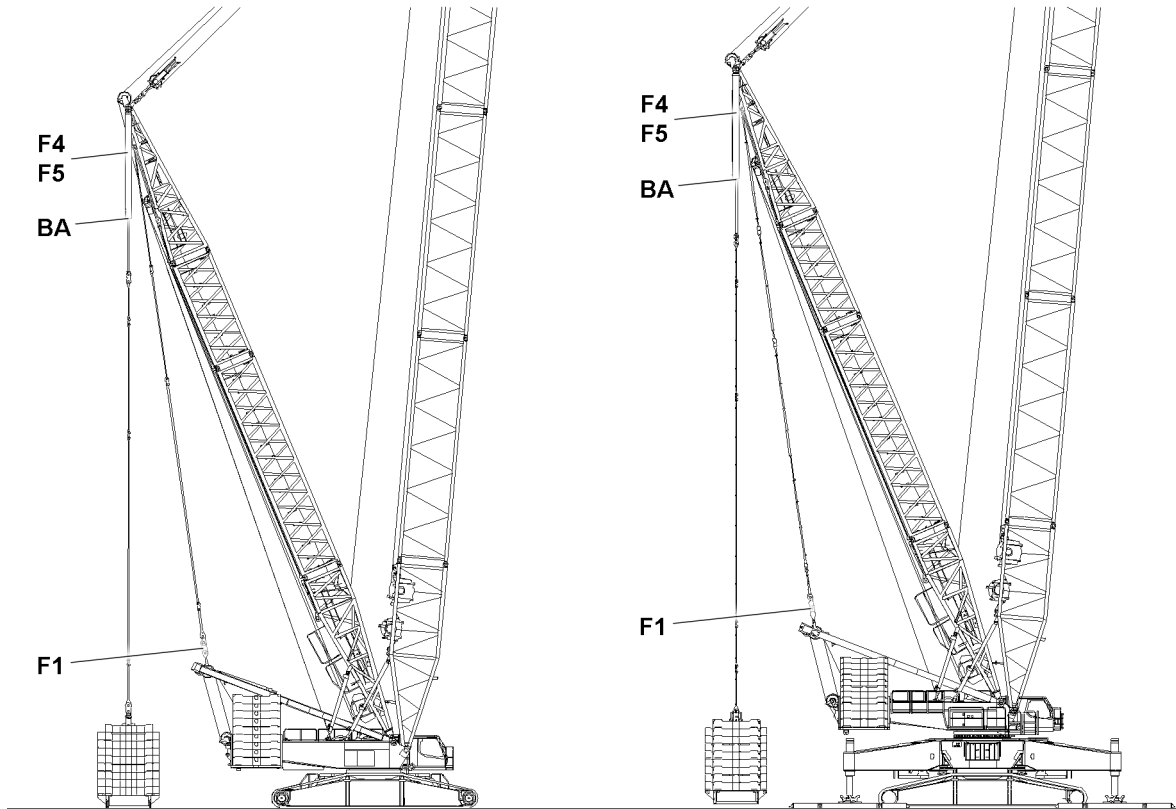
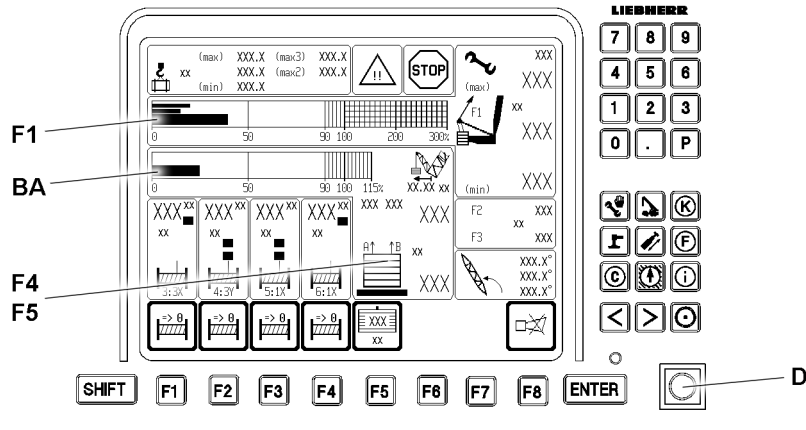

Fig.149281

In operating modes with derrick ballast, the difference of the forces of derrick ballast guying A and B is monitored on LICCON monitor 1.



DANGER

Danger of accident!

Large differences between these forces can damage the derrick end section and other crane components.

► There is a danger of accident.

The forces in the derrick ballast guyings A and B are shown and compared on LICCON monitor 1. If the difference exceeds a permissible value, an acoustic warning is issued and the two force values blink. However, **no shut-off of movements** occurs.

LWE/LR 1600-2-008/18109-09-02/en

If the difference of the forces of the derrick ballast guyings A and B exceeds the specified limit value, then this can have various causes:

- The flexing of the turntable.
- The ground under the derrick ballast is uneven.
- The crane is leaning to one side.
- The derrick ballast has been loaded on one side.
- The force measurement in one guying is incorrect.

The crane driver must recognize the correct cause and take countermeasures:

- The error, which caused the one-sided force, must be remedied.
- The following measures are permitted providing the ground is only slightly uneven:
Lock one ballast cylinder and use the other ballast cylinder to „Lift the ballast“ or „Lower the ballast“ until the difference between the forces reduces. Ensure that the derrick ballast is not tilted at an inadmissible angle with respect to the crane, otherwise the derrick ballast guide and attachments will be damaged.
- If the sensor values are implausible: Check if the pressure sensors for the ballast weighing or the inputs of the ballast weighing are faulty. If necessary, remove the sensor or replace the CPU.

13 Crawler operation with derrick ballast

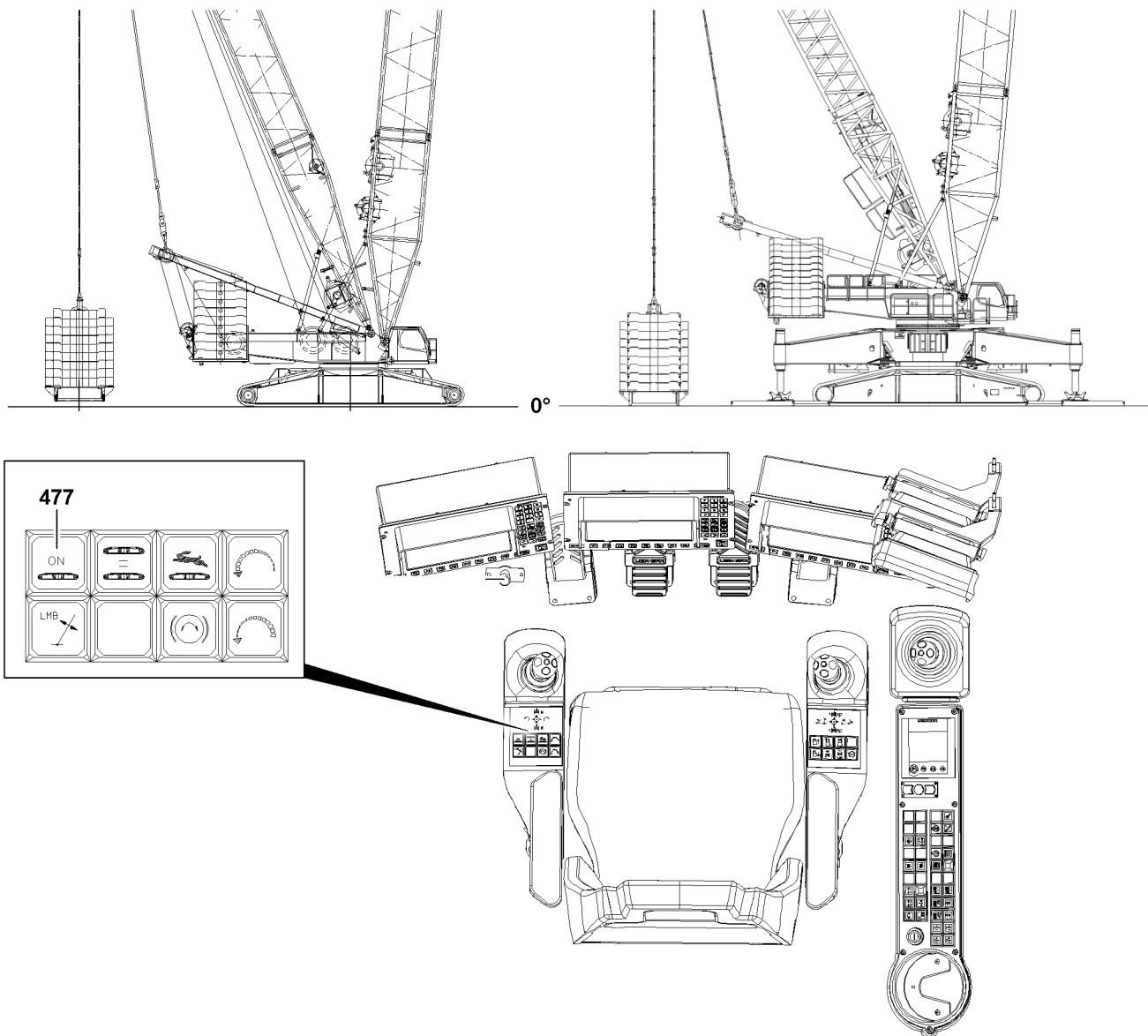

Fig.149287

13.1 Driving the crawler

Driving with raised, suspended derrick ballast.

Make sure that the following prerequisites are met:

- The derrick ballast is lifted off the ground.
- The derrick ballast icon on LICCON monitor 1 is shown in the suspended state.
- The derrick ballast is horizontally aligned.
- The ground is able to support the weight of the crane, the load and the derrick ballast.



Note

- ▶ Observe the danger notes, see chapter 4.10.
- ▶ Crawler driving is released when all four ground contact rollers are **not in contact with the ground**.
- ▶ The crawler operation must be switched on with the switch **477**.



DANGER

Danger of accident!

If the following points are not observed, the crane can topple over.

Death, severe bodily injuries, property damage.

- ▶ There are no persons or objects in the danger zone.
- ▶ The travel range must be monitored by cameras or a supervisor.
- ▶ Only drive at the lowest possible speed.
- ▶ Avoid jerky driving movements.
- ▶ The attached load and suspended derrick ballast must be secured to prevent it from swinging. If the derrick ballast swings by more than +/- 0.5 m, set the derrick ballast quickly on the ground with the pull cylinders. In this connection, the upper load threshold at test point 1 (F1) may not be exceeded.
- ▶ Steering maneuvers are prohibited.
- ▶ Uphill or downhill travel is prohibited.

14 Disassembly



WARNING

Danger of falling!

During assembly / disassembly, inspection and maintenance work, personnel must be secured with appropriate aids to prevent them from falling.

If this is not observed, the assembly personnel can fall down.

Death, severe bodily injuries, property damage.

- ▶ All work at a height, when there is a danger of falling, must be carried out with suitable aids.
- ▶ If aids are not available and work cannot be carried out from the ground, then assembly personnel must secure themselves with the supplied fall arrest system to prevent falling, see chapter 2.04.
- ▶ If fall protection equipment is available, then it must be used, see chapter 2.06.
- ▶ When lifting, lowering, swinging crane parts in and out, no persons may remain in the danger zone.
- ▶ If railings are present on the components, then they must be brought into the corresponding position and secured for assembly / disassembly work.
- ▶ Only step on the aids, ladders and catwalks with clean shoes.
- ▶ Keep aids, ladders and catwalks free of heavy dirt, snow and ice.
- ▶ During all assembly and disassembly work, maintenance work and inspections, travel or crane operation is prohibited.
- ▶ Remaining on a suspended load is prohibited.
- ▶ Stepping or walking on crane components and lattice sections, which have an incline of more than 20° is prohibited.
- ▶ For all assembly work, the crane operator of the main crane must be in voice contact with the crane operator / crane operators of the auxiliary crane / auxiliary cranes.
- ▶ For assembly / disassembly tasks, the crane operator may only initiate crane movements when the responsible guide has explicitly released the movement.

**WARNING**

Danger of impact / crushing!

When installing / removing crane components with the auxiliary crane, crane components can start to swing back and forth.

When lifting / lowering and positioning crane components, there is an increased danger of impacts / crushing.

Death, severe bodily injuries, property damage.

- ▶ Make sure that personnel cannot be caught by components.
- ▶ When working in danger zones: Use aids to protect limbs.
- ▶ Guide components with suitable aids to minimize oscillation.

**DANGER**

The components can fall down!

If the corresponding component is disengaged from the auxiliary crane before the corresponding component is pinned, then the corresponding component can fall down.

Death, severe bodily injuries, property damage.

- ▶ Do not disengage the auxiliary crane until the respective component is pinned and secured.

Make sure that the following prerequisites are met:

- The crane is properly supported and horizontally aligned.
- An auxiliary crane is available.
- The counterweight has been installed on the turntable according to the load chart.
- The maximum ground unevenness for the placement surface of the derrick ballast is plus / minus 1°.
- The LICCON overload protection has been set according to the data in the load chart.
- The LICCON overload protection settings have been compared with the actual set up configuration.

15 Setting down the suspended ballast pallet

**WARNING**

Danger of toppling the ballast stack!

The placement surface for the derrick ballast must be level, horizontal and of sufficient load bearing capacity, otherwise the ballast stacks can tip over.

Death, severe bodily injuries, property damage.

- ▶ Check the horizontal position of the crane during the set down procedure.
- ▶ Check the horizontal position of the derrick ballast during the set down procedure.
- ▶ Constantly check the differential forces in the guying on LICCON monitor 1.
- ▶ It is strictly prohibited for anyone to stand under the derrick ballast or in any part of the danger zone during the set down procedure.

Make sure that the following prerequisites are met:

- The placement surface for the derrick ballast must be level, horizontal and of sufficient load bearing capacity.
- A guide or crane driver monitor the setting down of the derrick ballast and the load.
- ▶ Press the button **445**.

Result:

- The piston rods of the pull cylinders extend.
- The derrick ballast is lowered.
- ▶ When the suspended ballast pallet touches the ground, the ground contact switches are actuated.

Result:

- The **turning the turntable** and **driving the crawler** crane movements turn off.

16 Removing the ballast plates

Make sure that the following prerequisite is met:

- The retaining chains are disassembled.



Note

- ▶ The ballast plates are marked with their own weights.



WARNING

The crane can topple over!

If more than 20 t are removed with one lift from a ballast stack or if the ballast is removed asymmetrically, then the crane can topple over.

Death, severe bodily injuries, property damage.

- ▶ A weight difference between the right and left ballast stack of more than 20 t * is prohibited.
- ▶ Alternately remove no more than maximum 20 t ballast assemblies from the ballast stack, symmetrically on the left and right.

16.1 Removing the ballast plates, fastening system: „Twistlock“

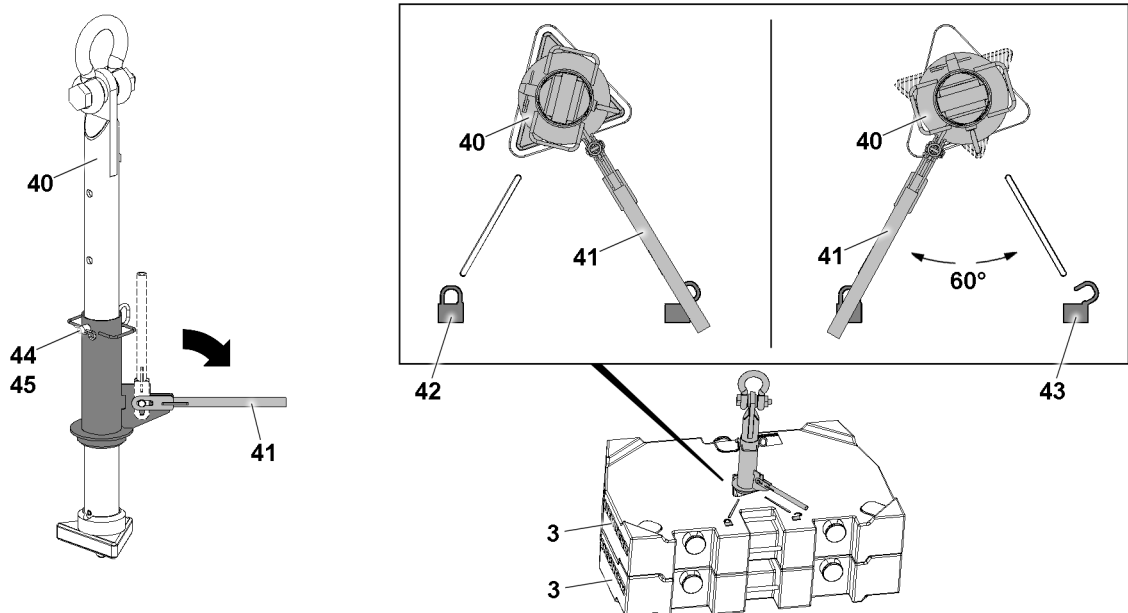

Fig.128899: Ballast plates, fastening system: „Twistlock“



DANGER

Danger of accident!

If more than the permissible two ballast plates are lifted with the receptacle stud, the receptacle stud will be overloaded and can be damaged.

Death, severe bodily injuries, property damage.

- ▶ Make sure that the ballast plates are placed correctly in the centerings.
- ▶ Replace damaged ballast plates.

To remove the ballast plate(s) **3**, use the receptacle stud **40**.

Before the receptacle stud **40** is guided into the ballast plates, it must be ensured that the length of the receptacle stud **40** is set correctly. The length of the receptacle stud **40** can be adjusted with the pin **44**.

If the length of the receptacle stud **40** is to be adjusted:

- ▶ Release and unpin the pin **44**.

- ▶ Adjust the length of the receptacle stud by moving the receptacle stud **40**.
- ▶ Insert the pin **44** and secure with the spring retainer.
- ▶ Attach the receptacle stud **40** to the auxiliary crane and guide it into the ballast plate(s).
- ▶ Pull the lever **41** up and fold it down.
- ▶ Turn the lever **41** 60° until the lever **41** points to the icon **42**.

Result:

- The receptacle stud **40** is locked with the ballast plate.
- ▶ Lift the ballast plate with the receptacle stud **40** and remove it from the ballast stack or the suspended ballast pallet.
- ▶ Turn the lever **41** 60° until the lever **41** points to the icon **43**.

Result:

- The receptacle stud **40** is unlocked from the ballast plate.
- ▶ Carefully pull the receptacle stud **40** out of the ballast plate.
- ▶ Alternately remove the ballast plates on both sides.

16.2 Removing the ballast plates, fastening points: Bitt

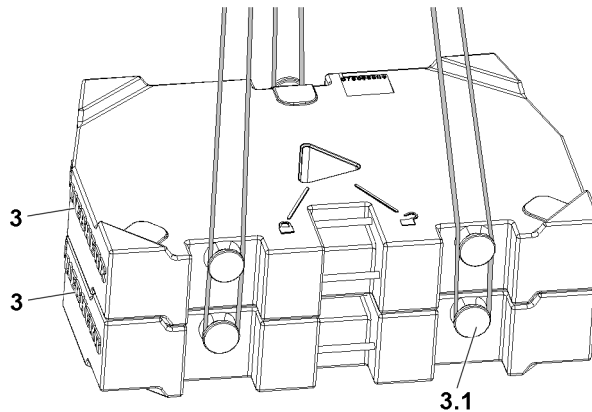

Fig.128900: Ballast plates, fastening system: „Bitt“

**WARNING**

Falling ballast plates!

If more than the permissible loads are lifted, then the bits **3.1** are overloaded and the ballast plates can fall down.

Death, severe bodily injuries, property damage.

- ▶ Lift no more than maximum 20 t with the ropes, 3 fastening points.
- ▶ Replace damaged ballast plates immediately.

**WARNING**

Incorrect handling of the fastening equipment!

If fastening equipment cannot be attached correctly and if it is not secured sufficiently to prevent it from loosening up, loads can fall down.

Death, severe bodily injuries, property damage.

- ▶ Make sure that the fastening equipment is correctly attached on the bits **3.1** and that it is secured sufficiently to prevent it from loosening up.

**Note**

- ▶ Remove the ballast plates individually or as a ballast assembly, maximum 20 t.
- ▶ The weight difference between the outer ballast stacks no more than maximum 20 t.

- ▶ Lift the ballast plate **3** or ballast assembly and remove it from the ballast stack or the suspended ballast pallet.

17 Disassembling the suspended ballast pallet

The unpinning of the erection racks differs due to the following prerequisites:

- The suspended ballast guide* is assembled: Unpin on the suspended ballast guide.
- The suspended ballast guide* is **not** assembled: Unpin on the D-guy rods.

Make sure that the following prerequisites are met:

- The ballast plates are removed.
- The suspended ballast pallet is standing on the ground.

17.1 Inserting the retaining pins

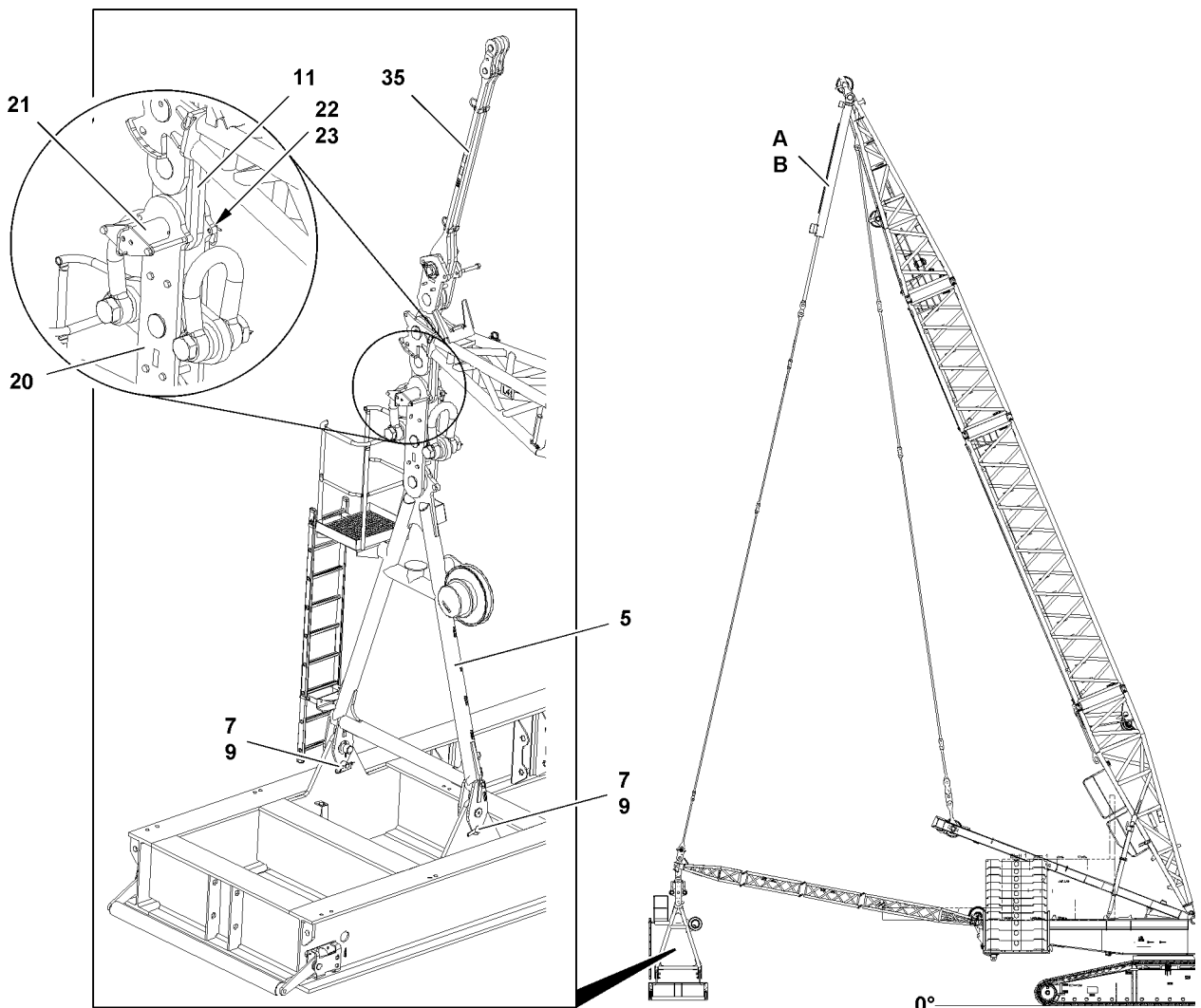

Fig.119254: Unpinning the suspended ballast pallet on the suspended ballast guide



WARNING

Unsecured erection racks!
Death, severe bodily injuries, property damage.

- ▶ Secure the erection frames to prevent them from tipping over: Pin and secure the retaining pins **7**.

- ▶ Insert the retaining pins **7** on the erection racks on both sides and secure with spring retainers **9**.

17.2 Unpinning the suspended ballast pallet on the suspended ballast guide*



WARNING

Unsecured erection racks!

Death, severe bodily injuries, property damage.

- ▶ Make sure that the erection racks are secured with retaining pins **7** to prevent them from tipping over.

The erection racks are unpinned at two points. The unpinning procedure is described for one pin as an example.

- ▶ Relieve the D-guy rods until the pin **21** can be unpinned.
- ▶ Unpin the suspended ballast guide on the bracket **20**: Remove the spring retainer **23** and spacer **22** and unpin pins **21**.
- ▶ Unpin the second erection rack.



Note

- ▶ For the LR1600/2-W, the suspended ballast pallet must be unpinned on the D-auxiliary rods.
- ▶ The disassembly of the D-auxiliary rods is described in section „Disassembling the D-auxiliary rods for the suspended ballast“.

17.3 Unpinning the suspended ballast pallet on the D-guy rods

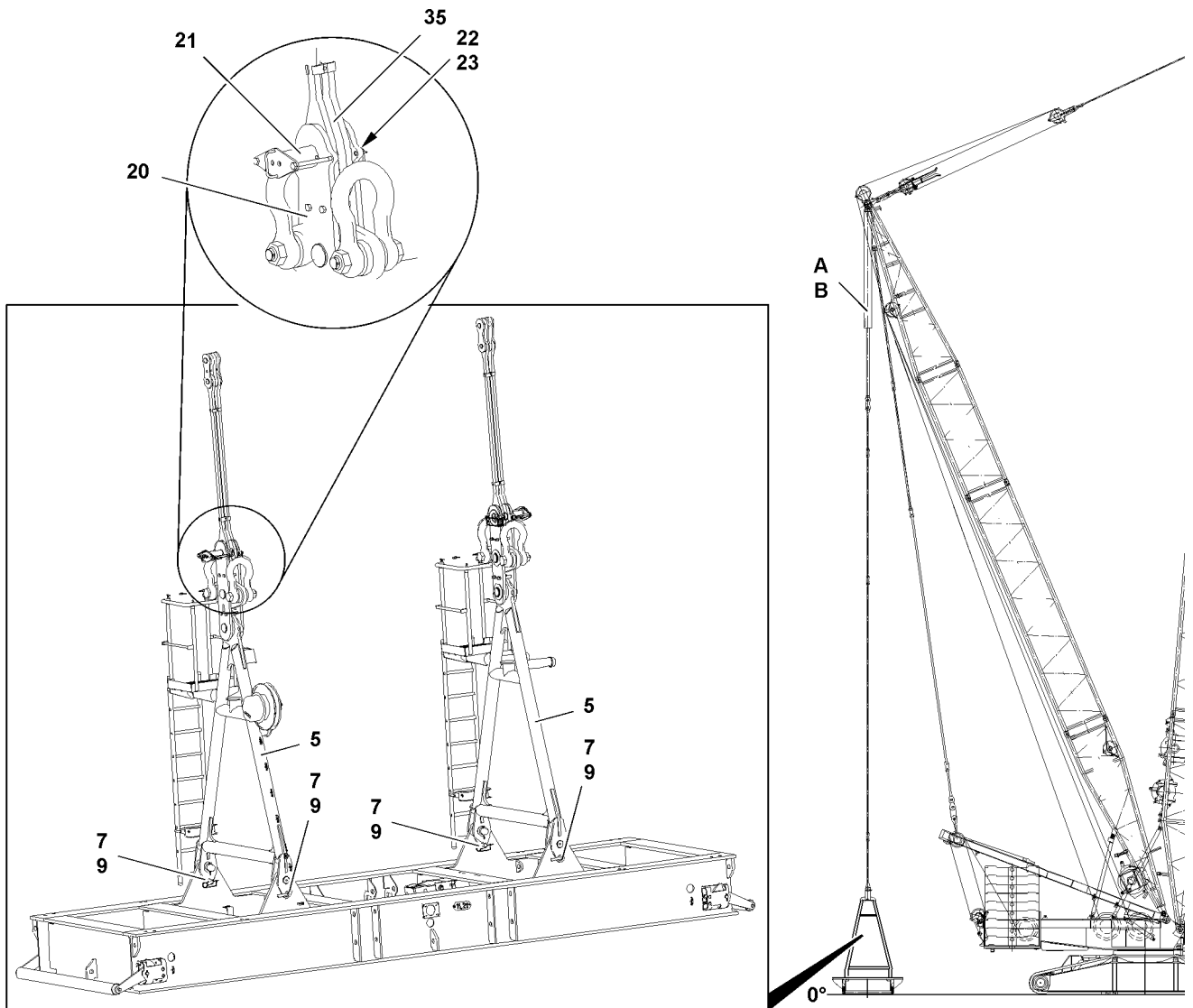

Fig.119253: Unpinning the suspended ballast pallet on the D-guy rods



WARNING

Unsecured erection racks!

Death, severe bodily injuries, property damage.

- ▶ Make sure that the erection racks are secured with retaining pins 7 to prevent them from tipping over.

The erection racks are unpinned at two points. The unpinning procedure is described for one pin as an example.

- ▶ Relieve the D-guy rods until the pin 21 can be unpinned.
- ▶ Unpin the D-guy rod 35 on the bracket 20: Remove the spring retainer 23 and spacer 22 and unpin pins 21.
- ▶ Unpin the second erection rack.

17.4 Removing the consoles for ballast centering

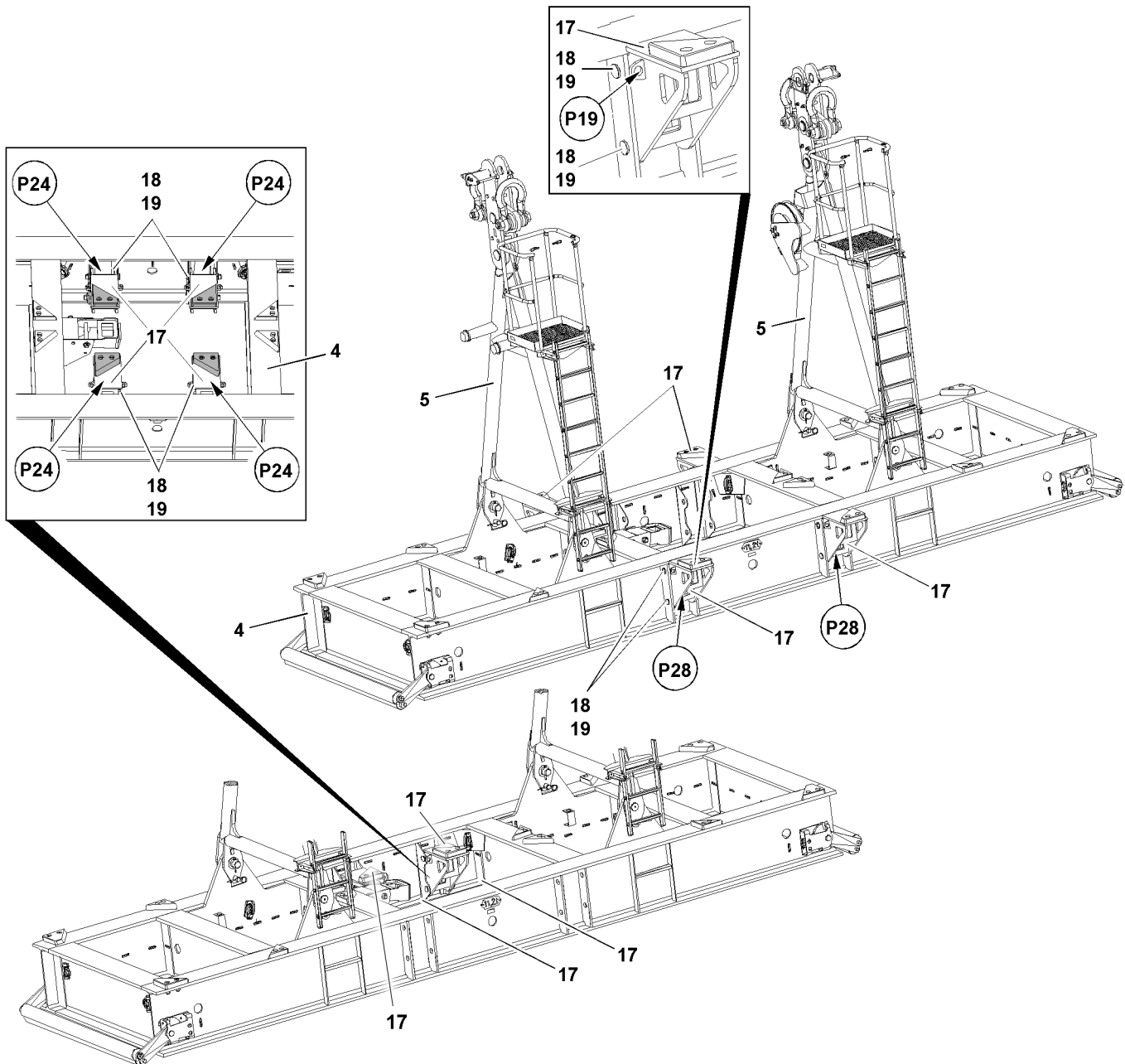

Fig.149292: Removing the consoles for ballast centering

Make sure that the following prerequisites are met:

- The erection racks **5** are in the assembly position.
- The ballast plates are completely removed from the suspended ballast pallet.



Note

- ▶ The disassembly is described as an example on one console for ballast centering **17**.
 - ▶ The disassembly of the additional consoles for ballast centering **17** is identical.
-
- ▶ Fasten the console for ballast centering **17** to the auxiliary crane at points **P19**.
 - ▶ Unpin the console for ballast centering **17** at point **P28**: Remove the spring retainer **19** and unpin the pin **18**.
 - ▶ Lift the console for ballast centering **17** with the auxiliary crane from the operating position **P28**.
 - ▶ Swing in the console for ballast centering **17** to the park position **P24** and pin with the pin **18** and secure with the spring retainer **19**.

- When the console for ballast centering **17** is pinned and secured properly in the park position **P24**:
- ▶ Remove the auxiliary crane.
 - ▶ Assemble additional consoles for ballast centering **17** in the park position.

17.5 Taking down the erection racks

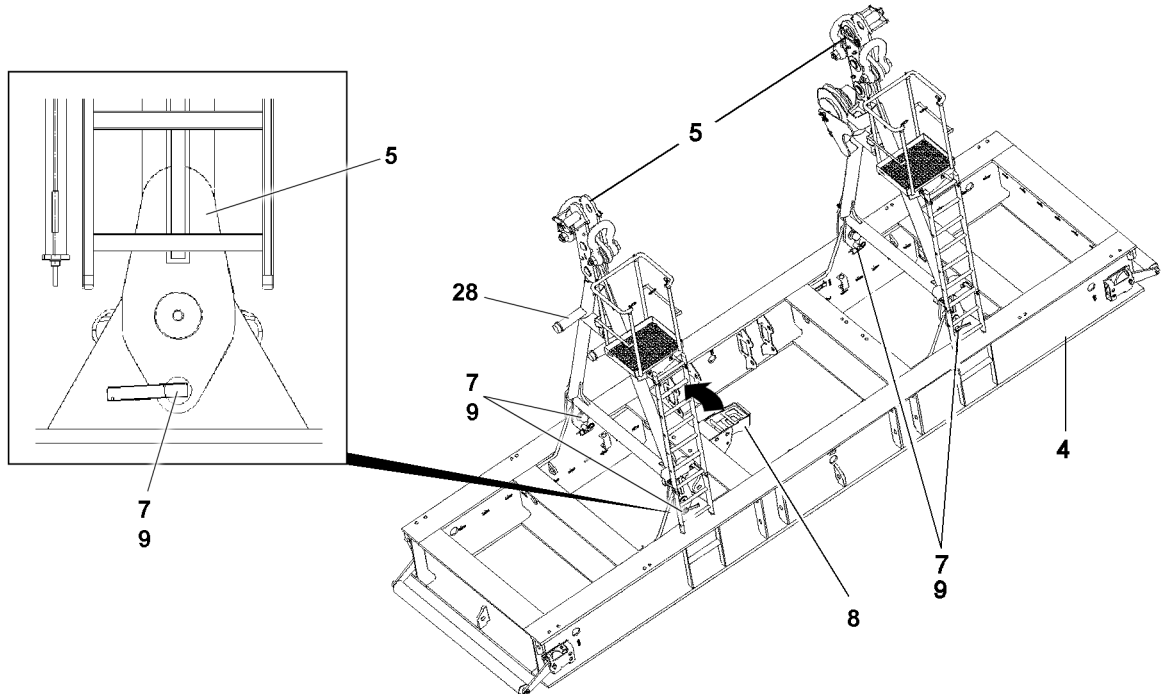

Fig.149293: Taking down the erection racks

Make sure that the following prerequisites are met:

- The consoles for ballast centering **17** are in the park position.
- The support for the erection rack **8** is in the operating position.



Note

- ▶ Take the erection rack **5** down first with the side supports **28**.

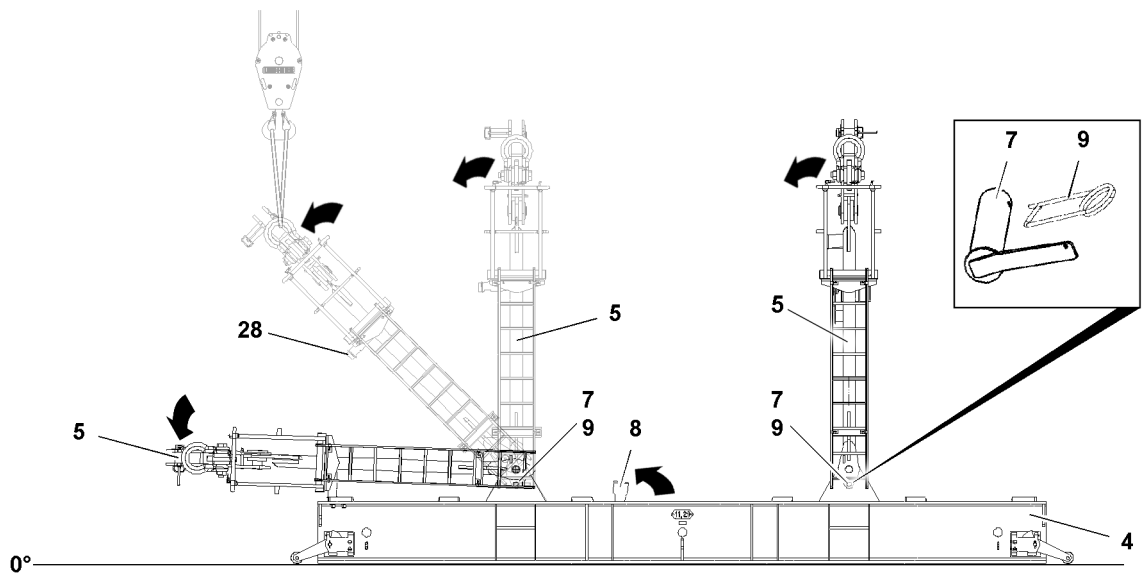

Fig.149294: Taking the first erection rack down

LWE/LR 1600-2-008/18109-09-02/en

**WARNING**

Danger of accident during disassembly of the erection racks!

Before unpinning the retaining pins **7**, the erection racks must hang securely on the auxiliary crane, otherwise the erection racks can tip over.

Death, severe bodily injuries, property damage.

- ▶ Never unpin the retaining pins of unsecured or unsupported erection racks.
- ▶ It is prohibited for anyone to remain under the erection racks or within the complete danger zone during the pinning and unpinning procedure.

- ▶ Fasten the erection rack **5** to the auxiliary crane and secure it to prevent it from tipping over.
- ▶ Remove both spring retainers **9** and unpin the retaining pins **7**.
- ▶ Insert the retaining pins **7** in the transport receptacle.
- ▶ Lower the erection rack **5** with the auxiliary crane until the supports **28** are resting on the suspended ballast frame **4**.

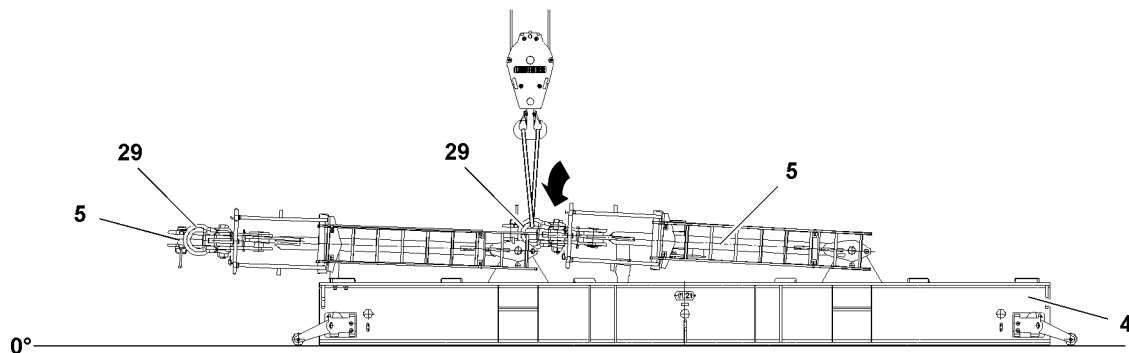

Fig.149295: Taking the second erection rack down

When the first erection rack is properly taken down:

- ▶ Take down the second erection rack on the support for the erection rack **8**.
- ▶ Remove the shackles **29** on the erection racks **5** and store them properly.

18 Disassembling the suspended ballast guide*

18.1 Disassembling the guy rods on the suspended ballast guide

18.1.1 Standard crane

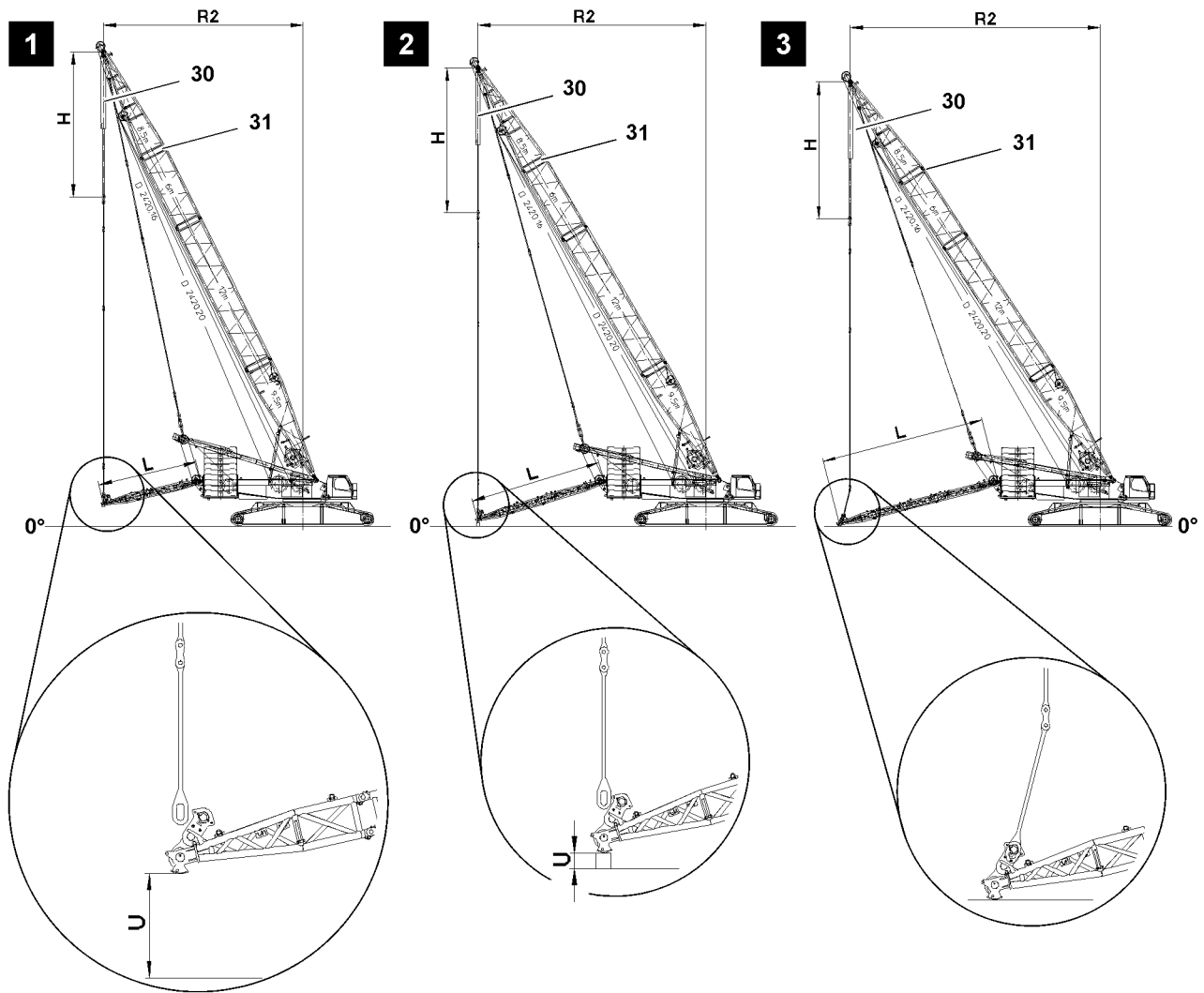

Fig.118919: Assembly positions depending on the derrick ballast radius

Depending on the derrick ballast radius, the suspended ballast guide is supported before disassembly on the turntable. Height of the substructure **U**, see chart.

To unpin the end section on the guy rods, the derrick radius **R2** and the dimension **H** are set depending on the derrick ballast radius with the derrick boom **31** and the hoist cylinders **30**, see chart.

Derrick ballast radius R1	Illustration	L	R2	H	U
15.0 m	1	7575 mm	15133 mm	11000 mm	1465 mm
17.5 m	2	10025 mm	17348 mm	11000 mm	250 mm
20.0 m	3	12475 mm	19000 mm	10400 mm	End section is placed on the ground

LWE/LR 1600-2-008/18109-09-02/en

Make sure that the following prerequisite is met:

- The suspended ballast pallet has been properly disassembled from the suspended ballast guide.

▶ Set the derrick boom **31** and the hoist cylinder **30** to the derrick radius **R2** and dimension **H**.

When the 15.0 m derrick ballast radius is disassembled:

▶ Lower the suspended ballast guide with the auxiliary crane to height **U** or take down the end section on a substructure, height **U**.

When the 17.5 m derrick ballast radius is disassembled:

▶ Lower the suspended ballast guide with the auxiliary crane and take down the end section on the substructure, height **U**.

When the 20.0 m derrick ballast radius is disassembled:

▶ Lower the suspended ballast guide with the auxiliary crane and take the end section down on the ground.

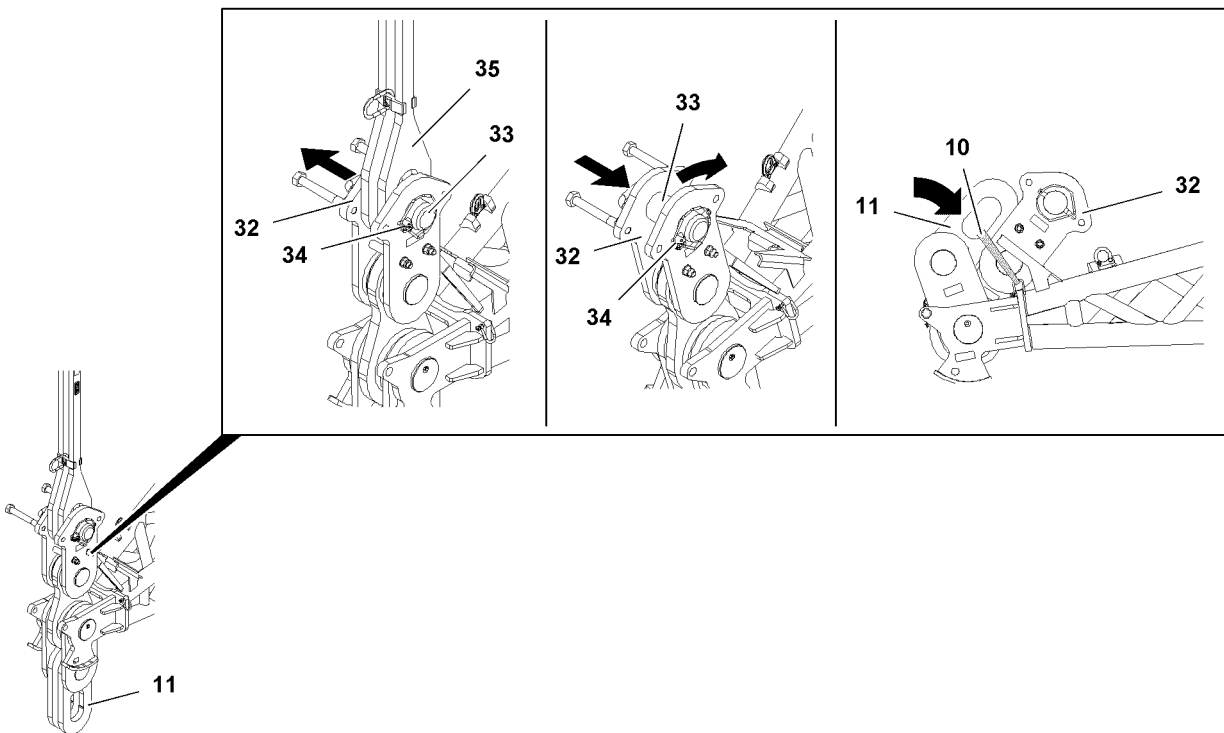

Fig.119200: Disassembling the guy rods on the end section of the suspended ballast guide

The guy rods are removed on both sides on the end section.

The pin procedure is described for one guy rod as an example.



WARNING

Swinging guy rod **35**!

Swinging guy rods can shear off limbs or cause serious crushing.

Death, severe bodily injuries, property damage.

▶ Before unpinning, make sure that the bracket **32** is secured to prevent it from folding down.

When the 20.0 m derrick ballast radius is disassembled:

▶ Before unpinning, make sure that the guy rod **35** is secured to prevent it from swinging.

- ▶ Unpin the guy rod **35** on the bracket **32**: Remove the locking pin **34** and unpin the pin **33**.
- ▶ Lift the guy rod **35** and fold the bracket **32** in direction of the pivot section.
- ▶ Insert the pin **33** and secure with the locking pin **34**.
- ▶ Fold the bracket **11** into the transport position in direction of the bracket **32**.
- ▶ Secure the bracket **11** and bracket **32** with the transport strap **10**.
- ▶ Unpin the second guy rod **35** on the end section.

18.1.2 Narrow track crane

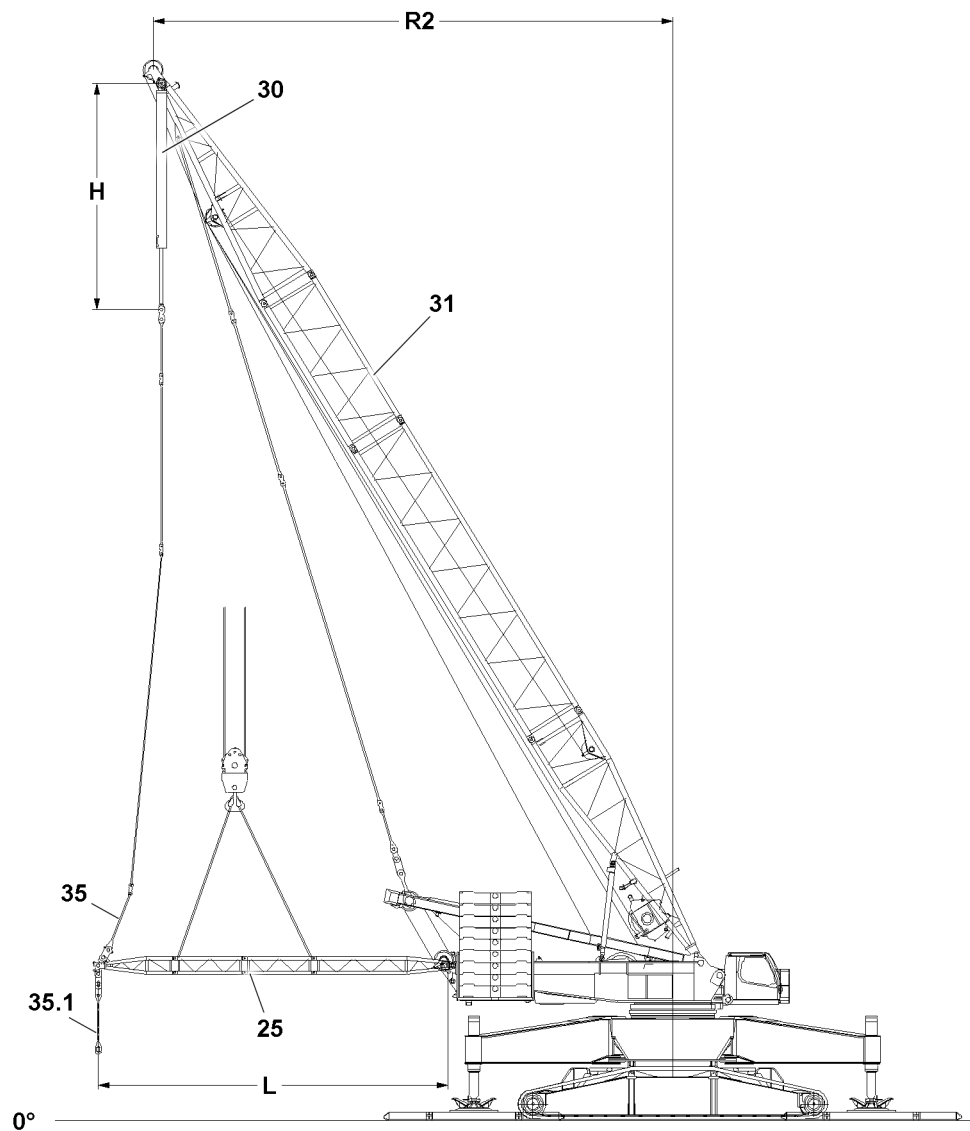

Fig.146512: Assembly positions depending on the derrick ballast radius

Make sure that the following prerequisites are met:

- The suspended ballast pallet has been properly disassembled from the suspended ballast guide.
- The suspended ballast guide is safely held by the auxiliary crane.

Disassembling the D-auxiliary rods for the suspended ballast



WARNING

Falling D-auxiliary rods!
Death, severe bodily injuries, property damage.

- ▶ Make sure that no personnel is within the danger zone during the disassembly of the D-auxiliary rods **35.1**.

- ▶ Fasten the D-auxiliary rods **35.1** to the auxiliary crane.

When the D-auxiliary rods **35.1** are safely held by the auxiliary crane:

- ▶ Unpin the D-auxiliary rods **35.1** on the suspended ballast guide **25**.
- ▶ Swing the D-auxiliary rods **35.1** out with the auxiliary crane and take it down.

Disassembling the D-guy rods

To be able to unpin the end section of the suspended ballast guide **25** on the D-guy rods, set the derrick boom **31** to the derrick boom radius **R2** and the hoist cylinder **30** to the dimension **H**, see chart.

Derrick ballast radius R	L	R2	H
15.0 m	7575 mm	15000 mm	—
17.5 m	10025 mm	17500 mm	—
20.0 m	12475 mm	18000 mm	7956 mm

Make sure that the following prerequisite is met:

- The suspended ballast guide is safely held by the auxiliary crane.

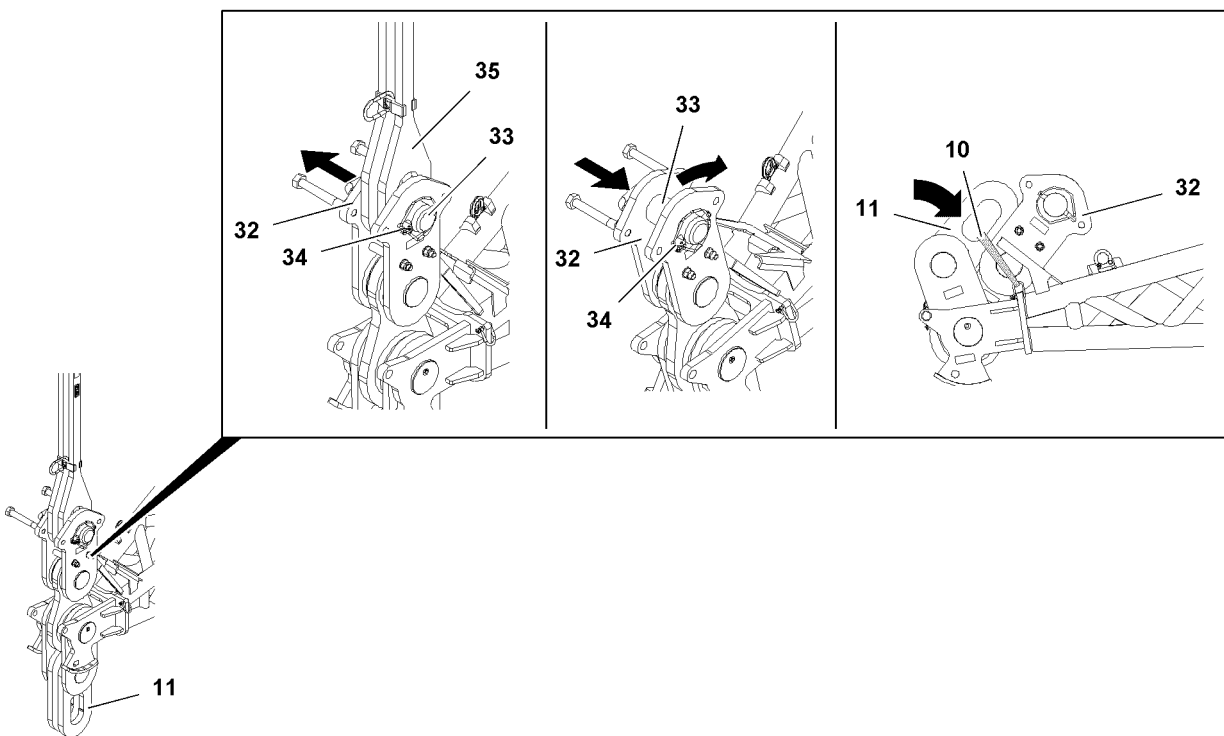

Fig.119200: Disassembling the guy rods on the end section of the suspended ballast guide **25**

- ▶ On both sides, take the brackets **11** down to the rear or fold them down.

The D-guy rods **35** are pinned on both sides on the end section of the suspended ballast guide. The pin procedure is described on the example for one D-guy rod.

- ▶ Remove the locking pin **34** and unpin the pin **33**.
- ▶ Position the brackets **32** and the D-guy rods **35** until the pin bores align.
- ▶ Pin the D-guy rods **35** on the brackets **32**: Insert the pin **33** and secure with the locking pin **34**.
- ▶ Assemble the second D-guy rod **35** on the end section of the suspended ballast guide.

Result:

- The suspended ballast guide **25** is disassembled on the D-guying.

18.2 Disassembling the suspended ballast guide on the turntable frame

18.2.1 Unpinning the suspended ballast guide on the turntable

Make sure that the following prerequisites are met:

- The suspended ballast pallet is properly disassembled.
- The suspended ballast guide is safely held by the auxiliary crane.

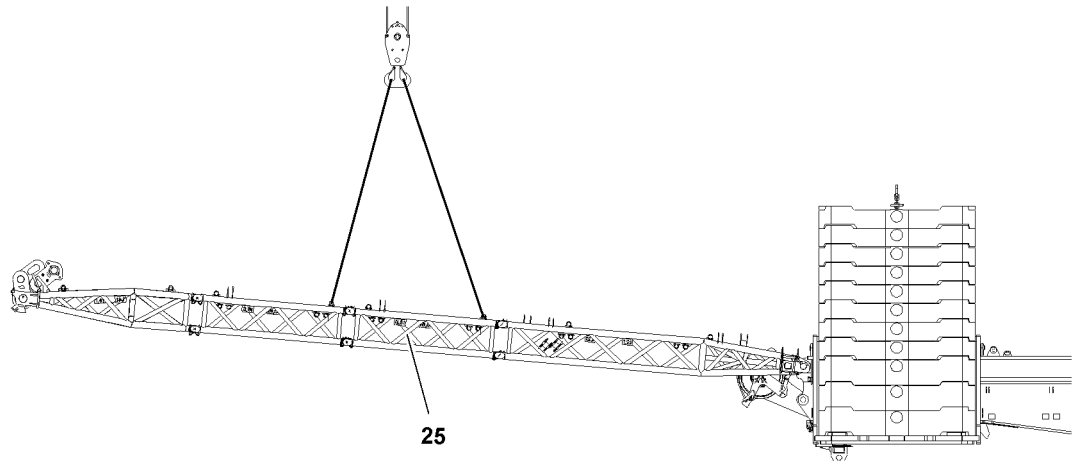

0°

Fig.146662: Suspended ballast guide secured for disassembly with the auxiliary crane



WARNING

Swinging of the suspended ballast guide!
Death, severe bodily injuries, property damage.

- ▶ Position the auxiliary crane in such a way that the suspended ballast guide **25** cannot swing after unpinning.



Note

- ▶ Unpin with the pin pulling device, see chapter 5.30.

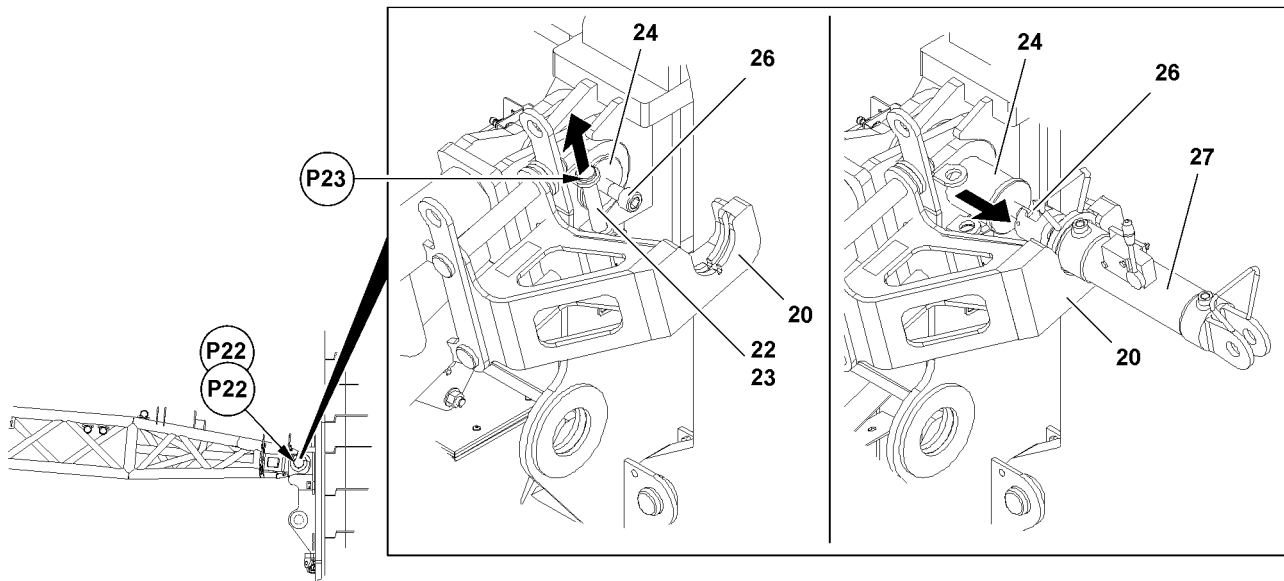

Fig. 119201: Unpinning the pin with the pin pulling device

The suspended ballast guide is unpinned on both sides on point **P22**. The unpinning procedure is described for one pin as an example.

- ▶ Release the pin **24** at point **P23**: Remove the spring retainer **23** and unpin the retaining pin **22**.
- ▶ Insert the pin pulling cylinder **27** on the console **20** and hang on the screw **26**.
- ▶ Unpin the suspended ballast guide on the turntable: Unpin the pin **24** with the pin pulling cylinder **27**.
- ▶ Unhook the pin pulling cylinder **26**.
- ▶ Unpin the second pin **24** on the suspended ballast guide.

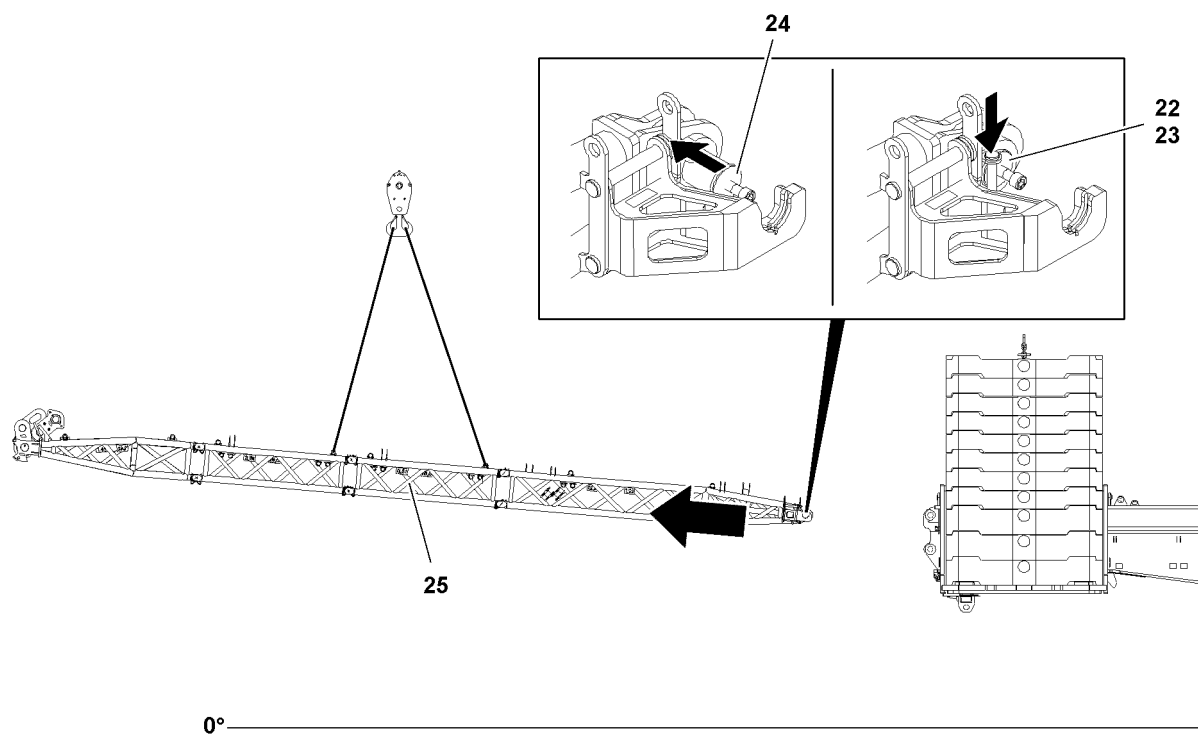

Fig. 146663: Removing the suspended ballast guide from the turntable

- ▶ Remove the suspended ballast guide **25** from the rear of the turntable.

The pins **24** are pinned on both sides in transport position. The pin procedure is described for one pin as an example.

- ▶ Insert the pin **24**.
- ▶ Secure the pin **24**: Insert the retaining pin **22** and secure with the spring retainer **23**.
- ▶ Insert the second pin **24**.
- ▶ Take down the suspended ballast guide **25** on the substructure on the ground.

18.2.2 Folding the consoles into the transport position

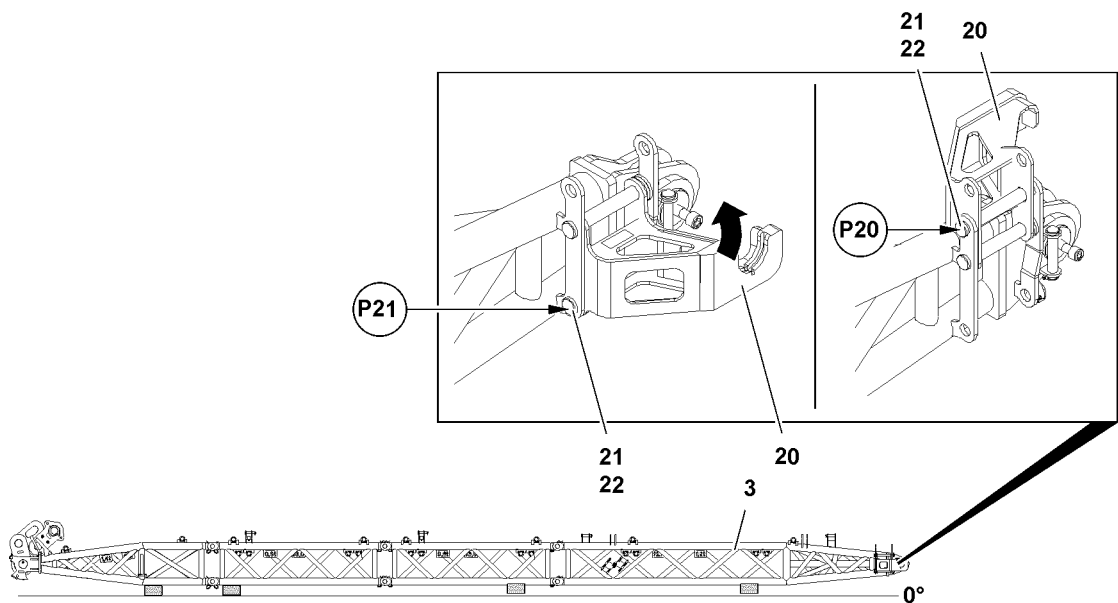

Fig.119203: Folding the consoles into the transport position

The consoles are folded on both sides on the pivot section into transport position. The assembly procedure is described for one console as an example.

- ▶ Unpin the console **20** at point **P21**: Remove the locking pin **22** and unpin the pin **21**.
- ▶ The console **20** can fold up in a controlled manner.
- ▶ Pin the console **20** at point **P20**: Insert the pin **21** and secure with the locking pin **22**.
- ▶ Fold the second console **20** into the transport position and pin it.

18.3 Disassembling the components for the suspended ballast guide



Note

- ▶ The disassembly procedure for the 20 m derrick ballast radius is described.
- ▶ For the 17.5 m derrick ballast radius, an intermediate section is solely installed. To be able to install the transport unit, both intermediate sections are pinned together.
- ▶ For the 15 m derrick ballast radius, **no** intermediate section is installed.

18.3.1 Disassembling the end section

Make sure that the following prerequisites are met:

- The lattice sections are horizontally supported.

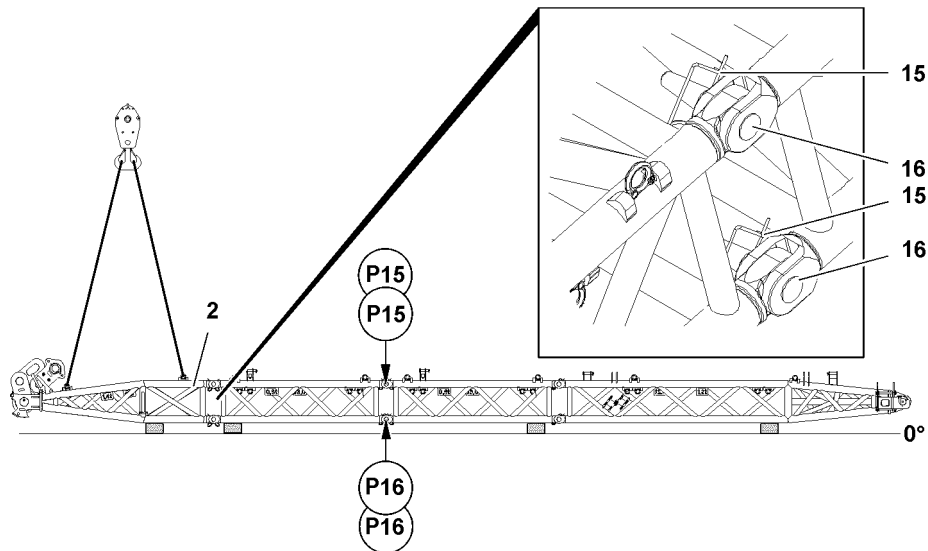

Fig.118914: Disassembling the end section

- ▶ Secure the end section 2 with the auxiliary crane.

The end section and the intermediate section are unpinned at four points. Every point is present on both sides of the component on one level.

- ▶ Unpin the end section 2 at point P16 on the intermediate section: Remove spring retainers 15 and unpin pins 16.
- ▶ Unpin the end section 2 at point P15 on the intermediate section: Remove spring retainers 15 and unpin pins 16.
- ▶ Remove the end section 2 and take it down.
- ▶ Remove the fastening equipment.

18.3.2 Disassembling the pivot section

Make sure that the following prerequisite is met:

- The lattice sections are horizontally supported.

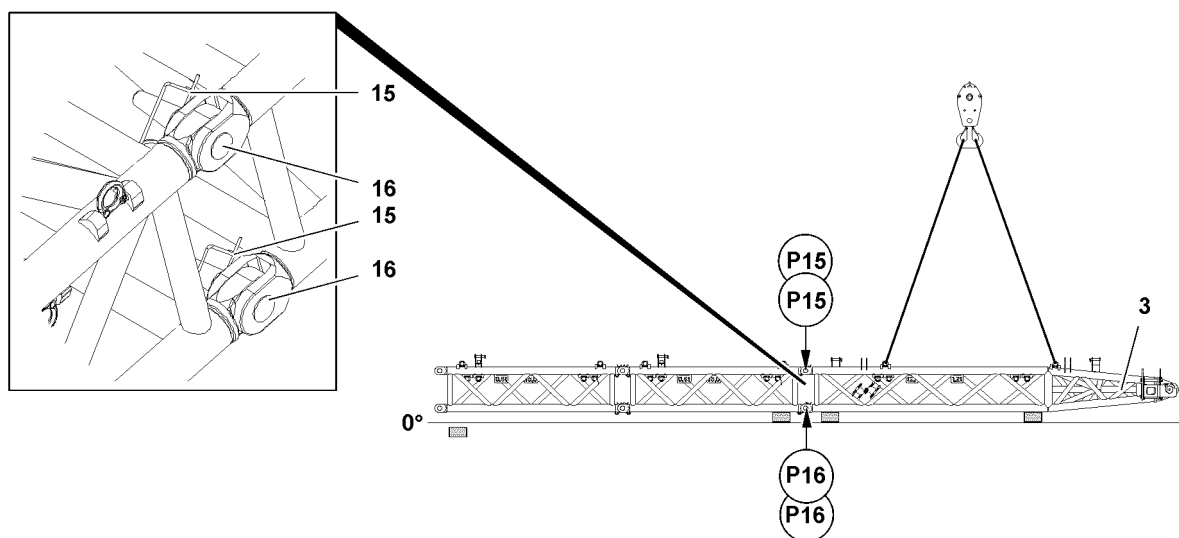

Fig.118913: Disassembling the pivot section

- ▶ Secure the pivot section 3 with the auxiliary crane.

The pivot section and the intermediate section are unpinned at four points. Every point is present on both sides of the component on one level.

- ▶ Unpin the pivot section **3** at points **P18** on the intermediate section: Remove spring retainers **15** and unpin pins **16**.
- ▶ Unpin the pivot section **3** at points **P17** on the intermediate section: Remove spring retainers **15** and unpin pins **16**.
- ▶ Support the pivot section **3**.
- ▶ Remove the fastening equipment.

18.4 Assembling the transport unit

Make sure that the following prerequisites are met:

- The suspended ballast guide is disassembled.
- The intermediate sections are pinned together.
- An auxiliary crane is available.

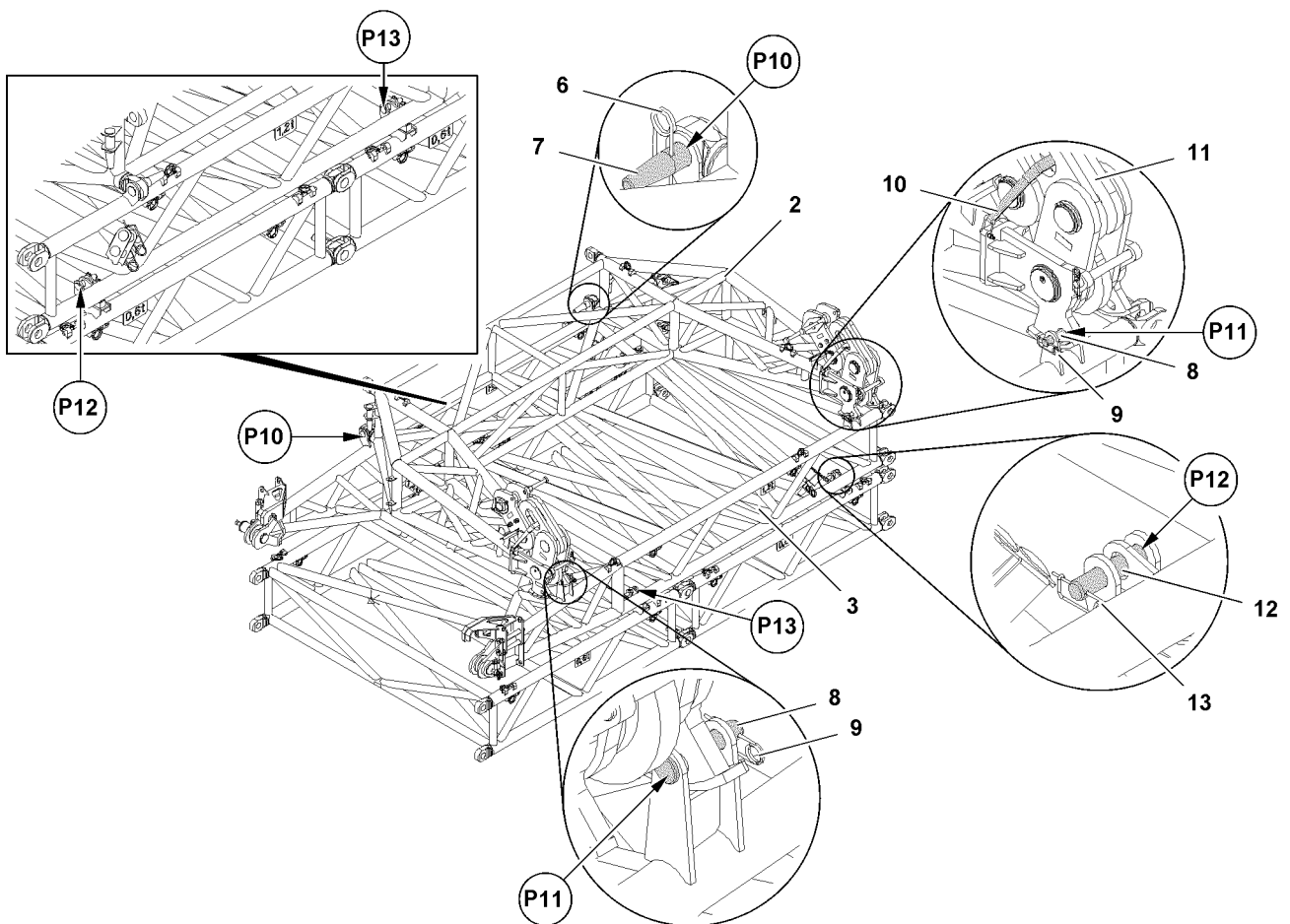

Fig.118549: Assembling the transport unit for the suspended ballast guide

- ▶ Fasten the auxiliary crane to the pivot section **3**.
- ▶ Position the pivot section **3** on the intermediate sections until the pin bores align.

The pivot section is pinned at four points. Every point is present on both sides of the component on one level.

- ▶ Pin the pivot section **3** at point **P12** on the lattice sections: Insert the pins **12** and secure with the spring retainers **13**.
- ▶ Pin the pivot section **3** at point **P13** on the lattice sections: Insert the pins **12** and secure with the spring retainers **13**.
- ▶ Fasten the auxiliary crane to the end section **2**.

**WARNING**

Unsecured brackets **11**!

Death, severe bodily injuries, property damage.

▶ Make sure that the brackets **11** are secured with transport straps **10**.

▶ Position the end section **2** on the pivot section until the pin bores align.

The end section is pinned at four points. Every point is present on both sides of the component on one level.

▶ Pin the end section **2** at point **P10** on the pivot section: Insert the pins **8** and secure with the spring retainers **6**.

▶ Pin the end section **2** at point **P11** on the pivot section: Insert the pins **8** and secure with the spring retainers **9**.

Result:

– The transport unit is installed for transport.

5.38 S/SL-boom

1	Component overview	3
2	Fastening points	3
3	Assembling the S/SL boom	6
4	Operating the crane	41
5	Disassembling the S/SL boom	42

Fig.195219

LWE/LR 1600-2-008/18109-09-02/en

1 Component overview



Note

- ▶ The boom components as well as the dimensions and weights are described in chapter 1.03.
- ▶ For the combination of the various boom systems, refer to the Rod plan and chapter 5.03.

2 Fastening points



WARNING

Falling lattice sections!

Death, severe bodily injuries, property damage.

- ▶ Make sure that the lattice sections are properly fastened on the respective fastening points.
- ▶ Make sure that the fastening equipment has the appropriate length and a sufficient load bearing capacity.
- ▶ Pay attention and adhere to the labels on the fastening points on the lattice sections and crane components.

2.1 Fastening points S-pivot section

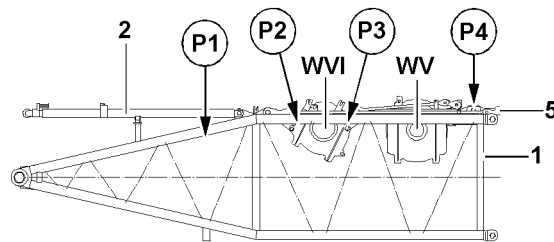

Fig.125155: Fastening points S-pivot section

Fastening points	
P1 + P3	S-pivot section without winch 5, without winch 6
P2 + P3	S-pivot section with winch 5, without winch 6
P1 + P3	S-pivot section without winch 5, with winch 6
P2 + P3	S-pivot section with winch 5, with winch 6

2.2 Fastening points S-intermediate sections 2825.25, 3 m

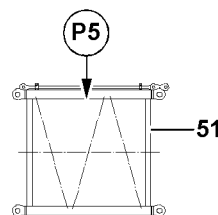

Fig.125156: Fastening points S-intermediate sections 2825.25, 3 m

**Note**

- ▶ The S-intermediate sections are available in various system dimensions.
- ▶ The lattice section must be fastened on both sides to the fastening points.

Fastening points	
P5	S-intermediate sections 2825.25, 3 m

2.3 Fastening points S-intermediate sections 2825.25, 12 m

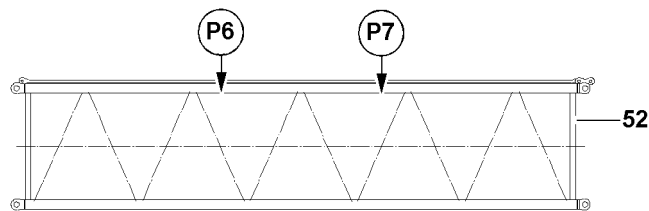

Fig.125157: Fastening points S-intermediate sections 2825.25, 12 m

**Note**

- ▶ The S-intermediate sections are available in various system dimensions.
- ▶ The distance between the fastening pints can vary, depending on the respective S-intermediate section.
- ▶ The lattice section must be fastened on both sides to the fastening points.

Fastening points	
P6 + P7	S-intermediate sections 2825.25, 12 m

2.4 Fastening points S-intermediate sections 2825.20, 6 m

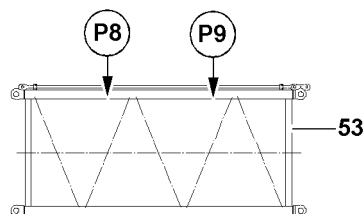

Fig.125158: Fastening points S-intermediate sections 2825.20, 6 m

**Note**

- ▶ The S-intermediate sections are available in various system dimensions.
- ▶ The distance between the fastening pints can vary, depending on the respective S-intermediate section.
- ▶ The lattice section must be fastened on both sides to the fastening points.

Fastening points	
P8 + P9	S-intermediate sections 2825.20, 6 m

2.5 Fastening points S-intermediate sections 2825.20, 12 m FLM for flying assembly

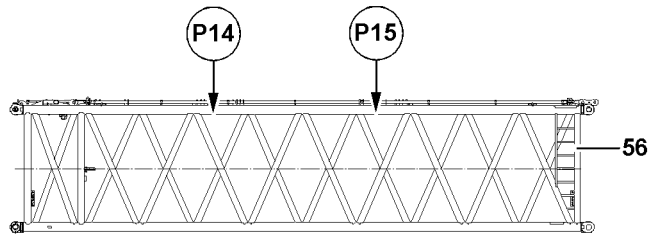

Fig.125161: Fastening points S-intermediate sections 2825.20, 12 m FLM for flying assembly



Note

- ▶ The S-intermediate sections are available in various system dimensions.
- ▶ The distance between the fastening pints can vary, depending on the respective S-intermediate section.
- ▶ The lattice section must be fastened on both sides to the fastening points.

Fastening points	
P14 + P15	S-intermediate sections 2825.20, 12 m FLM for flying assembly

2.6 Fastening points LI-intermediate sections 2420.10Z, 12 m

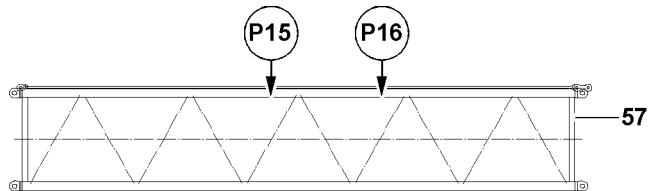

Fig.125162: Fastening points LI-intermediate sections 2420.10Z, 12 m



Note

- ▶ The S-intermediate sections are available in various system dimensions.
- ▶ The distance between the fastening points can vary.
- ▶ The lattice section must be fastened on both sides to the fastening points.

Fastening points	
P16 + P17	LI-intermediate sections 2420.10Z, 12 m

LWE/LR 1600-2-008/18109-09-02/en

2.7 Fastening points SL-reducer

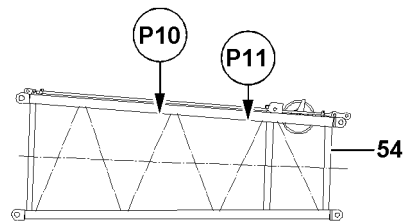

Fig.125159: Fastening points SL-reducer



Note

► The lattice section must be fastened on both sides to the fastening points.

Fastening points	
P10 + P11	SL-reducer

2.8 SW-end section fastening points

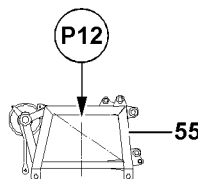

Fig.125160: SW-end section fastening points

Fastening points	
P12	SW-end section, without roller set

3 Assembling the S/SL boom



Note

► For the combination of the boom lattice sections, observe and adhere to the Rod plan and chapter 5.03.

**WARNING**

Danger of falling!

During assembly / disassembly, inspection and maintenance work, assembly personnel must be secured with appropriate aids to prevent them from falling.

Death, severe bodily injuries, property damage.

- ▶ All work at a height, when there is a danger of falling, must be carried out with suitable aids.
- ▶ If aids are not available and work cannot be carried out from the ground, then assembly personnel must secure themselves with the supplied fall arrest system to prevent falling, see chapter 2.04.
- ▶ If fall protection equipment is available, then it must be used, see chapter 2.06.
- ▶ When lifting, lowering, swinging crane parts in and out, no persons may remain in the danger zone.
- ▶ When closing or opening boom systems during boom assembly or boom disassembly, no persons may remain on the boom system or in the danger zone.
- ▶ If railings are present on the components, then they must be brought into the corresponding position and secured for assembly / disassembly work.
- ▶ Only step on the aids, ladders and catwalks with clean shoes.
- ▶ Keep aids, ladders and catwalks free of heavy dirt, snow and ice.
- ▶ During all assembly and disassembly work, maintenance work and inspections, travel or crane operation is prohibited.
- ▶ Remaining on a suspended load is prohibited.
- ▶ Stepping or walking on crane components and lattice sections, which have an incline of more than 20° is prohibited.
- ▶ For all assembly work, the crane driver of the main crane must be in voice contact with the crane driver / crane drivers of the auxiliary crane / auxiliary cranes.
- ▶ For assembly tasks, the crane driver may only initiate crane movements when the responsible guide has explicitly released the movement.

**WARNING**

The lattice sections can fall down!

If the lattice sections are not pinned and secured correctly, then they can fall down.

Death, severe bodily injuries, property damage.

- ▶ Insert or unpin both pins at the same horizontal level, i.e. **left and right**.
- ▶ Do not stand under the lattice sections or within the entire danger zone during the pinning and unpinning procedure of the boom.
- ▶ Safely secure the pins in the storage locations as well as in the receptacles.
- ▶ It is prohibited to lean the ladder against the component being disassembled.

**WARNING**

Danger of impact / crushing!

When installing / removing crane components with the auxiliary crane, crane components can start to swing back and forth.

When lifting / lowering and positioning crane components, there is an increased danger of impacts / crushing.

Death, severe bodily injuries, property damage.

- ▶ Make sure that personnel cannot be caught by components.
- ▶ Make sure that the crane is horizontally aligned.
- ▶ When working in danger zones: Use aids to protect limbs.
- ▶ Guide components with suitable aids to minimize oscillation.

**DANGER**

The components can fall down!

If the corresponding component is disengaged from the auxiliary crane before the corresponding component is pinned, then the corresponding component can fall down.

Death, severe bodily injuries, property damage.

- ▶ Do not disengage the auxiliary crane until the respective component is pinned and secured.

**WARNING**

The crane can topple over!

- ▶ The turntable may not be turned during the assembly of the boom.
- ▶ Observe the assembly conditions, see chapter 3.06.

**WARNING**

Danger of accident!

Death, severe bodily injuries, property damage.

- ▶ For assembly of the boom combinations, the rod plan must be observed and adhered to.
- ▶ Depending on the condition of the ground, the boom and the lattice sections must be supported from below for the assembly of the boom.
- ▶ Observe the technical safety instructions, see chapter 5.01.

Make sure that the following prerequisites are met:

- The crane is horizontally aligned.
- An auxiliary crane is available.
- An assembly scaffolding / work platform is available.
- The central ballast is installed according to the load chart.
- The counterweight has been installed on the turntable according to the load chart.
- The LICCON overload protection has been set according to the data in the load chart.

Empty page!

LWE/LR 1600-2-008/18109-09-02/en

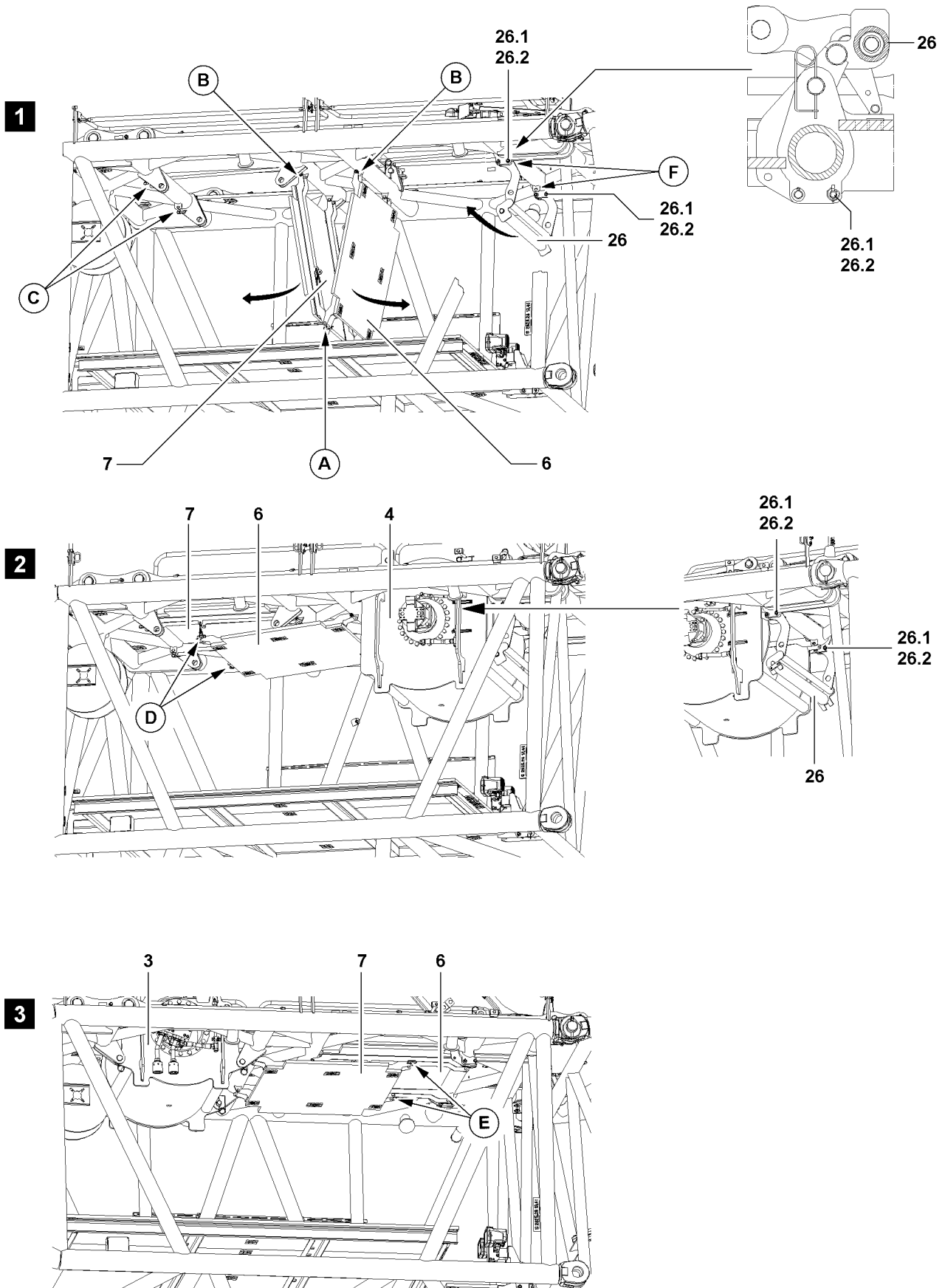

Fig.106747

3.1 Swinging the railing on the S-pivot section into the operating position



WARNING

Danger of falling!

During assembly and disassembly of the railings, assembly personnel must be secured with appropriate aids to prevent them from falling.

Even during the assembly of protective equipment there is a danger of falling.

Death, severe bodily injuries, property damage.

► For assembly and disassembly work, maintenance and inspection work on the S-pivot section, all railings must be assembled and secured.

► Only step on the S-pivot section **1** with „clean shoes“.

► Swing the railing on the S-pivot section **1** into the operating position, pin with the grip pin and secure with the spring retainer.

3.2 Assembling the catwalks



WARNING

Disassembled or incompletely assembled catwalks!

If the catwalks are not installed when the winches are missing or if the catwalks are not completely installed, then personnel can fall down.

Death, severe bodily injuries, property damage.

► For each non-assembled winch on the S-pivot section: Assemble the catwalk.

► The catwalks may only be accessed when they are pinned and secured in the operating position, check visually.



WARNING

Catwalks swung down!

Catwalks that swing down by themselves can cause severe face or head injuries for assembly personnel.

Death, severe bodily injuries, property damage.

► For safety reasons, assemble the catwalks always with two persons.



Note

► If winch 5 is not assembled, the protective roller **26** must be pinned in the „up“ position during crane operation.

► If winch 5 is to be assembled, then, before assembly of winch 5, the protective roller **26** must be folded down and pinned in the „down“ position.

Catwalks are assigned to the openings for the winches:

- Winch 5 – catwalk **6**.
- Winch 6 – catwalk **7**.

Make sure that the following prerequisite is met:

- The railings are pinned and secured in the operating position.

3.2.1 S-pivot section without winches

Make sure that the following prerequisites are met:

- Catwalks are pinned in the transport position in point **A**.
- The protective roller **26** is pinned and secured in the „up“ position.

► Release and unpin the catwalks in point **A**.

Swing the catwalks „up“ individually into the operating position and pin.

► Swing the catwalk **7** into the operating position and pin and secure in points **C**, see illustration **1**.

► Swing the catwalk **6** into the operating position and pin and secure in points **F**, see illustration **1**.

3.2.2 S-pivot section before installation of winch 5

Make sure that the following prerequisites are met:

- Winch 5 is not installed.
- Winch 6 is not installed.
- The protective roller **26** is pinned and secured in the „up“ position.
- The catwalk **6** and catwalk **7** are pinned and secured in the operating position.

- ▶ Hang the catwalk **6** on the auxiliary crane.

When the catwalk **6** is safely held by the auxiliary crane:

- ▶ Unpin the catwalk **6** in points **F**.
- ▶ Lower the catwalk **6** downward and remove the auxiliary crane.
- ▶ Swing the catwalk **6** upward to the opposite side and pin and secure in the points **D** of the catwalk **7**, see illustration **2**.
- ▶ Release and unpin the protective roller **26** in the „up“ position.
- ▶ Swing the protective roller **26** into the „down“ position, pin with the retaining pin **26.1** and secure with the locking pin **26.2**.

Result:

- Winch 5 can be installed.

3.2.3 S-pivot section before installation of winch 6

Make sure that the following prerequisites are met:

- Winch 5 is not installed.
- Winch 6 is not installed.
- The protective roller **26** is pinned and secured in the „up“ position.
- The catwalk **6** and catwalk **7** are pinned and secured in the operating position.

- ▶ Hang the catwalk **7** on the auxiliary crane.

When the catwalk **7** is safely held by the auxiliary crane:

- ▶ Unpin the catwalk **7** in points **C**.
- ▶ Lower the catwalk **7** downward and remove the auxiliary crane.
- ▶ Swing the catwalk **7** upward to the opposite side and pin and secure in the points **E** of the catwalk **6**, see illustration **3**.

Result:

- Winch 6 can be installed.

3.2.4 S-pivot section before installation of both winches

Make sure that the following prerequisites are met:

- The protective roller **26** is pinned and secured in the „up“ position.
- The catwalk **6** and catwalk **7** are pinned and secured in the operating position.



Note

- ▶ Lower the catwalks individually and one after the other with the auxiliary crane.

When the catwalk is safely held by the auxiliary crane:

- ▶ Release and unpin the catwalk in the operating position, see illustration **1**.
- ▶ Lower the catwalk and remove the auxiliary crane.

When the catwalk **6** and the catwalk **7** are lowered down:

- ▶ Pin and secure the catwalks in point **A**, see illustration **1**.
- ▶ Release and unpin the protective roller **26** in the „up“ position.
- ▶ Swing the protective roller **26** into the „down“ position, pin with the retaining pin **26.1** and secure with the locking pin **26.2**.

Result:

- Winch 5 and winch 6 can be assembled.

3.3 Assembling the boom



WARNING

The crane can topple over!

- ▶ The turntable may not be turned during the assembly of the boom.
- ▶ Observe the assembly conditions, see chapter 3.06.



WARNING

Danger of accident!

Death, severe bodily injuries, property damage.

- ▶ For assembly of the boom combinations, the rod plan must be observed and adhered to.
- ▶ Depending on the condition of the ground, the boom and the lattice sections must be supported from below for the assembly of the boom.
- ▶ Observe the technical safety instructions, see chapter 5.01.

Make sure that the following prerequisites are met:

- The crane is horizontally aligned.
- An auxiliary crane is available.
- An assembly scaffolding / work platform is available.
- The central ballast is installed according to the load chart.
- The counterweight has been installed on the turntable according to the load chart.
- The LICCON overload protection has been set according to the data in the load chart.

3.3.1 Turning the turntable into the assembly position



WARNING

The crane can topple over!

If the following conditions are not met before turning the turntable - **without** assembled S-boom, the crane can topple over.

Death, severe bodily injuries, property damage.

- ▶ Observe the specifications in the erection and take-down charts.
- ▶ Observe the maximum permissible ballast combinations depending on the assembly status, see chapter 3.06.

- ▶ Turn the turntable into the assembly position, see the „Erection and take down charts“.

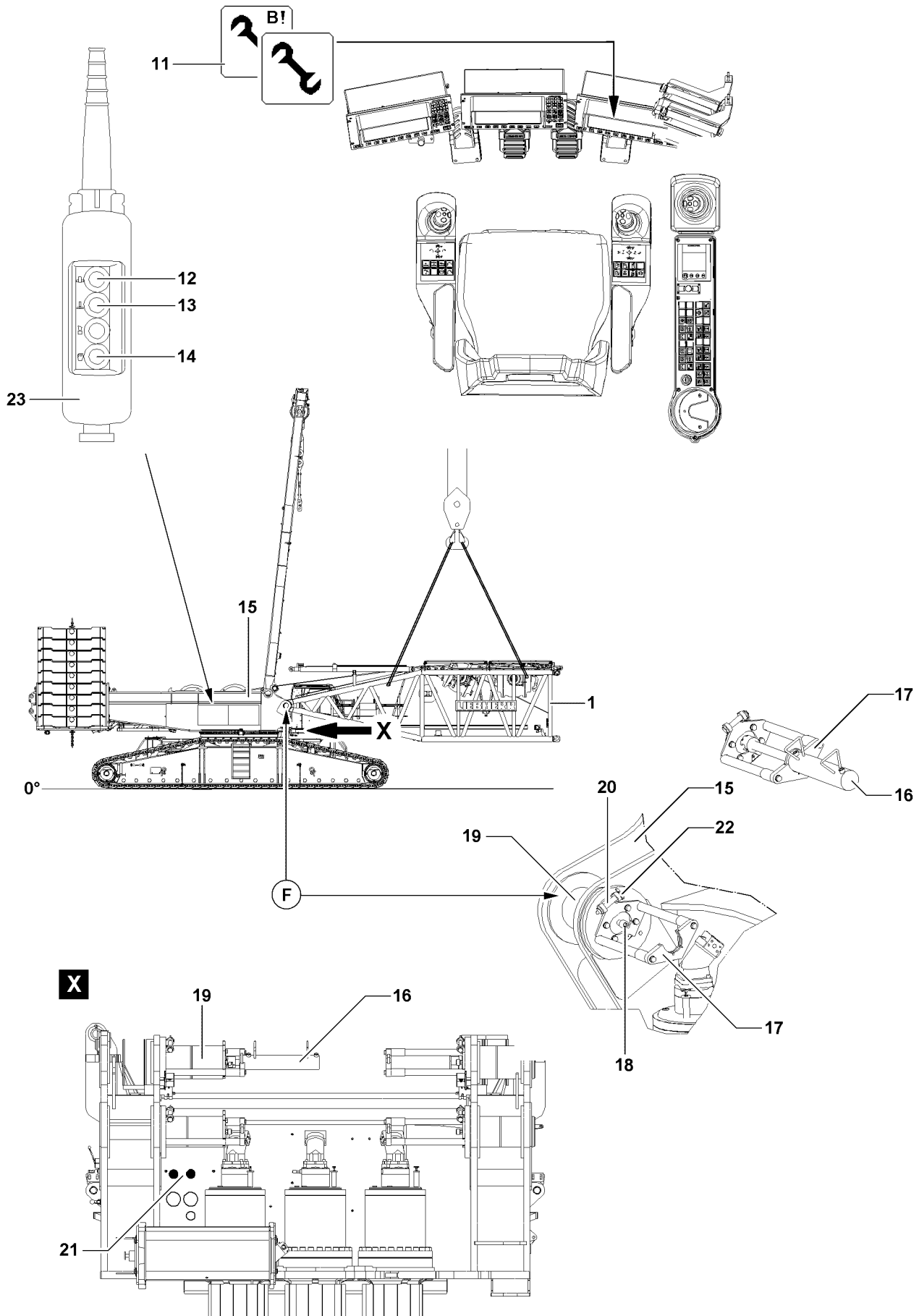

Fig.114052

LWE/LR 1600-2-008/18109-09-02/en

3.3.2 Exceeding the LICCON overload protection for assembly



WARNING

Danger of accident due to the „Exceedance of shut-off limits of the LICCON overload protection“ function!

If the shut off limits of the LICCON overload protection are exceeded, there is no additional protection against crane overload.

Due to erroneous operation or deliberate misuse, the crane could collapse, the boom can break off or the crane can topple over.

Death, severe bodily injuries, property damage.

- ▶ The function „Exceedance of shut off limits of the LICCON overload protection“ is only permissible in emergencies and for assembly purposes.
- ▶ The function „Exceeding the shut off limits of the LICCON overload protection“ may only be actuated by persons who know the effects of their actions regarding the function „Exceeding the shut off limits of the LICCON overload protection“.
- ▶ The „Exceedance of shut off limits of the LICCON overload protection“ function requires the presence of an authorized person and must be performed with utmost caution.
- ▶ Crane operation with activated function „Exceedance of shut off limits of the LICCON overload protection“ is prohibited.

-
- ▶ Exceeding the shut off limits of the LICCON overload protection: Engage assembly operation.

Result:

- The shut off limits of the LICCON overload protection are exceeded.
- The assembly icon appears on the LICCON monitor.



Note

- ▶ See chapter 4.02.

3.4 Pinning the S-pivot section on the turntable



Note

- ▶ Always arrange the intermediate sections according to the rod plan.
- ▶ Observe chapter 5.03.



WARNING

General danger notes!

- ▶ Support the S-boom during assembly with suitable materials.
- ▶ All pins are to be secured after assembly with the intended retaining elements.
- ▶ The guy rods must be inspected regularly, see chapter 8.15.

Make sure that the following prerequisite is met:

- The pins **20** in points **F** are unpinned.



Note

- ▶ Select the fastening points on the S-pivot section in such a way that the S-pivot section hangs horizontally on the auxiliary crane upon assembly. See section „Fastening points“.
- ▶ Fasten the S-pivot section **1** in the fastening points to the auxiliary crane.
- ▶ Swing the S-pivot section **1** in with the auxiliary crane to the pin points on the turntable.



Note

- ▶ The pin pulling device is operated with the control panel **23** of the turntable, see illustration.

Establish the hydraulic connection to the pin pulling device via two quick couplers.

**Note**

- ▶ When hooking the pin pulling cylinder **16**, make sure that the collar on the cylinder mount and the catch on the screw are properly hooked.
- ▶ Hang the pin pulling cylinder **16** into the receptacle **17** and the screw **18** on the pin **19**.
- ▶ Connect the pin pulling cylinder **16** to the quick couplers **21**, see hydraulic wiring diagram.

**WARNING**

Insufficiently secured connector pins!

Due to non-secured or insufficiently secured connector pins, the S-pivot section can fall down. Death, severe bodily injuries, property damage.

- ▶ Secure the pins **19** between the S-pivot section **1** and the turntable **15** after the pin procedure with the pins **20**.
- ▶ Pin the pins **19** on both sides with the hydraulic pin pulling cylinder **16**: Press the button **14** on the control panel **23** and hold down, then press the button **12** until the pin **19** is completely pinned.

When the pins **19** are completely pinned on the left and right on the S-pivot section **1**:

- ▶ Secure the pins **19** on the left and right: Insert the pin **20** and secure with the locking pin **22**.

Result:

- The pins **19** have been secured with the retaining pins **20** to prevent them from unpinning by themselves.

NOTICE

Damage to the S-pivot section!

When the installed S-pivot section is taken down on the ground, the S-pivot section can be damaged.

- ▶ Slowly take the S-pivot section **1** down with the auxiliary crane and at low speed onto the substructure.
- ▶ Before taking it down on the ground, support the S-pivot section **1**.
- ▶ Carefully take the S-pivot section **1** down on the substructure.
- ▶ Remove the auxiliary crane.

3.5 Establishing the electric and hydraulic connections on the S-pivot section

3.5.1 Establishing the electrical connections

NOTICE

Danger of damage to the electrical connections!

If the electrical connection between the terminal box and the S-pivot section and the cable drum in the S-pivot section is established before the boom end section is installed and electrically connected, then the electric connection can be damaged.

- ▶ Make sure that the electric connection between the terminal box in the S-pivot section and the cable drum in the S-pivot section is only established **after** assembly and the connection of the electric wiring for the boom end section.

**Note**

- ▶ To establish the electrical connections on the S-pivot section: Use the Electrical wiring diagram.

Make sure that the following prerequisite is met:

- The S-pivot section is completely assembled and taken down on the substructure.
- ▶ Establish the electrical connections.
- ▶ Make sure that all electrical connections to the S-pivot section have been established.

**WARNING**

Malfunction if dummy plugs are not installed!

If the dummy plugs on the non-required electrical connections are not installed, then malfunctions or functional limitations can occur on the crane.

- ▶ Make sure that all non-required electrical connections, which have a dummy plug are closed off with dummy plugs.
 - ▶ Pay attention to the Electrical wiring diagram.
-
- ▶ As a rule, close off on-required electrical connections (for example for accessories which cannot be installed) with the respective dummy plugs.

NOTICE

Property damage due to dirt and / or corrosion!

If non-required electrical connections are not closed off with the respective protective caps, then dirt and / or corrosion can damage the electrical connections.

This could result in malfunctions.

- ▶ Make sure that all non-required electrical connections are always closed off properly.
 - ▶ Pay attention to the Electrical wiring diagram.
-
- ▶ Close electrical connections, which have no dummy plugs, properly off with the corresponding protective caps.

3.5.2 Establishing the hydraulic connections

When connecting and releasing hydraulic lines with quick couplings, make sure that the coupling procedure is carried out correctly.

**Note**

- ▶ To connect or release the hydraulic lines with quick couplings, see chapter 5.01.

**WARNING**

Pressure in the hydraulic lines!

If the pressure supply is not interrupted before connecting / releasing the hydraulic lines, the hydraulic oil can escape with high pressure.

Death, severe bodily injuries, property damage.

- ▶ Release the pressure in the hydraulic system before connecting / disconnecting: Interrupt the pressure supply and wait for a short time.

**WARNING**

Loss of pressure or leakage!

Incorrectly coupled or self-loosening quick couplings (particularly return lines) can result in serious accidents due to component failure.

- ▶ Check that the quick couplings have been properly connected before using the crane.
-
- ▶ Connect the coupling components (sleeve and connector) and screw together with the knurled nut.
 - ▶ Tighten the hydraulic coupling by hand. Turn the knurled nut until it reaches a tangle, fixed stop position.
 - ▶ Establish the hydraulic connections, see the Hydraulic diagram.

4

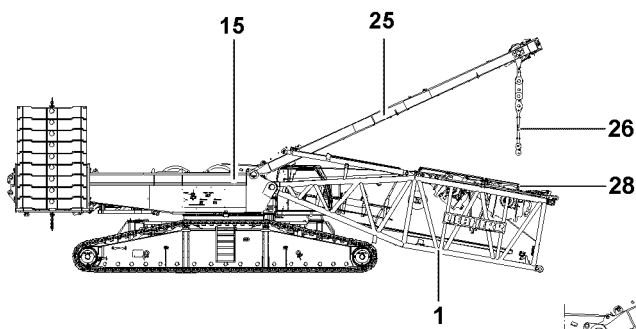

5

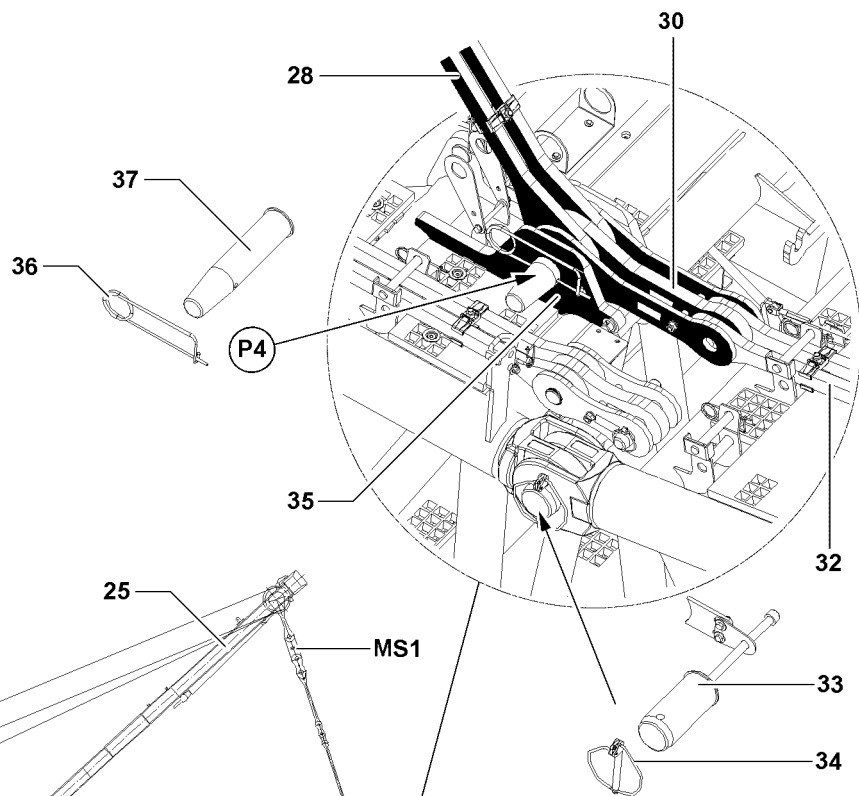
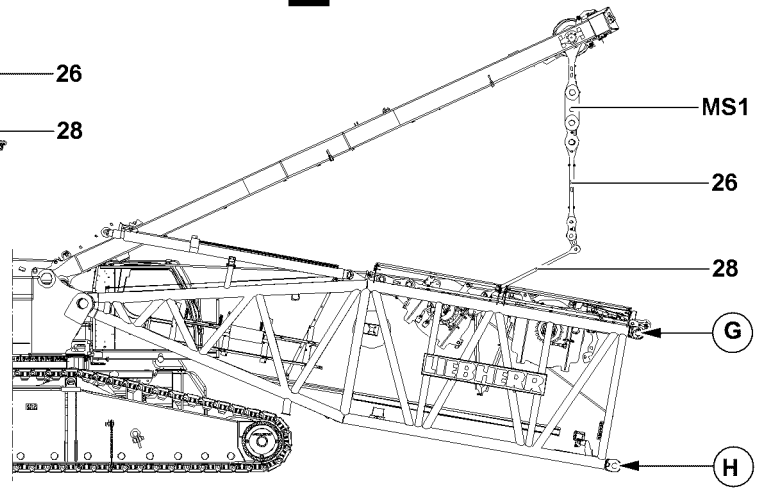

6

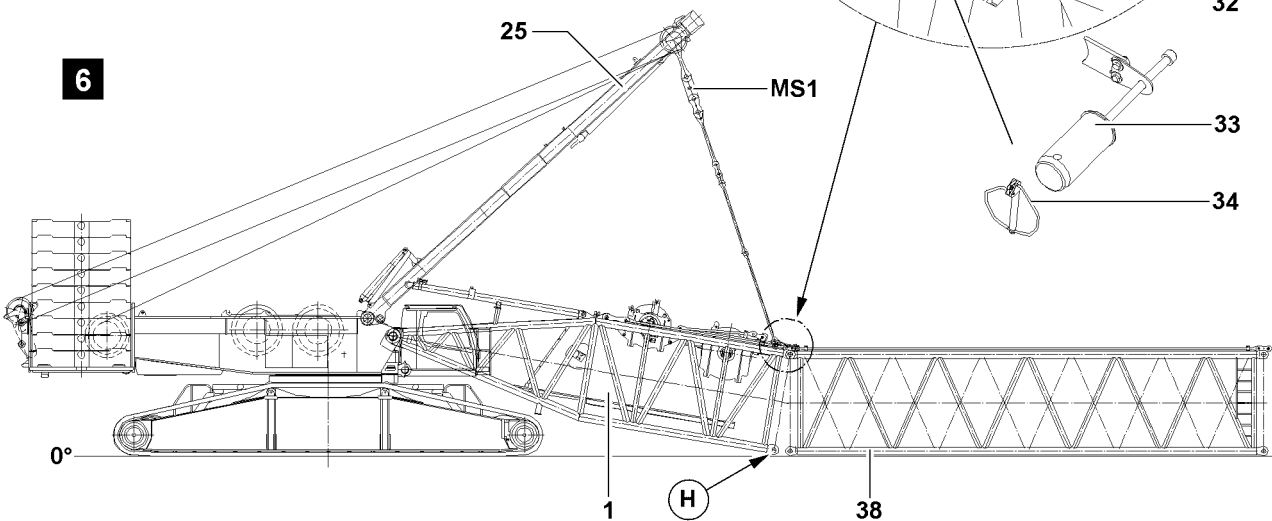

Fig.114058

LWE/LR 1600-2-008/18109-09-02/en

3.6 Assembling the S-lattice sections

The assembly of the lattice sections is carried out in various ways:

- „Closing“ the boom.
- Assembling the lattice sections in „flying mode“.



WARNING

General danger notes!

- ▶ Support the S-boom during assembly / disassembly with suitable materials.
- ▶ All pins must be secured after assembly with the intended retaining elements.
- ▶ The guy rods must be checked regularly, see chapter 8.15.
- ▶ The boom must be secured with the substructure or auxiliary crane, see chapter 5.01.
- ▶ It is prohibited for anyone to remain under the booms or within the complete danger zone during the pinning and unpinning procedure of the lattice sections.



Note

- ▶ For weights of the lattice section with placed guy rods, see chapter 1.03.
- ▶ The lattice sections are pinned with the aid of the pin pulling device, see chapter 5.30.

3.6.1 Assembling the S-lattice sections („close“ boom)

Make sure that the following prerequisites are met:

- The S-pivot section is pinned and secured on the turntable, point **P4**, see illustration 6.
- The S-pivot section is taken down on the ground.
- The auxiliary crane is removed.

Connecting the guy rods SA-frame with the guy rods S-pivot section

- ▶ Unpin the transport retainers for the guy rods **28**.
- ▶ Lower the SA-frame **25** forward until the guy rods **26** hang freely over the guy rods **28** of the S-pivot section **1**, see illustration 4.
- ▶ Pin the guy rods **26** of the SA-frame with the guy rods **28** of the S-pivot section, see illustration 5.
- ▶ Make sure that the guy rods **28** of the SA-frame are pinned on both sides on the assembly brackets **35** with the pins **37** and secured with spring retainers **36**.
- ▶ Erect the SA-frame **25** until the guy rods are completely tensioned, illustration 6.

Pinning the S-intermediate section on the S-pivot section „on top“

- ▶ Fasten the S-intermediate section **38** to the auxiliary crane and align on the S-pivot section **1**, illustration 6.

When the pin bores on the S-pivot section **1** and on the S-intermediate section **38** „on top“ (point **G**) align:

- ▶ Insert the pin **33** and secure with the locking pin **34**.

Closing the boom



WARNING

The crane can topple over!

If the following conditions are not met, the crane can topple over or be significantly damaged. Death, severe bodily injuries, property damage.

- ▶ During the „closing procedure“ of the S-intermediate sections, the maximum total force on test point **MS1** of 70 t may **not** be exceeded.
- ▶ The end section of the corresponding S/SL-boom combination may **not** lift off the ground during the „closing procedure“.
- ▶ Boom combinations only to certain system lengths may be closed with the SA-frame, see the following chart.

Counterweight and central ballast, see the Erection chart, depending on the boom length.			
Boom system	Maximum system length	MS1	Equipment
S	96 m	70 t	- with S- and WA-frame II guy rods
SL	102 m	70 t	- with S-guy rods - substructure on the S-pivot section and on the SW-end section
SL3	108 m	70 t	- with S-guy rods - substructure on the S-pivot section and on the SW-end section

**Note**

- ▶ The actual force on the test point **MS1** - which is exerted during the closing procedure of the boom system - is displayed on LICCON monitor 1.
- ▶ The actual force is noted and kept ready for the disassembly of the boom system.
- ▶ During the boom disassembly, the guying is tensioned with the noted actual force (assembly) so that the connector pins of the intermediate sections can be unpinned.

**Note**

- ▶ The guy rods of the intermediate sections are only assembled after the closing procedure.
- ▶ The brackets **30** and guy rods **32** are not pinned for the closing procedure.

The S-boom must be assembled to the required length before the S-boom can be closed. The assembly is described based on the example of an intermediate section.

- ▶ Position the S-intermediate section with the auxiliary crane on a S-lattice section until the pin points align.
- ▶ Pin the S-lattice sections „on top“ with each other: Insert the pin **33** on both sides and secure with the spring retainer **34**, see illustration **6**.
- ▶ Pin the S-lattice sections „on the bottom“ with each other: Insert the pin **33** on both sides and secure with the spring retainer **34**, see illustration **6**.

When the pins are properly pinned and secured on „top“ and „bottom“ between the S-lattice section and the S-intermediate section or the preassembled boom unit:

- ▶ Remove the auxiliary crane.

If additional lattice sections are assembled:

- ▶ Assemble additional lattice sections the same way as described in this section.

When the S/SL boom combination is assembled to the desired length:

- ▶ Lift the S-pivot section **1** with the SA-frame until the pin bores on the „bottom“ align in point **H**, illustration **6**.
- ▶ Read the actual force of the test point **MS1** on the LICCON monitor and note.
- ▶ Pin the S-lattice section on the S-pivot section „on the bottom“: Insert the pins **33** on both sides in point **H** and secure with linch pins **34**, see illustration **6**.

Empty page!

LWE/LR 1600-2-008/18109-09-02/en

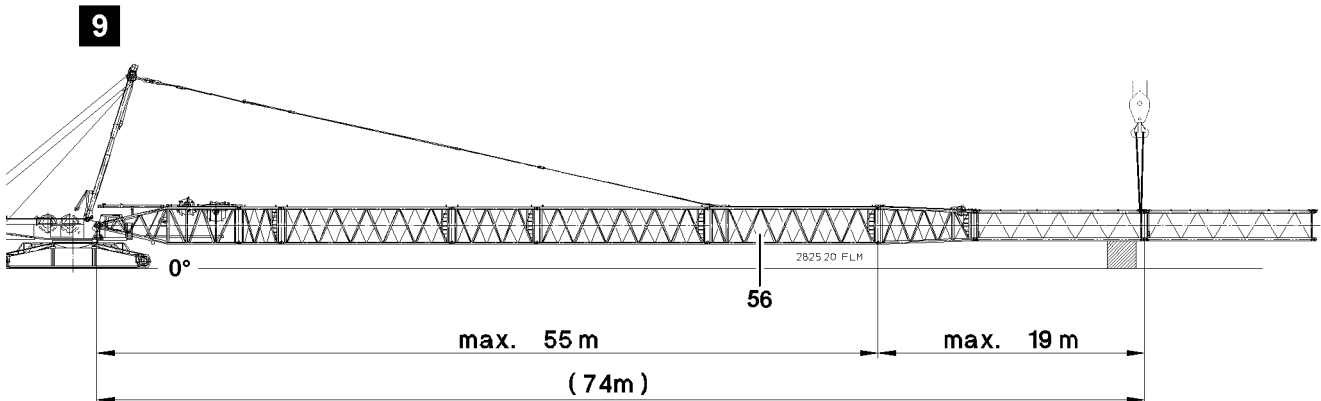
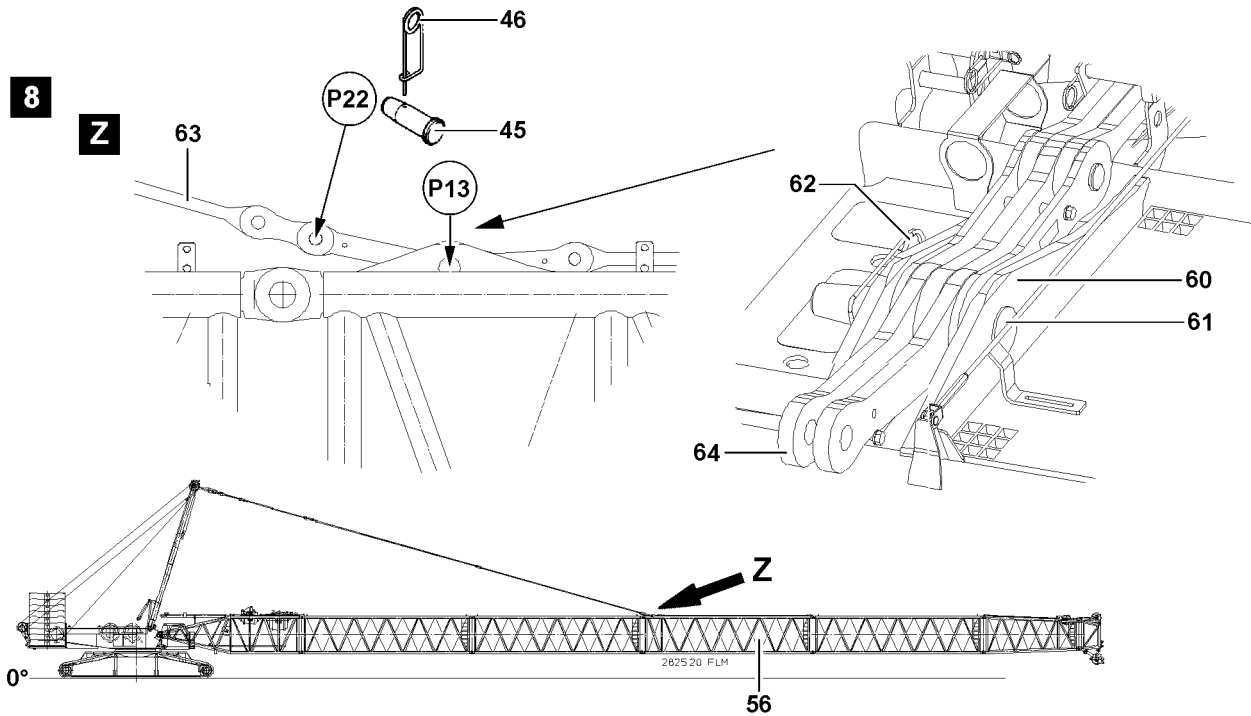
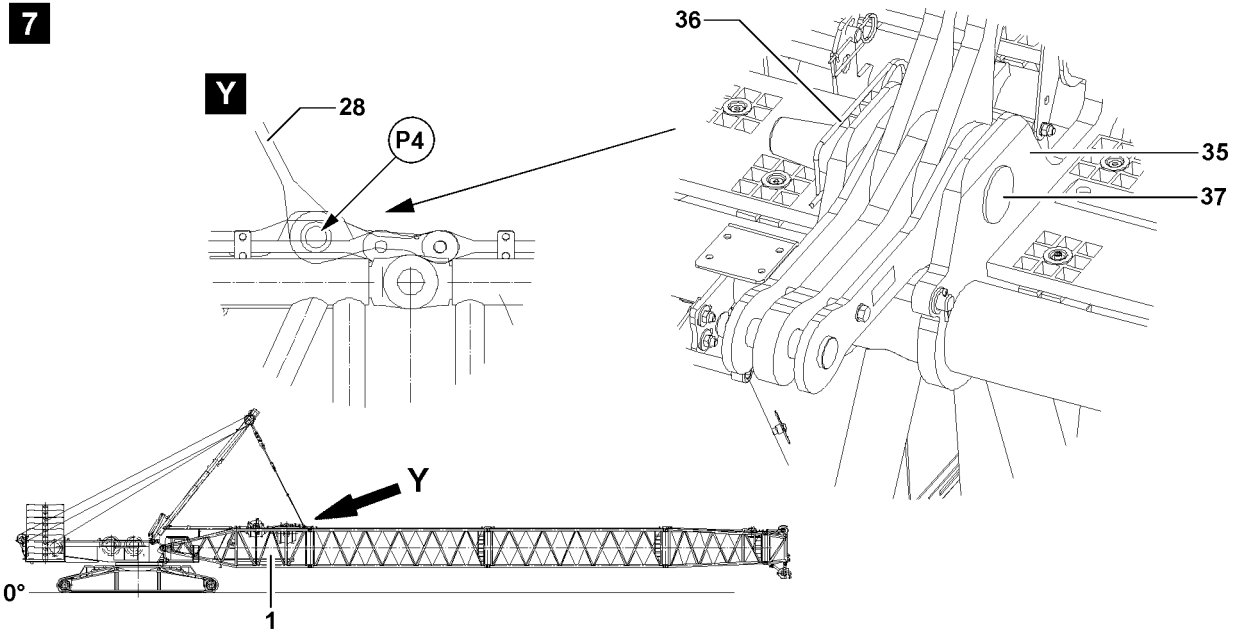

Fig.114053

LWE/LR 1600-2-008/18109-09-02/en

3.6.2 Assembling the S-lattice sections in „flying mode“

If spatial prerequisites on the job site are limited for the assembly of the S-boom, or if they are limited by buildings or similar, then the S-boom can be installed in „flying mode“.

For the „flying“ assembly, a differentiation is made between the guy points on the boom:

- Guying on S-pivot section **1**, see illustrations **7**.
- Guying on the S-intermediate section 12 m 2825.20 FLM **56** for flying assembly, see illustration **8**.



WARNING

General danger notes!

- ▶ Support the S-boom during assembly / disassembly with suitable materials.
- ▶ All pins are to be secured after assembly with the intended retaining elements.
- ▶ The guy rods must be inspected regularly, see chapter 8.15.
- ▶ Secure the boom with the substructure or auxiliary crane, see chapter 5.01.
- ▶ It is prohibited for anyone to remain under the booms or within the complete danger zone during the pinning and unpinning procedure of the lattice sections.



WARNING

Impermissible boom lengths guyed!

If impermissible boom lengths are guyed on the assembly brackets, then significant property damage can occur on the crane.

Death, severe bodily injuries, property damage.

- ▶ The maximum permissible boom lengths for the „flying“ assembly may not be exceeded.
- ▶ Tension the guy rods either on the assembly brackets **35**, point **P4**, illustration **7** or the guy rods **64**, point **P22**, illustration **8**.

When the boom system is longer than the permissible boom length for the „flying“ assembly:

- ▶ Support the boom on the end of the permissible boom length or secure with an auxiliary crane, see illustration **9**.
- ▶ The data in the erection and take-down charts as well as the load charts must be adhered to.

NOTICE

Property damage!

If the pins of the guy rods are not pinned from the „inside“ to the „outside“, the hoist rope can scrape on the pins and be damaged.

- ▶ Always insert the pins of the guy rods from the „inside“ to the „outside“, see the Rod plan.



Note

- ▶ For guying on the S-pivot section, the guy rods **28** are pinned on both sides on the assembly brackets **35**: Insert the pins **37** on both sides in point **P4** and secure with the spring retainer **36**, see illustration **7**.
- ▶ For guying on the S-intermediate section 12 m 2825.20 for flying assembly, the guy rods **63** are pinned on both sides on the guy rods **64**: Insert the pins **45** on both sides in point **P22** and secure with the spring retainer **46**, see illustration **8**.
- ▶ The pins **61** must be pinned on both sides on the assembly brackets **60** in point **P13** and secured with the spring retainer **62**, see illustration **8**.

10

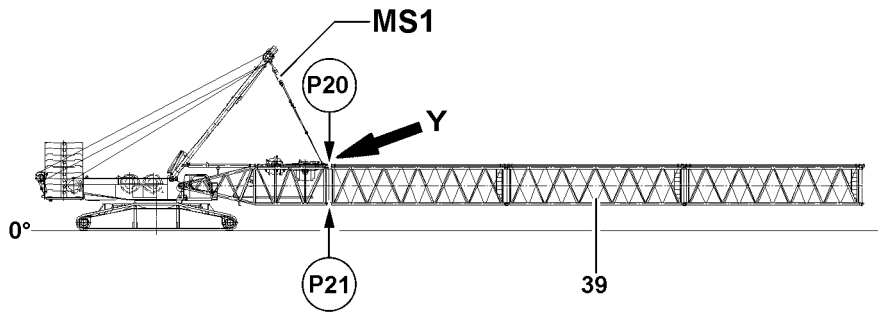

11

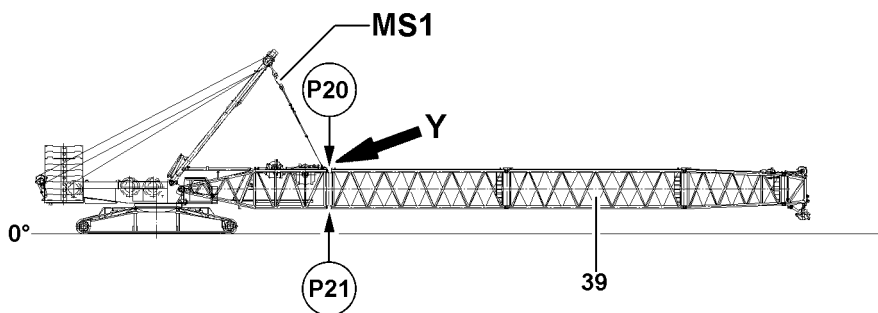

Y

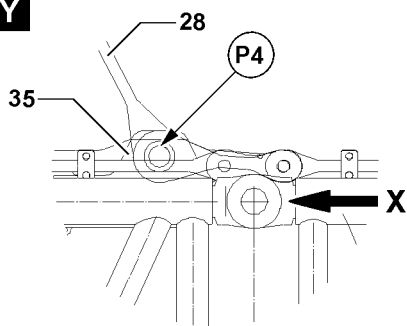

X

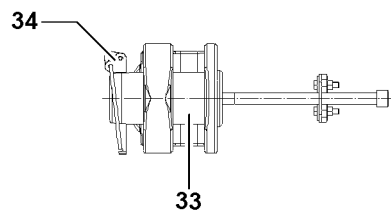

Fig.114054

Assembling the S-lattice sections in „flying mode“ on the S-pivot section



WARNING

The crane can topple over!

If the following conditions are not met, the crane can topple over or be significantly damaged. Death, severe bodily injuries, property damage.

- ▶ For the „flying“ boom assembly, the maximum permissible total force on the test point **MS1** may **not** be exceeded. The „actual force“ is displayed on LICCON monitor 1.
- ▶ The „flying“ boom assembly is only permissible up to a certain system length, observe the following charts.
- ▶ The specifications in the erection and take-down charts as well as the load charts must be observed.

		Counterweight ¹⁾ : 110 t			
		Central ballast ²⁾ : 5 t			
Boom system	Maximum system length	Equipment	MS1	Illustration	
S	48 m	- with SW-end section - with S- and WA-frame II guy rods	160 t	11	
S	52 m	- without SW-end section - with S- and WA-frame II guy rods	160 t	10	
SL	54 m	- with SW-end section - with S-guy rods	160 t	11	

1) This counterweight must be installed at least on the turntable for „flying assembly“.

2) This central ballast must be installed at least on the crawler center section for „flying assembly“.

10

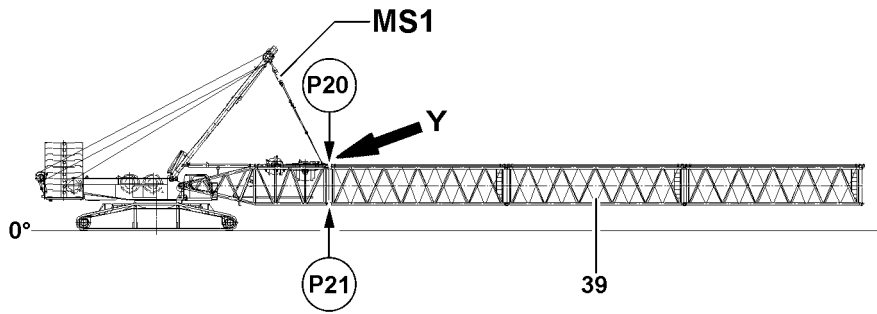

11

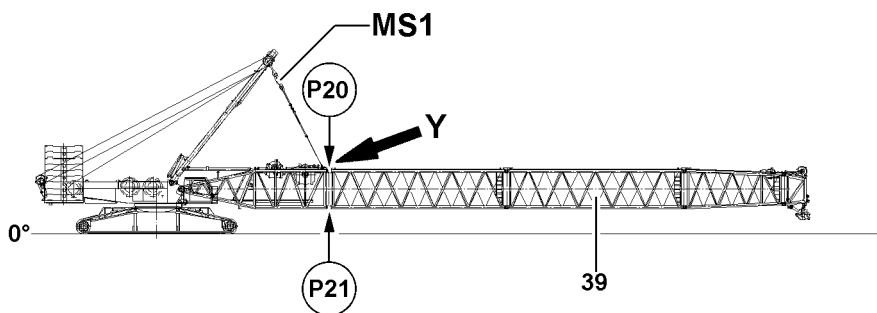

Y

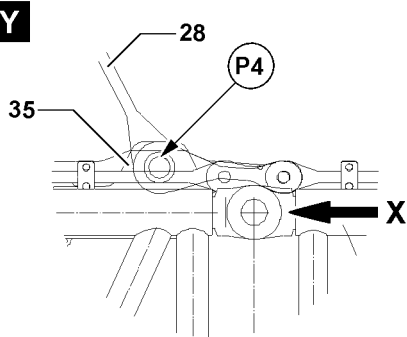

X

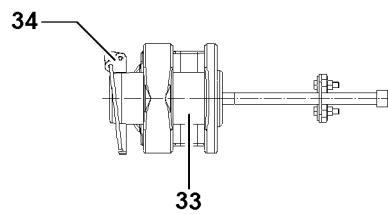

Fig.114054

Make sure that the following prerequisites are met:

- The S-pivot section is pinned and secured on the turntable.
- The S-pivot section is pinned on the assembly brackets **35** in point **P4** with the guy rods **28** and is in horizontal position, see detail **Y**.
- An auxiliary crane is available.



WARNING

Falling components!

If unsecured or non-supported components are assembled or disassembled, they can fall down. Death, severe bodily injuries, property damage.

- ▶ During pinning and unpinning of the intermediate sections it is prohibited for anyone to remain **under** or **on** the components as well as within the entire danger zone.
- ▶ Before unpinning: Support the components and boom.
- ▶ Secure the pins in the storage locations and in the receptacles.
- ▶ It is prohibited to lean a ladder against the crane section that is being disassembled.



Note

- ▶ The „actual force“ is displayed on the LICCON monitor.
- ▶ The flying assembly of the intermediate sections is carried out without a hook block.

For „flying“ assembly, the intermediate sections can be installed individually or as preassembled boom unit on the S-pivot section.

- ▶ Fasten the intermediate sections **39** or preassembled boom unit **39** to the auxiliary crane.
- ▶ Lift the intermediate sections **39** or preassembled boom unit **39** with the auxiliary crane and position on the S-pivot section until the pin points align.

When the pin points between the S-pivot section and the intermediate section or the preassembled boom unit align „on top“ and „bottom“:

- ▶ Pin the intermediate sections „on top“: Insert the pin **33** on both sides in point **P20** and secure with the spring retainer **34**, see detail **X**.
- ▶ Pin the intermediate sections „on the bottom“: Insert the pin **33** on both sides in point **P21** and secure with the spring retainer **34**, see detail **X**.

When the pins are properly pinned and secured on „top“ and „bottom“ between the S-pivot section and the S-intermediate section or the preassembled boom unit:

- ▶ Remove the auxiliary crane.

If additional lattice sections are assembled:

- ▶ Assemble additional lattice sections the same way as described in this section.

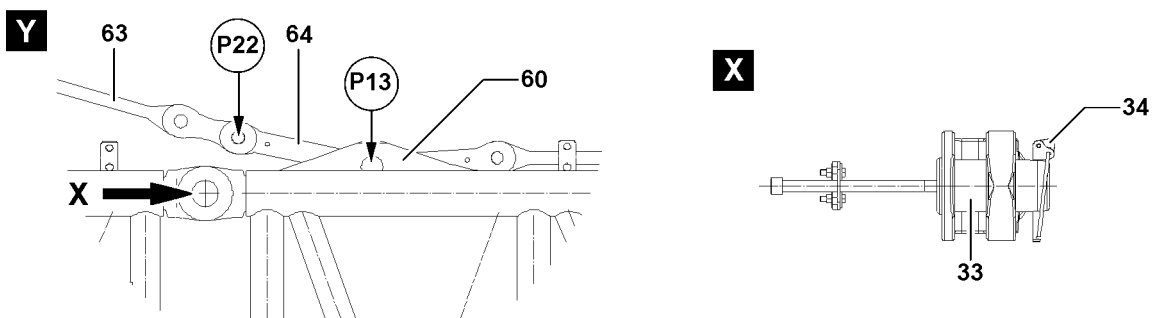
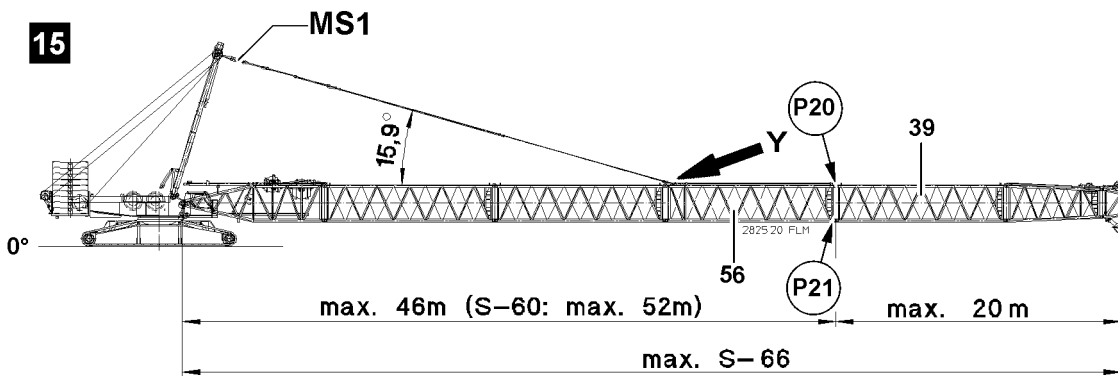
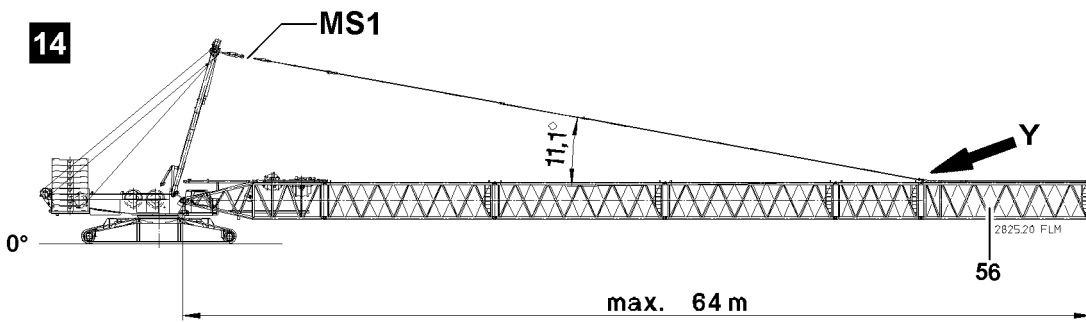
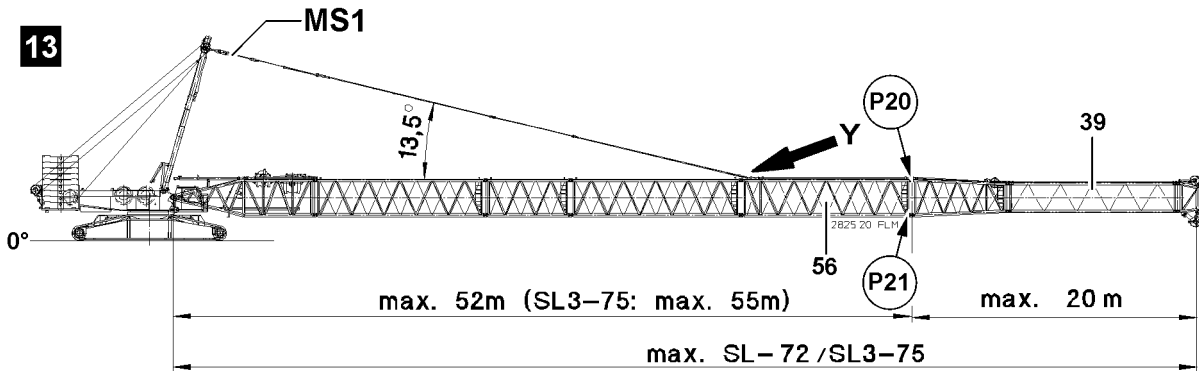
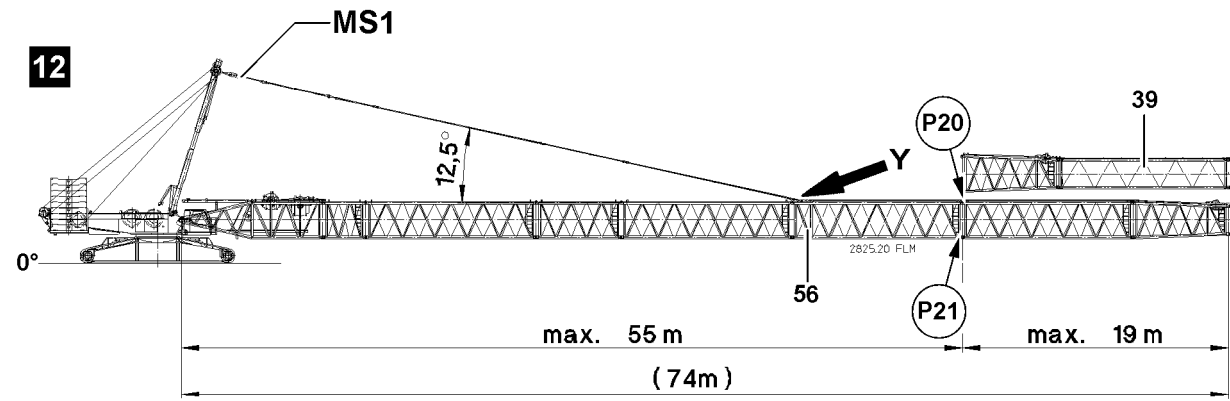

Fig.114055

LWE/LR 1600-2-008/18109-09-02/en

Assembling the S-lattice section in „flying mode“ on the intermediate section 12 m 2825.20 FLM



WARNING

The crane can topple over!

If the following conditions are not met, the crane can topple over or be significantly damaged. Death, severe bodily injuries, property damage.

- ▶ For the „flying“ boom assembly, the maximum permissible total force on the test point **MS1** may **not** be exceeded. The „actual force“ is displayed on LICCON monitor 1.
- ▶ The „flying“ boom assembly is only permissible up to a certain system length, observe the following charts.
- ▶ The specifications in the erection and take-down charts as well as the load charts must be observed.



Note

- ▶ The guy rods of the SA-frame are pinned with the guy rods **63** of the boom, see illustrations.
- ▶ The guy rods **63** are pinned with the guy rods **64** on the intermediate section 2825.20 FLM **56**, see detail Y.

Counterweight and central ballast, see the Erection chart, depending on the boom length.			
Boom system	Maximum system length	Equipment (without hook block)	Illustration
S	64 m	- partially equipped: Without WA-frame II guy rods	14
S	66 m	- with SW-end section with two roller sets - without WA-frame II guy rods	15
SL	74 m	- partially equipped: Without WA-frame II guy rods	12
SL	72 m	- with SW-end section with one roller set - without WA-frame II guy rods	13
SL3	74 m	- partially equipped: Without WA-frame II guy rods	12
SL3	75 m	- with F-adapter - without WA-frame II guy rods	13

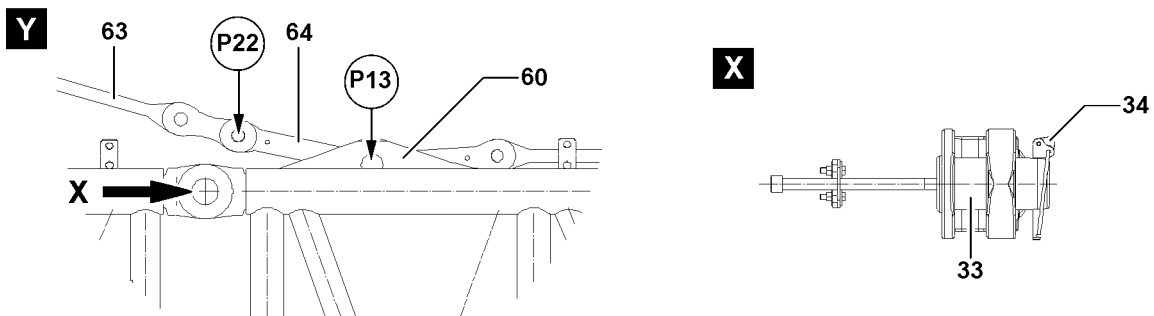
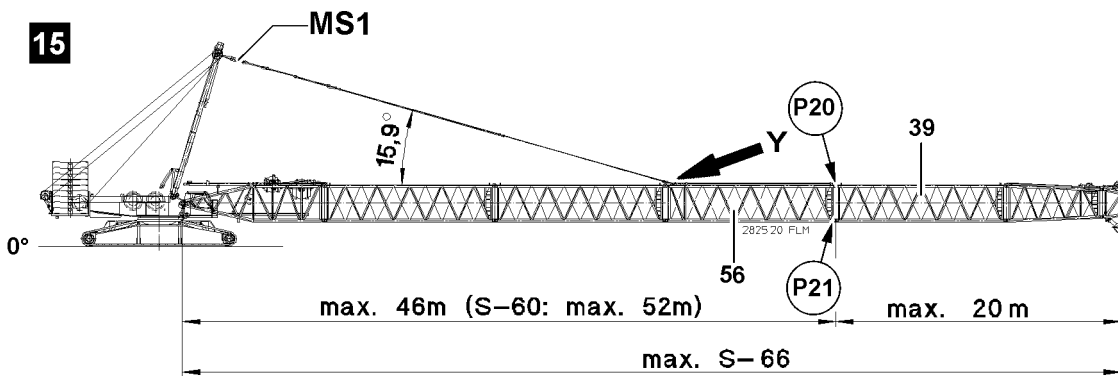
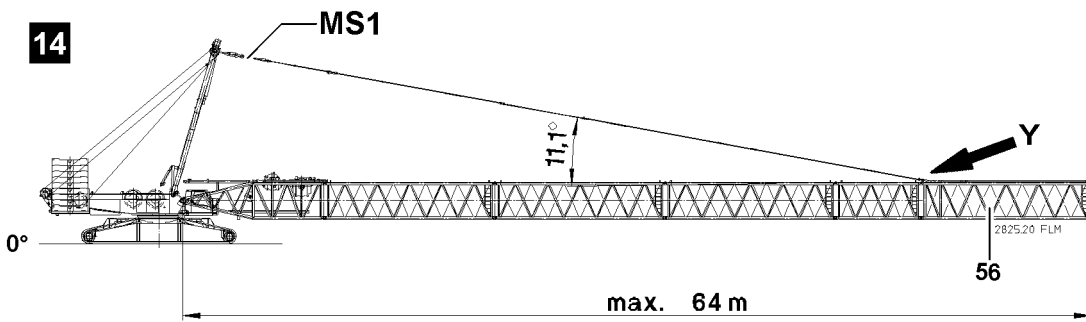
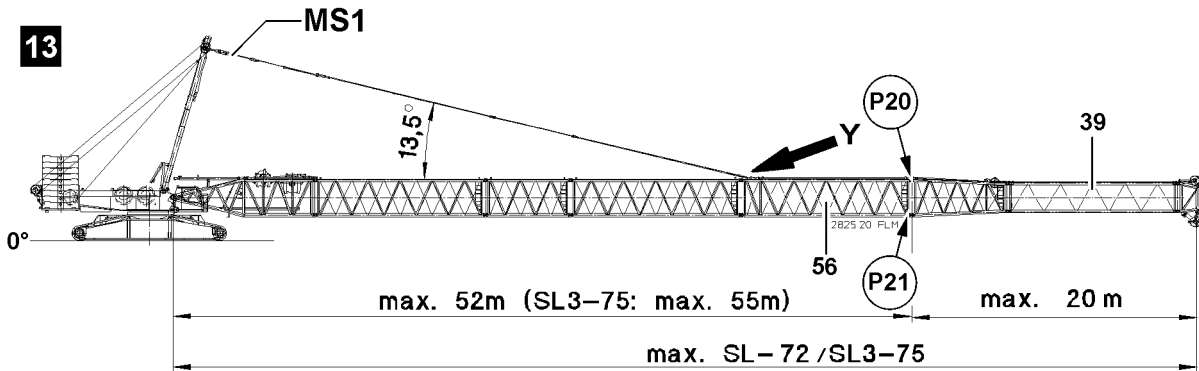
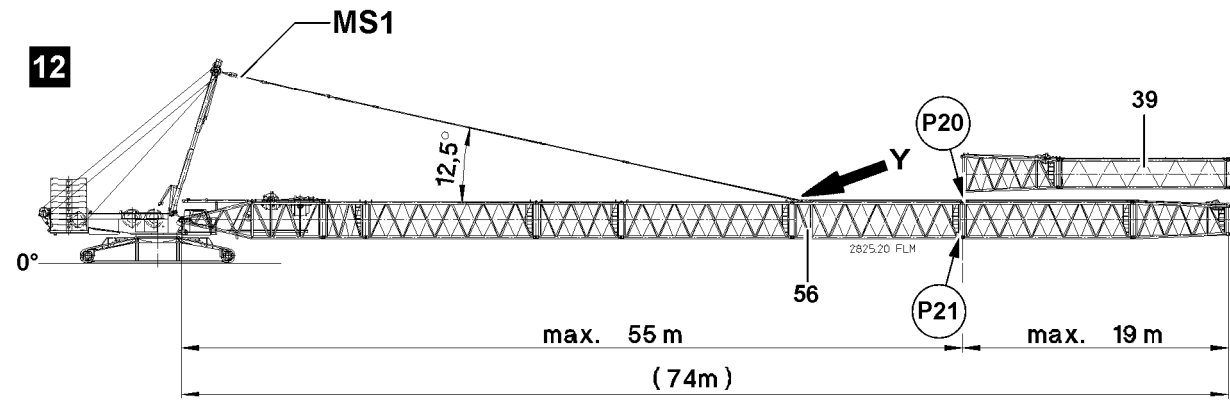

Fig.114055

LWE/LR 1600-2-008/18109-09-02/en

Make sure that the following prerequisites are met:

- The S-pivot section is pinned and secured on the turntable.
- The intermediate section 12 m 2825.20 FLM **56** is pinned on the assembly brackets **60** on point **P13** with the guy rods **64** and is in the horizontal position, see detail **Y**.
- An auxiliary crane is available.



WARNING

Falling components!

If unsecured or non-supported components are assembled or disassembled, they can fall down. Death, severe bodily injuries, property damage.

- ▶ During pinning and unpinning of the intermediate sections it is prohibited for anyone to remain **under** or **on** the components as well as within the entire danger zone.
- ▶ Before unpinning: Support the components and boom.
- ▶ Secure the pins in the storage locations and in the receptacles.
- ▶ It is prohibited to lean a ladder against the crane section that is being disassembled.



Note

- ▶ The „actual force“ is displayed on the LICCON monitor.
- ▶ The „flying“ assembly of the intermediate sections is carried out without a hook block.

For „flying“ assembly of the intermediate sections, they can be installed individually or as preassembled boom unit on the intermediate section **56**.

- ▶ Fasten the intermediate sections **39** or preassembled boom unit **39** to the auxiliary crane.
- ▶ Lift the intermediate sections **39** or preassembled boom unit **39** with the auxiliary crane and position on the S-pivot section until the pin points align.

When the pin points between the S-intermediate section **56** and the intermediate sections **39** or the preassembled boom unit **39** align „on top“ and „bottom“:

- ▶ Pin the intermediate sections „on top“: Insert the pin **33** on both sides in point **P20** and secure with the spring retainer **34**, see detail **X**.
- ▶ Pin the intermediate sections „on the bottom“: Insert the pin **33** on both sides in point **P21** and secure with the spring retainer **34**, see detail **X**.

When the pins are properly pinned and secured on „top“ and „bottom“ between the S-intermediate section **56** and the intermediate sections **39** or the preassembled boom unit **39**:

- ▶ Remove the auxiliary crane.

If additional lattice sections are assembled:

- ▶ Assemble additional lattice sections the same way as described in this section.

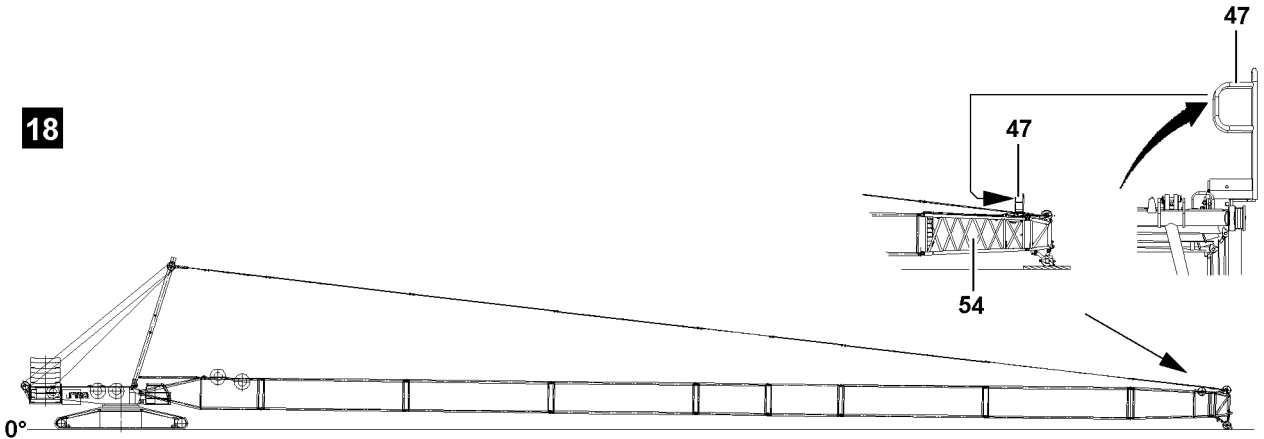
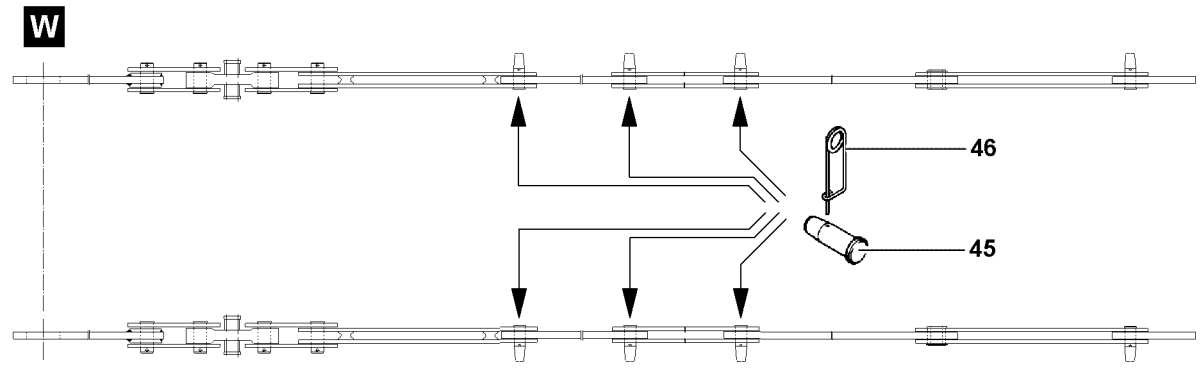
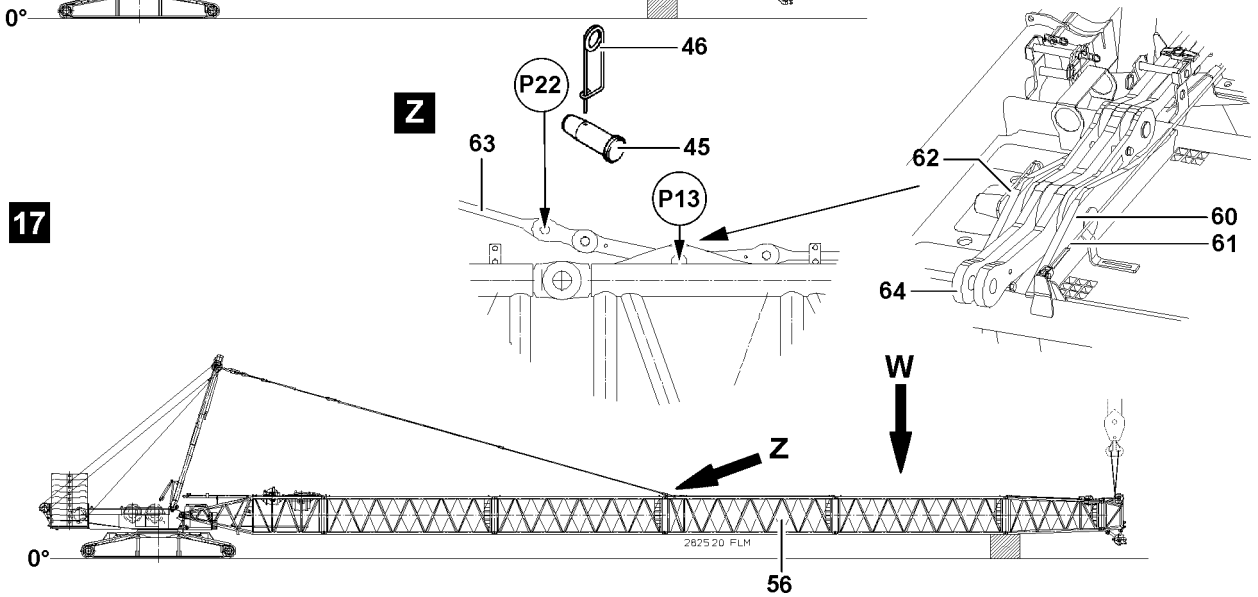
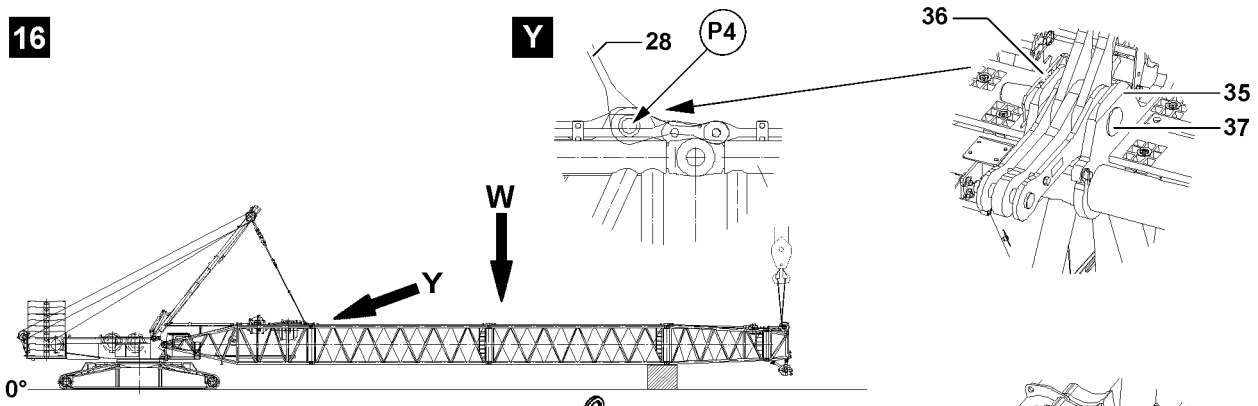

Fig.114056

LWE/LR 1600-2-008/18109-09-02/en

3.6.3 Assembling the S-guy rods



WARNING

Neglected inspection and maintenance on guy rods!

If the regular inspection and maintenance of the guy rods is not carried out or is carried out only in irregular intervals, then severe accidents can occur due to existing and unrecognized damage to the guy rods.

Death, severe bodily injuries, property damage.

- ▶ Inspect the guy rods before each assembly, see chapter 8.15.
- ▶ The S-guy rods must be assembled and secured, see the Rod plan. The numbering in the rod plan must be identical to the numbering on the guy rods.



Note

- ▶ The guy rods must be installed and secured according to the separately supplied rod plans. The numbering on the rod plans must be identical to the numbering on the guy rods.

Make sure that the following prerequisites are met:

- The folding platforms **47** on the SL-reducer **54** are folded and secured „upward“ in the operating position, see chapter 2.06.
- The boom is guyed in point **P4** on the S-pivot section **1**, see illustration **16**, detail **Y**.
- **Or** the boom is guyed in point **P13** on the S-intermediate section 12 m 2825.20 FLM for flying assembly, see illustration **17**, detail **Z**.
- **Or** the boom is laying on the ground with tensioned guy rods, see illustration **18**.



WARNING

Falling components!

If the intermediate sections are incompletely pinned or secured, then components can fall down.

Death, severe bodily injuries, property damage.

- ▶ Make sure that the intermediate sections or preassembled boom unit are pinned and secured on the S-pivot section.
- ▶ Make sure that the intermediate sections or preassembled boom unit is supported with suitable materials, secured with the auxiliary crane or the boom is placed on the ground.

When the boom is **not** laying on the ground:

- ▶ Support the boom and secure it with the auxiliary crane.
- ▶ Relieve the guy rods: Lower the SA-frame somewhat to the front.

Result:

- The guy rods between the SA-frame and the S-pivot section or the S-intermediate section for flying assembly are relieved.

The guy rods are taken down and secured for transport on the corresponding intermediate sections. Before assembly, the transport retainers must be released.

- ▶ Release the transport retainers of the guy rods.

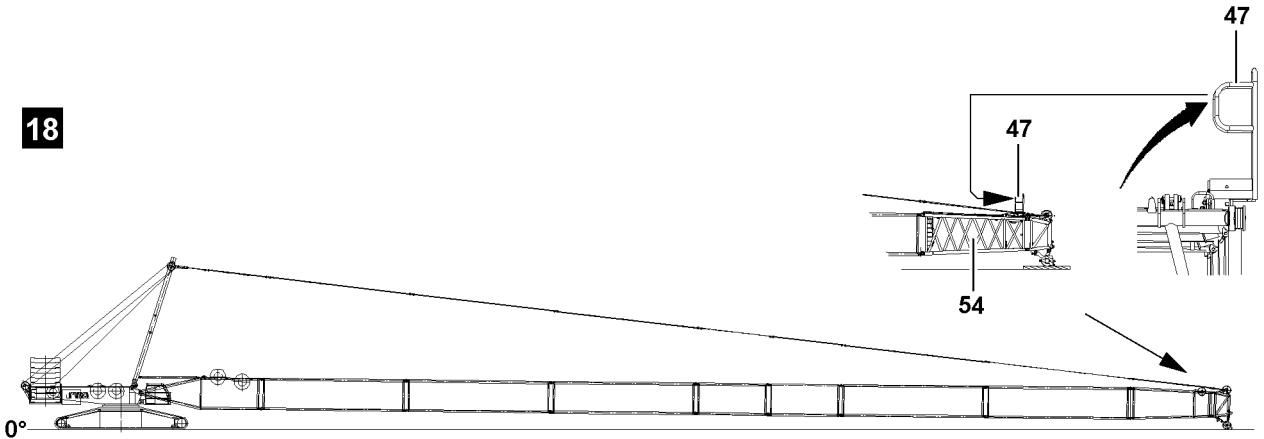
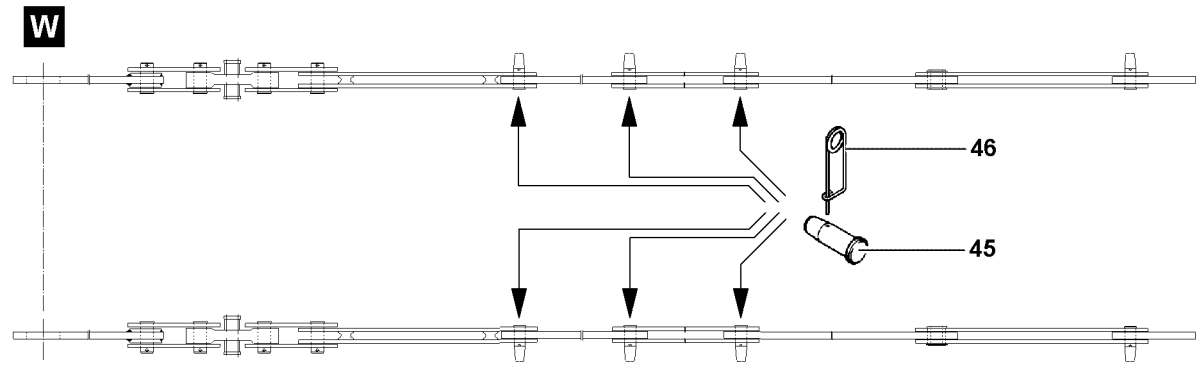
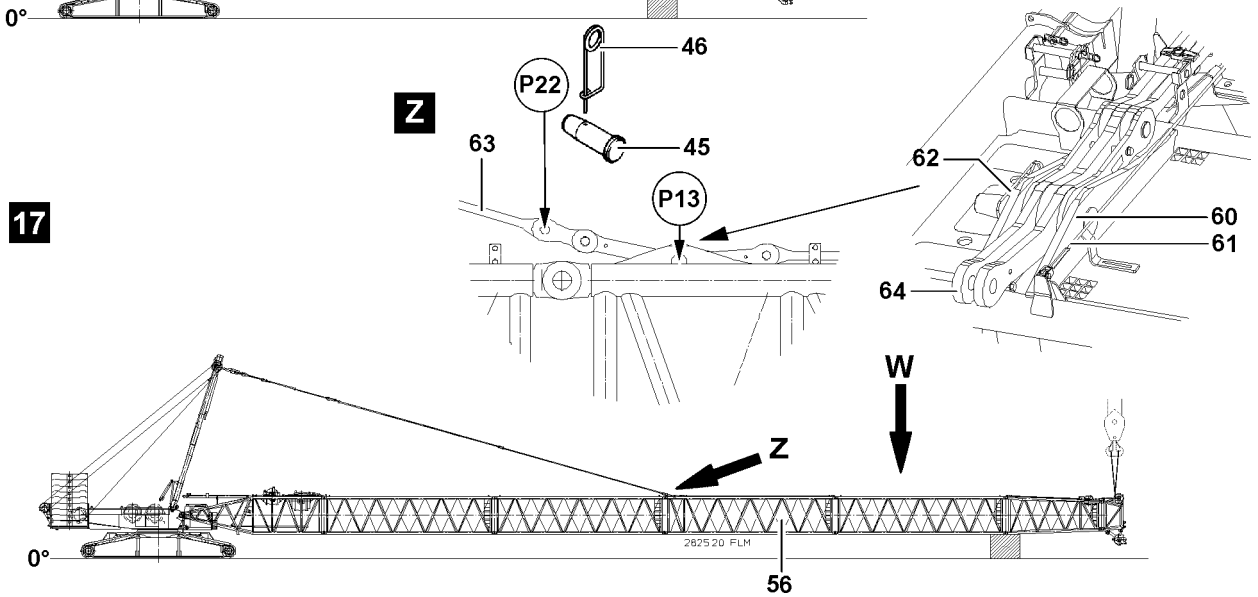
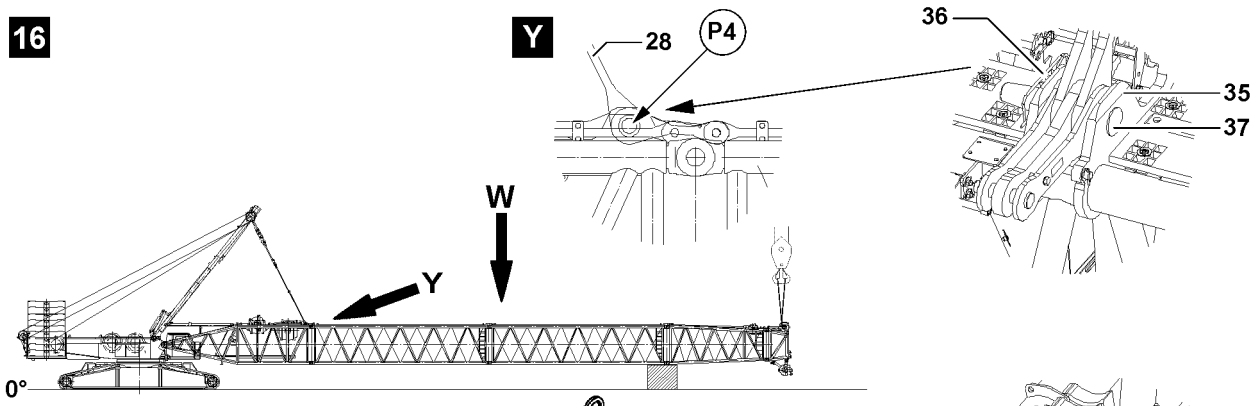

Fig.114056

LWE/LR 1600-2-008/18109-09-02/en

NOTICE

Danger of property damage!

If the pins of the guy rods are not pinned from the „inside“ to the „outside“, the hoist rope can scrape on the pins and be damaged.

- ▶ Always insert the pins of the guy rods from the „inside“ to the „outside“.
- ▶ Pay attention to the Rod plan.

**Note**

- ▶ The guy rods of the S-intermediate sections are pinned and secured together starting from the lugs on the fixed point of the S-end section.

- ▶ Pin and secure the guy rods for the intermediate sections according to the Rod plan.

**WARNING**

The boom can fold down!

By unpinning the guy rods on the assembly brackets **35** or the assembly brackets **60**, the boom can fold down.

Death, severe bodily injuries, property damage.

When the boom is guyed on the S-pivot section:

- ▶ Unpin the guy rods **28** on the assembly brackets **35**, point **P4**, see detail **Y** when it is ensured that the intermediate sections are supported with suitable materials or are held by the auxiliary crane or the boom is taken down on the ground.

When the boom is guyed on the S-intermediate section:

- ▶ Unpin the guy rods **63** on the guy rods **64**, point **P22**, see detail **Z** when it is ensured that the intermediate sections are supported with suitable materials or are held by the auxiliary crane or the boom is taken down on the ground.

- ▶ Make sure that all guy rods of the boom system are pinned and secured.

When the boom is guyed on the S-pivot section:

- ▶ Release the pins **37** on the assembly brackets **35** and unpin, see illustration **16**.
- ▶ Erect the SA-frame until the guy rods between the SA-frame and the S-end section tension, see illustration **18**.
- ▶ Remove the auxiliary crane.

or

When the boom is guyed on the S-intermediate section:

- ▶ Remove the spring retainer **62** on both sides and unpin the pin **61** on the assembly brackets **60**, see illustration **17**.
- ▶ Insert the pin **61** in the retainer **65** and secure with spring retainer **62**.
- ▶ Erect the SA-frame until the guy rods between the SA-frame and the S-end section tension, see illustration **18**.
- ▶ Remove the auxiliary crane on the S-boom head.

or

Remove the substructure.

- ▶ Guide the hoist rope over the rope pulley(s) on the S-boom head, see separate reeving plans.

3.7 Establishing the electrical connections

NOTICE

Damage to the electrical connection on the cable drum!

If the electrical connection from the cable drum to the terminal box on the S-pivot section is established first before the connection to the terminal box on the S-end section, the electrical connection can be damaged when spooling out the cable drum.

- ▶ Establish first the electrical connection from the cable drum in the S-pivot section to the terminal box on the S-end section and then the electrical connection from the terminal box in the S-pivot section to the cable drum.

**Note**

- ▶ To establish the electrical connections on the S-boom, use the separate Electrical wiring diagram.

Make sure that the following prerequisites are met:

- The S-boom is completely assembled.
 - The airplane warning light and the wind speed sensor are assembled.
- ▶ Establish the electrical connections.
 - ▶ Make sure that all electrical connections on the boom are established.

3.8 Checking the function of the safety equipment

**WARNING**

Non-functioning safety equipment!

Death, severe bodily injuries, property damage.

- ▶ Crane operation with non-functioning safety equipment is **prohibited**.

**Note**

- ▶ The function of the individual limit switches must be checked before erection.
- ▶ The function of the limit switch initiators must be checked in the test system, see the Diagnostics manual.

**Note**

- ▶ If a function check on the limit switches or on the safety equipment does not lead to the desired shut-offs, then the plug connections on the connector boxes or the components itself must be checked. If no visible connection errors or component defects can be found, contact **LIEBHERR** Service.

Make sure that the following prerequisites are met:

- All electrical connections have been made.
- The crane engine is running.
- The corresponding operating mode is set on the LICCON monitor.

3.8.1 Checking the wind speed sensor

- ▶ Check the movement and the function of the wind speed sensor.

3.8.2 Checking the airplane warning light

- ▶ Turn on the airplane warning light on with the button.
- ▶ Check the function visually.

3.8.3 Checking the hoist limit switch on the pulley head

**Note**

- ▶ When replacing or changing a hoist limit switch (HES), the corresponding hoist limit switch must have the correct bus address and the correct software version in order to be detected again by the bus system (LSB).

- ▶ Actuate the hoist limit switch manually on the pulley head.

Result:

- The spool up function of the hoist winch turns off.
- The icon „Hoist top“ appears on the LICCON monitor 0.
- The limit switch is functioning.

3.8.4 Checking the limit switch S-boom „steepest position“



Note

▶ The limit switch functions have to be checked individually before erection.

▶ Cover the limit switch initiators on the S-relapse cylinders individually with a metal plate.

Result:

- The limit switch is actuated manually.
- The spool up function of winch 4 (control winch) turns off.
- The „Boom limitation“ icon appears on LICCON monitor 0.
- The limit switch is functioning.

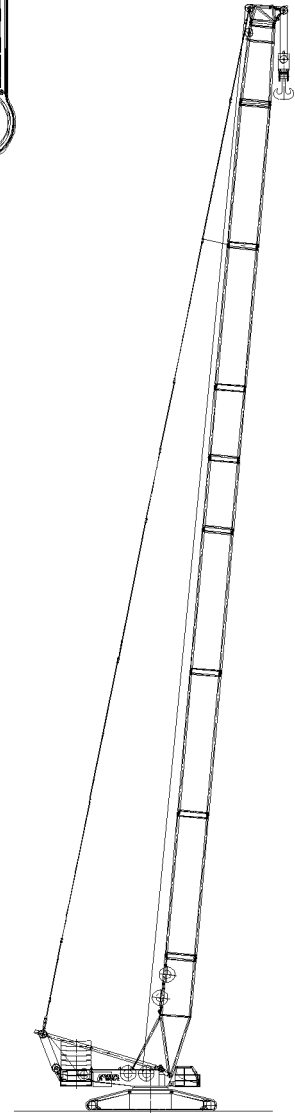
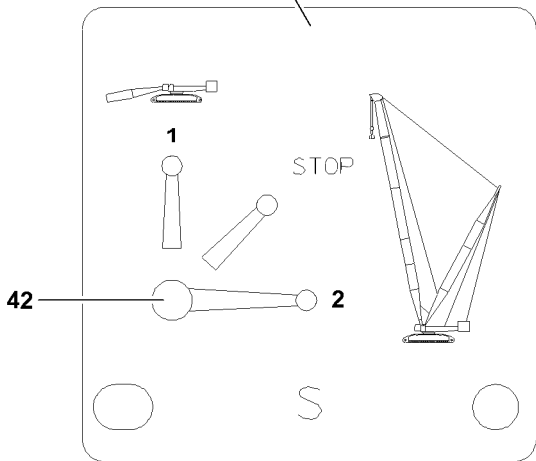
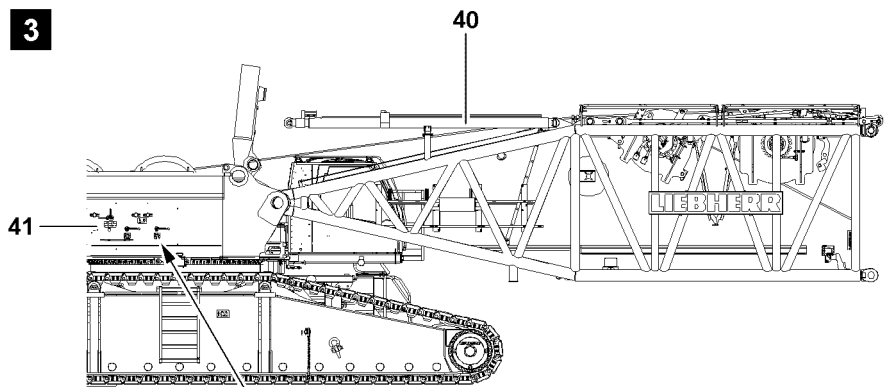
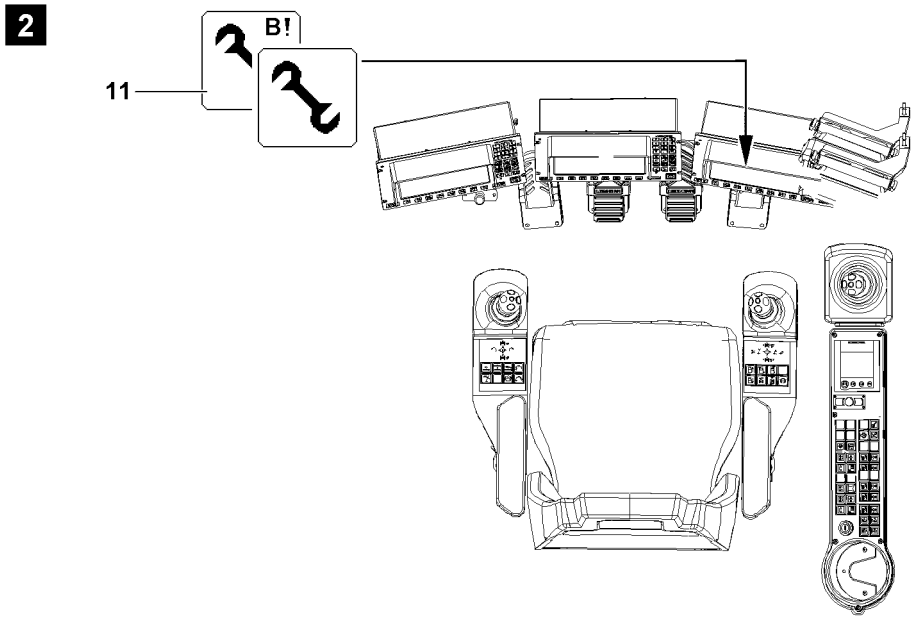
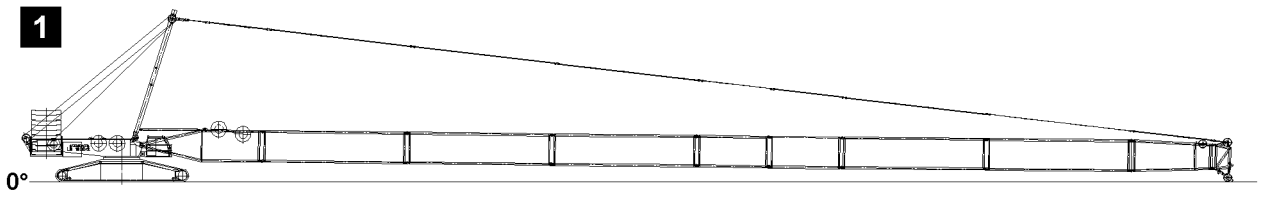

Fig.114057

LWE/LR 1600-2-008/18109-09-02/en

3.9 Erecting the S-boom



WARNING

The crane can topple over!

If the following conditions are not met before erecting the boom, the crane can topple over.

Death, severe bodily injuries, property damage.

- ▶ It is not permitted to turn the crane during the erection procedure.
- ▶ Observe the specifications in the erection and take-down charts.
- ▶ Observe the technical safety instructions, see chapter 5.01.
- ▶ Extend the S-relapse cylinder before erection.
- ▶ Do not allow slack rope formation on the control winch.



WARNING

Unutilized guy rods on boom!

If guy rods are on the lattice sections which are not used for operation, then there is a danger of accident.

Death, severe bodily injuries, property damage.

Guy rods can loosen up and fall down.

The load chart is invalid.

The load display of the LICCON computer system shows an incorrect value.

The weight of the boom is too heavy for erection.

- ▶ Disassemble and remove unutilized guy rods on the transport retainers before erecting the boom.



WARNING

Falling hoist rope!

If the hoist rope is not reeved with the respective length before the erection procedure, then it can fall down backward due to its own weight.

Death, severe bodily injuries, property damage.

- ▶ Reeve in the hoist rope properly according to the reeving plan.
- ▶ Reeve in the hoist rope with sufficient length before the erection procedure.
- ▶ The hoist rope must be constantly monitored during erection.
- ▶ Do not step into the danger zone.

Make sure that the following prerequisites are met:

- The crane is horizontally aligned.
- All electrical connections have been made.
- All hydraulic connections have been made.
- All limit switches are functioning.
- The central ballast has been attached according to the data in the load chart.
- The counterweight has been installed on the turntable according to the load chart.
- All pin connections are secured.
- The hoist rope has been correctly placed in the rope pulleys and is prevented from jumping out with the rope retaining pins.
- There are no loose parts on the boom.
- The LICCON overload protection has been set according to the data in the load chart.
- The LICCON overload protection settings have been compared with the actual set up configuration.
- The LICCON overload protection is exceeded.
- The assembly icon is visible on the LICCON monitor.
- No persons are present in the danger zone.

3.9.1 Extending the S-relapse cylinders



WARNING

The crane can topple over!

If the S-relapse cylinders are not extended before erecting the S-boom, then the S-boom can fall off to the rear during crane operation and the crane can topple over.

Death, severe bodily injuries, property damage.

- ▶ Extend the S-relapse cylinders **40** before erecting the S-boom.
- ▶ Secure the ball valve **42** during crane operation to prevent inadvertent actuation.

Ball valve positions, see illustration 3

2	Crane operation, extend the piston rod
1	Assembly, retract the piston rod
STOP	The piston rod cannot be retracted / extended

The piston rods on the S-relapse cylinders **40** can be extended with the ball valve **42**.

- ▶ Set the ball valve **42** to **Position 2**.

Result:

- The piston rods of the S-relapse cylinders **40** extend.



Note

- ▶ The ball valve **42** is secured by closing the cabinet door and removing the key.

When the piston rods of the S-relapse cylinders **40** are fully extended:

- ▶ Close the cabinet doors and pull out the key.
- ▶ Hand the key to an authorized person.

3.9.2 Erection procedure



DANGER

The crane can topple over!

- ▶ It is prohibited to turn the crane superstructure while erecting the boom.
- ▶ Observe the data in the Erection and take down charts.

Make sure that the following prerequisite is met:

- The boom has been lifted off the ground.

Reeving in the hook block

- ▶ Erect the boom until the end section lifts off the ground.
- ▶ Check the actual load on the LICCON monitor.

Problem remedy

Actual load on the LICCON monitor is larger than 0.0 t !

- ▶ Observe the notes for input of hook block weight, see chapter 4.02.



Note

- ▶ Hoist rope reeving, see chapter 4.06 and Reeving plan.
- ▶ Reeve in the hook block properly and secure the hoist rope on the rope fixed point, for reeving, see the reeving plan.
- ▶ Attach the hoist limit switch weight.
- ▶ Enter the weight of the hook block in the LICCON computer system.

Erecting the boom



WARNING

The crane can topple over!

In crane operation with exceeded LICCON overload protection, the crane can topple over. Death, severe bodily injuries, property damage.

- ▶ The boom radii listed in the load chart may not be exceeded or fallen below, even if there is no load on the hook.

If required in the erection and take down chart:

- ▶ Carry the hook block along with the auxiliary crane.



Note

- ▶ When the lowest operating position of the boom is reached, the LICCON overload protection is activated.
- ▶ The displays on the LICCON monitor turn off.
- ▶ In the maximum load icon, a load number appears in „t“ instead of the display „???“.

- ▶ Luff the boom up to the lowest operating position.

When the boom has reached the lowest operating position:

- ▶ Make sure that the assembly icon on the LICCON monitor turns off.

Result:

- The LICCON overload protection is active.

4 Operating the crane

4.1 Preparing for crane operation



Note

- ▶ Observe the notes, see chapter 4.02, chapter 4.05, chapter 4.08 and chapter 5.01.

Make sure that the following prerequisites are met:

- The LICCON overload protection is active.
- The LICCON overload protection has been set according to the data in the load chart.



WARNING

The crane can topple over!

- ▶ Check the horizontal position of the crane before and during operation.
- ▶ If the crane operator leaves the cab, even for a short time, the operating mode setting must be checked and reset if necessary before resuming crane operation.

4.2 Checking the settings

- ▶ Check the function of the overload protection by running against the operating positions „on top“ and „bottom“.
- ▶ Check the hoist limit switch by running against the hoist limit switch weight.
- ▶ Check the function of the limit switches on the jib stop cylinders.

5 Disassembling the S/SL boom



Note

- ▶ For the combination of the boom lattice sections, observe and adhere to the Rod plan and chapter 5.03.



WARNING

Danger of falling!

During assembly / disassembly, inspection and maintenance work, assembly personnel must be secured with appropriate aids to prevent them from falling.

Death, severe bodily injuries, property damage.

- ▶ All work at a height, when there is a danger of falling, must be carried out with suitable aids.
- ▶ If aids are not available and work cannot be carried out from the ground, then assembly personnel must secure themselves with the supplied fall arrest system to prevent falling, see chapter 2.04.
- ▶ If fall protection equipment is available, then it must be used, see chapter 2.06.
- ▶ When lifting, lowering, swinging crane parts in and out, no persons may remain in the danger zone.
- ▶ When closing or opening boom systems during boom assembly or boom disassembly, no persons may remain on the boom system or in the danger zone.
- ▶ If railings are present on the components, then they must be brought into the corresponding position and secured for assembly / disassembly work.
- ▶ Only step on the aids, ladders and catwalks with clean shoes.
- ▶ Keep aids, ladders and catwalks free of heavy dirt, snow and ice.
- ▶ During all assembly and disassembly work, maintenance work and inspections, travel or crane operation is prohibited.
- ▶ Remaining on a suspended load is prohibited.
- ▶ Stepping or walking on crane components and lattice sections, which have an incline of more than 20° is prohibited.
- ▶ For all assembly work, the crane driver of the main crane must be in voice contact with the crane driver / crane drivers of the auxiliary crane / auxiliary cranes.
- ▶ For assembly tasks, the crane driver may only initiate crane movements when the responsible guide has explicitly released the movement.



WARNING

The lattice sections can fall down!

If the lattice sections are not pinned and secured correctly, then they can fall down.

Death, severe bodily injuries, property damage.

- ▶ Insert or unpin both pins at the same horizontal level, i.e. **left and right**.
- ▶ Do not stand under the lattice sections or within the entire danger zone during the pinning and unpinning procedure of the boom.
- ▶ Safely secure the pins in the storage locations as well as in the receptacles.
- ▶ It is prohibited to lean the ladder against the component being disassembled.



WARNING

Danger of impact / crushing!

When installing / removing crane components with the auxiliary crane, crane components can start to swing back and forth.

When lifting / lowering and positioning crane components, there is an increased danger of impacts / crushing.

Death, severe bodily injuries, property damage.

- ▶ Make sure that personnel cannot be caught by components.
- ▶ Make sure that the crane is horizontally aligned.
- ▶ When working in danger zones: Use aids to protect limbs.
- ▶ Guide components with suitable aids to minimize oscillation.

**DANGER**

The components can fall down!

If the corresponding component is disengaged from the auxiliary crane before the corresponding component is pinned, then the corresponding component can fall down.

Death, severe bodily injuries, property damage.

- ▶ Do not disengage the auxiliary crane until the respective component is pinned and secured.

**WARNING**

The crane can topple over!

- ▶ The turntable may not be turned during the assembly of the boom.

- ▶ Observe the assembly conditions, see chapter 3.06.

**WARNING**

Danger of accident!

Death, severe bodily injuries, property damage.

- ▶ For assembly of the boom combinations, the rod plan must be observed and adhered to.

- ▶ Depending on the condition of the ground, the boom and the lattice sections must be supported from below for the assembly of the boom.

- ▶ Observe the technical safety instructions, see chapter 5.01.

Make sure that the following prerequisites are met:

- The crane is horizontally aligned.
- An auxiliary crane is available.
- An assembly scaffolding / work platform is available.
- The central ballast is installed according to the load chart.
- The counterweight has been installed on the turntable according to the load chart.
- The LICCON overload protection has been set according to the data in the load chart.

1

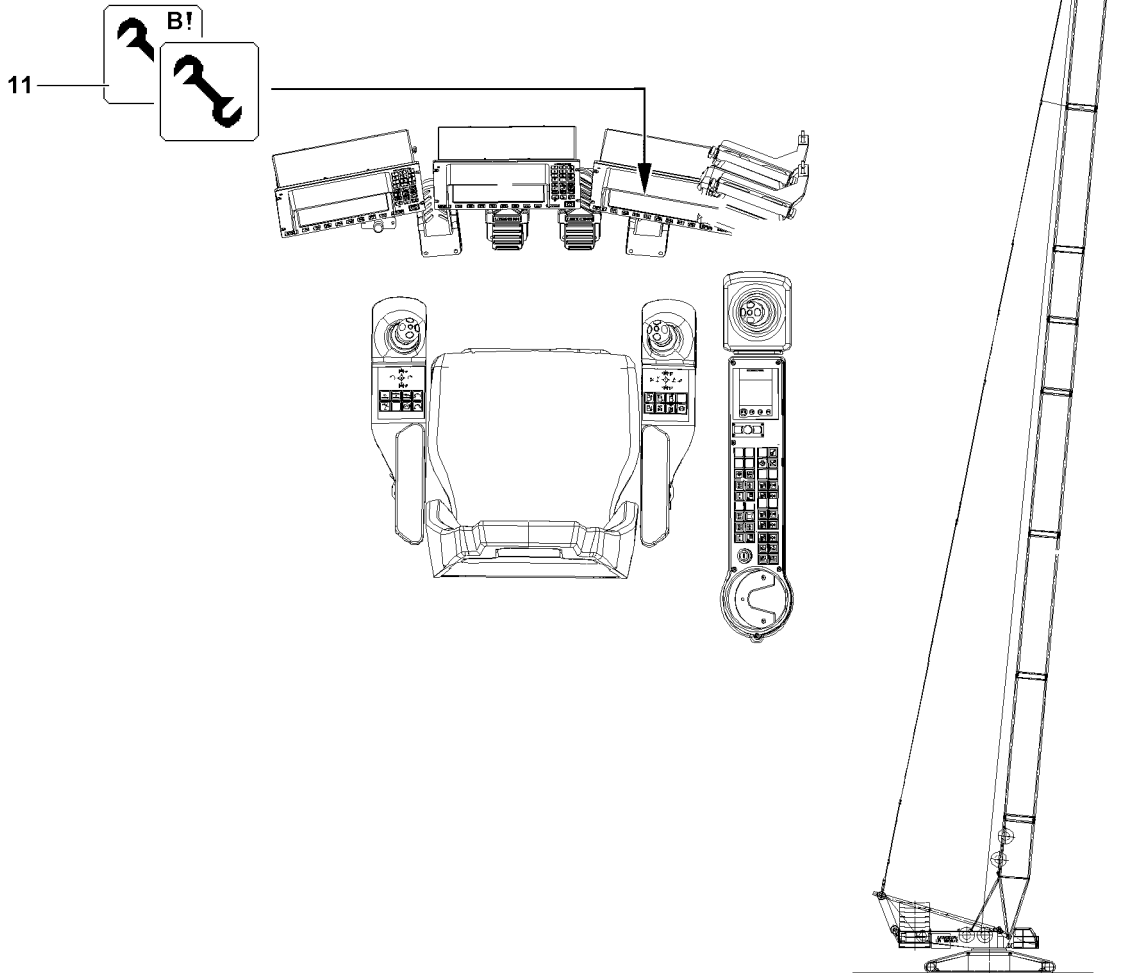

2

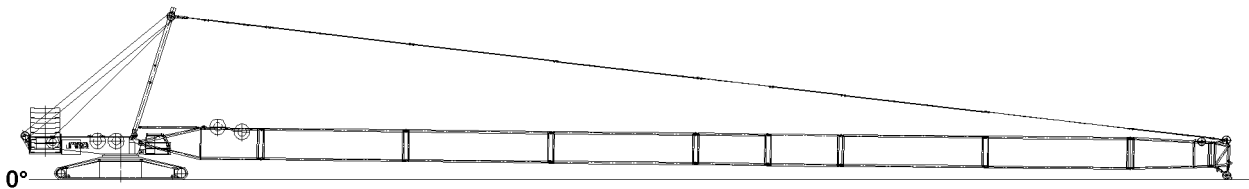

Fig.114059

LWE/LR 1600-2-008/18109-09-02/en

5.1 Turning the turntable into the disassembly position



WARNING

The crane can topple over!

If the following conditions are not met before turning the turntable, then the crane can topple over. Death, severe bodily injuries, property damage.

- ▶ Observe the specifications in the erection and take-down charts.
- ▶ Observe the maximum permissible ballast combinations depending on the assembly status, see chapter 3.06.

- ▶ Turn the turntable into the disassembly position, see „Erection and take-down charts“.

5.2 Taking the boom down



WARNING

The crane can topple over!

If the following conditions are not met before taking down the boom, the crane can topple over and fatally injure personnel.

- ▶ The turntable may not be turned during the disassembly of the boom.
- ▶ Observe the technical safety instructions, see chapter 5.01.
- ▶ Observe the specifications in the erection and take-down charts.

If required in the erection and take down chart:

- ▶ Carry the hook block along with the auxiliary crane.

NOTICE

Damage of boom components!

Taking down the boom system can lead to a collision between the hook block and the pulley head. Boom components can be severely damaged.

- ▶ Luff the boom system down at the same time and spool the hoist winch out.



Note

- ▶ Depending on the condition of the ground, the boom and the lattice sections must be supported for the disassembly of the boom.

Make sure that the following prerequisites are met:

- The crane is horizontally aligned.
- An auxiliary crane is available.
- An assembly scaffolding / work platform is available.
- The central ballast is installed according to the erection and take-down charts.
- The counterweight has been installed on the turntable according to the erection and take-down charts.
- The LICCON overload protection has been set according to the data in the load chart.

1

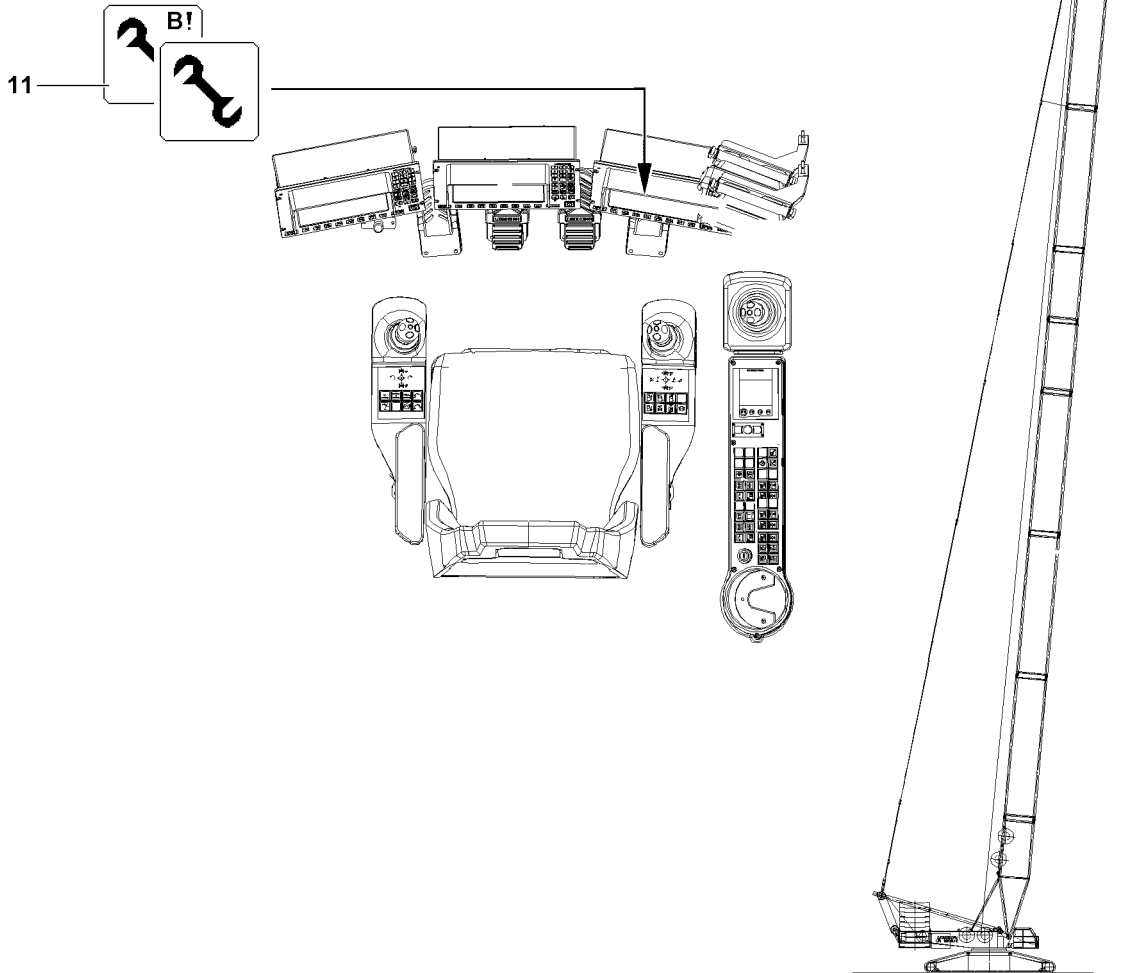

2

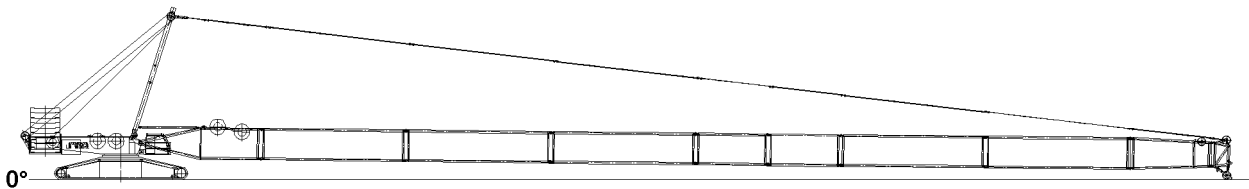

Fig.114059

LWE/LR 1600-2-008/18109-09-02/en

5.2.1 Luffing the boom down



Note

- ▶ The luff down movement is turned off as soon as the lowest operating position is reached.
- ▶ When the lowest operating position of the S-boom is reached, the load display in the maximum load icon turns off and instead of the load display appears the display „???“.
- ▶ Alarm functions appear on the crane operation screen.

- ▶ Luff the S-boom down to the „lowest“ operating position.

Result:

- The luff down movement is turned off.
- The „STOP“ icon appears on the LICCON monitor.
- The horn icon appears on the LICCON monitor.



WARNING

Danger of accident due to the „Exceedance of shut-off limits of the LICCON overload protection“ function!

If the shut off limits of the LICCON overload protection are exceeded, there is no additional protection against crane overload.

Due to erroneous operation or deliberate misuse, the crane could collapse, the boom can break off or the crane can topple over.

Death, severe bodily injuries, property damage.

- ▶ The function „Exceedance of shut off limits of the LICCON overload protection“ is only permissible in emergencies and for assembly purposes.
- ▶ The function „Exceeding the shut off limits of the LICCON overload protection“ may only be actuated by persons who know the effects of their actions regarding the function „Exceeding the shut off limits of the LICCON overload protection“.
- ▶ The „Exceedance of shut off limits of the LICCON overload protection“ function requires the presence of an authorized person and must be performed with utmost caution.
- ▶ Crane operation with activated function „Exceedance of shut off limits of the LICCON overload protection“ is prohibited.

- ▶ Exceeding the shut off limits of the LICCON overload protection: Engage assembly operation.

Result:

- The shut off limits of the LICCON overload protection are exceeded.
- The assembly icon appears on the LICCON monitor.



Note

- ▶ See chapter 4.02.

- ▶ At the same time, spool the hoist winch out and luff the S-boom down until the hook block touches the ground.

5.2.2 Reeving out the hook block

- ▶ Remove the hoist limit switch weight and reeve the hook block out.

5.2.3 Spooling the hoist rope up



WARNING

Spooling up of hoist rope!

Death, severe bodily injuries, property damage.

- ▶ All rope retaining pins / pipes on the S-boom are removed.
- ▶ Slowly spool up the hoist rope over the rope pulleys back to the winch.
- ▶ No one may be present in the danger zone.

NOTICE

Overspooled winch!

If the rope is pulled under the winch when spooling up, the settings of the cam limit switch are no longer correct and there is an increased danger of accident.

As a result, extensive adjustment work on the cam limit switch is required.

- ▶ All rope retaining pins / pipes on the S-boom are removed.
- ▶ Slowly spool up the hoist rope over the rope pulleys back to the winch.
- ▶ Stop the winch in time, with sufficient rope reserve.
- ▶ Do not overspool the winch.

- ▶ Spool the hoist rope up.

5.3 Disconnecting the electrical connections on the boom

Make sure that the following prerequisite is met:

- The S-boom is laying on the substructure on the ground.

NOTICE

Damage to the cable drum or the cable!

If the cable of the cable drum is not properly spooled up on the cable drum after unplugging the S-end section, then the cable drum or the cable can be significantly damaged.

- ▶ Spool the cable drum up after unplugging.

- ▶ Spool the cable drum up and secure it to prevent inadvertent spooling out.
- ▶ Make sure that all electrical connections on the S-boom have been disconnected.

5.4 Disconnecting the hydraulic connection on the boom

When releasing hydraulic lines with quick couplings, make sure that the coupling procedure is carried out correctly.

**WARNING**

Pressure in the hydraulic lines!

If the pressure supply is not interrupted before connecting / releasing the hydraulic lines, the hydraulic oil can escape with high pressure.

Death, severe bodily injuries, property damage.

- ▶ Release the pressure in the hydraulic system before connecting / disconnecting: Interrupt the pressure supply and wait for a short time.
- ▶ Install the coupling components (sleeve and connector) with the knurled nut.
- ▶ Disconnect the hydraulic connections.
- ▶ Install dust caps on the quick couplings.

Empty page!

LWE/LR 1600-2-008/18109-09-02/en

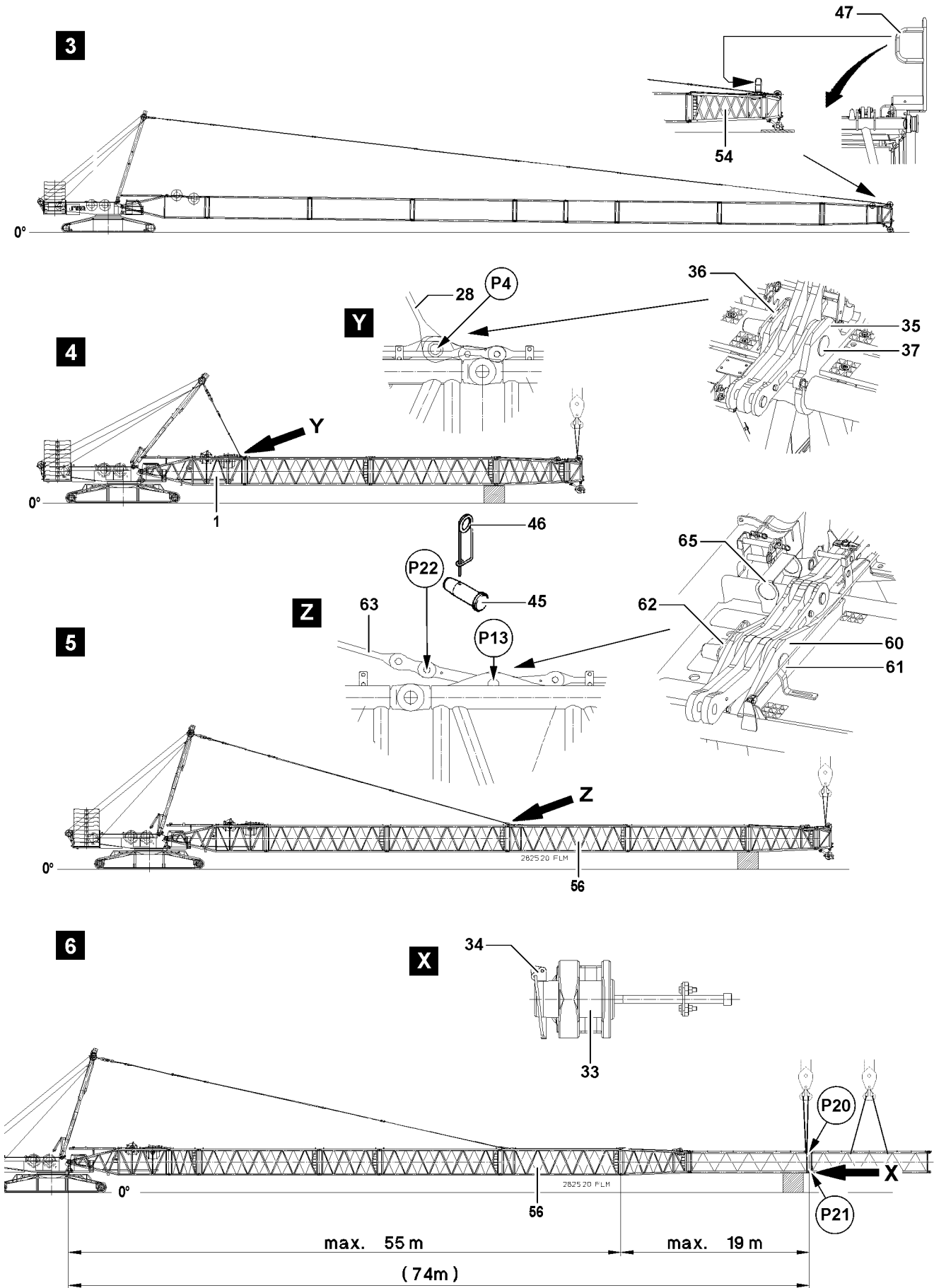

Fig.114060

LWE/LR 1600-2-008/18109-09-02/en

5.5 Disassembling the S-lattice sections

The disassembly of the lattice sections is carried out in various ways:

- Disassembling the lattice sections in „flying mode“.
- „Opening“ the boom.



WARNING

General danger notes!

- ▶ Support the S-boom during assembly / disassembly with suitable materials.
- ▶ All pins are to be secured after assembly with the intended retaining elements.
- ▶ The guy rods must be inspected regularly, see chapter 8.15.
- ▶ Secure the boom with the substructure or auxiliary crane, see chapter 5.01.
- ▶ It is prohibited for anyone to remain under the booms or within the complete danger zone during the pinning and unpinning procedure of the lattice sections.



Note

- ▶ For weights of the lattice section with placed guy rods, see chapter 1.03.
- ▶ The lattice sections are unpinning with the aid of the pin pulling device, see chapter 5.30.

Make sure that the following prerequisite is met:

- All electrical and hydraulic connections are separated on the boom.

5.5.1 Disassembling the S-intermediate sections in „flying“ mode

If spatial prerequisites on the job site are limited for the assembly of the S-boom, or if they are limited by buildings or similar, then the S-boom can be removed in „flying“ mode.

For the „flying“ disassembly, a differentiation is made between the guy points on the boom:

- Guying on S-pivot section, see illustration 4 detail Y.
- Guying on S-intermediate section 2825.20 for flying assembly, see illustration 5, detail Z.



WARNING

Impermissible boom lengths guyed in „flying“ mode!

If impermissible boom lengths are guyed on the assembly brackets, then severe property damage can occur on the crane.

Death, severe bodily injuries, property damage.

- ▶ The maximum permissible boom lengths for the „Flying assembly“ may not be exceeded, see section „Assembling the S-lattice sections“.
- ▶ Pin the guy rods either on the assembly brackets **35**, point **P4**, or the guy rods **64**, point **P22**.

When the boom is longer than the permissible boom length for the „flying“ assembly:

- ▶ Support the boom on the end of the permissible boom length or secure with an auxiliary crane, boom system SL-84 see illustration 6.
- ▶ The specifications in the erection and take-down charts as well as the load charts must be observed.



WARNING

The boom can fold down!

By unpinning the guy rods on the assembly brackets **35** or the assembly brackets **60**, the boom can fold down.

Death, severe bodily injuries, property damage.

- ▶ Unpin the guy rods **28** on the assembly brackets **35**, point **P4** when it is ensured that the intermediate sections are supported with suitable materials or are secured by the auxiliary crane or the boom is taken down on the ground.
- ▶ Unpin the guy rods **63** on the guy rods **64**, point **P22** when it is ensured that the intermediate sections are supported with suitable materials or are secured by the auxiliary crane or the boom is taken down on the ground.

Make sure that the following prerequisites are met:

- The boom is in a horizontal position.
- The guy rods are tensioned.
- Suitable materials to support the boom are available.
- An auxiliary crane is available.

Guying the S-boom in „flying mode“

Before the lattice sections can be disassembled in „flying“ mode, the boom must be guyed in „flying“ mode.

- ▶ Take the boom down on the ground, support it or secure it with an auxiliary crane.



Note

- ▶ The guy rods must be taken down to the point where the boom can be guyed on the assembly brackets **35** in point **P4** or the assembly brackets **60** in point **P13**.



Note

- ▶ To retain the system dimensions for on road travel the folding platforms **47** on the SL-reducer **54** must be folded in into the transport position and pinned, see illustration **3**.

- ▶ Bring the folding platforms **47** on the SL-reducer **54** into the transport position, see chapter 2.06.
- ▶ Make sure that the transport retainers for the guy rods on the intermediate sections are unpinned.

When the boom is longer than the permissible boom length for the „flying“ assembly:

- ▶ Support the boom on the end of the permissible boom length or secure with an auxiliary crane before the boom is guyed in „flying“ mode.
- ▶ Luff the SA-frame down and take the guy rods down on the S-intermediate sections in the transport retainers.

When the boom is guyed on the S-pivot section, see illustration **4**:

- ▶ Pin the guy rods on the assembly brackets **35**: Insert the pin **37** on point **P4** and secure with the spring retainer **36**.

The pin **61** for the guying on the S-intermediate section is secured in the retainer **65**.

When the boom is guyed on the S-intermediate section, see illustration **5**:

- ▶ Pin the guy rods on the assembly brackets **60**: Insert the pin **61** on point **P13** and secure with the spring retainer **62**.
- ▶ Disassemble the guy rods, which are laying on the boom and secure them in the transport retainers on the lattice sections.

Result:

- The S-intermediate sections can be disassembled in „flying“ mode.

Disassembling the S-intermediate section

Make sure that the following prerequisite is met:

- The boom is guyed on the S-intermediate section or on the S-pivot section.
- When the boom is longer than the permissible boom length for the „flying“ assembly: the boom is supported at the end of the permissible boom length or secured with the auxiliary crane.

The „flying“ disassembly is described on the example of one intermediate section, boom system SL-84, see illustration **6**.

- ▶ Secure the S-intermediate section with the auxiliary crane.
- ▶ Unpin the S-intermediate section on both sides „on the bottom“ at point **P21**: Remove the spring retainer **34** and unpin the pin **33**.
- ▶ Unpin the S-intermediate section on both sides „on top“ at point **P20**: Remove the spring retainer **34** and unpin the pin **33**.
- ▶ Remove the S-intermediate section.

If additional lattice sections are disassembled:

- ▶ Disassemble the additional lattice sections the same way as described in this section.

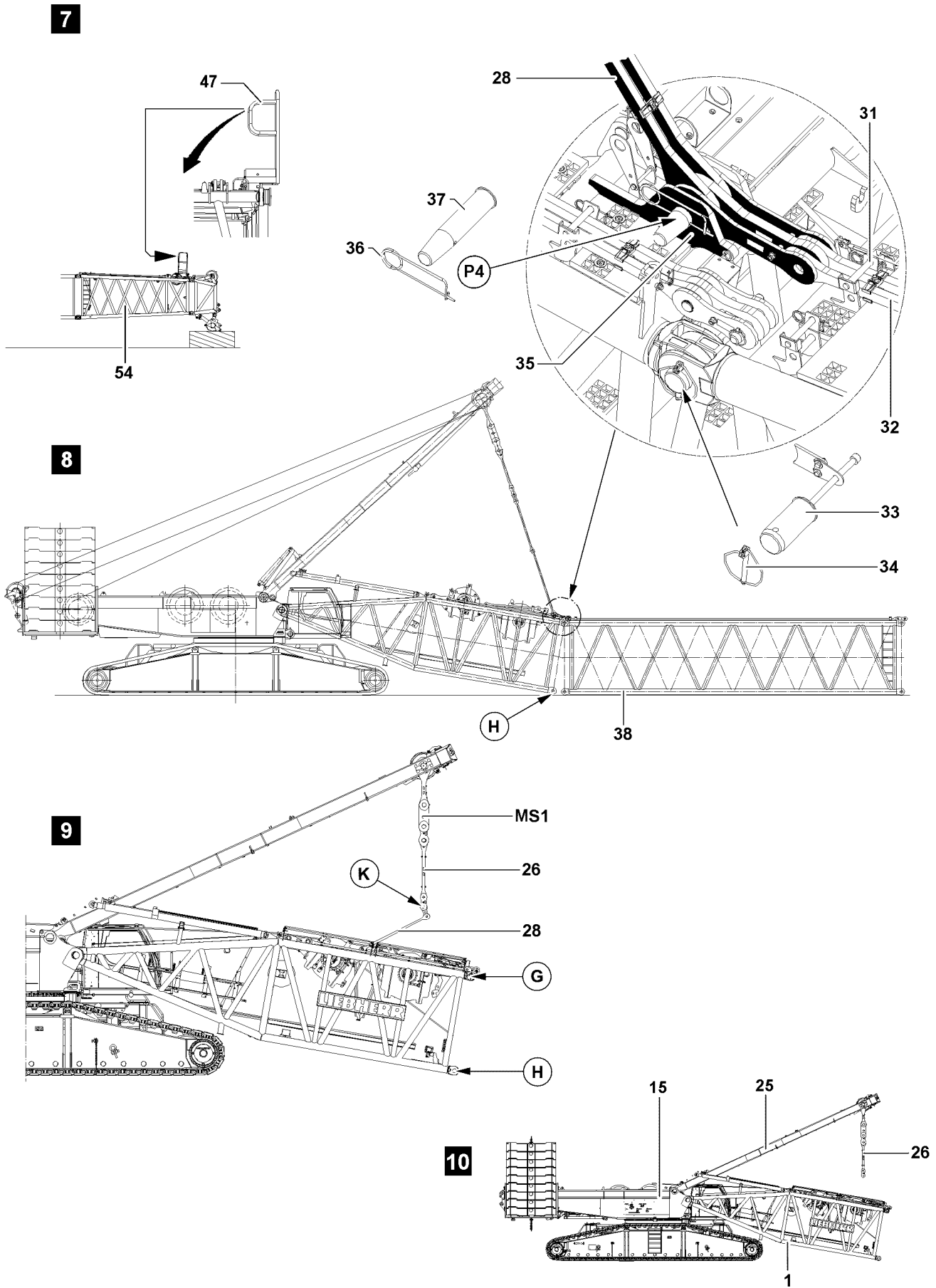

Fig.114061

LWE/LR 1600-2-008/18109-09-02/en

5.5.2 Disassembling the S-lattice sections („open“ boom)



WARNING

The crane can topple over!

If the following conditions are not met, the crane can topple over or be significantly damaged. Death, severe bodily injuries, property damage.

- ▶ The end section of the corresponding S/SL-boom combination may **not** lift off the ground during the „closing procedure“.
- ▶ With the SA-frame, boom combinations only to certain system lengths may be lifted / opened, see section „Assembling S-lattice sections (close boom)“.

Make sure that the following prerequisites are met:

- The guy rods are tensioned.
- Suitable materials to support the boom are available.
- An auxiliary crane is available.

Pinning the guy rods on the S-pivot section

- ▶ Luff the SA-frame down and take the boom down on the substructure on the ground.



Note

- ▶ To retain the system dimensions for on road travel the folding platforms **47** on the SL-reducer **54** must be folded in into the transport position and pinned, see illustration **7**.

- ▶ Bring the folding platforms **47** on the SL-reducer **54** into the transport position with the auxiliary crane, see chapter 2.06.
- ▶ Make sure that the transport retainers for the guy rods on the intermediate sections are unpinned.



Note

- ▶ The guy rods must be taken down to the point where the guy rods can be pinned on the assembly brackets **35** in point **P4**.
- ▶ Luff the SA-frame down and take the guy rods down on the S-intermediate sections in the transport retainers.
- ▶ Pin the guy rods **28** on the assembly brackets **35** on the S-pivot section: Insert the pin **37** and secure with the spring retainer **36**, see illustration **8**.
- ▶ Unpin the guy rods from each other and secure them individually with the transport retainers on the boom.

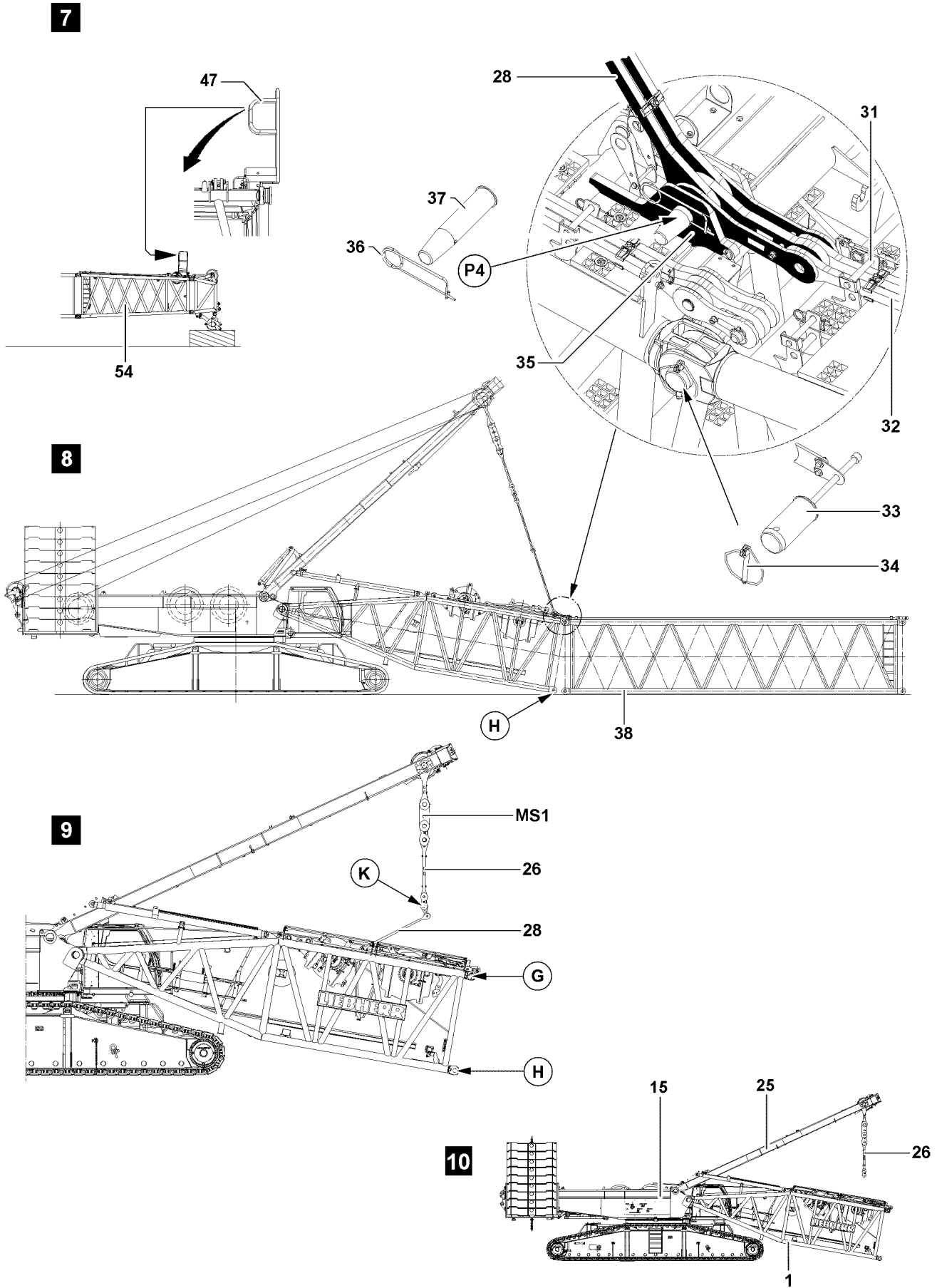

Fig.114061

LWE/LR 1600-2-008/18109-09-02/en

„Opening“ the S-boom



Note

- ▶ The ACTUAL force on the test point **MS1** is displayed on LICCON monitor 1.
 - ▶ Tension the guying on the SA-frame with the same force as for assembly, see the actual force which was measured and noted at assembly on the test point **MS1**.
 - ▶ The pins can be pulled easier and the pins and lugs are therefore not damaged.
-
- ▶ Lift the SA-frame and tension the guy rods until the force on test point **MS1** corresponds to the force at assembly.
 - ▶ Unpin the S-pivot section on both sides „on the bottom“ at point **H**: Remove the spring retainer **34** and unpin the pin **33**, see illustration **8**.
 - ▶ Lower the S-boom until the intermediate sections and the S-pivot section are lying on the substructure on the ground.
 - ▶ Unpin the S-pivot section on both sides „on top“ at point **G**: Remove the spring retainer **34** and unpin the pin **33**.
 - ▶ Lower the SA-frame and take the guy rods **28** down in the transport retainers on the S-pivot section.
 - ▶ Unpin the guy rods **28** on the guy rods **26** of the SA-frame, see illustration **9**.
 - ▶ Secure the guy rods **28** in the transport retainers.

Result:

- The S-lattice sections can be disassembled.

Disassembling the S-lattice sections

The disassembly is described using the example of one intermediate section, see illustration **8**.

- ▶ Unpin the S-intermediate section on both sides „on the bottom“: Remove the spring retainer **34** and unpin the pin **33**.
- ▶ Unpin the S-intermediate section on both sides „on top“: Remove the spring retainer **34** and unpin the pin **33**.
- ▶ Remove the S-intermediate section.

If additional lattice sections are disassembled:

- ▶ Disassemble the additional lattice sections the same way as described in this section.

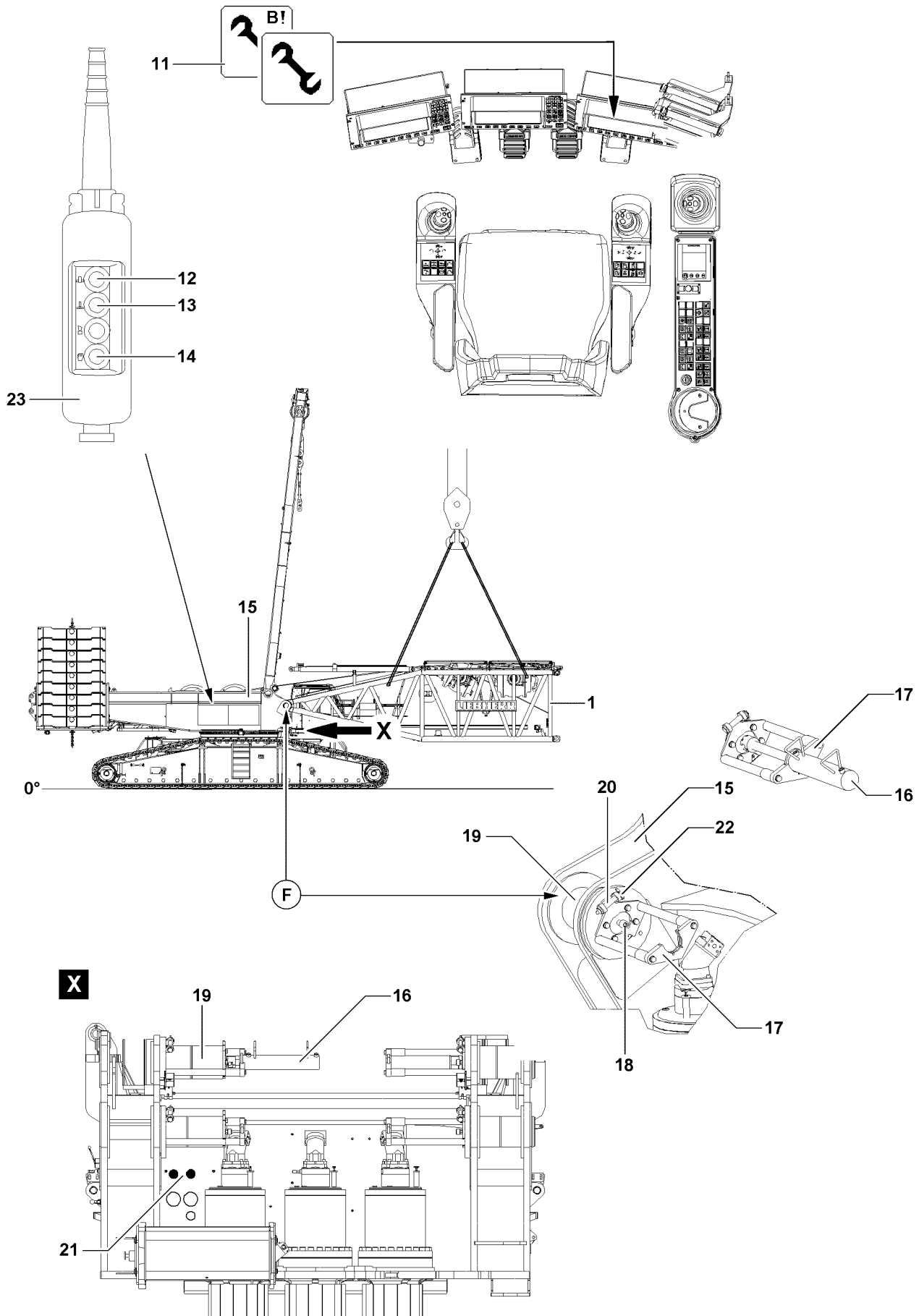

Fig.114052

5.6 Disassembling the S-pivot section



WARNING

General danger notes!

- ▶ Support the S-pivot section during disassembly with suitable materials.
- ▶ Insert and secure all pins after disassembly in the intended transport receptacles.
- ▶ The guy rods must be inspected regularly, see chapter 8.15.

Make sure that the following prerequisites are met:

- The SA-frame is erected to the point where the S-pivot section can be disassembled without obstructions.
- The electrical connections to the S-pivot section are properly disconnected.
- The hydraulic connections to the S-pivot section are properly disconnected.
- If dummy plugs are present, make sure that they are properly installed, see Electric wiring diagram.
- ▶ Fasten the S-pivot section **1** to the auxiliary crane.
- ▶ Lift the S-pivot section **1** with the auxiliary crane to the horizontal position.

The pin pulling cylinders on the turntable are activated with the control panel, see illustration.



Note

- ▶ The pin pulling device is operated with the control panel **23** of the turntable, see illustration.

Establish the hydraulic connection to the pin pulling device via two quick couplers, see detail X.

- ▶ Hang the pin pulling cylinder **16** into the receptacle **17** and the screw **18** on the pin **19**.
- ▶ Connect the pin pulling cylinder **16** to the quick couplers **21**, hydraulic turntable.



WARNING

Unsecured S-pivot section!

If the S-pivot section is not secured before unpinning the pins, then it will fold down.

Death, severe bodily injuries, property damage.

- ▶ Make sure that the S-pivot section **1** is secured with the auxiliary crane before unpinning the pin **19**.
- ▶ Release the pins **19** on both sides: Remove the spring retainer **22** and unpin the pin **20**.
- ▶ Unpin the pins **19** on both sides with the hydraulic pin pulling cylinder **16**: Press the button **14** on the control panel **23** and hold down, then press the button **13** until the pin **19** is completely unpinned.

When the pins **19** are completely unpinned on the left and right on the S-pivot section **1**:

- ▶ Insert the pin **20** and secure with the spring retainer **22**.

NOTICE

Property damage on the turntable and on the S-pivot section!

- ▶ Carefully swing the S-pivot section out with the auxiliary crane and at a low speed on the turntable.
- ▶ Carefully take the S-pivot section **1** down.
- ▶ Remove the auxiliary crane.

Empty page!

LWE/LR 1600-2-008/18109-09-02/en

5.39 LD/SLD/SD-boom combination

1	Component overview	3
2	Fastening points	3
3	Assembling the SLD / SD-boom	6
4	Operating the crane	57
5	Disassembling the SLD / SD-boom	57

Fig.195219

LWE/LR 1600-2-008/18109-09-02/en

1 Component overview



Note

- ▶ The boom components as well as the dimensions and weights are described in chapter 1.03.
- ▶ For the combination of the various boom systems, refer to the Rod plan and chapter 5.03.

2 Fastening points



WARNING

Falling lattice sections!

Death, severe bodily injuries, property damage.

- ▶ Make sure that the lattice sections are properly fastened on the respective fastening points.
- ▶ Make sure that the fastening equipment has the appropriate length and a sufficient load bearing capacity.
- ▶ Pay attention and adhere to the labels on the fastening points on the lattice sections and crane components.

2.1 Fastening points S-pivot section

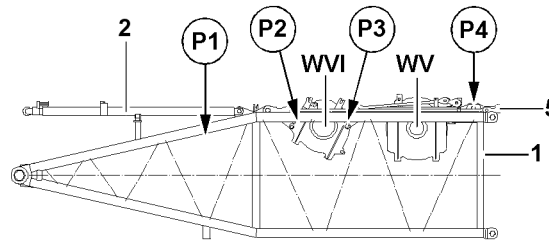

Fig.125155: Fastening points S-pivot section

Fastening points	
P1 + P3	S-pivot section without winch 5, without winch 6
P2 + P3	S-pivot section with winch 5, without winch 6
P1 + P3	S-pivot section without winch 5, with winch 6
P2 + P3	S-pivot section with winch 5, with winch 6

2.2 Fastening points S-intermediate sections 2825.25, 3 m

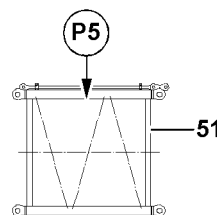

Fig.125156: Fastening points S-intermediate sections 2825.25, 3 m

LWE/LR 1600-2-008/18109-09-02/en

**Note**

- ▶ The S-intermediate sections are available in various system dimensions.
- ▶ The lattice section must be fastened on both sides to the fastening points.

Fastening points	
P5	S-intermediate sections 2825.25, 3 m

2.3 Fastening points S-intermediate sections 2825.25, 12 m

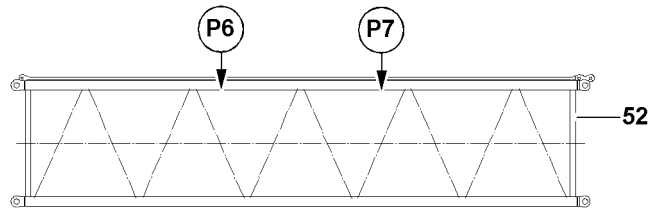

Fig.125157: Fastening points S-intermediate sections 2825.25, 12 m

**Note**

- ▶ The S-intermediate sections are available in various system dimensions.
- ▶ The distance between the fastening pints can vary, depending on the respective S-intermediate section.
- ▶ The lattice section must be fastened on both sides to the fastening points.

Fastening points	
P6 + P7	S-intermediate sections 2825.25, 12 m

2.4 Fastening points S-intermediate sections 2825.20, 6 m

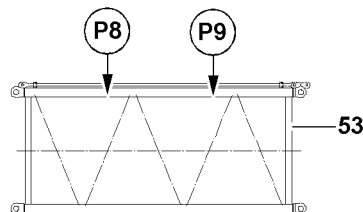

Fig.125158: Fastening points S-intermediate sections 2825.20, 6 m

**Note**

- ▶ The S-intermediate sections are available in various system dimensions.
- ▶ The distance between the fastening pints can vary, depending on the respective S-intermediate section.
- ▶ The lattice section must be fastened on both sides to the fastening points.

Fastening points	
P8 + P9	S-intermediate sections 2825.20, 6 m

2.5 Fastening points S-intermediate sections 2825.20, 12 m FLM for flying assembly

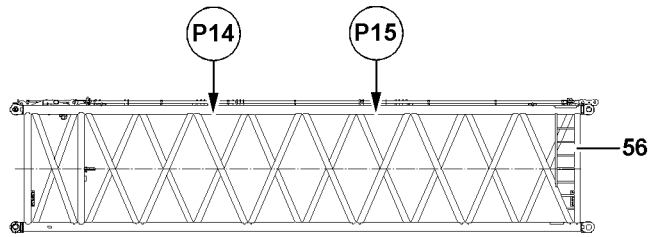

Fig.125161: Fastening points S-intermediate sections 2825.20, 12 m FLM for flying assembly



Note

- ▶ The S-intermediate sections are available in various system dimensions.
- ▶ The distance between the fastening pints can vary, depending on the respective S-intermediate section.
- ▶ The lattice section must be fastened on both sides to the fastening points.

Fastening points	
P14 + P15	S-intermediate sections 2825.20, 12 m FLM for flying assembly

2.6 Fastening points LI-intermediate sections 2420.10Z, 12 m

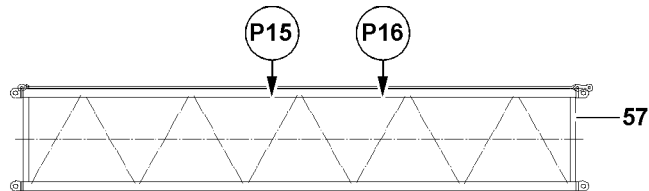

Fig.125162: Fastening points LI-intermediate sections 2420.10Z, 12 m



Note

- ▶ The S-intermediate sections are available in various system dimensions.
- ▶ The distance between the fastening points can vary.
- ▶ The lattice section must be fastened on both sides to the fastening points.

Fastening points	
P16 + P17	LI-intermediate sections 2420.10Z, 12 m

LWE/LR 1600-2-008/18109-09-02/en

2.7 Fastening points SL-reducer

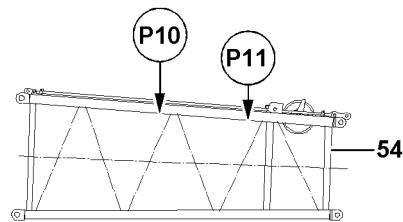

Fig.125159: Fastening points SL-reducer



Note

► The lattice section must be fastened on both sides to the fastening points.

Fastening points	
P10 + P11	SL-reducer

2.8 SW-end section fastening points

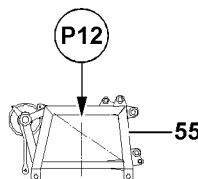

Fig.125160: SW-end section fastening points

Fastening points	
P12	SW-end section, without roller set

3 Assembling the SLD / SD-boom



Note

► For the combination of the boom lattice sections, observe and adhere to the Rod plan and chapter 5.03.

**WARNING**

Danger of falling!

During assembly / disassembly, inspection and maintenance work, assembly personnel must be secured with appropriate aids to prevent them from falling.

Death, severe bodily injuries, property damage.

- ▶ All work at a height, when there is a danger of falling, must be carried out with suitable aids.
- ▶ If aids are not available and work cannot be carried out from the ground, then assembly personnel must secure themselves with the supplied fall arrest system to prevent falling, see chapter 2.04.
- ▶ If fall protection equipment is available, then it must be used, see chapter 2.06.
- ▶ When lifting, lowering, swinging crane parts in and out, no persons may remain in the danger zone.
- ▶ When closing or opening boom systems during boom assembly or boom disassembly, no persons may remain on the boom system or in the danger zone.
- ▶ If railings are present on the components, then they must be brought into the corresponding position and secured for assembly / disassembly work.
- ▶ Only step on the aids, ladders and catwalks with clean shoes.
- ▶ Keep aids, ladders and catwalks free of heavy dirt, snow and ice.
- ▶ During all assembly and disassembly work, maintenance work and inspections, travel or crane operation is prohibited.
- ▶ Remaining on a suspended load is prohibited.
- ▶ Stepping or walking on crane components and lattice sections, which have an incline of more than 20° is prohibited.
- ▶ For all assembly work, the crane driver of the main crane must be in voice contact with the crane driver / crane drivers of the auxiliary crane / auxiliary cranes.
- ▶ For assembly tasks, the crane driver may only initiate crane movements when the responsible guide has explicitly released the movement.

**WARNING**

The lattice sections can fall down!

If the lattice sections are not pinned and secured correctly, then they can fall down.

Death, severe bodily injuries, property damage.

- ▶ Insert or unpin both pins at the same horizontal level, i.e. **left and right**.
- ▶ Do not stand under the lattice sections or within the entire danger zone during the pinning and unpinning procedure of the boom.
- ▶ Safely secure the pins in the storage locations as well as in the receptacles.
- ▶ It is prohibited to lean the ladder against the component being disassembled.

**WARNING**

Danger of impact / crushing!

When installing / removing crane components with the auxiliary crane, crane components can start to swing back and forth.

When lifting / lowering and positioning crane components, there is an increased danger of impacts / crushing.

Death, severe bodily injuries, property damage.

- ▶ Make sure that personnel cannot be caught by components.
- ▶ Make sure that the crane is horizontally aligned.
- ▶ When working in danger zones: Use aids to protect limbs.
- ▶ Guide components with suitable aids to minimize oscillation.

**DANGER**

The components can fall down!

If the corresponding component is disengaged from the auxiliary crane before the corresponding component is pinned, then the corresponding component can fall down.

Death, severe bodily injuries, property damage.

- ▶ Do not disengage the auxiliary crane until the respective component is pinned and secured.

**WARNING**

The crane can topple over!

- ▶ The turntable may not be turned during the assembly of the boom.
- ▶ Observe the assembly conditions, see chapter 3.06.

**WARNING**

Danger of accident!

Death, severe bodily injuries, property damage.

- ▶ For assembly of the boom combinations, the rod plan must be observed and adhered to.
- ▶ Depending on the condition of the ground, the boom and the lattice sections must be supported from below for the assembly of the boom.
- ▶ Observe the technical safety instructions, see chapter 5.01.

Make sure that the following prerequisites are met:

- The crane is horizontally aligned.
- An auxiliary crane is available.
- An assembly scaffolding / work platform is available.
- The central ballast is installed according to the load chart.
- The counterweight has been installed on the turntable according to the load chart.
- The LICCON overload protection has been set according to the data in the load chart.

Empty page!

LWE/LR 1600-2-008/18109-09-02/en

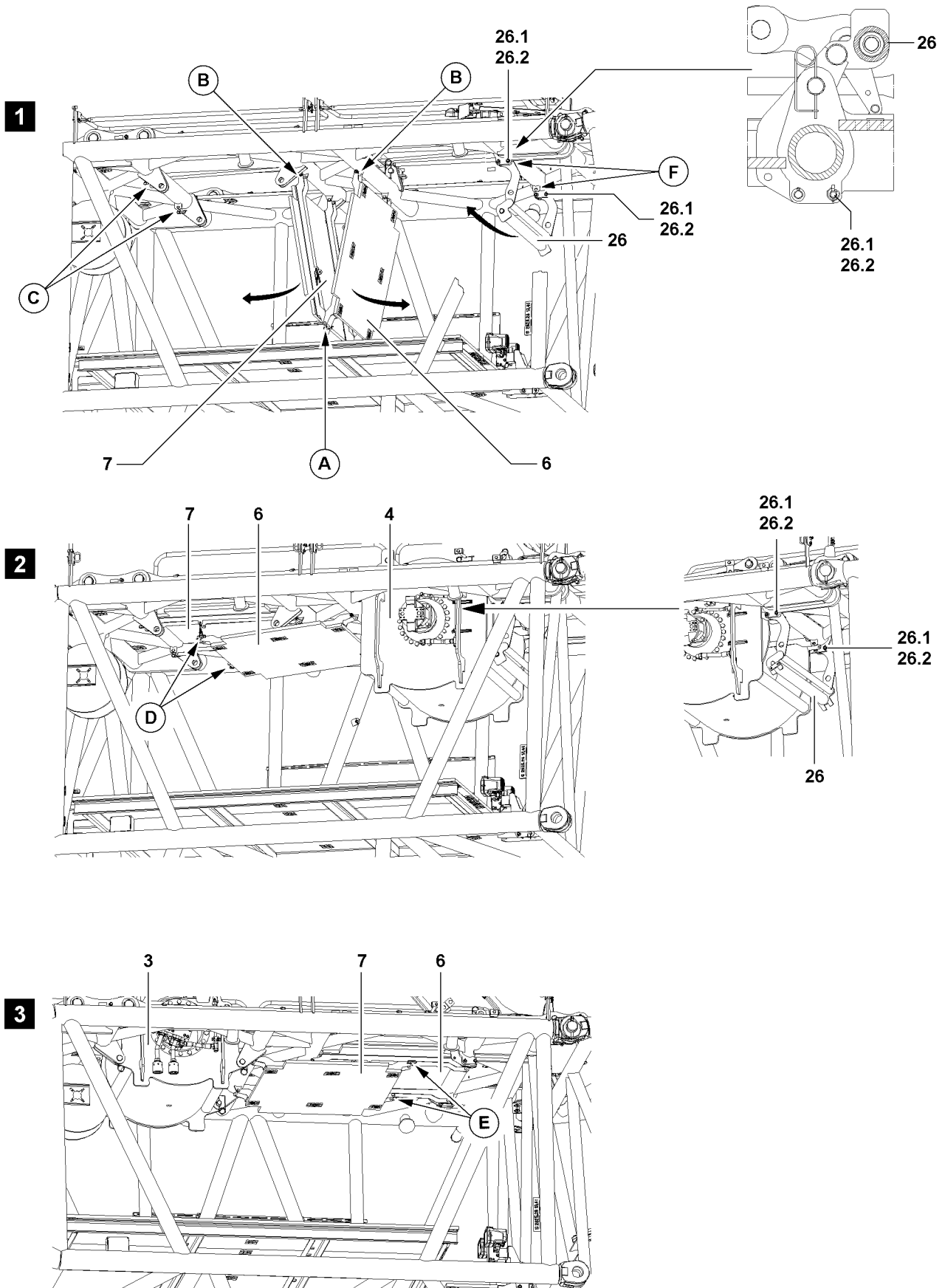

Fig.106747

3.1 Swinging the railing on the S-pivot section into the operating position



WARNING

Danger of falling!

During assembly and disassembly of the railings, assembly personnel must be secured with appropriate aids to prevent them from falling.

Even during the assembly of protective equipment there is a danger of falling.

Death, severe bodily injuries, property damage.

- ▶ For assembly and disassembly work, maintenance and inspection work on the S-pivot section, all railings must be assembled and secured.

- ▶ Only step on the S-pivot section **1** with „clean shoes“.

- ▶ Swing the railing on the S-pivot section **1** into the operating position, pin with the grip pin and secure with the spring retainer.

3.2 Assembling the catwalks



WARNING

Disassembled or incompletely assembled catwalks!

If the catwalks are not installed when the winches are missing or if the catwalks are not completely installed, then personnel can fall down.

Death, severe bodily injuries, property damage.

- ▶ For each non-assembled winch on the S-pivot section: Assemble the catwalk.

- ▶ The catwalks may only be accessed when they are pinned and secured in the operating position, check visually.



WARNING

Catwalks swung down!

Catwalks that swing down by themselves can cause severe face or head injuries for assembly personnel.

Death, severe bodily injuries, property damage.

- ▶ For safety reasons, assemble the catwalks always with two persons.



Note

- ▶ If winch 5 is not assembled, the protective roller **26** must be pinned in the „up“ position during crane operation.

- ▶ If winch 5 is to be assembled, then - before assembly of winch 5 - the protective roller **26** must be folded down and pinned in the „down“ position.

Catwalks are assigned to the openings for the winches:

- Winch 5 – catwalk **6**.
- Winch 6 – catwalk **7**.

Make sure that the following prerequisite is met:

- The railings are pinned and secured in the operating position.

3.2.1 S-pivot section without winches

Make sure that the following prerequisites are met:

- Catwalks are pinned in the transport position in point **A**.
- The protective roller **26** is pinned and secured in the „up“ position.

- ▶ Release and unpin the catwalks in point **A**.

Swing the catwalks „up“ individually into the operating position and pin.

- ▶ Swing the catwalk **7** into the operating position and pin and secure in points **C**, see illustration **1**.
- ▶ Swing the catwalk **6** into the operating position and pin and secure in points **F**, see illustration **1**.

3.2.2 S-pivot section before installation of winch 5

Make sure that the following prerequisites are met:

- Winch 5 is not installed.
- Winch 6 is not installed.
- The protective roller **26** is pinned and secured in the „up“ position.
- The catwalk **6** and catwalk **7** are pinned and secured in the operating position.

- ▶ Hang the catwalk **6** on the auxiliary crane.

When the catwalk **6** is safely held by the auxiliary crane:

- ▶ Unpin the catwalk **6** in points **F**.
- ▶ Lower the catwalk **6** downward and remove the auxiliary crane.
- ▶ Swing the catwalk **6** upward to the opposite side and pin and secure in the points **D** of the catwalk **7**, see illustration **2**.
- ▶ Release and unpin the protective roller **26** in the „up“ position.
- ▶ Swing the protective roller **26** into the „down“ position, pin with the retaining pin **26.1** and secure with the locking pin **26.2**.

Result:

- Winch 5 can be installed.

3.2.3 S-pivot section before installation of winch 6

Make sure that the following prerequisites are met:

- Winch 5 is not installed.
- Winch 6 is not installed.
- The protective roller **26** is pinned and secured in the „up“ position.
- The catwalk **6** and catwalk **7** are pinned and secured in the operating position.

- ▶ Hang the catwalk **7** on the auxiliary crane.

When the catwalk **7** is safely held by the auxiliary crane:

- ▶ Unpin the catwalk **7** in points **C**.
- ▶ Lower the catwalk **7** downward and remove the auxiliary crane.
- ▶ Swing the catwalk **7** upward to the opposite side and pin and secure in the points **E** of the catwalk **6**, see illustration **3**.

Result:

- Winch 6 can be installed.

3.2.4 S-pivot section before installation of both winches

Make sure that the following prerequisites are met:

- The protective roller **26** is pinned and secured in the „up“ position.
- The catwalk **6** and catwalk **7** are pinned and secured in the operating position.



Note

- ▶ Lower the catwalks individually and one after the other with the auxiliary crane.

When the catwalk is safely held by the auxiliary crane:

- ▶ Release and unpin the catwalk in the operating position, see illustration **1**.
- ▶ Lower the catwalk and remove the auxiliary crane.

When the catwalk **6** and the catwalk **7** are lowered down:

- ▶ Pin and secure the catwalks in point **A**, see illustration **1**.
- ▶ Release and unpin the protective roller **26** in the „up“ position.
- ▶ Swing the protective roller **26** into the „down“ position, pin with the retaining pin **26.1** and secure with the locking pin **26.2**.

Result:

- Winch 5 and winch 6 can be assembled.

3.3 Assembling the boom



WARNING

The crane can topple over!

- ▶ The turntable may not be turned during the assembly of the boom.
- ▶ Observe the assembly conditions, see chapter 3.06.



WARNING

Danger of accident!

Death, severe bodily injuries, property damage.

- ▶ For assembly of the boom combinations, the rod plan must be observed and adhered to.
- ▶ Depending on the condition of the ground, the boom and the lattice sections must be supported from below for the assembly of the boom.
- ▶ Observe the technical safety instructions, see chapter 5.01.

Make sure that the following prerequisites are met:

- The crane is horizontally aligned.
- An auxiliary crane is available.
- An assembly scaffolding / work platform is available.
- The central ballast is installed according to the load chart.
- The counterweight has been installed on the turntable according to the load chart.
- The LICCON overload protection has been set according to the data in the load chart.

3.3.1 Turning the turntable into the assembly position



WARNING

The crane can topple over!

If the following conditions are not met before turning the turntable - **without** assembled S-boom, the crane can topple over.

Death, severe bodily injuries, property damage.

- ▶ Observe the specifications in the erection and take-down charts.
- ▶ Observe the maximum permissible ballast combinations depending on the assembly status, see chapter 3.06.

- ▶ Turn the turntable into the assembly position, see the „Erection and take down charts“.

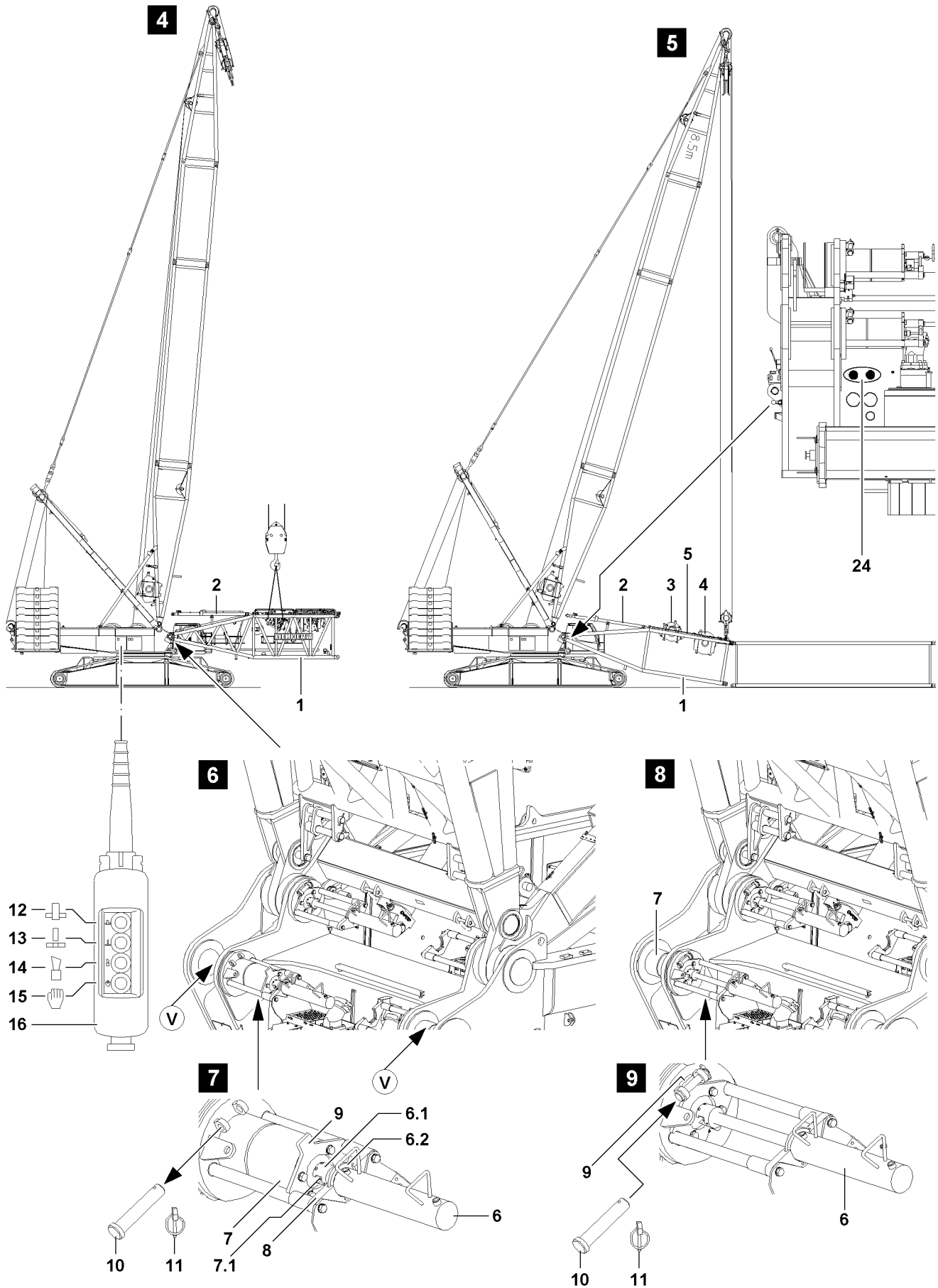

Fig.119482

LWE/LR 1600-2-008/18109-09-02/en

3.3.2 Exceeding the LICCON overload protection for assembly



WARNING

Danger of accident due to the „Exceedance of shut-off limits of the LICCON overload protection“ function!

If the shut off limits of the LICCON overload protection are exceeded, there is no additional protection against crane overload.

Due to erroneous operation or deliberate misuse, the crane could collapse, the boom can break off or the crane can topple over.

Death, severe bodily injuries, property damage.

- ▶ The function „Exceedance of shut off limits of the LICCON overload protection“ is only permissible in emergencies and for assembly purposes.
- ▶ The function „Exceeding the shut off limits of the LICCON overload protection“ may only be actuated by persons who know the effects of their actions regarding the function „Exceeding the shut off limits of the LICCON overload protection“.
- ▶ The „Exceedance of shut off limits of the LICCON overload protection“ function requires the presence of an authorized person and must be performed with utmost caution.
- ▶ Crane operation with activated function „Exceedance of shut off limits of the LICCON overload protection“ is prohibited.

-
- ▶ Exceeding the shut off limits of the LICCON overload protection: Engage assembly operation.

Result:

- The shut off limits of the LICCON overload protection are exceeded.
- The assembly icon appears on the LICCON monitor.



Note

- ▶ See chapter 4.02.

3.4 Pinning the S-pivot section on the turntable



Note

- ▶ Always arrange the intermediate sections according to the rod plan.
- ▶ Observe chapter 5.03.



WARNING

General danger notes!

- ▶ Support the S-boom during assembly with suitable materials.
- ▶ All pins are to be secured after assembly with the intended retaining elements.
- ▶ The guy rods must be inspected regularly, see chapter 8.15.

Make sure that the following prerequisite is met:

- The connector pins **7** on the turntable are unpinned, see illustration **7**.
- The retaining pins **10** are unpinned.



Note

- ▶ Select the fastening points on the S-pivot section in such a way that the S-pivot section hangs horizontally on the auxiliary crane upon assembly. See section „Fastening points“.
- ▶ Fasten the S-pivot section **1** in the fastening points to the auxiliary crane.
- ▶ Swing the S-pivot section **1** in with the auxiliary crane to the pin points on the turntable, illustration **4** and illustration **6**.



Note

- ▶ The pin pulling device is operated with the control panel **16** of the turntable, see illustration.

Establish the hydraulic connection to the pin pulling device via two quick couplers.

**Note**

- ▶ When hooking the pin pulling cylinder **6**, make sure that the collar **6.2** on the cylinder mount **8** and the catch **6.1** on the screw **7.1** are properly hooked.
- ▶ Hang the pin pulling cylinder **6** in the cylinder receptacle **8** and the screw **7.1** on the pin **7**.
- ▶ Connect the pin pulling cylinder **6** to the quick couplers **24**, see Hydraulic wiring diagram.

**DANGER**

Insufficiently secured connector pins!

Due to non-secured or insufficiently secured connector pins, the S-pivot section can fall down. Death, severe bodily injuries, property damage.

- ▶ Secure the connector pins **7** between the S-pivot section **1** and the turntable after the pinning procedure with the pins **10**.
- ▶ Pin the pins **7** on both sides with the hydraulic pin pulling cylinder **6**: Press the button **15** on the control panel **16** and hold down, then press the button **12** until the pin **7** is completely pinned.

When the pins **7** are completely pinned on the left and right on the S-pivot section:

- ▶ Secure the pins **7** on the left and right: Insert the pin **10** and secure with the locking pin **11**.

Result:

- The pins **7** have been secured with the retaining pins **10** to prevent them from unpinning by themselves.

NOTICE

Damage to the S-pivot section!

When the installed S-pivot section is taken down on the ground, the S-pivot section can be damaged.

- ▶ Slowly take the S-pivot section **1** down with the auxiliary crane and at low speed onto the substructure.
- ▶ Before taking it down on the ground, support the S-pivot section **1**.
- ▶ Carefully take the S-pivot section **1** down on the substructure.
- ▶ Remove the auxiliary crane.

3.5 Establishing the electric and hydraulic connections on the S-pivot section

3.5.1 Establishing the electrical connections

NOTICE

Danger of damage to the electrical connections!

If the electrical connection between the terminal box and the S-pivot section and the cable drum in the S-pivot section is established before the boom end section is installed and electrically connected, then the electric connection can be damaged.

- ▶ Make sure that the electric connection between the terminal box in the S-pivot section and the cable drum in the S-pivot section is only established **after** assembly and the connection of the electric wiring for the boom end section.

**Note**

- ▶ To establish the electrical connections on the S-pivot section: Use the Electrical wiring diagram.

Make sure that the following prerequisite is met:

- The S-pivot section is completely assembled and taken down on the substructure.
- ▶ Establish the electrical connections.
- ▶ Make sure that all electrical connections to the S-pivot section have been established.

**WARNING**

Malfunction if dummy plugs are not installed!

If the dummy plugs on the non-required electrical connections are not installed, then malfunctions or functional limitations can occur on the crane.

- ▶ Make sure that all non-required electrical connections, which have a dummy plug are closed off with dummy plugs.
 - ▶ Pay attention to the Electrical wiring diagram.
-
- ▶ As a rule, close off on-required electrical connections (for example for accessories which cannot be installed) with the respective dummy plugs.

NOTICE

Property damage due to dirt and / or corrosion!

If non-required electrical connections are not closed off with the respective protective caps, then dirt and / or corrosion can damage the electrical connections.

This could result in malfunctions.

- ▶ Make sure that all non-required electrical connections are always closed off properly.
 - ▶ Pay attention to the Electrical wiring diagram.
-
- ▶ Close electrical connections, which have no dummy plugs, properly off with the corresponding protective caps.

3.5.2 Establishing the hydraulic connections

When connecting and releasing hydraulic lines with quick couplings, make sure that the coupling procedure is carried out correctly.

**Note**

- ▶ To connect or release the hydraulic lines with quick couplings, see chapter 5.01.

**WARNING**

Pressure in the hydraulic lines!

If the pressure supply is not interrupted before connecting / releasing the hydraulic lines, the hydraulic oil can escape with high pressure.

Death, severe bodily injuries, property damage.

- ▶ Release the pressure in the hydraulic system before connecting / disconnecting: Interrupt the pressure supply and wait for a short time.

**WARNING**

Loss of pressure or leakage!

Incorrectly coupled or self-loosening quick couplings (particularly return lines) can result in serious accidents due to component failure.

- ▶ Check that the quick couplings have been properly connected before using the crane.
-
- ▶ Connect the coupling components (sleeve and connector) and screw together with the knurled nut.
 - ▶ Tighten the hydraulic coupling by hand. Turn the knurled nut until it reaches a tangle, fixed stop position.
 - ▶ Establish the hydraulic connections, see the Hydraulic diagram.

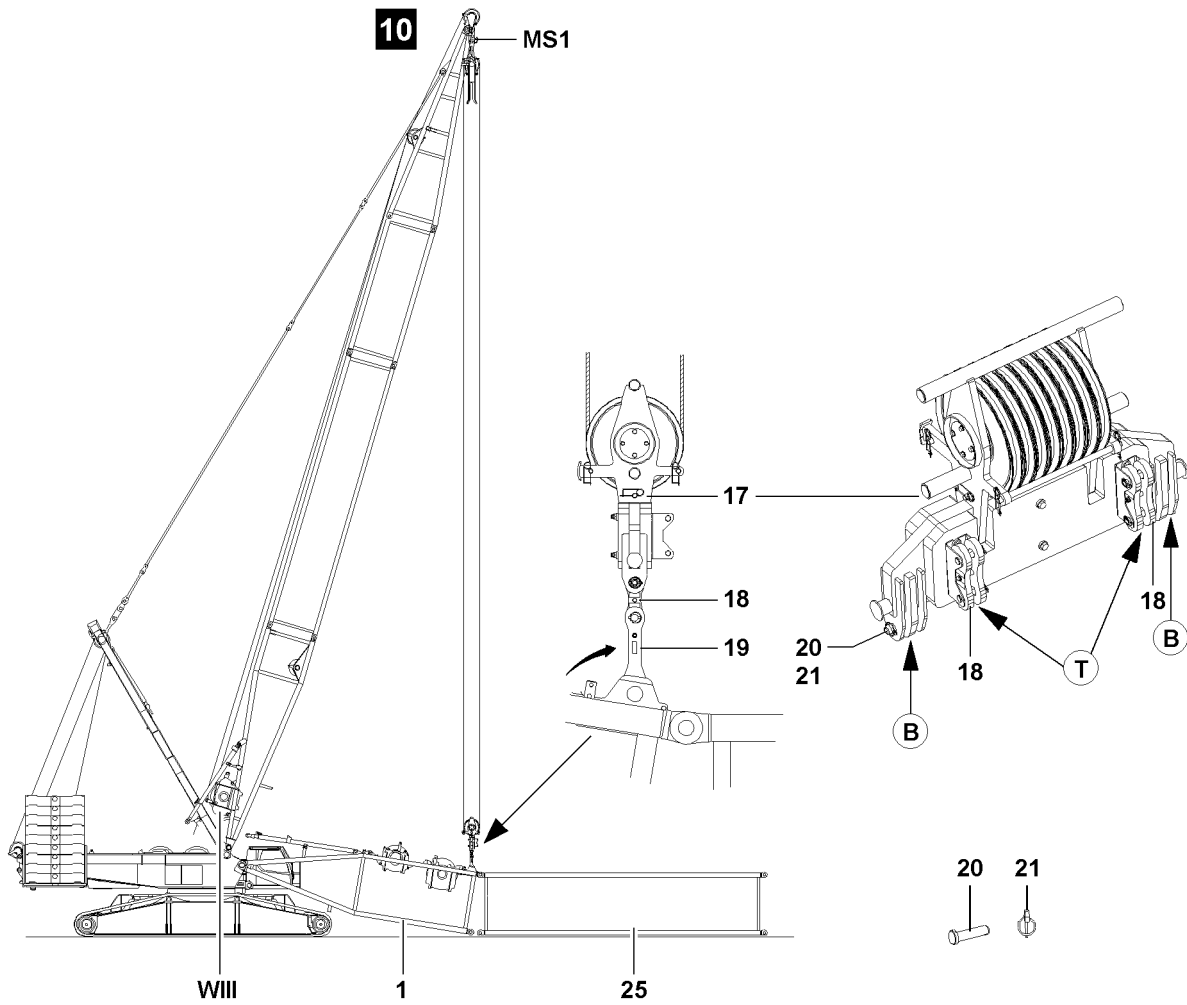

Fig.106748

LWE/LR 1600-2-008/18109-09-02/en

3.6 Pinning the upper pulley block on the S-pivot section

To be able to „close“ the S-boom combination after assembly, it is necessary to luff the D-boom down to the front and lower the upper pulley block via control winch 3 **W III** to the S-pivot section **1**. Then pin the upper pulley block **17** with the S-pivot section **1** and secure.



Note

- ▶ Luff the D-boom down to the front only to the point where the upper pulley block **17** „stands“ vertically above the pin points on the S-pivot section **1**.

Make sure that the following prerequisites are met:

- The S-pivot section **1** is pinned and secured on the turntable.
 - The S-pivot section **1** is taken down onto the substructure on the ground.
 - The auxiliary crane is removed.
- ▶ Luff the D-boom down to the front until the upper pulley block **17** hangs freely over the assembly bracket **19** of the S-pivot section **1**.
 - ▶ Lower the upper pulley block **17** to the S-pivot section **1**.
 - ▶ Remove the bracket **18** from the transport receptacle **T** on the upper pulley block **17**.
 - ▶ Pin the bracket **18** in the operating position **B** on the upper pulley block **17** with the pin **20** and secure with locking pin **21**.
 - ▶ Pin and secure the bracket **18** with the assembly brackets **19** of the S-pivot section **1**.
 - ▶ Use the pin **20** and locking pin **21**.

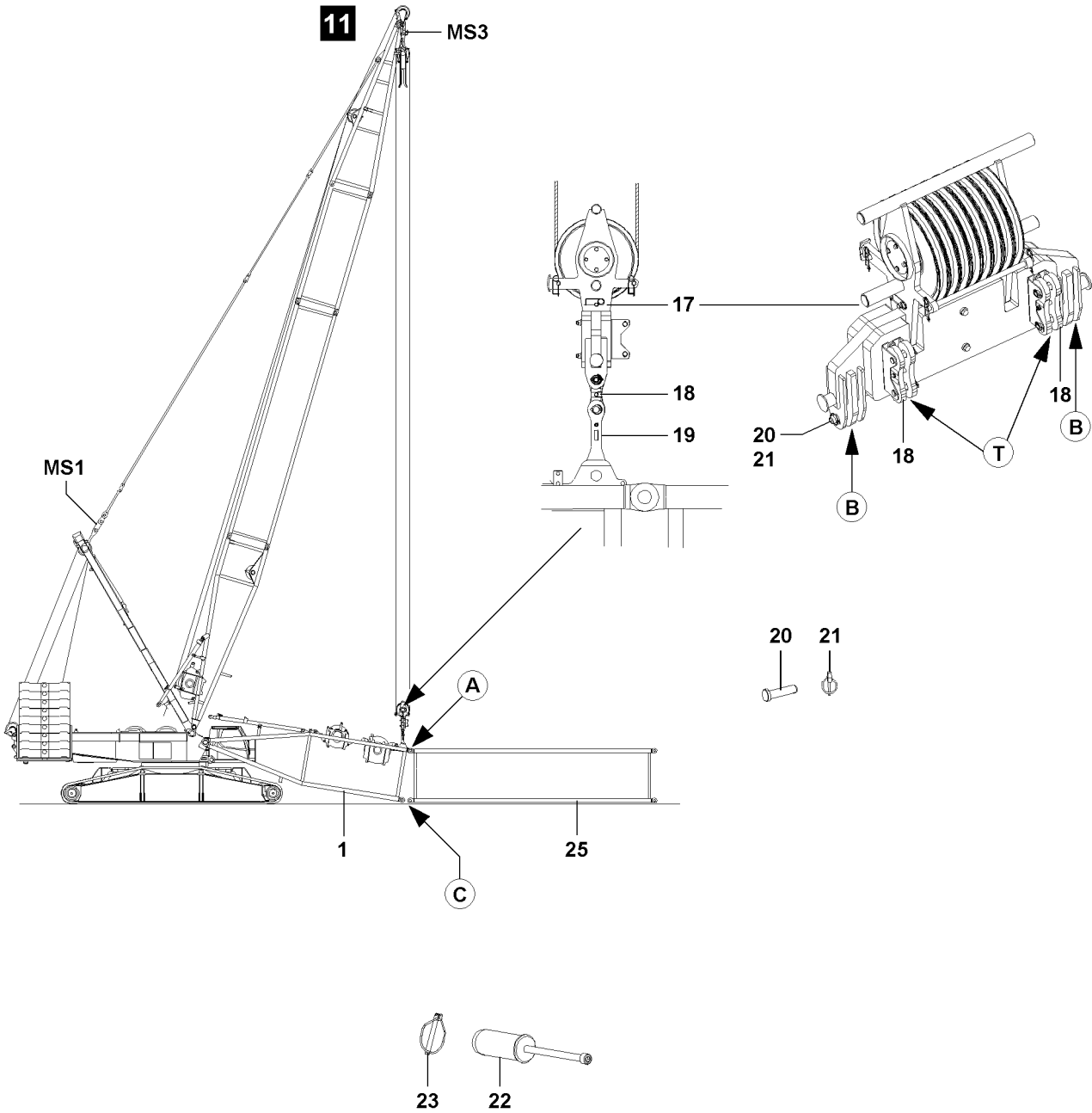

Fig.106749

LWE/LR 1600-2-008/18109-09-02/en

3.7 Assembling the S-intermediate sections on the S-pivot section

Make sure that the following prerequisites are met:

- The S-pivot section **1** is pinned and secured on the turntable.
- The S-pivot section **1** is taken down onto the substructure on the ground.
- The upper pulley block **17** is pinned and secured with the S-pivot section **1**.
- The auxiliary crane is removed.



Note

- ▶ The S-intermediate sections are pinned with the aid of the pin pulling device, see chapter 5.30.
- ▶ Support the S-intermediate sections for easier assembly / disassembly.



WARNING

General danger notes!

- ▶ All pins are to be secured after assembly with the intended retaining elements.

Pin the S-intermediate section **25** on the S-pivot section **1** „on top“.

- ▶ Fasten the S-intermediate section **25** to the auxiliary crane and align it with the S-pivot section **1**.

When the pin bores on the S-pivot section **1** and on the S-intermediate section **25** „on top“ (point **A**) align, illustration **11**:

- ▶ Insert the pin **22** from the inside to the outside and secure with the locking pin **23**, illustration **11**.

Assemble the S-boom to the required length and pin and secure the intermediate sections „on top“ and „bottom“.

- ▶ Insert the pin **22** from the inside to the outside and secure with the locking pin **23**.



WARNING

The crane can topple over!

If the following conditions are not met, the crane can topple over or be significantly damaged. Death, severe bodily injuries, property damage.

- ▶ During the „closing procedure“ of the S-intermediate sections, the maximum permissible total force of **146 t** on test point **MS1** may **not** be exceeded.
- ▶ During the „closing procedure“ of the S-intermediate sections, the maximum permissible total force of **90 t** on test point **MS3** may **not** be exceeded.
- ▶ The end section of the corresponding SL / S-boom combination may **not** lift off the ground during the „closing procedure“.

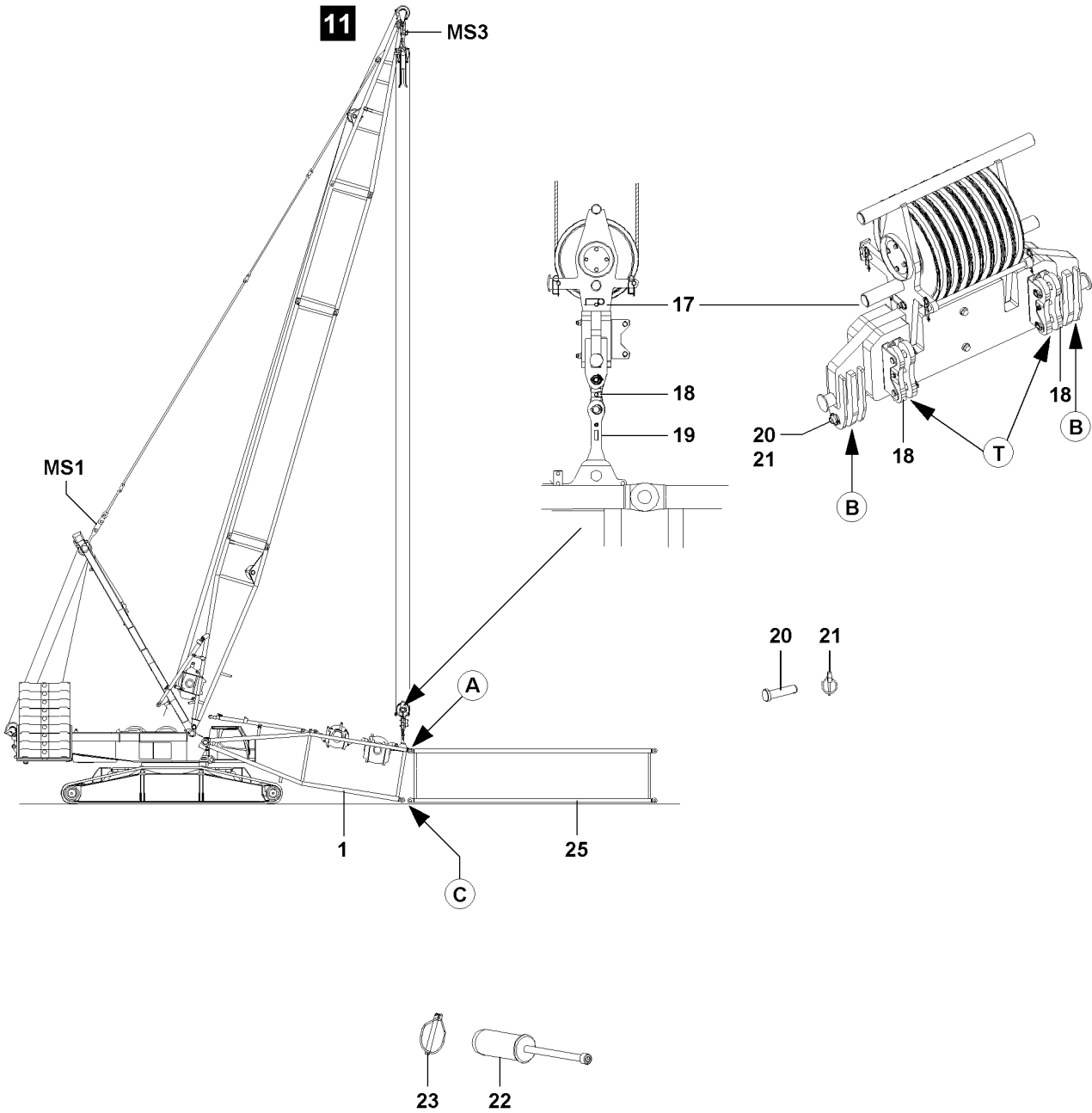

Fig.106749

LWE/LR 1600-2-008/18109-09-02/en

**Note**

- ▶ The actual forces of test point **MS1** and the test point **MS3** - which are used during the closing procedure of the S-boom system - are displayed on LICCON monitor 1.
- ▶ Note the actual forces of test point **MS1** and test point **MS3** and keep them ready for the disassembly of the S-boom system.
- ▶ At boom disassembly, „tension“ the control rope of winch 3 until the noted (assembly) actual forces of test point **MS1** and test point **MS3** on the LICCON monitor are reached, so that the connector pins of the S-intermediate sections can be unpinned.

When the SL / S-boom combination is assembled to the desired length:

- ▶ Lift the S-pivot section **1** with the upper pulley block **17** until the pin bores on the „bottom“ align in point **C**, illustration **11**.
- ▶ Insert the pin **22** from the inside to the outside and secure with the locking pin **23**, illustration **11**.

**WARNING**

Danger of fatal injury due to folding down of boom!

By unpinning the upper pulley block **17** on the assembly brackets **19**, the boom can suddenly fold down if the boom is not pinned in point **C** „on the bottom“.

Death, severe bodily injuries, property damage.

- ▶ It is prohibited for anyone to remain under the raised boom combination during the pinning / unpinning procedure.
- ▶ Unpin the upper pulley block **17** only when it is ensured that the S-pivot section **1** is pinned and secured „on top“ and „bottom“ with the S-intermediate section **25**.

When the S-boom is „closed“:

- ▶ Unpin the bracket **18** on the assembly bracket **19**: Release and unpin the pin **20**.
- ▶ Unpin the bracket **18** on the upper pulley block **17**: Release and unpin the pin **20**.
- ▶ Pin and secure the bracket **18** in the transport position **T** on the upper pulley block **17**.

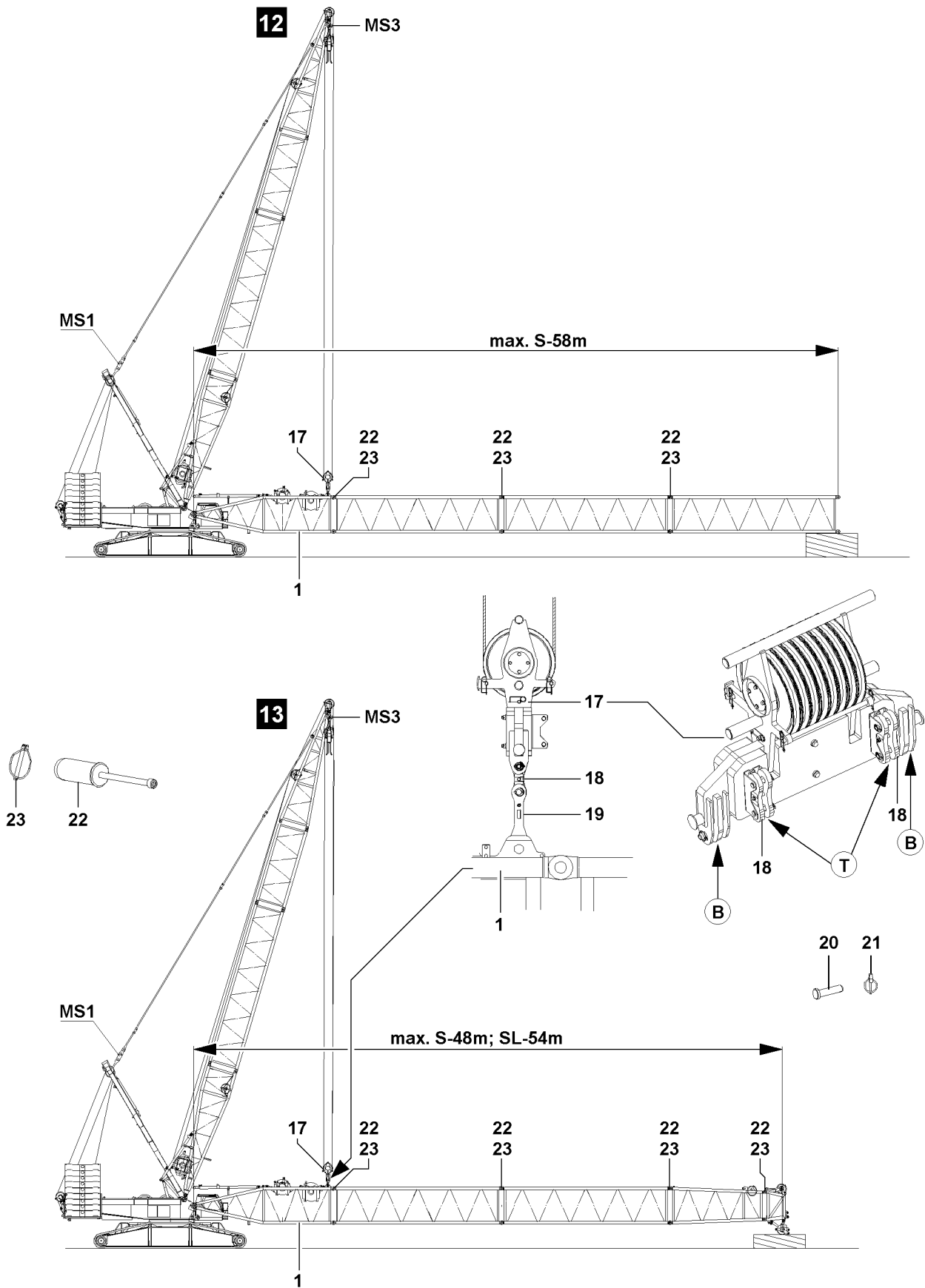

LWE/LR 1600-2-008/18109-09-02/en

Fig.106750: Flying assembly — Guying on S-pivot section

3.8 Assembling the SL/S-boom in „Flying mode“ (guying on S-pivot section)

If spatial prerequisites on the job site are limited for the assembly of the S-boom, or if they are limited by buildings or similar, then the S-boom can be assembled in „flying“ mode.



WARNING

General danger notes!

- ▶ Support the S-boom during assembly with suitable materials.
- ▶ All pins are to be secured after assembly with the intended retaining elements.



WARNING

The crane can topple over!

If the following conditions are not met, the crane can topple over or be significantly damaged. Death, severe bodily injuries, property damage.

- ▶ For the „flying mode“ boom assembly, the maximum permissible total force on the test point **MS1** and test point **MS3** may **not** be exceeded. The „Actual forces“ are shown on LICCON monitor 1.
- ▶ The „flying mode“ boom assembly is only permissible up to certain system lengths.
- ▶ The maximum permissible system lengths may **not** be exceeded, refer to the following chart.



Note

- ▶ Weights of the individual lattice sections, including the corresponding guy rods, see chapter 5.03.

Maximum permissible system lengths for a maximum total force MS1 of 200 t and a maximum total force MS3 of 138 t					
Boom system	Maximum system length	Equipment	DB _{min} ¹⁾	ZB _{min} ²⁾	Illustration
SL(D)	54.0 m		150 t	65 t	13
	60.0 m	- with reducer - without head	150 t	65 t	12
S(D)	48.0 m		150 t	65 t	13
	58.0 m		150 t	65 t	12
	66.0 m	- without reducer - without head	150 t	65 t	12

1) This counterweight must be installed at least on the turntable for „flying assembly“.

2) This central ballast must be installed at least on the crawler center section for „flying assembly“.

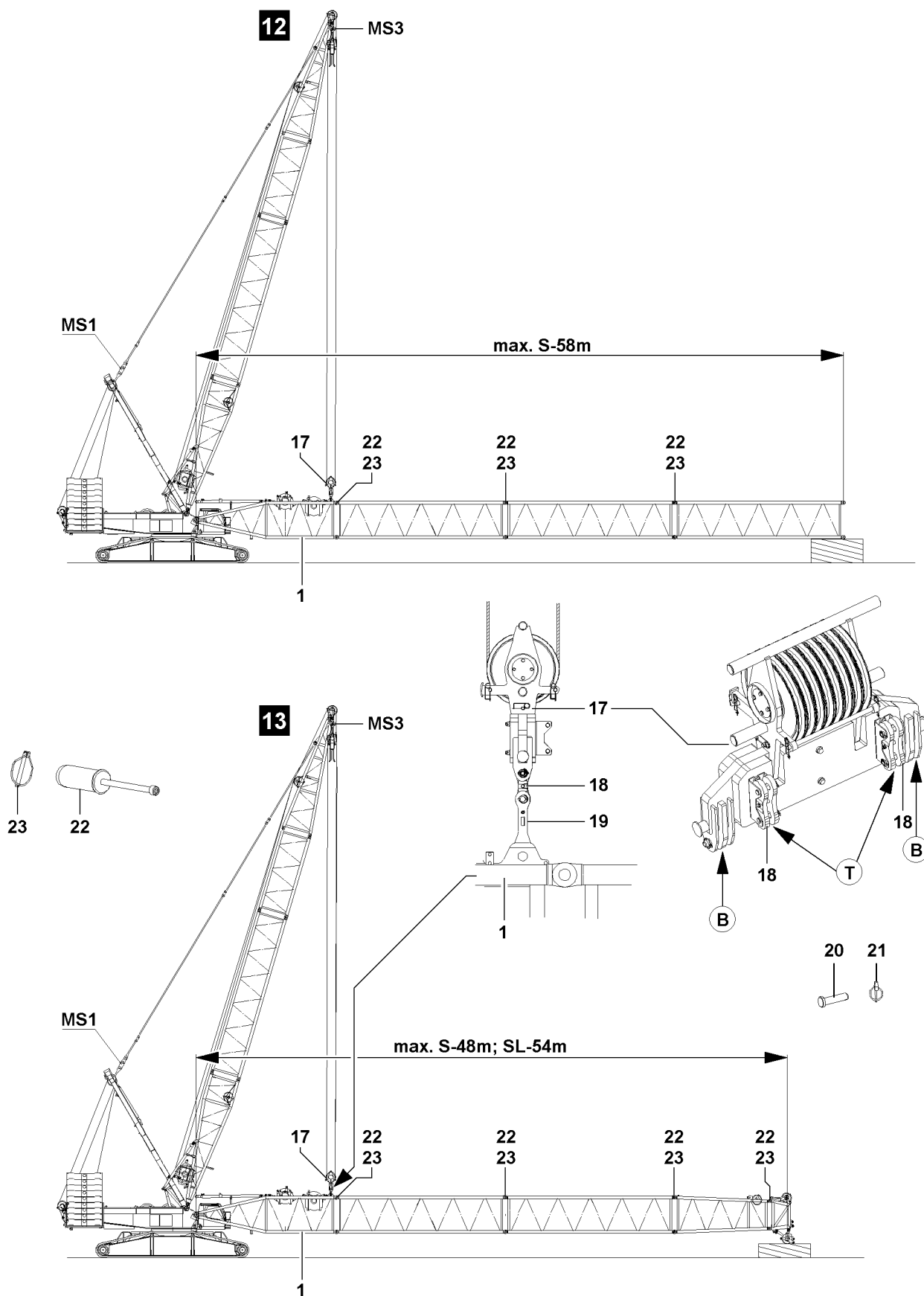

Fig.106750: Flying assembly — Guying on S-pivot section

LWE/LR 1600-2-008/18109-09-02/en

3.8.1 Assembling the S-intermediate sections in „flying mode“ on the S-pivot section

In „flying“ assembly, the intermediate sections can be pinned and secured with the auxiliary crane individually or as a preassembled unit on the pivot section.



WARNING

Impermissible boom lengths!

If impermissible boom lengths are installed on the crane, significant property damage can occur on the crane.

Death, severe bodily injuries, property damage.

- ▶ The maximum permissible boom lengths for the „flying assembly“ may not be exceeded.
- ▶ The specifications in the erection and take-down charts as well as the load charts must be observed.

Make sure that the following prerequisites are met:

- The S-pivot section is pinned and secured on the turntable.
- The S-pivot section is horizontally tensioned.
- A minimum of 150 t counterweight is placed on the turntable.
- A minimum of 65 t central ballast is installed on the crawler center section.
- An auxiliary crane is available.



WARNING

Falling components!

If unsecured or non-supported components are assembled or disassembled, they can fall down.

Death, severe bodily injuries, property damage.

- ▶ During pinning and unpinning of the intermediate sections it is prohibited for anyone to remain **under** or **on** the components as well as within the entire danger zone.
- ▶ Before unpinning: Support the components and boom.
- ▶ Secure the pins in the storage locations and in the receptacles.
- ▶ It is prohibited to lean a ladder against the crane section that is being disassembled.
- ▶ Fasten the S-intermediate sections or preassembled boom unit to the auxiliary crane.
- ▶ Lift the S-intermediate sections or the preassembled boom unit with the auxiliary crane and position on the S-pivot section **1**.

When the pin points between the S-pivot section **1** and the S-intermediate section **or** the S-pivot section **1** and pre-assembled boom unit align on „top“ and „bottom“:

- ▶ Insert the pins **22** „on top“ and „bottom“ and secure with locking pins **23**.

When the pins between the S-pivot section **1** and the S-intermediate section **or** the S-pivot section **1** and pre-assembled boom unit are properly pinned and secured on „top“ and „bottom“:

- ▶ Take the boom down on the substructure.
- ▶ Remove the auxiliary crane.

When the boom is safely taken down on the substructure:

- ▶ Unpin the bracket **18** on the assembly bracket **19**: Release and unpin the pin **20**.
- ▶ Unpin the bracket **18** on the upper pulley block **17**: Release and unpin the pin **20**.
- ▶ Pin and secure the bracket **18** in the transport position **T** on the upper pulley block **17**.

3.9 Flying assembly of the SD/SLD/SL(X)D-boom (guying on flying assembly intermediate section)

If spatial prerequisites on the job site are limited for the assembly of the S-boom, or if they are limited by buildings or similar, then the S-boom can be installed in flying mode.



WARNING

General danger notes!

- ▶ Support the S-boom during assembly with suitable materials.
- ▶ All pins are to be secured after assembly with the intended retaining elements.
- ▶ The guy rods must be inspected regularly, see chapter 8.15.

**Note**

- ▶ Weights of the individual lattice sections, see chapter 1.03.

**WARNING**

The crane can topple over!

If the following conditions are not met, the crane can topple over or be significantly damaged.

Death, severe bodily injuries, property damage.

- ▶ For the flying mode boom assembly, the maximum permissible total forces on test point 1 **MS1** and test point 3 **MS3** may not be exceeded. The „actual forces“ are shown on LICCON monitor 1.
- ▶ The flying boom assembly is only permissible up to the maximum system lengths according to the following chart overview.
- ▶ Always carry out the combination of the intermediate sections according to the rod plan.
- ▶ The data in the erection and take-down charts as well as the load charts must be observed.

**WARNING**

The crane can topple over!

If the crane is not sufficiently ballasted for flying assembly on the flying assembly intermediate section, then the crane can be overloaded and topple over.

Death, severe bodily injuries, property damage.

- ▶ Make sure that the central ballast is installed according to the requirements in the erection and take-down charts.
- ▶ Make sure that the counterweight is installed according to the requirements in the erection and take-down charts.
- ▶ Make sure that the derrick ballast is installed according to the requirements in the erection and take-down charts.
- ▶ Make sure that the maximum permissible boom lengths for the flying assembly are **not** exceeded.

Make sure that the following prerequisites are met:

- The crane is horizontally aligned.
- The S-pivot section is pinned and secured on the turntable.
- The counterweight is placed according to the specifications.
- The central ballast is placed according to the specifications.
- The S-intermediate sections are installed up to the flying assembly intermediate section.
- The guy rods **64** are properly pinned and secured with the hollow axle in point **P13** on bracket **60**.
- An auxiliary crane is available.

3.9.1 SLD-boom with SW-end section

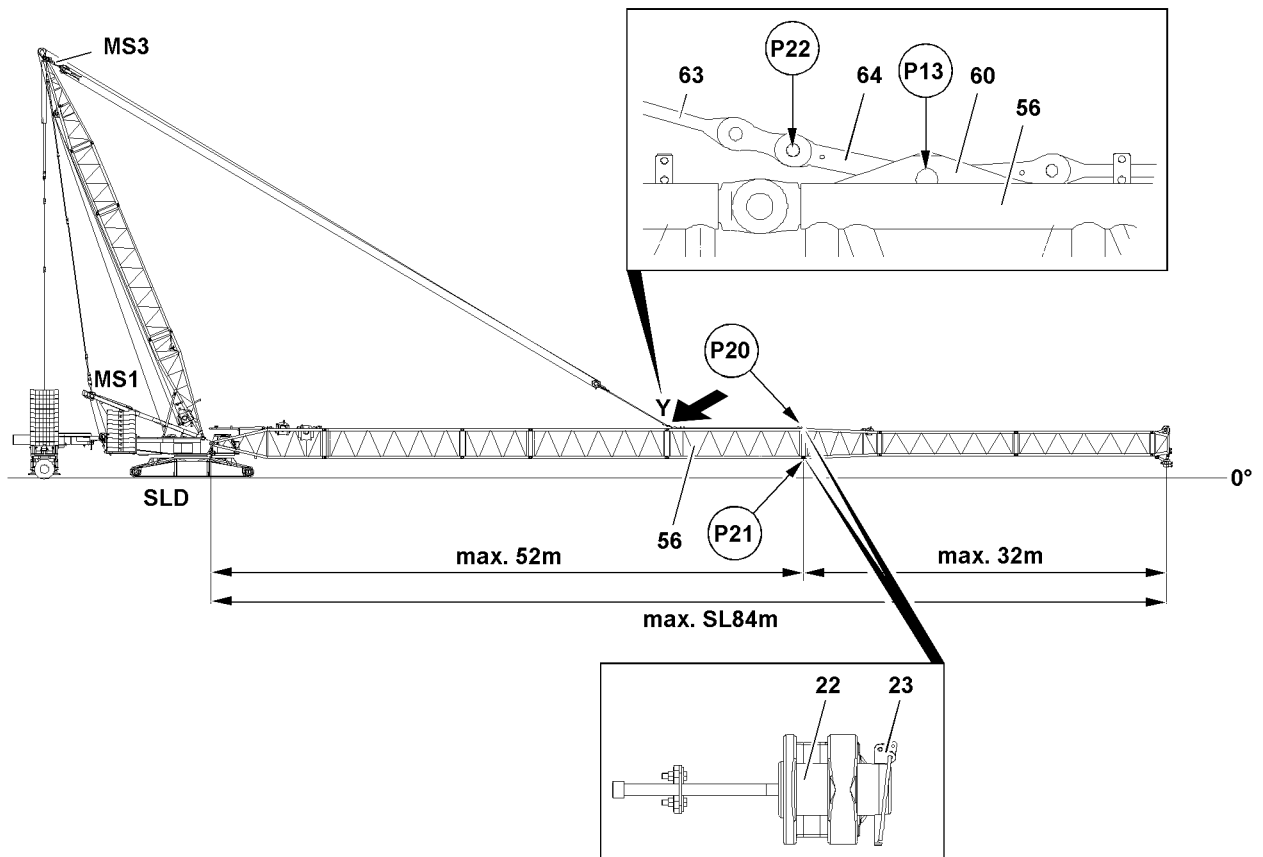

Fig.125178: SLD-boom with SW-end section

Counterweight, derrick ballast and central ballast, see Erection chart, depending on the boom length			
Boom system	Maximum permissible flying assembly length	Equipment (without hook block)	Preassembly according FLM ¹⁾
SLD	84 m	- partially equipped: - without WA-frame II guy rods - with SW-end section and one roller set	32 m

1) maximum permissible preassembly after flying assembly intermediate section (FLM-intermediate section) 56

LWE/LR 1600-2-008/18109-09-02/en

3.9.2 SD // SL2D // SL4D with end section

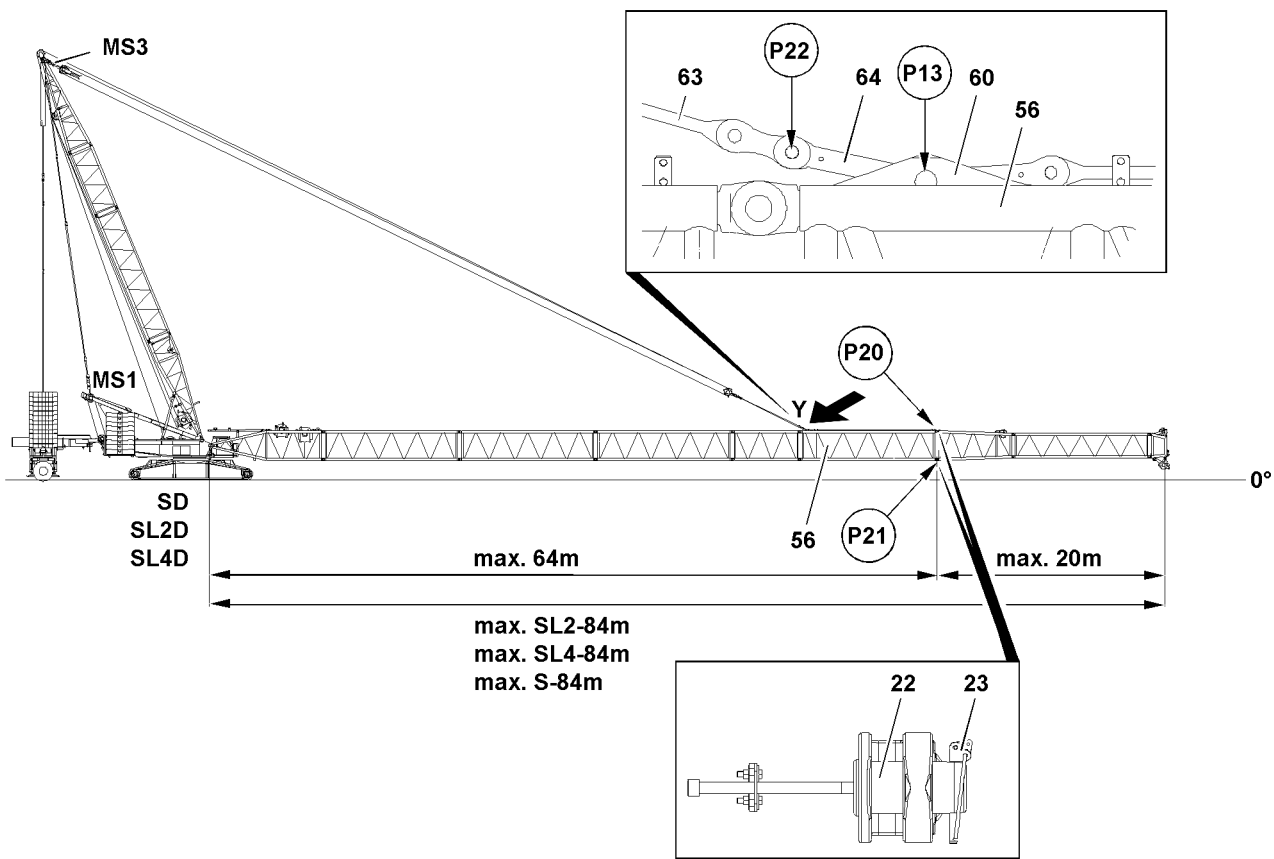

Fig.125179: SD // SL2D // SL4D with end section

Counterweight, derrick ballast and central ballast, see Erection chart, depending on the boom length			
Boom system	Maximum permissible flying assembly length	Equipment (without hook block)	Preassembly according FLM ¹⁾
SD	84 m	- partially equipped: - without WA-frame II guy rods - with SW-end section and two roller sets	20 m
SL2D		- partially equipped: - without WA-frame II guy rods - with SW-end section and one roller set	
SL4D		- partially equipped: - without WA-frame II guy rods - with F-adapter	

1) maximum permissible preassembly after flying assembly intermediate section (FLM-intermediate section) 56

3.9.3 SD // SLD // SL2D // SL4D

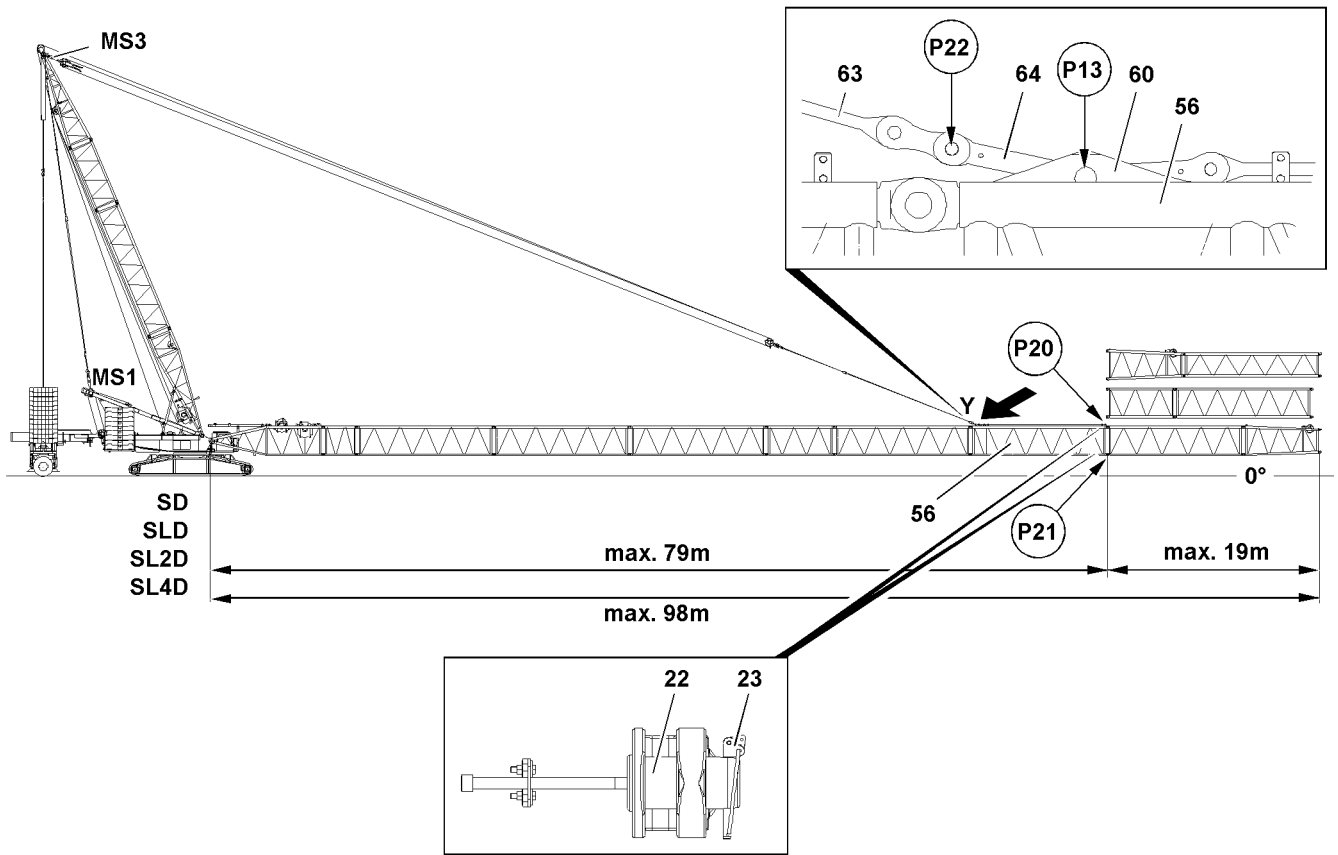

Fig.125182: SD // SLD // SL2D // SL4D

Counterweight, derrick ballast and central ballast, see Erection chart, depending on the boom length			
Boom system	Maximum permissible flying assembly length	Equipment (without hook block)	Preassembly according FLM ¹⁾
SD	98 m	- partially equipped: - without WA-frame II guy rods	19 m
SLD			
SL2D			
SL4D			

1) maximum permissible preassembly after flying assembly intermediate section (FLM-intermediate section) 56

LWE/LR 1600-2-008/18109-09-02/en

3.9.4 SL10D // SL11D – target boom lengths 102 m to 117 m

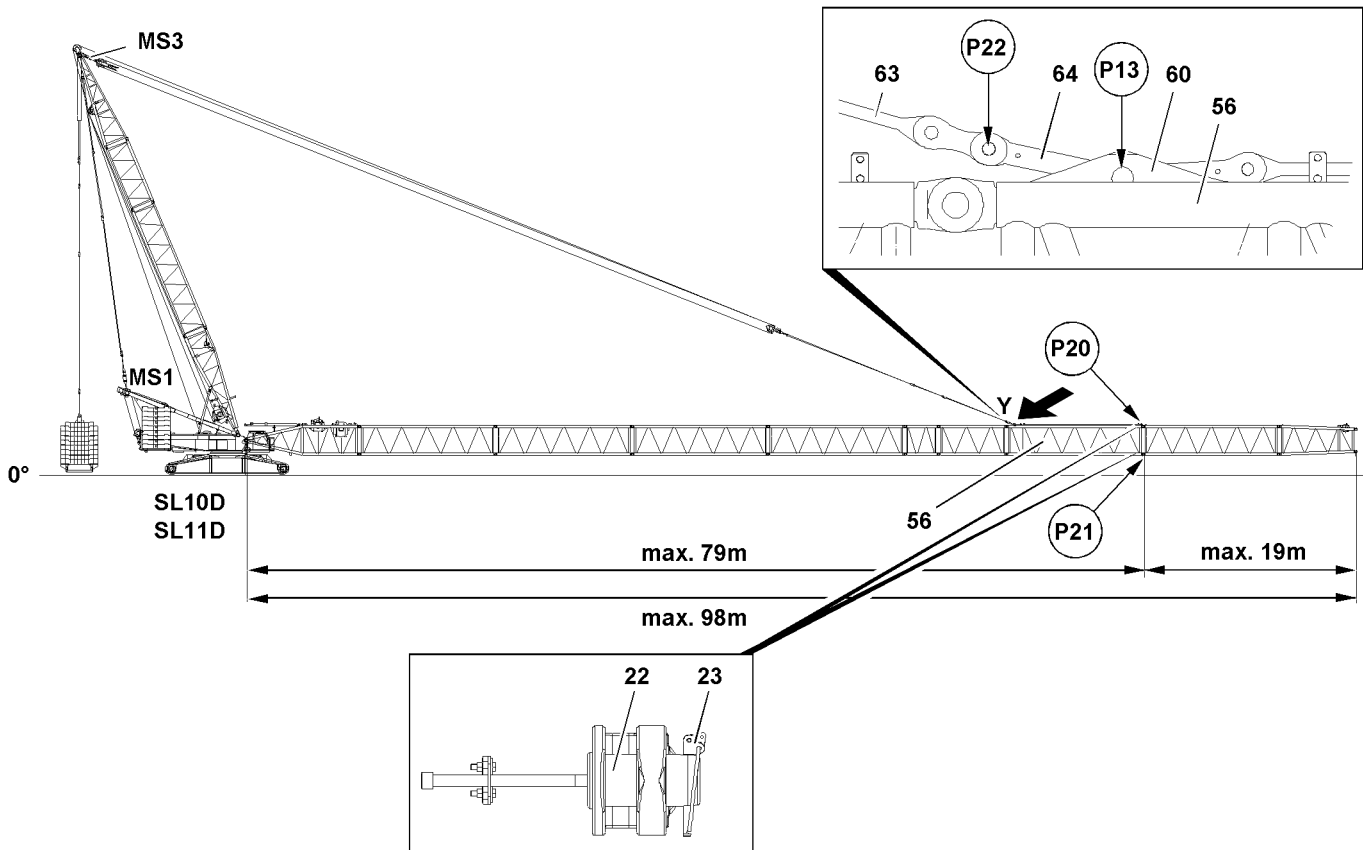

Fig.125183: SL10D // SL11D – target boom lengths 102 m to 117 m



WARNING

The crane can topple over!

If boom systems are assembled in flying mode, where their target boom / operational lengths are not released for the flying assembly, the crane can be overloaded and topple over.

Death, severe bodily injuries, property damage.

► For all not listed target boom / operational lengths the flying assembly is **prohibited**.

Counterweight, derrick ballast and central ballast, see Erection chart, depending on the boom length

Boom system	Maximum permissible flying assembly length ⁴⁾	Equipment (without hook block)	Preassembly according FLM ¹⁾
SL10D	98 m	- partially equipped:	19 m
SL11D		- without WA-frame II guy rods	

1) maximum permissible preassembly after flying assembly intermediate section (FLM-intermediate section) 56

4) only valid in connection with the target boom / operational length required for crane operation

3.9.5 SL10D // SL11D – target boom lengths 126 m , 129 m , 138 m , 141 m , 150 m , 153 m

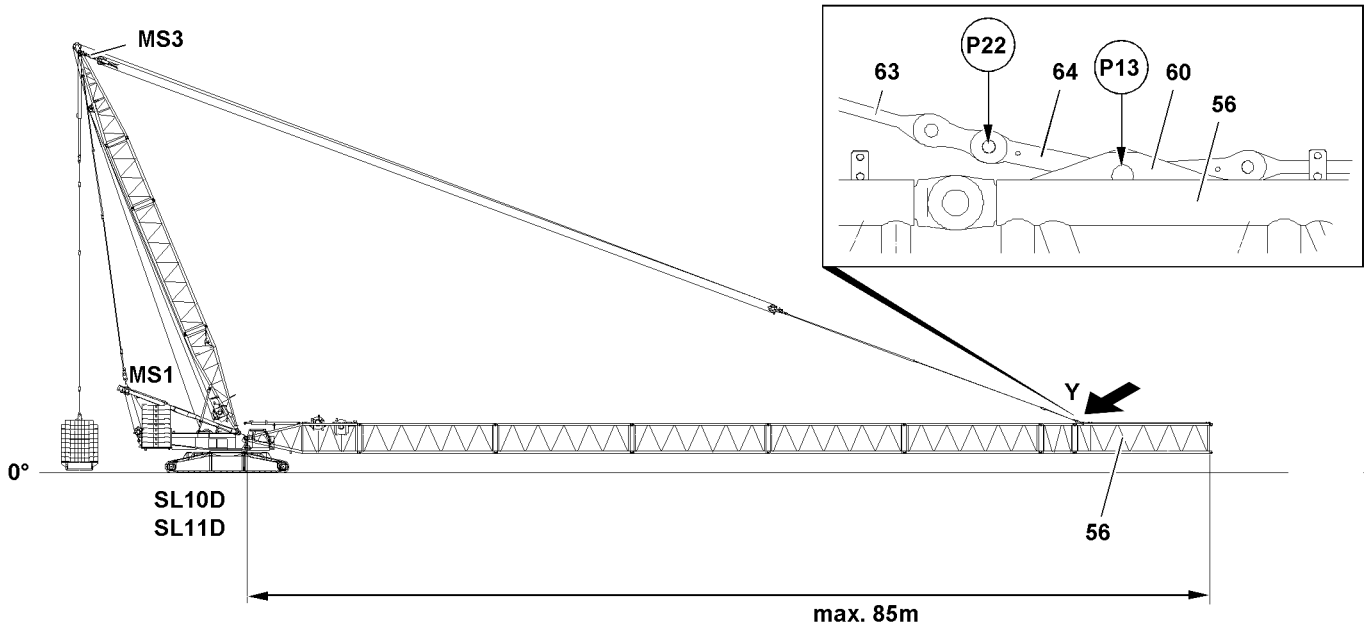

Fig.125184: SL10D // SL11D – target boom lengths 126 m , 129 m , 138 m , 141 m , 150 m , 153 m



WARNING

The crane can topple over!

If boom systems are assembled in flying mode, where their target boom / operational lengths are not released for the flying assembly, the crane can be overloaded and topple over. Death, severe bodily injuries, property damage.

► For all not listed target boom / operational lengths the flying assembly is **prohibited**.

Counterweight, derrick ballast and central ballast, see Erection chart, depending on the boom length			
Boom system	Maximum permissible flying assembly length ⁴⁾	Equipment (without hook block)	Preassembly according FLM ¹⁾
SL10D	85 m	- partially equipped:	3)
SL11D		- without WA-frame II guy rods	3)

1) maximum permissible preassembly after flying assembly intermediate section (FLM-intermediate section) **56**

3) no preassembly after flying assembly intermediate section (FLM-intermediate section) **56** possible

4) only valid in connection with the target boom / operational length required for crane operation

LWE/LR 1600-2-008/18109-09-02/en

3.9.6 SL13D, SL14D – target boom lengths 102 m to 111 m

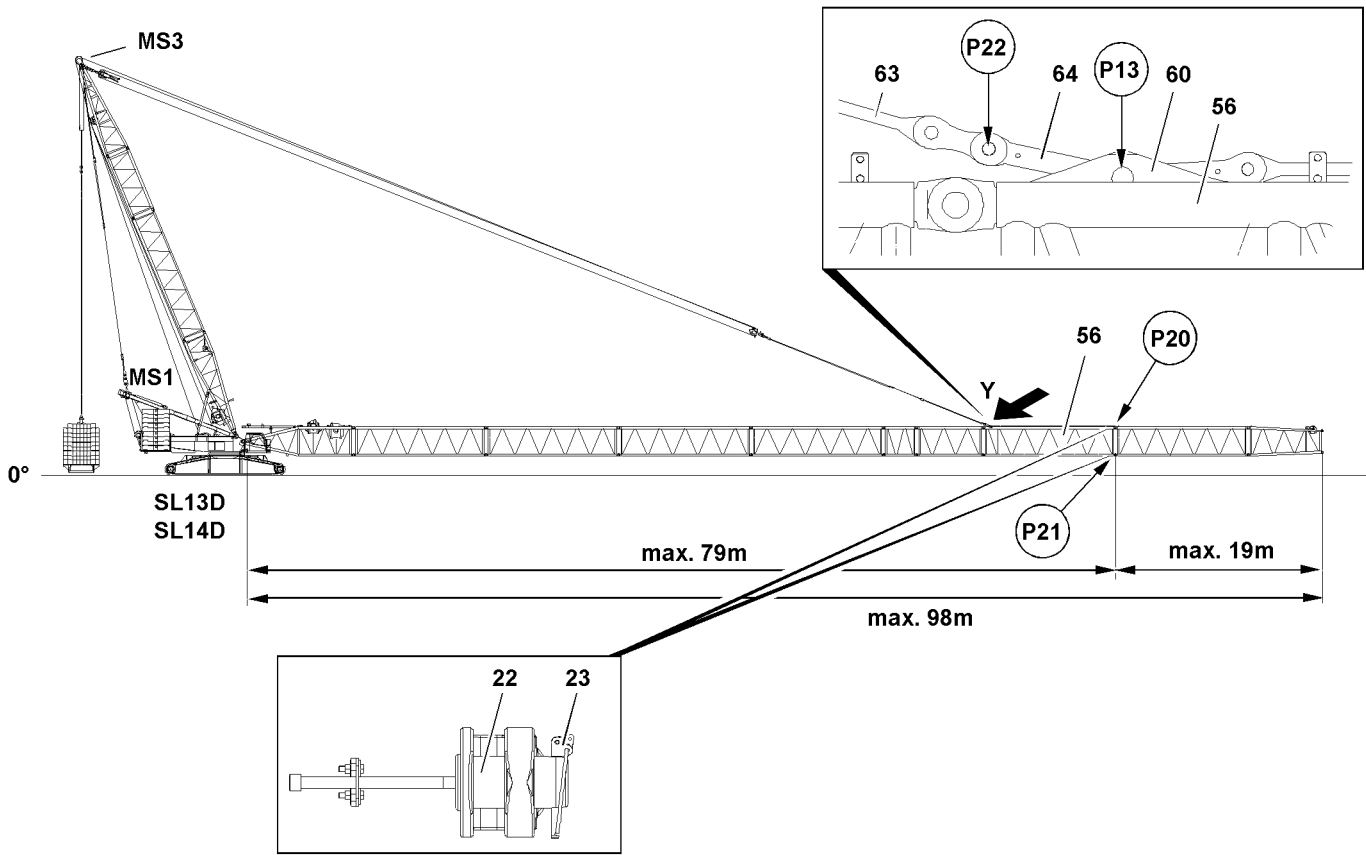

Fig.125185: SL13D, SL14D – target boom lengths 102 m to 111 m



WARNING

The crane can topple over!

If boom systems are assembled in flying mode, where their target boom / operational lengths are not released for the flying assembly, the crane can be overloaded and topple over.

Death, severe bodily injuries, property damage.

► For all not listed target boom / operational lengths the flying assembly is **prohibited**.

Counterweight, derrick ballast and central ballast, see Erection chart, depending on the boom length			
Boom system	Maximum permissible flying assembly length ⁴⁾	Equipment (without hook block)	Preassembly according FLM ¹⁾
SL13D	98 m	- partially equipped:	19 m
SL14D		- without WA-frame II guy rods	

1) maximum permissible preassembly after flying assembly intermediate section (FLM-intermediate section) 56

4) only valid in connection with the target boom / operational length required for crane operation

3.9.7 SL13D, SL14D – target boom lengths 114 m to 117 m

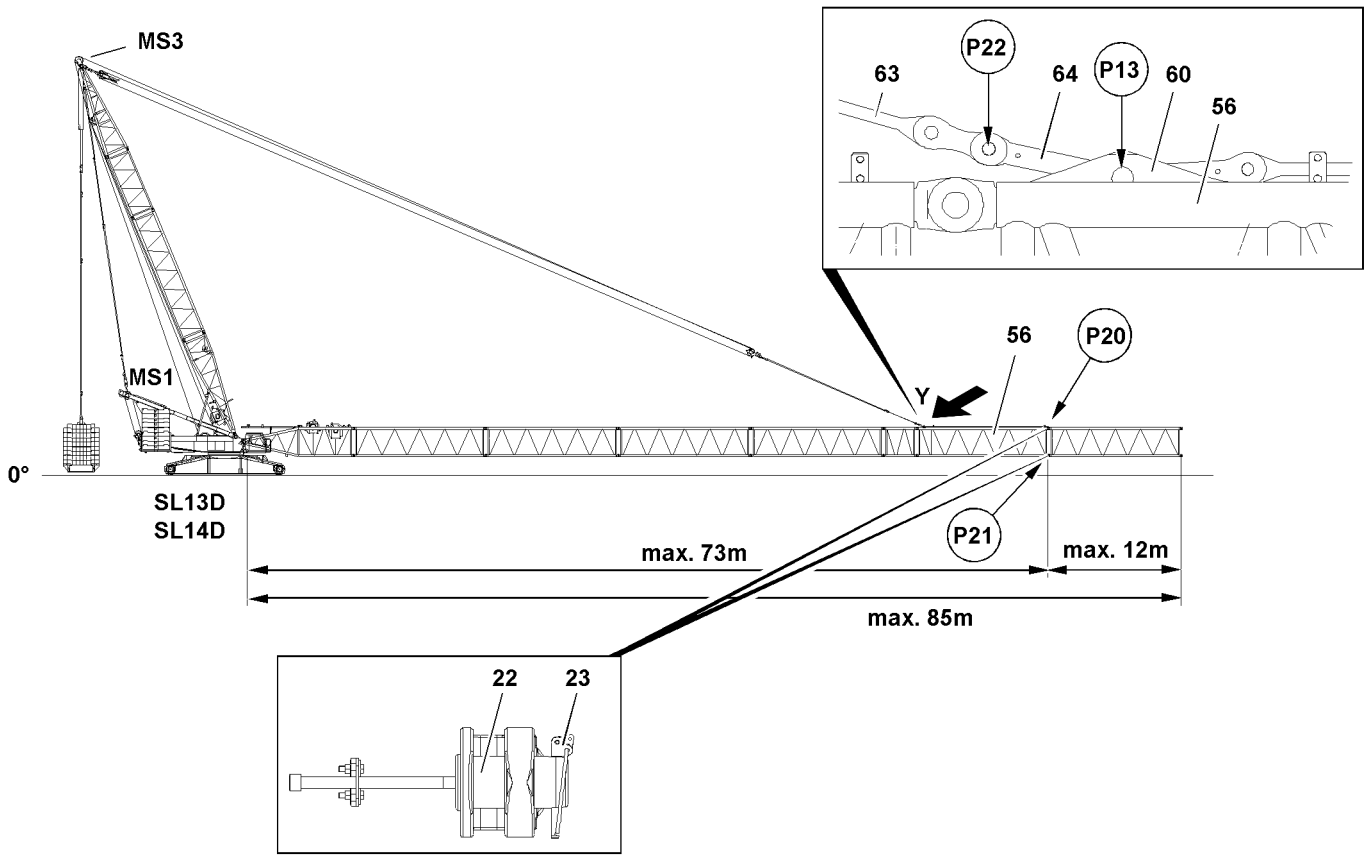

Fig.125186: SL13D, SL14D – target boom lengths 114 m to 117 m



WARNING

The crane can topple over!

If boom systems are assembled in flying mode, where their target boom / operational lengths are not released for the flying assembly, the crane can be overloaded and topple over.

Death, severe bodily injuries, property damage.

► For all not listed target boom / operational lengths the flying assembly is **prohibited**.

Counterweight, derrick ballast and central ballast, see Erection chart, depending on the boom length			
Boom system	Maximum permissible flying assembly length ⁴⁾	Equipment (without hook block)	Preassembly according FLM ¹⁾
SL13D	85 m	- partially equipped:	12 m
SL14D		- without WA-frame II guy rods	

1) maximum permissible preassembly after flying assembly intermediate section (FLM-intermediate section) 56

4) only valid in connection with the target boom / operational length required for crane operation

LWE/LR 1600-2-008/18109-09-02/en

3.9.8 SL13D, SL14D – target boom lengths 120 m to 156 m

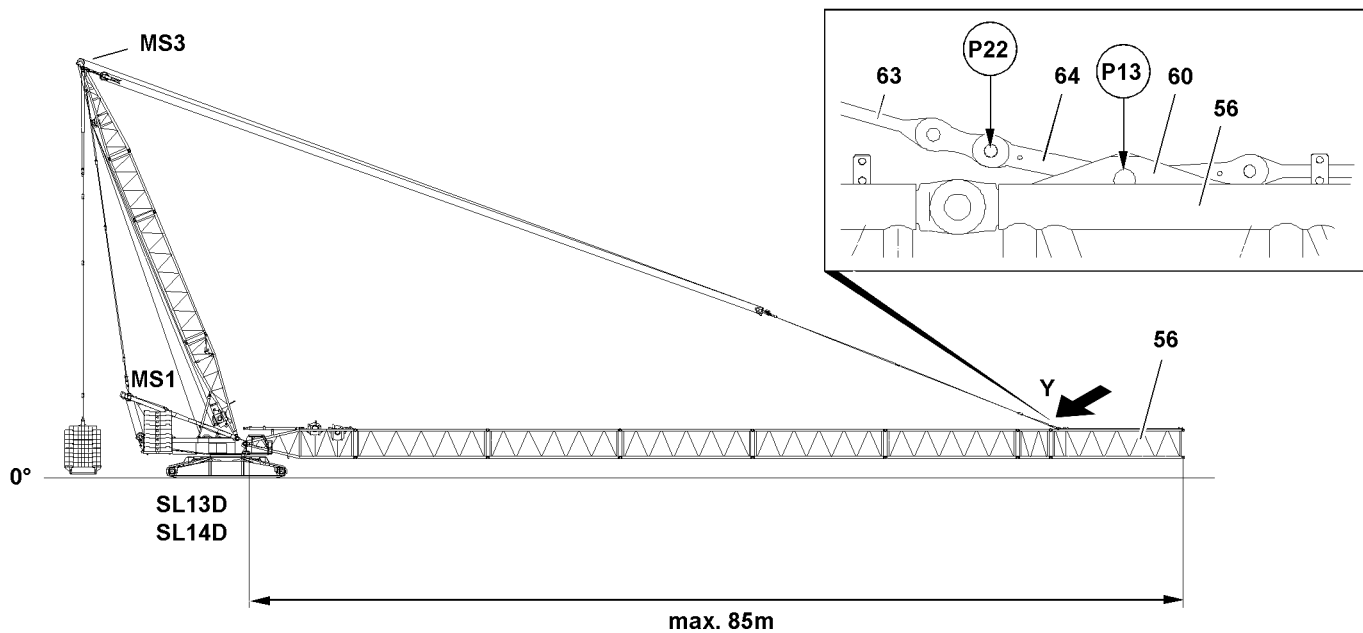

Fig.125187: SL13D // SL14D – target boom lengths 120 m to 156 m



WARNING

The crane can topple over!

If boom systems are assembled in flying mode, where their target boom / operational lengths are not released for the flying assembly, the crane can be overloaded and topple over.

Death, severe bodily injuries, property damage.

► For all not listed target boom / operational lengths the flying assembly is **prohibited**.

Counterweight, derrick ballast and central ballast, see Erection chart, depending on the boom length			
Boom system	Maximum permissible flying assembly length ⁴⁾	Equipment (without hook block)	Preassembly according FLM ¹⁾
SL13D	85 m	- partially equipped: - without WA-frame II guy rods	3)
SL14D			

1) maximum permissible preassembly after flying assembly intermediate section (FLM-intermediate section) **56**

3) no preassembly after flying assembly intermediate section (FLM-intermediate section) **56** possible

4) only valid in connection with the target boom / operational length required for crane operation

3.9.9 Assembling the S-intermediate sections in flying mode on the flying assembly intermediate section



WARNING

Falling components!

If unsecured or non-supported components are assembled or disassembled, they can fall down. Death, severe bodily injuries, property damage.

- ▶ During pinning and unpinning of the intermediate sections it is prohibited for anyone to remain **under** or **on** the components as well as within the entire danger zone.
- ▶ Before unpinning: Support the components and boom.
- ▶ Secure the pins in the storage locations and in the receptacles.
- ▶ It is prohibited to lean a ladder against the crane section that is being disassembled.



Note

- ▶ The „actual force“ is displayed on LICCON monitor.
- ▶ The flying assembly of the intermediate sections is carried out without a hook block.



WARNING

The crane can topple over!

If the derrick boom is luffed up to more than 85° to the horizontal, then the crane can topple over. Death, severe bodily injuries, property damage.

- ▶ Make sure that the derrick boom at S-boom assembly is not luffed up more than maximum 85° to the horizontal.

- ▶ Fasten the S-intermediate sections or preassembled boom unit to the auxiliary crane.
- ▶ Lift the S-intermediate sections or the preassembled boom unit with the auxiliary crane and position on the S-pivot section 1.

When the pin points between the S-pivot section 1 and the S-intermediate section **or** the S-pivot section 1 and pre-assembled boom unit align on „top“ and „bottom“:

- ▶ Insert the pin 22 in point P20 „on top“ and point P21 „on the bottom“ on both sides and secure with spring retainer 23.

When the pins between the S-pivot section 1 and the S-intermediate section **or** the S-pivot section 1 and pre-assembled boom unit are properly pinned and secured on „top“ and „bottom“:

- ▶ Take the boom down on the substructure.
- ▶ Remove the auxiliary crane.

When the boom is safely taken down on the substructure or held by an auxiliary crane:

- ▶ Slowly lower the upper pulley block in direction of the boom.
- ▶ Pull the upper pulley block with the auxiliary crane to the guy rods.
- ▶ Pin the upper pulley block with the guy rods of the intermediate sections.



WARNING

Overload of crane!

If the guy rods and the rope of winch 3 **W III** are tensioned when luffing up the derrick boom into the operating position, then the crane can be overloaded.

- ▶ Make sure, when luffing up the derrick boom into the operating position, that the guy rods and the rope of winch 3 **W III** always sag slightly.
- ▶ Make sure that no slack rope forms.
- ▶ Luff the derrick up to the operating position.



Note

- ▶ The S-intermediate section for flying assembly **56** weighs more in comparison to standard intermediate sections.
- ▶ The additional weight of the S-intermediate section for flying assembly **56** is not taken into account in the load charts and must therefore be added to the load to be lifted, as applicable.

- ▶ Spool up winch 3 **W III** until the guying between the upper pulley block and the S-intermediate section for flying assembly **56** is tensioned and the auxiliary crane is relieved.
- ▶ Pay attention to the horizontal alignment of the boom.

When the boom is tensioned horizontally:

- ▶ Remove the auxiliary crane.

Install the additional S- / L-intermediate sections and the respective end section, depending on the permissible boom length, individually or fully preassembled on the S-intermediate section for flying assembly **56**.



Note

- ▶ Note and observe the maximum permissible boom lengths for flying assembly.
- ▶ Assemble the S-intermediate sections or L-intermediate sections on the S-intermediate section for flying assembly **56**: Use the pin **22** and spring retainer **23**.



WARNING

Unutilized guy rods on boom!

If the guy rods, which are not needed for crane operation, are on the lattice sections, then they can release and fall down during crane operation.

Death, severe bodily injuries, property damage.

The load display of the LICCON computer system shows a value that is too high.

The weight of the boom is too heavy for erection.

- ▶ Disassemble and remove unutilized guy rods on the transport retainers before erecting the boom.
- ▶ Pin and secure the guy rods with each other.
- ▶ Hang the assembled boom on the auxiliary crane.
- or
- ▶ Support the assembled boom from below with materials of adequate load bearing capacity.
- ▶ Spool out winch 3 **WIII** until the guying between the upper pulley block and the S-intermediate section for flying assembly **56** is relieved.



DANGER

The boom can fold down!

If the pins on the brackets **60** are unpinned, then the boom can fold down by itself.

Death, severe bodily injuries, property damage.

- ▶ Make sure that the boom is safely held with the auxiliary crane or that it is supported with stable materials before the pins are unpinned in point **P13**.
- ▶ Unpin the pin in point **P13** from the brackets **60**.
- ▶ Tension the guying.

3.10 Assembling SD/SLD/SL(X)D-boom combination(s) with substructure

NOTICE

Overload of boom!

If the boom is not supported before the erection procedure, then the boom will be overloaded during the erection procedure.

The crane will be damaged.

- ▶ Support the SL-boom from a length of more than 114 m.
- ▶ Support the SL2/SL4 boom from a length of more than 120 m.
- ▶ Support the SL10-boom from a length of more than 123 m.
- ▶ Support the SL11-boom from a length of more than 123 m.
- ▶ Support the SL13-boom from a length of more than 117 m.
- ▶ Support the SL14-boom from a length of more than 117 m.
- ▶ Support the boom with suitable material of sufficient load bearing capacity.

The SL-boom combination - consisting of a S-pivot section and S- and L-intermediate sections, SL-reducer and the respective end section must be preassembled in a suitable location.

Swing the preassembled SL-boom combination with the auxiliary crane(s) in to the turntable, pin and secure.



Note

- ▶ The boom combinations must each be supported below the auxiliary guying to the heights noted in the following chart, see illustrations.

3.10.1 Supporting the SL-boom from a length of more than 114 m

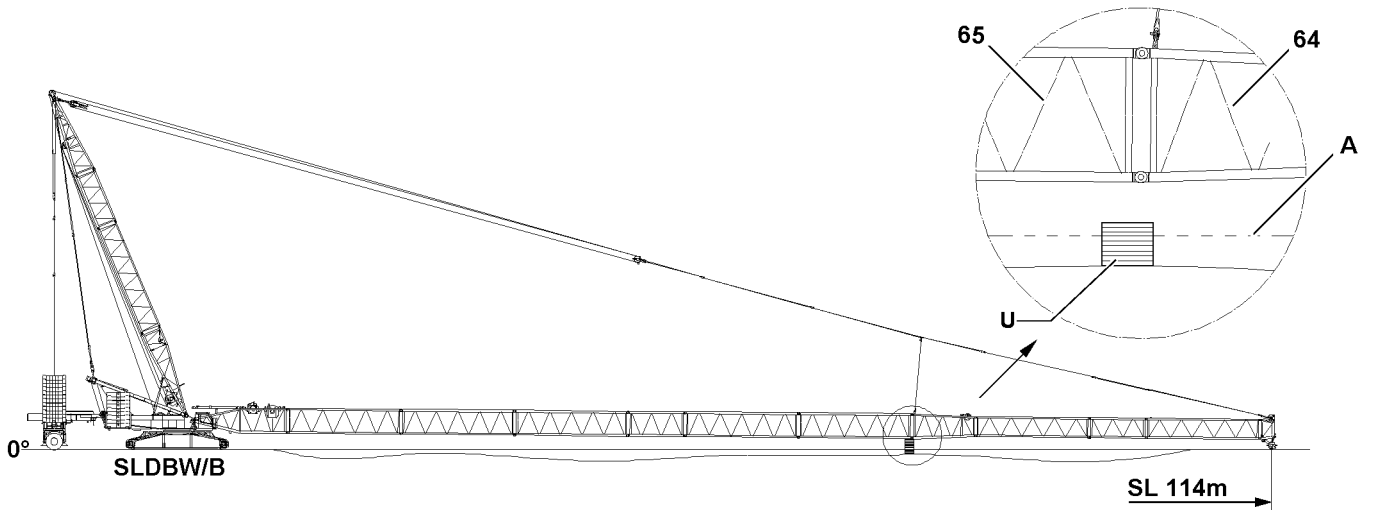

Fig.125174: Supporting from SL 114 m



Note

- ▶ The alignment level **A** is the placement level of the crane.

Operating mode	Support from length	Substructure U height
SL	114 m	0.3 m above alignment level A

LWE/LR 1600-2-008/18109-09-02/en

3.10.2 Supporting the SL2/SL4 boom from a length of more than 120 m

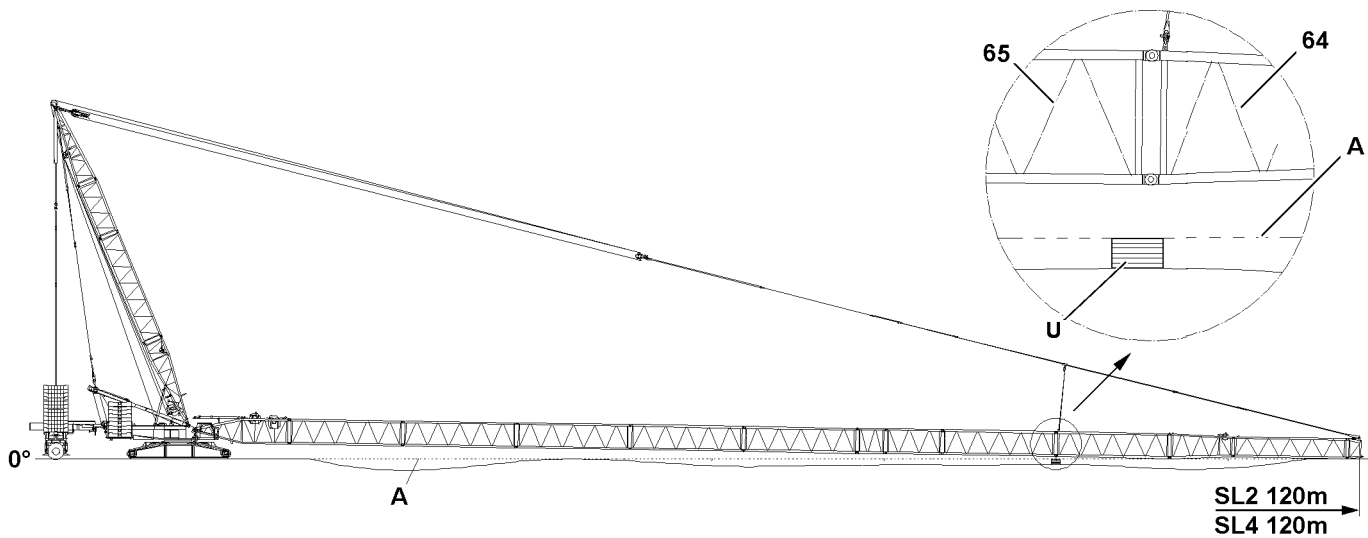

Fig.125172: Supporting from SL2 120 m // SL4 120 m



Note

- The alignment level **A** is the placement level of the crane.

Operating mode	Support from length	Substructure U height
SL2	120 m	to alignment level A
SL4	120 m	to alignment level A

3.10.3 Support the SL10-boom from a length of more than 123 m

NOTICE

Damage to the boom system!

- Make sure that the maximum permissible flexation of the boom system is not exceeded.

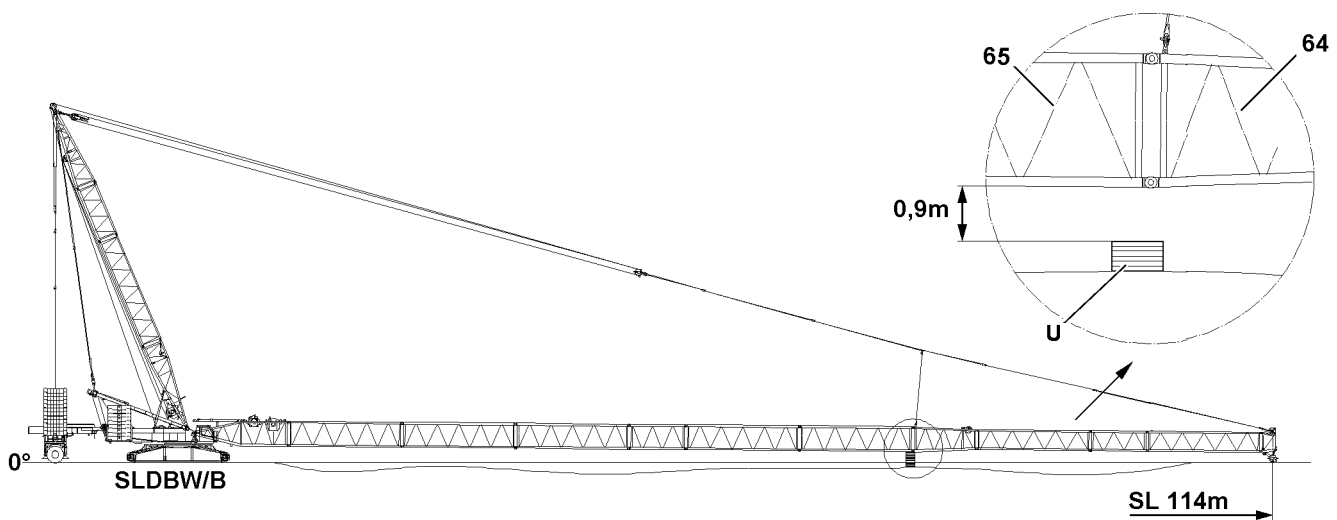

Fig.125173: Support from SL10- 123 m

Operating mode	Support from length	Maximum permissible flexation
SL10	123 m	0.9 m

3.10.4 Supporting the SL11-boom from a length of more than 123 m

NOTICE

Damage to the boom system!

- ▶ Make sure that the maximum permissible flexation of the boom system is not exceeded.

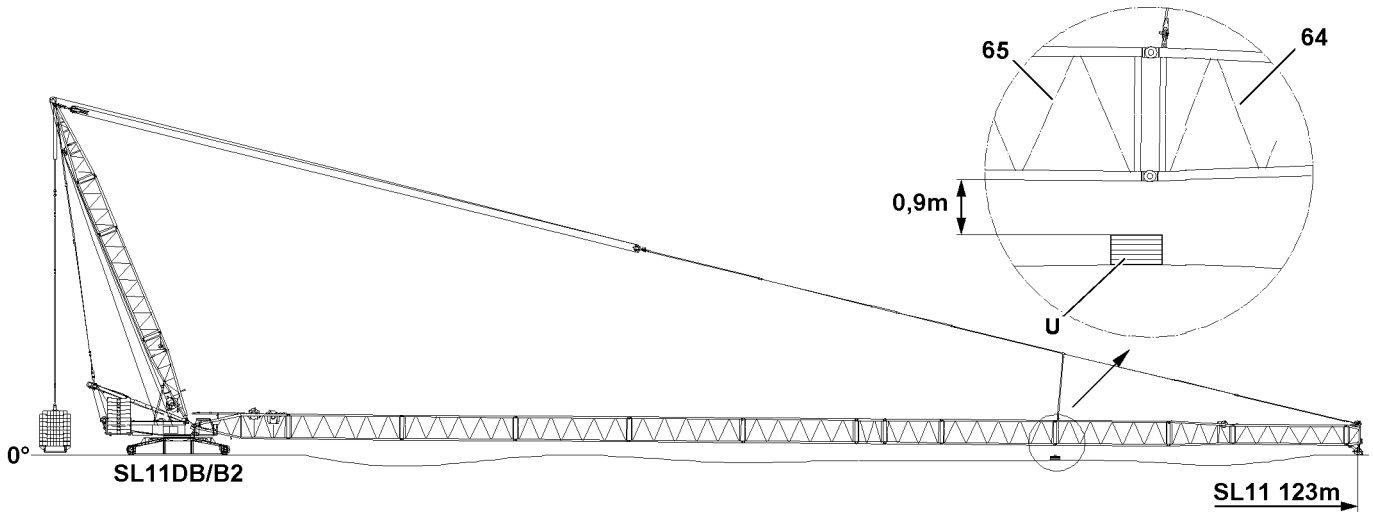

Fig.125175: Supporting from SL11- 123 m

Operating mode	Support from length	Maximum permissible flexation
SL11	123 m	0.9 m

3.10.5 Supporting the SL13-boom from a length of more than 117 m

NOTICE

Damage to the boom system!

- ▶ Make sure that the maximum permissible flexation of the boom system is not exceeded.

LWE/LR 1600-2-008/18109-09-02/en

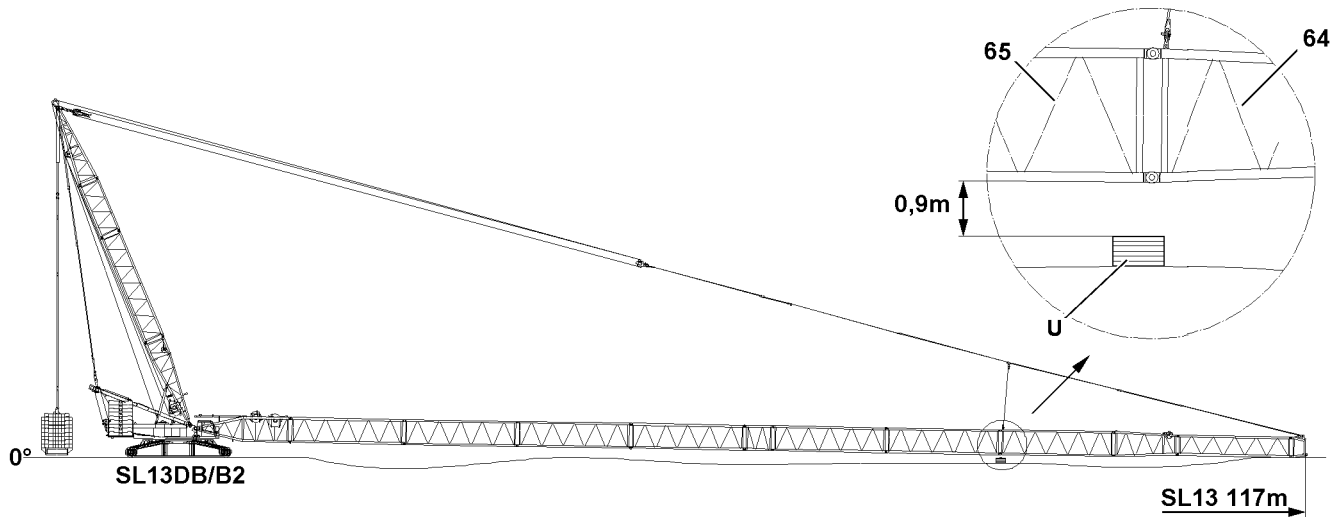

Fig.125177: Supporting from SL13 117 m

Operating mode	Support from length	Maximum permissible flexation
SL13	117 m	0.9 m

3.10.6 Supporting the SL14-boom from a length of more than 117 m

NOTICE

Damage to the boom system!

- Make sure that the maximum permissible flexation of the boom system is not exceeded.

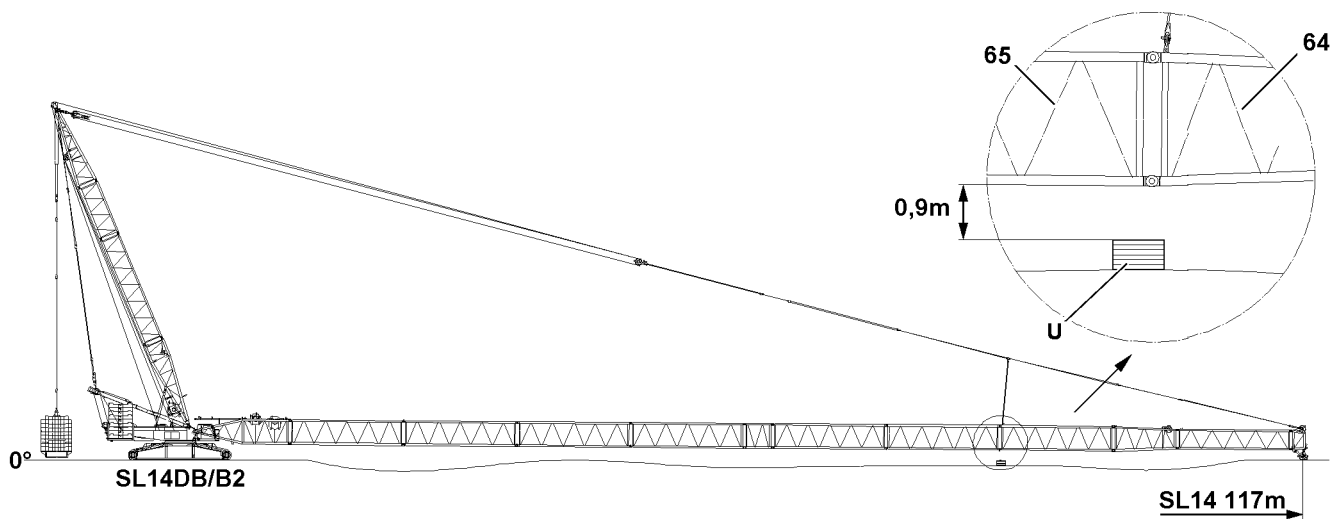

Fig.125176: Supporting from SL14 117 m

Operating mode	Support from length	Maximum permissible flexation
SL14	117 m	0.9 m

LWE/LR 1600-2-008/18109-09-02/en

3.10.7 Assembling the boom systems with the substructure



WARNING

Danger due to crane components!

Death, severe bodily injuries, property damage.

- ▶ Make sure that the ground has sufficient load-bearing capacity to take on the weight of the crane components or the preassembled boom safely.

- ▶ Preassemble the SL-boom combination in a suitable location.



WARNING

Danger of impact / crushing!

Death, severe bodily injuries, property damage.

- ▶ Make sure that there are no persons within the danger zone.
- ▶ Make sure that no obstacles or objects are within the danger zone.

- ▶ Swing the preassembled SL-boom combination with the auxiliary crane in to the turntable.
- ▶ Pin and secure the SL-boom combination with the S-pivot section on the turntable, see section „Pinning the S-pivot section on the turntable“.

When the boom combination is pinned on the turntable and secured:

- ▶ Take the boom combination down on the ground.

3.11 Establishing the electrical connections

NOTICE

Damage to the electrical connection on the cable drum!

If the electrical connection from the cable drum to the terminal box on the S-pivot section is established first before the connection to the terminal box on the S-end section, the electrical connection can be damaged when spooling out the cable drum.

- ▶ Establish first the electrical connection from the cable drum in the S-pivot section to the terminal box on the S-end section and then the electrical connection from the terminal box in the S-pivot section to the cable drum.



Note

- ▶ To establish the electrical connections on the S-boom, use the Electric wiring diagram.

Make sure that the following prerequisites are met:

- The S-boom is completely assembled.
- The airplane warning light and the wind speed sensor are assembled.

- ▶ Establish the electrical connections.
- ▶ Make sure that all electrical connections on the boom are established.

3.12 Checking the function of the safety equipment



WARNING

Non-functioning safety equipment!

Death, severe bodily injuries, property damage.

- ▶ Crane operation with non-functioning safety equipment is **prohibited**.



Note

- ▶ The function of the individual limit switches must be checked before erection.
- ▶ The function of the limit switch initiators must be checked in the test system, see the Diagnostics manual.

**Note**

- ▶ If a function check on the limit switches or on the safety equipment does not lead to the desired shut offs, then the plug connections on the connector boxes or the components itself must be checked. If no visible connection errors or component defects can be found, contact **LIEBHERR** Service.

Make sure that the following prerequisites are met:

- All electrical connections have been made.
- The crane engine is running.
- The corresponding operating mode is set on the LICCON monitor.

3.12.1 Checking the wind speed sensor

- ▶ Check the movement and the function of the wind speed sensor.

3.12.2 Checking the airplane warning light

- ▶ Turn on the airplane warning light on with the button.
- ▶ Check the function visually.

3.12.3 Checking the hoist limit switch on the pulley head**Note**

- ▶ When replacing or changing a hoist limit switch (HES), the corresponding hoist limit switch must have the correct bus address and the correct software version in order to be detected again by the bus system (LSB).

- ▶ Actuate the hoist limit switch manually on the pulley head.

Result:

- The spool up function of the hoist winch turns off.
- The icon „Hoist top“ appears on the LICCON monitor 0.
- The limit switch is functioning.

3.12.4 Checking the limit switch S-boom „steepest position“**Note**

- ▶ The limit switch functions have to be checked individually before erection.

- ▶ Cover the limit switch initiators on the S-relapse cylinders individually with a metal plate.

Result:

- The limit switch is actuated manually.
- The spool up function of winch 4 (control winch) turns off.
- The „Boom limitation“ icon appears on LICCON monitor 0.
- The limit switch is functioning.

Empty page!

LWE/LR 1600-2-008/18109-09-02/en

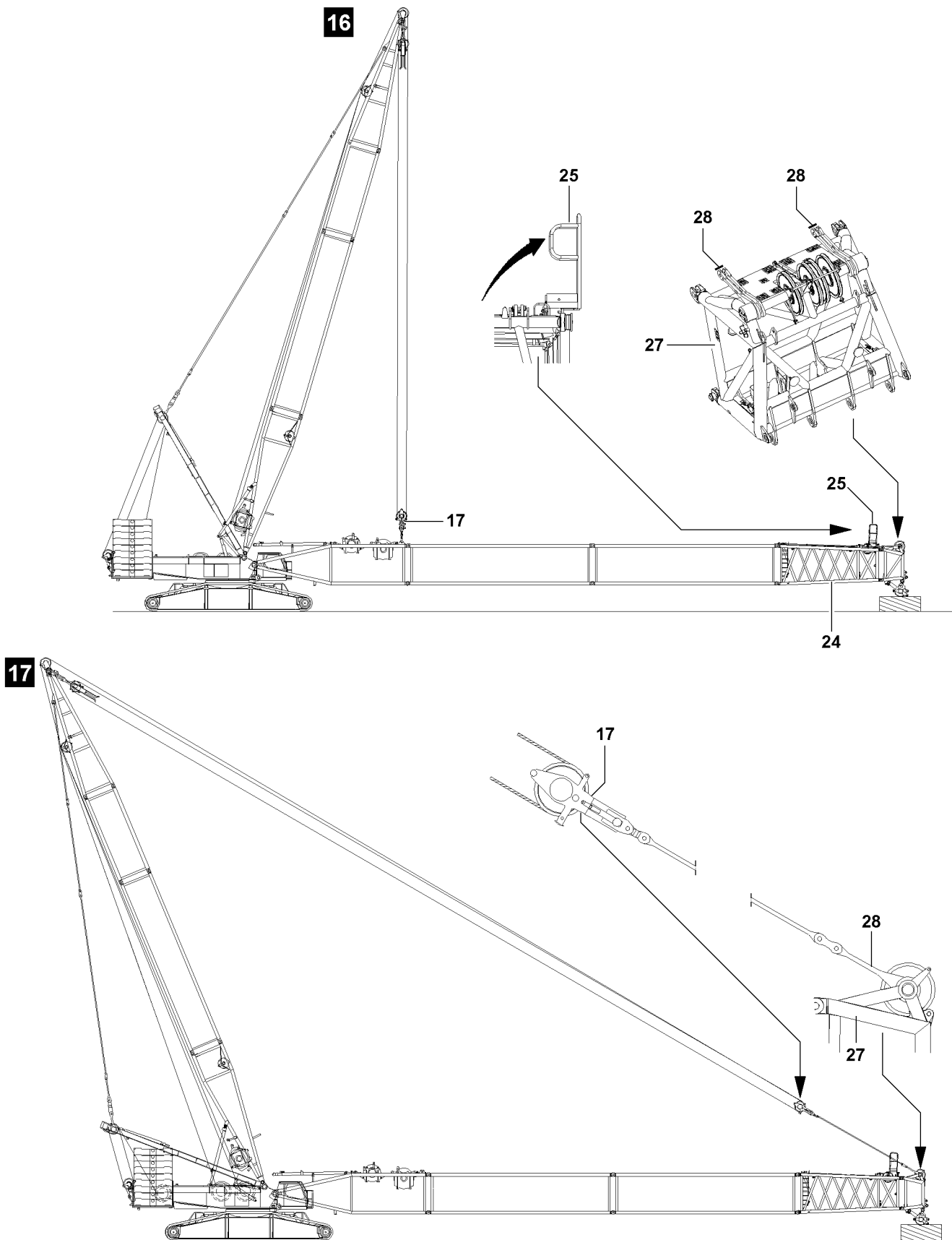

LWE/LR 1600-2-008/18109-09-02/en

Fig.106752

3.13 Assembling the S-guy rods



WARNING

Neglected inspection and maintenance on guy rods!

If the regular inspection and maintenance of the guy rods is not carried out or is carried out only in irregular intervals, then severe accidents can occur due to existing and unrecognized damage to the guy rods.

Death, severe bodily injuries, property damage.

- ▶ Inspect the guy rods before each assembly, see chapter 8.15.
- ▶ The S-guy rods must be assembled and secured, see the Rod plan. The numbering in the rod plan must be identical to the numbering on the guy rods.



Note

- ▶ The guy rods must be installed and secured according to the separately supplied rod plans. The numbering on the rod plans must be identical to the numbering on the guy rods.

Make sure that the following prerequisites are met:

- The S-boom is completely assembled.
- All lattice sections are properly pinned with each other.
- All pin connections are secured.
- The upper pulley block **17** is unpinned on the S-pivot section.
- The folding platforms **25** on the SL-reducer **24** are folded and secured „upward“ in the operating position, see chapter 2.06.

- ▶ Luff the D-boom down to the front.
- ▶ Lower the upper pulley block **17** to the boom: Spool out winch 3.

The guy rods are taken down and secured for transport on the corresponding intermediate sections. Before assembly, the transport retainers must be released.

- ▶ Release the transport retainers of the guy rods.

NOTICE

Danger of property damage!

If the pins of the guy rods are not pinned from the „inside“ to the „outside“, the hoist rope can scrape on the pins and be damaged.

- ▶ Always insert the pins of the guy rods from the „inside“ to the „outside“.
- ▶ Pay attention to the Rod plan.

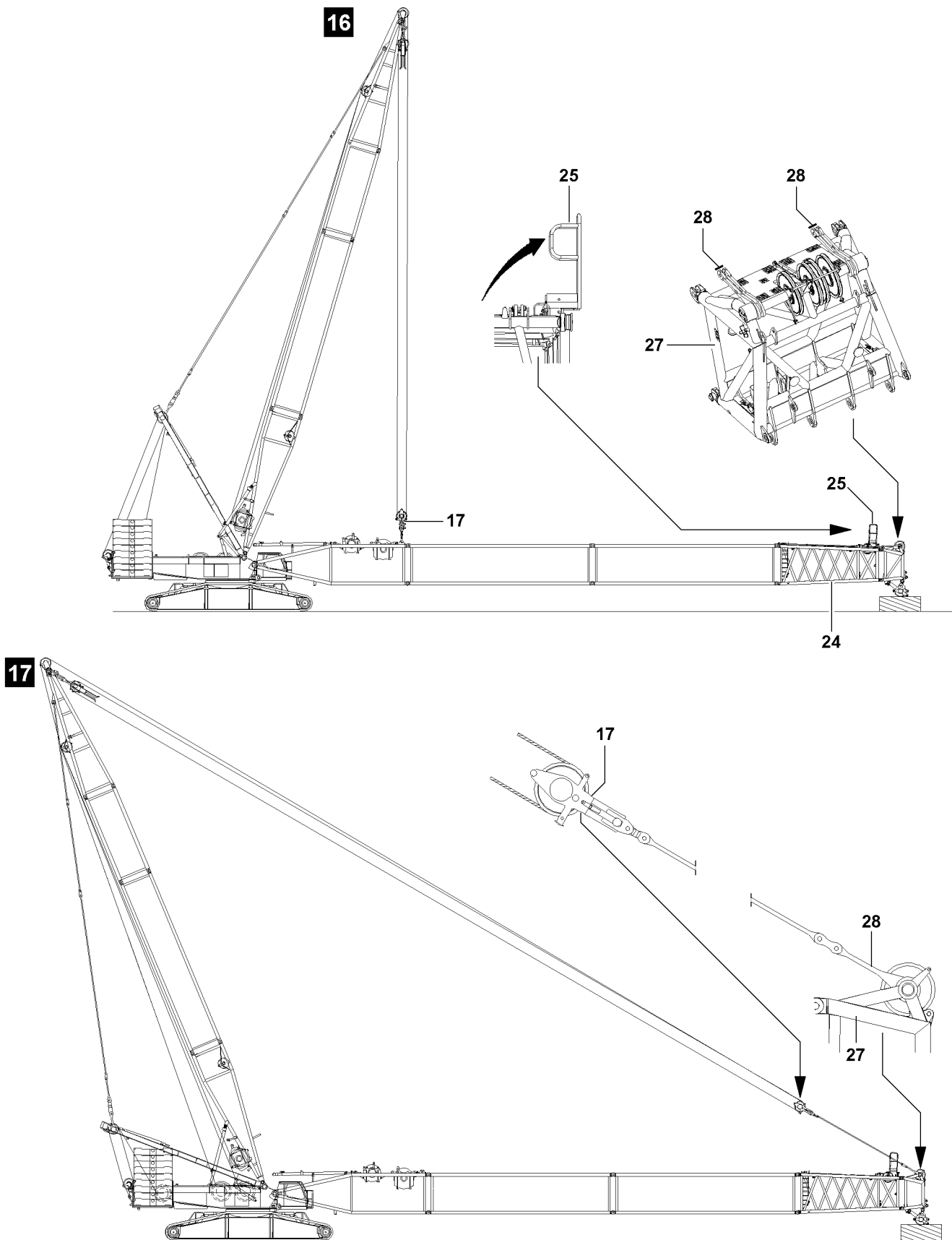

LWE/LR 1600-2-008/18109-09-02/en

Fig.106752

**Note**

- ▶ The guy rods of the S-intermediate sections are pinned and secured together starting from the lugs **28** on the fixed point of the S-end section.
-
- ▶ Pin and secure the guy rods for the intermediate sections according to the Rod plan.
 - ▶ Pin and secure the guy rods with the upper pulley block **17**.

**Note**

- ▶ The S-boom must remain on the ground when erecting the D-boom and may **not** be pulled up along.
-

When the guy rods are pinned and secured with the upper pulley block **17**:

- ▶ Erect the D-boom to operating position and at the same time, spool out winch 3.

When the D-boom has reached the operating position:

- ▶ Tension the guying between the D-boom and the S-boom head, see illustration **17**.
-

**WARNING**

The boom can fold down!

If the following notes are not observed, the boom can suddenly fold down when the auxiliary crane or the substructure is removed.

Death, severe bodily injuries, property damage.

- ▶ Remove the auxiliary crane or the substructure only if it is ensured that the D-boom is in operating position and the S-boom is safely being held by the guying.
-
- ▶ Remove the auxiliary crane on the S-boom head.
or
Remove the substructure.
 - ▶ Guide the hoist rope over the rope pulley(s) on the S-boom head, see separate reeving plans.

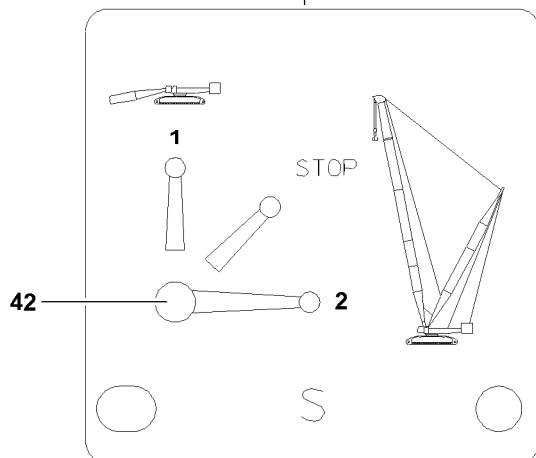
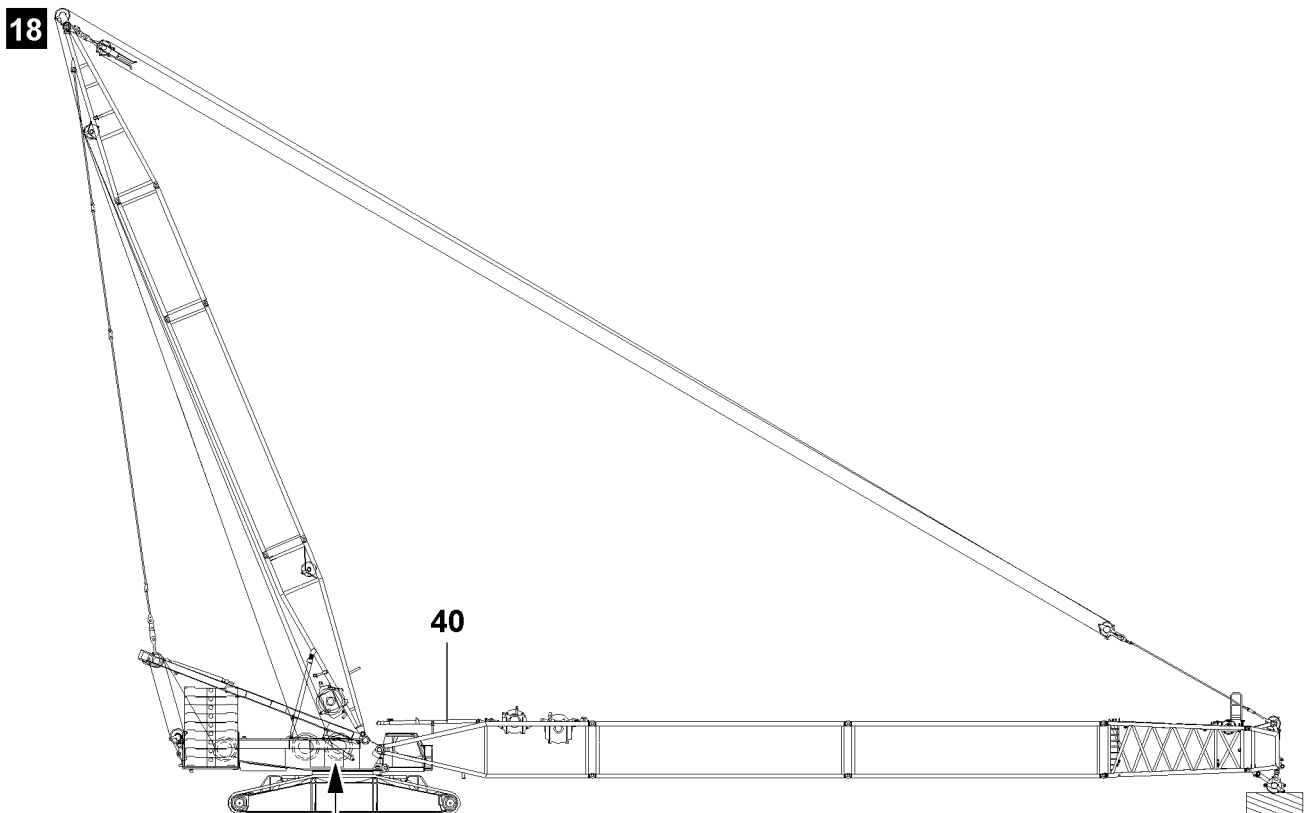

Fig.119483

LWE/LR 1600-2-008/18109-09-02/en

3.14 Erecting the boom



WARNING

The crane can topple over!

If the following conditions are not met before erecting the boom, the crane can topple over.

Death, severe bodily injuries, property damage.

- ▶ It is not permitted to turn the crane during the erection procedure.
- ▶ Observe the specifications in the erection and take-down charts.
- ▶ Observe the technical safety instructions, see chapter 5.01.
- ▶ Extend the S-relapse cylinder before erection.
- ▶ Do not allow slack rope formation on the control winch.



WARNING

Unutilized guy rods on boom!

If guy rods are on the lattice sections which are not used for operation, then there is a danger of accident.

Death, severe bodily injuries, property damage.

Guy rods can loosen up and fall down.

The load chart is invalid.

The load display of the LICCON computer system shows an incorrect value.

The weight of the boom is too heavy for erection.

- ▶ Disassemble and remove unutilized guy rods on the transport retainers before erecting the boom.



WARNING

Falling hoist rope!

If the hoist rope is not reeved with the respective length before the erection procedure, then it can fall down backward due to its own weight.

Death, severe bodily injuries, property damage.

- ▶ Reeve in the hoist rope properly according to the reeving plan.
- ▶ Reeve in the hoist rope with sufficient length before the erection procedure.
- ▶ The hoist rope must be constantly monitored during erection.
- ▶ Do not step into the danger zone.

Make sure that the following prerequisites are met:

- The crane is horizontally aligned.
- All electrical connections have been made.
- All hydraulic connections have been made.
- All limit switches are functioning.
- The central ballast has been attached according to the data in the load chart.
- The counterweight has been installed on the turntable according to the load chart.
- All pin connections are secured.
- The hoist rope has been correctly placed in the rope pulleys and is prevented from jumping out with the rope retaining pins.
- There are no loose parts on the boom.
- The LICCON overload protection has been set according to the data in the load chart.
- The LICCON overload protection settings have been compared with the actual set up configuration.
- The LICCON overload protection is exceeded.
- The assembly icon is visible on the LICCON monitor.
- No persons are present in the danger zone.

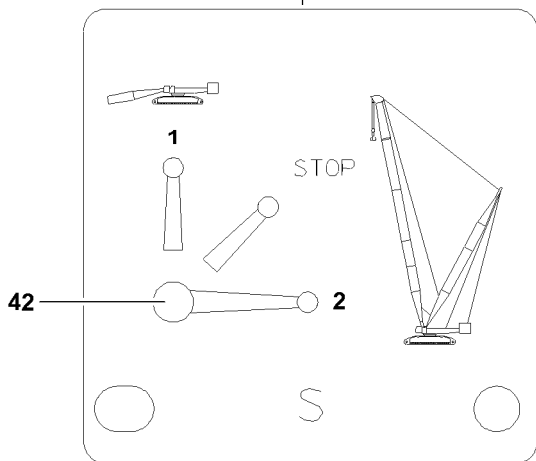
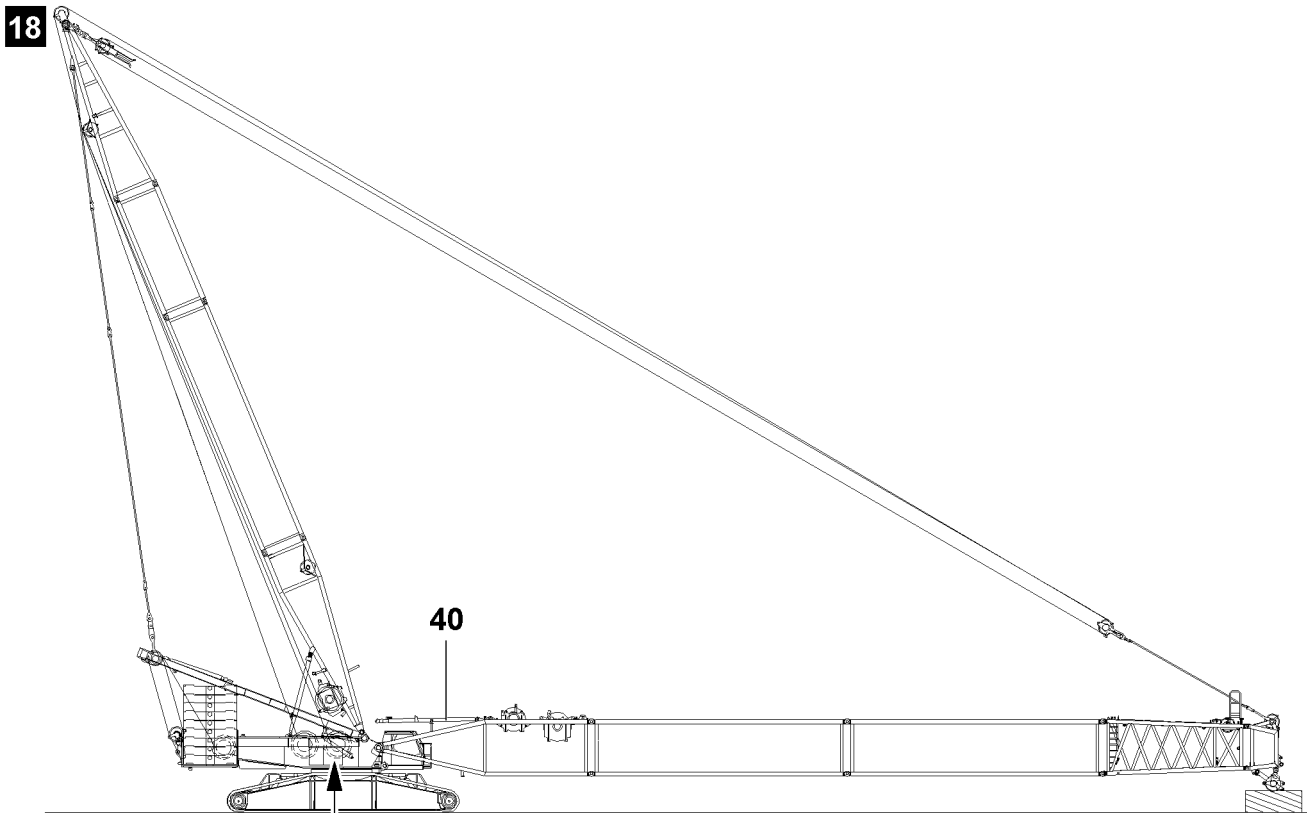

Fig.119483

LWE/LR 1600-2-008/18109-09-02/en

3.14.1 Extending the S-relapse cylinders

NOTICE

Damage to the relapse cylinders!

By extending the S-relapse cylinders, a collision with the D-relapse cylinders can occur. This can result in severe damage to the relapse cylinders.

- ▶ Extend the S-relapse cylinders only when the D-boom is in the operating position.



WARNING

The crane can topple over!

If the S-relapse cylinders are not extended before erecting the S-boom, then the S-boom can fall off to the rear during crane operation and the crane can topple over.

Death, severe bodily injuries, property damage.

- ▶ Extend the S-relapse cylinders **40** before erecting the S-boom.
- ▶ Secure the ball valve **42** during crane operation to prevent inadvertent actuation.

Ball valve positions	
2	Crane operation, extend the piston rod
1	Assembly, retract the piston rod
STOP	The piston rod cannot be retracted / extended

The piston rods on the S-relapse cylinders **40** can be extended with the ball valve **42**.

- ▶ Set the ball valve **42** to position **2**.

Result:

- The piston rods of the S-relapse cylinders **40** extend.



Note

- ▶ The ball valve **42** is secured by closing the cabinet door and removing the key.

When the piston rods of the S-relapse cylinders **40** are fully extended:

- ▶ Close the cabinet doors and pull out the key.
- ▶ Hand the key to an authorized person.

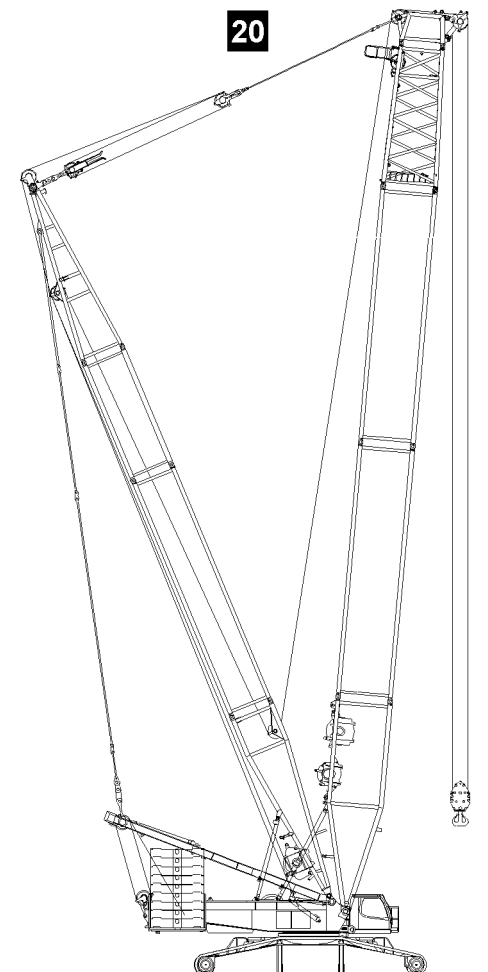
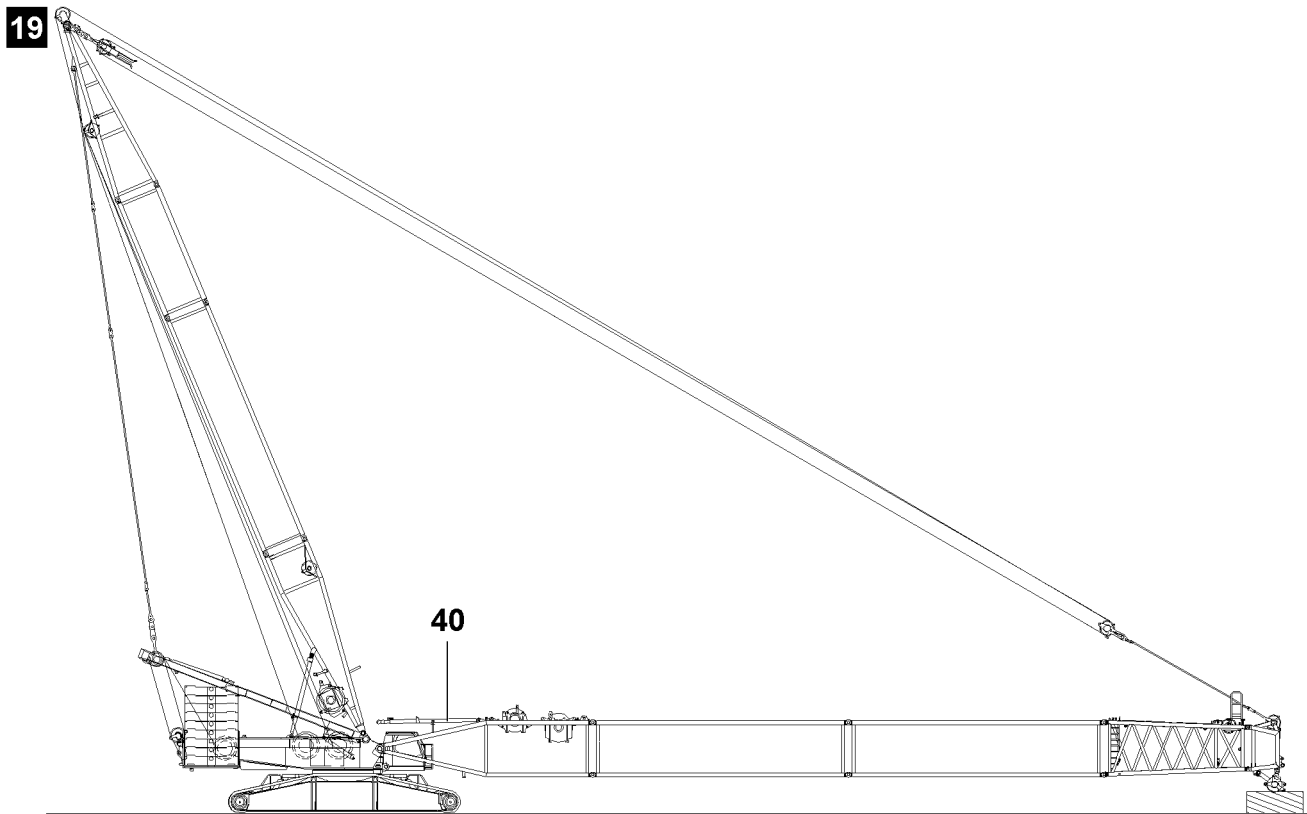

Fig.119484

LWE/LR 1600-2-008/18109-09-02/en

3.14.2 Erection procedure



DANGER

The crane can topple over!

- ▶ It is prohibited to turn the crane superstructure while erecting the boom.
- ▶ Observe the data in the Erection and take down charts.

Make sure that the following prerequisite is met:

- The boom has been lifted off the ground.

Reeving in the hook block

- ▶ Erect the boom until the end section lifts off the ground.
- ▶ Check the actual load on the LICCON monitor.

Problem remedy

Actual load on the LICCON monitor is larger than 0.0 t !

- ▶ Observe the notes for input of hook block weight, see chapter 4.02.



Note

- ▶ Hoist rope reevings, see chapter 4.06 and Reeving plan.

- ▶ Reeve in the hook block properly and secure the hoist rope on the rope fixed point, for reeving, see the reeving plan.
- ▶ Attach the hoist limit switch weight.
- ▶ Enter the weight of the hook block in the LICCON computer system.

Erecting the boom



WARNING

The crane can topple over!

In crane operation with exceeded LICCON overload protection, the crane can topple over. Death, severe bodily injuries, property damage.

- ▶ The boom radii listed in the load chart may not be exceeded or fallen below, even if there is no load on the hook.

If required in the erection and take down chart:

- ▶ Carry the hook block along with the auxiliary crane.



Note

- ▶ When the lowest operating position of the boom is reached, the LICCON overload protection is activated.
- ▶ The displays on the LICCON monitor turn off.
- ▶ In the maximum load icon, a load number appears in „t“ instead of the display „???“.

- ▶ Luff the boom up to the lowest operating position.

When the boom has reached the lowest operating position:

- ▶ Make sure that the assembly icon on the LICCON monitor turns off.

Result:

- The LICCON overload protection is active.

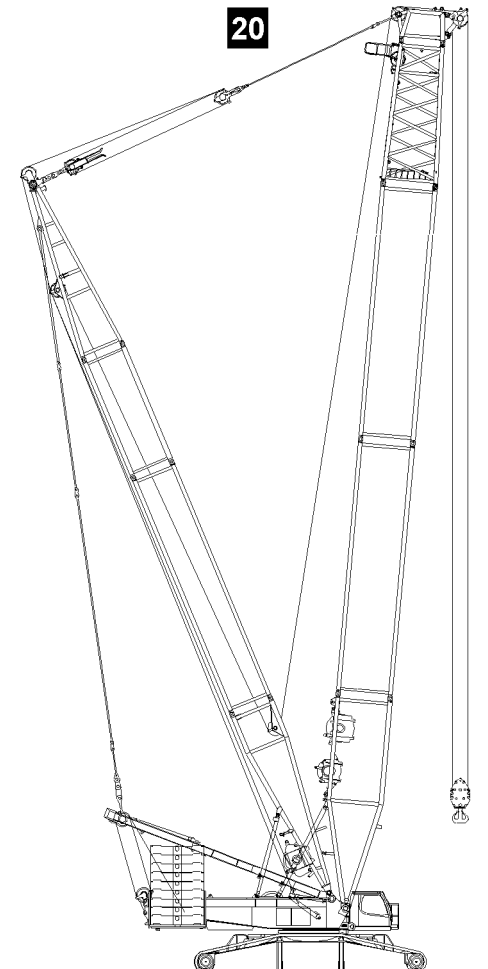
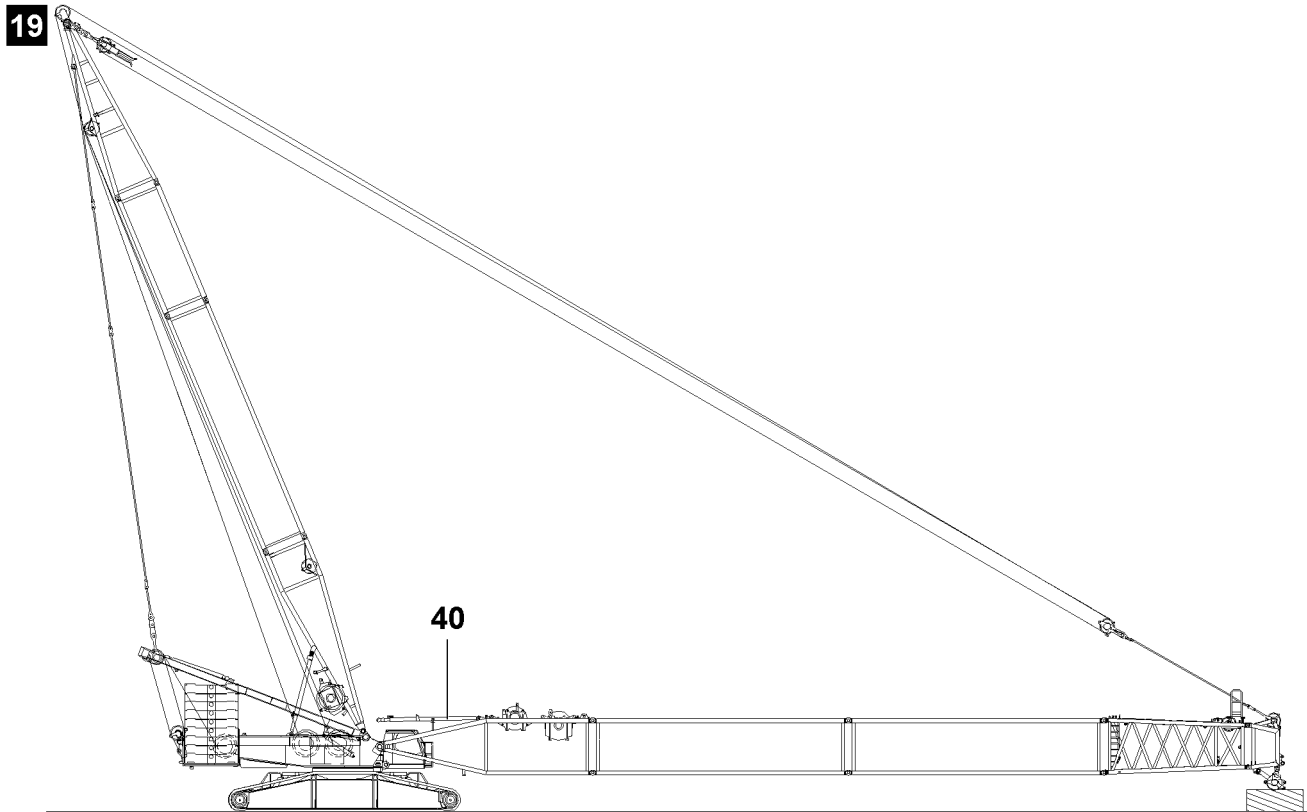

Fig.119484

LWE/LR 1600-2-008/18109-09-02/en

4 Operating the crane

4.1 Preparing for crane operation



Note

- ▶ Observe the notes, see chapter 4.02, chapter 4.05, chapter 4.08 and chapter 5.01.

Make sure that the following prerequisites are met:

- The LICCON overload protection is active.
- The LICCON overload protection has been set according to the data in the load chart.



WARNING

The crane can topple over!

- ▶ Check the horizontal position of the crane before and during crane operation.
- ▶ If the crane operator leaves the cab, even for a short time, the operating mode setting must be checked and reset if necessary before resuming crane operation.

4.1.1 Checking the settings

- ▶ Check the function of the overload protection by running against the operating positions „on top“ and „bottom“.
- ▶ Check the hoist limit switch by running against the hoist limit switch weight.
- ▶ Check the function of the limit switches on the jib stop cylinders.

5 Disassembling the SLD / SD-boom



WARNING

Danger of falling!

During assembly / disassembly, inspection and maintenance work, assembly personnel must be secured with appropriate aids to prevent them from falling.

Death, severe bodily injuries, property damage.

- ▶ All work at a height, when there is a danger of falling, must be carried out with suitable aids.
- ▶ If aids are not available and work cannot be carried out from the ground, then assembly personnel must secure themselves with the supplied fall arrest system to prevent falling, see chapter 2.04.
- ▶ If fall protection equipment is available, then it must be used, see chapter 2.06.
- ▶ When lifting, lowering, swinging crane parts in and out, no persons may remain in the danger zone.
- ▶ When closing or opening boom systems during boom assembly or boom disassembly, no persons may remain on the boom system or in the danger zone.
- ▶ If railings are present on the components, then they must be brought into the corresponding position and secured for assembly / disassembly work.
- ▶ Only step on the aids, ladders and catwalks with clean shoes.
- ▶ Keep aids, ladders and catwalks free of heavy dirt, snow and ice.
- ▶ During all assembly and disassembly work, maintenance work and inspections, travel or crane operation is prohibited.
- ▶ Remaining on a suspended load is prohibited.
- ▶ Stepping or walking on crane components and lattice sections, which have an incline of more than 20° is prohibited.
- ▶ For all assembly work, the crane driver of the main crane must be in voice contact with the crane driver / crane drivers of the auxiliary crane / auxiliary cranes.
- ▶ For assembly tasks, the crane driver may only initiate crane movements when the responsible guide has explicitly released the movement.

**WARNING**

The lattice sections can fall down!

If the lattice sections are not pinned and secured correctly, then they can fall down.

Death, severe bodily injuries, property damage.

- ▶ Insert or unpin both pins at the same horizontal level, i.e. **left and right**.
- ▶ Do not stand under the lattice sections or within the entire danger zone during the pinning and unpinning procedure of the boom.
- ▶ Safely secure the pins in the storage locations as well as in the receptacles.
- ▶ It is prohibited to lean the ladder against the component being disassembled.

**WARNING**

Danger of impact / crushing!

When installing / removing crane components with the auxiliary crane, crane components can start to swing back and forth.

When lifting / lowering and positioning crane components, there is an increased danger of impacts / crushing.

Death, severe bodily injuries, property damage.

- ▶ Make sure that personnel cannot be caught by components.
- ▶ Make sure that the crane is horizontally aligned.
- ▶ When working in danger zones: Use aids to protect limbs.
- ▶ Guide components with suitable aids to minimize oscillation.

**DANGER**

The components can fall down!

If the corresponding component is disengaged from the auxiliary crane before the corresponding component is pinned, then the corresponding component can fall down.

Death, severe bodily injuries, property damage.

- ▶ Do not disengage the auxiliary crane until the respective component is pinned and secured.

**WARNING**

The crane can topple over!

▶ The turntable may not be turned during the assembly of the boom.

▶ Observe the assembly conditions, see chapter 3.06.

**WARNING**

Danger of accident!

Death, severe bodily injuries, property damage.

- ▶ For assembly of the boom combinations, the rod plan must be observed and adhered to.
- ▶ Depending on the condition of the ground, the boom and the lattice sections must be supported from below for the assembly of the boom.
- ▶ Observe the technical safety instructions, see chapter 5.01.

Make sure that the following prerequisites are met:

- The crane is horizontally aligned.
- An auxiliary crane is available.
- An assembly scaffolding / work platform is available.
- The central ballast is installed according to the load chart.
- The counterweight has been installed on the turntable according to the load chart.
- The LICCON overload protection has been set according to the data in the load chart.

Empty page!

LWE/LR 1600-2-008/18109-09-02/en

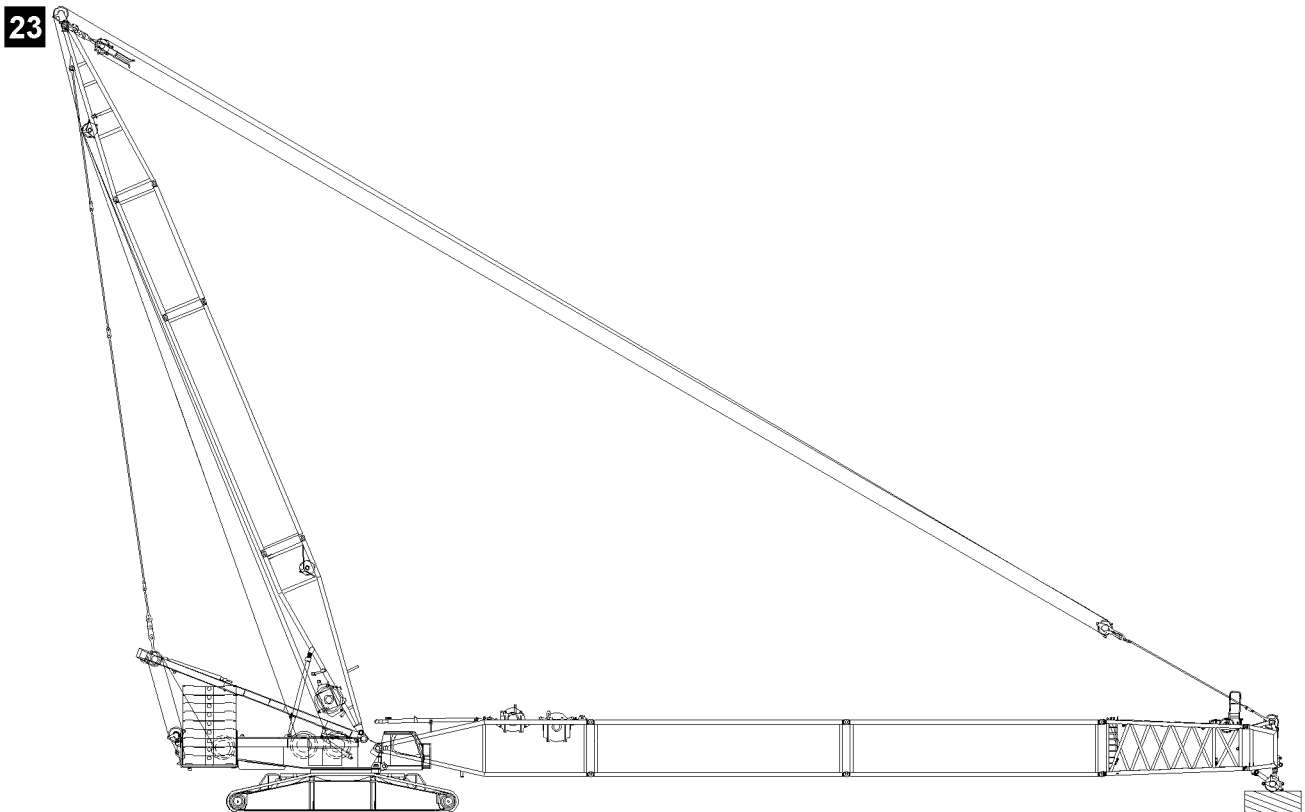
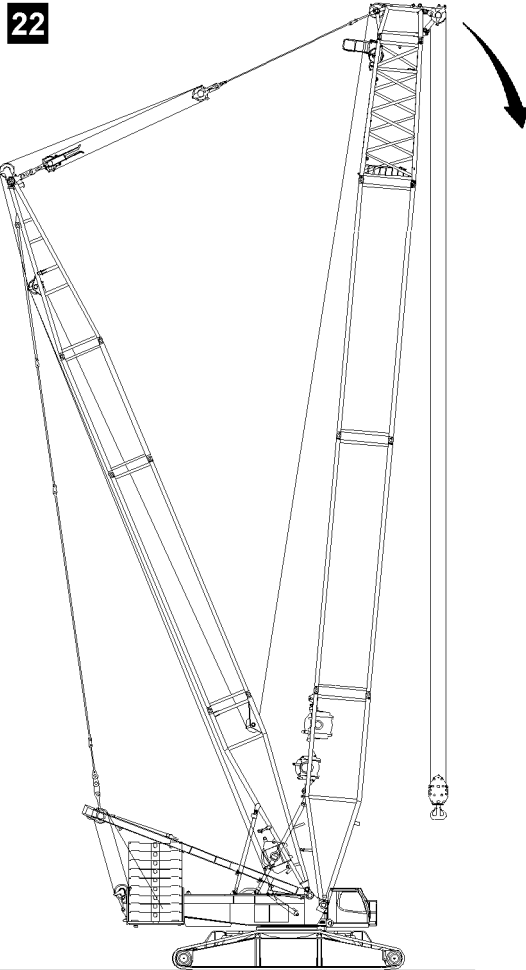

Fig.119485

LWE/LR 1600-2-008/18109-09-02/en

5.1 Taking the S-boom down



WARNING

The crane can topple over!

If the following conditions are not met before taking down the boom, the crane can topple over and fatally injure personnel.

- ▶ The turntable may not be turned during the disassembly of the boom
- ▶ Observe the technical safety instructions, see chapter 5.01.
- ▶ Observe the specifications in the erection and take-down charts.

If required in the erection and take down chart:

- ▶ Carry the hook block along with the auxiliary crane.

NOTICE

Damage of boom components!

Taking down the boom system can lead to a collision between the hook block and the pulley head. Boom components can be severely damaged.

- ▶ Luff the boom system down at the same time and spool the hoist winch out.
- ▶ When luffing the boom system down, the D-boom must remain in the operating position until the S-end section is laying on the ground or on a substructure.



Note

- ▶ Depending on the condition of the ground, the boom and the lattice sections must be supported for the disassembly of the boom.

Make sure that the following prerequisites are met:

- The crane is horizontally aligned.
- An auxiliary crane is available.
- An assembly scaffolding / work platform is available.
- The central ballast is installed according to the erection and take-down charts.
- The counterweight has been installed on the turntable according to the erection and take-down charts.
- The LICCON overload protection has been set according to the data in the load chart.

5.2 Luffing the boom down



Note

- ▶ The luff down movement is turned off as soon as the lowest operating position is reached.
- ▶ When the lowest operating position of the S-boom is reached, the load display in the maximum load icon turns off and instead of the load display appears the display „???“.
- ▶ Alarm functions appear on the crane operation screen.

- ▶ Luff the S-boom down to the „lowest“ operating position.

Result:

- The luff down movement is turned off.
- The „STOP“ icon appears on the LICCON monitor.
- The horn icon appears on the LICCON monitor.

**WARNING**

Danger of accident due to the „Exceedance of shut-off limits of the LICCON overload protection“ function!

If the shut off limits of the LICCON overload protection are exceeded, there is no additional protection against crane overload.

Due to erroneous operation or deliberate misuse, the crane could collapse, the boom can break off or the crane can topple over.

Death, severe bodily injuries, property damage.

- ▶ The function „Exceedance of shut off limits of the LICCON overload protection“ is only permissible in emergencies and for assembly purposes.
- ▶ The function „Exceeding the shut off limits of the LICCON overload protection“ may only be actuated by persons who know the effects of their actions regarding the function „Exceeding the shut off limits of the LICCON overload protection“.
- ▶ The „Exceedance of shut off limits of the LICCON overload protection“ function requires the presence of an authorized person and must be performed with utmost caution.
- ▶ Crane operation with activated function „Exceedance of shut off limits of the LICCON overload protection“ is prohibited.

- ▶ Exceeding the shut off limits of the LICCON overload protection: Engage assembly operation.

Result:

- The shut off limits of the LICCON overload protection are exceeded.
- The assembly icon appears on the LICCON monitor.

**Note**

- ▶ See chapter 4.02.

- ▶ At the same time, spool the hoist winch out and luff the S-boom down until the hook block touches the ground.

5.3 Reeving out the hook block

- ▶ Remove the hoist limit switch weight and reeve the hook block out.

5.4 Spooling the hoist rope up

**WARNING**

Spooling up of hoist rope!

Death, severe bodily injuries, property damage.

- ▶ All rope retaining pins / pipes on the S-boom are removed.
- ▶ Slowly spool up the hoist rope over the rope pulleys back to the winch.
- ▶ No one may be present in the danger zone.

NOTICE

Overspooled winch!

If the rope is pulled under the winch when spooling up, the settings of the cam limit switch are no longer correct and there is an increased danger of accident.

As a result, extensive adjustment work on the cam limit switch is required.

- ▶ All rope retaining pins / pipes on the S-boom are removed.
- ▶ Slowly spool up the hoist rope over the rope pulleys back to the winch.
- ▶ Stop the winch in time, with sufficient rope reserve.
- ▶ Do not overspool the winch.

- ▶ Spool the hoist rope up.

5.5 Disconnecting the electrical connections on the boom

Make sure that the following prerequisite is met:

- The S-boom is laying on the substructure on the ground.

NOTICE

Damage to the cable drum or the cable!

If the cable of the cable drum is not properly spooled up on the cable drum after unplugging the S-end section, then the cable drum or the cable can be significantly damaged.

- ▶ Spool the cable drum up after unplugging.
- ▶ Spool the cable drum up and secure it to prevent inadvertent spooling out.
- ▶ Make sure that all electrical connections on the S-boom have been disconnected.

5.6 Disconnecting the hydraulic connection on the boom

When releasing hydraulic lines with quick couplings, make sure that the coupling procedure is carried out correctly.



WARNING

Pressure in the hydraulic lines!

If the pressure supply is not interrupted before connecting / releasing the hydraulic lines, the hydraulic oil can escape with high pressure.

Death, severe bodily injuries, property damage.

- ▶ Release the pressure in the hydraulic system before connecting / disconnecting: Interrupt the pressure supply and wait for a short time.
- ▶ Install the coupling components (sleeve and connector) with the knurled nut.
- ▶ Disconnect the hydraulic connections.
- ▶ Install dust caps on the quick couplings.

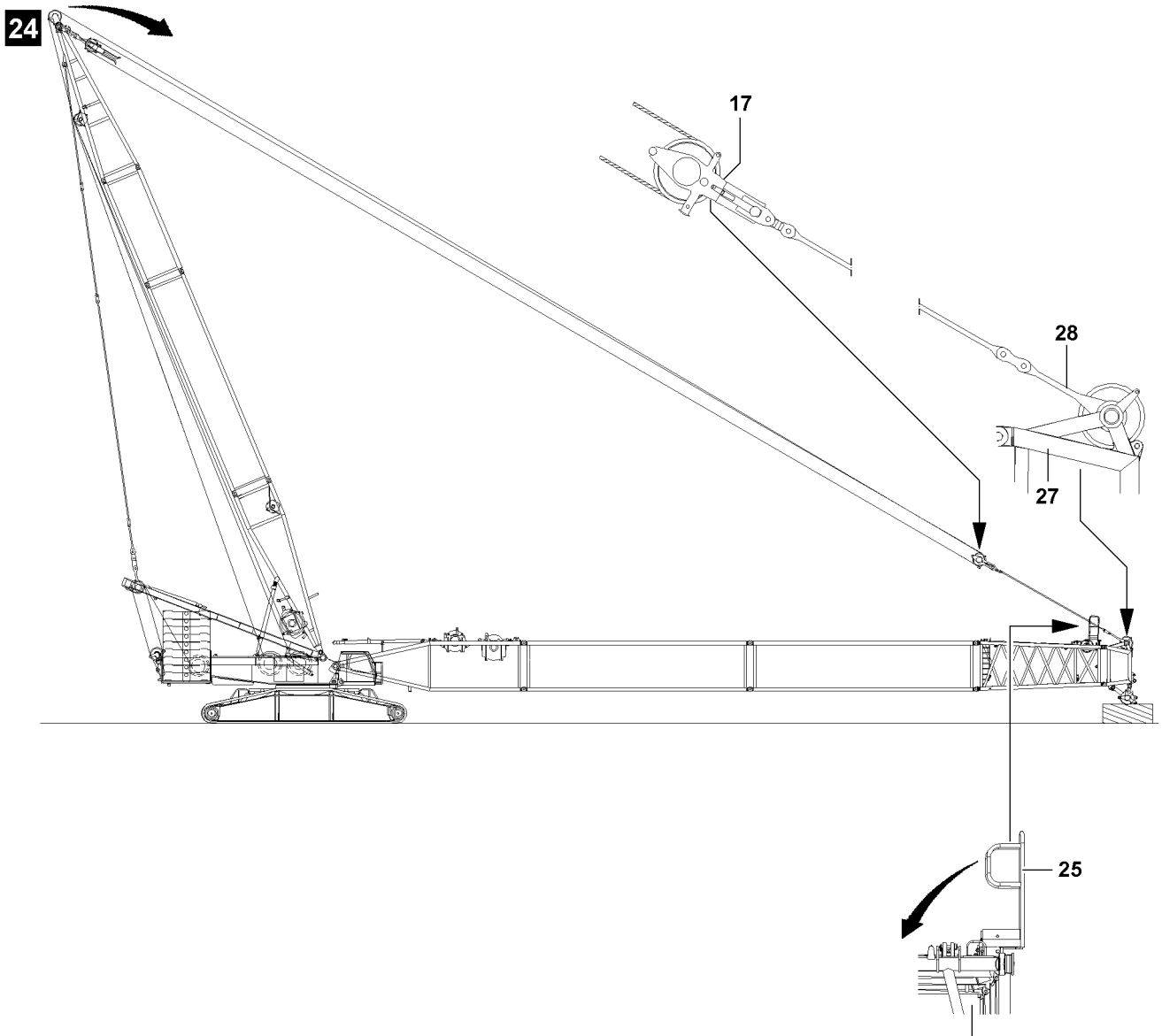

Fig.106833

LWE/LR 1600-2-008/18109-09-02/en

5.7 Disassembling the guy rods and folding in the folding platforms

- ▶ Relieve the guying: Luff the D-boom down to the front and at the same time spool out winch 3.

When the guying is relieved:

- ▶ Unpin the upper pulley block **17** on the guy rods.
- ▶ Take the guy rods down on the intermediate sections and secure with transport retainers.
- ▶ Disconnect the guy rods according to their association to the intermediate sections.

NOTICE

Damage to the intermediate sections!

- ▶ Do not pull the upper pulley block **17** over the intermediate sections, rather carry them along with the auxiliary crane.

When the guy rods are taken down in the transport retainers and secured:

- ▶ Erect the D-boom and spool the hoist rope up at the same time.



Note

- ▶ To retain the system dimensions for on road travel the folding platforms **25** must be folded in into the transport position and pinned, see illustration **24**.

-
- ▶ Bring the folding platforms **25** into the transport position, see chapter 2.06.

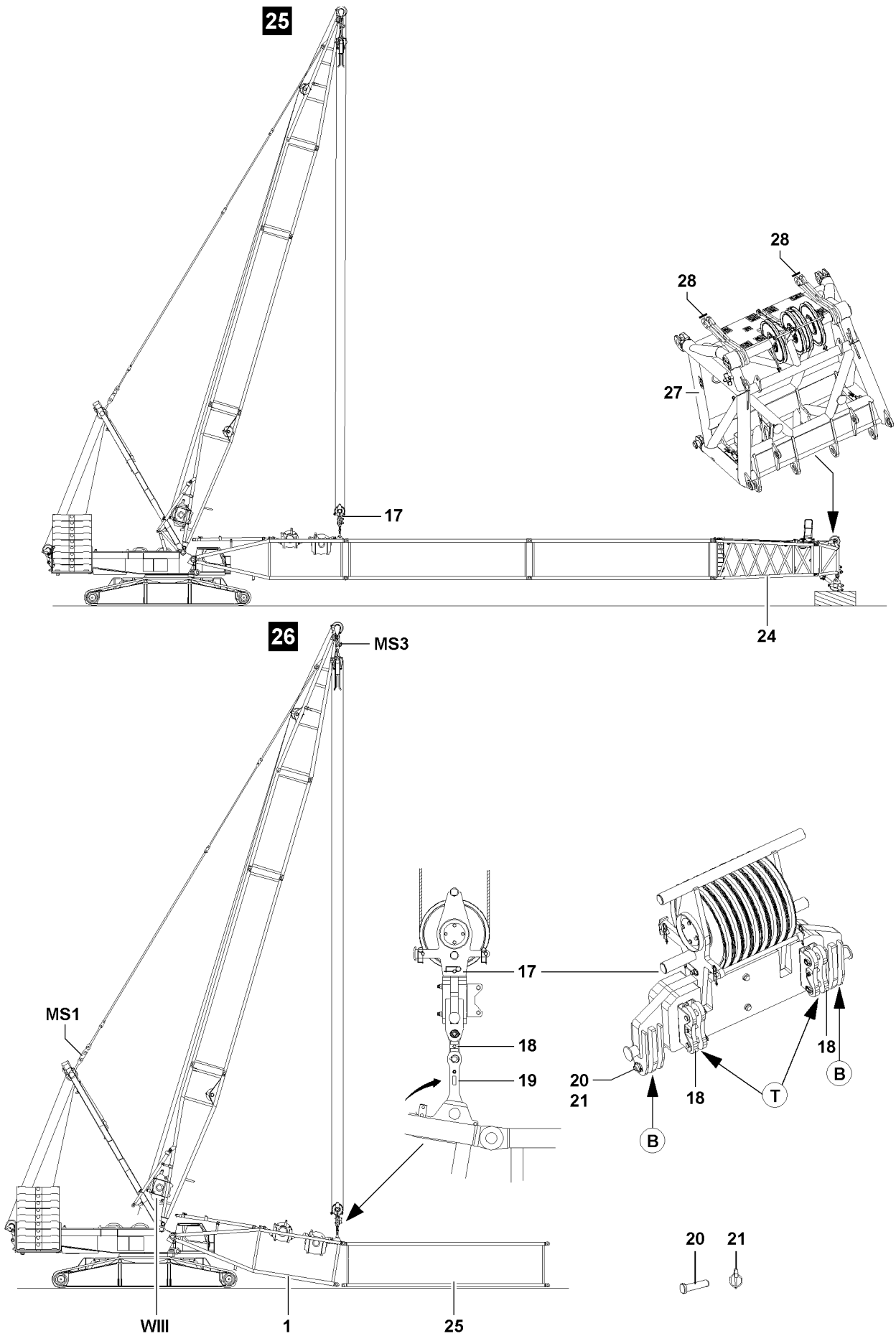

Fig.110730

LWE/LR 1600-2-008/18109-09-02/en

5.8 Disassembling the S-boom



WARNING

The boom can suddenly fold down!

If the following conditions are not met before disassembling the boom, the boom can fold down.

Death, severe bodily injuries, property damage.

- ▶ Support the S-boom during disassembly with suitable materials.
- ▶ During pinning and unpinning of the lattice sections, it is prohibited for anyone to remain **under** or **on** the components as well as within the entire danger zone.

Make sure that the following prerequisites are met:

- All electrical and hydraulic connections have been disconnected.
- The guy rods have been disassembled and taken down in the transport retainers.
- The folding platforms are pinned and secured in the transport position, see chapter 2.06.
- ▶ Lower the upper pulley block **17** until it is located over the assembly brackets **19** on the S-pivot section **1**.
- ▶ Pin and secure the upper pulley block **17** with the brackets **18** on the assembly bracket **19**.
- ▶ Use the pin **20** and locking pin **21**.



WARNING

The crane can topple over!

If the following conditions are not met, the crane can topple over or be significantly damaged.

Death, severe bodily injuries, property damage.

- ▶ The maximum permissible total force on test point **MS1 (200 t)** may **not** be exceeded.
- ▶ The maximum permissible total force on test point **MS3 (138 t)** may **not** be exceeded.
- ▶ Lifting the following boom lengths is permissible if the maximum permissible total force on test point 1 (MS1) and test point 3 (MS3) is noted, observe the following charts.

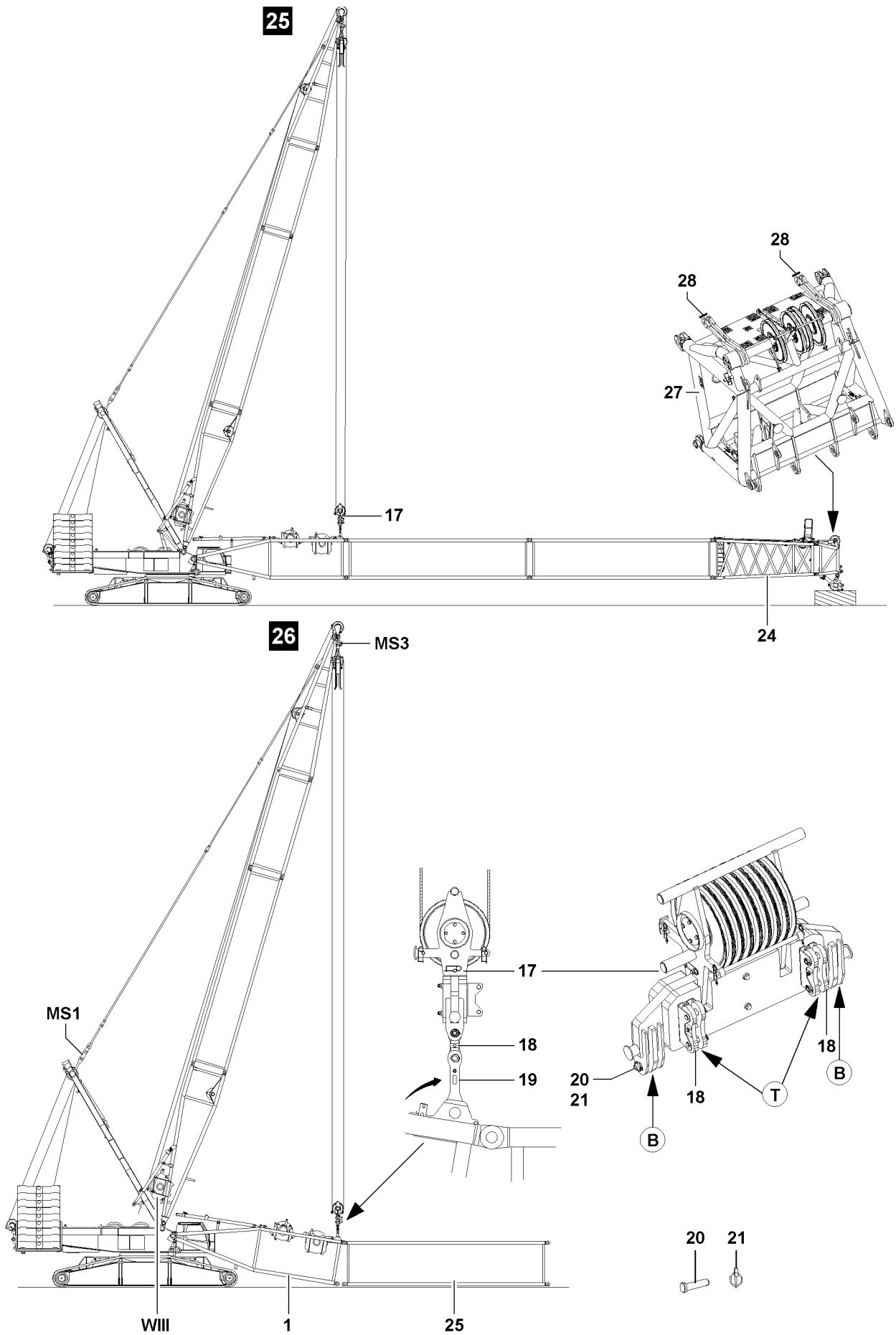

Fig.110730

LWE/LR 1600-2-008/18109-09-02/en

**Note**

- ▶ The actual forces on the test point **MS1** and on the test point **MS3** are shown on the LICCON monitor 1.
- ▶ Tension the guying on the SA-frame with the same force as during assembly.
- ▶ For this, refer to the ACTUAL force at test point 1 (MS1) measured and recorded during assembly.
- ▶ The pins can be pulled easier and the pins and lugs are therefore not damaged.

Maximum permissible system lengths for a maximum total force MS1 of 200 t and a maximum total force MS3 of 138 t					
Boom system	Maximum system length	Equipment	DB _{min} ¹⁾	ZB _{min} ²⁾	Illustration
SL(D)	54.0 m		150 t	65 t	13
	60.0 m	- with reducer - without head	150 t	65 t	12
S(D)	48.0 m		150 t	65 t	13
	58.0 m		150 t	65 t	12
	66.0 m	- without reducer - without head	150 t	65 t	12

1) This counterweight must be at least installed on the turntable for „disassembly“.

2) This central ballast must be at least installed on the crawler center section for „disassembly“.

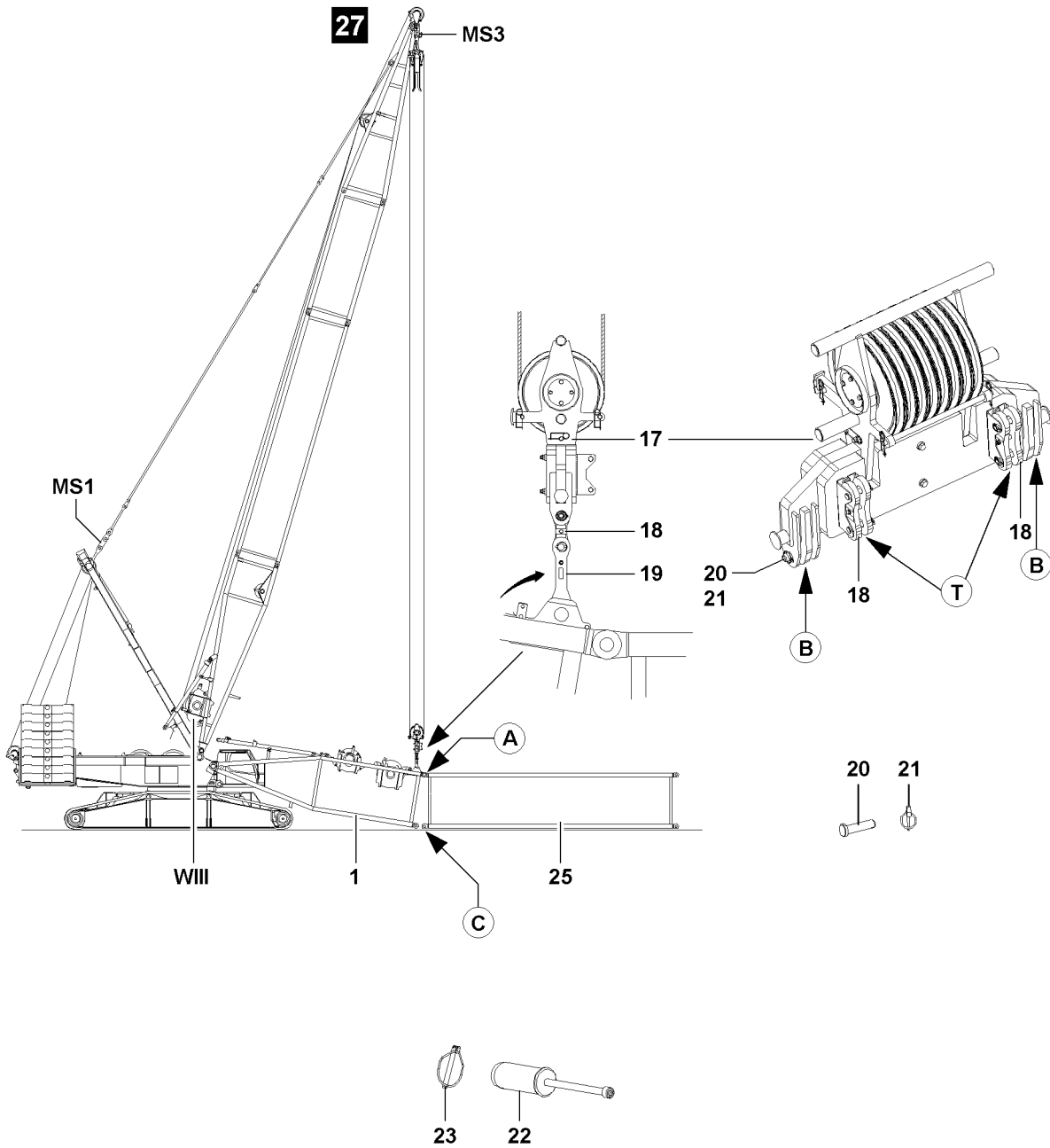

Fig.110790

LWE/LR 1600-2-008/18109-09-02/en

**Note**

- ▶ Unpin the intermediate sections with the pin pulling device, see chapter 5.30.

NOTICE

Danger of property damage!

If the maximum permissible total forces are not observed when lifting the boom system for disassembly, then crane components can be severely damaged.

- ▶ Do not exceed the maximum permissible total forces.

- ▶ Lift the S-boom from the substructure or off the ground by spooling up winch 3.

When the S-boom has been lifted off the ground and is safely held by winch 3:

- ▶ Unpin the S-pivot section **1** and S-intermediate section **25** at point **C** on both sides: Remove the locking pin **23** and unpin the pin **22**.

When the pins **22** are unpinned at point **C**:

- ▶ Carefully take the S-boom down on the ground.
- ▶ Unpin the S-pivot section **1** on both sides in point **A**: Remove the locking pin **23** and unpin the pin **22**.
- ▶ Relieve the guying by lowering the upper pulley block **17**.
- ▶ Unpin the upper pulley block **17** on the assembly brackets **19**: Remove the locking pin **21** and unpin the pin **20**.
- ▶ Unpin the bracket **18** on the upper pulley block **17** from the operating position **B** and pin it in the transport receptacle **T** on the upper pulley block **17**.
- ▶ Unpin and disassemble all intermediate sections.

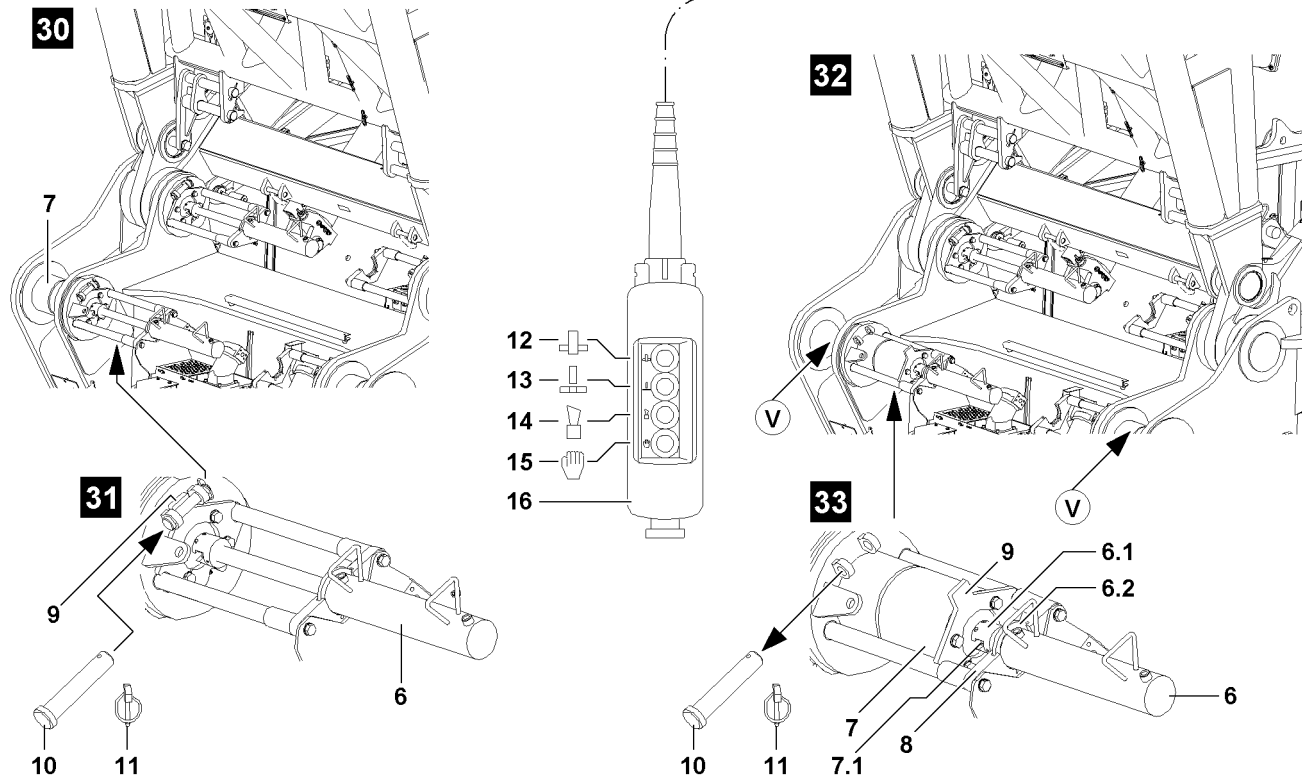
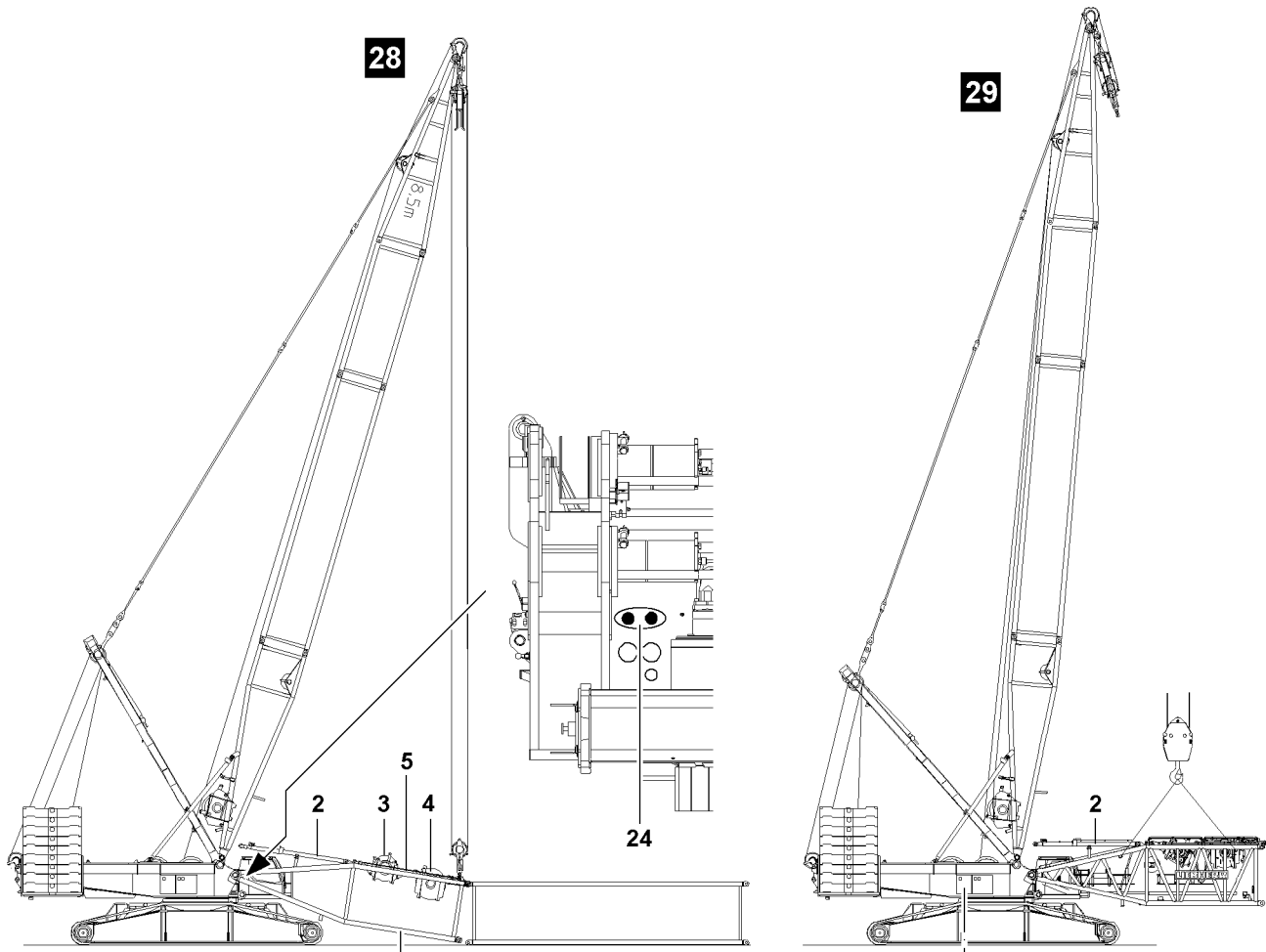

Fig.110791

LWE/LR 1600-2-008/18109-09-02/en

5.9 Unpinning the S-pivot section on the turntable



WARNING

General danger notes!

- ▶ Insert and secure all pins after disassembly in the intended transport receptacles.

Make sure that the following prerequisite is met:

- The D-boom is erected to the point where the S-pivot section can be disassembled without obstructions.



Note

- ▶ Select the fastening points on the S-pivot section in such a way that the S-pivot section hangs horizontally on the auxiliary crane upon assembly. See section „Fastening points“.

- ▶ Fasten the S-pivot section **1** on the fastening points **A** and fastening points **B** to the auxiliary crane.
or
Fasten the S-pivot section **1** on the fastening points **A** and fastening points **C** to the auxiliary crane.
- ▶ Lift the S-pivot section **1** with the auxiliary crane to the horizontal.

Establish the hydraulic connection to the pin pulling device via two quick couplers.

- ▶ Establish the hydraulic connection to the pin pulling device.



WARNING

Falling pivot section!

- ▶ Make sure that the pivot section is safely held by the auxiliary crane before unpinning the pins **7**.
- ▶ Unpin the retaining pin **10**.



Note

- ▶ When hooking the pin pulling cylinder **6**, make sure that the collar **6.2** on the cylinder mount **8** and the catch **6.1** on the screw **7.1** are properly hooked.
- ▶ Make sure that the retaining pins **10** are unpinned.
- ▶ Hook the pin pulling cylinder **6**.
- ▶ Connect the pin pulling cylinder **6** on the quick couplers **24**, illustration **28**.
- ▶ Unpin the connector pins **7** on both sides with the hydraulic pin pulling cylinder **6**: Press the button **15** on the control panel **16** and „hold it down“, then press the button **13** until the connector pin **7** is fully unpinned.

When the connector pins **7** are fully unpinned on both sides:

- ▶ Insert the retaining pins **10** in the pin bores and secure with locking pins **11**.
- ▶ Remove the pin pulling cylinder **6** from the cylinder receptacle **8**.
- ▶ Disconnect the hydraulic connections to the pin pulling device.

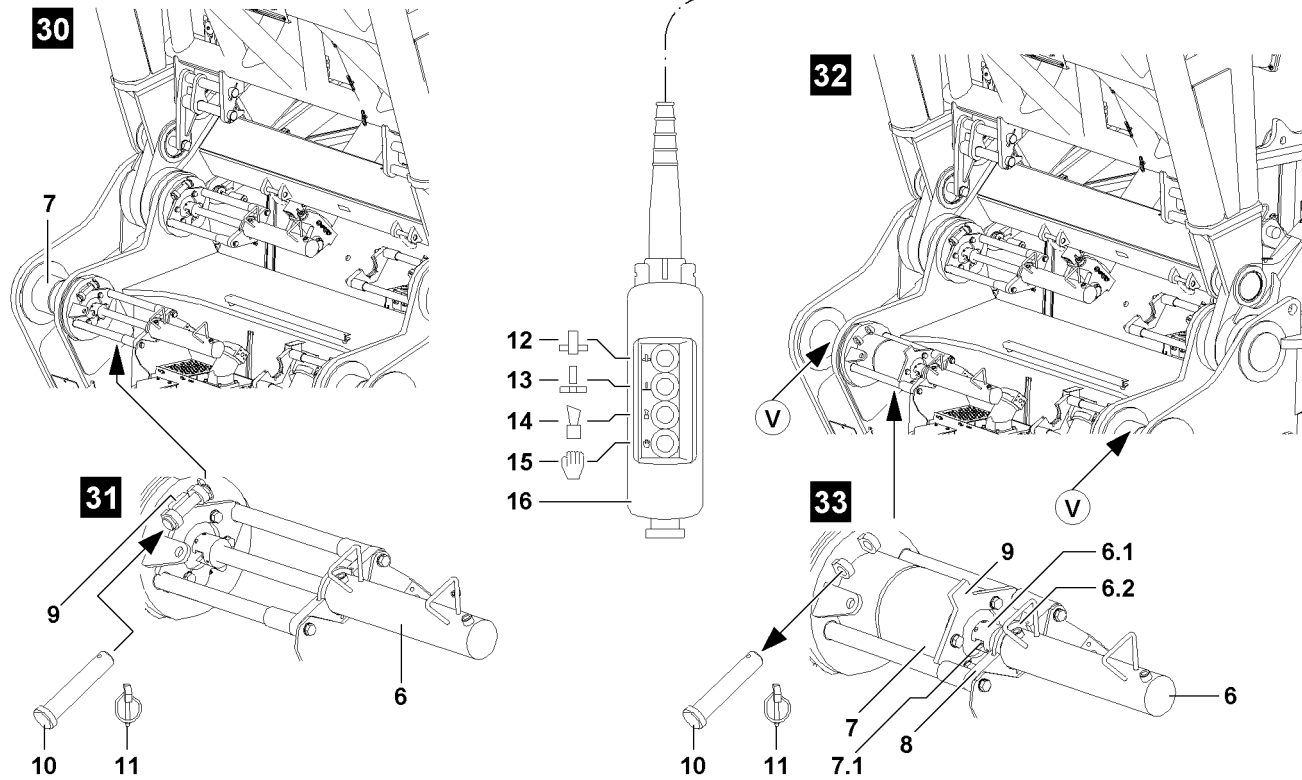
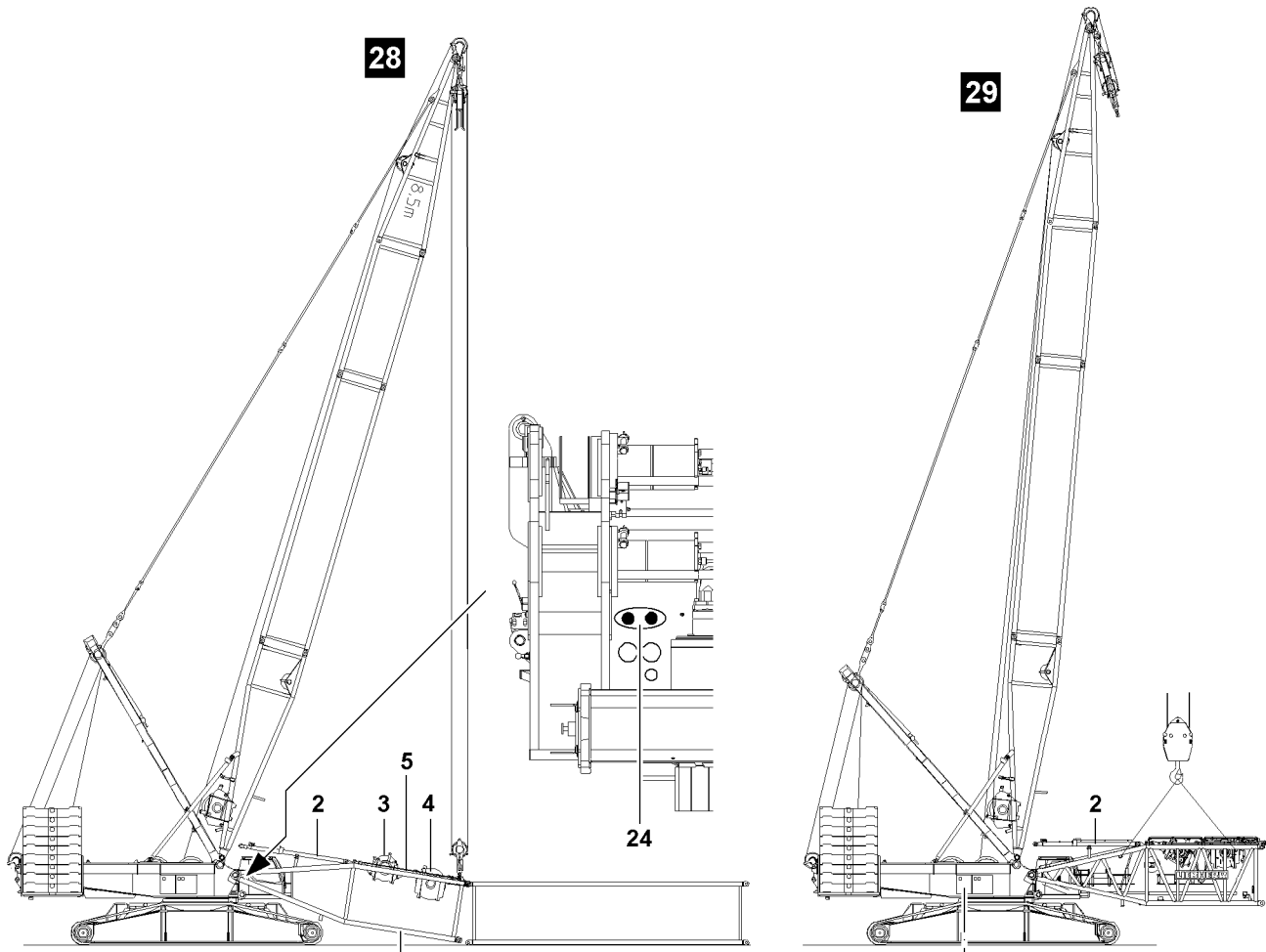

Fig.110791

LWE/LR 1600-2-008/18109-09-02/en

NOTICE

Damage to the turntable and the S-pivot section!

- ▶ Slowly swing the S-pivot section out with the auxiliary crane and at low speed on the turntable.

- ▶ Take the S-pivot section down with the auxiliary crane on the substructure on the ground.
- ▶ Remove the auxiliary crane.

**Note**

- ▶ Disassemble the D-boom, see chapter 5.05.
-

Empty page!

LWE/LR 1600-2-008/18109-09-02/en

5.42 HS auxiliary jib

1	Auxiliary jib „HS“	3
2	Installing the auxiliary jib „HS“ on the SL-boom	5
3	Erecting the SL-boom	15
4	Operating the crane	21
5	Removing the auxiliary jib „HS“	23

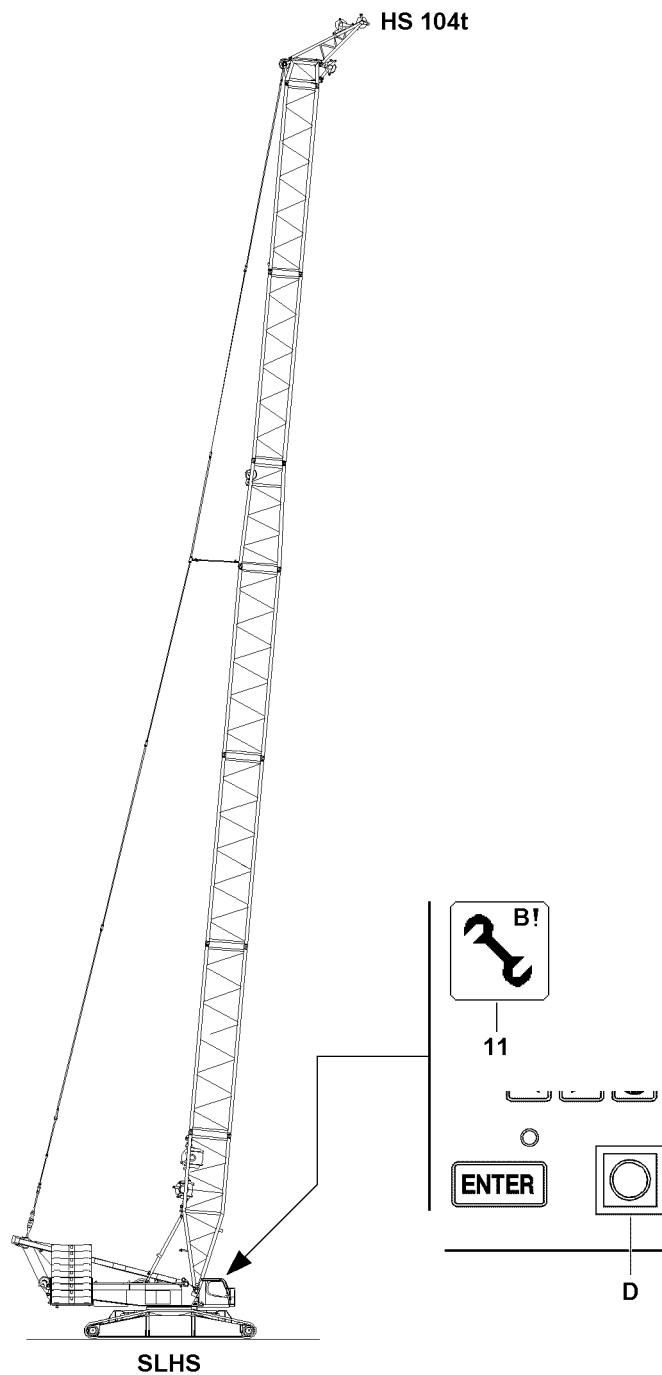

Fig.110792

1 Auxiliary jib „HS“



Note

► The auxiliary jib „HS“ is installed on the boom system SLHS on the SW-end section!

1.1 Component overview of auxiliary jib „HS“

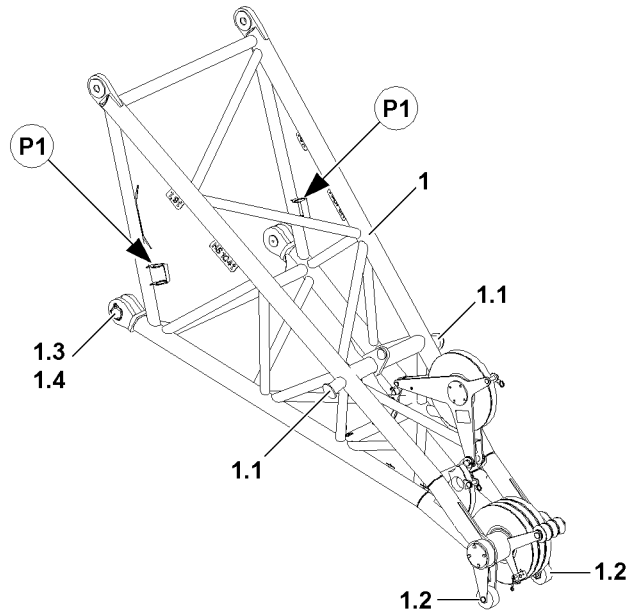

Fig.110603: Auxiliary jib "HS"

Position	Component	Weight
1	Auxiliary jib „HS“	1.9 t
1.1	Bitt	
1.2	Roller	
1.3	Pin	
1.4	Linch pin	

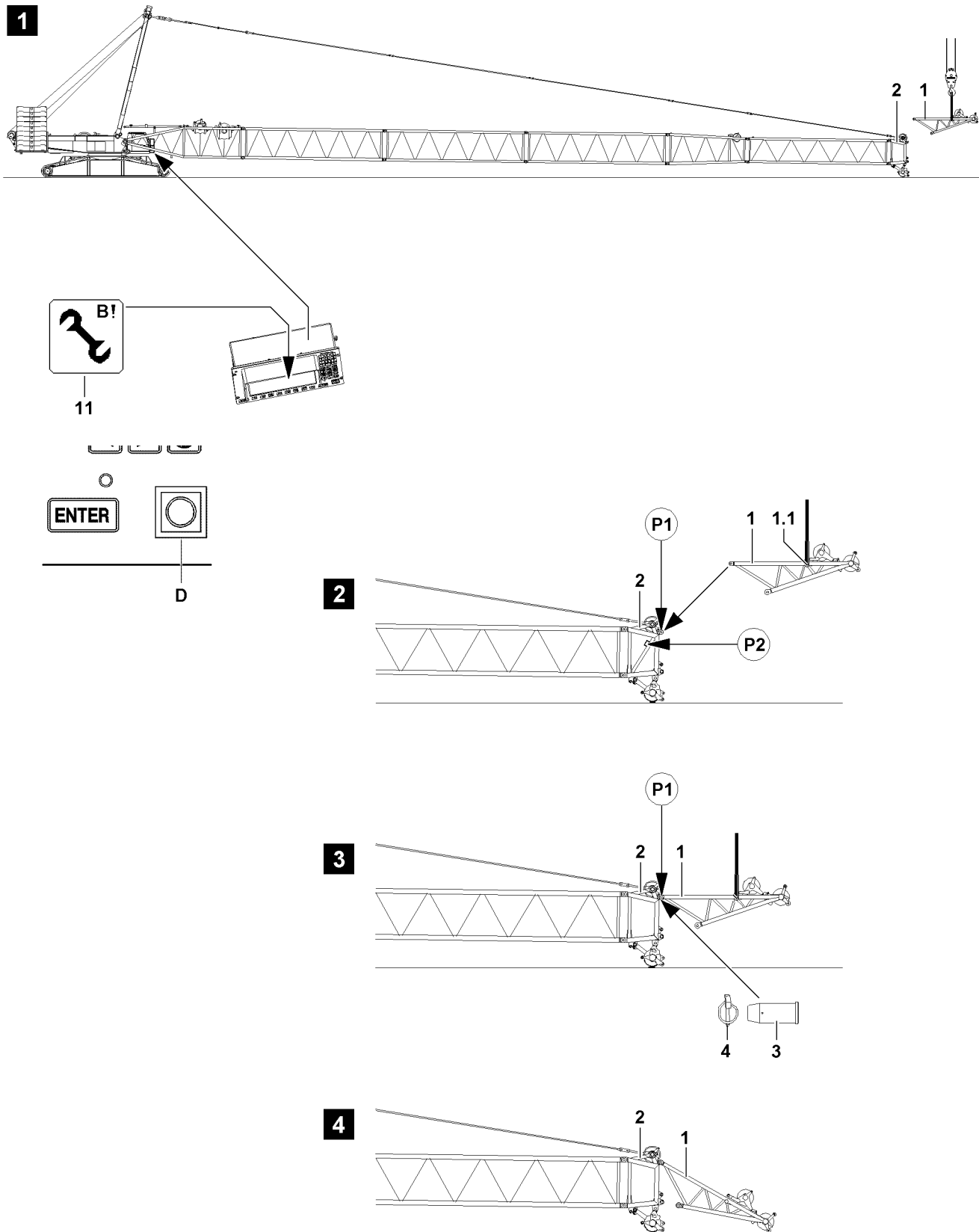

Fig.110793

2 Installing the auxiliary jib „HS“ on the SL-boom

2.1 Installing the auxiliary jib „HS“



WARNING

Risk of falling!

During assembly / disassembly work, personnel must be secured with appropriate aids to prevent them from falling. If this is not observed, assembly personnel can fall and suffer life-threatening or fatal injuries!

- ▶ Any work, where there is a danger of falling must be carried out with suitable aids (for example lifting platform, scaffolding, ladder, auxiliary crane)!
- ▶ If the work cannot be carried out with such aids nor from the ground, then the assembly personnel must secure themselves with approved fall arrest systems to avoid falling, see Crane operating instructions, Chapter 2.04!
- ▶ Approved fall arrest systems must be hung into the respective fastening points on the crane, see Crane operating instructions, chapter 2.06!
- ▶ If railings are present on the components, then they must be brought into the corresponding position and secured for assembly / disassembly work!
- ▶ Step on aids and fall arresters only with clean shoes!
- ▶ Keep aids and fall arresters clean and free from snow and ice!
- ▶ During all assembly and disassembly work, maintenance work and inspections, travel and crane operation is prohibited!



WARNING

Falling components!

If unsecured or non-supported components are assembled or disassembled, they can fall down. Personnel can be killed or seriously injured!

- ▶ During pinning and unpinning of the lattice sections, it is prohibited for anyone to remain **under** or **on** the components as well as within the entire danger zone!
- ▶ Support the boom and components before pinning / unpinning!
- ▶ Pin or unpin both pins that lie in one horizontal level, i.e. **left** and **right**!
- ▶ Secure the pins in the bearing points and in the receptacles!
- ▶ Do not disengage the auxiliary crane until each component is pinned on and secured!
- ▶ It is prohibited to lean a ladder against the component being disassembled!



WARNING

Danger of impact / crushing!

When installing / removing counterweight components with the auxiliary crane, crane components can start to swing back and forth!

When lifting / lowering and positioning crane components, there is an increased danger of impacts / crushing!

Personnel can be caught and severely injured or killed as a result!

- ▶ Make sure that personnel cannot be caught by components!
- ▶ When working in danger zones: Use aids to protect limbs!
- ▶ Guide components with suitable aids to minimize oscillation!

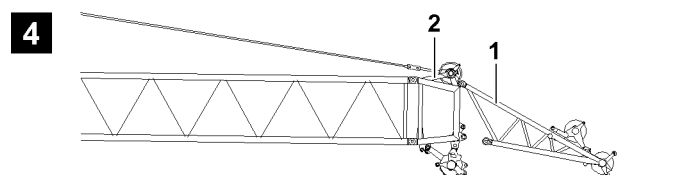
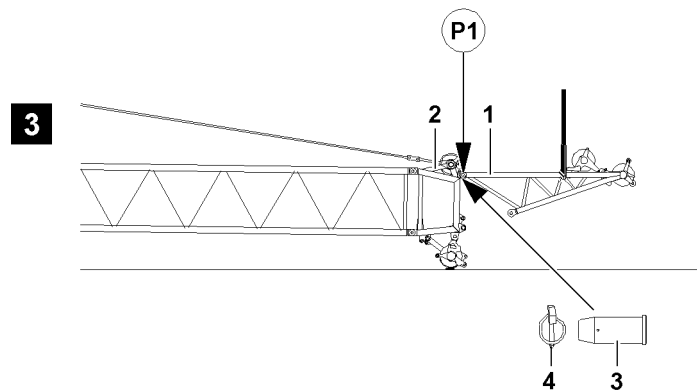
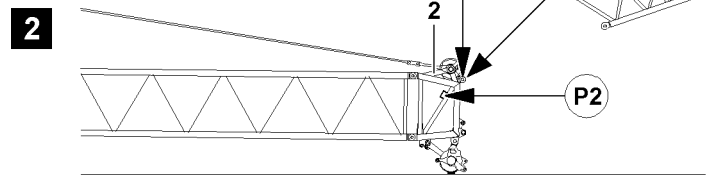
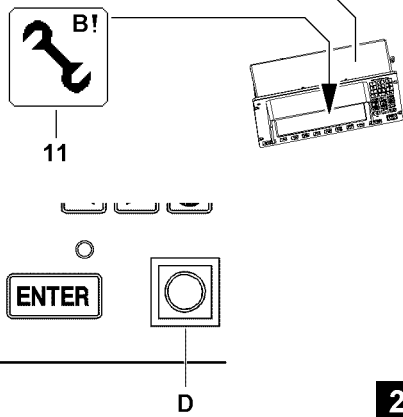
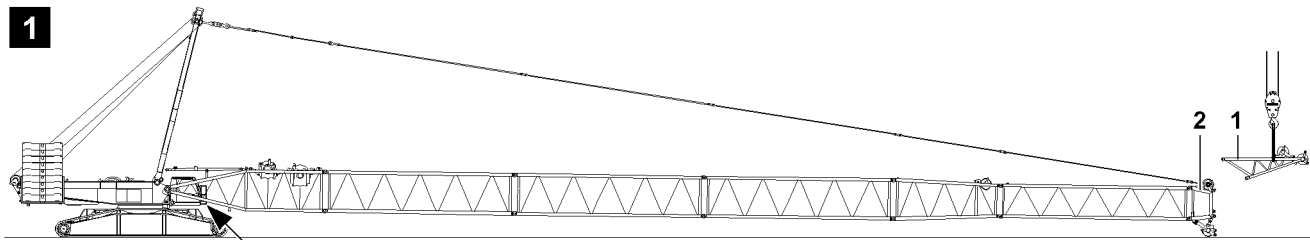

Fig.110793

LWE/LR 1600-2-008/18109-09-02/en

**Note**

- ▶ The SL-boom combination in connection with the auxiliary jib „HS“ must be installed according to the separately supplied rod and assembly plans!
- ▶ For installation of the SL-boom combination, see Crane operating instructions, chapter 5.38!

The auxiliary jib „HS“ **1** can be installed on the following basic configuration:

- SL-boom

**WARNING**

Assembly with turned on set up key!

When the set up key is engaged, the LICCON overload protection is exceeded!

In the event of deliberate improper use, the crane could collapse, the boom can break off or the crane can topple over!

Personnel can be killed!

This could result in high property damage!

- ▶ The set up key **D** may only be actuated by persons who know the effects of a bypass!
- ▶ Press the set up key **D** only when the set up status was correctly entered into the LICCON computer system!
- ▶ Observe the erection / take down charts!
- ▶ Crane operation with the set up key **D** turned on is strictly prohibited!

Make sure that the following prerequisites are met:

- The crane is aligned in horizontal direction.
- The SL-boom including SW-end section **2** is installed.
- The SL-boom is placed on a load-bearing support, illustration **1**.
- The counterweight has been installed to the turntable according to the load chart.
- The LICCON overload protection has been set according to the data in the load chart.
- The LICCON overload protection is bypassed.
- The assembly icon **11** is visible on the LICCON monitor.
- An auxiliary crane is available.

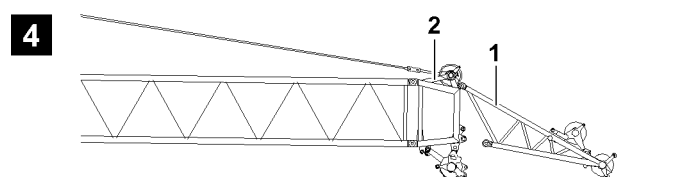
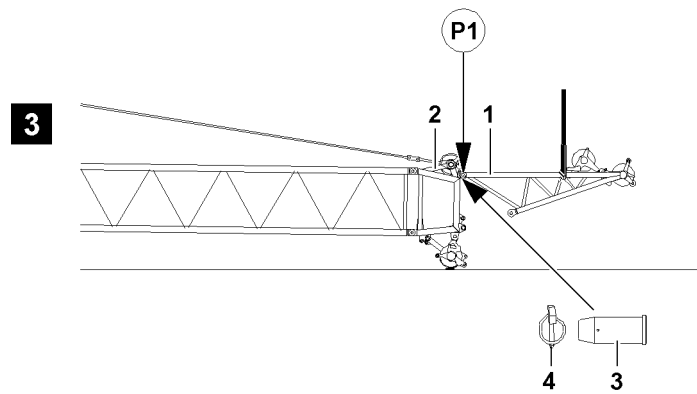
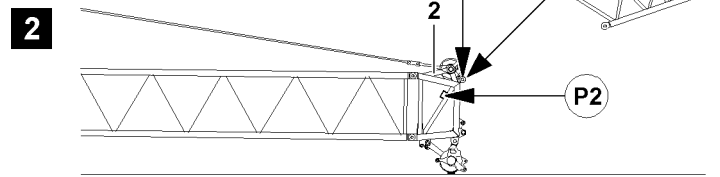
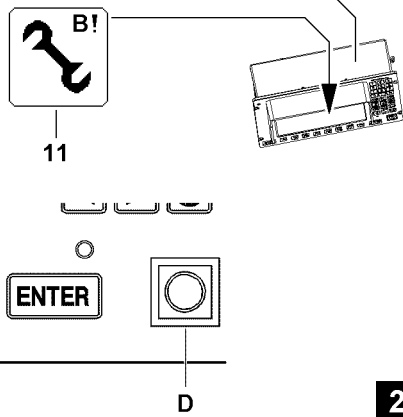
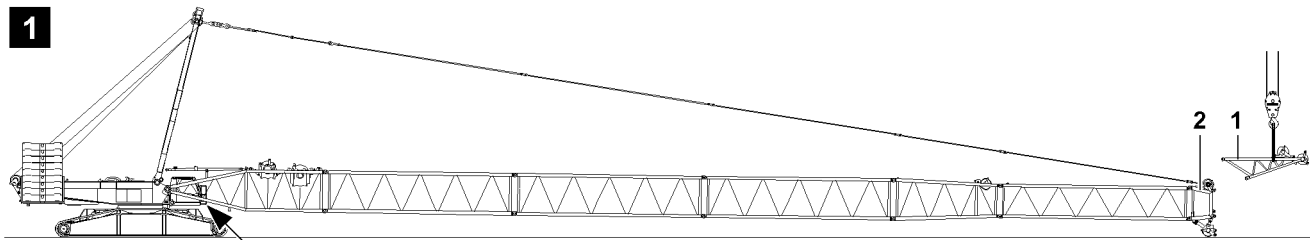

Fig.110793

LWE/LR 1600-2-008/18109-09-02/en

2.1.1 Installing the auxiliary jib „HS“ on the SW-end section

- ▶ Swing the auxiliary jib „HS“ 1 with the auxiliary crane in to the pin points, point **P1**, on the SW-end section **2**.
- ▶ Pin the auxiliary jib „HS“ 1 on the SW-end section **2** on both sides at point **P1** „on top“: Use pins **3**.
- ▶ Secure the pins **3** on both sides with lynch pins **4**.
- ▶ Carefully place the auxiliary jib „HS“ 1 with the auxiliary crane on the ground.
- ▶ Remove the auxiliary crane.
- ▶ Pull the hoist rope over the rope pulleys of the auxiliary jib „HS“ 1, see separate reeving plan.

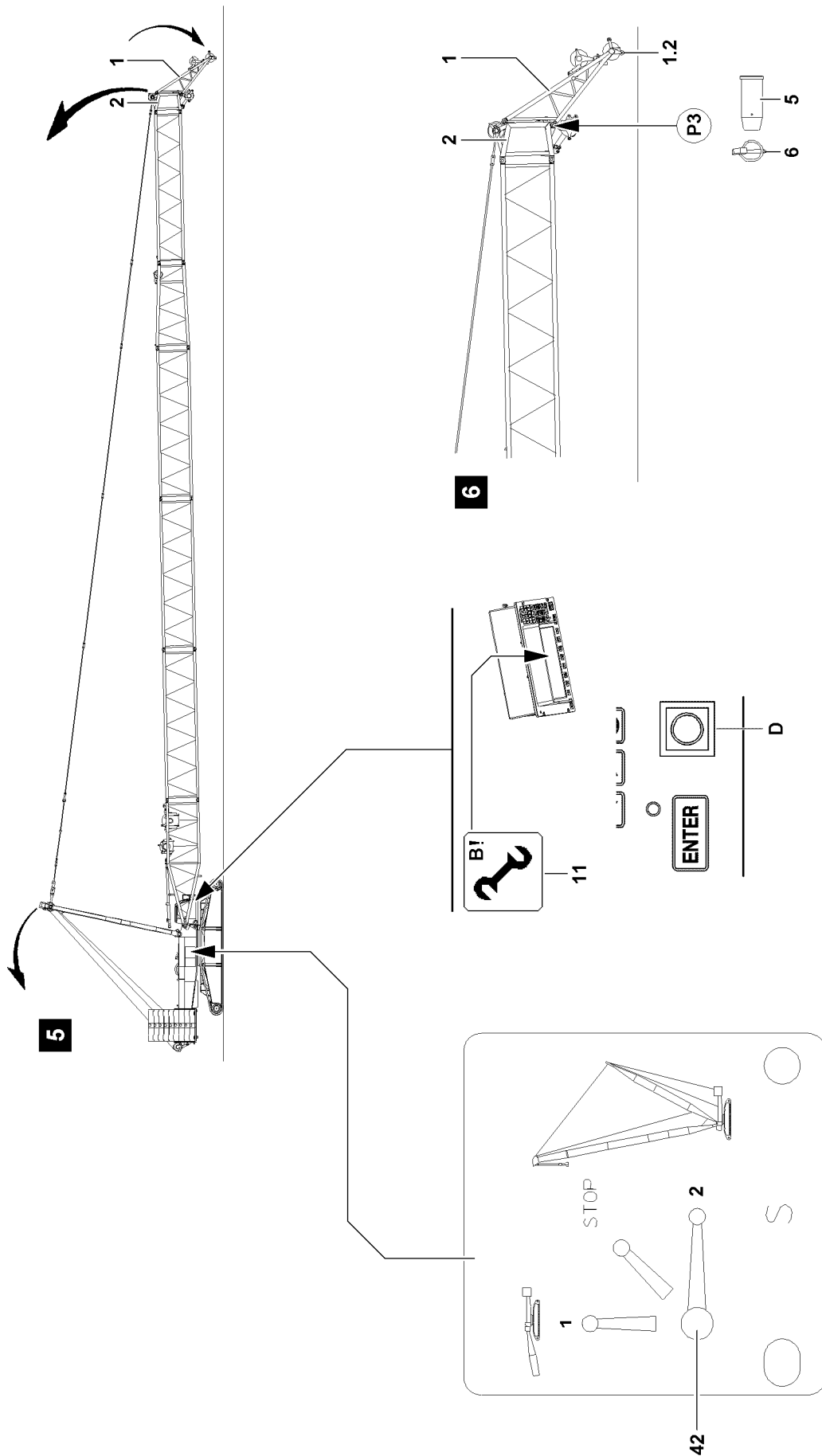

Fig.110794

2.2 Lifting the SL-boom off the ground



WARNING

The crane can topple over!

During erection of the SL-boom, the crane can be overloaded and topple over!

Personnel can be severely injured or killed!

- ▶ Observe the data in the erection and take down charts!
- ▶ It is prohibited to turn the crane superstructure while erecting the boom!

- ▶ Carefully luff the SL-boom up.

Result:

- Due to its own weight, the auxiliary jib „HS“ 1 runs on the rollers 1.2 slowly toward the „inside“.

- ▶ Luff the SLHS-boom up until the auxiliary jib „HS“ 1 lifts off the ground.

Result:

- The auxiliary jib „HS“ 1 supports itself at point P3 on the SW-end section 2.

- ▶ Pin the auxiliary jib „HS“ 1 at point P3 on the SW-end section 2: Insert the pin 5 and secure with linch pin 6.

NOTICE

Damage of auxiliary jib „HS“!

After the auxiliary jib „HS“ 1 is pinned on the SW-end section 2, the boom combination may not be placed on the ground in installed status, otherwise the auxiliary jib „HS“ 1 will be severely damaged!

- ▶ Place the boom combination only on the ground when the pins 5 are unpinned at point P3!

- ▶ Carefully place the boom combination down.

Result:

- The auxiliary jib „HS“ 1 folds out automatically when it is placed down and runs on the rollers 1.2 toward the „outside“.

2.3 Establishing the electrical connections

NOTICE

Damage to the electrical connection on the cable drum!

If the electrical connection from the cable drum on the S-pivot section to the terminal box on the S-pivot section is established first before the connection to the terminal box on the SW-end section, the electrical connection can be damaged when spooling out the cable drum!

- ▶ Establish first the electrical connection from the cable drum in the S-pivot section to the terminal box on the SW-end section and then the electrical connection from the terminal box in the S-pivot section to the cable drum in the S-pivot section!



Note

- ▶ To establish the electrical connections, use the separate electrical wiring diagram!

Make sure that the following prerequisites are met:

- The SLHS-boom is completely assembled.
- The airplane warning light and the wind speed sensor are assembled.
- ▶ Establish the electrical connections.
- ▶ Make sure that all electrical connections on the boom are established.

2.4 Checking the function of the safety devices



WARNING

Non-functioning safety devices!

If the function of the safety devices is defective, personnel can be severely injured or killed!

- ▶ Crane operation with non-functioning safety devices is **prohibited!**



Note

- ▶ The function of the individual limit switches must be checked before erection!
- ▶ The function of the limit switch initiators must be checked in the test system, see Diagnostics manual!



Note

- ▶ If a function check on the limit switches or on the safety devices does not lead to the desired shut offs, then the plug connections on the terminal boxes or the components itself must be checked!
- ▶ If no visible connection errors or component defects can be found, contact **LIEBHERR Service!**

Make sure that the following prerequisites are met:

- All electrical connections have been made.
- The crane engine is running.
- The corresponding operating mode is set on the LICCON monitor.

2.4.1 Checking the wind speed sensor

- ▶ Test the movement and the function of the wind speed sensor.

2.4.2 Checking the airplane warning light

- ▶ Turn the airplane warning light on.
- ▶ Visually check functionality.

2.4.3 Checking the hoist limit switch on the pulley head



Note

- ▶ When replacing or changing a hoist limit switch (HES), the corresponding hoist limit switch must have the correct bus address and the correct software version in order to be detected again by the bus system (LSB)!

- ▶ Actuate the hoist limit switch manually on the pulley head.

Result:

- The spool up function of the hoist winch turns off.
- The icon „Hoist top“ appears on the LICCON monitor 0.
- Limit switch is functioning.

2.4.4 Checking the limit switch SL-boom „steepest position“



Note

- ▶ The limit switch functions have to be checked individually before erection!

- ▶ Cover the limit switch initiators on the S-relapse cylinder individually with a metal plate.

Result:

- The hoist limit switch is actuated manually.
- The spool up function of winch 4 turns off.
- The icon „boom limitation“ appears on the LICCON monitor 0.
- Limit switch is functioning.

Empty page!

LWE/LR 1600-2-008/18109-09-02/en

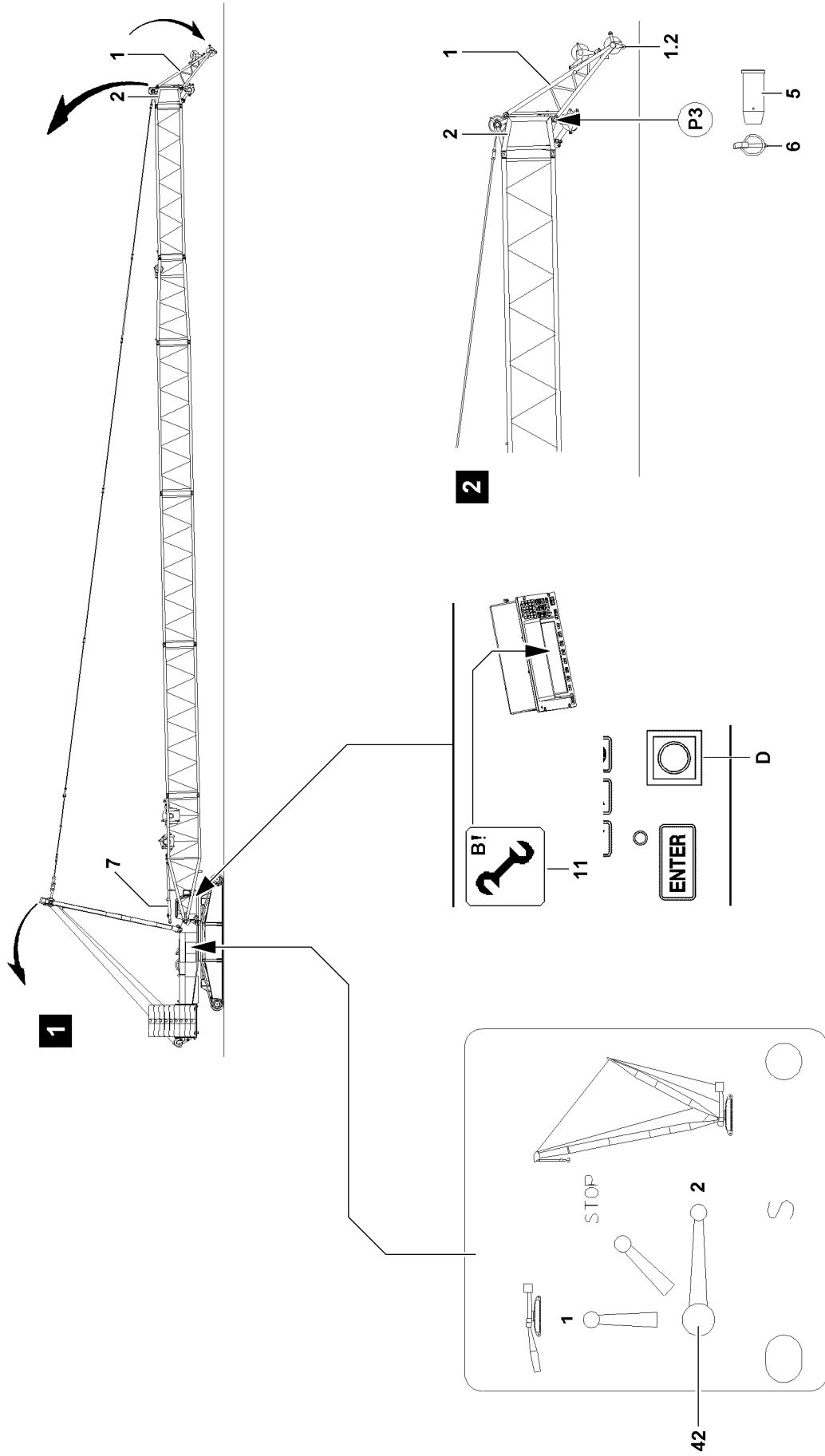

Fig.110795

3 Erecting the SL-boom

3.1 Erection procedure



DANGER

The crane can topple over!

- ▶ It is prohibited to turn the crane superstructure while erecting the boom!
- ▶ Observe the data in the erection and take down charts!



WARNING

The crane can topple over!

If the following conditions are not met before erecting the boom, the crane can topple over!

Personnel can be severely injured or killed!

- ▶ Observe the Safety technical notes, see Crane operating instructions, chapter 5.01!
- ▶ Extend the S-relapse cylinder **7** before erecting the boom combinations!
- ▶ Do not allow slack cable to build up on the control winch!



WARNING

Falling hoist rope!

If the hoist rope is not reeved before the erection procedure with the corresponding length on the auxiliary jib „HS“ **1**, then it can fall down backward due to its own weight!

Personnel can be severely injured or killed!

- ▶ Reeve the hoist rope with sufficient length on the auxiliary jib „HS“ **1** before the erection procedure!
- ▶ The hoist rope must be constantly monitored during erection procedure!
- ▶ Do not step into the danger zone!

Make sure that the following prerequisites are met:

- The crane is aligned in horizontal direction.
- All electrical connections have been established.
- All limit switches are functioning.
- The counterweight has been installed to the turntable according to the data in the erection and take down chart.
- All pin connections have been secured.
- The hoist rope has been correctly placed in the rope pulleys and is prevented from jumping out with the rope retaining pins.
- There are no loose parts on the boom.
- The LICCON overload protection has been adjusted according to the data in the load chart.
- The LICCON overload protection settings have been compared with the actual crane configuration.
- The LICCON overload protection is bypassed.
- The assembly icon **11** is visible on the LICCON monitor.

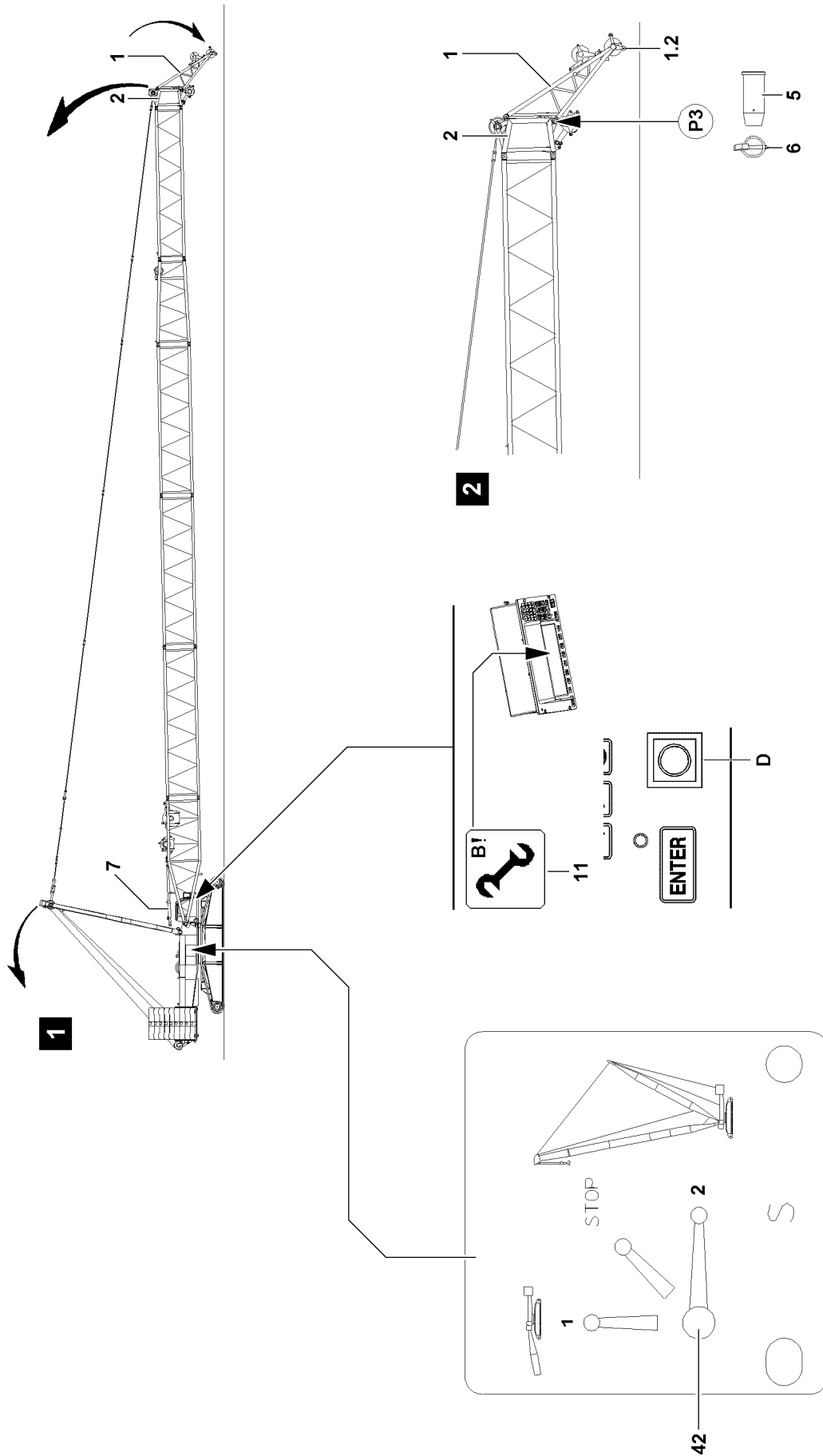

Fig.110795

LWE/LR 1600-2-008/18109-09-02/en

3.1.1 Extending the S-relapse cylinder



WARNING

The crane can topple over!

If the S-relapse cylinders **7** are not extended before erecting the SL-boom, then the SL-boom can fall down towards the rear during crane operation and the crane can topple over!

Personnel can be severely injured or killed!

- ▶ Extend the S-relapse cylinders **7** before erecting the SL-boom!
- ▶ Secure the ball valve **42** during crane operation to prevent inadvertent actuation!

Ball valve positions	
2	Crane operation, extend the piston rod
1	Assembly, retract the piston rod
STOP	The piston rod cannot be retracted / extended

Extend the piston rods on the S-relapse cylinders **7** by actuating the ball valve **42**.

- ▶ Set the ball valve **42** to **Position 2**.

Result:

- The piston rods of the S-relapse cylinders **7** extend.



Note

- ▶ The ball valve **42** is secured by closing the cabinet door and removing the key!
- ▶ Close the cabinet door and pull the key.
- ▶ Hand the key to an authorized person.

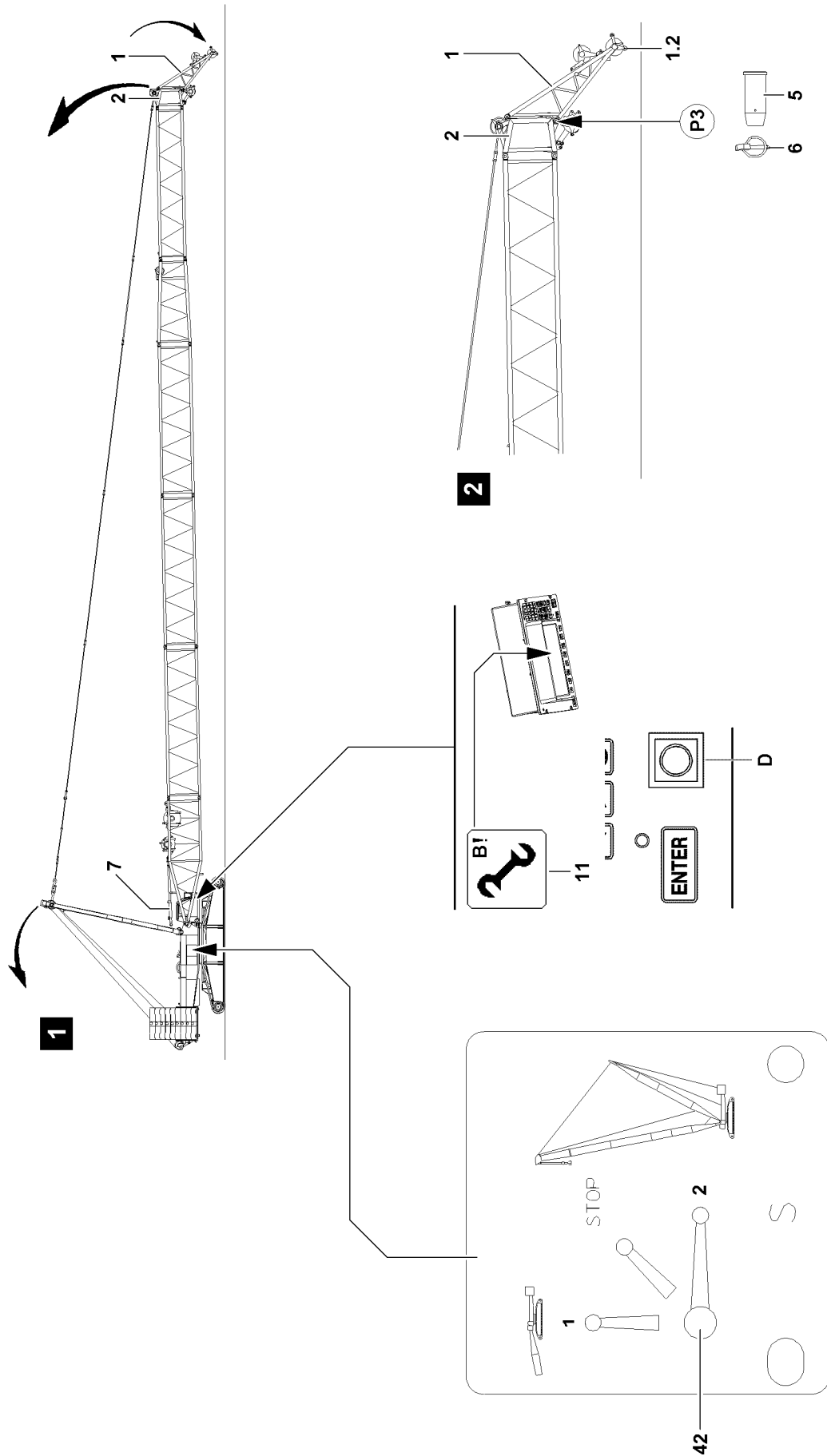

Fig.110795

LWE/LR 1600-2-008/18109-09-02/en

3.1.2 Erecting the boom



DANGER

The crane can topple over!

- ▶ It is prohibited to turn the crane superstructure while erecting the boom!
- ▶ Observe the data in the erection and take down charts!

Reeving in the hook block

- ▶ Reeve in the hook block properly and secure the hoist rope on the rope fixed point, for reeving, see separate reeving plans.
- ▶ Bolt in cable securing bolt and secure.
- ▶ Attach the hoist limit switch weight, see section Crane operating instructions, chapter 4.06!

Erection



WARNING

The crane can topple over!

In crane operation with exceeded LICCON overload protection, the crane can topple over!

Personnel can be severely injured or killed!

- ▶ The radii listed in the load chart may not be exceeded or fallen below, even if there is no load on the hook!



Note

- ▶ When the lowest operating position of the boom is reached, the LICCON overload protection is activated!
- ▶ In the maximum load icon appears a load number in „t“ instead of the display „???“!

- ▶ Luff the boom up to the lowest operating position.

When the boom has reached the lowest operating position:

- ▶ Make sure that the assembly icon **11** turns off on the LICCON monitor.

Result:

- The LICCON overload protection is active.

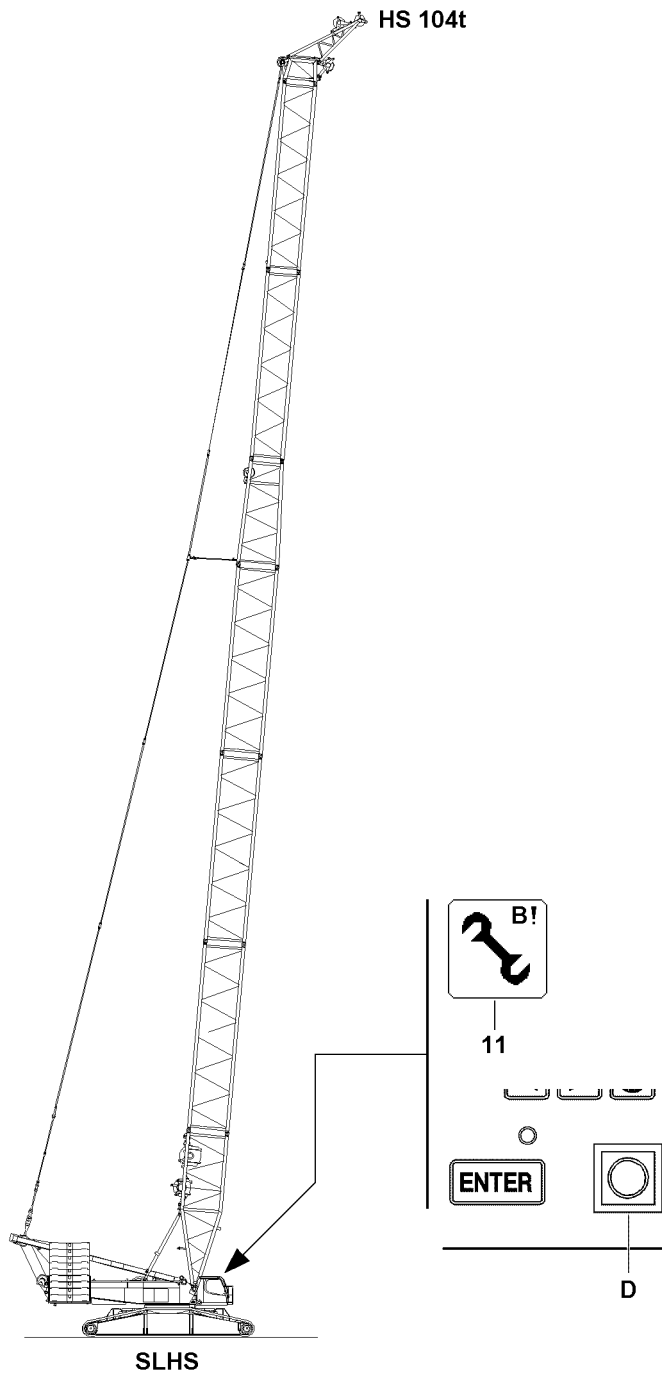

Fig.110792

LWE/LR 1600-2-008/18109-09-02/en

4 Operating the crane

4.1 Preparing for crane operation

**Note**

- ▶ Observe the notes, see Crane operating instructions, chapter 4.05, chapter 4.08 and chapter 5.01!

Make sure that the following prerequisites are met:

- The LICCON overload protection is active.
- The LICCON overload protection has been set according to the data in the load chart.

**WARNING**

The crane can topple over!

- ▶ Check the horizontal position of the crane before and during operation!
- ▶ If the crane operator leaves the cab, even for a short time, the operating mode setting must be checked and reset if necessary before resuming crane operation!

4.2 Checking the settings

- ▶ Check the function of the overload protection by running against the operating positions „on top“ and „bottom“.
- ▶ Check the hoist limit switch by running against the hoist limit switch weight.
- ▶ Check the function of the limit switches on the relapse cylinders.

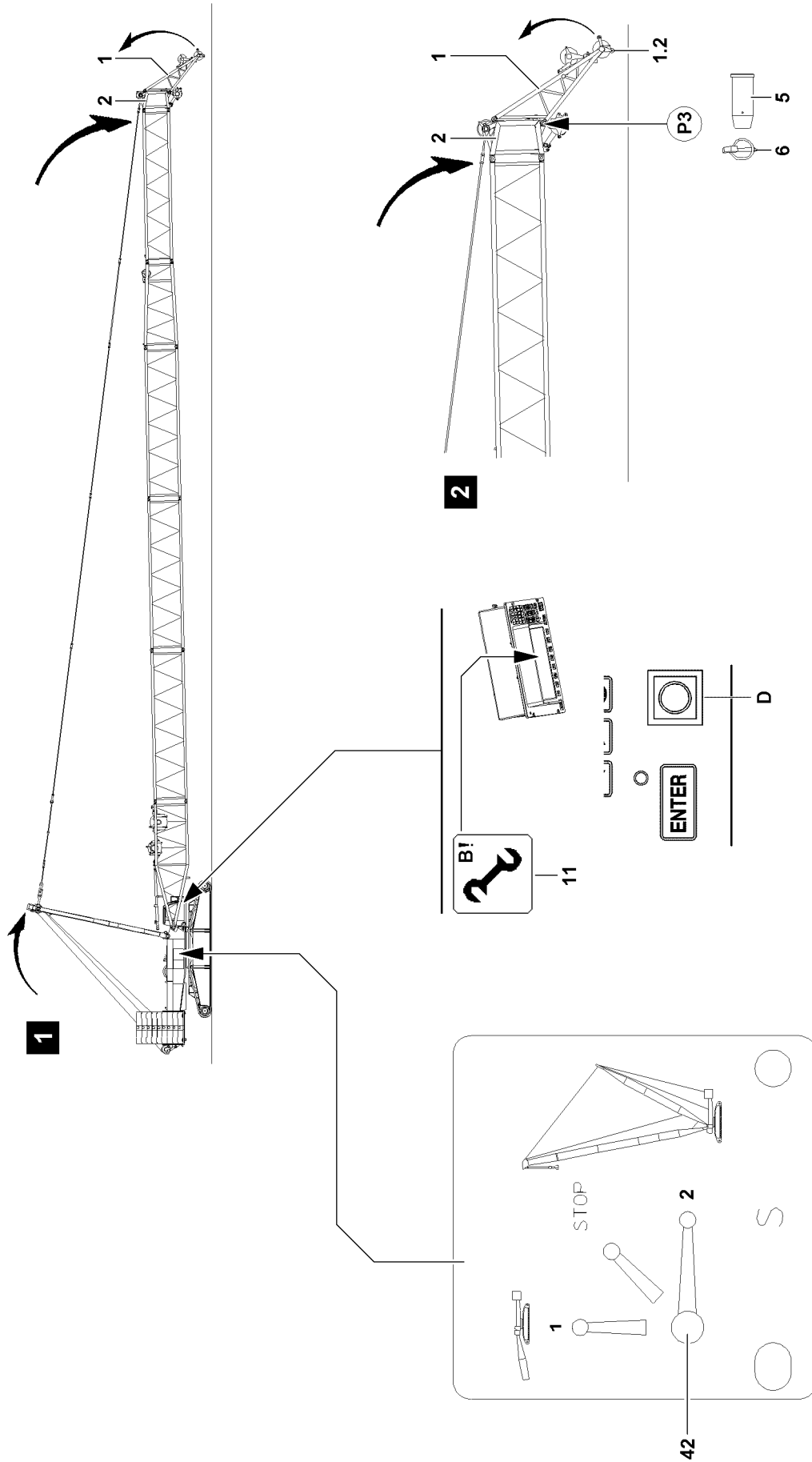

Fig.110796

LWE/LR 1600-2-008/18109-09-02/en

5 Removing the auxiliary jib „HS“



WARNING

Risk of falling!

During assembly / disassembly work, personnel must be secured with appropriate aids to prevent them from falling. If this is not observed, assembly personnel can fall and suffer life-threatening or fatal injuries!

- ▶ Any work, where there is a danger of falling must be carried out with suitable aids (for example lifting platform, scaffolding, ladder, auxiliary crane)!
- ▶ If the work cannot be carried out with such aids nor from the ground, then the assembly personnel must secure themselves with approved fall arrest systems to avoid falling, see Crane operating instructions, Chapter 2.04!
- ▶ Approved fall arrest systems must be hung into the respective fastening points on the crane, see Crane operating instructions, chapter 2.06!
- ▶ If railings are present on the components, then they must be brought into the corresponding position and secured for assembly / disassembly work!
- ▶ Step on aids and fall arresters only with clean shoes!
- ▶ Keep aids and fall arresters clean and free from snow and ice!
- ▶ During all assembly and disassembly work, maintenance work and inspections, travel and crane operation is prohibited!



WARNING

The lattice sections can fall down!

If the lattice sections are not pinned and secured correctly, then they can fall down and fatally injure personnel!

- ▶ Pin or unpin both pins at the same horizontal level, i.e. **left and right!**
- ▶ Do not stand under the booms or within the entire danger zone during the boom pinning and unpinning procedure!
- ▶ Safely secure the pins in the bearing points as well as receptacles!
- ▶ It is prohibited to lean the ladder against the component being disassembled!



WARNING

Danger of crushing!

When assembling crane components, limbs can be crushed or even severed due to oscillation of components!

- ▶ Make sure that the components do not swing back and forth during assembly!



DANGER

The components can fall down!

If the corresponding components are disengaged from the auxiliary crane before the corresponding component is pinned, the corresponding component can fall down and fatally injure personnel!

- ▶ Do not disengage the auxiliary crane until the corresponding component is pinned and secured!

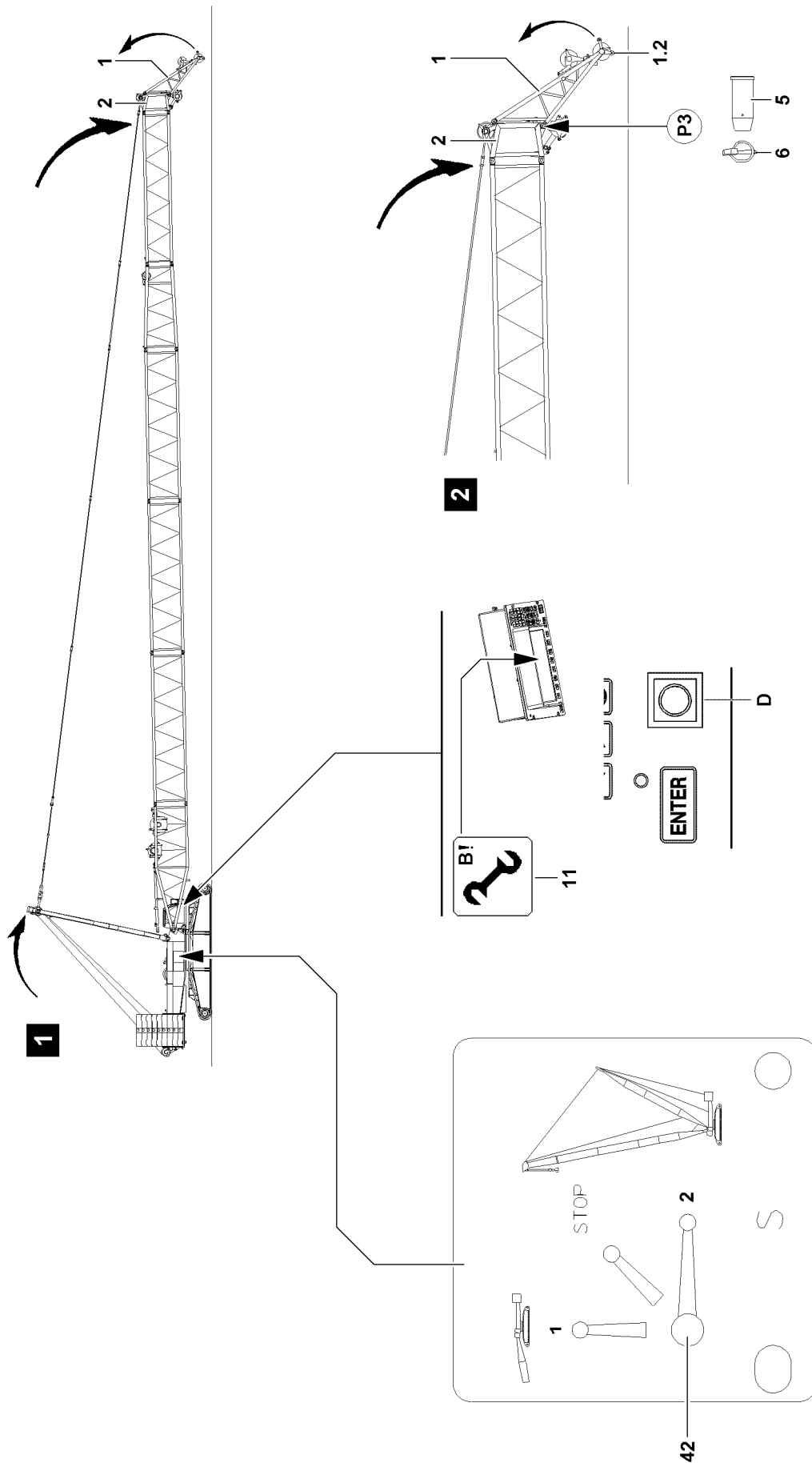

Fig.110796

LWE/LR 1600-2-008/18109-09-02/en

5.1 Placing the boom down



WARNING

The crane can topple over!

If the following conditions are not met before taking down the boom, the crane can topple over and fatally injure personnel!

- ▶ Observe the Safety technical notes, see Crane operating instructions, chapter 5.01!
- ▶ Observe the data in the erection and take down charts!

NOTICE

Damage of boom components!

Taking down the boom system can lead to a collision between the hook block and the pulley head. Boom components can be severely damaged!

- ▶ Luff the boom system down at the same time and spool the hoist winch out!

5.1.1 Luff the boom down



Note

- ▶ The luff down movement is turned off as soon as the lowest operating position of the S-boom is reached!
 - ▶ When the lowest operating position of the S-boom is reached, the load display in the maximum load icon turns off and instead of the load display appears the display „???“.
 - ▶ In the crane operating screen appear alarm functions!
-
- ▶ Luff the SL-boom down to the lowest operating position.

Result:

- The luffing movement is turned off.
- The „STOP“ icon appears on the LICCON monitor.
- The horn icon appears on the LICCON monitor.



WARNING

Assembly with turned on set up key!

When the set up key is engaged, the LICCON overload protection is exceeded!

In the event of deliberate improper use, the crane could collapse, the boom can break off or the crane can topple over!

Personnel can be killed!

This could result in high property damage!

- ▶ The set up key **D** may only be actuated by persons who know the effects of a bypass!
- ▶ Press the set up key **D** only when the set up status was correctly entered into the LICCON computer system!
- ▶ Observe the erection / take down charts!
- ▶ Crane operation with the set up key **D** turned on is strictly prohibited!

- ▶ Turn the set up key **D** to the right.

Result:

- The LICCON overload protection is deactivated.
 - The assembly icon **11** appears on the LICCON monitor.
- ▶ At the same time, spool the hoist winch out and luff the SL-boom down until the hook block touches the ground.

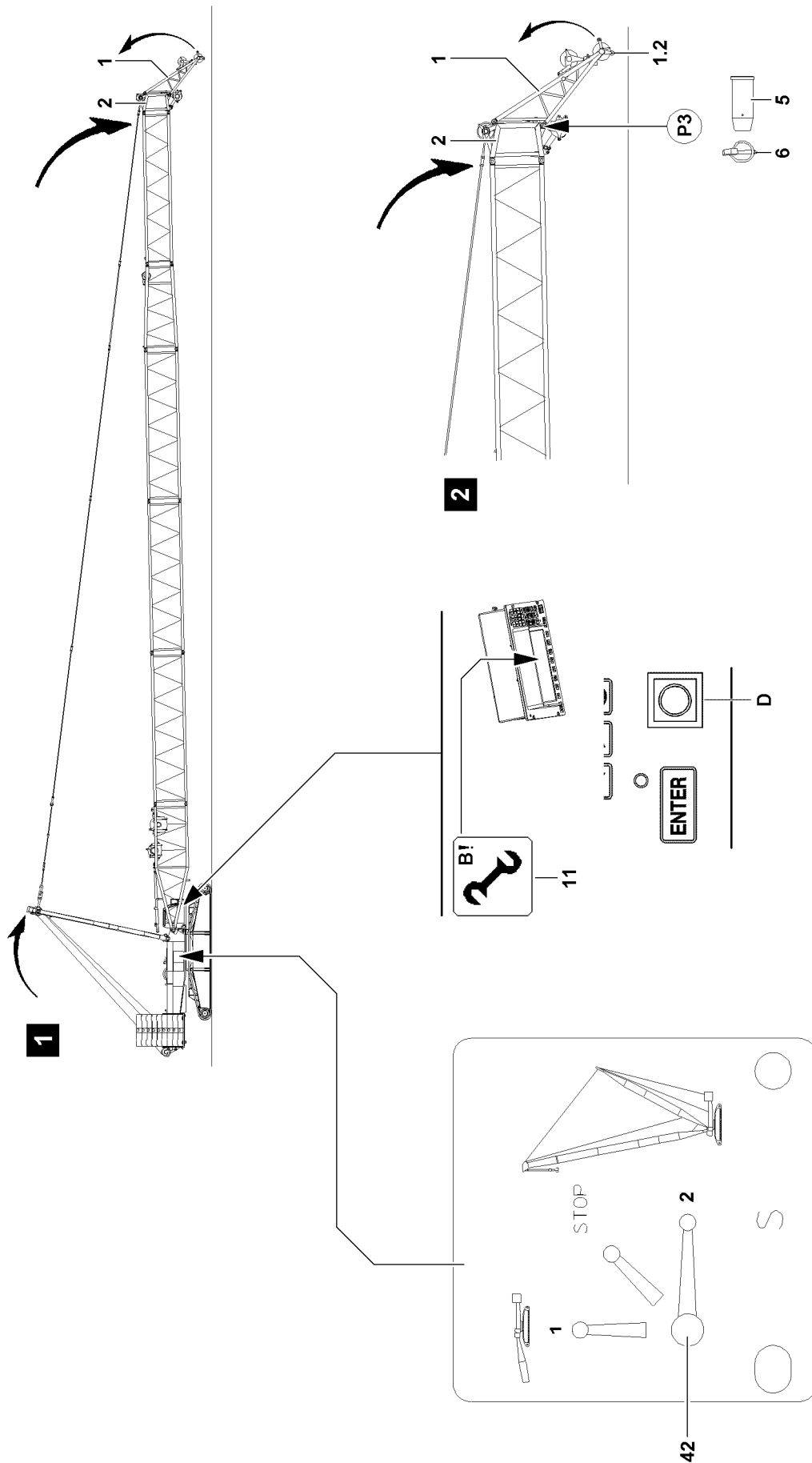

Fig.110796

LWE/LR 1600-2-008/18109-09-02/en

5.1.2 Unreeving the hook block

- ▶ Remove the hoist limit switch weight and unreeve the hook block.
- ▶ Carefully luff the SL-boom down until the auxiliary jib „HS“ 1 is just above the ground with the rollers 1.2.

When the rollers 1.2 are just above the ground:

- ▶ Unpin the pins 5 on the auxiliary jib „HS“ at point P3 „on the bottom“.

When the pins 5 are unpinned at point P3 „on the bottom“:

- ▶ Luff the SL-boom down slowly until the auxiliary jib „HS“ 1 folds out by itself.
- ▶ Continue to luff the SL-boom down.

Result:

- The auxiliary jib „HS“ 1 runs on the rollers 1.2 toward the „outside“.
- ▶ Place the SL-boom on the support.

5.1.3 Spooling the hoist rope up



WARNING

Falling hoist rope!

By spooling the hoist rope up, personnel can be severely injured or killed!

- ▶ All rope retaining pins / pipes on the auxiliary jib „HS“ 1 have been removed!
- ▶ All rope retaining pins / pipes on the SW-end section 3 and on the S-boom have been removed!
- ▶ Slowly spool up the hoist rope over the rope pulleys back to the winch!
- ▶ Make sure that no personnel may be found within the danger zone!

NOTICE

Over spooled winch!

If the rope is pulled under the winch when spooling up, then the adjustment of the winch turn sensor changes!

A new adjustment by **LIEBHERR Service** must be made!

- ▶ Stop the winch in time, with sufficient rope reserve!
- ▶ Do not over spool the winch!

- ▶ Spool up the hoist rope.

5.2 Disconnecting the electrical connections

Make sure that the following prerequisite is met:

- The SL-boom has been placed down.

NOTICE

Damage to the electrical connections on the cable drum!

If the electrical connection from the cable drum on the S-pivot section to the terminal box on the SW-end section is disconnected and spooled up, then the electrical connection from the cable drum to the terminal box on the S-pivot section can be damaged!

- ▶ Disconnect the electrical connection from the cable drum to the terminal box on the S-pivot section first and then the electrical connection from the terminal box to the SW-end section!
- ▶ Store the cable from the terminal box on the S-pivot section properly.
- ▶ Spool the cable drum up and secure it to prevent inadvertent spooling out.

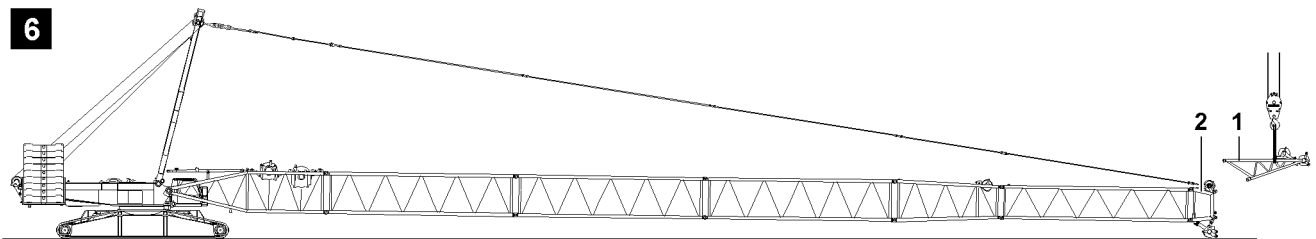
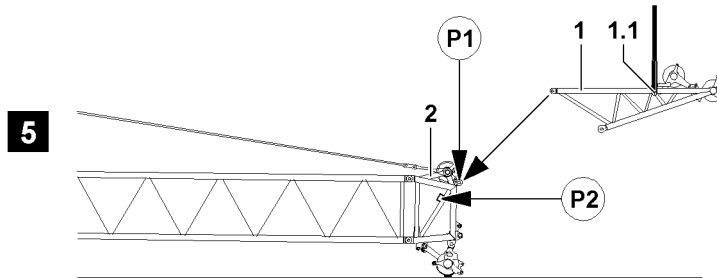
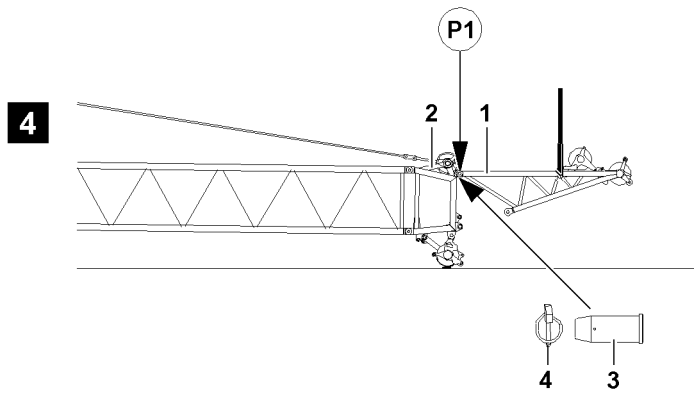
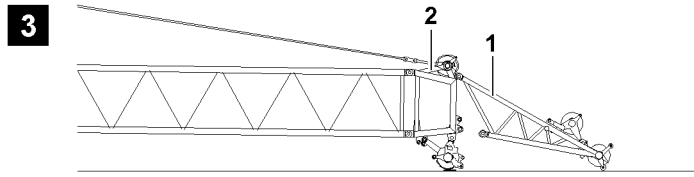

Fig.110608

LWE/LR 1600-2-008/18109-09-02/en

5.3 Removing the auxiliary jib „HS“



WARNING

Folding down boom!

If the following conditions are not met before disassembling the auxiliary jib „HS“ 1, the boom can fold down!

Personnel can be severely injured or killed!

- ▶ Support the SL-boom during disassembly with suitable materials!

Make sure that the following prerequisites are met:

- The SL-boom is placed on a load-bearing support.
- The auxiliary jib „HS“ 1 is laying on the ground.
- All electrical connections on the SL-boom are disconnected.

- ▶ Attach the auxiliary jib „HS“ 1 on the auxiliary crane.
- ▶ Lift the auxiliary jib „HS“ 1 with the auxiliary crane until the auxiliary jib „HS“ 1 hangs horizontally.
- ▶ Release and unpin pin 3 on the auxiliary jib „HS“ 1 at point P1.

When the pins 3 are unpinned:

- ▶ Remove the auxiliary jib „HS“ 1 with the auxiliary crane.
- ▶ Insert the pins 3 in the transport receptacle P2 on the SW-end section 2.



Note

- ▶ Carry out the removal of the SL-boom, see Crane operating instructions, chapter 5.38!
- ▶ Disassemble the SL-boom.

Empty page!

LWE/LR 1600-2-008/18109-09-02/en

5.61 Pulley cart

1	Overview components pulley cart	3
2	Installing / removing the pulley cart	5

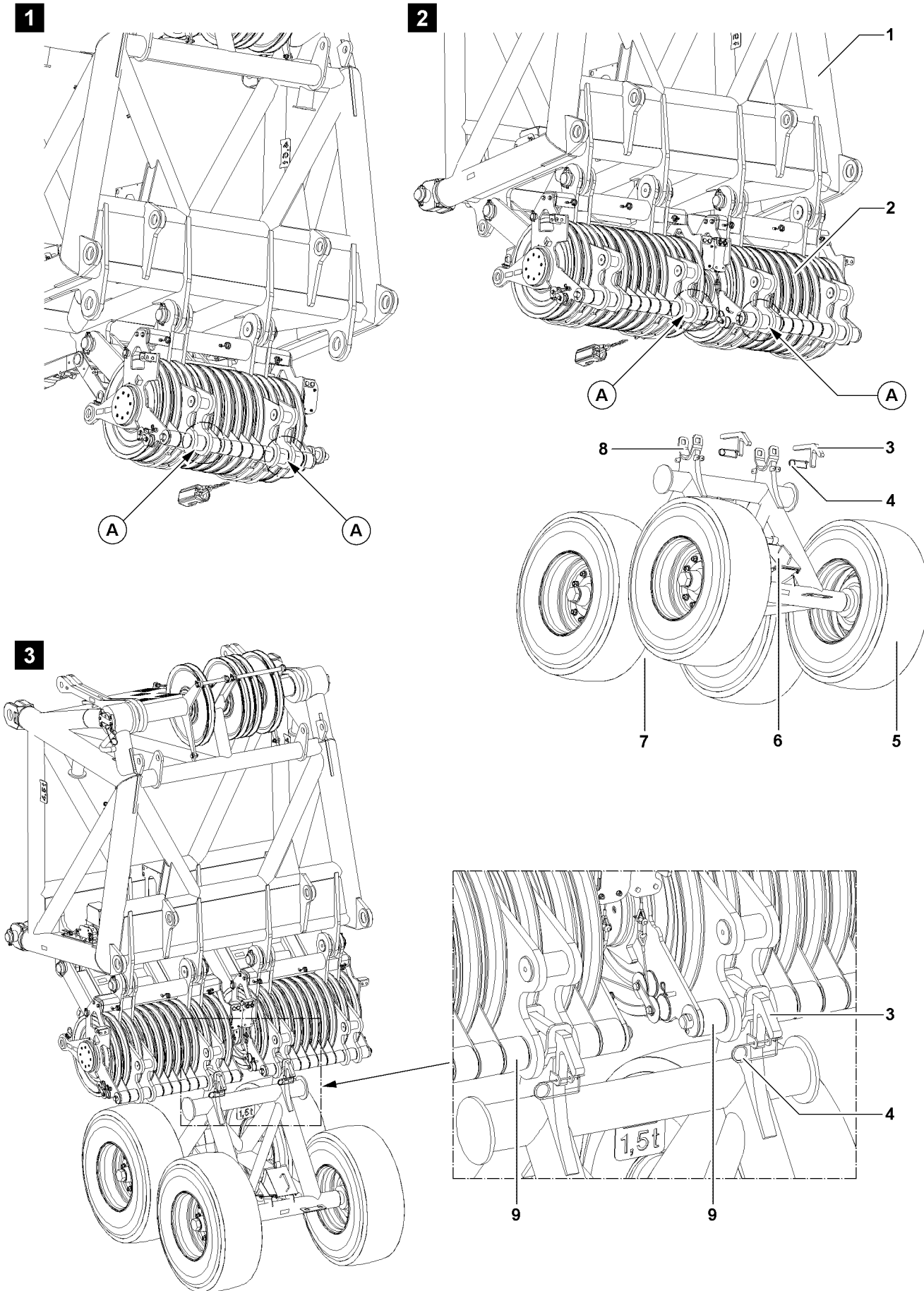

Fig.105346

LWE/LR 1600-2-008/18109-09-02/en

1 Overview components pulley cart

Position	Description
1	SW-end section
2	Roller set
3	Retainer
4	Spring retainer
5	Tires
6	Wedge
7	Pulley cart
8	Receptacle
9	Pulleys on the pulley set

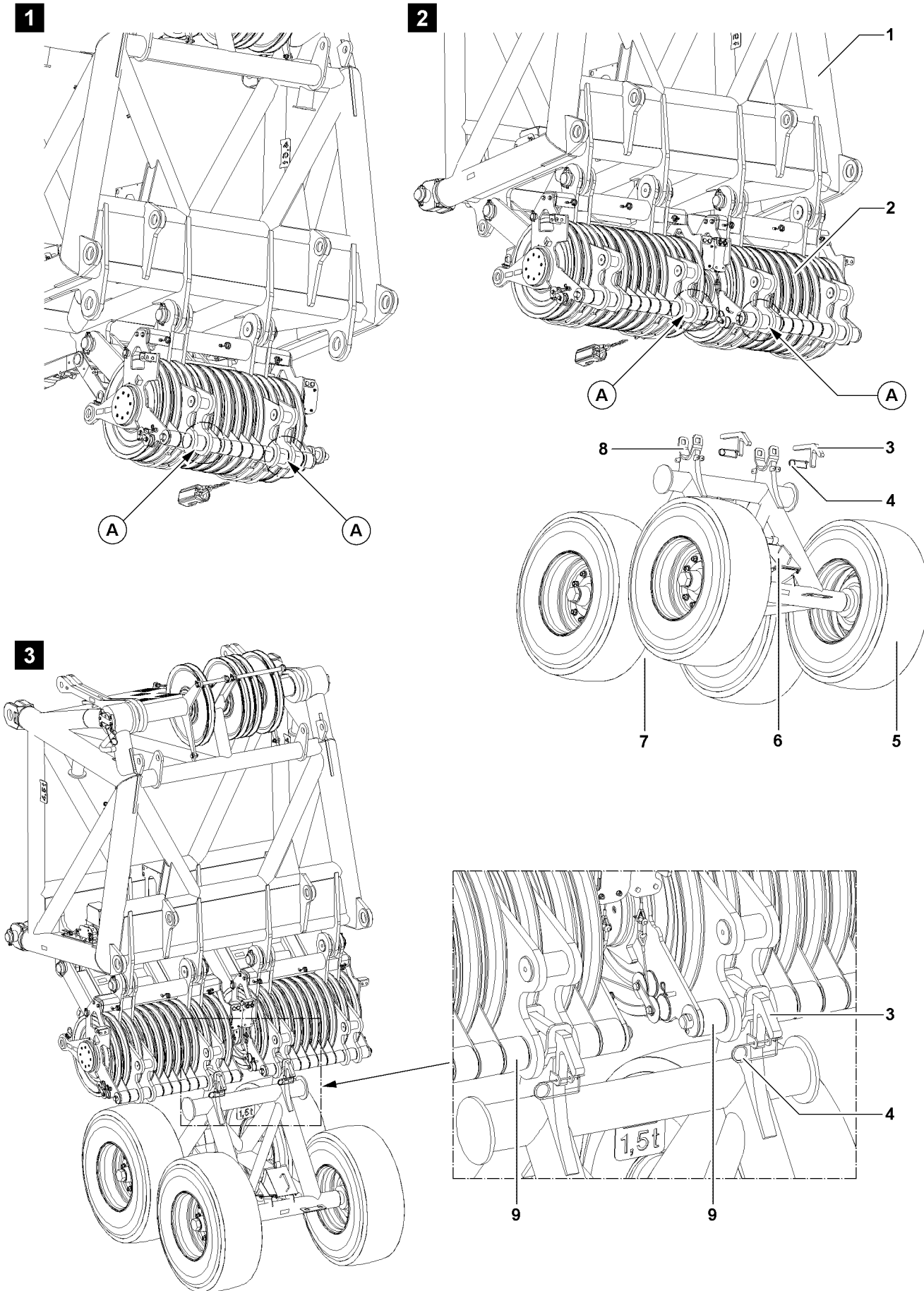

Fig.105346

LWE/LR 1600-2-008/18109-09-02/en

2 Installing / removing the pulley cart

2.1 Installing the pulley cart

- For illustration of a SW-end section with installed pulley set, see fig. 1.
- For installation of the pulley cart on example of a SW-end section with two pulley sets, see fig. 2 and fig. 3.
- ▶ Position the pulley cart 7 below the SW-end section 1 and secure the tires 5 with wedges 6.
- ▶ Slowly lower the SW-lattice jib until the pulleys of the pulley set 9 in point A are laying in the receptacle 8 of the pulley cart.
- ▶ Plug in the retainer 3 and secure with spring retainer 4.
- ▶ Remove the wedges 6.

2.2 Removing the pulley cart



WARNING

Risk of accident!

- ▶ Observe and adhere to the data in the erection and take down charts.
 - ▶ Observe chapter 5.07.
-
- ▶ Secure the pulley cart 7 with wedges 6.
 - ▶ Release the spring retainer 4 and pull the retainer 3.
 - ▶ Luff up boom combination.

Empty page!

LWE/LR 1600-2-008/18109-09-02/en

6 Additional equipment

LWE/LR 1600-2-008/18109-09-02/en

6.02 Heater / engine preheating / Air conditioning system Crane operator's cab

1 Heating the crane cab

3

Fig.195219

LWE/LR 1600-2-008/18109-09-02/en

1 Heating the crane cab

The cab can be heated with three independent heaters:

- Engine-dependent heater
- Engine-independent auxiliary heater with engine pre-heating, at ambient temperatures down to -40 °C , WEBASTO; Thermo 90 ST*
- Engine-independent auxiliary heater for cab preheating, at ambient temperatures less than -40 °C , WEBASTO; DBW 2020*

The individual heat adjustment (both for engine-dependent as well as the engine-independent auxiliary heater*) are made solely via the „Climate control settings“ menu on the touch display.

NOTICE

Damage in the electrical / electronic component area when carrying out electric welding work on the crane.

- ▶ Disconnect the negative and positive cables from the batteries and connect the positive cables to the vehicle ground.
-

2 Menu „Climate control settings“

2.1 General

The „Climate control settings“ menu is accessed - with the ignition turned on - by pressing the function key **F1** on the touch display.



Note

- ▶ The „Climate control settings“ menu is removed automatically after 30 sec. if no settings are changed during this time.

If the crane ignition is turned off, the LICCON computer system and the touch display also turn themselves off. The settings made in the „Climate control settings“ menu are retained.



Note

- ▶ If the auxiliary heater has been programmed, the settings are saved when the ignition is turned „OFF“.
-

2.2 Operating the touch display

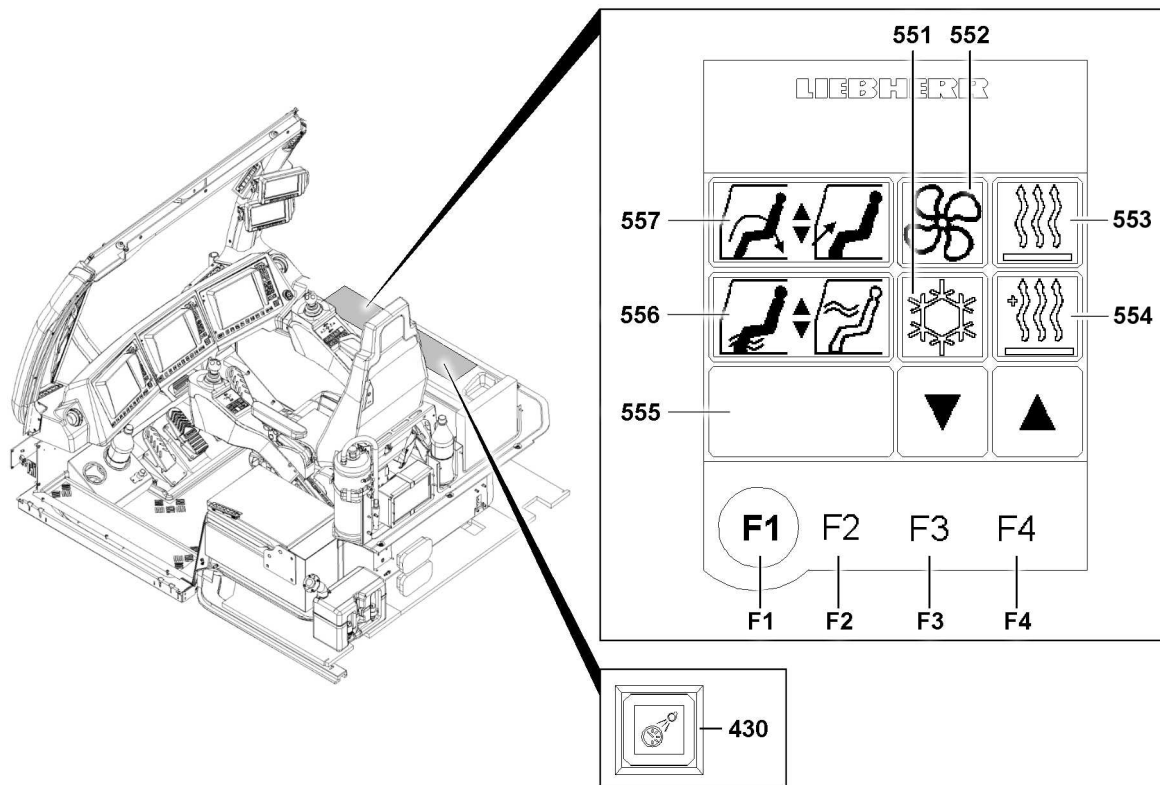

Fig.127301: Touch display in the right instrument panel

On the touch display, all functions are available for making and operating all heating, ventilation and air conditioning settings and for programming the auxiliary heater on the crane:

- **557** Recirculating air / fresh air
 - Function selection
- **556** Air distribution „up“ / „down“
 - Function selection
- **555** Status display
 - Display function

The status display **555** shows the following, depending on the selected function:

- The adjustment ratios between the overhead area and the floorboard area for recirculating air / fresh air.
- The adjustment ratios for air distribution.
- The temperature setting in manual heating mode.
- The temperature setting in AUTO heating mode.
- Climate control system „ON“.
- Climate control system „OFF“.
- The programming display for auxiliary heater.
- **551** Air conditioning system
 - Function selection
- **552** Fan / blower
 - Function selection
- **553** Heater
 - Function selection
- **554** Auxiliary heater
 - Function selection

The background illumination for the touch display can be turned on or off with the button **430**.

► Press the button **430**.

Result:

– The background illumination for the touch display is turned on.

► Press the button **430** again.

Result:

– The background illumination for the touch display is turned off.

2.3 Adjusting the recirculating air / fresh air

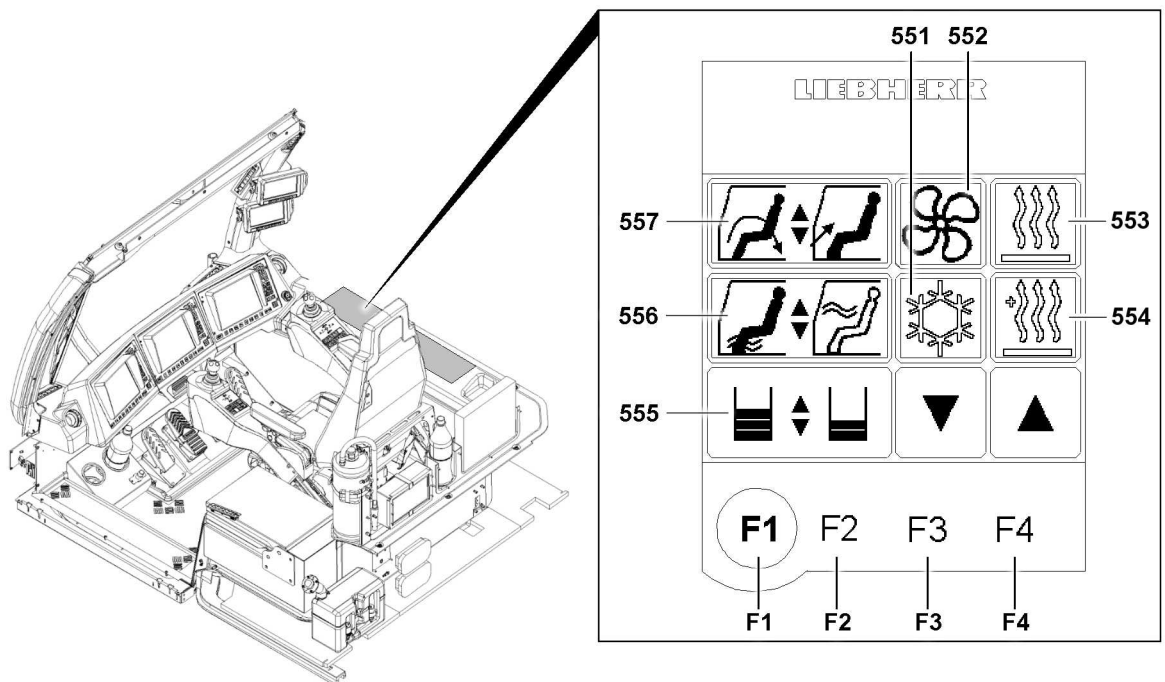









Fig.127302: Adjusting the recirculating air / fresh air

The „recirculating air / fresh air“ function is selected by „touching“ the icon **557** on the left touch display.

The adjustment rate is displayed in the status display **555** as a double bar display for „recirculating air“ and „fresh air“.

The adjustment rate between „recirculating air / fresh air“ is changed with the function key **F3** and the function key **F4**.

Adjustment rates for recirculating air / fresh air			
Status display	Recirculating air	Fresh air	Icon display
	5	0	 Fresh air „OFF“
	4	1	

Adjustment rates for recirculating air / fresh air			
	3	2	
	2	3	
	1	4	
	0	5	 <i>Recirculating air „OFF“</i>

- ▶ Select „Recirculating air / fresh air“ **557** function by „touching“.

Result:

- The „Recirculating air / fresh air“ icon is surrounded with a black border.
- The current adjustment rate is displayed in the status display **555** as a double bar display for „recirculating air“ and „fresh air“.

- ▶ Press the function key **F3**.

Result:

- The „proportion of circulating air“ is reduced, the „proportion of fresh air“ increases at the same time.

- ▶ Press the function key **F4**.

Result:

- The „proportion of fresh air“ is reduced, the „proportion of circulating air“ increases at the same time.

2.4 Adjusting the „lower“ / „upper“ air distribution

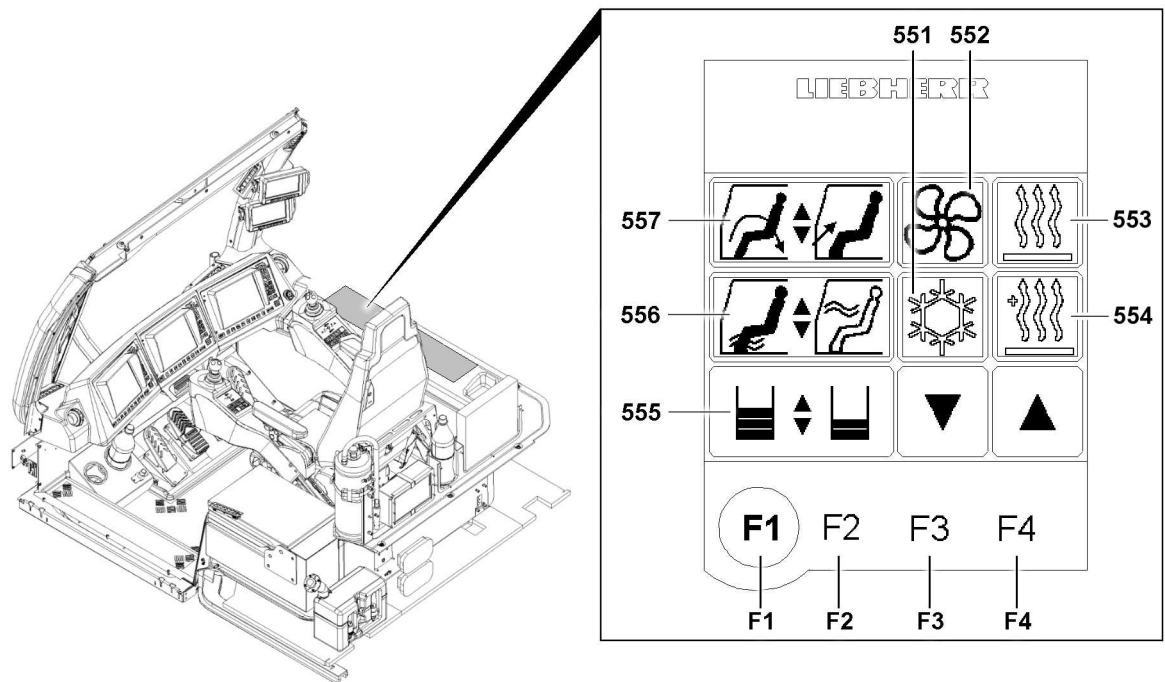



Fig.127302: Adjusting the lower / upper air distribution

The „lower“ / „upper“ air distribution function is selected by „touching“ the icon **556** on the left touch display.

The adjustment ratio is displayed in the Status display **555** - as a double bar display - for the „lower“ and „upper“ air distribution.

The „lower“ and „upper“ adjustment rate is changed with the function key **F3** and the function key **F4**.

Air distribution adjustment rates			
Status display	„Down“	„Up“	Icon display
	5	0	 Up „OFF“
	4	1	
	3	2	

Air distribution adjustment rates			
	2	3	
	1	4	
	0	5	 Down „OFF“

- ▶ Select Air distribution „upper / lower“ **556** function by „touching“.

Result:

- The „lower / upper“ air distribution icon is surrounded with a black border.
- The current adjustment rate is displayed in the status display **555** - as a double bar display - for „lower“ and „upper“.

- ▶ Press the function key **F3**.

Result:

- The proportion of air on the „bottom“ is reduced, the proportion of air on the „top“ increases at the same time.

- ▶ Press the function key **F4**.

Result:

- The proportion of air „on the top“ is reduced, the proportion of air „on the bottom“ increases at the same time.

2.5 Fan / blower adjustment

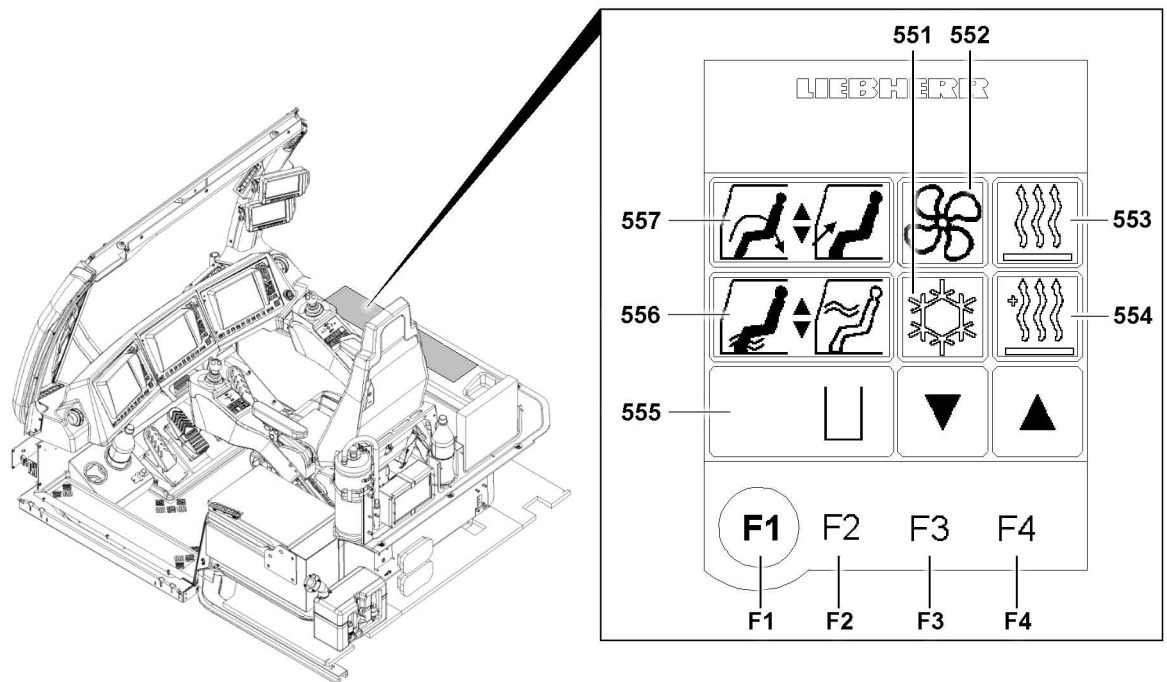

Fig.127303: Fan / blower adjustment

The „fan / blower“ function is selected by „touching“ the icon **552** on the left touch display.

The current „fan“ / „blower setting“ is shown as a bar display in the status display **555**.

The „fan“ / „blower setting“ is reduced with the function key **F3** and increased with the function key **F4**.

„Fan“ / „blower stage“		
Status display	Stage	Icon display
	5	
	4	
	3	
	2	
	1	
	0	 Fan „OFF“

LWE/LR 1600-2-008/18109-09-02/en

- ▶ Select „fan / blower **552**“ by „touch“.

Result:

- The „fan / blower“ icon is then surrounded with a black border.
- In the current status display **555**, the „fan“ / „blower stage“ is shown as a bar display.

- ▶ Press the function key **F3**.

Result:

- The „fan“ / „blower stage“ is reduced.

- ▶ Press the function key **F4**.

Result:

- The „fan“ / „blower stage“ is increased.

2.6 Climate control system operation

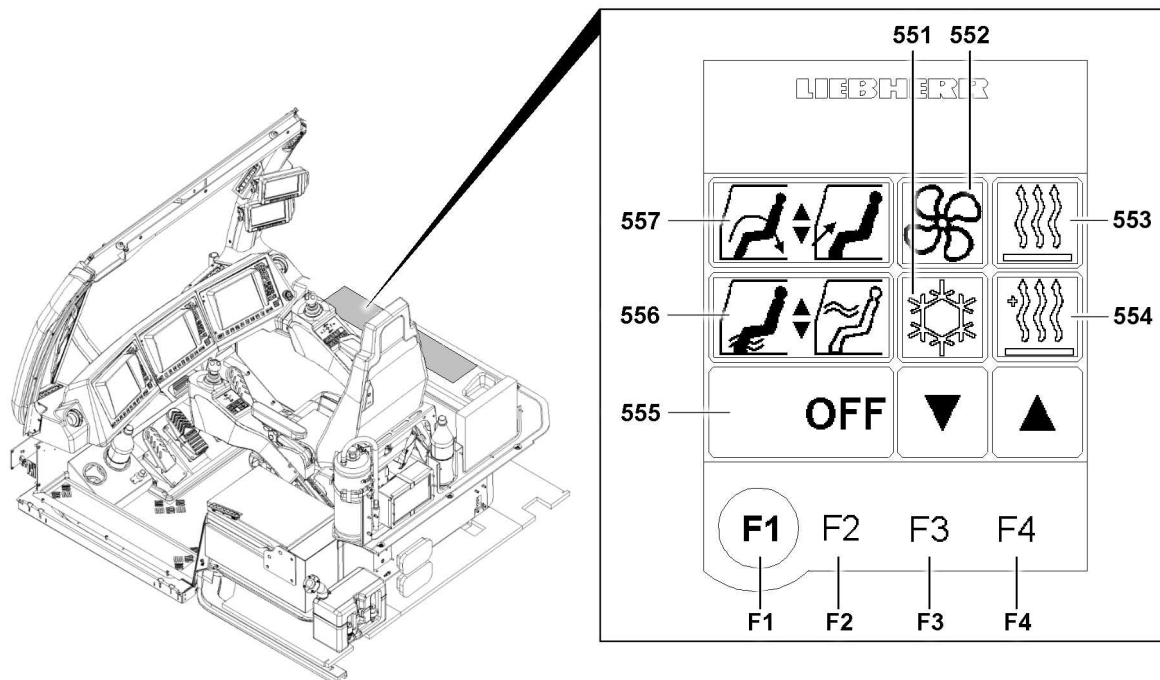

Fig.127304: Climate control system operation

The „Climate control system“ function is selected by „touching“ the icon **551** in the left touch display.





The status of the climate control system is displayed in the status display **555**.

The „Air conditioning system“ is turned off with the function key **F3** („OFF“) and turned with the function key **F4** („ON“).



Note

- ▶ The climate control system turns itself on automatically if the „AUTO“ heating mode is activated.

Air conditioning system		
Status display	Status	Icon display
	„OFF“	
	„ON“	

Make sure that the following prerequisites are met before operating the climate control system:

- The air intake opening for recirculated air operation is clear.
- All windows and the cab door are closed.
- The recirculating air / fresh air adjustment ratio is 5:0.
- ▶ Select „Climate control system **551**“ function by „touching“.

Result:

- The „Climate control system“ icon is surrounded with a black border.
- The switching status of the climate control system appears in the status display **555**.
- ▶ Press the function key **F3**.

Result:

- The climate control system is turned off.
- ▶ Press the function key **F4**.

Result:

- The climate control system is turned on.
- ▶ Open or close the air vents, as desired.
- ▶ Open the appropriate air vent for upward air distribution.
- ▶ Turn the fan / blower on.
- ▶ Select the heater and change into „MANUAL“ heating mode.
- ▶ Set the temperature stage.
- or**
- Select heater and change into „AUTO“ heating mode.
- ▶ Set the temperature in [°C] or [°F].

2.7 Turning the heater on

2.7.1 General

The „heater“ function is selected by „touching“ the icon **553** on the left touch display.

The status of the heater is displayed in the status display **555**.

The temperature is regulated in „MANUAL“ heating mode via the function key **F3** („reduce“ temperature) and function key **F4** („increase“ temperature).

Function key **F2** is used to switch from „MANUAL“ heating mode to „AUTO“ heating mode and vice versa.

2.7.2 Manual heating mode

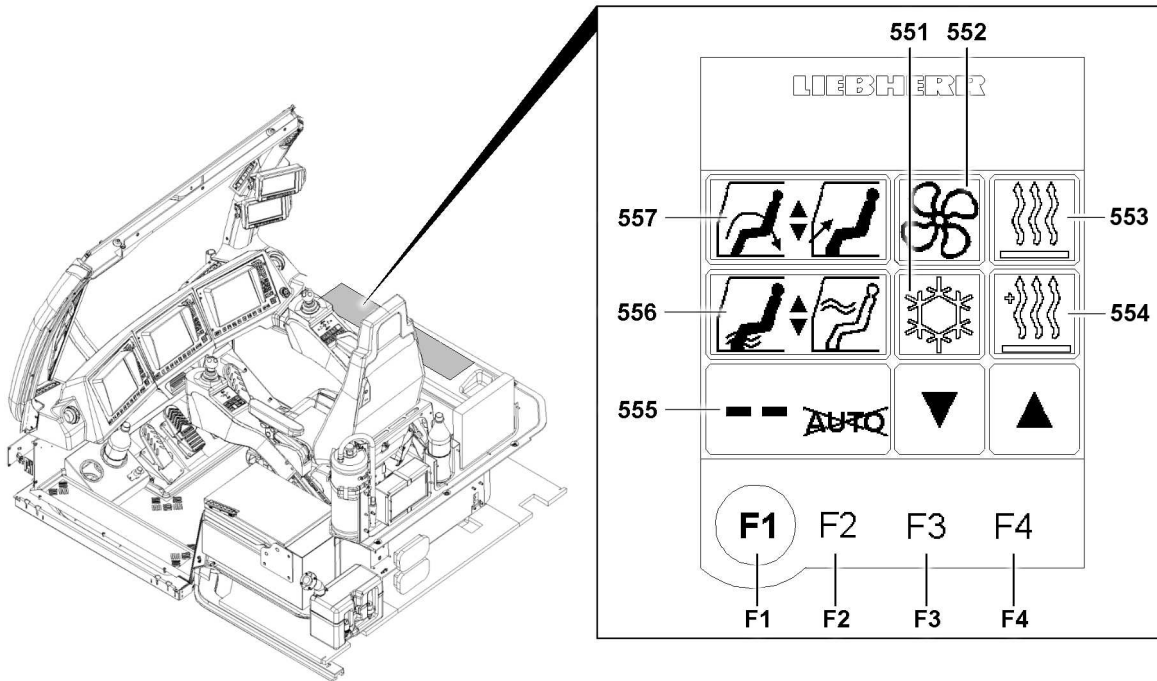

Fig.127305: Turning the heater on

In „MANUAL“ heating mode, the temperature stages - from stage 1 to stage 16 - are available to the crane driver for temperature adjustment.

With the function key **F3**, the temperature stages can be reduced from stage 16 in increments until „Heater OFF“.



Note

- ▶ If the status „Heater OFF“ is reached, the heater does not operate.
- ▶ The crane cab is **not** heated.

Press the function key **F4** to leave the „OFF“ status and to increase the temperature stages incrementally from stage 1 to maximum stage 16.

Heating mode „MANUAL“			
Status display	Status	Stage	Icon display
	„OFF“	--	 Heater „OFF“
	„ON“	1	
	„ON“	16	

- ▶ Select the „heater 553“ function by „touching“.

LWE/LR 1600-2-008/18109-09-02/en

Result:

- The „heater“ icon is then surrounded with a black border.
- The status display **555** contains the current status of the „heater“.

▶ Press the function key **F2**.

Result:

- Heating mode „AUTO“ is switched to heating mode „MANUAL“.

▶ Press the function key **F3**.

Result:

- The „temperature stages“ are reduced incrementally by one stage.
- The amount of warm air supply into the crane cab is reduced accordingly.

▶ Press the function key **F4**.

Result:

- The „temperature stages“ are increased incrementally by one stage.
- The amount of warm air supply into the crane cab is increased.

2.7.3 AUTO heating mode

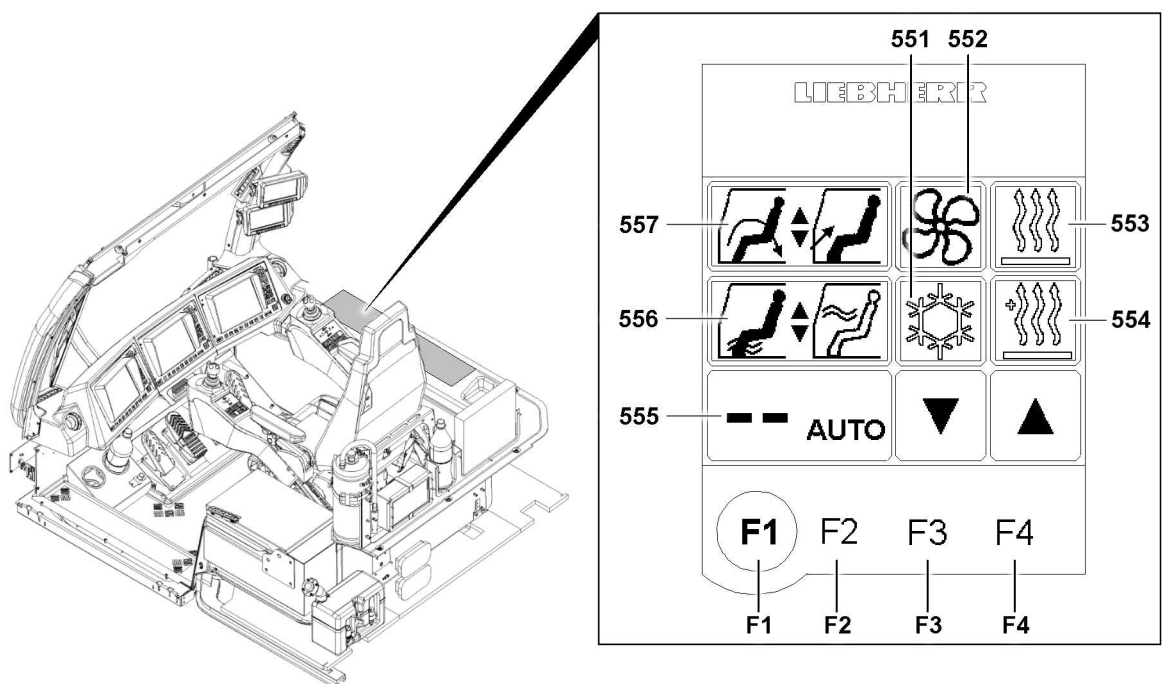

Fig.127306: AUTO heating mode

If heating mode „AUTO“ is selected, the climate control system is automatically enabled.

**Note**

- ▶ The blower / fan stage is automatically regulated in the „AUTO“ heating mode, whereby the maximum blower / fan stage is available, which was set before manually.

In „AUTO“ heating mode, the crane driver can adjust the temperature infinitely variable.

By pressing the function key **F3**, the temperature is reduced steplessly from maximum value to minimum value and if the function key **F3** is pressed again, the heater is turned off.

**Note**

- ▶ If a status „Heater OFF“ has been reached, the heater does **not** operate but the cab can continue to be cooled.
- ▶ The crane cab is **not** heated.

Leave the „OFF“ state by pressing the function key **F4** and the temperature can be increased infinitely variable from minimum value to maximum value.

Heating mode „AUTO“			
Status display	Status	Temperature in [°C] or [°F]	Icon display
	„OFF“	—	 <i>Heater „OFF“</i>
 <i>Minimum value</i>	„ON“	15	
 <i>Maximum value</i>	„ON“	30	

- ▶ Select the „heater **553**“ function by „touching“.

Result:

- The „heater“ icon is then surrounded with a black border.
- The status display **555** contains the current status of the „heater“.

- ▶ Press the function key **F2**.

Result:

- Heating mode „MANUAL“ is switched to heating mode „AUTO“.

- ▶ Press the function key **F3**.

Result:

- The „temperature setting“ is reduced in stages in 1 °C increments.
- The amount of warm air supply into the crane cab is regulated according to the current temperature setting.

- ▶ Press the function key **F4**.

Result:

- The „temperature setting“ is increased in stages in steps of 1 °C.
- The amount of warm air supply into the crane cab is regulated according to the current temperature setting.

2.8 Procedure for fogged windows

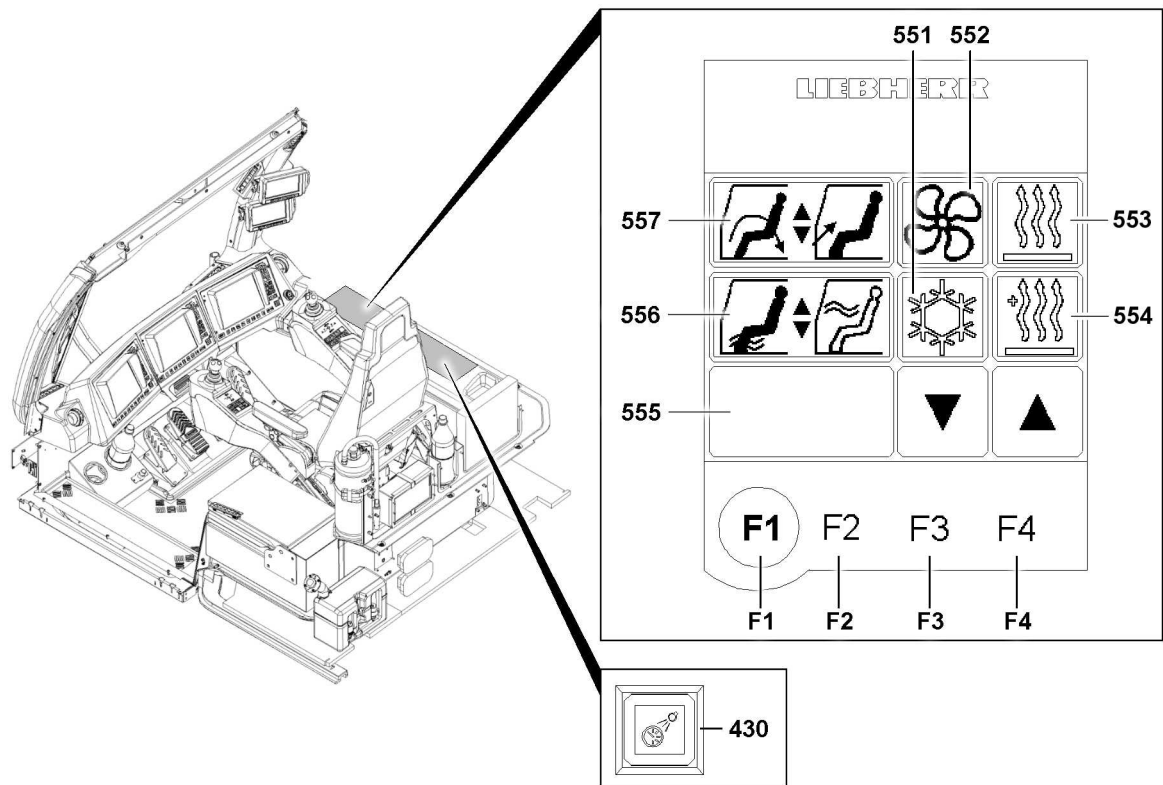

Fig.127301

2.8.1 General

A certain order must be followed to clear the windows quickly for subsequent crane operation. The settings can be made manually or semi-automatically.

2.8.2 Adjusting the settings manually in the „Climate control settings“ menu

- ▶ Set the air distribution **556** to maximum level „up“ - stage 5.
- ▶ Open the air vents.
- ▶ Set recirculating air **557** to maximum level - stage 5.
- ▶ Set the fan / blower **552** to maximum level - stage 5.
- ▶ Set the climate control system **551** to „ON“.
- ▶ Set the heater **553** to maximum possible level in „manual“ heating mode.
- ▶ If the crane engine is cold, add the auxiliary heater **554**, if required.

2.8.3 Making adjustments semi-automatically in the „Climate control settings“ menu

- ▶ Set the heater **553** to „AUTO“ heating mode.
- ▶ Set the air distribution **556** to maximum level „up“ - stage 5.
- ▶ Open the air vents.
- ▶ If the crane engine is cold, add the auxiliary heater **554**, if required.



Note

- ▶ The other functions are automatically added by the system.

2.9 Operating the engine-independent auxiliary heater

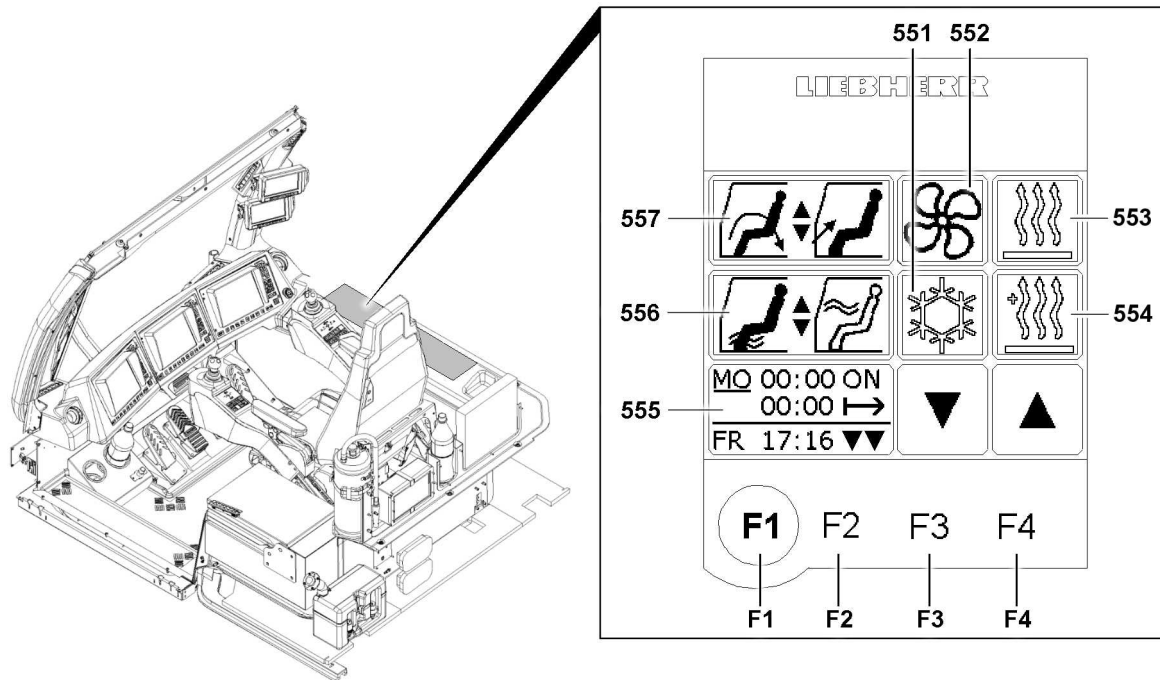

Fig.127307

The engine-independent auxiliary heater is used to heat the crane cab when the engine is turned off and as auxiliary heater at low ambient temperatures, if the engine-dependent heater is insufficient.

At ambient temperatures of below $-20\text{ }^{\circ}\text{C}$, the crane engine must be pre-heated by the engine-independent auxiliary heater. In this case, the crane cab does not have to be heated too.



Note

- In summer, run the auxiliary heater once a month for approx. 15 to 20 minutes.

Carry out maintenance work on the auxiliary heater according to the supplied manufacturer's operating instructions.

2.9.1 General

NOTICE

Damage of auxiliary heater!

- Fill all units with sufficient service fluids for winter operation according to the lubrication chart.



DANGER

Danger of poisoning and suffocation in enclosed areas!

- Only operate the engine-independent auxiliary heater in enclosed areas such as garages or workshops only if an exhaust system is used, even in „Programming mode“.



DANGER

Danger of explosion!

In areas where combustible fumes or dust could form, e.g. in the vicinity of storage areas for fuel, coal, wood dust or grain or similar and in the vicinity of filling stations or tank farms, there is a danger of explosion.

- Turn the auxiliary heater off.

2.9.2 Adding the engine-independent auxiliary heater manually

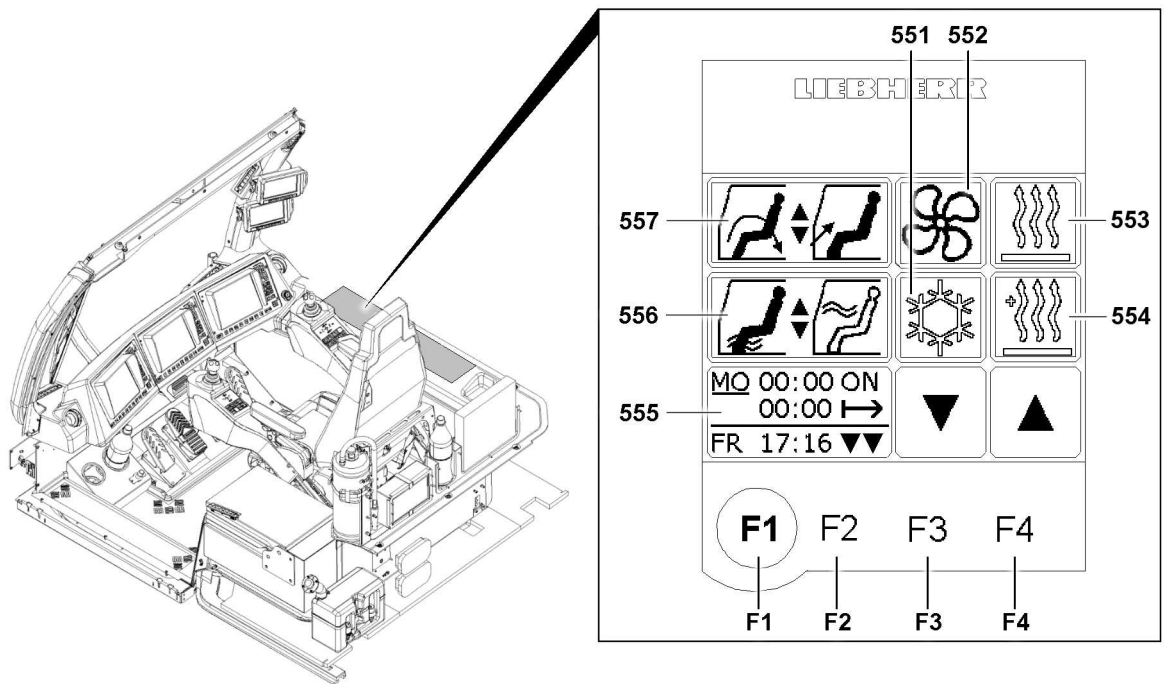

Fig.127307

The engine-independent auxiliary heater can be added manually in driving or crane operation mode. The auxiliary heater, icon **554**, must be selected and turned on.



If the auxiliary heater is in the „OFF“ state, pressing function key **F4** once adds the cab auxiliary heater.

Pressing the function key **F4** again turns engine preheating auxiliary heater on.



Note

► If the auxiliary heater it added for engine pre-heating, then the crane cab is **not** heated.

Manual auxiliary heater			
Status display	Function key F4	Function key F3	Icon display
MO 06:45 ON 00:30 → FR 17:16 OFF	▲ (F4)	---	 Auxiliary heater „OFF“
MO 06:45 ON 00:30 → FR 17:16 ON	▲ (F4)	▼ (F3)	 Auxiliary heater - cab „ON“
MO 06:45 ON 00:30 → FR 17:16 ON _≈	▲ (F4)	▼ (F3)	 Auxiliary heater - engine pre-heating „ON“

LWE/LR 1600-2-008/18109-09-02/en

Engaging the auxiliary heater

- ▶ Select heat **553** and set the required temperature via function key **F3** or function key **F4** (see section entitled „Turning the heater on“).



Note

- ▶ The temperature adjustment via function key **F3** or function key **F4** is only needed to heat the crane cab.

- ▶ Select auxiliary heater **554** and press function key **F3** or function key **F4** until the required setting is displayed in the status display **555** (see chart).

Result:

- The auxiliary heater is switched on.
- Depending on the setting, the crane cab or the engine is heated.



Note

- ▶ When the crane cab is „warm“ and the engine is at the operating temperature, turn the auxiliary heater off.
- ▶ This increases the service life of the auxiliary heater.

Turning the auxiliary heater off

- ▶ Select auxiliary heater **554** and press the function key **F3** until the status display **555** shows the setting auxiliary heater „OFF“ (**OFF**).

Result:

- The auxiliary heater is turned off.
- An shut off delay is carried out each time the auxiliary heater is turned off.
- ▶ Turn the battery master switch off if the crane is temporarily not being used.

2.9.3 Adding the engine-independent auxiliary heater in programming mode

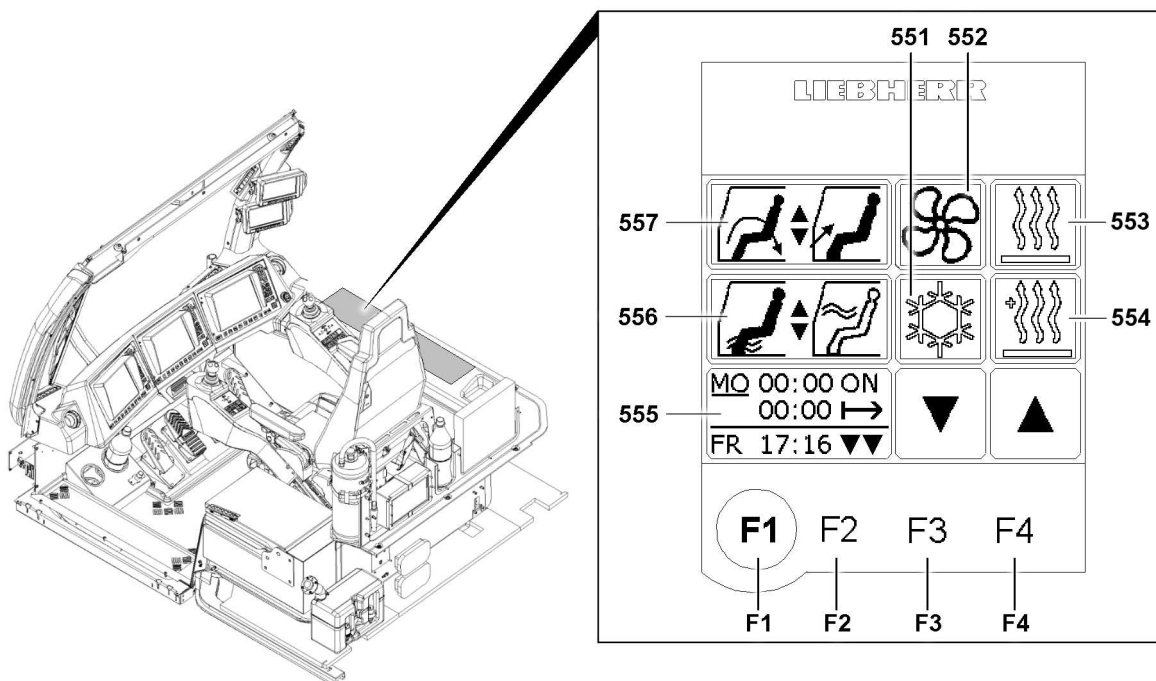

Fig.127307

The engine-independent auxiliary heater to heat the cab or for engine preheating can be programmed a **maximum** of one week in advance.



Note







- It is advisable to restrict auxiliary heater programming to two days, since there is a risk of the battery discharging extremely quickly at minus temperatures.

NOTICE

Clogging of auxiliary heater

In the transitional period, the auxiliary heater can clog up and be damaged as a result of the short time in operation.

- By selecting the program „Summer operation“, the clogging and damage of the auxiliary heater can be prevented.

Auxiliary heater programmed			
Status display	Function key F4	Function key F3	Icon display
<div style="border: 1px solid black; padding: 2px; width: fit-content;"> MO 06:45 ON 00:30 → FR 17:16 OFF </div>	▲ (F4)	---	 Auxiliary heater „OFF“
<div style="border: 1px solid black; padding: 2px; width: fit-content;"> MO 06:45 ON 00:30 → FR 17:16 ☼ </div>	▲ (F4)	▼ (F3)	 Auxiliary heater „Summer operation“
<div style="border: 1px solid black; padding: 2px; width: fit-content;"> MO 06:45 ON 00:30 → FR 17:16 ON </div>	▲ (F4)	▼ (F3)	 Auxiliary heater „On“
<div style="border: 1px solid black; padding: 2px; width: fit-content;"> MO 06:45 ON 00:30 → FR 17:16 ⌚ </div>	▲ (F4)	▼ (F3)	 Auxiliary heater „programmed“
<div style="border: 1px solid black; padding: 2px; width: fit-content;"> MO 06:45 ON 00:30 → FR 17:16 ON⌚ </div>	▲ (F4)	▼ (F3)	 Auxiliary heater with engine preheating „On“
<div style="border: 1px solid black; padding: 2px; width: fit-content;"> MO 06:45 ON 00:30 → FR 17:16 ⌚⌚ </div>	---	▼ (F3)	 Auxiliary heater with engine preheating „programmed“

LWE/LR 1600-2-008/18109-09-02/en

Programming the auxiliary heater

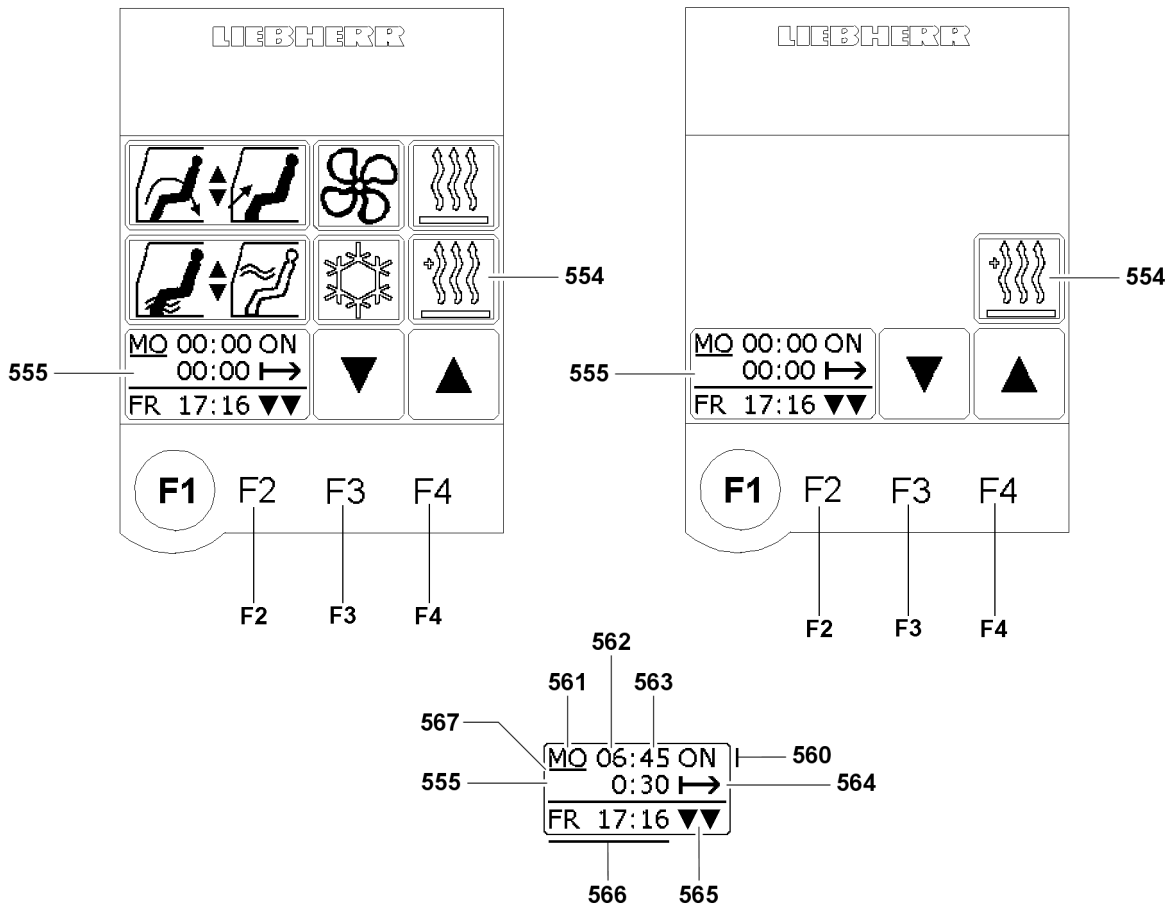

Fig.127308

In order to access auxiliary heater programming mode, press the function key **F4** until the status display shows the „clock“ (programming mode for cab heater), or the „clock with wave“ (programming mode for engine preheating), illustration 1.

The status display **555** contains the current day of the week with the time **566**. The time in the status display **555** is coupled to the „real-time clock“ in the test system.



Note

- ▶ The procedure for programming the auxiliary heater (to heat the crane cab or for engine preheating) is identical in both cases.

Make sure that the following prerequisites are met **before** the auxiliary heater is programmed:

- The desired temperature for the heater has been set.
- The fan / blower is set to stage 0 („OFF“).
- The desired programming mode, cab heater („clock“) or engine preheating („clock with wave“) has been set.

- ▶ Press the function key **F2**.

Result:

- The auxiliary heater programming interface is displayed, illustration 2.
- The status display **555** shows the cursor **567** below the editable input value.



Note

- ▶ The cursor **567** is positioned on day programming **560** by default.

- ▶ Press the function key **F4** and select the required day of the week **561** (**ascending** order).
- or
- ▶ Press the function key **F3** and select the required day of the week **561** (**descending** order).

Result:

- The selected day of the week is „set“.

- ▶ Press the function key **F2**.

Result:

- The cursor **567** changes from day programming **561** to hour programming **560**.

- ▶ Press the function key **F4** and select the desired hour **562** (**ascending** order).
- or
- ▶ Press the function key **F3** and select the desired hour **562** (**descending** order).

Result:

- The selected hour is „set“.

- ▶ Press the function key **F2**.

Result:

- The cursor **567** changes from hour programming **562** to minute programming **563**.

- ▶ Press the function key **F4** and select the desired minute **563** (**ascending** order).
- or
- ▶ Press the function key **F3** and select the desired minute **563** (**descending** order).

Result:

- The selected minute is „set“.

- ▶ Press the function key **F2**.

Result:

- The cursor **567** changes from minute programming **563** to turn on duration **564**.

- ▶ Press the function key **F4** and select the desired turn on duration **564** (**ascending**).
- or
- ▶ Press the function key **F3** and select the desired turn on duration **564** (**descending**).

Result:

- The selected turn on duration **564** is „set“.

**Note**

- ▶ The turn on duration **564** for the auxiliary heater is restricted to a maximum of **0:55 minutes**.
 - ▶ The cursor **567** automatically changes to the minutes setting for the turn on duration **564**.
 - ▶ The turn on duration **564** can only be changed in 5 minute increments.
-

- ▶ Press the function key **F2**.

Result:

- The cursor **567** changes from turn on duration **564** to day programming **560**.
- The programming for the auxiliary heater is complete.

- ▶ Select the auxiliary heater **554** icon by „touching“.

Result:

- The programmed settings are taken over.
- The „Climate control settings“ menu is displayed.
- The auxiliary heater starts to operate when the programmed turn on time for the heater operation is reached and turns the heater operation off again when the selected turn on duration has expired.

- The auxiliary heater runs in automatic regulating operation, depending on the heater setting in „manual“ or „AUTO“.

**Note**

- ▶ The auxiliary heater programming must be manually reset to „zero“ after the programmed heating period. Otherwise, the auxiliary heater is turned on automatically according to the programming.

Resetting the auxiliary heater programming

To reset the auxiliary heater programming, proceed as described in „Auxiliary heater programming“.

- ▶ Reset the values in the status display **555** to „zero“.

Result:

- The programming is turned off.

**Note**

- ▶ The programming can be manually changed at any time or it can be turned off altogether.

2.10 Bleeding the heating system

When draining the engine coolant, the contents of the heating system will also be drained because the engine and heater operate as one circuit. When refilling the system, it must be carefully bled.

- ▶ Fill the coolant via the expansion tank of the engine cooling circuit as specified in the lubrication chart.
- ▶ Start the engine as described in the Crane operating instructions, chapter 4.03.
- ▶ Set the heater to „warm“.
- ▶ Check the expansion tank for air bubbles.

Result:

- The engine is bled as soon as no more air bubbles rise up.

When no more air bubbles appear in the expansion tank:

- ▶ Set the heater to „cold“.

Result:

- The heater circuit will be bled.
- ▶ Check the expansion tank for air bubbles.

Result:

- The heater circuit is bled as soon as no more air bubbles rise up.

6.05 Emergency take-down

1	Emergency operation	3
2	Emergency operation with assembly plate Variation 1 (V1)	9
3	Emergency operation of slewing gear(s) with assembly plate Variation 1 (V1)	15
4	Emergency operation with assembly plate(s) Variation 2 (V2)	19
5	Emergency operation slewing gear(s) with assembly plate(s) Variation 2 (V2)	29
6	Emergency operation of winch 4 (W IV) on the LR1600/2 and LR1600/2-W	33
7	Ending emergency operation	37

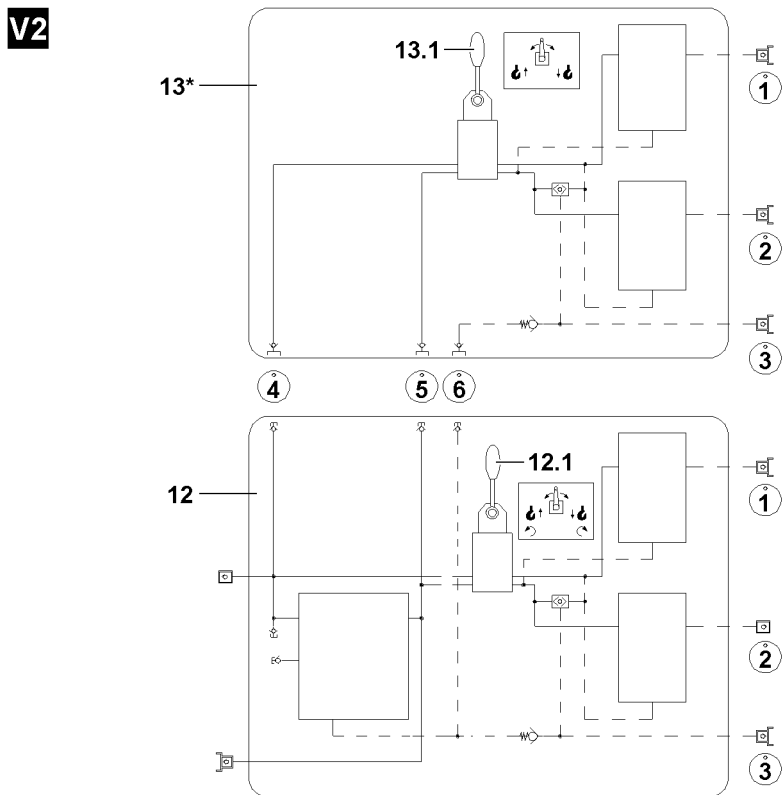
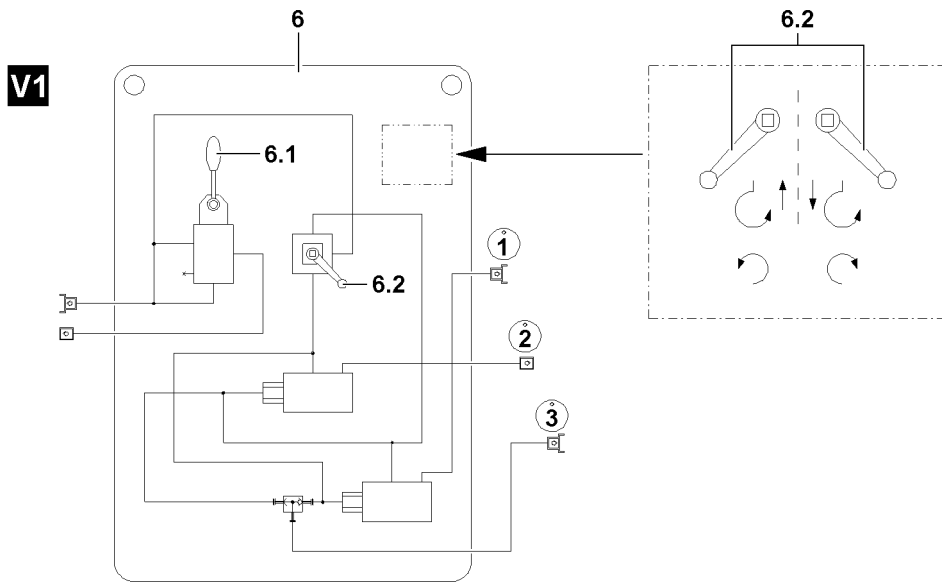

Fig.109407

LWE/LR 1600-2-008/18109-09-02/en

1 Emergency operation



Note

► The illustrations in this chapter are examples and may not apply exactly to your crane!



Note

► Before you start with preparations for emergency operation, check which of the following assembly plates you have available to carry out the emergency operation!

There are two **different** variations of assembly plates.

With variation 1 **V1**, all winches, which are equipped with the respective auxiliary hydraulic for emergency operation and the slewing gear can be actuated, each individually.

With variation 2 **V2**, which consists of two assembly plates, all winches, which are equipped with the respective auxiliary hydraulic for emergency operation can be actuated, each individually, **or** winch 1 **WI** and winch 2 **WII** can be actuated in parallel operation or the slewing gear can be actuated individually.



Note

► Observe the following charts!

	Variation 1 (V1)	Variation 2(V2)
	each in individual operation	each in individual operation
Winch 1	X	X
Winch 2	X	X
Winch 1II2 ¹⁾	—	X
Winch 3	X	X
Winch 4	X	X
Winch 5	X	X
Winch 6	X	X
Slewing gear	X	X

1) Parallel operation Winch 1 and winch 2 (1II2)

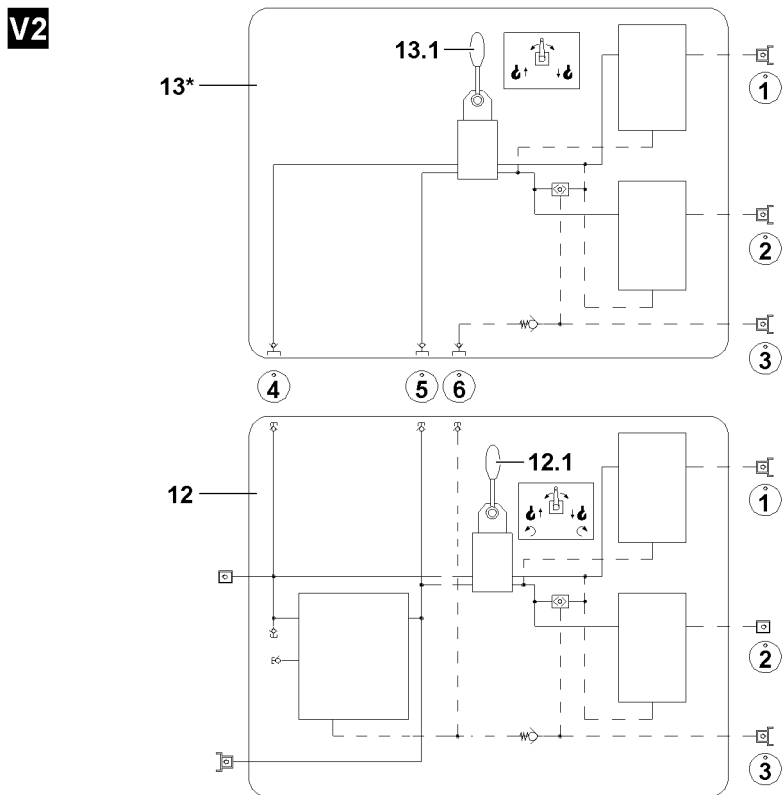
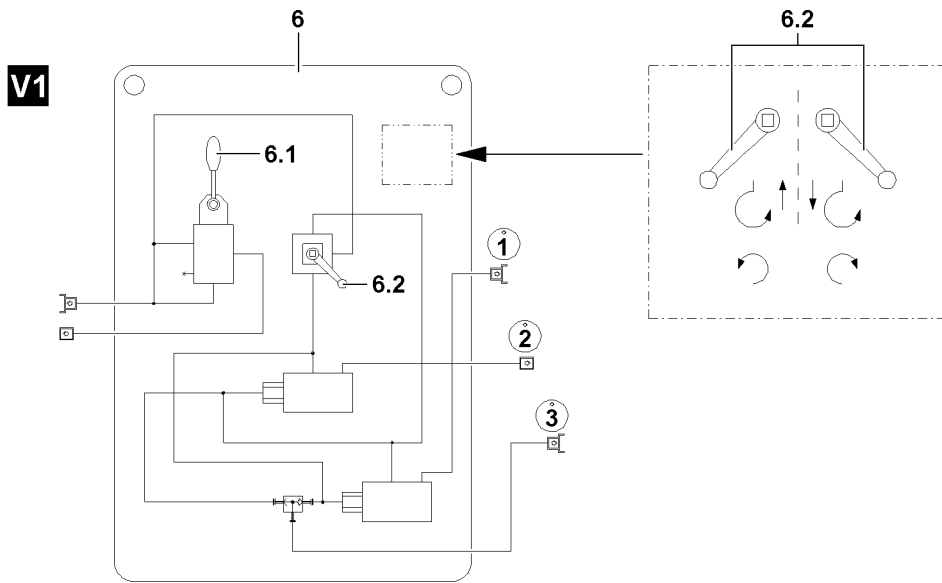

Fig.109407

LWE/LR 1600-2-008/18109-09-02/en

1.1 General danger notes



DANGER

Significant accident risk during emergency operation!

During an emergency operation, crane movements are no longer monitored by the LICCON computer system!

In the event of improper operation or deliberate misuse, the crane can topple over!

There is an increased risk of accident if the following danger notes are not observed!

Personnel can be severely injured or killed!

This could result in high property damage!

► All hazard warnings are to be observed and maintained!

General danger notes!

1. **Emergency operation of the crane superstructure may only be carried out:**

- To remove a dangerous situation.
- After consultation with customer service at LIEBHERR-Werk Ehingen GmbH.
- By authorized personnel who are knowledgeable of the hydraulic circuit diagram, the connection diagram and carrying out emergency operation.
- By authorized personnel who are aware of the risks of emergency operation.
- To carry out load reducing movements.

2. The danger zone must be blocked off!

3. No persons or objects may remain in the danger zone!

4. If a load is on the hook, then it must first be set down to relieve the boom!

5. During emergency operation, all safety devices, with the exception of „winch spooled out“ are automatically bypassed!

6. In the event of a defect or failure of the LICCON computer system, each step must be carried out and monitored with extreme caution and care, since a visual check on the LICCON monitor is no longer possible. Visual check!

7. All crane movements must be travelled with extreme caution and at the lowest speed!

8. The crane operator must be in visual contact with auxiliary personnel or guides person!



Note

Please note!

► The hydraulic supply for the crane can, to the extent that the crane has been equipped, take place through an emergency unit*. If this is not the case, the crane must be taken down by using additional auxiliary cranes!



WARNING

The crane can topple over!

► The boom may only be luffed down if the stability of the crane permits this action, observe information in the load tables and maintain them!

► When taking down the boom, the information in the erection and take down charts are to be observed and followed!

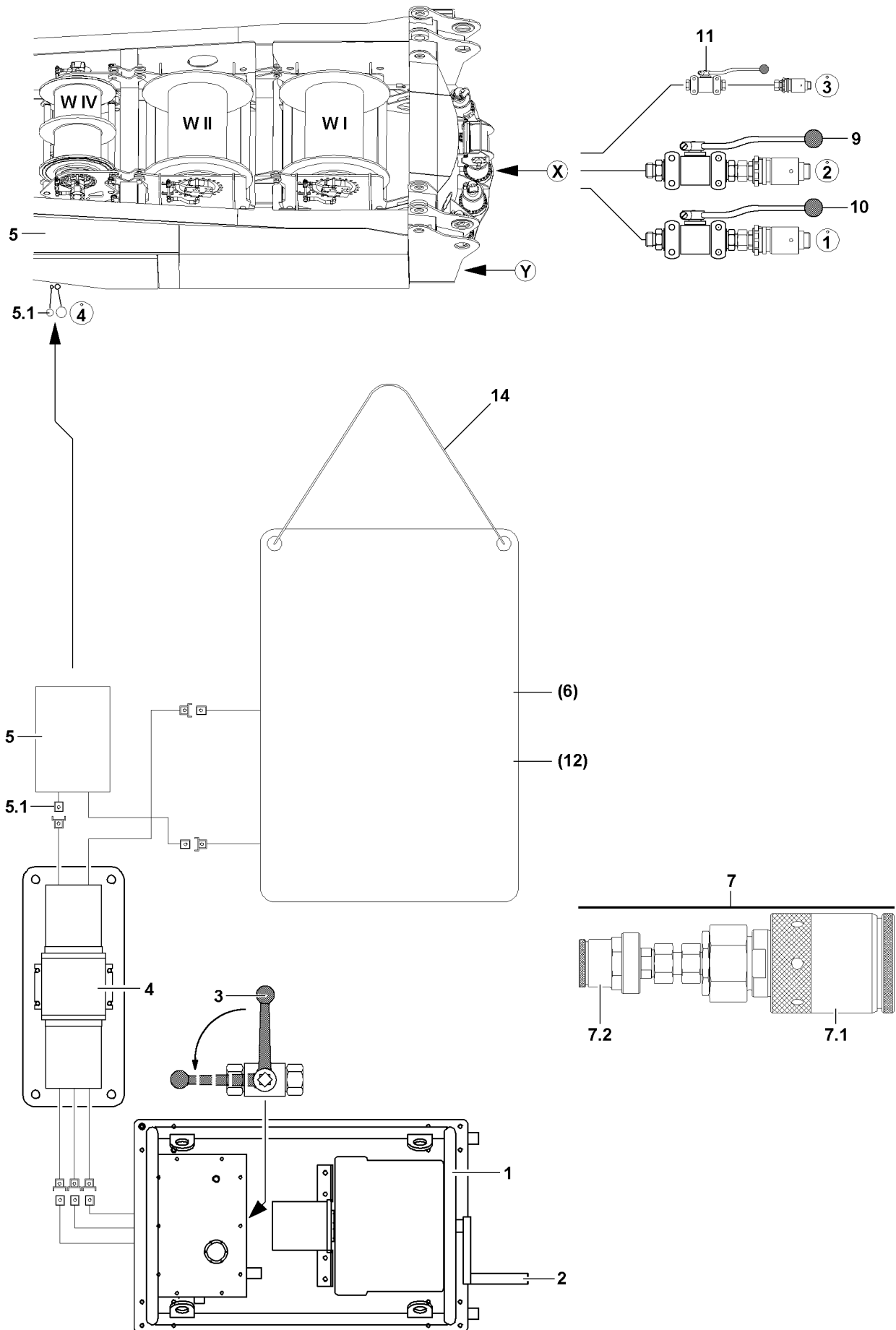

Fig.109408

LWE/LR 1600-2-008/18109-09-02/en

1.2 Handling of assembly plates



WARNING

Falling assembly plates!

Non-secured assembly plates can fall down when carrying out the emergency operation!

Personnel can be severely injured or killed!

- ▶ For emergency operation, secure the assembly plates with the chains **14** to prevent them from falling down!
- ▶ Do not secure the assembly plates near movable crane components!

1.3 Prerequisites for emergency operation



Note

- ▶ On the basis of different line diameters on the hydraulic lines, false couplings are prevented, additionally the hydraulic connections are identified with numbers!

Make sure that the following prerequisites are met:

- The hydraulic circuit diagram is available.
- The hydraulic system is functioning.
- An emergency operation aggregate **1** is available.
- A „Hydraulic transformer **4**“ is available.
- The assembly plate(s) are available.
- Reducer sections **7** (adapter) are available.
- The dust plugs for the hydraulic connections are removed.

1.4 Establishing the hydraulic connections



WARNING

Danger due to hydraulic pressure!

If the hydraulic lines are pressurized when releasing the connections, it can lead to severe injuries to assembly personnel!

- ▶ Relieve the pressure in the hydraulic lines before releasing!
- ▶ Establish the hydraulic connections from the emergency operation aggregate* **1** to the transformer **4**.
- ▶ Establish the hydraulic connection from the transformer **4** to the (suction line) on the turntable **5** of the crane, connection **5.1**.
- ▶ Hydraulic connection (return line, number **4**) from the turntable of the crane to the assembly plate **6** or to the assembly plate **12**.
- ▶ Establish the hydraulic connection (pressure line) from the transformer **4** to the assembly plate **6** or to the assembly plate **12**.

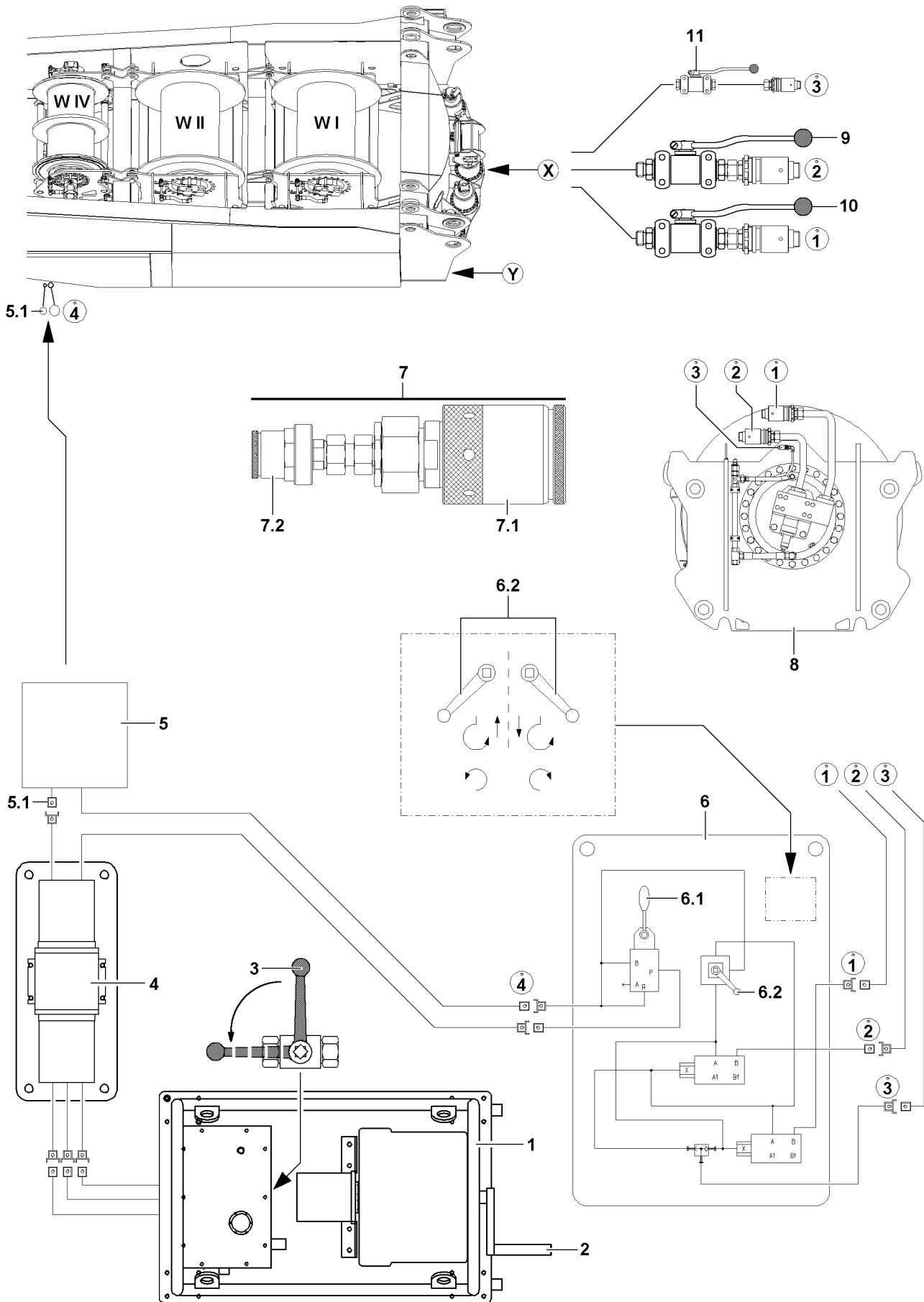

Fig.108301

LWE/LR 1600-2-008/18109-09-02/en

2 Emergency operation with assembly plate Variation 1 (V1)



Note

- ▶ The procedure of the emergency operation - except winch 4 on the LR1600/2 and LR1600/2-W - is identical for all winches and is described on the example of one winch!

Exception LR1600/2 and LR1600/2-W:

- ▶ Before emergency operation of winch 4 **W IV** on the LR1600/2 and LR1600/2-W, in addition to the hydraulic connections to lift, lower and for the control pressure of the brake, a control line must be connected, see section: „Emergency operation of winch 4 **W IV** on the LR1600/2 and LR1600/2-W!“

To carry out the emergency operation, use an emergency operation aggregate **1**, a hydraulic transformer **4** and the assembly plate **6**.

2.1 Functional selection on the assembly plate

With the ball valve **6.2** on the assembly plate **6** the following movements are preselected:

- Lift or lower
- Turn left or right
- ▶ Preselect crane movement: Activate ball valve **6.2** in the corresponding direction.

Moving the hand lever **6.1** determines the speed of the each crane movement.

- ▶ Operate the hand lever **6.1** and carry out the respective crane movement carefully.

2.2 Start the emergency operation aggregate

- ▶ Turn the crank **2** on the emergency operation aggregate* **1**.
- ▶ Switch the ball valve **3** to „horizontal“ position.



Note

- ▶ The engine rpm on the emergency operation aggregate can be set via a separate speed regulator!

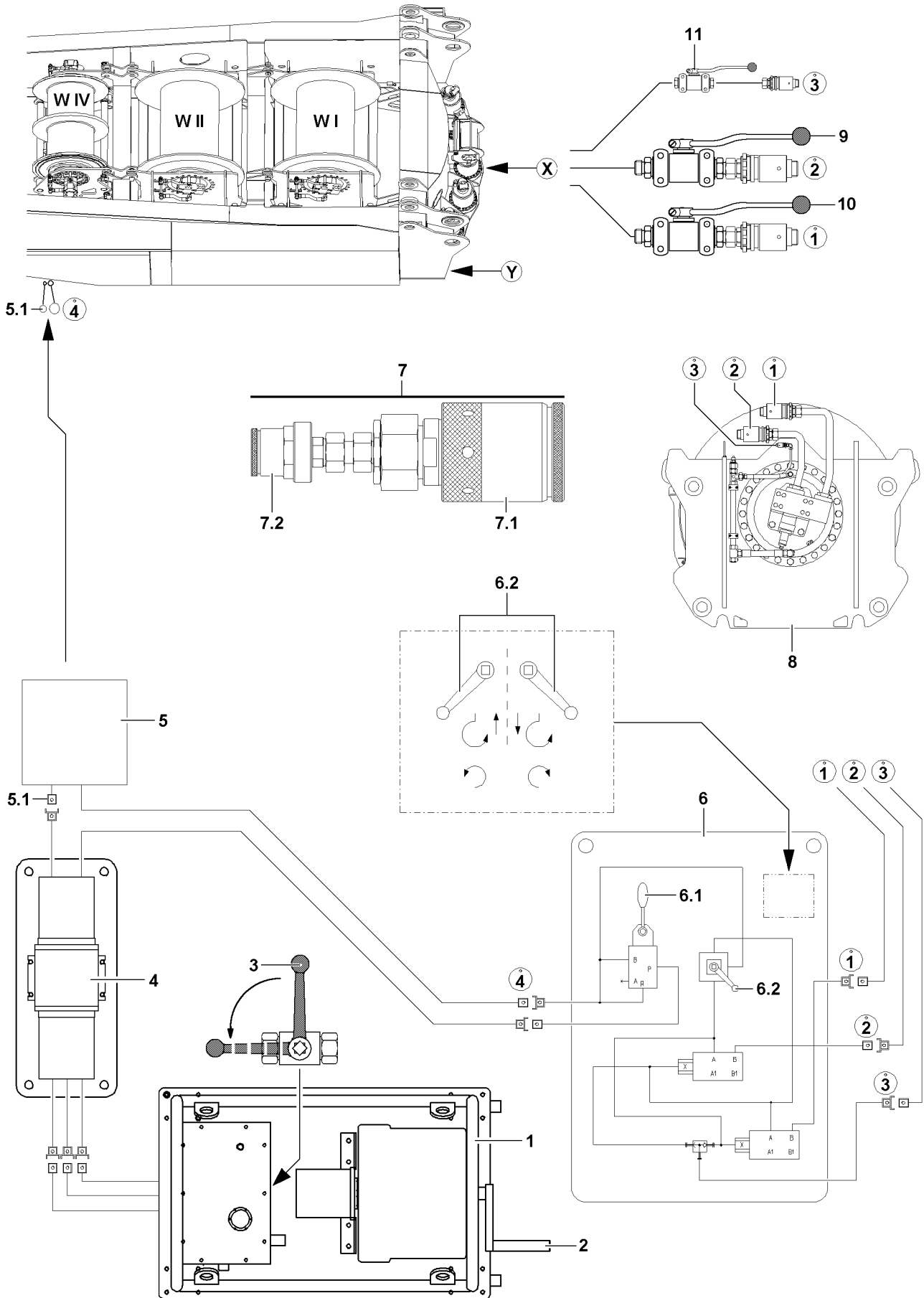

Fig.108301

LWE/LR 1600-2-008/18109-09-02/en

2.3 Emergency operation of winch 4 on the LR1600/2 and LR1600/2-W



WARNING

Emergency operation winch 4 **W IV!**

- ▶ Observe the section „Emergency operation of winch 4 (W IV) on the LR1600/2 and LR1600/2-W“!

2.4 Emergency operation winches

2.4.1 Establishing the hydraulic connections to the winch

Make sure that the following prerequisite is met:

- The pressure in the hydraulic system has been relieved.
- ▶ Release the hydraulic connections on the corresponding winch.
- ▶ Install the reducer sections **7** (adapter) with coupling sleeve **7.1** on the connection **1** and on the connection **2** of the winch **8**.



Note

- ▶ Observe the numbering of the hydraulic lines!
- ▶ Establish the hydraulic connections for the assembly plate **6** (connection **1**, connection **2** and brake **3**) to the winch **8**.

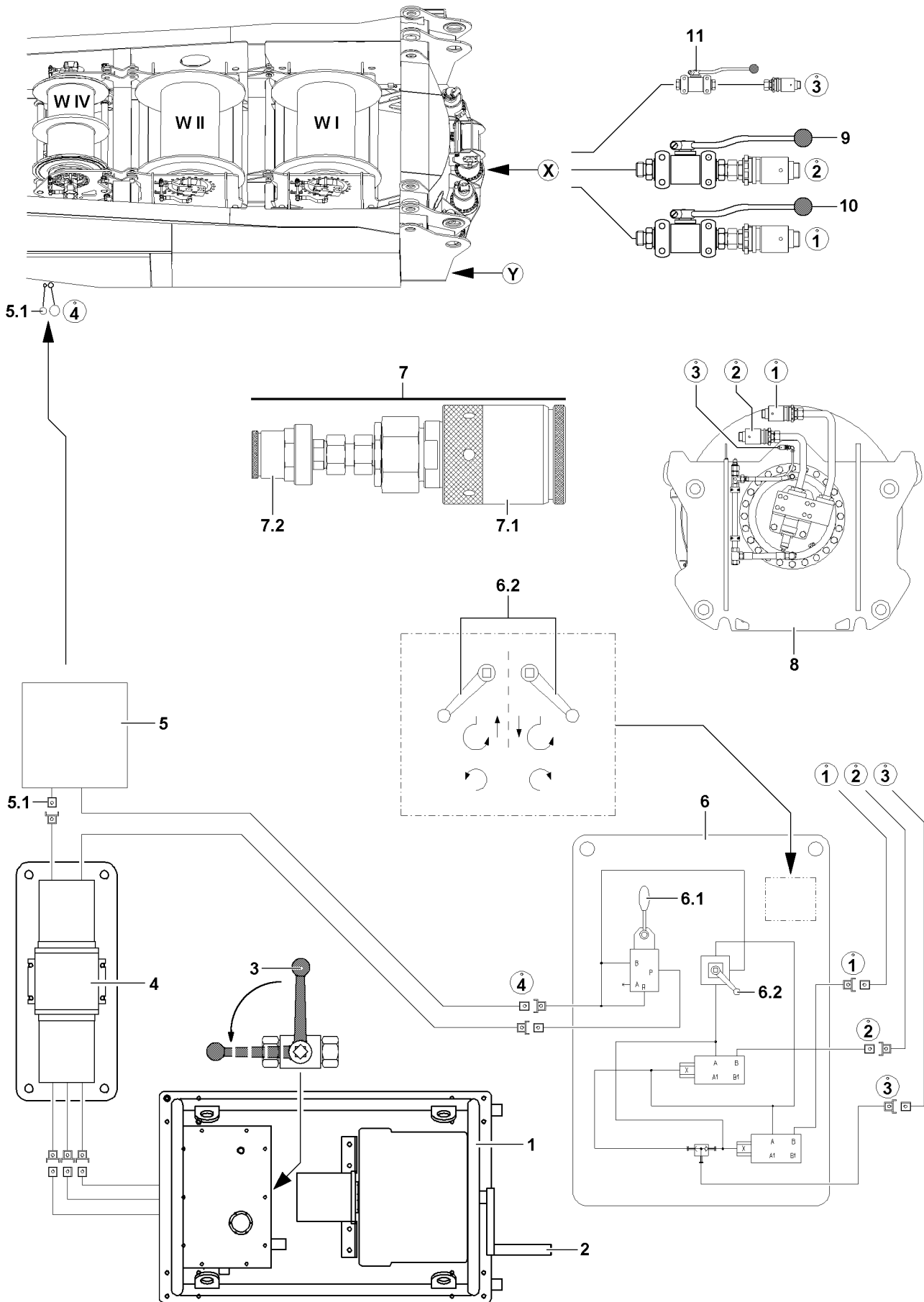

Fig.108301

LWE/LR 1600-2-008/18109-09-02/en

2.4.2 Spooling the winch out

- ▶ Set the ball valve **6.2** for the assembly plate **6** on „lower“.
- ▶ Move the manual lever **6.1** carefully.

Result:

- The winch spools out.

2.4.3 Spooling the winch up

- ▶ Set the ball valve **6.2** for the assembly plate **6** on „lift“.
- ▶ Move the manual lever **6.1** carefully.

Result:

- The winch spools up.

2.5 Disconnecting the hydraulic connections

Make sure that the following prerequisites are met:

- The emergency operation is completed.
 - The pressure in the hydraulic system has been relieved.
 - ▶ Disconnect the hydraulic connections from the winch **8** to the assembly plate **6**.
 - ▶ Remove the reducer sections **7** (adapter).
 - ▶ Close off the hydraulic connections of the winch **8** with dust caps.
- or**
- Reconnect the winch **8** onto the hydraulic system of the crane.

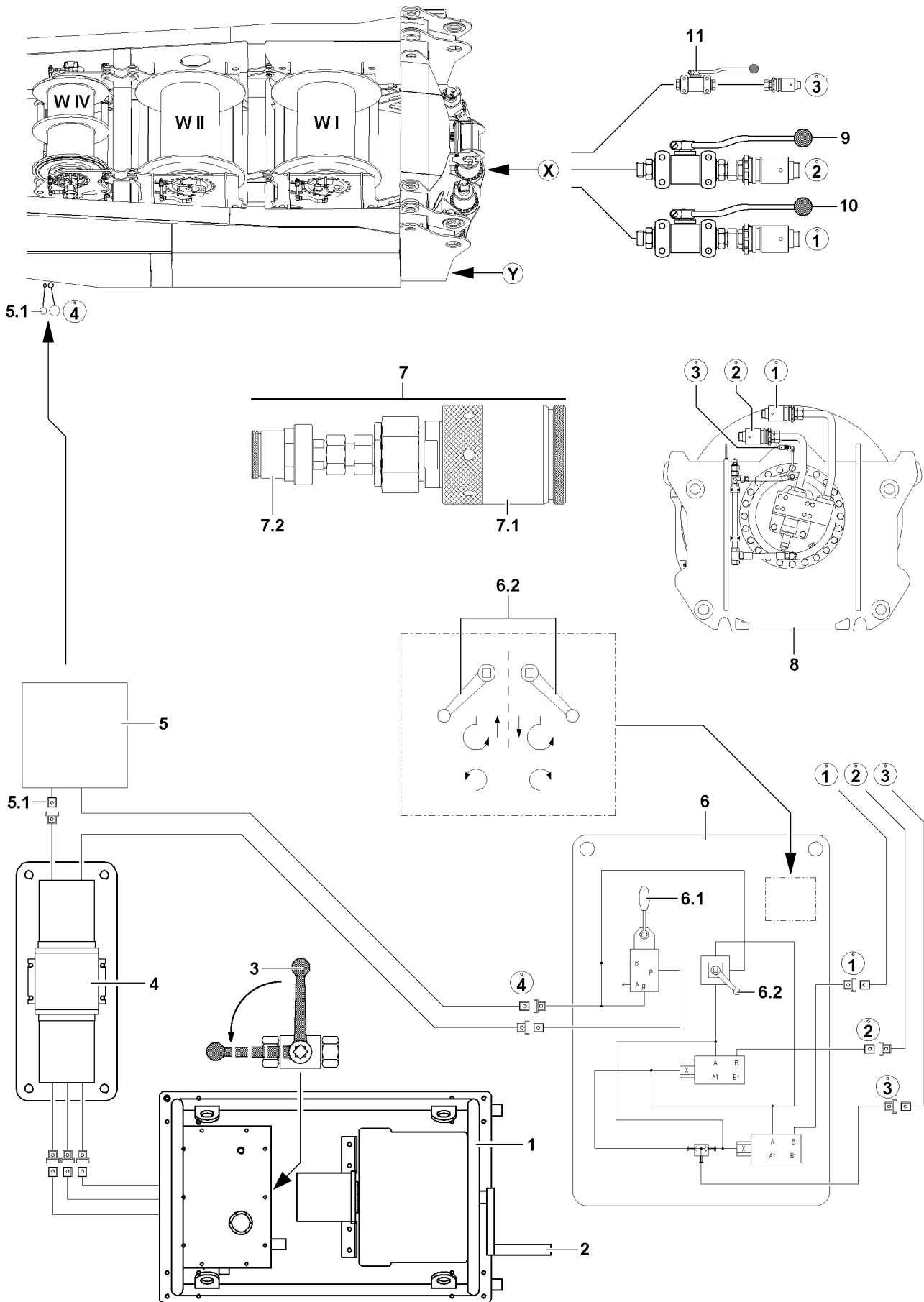

Fig.108301

LWE/LR 1600-2-008/18109-09-02/en

3 Emergency operation of slewing gear(s) with assembly plate Variation 1 (V1)



WARNING

Danger due to hydraulic pressure!

If the hydraulic lines are pressurized when releasing the connections, it can lead to severe injuries to assembly personnel!

- ▶ Relieve the pressure in the hydraulic lines before releasing!



Note

- ▶ For each crane type, the installation position of the ball valves for emergency operation of the slewing gear on the turntable varies!
- ▶ Possible installation positions of the ball valve: Point **X** or point **Y**!

3.1 Establishing the hydraulic connection to the slewing gears

Make sure that the following prerequisite is met:

- The pressure in the hydraulic system has been relieved.



Note

- ▶ Observe the numbering of the hydraulic lines!
- ▶ Establish the hydraulic connections of the assembly plate **6** (connection **1**, connection **2** and brake **3**) to the „Ball valves“ on the turntable.

3.2 Turning the turntable to the left

- ▶ Set the ball valve **9** into emergency operation position.
- ▶ Set the ball valve **10** into emergency operation position.
- ▶ Set the ball valve **11** into emergency operation position.
- ▶ Set the ball valve **6.2** for the assembly plate **6** on „turn left“.
- ▶ Move the manual lever **6.1** carefully.

Result:

- The turntable turns to the left.

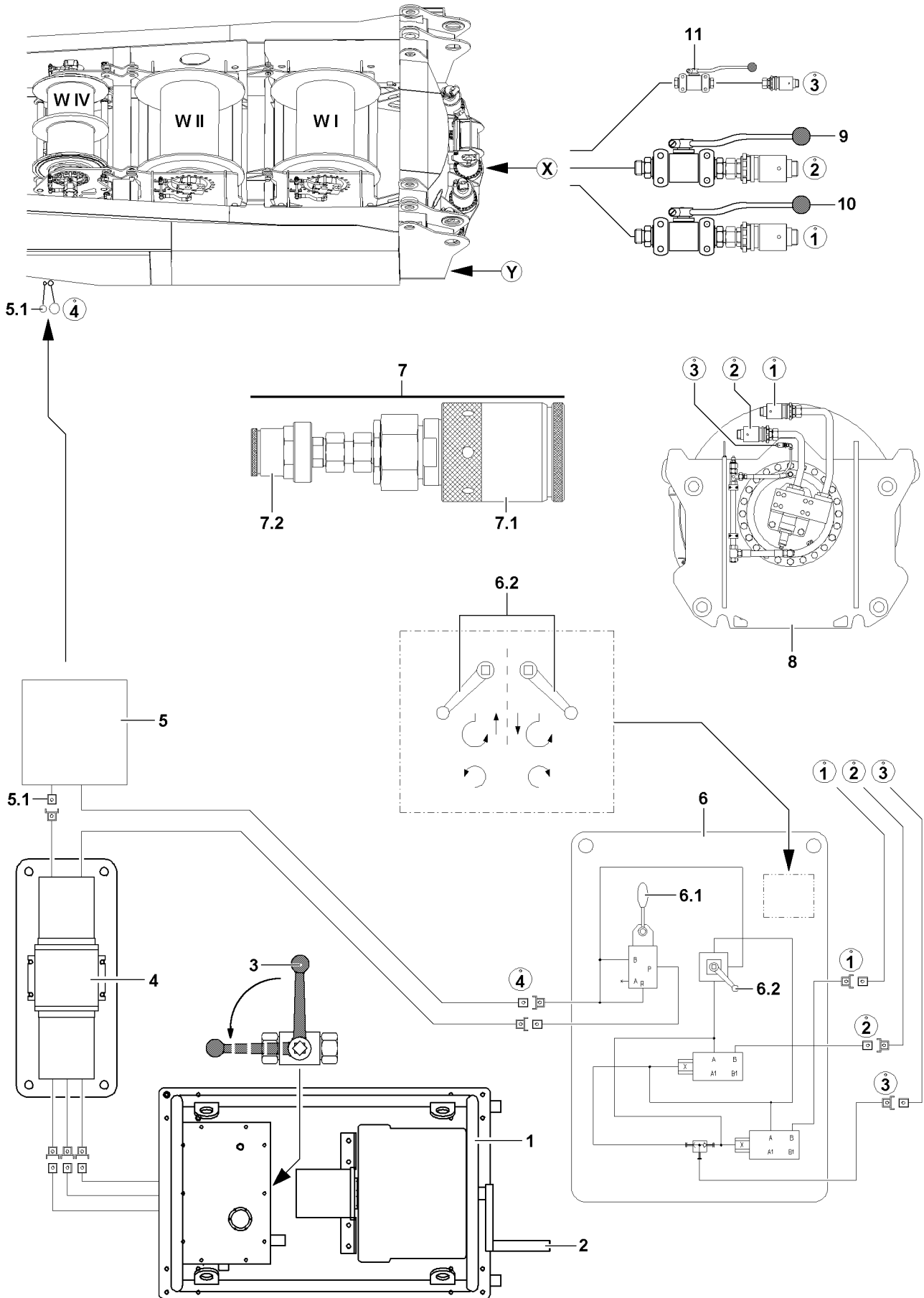

Fig.108301

LWE/LR 1600-2-008/18109-09-02/en

3.3 Turning the turntable to the right

- ▶ Set the ball valve **9** into emergency operation position.
- ▶ Set the ball valve **10** into emergency operation position.
- ▶ Set the ball valve **11** into emergency operation position.
- ▶ Set the ball valve **6.2** for the assembly plate **6** on „turn right“.
- ▶ Move the manual lever **6.1** carefully.

Result:

- The turntable turns to the right.

3.4 Disconnecting the hydraulic connections

Make sure that the following prerequisites are met:

- The emergency operation is completed.
- The pressure in the hydraulic system has been relieved.

Disconnect the hydraulic connections to the assembly plate **6**.

- ▶ Reposition the ball valve **9** in position for crane operation.
- ▶ Reposition the ball valve **10** in position for crane operation.
- ▶ Reposition the ball valve **11** in position for crane operation.

When the ball valve **9**, ball valve **10** and ball valve **11** are repositioned into crane operation position:

- ▶ Disconnect the hydraulic connections to the assembly plate **6**.
- ▶ Close off the hydraulic connections with dust plugs.

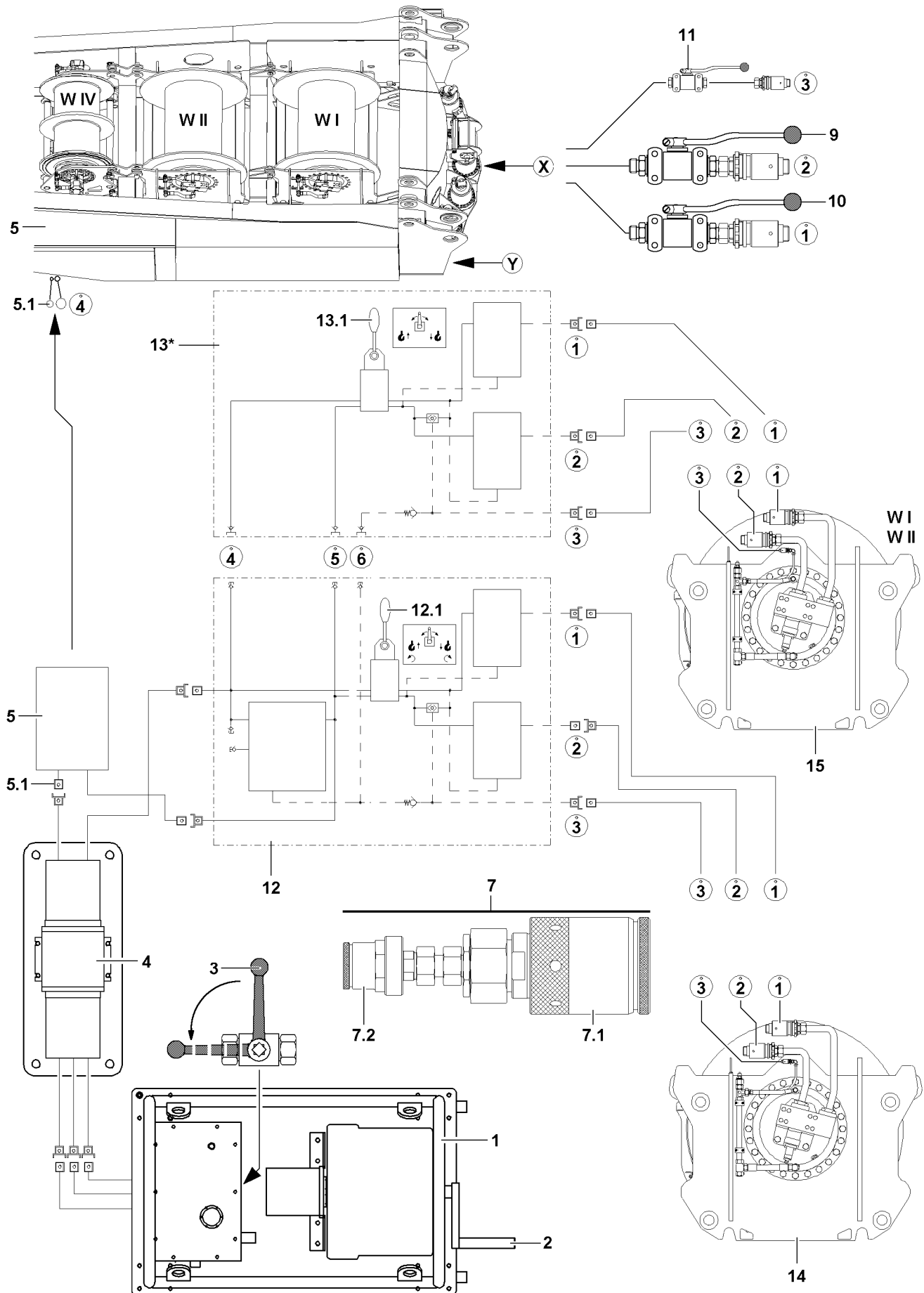

Fig.109393

LWE/LR 1600-2-008/18109-09-02/en

4 Emergency operation with assembly plate(s) Variation 2 (V2)



Note

- ▶ The procedure of the emergency operation - except winch 4 on the LR1600/2 and LR1600/2-W - is identical for all winches and is described on the example of one winch!

Exception LR1600/2 and LR1600/2-W:

- ▶ Before emergency operation of winch 4 **W IV** on the LR1600/2 and LR1600/2-W, in addition to the hydraulic connections to lift, lower and for the control pressure of the brake, a control line must be connected, see section: „Emergency operation of winch 4 **W IV** on the LR1600/2 and LR1600/2-W!“

To carry out the emergency operation, use an emergency operation aggregate **1**, a hydraulic transformer **4** and the assembly plate **12**. To carry out the emergency operation from winch 1 **W I** and winch 2 **W II** in parallel operation (1||2), in addition to the assembly plate **12**, the assembly plate **13** is needed. Connect the assembly plate **12** with the assembly plate **13** hydraulically on hydraulic connections 4, 5 and 6.

4.1 Start the emergency operation aggregate

- ▶ Turn the crank **2** on the emergency operation aggregate* **1**.
- ▶ Switch the ball valve **3** to „horizontal“ position.



Note

- ▶ The engine rpm on the emergency operation aggregate can be set via a separate speed regulator!

4.2 Emergency operation of winch 4 on the LR1600/2 and LR1600/2-W



WARNING

Emergency operation winch 4 **W IV**!

- ▶ Observe the section „Emergency operation of winch 4 (W IV) on the LR1600/2 and LR1600/2-W“!

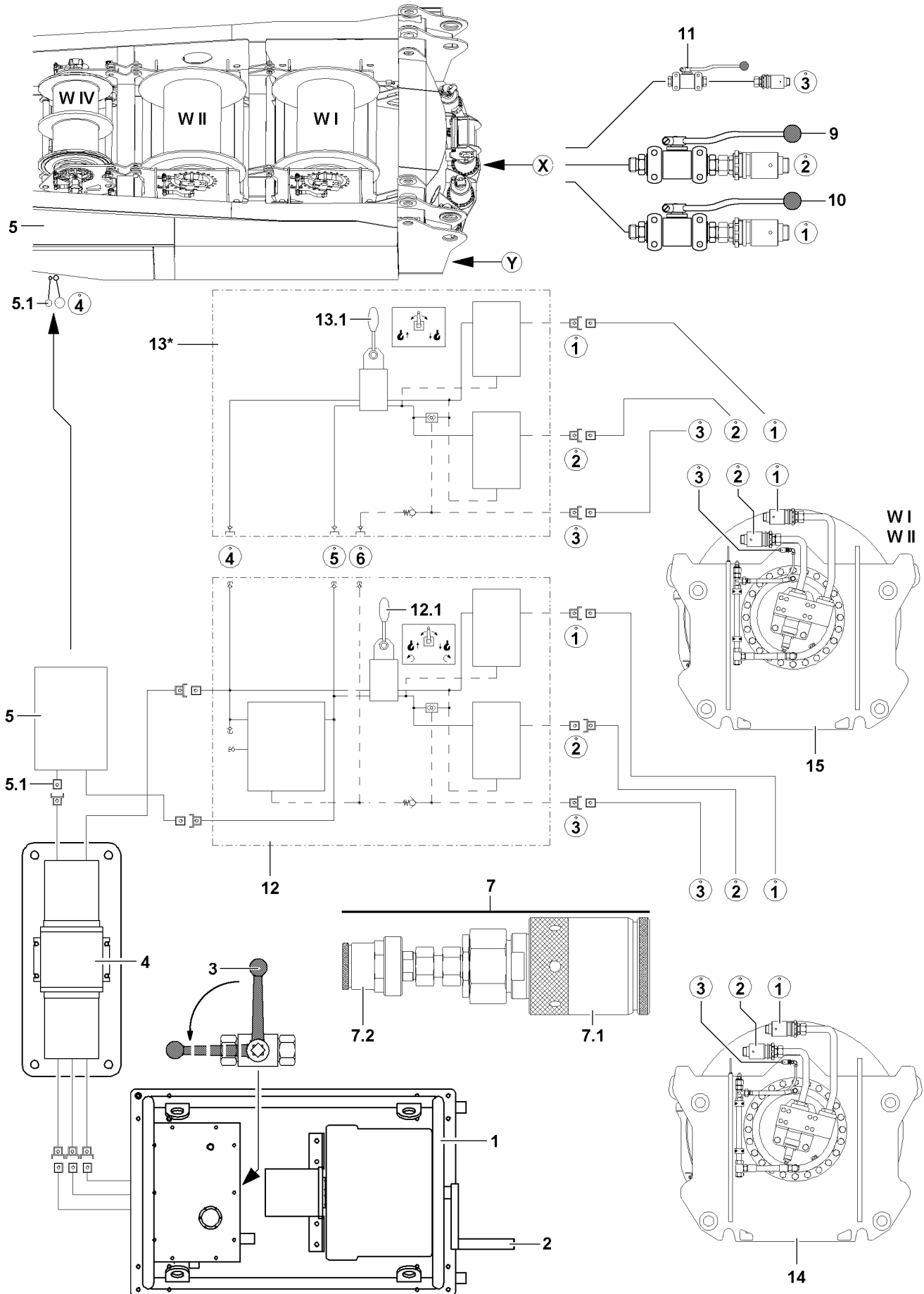

Fig.109393

LWE/LR 1600-2-008/18109-09-02/en

4.3 Emergency operation of winches, individual operation

**Note**

- ▶ The crane movements are actuated and the speed of the respective crane movement is determined via the ball valve **12.1** and ball valve **13.1**!

4.3.1 Establishing the hydraulic connections to the winch

Make sure that the following prerequisite is met:

- The pressure in the hydraulic system has been relieved.
- ▶ Release the hydraulic connections on the corresponding winch.
- ▶ Install the reducer sections **7** (adapter) with coupling sleeve **7.1** on the connection **1** and on the connection **2** of the respective winch.

**Note**

- ▶ Observe the numbering of the hydraulic lines!
- ▶ Establish the hydraulic connection of the assembly plate **12** (connection **1**, connection **2** and brake **3**) to the respective winch.

4.3.2 Spooling the winch out

- ▶ Set the ball valve **12.1** for the assembly plate **12** on „lower“.

Result:

- The winch spools out.

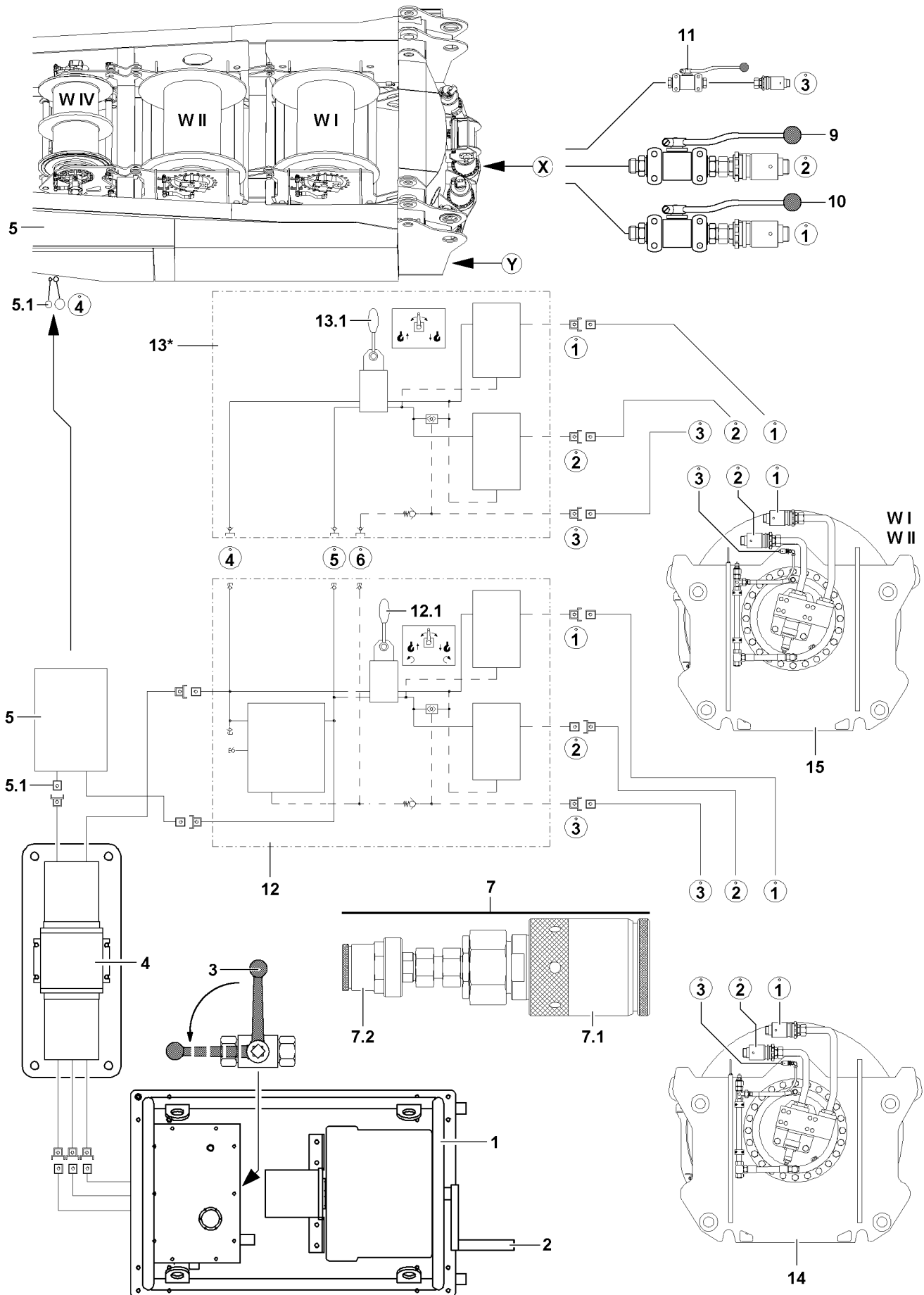

Fig.109393

LWE/LR 1600-2-008/18109-09-02/en

4.3.3 Spooling the winch up

- ▶ Set the ball valve **12.1** for the assembly plate **12** on „lift“.

Result:

- The winch spools up.

4.3.4 Disconnecting the hydraulic connections

Make sure that the following prerequisites are met:

- The emergency operation is completed.
 - The pressure in the hydraulic system has been relieved.
 - ▶ Separate the hydraulic connections from the respective winch to the assembly plate **12**.
 - ▶ Remove the reducer sections **7** (adapter).
 - ▶ Close off the hydraulic connections of the winch with dust plugs.
- or**
- Reconnect the winch to the hydraulic system of the crane.

4.4 Emergency operation of winches, parallel operation winch 1|12



Note

- ▶ The crane movements are actuated and the speed of the respective crane movement is determined via the ball valve **12.1** and ball valve **13.1**!



WARNING

Risk of accident!

If the following notes are not observed, dangerous situations can arise!

Personnel can be severely injured or killed!

- ▶ If winch 1 and winch 2 are actuated in emergency operation in parallel operation, then it must be ensured that the hook blocks are horizontally aligned!
- ▶ Always actuate winch 1 and winch 2 simultaneously!

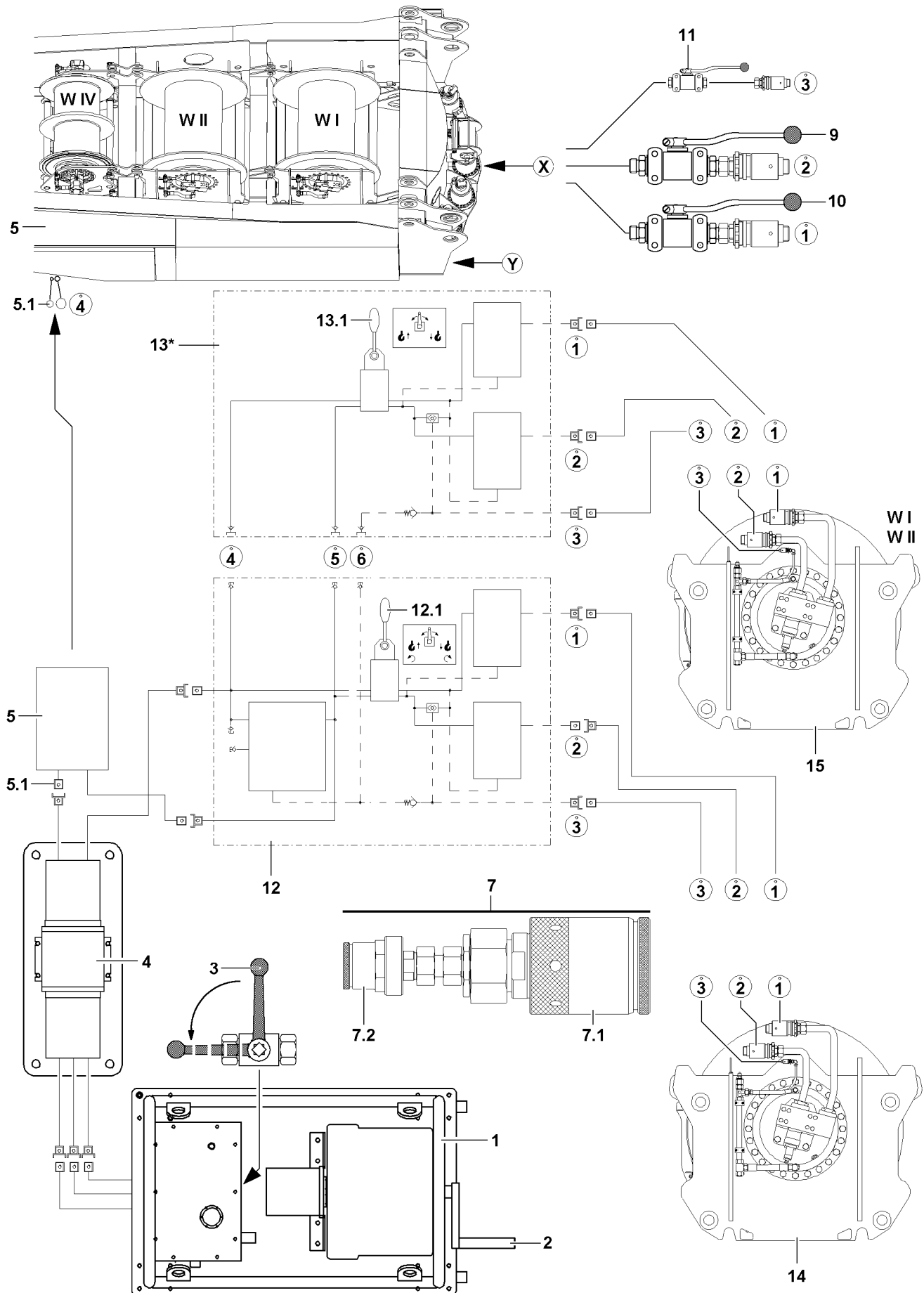

Fig.109393

LWE/LR 1600-2-008/18109-09-02/en

4.4.1 Establishing the hydraulic connections to the winches

Make sure that the following prerequisite is met:

- The pressure in the hydraulic system has been relieved.
- ▶ Release the hydraulic connections on winch 1 and winch 2.
- ▶ Install the reducer sections **7** (adapter) with coupling sleeve **7.1** on the connection **1** and on the connection **2** of the respective winch.



Note

- ▶ Observe the numbering of the hydraulic lines!
-
- ▶ Establish the hydraulic connections for the assembly plate **12** (connection **1**, connection **2** and brake **3**) to winch 1.
or
Establish the hydraulic connections for the assembly plate **12** (connection **1**, connection **2** and brake **3**) to winch 2.
 - ▶ Establish the hydraulic connections for the assembly plate **13** (connection **1**, connection **2** and brake **3**) to winch 1.
or
Establish the hydraulic connections for the assembly plate **13** (connection **1**, connection **2** and brake **3**) to winch 2.

4.4.2 Spooling the winches out



Note

- ▶ Check which winch you have connected to which assembly plate!
-

- ▶ Set the ball valve **12.1** for the assembly plate **12** on „lower“.

Result:

- Winch 1 **or** winch 2 spools out.

- ▶ Set the ball valve **13.1** for the assembly plate **13** on „lower“.

Result:

- Winch 2 **or** winch 1 spools out.

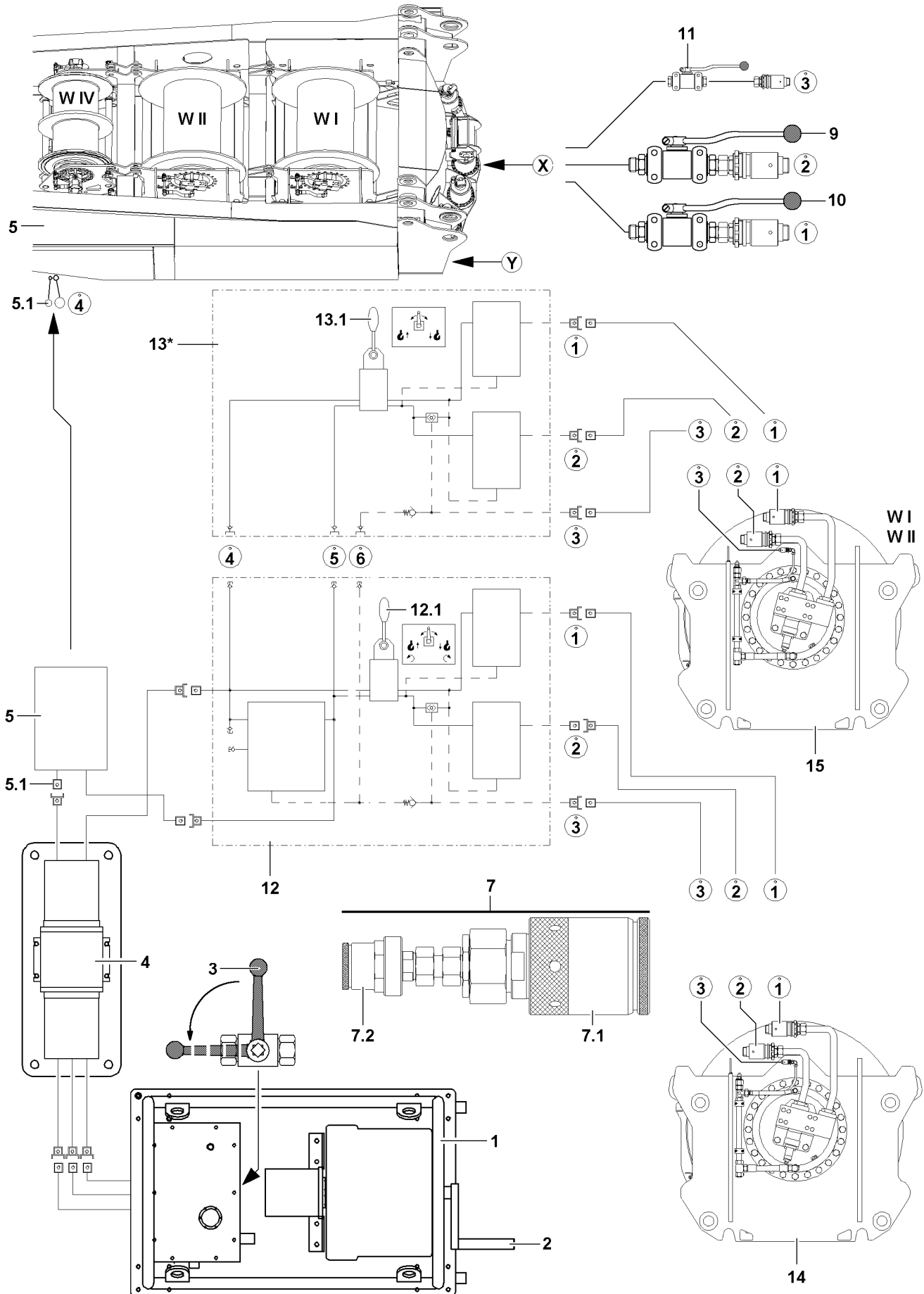

Fig.109393

LWE/LR 1600-2-008/18109-09-02/en

4.4.3 Spooling the winches up

- ▶ Set the ball valve **12.1** for the assembly plate **12** on „lift“.

Result:

- Winch 1 **or** winch 2 spools up.

- ▶ Set the ball valve **13.1** for the assembly plate **13** on „lift“.

Result:

- Winch 2 **or** winch 1 spools up.

4.4.4 Disconnecting the hydraulic connections

Make sure that the following prerequisites are met:

- The emergency operation is completed.
- The pressure in the hydraulic system has been relieved.
- ▶ Disconnect the hydraulic connections of winch 1 and winch 2 to the respective assembly plates.
- ▶ Remove the reducer sections **7** (adapter).
- ▶ Close off the hydraulic connections of the winches with dust plugs.
or
Reconnect the winches to the hydraulic system of the crane.

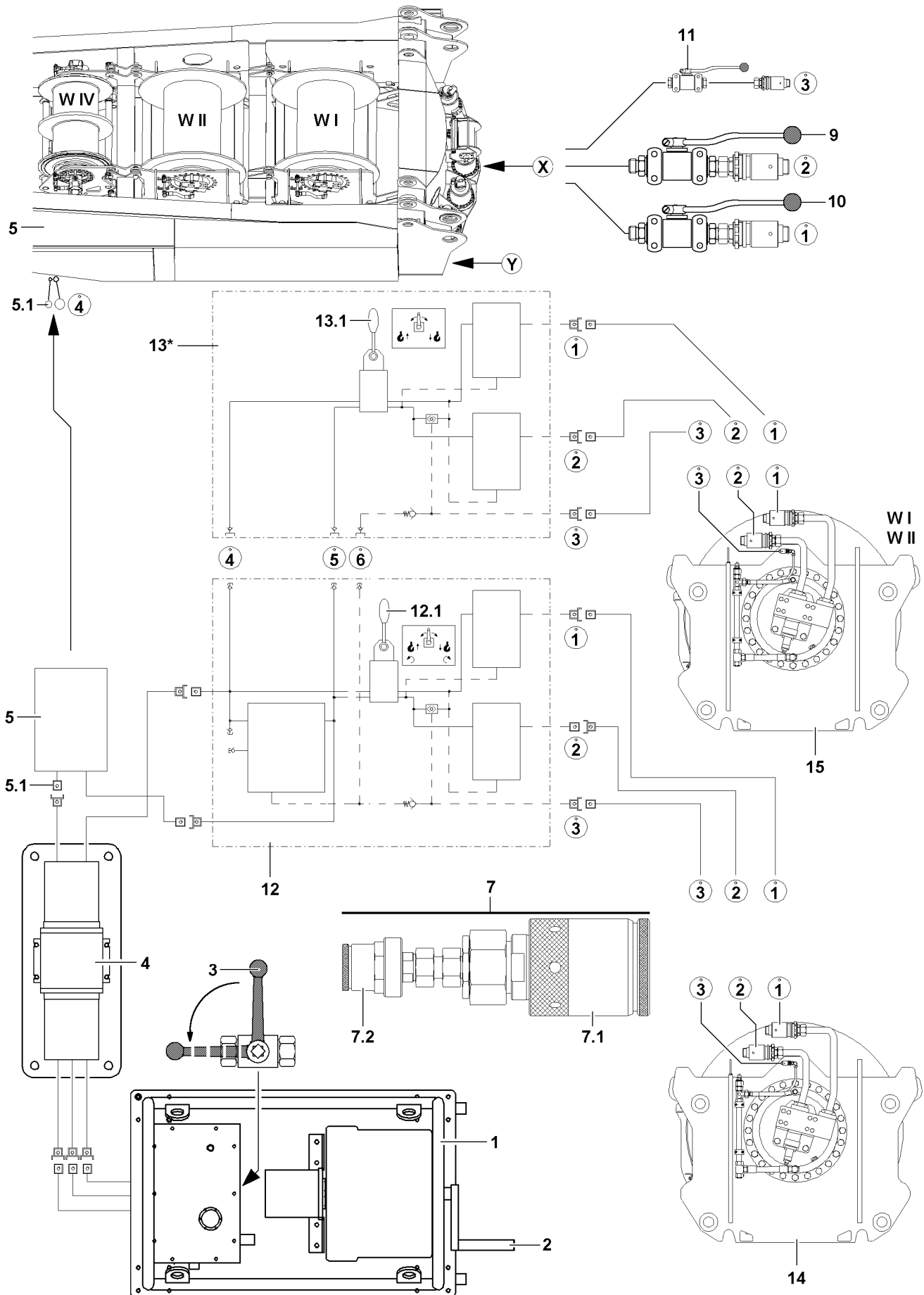

Fig.109393

LWE/LR 1600-2-008/18109-09-02/en

5 Emergency operation slewing gear(s) with assembly plate(s) Variation 2 (V2)



WARNING

Danger due to hydraulic pressure!

If the hydraulic lines are pressurized when releasing the connections, it can lead to severe injuries to assembly personnel!

- ▶ Relieve the pressure in the hydraulic lines before releasing!



Note

- ▶ For each crane type, the installation position of the ball valves for emergency operation of the slewing gear on the turntable varies!
- ▶ Possible installation positions of the ball valve: Point **X** or point **Y**!



Note

- ▶ The slewing movement is actuated and the speed of the slewing movement is determined via the ball valve **12.1**!

5.1 Establishing the hydraulic connection to the slewing gears

Make sure that the following prerequisite is met:

- The pressure in the hydraulic system has been relieved.



Note

- ▶ Observe the numbering of the hydraulic lines!
- ▶ Establish the hydraulic connections of the assembly plate **12** (connection **1**, connection **2** and brake **3**) to the „Ball valves“ on the turntable.

5.2 Turning the turntable to the left

- ▶ Set the ball valve **9** into emergency operation position.
- ▶ Set the ball valve **10** into emergency operation position.
- ▶ Set the ball valve **11** into emergency operation position.
- ▶ Set the ball valve **12.1** for the assembly plate **12** on „turn left“.

Result:

- The turntable turns to the left.

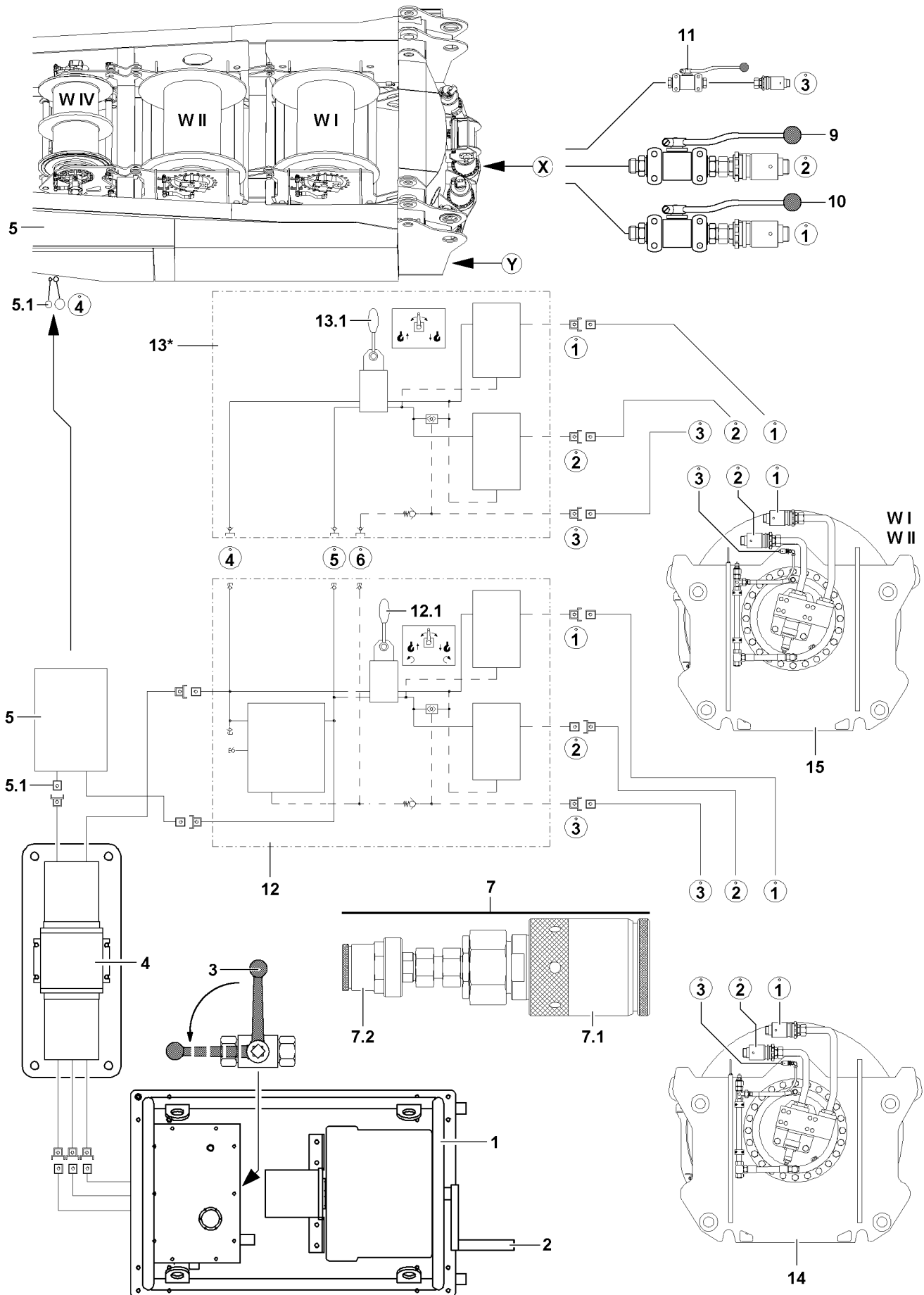

Fig.109393

LWE/LR 1600-2-008/18109-09-02/en

5.3 Turning the turntable to the right

- ▶ Set the ball valve **9** into emergency operation position.
- ▶ Set the ball valve **10** into emergency operation position.
- ▶ Set the ball valve **11** into emergency operation position.
- ▶ Set the ball valve **12.1** for the assembly plate **12** on „turn right“.

Result:

- The turntable turns to the right.

5.4 Disconnecting the hydraulic connections

Make sure that the following prerequisites are met:

- The emergency operation is completed.
- The pressure in the hydraulic system has been relieved.

Disconnect the hydraulic connections to the assembly plate **12**.

- ▶ Reposition the ball valve **9** in position for crane operation.
- ▶ Reposition the ball valve **10** in position for crane operation.
- ▶ Reposition the ball valve **11** in position for crane operation.

When the ball valve **9**, ball valve **10** and ball valve **11** are repositioned into crane operation position:

- ▶ Disconnect the hydraulic connections to the assembly plate **12**.
- ▶ Close off the hydraulic connections with dust plugs.

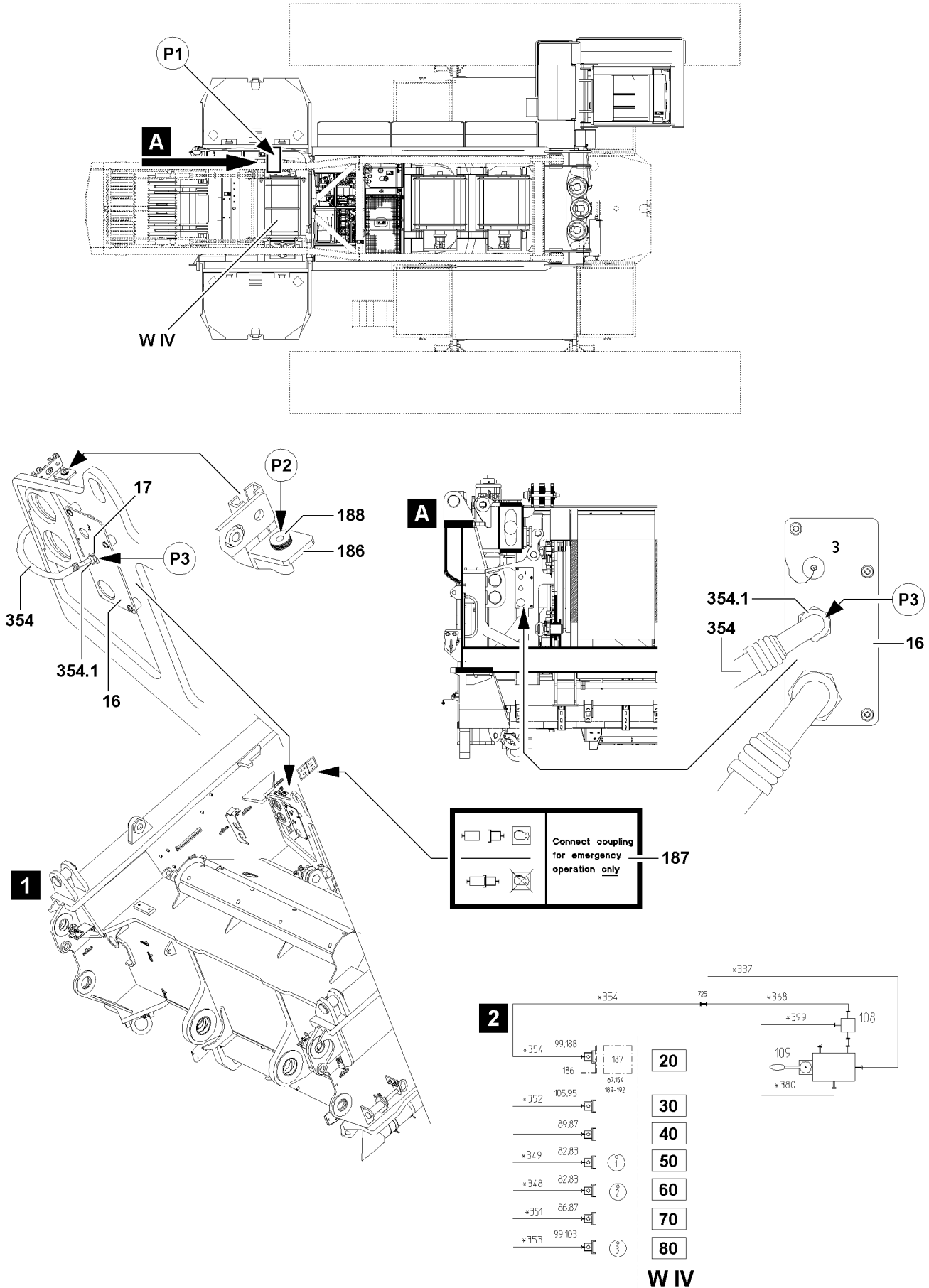

Fig.112453

LWE/LR 1600-2-008/18109-09-02/en

6 Emergency operation of winch 4 (W IV) on the LR1600/2 and LR1600/2-W

NOTICE

Damage of crane components!

If the hydraulic hose (control line) **354** for the emergency operation is not connected properly, then hydraulic parts or crane components can be damaged!

- ▶ Make sure, before starting the emergency operation, that the hydraulic hose **354** is properly connected!

6.1 Emergency operation winch 4 (WIV)

6.1.1 Establishing the hydraulic connections to winch 4 (WIV)



Note

- ▶ The hydraulic connections to winch 4 - connection 1, connection 2 and brake - have been established, see section „Emergency operation of winches“!
- ▶ Pay attention to the different variations of the assembly plates!

Before emergency operation of winch 4 **W IV**, in addition to the hydraulic connections for the emergency operation of the winch, the hydraulic hose **354** must be connected.

Make sure that the following prerequisites are met:

- The hydraulic connections to winch 4 are established.
- The hydraulic hose **354** is in park position, point **P2**.
- ▶ Release the hydraulic hose **354** with the fitting **354.1** on the plug **188** (park position), point **P2**.
- ▶ Guide the hydraulic hose **354** to the front to the connector plate **16**.
- ▶ Connect the hydraulic hose **354** with the fitting **354.1** on the supply line **17**, point **P3**, of the connector plate **16**.



Note

- ▶ Observe the notes in the sections „Emergency operation of winches“!

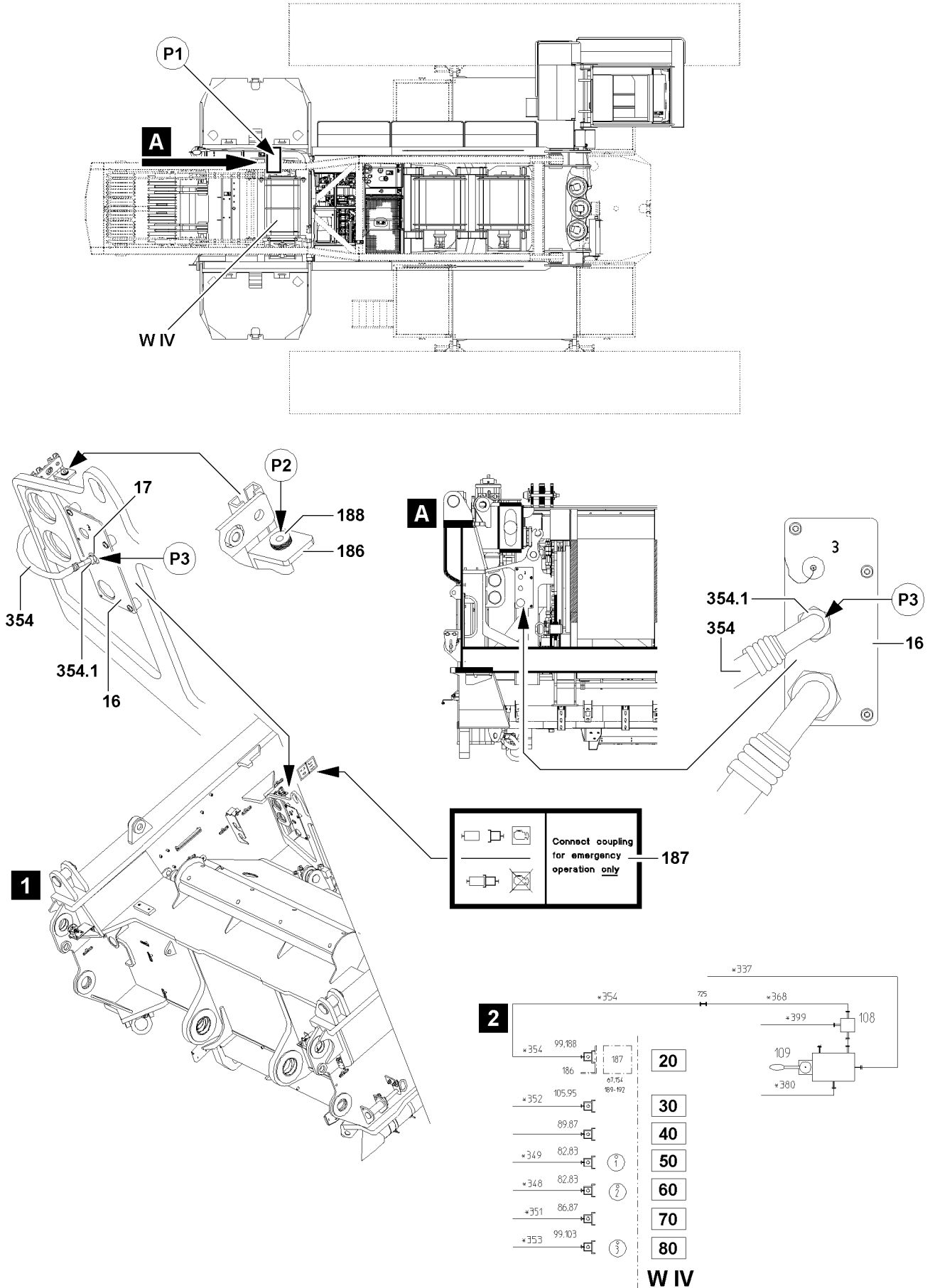

Fig.112453

LWE/LR 1600-2-008/18109-09-02/en

6.1.2 Spooling the winch out

- ▶ See section: „Emergency operation with assembly plate Variation 1 (V1)“
or
- ▶ See section: „Emergency operation with assembly plate Variation 2 (V2)“

6.1.3 Spooling the winch up

- ▶ See section: „Emergency operation with assembly plate Variation 1 (V1)“
or
- ▶ See section: „Emergency operation with assembly plate Variation 2 (V2)“

6.2 Disconnecting the hydraulic connections

Make sure that the following prerequisites are met:

- The emergency operation is completed.
- The pressure in the hydraulic system has been relieved.
- ▶ Disconnect the hydraulic connections from the winch 4 to the assembly plate.
- ▶ Remove the reducer sections (adapter).
- ▶ Close off the hydraulic connections of the winch 4 **W IV** with dust caps.
or
Reconnect the winch 4 **W IV** onto the hydraulic system of the crane.
- ▶ Disconnect the hydraulic hose **354** at point **P3**.
- ▶ Bring the hydraulic hose **354** in parking position: Install the fitting **354.1** onto the plug **188**.

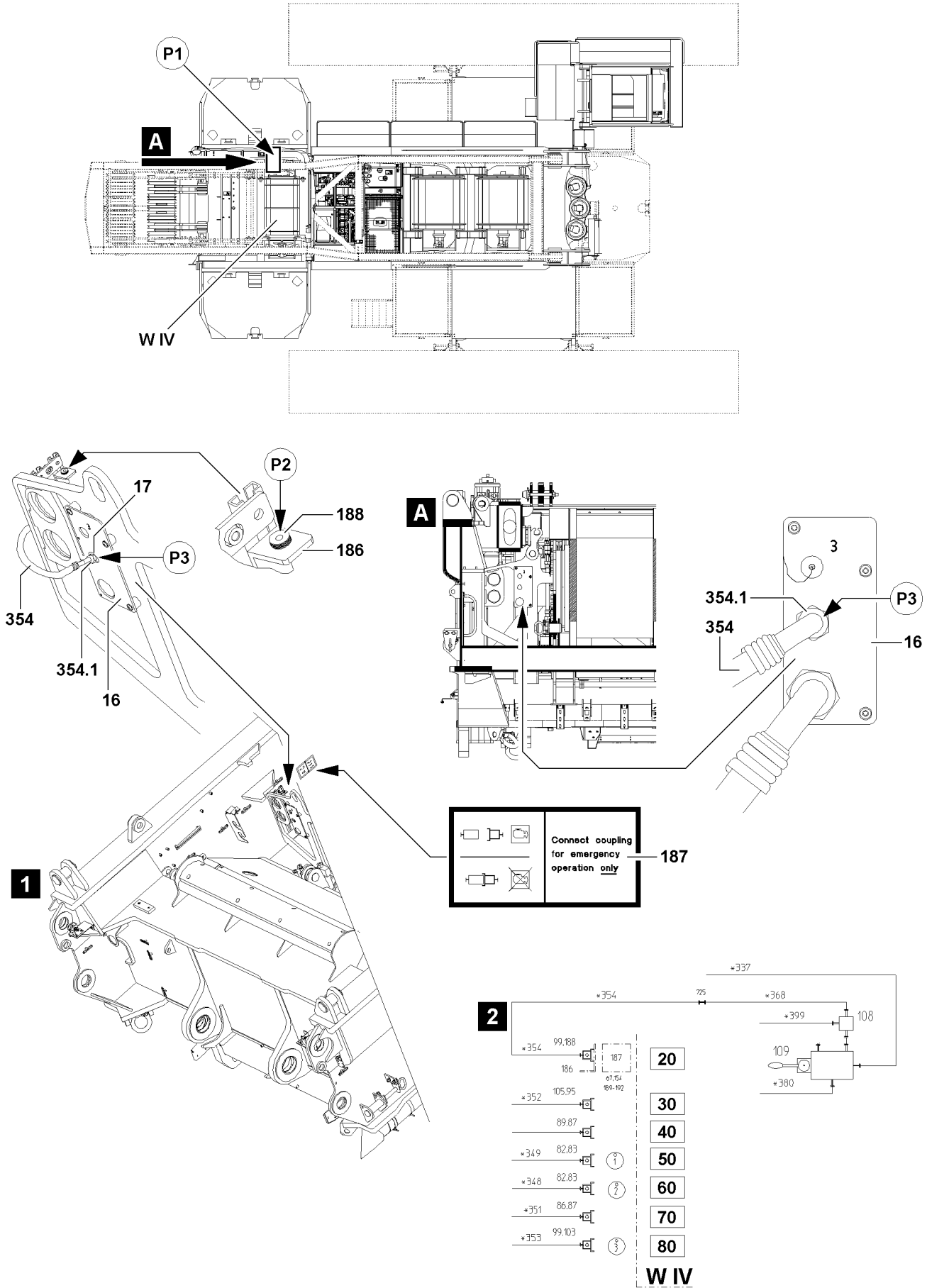

Fig.112453

LWE/LR 1600-2-008/18109-09-02/en

6.3 Connection schematic for emergency operation, illustration 2



Note

- ▶ See also Hydraulic schematic!

Position	Connection / description
20	Control pressure SA-frame
50	Lifting
60	Lowering
80	Replenishing pressure brake

7 Ending emergency operation

7.1 Procedure

- ▶ Turn the emergency operation aggregate* 1 off.
- ▶ Close the ball valve 3.
- ▶ Disconnect the hydraulic connections and close them off with dust plugs.

Empty page!

LWE/LR 1600-2-008/18109-09-02/en

7 Service and maintenance

LWE/LR 1600-2-008/18109-09-02/en

LWE/LR 1600-2-008/18109-09-02/en

7.01 Maintenance and service - General

1	Technical safety instructions	3
2	Warranty and coverage	7
3	Liebherr Service	8
4	Taking an oil sample	8
5	Cleaning	9
6	Disposal	10

Fig.195219

LWE/LR 1600-2-008/18109-09-02/en

1 Technical safety instructions



WARNING

Maintenance instructions **not** adhered to!

Death, severe injury, increased wear and failure of components.

- ▶ Observe the following listed safety notes and the generally applicable safety rules!
- ▶ Adhere to the maintenance intervals.
- ▶ Carry out only applicable maintenance tasks.
- ▶ Repair and maintenance tasks are to be carried out carefully.
- ▶ For aggregates and components: Follow the operating instructions of the manufacturer.

1.1 Description of intervals and tasks



Note

- ▶ Fill quantities and descriptions of service items and lubricants are specified in the Service fill.

The maintenance intervals and scope of maintenance are described in several chapters.

For crane maintenance, observe the following chapters:

- Crane operating instructions, chapter 7.02: Maintenance intervals - Crane chassis ¹⁾
- Crane operating instructions, chapter 7.02.50: Maintenance intervals Ballast trailer*¹⁾
- Crane operating instructions, chapter 7.03: Maintenance intervals - Crane superstructure ¹⁾
- Crane operating instructions, chapter 7.03.50: Maintenance intervals - Crane boom ¹⁾
- Crane operating instructions, chapter 7.04: Maintenance instructions - Crane chassis ²⁾
- Crane operating instructions, chapter 7.04.50: Ballast trailer maintenance instructions ²⁾
- Crane operating instructions, chapter 7.05: Maintenance instructions - Crane superstructure ²⁾
- Crane operating instructions, chapter 7.05.50: Crane boom maintenance instructions ²⁾
- Crane operating instructions, chapter 7.06: Fill quantities, lubrication chart
- Crane operating instructions, chapter 7.07: Operating fluids and lubricants

¹⁾ These chapters contain a list of maintenance intervals for all maintenance tasks.

²⁾ For aggregates, observe and adhere to additionally to the instructions of the manufacturer.

1.2 Definition of „Checking“

The action of „Checking“ includes all required task in connection with the maintenance, for example:

- Determining a specified value
- Cleaning
- Adjusting
- Refilling
- Replacing

1.3 Maintenance intervals

Use the following rules for interval determination:

- Carry out maintenance and inspection tasks on the crane chassis after reaching the specified driven mileage, operating hours or calendar intervals. The interval which occurs first is the deciding factor.
- Carry out maintenance and inspection tasks on the crane superstructure after reaching the specified operating hours or calendar intervals. The interval which occurs first is the deciding factor.
- The maintenance intervals complement each other. If a higher interval is coming up, then carry out the tasks according to the lower interval also.

1.4 Securing against operation



WARNING

Impermissible travel or crane operation during maintenance or repair tasks!
Death, severe injury, severe property damage.

- ▶ Make sure that travel and crane operation is not possible during maintenance and repair tasks.
- ▶ Show clearly with signs that maintenance or repair tasks are being carried out on the mobile crane.
- ▶ Use signs which show without a doubt that it is prohibited to drive and operate the crane.
- ▶ Adhere to the national regulations regarding tagging on mobile crane and signs.
- ▶ Turn the engine on the crane superstructure and the crane chassis off!
- ▶ Apply the „parking brake crane chassis“.

If possible:

- ▶ Lock the driver's cab and the crane cab.
- ▶ Hand the ignition key from the crane superstructure and the crane chassis to an authorized person.

1.5 Personnel



WARNING

Unauthorized and untrained expert personnel!

Improper maintenance, personal injury, property damage.

- ▶ Observe and follow the personnel requirements for the respective maintenance task.

If there are no personnel requirements:

- ▶ The crane operator can perform the maintenance task.
- ▶ Have the repair tasks performed exclusively by authorized and trained expert personnel.
- ▶ Make sure that only authorized persons are within the danger zone.

Maintenance tasks may only be carried out by expert, authorized and trained employees.

An expert is someone who possesses the required expert knowledge for performing a certain task. Requirements regarding the technical qualification depends on the type of task.

Requirements regarding the technical qualification of a person:

- Corresponding professional training.
- Professional experience or a currently performed corresponding professional activity.
- Participation in training to keep the expert knowledge up to date.

1.6 Securing against falls



WARNING

Personnel is **not** secured against falls!

During maintenance tasks on the crane superstructure or boom, personnel must be secured with appropriate safety measures to prevent them from falling. If this is **not** observed, working personnel can fall and be killed or severely injured.

- ▶ For all tasks on the crane where there is a danger of falling, take suitable safety measures.
- ▶ The crane superstructure or the boom may **not** be accessed without suitable aids.
- ▶ Suitable aids are, for example: Lifting platforms, scaffoldings, ladders, assembly platforms, auxiliary crane.
- ▶ If railings are present on the crane superstructure, then they must be swung into operating position and secured for all tasks. See the Crane operating instructions, chapter 2.06.
- ▶ Only step on such aids with clean shoes.
- ▶ Keep aids clean, free of snow and ice.
- ▶ If tasks cannot be carried out using these aids or from the ground, then the maintenance personnel must be protected from falling using approved fall arrest systems. See the Crane operating instructions, chapter 2.04.
- ▶ It is prohibited to step on the driver's cab or cab roof and specially marked surfaces. See the Crane operating instructions, chapter 2.05.

**WARNING**

Dirty slip-resistant mats!

Fall

- ▶ Keep slip-resistant mats clean and free of snow and ice!
- ▶ Only step on slip-resistant mats with clean shoes!
- ▶ Replace or renew missing or damaged slip-resistant mats!

1.7 Preventing fires

**WARNING**

Excess fuel, excess oil in engine compartment during operation!

Death, severe injury, fire damage.

- ▶ Check the diesel engine after repairs and Service tasks but also in regular intervals for leaking oil and fuel.
- ▶ Make sure that the V-area of the Diesel engine is free of oil and fuel.
- ▶ Do **not** spill any service fluids over the hot components.

**WARNING**

Disregard of general safety regulations during tasks on the fuel system or on the electrical system!

Severe burns, fire damage.

- ▶ Disconnect the battery from the power supply.
- ▶ Do **not** smoke.
- ▶ Do **not** work near open flames.
- ▶ Keep a functioning fire extinguisher ready.

**WARNING**

Sound insulation mats are contaminated with fuel, engine oil, gear oil, hydraulic oil or solvents!

The sound insulation mats can ignite. Severe burns, fire damage.

- ▶ Remove any polluted sound insulation mats **immediately** and **replace immediately** with **Original Liebherr spare parts**.

If there are sound insulation mats around the starter on the chassis:

- ▶ **Immediately** remove the part of the insulation mats in an area of 0,5 m around the starter. Do **not** replace the sound insulation mats.

If there are sound insulation mats in the engine compartment cover on the superstructure:

- ▶ Remove sound insulation mats **immediately** and do **not** replace them.
- ▶ In addition, observe the section „Sound insulation mats“.

1.8 Protecting from burns

**WARNING**

Hot surfaces!

Severe burns.

- ▶ Let any components to be maintained or inspected cool off.
- ▶ Let hot components cool off.
- ▶ Avoid contact with hands and skin.
- ▶ Wear personal protective equipment and suitable protective gloves.

**WARNING**

Hot Service fluids!

Severe burns.

- ▶ Let hot service fluids cool off.
- ▶ Avoid contact with hands, skin and eyes.
- ▶ Wear safety glasses.
- ▶ Wear personal protective equipment and suitable protective gloves.

**WARNING**

Electric short circuit!

Severe burns.

- ▶ Prevent short circuits in the electrical system, especially on the battery.
- ▶ Replace or change missing or defective protective insulation.

1.9 Protecting from scalding

**WARNING**

Cooling system is pressurized!

When the coolant reservoir is opened, hot coolant can escape explosively.

Severe scalding.

When the engine is warm:

- ▶ Do **not** open the cover of the coolant reservoir.
- ▶ To protect face, hands and arms from hot steam of hot coolant, cover the cap with a large rag when opening.

1.10 Rotating parts

**WARNING**

Rotating parts, ignition system on running engine!

The cooler fan can turn on suddenly.

Death, severe injury.

- ▶ Proceed especially careful.
- ▶ Do **not** reach into rotating parts.
- ▶ Never reach into the cooler fan when the engine is warm.

1.11 Protecting from aggressive environmental conditions

NOTICE

Aggressive environmental conditions!

When using cranes under aggressive environmental conditions, for example at places with maritime climates and particularly salty air, hydraulic cylinders can corrode and thereby be destroyed or severely damaged.

Elaborate and expensive repairs.

If the crane is taken out of operation for an extended period of time:

- ▶ Take down the crane.
- ▶ Fully retract all crane hydraulic cylinders.

When hydraulic cylinders can **not** be retracted completely:

- ▶ Protect exposed areas of the piston rod from corrosion, for example with grease.
- ▶ Grease any exposed areas on the piston rods, for example on luffing cylinders and ballasting cylinders, especially carefully.

1.12 Use of suitable operating fluids

**WARNING**

Operating fluids **not** suitable for ambient temperature!

Death, severe injuries, property damage.

- ▶ Adjust the operating fluids in time to the ambient temperatures.

1.13 Replacing damaged crane components



WARNING

Damaged crane components **not** replaced!
Death, severe injury, failure of components.

- ▶ Maintain crane components according to the data in the maintenance intervals, the maintenance guidelines and the chart for service items and lubricants.
- ▶ Replace damaged crane components immediately.

1.14 After replacement of components

Type of oil, see data tag and supplied „Service fill“.

The following instructions must be observed when replacing components such as engine, gear or axle:



WARNING

Maintenance of a replaced component **not** carried out!

- ▶ Before start up, be sure to refill with the correct type of oil to the center of the minimum / maximum mark.
- ▶ Carry out first maintenance. See chapter „Maintenance intervals“.
- ▶ Adhere to regular maintenance intervals.
- ▶ Follow the break-in instructions. See the Crane operating instructions, chapter 2.02.

1.15 Tire size

When changing certain tire sizes, the mobile crane must be modified.

Contact Liebherr customer service to change the following tire sizes:

- From 385/95 R 25 to 445/95 R 25
- From 385/95 R 25 to 525/80 R 25
- From 445/95 R 25 to 385/95 R 25
- From 525/80 R 25 to 385/95 R 25

2 Warranty and coverage

NOTICE

Maintenance intervals and maintenance guidelines **not** adhered to, impermissible lubricants used!
Damage, failure of crane components.

The warranty for the respective crane component is voided.

- ▶ Maintain crane components according to the data in the maintenance intervals, the maintenance guidelines and the chart for service items and lubricants.

NOTICE

Not using Original Liebherr spare parts and **not** using Original Liebherr Service items!

In the event that replacement parts are used that are **not** Original Liebherr replacement parts and **not** Original Liebherr service items and lubricants, Liebherr-Werk Ehingen GmbH disclaims all liability for system functionality as well as for the parts.

- ▶ Use exclusively Original Liebherr spare parts.



Note

- ▶ Original Liebherr replacement parts have been tested for crane operation and may be used without risking safety.

The buyer is entitled to warranty or coverage only:

- when exclusively Original Liebherr spare parts are used.

- when Liebherr Service items and Liebherr lubricants are used for the Liebherr crane.

3 Liebherr Service

Liebherr mobile cranes, whether truck-mounted, mobile or crawler cranes - are technically advanced products, which prove their worth daily even under tough conditions.

The high technical standards of these cranes provide functional security, resistance to failure and ease of maintenance.

Liebherr is continuously developing the drive and control components. The combination of well proven units and modern manufacturing methods produces cranes that are safe to operate and easy to maintain.

Several hundred cranes are built every year for the international market, supported by international service.

Liebherr's „After Sales Service“ plays an important role at Liebherr in ensuring operational readiness and high crane availability.

With Liebherr, Service begins when the crane is handed over. Your crane operators will be professionally trained in line with their level of knowledge and we devote much time to this.

We also train your workshop staff in all crane-specific matters, because we know that they can deal with more than just minor repairs themselves. Often there are specialists who can quickly and reliably carry out crane repairs.

We have special service advisers available who will solve any problems you may have. This phone contact saves time and money. You should take advantage of it as soon as possible.

Our service technicians are specialists with years of experience, who can be deployed from local support points. Naturally these experts have specialized knowledge and special tools.

But before you call these specialists, it is worth making use of the facilities for getting advice mentioned above.

4 Taking an oil sample



Note

- ▶ Liebherr recommends taking oil samples for the gears, engines and hydraulic system in regular intervals.
- ▶ Based on the trend analysis of the oil analysis results, changes can be determined in the lubricity of the oil and increased component wear.



WARNING

Tasks on components and operating fluids at operating temperature!
Burns.

- ▶ Carry out all tasks with utmost caution.
- ▶ Wear protective clothing.

Make sure that the following prerequisites are met:

- Oil has a normal operating temperature
- ▶ Always take oil in the same location.
- ▶ Take oil always according to the same method.
- ▶ Do **not** take oil right after an oil change.
- ▶ Do **not** take oil immediately after larger amounts of oil have been added.

**Note**

Recommendation:

- ▶ Fill oil into original laboratory sample containers.
- ▶ Fill oil exclusively in a clean and dry sample container.

5 Cleaning

5.1 Exhaust system

NOTICE

Ingress of water, steam or cleaning substances into the SCR-module!

Sensors for exhaust aftertreatment can be destroyed, the coating of the SCR catalytic converter can be washed off.

- ▶ Before cleaning, let the SCR system cool off (surface temperature 50 °C).
- ▶ Before cleaning, cover all openings.
- ▶ Make sure that **no** fluids and **no** dirt gets into the tailpipe opening of the SCR module.
- ▶ During cleaning, keep sufficient distance to the tailpipe opening.

5.2 Sound insulation mats

NOTICE

Improper cleaning (tools or cleaning methods)!

Sound insulation mats can be destroyed or damaged.

- ▶ Remove severe contamination with suitable tools, for example with soft plastic scrapers.
- ▶ Do **not** use tools with sharp edges.
- ▶ Use steam cleaners **exclusively** with extreme caution and with a sufficient distance to the sound insulation mats and with low water pressure.
- ▶ Do **not** use solvents for cleaning.

If sound insulation mats are contaminated with fuel, engine oil, gear oil, hydraulic oil or solvents:

- ▶ Observe section „Preventing fires“.

5.3 Slip-resistant mats

- ▶ Before every access: Check the slip-resistant mats for slip resistance and cleanliness.
- ▶ If dirty: Clean the slip-resistant mats with a brush with hard plastic bristles.
- ▶ For cleaning the surfaces, use commercially available cleaners.
- ▶ Flush with water.

5.4 Driver's cab and crane cab

**Note**

- ▶ The steering wheel, center console, instrument panel cover, floor covering and dirty upholstery in the driver's cab and the crane cab should only be cleaned with warm water mixed with dishwashing detergent!
- ▶ Do not use any scouring agents!

5.5 Ladders

- ▶ Remove any dirt on the ladders.
- ▶ Make sure that the grooves on the rungs are free of dirt.

6 Disposal

6.1 Operating fluids and lubricants



WARNING

Operating items and lubricants are dangerous waste products!

- ▶ Dispose of operating fluids and lubricants separately.
- ▶ Service items and lubricants may **not** be disposed of in the ground, bodies of waters, wastewater systems, sewers or in the groundwater.
- ▶ Dispose of operating items and lubricants in an environmentally safe manner.
- ▶ When disposing operating items and lubricants observe and follow the valid regulations of the relevant authorities.

Service items and lubricants are:

- Fuels
- Coolant
- Urea
- Engine oils, gear oils
- Hydraulic fluids
- Brake fluids
- Window washer concentrate
- Greases

6.2 Batteries



WARNING

Batteries contain harmful substances!

- ▶ Do **not** dispose of batteries in regular household trash.
- ▶ Collect batteries separately and send them for environmentally safe disposal.
- ▶ Leave batteries at a qualified workshop or at a collection points for used batteries.

7.02 Maintenance intervals Crawler chassis

1	Maintenance and inspection schedule	3
---	-------------------------------------	---

3

Fig.195219

LWE/LR 1600-2-008/18109-09-02/en

1 Maintenance and inspection schedule



Note

- ▶ Carry out maintenance work after reaching the specified operating hours or calendar intervals. The interval which occurs first is the deciding factor.
- ▶ The maintenance intervals complement each other. If a higher interval is coming up, then carry out the work according to the lower interval also.
- ▶ The operating hour meter of the crawler travel gear is the determining factor for the operator hour intervals.
- ▶ The „crawler travel gear“ operating hour meter* is located in the control cabinet.

First maintenance after	Operating hour intervals			Calendar intervals			Work to be carried out	O.K.
	10 h	100 h	1000 h	Daily	Weekly	Annually		
Safety systems								
						X	Personal protective equipment Follow the instructions of the manufacturer	□
						X	Height rescue system Follow the instructions of the manufacturer	
Fall protection equipment								
						X	Check protection points	□
						X	Check safety ropes	
						X	Check the ladders for technically immaculate condition	
						X	Check railings, steps and pedestals for safe function	
						X	Check catwalks and open mesh flooring for safe function	
Crane surface								
					X		Check accessible surfaces for cleanliness	□
						X	Check accessible surfaces for completeness and slip resistance	
						X	Check labels for completeness and legibility	
Rigging and fastening points								
				X ²⁾			Check condition and mounting	□
						X	Check for continued suitability by expert	

LWE/LR 1600-2-008/18109-09-02/en

First maintenance after	Operating hour intervals			Calendar intervals			Work to be carried out	O.K.
	10 h	100 h	1000 h	Daily	Weekly	Annually		
Travel gear								□
		X					Check for leaks	
	X						Grease the sprocket bearing if it is not lubricated via the central lubrication system	
		X					Check the mounting screws for tight seating	
		500 h					Check the gear oil via oil analysis	
200 h			1000 h			Every 4 years	Change the gear oil	
Crawler carrier								□
		X					Check track rollers, carrier rollers with oil lubrication for leaks	
	X						Grease the track rollers, carrier rollers if it is not lubricated via the central lubrication system	
	X				Every 4 weeks		Check the wear on the roll off surfaces of the track rollers / carrier rollers, replace the track rollers / carrier rollers if necessary	
	X				Every 4 weeks		Check for wear on the glide rails	
						X	Grease guide rails on sliding section	
						X	Lubricate the consoles	
					Every 4 weeks		Lubricate the connector pins between crawler carrier and crawler center section or crawler carrier and cross carriers	

First maintenance after	Operating hour intervals			Calendar intervals			Work to be carried out	O.K.
	10 h	100 h	1000 h	Daily	Weekly	Annually		
Crawler chain								□
		X					Check the connector pin retainer	
		X					Check for damage	
	X				Every 4 weeks		Check the chain tension, retension the track chain if necessary	
	X						Check the wear on the bores of the track pads, replace track pads if necessary	
	X						Check the wear on the connector pins of the track pads, replace pins if necessary	
	X				Every 4 weeks		Check the wear on the roll off surfaces of the track pads / track rollers, replace track pads if necessary	
					Every 4 weeks		Check the wear on the sprocket wheels and the transport cams of the track pads	
Assembly support								□
					X		Check the hydraulic cylinder for leaks	
						X	Check support beam for ease of movement, grease	
						X	Lubricate the bearing points of the support beams	
						X	Check sight gauge, adjust if necessary	
Crane support								□
					X		Check the hydraulic cylinder for leaks	
						X	Check support beams for ease of movement, grease	
						X	Lubricate the struts	
						X	Lubricate the mounting pins on the struts	
						X	Lubricate the support pad bearing	
Concrete ballast plates / concrete catwalks (central ballast) (only LR1500)								
				X			Check for damage	
						X ⁴⁾	Have an authorized inspector check that the fastening points are fit tightly and for continued suitability	

LWE/LR 1600-2-008/18109-09-02/en

First maintenance after	Operating hour intervals			Calendar intervals			Work to be carried out	O.K.
	10 h	100 h	1000 h	Daily	Weekly	Annually		
Pin connections								□
					Every 2 months ³⁾		Check the retainer of the pin connections	
					Every 2 months ³⁾		Check the pins and / or connector elements for damage, visual inspection	
					Every 2 months ³⁾		Check the retaining elements for damage, visual inspection	
Rotary connection								□
			X				Lubricate	
Hydraulic cylinder								□
					X		Check for leaks	
Hydraulic hose lines								□
				X			Check for leaks and damage	
						X	Have safe working condition checked by expert	
Central lubrication system								□
					Every 6 months ¹⁾		Carry out intermediate lubrication (with central lubrication system with control unit).	
		X					Check for correct function	
				X			Check the lubricant level	

¹⁾ if the crane is not moved: every 3 months

²⁾ before every start up: checking visually

³⁾ also for cranes used for a long period of time

⁴⁾ and at each assembly / disassembly

7.02.50 Maintenance intervals ballast trailer

1 Maintenance and inspection schedule

3

LWE/LR 1600-2-008/18109-09-02/en

Fig.195219

LWE/LR 1600-2-008/18109-09-02/en

1 Maintenance and inspection schedule



Note

- ▶ Carry out maintenance work after reaching the specified operating hours or calendar intervals. The interval which occurs first is the deciding factor!
- ▶ The maintenance intervals complement each other. If a higher interval is coming up, then carry out the work according to the lower interval also!

First maintenance after	Operating hour intervals			Calendar intervals			Work to be carried out	O.K.
	10 h	100 h	1000 h	Daily	Weekly	Annually		
Fall protection equipment								
						X	Check protection points	
						X	Check safety ropes	
						X	Check the ladders for technically immaculate condition	
						X	Check railings, steps and pedestals for safe function	
						X	Check catwalks and open mesh flooring for safe function	
Ballast trailer surface								
					X		Check accessible surfaces for cleanliness	
						X	Check accessible surfaces for completeness and slip resistance	
						X	Check labels for completeness and legibility	
Rigging and fastening points								
				X ²⁾			Check condition and mounting	
						X	Check for continued suitability by an authorized inspector, inspection expert	
Tires								
					X		Check for external damage and distortion	
					X		Check the tire pressure	
	X						Check lug nuts for tight seating, retighten if necessary	
						Every 5 years	Replace tires; have further service life confirmed by a tire manufacturer expert	
Axle link								
						X	Lubricate	
Hydraulic cylinder								
					X		Check for leaks	

First maintenance after	Operating hour intervals			Calendar intervals			Work to be carried out	O.K.
	10 h	100 h	1000 h	Daily	Weekly	Annually		
Hydraulic hose lines								
				X			Check for leaks and damage	
						X	Check for a safe condition by an authorized inspector, inspection expert	
Travel drive								
						X	Check the mounting screws for tight seating	
					X		Check for leaks	
						X	Check the oil level	
						Every 5 years	Change the gear oil if necessary	
Slewing gear								
						X	Check the mounting screws for tight seating	
					X		Check for leaks	
						X	Check the oil level	
						Every 5 years	Change the gear oil if necessary	
Central lubrication system								
				X			Check grease supply of central lubrication system. Fill the reservoir if the grease supply has dropped below 1/4 of the reservoir content.	
						X	Check for correct function	
Pin connections								
					Every 2 months ³⁾		Check the retainer of the pin connections	
					Every 2 months ³⁾		Check the pins and / or connector elements for damage, visual inspection	
					Every 2 months ³⁾		Check the retaining elements for damage, visual inspection	
Emergency control								
						X	Check for correct function	

²⁾ before every start up: checking visually

³⁾ also for cranes used for a long period of time

7.03 Maintenance intervals - Crane superstructure

1 Maintenance and inspection schedule

3

LWE/LR 1600-2-008/18109-09-02/en

Fig.195219

LWE/LR 1600-2-008/18109-09-02/en

1 Maintenance and inspection schedule



Note

- ▶ Carry out maintenance work after reaching the specified operating hours or calendar intervals. The interval which occurs first is the deciding factor!
- ▶ The maintenance intervals complement each other. If a higher interval is coming up, then carry out the work according to the lower interval also!

First maintenance after	Operating hour intervals			Calendar intervals			Work to be carried out	O.K.
	250 h	500 h	1000 h	Daily	Weekly	Annually		
Safety systems								
						X	Personal protective equipment Follow the instructions of the manufacturer	□
						X	Height rescue system Follow the instructions of the manufacturer	
Fall protection equipment								
						X	Check protection points	□
						X	Check safety ropes	
						X	Check the ladders for technically immaculate condition	
						X	Check railings, steps and pedestals for safe function	
						X	Check catwalks and open mesh flooring for safe function	
Crane surface								
					X		Check accessible surfaces for cleanliness	□
						X	Check accessible surfaces for completeness and slip resistance	
						X	Check labels for completeness and legibility	
Rigging and fastening points								
				X ²⁾			Check condition and mounting	□
						X	Check for continued suitability by an authorized inspector, inspection expert	
Load handling equipment and assembly aids								
				X ²⁾			Check for cracks, damage, wear and distortion	□
						X	Check for continued suitability by an authorized inspector, inspection expert	

LWE/LR 1600-2-008/18109-09-02/en

First maintenance after	Operating hour intervals			Calendar intervals			Work to be carried out	O.K.
	250 h	500 h	1000 h	Daily	Weekly	Annually		
Fastening equipment and load securing devices								<input type="checkbox"/>
				X ²⁾			Observe and adhere to the manufacturer's instructions	
Fire extinguishing system								<input type="checkbox"/>
						X	Carry out a visual inspection of the system For all other maintenance tasks, observe the instructions of the fire extinguisher manufacturer.	
						Every 5 years	Replace trigger elements and extinguisher tank.	
Diesel engine								<input type="checkbox"/>
				X			Check the oil level For all other maintenance tasks, observe the instructions of the engine manufacturer	
Cooling system								<input type="checkbox"/>
				X			Check the coolant level in the expansion tank	
			6000 h			Every 4 years	Replace the coolant if filled with Liebherr Antifreeze OS Mix	
			3000 h			Every 2 years	Replacing the coolant	
SCR Exhaust aftertreatment								<input type="checkbox"/>
			4500 h			Every 2 years	Replace foam and filter element of urea pump	
Engine independent heater (auxiliary heater)								<input type="checkbox"/>
				X			Check the fluid level in the expansion tank	
						Every 4 weeks ⁸⁾	Operate and check the function for 10 minutes with the engine cold and the highest fan stage	
						X ⁹⁾	Operate and burn-free for 15 minutes with the engine cold and the highest fan stage	
						X	Carry out maintenance work before and after every heating period	
						Every 2 years	Replace the fluid for the heating system	
				X			Check the fill level of the fuel container	

First maintenance after	Operating hour intervals			Calendar intervals			Work to be carried out	O.K.
	250 h	500 h	1000 h	Daily	Weekly	Annually		
Air filter								
					X		Check monitoring device	□
						X	Clean, change the filter insert Observe the instructions of the engine manufacturer	
Slewing ring connection								
	X						Lubricate the gears	□
						X ¹⁾	Lubricating the slewing ring connection	
					Every 6 months ¹⁾		Drain water on the water drain bores of the slewing ring connection (only LTM 11200-9.1, LTR 11200)	
250 h			1500 h			X	Check the mounting screws for tight seating	
						X	Checking the tilt play	
Winches								
250 h			X			X	Check the mounting screws for tight seating	□
				X			Check for leaks	
					X ⁶⁾		Check the oil level	
250 h			3000 h			Every 4 years	Change the gear oil	
			1500 h ⁴⁾			X ⁴⁾	Lubricate the space between V-ring / winch bearing (only for winches with a winch bearing that is lubricated with a grease fitting)	
			200 h			X	Check the condition of the tooth flanks; determining factor are the operating hours of the winch (only for winches with gear ring drive)	
						X	Check the remaining theoretical service life by an authorized inspector	
						Every 4 years	Check the remaining theoretical utilization life by an inspection expert	
Winch brakes								
				X			Check for leaks	□
						X	Check for correct function	

LWE/LR 1600-2-008/18109-09-02/en

First maintenance after	Operating hour intervals			Calendar intervals			Work to be carried out	O.K.
	250 h	500 h	1000 h	Daily	Weekly	Annually		
Relapse supports								
					Every 3 months ^{5), 6)}		Lubricating the bearings	□
X ^{2), 6)}							Check the oscillation guard for easy movement	
Relapse cylinder								
X ^{2), 6)}					X		Check for leaks	□
					Every 3 months ^{5), 6)}		Lubricating the bearings	
X ^{2), 6)}		X				X	Check pretension pressure (nitrogen)	
X ^{2), 6)}		X				X	Check the oil quantity	
Pneumatic springs								
X ^{2), 5), 6)}		X				X	Check for correct function	□
A-frame								
		X					Lubricate the bearing	□
X ^{2), 6)}						X	Check the lever for the limit switch on the A-frame 3 for easy movement and reset of spring	
X ^{2), 6)}						X	Check the rods with guide rail on the A-frame 2 and A-frame 3 for easy movement and distortion	
Counterweight frame								
						X	Check the cylinder stroke of the locking pin on the swinging arms (only LTM 1450-8.1)	□
Counterweight								
1000 km		or 10,000 km				X	Check tightening torque of mounting screws	□
Concrete ballast plates (ballast container) (only LR 13000)								
				X			Check for damage	□
						Every 5 years	Check by licensing agency	
Ballasting								
	X					X	Lubricating the bearings	□
						X	Check the swing play (only LTM 11200-9.1)	
						X	Check the braid ropes (only LTM 11200-9.1)	

First maintenance after	Operating hour intervals			Calendar intervals			Work to be carried out	O.K.
	250 h	500 h	1000 h	Daily	Weekly	Annually		
Press on pulleys of rope winches								□
	X					X	Grease guides	
Rope pulleys								□
					X ^{5), 6)}		Check groove base for cleanliness	
			X			X	Check for wear, damage, cracks and easy movement	
			3000 h			Every 3 years	Lubricate the bearings	
Carrier rollers								□
				X ²⁾			Check for damage and distortion	
			X			X	Check for wear, damage and easy movement	
			X			X	Check the mounting screws for tight seating	
Crane cab								□
				X			Check instruments for function	
				X			Check indicator lights for function	
						X	Replace the filter insert for switch cabinet ventilation	
						X	Replace filter insert in water heater	
				X			Check fluid level in expansion tank of engine regulation	
		X				X	Check the sliding or incline device for function	
		X				X	Lubricate the bearings of the sliding or incline device	
		X				X ⁷⁾	Check the lift device (telescope arm) for function	
		X				X ⁷⁾	Lubricate the bearings of the lift device and telescope arm	
Window washing bays, camera washing bays								□
				X			Check the fluid level in the reservoir for the washing bays	
Overload protection								□
				X			Check for correct function	
		X				X	Check length sensor for function	
		X				X	Check length sensor rope for damage	

LWE/LR 1600-2-008/18109-09-02/en

First maintenance after	Operating hour intervals			Calendar intervals			Work to be carried out	O.K.
	250 h	500 h	1000 h	Daily	Weekly	Annually		
Remote diagnostics device								□
						X	Check for correct function	
						X	Check the validity of the SIM card	
Electrical system								□
						X	Cable connections	
					Every 6 months ³⁾		Service the batteries	
					Every 6 months ³⁾		Empty the acid container	
						X ⁵⁾	Replace the interior compartment filter of the switch cabinet ventilation	
Fuel system								□
				X			Check for leaks	
						X	Check condition and mounting	
						X	Drain off water and sediments	
						X	Clean preliminary filter for auxiliary fuel pump	
	Every 50 h						Check fuel preliminary filter, drain off water if necessary	
		Every 1000 h					Replace preliminary fuel filter	
Slewing gear								□
250 h			X			X	Check the mounting screws for tight seating	
				X			Check for leaks	
					X		Check the oil level	
250 h			3000 h			Every 4 years	Change the gear oil	
Slewing gear brakes								□
				X			Check for leaks	
						X	Check for correct function	
Turntable lock								□
		X				X	Grease	
		X				X	Check for correct function	
Bearings								□
						X	Checking the retaining elements	

First maintenance after	Operating hour intervals			Calendar intervals			Work to be carried out	O.K.
	250 h	500 h	1000 h	Daily	Weekly	Annually		
Pin connections								
					Every 2 months ¹⁰⁾		Check the retainer of the pin connections	<input type="checkbox"/>
					Every 2 months ¹⁰⁾		Check the pins and / or connector elements for damage, visual inspection	
					Every 2 months ¹⁰⁾		Check the retaining elements for damage, visual inspection	
Pump distributor gear								
				X			Check for leaks	<input type="checkbox"/>
					X		Check the oil level	
500 h			1500 h			X	Change the gear oil	
Hydraulic hose lines								
				X			Check for leaks and damage	<input type="checkbox"/>
						X	Check for a safe condition by an authorized inspector, inspection expert	
Hydraulic system								
				X			Check the oil level	<input type="checkbox"/>
					X		Check for leaks	
250 h		X				X	Replace the servo pressure and replenishing pressure filter inserts	
250 h		X				X	Replace return filter inserts (only for cranes with open hydraulic circuit)	
250 h		X				X	Replace bleeder filter of hydraulic tank	
500 h			X			X	Check hydraulic oil, required degree of purity: 20/18/15 Take oil sample and have it tested by oil supplier	
Hydraulic cylinder								
					X		Check for leaks	<input type="checkbox"/>
					Every 3 months ^{5), 6)}		Lubricating the bearings	
Hydraulic pressure accumulator (nitrogen)								
		X ⁴⁾				X ⁴⁾	Check pretension pressures	<input type="checkbox"/>
Hydraulic coupling system LIKUFIX								
				X ^{2) 6)}			Check for leaks, dirt and lubricate the guides	<input type="checkbox"/>

LWE/LR 1600-2-008/18109-09-02/en

First maintenance after	Operating hour intervals			Calendar intervals			Work to be carried out	O.K.
	250 h	500 h	1000 h	Daily	Weekly	Annually		
Compressed air system								□
					X		Check for leaks	
					X		Check operating pressure	
					X		Check shut off pressure	
					X		Check operation of automatic drain valve	
						X	Replace air dryer granular cartridges	
						X	Clean air dryer preliminary filter	
Central lubrication system								□
					Every 6 months ¹⁾		Carrying out an intermediate lubrication	
		X					Check for correct function	
					X		Check the grease container fill level	
Emergency control								□
						X	Check for correct function	
Suspended ballast								□
						X	Check the fall protection equipment	
						X	Check frame, suspension and guide section for distortion and cracks	

- 1) if the crane is not moved: every 3 months
2) before every start up: checking visually
3) in hot climate zones: every 3 months
4) observe maintenance instructions - crane superstructure, chapter 7.05
5) and as necessary
6) and during assembly
7) in Great Britain: every 6 months
8) outside of the heating period
9) during the heating period
10) also for cranes used for a long period of time

7.03.50 Maintenance intervals - Crane boom

1 Maintenance and inspection schedule

3

Fig.195219

LWE/LR 1600-2-008/18109-09-02/en

1 Maintenance and inspection schedule



Note

- ▶ Carry out maintenance work after reaching the specified operating hours or calendar intervals. The interval which occurs first is the deciding factor!
- ▶ The maintenance intervals complement each other. If a higher interval is coming up, then carry out the work according to the lower interval also!

First maintenance after	Operating hour intervals			Calendar intervals			Work to be carried out	O.K.
	250 h	500 h	1000 h	Daily	Weekly	Annually		
Safety systems								
						X	Personal protective equipment Follow the instructions of the manufacturer	□
						X	Height rescue system Follow the instructions of the manufacturer	
Fall protection equipment								
						X	Check protection points	□
						X	Check safety ropes	
						X	Check the ladders for technically immaculate condition	
						X	Check railings, steps and pedestals for safe function	
						X	Check catwalks and open mesh flooring for safe function	
Surface of crane boom								
					X		Check accessible surfaces for cleanliness	□
						X	Check accessible surfaces for completeness and slip resistance	
						X	Check labels for completeness and legibility	
Rigging and fastening points								
				X ²⁾			Check condition and mounting	□
						X	Check for continued suitability by an authorized inspector, inspection expert	
Load handling equipment and assembly aids								
				X ²⁾			Check for cracks, damage, wear and distortion	□
						X	Check for continued suitability by an authorized inspector, inspection expert	

First maintenance after	Operating hour intervals			Calendar intervals			Work to be carried out	O.K.
	250 h	500 h	1000 h	Daily	Weekly	Annually		
Fastening equipment and load securing devices								<input type="checkbox"/>
				X ²⁾			Observe and adhere to the manufacturer's instructions	
Lattice sections								<input type="checkbox"/>
						X	Check cracks, damage and distortion	
						X	Check protection points	
						X	Check safety ropes	
						X	Check railings and pedestals for safe function	
						X	Check catwalks and open mesh flooring for safe function	
X ⁶⁾						X	Grease the lube points of lattice sections	
Guy rods								<input type="checkbox"/>
						X	Check for cracks, damage and distortion by an authorized person	
						Every 4 years	Check cracks, damage and distortion by an authorized inspector	
						X	Checking the retaining elements	
						X	Check labels for completeness and legibility	
X ⁶⁾						X	Lubricate the lube points of guy rods	
Fiber guy ropes								<input type="checkbox"/>
					Every 3 months ⁷⁾		Check braid and intermediate layers for damage and distortion	
					Every 3 months ⁷⁾		Check rope end connections for cracks, damage and distortion	
					Every 3 months ⁷⁾		Check rope grommet transitions for damage and distortion	
Relapse supports								<input type="checkbox"/>
					Every 3 months ^{5), 6)}		Lubricating the bearings	
X ^{2), 6)}							Check the oscillation guard for easy movement	

First maintenance after	Operating hour intervals			Calendar intervals			Work to be carried out	O.K.
	250 h	500 h	1000 h	Daily	Weekly	Annually		
Relapse cylinder								□
X ^{2), 6)}					X		Check for leaks	
					Every 3 months ^{5), 6)}		Lubricating the bearings	
X ^{2), 6)}		X				X	Check pretension pressure (nitrogen)	
X ^{2), 6)}		X				X	Check the oil quantity	
Hydraulic hose lines								□
				X			Check for leaks and damage	
						X	Check for a safe condition by an authorized inspector, inspection expert	
Hydraulic cylinder								□
					X		Check for leaks	
					Every 3 months ^{5), 6)}		Lubricating the bearings	
Hydraulic pressure accumulator (nitrogen)								□
		X ⁴⁾				X ⁴⁾	Check pretension pressures	
Rope pulleys								□
					X ^{5), 6)}		Check groove base for cleanliness	
			X			X	Check for wear, damage, cracks and easy movement	
			3000 h			Every 3 years	Lubricate the bearings	
Carrier rollers								□
				X ²⁾			Check for damage and distortion	
			X			X	Check for wear, damage and easy movement	
			X			X	Check the mounting screws for tight seating	
Auxiliary guying								□
						X ⁶⁾	Check the rope connection between the guy point and the lattice section	
						X ⁶⁾	Check cracks, damage and distortion	

First maintenance after	Operating hour intervals			Calendar intervals			Work to be carried out	O.K.
	250 h	500 h	1000 h	Daily	Weekly	Annually		
Pin connections								<input type="checkbox"/>
					Every 2 months ⁸⁾		Check the retainer of the pin connections	
					Every 2 months ⁸⁾		Check the pins and / or connector elements for damage, visual inspection	
					Every 2 months ⁸⁾		Check the retaining elements for damage, visual inspection	
Crane ropes								<input type="checkbox"/>
				X			Check for damage and distortion	
					Monthly ⁵⁾		Check, grease by expert personnel	
						X	Check by an authorized inspector	
						Every 4 years	Check by an inspection expert	

First maintenance after	Operating hour intervals			Calendar intervals			Work to be carried out	O.K.
	250 h	500 h	1000 h	Daily	Weekly	Annually		
Hook blocks								□
				X ³⁾			Check of the load hook for distortion, wear, damage and cracks by the crane operator	
			X			X	Check rope pulleys for distortion, wear, damage and cracks	
			3000 h			Every 3 years	Lubricate rope pulley bearings	
	100 h				Every 3 months ⁵⁾		Lubricate pressure bearings	
	100 h				Every 3 months ⁵⁾		Lubricate radial bushing	
	100 h				Every 3 months ⁵⁾		Lubricate suspension of hook beam	
					Every 6 months ⁵⁾		Replace batteries on incline sensor	
						X	Load hook: Check distance dimension (y)	
						X	Check of the load hook for distortion, wear, damage and cracks by an authorized person	
						Every 4 years	Check of the load hook for distortion, wear, damage and cracks by an inspection expert	

²⁾ before every start up: checking visually

³⁾ before starting crane operation: checking visually

⁴⁾ observe maintenance instructions - crane superstructure, chapter 7.05

⁵⁾ and as necessary

⁶⁾ and during assembly

⁷⁾ by authorized and trained expert personnel with boom taken down and before every erection procedure

⁸⁾ also for cranes used for a long period of time

Empty page!

LWE/LR 1600-2-008/18109-09-02/en

7.04 Maintenance guidelines - Crane chassis

1	Servicing the travel gear	3
2	Servicing the central lubrication system of the crawler carrier	11
3	Servicing the track chain	17
4	Ladders	29

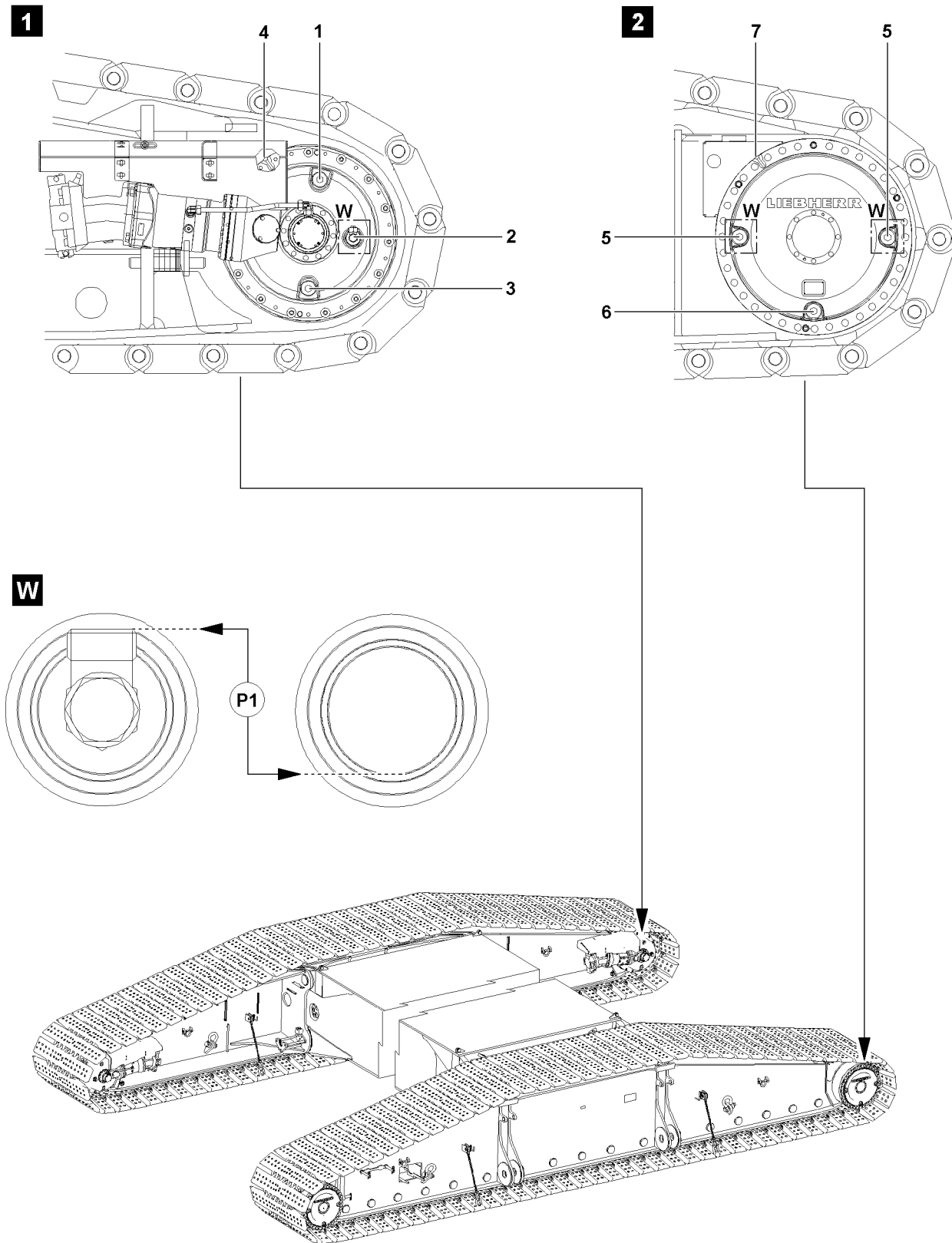

Fig.110046

LWE/LR 1600-2-008/18109-09-02/en

1 Servicing the travel gear



Note

- ▶ Use service items and lubricants according to the chart, see Crane operating instructions, chapter 7.07.
- ▶ Observe the maintenance intervals, see Crane operating instructions, chapter 7.02.

The travel gear consists of:

- Miter gear with brake, illustration 1
- Planetary gear, illustration 2



WARNING

Danger of burns during maintenance and inspection work!

Severe burns can result due to the travel gear and oils at operating temperatures.

- ▶ Avoid direct body contact to heated components and fluids.

NOTICE

Dirt in travel gear!

If any dirt gets inside of the travel gear, gear damage can occur.

- ▶ Make sure that no dirt gets into the inside of the travel gear during maintenance work.

The following maintenance openings are on the miter gear with brake, see illustration 1:

- 1 Oil filler plug, oil filler port
- 2 Oil level plug, oil level port
- 3 Oil drain plug, oil drain port
- 4 Grease lubrication miter gear

The following maintenance openings are on the planetary gear, see illustration 2:

- 5 Oil level plug, oil level port
- 6 Oil drain plug, oil drain port
- 7 Grease lubrication planetary gear



Note

- ▶ No separate oil filler port is located on the planetary gear, the oil level port is used for this purpose.
- ▶ Oil level ports on planetary gears and miter gears can be constructed differently.
- ▶ The planetary gear and the miter gear have separate, different sized oil chambers. The oil levels in the gear must be checked independently of each other.

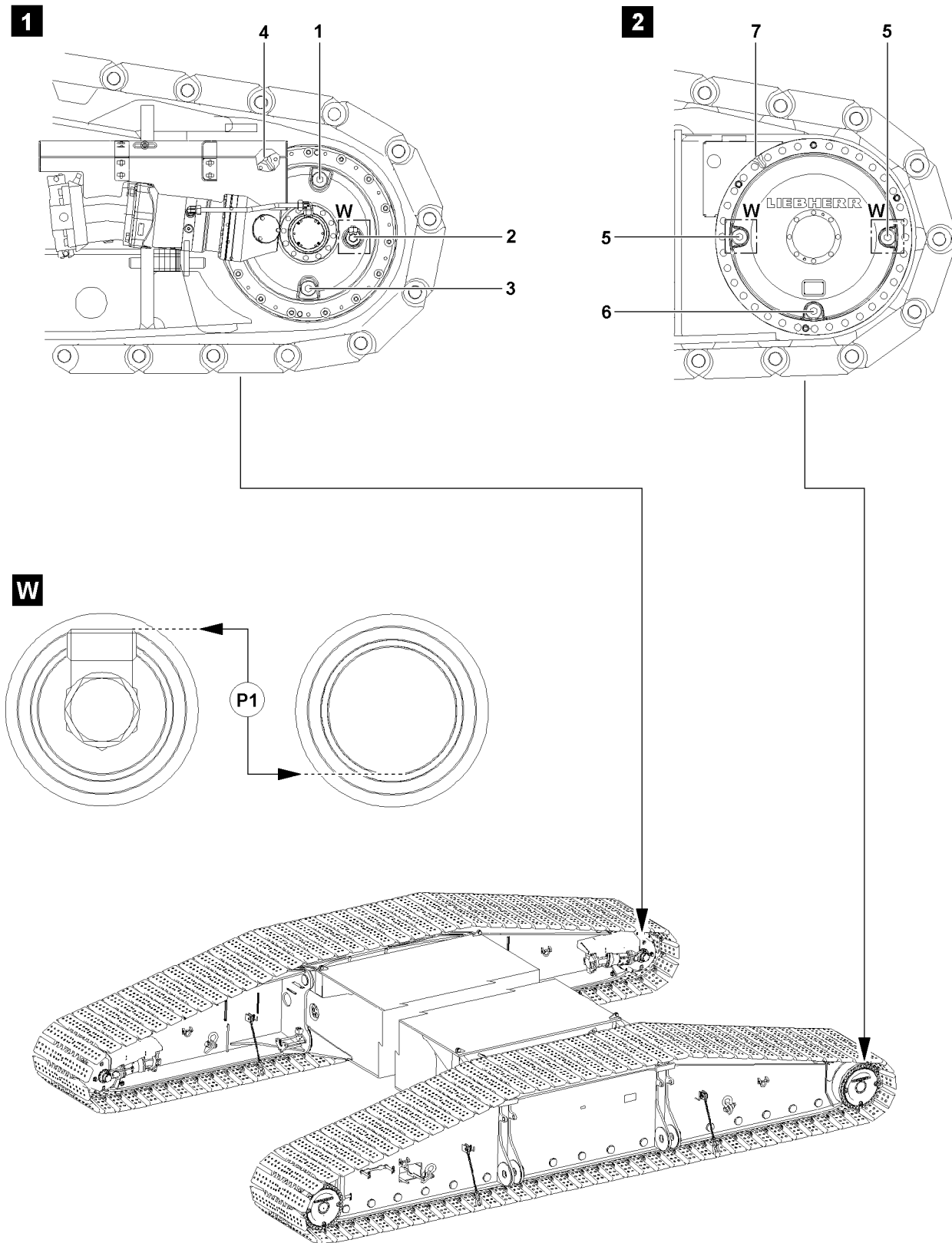

LWE/LR 1600-2-008/18109-09-02/en

Fig.110046

1.1 Checking for leaks

- ▶ Check visually to ensure that the travel gears do not leak.

1.2 Checking the oil level

NOTICE

Damage to the travel gear!

If seals are used repeatedly, it can result in loss of oil.

Due to loss of oil, the travel gears can wear significantly and / or be damaged.

- ▶ Use the seals on the maintenance ports only once.
-

NOTICE

Varying oil level in planetary gear!

Depending on the position of the gears in the planetary gear, the oil level can vary slightly upward.

When opening the oil level plug, oil can emerge despite correct fill quantity.

- ▶ The fill height must be at least at the height of the point **P1**.
 - ▶ If any oil emerged during the check, replace the same amount.
-

Make sure that the following prerequisites are met:

- The crane is in horizontal position.
- The travel gear is at a standstill.



Note

- ▶ To ensure a reliable oil level check, it must be ensured that the travel gears have been at a standstill for at least two minutes. This ensures that the oil has returned to the oil chamber completely.
-

- ▶ Open the oil level port carefully.
-

NOTICE

Insufficient oil fill quantity!

If the oil level drops below the fill level on point **P1**, the travel gears can be damaged.

- ▶ Add gear oil until the oil level is again on the fill level on point **P1**.
-

If gear oil must be added:

- ▶ Add oil on the oil filler port.
- ▶ If the oil level is on the fill level on point **P1**, then the oil level on the travel gear is OK.
- ▶ Close the maintenance ports tightly.

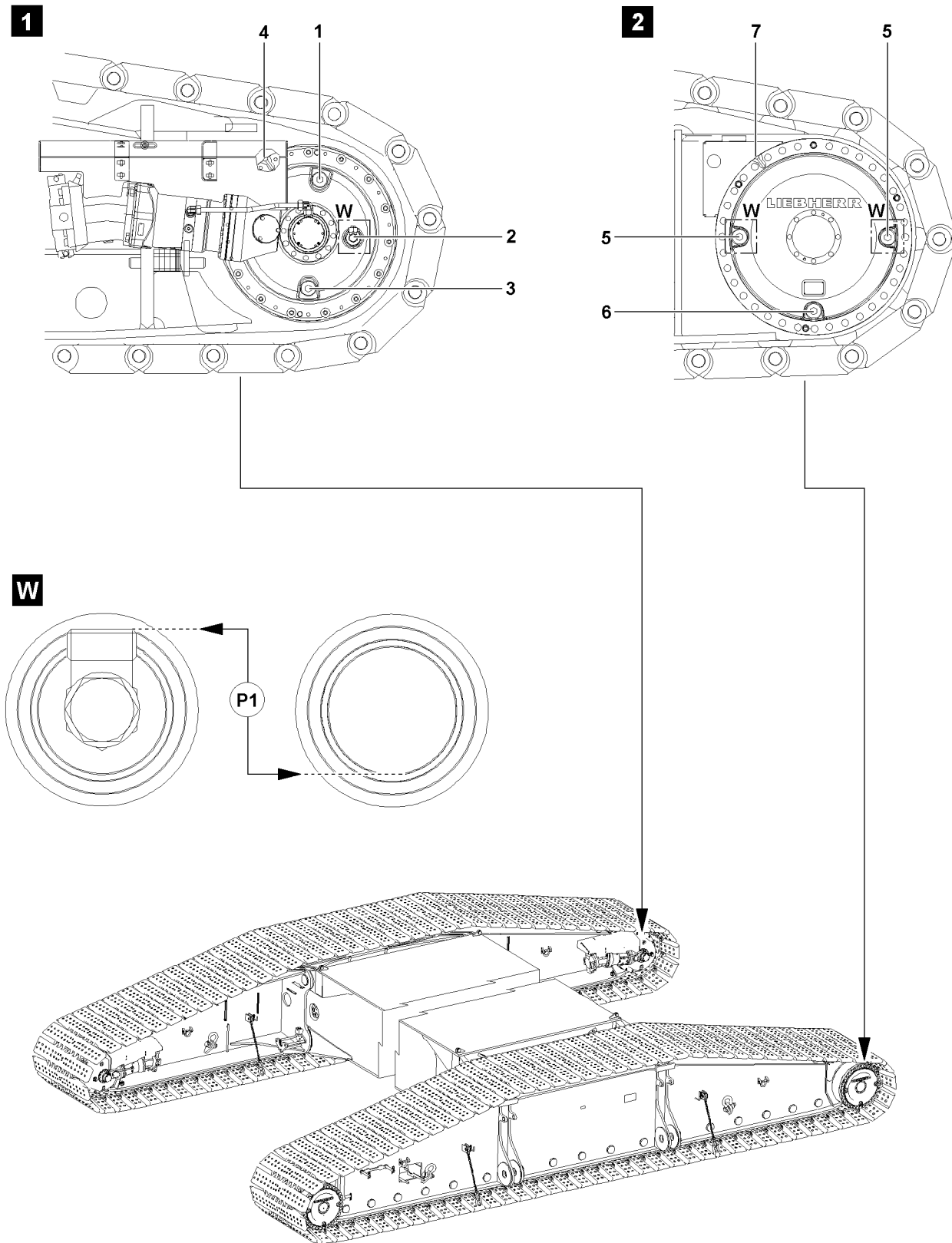

Fig.110046

LWE/LR 1600-2-008/18109-09-02/en

1.3 Changing the oil

NOTICE

Damage to the travel gear!

If seals are used repeatedly, it can result in loss of oil.

Due to loss of oil, the travel gears can wear significantly and / or be damaged.

- ▶ Use the seals on the maintenance ports only once.
-

1.3.1 Changing oil on the miter gear

Make sure that the following prerequisites are met:

- The crane is in horizontal position.
- The travel gear must be at a standstill.
- The travel gear is at operating temperature.
- A container to catch the used oil is available.



Note

- ▶ When selecting the container to catch the used oil, make sure that the container is sufficiently sized to be able to catch all the used oil.
 - ▶ For fill quantity of miter gear, see Crane operating instructions, chapter 7.06.
-

- ▶ Remove the oil filler plug **1**.
 - ▶ Remove the oil drain plug **3** and drain oil into a suitable container.
-



Note

- ▶ Allow the miter gear to empty completely.
- ▶ Clean the oil drain plug **3** and the sealing surface.
- ▶ Close off the oil drain port **3** tightly.
- ▶ Open the oil level port **2**.
- ▶ Add oil on the oil filler port **1** until it „stands“ at the height of the fill level on point **P1** of the oil level port **2** or until it starts to run over.
- ▶ Clean the sealing surfaces.
- ▶ Close off the oil level port **2** tightly.
- ▶ Close off the oil fill port **1** tightly.

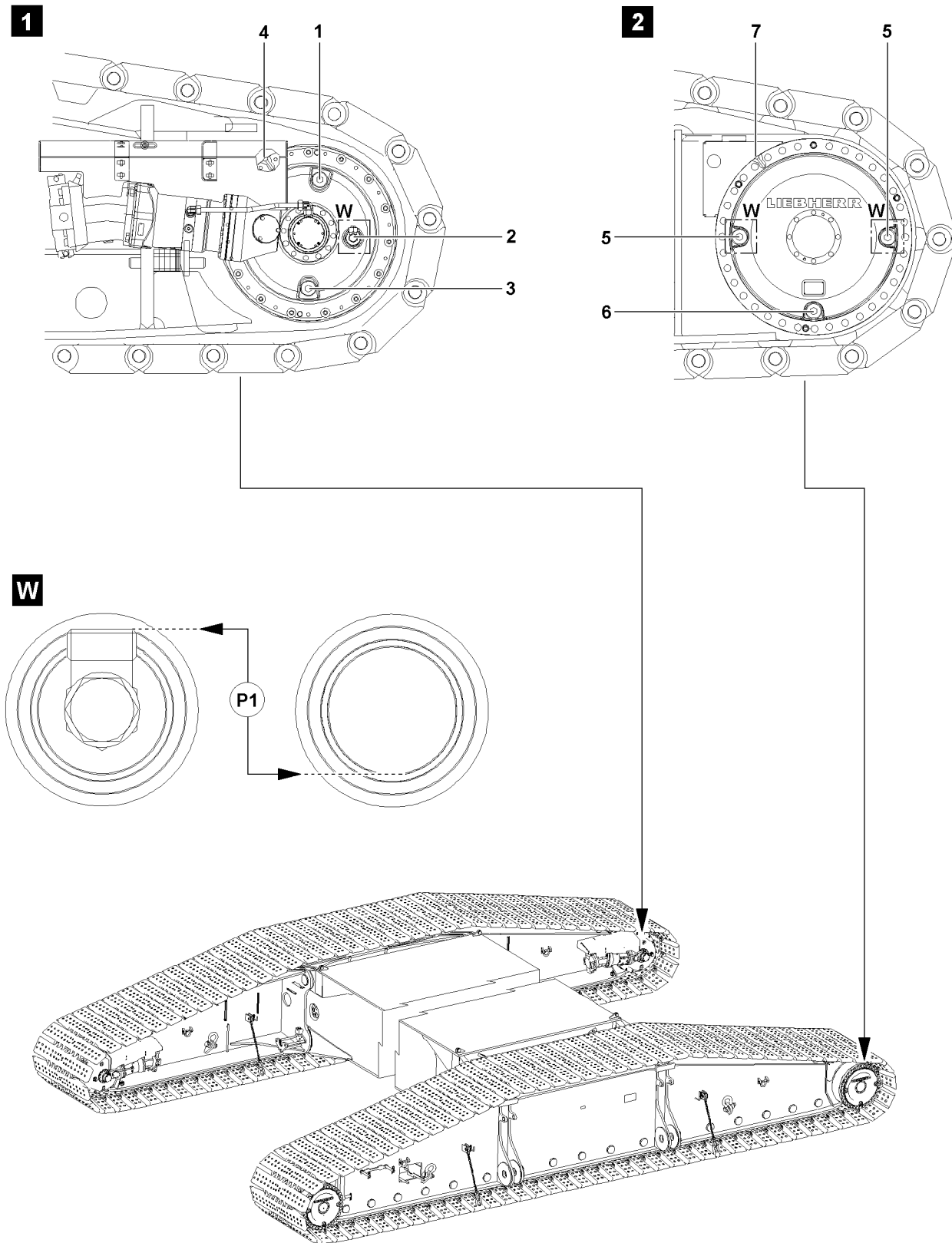

LWE/LR 1600-2-008/18109-09-02/en

Fig.110046

1.3.2 Changing oil on the planetary gear

Make sure that the following prerequisites are met:

- The crane is in horizontal position.
- The travel gear must be at a standstill.
- The travel gear is at operating temperature.
- A container to catch the used oil is available.

**Note**

- ▶ When selecting the container to catch the used oil, make sure that the container is sufficiently sized to be able to catch all the used oil.
- ▶ For fill quantity of planetary gear, see Crane operating instructions, chapter 7.06.

-
- ▶ Remove the oil level plugs **5**.
 - ▶ Remove the oil drain plug **6** and drain oil into a suitable container.

**Note**

- ▶ Allow the planetary gear to empty completely.
-
- ▶ Clean the oil drain plug **6** and the sealing surface.
 - ▶ Close off the oil drain port **6** tightly.
 - ▶ Add oil on the oil level port **5** until it „stands“ at the height of the fill level **P1** of the oil level ports **5** or until it starts to run over.
 - ▶ Clean the sealing surfaces.
 - ▶ Close off the oil level ports **5** tightly.

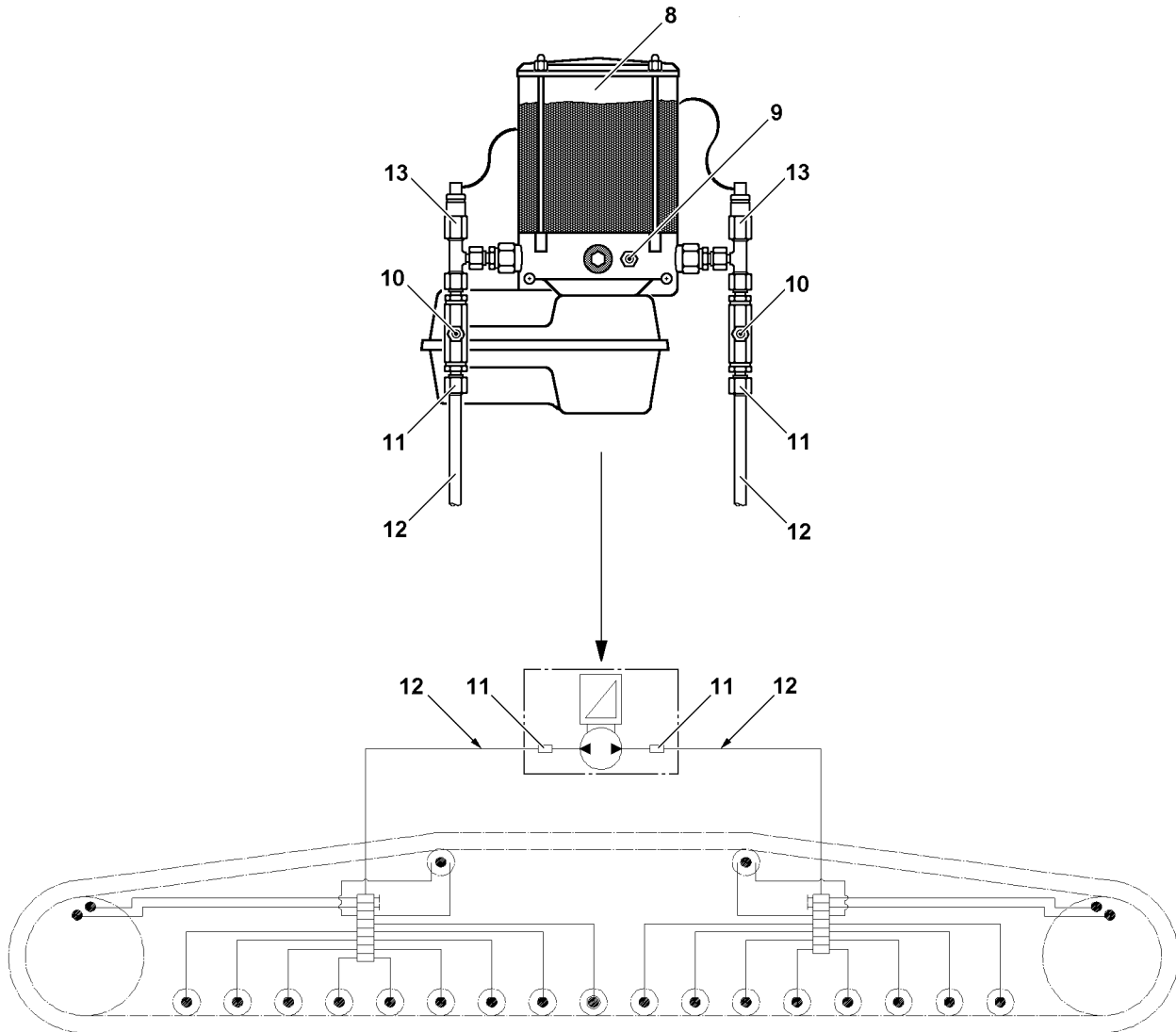

Fig.110102

LWE/LR 1600-2-008/18109-09-02/en

2 Servicing the central lubrication system of the crawler carrier



Note

- ▶ The illustrations in this chapter are examples and may not apply exactly to your crane.
- ▶ Use service items and lubricants according to the chart, see Crane operating instructions, chapter 7.07.
- ▶ Observe the maintenance intervals, see Crane operating instructions, chapter 7.02.

If the crane is driven via the crawler travel gear, then the central lubrication system for the crawler carrier turns on automatically and supplies all grease points with the correct amount of grease.

NOTICE

Insufficient lubrication!

The lubrication film is removed over time due to environmental influences.

Due to insufficient lubrication, the crawler carriers are exposed to significant wear and can be damaged.

- ▶ If the crawler carriers are not moved for a period of more than three months, then it must be lubricated every quarter, possibly with an external grease pump.



Note

- ▶ When putting the crane back into service after an extended downtime, check the central lubrication system for function.
- ▶ When working on the central lubrication system, observe utmost cleanliness.
- ▶ Every crawler carrier has a separate grease pump with several lubrication circuits.
- ▶ Every lubrication circuit has its own main line **12**.

On the grease pump, see illustration, there are the following maintenance relevant components:

- 8** Grease container
- 9** Grease fitting
 - Filling the grease container
- 10** Grease fitting
 - Fill the lube lines
- 11** Main line connection
- 12** Main line
- 13** Pressure relief valve

2.1 Filling the grease container

NOTICE

Insufficient lubrication!

In case of insufficient lubrication, the grease lubrication points can run dry.

This could result in high property damage.

- ▶ Fill the grease container **8** before it is completely empty.



Note

- ▶ Do not deplete the grease container **8**.
- ▶ If the grease container **8** is empty, the central lubrication system must be bled.
- ▶ Fill the grease container **8** with an external grease pump via the grease fitting **9**.

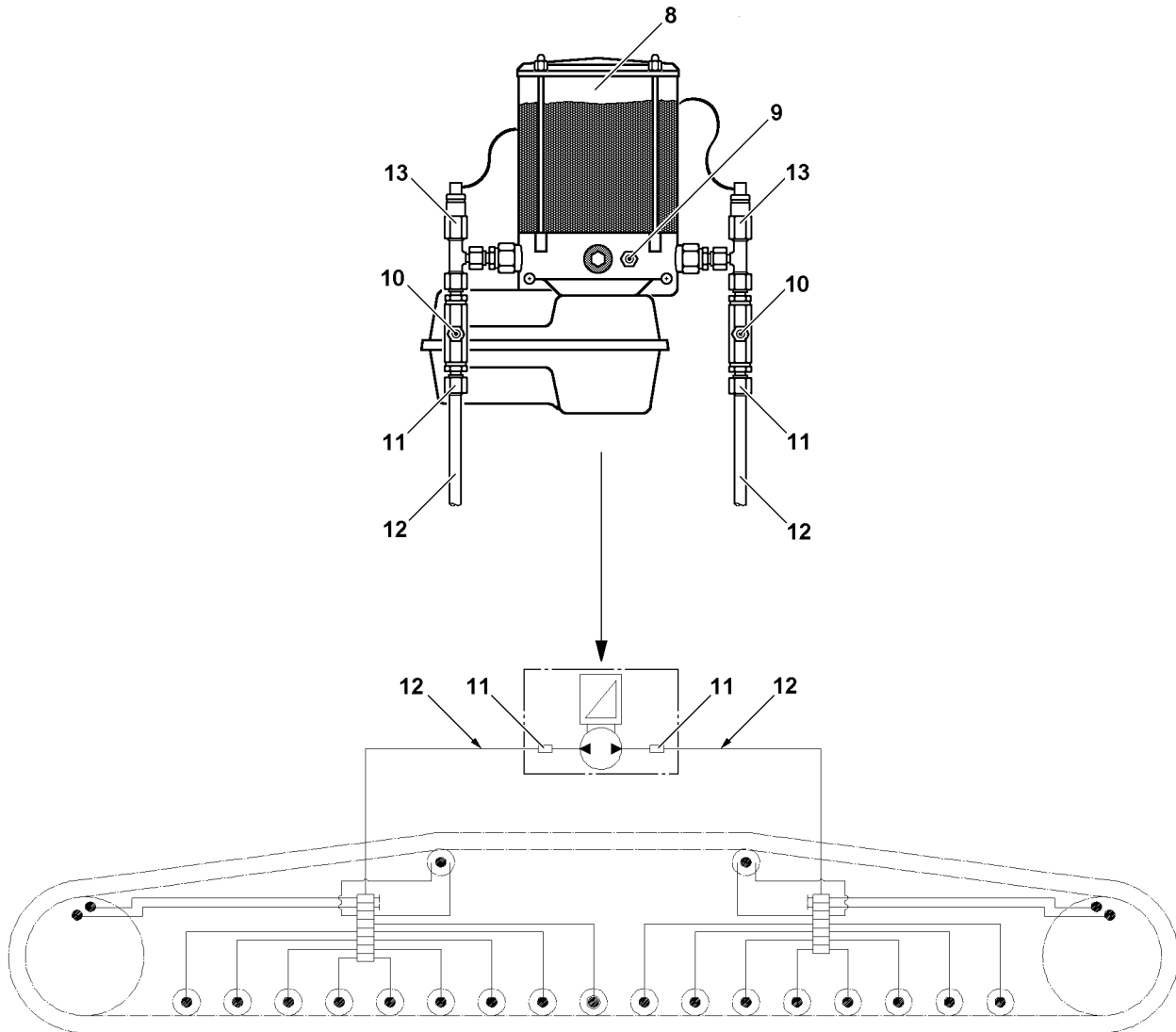

Fig.110102

2.2 Bleeding the central lubrication system

NOTICE

Insufficient lubrication!

If there is air in the grease pump, lubrication points can run dry.

- ▶ Bleed the central lubrication system carefully.

The central lubrication system of the crawler travel gear can be bled two ways:

- By actuation of the grease pump by simulating the crawler operation.
- By separate actuation of the grease pump with the aid of the electric wiring diagram.

2.2.1 Bleeding by simulating crawler operation



WARNING

Crane can start to drive unintentionally!

If the foot rocker in the crane operator's cab or the manual control lever on the radio remote control console* is moved too far while bleeding the grease pump, then the track chain can start to move.

The crane can start to drive and catch personnel.

Death, severe bodily injuries, property damage.

- ▶ Actuate the foot rocker carefully while bleeding the grease pump.
- ▶ Watch the emergence of grease from the grease pump from a safe position.

- ▶ Fill the grease container **8** with an external grease pump via the grease fitting **9**.
- ▶ Fill the main lines **12** with an external grease pump via the grease fittings **10** until grease free of air bubbles emerges on all grease points.



Note

- ▶ Carry out the bleeding procedure individually for each main line connection **11**.
- ▶ Every crawler carrier has a separate grease pump.

- ▶ Unscrew the main line **12** from the main line connection **11**.
- ▶ Start the crane engine.
- ▶ Select crawler operation.
- ▶ Actuate the foot rocker / manual control lever of the crawler carrier of the grease pump which is being bled only so far that the track chain does not start to move.

Result:

- The grease pump starts to supply.
- The acoustic signal crawler operation sounds.
- ▶ Actuate the foot rocker / manual control lever only until grease free of air bubbles emerges on the main line connection **11**.
- ▶ Reconnect the main line **12**.
- ▶ Actuate the foot rocker / manual control lever again until grease emerges again on at least one of the lube points in the bled lubrication circuit.

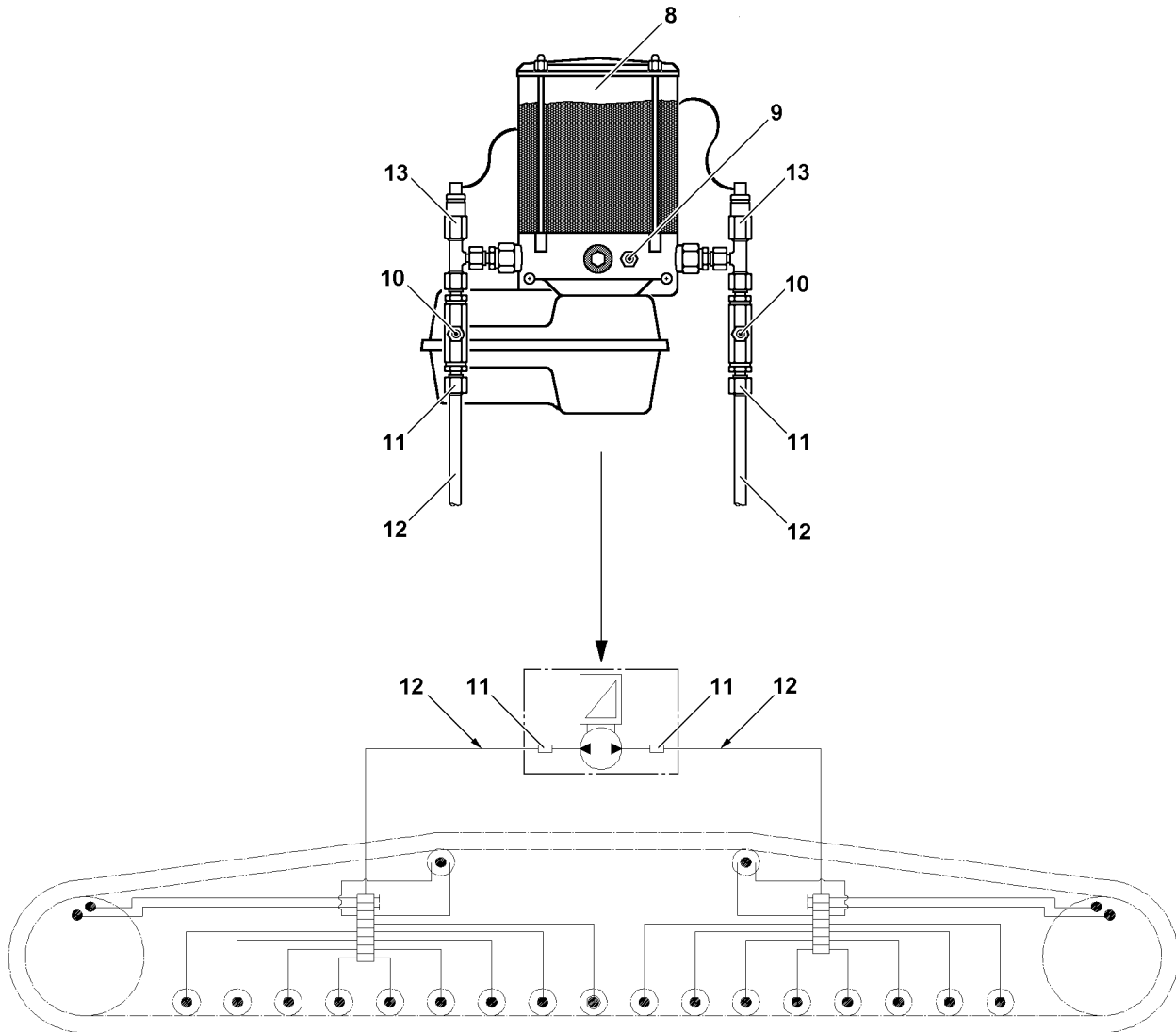

Fig.110102

LWE/LR 1600-2-008/18109-09-02/en

2.2.2 Bleeding by separate actuation of the grease pump



Note

- ▶ Work on the electrical system of the crane may only be carried out by authorized and trained expert personnel.

Make sure that the following prerequisite is met:

- The separate electric wiring diagram of the crane is available.
- ▶ Fill the grease container **8** with an external grease pump via the grease fitting **9**.
- ▶ Fill the main lines **12** with an external grease pump via the grease fittings **10** until grease free of air bubbles emerges on all grease points.



Note

- ▶ The bleeding procedure must be carried out individually for every main line connection **11**.
- ▶ Every crawler carrier has a separate grease pump.

- ▶ Unscrew the main line **12** from the main line connection **11**.
- ▶ Actuate the grease pump separately, see crane electric wiring plan.

Result:

- The grease pump starts to supply.
- ▶ Actuate the grease pump until grease free of air bubbles emerges on the main line connection **11**.
- ▶ Reconnect the main line **12**.
- ▶ Actuate the grease pump again until grease emerges again on at least one of the lube points in the bled lubrication circuit.

2.3 Bleeding repaired lubrication lines

NOTICE

Insufficient lubrication!

If there is air in the lubrication lines, lubrication points can run dry.

- ▶ If the lubrication lines are repaired or replaced, make sure that they are completely filled with grease.
- ▶ Fill lubrication lines completely with grease before installation.
- ▶ Check repaired lubrication lines for function and leaks.

2.4 Intermediate lubrication of crawler carriers

- ▶ Fill the main line **12** with an external grease pump via the grease fitting **10** until grease free of air bubbles emerges on all grease points.
or
Actuate the foot rocker / manual control lever in crawler operation until the grease pump starts to supply, but the track chain does not yet start to move. Continue actuation until grease emerges on all lube points.

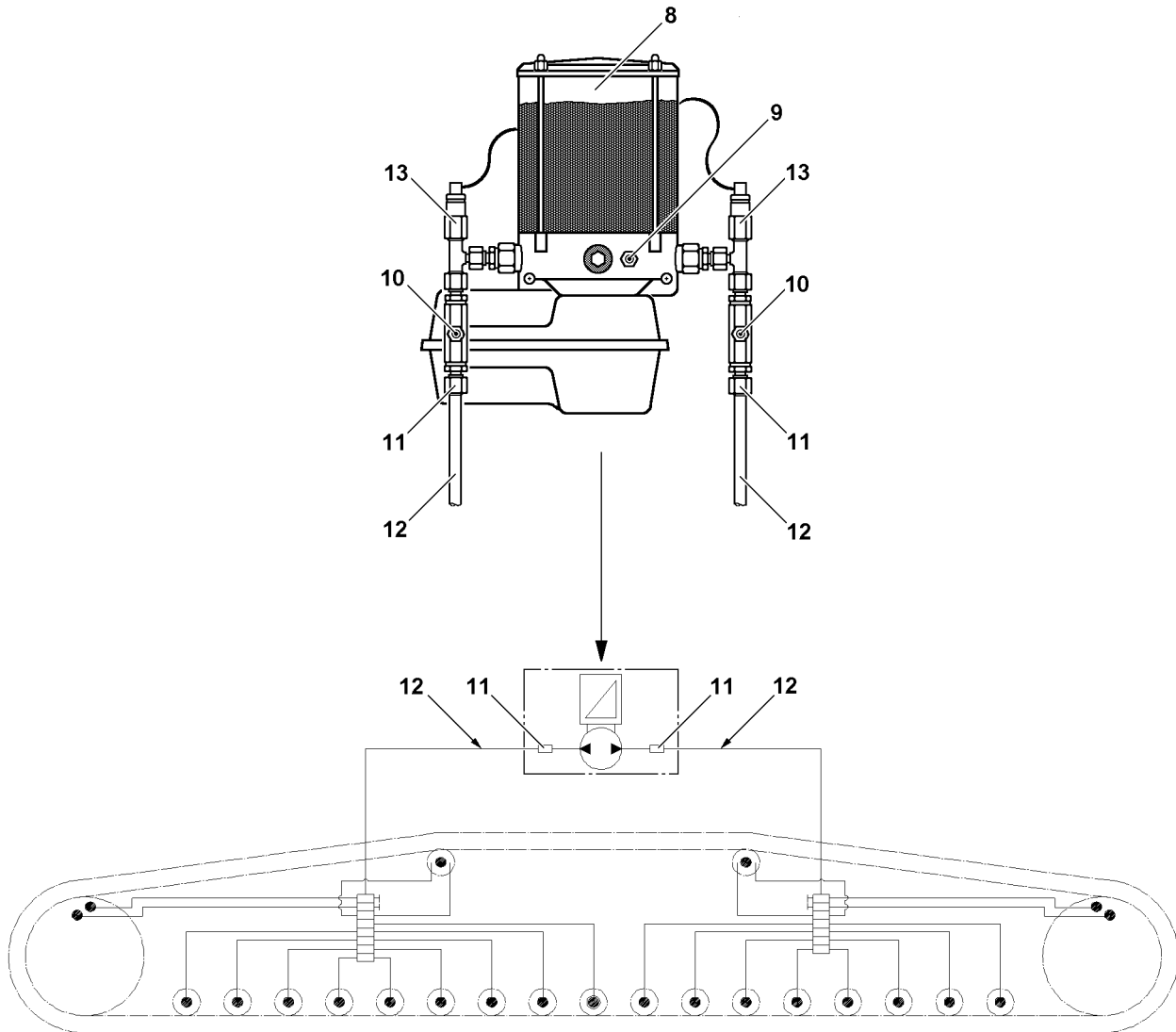

Fig.110102

LWE/LR 1600-2-008/18109-09-02/en

2.5 Troubleshooting on the central lubrication system

Problem	Cause	Remedy
The grease pump does not work	Electrical line interrupted, grease pump defective	Fix or replace the electrical line, replace the grease pump
Grease pump operates, but does not deliver	Air cushion in delivery piston, minimum fill level fallen below, grease pump element defective	Bleed grease pump, fill reservoir, replace grease pump element
No grease collar on all lube points	Grease pump does not work, system blocked	See „Grease pump does not work“ or „Grease emerges via pressure relief valve“
No grease collar on several lube points	Supply lines to secondary distributors broken or leaking, screw connections leaking	Replace lines, tighten or replace screw connections
No grease collar on one lube point	Associated lube line broken or leaking, screw connection leaking	Replace line, tighten or replace screw fitting
Grease pump speed reduced	High system pressure, low ambient temperature	Check the system / bearing points, if no damage is found: grease intermediately once or twice, if necessary ¹⁾
Grease escapes at the pressure relief valve	System pressure too high, distributor blocked, system blocked, defective valve spring on pressure relief valve	Check system, replace distributor, repair blocked / seized bearing point, replace pressure relief valve

1) See section „Intermediate lubrication of crawler carriers“.

If a problem cannot be remedied, contact the Service Dept. at Liebherr-Werk Ehingen.

3 Servicing the track chain



Note

► The illustrations in this chapter are examples and may not apply exactly to your crane.

In crawler operation, the components of the crawler travel gear are subject to wear caused by operation.

In order to continuously guarantee safe and effective crane operation, components must be checked at the specified maintenance intervals and replaced if necessary, see the Crane operating instructions, chapter 7.02.



WARNING

Maintenance interval exceeded!

Failure to observe the specified maintenance intervals can lead to increased crane failure time as well as to damage on the crawler travel gear.

Death, severe bodily injuries, property damage.

- Make sure that the maintenance intervals in the Crane operating instructions chapter 7.02 are observed.
- The crane operator is responsible for complying with the maintenance intervals, properly performing the specified maintenance tasks as well as initiating the corresponding measures as a result of the inspection results.

3.1 Tensioning the track chain

The track chain must be retensioned at the latest when three track pads **2** at point **P2** are laying flat on the glide rails **1.1** on the crawler carrier **1**.

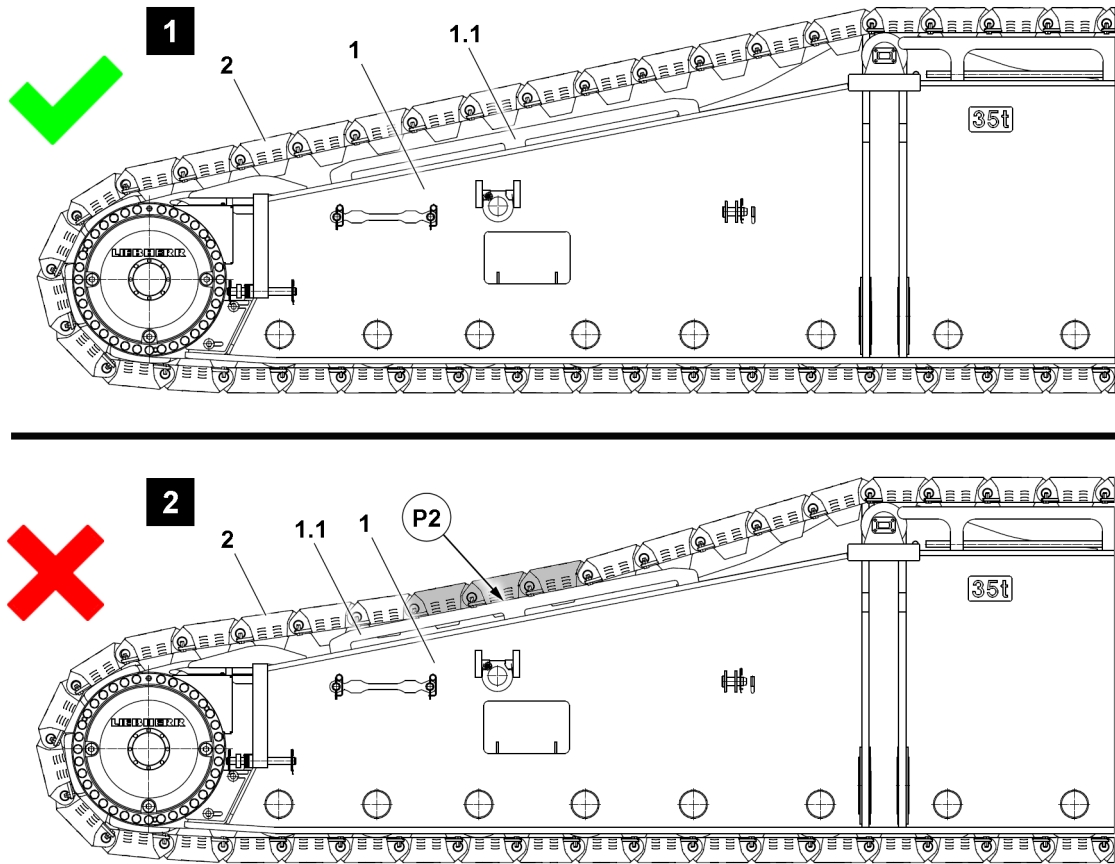

Fig.128220: Chain tension OK, illustration 1 // Track chain too slack, illustration 2

NOTICE

Damage to the track chain!

If the chain tension is not checked within the specified maintenance intervals, the track chain or the steel structure of the crawler carrier can be damaged.

- ▶ Observe and adhere to the maintenance intervals, see the Crane operating instructions, chapter 7.02.
- ▶ If **three** of the track pads **2** of the track chain lie flat on the glide rails **1.1** on the crawler carrier **1** (see point **P2**), then the track chain must be retensioned **immediately**.

The following applies in the case of crawler carriers **1** without glide rails **1.1** or with worn glide rails **1.1**:

- ▶ Make sure that the track pad cams never come into contact with the base steel structure of the crawler carrier. Always retension the track chain early on.

The following applies:

- ▶ The crane driver bears full responsibility for damage resulting from a non-tensioned track chain.

NOTICE

Glide rails worn!

If the glide rails on the crawler carriers are worn to the extent that the remaining material can be deformed or could break under the weight of the track chain, this could result in capital property damage to the crawler travel gear.

- ▶ Retension the track chain early on.
- ▶ Make sure that worn glide rails are replaced early on, please contact Customer Service at LIEBHERR-Werk Ehingen GmbH.

**Note**

- ▶ By extending the tension cylinder **14**, the sliding section **17** of the crawler carrier is moved in direction of the arrow.
- ▶ The chain tension is held by spacer plates **16**.

NOTICE

Foreign matter in track chains!

Foreign matter in the track chains and on the travel drive can cause damage.

- ▶ Before tensioning the track chains, check the track chains and the travel drives for foreign particles, such as rocks, and clean them, if necessary.

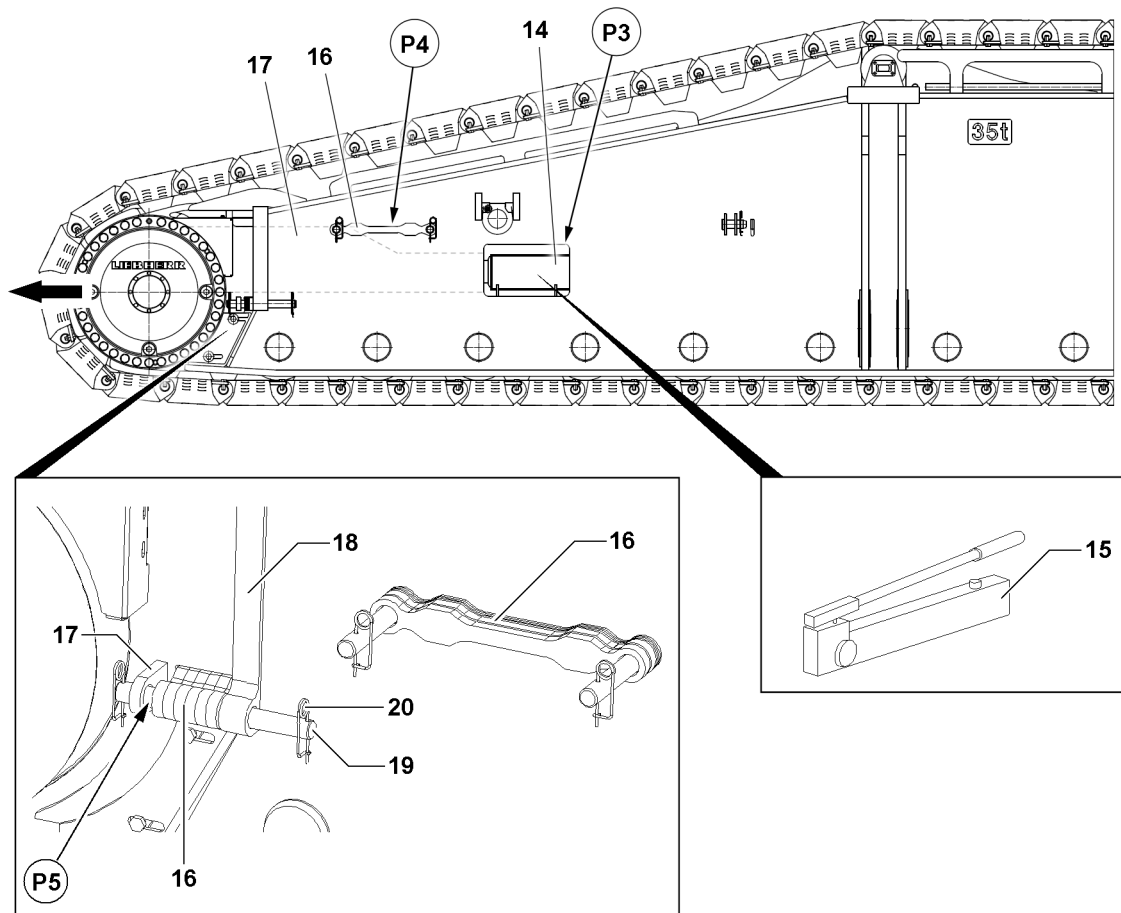

Fig.127101: Tensioning the track chain

Make sure that the following prerequisites are met:

- The crane is in horizontal position.
- The tension cylinder **14** is placed into the cylinder receptacle on point **P3**, see illustration.
- ▶ Extend the tension cylinder **14** with the hand pump **15** until the hand pump lever can no longer be moved.

Result:

- The track chain is tensioned.
- ▶ Remove the spacer plates **16** from the transport receptacle on point **P4**.
- ▶ On point **P5**, insert as many spacer plates **16** as fit into the gap between the sliding section **17** and the crawler carrier **18**.
- ▶ Secure the spacer plates **16** with pin **19** and spring retainer **20**.

**WARNING**

Danger of crushing!

When releasing the tension cylinder **14**, body parts, such as: Fingers, hands and arms can be crushed or severed.

- ▶ When relieving the tension cylinder **14**, any work on the crawler carrier is prohibited.
- ▶ Relieve the tension cylinder **14** again.
- ▶ After the tension procedure, drive the crawler back and forth about one crawler length in operating mode „Straight forward travel“.

Result:

- The tension of the track chain is reduced.
- ▶ Check the distance of the track chain to the steel construction of the crawler carrier again at point **P2**.

**Note**

- ▶ If necessary, repeat the tension procedure of the track chain and insert additional spacer plates **16**.
- ▶ If the lift on the tension cylinder **14** is no longer sufficient to tension the track chain, then trained expert personnel must remove one track pad.
- ▶ Take the relieved tension cylinder **14** from the cylinder receptacle on the crawler carrier **P3**.

Empty page!

LWE/LR 1600-2-008/18109-09-02/en

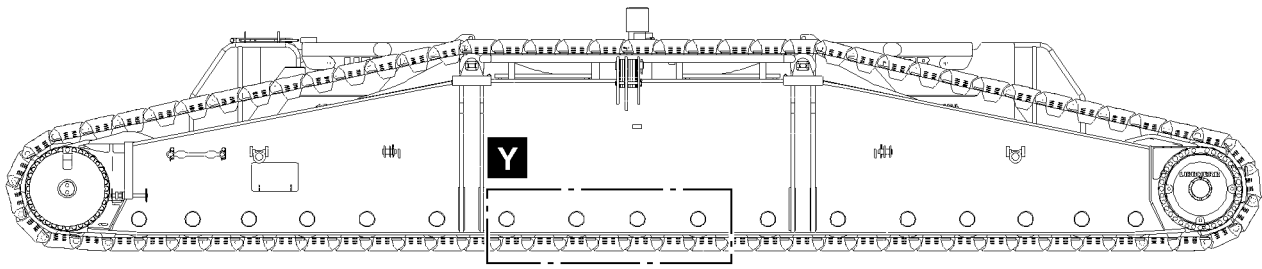

Y1

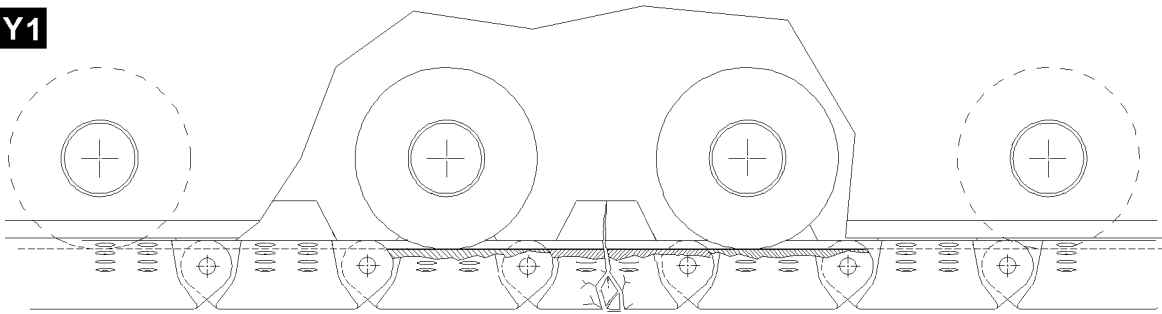

Y2

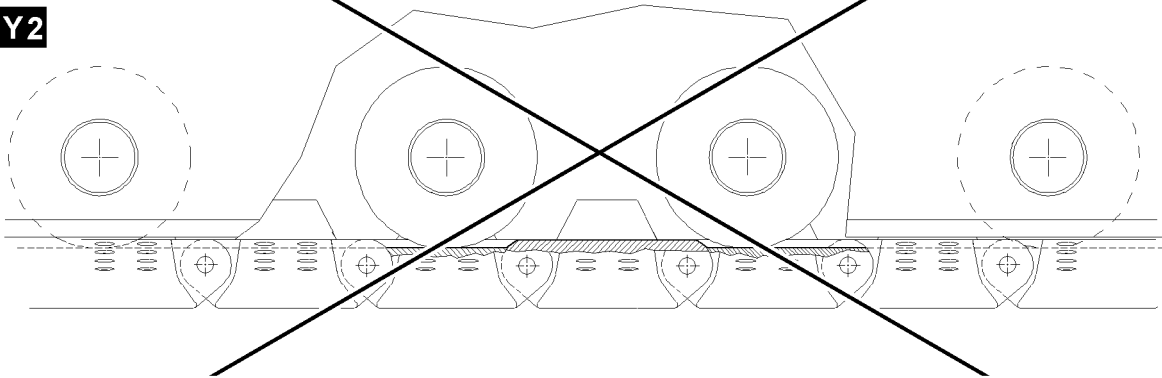

Y3

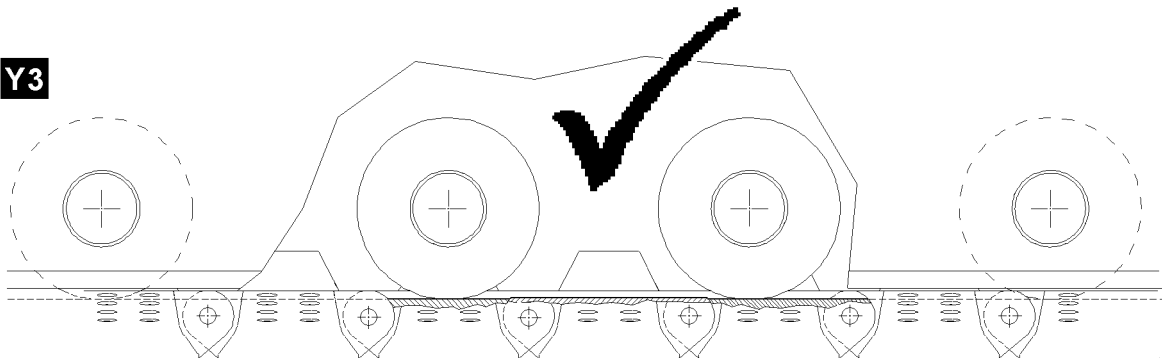

Fig.109917

LWE/LR 1600-2-008/18109-09-02/en

3.2 Checking wear on the track chain



WARNING

Track chain can be ripped off!

If the wear limit on the track pads **21**, pins **22** or track rollers **23** is exceeded, then the track chain can break off during crawler operation.

Death, severe bodily injuries, property damage.

- ▶ Random checks of the track pads **21**, pins **22** and track rollers **23** must be carried out within the specified intervals.
- ▶ During the random inspection of the track rollers, the first and last track roller on the crawler carrier must be included in the inspection.
- ▶ If a wear limit on the component is reached, then the component must be replaced or remachined.

NOTICE

Significant wear of crawler travel gear!

If an individual track pad **21** must be replaced then it may not be replaced with a track pad **21** that shows a much lower degree of wear.

Significant height differences between the individual track pads **21**, see illustration **Y2**, lead to an increased mechanical stress on the track pads **21** and the track rollers **23** of the crawler carrier.

- ▶ Replace a defective track pad **21** with a track pad **21** that shows a similar degree of wear, see illustration **Y3**.



Note

- ▶ Due to the break-in period of the components toward each other, a larger stretch of the track chains occurs on a new crawler travel gear. For that reason, it may be necessary to remove a track pad **21** earlier to be able to tension the track chain correctly.

The wear of the track pad **21**, pin **22** and track rollers **23** depends a various factors:

- Length of travel route
- Frequency of driving in curves
- Friction ratios track pad **21** - ground
- Evenness of the ground
- Type of ground
- Load bearing capacity of the ground / base
- Position of the total center of gravity
- Load on the hook
- Placed ballast on the crane

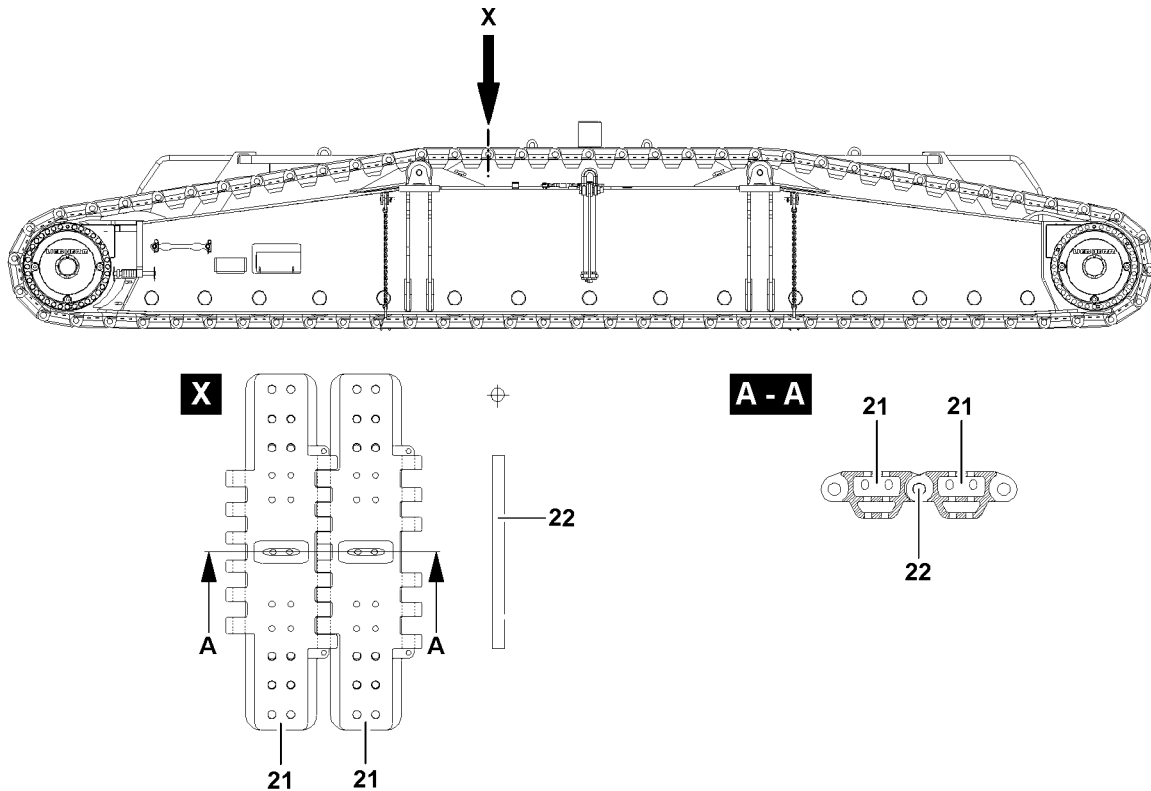

Fig.108536

3.2.1 Checking the wear on the connections of the track pads

NOTICE

Damage to the sprocket!

If the wear limit on the connections to the track pads is reached, it can lead to increased wear on the sprocket and on the transporting lugs of the track pads due to excessive chain stretch.

Expensive and extensive repairs can result.

- ▶ The random inspection of the pin diameter must be made within the specified intervals.
- ▶ If one pin **22** falls below the minimum permissible dimension, then it must be replaced with a new pin **22**.
- ▶ The random inspection of the bore diameter must be made within the specified intervals.
- ▶ If the bore diameter exceeds the maximum permissible dimension, then the track pad **21** must be replaced.

The track pads **21** of the crawler track are connected by pins **22**.

Wear limit bore for the track pad	
Initial diameter	48 mm
Maximum permissible upper limit	51 mm

Pin wear limit	
Initial diameter	45 mm
Maximum permissible minimum dimension	44 mm

Empty page!

LWE/LR 1600-2-008/18109-09-02/en

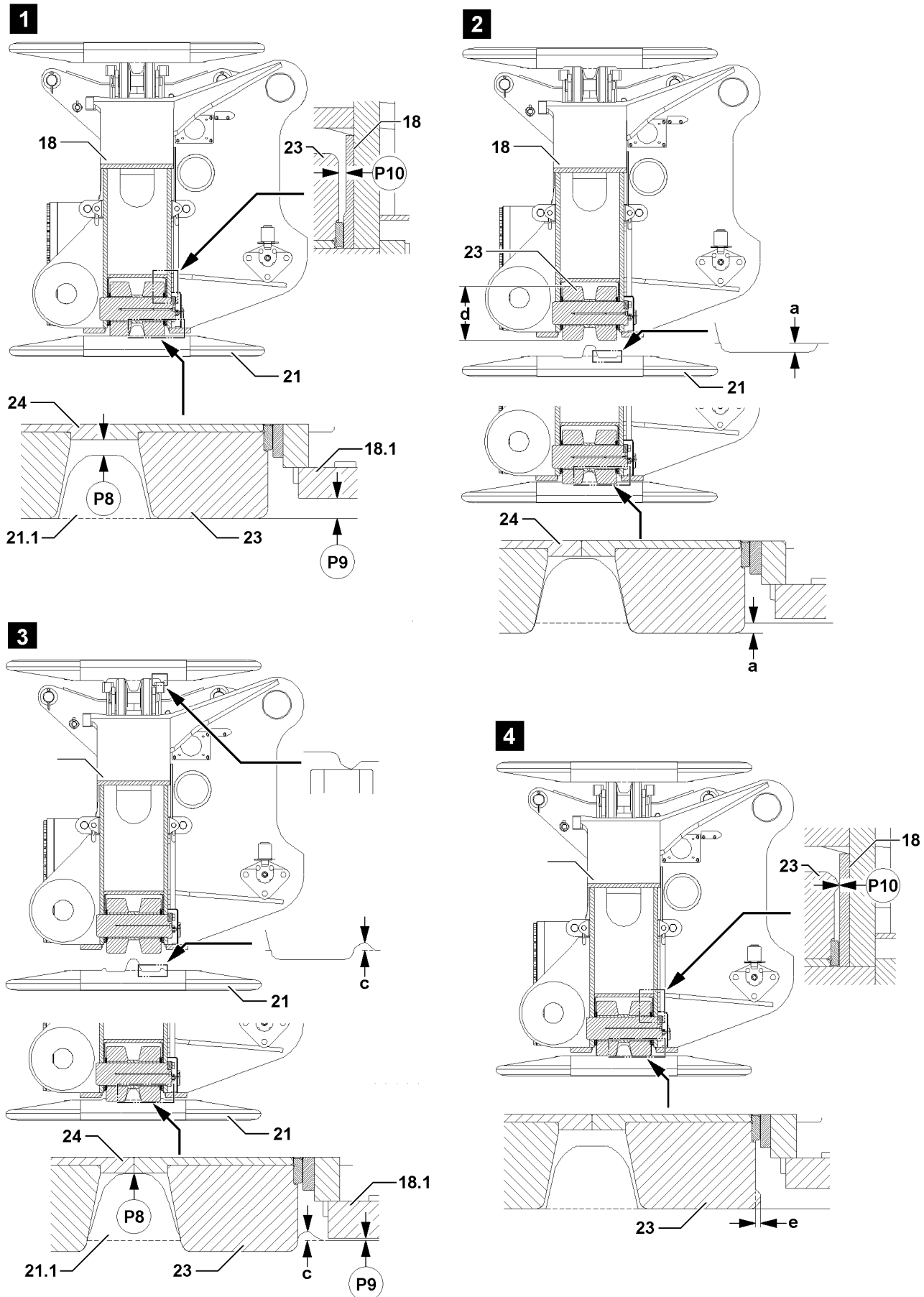

Fig.109882

LWE/LR 1600-2-008/18109-09-02/en

3.2.2 Checking the wear on the roll off surfaces of the track pads / track rollers

NOTICE

Destruction of track pad!

If a track pad **21** is not fixed or replaced after reaching the wear limit, then the track pad **21** will be destroyed and can cause damage to the crawler carrier **18**.

This could result in high property damage.

▶ Fix or replace the track pad **21** after reaching the wear limit.

NOTICE

Failure of track rollers!

If the track rollers **23** are not replaced after reaching the wear limit, then they can fail and cause damage to the crawler carrier **18** and track pad **21**.

This could result in high property damage.

▶ Replace track rollers **23** after reaching the wear limit.

NOTICE

Increased wear!

If the bulges on the track pads **21** and the track pads **23** become too large, see illustration **3** and illustration **4**, then it results in increased wear on the crawler travel gear.

This could result in high property damage.

▶ Grind off / remove bulges in time.

If the wear limits are not adhered to, the minimum distances are fallen below:

- On point **P8** between the transport cams **21.1** and track roller body **24**
- On point **P9** between the track pad **21** and base belt **18.1**
- On point **P10** between the track rollers **23** and crawler carrier **18**

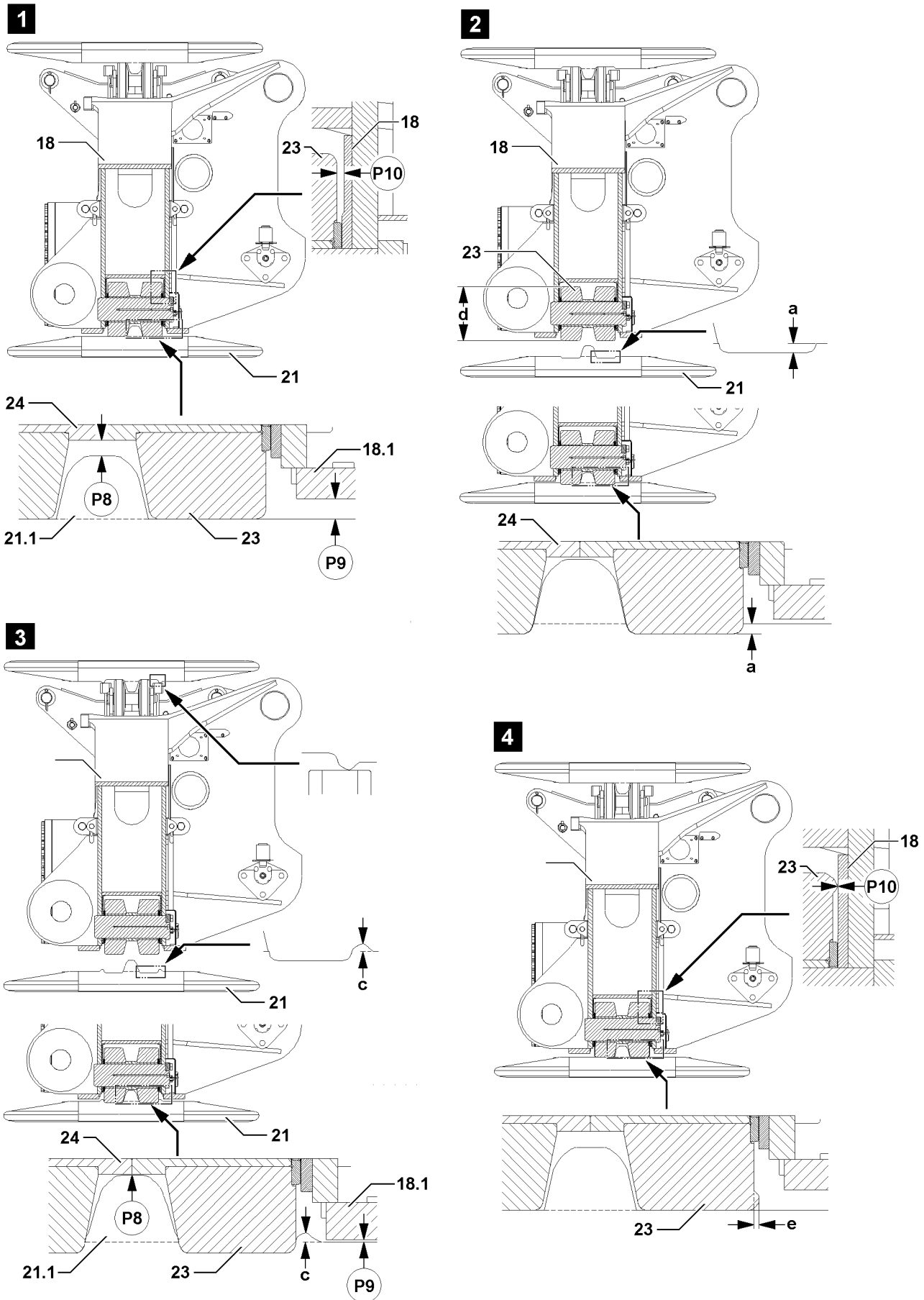

Fig.109882

LWE/LR 1600-2-008/18109-09-02/en

Wear limit track pad	
Maximum permissible run in depth a	6 mm
Maximum permissible bulge c	1)

Wear limit track roller	
Initial diameter	320 mm
Permissible minimum diameter d (measured in the center of the running surface)	318 mm
Maximum permissible bulge e	3 mm ²⁾

1) As soon as the bulge scrapes on the base belt of the crawler carrier, **grind bulge off!**

2) Valid for all track systems: If the bulge is larger than 3 mm , **grind the bulge off!**



WARNING

Danger of injury due to improper procedure!

- ▶ All work on the track chains must be carried out by trained expert personnel.



Note

- ▶ Track pads that have reached the maximum run in depth, or whose running surface is heavily worn, can be repaired by repair welds according to welding guideline or repair instructions of **LIEBHERR-Werk Ehingen GmbH**.
- ▶ Damage on sprocket and track pads - caused by operational wear - can be repaired by repair welds according to welding guidelines or repair instructions of **LIEBHERR-Werk Ehingen GmbH**.
- ▶ Please contact the Service Dept. at **LIEBHERR-Werk Ehingen GmbH**.
- ▶ Replace worn track rollers **23**.
- ▶ Grind off excessive bulges, see illustration **3** and illustration **4**.

4 Ladders



Note

- ▶ The following listed ladders are examples and may not match your crane exactly.



WARNING

Danger of falling!

If the following safety notes are **not** observed, personnel can fall down.

Death, severe bodily injuries, property damage.

- ▶ Observe and adhere to the installation and safety guidelines for ladders.
- ▶ Observe and adhere to the safety signs on the ladders.
- ▶ Install and secure the ladders properly.
- ▶ Do **not** use damaged ladders and replace them immediately.
- ▶ Repair the ladder exclusively through authorized service facilities.

4.1 Lubricating ladders

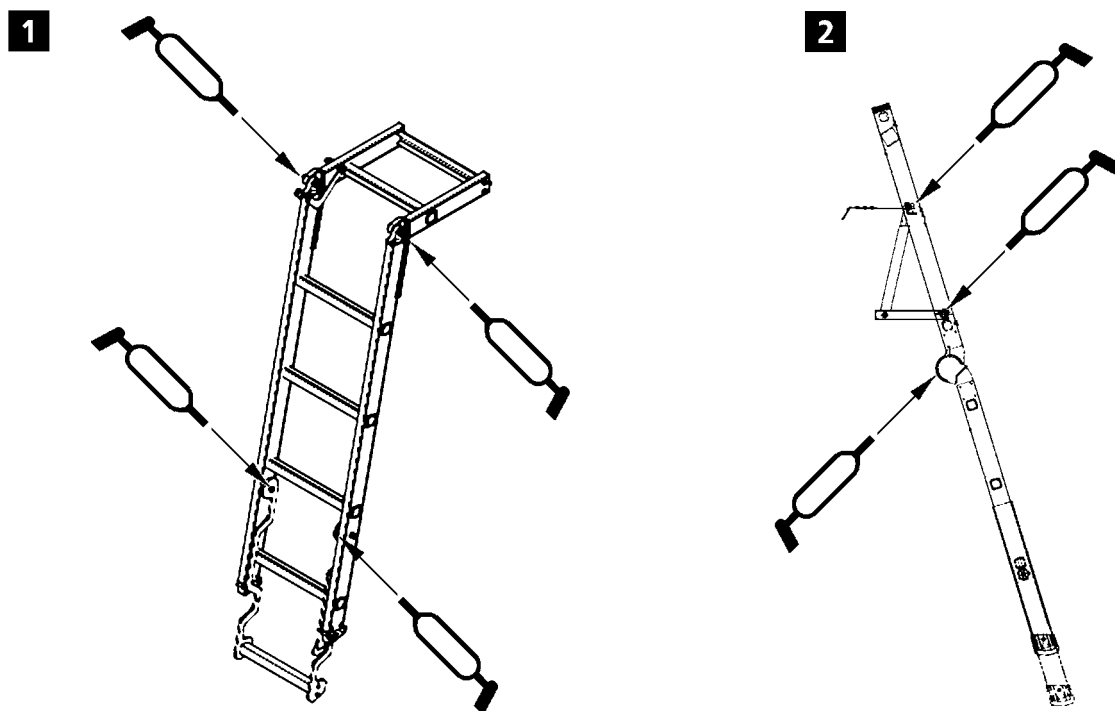

Fig.109766

- ▶ Grease joints and pivot points on the ladders regularly and check them for easy movement, see illustration 1 and illustration 2.
- ▶ Repairs and maintenance work on the ladder must be made by expert personnel.

7.04.50 Ballast trailer maintenance instructions

1	Maintenance	3
2	Ballast trailer tires	3
3	Hydraulic hose lines	3
4	Slewing gear	3
5	Central lubrication system	5
6	Wheel drive	6

Fig.195219

LWE/LR 1600-2-008/18109-09-02/en

1 Maintenance

**Note**

- ▶ For all maintenance work, use service items and lubricants according to the service fill list.
- ▶ Observe the ballast trailer maintenance intervals, see chapter 7.02.50.

2 Ballast trailer tires

2.1 Ballast trailer tires

**Note**

- ▶ See chapter 2.15.

2.2 Ballast trailer tires and disk wheels

**Note**

- ▶ See chapter 8.01.

3 Hydraulic hose lines

**Note**

- ▶ See chapter 7.05.

4 Slewing gear

Please maintain utmost cleanliness during all work to prevent dirt from entering inside the gear.

NOTICE

Dirt in the slewing gear!

If any dirt gets inside the slewing gear it can be damaged.

- ▶ Make sure that no dirt gets inside the slewing gear during maintenance work.

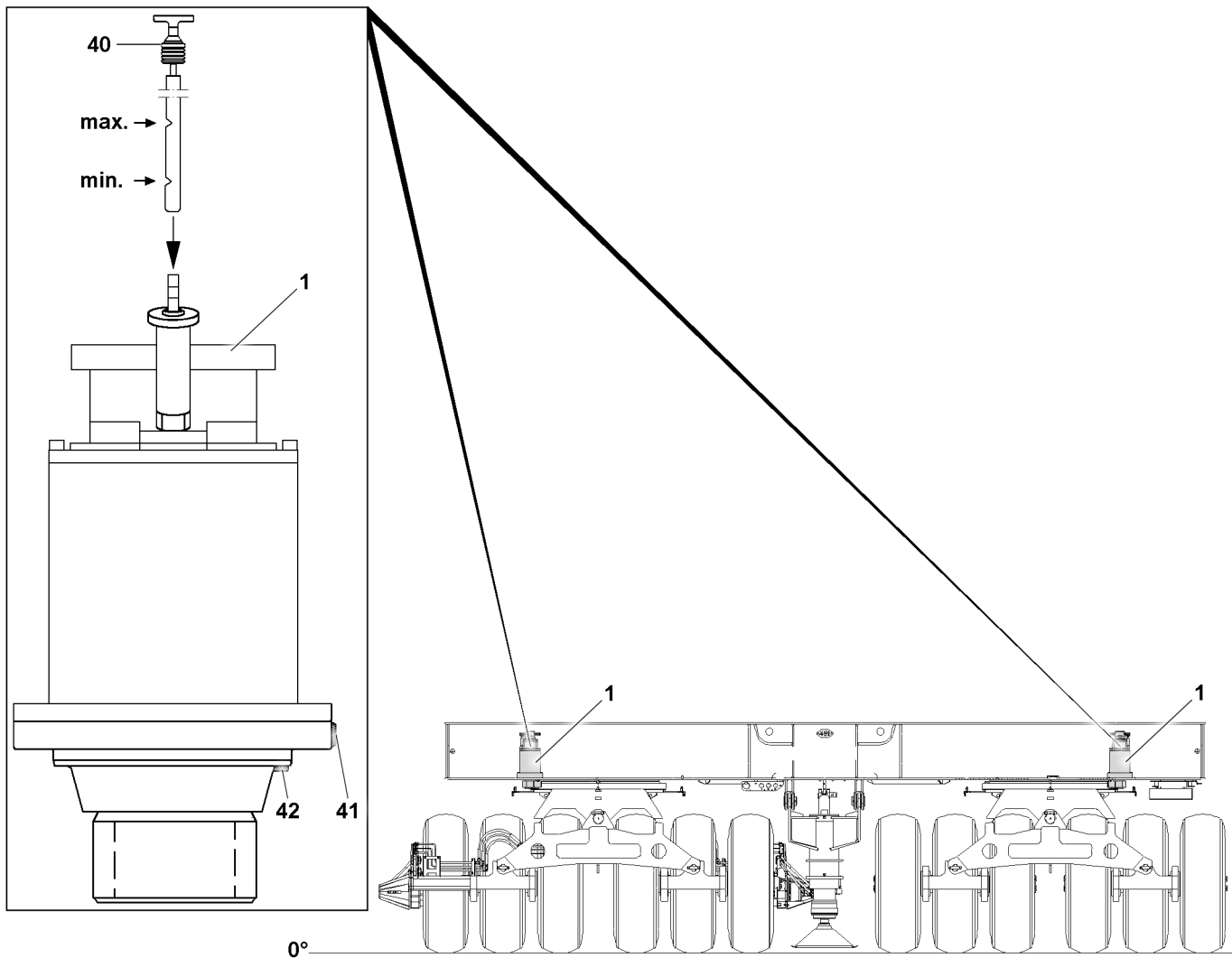

Fig.146303: Ballast trailer slewing gear

4.1 Checking for leaks

NOTICE

Leaky slewing gear!

If a leak was found on one or several slewing gears during the visual inspection, it can result in a failure of the affected slewing gear / slewing gears.

The slewing gears can be damaged, resulting in high property damage.

► Take the crane out of service, repair the leaky slewing gear / slewing gears and replace the slewing gear(s) if in doubt.

► Check visually to ensure that the slewing gears do not leak.

4.2 Checking the oil level

Make sure that the following prerequisite is met:

– Ballast trailer is in horizontal position.

- Remove and wipe off the dipstick **40**.
- Reinsert the dipstick **40** and pull it out again.

The oil level must be between the min. and max. mark on the dipstick **40**.

► Check the oil level.

NOTICE

Danger of gear damage!

If the oil level has dropped below the Minimum mark, top up engine oil as shown in the lubrication chart until the oil level is between the Minimum and Maximum marks.

If the required minimum mark is fallen below, the gear will be destroyed.

▶ Add oil, wait a short time and then check the oil level again.

▶ Reinsert the dipstick **40**.

4.3 Changing the oil

**Note**

▶ On the slewing gear, the gear oil can be drained as required from the oil drain plug **41** or from the oil drain plug **42** or from both oil drain plugs at the same time.

Make sure that the following prerequisites are met:

- Ballast trailer is in horizontal position.
- The slewing gear is warm.

- ▶ Open the oil filler port by unscrewing the dipstick **40**.
- ▶ Remove the oil drain plug **41** and oil drain plug **42** and drain the oil completely with the seal ring loosened.
- ▶ Clean the oil drain plug **41** and sealing surface on the housing.
- ▶ Clean the oil drain plug **42** and sealing surface on the housing.
- ▶ Reinstall the oil drain plug **41** and the oil drain plug **42** with a new seal ring and tighten.
- ▶ Add oil as specified in the lubrication chart at the oil filler port until the oil level is between the minimum and maximum mark on the dipstick **40**.
- ▶ Close the oil filler port by screwing in the dipstick **40**.
- ▶ Check the oil level as described in the section „Checking the oil level“.

5 Central lubrication system

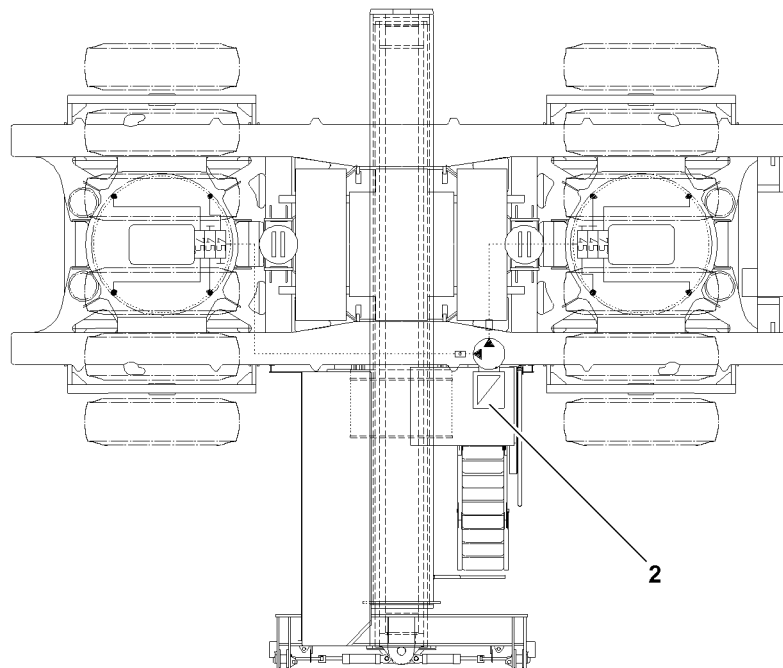

Fig.146304: Ballast trailer central lubrication system

**Note**

► For maintenance of the central lubrication system 2, see chapter 7.05.

6 Wheel drive

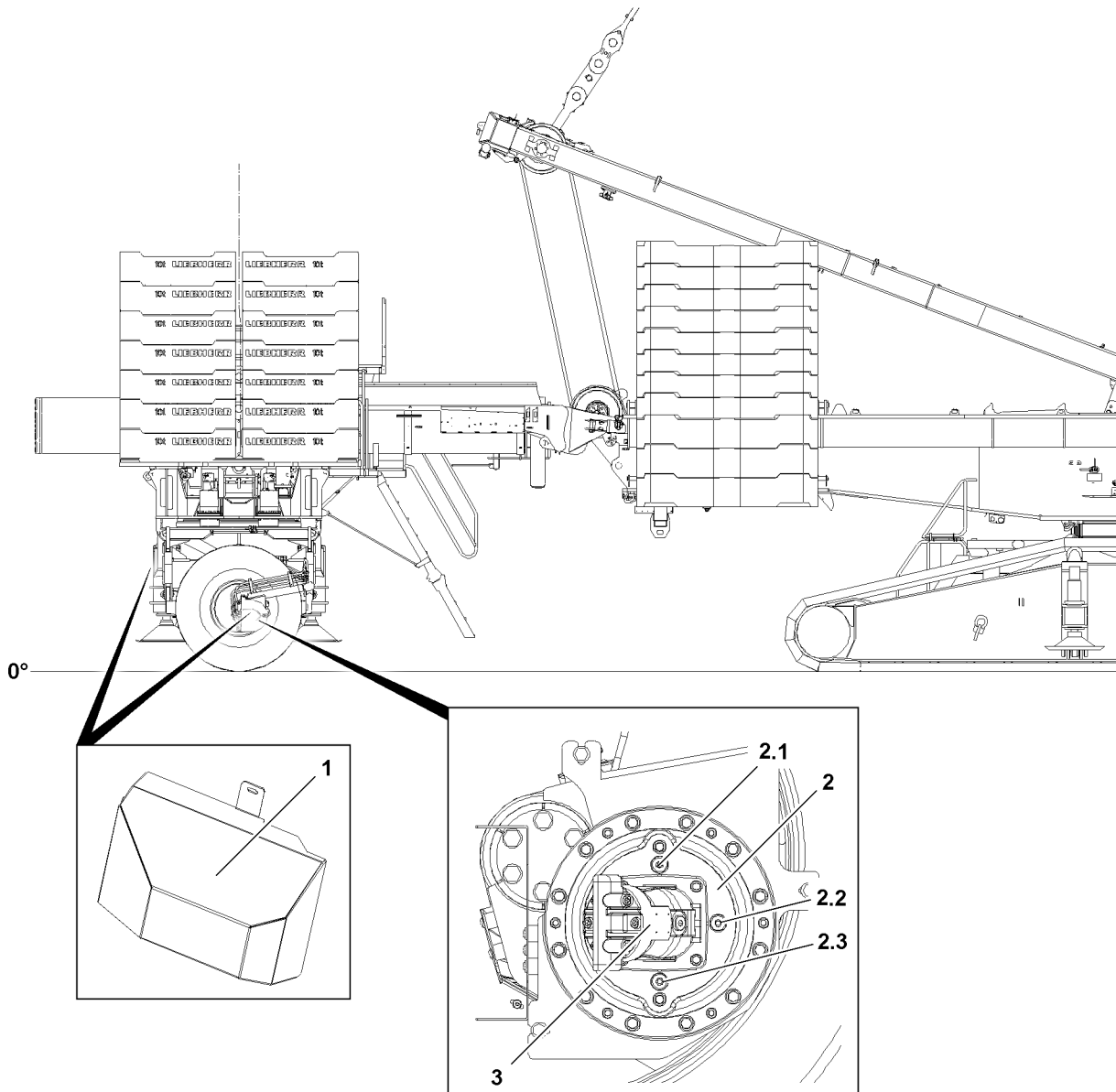

Fig. 146305: Ballast trailer wheel drive with hood

The wheel drive consists of:

- 1 Hood
- 2 Swing drive
- 3 Hydro motor

**WARNING**

Danger of burns during maintenance and inspection work!

Severe burns can result due to the crane components and service fluids at operating temperatures.

► Avoid direct body contact to heated crane components and service fluids.

NOTICE

Dirt in swing drive!

If any dirt gets into the inside of the swing drive it can be damaged.

- ▶ Make sure that no dirt gets into the inside of the swing drive during maintenance work.

The following maintenance ports are on the wheel drive **2**:

- 2.1** Oil filler plug, oil filler port
- 2.2** Oil level plug, oil level port
- 2.3** Oil drain plug, oil drain port

6.1 Checking for leaks

NOTICE

Leaky swing drive!

If a leakage is found during the visual inspection of the swing drive, it can result in failure of the swing drive.

The swing drive can be damaged, resulting in high property damage.

- ▶ Repair the leaky swing drive and replace the swing drive, if in doubt.
- ▶ Check visually to ensure that the swing drives do not leak.

6.2 Checking the oil level

NOTICE

Damage to swing drives!

If seals are used repeatedly, it can result in loss of oil.

Due to loss of oil, the swing drives can wear significantly and / or be damaged.

- ▶ Use the seals on the maintenance ports only once.

Make sure that the following prerequisite is met:

- Ballast trailer is in horizontal position.

**Note**

- ▶ To ensure a reliable oil level check, it must be ensured that the swing drives have been at a stand-still for at least two minutes. This ensures that the oil has returned to the oil chamber completely.
- ▶ Remove the hoods **1** on the swing drives **2**.
- ▶ Carefully unscrew the oil level plug **2.2**.

NOTICE

Insufficient oil fill quantity!

If the oil level drops below the fill level on the oil level plug **2.2**, the swing drives can be damaged.

- ▶ Add gear oil until the oil level is again on the fill level on the oil level plug **2.2**.

If oil must be added:

- ▶ Add oil in the oil filler port **2.1**.
- ▶ If the oil level is on the fill level on the oil level plug **2.2**, then the oil level on the swing drive is OK.
- ▶ Close the maintenance ports tightly.
- ▶ Reinstall the hoods **1** on the swing drives **2** again properly.

6.3 Changing the oil

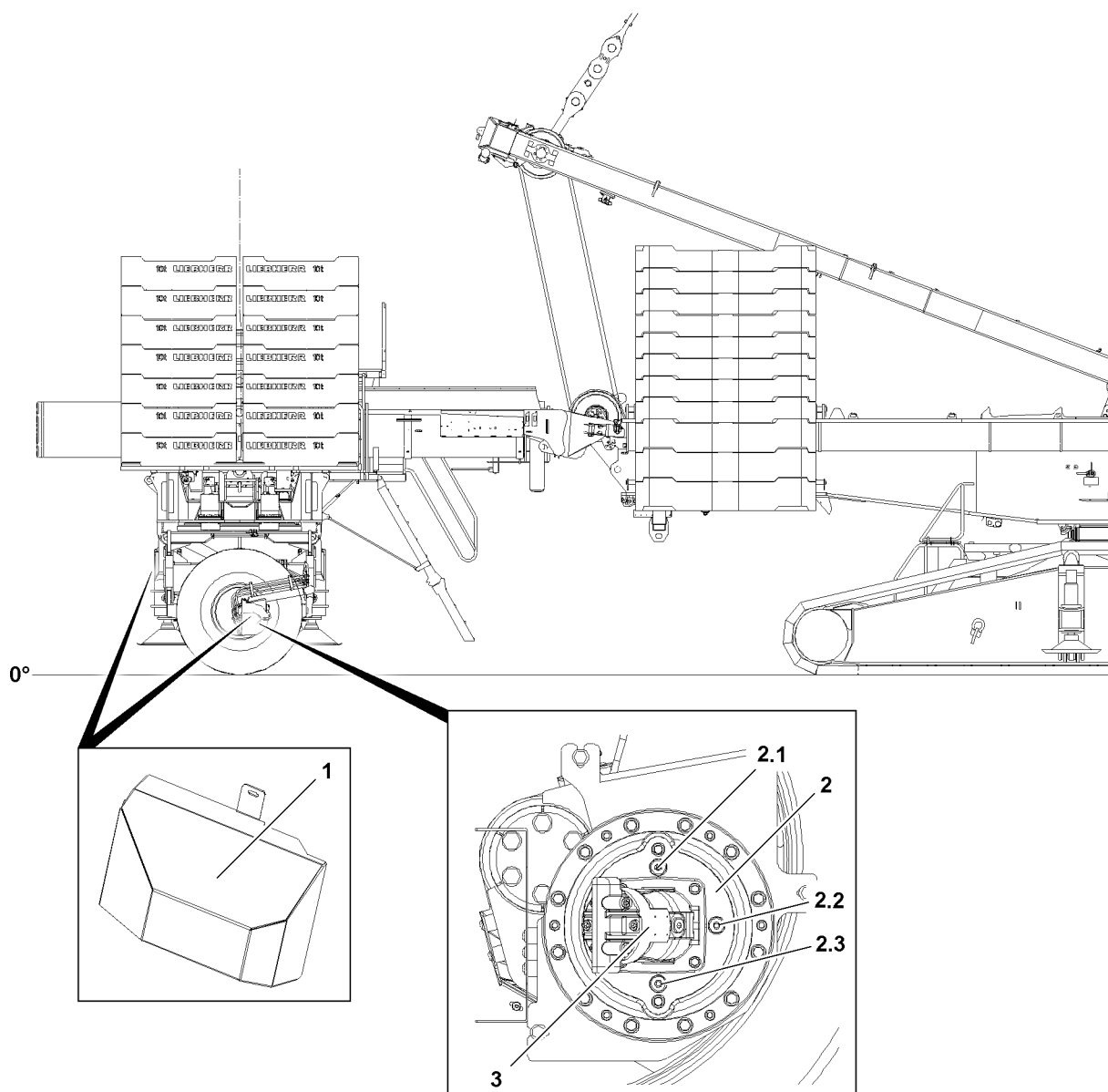

Fig.146305: Ballast trailer wheel drive with hood



Note

- ▶ Drain the gear oil through the oil drain plug 2.3.

Make sure that the following prerequisites are met:

- Ballast trailer is in horizontal position.
- The swing drive **2** is at a standstill.
- The swing drive is warm.
- A suitable container to catch the used oil is available.

NOTICE

Environmental risk!

If the oil collection container is too small, oil can overflow and be released in the environment.

This could result in environmental damage / pollution.

- ▶ The oil collection container must be sufficiently large.
 - ▶ Pay attention to the fill quantity of the swing drive.
 - ▶ Pay attention to cleanliness.
-



WARNING

Risk of burns during maintenance or inspection work!

While carrying out maintenance or inspection work, maintenance personnel can get severe burns on hot crane components.

When opening the oil drain plug, hot oil can cause burns on arms, hands, face or eyes.

Death, severe bodily injuries, property damage.

- ▶ Let any crane components to be serviced or inspected cool off to the „touch“.
 - ▶ Wear protective equipment.
-

- ▶ Remove the hoods **1** on the swing drives **2**.
 - ▶ Remove the oil filler plug **2.1**.
 - ▶ Unscrew the oil drain plug **2.3** with seal ring and drain oil into a suitable container.
-



Note

- ▶ Allow the swing drive **2** to empty completely.
-

- ▶ Clean the oil drain plug **2.3** and sealing surface on the housing.
- ▶ Screw in the oil drain plug **2.3** with a new seal ring and tighten.
- ▶ Open the oil level port **2.2**.
- ▶ Add oil on the oil filler port **2.1** until it is at the fill level on the oil level port **2.2** or until it starts to run over.
- ▶ Clean the sealing surface on the oil level port **2.2**.
- ▶ Close off the oil level port **2.2** tightly.
- ▶ Close off the oil fill port **2.1** tightly.
- ▶ Reinstall the hoods **1** on the swing drives **2** again properly.

Empty page!

LWE/LR 1600-2-008/18109-09-02/en

7.05 Maintenance guidelines - Crane superstructure

1	Crane engine	3
2	Pump distributor gear	9
3	Hydraulic system	11
4	Slewing ring connection	17
5	Central lubrication system	19
6	Hoist gear 1 to 6, illustration 1	29
7	Assembly winch, illustration 2	31
8	Slewing gear	33
9	Air dryer of the compressed air system of the crane superstructure	35
10	Electrical system - Lighting	35

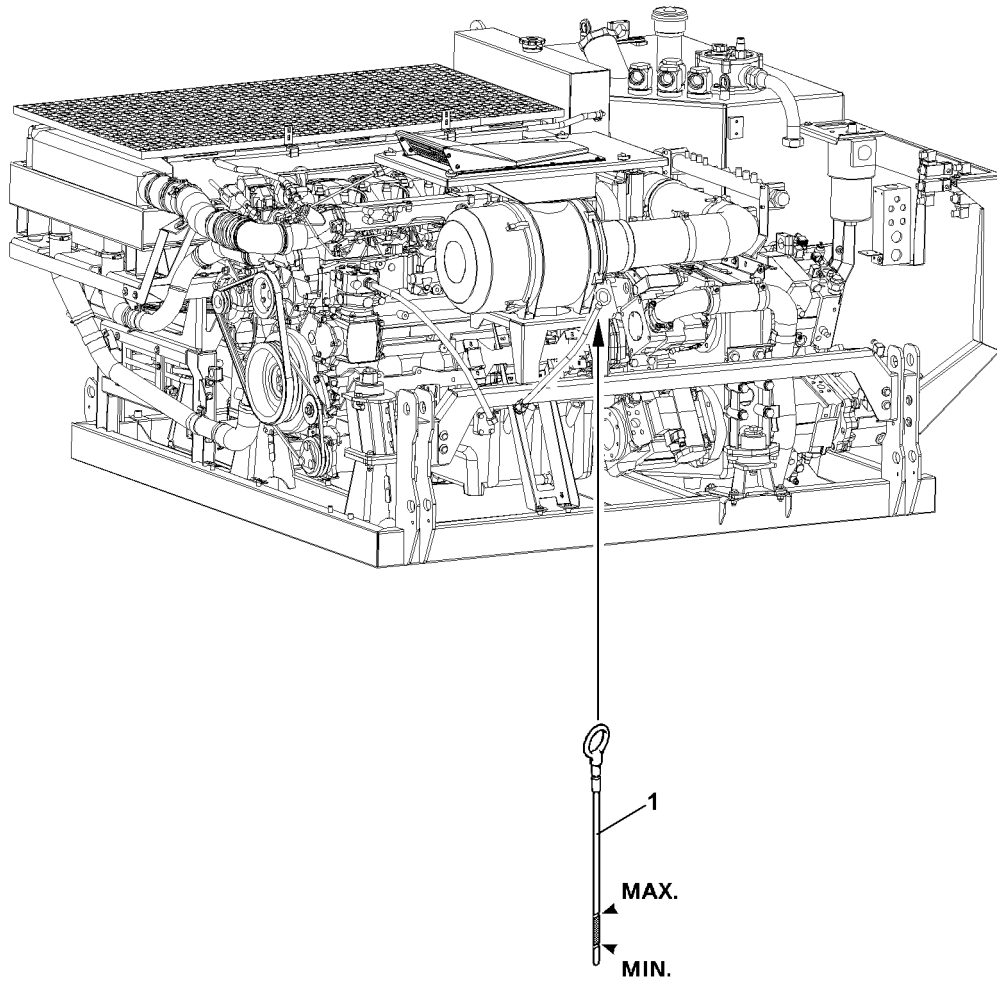

Fig.105381

1 Crane engine

Never step on fuel lines during maintenance or repair work in the engine area!



DANGER

Danger of fire!

- ▶ Make sure that the engine area is kept free of diesel fuel!
- ▶ Extreme cleanliness is vital, particularly during filter changes and bleeding. Wipe up any spilled fuel!
- ▶ When replacing the filter, it is recommended to put down cleaning rags before removing the filter in order to absorb fuel!

1.1 Engine oil

1.1.1 Checking the oil level

Make sure that the following prerequisites are met:

- The crane is in horizontal position.
 - The engine is turned off and the oil has collected in the oil pan.
- ▶ Remove the dipstick **1** and wipe it off.
 - ▶ Reinsert the dipstick **1** and pull it out again.

The oil level must be between the min. and max. marks on the dipstick **1**.

- ▶ Check the oil level.

NOTICE

Risk of damaging the engine!

If the oil level has dropped below the minimum mark, add engine oil according to the lubrication chart until the oil level is between the minimum and maximum marks!

- ▶ Add engine oil and check again!

- ▶ Reinsert the dipstick **1**.

1.1.2 Changing the oil

Refer to the separate operating instructions for „LIEBHERR Diesel engines“.

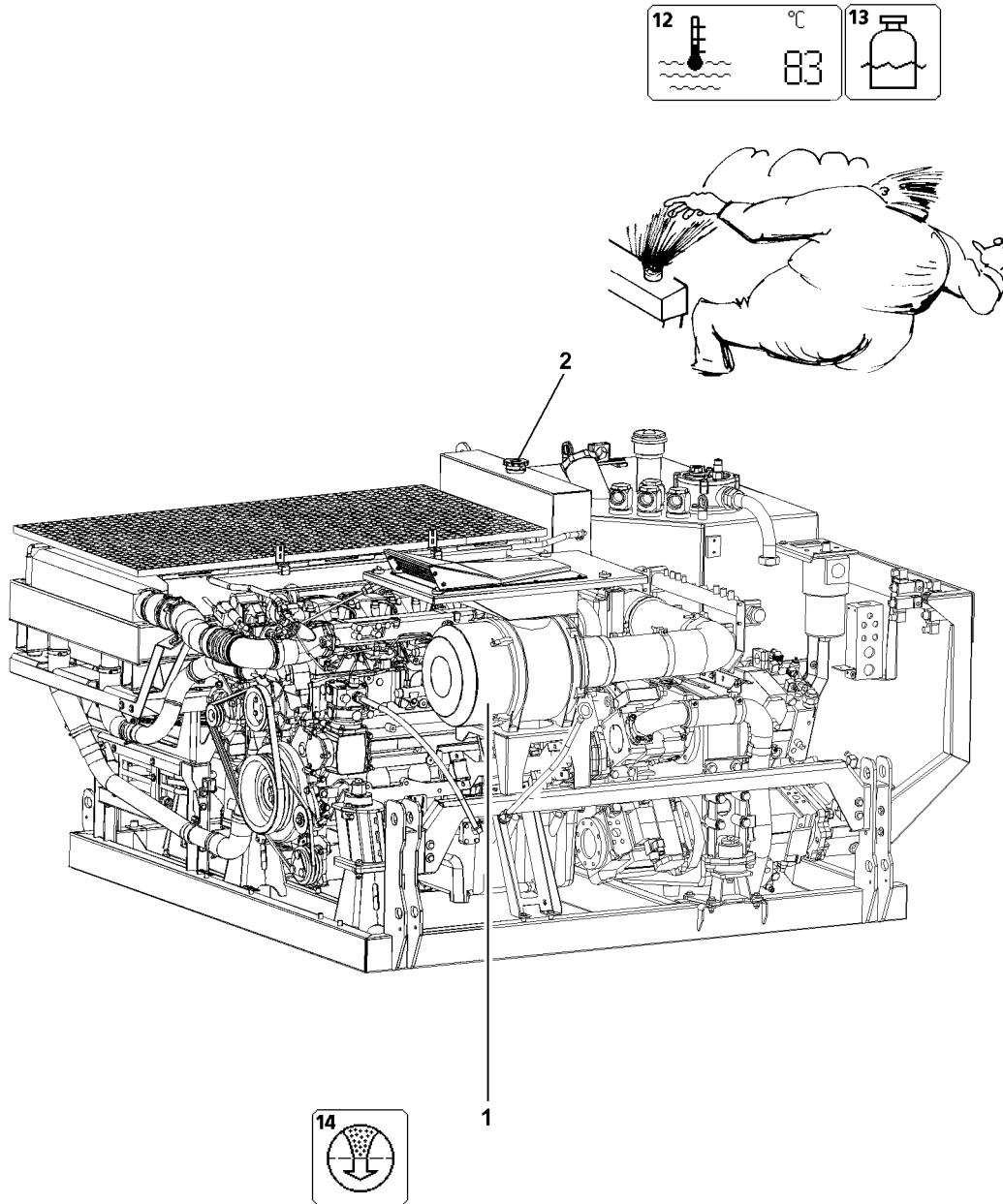

LWE/LR 1600-2-008/18109-09-02/en

Fig.105382

1.2 Engine coolant

The coolant level is monitored by the LICCON computer system. If the coolant level is too low the „Low coolant level“ **13** icon appears on the LICCON monitor.

The crane's engine coolant temperature can be read on the LICCON monitor in [°] on the „Engine coolant temperature“ icon.



WARNING

Danger of skin burns!

▶ Check the coolant only when the engine is cold!

- ▶ Turn the cap **2** on the filler neck of the water cooler expansion tank to the 1st notch.
- ▶ Release excess pressure.
- ▶ Remove the cap **2**.
- ▶ Check the coolant level.

Add coolant as specified in the lubrication chart only on the filler neck of the water cooler expansion tank.

▶ Add coolant to overflow level if necessary.

1.3 Air filter

The air filter **1** is monitored by the LICCON computer system. If the vacuum increases in the intake line due to dirty filter units, the „Air filter contaminated“ **14** icon is displayed on the LICCON monitor.

If the „Air filter contaminated“ **14** icon appears:

▶ Clean or replace the filter insert.

1.4 Diesel particle filter*



DANGER

Danger of igniting the diesel particle filter*!

▶ The diesel particle filter* may only be regenerated under the supervision of operating personnel!

Carry out the operation and maintenance of the diesel particle filter* according to the separate operating instructions of the diesel particle filter* manufacturer.

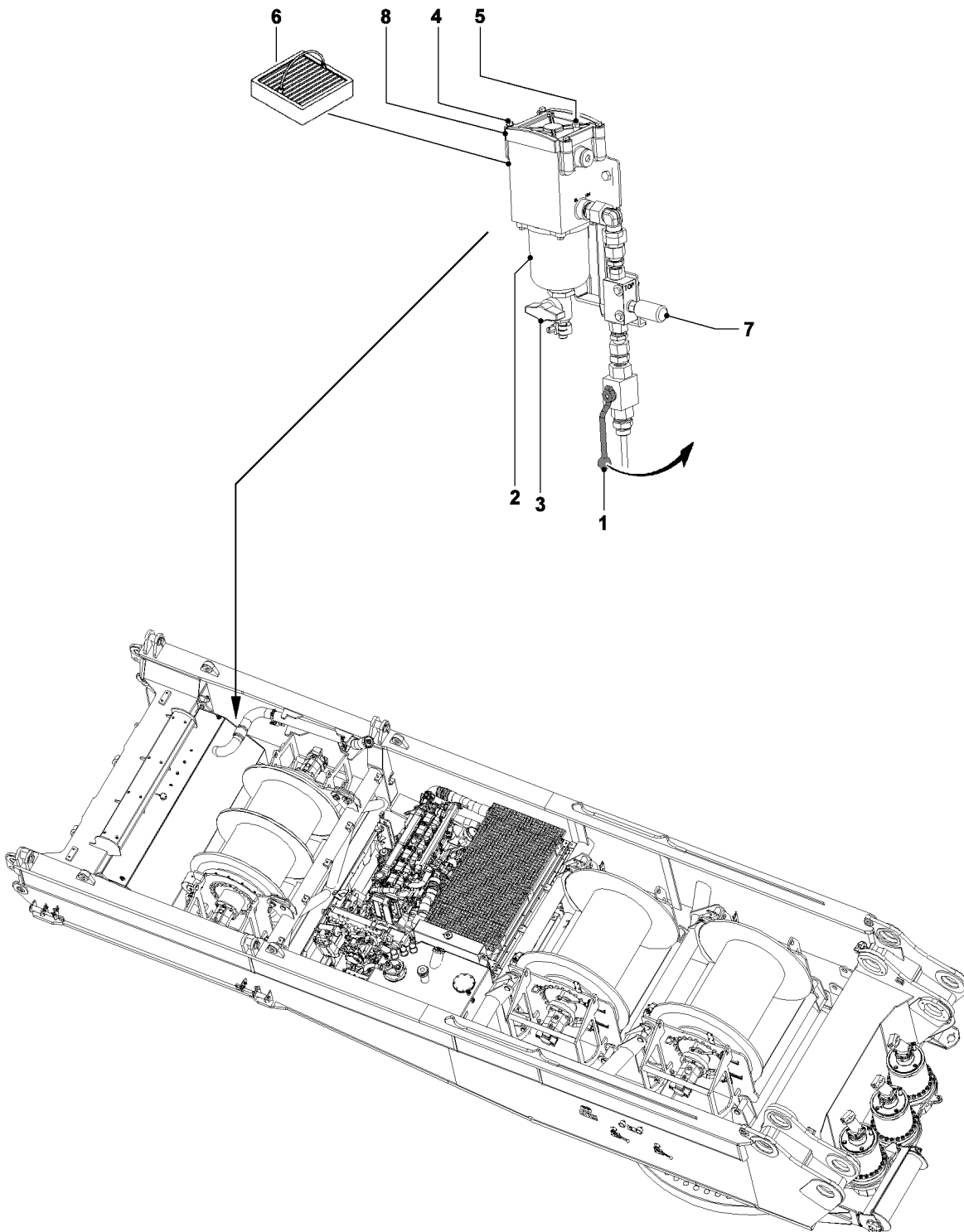

LWE/LR 1600-2-008/18109-09-02/en

Fig.105421

1.5 Fuel pre-filter

1.5.1 Draining the fuel pre-filter



Note

▶ The water separator **2** on the fuel pre-filter must be drained at regular intervals!

- ▶ Turn the engine off.
- ▶ Place a catch basin under the water separator.
- ▶ Close the ball valve **1**.
- ▶ Open the drain valve **3** and drain water until fuel emerges.
- ▶ Close the drain valve **3**.
- ▶ Open the ball valve **1**.
- ▶ Remove the catch basin and dispose of the fluid.

1.5.2 Cleaning the filter strainer



DANGER

Danger of fire and explosion!

- ▶ Do not smoke!
 - ▶ Avoid open flames!
 - ▶ Work only when the engine is turned off!
 - ▶ Maintain extreme cleanliness during all work!
-
- ▶ Turn the engine off.
 - ▶ Place a catch basin under the fuel pre-filter.
 - ▶ Close the ball valve **1**.
 - ▶ Open the drain valve **3** until no more fuel emerges.
 - ▶ Remove the catch basin and dispose of the fluid.
 - ▶ Remove the screws **4** and remove the cover **8**.
 - ▶ Remove the filter strainer **6** and clean it properly.
 - ▶ Insert the cleaned filter strainer **6** properly.
 - ▶ Install the cover **8** with seals properly.
 - ▶ Properly tighten the screws **4**.
 - ▶ Open the ball valve **1**.
 - ▶ Open the breather screw **5**.
 - ▶ Operate the hand pump **7** and properly bleed the fuel filter.
 - ▶ Properly tighten the breather screw **5**.
 - ▶ Start the engine and check the fuel pre-filter for leaks.

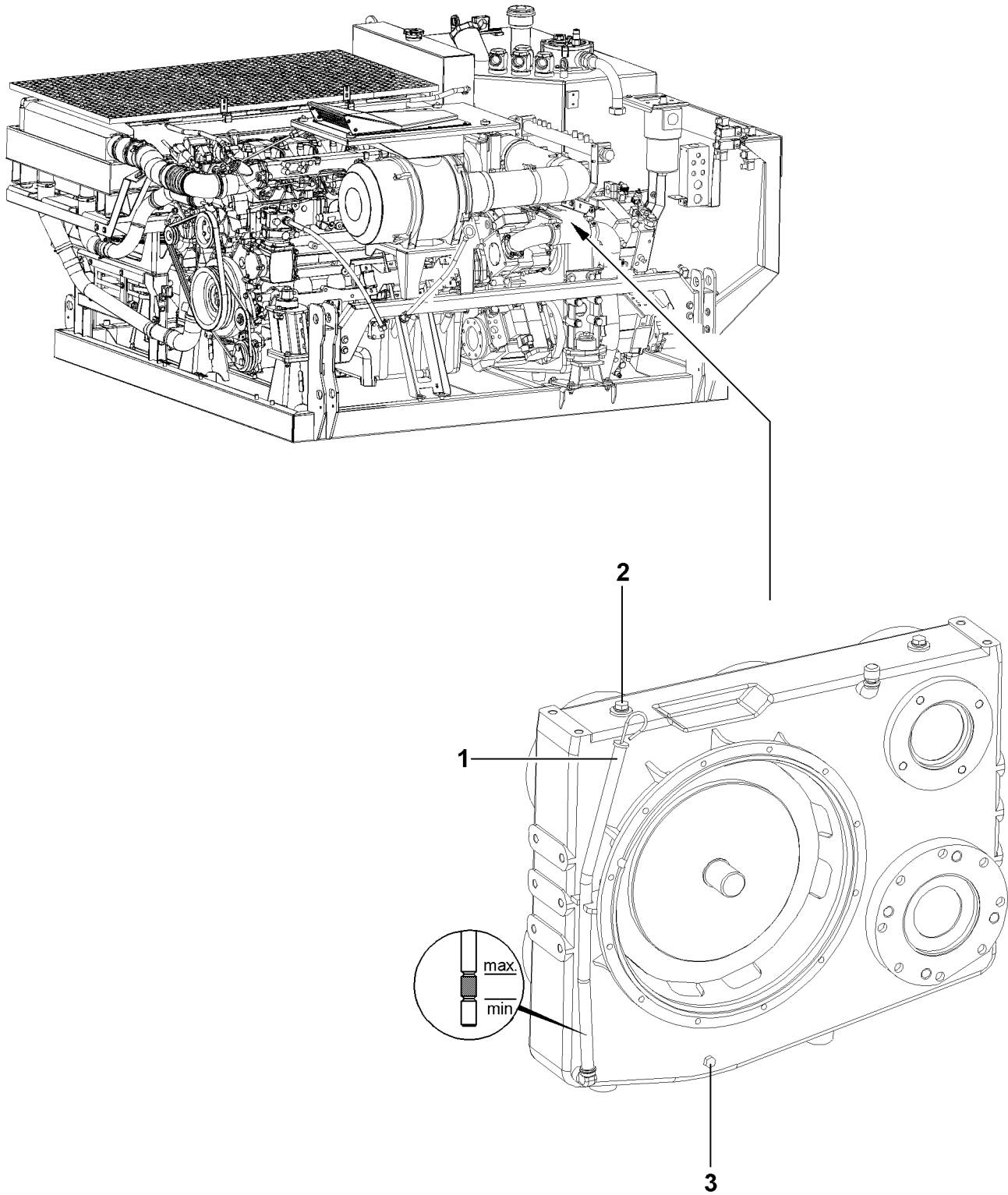

LWE/LR 1600-2-008/18109-09-02/en

Fig.105383

2 Pump distributor gear

Maintain utmost cleanliness during all work to prevent any dirt from entering the inside of the gear.

2.1 Checking the oil level

Make sure that the following prerequisite is met:

- The crane is in horizontal position.
- ▶ Remove the dipstick **1** and wipe it off.
- ▶ Reinsert the dipstick **1** and pull it out again.

The oil level must be between the min. and max. marks on the dipstick **1**.

- ▶ Check the oil level.

NOTICE

Danger of gear damage!

If the oil level has dropped below the minimum mark, add engine oil as specified in the lubrication chart until the oil level is between the minimum and maximum marks!

- ▶ Add oil and check again!

-
- ▶ Reinsert the dipstick **1**.

2.2 Changing the oil

Make sure that the following prerequisites are met:

- The crane is in horizontal position.
- The gear is warm.
- ▶ Remove the oil filler plug **2**.
- ▶ Remove the oil drain plug **3** and drain the oil.
- ▶ Install the oil drain plug **3** with new seal and tighten.
- ▶ Add oil as specified in the lubrication chart on the oil filler plug **2** until the oil level is between the min. and max. marks on the dipstick **1**.
- ▶ Install the oil filler plug **2** with new seal.
- ▶ Check the oil level.

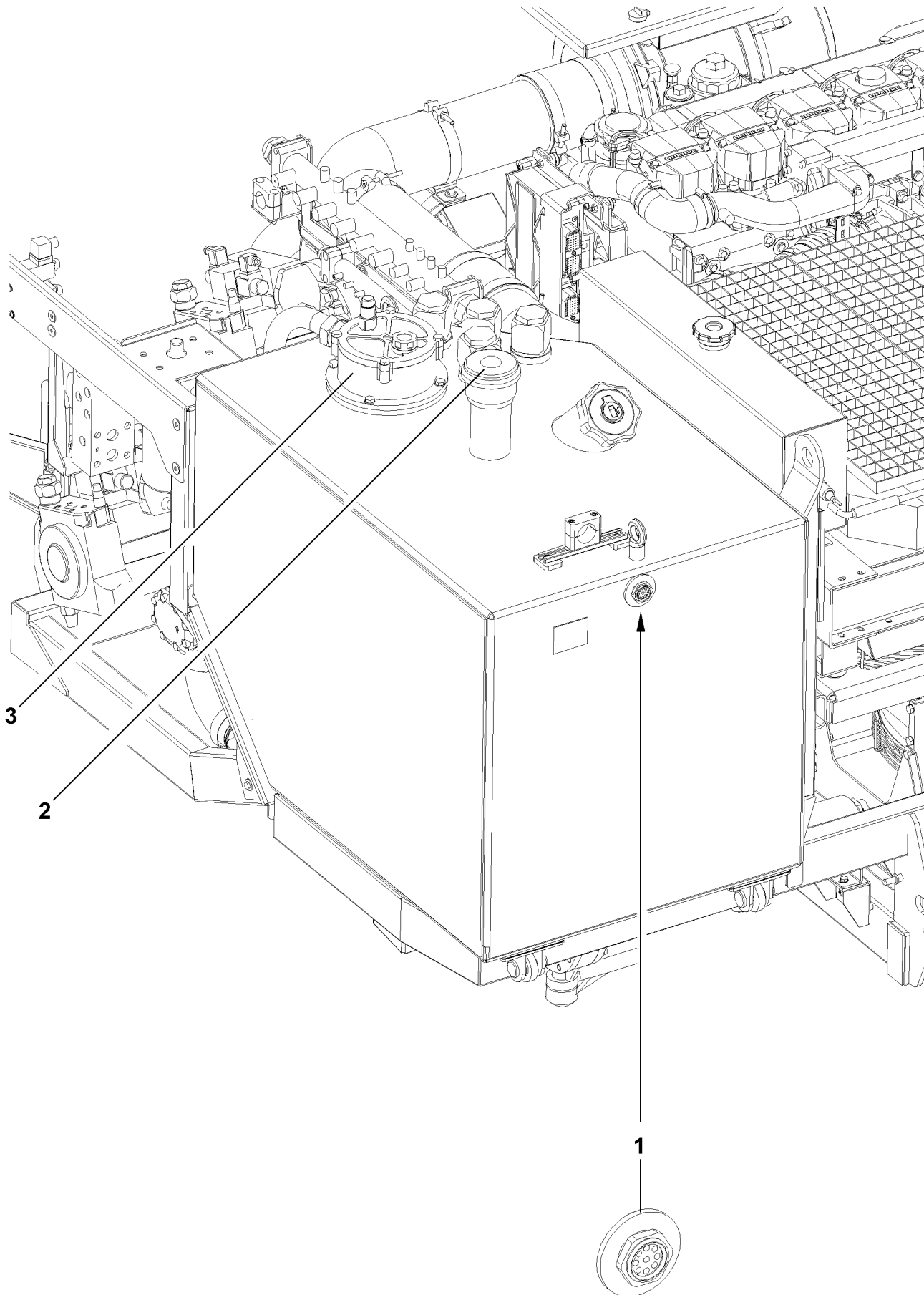

Fig.105414

3 Hydraulic system

When adding oil, observe utmost cleanliness.

3.1 Hydraulic tank

3.1.1 Checking the oil level

Make sure that the following prerequisites are met:

- The crane is in horizontal position.
- All hydraulic cylinders are fully retracted.

The oil level must be in the center of the oil level sight gauge **1**.

- ▶ Check the oil level on the oil level sight gauge **1** of the hydraulic oil tank.

Problem remedy

No oil is visible in the oil level sight gauge **1**?

- ▶ Add oil as specified in the lubrication chart with a fine-mesh strainer until the oil level is visible in the center of the oil level sight gauge **1**.
-

3.1.2 Checking the vent / breather filter

- ▶ Open the cover with the turn lock.
- ▶ Check the filter **2** for impurities (visual inspection).

In the event of heavy contamination:

- ▶ Replace the filter **2**.
- ▶ Close the cover with the turn lock again.

3.1.3 Return filter

The return filter **3** is equipped with a maintenance indicator. If the red mark is visible when the oil is at operating temperature, then the filter insert must be replaced.

- ▶ Remove the filter cover.
- ▶ Remove the filter insert.
- ▶ Rinse out the filter housing.
- ▶ Clean sealing surface on the cover and the filter housing.
- ▶ Insert a new filter insert.
- ▶ Lubricate the rubber seal ring in the cover with oil.
- ▶ Replace the filter cover and tighten.
- ▶ Start the engine and check the filter for leaks.
- ▶ Check the oil level and add oil if necessary.

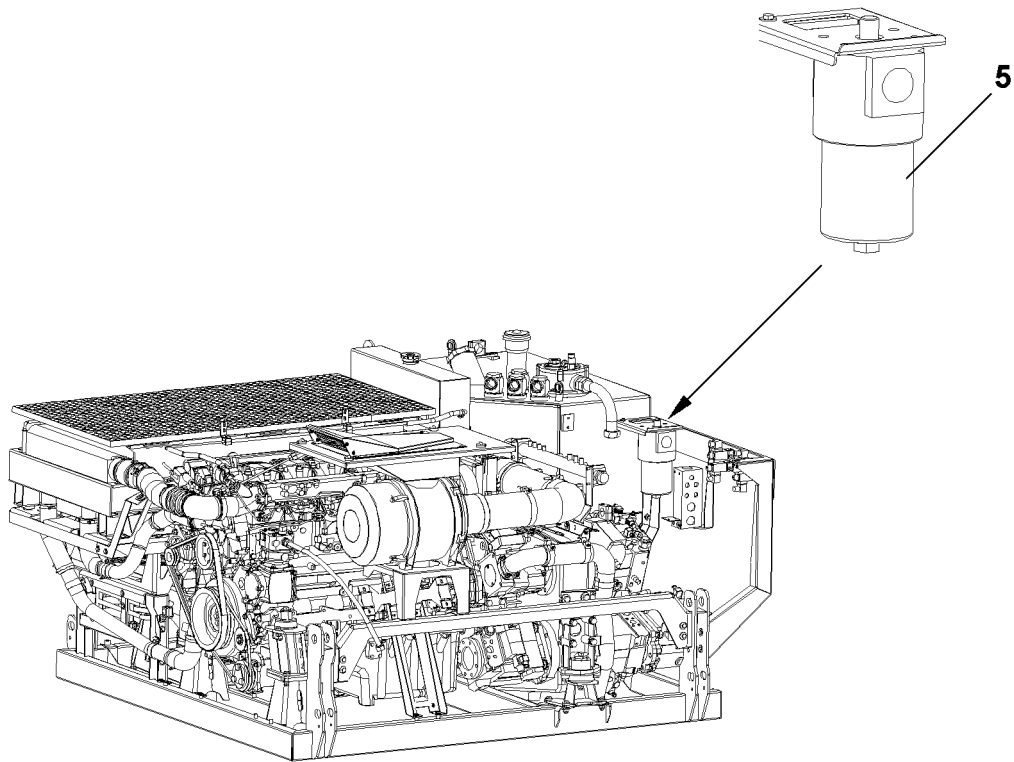

Fig.105415

3.2 Pressure filters in the crane hydraulic

The pressure filter 5 is equipped with a maintenance indicator. If the red bar indicator is visible when the oil is at operating temperature, then the filter cartridge must be replaced.

- ▶ Turn the engine off.
- ▶ Release the filter cartridge and collect any escaping oil in a suitable container.
- ▶ Remove and dispose of the filter cartridge.
- ▶ Clean the sealing surface on the filter bracket.
- ▶ Lubricate the rubber seal ring on the new oil filter cartridge with oil.
- ▶ Install a new filter cartridge and tighten.
- ▶ Start the engine and check for leaks.
- ▶ Slowly run through all crane movements.

Result:

- This bleeds the hydraulic system.
- ▶ Check the oil level again and add oil if necessary.

3.3 Diaphragm reservoirs

Various diaphragm reservoirs are installed in the hydraulic system. The pretension pressures are specified in the hydraulic circuit diagram as well as on the individual diaphragm reservoirs. The pretension pressure must be measured separately in each diaphragm reservoir.

NOTICE

Risk of damaging the hydraulic system!

If the ambient temperatures fluctuate considerably, for example after transfer to countries with extremely hot or cold temperatures or in countries with considerable differences between the summer and winter temperatures, the accumulator pressures may change!

- ▶ Check the accumulator pressures and correct if necessary!
-



DANGER

Risk of explosion!

The pressure in the nitrogen cylinder must be less than the maximum permissible operating pressure of the accumulator or the pressure gauge. Otherwise install a pressure reducer between the cylinder and the filling device!

- ▶ The diaphragm reservoir must be relieved on the fluid side!
 - ▶ Do not use air or oxygen to fill the diaphragm reservoir!
-

- ▶ Turn the engine off.

Result:

- The diaphragm reservoir is relieved on the fluid side.

The pretension pressure in the hydraulic reservoirs may only be checked by an expert with appropriate training and equipment. In addition, the national regulations for pressurized container inspections must also be observed.

- ▶ Check the pretension pressure with a testing and filling device and correct, if necessary.

3.4 Hydraulic hose lines

The hydraulic hose lines must be checked according to ISO 9927-1 by an **experienced technician** or **expert mechanic**, as required, depending on the duration of use and the operating conditions, but at least once a year.

Experienced technicians are persons who:

- possess sufficient knowledge about cranes due to their professional background and experience.
- are familiar with the relevant settings to detect any abnormal deviations from the nominal condition.
- have undergone special training.

Expert mechanics are mechanics, who:

- are experienced in the design, construction or maintenance of cranes.
- possess sufficient knowledge about the relevant settings and standards.
- are fully equipped to perform inspections.
- are able to assess the safety status of the crane.
- can decide which action needs to be taken to ensure the crane can continue to be operated safely.



Note

- ▶ The applicable national regulations must also be complied with!

3.4.1 Checking the hydraulic hoses within area of responsibility of the German employer's liability insurance associations

At least once a year, an **expert** must inspect the hydraulic hoses to ensure they are in operationally safe condition. The crane must be inspected by an **authorized inspector** every four years from the day it was first licensed. After the 12th year of operation, the crane must be inspected by the authorized inspector annually.

The **expert** or **authorized inspector** must document the fact that the hydraulic hoses can continue to be used in the crane!

An expert is someone:

- whose technical training and experience means that he has adequate knowledge in the field of hydraulic hoses and hose systems.
- who is familiar with the relevant occupational health and safety regulations.
- who is familiar with the relevant accident prevention guidelines.
- who is familiar with the directives and generally accepted technical regulations (e.g. DIN standards, VDE regulations, technical regulations of other EU member states or other countries that have signed the European Economic Community agreement).
- who can properly assess whether hydraulic hoses and hose systems are deemed safe in accordance with the guidelines and regulations stated above.

Authorized inspector(s) is / are:

- an authorized expert employed by the technical supervisory authorities.
- in Hamburg this is the Amt für Arbeitsschutz (office for occupational health and safety).
- in Hessen these are the technical supervisory offices.
- an authorized expert appointed by the professional associations.

3.4.2 Examples of possible defects in hose lines



DANGER

Risk of fire or accident!

If problems are discovered during inspections, then they must be remedied immediately or suitable measures are to be taken. Failure to do this can result in serious injury to persons, death or damage to property!

- ▶ Remedy problems or take suitable measures!

- Damage to the outer layer as far as the intermediate later (e.g. chafing, cuts and cracks).
- Outer layer brittleness (crack formation of the hose material).
- Deformation that differs from the natural shape of the hose or hose line, in depressurized as well as in pressurized condition or in bends, for example layer separation, bubbling, crushing or kinking.
- Leaks.
- Failure to follow installation instructions.
- Damage or deformation of hose fittings that inhibit the function and strength of the fitting or the hose / fitting connection.
- Hose slipping out of fitting.
- Fitting corrosion that inhibits function and strength.
- Storage time or usage period exceeded.

3.4.3 Maintenance of hose lines

- We recommend to check all hoses, hose lines and screw fittings daily, but at least every two weeks for leaks and externally recognizable signs of damage.
- Damaged parts must be replaced immediately! Oil spray can lead to injuries and fires!
- Hydraulic lines and hoses may not be repaired!
- Hoses that have already been used as a part of a hose line may not be reinstalled in hose lines.
- Always use Original Liebherr spare parts when replacing hoses and hose lines.
- Always ensure that the hoses are routed free of torsion. If high pressure hoses are being used, attach the screws of half clamps or full flange at both ends of the hose and then tighten.
- When using high pressure hoses with a bent fitting, tighten the end with the bent fitting first when tightening the flanges, then the end with the straight fitting.
- Any mounting clamps in the hose center may be attached and tightened only thereafter.
- Route the hoses in such a way that chafing with other hoses or other structures is prevented. Maintain a minimum clearance of approximately $\frac{1}{2}$ the outer diameter of the hose to other parts. The clearance may never be less than 10 to 15 mm.

3.4.4 Replacing the hose lines



DANGER

Risk of fire or accident!

Failure to replace hose lines at appropriate intervals can cause serious injury to persons, death or damage to property!

- ▶ Replace hose lines according to appropriate intervals!
-

This must be documented in the crane's log book by the **expert** or the **authorized inspector**.

The service life of a hose line may not exceed six years, including a storage period of a maximum of two years (pay attention to the manufacturing date on the hoses). The duration of use can also be defined by the **expert** or **authorized inspector** in accordance with existing test and empirical data in the individual application areas, taking the usage conditions into consideration.

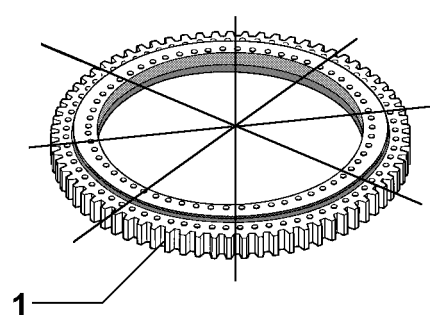
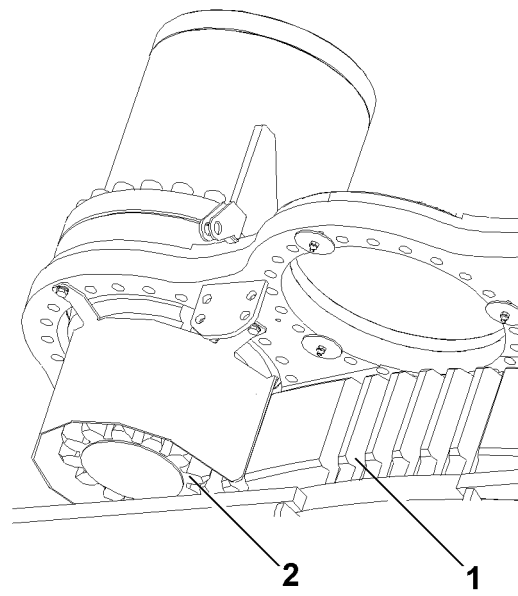
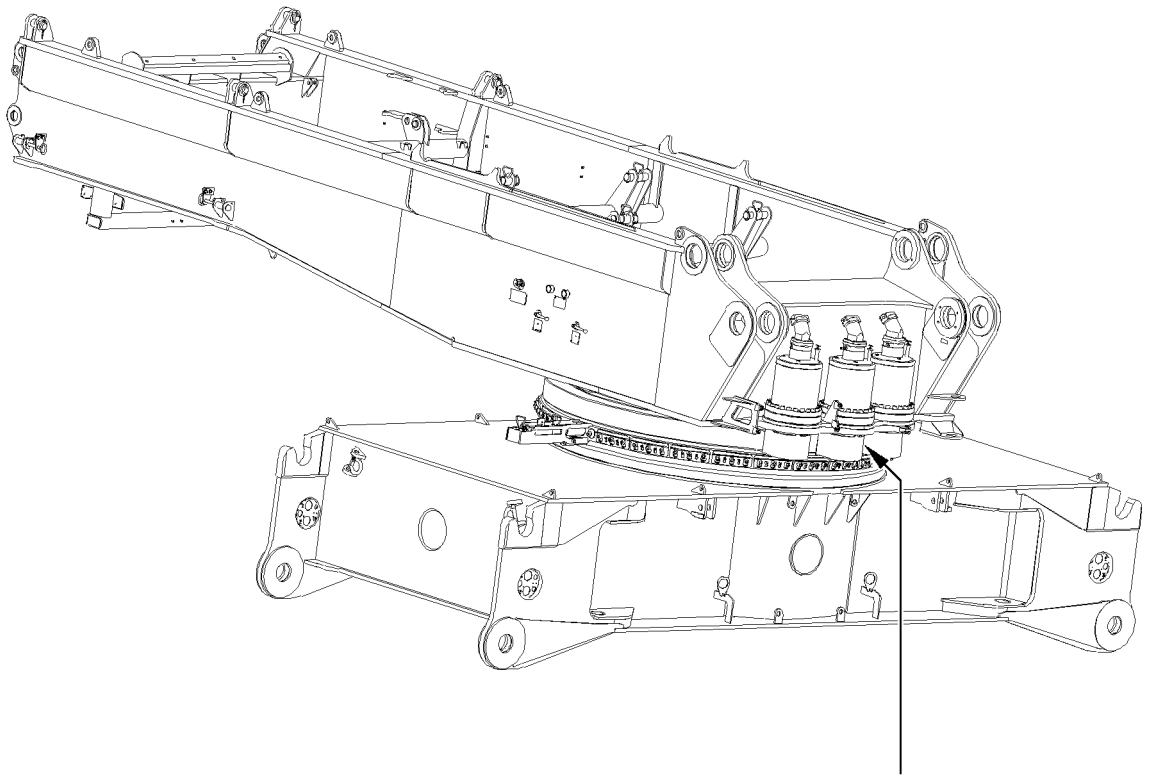

Fig.105416

4 Slewing ring connection

4.1 Lubricate the slewing ring connection

Perform lubrication with extreme care before and after long operating intervals, particularly before and after any winter break, in order to provide the best possible corrosion protection.

If the crane has not been moved for more than 3 months, then it must be lubricated every 3 months with an external grease pump until grease emerges from all grease points, see also section of „Central lubrication system“. Then the relevant crane movement must be repeated several times and the lubrication procedure must be carried out again.

- ▶ Lubricate the slewing ring connection.

4.2 Lubricating the gear ring and the slewing gear pinion

Before and after extended breaks in service, grease the gear ring **1** and the slewing gear pinion **2** to ensure the best possible protection from corrosion.

- ▶ Grease the gear ring **1** and the slewing gear pinion **2** externally.

4.3 Tilt play of roller ring connection

The wear of the roller ring connection is determined by measuring the „tilt play“ with the ring installed.



Note

- ▶ The determination of the „Tilt play“ must be carried out according to the **test instructions of Liebherr-Werk Ehingen GmbH!**
- ▶ Contact the Service Dept. at **Liebherr-Werk Ehingen GmbH** for **test instructions!**



DANGER

Danger of accident if tilt play of roller ring connection is too large!

If the permissible tilt play of 2.0 mm is exceeded, then safe crane operation is no longer possible!

- ▶ Replace the roller ring connection if the tilt play is larger than 2.0 mm !

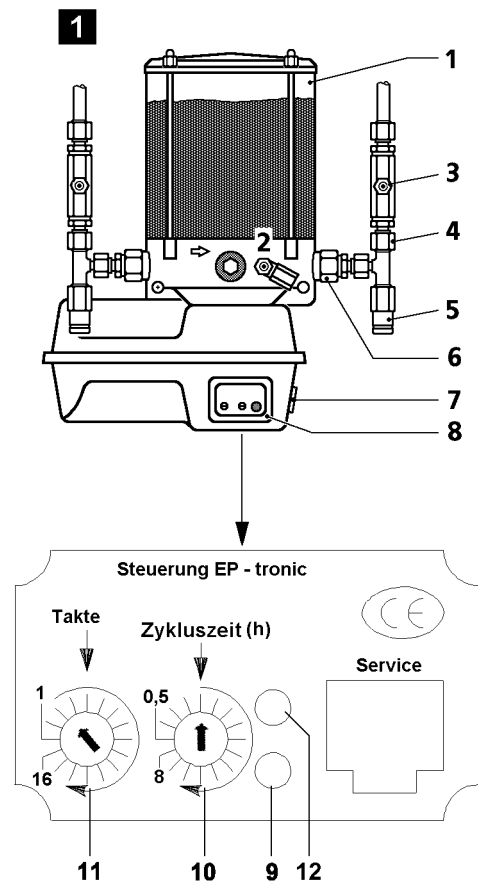
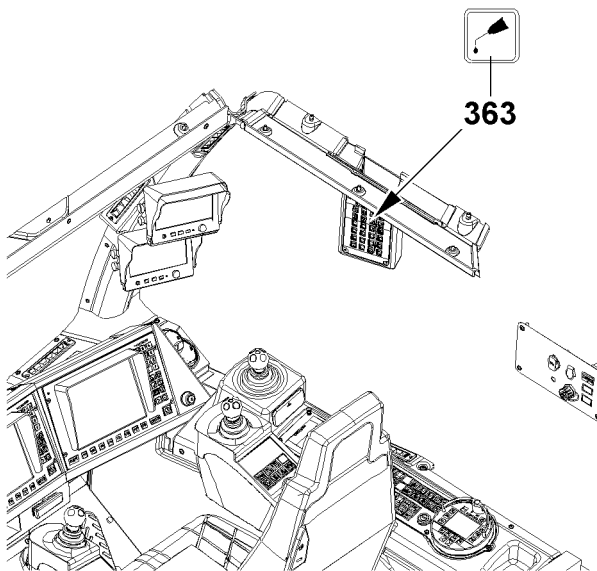
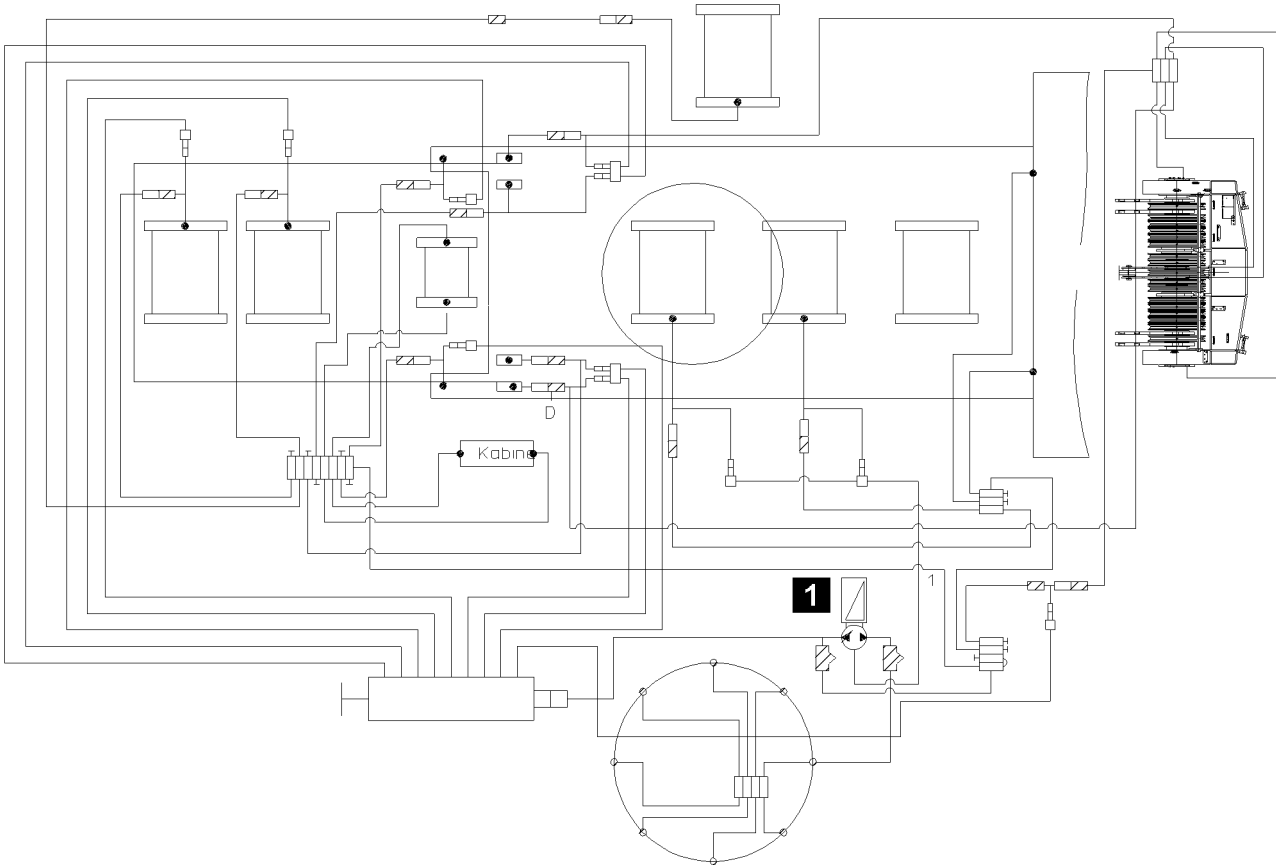

LWE/LR 1600-2-008/18109-09-02/en

Fig.108923

5 Central lubrication system

5.1 Overview of central lubrication system

The crane superstructure is equipped with a central lubrication system.

NOTICE

Dirty lubricant!

If the crane is not moved for longer than 3 months, then contaminants adhere to the lubricant! Components are exposed to increased wear!

If the crane has not been moved for longer than three months:

- ▶ Lubricate the grease fitting with an external grease pump until lubricant emerges on the sealing lips!
 - ▶ Repeat crane movements several times and carry out the lubrication procedure again!
-



Note

- ▶ Cleaning is permitted in washing bays or with steam cleaners!
-

The central lubrication system consists of the following components:



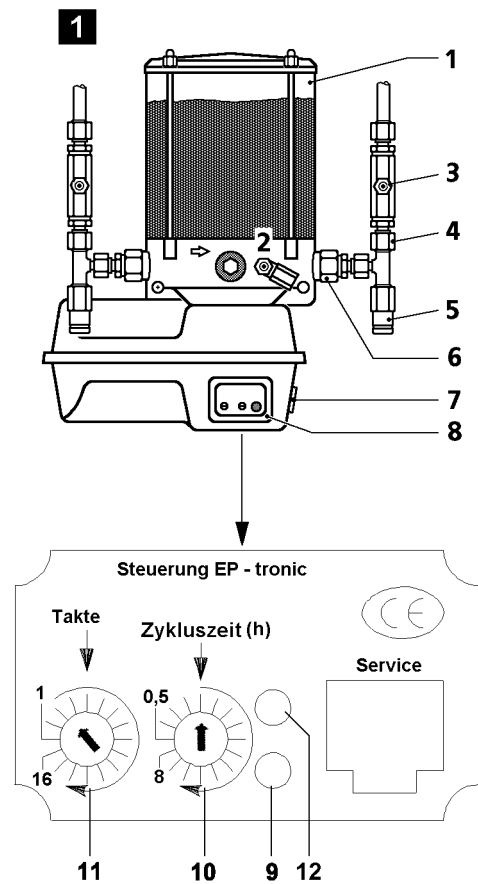
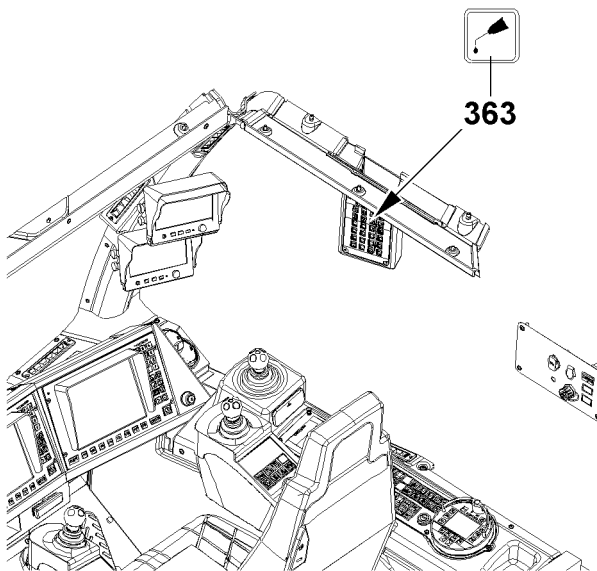
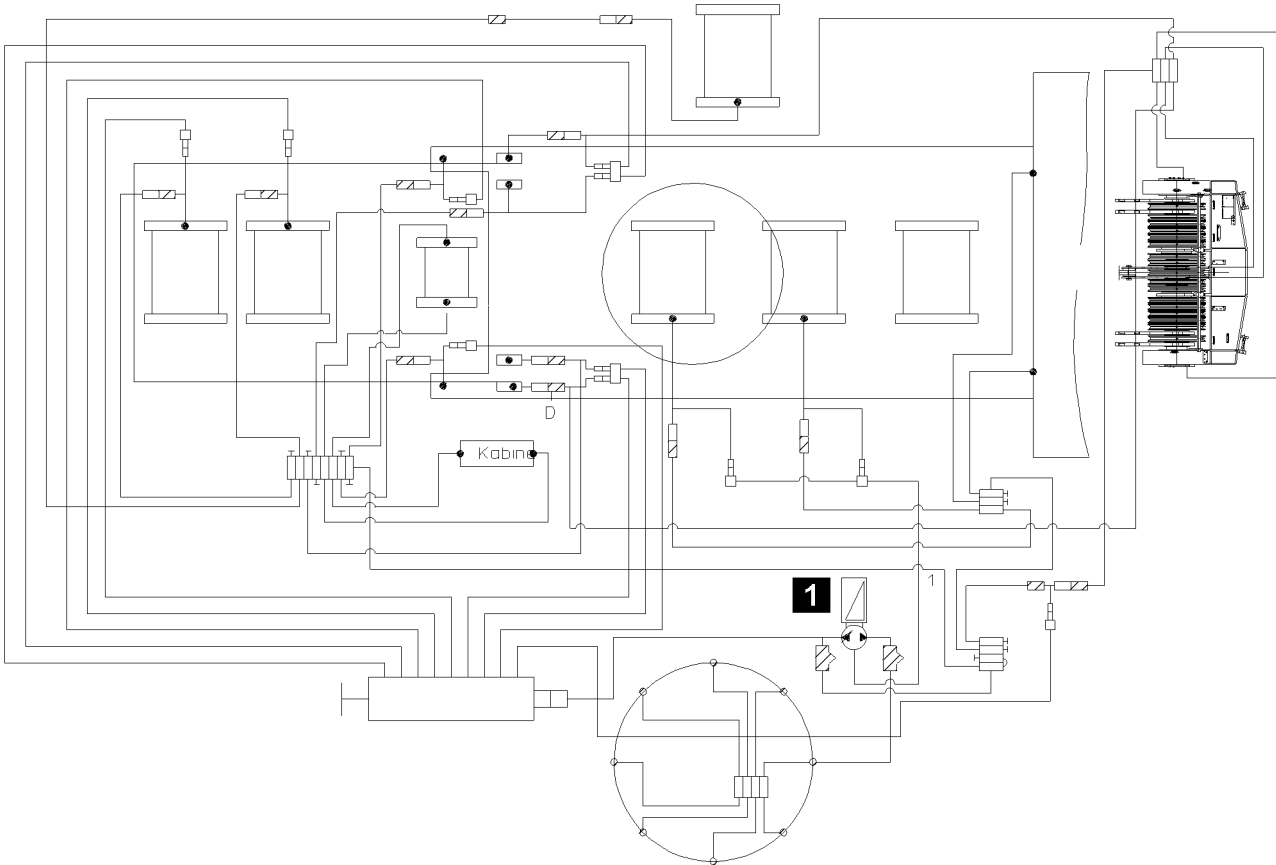







- 1 Grease container
- 2 Grease nipple
 - Fill the central lubrication pump
- 3 Grease nipple
 - Fill the lube lines
- 4 Pump outlet
- 5 Pressure relief valve
- 6 Pump element
- 7 Push button
- 8 Control
- 9 Green LED
 - Function display
- 10 Latched switch
 - Cycle time in hours
- 11 Latched switch
 - Lube time in cycles
- 12 Red LED
 - Fault display



LWE/LR 1600-2-008/18109-09-02/en

Fig.108923

5.2 Indicator lights of the central lubrication system

Position	Beacon	LED condition	Description
363		Orange: Blinks once after engine start.	
12		Red: Blinks once after engine start.	
9		Green: Blinks once after engine start.	
363		Yellow: Lights up during the lubrication time.	
9		Green: Lights up during the lubrication time.	Grease pump on, lubrication active
363		Orange: Blinks.	Error monitoring time, lubrication time
12		Red: Blinks fast.	
9		Green: Blinks fast.	
363		Red: Blinks fast.	
12		Red: Blinks very fast.	

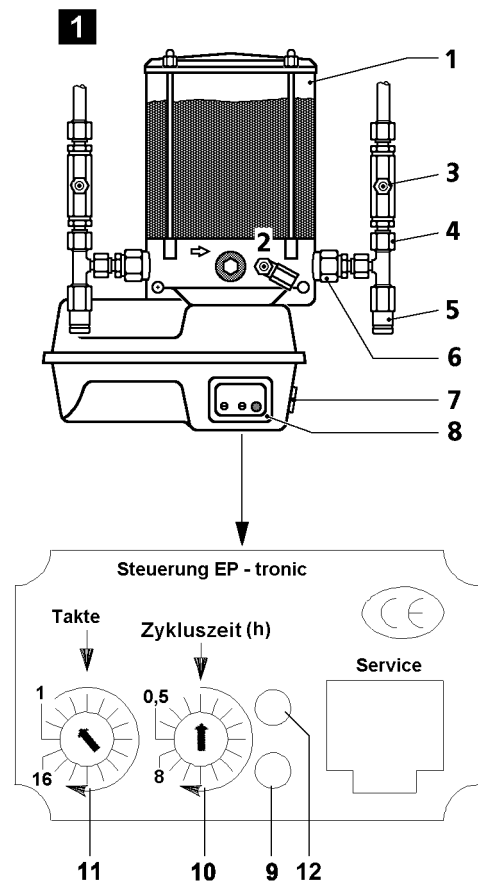
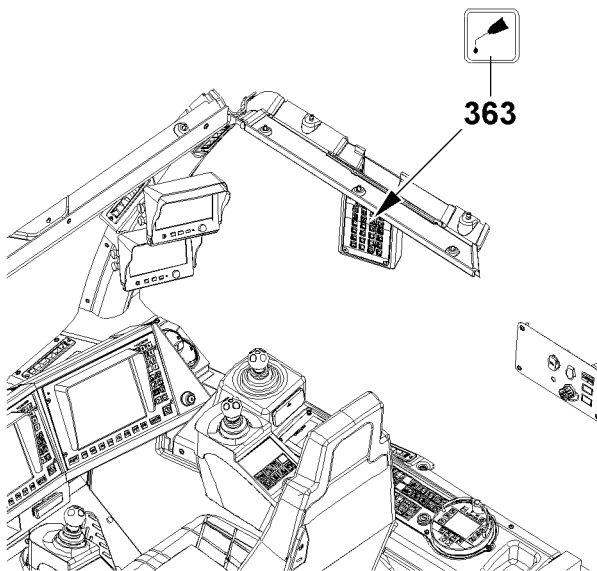
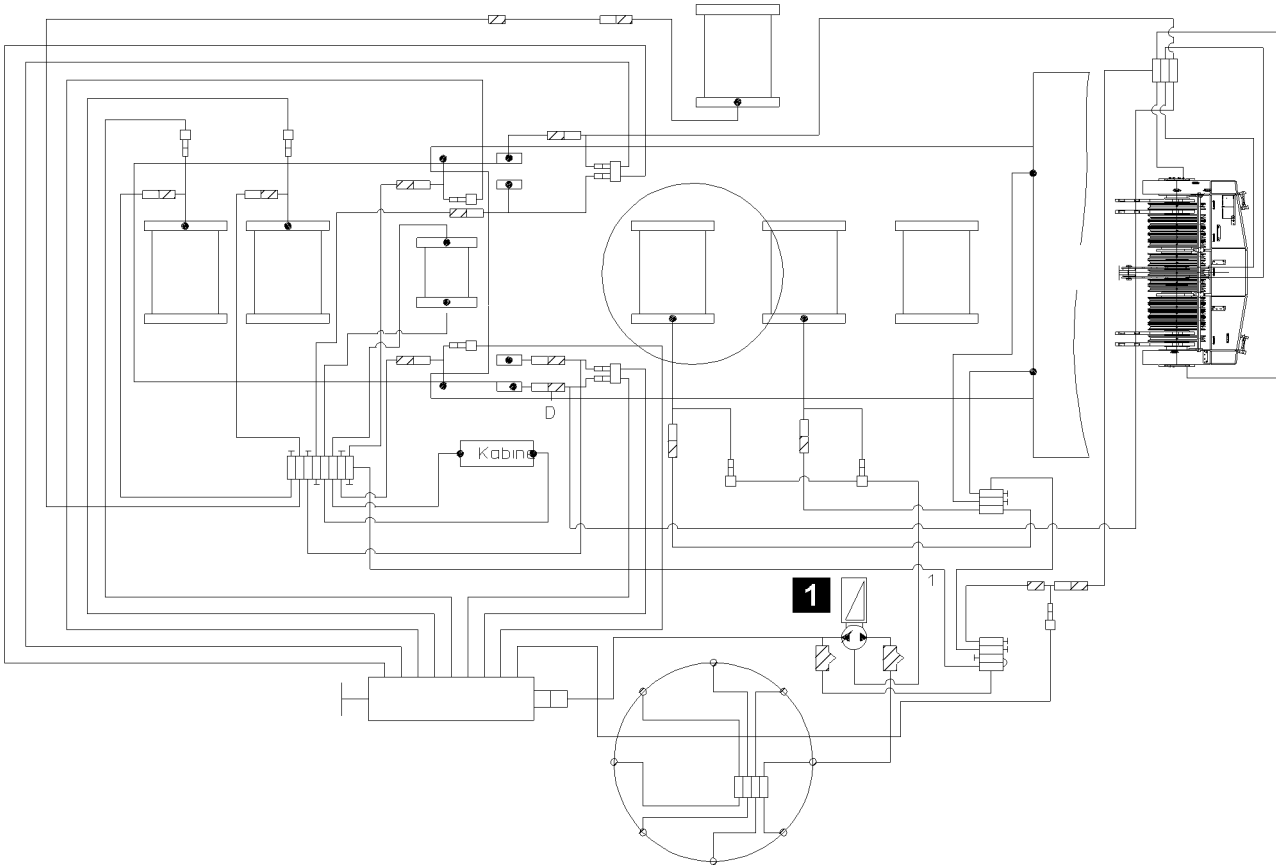

LWE/LR 1600-2-008/18109-09-02/en

Fig.108923

5.3 Servicing the central lubrication system

5.3.1 Setting the lubrication and break periods.



Note

- ▶ The pump running time is 3 cycles!
- ▶ The cycle time is 2.5 hours !
- ▶ During the lubrication procedure, the green LED **9** on the engine protection housing lights up!

The lubrication and pause time is set at the factory.

- ▶ Turn on the engine ignition.
- ▶ Set the cycles: Turn the latched switch **11**.
- ▶ Set the cycle time: Turn the latched switch **10**.
- ▶ Check functional readiness: Turn on the engine ignition.

Result:

- When turning the ignition on: The green LED **9** and the red LED **12** light up for approx. 2 s.
- The control **8** is functionally ready .

5.3.2 Checking the function of the central lubrication system

- ▶ Start the engine.
- ▶ Trigger 2 or 3 grease pulses using the push button **7**.

Result:

- Grease emerges on the grease points.
- If the system is blocked but the electric pump is properly functioning, the grease emerges through the pressure relief valve **5**.

5.3.3 Carrying out an intermediate lubrication

An intermediate lubrication is made in the following cases:

- After washing the crane
- After a repair
- ▶ With ignition turned on: Press the push button **7** on the engine protection housing of the grease pump.

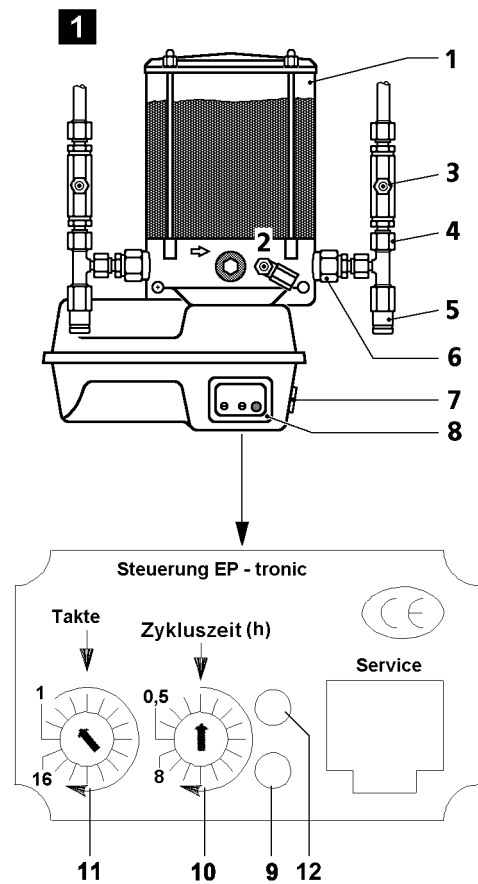
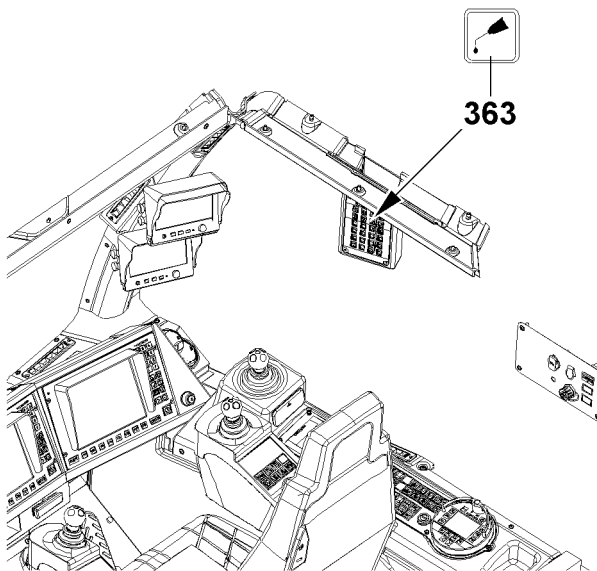
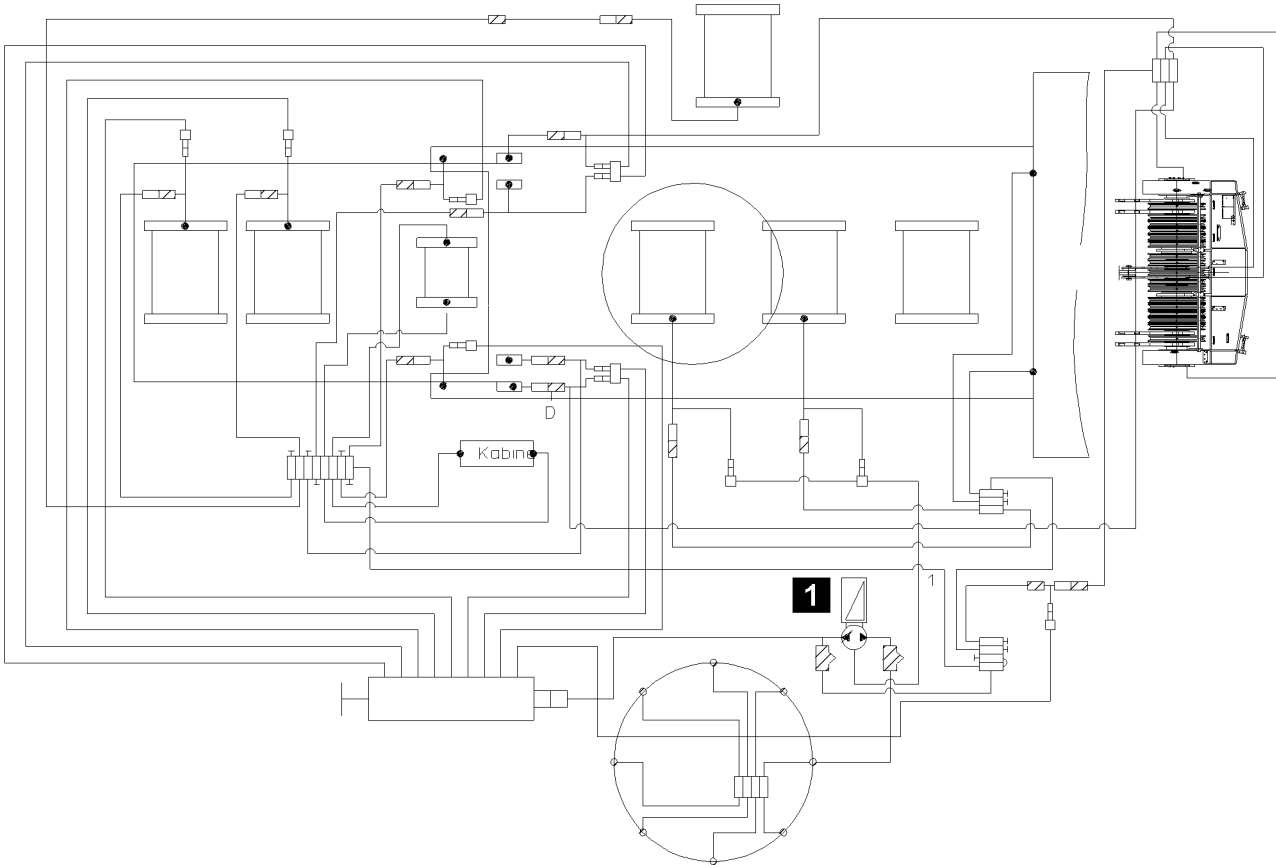

LWE/LR 1600-2-008/18109-09-02/en

Fig.108923

5.3.4 Filling the grease container of the central lubrication system

NOTICE

Insufficient lubrication!

If there is not enough grease in the container, components will be damaged or worn!

- ▶ There must always be sufficient grease in the grease container **1**!
- ▶ Observe utmost cleanliness when filling the grease container **1**!

-
- ▶ Fill the grease container **1** with a grease pump via the grease fitting **2** on the central lubrication pump.

5.3.5 Bleeding the central lubrication system

If the grease container **1** has been emptied, then it may be necessary to bleed the central lubrication system.

- ▶ Fill the grease container **1**.
- ▶ Unscrew the main line from the grease pump outlet **4**.
- ▶ Trigger additional lubricating pulses until there are no more air bubbles in the emerging grease at the grease pump outlet **4**.
- ▶ Reconnect the main line.
- ▶ Trigger an additional lubricating process.

5.3.6 Filling the lubrication lines

NOTICE

Risk of damage due to insufficient lubrication!

The lubrication lines must be refilled after any repair on components, which are lubricated with grease.

If this is not observed, the component may run dry!

- ▶ Sufficient grease must be available in the grease lines after every repair on greased components!
- ▶ Observe utmost cleanliness when filling the grease lines!

-
- ▶ Add grease with an external grease pump via the grease fitting **3**.

or

With the ignition turned on, press the push button **7** on the engine protection housing of the grease pump.

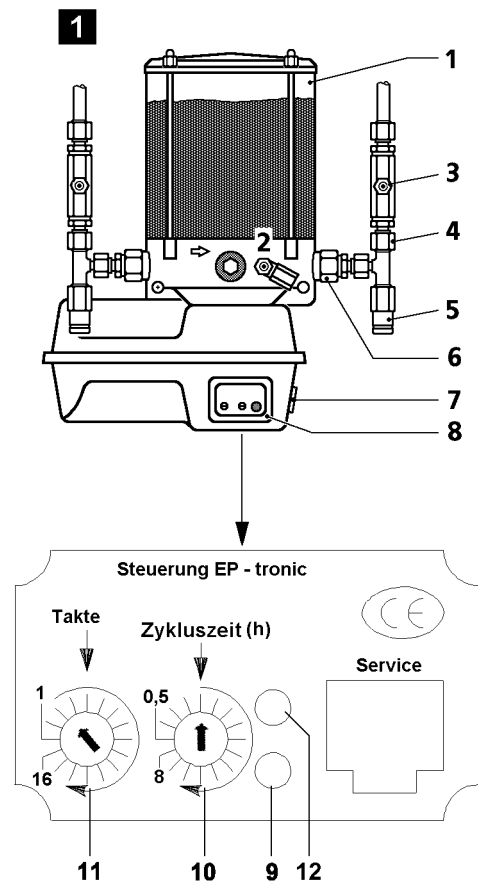
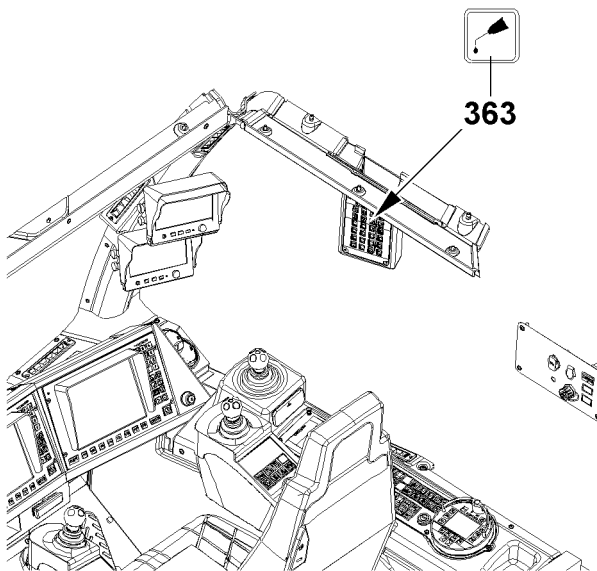
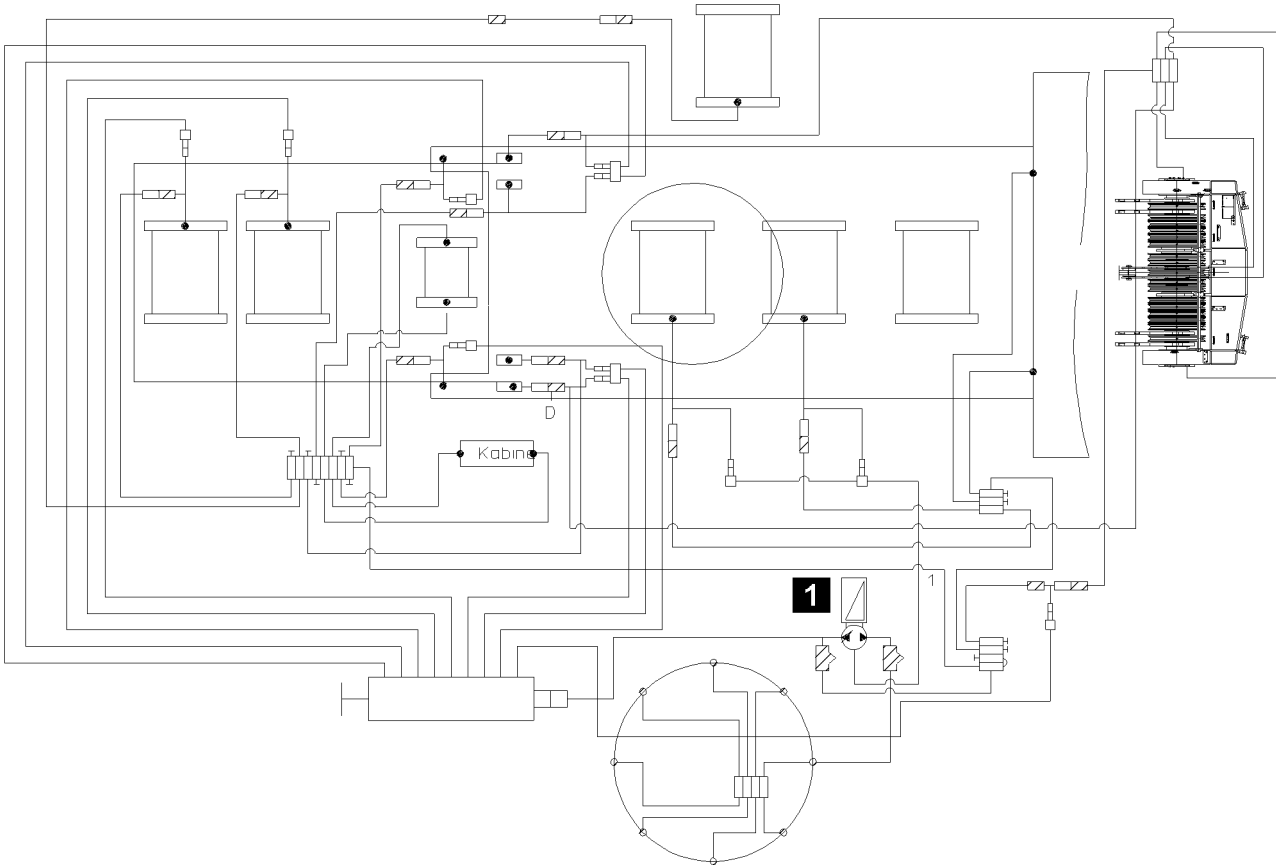

LWE/LR 1600-2-008/18109-09-02/en

Fig.108923

5.4 Troubleshooting on the central lubrication system

Problem	Cause	Remedy
The grease pump does not work.	Integrated electronic control defective, electrical line interrupted, grease pump defective.	Replace lower part of motor protection housing, replace electrical line, replace grease pump.
Grease pump operates, but does not deliver.	Air cushion in delivery piston, minimum fill level fallen below, grease pump element defective.	Bleed grease pump, fill reservoir, replace grease pump element.
No grease collar on all lube points.	Grease pump not operating, interval time too high or cycle time too short, system blocked.	See „Grease pump not operating“, reduce interval time or increase number of cycles, refer to „Grease emerges on pressure relief valve“.
No grease collar on several lube points.	Supply lines to secondary distributors broken or leaking, screw connections leaking.	Replace lines, tighten or replace screw connections.
No grease collar on one lube point.	Associated lube line broken or leaking, screw connection leaking.	Replace line, tighten or replace screw fitting.
Grease pump speed reduced.	Higher system pressure, lower ambient temperature.	Check system / bearing points, no damage: Grease intermediately once or twice, if necessary.
Grease escapes at the pressure relief valve.	System pressure too high, progressive distributor blocked, system blocked, defective valve spring.	Check system, replace distributor, repair blocked / seized bearing point, replace pressure relief valve.
The red LED blinks very fast.	Error CPU / memory.	Consult Liebherr Service.
The red LED and the indicator light blink fast.	Error in the monitoring period from cycle start.	The proximity switch is defective, consult Liebherr Service.

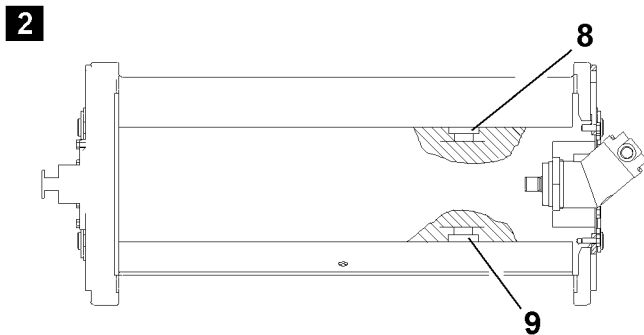
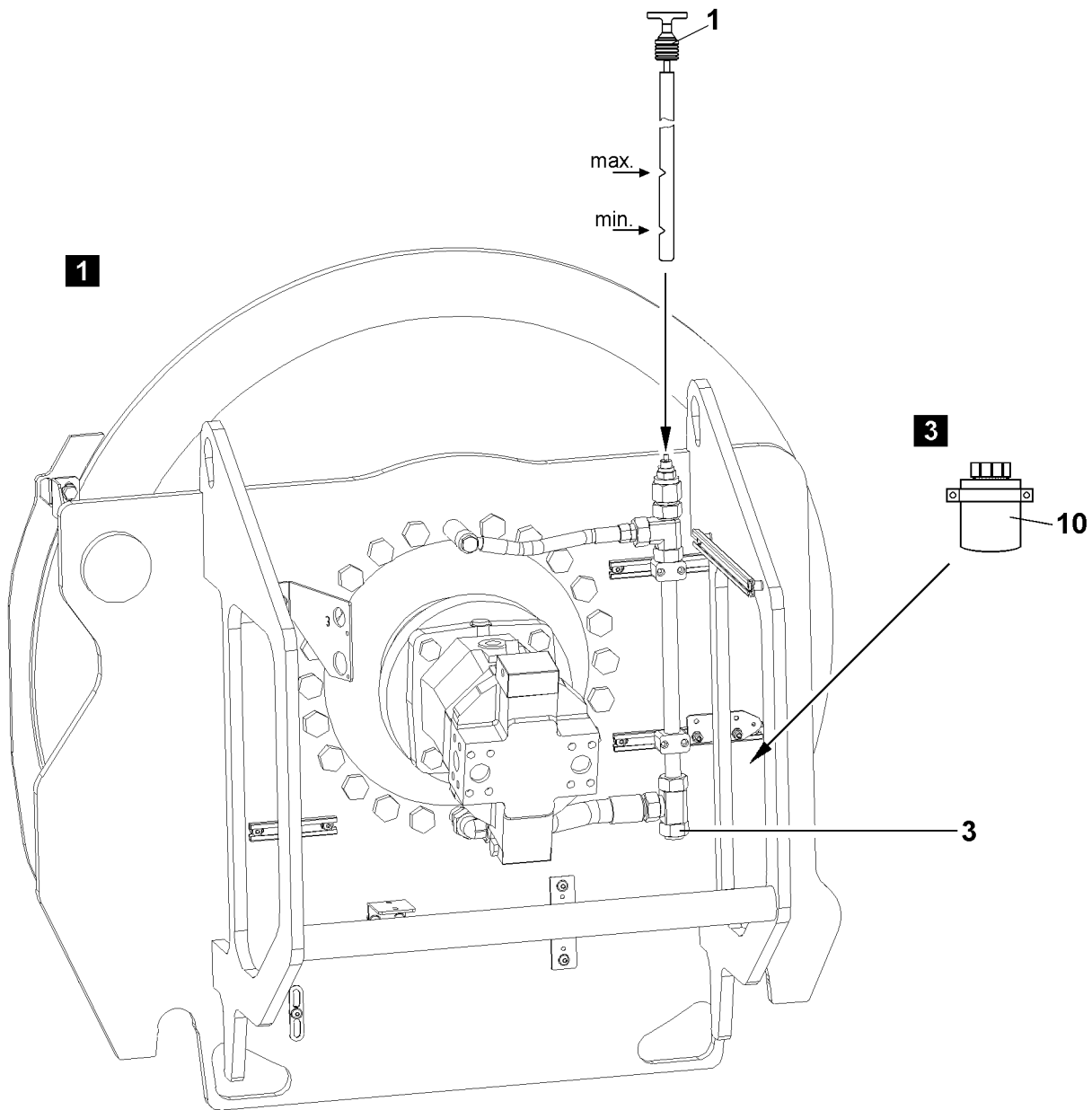

Fig.105418

LWE/LR 1600-2-008/18109-09-02/en

6 Hoist gear 1 to 6, illustration 1

Maintain utmost cleanliness during all work to prevent any dirt from entering the inside of the gear.

6.1 Overflow container, illustration 3

When the oil heats up in the hydraulic motor for the winches, the oil can enter the overflow container **10** via a check valve, but cannot flow back into the hydraulic system after cooling off. For this reason the oil that has collected in the overflow container **10** must be disposed of at regular intervals.

6.2 Winch

Make sure that the following prerequisites are met:

- The winch is inactive.
- The crane is in horizontal position.

6.2.1 Checking the oil level

- ▶ Remove the dipstick **1** and wipe it off.
- ▶ Reinsert the dipstick **1** and pull it out again.

The oil level must be between the min. and max. mark on the dipstick **1**.

- ▶ Check the oil level.

NOTICE

Danger of gear damage!

If the oil level has dropped below the minimum mark, add engine oil as specified in the lubrication chart until the oil level is between the minimum and maximum marks!

- ▶ Add oil and check again!

-
- ▶ Reinsert the dipstick **1**.

6.2.2 Oil change

- ▶ Pull out the oil dipstick **1**.
- ▶ Remove the oil drain plug **3** and drain the oil into a suitable container.
- ▶ Install the oil drain plug **3** with new seal and tighten.
- ▶ Add oil as specified in the lubrication chart at the oil filler port until the oil level is between the minimum and maximum mark on the dipstick **1**.
- ▶ Install the dipstick **1** and tighten.
- ▶ Check the oil level as described above.

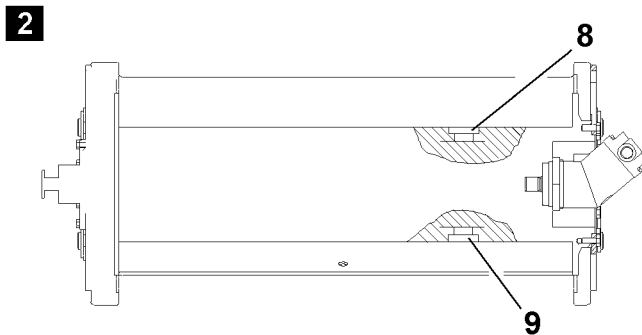
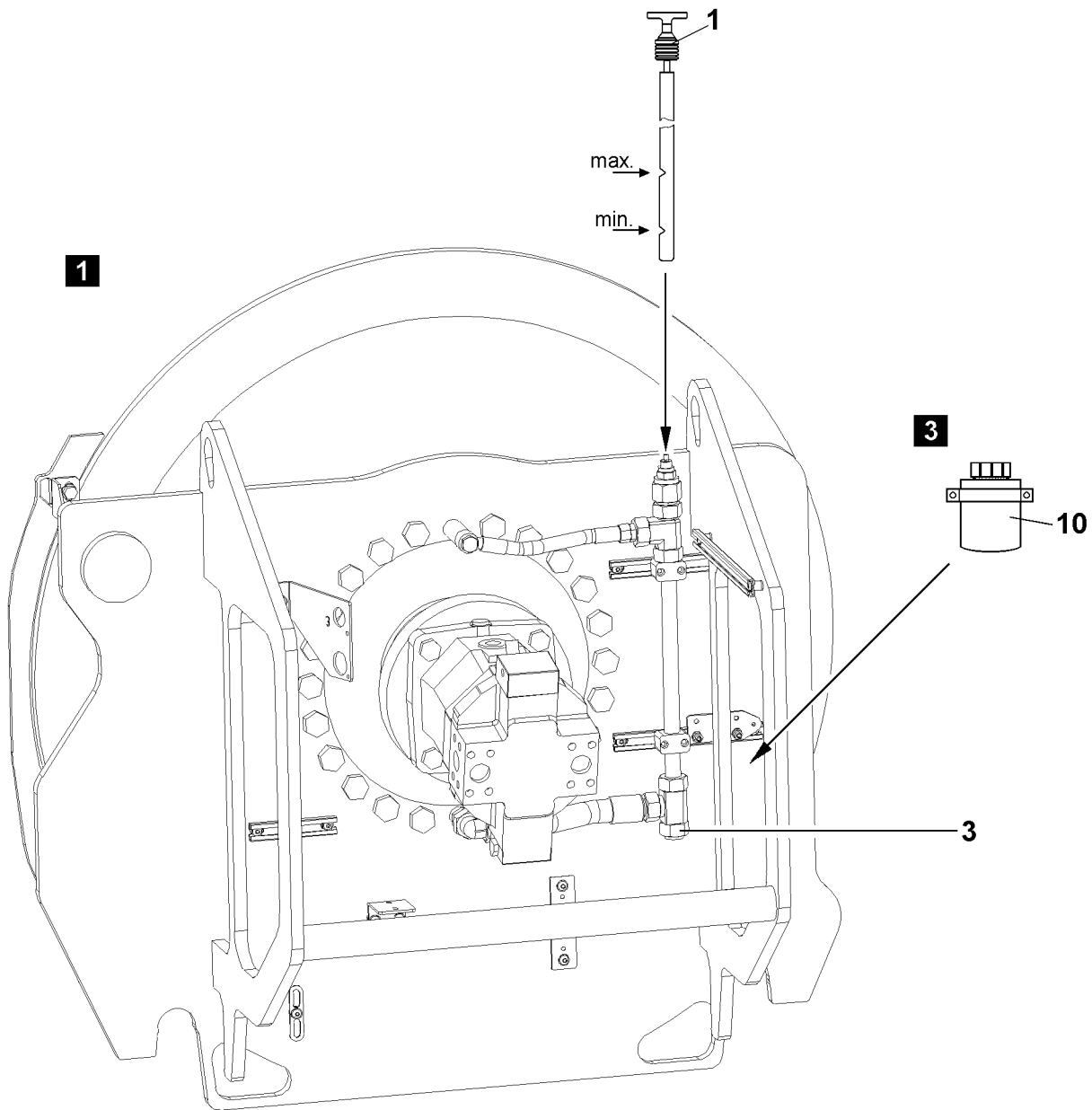

Fig.105418

LWE/LR 1600-2-008/18109-09-02/en

7 Assembly winch, illustration 2

7.1 Oil change

Ensure that the assembly winch has been spooled out.

- ▶ Remove the oil filler plug **8**.
- ▶ Remove the oil drain plug **9** and drain the oil into a suitable container.
- ▶ Install the oil drain plug **9** with new seal and tighten.
- ▶ Add oil as specified on the lubrication chart on the oil filler plug **8**.
- ▶ Install the oil filler plug **8** with new seal and tighten.

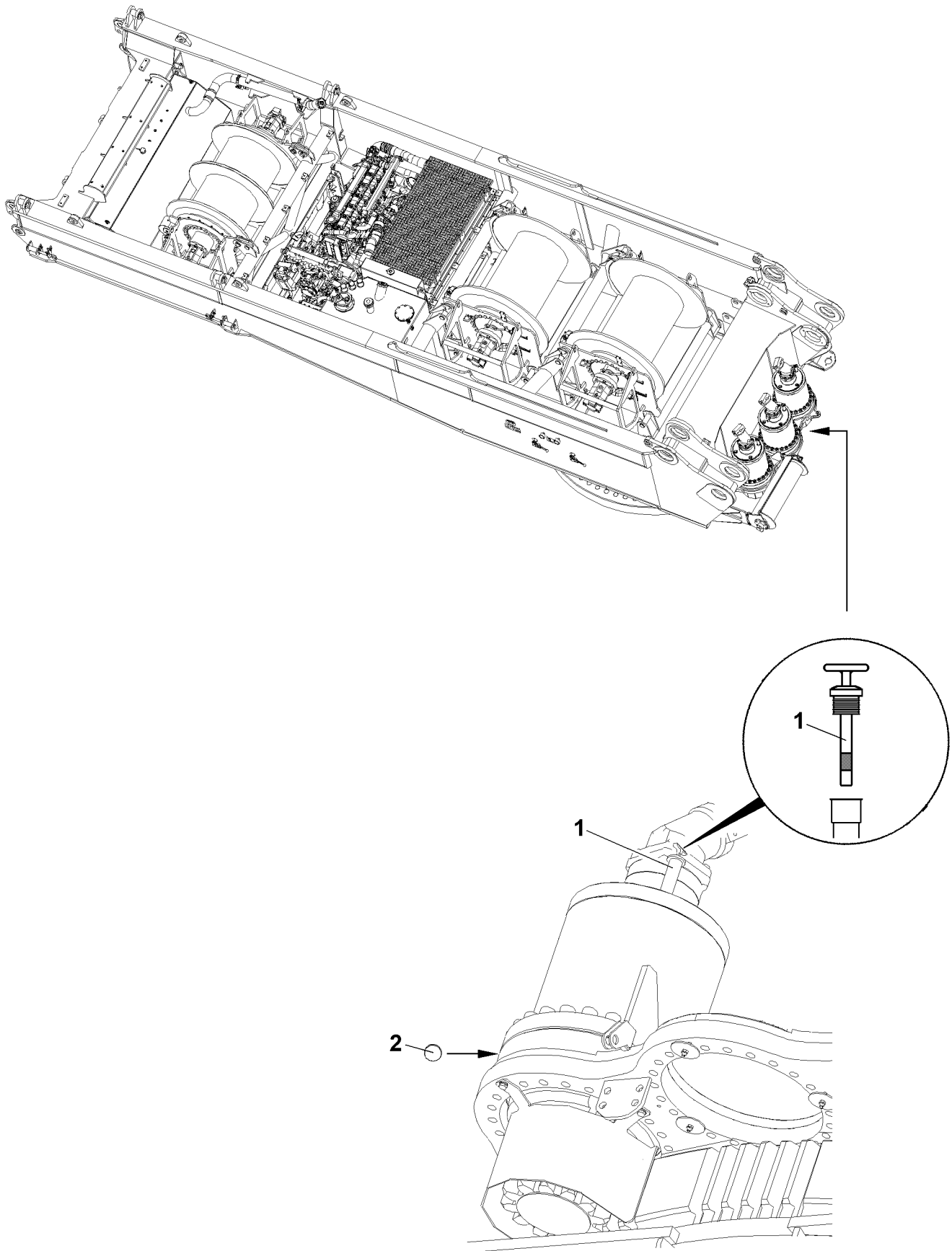

LWE/LR 1600-2-008/18109-09-02/en

Fig.105419

8 Slewing gear

Maintain utmost cleanliness during all work to prevent any dirt from entering the inside of the gear.

8.1 Checking the oil level

Make sure that the following prerequisite is met:

- The crane is in horizontal position.
- ▶ Remove the dipstick **1** and wipe it off.
- ▶ Reinsert the dipstick **1** and pull it out again.

The oil level must be between the two notches on the dipstick **1**.

- ▶ Check the oil level.

NOTICE

Danger of gear damage!

If the oil level has dropped below the lower notch, add oil as specified in the lubrication chart until the oil level is between the two notches!

- ▶ Add oil and check again!

-
- ▶ Reinsert the dipstick **1**.

8.2 Changing the oil

Make sure that the following prerequisites are met:

- The crane is in horizontal position.
- The gear is warm.
- ▶ Open the oil filler port by unscrewing the dipstick **1**.
- ▶ Remove the oil drain plug **2** with the seal ring and drain the oil.
- ▶ Clean the oil drain plug **2** and sealing surface on the housing.
- ▶ Install the oil drain plug **2** with new seal ring and tighten.
- ▶ Add oil as specified in the lubrication chart on the oil filler port until the oil level is between the two notches on the dipstick **1**.
- ▶ Close the oil filler port by screwing in the dipstick **1**.
- ▶ Check the oil level as described above.

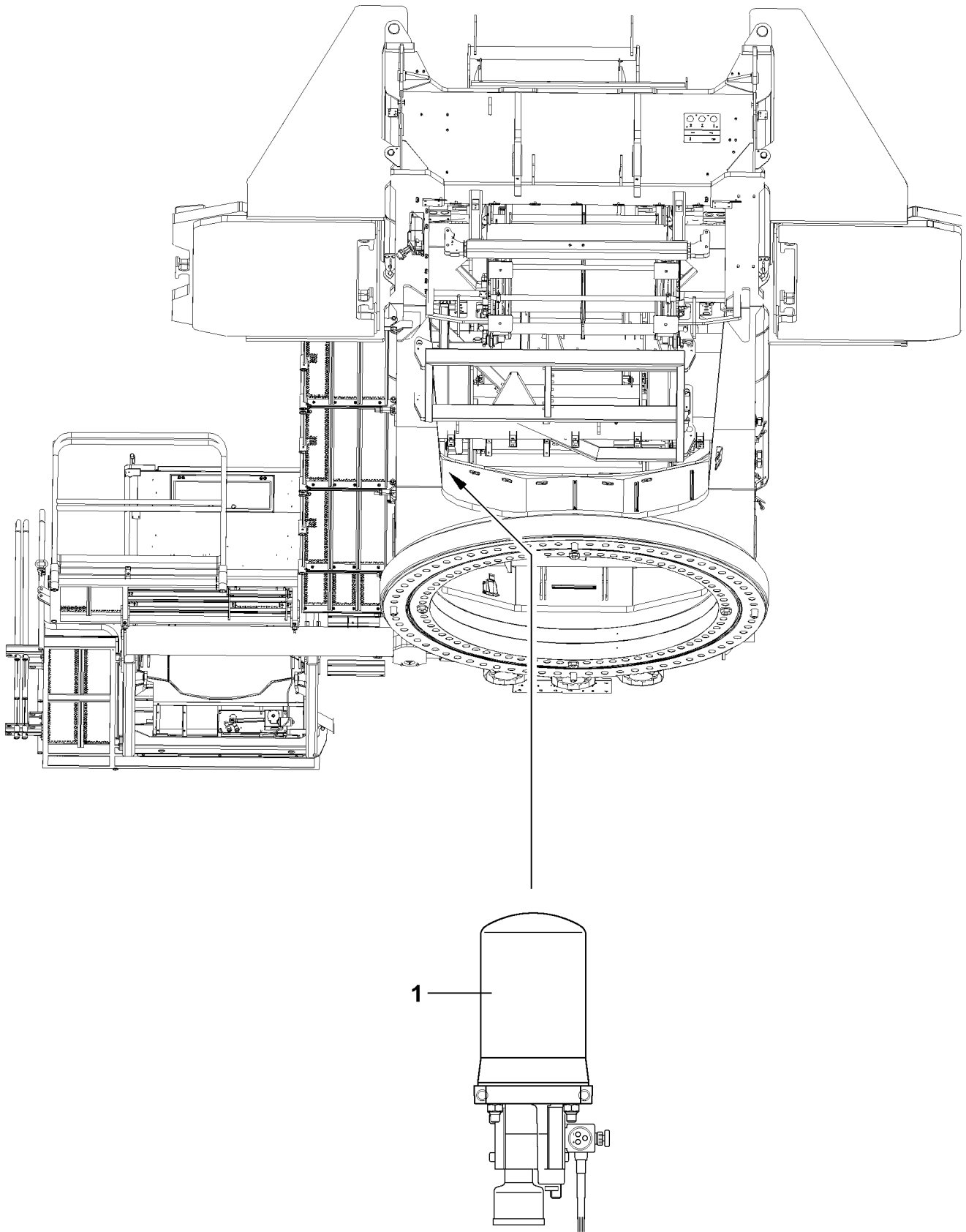

Fig.105420

9 Air dryer of the compressed air system of the crane superstructure

9.1 Replacing the granular cartridge



WARNING

Risk of accident due to pretensioned granular cartridge!

The granular cartridge 1 is under spring tension!

▶ Caution when replacing the granular cartridge!

▶ Replace the granular cartridge 1 once per year!

10 Electrical system - Lighting

The maintenance of the electrical system is essentially limited to replacing defective fuses and bulbs and maintaining the batteries.

NOTICE

Damage to electrical system!

Never short circuit defective fuses with wire or similar items!

▶ Always replace defective fuses with fuses of the same amperage!

▶ If there is a repeat problem with the same fuse, check the electrical system!

10.1 Battery maintenance



DANGER

Risk of fatal injury!

▶ Always disconnect the batteries from the power circuits when working on the electrical system of the crane and during all welding work!

▶ Keep batteries dry and clean.

▶ Do not bring oil, grease, fuel or solvents into contact with the battery casting compound.

▶ Release dirty terminals, clean and grease them with an acid-free and acid-resistant grease.

▶ Check the acid levels in batteries at least once a year. In summer and in hot climate zones, check it at least twice a year.

▶ On conventional batteries, check electrolyte level at regular intervals and add distilled water to the specified „max mark“, if necessary.

When adding distilled water:

▶ Measure the acid concentration only after 30 minutes. The acid temperature for measuring should be + 20 °C if possible.

Proceed as follows when checking the battery charge:

Specific weight	Charge condition
1.28/1.23*	Well charged
1.20/1.16*	Semi-charged, recharge
1.12/1.08*	Discharged, recharge immediately

* in tropical countries

Reduced battery performance requires greater power requirements.

- ▶ Ensure that batteries are well charged, particularly during the colder months.

10.2 Mixing battery acid

- ▶ Ensure that work area is well ventilated.



DANGER

Risk of explosion!

- ▶ When mixing battery acid, always pour distilled water into the container first, then the concentrated sulphuric acid!
- ▶ Observe this order, otherwise explosions and spattering can occur!

- ▶ Stir the mixture with an acid-proof stick (glass or plastic).

Desired acid concentration kg/l	1.23	1.24	1.25	1.26	1.27	1.28
Volume ratio of concentrated sulphuric acid (96 %) to distilled water	1:3.8	1:3.6	1:3.4	1:3.2	1:3.0	1:2.8

When adding the battery acid, the acid level should be 15 mm above the top edge of the battery plates and the temperature of the acid should be approximately 15 °C.

- ▶ Add battery acid to battery.

Wait approximately 20 minutes before connecting the battery. By that time, it will be balanced out.

- ▶ Connect the battery after approximately 20 minutes.

10.3 Removing and recharging the battery



WARNING

Danger of injuries!

- ▶ Do not place tools on batteries and keep open flames away!

10.3.1 Removing the battery

Make sure that the following prerequisites are met:

- The engine is turned off.
- All electrical users are turned off.

NOTICE

Damage to alternator!

- ▶ Do not disconnect batteries unless the engine has been turned off!
- ▶ Carry out work in well ventilated rooms and avoid sparks.
- ▶ Disconnect the negative terminal first (ground cable), then the positive terminal.
- ▶ Remove the battery.
- ▶ Avoid spark formation caused by electrostatic charge. To avoid this, touch the ground support point in the driver's cab.
- ▶ Do not tilt or shake the battery.

10.3.2 Recharging the battery

NOTICE

Damage to battery!

- ▶ Recharge only with direct current, the strength of which does not exceed 1/10 of the battery capacity!

Recharging example: A battery with 170 Ah should be charged with a maximum charging current of 17.0 A.

- ▶ Frozen batteries must be thawed out before charging.
- ▶ Remove all plugs before charging.
- ▶ Provide ventilation during charging (risk of oxyhydrogen gas explosion!).
- ▶ Connect the battery to a battery charger (positive to positive and negative to negative).
- ▶ Turn on the battery charger after connecting the battery.

Stop charging immediately if:

- The acid temperature exceeds 55 °C (casing more than warm to the touch).
 - The battery starts to give off gas.
 - The acid concentration or the charging voltage has not changed for 2 hours.
- ▶ Turn the battery charger off after charging, then remove the connector cables individually from battery and battery charger.

10.3.3 Installing the battery

- ▶ Reinstall the battery tightly in the vehicle.
- ▶ Avoid spark formation caused by electrostatic charge. To avoid this, touch the ground support point in the driver's cab.
- ▶ Connect the positive terminal to the battery first, then the negative terminal (ground cable).
- ▶ Check that the terminals are tightly seated (low transfer resistance).
- ▶ Grease the terminals and terminal posts with acid-free and acid-resistant grease (use corrosion protection even for modern maintenance-free batteries).

Empty page!

LWE/LR 1600-2-008/18109-09-02/en

7.05.50 Maintenance guidelines - Crane boom

1	Lattice mast boom	3
2	Rope pulleys and guide pulleys	4
3	Crane ropes	4

Fig.195219

LWE/LR 1600-2-008/18109-09-02/en

1 Lattice mast boom



WARNING

Danger of falling!
Death, severe injuries.

- ▶ For all work on the crane where there is a danger of falling, suitable safety measures must be taken, see Crane operating instructions, chapter 2.06.



Note

- ▶ The following illustration is an example and may not exactly match to your crane.

1.1 Lubricating the pin bores on the lattice sections and guy rods

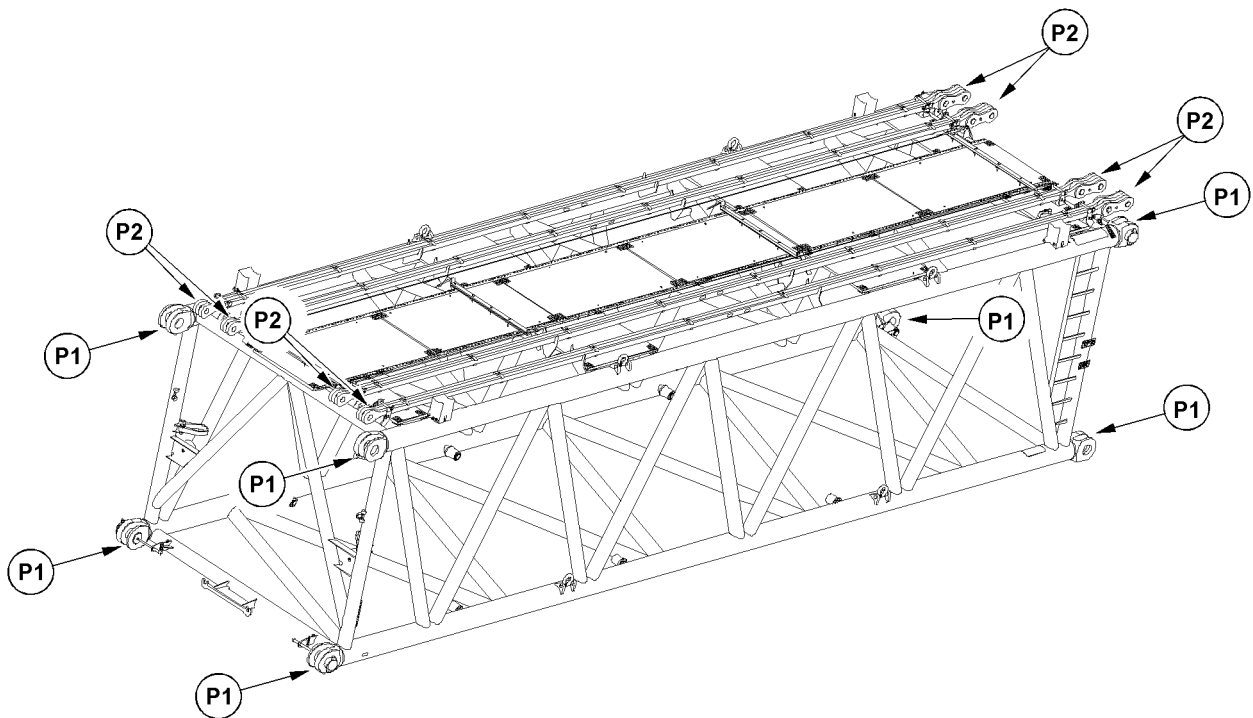

Fig.123861: Lube points on boom lattice sections and guy rods



Note

- ▶ For the pin bores on the lattice sections (points **P1**) and the guy rods (points **P2**), use special grease as lubricant. See Service fill and Crane operating instructions, chapter 7.07.
- ▶ Apply the grease on the pin bores over the entire circumference.
- ▶ The lubrication of the pin bores on the boom lattice sections and the guy rods is made before assembly or after disassembly.

Make sure that the following prerequisites are met:

- The lattice sections are not installed on the crane.
- The lattice sections are playing on a load bearing support on the ground.
- ▶ Grease the pin bores on the boom lattice sections and the guy rods.

2 Rope pulleys and guide pulleys

2.1 Check bearings for easy movement

Stiff or blocked rope pulleys or compensation pulleys wear rapidly and unevenly and cause serious rope abrasion.

Ineffective compensation pulleys can lead to irregular rope tension.

- ▶ Check the rope pulleys for proper movement in their bearings.

When rope pulleys are **not** easily moveable in their bearings:

- ▶ Fix the bearings.

2.2 Checking for mechanical damage

Ropes can cause mechanical damage, such as stress marks.

- ▶ Check guide pulleys and rope pulleys for mechanical damage.

3 Crane ropes

3.1 Personal protective equipment



WARNING

Injury due to wires and skin irritation due to lubricant!

- ▶ When working with ropes, always wear work gloves.



WARNING

Injuries if protective equipment is **not** worn!

- ▶ Wear hard hat, safety shoes and safety glasses.

3.2 Safe and problem-free operation



WARNING

Wear, overload, incorrect use, damage, improper maintenance!

Failure of ropes. Death, severe injuries, property damage.

- ▶ Prevent failure of ropes: Observe and adhere to the following notes.

Carry out the following measures to ensure safe and problem-free rope operation.

- Service ropes and rope end connections regularly according to the maintenance intervals.
- Check ropes and rope end connections regularly according to the inspection intervals.
- When it is determined that the ropes should be withdrawn from service, do **not** continue to use them further.
- Exclude contact of rope with components except rope drive elements.
- Exclude contact of rope with structural parts, power lines or other objects within the surrounding area.
- Avoid corrosive and chemical surroundings.
- Avoid excessive soiling.
- Avoid excessive heat influence.
- Ensure proper condition of all elements of rope drive.
- Ensure proper spooling formation on the rope drum.
- Use the entire rope length of hoist ropes.
- Avoid slack rope formation on the drum.
- Do **not** bring outer twists into the rope.
- Avoid shock relief of the rope, such as sudden set down of the load.

- Avoid **non-permissible** angular pull, for example by pulling the load at an angle.

3.3 Temperature operating limits

Adhere the temperature operating limits for steel ropes. The determining factors are wire material, lubricant, rope end connections. See Manufacturer's specifications.

3.4 Qualification Maintenance personnel

Make sure that the following prerequisites are met:

- The maintenance personnel is trained and instructed in maintenance tasks.
- The maintenance personnel is assigned (authorized) for the maintenance by the crane operator.

3.5 Damage on rope

Rope removal criteria: If severe damage reduces the operational safety, then the rope can reach the removal criteria.

This section provides an overview for possible damage on the rope. For clearer illustration, the distortions on the illustrations are exaggerated.

The displayed ropes show a condition, which is far above the removal criteria.

Damage on the rope causes uneven load distribution in the affected areas.

Damage on the rope is most often localized.

Typical examples for damage, which can be recognized during maintenance work:

- Broken strands
- Wire breaks
- Reduction of rope diameter
- Localized increase of rope diameter
- Corrosion
- Flattenings
- Corkscrew-like distortion
- Basket formation
- Protruding, distorted inlay or braiding
- Loop formation
- Kinking, rope loops (grommets) pulled closed
- Buckles
- Influence of heat or electrical voltage, such as arcing

3.5.1 Broken strands

A strand consists of several individual wires.

When a complete braid is broken, then the rope must be taken down.

3.5.2 Broken wire

Externally visible broken wires are the result of wear caused by operation.

Additional types of broken wires:

- Broken wire in the inside of the rope
- Broken wire in the strand valleys
- Broken wire on a rope connection

A broken wire does not endanger the safety of the rope.

3.5.3 Reduction of rope diameter

The rope diameter changes due to abrasion, settling and external influences.

Abrasion of cover wires of outer strands of rope due to frictional contact. Especially in those areas where ropes are in contact with the rope pulleys during start up or slow down of the load.

Wear is increased by lack of or incorrect lubrication and the effect of dust.

Abrasion reduces the tensile strength of steel ropes because the cross section of the steel is reduced.

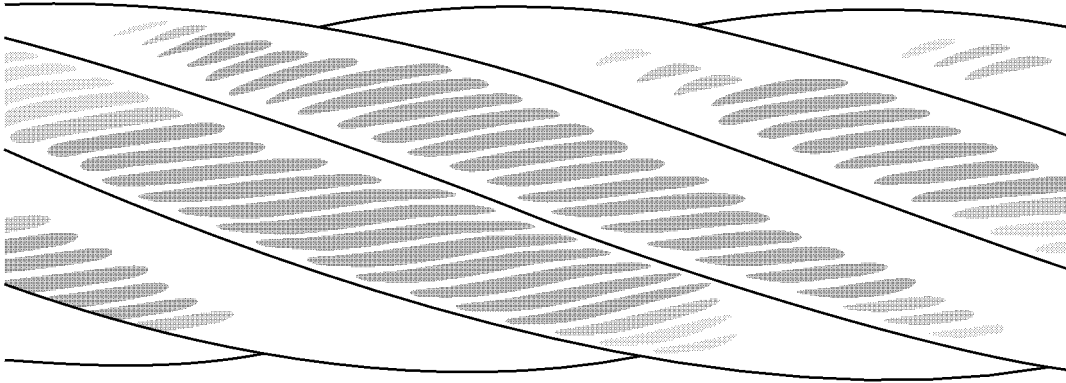

Fig.121001: External abrasion on the rope

When the rope diameter is reduced, the rope must be checked by **expert personnel for crane rope inspection**.

3.5.4 Localized increase of rope diameter

An increase, which occurs over a longer area of the rope can be caused by absorption of moisture in the fiber insert or due to corrosion in the inside of the rope.

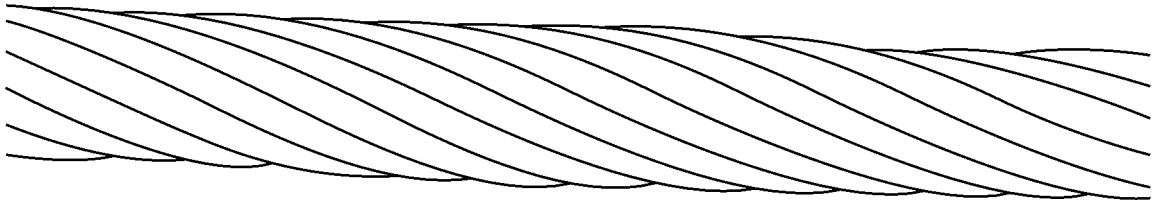

Fig.120992: Increase of rope diameter

When a localized increase of the rope diameter is present, then the rope must be checked by **expert personnel for crane rope inspection**.

3.5.5 Corrosion

Corrosion occurs due to insufficient lubrication, in maritime climates and in an atmosphere polluted by industrial fumes.

External corrosion is indicated by a rough wire surface. A superficial rust film can be wiped off.

Significant corrosion reduces the strength and elasticity of the rope due to the reduction of the rope diameter.

Inner corrosion is hard to detect.

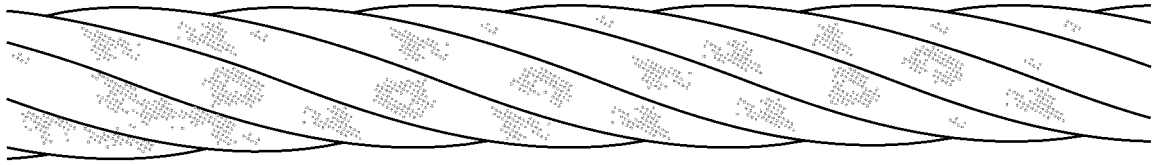

Fig.120994: External corrosion

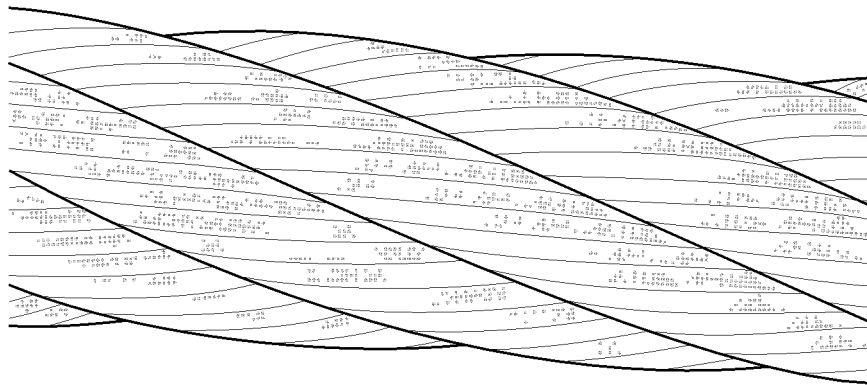

Fig.120995: Magnification of external corrosion for better depiction

When significant corrosion is present, the rope must be checked by **expert personnel for crane rope inspection**.

3.5.6 Flattening

Flattening occurs when the rope runs through the rope pulleys. In this area the rope wears quicker. Corrosion occurs faster on retaining ropes and guy ropes.

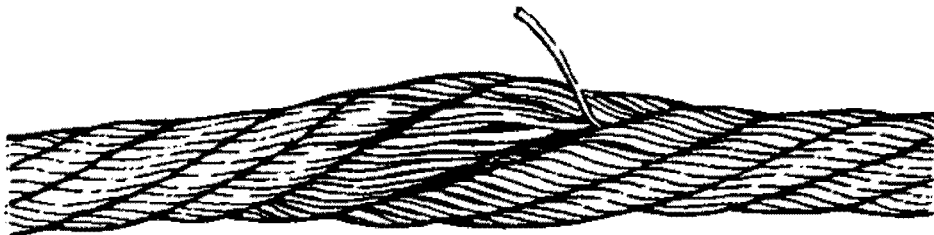

Fig.120997: Localized limited flattening, which leads to broken wires (single layer rope)

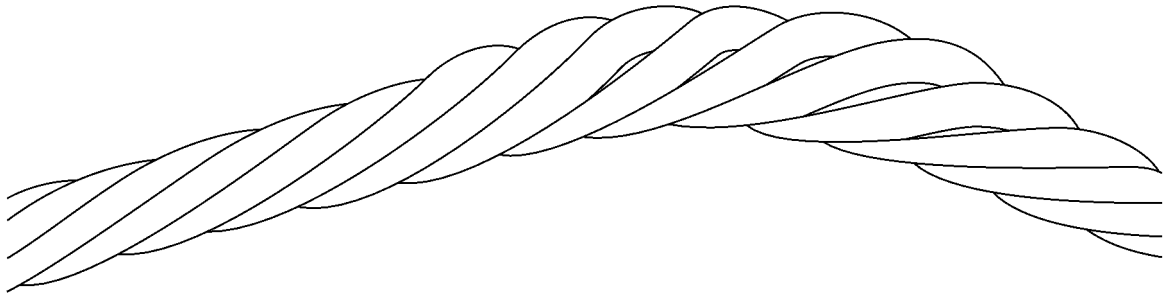

Fig.120996: Flattenings on multi layer spoolings

When flattening is present, the rope must be checked by **expert personnel for crane rope inspection**.

3.5.7 Corkscrew-like distortion

Distortion where the rope is in the form of a corkscrew along its longitudinal axis.

Corkscrew-like distortion causes rope wear, broken wires and bearing damage on rope pulleys.



Fig.120988: Corkscrew-like distortion

When corkscrew-like distortion is present, the rope must be checked by **expert personnel for crane rope inspection**.

3.5.8 Basket formation

This distortion occurs due to different layers between the outer strand layers and the inside of the rope.

Causes for basket formation are high angular pull angles during the run over the rope pulleys and run-in rope pulleys. Even load distribution over the entire cross section is not possible.

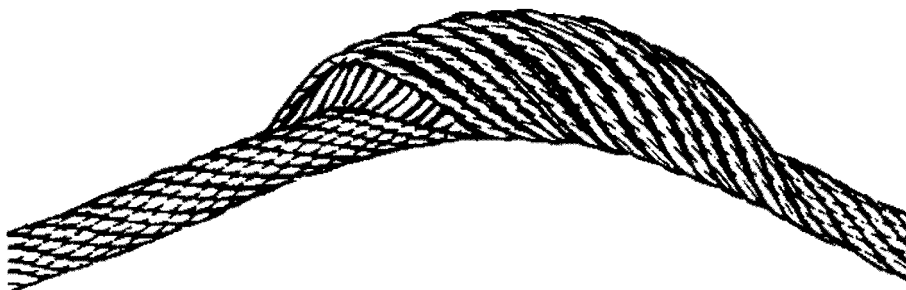

Fig.120989: Basket formation

When basket formation is present, then the rope must be taken down.

3.5.9 Protruding, distorted inlay, braiding

This distortion is a special form of basket formation: The insert or the core of the rope protrudes between the external braids or an external braid protrudes from the rope banding.

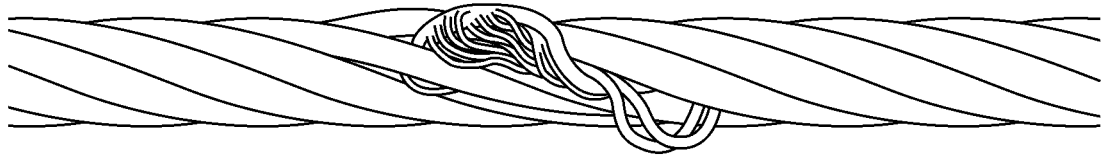

Fig.120990: Protrusion of an insert (rope single layer)



Fig.120991: Distorted or protruding strand

When the insert or a strand protrudes or is distorted, place the rope down. Have **expert personnel for crane rope inspection** check if the rope area with the distortion can be removed.

3.5.10 Loop formation

At loop formation individual wires protrude from the rope banding, when no broken wire ends can be seen.

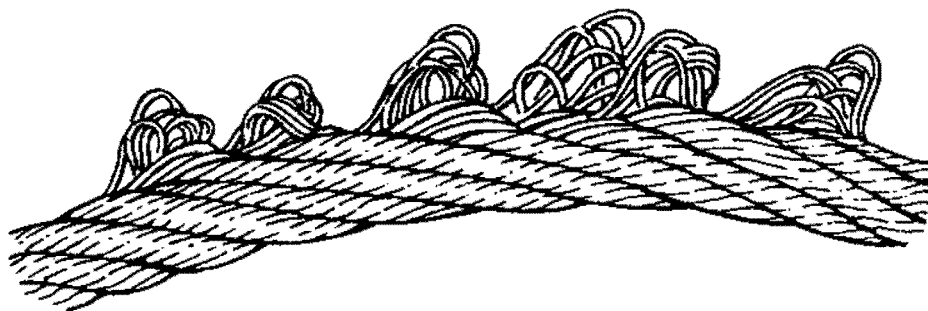

Fig.120993: Emergence of individual wires

When loop formation is present, take the rope down.

3.5.11 Kinking, rope loops (grommets) pulled closed

Deformation, where a loop has formed in the rope, without the possibility to rotate around its own axis during a load. The rope is subjected to more wear.

The rope is deformed. The strength remains only in part.

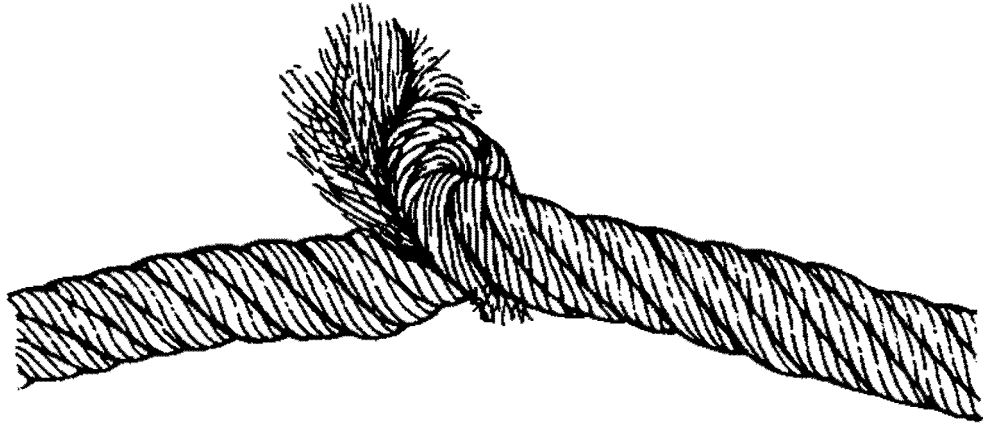

Fig.120998: Severe kinking or knots

When kinking or rope loops are present, place the rope down.

3.5.12 Buckles

Buckles are angular deformations. The rope was damaged due to external influences. Strong deformations of the rope cause stronger wear.

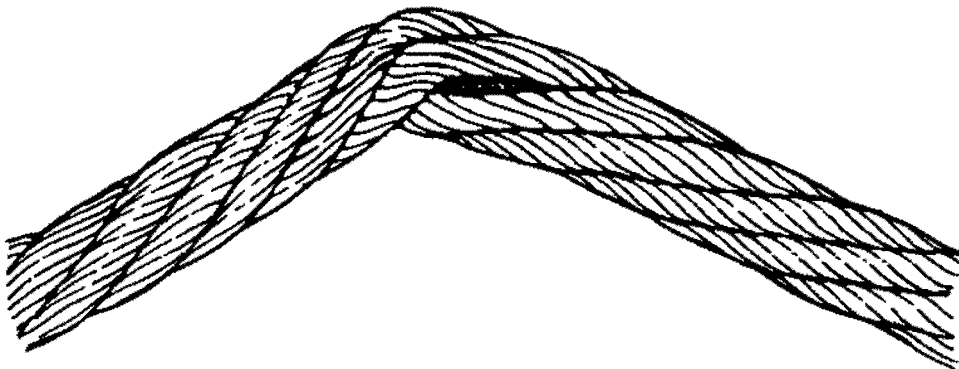

Fig.120999: Severe buckle

When buckles are present, take the rope down.

3.5.13 Effects of heat, arcs

Damage caused to the rope by welding work, for example.

Unusual heat impact is visible by tempering colors and loss of lubricant.

When heat impact has occurred on the rope, then the rope must be taken down.

3.6 Checking the ropes



WARNING

Operation with damaged rope!
Failure of rope. Death, severe injury, property damage.

When damage, wear and deformations are present:

- ▶ Have **expert personnel for crane rope inspection** determine if the rope has to be taken down.

The following sections describe the tasks for **daily visual inspection**.

The crane operator can carry out a daily visual inspection if he is sufficiently trained in the tasks and considered to be able to do so.

3.6.1 Intervals

Intervals and situations where the daily visual inspection must be made:

- Daily, before starting to work
- In case of change of the reeving of the crane rope due to
 - Transport
 - New reeving
 - Removal and installation

3.6.2 Areas

The rope must be checked over the entire length.

The following areas must be checked with special diligence:

- Rope end connections
- Safety coils and fixed point on the winch
- Areas of the rope which run through the hook block
- Areas of the rope which run over the rope pulleys or laying on the rope pulleys
- Areas of the rope which are spooled on the winch, especially cross over areas
- Areas of the rope which are laying above the compensation pulleys
- Areas of the rope which are subjected to abrasion due to external components
- All areas of the rope which are subjected to temperatures above 60°C

3.6.3 Documentation of rope condition

Every visible change of the wire rope must be documented in the crane records.

3.6.4 Checking the lubrication



WARNING

Missing lubrication!

Functional problems. Inner and outer corrosion.

- ▶ Lubricate the rope regularly.
- ▶ Make sure that the rope is lubricated all around.
- ▶ Select manual or automatic lubrication procedures.

The lubrication must be checked at least once a **month**.

When the rope shows signs of drying out:

- ▶ Lubricate the rope, see section „Lubricating the rope“.

3.6.5 Check for wear and distortion

- ▶ Check all visible parts of the rope for wear and distortion.
- ▶ Check the rope end connections and fixed points especially carefully for wear, damage, cracks and distortion.
- ▶ Check pressed together rope end connection for slipping and traces on the rope.



Note

- ▶ The maximum permissible number for broken wires over a certain rope length may not be exceeded.
- ▶ Determine the maximum permissible number of broken wires, see Crane operating instructions, chapter 8.04.
- ▶ Check the rope end connection and rope area near the rope end connection for broken wires.

When broken wires are present on the rope:

- ▶ Remove the broken wire, see section „Removing broken wires“.

When broken wires or damage is present on the rope end connection:

- ▶ Document visible changes of the rope condition.
- ▶ Have the rope checked by **expert personnel for crane rope inspection**.

When the rope can be shortened without reducing the operational safety:

- ▶ Shorten the rope, see section „Shortening the rope“.

3.6.6 Checking the rope drive for spooling problems

Lacking pretension of the rope on the winch can cause spooling problems in multi layer spooling.

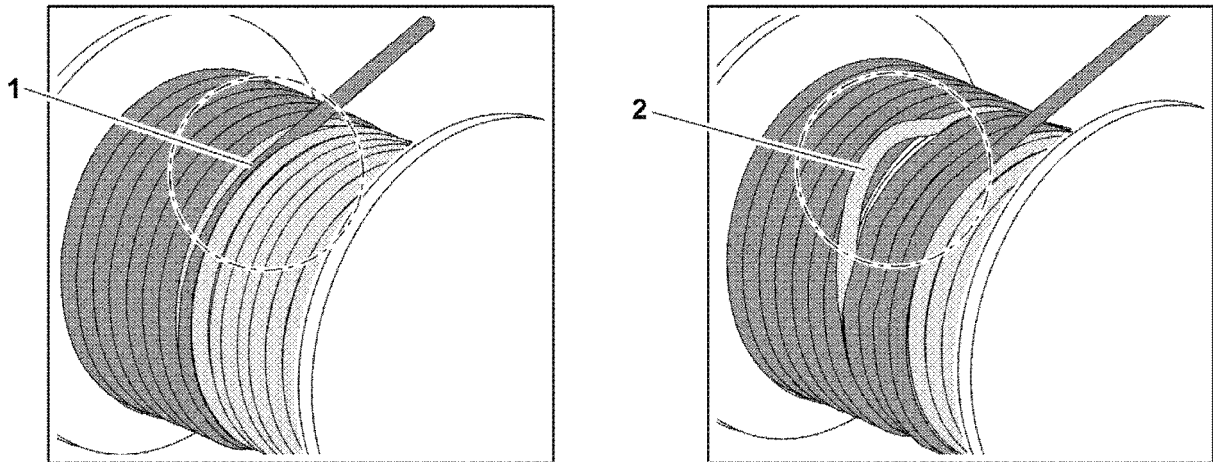

Fig.120967: Possible spooling problems on the rope winch

- 1** Cutting into the lower rope layers **2** Loop formation in the lower rope layers

- ▶ Check the spooling behavior of rope on the rope winch for cutting into the lower rope layers **1**.
- ▶ Check the spooling behavior of rope on the rope winch for loop formation in the lower rope layers **2**.

When spooling defects are found:

- ▶ Renew the pretension, see section „Renewing the pretension of hoist ropes“.
- ▶ Document visible changes of the rope condition.
- ▶ Have the rope checked by **expert personnel for crane rope inspection**.

3.6.7 Checking the position

- ▶ Check the correct position of the rope on the rope pulleys.

When the rope is **not** correctly laying on the rope pulley:

- ▶ Have the rope and rope pulley checked by **expert personnel for crane rope inspection**.

3.6.8 Checking for corrosion

A superficial „rust film“ can be wiped off.

- ▶ Do **not** clean the rope with solvents or cleaners.
- ▶ Clean the rope solely with a wire hand brush.
- ▶ Check rope for corrosion.

When the rope shows a rough surface:

- ▶ Document visible changes of the rope condition and have the rope checked by **expert personnel for crane rope inspection**.

If there is any uncertainty regarding the condition of the rope:

- ▶ Place the rope down or contact Liebherr Service.

3.6.9 Checking for flattenings

In the cross over area of the spooled up rope layers on the winch the rope is stressed more. The rope can be flattened as a result.

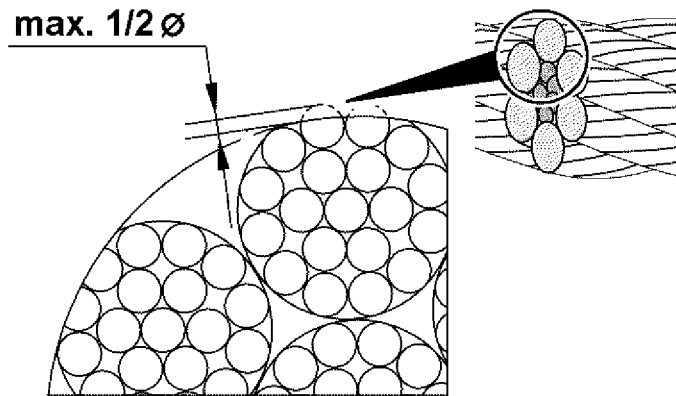

Fig.120966: Maximum flattening of wires on the outer strands

- ▶ Check the rope in the ascent zones of the rope spooling on the winch for flattenings.

When the outer braids are flattened more than half of the wire diameter:

- ▶ Document visible changes of the rope condition.
- ▶ Have the rope inspected by **expert personnel for crane rope inspection** or place the rope down.

When the rope can be shortened without reducing the operational safety:

- ▶ Shorten the rope on the rope drum fixed point, see section „Shortening the rope“.

3.7 Checking the control rope for distortions

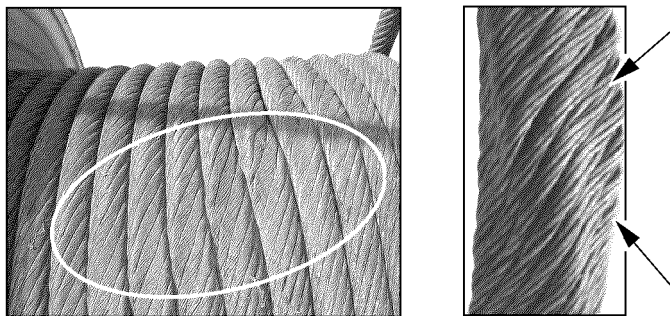

Fig.114002: Distortion on control ropes

- ▶ Check the first rope layer of the control rope for crushed areas and distortions.

When distortions are present:

- ▶ Have the rope checked by **expert personnel for crane rope inspection**.

3.8 Lubricating the rope



WARNING

Missing lubrication!

Functional problems. Inner and outer corrosion.

- ▶ Lubricate the rope regularly.
- ▶ Make sure that the rope is lubricated all around.
- ▶ Select manual or automatic lubrication procedures.

NOTICE

Too much or incorrect lubricant!

Excessive soiling. Wear on rope, on rope pulley and on winch. Recognition of take down criteria is impeded.

- ▶ Use lubricant, which is compatible with the rope and the original lubricant.

- ▶ Do **not** clean the rope with solvents or cleaners.
- ▶ Clean the rope solely with a wire hand brush.

Areas, which must be lubricated especially well are bending zones on winch and rope pulleys.

- ▶ Lubricate the rope.

3.9 Removing broken wires

NOTICE

Broken wires!

Damage of other components in crane operation, for example rope pulleys and compensation pulleys.

- ▶ Remove broken wires.

Make sure that the following prerequisite is met:

- Suitable pliers are on hand.

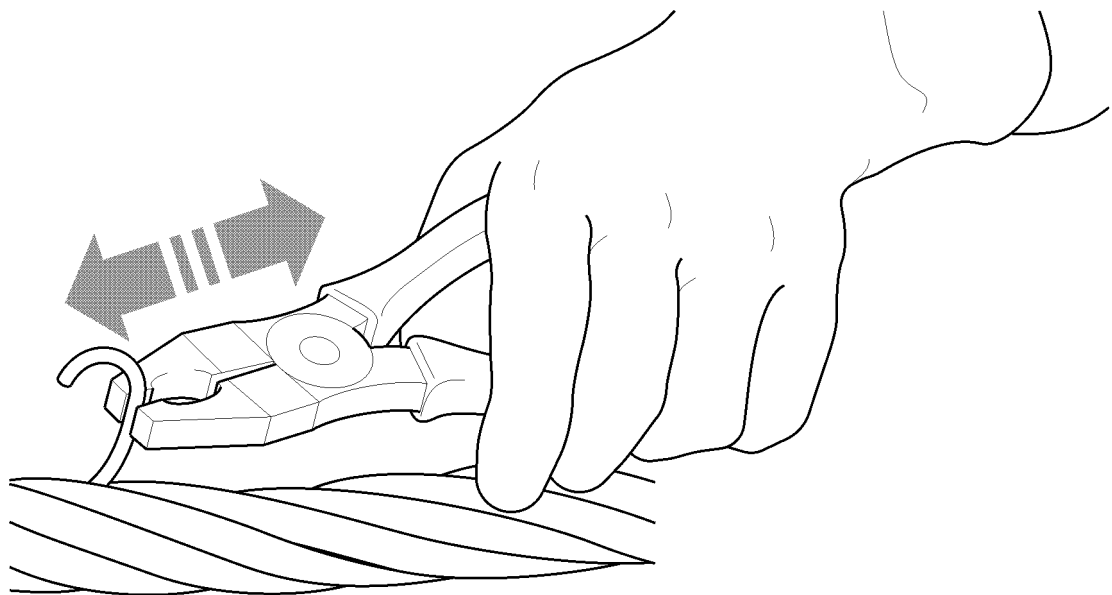

Fig.120979: Remove broken wire

- ▶ Grasp the wire on the upper end with pliers. Bend the wire back and forth until the wire breaks off in the braid valley.

The position of a broken wire is important for subsequent inspection. Individual broken wires are counted and are recorded later in the evaluation for withdrawal from service.

- ▶ Document the position of the broken wires in the crane record. Inspection checklist, see chapter 8.04.

3.10 Turning an extremely rotation-resistant hoist rope out



WARNING

Damage of rope due to incorrect procedure!

- ▶ Use extreme caution for the following procedures.
- ▶ Observe the following instructions exactly.

The cause for the turn-in of the hook block can have various reasons.

Check the crane for the following peculiarities:

- Scrub marks: Are hoist rope scrub marks present on the crane components? If scrub marks are present, check the hoist rope run and correct it.
- Rope pulleys: Did the groove diameter become too small?
 - Groove diameter dimensional stability must be present.
 - If this is not the case, the rope pulley must be replaced.
- Rope lubrication: Has the hoist rope been sufficiently lubricated? If the rope surface is dry, the hoist rope must be re-lubricated.

If the crane does not display other peculiarities, the hoist rope must be spun out.

The following sections describe two methods of how to spin out the hoist rope. The methods must be applied in the described sequence.

3.10.1 Spinning out with single strand reeving

- ▶ Reeve in the single strand hoist rope.
- ▶ Extend the boom to the maximal boom length and hook height.
- ▶ Lower hooks to approximately 1 m above the ground and allow the hoist rope to spin out.
- ▶ With an empty hook block, carry out one complete hoist cycle.
- ▶ Lower the hook again to approximately 1 m above the ground and allow the hoist rope to spin out again.
- ▶ Reeve the number of strands of hoist rope carefully and spin free where the twisting of the hook block is largest.
- ▶ Distribute the spin out to the entire rope length: Run at least two entire hoist cycles at maximum boom length and hook height.



Note

When the hook block continues to turn in:

- ▶ Spin the rope out, see section „Spinning out by turning the hook block out“.

3.10.2 Spinning out by turning out the hook block

Make sure that the following prerequisite is met:

- The hook block is reeved with the number of strands where the twisting is the largest.
- ▶ Extend the boom completely and lower the hook block.
- ▶ Attach a load of approximately 10 % of the nominal rope pull on the hook block.

Before lifting the load, a helper must rotate the twisted hook block to a straight position by hand until the rope strands no longer touch each other.

- ▶ Continue to turn the hook block by one entire turn.

Result:

- The rope strands touch again.

NOTICE

The hook block turns back under load in a straight position!

When the hook block turns back in a straight position:

- ▶ Release the hook block.
-
- ▶ Hold the hook block in the prescribed position until the load lifts off the ground.
 - ▶ Move the load until approximately 15 m before the uppermost hook position of the completely extended boom.
 - ▶ Lower load and set it down.

3.11 Renewing the pretension of hoist ropes

**WARNING**

Lacking pretension of the rope on the winch!

Excessive rope wear in the lower spooling layers, gap formation, rope cutting in.

When the lower rope layers on the winch are hardly used or **not**:

- ▶ Renew the pretension in the entire rope regularly.

Make sure that the following prerequisites are met:

- A reeving is selected where the entire rope length can be spooled.
- Clean spooling pattern on the drum at spooling.

**Note**

Recommendation!

- ▶ The rope application is the most economical when the entire rope length is utilized.

When only a part of the rope length is used for a longer period of time:

- ▶ Use a proportionally shorter rope.
-
- ▶ Spool the rope out until three safety coils.
 - ▶ Spool the rope up with a rope tensile force of 10 % of the maximum rope tensile force.

3.12 Shortening the rope

**WARNING**

Distortions and mechanical damage!

Operational safety significantly disturbed, uneven load distribution within the rope.

- ▶ Have the manufacturer check if the distorted and damaged area can be severed.

Visible form changes often occur localized or in short rope sections.

When a safe operation of the rope is ensured, a distorted and damaged area can be severed.

To shorten the rope there are different prerequisites:

- Rope shows flattenings
- Broken wires occur solely within the area of the rope end connection, the remaining rope is undamaged

**DANGER**

Minimum number of remaining coils on the winch fallen below!

Rope releases or rips off, falling load. Death, severe injury, property damage.

- ▶ Make sure, after shortening the rope that **at least three remaining coils** remain on the winch in all working positions of the crane.

Make sure that the following prerequisite is met:

- The rope was shortened by authorized and trained expert personnel.

Multi layer spooling: When the rope on the fixed point on the winch is shortened by half the winch diameter, then the service life of the rope increases significantly.

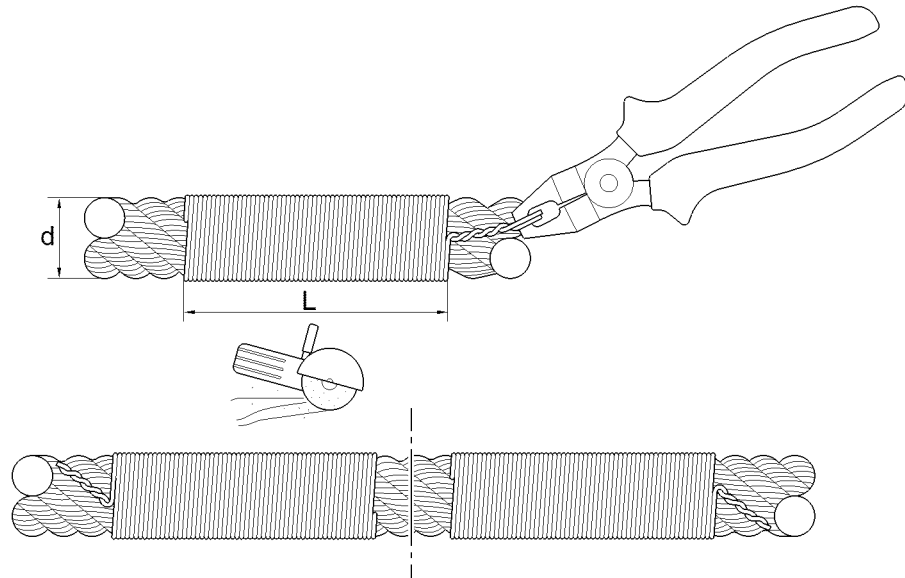

Fig.120972: Tie the rope before shortening it

d Rope nominal diameter

L Length of tie, at least 2d

The length of the tie **L** must be at least 2 times the rope nominal diameter (2d).

The shortening of the rope in this section applies to a single layer rope. On rotation-resistance, parallel roped ropes it may be necessary to tie several times to prevent the rope from jumping open when it is cut.

- ▶ Tie the rope on both sides with wire.
- ▶ Twist the end of the wire with the pliers to prevent them from releasing.



WARNING

Danger of injury due to flying sparks!

- ▶ Wear safety glasses and safety gloves.
- ▶ Separate the rope vertically to the rope axis.
- ▶ Fasten the end connections on the rope according to the manufacturer's instructions.
- ▶ Remove the tie on both ends of the separation from the rope.

Empty page!

LWE/LR 1600-2-008/18109-09-02/en

7.06 Fill quantities, lubrication schedule

1	Fill quantities	3
2	Lubrication schedule	7

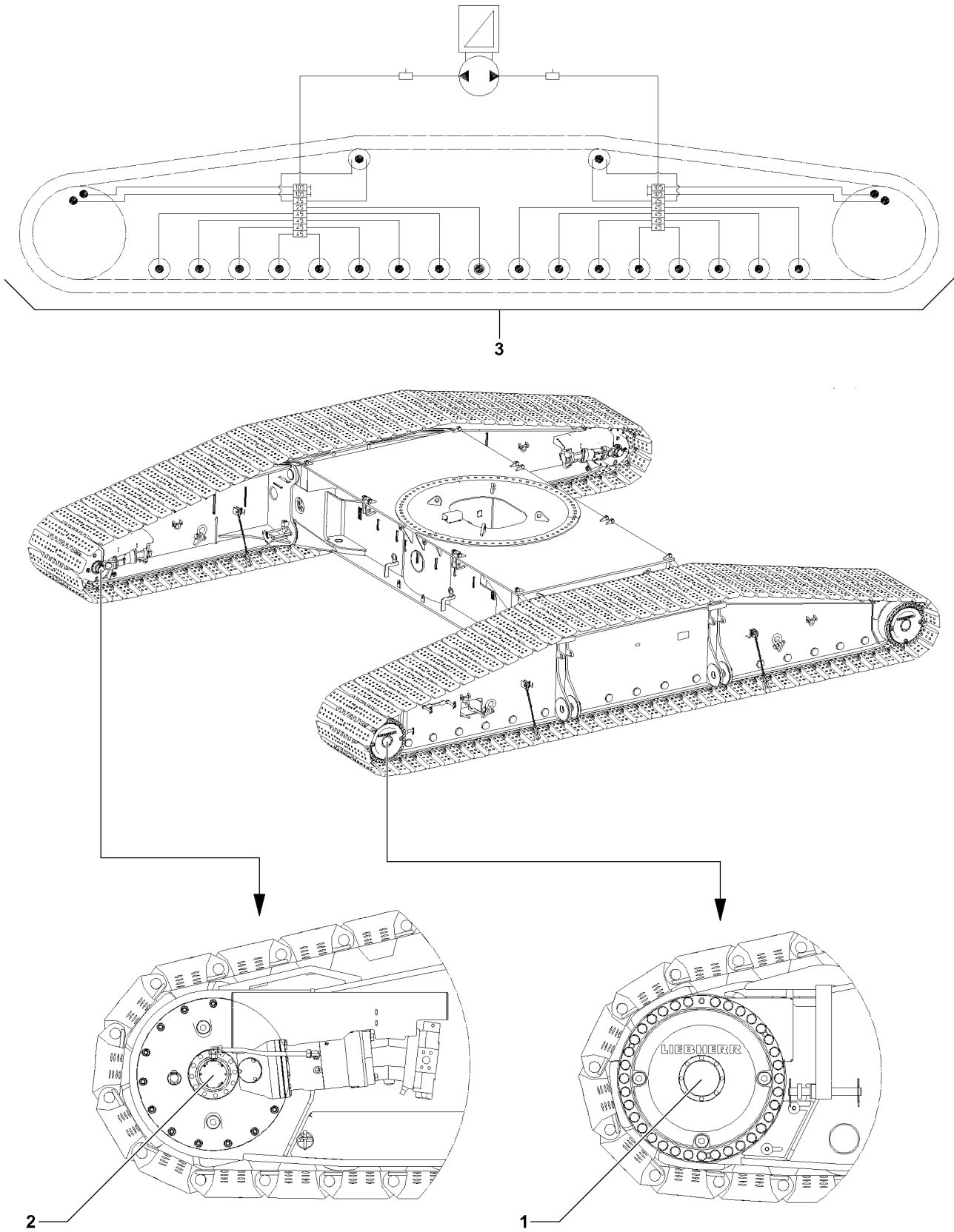

Fig.108919

LWE/LR 1600-2-008/18109-09-02/en

1 Fill quantities

1.1 Fill quantities for crawler chassis

The specified fill quantities (change quantities) are orientation values. The marks on the dipsticks, inspection ports and sight gauges are decisive for filling.

NOTICE

Danger of property damage!

► Do not mix synthetic oils with mineral oils!

Position	Components	Fill quantity
1	Planetary gear	35.0 l
2	Miter gear with brake	10.0 l
3	Central lubrication system	2.5 kg

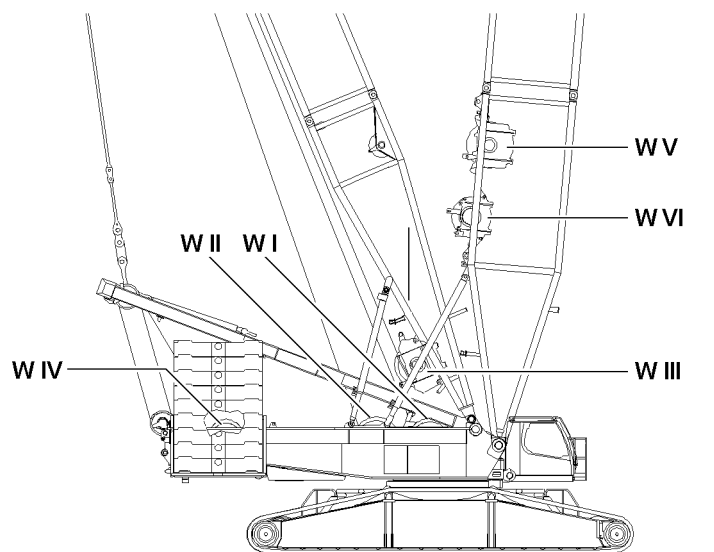
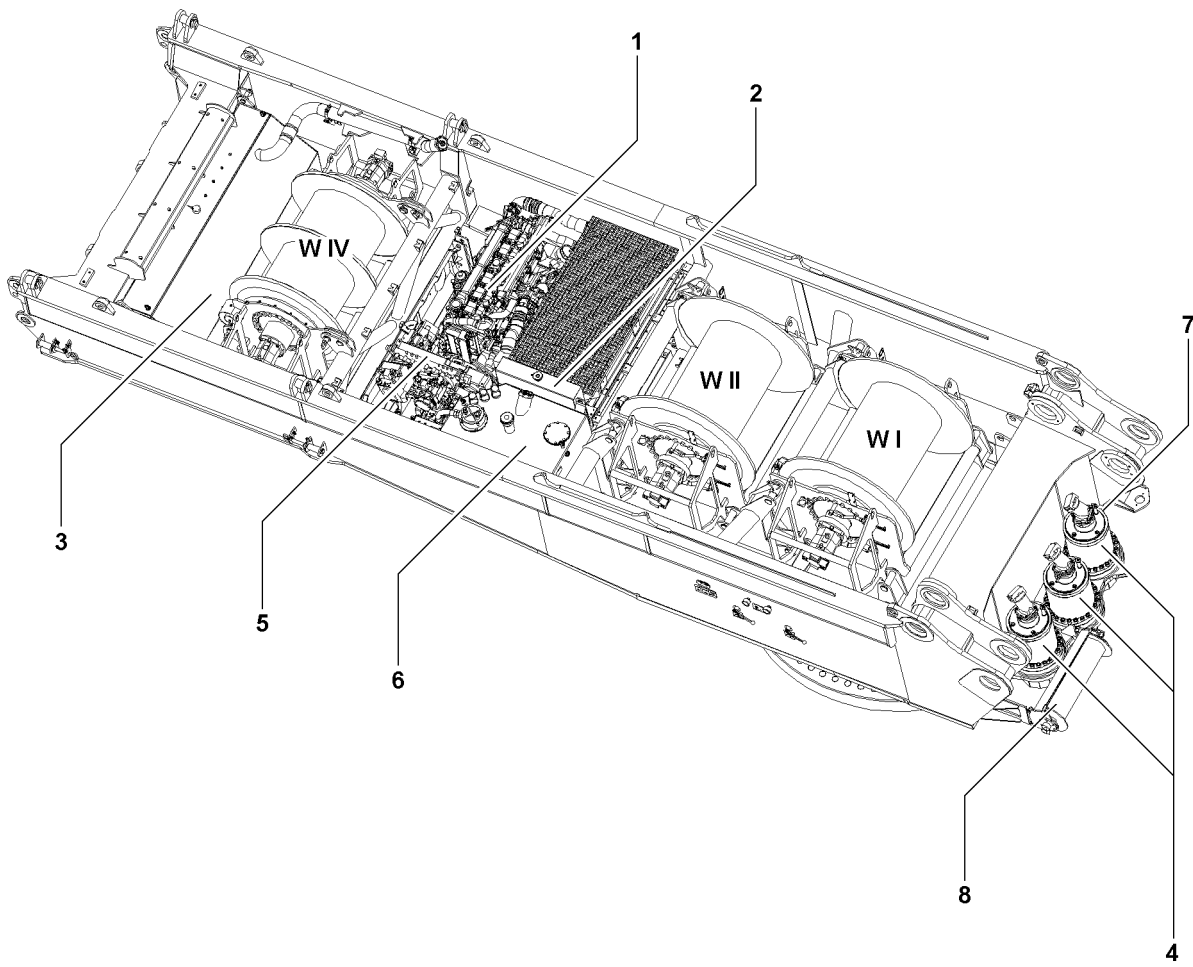

Fig.108922

LWE/LR 1600-2-008/18109-09-02/en

1.2 Fill quantities crane superstructure

The specified fill quantities (change quantities) are orientation values. The marks on the dipsticks, inspection ports and sight gauges are decisive for filling.

NOTICE

Danger of property damage!

► Do not mix synthetic oils with mineral oils!

Position	Components	Fill quantity
1	Diesel engine	37.0 l
2	Cooling system	76.0 l
3	Fuel tank	1485.0 l
4	Slewing gear	23.0 l
5	Pump distributor gear	15.0 l
6	Hydraulic oil tank ¹	565.0 l
7	Central lubrication system	4.0 kg
8	Assembly winch	0.4 l
W I	Winch W I	15.0 l
W II	Winch W II	15.0 l
W III	Winch W III	15.0 l
W IV	Winch W IV (double winch)	2 x 16.0 l
W V	Winch W V	15.0 l
W VI	Winch W VI (Type 2 with rope diameter 25 mm)	17.0 l
W VI	Winch W VI (Type 1 with rope diameter 28 mm)	20.0 l

¹ When the oil level is checked, all hydraulic cylinders must be retracted. The oil level must be in the center of the sight gauge.

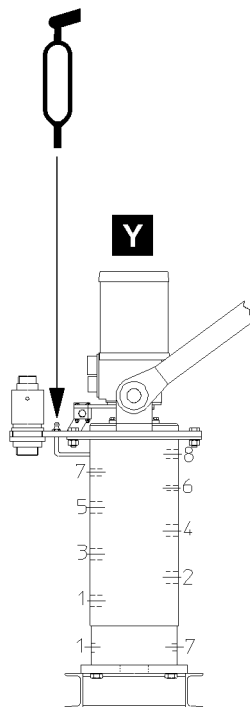
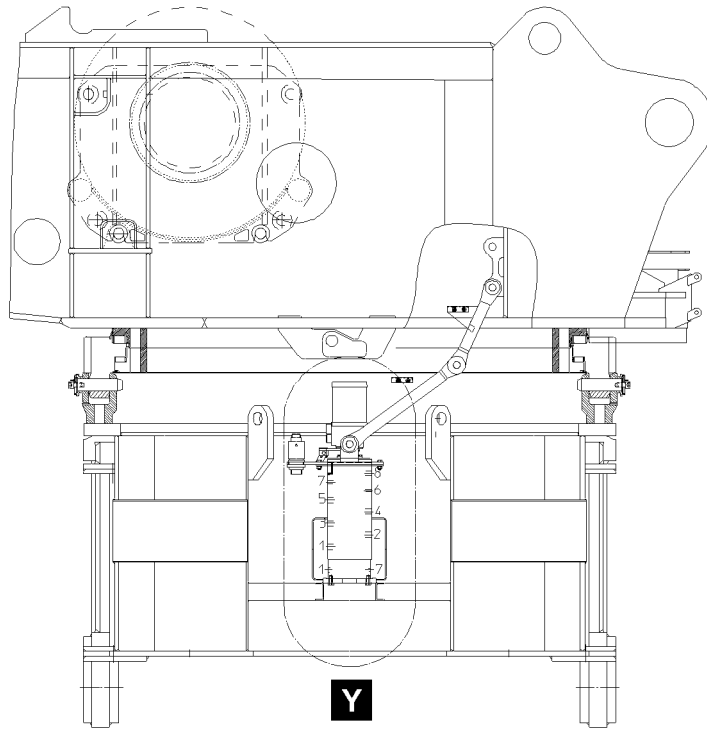

Fig.108151

LWE/LR 1600-2-008/18109-09-02/en

2 Lubrication schedule

2.1 Lubrication schedule - Crawler chassis

2.1.1 Rotary connection

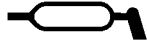

Fig.107729



Note

► The lube points are marked with this icon.

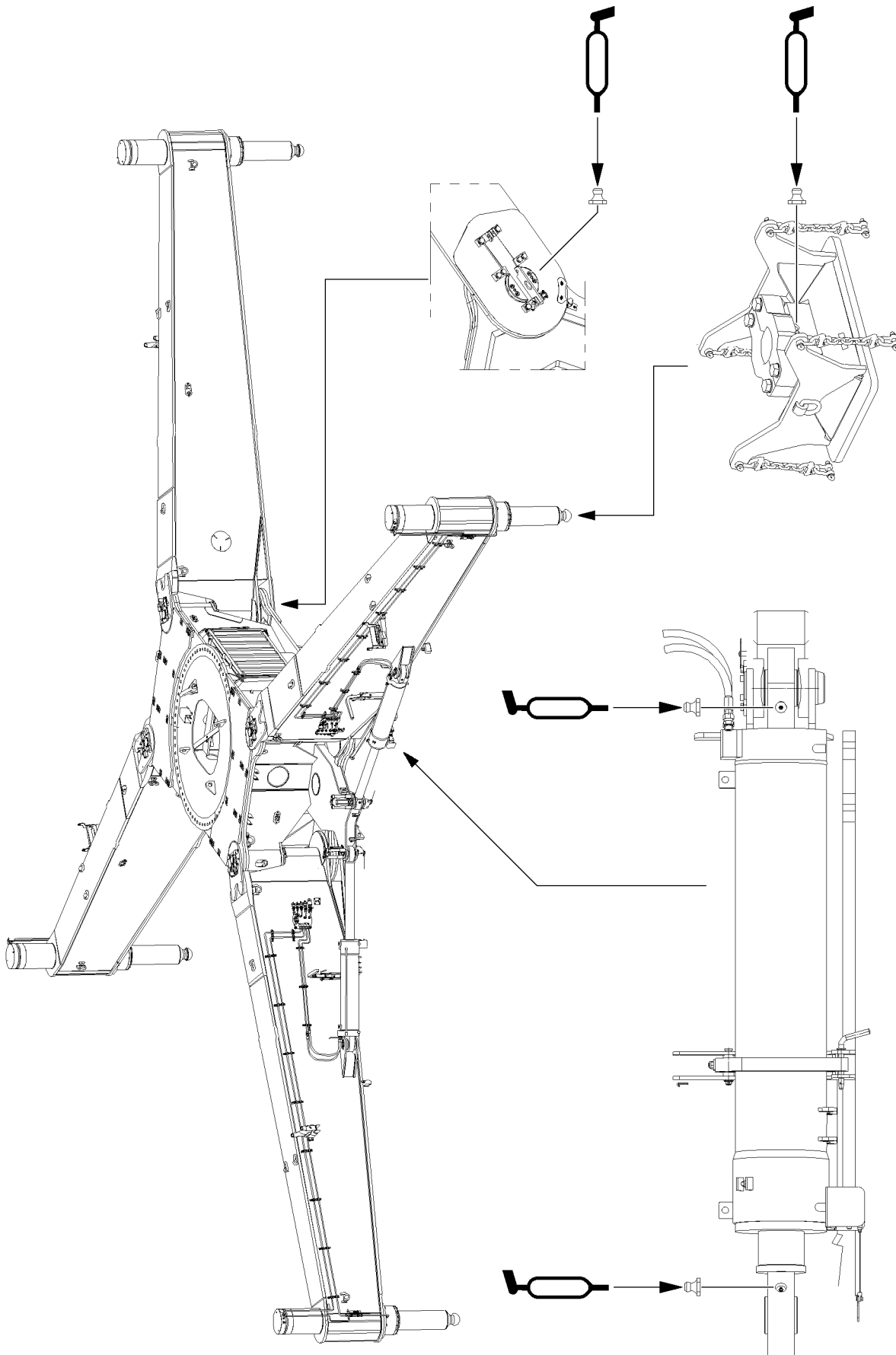

Fig.108964

LWE/LR 1600-2-008/18109-09-02/en

2.2 Lubrication schedule for crane support narrow crawler

2.2.1 Crane support

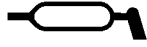

Fig.107729



Note

► The lube points are marked with this icon.

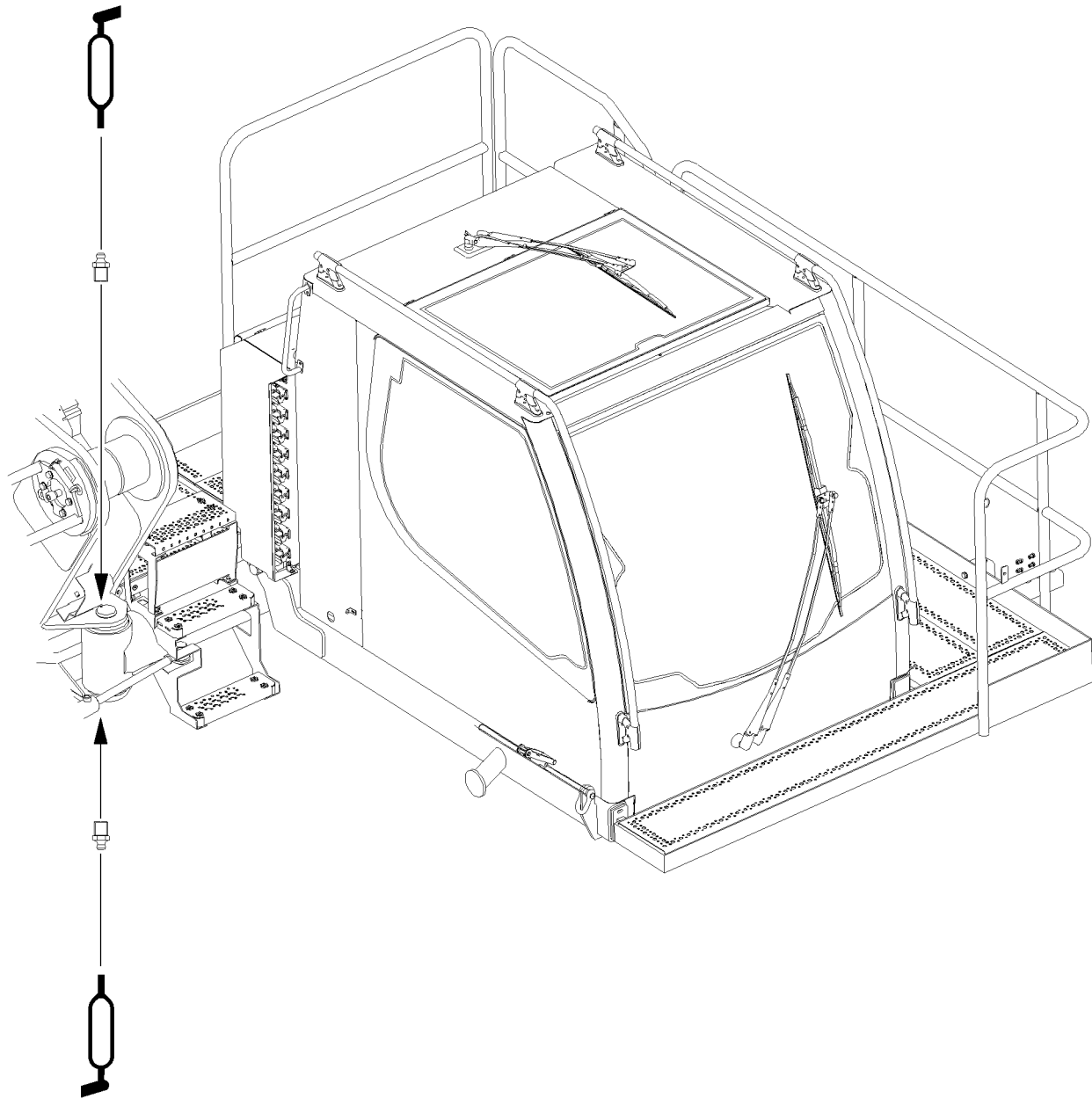

Fig.108995

LWE/LR 1600-2-008/18109-09-02/en

2.3 Lubrication schedule for crane superstructure

2.3.1 Swing arm crane operator's cab

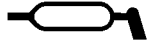

Fig.107729



Note

► The lube points are marked with this icon.

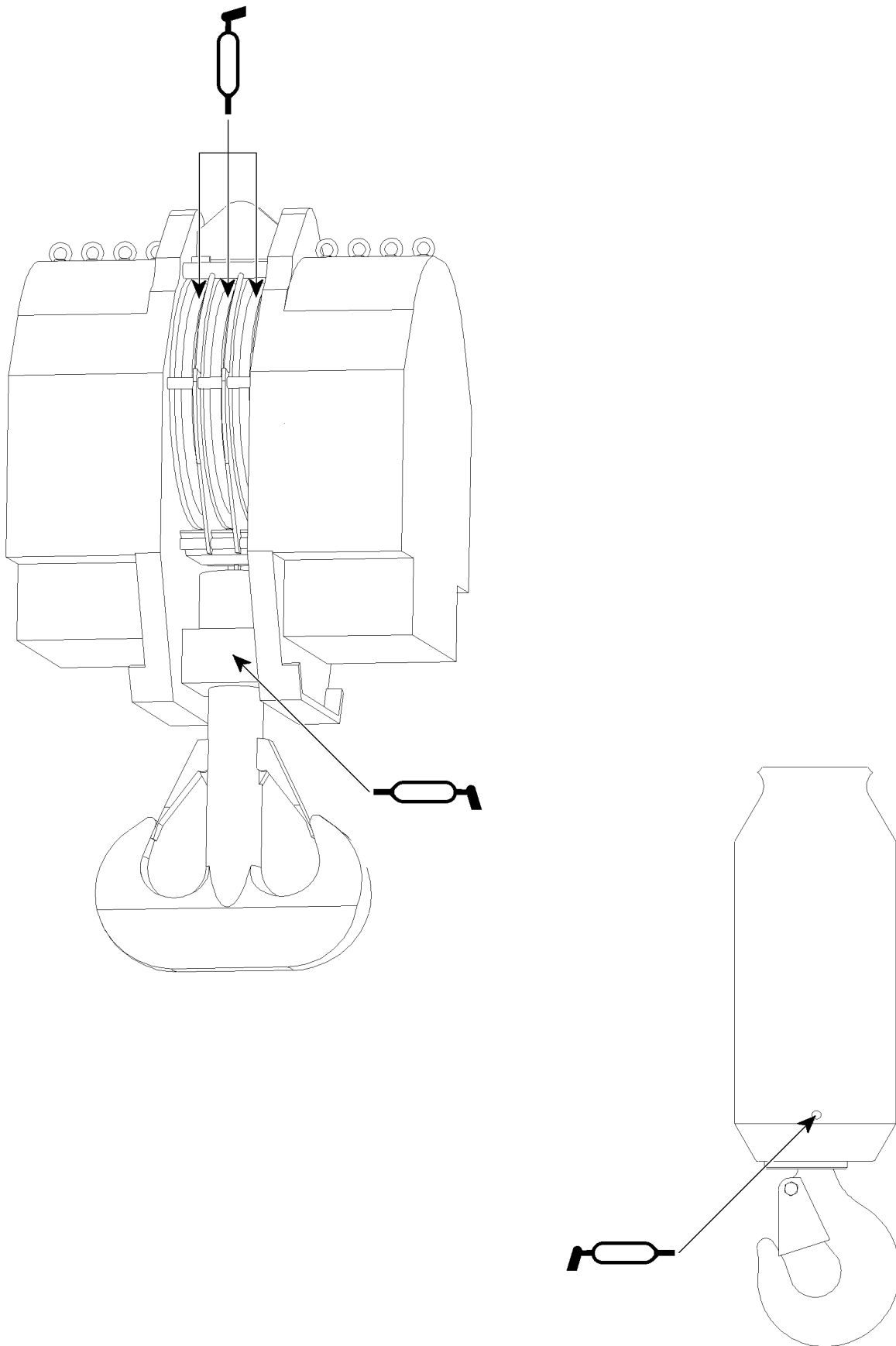

Fig.108145

2.4 Lubrication schedule - Equipment

2.4.1 Hook block / load hook

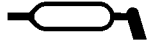

Fig.107729



Note

► The lube points are marked with this icon.

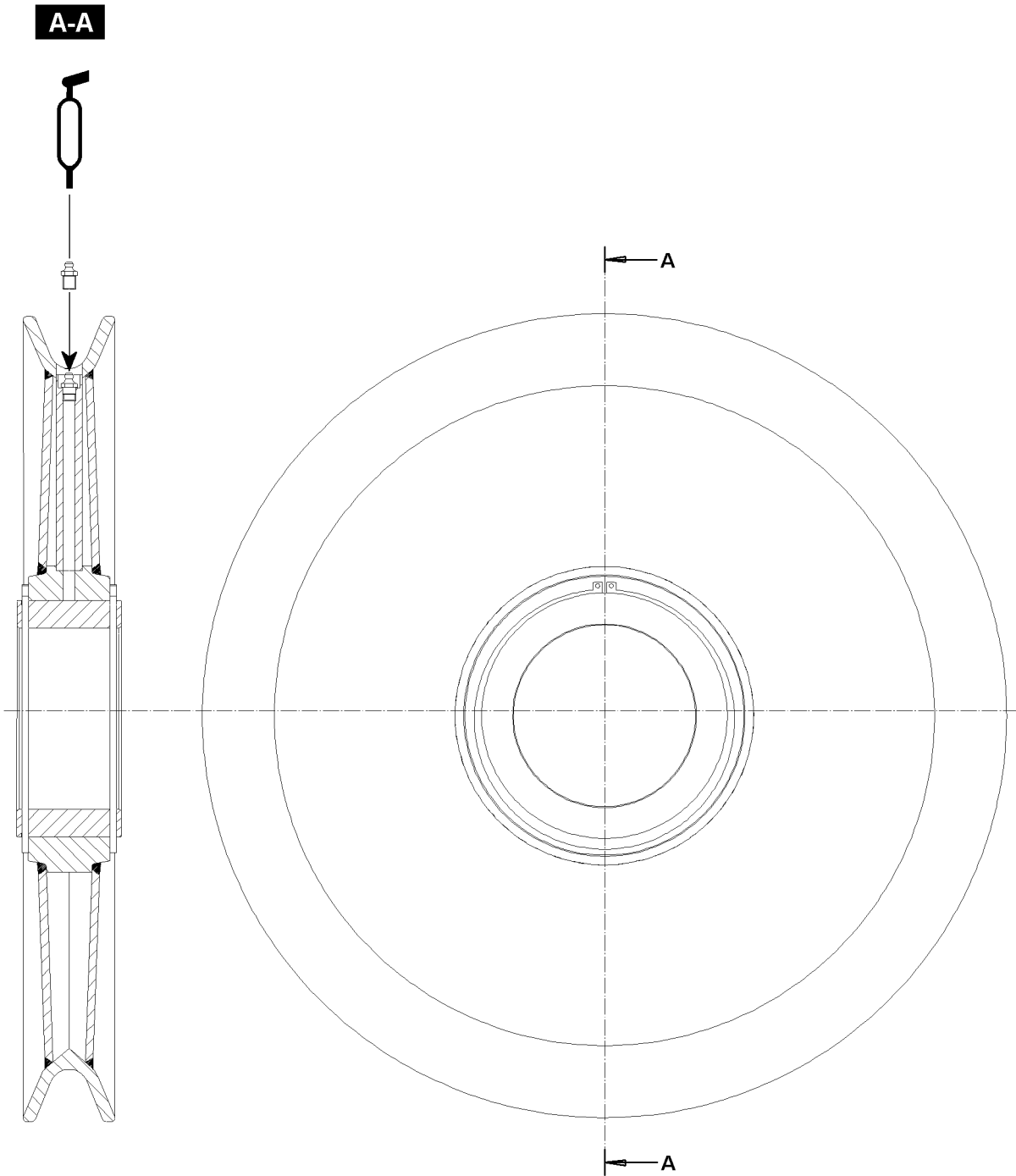

Fig.108928

2.4.2 Rope pulley

**Note**

- ▶ The rope pulley shown in this chapter is only an example and can deviate in type and version from other rope pulleys. The lubrication schedule is generally valid for all rope pulleys.
-



Fig.107729

**Note**

- ▶ The lube points are marked with this icon.
-

Empty page!

LWE/LR 1600-2-008/18109-09-02/en

7.07 Service fluids and lubricants

1	Specified service fluids and lubricants for Liebherr cranes	3
---	---	---

3

LWE/LR 1600-2-008/18109-09-02/en

Fig.195219

LWE/LR 1600-2-008/18109-09-02/en

1 Specified service fluids and lubricants for Liebherr cranes

No.	Crane components	Ambient temperature for driving and crane operation	
		-20 °C to +50 °C	-40 °C to +30 °C
1.1	Diesel engine with Exhaust aftertreatment US Tier 4, EU-Stage IV LMB D936 A7-04, D944 A7-04, D946 A7-04, D9508 A7-04 MTU 6R 1000 Euro V ECE R.49, K LMB D936 A7-50, D946 A7-50, D9508 A7-50	LWE Id. No.: 10871536 Liebherr Motoroil 5W-30 SAE 5W-30 and ACEA E6 or: SAE 10W-40 and ACEA E6 Observe the instructions of the engine manufacturer	LWE Id. No.: 10871536 Liebherr Motoroil 5W-30 SAE 5W-30 and ACEA E6 or: SAE 10W-40 and ACEA E6 Observe the instructions of the engine manufacturer Below -20 °C with pre-heating
		Note: To improve the cold start ability of the diesel engine at an ambient temperature below -10 °C , we recommend the use of Liebherr Motoroil 5W-30, LWE-Id no.: 10871536	
1.2	Diesel engine with Exhaust aftertreatment US Tier 4 interim, EU-Stage III B LMB D936 A7 SCR, D934 A7 SCR, D856 A7 SCR, D9508 A7 SCR MTU/Mercedes Benz OM 906, OM 926	LWE Id. No.: 10663796 Liebherr Motoroil 10W-40 low ash SAE 10W-40 low ash and ACEA E6 Observe the instructions of the engine manufacturer	LWE Id. No.: 11100934 Liebherr Motoroil 5W-30 low ash SAE 5W-30 low ash and ACEA E6 Observe the instructions of the engine manufacturer Below -20 °C with pre-heating
		Note: To improve the cold start ability of the diesel engine at an ambient temperature below -10 °C , we recommend the use of Liebherr Motoroil 5W-30 low ash, LWE-Id no.: 11100934	
1.3	Diesel engine without Exhaust aftertreatment US Tier 3, EU-Stage IIIA such as 1.2 or optionally also LMB D936 A6, D934 A6, D846 A7, D9508 A7 MTU/Mercedes Benz OM 906	LWE Id. No.: 861005308 Liebherr Motoroil 10W-40 SAE 10W-40 and ACEA E4 Observe the instructions of the engine manufacturer	LWE Id. No.: 10871536 Liebherr Motoroil 5W-30 SAE 5W-30 and ACEA E4 Observe the instructions of the engine manufacturer Below -20 °C with pre-heating
		Note: To improve the cold start ability of the diesel engine at an ambient temperature below -10 °C , we recommend the use of Liebherr Motoroil 5W-30, LWE-Id no.: 10871536	

No.	Crane components	Ambient temperature for driving and crane operation	
		-20 °C to +50 °C	-40 °C to +30 °C
1.4	Diesel engine without Exhaust aftertreatment Power band H and I ECE R.96 LMB D936 A7-03, D944 A7-03, D946 A7-03, D9508 A7-03	LWE Id. No.: 10871536 Liebherr Motoroil 5W-30 SAE 5W-30 and ACEA E4 or: SAE 10W-40 and ACEA E4 Observe the instructions of the engine manufacturer	LWE Id. No.: 10871536 Liebherr Motoroil 5W-30 SAE 5W-30 and ACEA E4 or: SAE 10W-40 and ACEA E4 Observe the instructions of the engine manufacturer Below -20 °C with pre-heating
		Note: To improve the cold start ability of the diesel engine at an ambient temperature below -10 °C , we recommend the use of Liebherr Motoroil 5W-30, LWE-Id no.: 10871536	
1.5	Diesel engine without Exhaust aftertreatment US Tier 2, EU-Stage II Cummins QSK 23	LWE Id. No.: 861005308 Liebherr Motoroil 10W-40 SAE 10W-40 and Cummins Engineering Standard CES 20078, 20077, 20076, 20075, 20071 SAE 10W-40 and API CI-4, CH-4, CF-4 SAE 10W-40 and ACEA E7, E5, E3, E2 Observe the instructions of the engine manufacturer	LWE Id. No.: 10871536 Liebherr Motoroil 5W-30 SAE 5W-30 and Cummins Engineering Standard CES 20078, 20077, 20076, 20075, 20071 SAE 5W-30 and API CI-4, CH-4, CF-4 SAE 5W-30 and ACEA E7, E5, E3, E2 Observe the instructions of the engine manufacturer Below -20 °C with pre-heating
		Note: To improve the cold start ability of the diesel engine at an ambient temperature below -10 °C , we recommend the use of Liebherr Motoroil 5W-30, LWE-Id no.: 10871536	
2	Drive axle with differentials, planetary gear and installed distributor gear	LWE Id. No.: 861901008 Liebherr Gear Hypoid 90 EP SAE 90 and API GL 5	LWE Id. No.: 10425142 Liebherr Syntogear Plus 75W-90 SAE 75W-90 and API GL 5
3	Axle drive ZF DK-7	LWE Id. No.: 861901008 Liebherr Gear Hypoid 90 EP ZF TE-ML 05	LWE Id. No.: 10425142 Liebherr Syntogear Plus 75W-90 ZF TE-ML 05
4.1	Vehicle distributor gear KESSLER VG 1800, VG 2400, VG 2550, VG 2600, VG 2700, VG 3750, VG 3751 W 3750, W 3751	LWE Id. No.: 861901008 Liebherr Gear Hypoid 90 EP SAE 90 and API GL 5	LWE Id. No.: 10425142 Liebherr Syntogear Plus 75W-90 SAE 75W-90 and API GL 5

No.	Crane components	Ambient temperature for driving and crane operation	
		-20 °C to +50 °C	-40 °C to +30 °C
4.2	Vehicle distributor gear with PTO for crane drive KESSLER VG 2700 with PTO VG 3751 with PTO	LWE Id. No.: 10425142 Liebherr Syntogear Plus 75W-90 SAE 75W-90 and API GL 5	LWE Id. No.: 10425142 Liebherr Syntogear Plus 75W-90 SAE 75W-90 and API GL 5
4.3	Vehicle distributor gear ZF Passau, STEYR PUCH VG 1200, VG 1600, VG 2000, VG 3800	LWE Id. No.: 861901008 Liebherr Gear Hypoid 90 EP ZF TE-ML 19	LWE Id. No.: 10425142 Liebherr Syntogear Plus 75W-90 ZF TE-ML 19
5	Miter gear for crane drive	LWE Id. No.: 10425142 Liebherr Syntogear Plus 75W-90 SAE 75W-90 and API GL 5	LWE Id. No.: 10425142 Liebherr Syntogear Plus 75W-90 SAE 75W-90 and API GL 5
6	Offset gear (drop box) ZF Passau, STEYR PUCH	LWE Id. No.: 861901008 Liebherr Gear Hypoid 90 EP ZF TE-ML 19	LWE Id. No.: 10425142 Liebherr Syntogear Plus 75W-90 ZF TE-ML 19
7.1	Pump distributor gear filled with mineral gear oil	LWE Id. No.: 861901008 Liebherr Gear Hypoid 90 EP SAE 90 and API GL 5	LWE Id. No.: 10425142 Liebherr Syntogear Plus 75W-90 SAE 75W-90 and API GL 5
7.2	Pump distributor gear filled with synthetic gear oil	LWE Id. No.: 861901208 Liebherr Gear PG 220 CLP PG 220, DIN 51517-3 WARNING: May not be mixed with other oils!	LWE Id. No.: 10664125 Liebherr Gear PG 150 CLP PG 150, DIN 51517-3 WARNING: May not be mixed with other oils!
7.3	Pump distributor gear LTC 1055-3.1	LWE Id. No.: 10425142 Liebherr Syntogear Plus 75W-90 SAE 75W-90 and API GL 5	LWE Id. No.: 10425142 Liebherr Syntogear Plus 75W-90 SAE 75W-90 and API GL 5
8.1	Powershift transmission ZF torque converter WG 120, WG 150, WG 180, WG 181, WG 200, WG 201	LWE Id. No.: 861005308 Liebherr Motoroil 10W-40 ZF TE-ML 03	LWE Id. No.: 861900608 Liebherr Hydraulic-Gear ATF ZF TE-ML 03 Below -20 °C run until warm according to the operating instructions

LWE/LR 1600-2-008/18109-09-02/en

No.	Crane components	Ambient temperature for driving and crane operation	
		-20 °C to +50 °C	-40 °C to +30 °C
8.2	Powershift transmission ZF torque converter WG 251* ZF ERGOPOWER WG 210, WG 260, WG 310 * also for ambient temperatures above -10 °C	LWE Id. No.: 861900608 Liebherr Hydraulic-Gear ATF ZF TE-ML 03	LWE Id. No.: 861900608 Liebherr Hydraulic-Gear ATF ZF TE-ML 03 Below -20 °C run until warm according to the operating in- structions
9	Powershift transmission CLARK	LWE Id. No.: 861005308 Liebherr Motoroil 10W-40 SAE 10W-40 and ACEA E4	LWE Id. No.: 861900608 Liebherr Hydraulic-Gear ATF ATF Dexron II D and ALLI- SON C4 Below -20 °C run until warm according to the operating in- structions
10	Offset gear (drop box) ALLISON	LWE Id. No.: 861005308 Liebherr Motoroil 10W-40 SAE 10W-40 and API CF, ACEA E4	LWE Id. No.: 861900608 Liebherr Hydraulic-Gear ATF ALLISON C4 Below -20 °C run until warm according to the operating in- structions
11.1	Automatic transmission ALLISON CLBT 740, CLBT 750, CLBT 754, CLBT 755 HT 755, HD 4560	LWE Id. No.: 861900608 Liebherr Hydraulic-Gear ATF ALLISON C4	LWE Id. No.: 861903708 CASTROL Transynd ALLISON C4 Below -20 °C run until warm according to the operating in- structions
11.2	Automatic transmission ZF	LWE Id. No.: 861900608 Liebherr Hydraulic-Gear ATF ZF TE-ML 14	LWE Id. No.: 861900608 Liebherr Hydraulic-Gear ATF ZF TE-ML 14 Below -20 °C run until warm according to the operating in- structions
12.1	Automatic transmission ZF AS-Tronic ZF TC-Tronic (basic gear) ZF TC-Tronic HD (basic gear)	LWE Id. No.: 10218305 ZF-Ecofluid M ZF TE-ML 02	LWE Id. No.: 10218305 ZF-Ecofluid M ZF TE-ML 02 below -20 °C preheat gear ac- cording to operating instructi- ons

No.	Crane components	Ambient temperature for driving and crane operation	
		-20 °C to +50 °C	-40 °C to +30 °C
12.2	Automatic transmission ZF TraXon ZF TraXon Torque (basic gear)	LWE Id. No.: 10218305 ZF-Ecofluid M ZF TE-ML 02	LWE Id. No.: 10218305 ZF-Ecofluid M ZF TE-ML 02 below -20 °C preheat gear according to operating instructions
13.1	Torque converter coupling ZF TC HD	LWE Id. No.: 10218305 ZF-Ecofluid M ZF TE-ML 02	LWE Id. No.: 10218305 ZF-Ecofluid M ZF TE-ML 02 below -20 °C preheat gear according to operating instructions
13.2	Torque converter coupling ZF TC 2	LWE Id. No.: 861900608 Liebherr Hydraulic-Gear ATF ZF TE-ML 14	LWE Id. No.: 861900608 Liebherr Hydraulic-Gear ATF ZF TE-ML 14
14	Transmission ZF ECO-Split	LWE Id. No.: 10218305 ZF-Ecofluid M ZF TE-ML 02	LWE Id. No.: 10218305 ZF-Ecofluid M ZF TE-ML 02
15	Slewing gear	LWE Id. No.: 861901208 Liebherr Gear PG 220 CLP PG 220, DIN 51517-3 WARNING: May not be mixed with other oils!	LWE Id. No.: 861901208 Liebherr Gear PG 220 CLP PG 220, DIN 51517-3 WARNING: May not be mixed with other oils!
16.1	Rope winch	LWE Id. No.: 861901208 Liebherr Gear PG 220 CLP PG 220, DIN 51517-3 WARNING: May not be mixed with other oils!	LWE Id. No.: 861901208 Liebherr Gear PG 220 CLP PG 220, DIN 51517-3 WARNING: May not be mixed with other oils!
16.2	Rope winch LR 13000	LWE Id. No.: 11000948 Liebherr Universal grease 9900 KPF2N-25, DIN 51502	LWE Id. No.: 11000948 Liebherr Universal grease 9900 KPF2N-25, DIN 51502
17	Winch of Telescopic boom guying	LWE Id. No.: 861901208 Liebherr Gear PG 220 CLP PG 220, DIN 51517-3 WARNING: May not be mixed with other oils!	LWE Id. No.: 861901208 Liebherr Gear PG 220 CLP PG 220, DIN 51517-3 WARNING: May not be mixed with other oils!
18.1	Crane hydraulics Crane chassis and crane superstructure Observe exceptions, see 18.2	LWE Id. No.: 861903508 Liebherr Hydraulic 37	LWE Id. No.: 10293807 Liebherr Hydraulic Plus Arctic

LWE/LR 1600-2-008/18109-09-02/en

No.	Crane components	Ambient temperature for driving and crane operation	
		-20 °C to +50 °C	-40 °C to +30 °C
18.2	Crane hydraulics Crane chassis and crane superstructure LTM 11200-9.1 LTR 11200 LR 13000, LR 11000, LR 1600/2, LR 1600/2-W LTC 1055-3.1	LWE Id. No.: 10293807 Liebherr Hydraulic Plus Arctic	LWE Id. No.: 10293807 Liebherr Hydraulic Plus Arctic
19	Brake system if hydraulically actuated	LWE Id. No.: 861000108 DOT 4 SAE J 1703e	LWE Id. No.: 861000108 DOT 4 SAE J 1703e
20	Clutch actuator	LWE Id. No.: 861000108 DOT 4 SAE J 1703e	LWE Id. No.: 861000108 DOT 4 SAE J 1703e
21	King pin bearing Gear shaft if not maintenance-free	LWE Id. No.: 861301308 Liebherr Special grease 9610 Plus KP2K-20, DIN 51502	LWE Id. No.: 10296825 Liebherr Universal grease Arctic KPFHC1N-60, DIN 51502
22.1	Glide and roller bearing roller bearing joint	LWE Id. No.: 861301308 Liebherr Special grease 9610 Plus KP2K-20, DIN 51502	LWE Id. No.: 10296825 Liebherr Universal grease Arctic KPFHC1N-60, DIN 51502
22.2	Rope pulley bearing	LWE Id. No.: 10296825 Liebherr Universal grease Arctic KPFHC1N-60, DIN 51502	LWE Id. No.: 10296825 Liebherr Universal grease Arctic KPFHC1N-60, DIN 51502
23	Central lubrication system	LWE Id. No.: 861301308 Liebherr Special grease 9610 Plus KP2K-20, DIN 51502	LWE Id. No.: 10296825 Liebherr Universal grease Arctic KPFHC1N-60, DIN 51502
24.1	Slewing ring connection Roller bearing	LWE Id. No.: 861301308 Liebherr Special grease 9610 Plus KP2K-20, DIN 51502	LWE Id. No.: 10296825 Liebherr Universal grease Arctic KPFHC1N-60, DIN 51502
24.2	Slewing ring connection LR 13000	LWE Id. No.: 11000948 Liebherr Universal grease 9900 KPF2N-25, DIN 51502	LWE Id. No.: 10296825 Liebherr Universal grease Arctic KPFHC1N-60, DIN 51502

No.	Crane components	Ambient temperature for driving and crane operation	
		-20 °C to +50 °C	-40 °C to +30 °C
25.1	Support plate with equalization	LWE Id. No.: 10877698 Loctite LB 8104 Silicone oil base WARNING: Do not use oils with another base!	LWE Id. No.: 10877698 Loctite LB 8104 Silicone oil base WARNING: Do not use oils with another base!
25.2	Glide shoes for cab guidance on vehicle frame LTC 1045-3.1 LTC 1050-3.1	LWE Id. No.: 861303608 Liebherr Telescope grease 9613 Plus KP2K-30, DIN 51502	LWE Id. No.: 861303608 Liebherr Telescope grease 9613 Plus KP2K-30, DIN 51502
26	Sliding beam Plastic glide bearing Beam for track adjustment	LWE Id. No.: 861303608 Liebherr Telescope grease 9613 Plus KP2K-30, DIN 51502	LWE Id. No.: 861303608 Liebherr Telescope grease 9613 Plus KP2K-30, DIN 51502
27.1	Telescopic boom Plastic glide bearing Corner guide top	LWE Id. No.: 861303608 Liebherr Telescope grease 9613 Plus KP2K-30, DIN 51502	LWE Id. No.: 861303608 Liebherr Telescope grease 9613 Plus KP2K-30, DIN 51502
27.2	Telescopic boom Outer glide bearing Lower shell Inner glide bearing (only during assembly)	LWE Id. No.: 861303308 Liebherr Special grease 1336 KP2K-30, DIN 51502 Spray grease	LWE Id. No.: 861303308 Liebherr Special grease 1336 KP2K-30, DIN 51502 Spray grease
27.3	Telescopic boom LTC 1045-3.1 LTM 1050-3.1	LWE Id. No.: 11651459 Bechem Berulub TCG 1 V	LWE Id. No.: 11651459 Bechem Berulub TCG 1 V
28	Boom lock	LWE Id. No.: 861301308 Liebherr Special grease 9610 Plus KP2K-20, DIN 51502	LWE Id. No.: 10296825 Liebherr Universal grease Arctic KPFHC1N-60, DIN 51502
29	Guide rail on Telescoping cylinder	LWE Id. No.: 861303308 Liebherr Special grease 1336 KP2K-30, DIN 51502 Spray grease	LWE Id. No.: 861303308 Liebherr Special grease 1336 KP2K-30, DIN 51502 Spray grease
30	Gear ring rotary connection Slewing gear drive pinion	LWE Id. No.: 861007708 RHS-Fluid OGPFOS-20, DIN 51502	LWE Id. No.: 861007708 RHS-Fluid OGPFOS-20, DIN 51502
31	Running rope	LWE Id. No.: 10173371 Liebherr WR-Lube SC Adhesive grease	LWE Id. No.: 10173371 Liebherr WR-Lube SC Adhesive grease

LWE/LR 1600-2-008/18109-09-02/en

No.	Crane components	Ambient temperature for driving and crane operation	
		-20 °C to +50 °C	-40 °C to +30 °C
32	Radiator fluid Diesel engine and heating system	LWE Id. No.: 10871121 Liebherr Antifreeze OS Mix Pre-mixed corrosion inhibitor / antifreeze WARNING: May not be diluted and / or mixed with other corrosion inhibitors / anti-freeze!	LWE Id. No.: 10871121 Liebherr Antifreeze OS Mix Pre-mixed corrosion inhibitor / antifreeze WARNING: May not be diluted and / or mixed with other corrosion inhibitors / anti-freeze!
33.1	Travel gears Crawler crane	see data tag	see data tag
33.2	Travel gears telescope crawler crane	see data tag	see data tag
34	Recovery winch	See the data tag and manufacturer's specifications	See the data tag and manufacturer's specifications
35	Recovery winch rope	See the manufacturer's specifications	See the manufacturer's specifications
36	Steering uncoupling LTC 1045-3.1 LTC 1050-3.1	LWE Id. No.: 10800345 Teflon Spray	LWE Id. No.: 10800345 Teflon Spray
37	Pin connections	LWE Id. No.: 11000948 Liebherr Universal grease 9900 KPF2N-25, DIN 51502	LWE Id. No.: 11000948 Liebherr Universal grease 9900 KPF2N-25, DIN 51502

7.15 Procedure in case of problems

1	Procedure to follow in case of a problem	3
2	Carrying out error diagnostics	9
3	Measures in clear problem cases	15
4	Measures for defective components	21

Fig.197077

LWE/LR 1600-2-008/18109-09-02/en

1 Procedure to follow in case of a problem

This chapter is supportive for the following questions:

- What to do in case of a problem?
- Which displays and component groups are relevant for error diagnostics?
- How can an error diagnostics be carried out?
- How to proceed in case of error messages of the LICCON computer system?
- Which measures are to be taken for defective components?
- Which measures are to be taken in clear problem cases?
- Which data is important for communication with Liebherr Service?



WARNING

Erroneous or insufficient repair!

If a crane is not properly or insufficiently repaired, then this can result in accidents!

Personnel can be killed or seriously injured!

This could result in property damage!

- ▶ The crane may only be repaired by authorized and trained expert personnel!



WARNING

Measures without the help of Liebherr Service!

Measures in case of a problem, which are carried out without consulting Liebherr Service can cause damage to the crane!

Personnel can be killed or seriously injured!

This could result in property damage!

- ▶ If problems remain or in case of error messages, consult Liebherr Service to determine the cause of the problem and further procedure.



WARNING

Problems with raised load!

If a crane is checked, diagnosed or repaired with a raised load, then there is a danger of accidents!

During accidents, personnel could be killed or seriously injured!

This could result in property damage!

- ▶ If possible, set the load down!
- ▶ If possible, place down the boom system!
- ▶ If the load cannot be set down and / or the boom system cannot be placed down, secure a wide-ranging danger zone!



Note

- ▶ The display illustrations in this chapter are only examples. The display values may differ depending on the crane. In addition, some illustrations show a display with multiple icons. In normal crane operation, an identical display may **not** appear on the LICCON monitors.

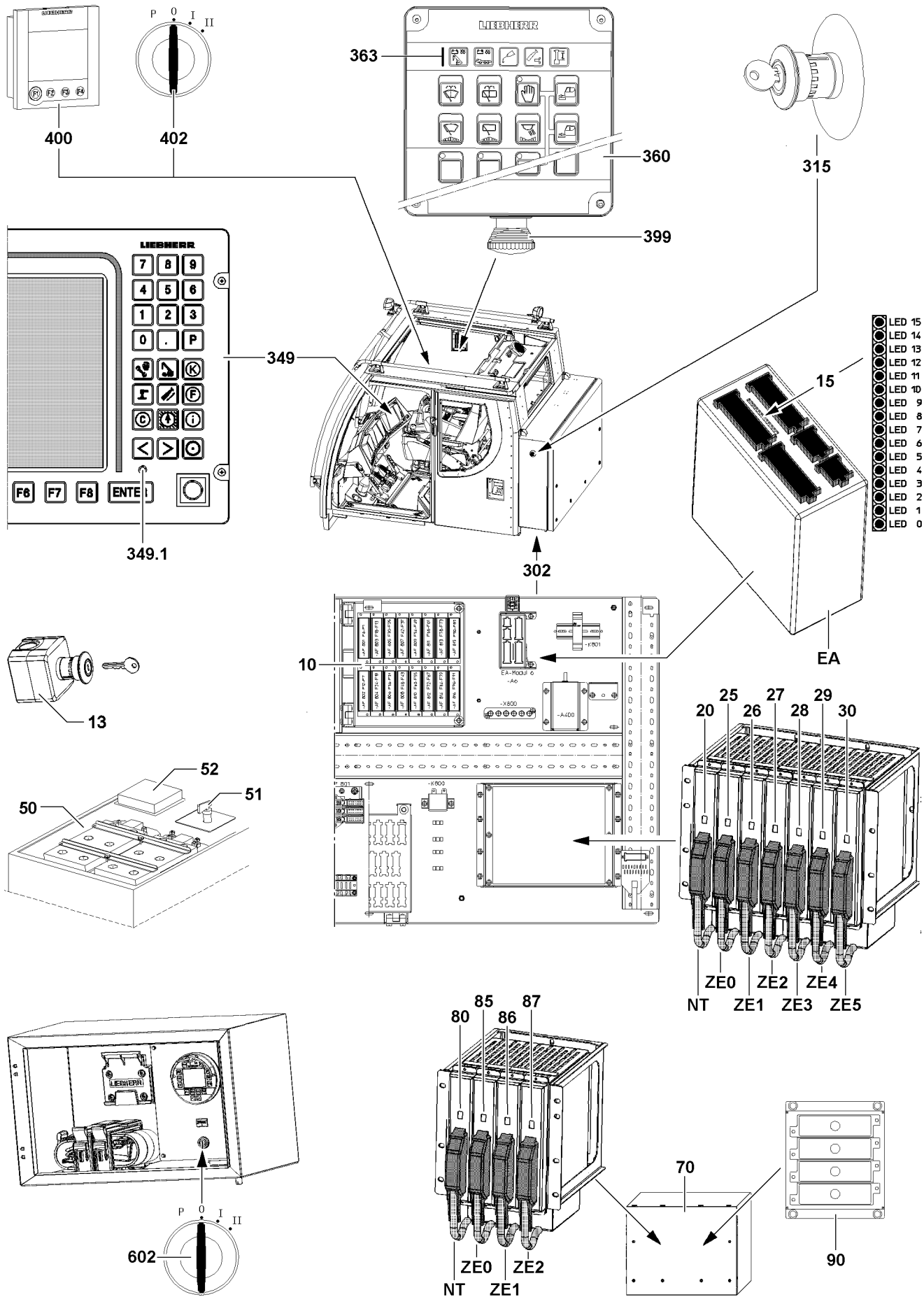

Fig.113281

LWE/LR 1600-2-008/18109-09-02/en

1.1 Overview of displays and component groups for error diagnostics

Various displays and component groups allow the crane driver:

- To localize errors.
- To prepare quicker and more precise communication with Liebherr Service.
- To diagnose and remedy errors with the help of the „Diagnostics operating instructions“.



Note

- ▶ If separate Operating instructions have been provided by the supplier as part of the scope of delivery for the crane, then it must be observed!

Position	Crane operator's cab
349	LICCON monitor
349.1	LED-display power supply LICCON monitor
360	Operating and control unit (BKE)
363	Indicator lights BKE
399	EMERGENCY STOP switch in BKE
400	Touch display
402	Ignition switch Crane operator's cab

Position	Crane general
10	Fuses in the control cabinet
13	EMERGENCY STOP switch* (illustration exemplary)
15	LED display I / O module
20	LED display power supply
25–30	LED displays CPU0 to CPU5
50	Battery box (illustration exemplary)
51	Mechanical battery master switch (if present - illustration exemplary)
52	Fuses Battery box (illustration exemplary)
302	Switch box
315	EMERGENCY STOP switch*
602	Ignition switch chassis (only narrow track crawler track)
EA	I / O module
NT	Power supply
CPU0-5	CPU 0 to 5

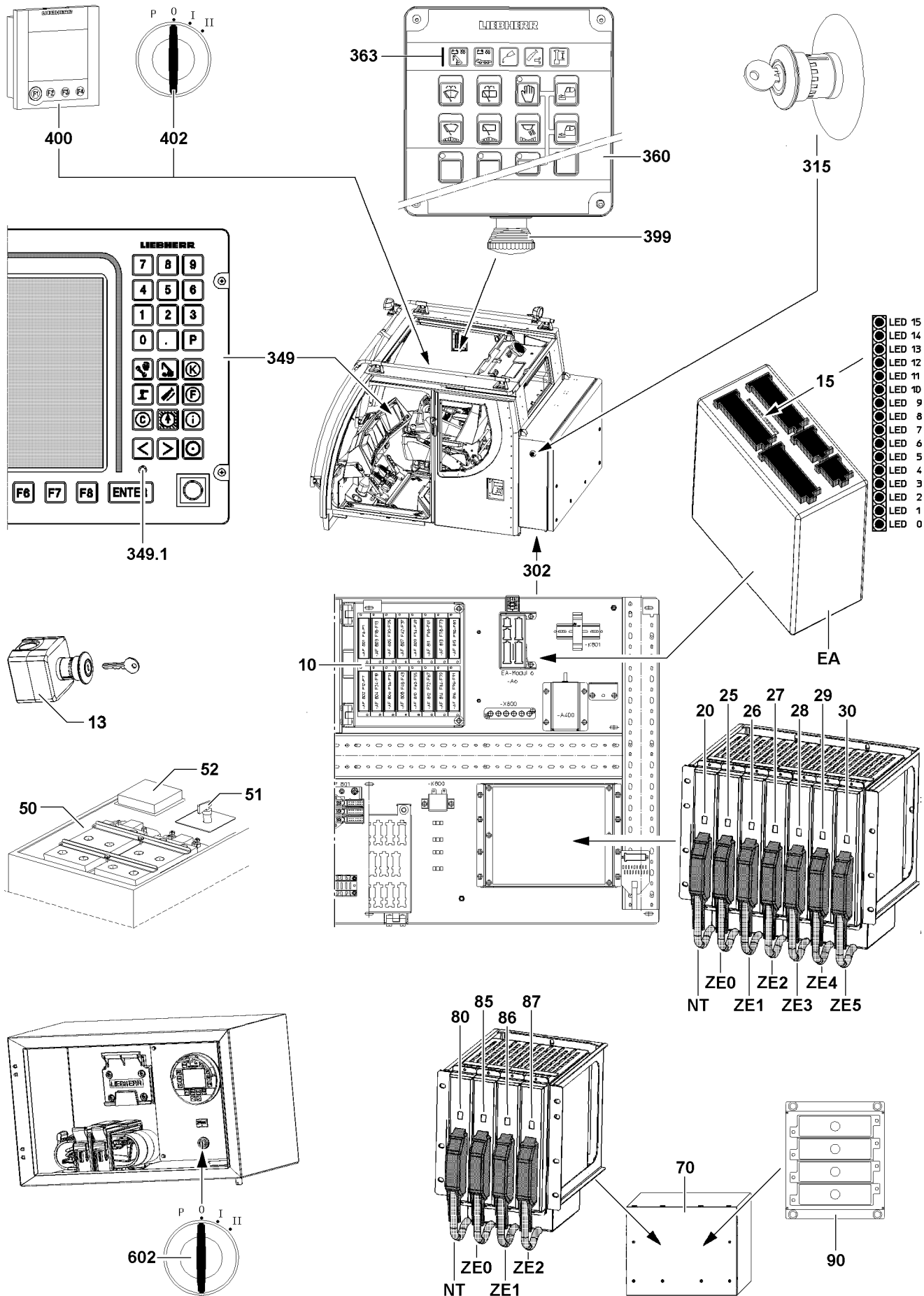

Fig.113281

LWE/LR 1600-2-008/18109-09-02/en

Position	Switch cabinet Ballast trailer* 70
NT	Power supply
CPU0	CPU 0
CPU1	CPU 1
CPU2	CPU 2
80	LED display power supply
85–87	LED displays CPU0 to CPU2
90	Fuses Switch cabinet (illustration exemplary)

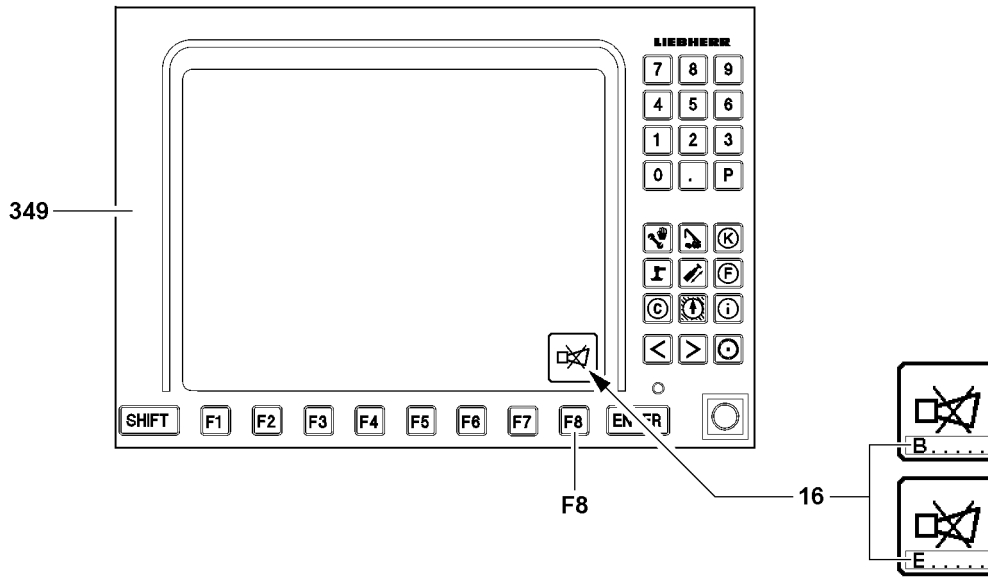

Fig.113283

1.2 Type of problem

Problems can be assigned to various error sources:

- Operating error / system error
 - Displayed by error messages
 - to be remedied by crane operator
- Errors on mechanics / components
 - To be remedied by crane operator / Liebherr Service.
- Combination of error sources
 - To be remedied by crane operator / Liebherr Service.



Note

Evaluation of error messages

- ▶ With the aid of the „LICCON Error Code Manual“ (LICCON error code list) and the Diagnostics manual, all error messages can be evaluated!

1.2.1 Error messages LICCON monitor

A distinction is made between two types

- Operating errors
 - Displayed in field **16** by error number / LEC: B.....
- System errors in LICCON computer system
 - Displayed in field **16** by error number / LEC: E.....

1.2.2 Error messages via LED on components

LED displays are on the following components:

- LED display I / O module
- LED display power supply
- LED display CPU

2 Carrying out error diagnostics

The crane is monitored:

- By the LICCON computer system for operating / system errors
- By indicator lights and control displays

If errors occur, error messages are issued and / or indicator lights light up.

Error messages appear:

- In LICCON monitor
- On I / O module, power supply (NT) or CPU

Indicator lights are located within view:

- In the Crane operator's cab
- On Components
- In the switch cabinets

**WARNING**

Risk of accident!

When carrying out the error diagnostics, there is a danger of accidents!

During accidents, personnel could be killed or seriously injured!

This could result in property damage!

- ▶ Take the crane out of service!
- ▶ In case of safety defects, secure the crane to prevent continued operation!
- ▶ The crane may only be inspected, diagnosed and repaired at a standstill and in shut down condition!
- ▶ Inspections, error diagnostics and repairs, for which the crane must be in operation are only permissible with extreme caution and constant visual and voice contact between all associated personnel!
- ▶ Inspections, error diagnostics and repairs may only be carried out by expert or trained personnel!
- ▶ For inspections, error diagnostics and repairs of electrical devices on the crane, power must be turned off and ensured to remain so for the duration of the work!
- ▶ Test operation after a repair must be made by the crane operator or in his presence!

**Note**

- ▶ Always observe error messages and illuminated indicator lights!
- ▶ For overview of indicator lights on the crane superstructure, see Crane operating instructions, chapter 4.01.
- ▶ For detailed procedure in case of error messages, see Diagnostics operating instructions.

Several possibilities exist for an error diagnostics:

- Without the help of Liebherr Service
- With the help of Liebherr Service: Error diagnostics by phone
- With the help of Liebherr Service: Remote diagnostics

2.1 Error diagnostics without the help of Liebherr Service

**WARNING**

Acting on your own authority!

If measures are carried out on your own authority in case of a problem, then this can result in damage to the crane!

Damage on the crane can cause erroneous functions and accidents!

Personnel can be severely injured or killed!

This could result in property damage!

- ▶ Observe and adhere to the notes and instructions in this chapter.
- ▶ Observe the Diagnostics operating instructions.
- ▶ In case of lack of clarity, contact Liebherr Service.
- ▶ If problems remain or in case of error messages, consult Liebherr Service to determine the cause of the problem and further procedure.

2.1.1 Error message in the LICCON monitor

Error messages are always shown in the LICCON monitor **349**, which also shows the set up screen and the crane operating screen.

After display of an error message in the LICCON monitor **349**:

- ▶ Press the function key **F8**.

Result:

- Acoustic warning is turned off.

- ▶ Press function key **F8** again.

Result:

- The error code with error text is displayed (error determination display in „test system“).

- In addition, all errors are listed in a separate error list (error text, cause, remedy).

In the error code, two different error types are differentiated:

- Operating errors - Error code starts with a „B“.
- System errors / application errors - Error code starts with an „E“.

If an error code starts with a „B“:

- ▶ Correct the operating error.

If an error code starts with an „E“:

- ▶ Call up the test system, see Diagnostics operating instructions.
- or**

In case of lack of clarity:

Consult Liebherr Service.

2.1.2 Calling up the test system



Note

- ▶ For calling up the test system, see Diagnostics operating instructions!

2.1.3 Problems on the mechanics / components of the crane

- ▶ Determine the damage and remedy it properly by using **original spare parts**.

2.1.4 Problems on pipes / hoses

Supply lines, return lines and control lines handle various media:

- Pneumatic pipes / hoses
- Hydraulic pipes / hoses
- Pipes / hoses for fluids and gases

- ▶ Determine the damage and remedy it properly by using **original spare parts**.

2.1.5 Problems in electrical connections of the crane

- If a component / component group does no longer react, then the electrical connections may be interrupted.

- ▶ Check the error messages.
- ▶ Check the plug connections.
- ▶ Check the electrical connections visually.

Problem remedy

The erection of the crane, for example after assembly on a new job site or with another equipment configuration, is not possible due to an error message?

- ▶ As the first step, make sure that all electrical connections have been made.
- ▶ Check if all sensors or dummy plugs with integrated electronic have been connected properly.

- ▶ Determine the damage and remedy it properly by using **original spare parts**.

or

In case of lack of clarity:

Observe the Diagnostics operating instructions.

or

Consult Liebherr Service.

2.2 Error diagnostics with the help of Liebherr Service

2.2.1 Which data is required by Liebherr Service?

If the assistance of Liebherr Service is required, always provide the following information:

- Crane type
- Crane number
- Complete error number and any error message displayed on the LICCON monitor
- For certain errors: LED displays of power supply **NT** and CPUs **ZE**
- Application conditions of crane
- Action during which the error occurs
- Possibly frequency of error

2.2.2 Error diagnostics by phone

If there is any lack of clarity, contact Liebherr Service to determine the cause of the problem and further procedure.

- ▶ Contact Liebherr Service.
- ▶ Observe and adhere to the notes and instructions given by Liebherr Service.

2.2.3 Remote diagnostics*

The remote diagnostics makes it possible for Liebherr Service to check Liebherr cranes from a remote location in case of problems.

Make sure that the following prerequisite is met:

- The crane is equipped with the optional Remote diagnostics*.
- ▶ Contact Liebherr service by phone.
- ▶ Follow the instructions given by Liebherr Service to set up the Remote diagnostics*.
- ▶ Keep the phone connection to Liebherr Service up during the Remote diagnostics*.

Empty page!

LWE/LR 1600-2-008/18109-09-02/en

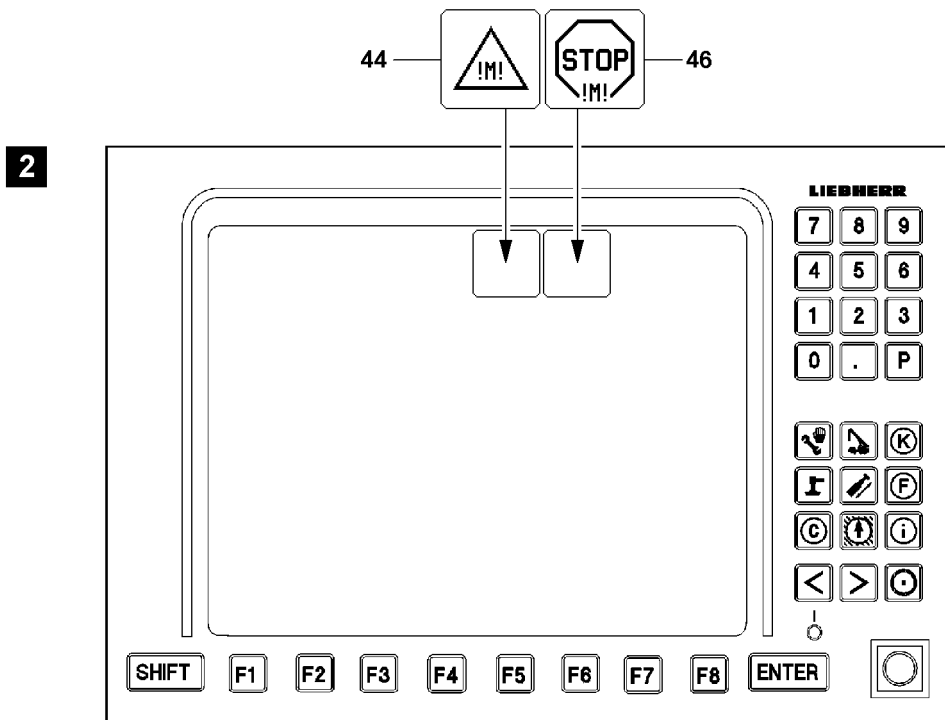
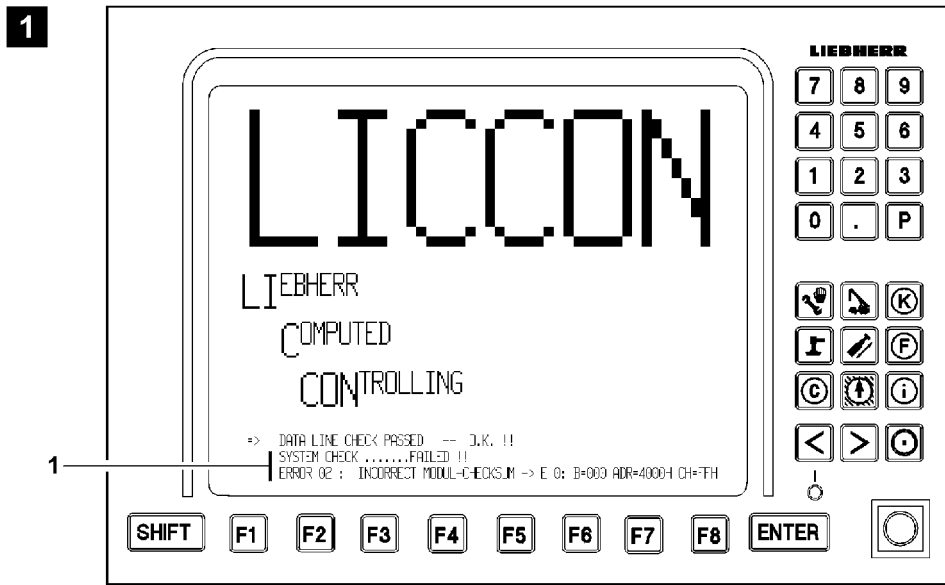

Fig.112959

LWE/LR 1600-2-008/18109-09-02/en

3 Measures in clear problem cases



Note

If a problem occurs, which is not described in this chapter:

- ▶ Contact Liebherr Service to determine the cause of the problem and further procedure.

3.1 Remediating temporary errors during system start



Note

- ▶ While the LICCON computer system starts, temporary error messages **1** can occur, see illustration **1**.

Errors, which occur temporarily, can have various causes, for example:

- Fluctuations in the power supply
- Loose connection in plug connections of electrical lines
- Error message can be a follow up error (of an already remedied error)
- ▶ Turn the LICCON computer system off and restart it after waiting for at least 5 s.
- ▶ Repeat this procedure up to three times (wait 2 min after 3 start attempts).

If the same error image appears several times:

- ▶ Call up the test system, see Diagnostics operating instructions.
- ▶ Contact Liebherr Service to determine the cause of the problem and further procedure.

3.2 Monitoring function reports a problem



Note

- ▶ For a detailed description of monitoring functions, see Crane operating instructions, chapter 4.02.

NOTICE

Danger of severe engine damage!

If the monitoring functions report a problem and / or warning occurrence, then you must react immediately and remedy the problem!

- ▶ React to problems and / or warning occurrences immediately and remedy the problem!
- ▶ If necessary, stop crane operation and turn the engine off!

The following alarm functions are indicated by blinking icons on the LICCON monitor (illustration **2**):

- **44** Advance warning - engine
- **46** Engine stop
- ▶ If an „Advance warning - engine“ **44** or an „Engine stop“ **46** is triggered, react immediately.
- ▶ In case of an Engine stop **46**, stop crane operation and turn the engine off.
- ▶ Find the cause and remedy it.

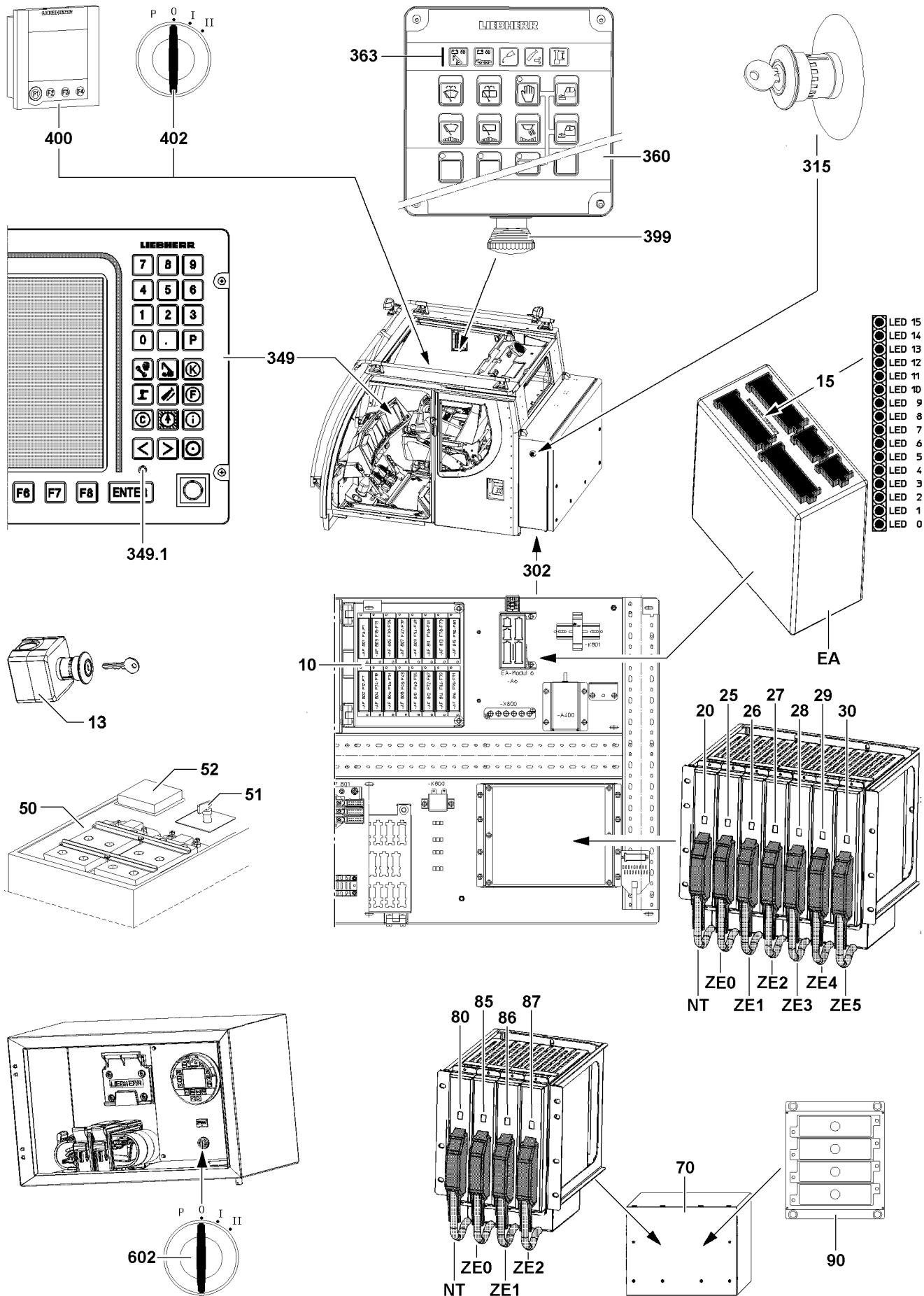

Fig.113281

LWE/LR 1600-2-008/18109-09-02/en

3.3 Engine does not start

Make sure that:

- There is sufficient fuel in the fuel tanks.
- There is sufficient voltage in the batteries.

3.3.1 Checking the EMERGENCY STOP switch

Make sure that no EMERGENCY STOP switch is actuated:

- EMERGENCY STOP switch* **13** (crane general)
- EMERGENCY STOP switch **315** (on switch cabinet)
- EMERGENCY STOP switch **399** in crane operator's cab

3.3.2 The engine does not start?

No EMERGENCY STOP switch is actuated:

- ▶ Turn the ignition off (turn ignition switch **402** or ignition switch **602** to position **0**).
- ▶ Try to start the engine via the ignition switch **402** or ignition switch **602**.

If the engine still cannot be started:

- ▶ Monitor and evaluate the indicator lights **363** on the BKE **360**, see Crane operating instructions, chapter 4.03, section „Start the engine and turn it off“.

If the error cannot be remedied:

- ▶ Contact Liebherr Service to determine the cause of the problem and further procedure.

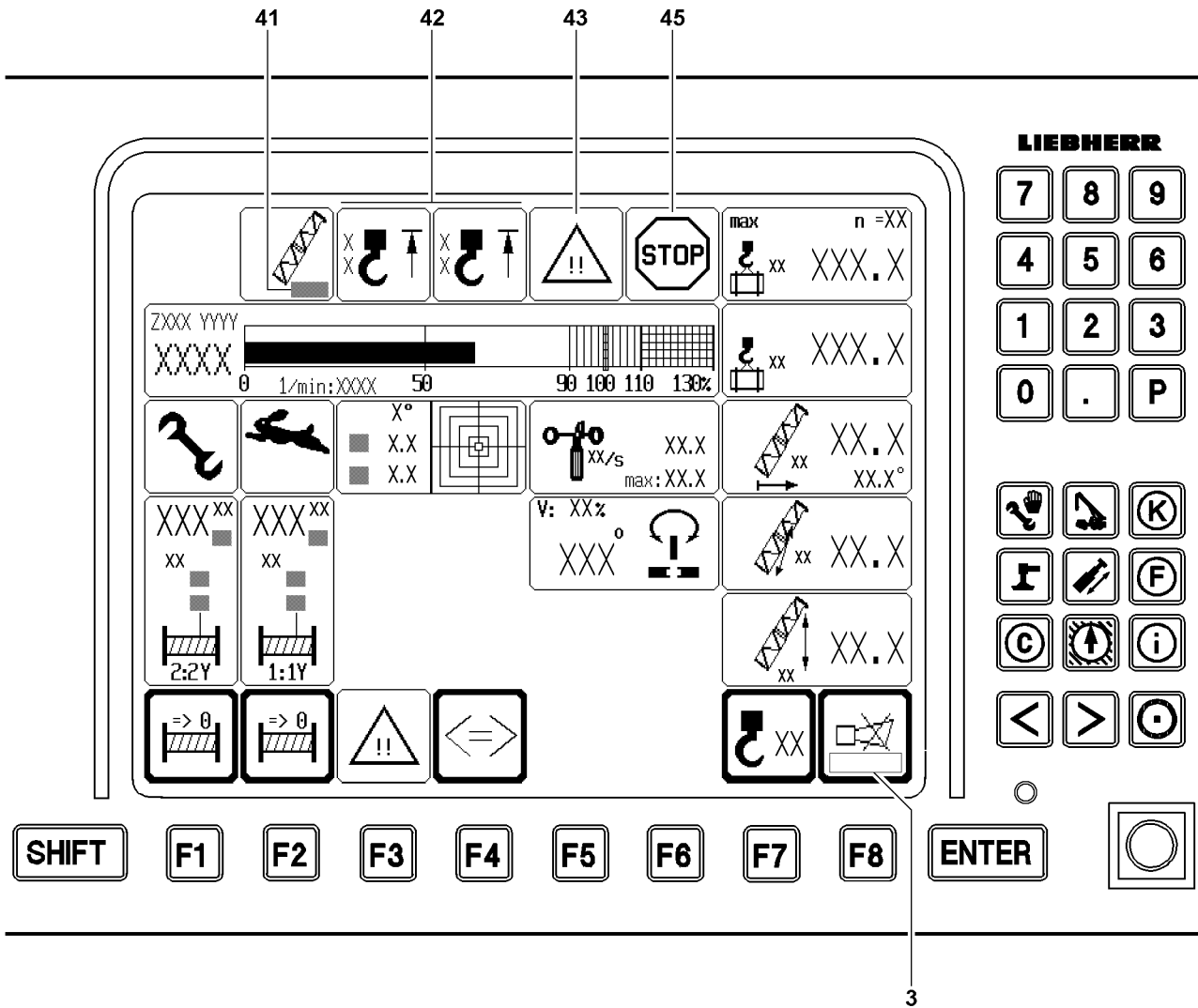

Fig.112964

3.4 LICCON monitor

3.4.1 Operating errors: Did an alarm function occur?



Note

- ▶ For procedure of shut off of crane movement, see Crane operating instructions, chapter 4.20.
 - ▶ For a detailed description of alarm functions, see Crane operating instructions, chapter 4.02.
 - ▶ In case of an alarm function, an error message **3** with LICCON error code appears at the same time.
-

The following alarm functions are indicated by blinking icons on the LICCON monitor:

- **41** Boom limitation
- **42** Hoist top limit switch
- **43** Advance warning
- **45** LMB Stop

The limit ranges of the crane movements are monitored by:

- Hoist limit switch
- Angle sensors
- Pressure sensors
- Pull test brackets (force test boxes)
- Wind sensor
- Inductive sensors

If the limit ranges for these sensors are exceeded, the crane movements are turned off (LMB-STOP).

- ▶ Correct the operating error.

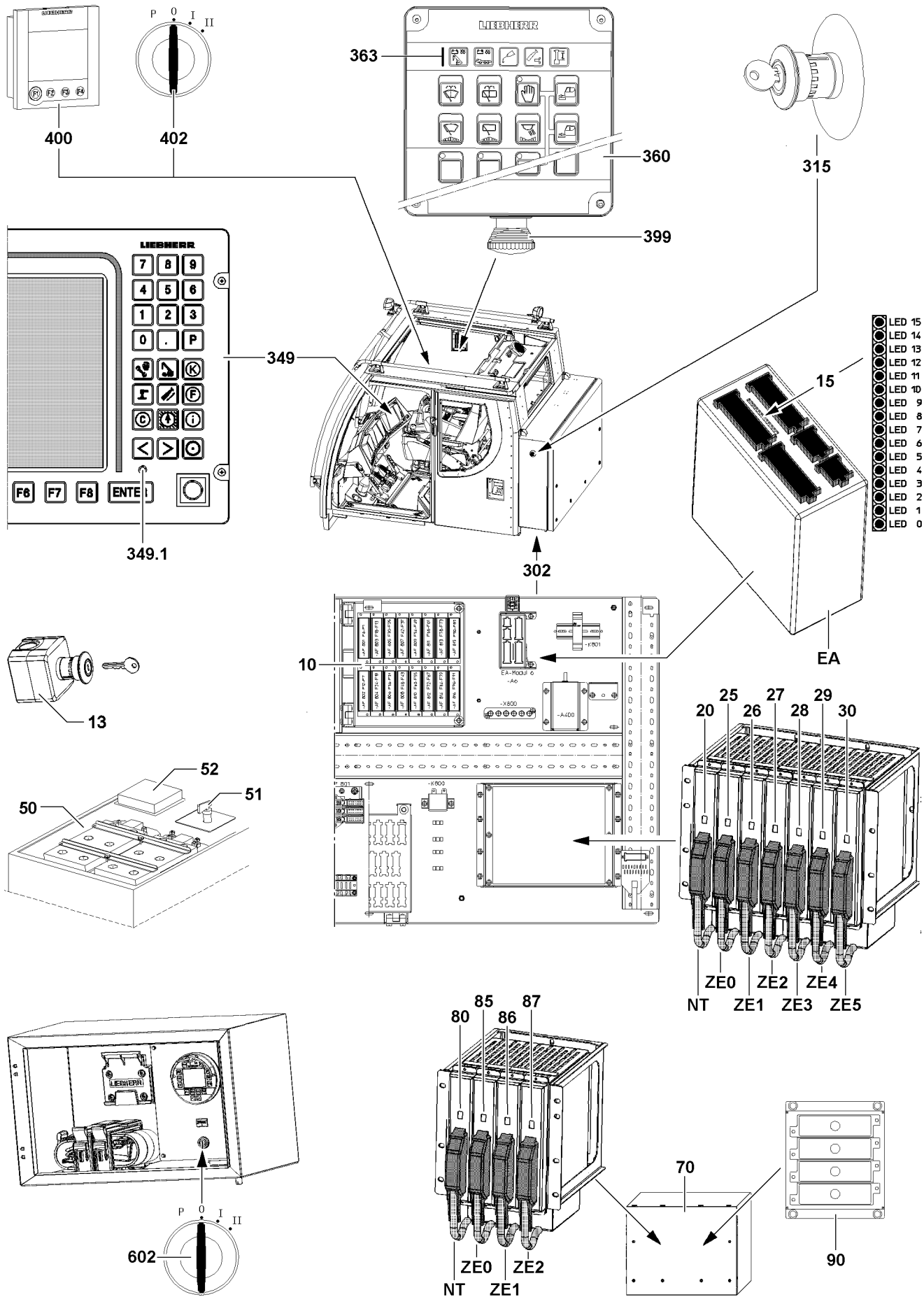

Fig.113281

LWE/LR 1600-2-008/18109-09-02/en

4 Measures for defective components



WARNING

Impairment of crane safety!

When using non-original spare parts, crane safety can be impaired!

Changed or manipulated components can fail!

Safety relevant components can malfunction!

The crane license as well as the manufacturer's warranty will become void!

Risk of accident!

Personnel can be severely injured or killed!

This could result in property damage!

- ▶ Use only original spare parts or spare parts approved by Liebherr Werk Ehingen!
- ▶ Leave installed original parts unchanged!

Make sure that the following prerequisites are met:

- Error diagnostics has been carried out.
- Defective component has been determined.

4.1 Failure of hydraulic, electric or engine



Note

If the crane is equipped with the optional „Hydraulic emergency control*“, then the crane can be taken down in case of failure of the crane hydraulic, crane electric or crane engine.

- ▶ For hydraulic emergency control, see Crane operating instructions, chapter 6.05.

- ▶ Take the crane down with the hydraulic emergency control* and repair it, contact Liebherr Service if necessary.

or

If the crane has no „Hydraulic emergency control*“:

Secure the crane and danger zone wide-ranging.

- ▶ Fix the crane, contact Liebherr Service if necessary.

4.2 Defective power supply (NT)

- ▶ Replace the defective power supply (NT) with a functioning power supply (NT).



Note

- ▶ For instruction of replacement of a defective power supply (NT), see Diagnostics operating instructions.

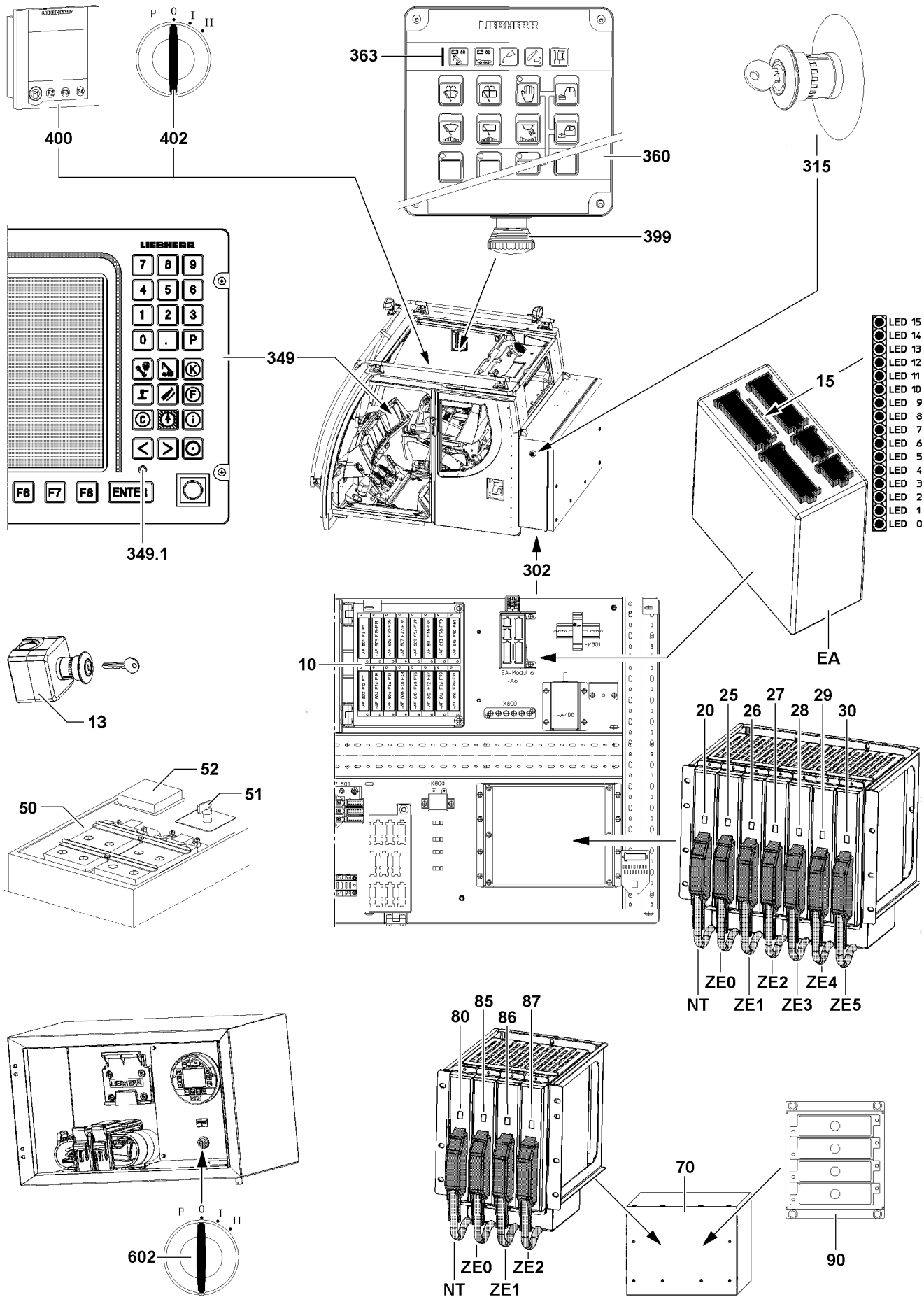

Fig.113281

LWE/LR 1600-2-008/18109-09-02/en

4.3 Defective Central processing unit (CPU)

- ▶ Replace a defective CPU with a functioning CPU.



Note

- ▶ For instruction of replacement of a defective CPU, see Diagnostics operating instructions.

4.4 Replacing a defective fuse

If a fuse is defective, then it must be replaced.

Make sure that the following prerequisites are met:

- Mechanical battery master switch **51** (if present) is in position **0**.
- Ignition switch **402** is in position **0**.
- Ignition switch **602** is in position **0**.
- A spare fuse of the same size and strength is available.

Fuses are located:

- **10** In the fuse box switch cabinet
- In the battery box **50** (Fuses **52**)
- In the fuse box **90** (switch cabinet ballast trailer)
- Directly on the individual components

- ▶ Replace a defective fuse
- ▶ Check the function.

Problem remedy

The same fuse fails again?

- ▶ Continue troubleshooting, contact Liebherr Service if necessary.
- ▶ Never bypass a defective fuse or replace it with a stronger fuse.

4.5 The LICCON monitor remains dark

If the LICCON monitor **349** does not turn on after turn on:

- ▶ See section Monitor errors in the Diagnostics operating instructions.

If the problem cannot be remedied:

- ▶ Contact Liebherr Service to determine the cause of the problem and further procedure.

4.6 The touch display remains dark

If the Touch display **400** does not turn on after turning the ignition on:

- ▶ Check the error messages.

If the problem cannot be remedied:

- ▶ Contact Liebherr Service to determine the cause of the problem and further procedure.

4.7 Defective sensors

4.7.1 General

Depending on the classification of the sensor, crane operation with defective sensor:

- Can be continued without restriction.
- Can be continued with restriction.
- Can be continued only in LMB emergency operation.

**WARNING**

Limited warning functions!

If there is a defect on a participating sensor (LMB) and the crane is continued to be operated by bypassing the sensor other otherwise, then the warning functions and the shut offs of the LICCON overload protection are deactivated / limited!

- ▶ If there is a defect on a participating sensor (LMB), then the crane may be operated further only in emergency cases!
- ▶ Fix / replace the sensor before starting crane operation again!

Certain crane functions are also monitored with two sets of sensors.

If a defective sensor is shown:

- ▶ Replace / repair the defective sensor.

4.8 Defective limit switch

Depending on the classification of the limit switch, crane operation with defective limit switch:

- Can be continued without restriction.
- Can be continued with restriction.
- Can be continued only in LMB emergency operation.

Certain crane functions are monitored with two sets of limit switches.

**WARNING**

Limited warning functions!

If one of the double version limit switches is not ok and the crane is continued to be operated, then the warning functions of the LICCON overload protection are limited!

- ▶ The crane can only be operated in an emergency after failure of a double version limit switch!

If a defective limit switch is shown:

- ▶ Replace / repair the defective limit switch.

4.9 Bypass of overload protection

To bring the crane into safe condition after failure of a component required for the overload protection, it can be necessary that the overload protection has to be bypassed.

**DANGER**

Bypassing the overload protection!

If the overload protection is bypassed, there is no further protection against crane overload!

In the event of deliberate improper use, the crane could collapse, the boom can break off or the crane can topple over!

Personnel can be killed or seriously injured!

This could result in property damage!

- ▶ The bypass of the overload protection is only permitted in emergency cases!
- ▶ The bypass may only be carried out by persons who are aware of the effects of their acts regarding the bypass of the overload protection!
- ▶ Bypassing the overload protection requires the presence of an authorized person and must be performed with utmost caution!
- ▶ Missing values must be monitored manually and must match the load chart.
- ▶ Crane operation with bypassed overload protection is prohibited!

**WARNING**

Bypassed overload protection!

If the overload protection is bypassed, crane movements are no longer monitored!

The crane can be overloaded and collapse!

Personnel can be killed or seriously injured!

This could result in property damage!

- ▶ Only carry out crane movements within the range of the load chart as well as the erection / take down charts!

As a rule, all specifications in the load chart must be adhered to strictly:

- The exact weight of the load, including load suspension equipment, must be known.
- The boom status and the boom geometry must be known.
- The boom length and boom radius must be measured manually.
- All values must match the values in the respective load chart.

**Note**

- ▶ Depending on the configuration of the crane, the overload protection of the crane is bypassed various ways, see the following sections.

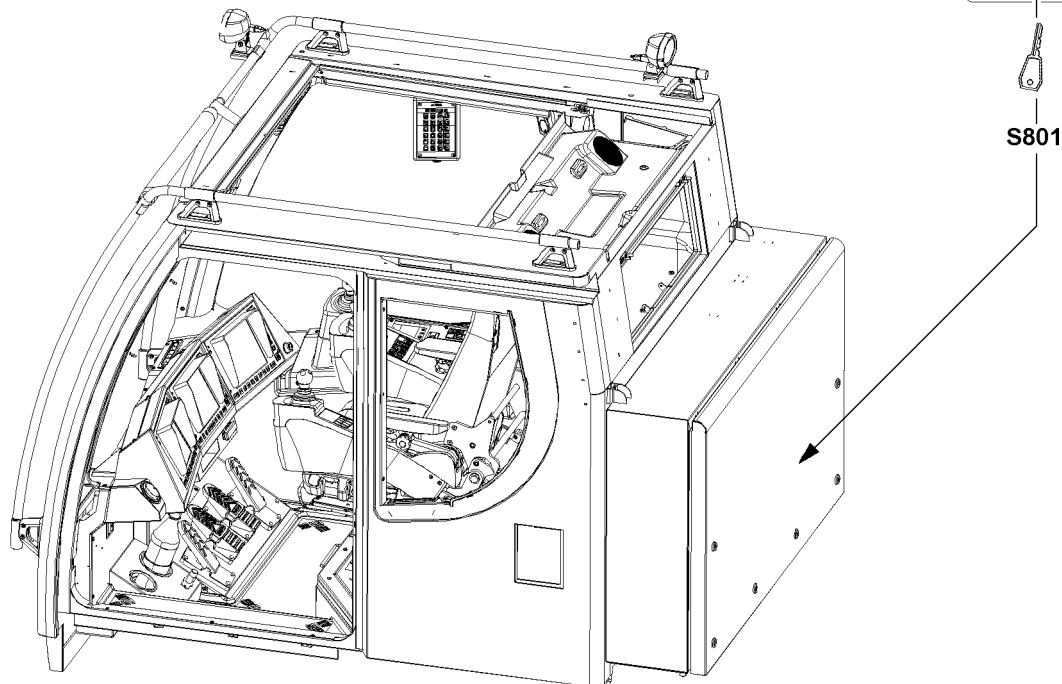
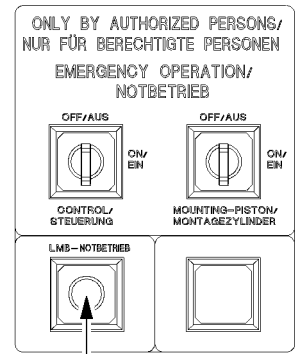
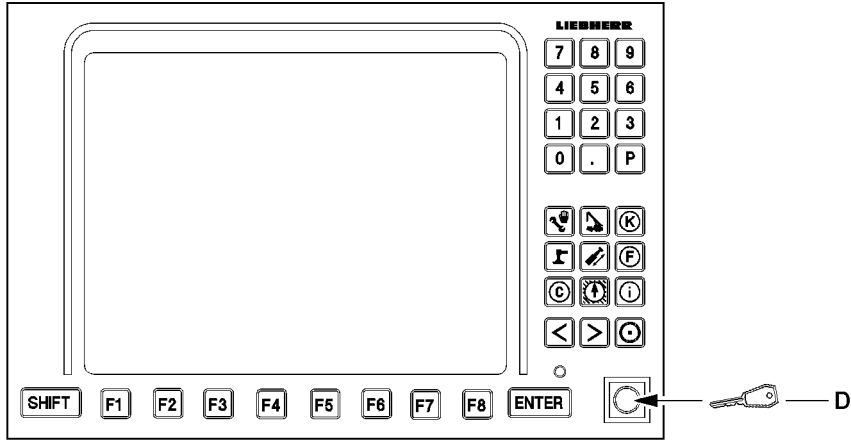

Fig.113282

4.9.1 Bypass of overload protection: Failure of the overload protection



Note

- ▶ Does **not** apply for cranes with CE-mark and configuration according to EN 13000:2010!
- ▶ For description of set up button **D**, see Crane operating instructions, chapter 4.02!

- ▶ Press the set up button **D**:

Result:

- The overload protection is bypassed.
- The crane is in emergency operation.

To turn the bypass of overload protection off:

- ▶ Press the set up button **D** again.

Result:

- The bypass of the overload protection is turned off.

4.9.2 Bypass of overload protection: Failure of overload protection (according to EN 13000:2010)



Note

- ▶ Applies **only** for cranes with configuration according to EN 13000:2010!
- ▶ For location and description of the bypass device outside the crane operator's cab, see Crane operating instructions, chapter 4.01 and chapter 4.02.

The bypass of the overload protection can be carried out with the restriction, that:

- The bypass is automatically reset when the engine is turned off.
- The bypass is automatically reset after no later than 30 minutes.
- The bypass of the overload protection limits the working speed to no more than maximum 15%.

The bypass is made by actuating the key button **S801**:

- ▶ Actuate the key button **S801**.

Result:

- The overload protection is bypassed.
- The crane is in emergency operation.

To turn the bypass of overload protection off:

- ▶ Actuate the key button **S801** again.

Result:

- The bypass of the overload protection is turned off.

4.10 Ending the load lift to avert emergency situations

When the crane movements must be carried out manually (for example with the optional „Hydraulic emergency control*“).

**WARNING**

Crane operation without overload protection!

If the LICCON overload protection is no longer functioning properly because of one or more errors, then there is a danger of accidents if crane operation is continued!

Due to operation of the crane with failed LICCON overload protection, the crane can be overloaded and collapse!

Personnel can be killed or seriously injured!

This could result in property damage!

- ▶ Crane operation without overload protection is only permissible in emergency cases!
- ▶ Crane operation without overload protection may only be carried out by persons who know the effects of their actions regarding crane operation without overload protection!
- ▶ Crane operation without overload protection requires the presence of an authorized person and must be performed with utmost caution!
- ▶ Missing values must be monitored manually and must match the load chart.
- ▶ Do not take up regular crane operation again until the overload protection is functioning again!

Ending the load lift to avert emergency situations:

- Before continuing the load lift, contact the nearest Liebherr Service center or the Liebherr-Werk in Ehingen.

If this is not possible, then the load lift can be completed with utmost caution, as follows:

- All values that are needed for the exact determination of the equipment configuration and the associated load chart must be measured or manually determined.

As a rule, all specifications in the load chart must be adhered to strictly:

- The exact weight of the load, including load suspension equipment, must be known.
- The boom status and the boom geometry must be known.
- The boom length and boom radius must be measured manually.
- All values must match the values in the respective load chart.

8 Inspections of cranes

LWE/LR 1600-2-008/18109-09-02/en

LWE/LR 1600-2-008/18109-09-02/en

8.01 Periodic crane inspections

1	General information	3
2	Inspection of carrying crane structures, especially steel structures	4
3	Inspection of locking system of telescopic boom	79
4	Inspection of safety ropes and anchor points	81
5	Inspection of load handling equipment and assembly aids	83
6	Inspection of fastening equipment	84
7	Inspection of diaphragm reservoir	84
8	Inspection of relapse cylinders	84
9	Inspection of rope pulleys	85
10	Inspection of carrier rollers	85
11	Inspection of extension conditions of sliding beams	87
12	Inspection of the function of the overload protection	87
13	Inspecting the pin connections	87
14	Inspection of slewing ring connection	87
15	Inspection of the mounting of the load bearing equipment	88
16	Inspection of the tele extension with eccentric, illustration 1	89
17	Inspection of change over pulleys, illustration 2	90
18	Inspection of the oil and fuel tanks	90

Fig.195219

LWE/LR 1600-2-008/18109-09-02/en

1 General information

This crane was tested at the manufacturer's facilities prior to shipment in accordance with the valid ISO, FEM and DIN Standards and DGUV 52 (DGUV 309-001).

The safety level achieved during initial start up may not be attainable during operation.

Examples of the root cause of such deviations include; e.g., wear and tear, corrosion, effects of external forces, changes in the environment and changes to the mode of operation.

The operator is responsible for taking the necessary steps to ensure that the level of safety is maintained.

Periodic inspections are regulated nationally in the BetrSichV.

The crane operator is therefore obligated to have the crane inspected by an **authorized inspector**, at intervals depending on the operational conditions but at least once per year, from the first day of vehicle registration.

Every 4 operating years, in the 13th operating year and thereafter at least annually, from the first day of vehicle registration, the crane must be inspected by an **inspection expert**.

Periodic inspection are principally a visual inspection, where the inspector (either type) appraises the condition of the crane and its components.



WARNING

There is a risk of weakening the supporting components when major changes or repairs are made to the crane!

- ▶ In this case, the operator must have the crane reinspected by an inspection expert before placing it back into service!

In addition, all respective local and national regulations also apply.

Authorized inspector

Authorized inspectors are those persons who through their professional training, their professional experience and their recent professional activity have the necessary knowledge for the inspection of work equipment.

Authorized inspector for pressure tanks

Authorized inspector for pressure tanks are authorized inspectors who additionally:

- Have relevant technical professional training.
- Have at least one year of experience with the manufacture, assembly, operation or maintenance of the equipment or components to be inspected in accordance with BetrSichV.
- Keep their knowledge about pressure-related hazards up to date by participating in training or instruction, in particular with regard to the following topics:
 - Design and manufacturing processes
 - Equipment and safeguarding concepts
 - Assembly, installation and operation / use
 - Destined use
 - Risk assessment
 - Inspections, inspection periods, inspection procedures including assessment of the results
 - Relevant influences and damage symptoms found in practice

Inspection expert

Inspection experts are authorized inspectors who also:

- Have completed training as an engineer or have equivalent knowledge and experience in the subject area with which their activities are involved.
- Have at least three years of experience in the design, construction, maintenance or inspection of cranes, of which at least half a year were involved in the inspection activities of an inspection expert.
- Possess sufficient knowledge of the relevant regulations and rules.
- Have the necessary facilities for inspection and documentation.
- Keep their professional knowledge up to date.

To ensure the high safety standard of the crane, it is recommended, no later than the 12th year, in the 20th year, in the 26th year and then every 4 years, to have the crane undergo a **general inspection** by an **inspection expert**. At that time, in addition to the usual scope of inspection, all load carrying parts of the crane - the complete steel structure with all welding seams as well as all components and connecting devices - are to be subjected to a complete visual inspection. The following procedural notes for repeat inspections are to be observed for that.

The purpose of the inspections is to avoid accidents by detecting deficiencies early on. Any deficiencies found by the inspector must be documented, corrected and subsequently reinspected.

A number of important examples of items that are particularly important during the periodic crane inspections are listed in the following. We wish to advise that the **authorized inspectors** or **inspection experts** take sole responsibility for the crane inspections that they carry out.



Note

- ▶ The inspection may not be solely limited to the following positions shown in the sample construction illustrations. Rather the **entire** crane structure must be subjected to a careful inspection!

In the Crane operating instructions, chapter 8.90 is a checklist to assist the inspector during the periodic inspections of Liebherr mobile and crawler cranes.

If the inspector has any questions they should be directed through the Service Department of Liebherr-Werk Ehingen GmbH to the technical departments.



WARNING

Danger of accident!

- ▶ Adhere to the following inspection guidelines and intervals.

2 Inspection of carrying crane structures, especially steel structures

2.1 Basic principles and procedure



DANGER

Danger of fatal injury!

The crane structures, particularly steel constructions, have to be checked by an **authorized inspector** or **inspection expert** at least once a year. If this is not the case, they could fail and cause fatal injury or seriously damage the crane!

- ▶ Crane structures, particularly steel constructions must be checked by an **authorized inspector** or an **inspection expert** at least once a year!
- ▶ Shorten the inspection intervals when the crane is subjected to above-average load spectrums, for example when handling large material quantities or frequently erecting long boom systems.
- ▶ When the crane was subjected to excessive operating loads; e.g., due to an unusual impact, the crane structure, especially the steel structures must be inspected immediately!

Crane structures, especially steel structures, such as booms, turntables, chassis, support equipment (e.g., sliding beams or folding outriggers) must be carefully inspected, at the very least during the annual recommended crane inspections. Inspect welding seams especially through an intensive visual inspection.

If paint damage with corrosion (rust) is found on load carrying parts of the crane structure, especially on telescopic booms, lattice booms, lattice jibs, pull rods etc., then the rust must be removed, primed and painted.

During an electrolyte process, such as corrosion in combination with water, an atomic hydrogen is created, which causes to hydrogen induced corrosion with resulting cracks on high tensile fine grain construction steel.

If disassembly and assembly work on the crane is required to carry out the inspections, then they must be carried out by taking the manufacturer's data into account or in coordination with the crane manufacturer.

We would like to point out that the framework of mobile cranes is designed for a limited number of stress work cycles. This also determines the utilization or service life of the framework. The service life is not determined solely by the number of stress cycles. It also depends on the loads (load spectrum) applied during the time in operation.

Liebherr mobile and crawler cranes are designed for specific characteristics and movements, such as constant deployment of drive forces, only occasional operation and load conditions according to EN 13000.

Liebherr mobile and crawler cranes are designed for assembly operation and, according to grouping in class A1 according to ISO 4301-1, they can only take on a limited number of work cycles ($N = 63000$) with a collective class Q1 = light ($k_p = 0.125$).

Example of a load collective according to grouping in collective class Q₁ = light ($k_p = 0.125$).

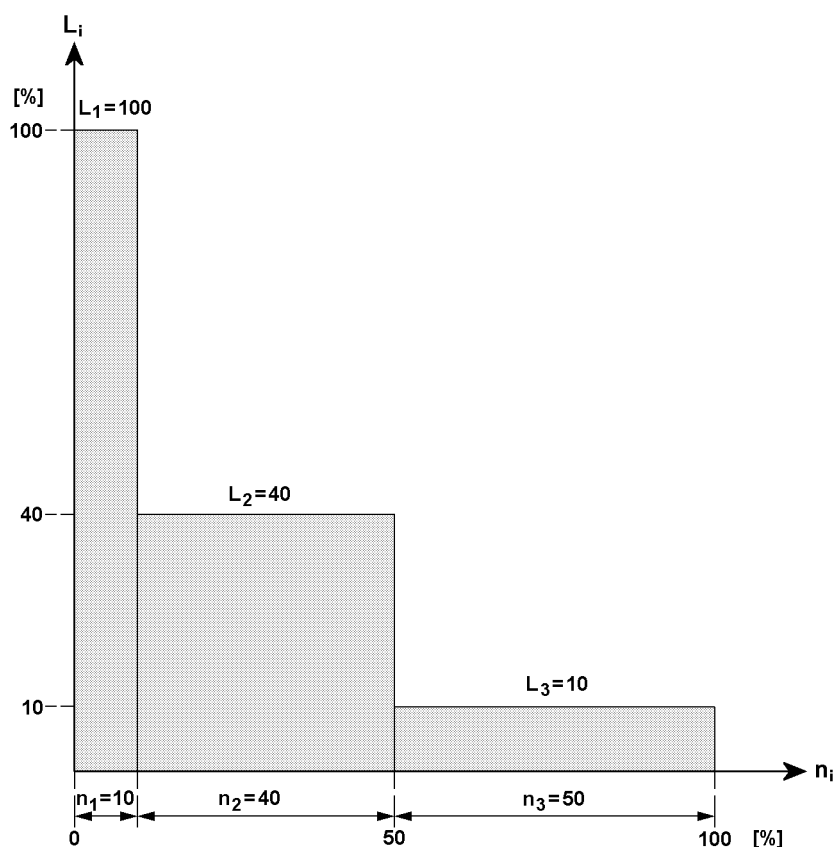

Fig.104716

L_i: Load proportion in relation to maximum load [%]

n_i: Load cycles in relation to maximum number [%]



Note

- ▶ The service life of Liebherr mobile and crawler cranes can be drastically reduced, for example when used in magnet, grapple or material handling applications!
- ▶ Repeated inspection of crane structure, especially the steel structure and the welding seams must then be carried out in shorter intervals than specified.

For that reason, the steel structures and the welding joints must be subjected to a visual intensive inspection by the **authorized inspector** or **inspection expert** during the specified periodic inspections.

If any damage (such as cracks or suspicion of cracks) are apparent on any part of the steel structure, the total extent of the damage must be determined by qualified specialists using appropriate material

testing methods, such as magnetic crack detection, ultrasound or x-rays. Thereafter, the qualified personnel must determine whether or not the damaged area can be repaired by welding or by other means.

The following diagrams are samples of the load-bearing welding structures. The welding joints or seams or steel structural zones that require inspection may be present more than once and in various forms. The joints or zones must be inspected all around at the locations identified by arrows.



Note

- ▶ The scope and extent of all inspections remain the sole responsibility of the inspectors!
- ▶ The scope and results of tests should be documented to permit reproducibility. This documentation forms part of the crane records and should be safely stored during the entire service life of the crane!
- ▶ The following diagrams are provided to assist the inspector. The illustrations are only examples and are not necessarily 100 % complete!

2.2 Repair welding

Defects such as cracks or permanent deformation on load-bearing steel components must be immediately reported to the Service Department at **Liebherr-Werk Ebingen GmbH**.

The defect must immediately be appraised by an inspection expert according to standard welding technology rules. The inspection expert must immediately ascertain if the crane can continue to be safely operated due to danger of accident until a repair welding is performed.

Repair welding may solely be made in consultation and under the instructions of the Customer Service at **Liebherr-Werk Ebingen GmbH** by authorized and trained expert personnel.



WARNING

Repair welding **not** according to regulations!
Death, severe bodily injuries, property damage.

- ▶ Contact Customer Service at **Liebherr-Werk Ebingen GmbH**.
- ▶ Coordinate the procedure for repair welding with **Liebherr-Werk Ebingen GmbH**.



Note

Exclusion of liability!

For repair welding, which were not carried out by personnel from **Liebherr-Werk Ebingen GmbH** or by authorized personnel from **Liebherr-Werk Ebingen GmbH**, **Liebherr-Werk Ebingen GmbH** excludes any liability, for system functionality as well as for the parts.

- ▶ Have repair welding made solely by personnel of **Liebherr-Werk Ebingen GmbH** or by personnel authorized by **Liebherr-Werk Ebingen GmbH**.

2.3 Example for test points

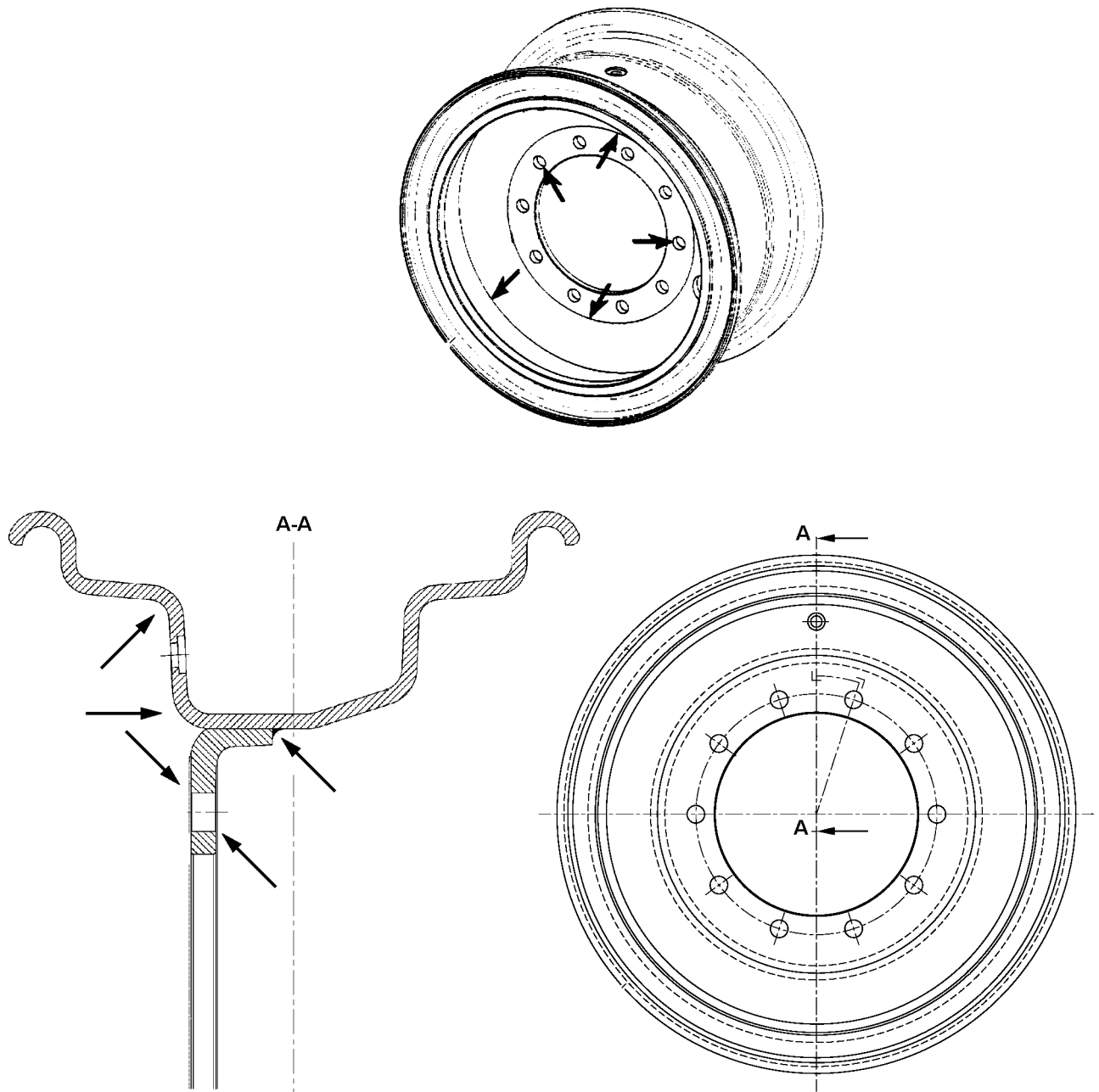

Fig.118052: Example for 1-part disk wheel

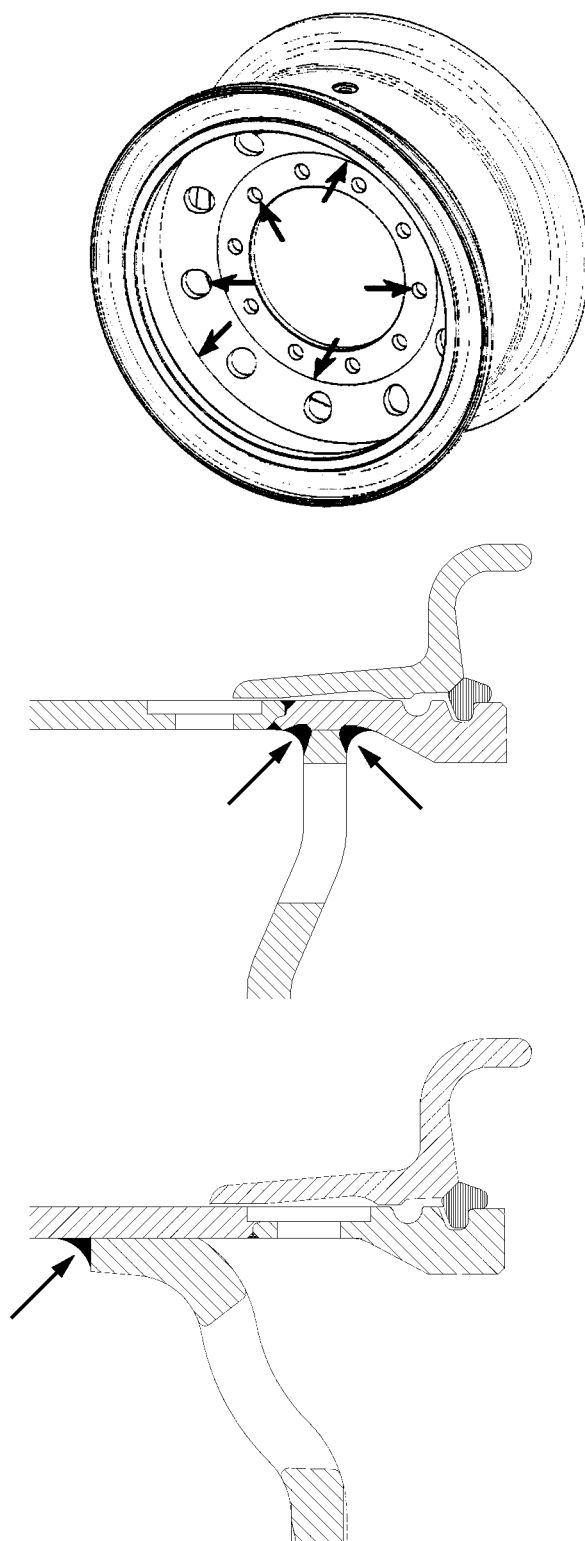
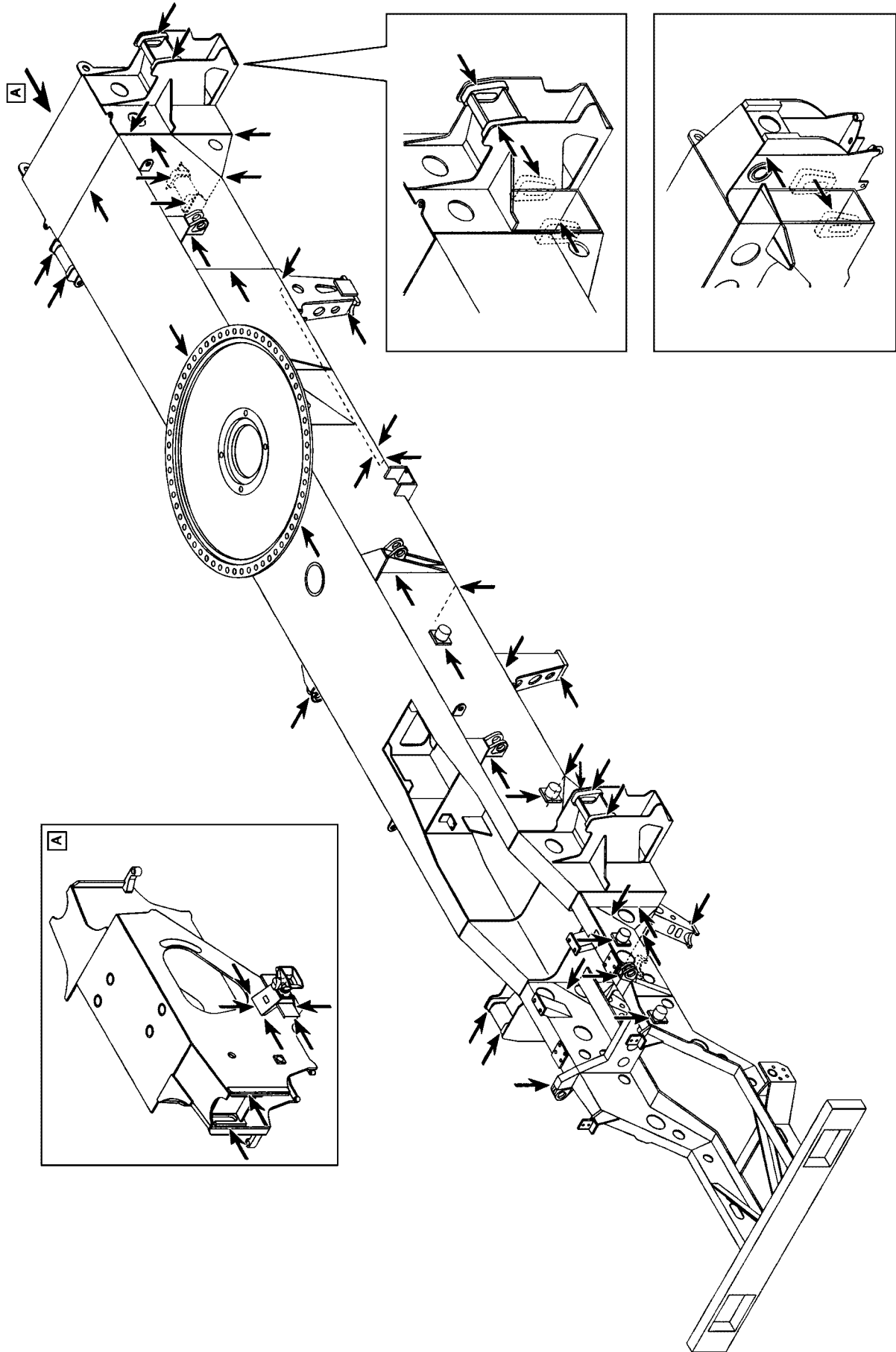

Fig.118053: Example for 3-part disk wheel



LWE/LR 1600-2-008/18109-09-02/en

Fig.185046: Example for vehicle frames

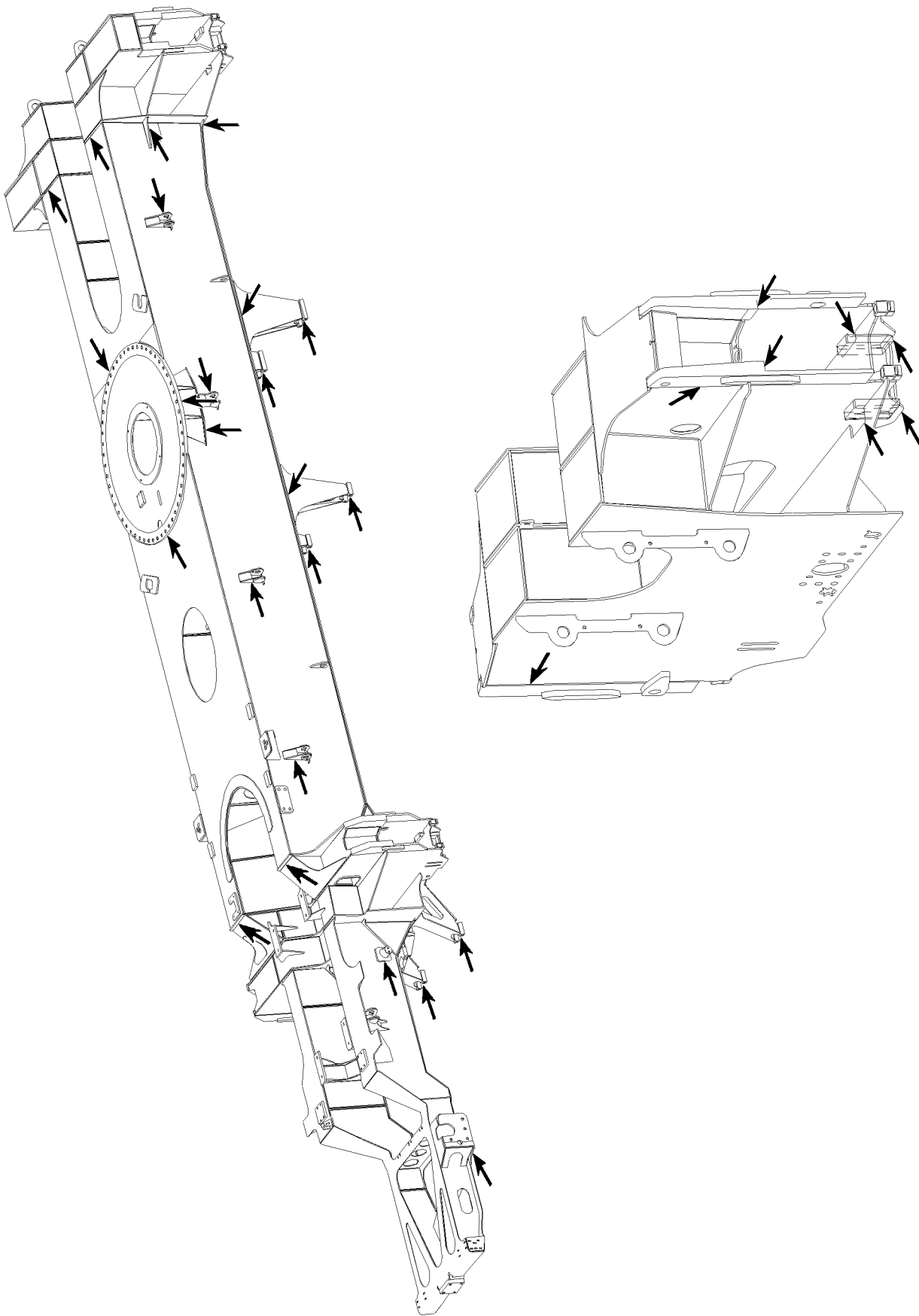
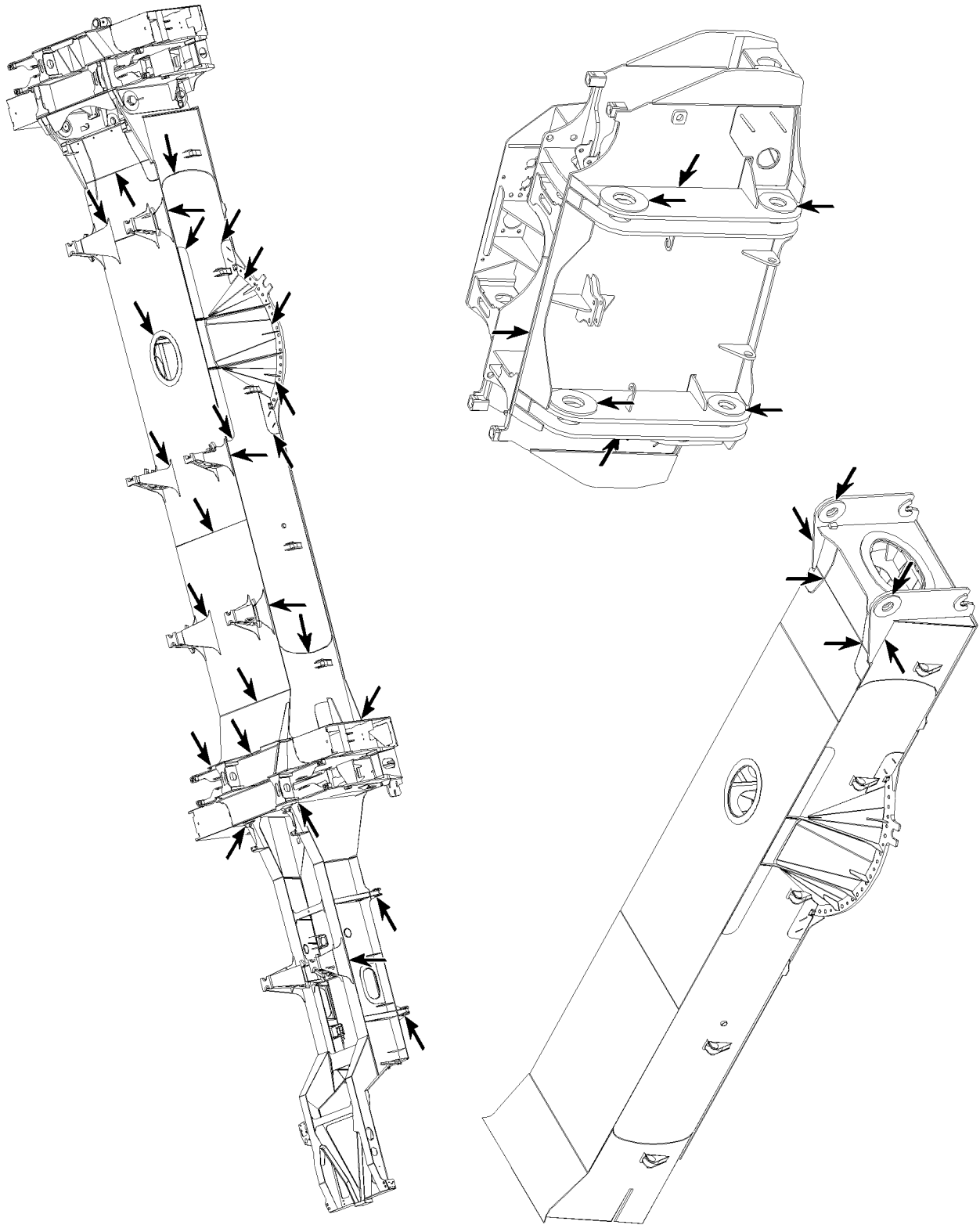

Fig.105702: Example for vehicle frames



LWE/LR 1600-2-008/18109-09-02/en

Fig.105719: Example for vehicle frames

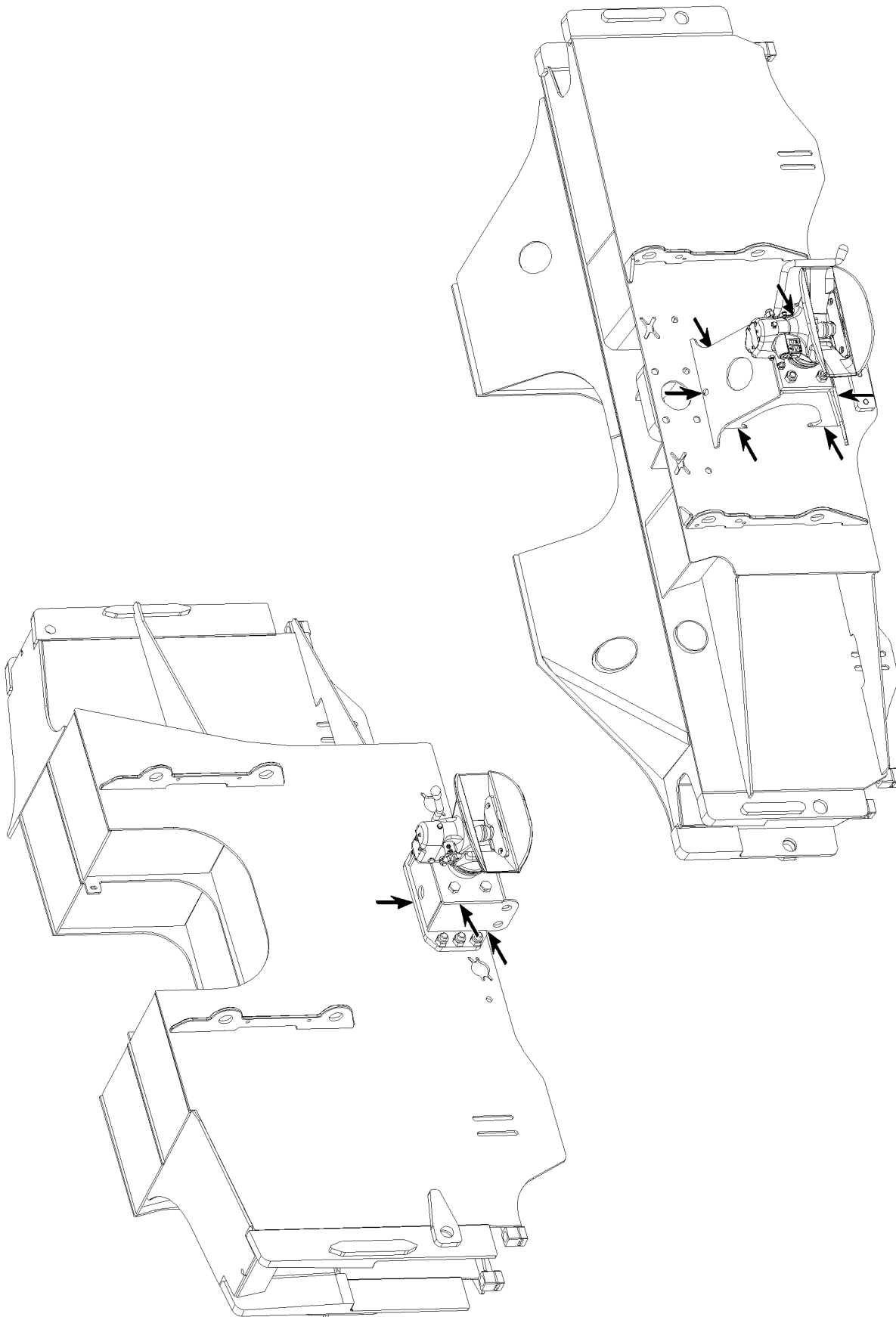
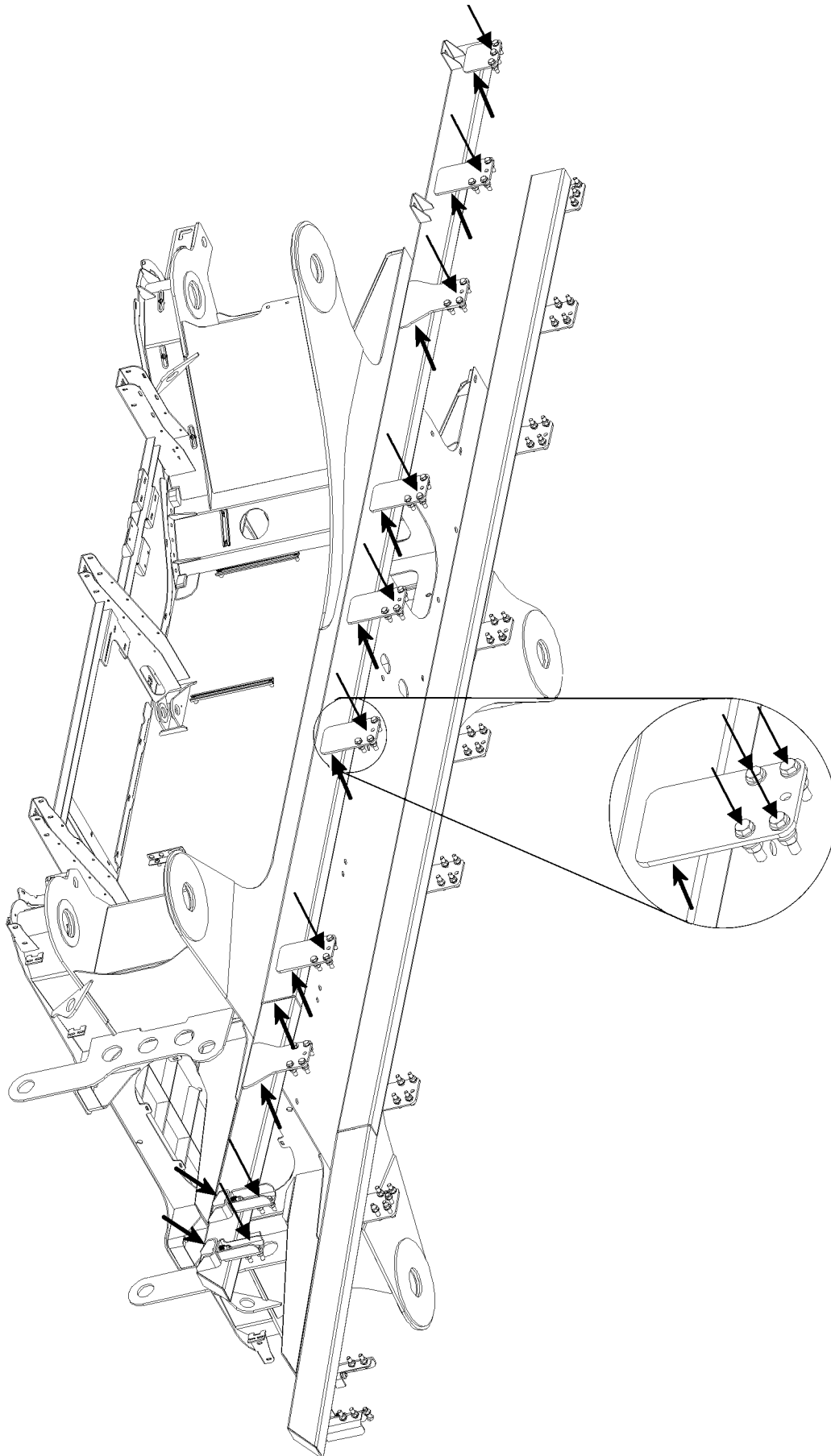

Fig.105687: Example for tow coupling



LWE/LR 1600-2-008/18109-09-02/en

Fig.113940: Example for intermediate frame

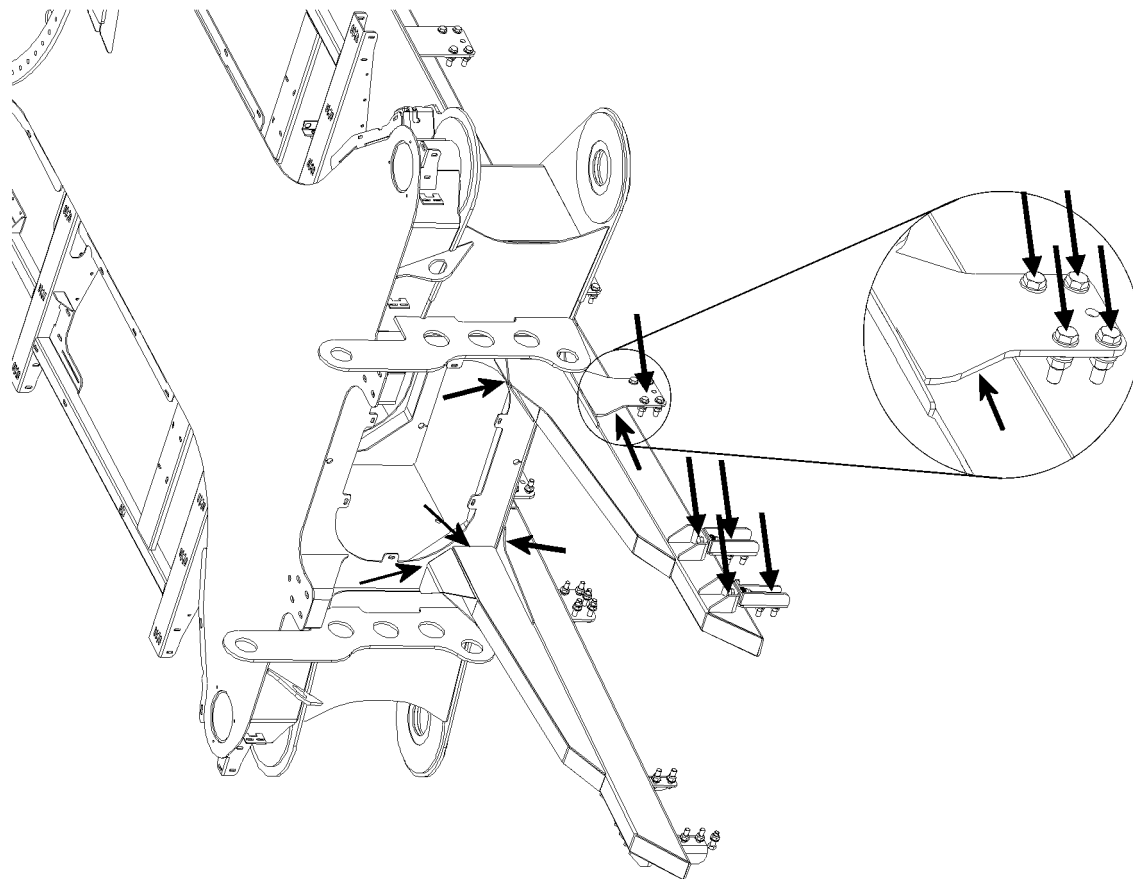
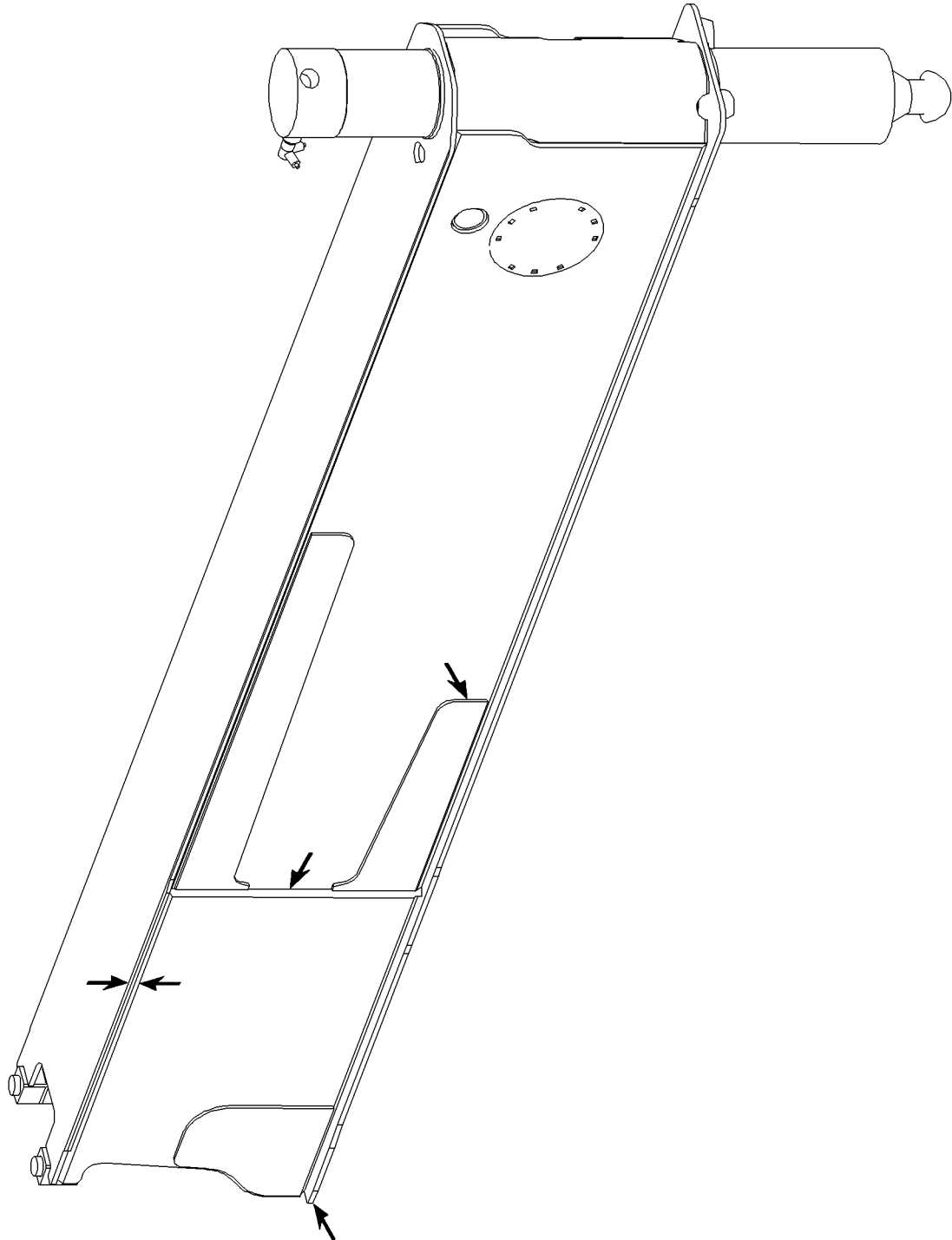

Fig.114000: Example for intermediate frame

LWE/LR 1600-2-008/18109-09-02/en



LWE/LR 1600-2-008/18109-09-02/en

Fig.105698: Example for sliding beam

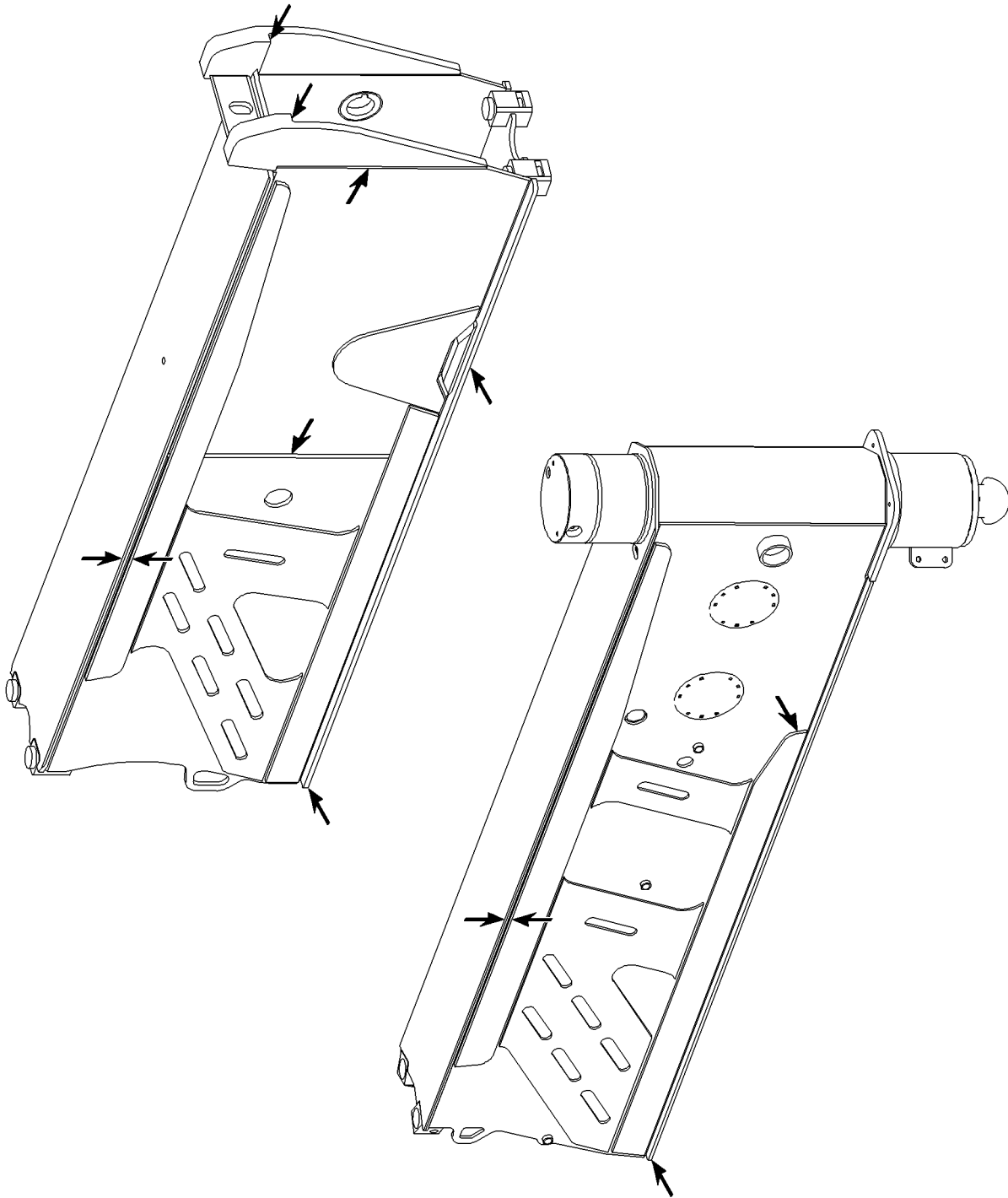
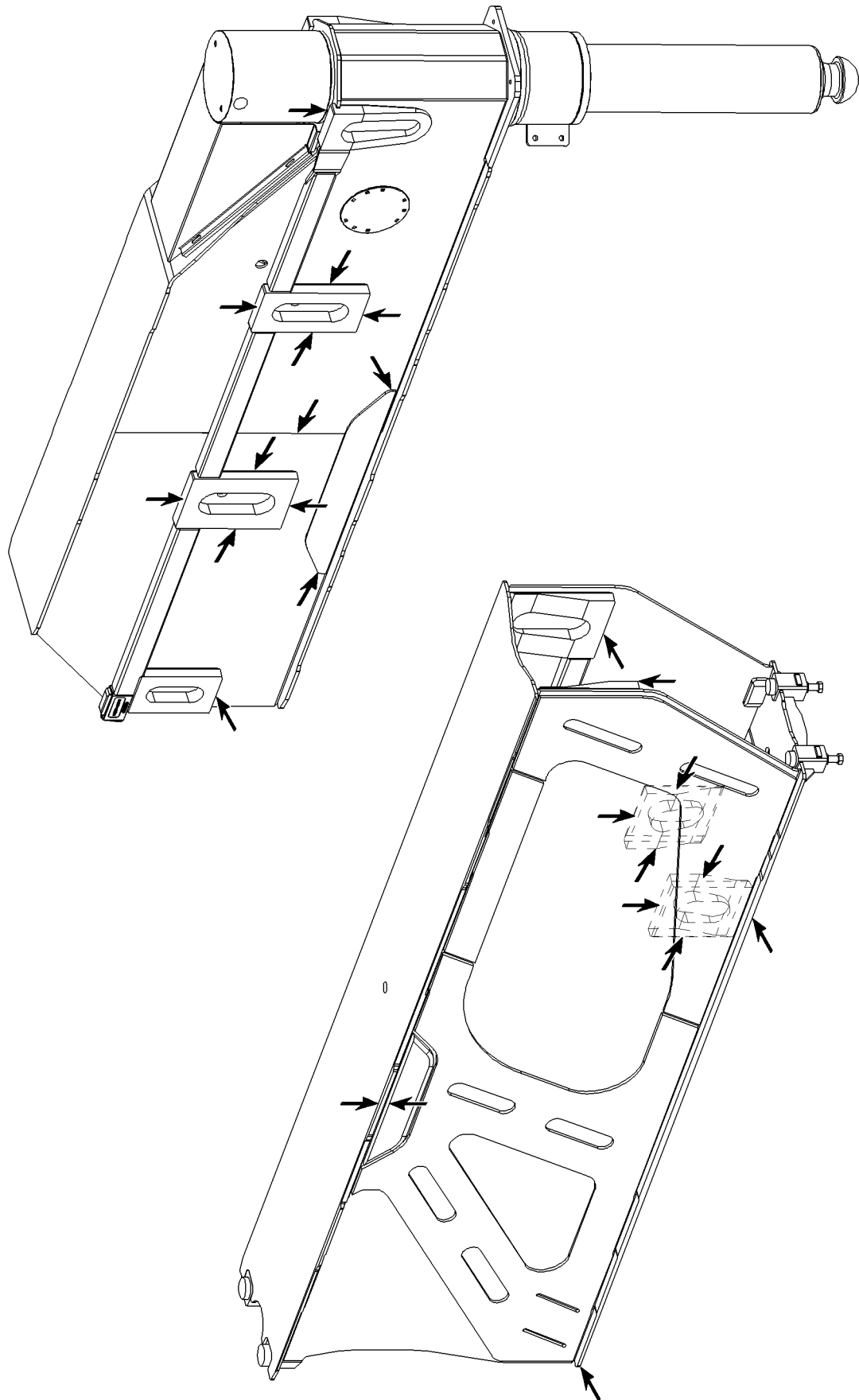

Fig.105717: Example for sliding beam

LWE/LR 1600-2-008/18109-09-02/en



LWE/LR 1600-2-008/18109-09-02/en

Fig.105718: Example for sliding beam

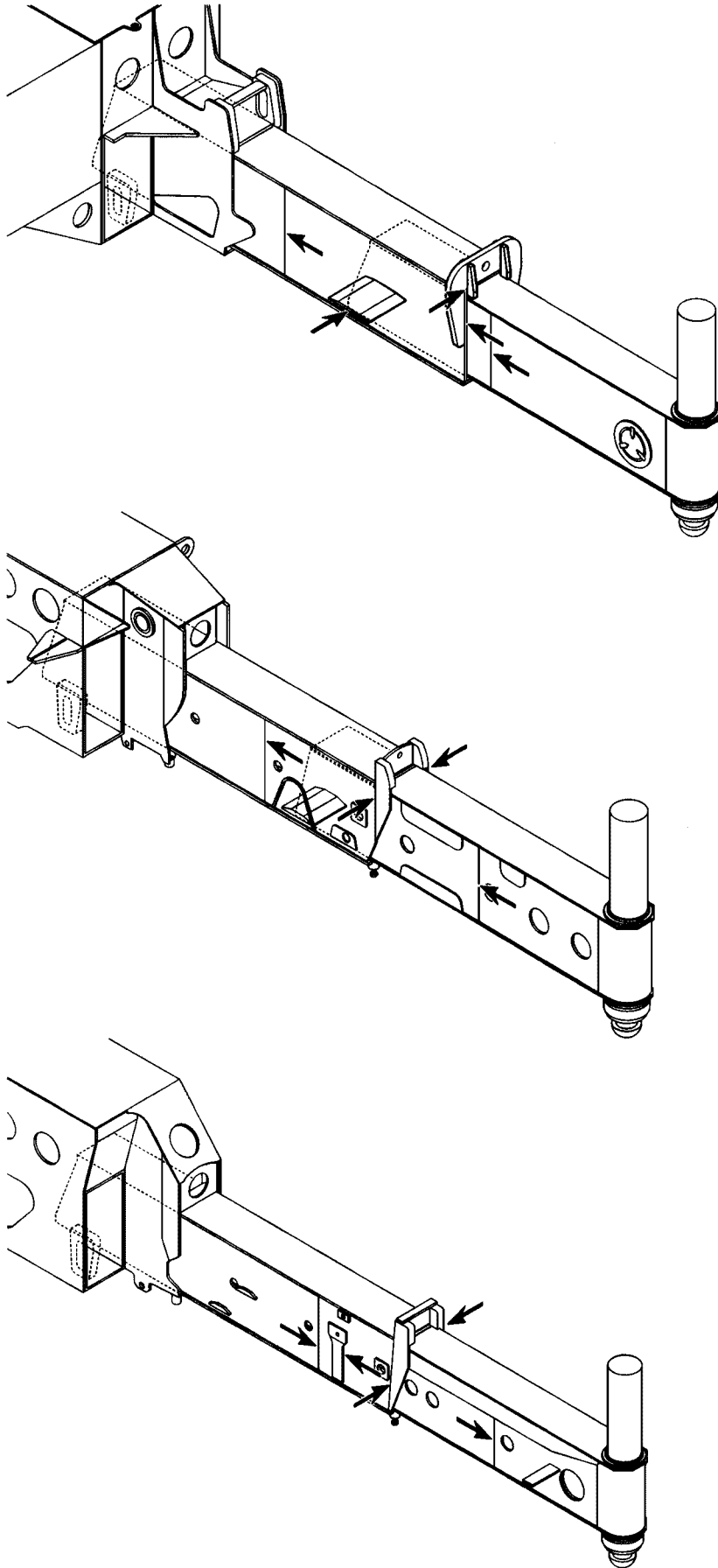
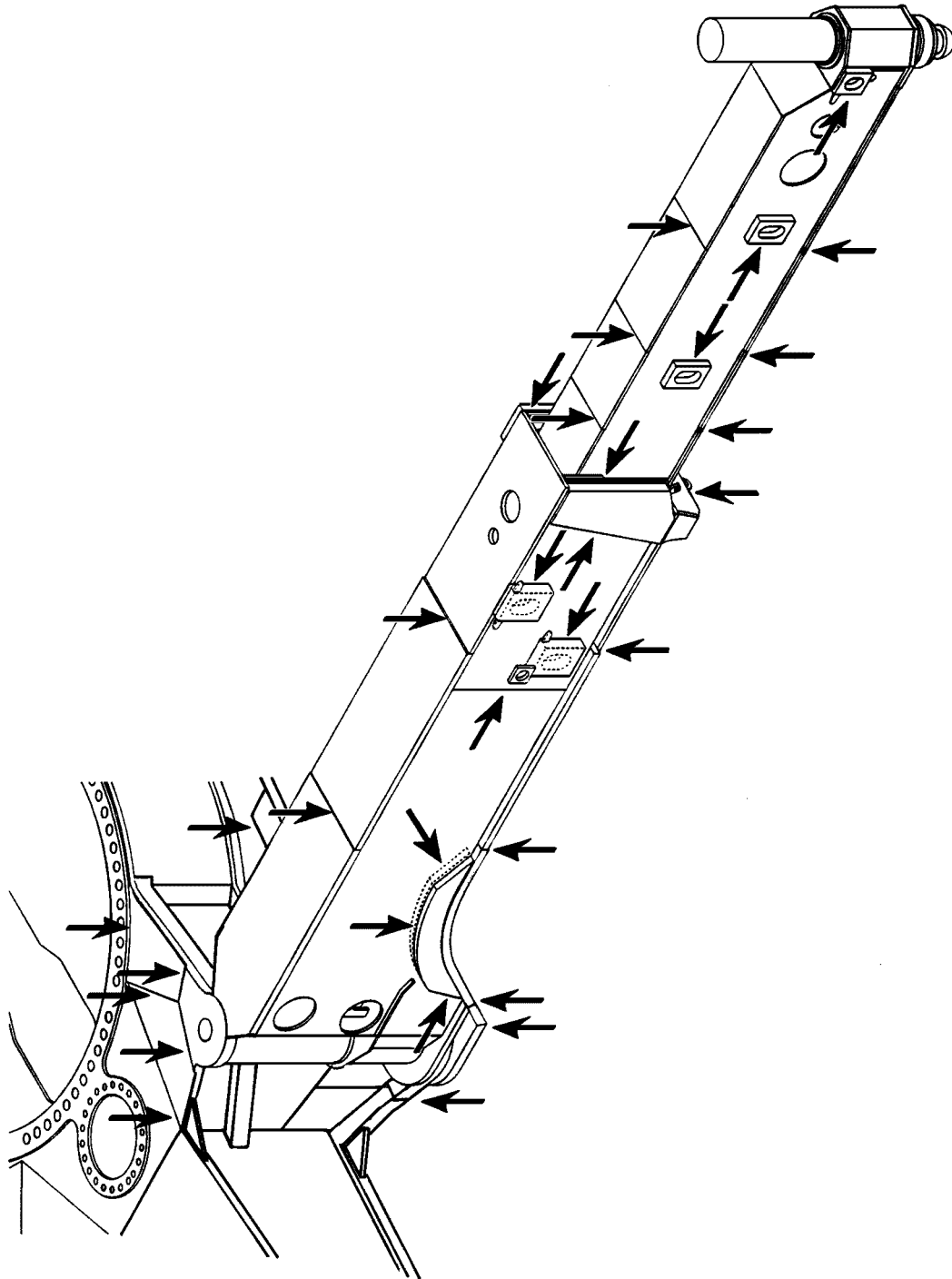

Fig.185047: Example for sliding beam

LWE/LR 1600-2-008/18109-09-02/en



LWE/LR 1600-2-008/18109-09-02/en

Fig.185060: Example for swingable sliding beam

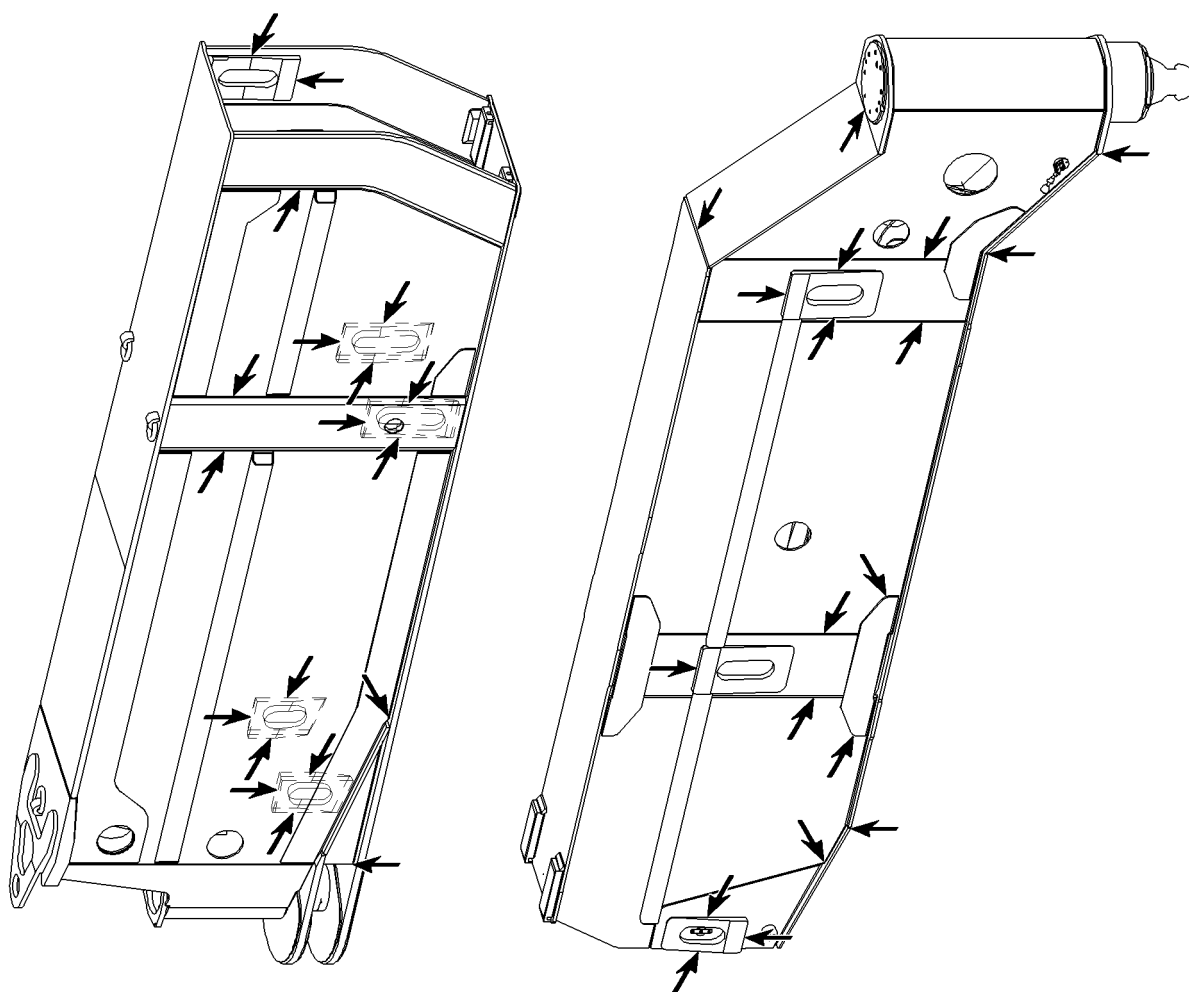
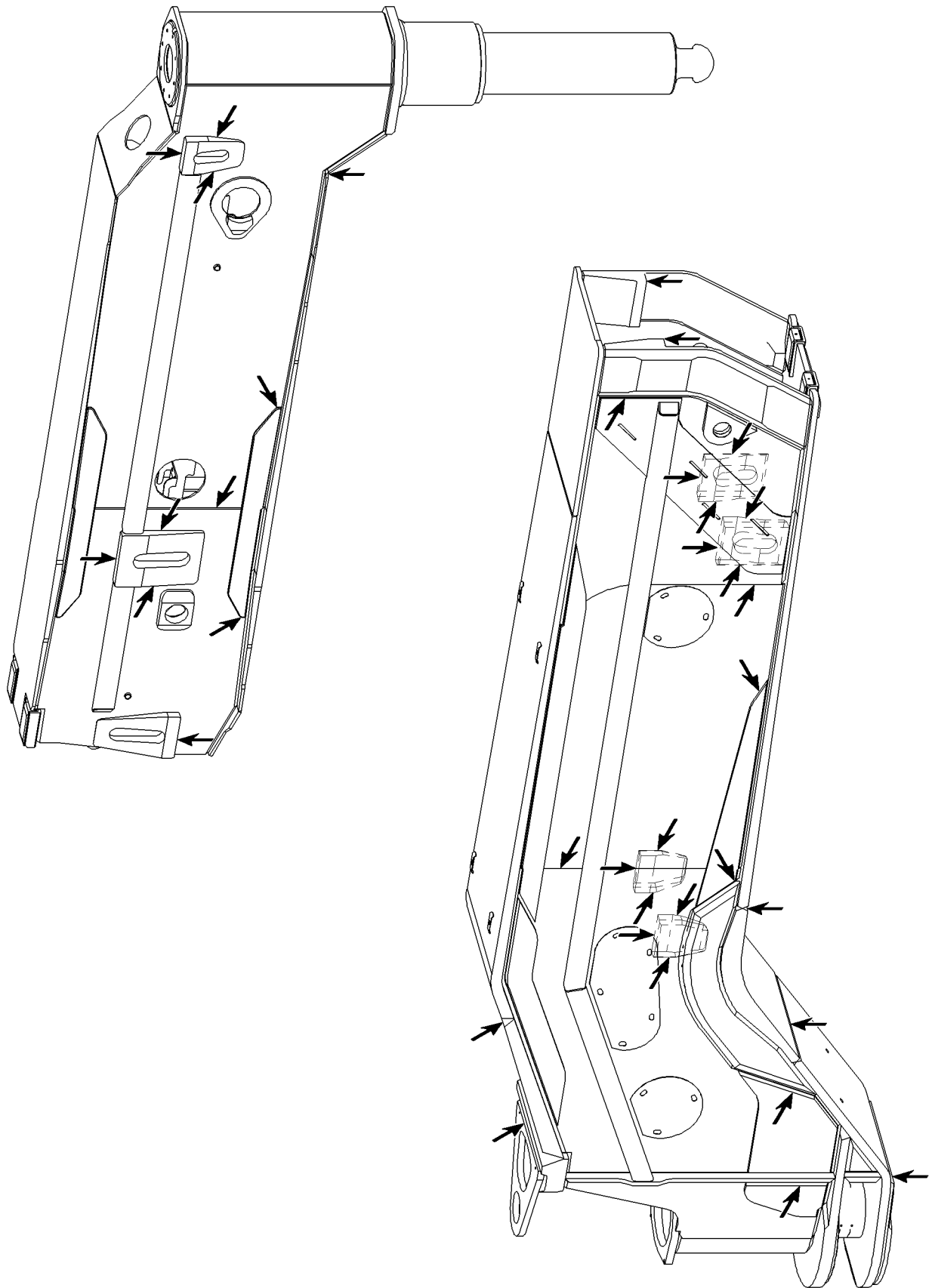

Fig.105690: Example for swingable sliding beam



LWE/LR 1600-2-008/18109-09-02/en

Fig.105704: Example for swingable sliding beam

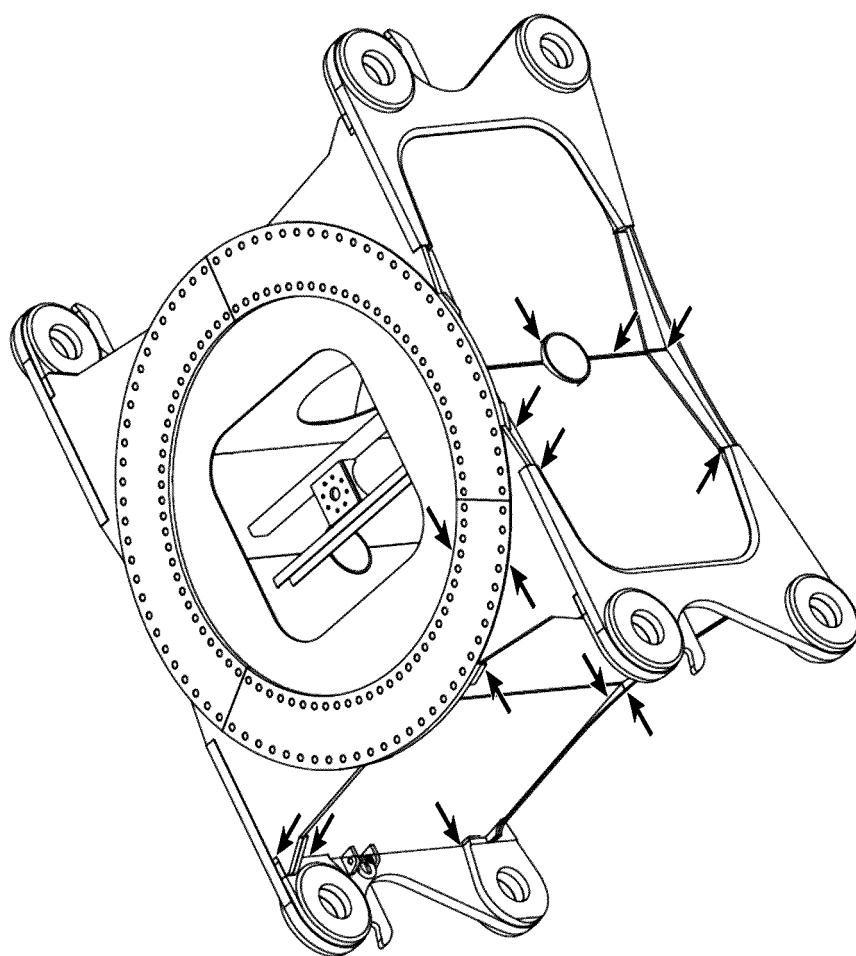
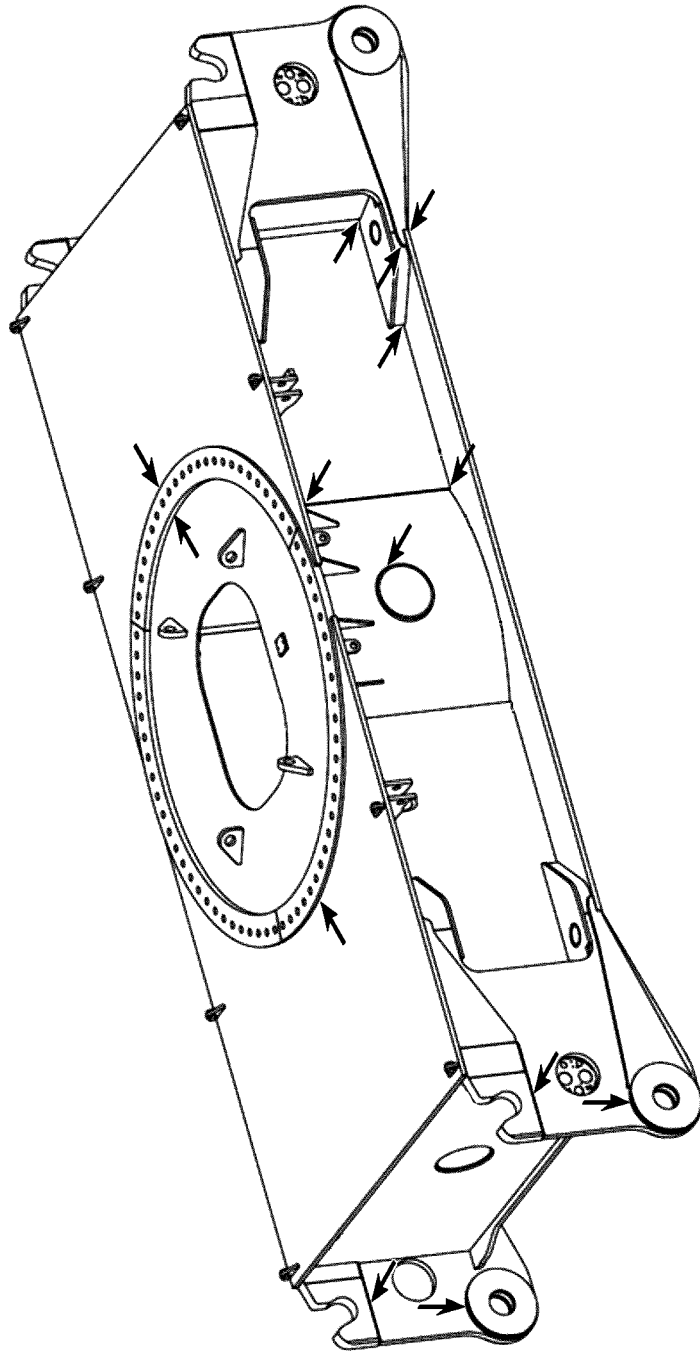

Fig.105725: Example for crawler center section

LWE/LR 1600-2-008/18109-09-02/en



LWE/LR 1600-2-008/18109-09-02/en

Fig.105726: Example for crawler center section

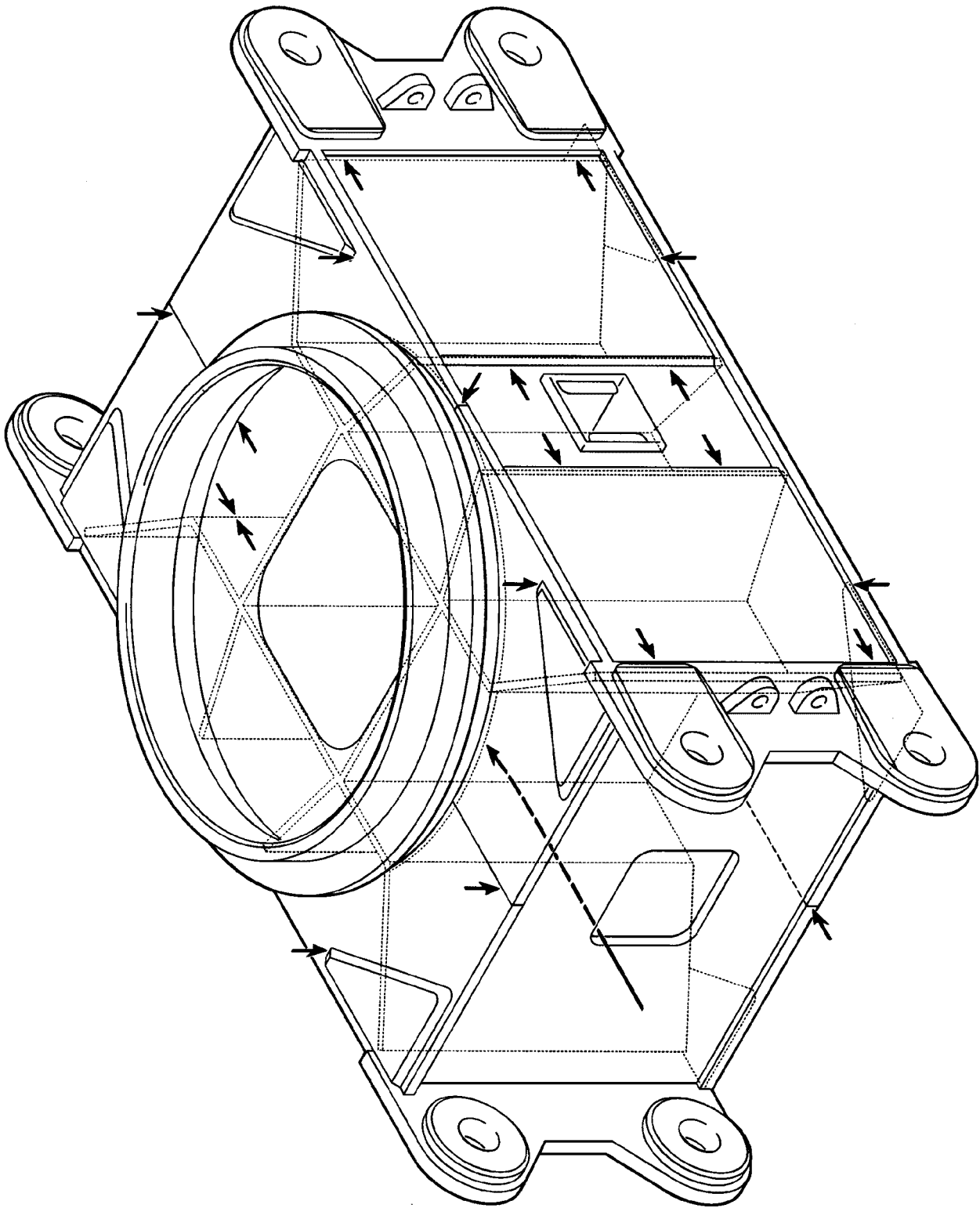
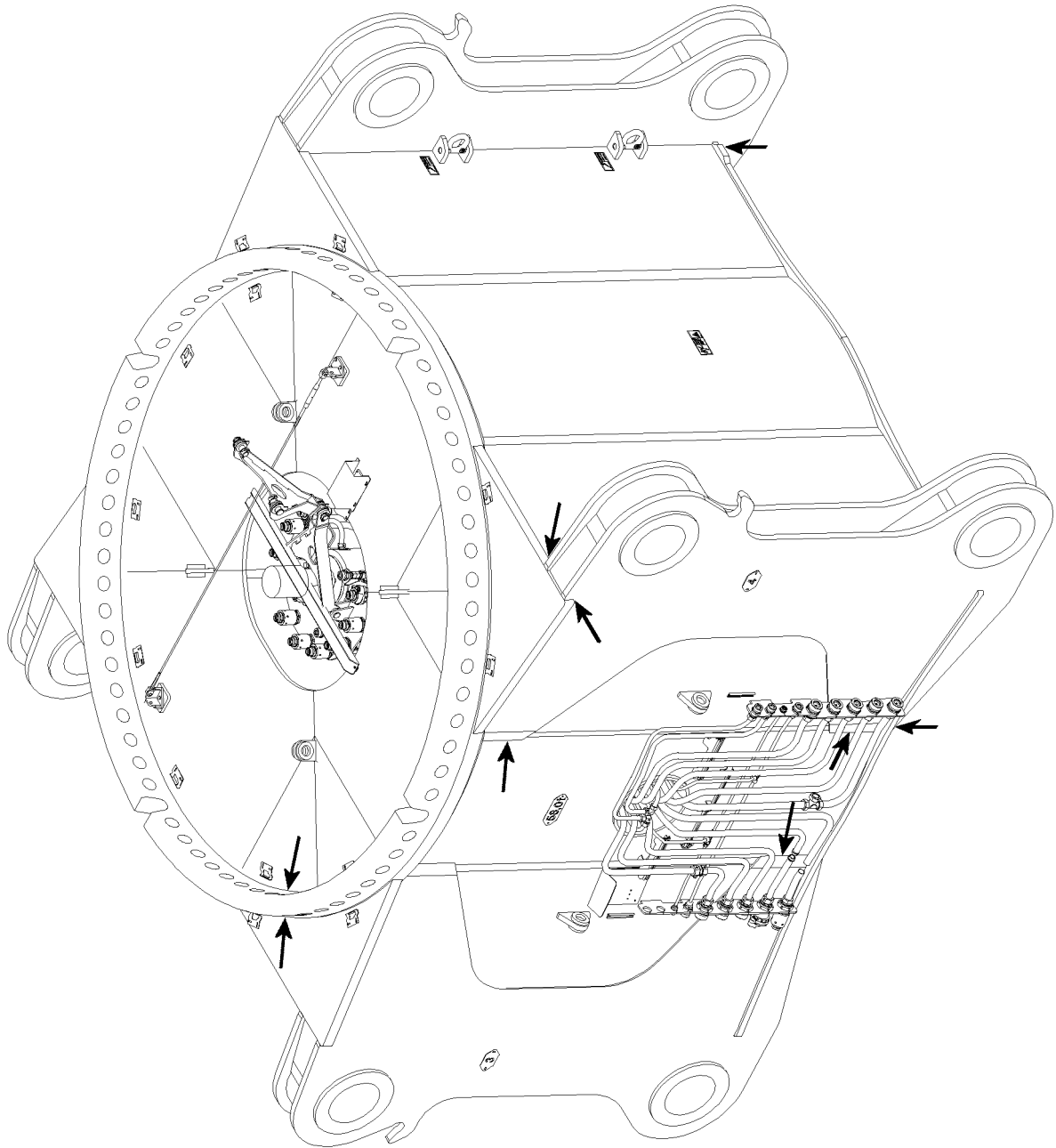

Fig.187347: Example for crawler center section

LWE/LR 1600-2-008/18109-09-02/en



LWE/LR 1600-2-008/18109-09-02/en

Fig.115920: Example for crawler center section

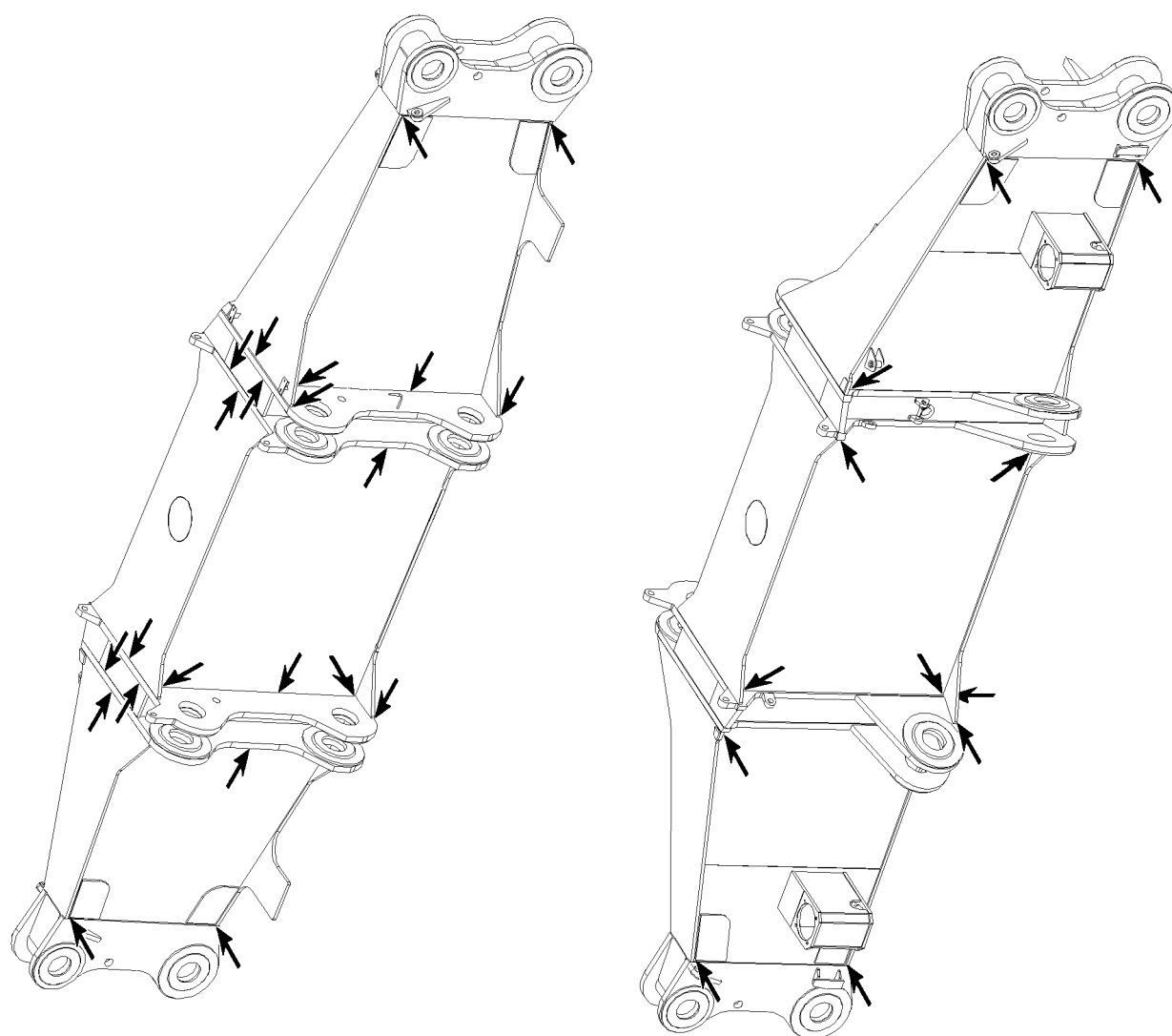
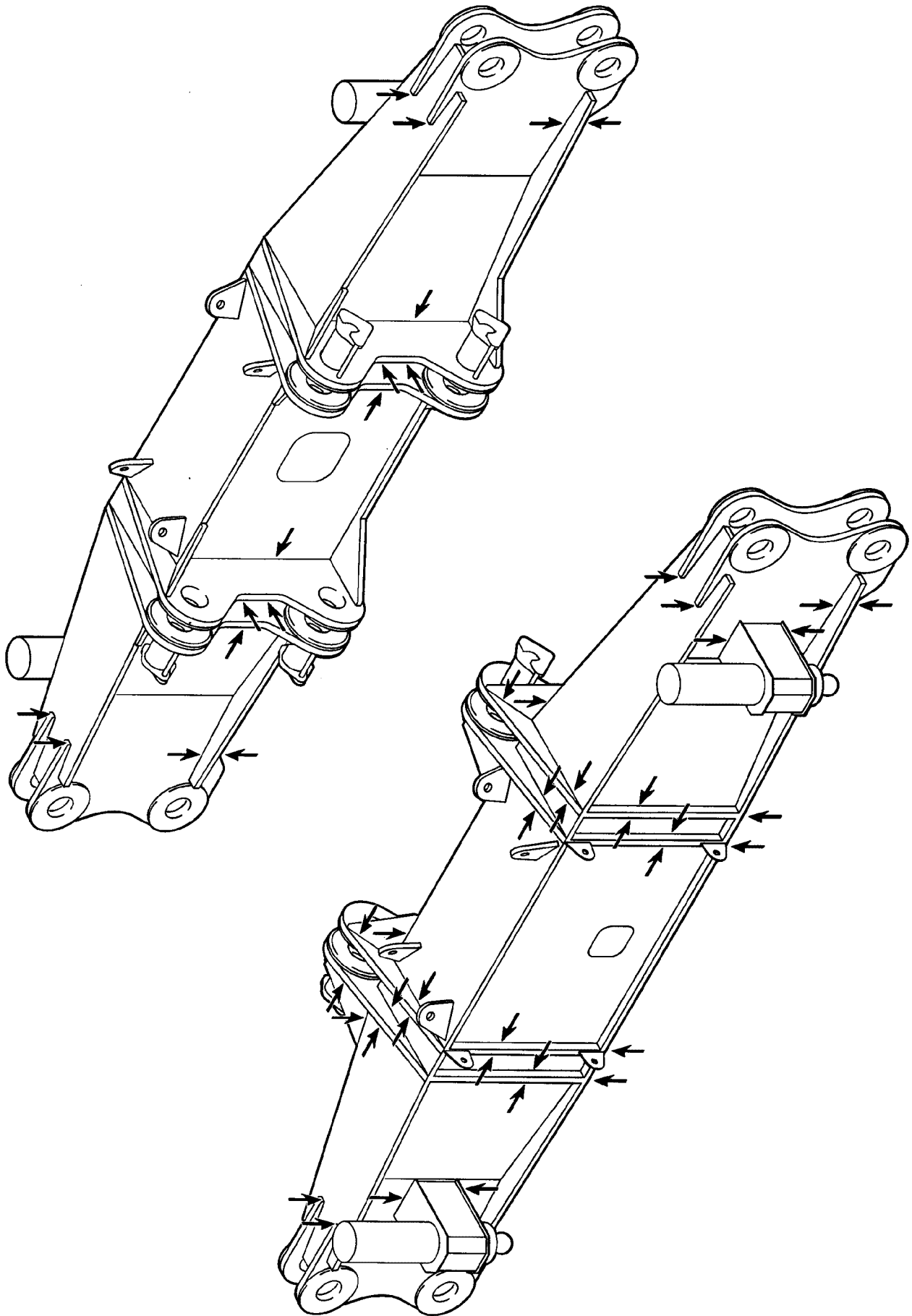

Fig.105727: Example for cross carrier



LWE/LR 1600-2-008/18109-09-02/en

Fig.187348: Example for cross carrier

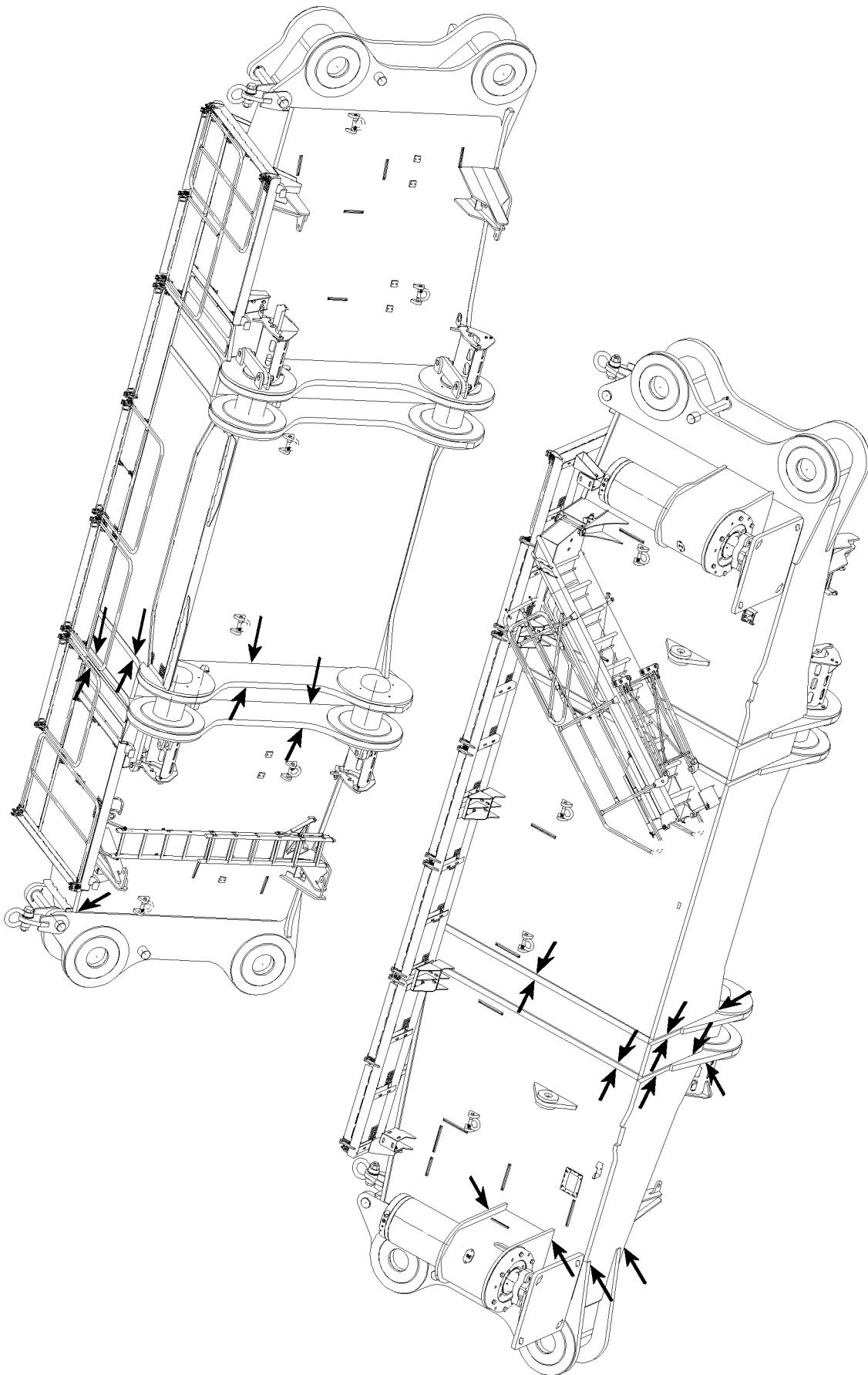
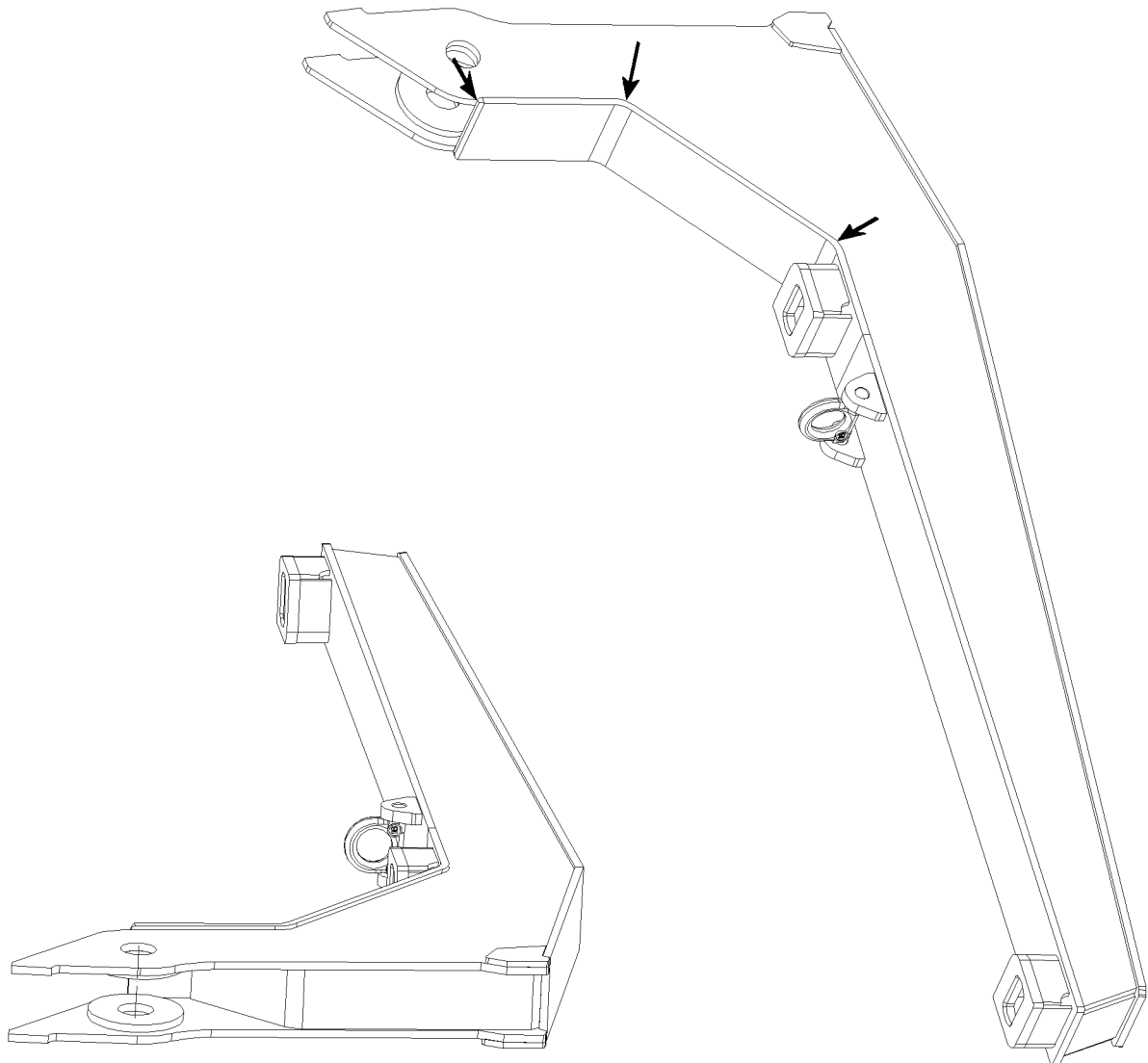

Fig.115921: Example for cross carrier

LWE/LR 1600-2-008/18109-09-02/en



LWE/LR 1600-2-008/18109-09-02/en

Fig.115919: Example for carrier for central ballast

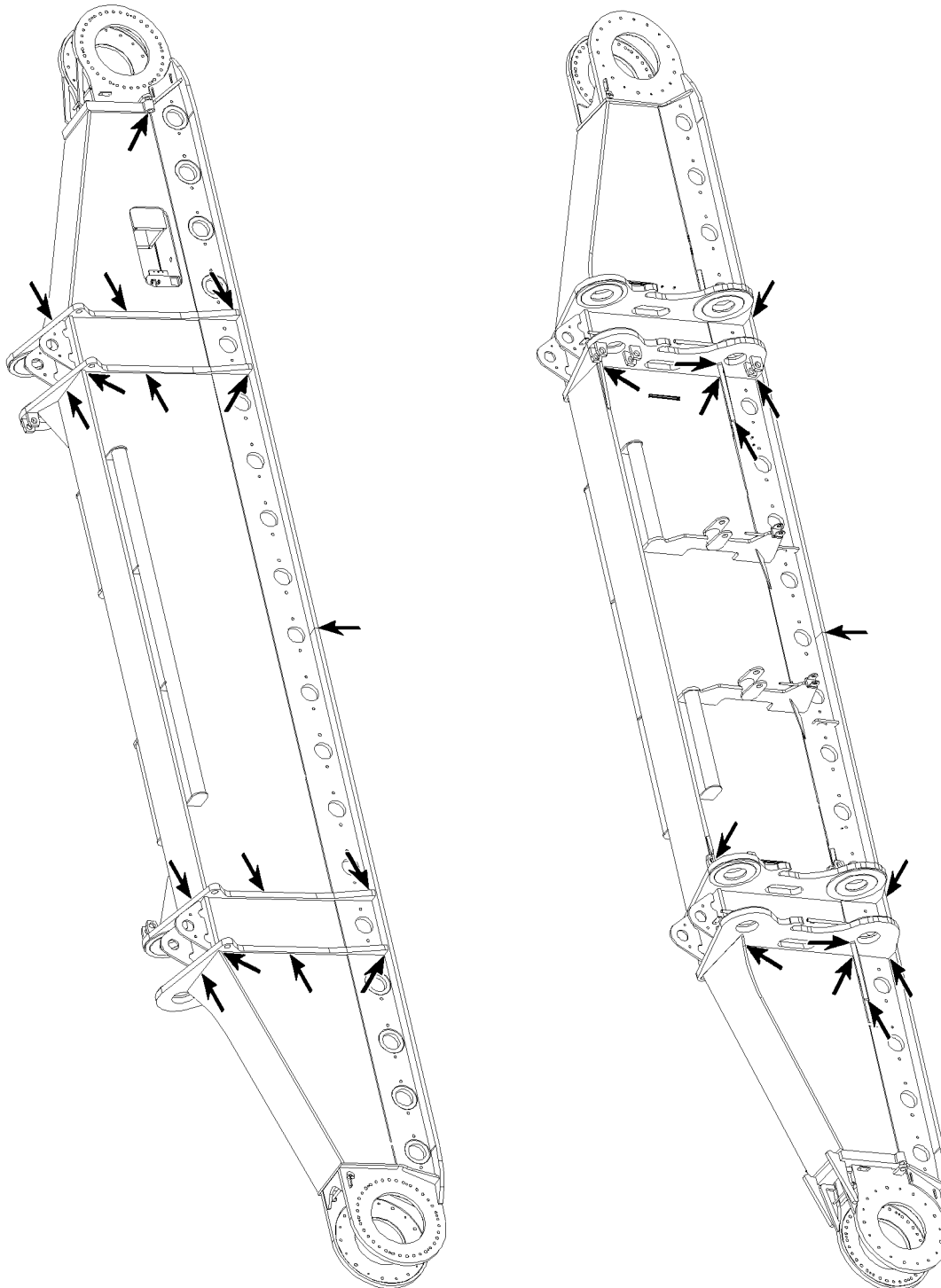
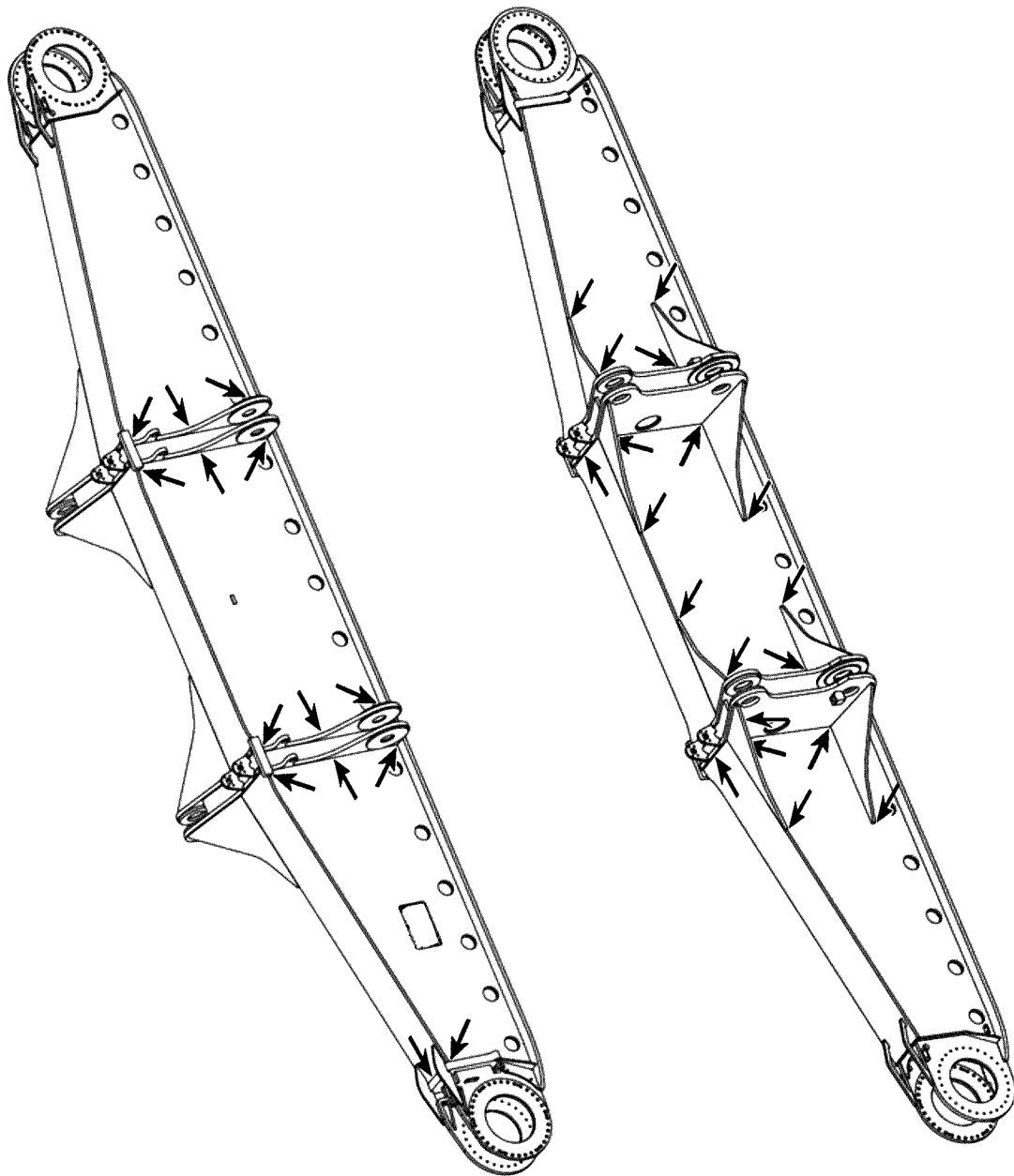

Fig.105728: Example for crawler carrier



LWE/LR 1600-2-008/18109-09-02/en

Fig.105729: Example for crawler carrier

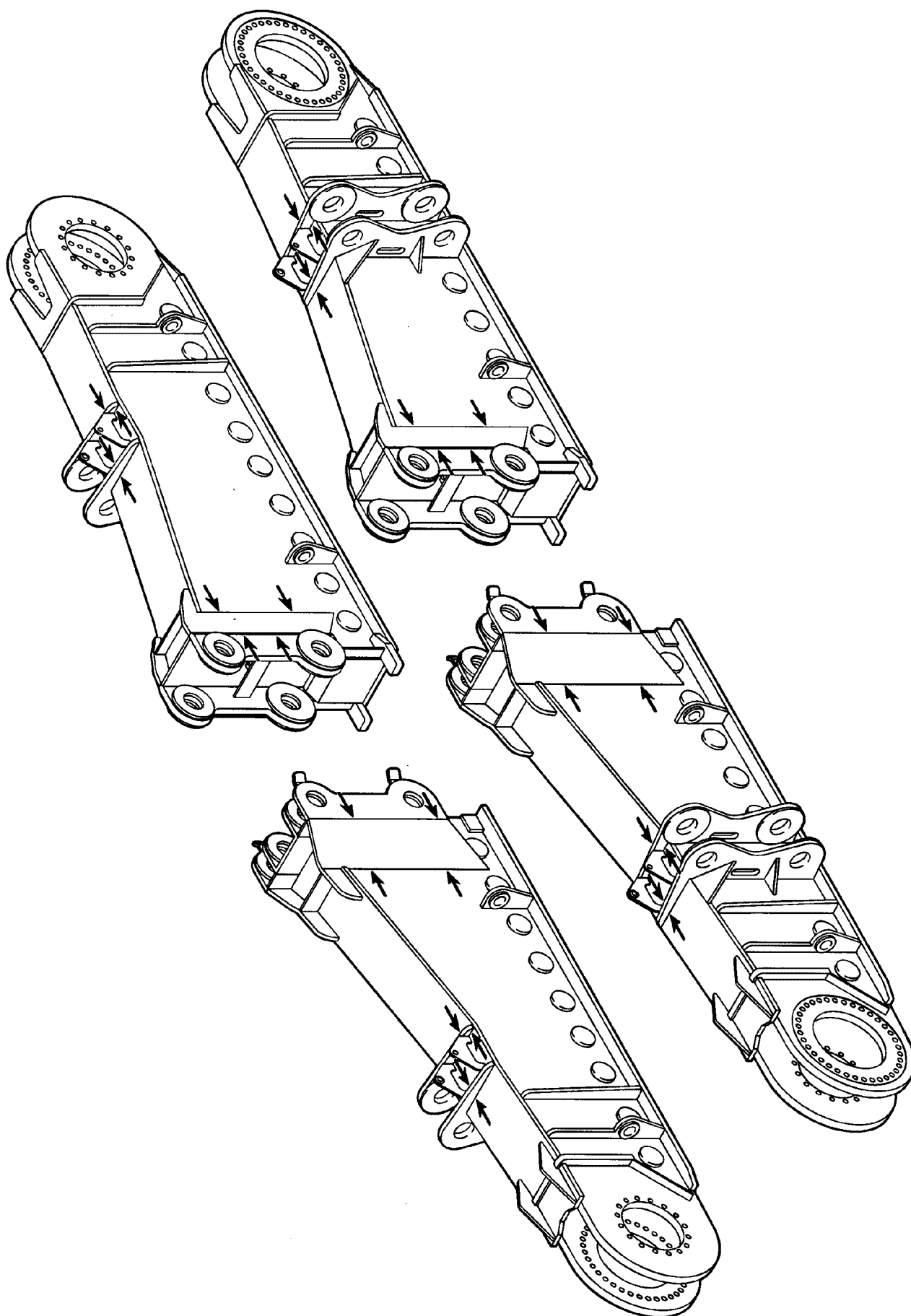
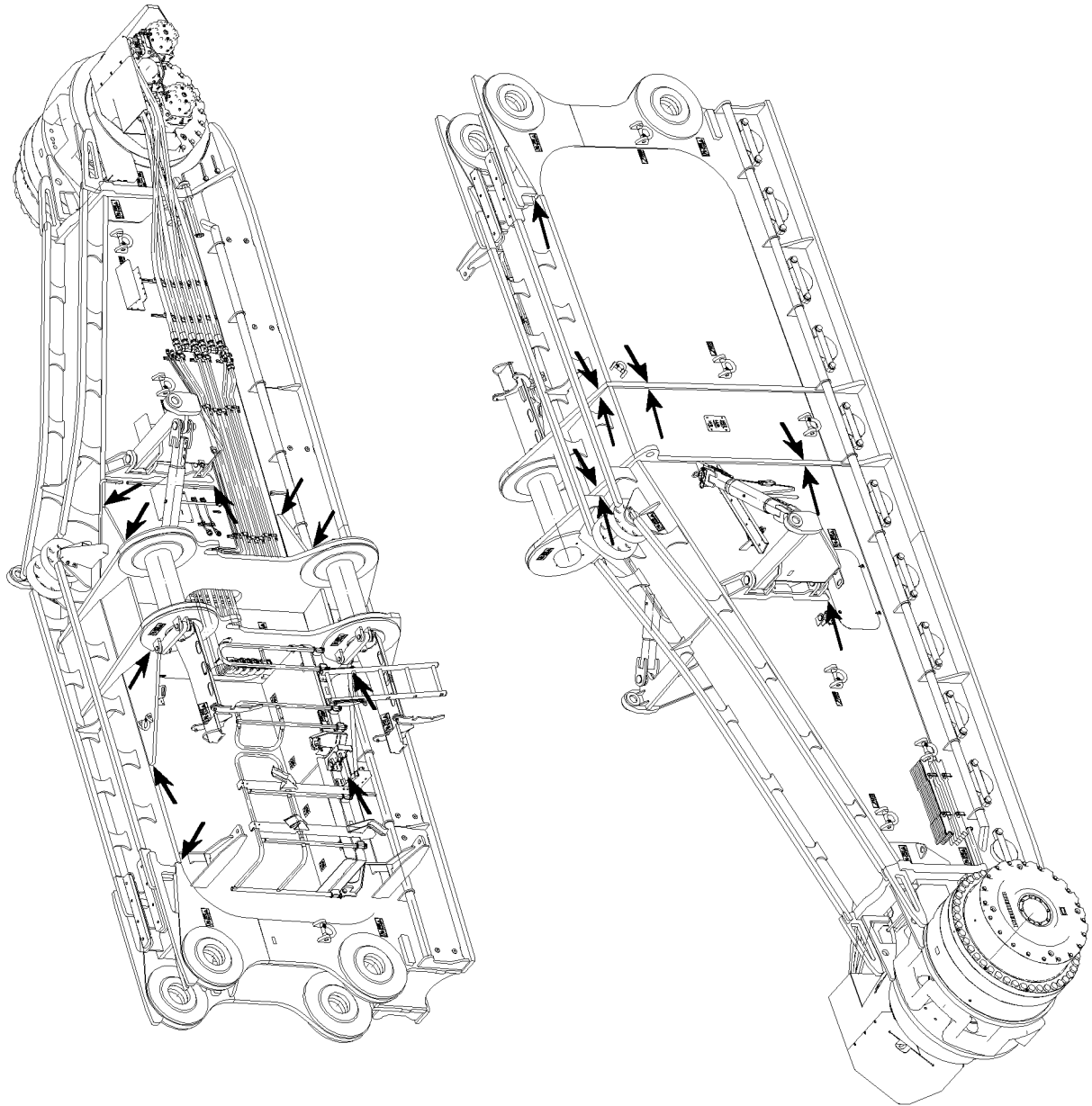

Fig.187349: Example for crawler carrier



LWE/LR 1600-2-008/18109-09-02/en

Fig.115917: Example for crawler carrier

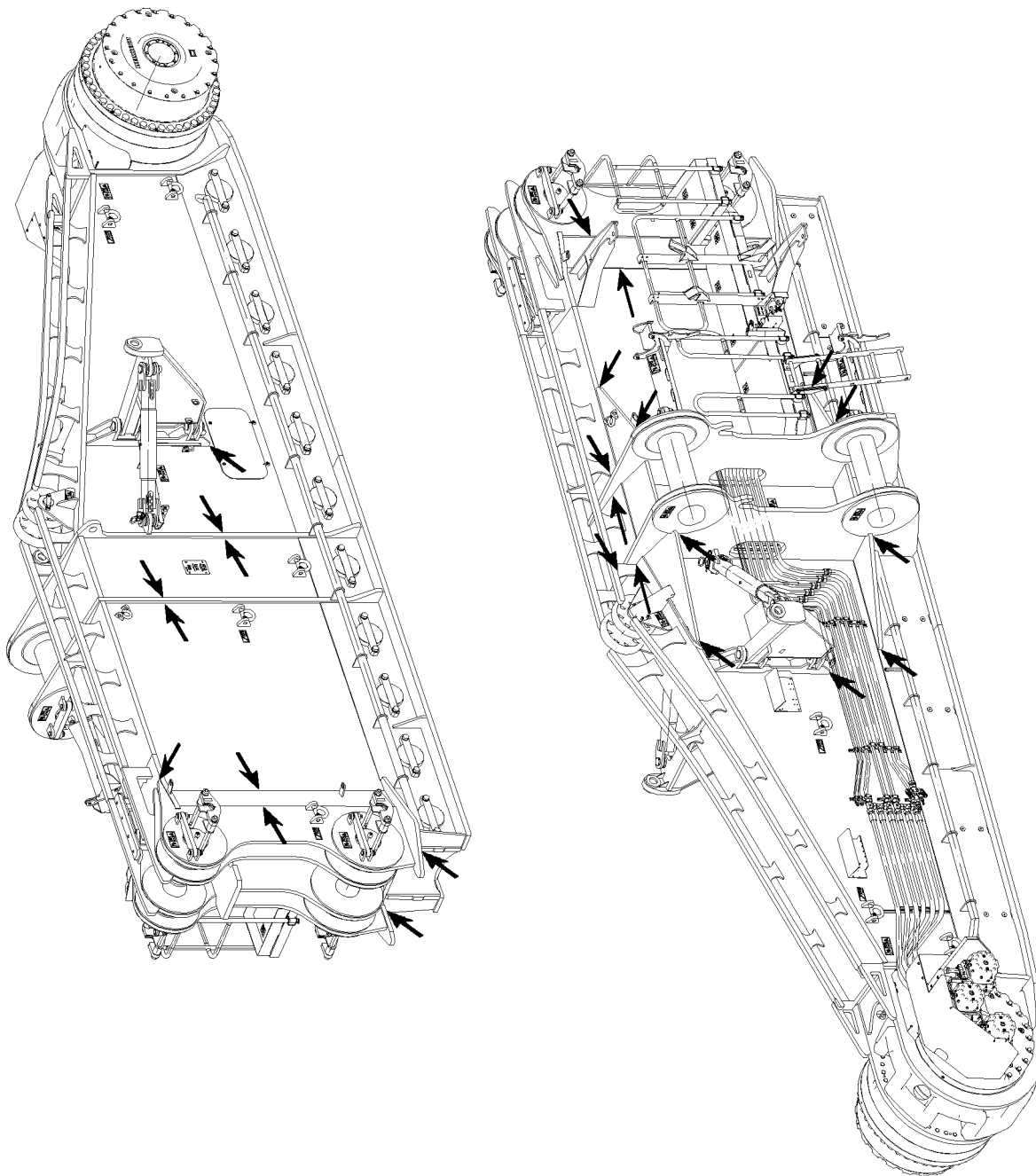
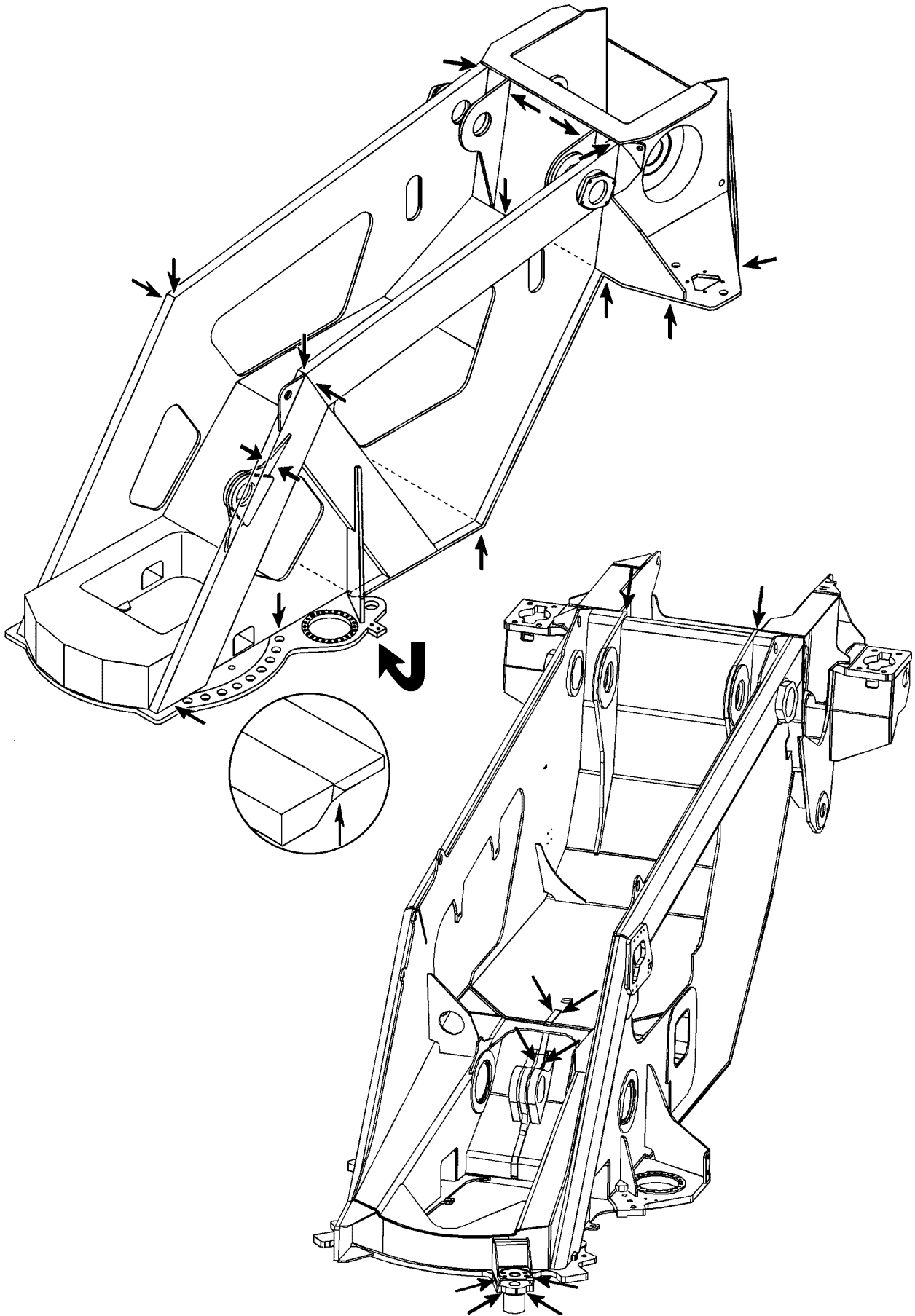

Fig.115918: Example for crawler carrier

LWE/LR 1600-2-008/18109-09-02/en



LWE/LR 1600-2-008/18109-09-02/en

Fig.185048: Example for turntable frame

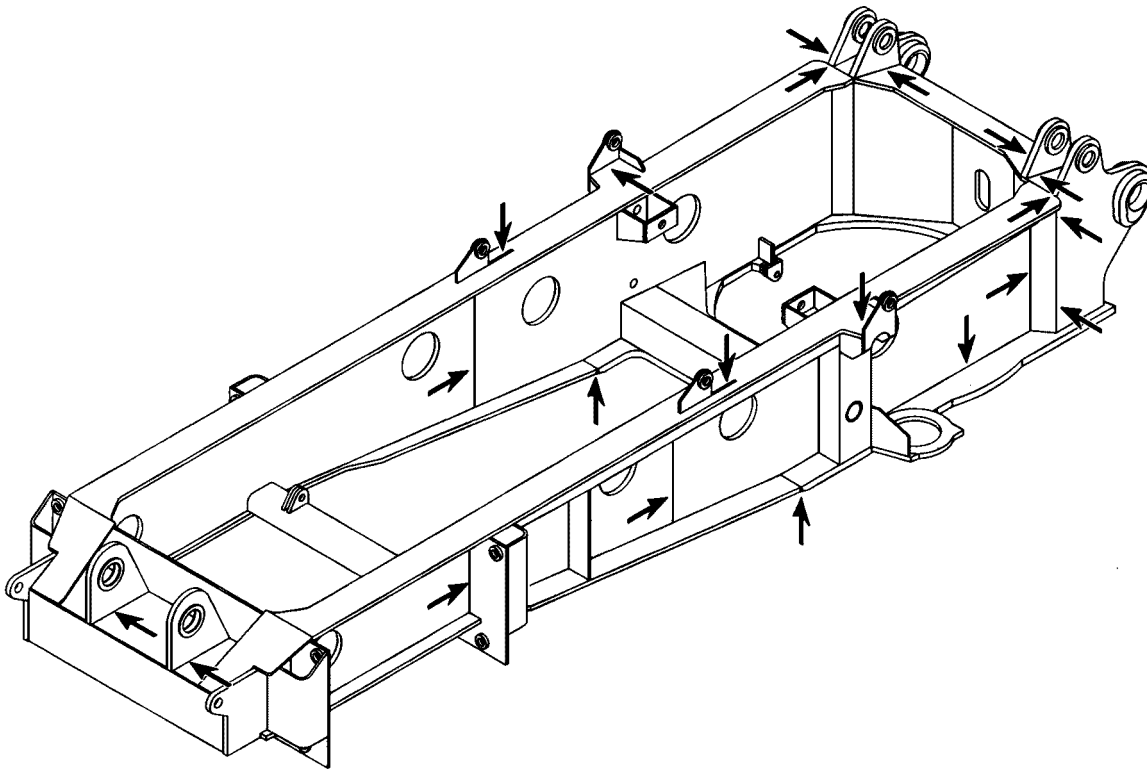

Fig.185049: Example for turntable frame

LWE/LR 1600-2-008/18109-09-02/en

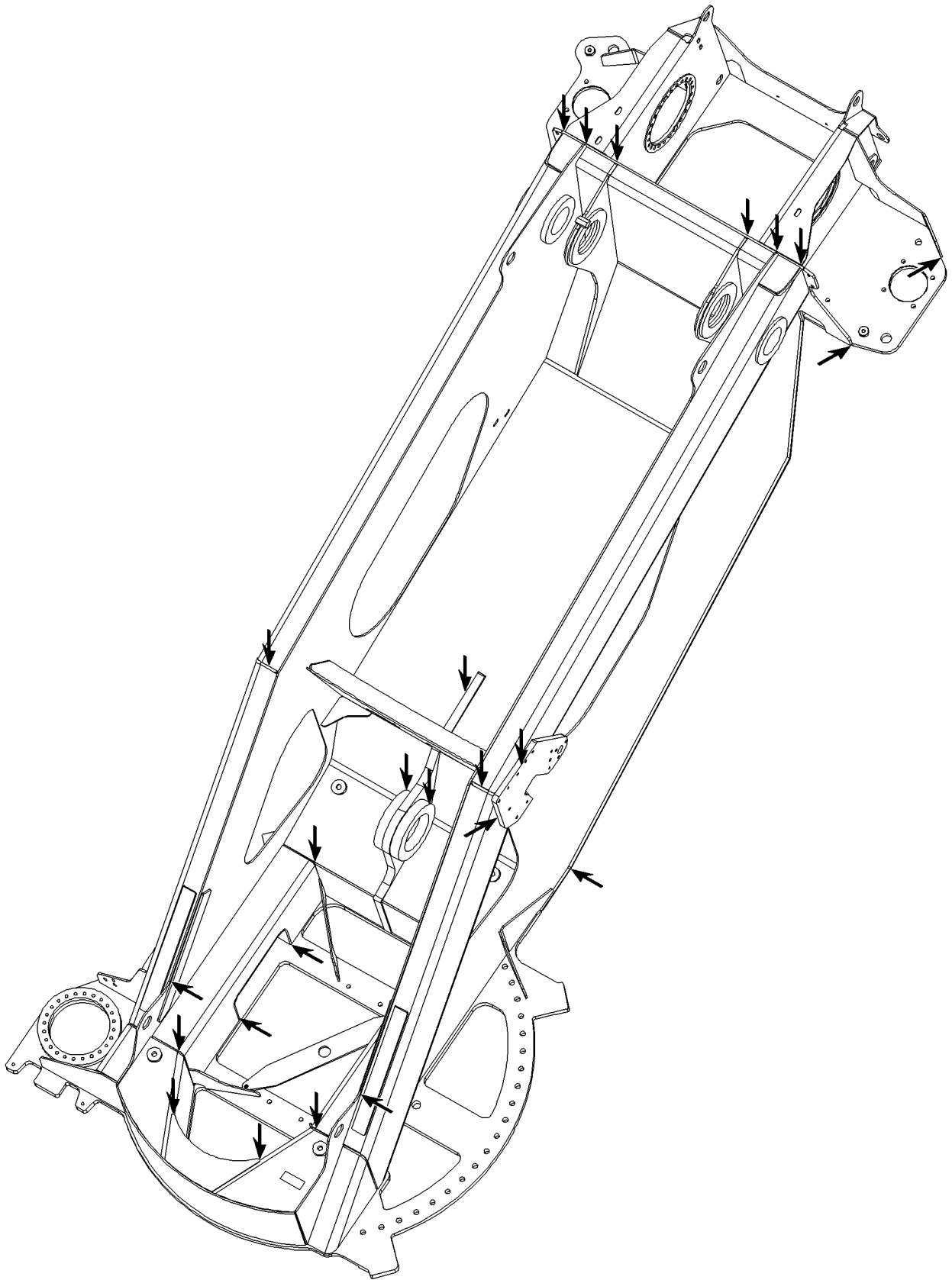

Fig.105700: Example for turntable frame

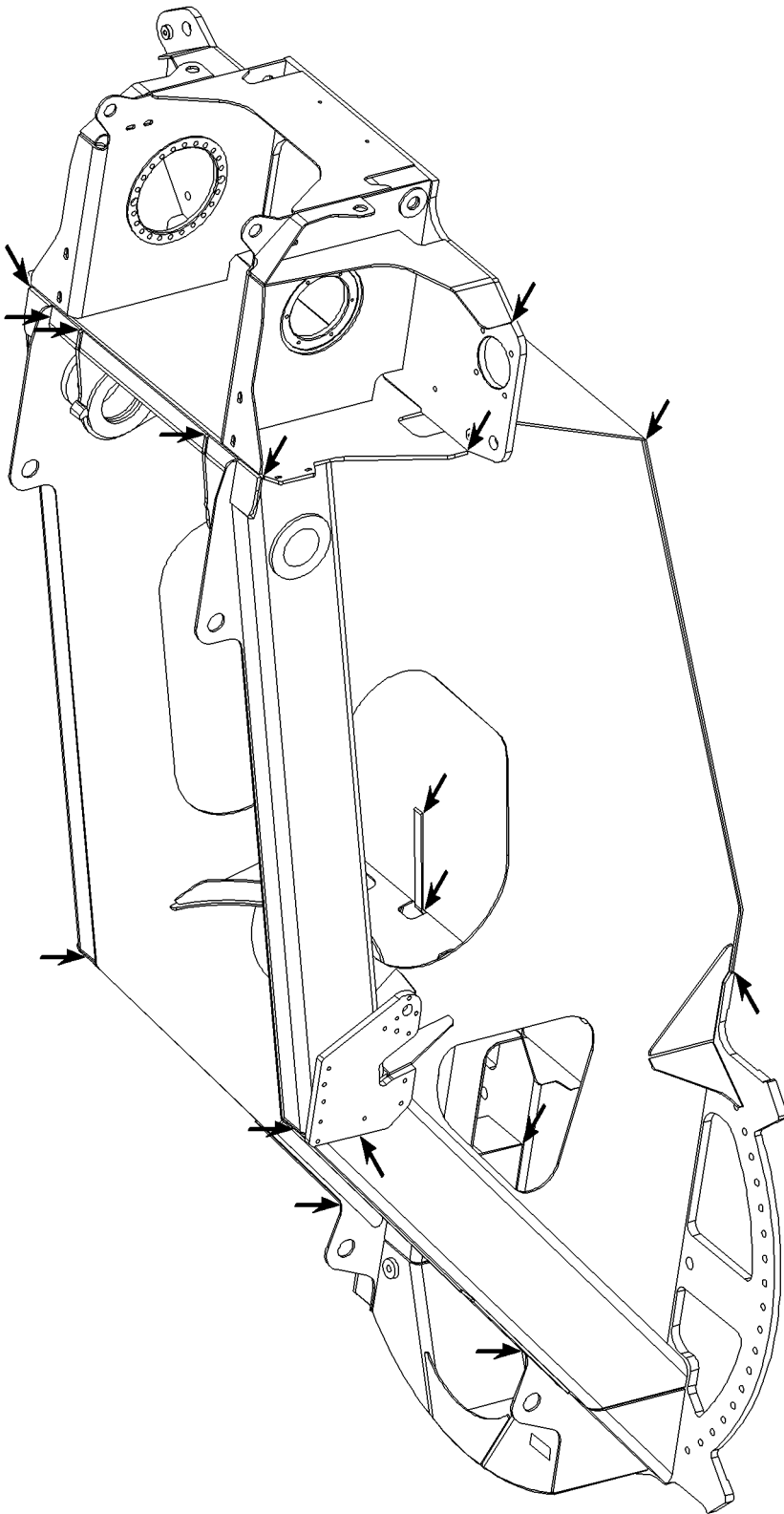
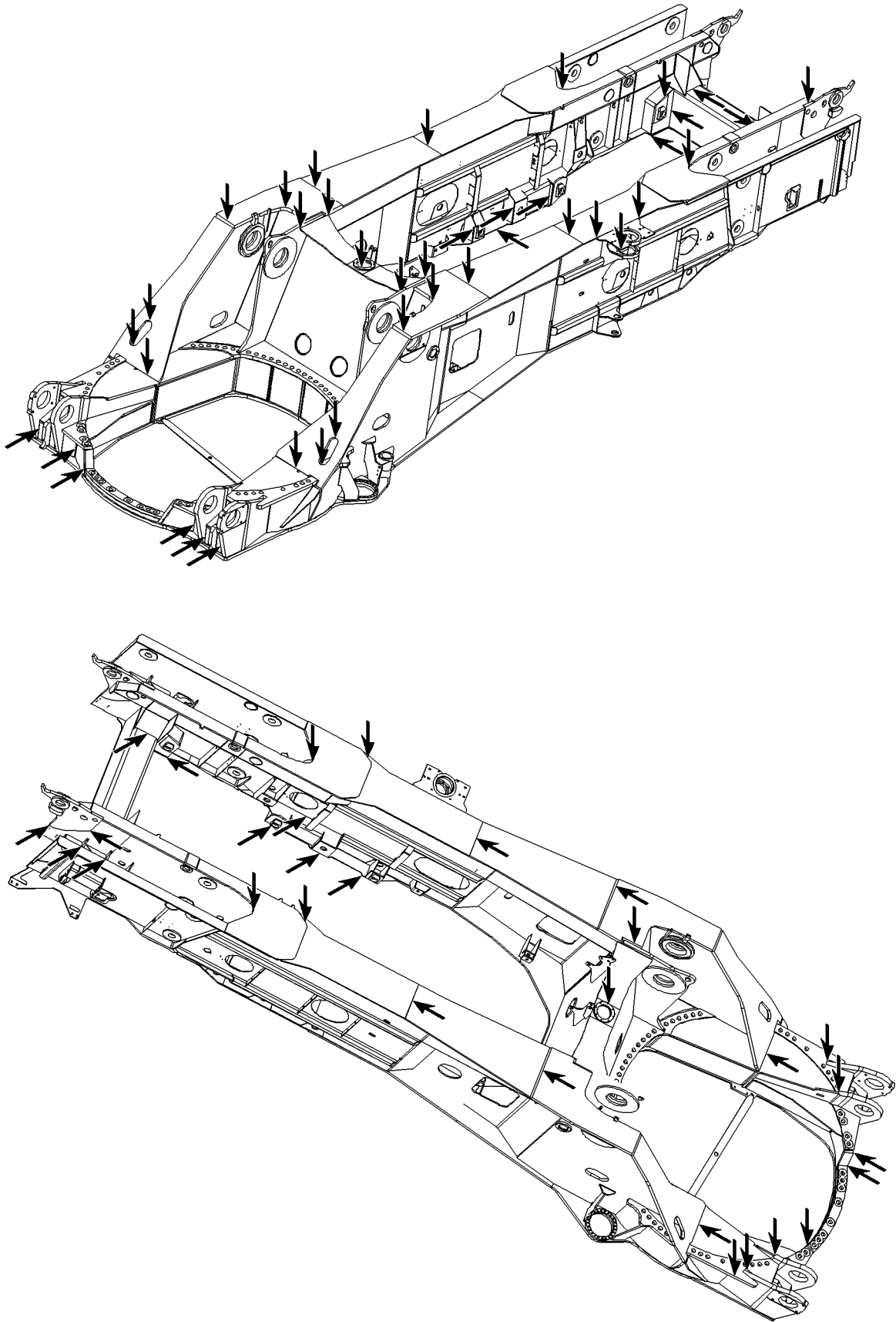

Fig.105701: Example for turntable frame



LWE/LR 1600-2-008/18109-09-02/en

Fig.105706: Example for turntable frame

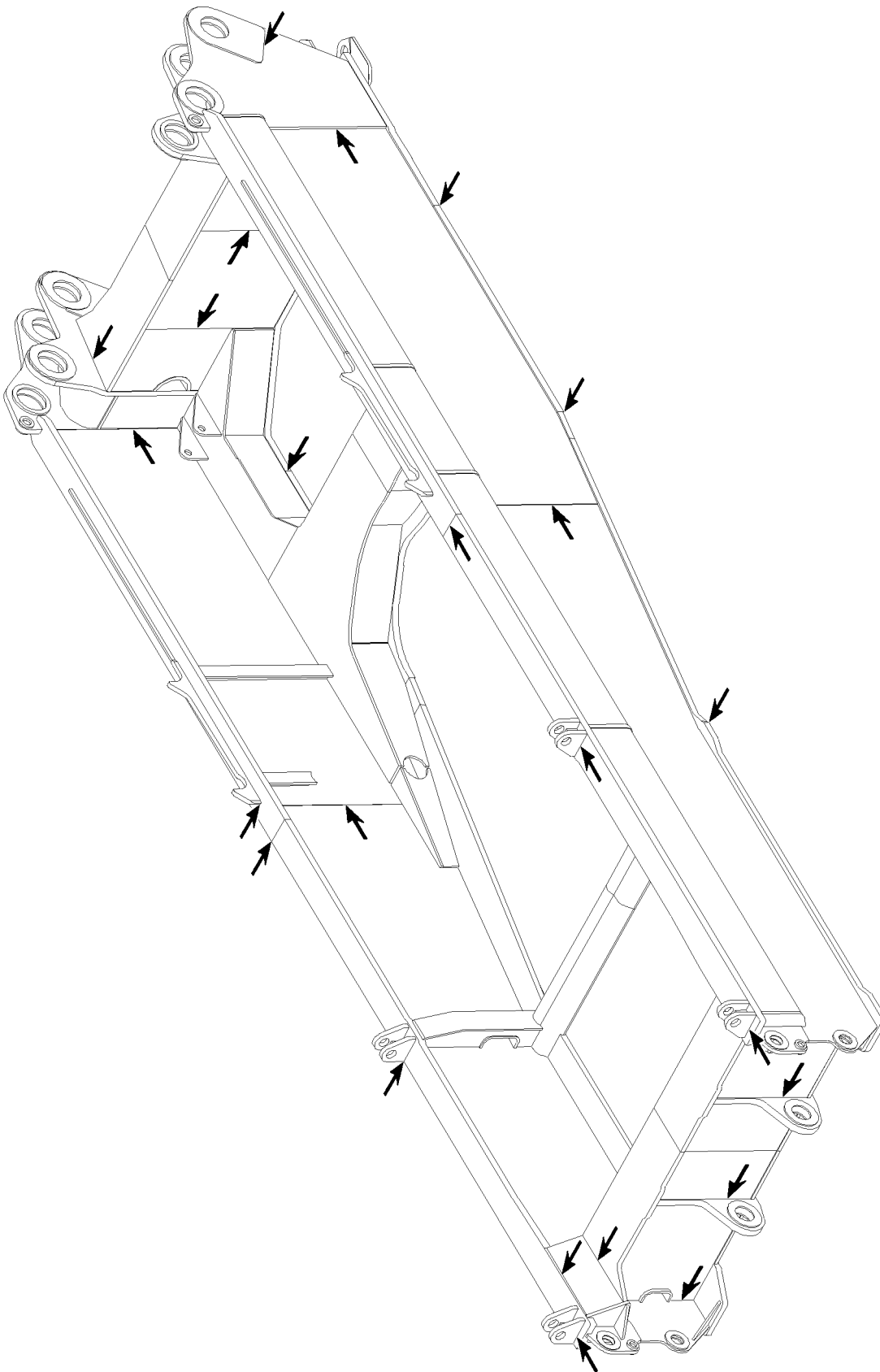
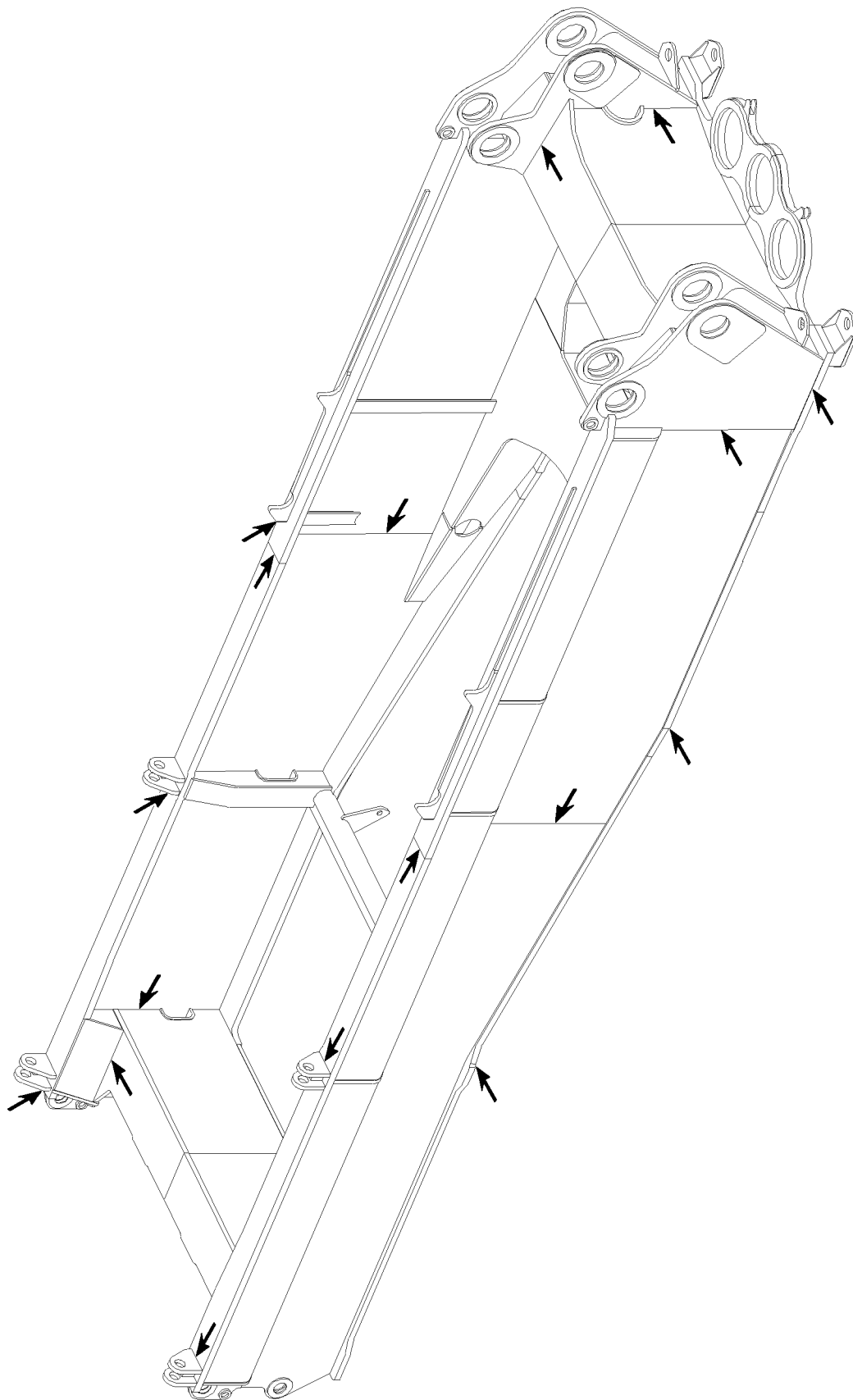

Fig.105694: Example for turntable frame



LWE/LR 1600-2-008/18109-09-02/en

Fig.105695: Example for turntable frame

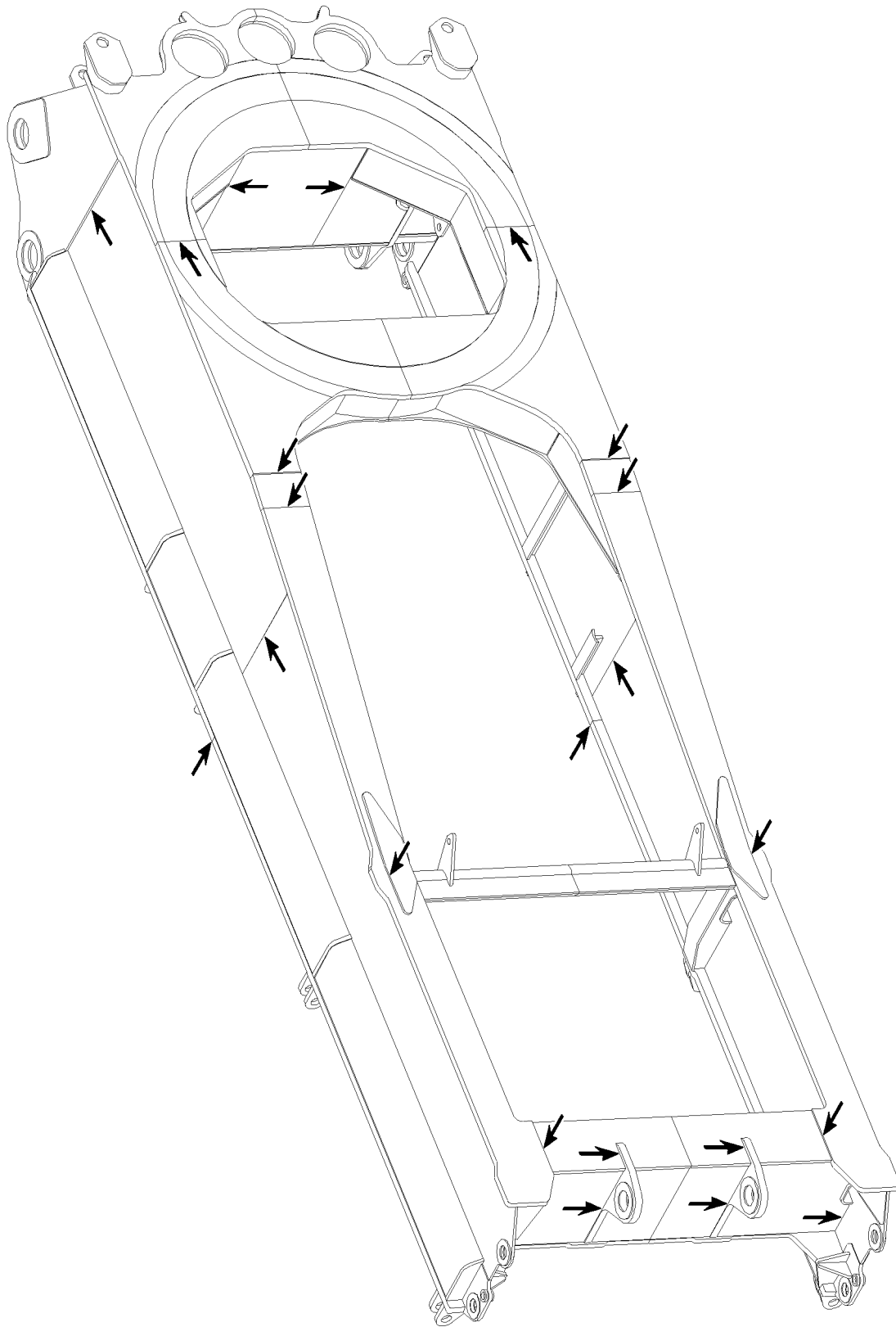
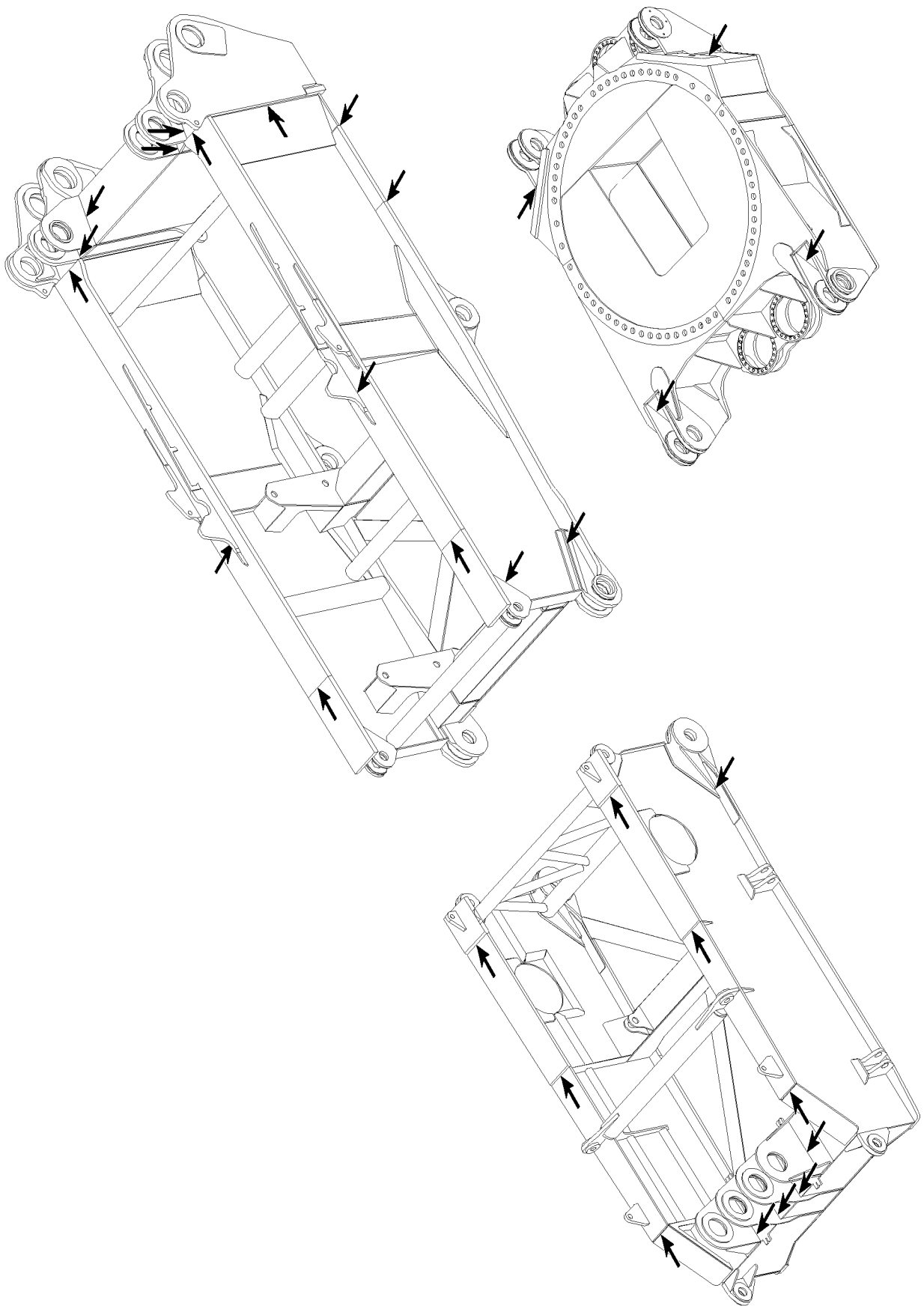

Fig.105696: Example for turntable frame



LWE/LR 1600-2-008/18109-09-02/en

Fig.105691: Example for turntable frame

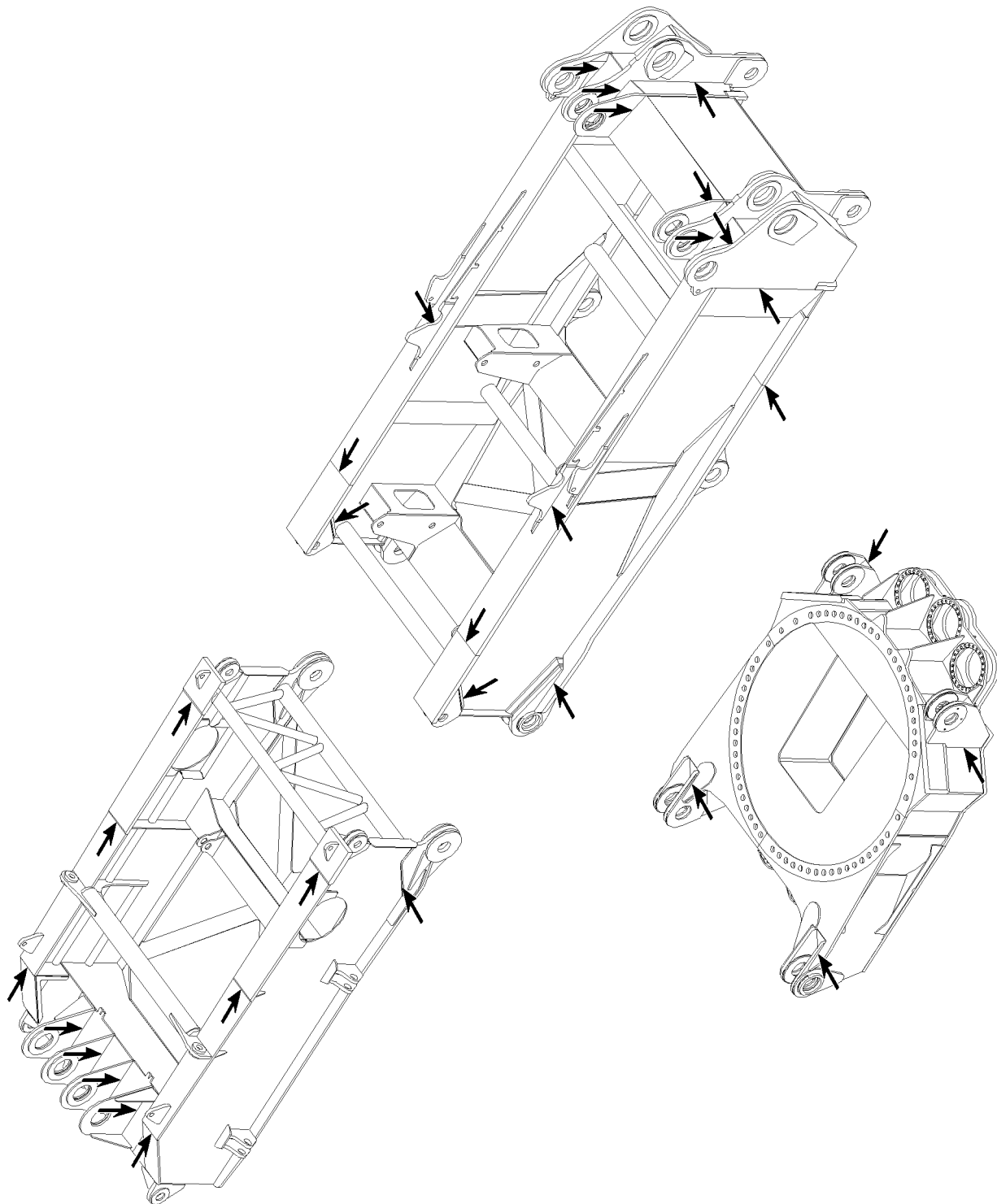
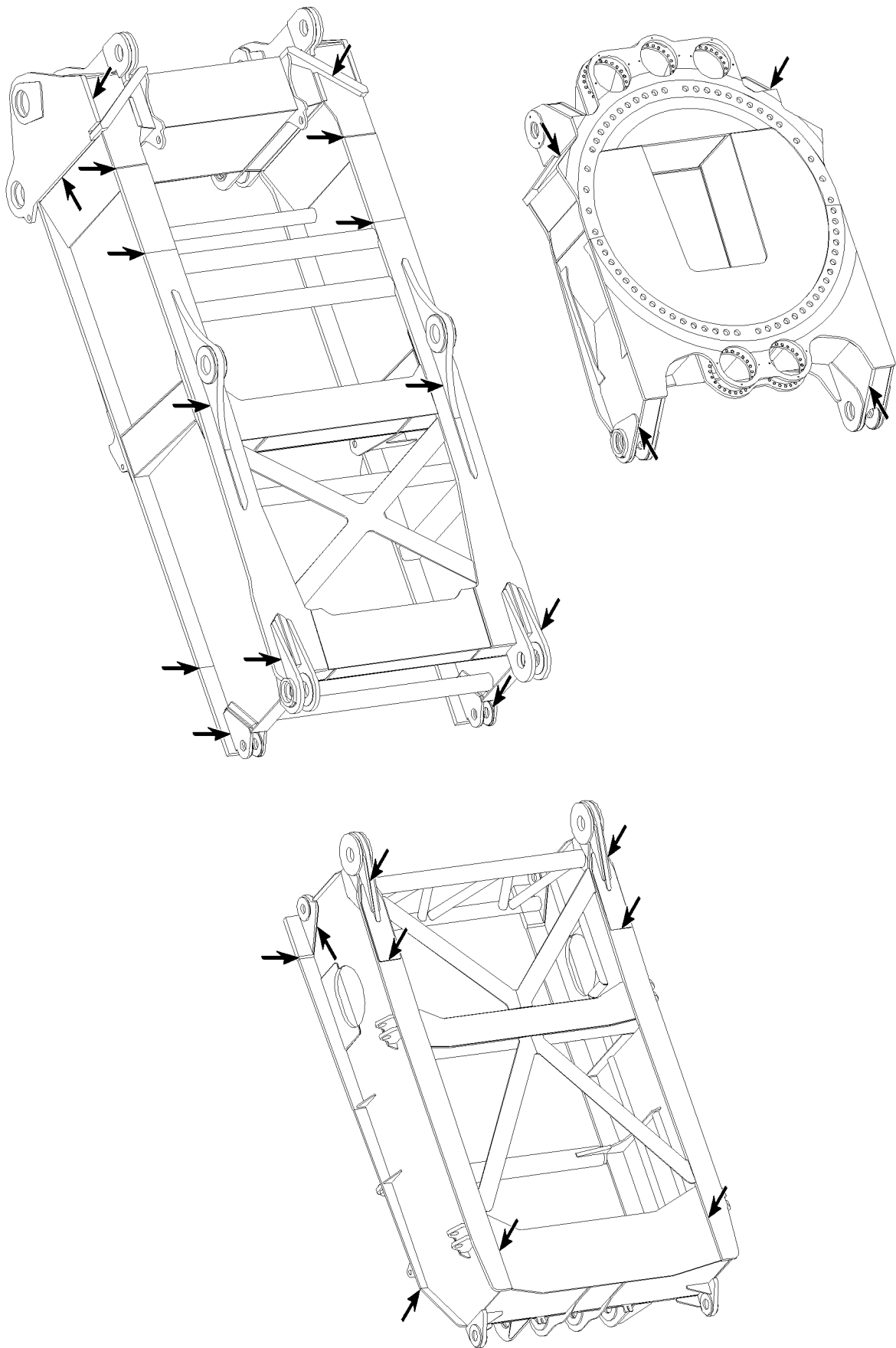

Fig.105692: Example for turntable frame



LWE/LR 1600-2-008/18109-09-02/en

Fig.105693: Example for turntable frame

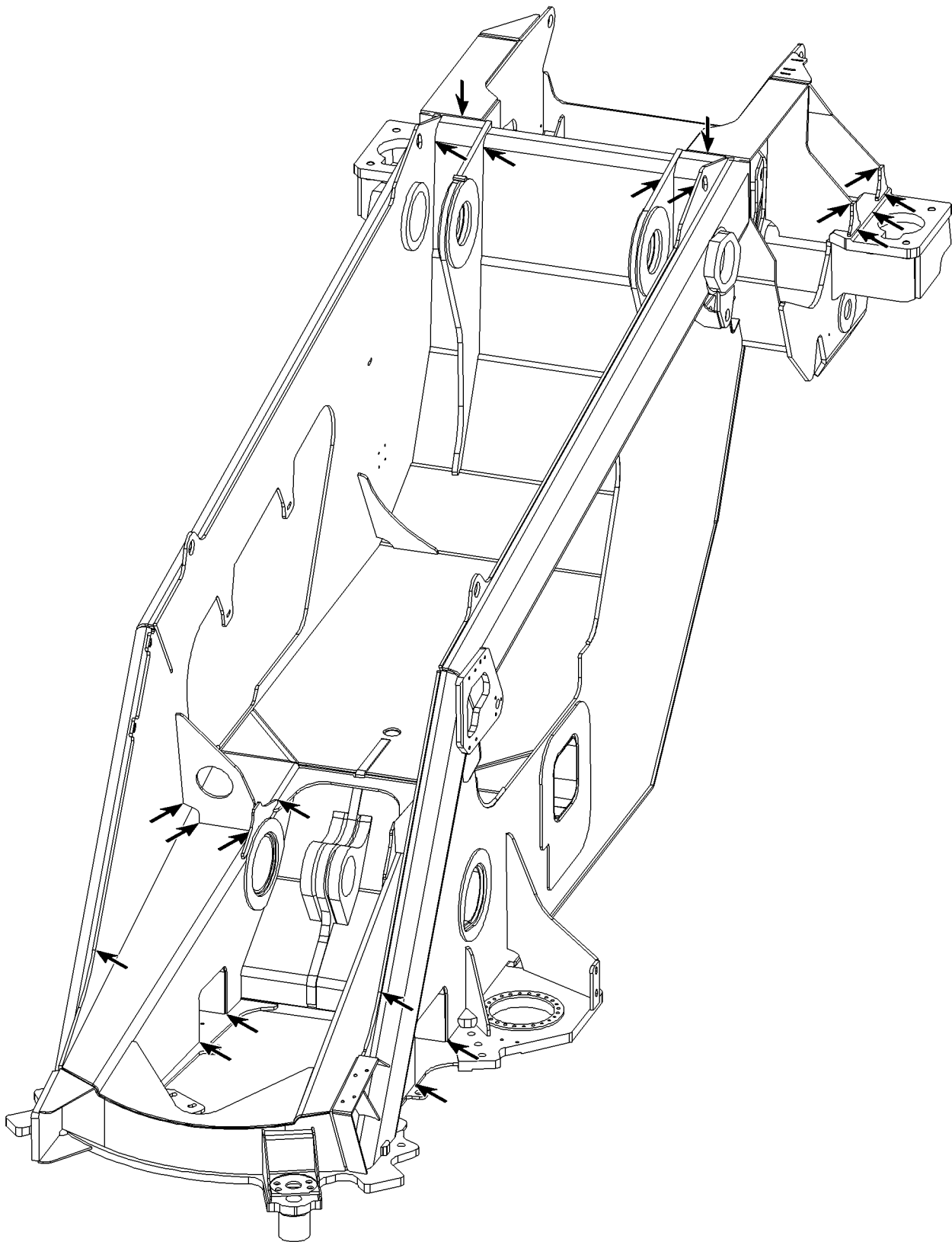
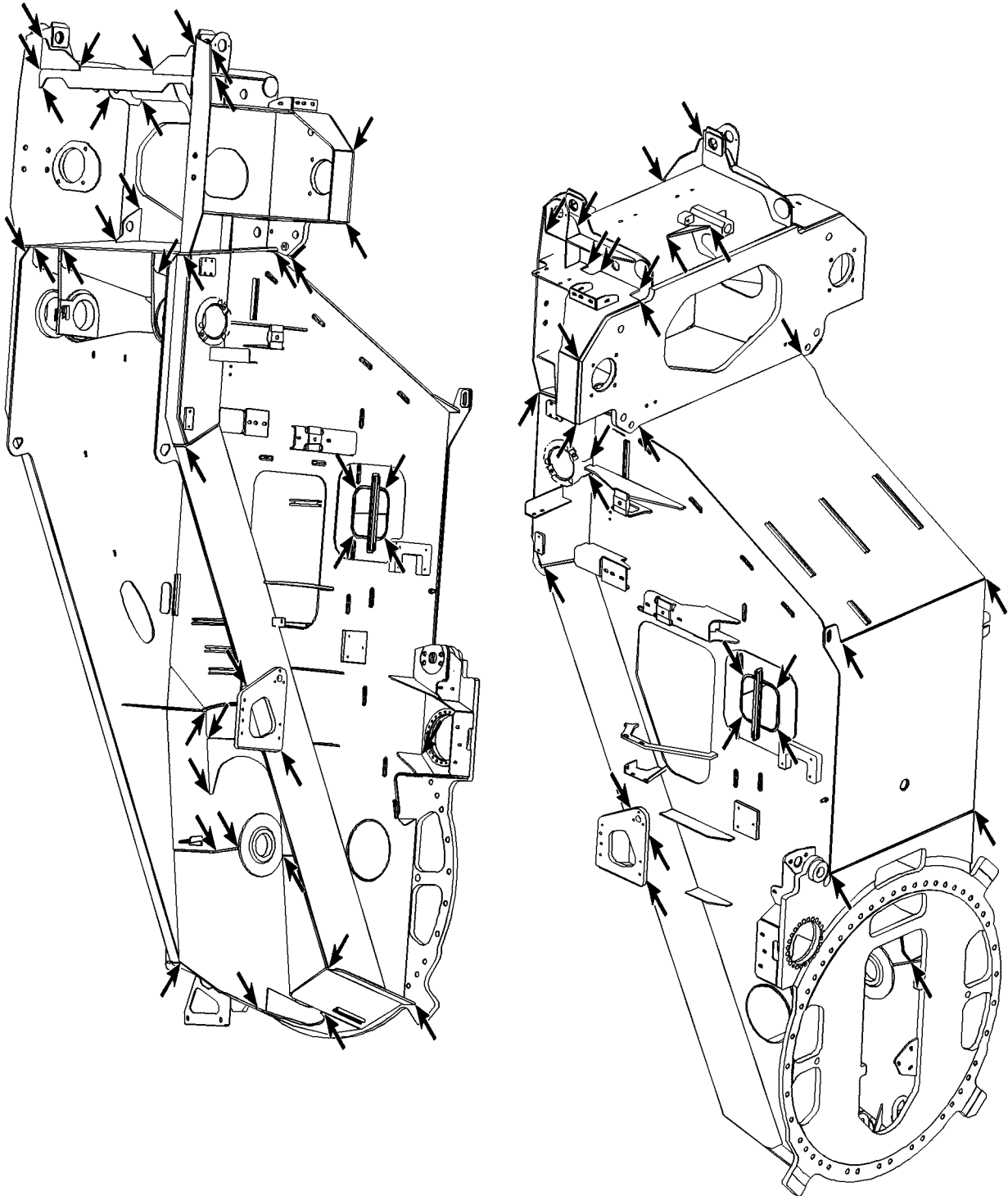

Fig.105722: Example for turntable frame



LWE/LR 1600-2-008/18109-09-02/en

Fig.105932: Example for turntable frame

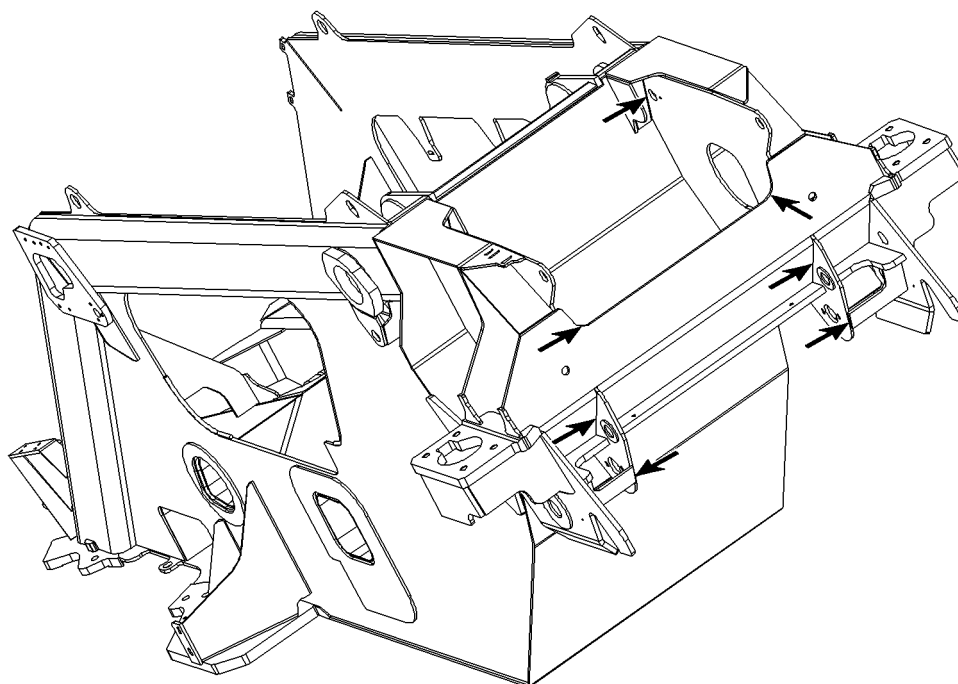
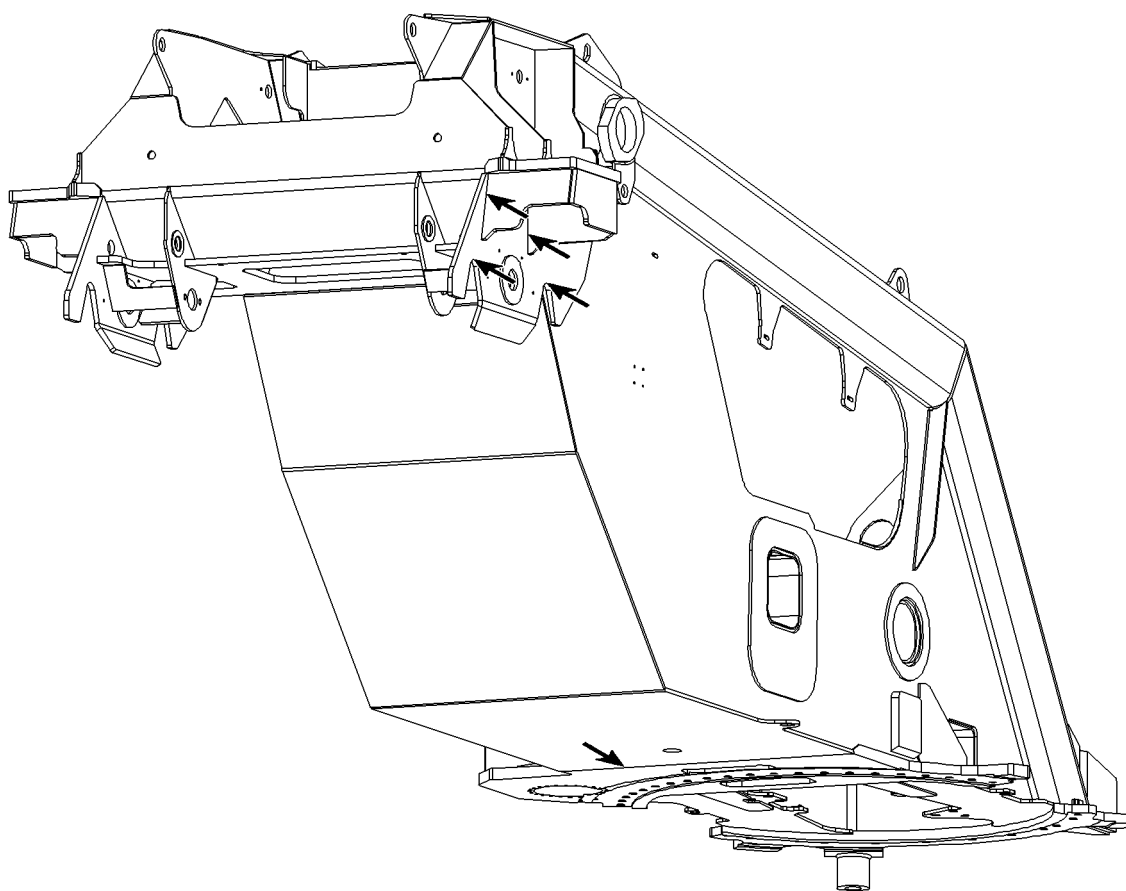
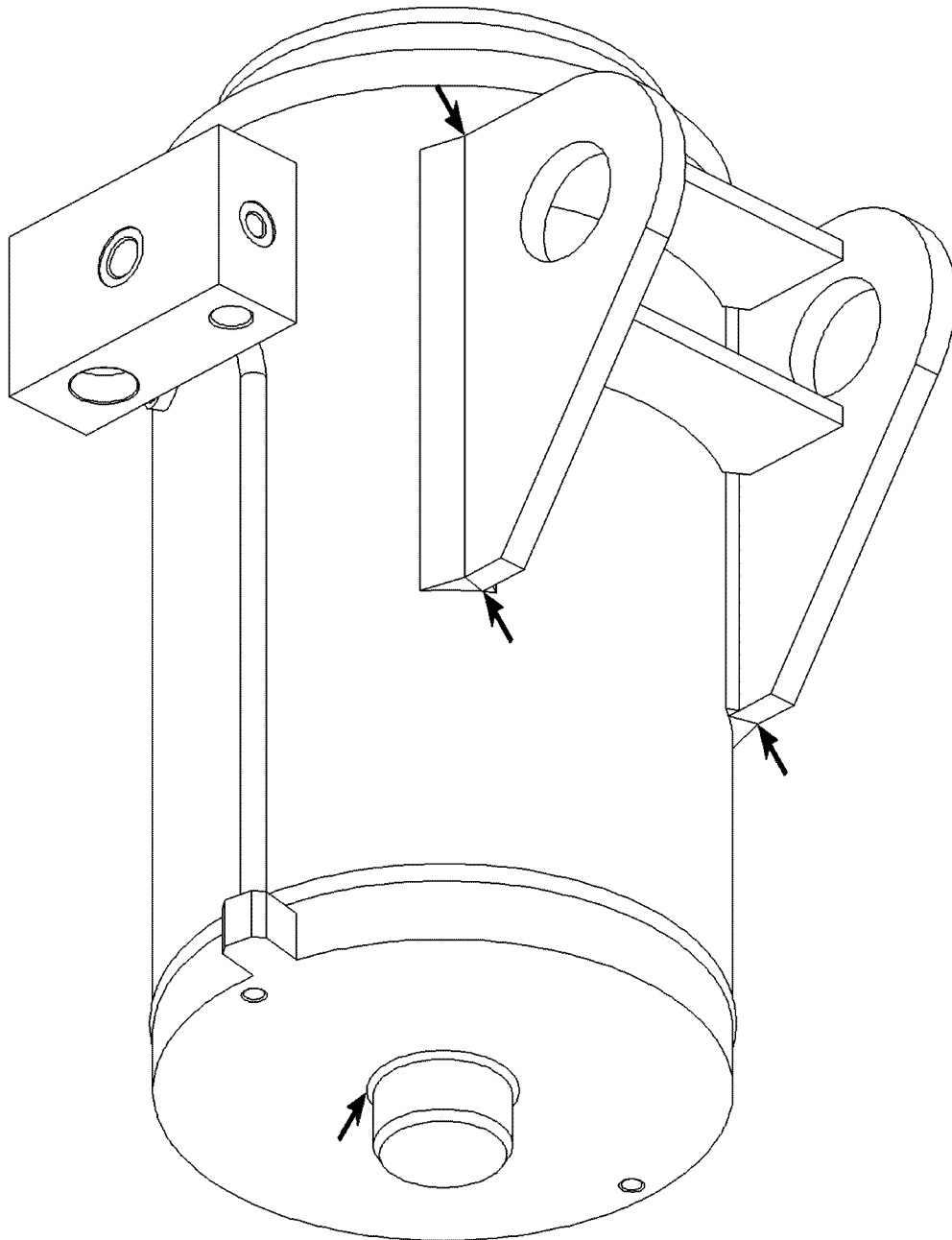

Fig.105723: Example for turntable frame



LWE/LR 1600-2-008/18109-09-02/en

Fig.105801: Example for ballast cylinder

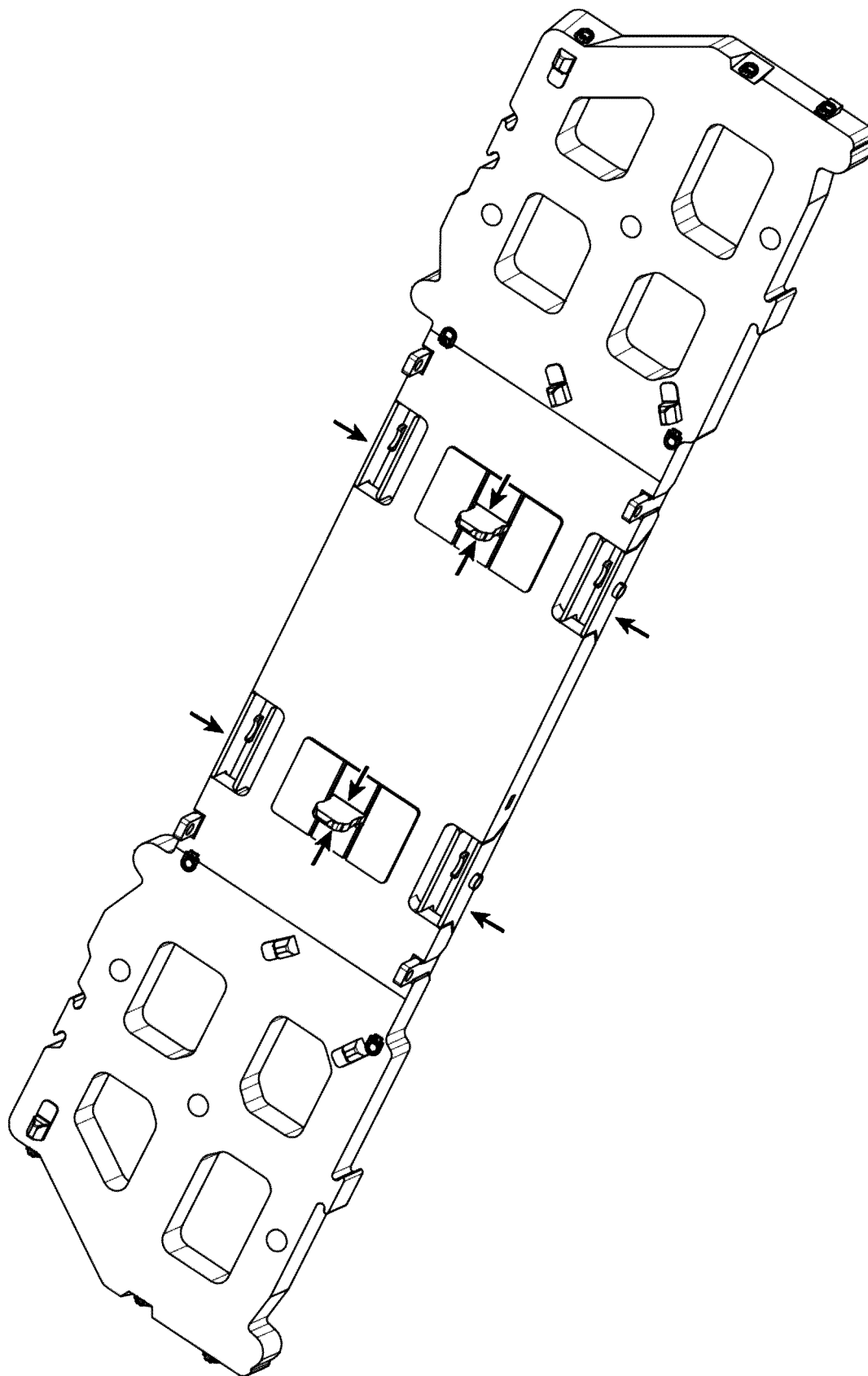
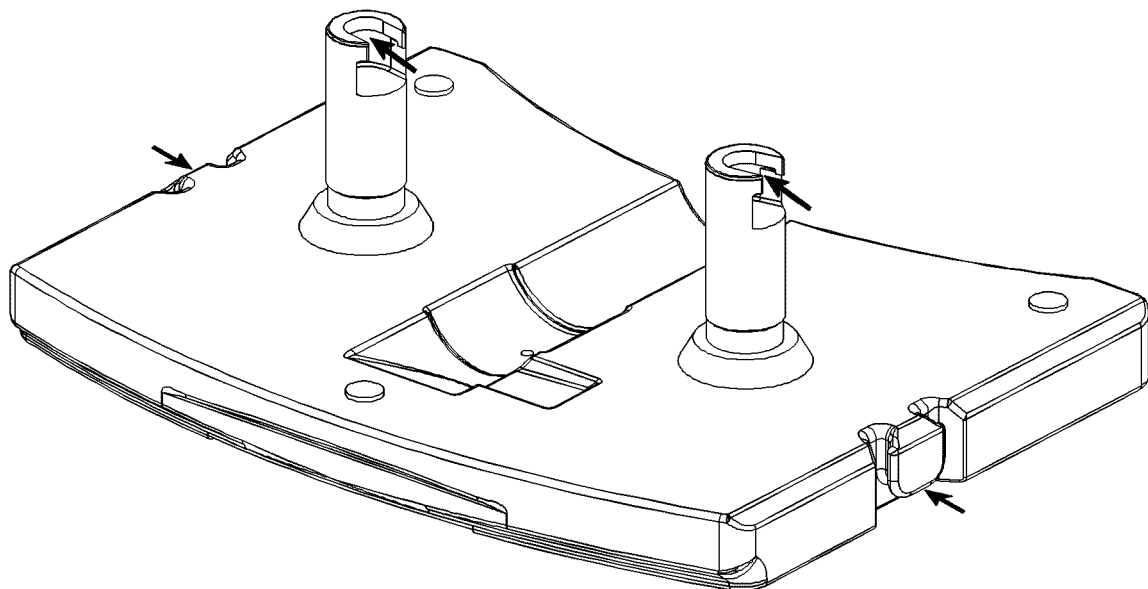
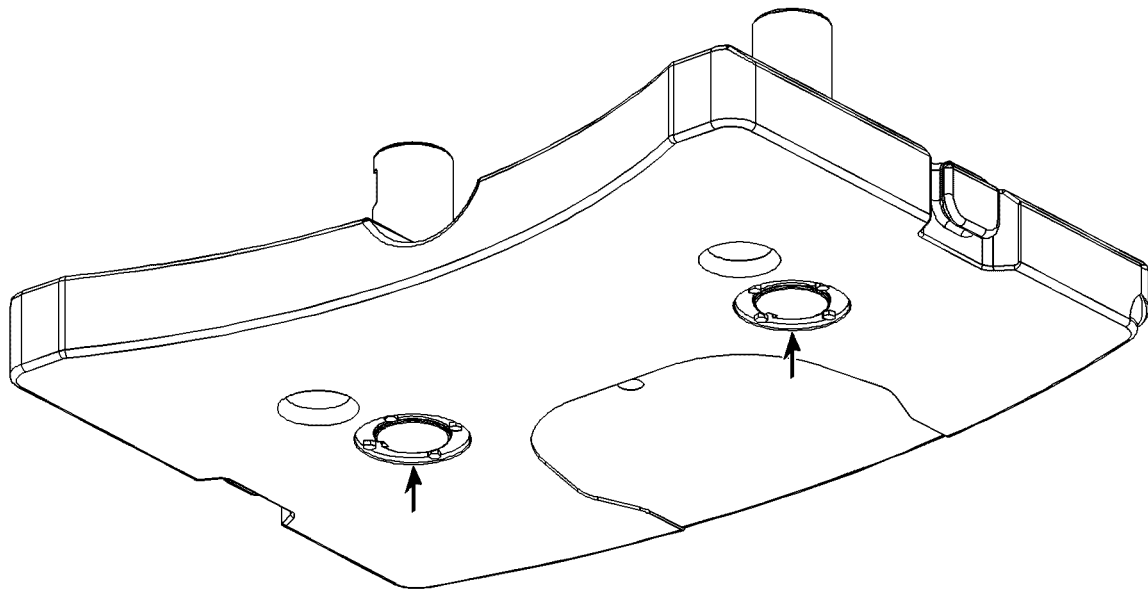

Fig.105705: Example for mounting plate

LWE/LR 1600-2-008/18109-09-02/en



LWE/LR 1600-2-008/18109-09-02/en

Fig.105807: Example for base plate

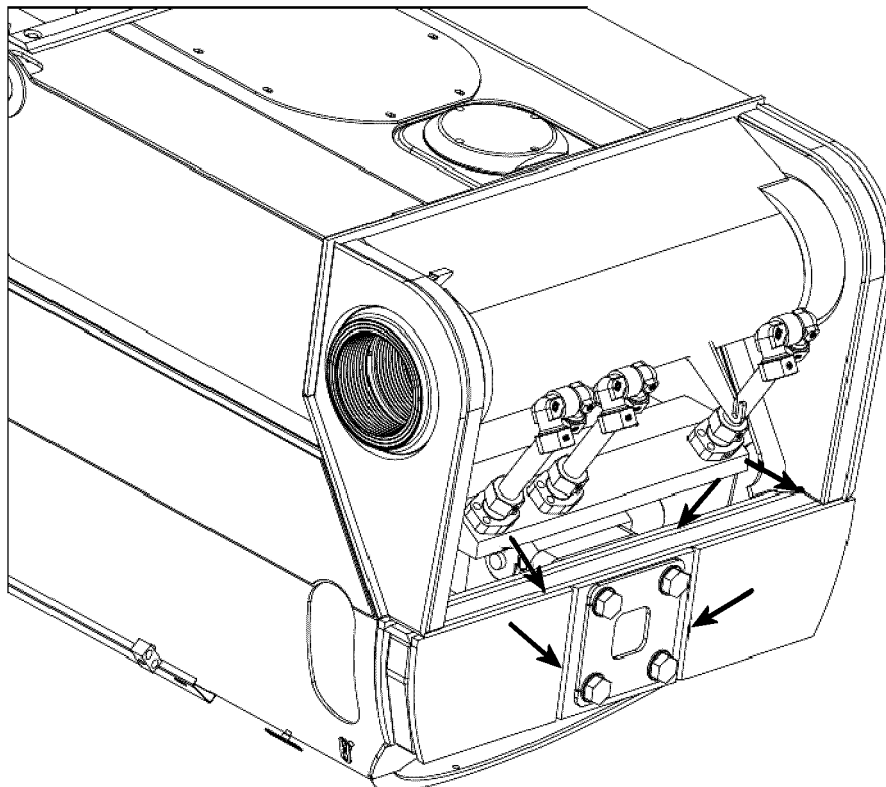
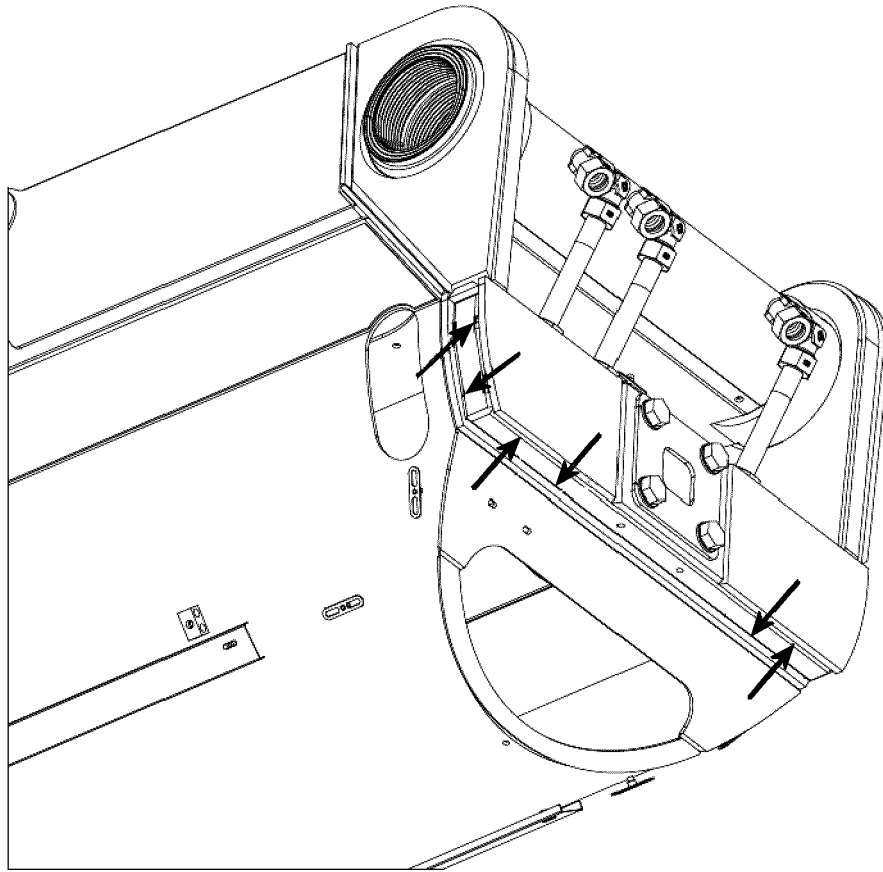
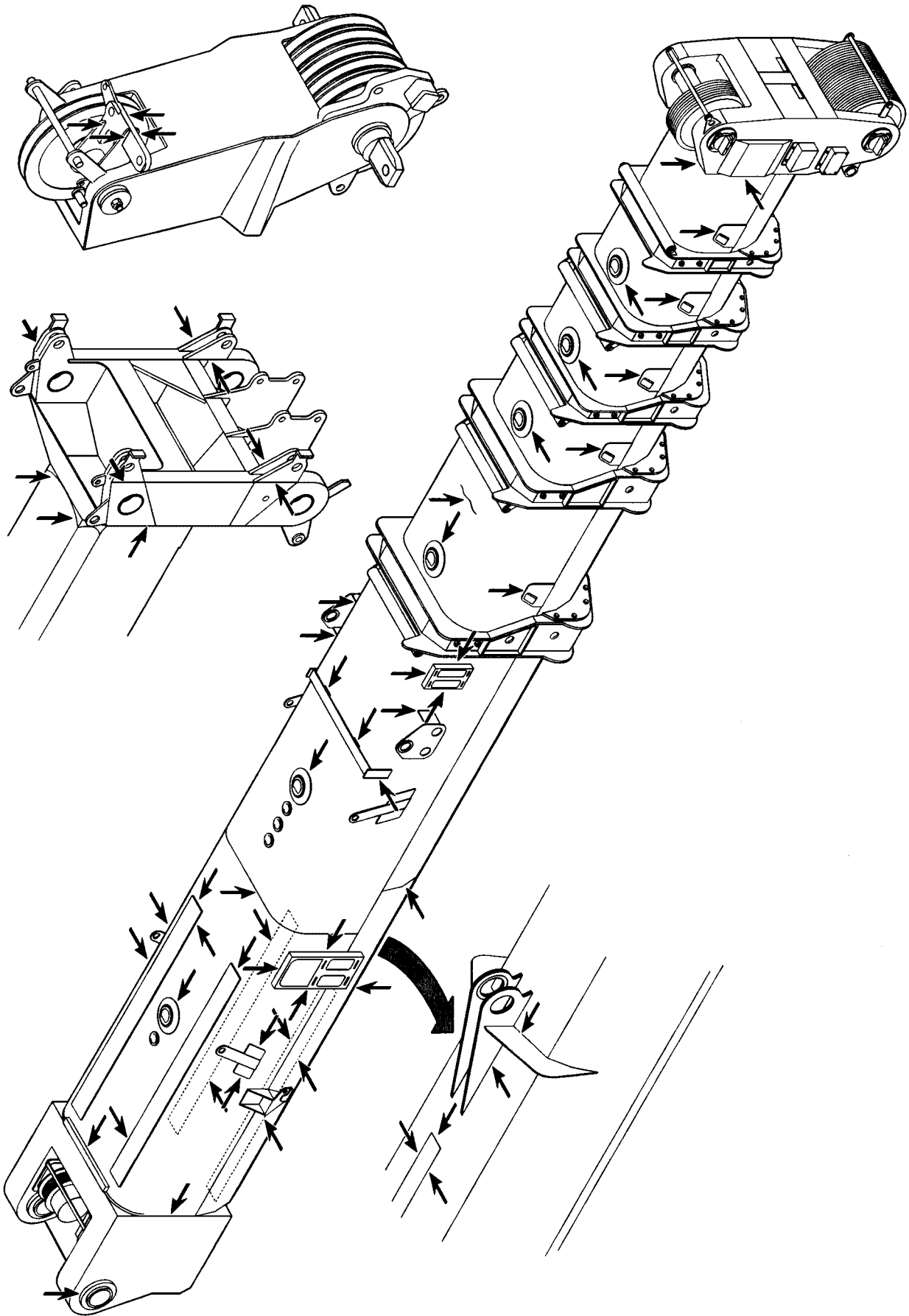

Fig.120273: Example for pivot section

LWE/LR 1600-2-008/18109-09-02/en



LWE/LR 1600-2-008/18109-09-02/en

Fig.185050: Example for telescopic boom

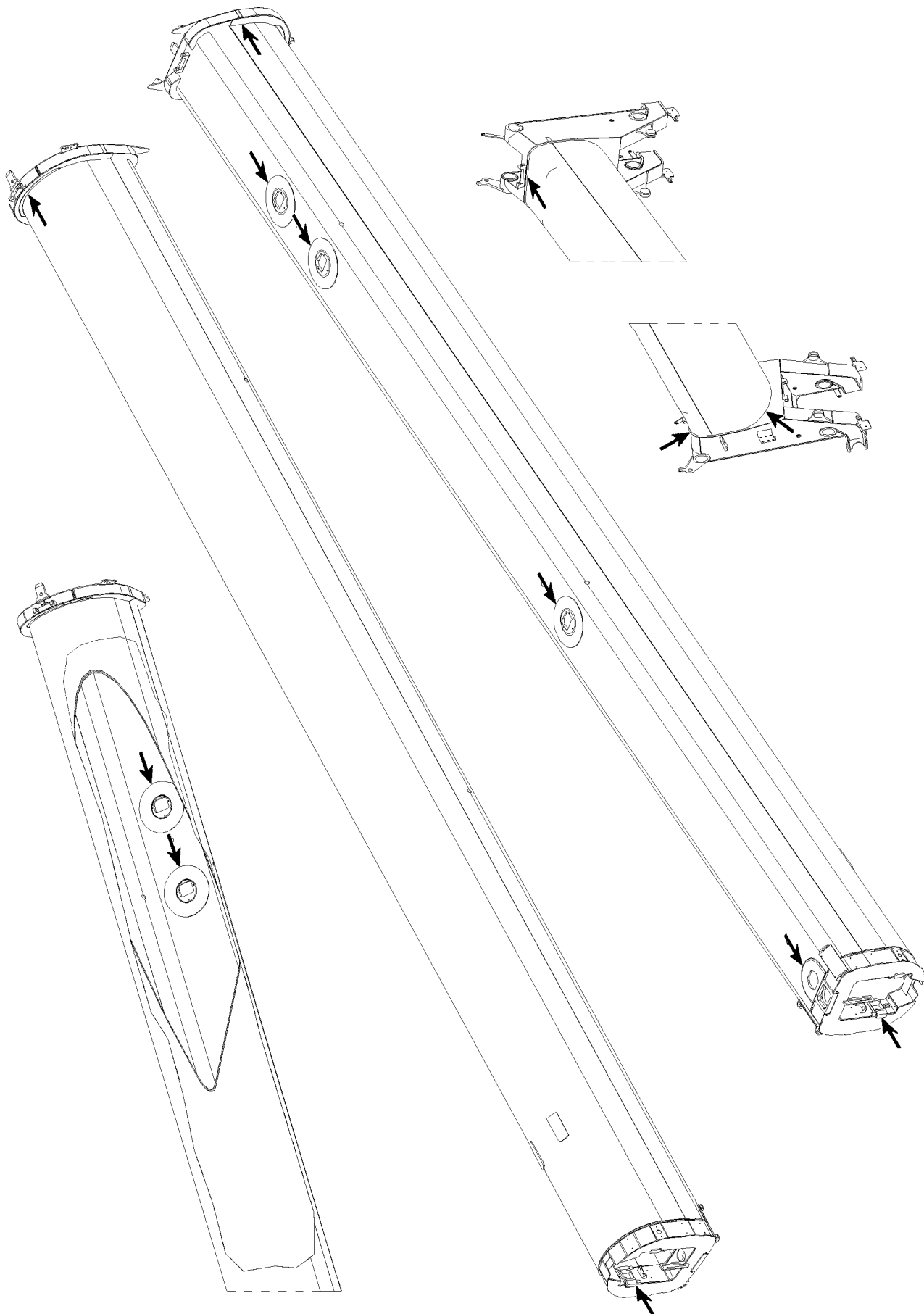
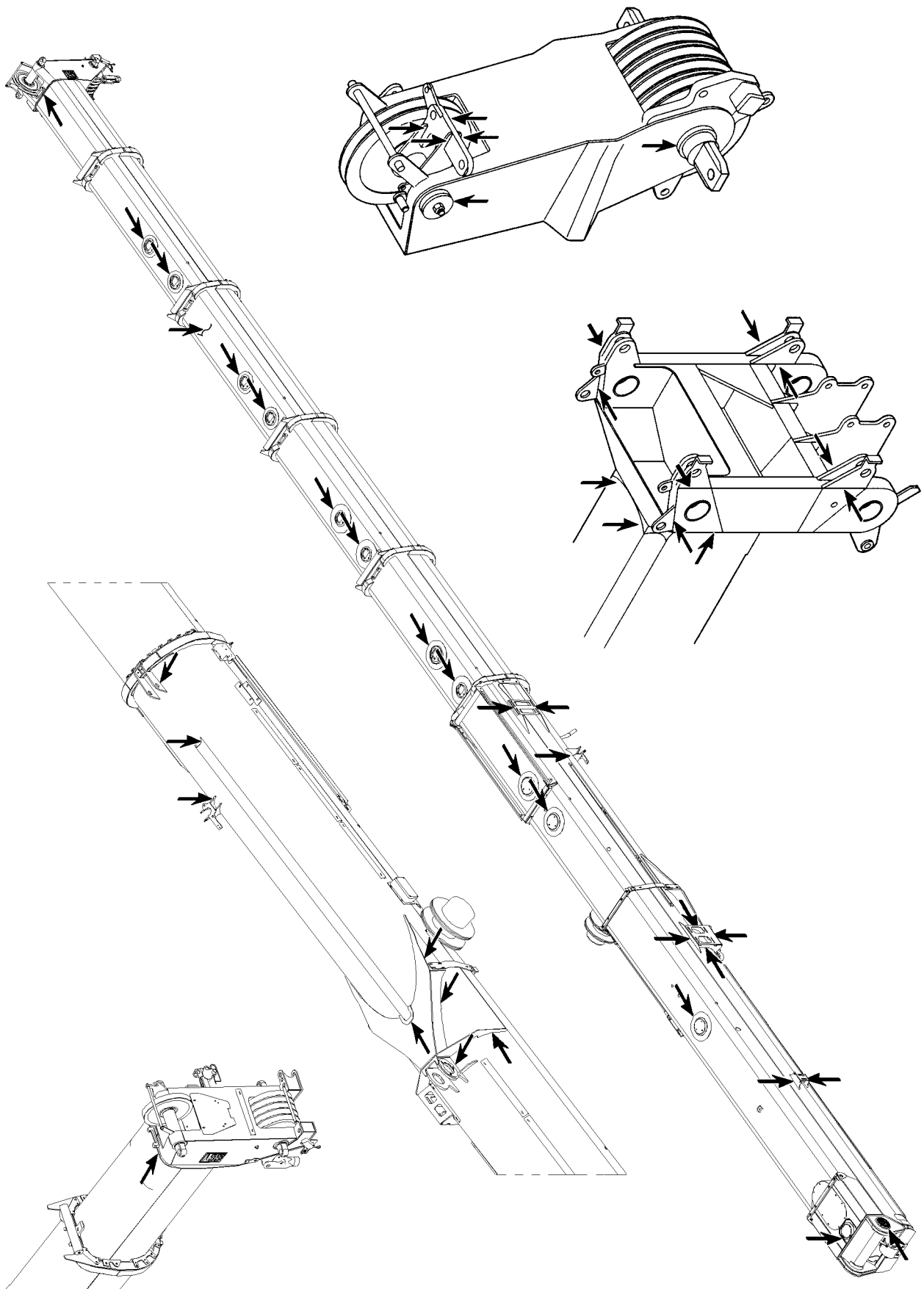

Fig.105710: Example for telescopic boom

LWE/LR 1600-2-008/18109-09-02/en



LWE/LR 1600-2-008/18109-09-02/en

Fig.105711: Example for telescopic boom

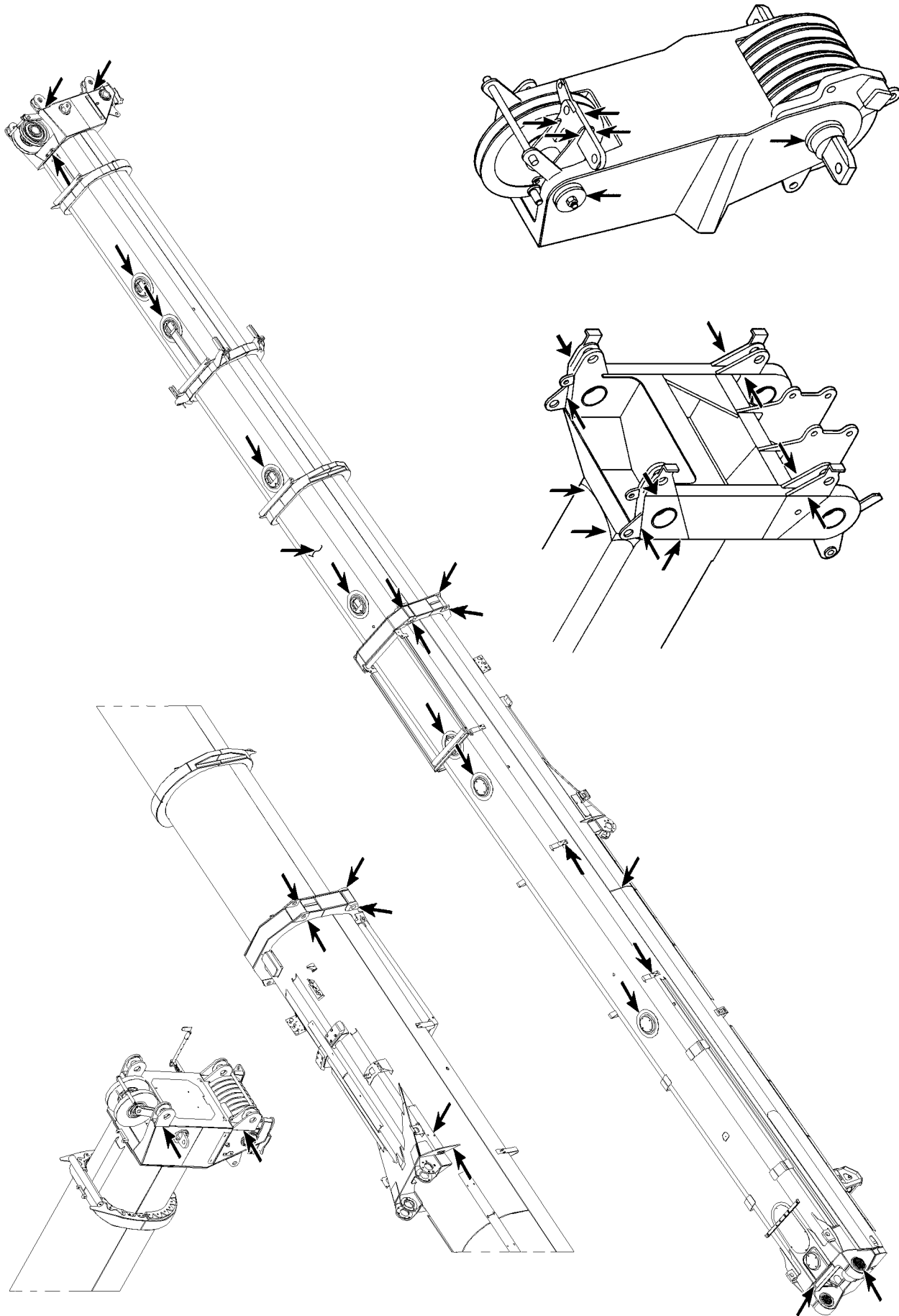
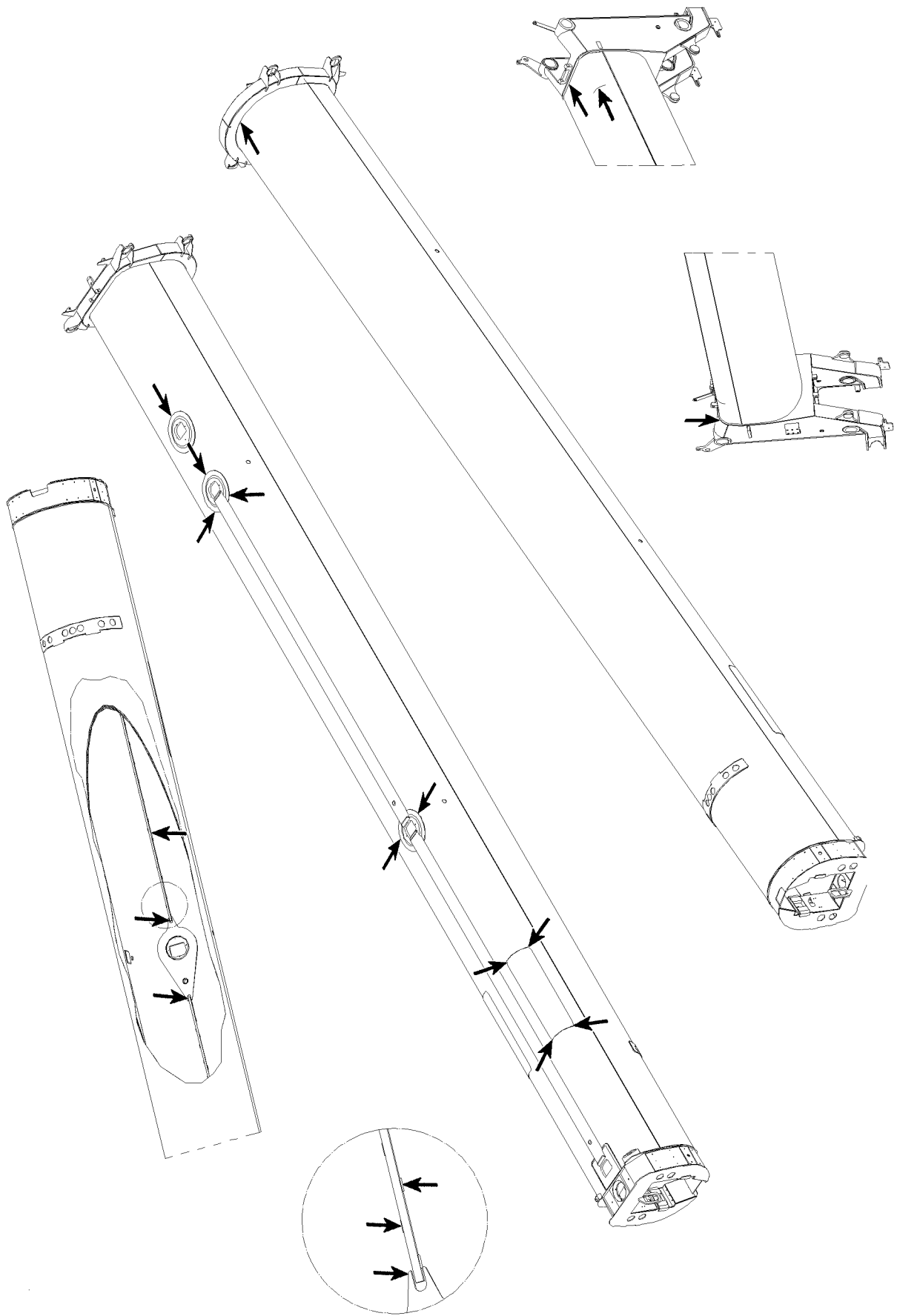

Fig.105720: Example for telescopic boom

LWE/LR 1600-2-008/18109-09-02/en



LWE/LR 1600-2-008/18109-09-02/en

Fig.105721: Example for telescopic boom

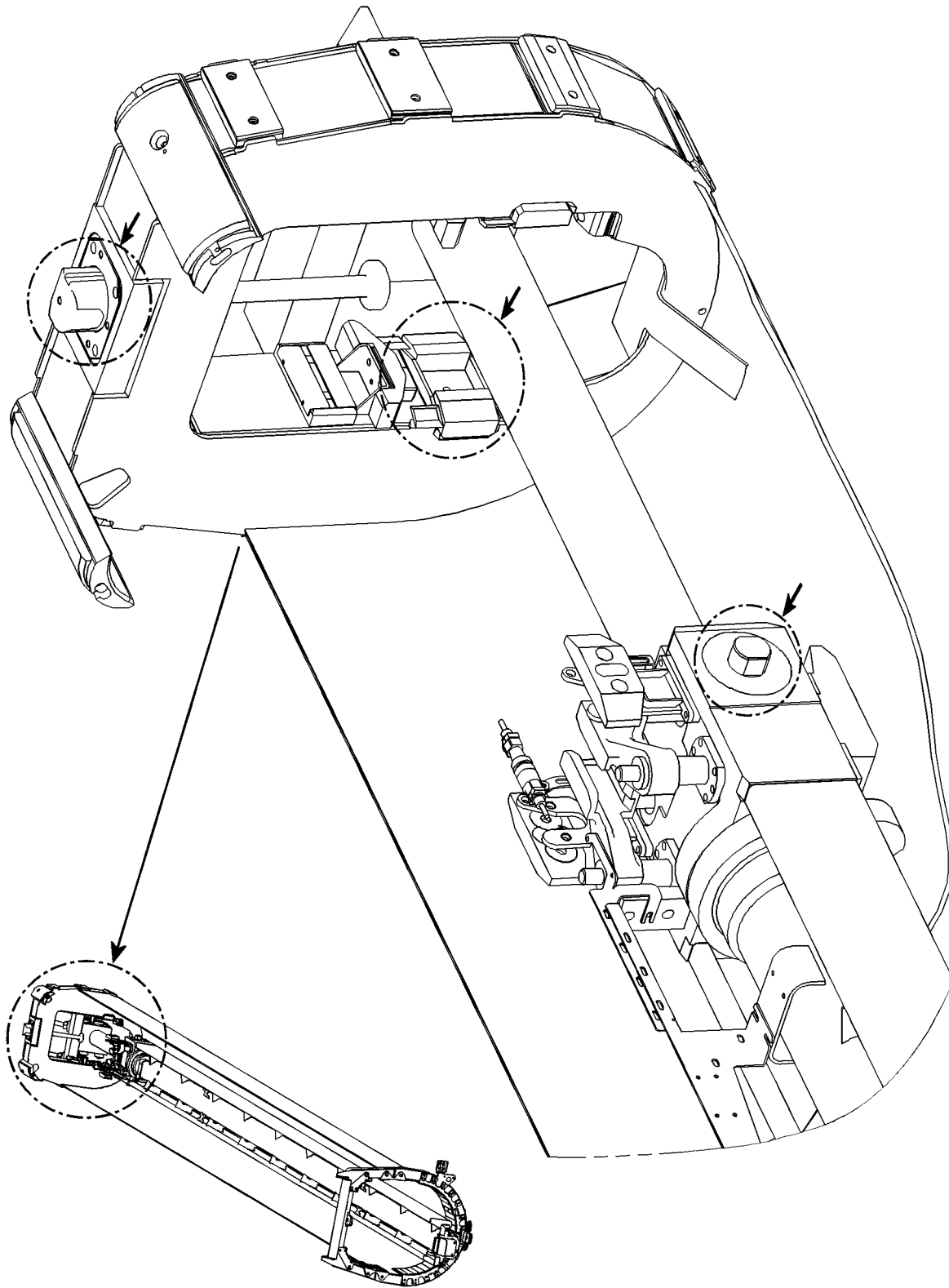

LWE/LR 1600-2-008/18109-09-02/en

Fig.105891: Example for push out mechanics telescopic boom

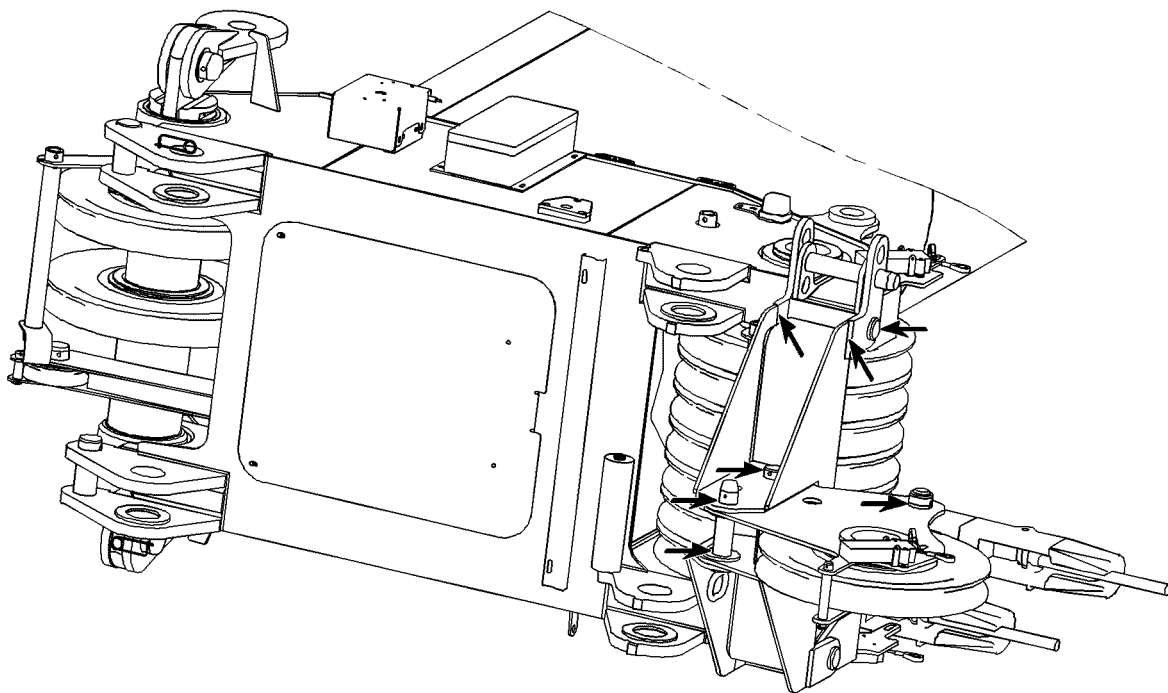
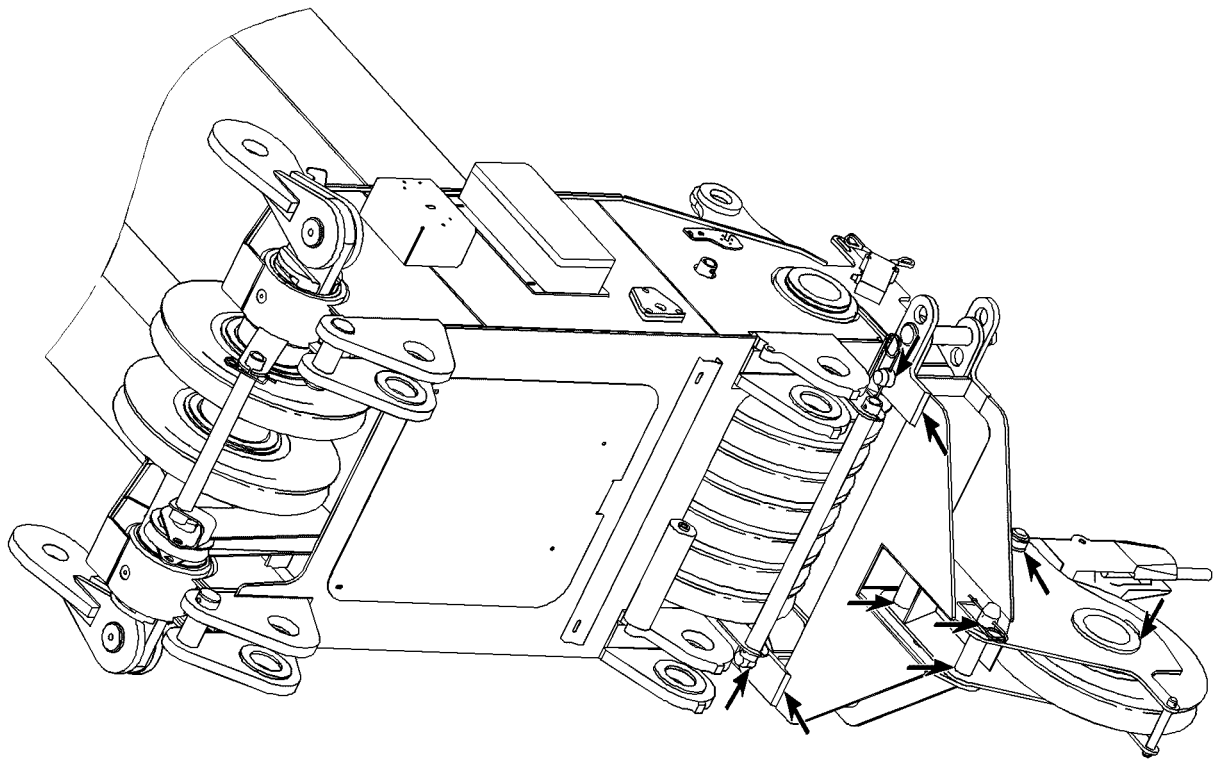

LWE/LR 1600-2-008/18109-09-02/en

Fig.105892: Example for boom nose

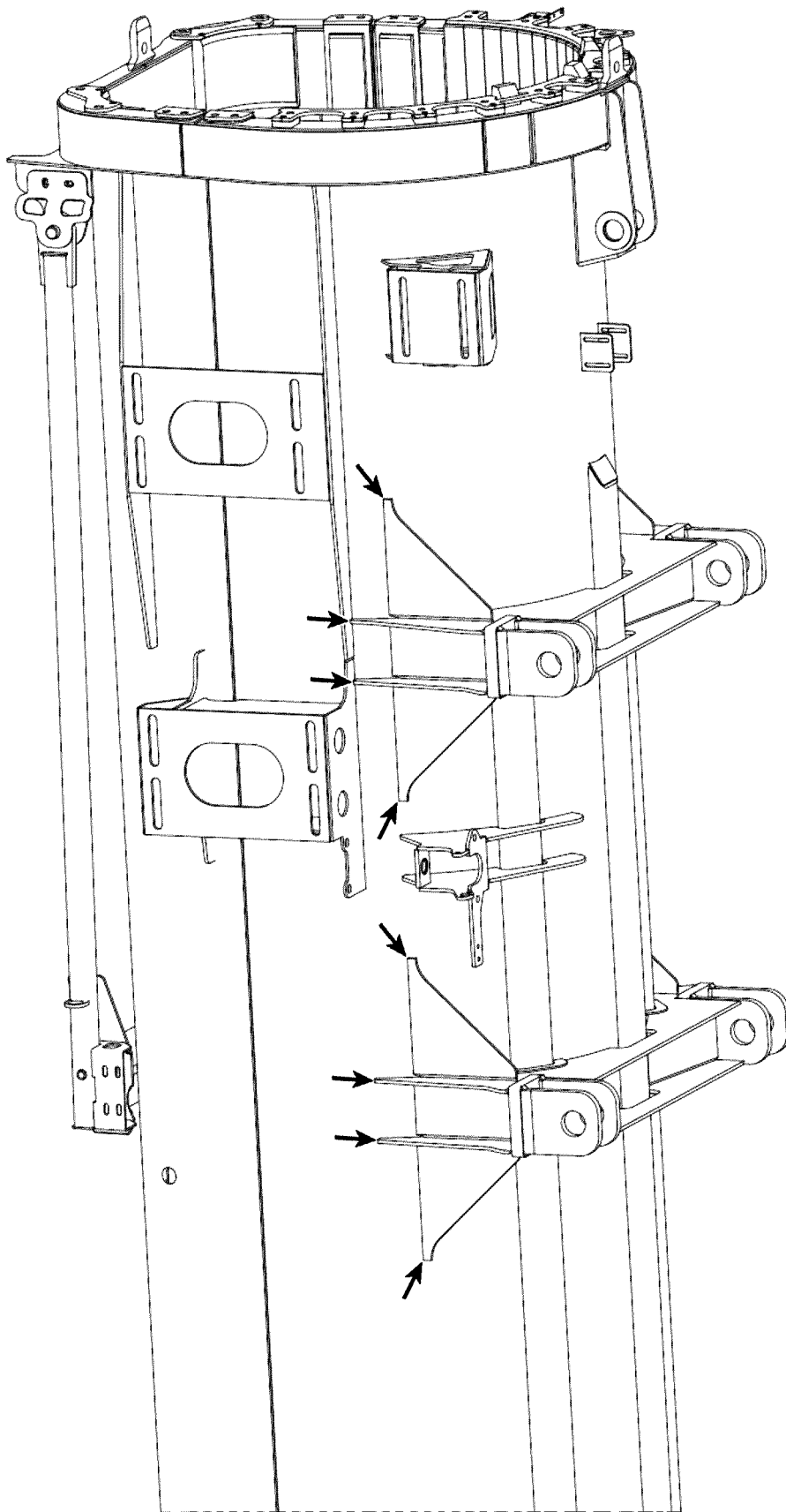
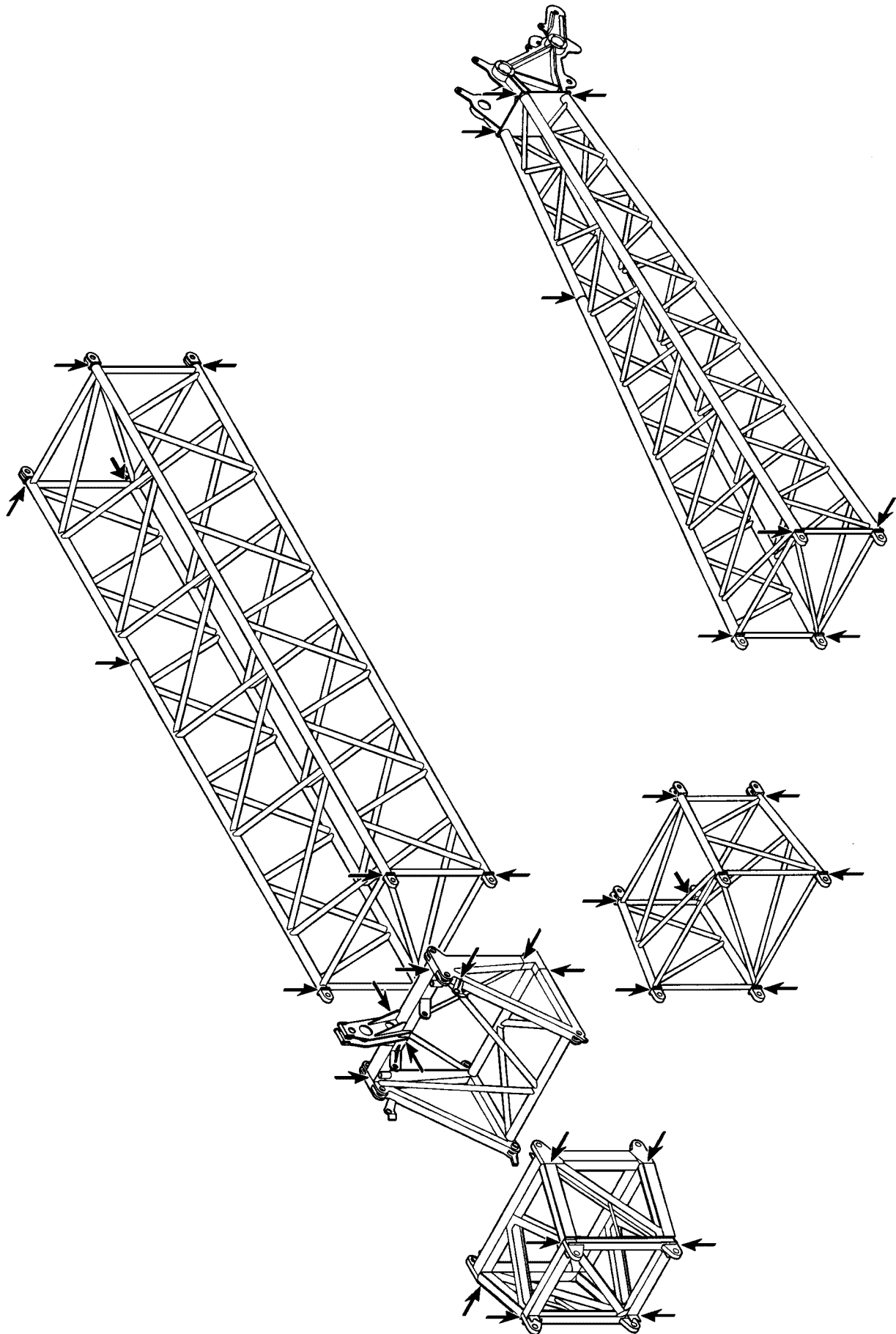

Fig.105689: Example for dolly console

LWE/LR 1600-2-008/18109-09-02/en



LWE/LR 1600-2-008/18109-09-02/en

Fig.185051: Example for lattice jib

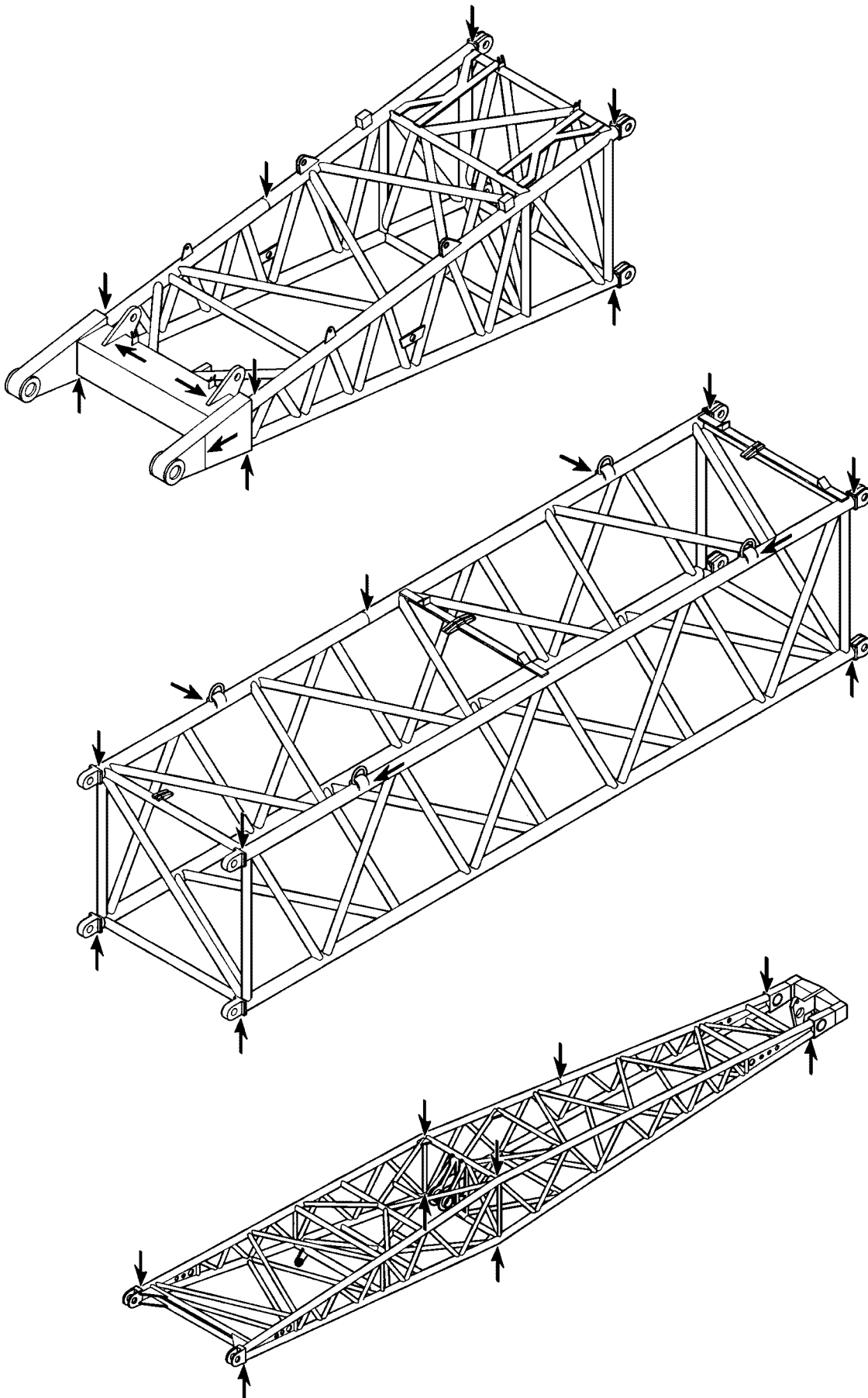
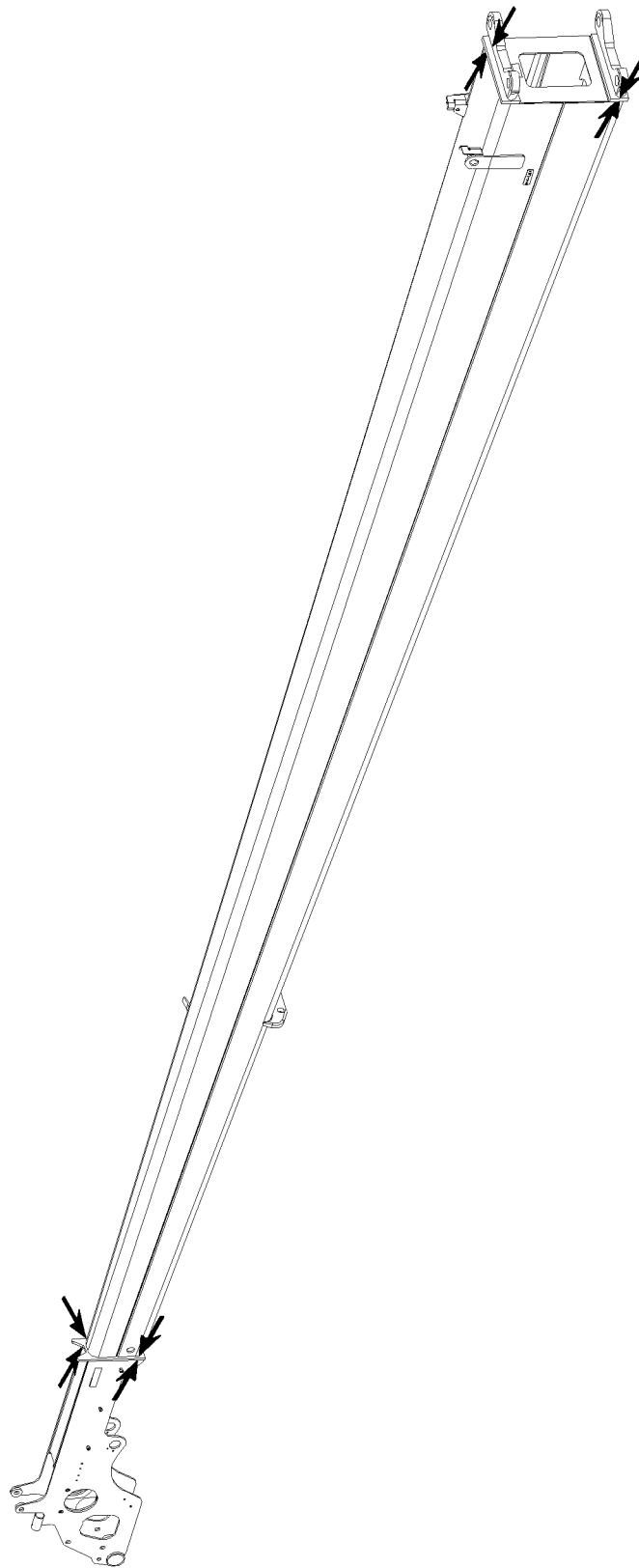

Fig.185052: Example for NA / WA-frame

LWE/LR 1600-2-008/18109-09-02/en



LWE/LR 1600-2-008/18109-09-02/en

Fig.105713: Example for end section

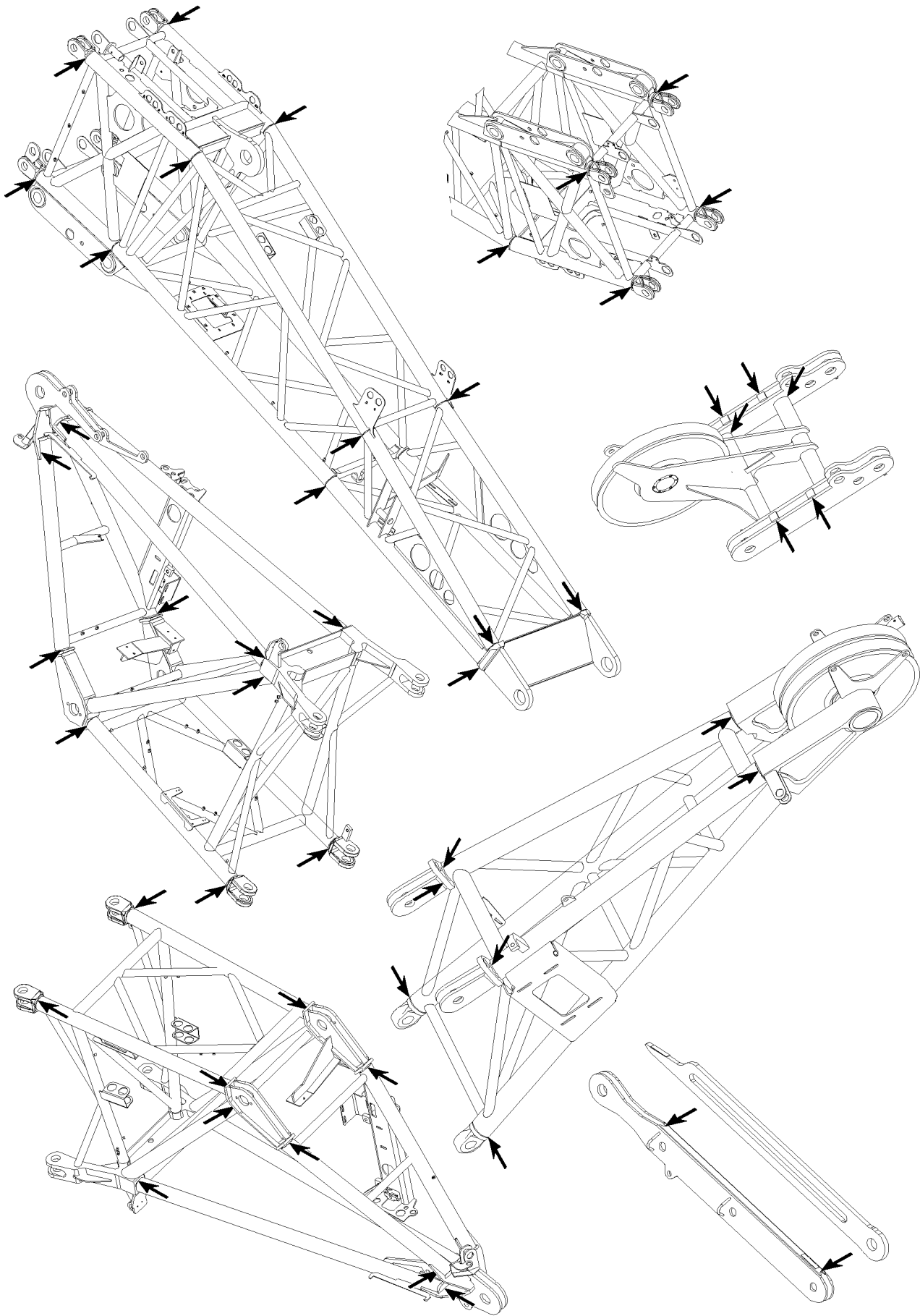
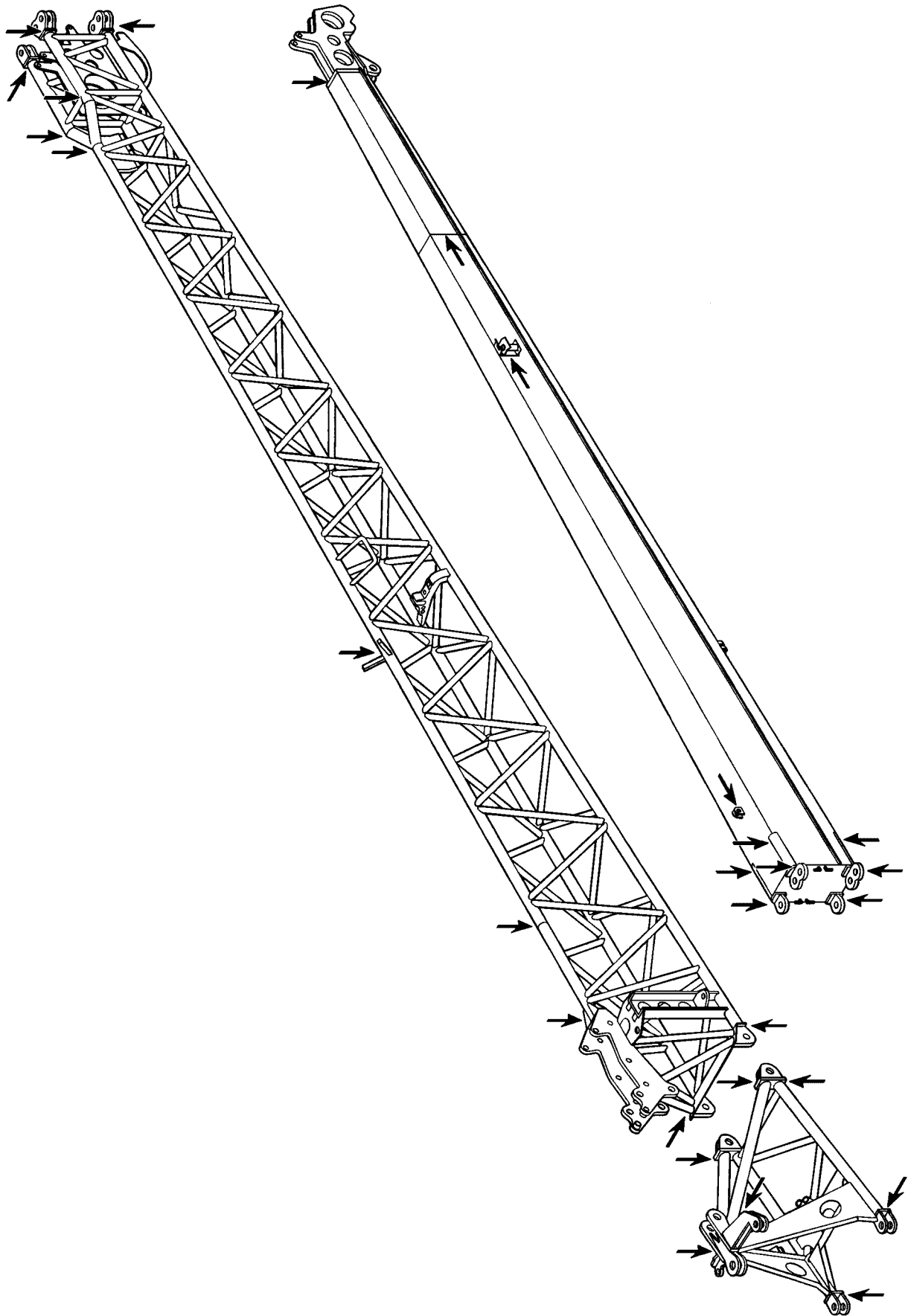

Fig.105836: Example for pivot section, adapter and boom nose

LWE/LR 1600-2-008/18109-09-02/en



LWE/LR 1600-2-008/18109-09-02/en

Fig.185058: Example for folding jib

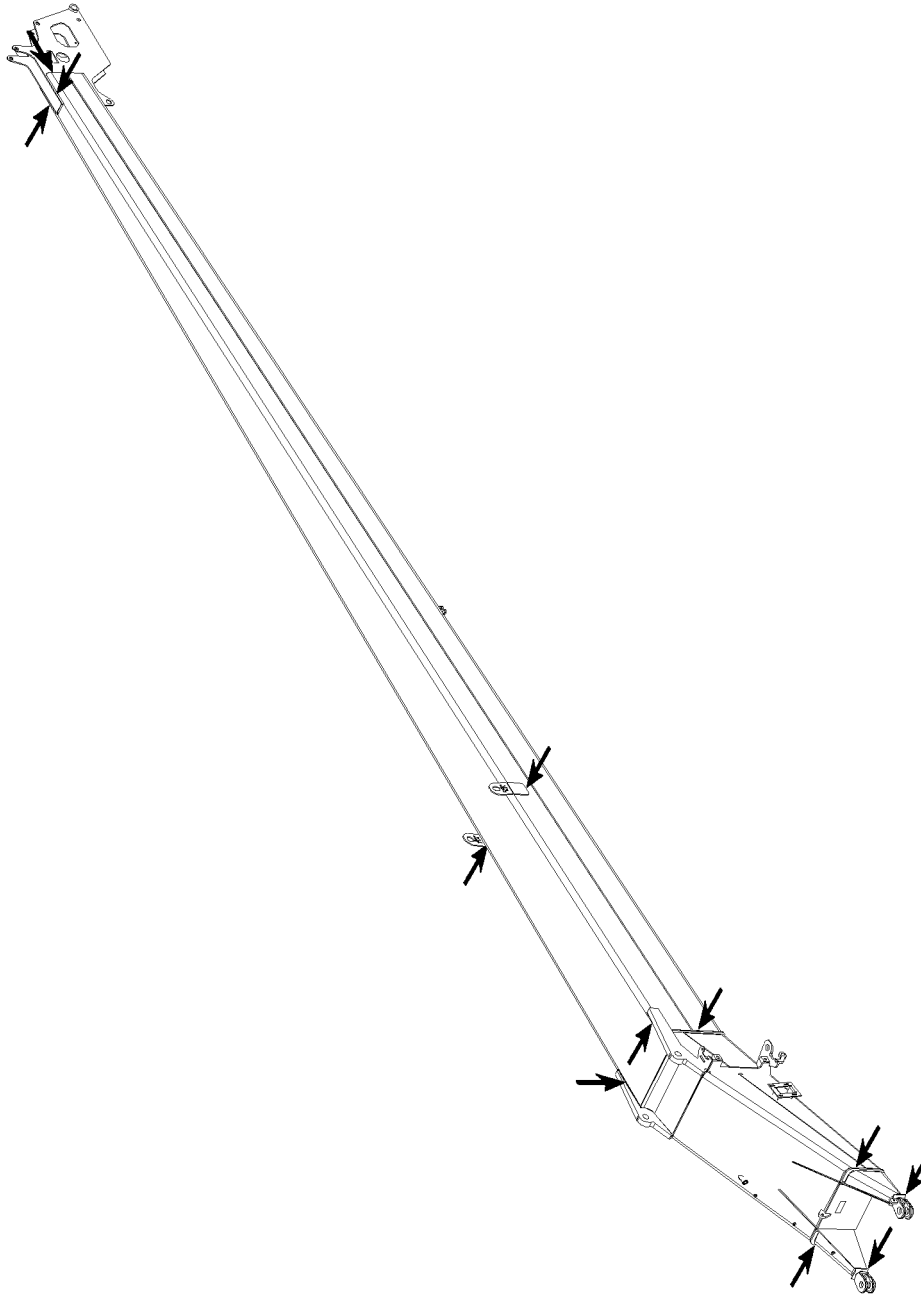
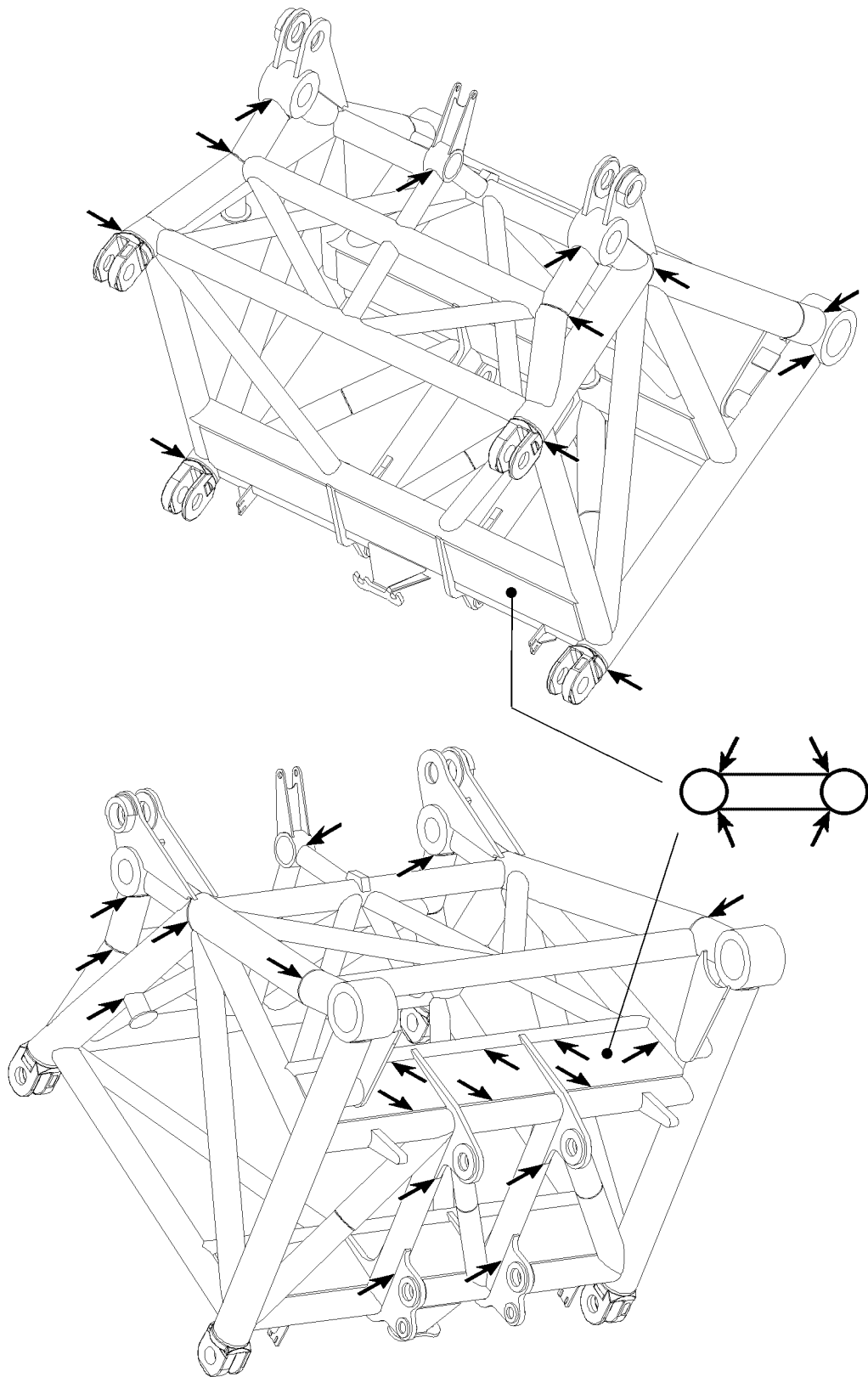

Fig.105697: Example for folding jib

LWE/LR 1600-2-008/18109-09-02/en



LWE/LR 1600-2-008/18109-09-02/en

Fig.105732: Example for W-connector head

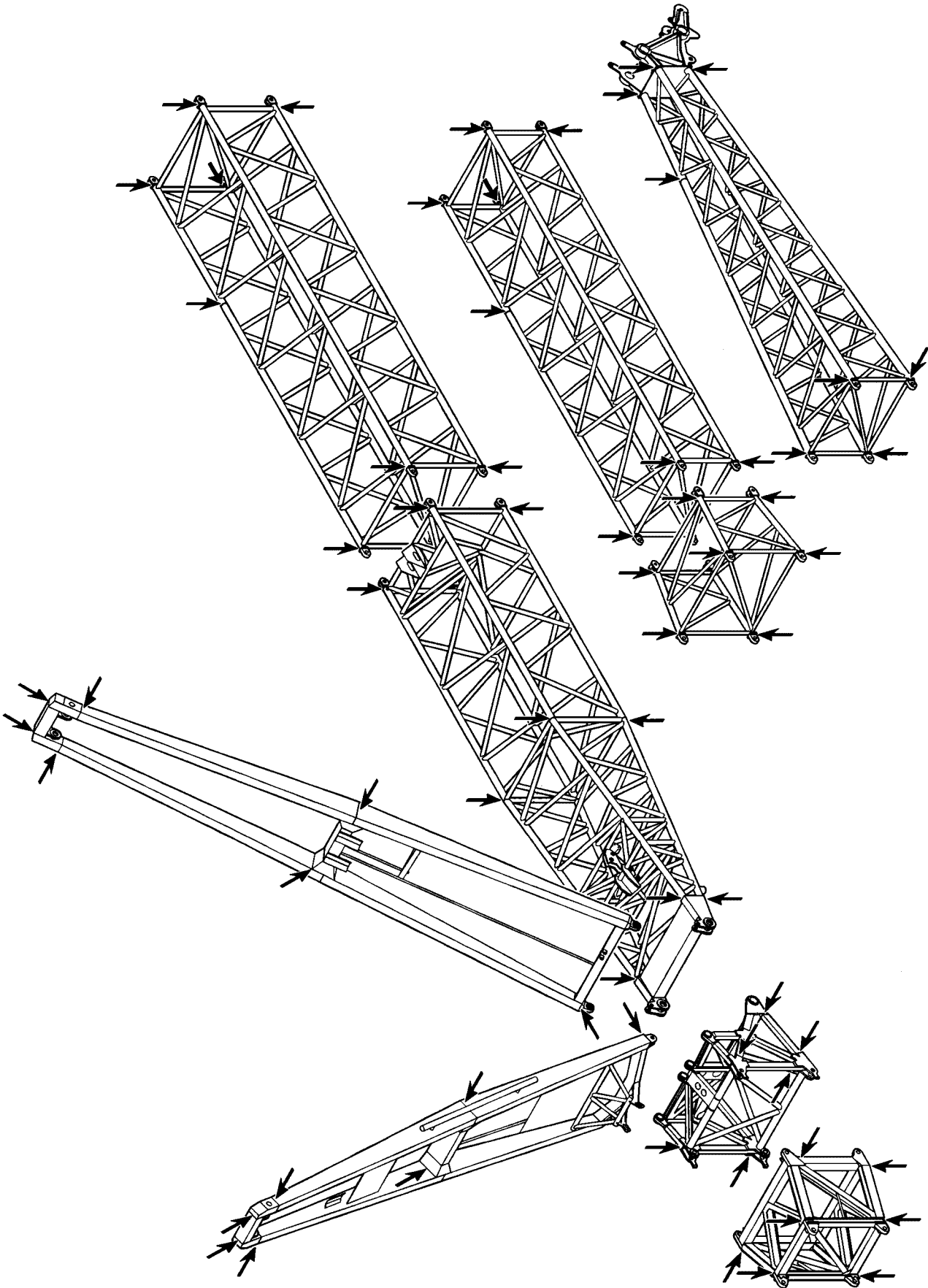
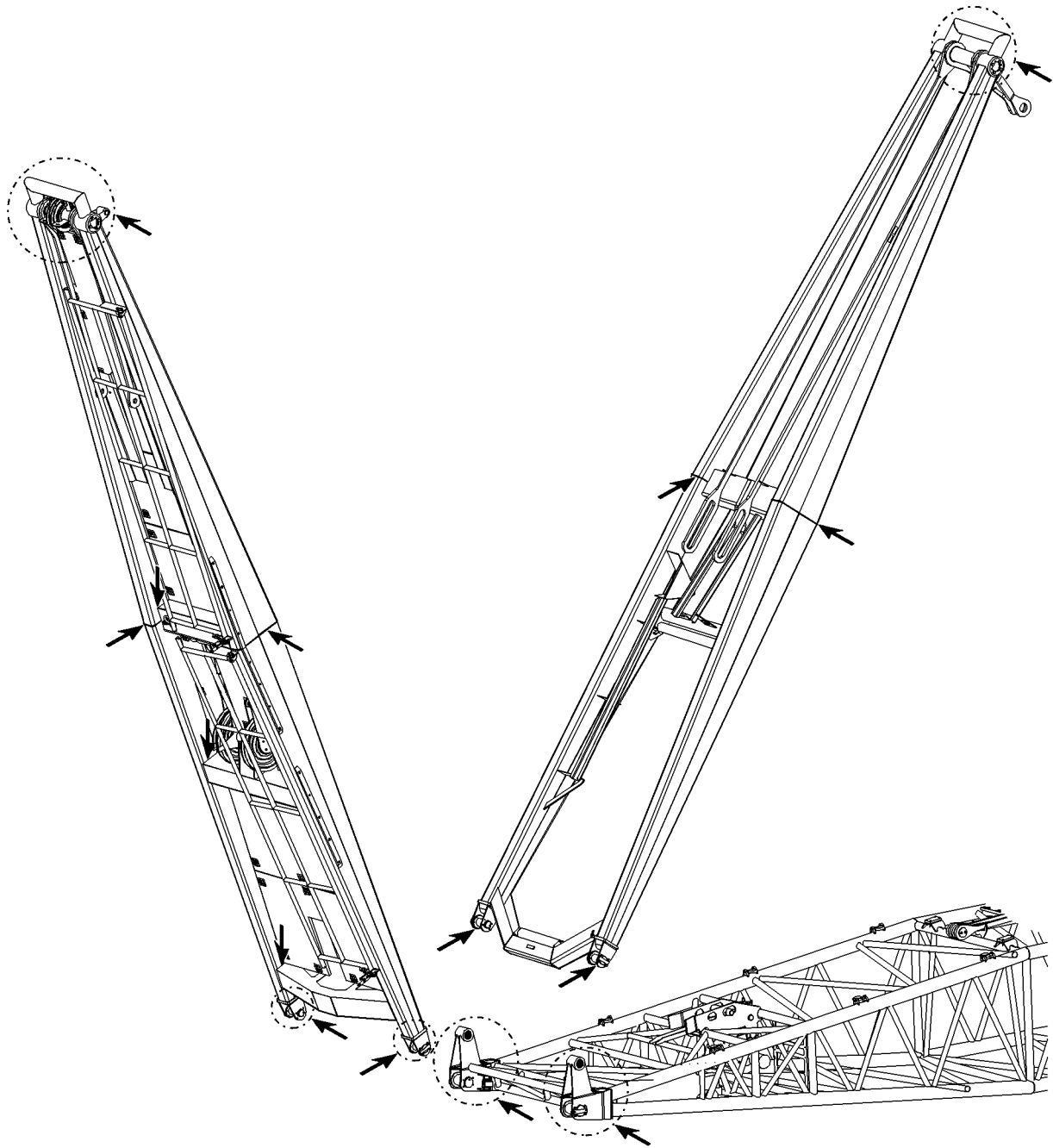

Fig.185053: Example for assembly unit with lattice jib

LWE/LR 1600-2-008/18109-09-02/en



LWE/LR 1600-2-008/18109-09-02/en

Fig.105838: Example for NA frames

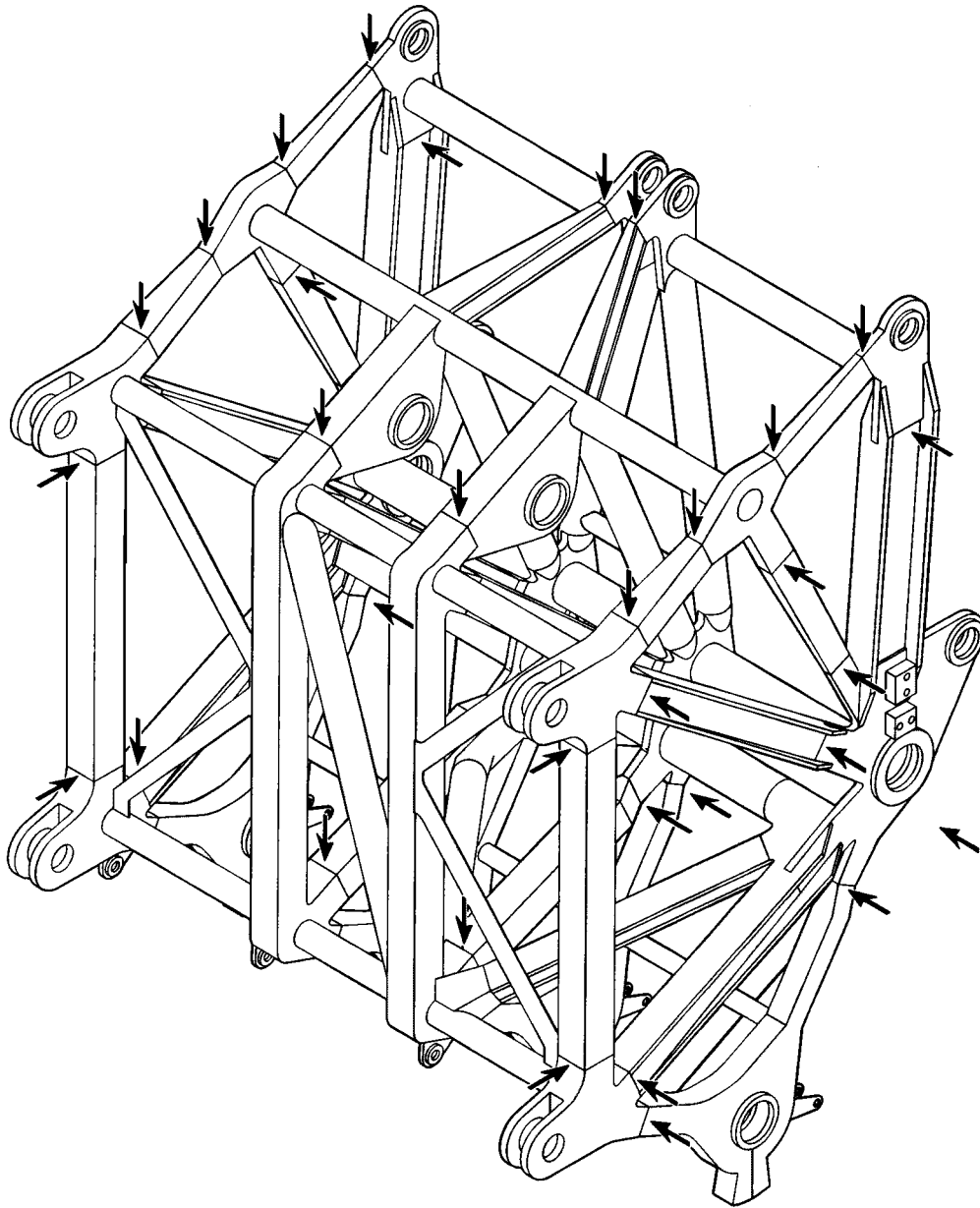
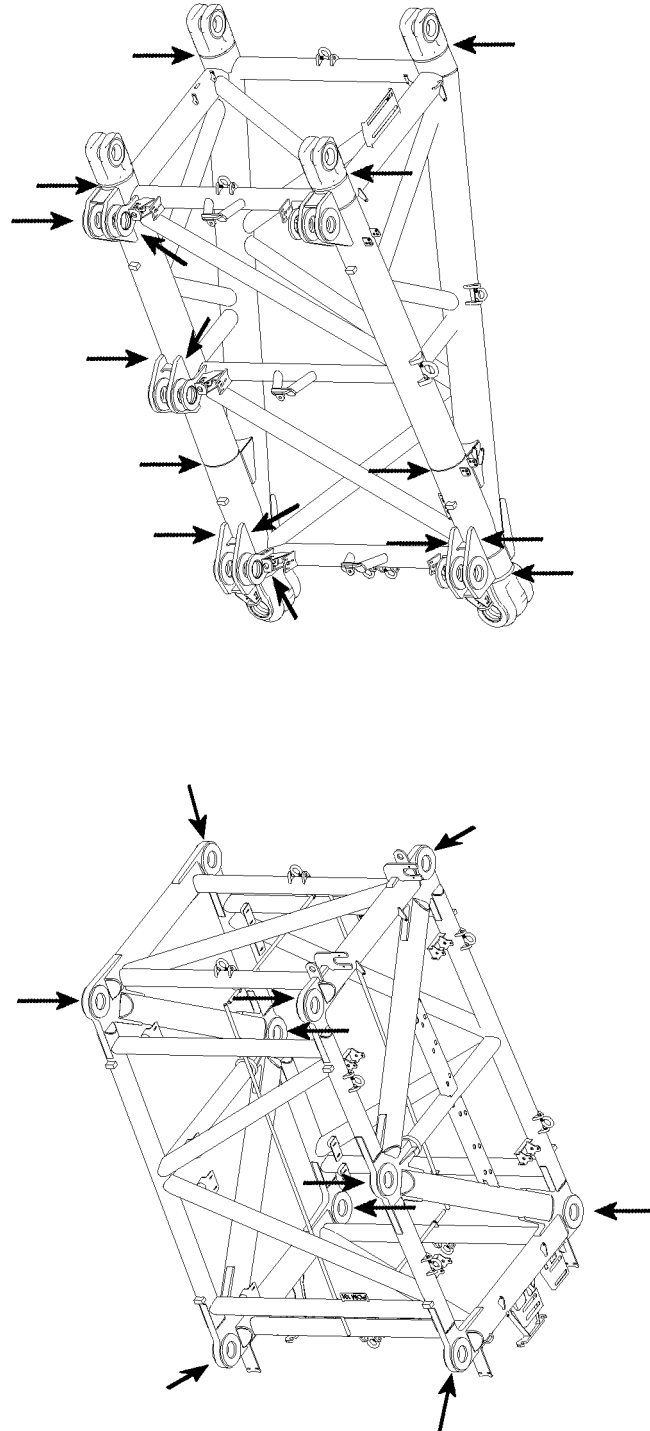

Fig.185054: Example for pulley head

LWE/LR 1600-2-008/18109-09-02/en



LWE/LR 1600-2-008/18109-09-02/en

Fig.116609: Example for P-adapter

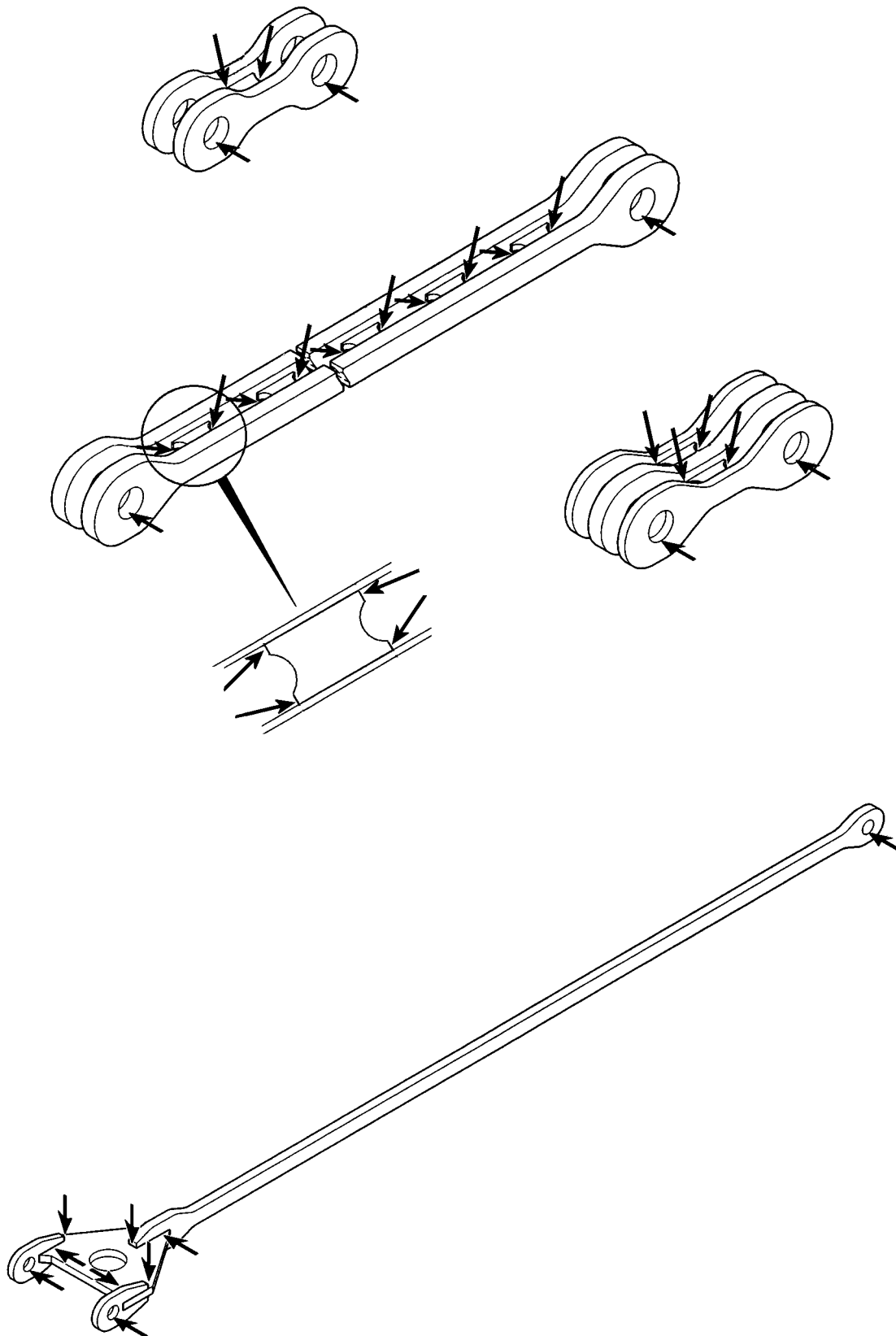
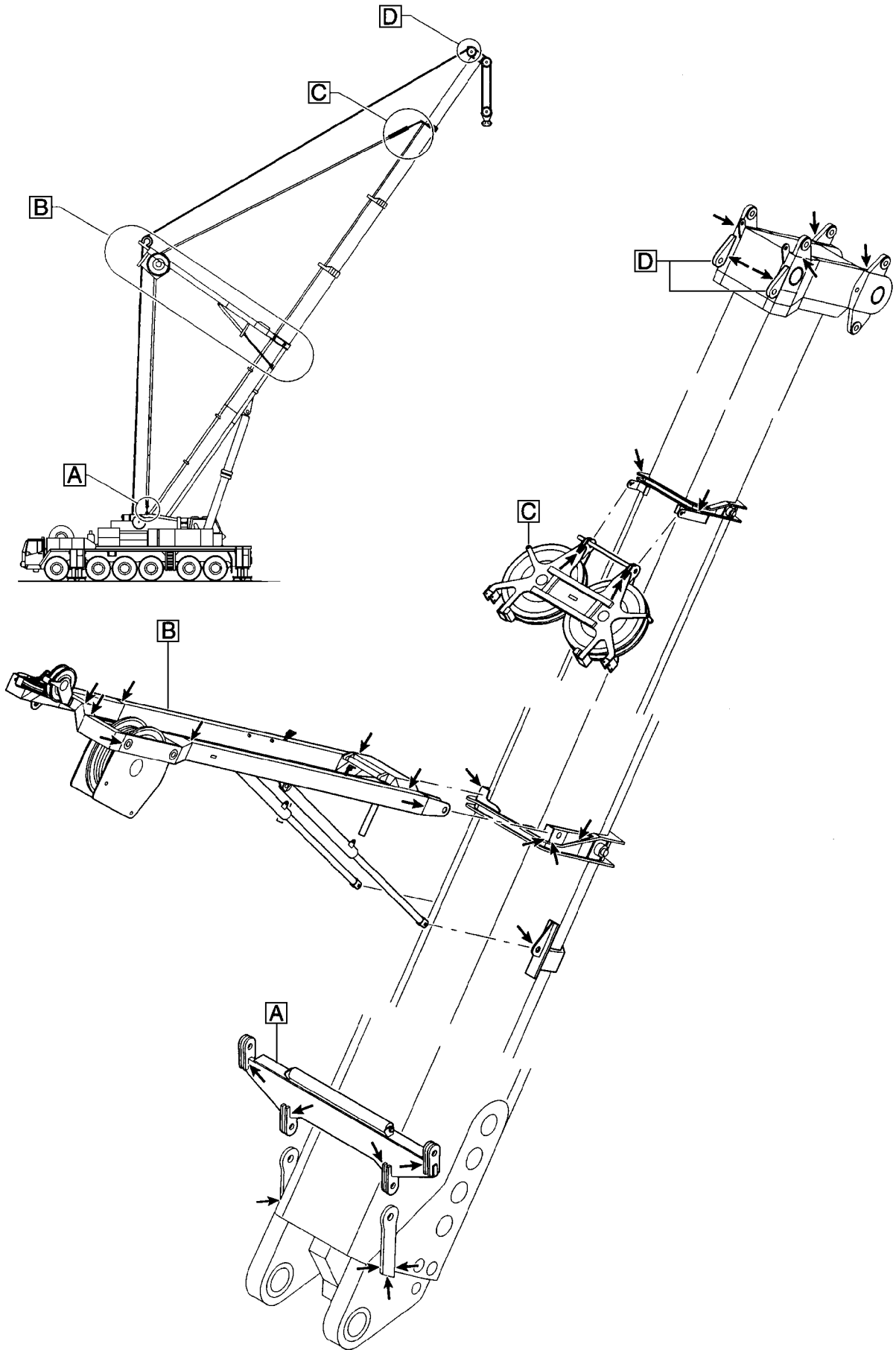

Fig.185055: Example for guy rod



LWE/LR 1600-2-008/18109-09-02/en

Fig.185059: Example for TA-guying

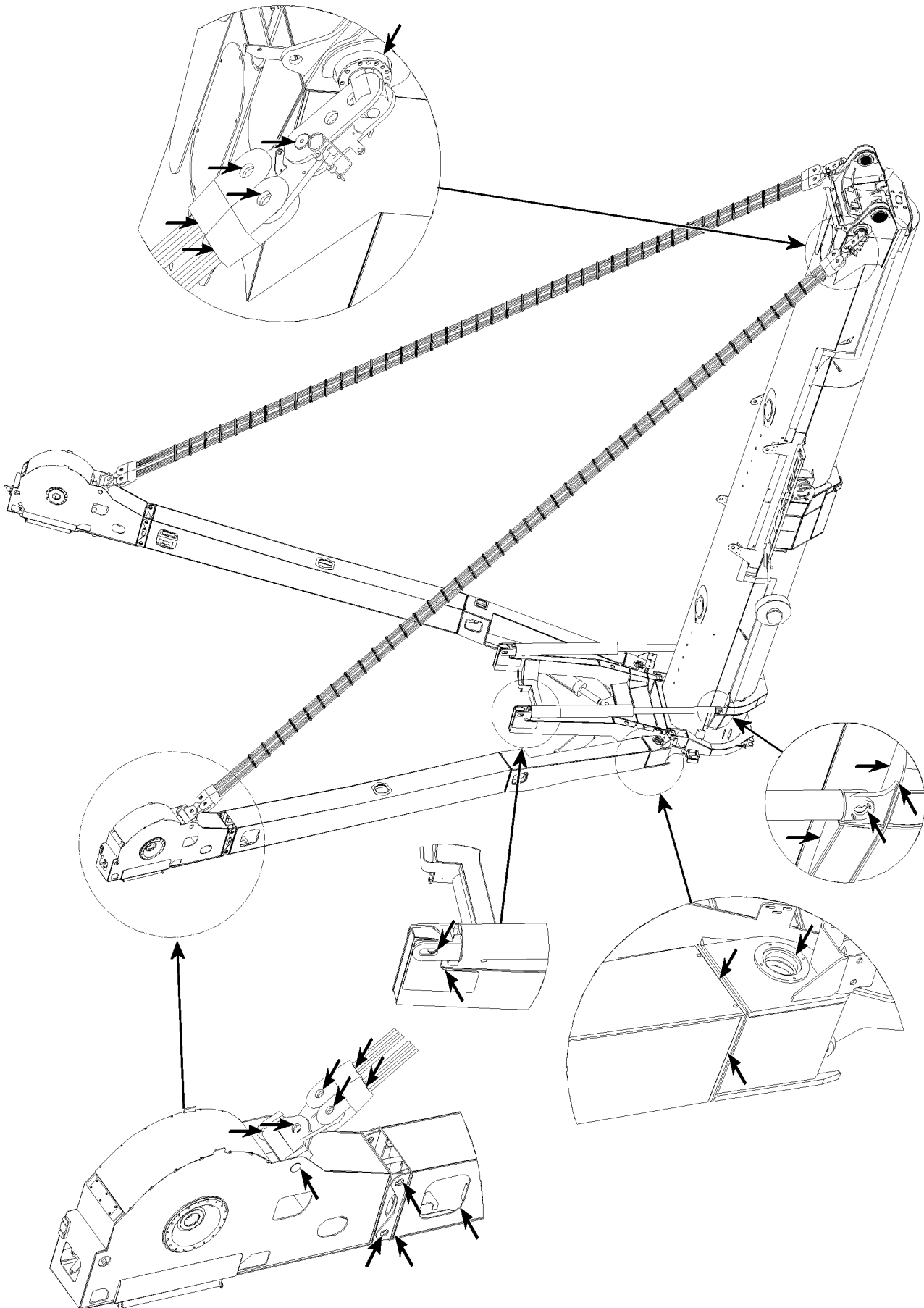
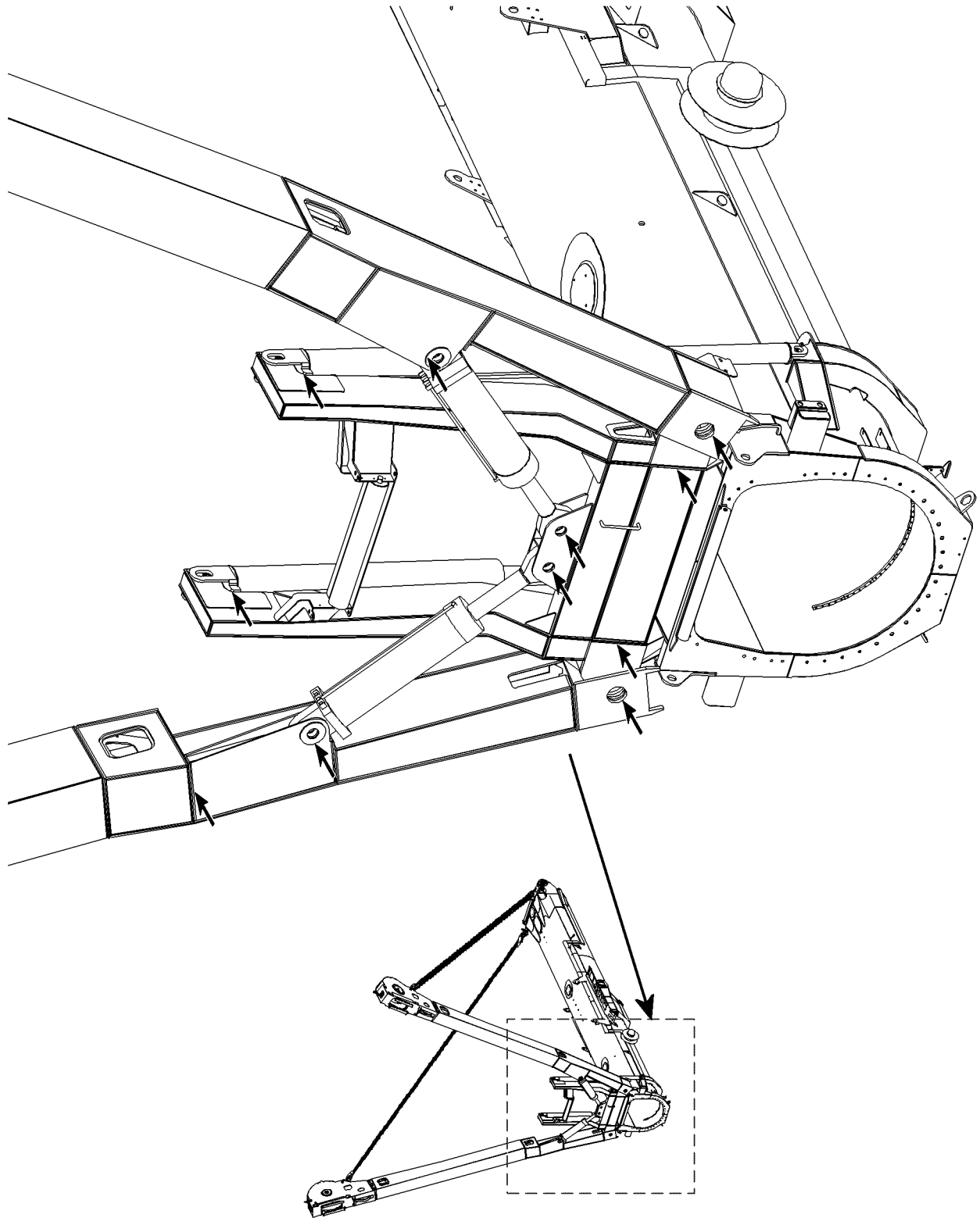

Fig.105707: Example for TY-guying

LWE/LR 1600-2-008/18109-09-02/en



LWE/LR 1600-2-008/18109-09-02/en

Fig.105708: Example for TY-guying

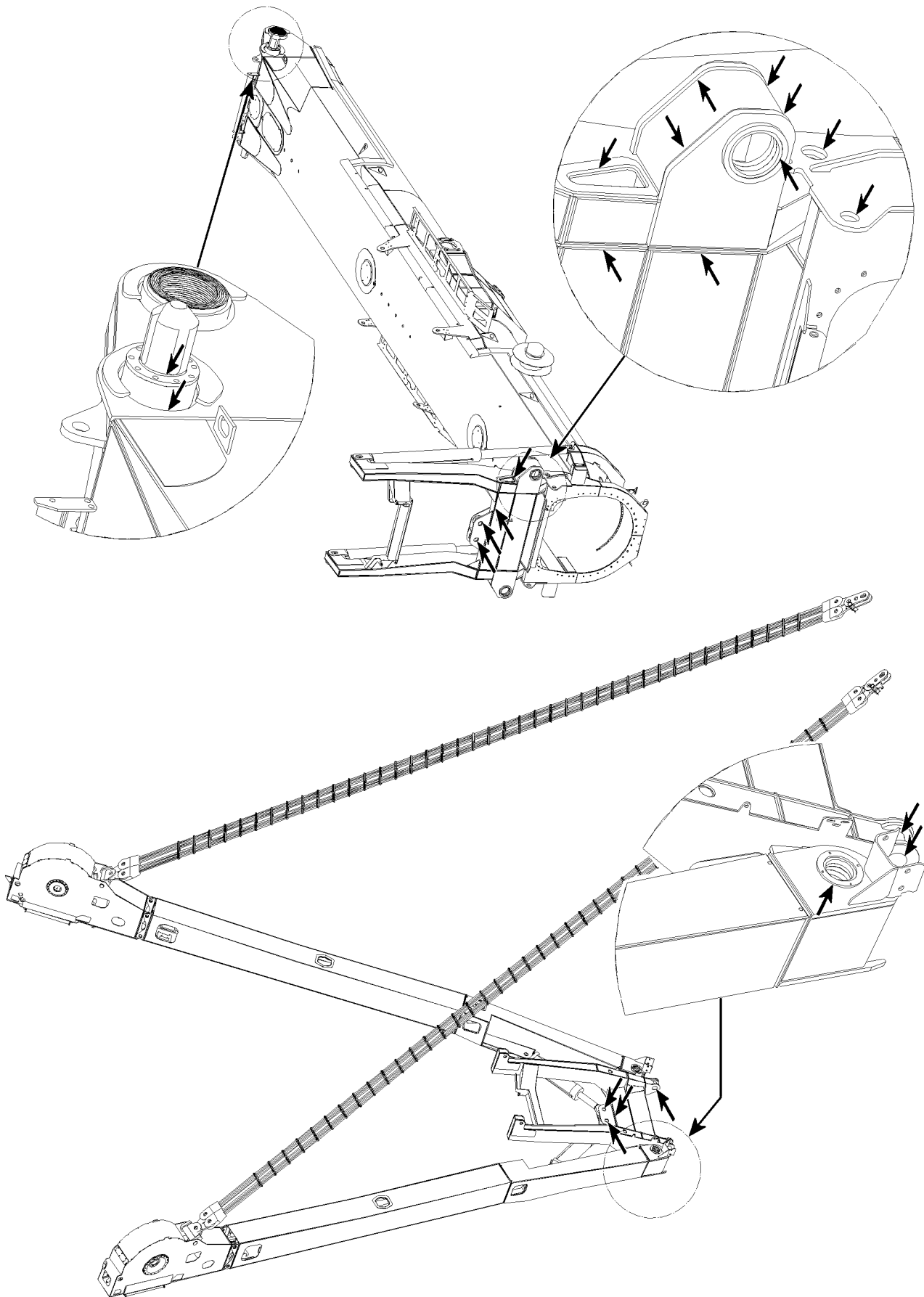

Fig.105709: Example for TY-guying

LWE/LR 1600-2-008/18109-09-02/en

2.4 Rigging and fastening points

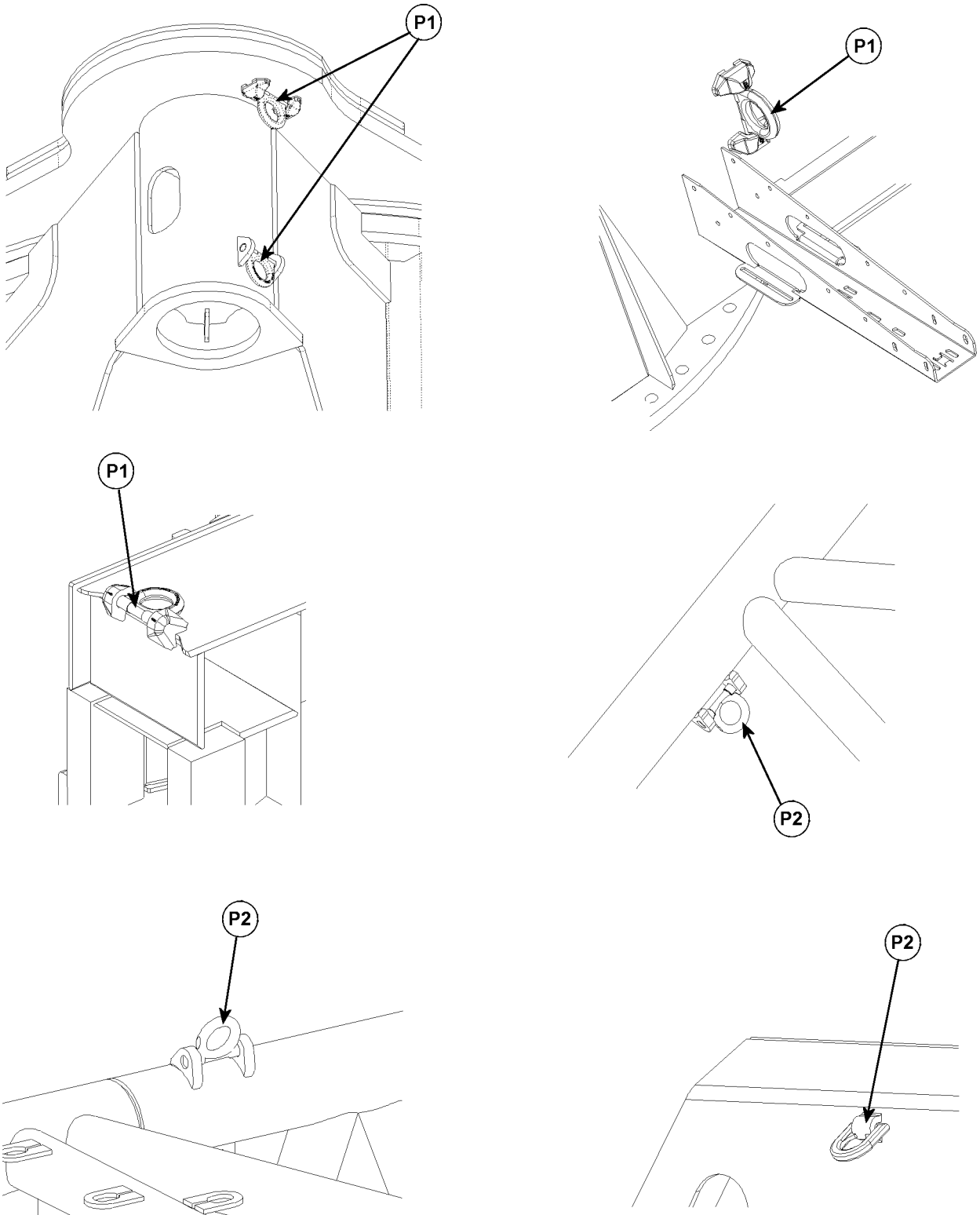

Fig.121160: Examples for rigging and fastening points

P1 Rigging points

P2 Fastening points

LWE/LR 1600-2-008/18109-09-02/en

**WARNING**

Unsafe rigging point or fastening point!

The mobile crane or component can rip free and fall down!

When a rigging point or fastening point is not safe for operation:

- ▶ Have the rigging point or fastening point replaced by authorized and trained expert personnel.
- ▶ Avoid damage on the rigging device due to sharp-edged exposure.

Make sure that the following damage does **not** occur:

- Crushing points
- Shearing points
- Catch points
- Impact points

Inspection criteria:

- Completeness of rigging point.
- Distortion of carrying parts.
- Mechanical damage such as severe nicks.
- Changes in diameter due to wear.
- Significant corrosion (pitting)
- Cracks on carrying parts.
- Cracks or other damage on the welding seam.

Check the rigging points **P1** and fastening points **P2** before every start up and at regular intervals.

2.5 Inspecting the lattice sections

**Note**

- ▶ The illustration is only an example and is valid for all lattice sections!
- ▶ Check all diagonal and frame pipe connections!
- ▶ Check all bores of the fork - finger connections!

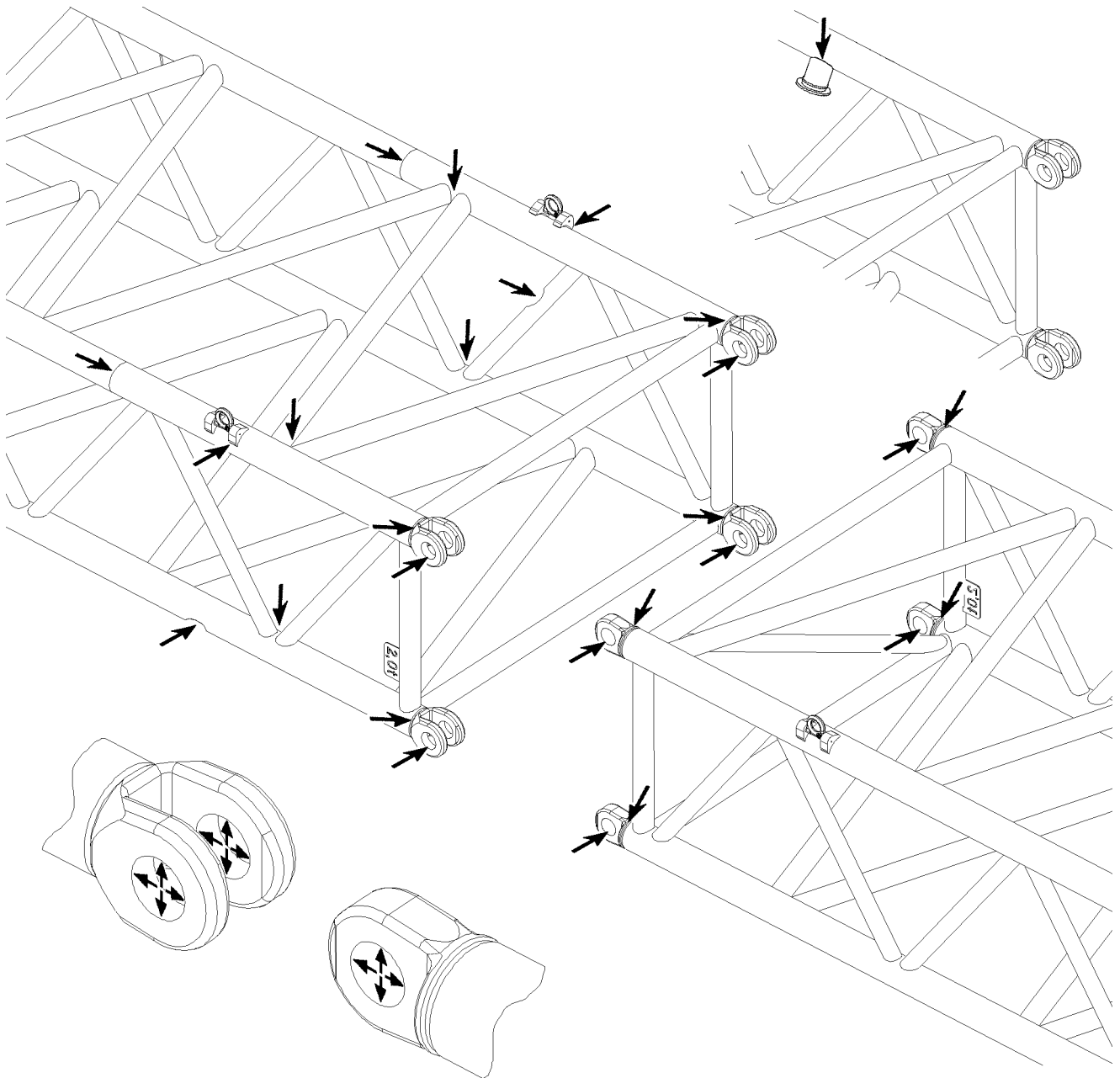

Fig.121023: Example for lattice sections

3 Inspection of locking system of telescopic boom

3.1 For cranes with pneumatic boom locking system

- For inspection of function, see chapter 8.11.
- For inspection of pin wear pattern, see chapter 8.11.
- For inspection of wear, see chapter 8.11.
- For inspection of safety control, see chapter 8.11.

3.2 For cranes with telescopic boom system Telematik

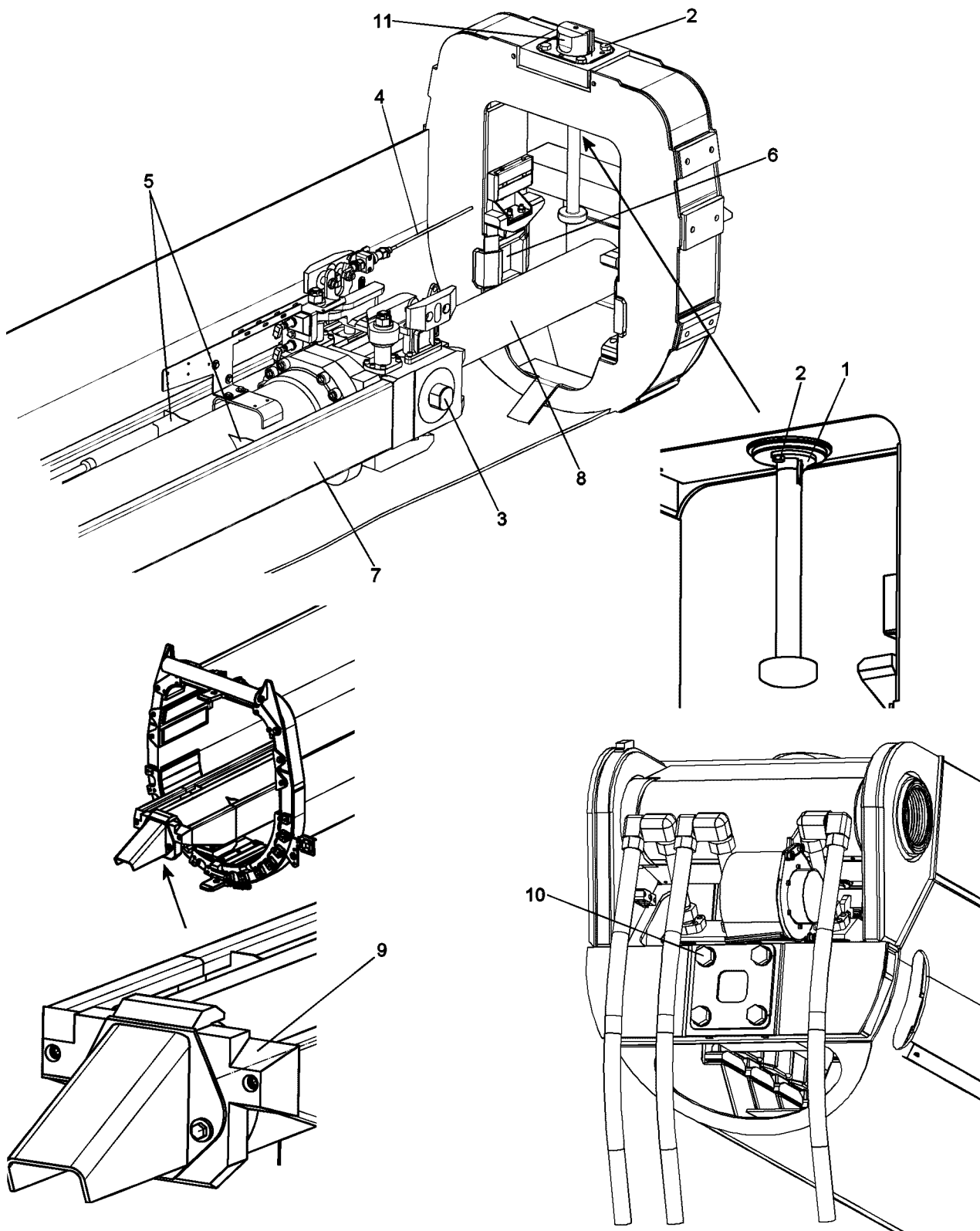

Fig.109286

- Inspection of the pull knob safety **1** and all mounting screws **2** for tight seating
- Inspection of twist guards of cylinder pinning **3** and the telescopic boom pinning **11**
- Inspection of the length sensor rope **4** for damage
- Inspection of the cylinder barrel in the area of all welding seams **5** for crack formation
- Inspection of the locking pockets **6** for damage

- Grease the guide rail 7
- In case of leakage: Inspection of the piston rod 8 for grooves
- Inspection of the wear pattern on the cylinder pinning 3 and the telescopic boom pinning 11
- Inspection of guide rail 7 for distortion of contour
- Inspection of plastic guide 9 on cylinder bottom for damage
- Inspection of all mounting screws 10 on the push out cylinder for tight seating

4 Inspection of safety ropes and anchor points

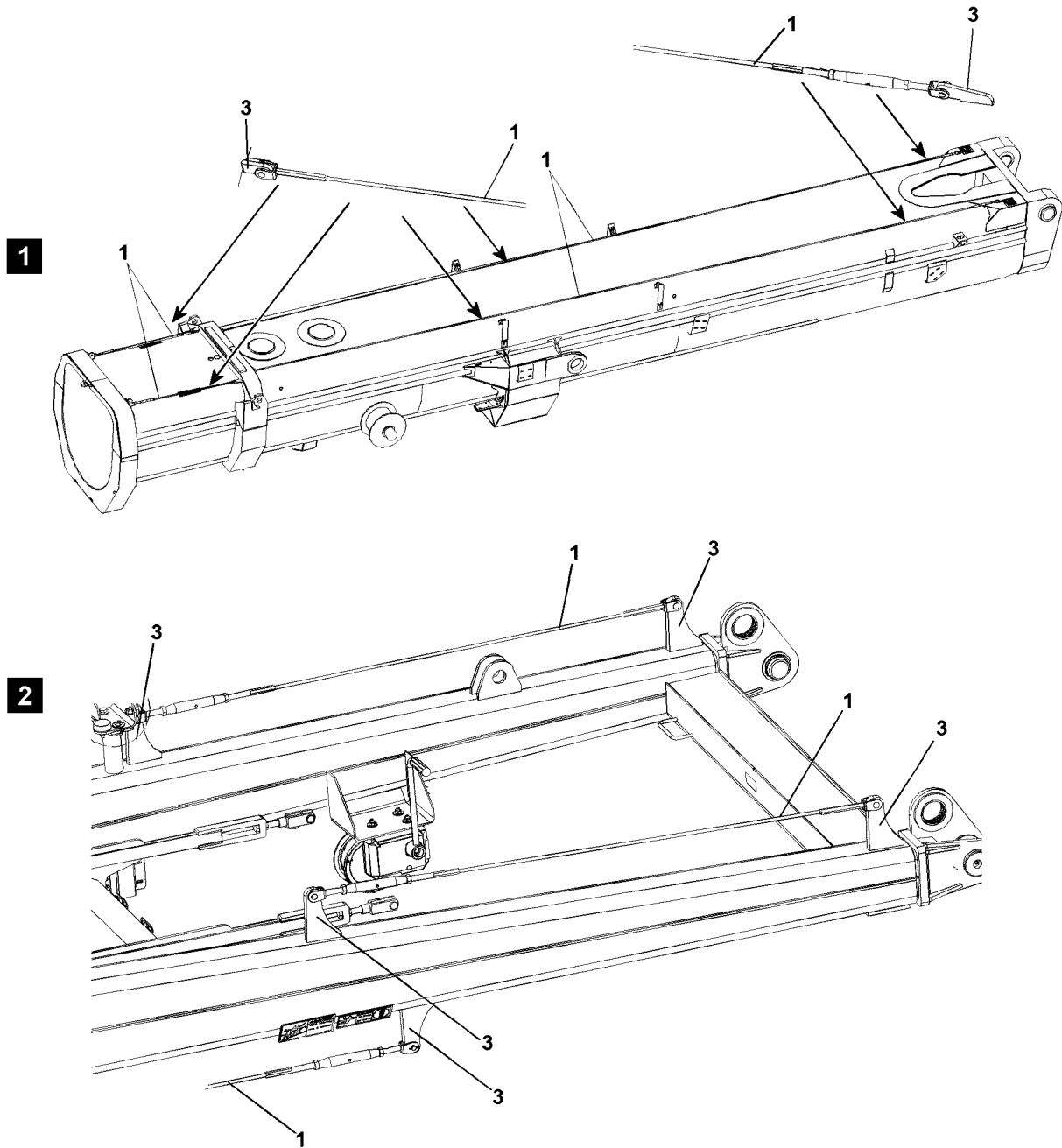

Fig.127130

**WARNING**

Danger of falls due to damaged safety ropes or anchor points!

The safety ropes **1** and anchor points **3** must be checked **at least once a year** by **authorized inspectors** for safety and damage!

If any defects are found on the safety ropes **1** or anchor points **3** during the inspections, then the safety ropes **1** or anchor points **3** must be replaced immediately by authorized and trained specialists! If this is not observed, assembly personnel could be killed or fatally injured in a fall!

- ▶ The rope pretension on the safety ropes must be 800 N !
- ▶ Have damaged safety ropes **1** or anchor points **3** replaced immediately by trained expert personnel!

**Note**

Document the inspections in writing!

- ▶ The scope and results of tests should be documented to permit reproducibility. This documentation forms part of the crane records and should be safely stored during the entire service life of the crane.

4.1 Checking of rope pretension on telescopic booms, illustration 1

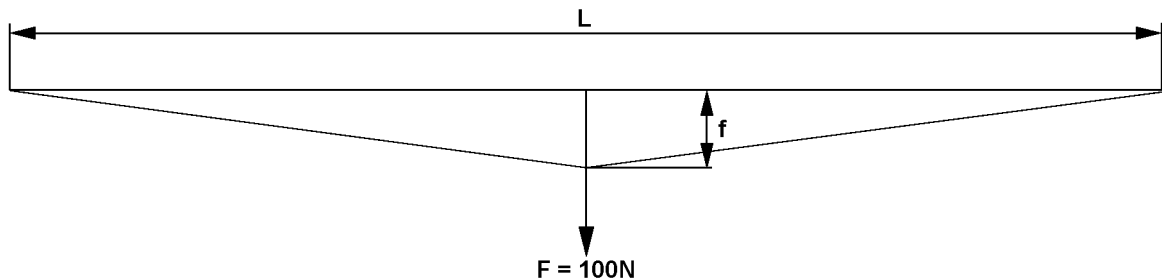

Fig.112738

The rope pretension must be 800 N. This can be checked with the aid of a spring balance, which is pulled centered on the safety rope. If the specified deflection (f) depending on the rope length (L) according to the following charts results for the raised load $F = 100\text{ N}$ then the rope pretension of 800 N is set correctly.

Rope pretension is 800 N if:					
Rope length (L)	1.0 m	1.5 m	2.0 m	2.5 m	3.5 m
Deflection (f)	15 mm	25 mm	30 mm	40 mm	55 mm

Rope pretension is 800 N if:					
Rope length (L)	5.5 m	7.5 m	9.5 m	11.5 m	13.5 m
Deflection (f)	85 mm	115 mm	145 mm	180 mm	215 mm

4.2 Inspection of rope pretension on lattice sections, illustration 2

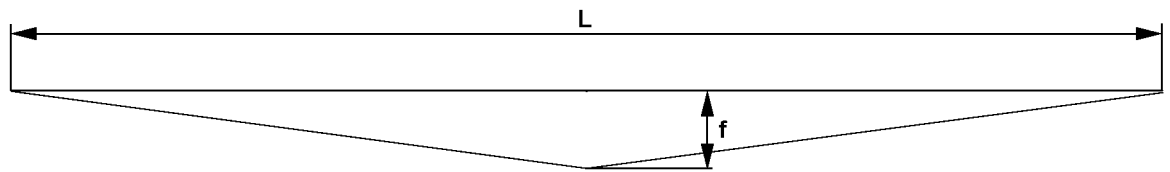

Fig.117747

The rope pretension is 800 N, if a sag (f) according to the chart is present on the safety rope according to the rope length (L).

Rope pretension is 800 N if:					
Rope length (L)	1.0 m	1.5 m	2.0 m	2.5 m	3.5 m
Deflection (f)	0	1 mm	2 mm	3 mm	6 mm

Rope pretension is 800 N if:					
Rope length (L)	5.5 m	7.5 m	9.5 m	11.5 m	13.5 m
Deflection (f)	15 mm	28 mm	45 mm	66 mm	90 mm

5 Inspection of load handling equipment and assembly aids



WARNING

Load handling equipment and / or assembly aids **not** inspected!

Death, severe bodily injuries, property damage.

► Inspect load handling equipment and / or assembly aids at least once a year.

The recurring inspection of the load handling equipment and / or assembly aids must be carried out once a year.

The inspections of load handling equipment and / or assembly aids must be recorded.

The welding seams must be subjected to a visual inspection.

Inspect load handling equipment and assembly aids for:

- Damage
- Wear
- Cracks

Replace damaged, worn or ripped load handling equipment and assembly aids immediately.

Repairs on load handling equipment and assembly aids may solely be made in consultation and under the instructions of the Customer Service at **Liebherr-Werk Ehingen GmbH** by authorized and trained expert personnel.



Note

- Document the scope of the inspection and the results in writing and comprehensibly.
- Save the documentation as a part of the crane records for the entire service life of the crane.

6 Inspection of fastening equipment



WARNING

Fastening equipment **not** inspected!
Death, severe bodily injuries, property damage.

- ▶ Inspect the fastening equipment at least once a year.

The recurring inspection of the fastening equipment must be carried out once a year.

The inspections of the fastening equipment must be recorded.

The welding seams must be subjected to a visual inspection.

Inspect the fastening equipment according to the specifications of the corresponding regulations and standards.

Replace damaged, worn or ripped fastening equipment immediately.



Note

- ▶ Document the scope of the inspection and the results in writing and comprehensibly.
- ▶ Save the documentation as a part of the crane records for the entire service life of the crane.

7 Inspection of diaphragm reservoir



Note

- ▶ The national regulations for pressurized container inspection must be observed!

The inspection of the diaphragm reservoir for specified gas pressure must be carried out by an **authorized inspector**, see chapter 7.04 and chapter 7.05.

8 Inspection of relapse cylinders



WARNING

Fatal accidents due to defective relapse cylinders!
Loss of oil or corrosion can damage the relapse cylinders!
Safe crane operation is no longer ensured!

- ▶ Crane operation with defective relapse cylinders is prohibited!

8.1 Pressure test of relapse cylinders

The relapse cylinders must be inspected annually by an **authorized inspector**. The purpose of the inspections is to avoid accidents by detecting deficiencies early on.

8.2 Checking the gas pressure and oil fill before operation



WARNING

Fatal accidents due to defective relapse cylinders!
Loss of oil or corrosion can damage the relapse cylinders!
Safe crane operation is no longer ensured!

- ▶ Before every start-up: Carry out a visual inspection for leaks, damage and corrosion on the relapse cylinders.
- ▶ If any defects are found, the relapse cylinders must be inspected by the cylinder manufacturer!

The gas pressure and the oil fill must be checked by an **authorized inspector** for pressure tanks.

8.3 Inspection of the safety controls on the relapse cylinders

Inspecting the interlocking system or limit switches on the relapse cylinders and the boom A-frames, see Chapter 8.12.

9 Inspection of rope pulleys

9.1 Checking for damage and cracks



DANGER

Danger of accident in case of damage or cracks!

- ▶ Replace rope pulley immediately!

Check the entire rope pulley assemblies for damage and cracks once a year.

If rope pulleys are subjected to any impacts (e.g., with buildings) or are otherwise overloaded, they must be visually inspected for damage or cracks immediately.

9.2 Checking the groove diameter

NOTICE

Worn rope pulleys!

The functionality and service life of the rope is reduced. Damage on rope.

- ▶ Before placing the rope, check the groove diameter of rope pulleys.

Visible wear on rope pulleys:

- Reduced groove diameter
- Negative impressions of the rope profile in the groove

Make sure that the following tools are available:

- Groove caliber

Make sure that the following prerequisites are met:

- All components to be inspected are cleaned.
- The rope does **not** obstruct the inspection of the components



Note

- ▶ The actual groove diameter **must** be larger than the actual diameter of the rope!

The groove diameter of rope pulleys and winches must be at least 6 % larger than the nominal rope diameter.

Check the rope pulleys with a groove caliber for wear. When wear exists on the rope grooves: Fix the rope pulleys or replace.

10 Inspection of carrier rollers

10.1 Checking visually



DANGER

Damaged carrier rollers!

Breakage and falling components. Death, severe bodily injuries, property damage.

- ▶ Carry out a visual inspection according to the maintenance intervals.
- ▶ Replace the carrier roller immediately.

The visual inspection must be carried out according to the following criteria:

- Wear
- Damage
- Cracks

Visible wear on carrier rollers:

- Negative imprints of the rope profile on the circumference of the carrier rollers
- Lead-in tracks

10.2 Checking the depth of the lead-in tracks



DANGER

Worn carrier rollers!

Breakage and falling components. Damage to ropes. Death, severe bodily injuries, property damage.

- ▶ Check the depth of the lead-in tracks.
- ▶ Replace worn carrier rollers immediately.

Make sure that the following prerequisites are met:

- All components to be inspected are cleaned.
- The rope does **not** obstruct the inspection of the components.

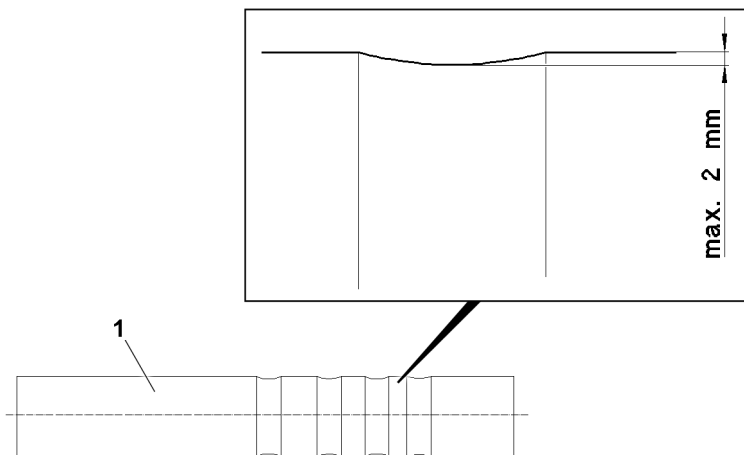

Fig.124864: Permissible depth of the lead-in tracks

1 Carrier roller

The depth of the lead-in tracks may be maximum 2 mm.

10.3 Checking bearings for easy movement

Stiff or blocked carrier rollers wear unevenly and cause serious rope abrasion.

Ineffective carrier rollers can lead to irregular rope tension.

Tasks to check the carrier rollers:

- Check the carrier rollers for proper movement in their bearings.
- When carrier rollers are **not** easily moveable in their bearings: Fix the bearings.

10.4 Checking the tightening torque

The tightening torque of screws must be checked according to maintenance interval.

11 Inspection of extension conditions of sliding beams

The extension conditions of the sliding beams must be inspected annually by an **authorized inspector**.

Check the extension conditions on every sliding beam:

- Check if the position 0 % of the LICCON display matches the actual condition of the sliding beam.
- Check if the position 100 % of the LICCON display matches the actual condition of the sliding beam.

12 Inspection of the function of the overload protection

Position the longest boom at minimum and maximum radius: Check the load indicator, using the hook block as a test load.

The display reading may not deviate by more than 10 % off the true load value at these two extreme positions.

Measure the indicated radius for the longest boom at its minimum radius and at a boom angle of 45°.

The indicator readings may not deviate more than 10 % off the measured boom radius.

13 Inspecting the pin connections



WARNING

Pin connections **not** inspected!

Death, severe bodily injuries, property damage.

- ▶ Inspect the pin connections at least once a year.

The recurring inspection of all pin connections must be carried out once a year.

The inspections of the pin connection must be recorded.

Check the pin connections for:

- Properly secured pin connections
- Damage to the pins and / or connector elements
- Damage to the retaining elements

Replace damaged pins immediately.

Immediately replace damaged, bent or broken retaining elements.

Only replace damaged pins with identical pins.

Only replace damaged retaining elements with identical retaining elements.



Note

- ▶ Document the scope of the inspection and the results in writing and comprehensibly.
- ▶ Save the documentation as a part of the crane records for the entire service life of the crane.

14 Inspection of slewing ring connection

14.1 Checking the tilt play

The wear of the slewing ring connection is determined by measuring the tilt play with the ring installed.

The permissible tilt play depends on the type of slewing ring connection.

**WARNING**

The tilt play of the slewing ring connection is too large!
If the permissible tilt play is exceeded, then safe crane operation is **no** longer possible.
Death, severe bodily injuries, property damage.

When the permissible tilt play is exceeded:

- ▶ Replace the slewing ring connection.

The determination of the tilt play must be carried out according to the **test instructions** of **Liebherr-Werk Ehingen GmbH**.

Request the test instructions and permissible tilt play: Contact Liebherr Service.

15 Inspection of the mounting of the load bearing equipment

15.1 Check the mounting screws for tight seating

The mounting screws must be checked for a tight fit during the annual crane inspection.

The mounting screws are pre-stressed at the factory, so that no loosening of the screw connections will occur during normal crane operation.

The screw connection may become overloaded and the mounting screws may be permanently stretched if the crane is overloaded or if the load is pulled free. The mounting screws must be checked immediately for a tight fit after an overload.

Check the tightening torque of the mounting screws of load bearing equipment for a tight fit:

- Slewing ring connection
- Winches
- Slewing gears
- Transmission
- Trailer coupling

If a mounting screw can be tightened, then the mounting screw is loose. Follow the instructions in section „Checking the mounting screws for damage“.

15.2 Checking the mounting screws for damage

Completely unscrew the loose mounting screws and check in detail for damage.

Completely unscrew the adjacent mounting screws and check in detail for damage.

Replace the mounting screw if any of the following damage is present:

- The mounting screw is stretched by more than 2 % (in relation to its original length).
- Cracks, permanent deformation or other damage is visible on the mounting screw.
- The mounting screw is uneven.
- There is pitting.
- The thread is hard to move.

If there is **no** damage, reuse the checked mounting screws (expansion screws) a maximum of two times.

16 Inspection of the tele extension with eccentric, illustration 1

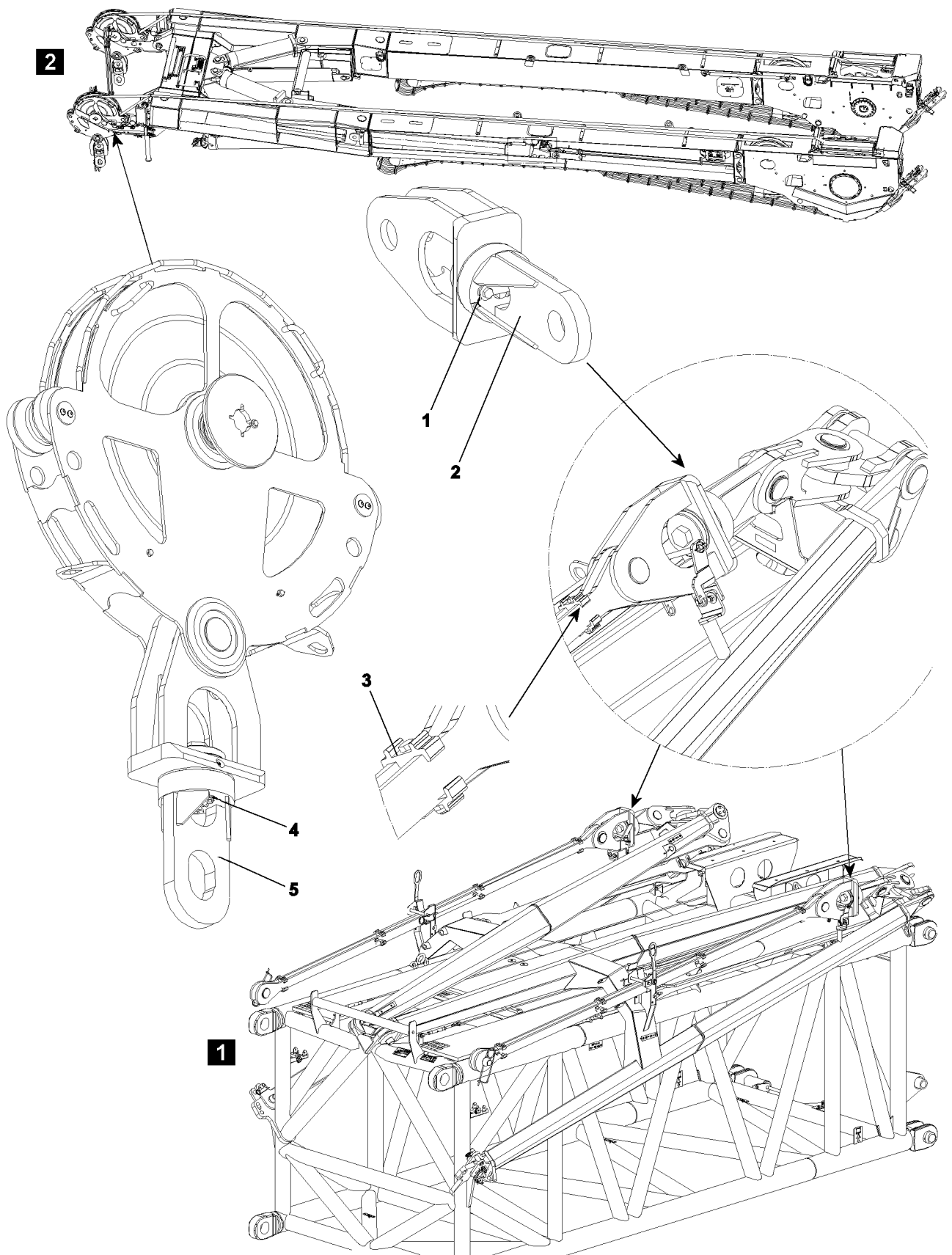

LWE/LR 1600-2-008/18109-09-02/en

Fig. 109096

- Inspection of twist guard **1** for damage and loose screw connection.
- Inspection of swivel **2** for easy turnability.
- Inspection of all clamps **3** for damage and function.

17 Inspection of change over pulleys, illustration 2

- Inspection of twist guard **4** for damage and loose screw connection.
- Inspection of swivel **5** for easy turnability.

18 Inspection of the oil and fuel tanks

Visually check the oil and fuel tanks at least once a year for leaks and safe mounting.

Repairs may only be carried out by authorized and trained specialists.

Improper repairs; e.g., welding, hard or soft soldering is not permitted, particularly if the Service department at Liebherr-Werk Ehingen GmbH has not been consulted!

8.03 Inspection of winches

1	Inspecting the hoist and retracting winches	3
2	Inspection of the auxiliary reeving winch, recovery winch and spare wheel winch	4
3	Monitoring the winches	5

Fig.195219

LWE/LR 1600-2-008/18109-09-02/en

1 Inspecting the hoist and retracting winches

The hoist and retracting winches are designed in sealed planetary gear version. These gears are sized for long service life and the drive shafts and gears are rated for endurance.

Even though the hoist and retracting winches are designed for long life, an external visual inspection is not adequate, since their life can be significantly affected by bad maintenance (insufficient oil), using oil that does not meet specification requirements, defective seals, improper operation or overloading.

The annual inspection must therefore be carried out by an **expert** in accordance with the following specification.

The winches must be inspected by an **authorized inspector** every four years after the initial license.

Within the territorial validity of the BGV D6, after the 10th year in operation, counted from the first day of initial license, when the theoretical utilization time is not over, the winches must be checked annually by an **authorized inspector**.

1.1 Checking the groove diameter



WARNING

Worn winches!

Damage of flanged disks, high rope wear, operational problems. Broken rope, falling load.

► Before placing the rope, check the groove diameter of winches.

Visible wear on winches:

- Reduced groove diameter
- Mechanical damage, for example scrub marks or scouring on flanged disks

Make sure that the following tools are available:

- Groove caliber

Make sure that the following prerequisites are met:

- All components to be inspected are cleaned
- The rope does **not** obstruct the inspection of the components



Note

► The groove radius may **not** be smaller than the actual diameter of the rope.

The groove diameter of rope pulleys and winches must be at least 6 % larger than the nominal rope diameter.

Check winches with a groove caliber for wear. When wear is present: Fix the winch or replace.

1.2 Inspection intervals

At least once a year, see Crane operating instructions, chapter 7.03.

1.3 Checking the oil level

Check the oil level with the dipstick.

For hoist and retracting winches **without** a dipstick, we recommend that the oil is drained and the amount compared to the specified oil quantity.

1.4 Evaluating oil color

Assume that the oil has been overheated if it is black and / or a burnt oil smell is detected. Change the oil.

1.5 Checking for solid foreign substances

In general, the oil must be analyzed by a qualified laboratory.

For simple testing, the following procedure can be used:

- Drip the used oil on a specified filter fleece.
- Visual inspection with a magnifying glass may reveal coarse particles.
- If coarse particles are found: Have the components of the oil analyzed by a qualified laboratory.

NOTICE

Danger of property damage!

- ▶ Repairs may only be carried out by authorized and especially trained personnel.
 - ▶ Replace damaged parts and change the gear oil.
-

1.6 Visual inspection for leaks

The gears must be checked for leaks, since oil losses - in addition to polluting the environment - can lead to gear failure.

1.7 Inspecting the gear brakes

Check the brakes each time the gears are inspected.

In order to do so, proceed as follows:

- Attach a load, which creates the maximum rope pull in the uppermost layer of the coil and raise it just off the ground.
- Remove the plug on the brake lifting magnet.
This means the brake remains applied when activated.
- Activate the winch in the lowering direction.



Note

- ▶ The brake may not slip, in other words, the winch may not turn. If the brake slips, contact the Service department at Liebherr-Werk Ehingen GmbH!
 - ▶ Only operate the crane after it has been checked and approved for use by the Service department at Liebherr Werk Ehingen GmbH!
-

NOTICE

Danger of property damage!

- ▶ Only qualified personnel with specialized knowledge may be used to evaluate gears and brakes!
-

1.8 Documenting the completed inspection

The results of the annual inspections and maintenance work, including the steps taken, must be documented by the competent or authorized inspector, including attachments from the inspection labs and qualified service companies if applicable.

This documentation must be filed in the crane inspection log under the heading "Periodic inspections".

2 Inspection of the auxiliary reeving winch, recovery winch and spare wheel winch

The inspection of the auxiliary reeving winch, recovery winch and spare wheel winch regarding scope and content is made according to the manufacturer's instructions.

- Inspect the auxiliary reeving winch, recovery winch and spare wheel winch according to the manufacturer's instructions.

- Request data about the service life of the auxiliary reeving winch, recovery winch and spare wheel winch from the respective manufacturer.

3 Monitoring the winches

3.1 Theoretical service life

The designer of your crane used a theoretical total operating time when designing and sizing the winches. This resulted in the theoretical service life of the equipment.

The winches of your crane are classified according to ISO 4301/1 as follows:

Winches	Classification
Power train group:	M3
Load spectrum:	L1
Load spectrum factor Km:	0.125
Theoretical service life D:	3200 h



Note

- ▶ The „theoretic service life“ is not equal to the real (true) service life of a winch!

The actual life of the winch is affected by many additional outside factors; for example:

- Overloads caused by unapproved use of the crane.
- Inadequate maintenance: Oil is not changed in a timely manner
- Improper operation:
 - Extreme acceleration or deceleration of the load
 - Load falling into the ropes
- Maintenance errors:
 - Using the wrong type of oil
 - Too much or too little oil
 - Contamination during oil change
- Assembly errors during repair and maintenance
- Undetected leaks
- Incorrectly set safety equipment
- Hidden damage from accidents
- Extreme environmental conditions:
 - Extreme low or high temperatures
 - Corrosive atmosphere
 - Dust and dirt

3.2 Used proportion of the theoretical service life

The crane operator is obligated to carry out an inspection of the crane at least once a year.

At this time, the actually used part of the theoretical service life must also be calculated. If necessary, the crane operator must contract an authorized inspector.

For the determination of the used part of the theoretical service life, the actual operating conditions (load spectrum) and the hoist gear operating hours for each inspection interval are to be determined. The operator is responsible for the documentation in the crane inspection log.

3.2.1 Determining the operating conditions (load spectrum)

The load spectrum of the crane is divided into groups, please refer to ISO 4301/1.

Select one of the following load spectrums and record it in the crane inspection log for the respective inspection interval based on the actual operating conditions. A more precise determination of the load spectrum is permissible.

Load spectrum class: Light L1

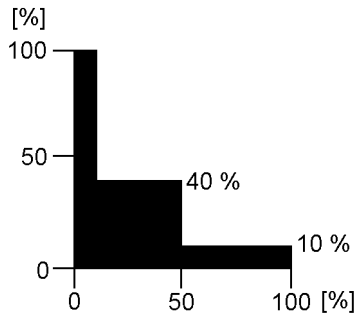

Fig.195234: Graphic illustration Load spectrum L1

Definition:

Power train or parts thereof are subjected to maximum stress only in exceptional cases, but normally only operate at very light loads.

Operating time rates:

- 10 % of the time at maximum load (dead load and 1/1 working load)
- 40 % of the time with dead load and 1/3 working load
- 50 % of the time only with dead load

Factor of load spectrum:

$K_m = 0.125$



Note

- Load spectrum L1 with load spectrum factor $K_m = 0.125$ is normally applied to cranes used for assembly operations!

Load spectrum class: Medium L2

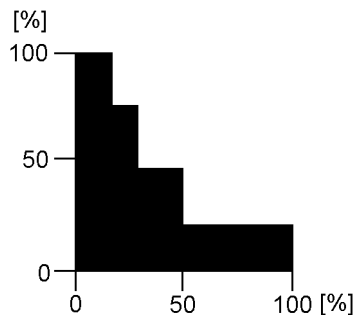

Fig.195235: Graphic illustration Load spectrum L2

Definition:

Power train or parts thereof are subjected to maximum load relatively often, but normally only operate at light load.

Operating time rates:

- 1/6 of the time at maximum load (dead load and 1/1 working load)
- 1/6 of the time with dead load and 2/3 working load

1/6 of the time with dead load and 1/3 working load
 50 % of the time only with dead load

Factor of load spectrum:
 $K_m = 0.25$

Load spectrum class: Heavy L3

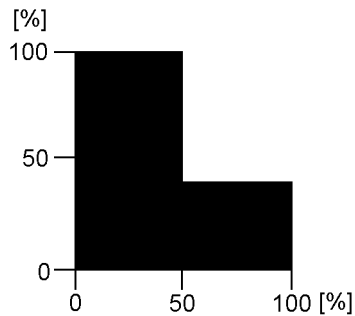

Fig.195236: Graphic illustration Load spectrum L3

Definition:

Power train or parts thereof are frequently subjected to maximum load and normally operate at medium load.

Operating time rates:

50 % of the time at maximum load (dead load and 1/1 working load)
 50 % of the time only with dead load

Factor of load spectrum:
 $K_m = 0.5$

Load spectrum class: Very heavy L4

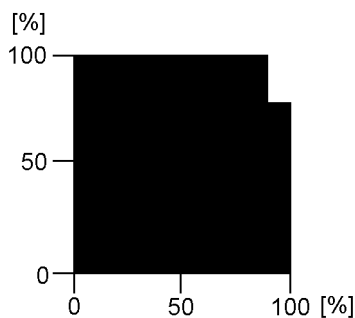

Fig.195237: Graphic illustration Load spectrum L4

Definition:

Power train or parts thereof are regularly subjected to near maximum loads.

Operating time rates:

90 % of the time at maximum load (dead load and 1/1 working load)
 10 % of the time only with dead load

Factor of load spectrum:
 $K_m = 1$

3.2.2 Determining the effective operating hours T_i

The effective operating hours calculated as follows must be entered into the crane inspection log for the respective inspection interval.

There are four different scenarios:

1. Operating hour meter installed on every winch.
If an operating hour meter is installed on every winch in your crane, the effective operating hours T_i can be read directly during each inspection.
2. Operating hour meter installed for the overall crane drive.
The winch proportion of the total superstructure operating hours must be estimated.
For cranes used in assembly operations, the operating time for the hoist winches can be estimated generally at 20 % of the total operating hours of the superstructure.
3. One operating hour meter is used for both the crane engine and the crane drive
The winch proportion of the total crane operating hours must be estimated.
For cranes used in assembly operations, the operating time for the superstructure can be estimated at 60 % of the total operating hours of the crane. If the hoist winch proportion is estimated at 20 % of the superstructure operating hours (see previous item), then the result in relation to the **total** operating hours of the crane is: 12 %.
4. No operating hour meter is available.
In this case, the operator must estimate and document the actual operating hours of the winch.
The approximate percentages stated above normally apply to main hoist winches. For auxiliary hoist winches or boom control winches, the proportion of the total operating hours can be significantly less and should therefore be estimated by the operator.

3.2.3 Determining the used proportion of the theoretical service life

For an inspection interval i (max. 1 year), the actually used proportion S_i of the theoretical Service life is derived from the formula:

$$S_i = \frac{K_{m_i}}{K_m} \times T_i$$

Fig.195230

Abbreviation	Explanation
S_i	Used proportion of the theoretical service life.
K_m	Load spectrum factor that was used to calculate the winch rates. This factor is provided in the Operating instructions.
K_{m_i}	Load spectrum factor for inspection interval i according to section „Determining the operating conditions“.
T_i	Effective operating hours for inspection interval i according to section „Determining the effective operating hours T_i “.

The actually used proportion is subtracted from the remaining theoretical service life D_i after each inspection interval (see example).

If the remaining theoretical service life is not long enough to cover the next projected operating period, a general overhaul of the winch is required.

If the theoretical service life D has been reached (see chapter on „Theoretical service life“), then the winch may only be operated after conducting a general overhaul.

A general overhaul of the winch is required not later than 10 years after start up.

The general overhaul must be arranged by the operator and carried out by the manufacturer or the manufacturer's authorized representatives and must be documented in the inspection log. After the

general overhaul, the manufacturer or the manufacturer's authorized representative will define a new theoretical service life D.

When the design life has not been reached after 10 years, continued operation of the winch without a general overhaul is acceptable, when the crane's authorized inspector has confirmed the accuracy of the actual usage calculation by signing the crane inspection log at each authorized inspection interval.

In such a case, the authorized crane inspector must thoroughly inspect the winch. This comprises at least:

- External visual inspection (leaks damage, deformation, etc.).
- Oil check, especially for metal residues.
- Load test at minimum and maximum rope tension and at maximum possible speed in both cases. At least one layer must be spooled up. Pay particular attention to any unusual noises during this load test.

The authorized crane inspector must confirm this inspection in the crane inspection log and must make a statement regarding suitability of the winch for continued operation. The next inspection must take place at the end of the 12th operating year and annually thereafter.

3.3 Example

According to the manufacturer's operating instructions, a crane with a separate operating hour meter for the travel drive and the crane drive is classified as follows:

- Power train group: M3
- Load spectrum: Light L1
- Factor of load spectrum: $K_m = 0.125$
- Theoretical service life: $D = 3200$ h

Actual usage proportion S of the theoretical service life is calculated using the individual inspection intervals as follows:

3.3.1 First inspection (first year)

The crane was used for assembly work during the past year:

Load spectrum L1, in other words $K_{m1} = 0.125$.

The superstructure operating hour meter indicates 800 h. The winch was operated about 20 % of the time; i.e. $T_1 = 160$ h.

The actual usage proportion S of the theoretical service life at the time of the first inspection is therefore:

$$S_1 = \frac{0,125}{0,125} \times 160 \text{ h} = 160 \text{ h}$$

Fig.195231

Remaining theoretical service life:

$$D_1 = 3200 \text{ h} - 160 \text{ h} = 3040 \text{ h}$$

The above values are recorded in the crane inspection log.

3.3.2 Second inspection (second year)

The crane was used at a harbor for unloading work:

Load spectrum L3, in other words $K_{m2} = 0.5$.

The superstructure operating hour meter indicates 2000 h ; i.e., during this period:

2000 h – 800 h = 1200 h (800 h were used during the first year of operation)

The winch was operated about 40 % of the time; i.e. $T_2 = 480$ h.

The actual usage proportion S_2 of the theoretical service life at the time of the second inspection is therefore:

$$S_2 = \frac{0,5}{0,125} \times 480 \text{ h} = 1920 \text{ h}$$

Fig.195232

Remaining theoretical service life:

$$D_2 = 3040 \text{ h} - 1920 \text{ h} = 1120 \text{ h}$$

3.3.3 Third inspection (third year)

The crane was used for assembly work and occasionally at a harbor for unloading work:

Load spectrum L2, in other words $Km_3 = 0.25$.

The superstructure operating hour meter indicates 3000 h ; i.e., during this period:

$$3000 \text{ h} - 2000 \text{ h} = 1000 \text{ h} \text{ (2000 h were used during the first two years of operation)}$$

The winch was operated about 30 % of the time; i.e. $T_3 = 300 \text{ h}$.

The actual usage proportion S_3 of the theoretical service life at the time of the third inspection is therefore:

$$S_3 = \frac{0,25}{0,125} \times 300 \text{ h} = 600 \text{ h}$$

Fig.195233

Remaining theoretical service life:

$$D_3 = 1120 \text{ h} - 600 \text{ h} = 520 \text{ h}$$

3.4 Chart for determining the theoretically remaining service life

Chart 1 includes an example.

The remaining theoretical service life is to be documented in chart 2.

LWE/LR 1600-2-008/18109-09-02/en

Chart to determine the remaining theoretical service life of winch No. 1 (Main hoist winch)

Crane type: LTM 1050
 Fabrication No.: 0010 540 08
 Put in service: 12345
 Serial number of winch according to data tag: 0815
 Last general overhaul performed on:
 Configuration data of winch (see Operating Manual):
 Drive gear group: M 3
 Load collective: L 1
 Factor of load collective Km: 0.125
 Theoretical service life D: 3200 hrs.

S_i = Used part of theoretical service life since last inspection
 D_i = Remaining theoretical service life
 D_{i-1} = Remaining theoretical service life after previous inspection
 Km = Factor of load collective, which was taken for calculation of winch.
 This factor is to be taken from the Operating Manual
 Km_i = Factor of load collective in inspection interval i
 T_i = Effective operating hours in inspection interval i

(*) In the following pages, carry over the last line from the previous page.

Inspection interval No. (max. annually)	Date of initial service data of inspection	Operating conditions since last inspection (load collective)	Factor of load collective	Total crane operating hours	Operating hours of super-structure	Operating hours of super-structure since last inspection	Operating hours of winch	Operating hours of winch since last inspection T_i	Used part of theoretical service life D_i : $S_i = \frac{Km_i}{Km} \times T_i$	Remaining theoretical service life $D_i = D_{i-1} - S_i$	Name of inspector	Signature	Remarks	Name of expert	Signature
(*) 0	10.06.90	-	-	-	0	0	-	0	0	3200					
1	05.06.91	L1	0,125	-	800	800	-	160 (20% of 800)	160	3040	Müller				
2	20.05.92	L3	0,5	-	2000	1200	-	480 (40% of 1200)	1920	1120	Huber				
3	18.05.93	L2	0,25	-	3000	1000	-	300 (30% of 1000)	600	520	Mater				
4															

CAUTION: Perform general overhaul at least once every 10 years! In case of deviation, see guidelines in this chapter.

General overhaul last performed on :

Fig.121551-en: Chart 1

Chart to determine the remaining theoretical service life of winch No.

- Crane type:
- Fabrication No.:
- Put in service:
- Serial number of winch according to data tag:
- Last general overhaul performed on:
- Configuration data of winch (see Operating Manual):
 Drive gear group: M.....
 Load collective: L.....
- Factor of load collective Km :
- Theoretical service life D :
- S_i = Used part of theoretical service life since last inspection
 D_i = Remaining theoretical service life
 D_{i-1} = Remaining theoretical service life after previous inspection
 Km = Factor of load collective, which was taken for calculation of winch.
 This factor is to be taken from the Operating Manual
 Km_i = Factor of load collective in inspection interval i
 T_i = Effective operating hours in inspection interval i
- *) In the following pages, carry over the last line from the previous page.

Inspection interval No. (max. annually)	Date of initial service data of inspection	Operating conditions since last inspection (load collective)	Factor of load collective	Total crane operating hours	Operating hours of super-structure	Operating hours of super-structure since last inspection	Operating hours of winch	Operating hours of winch since last inspection T_i	Used part of theoretical service life D : $S_i = \frac{Km_i}{Km} \times T_i$	Remaining theoretical service life $D_i = D_{i-1} - S_i$	Name of inspector	Signature	Remarks	Name of expert	Signature	
i			Km_i	[h]	[h]	[h]	[h]	[h]	[h]	[h]						
(*)																

CAUTION: Perform general overhaul at least once every 10 years! In case of deviation, see guidelines in this chapter.

General overhaul last performed on :

LWE/LR 1600-2-008/18109-09-02/en

Empty page!

LWE/LR 1600-2-008/18109-09-02/en

8.04 Inspection of crane wire ropes

1	Crane ropes	3
2	Importance of inspection	3
3	Personal protective equipment	3
4	Qualification Inspection personnel	3
5	Unscheduled inspection	3
6	Intervals	4
7	Areas	4
8	Documenting inspection results	5
9	Wire ropes and rope end connections	5
10	Degree of severity	7
11	Abbreviations Rope diameter	7
12	Distortions and mechanical damage	8
13	Removal criteria Overview	8
14	Checking for broken strands	9
15	Determining the number of broken wires	9
16	Checking the rope end connection	14
17	Checking of rope diameter	14
18	Corrosion	17
19	Corkscrew-like distortion	19
20	Basket formation	20
21	Protruding, distorted insert or strand	21
22	Loop formation	22
23	Kinking or rope loops pulled closed	23
24	Buckles	24
25	Effects of heat, arcs	25
26	Combined degree of severity	25
27	Flattenings	25
28	Current checklist	28

Fig.195219

LWE/LR 1600-2-008/18109-09-02/en

1 Crane ropes

This chapter applies, for example, for the following crane ropes:

- Hoist ropes
- Control ropes for the boom system
- Control ropes of the telescopic boom with rope mechanism: Pull-out ropes and return ropes
- Guy ropes for boom system

2 Importance of inspection

Rope removal criteria: If severe damage reduces the operational safety, then the rope has reached the removal criteria.

The importance of regular inspections is demonstrated by:

- Evaluation of operational safety of ropes
- Determination of rope removal criteria
- Determination of next inspection

3 Personal protective equipment



WARNING

Wires and lubricant!

Severe injury and skin irritation.

- ▶ When working with ropes, always wear work gloves.



WARNING

Protective equipment **not** worn!

Severe injuries.

- ▶ Wear hard hat, safety shoes and safety glasses.

4 Qualification Inspection personnel

Make sure that the following prerequisites are met:

- Inspection personnel are **expert personnel for crane rope inspection**.
- **Expert personnel for crane rope inspection:**
 - Are trained in the inspection of crane ropes according to **DIN ISO 4309** and have practical experience in the evaluation of rope removal criteria.
 - Have practical experience in the evaluation of rope removal criteria according to **DIN ISO 4309**.
- The inspection personnel is assigned (authorized) for the maintenance by the crane operator.

5 Unscheduled inspection

In the following situations the rope must be inspected:

- After unusual strain
- If non-visible damage is suspected
- when a rope or the rope end connection is damaged
- when the rope has been placed again after removal
- when the rope has been out of service for longer than three months

6 Intervals

Intervals for crane inspection:

- according to determination by **expert personnel for crane rope inspection**
- or **at least once a year**



Note

- ▶ Shortening the inspection interval: The older a rope is the more frequently will wire breaks occur.

Determining factors for determination of inspection intervals are:

- Legal regulations in the country where the crane is operated
- Climate conditions under which the rope drive is utilized
- Power train group
- Results of previous inspections on current or comparable machine and under comparable operating conditions
- Frequency and type of use of a rope
- Service life of rope

7 Areas



WARNING

Broken wires and distortions on ropes in cross over areas!

Rope performance can be greatly reduced. Rope breakage. Death, severe injuries, property damage.

- ▶ Inspection rope cross over areas especially diligently.

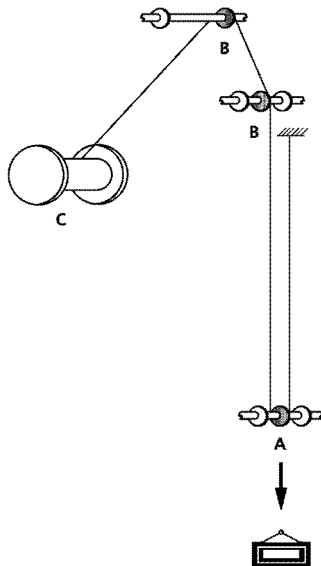

Fig.120969: Important inspection areas for multi layer spooled up ropes

- | | |
|---|---|
| <p>A Rope sections, which run in the area of the load rise into the lower rope pulleys (the load is raised here).</p> <p>B Rope intake on the first rope pulley in the area of the load rise.</p> | <p>C Rope sections, which are subjected in the cross over areas to the strongest effects (maximum deflection angle).</p> |
|---|---|

The rope must be checked over the entire length.

The following areas must be checked with special diligence:

- Rope end connections
- Safety coils and fixed point on the winch
- Areas of the rope which run through the hook block.
- Areas of the rope that run over the rope pulleys or lay on the rope pulleys.
- Areas of the rope that are spooled on the winch, especially cross over areas.
- Areas of the rope which are laying above the compensation pulleys.
- Areas of the rope which are subjected to abrasion due to external components.
- All areas of the rope that are subjected to temperatures above 60 °C.

8 Documenting inspection results



Note

- ▶ Document the results of the inspections in an inspection checklist.
- ▶ Form for an inspection checklist, see section „Current checklist“.

9 Wire ropes and rope end connections



WARNING

Wire rope with impermissible rope end connection!

The wire rope can fail. The load can fall down.

Death, severe bodily injuries, property damage.

- ▶ Select the permissible rope type for the respective application.
- ▶ Select the permissible rope end connection for the respective rope type.
- ▶ Observe and adhere to the warning display on the lock.

Wire rope application	Rope type
Hoist rope	Rotation-resistant rope
Guy rope or control rope	Non-rotation resistant rope
Auxiliary rope or assembly rope	Non-rotation resistant rope

Rope type depending on the application

The type of rope that is selected determines the corresponding rope end connections.

9.1 Rotation-resistant ropes with rope end connections

Use rotation-resistant ropes as **hoist ropes**.

Rotation-resistant ropes are special ropes that produce extremely little torque and twisting at the rope end connection when they are under strain.

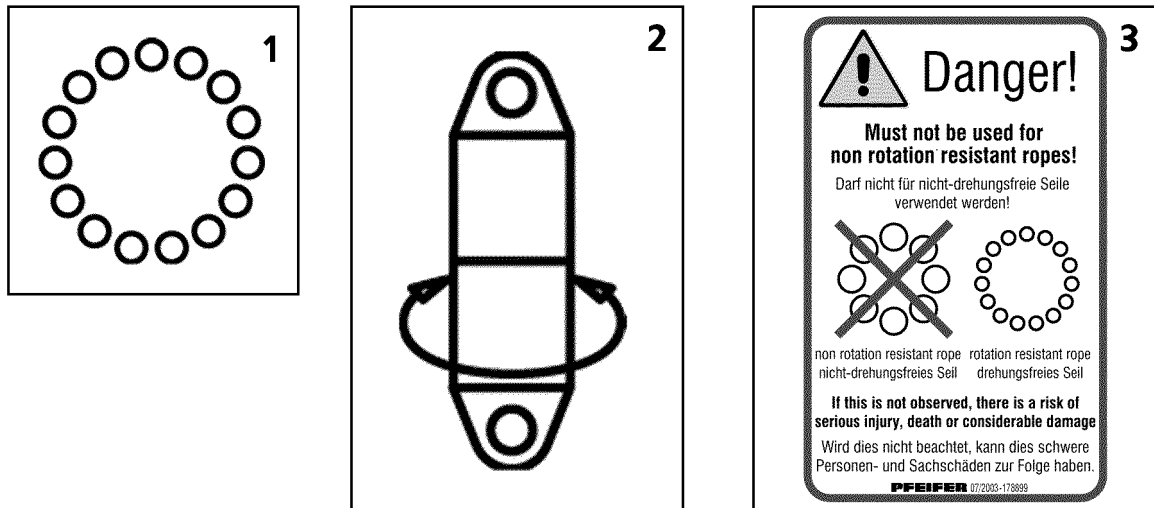

Fig.195653: Symbols for rotation-resistant ropes with rope end connections

- 1 Rotation-resistant rope symbol 3 Warning display on the PFEIFER lock
 2 Rotating rope end connection symbol

Typical rotation-resistant rope structures are wire ropes with 15 to 18 outer strands. Rotation-resistant ropes are symbolically depicted with 15 outer strands (circles), see illustration 1.

9.1.1 Non-rotating rope end connection



Note

- In the case of a rotation-resistant ropes, Liebherr recommends the use of a lock **without** a swivel or a wedge lock. This can reduce the stress on the hoist ropes.

9.1.2 Rotating rope end connection



Note

- In the case of rotation-resistant ropes, Liebherr recommends **not** using a lock **with** a swivel and **not** to use a twist compensator / swivel.

To reduce a problematic turning behavior, the following rope end connections can be used in an individual case and after consultation with Liebherr customer service:

- Lock **with** swivel
- Twist compensator / swivel

9.2 Non-twisting ropes with rope end connections



WARNING

Wire rope with impermissible rope end connection!

The wire rope can fail. The load call fall down.

Death, severe bodily injuries, property damage.

- Use a lock **without** a swivel or a wedge lock.
- **Never** use a lock **with** a swivel with non-twisting rope.
- **Never** use a twist compensator / swivel with a non-twisting rope.

Use non-twisting ropes as **guy ropes** or **control ropes**, **auxiliary ropes** or **assembly ropes**.

Non-twisting ropes generate high torque levels on the rope end connection under strain. For this reason, the rope ends must be protected from twisting using an appropriate rope end connection to prevent the wire rope from unscrewing under strain.

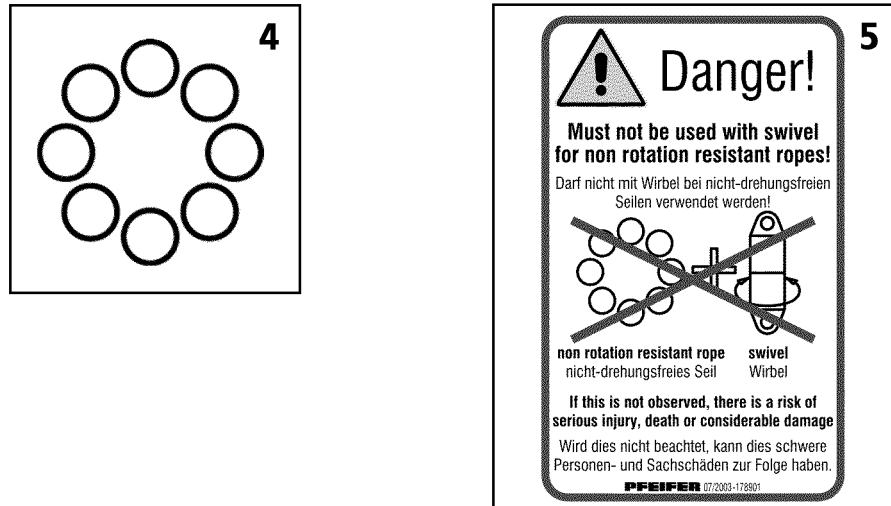

Fig.195654: Symbols for non-twisting ropes with rope end connections

4 Non-twisting rope symbol

5 Warning display on the PFEIFER lock / wedge lock

Typical non-twisting rope structures are wire ropes with eight or ten outer strands. Non-twisting ropes are symbolically depicted with eight outer strands (circles), see illustration 4.

Only use non-twisting ropes with the following **non-twisting** rope end connections:

- Lock **without** swivel
- Wedge lock

A non-rotating rope end connection is also the mounting of the rope on the fixed point of the winch drum.

10 Degree of severity

The deciding factor for the removal criteria is which removal criteria are present and to which degree they occur.

When various removal criteria are **not** present to a full degree, then the removal criteria must be evaluated as a total entity. For every individual removal criteria a degree of severity must be determined (percentage value).

For a certain rope section the sum of individual degrees of severity results in a **combined degree of severity**, see section „Combined degree of severity“.

When the combined degree of severity is more than 100 %, then the rope must be taken down.

11 Abbreviations Rope diameter

Abbreviations	Description
Rope nominal diameter d	Rope diameter, identification of rope
Reference diameter d_{ref}	Measured rope diameter of a straight rope section, directly after placing the rope
6d	Length of 6-fold rope nominal diameter
30d	Length of 30-fold rope nominal diameter

Abbreviations Rope diameter

LWE/LR 1600-2-008/18109-09-02/en

12 Distortions and mechanical damage



WARNING

Distortions and mechanical damage!

Operational safety significantly disturbed, uneven load distribution within the rope.

- ▶ Have the manufacturer check if the distorted and damaged area can be severed.

Visible form changes often occur localized or in short rope sections.

When a safe operation of the rope is ensured, a distorted and damaged area can be severed.

13 Removal criteria Overview

The following chart provides an overview between removal criteria and the respective method for inspection. The degree is described, when the removal criteria is reached.

The removal criteria is described in detail in the subsequent sections.



Note

When the rope for parallel operation has reached the removal criteria:

- ▶ Often, both ropes must be replaced. The new rope has a larger diameter and other elongation characteristics.

Removal criteria	Degree for removal criteria	Inspection method
Broken strands	One strand is broken	Visual check
Broken wires on ropes, which run over rope pulleys and are spooled in multiple layers	Maximum number of broken wires reached, see Section Determining the number of broken wires	Count
Broken wire in the strand valleys	Two or more broken wires in strand valleys, on the contact points of two neighboring strands within an angular length (corresponds approx. to 6d)	Count
Broken wires in the area of the rope end connection	Two or more broken wires, according to decision of expert personnel for crane rope inspection	Visual inspection, test with marlin spike
Broken wire nests	On occurrence	Visual check
Reduction rope diameter at even diameter reduction	Maximum reduction of rope diameter reached	Measurement, calculation
Localized increase of rope diameter	Maximum increase of rope diameter reached	Measurement
Significant corrosion	Surface of rope is significantly affected or rust film emerges, according to decision of expert personnel for crane rope inspection	Visual check
Corkscrew-like distortion	Maximum permissible distortion reached	Measurement, calculation
Basket formation	On occurrence	Visual check
Wires or bunches of wires protruding from the rope	On occurrence, if more than one wire protrudes from the rope	Visual check

Removal criteria	Degree for removal criteria	Inspection method
Flattenings	Larger than half of the diameter of the outer strand, according to decision of expert personnel for crane rope inspection	Visual check
Loop formation	Loops on several wires	Visual check
Kinking or remaining distortion	On occurrence	Visual check
Buckles or contusions	On occurrence, according to decision of expert personnel for crane rope inspection	Visual check
Heat influence, electric voltage	Bluish discoloration, broken or melted wires	Visual check
Damage on rope end connections: Material cracks, deformation, wear, corrosion, traces of slipping between the locking clamp and rope	According to decision of expert personnel for crane rope inspection	Visual inspection
Combined degree of severity	Degree of severity 100 % or above, according to decision of expert personnel for crane rope inspection	Calculation of individual degrees of severity

Removal criteria Overview

14 Checking for broken strands

A strand consists of several individual wires.

If a complete strand is broken:

- ▶ Take the rope down.

15 Determining the number of broken wires

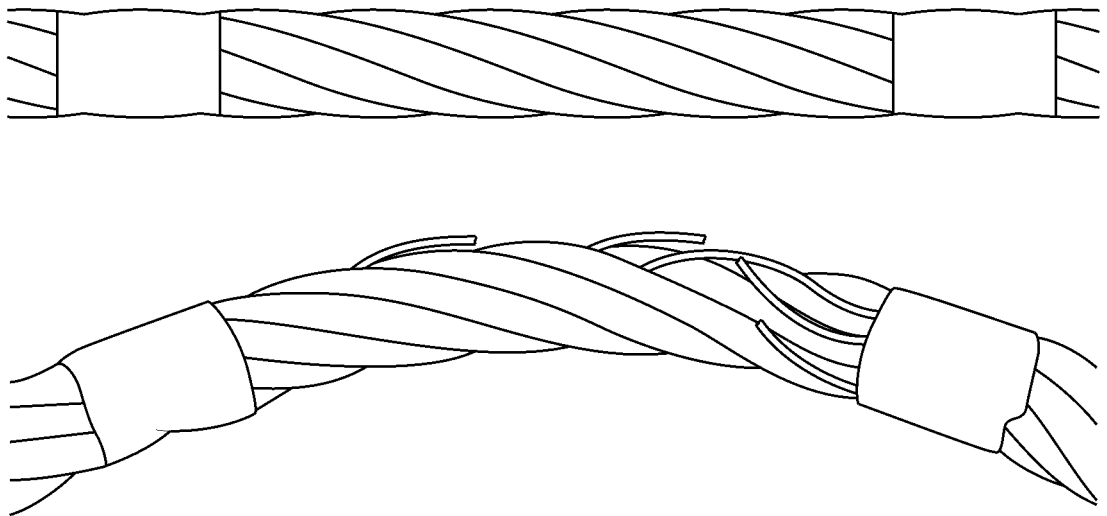

Fig.120980: Determine broken wires by bending

By bending the rope, broken wires can be recognized better.

Make sure that the following prerequisites are met:

- The rope is clean.
- Inspection checklist is on hand.

15.1 Scattered occurring broken wires

The following different rope types each have their own chart for the permissible number of broken wires:

- Single layer and parallel roped ropes
- Rotation resistant ropes

The charts in this section are valid exclusively for **scattered occurring broken wires**.

15.1.1 Wire break increase rate

The wire break increase rate is an increase of broken wires, which can skyrocket with increasing use of the rope.

- Include the inspection checklists for the previous inspection and use it to draw a conclusion for the wire break rate increase.

15.1.2 Single layer and parallel roped ropes

Rope category number RCN	Total number of load carrying wires in the outer strand layer of rope ¹ n	Number of visible outer wire breaks ²					
		Rope sections, which run over steel pulleys and / or spool up on a single layer spooling drum (coincidental distribution of broken wires)				Rope sections, which spool up on a multi layer drum ³	
		Class M1 to M4, or class unknown ⁴				All classes	
		Lang lay		Even lay		Lang lay and even lay	
		Over a length of 6d ⁵	Over a length of 30d ⁵	Over a length of 6d ⁵	Over a length of 30d ⁵	Over a length of 6d ⁵	Over a length of 30d ⁵
01	$n \leq 50$	2	4	1	2	4	8
02	$51 \leq n \leq 75$	3	6	2	3	6	12
03	$76 \leq n \leq 100$	4	8	2	4	8	16
04	$101 \leq n \leq 120$	5	10	2	5	10	20
05	$121 \leq n \leq 140$	6	11	3	6	12	22
06	$141 \leq n \leq 160$	6	13	3	6	12	26
07	$161 \leq n \leq 180$	7	14	4	7	14	28
08	$181 \leq n \leq 200$	8	16	4	8	16	32
09	$201 \leq n \leq 220$	9	18	4	9	18	36
10	$221 \leq n \leq 240$	10	19	5	10	20	38
11	$241 \leq n \leq 260$	10	21	5	10	20	42
12	$261 \leq n \leq 280$	11	22	6	11	22	44

Rope category number RCN	Total number of load carrying wires in the outer strand layer of rope ¹ n	Number of visible outer wire breaks ²					
		Rope sections, which run over steel pulleys and / or spool up on a single layer spooling drum (coincidental distribution of broken wires)				Rope sections, which spool up on a multi layer drum ³	
		Class M1 to M4, or class unknown ⁴				All classes	
		Lang lay		Even lay		Lang lay and even lay	
		Over a length of 6d ⁵	Over a length of 30d ⁵	Over a length of 6d ⁵	Over a length of 30d ⁵	Over a length of 6d ⁵	Over a length of 30d ⁵
13	281 ≤ n ≤ 300	12	24	6	12	24	48
	n > 300	0.04 x n	0.08 x n	0.02 x n	0.04 x n	0.08 x n	0.16 x n

Note: Ropes with outer strands in the Seale type, number of wires per strand 19 or less (for example 6 × 19 Seale), are classified in this chart as two lines over the line, which would be defined due to the number of load carrying wires in the outer strands.

Number of visible broken wires (reached or exceeded) for removal criteria is reached, for **single-layer** and **parallel roped ropes** according to **DIN ISO 4309**

- 1) For the purpose of this international standard, fill wires are not considered to be load carrying wires and are not included in the value for n.
- 2) A broken wire has two ends (counted as one wire).
- 3) The values apply for damage in the cross over areas and the layers of coils due to deflection angles (not for rope sections, which run only over rope pulleys and do not spool up on the winch).
- 4) For ropes on drive gears of groups M5 to M8 twice the number of broken wires listed can be used.
- 5) d = Rope nominal diameter

- ▶ Check the rope over the entire length for visible broken wires.

When visible broken wires are scattered present:

- ▶ On the point of a broken wire, mark the rope sections on a length of 30d in both directions.
- ▶ Count visible broken wires in the marked rope sections and record them.
- ▶ Take the RCN (Rope category number) from the manufacturer's documentation of the rope.

When the make for single layer and parallel roped ropes is **not** listed in the chart:

- ▶ Determine the total number of load carrying wires in the rope: Add all wires in the strands of the outer layer, do **not** count fill wires.
- ▶ Compare the number of broken wires of each marked rope section 30d with the number of broken wires in the chart.

When the number of visible broken wires is smaller than listed in the chart:

- ▶ Within the rope section with the most broken wires: Mark the rope section with the most broken wires on a length of 6d.
- ▶ Count visible broken wires in the marked rope sections 6d and record them.
- ▶ Compare the number of broken wires of the marked rope section with the number of broken wires in the chart.

When the number of visible broken wires is equal to or larger than that listed in the chart:

- ▶ Take the rope down.
- ▶ Enter the results in the inspection checklist.

15.1.3 Rotation resistant ropes

Rope category number RCN	Total number of load carrying wires in the outer strands of rope ¹ n	Number of visible outer wire breaks ²			
		Rope sections, which run over steel pulleys and / or spool up on a single layer spooling drum (coincidental distribution of broken wires)		Rope sections, which spool up on a multi layer drum ³	
		Over a length of 6d ⁴	Over a length of 30d ⁴	Over a length of 6d ⁴	Over a length of 30d ⁴
21	4 strands $n \leq 100$	2	4	2	4
22	3 or 4 strands $n \geq 100$	2	4	4	8
	At least 11 strands in the outer layer				
23-1	$71 \leq n \leq 100$	2	4	4	8
23-2	$101 \leq n \leq 120$	3	5	5	10
23-3	$121 \leq n \leq 140$	3	5	6	11
24	$141 \leq n \leq 160$	3	6	6	13
25	$161 \leq n \leq 180$	4	7	7	14
26	$181 \leq n \leq 200$	4	8	8	16
27	$201 \leq n \leq 220$	4	9	9	18
28	$221 \leq n \leq 240$	5	10	10	19
29	$241 \leq n \leq 260$	5	10	10	21
30	$261 \leq n \leq 280$	6	11	11	22
31	$281 \leq n \leq 300$	6	12	12	24
	$n > 300$	6	12	12	24

Note: Ropes with outer strands in Seale type, number of wires in each strand 19 or less (for example 18 × 19 Seale - WSC), are classified in this chart as two lines over the line, which would be defined due to the number of load carrying wires in the outer strands.

Number of visible broken wires (reached or exceeded) is achieved in the rope removal criteria, for **rotation-resistant** ropes according to **DIN ISO 4309**

1) For the purpose of this international standard, fill wires are not considered to be load carrying wires and are not included in the value for n.

2) A broken wire has two ends (counted as one wire).

3) The values apply for damage in the cross over areas and the layers of coils due to deflection angles (not for rope sections, which run only over rope pulleys and do not spool up on the drum).

4) d = Rope nominal diameter

- ▶ Check the rope over the entire length for visible broken wires.

When visible broken wires are scattered present:

- ▶ On the point of a broken wire, mark the rope sections on a length of 30d in both directions.
- ▶ Count visible broken wires in the marked rope sections and record them.
- ▶ Take the RCN (Rope category number) from the manufacturer's documentation of the rope.

When the make for rotation-resistant ropes is **not** listed in the chart:

- ▶ Determine the total number of load carrying wires in the rope: Add all wires in the strands of the outer layer, do **not** count fill wires.

- ▶ Compare the number of broken wires of each marked rope section 30d with the number of broken wires in the chart.

When the number of visible broken wires is smaller than listed in the chart:

- ▶ Within the rope section with the most broken wires: Mark the rope section with the most broken wires on a length of 6d.
- ▶ Count visible broken wires in the marked rope sections 6d and record them.
- ▶ Compare the number of broken wires of the marked rope section with the number of broken wires in the chart.

When the number of visible broken wires is equal to or larger than that listed in the chart:

- ▶ Take the rope down.
- ▶ Enter the results in the inspection checklist.

15.2 Broken wire in the strand valleys

The broken wires in these areas point to the fact that the condition in the inside of the rope is deteriorating.

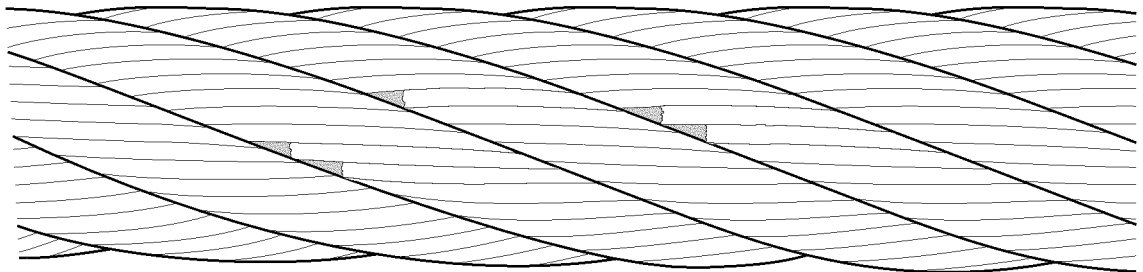

Fig.121005: Broken wire in the strand valleys

When two or more broken wires occur within a 6d long rope section:

- ▶ Take the rope down.

15.3 Broken wires on rope end connections

- ▶ Check the area near the rope end connections and carefully check for broken wires.

Loose wires are a sign of broken wires in the rope end connection.

- ▶ Use a marlin spike to check for loose wires.

When broken wires are near a rope end connection and two or more wires are affected:

- ▶ Take the rope down.

or

When the remaining rope lengths fulfil the minimum number of remaining coils in all operating positions:

- ▶ Shorten the rope, see chapter 7.05.50.
- ▶ Attach the rope end connection.

15.4 Broken wires in rope sections, which are not spooled up on the winch

When the broken wires are concentrated on one or two strands, the removal criteria can be present at fewer broken wires as noted in the chart (rope section in the length of 6d).

- ▶ Have the rope removal criteria determined by **expert personnel for crane rope inspection**.

15.5 Broken wire nests

When broken wires are very close to each other or when the broken wires are concentrated on one strand, then the rope must be taken down, even at fewer broken wires than noted in the chart (rope section 6d).

- ▶ Have the rope removal criteria determined by **expert personnel for crane rope inspection**.

16 Checking the rope end connection

The removal criteria are evaluated by the **expert personnel for crane rope inspection**.

Check for broken wires, see section „Broken wires on rope end connections“.

16.1 Pressed rope end connection

Example of a pressed rope end connection: Locking clamp.

- ▶ Check the rope end connections for signs of possible slipping between the locking clamp and the wire rope.
- ▶ Check the rope end connections for material cracks.
- ▶ Check rope end connections for corrosion, deformation and wear.

16.2 Enlarged rope end connection

Example of an enlarged rope end connection: Locking cast sleeve.

- ▶ If present: Remove the beam.
- ▶ Check rope end connections for corrosion, deformation and wear.

If the rope connection is on a flat rope:

- ▶ Check the cone setting, see chapter 8.04.10.

16.3 Detachable rope end connection

Example of a detachable rope end connection: Wedge lock.

- ▶ Check that the rope end connections are fit tightly and correctly installed.
- ▶ Check the wire rope inside and at the outlet of the rope end connection. Check the rope according to the removal criteria in this chapter.

17 Checking of rope diameter

17.1 Even reduction of rope diameter



WARNING

Spooling problems due to reduced rope diameter!

- ▶ Take the rope down even when the removal criteria according to **DIN ISO 4309** has not yet been reached.

The values in this section do **not** apply for rope sections, which were damaged in cross over areas due to multi layer spooling on a winch.

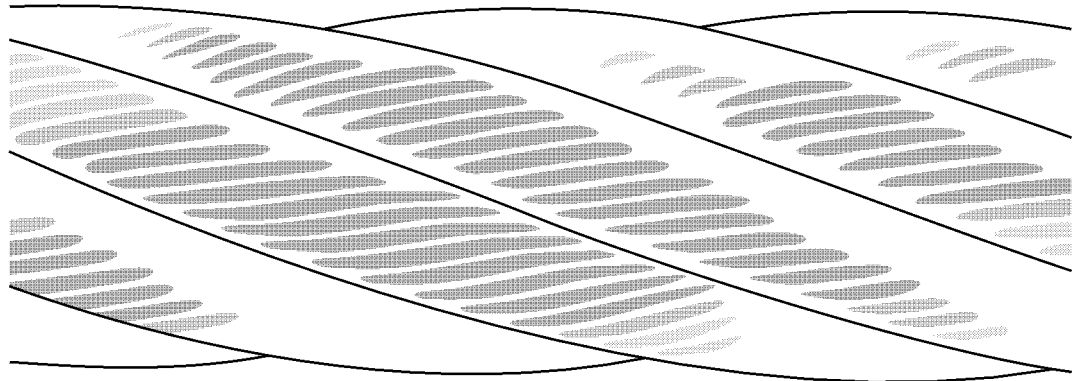

Fig.121001: External abrasion on the rope

The rope diameter changes due to abrasion, settling and external influences.

Abrasion of cover wires of outer strands of rope due to frictional contact. Especially in those areas where ropes are in contact with the rope pulleys during start up or slow down of the load.

Wear is increased by lack of or incorrect lubrication and the effect of dust.

Abrasion reduces the tensile strength of steel ropes because the cross section of the steel is reduced.

Additional possible causes for reduction of rope diameter:

- Wear in the inside of the rope
- Wear of fiber insert
- Breakage of a steel insert
- Broken inner strands

This section is valid solely for the following ropes:

- Ropes, which spool up on single layer winches
- Ropes, which run through a steel rope pulley

$$d_v = \frac{d_{\text{ref}} - d_m}{d} \times 100 \%$$

Fig.121372: Formula Reduction of rope diameter

d_v = even reduction of rope diameter

d_{ref} = rope diameter, which was determined before placement

d_m = measured rope diameter

d = rope nominal diameter: Take value from inspection checklist

The following chart applies exclusively for ropes, which spool up on single layer winches and / or run through a steel rope pulley.

Rope type	Even reduction of diameter d_v (in percentages of rope nominal diameter d)	Classification of degree of severity	
		Description	%
	Less than 6 %	—	0
Single layer rope with fiber insert	6 % and above, but less than 7 %	Light	20
	7 % and above, but less than 8 %	Medium	40
	8 % and above, but less than 9 %	High	60
	9 % and above, but less than 10 %	Very high	80
	10 % and above	Rope removal criteria	100

Rope type	Even reduction of diameter d_v (in percentages of rope nominal diameter d)	Classification of degree of severity	
		Description	%
Single layer rope with steel insert or parallel roped rope	Less than 3.5 %	—	0
	3.5 % and above, but less than 4.5 %	Light	20
	4.5 % and above, but less than 5.5 %	Medium	40
	5.5 % and above, but less than 6.5 %	High	60
	6.5 % and above, but less than 7.5 %	Very high	80
	7.5 % and above	Rope removal criteria	100
Rotation-resistant rope	Less than 1 %	—	0
	1 % and above, but less than 2 %	Light	20
	2 % and above, but less than 3 %	Medium	40
	3 % and above, but less than 4 %	High	60
	4 % and above, but less than 5 %	Very high	80
	5 % and above	Rope removal criteria	100

Degree of severity and removal criteria depending on rope type and even diameter reduction according to DIN ISO 4309

The medium value from the smallest and the largest measured diameter results in the value for d_m .

- ▶ Measure rope diameter on several locations and calculate measured diameter d_m .
- ▶ Calculate even reduction d_v of rope diameter with formula.
- ▶ Read the degree of severity in the chart, depending on the rope type.
- ▶ Document the degree of severity in the inspection checklist.

When the degree of severity has reached 100 %:

- ▶ Take the rope down.

17.2 Localized reduction of rope diameter

Localized reductions of rope diameter point to the fact that a rope insert may have failed, for example.



Fig. 120983: Localized reduction of rope diameter

- ▶ Check the rope for localized reduction of rope diameter.

When a localized reduction of the rope diameter is found:

- ▶ Take the rope down.

17.3 Localized increases of rope diameter

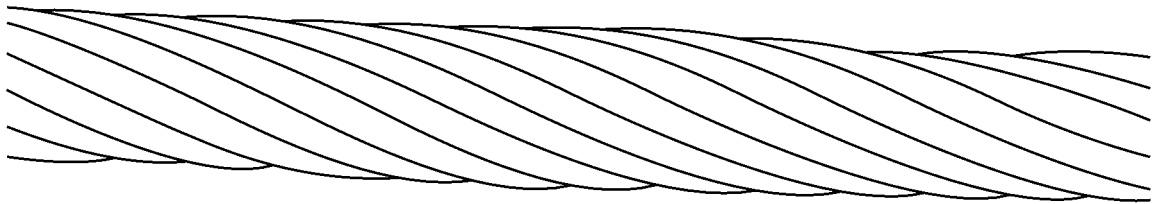

Fig.120992: Localized increase of rope diameter

An increase over a longer area of the rope can be caused by absorption of moisture in the fiber insert or due to corrosion in the inside of the rope.

Rope insert	Maximum increase of rope diameter during operation
Steel	5 %
Fiber	10 %

► Check the rope for increases in rope diameter.

When the increases exceed the maximum values:

► Take the rope down.

18 Corrosion

Corrosion occurs due to insufficient lubrication, in maritime climates and in an atmosphere polluted by industrial fumes.

External corrosion is indicated by a rough wire surface. A superficial rust film can be wiped off.

Significant corrosion reduces the strength and elasticity of the rope due to the reduction of the rope diameter.

Inner corrosion is hard to detect.

Do **not** use solvents to clean the rope.

Make sure that the following prerequisite is met:

- Rope is cleaned (wiped and brushed).

18.1 External corrosion

The various types of corrosion are classified and noted with the classification for removal criteria in percentages:

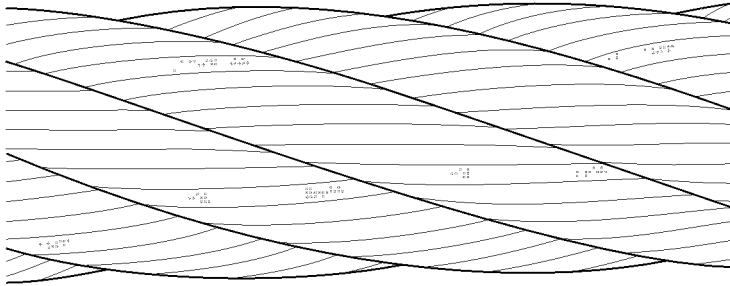

Fig.120984: Surface light corrosion: Classification 0 % of removal criteria

Superficial light corrosion (rust film) can be wiped off.

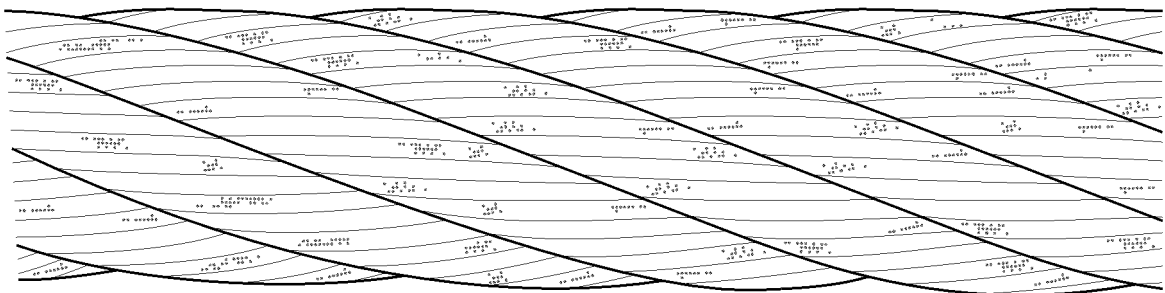

Fig.120985: Surface feels rough: Classification 20 % of removal criteria

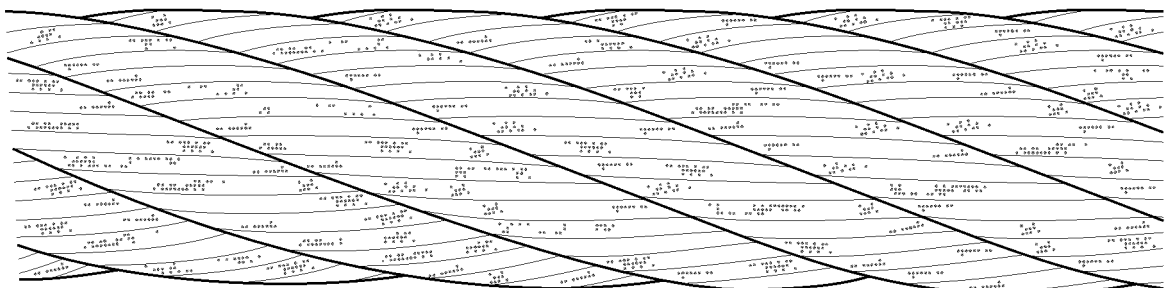

Fig.120986: Surface feels very rough: Classification 60 % of removal criteria

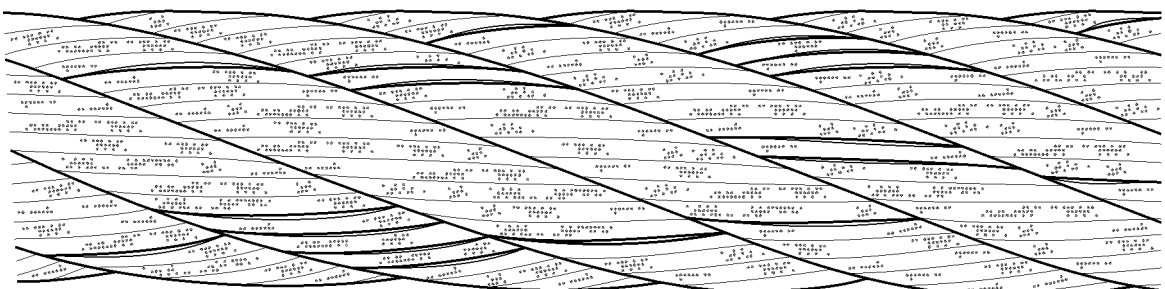

Fig.120987: Surface very decayed, spaces between individual wires can be easily recognized: Classification 100 % of removal criteria

When 100 % of removal criteria is reached:

- ▶ Take the rope down.

18.2 Internal corrosion

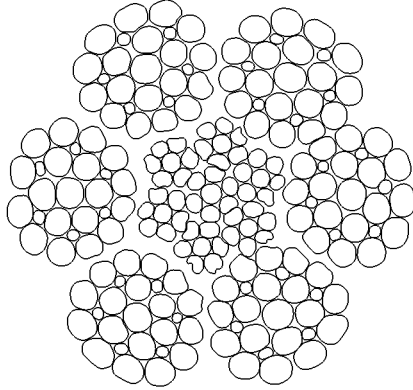

Fig.120982: Corrosion in the inside of the rope

Internal corrosion is present when clearly visible corrosion particles migrate between the valleys of the outer strands: Classification 100 % removal criteria.

When internal corrosion is found:

- ▶ Have the rope removal criteria evaluated by **expert personnel for crane rope inspection** or place the rope down.

18.3 Friction corrosion

Friction corrosion occurs as a type of brown powder, which migrates from the inside of the rope to the outside: Classification 100 % of removal criteria.

- ▶ Check the rope diligently for friction corrosion.

If friction corrosion is found:

- ▶ Have the rope removal criteria evaluated by **expert personnel for crane rope inspection** or place the rope down.

19 Corkscrew-like distortion



Fig.120988: Corkscrew-like distortion

Distortion where the rope is in the form of a corkscrew along its longitudinal axis.

Effects of corkscrew-like distortion:

- Irregular rope drive
- Rope wear
- Broken wire
- Bearing damage on rope pulleys

If the distortion is very pronounced, then other components can be affected in their function when the affected rope section runs through in crane operation.

- ▶ Check the entire rope for corkscrew-like distortion.

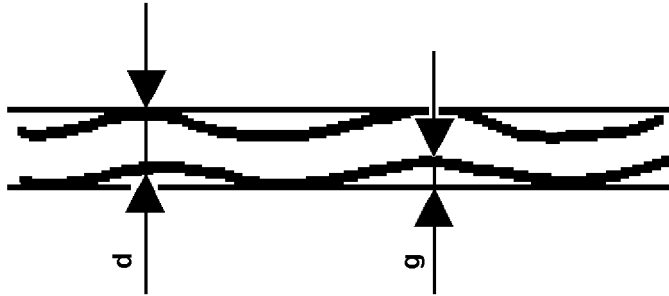

Fig.123988: Example for corkscrew-type distortion

d Rope nominal diameter

g Distance

Rope section	Conditions for removal criteria, formula
Straight rope section, which does not run through or around a rope pulley or spool up on a winch	$g \geq \frac{1}{3} \times d$
Straight rope section, which runs through or around a rope pulley or spools up on a winch	$g \geq \frac{1}{10} \times d$

When corkscrew-like distortion is present:

- ▶ Determine the rope nominal diameter **d** and distance **g** on the rope.
- ▶ Check the removal criteria with the formula.

When the removal criteria is reached:

- ▶ Take the rope down.

20 Basket formation

This distortion occurs due to different layers between the outer strand layers and the inside of the rope.

Causes for basket formation are high angular pull angles during the run over the rope pulleys and run-in rope pulleys. Even load distribution over the entire cross section is not possible.

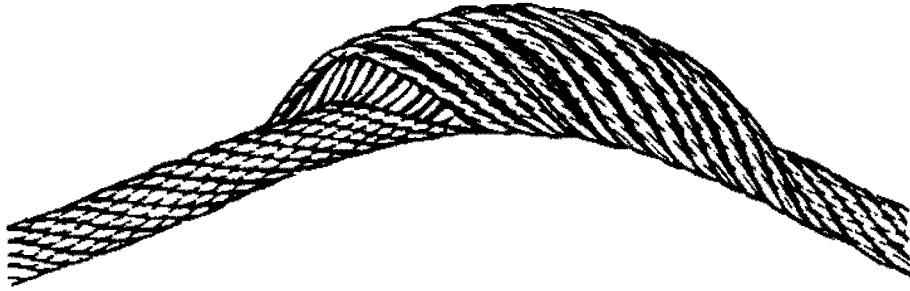

Fig.120989: Basket formation

- ▶ Check the entire rope for basket formation.

When basket formation is present:

- ▶ Take the rope down.

21 Protruding, distorted insert or strand

This distortion is a special form of basket formation. The insert or the core of the rope protrudes between the outer strands or an outer strand protrudes from the rope banding.

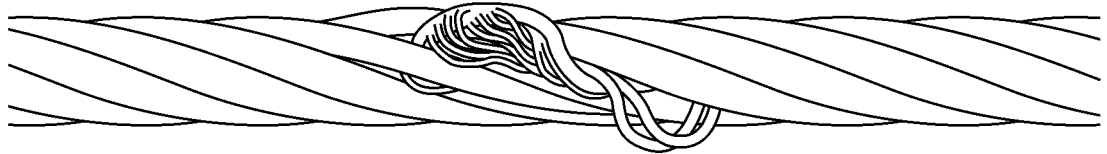

Fig.120990: Protrusion of an insert (rope single layer)



Fig.120991: Distorted or protruding strand

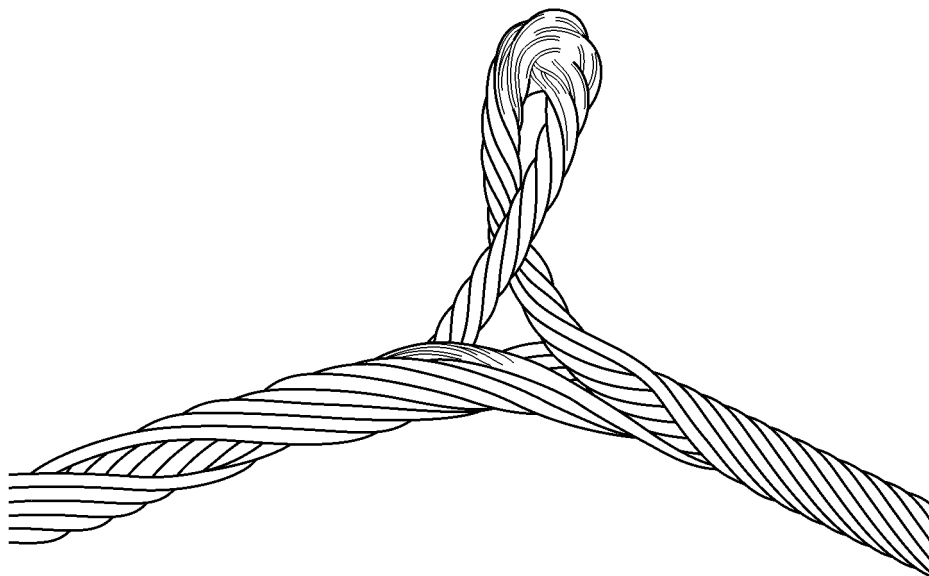

Fig.121373: Protrusion of rope insert on rotation-resistant rope

When the insert or a strand protrudes or is distorted, place the rope down. Have authorized inspector for crane rope inspection check if the rope area with the distortion can be removed.

- ▶ Check the entire rope for protruding, distorted insert or strand.

When protruding, distorted insert or braid is present:

- ▶ Take the rope down.
- ▶ Have **expert personnel for crane rope inspection** check if the rope area with the distortion can be removed.

22 Loop formation

At loop formation individual or several wires protrude from the rope and bulge upward (bird-caging).

These areas are most often on the opposite side of the rope pulley groove.

Make sure that the following prerequisite is met:

- There are **no** broken wire ends present.

If only a core wire of the rope insert protrudes through the outer strands, then the rope does not have to be taken down when:

- The wire can be removed.
- The wire does not disturb other elements of the rope drive.

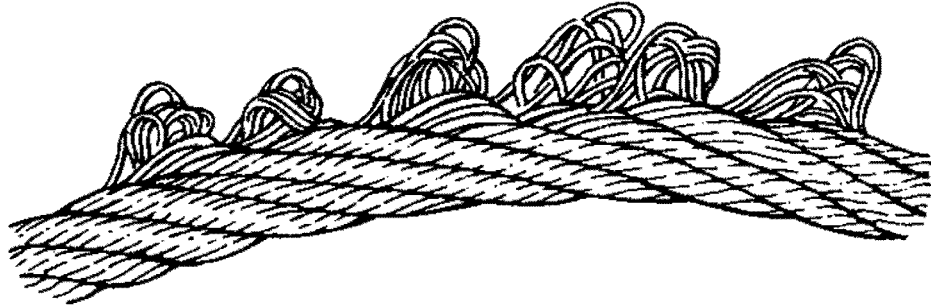

Fig.120993: Emergence of individual wires

► Check rope for loop formation.

When solely a core wire protrudes:

► Remove the core wire.

When several wires are affected from the loop formation:

► Take the rope down.

23 Kinking or rope loops pulled closed

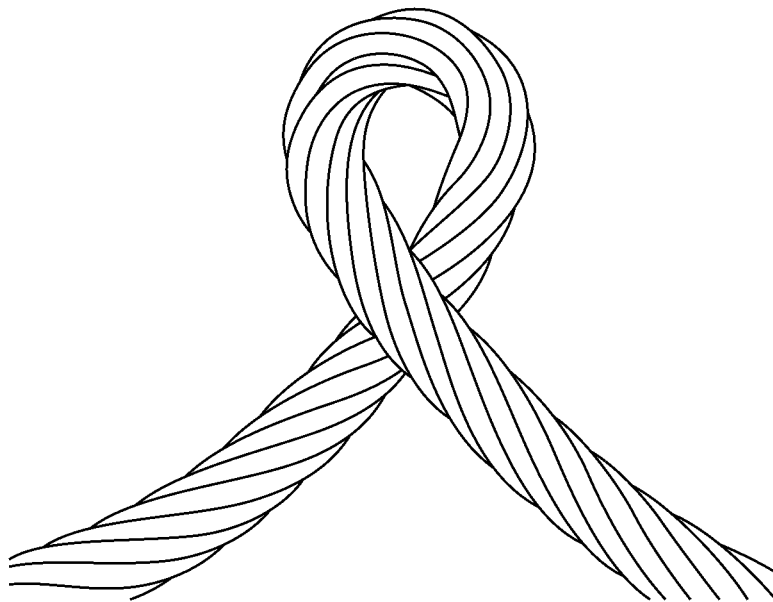

Fig.121007: Kinking or rope loop pulled closed

At this deformation a loop has formed in the rope, without the possibility to rotate around its own axis during a load. The rope is subjected to more wear.

The rope is significantly distorted. The strength remains only in part.

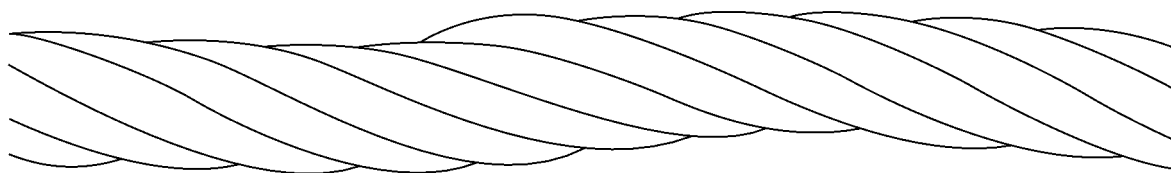

Fig.121002: Positive Kinking

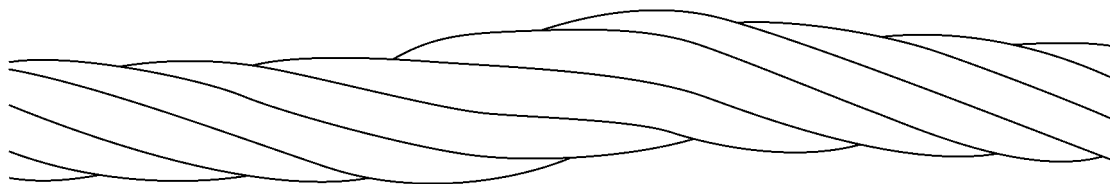

Fig.121003: Negative Kinking

- ▶ Check the rope for kinking or rope loops pulled closed.

When kinking or rope loops pulled closed occur:

- ▶ Take the rope down.

24 Buckles

Buckles are angular deformations. The rope was damaged due to external influences. Strong deformations of the rope cause stronger wear.

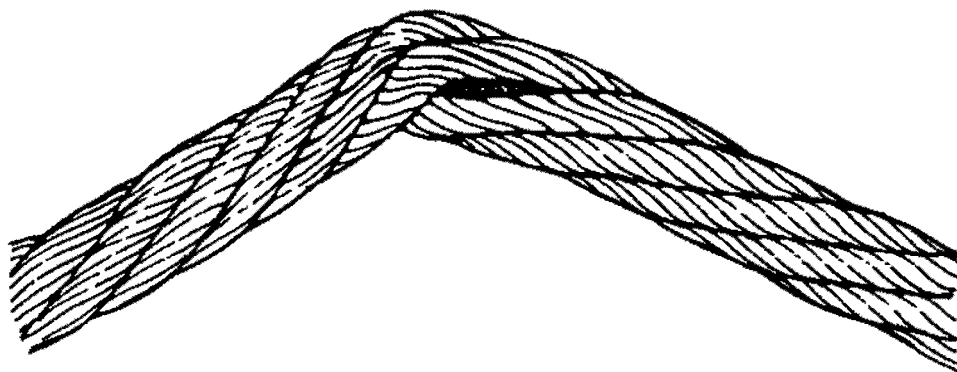

Fig.120999: Severe buckle

A buckle is a serious matter if a fold is visible on the underside of the rope.

When buckles are present:

- ▶ Have the rope inspected by **expert personnel for crane rope inspection**.

When a distortion and degree of severity permits further operation:

- ▶ Shorten the inspection interval.

When the removal criteria is reached:

- ▶ Take the rope down.

25 Effects of heat, arcs

Damage caused to the rope by welding work, for example.

Exceptional thermal effect is visible through tempering colors, the loss of lubricant and by localized melting of wires.

When thermal effect has occurred on the rope:

- ▶ Take the rope down.

26 Combined degree of severity



Note

- ▶ For a method to determine the effect of a combined degree of severity and damage on the rope, see **DIN ISO 4309**.

When the condition of the rope deteriorates, then often a combination of various causes occurs.

To determine the degree of severity, the **expert personnel for crane rope inspection** must:

- take different damage within a rope section into account
- evaluate the entire effect of the damage and the distortions
- decide about the operational safety of the rope
- evaluate if inspection intervals must be adjusted
- decide if the rope must be taken down

When the combined degree of severity is more than 100 %, then the rope must be taken down.

27 Flattenings

Effects of flattenings on the rope:

- Rope sections with flattenings, which move **over the rope pulleys** tend to higher wear and a higher number of broken wires.
- Rope pulleys can be damaged.
- Flattenings on **stationary ropes** (guy ropes boom) promote quicker corrosion, especially in the areas where the outer strands have opened.

Flattened rope sections must be checked in shorter intervals for broken wires and corrosion.

27.1 Shorting the intervals

- ▶ Check the entire rope for flattenings.

When flattenings are present on stationary ropes:

- ▶ Shorten the intervals for rope inspection.

When it is **not** possible to shorten the intervals for the rope inspection:

- ▶ Take the rope down.

27.2 Improper mechanical damage

An improper mechanical damage occurs, for example, when the rope is trapped.

- ▶ Take the rope down immediately or shorten it, see chapter 7.05.50.

27.3 Operational transverse pressure

Operational transverse pressure causes flattenings, for example in the incline range of multi layer spooling.

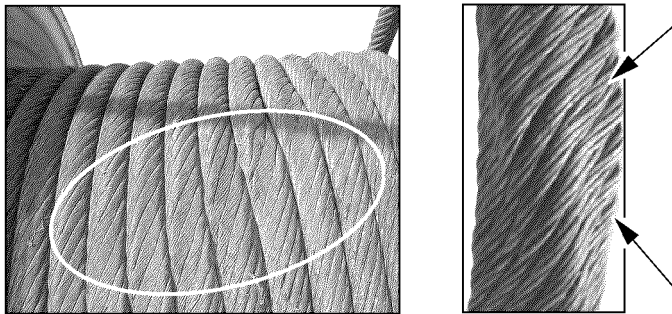

Fig.114002: Flattenings

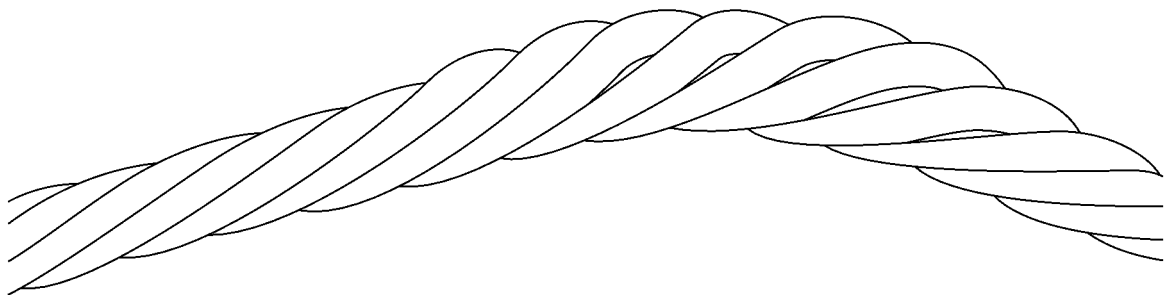

Fig.120996: Flattenings on multi layer spoolings

- ▶ Check the first rope layer of the winches for crushed areas and distortions.

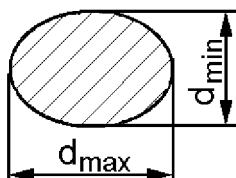

Fig.121006: Largest and smallest diameter on the distortion area

$$V = \frac{d_{\max} - d_{\min}}{d} \times 100 \%$$

Fig.121374: Formula to calculate the distortion

V Rope distortion in percentages

d_{ma} Largest diameter of distortion area

d Rope nominal diameter

x

d_{mi} Smallest diameter of distortion area

n

When distortions are present:

- ▶ Determine the number of broken wires See section „Determining the number of broken wires“.

When the number of permissible broken wires is exceeded:

- ▶ Take the rope down.
- ▶ Calculate the distortion V with the formula and document it in the inspection checklist.

When distortion V is larger than 5 %:

- ▶ Check the rope before every assembly and erection procedure.

When distortion V is larger than 10 %:

- ▶ Document the degree of severity of 50 % in the inspection checklist.

When distortion V is larger than 20 %:

- ▶ The degree of severity of 100 % is reached: Take the rope down.

28 Current checklist

Crane and use:		RCN ³⁾ :		Installation date:																				
Rope application:		Nominal diameter:		Take-down date:																				
Brand name:		<input type="radio"/> Right hand <input type="radio"/> Lang's lay <input type="radio"/> IWRC <input type="radio"/> Bare		Minimum tensile strength																				
Make ¹⁾ :		<input type="radio"/> Left hand <input type="radio"/> Ordinary lay <input type="radio"/> FC <input type="radio"/> WSC		Permissible number of visible external broken wires																				
Direction of lay ¹⁾ :		<input type="radio"/> IWRC <input type="radio"/> Bare		Datum diameter																				
Intermediate layer ¹⁾ :		<input type="radio"/> FC <input type="radio"/> Galvanized		Permissible diameter reduction: 6d: 30d:																				
Wire surface ¹⁾ :		Rope end connections:																						
Date	JJ/MM/TT	6d	30d	Number in length of	6d	30d	Position in the rope	6d	30d	Actual reduction to datum diameter	Position in the rope	Severity level ²⁾	Diameter	Position in the rope	Severity level ²⁾	Corrosion	Position in the rope	Severity level ²⁾	Damage, deformation	Position in the rope	Severity level ²⁾	Combined severity level ²⁾	Name of expert for the wire rope inspection	Signature

1) Check where applicable.
 2) State extent of damage; slight or 20%; medium or 40%; high or 60%; very high or 80%; take-down or 100%
 3) RCN = Rope Category Number

Fig.121370-en: Form for current checklist

LWE/LR 1600-2-008/18109-09-02/en

Empty page!

LWE/LR 1600-2-008/18109-09-02/en

8.05 Inspection of load hooks

1	Safety guidelines	3
2	Inspection intervals	3
3	Inspecting and monitoring the load hook	3

Fig.195219

LWE/LR 1600-2-008/18109-09-02/en

1 Safety guidelines



DANGER

Death, severe injury, property damage due to welding on load hooks!

- ▶ Do **not** weld load hooks to repair wear.
- ▶ Replace the load hook in case of impermissible wear.
- ▶ Contact Liebherr Service.

Make sure that the following regulation is followed:

- Do **not** carry out any welding work on load hooks, for example to repair wear.

2 Inspection intervals

By recognizing defects in time, accidents are prevented.

An inspection must be made before operation.

Load hooks must be inspected as needed, but at least once a year by an expert.

The load hook must be inspected every 4 years by an expert.

3 Inspecting and monitoring the load hook

Any defects found must be remedied and documented.

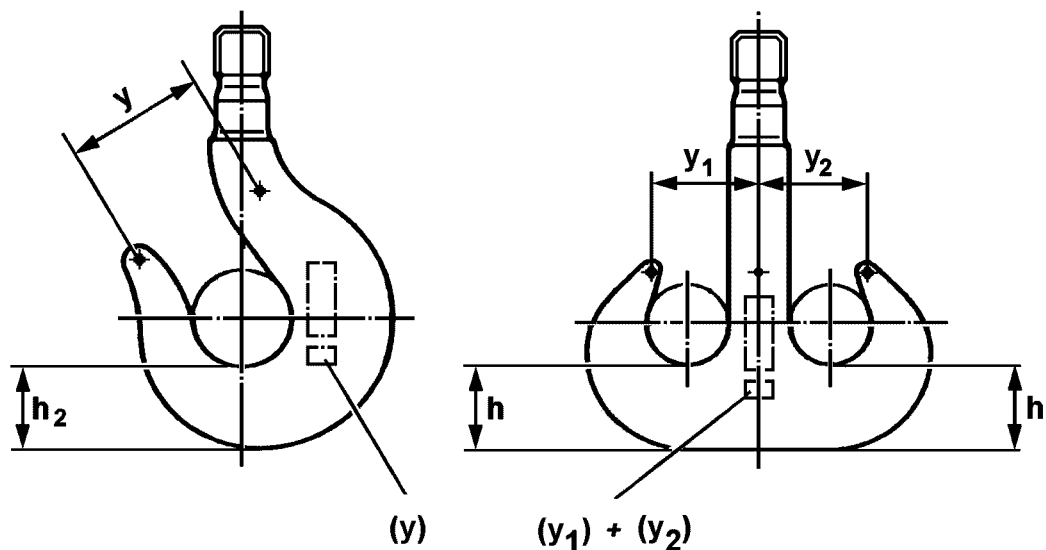

Fig.121531: Description of measured distances of load hooks

3.1 Checking the load hook for distortion



DANGER

Death, severe injury, property damage due to expansion of hook jaw!

- ▶ Replace the load hook in case of impermissible expansion.
- ▶ Contact Liebherr Service.

The initial dimension (**y**) for the single hook is marked on the load hook.

The initial dimension (**y₁**) and the initial dimension (**y₂**) for the double hook is marked on the load hook.

The expansion of the hook jaw may not exceed more than 10 % in reference to the initial dimension (**y**) or the initial dimension (**y₁**) and the initial dimension (**y₂**).

- ▶ Measure dimension **y** or dimension **y₁** and dimension **y₂** from center punch to center punch.
- ▶ Check for dimensional accuracy within the permissible tolerance.

3.2 Checking the load hook for surface cracks



DANGER

Death, severe injury, property damage due to surface cracks and damage on the load hook!

- ▶ Replace the load hook in case of surface cracks and damage.
- ▶ Contact Liebherr Service.

When distortions are found on the hook jaw:

- ▶ Check the load hook for surface cracks with a suitable procedure.
- ▶ Check the load hook for damage

3.3 Checking the load hook for wear



DANGER

Death, severe injury, property damage due to wear on the hook base!

- ▶ Replace the load hook in case of impermissible wear.
- ▶ Contact Liebherr Service.

The wear on the hook base may be no more than 5 % of the initial nominal dimension **h₂** for single hooks or initial nominal dimension **h** for double hooks.

The initial nominal dimensions **h₂** for single hooks and **h** for double hooks are listed in the chart.

Hook Number	Single hook h ₂ [mm]	Double hook h [mm]
4	67	—
5	75	—
6	85	75
8	95	85
10	106	95
12	118	106
16	132	118
20	150	132
25	170	150
32	—	170

Hook Number	Single hook h_2 [mm]	Double hook h [mm]
40	—	190
50	—	212
63	—	236
80	—	265
100	—	300
125	—	335
160	—	375
200	—	425
250	—	475
320	—	545

Initial nominal dimensions h_2 for single hooks and h for double hooks

- ▶ Measure dimension h_2 for single hooks or dimension h for double hooks.
- ▶ Check for dimensional accuracy within the permissible tolerance.

3.4 Checking load hooks for corrosion and wear



DANGER

Death, severe injury, property damage due to corrosion and wear on the thread!

- ▶ Replace load hooks which are **not** dimensionally accurate.

When wear or impermissible axial play on the hook nut is present:

- ▶ Replace the hook nut.
- ▶ Contact Liebherr Service.

To check the threads regarding corrosion and wear, the hook nut must be unscrewed from the hook shaft.

- ▶ Check the load hook thread and hook nut for corrosion and wear.

When reconditioning work is required to remove corrosion notches:

- ▶ Carry out a test for dimensional accuracy.

Empty page!

LWE/LR 1600-2-008/18109-09-02/en

8.06 Inspection of hydraulic hose lines

1	Safety guidelines	3
2	Inspection intervals	3
3	Checking the end of the service life	3
4	Inspecting the hydraulic hose lines for damage	4
5	Inspecting the hydraulic hose lines for leaks	5
6	Documenting the inspection	5
7	Replacing hydraulic hose lines	5

Fig.195219

LWE/LR 1600-2-008/18109-09-02/en

1 Safety guidelines



WARNING

Damaged and leaky hydraulic hose lines!
Fire, accidents, death, severe injury, property damage.

If leaky areas are found:

- ▶ Have these leaky areas inspected immediately by authorized and trained expert personnel and remedied.

If damage is found:

- ▶ Have the hydraulic hose lines replaced exclusively by authorized and trained expert personnel.

If it is determined that the service life is over:

- ▶ Have the hydraulic hose lines replaced exclusively by authorized and trained expert personnel.

Make sure that the following prerequisite is met:

- A **competent person for hydraulic hose lines** inspects the hydraulic hose lines.

A **competent person for hydraulic hose lines** has the following knowledge:

- Knowledge and experience in hydraulic and mechanics
- Knowledge of all requirements regarding valid standards:
 - ISO 8331
 - ISO 2230
 - ISO 1402
 - ISO/TR
 - EN 853 to EN 857
 - National regulations
- **or:** Knowledge of all requirements regarding the valid German standards, for example:
 - DIN 20066:202-10
 - BGR 237 Feb 2008, BG-Regulation

2 Inspection intervals

The inspection of hydraulic hose lines must be carried out in the following intervals:

- when the crane is **up to 10 years** old, at least one inspection every twelve months
- when the crane is **older than 10 years**, at least one inspection every six months

3 Checking the end of the service life

Hydraulic hose lines have a limited service life.

When hydraulic hose lines are properly stored, installed and used, then the manufacturer guarantees a service life of at least 10 years.

The life expectancy of hydraulic hose lines can deviate significantly from the noted service life of hydraulic hose lines.



Note

Special case: Active rear axle steering!

- ▶ The life expectancy of hydraulic hose lines is six years, including a storage period of maximum two years.

The life expectancy of a hydraulic hose line depends on various factors:

- Environmental influences, for example: Temperature, humidity, corrosive air
- Use

- Working cycles
- Number of bending cycles
- Friction
- Fluid

The following factors reduce the life expectancy significantly:

- Heat
- Repeated bending under pressure

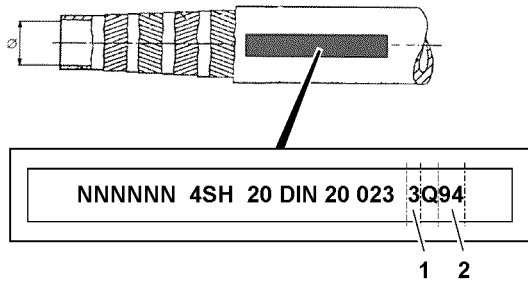

Fig.120159: Example for identification of hydraulic hose lines

The manufacturing date is marked on the fixtures or fittings.

- ▶ Read the quarter **1** of manufacture.
- ▶ Read the year **2** of manufacture.

When the life expectancy of a hydraulic hose line has been exceeded, then a **competent person** can decide **not** to replace the hydraulic hose line. Document the decisions, see section „Documenting the inspection“.

When the end of the service life is determined:

- ▶ Have the hydraulic hose lines replaced exclusively by authorized and trained expert personnel.

4 Inspecting the hydraulic hose lines for damage

Hydraulic hose lines must be replaced when one of the following damage is present:

- Damage on outer surface, such as chafe marks, cuts and cracks
- Brittleness due to aging of outer layer (cracks)
- Distortion, such as splitting of hose layers, bubbles, crushed areas, kinks, rotational stress
- Leakages
- Damage or distortion of hose fixtures or hose fitting (seal is endangered)
- Movement between hose and hose line, hose working itself loose from the fixture or the fitting
- Requirements for installation **not** observed
- Corrosion of fixture or fitting (solidness or function of fitting is endangered)

When the hydraulic hose line is **not** completely accessible:

- ▶ Remove the hydraulic hose line.

When the hydraulic hose line is protected with a protective hose:

- ▶ Check the hose protection for abrasion. Abrasion on a hose protective hose can indicate abrasion on the hydraulic hose line.
- ▶ Check hydraulic hose lines for distortion in pressureless and pressurized status and during bending.

When the hydraulic hose line is slightly damaged, then a **competent person** can decide **not** to replace the hydraulic hose line. Document the decisions, see section „Documenting the inspection“.

If damage is found:

- ▶ Have the hydraulic hose lines replaced exclusively by authorized and trained expert personnel.

5 Inspecting the hydraulic hose lines for leaks

- ▶ Check the crane for escaped hydraulic oil.
- ▶ Check the crane for leaks by visually checking the ground under the crane.

When the hydraulic system leaks:

- ▶ Have these leaks inspected immediately by authorized and trained expert personnel and remedied.
or
Contact Liebherr Service.

6 Documenting the inspection

Make sure that the following prerequisite is met:

- A **competent person for hydraulic hose lines** documents noticeable observations.

The following data about hydraulic hose lines is documented:

- Installation location
- Condition
- Date
- Time
- ▶ Document noticeable observations comprehensibly.

When the life expectancy of a hydraulic hose line has been exceeded or if the hydraulic hose line is slightly damaged, then a **competent person** can decide **not** to replace the hydraulic hose line.

When the hydraulic hose line is **not** replaced:

- ▶ Document decisions and replacements comprehensibly.
- ▶ Document the date for the next inspection comprehensibly.

7 Replacing hydraulic hose lines

To ensure maximum safety, sealing and service life, the following guidelines apply for replacement of hydraulic hose lines.



WARNING

Impermissible spare parts!

Death, severe injury, property damage.

- ▶ Do **not** use repaired or used hydraulic hose lines.
- ▶ Use exclusively Original Liebherr spare parts.
- ▶ Use exclusively hydraulic hose lines according to manufacturer's specification (including fixtures, rubber piece goods and manufacturing process).

NOTICE

Routing of hydraulic hose lines changed!

Abrasion. Incorrect bending radius. Stress. Shortened service life.

- ▶ Keep the routing of hydraulic hose lines.
- ▶ Inspect the hydraulic hose lines according to intervals.

- ▶ Adhere to the hose bending radii according to the manufacturer's specifications.
- ▶ Ensure the routing of hydraulic hose lines according to manufacturer's specifications (pressureless and pressurized condition).
- ▶ Ensure the distance between lines and structures.

If necessary:

- ▶ Check moving parts in the area of hydraulic hose lines.

When the hydraulic hose line is installed in straight direction:

- ▶ Ensure a sag of the hose.
- ▶ Avoid mechanical tension and twisting of the hose during installation.
- ▶ Fasten the hydraulic hose line according to manufacturer's specification.
- ▶ Do not cross hydraulic hose lines for high pressure and low pressure.
- ▶ Keep hydraulic hose lines away from hot components.

When hydraulic hose lines are in a surrounding with high temperatures:

- ▶ Install protective insulation according to manufacturer's specifications.

8.12 Inspection of safety switching on the relapse supports

1 S-boom relapse retainer

3

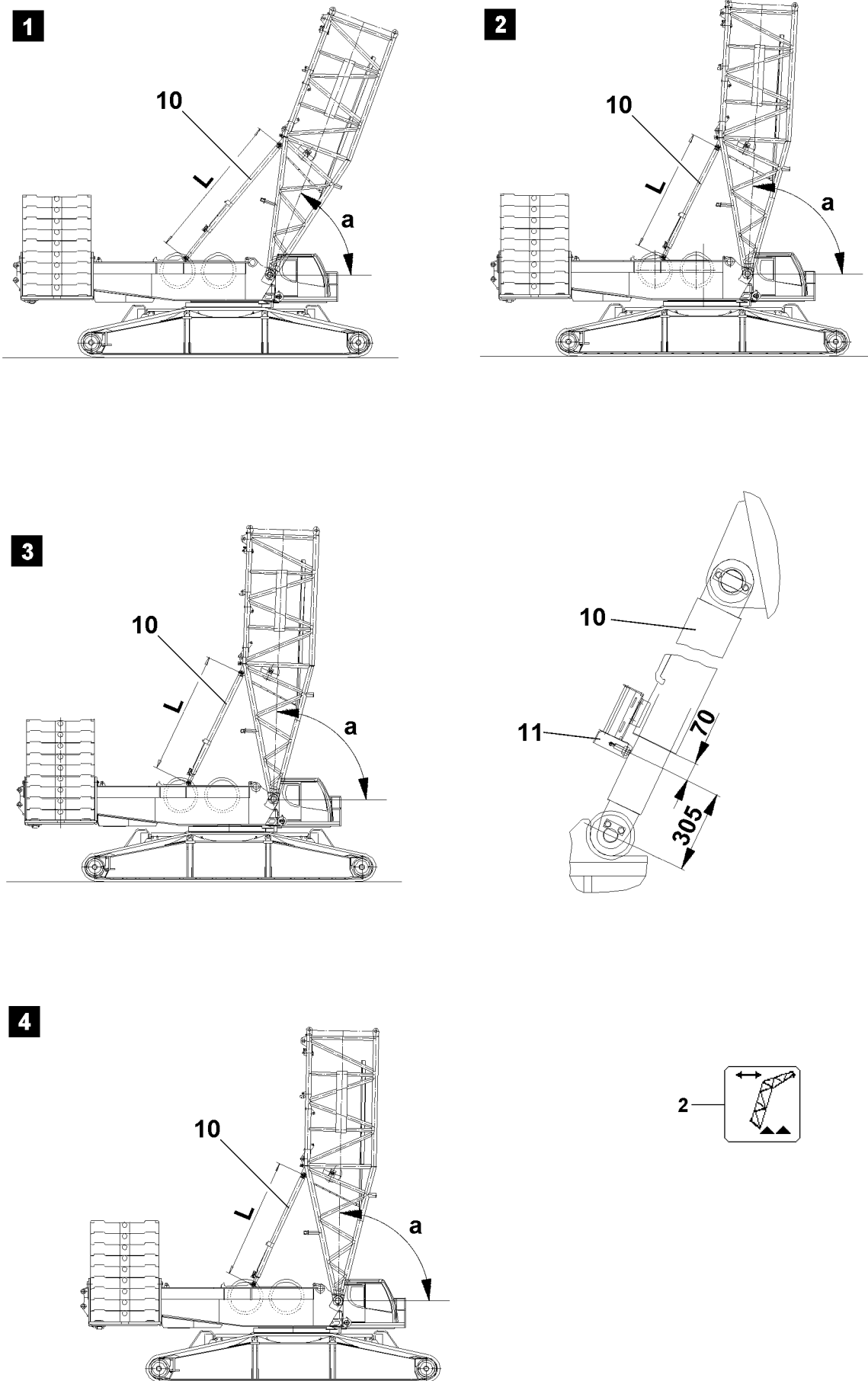

Fig.105322

1 S-boom relapse retainer

Two hydraulic cylinders prevent the boom from falling backward.

They are controlled on high or low pressure, depending on the operating mode or boom length.

In steepest boom position, the luffing up movement is turned off by the actuated limit switches in the cylinders **10**

1.1 Checking limit switch initiators for function

Cover limit switch initiators **11** on the S-relapse cylinder **10** individually with a metal plate.

- The S-boom „luffing up“ movement must turn off.
- The icon **2** must appear on the LICCON monitor.

	Angle a	Cylinder length L
Figure 1, cylinder extended	69,7°	5486 mm
Figure 2, steepest position	87°	4595 mm
Figure 3, electric shut off	88°	4541 mm
Figure 4, block position	89°	4486 mm

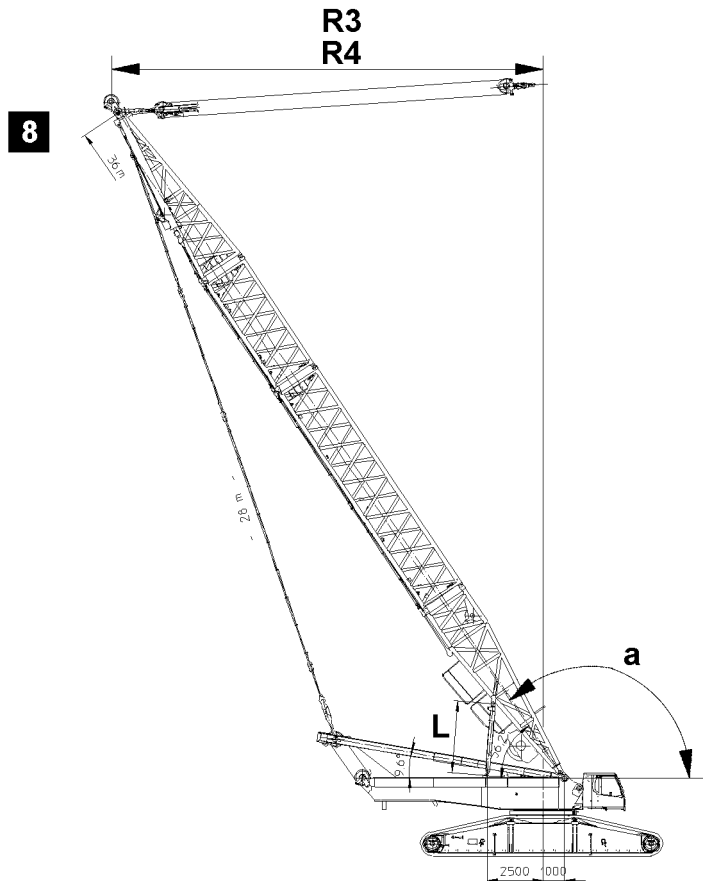
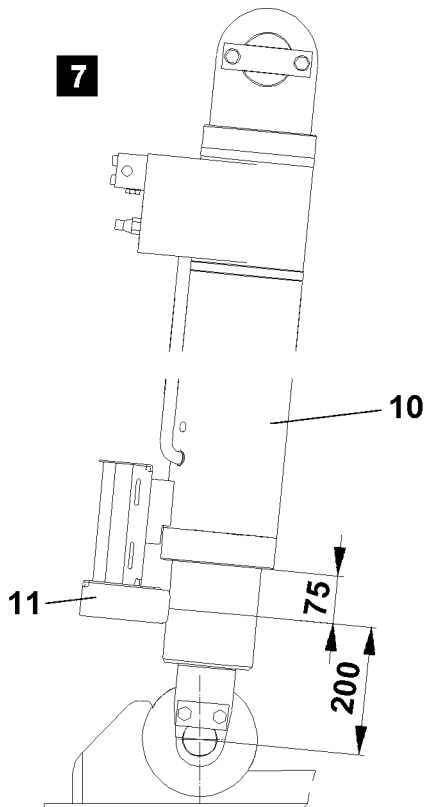
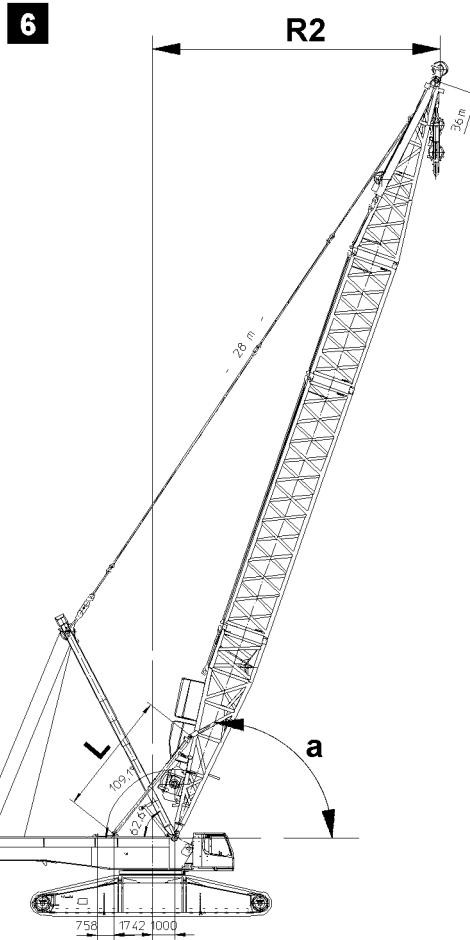
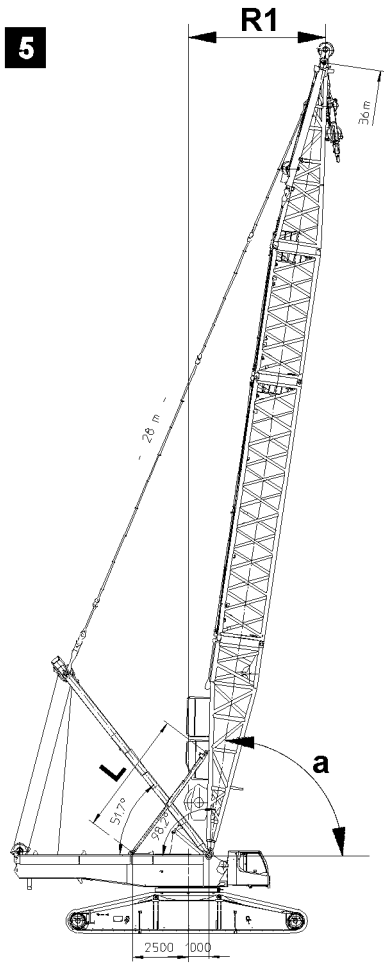

Fig.105323

LWE/LR 1600-2-008/18109-09-02/en

2 Derrick relapse retainer

Two hydraulic cylinders prevent the derrick from falling backward.

- If the limit switches on the cylinders are actuated, the winch 4 „spool up“ movement is shut off.

2.1 Checking limit switch initiators for function

Cover limit switch initiators **11** on the D-relapse cylinder **10** individually with a metal plate.

- The D-boom „luffing up“ movement must turn off.

2.2 Illustration

	Radius R	D 36 m	D 30 m	Angle a	Cylinder length L
Figure 5, cylinder extended	R 1	6,3 m	5,4 m	81,8°	5645 mm
Figure 6, installing position	R 2	13,1 m	11,1 m	70,9°	5645 mm
Figure 7, electric shut off	R 3	19,0 m	15,7 m	122,8°	3307 mm
Figure 8, block position	R 4	19,5 m	16,2 m	123,8°	3245 mm

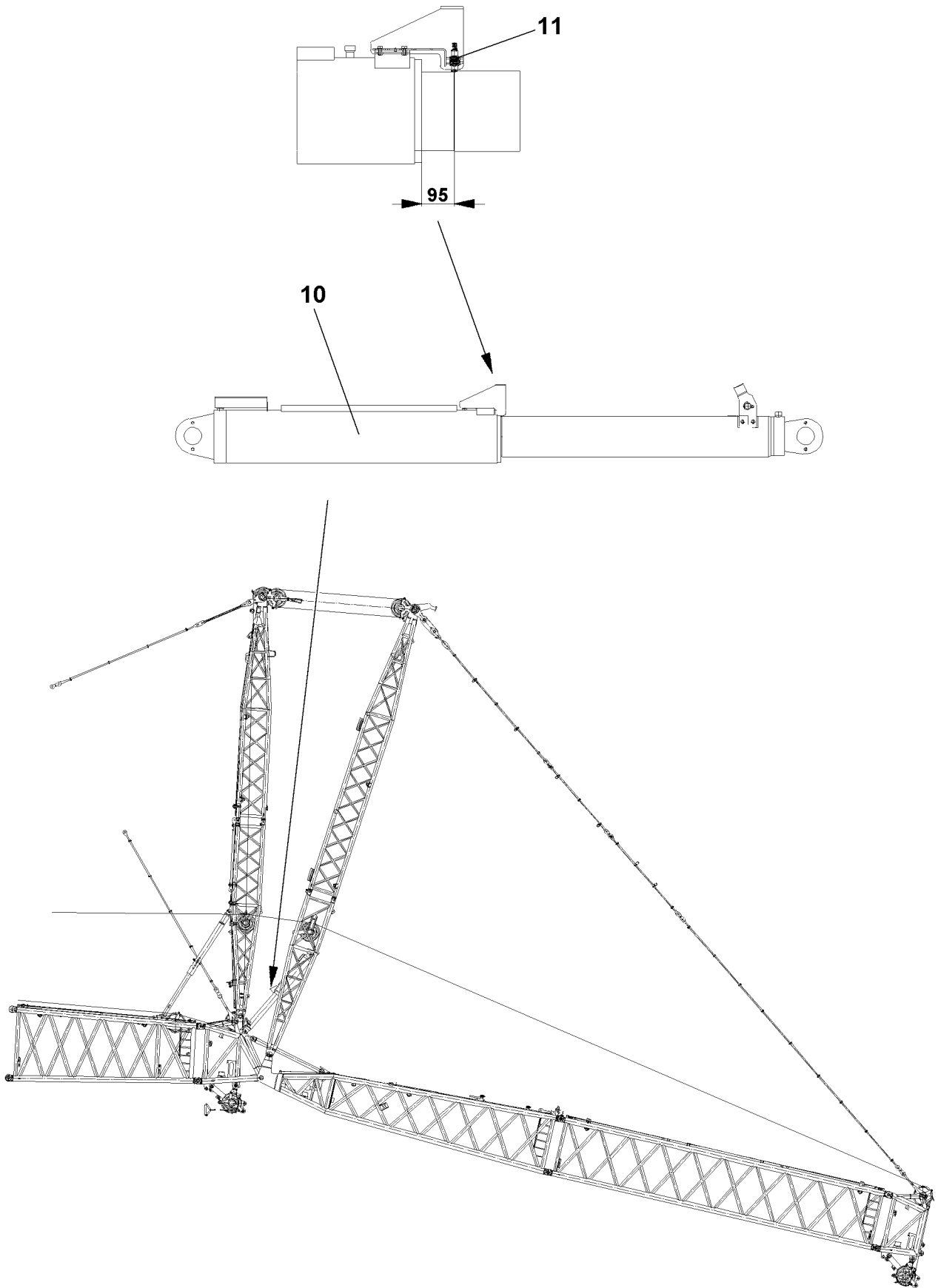

Fig.105324

LWE/LR 1600-2-008/18109-09-02/en

3 W-lattice jib

3.1 Checking limit switch initiators for function

- Cover limit switch initiators **11** on the W-relapse cylinder **10** individually with a metal plate.
- The W-control winch „spool up“ movement must turn off.

3.2 Checking limit switch initiators on switch point „steepest position“

Before erecting the boom, check the function of the limit switch initiators **11** in installed condition. Pull up both SA-brackets to the specified dimension (see illustration) until the switch contact opens.

- The W-control winch „spool up“ movement must turn off.
- The icon must appear on the LICCON monitor.

After successful check, reset the SA-brackets to set-up condition.

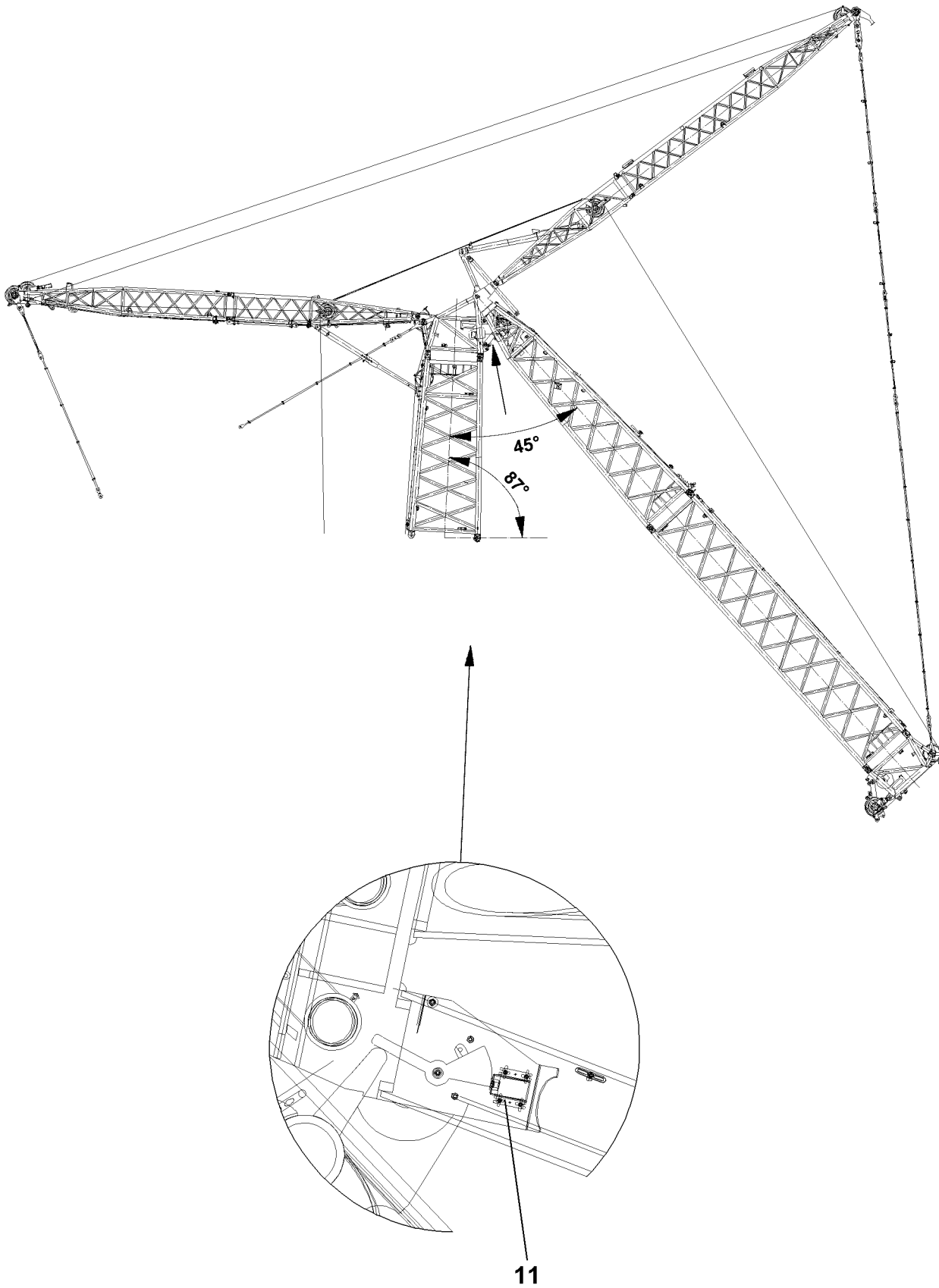

LWE/LR 1600-2-008/18109-09-02/en

Fig.105325

3.3 W-lattice jib „bottom“

3.3.1 Checking limit switch initiators for function

Cover the limit switch initiators **11** individually with a metal plate.

- The W-control winch „reel off“ movement must turn off.
- Switch position „luffing jib bottom“, approx. 45°. Limit switch initiators **11**, see illustration.

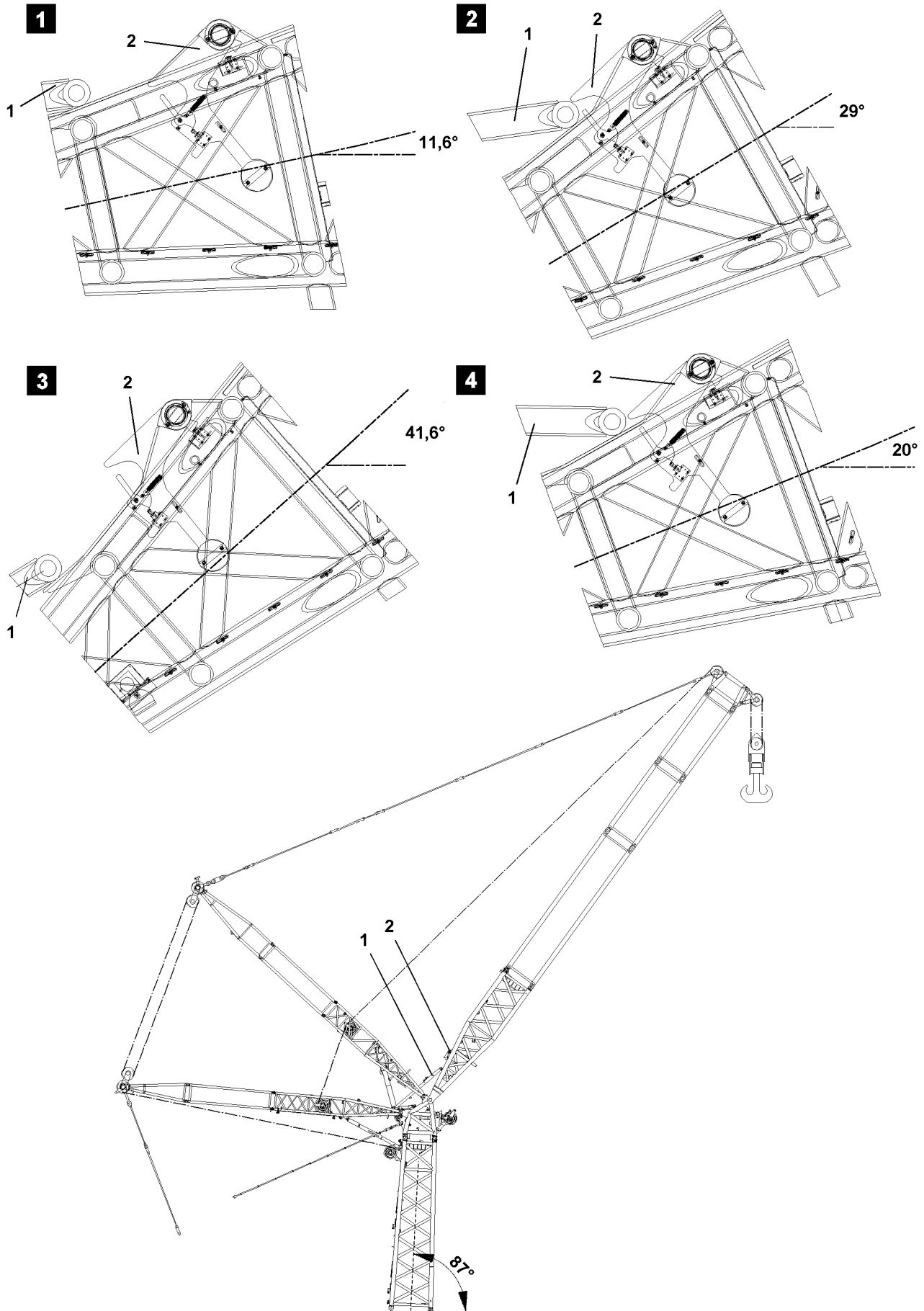

Fig.102346

3.4 Function check of limit switch initiators on the mechanical relapse retainer

- 1 Mechanical relapse support
- Oscillating safety 2 for mechanical relapse support

In addition to the relapse cylinders, the lattice jib is also secured by a mechanical relapse support 1, which engages in steepest lattice jib position into the flap of the oscillating safety 2. The luffing up movement is turned off by the actuated limit switches on the oscillating safety.



WARNING

Danger of tipping over if the oscillating safety is hard to move!

If the oscillating safety 2 is hard to move, the mechanical relapse retainer will no longer function. The W-lattice jib can tip backwards uncontrolled and cause the crane to topple over!

- ▶ Crane operation with hard to move oscillation safety 2 is prohibited!
 - ▶ Before erection, the pendulum of the mechanical relapse retainer must be checked for easy movement over the complete swing range of the pendulum.
-

Depending on the lattice jib position (boom position = 87°), the flap on the oscillation safety is swung out by the weight of the pendulum:

- 16,4° the flap can be pushed closed , see illustration 1
- 29° the flap can be pushed open, see illustration 2
- 45° the flap is swung out, see illustration 3
- 5,0° the flap is swung in , see illustration 4

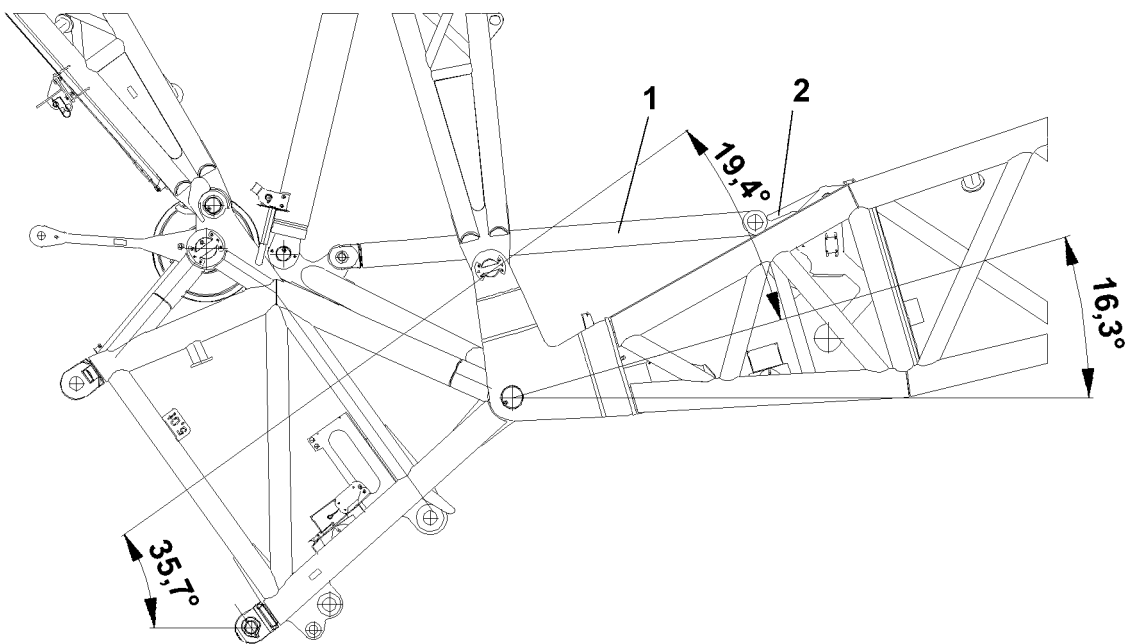
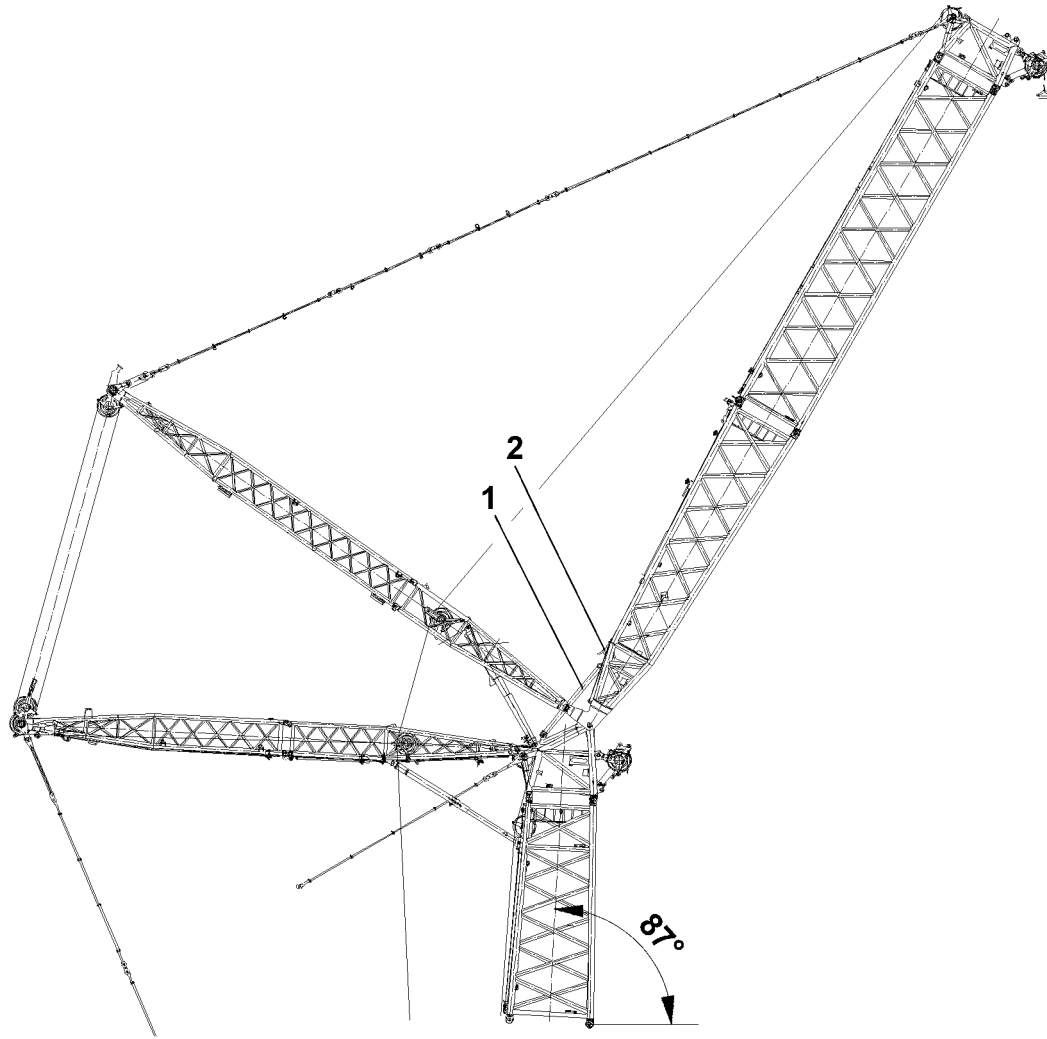

Fig.105380

LWE/LR 1600-2-008/18109-09-02/en

3.5 Flap of oscillating safety 2 on collision with mechanical relapse support 1

**WARNING**

Risk of collision!

If the angle between the boom and the lattice jib is smaller than or equal to $19,4^\circ$, the mechanical relapse support 1 will collide with the flap on the oscillating safety 2. The lattice jib can tip backwards uncontrolled and cause the crane to topple over!

- ▶ Never fall below an angle of 19.4° when luffing up!
 - ▶ Check visually!
-

Empty page!

LWE/LR 1600-2-008/18109-09-02/en

8.14 Inspection of accumulator pressure in anti-tilt cylinder

1 Checking jib stop cylinder pressure

3

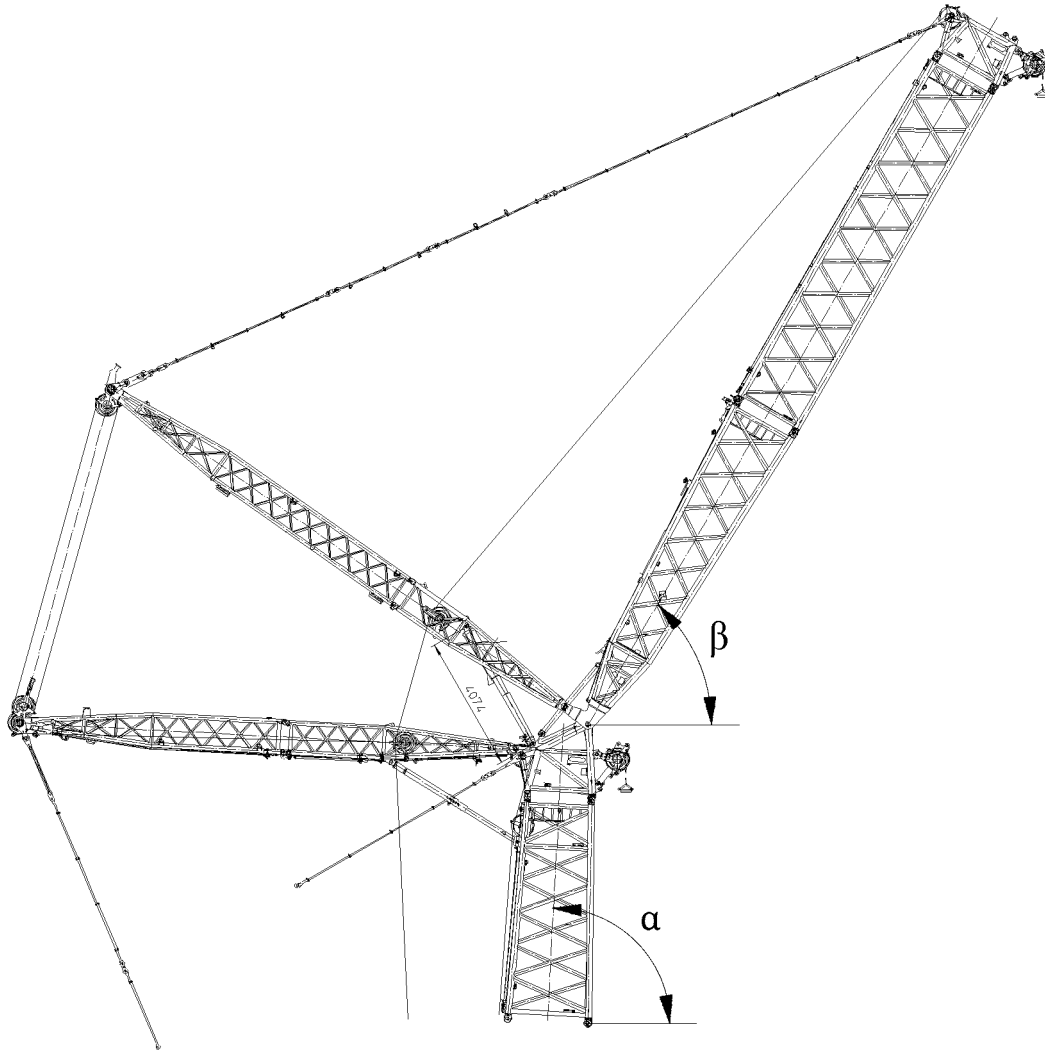

Fig.105350

1 Checking jib stop cylinder pressure

The jib stop cylinder pressure must be checked using the LICCON operation display before and after crane operation, „see diagnosis“.

The actual pressure displayed on the LICCON operation display must correspond with the target pressure in the table.



Note

- ▶ The specified target pressure depends on the outside temperature.
- ▶ The maximum permitted difference between the target pressure and the actual pressure is +/- 10 bar.

The jib stop cylinder pressure is checked as follows:

- Checking cylinder pressure with „jib stop extended to maximum limit“
- Checking cylinder pressure with „jib stop in test position“

1.1 Checking cylinder pressure with „jib stop extended to maximum limit“

- Set main boom and lattice jib to angles specified in table.
- Compare target pressure in table with actual pressure in LICCON operation display.

„Extend jib stop to maximum limit“								
Boom angle α	Lattice jib angle β	Cylinder length	Stroke	Target pressure				
				-40° C	-20° C	0° C	20° C	40° C
87°	42,9°	4600 mm	1100 mm	119,3 bar	129,5 bar	139,8 bar	150,0 bar	160,2 bar

1.2 Testing cylinder pressure with „jib stop in test position“

- Set main boom and lattice jib to angles specified in table.
- Compare target pressure in table with actual pressure in LICCON operation display.

„Jib stop in test position“								
Boom angle (α)	Lattice jib angle (β)	Cylinder length mm	Stroke mm	Target pressure				
				-40° C	-20° C	0° C	20° C	40° C
87°	60°	4074 mm	574 mm	172,5 bar	187,4 bar	202,1 bar	216,9 bar	231,8 bar

Empty page!

LWE/LR 1600-2-008/18109-09-02/en

8.15 Inspection of guy rods

1	Safety guidelines	3
2	Inspection intervals	3
3	Checking the guy rods	3

Fig.195219

LWE/LR 1600-2-008/18109-09-02/en

1 Safety guidelines



WARNING

Damaged guy rods!

Accident. Death, severe injury, property damage.

▶ Crane operation with damaged guy rods **1** is prohibited.

▶ Replace damaged guy rods **1**.

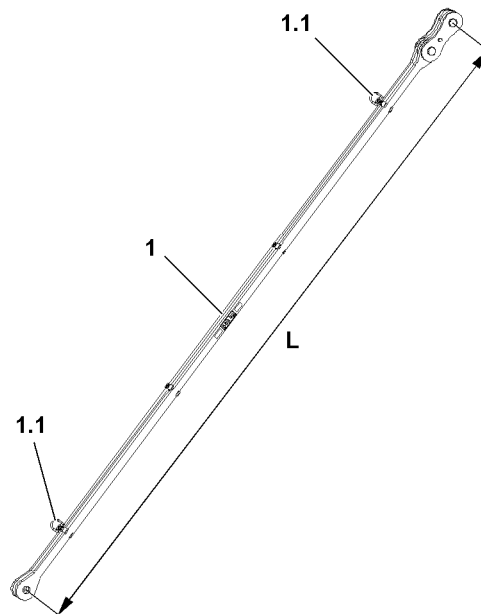

Fig.123845: Guy rod

Make sure that the following prerequisites are met:

- **Authorized and trained expert personnel** checks the guy rods **1**.
- A checklist for documentation of the inspection is on hand

2 Inspection intervals

The inspection of the guy rods **1** must be carried out in the following intervals:

- One inspection of the guy rods every 12 months by an expert.
- One inspection of the guy rods every four years by an authorized inspector.

After a load rip-off or overload of the crane:

- immediate inspection of guy rods by an expert

3 Checking the guy rods

3.1 Inspection



Note

- ▶ All inspections of the guy rods **1** must be documented.

The guy rods must be inspected in removed condition.

**WARNING**

The guy rods **1** can be ripped off!

If a damaged guy rod **1** is used further, it can rip off in crane operation.

Death, severe injury, property damage.

- ▶ Crane operation with damaged guy rods is prohibited.
- ▶ Repairs on guy rods **1** (for example: through welding) are prohibited.
- ▶ Replace damaged guy rods immediately.
- ▶ If one of the following stated damage is found, then the guy rods **1** may no longer be used.

3.2 Cracks and dents

- ▶ Check the guy rods **1** thoroughly through a visual inspection for cracks and dents.

Problem remedy

Damage to guy rods is not clearly evidenced through a visual inspection?

- ▶ Check the respective areas of the guy rods thoroughly, for example with a magnetic particle test.
- ▶ If damage is found: Replace the guy rods **1** immediately.

3.3 Elongation

**Note**

- ▶ The initial dimension **L** of the guy rods **1** refers to the bore spacing of the pin bores.
- ▶ The initial dimension **L** of the guy rods **1** is listed in the separate rod plan.
- ▶ Check the elongation of the guy rods **1** by measuring the guy rods.

**WARNING**

The guy rods can be ripped off!

The permissible elongation of the guy rods **1** may be a maximum of 0.2 %, for example 14 mm , at an initial dimension **L** of 7000 mm.

Death, severe injury, property damage.

- ▶ If the maximum permissible elongation is reached or exceeded: Replace the guy rods **1** immediately.
- ▶ If an elongation of the guy rods of more / equal to 0.2 % of the initial dimension **L** is proven: Replace the guy rods **1** immediately.

3.4 Wear

- ▶ Check the bores, pins and pin retainers for signs of wear.
- ▶ If respective wear is present in the stated areas: Replace the guy rods **1** immediately.

3.5 Ductile deformation

- ▶ If a guy rod **1** shows any ductile deformation: Replace the guy rod **1** immediately.

3.6 Paint / coating

- ▶ The guy rods **1** must be checked for paint damage or corrosion.
- ▶ If damage is present on the paint finish / coating: Repair the paint / coating of the guy rods **1** expertly.

NOTICE

Danger of property damage!

- ▶ Never store guy rods **1** in or near aggressive media, for example: Seawater.
- ▶ Always store the guy rods **1** properly and outside of aggressive media.

3.7 Fastening points

- ▶ Check the fastening points **1.1** of the guy rods **1** for damage.
- ▶ Replace damaged fastening points **1.1**.

Empty page!

LWE/LR 1600-2-008/18109-09-02/en

8.16 Inspection of fiber guy ropes

1	Safety guidelines	3
2	Inspection intervals	4
3	Inspecting the fiber guy ropes	4

Fig.195219

LWE/LR 1600-2-008/18109-09-02/en

1 Safety guidelines



WARNING

Damaged fiber guy rope!
Accident. Death, severe injury, property damage.

If damage is found:

- ▶ Have fiber guy rope **1** inspected by authorized and trained expert personnel.

When no final evaluation of the damage can be made:

- ▶ Send the fiber guy rope **1** to the rope manufacturer for inspection and damage evaluation.

If it is found that a fiber guy rope **1** cannot be used any longer or cannot be repaired:

- ▶ Replace the fiber guy rope **1**.

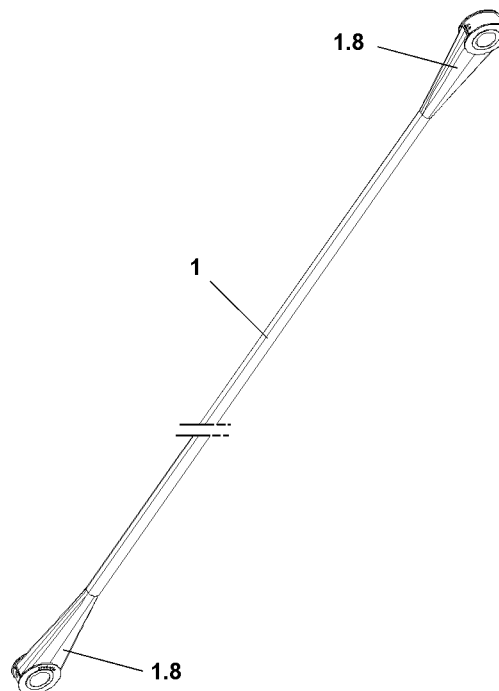

Fig.123614: Fiber guy rope

Make sure that the following prerequisites are met:

- **Authorized and trained expert personnel** inspects the fiber guy rope **1**.
- **In case of doubt:** Rope manufacturer inspects the fiber guy rope **1**

The authorized and trained expert personnel has the following expertise:

- Knowledge about technical design and the condition of fiber guy ropes **1**
- Knowledge about relevant inspection criteria for fiber guy ropes **1**
- Knowledge and experience in the use of various test procedures to determine the scope of the damage
- Knowledge and experience in the evaluation of rope damage on fiber guy ropes **1**
- Has the knowledge about inspection intervals for the required inspections, as specified by the manufacturer
- Knowledge and experience in the evaluation of further use of the fiber guy ropes **1** is permissible
- Knowledge about the required prerequisites for the inspection of fiber guy ropes **1**, as specified by the manufacturer

2 Inspection intervals

Inspection intervals for fiber guy ropes, see Crane operating instructions, chapter 7.03.50.

After a load rip-off or overload of the crane:

- Immediate inspection of fiber guy ropes by an expert

3 Inspecting the fiber guy ropes

3.1 Composition

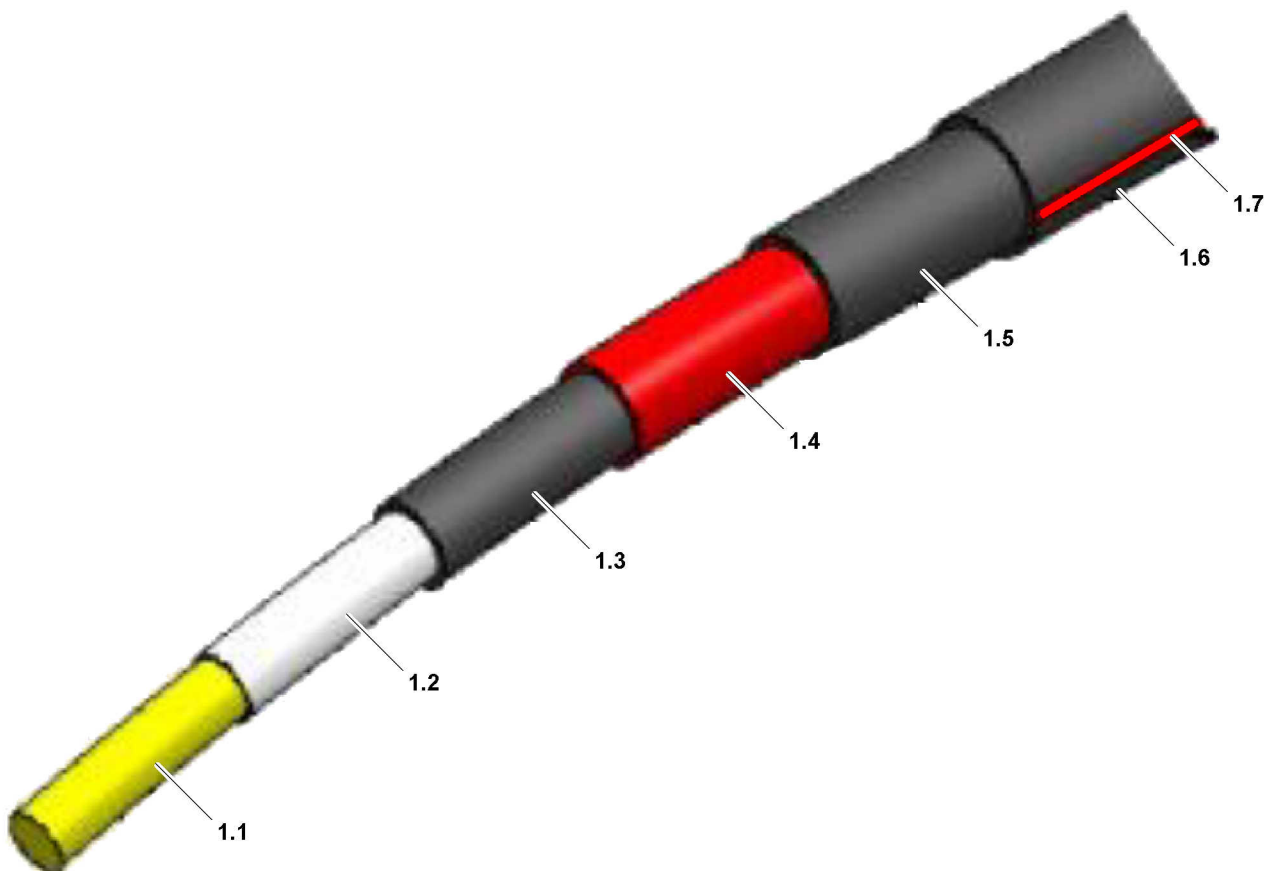

Fig.123619: Composition of a fiber guy rope

1.1 Aramid suspension rope (yellow)	1.4 Inner braiding (red)	1.7 Twist display
1.2 Compression band	1.5 Intermediate layer	
1.3 Sealing band	1.6 Outer braiding	

3.2 Inspection



Note

- All inspections of the fiber guy ropes **1** must be documented.

The inspection of the fiber guy ropes can be made via a visual inspection.

The fiber guy ropes must be inspected in removed condition.

The degree of severity of possible damage and further use of the fiber guy ropes depends mainly on which layers of the rope structure were damaged where and how.

In case of obvious severe rope damage, a safe crane operation should always be the priority and the respective fiber guy rope should be replaced.

If there is any doubt regarding the rope damage, only a detailed inspection of the fiber guy rope by the rope manufacturer can provide information if further use is possible or permissible.



WARNING

The fiber guy ropes can rip off!

Depending on the degree of severity, a damaged fiber guy rope can rip off in crane operation.

- ▶ To ensure a safe crane operation: Continue to use damaged fiber guy ropes only after and extensive inspection and release by the rope manufacturer.



Note

- ▶ If one or several fiber guy rope(s) must be replaced, inform Liebherr Service.

To determine the degree of severity of a damaged fiber guy rope, have the fiber guy rope inspected by the rope manufacturer.

The rope manufacturer decides after intensive inspection of the damage:

- if a repair of the fiber guy rope is possible
- if further use of the fiber guy rope is possible or useful

Only use the fiber guy rope again if the rope manufacturer declares that the damage is harmless and releases the fiber guy rope for further use.



Note

- ▶ The following listed fiber guy rope damage is an example.

3.3 Grommets and rope end connections

The grommets 1.8 and the rope end connections must be thoroughly inspected visually for cracks and dents.



Note

- ▶ If there is any doubt, have the respective areas of the grommet 1.8 thoroughly tested, for example with a magnetic particle test.

Check the pin bores for expansion, elongation and diameter changes.

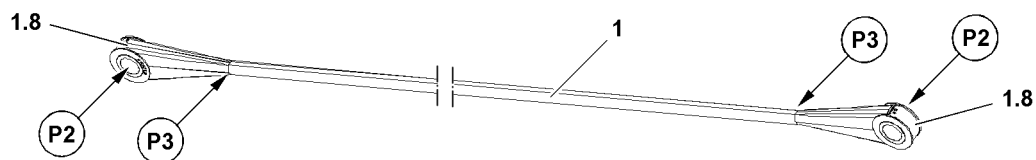

Fig.123700: Grommets and rope end connections on fiber guy rope

- ▶ Remove the fiber guy rope 1.
- ▶ Inspect the fiber guy rope.

**DANGER**

Damaged fiber guy ropes can rip off!

If a fiber guy rope **1** is damaged in the area of the grommet **1.8** or the rope end connection, then the load capacity is significantly reduced.

The grommet **1.8** or the rope end connection can rip off if used further under load in crane operation. Death, severe injury, property damage.

- ▶ Crane operation with damaged rope end connection is prohibited.
- ▶ Replace fiber guy ropes **1** with damaged grommet **1.8** or rope end connection.

- ▶ Check grommets **1.8** on the pin bores **P2** and the rope - grommet transitions **P3**.

When cracks or other severe damage are present:

- ▶ Replace the fiber guy rope **1**.

3.4 Damage symptoms of fiber guy rope

3.4.1 Damaged outer braiding

The fiber guy rope is damaged on the outer braiding **1.6**.

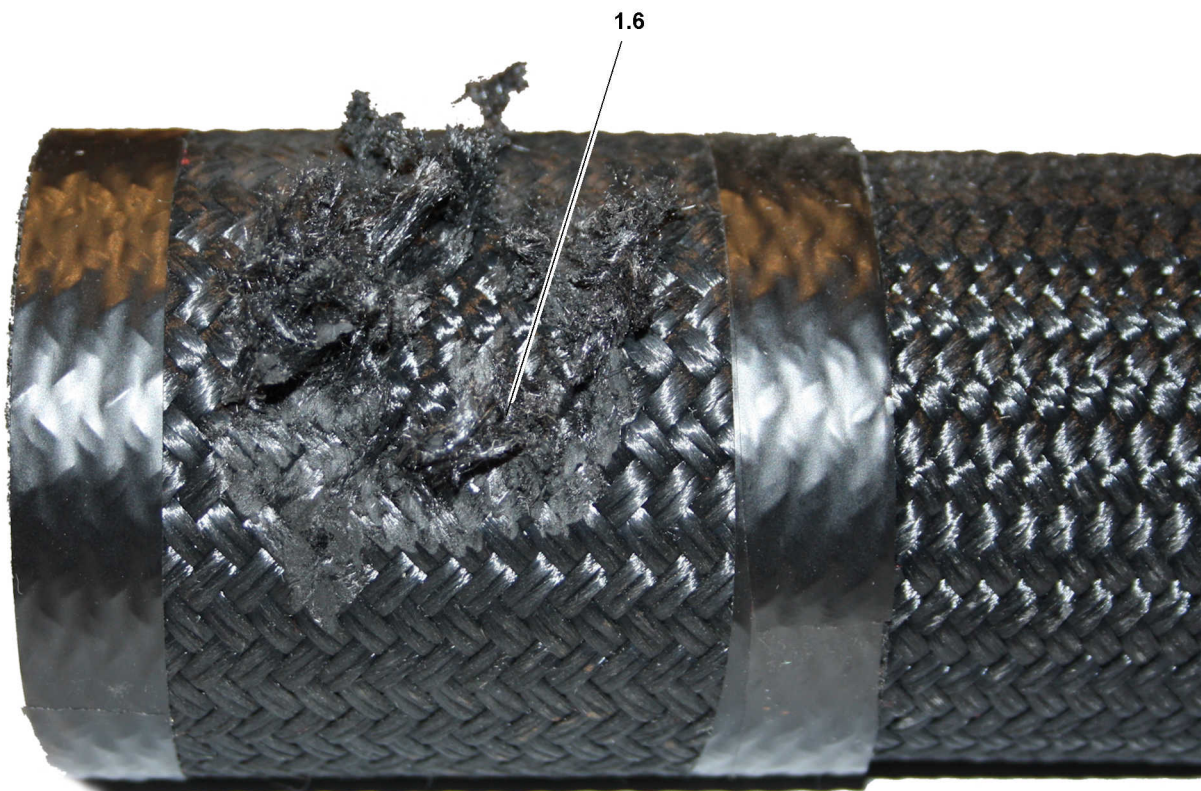

Fig.123615: Damage on outer braiding 1.6

- ▶ Remove the fiber guy rope.
- ▶ Inspect the fiber guy rope.

**WARNING**

Fiber guy rope ripping off!

If the outer braiding **1.6** is not properly repaired, then the outer braiding **1.6** can unravel widely if further used and the braiding underneath can be damaged.

Death, severe injury, property damage.

- ▶ Seal fibers of the outer braiding **1.6** with approved repair agents to prevent further unraveling of the outer braiding **1.6**.

If solely the outer braiding **1.6** is damaged:

- ▶ Carefully remove protruding fibers with a sharp knife or scissors.
- ▶ Repair the outer braiding **1.6** properly with approved repair agents to prevent it from unraveling further.

Result:

- The fiber guy rope can be further used for crane operation.

3.4.2 Damaged rope braiding

The fiber guy rope is damaged on the outer braiding **1.6** and the intermediate layer **1.5**.

The inner braiding (red) **1.4** is visible.

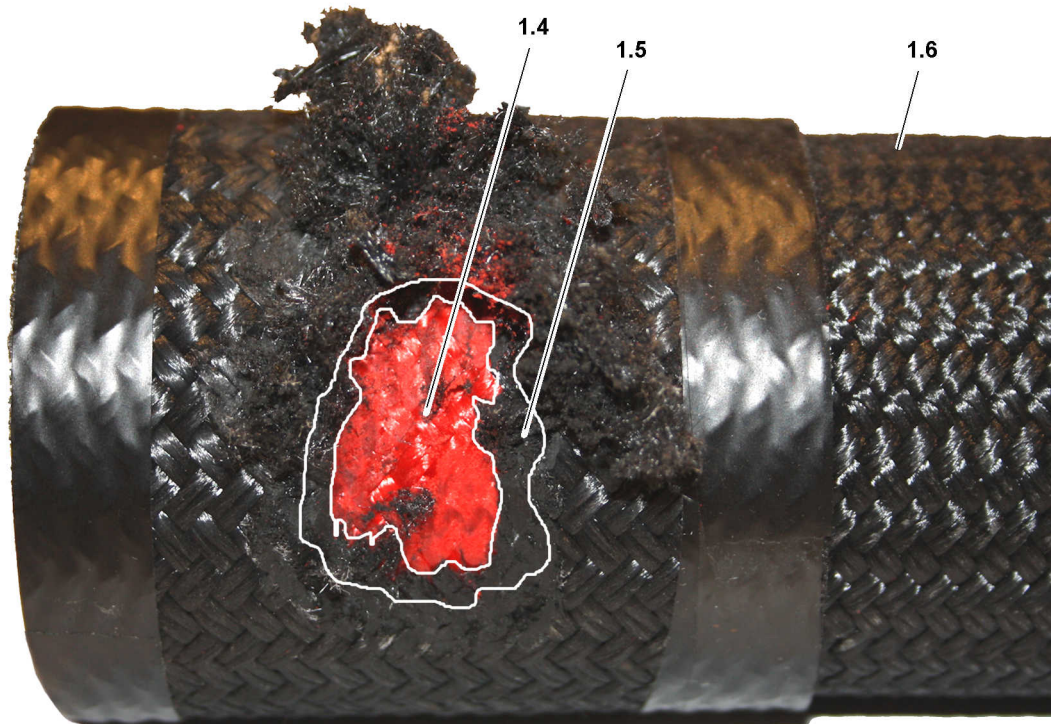

Fig.123616: Damage of outer two rope braidings, inner braiding (red) is undamaged

- ▶ Remove the fiber guy rope.
- ▶ Inspect the fiber guy rope.

**WARNING**

Damaged fiber guy ropes can rip off!

If a fiber guy rope is damaged, then it can rip off if used further under load in crane operation.

Death, severe injury, property damage.

- ▶ Crane operation with damaged fiber guy rope is prohibited.
- ▶ Replace the damaged fiber guy rope.

When the outer braiding **1.6** and the intermediate layer **1.5** are damaged:

- ▶ Replace the fiber guy rope.

3.4.3 Damaged intermediate layers

The fiber guy rope shows grave damage.

The Aramid suspension rope **1.1** is visible and / or damaged.

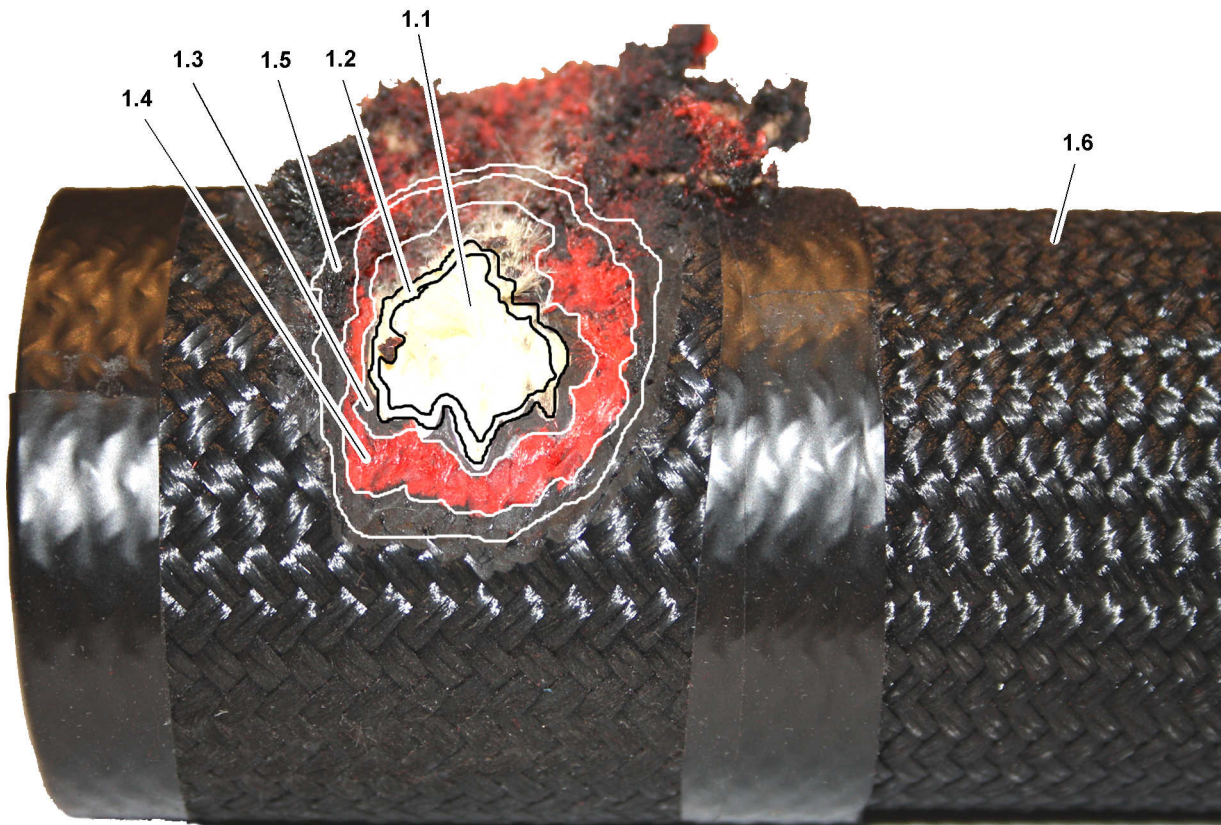

Fig.123617: Damage of outer braiding and all intermediate layers

- ▶ Remove the fiber guy rope.
- ▶ Inspect the fiber guy rope.



DANGER

Damaged fiber guy ropes can rip off!

If a fiber guy rope is damaged into the carrying structure of the Aramid suspension rope (yellow) **1.1** then the fiber guy rope will rip off if used further under load in crane operation.

Death, severe injury, property damage.

- ▶ Crane operation with damaged fiber guy rope is prohibited.
- ▶ Replace the damaged fiber guy rope.

When the outer braiding **1.6** and all intermediate layers are damaged up to the Aramid suspension rope (yellow) **1.1**:

- ▶ Replace the fiber guy rope.

3.4.4 Buckles

Buckles are angular deformations.

The rope was damaged due to external influences.

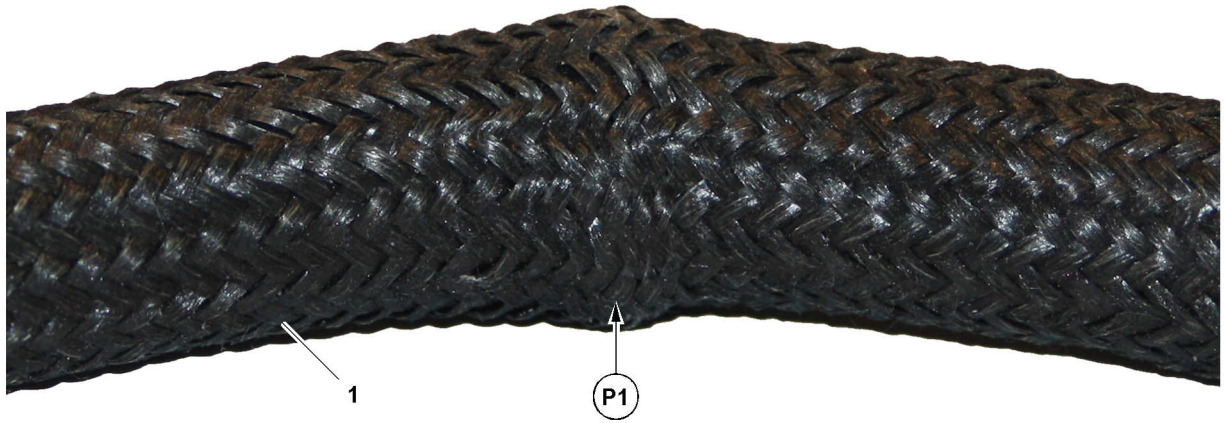

Fig.123618: Fiber guy rope buckled at point **P1**

- ▶ Remove the fiber guy rope.
- ▶ Inspect the fiber guy rope.



DANGER

Damaged fiber guy ropes can rip off!

If a fiber guy rope is buckled, then the load capacity is significantly reduced.

The fiber guy rope can rip off if further used under load in crane operation.

Death, severe injury, property damage.

- ▶ Crane operation with buckled fiber guy rope is prohibited.
- ▶ Replace the damaged fiber guy rope.

A buckle is severe if a fold / compression well as a clear buckle is visible on one side of the fiber guy rope (for example at point **P1**).

When a buckle is present:

- ▶ Replace the fiber guy rope.
- ▶ Have the fiber guy rope inspected by the rope manufacturer.

Empty page!

LWE/LR 1600-2-008/18109-09-02/en

8.17 Inspection of ladders

1	Safety guidelines	3
2	Inspection intervals	3
3	Inspecting ladders	3
4	Inspection sheet and check list	3

Fig.195219

LWE/LR 1600-2-008/18109-09-02/en

1 Safety guidelines



WARNING

Damaged ladders!
Accident. Death, severe injury, property damage.

If damage is found:

- ▶ Have ladders repaired by authorized and trained expert personnel.

If it is determined that the ladder cannot be repaired:

- ▶ Scrap the ladder immediately.

Make sure that the following prerequisite is met:

- **Authorized and trained expert personnel** checks the ladders.

The authorized and trained expert personnel has the following expertise:

- Knowledge, experience and abilities in repairing ladders
- Is familiar with the necessary prerequisites as determined by the contractor for the inspection of ladders
- Has the knowledge about the type, scope and intervals for the required inspections as determined by the contractor

2 Inspection intervals

The inspection of ladders must be carried out in the following intervals:

- The contractor determines the **required** intervals
- But there must be at least one inspection every **12 months**

Intervals depend on:

- Operating conditions
- Frequency of use
- Operational demands during use
- Frequency and severity of defects found during previous inspections

3 Inspecting ladders

Make sure that the following prerequisites are met:

- Ladder inspection sheets are on hand. For blank form, see section „Inspection form for the inspection of ladders and steps“
- Check lists are on hand. For blank form, see section „Check list for the inspection of ladders and steps“
- ▶ For every ladder and every step: Enter the data in the ladder inspection form.
or
Get the ladder inspection form for ladders or steps.
- ▶ Check the ladders and steps according to the check list and document the results.
- ▶ Collect the ladder inspection forms and check lists in the crane documentation.

4 Inspection sheet and check list

The following is shown, as an example: Inspection form and check list for the inspection of ladders and steps.

4.1 Inspection form for the inspection of ladders and steps

Ladder control sheet	
Stock no. of the ladder/steps	
Location/installation location	
Ladder type	Stepladder
	Leaning ladder
	Leaning ladder with overshoot
	Vertical ladder
	Vertical ladder with overshoot aid
	Platform ladder
	Steps
Material of the ladder	Aluminium
	Plastic
	Steel
	Stainless steel
Number of rungs/stairs	
Ladder length/ladder shortened to	
Manufacturer/dealer	
Article/type number	
Date of purchase	
Date of discard	
Name of representative	
Next inspection	

Control sheet for inspecting ladders and steps

Fig.121361-en

4.2 Check list for the inspection of ladders and steps

Inspection criteria	1st Inspection	2nd Inspection	3rd Inspection	4th Inspection	5th Inspection
1. Beams					
Deformation					
Damage (for example cracks)					
Sharp edges, splinters, burrs					
Wear					
Protective treatment					
2. Rungs/stairs/platform					
Deformation					
Damage					
Sharp edges, splinters, burrs					
Connection to the beam (for example, flanging, screw/rivet connections, welding seam)					
Wear (for example, stepping surfaces, platform overlay)					
3. Spreader safety					
Completeness/fastening					
Functionality					
Damage					
4. Fitting parts					
Damage/corrosion					
Completeness/fastening					
Functionality					
Wear					
Lubrication (mechanical parts)					

Fig.121362-en

Inspection criteria	1st Inspection	2nd Inspection	3rd Inspection	4th Inspection	5th Inspection
5. Ladder/stands/pulleys					
Completeness/fastening					
Wear/damage					
Functionality					
6. Accessories (for example, beam extension, base expansion, wall support)					
Completeness/fastening					
7. Identification					
Operating instructions (for example, pictogram)					
8. Inspection result					
Ladder OK and usable					
Repair necessary					
Discard ladder immediately					
Comments					
Next inspection (month/year)					
Ladder inspected					
Date					
Signature					

Check list for inspecting ladders and steps

Fig.121363-en

8.90 Inspection chart for cranes

1 Inspection chart for recurring inspections of Liebherr cranes

3

LWE/LR 1600-2-008/18109-09-02/en

Fig.195219

LWE/LR 1600-2-008/18109-09-02/en

1 Inspection chart for recurring inspections of Liebherr cranes

The following is a checklist to assist the inspector during the periodic inspections of Liebherr mobile and crawler cranes.

Company:	Inspector:
Crane manufacturer: Liebherr	Crane type:
Serial number:	Stock number:
Year of construction:	Date:
Inspector's signature for No. 1 to 22:	

1. inspection category: Crane document						
Component to be inspected	A	B	C	D	E	Comments
Crane inspection log						
Operating and installation instructions						
Crane control log						
Load chart manual						
Job planner						

2. inspection category: Signs / identification						
Component to be inspected	A	B	C	D	E	Comments
Factory tag						
Load data						
Operating instruction label						
Prohibition and command signs						
Other safety signs						

3. inspection category: Travel gear ¹						
Component to be inspected	A	B	C	D	E	Comments
Frame ²						
Supports ³						
Axles						
Wheels						
Tires						
Bearings						
Transmission						
Universal drive shaft						
Leaf springs / springs						
Shock absorbers						

3. inspection category: Travel gear ¹						
Component to be inspected	A	B	C	D	E	Comments
Steering						
Brakes						
Hydraulic axle suspension						

4. inspection category: Chassis ¹						
Component to be inspected	A	B	C	D	E	Comments
Coverings						
Accessible surfaces						
Counterweight holders ²						
Towing devices						
Accesses, ladders						
Holding devices, handles						
Platforms, railings						
Retainer for hook block ²						
Boom support ²						

5. inspection category: Chassis - driver's cab ¹						
Component to be inspected	A	B	C	D	E	Comments
Doors						
Windows / windshields						
Window wipers						
Mirrors						
Seat						
Heater						
Ventilation						
Sound absorber						
Trip recorder						
First aid kit						
Spare bulbs						
Hazard warning triangle						
Safety vest						

6. inspection category: Chassis - drive ¹						
Component to be inspected	A	B	C	D	E	Comments
Combustion engine						
Exhaust system						
Fuel tank						

6. inspection category: Chassis - drive ¹						
Component to be inspected	A	B	C	D	E	Comments
Urea container						
Fuel container						
Filters						
Sound absorber						
Engine mount						
Oil levels						
Fuel lines						
Urea lines						
Fuel lines						

7. inspection category: Chassis - hydraulics ¹						
Component to be inspected	A	B	C	D	E	Comments
Oil container						
Filter with maintenance indicator						
Pumps						
Motors						
Valves						
Lines						
Hoses						
Cylinder						
Pressure limiting valves						

8. inspection category: Chassis - compressed air system ¹						
Component to be inspected	A	B	C	D	E	Comments
Compressor						
Filters						
Air tanks						
Valves						
Lines						
Hoses						
Cylinder						

9th inspection category: Chassis - electrical system ¹						
Component to be inspected	A	B	C	D	E	Comments
Motors						
Generators						
Battery						

9th inspection category: Chassis - electrical system ¹						
Component to be inspected	A	B	C	D	E	Comments
Switches / buttons						
Lines						
Fuses						
Resistors						
Lighting						
Brake lights						
Blinkers						
Tail lights						
Working lights						
Signaling systems						
Indicator lights						
Battery switch						
Limit switches: Transmission, steering, drive train						
Support pressure indicator ²						

10th inspection category: Chassis - control systems ¹						
Component to be inspected	A	B	C	D	E	Comments
Engine regulation						
Transmission						
Couplings						
Circuits						
Brakes						
Steering						
Control displays						
Engine shut off line						
Control of supports ²						
Axle suspension						
Crane leveling						
Rear axle steering						

11th inspection category: Superstructure						
Component to be inspected	A	B	C	D	E	Comments
Frame						
Coverings						
Treads						
Bearings						

11th inspection category: Superstructure						
Component to be inspected	A	B	C	D	E	Comments
Counterweights						
Relapse retainer						
Slewing ring connection: Tilt play						
Slewing ring connection: Mounting screws						
Slewing ring connection: Gears						
Slewing gear: Mounting screws						
Slewing gear: Gears						

12th inspection category: Superstructure - crane operator's cab						
Component to be inspected	A	B	C	D	E	Comments
Doors						
Windows / windshields						
Window wipers						
Mirrors						
Seat						
Heater						
Ventilation						
Muffler						
Joystick for working functions						
Gear shifts						
Safety: Crushing / shear locations						

13th inspection category: Superstructure - Retaining and protection devices						
Component to be inspected	A	B	C	D	E	Comments
Accesses, ladders						
Handles						
Coverings						
Covers						
Hatches						
Treads						

14th inspection category: Superstructure - drive train						
Component to be inspected	A	B	C	D	E	Comments
Combustion engine						
Exhaust system						
Fuel tank						
Urea container						

14th inspection category: Superstructure - drive train						
Component to be inspected	A	B	C	D	E	Comments
Fuel container						
Filters						
Sound absorber						
Engine mount						
Fuel lines						
Urea lines						
Fuel lines						

15. inspection category: Superstructure - hydraulic system						
Component to be inspected	A	B	C	D	E	Comments
Oil container						
Filters						
Pumps						
Motors						
Valves						
Lines						
Hoses						
Cylinder						
Pressure limiting valves						
Lowering brake valves						
Brake control: Hoist gear						
Brake control: Slewing gear						

16th inspection category: Superstructure - electrical system						
Component to be inspected	A	B	C	D	E	Comments
Motors						
Generators						
Batteries						
Switches / buttons						
Lines						
Fuses						
Resistors						
Lighting						
Signal lights						

17. inspection category: Superstructure - control systems						
Component to be inspected	A	B	C	D	E	Comments
Engine regulation						
Transmission						
Flexible couplings						
Circuits						
Engine shut off line						
Control displays						

18. inspection category: Superstructure - rope drives						
Component to be inspected	A	B	C	D	E	Comments
Winch 1 ³						
Winch 2 ³						
Winch 3 ³						
Winch 4 ³						
Winch 5 ³						
Winch 6 ³						
Assembly winches ³						
Rope pulleys						
Rope end connection						
Rope for winch 1						
Rope for winch 2						
Rope for winch 3						
Rope for winch 4						
Rope for winch 5						
Rope for winch 6						
Rope for assembly winches						
Guy ropes						

19th inspection category: Superstructure - hook						
Component to be inspected	A	B	C	D	E	Comments
Pulleys						
Rope guards on pulleys						
Axle support						
Load hook						
Load hook mounting						
Hook retention						

LWE/LR 1600-2-008/18109-09-02/en

20th inspection category: Superstructure - safety and switch systems						
Component to be inspected	A	B	C	D	E	Comments
Hoist emergency limit switch I						
Hoist emergency limit switch II						
Lowering emergency limit switch I						
Lowering emergency limit switch II						
Boom emergency limit switch I						
Boom emergency limit switch II						
Luffing jib: Boom limit switch I						
Luffing jib: Boom limit switch II						
Load torque limiter						
Angle display: Boom						
Angle display: Luffing jib						
Angle display: Slewing gear						
Safety devices: Control						
Working range limitation						
Pressure sensors						
Speed sensor						
Wind sensor						
Sliding beam monitoring						
Support pressure indicator						
Incline display						
Length indicator: Radius, boom length						
Emergency off system						
Engine stop						

21th inspection category: Boom						
Component to be inspected	A	B	C	D	E	Comments
Weld structure						
Rope pulleys						
Change over pulleys feed mechanism						
Luffing cylinder						
Telescoping cylinder						
Boom extension ropes						
Boom retraction ropes						
Boom bearings						
Boom pinning						
Guy rods						
Guy ropes						

21th inspection category: Boom						
Component to be inspected	A	B	C	D	E	Comments
Control ropes						
Guide ropes						
Safety ropes						
Relapse cylinders						
Pin connections						

22. inspection category: Equipment						
Component to be inspected	A	B	C	D	E	Comments
Weld structure						
Rope pulleys						
Relapse cylinder						
Relapse support						
Oscillation guard						
A-frame bearings						
Pinning of components						
Guy rods with pinning						
Rods with guide rail on A-frame 2 and A-frame 3						
All limit switches with switch mechanism						
Pin connections						

Inspection chart for periodic inspections of Liebherr mobile and crawler cranes

Inspection criteria:

- A = Present / complete
- B = Condition / maintenance
- C = Function
- D = Repair / replace
- E = Re-inspection required

Evaluation:

- Satisfactory = x
- Unsatisfactory = -
- Not required = 0

Comments:

- ¹ Inspection of the crane carrier vehicle road worthiness is also fulfilled if it has already been certified by the road traffic department certification authority. For cranes that are not certified for use on public roads, an expert or authorized inspector must conduct the required tests to validate the vehicle's road worthiness.
- ² These inspections must be carried out by an authorized inspector even if it has passed the road traffic department test and is certified.
- ³ Inspection of the winches with respect to the actually used proportion of their design life.

Empty page!

LWE/LR 1600-2-008/18109-09-02/en

90 Attachment

LWE/LR 1600-2-008/18109-09-02/en

LWE/LR 1600-2-008/18109-09-02/en

90.01 Foreword to attachment

1 Foreword

3

LWE/LR 1600-2-008/18109-09-02/en

Fig.195219

LWE/LR 1600-2-008/18109-09-02/en

1 Foreword

This crane may only be used in a flawless technical condition and according to its mission as well as with constant awareness of safety and dangers. Any problems, which could affect safety, must be fixed immediately.



Note

- ▶ Modifications on the crane may only be made with written approval by Liebherr-Werk Ehingen GmbH.

1.1 Change to the operating instructions

Changes to the operating instructions are received in the form of chapters. The chapter to be replaced must be removed from the operating instructions and replaced with the new chapter in the same location.

When you receive a change to the operating instructions:

- ▶ Remove the chapter to be replaced from the operating instructions.
- ▶ File the new chapter in the same location in the operating instructions.
- ▶ Destroy the replaced chapter.
- ▶ Fill out the change confirmation form in chapter 90.05 of the operating instructions.

1.2 Update to the operating instructions

Updates to the operating instructions, which you receive in the circular as Customer information, must be filed in the operating instructions in chapter 90.05.



Fig.113870: Customer information decal

When you receive an update to the operating instructions:

- ▶ Attach the decals **1**, which are enclosed in the customer information to the footer of the respective chapter. See the following example.



Note

Example: Update to the operating instructions!

If there is an update that concerns the operating instructions, chapter 2.04:

- ▶ Attach the decal **1** in the footer of chapter 2.04.
- ▶ File the update in chapter 90.05 of the operating instructions.
- ▶ Fill out the update confirmation form in chapter 90.05 of the operating instructions.

Empty page!

LWE/LR 1600-2-008/18109-09-02/en

90.05 Update confirmation

1	Change confirmation form	3
2	Update confirmation	3
3	Customer information	4

Fig.195219

LWE/LR 1600-2-008/18109-09-02/en

3 Customer information

LWE/LR 1600-2-008/18109-09-02/en

Index

3

- 30m derrick **5.36.10 - 12, 5.36.10 - 15**
- 36m derrick **5.36.10 - 13, 5.36.10 - 14, 5.36.10 - 16**
- 36m derrick with suspended ballast guide **5.36.10 - 18**
- 3-point support **2.04.10 - 9**

7

- 7725039 – Warning of high voltage **2.05 - 3**
- 772564008 – Slewing range **2.05 - 3**
- 772580408 – Limitation of maximum travel speed **2.05 - 4**

9

- 9402377 – Fastening point / lifting point **2.05 - 10**
- 9412158 – Reading the operating instructions **2.05 - 5**
- 97001802 – Falling platform **2.05 - 35**
- 97003109 – Accessing the step ladder **2.05 - 15**
- 97003110 – Folding the step ladder in and out **2.05 - 16**
- 97003112 – Maximum suspended load **2.05 - 22**
- 97004046 – Safety harness, maximum two persons **2.05 - 6**
- 97006167 – Identifying the support base **2.05 - 16, 2.05 - 16**
- 97008514 – Warning of head injuries **2.05 - 17**
- 97009799 – Data logger **2.05 - 17**
- 97011336 - Transport weights of the components **2.05 - 36**
- 97011689 – Danger of crushing **2.05 - 19**
- 97011690 – Overload of cab is prohibited **2.05 - 19**
- 97012095 – Maximum load **2.05 - 18**
- 97012737 – Danger of accident **2.05 - 21**
- 97012949 – Maximum load **2.05 - 17**
- 97016304 – Refueling **2.05 - 20**
- 97016392 – Crushing danger for feet **2.05 - 21**
- 97016911 – Danger of collision **2.05 - 30**
- 97017585 – Falling telescopic boom during disassembly / assembly **2.05 - 6**
- 97018351 – Falling telescopic boom during transport! **2.05 - 7**
- 97018564 – Falling telescopic boom during transport! **2.05 - 7**
- 97023034 – Disassembling **2.05 - 21**
- 97027147 – Overloading of the combi box is prohibited **2.05 - 7**
- 97033982 – Assembling / disassembling the Derrick pivot section **2.05 - 26**
- 97036732 – Access via 3-point support **2.05 - 22**
- 97036733 – Fastening point **2.05 - 8**
- 97036734 – Rigging point **2.05 - 33**

- 97036735 – Fastening point for lattice section **2.05 - 11**
- 97036736 – Fastening point for lattice sections **2.05 - 11**
- 97036917 – Maximum suspended load **2.05 - 23**
- 97037383 – Urea **2.05 - 23**
- 97037625 – Suspended load Fastening points / rigging points **2.05 - 10**
- 97037871 – Fastening points for lattice sections **2.05 - 13**
- 97037952 – Warning of fatal electric shock **2.05 - 23**
- 97038442 – Fastening point for lattice section **2.05 - 12**
- 97038452 – Fastening point for lattice sections **2.05 - 12**
- 97038454 – Fastening point for lattice sections **2.05 - 12**
- 97039035 – Suspended load Assembly unit **2.05 - 14**
- 97039753 – Danger of stumbling **2.05 - 30**
- 97041305 – Overload of components **2.05 - 25**
- 97042730 – Falling luffing cylinder **2.05 - 24**
- 97042797 – Overload of components **2.05 - 24**
- 97046488 – Corrosion inhibitor - antifreeze fluids **2.05 - 20**
- 97047566 – Center of gravity of the counterweight **2.05 - 39, 2.05 - 40, 2.05 - 40, 2.05 - 40, 2.05 - 41, 2.05 - 41**
- 97047810 – Pinning brackets **2.05 - 24**
- 97053409 – Entanglement hazard during winch operation **2.05 - 19**
- 97057097 – Fastening point to turn the component **2.05 - 14**
- 97057524 – Fastening point for assembly of lattice sections **2.05 - 13**
- 97057767 – Fastening points for lattice sections **2.05 - 13**
- 97059339 – Suspended load Derrick pivot section **2.05 - 14**
- 97068370 – Closing the cab door **2.05 - 18**
- 97068839 - Transport weights of the components / fastening length of the fastening equipment **2.05 - 36**
- 97069053 – Storage boxes open **2.05 - 18**
- 97070905 – Removing the auxiliary jib (boom nose) **2.05 - 25**
- 97094940 – Spark catcher **2.05 - 34**
- 97095312 – Suspended load and fastening points for counterweight frame **2.05 - 15**
- 97096132 – Fastening points for N-assembly unit **2.05 - 11**
- 97097951 – Counterweight **2.05 - 26**
- 97106824 – Installing the N-assembly unit **2.05 - 10**
- 97107101 – Unlocking the telescopic boom locking pin **2.05 - 27**
- 97107199 – Do not unlock the telescopic boom locking pin **2.05 - 27**
- 971494208 – Limitation of maximum travel speed **2.05 - 28**
- 971539808 – Warning notice for unpinning the auxiliary boom on the pulley head **2.05 - 28**

971539908 – Warning notice for unlocking the auxiliary boom **2.05 - 29**
 973974408 - Transport weights of the components **2.05 - 35**
 973974608 - Transport weights of the components **2.05 - 36**
 976624808 – Fastening the load **2.05 - 38**
 977055908 – Fastening point for swingable sliding beam **2.05 - 27**
 978673908 – Warning of suspended load **2.05 - 29**
 978674008 – Access for unauthorized personnel prohibited **2.05 - 29**
 978674108 – Warning of crushing danger **2.05 - 30**
 978674308 – Radio remote control **2.05 - 31**
 978674408 – Danger of burns to hands **2.05 - 31**
 978674508 – Warning of rotating parts **2.05 - 31**
 978674608 - Crushing danger for hands **2.05 - 32**
 978674808 – Personal protective equipment **2.05 - 32**
 978674908 – Accessing the area is prohibited **2.05 - 32**
 978675008 – Access prohibited **2.05 - 33**
 978687408 – Rigging point **2.05 - 33**
 978867108 – Warning of fatal electric shock **2.05 - 34**
 979383308 – Oil change **2.05 - 34**
 979561108 – Counterweight **2.05 - 35**

A

Abbreviations Rope diameter **8.04 - 7**
 Accelerating, changing the load **2.04 - 21**
 Access to lattice sections or booms **2.04 - 15**
 Acoustic / visual warnings outside the crane operator's cab **4.20 - 13, 4.20 - 61**
 Acoustic / visual warnings within the crane operator's cab **4.20 - 11, 4.20 - 59**
 Acoustic and optical warning devices **4.04 - 11**
 Acoustic signal „Horn“ **4.02 - 93, 4.02 - 179**
 Acoustic signal „Short horn“ **4.02 - 93, 4.02 - 179**
 Acoustic warning on monitor 0 **4.02 - 93**
 Acoustic warning on monitor 1 **4.02 - 179**
 Activating / deactivating individual winches **4.02 - 187**
 Activating crawler operation **4.10 - 29**
 Activating the bypass at assembly and disassembly **5.01 - 27**
 Activating the bypass at crawler assembly and crawler disassembly **5.01 - 26**
 Activating the creeper gear **4.10 - 29**
 Activating „parallel travel“ **4.10 - 37**
 Active stand-by operation / alarm **4.02 - 219**
 Actual load **4.02 - 5**
 Actuating of winch and / or crane movements during assembly / disassembly **5.01 - 28**
 Actuating the main current circuit **4.03 - 5**
 Adapting the consoles to the crane driver **4.03 - 17**
 Adapting the input value hook block weight **4.02 - 57**

Adding the engine-independent auxiliary heater in programming mode **6.02 - 18**
 Adding the engine-independent auxiliary heater manually **6.02 - 17**
 Adding „Power Plus“ **4.05 - 9**
 Additional controls for certain crawler cranes **5.01 - 6**
 Additional controls for cranes on tires on the front and supported on the rear **5.01 - 5**
 Additional controls for cranes supported on the front and on tires on the rear **5.01 - 5**
 Additional controls for cranes with a derrick boom **5.01 - 6**
 Additional controls for cranes with crane support **5.01 - 5**
 Additional controls for cranes with luffing auxiliary boom / accessories **5.01 - 6**
 Additional controls for freestanding crane operation (on tires) **5.01 - 6**
 Additional emergency operating modes **4.02 - 99**
 Additional notes **0.01 - 2**
 Additional risks **2.04 - 72**
 Adjusting the arm rests **4.03 - 17**
 Adjusting the consoles **4.03 - 15**
 Adjusting the control parameters **4.03 - 39**
 Adjusting the crane operator's seat **4.03 - 15**
 Adjusting the derrick ballast **4.03 - 39**
 Adjusting the mechanical auxiliary support **3.04 - 5**
 Adjusting the parallel control of winch 1 and winch 2 **4.05 - 15**
 Adjusting the recirculating air / fresh air **6.02 - 5**
 Adjusting the settings manually in the „Climate control settings“ menu **6.02 - 15**
 Adjusting the „lower“ / „upper“ air distribution **6.02 - 7**
 Adjustment of reeving **4.03 - 43**
 Adjustment procedure **5.35.10 - 41**
 Advance warning LMB / advance warning engine monitoring **4.02 - 89**
 After engine start: Checking the instruments on the LICCON monitor **4.03 - 31**
 After replacement of components **7.01 - 7**
 Aids for work at a height **2.04 - 13**
 Air dryer of the compressed air system of the crane superstructure **7.05 - 35**
 Air filter **7.05 - 5**
 Airplane warning light **4.03 - 3**
 Alarm functions **4.02 - 73, 4.02 - 159**
 Aligning the ballast trailer **5.35.10 - 19**
 Aligning the crane **2.04 - 37**
 Aligning the hook blocks horizontally **4.05 - 15**
 Aligning the suspended ballast pallet horizontally **5.36.10 - 38**
 Aligning the wheel sets in the circular travel position **5.35.10 - 47, 5.35.10 - 115**
 Aligning the wheel sets in the towing position **5.35.10 - 43, 5.35.10 - 111**
 Aligning the wheel sets into parallel travel position **5.35.10 - 51**
 Ambient temperature **0.01 - 6**
 Ambient temperatures below -20°C **2.08 - 3**

- Angle adjustment on the fixed lattice jib with mechanical adjustment **5.01 - 36**
- Angle sensors **4.04 - 21**
- Angular pulling **4.08 - 11**
- Antifall guards on the crane **2.06 - 1**
- Applying and releasing the slewing gear brake manually **4.05 - 27**
- Applying the slewing gear brake with the pedal **4.05 - 29**
- Areas **7.05.50 - 11, 8.04 - 4**
- Areas in the winch - pulley head assignment screen **4.02 - 39**
- Arrangement of intermediate sections **5.03 - 5**
- Arrangement of intermediate sections on the boom **5.03 - 3**
- Assemble SA-frame **3.05 - 5**
- Assembling **5.36.10 - 19**
- Assembling / disassembling **5.01 - 22**
- Assembling / disassembling of booms **5.01 - 29**
- Assembling / disassembling of boom systems for supporting on ascending terrain (assembly / disassembly schematic) **5.01 - 61**
- Assembling / disassembling of boom systems for supporting on descending terrain (assembly / disassembly schematic) **5.01 - 64**
- Assembling / disassembling of lattice sections for lattice mast cranes **5.01 - 51**
- Assembling / disassembling the crane component **2.08 - 6**
- Assembling / disassembling the electrical lines **5.01 - 24**
- Assembling / disassembling the hydraulic lines **5.01 - 25**
- Assembling / disassembling the lattice sections on telescopic cranes with a luffing lattice jib **5.01 - 39**
- Assembling / disassembling the lattice sections on telescopic cranes with an auxiliary boom, with an auxiliary crane **5.01 - 43**
- Assembling / disassembling the lattice sections on telescopic cranes with an auxiliary boom, without an auxiliary crane **5.01 - 47**
- Assembling / disassembling the roller set **5.14 - 5**
- Assembling / disassembling the turntable **3.01 - 17**
- Assembling / disassembling the wedge lock **4.06 - 21**
- Assembling of boom systems on ascending terrain **5.01 - 61**
- Assembling of boom systems on descending terrain **5.01 - 64**
- Assembling of lattice sections **5.01 - 51**
- Assembling platforms and ladder **2.06 - 11**
- Assembling SD/SLD/SL(X)D-boom combination(s) with substructure **5.39 - 38**
- Assembling SWF-boom **5.17 - 5**
- Assembling the 36t boom nose on the SW-end section **5.10 - 5**
- Assembling the auxiliary jib **5.13 - 4**
- Assembling the ballast trailer **5.35.10 - 9**
- Assembling the ballast trailer guide **5.35.10 - 10**
- Assembling the ballast trailer guying **5.35.10 - 25**
- Assembling the boom **5.38 - 13, 5.39 - 13**
- Assembling the boom nose **5.10 - 7**
- Assembling the boom systems with the substructure **5.39 - 43**
- Assembling the catwalks **5.38 - 11, 5.39 - 11**
- Assembling the components for the suspended ballast guide **5.36.10 - 22**
- Assembling the consoles for ballast centering **5.36.10 - 34**
- Assembling the counterweight brackets on the turntable **4.07 - 8**
- Assembling the crawler carrier **3.01 - 13, 3.01 - 35**
- Assembling the D-auxiliary rods for the suspended ballast **5.36.10 - 30**
- Assembling the D-boom **5.05 - 6**
- Assembling the D-guy rods **5.05 - 23, 5.36.10 - 29**
- Assembling the double cone pins horizontally **5.01 - 13**
- Assembling the double cone pins vertically **5.01 - 13**
- Assembling the end section **5.36.10 - 22**
- Assembling the FAB-guy ropes **5.13.20 - 26, 5.13.20 - 36, 5.13.20 - 42**
- Assembling the F-assembly unit **5.13.20 - 14, 5.17 - 9**
- Assembling the F-assembly unit with F-end section **5.13.20 - 24, 5.13.20 - 33, 5.13.20 - 40**
- Assembling the F-auxiliary jib **5.13 - 13**
- Assembling the F-guy ropes and the FAB-guy ropes **5.13.20 - 17**
- Assembling the first crawler carrier **3.01 - 33**
- Assembling the fixed lattice jib on the TF-adapter **5.01 - 33**
- Assembling the F-jib **5.13.20 - 9**
- Assembling the F-jib — assembly variants **5.13.20 - 12**
- Assembling the guy rods on the suspended ballast guide **5.36.10 - 27**
- Assembling the guy rods WA-frame **2 5.07 - 15, 5.08 - 9**
- Assembling the lattice sections **5.13.20 - 22**
- Assembling the lattice sections on a luffing lattice jib **5.01 - 39**
- Assembling the lattice sections on an auxiliary boom with an auxiliary crane **5.01 - 43**
- Assembling the lattice sections on an auxiliary boom without an auxiliary crane **5.01 - 47**
- Assembling the load hook * **4.06 - 16**
- Assembling the pivot section **5.36.10 - 22**
- Assembling the railing on the D-pivot section **5.05 - 8**
- Assembling the railing on the SL-reducer **2.06 - 20**
- Assembling the railing on the S-pivot section and the derrick pivot section **2.06 - 19**
- Assembling the railings **2.06 - 9, 2.06 - 11**
- Assembling the roller set **5.14 - 5**
- Assembling the S/SL boom **5.38 - 6**
- Assembling the S-guy rods **5.38 - 33, 5.39 - 47**
- Assembling the S-intermediate sections in flying mode on the flying assembly intermediate section **5.39 - 37**

Assembling the S-intermediate sections in „flying mode“ on the S-pivot section **5.39 - 27**
Assembling the S-intermediate sections on the S-pivot section **5.39 - 21**
Assembling the SL/S-boom in „Flying mode“ (guying on S-pivot section) **5.39 - 25**
Assembling the SL2DF/SL4DF-/SL10DF-boom combination with supporting base **5.13 - 11**
Assembling the S-lattice section in „flying mode“ on the intermediate section 12m 2825.20 FLM **5.38 - 29**
Assembling the S-lattice sections **5.38 - 19**
Assembling the S-lattice sections („close“ boom) **5.38 - 19**
Assembling the S-lattice sections in „flying mode“ **5.38 - 23**
Assembling the S-lattice sections in „flying mode“ on the S-pivot section **5.38 - 25**
Assembling the SLD / SD-boom **5.39 - 6**
Assembling the suspended ballast guide * **5.36.10 - 20**
Assembling the suspended ballast guide on the turntable frame **5.36.10 - 23**
Assembling the suspended ballast pallet **5.36.10 - 31**
Assembling the transport unit **5.36.10 - 75**
Assembling the turntable extension **4.07.10 - 6**
Assembling the turntable extension on the turntable **4.07.10 - 7**
Assembling the W-boom system **5.07 - 5**
Assembling the W-guy rods **5.07 - 21**
Assembling the W-lattice jib **5.07 - 19**
Assembling the W-lattice section **5.07 - 19**
Assembling the W-transport unit 1 **5.07 - 9**
Assembling the W-transport unit 2 **5.07 - 9**
Assembling the W-transport unit 3 **5.07 - 9**
Assembling the W-transport units **5.07 - 9, 5.08 - 9**
Assembling the WV-boom system **5.08 - 5**
Assembling the WV-lattice jib **5.08 - 9**
Assembling winch 1 **3.07 - 5**
Assembly / disassembly of the crawler carriers with SA-frame **3.01 - 27**
Assembly / disassembly of the crawler carriers with the auxiliary crane **3.01 - 11**
Assembly and disassembly of winch 1 **3.07 - 17**
Assembly conditions **3.06 - 1**
Assembly conditions for operation on crawlers **3.06 - 3**
Assembly D-boom **5.05 - 5**
Assembly drawings **5.01 - 24**
Assembly hoist winches **3.07 - 1**
Assembly of crawler carriers with the auxiliary crane **3.01 - 11**
Assembly of SA bracket **3.05 - 1**
Assembly of the crawler carrier with SA-frame **3.01 - 27**
Assembly of the second crawler carrier **3.01 - 37**
Assembly rope **1.03 - 22**
Assembly variant V1 **5.13.20 - 12**
Assembly variant V1 — Assembling the F-jib in parts **5.13.20 - 14**

Assembly variant V2 **5.13.20 - 12**
Assembly variant V2 — Assembling the complete F-jib (maximum length of 12m) on the ground **5.13.20 - 24**
Assembly variant V3 **5.13.20 - 12**
Assembly variant V3 — Assembling the complete F-jib (maximum length of 12m) in flying mode **5.13.20 - 32**
Assembly variant V4 **5.13.20 - 12**
Assembly variant V4 — Assembling the complete F-jib (maximum length of 12m) in flying mode **5.13.20 - 39**
Assembly winch, illustration 2 **7.05 - 31**
Assigning winch(es) **4.02 - 49**
Attaching / removing the hoist limit switch weight **4.06 - 19**
Attaching and removing the load hook * **4.06 - 16**
Attaching the hoist limit switch weight **4.06 - 19**
Attaching the mechanical auxiliary support **3.04 - 3**
Attachment points SA-frame **3.05 - 3**
AUTO heating mode **6.02 - 13**
Auxiliary equipment **2.08 - 3**
Auxiliary guying **5.01 - 8, 5.03 - 7**
Auxiliary jib „HS“ **5.42 - 3**

B

Ballasting the ballast trailer **5.35.10 - 27**
Ballasting the suspended ballast pallet **5.36.10 - 38**
Ballast pallet suspended ballast **1.03 - 19**
Ballast plate for central ballast / counterweight / derrick ballast **1.03 - 8**
Ballast trailer **1.03 - 17**
Ballast trailer drive * **5.35.10 - 63**
Ballast trailer lifted **5.35.10 - 67, 5.35.10 - 69**
Ballast trailer maintenance instructions **7.04.50 - 1**
Ballast trailer on the ground **5.35.10 - 67, 5.35.10 - 69**
Ballast trailer tires **7.04.50 - 3, 7.04.50 - 3**
Ballast trailer tires and disk wheels **7.04.50 - 3**
Ballast trailer with wheel drive **1.03 - 18**
Ball locking pin **5.01 - 20**
Basic principles and procedure **8.01 - 4**
Basket formation **7.05.50 - 8, 8.04 - 20**
Batteries **7.01 - 10**
Battery maintenance **7.05 - 35**
Before starting to work **2.04 - 62**
Bleeding by separate actuation of the grease pump **7.04 - 15**
Bleeding by simulating crawler operation **7.04 - 13**
Bleeding repaired lubrication lines **7.04 - 15**
Bleeding the central lubrication system **7.04 - 13, 7.05 - 25**
Bleeding the heating system **6.02 - 22**
Block position of the relapse cylinders when setting down the load **5.01 - 6**
Block position relapse cylinders **5.35.10 - 59**
Boom component overview **1.01 - 5**
Boom components **5.03 - 3**

Boom length **4.02 - 69**
 Boom limitation **4.02 - 73**
 Boom nose **1.03 - 12, 5.10 - 1**
 Boom systems **5.03 - 1**
 Breaking away fixed loads **4.08 - 13**
 Brief description **4.08 - 16**
 Bringing the guy rods on the ballast trailer into the operating position **5.35.10 - 13**
 Bringing the guy rods on the ballast trailer into the transport position **5.35.10 - 99**
 Bringing the pulley retainer into transport position **5.05 - 41**
 Bringing the pulley retainers into operating position **5.05 - 21**
 Bringing the pull test brackets into operating position **5.05 - 19**
 Bringing the pull test brackets into transport position **5.05 - 43**
 Bringing the railing on the turntable extension into the operating position **2.06 - 16, 4.07.10 - 7**
 Bringing the railing on the turntable extension into the transport position **2.06 - 17, 4.07.10 - 20**
 Bringing the railings on the counterweight brackets into the operating position **2.06 - 14, 4.07 - 7**
 Bringing the railings on the counterweight brackets into the transport position **2.06 - 15, 4.07 - 22**
 Broken strands **7.05.50 - 5**
 Broken wire **7.05.50 - 5**
 Broken wire in the strand valleys **8.04 - 13**
 Broken wire nests **8.04 - 14**
 Broken wires in rope sections, which are not spooled up on the winch **8.04 - 13**
 Broken wires on rope end connections **8.04 - 13**
 Buckles **7.05.50 - 10, 8.04 - 24, 8.16 - 8**
 Bypass at assembly and disassembly **5.01 - 28**
 Bypassing the hoist top shut-off **5.01 - 11**
 Bypassing the LICCON overload protection **5.01 - 10**
 Bypassing the overload protection **5.01 - 9**
 Bypassing the PAT overload protection **5.01 - 10**
 Bypass of overload protection **4.04 - 5, 7.15 - 24**
 Bypass of overload protection: Emergency situation (according to EN 13000:2010) **4.04 - 6**
 Bypass of overload protection: Failure of overload protection (according to EN 13000:2010) **4.04 - 6, 7.15 - 27**
 Bypass of overload protection: Failure of the overload protection **4.04 - 5, 7.15 - 27**
 Bypass of support beam monitoring **4.02 - 195**
 Bypass of the hoist top shut off **4.20 - 41, 4.20 - 89**
 Bypass when assembling / disassembling **5.01 - 27**
 Bypass when assembling / disassembling the crawler **5.01 - 26**
 Bypass „Hoist top“ **4.02 - 101**

C

Calculation example **4.10 - 12**
 Calculation examples **2.04 - 32**

Calculation of required length of transfers in uphill / downhill slopes **4.10 - 11**
 California Proposition 65 **2.04 - 3**
 Calling up the test system **7.15 - 11**
 Camera monitoring **4.01 - 9**
 Carrying out an intermediate lubrication **7.05 - 23**
 Carrying out crane movements **4.05 - 5**
 Carrying out erection procedures (assembly operation) **4.20 - 45, 4.20 - 93**
 Carrying out error diagnostics **7.15 - 9**
 Carrying out take down procedures (assembly operation) **4.20 - 49, 4.20 - 97**
 Case 1 **5.35.10 - 59**
 Case 2 **5.35.10 - 61**
 Case 3 **5.35.10 - 61**
 CE marking **0.01 - 5**
 Center of gravity display **4.10 - 6**
 Central ballast **3.03 - 1**
 Central ballast bracket **1.03 - 7**
 Central ballast combinations **3.03 - 5**
 Central ballast plates **3.03 - 3**
 Central lubrication system **7.04.50 - 5, 7.05 - 19**
 Change confirmation form **90.05 - 3**
 Change to the operating instructions **90.01 - 3**
 Changing maximum winch speed **4.02 - 185**
 Changing minimum and maximum support force limits **4.02 - 203**
 Changing oil on the miter gear **7.04 - 7**
 Changing oil on the planetary gear **7.04 - 9**
 Changing the maximum rotation speed of slewing gear **4.02 - 185**
 Changing the oil **7.04 - 7, 7.04.50 - 5, 7.04.50 - 8, 7.05 - 3, 7.05 - 9, 7.05 - 33**
 Changing the set up configuration and hoist rope reeving **4.03 - 37**
 Changing the travel direction **4.10 - 33**
 Chart for determining the theoretically remaining service life **8.03 - 10**
 Check bearings for easy movement **7.05.50 - 4**
 Check for wear and distortion **7.05.50 - 11**
 Checking and accepting the changed set up configuration and hoist rope reeving **4.03 - 37**
 Checking bearings for easy movement **8.01 - 86**
 Checking cylinder pressure with „jib stop extended to maximum limit“ **8.14 - 3**
 Checking for broken strands **8.04 - 9**
 Checking for corrosion **7.05.50 - 12**
 Checking for damage and cracks **8.01 - 85**
 Checking for flattenings **7.05.50 - 13**
 Checking for leaks **7.04 - 5, 7.04.50 - 4, 7.04.50 - 7**
 Checking for mechanical damage **7.05.50 - 4**
 Checking for solid foreign substances **8.03 - 4**
 Checking jib stop cylinder pressure **8.14 - 3**
 Checking limit switch initiators for function **8.12 - 3, 8.12 - 5, 8.12 - 7, 8.12 - 9**
 Checking limit switch initiators on switch point „steepest position“ **8.12 - 7**
 Checking load hooks for corrosion and wear **8.05 - 5**

Checking of rope diameter **8.04 - 14**
Checking of rope pretension on telescopic booms, illustration 1 **8.01 - 82**
Checking the airplane warning light **5.07 - 25, 5.13 - 23, 5.13.20 - 44, 5.38 - 36, 5.39 - 44, 5.42 - 12**
Checking the battery voltage **4.03 - 13**
Checking the central lubrication system **4.03 - 9**
Checking the control rope for distortions **7.05.50 - 13**
Checking the coolant level **4.03 - 9**
Checking the depth of the lead-in tracks **8.01 - 86**
Checking the EMERGENCY STOP switch **7.15 - 17**
Checking the end of the service life **8.06 - 3**
Checking the fuel level **4.03 - 13**
Checking the function of the central lubrication system **7.05 - 23**
Checking the function of the hoist limit switch **5.10 - 11**
Checking the function of the safety devices **5.07 - 25, 5.08 - 9, 5.42 - 12**
Checking the function of the safety equipment **5.05 - 25, 5.13 - 21, 5.13.20 - 44, 5.38 - 36, 5.39 - 43**
Checking the gas pressure and oil fill before operation **8.01 - 84**
Checking the groove diameter **8.01 - 85, 8.03 - 3**
Checking the guy rods **8.15 - 3**
Checking the hoist limit switch on the pulley head **5.07 - 27, 5.13 - 23, 5.13.20 - 44, 5.38 - 36, 5.39 - 44, 5.42 - 12**
Checking the horn **4.03 - 23**
Checking the hydraulic hoses within area of responsibility of the German employer's liability insurance associations **7.05 - 14**
Checking the length sensor value on the ballast trailer **5.35.10 - 87**
Checking the limit switches **5.07 - 27**
Checking the limit switches in general **5.13.20 - 44**
Checking the limit switch S-boom „steepest position“ **5.07 - 27, 5.13 - 23, 5.38 - 37, 5.39 - 44**
Checking the limit switch SL-boom „steepest position“ **5.42 - 12**
Checking the load hook for distortion **8.05 - 4**
Checking the load hook for surface cracks **8.05 - 4**
Checking the load hook for wear **8.05 - 4**
Checking the lubrication **7.05.50 - 11**
Checking the mounting screws for damage **8.01 - 88**
Checking the oil levels and filters **4.03 - 7**
Checking the oscillation guard **5.07 - 25**
Checking the position **7.05.50 - 12**
Checking the retaining elements **5.01 - 14**
Checking the rope drive for spooling problems **7.05.50 - 12**
Checking the rope end connection **8.04 - 14**
Checking the ropes **7.05.50 - 10**
Checking the safety measures **2.04 - 38**
Checking the tightening torque **8.01 - 86**
Checking the tilt play **8.01 - 87**
Checking the vent / breather filter **7.05 - 11**

Checking the wear on the connections of the track pads **7.04 - 24**
Checking the wear on the roll off surfaces of the track pads / track rollers **7.04 - 27**
Checking the window cleaning fluid **4.03 - 11**
Checking the wind speed sensor **5.07 - 25, 5.13 - 23, 5.13.20 - 44, 5.38 - 36, 5.39 - 44, 5.42 - 12**
Checking visually **8.01 - 85**
Checking wear on the track chain **7.04 - 23**
Check list for the inspection of ladders and steps **8.17 - 5**
Checks before starting to work with the crane **4.08 - 4**
Checks before start up **4.03 - 7**
Checks via the LICCON computer system **4.03 - 13**
Check the mounting screws for tight seating **8.01 - 88**
Circular travel **5.35.10 - 47, 5.35.10 - 117**
Cleaning **7.01 - 9**
Cleaning the filter strainer **7.05 - 7**
Climate control system operation **6.02 - 10**
Climbing up / climbing down the counterweight bracket **4.07 - 7**
Closing the boom **5.38 - 19**
Closing the end section **5.01 - 30**
Closing the fixed lattice jib **5.01 - 35**
Closing the side window pane **2.04 - 20**
Combinations of boom heads / end sections with roller sets **5.14 - 4**
Combined degree of severity **8.04 - 25**
Comparison **4.02 - 5**
Compensating for ground unevenness **5.35.10 - 61**
Component description and general notes **5.35.10 - 3**
Component overview crawler travel gear **1.01 - 3, 3.01 - 3**
Component overview derrick ballast **1.01 - 6**
Component overview of auxiliary jib „HS“ **5.42 - 3**
Component overview of suspended ballast **5.36.10 - 3**
Component overview SA-frame **3.05 - 3**
Component overview turntable **1.01 - 4**
Component overview W-boom system **5.07 - 3**
Components **3.03 - 3**
Components overview **5.05 - 3**
Composition **8.16 - 4**
Confirm the selection **4.02 - 51**
Connecting the assembly winch rope with the rope pulley retainer **5.13.20 - 18**
Connecting the guy rods SA-frame with the guy rods S-pivot section **5.38 - 19**
Connection schematic for emergency operation, illustration 2 **6.05 - 37**
Consoles central ballast **3.03 - 3**
Control cabinet **4.01 - 5**
Control measures **5.01 - 4**
Control panel, left **4.01 - 23**
Control panel, right **4.01 - 25**

Control release **4.04 - 19**
Control ropes **1.03 - 22**
Control units crane chassis **4.01 - 31**
Conversion chart **0.01 - 8**
Conversion chart for wind force **2.04 - 45**
Corkscrew-like distortion **7.05.50 - 8, 8.04 - 19**
Corrective steering **5.35.10 - 53**
Corrective steering the wheel sets **5.35.10 - 45**
Corrosion **7.05.50 - 6, 8.04 - 17**
Cotter pin **5.01 - 16**
Counter-rotating the tracks to the left **4.10 - 39**
Counter-rotating the tracks to the right **4.10 - 39**
Counterweight **1.02 - 4, 4.07 - 1, 4.07 - 3, 4.07.10 - 3**
Counterweight and / or ballast **2.04 - 64**
Counterweight bracket **1.03 - 8, 4.07 - 4**
Counterweight
plate **4.07 - 3, 4.07 - 4, 4.07.10 - 3, 4.07.10 - 4**
Cracks and dents **8.15 - 4**
Crane **2.04 - 71**
Crane and crane components **2.04 - 21**
Crane cab **2.04 - 17**
Crane cab with incline adjustment **2.04 - 19**
Crane control **1.02 - 4**
Crane documentation **0.01 - 2**
Crane drive **1.02 - 4**
Crane engine **4.02 - 215, 7.05 - 3**
Crane geometry and load information **4.02 - 59**
Crane incline **4.02 - 105**
Crane in operation **2.04 - 4**
Crane movement - Telescoping **4.08 - 5**
Crane on floating device **2.25 - 1**
Crane operation in case of thunderstorms **2.04 - 42**
Crane operation in Support program **4.02 - 191**
Crane operation with a load **2.04 - 63**
Crane operation with derrick ballast **5.35.10 - 71, 5.36.10 - 44**
Crane operator's cab **1.02 - 4**
Crane operator responsibilities **2.04 - 22**
Crane out of service **2.04 - 5**
Crane rope pretension **4.08 - 15**
Crane ropes **7.05.50 - 4, 8.04 - 3**
Crane speeds **1.03 - 21**
Crane start up and taking the crane out of service **4.03 - 1**
Crane superstructure **1.02 - 3**
Crane superstructure in the 0° position or 180° position **2.04 - 17**
Crane superstructure turned **2.04 - 19**
Crane support **7.06 - 9**
Cranes with cam limit switch **5.01 - 3**
Cranes with lattice mast boom **2.08 - 5, 2.08 - 7**
Cranes with telescopic boom **2.08 - 6, 2.08 - 7**
Cranes with winch speed sensor **5.01 - 4**
Crane transport on floating devices **2.25 - 4**
Crawler carrier **1.03 - 4**
Crawler carrier assembly **3.01 - 1**
Crawler center section **1.03 - 5**
Crawler operation with derrick ballast **5.36.10 - 56**
Crawler travel gear **1.02 - 3**

Creeper gear or very slow movement **2.04 - 53**
Current checklist **8.04 - 28**
Current load **4.02 - 63**
Customer information **90.05 - 4**

D

Damaged intermediate layers **8.16 - 8**
Damaged outer braiding **8.16 - 6**
Damaged rope braiding **8.16 - 7**
Damage on rope **7.05.50 - 5**
Damage symptoms of fiber guy rope **8.16 - 6**
Danger of crushing **4.08 - 14**
Danger of exceeding F1max assembly **4.20 - 53, 4.20 - 101**
Danger of falling **4.08 - 14**
Dangers on the crane **2.04 - 3**
Danger zone of crane **2.04 - 4**
Data logger **0.01 - 1**
D-boom **5.05 - 1**
Deactivating the bypass at crawler assembly and crawler disassembly **5.01 - 26**
Decrease crane utilization **2.08 - 7**
Defective Central processing unit (CPU) **7.15 - 23**
Defective limit switch **7.15 - 24**
Defective power supply (NT) **7.15 - 21**
Defective sensors **7.15 - 23**
Defined ballast trailer operation **5.35.10 - 67**
Definition of assembly conditions **3.06 - 3**
Definition of directional data for crawler cranes **0.01 - 7**
Definition of directional data for mobile cranes **0.01 - 7**
Definition of „Checking“ **7.01 - 3**
Degree of severity **8.04 - 7**
D-end section 8.5m **1.03 - 15**
Derrick ballast, weight and utilization **4.02 - 151**
Derrick ballast - ballast trailer **5.35.10 - 1**
Derrick ballast radii and standing levels **5.36.10 - 7**
Derrick ballast radii and standing levels - narrow track crane **5.36.10 - 14**
Derrick ballast radii and standing levels - standard crane **5.36.10 - 11**
Derrick ballast - suspended ballast **5.36.10 - 1**
Derrick ballast without suspended ballast guide **5.36.10 - 11**
Derrick ballast with suspended ballast guide **5.36.10 - 13**
Derrick boom angle **4.02 - 149**
Derrick relapse retainer **8.12 - 5**
Descending from lattice sections or booms **2.04 - 15**
Description of acoustic / visual warnings **4.20 - 9, 4.20 - 57**
Description of intervals and tasks **7.01 - 3**
Description using the example LR 1600-2, SL3F **4.08 - 16**
Destined use **0.01 - 5, 2.04 - 68, 2.04 - 70, 2.25 - 3**
Detachable rope end connection **8.04 - 14**

Detaching the hoist rope **4.06 - 11, 4.06 - 15, 4.06 - 18**
Detent pin **5.01 - 18**
Determination of forces in operating mode with derrick ballast **5.35.10 - 77, 5.36.10 - 46**
Determining the effective operating hours Ti **8.03 - 8**
Determining the number of broken wires **8.04 - 9**
Determining the operating conditions (load spectrum) **8.03 - 5**
Determining the used proportion of the theoretical service life **8.03 - 8**
Diaphragm reservoirs **7.05 - 13**
Diesel engine **1.02 - 3**
Diesel particle filter * **7.05 - 5**
Difference force monitoring of ballast guying **5.35.10 - 89**
Differential force monitoring for derrick ballast-guying **5.36.10 - 54**
Dimensions and weights **1.03 - 3, 3.01 - 3, 3.07 - 3**
D-intermediate section 12m, 2420.20 **1.03 - 16**
D-intermediate section 6m, 2420.16 **1.03 - 15**
Disassemble SA-frame **3.05 - 13**
Disassembling of lattice sections **5.01 - 53**
Disassembling the 36t boom nose **5.10 - 15**
Disassembling the 36t boom nose on the SW-end section **5.10 - 19**
Disassembling the assembly support **3.01 - 25, 3.01 - 49**
Disassembling the assembly supports **3.01 - 51**
Disassembling the auxiliary jib **5.13 - 33**
Disassembling the ballast trailer guide **5.35.10 - 107**
Disassembling the ballast trailer guying **5.35.10 - 99**
Disassembling the components for the suspended ballast guide **5.36.10 - 73**
Disassembling the counterweight **4.07 - 15**
Disassembling the crawler carriers **3.01 - 25**
Disassembling the D-auxiliary rods for the suspended ballast **5.36.10 - 69**
Disassembling the D-boom **5.05 - 37**
Disassembling the D-guy rods **5.05 - 45, 5.36.10 - 70**
Disassembling the D-lattice sections **5.05 - 49**
Disassembling the end section **5.36.10 - 73**
Disassembling the FAB-guy rope **5.13.20 - 53, 5.13.20 - 60**
Disassembling the F-assembly unit **5.13 - 45, 5.13.20 - 59, 5.17 - 31**
Disassembling the F-assembly unit with F-end section **5.13.20 - 65**
Disassembling the first crawler carrier **3.01 - 43, 3.01 - 45**
Disassembling the F-jib **5.13.20 - 47**
Disassembling the F-jib — disassembly variants **5.13.20 - 49**
Disassembling the guy rods and folding in the folding platforms **5.39 - 65**
Disassembling the guy rods on the suspended ballast guide **5.36.10 - 67**
Disassembling the lattice sections **5.13.20 - 52**

Disassembling the lattice sections on a luffing lattice jib **5.01 - 41**
Disassembling the lattice sections on an auxiliary boom with an auxiliary crane **5.01 - 45**
Disassembling the lattice sections on an auxiliary boom without an auxiliary crane **5.01 - 49**
Disassembling the pivot section **5.36.10 - 74**
Disassembling the railing on the D-pivot section **5.05 - 51**
Disassembling the roller set **5.14 - 7**
Disassembling the S/SL boom **5.38 - 42**
Disassembling the S-boom **5.39 - 67**
Disassembling the second crawler carrier **3.01 - 47**
Disassembling the S-intermediate section **5.38 - 52**
Disassembling the S-intermediate sections in „flying“ mode **5.38 - 51**
Disassembling the S-lattice sections **5.38 - 51, 5.38 - 57**
Disassembling the S-lattice sections („open“ boom) **5.38 - 55**
Disassembling the SLD / SD-boom **5.39 - 57**
Disassembling the S-pivot section **5.38 - 59**
Disassembling the suspended ballast guide * **5.36.10 - 67**
Disassembling the suspended ballast guide on the turntable frame **5.36.10 - 71**
Disassembling the suspended ballast pallet **5.36.10 - 61**
Disassembling the SWF-booms **5.17 - 23**
Disassembling the turntable extension **4.07.10 - 14**
Disassembling the turntable extension on the turntable **4.07.10 - 19**
Disassembling the WA-frame 2 guy rods **5.07 - 49, 5.08 - 27**
Disassembling the W-boom system **5.07 - 37**
Disassembling the W-guy rods **5.07 - 45**
Disassembling the W-lattice jib **5.07 - 45**
Disassembling the W-lattice section **5.07 - 45**
Disassembling the W-transport unit 1 **5.07 - 55**
Disassembling the W-transport unit 2 **5.07 - 55**
Disassembling the W-transport unit 3 **5.07 - 55**
Disassembling the W-transport units **5.07 - 53, 5.08 - 27**
Disassembling the WV-boom system **5.08 - 19**
Disassembling the WV-lattice jib **5.08 - 27**
Disassembly **3.02 - 11, 5.36.10 - 57**
Disassembly D-boom **5.05 - 33**
Disassembly of boom systems on ascending terrain **5.01 - 62**
Disassembly of boom systems on descending terrain **5.01 - 65**
Disassembly of crawler carrier with the auxiliary crane **3.01 - 19**
Disassembly of the crawler carrier with SA-frame **3.01 - 39**
Disassembly variant V1 **5.13.20 - 49**
Disassembly variant V2 **5.13.20 - 49**

Disassembly variant V2 — Disassembling the F-jib completely as the F-assembly unit with the F-end section (maximum length 12m) **5.13.20 - 59**

Disassembly variation V1 — Disassembling the F-jib in parts **5.13.20 - 52**

Disconnecting the connections of the central lubrication system to winch 1 **3.07 - 15**

Disconnecting the connections to winch 1 **3.07 - 15**

Disconnecting the electrical and hydraulic connections between the D-end section and the D-pivot section **5.05 - 45**

Disconnecting the electrical connections **5.07 - 43, 5.08 - 27, 5.13 - 43, 5.13.20 - 51, 5.17 - 31, 5.42 - 27**

Disconnecting the electrical connections on the boom **5.38 - 48, 5.39 - 63**

Disconnecting the electrical connections to winch 1 **3.07 - 15**

Disconnecting the electric connection to the crawler travel gears **3.01 - 43**

Disconnecting the hydraulic and electrical connections to the crawler travel gear **3.01 - 21**

Disconnecting the hydraulic connection on the boom **5.38 - 48, 5.39 - 63**

Disconnecting the hydraulic connections **6.05 - 13, 6.05 - 17, 6.05 - 23, 6.05 - 27, 6.05 - 31, 6.05 - 35**

Disconnecting the hydraulic connections to winch 1 **3.07 - 15**

Disconnecting the hydraulic connection to the crawler travel gears **3.01 - 43**

Disconnect the electrical connections **3.05 - 13**

Disconnect the hydraulic connections. **3.05 - 13**

Disengage / engage the coupling control on the pump distributor gear **4.03 - 25**

Disengage the coupling control **4.03 - 25**

Display area of load chart values **4.02 - 19**

Display current support forces **4.02 - 201**

Displays in the crane operation program **4.02 - 207**

Disposal **7.01 - 10**

Distortions and mechanical damage **8.04 - 8**

Distribution of surface pressure **4.10 - 6**

Documentation of rope condition **7.05.50 - 11**

Documenting inspection results **8.04 - 5**

Documenting the completed inspection **8.03 - 4**

Documenting the inspection **8.06 - 5**

Documenting the inspections in writing **2.06 - 25**

D-pivot section 9.5m **1.03 - 15**

Draining the fuel pre-filter **7.05 - 7**

Drive **1.02 - 3**

Driver's cab and crane cab **7.01 - 9**

Driving / swinging in specified direction **2.04 - 55**

Driving from the crane operator's cab **4.10 - 1**

Driving the crawler **4.10 - 31, 5.36.10 - 56**

Driving the crawler crane **4.10 - 21**

Driving the crawler forward and backward **4.10 - 35**

Driving uphill / downhill **4.10 - 11**

Driving with a load and / or Derrick ballast **4.10 - 8**

Driving with an extremely reduced load **2.04 - 61**

Driving with a reduced load **2.04 - 61**

Driving with a trailer **2.04 - 61**

Driving without a load and without derrick ballast **4.10 - 9**

Driving with the ballast trailer **5.35.10 - 57**

Ductile deformation **8.15 - 4**

Dynamic utilization bar **4.02 - 65**

E

Effects of heat, arcs **7.05.50 - 10, 8.04 - 25**

Electrical connections **3.01 - 17, 3.01 - 21**

Electrical system **1.02 - 4**

Electrical system - Lighting **7.05 - 35**

Elongation **8.15 - 4**

Emergency crane cab exit **2.04 - 7**

Emergency equipment **4.01 - 3**

Emergency exit **2.04 - 6**

Emergency exit - driver's cab **2.04 - 6**

Emergency exit through front window **2.04 - 7**

Emergency exit through the roof window **2.04 - 7**

Emergency exit with EMERGENCY hammer * **2.04 - 8**

Emergency operation **6.05 - 3**

Emergency operation - circular travel **5.35.10 - 115**

Emergency operation LICCON overload protection (crane without CE mark) **4.02 - 99**

Emergency operation LICCON overload protection (EN 13000:2010 active) **4.02 - 97**

Emergency operation of ballast trailer **5.35.10 - 109**

Emergency operation of slewing gear(s) with assembly plate Variation 1 (V1) **6.05 - 15**

Emergency operation of winch 4 (W IV) on the LR1600/2 and LR1600/2-W **6.05 - 33**

Emergency operation of winch 4 on the LR1600/2 and LR1600/2-W **6.05 - 11, 6.05 - 19**

Emergency operation of winches, individual operation **6.05 - 21**

Emergency operation of winches, parallel operation winch 11I2 **6.05 - 23**

Emergency operation slewing gear(s) with assembly plate(s) Variation 2 (V2) **6.05 - 29**

Emergency operation - towing **5.35.10 - 111**

Emergency operation winch 4 (WIV) **6.05 - 33**

Emergency operation winches **6.05 - 11**

Emergency operation with a defective CPU **5.35.10 - 109**

Emergency operation with assembly plate(s) Variation 2 (V2) **6.05 - 19**

Emergency operation with assembly plate Variation 1 (V1) **6.05 - 9**

Emergency stop (quick stop) **2.04 - 53**

EMERGENCY STOP switch / EMERGENCY OFF switch **4.04 - 17**

Emergency take-down **6.05 - 1**

Endangering air traffic **2.04 - 5**

Ending crane operation **2.04 - 68**

Ending emergency operation **6.05 - 37**

Ending the load lift to avert emergency situations **7.15 - 27**
End operation, no longer follow my instructions **2.04 - 53**
End section **5.36.10 - 5**
Engaging the auxiliary heater **6.02 - 18**
Engaging the coupling control **4.03 - 27**
Engine coolant **7.05 - 5**
Engine does not start **7.15 - 17**
Engine monitoring **4.03 - 31**
Engine monitoring icons **4.02 - 215**
Engine oil **7.05 - 3**
Engine preheating **2.08 - 4**
Engine type D 846 A7 **1.02 - 3**
Engine type D 856 A7 SCR **1.02 - 4**
Enlarged rope end connection **8.04 - 14**
Entering and exiting with a retractable / extendable step **2.04 - 17**
Enter the hook block weight **4.02 - 55**
Equipment and spare parts **0.01 - 7**
Equipment in the cab **4.01 - 3**
Erecting / taking down **5.01 - 67**
Erecting / taking down for crawler cranes **5.01 - 68**
Erecting / taking down for mobile cranes **5.01 - 67**
Erecting / taking down the boom **5.10 - 11**
Erecting the D-boom **5.05 - 27**
Erecting the erection racks **5.36.10 - 32**
Erecting the FA-frame **5.13.20 - 17, 5.13.20 - 27, 5.13.20 - 36, 5.13.20 - 42**
Erecting the SA-frame **5.02 - 5**
Erecting the S-boom **5.38 - 39**
Erecting the SL-boom **5.42 - 15**
Erecting the SLF-boom **5.13 - 25**
Erecting the SWF-booms **5.17 - 11**
Erection **5.42 - 19**
Error diagnostics by phone **7.15 - 12**
Error diagnostics without the help of Liebherr Service **7.15 - 10**
Error diagnostics with the help of Liebherr Service **7.15 - 12**
Error message in the LICCON monitor **7.15 - 10**
Error messages **4.02 - 5**
Error messages by the LICCON computer system **4.04 - 11**
Error messages LICCON monitor **7.15 - 9**
Error messages via LED on components **7.15 - 9**
Establishing the connections of the central lubrication system to winch 1 **3.07 - 11**
Establishing the connection to the turntable **3.07 - 11**
Establishing the electrical connection between the boom nose and the SW-end section **5.10 - 9**
Establishing the electrical connection from the ballast trailer to the turntable **5.35.10 - 15**
Establishing the electrical connections to winch 1. **3.07 - 11**
Establishing the electrical connection to the crawler travel gears **3.01 - 37**

Establishing the electrical connection to the hoist limit switch **5.10 - 9**
Establishing the electrical connection to the pressure test bracket **5.10 - 9**
Establishing the electric and hydraulic connections on the D-end section **5.05 - 24**
Establishing the electric and hydraulic connections on the D-pivot section **5.05 - 12**
Establishing the electric and hydraulic connections on the S-pivot section **5.38 - 16, 5.39 - 16**
Establishing the hydraulic and electrical connections to the crawler travel gear **3.01 - 17**
Establishing the hydraulic connection from the ballast trailer to the turntable **5.35.10 - 15**
Establishing the hydraulic connections **5.05 - 12, 5.05 - 24, 5.38 - 17, 5.39 - 17, 6.05 - 7**
Establishing the hydraulic connections to the winch **6.05 - 11, 6.05 - 21**
Establishing the hydraulic connections to the winches **6.05 - 25**
Establishing the hydraulic connections to winch 1 **3.07 - 11**
Establishing the hydraulic connections to winch 4 (WIV) **6.05 - 33**
Establishing the hydraulic connection to the crawler travel gears **3.01 - 37**
Establishing the hydraulic connection to the slewing gears **6.05 - 15, 6.05 - 29**
Establishing the hydraulic connection to the turntable **3.02 - 9**
Establish the hydraulic connections. **3.05 - 11**
Evaluating oil color **8.03 - 3**
Even reduction of rope diameter **8.04 - 14**
Example **8.03 - 9**
Example for crane on crawler with derrick boom, suspended ballast and long (main) boom system **2.04 - 34**
Example for crane on crawler with derrick boom, suspended ballast and short (main) boom system **2.04 - 34**
Example for crane on supports **2.04 - 35**
Example for test points **8.01 - 7**
Examples for the load bearing capacity of the ground **2.04 - 32**
Examples of possible defects in hose lines **7.05 - 14**
Exceedance of maximum value test point 1 (force F1) in crane operation **4.20 - 37, 4.20 - 85**
Exceedance of the maximum permissible load moment **4.20 - 33, 4.20 - 81**
Exceeding the LICCON overload protection for assembly **5.05 - 7, 5.38 - 15, 5.39 - 15**
Exceeding the shut off limits of the LICCON overload protection **4.02 - 95**
Exceeding the shut off limits of the LICCON overload protection during erection / take down procedures (assembly operation) **4.20 - 45, 4.20 - 93**
Exhaust emissions **2.04 - 3**
Exhaust system **7.01 - 9**
Extending the boom **2.04 - 59**

Extending the D-relapse cylinder **5.05 - 28**
Extending the S-relapse cylinder **5.42 - 17**
Extending the S-relapse cylinders **5.38 - 40, 5.39 - 53**
Extending the support cylinders **5.35.10 - 101**
External corrosion **8.04 - 17**

F

F1-assembly maximum force **4.02 - 139**
Failure of hydraulic, electric or engine **7.15 - 21**
Failure of sensor / limit switch **4.02 - 81**
Failure of the overload protection **4.04 - 5**
Fall protection equipment on the counterweight brackets **2.06 - 13**
Fall protection equipment on the crane chassis **2.06 - 5**
Fall protection equipment on the crane operator's cab **2.06 - 9**
Fall protection equipment on the crane superstructure **2.06 - 11**
Fall protection equipment on the pivot sections and lattice mast boom **2.06 - 19**
Fall protection equipment on the turntable extension **2.06 - 15**
Fan / blower adjustment **6.02 - 9**
F-assembly conditions **5.17 - 9**
F-assembly unit **1.03 - 13, 5.13.20 - 5, 5.13.20 - 8**
F-assembly unit, see illustration 1 **5.13 - 3, 5.17 - 3**
Fastening **2.04 - 22**
Fastening device **2.04 - 71**
Fastening point for end section **2.05 - 15**
Fastening points D-end section **5.05 - 4**
Fastening points D-intermediate section 2420.16 6m **5.05 - 4**
Fastening points D-intermediate section 2420.20 12m **5.05 - 3**
Fastening points D-pivot section **5.05 - 3**
Fastening points for the F-jib **5.13.20 - 5**
Fastening points LI-intermediate sections 2420.10Z, 12m **5.38 - 5, 5.39 - 5**
Fastening points S-intermediate sections 2825.20, 12m FLM for flying assembly **5.38 - 5, 5.39 - 5**
Fastening points S-intermediate sections 2825.20, 6m **5.38 - 4, 5.39 - 4**
Fastening points S-intermediate sections 2825.25, 12m **5.38 - 4, 5.39 - 4**
Fastening points S-intermediate sections 2825.25, 3m **5.38 - 3, 5.39 - 3**
Fastening points SL-reducer **5.38 - 6, 5.39 - 6**
Fastening points S-pivot section **5.38 - 3, 5.39 - 3**
Fastening points W-transport units **5.07 - 3**
Fastening positions for assembling / disassembling of the lattice jib **5.01 - 30**
Fastening the hoist rope **4.06 - 17**
Fastening the load **4.08 - 7**
Fastening the load hook * **4.06 - 16**
Fast mode (Rapid gear) **4.02 - 101**
F-connector head **1.03 - 12**

F-connector head on the boom end **5.13 - 9**
F-end section **1.03 - 14, 5.13.20 - 4, 5.13.20 - 7**
F-end section, see illustration 2 **5.13 - 3, 5.17 - 3**
Filling the grease container **7.04 - 11**
Filling the grease container of the central lubrication system **7.05 - 25**
Filling the lubrication lines **7.05 - 25**
Filling the windshield washer system **4.03 - 21**
Fill quantities **7.06 - 3**
Fill quantities, lubrication schedule **7.06 - 1**
Fill quantities crane superstructure **7.06 - 5**
Fill quantities for crawler chassis **7.06 - 3**
F-intermediate section 12m **5.13.20 - 4, 5.13.20 - 7**
F-intermediate section 12m, 1916.06 **1.03 - 14**
F-intermediate section 6m **5.13.20 - 3, 5.13.20 - 6**
F-intermediate section 6m, 1916.06 **1.03 - 14**
F-intermediate sections 6m and 12m, see illustration 3 **5.13 - 3, 5.17 - 3**
First aid measures after rescue **2.04 - 16**
First inspection (first year) **8.03 - 9**
Fitting the hoist rope on the rope lock, L-shaped rope end connection **4.06 - 14**
Fixtures in cabinet **4.01 - 31**
F-jib **5.13.20 - 8**
Flap of oscillating safety 2 on collision with mechanical relapse support 1 **8.12 - 13**
Flattening **7.05.50 - 7**
Flattenings **8.04 - 25**
Floating device **2.25 - 3**
Floating device, non-supported/non-jacked up **2.25 - 4**
Floating device, supported/jacked up **2.25 - 4**
Flying assembly / disassembly of lattice sections **5.01 - 55**
Flying assembly of F-auxiliary jib (12m) **5.13 - 17, 5.17 - 9**
Flying assembly of lattice sections **5.01 - 55**
Flying assembly of the SD/SLD/SL(X)D-boom (guying on flying assembly intermediate section) **5.39 - 27**
Flying disassembly of lattice sections **5.01 - 57**
Folding platform operating position **2.06 - 20**
Folding platform transport position **2.06 - 20**
Folding the consoles into the transport position **5.36.10 - 73**
Folding the consoles into working position **5.36.10 - 24**
Force distribution when driving on pressure distributor plates **4.10 - 25**
Force F1 (test point 1) between guying SA-frame and the derrick end section **5.35.10 - 77**
Force F1 (test point 1) guying of SA-frame - derrick end section **5.36.10 - 46**
Force F4/F5 (test point 4/5) in the guying derrick ballast - derrick end section **5.35.10 - 77, 5.36.10 - 47**
For cranes with pneumatic boom locking system **8.01 - 79**
For cranes with telescopic boom system Telematik **8.01 - 80**
Foreword **90.01 - 3**

Foreword to attachment **90.01 - 1**
F-pivot section **5.13.20 - 3, 5.13.20 - 6**
Frame **1.02 - 3, 1.02 - 3**
F-relapse support **5.13.20 - 34**
Friction corrosion **8.04 - 19**
Fuel pre-filter **7.05 - 7**
Functional selection on the assembly plate **6.05 - 9**
Function check before lifting the derrick bal-
last **5.36.10 - 41**
Function check of limit switch initiators on the mecha-
nical relapse retainer **8.12 - 11**
Function key line **4.02 - 169, 4.02 - 207, 4.02 - 215**
Function key line in the set up program **4.02 - 25**

G

General checks **4.03 - 11**
General controls before crane operation **5.01 - 5**
General danger notes **6.05 - 5**
General information **8.01 - 3**
General information line **4.02 - 17**
General safety technical guidelines **2.04 - 1**
General safety technical notes for operation with bal-
last trailer **2.15 - 1**
Getting the control rope with assembly rope **5.07 - 13**
Gravity actuated relapse retainer **4.04 - 19**
Grommets and rope end connections **8.16 - 5**
Ground connection **1.01 - 7**
Grounding **2.04 - 39**
Grounding the crane **2.04 - 39**
Grounding the load **2.04 - 40**
Ground pressure **1.03 - 20**
Guide complete for ballast trailer **1.03 - 18**
Guide with adapter complete, for ballast trailer **1.03 - 19**
Guiding crane structures, lattice sections or crane
components **5.01 - 24**
Guiding the load **4.08 - 13**
Guying the pivot section in flying mode with the der-
rick boom **5.01 - 59**
Guying the pivot section in flying mode with the SA-
frame **5.01 - 57**
Guying the S-boom in „flying mode“ **5.38 - 52**
Guy rods **5.01 - 8**
Guy ropes **1.03 - 22**

H

Handling of assembly plates **6.05 - 7**
Handling of hook blocks **5.19 - 5**
Hand signals **2.04 - 52**
Hand signals for guidance **2.04 - 52**
Hard hat **2.04 - 12**
Hearing protection **2.04 - 13**
Heated crane components **2.04 - 4, 2.04 - 22**
Heater / engine preheating / Air conditioning system
Crane operator's cab **6.02 - 1**
Heating the crane cab **6.02 - 3**
Height dependant wind speed **2.04 - 46**

Height rescue system **2.04 - 11**
Hoist gear, hoist rope **2.04 - 65**
Hoist gear 1 to 6, illustration 1 **7.05 - 29**
Hoist limit switch „Hoist top“ **4.04 - 11**
Hoist ropes **1.03 - 21**
Hoist top limit switch HES1 **4.02 - 83**
Hoist top limit switch HES2 and HES3 **4.02 - 85**
Holding the luffing lattice jib **5.01 - 33**
Hook block / load hook **7.06 - 13**
Hook block overview **5.19 - 5**
Hook blocks **5.19 - 1**
Hooking the hoist rope on the rope lock **4.06 - 10**
Horizontal movements **2.04 - 55**
HS auxiliary jib **5.42 - 1**
HSDBW/B // HSLDB/BW // HSL2DBW/B-boom com-
binations **1.01 - 24**
HSDWBW/B // HSDWVB/BW-boom combinati-
ons **1.01 - 26**
HSL2DFB/BW // HSL4DFB/BW-boom combinati-
ons **1.01 - 28**
Hydraulic aggregate on the crawler **5.30 - 5**
Hydraulic aggregate on wheels **5.30 - 4**
Hydraulically adjustable auxiliary boom **2.04 - 65**
Hydraulic connections **3.01 - 17, 3.01 - 21**
Hydraulic hose lines **7.04.50 - 3, 7.05 - 13**
Hydraulic oil, diesel fuel, operating fluids **2.04 - 4**
Hydraulic oil level **5.30 - 3**
Hydraulic safety valves **4.04 - 19**
Hydraulic system **7.05 - 11**
Hydraulic tank **7.05 - 11**

I

Identification of sliding beam **2.05 - 37**
Identifications on auxiliary weights **2.05.10 - 5**
Identifications on auxiliary weights at deli-
very **2.05.10 - 5**
Identifications on auxiliary weights for reor-
der **2.05.10 - 6**
Identifications on single hook or double
hook **2.05.10 - 4**
Identifications on the hook block or load
hook **2.05.10 - 3**
Identification Track width retracted **2.05 - 38**
Illustration **8.12 - 5**
Impact protection **5.01 - 14**
Importance of inspection **8.04 - 3**
Improper mechanical damage **8.04 - 25**
Increased corrosion **2.25 - 5**
Increase the hook block weight **2.08 - 6**
Increasing and decreasing the engine rpm with the
button **4.05 - 7**
Increasing the engine rpm via the pedal **4.05 - 7**
Increasing the hook block weight **4.08 - 18**
Increasing the reeving number **4.08 - 18**
Indicator lights of the central lubrication sys-
tem **7.05 - 21**
Indicator lights on the BKE „363“ **4.01 - 11**
Input window hook block weight **4.02 - 53**

Inserting the retaining pins **5.36.10 - 61**
 Inspecting and monitoring the load hook **8.05 - 3**
 Inspecting ladders **8.17 - 3**
 Inspecting safety ropes and anchor points **2.06 - 25**
 Inspecting the fiber guy ropes **8.16 - 4**
 Inspecting the gear brakes **8.03 - 4**
 Inspecting the hoist and retracting winches **8.03 - 3**
 Inspecting the hydraulic hose lines for damage **8.06 - 4**
 Inspecting the hydraulic hose lines for leaks **8.06 - 5**
 Inspecting the lattice sections **8.01 - 78**
 Inspecting the pin connections **8.01 - 87**
 Inspecting tires and disk wheels **2.15 - 4**
 Inspection **8.15 - 3, 8.16 - 4**
 Inspection before start up **2.04 - 69**
 Inspection chart for cranes **8.90 - 1**
 Inspection chart for recurring inspections of Liebherr cranes **8.90 - 3**
 Inspection form for the inspection of ladders and steps **8.17 - 4**
 Inspection intervals **8.03 - 3, 8.05 - 3, 8.06 - 3, 8.15 - 3, 8.16 - 4, 8.17 - 3**
 Inspection of accumulator pressure in anti-tilt cylinder **8.14 - 1**
 Inspection of carrier rollers **8.01 - 85**
 Inspection of carrying crane structures, especially steel structures **8.01 - 4**
 Inspection of change over pulleys, illustration 2 **8.01 - 90**
 Inspection of crane wire ropes **8.04 - 1**
 Inspection of diaphragm reservoir **8.01 - 84**
 Inspection of extension conditions of sliding beams **8.01 - 87**
 Inspection of fastening equipment **8.01 - 84**
 Inspection of fiber guy ropes **8.16 - 1**
 Inspection of guy rods **8.15 - 1**
 Inspection of hydraulic hose lines **8.06 - 1**
 Inspection of ladders **8.17 - 1**
 Inspection of load handling equipment and assembly aids **8.01 - 83**
 Inspection of load hooks **8.05 - 1**
 Inspection of locking system of telescopic boom **8.01 - 79**
 Inspection of relapse cylinders **8.01 - 84**
 Inspection of rope pretension on lattice sections, illustration 2 **8.01 - 83**
 Inspection of rope pulleys **8.01 - 85**
 Inspection of safety ropes and anchor points **8.01 - 81**
 Inspection of safety switching on the relapse supports **8.12 - 1**
 Inspection of slewing ring connection **8.01 - 87**
 Inspection of the auxiliary reeving winch, recovery winch and spare wheel winch **8.03 - 4**
 Inspection of the function of the overload protection **8.01 - 87**
 Inspection of the mounting of the load bearing equipment **8.01 - 88**

Inspection of the oil and fuel tanks **8.01 - 90**
 Inspection of the safety controls on the relapse cylinders **8.01 - 85**
 Inspection of the tele extension with eccentric, illustration 1 **8.01 - 89**
 Inspection of winches **8.03 - 1**
 Inspection sheet and check list **8.17 - 3**
 Installations in the cab **4.01 - 3**
 Installing / removing the pulley cart **5.61 - 5**
 Installing a double hook block for parallel operation **5.19 - 17**
 Installing a double hook block for single operation **5.19 - 7**
 Installing the adapter for the ballast trailer on the turntable **5.05 - 27**
 Installing the assembly supports **3.01 - 5, 3.01 - 7**
 Installing the auxiliary guying **5.03 - 7**
 Installing the auxiliary jib „HS“ **5.42 - 5**
 Installing the auxiliary jib „HS“ on the SL-boom **5.42 - 5**
 Installing the auxiliary jib „HS“ on the SW-end section **5.42 - 9**
 Installing the auxiliary weights **5.19 - 9, 5.19 - 19, 5.19 - 29**
 Installing the battery **7.05 - 37**
 Installing the block connector **5.19 - 17**
 Installing the central ballast **3.03 - 7**
 Installing the console **3.03 - 9**
 Installing the consoles with placed central ballast plates **3.03 - 9**
 Installing the counterweight **4.07 - 6**
 Installing the D-lattice sections on the D-pivot section **5.05 - 15**
 Installing the front and rear platforms **2.06 - 5**
 Installing the hook block **5.19 - 7, 5.19 - 17**
 Installing the mechanical auxiliary support **3.04 - 3**
 Installing the platform **2.06 - 9**
 Installing the pulley block on cross brace **5.19 - 7**
 Installing the pulley blocks on the cross brace **5.19 - 17**
 Installing the pulley cart **5.61 - 5**
 Installing the single blocks **5.19 - 29**
 Installing the steps **2.06 - 7**
 Installing the turntable **3.02 - 7**
 Installing the wedge lock **4.06 - 22**
 Instructions for resuming crane movements for cranes with CE mark **4.20 - 7**
 Instructions for resuming crane movements for cranes without CE mark **4.20 - 55**
 Instrument panel **4.01 - 17**
 Interfaces **4.01 - 5**
 Interior equipment **4.01 - 5**
 Intermediate lubrication of crawler carriers **7.04 - 15**
 Intermediate sections **5.36.10 - 6**
 Internal corrosion **8.04 - 19**
 Interrupting crane operation **2.04 - 65**
 Intervals **7.05.50 - 11, 8.04 - 4**

J

Job planning **2.03 - 1**

K

Key button „Ballast trailer lifted off“ **5.35.10 - 65**

Kinking, rope loops (grommets) pulled closed **7.05.50 - 9**

Kinking or rope loops pulled closed **8.04 - 23**

L

Labeling of load lifting equipment **2.05.10 - 1**

Ladder access **2.04.10 - 9**

Ladder inspection **2.04.10 - 8**

Ladders **2.04.10 - 1, 7.01 - 9, 7.04 - 29**

Ladder safeguards **2.04.10 - 9**

Latch **5.01 - 19**

Lattice mast boom **7.05.50 - 3**

Lattice sections **2.04 - 21**

LD/SLD/SD-boom combination **5.39 - 1**

Lead and lead compounds **2.04 - 3**

Leaning (extension) ladder **2.04.10 - 13**

Leaning (extension) ladder with transition **2.04.10 - 15**

Legal prerequisites **2.04 - 69**

Lengths of crawler track with superstructure **1.03 - 4**

Leveling instrument in the BTT **4.04 - 9**

Leveling instruments **4.04 - 9**

Leveling instruments in the LICCON monitor **4.04 - 9**

LICCON computer system **4.01 - 9, 4.02 - 1, 4.04 - 3, 4.05 - 3**

LICCON computer system after engine start **4.03 - 35**

LICCON computer system boot up **4.02 - 7**

LICCON computer system in stand-by mode **4.02 - 217**

LICCON job planner **2.04 - 33**

LICCON monitor **7.15 - 19**

LICCON Monitor 0 **4.02 - 9**

LICCON Monitor 1 **4.02 - 9**

LICCON overload protection **4.04 - 3, 5.35.10 - 73, 5.36.10 - 45**

Liebherr Service **7.01 - 8**

Lifting, illustration 1 **4.03 - 45**

Lifting / lowering a load **4.05 - 13**

Lifting / lowering a load with even speed **2.04 - 54**

Lifting / lowering the derrick ballast using the instrument panel **5.36.10 - 43**

Lifting / lowering the derrick ballast using the radio remote control BTT-E **5.36.10 - 44**

Lifting above ground level, illustration 2A **4.03 - 45**

Lifting a load with two cranes **2.04 - 49**

Lifting and lowering the ballast trailer with the pull cylinders **5.35.10 - 33**

Lifting and lowering the derrick ballast using the pull cylinders **5.36.10 - 42**

Lifting below ground, illustration 3 **4.03 - 45**

Lifting of personnel **2.04 - 68**

Lifting slowly **2.04 - 54**

Lifting the ballast trailer **5.35.10 - 33**

Lifting the ballast trailer with the support cylinders **5.35.10 - 43, 5.35.10 - 47, 5.35.10 - 49, 5.35.10 - 55, 5.35.10 - 111, 5.35.10 - 115**

Lifting the boom **2.04 - 58**

Lifting the boom and lower the load at the same time **2.04 - 60**

Lifting the crawler center section **3.01 - 9**

Lifting the derrick ballast **5.36.10 - 43**

Lifting the load **4.08 - 11**

Lifting the SL-boom off the ground **5.42 - 11**

Lifting winch 1 from the flatbed trailer **3.07 - 7**

Lifting with auxiliary winch **2.04 - 58**

Lifting with main winch **2.04 - 58**

Lift the crawler track **3.01 - 23**

Lift the turntable from transport vehicle **3.02 - 5**

Light and / or heavy work **2.04.10 - 10**

LI-intermediate section 12m **1.03 - 11**

LI-intermediate section 6m **1.03 - 10**

Limit sign auxiliary boom / accessory **4.02 - 77**

Limit signs main boom **4.02 - 73**

Limit switch Boom system **4.04 - 21**

Limit switch D-boom, relapse cylinder **5.05 - 25**

Limit switch winch spooled out **4.04 - 13**

Linch pin **5.01 - 17**

LMB STOP / Engine monitoring STOP **4.02 - 91**

Load bearing crane structures **2.08 - 7**

Load burdens on the ground on cranes on crawlers **2.04 - 31**

Load burdens on the ground on cranes on supports **2.04 - 31**

Load display **4.03 - 45**

Load handling equipment **1.03 - 20**

Loading the preassembled lattice jib **5.01 - 36**

Load min / max **4.02 - 175**

Loads on the ground due to crane operation **2.04 - 31**

Load spectrum class: Heavy L3 **8.03 - 7**

Load spectrum class: Light L1 **8.03 - 6**

Load spectrum class: Medium L2 **8.03 - 6**

Load spectrum class: Very heavy L4 **8.03 - 7**

Load take-on with two auxiliary cranes **3.02 - 5**

Load take up on high rise, illustration 2B **4.03 - 45**

Load take-up with an auxiliary crane **3.02 - 3**

Load weighing **4.03 - 43**

Load weighing and load display **4.03 - 41**

Localized increase of rope diameter **7.05.50 - 6**

Localized increases of rope diameter **8.04 - 17**

Localized reduction of rope diameter **8.04 - 16**

Locking the engine rpm **4.05 - 7**

Loop formation **7.05.50 - 9, 8.04 - 22**

Lowering slowly **2.04 - 55**

Lowering the ballast trailer **5.35.10 - 33**

Lowering the ballast trailer with the support cylinders **5.35.10 - 43, 5.35.10 - 47, 5.35.10 - 51, 5.35.10 - 55, 5.35.10 - 113, 5.35.10 - 117**

Lowering the boom **2.04 - 59**

Lowering the boom and lift the load at the same time **2.04 - 60**
 Lowering the crawler center section to the support **3.01 - 49**
 Lowering the crawler track **3.01 - 17**
 Lowering the derrick ballast **5.36.10 - 43**
 Lowering the hook block **4.06 - 11, 4.06 - 15, 5.19 - 3**
 Lowering the hook block if slack rope forms **5.19 - 3**
 Lowering the load hook **4.06 - 18**
 Lowering the load while stationary **2.04 - 55**
 Lubricate the slewing ring connection **7.05 - 17**
 Lubricating ladders **7.04 - 30**
 Lubricating the gear ring and the slewing gear pinion **7.05 - 17**
 Lubricating the pin bores on the lattice sections and guy rods **7.05.50 - 3**
 Lubricating the rope **7.05.50 - 14**
 Lubrication schedule **7.06 - 7**
 Lubrication schedule - Crawler chassis **7.06 - 7**
 Lubrication schedule - Equipment **7.06 - 13**
 Lubrication schedule for crane superstructure **7.06 - 11**
 Lubrication schedule for crane support narrow crawler **7.06 - 9**
 Luffing in with suspended load **4.20 - 31, 4.20 - 79**
 Luffing the boom **4.05 - 23**
 Luffing the boom
 down **5.10 - 17, 5.19 - 3, 5.38 - 47, 5.39 - 61**
 Luffing the boom in S/SL/SLF/SL2DB/SDB/SDWV(B/BW) operating modes **4.05 - 23**
 Luffing the D-boom down **5.05 - 37**
 Luffing the derrick, for all D-operating modes **4.05 - 25**
 Luffing the lattice jib during SDWV(B/BW) operation **4.05 - 25**
 Luffing the lattice jib during SW/SDW(B/BW) operation **4.05 - 25**
 Luffing the main boom in operating mode SDW (B/BW) **4.05 - 23**
 Luffing the main boom in operating mode SW **4.05 - 23**
 Luffing the S-boom down **5.13.20 - 50**
 Luffing the SLF-boom down **5.13 - 37**
 Luffing the W-lattice jib down **5.07 - 41, 5.17 - 27**
 Luffing the WV-lattice jib down **5.08 - 23**
 Luff the boom down **5.42 - 25**

M

Machine related movements **2.04 - 58**
 Maintenance intervals - Crane superstructure **7.03 - 1**
 Maintenance **2.08 - 7, 7.04.50 - 3**
 Maintenance and inspection schedule **7.02 - 3, 7.02.50 - 3, 7.03 - 3, 7.03.50 - 3**
 Maintenance and service - General **7.01 - 1**
 Maintenance guidelines - Crane boom **7.05.50 - 1**
 Maintenance guidelines - Crane chassis **7.04 - 1**

Maintenance guidelines - Crane superstructure **7.05 - 1**
 Maintenance intervals **7.01 - 3**
 Maintenance intervals / maintenance instructions for the ballast trailer **5.35.10 - 117**
 Maintenance intervals ballast trailer **7.02.50 - 1**
 Maintenance intervals - Crane boom **7.03.50 - 1**
 Maintenance intervals Crawler chassis **7.02 - 1**
 Maintenance of hose lines **7.05 - 15**
 Making adjustments semi-automatically in the „Climate control settings“ menu **6.02 - 15**
 Manual heating mode **6.02 - 12**
 Manual operation for assembly **5.35.10 - 55**
 Manual rope winches **5.01 - 7**
 Manufacturer **0.01 - 1**
 Maximum load **4.02 - 61**
 Maximum load according to load chart and reeving **4.02 - 5**
 Maximum permissible ground unevenness **5.35.10 - 61**
 Maximum sound power level **2.05 - 26**
 Measurement of wind speed **2.04 - 44**
 Measures for defective components **7.15 - 21**
 Measures in clear problem cases **7.15 - 15**
 Mechanical auxiliary support **1.03 - 4, 3.04 - 1**
 Menu „Climate control settings“ **6.02 - 3**
 Minimum / maximum support forces **4.20 - 24, 4.20 - 72**
 Minimum rope coils **5.01 - 3**
 Minimum rope reeving / minimum hook block weight **2.05 - 42**
 Mixing battery acid **7.05 - 36**
 Mobile cranes **2.04 - 21**
 Monitored auxiliary functions for crane operation **4.02 - 103**
 Monitoring function reports a problem **7.15 - 15**
 Monitoring mode / control mode **4.02 - 197**
 Monitoring of crane movement **4.20 - 17, 4.20 - 65**
 Monitoring of maximum load on the LICCON monitor 0 **5.35.10 - 81, 5.36.10 - 50**
 Monitoring of minimum force F1 **5.35.10 - 79, 5.36.10 - 48**
 Monitoring of relapse cylinders **4.02 - 119**
 Monitoring of test point 1-operational maximum force (= F1max operation) **5.35.10 - 81, 5.36.10 - 50**
 Monitoring support beams * **4.02 - 195**
 Monitoring the winches **8.03 - 5**
 Monitors and displays **4.01 - 9**
 Movement on the crane **2.04 - 6**
 Move the selector arrow to the left **4.02 - 47**
 Move the selector arrow to the right **4.02 - 47**
 Move the winch selector „down“ **4.02 - 51**
 Move the winch selector „up“ **4.02 - 51**
 Moving away from me **2.04 - 56**
 Moving both track chains **2.04 - 56**
 Moving one track chain **2.04 - 57**
 Moving the assembly support out **3.01 - 47**
 Moving the cab to the horizontal position **4.03 - 19**
 Moving toward me **2.04 - 56**

N

Narrow track crane **5.36.10 - 29, 5.36.10 - 69**
Narrow track crane: Standing levels at D36m with guide B2 **5.36.10 - 11**
Narrow track crane: Standing levels at D36m without guide **5.36.10 - 10**
Negative longitudinal incline (illustration 4 to 6) **4.10 - 17**
Noise emission **1.03 - 20**
No load chart is available **4.02 - 97**
Non-destined use **0.01 - 5, 2.25 - 3**
Non-rotating rope end connection **8.04 - 6**
Non-twisting ropes with rope end connections **8.04 - 6**
Note for assembly aid **2.05 - 5**
Notes to change the wheel sets **5.35.10 - 39**
Note Weight sliding beams **2.05 - 39**

O

Obligations of the crane operator **2.04 - 23**
Oil change **7.05 - 29, 7.05 - 31**
Opening the end section **5.01 - 32**
Opening the roof window **4.03 - 23**
Operating and control instruments on the crane superstructure **4.01 - 1**
Operating and monitoring instruments **4.01 - 3**
Operating buttons on the BKE „370“ **4.01 - 12**
Operating buttons on the BKE „385“ **4.01 - 14**
Operating conditions **2.25 - 3**
Operating console **4.01 - 11**
Operating elements crane operator's seat **4.01 - 27**
Operating elements for the crawler operation **4.10 - 27**
Operating elements Master switch (MS) 3 **4.01 - 27**
Operating elements of the LICCON computer system on monitor 0 **4.02 - 11**
Operating elements of the LICCON computer system on monitor 1 **4.02 - 135**
Operating elements on control platform **4.01 - 21**
Operating elements on the control panels **4.01 - 23, 5.35.10 - 7**
Operating elements on the operating and control unit (BKE) **4.01 - 11**
Operating errors: Did an alarm function occur? **7.15 - 19**
Operating errors in the set up program **4.02 - 35**
Operating fluids and lubricants **7.01 - 10**
Operating mode preselection on the LICCON computer system **4.02 - 7**
Operating modes with derrick boom **4.02 - 139**
Operating modes without derrick boom **4.02 - 139**
Operating the assembly winch **4.05 - 21**
Operating the engine-independent auxiliary heater **6.02 - 16**
Operating the touch display **6.02 - 4**
Operating the window washer system **4.03 - 21**

Operating the window wiper / window washer system **4.03 - 21**
Operating the window wipers **4.03 - 21**
Operating units in the cab **4.01 - 7**
Operating winch 1 - hoist winch **4.05 - 13**
Operating winch 2 - hoist winch **4.05 - 13**
Operating winch 6 - hoist winch **4.05 - 19**
Operating winch 6 in parallel operation of winch 1 and winch 2 **4.05 - 19**
Operating winch 6 in single operation of winch 1 and winch 2 **4.05 - 19**
Operational transverse pressure **8.04 - 26**
Optimizing measures for travel route **4.10 - 5**
Optional equipment and functions **0.01 - 7**
Other operating elements **4.02 - 131**
Overflow container, illustration 3 **7.05 - 29**
Overload monitoring in operating mode with derrick ballast **5.35.10 - 81, 5.36.10 - 50**
Overload protection (LMB) **4.02 - 5**
Overview components pulley cart **5.61 - 3**
Overview load chart for cranes with CE mark **4.20 - 7**
Overview load chart for cranes without CE mark **4.20 - 55**
Overview of acoustic / visual warnings for cranes with CE mark **4.20 - 9**
Overview of acoustic / visual warnings for cranes without CE mark **4.20 - 57**
Overview of boom nose components **5.10 - 3**
Overview of central lubrication system **7.05 - 19**
Overview of displays and component groups for error diagnostics **7.15 - 5**
Overview of the retaining elements **5.01 - 15**
Overview WV-lattice jib **5.08 - 3**

P

Paint / coating **8.15 - 4**
Parallel operation: Lifting / lowering a load **4.05 - 17**
Parallel travel **5.35.10 - 49**
Pedal carrier **4.01 - 29, 4.10 - 27**
Periodic crane inspections **8.01 - 1**
Permissible central ballast assemblies **3.03 - 5**
Permissible counterweight assemblies **4.07 - 5, 4.07.10 - 5**
Permissible turntable ballast - ballast combinations **3.06 - 3**
Personal protective equipment **2.04 - 8, 2.06 - 3, 7.05.50 - 4, 8.04 - 3**
Personnel **7.01 - 4**
Personnel and qualification **2.04 - 70**
Picking up and lowering overhead loads **4.08 - 18**
Picking up the fastening equipment **4.08 - 15**
Pin connections **5.01 - 11**
Pin intake gear winch 4 on turntable **3.05 - 9**
Pinning **3.02 - 9**
Pinning and unpinning the pin with pin pulling cylinder 2 **5.30 - 6**
Pinning and unpinning the pin with pin pulling cylinder 3 **5.30 - 7**

Pinning or unpinning pins **5.30 - 6, 5.30 - 7**
 Pinning procedure **5.35.10 - 19**
 Pinning the ballast trailer on the turntable **5.35.10 - 15**
 Pinning the collar pin **5.01 - 12**
 Pinning the D-pivot section on the SA-frame **5.05 - 11**
 Pinning the FAB-guy ropes with the lugs of the L-intermediate section **5.13.20 - 19**
 Pinning the guy rods on the S-pivot section **5.38 - 55**
 Pinning the pulley block on the pull test brackets **5.05 - 21**
 Pinning the Quick Connection **3.02 - 9**
 Pinning the relapse supports **5.07 - 17, 5.08 - 9**
 Pinning the S-intermediate section on the S-pivot section „on top“ **5.38 - 19**
 Pinning the S-pivot section on the turntable **5.38 - 15, 5.39 - 15**
 Pinning the strut on the ballast trailer **5.35.10 - 101**
 Pinning the suspended ballast guide on the turntable **5.36.10 - 25**
 Pinning the suspended ballast pallet on the D-guy rods **5.36.10 - 36**
 Pinning the suspended ballast pallet on the suspended ballast guide * **5.36.10 - 35**
 Pinning the upper pulley block on the S-pivot section **5.39 - 19**
 Pinning the upper pulley block with the lower pulley block **5.05 - 39**
 Pinning the W-transport units together **5.07 - 11**
 Pinning winch 1 with the turntable **3.07 - 9**
 Pin pulling device **5.30 - 1, 5.30 - 3, 5.30 - 4**
 Pin roller bearings. **3.05 - 7**
 Pin the SA-frame on the turntable **3.05 - 5**
 Pivot section **5.36.10 - 6**
 Place the pulley block into the transport receptacle on the D-pivot section **5.05 - 49**
 Placing a shorter crane rope **4.08 - 15**
 Placing the ballast plates, fastening points: Bitt **5.36.10 - 40**
 Placing the ballast plates, fastening system: „Twistlock“ **5.36.10 - 39**
 Placing the boom down **5.42 - 25**
 Placing the central ballast plates **3.03 - 11**
 Placing the central ballast plates, attachment points: Bitt **3.03 - 17**
 Placing the central ballast plates, attachment system: „Twist lock“ **3.03 - 13**
 Placing the counterweight plates **4.07 - 9, 4.07.10 - 8**
 Placing the counterweight plates, fastening points: Bitt **4.07 - 12, 4.07.10 - 11**
 Placing the counterweight plates, fastening system: „Twistlock“ **4.07 - 11, 4.07.10 - 10**
 Placing the hoist rope or the control rope **5.01 - 3**
 Placing the pulley block on the ground **5.05 - 41**
 Placing the SA-frame onto the turntable **5.02 - 11**
 Placing the turntable on the crawler center section **3.02 - 7**
 Placing the W-lattice jib down **5.07 - 39, 5.07 - 43**

Placing the WV-lattice jib down **5.08 - 21, 5.08 - 25**
 Planning Crane operation **2.03 - 3**
 Platform ladder **2.04.10 - 17**
 Platforms on the crane chassis **2.06 - 5**
 Pneumatic springs **5.01 - 7**
 Positive longitudinal incline (illustration 1 to 3) **4.10 - 15**
 Possible engine monitoring advance warning, warning and STOP events **4.02 - 211**
 Possible weighing errors **4.03 - 43**
 Power supply for the crane * **4.03 - 3**
 Pre-assembling the ballast trailer **5.35.10 - 10**
 Preface **0.01 - 1**
 Preheating the hydraulic oil **2.08 - 4**
 Preheating time **2.08 - 4**
 Preparatory work **5.30 - 6, 5.30 - 7**
 Prepare intake gear winch 4 for transport **3.05 - 15**
 Preparing the crawler carrier for assembly **3.01 - 13, 3.01 - 33**
 Preparing the crawler carrier for disassembly **3.01 - 23, 3.01 - 43**
 Preparing the hook block **4.06 - 9, 4.06 - 13**
 Preparing the hook block for crane operation **5.19 - 11, 5.19 - 21, 5.19 - 31**
 Preparing the hook block for removal **5.19 - 13, 5.19 - 23, 5.19 - 33**
 Preparing the roller bearings for transport **3.05 - 17**
 Preparing the rope pulley retainer for the assembly of the F-jib **5.13.20 - 16, 5.13.20 - 35**
 Prerequisites **2.04 - 70**
 Prerequisites for crane equipment and accessories **2.04 - 69**
 Prerequisites for driving / moving crawler cranes (crawler operation) **4.10 - 3**
 Prerequisites for driving on uphill / downhill slopes with boom angle adjustment **4.10 - 15**
 Prerequisites for driving on uphill / downhill slopes without boom angle adjustment **4.10 - 19**
 Prerequisites for driving under observation of the boom position **4.10 - 12**
 Prerequisites for driving with a load and / or derrick ballast **4.10 - 8**
 Prerequisites for driving without a load and without derrick ballast **4.10 - 10**
 Prerequisites for emergency operation **6.05 - 7**
 Prerequisites for lifting of personnel **2.04 - 68**
 Prerequisites for operation with lifting cage (cherry picker) **2.04 - 69**
 Presettings **5.35.10 - 73, 5.36.10 - 45**
 Pressed rope end connection **8.04 - 14**
 Pressure filters in the crane hydraulic **7.05 - 13**
 Pressure monitoring in extension cylinder **5.35.10 - 57**
 Pressure monitoring in the relapse cylinders **4.04 - 15**
 Pressure test of relapse cylinders **8.01 - 84**
 Pretensioning the hoist rope with pretensioning ballast with two hook operation **4.08 - 18**
 Preventing fires **7.01 - 5**

Priority acoustic signal **4.02 - 93, 4.02 - 179**
Problems in electrical connections of the crane **7.15 - 11**
Problems on pipes / hoses **7.15 - 11**
Problems on the mechanics / components of the crane **7.15 - 11**
Procedure **5.35.10 - 57, 6.05 - 37**
Procedure for fogged windows **6.02 - 15**
Procedure for shut off of crane movements **4.20 - 1**
Procedure in case of problems **7.15 - 1**
Procedure in case of slack rope **5.19 - 3**
Procedure to follow in case of a problem **7.15 - 3**
Product description **1.02 - 1**
Programming the auxiliary heater **6.02 - 20**
Protecting from aggressive environmental conditions **7.01 - 6**
Protecting from burns **7.01 - 5**
Protecting from scalding **7.01 - 6**
Protective gloves **2.04 - 13**
Protruding, distorted inlay, braiding **7.05.50 - 9**
Protruding, distorted insert or strand **8.04 - 21**
PSAgA, rescue equipment and tools **2.04 - 71**
Pull cylinder on block **5.35.10 - 77, 5.36.10 - 47**
Pulley cart **1.03 - 13, 5.61 - 1**
Pulley head height **4.02 - 71**
Pulley retainer and platforms on the SL-reducer **5.13.20 - 13**
Pulley set 300t **1.03 - 12**
Pulley set 320t **1.03 - 13**
Pulling the pulley block to the D-end section and placing it down **5.05 - 17**
Pump distributor gear **7.05 - 9**

Q

Qualification Inspection personnel **8.04 - 3**
Qualification Maintenance personnel **7.05.50 - 5**
Quick test Crane geometry **4.04 - 3**
Quick test EMERGENCY STOP switch / EMERGENCY OFF switch **4.04 - 17**
Quick test Hoist limit switch **4.04 - 11**
Quick test Leveling instrument **4.04 - 9**
Quick test Limit switch winch **4.04 - 15**
Quick test Overload protection **4.04 - 3**
Quick test Wind speed sensor **4.04 - 13**

R

Radii **5.35.10 - 5**
Radius **4.02 - 67**
Ram work or pulling sheet piles **4.08 - 14**
Recharging the battery **7.05 - 36**
Reduce rope pull **2.08 - 6**
Reducing rope unwinding **4.08 - 15**
Reduction of rope diameter **7.05.50 - 5**
Reeving in / reeving out the hook block, L-shaped rope end connection (LR 11000 only) **4.06 - 11**
Reeving in the hoist rope **4.06 - 5**

Reeving in the hoist rope with the assembly winch **4.06 - 6**
Reeving out the hook block **5.38 - 47, 5.39 - 62**
Reeving the hook block in and out **4.06 - 8**
Reeving the W-control rope in **5.07 - 13, 5.07 - 13, 5.08 - 9**
Regulating the engine rpm **4.05 - 7**
Relapse cylinder **5.01 - 6, 5.35.10 - 59**
Releasing the counterweight **4.07 - 16, 4.07.10 - 15**
Releasing the electrical connection from the ballast trailer to the turntable **5.35.10 - 105**
Releasing the engine rpm lock **4.05 - 9**
Releasing the F-relapse support **5.13.20 - 15, 5.13.20 - 25, 5.13.20 - 41**
Releasing the hydraulic connections from the ballast trailer to the turntable **5.35.10 - 105**
Remarks **4.02 - 201**
Remedying temporary errors during system start **7.15 - 15**
Remote diagnostics * **7.15 - 12**
Removal criteria Overview **8.04 - 8**
Remove the end section on the leaning ladder **2.04.10 - 10**
Remove the SA-frame from the turntable **3.05 - 19**
Removing and recharging the battery **7.05 - 36**
Removing broken wires **7.05.50 - 14**
Removing the auxiliary jib „HS“ **5.42 - 23, 5.42 - 29**
Removing the auxiliary weights **5.19 - 13, 5.19 - 23, 5.19 - 33**
Removing the ballast plates **5.35.10 - 92, 5.36.10 - 59**
Removing the ballast plates, fastening points: Bitt **5.35.10 - 97, 5.36.10 - 60**
Removing the ballast plates, fastening system: „Twistlock“ **5.35.10 - 95, 5.36.10 - 59**
Removing the ballast trailer **5.35.10 - 91**
Removing the battery **7.05 - 36**
Removing the block connector **5.19 - 27**
Removing the catwalks for transport **2.06 - 13**
Removing the central ballast **3.03 - 19**
Removing the central ballast plates **3.03 - 21**
Removing the central ballast plates, attachment points: Bitt **3.03 - 25**
Removing the central ballast plates, attachment system: „Twist lock“ **3.03 - 21**
Removing the consoles **3.03 - 27**
Removing the consoles for ballast centering **5.36.10 - 64**
Removing the consoles with placed central ballast plates **3.03 - 27**
Removing the counterweight brackets on the turntable **4.07 - 21**
Removing the counterweight plates **4.07 - 18, 4.07.10 - 17**
Removing the counterweight plates, fastening points: Bitt **4.07 - 20, 4.07.10 - 19**
Removing the counterweight plates, fastening system: „Twistlock“ **4.07 - 18, 4.07.10 - 17**
Removing the front and rear platforms **2.06 - 5**

Removing the hoist limit switch weight **4.06 - 20**
 Removing the hook block **5.19 - 13, 5.19 - 23**
 Removing the load hook * **4.06 - 18**
 Removing the platform **2.06 - 9**
 Removing the pulley block on cross brace **5.19 - 15**
 Removing the pulley blocks on the cross brace **5.19 - 27**
 Removing the pulley cart **5.61 - 5**
 Removing the single blocks **5.19 - 33**
 Removing the transport unit **5.36.10 - 20**
 Removing the turntable **3.02 - 11**
 Removing the wedge lock **4.06 - 22**
 Removing winch 1 **3.07 - 13**
 Renewing the pretension of hoist ropes **7.05.50 - 16**
 Repair welding **8.01 - 6**
 Replacing a defective fuse **7.15 - 23**
 Replacing damaged crane components **7.01 - 7**
 Replacing hydraulic hose lines **8.06 - 5**
 Replacing safety ropes subjected to a fall **2.06 - 23**
 Replacing the granular cartridge **7.05 - 35**
 Replacing the hose lines **7.05 - 15**
 Rescue **2.04 - 71**
 Rescuing the assembly personnel **2.04 - 16**
 Resetting the auxiliary heater programming **6.02 - 22**
 Respiratory protection **2.04 - 13**
 Restoring hoist rope pretension **4.08 - 16**
 Resuming crane operation **2.04 - 67**
 Retaining clips **5.01 - 21**
 Retaining elements **5.01 - 14**
 Retaining the engine monitoring screen **4.02 - 213**
 Retracting the boom **2.04 - 59**
 Retracting the D-relapse cylinder **5.05 - 47**
 Retracting the support cylinders **5.35.10 - 23**
 Return filter **7.05 - 11**
 Rigging and fastening points **8.01 - 77**
 Rigging the guy rods on lattice booms on placed down boom system **5.01 - 68**
 Roller set **5.14 - 1**
 Rope end connections **4.06 - 3**
 Rope end connections with locking clamp or locking cast sleeve **4.06 - 3**
 Rope end connection without locking clamp or locking cast sleeve **4.06 - 4**
 Rope pulley **7.06 - 15**
 Rope pulleys **5.01 - 3**
 Rope pulleys and guide pulleys **7.05.50 - 4**
 Rope pulleys and hydraulic cylinders **2.08 - 8**
 Rope reeving **4.06 - 1, 4.06 - 22**
 Ropes **1.03 - 21, 5.01 - 3**
 Rotary connection **7.06 - 7**
 Rotating parts **7.01 - 6**
 Rotating rope end connection **8.04 - 6**
 Rotation resistant ropes **8.04 - 12**
 Rotation-resistant ropes with rope end connections **8.04 - 5**

S

S // SL // SL(HS) // SL9-boom combinations **1.01 - 8**

S/SL-boom **5.38 - 1**
 Safe and problem-free operation **7.05.50 - 4**
 Safety and warning display **0.01 - 1**
 Safety devices on the crane **4.04 - 9**
 Safety equipment **0.01 - 6, 4.04 - 1**
 Safety goggles **2.04 - 13**
 Safety guidelines for travel operation **5.35.10 - 59**
 Safety guidelines in case of external power supply **2.04 - 39**
 Safety harness with height safety equipment **2.04 - 9**
 Safety locking pin **5.01 - 16**
 Safety ropes on the lattice sections **2.06 - 23**
 Safety shoes **2.04 - 13**
 Safety signs **2.04.10 - 3**
 Safety systems **1.02 - 4**
 Safety technical notes for assembly and disassembly **5.01 - 1**
 SA-frame **1.03 - 6, 5.02 - 1, 5.02 - 3**
 S-boom relapse retainer **8.12 - 3**
 Scattered occurring broken wires **8.04 - 10**
 SD // SL2D // SL4D with end section **5.39 - 30**
 SD // SLD // SL2D // SL4D **5.39 - 31**
 SDBW/B // SLDB/BW // SL2DBW/B-boom combinations **1.01 - 12**
 SDWBW/B // SDWVB/BW-boom combinations **1.01 - 16**
 Second inspection (second year) **8.03 - 9**
 Securing against falls **7.01 - 4**
 Securing against operation **7.01 - 4**
 Securing bracket **2.04 - 20**
 Securing personnel on shut off crane **2.04 - 70**
 Securing persons to prevent them from falling **2.04 - 14**
 Securing the counterweight **4.07 - 13, 4.07.10 - 12**
 Selecting a pulley head **4.02 - 47**
 Selecting a pulley head and assigning it to winches **4.02 - 45**
 Selecting the location **2.04 - 24**
 Selecting the set up configuration with short code **4.03 - 37**
 Selecting the travel speed **4.10 - 29**
 Separating the FA-frame relapse retainers **5.13.20 - 15, 5.13.20 - 25, 5.13.20 - 35, 5.13.20 - 42**
 Separating the WA-frame 2 **5.07 - 53**
 Service fluids and lubricants **7.07 - 1**
 Servicing the central lubrication system **7.05 - 23**
 Servicing the central lubrication system of the crawler carrier **7.04 - 11**
 Servicing the track chain **7.04 - 17**
 Servicing the travel gear **7.04 - 3**
 Servo oil pressure monitoring in the winches **4.04 - 15**
 Setting down the suspended ballast pallet **5.36.10 - 58**
 Setting mode **4.02 - 199**
 Setting the adapter on the ballast trailer guide **5.35.10 - 17**
 Setting the ballast trailer radii **5.35.10 - 35**

Setting the FA-frame in the operating position **5.13.20 - 20, 5.13.20 - 30, 5.13.20 - 38, 5.13.20 - 43**
Setting the flap „down-ward“ **5.13.20 - 18, 5.13.20 - 26, 5.13.20 - 34, 5.13.20 - 41**
Setting the hoist rope reeving **4.03 - 37**
Setting the lubrication and break periods. **7.05 - 23**
Setting the operating mode and set up configuration **4.02 - 15**
Setting the operating mode and set up configuration via the 4-digit short code **4.02 - 15**
Setting the operating mode and set up configuration via the function keys **4.02 - 15**
Setting the relapse retainer **5.13 - 27**
Setting the set up configuration with the function keys **4.03 - 37**
Setting the suspended ballast pallet in the assembly position **5.36.10 - 31**
Setting the wheel sets **5.35.10 - 55**
Setting up parallel operation **4.05 - 15**
Setting winch 1 into the turntable **3.07 - 9**
Set up program areas **4.02 - 17**
Shortening the rope **7.05.50 - 16**
Shorting the intervals **8.04 - 25**
Showing the horizontal distance **2.04 - 57**
Showing the vertical distance **2.04 - 54**
Shut off due to error message **4.20 - 24, 4.20 - 72**
Shut off hoist top **4.20 - 23, 4.20 - 71**
Shut off Luffing the auxiliary boom / accessory up / down **4.20 - 19, 4.20 - 67**
Shut off luffing the main boom up / down **4.20 - 18, 4.20 - 66**
Shut off maximum / minimum value test point 1 (force F1) **4.20 - 21, 4.20 - 69**
Shut off maximum value F1 in crane operation **4.20 - 21, 4.20 - 69**
Shut off minimum value F1 in crane operation **4.20 - 21, 4.20 - 69**
Shut off of crane movement: LMB STOP by LICCON overload protection **4.20 - 27, 4.20 - 75**
Shut off spooling the winch up / out **4.20 - 22, 4.20 - 70**
Signs **2.05 - 3**
Signs on the crane **2.05 - 1**
Single hook blocks **5.19 - 29**
Single layer and parallel roped ropes **8.04 - 10**
Single strand height safety equipment **2.04 - 11**
S-intermediate section 12m **1.03 - 10**
S-intermediate section 3m **1.03 - 9**
S-intermediate section 6m **1.03 - 9**
SL10D // SL11D – target boom lengths 102m to 117m **5.39 - 32**
SL10D // SL11D – target boom lengths 126m, 129m, 138m, 141m, 150m, 153m **5.39 - 33**
SL10DFB/B2 // SL11DB/B2- boom combinations **1.01 - 20**
SL13D, SL14D – target boom lengths 102m to 111m **5.39 - 34**

SL13D, SL14D – target boom lengths 114m to 117m **5.39 - 35**
SL13D, SL14D – target boom lengths 120m to 156m **5.39 - 36**
SL13DFB/B2 // SL14DB/B2-boom combinations **1.01 - 22**
SL2DFB/BW // SL4DFB/BW // SL5DFB/BW/B-boom combinations **1.01 - 18**
SLD-boom with SW-end section **5.39 - 29**
Slewing gear **1.02 - 4, 7.04.50 - 3, 7.05 - 33**
Slewing range **4.02 - 113**
Slewing ring connection **7.05 - 17**
SLF // SL3F // SL8F3-boom combinations **1.01 - 10**
SLF-assembly conditions **5.13 - 9**
SLF-boom combination **5.13 - 1**
SLF boom combination- fiber guy ropes **5.13.20 - 1**
Slip-resistant mats **7.01 - 9**
Slopes and excavations **2.04 - 28**
Slowing down a slewing movement **4.05 - 27**
SL-reducer section 6.75m **1.03 - 10**
Sound insulation mats **7.01 - 9**
Special case - F-end section is pinned with F-pivot section (12m F-jib) **5.13 - 9**
Special functions **4.02 - 95**
Specified service fluids and lubricants for Liebherr cranes **7.07 - 3**
Spinning out by turning out the hook block **7.05.50 - 15**
Spinning out with single strand reeving **7.05.50 - 15**
S-pivot section 10m **1.03 - 8**
S-pivot section before installation of both winches **5.38 - 12, 5.39 - 12**
S-pivot section before installation of winch 5 **5.38 - 12, 5.39 - 12**
S-pivot section before installation of winch 6 **5.38 - 12, 5.39 - 12**
S-pivot section without winches **5.38 - 11, 5.39 - 11**
Split pin **5.01 - 15**
Spooling op loose hoist rope **5.19 - 3**
Spooling the hoist rope up **5.38 - 47, 5.39 - 62, 5.42 - 27**
Spooling the winches out **6.05 - 25**
Spooling the winches up **6.05 - 27**
Spooling the winch out **6.05 - 13, 6.05 - 21, 6.05 - 35**
Spooling the winch up **6.05 - 13, 6.05 - 23, 6.05 - 35**
Spring retainer **5.01 - 18**
Stability and tipping safety for ballast trailer not assembled on the turntable **5.35.10 - 5**
Stacking the ballast plates on the ballast trailer, fastening points: Bitt **5.35.10 - 31**
Stacking the ballast plates on the ballast trailer, fastening system „Twistlock“ **5.35.10 - 29**
Standard crane **5.36.10 - 27, 5.36.10 - 67**
Standing levels at D30m without guide **5.36.10 - 8**
Standing levels at D36m with guide B2 **5.36.10 - 9**
Standing levels of the suspended ballast **5.36.10 - 18**
Standing levels of the suspended ballast, reference placement surface of the crawler **5.36.10 - 15, 5.36.10 - 17**

Starting / stopping the program **4.02 - 189**
 Starting and stopping the engine **4.03 - 25**
 Starting LICCON computer system in stand-by mode **4.02 - 217**
 Starting out in strong side wind **4.05 - 29**
 Starting the engine **4.03 - 29**
 Starting the input window hook block weight **4.02 - 53**
 Starting the program **4.02 - 181, 4.02 - 189, 4.02 - 205, 4.02 - 209**
 Starting the winch - pulley head assignment screen **4.02 - 39**
 Starting to drive **2.04 - 60**
 Start operation, follow my instructions **2.04 - 52**
 Start prevention **4.02 - 219**
 Start the emergency operation aggregate **6.05 - 9, 6.05 - 19**
 Steering ability **4.10 - 7**
 Steering and corrective steering of the wheel sets **5.35.10 - 53**
 Steering programs **5.35.10 - 37**
 Steering the crane **4.10 - 39**
 Steering the tracks to the left **4.10 - 39**
 Steering the tracks to the right **4.10 - 39**
 Stepladder **2.04.10 - 12**
 Steps during crane operation **2.06 - 7**
 Steps on the crane chassis **2.06 - 7**
 Steps while the crane is at a standstill **2.06 - 7**
 Stop (normal stop) **2.04 - 52**
 Stopping the mobile crane **2.04 - 61**
 Stopping the program **4.02 - 189**
 Stopping the pull cylinder on the derrick ballast **5.35.10 - 33, 5.36.10 - 43**
 Stopping the slewing movement in strong side wind **4.05 - 29**
 Suitable distribution of surface pressure **4.10 - 7**
 Supplied fall arrest system **2.04 - 8**
 Support **2.04 - 35**
 Support force display **4.02 - 115**
 Support force monitoring * **4.02 - 197**
 Supporting the ballast trailer **5.35.10 - 101**
 Supporting the crane **2.04 - 36, 2.08 - 5**
 Supporting the crane with variable support **2.04 - 36**
 Supporting the crawler center section **3.01 - 5, 3.01 - 49**
 Supporting the SL11-boom from a length of more than 123m **5.39 - 41**
 Supporting the SL13-boom from a length of more than 117m **5.39 - 41**
 Supporting the SL14-boom from a length of more than 117m **5.39 - 42**
 Supporting the SL2/SL4 boom from a length of more than 120m **5.39 - 40**
 Supporting the SL-boom from a length of more than 114m **5.39 - 39**
 Support plates **2.04 - 35**
 Support the SL10-boom from a length of more than 123m **5.39 - 40**

Surface pressures and force distribution when driving the crane **4.10 - 23**
 Surface pressures in case of wind load on boom **4.10 - 23**
 Suspended ballast guide * **5.36.10 - 3, 5.36.10 - 4**
 Suspended ballast guide B2, end section **1.03 - 20**
 Suspended ballast guide B2, intermediate section **1.03 - 20**
 Suspended ballast guide B2, pivot section **1.03 - 19**
 Suspended ballast pallet **5.36.10 - 4, 5.36.10 - 6**
 Suspended load fastening point **2.05 - 8, 2.05 - 9, 2.05 - 9**
 SW // SWF-boom combinations **1.01 - 14**
 SW/SDW boom combination **5.07 - 1**
 SW-end section **1.03 - 11**
 SW-end section and roller set components **5.14 - 3**
 SW-end section fastening points **5.38 - 6, 5.39 - 6**
 SWF-boom combination **5.17 - 1**
 Swing arm crane operator's cab **7.06 - 11**
 Swinging the folding consoles into operating position **5.05 - 27**
 Swinging the railing on the S-pivot section into the operating position **5.38 - 11, 5.39 - 11**
 Switch for crawler operation **4.10 - 27**
 Switching back to the crane operation program **4.02 - 187**
 Switching the slewing gear to freewheeling **4.05 - 31**

T

Take down procedure **5.02 - 11**
 Taking an oil sample **7.01 - 8**
 Taking down the erection racks **5.36.10 - 65**
 Taking on a load **4.08 - 7**
 Taking on a load with cross beam **4.08 - 9**
 Taking over the previously selected set up configuration and hoist rope reeving **4.03 - 35**
 Taking over the settings into the crane operating screen **4.02 - 51**
 Taking the boom down **5.38 - 45**
 Taking the FA-frame down **5.13.20 - 56, 5.13.20 - 62**
 Taking the lattice jib down into the roller cart **5.01 - 30**
 Taking the S-boom down **5.13.20 - 49, 5.39 - 61**
 Taking the SLF-boom down **5.13 - 37, 5.13 - 41**
 Taking the support frames down **5.13.20 - 19, 5.13.20 - 37, 5.13.20 - 43**
 Taking the SWF-booms down **5.17 - 25, 5.17 - 29**
 Technical data **1.03 - 1**
 Technical safety instructions **7.01 - 3**
 Telescopic boom **4.08 - 15**
 Telescopic boom distortion because of sunshine on one side **4.08 - 4**
 Telescoping the ballast trailer guide in **5.35.10 - 35**
 Telescoping the ballast trailer guide out **5.35.10 - 35**
 Temperature operating limits **7.05.50 - 5**
 Tensioning the track chain **7.04 - 18**
 Terminology **1.01 - 1**
 Terms and abbreviations **2.04 - 70**

Test brackets (KMD = force test box) **4.04 - 21**
Testing cylinder pressure with „jib stop in test position“ **8.14 - 3**
Testing the limit switch flap W-lattice jib „Steepest position“, relapse cylinder **5.07 - 27**
Testing the limit switch W-lattice jib „Steepest position“, relapse cylinder **5.07 - 27, 5.07 - 27**
Test point 1 = F1 **4.02 - 137**
Test point 1 = F1 / icon description **4.02 - 141**
Test point 2 = F2 and test point 3 = F3 **4.02 - 147**
The Control parameter program **4.02 - 181**
The Crane operation program on monitor 0 **4.02 - 59**
The Crane operation program on monitor 1 **4.02 - 137**
The engine does not start? **7.15 - 17**
The Engine monitoring program **4.02 - 209**
The function key line in the Crane operation program **4.02 - 127**
The LICCON monitor remains dark **7.15 - 23**
The L-shaped rope end connection with locking clamp or locking cast sleeve (LR 11000 only) **4.06 - 4**
Theoretical service life **8.03 - 5**
The set up program **4.02 - 15**
The Support program **4.02 - 189**
The touch display remains dark **7.15 - 23**
The winch - pulley head assignment screen **4.02 - 39**
The Working range limitation program * **4.02 - 205**
Third inspection (third year) **8.03 - 10**
Tilting the cab upward **4.03 - 19**
Tilting the crane cab **4.03 - 19**
Tilt play of roller ring connection **7.05 - 17**
Tires foamed with special foam **2.15 - 6**
Tire size **7.01 - 7**
Tires with air inflation **2.15 - 5**
Towing **5.35.10 - 43, 5.35.10 - 113**
Tracks **1.02 - 3**
Traffic endangerment and environmental damage **2.04 - 5**
Transfer (between two cranes or two hooks) **2.04 - 57**
Transport **2.04 - 21**
Transporting the hook block **4.08 - 9**
Transport unit **5.36.10 - 5**
Travel gears / hydraulic motors / track rollers **4.10 - 5**
Travel operation **2.04 - 60**
Travel power **1.02 - 3**
Travel route **4.10 - 4**
Troubleshooting on the central lubrication system **7.04 - 17, 7.05 - 27**
Turning / driving in reverse **2.04 - 61**
Turning an extremely rotation-resistant hoist rope out **7.05.50 - 15**
Turning the auxiliary heater off **6.02 - 18**
Turning the crane superstructure **4.05 - 31**
Turning the engine off **4.03 - 33, 4.03 - 33**
Turning the engine off in the event of danger **4.03 - 33**

Turning the heater and climate control system on **4.03 - 19**
Turning the heater on **6.02 - 11**
Turning the hydraulic oil preheating on **2.08 - 4**
Turning the main current circuit off **4.03 - 5**
Turning the power supply of the main current circuit on / off **4.03 - 5**
Turning the rapid gear on **4.10 - 29**
Turning the turntable into assembly position **5.05 - 7**
Turning the turntable into the assembly position **5.38 - 13, 5.39 - 13**
Turning the turntable into the disassembly position **5.38 - 45**
Turning the turntable to the left **6.05 - 15, 6.05 - 29**
Turning the turntable to the right **6.05 - 17, 6.05 - 31**
Turning the „Power Plus“ off **4.05 - 9**
Turntable assembly **3.02 - 1**
Turntable extension **4.07.10 - 1, 4.07.10 - 4**
Turntable with crawler center section **1.03 - 6**
Turntable with Quick Connection **1.03 - 5**
Turntable with Quick Connection * **3.02 - 3**
Two strand height safety equipment **2.04 - 11**
Type of problem **7.15 - 9**
Types of ladders **2.04.10 - 12**

U

Undefined ballast trailer operation **5.35.10 - 69**
Unpinning procedure **5.35.10 - 103**
Unpinning the ballast trailer on the turntable **5.35.10 - 103**
Unpinning the guy rods **5.35.10 - 99**
Unpinning the lattice components **5.01 - 61**
Unpinning the relapse supports **5.07 - 47, 5.08 - 27**
Unpinning the retaining pin **5.36.10 - 38**
Unpinning the S-pivot section on the turntable **5.39 - 73**
Unpinning the suspended ballast guide on the turntable **5.36.10 - 71**
Unpinning the suspended ballast pallet on the D-guy rods **5.36.10 - 63**
Unpinning the suspended ballast pallet on the suspended ballast guide * **5.36.10 - 62**
Unpinning winch 1 on the turntable **3.07 - 17**
Unpin the SA-frame on the turntable **3.05 - 19**
Unreeving the hook block **4.06 - 10, 4.06 - 14, 5.42 - 27**
Unreeving the W-control rope **5.07 - 51**
Unreeving the W-control rope on the pulley sets **5.07 - 51**
Unreeving the W-control rope on the WA-frame 2 **5.07 - 51**
Unreeving the W-control ropes **5.08 - 27**
Unscheduled inspection **8.04 - 3**
Update confirmation **90.05 - 1, 90.05 - 3**
Update to the operating instructions **90.01 - 3**
Used proportion of the theoretical service life **8.03 - 5**
Use of suitable operating fluids **7.01 - 6**
User guidelines **2.04.10 - 8**

User inter-
face **4.02 - 41, 4.02 - 53, 4.02 - 183, 4.02 - 205**
Utilization conditions **5.35.10 - 85, 5.36.10 - 52**

V

Vehicle height **2.05 - 4**
Vertical ladder with transition aid **2.04.10 - 16**
Vertical movements **2.04 - 54**
Vibrations **1.03 - 21**
Vibration sensor **4.05 - 11**
Vibration sensor winch 1 **4.05 - 11**
Vibration sensor winch 2 or slewing gear **4.05 - 11**
Visual check for damage **4.08 - 4**
Visual inspection for leaks **8.03 - 4**
Visual inspections **4.03 - 7**

W

WA-frame 1 and WA-frame 2, end sections (transport unit 2) **1.03 - 16**
WA-frame 2, pivot section (transport unit 3) **1.03 - 17**
Waiting for the boot up phase **4.03 - 35**
Walking on lattice sections or booms **2.04 - 15**
Walking on the telescopic boom **2.04 - 15**
Warning apparel **2.04 - 13**
Warranty and coverage **7.01 - 7**
W-connector head **1.03 - 17**
W-connector head components **5.14 - 3**
Wear **8.15 - 4**
Weights **5.01 - 7**
Welding work on the load **2.04 - 72**
Wheel drive **7.04.50 - 6**
Which data is required by Liebherr Service? **7.15 - 12**
While working with the crane **2.04 - 62**
Winch **7.05 - 29**
Winch 1 **1.03 - 7**
Winch 2 **1.03 - 7**
Winch and master switch assignment to operating modes **4.05 - 3**
Winch component overview **1.01 - 6**
Winch display **4.02 - 121, 4.02 - 163**
Winch displays **4.02 - 161**
Winches **1.02 - 4, 4.02 - 185**
Winches 3 to 6 **4.02 - 161**
Wind influences **2.04 - 43**
Wind influences during crane operation **2.04 - 48**
Wind influences during erection and take-down **2.04 - 47**
Wind influences for „Crane out of operation“ **2.04 - 49**
Wind speed **4.02 - 107**
Wind speed, wind gust speed and wind direction **2.04 - 44**
Wind speed charts for variable support **2.04 - 44**
Wind speed sensor **4.04 - 13**
Winter operation **2.08 - 3**
Wire break increase rate **8.04 - 10**

Wire ropes **4.06 - 3**
Wire ropes and rope end connections **4.06 - 3, 8.04 - 5**
W-lattice jib **8.12 - 7**
W-lattice jib „bottom“ **8.12 - 9**
Working in low temperatures **2.08 - 1**
Working in the vicinity of electricity transmission lines **4.08 - 14**
Working in the vicinity of transmitters **2.04 - 41**
Working on lattice sections or booms **2.04 - 15**
Working on the crane superstructure or boom **2.04 - 23**
Working on the telescopic boom head and / or auxiliary boom **2.04 - 14**
Working ranges of several cranes overlap **2.04 - 51**
Working with a high rope pull **4.08 - 15**
Working with a load **4.08 - 1**
Work station - Crane operator's cab **4.03 - 15**
W-pivot section 10.75m with pivot section WA-frame 1 (transport unit 1) **1.03 - 16**
WV-lattice jib **5.08 - 1**

”

„Closing“ the D-boom **5.05 - 19**
„Opening“ the D-boom and place it down **5.05 - 47**
„Opening“ the S-boom **5.38 - 57**
„Power Plus“ **4.05 - 9**